

# B930 / MPS930b

# Maintenance Manual

011714G

## Copyright Information

---

Copyright © 2007 by Oki Data. All Rights Reserved

## Disclaimer

---

Every effort has been made to ensure that the information in this document is complete, accurate, and up-to-date. The manufacturer assumes no responsibility for the results of errors beyond its control. The manufacturer also cannot guarantee that changes in software and equipment made by other manufacturers and referred to in this guide will not affect the applicability of the information in it. Mention of software products manufactured by other companies does not necessarily constitute endorsement by the manufacturer.

While all reasonable efforts have been made to make this document as accurate and helpful as possible, we make no warranty of any kind, expressed or implied, as to the accuracy or completeness of the information contained herein.

The most up-to-date drivers and manuals are available from the web site:  
<http://www.okiprintingsolutions.com>



# Contents

<b>Chapter 1 Introduction.....</b>	<b>1-1</b>
Conventions.....	1-1
Safety .....	1-1
Laser Beams .....	1-1
<b>Chapter 2 Principles of Operation .....</b>	<b>2-1</b>
Engine .....	2-1
Summary of Print Process .....	2-1
Driving Force Transmission Path .....	2-4
Main Motor.....	2-4
Drum Motor.....	2-5
Paper Transport .....	2-5
Paper Transport Path .....	2-5
Layout of Paper Transport Path .....	2-6
Functions of Main Components .....	2-7
Paper Cassette.....	2-7
Paper Feeder.....	2-8
MPF .....	2-9
Xero .....	2-11
Fuser .....	2-13
Exit.....	2-14
Drive.....	2-15
Electrical Components and Controller .....	2-16
Control.....	2-17
Paper Size Control .....	2-17
ROS Control .....	2-18
Fuser Control.....	2-18
Schematic Diagram of Safety System .....	2-19
1000 Sheet Feeder.....	2-19
Driving Force Transmission Path .....	2-19
Main Motor.....	2-19
Paper Transport .....	2-20
Paper Transport Path .....	2-20
Layout of Paper Transport Path .....	2-21
Paper Transport .....	2-22
Paper Transport Path .....	2-22
Layout of Paper Transport Path .....	2-23
Functions of Main Components .....	2-24
Paper Cassette.....	2-24
Paper Feeder.....	2-25
Main Components .....	2-27
Control.....	2-28
Paper Size Control .....	2-28
Exit 2.....	2-29
Driving Force Transmission Path .....	2-29
Motor Assy Exit 2.....	2-29
Motor Assy-offset.....	2-29
Paper Transport .....	2-30
Paper Transport Path .....	2-30
Layout of Paper Transport Path .....	2-30
Functions of Main Components .....	2-31

---

HCF.....	2-33
Overview .....	2-33
Configuration.....	2-33
Main Functions.....	2-34
Paper Capacity .....	2-34
Paper Size .....	2-34
Feedable Paper Weight .....	2-34
Paper Feeding.....	2-34
Outline.....	2-34
Feeder Block Operation .....	2-36
Transport Block Operation .....	2-37
M/C Status Monitoring.....	2-38
Static Paper Jam Detection .....	2-38
Interlock Detection .....	2-39
Tray Insertion Detection.....	2-39
Paper Size Detection.....	2-40
Tray Lifting.....	2-41
No-Paper Detection.....	2-42
Remaining Paper Volume Detection .....	2-42
Tandem Tray.....	2-43
Driving Force Transmission Path .....	2-43
Main Motor .....	2-43
Paper Transport .....	2-44
Paper Transport Path.....	2-44
Layout of Paper Transport Path.....	2-45
Functions of Main Components.....	2-46
Paper Cassette .....	2-46
Paper Feeder .....	2-48
Main Components.....	2-49
Paper Size Control.....	2-50
Duplex.....	2-51
Driving Force Transmission Path .....	2-51
MOTOR ASSY DUP .....	2-51
Paper Transport .....	2-51
Paper Transport Path.....	2-51
Layout of Paper Transport Path .....	2-52
Functions of Main Components.....	2-53
Finisher .....	2-54
Overview .....	2-54
Configuration.....	2-54
Paper Size and Weight .....	2-55
Functions and Applicable Trays.....	2-56
Paper Transfer .....	2-56
H-TRA .....	2-59
From H-TRA to Puncher .....	2-59
From Puncher to Compile Tray.....	2-60
From Compile Tray to Stacker Tray.....	2-62
From Puncher to Top Tray.....	2-62
Functions of Sensors along the Paper Path .....	2-63
Puncher.....	2-64
Adjusting Punching Positions .....	2-65
Punching .....	2-65
Detecting Punch Dust Full.....	2-66
Detecting Punch Dust Box .....	2-66
Functions of Puncher Sensors/Motors .....	2-66

---

Compile Tray .....	2-68
Outline of Operation .....	2-68
Capacity of Compile Tray .....	2-68
Compile Tray Operation with Multiple Paper Sizes .....	2-69
Tamping .....	2-69
Front Tamping .....	2-69
Rear Tamping .....	2-70
Center Tamping .....	2-70
Determining Tamper Home Position .....	2-71
Tamping .....	2-71
Offsetting .....	2-71
Functions of Compile Tray Sensors/Motors .....	2-72
Stapler .....	2-72
Stapling Operation .....	2-72
Staple Positions .....	2-72
Paper Sizes That Allow Stapling .....	2-73
Stapler Head .....	2-75
Functions of Stapler Sensors/Motors .....	2-76
Operation .....	2-77
Functions of Top Tray Sensors .....	2-77
Stacker Tray .....	2-77
Operation .....	2-77
Full Stack Detection .....	2-79
Functions of Stacker Tray Sensors/Motors .....	2-80
Power Supply and Interlock .....	2-81
<b>Chapter 3 Installation .....</b>	<b>3-1</b>
Engine .....	3-1
Installation .....	3-1
Unpacking .....	3-1
Installation Procedures .....	3-5
1000 Sheet Feeder .....	3-6
Installation .....	3-6
Unpacking .....	3-6
Installation Procedures .....	3-6
Duplex .....	3-8
Installation .....	3-8
Unpacking .....	3-8
Installation Procedures .....	3-9
Exit 2 .....	3-11
Installation .....	3-11
Unpacking .....	3-11
Installation Procedures .....	3-13
High Capacity Feeder (HCF) .....	3-13
Installation .....	3-13
Unpacking .....	3-14
Installation procedures .....	3-15
Tandem Tray .....	3-17
Installation .....	3-17
Unpacking .....	3-17
Installation Procedures .....	3-17
Finisher .....	3-19
Installation .....	3-19
Unpacking .....	3-19
Installation Procedures .....	3-22
<b>Chapter 4 Wiring .....</b>	<b>4-1</b>

---

---

General Wiring Diagram .....	4-1
Engine.....	4-2
Wiring Diagram between Parts.....	4-3
Configuration.....	4-3
Notes on Using the Wiring Diagram between Parts.....	4-4
1 Power supply.....	4-6
2 Fuser.....	4-7
3 Paper Feed.....	4-8
4 Xero / Deve.....	4-9
5 Drive / CRUM.....	4-11
6 Tray1.....	4-13
7 Tray2.....	4-14
8 MPF.....	4-16
9 ROS.....	4-19
10 Exit.....	4-19
11 Controller.....	4-21
1000 Sheet Feeder.....	4-22
General Wiring Diagram.....	4-22
Wiring Diagram between Parts.....	4-22
Configuration.....	4-22
Notes on Using the Wiring Diagram between Parts.....	4-23
1 Drive.....	4-24
2 Tray3.....	4-26
3 Tray4.....	4-28
Duplex.....	4-30
General Wiring Diagram.....	4-30
Wiring Diagram between Parts.....	4-32
Configuration.....	4-32
Notes on Using the Wiring Diagram between Parts.....	4-32
1 Duplex.....	4-33
Exit.....	4-35
General Wiring Diagram.....	4-35
Wiring Diagram between Parts.....	4-36
Configuration.....	4-36
Notes on Using the Wiring Diagram between Parts.....	4-37
1 Motor / Solenoid.....	4-38
2 Sensor / Fan.....	4-39
Finisher.....	4-41
General Wiring Diagram.....	4-41
Configuration.....	4-42
Notes on Using the Wiring Diagram between Parts.....	4-44
1 Power Supply.....	4-46
2 H-Transport.....	4-47
3 Sensor (Paper feed section).....	4-48
4 Sensor (Exit section).....	4-50
5 Motor.....	4-51
6 Motor / Clutch / Solenoid.....	4-52
7 Tamper.....	4-54
8 Stapler.....	4-55
9 Puncher1.....	4-56
10 Puncher2.....	4-57
HCF.....	4-59
General Wiring Diagram.....	4-59
Wiring Diagram between Parts.....	4-60
Configuration.....	4-60

Notes on Using the Wiring Diagram between Parts .....	4-61
1 Switch.....	4-62
2 Sensor.....	4-63
3 Sensor/Motor/Solenoid.....	4-65
Tandem Tray .....	4-67
General Wiring Diagram.....	4-67
Wiring Diagram between Parts .....	4-68
Configuration .....	4-68
Notes on Using the Wiring Diagram between Parts .....	4-69
1 Drive.....	4-70
2 Tray3.....	4-72
3 Tray4.....	4-74
<b>Chapter 5 Plug/Jack.....</b>	<b>5-1</b>
Engine .....	5-1
Connector [P (plug) / J (jack)] .....	5-1
List of P/J.....	5-1
P/J layout diagram.....	5-3
1000 Sheet Feeder.....	5-13
Connector [P (plug) / J (jack)] .....	5-13
List of P/J.....	5-14
P/J layout diagram.....	5-14
Duplex .....	5-16
Connector [P (plug) / J (jack)] .....	5-16
List of P/J.....	5-17
Exit 2.....	5-18
Connector [P (plug) / J (jack)] .....	5-18
List of P/J.....	5-18
Finisher.....	5-20
Connector [P (plug) / J (jack)] .....	5-20
List of P/J.....	5-20
P/J layout diagram.....	5-22
HCF .....	5-29
Connector [P (plug) / J (jack)] .....	5-29
List of P/J.....	5-29
Tandem Tray .....	5-32
Connector [P (plug) / J (jack)] .....	5-32
List of P/J.....	5-32
P/J layout diagram.....	5-34
<b>Chapter 6 Removal / Replacement Procedures .....</b>	<b>6-1</b>
Before starting service work .....	6-1
Confirmation after service.....	6-1
Description of procedures.....	6-1
IOT Covers .....	6-5
Fuser Cover (FR, PR) .....	6-5
Top Rear Cover (PR) .....	6-6
Interlock Switch.....	6-7
Console Panel.....	6-8
Top Cover Assembly (PR) .....	6-9
Front Cover Assembly.....	6-10
Front Cover .....	6-11
Inner Cover Assembly (MN).....	6-12
Upper Right Cover .....	6-13
Lower Right Cover .....	6-14
ESS Cap Cover (PR) .....	6-15
Upper Rear Cover.....	6-16

---

Lower Rear Cover (PR) .....	6-17
MCU Cap Cover .....	6-18
Transportation & Registration .....	6-19
Switch Assembly PS (Tray 1) .....	6-19
Switch Assembly P S (Tray 2) .....	6-20
Feeder 1 Assembly .....	6-21
Feeder 2 Assembly .....	6-23
Front Side Guide Assembly .....	6-26
Rear Side Guide .....	6-28
End Guide .....	6-30
60T Sector Gear .....	6-32
Tray 1&2 Feed Lift Up Motor .....	6-33
Spacer .....	6-34
Gear (31T) .....	6-35
Oneway Clutch .....	6-37
Oneway Gear .....	6-38
Gear (13T) .....	6-39
Actuator .....	6-39
No Paper Sensor .....	6-40
Level Sensor .....	6-41
Pre-Feed Sensor .....	6-43
Gear (28T/21T) .....	6-44
Gear (29T) .....	6-45
Feed Roller Assembly .....	6-46
Oneway Clutch .....	6-47
Oneway Gear (22T) .....	6-47
Friction Clutch .....	6-48
Retard Roller Assembly .....	6-49
Spacer .....	6-50
Gear (33T) .....	6-51
Nudger Roller Assembly .....	6-52
Gear (25T) .....	6-53
Gear (27T) .....	6-54
MPF .....	6-55
MPF Feeder Assembly .....	6-55
Actuator .....	6-56
Photo In Sensor .....	6-57
Pinch Roll Assembly .....	6-58
MPF RR Cover .....	6-59
Collar .....	6-60
Pick Up Gear .....	6-61
Gear 18T .....	6-62
Retard Pad Assembly .....	6-62
Drive Roll Assembly .....	6-64
Pick Up Solenoid .....	6-65
Pick Up Shaft Assembly .....	6-66
Feed Roller Assembly .....	6-68
Cam Gear .....	6-69
Pinion Gear .....	6-70
Front Side Guide .....	6-72
Rear Side Guide .....	6-72
MSI Sensor Assembly .....	6-73
Transportation & Registration .....	6-74
TA Bracket Assembly .....	6-74
CAB Switch I/L .....	6-75

---

TA Roller Assembly.....	6-76
Lower Left Hand Cover Assembly C.....	6-77
Lower Left Hand Bracket Assembly C.....	6-78
TA Pinch Roller.....	6-79
BTR Housing Assembly.....	6-80
Left Hand Cover Assembly.....	6-81
Registration Roller Assembly P.....	6-82
Registration Transport Assembly.....	6-83
Registration Clutch Assembly H.....	6-85
Registration Roller Assembly.....	6-86
Registration Sensor Assembly.....	6-87
TA Clutch Assembly.....	6-88
Sensor.....	6-89
ROS & Xerographics.....	6-91
Xerographic Interlock Switch Assembly.....	6-91
Humidity & Temperature Sensor.....	6-97
CP1 CRUM PWBA Housing.....	6-103
CP1 Toner CRUM PWBA.....	6-104
CTG30 Sub-Guide Assembly.....	6-105
Depense Motor Assembly 30K.....	6-107
Fuser Fan.....	6-108
ROS Assembly 12.....	6-109
Intake Duct.....	6-111
CRU Fan.....	6-113
Fuser & Exit 1.....	6-114
Photo Sensor.....	6-114
Fuser Assembly.....	6-115
Exit Transport Assembly.....	6-116
Offset Motor Assembly.....	6-119
Photo In Sensor (Offset).....	6-120
Photo In Sensor.....	6-121
19T Gear.....	6-122
Exit Gear.....	6-123
OCT Roll Assembly.....	6-124
Offset Gear.....	6-126
Exit 1 Top Cover.....	6-128
Drives.....	6-128
Synchronous Ban Belt.....	6-128
Motor Assembly 242.....	6-129
Electrical.....	6-131
High Voltage Power Supply-Y2.....	6-131
Power Switch.....	6-132
Exit PWBA.....	6-133
MCU F PWBA.....	6-134
Power Unit.....	6-136
AC Chassis Assembly XC.....	6-137
Ground Fault Breaker INL.....	6-139
MN Outlet.....	6-140
ESS Cover Assembly.....	6-141
1000 Sheet Feeder.....	6-142
Top Cover.....	6-142
Foot Cover.....	6-143
Right Cover.....	6-144
Left Cover.....	6-144
Rear Cover.....	6-145

---

Caster (Stopper).....	6-146
Caster.....	6-146
Tray 3 Paper Size Switch .....	6-147
Tray 4 Paper Size Switch .....	6-148
Tray 3 Feeder.....	6-149
Tray 4 Feeder.....	6-151
Front Side Guide Assembly.....	6-152
Rear Side Guide.....	6-154
End Guide .....	6-156
Sector Gear (60T) .....	6-158
Tray 1/2 Feed Lift Up Motor .....	6-159
Spacer .....	6-160
Gear (31T).....	6-161
Oneway Clutch .....	6-162
Oneway Gear .....	6-163
Gear (13T).....	6-164
Actuator .....	6-165
No Paper Sensor.....	6-166
Level Sensor .....	6-167
Pre Feed Sensor .....	6-168
28T/21T Gear .....	6-169
Gear (29T).....	6-170
Feed Roller Assembly .....	6-171
Oneway Clutch.....	6-172
Oneway Gear (22T).....	6-173
Friction Clutch .....	6-174
Retard Roller Assembly.....	6-175
Spacer .....	6-176
Gear (33T).....	6-177
Nudger Roller Assembly.....	6-178
Gear (25T).....	6-179
Gear (27T).....	6-180
Tray 3 Feed Out Sensor.....	6-181
Tray 4 Feed Out Sensor.....	6-182
Upper Takeaway Roll Assembly .....	6-183
Lower Takeaway Roll Assembly .....	6-184
Upper Roll Assembly.....	6-185
Lower Roll Assembly.....	6-186
Upper Pinch Roll .....	6-187
Lower Pinch Roll .....	6-188
Left Cover Interlock Switch.....	6-189
Tray Module PWB .....	6-190
Clutch .....	6-191
Main Motor .....	6-193
Duplex Unit .....	6-194
Duplex Transport Unit .....	6-194
Roll Gear 28 .....	6-196
Idle Gear 33 74.....	6-198
Idle Gear 33.....	6-201
Idle Gear 42.....	6-204
I/L Switch, Cab .....	6-207
Duplex Actuator.....	6-210
Duplex Motor Assembly .....	6-212
Duplex PWBA.....	6-215
Photo In Sensor.....	6-218



---

Duplex Roller A3L .....	6-220
Duplex Roller Assembly .....	6-221
Exit 2 .....	6-222
Exit 2 Transport Assembly .....	6-222
Inverter Roll Assembly .....	6-223
Tray 2 Guide .....	6-226
Full B Actuator.....	6-228
OCT Roll Assembly .....	6-230
Exit Pinch Roller.....	6-231
Exit Actuator.....	6-232
I/L CAB Switch .....	6-233
Offset Gear 2.....	6-234
FU Solenoid Assembly.....	6-236
Solenoid Assembly.....	6-239
Offset Motor Assembly.....	6-240
Photo In Sensor .....	6-242
OCT Photo In Position Sensor .....	6-243
Exit 2 Motor Assembly .....	6-244
Photo In Sensor .....	6-246
Exit Fan .....	6-247
Finisher Unit .....	6-250
Transport Assembly .....	6-250
Staple Finisher .....	6-251
Rear Cover.....	6-253
Top Cover Assembly .....	6-254
Drive Belt.....	6-254
D-Belt Roller Assembly .....	6-255
I-Belt Roller Assembly.....	6-257
Support Roller .....	6-258
Transport Belt.....	6-259
Motor Assembly .....	6-260
Left Top Cover .....	6-262
DL PI-Sensor (H-Transport Interlock Sensor).....	6-262
Sensor Assembly (H-Transport Entrance Sensor).....	6-263
Sensor (H-Transport Exit Sensor).....	6-264
Top Cover .....	6-265
SCT Tray Assembly .....	6-266
Eject Cover.....	6-267
Stacker Tray Assembly .....	6-268
Bottom Cover .....	6-269
Lower Rear Cover .....	6-270
Upper Rear Cover .....	6-271
Top Front Cover.....	6-272
Interlock Switch (Finisher Front Door Switch).....	6-273
Front Cover Assembly.....	6-274
Inner Cover .....	6-275
Left Hand Front Cover.....	6-276
Left Hand Top Cover.....	6-277
Replacement .....	6-278
Left Carriage Assembly.....	6-278
Right Carriage Assembly .....	6-280
Cover Assembly Sensor (Stacker Height Sensor 1) .....	6-282
Cover Assembly Sensor (Stacker Height Sensor 2) .....	6-283
Sensor (Stacker Encode Sensor).....	6-284
Sensor (Upper Limit Sensor/ Stacker No Paper Sensor).....	6-285

---

---

Stacker Bracket Assembly .....	6-286
DC Motor Assembly (Elevator Motor).....	6-289
Punch Frame Assembly .....	6-290
Punch Motor Bracket Assembly (Puncher Move Motor).....	6-293
Sensor (Side Registration Sensor 1 & 2) .....	6-293
Punch Bracket Assembly 2&3 .....	6-295
Guide Assembly .....	6-296
Bracket Assembly (Puncher Motor).....	6-297
Sensor (Puncher Motor Sensor).....	6-299
Sensor (Punch Hole Select/Puncher Front/Puncher Home) .....	6-300
Sensor (Puncher Move Home Sensor) .....	6-301
Sensor (Punch Box Set Sensor) .....	6-302
Stapler Unit.....	6-303
Stapler Assembly .....	6-306
Sensor (Stapler Move Home Position Sensor).....	6-309
Eject Unit Chute Assembly .....	6-310
Solenoid Assembly (Sub Paddle Solenoid).....	6-314
Cyclone Paddle .....	6-316
Paddle Shaft Assembly .....	6-316
Eject Clamp Bracket Assembly .....	6-318
DC Motor Assembly (Eject Clamp Motor).....	6-320
Sensor (Eject Clamp Home Sensor) .....	6-322
Sensor Assembly (Eject Cover Switch).....	6-323
Compiler Tray Assembly .....	6-325
Front Tamper Home Sensor & Rear Tamper Home Sensor .....	6-327
Compiler Tray No Paper Sensor & Paper Actuator Sensor .....	6-329
Motor Assembly 2 (Front Tamper Motor) .....	6-330
Motor Assembly (Rear Tamper Motor).....	6-332
Eject Roll Shaft Assembly .....	6-333
Paddle-set Clamp.....	6-335
Z34 Clutch .....	6-335
Eject Bracket Assembly.....	6-337
Set Clamp Home Sensor.....	6-337
Sensor Assembly (Compile Exit Sensor) .....	6-338
Lower Exit Roll Assembly.....	6-340
Right Lower Exit Chute Assembly .....	6-344
Exit 1 & Exit 2 Pinch Roller Assembly .....	6-348
Paddle Shaft Assembly .....	6-349
Upper Exit Open Chute Assembly.....	6-351
Pinch Roller .....	6-351
Gate.....	6-352
Buffer Gate .....	6-354
Buffer Path Sensor Assembly .....	6-355
Buffer Roll Assembly .....	6-356
Bottom Buffer Chute Assembly .....	6-359
Exit Pinch Roller Assembly .....	6-360
Upper Entrance Chute Assembly .....	6-361
Entrance Pinch Roller Assembly .....	6-363
Transport Entrance Sensor .....	6-363
Entrance Roll Assembly .....	6-365
Finisher Transport Motor & Belt Assembly.....	6-367
Transport Gate Solenoid Bracket Assembly .....	6-369
Buffer Gate Solenoid Bracket Assembly .....	6-370
Top Tray Exit Sensor.....	6-372
Exit Pinch Roller Assembly .....	6-372

---

Top Exit Roll Assembly .....	6-373
Top Tray Full Sensor.....	6-377
Lower Left Top Exit Chute Assembly .....	6-378
Pinch Roller.....	6-379
Gate Sensor.....	6-380
Transport Roll Assembly.....	6-381
Exit Motor Assembly & Belt.....	6-385
Registration Motor Assembly & Belt.....	6-387
Horizontal Transport PWBA .....	6-388
Main-C PWBA .....	6-389
C LVPS .....	6-391
Punch Full Sensor.....	6-392
Left Hinge Assembly/Right Hinge Assembly.....	6-393
Upper Chute Spring .....	6-394
Pinch Roller & Pinch Spring .....	6-395
Top Paper Guide.....	6-396
25N Magnet.....	6-397
High Capacity Feeder (HCF) .....	6-398
HCF Top Cover LG .....	6-398
HCF Right Hand Cover .....	6-399
HCF Tray Set Sensor.....	6-400
HCF Size Sensor R/L.....	6-401
Frame Rack Caster .....	6-402
HCF Left Hand Cover.....	6-402
HCF Rear Cover .....	6-403
Front Cover Assembly.....	6-404
Guide Pin / End Plate.....	6-404
End Guide Assembly.....	6-405
Cable.....	6-406
Right PF2 Gear Bracket Assembly .....	6-409
Bottom Plate Assembly .....	6-410
HCF Feeder Assembly.....	6-411
HCF Motor Assembly .....	6-411
Drive Frame Assembly.....	6-412
Solenoid Assembly.....	6-412
HCF Pre Feed Sensor.....	6-413
Actuator.....	6-414
HCF Level Sensor.....	6-415
HCF No Paper Sensor .....	6-416
Feeder Shaft Assembly.....	6-417
Nudger Roll Assembly.....	6-418
Feed Roll Assembly .....	6-419
Lower Feeder Assembly .....	6-420
Retard Shaft Assembly .....	6-420
Retard Roller Assembly .....	6-421
Top Cover Assembly S .....	6-422
Transport Interlock Switch.....	6-424
HCF TA Sensor Assembly .....	6-425
TA Roller Assembly P .....	6-425
Motor Assembly .....	6-426
Interlock Docking Switch Assembly (HCF Side Out Switch) .....	6-427
PWB Assembly .....	6-428
Tandem Tray .....	6-429
Top Cover .....	6-429
Foot Cover .....	6-430

---

---

Right Cover .....	6-431
Left Lower Cover .....	6-432
Rear Cover .....	6-433
Stopper Caster .....	6-433
Caster .....	6-434
Roll (Center) .....	6-435
Roll (Outboard) .....	6-436
Tray 4 Assembly .....	6-437
Tray 3 Assembly .....	6-438
Tray 3 Cover .....	6-439
Rear Tray Cables .....	6-440
Front Right Tray Cable .....	6-443
Front Left Tray Cable .....	6-445
Bottom Plate .....	6-447
Rack Gear (Tray 3) .....	6-448
Pinion (Tray 3) .....	6-450
Tray 4 Cover .....	6-452
Tray 4 Transport Assembly .....	6-452
Rear Tray Cables (Tray 4) .....	6-453
Front Tray Cables (Tray 4) .....	6-456
Bottom Plate (Tray 4) .....	6-458
Rack Gear (Tray 4) .....	6-458
Pinion (Tray 4) .....	6-460
Takeaway Roll Assembly .....	6-462
Tray 4 Feeder .....	6-463
Tray 4 Feed Out Sensor .....	6-464
Tray 3 Paper Size Switch .....	6-465
Tray 4 Paper Size Switch .....	6-466
Tray 3 Feeder .....	6-467
Takeaway Roll Assembly .....	6-470
Tray 3 Feed Out Sensor .....	6-471
Tray 3/4 Feed Lift Up Motor .....	6-472
Spacer .....	6-472
31T Gear .....	6-473
Oneway Clutch .....	6-474
Oneway Gear .....	6-475
13T Gear .....	6-476
Actuator .....	6-477
Level Sensor .....	6-478
No Paper Sensor .....	6-479
Pre Feed Sensor .....	6-480
28T/21T Gear .....	6-481
29T Gear .....	6-482
Feed Roller Assembly .....	6-483
Oneway Clutch .....	6-484
22T Oneway Gear .....	6-485
Friction Clutch .....	6-486
Retard Roller Assembly .....	6-487
Spacer .....	6-488
33T Gear .....	6-489
Nudger Roller Assembly .....	6-490
25T Gear .....	6-491
27T Gear .....	6-492
Left Cover Assembly .....	6-493
Pinch Roll .....	6-494

Left Cover Interlock Switch .....	6-496
Tray 3 Gear Assembly .....	6-497
Tray 4 Gear Assembly .....	6-498
Main Motor .....	6-499
Tray Module PWB .....	6-500
Takeaway Clutch.....	6-502
<b>Chapter 7 Troubleshooting .....</b>	<b>7-1</b>
Progressing with the Troubleshooting .....	7-2
Flow of Troubleshooting.....	7-2
Preparatory Requirements.....	7-2
Cautions for Service Operations .....	7-3
Cautions for FIP Use.....	7-4
FIP .....	7-6
FIP.....	7-6
Flow of FIP .....	7-6
Error/Status Code List.....	7-6
Error Code FIP .....	7-18
Prefeed SENSOR #1 on JAM (Tray 1 paper feed) .....	7-18
Registration Sensor on JAM (Tray 1 paper feed).....	7-19
Prefeed Sensor #2 on JAM (Tray 2 paper feed) .....	7-21
Tray 2 Feed Out Sensor on JAM (Tray 2 paper feed).....	7-23
Registration Sensor on JAM (Tray 2 paper feed).....	7-24
Tray 2 Feed Out Sensor Static JAM .....	7-26
Registration Sensor on JAM (MPF paper feed) .....	7-27
Registration Sensor off JAM (Too Long).....	7-28
Registration Sensor off JAM (Too Short).....	7-29
Exit Sensor 1 on JAM.....	7-30
Registration Sensor Static on JAM .....	7-32
Exit Sensor 1 off JAM.....	7-32
Exit Sensor 1 off (too short) JAM .....	7-33
Exit Sensor 1 Static JAM.....	7-34
Exit Sensor 2 on JAM.....	7-35
Exit Sensor2 off JAM.....	7-36
Tray1 Lift up /No tray fail .....	7-38
Tray2 Lift up /No tray fail .....	7-40
Exit Module Communication fail.....	7-42
Tray 1 cassette Size fail .....	7-43
Tray 2 cassette Size fail .....	7-44
Toner Cartridge Empty fail .....	7-45
XERO/DEVE Cartridge Set fail .....	7-46
ATC Sensor fail .....	7-47
XERO/DEVE Cartridge Life Over.....	7-47
XERO/DEVE Cartridge CRUM Communication fail .....	7-48
XERO/DEVE Cartridge CRUM Data Write fail .....	7-48
XERO/DEVE Cartridge CRUM ID fail .....	7-49
Toner Cartridge CRUM Communication fail.....	7-50
MCU Toner Cartridge CRUM Data Write fail .....	7-50
Toner Cartridge CRUM ID fail .....	7-51
Main Motor stop error.....	7-51
Image Ready error .....	7-52
Main Motor fail.....	7-52
Drum Motor fail.....	7-53
Laser Power fail .....	7-54
ROS Motor fail.....	7-54
Fuser On Time fail.....	7-55

---

Over Heat Temp fail .....	7-56
Center STS fail .....	7-57
REAR STS fail .....	7-58
P/R STS fail .....	7-59
Cold-Sagging recovery fail .....	7-59
Hot-Sagging recovery fail .....	7-60
Fuser Fan fail .....	7-61
Dispense Motor fail .....	7-62
RAM read/write Check fail .....	7-63
NVM data defect .....	7-63
NVM read/write cannot be executed .....	7-63
CPU Power to access NVM is not enough .....	7-64
CRUM ASIC fail .....	7-64
The PPM information is defect .....	7-64
CRU Fan defect .....	7-65
OCT1 Defect .....	7-66
Tray1 Size sensor broken .....	7-66
Tray2 Size sensor broken .....	7-67
L/H Cover Assembly open .....	7-68
IOT Front Cover open .....	7-69
L/H-L Cover open .....	7-69
Toner Cartridge was PRENEAR empty .....	7-70
Drum life was near to end .....	7-71
No paper in the select paper tray .....	7-71
Paper size mismatch in width .....	7-72
Tray 1 Paper size mismatch in length .....	7-73
Tray 2 Paper size mismatch in length .....	7-75
Face Down Tray1 FULL .....	7-78
Face Down Tray2 FULL .....	7-78
Temperature SENSOR fail .....	7-79
Humidity Sensor fail .....	7-80
Prefeed Sensor #3 on JAM (Tray3 paper feed) .....	7-81
Tray 3 Feed Out Sensor on JAM (Tray 3 paper feed) .....	7-83
Tray 2 Feed Out Sensor on JAM (Tray 3 paper feed) .....	7-85
Registration Sensor on JAM (Tray3 paper feed) .....	7-86
Tray 4 Feed Out Sensor on JAM (Tray 4 paper feed) .....	7-88
Tray 3 Feed Out Sensor on JAM (Tray 4 paper feed) .....	7-90
Tray 2 Feed Out Sensor on JAM (Tray 3 paper feed) .....	7-92
Registration Sensor on JAM (Tray 4 paper feed) .....	7-94
Prefeed Sensor #4 on JAM (Tray4 paper feed) .....	7-95
Tray 3 Feed Out Sensor Static JAM .....	7-97
Tray 4 Feed Out Sensor Static JAM .....	7-98
Tray 3 Lift up /No tray fail .....	7-99
Tray 4 Lift up /No tray fail .....	7-102
Tray 3 cassette Size fail .....	7-104
Tray 4 cassette Size fail .....	7-105
Tray Module NVM out-of-order .....	7-106
Tray Module NVM R/W error .....	7-107
Tray Module Communication fail .....	7-108
TM type error .....	7-108
Tray 3 Size sensor broken .....	7-109
Tray4 Size sensor broken .....	7-110
TM Cover open .....	7-111
No paper in the select paper tray .....	7-112
Paper size mismatch in width .....	7-113

---

Tray 3 Paper size mismatch in length .....	7-114
Tray 4 Paper size mismatch in length .....	7-116
Registration Sensor on JAM (Duplex paper feed).....	7-119
Registration Sensor on JAM (Duplex paper feed).....	7-120
Duplex Sensor Static JAM .....	7-121
Duplex Module Communication fail.....	7-124
DUP MODULE Type fail.....	7-125
DUP Cover open .....	7-125
Exit Sensor2 ON, in FDT1/Fin simp job .....	7-126
Exit Sensor 2 Static JAM.....	7-127
OCT2 fail .....	7-128
L/H-H Cover open .....	7-128
F4-12 Finisher H-Transport Entrance Sensor On Jam .....	7-129
F4-22 Finisher H-Transport Exit Sensor On Jam A .....	7-131
F4-32 Finisher Transport Entrance Sensor On Jam .....	7-134
F4-42 Finisher Buffer Path Sensor On Jam A.....	7-136
F4-52 Finisher Compile Exit Sensor On Jam A .....	7-140
F4-51 Finisher Compile Exit Sensor Off Jam A .....	7-144
F4-61 Finisher Set Eject Jam .....	7-147
F4-71 Finisher Top Tray Exit Sensor On Jam A .....	7-149
F4-72 Finisher Top Tray Exit Sensor Off Jam A .....	7-152
F4-82 Finisher Gate Sensor On Jam .....	7-156
F4-16 Finisher H-Transport Entrance Sensor Static Jam A.....	7-159
F4-26 Finisher H-Transport Exit Sensor Static Jam .....	7-161
F4-36 Finisher Transport Entrance Sensor Static Jam .....	7-163
F4-46 Finisher Buffer Path Sensor Static Jam A .....	7-164
F4-56 Finisher Compile Exit Sensor Static Jam .....	7-167
F4-66 Finisher Compile No Paper Sensor Static Jam .....	7-170
F4-76 Finisher Top Tray Exit Sensor Static Jam A.....	7-172
F4-83 Finisher Gate Sensor Static Jam (to Top Tray) A.....	7-174
F4-86 Finisher Gate Sensor Static Jam (to Stacker Tray) A.....	7-176
H5-11 Stacker Tray Fail .....	7-178
H5-12 Stacker Tray Upper Limit Fail. ....	7-180
H5-13 Stacker Tray Lower Limit Fail. ....	7-183
H5-21 Front Tamper Home Sensor On Fail. ....	7-186
H5-22 Rear Tamper Home Sensor On Fail .....	7-188
H5-23 Front Tamper Home Sensor Off Fail. ....	7-189
H5-24 Rear Tamper Home Sensor Off Fail .....	7-191
H5-31 Puncher Sensor On Fail .....	7-193
H5-32 Puncher Sensor Off Fail .....	7-195
H5-33 Puncher Move Home Sensor On Fail .....	7-197
H5-34 Puncher Move Home Sensor OFF Fail .....	7-198
H5-81 Eject Clamp Home Sensor On Fail .....	7-200
H5-82 Eject Clamp Home Sensor Off Fail .....	7-201
H5-83 Set Clamp Home Sensor On Fail .....	7-203
H5-84 Set Clamp Home Sensor Off Fail .....	7-205
H5-86 Side Registration Sensor Off Fail .....	7-208
H5-91 Stapler Fail .....	7-210
H5-95 Stapler Move Position Sensor On Fail .....	7-211
H5-96 Stapler Move Position Sensor OFF Fail .....	7-213
H5-4 Finisher NVM R/W error .....	7-214
H5-7 MCU-Finisher comm. error .....	7-215
H5-8 Finisher type error .....	7-215
Stacker Tray Full (No Mix): Finisher .....	7-216
Stacker Tray Full (Mix Size): Finisher .....	7-218

---

Finisher Top Tray Full . . . . .	7-221
Staple Pin Empty . . . . .	7-222
Staple Pin Not Ready . . . . .	7-223
Staple NG: Finisher . . . . .	7-224
Stacker Lower Safety: Finisher . . . . .	7-226
Stacker Set Over Count: Finisher . . . . .	7-228
Punch Waste Box Overflow: Finisher . . . . .	7-228
No Punch Waste Box . . . . .	7-229
Finisher Front Cover Open. . . . .	7-231
Finisher H-Transport Cover Open. . . . .	7-232
Finisher Eject Cover Open . . . . .	7-233
C5-1 HCF F/O Sensor On Jam (HCF T/A Sensor On Jam).....	7-235
C5-2 HCF F/O#2 Sensor On Jam .....	7-239
C5-3 HCF Registration Sensor On Jam. . . . .	7-241
C8-5 HCF F/O Sensor Static Jam .....	7-243
H1-5 HCF Lift Up Fail .....	7-246
H6-4 HCF NVM R/W Error. . . . .	7-249
HCF Communication fail. . . . .	7-250
HCF Top Cover Open .....	7-250
HCF Home Position S/W Open .....	7-251
Prefeed SENSOR#3 on JAM (Tray3 paper feed).....	7-253
Tray 3 Feed Out Sensor on JAM (Tray 3 paper feed).....	7-255
Tray 2 Feed Out Sensor on JAM (Tray 3 paper feed).....	7-257
Registration Sensor on JAM (Tray3 paper feed).....	7-258
Tray 4 Feed Out Sensor on JAM (Tray 4 paper feed).....	7-260
Tray 3 Feed Out Sensor on JAM (Tray 4 paper feed).....	7-262
Tray 2 Feed Out Sensor on JAM (Tray 3 paper feed) TTM .....	7-264
Registration Sensor on JAM (Tray4 paper feed).....	7-266
Prefeed Sensor #4 on JAM (Tray4 paper feed) .....	7-268
Tray 3 Feed Out Sensor Static JAM.....	7-270
Tray 4 Feed Out Sensor Static JAM.....	7-270
Tray3 Lift up /No tray fail .....	7-271
Tray4 Lift up /No tray fail .....	7-274
Tray 3 cassette Size fail .....	7-277
Tray 4 cassette Size fail .....	7-278
Tray Module NVM out-of-order.....	7-279
Tray Module NVM R/W error .....	7-279
Tray Module Communication fail .....	7-280
TM type error.....	7-280
Tray3 Size sensor broken .....	7-281
Tray4 Size sensor broken .....	7-282
TM Cover open.....	7-283
No paper in the select paper tray .....	7-284
Paper size mismatch in width .....	7-285
Tray 3 Paper size mismatch in length .....	7-286
Tray 4 Paper size mismatch in length .....	7-289
Image Quality Trouble.....	7-292
Entry Chart for Image Quality Troubleshooting .....	7-292
Faint print (Low contrast).....	7-293
Blank print (No print) .....	7-294
Solid black .....	7-295
Vertical blank lines (White stripes in paper transport direction).....	7-296
Horizontal band cross out.....	7-298
Vertical stripes.....	7-299
Horizontal stripes.....	7-300



Partial lack of Image.....	7-302
Spots.....	7-303
Afterimage.....	7-304
Background (Fog).....	7-305
Skew.....	7-306
Paper damage.....	7-307
No fix.....	7-308
Abnormal Noise Trouble.....	7-310
Entry Chart for Abnormal Noise Troubleshooting.....	7-310
Operation Mode Tables.....	7-311
Normal Operation.....	7-311
During Paper Feeding/Ejecting (Tray 1 - Exit1 Face Down Tray).....	7-314
During Paper Feeding/Ejecting (Tray 2 - Exit 1 Face Down Tray).....	7-316
During Paper Feeding/Ejecting (MPF - Exit 1 Face Down Tray).....	7-318
During Paper Feeding (Tray 3).....	7-320
During Paper Feeding (Tray 4).....	7-322
During Duplex Printing.....	7-324
When Ejecting Paper to Exit 2.....	7-325
During Paper Feeding (to Option DUPLEX).....	7-326
H-TRANSPORT.....	7-328
Top Tray Exiting.....	7-329
Stacker Tray Exiting.....	7-331
During Punching.....	7-333
During Tamping.....	7-334
During Stapling.....	7-335
When Power is Turned On / When Tray is Inserted.....	7-335
During Paper Feeding.....	7-336
During Paper Feeding (Tray 3).....	7-337
During Paper Feeding (Tray 4).....	7-339
Judgment of Print Consistency.....	7-341
Preventive maintenance.....	7-346
<b>Chapter 8 Diagnostics.....</b>	<b>8-1</b>
Entering the Diagnostic Mode.....	8-1
MENU STRUCTURE.....	8-1
Input Tests.....	8-1
Output Tests.....	8-1
Alignment.....	8-1
Maintenance Info.....	8-1
Operator Panel Print Summary.....	8-2
Test Print.....	8-2
Flash Summary.....	8-2
Print Summary.....	8-2
Input Tests.....	8-2
NOTES AND WARNINGS.....	8-2
Output Tests.....	8-9
NOTES AND WARNINGS.....	8-9
Alignment.....	8-14
Maintenance Info.....	8-17
Operator Panel.....	8-18
Test Print.....	8-18
Flash Summary.....	8-18
Print Summary.....	8-19
<b>Chapter 9 Controller/ESS.....</b>	<b>9-1</b>
50PPM Controller Architecture.....	9-1
Actual Controller Layout (PN 101K54690).....	9-2

---

Removal / Installation process .....	9-2
Typical reasons for Controller removal .....	9-4
.....	9-4
<b>Chapter 10 Parts Identification .....</b>	<b>10-1</b>
Engine.....	10-2
Covers 2	
Covers (illustration 1 of 2) 2	
Covers (illustration 2 of 2) 3	
Tray & Feeder 4	
Tray (1/2) & Feeder (1/2) illustrations 5	
Tray (2/2) illustration 7	
Feeder (2/2) illustration 9	
MPF Assembly 11	
MPF Assembly illustration 11	
MPF Lower Frame Assembly illustration 13	
MPF Tray Assembly illustration 15	
L/H Lower 16	
L/H Lower illustration 17	
L/H Upper illustration 19	
L/H Chute Assembly illustration 20	
L/H Cover Assembly illustration 21	
Registration illustration 22	
ROS, CRU & Toner Dispense 23	
ROS, CRU & Toner Dispense illustrations 24	
Fuser & Exit 1 Unit 25	
Fuser & Exit 1 Unit illustrations 26	
Exit 1 illustration 27	
Drive 28	
Drive illustration 29	
Electrical 30	
Electrical (1/2) illustration 31	
Electrical (2/2) illustration 33	
1000 Sheet Feeder .....	10-35
Covers 35	
Covers illustration 35	
Tray (1/2) & Feeder (1/2) illustrations 36	
Tray (2/2) illustration 38	
Feeder (2/2) illustration 40	
Transportation illustration 42	
Drive & Electrical illustration 44	
Duplex Unit .....	10-46
Duplex Unit 46	
Duplex Unit illustration 46	
Inner Chute Assembly illustration 48	
Exit 2 .....	10-50
Exit 2 50	
L/H Upper Chute Assembly illustration 50	
Tray Guide Assembly illustration 52	

---

Finisher Unit .....	10-54
Finisher Unit 54	
Finisher Unit illustration 54	
H-Transport Assembly (1/2) illustration 55	
H-Transport Assembly (2/2) illustration 56	
Finisher Cover (1/2) illustration 58	
Finisher Cover (2/2) illustration 59	
Finisher Stack illustration 61	
Finisher Punch illustration 63	
Finisher Staple illustration 65	
Finisher Eject (1/3) illustration 67	
Finisher Eject (2/3) illustration 69	
Finisher Eject (3/3) illustration 71	
Finisher Transport (1/2) illustration 73	
Finisher Transport (2/2) illustration 75	
Finisher Electrical illustration 77	
Finisher Harness illustration 79	
HCF .....	10-81
HCF 81	
Cover illustration 81	
Tray (1/2) illustration 83	
Tray (2/2) illustration 85	
Feeder (1/3) illustration 87	
Feeder (2/3) illustration 89	
Feeder (3/3) illustration 91	
Drive & Transportation illustration 93	
Electrical illustration 95	
Tandem Tray .....	10-97
Tandem Tray 97	
Cover illustration 97	
Tray 3 illustration 99	
Tray 4 illustration 101	
Feeder (1/3) illustration 103	
Feeder (2/3) illustration 105	
Feeder (3/3) illustration 106	
Transportation illustration 108	
Drive & Electrical illustration 110	

---

# Chapter 1 Introduction

This manual is a standard service manual containing information required for maintenance of this laser printer (standard specifications).

This manual is intended for use by OEMs when they provide maintenance services for this laser printer or when they prepare maintenance data. It is prohibited to use this manual for other purposes.

This document is protected by copyright. It is illegal to photocopy or duplicate any part of this document in any form without previous permission in writing.

Additional information about this printer, such as specifications, can be found in other supplied documents.

## Conventions

*The term “MSI” should be translated to “MPF” (Multi Purpose Feeder) in any text or illustration.*

*Tray numbering for all text and illustrations should be transposed in the following manner:*

Printed Tray #	OKI Tray #
MSI/MPF	5
HCF	6

Maintenance operations requiring special cautions or additional information to descriptions of this manual are presented as “Warning”, “Caution”, or “Note”, according to their nature.



*If instructions are not observed, death or serious injury may be caused.*



*If instructions are not observed, injuries of workers or physical damages to assets (including this laser printer) may result.*

**NOTE** Particularly important essentials for procedures, steps, rules, and other conditions.

*Reference* Incidental information to descriptions.

## Safety

To prevent possible accidents during maintenance operation, you should strictly observe the “Warning” and “Caution” information in this manual.

Performing dangerous operations and procedures out of range of this manual should be avoided.

Occasionally procedures not covered by this manual may be required in actual operation, which

### Laser Beams

This laser printer has a switch (INTERLOCK S/W 5V) which removes power to the laser beam output circuit, preventing operation of the laser beam output unit (ROS ASSY-12). The switch automatically removes power when the CRU is removed.

Do not turn the switch ON except for normal operation to prevent laser emissions during maintenance.

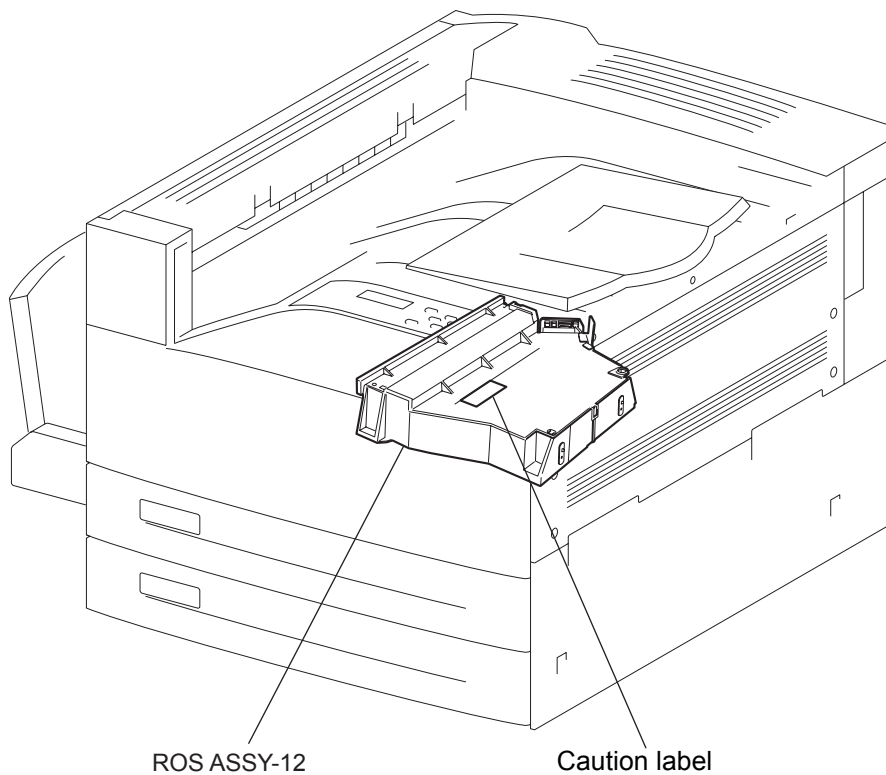


- If your eyes are exposed to laser beams, you may lose your eyesight.
- Never open any cover if warning label for laser beams is attached there.
- Before disassembling and reassembling this laser printer, be sure to turn it OFF.
- When servicing this laser printer while it is running, be sure to follow the procedures specified in this manual.
- You should understand the laser beam is capable of causing injury to the human body, including anyone in the general area.

**NOTE Laser beams have the following characteristics:**

- Frequencies are smaller in width than other beams (sun and electric bulbs) and phases are uniform so that high monochromatic and convergence performance can be obtained and thin beams of light can reach places at a long distance.
- Due to the high convergence, beams are concentrated in high density and high temperature, which is dangerous to human body.

**Reference:** *Laser beams of this laser printer are invisible rays which you cannot see.*



# Chapter 2 Principles of Operation

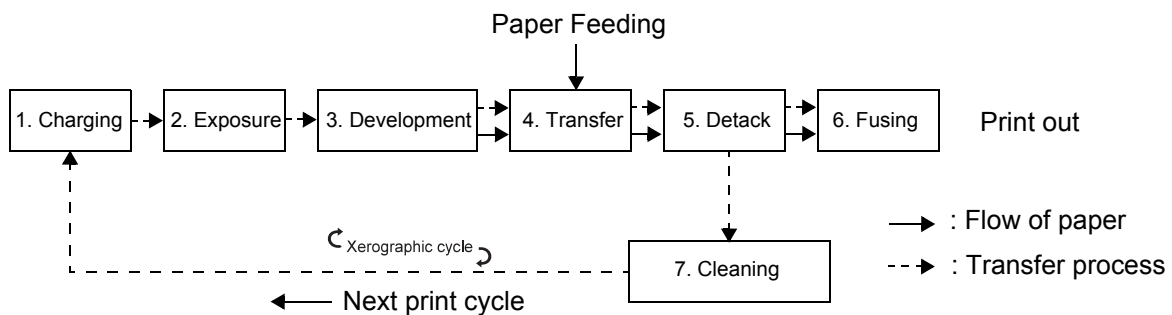
## Engine

### Summary of Print Process

Electrophotography is used in the FIO printer to print image on paper using a video signal sent from the PWBA ESS to the PWBA MCU F. The electrophotography is composed of the following 7 steps.

1. Charging  
Negative charges are uniformly distributed over the drum surface by the Bias Charge Roll.
2. Exposure  
The laser scanner scans the drum surface with a laser beam modulated with the signal from the PWBA ESS (controller), to create an invisible electrostatic latent image on the drum surface.
3. Development  
During development, toner particles are attracted to the electrostatic latent image on the drum surface, forming a visible toner image.
4. Transfer  
The toner image is transferred from the drum surface to the paper.
5. Detack  
Electric charges on the paper are partially neutralized. As a result, the paper is stripped off the drum surface.
6. Fusing  
The toner image is permanently fixed to the paper by heat and pressure.
7. Cleaning  
The remaining toner is removed from the drum surface.

- Summary of print process



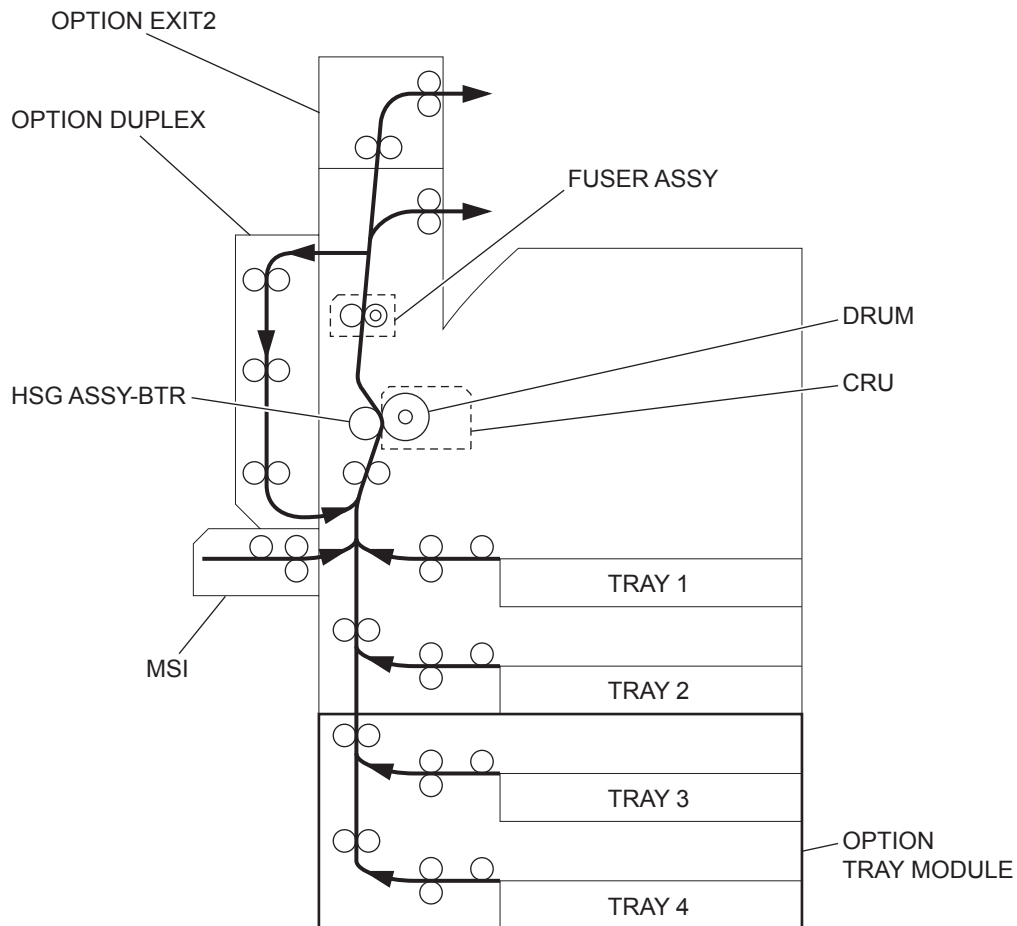
By rotating the drum, the drum surface undergoes various steps including charging, exposure, development, transfer, detack, and cleaning. A toner image is created on the drum surface and transferred to the paper. The paper is subject to the transfer, detack, and fusing steps by the paper transport mechanism. When the paper is positioned relative to the image, the toner image is transferred to the paper from the drum surface, and then fused.

Main components directly associated with the print process and paper transport are illustrated in the following figures.

- Components associated with print process







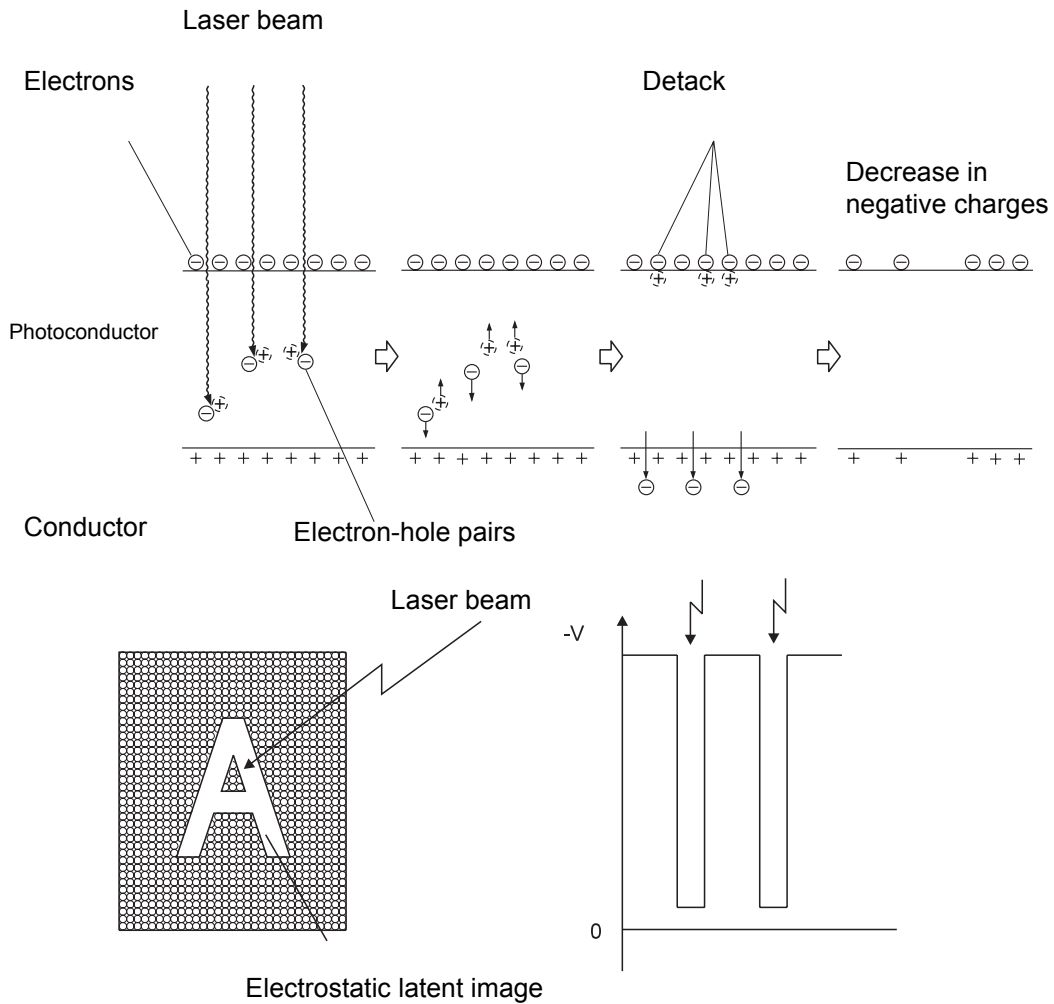
In the exposure step, the negatively charged drum surface is scanned by a laser beam. The laser diode of the ROS (Raster Output Scanner) passes through a rotating polygon mirror (6 facets) and lens scanning the drum from one end to the other.

The radiation of the laser beam varies according to a video signal from the PWBA ESS.

The laser beam shot at the drum excites electrons directed to the photo conductor. As a result, electron-hole pairs are induced in the photoconductive layer. Since electrons are moved toward the body inside the drum by the electric field, the electron-hole pairs move to the surface of the photoconductive layer. Negative charges in the portion decrease, thus creating an invisible electrostatic latent image there.

Toner particles are adsorbed onto this electrostatic latent image in the next step. Thus, the image is developed. The toner particles adsorbed to the drum are attracted to positive charges supplied by the BTR, and are transferred to the paper. The drum is sent for detack and cleaning steps.

- Electrostatic latent image formed on drum



In the cleaning step, the remaining toner is removed from the drum surface. The drum surface is prepared for the next cycle.

The toner is scraped off the drum surface by a cleaning blade.

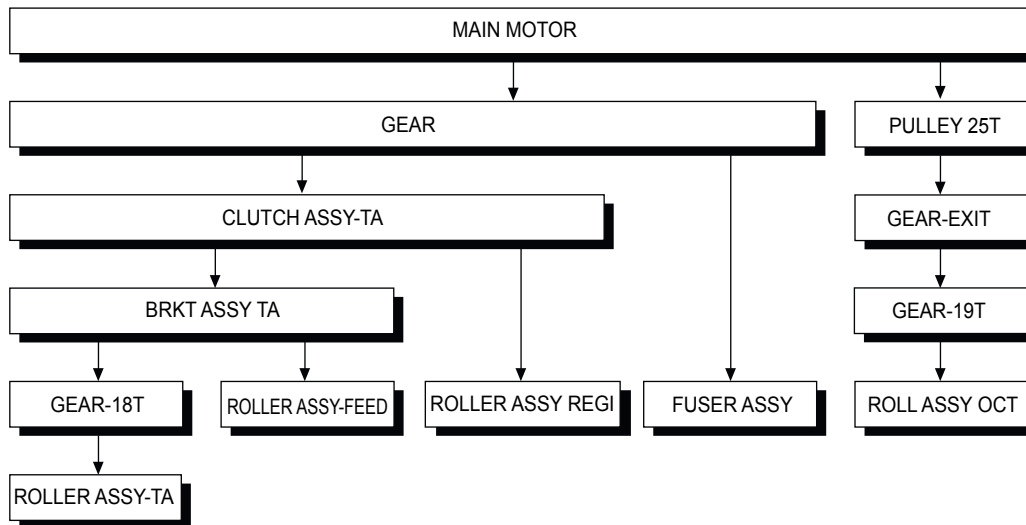
**NOTE** The toner scraped off in the cleaning step is collected in a recovery toner compartment partitioned from unused toner. The transfer rate is normally more than 90%, but varies depending on the image coverage range and environmental conditions such as temperature and humidity. The used toner cannot be reused.

**NOTE** When the printing step is started, the whole drum surface is scanned with a laser beam. If charges generated in the previous step remain on the drum surface, they are completely removed. At the beginning and end of the continuous printing step, a negative high voltage is applied to the BTR. If toner particles adhere to the BTR in the previous printing step, the toner particles are returned to the drum surface. In this way, the surface of the BTR is cleaned.

## Driving Force Transmission Path

### Main Motor

The rotating force of the MAIN MOTOR is transmitted through the GEAR and the PULLEY 25T to components that need mechanical driving force as shown in the following flow.



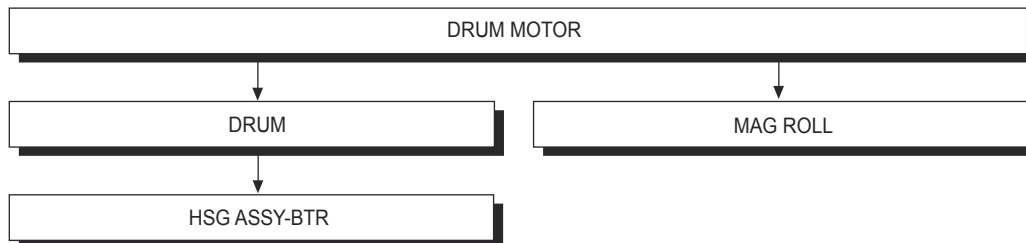
The driving force transmitted to the GEAR drives the ROLLER ASSY-TA, ROLLER ASSY-FEED, ROLLER ASSY REGI, FUSER ASSY, and ROLL ASSY OCT through the clutch and gears.

The driving force transmitted to the PULLEY 25T drives the EXIT1 (ROLL ASSY-OCT) through the gears.

The driving force transmitted to the FUSER ASSY drives the Heat Roll.

## Drum Motor

The rotating force of the DRUM MOTOR is transmitted through the gears to components that need mechanical driving force as shown in the following flow.

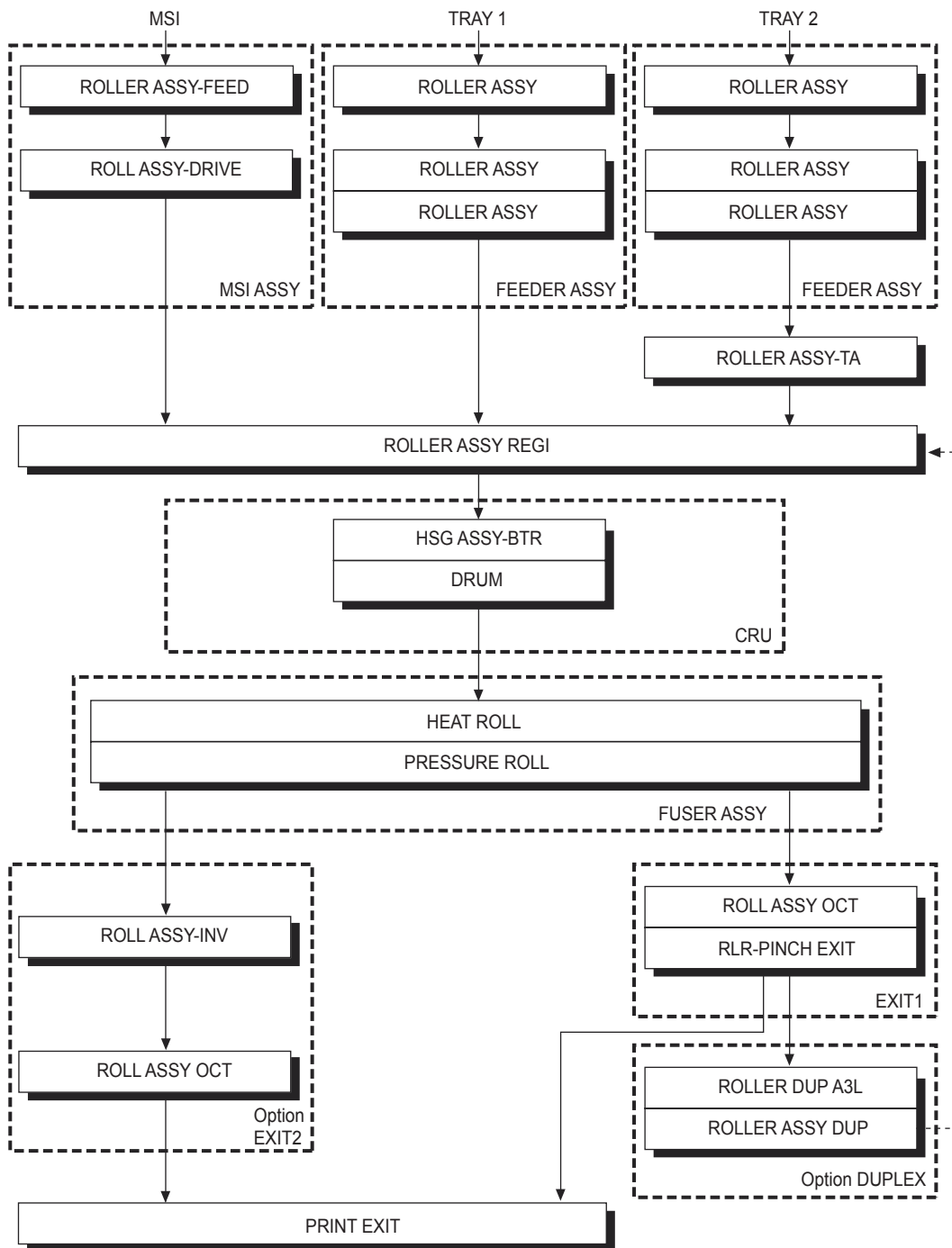


The driving force transmitted to the CRU drives the DRUM. The driving force is then transmitted to the BTR by direct contact with the DRUM.

## Paper Transport

### Paper Transport Path

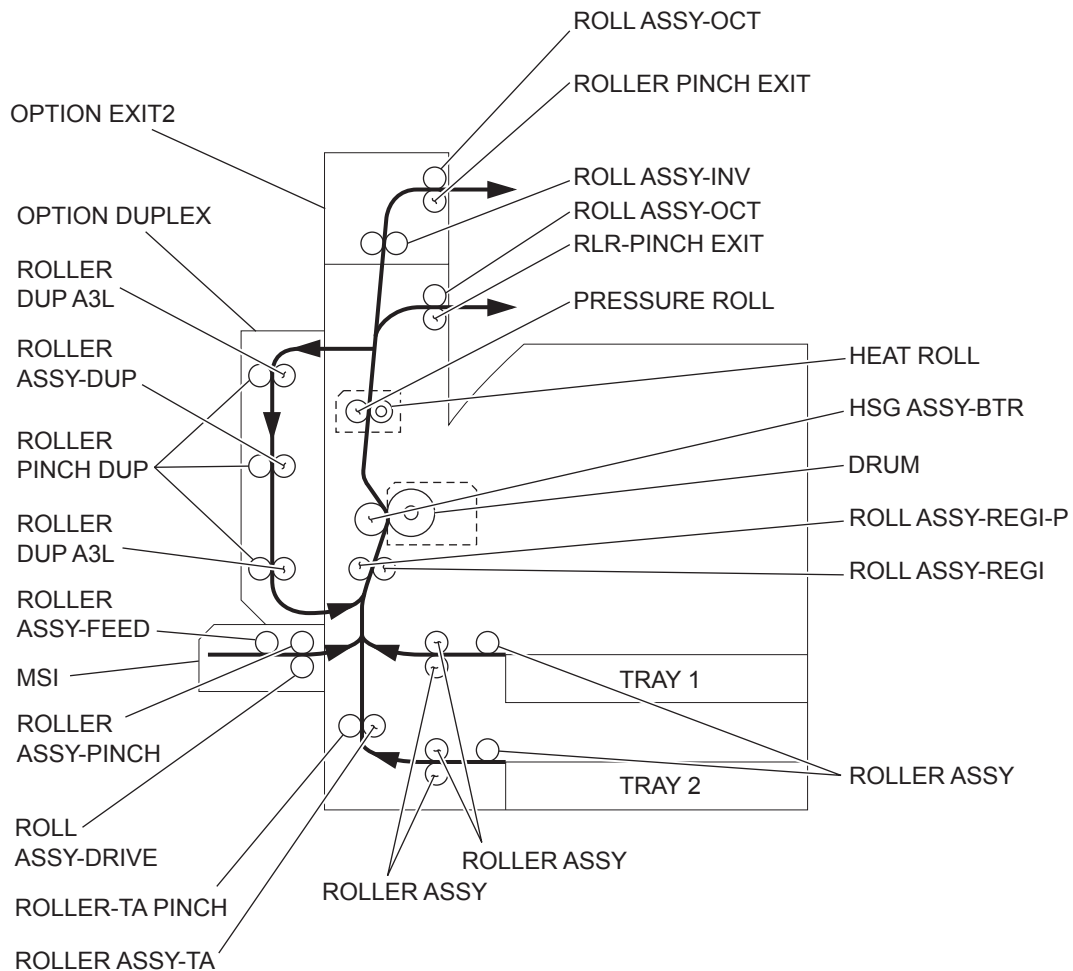
Paper is supplied from the MPF, Tray1 or Tray2, and is transported to the printer along the paper transport path shown below.



## Layout of Paper Transport Path

The following is a cross section of the FIO laser printer, showing main components directly associated with the paper path and transport.

- Main components associated with transport of paper



## Functions of Main Components

This chapter describes the functions of the main components of the FIO laser printer.

- 4.1 Paper Cassette
- 4.2 Paper Feeder
- 4.3 MPF
- 4.4 Xero
- 4.5 Fuser
- 4.6 Drive
- 4.7 Electrical Components and Rollers

### Paper Cassette

It is necessary to adjust the FRONT SIDE GUIDE ASSY, REAR SIDE GUIDE and END GUIDE of the Paper Cassette to match the paper size.

#### FRONT SIDE GUIDE ASSY and REAR SIDE GUIDE

The FRONT SIDE GUIDE ASSY can be adjusted to different paper sizes by moving it to the front or rear. These guides come into contact with the front and rear edges of the paper and hold it in position.

The REAR SIDE GUIDE moves together with the FRONT SIDE GUIDE ASSY.

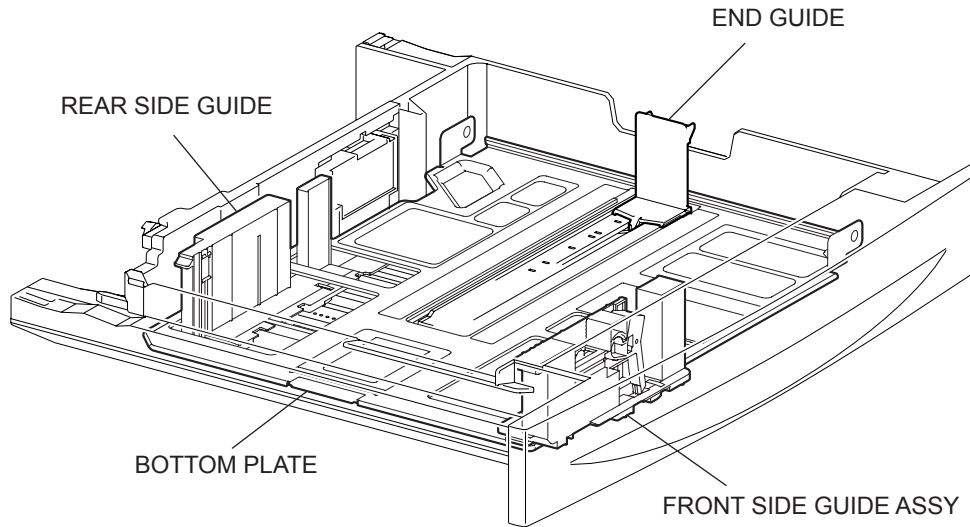
#### END GUIDE

The Paper Cassette is so designed that it can adapt to the paper length in the paper feed direction by moving the END GUIDE to the left or right.

#### BOTTOM PLATE

The force pushing up the BOTTOM PLATE is transmitted by the driving force of the MOTOR on the FEEDER ASSEMBLY to the LIFT UP SHAFT through the GEAR (13T/60T) and SECTOR GEAR (60T). The BOTTOM PLATE is pushed up by the rotation of the LIFT UP SHAFT, which causes the supplied paper to get in contact with the ROLLER ASSY (NUDGER).

- Paper Cassette



#### Detection of paper size

The paper size to which the cassette is set is transmitted to the switches S/W1 to S/W5 on the SWITCH ASSY P S by moving these guides. The paper size is detected by the ON/OFF information of these switches.

Paper sizes that can be automatically detected are as 5.1 Paper Size Control

### Paper Feeder

Since the Tray1 and Tray2 are functionally equivalent in terms of the SWITCH ASSY P S, NO PAPER SENSOR, LEVEL SENSOR and PRE FEED SENSOR, only the components of one tray are described here.

The Paper Feeder is a mechanical unit for supplying paper from the Paper Cassette to the printer. The driving force from the TRAY 1/2 FEED LIFT UP MOTOR on the FEEDER ASSY is transmitted to the three ROLLER ASSY to feed paper.

When the ROLLER ASSY (NUDGER) picks up some sheets of paper and the remaining paper decreases, the ACTUATOR of the LEVEL SENSOR lowers accordingly. When the LEVEL SENSOR detects the lowering, the TRAY 1/2 FEED LIFT UP MOTOR is activated to lift the LIFT UP SHAFT and the BOTTOM PLATE is also lifted accordingly. Thus, the remaining paper is ready to be fed out.

#### TRAY 1/2 FEED LIFT UP MOTOR

This motor is activated to feed paper and to lift the BOTTOM PLATE. When feeding paper, it rotates forward to drive the ROLLER ASSY (NUDGER). When lifting the BOTTOM PLATE, it rotates reversely to drive the tray module gears to lift the LIFT UP SHAFT.

#### SWITCH ASSY P S

This SWITCH ASSY P S switches for setting the size of paper supplied from each Paper Cassette. A signal indicating the set size is transmitted as a voltage to the PWBA MCU F.

#### NO PAPER SENSOR

If paper runs out in a Paper Cassette, the ACTUATOR lowers and the flag of the ACTUATOR that has stayed in the NO PAPER SENSOR sensing area leaves there. Thus, the light

of the sensor is transmitted. When the sensing area is blocked (paper is present), the signal becomes OFF.

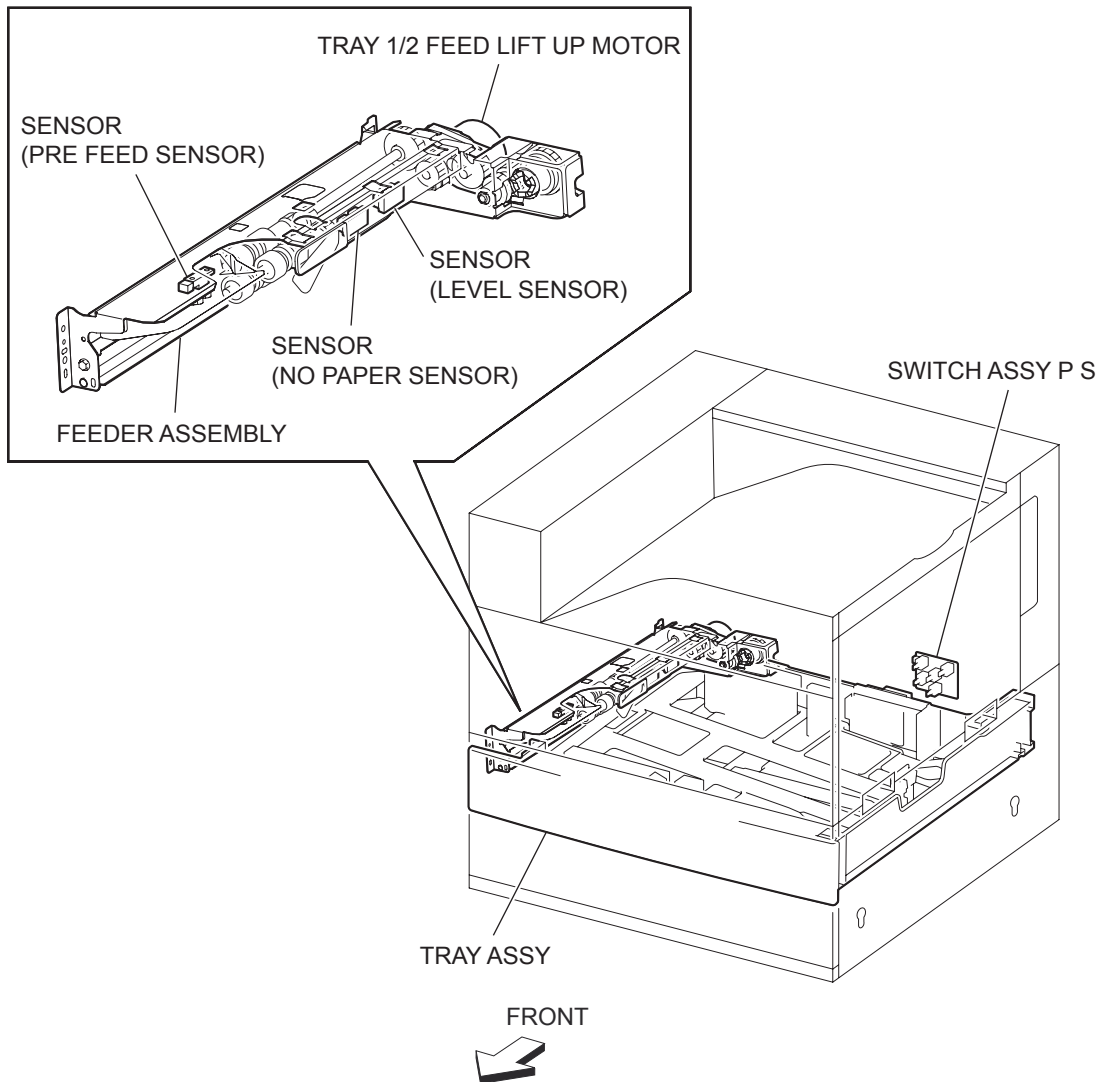
#### LEVEL SENSOR

This sensor detects, by the ACTUATOR position, whether paper in the Paper Cassette is lifted. When the flag of the ACTUATOR leaves the LEVEL SENSOR sensing area, the sensor detects that the paper has been lifted.

#### PRE FEED SENSOR

This sensor detects a paper jam in the Paper Cassette by the paper position and sensor ON/OFF time.

The sensor ON/OFF states can be monitored by paper passing through the PRE FEED SENSOR sensing area.



## MPF

The MPF is a mechanical unit to feed manually supplied paper to the printer. The driving force from the MAIN MOTOR of the MAIN ASSY 242 is transmitted to the ROLLER ASSY-FEED to feed paper.

#### ROLLER ASSY-FEED

The ROLLER ASSY-FEED feeds paper set on the MPF.

#### ROLLER ASSY-DRIVE

The ROLLER ASSY-DRIVE feeds paper into the printer.

**SOLENOID PICK UP**

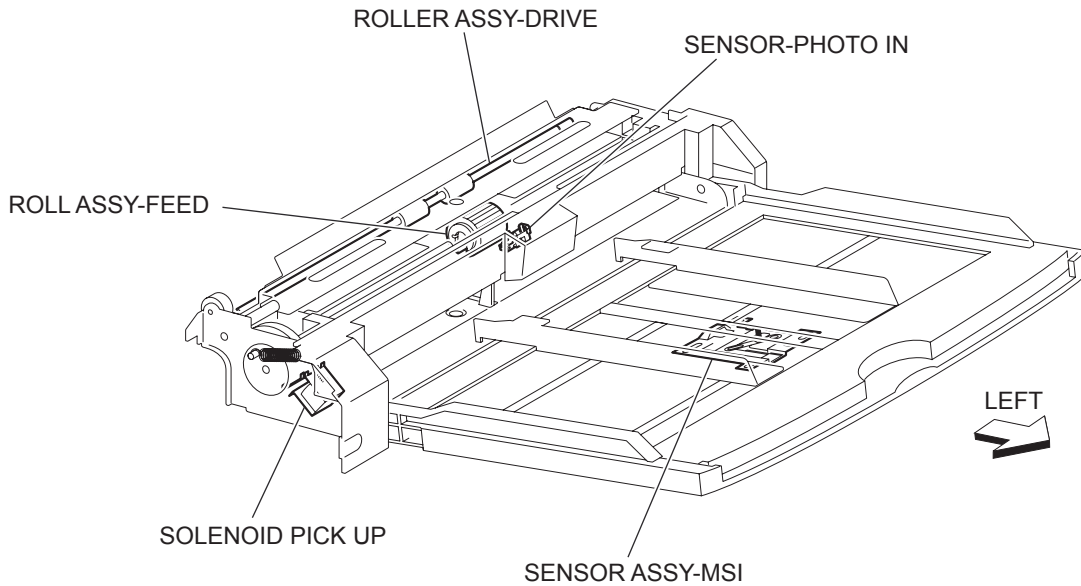
The SOLENOID PICK UP transmits the driving force from the MAIN MOTOR to the ROLLER ASSY-FEED.

**SENSOR-PHOTO IN**

The SENSOR-PHOTO IN detects whether paper is present on the MPF.

**SENSOR ASSY-MPF**

The SENSOR ASSY-MPF detects the width (length in the main scanning direction) of paper on the MPF.



**Detecting paper size**

The size of paper on the MPF is transmitted to the SENSOR ASSY-MPF by moving the MPF paper guide, and is determined by the PWBA MCU F.

Paper sizes that can be automatically detected are as follows:

Paper size	Width (mm)	Feed length (mm)
Side-Guide Stopper (min.)	84	-
Paper detection area (min.)	88.2	-
3.5" x 8.5" SEF	88.9	215.9
Post Card SEF	101.6	152.4
5.5" x 8.5" SEF	139.7	215.9
Postcard LEF	148	100
A6 LEF	148	105
A5 SEF	148	210
Post Card LEF	152.4	101.6
B6 LEF	182	128.5
B5 SEF	182	257
Monarch LEF	190.5	98.4
A5 LEF	210	148
A4 SEF	210	297
5.5" x 8.5" LEF	215.9	139.7
5.5" x 11" SEF (Letter)	215.9	279.4



5.5" x 13" SEF (Legal)	215.9	330.2
5.5" x 14" SEF (Legal)	215.9	355.6
DL LEF	220	110
C5 LEF	229	162
C4 SEF	229	324
Rectangular LEF	235	120
Com10 LEF	241.3	104.8
B5 LEF	257	182
B4 SEF	257	364
Executive LEF	266.7	184.2
16K LEF TFX(PRC)	267(270)	194(195)
8K SEF TFX(PRC)	267(270)	389(390)
8.5" x 11" SEF (Letter)	279.4	215.9
11" x 17" LEF	279.4	431.8
A4 LEF	297	210
A3 SEF	297	420
Stopper (max.)	303	-

## Xero

### CRU

The CRU is made up of the following main six components.

- Drum

The Drum is composed of a photoconductive surface layer (an insulator in the dark but becomes conductor when receiving light) and a conductive inner layer (aluminum cylinder).

The Drum retains electric charges on the surface in the dark, and becomes conductive when exposed to light.

- BCR

The BCR (Bias Charge Roll) uniformly distributes negative charges on the Drum surface.

- Auger

The Auger is a spiral mixer to stir toner supplied from the Toner Cartridge and carriers in the Xero/Deve Cartridge.

- Magnet Roll

The Magnet Roll retains developer in a thin layer on its surface, and feeds toner to the gap between the Drum and the Magnet Roll.

- Finger

The Finger is a mechanism to prevent paper from being caught.

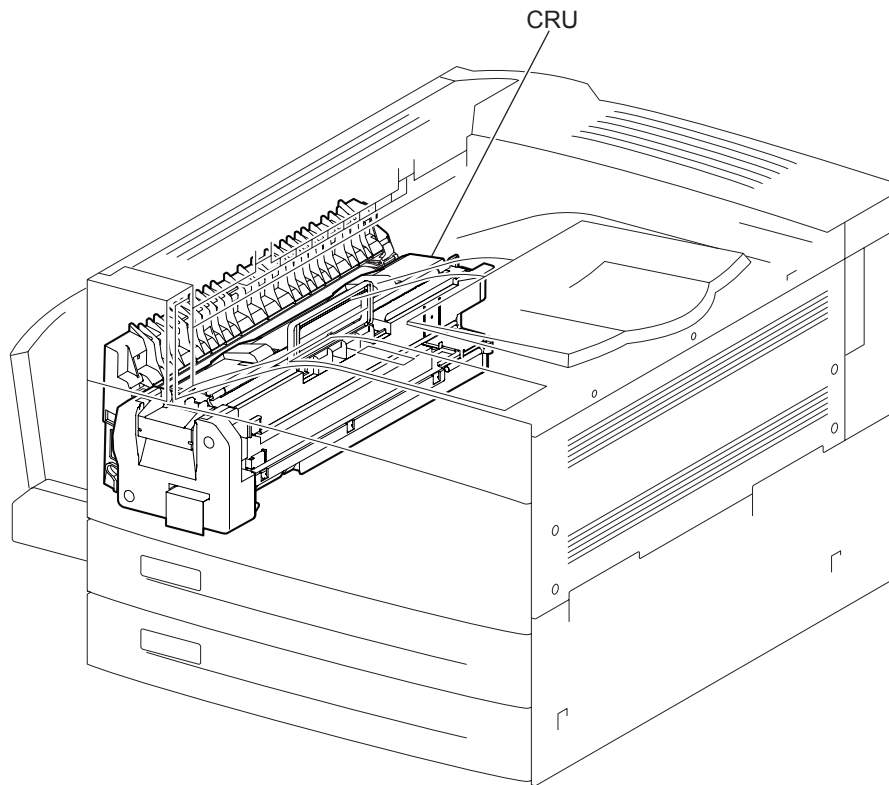
- Cleaning Blade

The Cleaning Blade scrapes toner remaining after the transfer step off the drum surface.

### HSG ASSY-BTR

The BTR of the HSG ASSY-BTR is driven by direct contact with the Drum of the CRU.

The BTR applies positive charges to the rear surface of the paper when the paper passes between the BTR and Drum. The negatively charged toner image is attracted by positive charges on the rear surface of the paper. Thus, the toner image is transferred from the drum surface to the paper surface.



## ROS ASSY

The ROS ASSY-12 scans the drum surface with a laser beam. It consists of four main components: LD (Laser Diode) PWB, ROS MOTOR, POLYGON MIRROR, and SOS PWB.

### (1) LD PWB

The LD PWB generates a laser beam with the two LDs of LD1 and LD2. The beam is turned ON or OFF according to a print data signal.

### (2) ROS MOTOR / POLYGON MIRROR

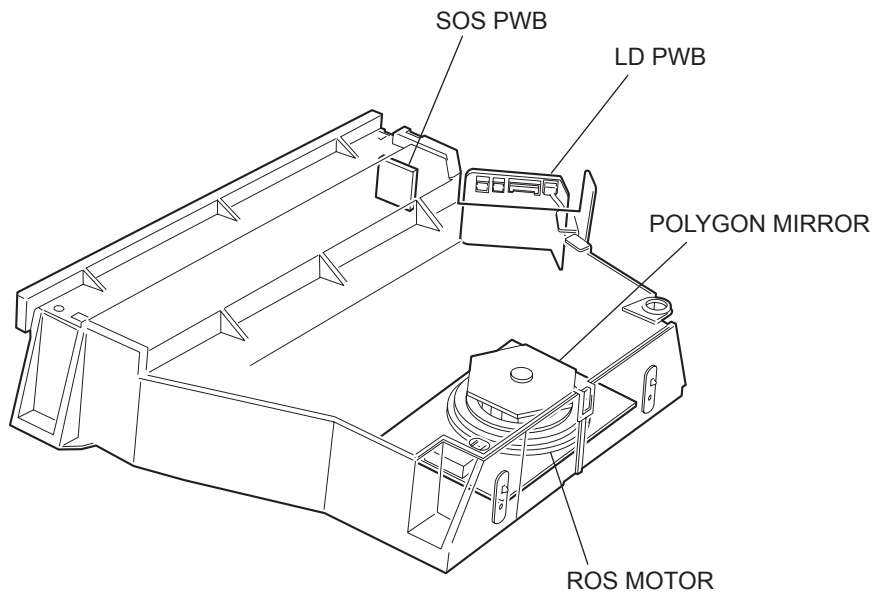
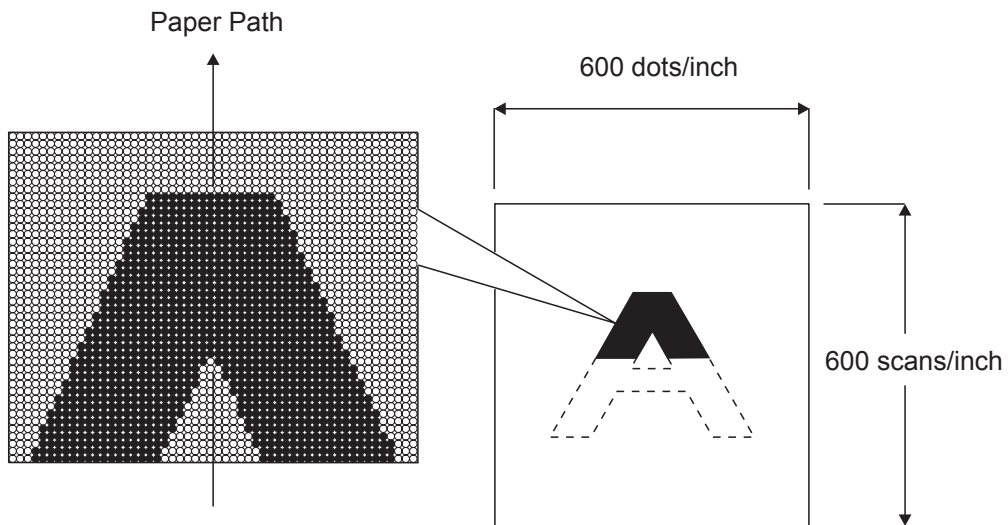
The Polygon Mirror is mounted to the shaft of the ROS Motor, and is rotated at a high speed by the ROS Motor. The mirror rotation shifts the incidence and reflection angles of a laser beam to scan the laser beam in the drum axial direction. The laser beam reached the Polygon Mirror passes through the Lens L1, Lens L2 and Window, and then arrives at the drum surface.

### (3) SOS PWB

When a laser beam hits the SOS Sensor on the SOS PWB, the beam is converted to an electrical signal (SOS signal), and detects the initial position where a scan starts on each line.

When a laser beam is scanned across the drum surface from one end to the other while turning ON and OFF the beam, one line of latent image is created. If the scanning by the laser beam is repeated while rotating the drum, a two-dimensional image is created. The resolution in the scanning direction (from right to left) is determined by the rotational speed of the ROS Motor, depending on how quickly the laser is adjusted. The resolution in the process direction (from top to bottom) is determined by the rotational speed of the ROS Motor. (The higher the scanning speed becomes, the earlier scanning of the next row can be started.)

Conceptual diagram of image creation by scanning:



## Fuser

### Heat Roll

The Heat Roll is a hollow metal tube with its surface coated. This tube is heated by the inner Heater Rod. The heat is applied to the paper passing between the Heat Roll and Pressure Roll, fusing and fixing the toner on the paper.

### Pressure Roll

The Pressure Roll is a metal shaft coated with sponge rubber. Pressure is applied to the paper between the Pressure Roll and Heat Roll, pressing the melted toner against the paper.

### Heater Rod

The Heater Rod of the lamp comprises a quartz glass tube containing a heater coil. A terminal is mounted to the end of the Heater Rod via a harness. Three Heater Rods are provided: the Main Heater Rod to heat entire Heat Roll, and the Sub Heater Rods 1 and 2 to heat the central portion of the Heat Roll.

### Thermostat

If the Heat Roll temperature exceeds the preset temperature, the Thermostat cuts off the circuits of the Main Heater Rod and Sub Heater Rods 1 and 2.

### Center Thermistor

The Center Thermistor monitors the surface temperature of the paper-feed portion of the Heat Roll to control ON/OFF of the Main Heater Rod and Sub Heater Rods 1 and 2.

### Rear Thermistor

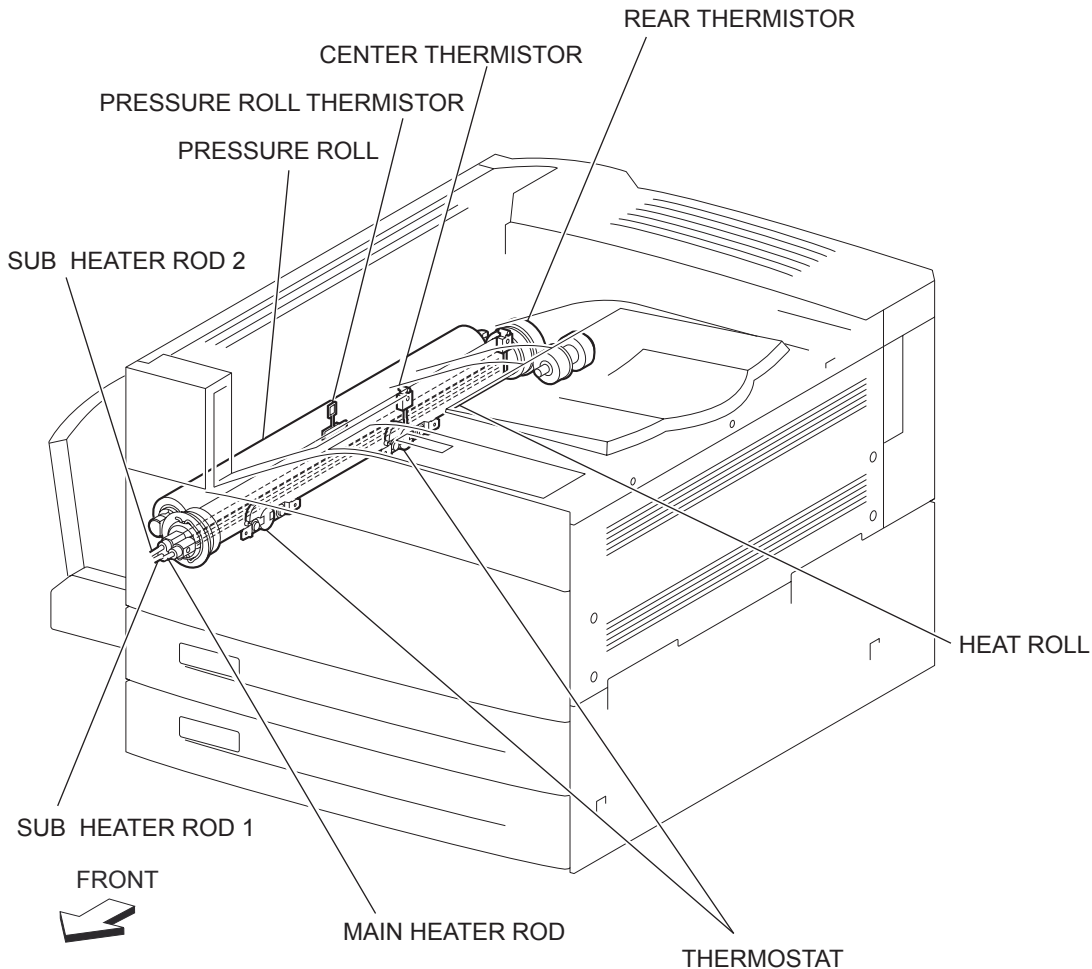
The Rear Thermistor monitors the surface temperature at rear side of the Heat Roll to switch the heater rod to use.

### Pressure Roll Thermistor

The Pressure Roll Thermistor monitors the temperature of the Pressure Roll to control the idling time for fuser warm-up before printing.

### Fuser Exit Sensor

The Fuser Exit Sensor detects the arrival of paper at the detection point in the exit area of the Fuser, and also detects the ejection of paper from this point.



## Exit

The Exit1 is a component to eject printed paper from the printer to the Face Down Tray. With the optional Exit2 installed, it is also possible to eject paper to the Exit2 Face Down Tray by changing the orientation of the Gate-Exit 1 on the Exit1.

### MOTOR ASSY 242

The MOTOR ASSY 242 drives the ROLL ASSY OCT that feeds paper to each tray. With the optional Duplex installed, this motor also has a function to reversely feed paper to the Duplex.

### ROLL ASSY OCT

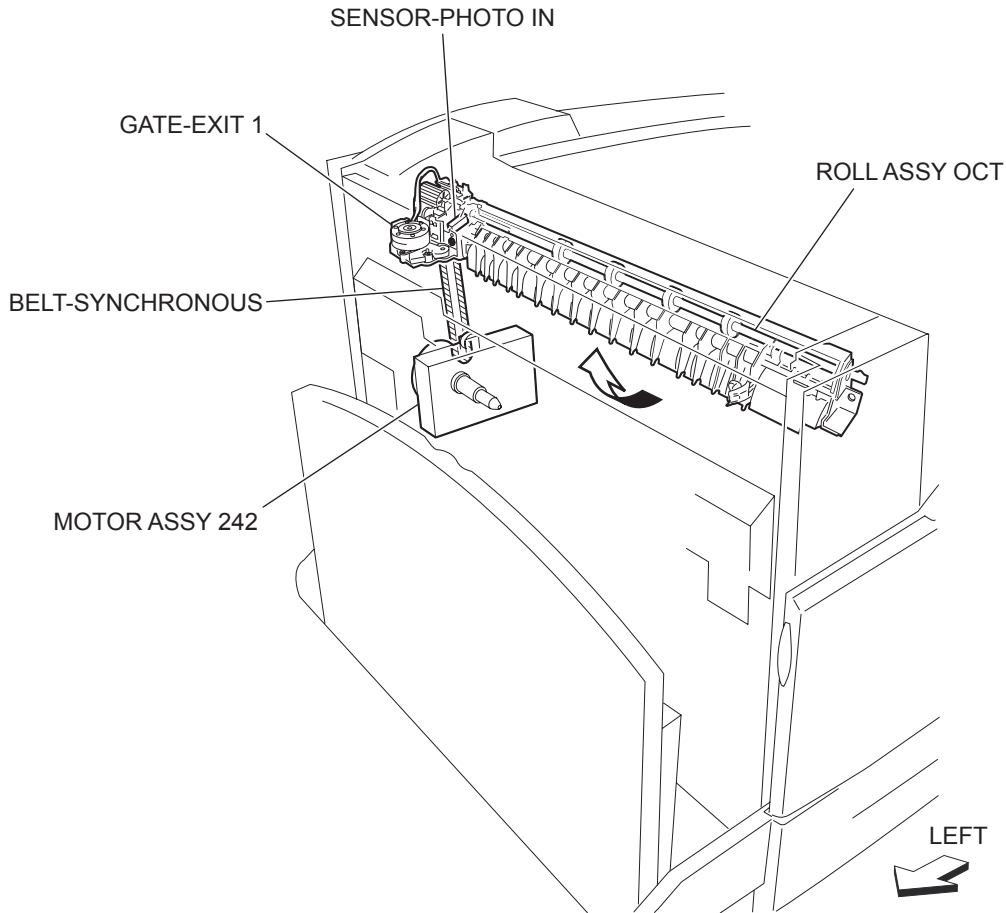
The ROLL ASSY OCT feeds printed paper from the Fuser to the Face Down Trays.

### SENSOR-PHOTO IN

The SENSOR-PHOTO IN detects Exit1 Face Down Tray full by moving the ACTUATOR up and down.

#### GATE-EXIT 1

The GATE-EXIT 1 switches the paper transport path. When the GATE-EXIT 1 is lifted, paper is fed to the Exit1 Face Down Tray. When it is lowered, paper is fed to the Exit2 Face Down Tray.



## Drive

#### MAIN ASSY 242

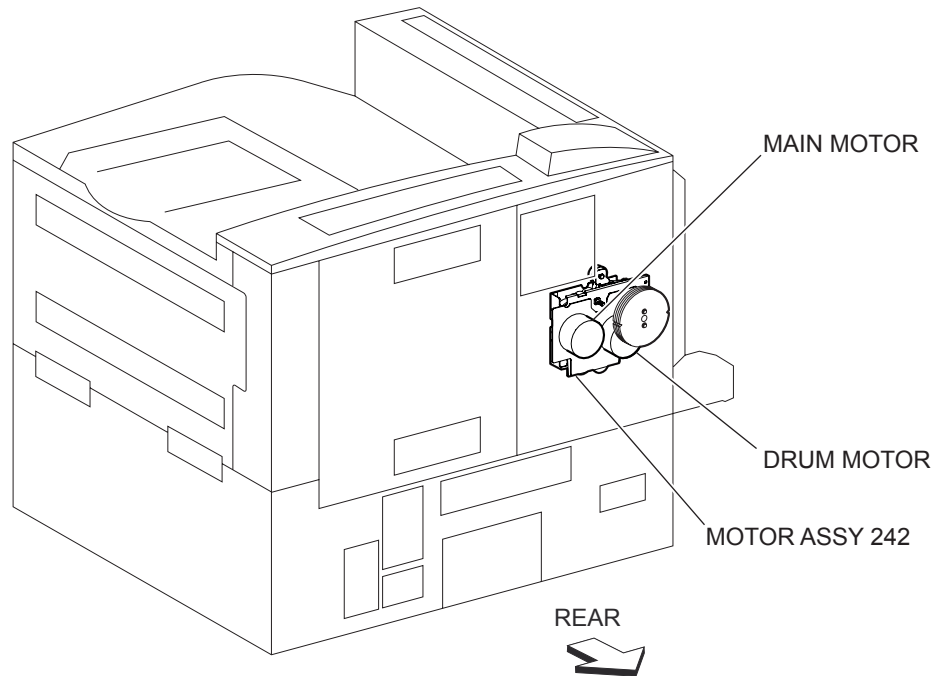
The MAIN ASSY 242, comprising the Main Motor, Fuser Motor and gears, transmits driving force to the components of the printer.

#### Main Motor

The Main Motor is a DC brushless motor to drive the ROLL ASSY OCT, FUSER ASSY, ROLL ASSY REGI, and ROLLER ASSY-TA.

#### Drum Motor

The Drum Motor is a DC brushless motor to drive the CRU Drum, Mag Roll and HSG ASSY-BTR.



## Electrical Components and Controller

### SWITCH-POWER

Turning ON/OFF the SWITCH-POWER supplies/cuts off the main power of the printer.

### OUTLET MN

The OUTLET MN supplies the power to the Finisher directly from the main POWER UNIT.

### SWITCH (24V Interlock Switch)

The SWITCH (24V Interlock Switch) is a safety switch to cut off a 24 VDC power supply from the POWER UNIT to the PSHV-Y2, PWBA MCU F and to the MOTOR ASSY 242, while the COVER ASSY FRONT and the COVER ASSY-LH are open.

### SWITCH ASSY XERO INTLK (5V Interlock Switch)

The SWITCH ASSY XERO INTLK (5V Interlock Switch) is a safety switch to cut off a 5 VDC power supply from the POWER UNIT to the LD PWB of the ROS ASSY-12 while the CRU is removed.

### SWITCH-I/L,CAB

The SWITCH-I/L,CAB detects open/close of the COVER ASSY LH LOW C.

### FAN FUSER

The FAN FUSER discharges air from the printer to prevent excessive temperature increase.

### POWER UNIT

The POWER UNIT generates low voltages (5 V and 3.3 V for logic circuits, 5 V for Laser Diodes, and 24 V for motors/clutches) from AC power. It also contains the Fuser Relay to feed/cut off AC power to the Heater Rod of the FUSER ASSY.

### PSHV-Y2

The PSHV-Y2 generates AC power and a high DC voltage, and feeds them to the charging (BCR), development (Magnet Roll), transfer (BTR), and peeling (Detack Saw) units.

### PWBA MCU F

The PWBA MCU F controls printing operation based on the communication with the Print Controller and on sensor/switch information. It also controls optional module boards.

### PWBA ESS

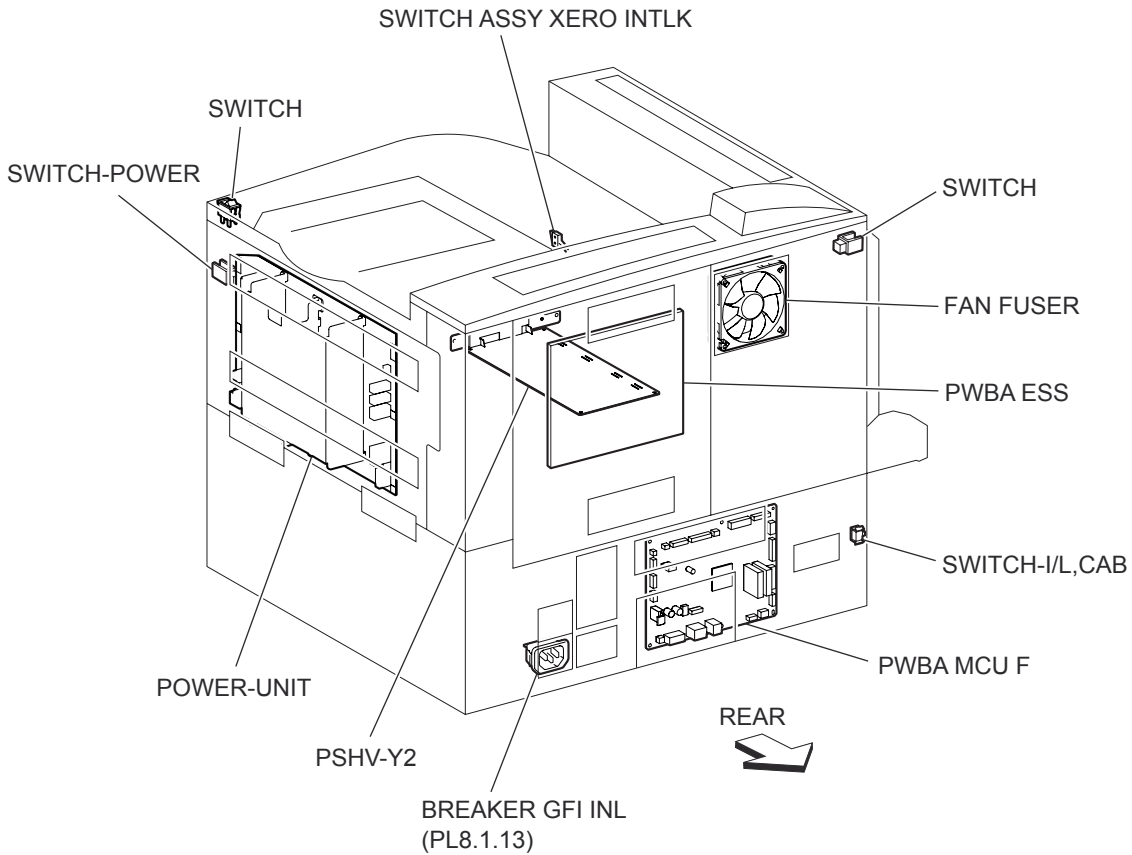
The PWBA ESS connected to the PWBA MCU F controls the entire system.

**ROLLER ASSY-TA**

The ROLLER ASSY-TA feeds paper from the Tray2 or an optional tray to the CRU or Fuser.

**ROLLER ASSY REGI**

The ROLLER ASSY REGI feeds paper from the Tray2, optional tray or MPF to the CRU or Fuser.



**Control**

**Paper Size Control**

***Paper Cassette Feeding***

The following table gives the states (ON/OFF) of the switches on the Switch ASSY P S, corresponding to the paper sizes of the Paper Cassette.

**NOTE** The switches on the Switch ASSY P S are denoted by “S/W2”, “S/W4”, “S/W3”, “S/W5”, and “S/W1” respectively from the left side.

Paper Size	ANALOG SWITCH				DIGITAL SWITCH
	S/W1	S/W2	S/W3	S/W4	S/W5
No Cassette	OFF	OFF	OFF	OFF	OFF
5.5" x 8.5"SEF/A5 SEF	OFF	OFF	ON	OFF	OFF
B5 SEF	OFF	OFF	ON	ON	ON
8.5" x 13"SEF	OFF	ON	OFF	ON	OFF
8.5" x 14"SEF	OFF	ON	OFF	ON	ON
A4 SEF	OFF	ON	ON	OFF	OFF
8.5" x 11"SEF	OFF	ON	ON	OFF	ON
A4 LEF	ON	OFF	ON	OFF	OFF

A3 SEF	ON	OFF	ON	ON	OFF
B5 LEF/Executive LEF	ON	ON	OFF	OFF	ON
8K SEF(TFX/GCO)	ON	ON	OFF	ON	OFF
B4 SEF	ON	ON	OFF	ON	ON
8.5" x 11"LEF	ON	ON	ON	OFF	OFF
16K LEF(TFX/GCO)	ON	ON	ON	OFF	ON
11" x 17"LEF	ON	ON	ON	ON	ON

## ROS Control

### **Rotation of ROS Motor**

The ON/OFF control of the ROS Motor is performed according to the mode of operation as shown below.

Operation mode	ROS Motor ON/OFF
Standby mode	Always OFF
Print mode	Turns ON upon receiving the signal from the controller, and turns OFF after a preset time has passed from the end of printing. Also turns OFF if a print command is not received within 30 seconds from the reception of the signal.
Sleep mode	Always OFF

### **Determination of ROS Ready**

The ROS goes into ready state after the specified period passes since the reception of the ROS MPA start signal and the SOS cycle exceeds the reference value.

### **ROS Reference Value**

ROS reference value	Description
Ready reference value	SOS signal interval (equivalent to 98% or more of the rated rpm of the ROS Motor)
Fail reference value	SOS signal interval (less than 98% of the rated rpm of the ROS Motor)

## Fuser Control

### **Fuser Control Method**

The ON/OFF control of the Main/Sub Heater Rods is performed based on the Fuser control temperature. The Fuser transits between the five states (Warm UP, Ready, Standby, Print, and Low Power) depending on the Heat Roll surface temperature or printer conditions.

The Fuser temperature control starts when the Fuser Ready in the POWER UNIT is turned ON after a preset time period has passed from power ON. If a failure occurs, the Heater Rods are turned OFF, then the Fuser Ready is turned OFF, and then the Fuser temperature control is stopped.

### **Main/Sub Heater Rods ON/OFF Control**

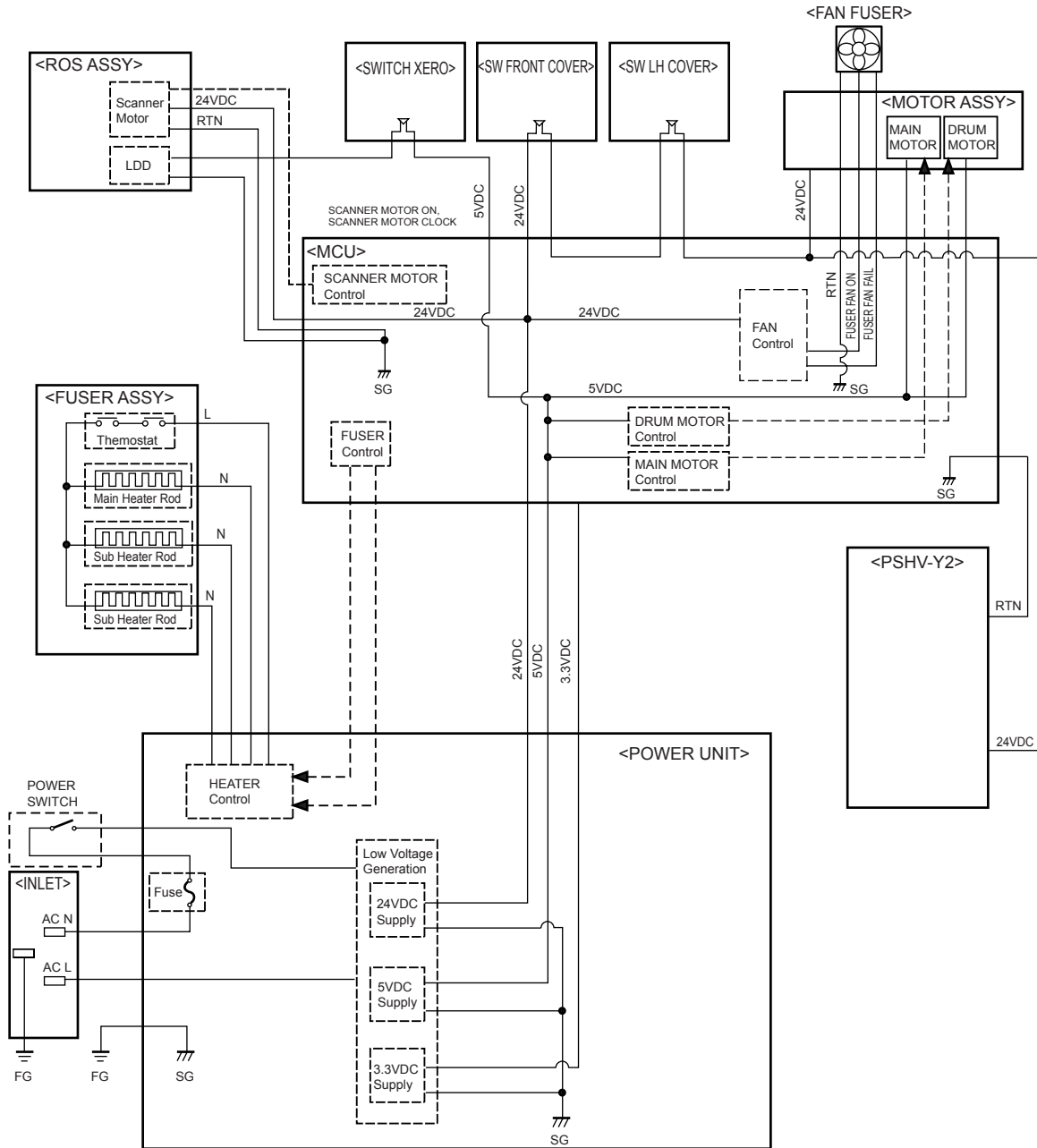
The Center and Rear Thermistors detect the Heat Roll surface temperature (Fuser temperature) to regulate the temperature at the target control temperature by turning ON or OFF the Main/Sub Heater Rods.

### **Fuser Warm-up**



The Fuser warm-up starts at the time of power ON, interlock open/close, jam reset, or return from the Low Power mode, and ends when the Ready temperature is attained, when a failure occurs, or when executing Diagnosis.

## Schematic Diagram of Safety System

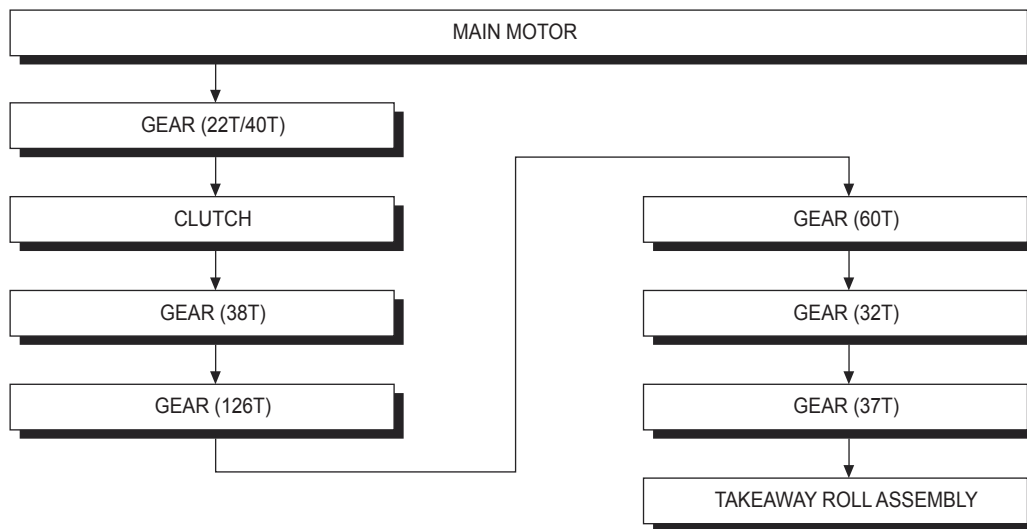


## 1000 Sheet Feeder

### Driving Force Transmission Path

#### Main Motor

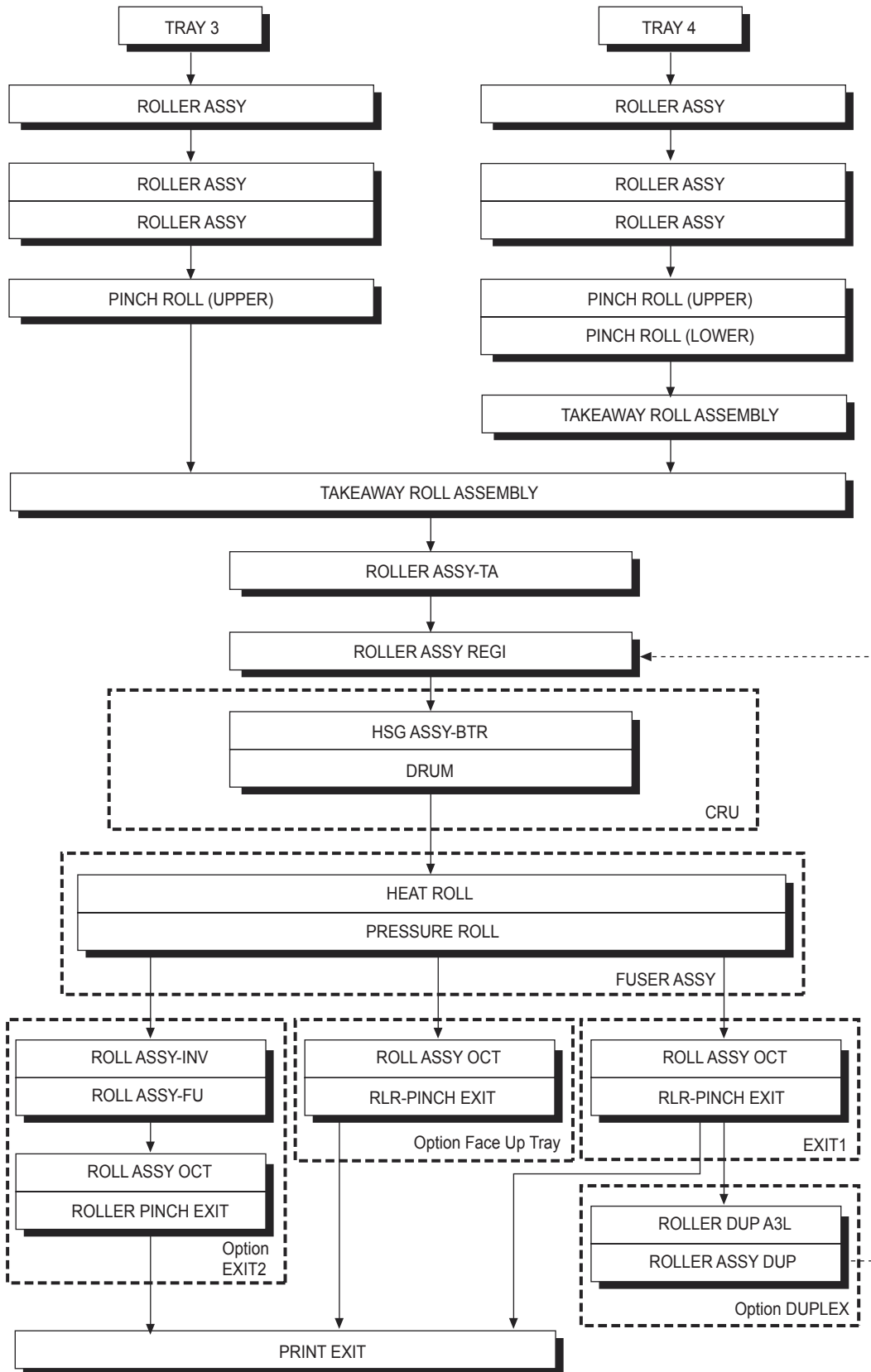
The rotating force of the MAIN MOTOR is transmitted through the gears to components that need mechanical driving force as shown in the following flow.



## Paper Transport

### Paper Transport Path

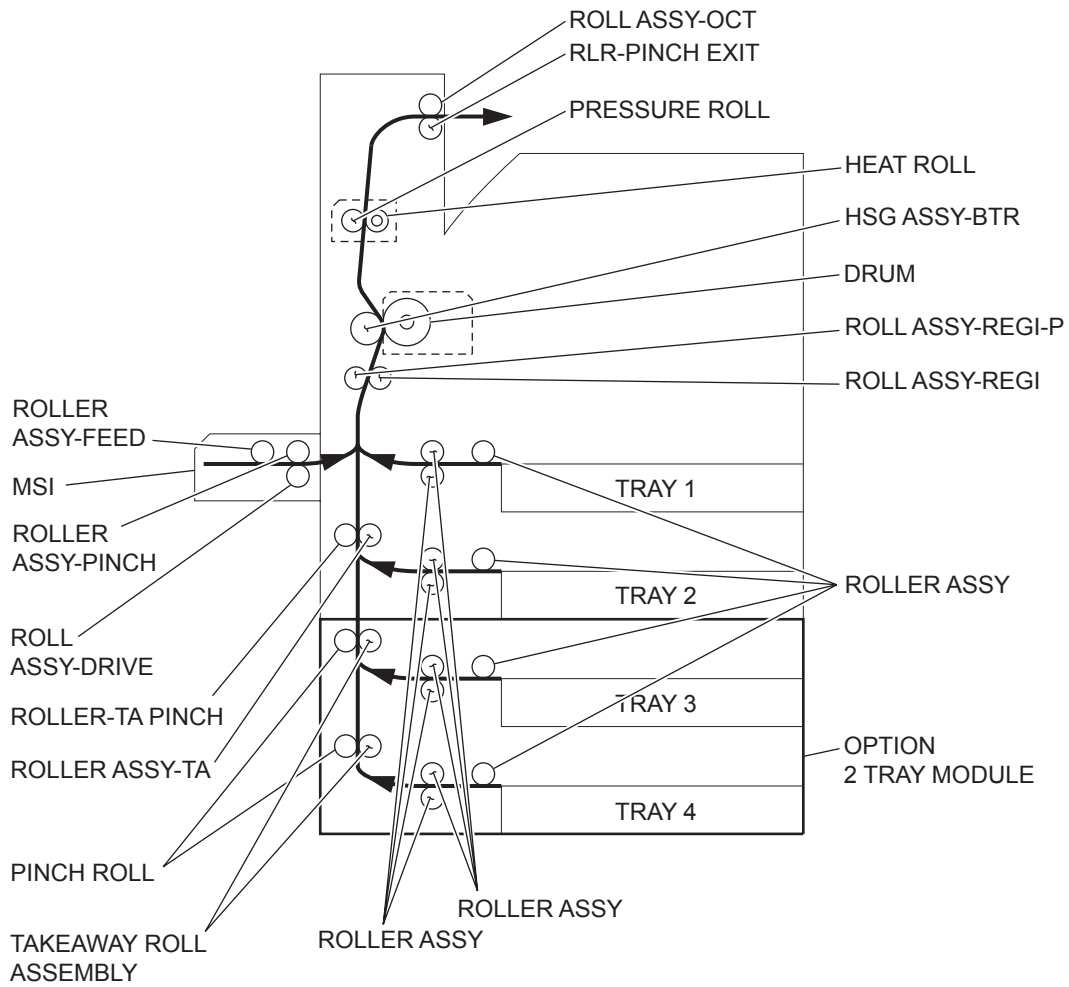
Paper is supplied from the Tray3 or Tray4, and is transported to the printer along the paper transport path shown below.



### Layout of Paper Transport Path

The following is a cross section of the FIO laser printer and the optional 2 TRAY MODULE, showing main components directly associated with the paper path and transport.

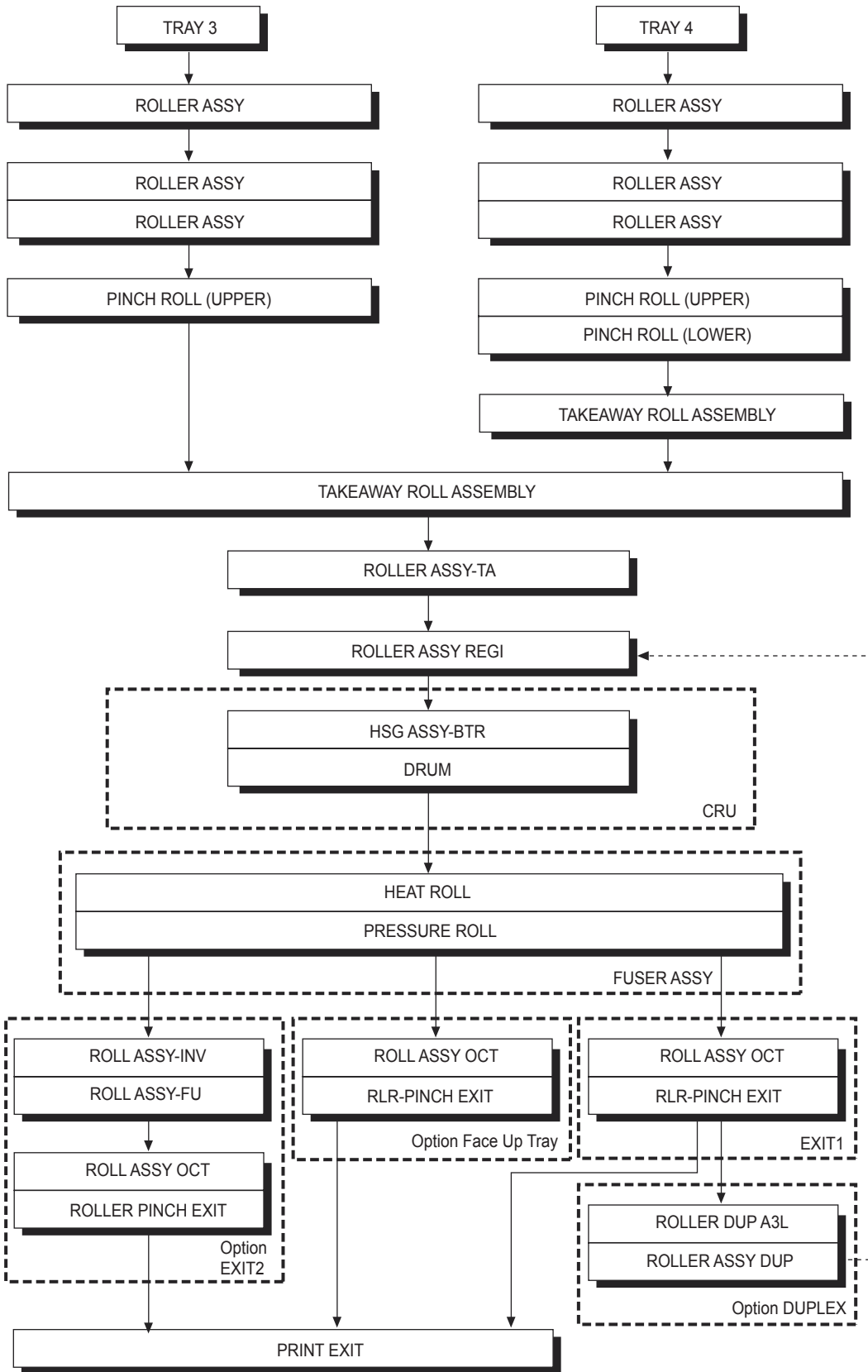
- Main components associated with the paper transport



## Paper Transport

### Paper Transport Path

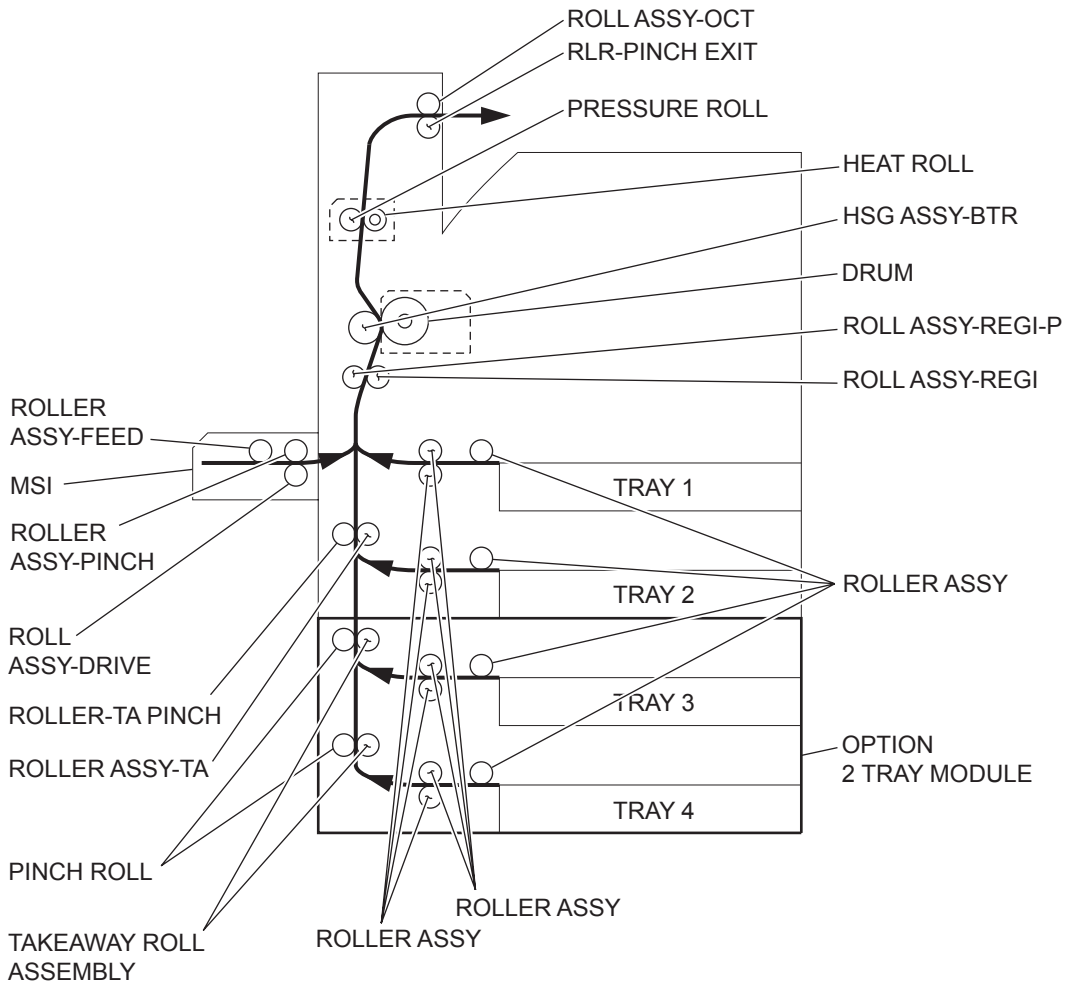
Paper is supplied from the Tray3 or Tray4, and is transported to the printer along the paper transport path shown below.



**Layout of Paper Transport Path**

The following is a cross section of the FIO laser printer and the optional 2 TRAY MODULE, showing main components directly associated with the paper path and transport.

- Main components associated with the paper transport



## Functions of Main Components

When the optional 2 TRAY MODULE is installed under the printer, additional trays are available. The following chapters outline the functions of the main components of the 2 TRAY MODULE.

- 10.1 Paper Cassette
- 10.2 Paper Feeder
- 10.3 Main Components

### Paper Cassette

It is necessary to adjust the FRONT SIDE GUIDE ASSY, REAR SIDE GUIDE and END GUIDE on the Paper Cassette to match the paper size.

#### FRONT SIDE GUIDE ASSY and REAR SIDE GUIDE

The FRONT SIDE GUIDE ASSY can be adjusted to different paper sizes by moving it to the front or rear. These guides come into contact with the front and rear edges of the paper and hold it in position.

The REAR SIDE GUIDE moves together with the FRONT SIDE GUIDE ASSY.

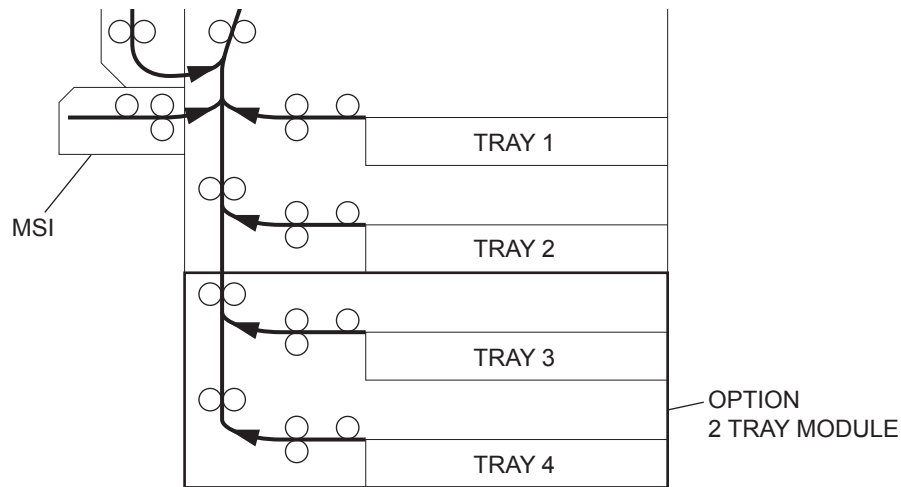
## END GUIDE

The Paper Cassette is so designed that it can adapt to the paper length in the paper feed direction by moving the END GUIDE to the left or right.

## BOTTOM PLATE

The force pushing up the BOTTOM PLATE is transmitted by the driving force of the MOTOR on the FEEDER ASSEMBLY to the LIFT UP SHAFT through the GEAR (13T/60T) and SECTOR GEAR (60T). The BOTTOM PLATE is pushed up by turning the LIFT UP SHAFT, which causes the supplied paper to get in contact with the ROLLER ASSY (NUDGER).

- Paper Cassette



## Detection of paper size

The paper size to which the cassette is set is transmitted to the switches S/W1 to S/W5 on the TRAY 3/4 PAPER SIZE SWITCH by moving these guides. The paper size is detected by the ON/OFF information of these switches.

Paper sizes that can be automatically detected are as 4.1 Paper Size Control:

## Paper Feeder

Since the Tray3 and Tray4 are functionally equivalent in terms of the TRAY 3/4 PAPER SIZE SWITCH, NO PAPER SENSOR, LEVEL SENSOR and PRE FEED SENSOR, only the components of one tray are described here.

The Paper Feeder is a mechanical unit for supplying paper from the Paper Cassette to the printer. The driving force from the TRAY 1/2 FEED LIFT UP MOTOR on the FEEDER ASSY is transmitted to the three ROLLER ASSYs to feed paper.

When the ROLLER ASSY (NUDGER) picks up some sheets of paper and the remaining paper decreases, the ACTUATOR (SUPPORT ASSEMBLY) of the LEVEL SENSOR lowers accordingly. When the LEVEL SENSOR detects the lowering, the TRAY 1/2 FEED LIFT UP MOTOR is activated to turn the LIFT UP SHAFT and the BOTTOM PLATE is also lifted accordingly. Thus, the remaining paper is ready to be fed out.

## TRAY 1/2 FEED LIFT UP MOTOR

This motor is activated to feed paper and to lift the BOTTOM PLATE. When feeding paper, it rotates forward to drive the ROLLER ASSY (NUDGER). When lifting the BOTTOM PLATE, it rotates reversely to drive the tray module gears to turn the LIFT UP SHAFT.

## TRAY 3/4 PAPER SIZE SWITCH

This TRAY 3/4 PAPER SIZE SWITCH switches for setting the size of paper supplied from each Paper Cassette. A signal indicating the set size is transmitted as a voltage to the PWBA MCU F.

#### NO PAPER SENSOR

If paper runs out in the Paper Cassette, the ACTUATOR lowers and the flag of the ACTUATOR that has stayed in the NO PAPER SENSOR sensing area leaves there. Thus, the light of the sensor is transmitted. When the sensing area is blocked (paper is present), the signal becomes OFF.

#### LEVEL SENSOR

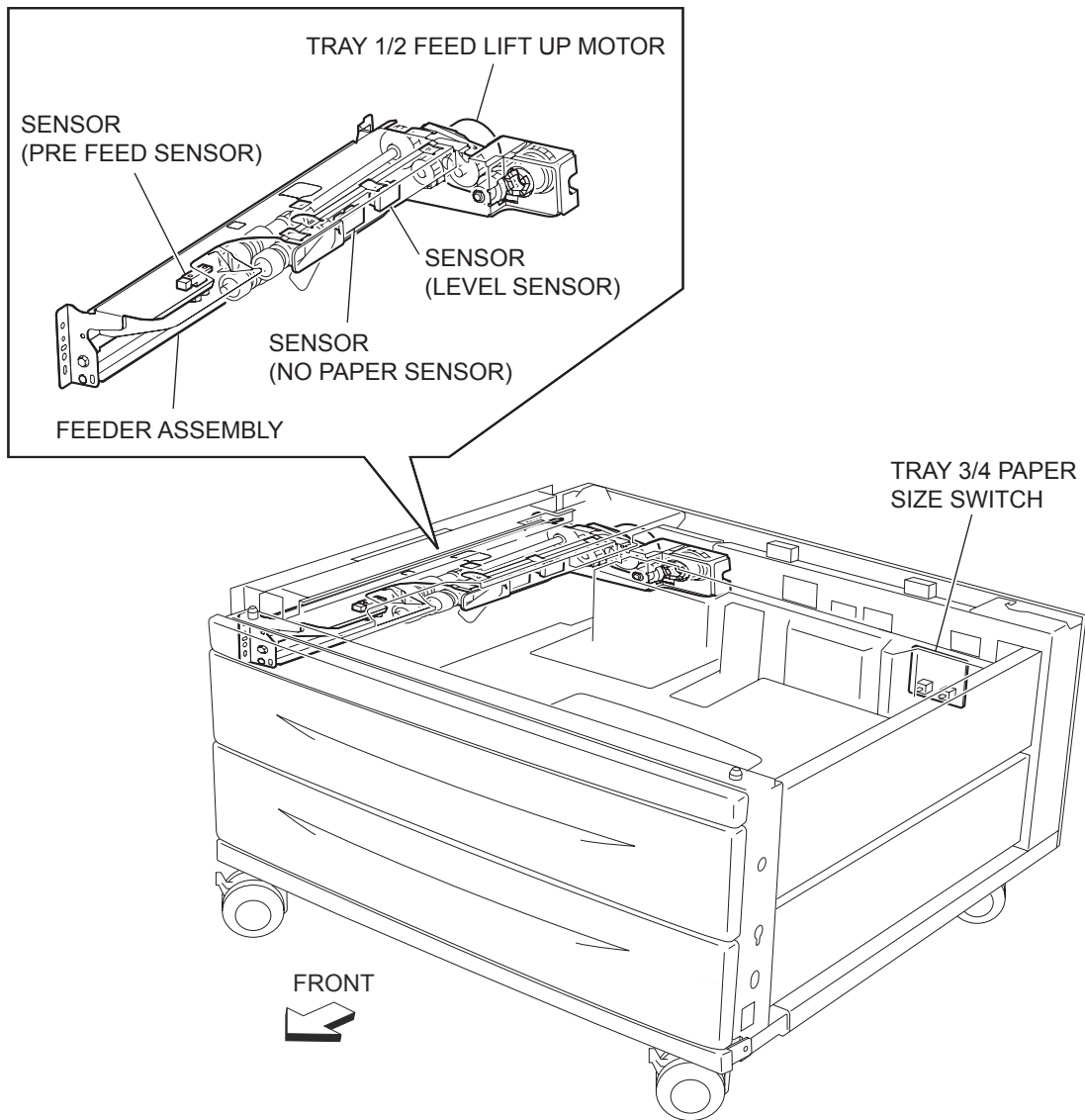
This sensor detects, by the ACTUATOR position, whether paper in the Paper Cassette is lifted. When the flag of the ACTUATOR leaves the LEVEL SENSOR sensing area, the sensor detects that the paper has been lifted.

#### PRE FEED SENSOR

This sensor detects a paper jam in the Paper Cassette by the paper position and sensor ON/OFF time.

The sensor ON/OFF states can be monitored by paper passing through the PRE FEED SENSOR sensing area.





## Main Components

### LEFT COVER INTERLOCK SWITCH

The LEFT COVER INTERLOCK SWITCH detects open/close of the LEFT COVER ASSEMBLY.

### TRAY 3 FEED OUT SENSOR

The TRAY 3 FEED OUT SENSOR detects paper fed from the Tray 3 or Tray 4.

### TRAY 4 FEED OUT SENSOR

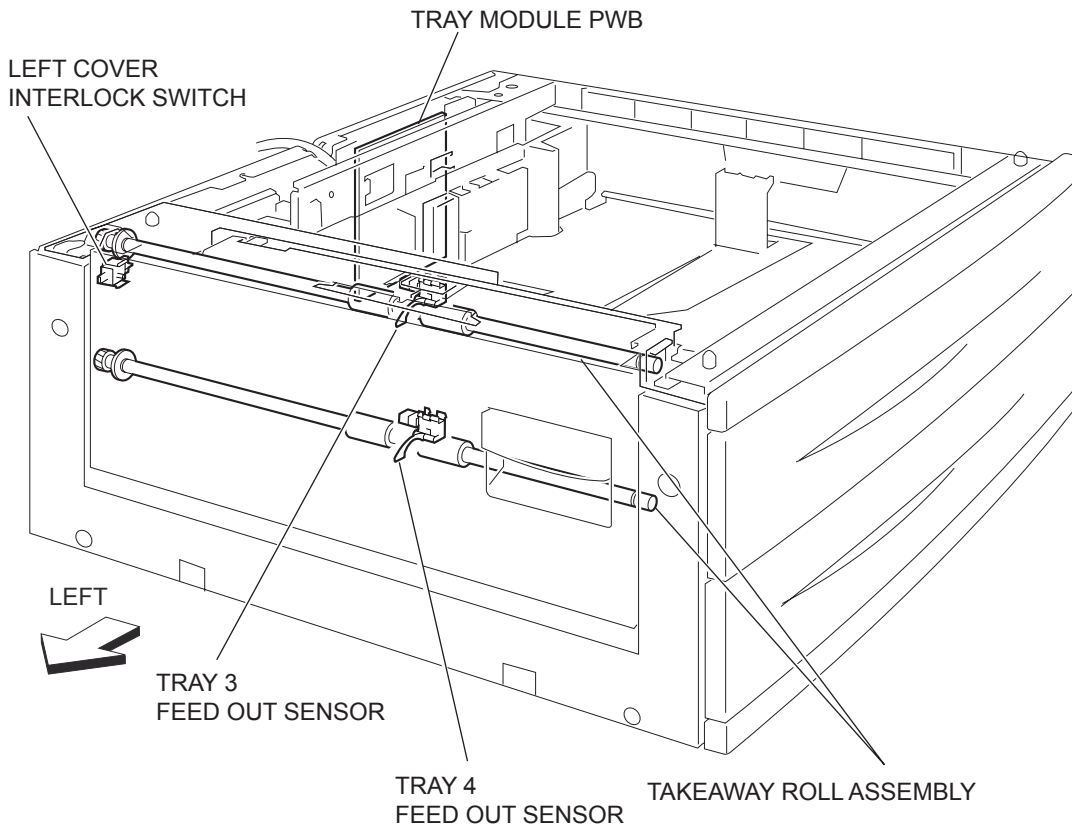
The TRAY 4 FEED OUT SENSOR detects paper fed from the Tray 4.

### TAKEAWAY ROLL ASSEMBLY

The TAKEAWAY ROLL ASSEMBLY feeds paper from the Tray 3 or Tray 4 to the printer.

### TRAY MODULE PWB

The TRAY MODULE PWB that contains a CPU controls paper feed in the 2 TRAY MODULE upon receiving a command from the PWBA MCU F and sensor/switch information.

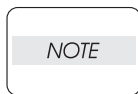


## Control

### Paper Size Control

#### *Paper Cassette Feeding*

The following table gives ON/OFF states of the switches on the TRAY 3/4 PAPER SIZE SWITCH, corresponding to the paper sizes on the Paper Cassette.



**NOTE**The switches on the TRAY 3/4 PAPER SIZE SWITCH are denoted by “S/W2”, “S/W4”, “S/W3”, “S/W5”, and “S/W1” respectively from the left side.

Paper Size	ANALOG SWITCH				DIGITAL SWITCH
	S/W1	S/W2	S/W3	S/W4	S/W5
No Cassette	OFF	OFF	OFF	OFF	OFF
5.5" x 8.5"SEF/A5 SEF	OFF	OFF	ON	OFF	OFF
B5 SEF	OFF	OFF	ON	ON	ON
8.5" x 13"SEF	OFF	ON	OFF	ON	OFF
8.5" x 14"SEF	OFF	ON	OFF	ON	ON
A4 SEF	OFF	ON	ON	OFF	OFF
8.5" x 11"SEF	OFF	ON	ON	OFF	ON

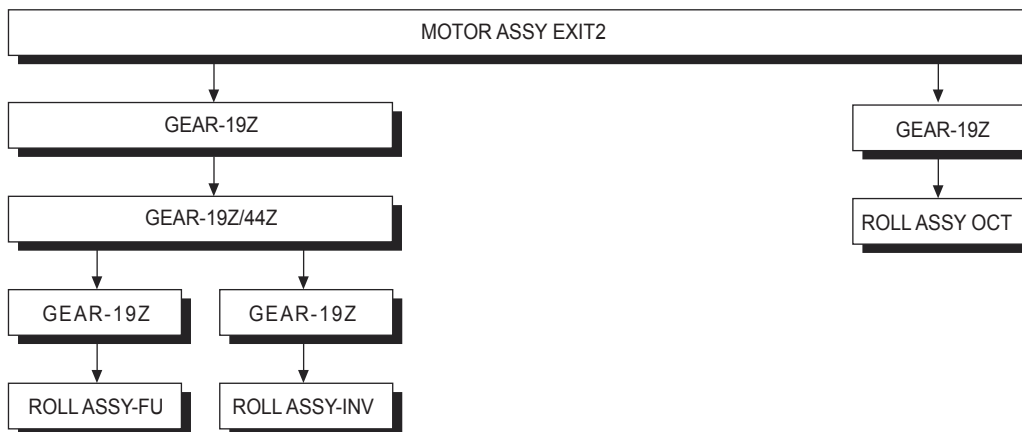
A4 LEF	ON	OFF	ON	OFF	OFF
A3 SEF	ON	OFF	ON	ON	OFF
B5 LEF/Executive LEF	ON	ON	OFF	OFF	ON
8K SEF(TFX/GCO)	ON	ON	OFF	ON	OFF
B4 SEF	ON	ON	OFF	ON	ON
8.5" x 11"LEF	ON	ON	ON	OFF	OFF
16K LEF(TFX/GCO)	ON	ON	ON	OFF	ON
11" x 17"LEF	ON	ON	ON	ON	ON

## Exit 2

### Driving Force Transmission Path

#### Motor Assy Exit 2

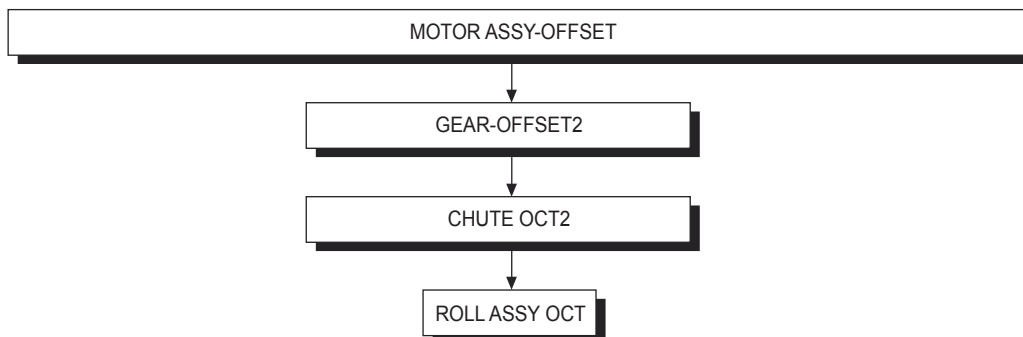
The rotating force of the MOTOR ASSY EXIT2 is transmitted through the gears to components that need mechanical driving force as shown in the following flow.



The transmitted driving force drives the ROLL ASSY-FU, ROLL ASSY-INV and ROLL ASSY OCT through the gears.

#### Motor Assy-offset

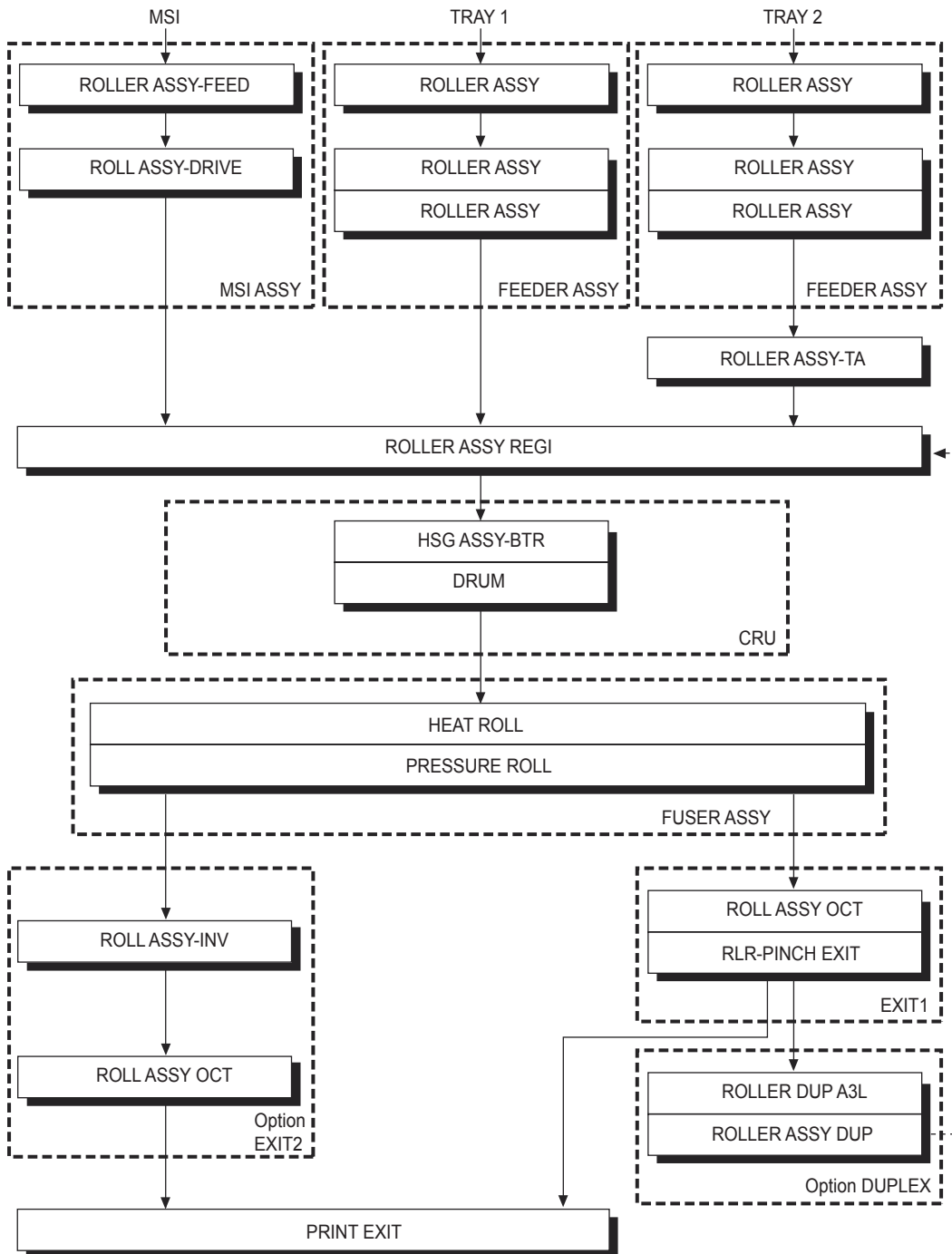
The rotating force of the MOTOR ASSY-OFFSET is transmitted to component that need mechanical actions as shown in the following flow. The ROLL ASSY OCT goes to the OFFSET position by lateral movement not by rotary motion.



# Paper Transport

## Paper Transport Path

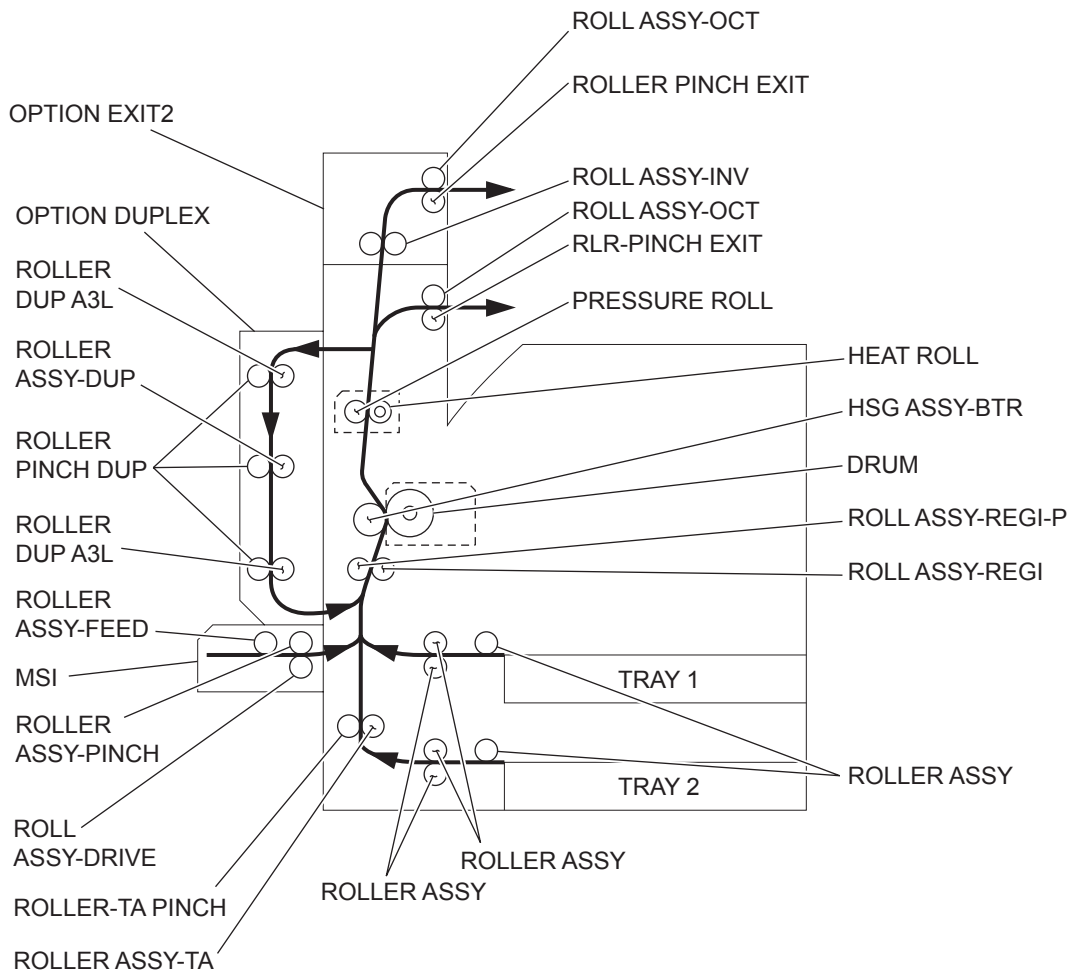
With the optional EXIT2 installed, paper is supplied from the MPF, Tray1 or Tray2, and is transported to the printer along the paper transport path shown below.



## Layout of Paper Transport Path

The following figure illustrates the main components directly associated with the paper path and transport with the optional EXIT2 installed.

- Main components associated with transport of paper



## Functions of Main Components

When the optional EXIT2 is installed on the top of the printer, offset transfer of paper is available with the FIO laser printer.

This chapter outlines the functions of the main components of the EXIT2.

### MOTOR ASSY EXIT 2

The MOTOR ASSY EXIT 2 is a stepping motor to drive the ROLL ASSY-FU, ROLL ASSY-INV and ROLL ASSY OCT. Forward rotation of this motor drives these rollers to feed paper to the Exit2 Face Down Tray. Reverse rotation of this motor drives the ROL ASSY-INV to feed paper to the optional DUPLEX.

### MOTOR ASSY-OFFSET

The MOTOR ASSY-OFFSET is a stepping motor to move the ROLL ASSY OCT forward or rearward. Forward rotation of this motor moves the ROLL ASSY OCT to the front side. Reverse rotation of this motor moves it to the rear side.

### SOLENOID ASSY FU

The SOLENOID ASSY FU is a solenoid to activate the GATE-EXIT,2 for switching the paper transport path. By lifting the iron core of the SOLENOID ASSY FU, the GATE-EXIT,2 is raised to eject paper to the Exit2 Face Down Tray.

### PWBA EXIT

The PWBA EXIT that contains a CPU controls paper feed in the EXIT2 upon receiving a command from the PWBA MCU F and sensor/switch information.

#### SWITCH-I/L,CAB

The SWITCH-I/L,CAB detects open/close of the CHUTE LH HIGH.

#### SENSOR-PHOTO IN

The SENSOR-PHOTO IN detects whether paper is remaining in the EXIT2.

#### SENSOR

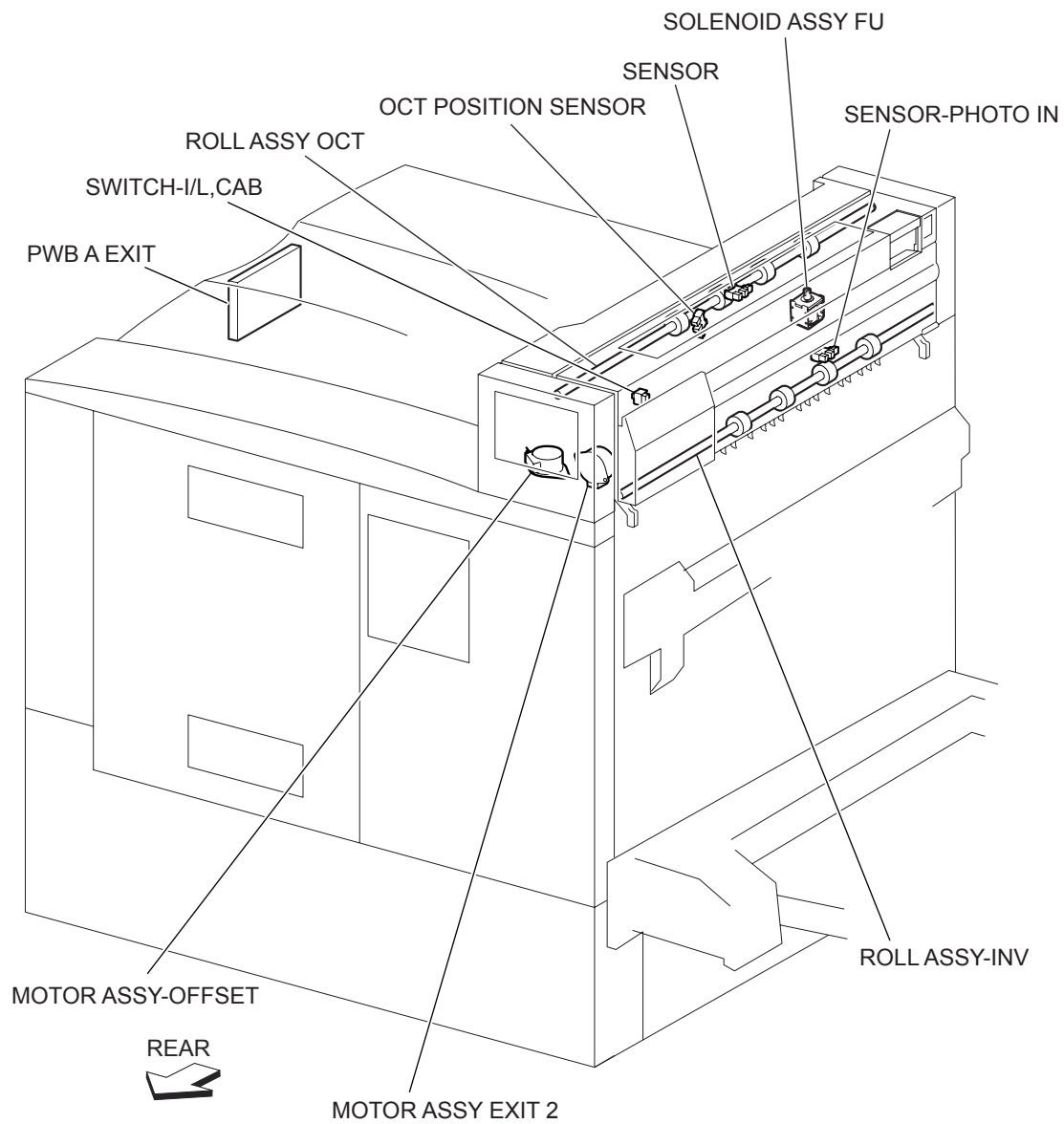
The SENSOR also detects whether paper is remaining in the EXIT2.

#### OCT POSITION SENSOR

The OCT POSITION SENSOR detects the ROLL ASSY OCT position.

#### ROLL ASSY-INV / ROLL ASSY OCT

The ROLL ASSY-INV and ROLL ASSY OCT are rollers to eject paper to the Exit2 Face Down Tray or to feed paper to the optional DUPLEX.



# HCF

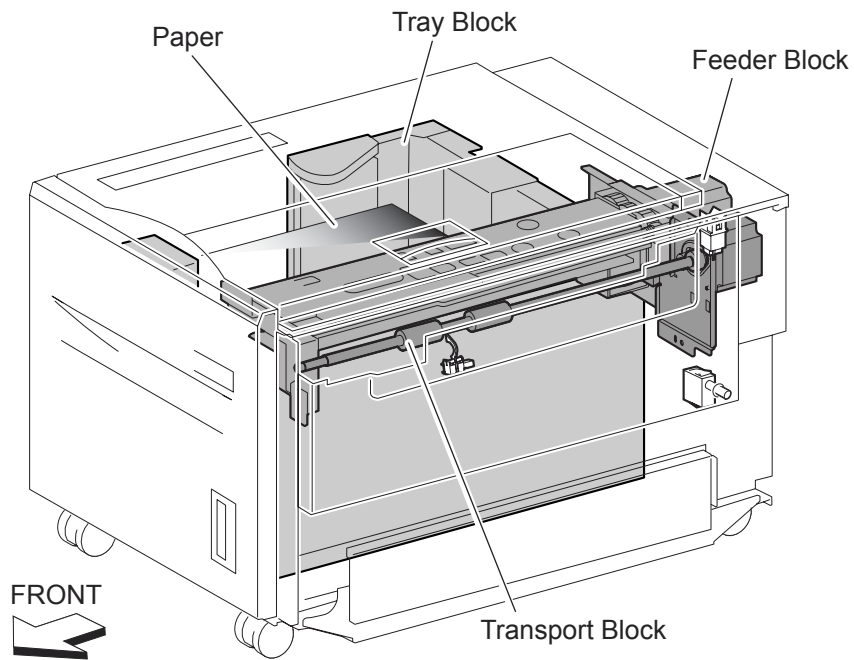
## Overview

The HCF, a paper feeder connected to the Printer, has a function to feed up to 2,000 sheets of paper. The following outlines the operation of the HCF.

## Configuration

The HCF is composed of the following three blocks.

- Tray Block: Contains paper.
- Feeder Block: Feeds paper from the Tray to the Transport Block.
- Transport Block: Transfers paper from the Feeder Block to the Printer.



## Main Functions

In addition to the paper feed feature, the HCF has functions to:

- M/C status monitoring
- Paper size detection
- No-paper detection
- Tray lifting
- Remaining paper volume detection
- Paper jam detection

See the items below for details of each function.

## Paper Capacity

Paper volume loaded in the Tray: 2,000 sheets maximum (20 lb 4024DP)

Paper height: 220 mm maximum

## Paper Size

The HCF accepts the following paper sizes.

- A4 LEF
- B5 LEF
- Letter (8.5" x 11") LEF
- 7.25" x 10.5" LEF

## Feedable Paper Weight

56 - 216 gsm

## Paper Feeding

### Outline

The HCF feeds paper from the Tray to the IOT through the Feeder Block and the Transport Block.

Feeder Block



This block comprises Roll Assy Nudger (called “Nudger Roll” hereafter) to feed paper from the Tray, Roll Assy Feed (“Feed Roll” hereafter) and Roll Assy Retard (“Retard Roll” hereinafter) to feed paper from the Nudger Roll to the Transport Block.

These rollers are driven by the Feed Motor (stepping motor) on the Feeder Assy HCF at prescribed timings.

The paper fed by the Feed Roll and Retard Roll passes through the Pre Feed Sensor installed in the following stage.

The Pre Feed Sensor detects the presence of paper fed from the Tray.

The Pre Feed Sensor controls the Feed Motor speed, and ON/OFF operation of the Nudger Solenoid.

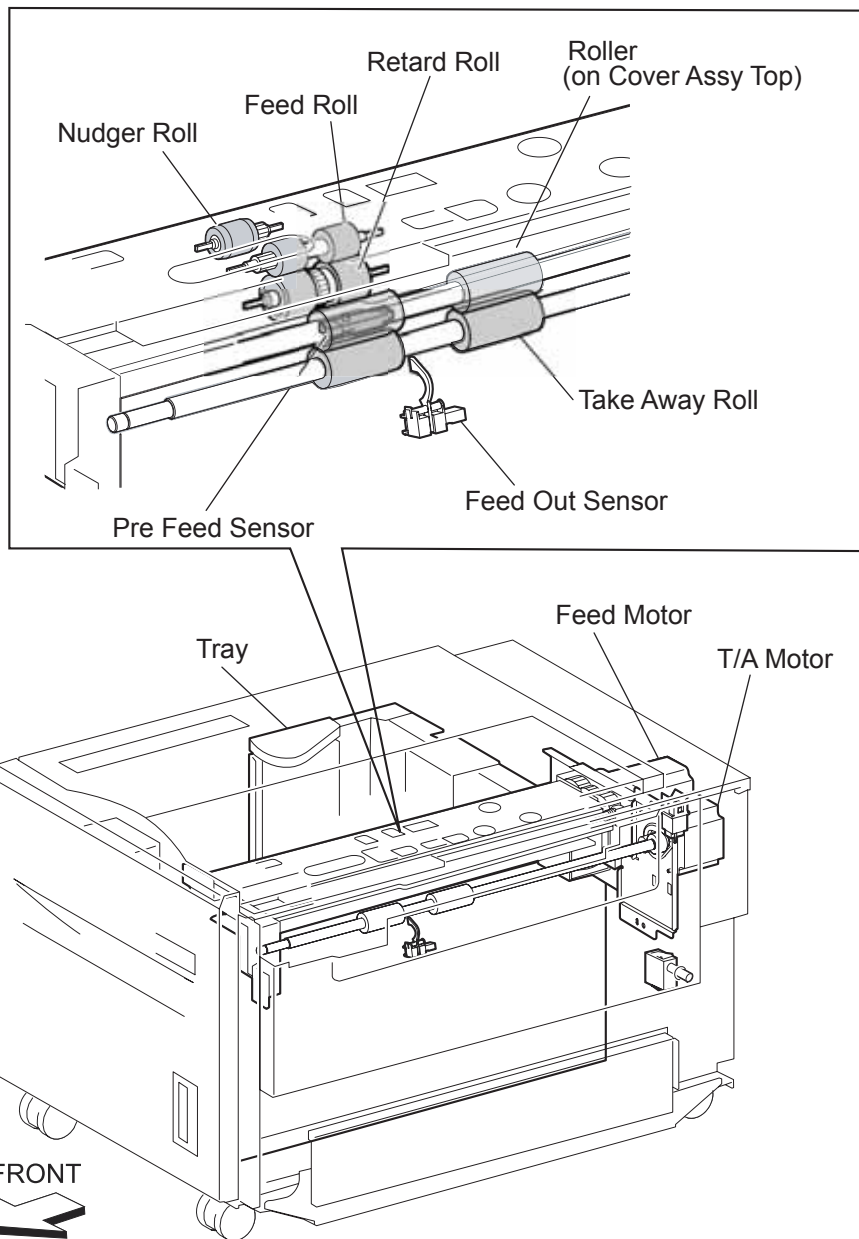
#### Transport Block

This block transfers paper fed from the Feeder Block to the IOT with the Roller Assy TA (“Take Away Roll” hereinafter) and with the roller installed inside the Cover Assy Top.

The Take Away Roll is driven by the Motor Assy (stepping motor) (“T/A Motor” hereinafter) installed on the rear side.

The paper fed with the Take Away Roll passes through the Feed Out Sensor installed in the following stage.

The Feed Out Sensor detects the presence of paper fed from the Tray, and controls the Feed Motor stop and the T/A Motor speed. It also detects paper jams to identify paper jam zone.



## Feeder Block Operation

Upon receiving the feed start signal from the controller, the HCF activates the Nudger Solenoid after a preset time has passed to press the Nudger Roll against the paper in the Tray.

Further, after a preset time has passed after receiving the feed start signal, the HCF rotates forward the Feed Motor to feed paper from the Tray to the Feed Roll side with the Nudger Roll.

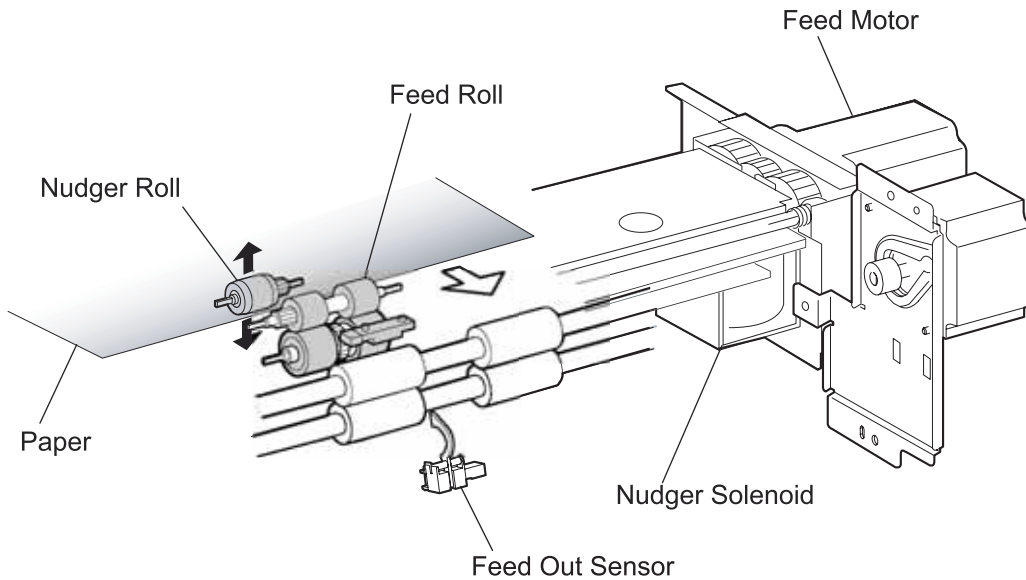
When the end of paper reaches the Pre Feed Sensor (reflective photo-sensor) and the Sensor turns ON, the Nudger Solenoid is deactivated so that the Nudger Roll separates from the paper in the Tray.

The Nudger Solenoid keeps activated at high-voltage for a specified time from its actuation. After that, it still keeps activated at low-voltage until it is deactivated. If the HCF receives the feed start signal for the next paper while the solenoid is activated at low-voltage, it maintains the actuation state at the low-voltage, while pressing the Nudger Roll against the paper in the Tray.

When the paper is transferred to the IOT and the Feed Out Sensor turns ON, the Nudger Solenoid is re-activated for a preset time.

Feed Motor start/stop timing and revs are controlled based on the Feed Motor Start signal and the Pre Feed Sensor ON timing.

Thus, paper is fed from the Tray to the Transport Block.



### Transport Block Operation

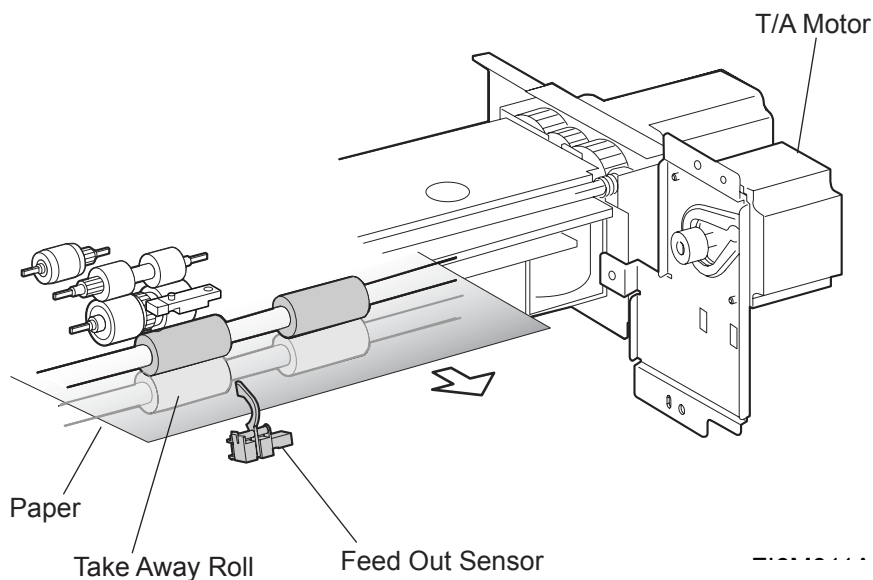
Upon receiving the feed start signal from the controller, the HCF activates the T/A Motor at a high speed after a preset time has passed. This rotating power of the T/A Motor is transmitted to the Take Away Roll, and the paper from the Feeder Block is transferred to the IOT.

When the Feed Out Sensor (photo-sensor) is turned ON (light receiving) by the paper fed with the Take Away Roll, the T/A motor speed decreases after a preset time has passed.

When the Regi Sensor in the IOT is turned ON by the paper fed from the HCF, the T/A Motor starts stopping by the trigger of the sensor ON.

When the next feed start signal is received before the T/A Motor is turned OFF, however, the T/A motor continues to rotate.

Thus, paper is transferred from the Transport Block to the IOT.



### Feeder Block Sensor/Motor Functions

Functions of the sensors and motors of the Feeder Block are outlined below.

(1) Feed Motor

The Feed Motor is a stepping motor that rotates forward the Nudger Roll and Feed Roll to feed paper from the Tray to the Transport Block. The motor also lifts the Tray by reverse rotation. (For details, see Sections 5 and 7.)

(2) Nudger Solenoid

The Nudger Solenoid raises or lowers the Nudger Roll. The solenoid keeps activated from the beginning of paper feed until the Pre Feed Sensor turns ON.

The solenoid is activated when the Tray is inserted and when the power is turned ON to check the presence of paper in the Tray. (For details, see Section 6.)

(3) Pre Feed Sensor

The Pre Feed Sensor detects whether paper has been fed from the Tray, and controls the Feed Motor speed. The sensor also becomes a trigger to deactivate the Nudger Solenoid. The sensor turns ON upon detecting paper, and determines that paper is present.

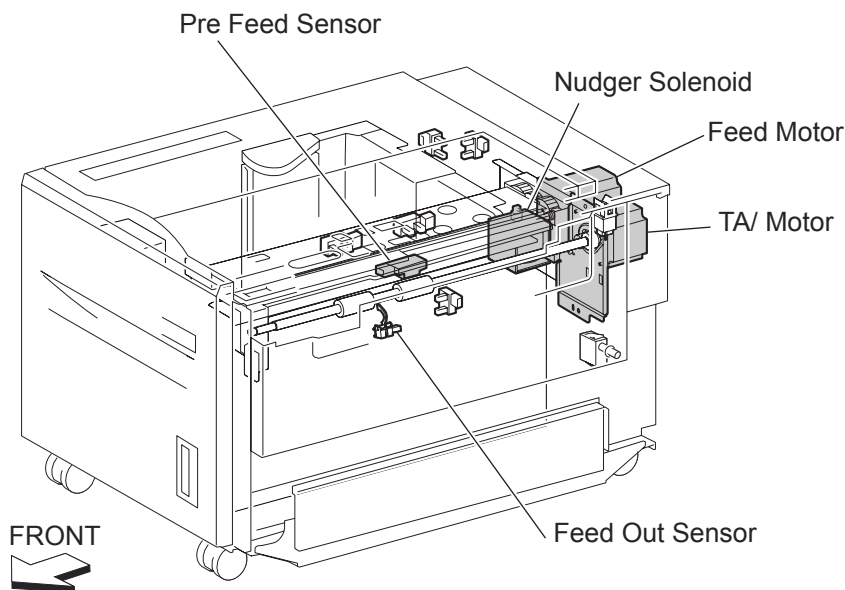
(4) T/A Motor

The T/A Motor is a stepping motor that rotates the Take Away Roll to feed paper to the IOT.

(5) Feed Out Sensor

The Feed Out Sensor detects whether paper has been fed from the Tray, and becomes a trigger to stop the Feed Motor and also to control the T/A Motor speed.

The sensor turns ON (light receiving) upon detecting paper, and determines that paper is present.



## M/C Status Monitoring

This function includes detection of static paper jams, interlocking, and insertion of the Tray.

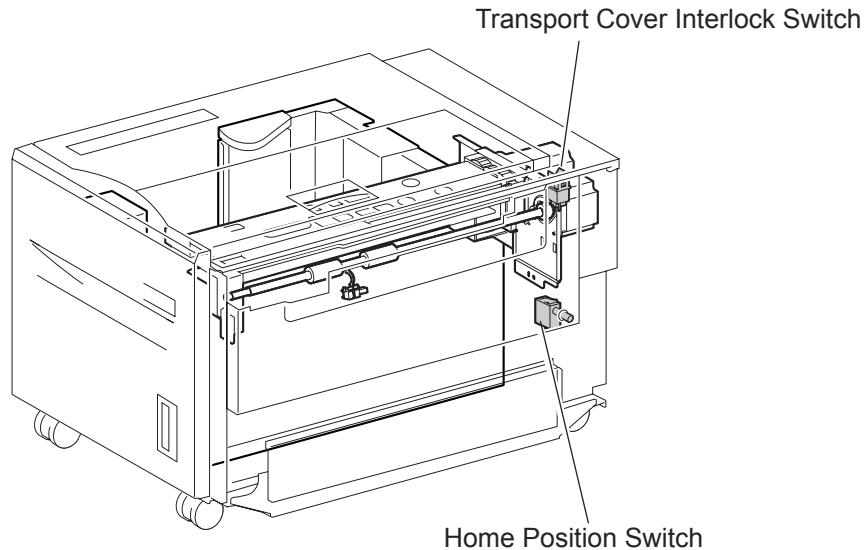
### Static Paper Jam Detection

Checks the states of all relevant sensors on the paper path to detect paper jams. When paper is present on the sensor, it is treated as a static jam. This detection of paper jam is carried out during the startup procedure and at every Jam/Fail detection. The states of all relevant sensors are checked during the startup procedure. In addition, the sensor states are always checked at every constant time for the Jam/Fail detection, in order to monitor the variation in sensor levels.

## Interlock Detection

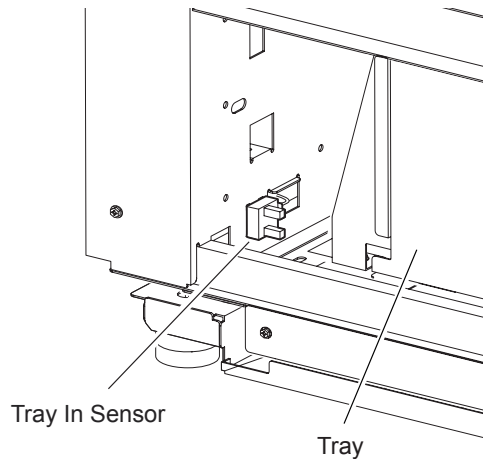
Checks the “Open” state of the Transport Cover Interlock Switch and the Home Position Switch. This checking is constantly carried out while the power is ON.

When “Open” of the Transport Cover Interlock Switch is detected, printing operation is inhibited, and the 24 V supply to the Feed Motor and the T/A Motor is shut off. When “Open” of the Home Position Switch is detected, transfer of paper from the HCF is inhibited.



## Tray Insertion Detection

The Tray In Sensor checks whether the Tray is properly set. This checking is constantly carried out while the power is ON. Printing operation is inhibited if the Tray In Sensor OFF (Tray is not present) is detected before starting printing.



Functions of sensors used for M/C status monitoring

The following outlines the functions of the sensors used for monitoring M/C status.

### (1) Transport Cover Interlock Switch (Safety interlock)

Detects open/close of the Transport Cover. The ON state of this switch indicates that the Transport Cover is closed.

(2) Home Position Switch

Detects the coupling of the HCF with the IOT. The OFF state of this switch indicates that the HCF is separated from the IOT. In this case, transfer of paper is inhibited.

(3) Tray In Sensor

Detects insertion of the Tray into the HCF. This sensor turns ON when the Tray is properly inserted. While it is OFF, paper feeding from the Tray is inhibited.

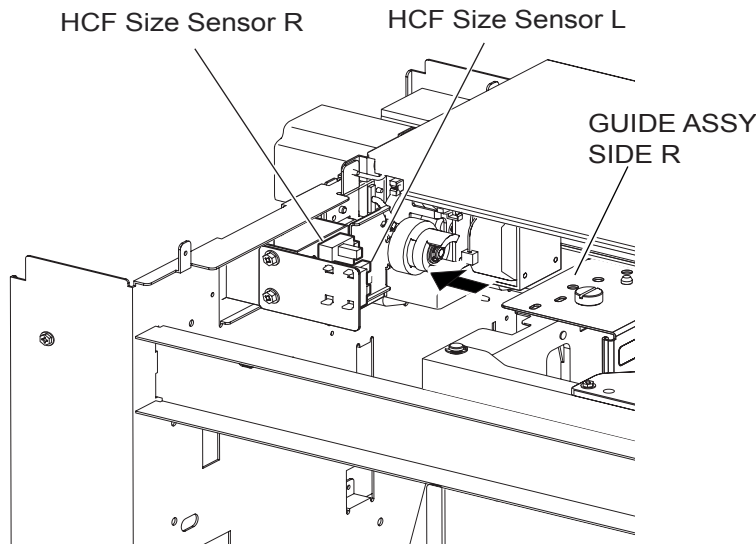
## Paper Size Detection

Paper size is automatically detected by loading paper in the Tray and by the GUIDE ASSY SIDE R that is attached to the Tray and aligned with the side of paper. The position of the GUIDE ASSY SIDE R is detected by the HCF Size Sensor R and the HCF Size Sensor L.

**NOTE** Detectable paper size and sensor level pattern are as follows:

Table 1: Paper Size	Table 2: HCF Size Sensor R	Table 3: HCF Size Sensor L
B5L	OFF	OFF
7.25" x 10.5" L		
8.5" x 11" L	ON	OFF
A4L	OFF	ON

(Note: B5L and 7.25" x 10.5" L can be switched by the NVM.)



Detection of paper size is carried out during the startup procedure, and when a specified time has passed from the Tray In Sensor level change "OFF to ON" with the Tray inserted. Paper size is also detected at every constant time. When the same size has been detected a specified times consecutively, the size of paper loaded in the Tray is determined.

If a sensor level pattern does not match any of those in the above table, paper size cannot be determined. In this case, though the Tray is lifted, print start by feeding paper from the Tray is inhibited.

### Function of the sensor used for paper size detection

The following outlines the function of the sensor used for detecting paper size.

(1) Size Sensors

There are two Size Sensors: HCF Size Sensor R and HCF Size Sensor L.

By moving the GUIDE ASSY SIDE R to turn ON/OFF these sensors, and by using the resulting sensor level patterns, paper size can be determined.

## Tray Lifting

Tray lift operation starts automatically when the Tray is inserted with paper loaded.

The paper is lifted and stops at the feeding position. At the same time, detection of no paper and remaining paper volume becomes available.

The Tray lifting operation when the power is turned ON or when the Tray is inserted is carried out in the following procedure.

- Activate the Nudger Solenoid.
- Check the Level Sensor status a specified time has passed after the Nudger Solenoid is activated.
- When the sensor is OFF, rotate reversely the Feed Motor to lift the Tray.

When the sensor is turned ON by the lift operation, stop the Feed Motor after a specified time has passed to stop lifting the Tray.

If the sensor is ON at power ON, the Tray is regarded to be already at the feeding position. Therefore, the Tray is no longer lifted.

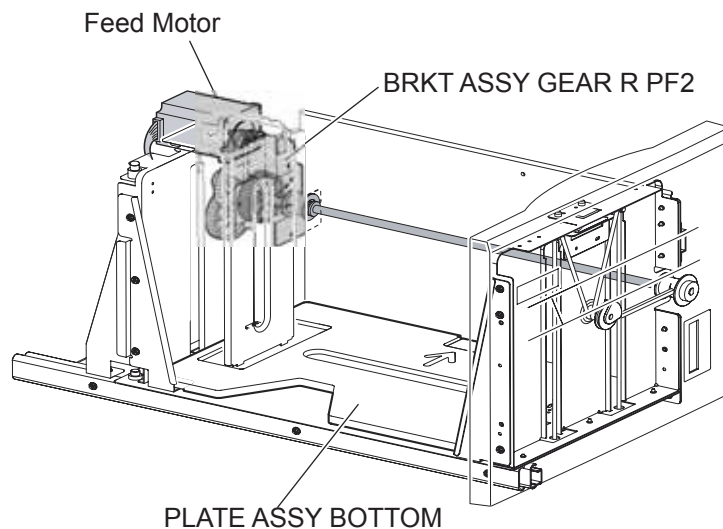
While paper is being transferred to the IOT, the Tray lifting is carried out in the following procedure.

- If Level Sensor OFF is detected when the Nudger Solenoid is deactivated during paper feeding, quick lifting of the Tray is carried out.

In this case, rotate reversely the Feed Motor a specified time has passed after completion of the paper transfer to the IOT, and then stop the motor after a specified time has passed. The quick lifting is carried out while the motor is rotating reversely. The Nudger Solenoid is deactivated during the quick lifting. At this time, the Nudger Roll is off the paper, and therefore no paper is fed.

The tray lift operation is not carried out when a paper jam occurs in the HCF or when the Transport Cover Interlock Switch or the Home Position Switch detects Interlock Open.

Lowering the Tray is carried out when the Tray is removed. No motor is used during the lowering operation. The Tray descends only by the paper weight and the PLATE ASSY BOTTOM.



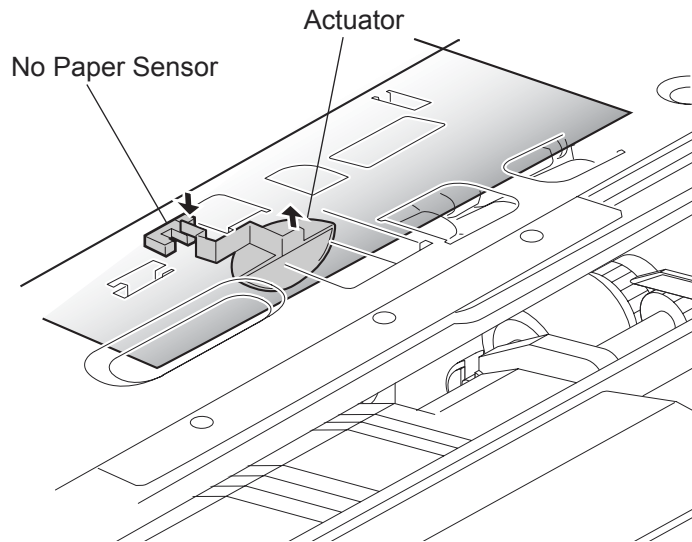
## No-Paper Detection

This function checks whether paper is loaded or not in the Tray.

When paper is present, the actuator in the middle of the HCF is raised by the lifting of paper and leaves the sensing area of the No Paper Sensor (photo-sensor), which makes the sensor light-receivable. Thus, presence of paper is detected.

On the other hand, if paper end occurs when the Tray is at the feeding position, the actuator comes inside the sensing area of the No Paper Sensor, which blocks the light transmission of the sensor. Thus, "No-Paper" is detected.

If the Tray is not lifted, the actuator remains in the sensing area of the sensor, while blocking the light transmission of the sensor. In this case, "No-Paper" is determined regardless of the presence of paper in the Tray.



Detection of "No-Paper" is carried out at every constant period after the lifting operation is completed.

When "No-Paper" is detected, paper transfer from the HCF is inhibited.

If "No-Paper" is detected during printing, print operation of the next paper is stopped. However, when the printer is operating in the ATS Mode and there is paper of the same size in another Tray, paper is automatically fed out of the Tray.

Function of sensor used for No-Paper detection

The following outlines the function of the sensor used for detecting No-Paper.

(1) No Paper Sensor

Detects whether paper is present or not in the Tray.

When this sensor is OFF (light receiving) while the Tray is at the feeding position, the presence of paper is detected.

## Remaining Paper Volume Detection

This function determines the paper volume remaining in the Tray by using the Feed Motor rotation time and the Level Sensor ON timing during the Tray lifting time. Thus, the printer notifies operators of remaining paper volume as 25%, 50%, 75%, FULL, or 0 (zero).

If the remaining paper volume becomes zero before "No-Paper" is detected, the indication remains at (25%).

When the No Paper Sensor detects "No-Paper", the indication becomes (0) (zero).



When a fault occurs, determination of remaining paper volume is carried out as shown below.

- When the Interlock becomes open during lifting operation

Remaining paper volume is determined based on the total of the time until Interlock open + the time from the Feed Motor forward/reverse rotation until the Level Sensor ON.

- When the power is turned OFF and ON during lifting operation

Remaining paper volume is determined by the lifting time after power ON. (In this case, be careful that the actual volume of the remaining paper in the Tray may differ from the indication.)

- When the power is turned OFF and ON while the Tray is at the feeding position

If the Level Sensor is ON when the power is turned ON, the remaining paper volume before the previous power OFF is regarded as the remaining paper volume at that time.

If the sensor is OFF when the power is turned ON, the HCF regards that the Tray has been removed, and determines the remaining paper volume based on the time from the Feed Motor forward/reverse rotation until the Level Sensor ON.

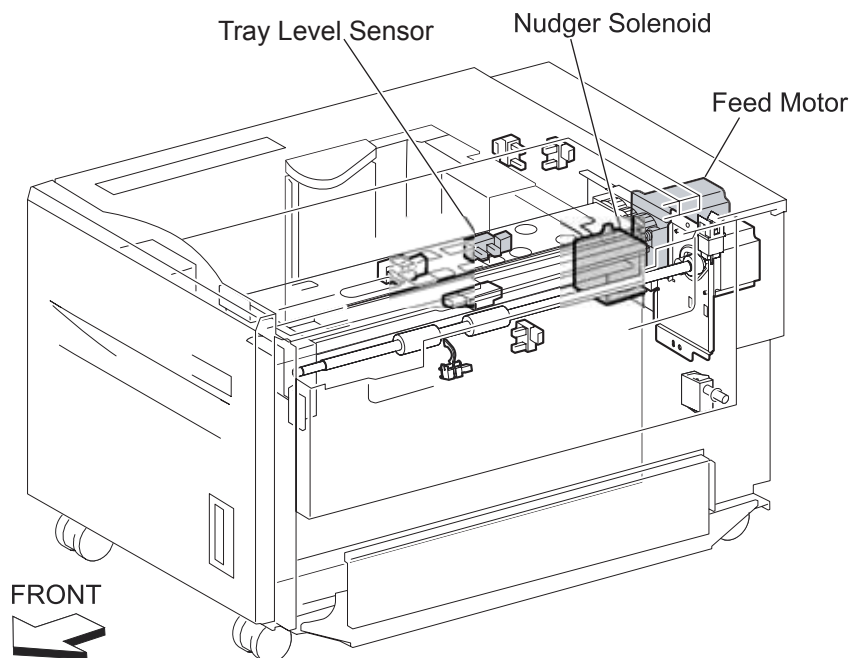
Function of sensor used for remaining paper volume detection

The following outlines the function of the sensor used for detecting the volume of remaining paper

#### (1) Tray Level Sensor

Detects the paper feeding position (paper height) in the Tray to control the paper position.

While this sensor is OFF, lifting the Tray is continued until the sensor turns ON.

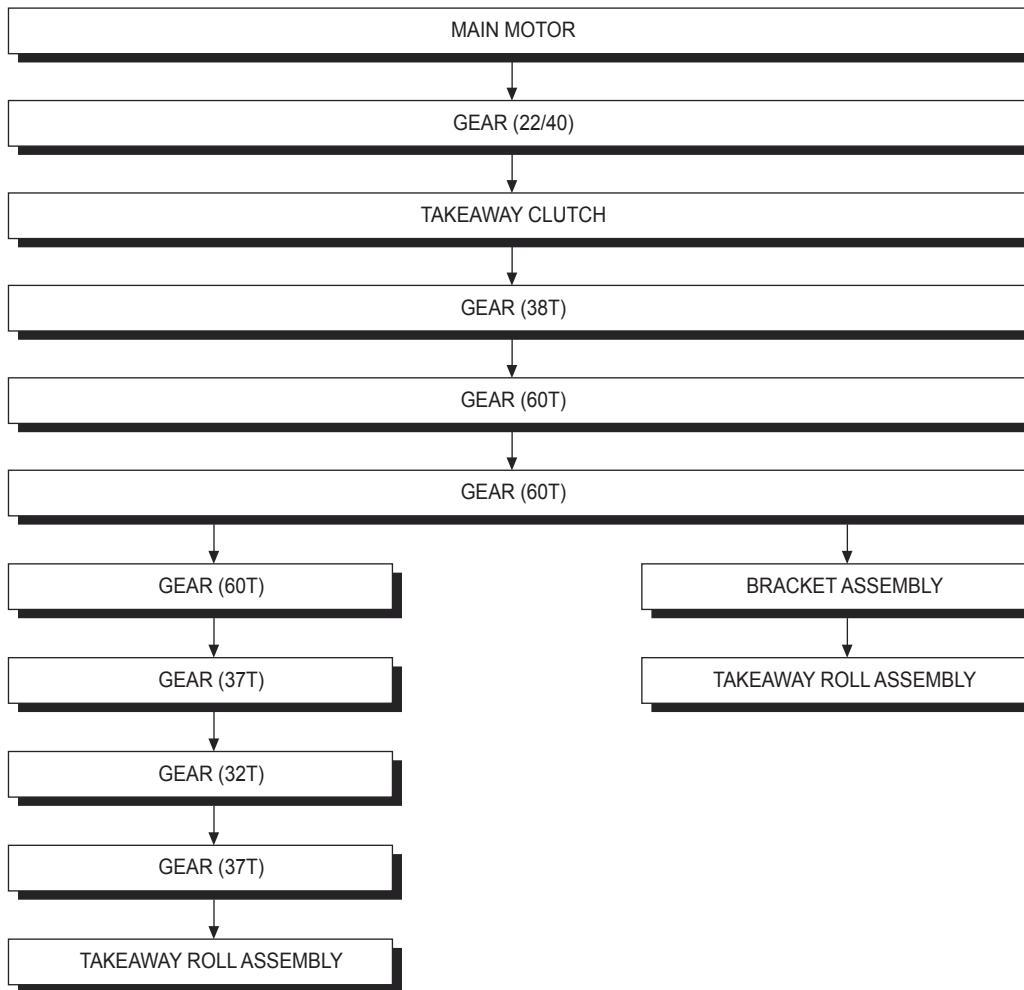


## Tandem Tray

### Driving Force Transmission Path

#### Main Motor

The rotating force of the MAIN MOTOR is transmitted through the gears to components that need mechanical driving force as shown in the following flow.

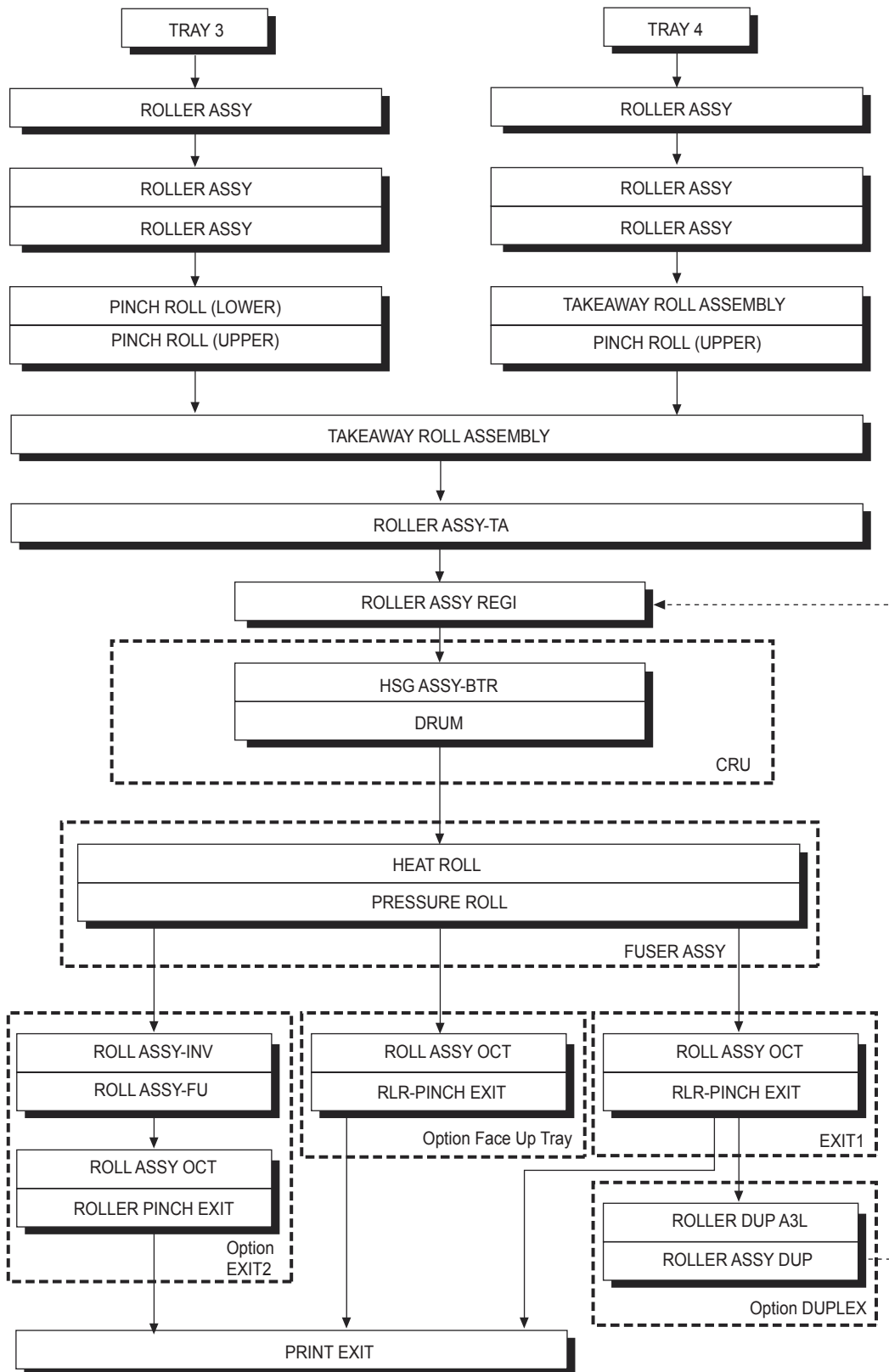


The driving force transmitted to the GEAR drives the TAKEAWAY ROLL ASSEMBLY through the clutch and gears.

## Paper Transport

### Paper Transport Path

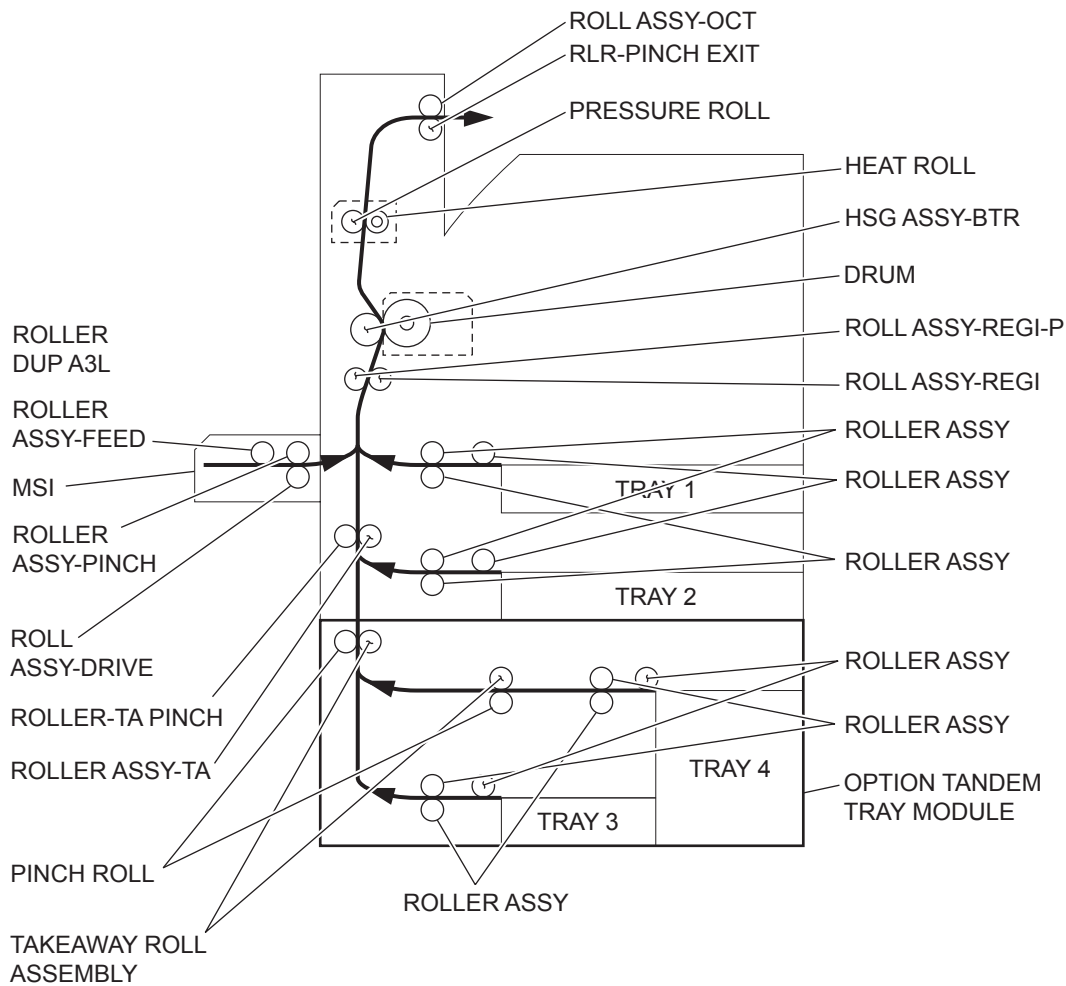
Paper is supplied from the Tray3 or Tray4, and is transported to the printer along the paper transport path shown below.



### Layout of Paper Transport Path

The following is a cross section of the FIO laser printer and the optional TANDEM TRAY MODULE, showing main components directly associated with the paper path and transport.

- Main components associated with the paper transport



## Functions of Main Components

When the optional TANDEM TRAY MODULE is installed under the printer, additional trays are available.

The following chapters outline the functions of the main components of the TANDEM TRAY MODULE.

24.1 Paper Cassette

24.2 Paper Feeder

24.3 Main Components

### Paper Cassette

It is necessary to adjust the FRONT SIDE GUIDE and REAR SIDE GUIDE on the Paper Cassette to match the paper size.

#### FRONT SIDE GUIDE / REAR SIDE GUIDE

The FRONT SIDE GUIDE can be adjusted to different paper sizes by moving it to the front or rear. These guides come into contact with the front and rear edges of the paper and hold it in position.

The REAR SIDE GUIDE moves together with the FRONT SIDE GUIDE.

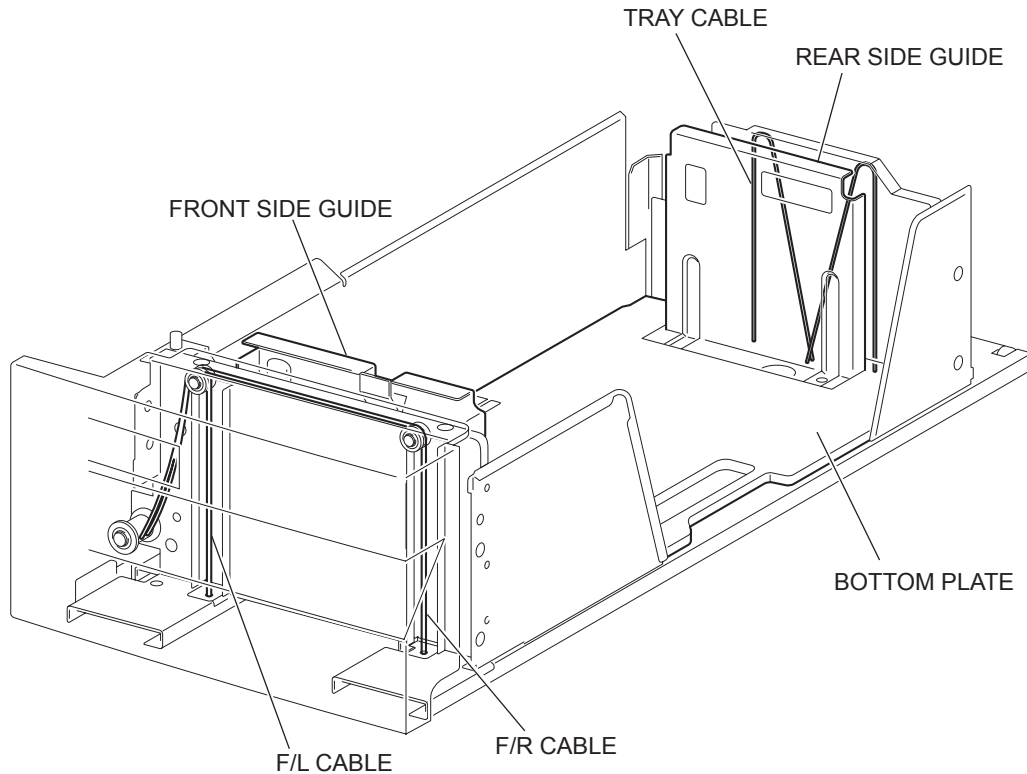
#### BOTTOM PLATE

Regarding the Tray3, the force pushing up the BOTTOM PLATE is transmitted by the driving force of the MOTOR on the FEEDER ASSEMBLY to the LIFT SHAFT ASSEMBLY through

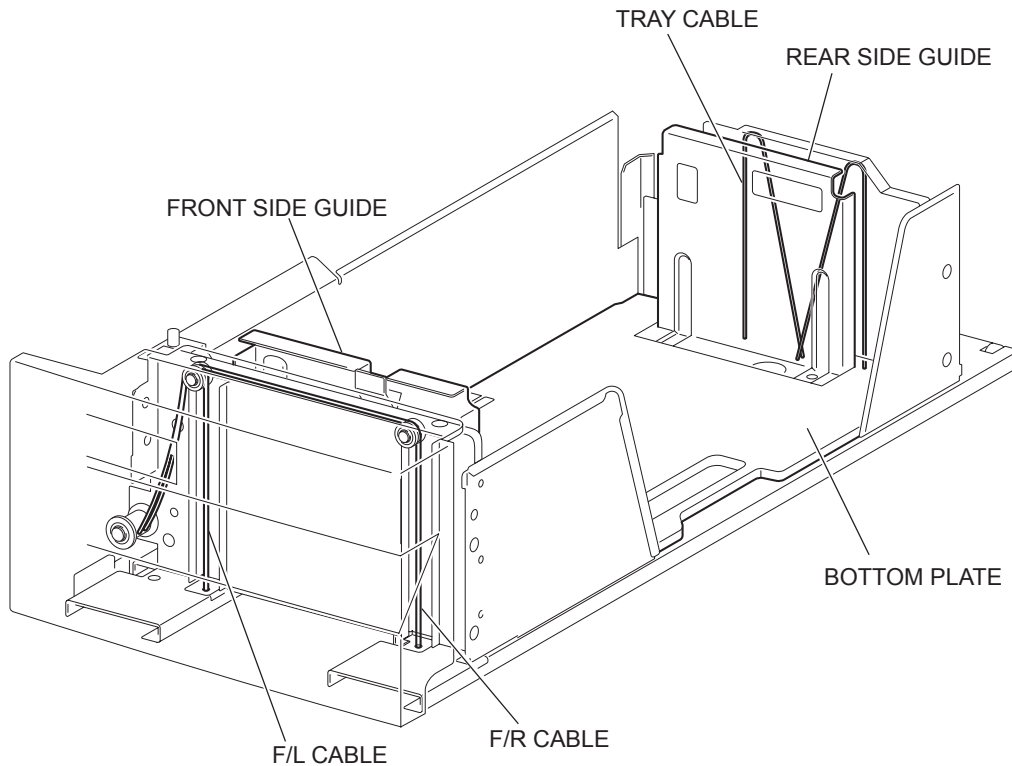
the GEAR ASSEMBLY (Tray 3). The BOTTOM PLATE is pushed up via the TRAY CABLE, F/R CABLE and F/L CABLE by the rotation of the LIFT SHAFT ASSEMBLY, which causes the supplied paper to get in contact with the ROLLER ASSY (NUDGER).

Regarding the Tray4, the force pushing up the BOTTOM PLATE is transmitted to the LIFT SHAFT ASSEMBLY through the GEAR ASSEMBLY (Tray 4). The BOTTOM PLATE is pushed up via the FRONT TRAY CABLE and REAR TRAY CABLE by the rotation of the LIFT SHAFT ASSEMBLY, which causes the supplied paper to get in contact with the ROLLER ASSY (NUDGER).

- Tray3 Paper Cassette



- Tray4 Paper Cassette



#### Detection of paper size

The paper size to which the cassette is set is transmitted to the switches S/W1 and S/W3 on the TRAY 3/4 PAPER SIZE SWITCH by moving these guides. The paper size is detected by the ON/OFF information of these switches.

Paper sizes that can be automatically detected are as 4.1 Paper Size Control:

### Paper Feeder

Since the Tray3 and Tray4 are functionally equivalent in terms of the TRAY 3/4 PAPER SIZE SWITCH, NO PAPER SENSOR, LEVEL SENSOR and PRE FEED SENSOR, only the components of one tray are described here.

The Paper Feeder is a mechanical unit for supplying paper from the Paper Cassette to the printer. The driving force from the TRAY 1/2 FEED LIFT UP MOTOR on the FEEDER ASSY is transmitted to the three ROLLER ASSYS to feed paper.

When the ROLLER ASSY (NUDGER) picks up some sheets of paper and the remaining paper decreases, the ACTUATOR (SUPPORT ASSEMBLY) of the NO PAPER SENSOR lowers accordingly.

#### TRAY 1/2 FEED LIFT UP MOTOR

This motor is activated to feed paper and to lift the BOTTOM PLATE. When feeding paper, it rotates forward to drive the ROLLER ASSY (NUDGER).

#### TRAY 3/4 PAPER SIZE SWITCH

This TRAY 3/4 PAPER SIZE SWITCH switches for setting the size of paper supplied from each Paper Cassette. A signal indicating the set size is transmitted as a voltage to the PWBA MCU F.

## NO PAPER SENSOR

If paper runs out in the Paper Cassette, the ACTUATOR (SUPPORT ASSEMBLY) lowers and the flag of the ACTUATOR (SUPPORT ASSEMBLY) that has stayed in the NO PAPER SENSOR sensing area leaves there. Thus, the light of the sensor is transmitted. When the sensing area is blocked (paper is present), the signal becomes OFF.

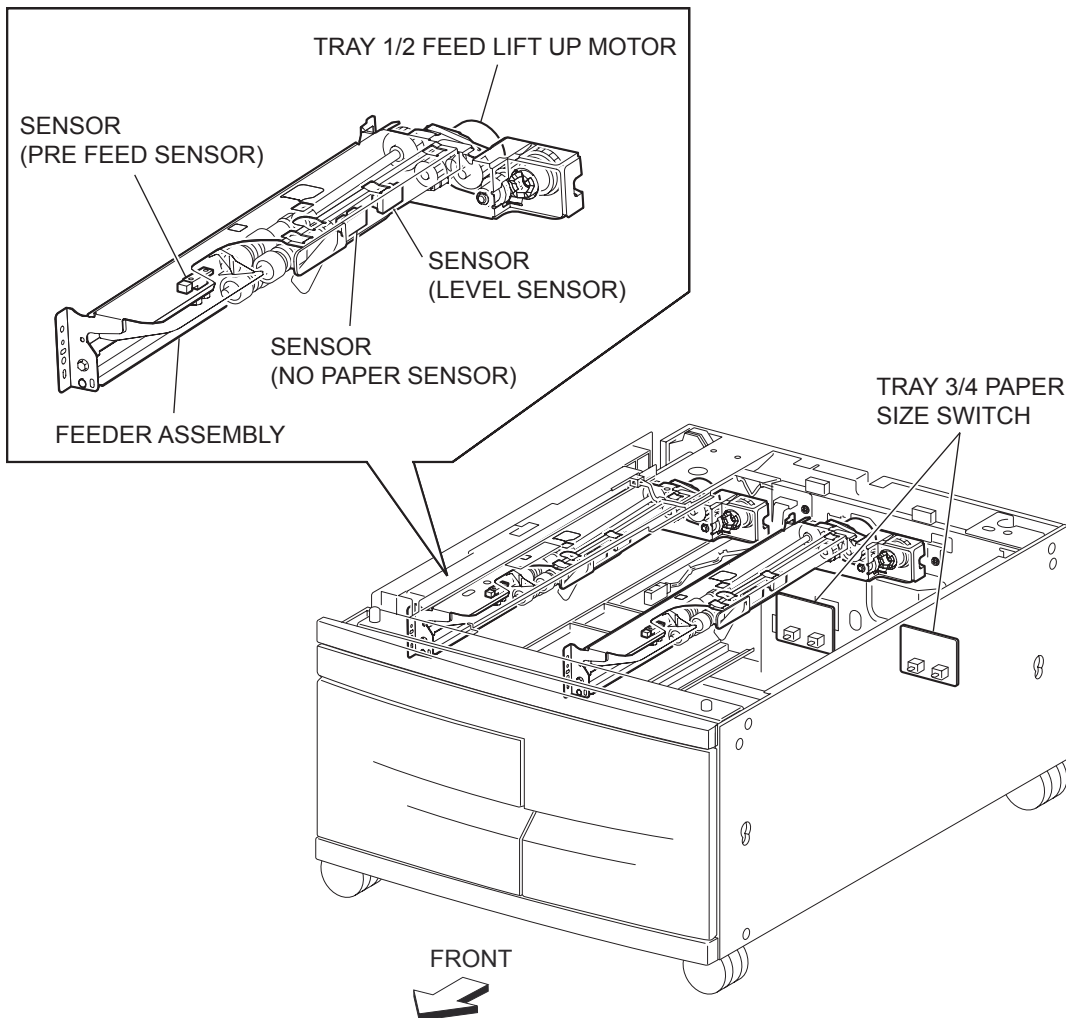
## LEVEL SENSOR

This sensor detects, by the ACTUATOR position, whether paper in the Paper Cassette is lifted. When the flag of the ACTUATOR leaves the LEVEL SENSOR sensing area, the sensor detects that the paper has been lifted.

## PRE FEED SENSOR

This sensor detects a paper jam in the Paper Cassette by the paper position and sensor ON/OFF time.

The sensor ON/OFF states can be monitored by paper passing through the PRE FEED SENSOR sensing area.



## Main Components

### LEFT COVER INTERLOCK SWITCH

The LEFT COVER INTERLOCK SWITCH detects open/close of the LEFT COVER ASSEMBLY.

### TRAY 3 FEED OUT SENSOR

The TRAY 3 FEED OUT SENSOR detects paper fed from the Tray 3 or Tray 4.

#### TRAY 4 FEED OUT SENSOR

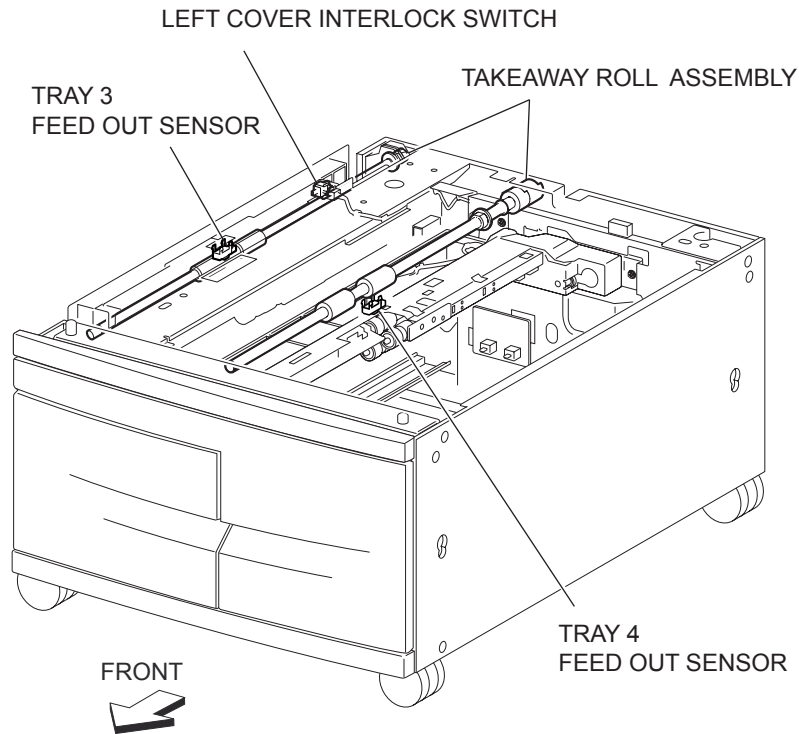
The TRAY 4 FEED OUT SENSOR detects paper fed from the Tray 4.

#### TAKEAWAY ROLL ASSEMBLY

The TAKEAWAY ROLL ASSEMBLY feeds paper from the Tray 3 or Tray 4 to the printer.

#### TRAY MODULE PWB

The TRAY MODULE PWB that contains a CPU controls paper feed in the TANDEM TRAY MODULE upon receiving a command from the PWBA MCU F and sensor/switch information.



## Paper Size Control

### *Paper Cassette Feeding*

The following table gives ON/OFF states of the switches on the TRAY 3/4 PAPER SIZE SWITCH, corresponding to the paper sizes of the Paper Cassette.

**NOTE** The switches on the TRAY 3/4 PAPER SIZE SWITCH are denoted by “S/W1” and “S/W3” respectively from the left side.

Paper Size	ANALOG SWITCH	
	S/W1	S/W3
No Cassette	OFF	OFF
B5L/7.25" x 10.5"L	OFF	ON
8.5" x 11"L	ON	OFF

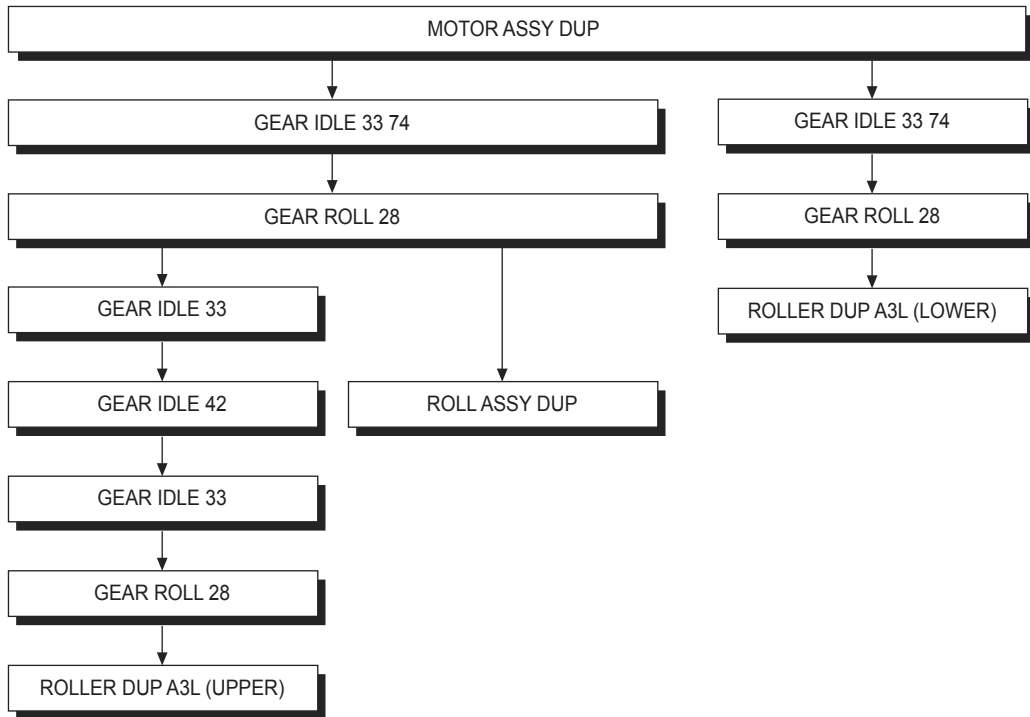


# Duplex

## Driving Force Transmission Path

### MOTOR ASSY DUP

The rotating force of the MOTOR ASSY DUP is transmitted through the gears to components that need mechanical driving force as shown in the following flow.

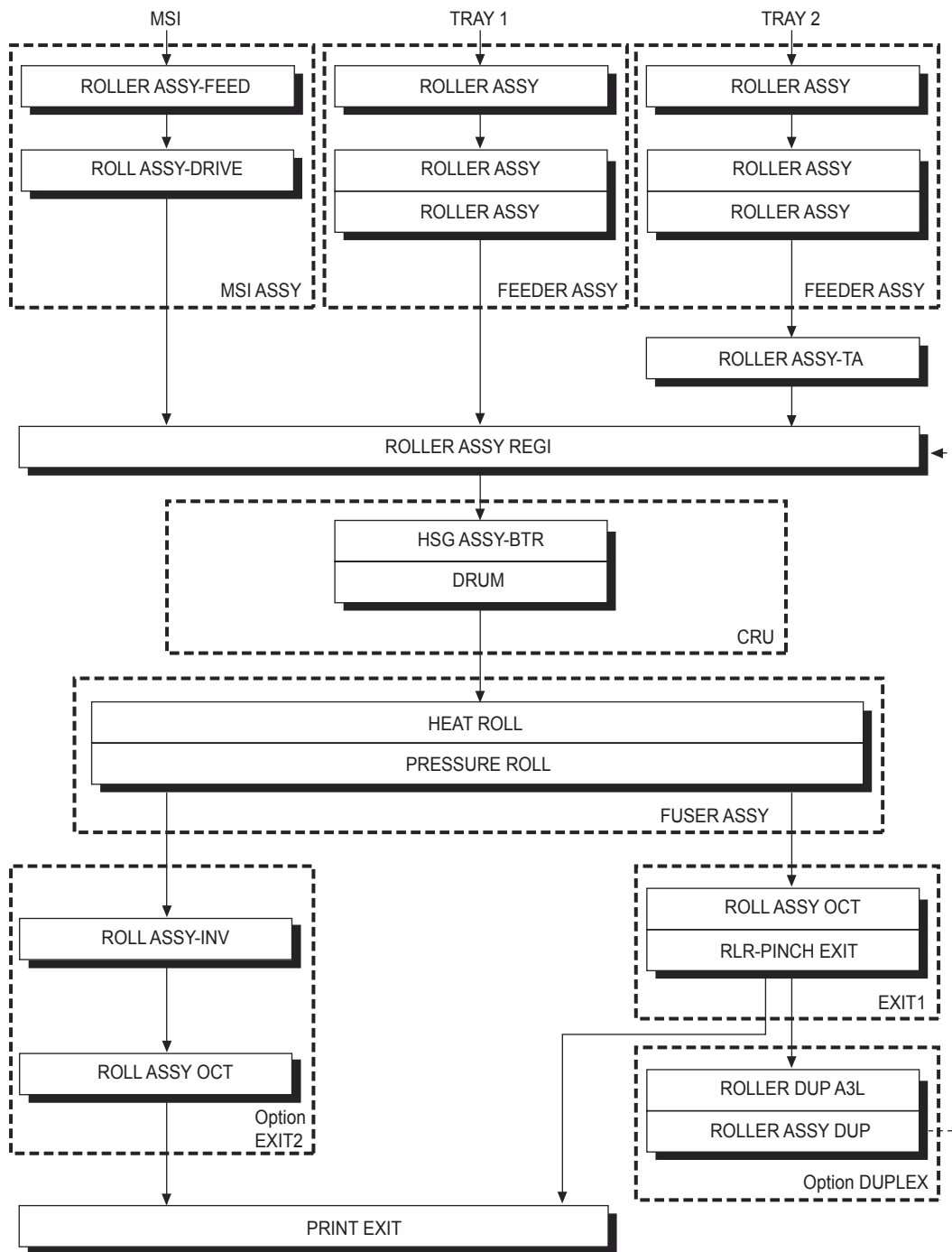


The transmitted driving force drives the ROLLER DUP A3L (UPPER), ROLLER ASSY DUP and ROLLER DUP A3L (LOWER) through the gears.

## Paper Transport

### Paper Transport Path

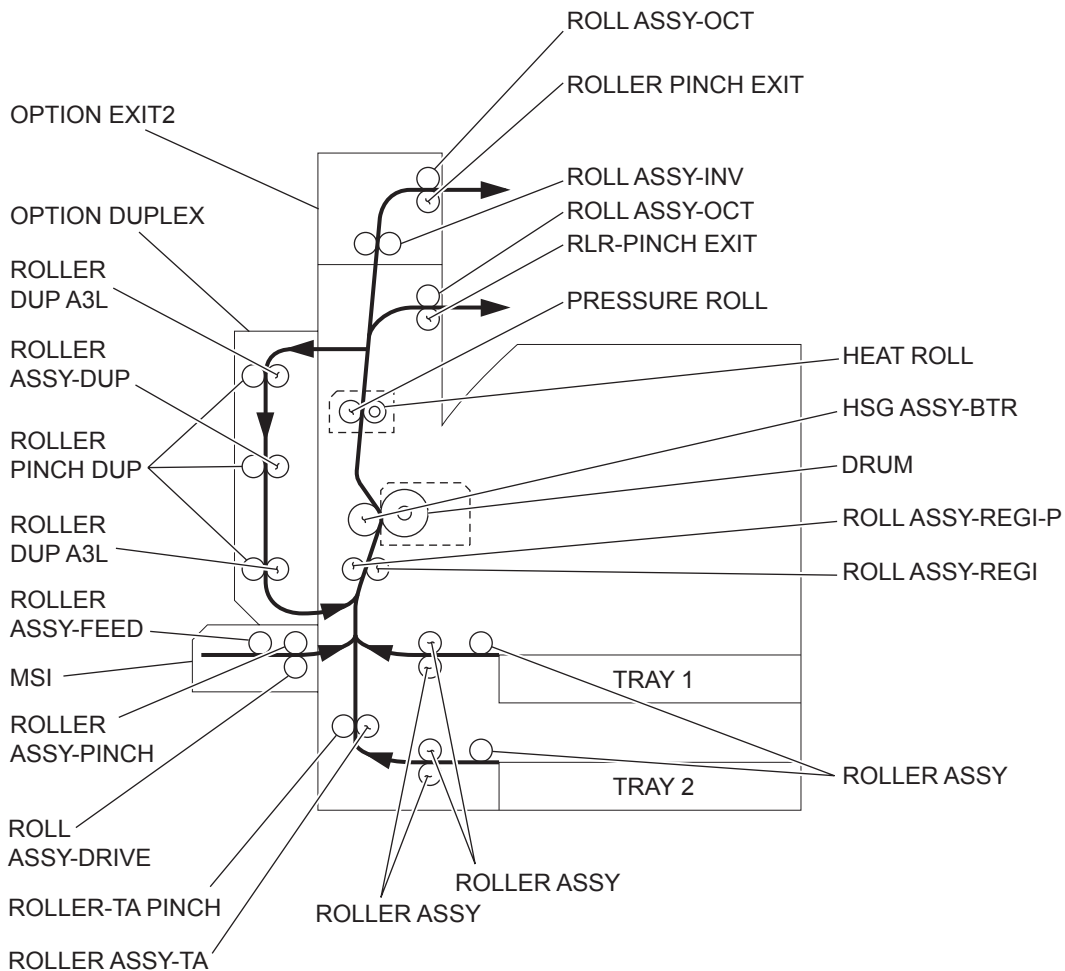
With the optional DUPLEX installed, paper is supplied from the MPF, Tray1 or Tray2, and is transported to the printer along the paper transport path shown below.



## Layout of Paper Transport Path

The following figure illustrates the main components directly associated with the paper path and transport with the optional DUPLEX installed.

- Main components associated with transport of paper



## Functions of Main Components

When the optional DUPLEX is installed to the left of the printer, duplex (double-sided) printing is available with the FIO laser printer.

The following outlines the functions of the main components of the DUPLEX.

### SWITCH-I/L,CAB

The SWITCH-I/L,CAB detects open/close of the COVER DUP.

### SENSOR-PHOTO IN

The SENSOR-PHOTO IN detects whether paper is remaining in the Duplex.

### ROLLER DUP A3L (UPPER/LOWER) / ROLL ASSY DUP

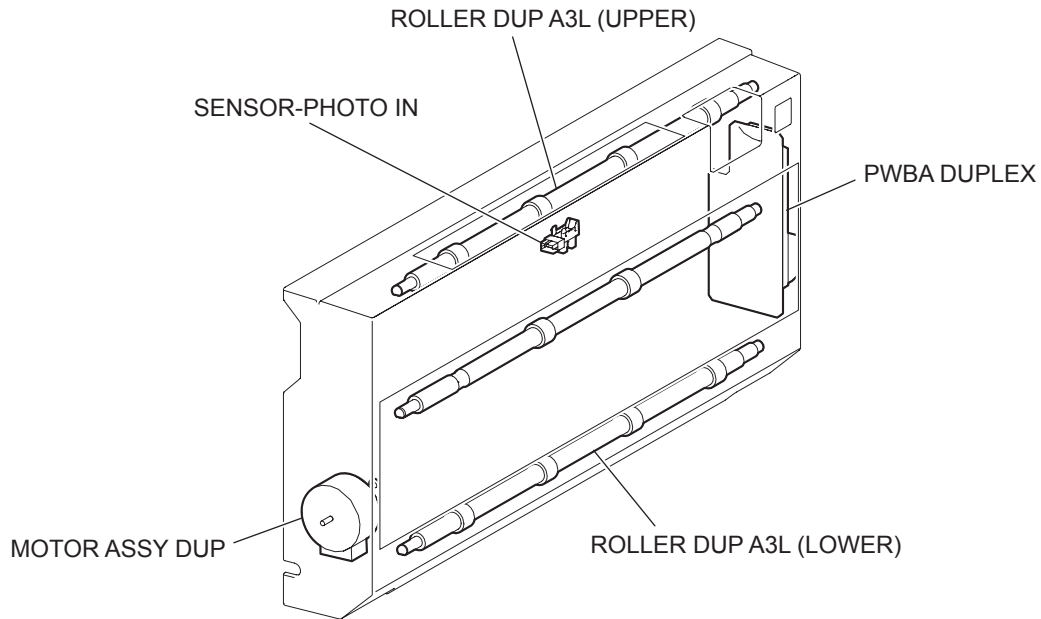
The ROLLER DUP A3L (UPPER), ROLLER DUP A3L (LOWER) and ROLL ASSY DUP re-feed the paper printed on the front side, through the Duplex to the printer to print on the rear side.

### PWBA DUPLEX

The PWBA DUPLEX that contains a CPU controls paper feed in the Duplex upon receiving a command from the PWBA MCU F and sensor/switch information.

### MOTOR ASSY DUP

The MOTOR ASSY DUP transmits driving force to the ROLLER DUP A3L (UPPER), ROLL ASSY DUP and ROLLER DUP A3L (LOWER) that feed paper.



## Finisher

### Overview

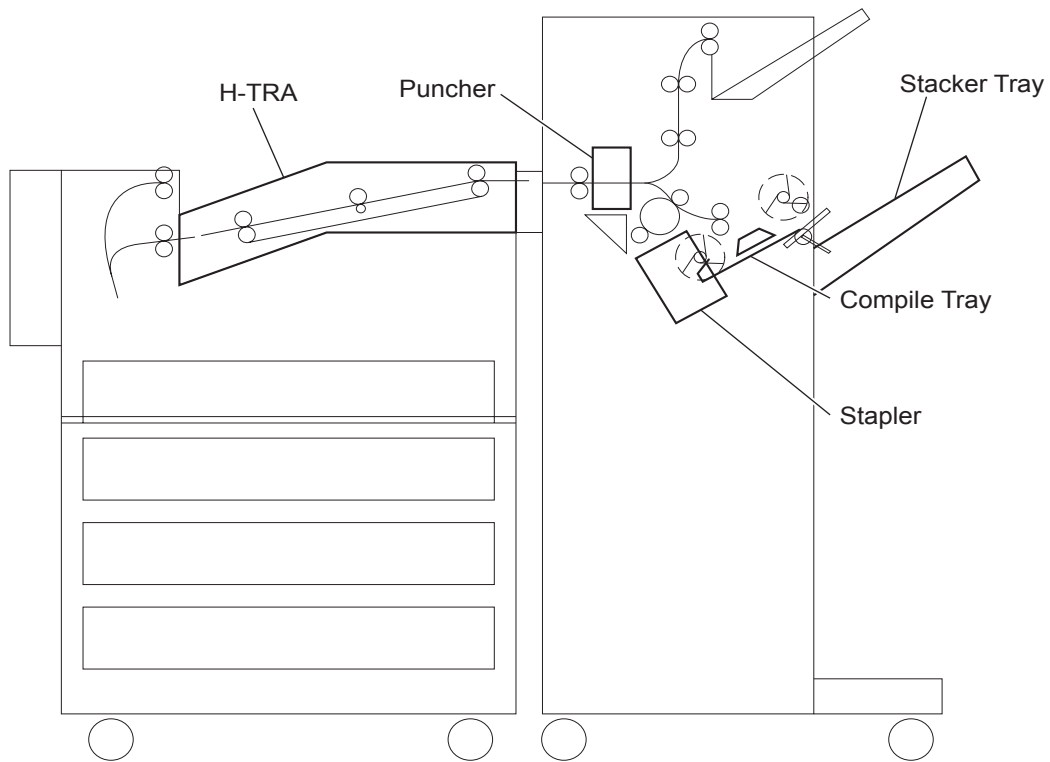
The Finisher performs post-processing, such as stapling, punching, and stacking paper transferred from the IOT, and ejects paper to the Top Tray or the Stacker Tray.

The following outlines the operation of the Finisher.

### Configuration

The Finisher is composed of the following five blocks:

- Horizontal-Transport Block to feed paper from the IOT to the Finisher (called “H-TRA” hereafter)
- Puncher Block to punch paper
- Compile Tray Block to align paper
- Stapler Block to staple a set of paper at specified positions
- Stacker Tray Block to stack paper



## Paper Size and Weight

The following shows paper sizes and weight that the Finisher can handle, as well as applicable functions for each paper size.

The IOT and the Finisher handle different paper sizes and weights. For this reason, if the IOT has printed paper that the Finisher cannot handle, the Exit Gate in the IOT is switched to eject the paper from Exit 2 onto the H-TRA.

### Paper Size/Orientation and Applicable Functions

Paper size	Inches	SEF/ LEF	mm (Finished Size)	Top Tray	Stacker			
				Stack	Stack	Offset Stack	Punch (*1)	Staple
B5		SEF	182 x 257	Yes	No	No	No	No
		LEF		Yes	Yes	Yes	Yes 2	Yes
Executive	7.25 x 10.5	SEF	184.2 x 270	Yes	No	No	No	No
		LEF		Yes	Yes	Yes	Yes 2,3,4	No
Letter	8.5 x 11	SEF	215.9 x 279.4	Yes	Yes	Yes	Yes 2	Yes
		LEF		Yes	Yes	Yes	Yes 2,3,4	Yes
A4		SEF	210 x 297	Yes	Yes	Yes	Yes 2	Yes
		LEF		Yes	Yes	Yes	Yes 2,3,4	Yes
XXX	8,5 x 13	SEF		Yes	Yes	Yes	Yes 2	Yes
Legal	8.5 x 14	SEF		Yes	Yes	Yes	Yes 2	Yes
B4		SEF	257 x 364	Yes	Yes	Yes	Yes 2	Yes

A3		SEF	297 x 420	Yes	Yes	Yes	Yes 2,3,4	Yes
Ledger	11 x 17	SEF		Yes	Yes	Yes	Yes 2,3,4	Yes
Custom size	Same width with standard size			Yes	Yes	Yes	Yes	Yes
Custom size	Besides above			Yes	Yes (*2)	Yes (*2)	No	No

Note:

\*1: Numbers (2, 3, 4) mean 2 holes, 3 holes, and 4 holes, respectively.

\*2: Applicable within the following range:

Paper width: 203.2 - 297 mm

Paper length: 182 - 431.8 mm

Paper Wight

- For punching: 52 - 176 gsm

- For stapling: 52 - 226 gsm (\*1)

- For ejecting in the Stacker Tray: 52 - 226 gsm

- For ejecting in the Top Tray: 52 - 226 gsm

(\*1: The amount of paper capable of being stapled will be less than 50 if paper weight is greater than 90 gsm.)

## Functions and Applicable Trays

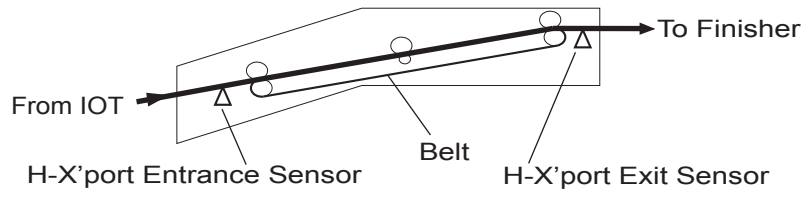
Processing	Destination of paper
No post-processing	Top Tray or Stacker Tray
Punching	Top Tray or Stacker Tray
Stapling	Stacker Tray
Punching & Stapling	Stacker Tray

## Paper Transfer

This section describes transfer of paper from the IOT to a specified tray.

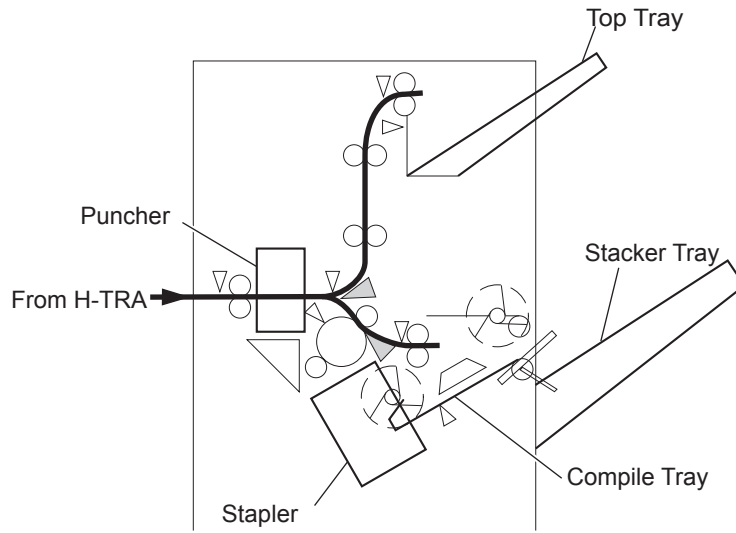
The following figures illustrate layouts (side view viewing from the front side) of sensors, rollers, and main blocks, as well as a layout (rear view) of the main components.

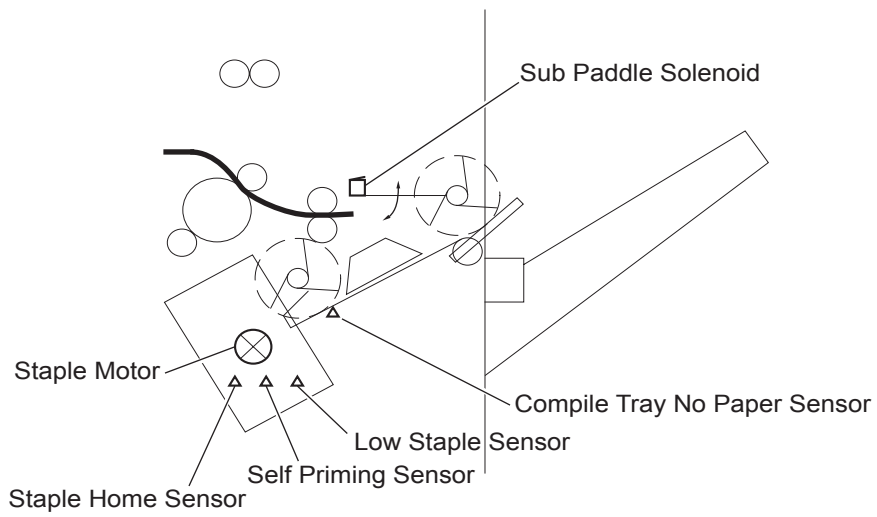
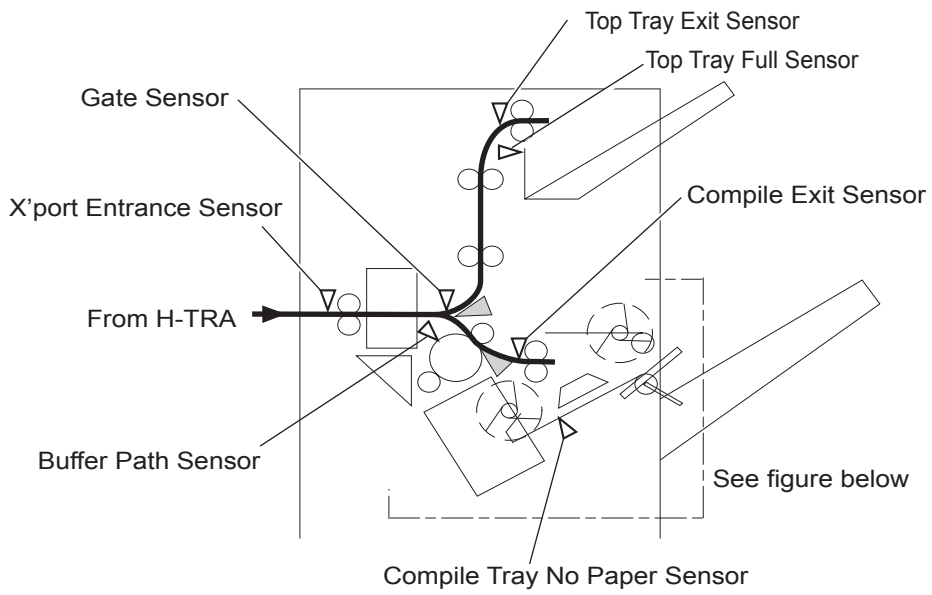
< H-TRA >



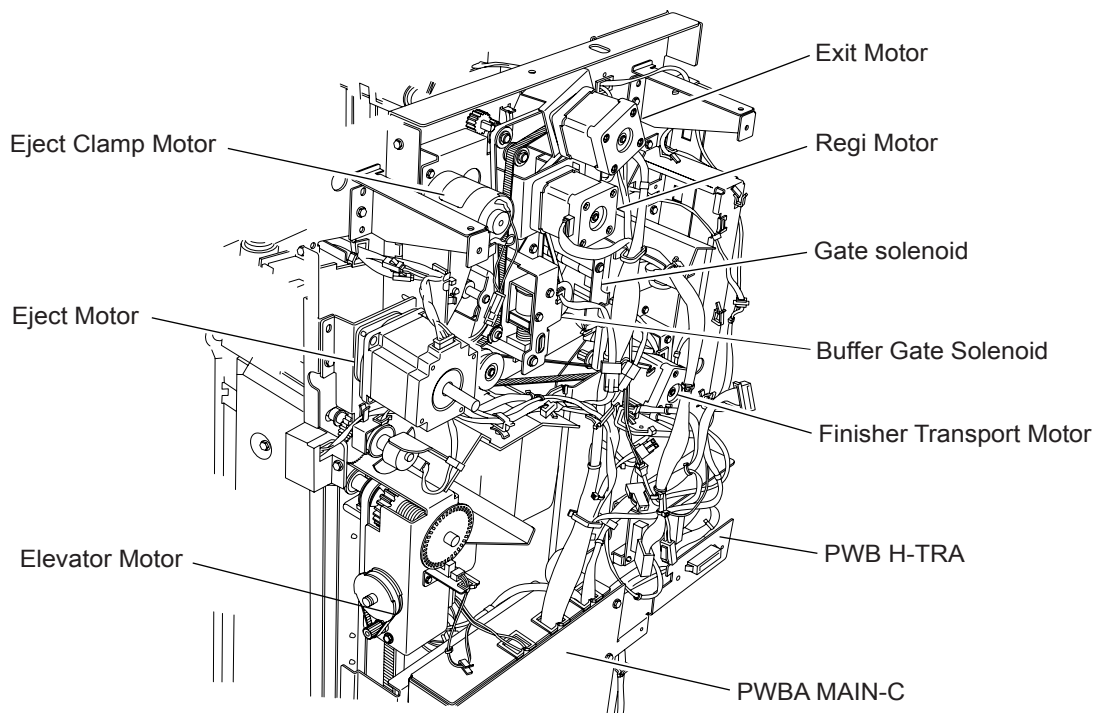
FI6P030A1

< Finisher >







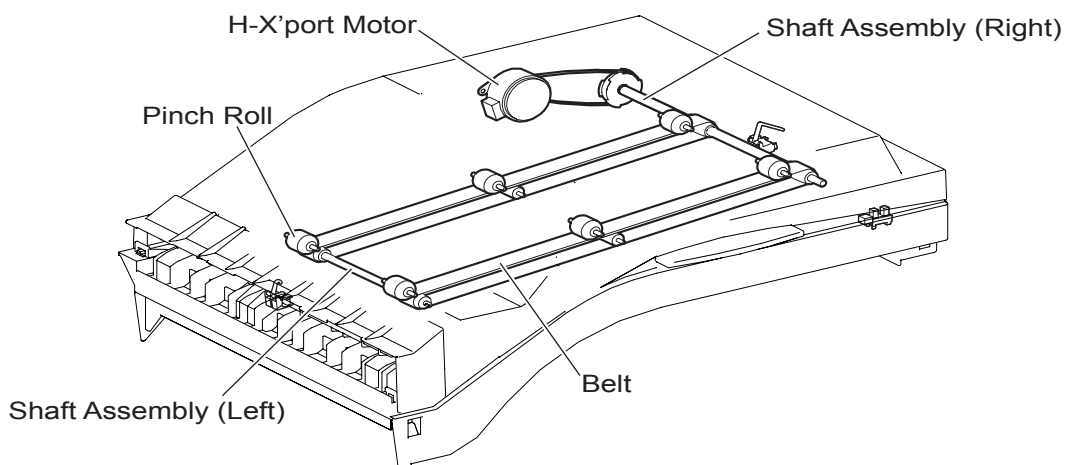


## H-TRA

When the Finisher is designated by the command of IOT, the Exit Gate in the IOT opens and paper is fed from Exit 1 on the H-TRA.

The H-X'port Motor is activated by the trigger of IOT's Regi Clutch ON to drive the feed belts in the H-TRA. The motor power is transmitted to the two belts between Shaft Assembly (Right) and Shaft Assembly (Left).

The paper fed to the H-TRA is securely held between the belts and the Pinch Rolls, and fed to the Finisher.



## From H-TRA to Puncher

The paper fed from the H-TRA is fed into the Finisher by the Roll Assy Ent located on the X'port section of the Finisher that is driven by the Finisher Transport Motor.

Paper route inside the Finisher is determined by the Transfer Gate.

The Transfer Gate is switched by the Transport Gate Solenoid ON/OFF controlled by the IOT.

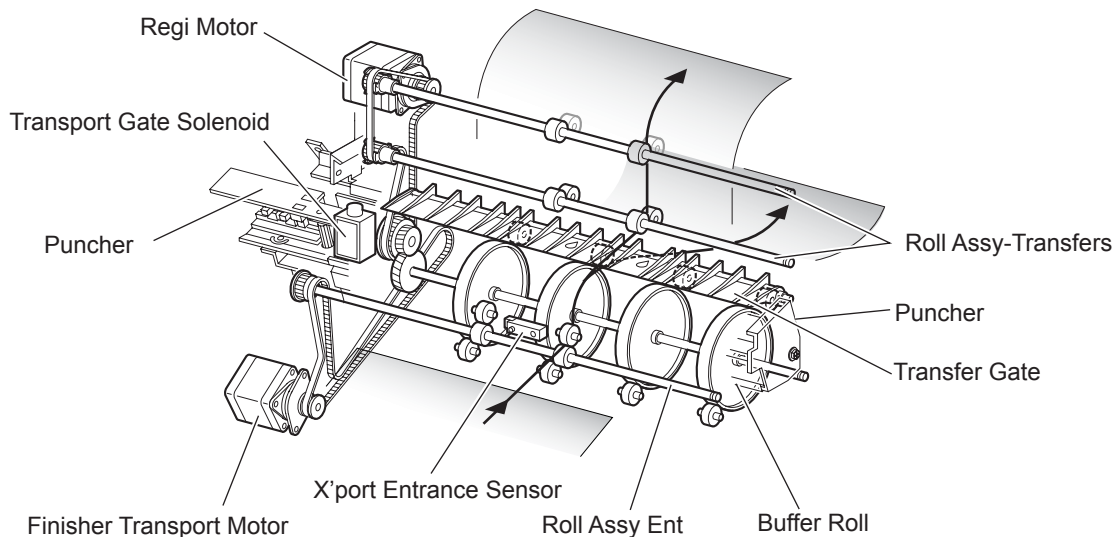
The paper is further fed in the Finisher by the Roll Assy-Transfers or the Buffer Roll that are driven by the Regi Motor, and passes through the Puncher.

The X'port Entrance Sensor becomes "LOW" upon detecting paper. After a certain time has passed from the level transition to "H", the Regi Motor that drives the Roll Assy-Transfers or the Buffer Roll, starts reverse rotation.

The paper is returned to the Puncher by the Roll Assy-Transfers or the Buffer Roll, and is stopped with its end gently pressed against the Guide Assy.

The stopper in the Guide Assy lies to let paper pass through when feeding paper to the exit (while the Regi Motor is rotating forward), but rises when paper is returned (while the Regi Motor is rotating reversely) to stop the paper.

Thus, punch hole positions in the paper feed direction are determined. (For determining punch hole positions in the paper width direction, see Section 3.)



## From Puncher to Compile Tray

The paper is transferred to the Compile Tray by the Buffer Roll (driven by the Regi Motor) and by the Roll Assy-Exit Low (driven by the Exit Motor).

When the first paper reaches the Compile Tray, the Eject Clamp Motor is activated to lower the Eject Clamp so that the Eject Clamp and the Shaft Assy-Eject Roll can clamp the paper.

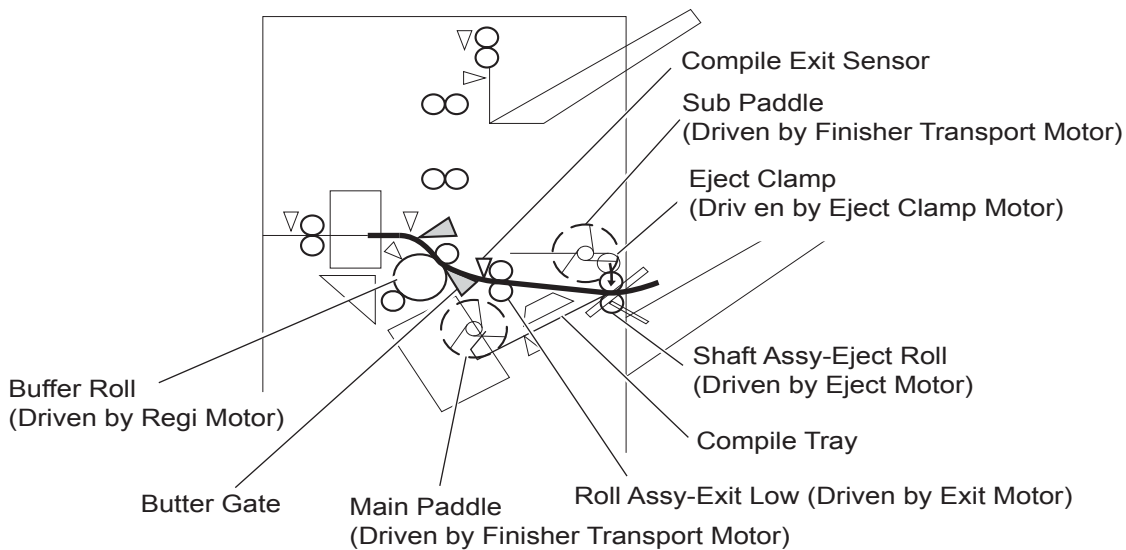
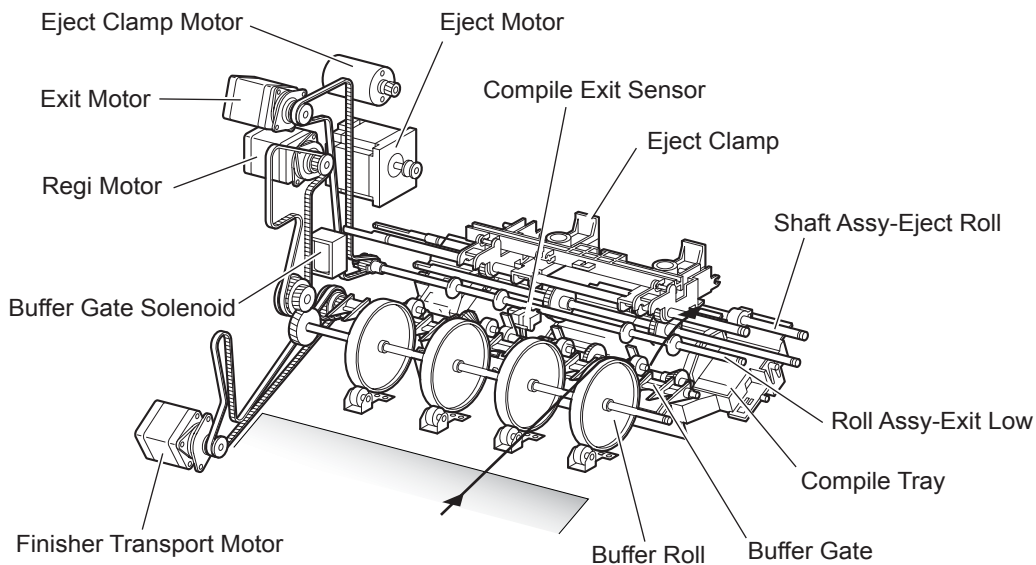
Thus, the paper transferred from the Puncher is held by the Shaft Assy-Eject Roll and the Eject Clamp driven by the Eject Motor, and is fed to the exit.

When the paper rear end passes through the Compile Exit Sensor, the Eject Motor starts reverse rotation to return the paper to the Compile Tray.

When the following paper reaches the Compile Tray, the Eject Clamp is raised and the paper that has passed through the Roll Assy-Exit Low falls on the Compile Tray.

At this time, the Main Paddle is rotated by the Shaft Assy-Paddle (driven by the Finisher Transport Motor) to feed the paper so that the paper rear end butts against the rear wall of the Compile Tray.

The Sub Paddle Solenoid of the Chute Assy Eject is activated to lower the Sub Paddle (driven by the Finisher Transport Motor) so that the paper can be fed to the Compile Tray.



When printing multiple sets, while stapling the first set on the Compile Tray or ejecting it to the Stacker Tray, the first paper of the second set shall not be fed to the Compile Tray.

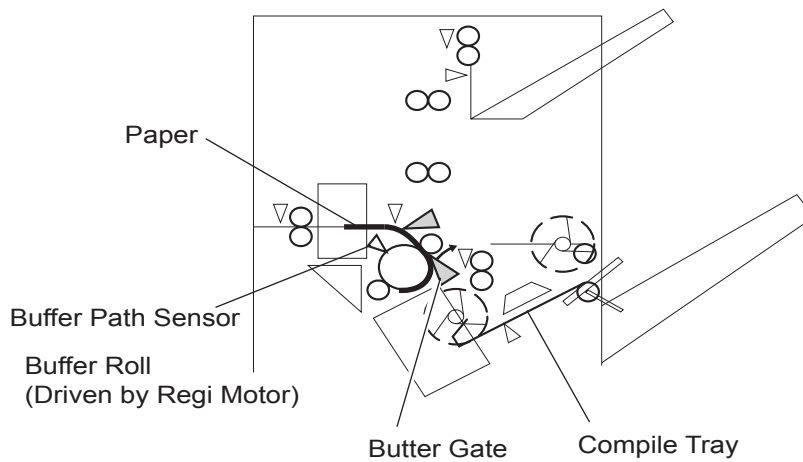
To this end, when the first paper of the second set reaches the Finisher, the Buffer Gate Solenoid is activated by the IOT command and by the X'port Entrance Sensor to switch the Buffer Gate.

Thus, the paper route is switched in the Buffer Roll's circumferential direction. (This operation is called "Buffer Path" hereafter.)

The first paper of the second set is aligned with the second paper, and then they are fed together to the Compile Tray.

Even for one sheet of paper, the Buffer Path operation is executed in the same way. The paper is stacked temporarily on the Compile Tray, and then ejected in the Stacker Tray.

After Buffer Path is executed for the first paper, if the second paper of a different size comes, the first paper is fed to the Compile Tray, but the second one is fed to the Compile Tray without Buffer Path. At this time, a certain delay time is provided to avoid the second paper from colliding with the first one.



### From Compile Tray to Stacker Tray

Stapled paper on the Compile Tray (stapling mode) or aligned paper (non-stapling mode) are held between the Eject Clamp (lowered by the Eject Clamp Motor) and the Shaft Assy-Eject Roll. The Shaft Assy-Eject Roll is driven by the Eject Motor to transfer paper to the Stacker Tray. After paper is transferred to the Stacker Tray, it is held by the Paddle-Set Clamp attached to the Shaft Assy-Eject Roll.

### From Puncher to Top Tray

The paper to be ejected to the Top Tray is switched the paper path by the Transfer Gate located behind the Puncher, and fed in the Roll Assy-Transfer direction.

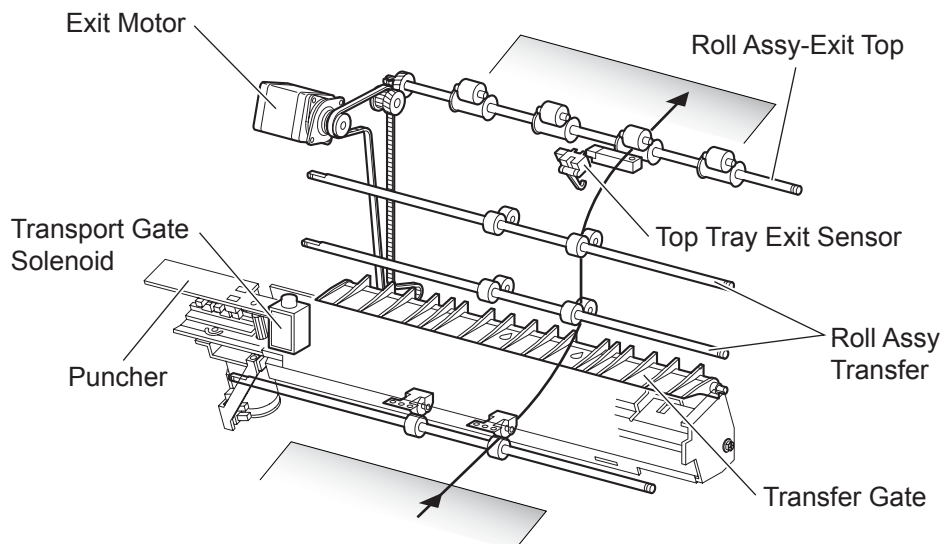
The Transfer Gate is switched by the Transport Gate Solenoid. While the solenoid is activated, paper is fed in the Roll Assy-Transfer direction.

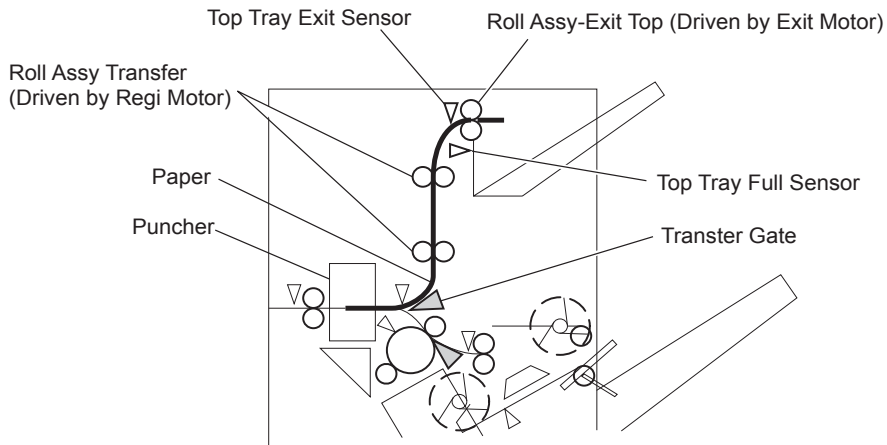
The two Roll Assy-Transfers driven by the Regi Motor feed paper to the Roll Assy-Exit Top at the top of the Finisher.

The Roll Assy-Exit Top driven by the Exit Motor to eject the paper to the Top Tray.

The Roll Assy-Exit Top decelerates after a pre-specified period of time from the following trigger events.

1. Models without puncher: ENT SNR transition to "Low".
2. Models with puncher: Restart of the Roll Assy-Exit Top after punching





## Functions of Sensors along the Paper Path

### H-TRA

#### 1. H-X'port Entrance Sensor

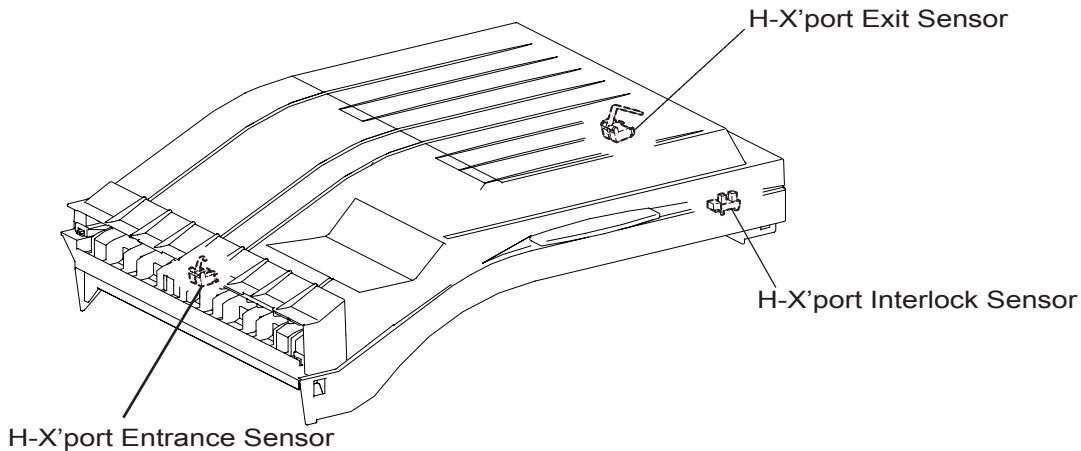
A photo-interrupter to detect whether paper is fed from the IOT to the H-TRA  
It turns "H" (+5 V) (light receiving) when paper enters the H-TRA.

#### 2. H-X'port Exit Sensor

A photo-interrupter to detect whether paper passes through the H-TRA  
It turns "H" (+5 V) (light receiving) when paper reaches this sensor, and turns "L" (0 V) when paper exits from the H-TRA.

#### 3. H-X'port Interlock Sensor

A photo-interrupter to detect open/close of the Cover Assy Top of the H-TRA  
It turns "H" (+5 V) (light receiving) when the Cover Assy Top opens.



### Finisher

#### 1. X'port Entrance Sensor

A reflective photo-sensor to detect whether paper is fed from the H-TRA to the Finisher  
turns "H" (+5 V) while paper is present within the sensing area.

When the level turns "H" due to the first paper of the second set during multi-set printing, activates the Buffer Gate Solenoid to switch the Buffer Gate so that the paper goes in the Buffer Roll's circumferential direction.

#### 2. Gate Sensor

A reflective photo-sensor to detect the front end of paper  
it turns "L" (0 V) when the front end reaches the sensing area.

### 3. Compile Exit Sensor

A photo-interrupter to detect whether paper passes through the Compile Exit Sensor it turns "H" (+5 V) (light receiving) when the actuator is driven out of the sensing area by the paper.

When the level tunes "H", activates the Front Tamper Motor and the Rear Tamper Motor on the Compile Tray.

This sensor is also used to control ON/OFF of the Eject Motor.

### 4. Compile Tray No Paper Sensor

A photo-interrupter to detect whether paper is present or not on the Compile Tray.

While paper is present, the actuator is outside the sensing area, and the sensor turns at "H" (+5 V) (light receiving).

### 5. Buffer Path Sensor

A photo-interrupter to detect whether paper is fed toward the Buffer Roll

While paper is present, the actuator is outside the sensing area, and the sensor turns at "H" (+5 V) (light receiving).

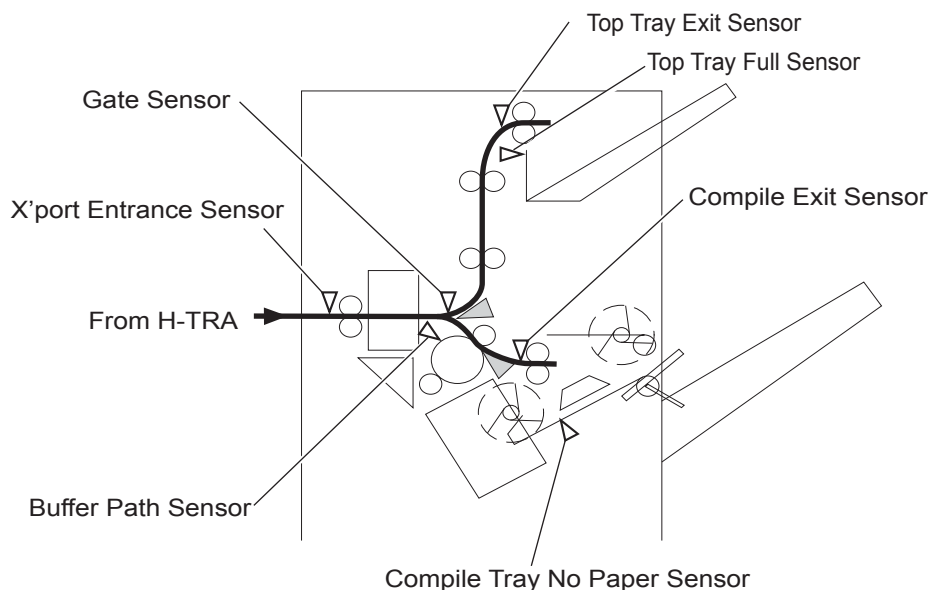
### 6. Top Tray Exit Sensor

A photo-interrupter to detect whether paper is fed to the Roll Assy-Exit Top at the exit side of the Top Tray

When the paper is fed, the actuator leaves from the sensing area, and the sensor tunes "H" (+5 V).

### 7. Top Tray Full Sensor

A reflective photo-sensor to detect the stack volume of paper in the Top Tray



## Puncher

This section describes the paper punching operation of the Puncher.

Four types of Puncher are provided: 2/3-hole type, 2/4-hole type, 2-hole type and 3-hole type. (For overseas specifications, 2/3-hole type, 2/4-hole type and 3-hole type are provided.)

The following explains the 2/3-hole type (2-hole/3-hole auto-switching).

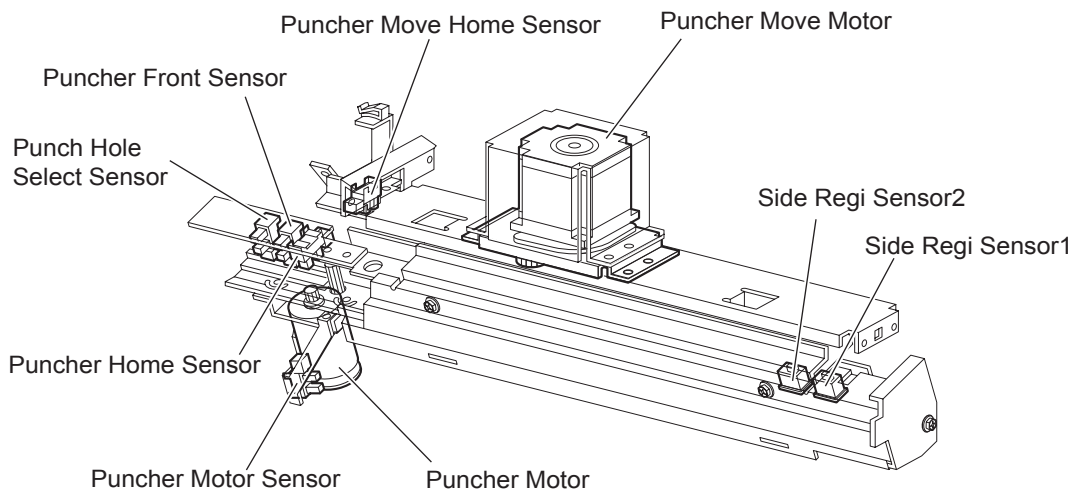
Every type has the same construction, except for the Punch Hole Select Sensor that is provided for the 2-hole type and 3-hole type only. But the sensor is not working currently.

## Adjusting Punching Positions

The punching positions from the paper edge in the direction of feed are determined by gently pressing the paper against the Guide Assy (see Section 2.2).

While the punching positions from the paper edge in the direction of paper width are determined by the following method.

- Activate the Puncher Move Motor and move the Puncher to the front side until the Puncher Move Home Sensor turns "L".
- Rotate reversely the motor and move the Puncher to the rear side until the sensor turns "H" to determine the home position.
- The Puncher Move Motor is run to move the puncher to the front until the Side Regi Sensor1 or 2 detects the paper edge, and then the puncher is further moved to the front according to the pulse-number determined by the paper size.(The Puncher Move Motor stops at this position.)



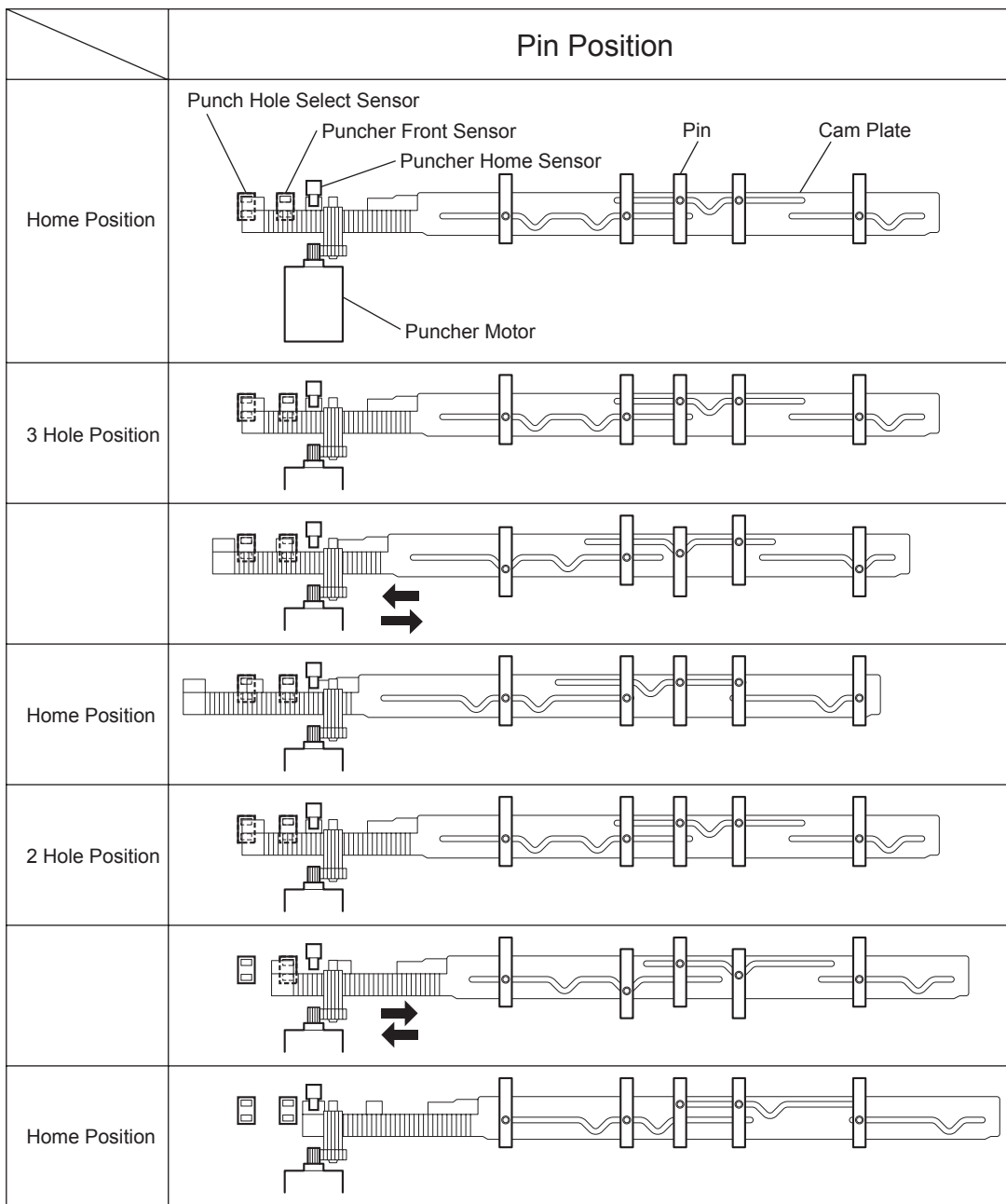
## Punching

After punching positions are determined, activate the Puncher Motor to move the Cam Plate. With the movement of the Cam Plate, the pins descend along the guide holes to punch the paper.

This operation is performed for each sheet of paper.

The Cam Plate can lower the pins even while it is moving to the front or rear side.

The Puncher Motor is rotated forward or reversely for each sheet of paper, which is triggered by the Puncher Front Sensor ON/OFF.



## Detecting Punch Dust Full

Punch dust is stored in the Punch Dust Box.

A sensor is provided to detect punch dust full.

When punch dust full is detected, it is notified to the operator only once.

Even if punch dust is not removed, the finisher can still punch paper. However it can spread punch dust inside the machine.

## Detecting Punch Dust Box

The Punch Box Set Sensor detects whether the Punch Dust Box is properly set.

When the sensor does not detect that the box is properly set for four seconds, the punch dust box count is reset. This time period can be changed by rewriting the non-volatile memory.

## Functions of Puncher Sensors/Motors



1. Side Regi Sensor 1

A reflective photo-sensor to detect the side edge of large paper

Paper side edge is detected by ON/OFF of this sensor while shifting the Puncher (containing this sensor) in the direction of paper width. The sensor remains at "H" (+5 v) while paper is present, and turns "L" when paper side edge is detected.

2. Side Regi Sensor 2

A reflective photo-sensor to detect the side edge of small paper. This sensor has the same function as the Side Regi Sensor 1.

3. Puncher Move Home Sensor

A photo-interrupter to detect the home position of the moving Puncher. It turns "H" (+5 v) (light blocking) when the home position is detected.

4. Puncher Home Sensor

A photo-interrupter to detect the home position of the Cam Plate that lowers the punching pins. It turns "H" (+5 V) when the home position is detected.

5. Punch Hole Select Sensor

A photo-interrupter to detect the rear position of the Cam Plate. It turns "H" (+5 V) when the rear position is detected. This sensor also detects the Cam position to switch punch holes (2-hole/3-hole).

6. Puncher Front Sensor

A photo-interrupter to detect the front position of the Cam Plate. It turns "H" (+5 V) when the front position is detected. This sensor is used to determine to which side (front or rear) the Cam Plate should be moved.

7. Puncher Motor Sensor

A photo-interrupter to detect pulse generated by the actuator attached to the Puncher Motor. It counts Puncher Motor revolutions, and becomes a trigger to stop the motor (by shutting off the current).

8. Puncher Move Motor

A stepping motor to move the Puncher in the paper width direction

9. Puncher Motor

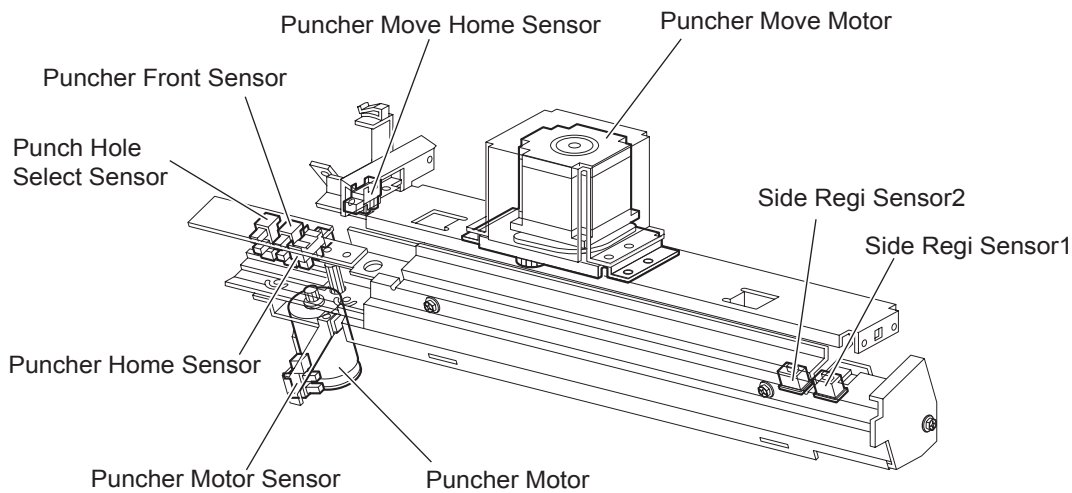
A DC motor to move the Cam Plate that lowers the punching pins. Forward rotation of the motor moves the Cam Plate to the front side, and reverse rotation moves it to the rear side.

10. Punch Box Set Sensor

A photo-interrupter to detect whether the Dust Box is properly set. When the Punch Dust Box is properly set, the actuator of the box blocks the light transmission of the sensor, which turns the sensor to "H" (+5 V).

11. Punch Full Sensor

A photo-interrupter to detect the Punch Dust Box is filled with punch dust.



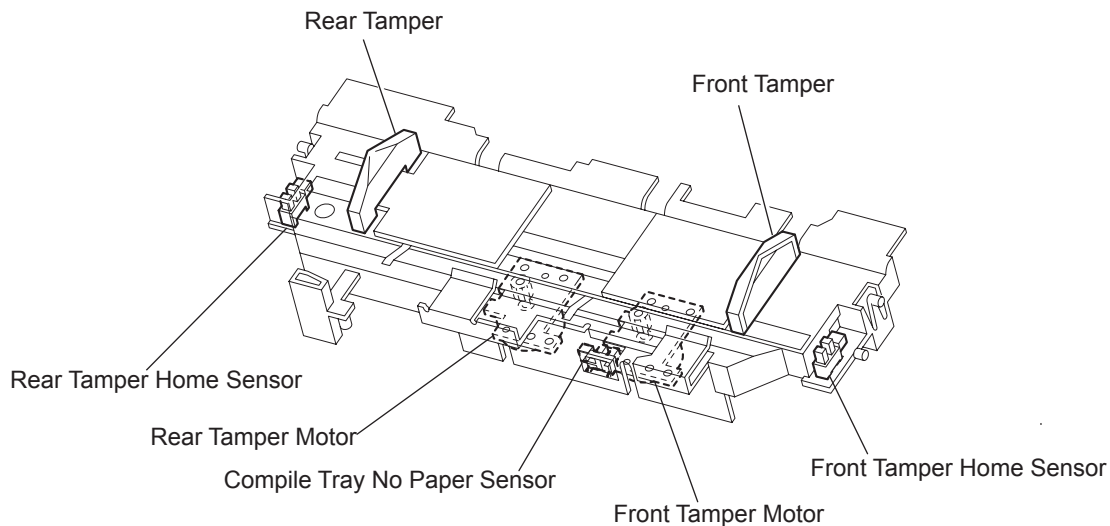
## Compile Tray

This section describes the operation of the Compile Tray that aligns the paper edge transferred from the Puncher.

### Outline of Operation

When paper is fed onto the Compile Tray, tamping operation is performed to align the paper edge in the paper width direction.

When ejecting stapled sets of paper to the Stacker Tray, if they are stacked in the Stacker Tray with the same staple position, the height of the stapled portion will increase. This will cause improper compiling of paper due to butting of the following paper. To prevent such improper compiling, offsetting is required by shifting the staple position between sets of paper.



### Capacity of Compile Tray

Paper volume that can be stacked on the Compile Tray is limited as shown in the table below. The number of sheets depends on whether paper is stapled or not, as well as on paper size.

If the number of sheets of one set to be stapled exceeds the limit, the exceeding sheets are not stacked on the Compile Tray, and are forcibly ejected to the Stacker Tray without being stapled. This forcible ejection is performed to prevent damage to the Staple Assembly.

When feeding large paper in the non-staple mode, there may be a misalignment depending on paper characteristics. For this reason, the default paper capacity is set to a smaller value.

Compile Tray Paper Capacity

Condition	Min.	Default	Max.
Staple mode	2	50	75
For small paper (less than 216 mm in the feed direction) in non-staple mode	10	50	100
For large paper (216 mm or more in the feed direction) in non-staple mode	10	25	100

## Compile Tray Operation with Multiple Paper Sizes

When two or more paper sizes are used and their widths are same (example: A4L and A3S), all the sheets are compiled and stapled as a set on the Compile Tray, and then ejected to the Stacker Tray.

While if two or more paper sizes with different paper width are used, stapling paper on the Compile Tray is stopped when a different size is detected. Such different-size sheets of paper are forcibly ejected to the Stacker Tray.

## Tamping

When paper is fed from the Puncher to the Compile Tray, tamping operation is performed to align the paper in the paper width direction on the Compile Tray.

Tamping is an operation to align paper to the specified position on the Compile Tray using the Front Tamper or Rear Tamper by moving them to the end of paper by the respective motors.

Tamping is executed each time when a sheet of paper reaches the Compile Tray. Additional tamping is executed after tamping the last sheet.

There are three types of tamping.

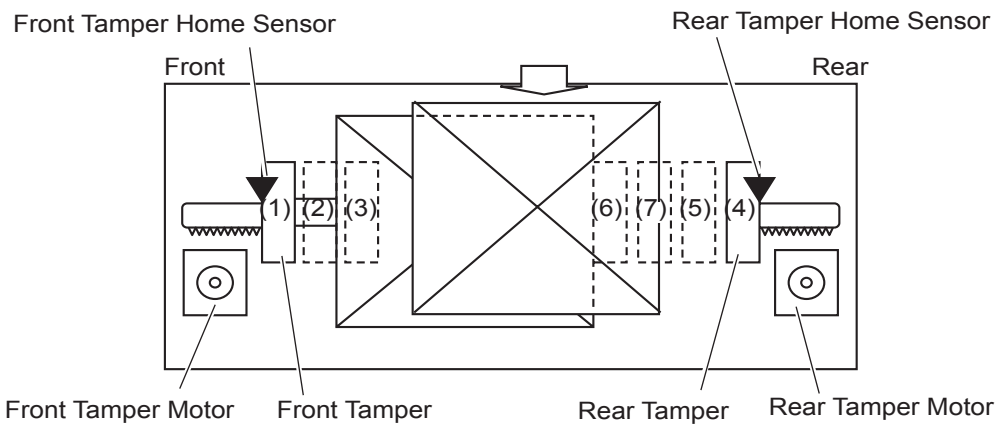
- Front Tamping  
Tampering by the Rear Tamper with the Front Tamper fixed at the home position
- Rear Tamping  
Tampering by the Front Tamper with the Rear Tamper fixed at the home position
- Center Tamping  
Tampering by the Front and Rear Tampers to align paper to the almost center

## Front Tamping

Front Tamping is used in the following cases.

- In the non-staple mode
- When executing front stapling (corner)

The tamper positions during Front Tamping are shown below:

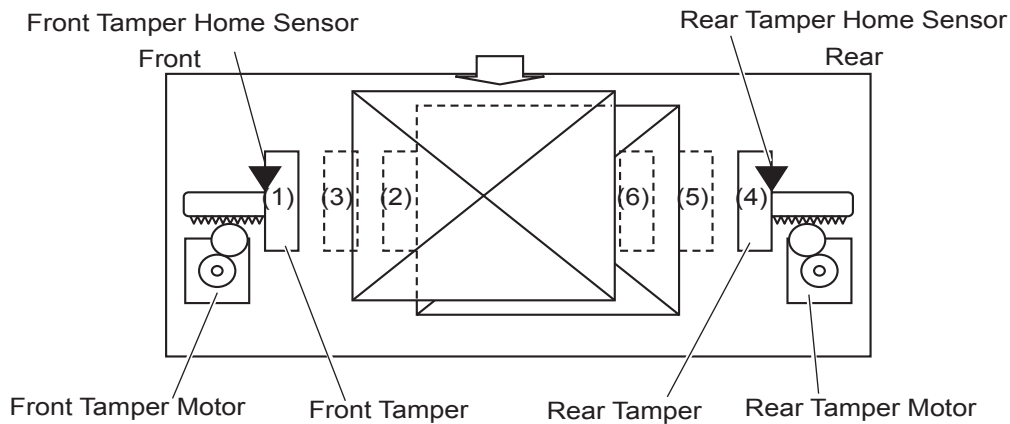


1. Front Tamper home position (Front Tamper Home Sensor position)
2. Front Tamper size position
3. Front Tamper offset position
4. Rear Tamper home position (Rear Tamper Home Sensor position)
5. Rear Tamper standby position
6. Rear Tamper tamping position
7. Rear Tamper offset position

## Rear Tamping

Rear Tamping is used in the following cases.

- When executing rear stapling (corner)
- When executing dual stapling
- The tamper positions during Rear Tamping are shown below:



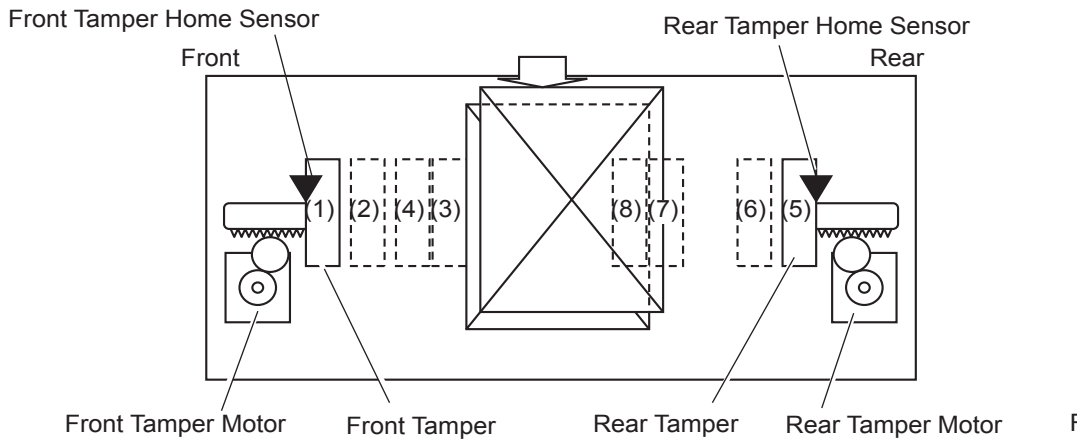
1. Front Tamper home position (Front Tamper Home Sensor position)
2. Front Tamper tamping position
3. Front Tamper offset position
4. Rear Tamper home position (Rear Tamper Home Sensor position)
5. Rear Tamper size position
6. Rear Tamper offset position

## Center Tamping

Center Tamping is used in the following case.

- When executing rear stapling (straight)

The tamper positions during Center Tamping are shown below:



1. Front Tamper home position (Front Tamper Home Sensor position)
2. Front Tamper standby position
3. Front Tamper tamping position
4. Front Tamper offset position
5. Rear Tamper home position (Rear Tamper Home Sensor position)
6. Rear Tamper standby position
7. Rear Tamper size position
8. Rear Tamper offset position

### Determining Tamper Home Position

When the Compile Exit Sensor turns “H” (+5 V) (light receiving), the Front and Rear Tamper Motors on the Compile Tray are activated, and the Front and Rear Tampers start moving.

The Front Tamper home position is determined when the Front Tamper enters the Front Tamper Home Sensor sensing area.

In the same way, the Rear Tamper home position is determined when the Rear Tamper enters the Rear Tamper Home Sensor sensing area.

### Tamping

Tamping is executed after a preset time has passed after the Compile Tray No Paper Sensor turns “H” (+5 V) when paper is detected on the Compile Tray.

### Offsetting

Offsetting is an operation to shift the position of paper to be ejected to the Stacker Tray so that boundaries between paper units (sets of paper, job unit, etc.) can be easily recognized.

Offsetting is executed for staple positions.

#### During Front Stapling (Corner)

Shifts stapled sheets using the Front Tamper by 20 mm to the rear side before ejecting them to the Stacker Tray.

#### During Rear Stapling (Corner/Straight)

For paper with a width of 216 mm or more [Rear Staple (Corner)]:

Shifts stapled sheets using the Rear Tamper by 20 mm to the front side before ejecting them to the Stacker Tray.

For paper with a width of less than 216 mm [Rear Staple (Straight)]:

Shifts stapled sheets using the Front Tamper by 9 mm to the rear side before ejecting them to the Stacker Tray.

### During Dual Stapling

Shifts stapled sheets using the Front Tamper by 9 mm to the rear side before ejecting them to the Stacker Tray.

Offsetting is not executed (0 mm) for small paper.

## Functions of Compile Tray Sensors/Motors

### 1. Compile Tray No Paper Sensor

A photo-interrupter to detect whether paper is present or not on the Compile Tray. When paper is detected, the actuator leaves the sensing area, which turns the sensor to "H" (+5 V) (light receiving).

### 2. Front Tamper Home Sensor

A photo-interrupter to detect the Front Tamper home position. When the Front Tamper comes to the home position, it enters the sensor's sensing area, which turns the sensor to "H" (+5 V) (light blocking).

### 3. Rear Tamper Home Sensor

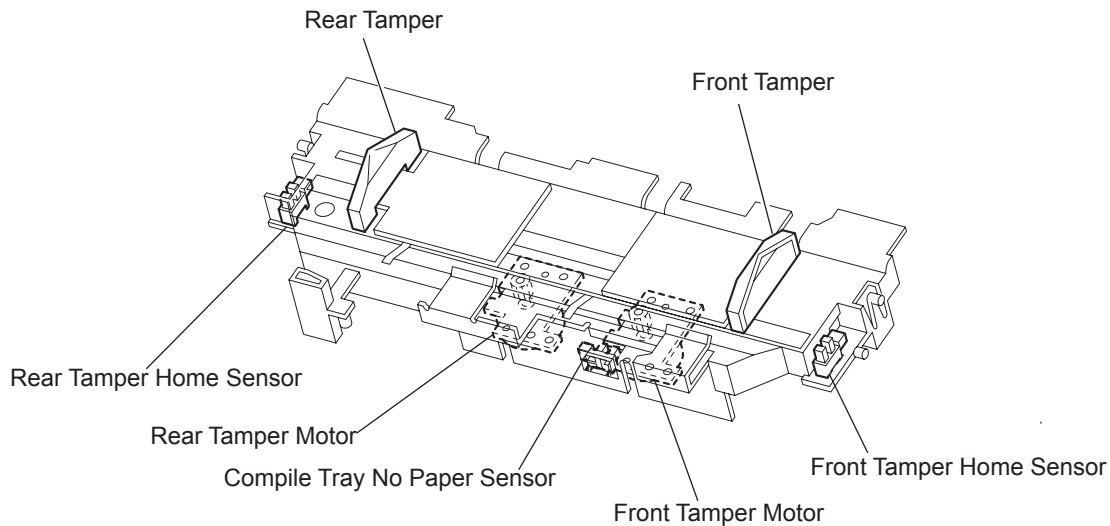
A photo-interrupter to detect the Rear Tamper home position. When the Rear Tamper comes to the home position, it enters the sensor's sensing area, which turns the sensor to "H" (+5 V) (light blocking).

### 4. Front Tamper Motor

A stepping motor to move the Front Tamper for tamping. Clockwise rotation of this motor moves the Front Tamper to the rear side. Counterclockwise rotation of this motor moves the tamper to the front side.

### 5. Rear Tamper Motor

A stepping motor to move the Rear Tamper for tamping. Clockwise rotation of this motor moves the Rear Tamper to the front side. Counterclockwise rotation of this motor moves the tamper to the rear side.



## Stapler

This section describes the operation of the Stapler.

### Stapling Operation

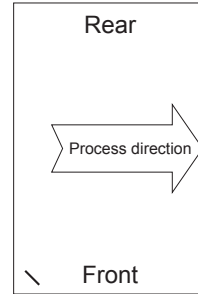
Sheets of paper fed from the Puncher are tamped on the Compile Tray, and then stapled at specified positions by the command of IOT.

### Staple Positions

There are the following four stapling modes.

**Front Staple (Corner) [Front Corner]**

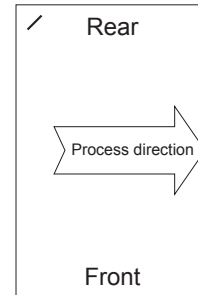
The Stapler staples a set of paper obliquely (45 degrees) after the Rear Tamper aligns the paper to the front side.



**Rear Staple (Corner) [Rear Corner]**

This type of stapling is applied for paper with a width of 216 mm or more.

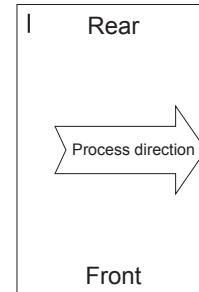
The Stapler moves to the rear corner and staples a set of paper obliquely (45 degrees) after the Front Tamper aligns the paper to the rear side.



**Rear Staple (Straight) [Rear Straight]**

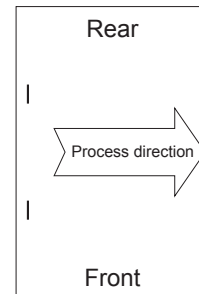
This type of stapling is applied for paper with a width of less than 216 mm.

The Stapler staples a set of paper in parallel with the paper edge after the Front Tamper aligns the paper to the rear side.



**Dual Staple [Dual]**

The Stapler staples a set of paper at fixed positions (front/rear sides) in parallel with the paper edge, after the Front Tamper aligns the paper to the specified position for each paper size.



## Paper Sizes That Allow Stapling

Paper size that allows stapling depends on stapling positions.

The following table shows paper sizes and the applicability of stapling for each staple position.

	Front Corner	Rear Corner	Rear Straight	Dual
A3SEF	Yes	Yes	No	Yes
A4LEF	Yes	Yes	No	Yes

11 x 17SEF	Yes	Yes	No	Yes
8.5 x 11LEF	Yes	Yes	No	Yes
8KSEF(GCO), 16KLEF(GCO)	Yes	Yes	No	Yes
B4SEF, B5LEF	Yes	Yes	No	Yes
8 x 10LEF	Yes	Yes	No	Yes
8.5 x 14SEF / 8.5 x 13SEF / 8.5 x 11SEF	Yes	No	Yes	Yes
A4SEF	Yes	No	Yes	Yes
8 x 10SEF	Yes	No	Yes	Yes

Yes: Applicable

No: Not applicable

## 0.1 Stapling One Sheet

Upon receiving the stapling command from the IOT with one sheet remaining on the Compile Tray, the Finisher ejects the paper to the Stacker Tray without stapling it.

## 0.2 Stapling Multi-Size Paper

When sheets with different sizes and same width (example: A4L and A3S) are present on the Compile Tray, all the sheets are stapled, and then ejected to the Stacker Tray.

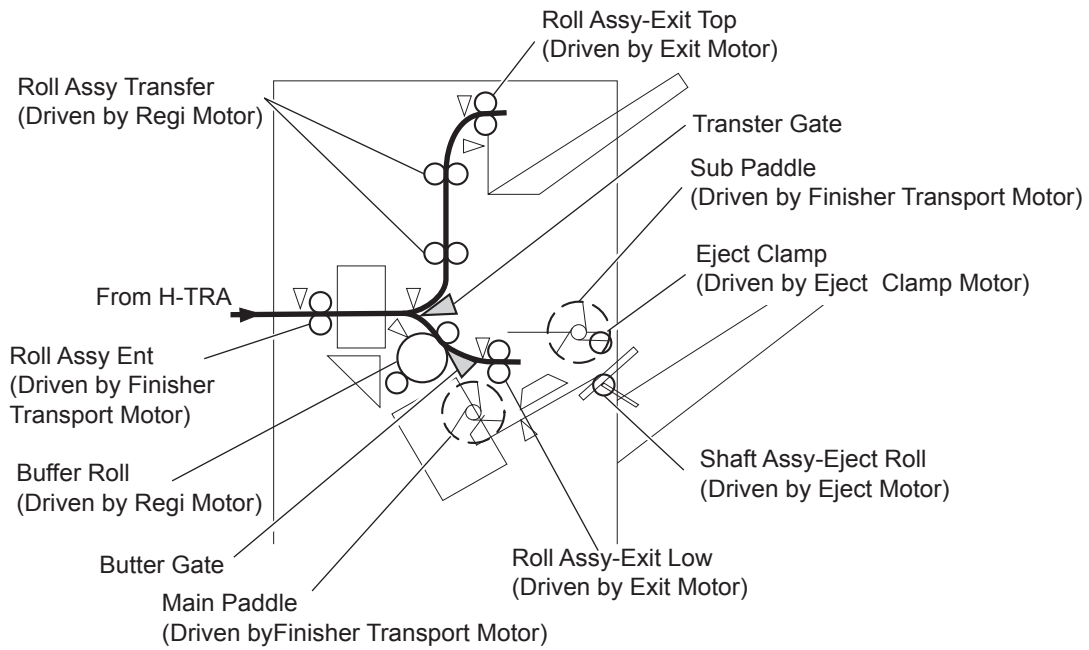
While if sheets with different widths are present on the Compile Tray, stapling is stopped when a different width is detected. Such different-width sheets are forcibly ejected to the Stacker Tray.

## 0.3 Paper Limits for Stapling

The number of sheets to be stapled is limited to prevent damage to the Stapler.

- If the number of sheets of one set to be stapled exceeds the limit of the Compile Tray, the exceeding sheets are not stacked on the Compile Tray, and are forcibly ejected to the Stacker Tray without being stapled.
- After the forcible ejection of paper, if the number of following sheets of one set to be stapled exceeds the limit of the Compile Tray, the exceeding sheets are also ejected forcibly to the Stacker Tray without being stapled.
- After that, even if the number of following sheets of one set to be stapled falls within the limit, the sheets are also ejected forcibly to the Stacker Tray without being stapled.





Upper limit of Compile Tray paper capacity when stapling: default: 50 (variable (10 to 100) by the non-volatile memory),

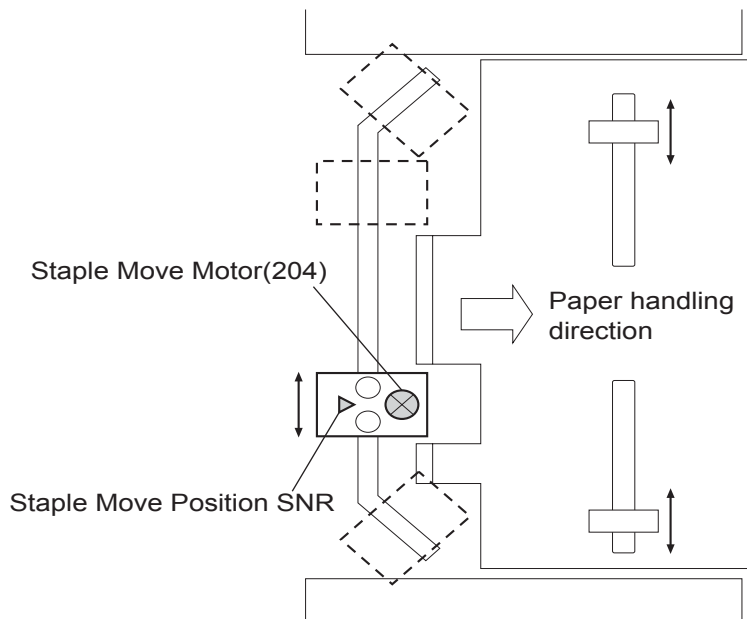
## 0.4 Stapler Operation

The Stapler stays at the front home position, that is, at the Front Staple (Corner) position when the power is turned ON.

The Stapler starts stapling when a set of sheets to be stapled is stacked on the Compile Tray.

The Stapler does not move during stapling in the Front Staple mode.

In any mode other than the Front Staple mode, the Stapler moves to the specified position, and then performs stapling.



## Stapler Head

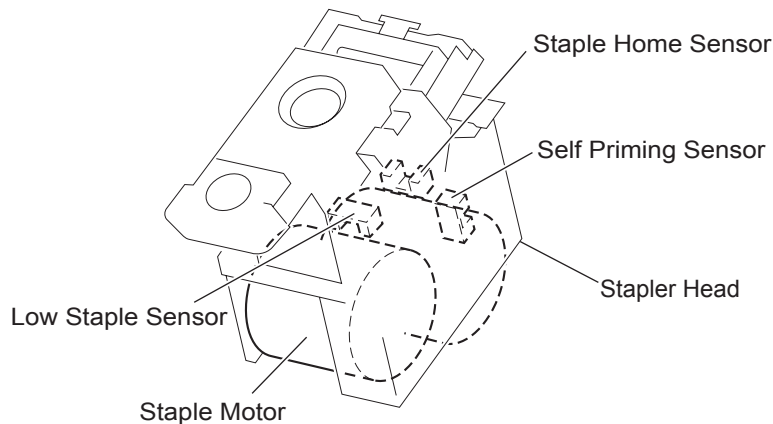
Stapling operation is executed by closing the Stapler Head.

The Stapler Head, containing the Staple Motor, the Staple Home Sensor, the Self Priming Sensor, and the Low Staple Sensor, is activated by the Staple Motor.

Forward (clockwise) rotation of the motor drives the Stapler to staple a set of sheets, and returns the stapling unit to the home position.

If stapling fails, the motor rotates reversely (counterclockwise) to return the Stapler Head to the home position.

When staples become low, the Low Staple Sensor detects it and stapling stops automatically displaying an alarm message. The message is also displayed when the Staple Cartridge is not installed.



## Functions of Stapler Sensors/Motors

### 1. Stapler Move Home Position Sensor

A photo-interrupter to detect the Stapler home position, Rear Staple (Corner) position, and Rear Staple (Straight) position. It turns "H" (+5 V) (light blocking) when the Stapler comes at the specified position.

### 2. Stapler Move Motor

A DC motor to move the Stapler Head. Clockwise rotation of this motor moves the Stapler Head to the rear side, while counterclockwise rotation moves the Stapler Head to the front side.

### 3. Low Staple Sensor (in the Stapler Head). A photo-interrupter to detect near end of staples

It turns "H" (+5 V) when staples become 20 staple left.

### 4. Self Priming Sensor (in the Stapler Head)

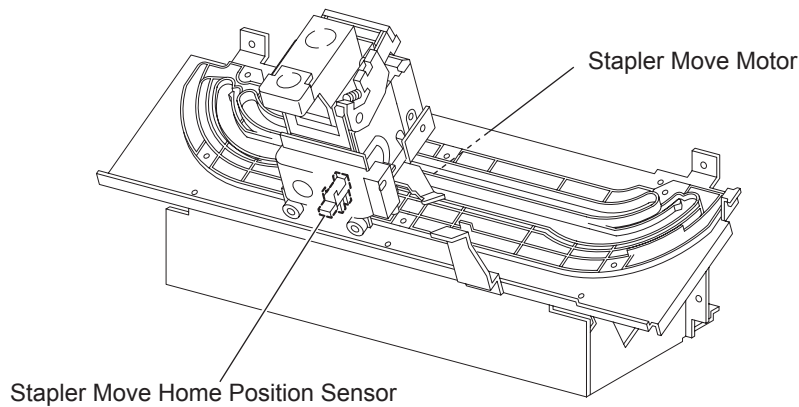
A photo-interrupter to detect that staples are at the Stapler Head end, and also to detect failure in stapling. "L" (0 V) (light blocking) when stapling is ready.

### 5. Staple Home Sensor (in the Stapler Head)

A photo-interrupter to detect the Stapler Head home position, and also to detect failure in stapling. This sensor also functions as a trigger to stop the Staple Motor. It turns "L" (0 V) (light blocking) while the Stapler Head stays at the home position.

### 6. Staple Motor (in the Stapler Head)

A DC motor to activate the Stapler Head for stapling. Clockwise rotation of this motor enables stapling, while counterclockwise rotation returns the Stapler Head.



## Operation

The Top Tray contains the Top Tray Full Sensor to detect the paper stack volume in the Top Tray. Once the sensor detects “full stack” (500 sheets) of the Top Tray, ejection of paper to the Top Tray is inhibited until “full stack” is reset.

## Functions of Top Tray Sensors

### 1. Top Tray Exit Sensor

A photo-interrupter to detect that paper has come to the Roll Assy-Exit Top at the exit of the Top Tray. When paper reaches the Roll Assy-Exit Top, the actuator leaves the sensing area, which turns the sensor to “H” (+5 V).

### 2. Top Tray Full Sensor

A reflective photo-sensor to detect the paper stack volume in the Top Tray. It turns “H” (+5 V) when it detects “full stack”.

## Stacker Tray

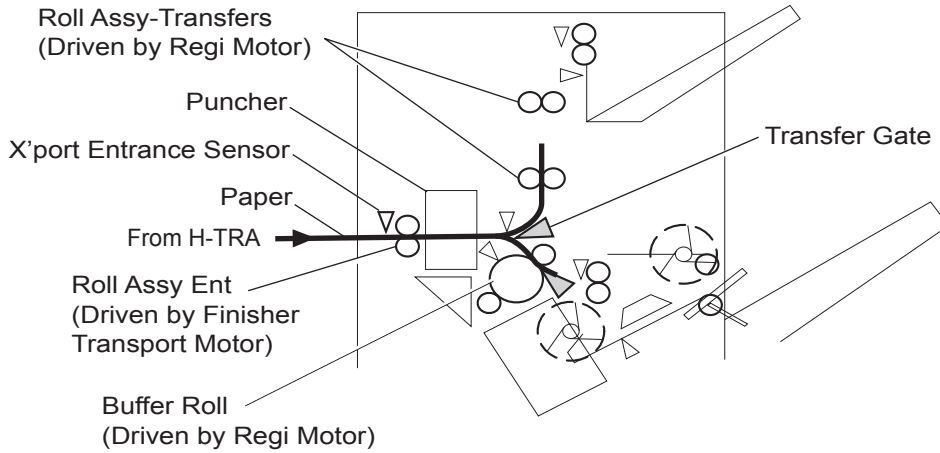
The Stacker Tray goes up and down to an appropriate position according to the volume of paper fed from the Compile Tray so as to properly stack paper to “full stack”.

## Operation

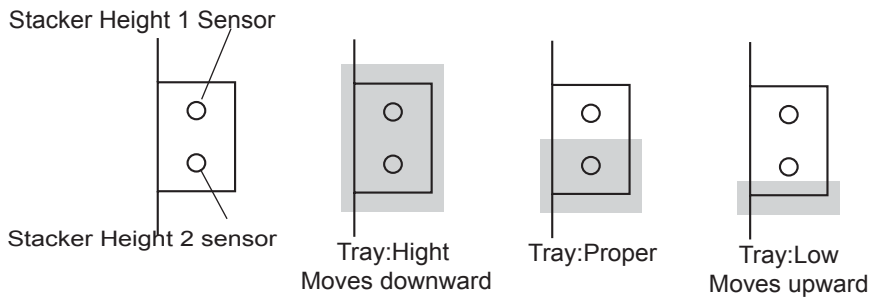
The Stacker Tray moves to an appropriate position according to the volume of paper fed from the Compile Tray. The Stacker Height Sensor 1 and the Stacker Height Sensor 2 detect the height of paper in the Stacker Tray, and the Stacker Encode Sensor determines the volume of paper in the tray.

When paper or the Stacker Tray comes between the light emitter and the photo-receiver of the Stacker Height Sensor 1 and Stacker Height Sensor 2, the emitted light is blocked and the sen-

sors turn “H”. The height of paper or the Stacker Tray is detected based on the levels of these sensors.



This sensor information is used to control the Elevator Motor. The motor is activated to move the Stacker Tray while the Stacker Height Sensor 1 turns into the light blocking state to the light receiving state.

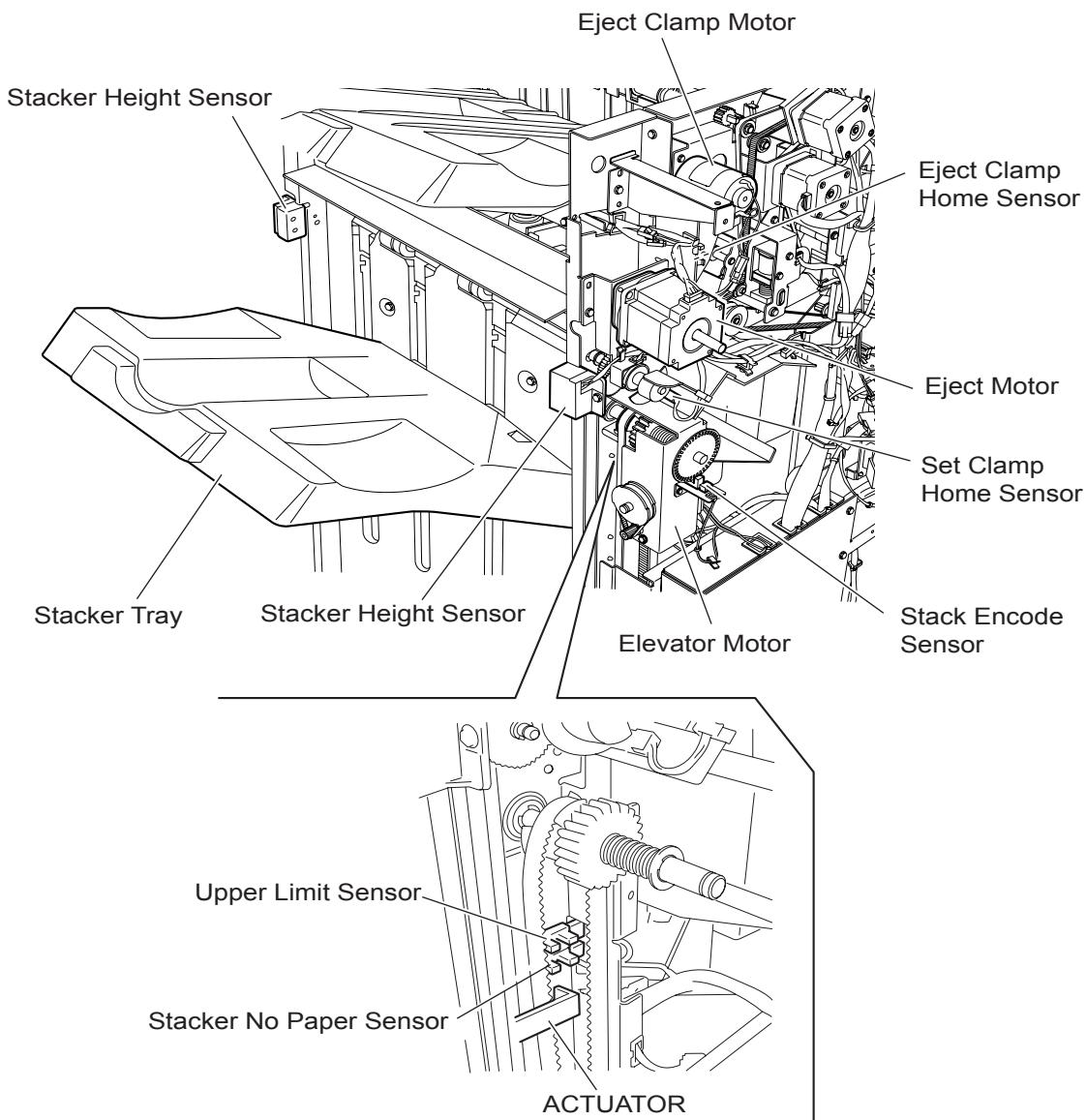


The Stacker No Paper Sensor is turned ON or OFF by the Actuator attached to the Carriage Assy R on the rear side of the Finisher. In case the Stacker Tray abnormally goes up above the Stacker No Paper Sensor, the Upper Limit Sensor is installed above the Stacker No Paper Sensor for the protection against the abnormal operation.

If an operator removes paper from the Stacker Tray during printing, it is detected by the Stacker Height Sensor 2, and the ejection of paper to the Stacker Tray is inhibited. Then the Elevator Motor is activated to move the Stacker Tray to the Stacker Height Sensor 1 sensing area. Thus, the ejection of paper to the Stacker Tray is restored.

If an operator removes paper from the Stacker Tray while printing is stopped, it is detected by the Stacker Height Sensor 2. After three seconds have passed, the Elevator Motor is activated to move the Stacker Tray to the Stacker Height Sensor 1 sensing area. Thus, the ejection of paper to the Stacker Tray is restored.

The Stacker Tray lowers according to the volume of paper it contains. If any obstacle under the tray hinders the tray from lowering, “Stacker Lower safety Warning” is detected and the Stacker Tray is stopped.



## Full Stack Detection

“Full stack” is detected when paper in the Stacker Tray becomes full to prevent paper jam or falling of paper to the floor. The Stacker Tray can stack up to approx. 3000 sheets.

The paper volume in the Stacker Tray is detected at every 10% (approx. 300 sheets) and notified to the Controller.

Furthermore, the Stacker Tray can stack up to 200 sets (default) of stapled paper. (This value can be changed by the non-volatile memory between 10 and 200.)

The Stacker Tray can continue to stack paper until paper volume reaches either of the limits above.

In the “mix stacking” mode, all the sizes are allowed until paper volume of approx. 300 sheets in the Stacker Tray is detected.

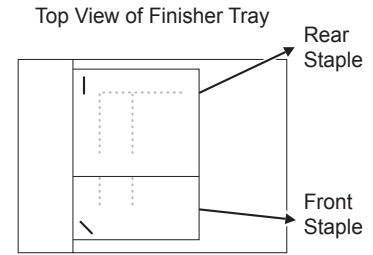
The “mix stacking” means one of the following cases:

- A larger (any side of paper) sheet of paper is stacked on a smaller sheet  
Example: A4LEF (297x210) paper is stacked on A4SEF (210x297) paper.

Note:

When B5LEF (257x182) paper is stacked on A4LEF (297x210) paper, this is not “mix stacking”.

- A sheet of paper of less than 11 inches is stacked in the Stacker Tray with the Staple Mode changed.



- An operator put a sheet (or sheets) when no paper is remaining in the Stacker Tray. (The size and condition of paper stacked in the tray are not identified.)
- Paper was present in the Stacker Tray when power was turned ON. (The size and condition of paper stacked in the tray are not identified.)
- The Finisher entered the Sleep Mode with "mix stacking" and then has exited the Sleep Mode.
- The post-processing mode has changed.

## Functions of Stacker Tray Sensors/Motors

### 1. Stacker Height Sensor 1

A pair of light emitter and photo-receiver to detect the height of paper in the Stacker Tray. This sensor is used to control the Elevator Motor. When blocked by paper or the tray, this sensor turns "H" deciding that the Stacker Tray is above the reference level. To the contrary, when receiving light, this sensor turns "L" deciding that the Stacker Tray is below the reference level. The "H" to "L" turning point of the sensor is defined as the reference level.

### 2. Stacker Height Sensor 2

A pair of light emitter and photo-receiver to detect the height of paper in the Stacker Tray (same function as Stacker Height Sensor 1). This sensor is also used to control the Elevator Motor. When blocked by paper or the tray, this sensor turns "H" deciding that the Stacker Tray is above the reference level. To the contrary, when receiving light, this sensor turns "L" deciding that the Stacker Tray is below the reference level.

### 3. Stacker No Paper Sensor

A photo-interrupter to detect that the Stacker Tray is at the highest position, and also to detect "no paper". When the Actuator attached to the Carriage Assy R enters the sensing area, the emitted light is blocked, which turns the sensor to "H" (+5 V).

### 4. Upper Limit Sensor

A photo-interrupter to detect the Stacker Tray's abnormal elevation above the top position (Stacker No Paper Sensor position). When the Actuator attached to the Carriage Assy R enters the sensing area, the emitted light is blocked, which turns the sensor to "H" (+5 V).

### 5. Stack Encode Sensor

A photo-interrupter to count pulse of the Encoder attached to the Shaft-Elev. The paper volume in the Stacker Tray is detected based on this count.

### 6. Elevator Motor

A DC motor to elevate or lower the Stacker Tray. Clockwise rotation elevates the tray, and counterclockwise rotation lowers the tray.

### 7. Eject Motor

A DC motor to eject stapled or non-stapled paper to the Stacker Tray. Clockwise rotation ejects paper to the Stacker Tray, and counterclockwise rotation reverses the Eject Roll to feed the paper from the Puncher to the Compile Tray.

### 8. Eject Clamp Motor

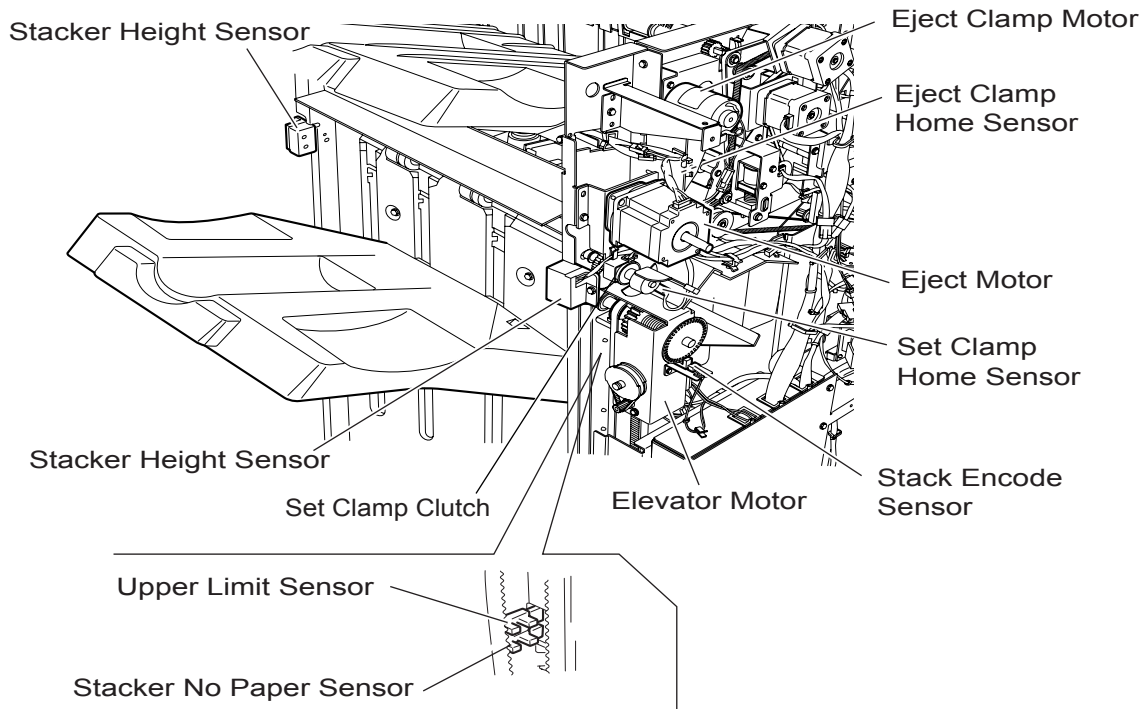
A DC motor to elevate or lower the Eject Clamp when feeding paper from the Puncher to the Compile Tray or from the Compile Tray to the Stacker Tray

9. Set Clamp Home Sensor

A photo-interrupter to detect the Set Clamp home position. This sensor functions as a trigger to control ON/OFF of the Set Clamp Clutch.

10. Set Clamp Clutch

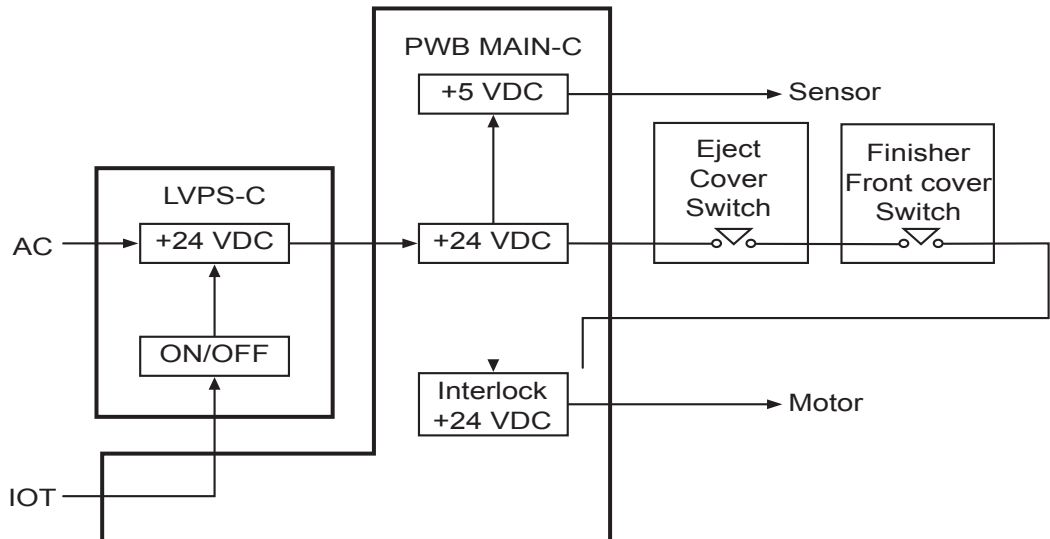
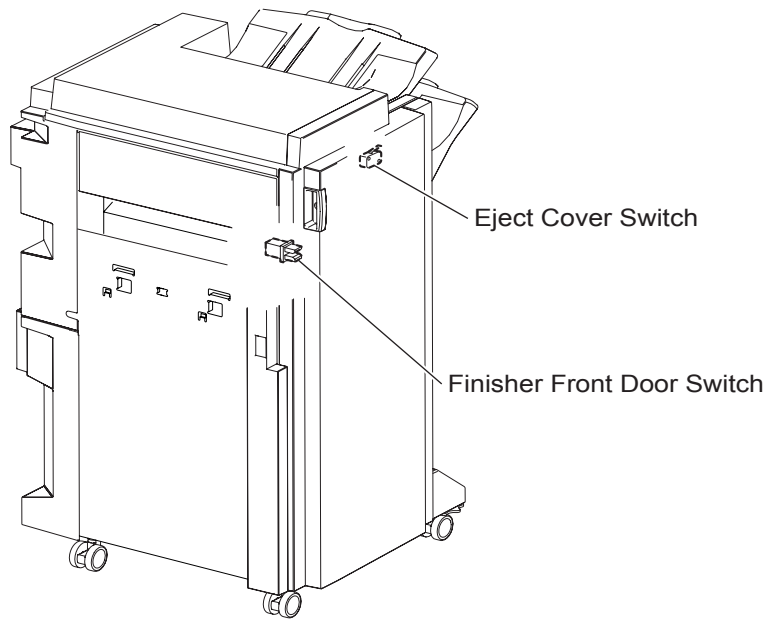
When this clutch is activated, it transmits the Eject Motor rotating power to the Shaft Assy-Eject Roll.



## Power Supply and Interlock

The Finisher is equipped with the following interlock switches.

- Finisher Front Door Switch:  
Turns OFF when the Cover Assy Front opens, shutting off the Interlock, +24 VDC line in the Finisher.
- Eject Cover Switch:  
Turns OFF when the COVER EJECT on the right side opens, shutting off the Interlock, +24 VDC line in the Finisher.





# Chapter 3 Installation

## Engine

### Installation

#### *Installation Location*

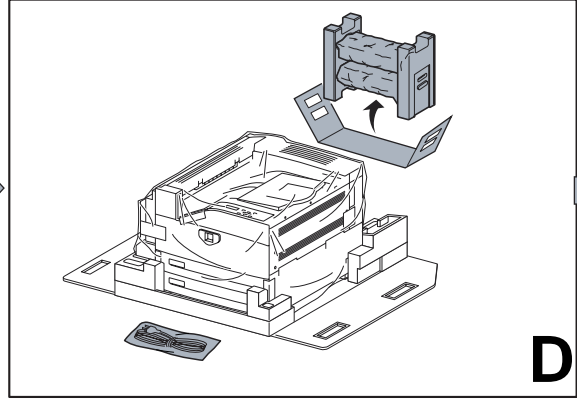
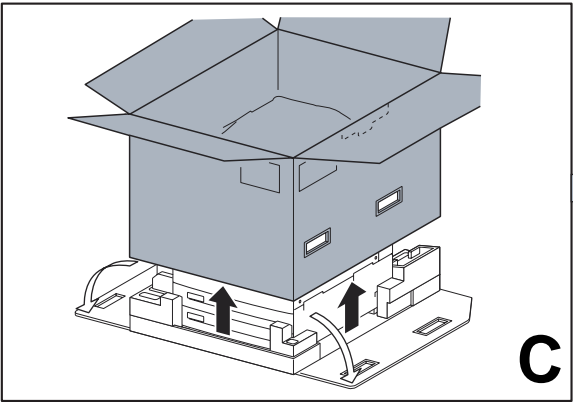
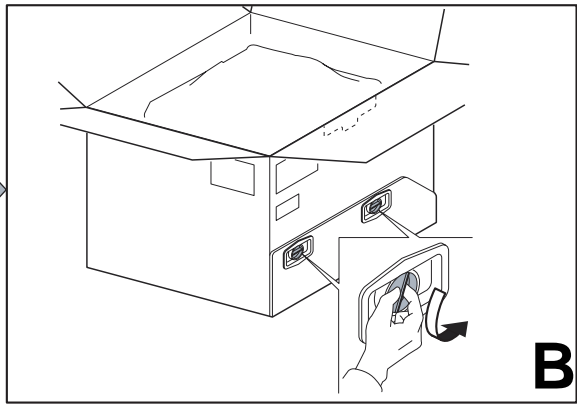
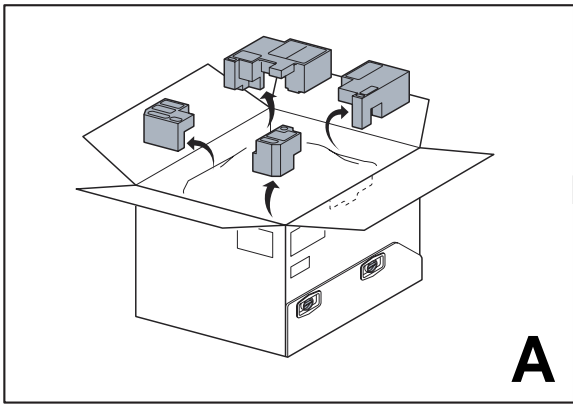
- Get the necessary space for operation of this laser printer.
- Install where the temperature and the humidity meet the following environment:
- During operation: 5 to 35 degrees C / 15 to 85%RH (70%RH at 35 degrees C, 85%RH at 32 degrees C).
- No condensation
- Not in operation: -20 to 40 degrees C / 5 to 85%RH (A place with no condensation)
- Install in a flat place with the angle of gradient of 5 degree or less.
- Install in a place with the illumination of 3000 Lux or less. (Avoid direct sunlight.)
- Avoid a place near a water system, a humidifier or fire, a dusty place, or a place which gets direct air from air conditioning.
- Avoid any location where volatile or flammable gas is generated.
- Avoid an ill-ventilated place.
- Avoid an unstable and non-durable place.

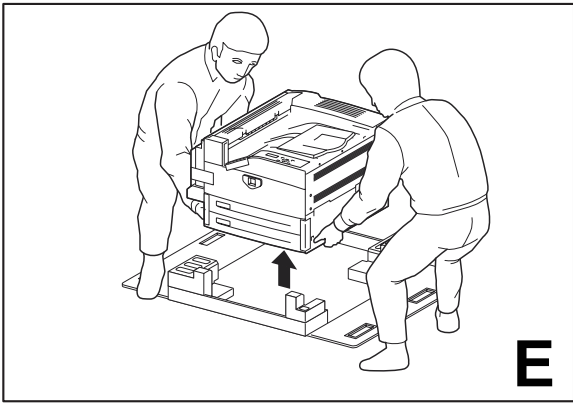
### Unpacking

#### *Unpacking Laser Printer*

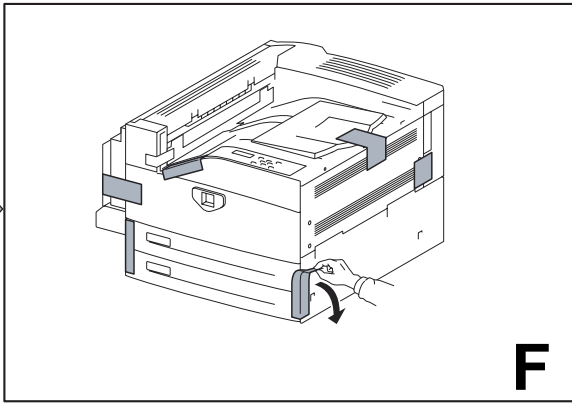
Unpack the carton and confirm that the laser printer and the attachments are undamaged.

- 1) Printer
- 2) Paper Cassette
- 3) CRU
- 4) TONER CARTRIDGE
- 5) Power Cable
- 6) User Guide

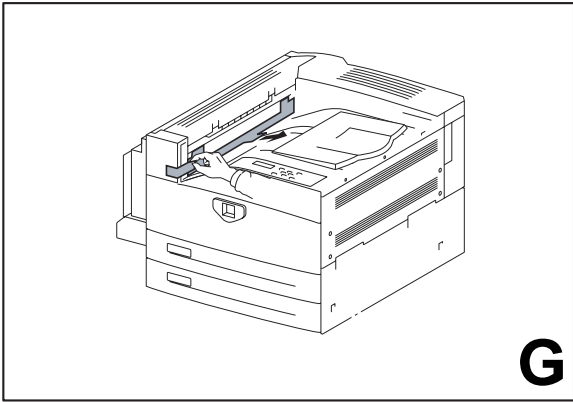




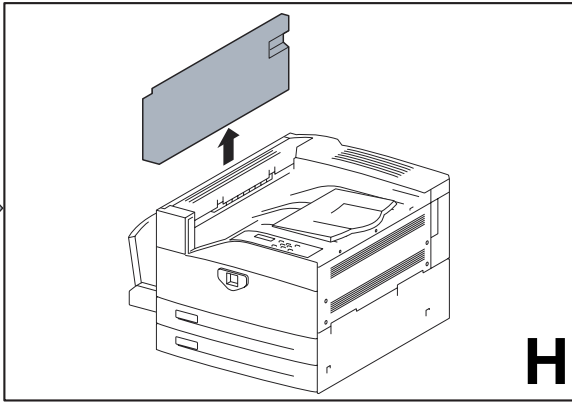
**E**



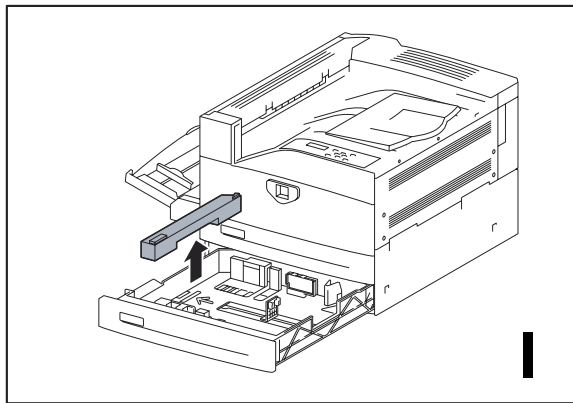
**F**



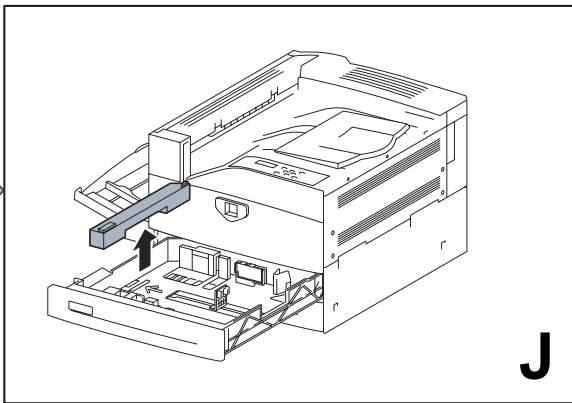
**G**



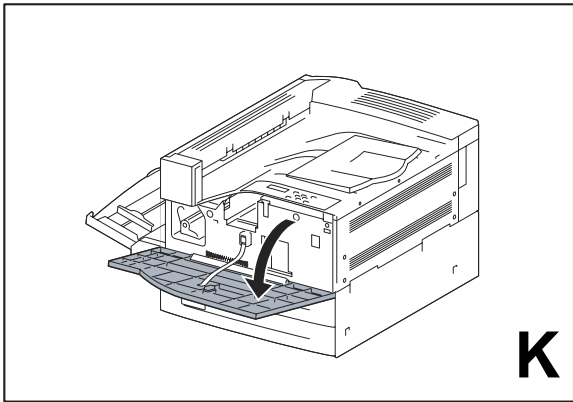
**H**



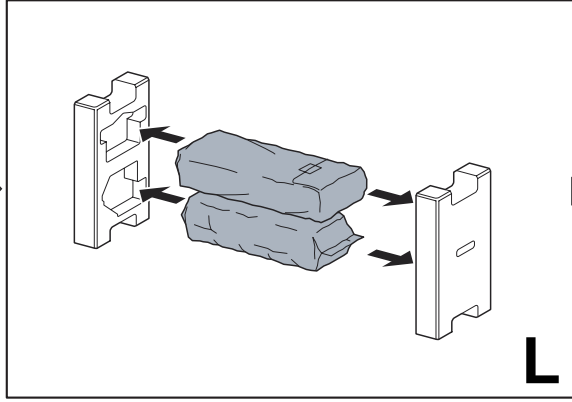
**I**



**J**

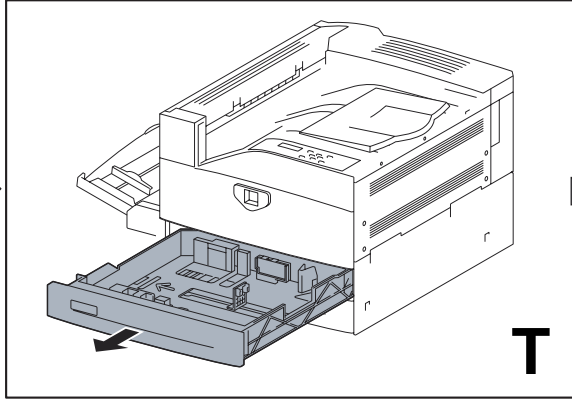
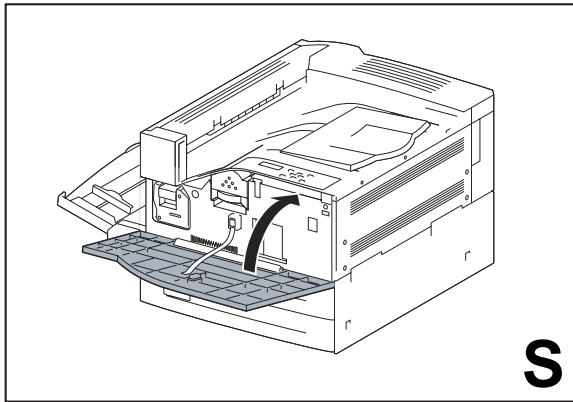
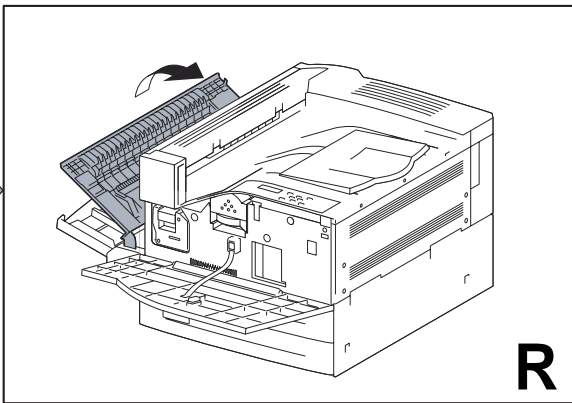
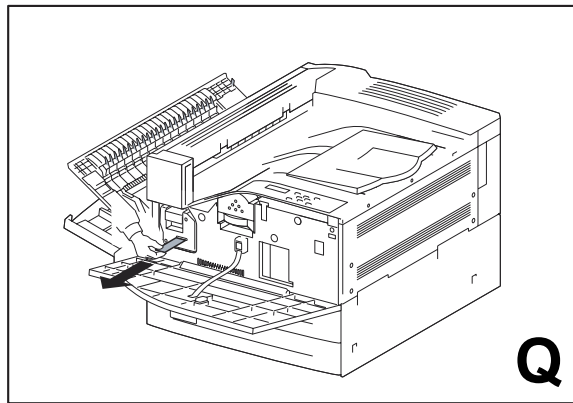
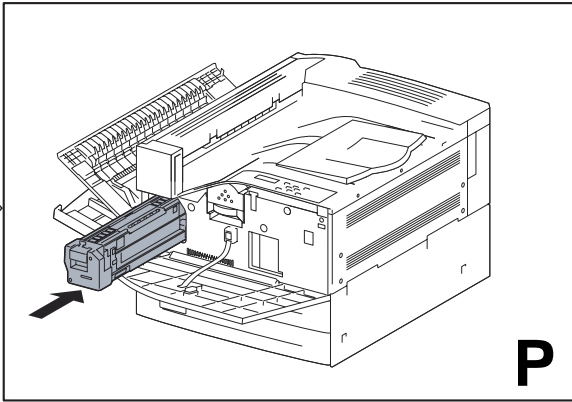
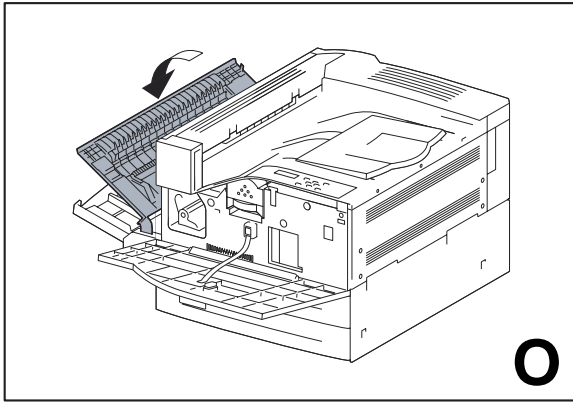
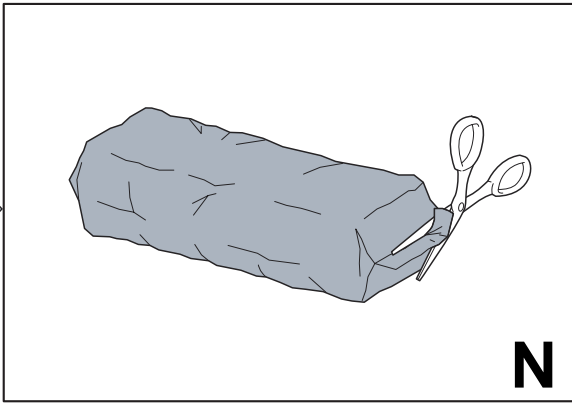
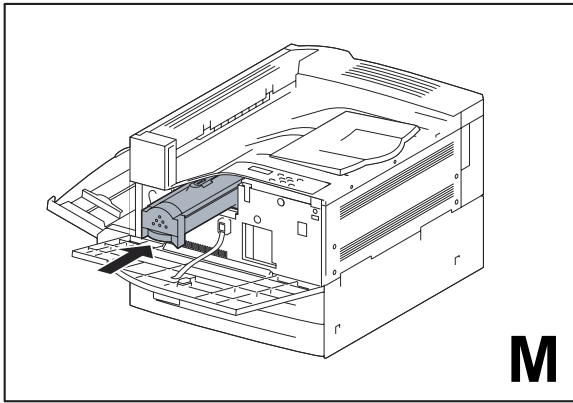


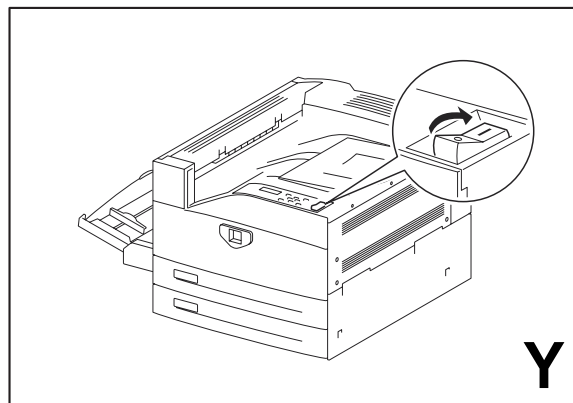
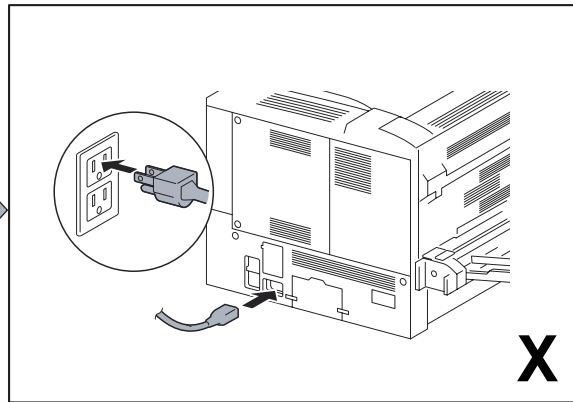
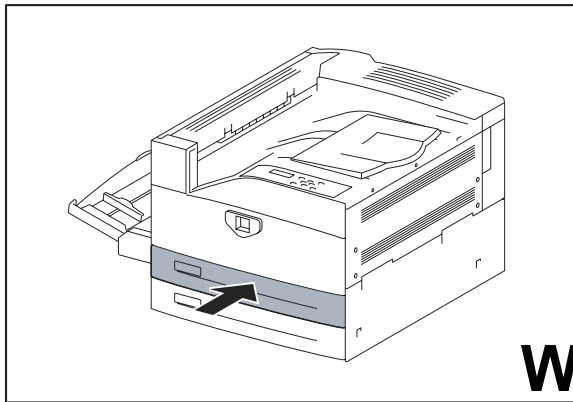
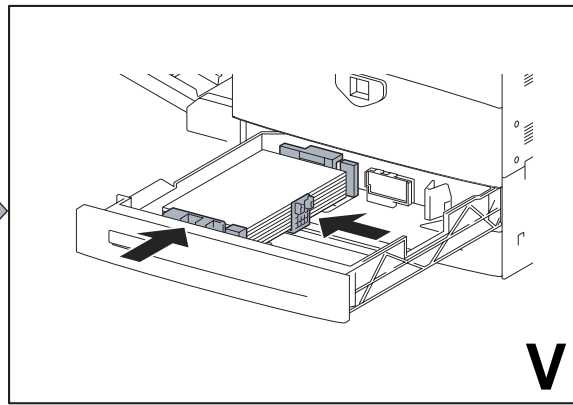
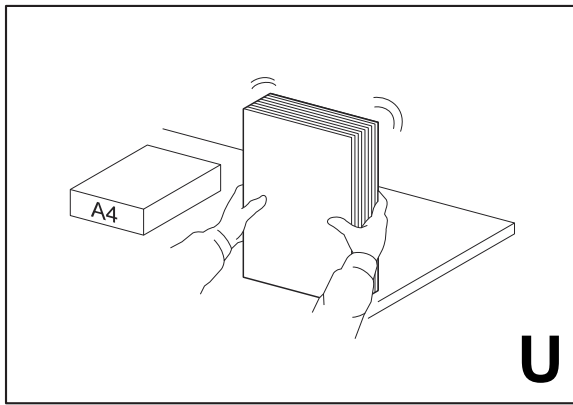
**K**



**L**







## Installation Procedures

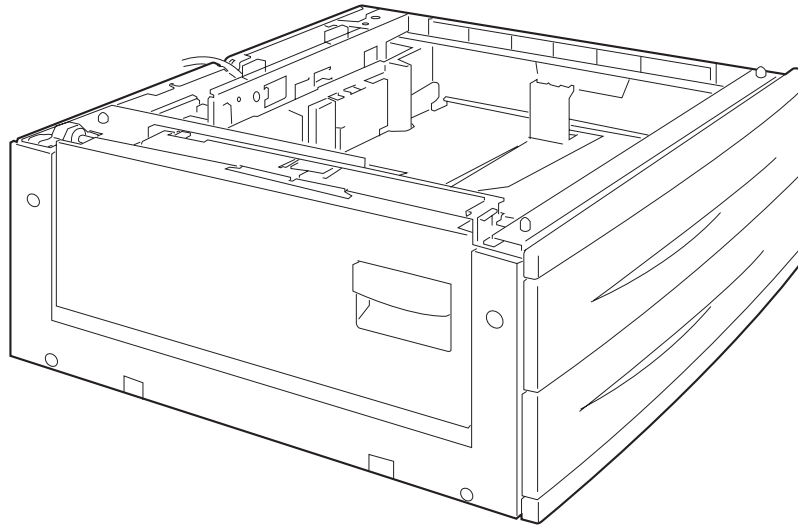
### *Installing Laser Printer*

1. Unpack the laser printer, and place it in the installation location after removing packing materials as shown in figures A through E.
2. Peel off packing tapes applied to the laser printer as shown in figures F through G.
3. Remove the packing materials from inside of the printer. (H, J)
4. Open the COVER ASSY FRONT, and install the TONER CARTRIDGE (K).
5. Unpack the Toner Cartridge, then be sure to shake it seven to eight times holding both sides (L,M).
6. Unpack the CRU (N).
7. Open the COVER ASSY-LH and install the CRU (O,P).
8. Pull off the seal from the CRU (Q).

**NOTE** When removing the seal, draw it out straight and horizontally. After the removal, be careful not to shake or give a shock to the CRU.

9. Close the COVER ASSY-LH and COVER ASSY FRONT. (R,S)
10. Draw out the paper cassette and load paper in the cassette (T,U,V).
11. Push the paper tray into the laser printer (W).
12. If using only the base unit execute the remaining steps; else, install additional items.
13. Connect the power cord (X).
14. Turn on the power switch of the laser printer (Y).
15. Try some test prints with each of the paper-feed trays to confirm that there is no problem.

## 1000 Sheet Feeder



### Installation

#### Unpacking

Unpack the carton, and confirm that all components are accounted for and without any damage.

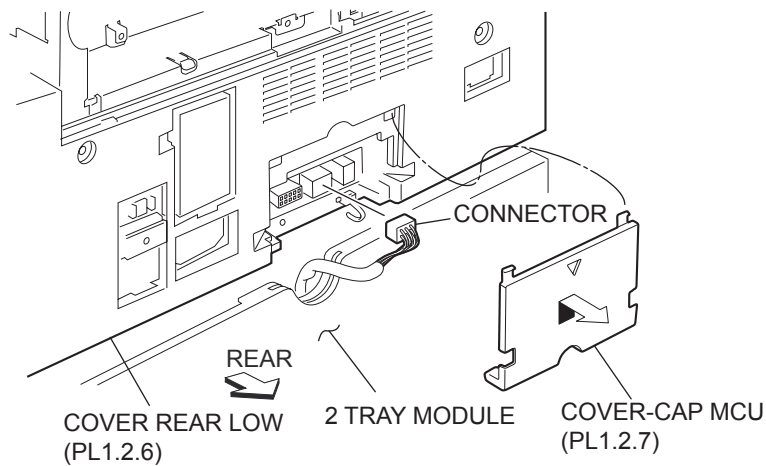
- 1) 2 TRAY MODULE unit
- 2) SCREW (2 pcs) to install the 2 TRAY MODULE

#### Installation Procedures

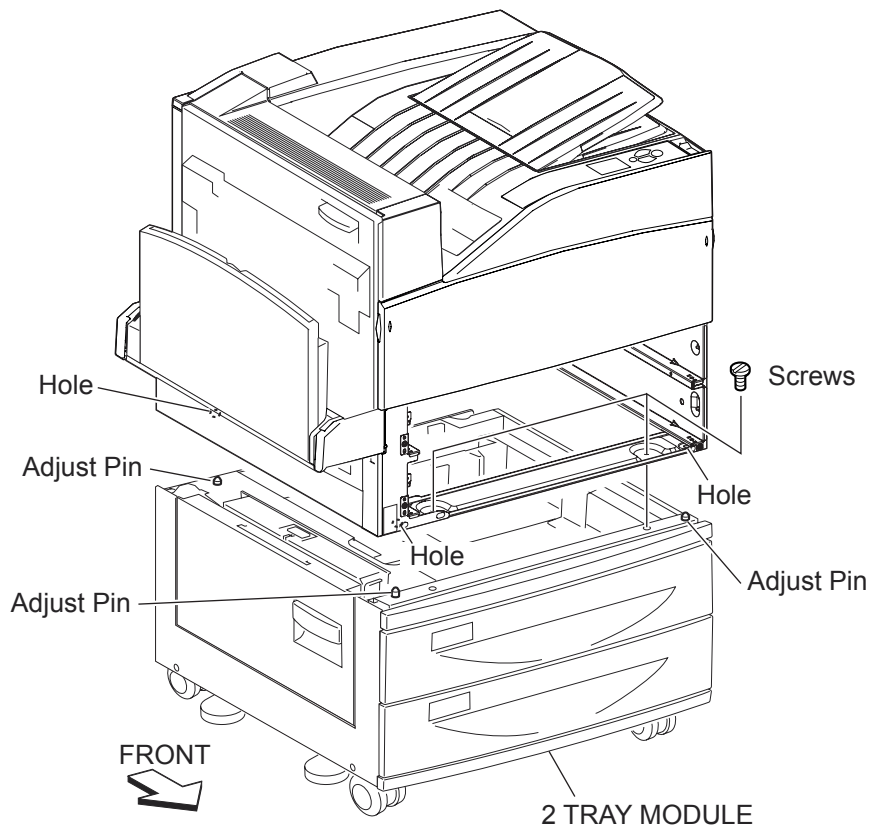
For details, refer to the Instruction Manual supplied with the main unit.

1. Unpack the optional 2 TRAY MODULE, remove packing materials, and check the attached articles.
2. Remove the Tray1 and Tray2 from the printer.
3. Place the printer on the 2 TRAY MODULE so that the three Adjust Pins on top of the two TRAY MODULE is inserted into the holes of the printer.

4. Remove the COVER-CAP MCU on the rear of the printer. Place finger on top edge of option cover cap MCU and push down to release the cover.

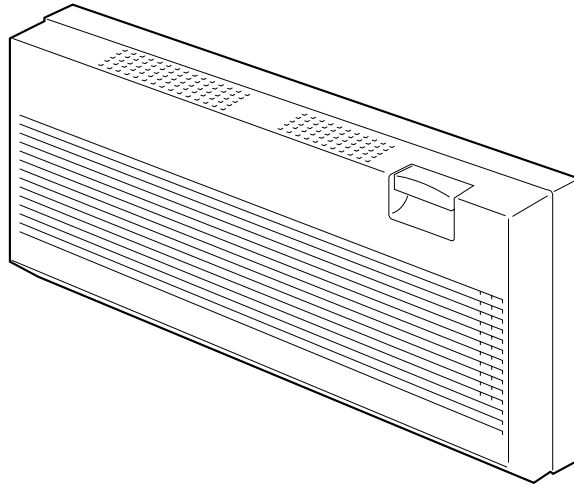


5. Connect the harness connector of the cable to the connector on the rear panel of the printer, and then attach the COVER-CAP MCU.



6. Remove Trays 1 and 2.  
To remove the trays pull tray 1 out until you hit the stops, then place your hands on the left and right side edges of the paper tray. Lift up and pull back towards you with your left hand to release the left side of the tray. Lift up and pull back towards you to release the right side of the tray. Repeat to remove the other tray.
7. Fasten the optional 2 TRAY MODULE to the printer with two Screws.
8. Install the Tray1 and Tray2.
9. Turn ON the power switch of the printer. Note that trays are now displayed in the Operator panel.

# Duplex



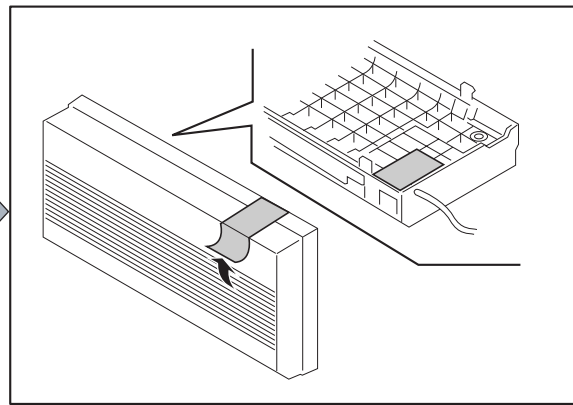
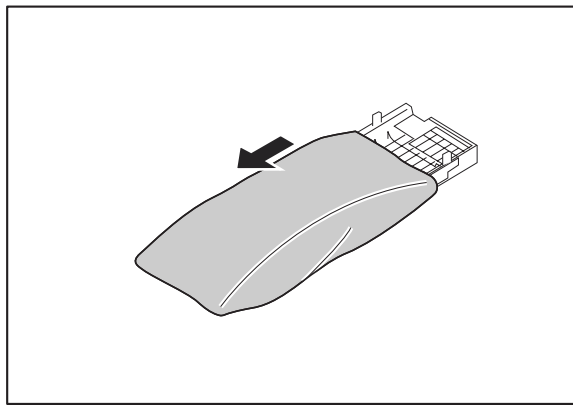
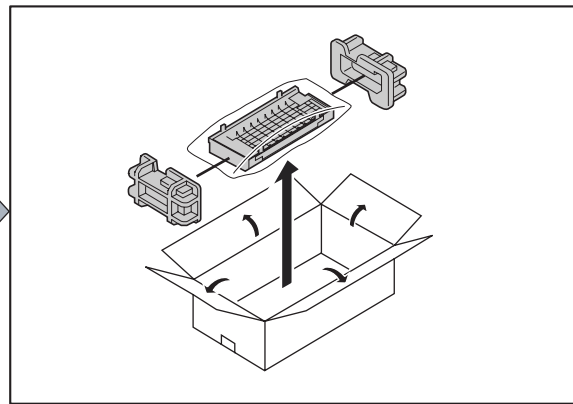
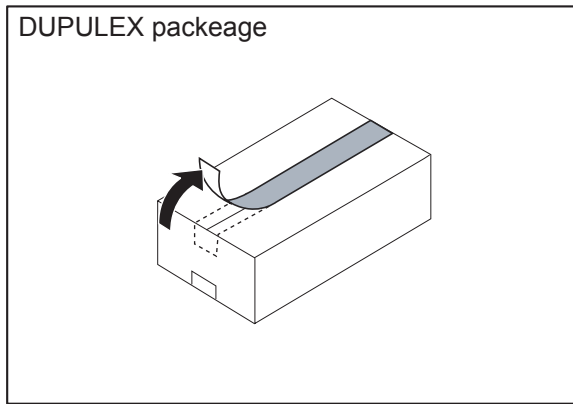
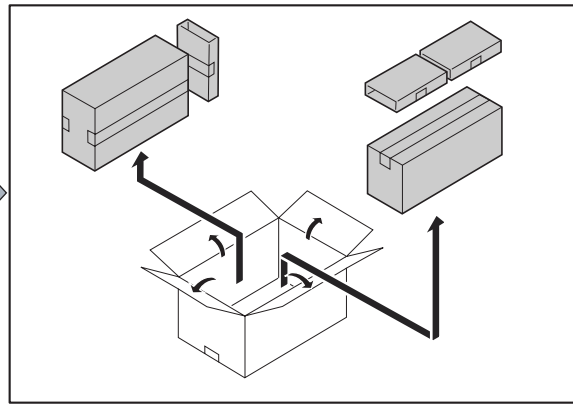
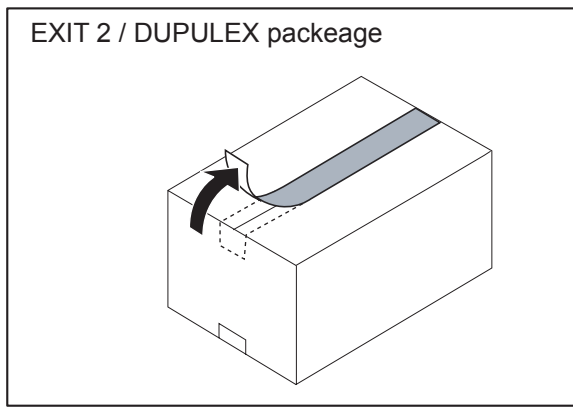
## Installation

### Unpacking

Unpack the carton, and confirm that the number of the Option DUPLEX and the attachments, and their appearances have no problem.

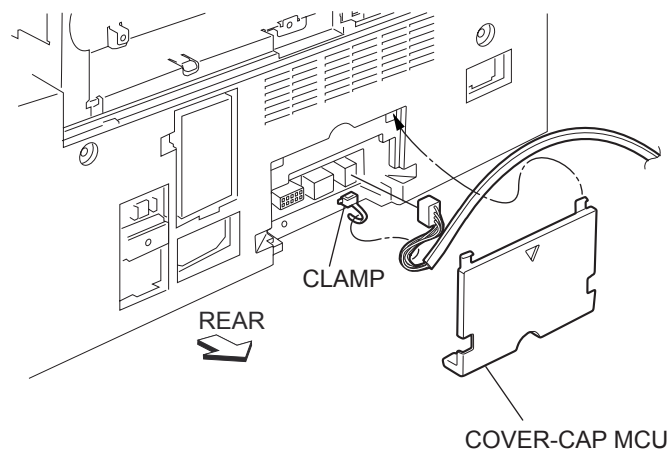
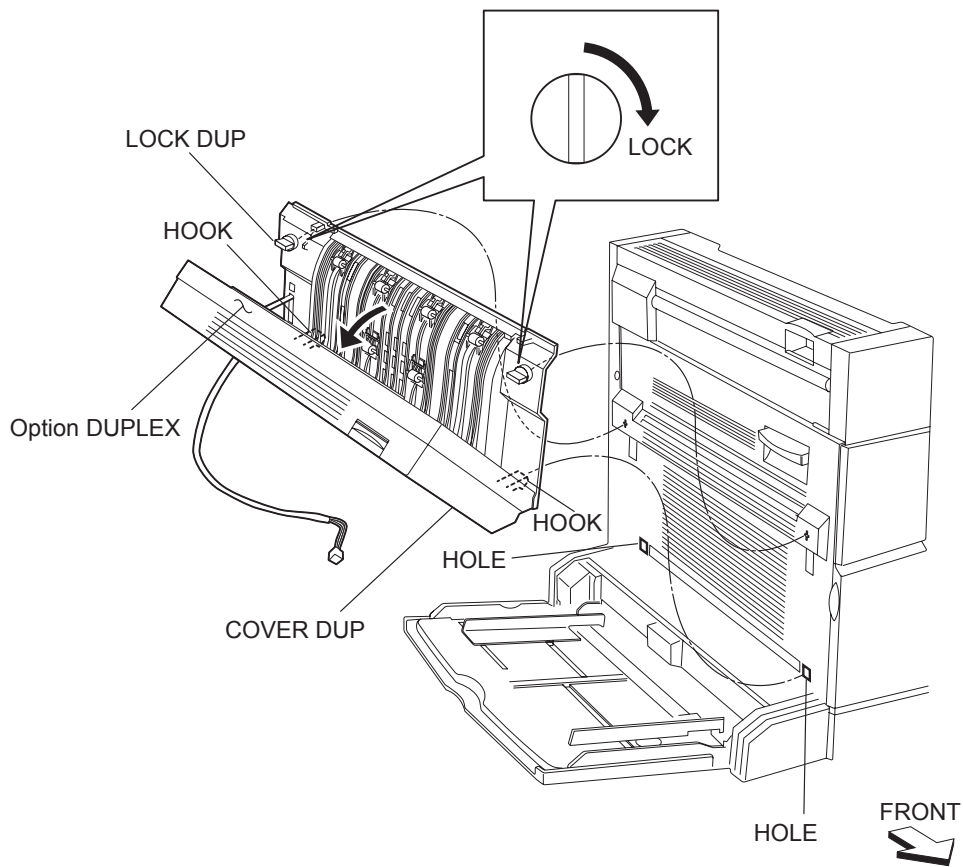
- 1) DUPLEX unit





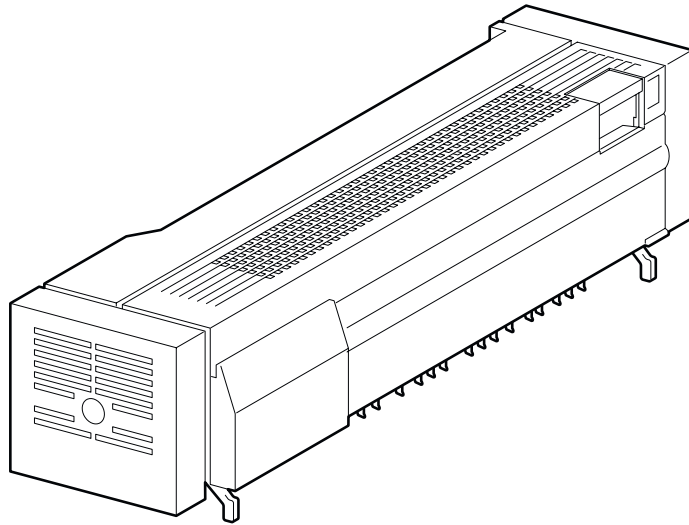
## Installation Procedures

- 1) Unpack the optional DUPLEX, remove packing materials, and check the attached articles.
- 2) Insert the hooks at the lower part of the DUPLEX into the holes on the left side of the printer.
- 3) Open the COVER DUP and turn the two LOCK DUPs on the DUPLEX to secure the DUPLEX.
- 4) Remove the COVER-CAP MCU from the rear of the printer.
- 5) Connect the HARN ASSY DUP A to the connector on the rear panel of the printer, and then attach the COVER-CAP MCU.



- 6) Turn ON the power switch of the printer.
- 7) Try some test duplex-printings to confirm that there is no problem.

## Exit 2

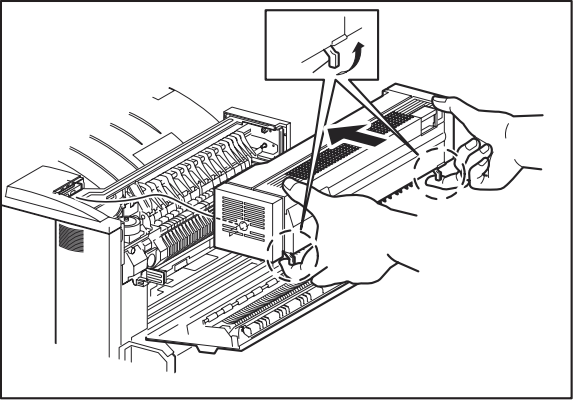
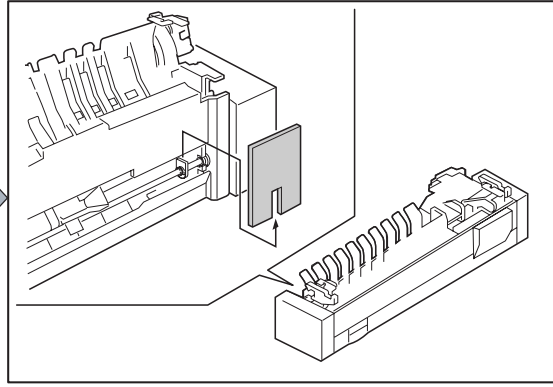
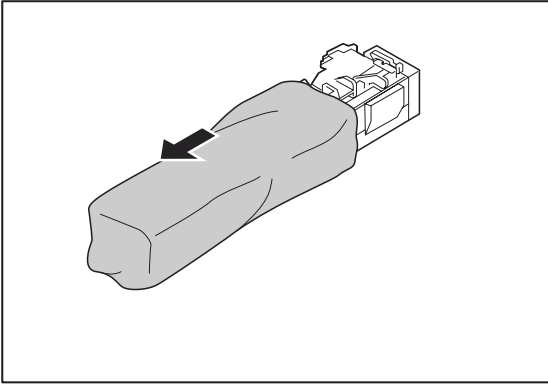
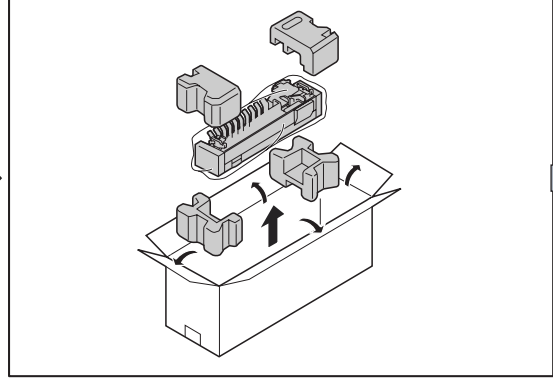
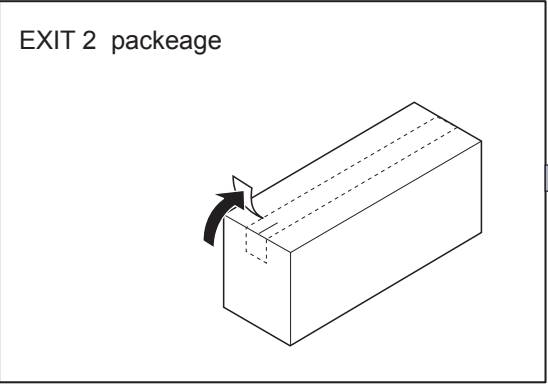
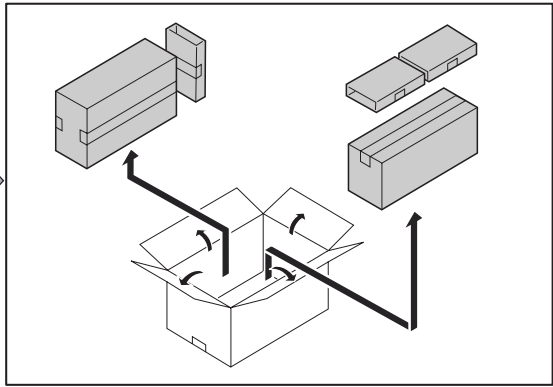
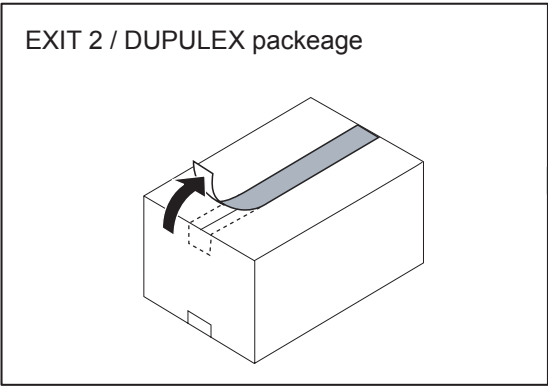


### Installation

#### Unpacking

Unpack the carton and confirm that the number of the Option EXIT2 and the attachments are undamaged.

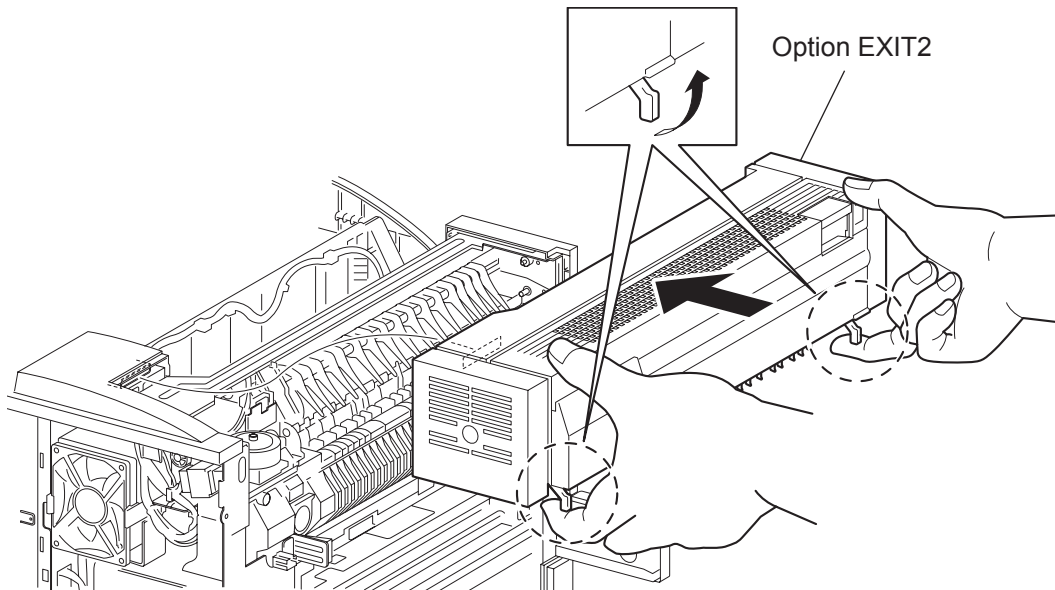
- 1) EXIT2 unit



## Installation Procedures

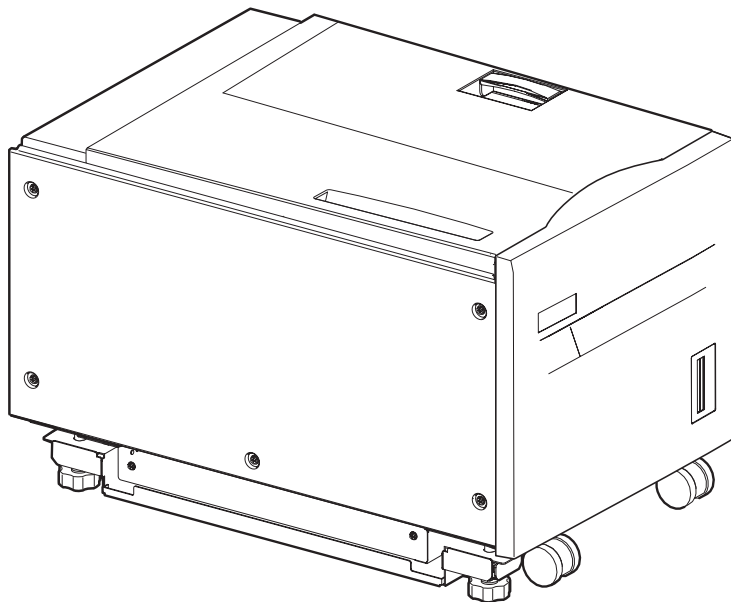
**NOTE** The optional EXIT2 can be installed only when the printer is installed with the optional DUPLEX.

- 1) Unpack the optional EXIT2, remove packing materials, and check the attached articles.
- 2) Remove the COVER-TOP, EXIT 1 from the printer.
- 3) Install the EXIT2 on the printer while lifting up the two hooks on the bottom of the EXIT2.



- 4) Connect the power cord of the printer.
- 5) Turn ON the power switch of the printer.
- 6) Try some test duplex-printings to eject the them onto the EXIT2, and confirm that there is no problem.

## High Capacity Feeder (HCF)

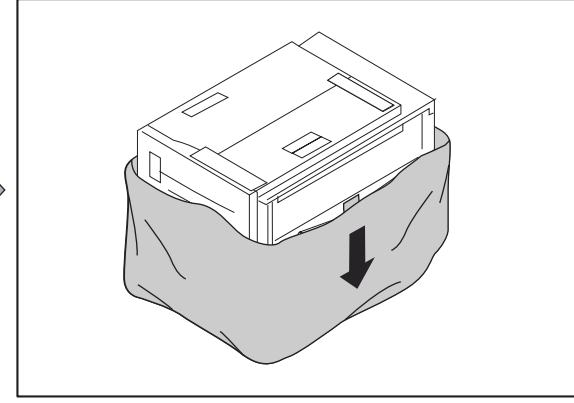
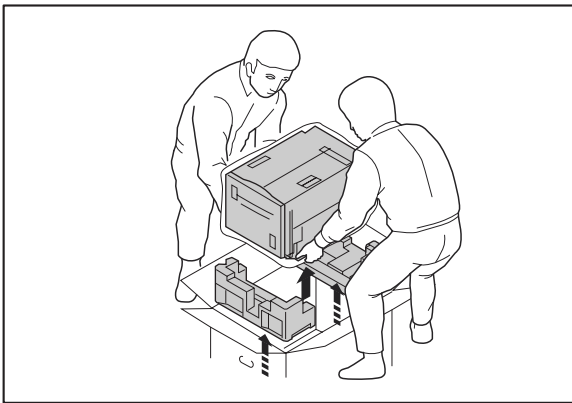
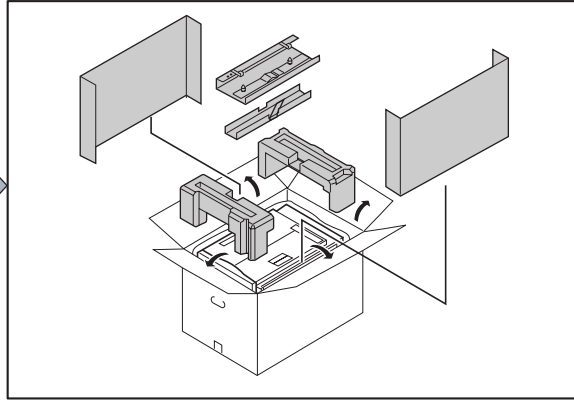
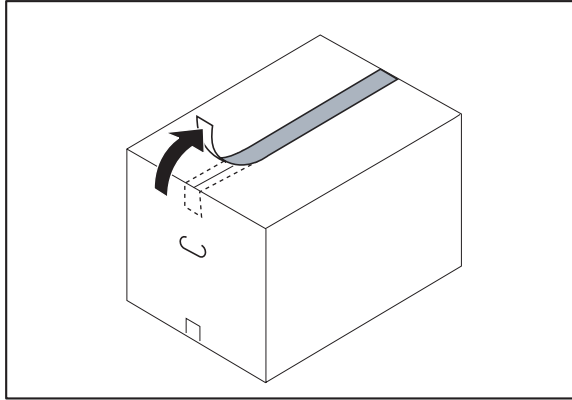


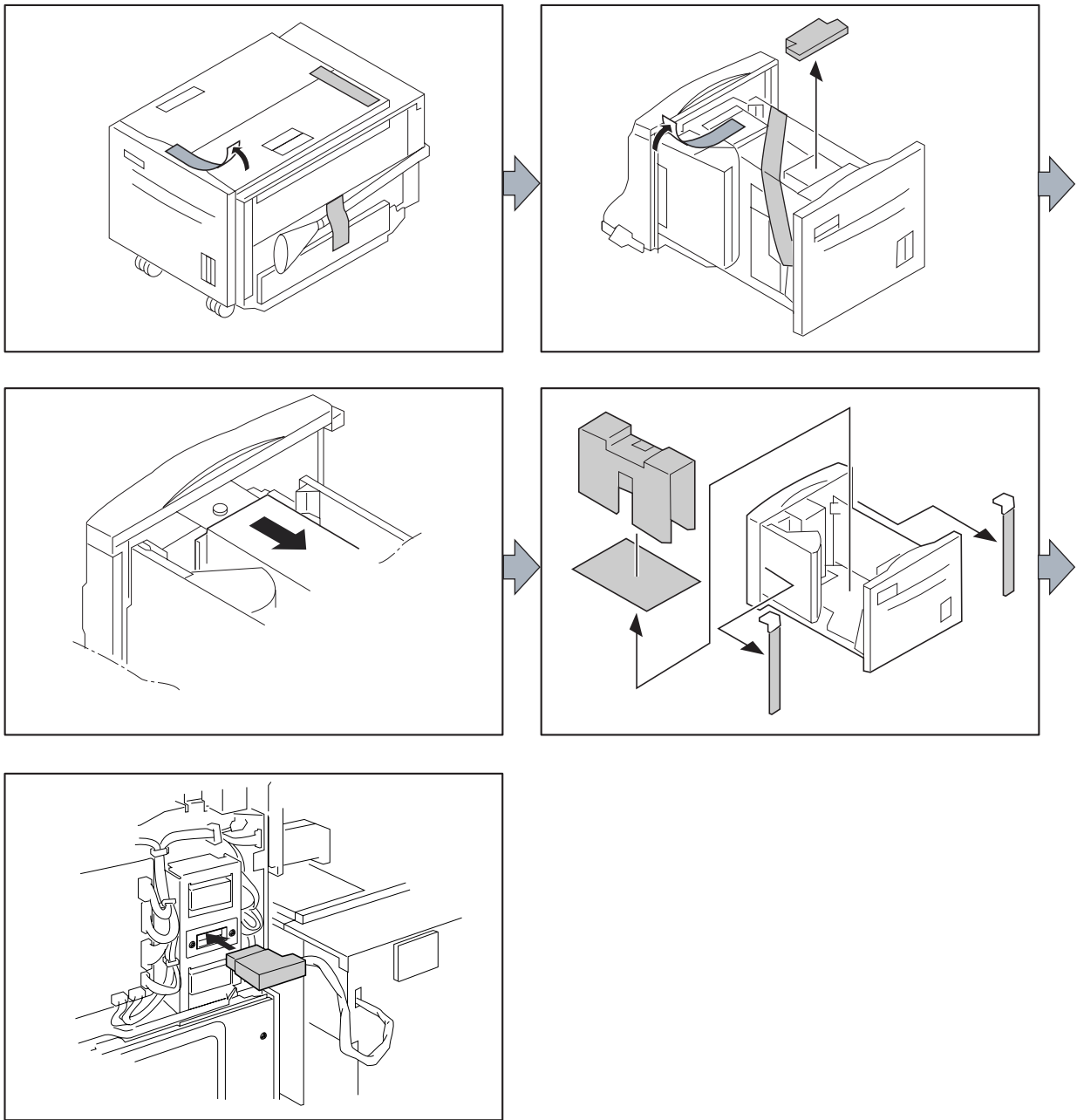
### Installation

## Unpacking

Unpack the carton, and confirm that the number of the Option HCF and the attachments, and their appearances have no problem.

- 1) Option HCF main unit
- 2) JOINT BRACKET
- 3) Screws (2 pieces) (For fixing the JOINT BRACKET to the Tandem Tray Module or 2 Tray Module under the printer)





## Installation procedures

- 1) Unpack the Option HCF, remove packing materials, and confirm the attachments.
- 2) Install the JOINT BRACKET to the Tandem Tray or 2 Tray Module installed under the laser printer as shown in the figure using the two SCREWS.
- 3) Move the HCF toward the laser printer so that the projections of the JOINT BRACKET put into the holes of the BRACKET on the HCF to engage them.
- 4) Remove the HCF Sliding fixing Screw as shown below.

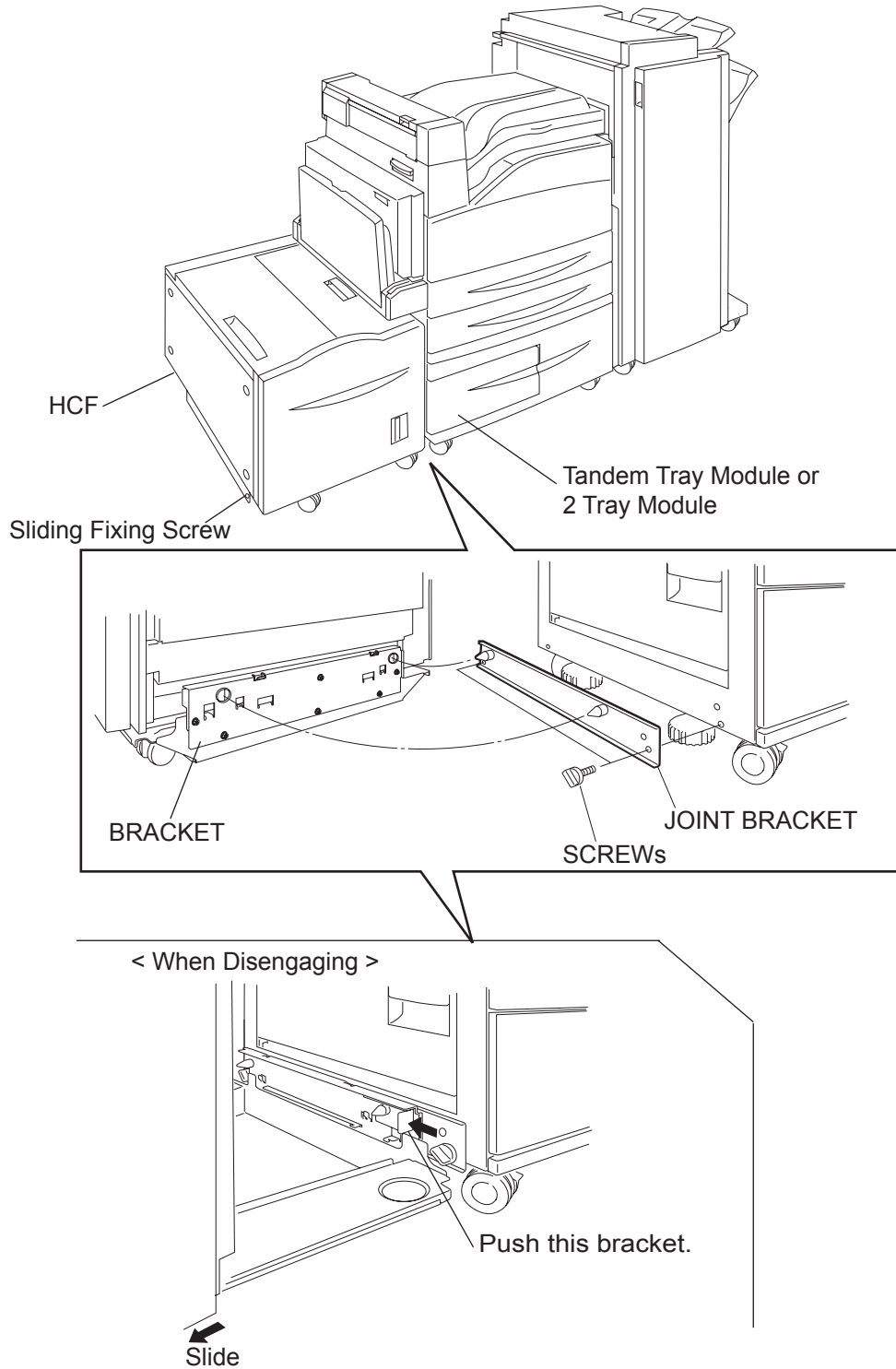
**NOTE** After removing the Sliding fixing Screw slides the HCF once, and make sure that the HCF is engaged with the printer surely.

- 5) Connect the connection cable of the HCF to the laser printer.

**NOTE** When connecting, be sure not to twist and pinch the cable.

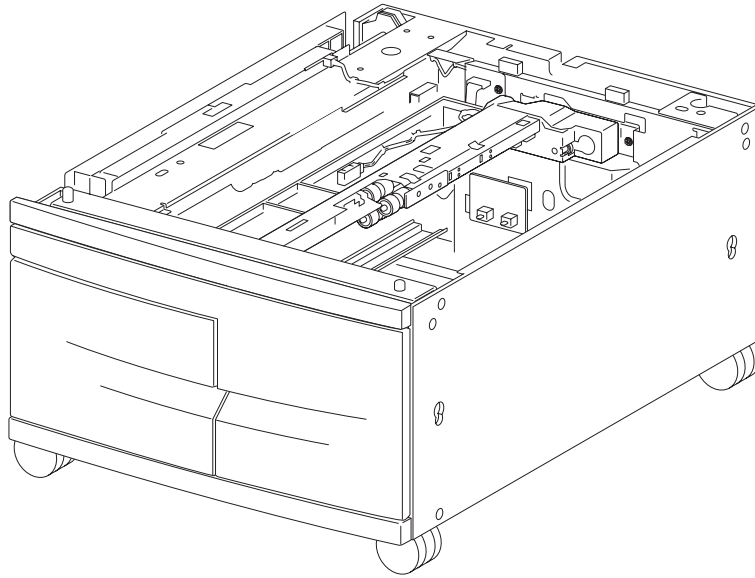
- 6) After installing the equipment, turn on the power switch of the laser printer.

7) Try running some test prints with the newly installed paper-feed tray to confirm that there is no problem.





# Tandem Tray



## Installation

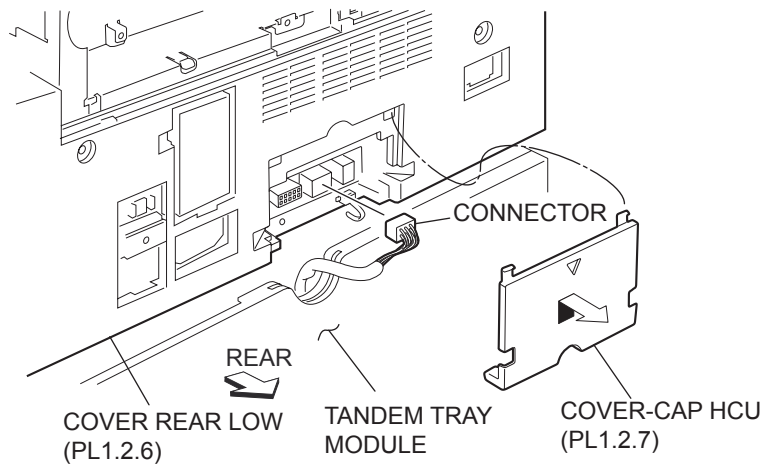
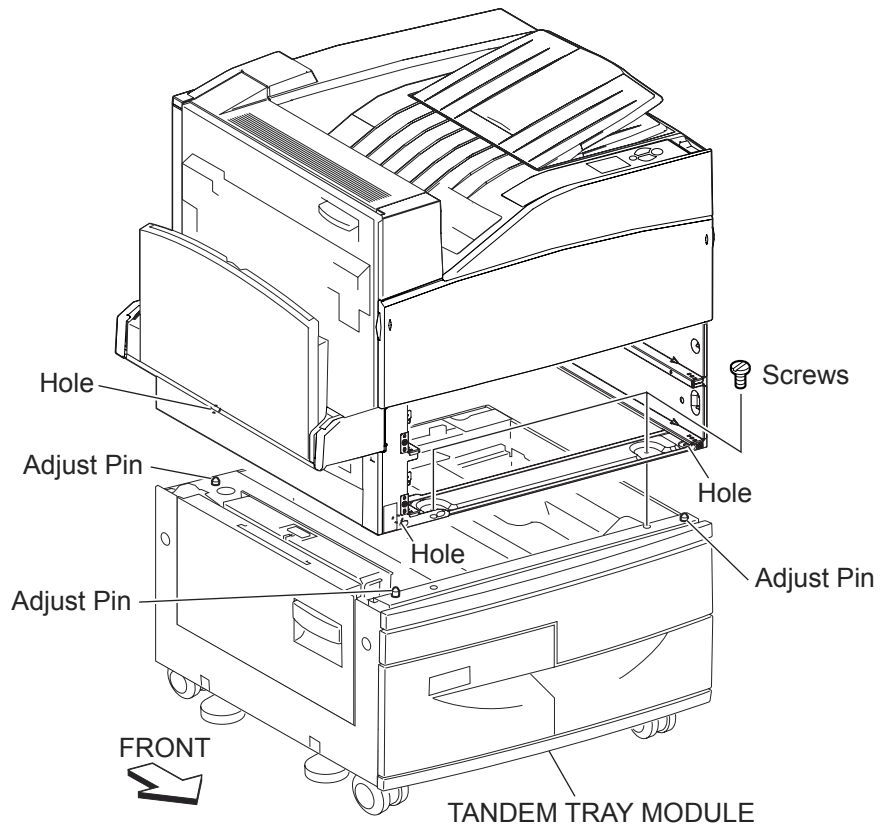
### Unpacking

Unpack the carton, and confirm that the number of the Option TANDEM TRAY MODULE and the attachments, and their appearances have no problem.

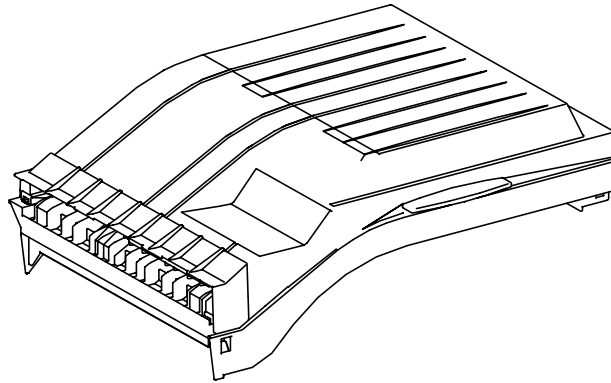
- 1) TANDEM TRAY MODULE unit
- 2) SCREW (2 pcs) to install the TANDEM TRAY MODULE

### Installation Procedures

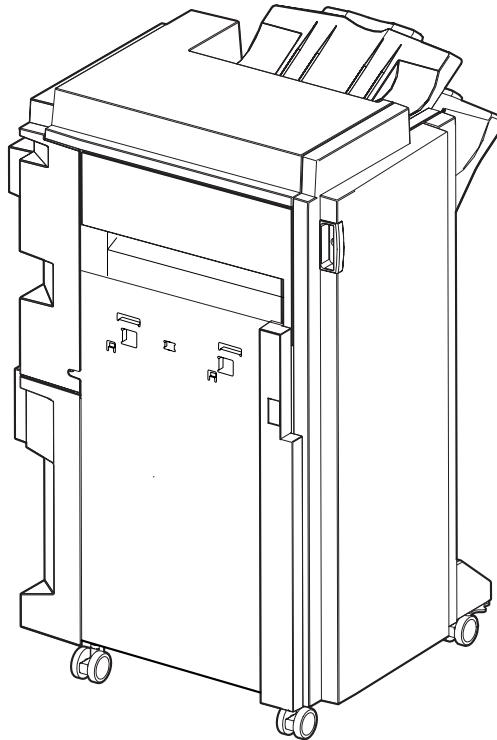
1. Unpack the optional TANDEM TRAY MODULE, remove packing materials, and check the attached articles.
2. See "1000 Sheet Feeder" on page 6 for installations instructions. The Tandem feeder is installed in a similar manner.



# Finisher



Horizontal Transport



Finisher

## Installation

### Unpacking

#### ***Unpacking Option Horizontal-Transport***

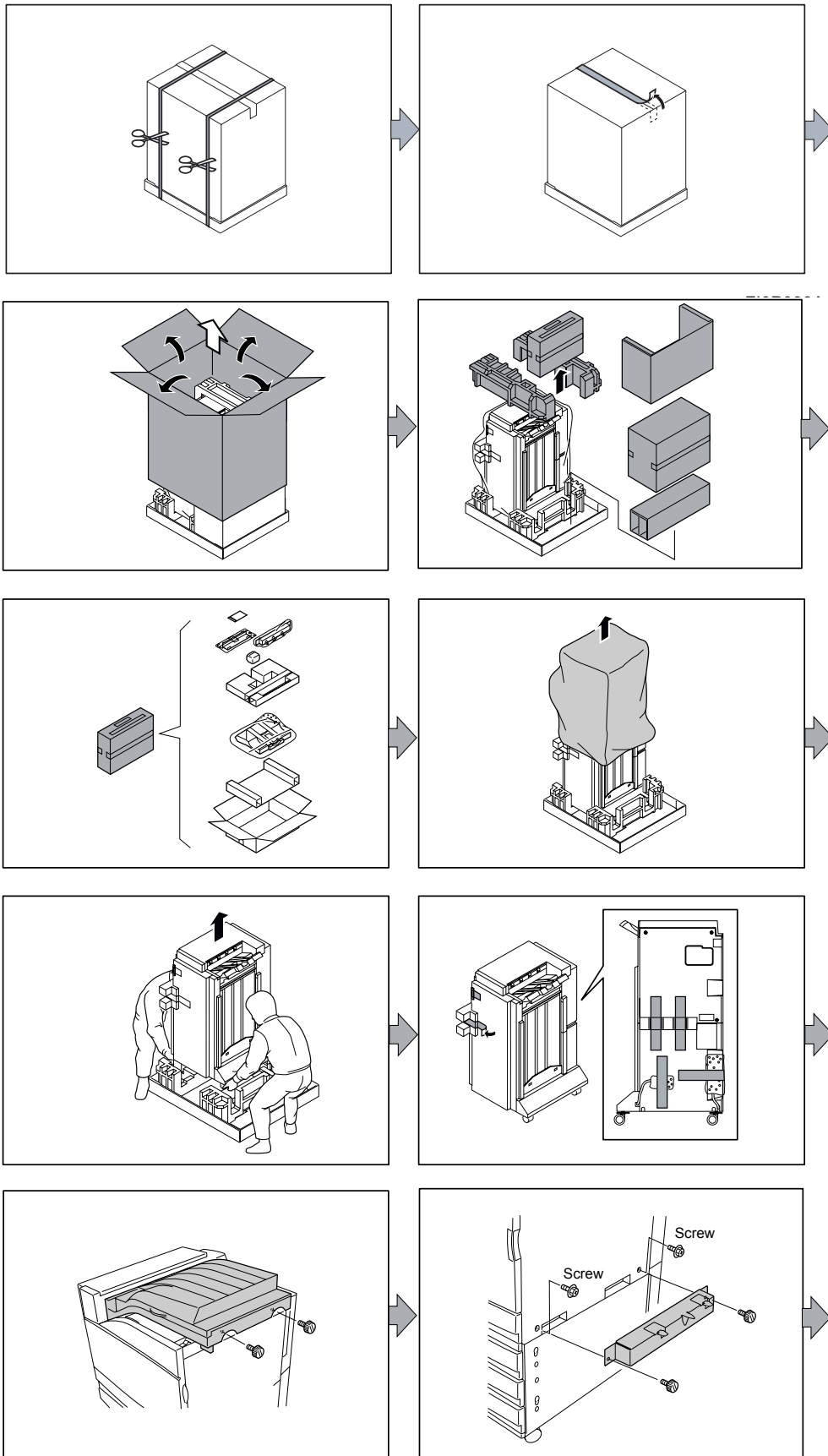
Unpack the carton, and confirm that the number of the Option Horizontal-Transport and the attachments, and their appearances have no problem.

- 1) Option Horizontal-Transport main unit
- 2) Screws (2 pieces) (For Horizontal-Transport securing)

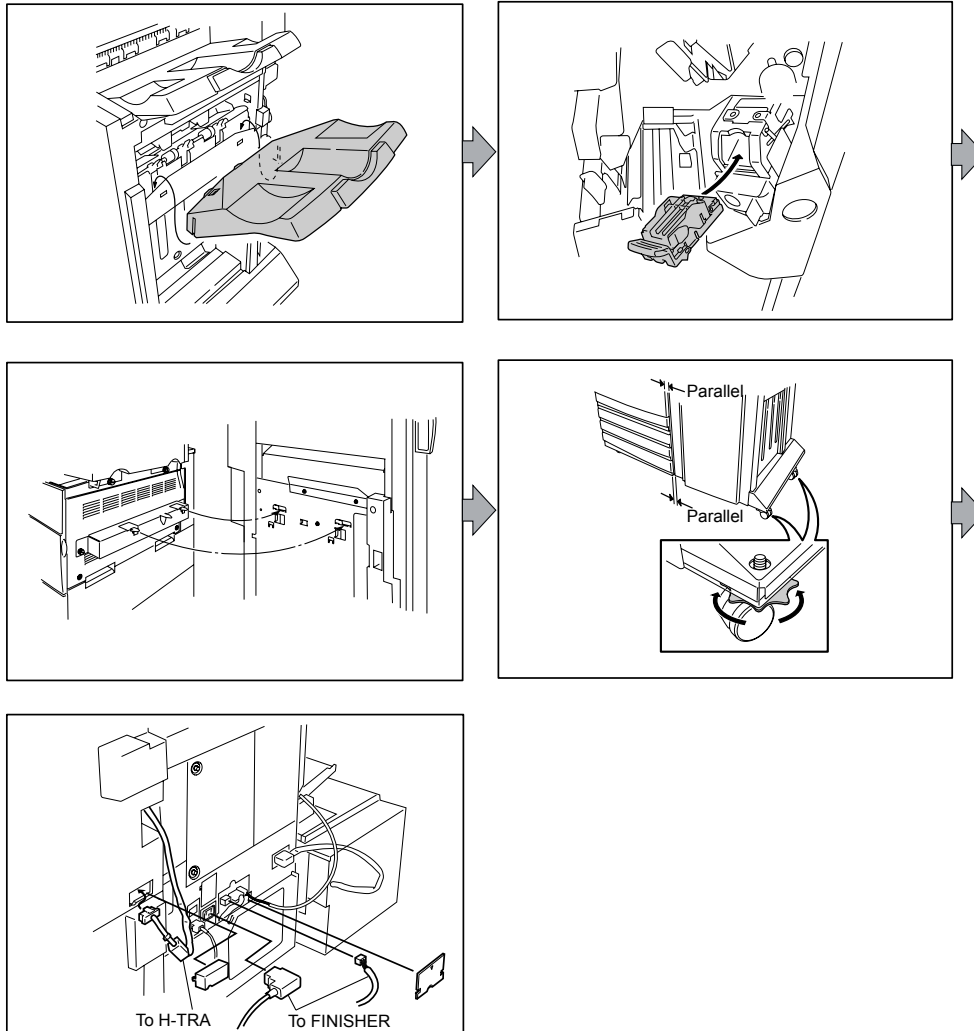
#### ***Unpacking Option Finisher***

Unpack the carton, and confirm that the number of the Option Finisher and the attachments, and their appearances have no problem.

- 1) Option Finisher main unit
- 2) PLATE ASSY DOCKING IOT (1 piece)
- 3) Screws (2 pieces) (For PLATE ASSY DOCKING IOT securing)



**NOTE** \*There is a box of parts inside the finisher cabinet that must be removed before proceeding to the next step.

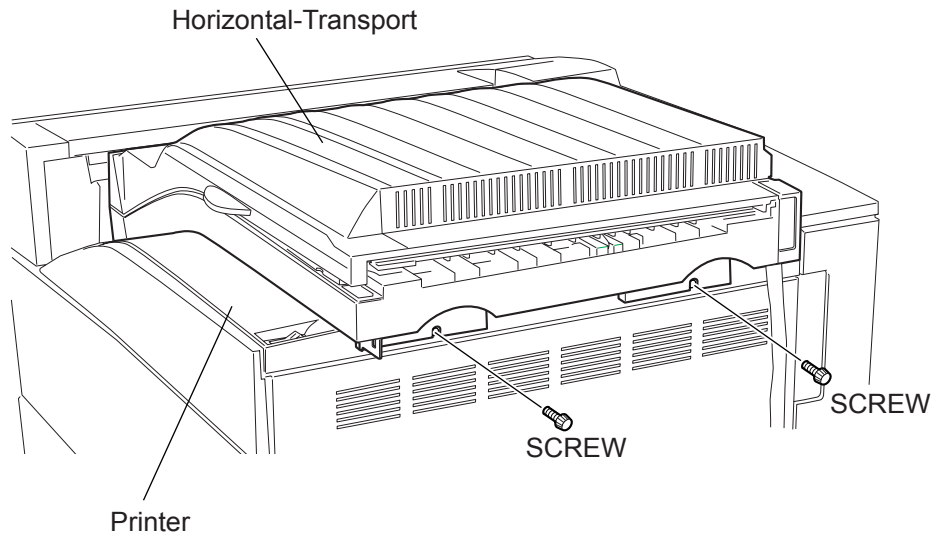


## Installation Procedures

### *Installing Option Horizontal-Transport*

For details, refer to the Instruction Manual supplied with the main unit or Chapter3 RRP25.1 H-TRANSPORT ASSEMBLY.

- 1) Unpack the Horizontal-Transport, remove packing materials, and confirm the attachments.
- 2) Remove the ACTUATOR (PL6.2.27) and WEIGHT ASSY-PAPER (PL6.2.28) for full stack sensor on the Exit 1 of the laser printer.
- 3) Place the Horizontal-Transport on top of the laser printer.
- 4) Fix the Horizontal-Transport to the laser printer surely using the two SCREWS.

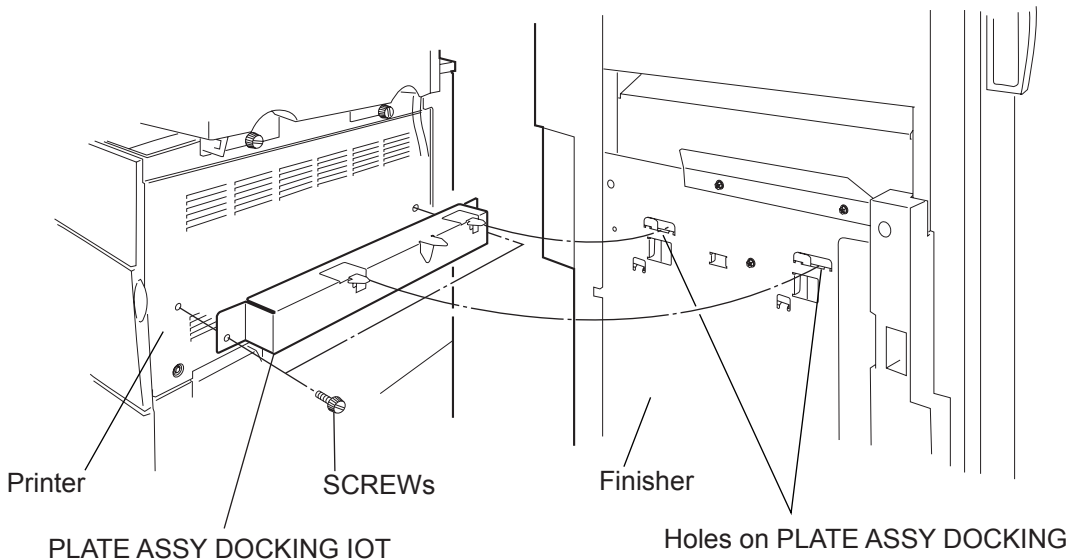


- 5) After installing the Finisher, connect the connection cable of the Horizontal-Transport to the Finisher.
- 6) After completing the installation, turn on the power of the laser printer.
- 7) Try running some test prints with the newly installed equipment to confirm that there is no problem.

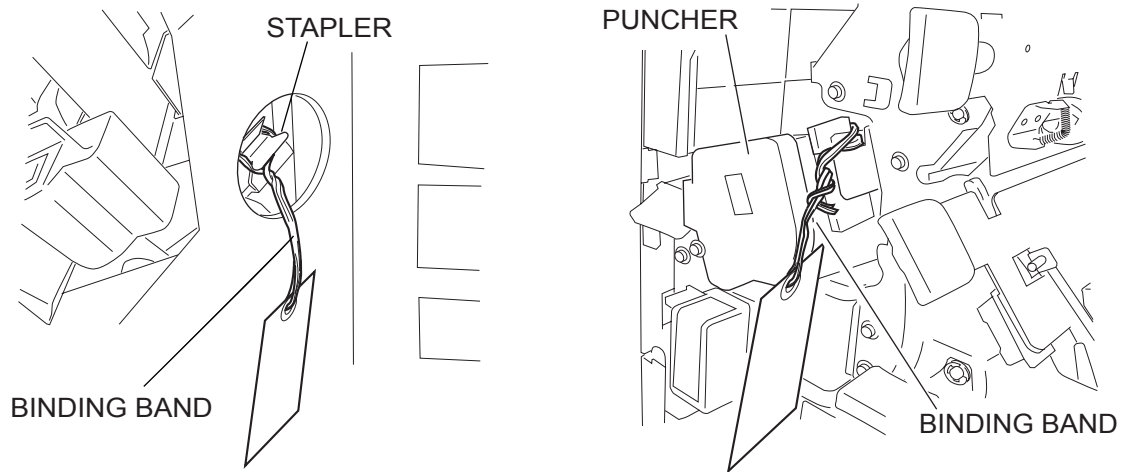
### ***Installing Option Finisher***

For details, refer to the Instruction Manual supplied with the main unit or Chapter3 RRP25.2 STAPLE FINISHER.

- 1) Unpack the Finisher, remove packing materials, and confirm the attachments.
- 2) Install the PLATE ASSY DOCKING IOT (supplied accessory of the Finisher) to the laser printer as shown in the figure, and fix the PLATE ASSY DOCKING IOT to laser printer surely using two SCREWS.

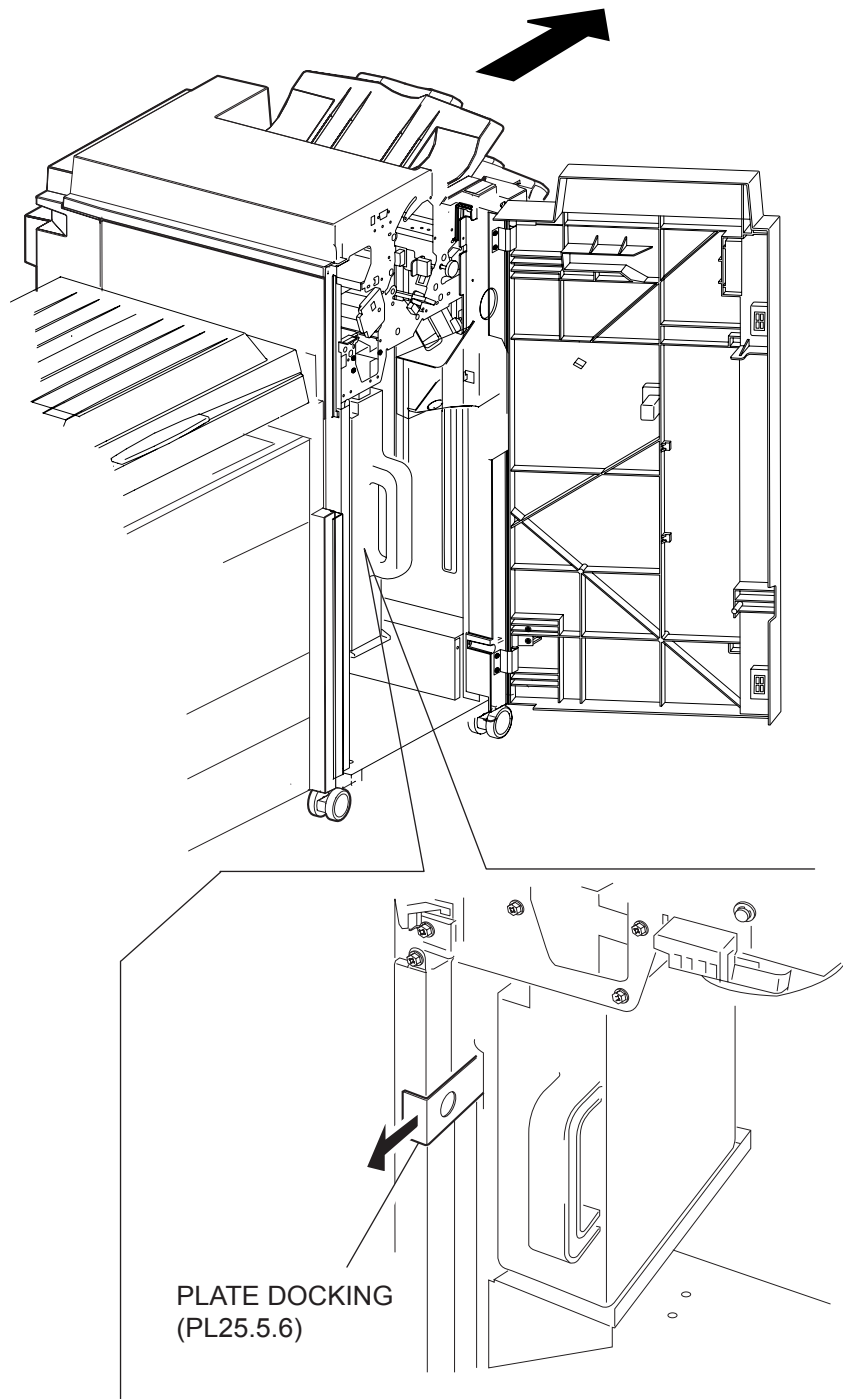


- 3) Open the COVER ASSY FRONT of the Finisher.
- 4) Release the BINDING BANDS securing the puncher and stapler with the frame of the Finisher.



5) While pulling the PLATE DOCKING inside the Finisher, move the Finisher toward the laser printer so that the projections of the PLATE ASSY DOCKING IOT put into the holes on the PLATE ASSY DOCKING of the finisher.






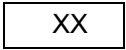
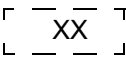
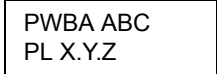

- 6) Release the hand from the PLATE DOCKING to engage the PLATE ASSY DOCKING IOT and PLATE DOCKING.
- 7) Close the FRONT ASSY COVER of the Finisher.
- 8) Connect the connection cable of the Horizontal-Transport to the Finisher.
- 9) Connect the power cord and connection cable to the laser printer.
- 10) After completing the installation, turn on the power of the laser printer.
- 11) Try running some test prints with the newly installed equipment to confirm that there is no problem.



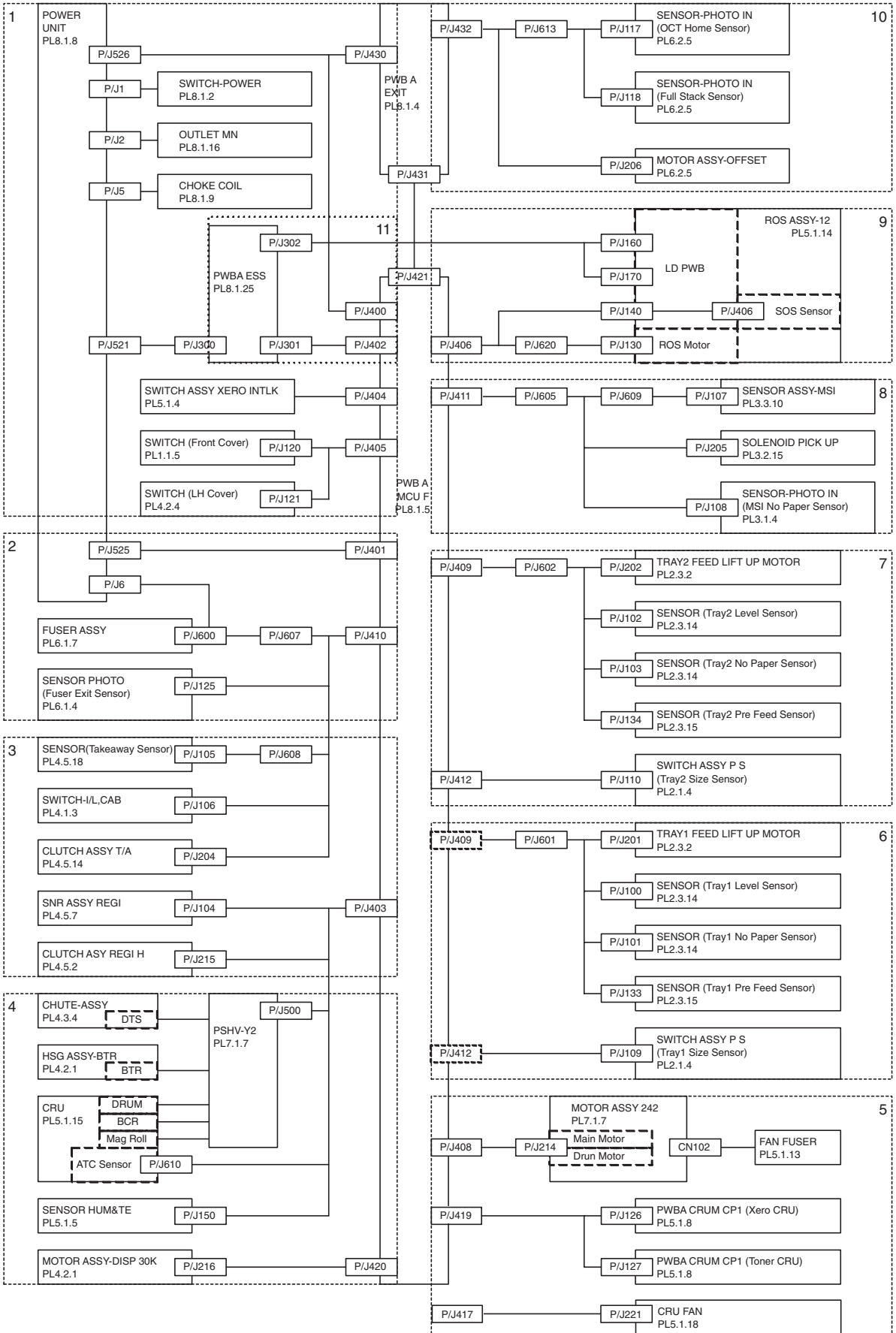
# Chapter 4 Wiring

## General Wiring Diagram

The following describes the legend of the general wiring diagram shown on the next page.

Symbols	Description
	Denotes a connection between parts with harnesses and wires.
	A frame not having parts name inside denotes the connector (P/J). Numeric value inside implies the connector number.
	A frame of broken line denotes the connector (P/J) written in several places separately. Numeric value inside implies the connector number.
	A frame having parts name inside denotes the parts. PL X.Y.Z implies the item "Z" of plate (PL) "X.Y" in Chapter 5. Parts List.
	A frame of dotted line denotes the section in "2. Wiring Diagram between Parts", and numeric value implies the section number.

# Engine



# Wiring Diagram between Parts

## Configuration

The wiring diagram is separated into 11 sections to show detailed connection between parts.

### 1 Power supply

- Connection between POWER UNIT and PWBA ESS
- Connection between POWER UNIT and PWB A EXIT
- Connection between POWER UNIT and PWB A MCU F
- Connection between POWER UNIT and CHOKE COIL
- Connection between POWER UNIT and OUTLET MN
- Connection between POWER UNIT and SWITCH-POWER
- Connection between POWER UNIT and BRACKER GFI INL
- Connection between PWB A MCU F and SWITCH (LH Cover)
- Connection between PWB A MCU F and SWITCH (Front Cover)
- Connection between PWB A MCU F and SWITCH ASSY XERO INTLK

### 2 Fuser

- Connection between PWB A MCU F and POWER UNIT
- Connection between PWB A MCU F and FUSER ASSY
- Connection between PWB A MCU F and SENSOR PHOTO (Fuser Exit Sensor)
- Connection between POWER UNIT and FUSER ASSY

### 3 Paper feed

- Connection between PWB A MCU F and CLUTCH ASY REGI H
- Connection between PWB A MCU F and SNR ASSY REGI
- Connection between PWB A MCU F and SWITCH-I/L,CAB
- Connection between PWB A MCU F and SENSOR (Takeaway Sensor)
- Connection between PWB A MCU F and CLUTCH ASSY T/A

### 4 Xero / Deve

- Connection between PWB A MCU F and PSHV-Y2
- Connection between PWB A MCU F and CRU (ATC Sensor)
- Connection between PWB A MCU F and SENSOR HUM&TE
- Connection between PWB A MCU F and MOTOR ASSY-DISP 30K

### 5 Drive / CRUM

- Connection between PWB A MCU F and MOTOR ASSY 242
- Connection between PWB A MCU F and PWBA CRUM CP1 (Xero CRU)
- Connection between PWB A MCU F and PWBA CRUM CP1 (Toner CRU)
- Connection between PWB A MCU F and CRU FAN
- Connection between MOTOR ASSY 242 and FAN FUSER

### 6 Tray1

- Connection between PWB A MCU F and TRAY1 FEED LIFT UP MOTOR
- Connection between PWB A MCU F and SENSOR (Tray1 Level Sensor)
- Connection between PWB A MCU F and SENSOR (Tray1 No Paper Sensor)
- Connection between PWB A MCU F and SENSOR (Tray1 Pre Feed Sensor)
- Connection between PWB A MCU F and SWITCH ASSY P S (Tray1 Size Sensor)

## Tray2

- Connection between PWB A MCU F and TRAY2 FEED LIFT UP MOTOR
- Connection between PWB A MCU F and SENSOR (Tray2 Level Sensor)
- Connection between PWB A MCU F and SENSOR (Tray2 No Paper Sensor)
- Connection between PWB A MCU F and SENSOR (Tray2 Pre Feed Sensor)
- Connection between PWB A MCU F and SWITCH ASSY P S (Tray2 Size Sensor)

## 8 MPF

- Connection between PWB A MCU F and SENSOR ASSY-MPF
- Connection between PWB A MCU F and SOLENOID PICK UP
- Connection between PWB A MCU F and SENSOR-PHOTO IN (MPF No Paper Sensor)

## 9 ROS

- Connection between PWBA ESS and ROS ASSY-12
- Connection between PWB A MCU F and ROS ASSY-12

## 10 EXIT

- Connection between PWB A EXIT and SENSOR-PHOTO IN (OCT Home Sensor)
- Connection between PWB A EXIT and SENSOR-PHOTO IN (Full Stack Sensor)
- Connection between PWB A EXIT and MOTOR ASSY-OFFSET
- Connection between PWB A EXIT and PWB A MCU F

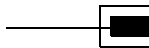
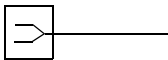
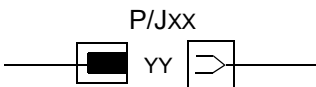
## 11 Controller

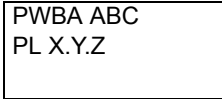
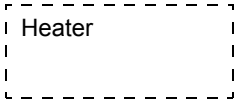

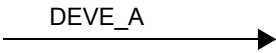
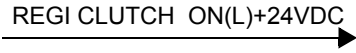
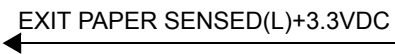

- Connection between PWB A EXIT and PWBA ESS

### Notes on Using the Wiring Diagram between Parts

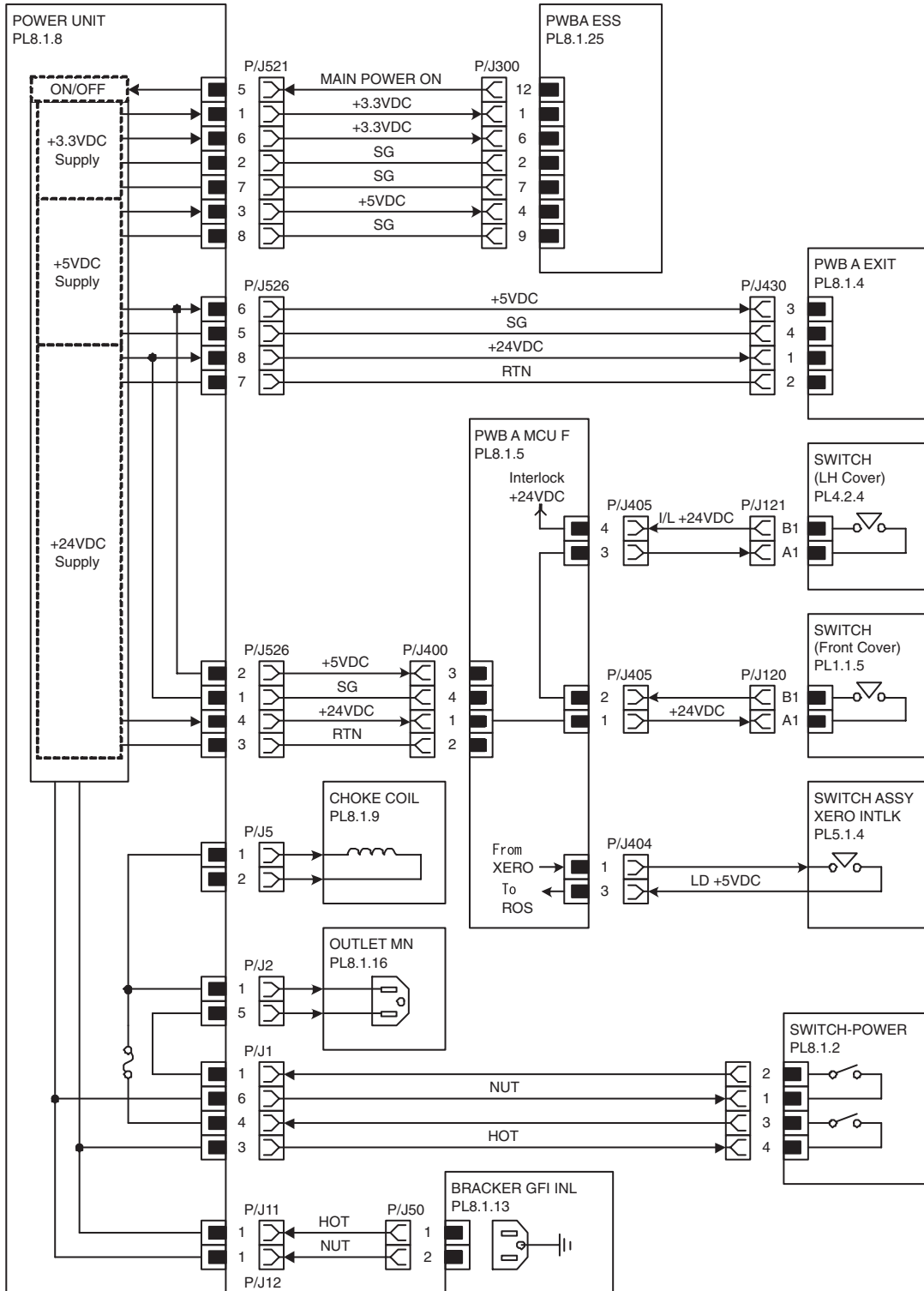
The following describes the legend of the wiring diagrams between parts shown on the following pages.

**NOTE** The description of general symbols is omitted.

Symbols	Description
	Denotes a plug.
	Denotes a jack.
	Denotes Pin yy and Jack yy of the connector Pxx and Jxx.

Symbols	Description
	<p>Denotes the parts.            PL X.Y.Z implies the item "Z" of plate (PL) "X.Y" in Chapter 5. Parts List.</p>
	<p>Denotes functional parts attached with functional parts name.</p>
	<p>Denotes the control and its outline in PWB.</p>
	<p>Denotes a connection between parts with harnesses or wires, attached with signal name/contents.</p>
	<p>Denotes the function, and logic value of the signal to operate the function (Low: L, High: H).            The given voltage is for signal in high status.            The arrow indicates the direction of signal.</p>
	<p>Denotes the function, and logic value of the signal when the function operated (Low: L, High: H).            The given voltage is for signal in high status.            The arrow indicates the direction of signal.</p>
	<p>Denotes a connection between wires.</p>
<p>I/L +24VDC</p>	<p>Denotes DC voltage when the interlock switch in HNB MCU WITH CPU turns on</p>
<p>+5VDC +3.3VDC</p>	<p>Denotes DC voltage.</p>
<p>SG</p>	<p>Denotes signal ground.</p>
<p>AG</p>	<p>Denotes analog ground.</p>
<p>RTN</p>	<p>Denotes the return.</p>

# 1 Power supply





Signal line name	Description
MAIN POWER ON	ON/OFF control signal of Power Supply in POWER UNIT

- Short protection (over-current protection) & Over-voltage protection of POWER UNIT
  - Each output has the short protection and over-voltage protection functions as shown on the table below:

	Output Status		
	3.3VDC	5VDC	24VDC
Over-current value	9 - 14A	7 - 11A	14 - 19A
3.3V short	Cut off	Cut off	Cut off
5V short	Normal output	Cut off	Cut off
24V short	Normal output	Cut off	Cut off
Over-voltage value	4 - 5V	6 - 8V	26.7 - 32V
3.3V	Cut off	Cut off	Cut off
5V	Cut off	Cut off	Cut off
24V	Normal output	Cut off	Cut off

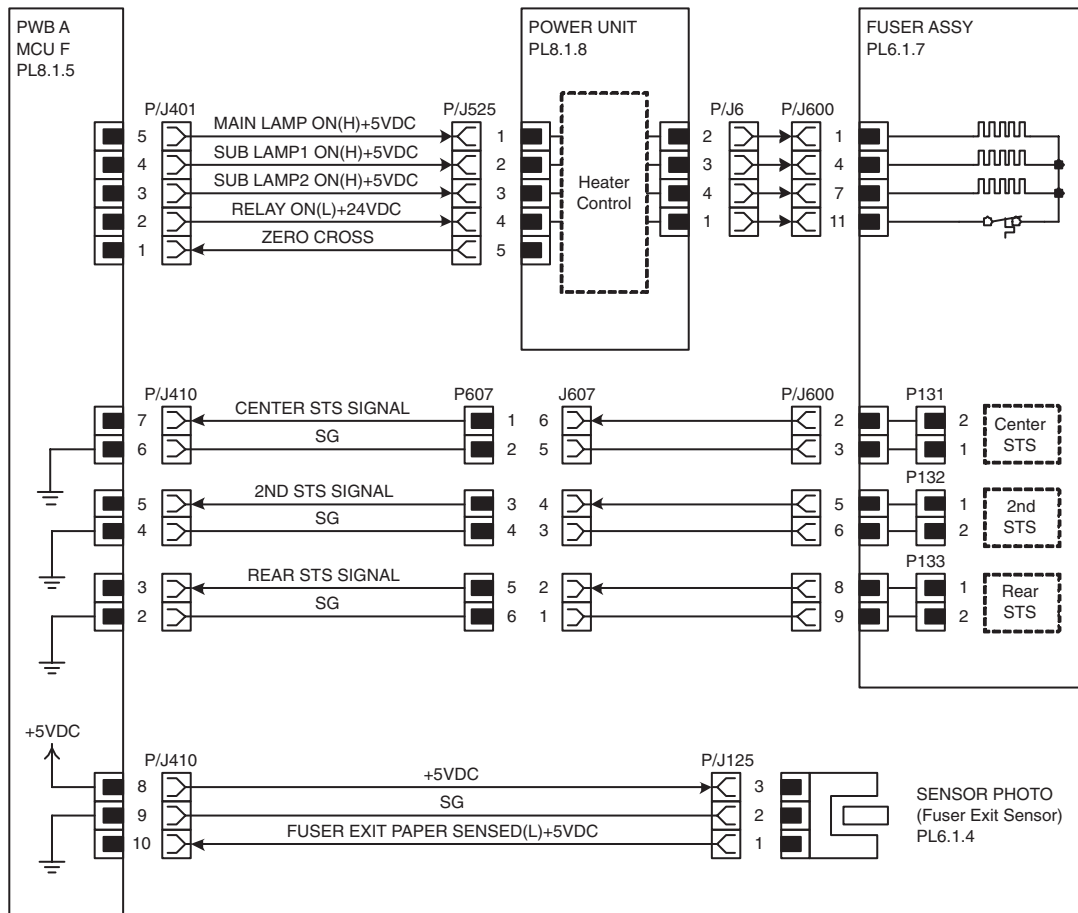
In the case of short protection (over-current protection) cut off:

After the clearance of the shortage, power off, allow 10 sec. and power on; the output is restored.

In the case of over-voltage protection Cut off:

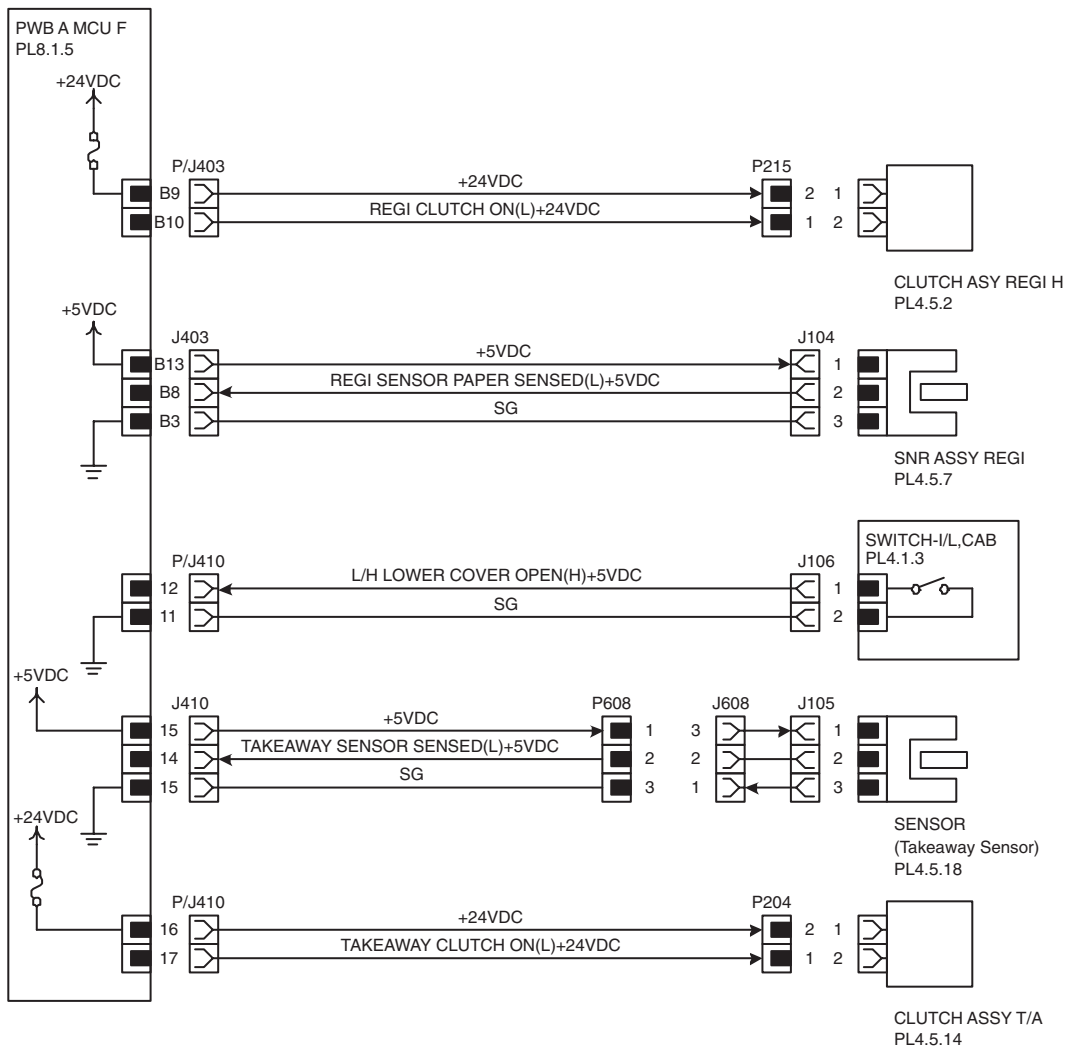
After the overvoltage protection functions, power off, allow 10 sec. and power on; the output is restored.

## 2 Fuser



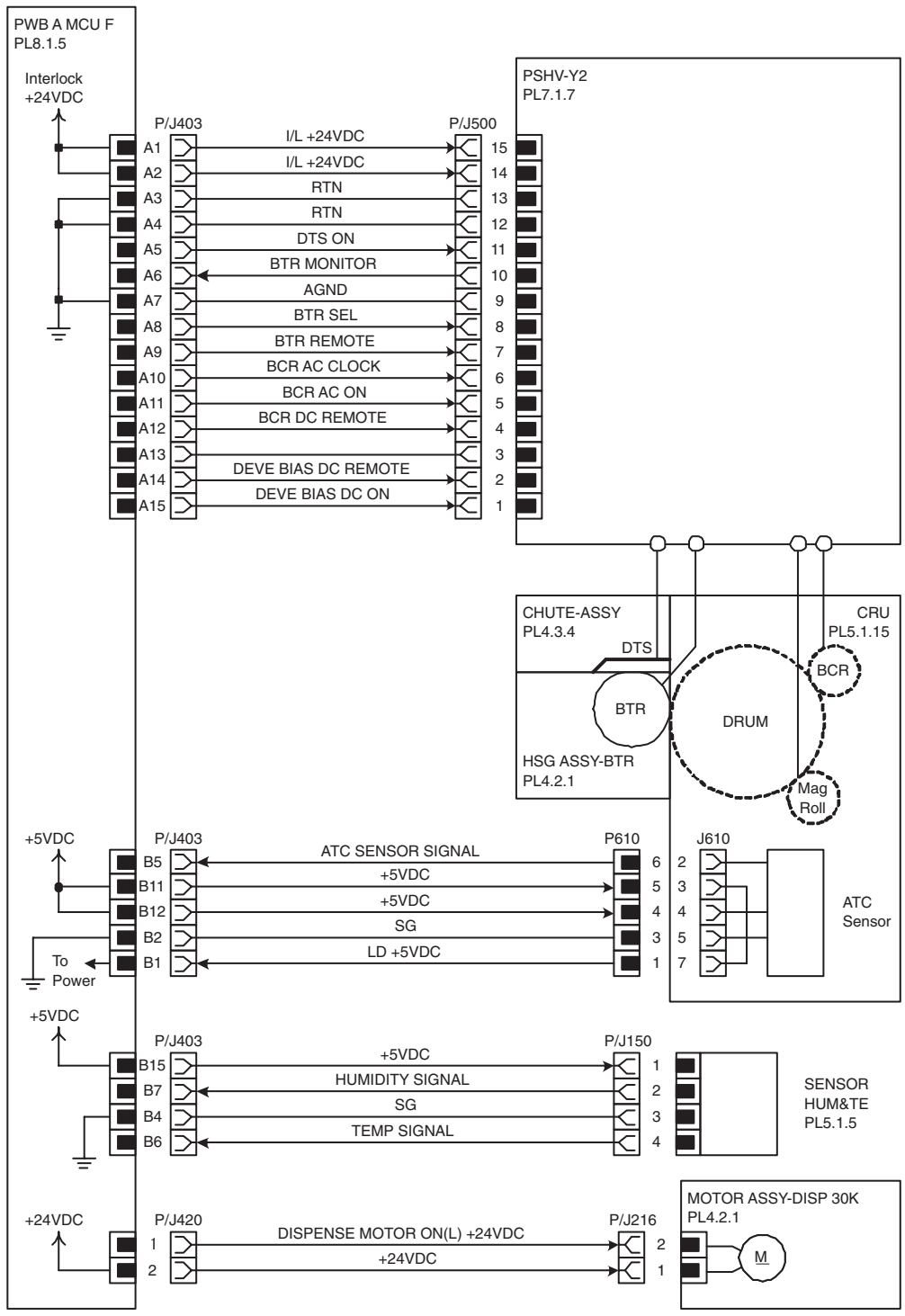
Signal line name	Description
MAIN HEATER ON(H)+5VDC	ON/OFF control signal of Main Heater in FUSER ASSY
SUB HEATER1 ON(H)+5VDC	ON/OFF control signal of Sub Heater1 in FUSER ASSY
SUB HEATER2 ON(H)+5VDC	ON/OFF control signal of Sub Heater2 in FUSER ASSY
RELAY ON(L)+24VDC	ON/OFF control signal of Fuser Relay in FUSER ASSY
ZERO CROSS	ZERO CROSS signal
CENTER STS SIGNAL	Heart Roll surface temperature data (analog value) measured by Center STS in FUSER ASSY
2ND STS SIGNAL	Heart Roll surface temperature data (analog value) measured by 2nd STS in FUSER ASSY
REAR STS SIGNAL	Heart Roll surface temperature data (analog value) measured by Rear STS in FUSER ASSY
FUSER EXIT PAPER SENSED(L)+5VDC	Paper detection signal in fuser by Fuser Exit Sensor in FUSER ASSY

### 3 Paper Feed



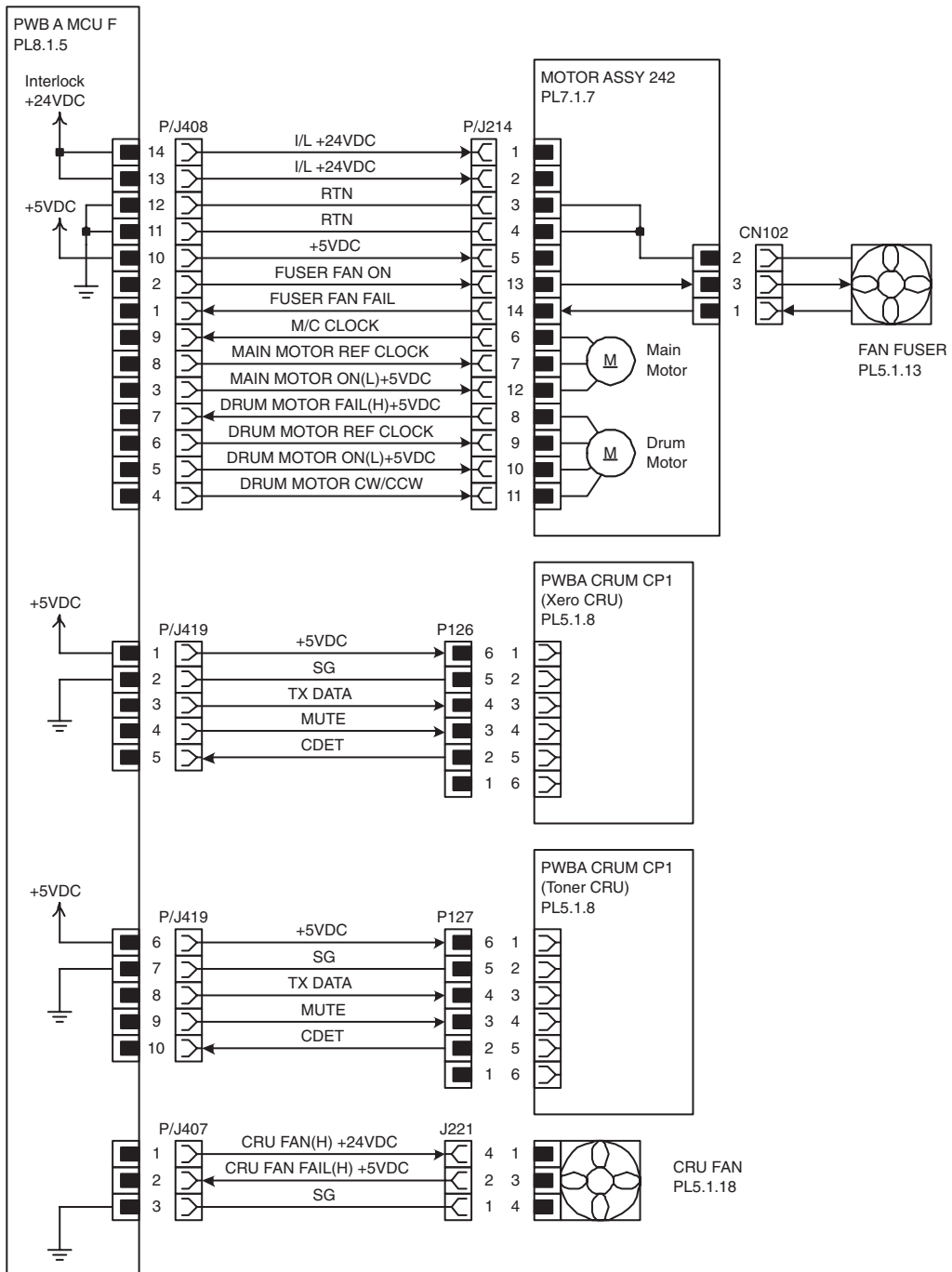
Signal line name	Description
REGI CLUTCH ON(L)+24VDC	CLUTCH ASY REGI H(Regi Clutch) ON/OFF control signal
REGI SENSOR PAPER SENSED(L)+5VDC,	Paper detection signal by SNR ASSY REGI in Registration
L/H LOWER COVER OPEN(H)+5VDC	L/H LOWER COVER open/close detection signal by SWITCH-I/L,CAB
TAKEAWAY SENSOR SENSED(L)+5VDC	Paper detection signal by SNR TAKEAWAY in transport section
TAKEAWAY CLUTCH ON(L)+24VDC	CLUTCH ASY T/A ON/OFF control signal

#### 4 Xero / Deve



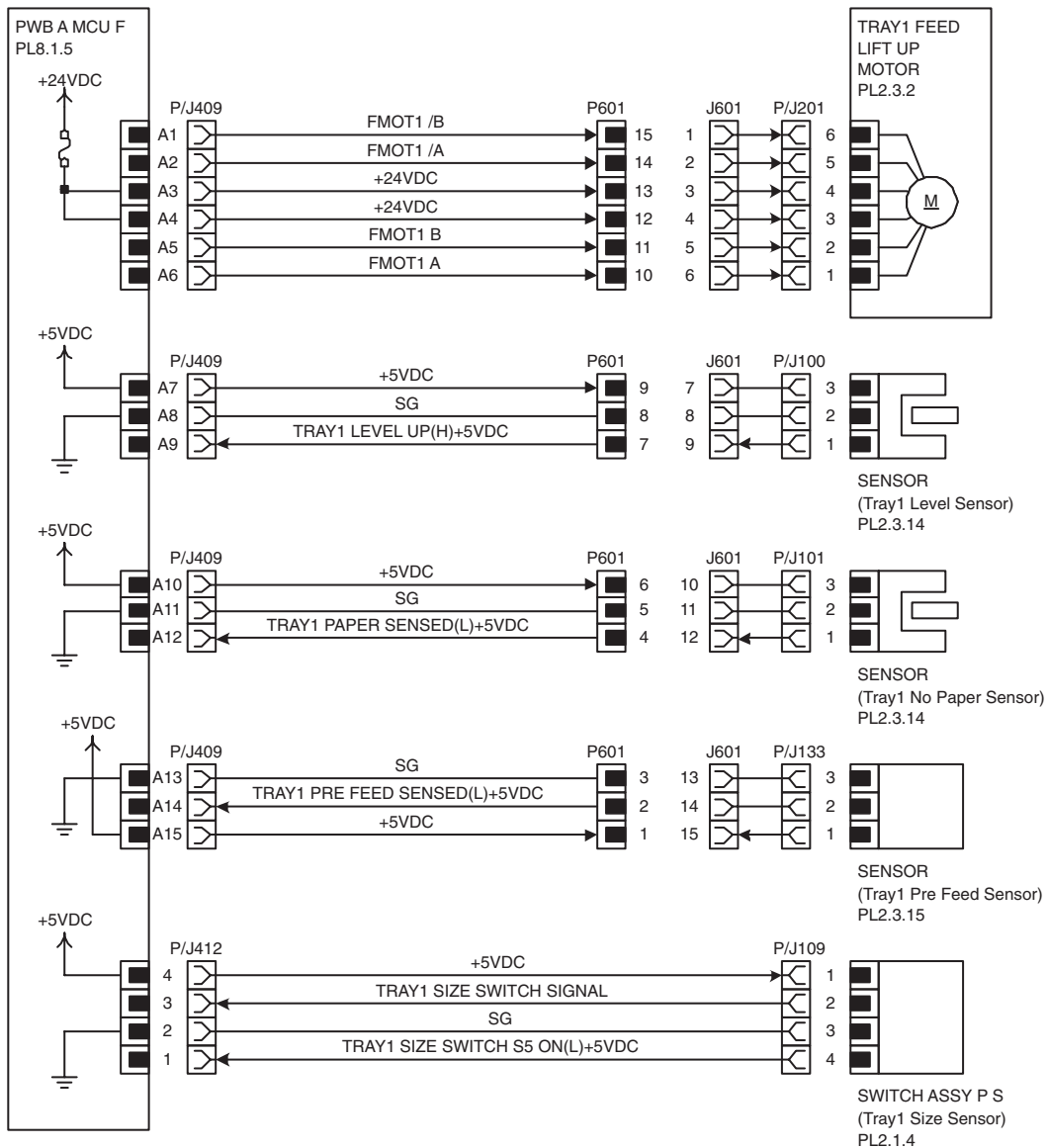
Signal line name	Description
DTS ON	ON/OFF control signal of DTS output
BTR MONITOR	Voltage monitor signal of BTR output (analog value)
BTR SEL	Polarity switching signal of BTR output
BTR REMOTE	Current control signal of BTR DC output (analog value)
BCR AC CLOCK	Clock signal of BCR AC output
BCR AC ON	ON/OFF control signal of BCR AC output
BCR DC REMOTE	ON/OFF control signal of BCR DC output (analog value)
DEVE BIAS DC REMOTE	DEVE BIAS DC voltage output signal
DEVE BIAS DC ON	ON/OFF control signal of DEVE BIAS DC output
ATC SENSOR SIGNAL	Toner concentration in the developing unit detection signal (analog value) measured by ATC Sensor in CRU
HUMIDITY SIGNAL	Humidity detection signal (analog value) measured by SENSOR HUM&TE in the machine
TEMP SIGNAL	Temperature detection signal (analog value) measured by SENSOR HUM&TE in the machine
DISPENSE MOTOR ON(L) +24VDC	MOTOR ASSY-DISP 30K ON/OFF control signal

## 5 Drive / CRUM



Signal line name	Description
FUSER FAN ON	High Speed / Low Speed switching signal of FAN FUSER
FUSER FAN FAIL(H)+5VDC	Fail detection signal of FAN FUSER
M/C CLOCK	Clock signal from Main Motor in MOTOR ASSY 242
MAIN MOTOR REF CLOCK	Reference Clock signal to Main Motor in MOTOR ASSY 242
MAIN MOTOR ON(L)+5VDC	ON/OFF control signal of Main Motor in MOTOR ASSY 242
DRUM MOTOR FAIL(H)+5VDC	Fail detection signal of Drum Motor in MOTOR ASSY 242
DRUM MOTOR REF CLOCK	Reference clock signal to Drum Motor in MOTOR ASSY 242
DRUM MOTOR ON(L)+5VDC	ON/OFF control signal of Drum Motor in MOTOR ASSY 242
DRUM MOTOR CW/CCW	Rotation direction switching signal of Drum Motor in MOTOR ASSY 242
TX DATA, MUTE, CDET	Read/Write control signal of PWBA CRUM CP1
CRU FAN ON(H)+24VDC	ON/OFF control signal of CRU FAN
CRU FAN FAIL(H)+5VDC	Fail detection signal of CRU FAN

## 6 Tray1



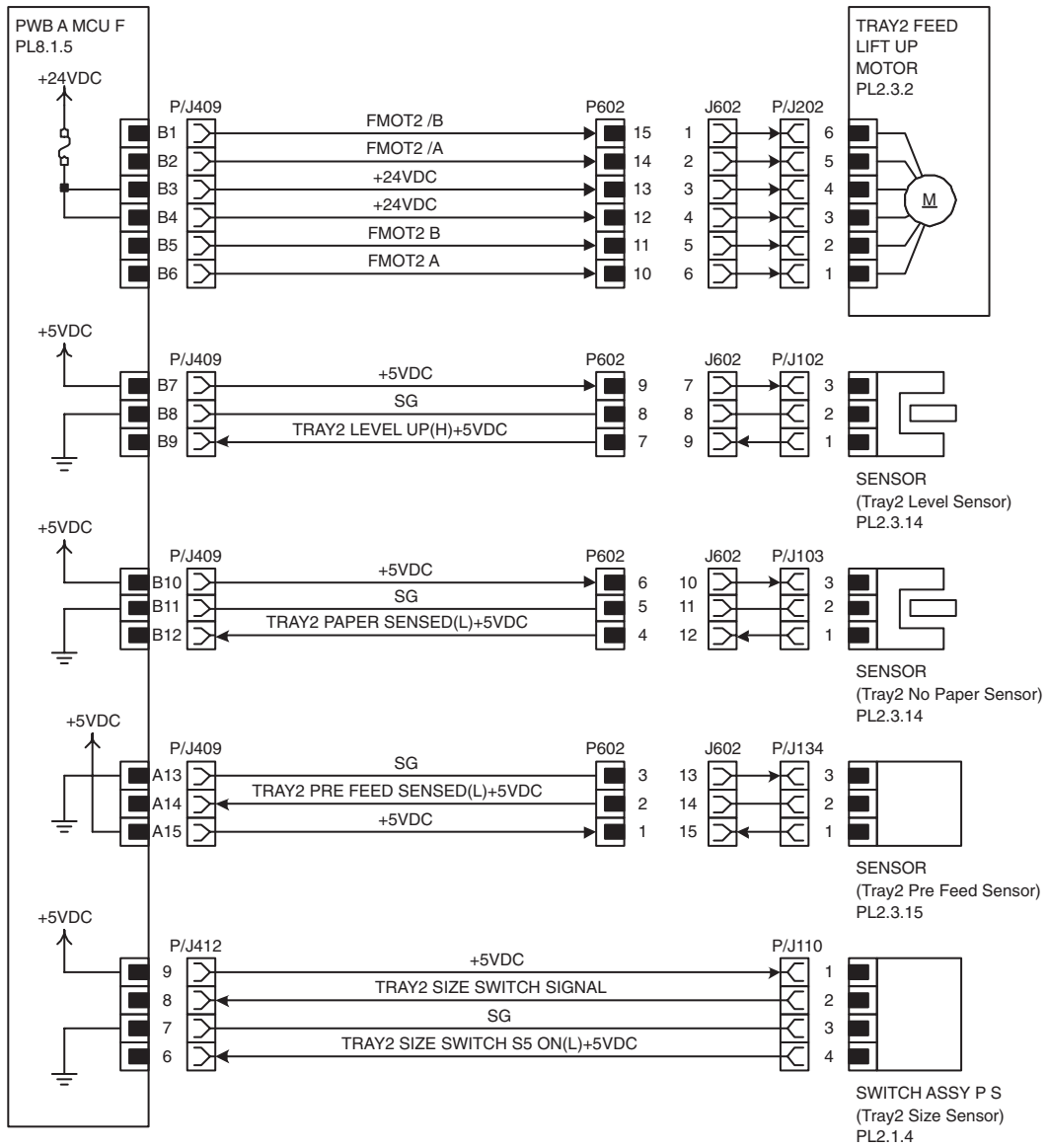
Signal line name	Description
FMOT1 A, FMOT1 B, FMOT1 /A, FMOT1 /B	TRAY1 FEED LIFT UP MOTOR exciting signal
TRAY1 LEVEL UP(H)+5VDC	Rise (paper feed possible level) detection signal of plate in Tray1 by SENSOR (Tray1 Level Sensor)
TRAY1 PAPER SENSED(L)+5VDC	Paper detection signal in Tray1 of SENSOR (Tray1 No Paper Sensor)
TRAY1 PRE FEED SENSED(L)+5VDC	Feed paper detection signal from Tray1 by SENSOR (Tray1 Pre Feed Sensor)
TRAY1 SIZE SWITCH SIGNAL	Paper size detection signal (analog value) of SWITCH ASSY P S (Tray1 Size Sensor)
TRAY1 SIZE SWITCH S5 ON(L)+5VDC	S5 in SWITCH ASSY P S (Tray1 Size Sensor) ON/OFF detection signal

- Paper size detection
  - The ON/OFF pattern of each switch (S1-S5) of SWITCH ASSY P S and the relation of paper size and the output voltage of TRAY1 SIZE SWITCH SIGNAL are as follows.

Paper Size	S1	S2	S3	S4	S5	Output Voltage(V)
No Tray	OFF	OFF	OFF	OFF	OFF	4.66A}0.05
5.5 "A~8.5" SEF/A5 SEF	OFF	OFF	ON	OFF	OFF	4.01A}0.05
B5 SEF	OFF	OFF	ON	ON	ON	3.69A}0.05
8.5 "A~13" SEF	OFF	ON	OFF	ON	OFF	3.07A}0.05
8.5"A~14"SEF	OFF	ON	OFF	ON	ON	
A4 SEF	OFF	ON	ON	OFF	OFF	2.75A}0.05
8.5"A~11"SEF	OFF	ON	ON	OFF	ON	
A4 LEF	ON	OFF	ON	OFF	OFF	1.52A}0.05
A3 SEF	ON	OFF	ON	ON	OFF	1.21A}0.05
B5 LEF/ Executive LEF	ON	ON	OFF	OFF	ON	0.91A}0.05
8K SEF (TFX/GCO)	ON	ON	OFF	ON	OFF	0.60A}0.05
B4 SEF	ON	ON	OFF	ON	ON	
8.5"A~11"LEF	ON	ON	ON	OFF	OFF	0.30A}0.05
16K LEF(TFX/GCO)	ON	ON	ON	OFF	ON	
11"A~17"LEF	ON	ON	ON	ON	ON	0.00A}0.05

## 7 Tray2



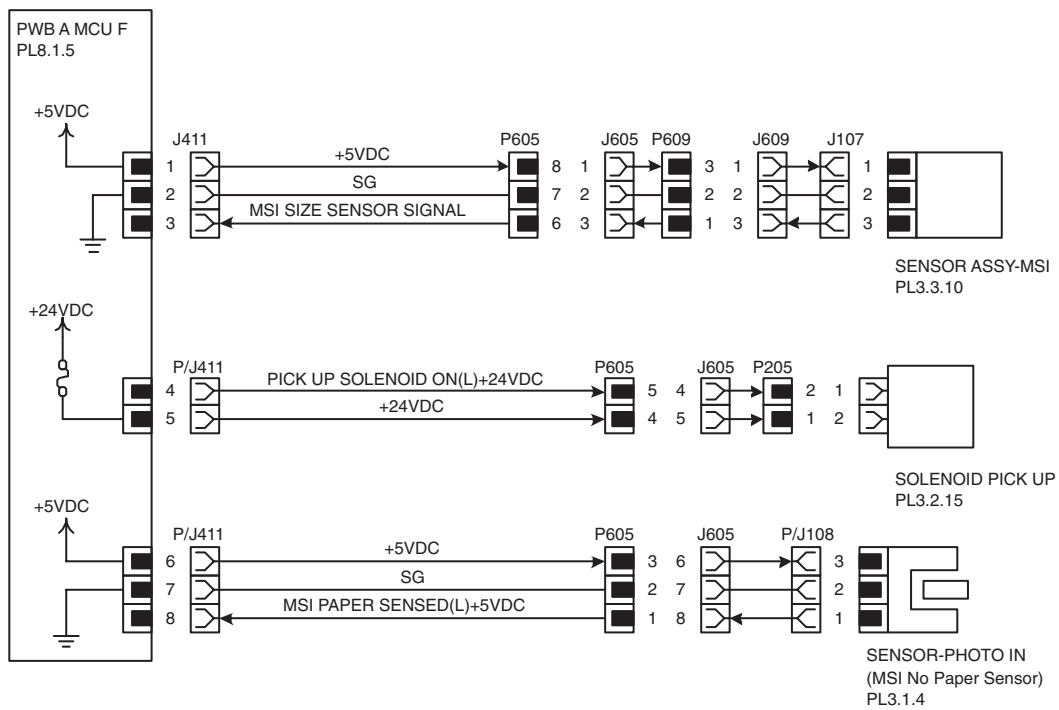


Signal line name	Description
FMOT2 A, FMOT2 B, FMOT2 /A, FMOT2 /B	TRAY2 FEED LIFT UP MOTOR exciting signal
TRAY2 LEVEL UP(H)+5VDC	Rise (paper feed possible level) detection signal of plate in Tray2 by SENSOR (Tray2 Level Sensor).
TRAY2 PAPER SENSED(L)+5VDC	Paper detection signal in Tray2 of SENSOR (Tray2 No Paper Sensor)
TRAY2 PRE FEED SENSED(L)+5VDC	Feed paper detection signal from Tray2 by SENSOR (Tray2 Pre Feed Sensor)
TRAY2 SIZE SWITCH SIGNAL	Paper size detection signal (analog value) of SWITCH ASSY P S (Tray2 Size Sensor)
TRAY2 SIZE SWITCH S5 ON(L)+5VDC	S5 in SWITCH ASSY P S (Tray2 Size Sensor) ON/OFF detection signal

- Paper size detection
  - The ON/OFF pattern of each switch (S1-S5) of SWITCH ASSY P S and the relation of paper size and the output voltage of TRAY2 SIZE SWITCH SIGNAL are as follows.

Paper Size	S1	S2	S3	S4	S5	Output Voltage(V)
No Tray	OFF	OFF	OFF	OFF	OFF	4.66A}0.05
5.5"Å~8.5"SEF/A5 SEF	OFF	OFF	ON	OFF	OFF	4.01A}0.05
B5 SEF	OFF	OFF	ON	ON	ON	3.69A}0.05
8.5"Å~13"SEF	OFF	ON	OFF	ON	OFF	3.07A}0.05
8.5"Å~14"SEF	OFF	ON	OFF	ON	ON	
A4 SEF	OFF	ON	ON	OFF	OFF	2.75A}0.05
8.5"Å~11"SEF	OFF	ON	ON	OFF	ON	
A4 LEF	ON	OFF	ON	OFF	OFF	1.52A}0.05
A3 SEF	ON	OFF	ON	ON	OFF	1.21A}0.05
B5 LEF/ Executive LEF	ON	ON	OFF	OFF	ON	0.91A}0.05
8K SEF (TFX/GCO)	ON	ON	OFF	ON	OFF	0.60A}0.05
B4 SEF	ON	ON	OFF	ON	ON	
8.5"Å~11"LEF	ON	ON	ON	OFF	OFF	0.30A}0.05
16K LEF(TFX/GCO)	ON	ON	ON	OFF	ON	
11"Å~17"LEF	ON	ON	ON	ON	ON	0.00A}0.05

## 8 MPF



Signal line name	Description
MPF SIZE SENSOR SIGNAL	MPF Paper size detection signal (analog value) in the main scan direction of SENSOR ASSY-MPF
PICK UP SOLENOID ON(L)+24VDC	SOLENOID PICK UP ON/OFF control signal
MPF PAPER SENSED(L)+5VDC	Paper detection signal in MPF by SENSOR-PHOTO IN (MPF No Paper Sensor)

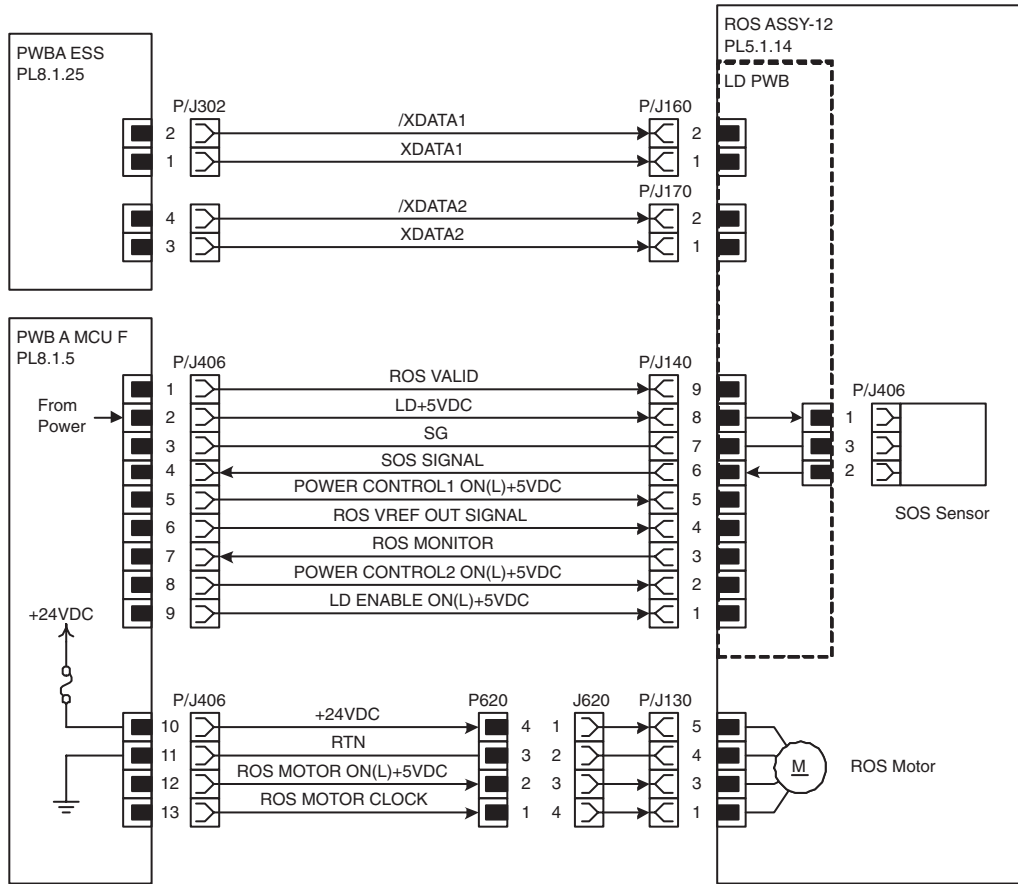
◆ MPF Paper size detection in the main scan direction

The paper guide of MPF is interlocked with, variable resistance of SENSOR ASSY-MPF changes, and the output voltage of MPF SIZE SENSOR SIGNAL changes.

The relation between the output voltage of MPF SIZE SENSOR SIGNAL and paper size is shown below.

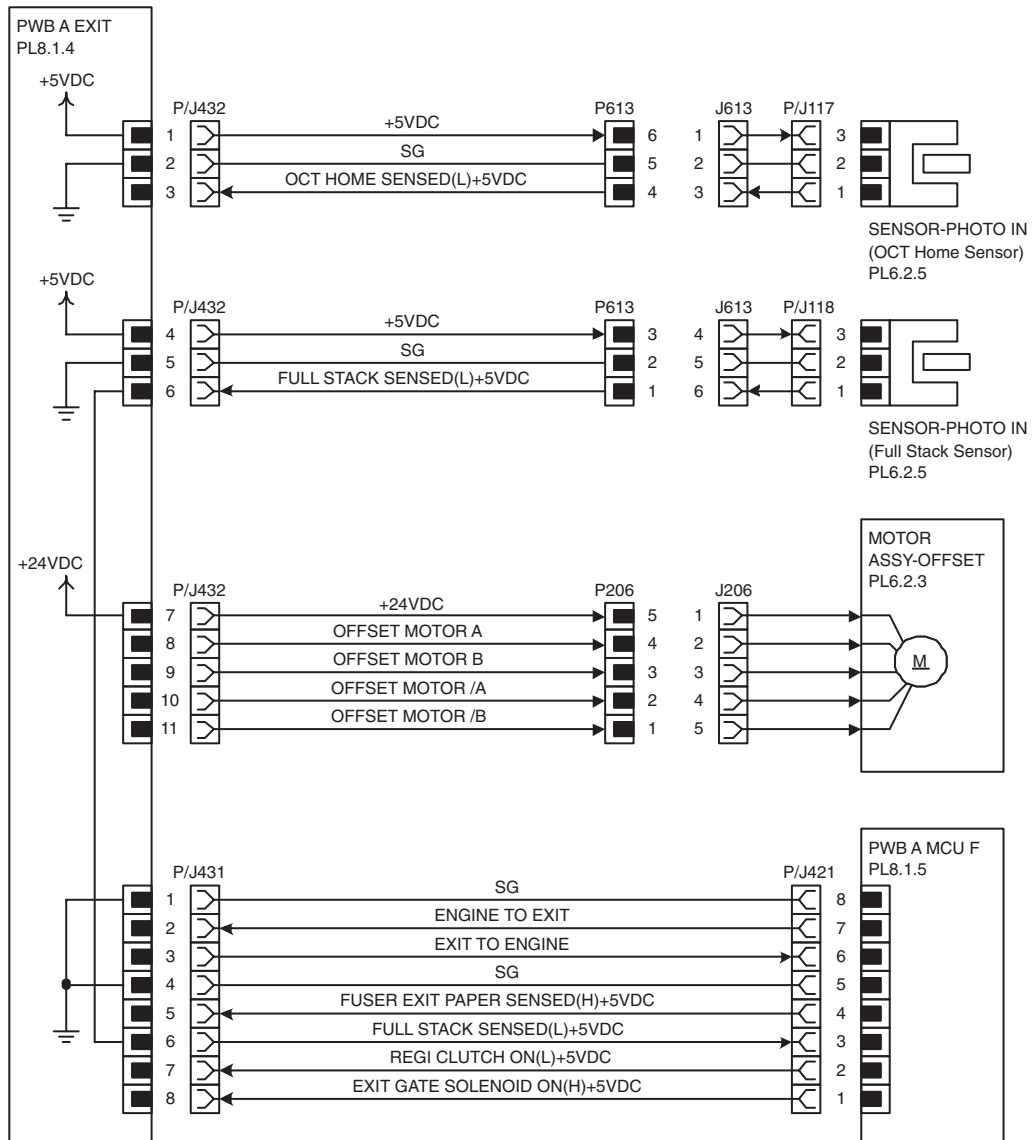
Paper size	Feed length (mm)	Output Voltage(V)
Guide stopper (MIN)	84	4.72
Paper detection range (MIN)	88.2	4.72
3.5"A~8.5"SEF	88.9	4.71
Post Card SEF	101.6	4.48
5.5"A~8.5"SEF	139.7	3.79
Japanese Post card LEF	148	3.64
A6 LEF	148	3.64
A5 SEF	148	3.64
Post Card LEF	152.4	3.56
B6LEF	182	3.03
B5SEF	182	3.03
Monarch LEF	190.5	2.87
A5 LEF	210	2.52
A4 SEF	210	2.52
5.5"A~8.5"LEF	215.9	2.41
5.5"A~11"SEF(Letter)	215.9	2.41
5.5"A~13"SEF(Legal)	215.9	2.41
5.5"A~14"SEF(Legal)	215.9	2.41
DL LEF	220	2.34
C5 LEF	229	2.18
C4 SEF	229	2.18
Vertical (Long size) No.3 LEF	235	2.07
Com10LEF	241.3	1.95
B5 LEF	257	1.67
B4 SEF	257	1.67
Executive LEF	266.7	1.50
16K LEF (TFX)	267(270)	1.49(1.44)
8K SEF (TFX)	267(270)	1.49(1.44)
8.5"A~11"SEF (Letter)	279.4	1.27
11A~17"LEF	279.4	1.27
A4 LEF	297	0.95
A3 SEF	297	0.95
Guide stopper (MAX)	303	0.84

## 9 ROS



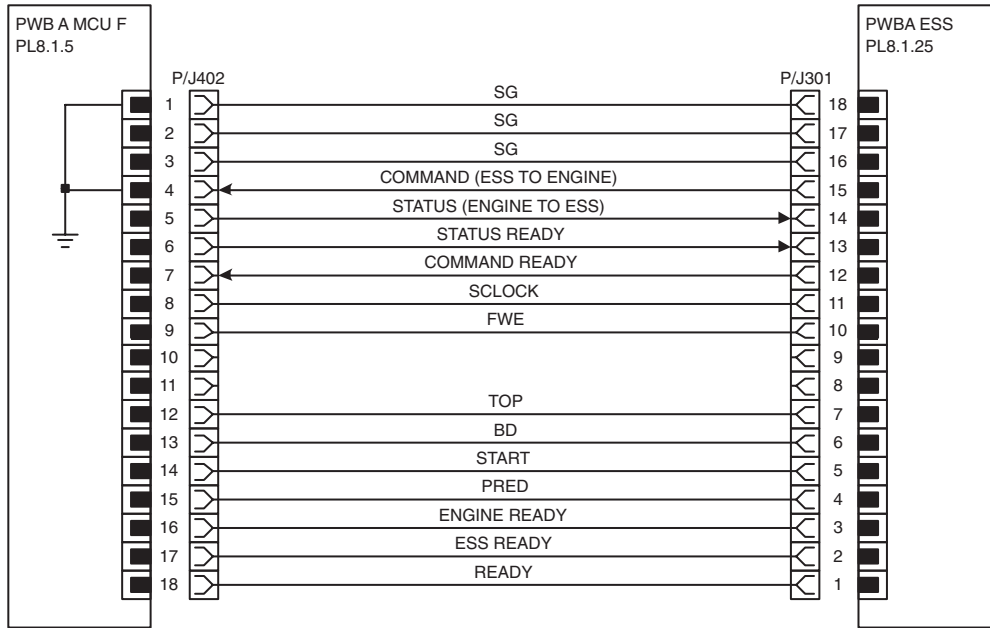
Signal line name	Description
/XDATA1, XDATA1, /XDATA2, XDATA2	Pixel data signals to make LD (Laser Diodes) in ROS ASSY-12 emit the light
ROS VALID	Compulsive putting-out-lights signal of LD in ROS ASSY-12
LD+5VDC	Power supply voltage for LD in ROS ASSY-12
SOS SIGNAL	Scanning start reference signal based on the input of laser beam to the SOS Sensor in ROS ASSY-12
POWER CONTROL1 ON(L)+5VDC	ON/OFF control signal of LD Power in ROS ASSY-12
ROS VREF OUT SIGNAL	Voltages for adjusting light quantity of LD in ROS ASSY-12
ROS MONITOR	Light quantity monitor signal for LD in ROS ASSY-12
POWER CONTROL2 ON(L)+5VDC	ON/OFF control signal of LD Power in ROS ASSY-12
LD ENABLE ON(L)+5VDC	Enable signal of LD in ROS ASSY-12
ROS MOTOR ON(L)+5VDC	ON/OFF control signal of ROS Motor in ROS ASSY-12
ROS MOTOR CLOCK	Clock signal of ROS Motor in ROS ASSY-12

## 10 Exit



Signal line name	Description
OCT HOME SENSED(L)+5VDC	OCT home position detection signal by SENSOR-PHOTO IN (OCT Home Sensor)
FULL STACK SENSED(L)+5VDC	Stacker tray paper full detection signal by SENSOR-PHOTO IN (Full Stack Sensor)
OFFSET MOTOR A, OFFSET MOTOR B, OFFSET MOTOR /A, OFFSET MOTOR /B	MOTOR ASSY-OFFSET exciting signal
ENGINE TO EXIT	Communication signal of PWB A MCU F (Engine) and PWB A EXIT (Exit) (Engine->Exit)
EXIT TO ENGINE	Communication signal of PWB A EXIT (Exit) and PWB A MCU F (Engine) (Exit->Engine)
FUSER EXIT PAPER SENSED(H)+5VDC	Paper detection signal in fuser by Fuser Exit Sensor in FUSER ASSY (Engine->Exit)
REGI CLUTCH ON(L)+5VDC	CLUTCH ASY REGI H(Regi Clutch) ON/OFF control signal (Engine->Exit)
EXIT GATE SOLENOID ON(H)+5VDC	SOLENOID ASSY (Exit Gate Solenoid) ON/OFF control signal (Engine->Exit)

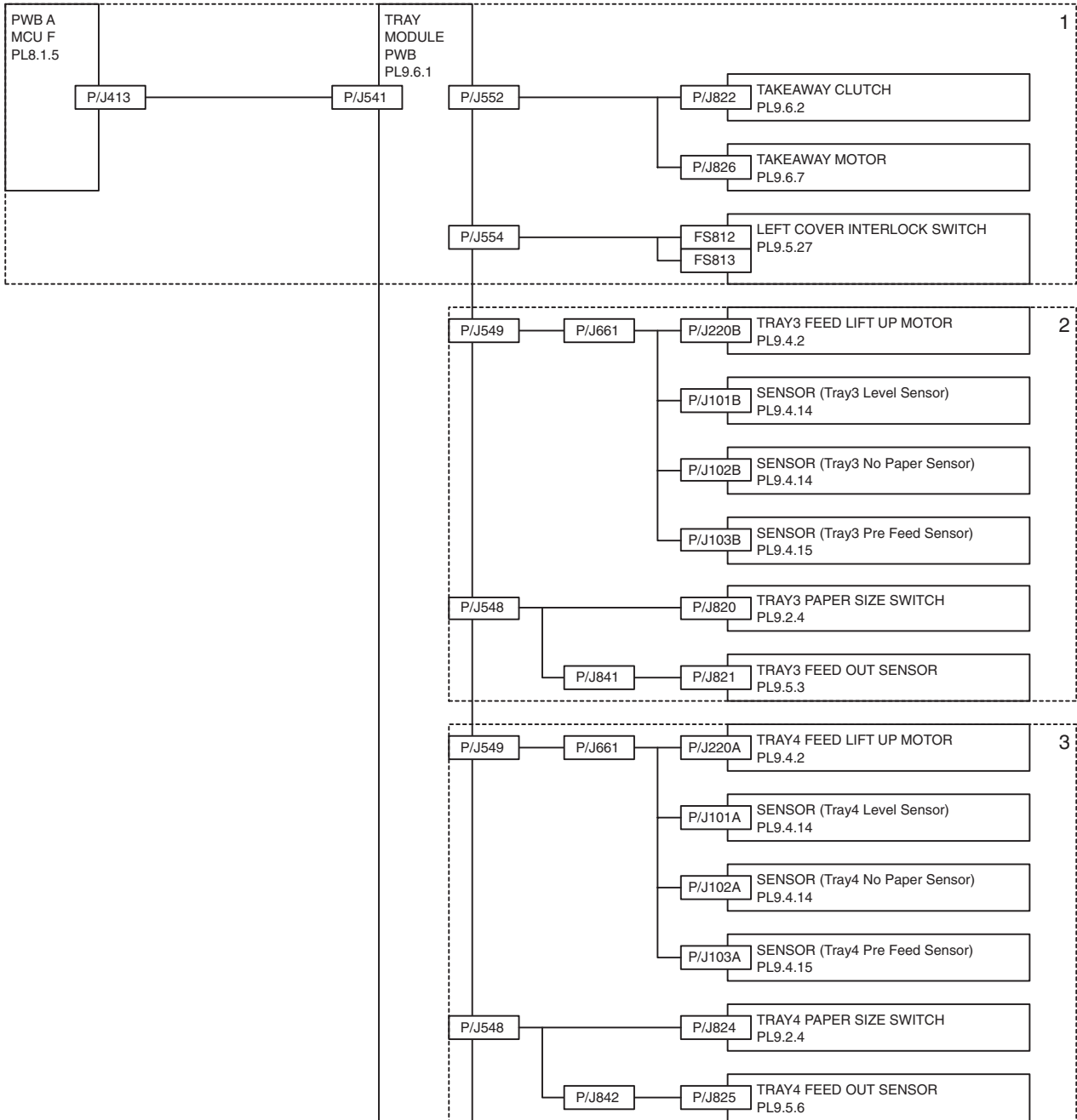
# 11 Controller



Signal line name	Description
COMMAND (ESS TO ENGINE)	Communication signal of PWB A ESS (ESS) and PWB A MCU F (Engine)
STATUS (ENGINE TO ESS)	
STATUS READY	
COMMAND READY	
SCLOCK	
FWE	
TOP	
BD	
START	
PRED	
ENGINE READY	
ESS READY	
READY	

# 1000 Sheet Feeder

## General Wiring Diagram



## Wiring Diagram between Parts

### Configuration

The wiring diagram is separated into 3 sections to show detailed connection between parts.

#### 1 Drive

- Connection between TRAY MODULE PWB and CLUTCH (Takeaway Clutch)
- Connection between TRAY MODULE PWB and MAIN MOTOR
- Connection between TRAY MODULE PWB and LEFT COVER INTERLOCK SWITCH



- Connection between TRAY MODULE PWB and PWB A MCU F

## 2 Tray3

- Connection between TRAY MODULE PWB and TRAY3 FEED LIFT UP MOTOR
- Connection between TRAY MODULE PWB and SENSOR (Tray3 Level Sensor)
- Connection between TRAY MODULE PWB and SENSOR (Tray3 No Paper Sensor)
- Connection between TRAY MODULE PWB and SENSOR (Tray3 Pre Feed Sensor)
- Connection between TRAY MODULE PWB and TRAY3 PAPER SIZE SWITCH
- Connection between TRAY MODULE PWB and TRAY3 FEED OUT SENSOR

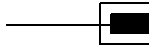
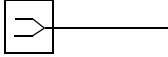
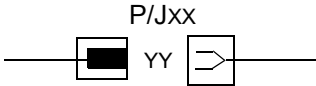
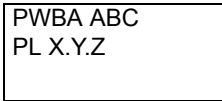
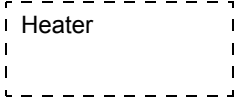
## 3 Tray4


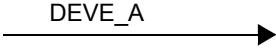
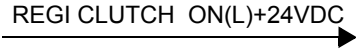
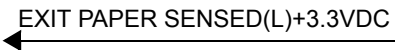

- Connection between TRAY MODULE PWB and TRAY4 FEED LIFT UP MOTOR
- Connection between TRAY MODULE PWB and SENSOR (Tray4 Level Sensor)
- Connection between TRAY MODULE PWB and SENSOR (Tray4 No Paper Sensor)
- Connection between TRAY MODULE PWB and SENSOR (Tray4 Pre Feed Sensor)
- Connection between TRAY MODULE PWB and TRAY4 PAPER SIZE SWITCH
- Connection between TRAY MODULE PWB and TRAY4 FEED OUT SENSOR

## Notes on Using the Wiring Diagram between Parts

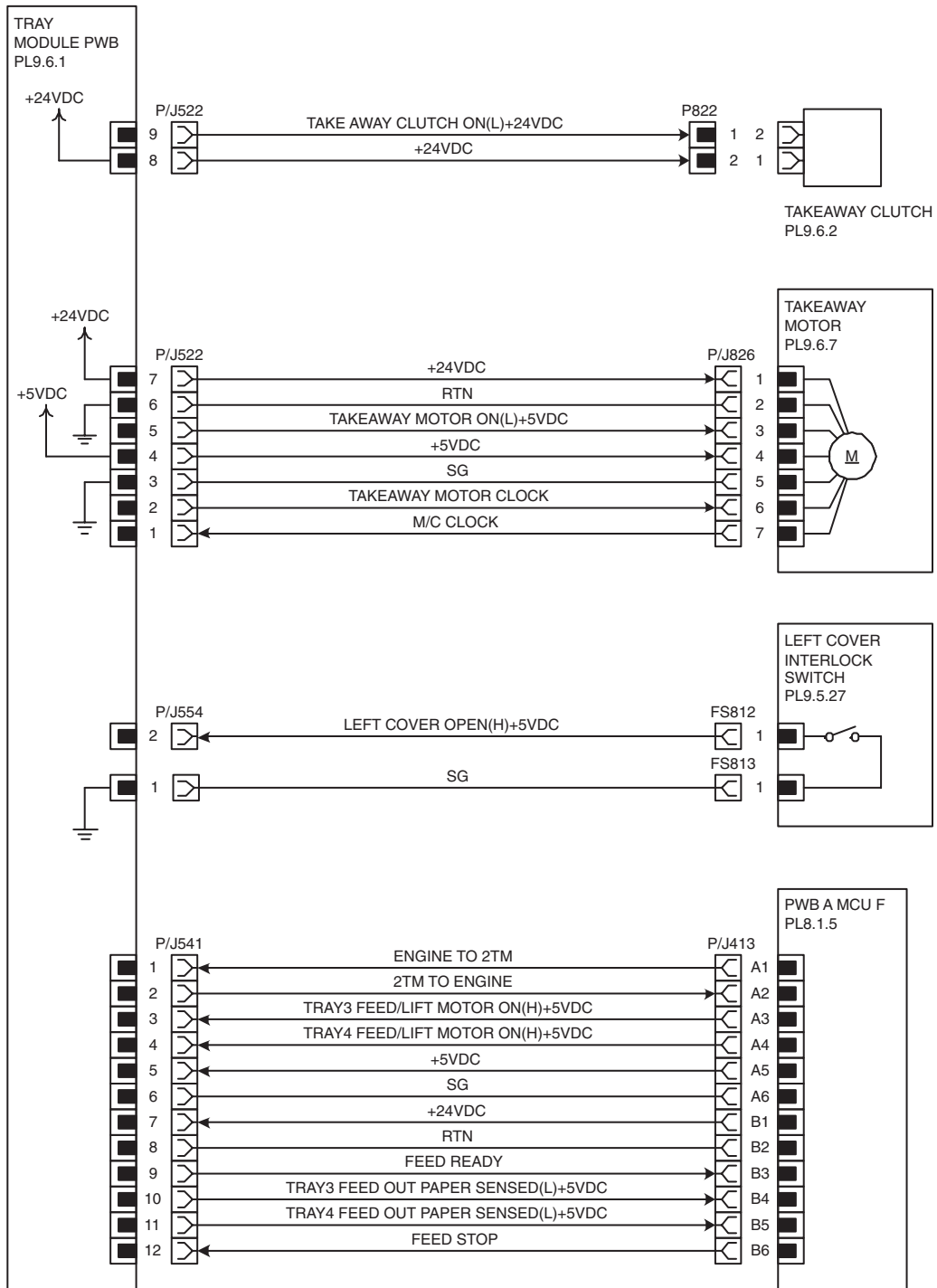
The following describes the legend of the wiring diagrams between parts shown on the following pages.

Note that the description of general symbols is omitted.

Symbols	Description
	Denotes a plug.
	Denotes a jack.
	Denotes Pin yy and Jack yy of the connector Pxx and Jxx.
	Denotes the parts. PL X.Y.Z implies the item "Z" of plate (PL) "X.Y" in Chapter 5. Parts List.
	Denotes functional parts attached with functional parts name.

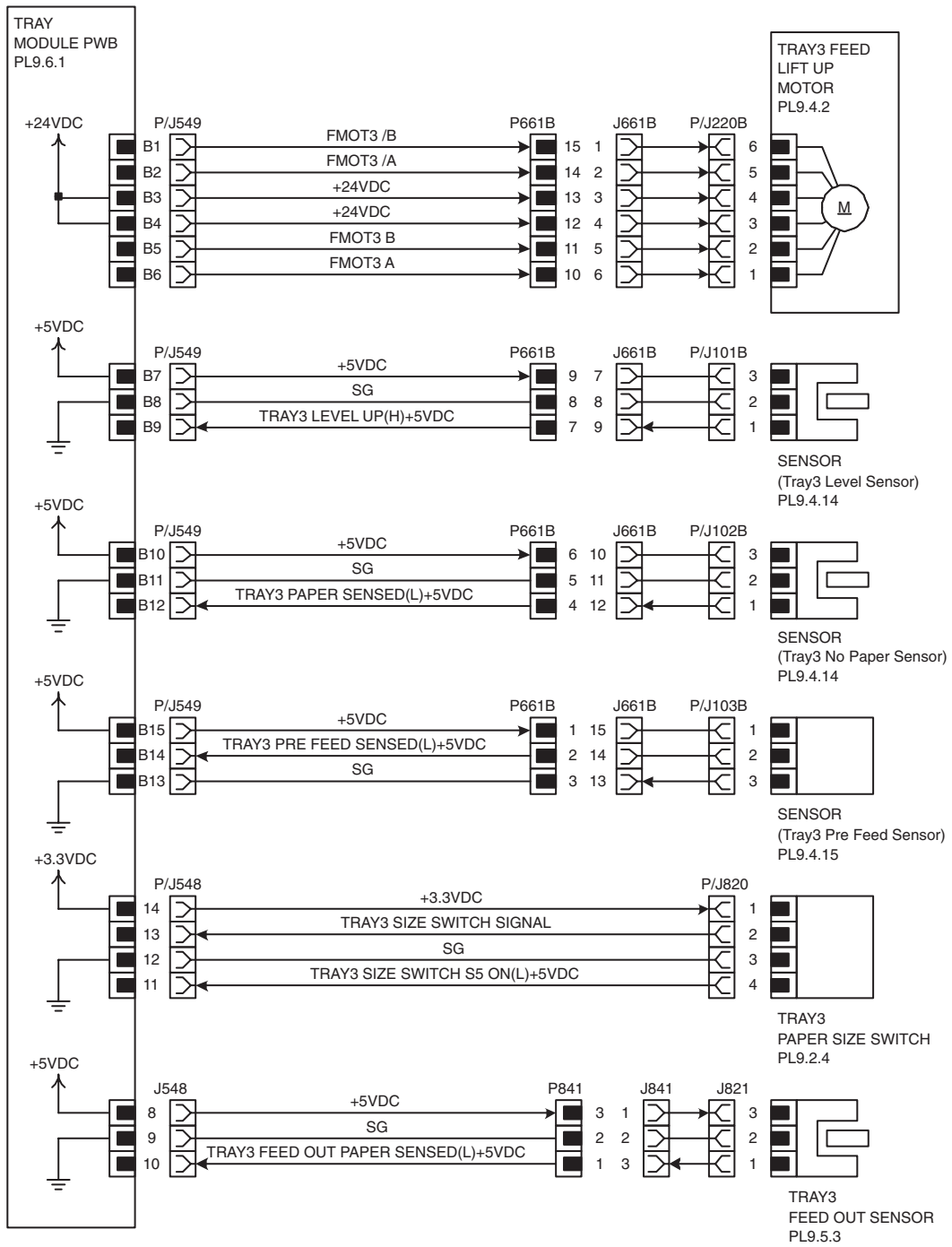
Symbols	Description
	Denotes the control and its outline in PWB.
	Denotes a connection between parts with harnesses or wires, attached with signal name/contents.
	Denotes the function, and logic value of the signal to operate the function (Low: L, High: H). The given voltage is for signal in high status. The arrow indicates the direction of signal.
	Denotes the function, and logic value of the signal when the function operated (Low: L, High: H). The given voltage is for signal in high status. The arrow indicates the direction of signal.
	Denotes a connection between wires.
I/L +24VDC	Denotes DC voltage when the interlock switch in HNB MCU WITH CPU turns on
+5VDC +3.3VDC	Denotes DC voltage.
SG	Denotes signal ground.
AG	Denotes analog ground.
RTN	Denotes the return.

## 1 Drive



Signal line name	Description
TAKEAWAY CLUTCH ON(L)+24VDC	TAKEAWAY CLUTCH ON/OFF control signal
TAKEAWAY MOTOR ON(L)+5VDC	TAKEAWAY MOTOR ON/OFF control signal
TAKEAWAY MOTOR CLOCK	Clock signal to TAKEAWAY MOTOR
M/C CLOCK	Clock signal from TAKEAWAY MOTOR
LEFT COVER OPEN(H)+5VDC	LEFT COVER open/close detection signal by LEFT COVER INTERLOCK SWITCH
ENGINE TO 2TM	Communication signal of PWB A MCU F (Engine) and TRAY MODULE PWB (2TM) (Engine->2TM)
2TM TO ENGINE	Communication signal of TRAY MODULE PWB (2TM) and PWB A MCU F (Engine) (2TM->Engine)
TRAY3 FEED/LIFT MOTOR ON(H)+5VDC	TRAY3 FEED LIFT UP MOTOR ON/OFF control signal (Engine->2TM)
TRAY4 FEED/LIFT MOTOR ON(H)+5VDC	TRAY4 FEED LIFT UP MOTOR ON/OFF control signal (Engine->2TM)
FEED READY	Feed ready signal from 2TM (2TM->Engine)
TRAY3 FEED OUT PAPER SENSED(L)+5VDC	Paper detection signal by TRAY3 FEED OUT SENSOR in transport section (2TM->Engine)
TRAY4 FEED OUT PAPER SENSED(L)+5VDC	Paper detection signal by TRAY4 FEED OUT SENSOR in transport section (2TM->Engine)
FEED STOP	Feed stop signal to 2TM (Engine->2TM)

## 2 Tray3



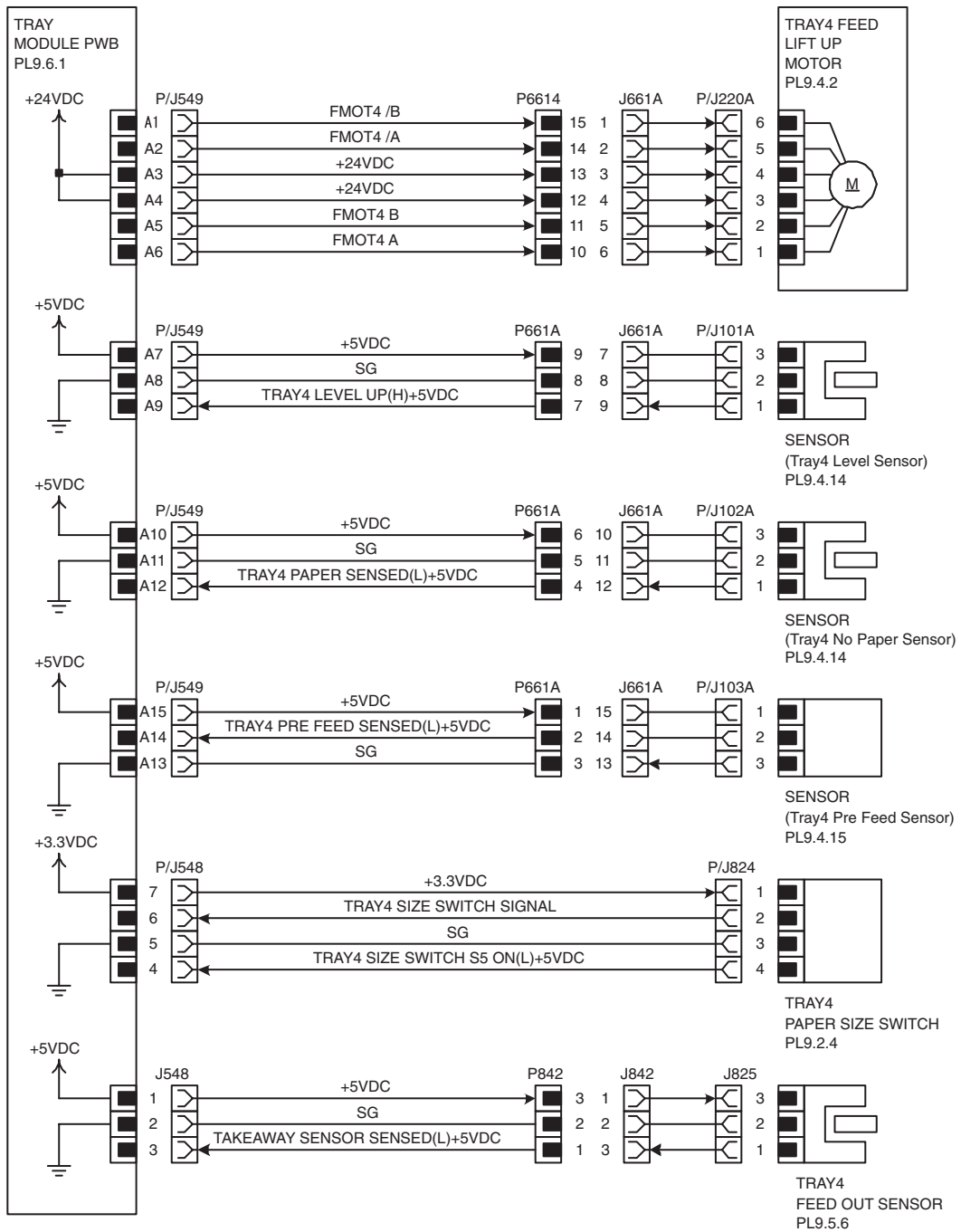
Signal line name	Description
FMOT3 A, FMOT3 B, FMOT3 /A, FMOT3 /B	TRAY3 FEED LIFT UP MOTOR exciting signal
TRAY3 LEVEL UP(H)+5VDC	Rise (paper feed possible level) detection signal of plate in Tray3 by SENSOR (Tray3 Level Sensor)
TRAY3 PAPER SENSED(L)+5VDC	Paper detection signal in Tray3 of SENSOR (Tray3 No Paper Sensor)
TRAY3 PRE FEED SENSED(L)+5VDC	Feed paper detection signal from Tray3 by SENSOR (Tray3 Pre Feed Sensor)
TRAY3 SIZE SWITCH SIGNAL	Paper size detection signal (analog value) of TRAY3 PAPER SIZE SWITCH
TRAY3 SIZE SWITCH S5 ON(L)+5VDC	S5 in TRAY3 PAPER SIZE SWITCH ON/OFF detection signal
TRAY3 FEED OUT PAPER SENSED(L)+5VDC	Paper detection signal by TRAY3 FEED OUT SENSOR in transport section

#### Paper size detection

- The ON/OFF pattern of each switch (S1-S5) of TRAY3 PAPER SIZE SWITCH and the relation of paper size and the output voltage of TRAY3 SIZE SWITCH SIGNAL are as follows.

Paper Size	S1	S2	S3	S4	S5	Output Voltage(V)
No Tray	OFF	OFF	OFF	OFF	OFF	3.06A}0.05
5.5"A~8.5" SEF/A5 SEF	OFF	OFF	ON	OFF	OFF	2.65A}0.05
B5 SEF	OFF	OFF	ON	ON	ON	2.45A}0.05
8.5"A~13"SEF	OFF	ON	OFF	ON	OFF	2.05A}0.05
8.5"A~14"SEF	OFF	ON	OFF	ON	ON	
A4 SEF	OFF	ON	ON	OFF	OFF	1.85A}0.05
8.5"A~11"SEF	OFF	ON	ON	OFF	ON	
A4 LEF	ON	OFF	ON	OFF	OFF	1.07A}0.05
A3 SEF	ON	OFF	ON	ON	OFF	0.87A}0.05
B5 LEF/ Executive LEF	ON	ON	OFF	OFF	ON	0.68A}0.05
8K SEF (TFX/GCO)	ON	ON	OFF	ON	OFF	0.49A}0.05
B4 SEF	ON	ON	OFF	ON	ON	
8.5"A~11"LEF	ON	ON	ON	OFF	OFF	0.29A}0.05
16K LEF(TFX/GCO)	ON	ON	ON	OFF	ON	
11"A~17"LEF	ON	ON	ON	ON	ON	0.10A}0.05

### 3 Tray4



Signal line name	Description
FMOT4 A, FMOT4 B, FMOT4 /A, FMOT4 /B	TRAY4 FEED LIFT UP MOTOR exciting signal
TRAY4 LEVEL UP(H)+5VDC	Rise (paper feed possible level) detection signal of plate in Tray4 by SENSOR (Tray4 Level Sensor)
TRAY4 PAPER SENSED(L)+5VDC	Paper detection signal in Tray4 of SENSOR (Tray4 No Paper Sensor)
TRAY4 PRE FEED SENSED(L)+5VDC	Feed paper detection signal from Tray4 by SENSOR (Tray4 Pre Feed Sensor)
TRAY4 SIZE SWITCH SIGNAL	Paper size detection signal (analog value) of TRAY4 PAPER SIZE SWITCH
TRAY4 SIZE SWITCH S5 ON(L)+5VDC	S5 in TRAY4 PAPER SIZE SWITCH ON/OFF detection signal
TRAY4 FEED OUT PAPER SENSED(L)+5VDC	Paper detection signal by TRAY4 FEED OUT SENSOR in transport section

◆ Paper size detection

The ON/OFF pattern of each switch (S1-S5) of TRAY4 PAPER SIZE SWITCH and the relation of paper size and the output voltage of TRAY4 SIZE SWITCH SIGNAL are as follows.

Paper Size	S1	S2	S3	S4	S5	Output Voltage(V)
No Tray	OFF	OFF	OFF	OFF	OFF	3.06A}0.05
5.5"A~8.5"SEF/A5 SEF	OFF	OFF	ON	OFF	OFF	2.65A}0.05
B5 SEF	OFF	OFF	ON	ON	ON	2.45A}0.05
8.5"A~13"SEF	OFF	ON	OFF	ON	OFF	2.05A}0.05
8.5"A~14"SEF	OFF	ON	OFF	ON	ON	
A4 SEF	OFF	ON	ON	OFF	OFF	1.85A}0.05
8.5"A~11"SEF	OFF	ON	ON	OFF	ON	
A4 LEF	ON	OFF	ON	OFF	OFF	1.07A}0.05
A3 SEF	ON	OFF	ON	ON	OFF	0.87A}0.05
B5 LEF/ Executive LEF	ON	ON	OFF	OFF	ON	0.68A}0.05
8K SEF (TFX/GCO)	ON	ON	OFF	ON	OFF	0.49A}0.05
B4 SEF	ON	ON	OFF	ON	ON	
8.5"A~11"LEF	ON	ON	ON	OFF	OFF	0.29A}0.05
16K LEF(TFX/GCO)	ON	ON	ON	OFF	ON	
11"A~17"LEF	ON	ON	ON	ON	ON	0.10A}0.05

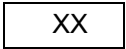
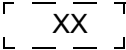
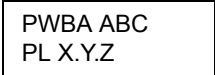

## Duplex

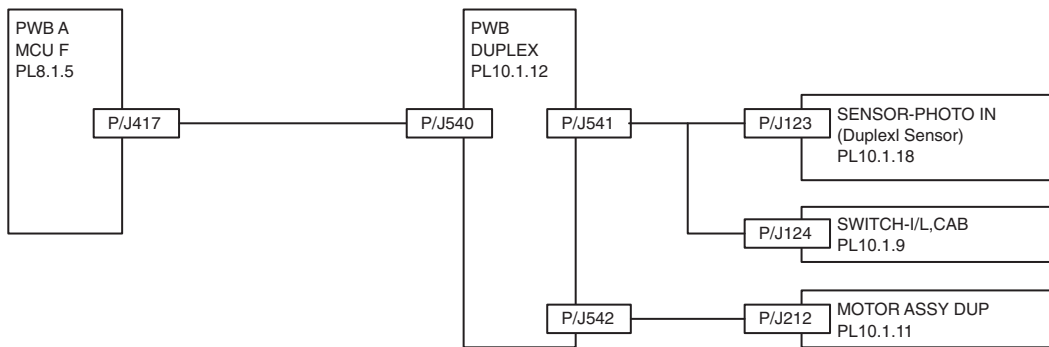
### General Wiring Diagram

The following describes the legend of the general wiring diagram shown on the next page.

Symbols	Description
—————	Denotes a connection between parts with harnesses and wires.



Symbols	Description
	<p>A frame not having parts name inside denotes the connector (P/J).            Numeric value inside implies the connector number.</p>
	<p>A frame of broken line denotes the connector (P/J) written in several places separately.            Numeric value inside implies the connector number.</p>
	<p>A frame having parts name inside denotes the parts.            PL X.Y.Z implies the item "Z" of plate (PL) "X.Y" in Chapter 5. Parts List.</p>
	<p>A frame of dotted line denotes the section in "2. Wiring Diagram between Parts", and numeric value implies the section number.</p>



## Wiring Diagram between Parts

### Configuration

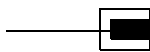
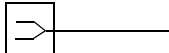
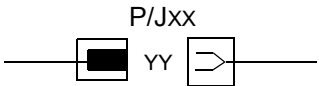
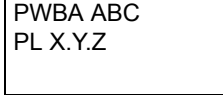
The wiring diagram is separated into 1 sections to show detailed connection between parts.



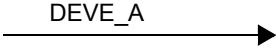
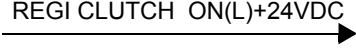
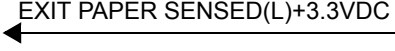
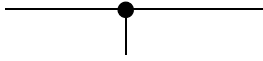
- 1 Duplex
  - Connection between PWBA DUPLEX and SENSOR-PHOTO IN (Duplex Sensor)
  - Connection between PWBA DUPLEX and SWITCH-I/L,CAB (Duplex Open Switch)
  - Connection between PWBA DUPLEX and MOTOR ASSY DUP
  - Connection between PWBA DUPLEX and PWB A MCU F

### Notes on Using the Wiring Diagram between Parts

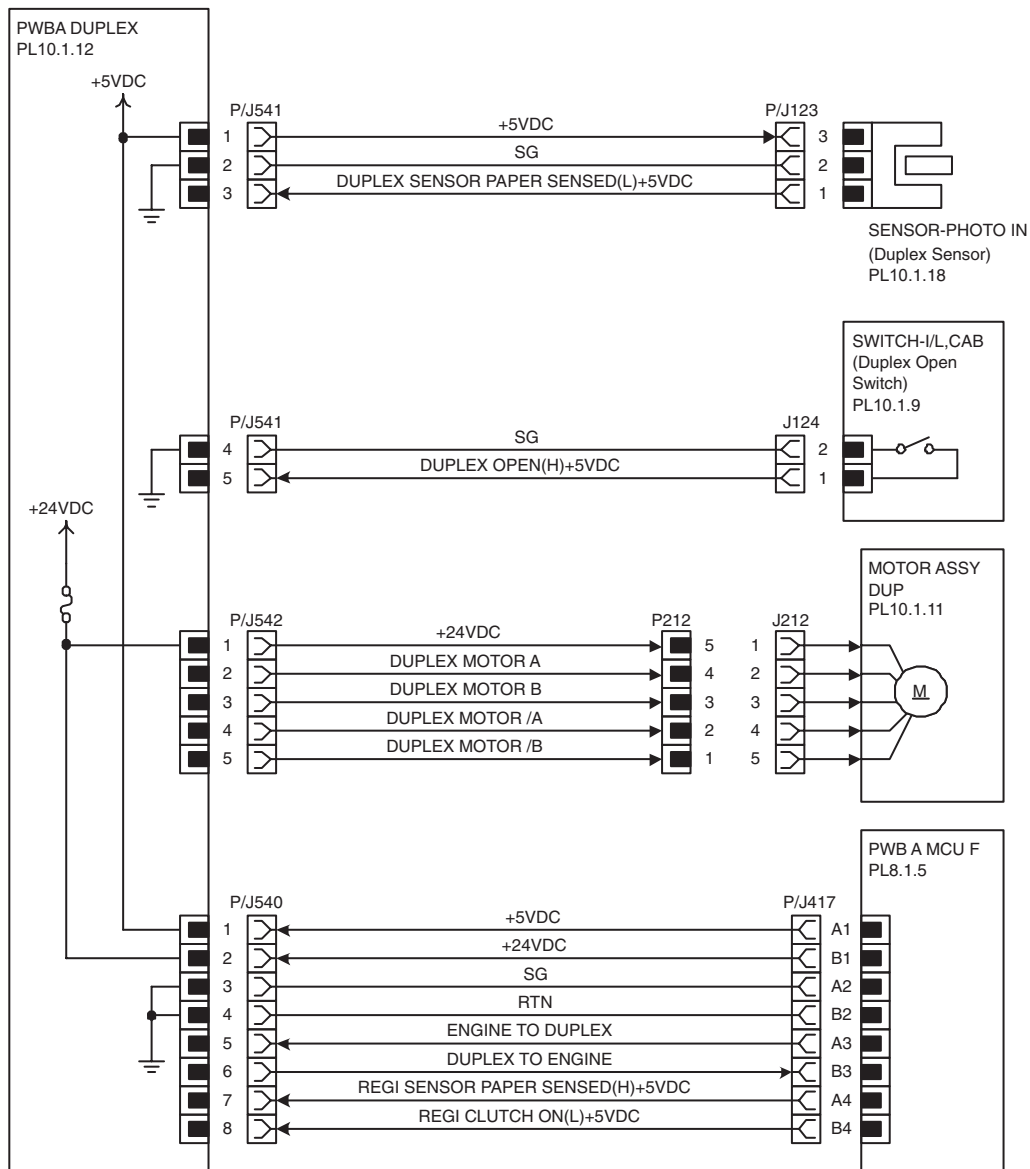
The following describes the legend of the wiring diagrams between parts shown on the following pages.

Note that the description of general symbols is omitted.

Symbols	Description
	Denotes a plug.
	Denotes a jack.
	Denotes Pin yy and Jack yy of the connector Pxx and Jxx.
	Denotes the parts. PL X.Y.Z implies the item "Z" of plate (PL) "X.Y" in Chapter 5. Parts List.

Symbols	Description
	Denotes functional parts attached with functional parts name.
	Denotes the control and its outline in PWB.
	Denotes a connection between parts with harnesses or wires, attached with signal name/contents.
	Denotes the function, and logic value of the signal to operate the function (Low: L, High: H). The given voltage is for signal in high status. The arrow indicates the direction of signal.
	Denotes the function, and logic value of the signal when the function operated (Low: L, High: H). The given voltage is for signal in high status. The arrow indicates the direction of signal.
	Denotes a connection between wires.
I/L +24VDC	Denotes DC voltage when the interlock switch in HNB MCU WITH CPU turns on
+5VDC +3.3VDC	Denotes DC voltage.
SG	Denotes signal ground.
AG	Denotes analog ground.
RTN	Denotes the return.

## 1 Duplex


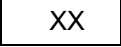
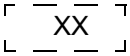
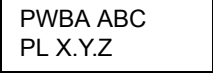



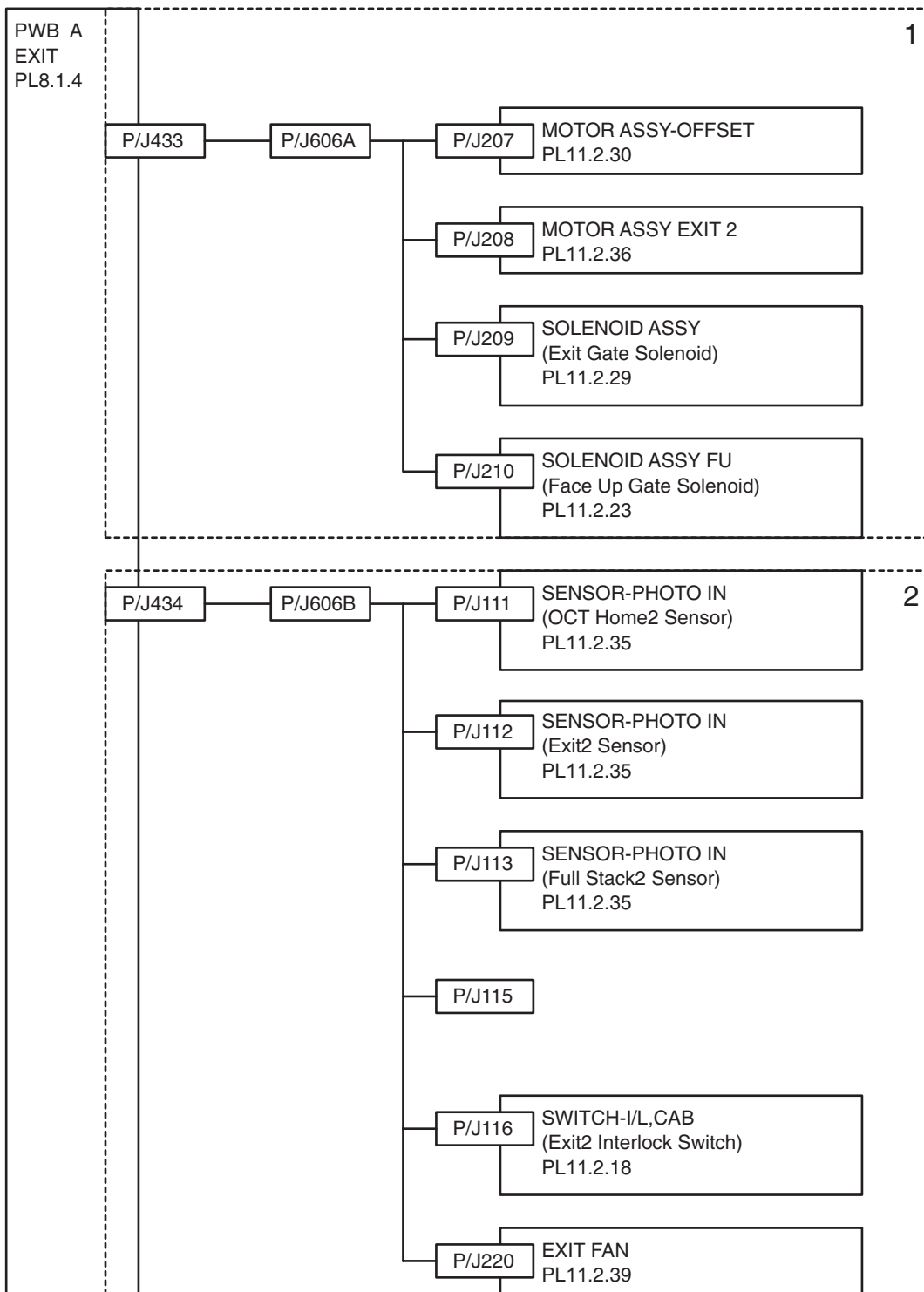
Signal line name	Description
DUPLEX SENSOR PAPER SENSED(L)+5VDC	Paper detection signal by SENSOR-PHOTO IN (Duplex Sensor) in duplex
DUPLEX OPEN(H)+5VDC	DUPLEX COVER open/close detection signal by SWITCH-I/L,CAB (Duplex Open Switch)
DUPLEX MOTOR A, DUPLEX MOTOR B, DUPLEX MOTOR /A, DUPLEX MOTOR /B,	MOTOR ASSY DUP exciting signal
ENGINE TO DUPLEX	Communication signal of PWB A MCU F (Engine) and PWBA DUPLEX (Duplex) (Engine->Duplex)
DUPLEX TO ENGINE	Communication signal of PWBA DUPLEX (Duplex) and PWB A MCU F (Engine) (Duplex->Engine)
REGI SENSOR PAPER SENSED(H)+5VDC	Paper detection signal by SNR ASSY REGI in Registration (Engine->Duplex)
REGI CLUTCH ON(L)+5VDC	CLUTCH ASY REGI H(Regi Clutch) ON/OFF control signal (Engine->Duplex)

# Exit

## General Wiring Diagram

The following describes the legend of the general wiring diagram shown on the next page.

Symbols	Description
	Denotes a connection between parts with harnesses and wires.
	A frame not having parts name inside denotes the connector (P/J). Numeric value inside implies the connector number.
	A frame of broken line denotes the connector (P/J) written in several places separately. Numeric value inside implies the connector number.
	A frame having parts name inside denotes the parts. PL X.Y.Z implies the item "Z" of plate (PL) "X.Y" in Chapter 5. Parts List.
	A frame of dotted line denotes the section in "2. Wiring Diagram between Parts", and numeric value implies the section number.



## Wiring Diagram between Parts

### Configuration

The wiring diagram is separated into 2 sections to show detailed connection between parts.

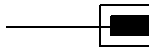

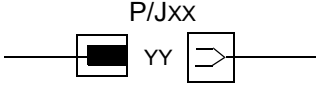
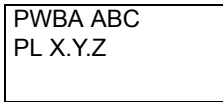
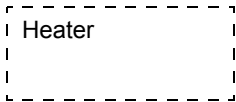

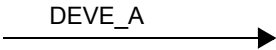
- 1 Motor / Solenoid
- Connection between PWB A EXIT and MOTOR ASSY-OFFSET

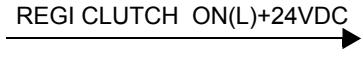
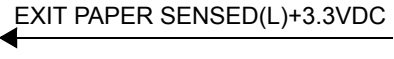
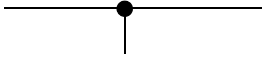
- Connection between PWB A EXIT and MOTOR ASSY EXIT 2
  - Connection between PWB A EXIT and SOLENOID ASSY (Exit Gate Solenoid)
  - Connection between PWB A EXIT and SOLENOID ASSY FU (Face Up Gate Solenoid)
- 2 Sensor / Fan
    - Connection between PWB A EXIT and SENSOR-PHOTO IN (OCT Home2 Sensor)
    - Connection between PWB A EXIT and SENSOR-PHOTO IN (Exit2 Sensor)
    - Connection between PWB A EXIT and SENSOR-PHOTO IN (Full Stack2 Sensor)
    - Connection between PWB A EXIT and SWITCH-I/L,CAB (Face Up Detect Switch)
    - Connection between PWB A EXIT and SWITCH-I/L,CAB (Exit2 Interlock)
    - Connection between PWB A EXIT and EXIT FAN

### Notes on Using the Wiring Diagram between Parts

The following describes the legend of the wiring diagrams between parts shown on the following pages.

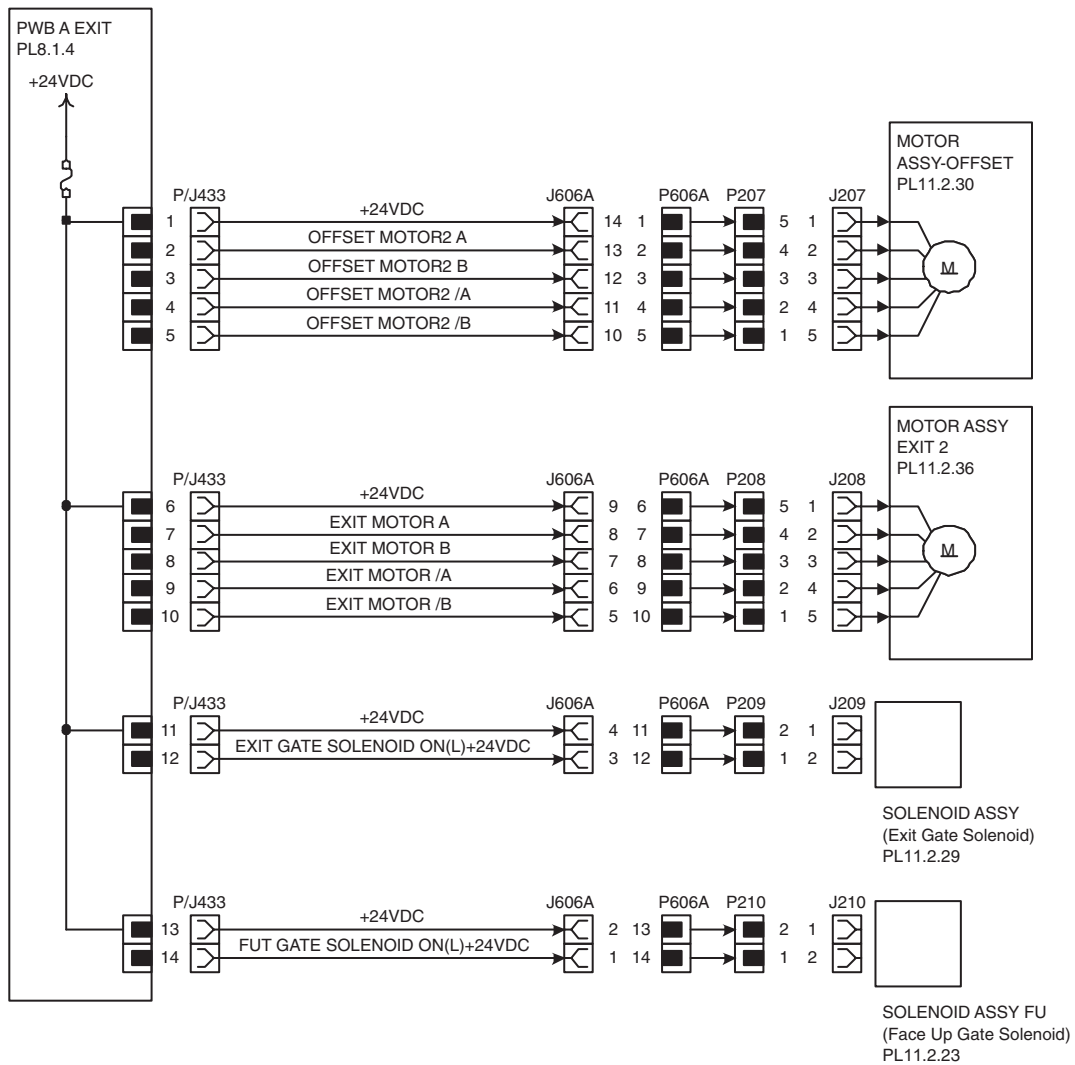
Note that the description of general symbols is omitted.

Symbols	Description
	Denotes a plug.
	Denotes a jack.
	Denotes Pin yy and Jack yy of the connector Pxx and Jxx.
	Denotes the parts. PL X.Y.Z implies the item "Z" of plate (PL) "X.Y" in Chapter 5. Parts List.
	Denotes functional parts attached with functional parts name.
	Denotes the control and its outline in PWB.
	Denotes a connection between parts with harnesses or wires, attached with signal name/contents.

Symbols	Description
	<p>Denotes the function, and logic value of the signal to operate the function (Low: L, High: H). The given voltage is for signal in high status. The arrow indicates the direction of signal.</p>
	<p>Denotes the function, and logic value of the signal when the function operated (Low: L, High: H). The given voltage is for signal in high status. The arrow indicates the direction of signal.</p>
	<p>Denotes a connection between wires.</p>
<p>I/L +24VDC</p>	<p>Denotes DC voltage when the interlock switch in HNB MCU WITH CPU turns on</p>
<p>+5VDC +3.3VDC</p>	<p>Denotes DC voltage.</p>
<p>SG</p>	<p>Denotes signal ground.</p>
<p>AG</p>	<p>Denotes analog ground.</p>
<p>RTN</p>	<p>Denotes the return.</p>

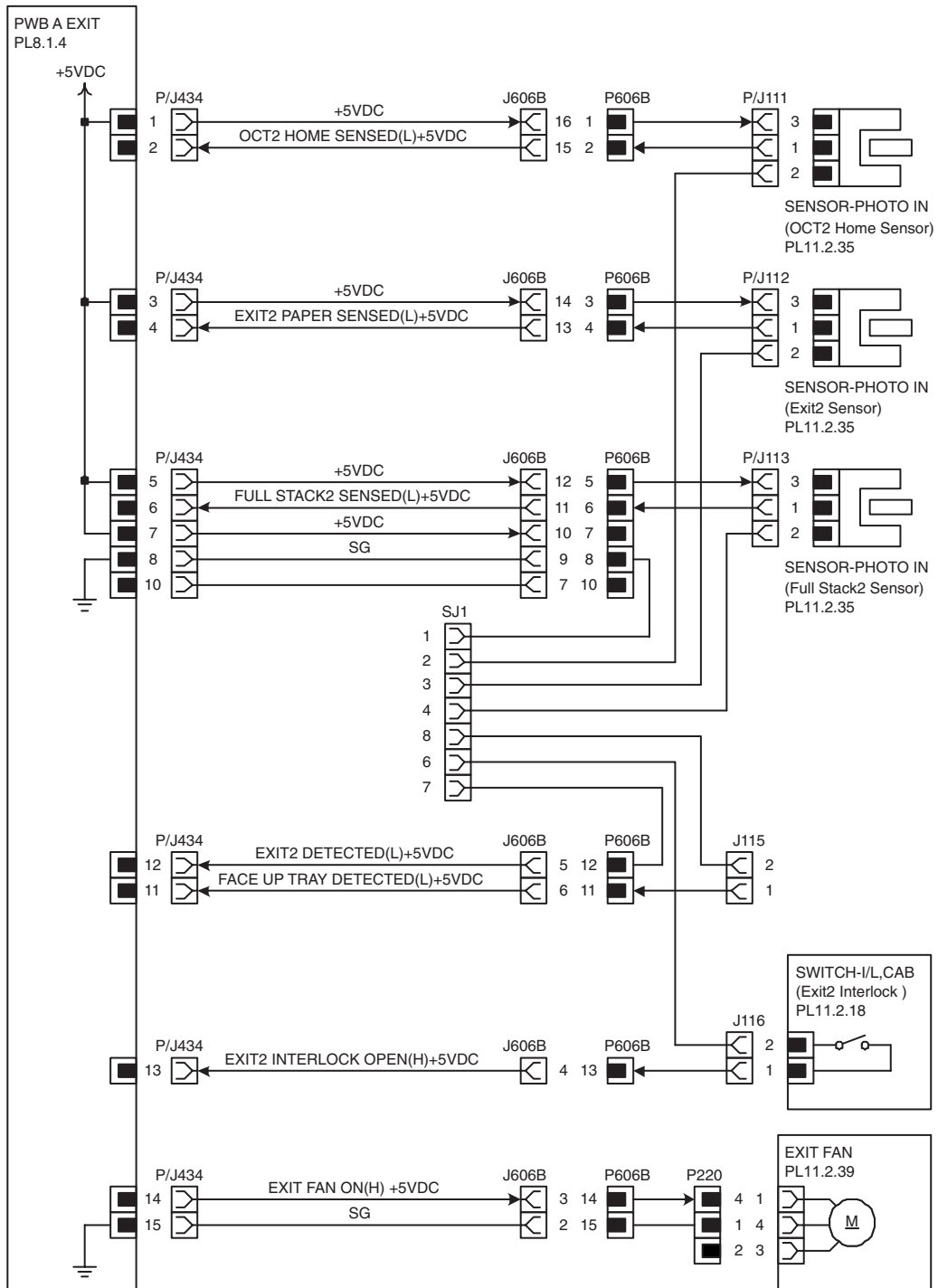
## 1 Motor / Solenoid





Signal line name	Description
OFFSET MOTOR2 A, OFFSET MOTOR2 B, OFFSET MOTOR2 /A, OFFSET MOTOR2 /B	MOTOR ASSY-OFFSET exciting signal
EXIT MOTOR A, EXIT MOTOR B, EXIT MOTOR /A, EXIT MOTOR /B,	MOTOR ASSY EXIT 2 exciting signal
EXIT GATE SOLENOID ON(L)+24VDC	SOLENOID ASSY (Exit Gate Solenoid) ON/OFF control signal
FUT GATE SOLENOID ON(L)+24VDC	SOLENOID ASSY FU (Face Up Gate Solenoid) ON/OFF control signal

## 2 Sensor / Fan



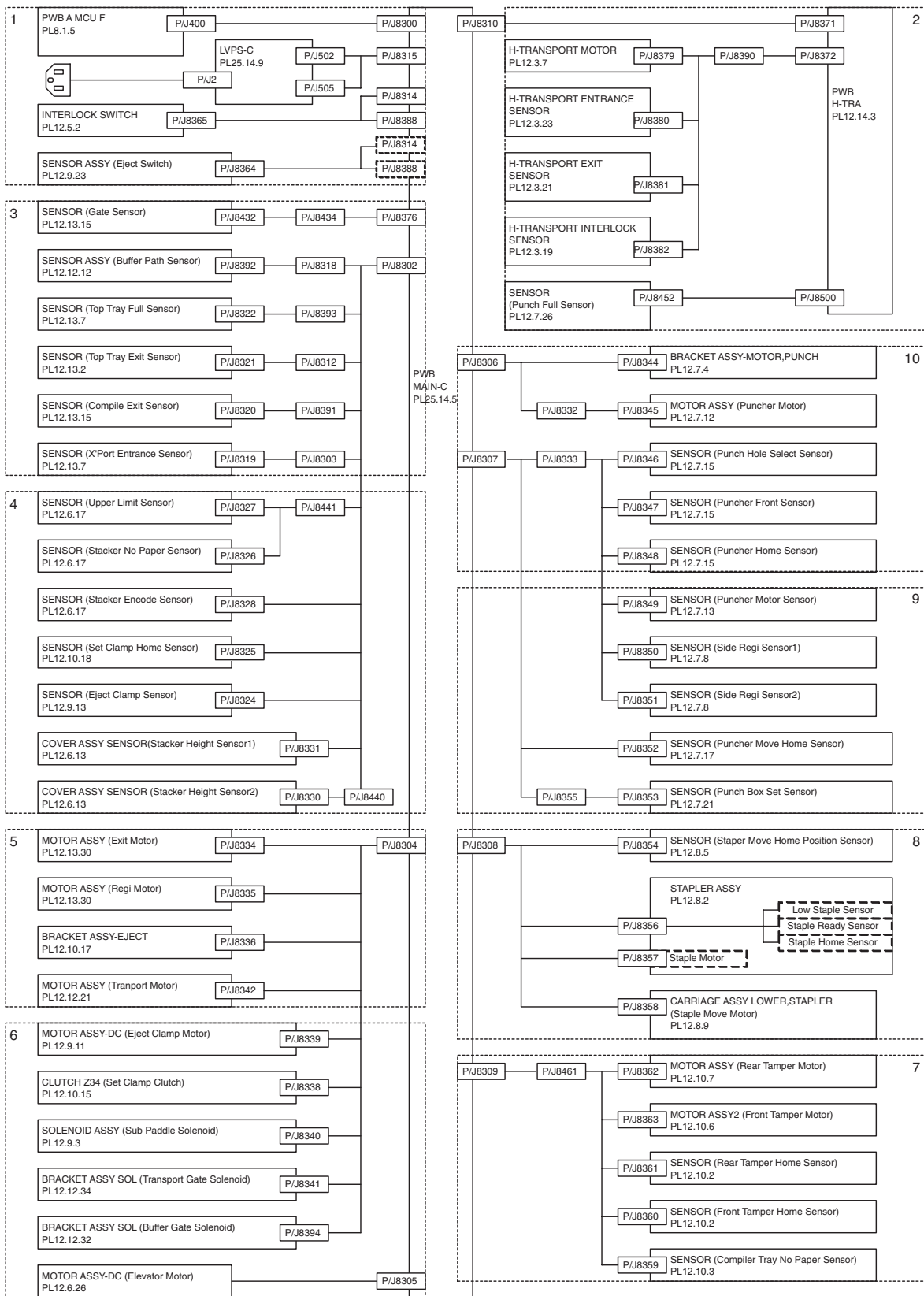
Signal line name	Description
OCT2 HOME SENSED(L)+5VDC	OCT2 home position detection signal by SENSOR-PHOTO IN (OCT2 Home Sensor)
EXIT2 PAPER SENSED(L)+5VDC	Paper detection signal by SENSOR-PHOTO IN (Exit2 Sensor) in Exit2 transport section
FULL STACK2 SENSED(L)+5VDC	Stacker tray paper full detection signal by SENSOR-PHOTO IN (Full Stack2 Sensor)
EXIT2 DETECTED(L)+5VDC	Exit2 set detection signal
FACE UP TRAY DETECTED(L)+5VDC	Face Up Tray wearing detection signal by SWITCH-I/L,CAB (Face Up Detect Switch)
EXIT2 INTERLOCK OPEN(H)+5VDC	Exit2 Cover Open/close detection signal by SWITCH-I/L,CAB (Exit2 Interlock)
EXIT FAN ON(H) +5VDC	EXIT FAN ON/OFF control signal

## Finisher

### General Wiring Diagram

The following describes the legend of the general wiring diagram shown on the next page.

Symbols	Description	
—————	Denotes a connection between parts with harnesses and wires.	
<table border="1" style="display: inline-table; vertical-align: middle;"><tr><td>XX</td></tr></table>	XX	A frame not having parts name inside denotes the connector (P/J). Numeric value inside implies the connector number.
XX		
<table border="1" style="display: inline-table; vertical-align: middle;"><tr><td>— — — — XX — — — —</td></tr></table>	— — — — XX — — — —	A frame of broken line denotes the connector (P/J) written in several places separately. Numeric value inside implies the connector number.
— — — — XX — — — —		
<table border="1" style="display: inline-table; vertical-align: middle;"><tr><td>PWBA ABC PL X.Y.Z</td></tr></table>	PWBA ABC PL X.Y.Z	A frame having parts name inside denotes the parts. PL X.Y.Z implies the item "Z" of plate (PL) "X.Y" in Chapter 5. Parts List.
PWBA ABC PL X.Y.Z		
<table border="1" style="display: inline-table; vertical-align: middle;"><tr><td>1</td></tr></table>	1	A frame of dotted line denotes the section in "2. Wiring Diagram between Parts", and numeric value implies the section number.
1		



## Configuration

The wiring diagram is separated into 10 sections to show detailed connection between parts.

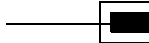
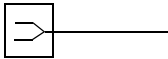
- 1 Power Supply
  - Connection between PWB MAIN-C and PWB A MCU F
  - Connection between PWB MAIN-C and LVPS-C
  - Connection between PWB MAIN-C and PWB T-TRA
  - Connection between PWB MAIN-C and INTERLOCK SWITCH (Front Door Switch)
  - Connection between PWB MAIN-C and SENSOR ASSY (Eject Switch)
  
- 2 H-Transport
  - Connection between PWB T-TRA and H-TRANSPORT MOTOR
  - Connection between PWB T-TRA and H-TRANSPORT ENTRANCE SENSOR
  - Connection between PWB T-TRA and H-TRANSPORT EXIT SENSOR
  - Connection between PWB T-TRA and H-TRANSPORT INTERLOCK SENSOR
  - Connection between PWB T-TRA and SENSOR (Punch Full Sensor)
  
- 3 Sensor (Paper feed section)
  - Connection between PWB MAIN-C and SENSOR ASSY (Buffer Path Sensor)
  - Connection between PWB MAIN-C and SENSOR (Top Tray Full Sensor)
  - Connection between PWB MAIN-C and SENSOR (Top Tray Exit Sensor)
  - Connection between PWB MAIN-C and SENSOR (Compile Exit Sensor)
  - Connection between PWB MAIN-C and SENSOR (X<sup>3</sup> Port Entrance Sensor)
  - Connection between PWB MAIN-C and SENSOR (Gate Sensor)
  
- 4 Sensor (Exit section)
  - Connection between PWB MAIN-C and SENSOR (Upper Limit Sensor)
  - Connection between PWB MAIN-C and SENSOR (Stacker No Paper Sensor)
  - Connection between PWB MAIN-C and SENSOR (Stacker Encode Sensor)
  - Connection between PWB MAIN-C and SENSOR (Set Clamp Home Sensor)
  - Connection between PWB MAIN-C and SENSOR (Eject Clamp Sensor)
  - Connection between PWB MAIN-C and COVER ASSY SENSOR (Stacker Height Sensor1)
  - Connection between PWB MAIN-C and COVER ASSY SENSOR (Stacker Height Sensor2)
  
- 5 Motor
  - Connection between PWB MAIN-C and MOTOR ASSY (Exit Motor)
  - Connection between PWB MAIN-C and MOTOR ASSY (Regi Motor)
  - Connection between PWB MAIN-C and BRACKET ASSY-EJECT
  - Connection between PWB MAIN-C and MOTOR ASSY (Transport Motor)

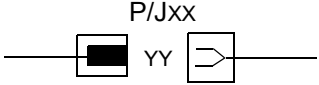
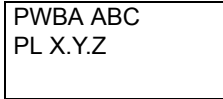


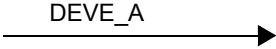
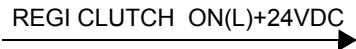
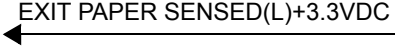

- 6 Motor / Clutch / Solenoid
  - Connection between PWB MAIN-C and MOTOR ASSY-DC (Eject Clamp Motor)
  - Connection between PWB MAIN-C and CLUTCH Z34 (Set Clamp Clutch)
  - Connection between PWB MAIN-C and SOLENOID ASSY (Sub Paddle Solenoid)
  - Connection between PWB MAIN-C and BRACKET ASSY SOL (Transport Gate Solenoid)
  - Connection between PWB MAIN-C and BRACKET ASSY SOL (Buffer Gate Solenoid)
  - Connection between PWB MAIN-C and MOTOR ASSY-DC (Elevator Motor)
  
- 7 Tamper
  - Connection between PWB MAIN-C and MOTOR ASSY (Rear Tamper Motor)
  - Connection between PWB MAIN-C and MOTOR ASSY2 (Front Tamper Motor)
  - Connection between PWB MAIN-C and SENSOR (Rear Tamper Home Sensor)
  - Connection between PWB MAIN-C and SENSOR (Front Tamper Home Sensor)
  - Connection between PWB MAIN-C and SENSOR (Compiler Tray No Paper Sensor)
  
- 8 Stapler
  - Connection between PWB MAIN-C and SENSOR (Stapler Move Home Position Sensor)
  - Connection between PWB MAIN-C and STAPLER ASSY
  - Connection between PWB MAIN-C and CARRIAGE ASSY LOWER, STAPLER (Stapler Move Motor)
  
- 9 Puncher1
  - Connection between PWB MAIN-C and SENSOR (Punch Box Set Sensor)
  - Connection between PWB MAIN-C and SENSOR (Punch Move Home Sensor)
  - Connection between PWB MAIN-C and SENSOR (Side Regi Sensor1)
  - Connection between PWB MAIN-C and SENSOR (Side Regi Sensor2)
  - Connection between PWB MAIN-C and SENSOR (Puncher Motor Sensor)
  
- 10 Puncher2
  - Connection between PWB MAIN-C and BRACKET ASSY-MOTOR,PUNCH
  - Connection between PWB MAIN-C and MOTOR ASSY (Puncher Motor)
  - Connection between PWB MAIN-C and SENSOR (Punch Hole Select Sensor)
  - Connection between PWB MAIN-C and SENSOR (Punch Front Sensor)
  - Connection between PWB MAIN-C and SENSOR (Punch Home Sensor)

### Notes on Using the Wiring Diagram between Parts

The following describes the legend of the wiring diagrams between parts shown on the following pages.

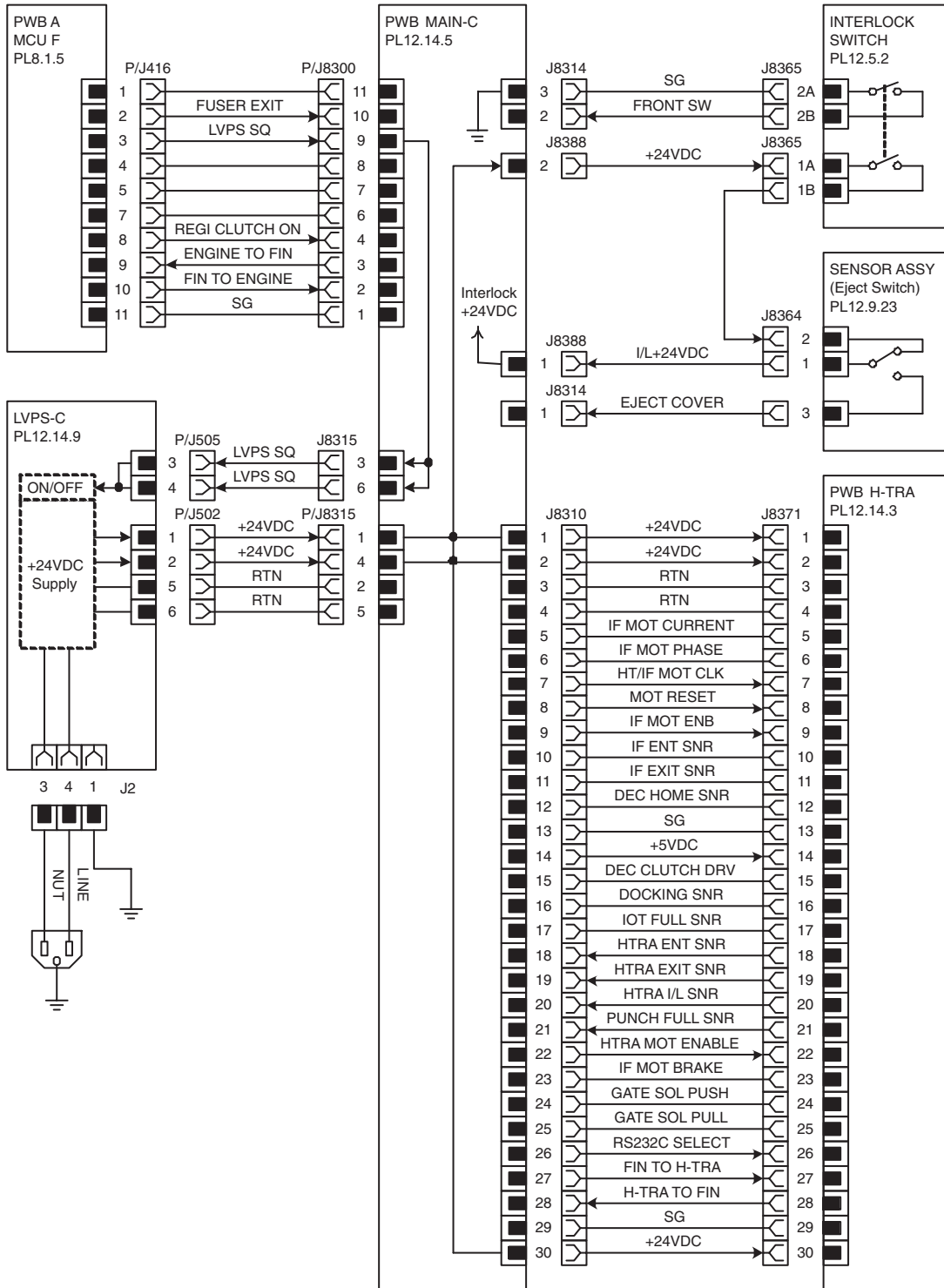
Note that the description of general symbols is omitted.

Symbols	Description
	Denotes a plug.
	Denotes a jack.

Symbols	Description
	Denotes Pin yy and Jack yy of the connector Pxx and Jxx.
	Denotes the parts. PL X.Y.Z implies the item "Z" of plate (PL) "X.Y" in Chapter 5. Parts List.
	Denotes functional parts attached with functional parts name.
	Denotes the control and its outline in PWB.
	Denotes a connection between parts with harnesses or wires, attached with signal name/contents.
	Denotes the function, and logic value of the signal to operate the function (Low: L, High: H). The given voltage is for signal in high status. The arrow indicates the direction of signal.
	Denotes the function, and logic value of the signal when the function operated (Low: L, High: H). The given voltage is for signal in high status. The arrow indicates the direction of signal.
	Denotes a connection between wires.
<p data-bbox="368 1577 512 1608">I/L +24VDC</p>	Denotes DC voltage when the interlock switch in HNB MCU WITH CPU turns on
<p data-bbox="384 1682 496 1738">+5VDC +3.3VDC</p>	Denotes DC voltage.
<p data-bbox="419 1812 461 1843">SG</p>	Denotes signal ground.
<p data-bbox="419 1913 461 1944">AG</p>	Denotes analog ground.

Symbols	Description
RTN	Denotes the return.

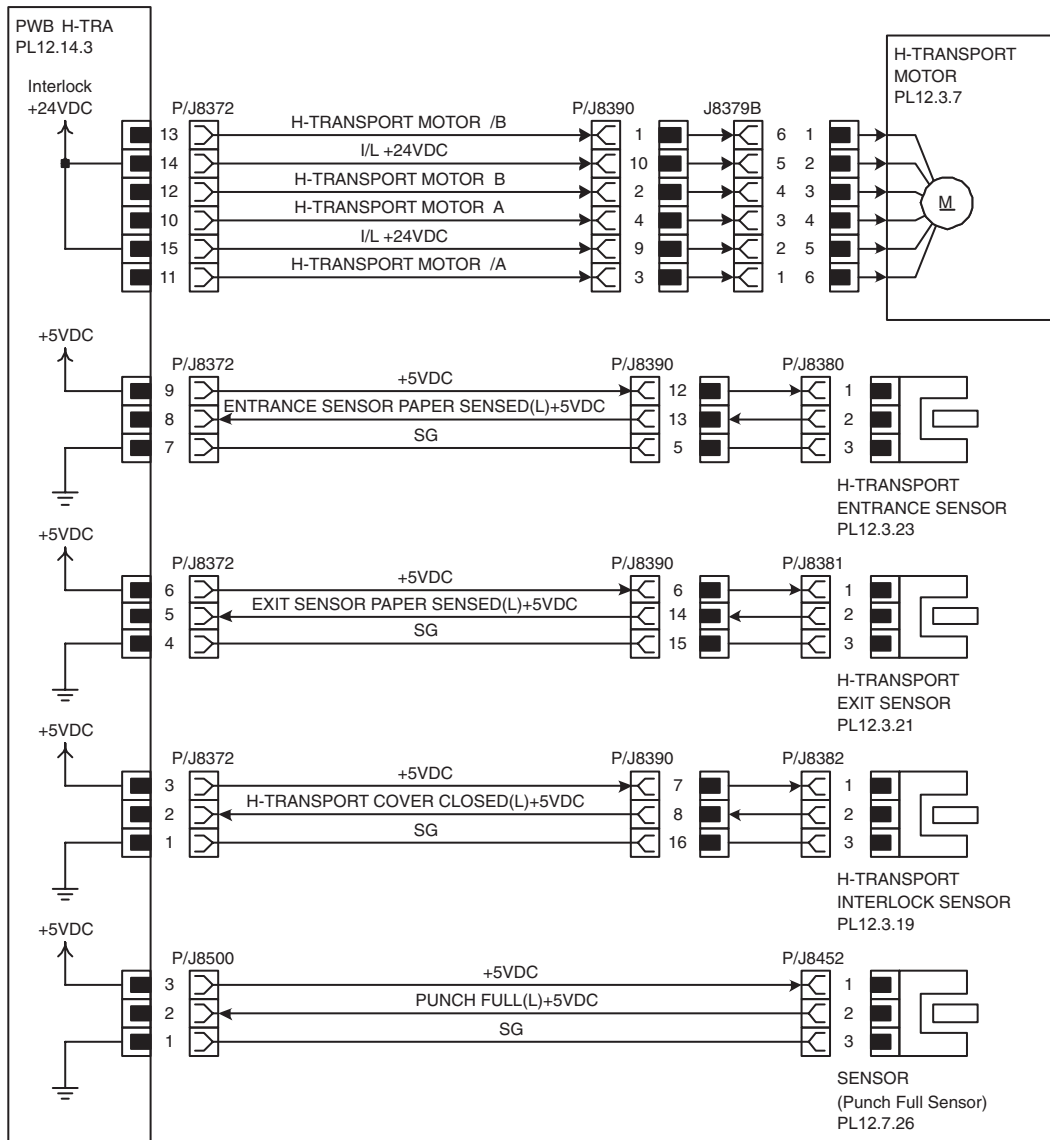
# 1 Power Supply





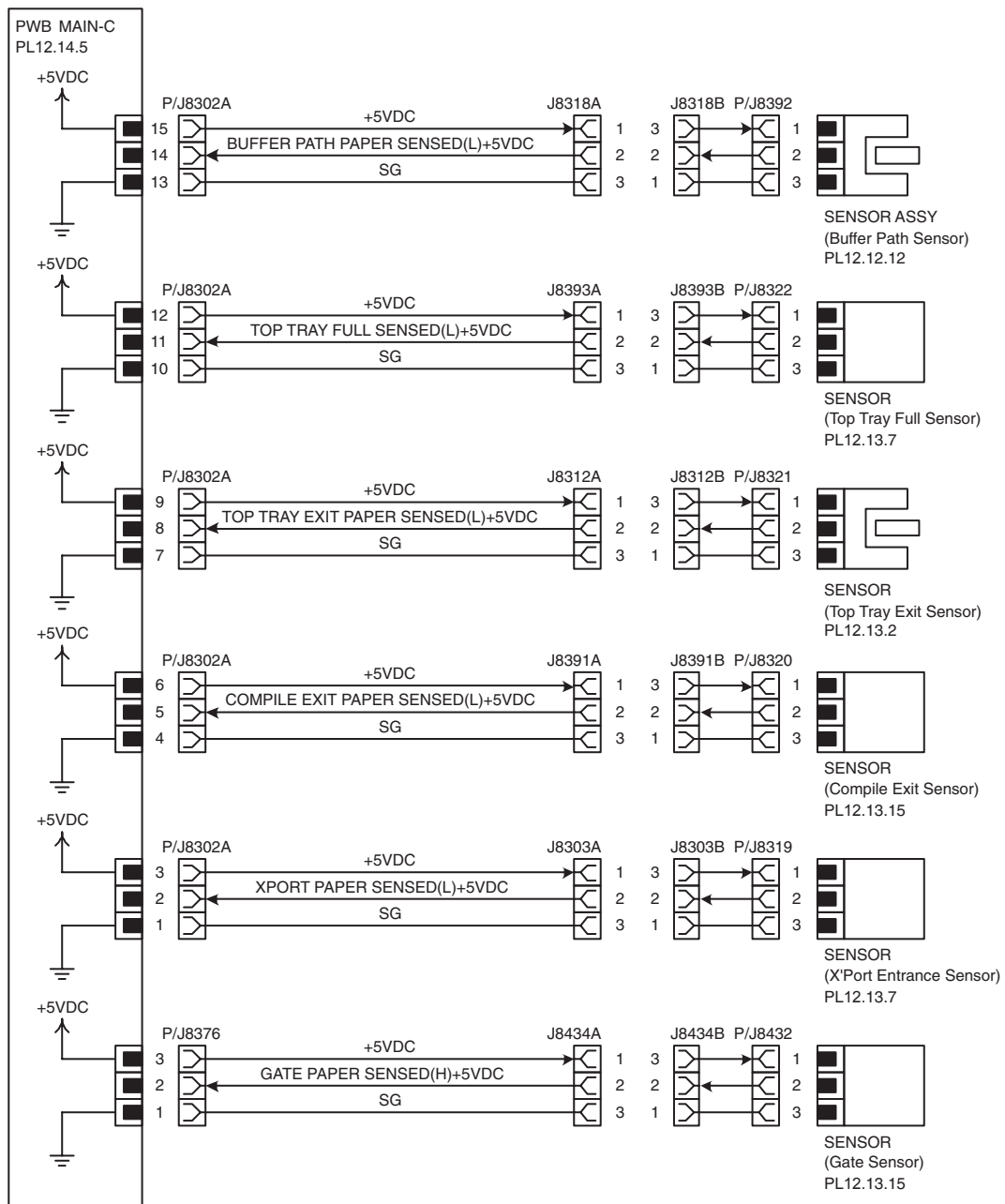
Signal line name	Description
LVPS SQ	ON/OFF control signal of LVPS-C (Finisher) from PWB A MCU F (Engine)
FUSER EXIT (FUSER EXIT PAPER SENSED(H)+5VDC)	Paper detection signal in fuser by Fuser Exit Sensor in FUSER ASSY (Engine->Finisher)
REGI CLUTCH ON (REGI CLUTCH ON(L)+5VDC)	CLUTCH ASY REGI H(Regi Clutch) ON/OFF control signal (Engine->Finisher)
ENGINE TO FIN	Communication signal of PWB A MCU F (Engine) and PWB MAIN-C (Finisher) (Engine->Finisher)
FIN TO ENGINE	Communication signal of PWB MAIN-C (Finisher) and PWB A MCU F (Engine) (Finisher->Engine)
FRONT SW	FINISHER FRONT DOOR open/close detection signal
EJECT COVER	FINISHER EJECT COVER open/close detection signal
IF MOT CURRENT	Not used
IF MOT PHASE	Not used
HT/IF MOT CLK	H-TRANSPORT MOTOR clock signal
MOT RESET	H-TRANSPORT MOTOR reset signal
IF MOT ENB	Current setting value switching signal of H-TRANSPORT MOTOR
IF ENT SNR	Not used
IF EXIT SNR	Not used
DEC HOME SNR	Not used
DEC CLUTCH DRV	Not used
DOCKING SNR	Not used
IOT FULL SNR	Not used
HTRA ENT SNR	Paper detection signal by H-TRANSPORT ENTRANCE SENSOR in H-Transport
HTRA EXIT SNR	Paper detection signal by H-TRANSPORT EXIT SENSOR in H-Transport
HTRA I/L SNR	H-TRANSPORT COVER open/close detection signal by H-TRANSPORT INTERLOCK SENSOR
PUNCH FULL SNR	Punch waste full detection signal of Punch dust box
HTRA MOT ENABLE	H-TRANSPORT MOTOR ON/OFF control signal
IF MOT BRAKE	Not used
GATE SOL PUSH	Not used
GATE SOL PULL	Not used
RS232C SELECT	Communication selection signal of Engine and PC (Download Mode change)
FIN TO H-TRA	Communication signal of PWB MAIN-C (Finisher) and PWB H-TRA(H-Transport) (Finisher->H-Transport)
H-TRA TO FIN	Communication signal of PWB H-TRA(H-Transport) and PWB MAIN-C (Finisher) (H-Transport->Finisher)

## 2 H-Transport



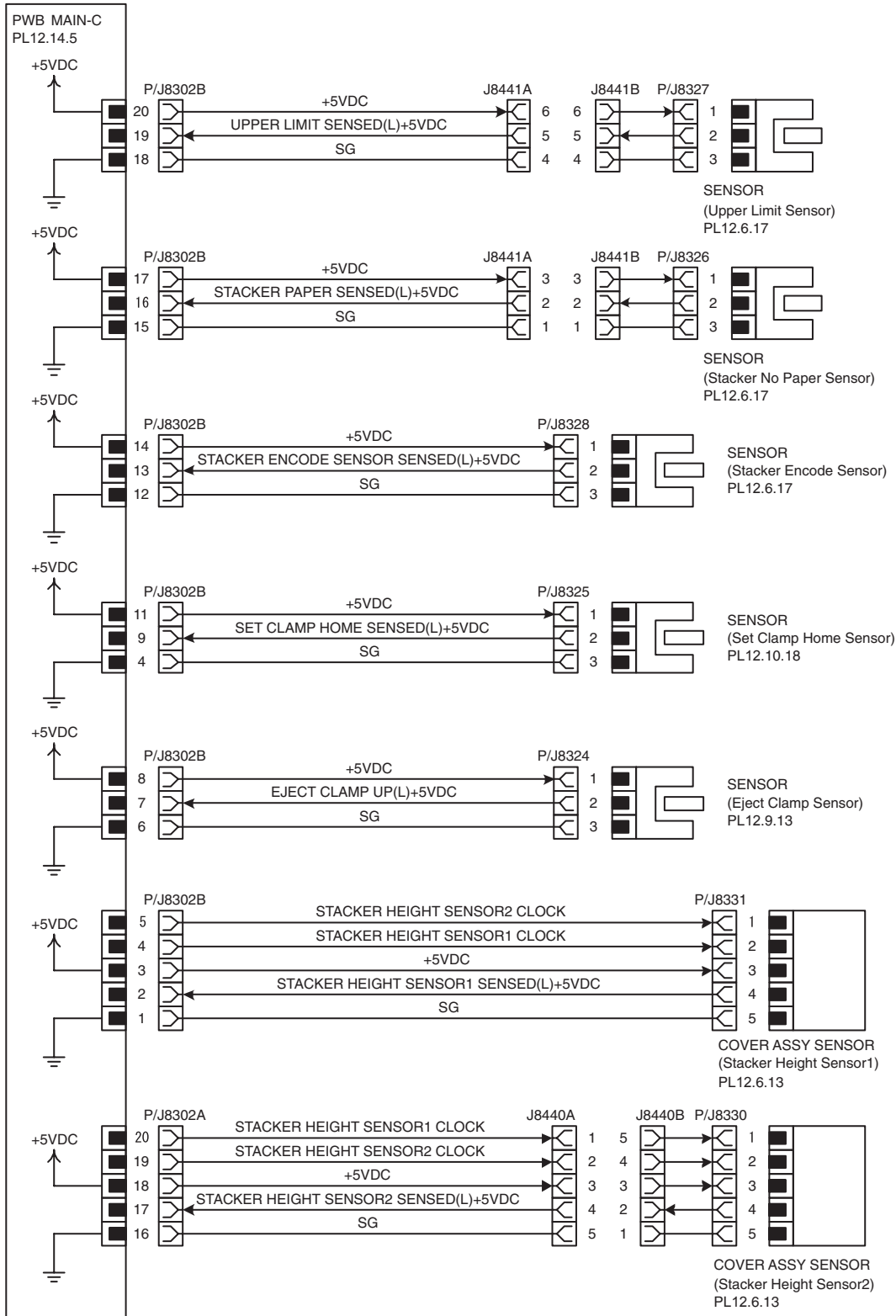
Signal line name	Description
H-TRANSPORT MOTOR A, H-TRANSPORT MOTOR B, H-TRANSPORT MOTOR /A, H-TRANSPORT MOTOR /B	H-TRANSPORT MOTOR exciting signal
ENTRANCE SENSOR PAPER SENSED(L)+5VDC	Paper detection signal by H-TRANSPORT ENTRANCE SENSOR in H-Transport
EXIT SENSOR PAPER SENSED(L)+5VDC	Paper detection signal by H-TRANSPORT EXIT SENSOR in H-Transport
H-TRANSPORT COVER CLOSED(L)+5VDC	H-TRANSPORT COVER open/close detection signal by H-TRANSPORT INTERLOCK SENSOR
PUNCH FULL(L)+5VDC	Punch waste full detection signal of Punch dust box by PUNCH FULL SENSOR

### 3 Sensor (Paper feed section)



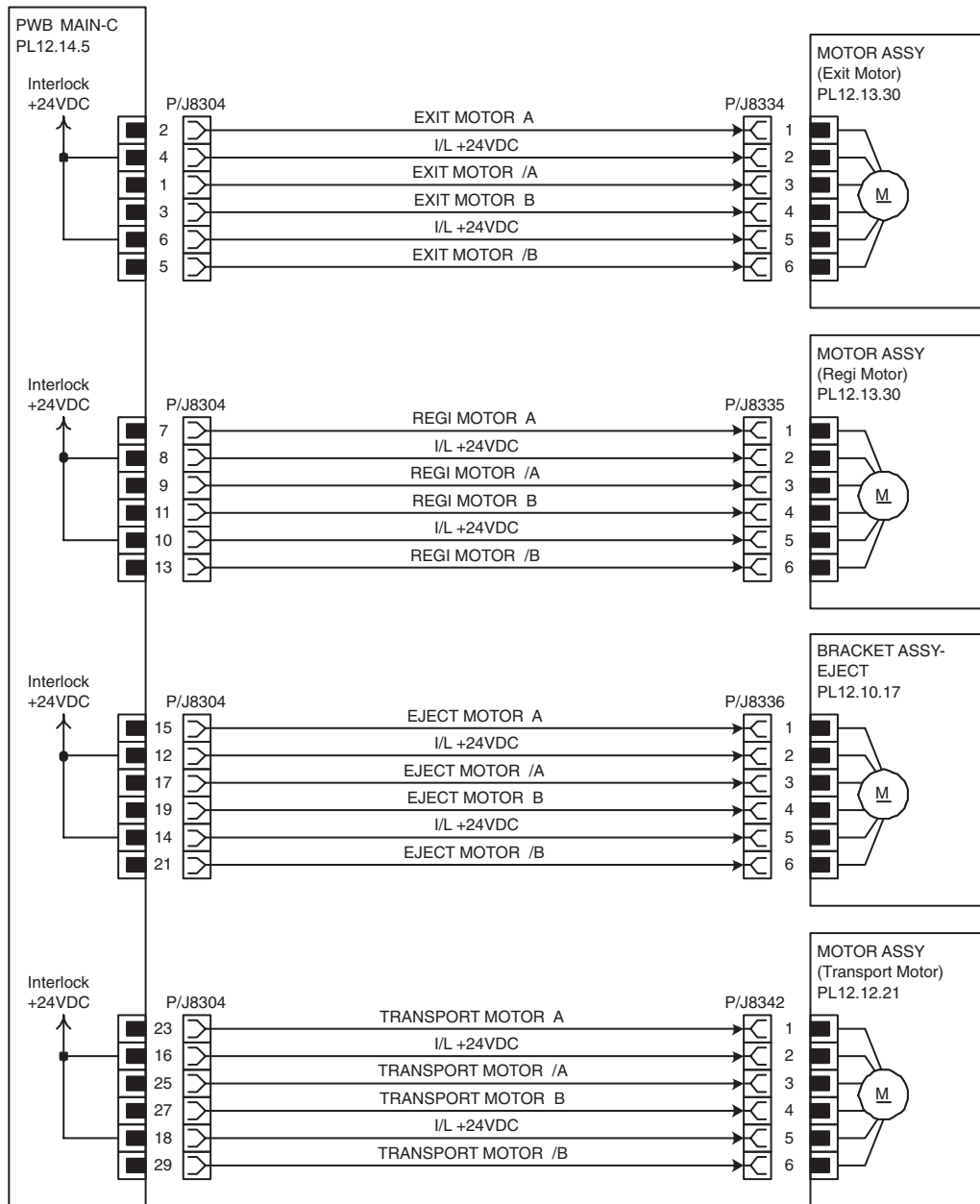
Signal line name	Description
BUFFER PATH PAPER SENSED(L)+5VDC	Paper detection signal by SENSOR ASSY (Buffer Path Sensor) in Buffer Path
TOP TRAY FULL SENSED(L)+5VDC	Top Tray paper full detection signal by SENSOR (Top Tray Full Sensor)
TOP TRAY EXIT PAPER SENSED(L)+5VDC	Discharge paper detection signal to Top Tray by SENSOR (Top Tray Exit Sensor)
COMPILE EXIT PAPER SENSED(L)+5VDC	Transport paper detection signal to Compile Tray by SENSOR (Compile Exit Sensor)
XPORT PAPER SENSED(L)+5VDC	Paper detection signal by SENSOR (X'Port Entrance Sensor) in transport section AB
GATE SENSOR PAPER SENSED(H) +5VDC	Paper detection signal by SENSOR (Gate Sensor) in gate

# 4 Sensor (Exit section)



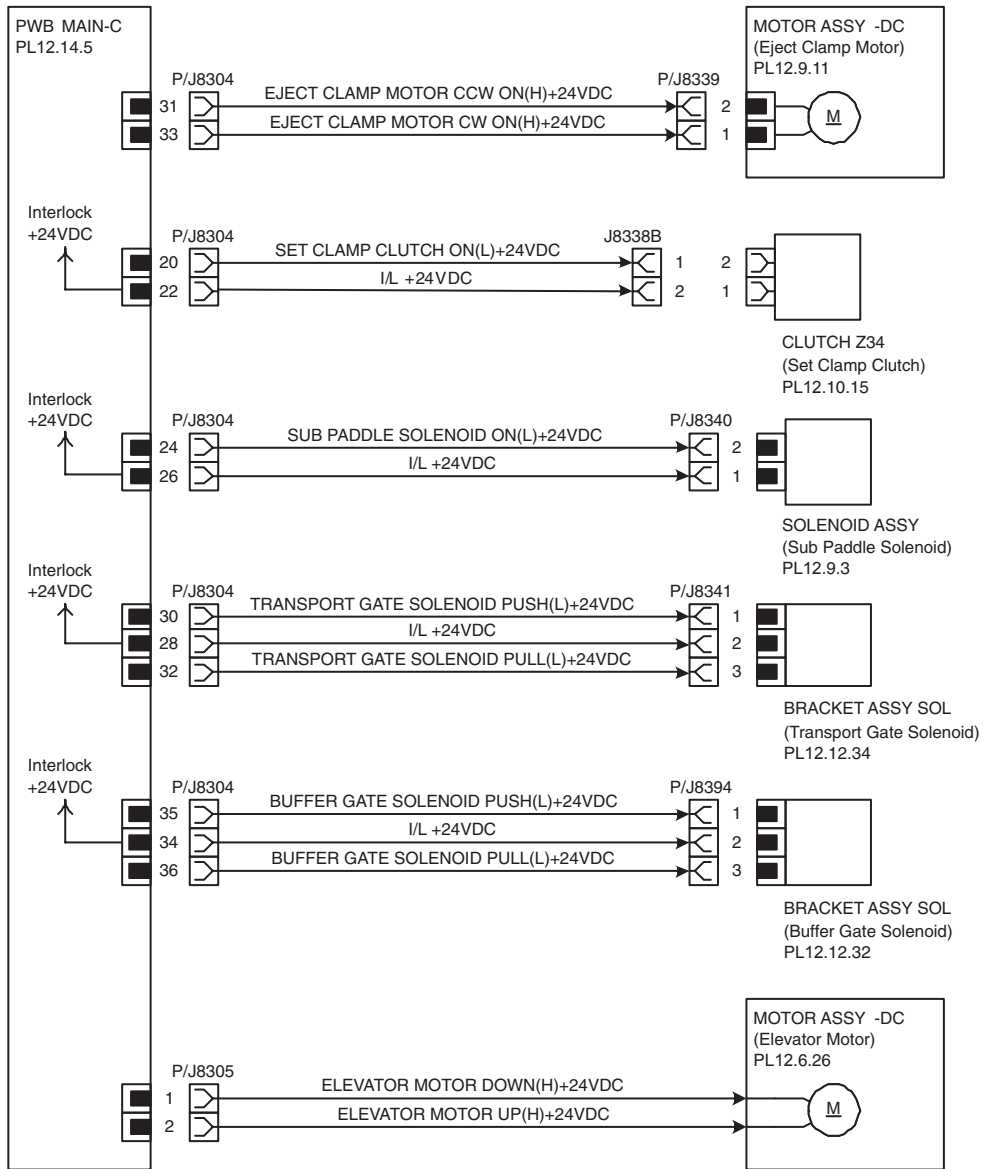
Signal line name	Description
UPPER LIMIT SENSED(L)+5VDC	Maximum detection signal at the time of Stack Tray rise by SENSOR (Upper Limit Sensor)
STACKER PAPER SENSED(L)+5VDC	Paper detection signal in Stack Tray by SENSOR (Stacker No Paper Sensor)
STACKER ENCODE SENSOR SENSED(L)+5VDC	Encoder pulse count detection signal by SENSOR (Stacker Encode Sensor) (The quantity of the paper discharged by the pulse count on Stack Tray is detected)
SET CLAMP HOME SENSED(L)+5VDC	Set Clamp home position detection signal by SENSOR (Set Clamp Home Sensor)
EJECT CLAMP UP(L)+5VDC	Eject Clamp up/down detection signal by SENSOR (Eject Clamp Sensor)
STACKER HEIGHT SENSOR1 CLOCK	Abnormal conditions signal for driving the infrared rays Light Emitting Diode of STACKER HEIGHT SENSOR1
STACKER HEIGHT SENSOR2 CLOCK	Abnormal conditions signal for driving the infrared rays Light Emitting Diode of STACKER HEIGHT SENSOR2
STACKER HEIGHT SENSOR1 SENSED(L)+5VDC	Height detection signal of Stack Tray by COVER ASSY SENSOR (Stacker Height Sensor1)
STACKER HEIGHT SENSOR2 SENSED(L)+5VDC	Height detection signal of Stack Tray by COVER ASSY SENSOR (Stacker Height Sensor2)

## 5 Motor



Signal line name	Description
EXIT MOTOR A, EXIT MOTOR /A, EXIT MOTOR B, EXIT MOTOR /B	MOTOR ASSY (Exit Motor) exciting signal
REGI MOTOR A, REGI MOTOR /A, REGI MOTOR B, REGI MOTOR/B	MOTOR ASSY (Regi Motor) exciting signal
EJECT MOTOR A, EJECT MOTOR /A, EJECT MOTOR B, EJECT MOTOR /B	BRACKET ASSY-EJECT exciting signal
TRANSPOER MOTOR A, TRANSPOER MOTOR /A, TRANSPOER MOTOR B, TRANSPOER MOTOR /B	MOTOR ASSY (Transport Motor) exciting signal

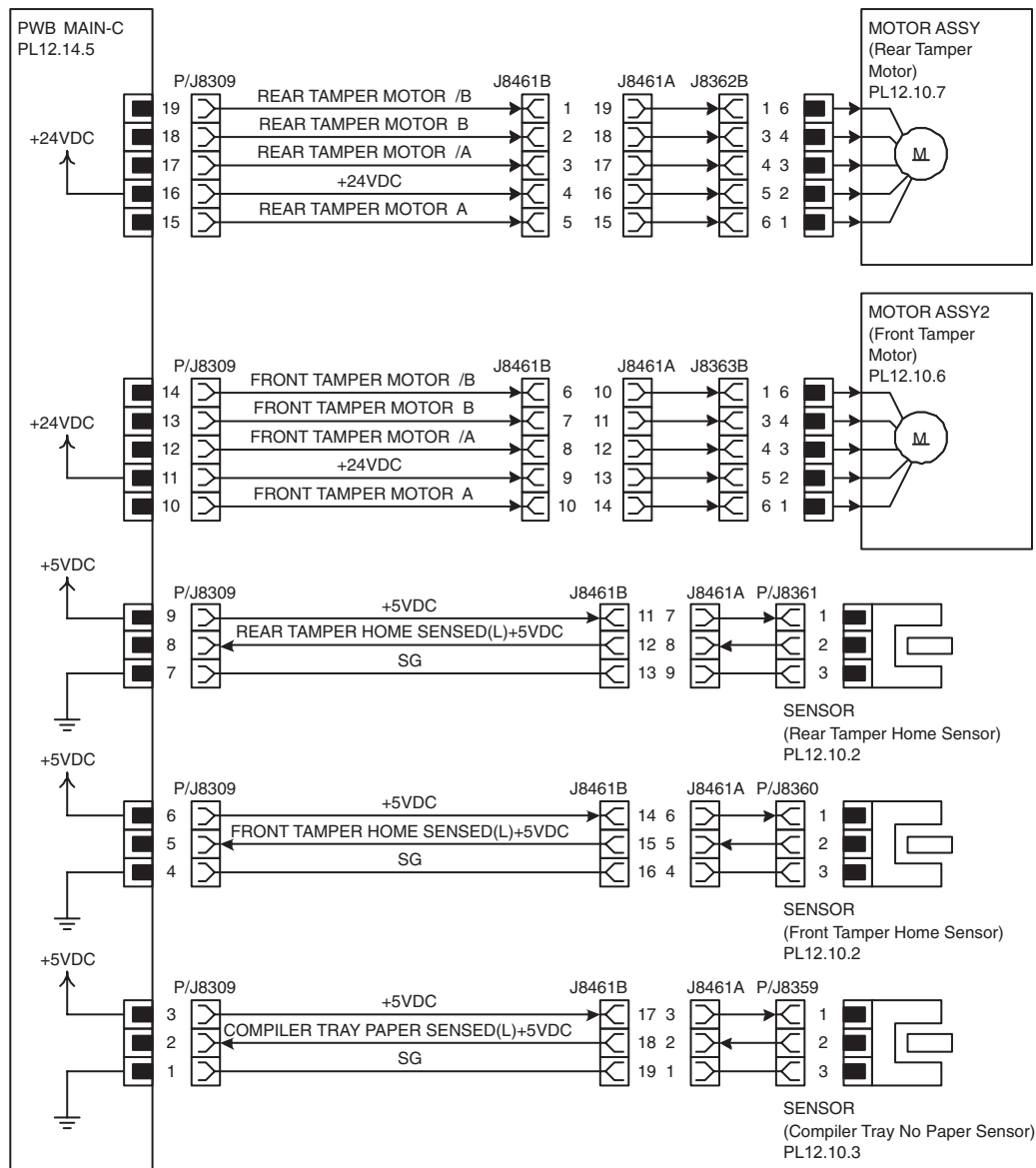
## 6 Motor / Clutch / Solenoid



Signal line name	Description
EJECT CLAMP MOTOR CCW ON(H)+24VDC	CCW direction rotation ON/OFF control signal of MOTOR ASSY-DC (Eject Clamp Motor) (Eject Clamp UP/DOWN)
EJECT CLAMP MOTOR CW ON(H)+24VDC	CW direction rotation ON/OFF control signal of MOTOR ASSY-DC (Eject Clamp Motor) (Reverse)
SET CLAMP CLUTCH ON(L)+24VDC	CLUTCH Z34(Set Clamp Clutch) ON/OFF control signal
SUB PADDLE SOLENOID ON(L)+24VDC	SOLENOID ASSY (Sub Paddle Solenoid) ON/OFF control signal
TRANSPORT GATE SOLENOID PUSH(L)+24VDC	BRACKET ASSY SOL (Transport Gate Solenoid) Push signal (Stacker side)
TRANSPORT GATE SOLENOID PULL(L)+24VDC	BRACKET ASSY SOL (Transport Gate Solenoid) Pull signal (SCT side)
BUFFER GATE SOLENOID PUSH(L)+24VDC	BRACKET ASSY SOL (Buffer Gate Solenoid) Push signal (Stacker side)
BUFFER GATE SOLENOID PULL(L)+24VDC	BRACKET ASSY SOL (Buffer Gate Solenoid) ÇA Pull signal (Buffer side)
ELEVATOR MOTOR DOWN(H)+24VDC	Stack Tray downward direction ON/OFF control signal of MOTOR ASSY-DC (Elevator Motor)
ELEVATOR MOTOR UP(H)+24VDC	Stack Tray rise direction ON/OFF control signal of MOTOR ASSY-DC (Elevator Motor)

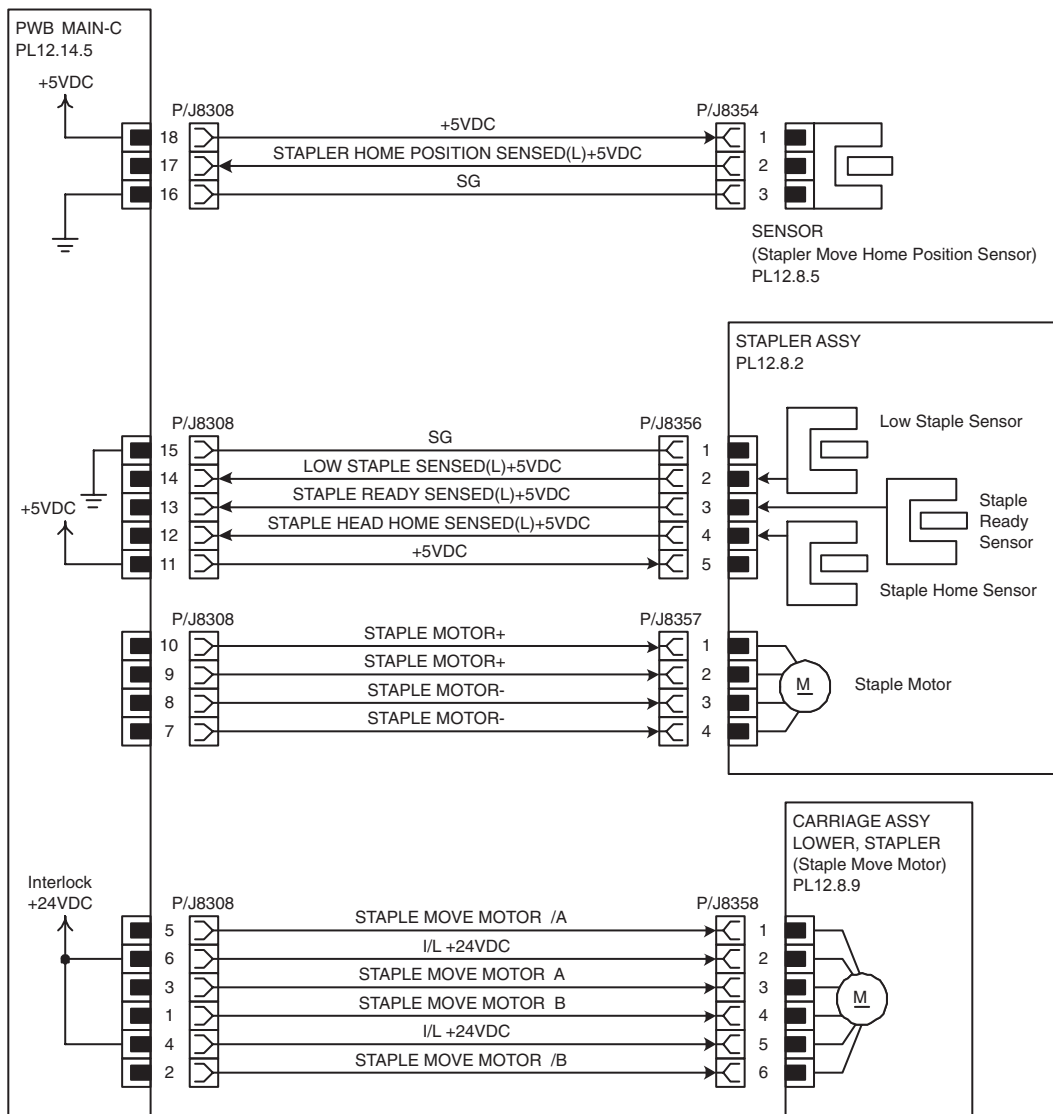
## 7 Tamper





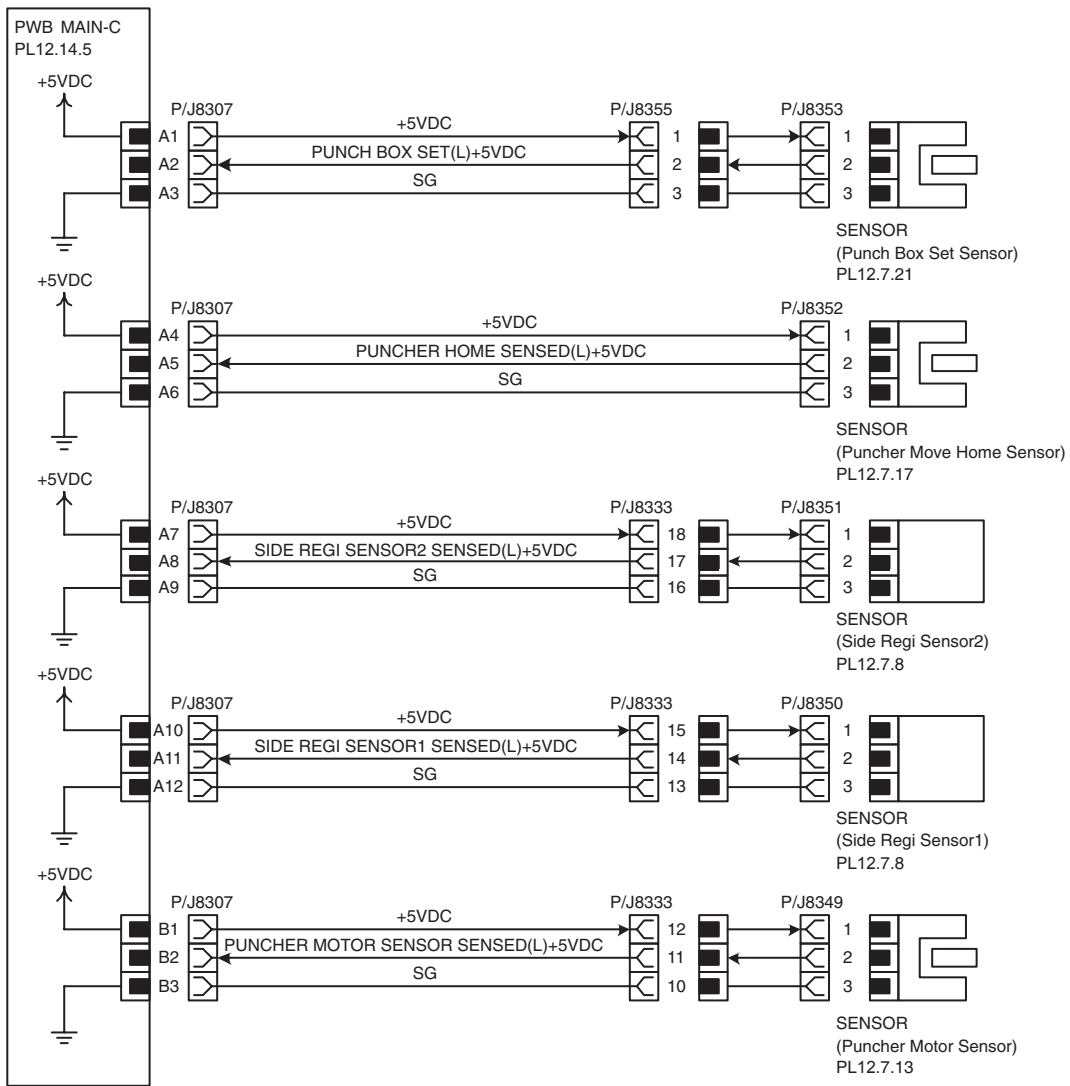
Signal line name	Description
REAR TAMPER MOTOR A, REAR TAMPER MOTOR /A, REAR TAMPER MOTOR B, REAR TAMPER MOTOR /B	MOTOR ASSY (Rear Tamper Motor) exciting signal
FRONT TAMPER MOTOR A, FRONT TAMPER MOTOR /A, FRONT TAMPER MOTOR B, FRONT TAMPER MOTOR /B	MOTOR ASSY (Front Tamper Motor) exciting signal
REAR TAMPER HOME SENSED(L)+5VDC	Rear Tamper home position detection signal by SENSOR (Rear Tamper Home Sensor)
FRONT TAMPER HOME SENSED(L)+5VDC	Front Tamper home position detection signal by SENSOR (Front Tamper Home Sensor)
COMPILER TRAY PAPER SENSED(L)+5VDC	Paper detection signal in Compiler Tray by SENSOR (Compiler Tray No Paper Sensor)

## 8 Stapler



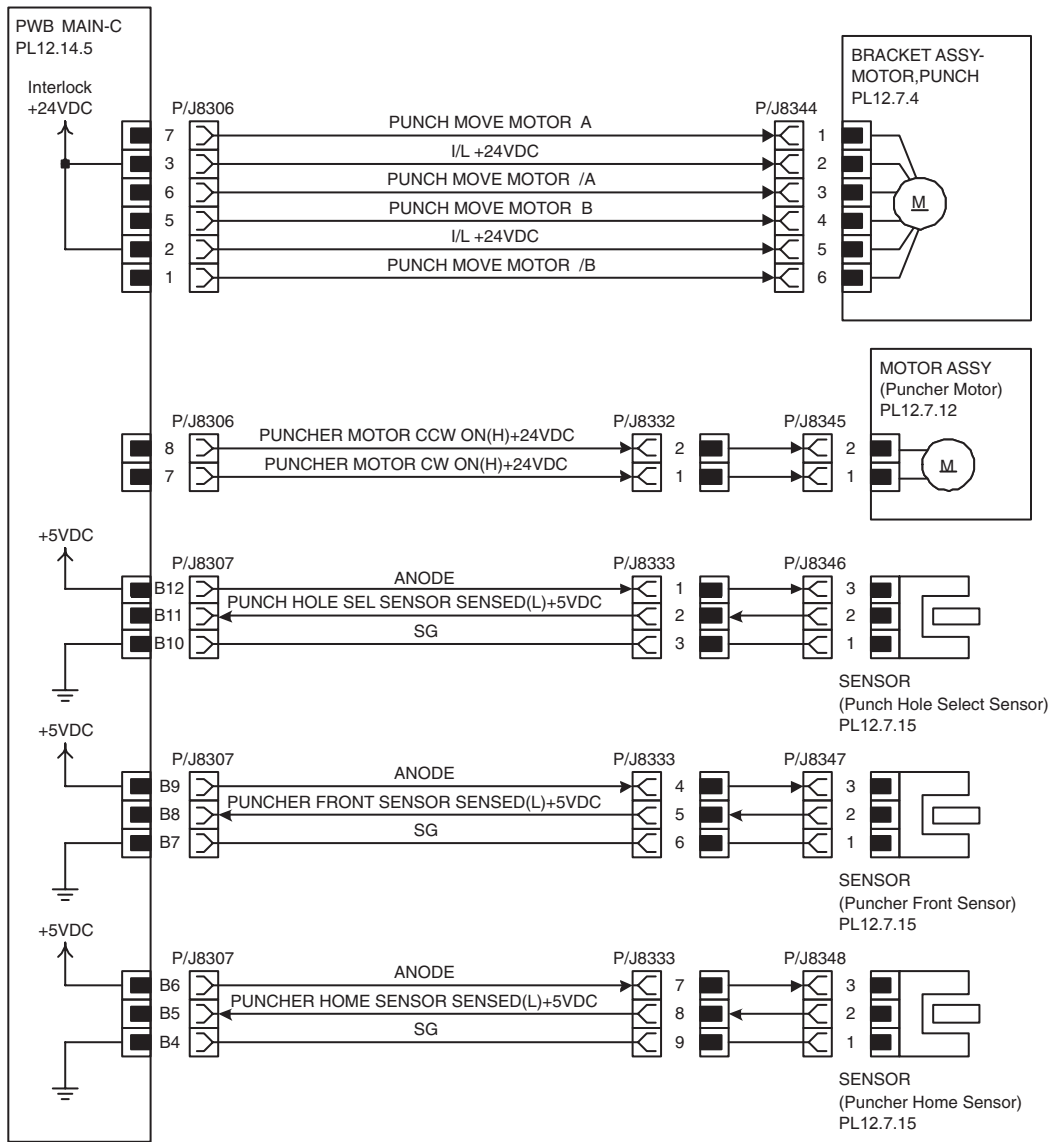
Signal line name	Description
STAPLER HOME POSITION SENSED(L)+5VDC	Stapler home position detection signal by SENSOR (Stapler Move Home Position Sensor)
LOW STAPLE SENSED(L)+5VDC	Detection signal of the needle of Stapler by Low Staple Sensor in STAPLER ASSY.
STAPLE READY SENSED(L)+5VDC	Detection signal of the Ready state of Stapler by Staple Ready Sensor in STAPLER ASSY
STAPLE HEAD HOME SENSED(L)+5VDC	Stapler Head home position detection signal by Staple Home Sensor in STAPLER ASSY
STAPLE MOTOR +, STAPLE MOTOR -	exciting signal of Staple Motor in STAPLER ASSY
STAPLE MOVE MOTOR A, STAPLE MOVE MOTOR /A, STAPLE MOVE MOTOR B, STAPLE MOVE MOTOR /B	CARRIAGE ASSY LOWER, STAPLER (Staple Move Motor) exciting signal

## 9 Puncher1



Signal line name	Description
PUNCH BOX SET(L)+5VDC	Punch Box wearing direction signal by SENSOR (Punch Box Set Sensor)
PUNCHER HOME SENSED(L)+5VDC	Puncher home position detection signal by SENSOR (Puncher Move Home Sensor)
SIDE REGI SENSOR2 SENSED(L)+5VDC	Paper detection signal by SENSOR (Side Regi Sensor2)
SIDE REGI SENSOR1 SENSED(L)+5VDC	Paper detection signal by SENSOR (Side Regi Sensor1)
PUNCHER MOTOR SENSOR SENSED(L)+5VDC	Number-of-rotations detection signal of Puncher Motor by SENSOR (Puncher Motor Sensor)

## 10 Puncher2


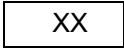
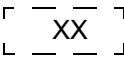
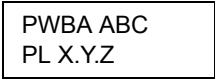



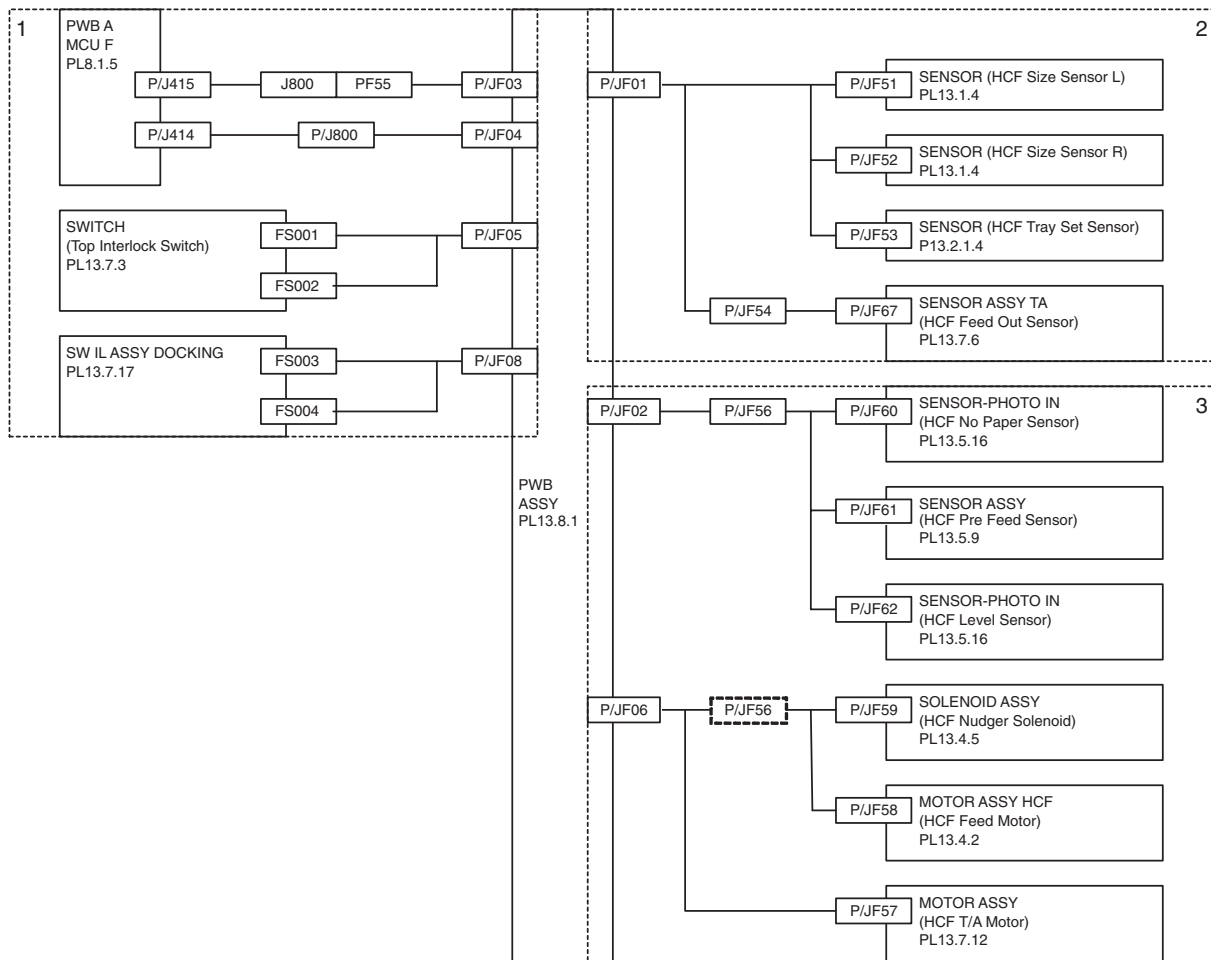
Signal line name	Description
PUNCH MOVE MOTOR A, PUNCH MOVE MOTOR /A, PUNCH MOVE MOTOR B, PUNCH MOVE MOTOR /B	BRACKET ASSY-MOTOR,PUNCH exciting signal
PUNCHER MOTOR CCW ON(H)+24VDC	CCW direction rotation ON/OFF control signal of MOTOR ASSY (Puncher Motor) (It moves to the Puncher Rear side)
PUNCHER MOTOR CW ON(H)+24VDC	CW direction rotation ON/OFF control signal of MOTOR ASSY (Puncher Motor) (It moves to the Puncher Front side)
PUNCH HOLE SEL SENSOR SENSED(L)+5VDC	2 holes / 3 hole change detection signal by SENSOR (Punch Hole Select Sensor).
PUNCHER FRONT SENSOR SENSED(L)+5VDC	Puncher ÇA Cam Plate of Puncher Front Position of SENSOR (Puncher Front Sensor)
PUNCHER HOME SENSOR SENSED(L)+5VDC	Cam Plate of Puncher home position detection signal by SENSOR (Puncher Home Sensor)

# HCF

## General Wiring Diagram

The following describes the legend of the general wiring diagram shown on the next page.

Symbols	Description
	Denotes a connection between parts with harnesses and wires.
	A frame not having parts name inside denotes the connector (P/J). Numeric value inside implies the connector number.
	A frame of broken line denotes the connector (P/J) written in several places separately. Numeric value inside implies the connector number.
	A frame having parts name inside denotes the parts. PL X.Y.Z implies the item "Z" of plate (PL) "X.Y" in Chapter 5. Parts List.
	A frame of dotted line denotes the section in "2. Wiring Diagram between Parts", and numeric value implies the section number.



## Wiring Diagram between Parts

### Configuration

The wiring diagram is separated into 3 sections to show detailed connection between parts.

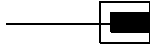
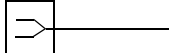
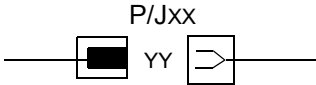
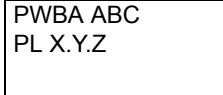
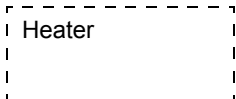
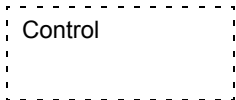
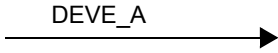
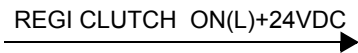
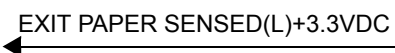
- 1 Switch
  - Connection between PWB ASSY and PWB A MCU F
  - Connection between PWB ASSY and SW IL ASSY DOCKING
  - Connection between PWB ASSY and SWITCH (Top Interlock Switch)
- 2 Sensor
  - Connection between PWB ASSY and SENSOR (HCF Size Sensor L)
  - Connection between PWB ASSY and SENSOR (HCF Size Sensor R)
  - Connection between PWB ASSY and SENSOR (HCF Tray Set Sensor)
  - Connection between PWB ASSY and SENSOR ASSY TA (HCF Feed Out Sensor)
- 3 Sensor/Motor/Solenoid
  - Connection between PWB ASSY and MOTOR ASSY HCF (HCF Feed Motor)
  - Connection between PWB ASSY and MOTOR ASSY HCF (HCF T/A Motor)
  - Connection between PWB ASSY and SOLENOID ASSY (HCF Nudger Solenoid)
  - Connection between PWB ASSY and SENSOR-PHOTO IN (HCF Level Sensor)

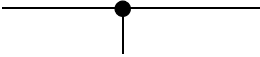
- Connection between PWB ASSY and SENSOR ASSY (HCF Pre Feed Sensor)
- Connection between PWB ASSY and SENSOR-PHOTO IN (HCF No Paper Sensor)

### Notes on Using the Wiring Diagram between Parts

The following describes the legend of the wiring diagrams between parts shown on the following pages.

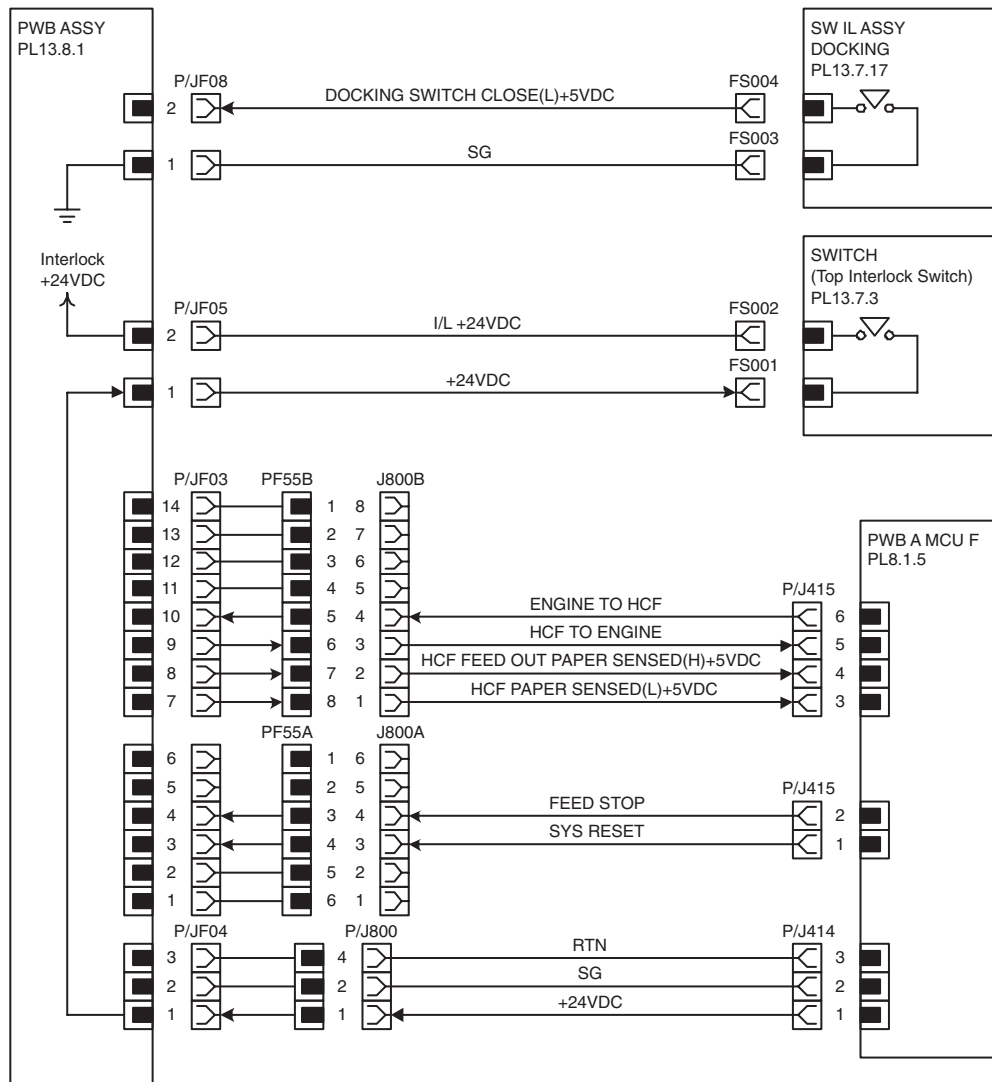
Note that the description of general symbols is omitted.

Symbols	Description
	Denotes a plug.
	Denotes a jack.
	Denotes Pin yy and Jack yy of the connector Pxx and Jxx.
	Denotes the parts. PL X.Y.Z implies the item "Z" of plate (PL) "X.Y" in Chapter 5. Parts List.
	Denotes functional parts attached with functional parts name.
	Denotes the control and its outline in PWB.
	Denotes a connection between parts with harnesses or wires, attached with signal name/contents.
	Denotes the function, and logic value of the signal to operate the function (Low: L, High: H). The given voltage is for signal in high status. The arrow indicates the direction of signal.
	Denotes the function, and logic value of the signal when the function operated (Low: L, High: H). The given voltage is for signal in high status. The arrow indicates the direction of signal.

Symbols	Description
	Denotes a connection between wires.
I/L +24VDC	Denotes DC voltage when the interlock switch in HNB MCU WITH CPU turns on
+5VDC +3.3VDC	Denotes DC voltage.
SG	Denotes signal ground.
AG	Denotes analog ground.
RTN	Denotes the return.

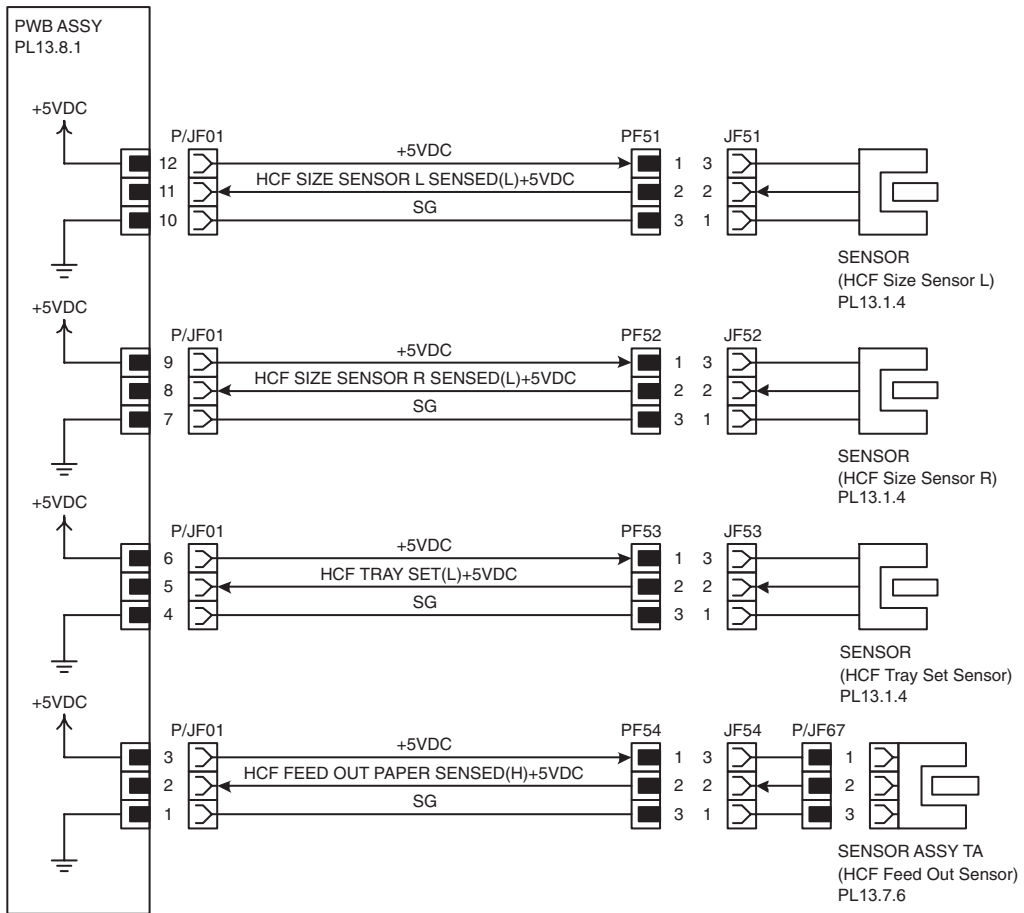
## 1 Switch





Signal line name	Description
DOCKING SWITCH CLOSE(L)+5VDC	wearing detection signal of HCF and Engine by SW IL ASSY DOCKING Ai Low Af wearing Aj
ENGINE TO HCF	Communication signal of PWB ASSY(HCF) and PWB A MCU F (Engine) (Engine->HCF)
HCF TO ENGINE	Communication signal of PWB ASSY(HCF) and PWB A MCU F (Engine) (HCF->Engine)
HCF FEED OUT PAPER SENSED(H)+5VDC	Paper detection signal by HCF Feed Out Sensor in transport section (HCF->Engine)
HCF PAPER SENSED(L)+5VDC	Paper detection signal in HCF Tray of HCF No Paper Sensor (HCF->Engine)
FEED STOP	Feed Stop signal to HCF (Engine->HCF)
SYS RESET	System Reset signal to HCF (Engine->HCF)

## 2 Sensor

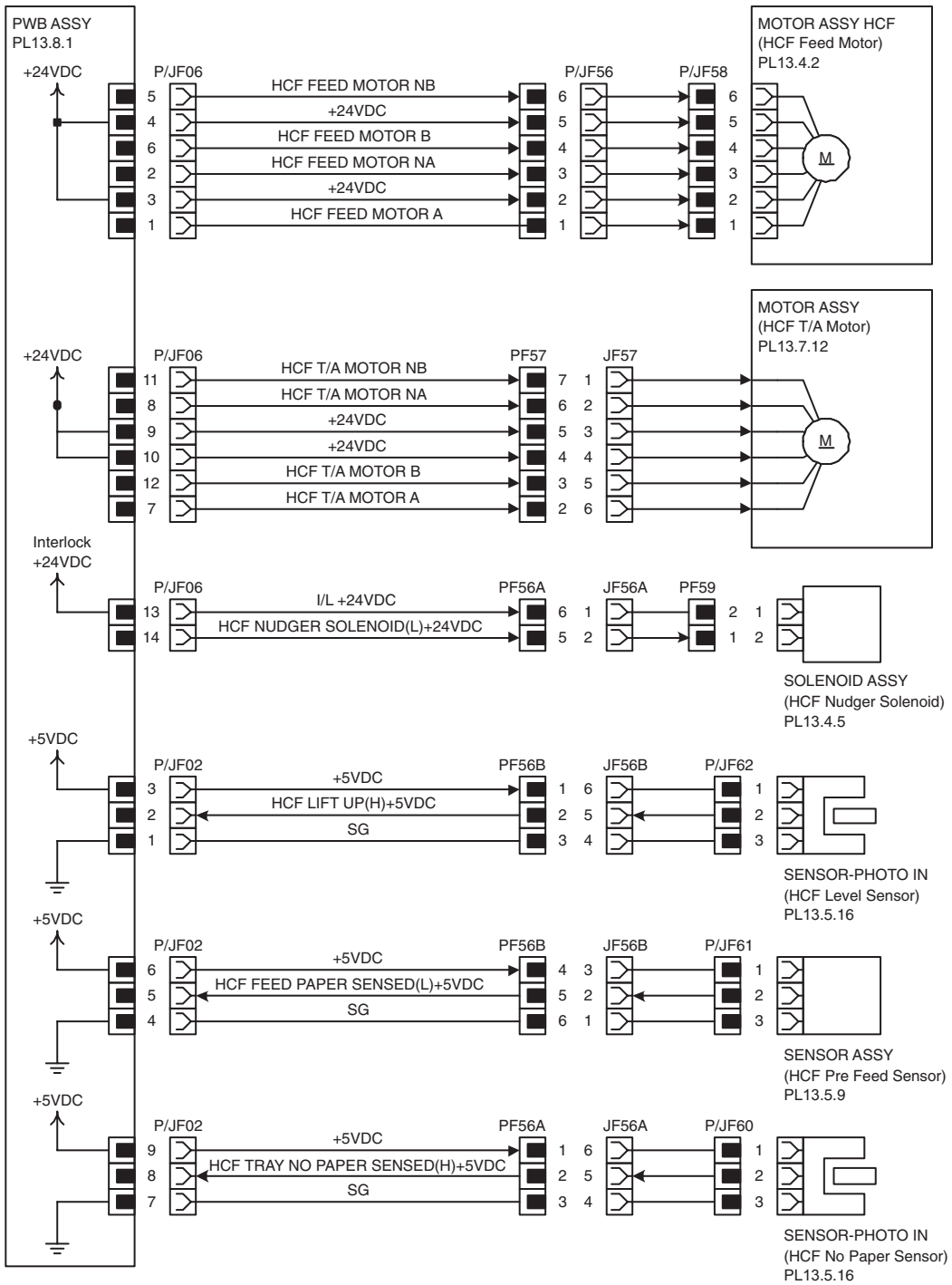


Signal line name	Description
HCF SIZE SENSOR L SENSED(L)+5VDC	HCF Size Sensor L ON/OFF detection signal
HCF SIZE SENSOR R SENSED(L)+5VDC	HCF Size Sensor R ON/OFF detection signal
HCF TRAY SET(L)+5VDC	HCF Tray set signal by HCF Tray Set Sensor
HCF FEED OUT PAPER SENSED(H)+5VDC	Paper detection signal by HCF Feed Out Sensor in transport section

- Paper size detection
  - The ON/OFF pattern of HCF SIZE SENSOR L and HCF SIZE SENSOR R and the relation of paper size are as follows.

Paper Size	SENSOR L	SENSOR R
B5 LEF / 7.25"A~10.5" LEF	OFF	OFF
8.5"A~11" LEF	ON	OFF
A4 LEF	OFF	ON

### 3 Sensor/Motor/Solenoid


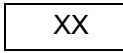
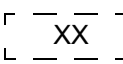
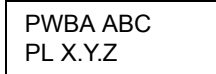



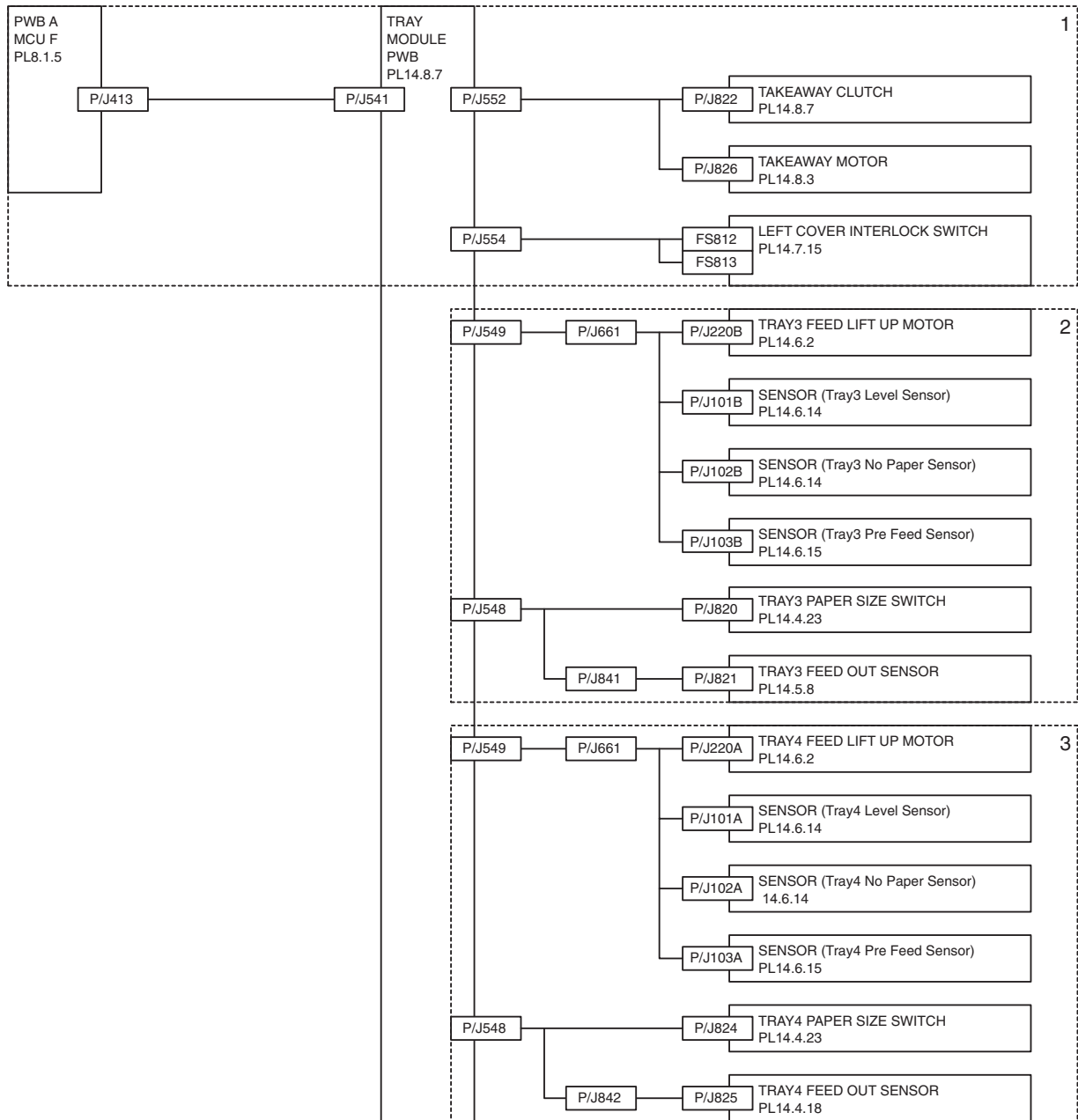
Signal line name	Description
HCF FEED MOTOR A, HCF FEED MOTOR NA, HCF FEED MOTOR B, HCF FEED MOTOR NB,	HCF Feed Motor exciting signal
HCF T/A MOTOR A, HCF T/A MOTOR NA, HCF T/A MOTOR B, HCF T/A MOTOR NB,	HCF T/A Motor exciting signal
HCF NUDGER SOLENOID(L)+24VDC	HCF Nudger Solenoid ON/OFF control signal
HCF LIFT UP(H)+5VDC	Rise (paper feed possible level) detection signal of plate in HCF by HCF Level Sensor
HCF FEED PAPER SENSED(L)+5VDC	Feed paper detection signal from HCF by HCF Pre Feed Sensor
HCF TRAY NO PAPER SENSED(H)+5VDC	Paper detection signal in HCF Tray by HCF No Paper Sensor (High: No paper)

## Tandem Tray

### General Wiring Diagram

The following describes the legend of the general wiring diagram shown on the next page.

Symbols	Description
	Denotes a connection between parts with harnesses and wires.
	A frame not having parts name inside denotes the connector (P/J). Numeric value inside implies the connector number.
	A frame of broken line denotes the connector (P/J) written in several places separately. Numeric value inside implies the connector number.
	A frame having parts name inside denotes the parts. PL X.Y.Z implies the item "Z" of plate (PL) "X.Y" in Chapter 5. Parts List.
	A frame of dotted line denotes the section in "2. Wiring Diagram between Parts", and numeric value implies the section number.



## Wiring Diagram between Parts

### Configuration

The wiring diagram is separated into 3 sections to show detailed connection between parts.

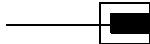
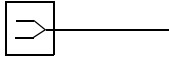
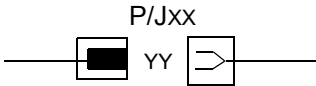
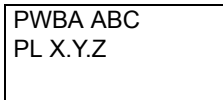
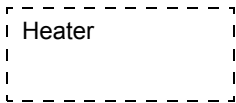

- 1 Drive
  - Connection between TRAY MODULE PWB and CLUTCH (Takeaway Clutch)
  - Connection between TRAY MODULE PWB and MAIN MOTOR
  - Connection between TRAY MODULE PWB and LEFT COVER INTERLOCK SWITCH
  - Connection between TRAY MODULE PWB and PWB A MCU F
  
- 2 Tray3
  - Connection between TRAY MODULE PWB and TRAY3 FEED LIFT UP MOTOR

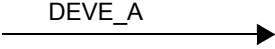
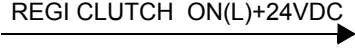
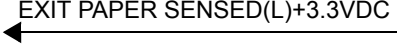

- Connection between TRAY MODULE PWB and SENSOR (Tray3 Level Sensor)
  - Connection between TRAY MODULE PWB and SENSOR (Tray3 No Paper Sensor)
  - Connection between TRAY MODULE PWB and SENSOR (Tray3 Pre Feed Sensor)
  - Connection between TRAY MODULE PWB and TRAY3 PAPER SIZE SWITCH
  - Connection between TRAY MODULE PWB and TRAY3 FEED OUT SENSOR
- 3 Tray4
    - Connection between TRAY MODULE PWB and TRAY4 FEED LIFT UP MOTOR
    - Connection between TRAY MODULE PWB and SENSOR (Tray4 Level Sensor)
    - Connection between TRAY MODULE PWB and SENSOR (Tray4 No Paper Sensor)
    - Connection between TRAY MODULE PWB and SENSOR (Tray4 Pre Feed Sensor)
    - Connection between TRAY MODULE PWB and TRAY4 PAPER SIZE SWITCH
    - Connection between TRAY MODULE PWB and TRAY4 FEED OUT SENSOR

### Notes on Using the Wiring Diagram between Parts

The following describes the legend of the wiring diagrams between parts shown on the following pages.

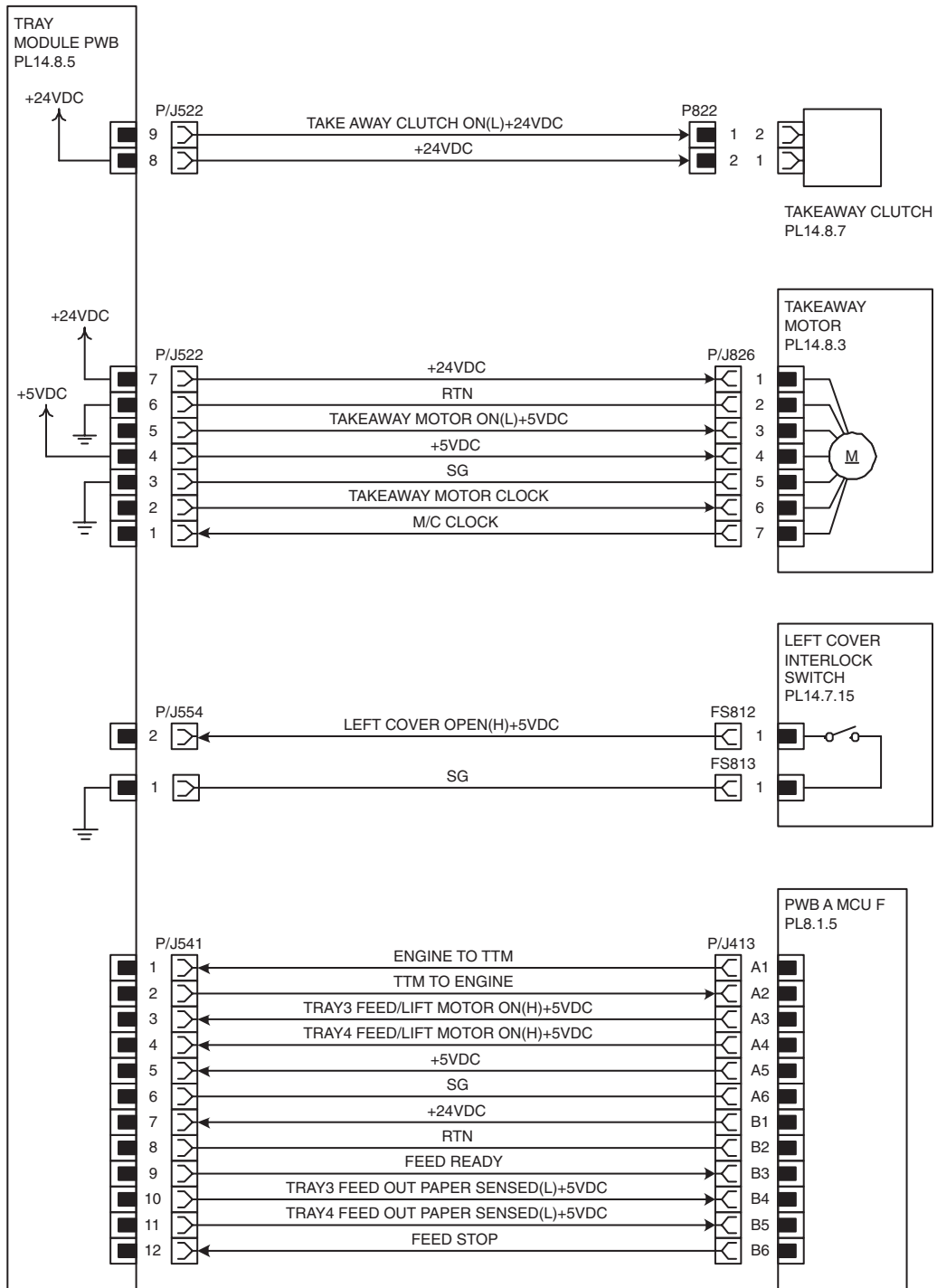
Note that the description of general symbols is omitted.

Symbols	Description
	Denotes a plug.
	Denotes a jack.
	Denotes Pin yy and Jack yy of the connector Pxx and Jxx.
	Denotes the parts. PL X.Y.Z implies the item "Z" of plate (PL) "X.Y" in Chapter 5. Parts List.
	Denotes functional parts attached with functional parts name.
	Denotes the control and its outline in PWB.

Symbols	Description
	Denotes a connection between parts with harnesses or wires, attached with signal name/contents.
	Denotes the function, and logic value of the signal to operate the function (Low: L, High: H). The given voltage is for signal in high status. The arrow indicates the direction of signal.
	Denotes the function, and logic value of the signal when the function operated (Low: L, High: H). The given voltage is for signal in high status. The arrow indicates the direction of signal.
	Denotes a connection between wires.
I/L +24VDC	Denotes DC voltage when the interlock switch in HNB MCU WITH CPU turns on
+5VDC +3.3VDC	Denotes DC voltage.
SG	Denotes signal ground.
AG	Denotes analog ground.
RTN	Denotes the return.

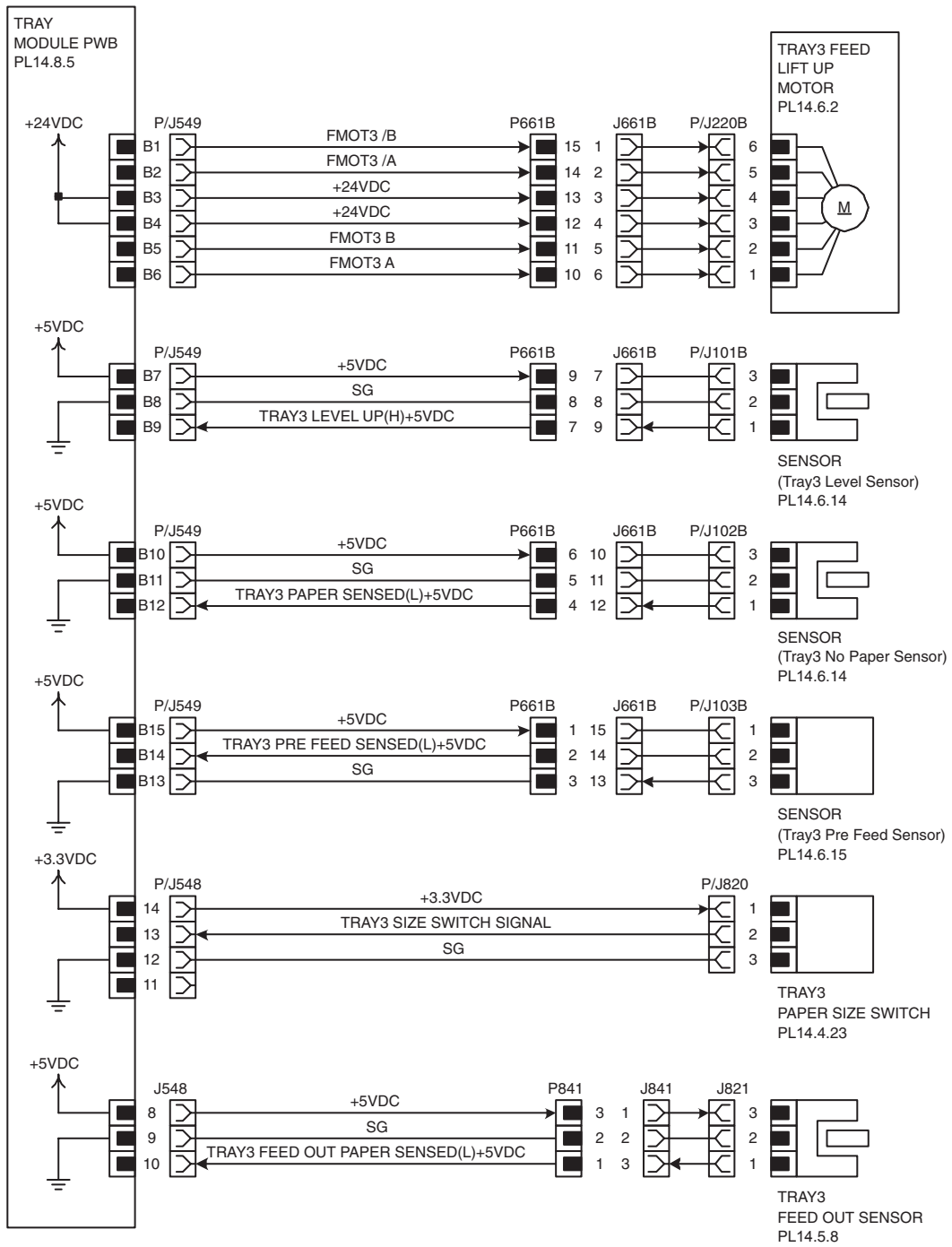
## 1 Drive





Signal line name	Description
TAKEAWAY CLUTCH ON(L)+24VDC	TAKEAWAY CLUTCH ON/OFF control signal
TAKEAWAY MOTOR ON(L)+5VDC	TAKEAWAY MOTOR ON/OFF control signal
TAKEAWAY MOTOR CLOCK	Clock signal to TAKEAWAY MOTOR
M/C CLOCK	Clock signal from TAKEAWAY MOTOR
LEFT COVER OPEN(H)+5VDC	LEFT COVER open/close detection signal by LEFT COVER INTERLOCK SWITCH
ENGINE TO TTM	Communication signal of PWB A MCU F (Engine) and TRAY MODULE PWB (TTM) (Engine->TTM)
TTM TO ENGINE	Communication signal of TRAY MODULE PWB (TTM) and PWB A MCU F (Engine) (TTM->Engine)
TRAY3 FEED/LIFT MOTOR ON(H)+5VDC	TRAY3 FEED LIFT UP MOTOR ON/OFF control signal (Engine->TTM)
TRAY4 FEED/LIFT MOTOR ON(H)+5VDC	TRAY4 FEED LIFT UP MOTOR ON/OFF control signal (Engine->TTM)
FEED READY	Feed ready signal from TTM (TTM->Engine)
TRAY3 FEED OUT PAPER SENSED(L)+5VDC	Paper detection signal by TRAY3 FEED OUT SENSOR in transport section (TTM->Engine)
TRAY4 FEED OUT PAPER SENSED(L)+5VDC	Paper detection signal by TRAY4 FEED OUT SENSOR in transport section (TTM->Engine)
FEED STOP	Feed stop signal to TTM (Engine->TTM)

## 2 Tray3



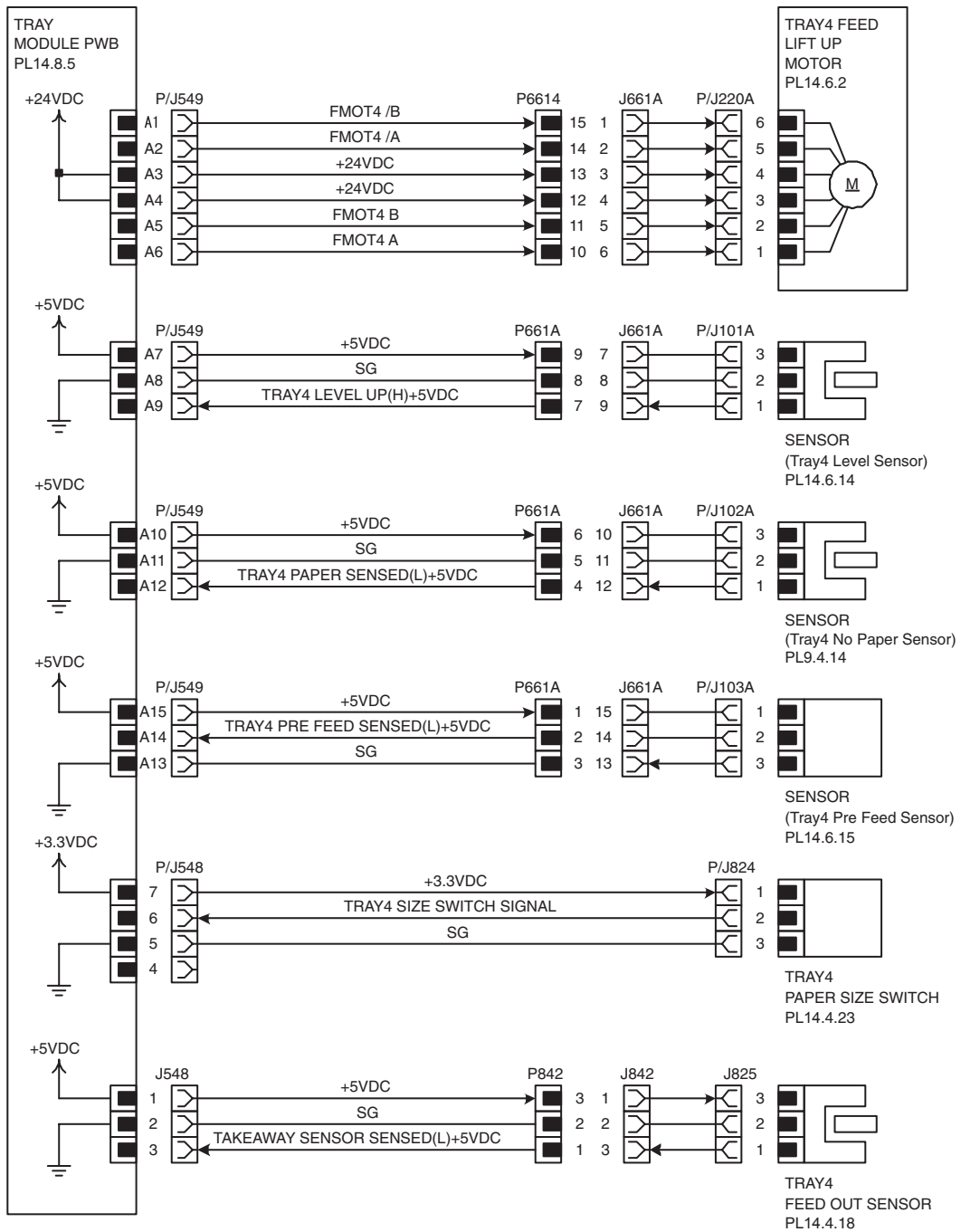
Signal line name	Description
FMOT3 A, FMOT3 B, FMOT3 /A, FMOT3 /B	TRAY3 FEED LIFT UP MOTOR exciting signal
TRAY3 LEVEL UP(H)+5VDC	Rise (paper feed possible level) detection signal of plate in Tray3 by SENSOR (Tray3 Level Sensor)
TRAY3 PAPER SENSED(L)+5VDC	Paper detection signal in Tray3 of SENSOR (Tray3 No Paper Sensor)
TRAY3 PRE FEED SENSED(L)+5VDC	Feed paper detection signal from Tray3 by SENSOR (Tray3 Pre Feed Sensor)
TRAY3 SIZE SWITCH SIGNAL	Paper size detection signal (analog value) of TRAY3 PAPER SIZE SWITCH
TRAY3 FEED OUT PAPER SENSED(L)+5VDC	Paper detection signal by TRAY3 FEED OUT SENSOR in transport section

#### Paper size detection

- The ON/OFF pattern of each switch (S1, S2) of TRAY3 PAPER SIZE SWITCH and the relation of paper size and the output voltage of TRAY3 SIZE SWITCH SIGNAL are as follows.

Paper Size	S1	S2	Output Voltage(V)
No Tray	OFF	OFF	3.06A $\pm$ 0.03
B5 LEF / 7.25"A~10.5" LEF	OFF	ON	2.61A $\pm$ 0.03
8.5"A~11" LEF	ON	OFF	1.41A $\pm$ 0.03
A4 LEF	ON	ON	1.00A $\pm$ 0.03

### 3 Tray4



Signal line name	Description
FMOT4 A, FMOT4 B, FMOT4 /A, FMOT4 /B	TRAY4 FEED LIFT UP MOTOR exciting signal
TRAY4 LEVEL UP(H)+5VDC	Rise (paper feed possible level) detection signal of plate in Tray4 by SENSOR (Tray4 Level Sensor)
TRAY4 PAPER SENSED(L)+5VDC	Paper detection signal in Tray4 of SENSOR (Tray4 No Paper Sensor)
TRAY4 PRE FEED SENSED(L)+5VDC	Feed paper detection signal from Tray4 by SENSOR (Tray4 Pre Feed Sensor)
TRAY4 SIZE SWITCH SIGNAL	Paper size detection signal (analog value) of TRAY4 PAPER SIZE SWITCH
TRAY4 FEED OUT PAPER SENSED(L)+5VDC	Paper detection signal by TRAY4 FEED OUT SENSOR in transport section

Paper size detection

- The ON/OFF pattern of each switch (S1, S2) of TRAY4 PAPER SIZE SWITCH and the relation of paper size and the output voltage of TRAY4 SIZE SWITCH SIGNAL are as follows.

Paper Size	S1	S2	Output Voltage(V)
No Tray	OFF	OFF	3.06A $\pm$ 0.03
B5 LEF / 7.25"A~10.5" LEF	OFF	ON	2.61A $\pm$ 0.03
8.5"A~11" LEF	ON	OFF	1.41A $\pm$ 0.03
A4 LEF	ON	ON	1.00A $\pm$ 0.03

# Chapter 5 Plug/Jack

## Engine

### Connector [P (plug) / J (jack)]

#### List of P/J

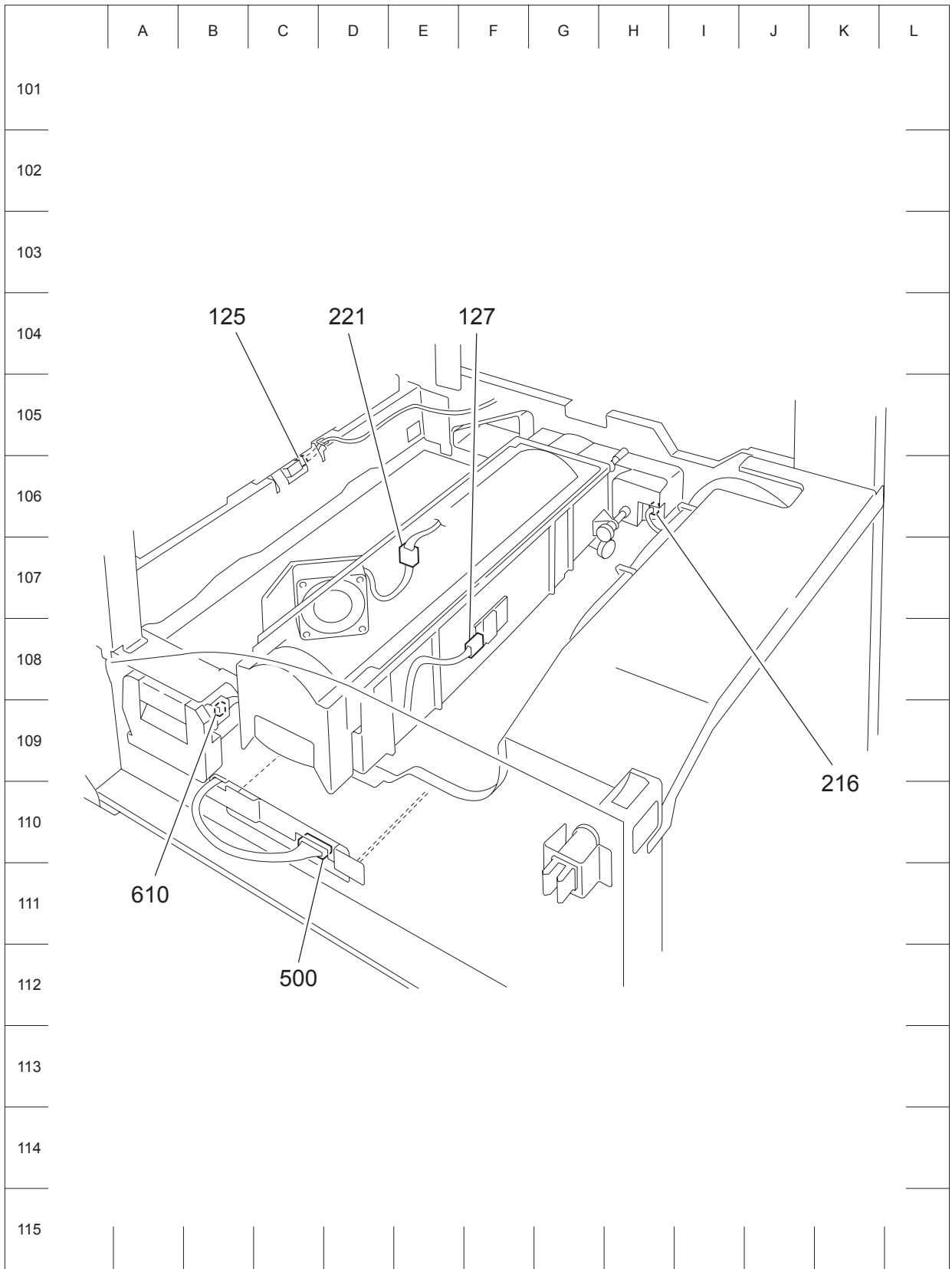
P/J	Coordinates	Remarks
1	D-204	Connects Power Unit and Main Switch Harness Assembly
2	D-243	Connects Power Unit and Finisher Outlet
3	D-245	Connects Power Unit and Heater Harness Assembly
6	E-245	Connects Power Unit and Fuser AC Harness Assembly
7	E-245	Not Connects
11	D-245	Connects Power Unit and GFI
12	D-245	Connects Power Unit and GFI
20	J-141	Connects Main Lamp and Fuser Harness Assembly
21	J-141	Connects Sub Lamp 1 and Fuser Harness Assembly
22	J-141	Connects Sub Lamp 2 and Fuser Harness Assembly
50	F-229	Connects GFI and Power Unit
56	B-238	Connects Main Switch and Main Switch Harness Assembly
57	B-239	Connects Main Switch and Main Switch Harness Assembly
68	B-239	Connects Main Switch and Main Switch Harness Assembly
69	B-239	Connects Main Switch and Main Switch Harness Assembly
72	F-230	Connects GFI and Frame (Earth)
73	G-230	Connects Finisher Outlet and Power Unit
74	G-230	Connects Finisher Outlet and Power Unit
75	G-230	Connects Finisher Outlet and Frame (Earth)
100	G-180	Connects Tray 1 Level Sensor and Tray 1 Feeder Harness Assembly
101	G-180	Connects Tray 1 No Paper Sensor and Tray 1 Feeder Harness Assembly
102	G-180	Connects Tray 2 Level Sensor and Tray 2 Feeder Harness Assembly
103	G-180	Connects Tray 2 No Paper Sensor and Tray 2 Feeder Harness Assembly
104	F-167	Connects REGI Sensor and REGI Harness Assembly
105	F-186	Connects Take Away Sensor and Take Away Sensor Harness Assembly
106	D-183	Connects LHL Switch and PH Harness Assembly
107	D-153	Connects MPF Size Sensor and MPF Sensor Harness Assembly
108	G-152	Connects MPF No Paper Sensor and MPF Harness Assembly
109	D-200	Connects Tray 1 Size Sensor and Size Harness Assembly
110	D-201	Connects Tray 2 Size Sensor and Size Harness Assembly
117	B-134	Connects OCT Home 1 Sensor and OCT Harness Assembly
118	B-134	Connects Full Stack Sensor and OCT Harness Assembly
120	H-196	Connects LH Cover Interlock Switch and PWBA MCU
121	C-244	Connects Front Cover Interlock Switch and INTLK Harness Assembly
125	C-106	Connects Fuser Exit Sensor and PH Harness Assembly
126	D-122	Connects XERO CRU and Crum Harness Assembly
127	F-108	Connects Toner CRU and Crum Harness Assembly
130	E-124	Connects ROS (Scanner) and ROS Harness Assembly
131	B-139	Connects Center STS and FUSER Outlet
132	B-139	Connects 2nd STS and FUSER Outlet
133	B-139	Connects Rear STS and FUSER Outlet

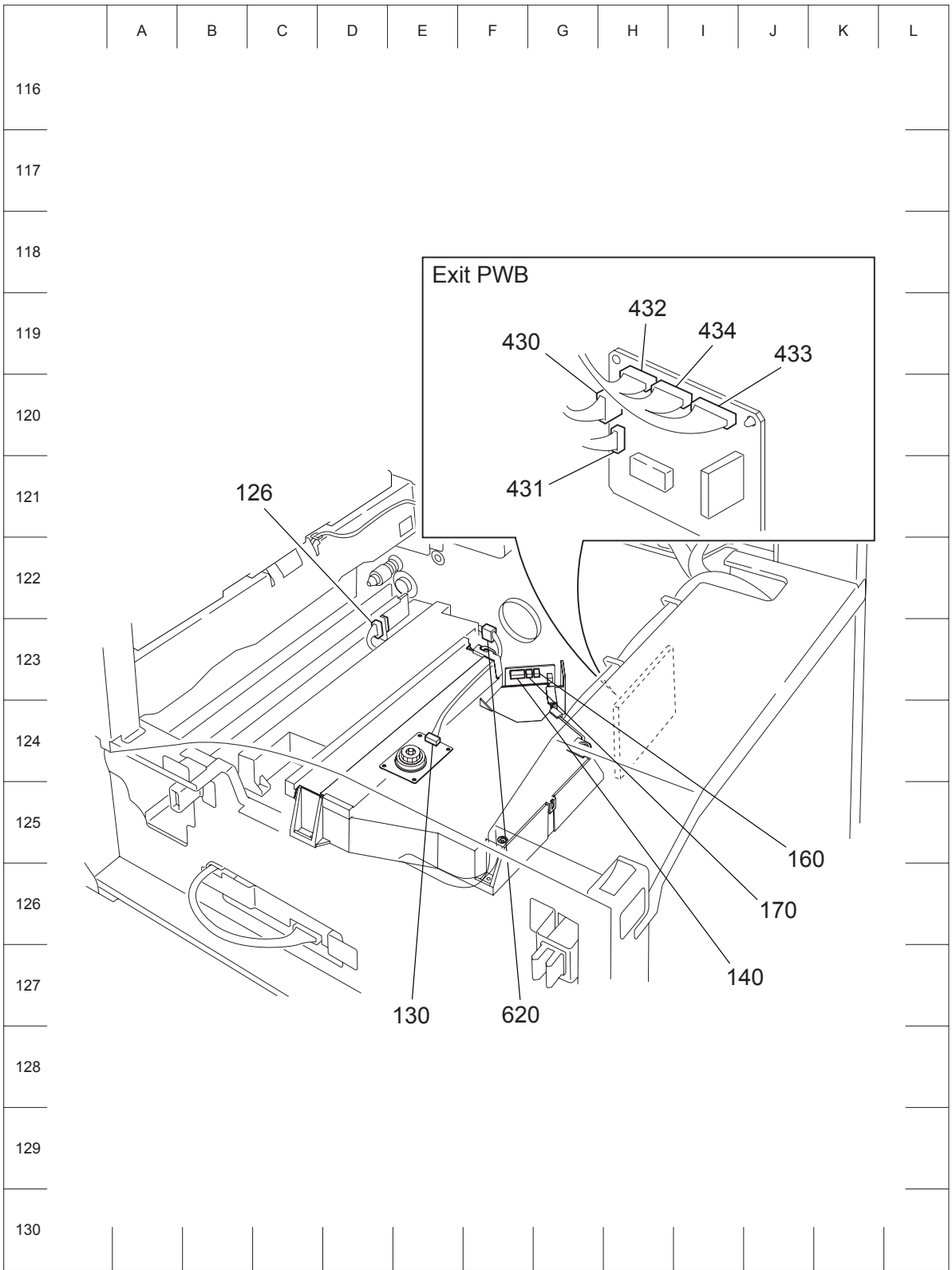
P/J	Coordinates	Remarks
133	H-181	Connects Tray 1 Pre Feed Sensor and Tray 1 Feeder Harness Assembly
134	H-181	Connects Tray 2 Pre Feed Sensor and Tray 2 Feeder Harness Assembly
140	F-123	Connects ROS and ROS Harness Assembly
150	G-166	Connects Hum & Temp Sensor and REGI Harness Assembly
160	F-123	Connects ROS and ROS Harness Assembly
170	F-123	Connects ROS and ROS Harness Assembly
201	E-180	Connects Tray 1 Feed Liftup Motor and Tray 1 Feeder Harness Assembly
202	E-180	Connects Tray 2 Feed Liftup Motor and Tray 2 Feeder Harness Assembly
204	H-199	Connects Takeaway Clutch and PH Harness Assembly
205	D-151	Connects MPF Feed Solenoid and MPF Harness Assembly
206	G-196	Connects No.1 OCT MOT and EXIT Harness Assembly
214	G-198	Connects Drive Assembly and Drive Harness Assembly
215	E-166	Connects REGI Clutch and REGI Harness Assembly
216	H-106	Connects Dispense MOT and LV PWR Harness Assembly
221	E-107	Connects PWBA MCU and CRU Fan
311	B-242	Connects Console Panel and Console Panel Harness Assembly
400	C-214	Connects PWBA MCU and LV PWR Harness Assembly
401	C-214	Connects PWBA MCU and LV PWR Harness Assembly
402	D-212	Connects PWBA MCU and ESS Harness Assembly
403	F-211	Connects PWBA MCU and REGI Harness Assembly
404	E-212	Connects PWBA MCU and XERO Harness Assembly
405	G-212	Connects PWBA MCU and INTLK Harness Assembly
406	D-212	Connects PWBA MCU and ROS Harness Assembly
407	C-212	Connects PWBA MCU and ROS Harness Assembly
408	G-211	Connects PWBA MCU and Drive Harness Assembly
409	G-213	Connects PWBA MCU and Feeder Harness Assembly
410	G-212	Connects PWBA MCU and PH Harness Assembly
411	G-214	Connects PWBA MCU and MPF Harness Assembly
412	C-213	Connects PWBA MCU and Size Harness Assembly
413	D-214	Connects PWBA MCU and Tray Module Harness Assembly
414	F-214	Connects PWBA MCU and HCF Harness Assembly
415	F-214	Connects PWBA MCU and HCF Harness Assembly
416	D-214	Connects PWBA MCU and Output Unit
417	E-214	Connects PWBA MCU and DUP Harness Assembly
419	D-212	Connects PWBA MCU and Crum Harness Assembly
420	C-212	Connects PWBA MCU and LV PWR Harness Assembly
421	C-213	Connects PWBA MCU and LV PWR Harness Assembly
430	H-120	Connects PWBA EXIT and LV PWR Harness Assembly
431	H-120	Connects PWBA EXIT and LV PWR Harness Assembly
432	H-120	Connects PWBA EXIT and EXIT Harness Assembly
433	I-120	Connects PWBA EXIT and EXIT Harness Assembly
434	I-120	Connects PWBA EXIT and EXIT Harness Assembly
500	C-110	Connects HVPS and REGI Harness Assembly
521	I-246	Connects Power Unit and LV PWR Harness Assembly
525	I-247	Connects Power Unit and LV PWR Harness Assembly
526	I-245	Connects Power Unit and LV PWR Harness Assembly
600	A-139	Connects FUSER and FUSER AC Harness Assembly
600	H-196	Connects FUSER Assembly and Fuser Harness Assembly

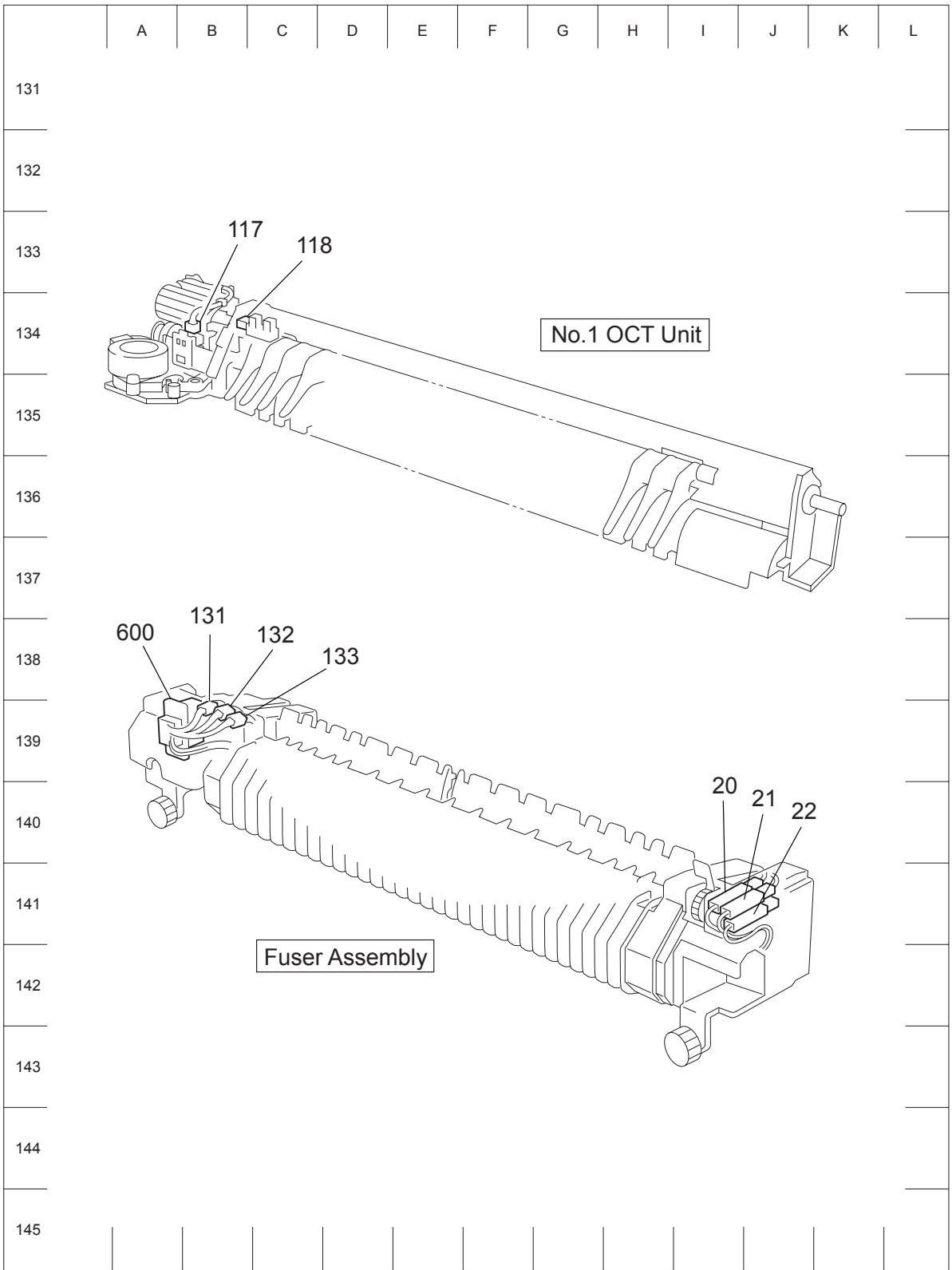


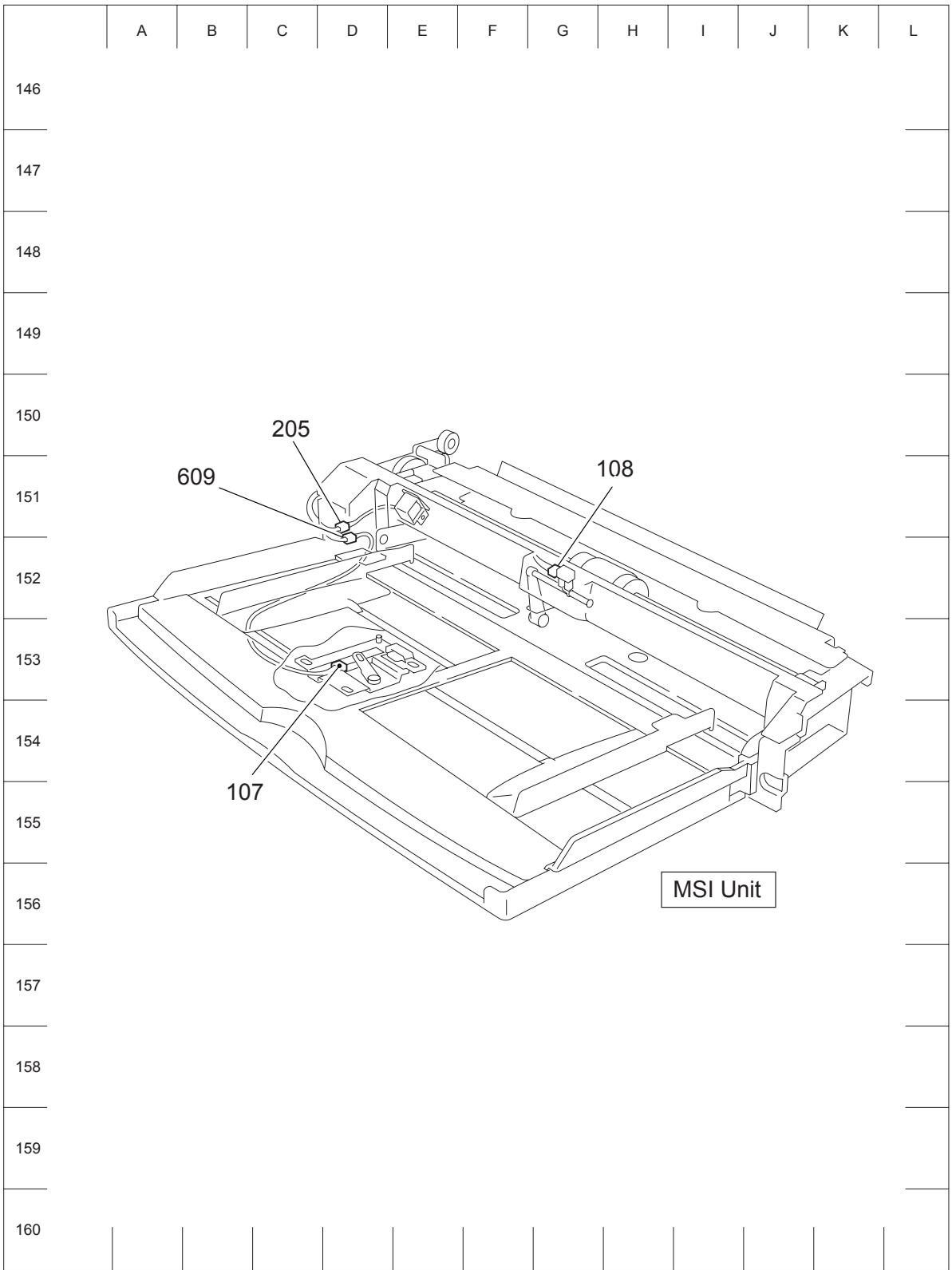
P/J	Coordinates	Remarks
601	C-183	Connects Tray 1 Feeder Harness Assembly and Feeder Harness Assembly
602	C-184	Connects Tray 2 Feeder Harness Assembly and Feeder Harness Assembly
605	I-199	Connects MPF Assembly and MPF Harness Assembly
606	G-195	Connects EXIT 2 Harness Assembly and EXIT Harness Assembly
607	G-199	Connects Fuser Harness Assembly and PH Harness Assembly
608	C-184	Connects Take Away Sensor Harness Assembly and PH Harness Assembly
609	D-151	Connects MPF Sensor Harness Assembly and MPF Harness Assembly
610	B-109	Connects ATC Sensor and REGI Harness Assembly
613	G-196	Connects OCT Harness Assembly and EXIT Harness Assembly
620	F-122	Connects ROS and ROS Harness Assembly
800	H-200	Connects HCF and HCF Harness Assembly

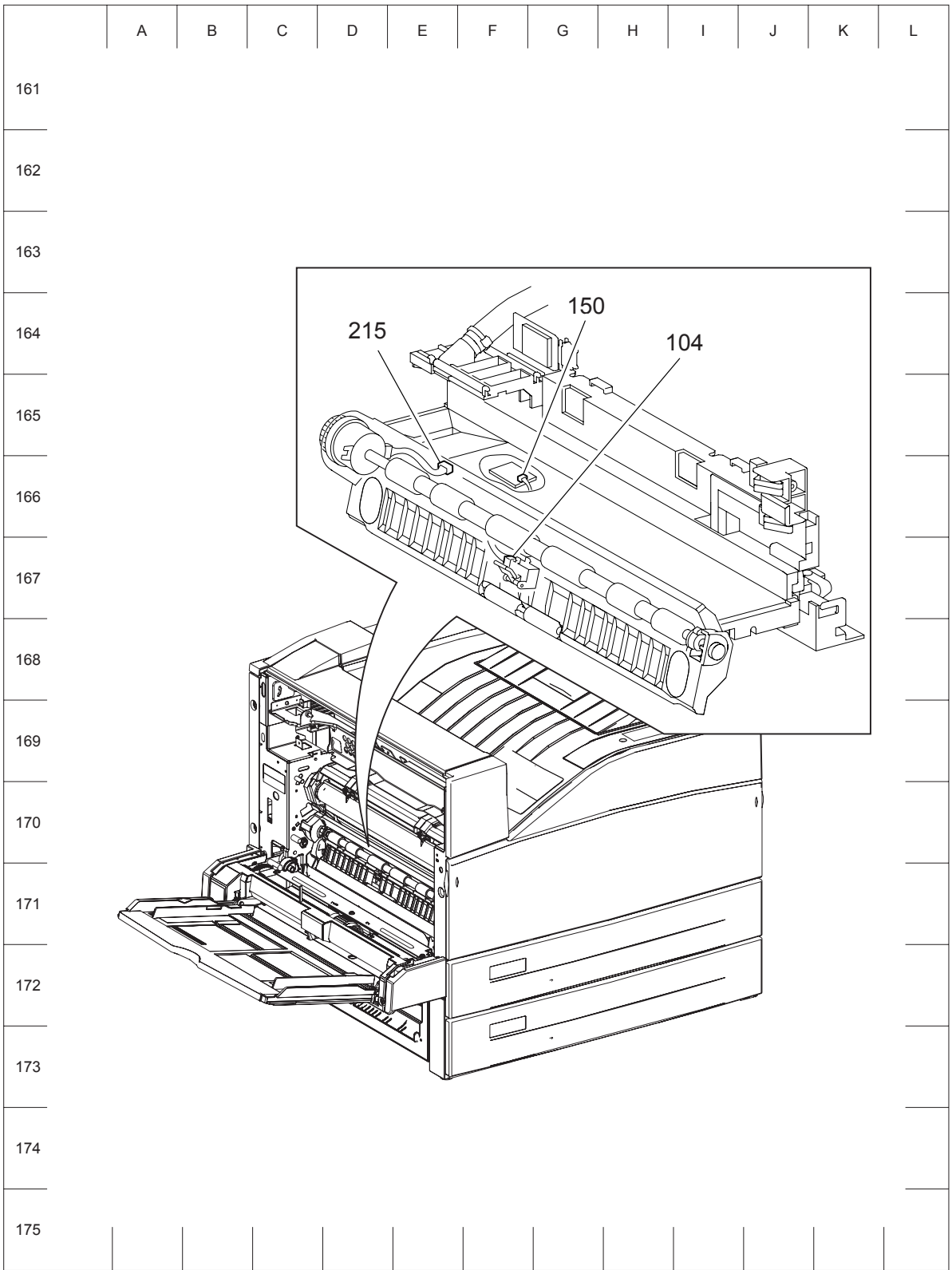
**P/J layout diagram**

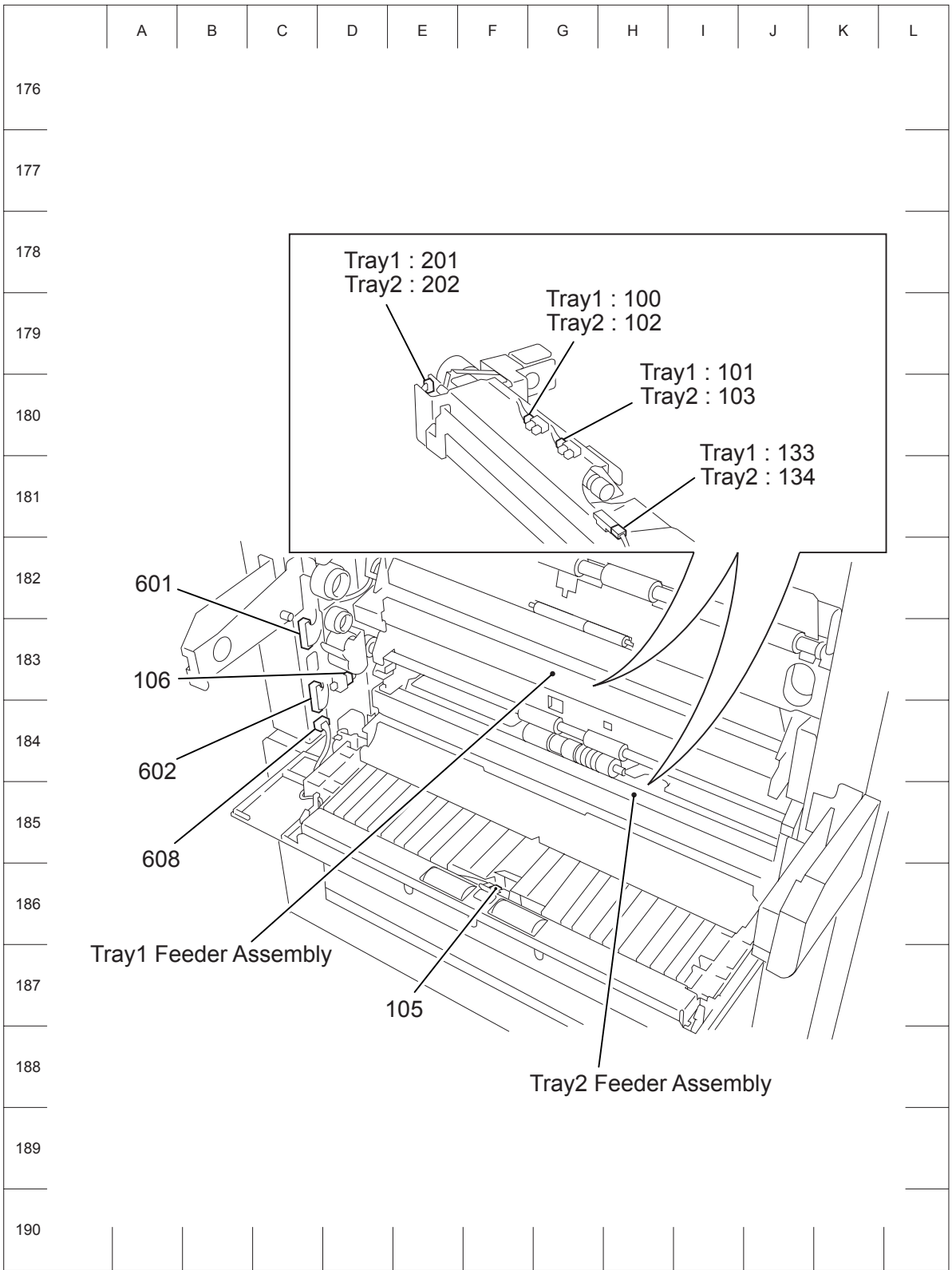


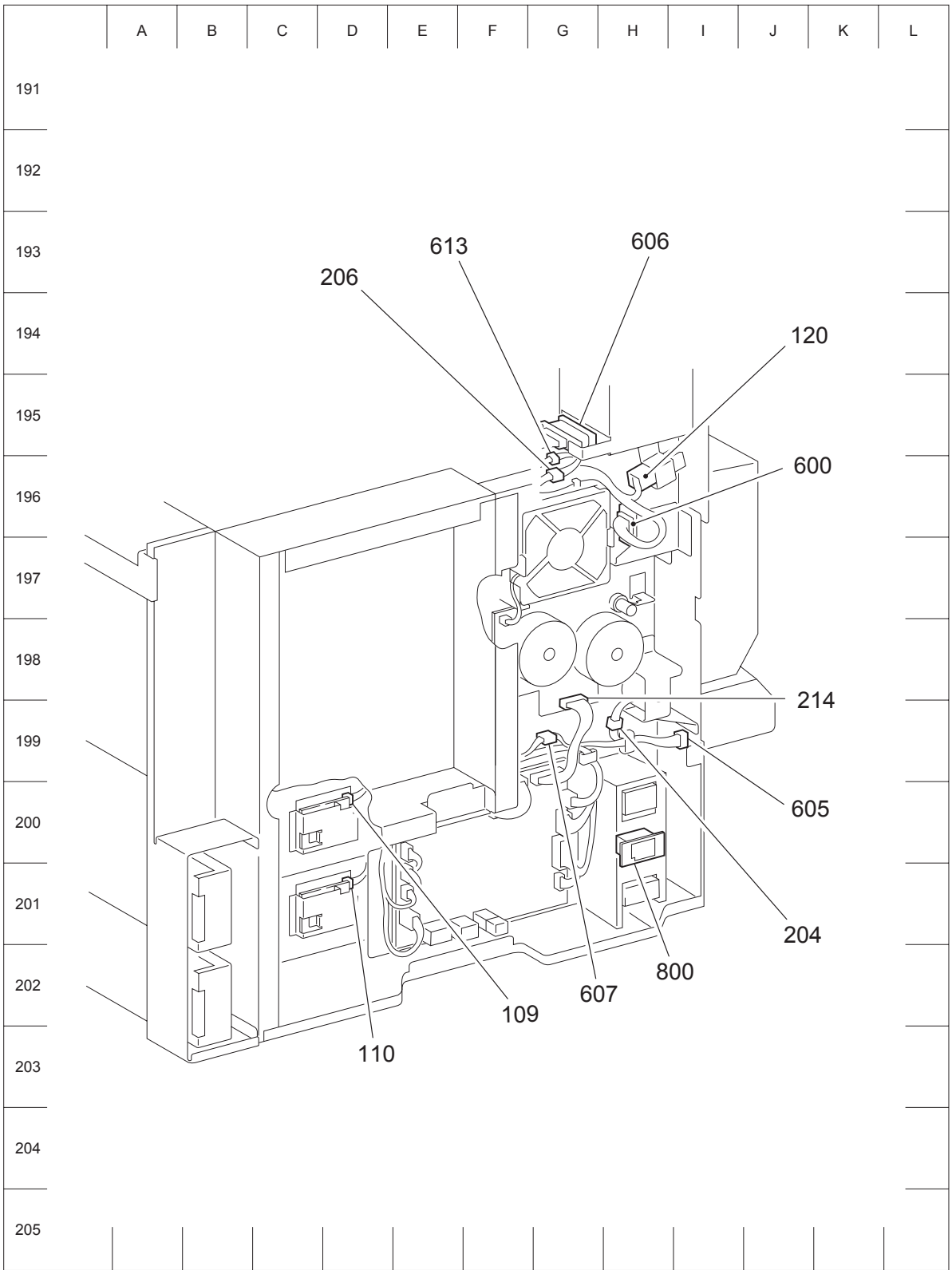




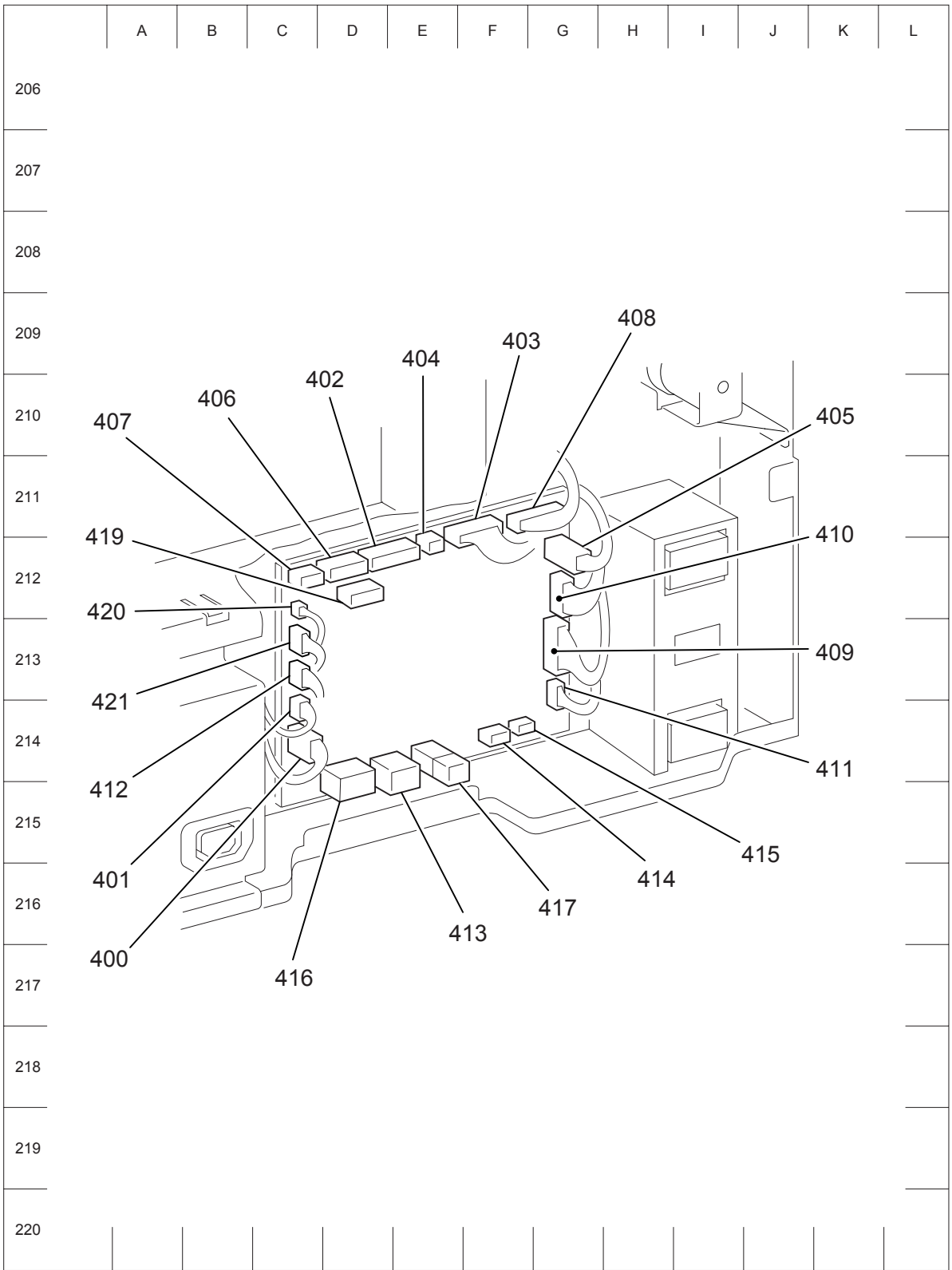


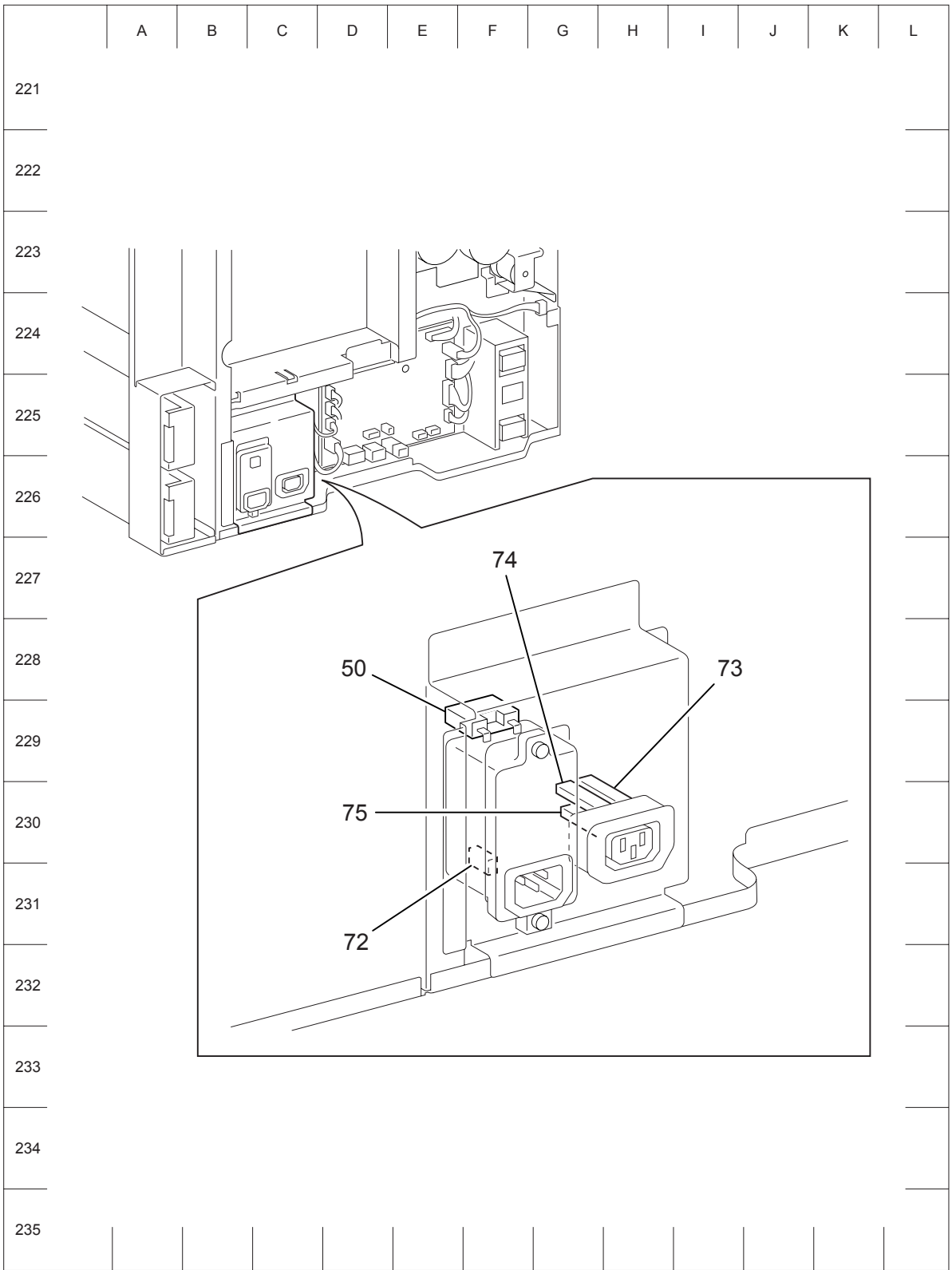


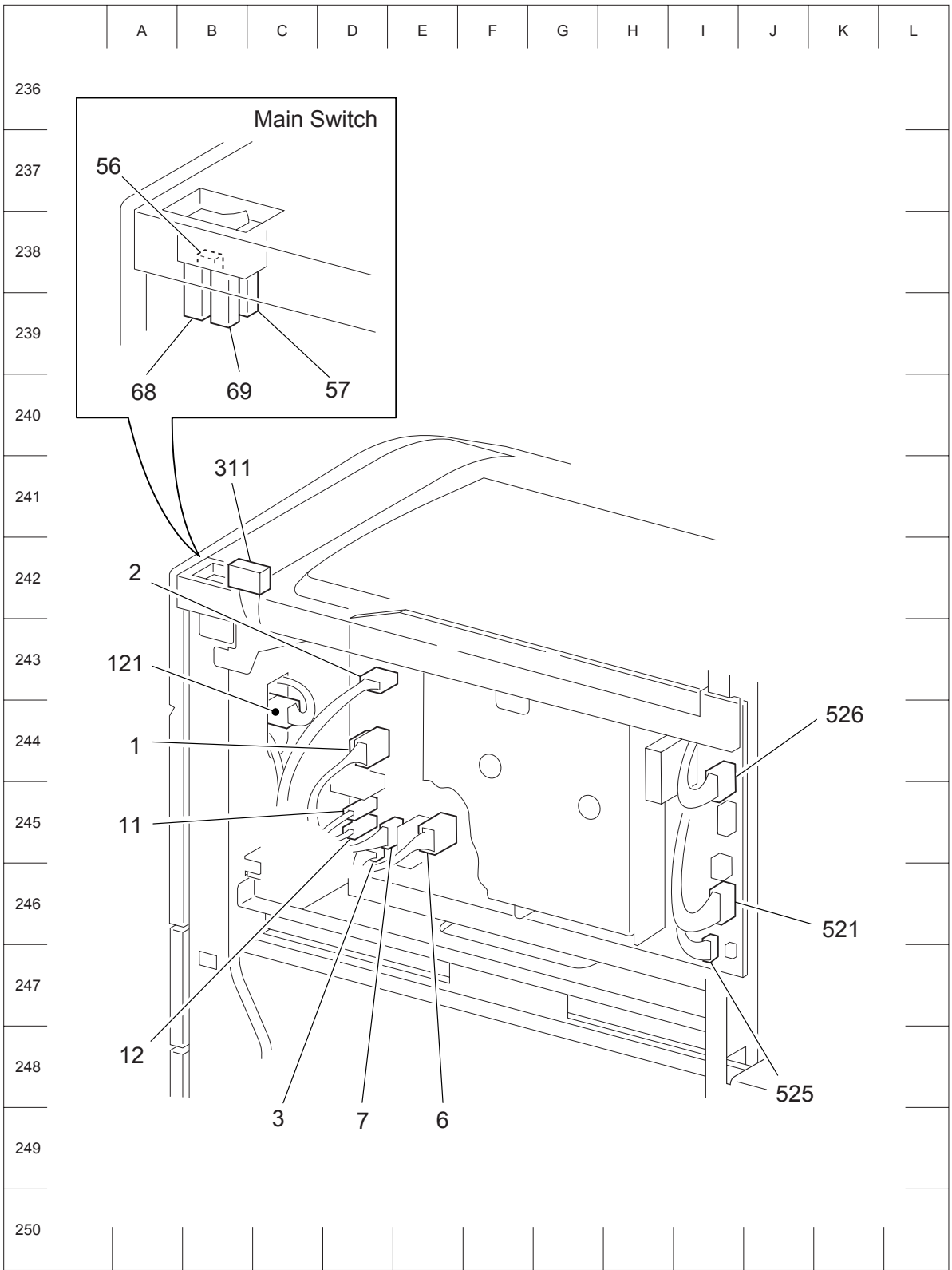










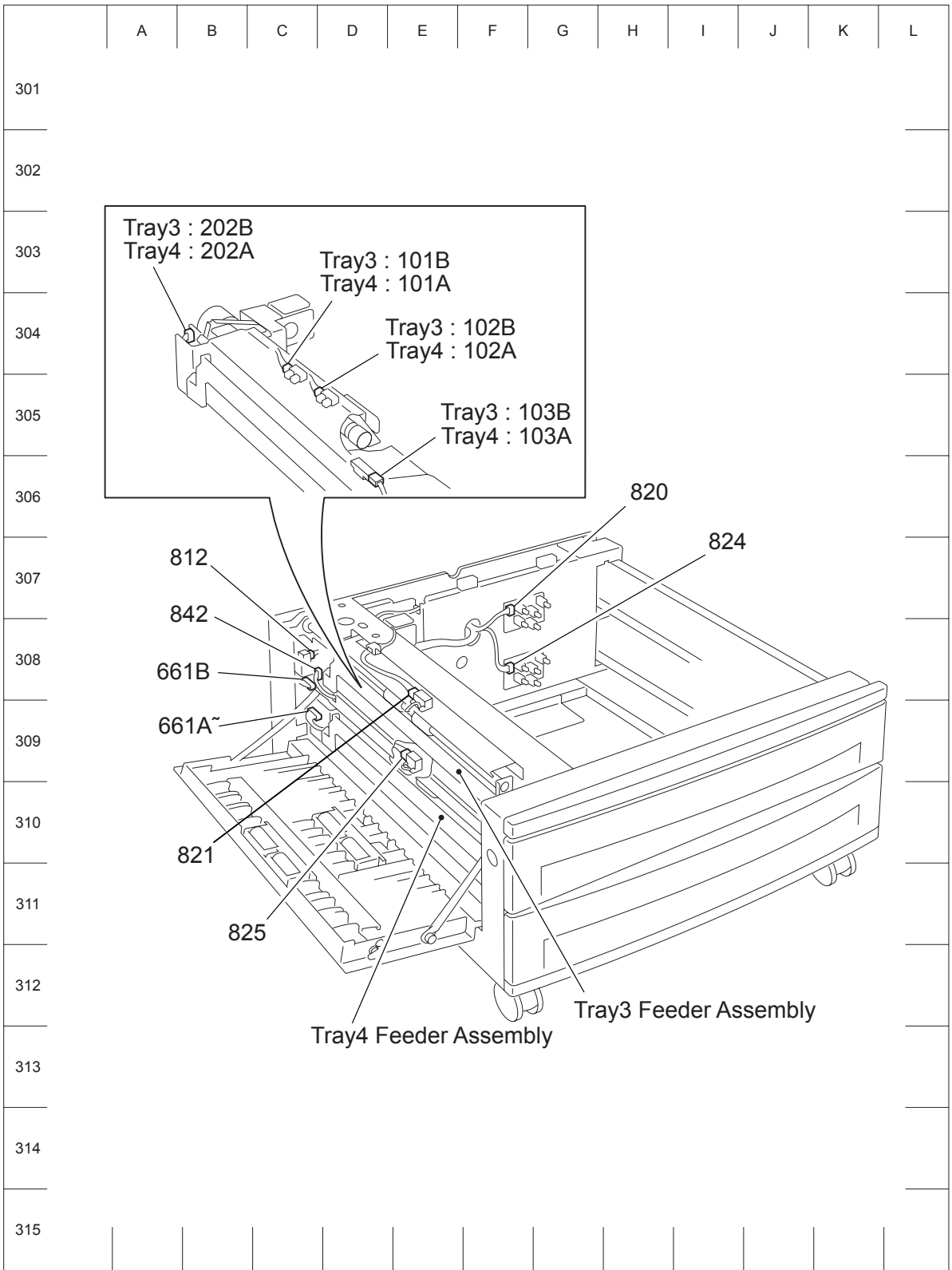


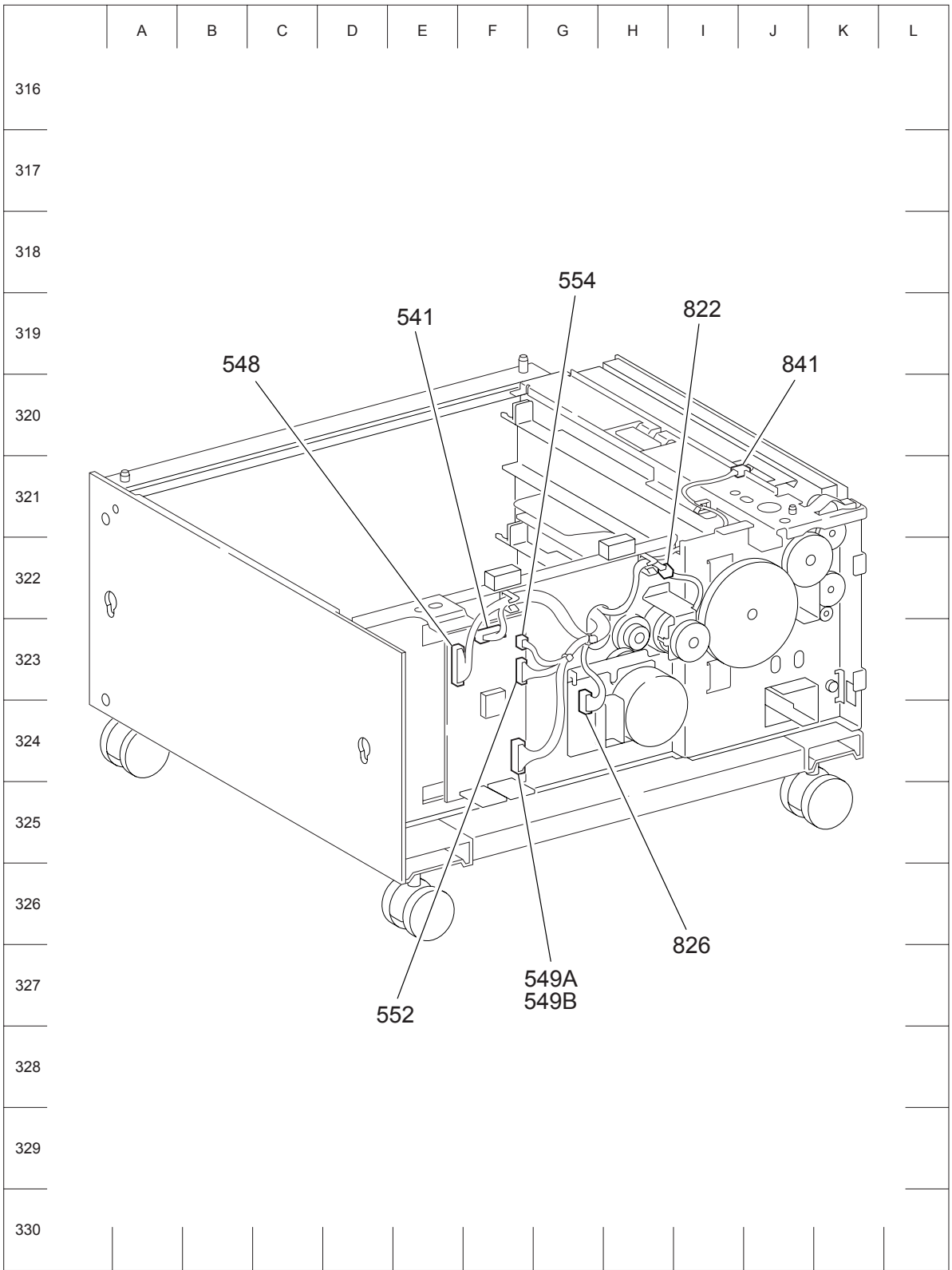
**1000 Sheet Feeder**  
**Connector [P (plug) / J (jack)]**

## List of P/J

P/J	Coordinates	Remarks
101A	C-304	Connects Level Sensor 4 and Tray 4 Harness Assembly
101B	C-304	Connects Level Sensor 3 and Tray 3 Harness Assembly
102A	D-305	Connects No Paper Sensor 4 and Tray 4 Harness Assembly
102B	D-305	Connects No Paper Sensor 3 and Tray 3 Harness Assembly
103A	D-306	Connects Pre Feed Sensor 4 and Tray 4 Harness Assembly
103B	D-306	Connects Pre Feed Sensor 3 and Tray 3 Harness Assembly
202A	B-304	Connects FMOT 4 and Tray 4 Harness Assembly
202B	B-304	Connects FMOT 3 and Tray 3 Harness Assembly
541	F-323	Connects PWBA ABC TM and Tray Module Harness Assembly
548	E-323	Connects PWBA ABC TM and Size Switch Harness Assembly
549A	F-324	Connects PWBA ABC TM and Feeder Harness Assembly
549B	F-324	Connects PWBA ABC TM and Feeder Harness Assembly
552	F-323	Connects PWBA ABC TM and T/A Harness Assembly
554	F-323	Connects PWBA ABC TM and Interlock Switch Harness Assembly
661A	D-309	Connects Tray 4 Harness Assembly and Feeder Harness Assembly
661B	D-308	Connects Tray 3 Harness Assembly and Feeder Harness Assembly
812	D-308	Connects Interlock Switch and Interlock Switch Harness Assembly
820	G-307	Connects Size Switch 3 and Size Switch Harness Assembly
821	E-308	Connects F-Out Sensor 3 and F-Out Sensor 3 Harness Assembly
822	I-322	Connects T/A Clutch and T/A Harness Assembly
824	G-308	Connects Size Switch 4 and Size Switch Harness Assembly
825	E-309	Connects F-Out Sensor 4 and F-Out Sensor 4 Harness Assembly
826	G-324	Connects T/A Motor and T/A Harness Assembly
841	I-320	Connects F-Out Sensor 3 Harness Assembly and Size Switch Harness Assembly
842	D-308	Connects F-Out Sensor 4 Harness Assembly and Size Switch Harness Assembly

## P/J layout diagram



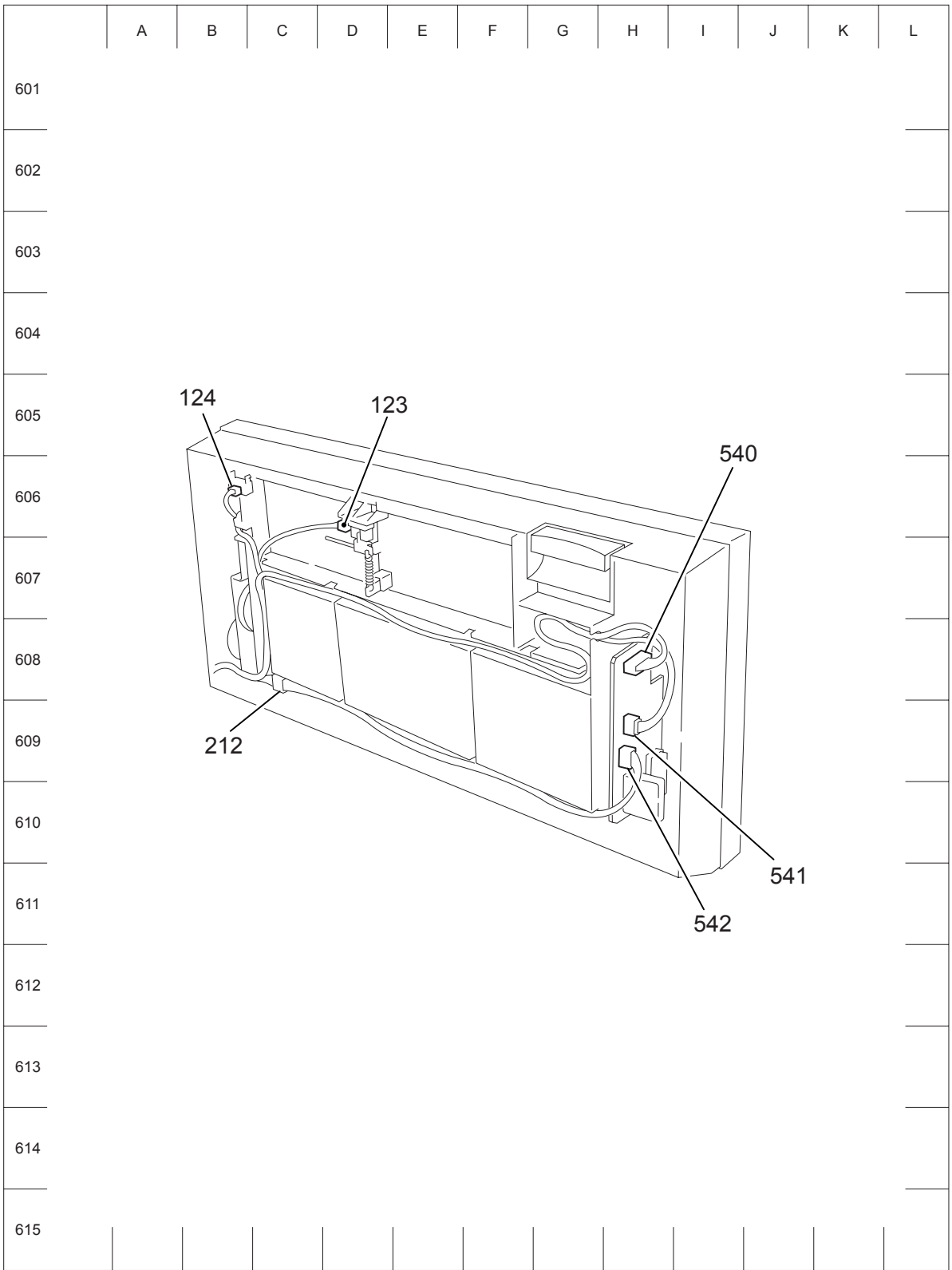


## Duplex

Connector [P (plug) / J (jack)]

**List of P/J**

P/J	Coordinates	Remarks
123	D-606	Connects DUP Sensor and DUP Sensor Harness Assembly
124	B-606	Connects DUP Open Switch and Sensor Harness Assembly
212	C-608	Connects DUP Motor and DUP Motor Harness Assembly
540	H-608	Connects PWBA DUP and DUP Harness Assembly
541	H-609	Connects PWBA DUP and DUP Sensor Harness Assembly
542	H-609	Connects PWBA DUP and DUP Motor Harness Assembly



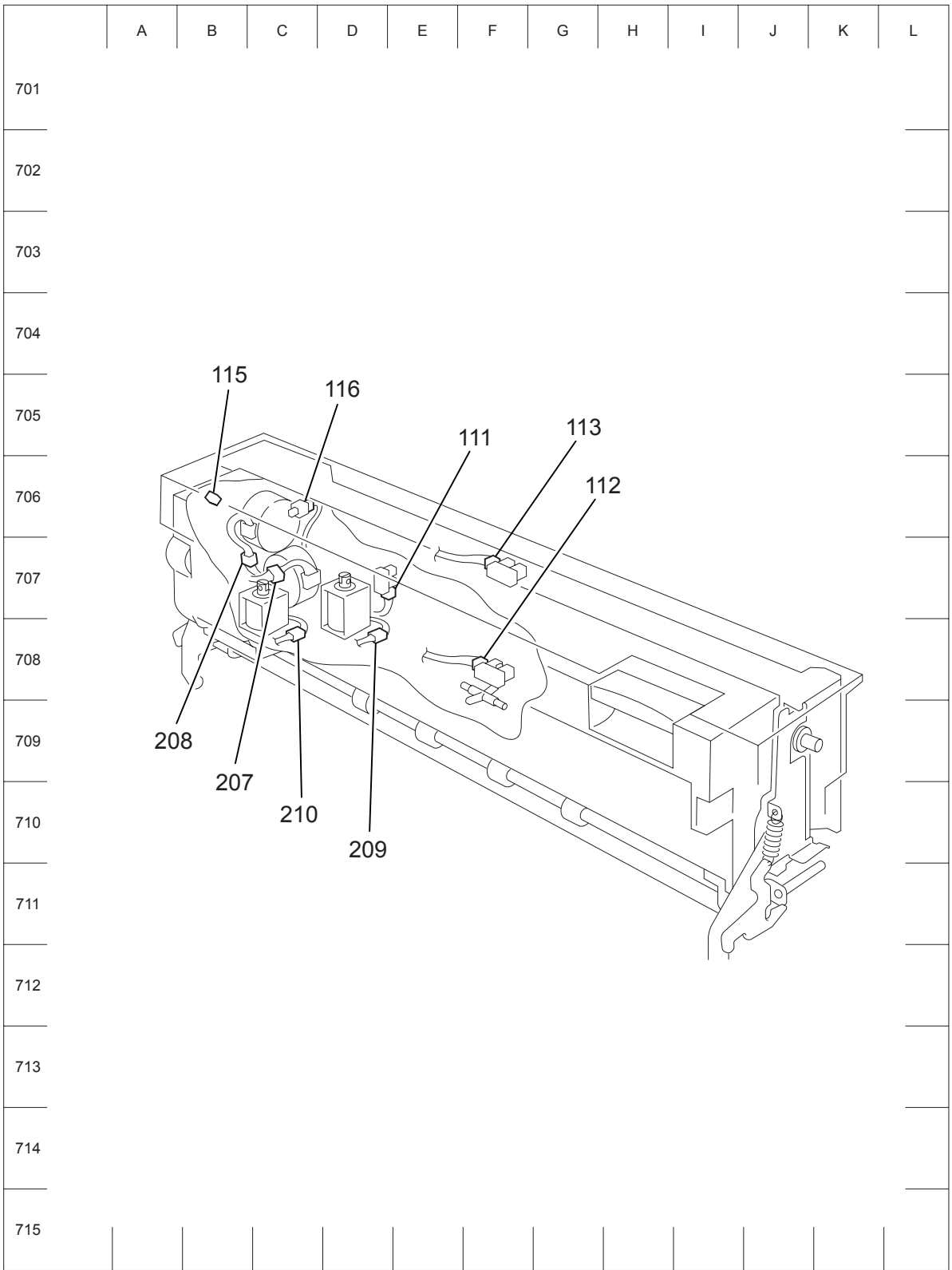
## Exit 2

### Connector [P (plug) / J (jack)]

#### List of P/J



P/J	Coordinates	Remarks
111	D-707	Connects OCT Home 2 Sensor and Exit 2 Harness Assembly
112	F-708	Connects Exit 2 Sensor and Exit 2 Harness Assembly
113	F-707	Connects Full Stack Sensor and Exit 2 Harness Assembly
115	B-706	Not Used
116	C-706	Connects Interlock Switch and Exit 2 Harness Assembly
207	C-707	Connects No.2 OCT Motor and Exit 2 Harness Assembly
208	B-707	Connects Exit Drive Motor and Exit 2 Harness Assembly
209	D-708	Connects Exit Gate Solenoid and Exit 2 Harness Assembly
210	C-708	Connects Fut Gate Solenoid and Exit 2 Harness Assembly



# Finisher

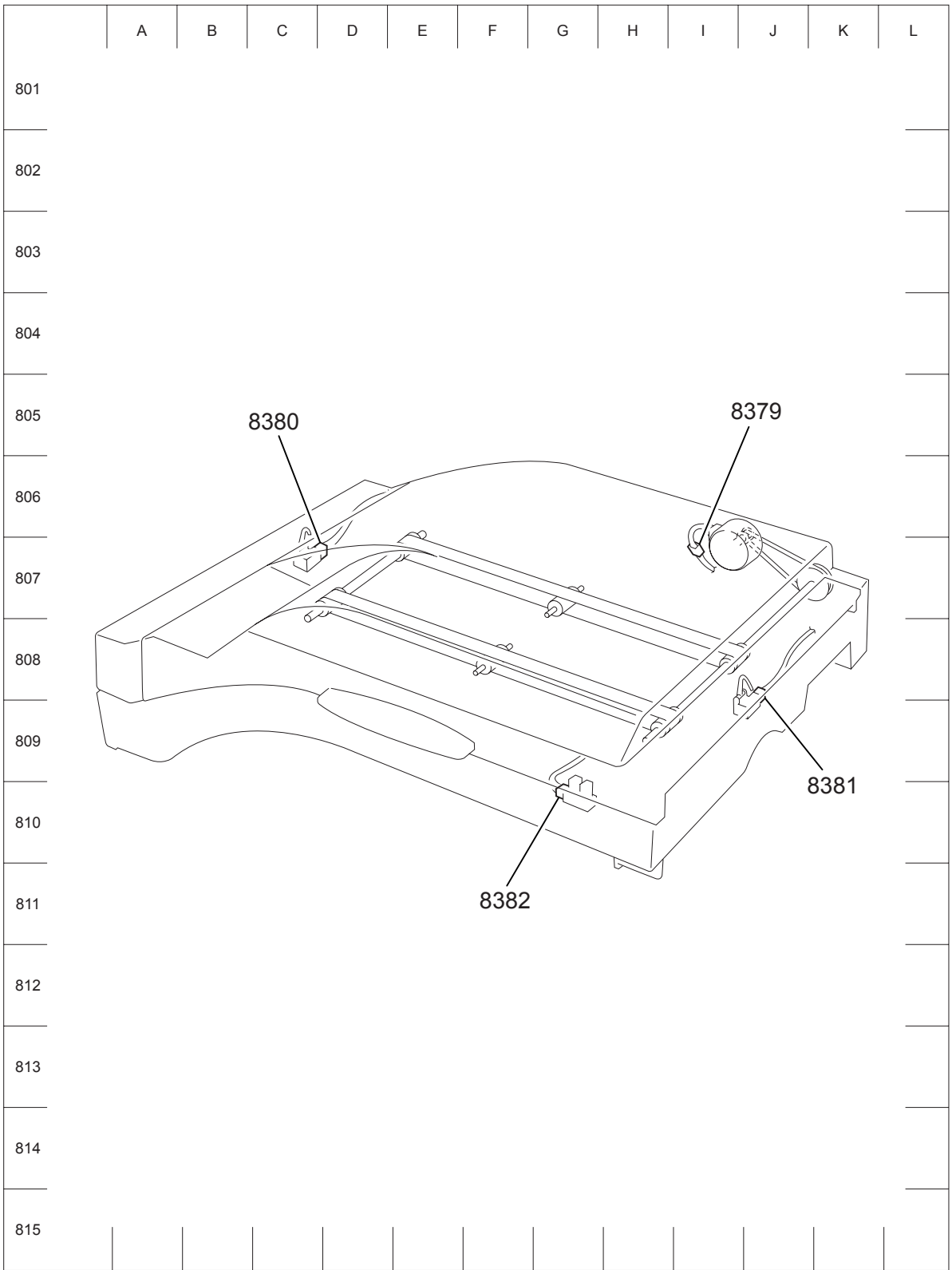
## Connector [P (plug) / J (jack)]

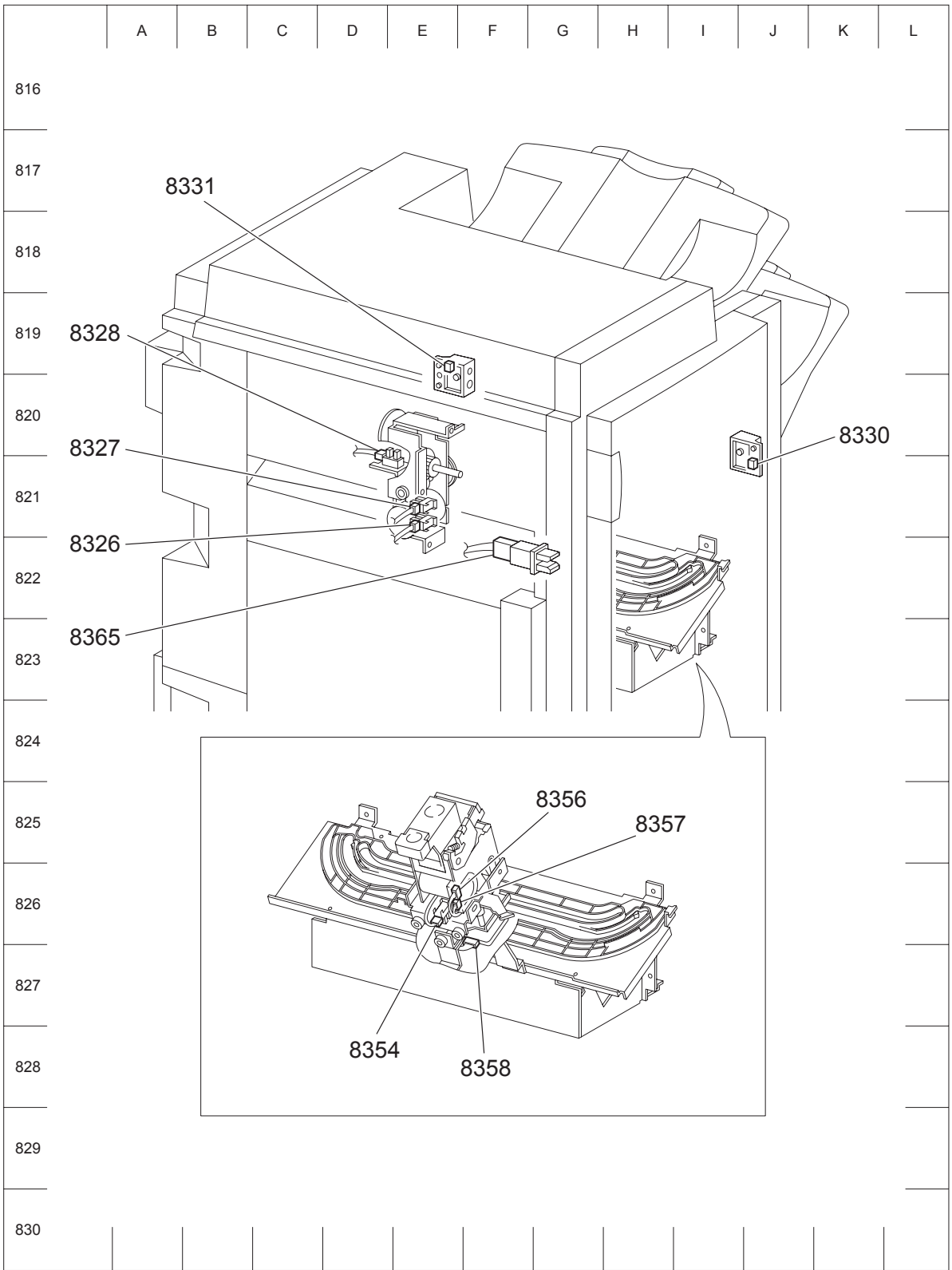
### List of P/J

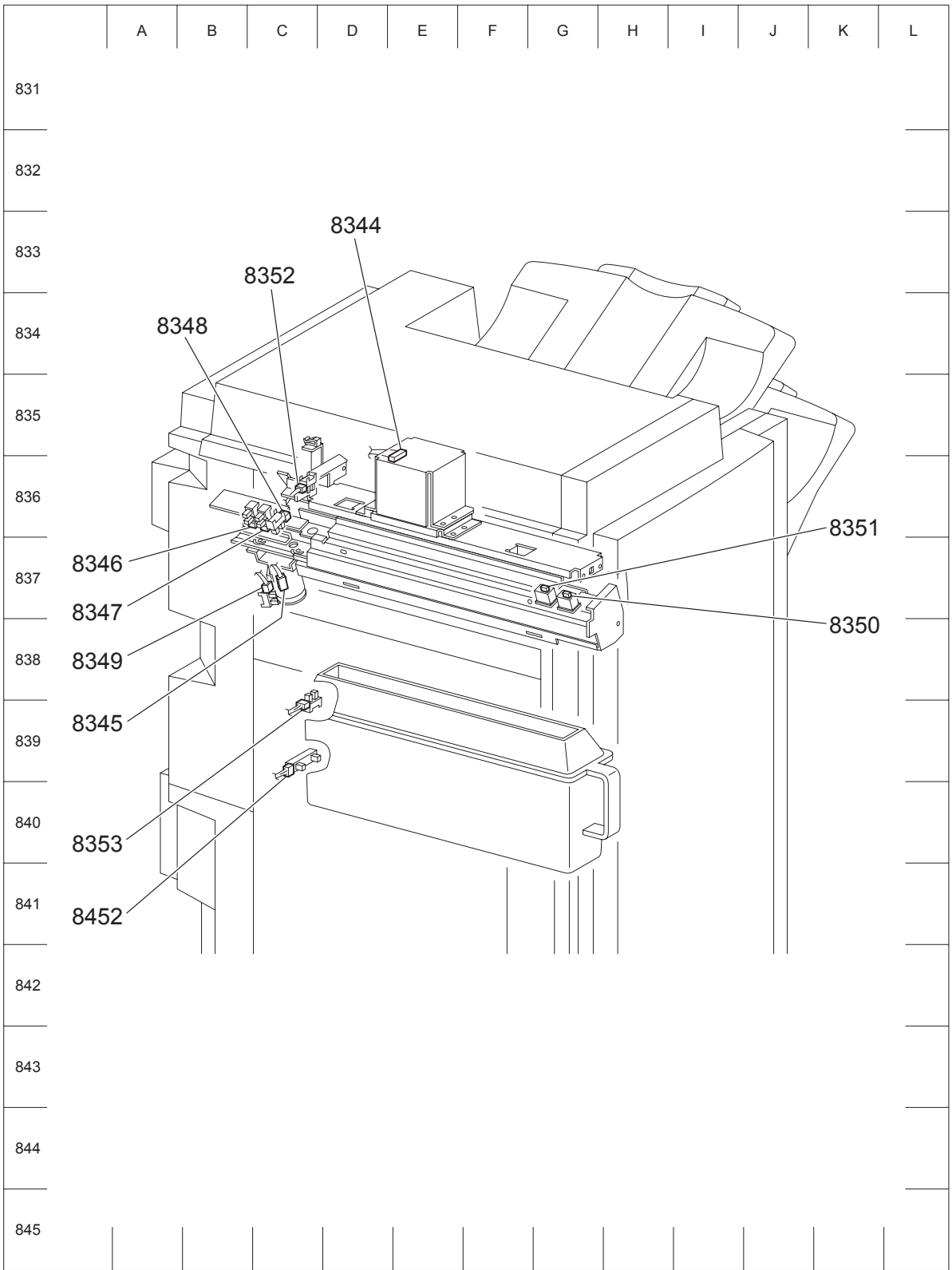
P/J	Coordinates	Remarks
2	E-903	Connects LVPS and AC Inlet Harness Assembly
502	B-902	Connects LVPS and LVPS Harness Assembly
505	B-902	Connects LVPS and LVPS Harness Assembly
8300	G-894	Connects PWBA Main-C and I/F Harness Assembly
8301	G-894	Not Connects
8302	E-895	Connects PWBA Main-C and Main Sensor Harness Assembly
8304	E-892	Connects PWBA Main-C and Main Drive Harness Assembly
8305	E-894	Connects PWBA Main-C and Elevator Motor
8306	G-892	Connects PWBA Main-C and Punch Drive Harness Assembly
8307	G-893	Connects PWBA Main-C and Punch Sensor Harness Assembly
8308	F-892	Connects PWBA Main-C and Staple Harness Assembly
8309	E-894	Connects PWBA Main-C and Compiler Harness Assembly
8310	G-895	Connects PWBA Main-C and Htra Harness Assembly
8311	E-896	Not Connects
8313	F-896	Not Connects
8314	F-896	Connects PWBA Main-C and Interlock Harness Assembly
8315	E-896	Connects PWBA Main-C and LVPS Harness Assembly
8316	G-896	Not Connects
8317	E-896	Not Connects
8319	E-883	Connects X'port Ent Sensor and Harness Assembly
8320	F-853	Connects Compile Exit Sensor and Comp Sensor Harness Assembly
8321	F-881	Connects Top Tray Exit Sensor and Top Tray Exit Sensor Harness Assembly
8322	F-881	Connects Top Tray Full Sensor and Top Tray Full Sensor Harness Assembly
8324	E-852	Connects Eject Clamp Home Sensor and Main Sensor Harness Assembly
8325	E-868	Connects Set Clamp Home Sensor and Main Sensor Harness Assembly
8326	E-821	Connects Stacker No Paper Sensor and Main Sensor Harness Assembly
8327	E-821	Connects Upper Limit Sensor and Main Sensor Harness Assembly
8328	D-821	Connects Stack Encoder Sensor and Main Sensor Harness Assembly
8330	J-821	Connects Stack Height Sensor 2 and Main Sensor Harness Assembly
8331	E-819	Connects Stack Height Sensor 1 and Main Sensor Harness Assembly
8334	C-880	Connects Exit Motor and Main Drive Harness Assembly
8335	D-881	Connects Regi Motor and Main Drive Harness Assembly
8336	D-866	Connects Eject Motor and Main Drive Harness Assembly
8338	E-868	Connects Set Clamp Clutch and Main Drive Harness Assembly
8339	C-851	Connects Eject Clamp Motor and Main Drive Harness Assembly
8340	H-852	Connects Sub Paddle Solenoid and Main Drive Harness Assembly
8341	C-853	Connects Transport Gate Solenoid and Main Drive Harness Assembly
8342	B-884	Connects Fin Transport Motor and Main Drive Harness Assembly
8344	E-835	Connects Puncher Move Motor and Punch Drive Harness Assembly
8345	C-837	Connects Puncher Motor and Punch Unit Harness Assembly
8346	C-836	Connects Punch Hole Select Sensor and Punch Unit Harness Assembly
8347	C-836	Connects Puncher Front Sensor and Punch Unit Harness Assembly
8348	C-836	Connects Puncher Home Sensor and Punch Unit Harness Assembly
8349	C-837	Connects Puncher Motor Sensor and Punch Unit Harness Assembly
8350	G-837	Connects Side Regi Sensor 1 and Punch Unit Harness Assembly
8351	G-837	Connects Side Regi Sensor 2 and Punch Unit Harness Assembly
8352	C-836	Connects Puncher Move Home Sensor and Punch Sensor Harness Assembly

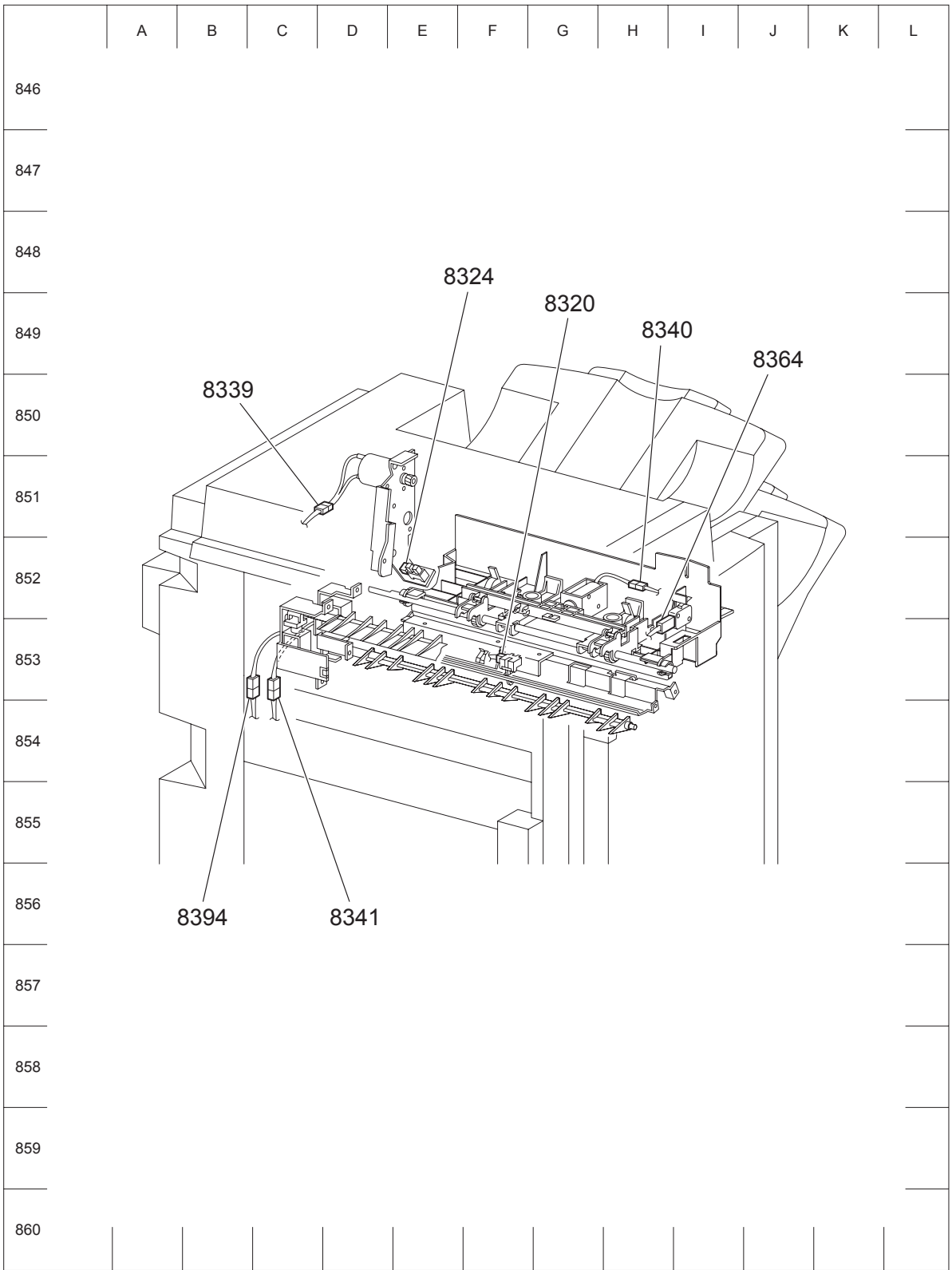
P/J	Coordinates	Remarks
8353	C-838	Connects Punch Box Set Sensor and Punch Box Set Sensor Harness Assembly
8354	E-826	Connects Stapler Move Position Sensor and Staple Harness Assembly
8356	F-826	Connects Stapler Unit and Staple Harness Assembly
8357	F-826	Connects Stapler Unit and Staple Harness Assembly
8358	F-826	Connects Stapler Move Motor and Staple Harness Assembly
8359	G-869	Connects Compile Tray No Paper and Compiler Harness Assembly
8360	I-869	Connects Front Tamper Home Sensor and Compiler Harness Assembly
8361	E-868	Connects Rear Tamper Home Sensor and Compiler Harness Assembly
8362	F-868	Connects Rear Tamper Motor and Compiler Harness Assembly
8363	G-869	Connects Front Tamper Motor and Compiler Harness Assembly
8364	H-852	Connects Eject Cover Switch and Interlock Harness Assembly
8365	F-822	Connects Finisher Front Door Switch and Interlock Harness Assembly
8371	I-898	Connects PWBA Htra and Htra Harness Assembly
8372	I-898	Connects PWBA Htra and H-X'port 1 Harness Assembly
8373	I-898	Not Connects
8376	E-895	Connects PWBA Main-C and Gate Sensor 1 Harness Assembly
8379	I-807	Connects H-X'Port Ent Sensor and H-X'Port Harness Assembly
8380	C-807	Connects H-X'Port Motor and H-X'Port Harness Assembly
8381	J-809	Connects H-X'Port Exit Sensor and H-X'Port Harness Assembly
8382	G-810	Connects H-X'Port Interlock Sensor and H-X'Port Harness Assembly
8389	F-892	Not Connects
8392	F-882	Connects Buffer Path Sensor and Buffer Path Sensor Harness Assembly
8394	B-853	Connects Buffer Gate Solenoid and Main Drive Harness Assembly
8394	J-898	Connects PWBA Htra and Htra Assembly
8432	E-882	Connects Gate Sensor and Gate Sensor Harness Assembly
8452	C-839	Connects Punch Full Sensor and Punch Full Sensor Harness Assembly
8500	I-898	Connects PWBA Htra and Punch Full Sensor Harness Assembly

**P/J layout diagram**

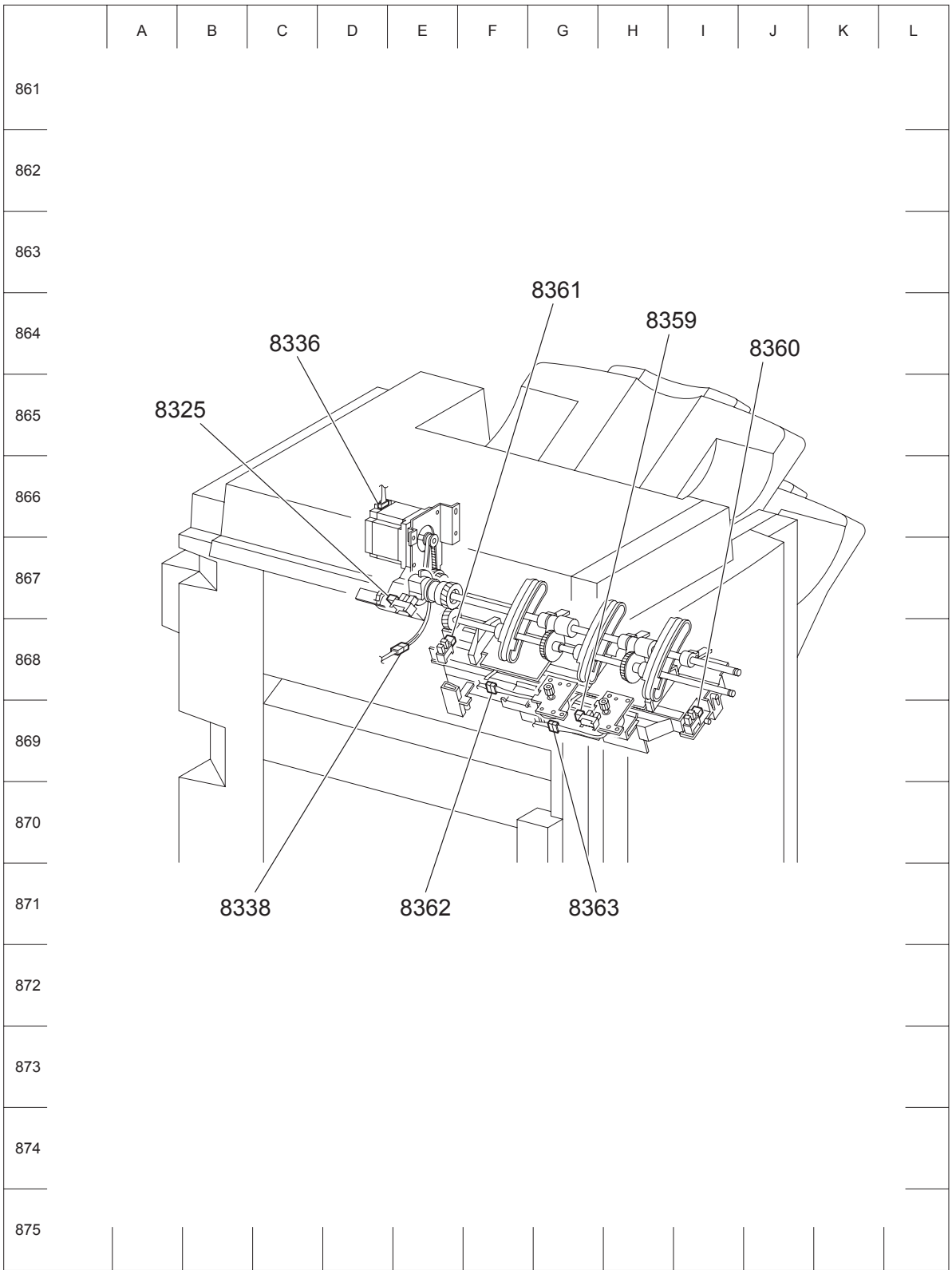


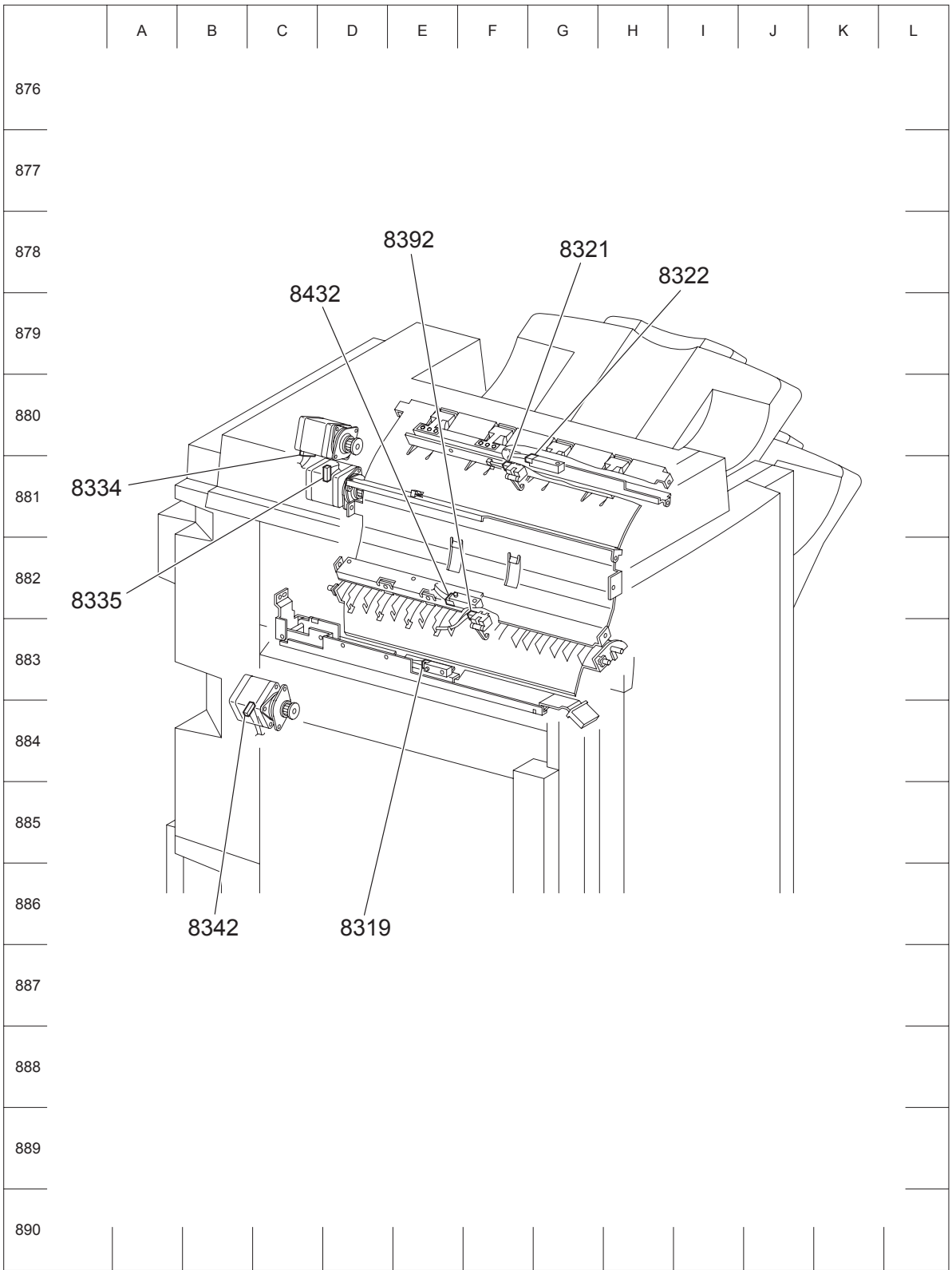


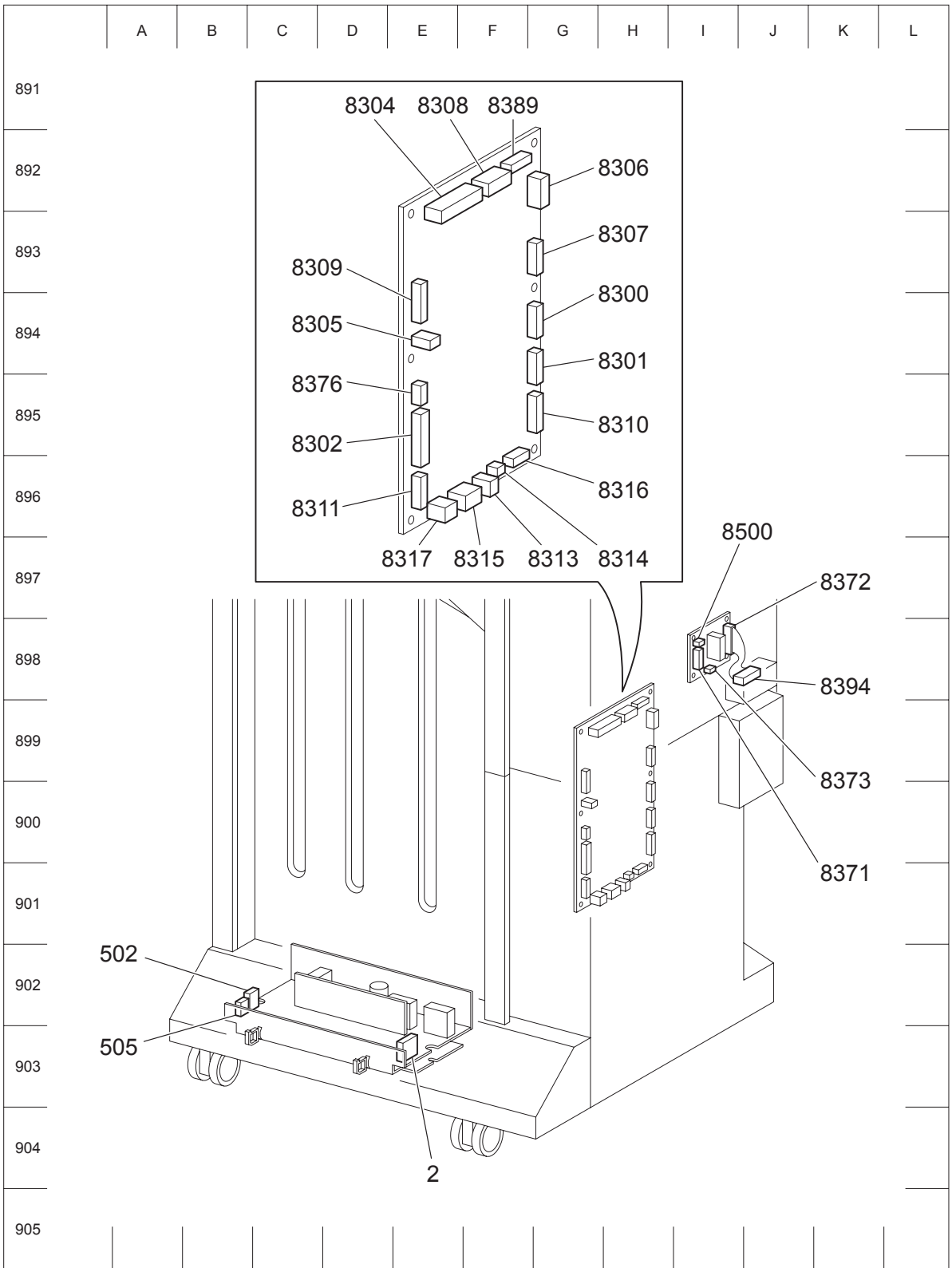












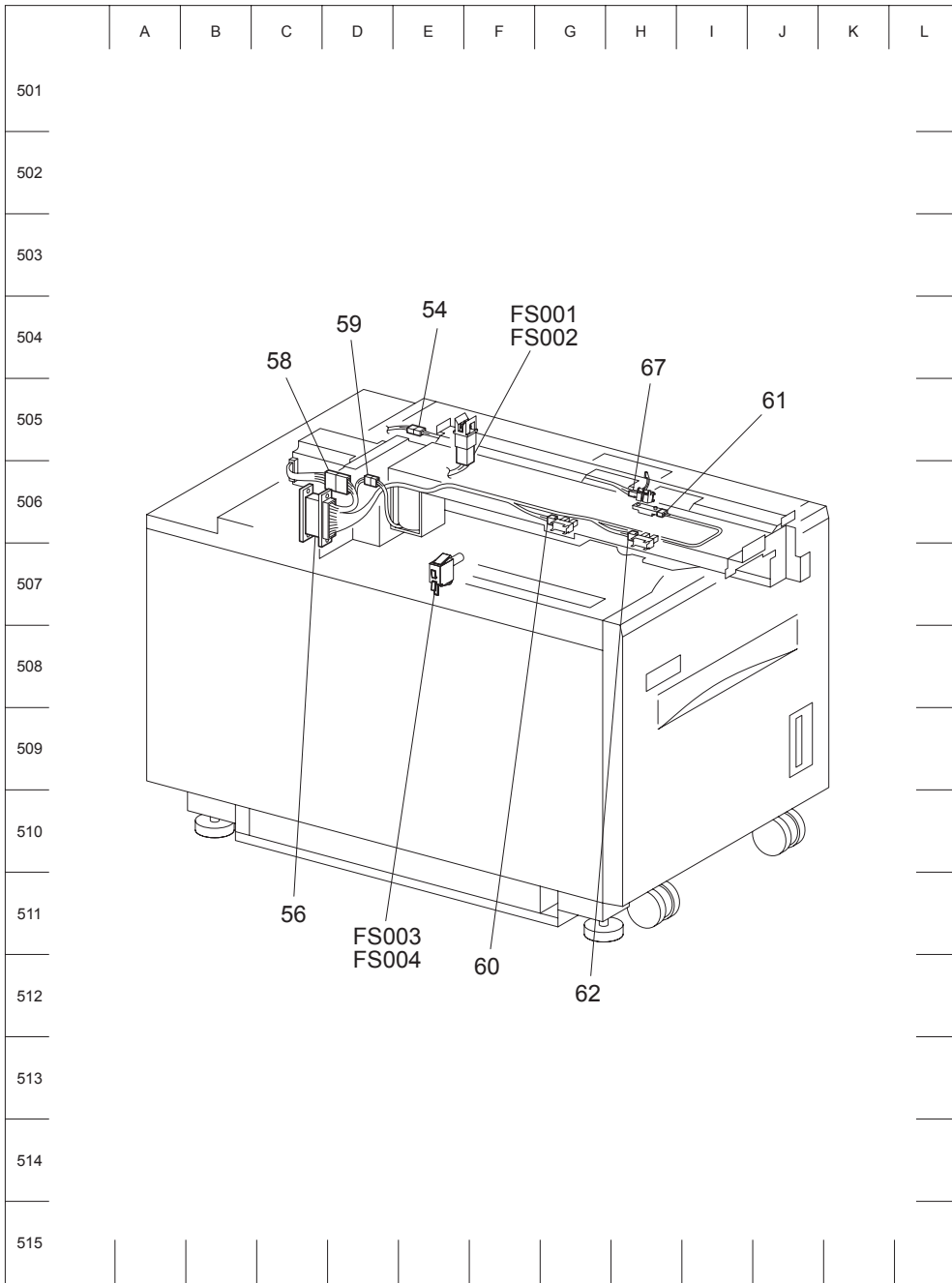
# HCF

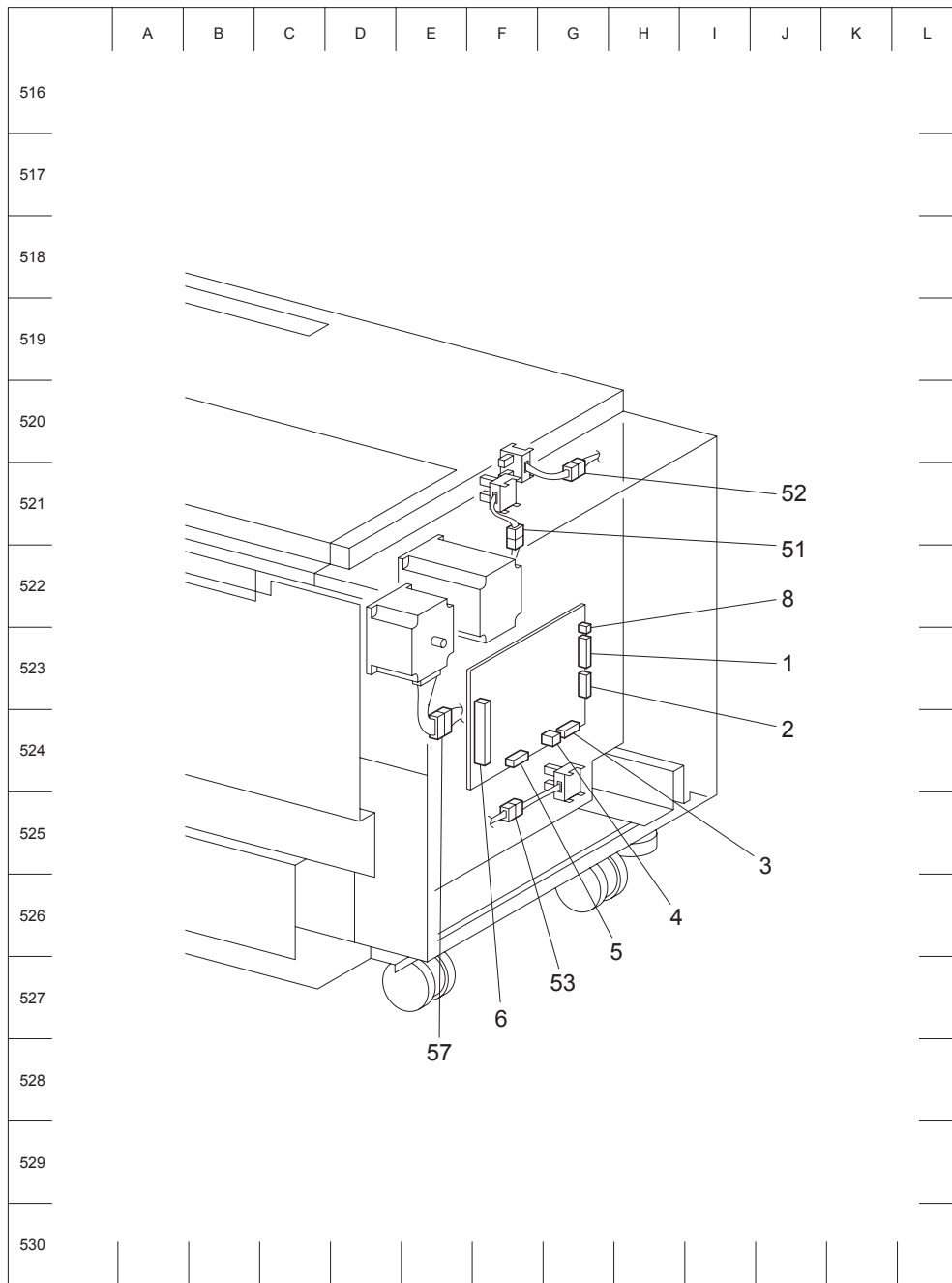
## Connector [P (plug) / J (jack)]

### List of P/J

P/J	Coordinates	Remarks
1	G-523	Connects PWBA HCF and Sensor Harness Assembly
2	G-523	Connects PWBA HCF and HCF Feeder 1 Harness Assembly
3	G-524	Connects PWBA HCF and HCF Harness Assembly
4	G-524	Connects PWBA HCF and HCF Harness Assembly
5	F-524	Connects PWBA HCF and Interlock Switch Harness Assembly
6	F-524	Connects PWBA HCF and HCF Feeder 1 Harness Assembly
8	G-523	Connects PWBA HCF and Side Out Switch Harness Assembly
51	F-521	Connects Size A Sensor and Sensor Harness Assembly
52	G-521	Connects Size B Sensor and Sensor Harness Assembly
53	F-525	Connects Tray In Sensor and Sensor Harness Assembly
54	E-505	Connects Feed Out Sensor Harness Assembly and Sensor Harness Assembly
56	C-506	Connects HCF Feeder Harness Assembly and HCF Feeder 1 Harness Assembly
57	E-524	Connects T/A Motor and HCF Feeder 1 Harness Assembly
58	D-506	Connects Feed Motor and HCF Feeder Harness Assembly
59	D-506	Connects NUG Solenoid and HCF Feeder Harness Assembly
60	G-506	Connects No Paper Sensor and HCF Feeder Harness Assembly
61	H-506	Connects PF Sensor and HCF Feeder Harness Assembly
62	H-506	Connects Level Sensor and HCF Feeder Harness Assembly
67	H-506	Connects Feed Out Sensor and Feed Out Sensor Harness Assembly
FS001	E-505	Connects Trans Interlock Switch and Interlock Switch Harness Assembly
FS002	E-505	Connects Trans Interlock Switch and Interlock Switch Harness Assembly
FS003	E-507	Connects HCF Side Out Switch and Side Out Switch Harness Assembly
FS004	E-507	Connects HCF Side Out Switch and Side Out Switch Harness Assembly

## PL 0.5 P/J layout diagram





## Tandem Tray

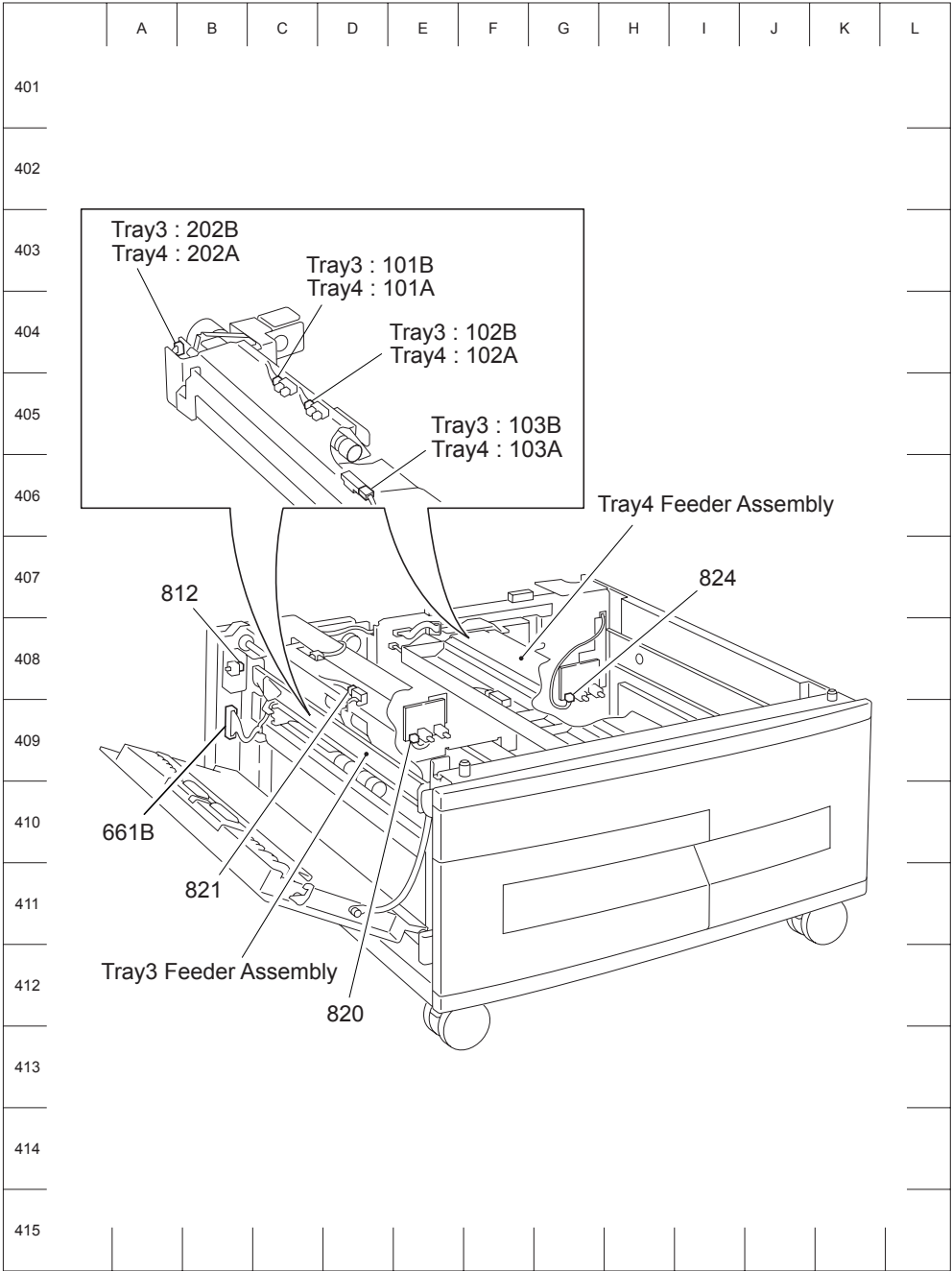
### Connector [P (plug) / J (jack)]

#### List of P/J

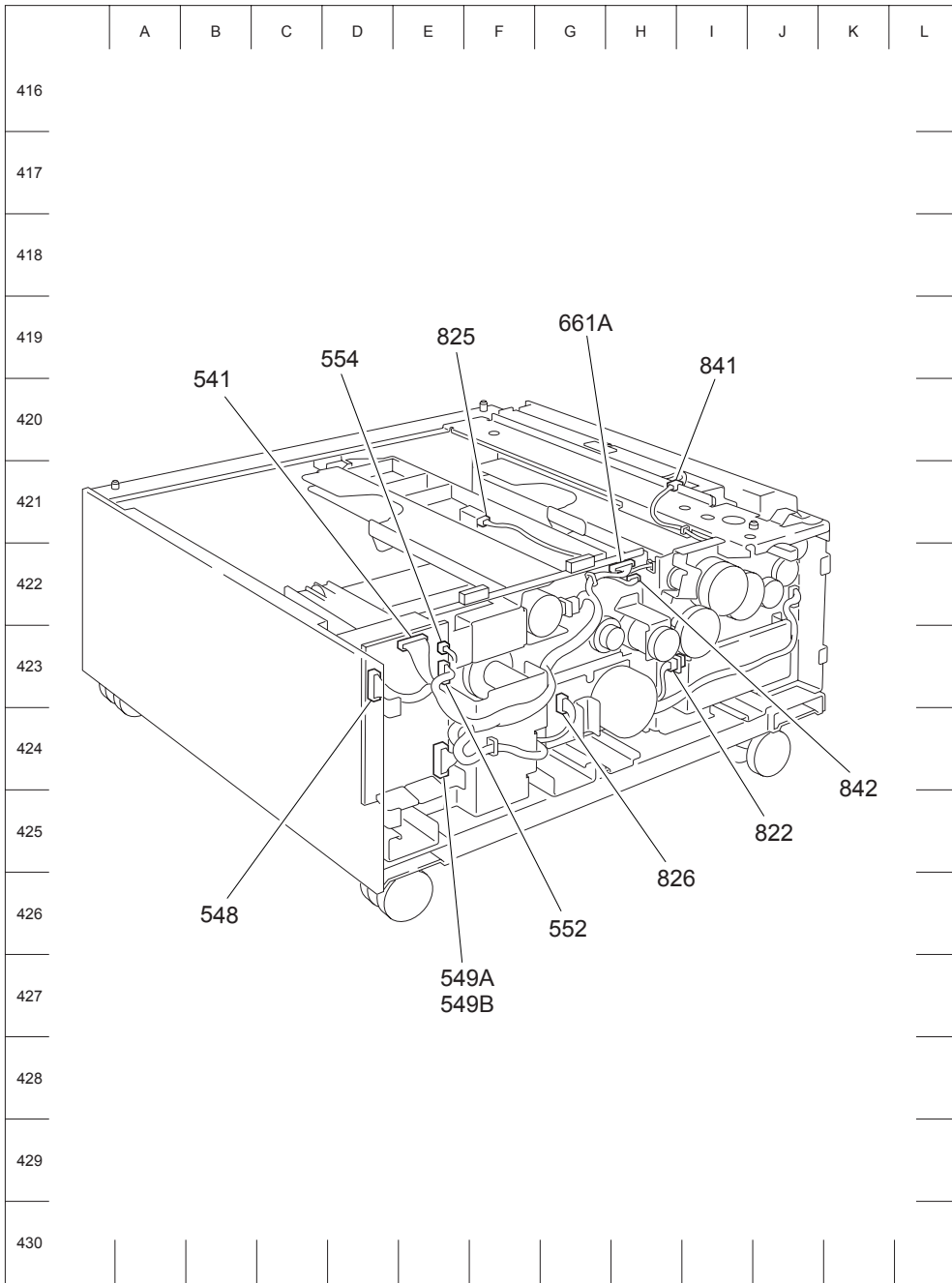
P/J	Coordinates	Remarks
101A	C-404	Connects Level Sensor 4 and Tray 4 Harness Assembly
101B	C-404	Connects Level Sensor 3 and Tray 3 Harness Assembly
102A	D-405	Connects No Paper Sensor 4 and Tray 4 Harness Assembly

P/J	Coordinates	Remarks
102B	D-405	Connects No Paper Sensor 3 and Tray 3 Harness Assembly
103A	D-406	Connects Pre Feed Sensor 4 and Tray 4 Harness Assembly
103B	D-406	Connects Pre Feed Sensor 3 and Tray 3 Harness Assembly
202A	A-404	Connects FMOT 4 and Tray 4 Harness Assembly
202B	A-404	Connects FMOT 3 and Tray 3 Harness Assembly
541	E-423	Connects PWBA ABC TM and Tray Module Harness Assembly
548	D-423	Connects PWBA ABC TM and Size Switch Harness Assembly
549A	E-424	Connects PWBA ABC TM and Feeder Harness Assembly
549B	E-424	Connects PWBA ABC TM and Feeder Harness Assembly
552	E-423	Connects PWBA ABC TM and T/A Harness Assembly
554	E-423	Connects PWBA ABC TM and Interlock Switch Harness Assembly
661A	H-412	Connects Tray 4 Harness Assembly and Feeder Harness Assembly
661B	B-409	Connects Tray 3 Harness Assembly and Feeder Harness Assembly
812	B-408	Connects Interlock Switch and Interlock Switch Harness Assembly
820	E-409	Connects Size Switch 3 and Size Switch Harness Assembly
821	B-408	Connects F-Out Sensor 3 and F-Out Sensor 3 Harness Assembly
822	I-423	Connects T/A Clutch and T/A Harness Assembly
824	E-408	Connects Size Switch 4 and Size Switch Harness Assembly
825	F-421	Connects F-Out Sensor 4 and F-Out Sensor 4 Harness Assembly
826	G-423	Connects T/A Motor and T/A Harness Assembly
841	I-420	Connects F-Out Sensor 3 Harness Assembly and Size Switch Harness Assembly
842	H-422	Connects F-Out Sensor 4 Harness Assembly and Size Switch Harness Assembly

**P/J layout diagram**









# Chapter 6 Removal / Replacement Procedures

Parts removal and replacement procedures are described in thin this chapter.

**NOTE** Parts are controlled as spare parts. When servicing parts for which there are no procedures, observe their condition in the parts lists.

**NOTE** Though the optional parts are assumed to be removed, they may not be removed if not required for the purpose of service.

## Before starting service work

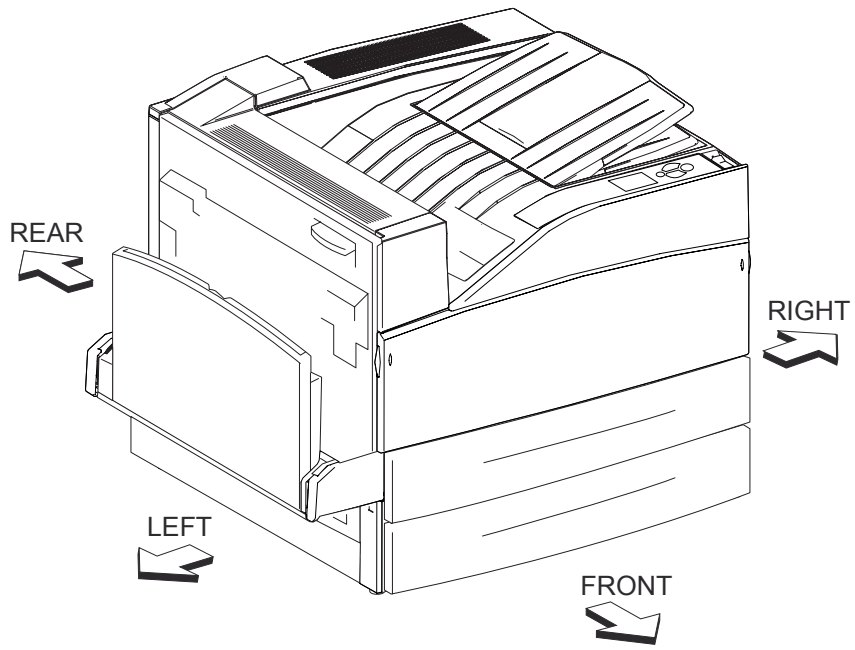
- Turn the power OFF and remove the power cord from the electric outlet.
- When performing service operation for parts around the Fuser Assembly, start the service after the Fuser Assembly and parts around it have cooled down.
- To prevent damage, do not use force to remove or install parts.
- Since a wide variety of screws are used, be careful not to mistake their positions, to prevent crushing of the screw holes or other troubles.
- Wear a antistatic wrist band to remove static electricity from the human body.

## Confirmation after service

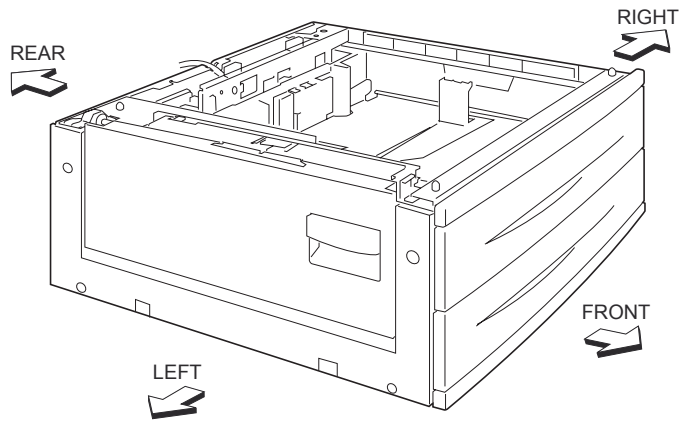
Be sure to run the machine in all modes of operation to ensure that the machine is completely operational.

## Description of procedures

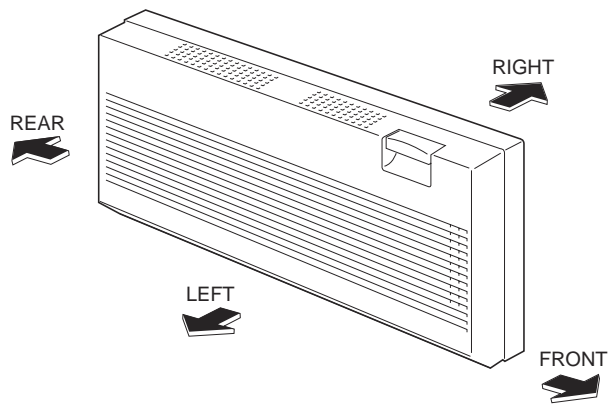
- "RRP X.Y "AAAAA" at the top of procedures represent the procedure number and the part name.
- "(PL X.Y.Z)" following the part name in procedures represent that the parts are those of the plate (PL) "X.Y", item "Z" in Chapter 5, Parts List.
- In the procedures, directions are represented as follows.
  - Front: Front when you are facing the front of this machine.
  - Rear: Inner direction when you are facing the front of this machine.
  - Left: Left hand when you are facing the front of this machine.
  - Right: Right hand when you are facing the front of this machine



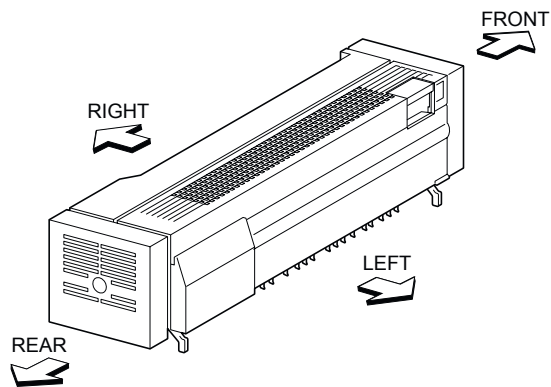
**Figure 1 Machine IOT Directions**



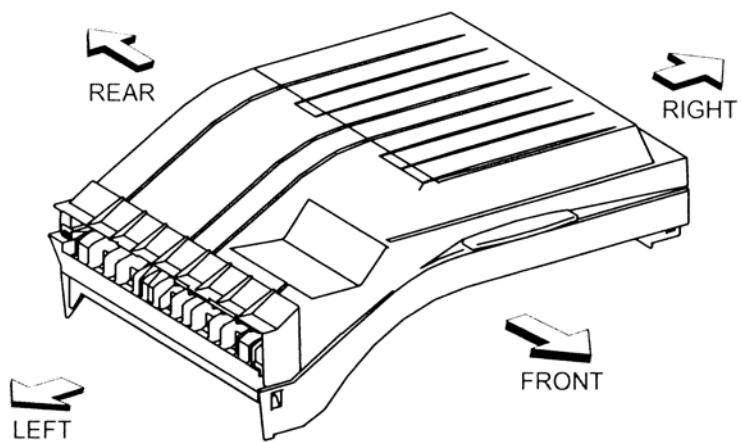
**Figure 2 1000 Sheet Feeder Directions**



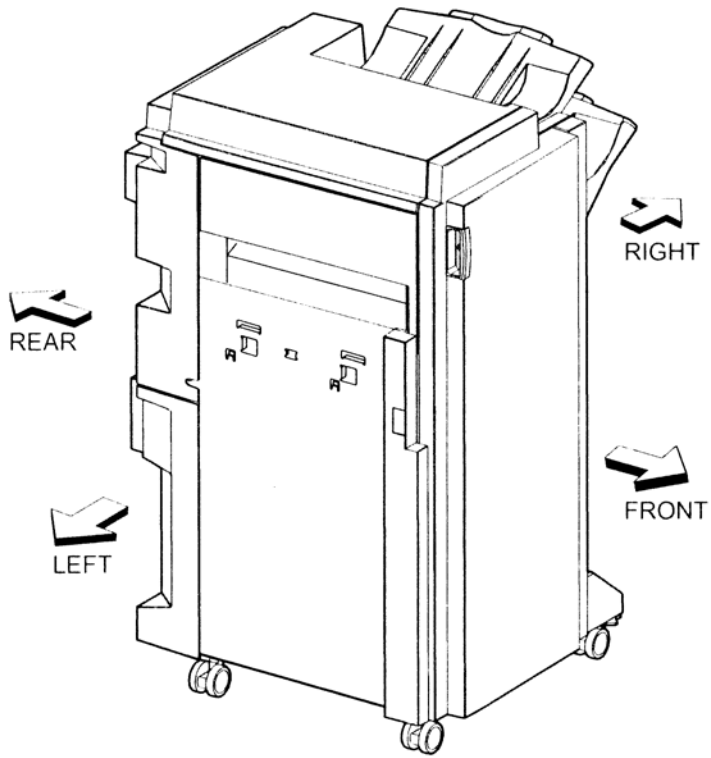
**Figure 3 Duplex Unit Directions**



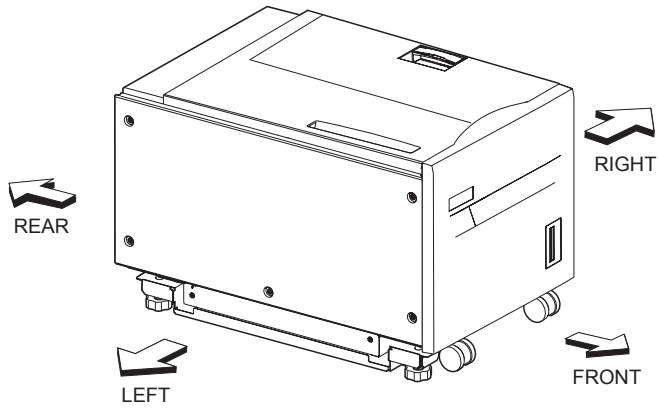
**Figure 4 Exit 2 Directions**



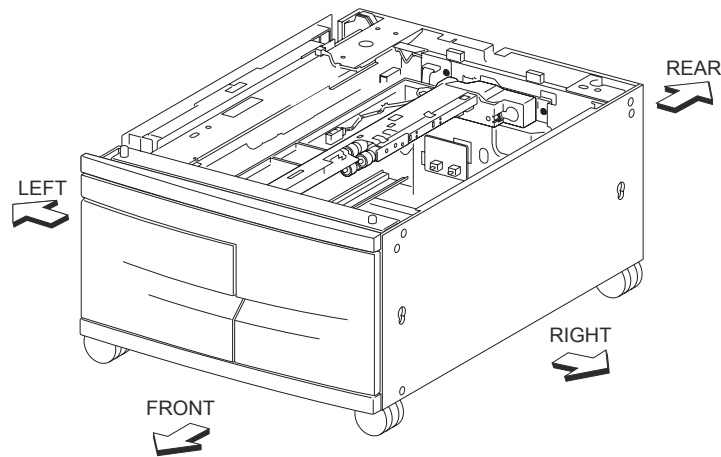
**Figure 5 Finisher Horizontal Transport Directions**



**Figure 6 Finisher Unit Directions**



**Figure 7 High Capacity Feeder Directions**



**Figure 8 Tandem Tray Directions**

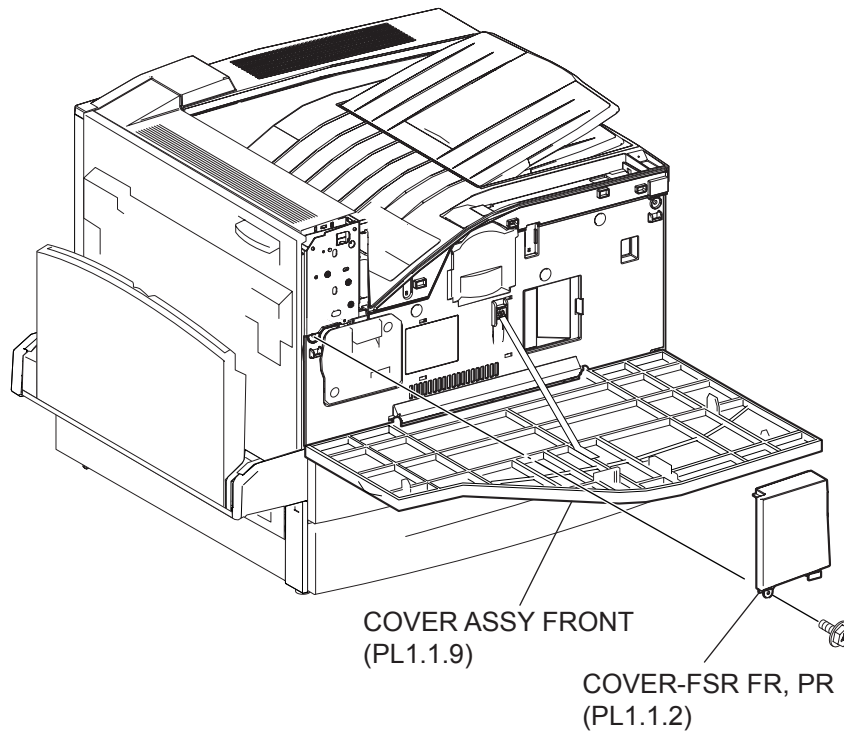
- The screws in procedures are expressed with their replacing position, color, characteristics and nominal length, etc.
- "RRP X.Y" in the midst or at the end of sentences in the procedures indicate that work procedures related with the "RRP X.Y" are described.
- "Figure X" at the end of the sentences of procedures indicate that illustrations instructive for the "RRP X.Y" are included.
- The screws in the illustrations should be removed using a plus (+) screwdriver unless otherwise specified.
- A black arrow in the illustrations indicate movement in the arrow mark direction.
- Numbered black arrows indicate movement in the order of the numbers.
- White arrows (FRONT) in the illustrations indicate the front direction.
- For the positions of the connectors (P/J), refer to Chapter 7, Electric wiring.

## IOT Covers

### Fuser Cover (FR, PR)

#### Removal

1. Open the Front Cover Assembly (PL 1.1.9).
2. Remove the screw (Del Tite, M3x8mm) securing the Fuser Cover (FR, PR) to the machine.
3. Remove the Fuser Cover (FR, PR).



**Figure 1 Front and Fuser Cover**

### **Replacement**

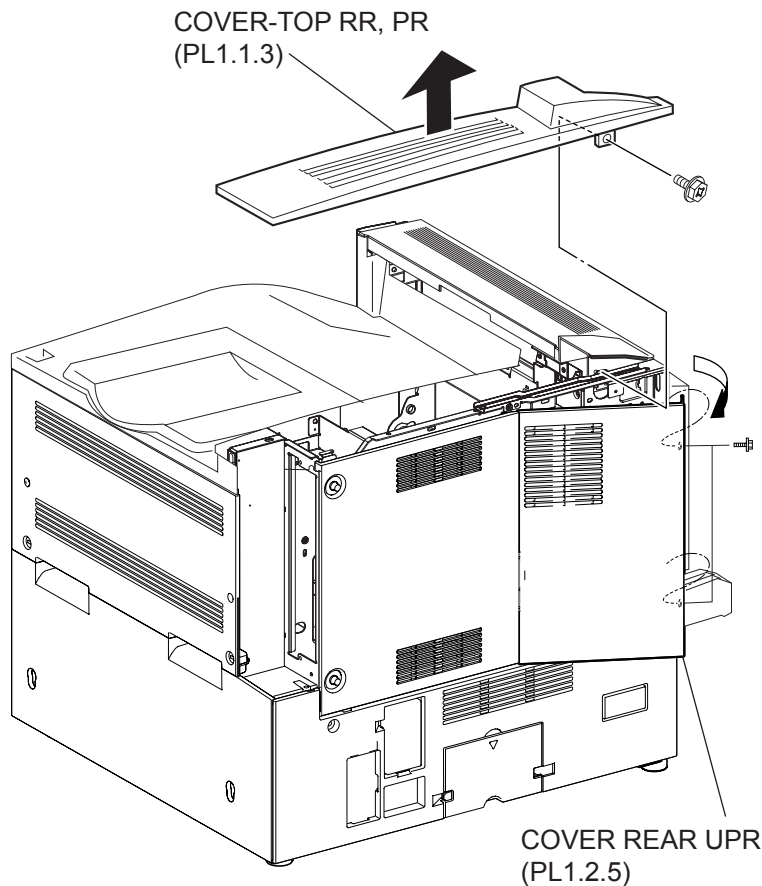
1. Install the Fuser Cover (FR, PR) to the machine using the screw (Del Tite, M3x8mm).
2. Close the Front Cover Assembly (PL 1.1.9).

### **Top Rear Cover (PR)**

#### **Removal**

1. Remove the ESS Cap Cover (PR) (PL 1.2.4).
2. Remove the two screws (Del Tite, M3x8mm) securing the Upper Rear Cover (PL 1.2.5) to the machine.
3. Open the Upper Rear Cover.
4. Remove the screw (Del Tite, M3x8mm) securing the Top Cover (RR, PR) to the machine.
5. Remove the Top Cover (RR, PR) by moving it in the direction of the arrow.





**Figure 1 Top Cover**

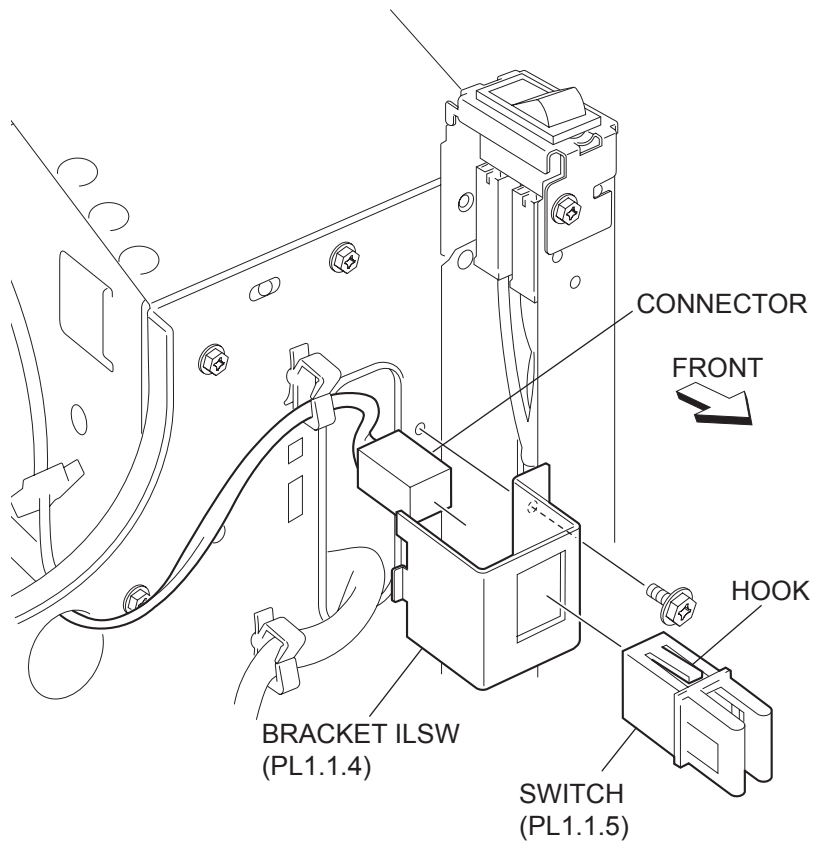
## Replacement

1. Install the Top Cover (RR, PR) to the machine using the screw (Del Tite, M3x8mm).
2. Close the Upper Rear Cover (PL 1.2.5).
3. Install the Upper Rear Cover to the machine using the two screws (Del Tite, M3x8mm)
4. Install the ESS Cap Cover (PR) (PL 1.2.4).

## Interlock Switch

### Removal

1. Remove the Top Cover Assembly (PR) (PL 1.1.8).
2. Remove the Front Cover Assembly (PL 1.1.9).
3. Remove the Fuser Cover (FR, PR) (PL 1.1.2).
4. Remove the Inner Cover Assembly (MN) (PL 1.1.13).
5. Remove the screw (Del Tite, M3x6mm) securing the Bracket ILSW (PL 1.1.4) to the machine.
6. Disconnect the connector (P/J140) of the Interlock Harness Assembly (A) (PL 8.2.10) from the switch.
7. Remove the Switch together with the Bracket ILSW.
8. Release the hooks on the switch by pressing the hooks on the Switch.
9. Remove the Switch.



**Figure 1 Interlock Switch**

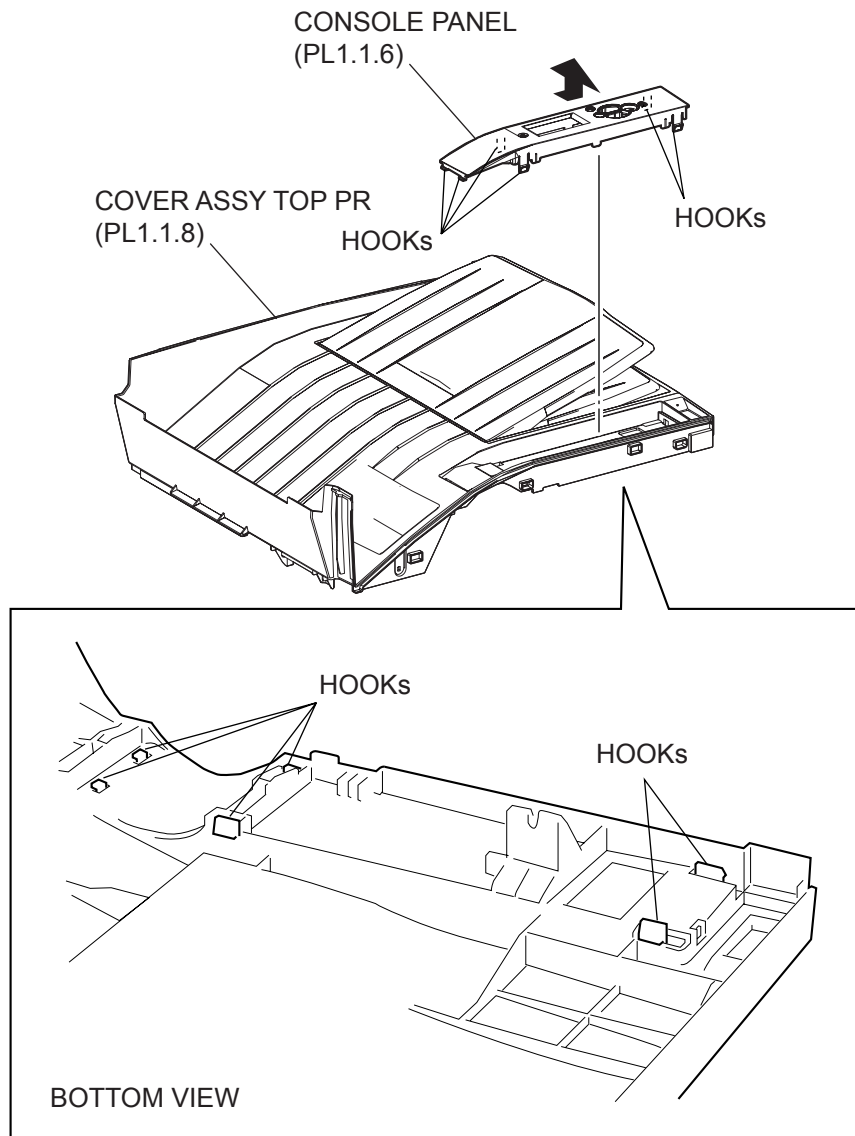
## Replacement

1. Install the Switch to the Bracket ILSW (PL 1.1.4) while pressing the hook on the switch.
2. Connect connector (P/J140) of the Interlock Harness Assembly (A) (PL 8.2.10) to the SWITCH.
3. Install the Bracket ILSW to the machine using the screw (Del Tite, M3x6mm).
4. Install the Inner Cover Assembly (MN) (PL 1.1.13).
5. Install the Fuser Cover (FR, PR) (PL 1.1.2).
6. Install the Front Cover Assembly (PL 1.1.9).
7. Install the Top Cover Assembly (PR) (PL 1.1.8).

## Console Panel

### Removal

1. Remove the Top Cover Assembly (PR) (PL 1.1.8).
2. Place the Top Cover Assembly (PR) up side down, and remove the Console Panel by releasing the six hooks securing the Console Panel to the Top Cover Assembly (PR).
3. Move the Console Panel in the arrow direction to remove.



**Figure 1 Console Panel**

### **Replacement**

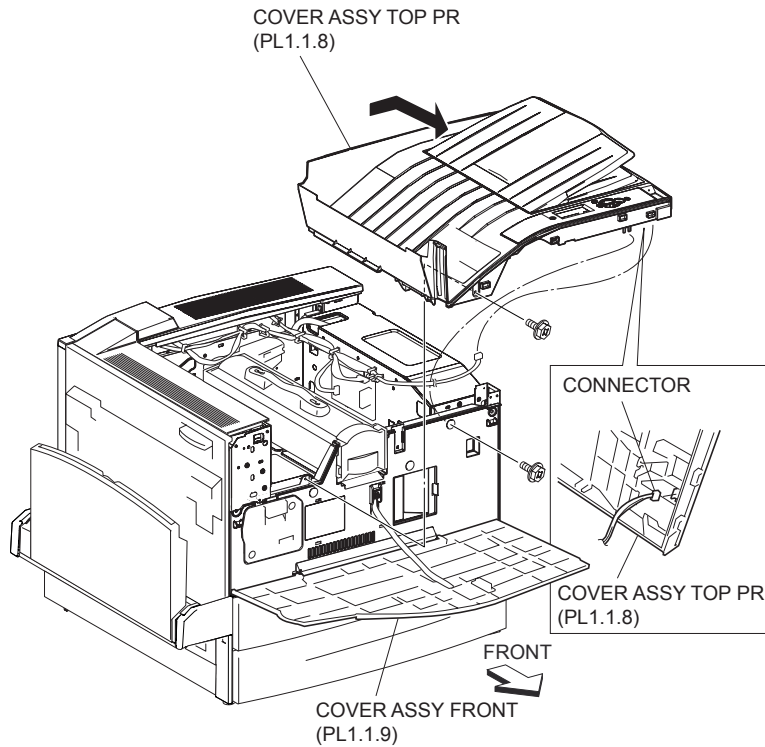
1. Fit the left side hooks of the Console Panel into the holes on the Top Cover Assembly (PR) (PL 1.1.8).
2. Install the Console Panel to the Top Cover Assembly (PR) using six hooks.
3. Install the Top Cover Assembly (PR) (PL 1.1.8).

### **Top Cover Assembly (PR)**

#### **Removal**

1. Open the Front Cover Assembly (PL 1.1.9).
2. Remove the Fuser Cover (FR, PR) (PL 1.1.2).
3. Remove the two screws (Del Tite, M3x8mm) securing the Top Cover Assembly (PR) to the machine.
4. Remove the Top Cover Assembly (PR) by moving it in the direction of the arrow.

5. Disconnect the connector (P/J301) of the Console Panel Harness Assembly (PL 1.1.7) from the Top Cover Assembly (PR).



**Figure 1 Top Cover Assembly**

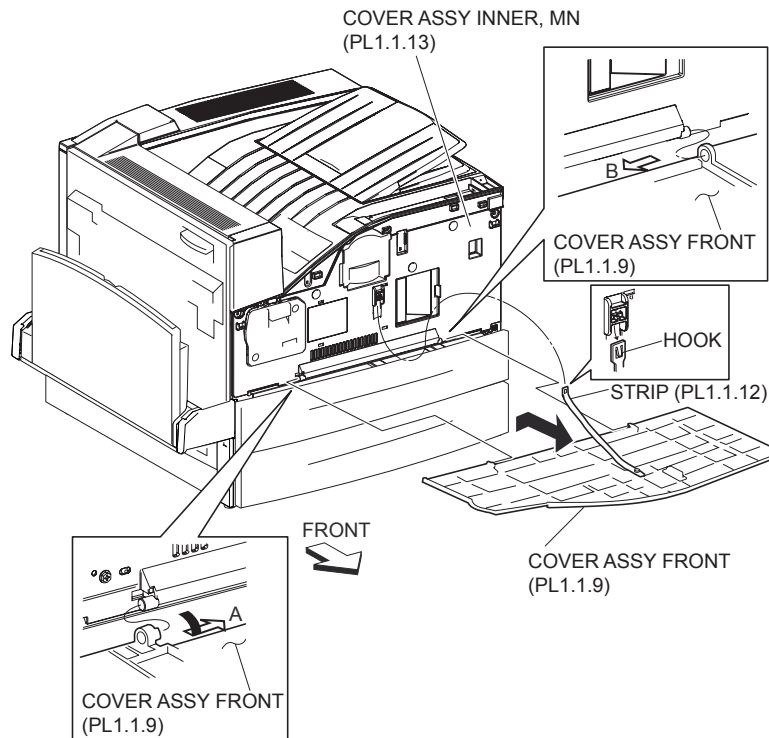
## Replacement

1. Connect the connector (P/J301) of the Console Panel Harness Assembly (PL 1.1.7) to the Top Cover Assembly (PR).
2. Install the Top Cover Assembly (PR) while moving it in the direction of the arrow (to the front).
3. Install the Top Cover Assembly (PR) to the machine using the two screws (Del Tite, M3x8mm).
4. Install the Fuser Cover (FR, PR) (PL 1.1.2).
5. Close the Front Cover Assembly (PL 1.1.9).

## Front Cover Assembly

### Removal

1. Open the Front Cover Assembly.
2. Remove the Strip (PL 1.1.12) securing the Front Cover Assembly to the Inner Cover Assembly (MN) (PL 1.1.13) by releasing the hook.
3. With the Front Cover Assembly open, slide the Front Cover Assembly in the direction of the arrow A to release the lower right holder from the boss on the right of the printer.
4. While the lower right holder of the Front Cover Assembly is released, place the cover slightly obliquely to the printer and slide it in the direction of the arrow B to release the lower left holder from the boss on the left of the printer.
5. Remove the Front Cover Assembly.



**Figure 1 Front Cover Assembly**

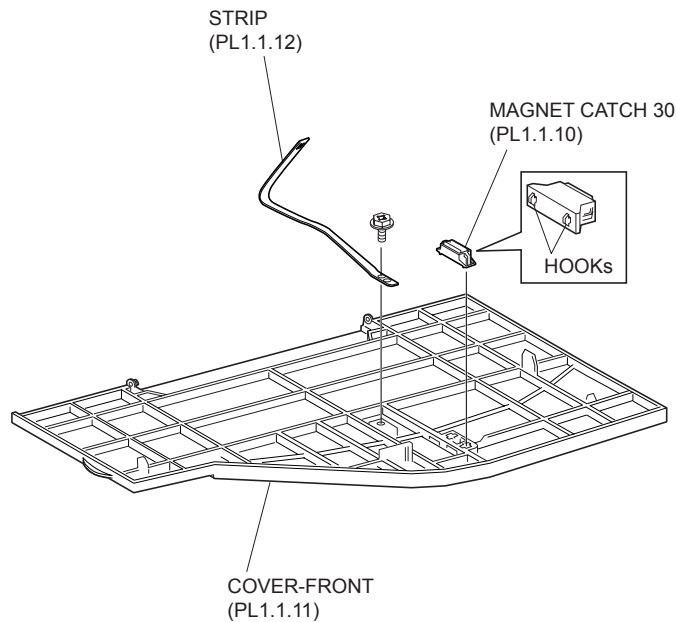
## Replacement

1. Place the Front Cover Assembly to parallel to the printer, and fit the lower left holder onto the boss on the left of the printer.
2. While placing the Front Cover Assembly to parallel to the printer, slide it in the direction of the arrow A so that the boss on the lower left of the Front Cover Assembly fit the holder on the printer first, and slide the Front Cover Assembly in the direction of arrow B so that the boss on the lower right fits in the holder on the printer.
3. Install the Strip (PL 1.1.12) to the Inner Cover Assembly (MN) (PL 1.1.13) with the hook.
4. Close the Front Cover Assembly.

## Front Cover

### Removal

1. Remove the Front Cover Assembly (PL 1.1.9).
2. Remove the screw (Silver, M3x8mm) securing the Strip (PL 1.1.12) to the Front Cover (PL 1.1.11), remove the Strip.
3. Release the two hooks on the Front Cover securing the Magnet Catch 30 (PL 1.1.10) to the Front Cover, remove the Magnet Catch 30.



**Figure 1 Front Cover**

## Replacement

1. Install the Magnet Catch 30 (PL 1.1.10) to the Front Cover (PL 1.1.11), and secure with two hooks.
2. Install the Strip to the Front Cover using the screw (Silver, M3x8mm).

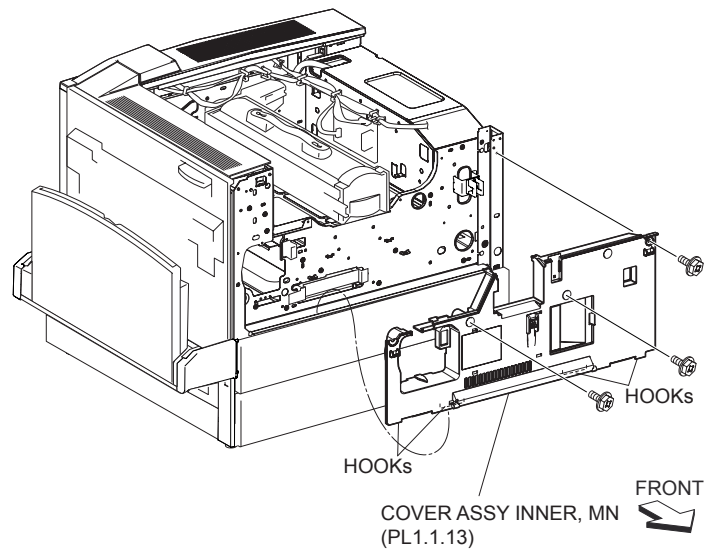
**NOTE** The Strip has two holes, be sure to use bottom hole when tightening.

3. Install the Front Cover Assembly (PL 1.1.9).

## Inner Cover Assembly (MN)

### Removal

1. Remove the Top Cover Assembly (PR) (PL 1.1.8).
2. Remove the Front Cover Assembly (PL 1.1.9).
3. Remove the Fuser Cover (FR, PR) (PL 1.1.2).
4. Remove the CRU (PL 5.1.15).
5. Remove the three screws (Del Tite, M3x8mm) securing the Inner Cover Assembly (MN) to the machine.
6. Remove the Inner Cover Assembly (MN).



**Figure 1 Inner Cover Assembly**

## Replacement

1. Install the Inner Cover Assembly (MN) to the machine using the three screws (Del Tite, M3x8mm).

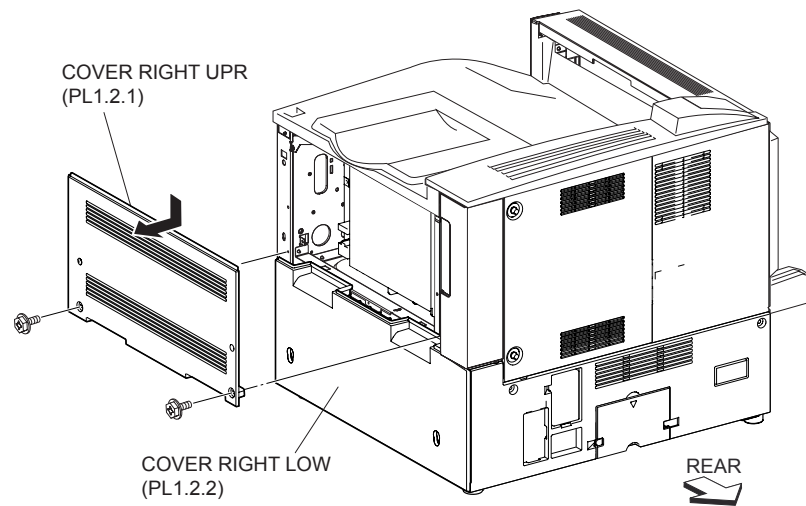
**NOTE** When installing, be sure to put the four lower hooks on the Inner Cover Assembly (MN) inside the Bracket on the printer.

2. Install the CRU (PL 5.1.15).
3. Install the Fuser Cover (FR, PR) (PL 1.1.2).
4. Install the Front Cover Assembly (PL 1.1.9).
5. Install the Top Cover Assembly (PR) (PL 1.1.8).

## Upper Right Cover

### Removal

1. Remove the two screws (Del Tite, M3x8mm) securing the Upper Right Cover to the machine.
2. Move the upper rib of the Upper Right Cover in the direction of the arrow to release the upper rib.
3. Move the Lower Right Cover (PL 1.2.2) downward to release the lower rib.
4. Remove the Upper Right Cover.



**Figure 1 Right Upper Cover**

## Replacement

1. Move the upper rib on the Upper Right Cover in the opposite direction of the arrow to engage them to the frame.
2. Install the Upper Right Cover to the machine using the two screws (Del Tite, M3x8mm).

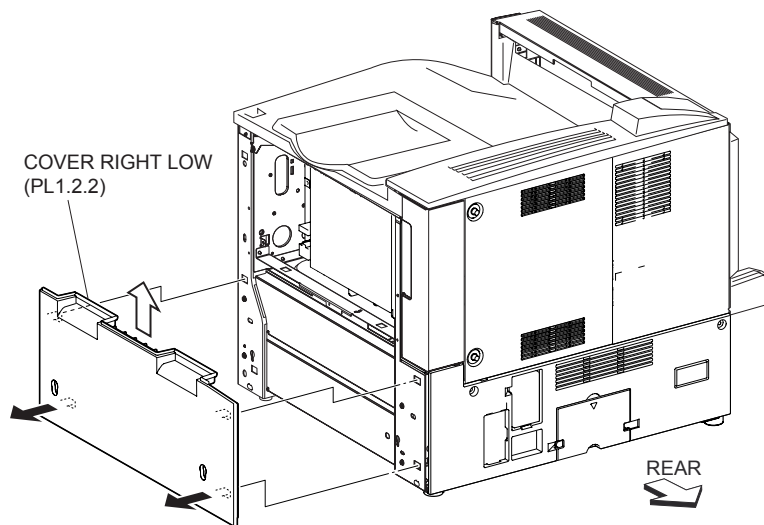
**NOTE** Be sure to secure the lower rib on the Upper Right Cover to the upper part of the Lower Right Cover (PL 1.2.2).

## Lower Right Cover

### Removal

1. Remove the Upper Right Cover (PL 1.2.1).
2. Pull out the Tray 3 and Tray 4.
3. Remove the Lower Right Cover by pulling the center of it upward.





**Figure 1 Lower Right Cover**

### **Replacement**

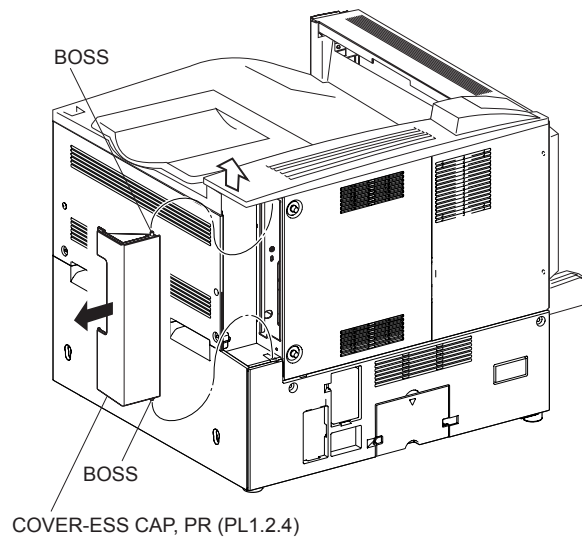
1. Fit the four bosses on the back of the Lower Right Cover into the four holes on the frame, and push the COVER RIGHT downward to install.
2. Install the Tray 3 and Tray 4.
3. Install the Upper Right Cover (PL 1.2.1).

### **ESS Cap Cover (PR)**

#### **Removal**

1. Open the ESS Cap Cover (PR).
2. Remove the lower boss on the ESS Cap Cover (PR) (PL 1.2.4) securing the ESS Cap Cover (PR) to the printer.

**NOTE** To remove the ESS Cap Cover (PR) easily, push down on the cover of the retainer of the boss.



**Figure 1 ESS Cover**

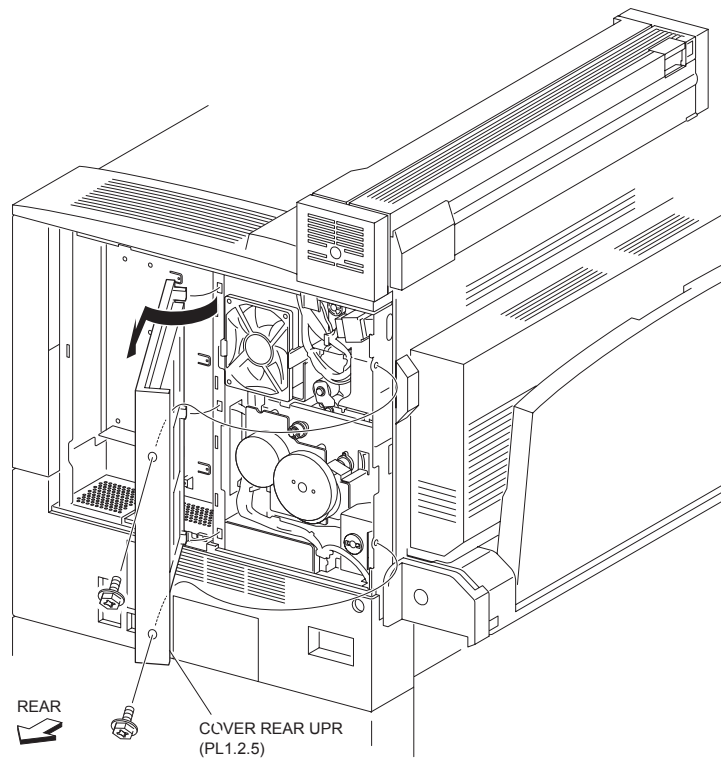
### **Replacement**

1. Put the upper boss on the ESS Cap Cover (PR) into the hole of the printer to fix the ESS Cap Cover (PR).
2. Put the lower boss on the ESS Cap Cover (PR) into the hole of the printer.
3. Close the ESS Cap Cover (PR).

### **Upper Rear Cover**

#### **Removal**

1. Remove the ESS Cover Assembly (PL 8.1.20).
2. Remove the two screws (Del Tite, M3x8mm) securing the Upper Rear Cover to the machine.
3. Remove the Upper Rear Cover by moving it in the direction of the arrow.



**Figure 1 Upper Rear Cover**

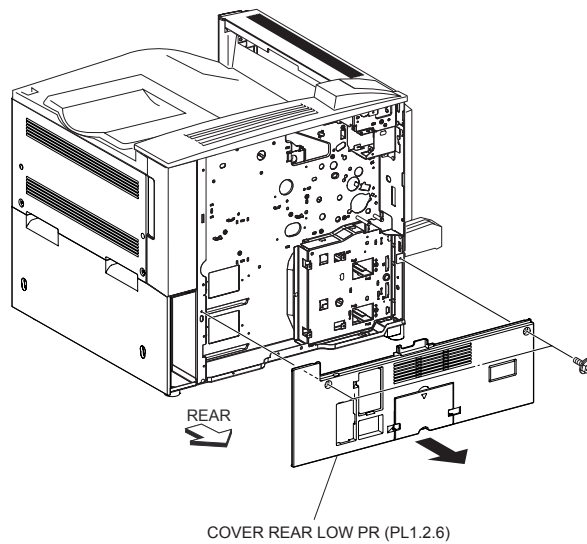
## **Replacement**

1. Install the Upper Rear Cover to the machine, and attach using two screws (Del Tite, M3x8mm).
2. Install the ESS Cover Assembly (PL 8.1.20).

## **Lower Rear Cover (PR)**

### **Removal**

1. Remove the ESS Cover Assembly (PL 8.1.20).
2. Remove the Upper Rear Cover (PL 1.2.5).
3. Remove the two screws (Del Tite, M3x8mm) securing the Lower Rear Cover (PR) to the machine.
4. Remove the Lower Rear Cover (PR) by moving it in the direction of the arrow.



**Figure 1 Lower Rear Cover**

## Replacement

1. Install the Lower Rear Cover (PR) to the machine using two screws (Del Tite, M3x8mm).

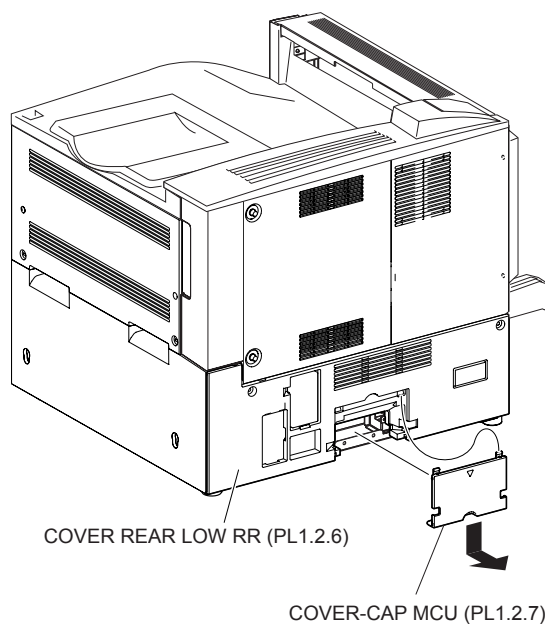
**NOTE** Be sure to attach the lower four hooks on the Lower Rear Cover (PR) to the Bracket on the printer.

2. Install the Upper Rear Cover (PL 1.2.5).
3. Install the ESS Cover Assembly (PL 8.1.20).

## MCU Cap Cover

### Removal

1. Remove the MCU Cap Cover (PL 1.2.7) from the Lower Rear Cover (PR) (PL 1.2.6) by pressing down on the top edge of the MCU Cap Cover in the direction of the down arrow.



**Figure 1 MCU Cap Cover**

## Replacement

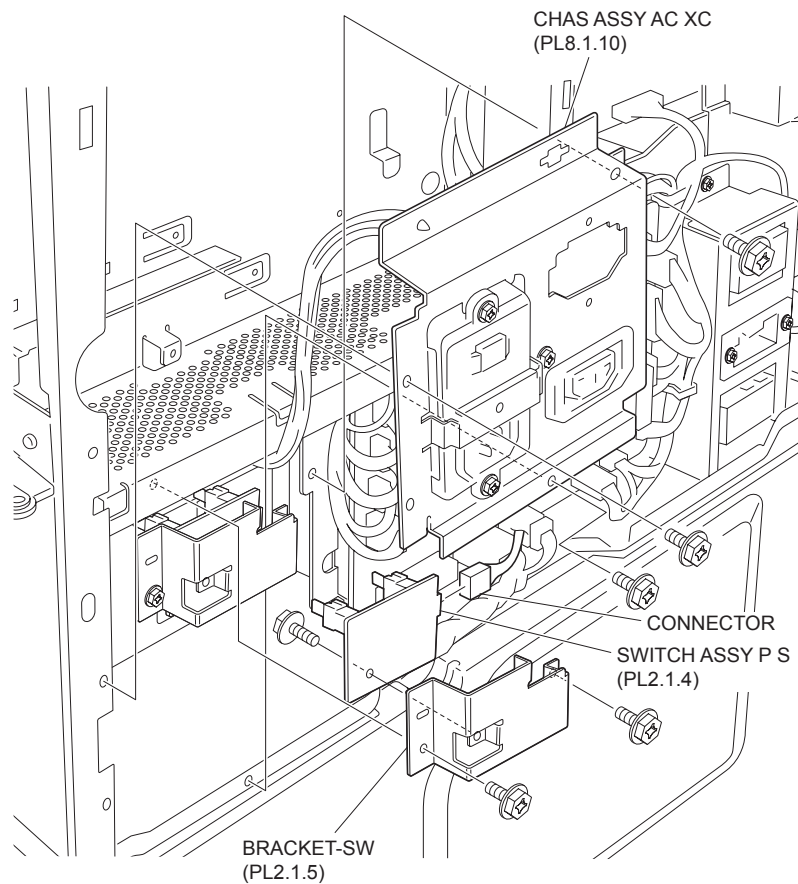
1. Install the MCU Cap Cover (PL 1.2.7) to the Lower Rear Cover (PR) (PL 1.2.6) by moving the MCU Cap Cover in the opposite direction of the arrow.

# Transportation & Registration

## Switch Assembly PS (Tray 1)

### Removal

1. Remove the ESS Cover Assembly (PL 8.1.20).
2. Remove the Upper Rear Cover (PL 1.2.5).
3. Remove the Lower Rear Cover (PR) (PL 1.2.6).
4. Remove the three screws (Del Tite, M3x6mm) securing the AC Chassis Assembly (XC) (PL 8.1.10) to the machine.
5. Remove the two screws (Del Tite, M3x6mm) securing the Switch Bracket (PL 2.1.5) to the machine.
6. Remove the Switch Assembly P S together with the Switch Bracket.
7. Disconnect the connector (P/J109) of the Size Harness Assembly (A) (PL 8.2.3) from the Switch Assembly P S.
8. Remove the screw (Del Tite, M3x6mm) securing the Switch Assembly P S (PL 2.1.4) to the Switch Bracket.
9. Remove the Switch Assembly P S.



**Figure 1 Tray 1 P S Switch Assembly**

## Replacement

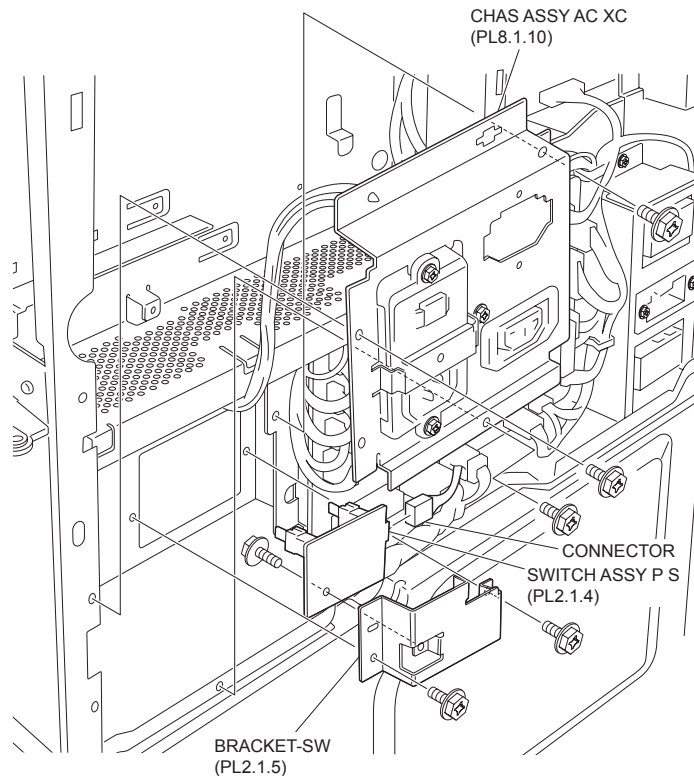
1. Install the Switch Assembly P S (PL 2.1.4) to the Switch Bracket (PL 2.1.5) using the screw (Del Tite, M3x6mm).
2. Connect the connector (P/J109) of the Size Harness Assembly (A) (PL 8.2.3) to the Switch Assembly P S.
3. Install the Switch Assembly P S to the machine together with the Switch Bracket using the two screws (Del Tite, M3x6mm).
4. Install the AC Chassis Assembly (XC) (PL 8.1.10) to the machine using the three screws (Del Tite, M3x6mm).
5. Install the Lower Rear Cover (PR) (PL 1.2.6).
6. Install the Upper Rear Cover (PL 1.2.5).
7. Install the ESS Cover Assembly (PL 8.1.20).

## Switch Assembly P S (Tray 2)

### Removal

1. Remove the ESS Cover Assembly (PL 8.1.20).
2. Remove the Upper Rear Cover (PL 1.2.5).
3. Remove the Lower Rear Cover (PR) (PL 1.2.6).
4. Remove the three screws (Del Tite, M3x6mm) securing the AC Chassis Assembly (XC) (PL 8.1.10) to the machine.

5. Remove the two screws (Del Tite, M3x6mm) securing the Switch Bracket (PL 2.1.5) to the machine.
6. Disconnect the connector (P/J110) of the Size Harness Assembly (A) (PL 8.2.3) from the Switch Assembly P S.
7. Remove the Switch Assembly P S together with the Switch Bracket.
8. Remove the screw (Del Tite, M3x6mm) securing the Switch Assembly P S (PL 2.1.4) to the Switch Bracket.
9. Remove the Switch Assembly P S.



**Figure 1 Tray 2 P S switch Assembly**

## Replacement

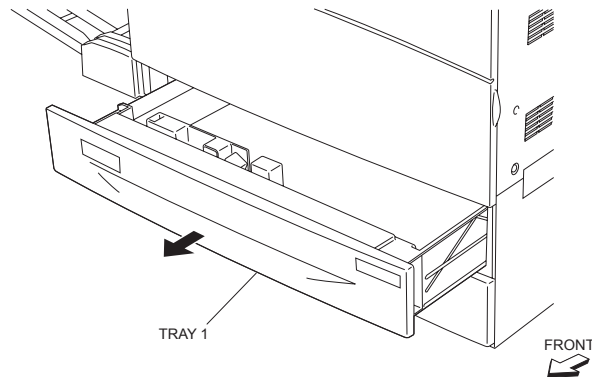
1. Install the Switch Assembly P S (PL 2.1.4) to the Switch Bracket (PL 2.1.5) using the screw (Del Tite, M3x6mm).
2. Connect the connector (P/J110) of the Size Harness Assembly (A) (PL 8.2.3) to the Switch Assembly P S.
3. Install the Switch Assembly P S to the machine together with the Switch Bracket using the two screws (Del Tite, M3x6mm).
4. Install the AC Chassis Assembly (XC) (PL 8.1.10) to the machine using the three screws (Del Tite, M3x6mm).
5. Install the Lower Rear Cover (PR) (PL 1.2.6).
6. Install the Upper Rear Cover (PL 1.2.5).
7. Install the ESS Cover Assembly (PL 8.1.20).

## Feeder 1 Assembly

### Removal

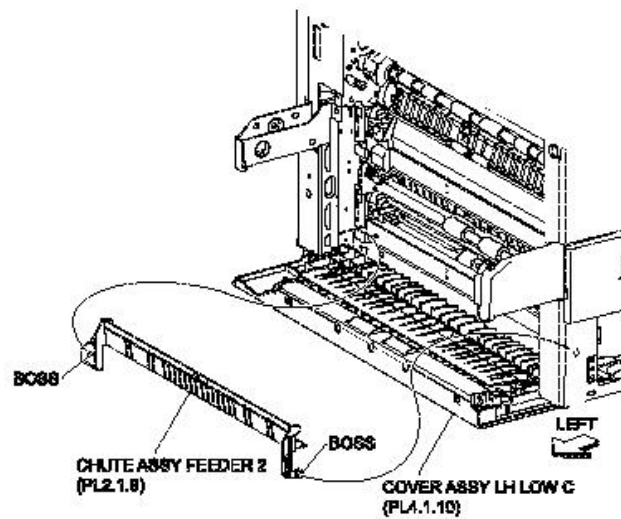
1. Remove the MPF RR Cover (PL 3.1.14).

2. Remove the MPF Feeder Assembly (PL 3.1.1).
3. Remove the Left Hand Cover Assembly (PL 4.2.8).
4. Remove the TA Bracket Assembly (PL 4.1.1).
5. Pull out Tray 1.



**Figure 1 Tray 1**

6. Remove the bosses on both ends on the Feeder Chute Assembly (PL 2.1.6), the right one first and remove the Feeder Chute Assembly.



**Figure 2 Feeder Chute Assembly**

7. Release the Feeder C Harness Assembly (PL 8.2.1) from the two clamps on the machine.
8. Disconnect the connector (P/J601) of the Feeder C Harness Assembly (PL 8.2.1) from the machine.
9. Remove the two screws (Del Tite, M3x8mm) securing the Feeder 1 Assembly to the machine.
10. Remove the Feeder 1 Assembly by moving it in the direction of the arrow.



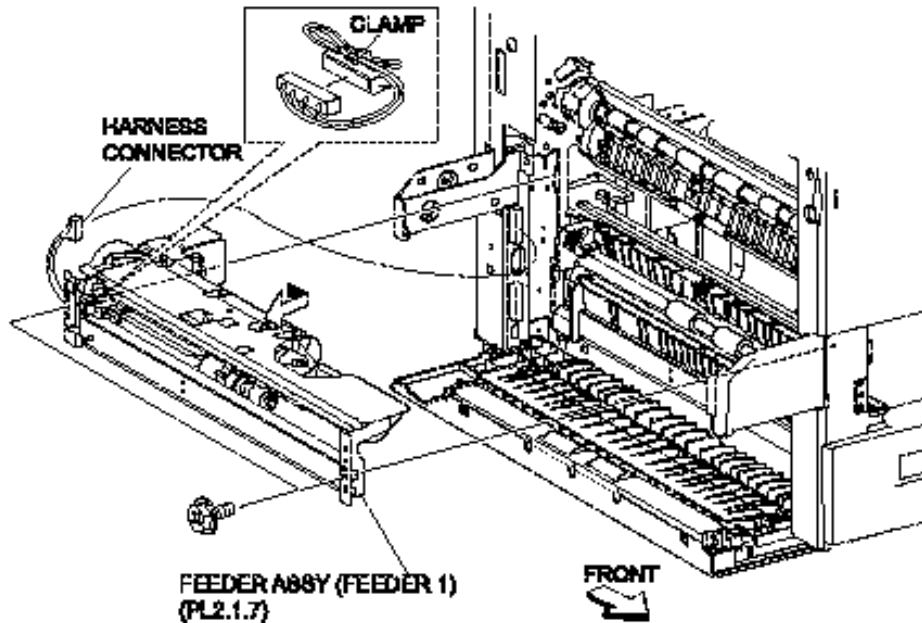


Figure 3 Feeder Assembly (Feeder 1)

## Replacement

1. Insert the Feeder 1 Assembly from the left side (Rear) and attach it using the two screws (Del Tite, M3x8mm).

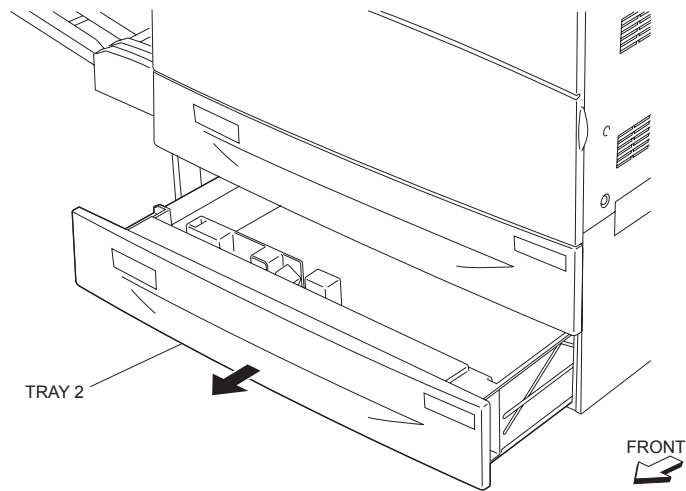
**NOTE** When installing the Feeder 1 Assembly, be sure to fit the two bosses on the machine into the holes on the Feeder 1 Assembly.

2. Connect the connector (P/J601) of the Feeder C Harness Assembly (PL 8.2.1) to the machine.
3. Secure the Feeder C Harness Assembly (PL 8.2.1) to the two clamps on the machine.
4. Fit the bosses on both ends on the Feeder Chute Assembly (PL 2.1.6) into the machine, the left one first, and install the Feeder Chute Assembly.
5. Close the Tray 1.
6. Install the TA Bracket Assembly (PL 4.1.1).
7. Install the Left Hand Cover Assembly (PL 4.2.8).
8. Install the MPF Feeder Assembly (PL 3.1.1).
9. Install the MPF RR Cover (PL 3.1.14).

## Feeder 2 Assembly

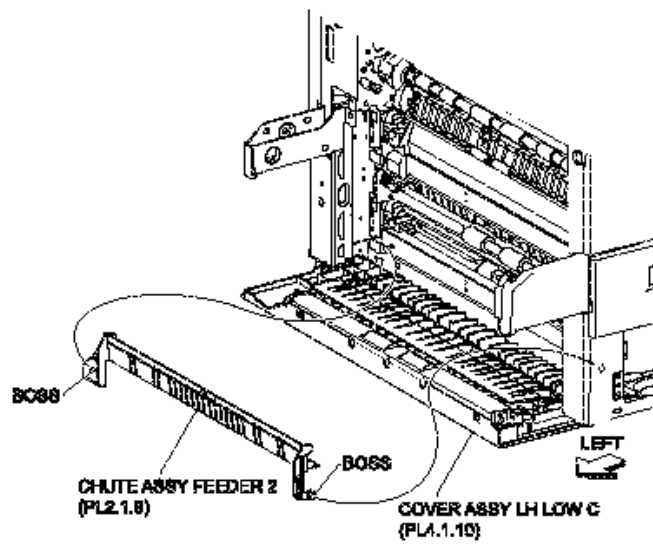
### Removal

1. Remove the MPF RR Cover (PL 3.1.14).
2. Remove the MPF Feeder Assembly (PL 3.1.1).
3. Remove the Left Hand Cover Assembly (PL 4.2.8).
4. Open the Left Hand Lower C Cover Assembly (PL 4.1.10).
5. Remove the TA Bracket Assembly (PL 4.1.1).
6. Pull out the Tray 2.



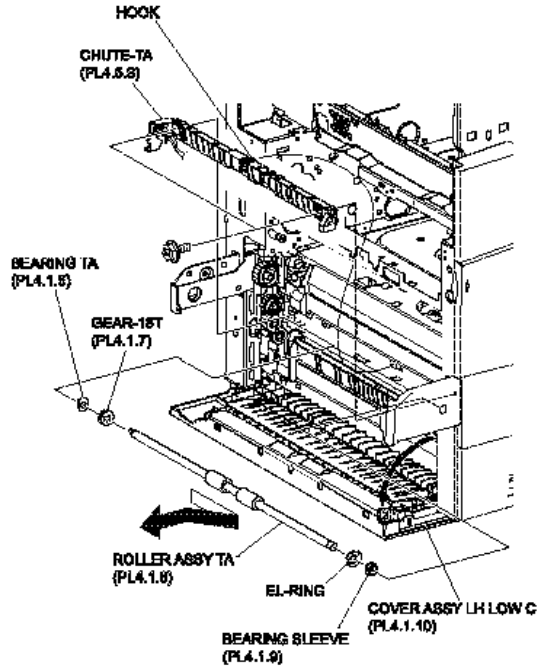
**Figure 1 Tray 2**

7. Release the boss on the both ends of the Feeder Chute Assembly 2 (PL 2.1.9) securing it to the machine, the right one first, and remove the Feeder Chute Assembly 2.



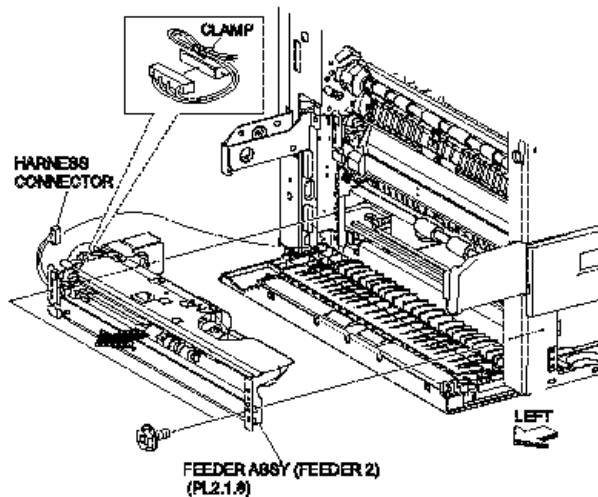
**Figure 2 Feeder Chute Assembly**

8. Remove the two screws (Del Tite, M3x6mm) securing the TA Chute (PL 4.5.9) to the machine and remove the TA Chute while pulling its center.
9. Remove the TA Roller Assembly (PL 4.1.8).



**Figure 3 TA Chute**

10. Release the Feeder C Harness Assembly (PL 8.2.1) from the two clamps on the machine.
11. Disconnect the connector (P/J602) of the Feeder C Harness Assembly from the machine.
12. Remove the two screws (Del Tite, M3x8mm) securing the Feeder 2 Assembly to the machine.
13. Remove the Feeder 2 Assembly by moving it in the direction of the arrow.



**Figure 4 Feeder Assembly (Feeder 2)**

## Replacement

1. Insert the Feeder 2 Assembly from the left side (Rear) and attach it using two screws (Del Tite, M3x8mm).

**NOTE** When installing the Feeder 2 Assembly, be sure to fit the two bosses on the machine into the holes on the Feeder 2 Assembly.

2. Connect the connector (P/J602) of the Feeder C Harness Assembly (PL 8.2.1) to the machine.
3. Secure the Feeder C Harness Assembly to the two clamps on the machine.
4. Install the TA Roller Assembly (PL 4.1.8) (RRP 4.3).
5. Install the TA Chute (PL 4.5.9) to the machine using the two screws (Del Tite, M3x6mm

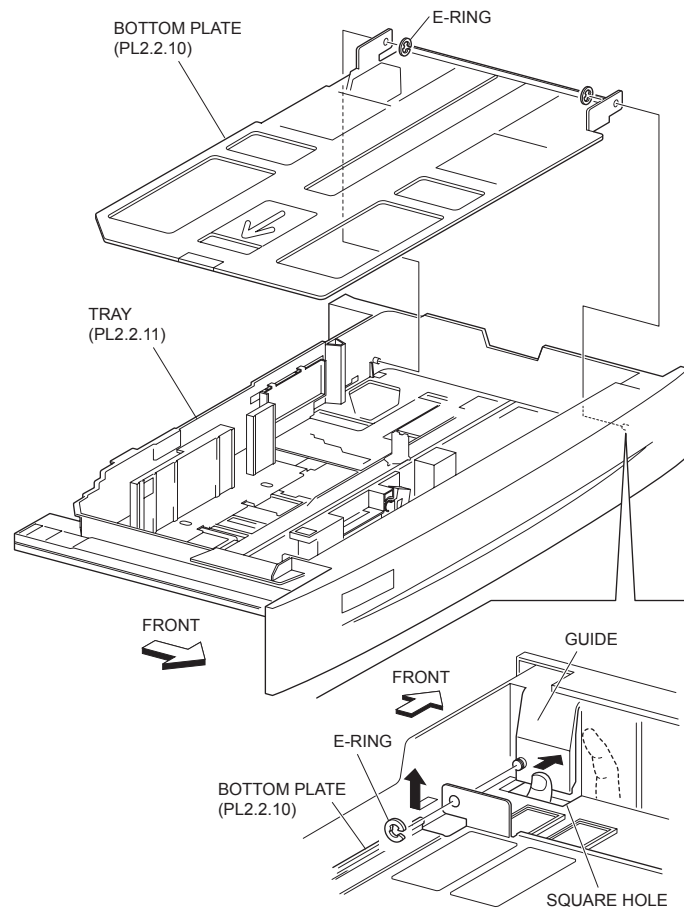
**NOTE** When installing the TA Chute, be sure to fit the bosses on the TA Chute into the holes on the machine.

6. Fit the bosses on both ends of the Feeder Chute Assembly 2 (PL 2.1.9) into the machine, the left one first, and install the Feeder Chute Assembly 2.
7. Close the Tray 2.
8. Install the TA Bracket Assembly (PL 4.1.1).
9. Close the Left Hand Lower C Cover Assembly (PL 4.1.10).
10. Install the Left Hand Cover Assembly (PL 4.2.8).
11. Install the MPF Feeder Assembly (PL 3.1.1).
12. Install the MPF RR Cover (PL 3.1.14).

## Front Side Guide Assembly

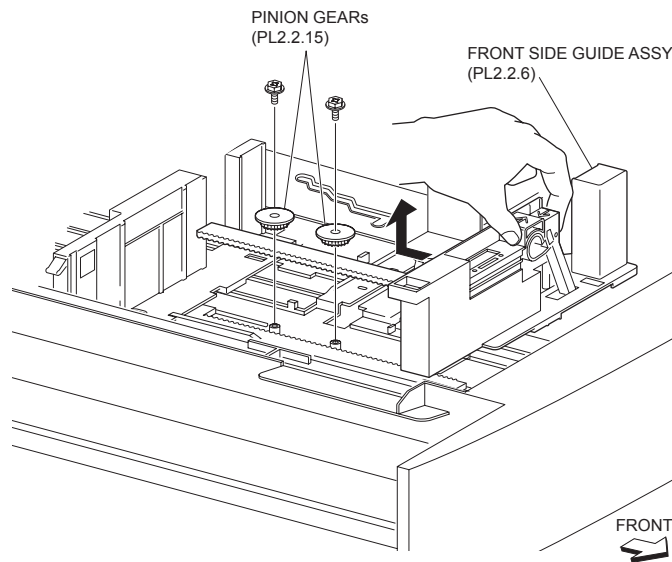
### Removal

1. Remove the Tray Assembly (PL 2.2.1).
2. Remove E-rings on both ends (front/rear) securing the Bottom Plate (PL 2.2.10) to the Tray (PL 2.2.11).
3. Push the guide on the front in the arrow direction shown in the figure by finger to release the boss on the Tray from the Bottom Plate.
4. Remove the Bottom Plate by moving it in the direction of the arrow.



**Figure 1 Removing Bottom Plate**

5. Remove the two screws (Silver, M3x8mm) each securing one of the Pinion Gears (PL 2.2.15) to the Tray.
6. Remove the Pinion Gears.
7. After sliding the Front Side Guide Assembly inward, remove the Front Side Guide Assembly in the direction of the arrow.



**Figure 2 Front Side Guide**

## Replacement

1. Fit the bosses on the lower part of the Front Side Guide Assembly to the holes on the Tray (PL 2.2.11).
2. Slide the Front Side Guide Assembly fully outward.
3. Install the two Pinion Gears (PL 2.2.15) to the Tray using one screw (Silver, M3x8mm) each.

**NOTE** Before installing the Pinion Gears, make sure that the Front Side Guide Assembly and the Rear Side Guide (PL 2.2.9) are placed fully outward. After installing the Pinion Gears, make sure that the Front Side Guide Assembly and the Rear Side Guide slide smoothly.

4. Fit the rear guide hole on the Bottom Plate (PL 2.2.10) to the boss on the Tray.
5. Install the Bottom Plate to the Tray.

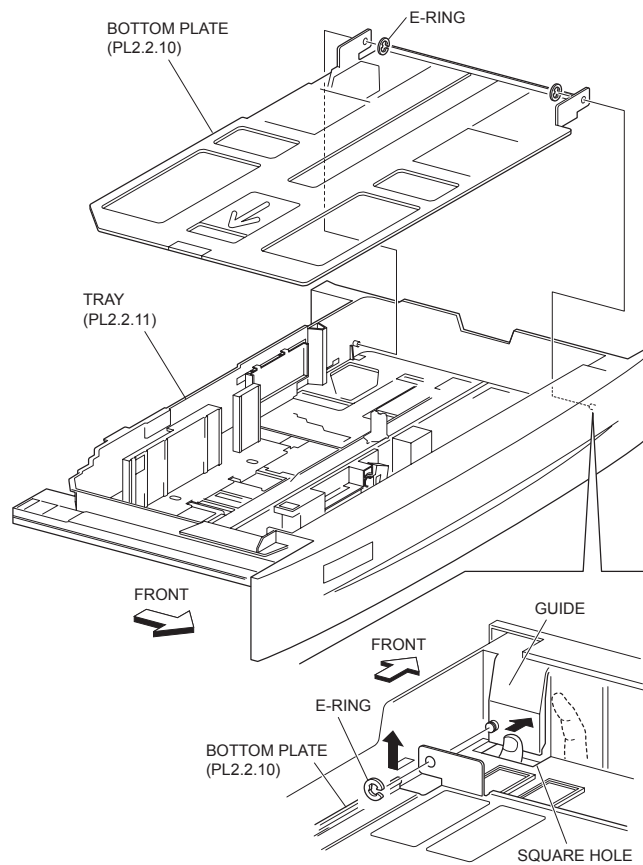
**NOTE** Be sure to fit the front guide hole on the Bottom Plate to the boss on the Tray.

6. Fix the Bottom Plate to the Tray using the two E-rings on front and rear.
7. Insert the Tray Assembly (PL 2.2.1).

## Rear Side Guide

### Removal

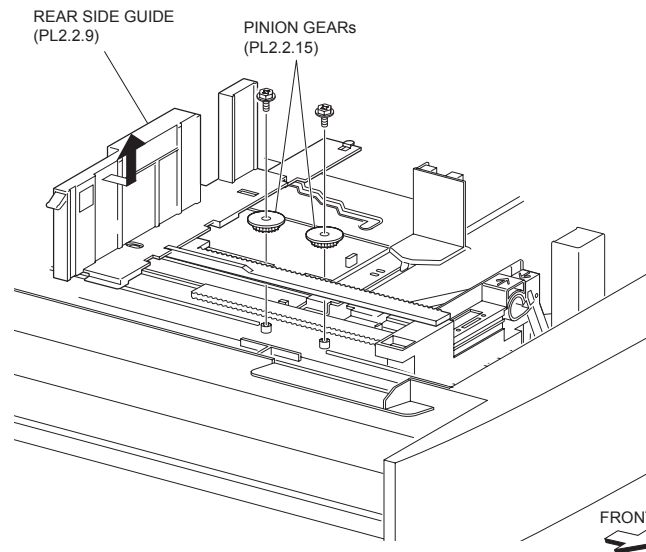
1. Remove the Tray Assembly (PL 2.2.1).
2. Remove E-rings on both ends (front/rear) securing the Bottom Plate (PL 2.2.10) to the Tray (PL 2.2.11).
3. Push the guide on the front in the direction of the arrow, with your finger as shown in the figure to release the boss on the Tray from the Bottom Plate.
4. Remove the Bottom Plate by moving it in the direction of the arrow.



**Figure 1 Removing Bottom Plate**

5. Remove the two screws (Silver, M3x8mm) each securing one of the Pinion Gears (PL 2.2.15) to the Tray.
6. Remove the Pinion Gears.
7. After sliding the Rear Side Guide inward, remove the Rear Side Guide in the direction of the arrow.

**NOTE** Be sure to release the bosses on the Rear Side Guide from the holes on the Side Guide Actuator (PL 2.2.12).



**Figure 2 Rear Side Guide**

## Replacement

1. Fit the bosses on the lower part of the Rear Side Guide to the holes on the Tray (PL 2.2.11).

**NOTE** Be sure to fit the bosses on the Rear Side Guide into the holes on the Side Guide Actuator (PL 2.2.12).

2. Slide the Rear Side Guide fully outward.
3. Install the two Pinion Gears (PL 2.2.15) to the Tray using one screw (Silver, M3x8mm) each.

**NOTE** Before installing the Pinion Gears, make sure that the Rear Side Guide and the Front Side Guide Assembly (PL 2.2.6) are placed fully outward. After installing the Pinion Gears, make sure that the Front Side Guide Assembly and the Rear Side Guide slide smoothly.

4. Fit the rear guide hole on the Bottom Plate (PL 2.2.10) to the boss on the Tray.
5. Install the Bottom Plate to the Tray.

**NOTE** Be sure to fit the front guide hole on the Bottom Plate to the boss on the Tray.

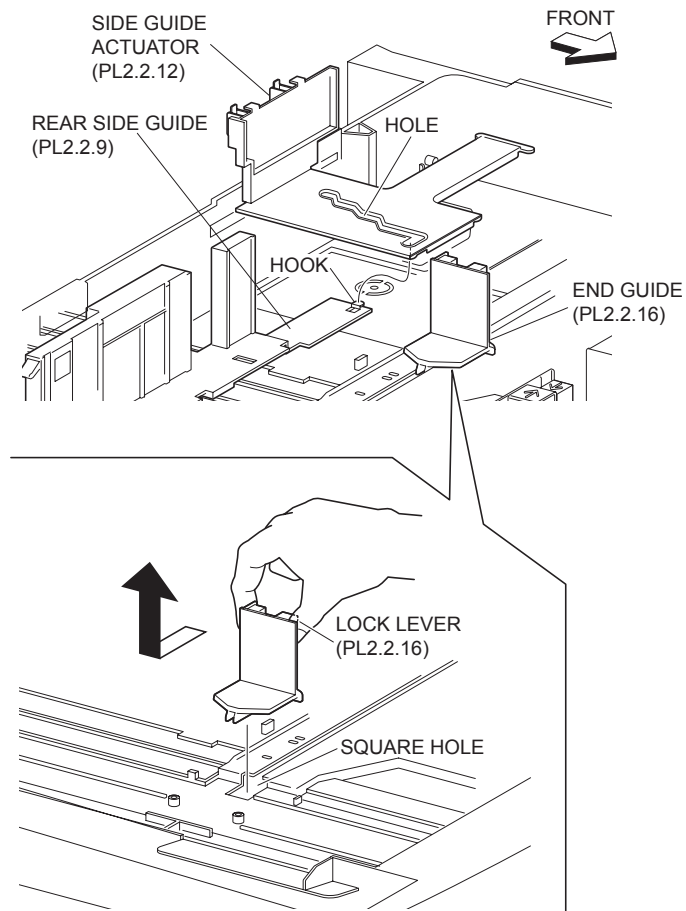
6. Fix the Bottom Plate to the Tray using the two E-rings on front and rear.
7. Insert the Tray Assembly (PL 2.2.1).

## End Guide

### Removal

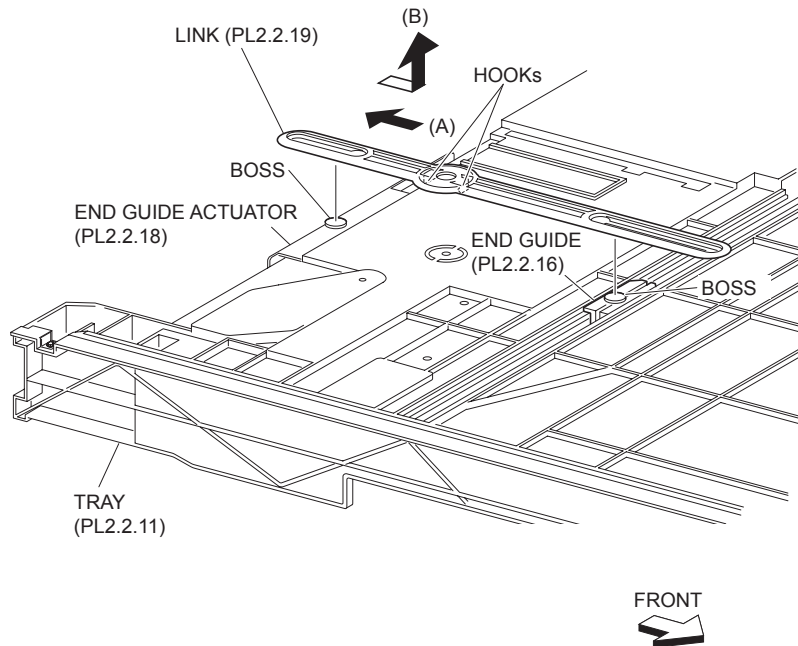
1. Remove the Tray Assembly (PL 2.2.1).
2. Remove the Front Side Guide Assembly (PL 2.2.6).
3. Remove the Rear Side Guide (PL 2.2.9).
4. Remove the Side Guide Actuator (PL 2.2.12).
5. Remove the two hooks securing the Link(PL 2.2.19) to the Tray (PL 2.2.11).





**Figure 1 End Guide**

6. Release the boss on the End Guide Actuator (PL 2.2.18) from the hole on the Link by moving the Link in the direction of the arrow (A), with its center slightly lifted.
7. Release the boss on the End Guide from the hole on the Link by moving the Link in the direction of the arrow (B).
8. Sliding the End Guide inward as shown in the figure to remove.



**Figure 2 End Guide Link**

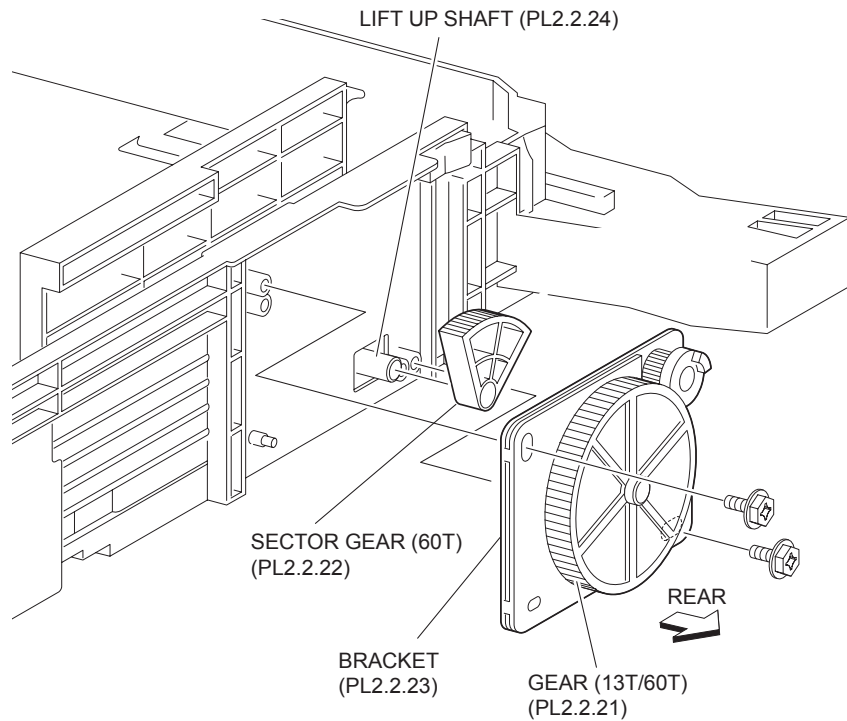
## Replacement

1. Fit the boss on the lower part of the End Guide to the groove on the Tray (PL 2.2.11).
2. Slide the End Guide to around the center of the groove on the Tray.
3. Put the boss on the End Guide into the hole on the Link (PL 2.2.19).
4. Put the boss on the End Guide Actuator (PL 2.2.18) into the hole on the Link by moving the Link in the direction of the arrow (A).
5. Install the Link to the Tray using the two hooks.
6. Install the Side Guide Actuator (PL 2.2.12) to the Rear Side Guide (PL 2.2.9) using the hook.
7. Install the Rear Side Guide (PL 2.2.9).
8. Install the Front Side Guide Assembly (PL 2.2.6).
9. Insert the Tray Assembly (PL 2.2.1).

## 60T Sector Gear

### Removal

1. Remove the Tray Assembly (PL 2.2.1).
2. Remove the two screws (Silver, M3x8mm) securing the Bracket (PL 2.2.23) to the Tray (P2.2.11) and remove the Bracket.
3. Remove the 60T Sector Gear.



FI32015A1

**Figure 1 Sector Gear**

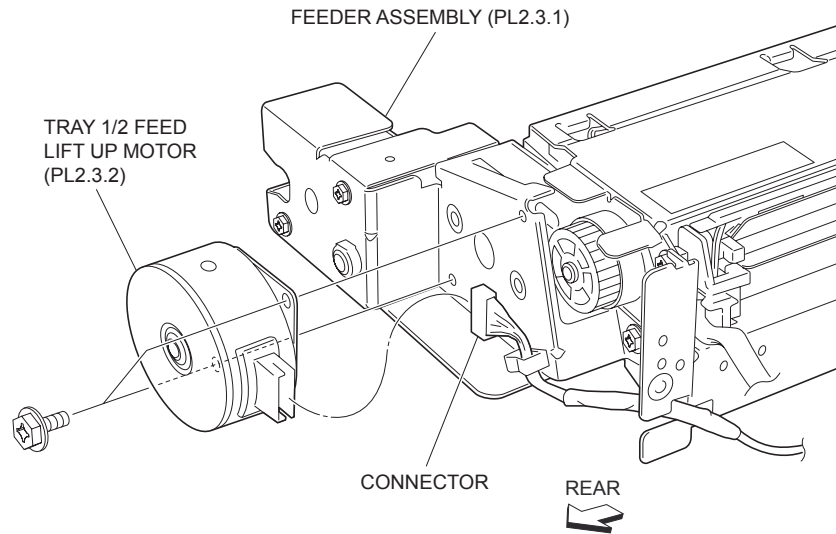
### Replacement

1. Engage the 60T Sector Gear with the Gear (13T/60T) (PL 2.2.21).
2. Fit the D-shaped on the Lift Up Shaft into the hole on the 60T Sector Gear, and install the Bracket (PL 2.2.23) to the Tray using two screws (Silver, M3x8mm).
3. Insert the Tray Assembly (PL 2.2.1).

## Tray 1&2 Feed Lift Up Motor

### Removal

1. Remove the MPF RR Cover (PL 3.1.14).
2. Remove the MPF Feeder Assembly (PL 3.1.1).
3. Remove the Left Hand Cover Assembly (PL 4.2.8).
4. Remove the TA Bracket Assembly (PL 4.1.1).
5. Remove the Feeder 1 or Feeder 2 Assembly (PL 2.3.1).
6. Disconnect the connector (Tray 1:P/J201, Tray 2:P/J202) of the Wire Harness (PL 2.3.16) from the Tray 1&2 Feed Lift Up Motors.
7. Remove the two screws (M3x6mm) securing the Tray 1&2 Feed Lift Up Motors to the Feeder Assembly (PL 2.3.1).
8. Remove the Tray 1&2 Feed Lift Up Motors.



F132016A1

**Figure 1 Tray 1/2 Feed Lift Motor**

## Replacement

1. Install the Tray 1&2 Feed Lift Up Motors to the Feeder Assembly (PL 2.3.1) using the two screws (M3x6mm).
2. Connect the connector (Tray 1:P/J201, Tray 2:P/J202) of the Wire Harness (PL 2.3.16) to the Tray 1&2 Feed Lift Up Motors.
3. Install the Feeder 1 or Feeder 2 Assembly (PL 2.3.1).
4. Install the TA Bracket Assembly (PL 4.1.1).
5. Install the Left Hand Cover Assembly (PL 4.2.8).
6. Install the MPF Feeder Assembly (PL 3.1.1).
7. Install the MPF RR Cover (PL 3.1.14).

## Spacer

### Removal

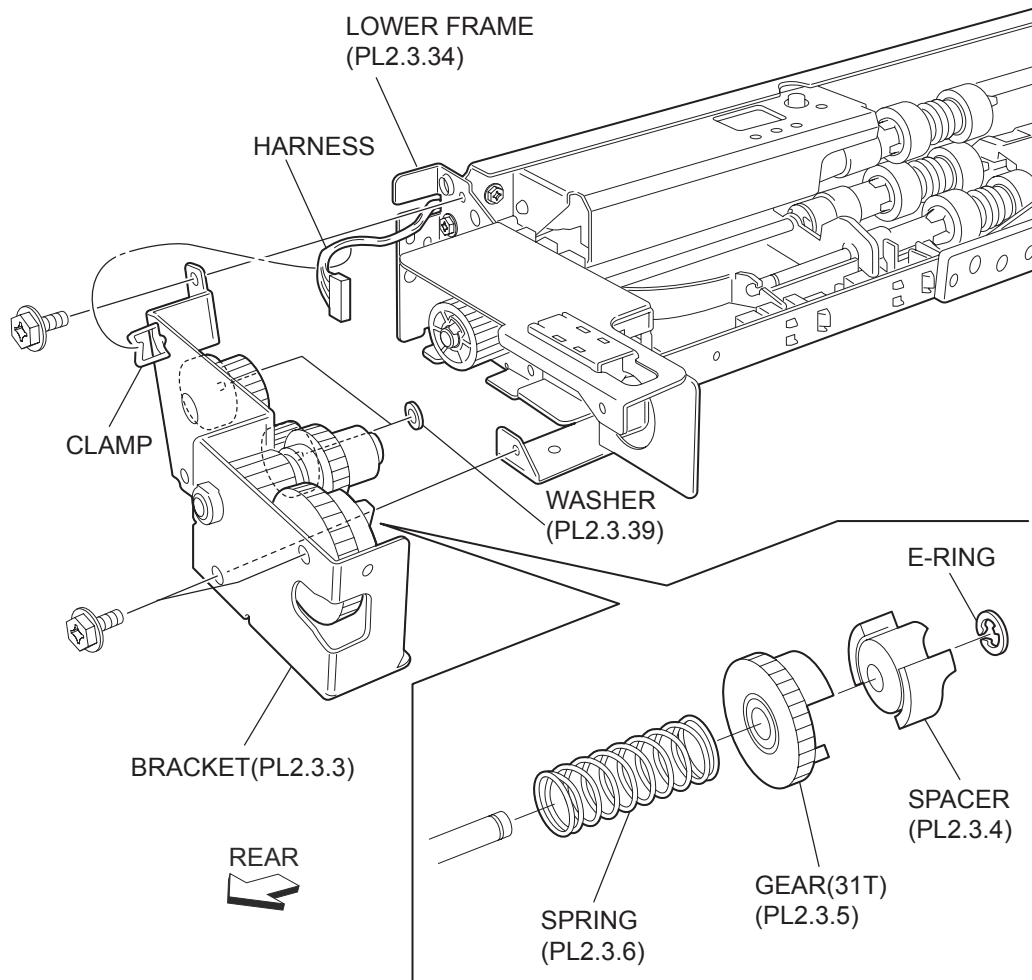
1. Remove the MPF RR Cover (PL 3.1.14).
2. Remove the MPF Feeder Assembly (PL 3.1.1).
3. Remove the Left Hand Cover Assembly (PL 4.2.8).
4. Remove the TA Bracket Assembly (PL 4.1.1).
5. Remove the Feeder 1 or Feeder 2 Assembly (PL 2.3.1).
6. Release the Wire Harness (PL 2.3.16) from the clamp on the Bracket (PL 2.3.3).
7. Remove the three screws (Del Tite, M3x6mm) securing the Bracket to the Lower Frame (PL 2.3.34).

**NOTE** Note that the Gears attached on the Bracket may be detached.

8. Remove E-rings securing the Spacer, Gear (31T) (PL 2.3.5) and the Spring (PL 2.3.6) to the Bracket.

**NOTE** Note that Spring may pop out.

9. Remove the Spacer.



FI32017A1

**Figure 1 Spacer**

## Replacement

1. Install the Spacer to the Bracket (PL 2.3.3) together with the Gear (31T) (PL 2.3.5) and the Spring (PL 2.3.6), and fix them using E-ring.
2. Install the Bracket to the Lower Frame (PL 2.3.34) using the three screws (Del Tite, M3x6mm).

**NOTE** Make sure that the Gears attached on the Bracket are correctly installed.

3. Secure the Wire Harness (PL 2.3.16) to the clamp on the Bracket.
4. Install the Feeder 1 or Feeder 2 Assembly (PL 2.3.1).
5. Install the TA Bracket Assembly (PL 4.1.1).
6. Install the Left Hand Cover Assembly (PL 4.2.8).
7. Install the MPF Feeder Assembly (PL 3.1.1).
8. Install the MPF RR Cover (PL 3.1.14).

## Gear (31T)

### Removal

1. Remove the MPF RR Cover (PL 3.1.14).

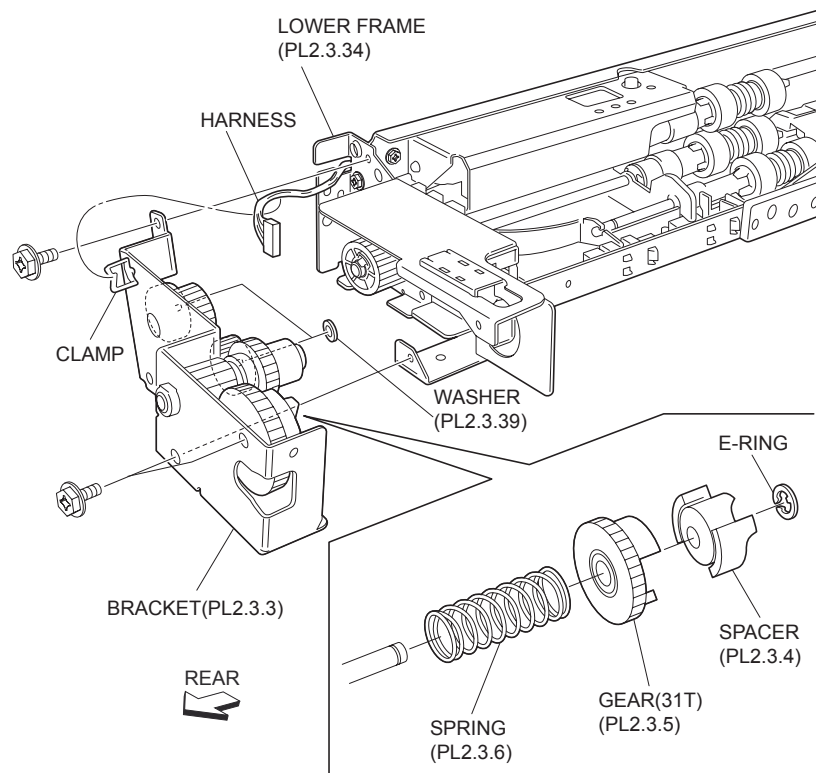
2. Remove the MPF Feeder Assembly (PL 3.1.1).
3. Remove the Left Hand Cover Assembly (PL 4.2.8).
4. Remove the TA Bracket Assembly (PL 4.1.1).
5. Remove the Feeder 1 or Feeder 2 Assembly (PL 2.3.1).
6. Release the Wire Harness (PL 2.3.16) from the clamp on the Bracket (PL 2.3.3).
7. Remove the three screws (Del Tite, M3x6mm) securing the Bracket to the Lower Frame (PL 2.3.34).

**NOTE** Note that the Gears attached on the Bracket may be detached.

8. Remove E-rings securing Gear (31T), Spacer (PL 2.3.4) and Spring (PL 2.3.6) to Bracket.

**NOTE** Note that Spring can pop out.

9. Remove Gear (31T).



FI32018A1

**Figure 1 31T Gear**

## Replacement

1. Install Gear (31T) to Bracket (PL 2.3.3), together with Spacer (PL 2.3.4) and Spring (PL 2.3.6), using E-rings.
2. Install Bracket to Lower Frame (PL 2.3.34) using three screws (Del Tite, M3x6mm).

**NOTE** Make sure that the Gears attached on the Bracket are properly installed.

3. Secure the Wire Harness (PL 2.3.16) to the clamp on the Bracket.
4. Install the Feeder 1 or Feeder 2 Assembly (PL 2.3.1).
5. Install the TA Bracket Assembly (PL 4.1.1).
6. Install the Left Hand Cover Assembly (PL 4.2.8).
7. Install the MPF Feeder Assembly (PL 3.1.1).

8. Install the MPF RR Cover (PL 3.1.14).

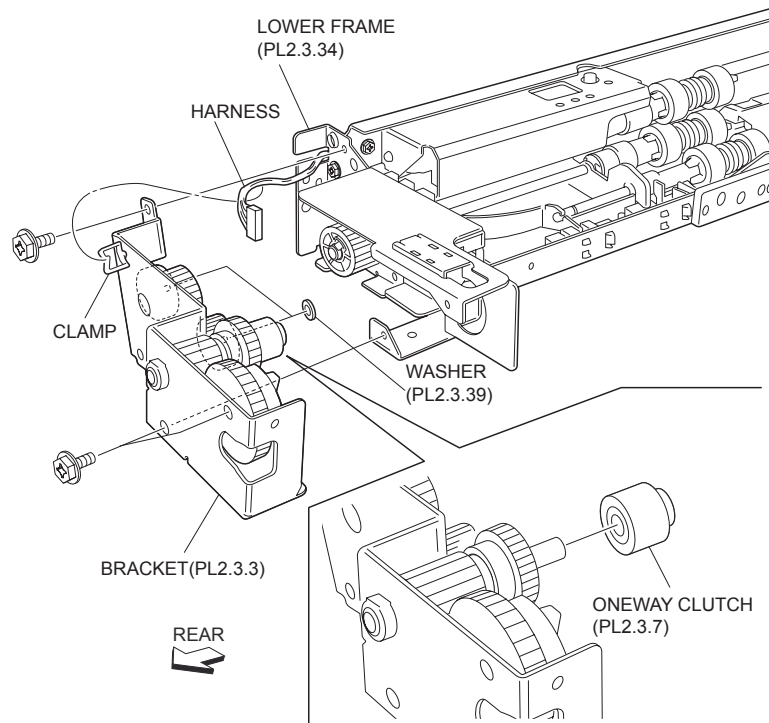
## Oneway Clutch

### Removal

1. Remove the MPF RR Cover (PL 3.1.14).
2. Remove the MPF Feeder Assembly (PL 3.1.1).
3. Remove the Left Hand Cover Assembly (PL 4.2.8).
4. Remove the TA Bracket Assembly (PL 4.1.1).
5. Remove the Feeder 1 or Feeder 2 Assembly (PL 2.3.1).
6. Release the Wire Harness (PL 2.3.16) from the clamp on the Bracket (PL 2.3.3).
7. Remove the three screws (Del Tite, M3x6mm) securing the Bracket to the Lower Frame (PL 2.3.34)

**NOTE** Note that the Gears attached on the Bracket may be detached.

8. Remove the Oneway Clutch.



FI32019A1

**Figure 1 Oneway Clutch**

### Replacement

1. Install the Oneway Clutch.
2. Install the Bracket (PL 2.3.3) to the Lower Frame (PL 2.3.34) using the three screws (Del Tite, M3x6mm).

**NOTE** Make sure that the Gears attached on the Bracket are properly installed.

3. Secure the Wire Harness (PL 2.3.16) to the clamp on the Bracket.
4. Install the Feeder 1 or Feeder 2 Assembly (PL 2.3.1).
5. Install the TA Bracket Assembly (PL 4.1.1).

6. Install the Left Hand Cover Assembly (PL 4.2.8).
7. Install the MPF Feeder Assembly (PL 3.1.1).
8. Install the MPF RR Cover (PL 3.1.14).

## Oneway Gear

### Removal

1. Remove the MPF RR Cover (PL 3.1.14).
2. Remove the MPF Feeder Assembly (PL 3.1.1).
3. Remove the Left Hand Cover Assembly (PL 4.2.8).
4. Remove the TA Bracket Assembly (PL 4.1.1).
5. Remove the Feeder 1 or Feeder 2 Assembly (PL 2.3.1).
6. Remove the Oneway Clutch (PL 2.3.7).
7. Remove the Oneway Gear.

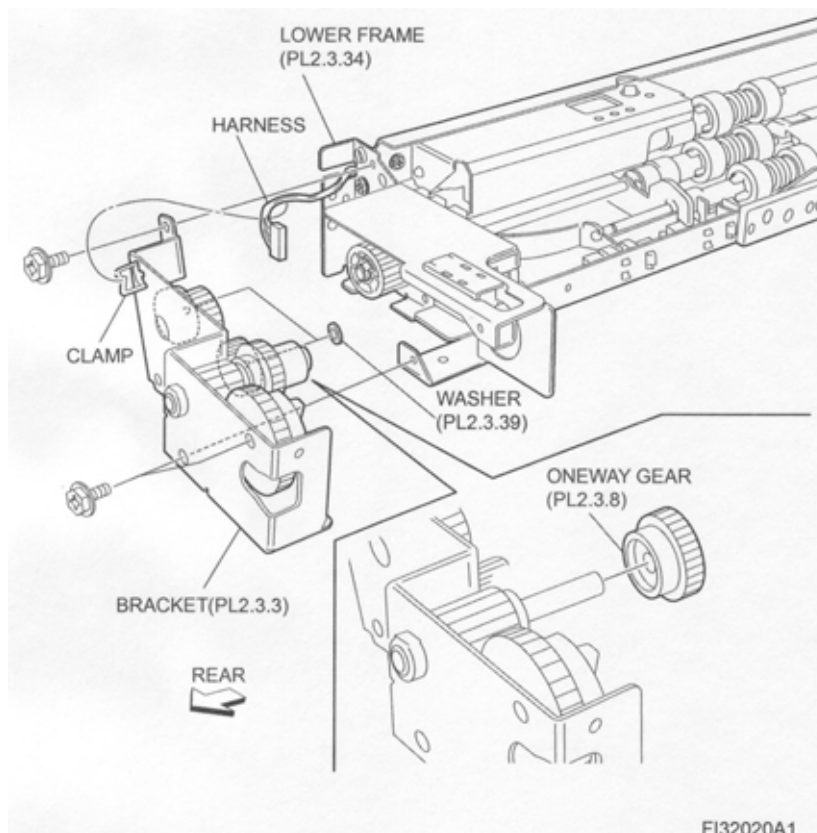


Figure 1 Oneway Gear

### Replacement

1. Install the Oneway Gear.
2. Install the Oneway Clutch (PL 2.3.7) (RRP 2.12).
3. Install the Feeder 1 or Feeder 2 Assembly (PL 2.3.1).
4. Install the TA Bracket Assembly (PL 4.1.1).
5. Install the Left Hand Cover Assembly (PL 4.2.8).
6. Install the MPF Feeder Assembly (PL 3.1.1).
7. Install the MPF RR Cover (PL 3.1.14).



## Gear (13T)

### Removal

1. Remove the MPF RR Cover (PL 3.1.14).
2. Remove the MPF Feeder Assembly (PL 3.1.1).
3. Remove the Left Hand Cover Assembly (PL 4.2.8).
4. Remove the TA Bracket Assembly (PL 4.1.1).
5. Remove the Feeder 1 or Feeder 2 Assembly (PL 2.3.1).
6. Remove the Oneway Clutch (PL 2.3.7) (RRP 2.12).
7. Remove the Oneway Gear (PL 2.3.8).
8. Remove the Gear (13T).

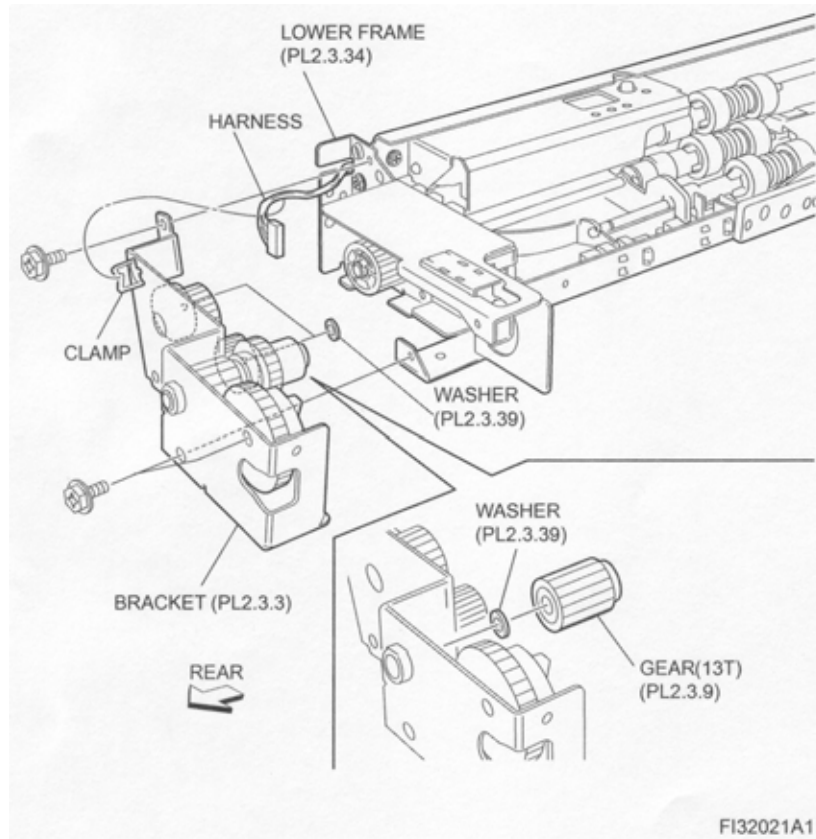


Figure 1 13T Gear

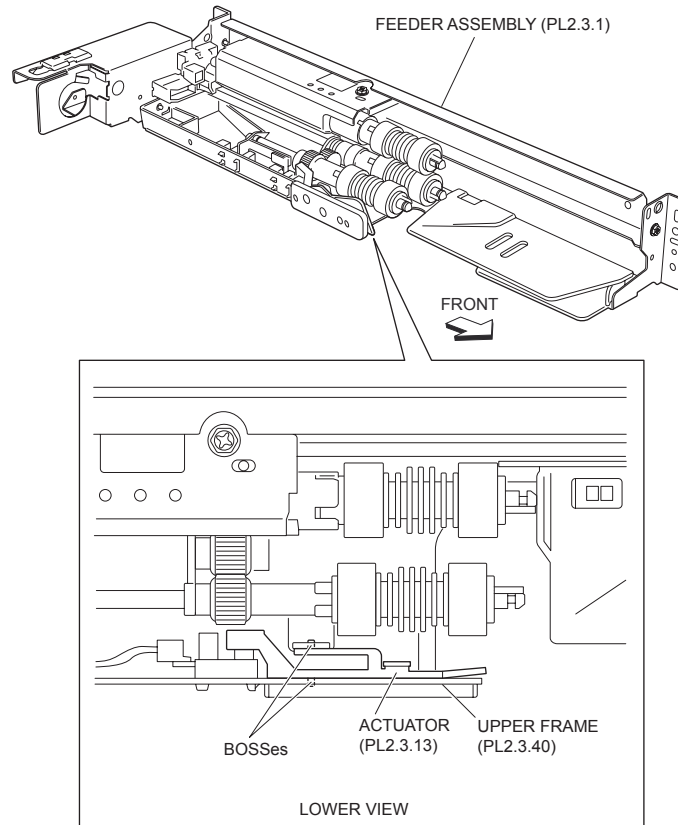
### Replacement

1. Install the Gear (13T).
2. Install the Oneway Gear (PL 2.3.8) (RRP 2.13).
3. Install the Oneway Clutch (PL 2.3.7) (RRP 2.12).
4. Install the Feeder 1 or Feeder 2 Assembly (PL 2.3.1).
5. Install the TA Bracket Assembly (PL 4.1.1).
6. Install the Left Hand Cover Assembly (PL 4.2.8).
7. install the MPF Feeder Assembly (PL 3.1.1).
8. Install the MPF RR Cover (PL 3.1.14).

## Actuator

## Removal

1. Remove the MPF RR Cover (PL 3.1.14).
2. Remove the MPF Feeder Assembly (PL 3.1.1).
3. Remove the Left Hand Cover Assembly (PL 4.2.8).
4. Remove the TA Bracket Assembly (PL 4.1.1).
5. Remove the Feeder 1 or Feeder 2 Assembly (PL 2.3.1).
6. Remove the two bosses on the Actuator securing the Actuator to the Feeder Assembly (PL 2.3.1).
7. Remove the Actuator.



FI32022A1

**Figure 1 Actuator**

## Replacement

1. Install Actuator.

**NOTE** Fit the bosses on the Actuator into the holes on the Feeder Assembly (PL 2.3.1).

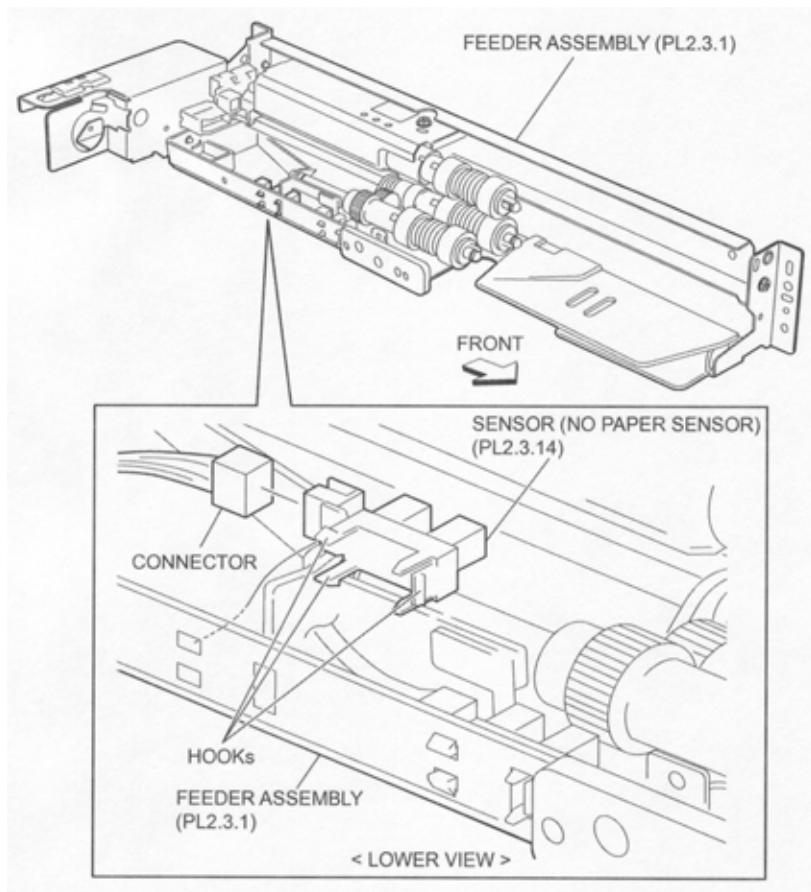
2. Install the Feeder 1 or Feeder 2 Assembly (PL 2.3.1).
3. Install the TA Bracket Assembly (PL 4.1.1).
4. Install the Left Hand Cover Assembly (PL 4.2.8).
5. Install the MPF Feeder Assembly (PL 3.1.1).
6. Install the MPF RR Cover (PL 3.1.14).

## No Paper Sensor

### Removal

1. Remove the MPF RR Cover (PL 3.1.14).

2. Remove the MPF Feeder Assembly (PL 3.1.1).
3. Remove the Left Hand Cover Assembly (PL 4.2.8).
4. Remove the TA Bracket Assembly (PL 4.1.1).
5. Remove the Feeder 1 or Feeder 2 Assembly (PL 2.3.1).
6. Disconnect the connector (Tray 1:P/J101, Tray 2:P/J103) of the Wire Harness from the No Paper Sensor.
7. Release the hooks securing the No Paper Sensor to the Feeder Assembly (PL 2.3.1) as shown in the figure.
8. Remove the No Paper Sensor.



**Figure 1 No Paper Sensor**

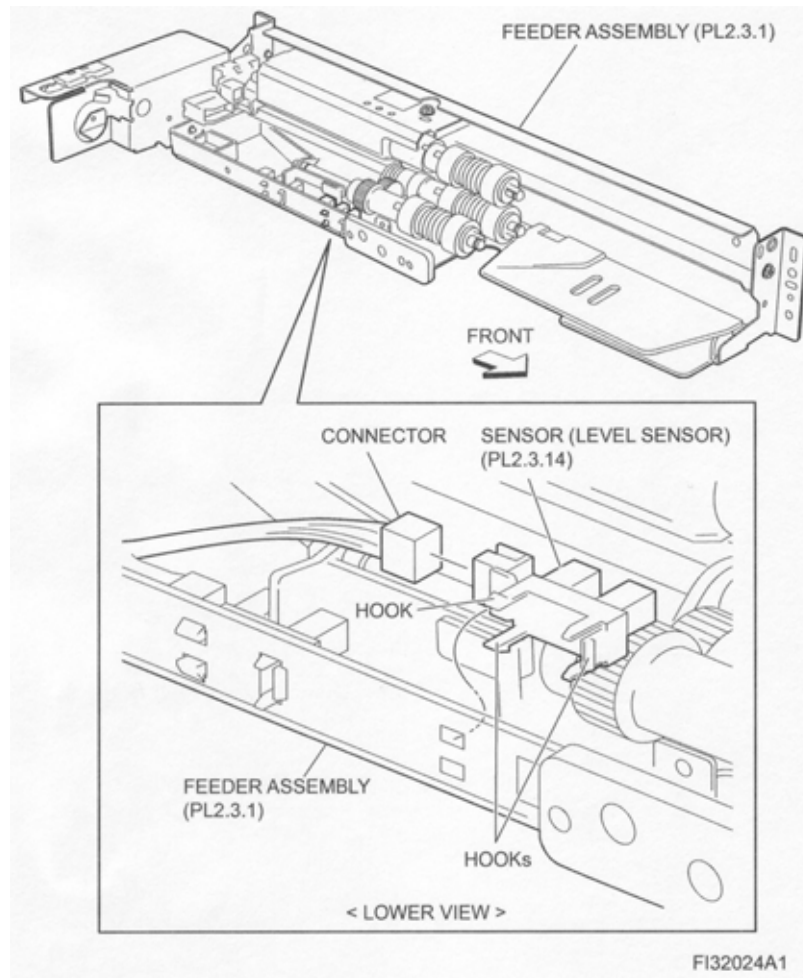
## Replacement

1. Secure the No Paper Sensor to the Feeder Assembly (PL 2.3.1) using the hooks.
2. Connect the connector (Tray 1:P/J101, Tray 2:P/J103) of the Wire Harness to No Paper Sensor.
3. Install the Feeder 1 or Feeder 2 Assembly (PL 2.3.1).
4. Install the TA Bracket Assembly (PL 4.1.1).
5. Install the Left Hand Cover Assembly (PL 4.2.8).
6. Install the MPF Feeder Assembly (PL 3.1.1).
7. Install the MPF RR Cover (PL 3.1.14).

## Level Sensor

### Removal

1. Remove the MPF RR Cover (PL 3.1.14).
2. Remove the MPF Feeder Assembly (PL 3.1.1).
3. Remove the Left Hand Cover Assembly (PL 4.2.8).
4. Remove the TA Bracket Assembly (PL 4.1.1).
5. Remove the Feeder 1 or Feeder 2 Assembly (PL 2.3.1).
6. Remove the Actuator (PL 2.3.13).
7. Disconnect the connector (Tray 1:P/J100, Tray 2:P/J102) of the Wire Harness from the Level Sensor.
8. Release the hooks securing the Level Sensor to the Feeder Assembly (PL 2.3.1) as shown in the figure.
9. Remove the Level Sensor.



**Figure 1 Level Sensor**

## Replacement

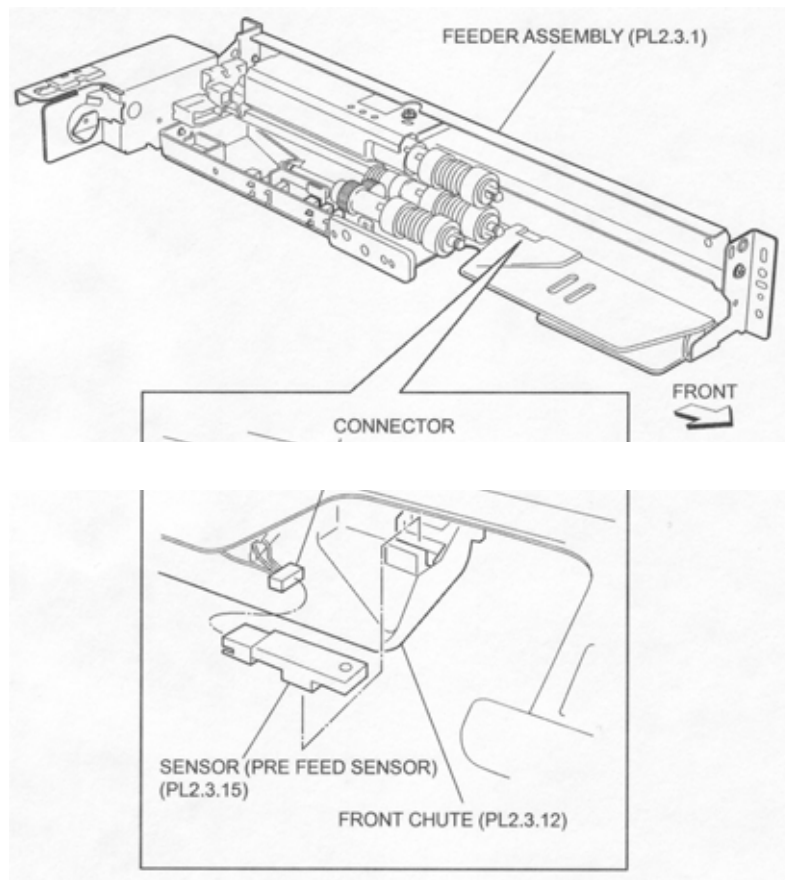
1. Secure the Level Sensor to the Feeder Assembly (PL 2.3.1) using the hooks.
2. Connect the connector (Tray 1:P/J100, Tray 2:P/J102) of the Wire Harness to the Level Sensor.
3. Install the Actuator (PL 2.3.13).
4. Install the Feeder 1 or Feeder 2 Assembly (PL 2.3.1).
5. Install the TA Bracket Assembly (PL 4.1.1).
6. Install the Left Hand Cover Assembly (PL 4.2.8).
7. Install the MPF Feeder Assembly (PL 3.1.1).

8. Install the MPF RR Cover (PL 3.1.14).

## Pre-Feed Sensor

### Removal

1. Remove the MPF RR Cover (PL 3.1.14).
2. Remove the MPF Feeder Assembly (PL 3.1.1).
3. Remove the Left Hand Cover Assembly (PL 4.2.8).
4. Remove the TA Bracket Assembly (PL 4.1.1).
5. Remove the Feeder 1 or Feeder 2 Assembly (PL 2.3.1).
6. Remove the Pre-Feed Sensor from the Front Chute (PL 2.3.12) as shown.
7. Disconnect the connector (Tray 1:P/J133, Tray 2:P/J134) of the Wire Harness from the Pre-Feed Sensor.



**Figure 1 Pre Feed Sensor**

### Replacement

1. Connect the connector (Tray 1:P/J133, Tray 2:P/J134) of the Wire Harness to the Pre-Feed Sensor.
2. Install the Pre-Feed Sensor to the Front Chute (PL 2.3.12).
3. Install the Feeder 1 or Feeder 2 Assembly (PL 2.3.1).
4. Install the TA Bracket Assembly (PL 4.1.1).
5. Install the Left Hand Cover Assembly (PL 4.2.8).
6. Install the MPF Feeder Assembly (PL 3.1.1).
7. Install the MPF RR Cover (PL 3.1.14).

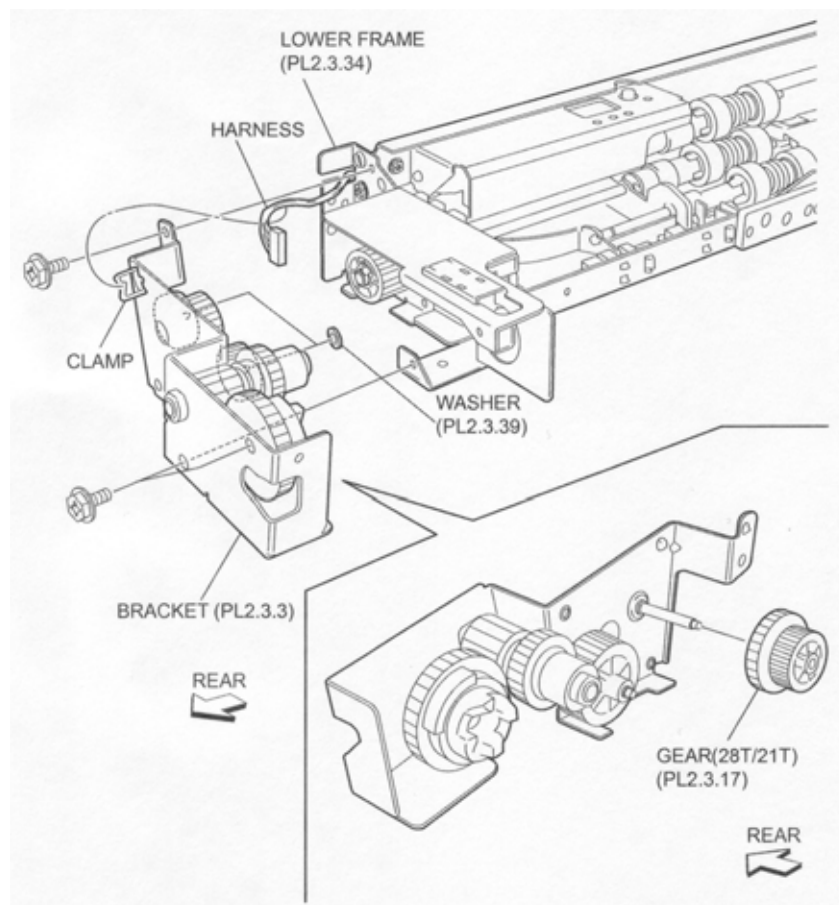
## Gear (28T/21T)

### Removal

1. Remove the MPF RR Cover (PL 3.1.14).
2. Remove the MPF Feeder Assembly (PL 3.1.1).
3. Remove the Left Hand Cover Assembly (PL 4.2.8).
4. Remove the TA Bracket Assembly (PL 4.1.1).
5. Remove the Feeder 1 or Feeder 2 Assembly (PL 2.3.1).
6. Release the Wire Harness (PL 2.3.16) from the clamp on the Bracket (PL 2.3.3).
7. Remove the three screws (Del Tite, M3x6mm) securing the Bracket to the Lower Frame (PL 2.3.34).

**NOTE** Note that the Gears attached on the Bracket may be detached.

8. Remove the Gear (28T/21T).



**Figure 1 Gear Removal**

### Replacement

1. Install the Gear (28T/21T).
2. Install the Bracket (PL 2.3.3) to the Lower Frame (PL 2.3.34) using the three screws (Del Tite, M3x6mm).

**NOTE** Make sure that the Gears attached on the Bracket are properly installed.

3. Secure the Wire Harness (PL 2.3.16) connector to the clamp on the Bracket.
4. Install the Feeder 1 or Feeder 2 Assembly (PL 2.3.1).

5. Install the TA Bracket Assembly (PL 4.1.1).
6. Install the Left Hand Cover Assembly (PL 4.2.8).
7. Install the MPF Feeder Assembly (PL 3.1.1).
8. Install the MPF RR Cover (PL 3.1.14).

## Gear (29T)

### Removal

1. Remove the MPF RR Cover (PL 3.1.14).
2. Remove the MPF Feeder Assembly (PL 3.1.1).
3. Remove the Left Hand Cover Assembly (PL 4.2.8).
4. Remove the TA Bracket Assembly (PL 4.1.1).
5. Remove the Feeder 1 or Feeder 2 Assembly (PL 2.3.1).
6. Release the Wire Harness (PL 2.3.16) from the clamp on the Bracket (PL 2.3.3).
7. Remove the three screws (Del Tite, M3x6mm) securing the Bracket to the Lower Frame (PL 2.3.34).

**NOTE** Note that the Gears attached on the Bracket may be detached.

8. Remove the Gear (29T).

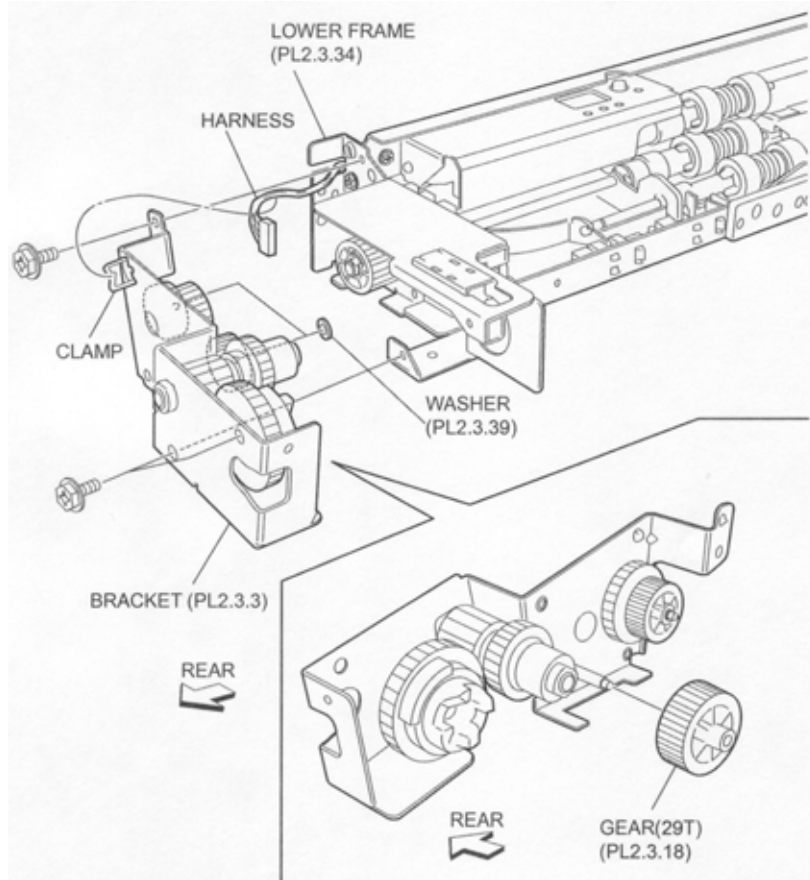


Figure 1 29T Gear

### Replacement

1. Install the Gear (29T).
2. Install the Bracket (PL 2.3.3) to the Lower Frame (PL 2.3.34) using three screws (Del Tite, M3x6mm).

**NOTE** Make sure that the Gears attached on the Bracket are properly installed.

3. Secure the Wire Harness (PL 2.3.16) to the clamp on the Bracket.
4. Install the Feeder 1 or Feeder 2 Assembly (PL 2.3.1).
5. Install the TA Bracket Assembly (PL 4.1.1).
6. Install the Left Hand Cover Assembly (PL 4.2.8).
7. Install the MPF Feeder Assembly (PL 3.1.1).
8. Install the MPF RR Cover (PL 3.1.14).

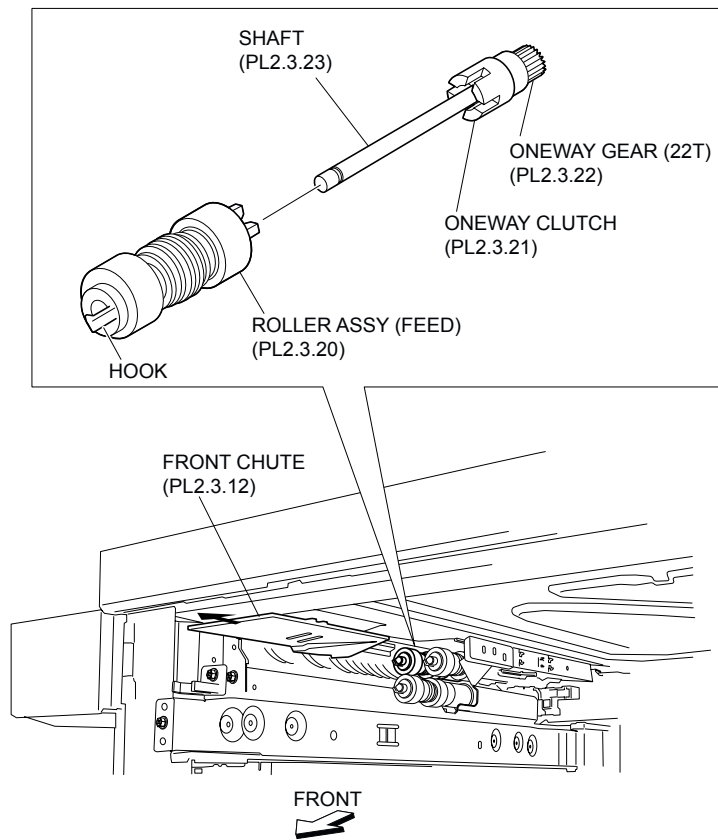
## Feed Roller Assembly

### Removal

1. Pull out the Tray 1 or Tray 2.
2. Move the Front Chute (PL 2.3.12) in the direction of the arrow.
3. Release the hook securing the Feed Roller Assembly to the Shaft (PL 2.3.23) as shown in the figure.
4. Remove the Feed Roller Assembly.

**NOTE** Note that the Oneway Clutch (PL 2.3.21) and the Oneway Gear (22T) (PL 2.3.22) may be detached.

**NOTE** When removing, do not hold the rubber roller of the Feed Roller Assembly.



**Figure 1 Feed Roller Assembly**



## Replacement

1. Install the Feed Roller Assembly to the Shaft (PL 2.3.23), and fix it using hook.

**NOTE** When installing, do not hold the rubber roller of the Feed Roller Assembly.

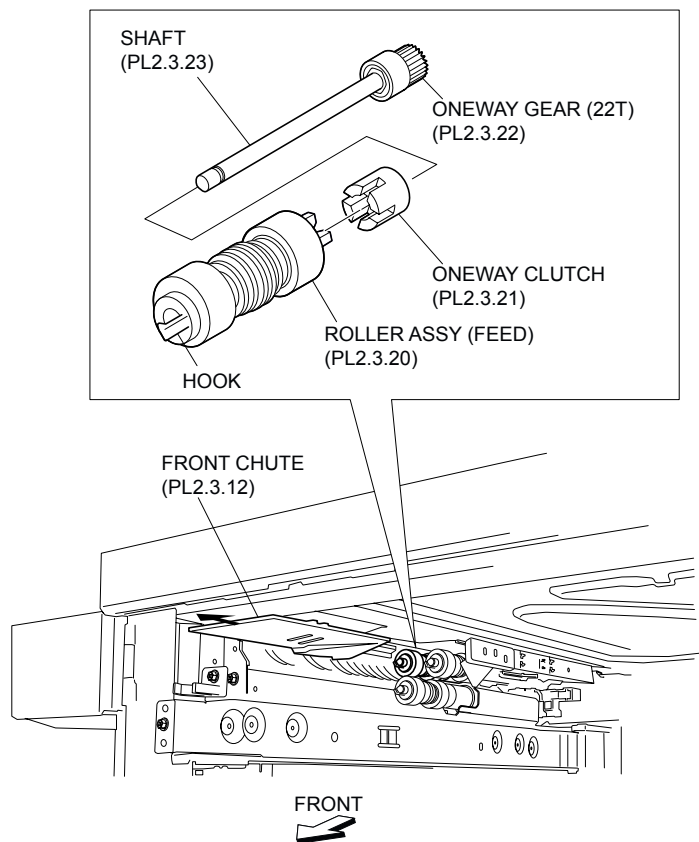
2. Move the Front Chute (PL 2.3.12) in the opposite direction of the arrow (to the rear side).
3. Close the Tray 1 or Tray 2.

## Oneway Clutch

### Removal

1. Pull out the Tray 1 or Tray 2.
2. Remove the Feed Roller Assembly (PL 2.3.20).
3. Remove the Oneway Clutch.

**NOTE** Note that Oneway Gear (22T) (PL 2.3.22) may be detached.



**Figure 1 Oneway Clutch**

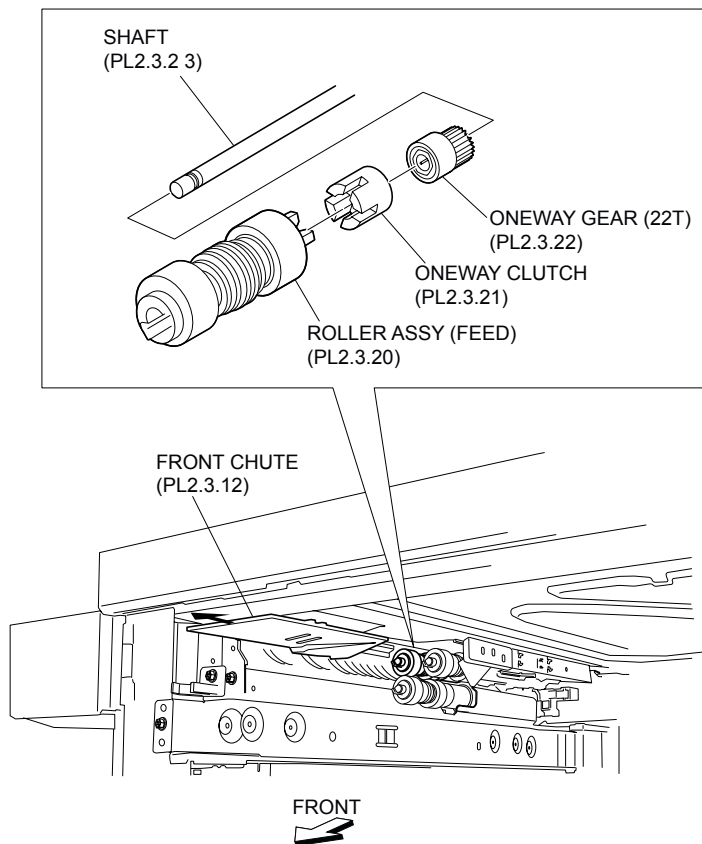
### Replacement

1. install the Oneway Clutch.
2. Install the Feed Roller Assembly (PL 2.3.20) (RRP 2.21).
3. Close the Tray 1 or Tray 2.

## Oneway Gear (22T)

### Removal

1. Pull out the Tray 1 or Tray 2.
2. Remove the Feed Roller Assembly (PL 2.3.20) (RRP 2.21).
3. Remove the Oneway Clutch (PL 2.3.21).
4. Remove the Oneway Gear (22T).



**Figure 1 Oneway Gear**

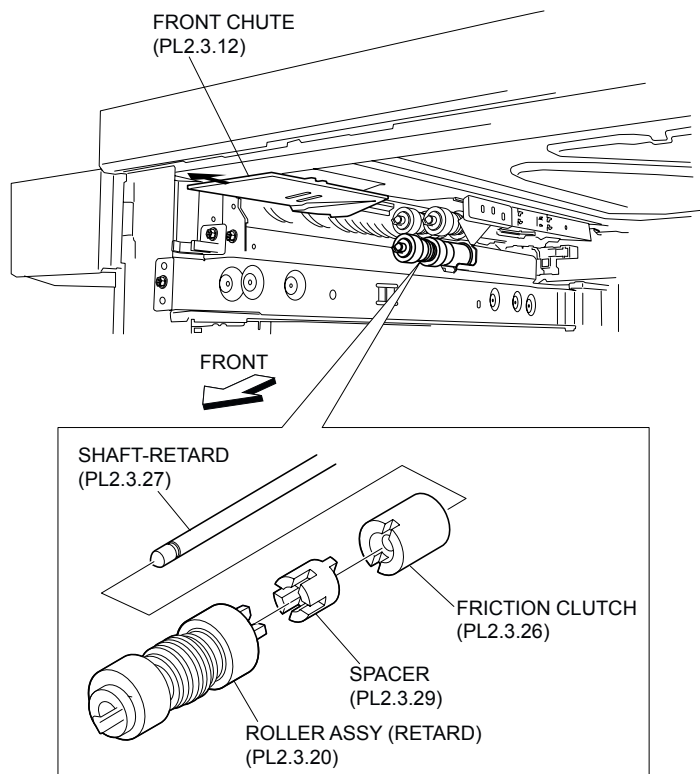
### Replacement

1. Install the Oneway Gear (22T).
2. Install the Oneway Clutch (PL 2.3.21) (RRP 2.22).
3. Install the Feed Roller Assembly (PL 2.3.20) (RRP 2.21).
4. Close the Tray 1 or Tray 2.

### Friction Clutch

#### Removal

1. Pull out the Tray 1 or Tray 2.
2. Remove the Retard Roller Assembly (PL 2.3.20).
3. Remove the Spacer (PL 2.3.29).
4. Remove the Friction Clutch.



**Figure 1 Friction Clutch**

## Replacement

1. Install the Friction Clutch.
2. Install the Spacer (PL 2.3.29) (RRP 2.26).
3. Install the Retard Roller Assembly (PL 2.3.20) (RRP 2.25).
4. Close the Tray 1 or Tray 2.

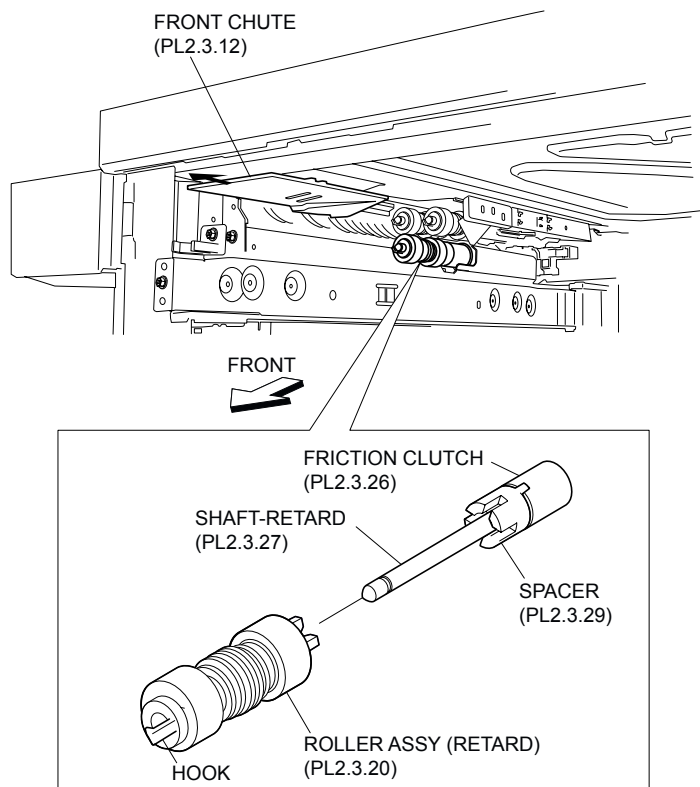
## Retard Roller Assembly

### Removal

1. Pull out the Tray 1 or Tray 2.
2. Move the Front Chute (PL 2.3.12) in the direction of the arrow.
3. Release the hook securing the Retard Roller Assembly to the Retard Shaft (PL 2.3.27) as shown in the figure.
4. Remove the Retard Roller Assembly.

**NOTE** Note that the **Spacer (PL 2.3.29)** and the **Friction Clutch (PL 2.3.26)** may be detached.

**NOTE** When removing, do not hold the rubber roller of the Retard Roller Assembly.



**Figure 1 Retard Roller Assembly**

## Replacement

1. Install the Retard Roller Assembly to the Retard Shaft (PL 2.3.27), and fix it using the hook.

**NOTE** When installing, do not hold the rubber roller of the Retard Roller Assembly.

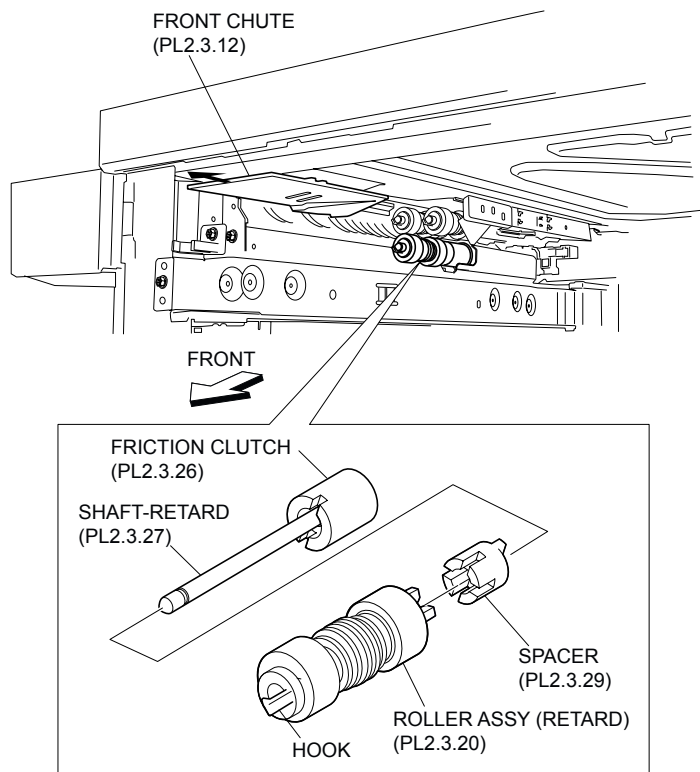
2. Move the Front Chute(PL 2.3.12) in the opposite direction of the arrow (to the rear side).
3. Close the Tray 1 or Tray 2.

## Spacer

### Removal

1. Pull out the Tray 1 or Tray 2.
2. Remove the Retard Roller Assembly (PL 2.3.20).
3. Remove the Spacer.

**NOTE** Note that the Friction Clutch (PL 2.3.26) may be detached.



**Figure 1 Spacer**

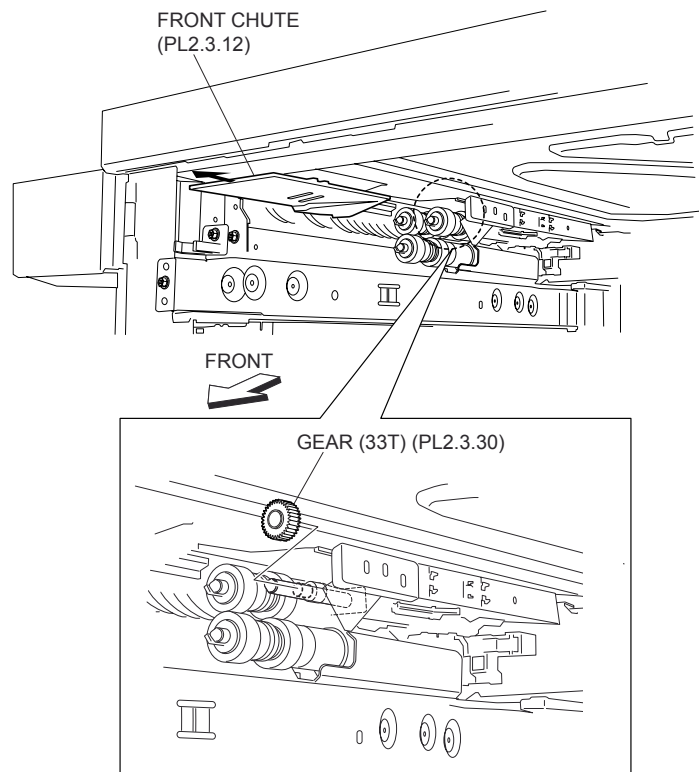
### Replacement

1. Install the Spacer.
2. Install the Retard Roller Assembly (PL 2.3.20).
3. Close the Tray 1 or Tray 2.

### Gear (33T)

#### Removal

1. Pull out the Tray 1 or Tray 2.
2. Remove the Nudger Roller Assembly (PL 2.3.20).
3. Remove the Gear (25T) (PL 2.3.33).
4. Remove the Gear (33T).



**Figure 1 33T Gear**

## Replacement

1. Install the Gear (33T).
2. Install the Gear (25T) (PL 2.3.33) (RRP 2.29).
3. Install the Nudger Roller Assembly (PL 2.3.20) (RRP 2.28).
4. Close the Tray 1 or Tray 2.

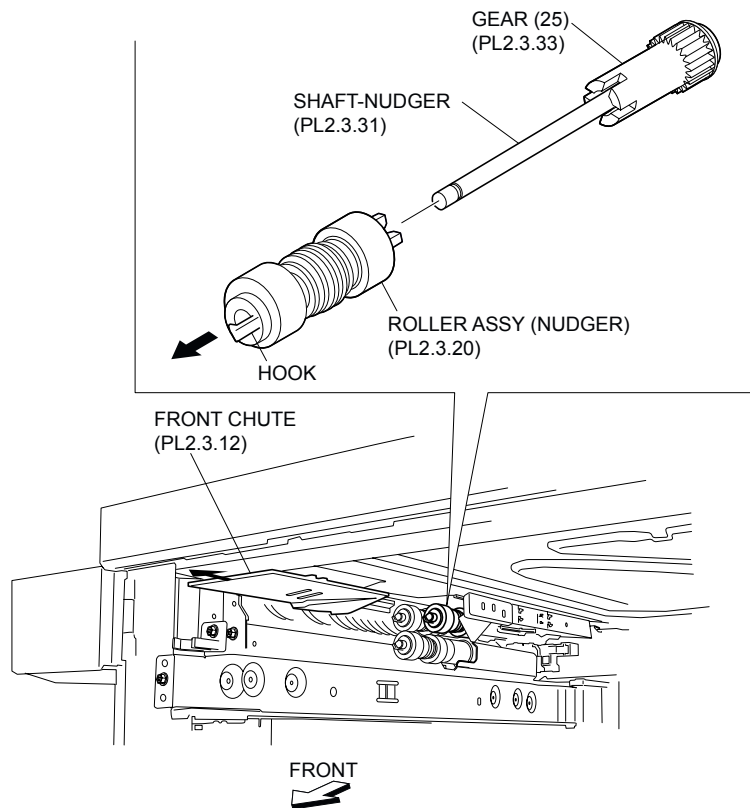
## Nudger Roller Assembly

### Removal

1. Pull out the Tray 1 or Tray 2.
2. Move the Front Chute (PL 2.3.12) in the direction of the arrow.
3. Release the hook securing the Nudger Roller Assembly to the Nudger Shaft (PL 2.3.31) as shown in the figure.
4. Remove the Nudger Roller Assembly.

**NOTE** Note that the Gear (25T) (PL 2.3.33) may be detached.

**NOTE** When removing, do not hold the rubber roller of the Nudger Roller Assembly.



**Figure 1 Nudger Roller Assembly**

## Replacement

1. Install the Nudger Roller Assembly to the Nudger Shaft (PL 2.3.31), and fix it using the hook.

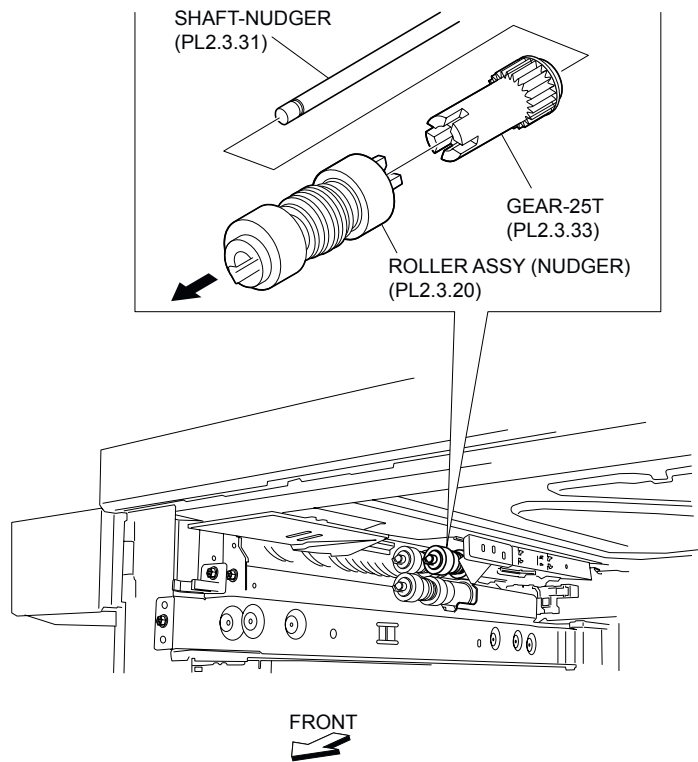
**NOTE** When installing, do not hold the rubber roller of the Nudger Roller Assembly.

2. Move the Front Chute (PL 2.3.12) in the opposite direction of the arrow (to the rear side).
3. Close the Tray 1 or Tray 2.

## Gear (25T)

### Removal

1. Pull out the Tray 1 or Tray 2.
2. Remove the Nudger Roller Assembly (PL 2.3.20).
3. Remove the Gear (25T).



**Figure 1 25T Gear**

## Replacement

1. Install the Gear (25T).
2. Install the Nudger Roller Assembly (PL 2.3.20) (RRP 2.28).
3. Close the Tray 1 or Tray 2.

## Gear (27T)

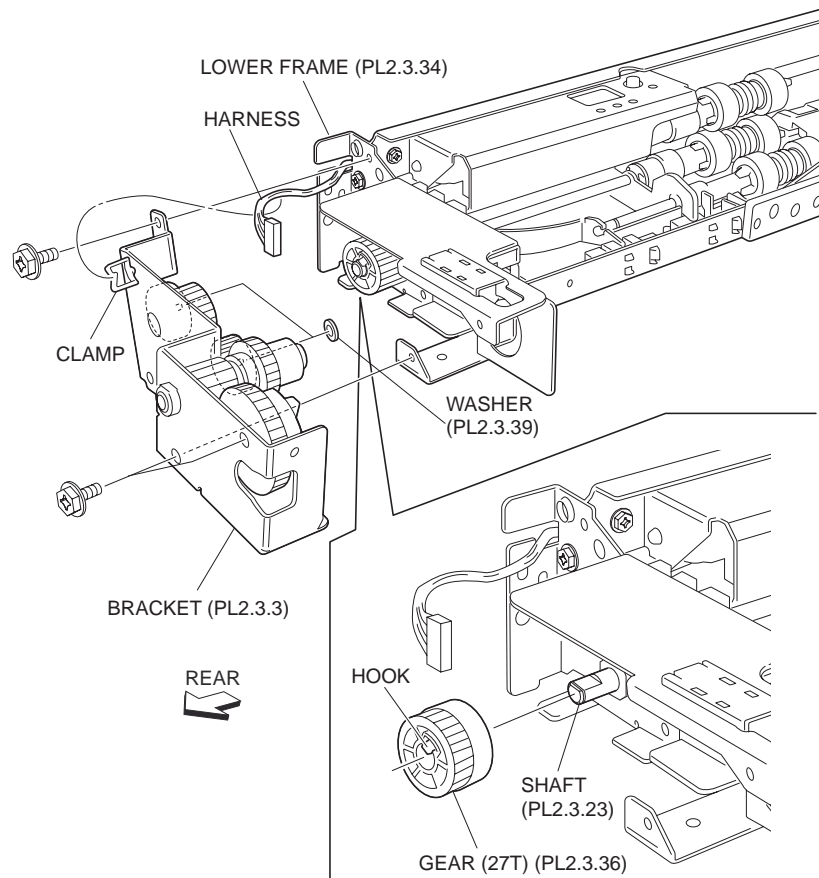
### Removal

1. Remove the MPF RR Cover (PL 3.1.14).
2. Remove the MPF Feeder Assembly (PL 3.1.1).
3. Remove the Left Hand Cover Assembly (PL 4.2.8).
4. Remove the TA Bracket Assembly (PL 4.1.1).
5. Remove the Feeder 1 or Feeder 2 Assembly (PL 2.3.1).
6. Release the Wire Harness (PL 2.3.16) from the clamp on the Bracket (PL 2.3.3).
7. Remove the three screws (Del Tite, M3x6mm) securing the Bracket to the Lower Frame (PL 2.3.34).

**NOTE** Note that the Gears attached on the Bracket may be detached.

8. Release the hook securing the Gear (27T) to the Shaft (PL 2.3.23) as shown in the figure.
9. Remove the Gear (27T).





**Figure 1 27T Gear**

## Replacement

1. Install the Gear (27T) to the Shaft (PL 2.3.23) using the hook.
2. Install Bracket (PL 2.3.3) to Lower Frame (PL 2.3.34) using three screws (Del Tite, M3x6mm).

**NOTE** Make sure that the Gears attached on the Bracket are properly installed.

3. Secure the Wire Harness (PL 2.3.16) to the clamp on the Bracket.
4. Install the Feeder 1 or Feeder 2 Assembly (PL 2.3.1).
5. Install the TA Bracket Assembly (PL 4.1.1).
6. Install the Left Hand Cover Assembly (PL 4.2.8).
7. Install the MPF Feeder Assembly (PL 3.1.1).
8. Install the MPF RR Cover (PL 3.1.14).

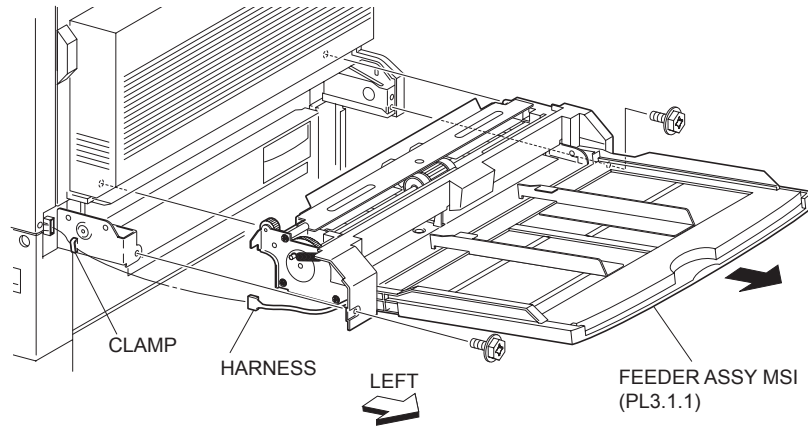
## MPF

### MPF Feeder Assembly

#### Removal

1. Remove the MPF RR Cover (PL 3.1.14).

2. Disconnect the connector (P/J605) of the MPF Harness Assembly A (PL 8.2.2) from the machine.
3. Release MPF Harness Assembly A from the clamp.
4. Remove the two screws (Del Tite, M3x8mm) securing the MPF Feeder Assembly to the machine.
5. Remove the MPF Feeder Assembly.



**Figure 1 MPF Feeder Assembly**

## Replacement

1. Install the MPF Feeder Assembly to the machine using two screws (Del Tite, M3x8mm).

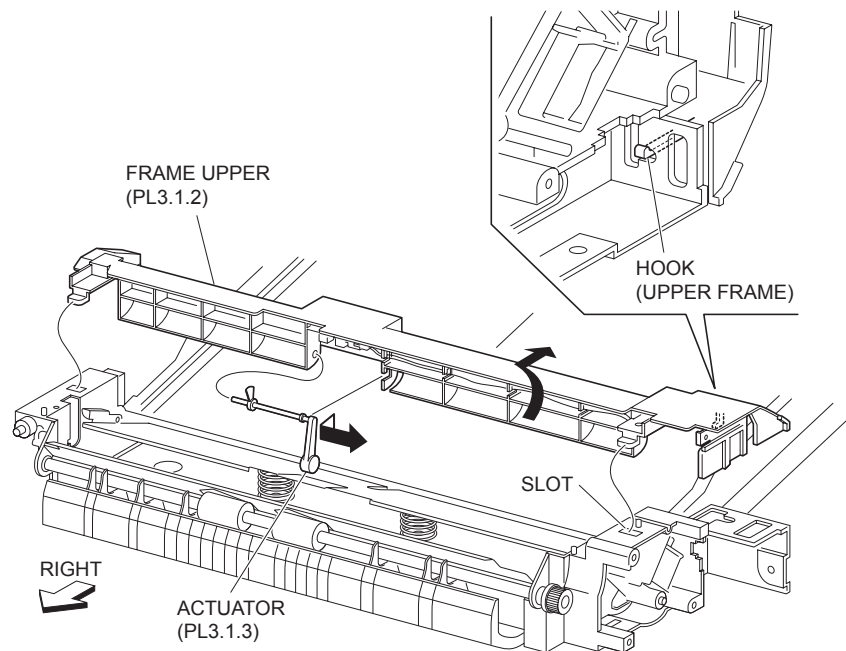
**NOTE** Place the MPF Harness Assembly A (PL 8.2.2) along the slot on the left on the MPF Feeder Assembly so that it does not pinch the harness between the feeder and the machine.

2. Connect the connector (P/J605) of the MPF Harness Assembly A to the machine.
3. Secure the MPF Harness Assembly A to the clamp.
4. Install the MPF RR Cover (PL 3.1.14).

## Actuator

### Removal

1. Remove the MPF RR Cover (PL 3.1.14).
2. Remove the MPF Feeder Assembly (PL 3.1.1).
3. Remove the two hooks securing the Upper Frame (PL 3.1.2) to the machine.
4. Remove the Upper Frame by moving it in the direction of the arrow.
5. Pull the right side of the Actuator toward you first, and pull out it from the hole on the Upper Frame.
6. Remove the Actuator.



**Figure 1 Actuator**

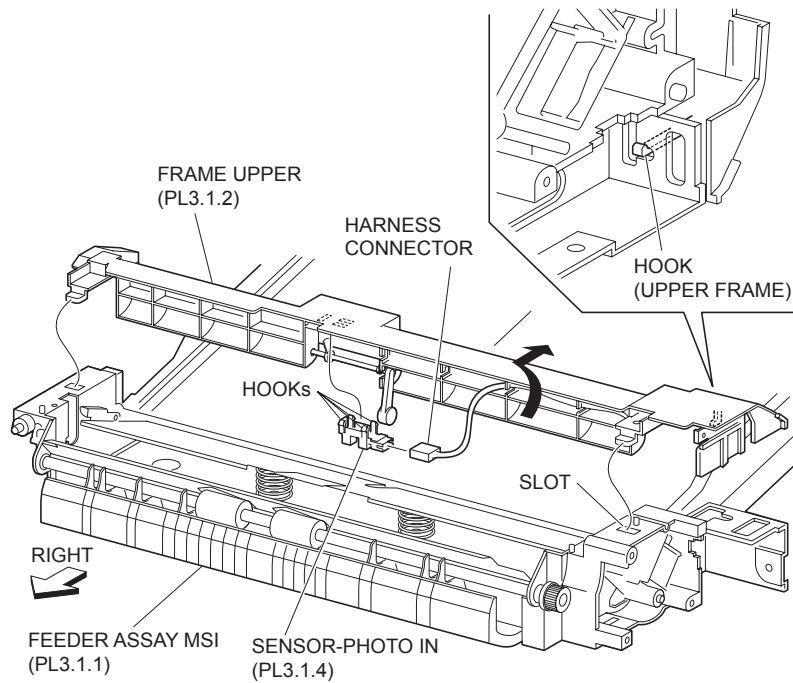
## Replacement

1. Install the Actuator in the opposite direction shown in the figure to the Upper Frame (PL 3.1.2)
2. Install the Upper Frame by moving it in the opposite direction of the arrow.
3. Fix the Upper Frame to the machine using the two hooks.
4. Install the MPF Feeder Assembly (PL 3.1.1).
5. Install the MPF RR Cover (PL 3.1.14).

## Photo In Sensor

### Removal

1. Remove the MPF RR Cover (PL 3.1.14).
2. Remove the MPF Feeder Assembly (PL 3.1.1).
3. Release the two hook securing the Upper Frame (PL 3.1.2) to the MPF Feeder Assembly, and move the Upper Frame in the direction of the arrow to remove.
4. Disconnect the connector (P/J108) of the MPF Harness Assembly (PL 3.1.5) from the Photo In Sensor.
5. Release the hooks securing the Photo In Sensor to the Upper Frame.
6. Remove the Photo In Sensor.



**Figure 1 Photo In Sensor**

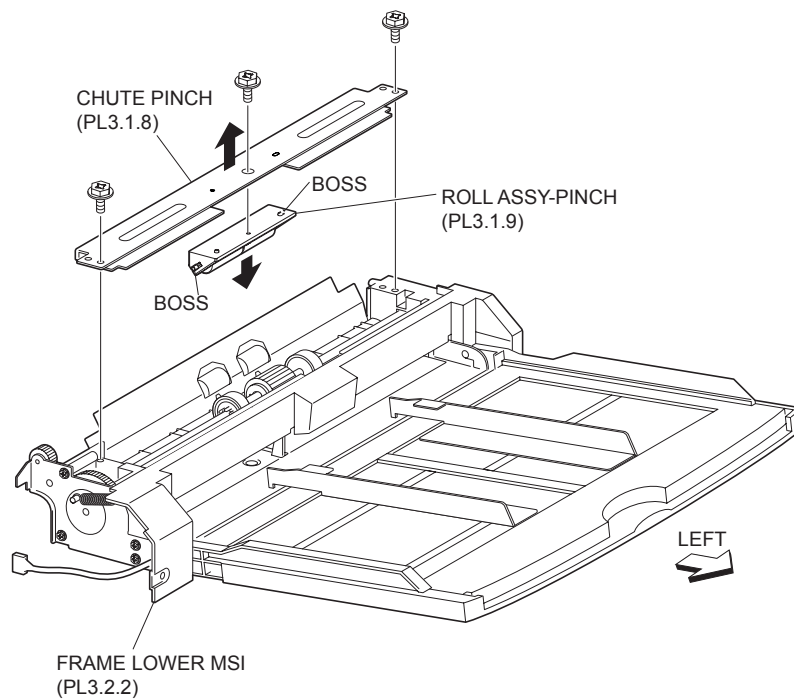
## Replacement

1. Secure the Photo In Sensor to the Upper Frame (PL 3.1.2) using the hooks.
2. Connect the connector (P/J108) of the MPF Harness Assembly (PL 3.1.5) to the Photo In Sensor.
3. Install the Upper Frame using the two hooks by moving it in the opposite direction of the arrow.
4. Install the MPF Feeder Assembly (PL 3.1.1).
5. Install the MPF RR Cover (PL 3.1.14).

## Pinch Roll Assembly

### Removal

1. Remove the MPF RR Cover (PL 3.1.14).
2. Remove the MPF Feeder Assembly (PL 3.1.1).
3. Remove the two screws (Silver, M3x8mm) securing the Pinch Chute (PL 3.1.8) to the MPF Lower Frame (P3.2.2) to remove the Pinch Chute.
4. Remove the screw (Silver, M3x8mm) securing the Pinch Roll Assembly to the Pinch Chute.
5. Release the bosses securing the Pinch Roll Assembly to the Pinch Chute.
6. Remove the Pinch Roll Assembly by moving it in the direction of the arrow.



**Figure 1 Pinch Roll Assembly**

## Replacement

1. Install the Pinch Roll Assembly by moving it in the opposite direction of the arrow.

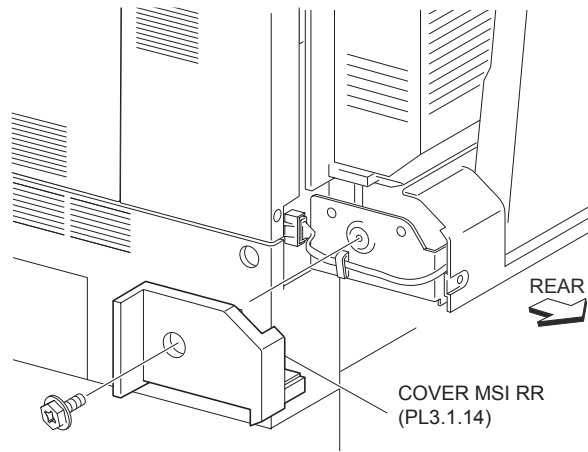
**NOTE** Fit the bosses on the Pinch Roll Assembly in the holes on the Pinch Chute (PL 3.1.8).

2. Install the Pinch Roll Assembly to the Pinch Chute using the screw (Silver, M3x8mm).
3. Install the Pinch Chute to the MPF Lower Frame (PL 3.2.2) using the two screws (Silver, M3x8mm).
4. Install the MPF Feeder Assembly (PL 3.1.1).
5. Install the MPF RR Cover (PL 3.1.14).

## MPF RR Cover

### Removal

1. Remove the screw (Del Tite, M3x8mm) securing the MPF RR Cover to the machine.
2. Remove the MPF Cap Cover, RR.



**Figure 1 MPF Cover**

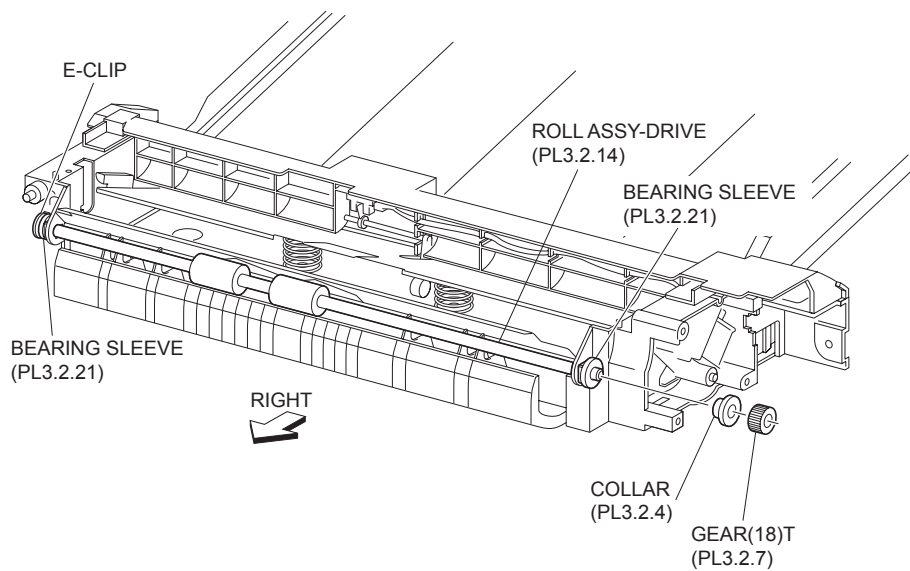
### Replacement

1. Secure the MPF RR Cover to the machine using the screw (Del Tite, M3x8mm).

### Collar

#### Removal

1. Remove the MPF RR Cover (PL 3.1.14).
2. Remove the MPF Feeder Assembly (PL 3.1.1).
3. Remove the Gear 18T (PL 3.2.7).
4. Remove the Collar from the Drive Roll Assembly (PL 3.2.14).



**Figure 1 Collar**

### Replacement

1. Install the Collar to the Drive Roll Assembly (PL 3.2.14).
2. Install the Gear 18T (PL 3.2.7) (RRP 3.8).
3. Install the MPF Feeder Assembly (PL 3.1.1).
4. Install the MPF RR Cover (PL 3.1.14).

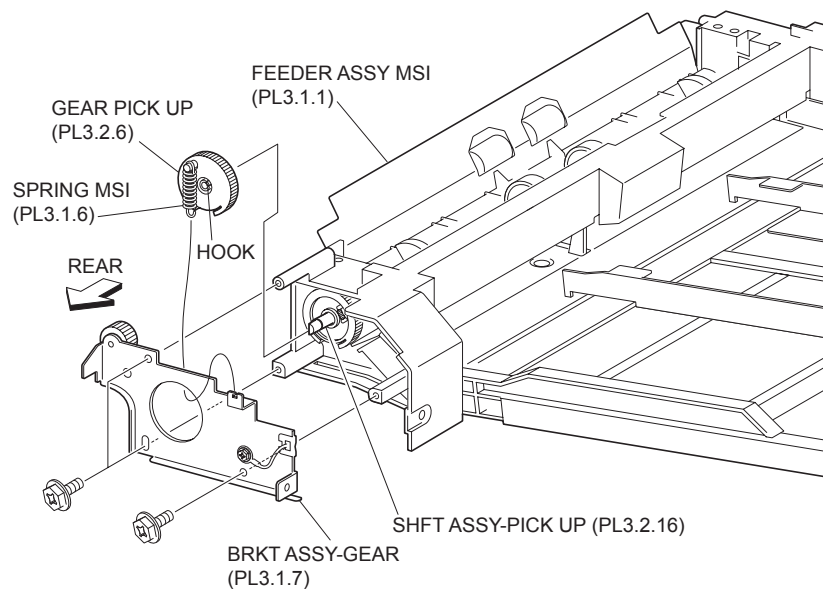
## Pick Up Gear

### Removal

1. Remove the MPF RR Cover (PL 3.1.14).
2. Remove the MPF Feeder Assembly (PL 3.1.1).
3. Remove the MPF Spring (PL 3.1.6) from the Gear Bracket Assembly (PL 3.1.7).

**NOTE** Leave another hook of the MPF Spring hooked on the Pick Up Gear.

4. Remove the three screws (Silver, M3x8mm) securing the Gear Bracket Assembly to the MPF Feeder Assembly to remove the Gear Bracket Assembly.
5. Release the hooks securing the Pick Up Gear to the Pick Up Shaft Assembly (PL 3.2.16) (RRP 3.12).
6. Remove the Pick Up Gear.



**Figure 1 Pick Up Gear**

### Replacement

1. Install the Pick Up Gear to the Cam Gear (PL 3.2.22) using the CAM Spring Gear (PL 3.2.26).

**NOTE** Insert Pick Up Gear until the hooks on Stopper Lever (PL 3.2.3) securing Pick Up Gear are locked firmly.

2. Install the Gear Bracket Assembly (PL 3.1.7) to the MPF Feeder Assembly using the three screws (Silver, M3x8mm).
3. Secure the MPF Spring to the Gear Bracket Assembly.
4. Install the MPF Feeder Assembly (PL 3.1.1).
5. Install the MPF RR Cover (PL 3.1.14).

## Gear 18T

### Removal

1. Remove the MPF RR Cover (PL 3.1.14).
2. Remove the MPF Feeder Assembly (PL 3.1.1).
3. Remove E-rings securing the Drive Roll Assembly (PL 3.2.14) to the MPF Lower Frame (PL 3.2.2).
4. Remove the Gear 18T.

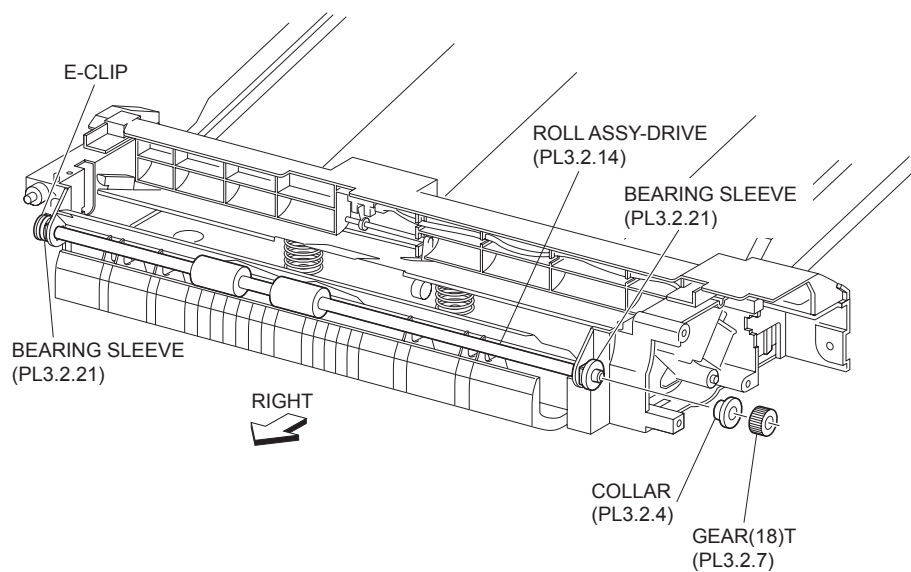


Figure 1 18T Gear

### Replacement

1. Install the Gear 18T.
2. Install the Drive Roll Assembly (PL 3.2.14) to the MPF Lower Frame (PL 3.2.2) using the E-rings.
3. Install the MPF Feeder Assembly (PL 3.1.1).
4. Install the MPF RR Cover (PL 3.1.14).

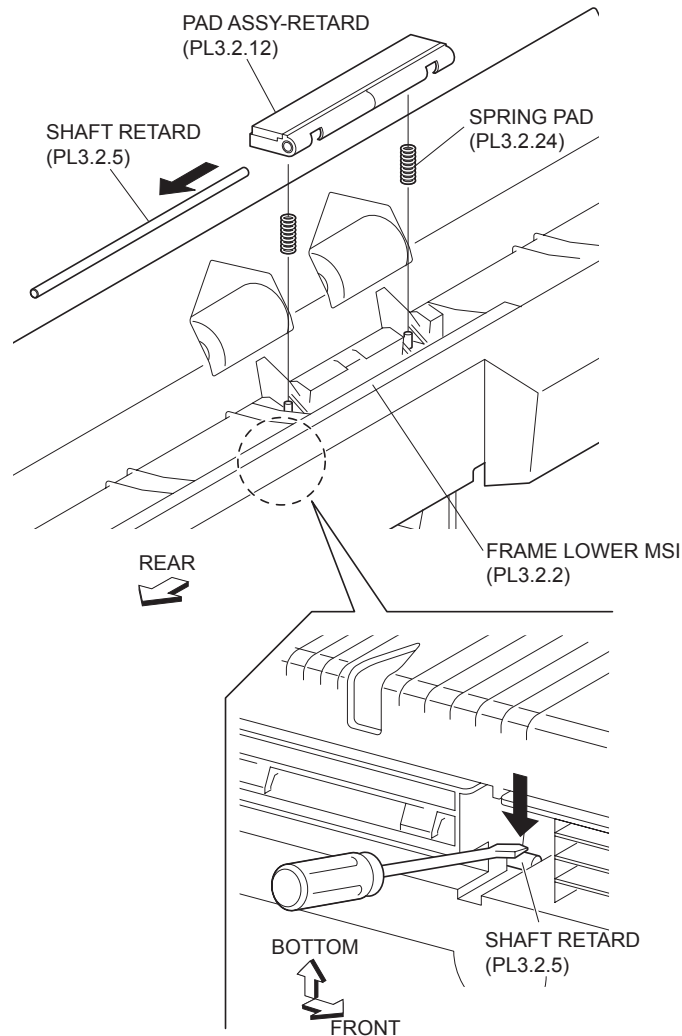
## Retard Pad Assembly

### Removal

1. Remove the MPF RR Cover (PL 3.1.14).
2. Remove the MPF Feeder Assembly (PL 3.1.1).
3. Remove the Feed Roller Assembly (PL 3.2.20).



4. Remove the Pick Up Shaft Assembly (PL 3.2.16).
5. Remove two Spring PADS (PL 3.2.24) under the Retard Pad Assembly (PL 3.2.12).
6. Remove the Retard Pad Assembly and the Retard Shaft (PL 3.2.5) by moving it in the direction of the arrow, from the backside.
7. Remove the Retard Shaft from the Retard Pad Assembly.



**Figure 1 Retard Pad Assembly**

## Replacement

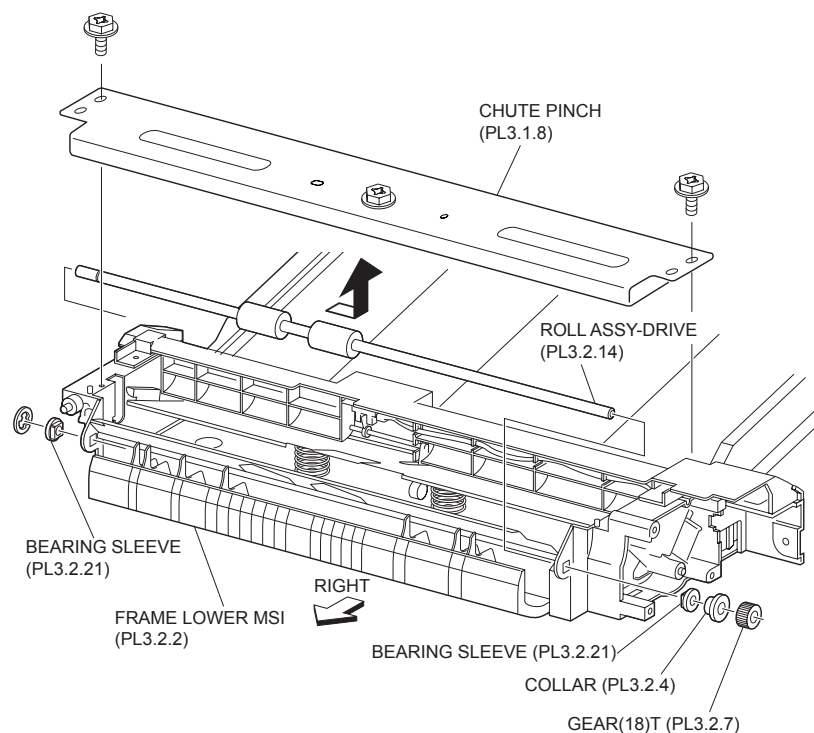
1. Move the Retard Pad Assembly and the Retard Shaft (PL 3.2.5) in the direction of the arrow and install them.
2. Install two the Spring PADS (PL 3.2.24) between the Retard Pad Assembly and the MPF Lower Frame (PL 3.2.2).
3. Install the Pick Up Shaft Assembly (PL 3.2.16).
4. Install the Feed Roller Assembly (PL 3.2.20).
5. Install the MPF Feeder Assembly (PL 3.1.1).
6. Install the MPF RR Cover (PL 3.1.14).

# Drive Roll Assembly

## Removal

1. Remove the MPF RR Cover (PL 3.1.14).
2. Remove the MPF Feeder Assembly (PL 3.1.1).
3. Remove the two screws (Silver, M3x8mm) securing the Pinch Chute (PL 3.1.8) to the MPF Lower Frame (PL 3.2.2).
4. Remove Gear 18T (PL 3.2.7).
5. Remove the Collar (PL 3.2.4).
6. Remove the two Bearing Sleeves (PL 3.2.21) left and right, securing the Drive Roll Assembly to the MPF Lower Frame.
7. Remove the Drive Roll Assembly.

**NOTE** When removing, do not hold the rubber rollers of the Drive Roll Assembly.



**Figure 1 Drive Roll Assembly**

## Replacement

1. Install the Drive Roll Assembly to the MPF Lower Frame (PL 3.2.2).

**NOTE** When installing, do not hold the rubber rollers of the Drive Roll Assembly.

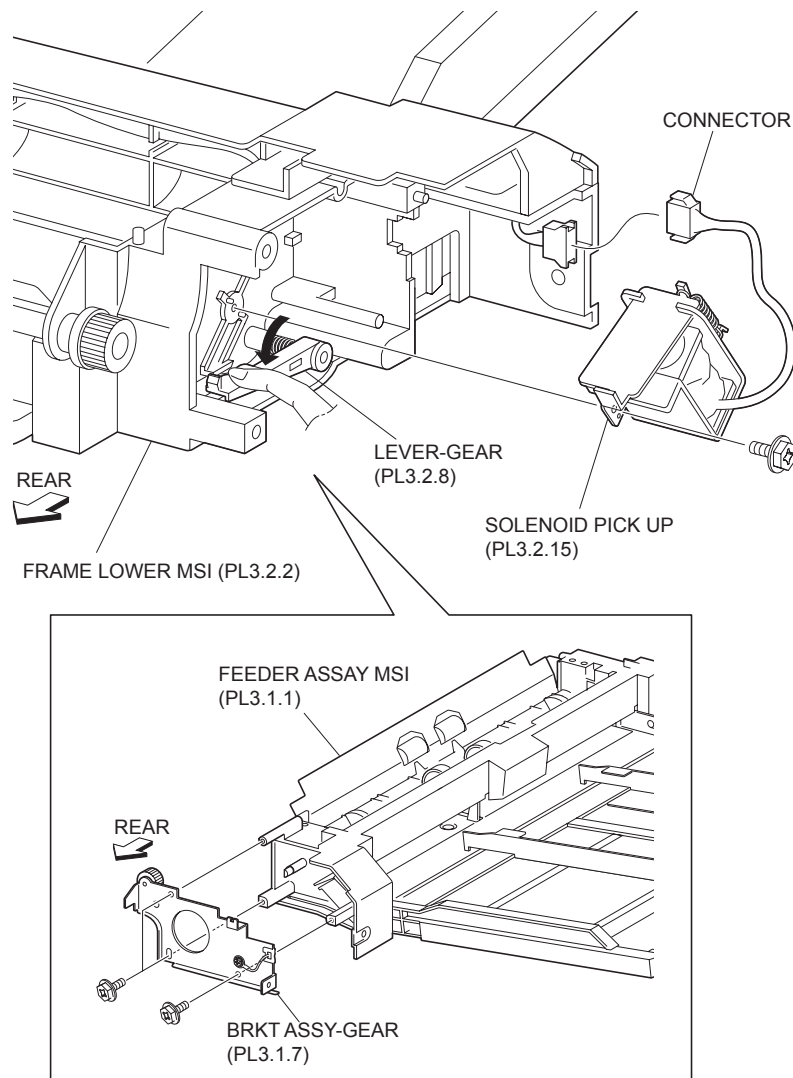
2. Install the Drive Roll Assembly to the MPF Lower Frame using the two Bearing Sleeves (PL 3.2.21) left and right.
3. Install the Collar (PL 3.2.4).
4. Install the Gear 18T (PL 3.2.7).
5. Install the Pinch Chute (PL 3.1.8) to MPF Lower Frame using the two screws (Silver, M3x8mm).
6. Install the MPF Feeder Assembly (PL 3.1.1).
7. Install the MPF RR Cover (PL 3.1.14).

# Pick Up Solenoid

## Removal

1. Remove the MPF RR Cover (PL 3.1.14).
2. Remove the MPF Feeder Assembly (PL 3.1.1).
3. Remove the Pick Up Gear (PL 3.2.6).
4. Remove the Cam Gear (PL 3.2.22).
5. Remove the three screws (Silver, M3x8mm) securing the Gear Bracket Assembly (PL 3.1.7) to the MPF Lower Frame (PL 3.2.2).
6. Remove the screw (Del Tite, M3x6mm) securing the Pick Up Solenoid to the Gear Bracket Assembly.
7. Disconnect the connector (P/J205) of the MPF Harness Assembly (PL 3.1.5) from the Pick Up Solenoid.
8. Remove the Pick Up Solenoid.

**NOTE** When removing, lower the LEVER-Gear (PL 3.2.8) as shown in the figure.



**Figure 1 Pickup Solenoid**

## Replacement

1. Install the Pick Up Solenoid to the Gear Bracket Assembly (PL 3.1.7) using the screw (Del Tite, M3x6mm).

**NOTE** When installing, lower the LEVER-Gear (PL 3.2.8) as shown in the figure.

2. Connect the connector (P/J205) of the MPF Harness Assembly (PL 3.1.5) to the Pick Up Solenoid.
3. Install the Gear Bracket Assembly to the MPF Lower Frame (PL 3.2.2) using the three screws (Silver, M3x8mm).

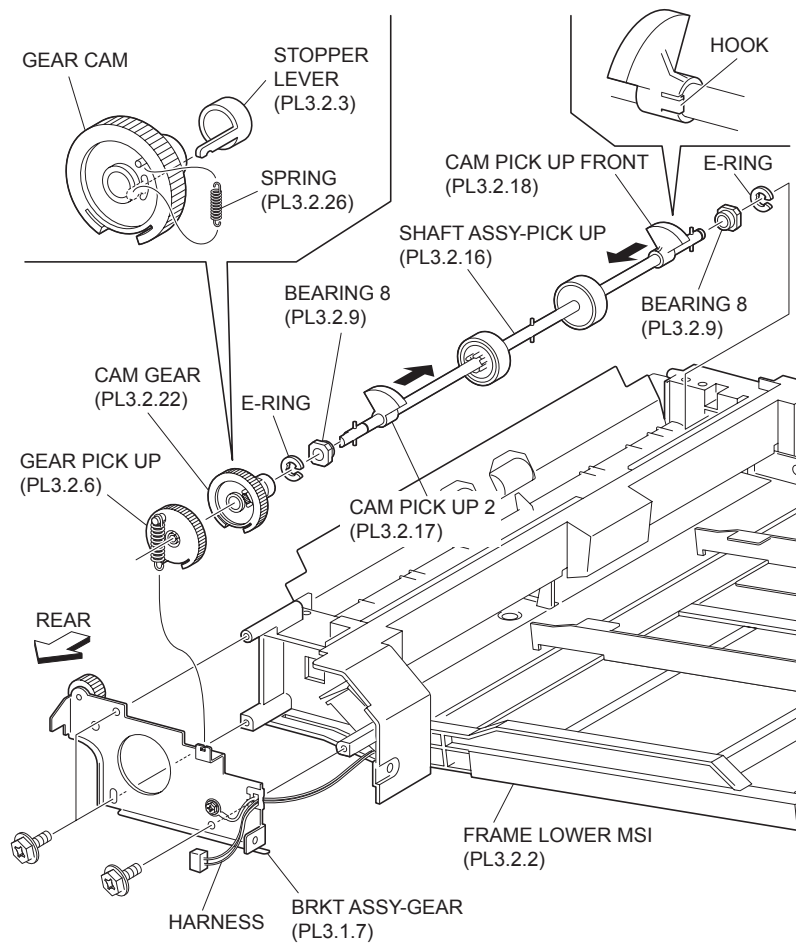
**NOTE** Be careful not to pinch the harness.

4. Install the Cam Gear (PL 3.2.22).
5. Install the Pick Up Gear (PL 3.2.6).
6. Install the MPF Feeder Assembly (PL 3.1.1).
7. Install the MPF RR Cover (PL 3.1.14).

## Pick Up Shaft Assembly

### Removal

1. Remove the MPF RR Cover (PL 3.1.14).
2. Remove the MPF Feeder Assembly (PL 3.1.1).
3. Remove the Feed Roller Assembly (PL 3.2.20).
4. Remove the Pick Up Gear (PL 3.2.6).
5. Remove the Cam Gear (PL 3.2.22).
6. Remove the Stopper Lever (PL 3.2.3).
7. Remove the three screws (Silver, M3x8mm) securing the Gear Bracket Assembly (PL 3.1.7) to the MPF Lower Frame (P3.2.2) to remove the Gear Bracket Assembly.
8. Remove E-rings left and right, which secures the Pick Up Shaft Assembly to the MPF Lower Frame.
9. Slide the two Bearing 8s (PL 3.2.9) left and right inward, and slide the Front Pick Up Cam (PL 3.2.18) and the Pick Up Cam 2 (PL 3.2.17) inward too.
10. Remove the Pick Up Shaft Assembly from the MPF Lower Frame, together with the two Bearing 8s, Front Pick Up Cam and Pick Up Cam 2.



**Figure 1 Pickup Shaft Assembly**

## Replacement

1. Install the Pick Up Shaft Assembly to the MPF Lower Frame (PL 3.2.2) together with the two Bearing 8s (PL 3.2.9), Front Pick Up Cam (PL 3.2.18) and Pick Up Cam 2 (PL 3.2.17).
2. Install the Pick Up Shaft Assembly to the MPF Lower Frame (PL 3.2.2) using the two E-rings left and right.
3. Install the Gear Bracket Assembly (PL 3.1.7) to the MPF Lower Frame using the three screws (Silver, M3x8mm).

**NOTE** Be careful not to pinch the harness.

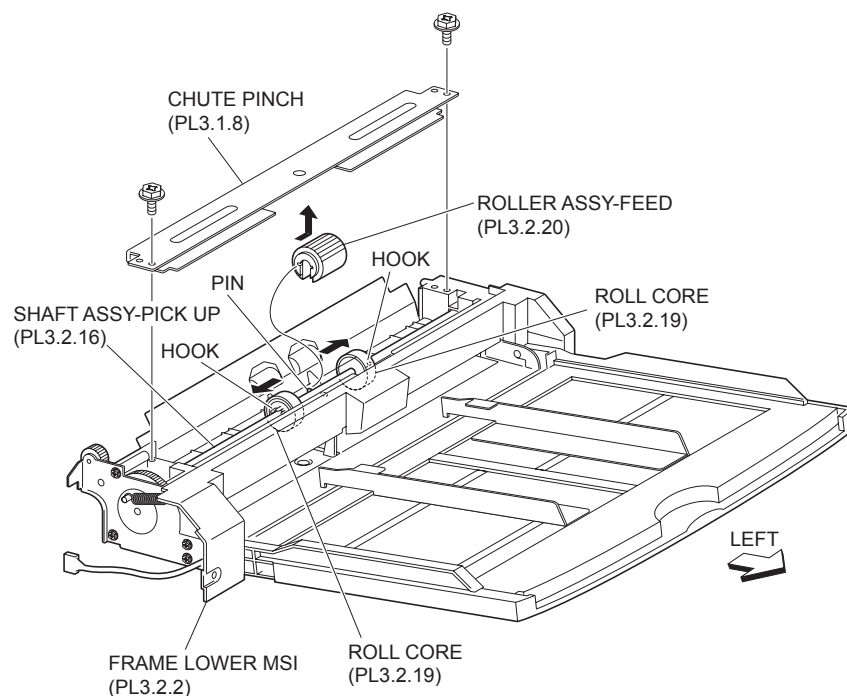
4. Install the Stopper lever (PL 3.2.3).
5. Install the Cam Gear (PL 3.2.22).
6. Install the Pick Up Gear (PL 3.2.6).
7. Install the Feed Roller Assembly (PL 3.2.20) (RRP 3.13).
8. Install the MPF Feeder Assembly (PL 3.1.1).
9. Install the MPF RR Cover (PL 3.1.14).

## Feed Roller Assembly

### Removal

1. Remove the MPF RR Cover (PL 3.1.14).
2. Remove the MPF Feeder Assembly (PL 3.1.1).
3. Remove the two screws (Silver, M3x8mm) securing the Pinch Chute (PL 3.1.8) to the MPF Lower Frame (P3.2.2) to remove the Pinch Chute.
4. While releasing the two hooks of the Core Roll (PL 3.2.19) left and right securing the Feed Roller Assembly to the Pick Up Shaft Assembly (PL 3.2.16) as shown in the figure, and slide the Feed Roller Assembly outward.
5. Remove the Feed Roller Assembly from the Pick Up Shaft Assembly by moving it in the direction of the arrow (to the front).

**NOTE** When removing, do not hold the rubber roller of the Feed Roller Assembly.



## Figure 1 Feed Roll Assembly

### Replacement

1. Move the Feed Roller Assembly from the Pick Up Shaft Assembly (PL 3.2.16) in the opposite direction of the arrow to instal.

**NOTE** When installing, do not hold the rubber roller of the Feed Roller Assembly.

2. Slide the two Core Rolls (PL 3.2.19) left and right until their hooks are properly secured.
3. Install the Pinch Chute (PL 3.1.8) to the MPF Lower Frame (PL 3.2.2) using the two screws (Silver, M3x8mm).
4. Install the MPF Feeder Assembly (PL 3.1.1).
5. Install the MPF RR Cover (PL 3.1.14).

### Cam Gear

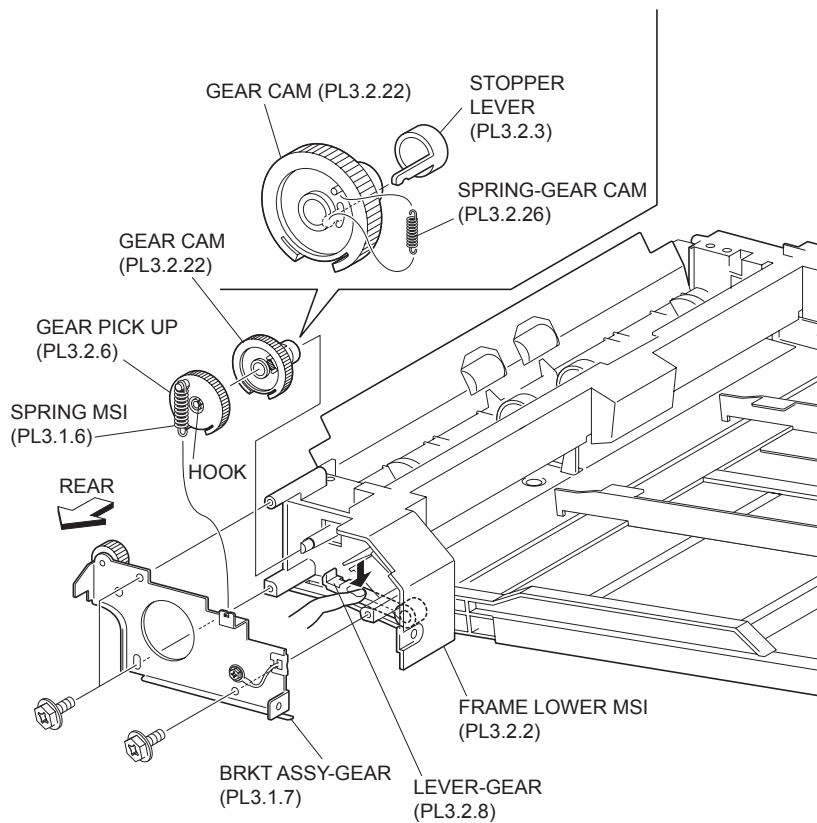
#### Removal

1. Remove the MPF RR Cover (PL 3.1.14).
2. Remove the MPF Feeder Assembly (PL 3.1.1).
3. Remove the MPF Spring (PL 3.1.6) from the Gear Bracket Assembly (PL 3.1.7).

**NOTE** Leave one end of the MPF Spring hooked on the Gear.

4. Remove the three screws (Silver, M3x8mm) securing the Gear Bracket Assembly (PL 3.1.7) to the MPF Lower Frame to remove the Gear Bracket Assembly.
5. While releasing the hooks securing the Pick Up Gear to the Pick Up Shaft Assembly (PL 3.2.16), remove the Pick Up Gear together with the MPF Spring and the Cam Gear.
6. Remove the Cam Gear Spring (PL 3.2.26) securing the Cam Gear to the Pick Up Gear.
7. Remove the Cam Gear.

**NOTE** When removing, lower the Lever-Gear (PL 3.2.8) as shown un the figure.



**Figure 1 Cam Gear**

## Replacement

1. Install the Cam Gear to the Pick Up Gear (PL 3.2.6) using the Cam Gear Spring (PL 3.2.26).

**NOTE** When installing, lower the LEVER-Gear (PL 3.2.8) as shown in the figure.

2. Install the Pick Up Gear together with the MPF Spring (PL 3.1.6) to the Pick Up Shaft Assembly (PL 3.2.16) (RRP 3.12).

**NOTE** Insert Pick Up Gear until the hooks on Stopper Lever (PL 3.2.3) securing Pick Up Gear are locked firmly.

3. Install the Gear Bracket Assembly to the MPF Lower Frame using the three screws (Silver, M3x8mm).
4. Secure the MPF Spring to the Gear Bracket Assembly.
5. Install the MPF Feeder Assembly (PL 3.1.1).
6. Install the MPF RR Cover (PL 3.1.14).

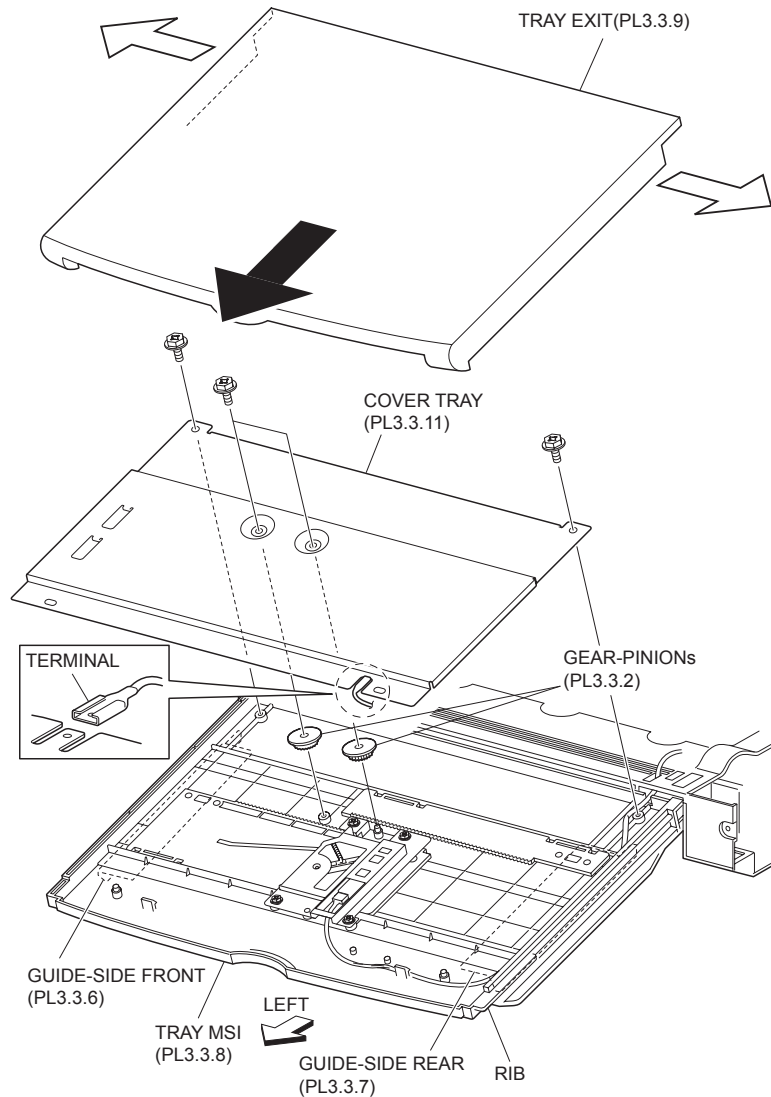
## Pinion Gear

### Removal

1. Remove the MPF RR Cover (PL 3.1.14).
2. Remove the MPF Feeder Assembly (PL 3.1.1).
3. Spread the ribs on both ends of Exit Tray (PL 3.3.9) securing the Exit Tray to the MPF Tray (PL 3.3.8) and move the MPF Tray in the direction of the arrow to remove.



4. Remove the four screws (Silver, M3x6mm) securing the Tray Cover (PL 3.3.11) to the MPF Tray.
5. Disconnect the Terminal from the Tray Cover, and remove the Tray Cover.
6. Remove the Pinion Gears.



**Figure 1 Pinion Gear**

## Replacement

1. Install the Pinion Gears.

**NOTE** Be sure to move the Front Side Guide (PL 3.3.6) and the Rear Side Guide (PL 3.3.7) toward the most inward before install the Pinion Gears. Also, check that Front Side Guide and Rear Side Guide are moved smoothly.

2. Connect the Terminal to the Tray Cover (PL 3.3.11).
3. Install the Tray Cover.

**NOTE** Fit the shafts of the Pinion Gear into the holes in the center of the Tray Cover.

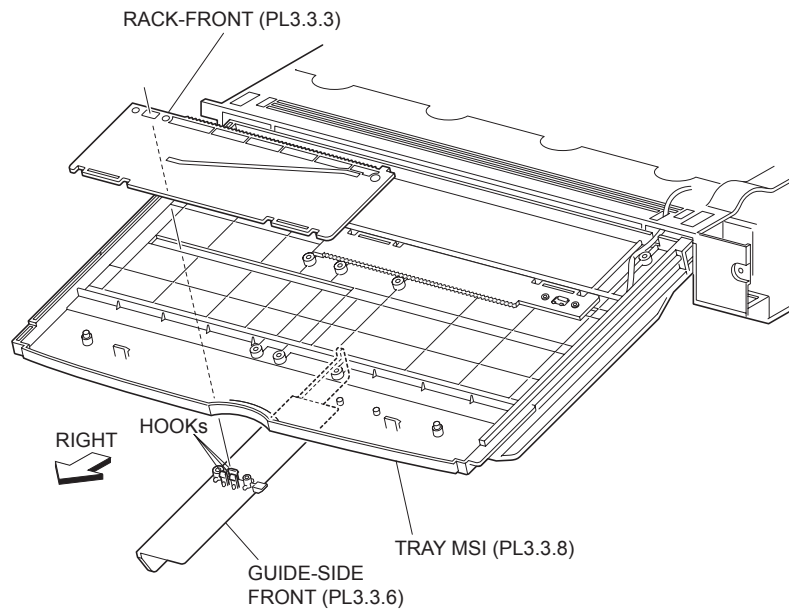
4. Install the Tray Cover to the MPF Tray (PL 3.3.8) using the three screws (Silver, M3x6mm).
5. While spreading the both ends of Exit Tray (PL 3.3.9) outward, move the MPF Tray in the opposite direction of the arrow to install.
6. Install the MPF Feeder Assembly (PL 3.1.1).

7. Install the MPF RR Cover (PL 3.1.14).

## Front Side Guide

### Removal

1. Remove the MPF RR Cover (PL 3.1.14).
2. Remove the MPF Feeder Assembly (PL 3.1.1).
3. Remove the Pinion Gear (PL 3.3.2).
4. Remove the MPF Sensor Assembly (PL 3.3.10).
5. Release the hook securing the Front Side Guide to the Front Rack (PL 3.3.3).
6. Remove the Front Side Guide.



**Figure 1 Front Side Guide**

### Replacement

1. Secure the Front Side Guide to the Front Rack (PL3.3.3) using the hook.
2. Install the MSI Sensor Assembly (PL3.3.10) .
3. Install the Pinion Gear (PL3.3.2) .
4. Install the MSI Feeder Assembly (PL3.1.1) .
5. Install the MSI Cover, RR (PL3.1.14) .

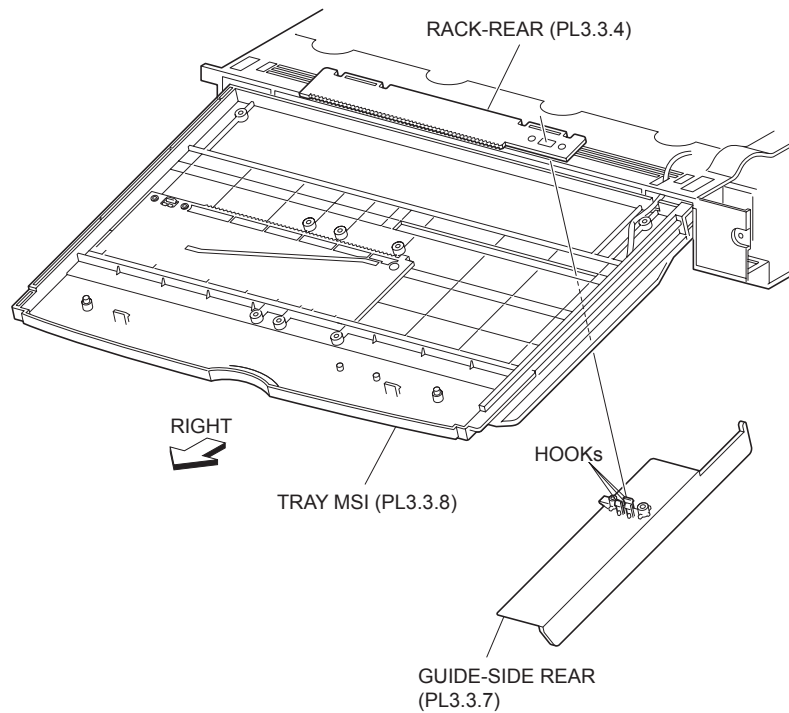
**NOTE** After the installation, be sure to perform Side Guide Adjust.

## Rear Side Guide

### Removal

1. Remove the MSI Cover, RR (PL 3.1.14) .
2. Remove the MSI Feeder Assembly (PL 3.1.1) .
3. Remove the Pinion Gear (PL 3.3.2) .

4. Remove the MSI Sensor Assembly (PL 3.3.10) .
5. Release the hook securing the Rear Side Guide to the Rear Rack (PL 3.3.4) .
6. Remove the Rear Side Guide.



**Figure 1 Rear Side Guide**

## Replacement

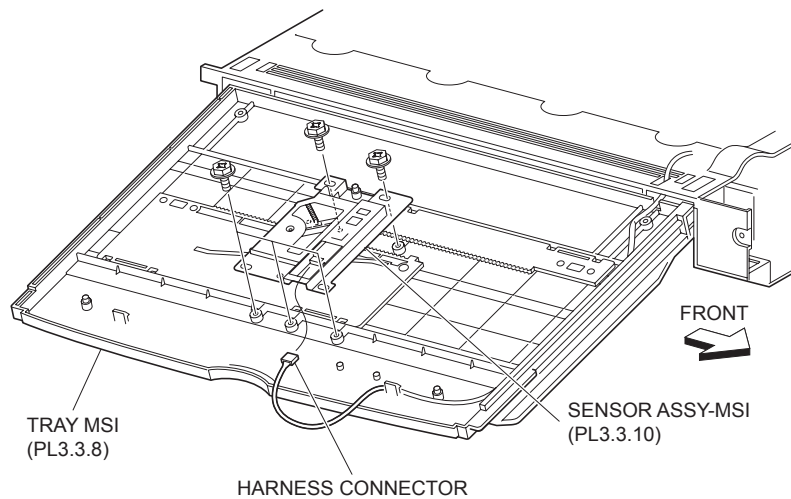
1. Install the Rear Side Guide to the Rear Rack (PL 3.3.4) using the hook.
2. Install the MSI Sensor Assembly (PL 3.3.10) .
3. Install the Pinion Gear (PL 3.3.2) .
4. Install the MSI Feeder Assembly (PL 3.1.1) .
5. Install the MSI Cover, RR (PL 3.1.14) .

**NOTE** After the installation, be sure to perform Side Guide Adjust.

## MSI Sensor Assembly

### Removal

1. Remove the MSI Cover, RR (PL 3.1.14) .
2. Remove the MSI Feeder Assembly (PL 3.1.1) .
3. Remove the Pinion Gear (PL 3.3.2) .
4. Disconnect the connector (P/J107) of the Size Harness Assembly (PL 3.3.13) from the MSI Sensor Assembly .
5. Remove the five screws (Silver, M3x6mm) securing the MSI Sensor Assembly to the MSI Tray (PL 3.3.8).
6. Remove the MSI Sensor Assembly.



**Figure 1 MSI Sensor Assembly**

## Replacement

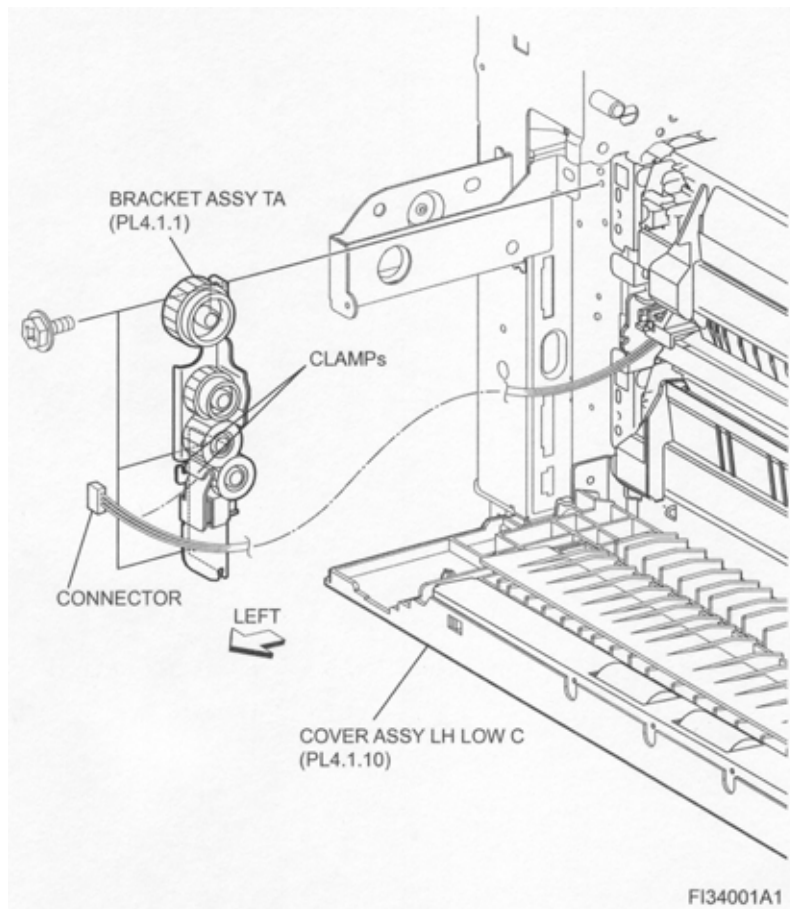
1. Install the MSI Sensor Assembly to the MSI Tray (PL 3.3.8) using five screws (Silver, M3x6mm).
2. Connect the connector (P/J107) of the Size Harness Assembly (PL 3.3.13) to MSI Sensor Assembly.
3. Install the Pinion Gear (PL 3.3.2) .
4. Install the MSI Feeder Assembly (PL 3.1.1) .
5. Install the MSI Cover, RR (PL 3.1.14) .

# Transportation & Registration

## TA Bracket Assembly

### Removal

1. Remove the MSI Cover, RR (PL 3.1.14) .
2. Remove the MSI Feeder Assembly (PL 3.1.1) .
3. Remove the Left Hand Cover Assembly (PL4.2.8) .
4. Open the Lower Left Hand Cover Assembly C (PL4.1.10).
5. Remove the three screws (DEL TITE, M3x8mm) securing the TA Bracket Assembly to the printer .
6. Release the Exit Harness Assembly C (PL8.2.6) from the clamp on the TA Bracket Assembly.
7. Remove the TA Bracket Assembly.



**Figure 1 TA Bracket Assembly**

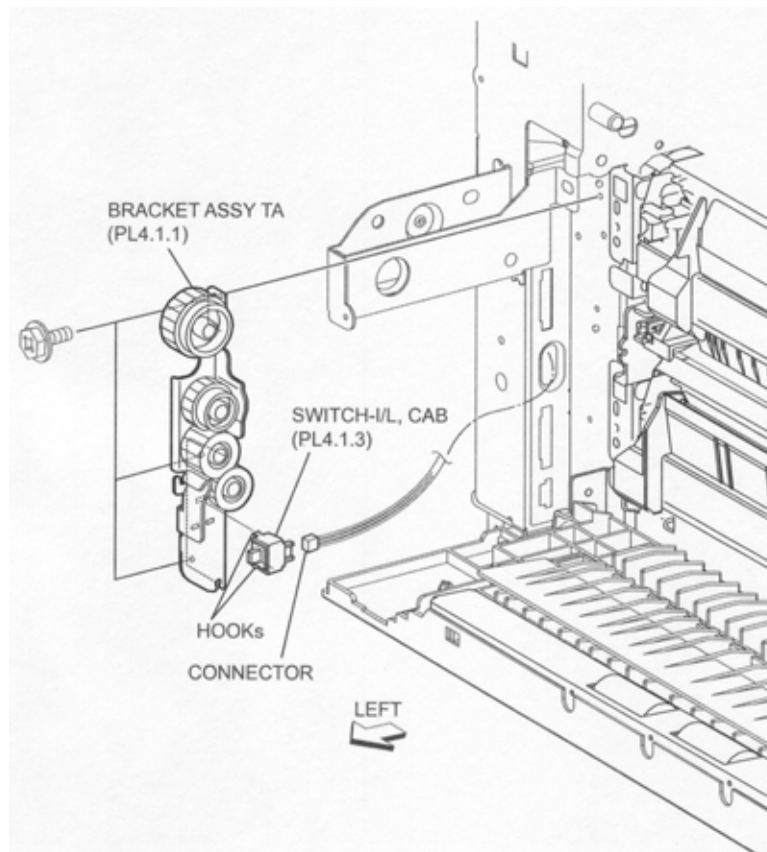
## Replacement

1. Clamp the Exit Harness Assembly C (PL8.2.6) with the clamp on the TA Bracket Assembly.
2. Install the TA Bracket Assembly to the printer using the three screws (DEL TITE, M3x8mm).
3. Close the Lower Left Hand Cover Assembly C (PL4.1.10).
4. Install the Left Hand Cover Assembly (PL4.2.8) .
5. Install the MSI Feeder Assembly (PL 3.1.1) .
6. Install the MSI Cover, RR (PL 3.1.14) .

## CAB Switch I/L

### Removal

1. Remove the MSI Cover, RR (PL 3.1.14) .
2. Remove the MSI Feeder Assembly (PL 3.1.1) .
3. Remove the Left Hand Cover Assembly (PL 4.2.8) .
4. Remove the TA Bracket Assembly (PL 4.1.1) .
5. Disconnect the connector (P/J106) of the PH Harness Assembly C (PL 8.2.7) from the Cab Switch I/L .
6. Release the hooks securing the Cab Switch I/L to the TA Bracket Assembly.
7. Remove the Cab Switch I/L.



**Figure 1 Cab Switch**

## Replacement

1. Secure the Cab Switch I/L to the TA Bracket Assembly using the hooks.
2. Connect the connector (P/J106) of the PH Harness Assembly C (PL 8.2.7) to the Cab Switch I/L.
3. Install the TA Bracket Assembly (PL 4.1.1) .
4. Install the Left Hand Cover Assembly (PL 4.2.8) .
5. Install the MSI Feeder Assembly (PL 3.1.1) .
6. Install the MSI Cover, RR (PL 3.1.14) .

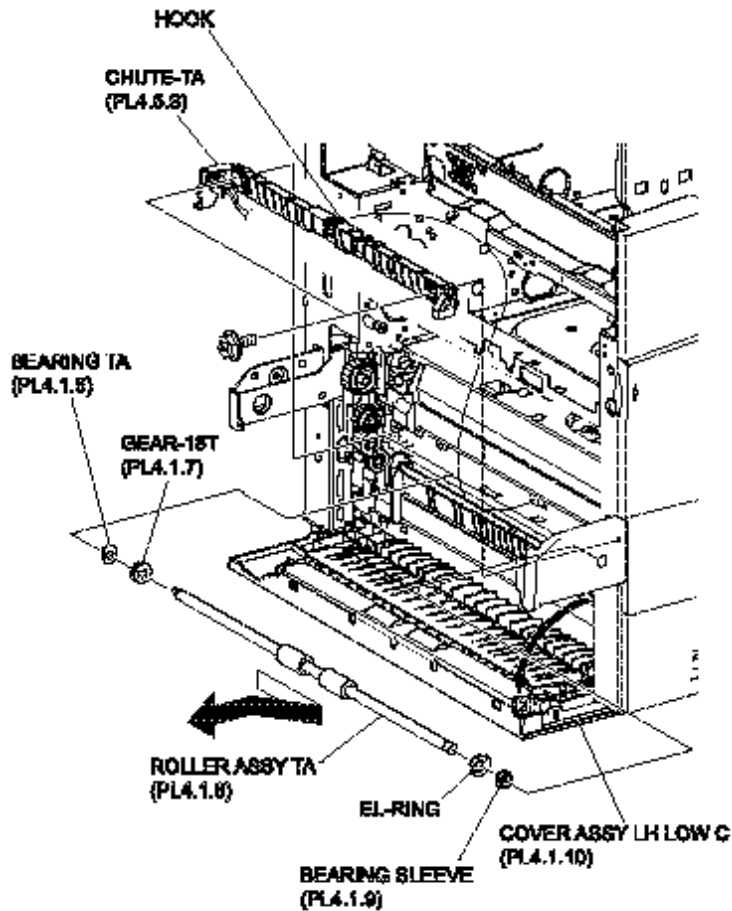
## TA Roller Assembly

### Removal

1. Remove the MSI Cover, RR (PL 3.1.14) .
2. Remove the MSI Feeder Assembly (PL 3.1.1) .
3. Remove the Left Hand Cover Assembly (PL 4.2.8) .
4. Open the Lower Left Hand Cover Assembly C (PL 4.1.10).
5. Remove the two screws (DEL TITE, M3x6mm) securing the TA Chute (PL 4.5.9) to the machine and remove the TA Chute while pulling its center .
6. Remove the E-ring on the right side (front), securing the TA Roller Assembly to the machine.
7. Remove the TA Roller Assembly by moving it in the direction of the arrow.

**NOTE** Note that TA Bearing (PL 4.1.6), BEARING SLEEVE (PL 4.1.9) and 18T GEAR (PL 4.1.7) are detached.

**NOTE** When removing, do not hold the rubber rollers of the TA Roller Assembly.



**Figure 1 TA Roller Assembly**

## Replacement

1. Insert the TA Roller Assembly into the hole on the machine together with the TA Bearing (PL 4.1.6), Bearing Sleeve (PL 4.1.9) and 18T GEAR (PL 4.1.7).

**NOTE** When installing, do not hold the rubber rollers of the TA Roller Assembly.

2. Install the TA Roller Assembly using the E-ring.
3. Install the TA Chute (PL 4.5.9) to the machine using the two screws (DEL TITE, M3x6mm).

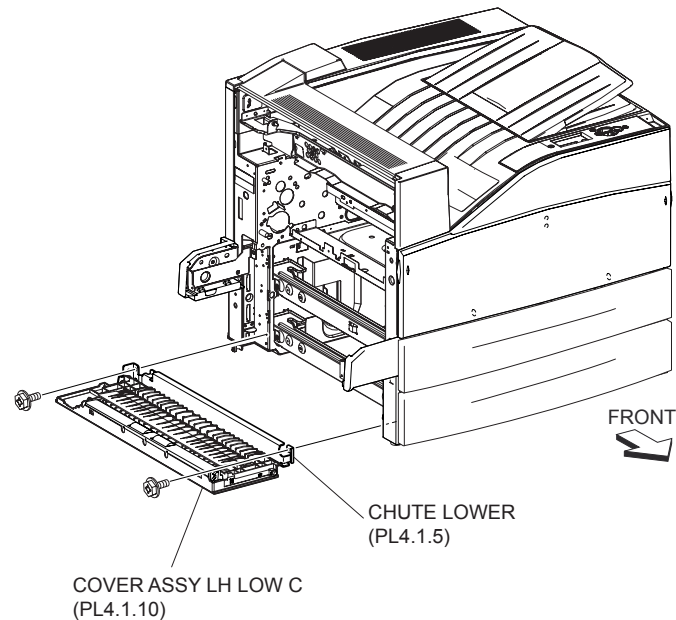
**NOTE** When installing the TA Chute, be sure to fit the hooks on TA Chute into the holes on the machine.

4. Close the Lower Left Hand Cover Assembly C (PL 4.1.10).
5. Install the Left Hand Cover Assembly (PL 4.2.8) .
6. Install the MSI Feeder Assembly (PL 3.1.1) .
7. Install the MSI Cover, RR (PL 3.1.14) .

## Lower Left Hand Cover Assembly C

### Removal

1. Open Lower Left Hand Cover Assembly C.
2. Remove the two screws (DEL TITE SEMS, M3x6mm) securing the Lower Chute (PL 4.1.5) to the machine .
3. Remove the Lower Left Hand Cover Assembly C together with the Lower Chute.



**Figure 1 Lower Cover Assembly**

## Replacement

1. Install the Lower Left Hand Cover Assembly C together with the Lower Chute (PL 4.1.5) using the two screws (DEL TITE SEMS, M3x6mm).
2. Close the Lower Left Hand Cover Assembly C.

## Lower Left Hand Bracket Assembly C

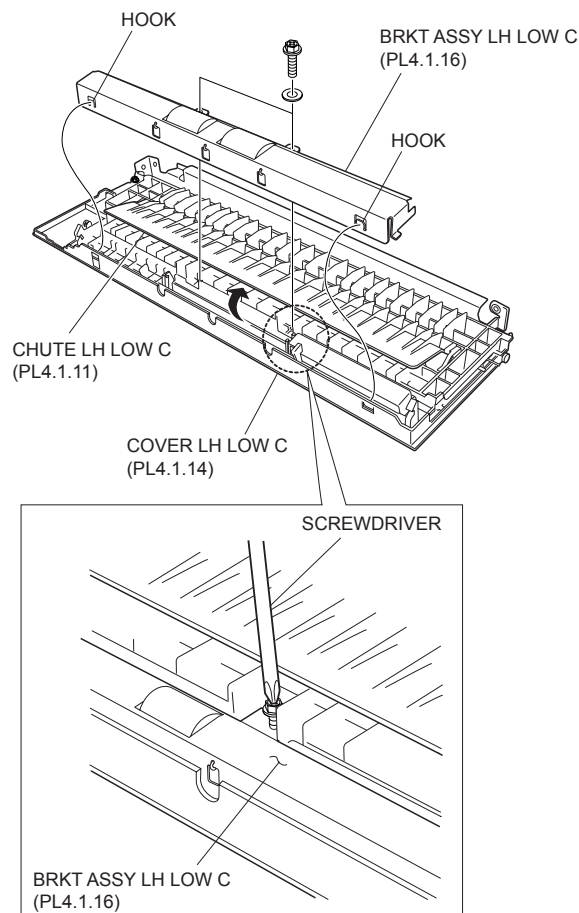
### Removal

1. Open the Left Hand Cover Assembly (PL 4.2.8) .
2. Remove the Lower Left Hand Cover Assembly C (PL 4.1.10) .
3. Lift the Lower Left Hand Chute C(PL 4.1.11) inside the Lower Left Hand Cover C, and remove the two screws (Silver, M3x8mm) and two washers securing Lower Left Hand Bracket Assembly C to the Lower Left Hand Cover C .

**NOTE** When removing the screws (Silver, M3x8mm) using a serewdriver by tilting it, with Lower Left Hand Chute Clifted, be careful not to damage Lower Left Hand Chute C.

4. Remove the two hooks securing the Lower Left Hand Bracket Assembly C to the Lower Left Hand Cover C.
5. Remove the Lower Left Hand Bracket Assembly C.





**Figure 1 Lower C Bracket Assembly**

## Replacement

1. Install the Lower Left Hand Bracket Assembly C to the Lower Left Hand Cover C (PL 4.1.14) using the two screws (Silver, M3x8mm) and two washers.

**NOTE** Fit the two hooks on the Lower Left Hand Bracket Assembly C into the Lower Left Hand Cover C.

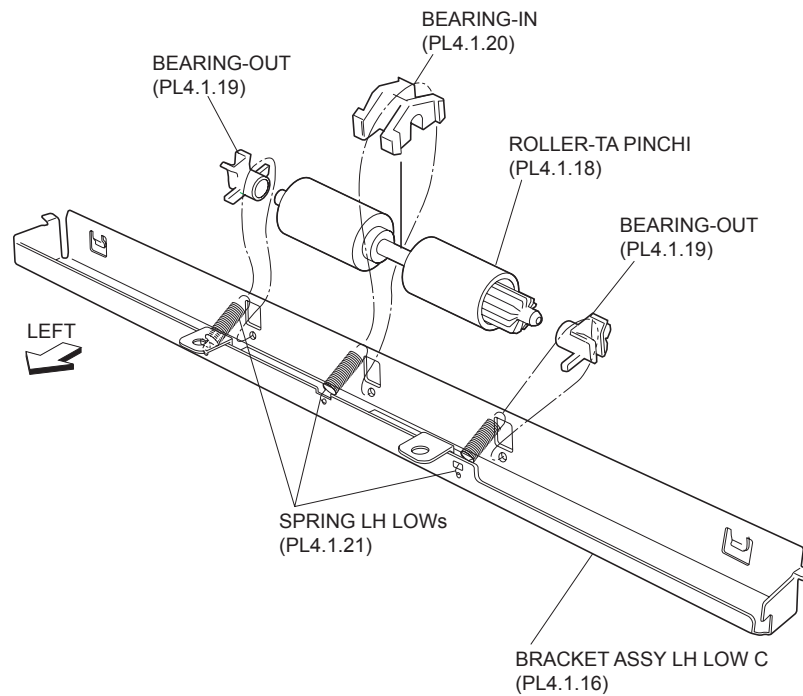
2. Install the Lower Left Hand Cover Assembly C (PL 4.1.10) .
3. Close the Left Hand Cover Assembly (PL 4.2.8) .

## TA Pinch Roller

### Removal

1. Open the Left Hand Cover Assembly (PL 4.2.8).
2. Remove the Lower Left Hand Bracket Assembly C (PL 4.1.16) .
3. Remove the hook only one side (lower side) of the three Lower Left Hand Springs (PL 4.1.21) as shown .
4. Remove the TA Pinch Roller.

**NOTE** Note that BEARING-IN (PL 4.1.20) and two BEARING-OUTs (PL 4.1.19) are detached.



**Figure 1 Pinch Roller**

## Replacement

1. Install the TA Pinch Roller to the Lower Left Hand Bracket Assembly C (PL 4.1.16). Then, install the BEARING-IN (PL 4.1.20) in the center of the shaft of the TA Pinch Roller, the BEARING-OUT (PL 4.1.19) on both sides of the shaft in the direction shown in the figure, and secure the bearings with the three Lower Left Hand Springs (PL 4.1.21).
2. Install the Lower Left Hand Bracket Assembly C (PL 4.1.16) .
3. Close the Left Hand Cover Assembly (PL 4.2.8).

## BTR Housing Assembly

### Removal

1. Open the Left Hand Cover Assembly (PL 4.2.8) .
2. Remove the BTR Housing Assembly toward upward by pinching the levers left and right which secures BTR Housing Assembly to the Left Hand Chute Cover (PL 4.3.1) .

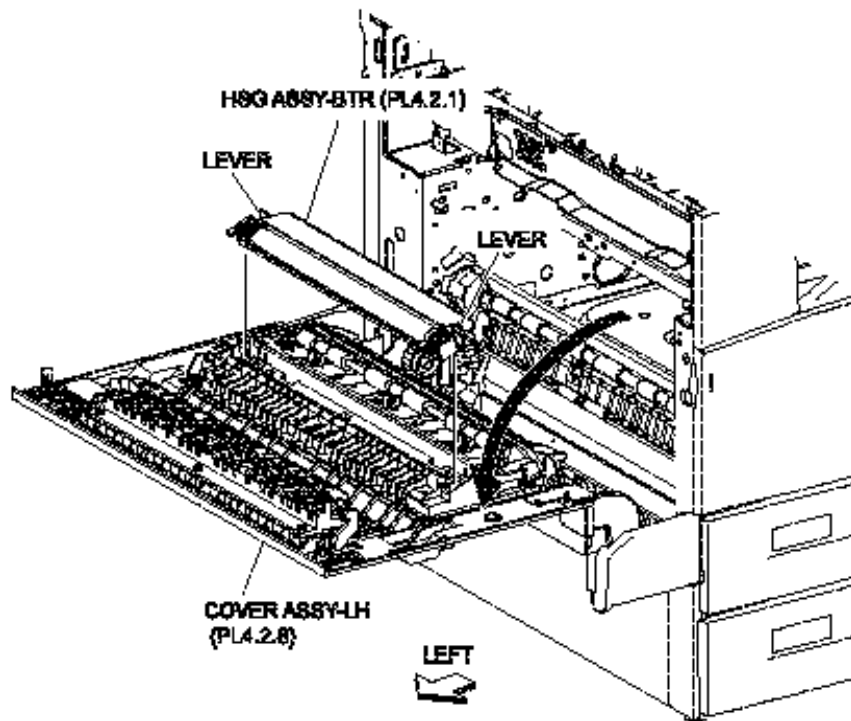


Figure 1 BTR Housing Assembly

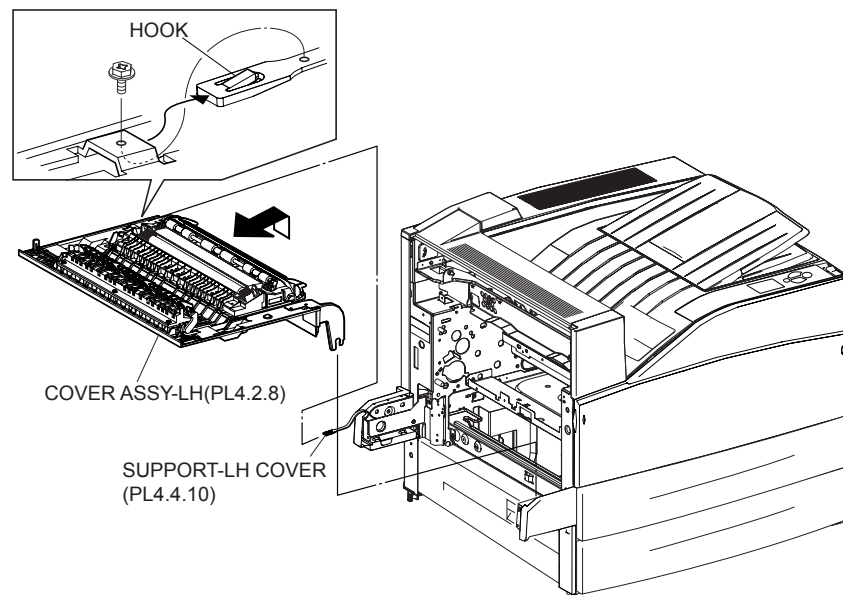
## Replacement

1. Install the BTR Housing Assembly.
2. Close the Left Hand Cover Assembly (PL 4.2.8) .

## Left Hand Cover Assembly

### Removal

1. Open the Left Hand Cover Assembly.
2. Remove the screw securing the Left Hand Support Cover (PL 4.4.10) to Left Hand Cover Assembly .
3. Remove the Left Hand Cover Assembly by moving it in the direction of the arrow.



**Figure 1 Left Hand Cover Assembly**

### Replacement

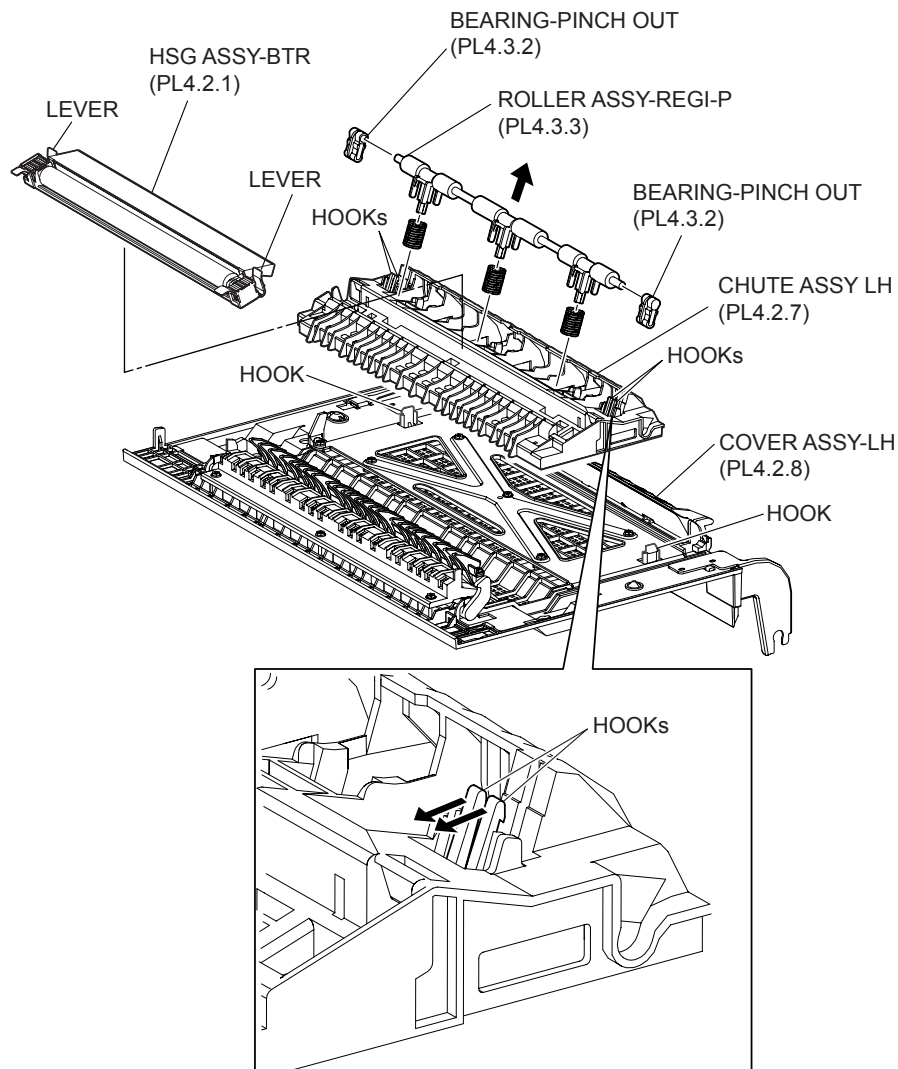
1. Install the Left Hand Cover Assembly.
2. Install the Left Hand Support Cover (PL 4.4.10) to Left Hand Cover Assembly using the one screw.
3. Close the Left Hand Cover Assembly.

### Registration Roller Assembly P

#### Removal

1. Remove the Left Hand Cover Assembly (PL 4.2.8) .
2. Remove the two hooks securing the Left Hand Chute Assembly (PL 4.2.7) to the Left Hand Cover Assembly as shown .
3. Remove the BTR Housing Assembly (PL 4.2.1) .
4. Remove the hooks of the two Pinch Out Bearings left and right securing the Registration Roller Assembly P to the Chute Assembly as shown in the figure.
5. Move the Registration Roller Assembly P in the direction of the arrow to remove.

**NOTE** When removing, do not hold the rubber rollers of the Registration Roller Assembly P.



**Figure 1 Registration Roller Assembly**

## Replacement

1. Move the Registration Roller Assembly P together with the two Pinch Out Bearings (PL 4.3.2) in the opposite direction of the arrow to install.

**NOTE** Insert the hooks of the two Pinch Out Bearings left and right, until they are secured firmly.

**NOTE** When installing, do not hold the rubber rollers of the Registration Roller Assembly P.

2. Install the BTR Housing Assembly (PL 4.2.1) .
3. Install the Left Hand Chute Assembly (PL 4.2.7) to the Left Hand Cover Assembly (PL 4.2.8) using the two hooks.
4. Install the Left Hand Cover Assembly (PL 4.2.8) .

## Registration Transport Assembly

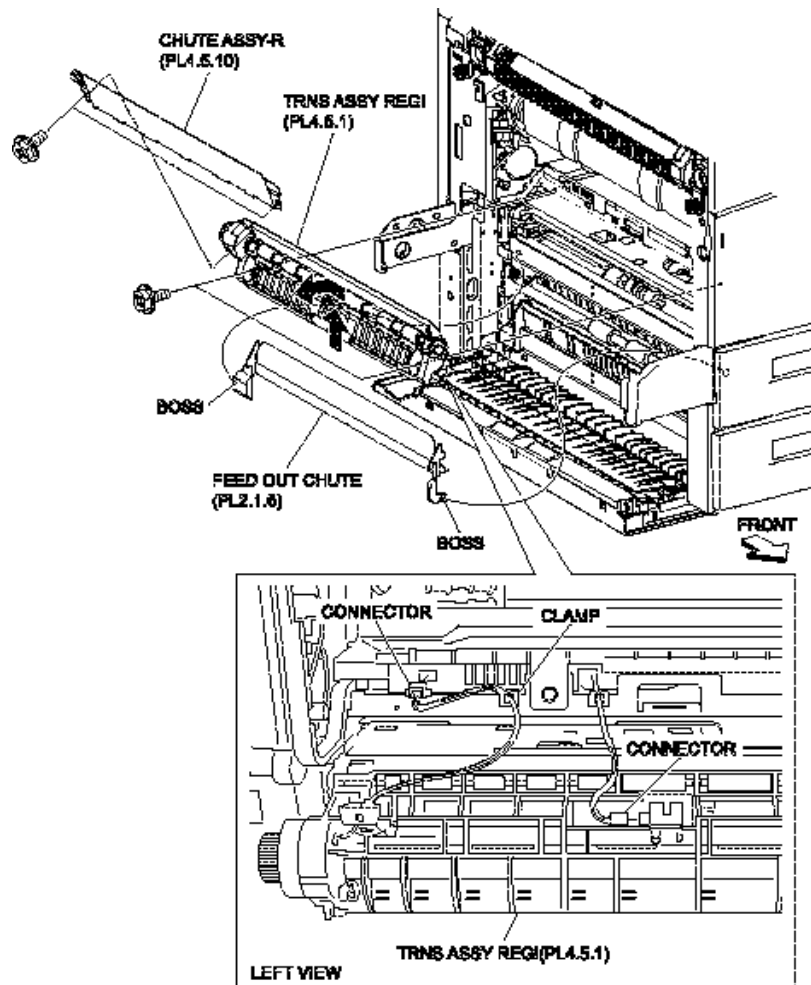
### Removal

1. Remove the MSI Cover, RR (PL 3.1.14) .

2. Remove the MSI Feeder Assembly (PL 3.1.1) .
3. Remove the Left Hand Cover Assembly (PL 4.2.8) .
4. Remove the bosses on both ends on the Feed Out Chute (PL2.1.13), the right one first, and remove the Feed Out Chute .
5. Remove the two screws (Silver, M3x8mm) securing the Right Chute Assembly (PL 4.5.10) to the Registration Transport Assembly (PL 4.5.1) to remove the Right Chute Assembly.
6. Remove the two screws (DEL TITE, M3x8mm) securing the Registration Transport Assembly to the machine and, while pushing the Registration Transport Assembly toward left fully and lifting its center upward, move it in the direction of the arrow to remove.

**NOTE** When removing the Registration Transport Assembly, be careful not to damage the two harnesses located on the backside of it.

7. Release the connector (P/J104) of the Front Harness Assembly A (PL5.1.9) from the clamp.
8. Disconnect the connector (P/J215) of the Front Harness Assembly A from the Registration Transport Assembly.
9. Release the harness of the Registration Clutch Assembly H from the clamp.



**Figure 1 Registration Transport Assembly**

## Replacement

1. Connect the connector (P/J215) of the Front Harness Assembly A (PL 5.1.9) to the machine.
2. Connect the connector (P/J104) of the Front Harness Assembly A to the Registration Transport Assembly.
3. Secure the harness of the Registration Clutch Assembly H to the clamp.
4. Install the Registration Transport Assembly by pushing it to the left fully, and moving it in the opposite direction of the arrow.

**NOTE** Fit the bosses on the center-rear of the Registration Transport Assembly in the holes on the machine.

5. Install the Registration Transport Assembly to the machine using the two screws (DEL TITE, M3x8mm).
6. Install the Right Chute Assembly (PL 4.5.10) to the Registration Transport Assembly (PL 4.5.1) using the two screws (Silver, M3x8mm).

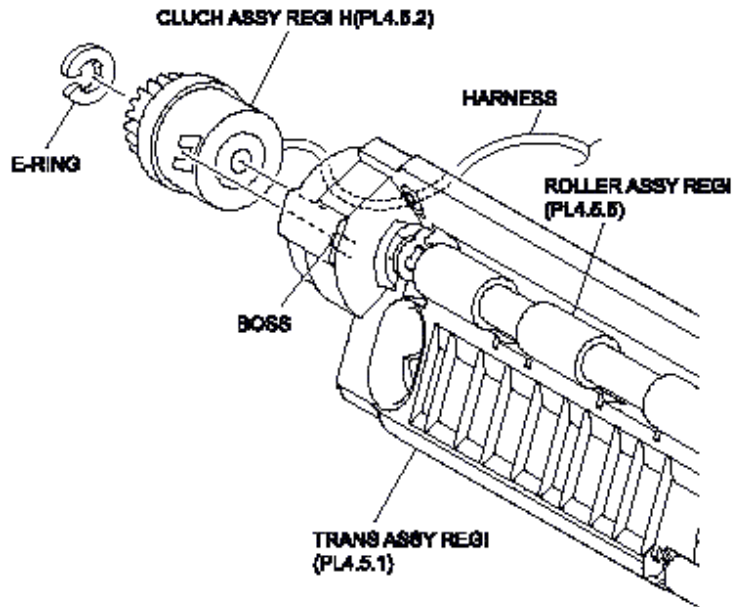
**NOTE** Be sure to put the boss on the backside center of the Registration Transport Assembly into the hole on the printer, Also, be sure to secure the Right Chute Assembly with its left (rear) side on front of the boss on the printer.

7. Fit the bosses on the both ends on the Feeder Chute Assembly (PL 2.1.6) into the machine, the left one first, and install the Feeder Chute Assembly.
8. Install the Left Hand Cover Assembly (PL 4.2.8) .
9. Install the MSI Feeder Assembly (PL 3.1.1) .
10. Install the MSI Cover, RR (PL 3.1.14) .

## Registration Clutch Assembly H

### Removal

1. Remove the MSI Cover, RR (PL 3.1.14) .
2. Remove the MSI Feeder Assembly (PL 3.1.1) .
3. Remove the Left Hand Cover Assembly (PL 4.2.8) .
4. Remove the Registration Transport Assembly (PL 4.5.1) .
5. Remove the E-ring securing the Registration Clutch Assembly H to the Registration Roller Assembly (PL 4.5.5) .
6. Remove the Registration Clutch Assembly H together with the harness.



**Figure 1 Registration Clutch Assembly**

## Replacement

1. Install the Registration Clutch Assembly H together with the harness.

**NOTE** Put the harness through the hole of the Registration Chute Assembly H as shown in the figure. Be careful not to pinch the harness.

2. Install the Registration Clutch Assembly H to the Registration Roller Assembly (PL 4.5.5) using E-ring.

**NOTE** Fit the boss on the Registration Transport Assembly (PL 4.5.1) in the slot on the Registration Clutch Assembly H.

3. Install the Registration Transport Assembly (PL 4.5.1) .
4. Install the Left Hand Cover Assembly (PL 4.2.8) .
5. Install the MSI Feeder Assembly (PL 3.1.1) .
6. Install the MSI Cover, RR (PL 3.1.14) .

## Registration Roller Assembly

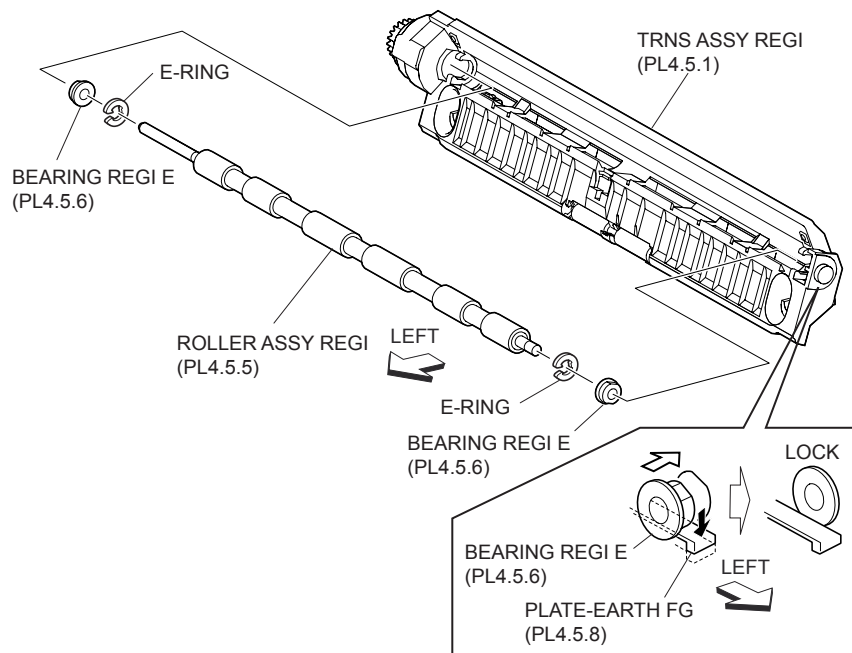
### Removal

1. The MSI Cover, RR (PL 3.1.14) .
2. Remove the MSI Feeder Assembly (PL 3.1.1) .
3. Remove the Left Hand Cover Assembly (PL 4.2.8) .
4. Remove the Registration Transport Assembly (PL 4.5.1) .
5. Remove the Registration Clutch Assembly H (PL 4.5.2) .
6. Remove the two E-rings left and right which secure the Registration Roller Assembly to the Registration Transport Assembly. Remove the two Registration Bearings E (PL 4.5.6) left and right .



- Remove the Registration Roller Assembly.

**NOTE** When removing, do not hold the rubber rollers of the Registration Roller Assembly.



**Figure 1 Registration Roller Assembly**

## Replacement

- Install the Registration Roller Assembly to the Registration Transport Assembly (PL 4.5.1), together with the two Registration Bearings E (PL 4.5.6) left and right.

**NOTE** While pressing the Earth Plate FG (PL 4.5.8), install the front side Registration Bearings E to the Registration Transport Assembly.

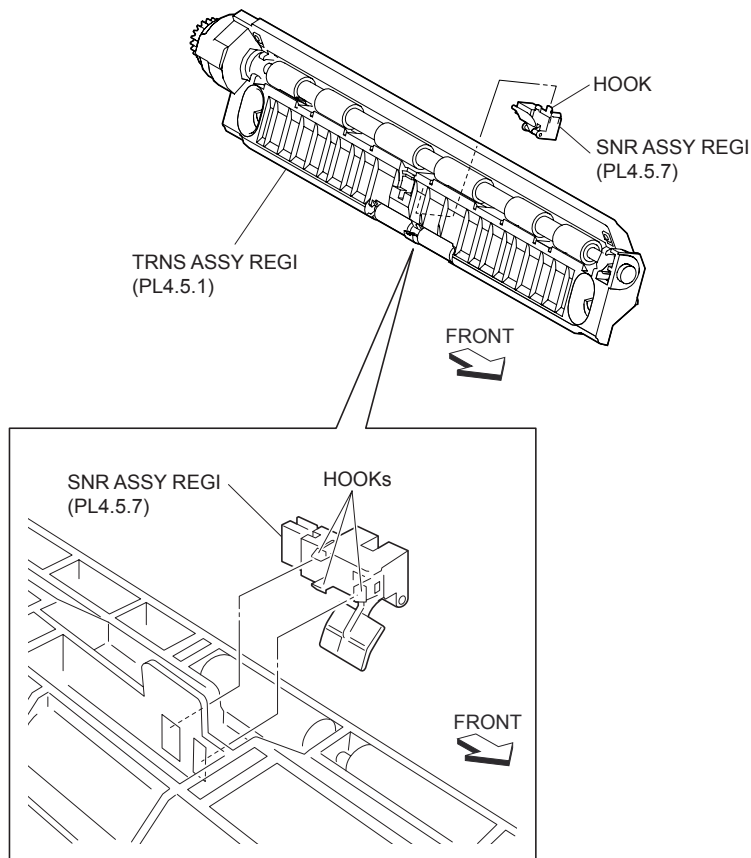
**NOTE** When installing, do not hold the rubber rollers of the Registration Roller Assembly.

- Secure the Registration Roller Assembly to the Registration Transport Assembly using the two E-rings left and right.
- Install the Registration Clutch Assembly H (PL 4.5.2) .
- Install the Registration Transport Assembly (PL 4.5.1) .
- Install the Left Hand Cover Assembly (PL 4.2.8) .
- Install the MSI Feeder Assembly (PL 3.1.1) .
- Install the MSI Cover, RR (PL 3.1.14) .

## Registration Sensor Assembly

### Removal

- Remove the MSI Cover, RR (PL 3.1.14) .
- Remove the MSI Feeder Assembly (PL 3.1.1) .
- Remove the Left Hand Cover Assembly (PL 4.2.8) .
- Remove the Registration Transport Assembly (PL 4.5.1) .
- Release the three hooks securing the Registration Sensor Assembly to the Registration Transport Assembly .
- Remove the Registration Sensor Assembly.



**Figure 1 Registration Sensor Assembly**

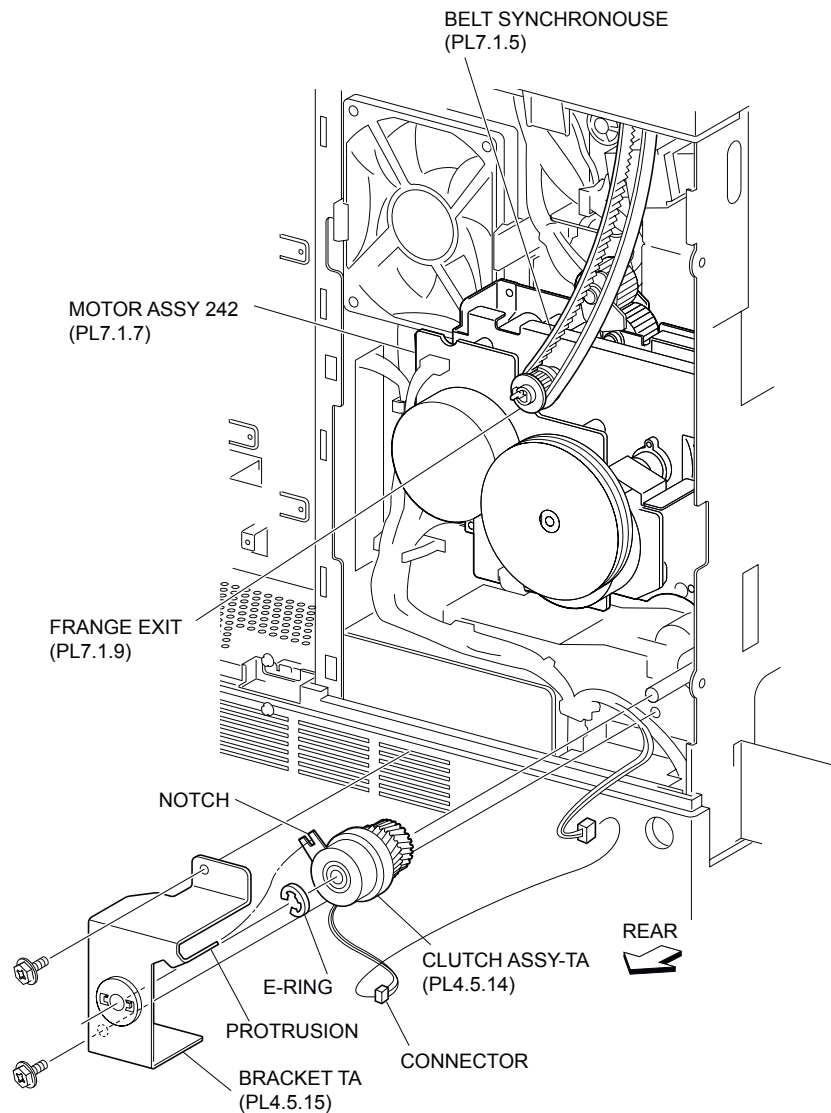
## Replacement

1. Secure the Registration Sensor Assembly to the Registration Transport Assembly (PL 4.5.1) using the three hooks.
2. Install the Registration Transport Assembly (PL 4.5.1) .
3. Install the Left Hand Cover Assembly (PL 4.2.8) .
4. Install the MSI Feeder Assembly (PL 3.1.1) .
5. Install the MSI Cover, RR (PL 3.1.14) .

## TA Clutch Assembly

### Removal

1. Remove the ESS Cover Assembly (PL 8.1.20) .
2. Remove the Upper Rear Cover (PL 1.2.5) .
3. Disconnect the connector (P/J204) of the PH Harness Assembly C (PL 8.2.7) from the TA Clutch Assembly .
4. Remove the screws securing the TA Bracket (PL 4.5.15) to the machine and the Motor Assembly 242 (PL 7.1.7) to remove the TA Bracket.
5. Remove the E-ring securing the TA Clutch Assembly to the machine.
6. Remove the TA Clutch Assembly.



**Figure 1 TA Clutch Assembly**

## Replacement

1. Install the TA Clutch Assembly to the machine using the E-ring.
2. Install the TA Bracket (PL 4.5.15) to the machine and the Motor Assembly 242 (PL 7.1.7) using the two screws.

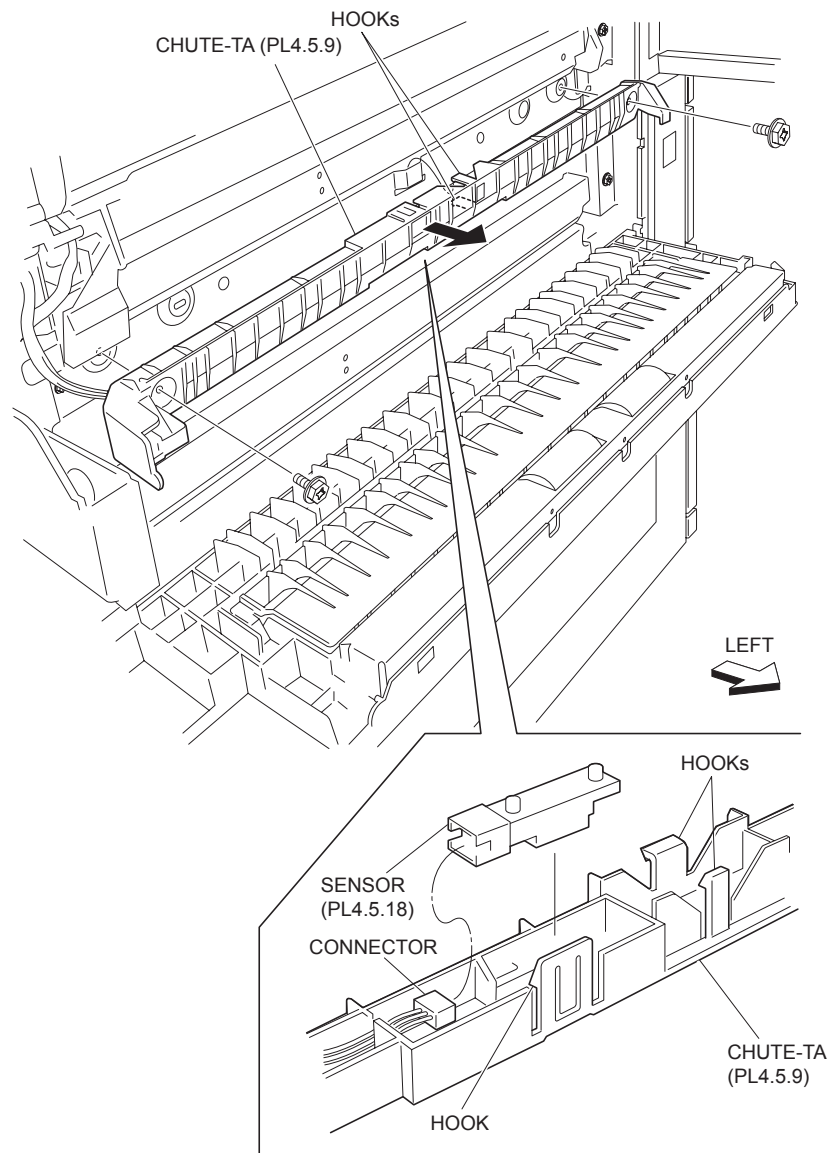
**NOTE** When installing the TA Clutch Assembly, be sure to fit the protrusion on the TA Bracket into the notch on the TA Clutch Assembly.

3. Connect the connector (P/J204) of the PH Harness Assembly C (PL 8.2.7) to the TA Clutch Assembly.
4. Install the Upper Rear Cover (PL 1.2.5) .
5. Install the ESS Cover Assembly (PL 8.1.20) .

## Sensor

### Removal

1. Remove the MSI Feeder Assembly (PL 3.1.1) .
2. Remove the Left Hand Cover Assembly (PL 4.2.8) .
3. Open the Lower Left Hand Cover Assembly C (PL 4.1.10).
4. Remove the two screws (Del Tite, M3x6mm) securing the TA Chute (PL 4.5.9) to the machine.
5. Remove the TA Chute while pulling its center.
6. Disconnect the connector (P/J105) of the PH Harness Assembly C (PL 8.2.7) from the Sensor.
7. Release the hook securing the Sensor to the TA Chute as shown in the figure.
8. Remove the Sensor.



**Figure 1 Sensor**

## Replacement

1. Secure the Sensor to the TA Chute (PL 4.5.9) using the hook.
2. Connect the connector (P/J105) of the PH Harness Assembly C (PL 8.2.7) to the Sensor.
3. Install the TA Chute to the machine using the two screws (Del Tite, M3x6mm).

**NOTE** When installing the TA Chute, be sure to fit the bosses on the TA Chute into the holes on the machine.

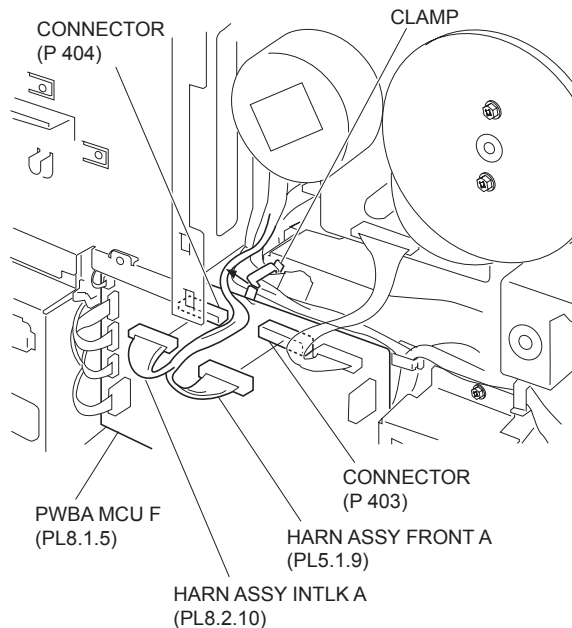
4. Close the Lower Left Hand Cover Assembly C (PL 4.1.10).
5. Install the Left Hand Cover Assembly (PL 4.2.8) .
6. Install the MSI Feeder Assembly (PL 3.1.1) .

## ROS & Xerographics

### Xerographic Interlock Switch Assembly

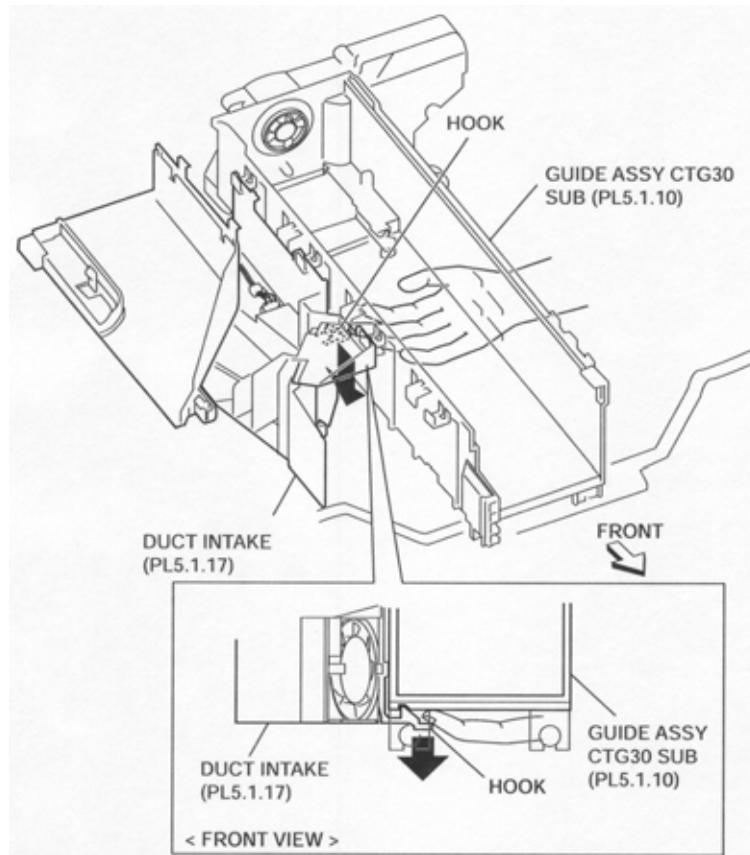
#### Removal

1. Remove the Fuser Cover (FR, PR) (PL 1.1.2) .
2. Remove the Top Cover Assembly PR (PL 1.1.8) .
3. Pull out the CRU (PL 5.1.15).
4. Pull out the Toner Cartridge (PL 5.1.16).
5. Remove the Front Cover Assembly (PL 1.1.9) .
6. Remove the Inner Cover Assembly, MN (PL 1.1.13) .
7. Pull out the High Voltage Power Supply-Y2 (PL 8.1.1) .
8. Remove the CTG30 Sub-Guide Assembly (PL 5.1.10) .
9. Remove the Lower PR Rear Cover (PL 1.2.6) .
10. Disconnect the connector (P/J403) of the Front Harness Assembly A (PL 5.1.9) and the connector (P/J404) of the Interlock Harness Assembly A (PL 8.2.10) from the MCU F PWBA (PL 8.1.5) .



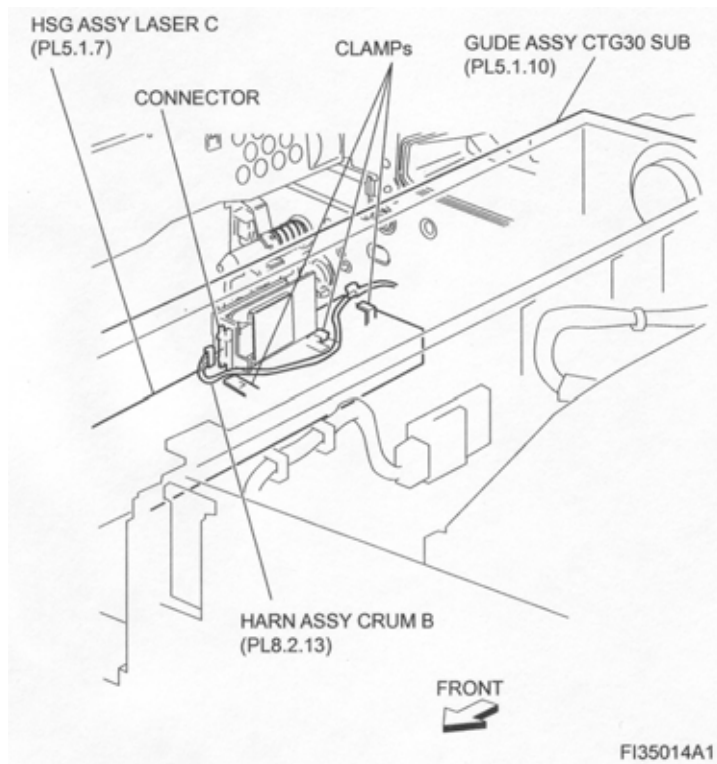
**Figure 1 Disconnect Harnesses**

11. Release the Front Harness Assembly A and Interlock Harness Assembly A from the clamp on the machine.
12. Remove the Intake Duct (PL 5.1.17) .

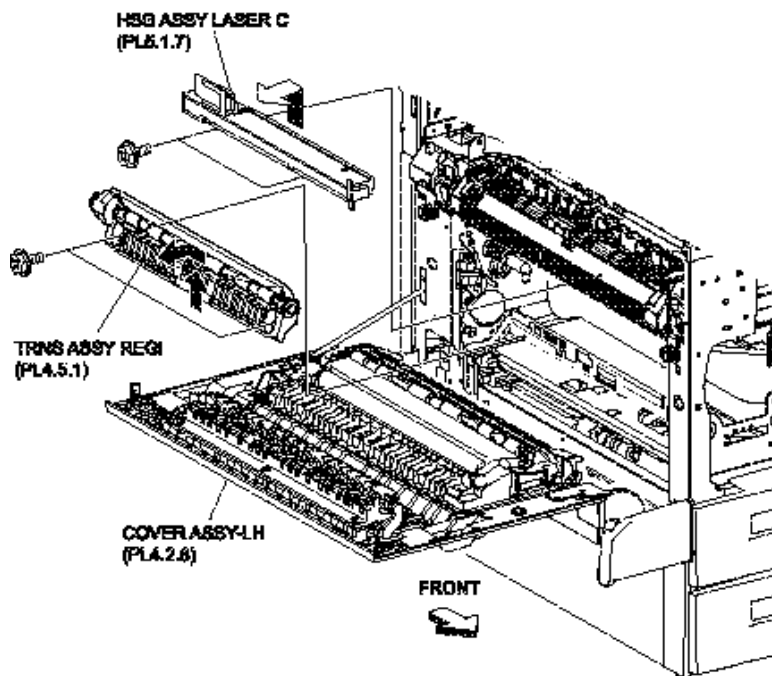


**Figure 2 Intake Duct**

13. Release the CRUM B Harness Assembly (PL 8.2.13) from the clamp on the Laser C Housing Assembly .
14. Disconnect the connector (P/J126) of the CRUM B Harness Assembly from the Laser C Housing Assembly (PL 5.1.7).
15. Open the Left Hand Cover Assembly (PL 4.2.8).
16. Remove the Registration Transport Assembly (PL 4.5.1) .
17. Remove the two screws (Del Tite, M3x7mm) securing the Laser C Housing Assembly (PL 5.1.7) to the machine .
18. Remove the Laser C Housing Assembly by moving it in the direction of the arrow.



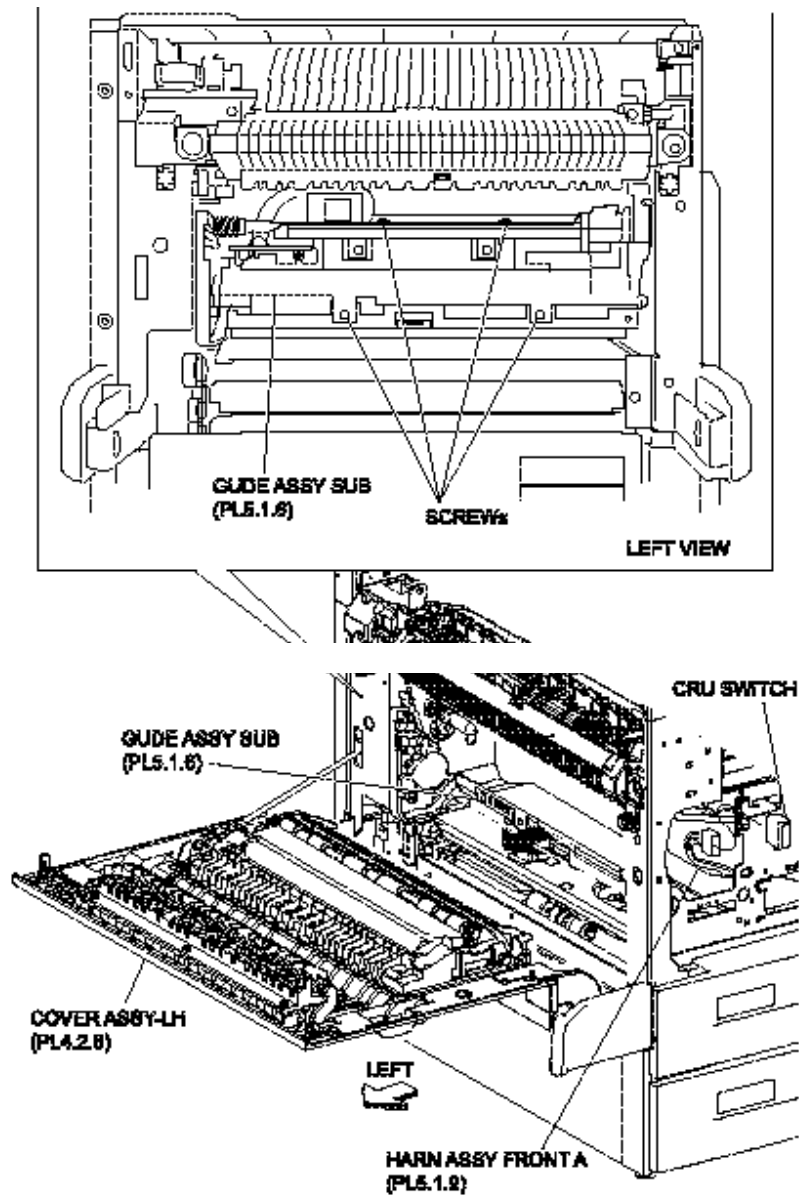
**Figure 3 Harness Assembly**



**Figure 4 Registration Transport Assembly**

19. Remove the four screws (Del Tite, M3x8mm) securing the Sub-Guide Assembly (PL 5.1.6) to the machine .

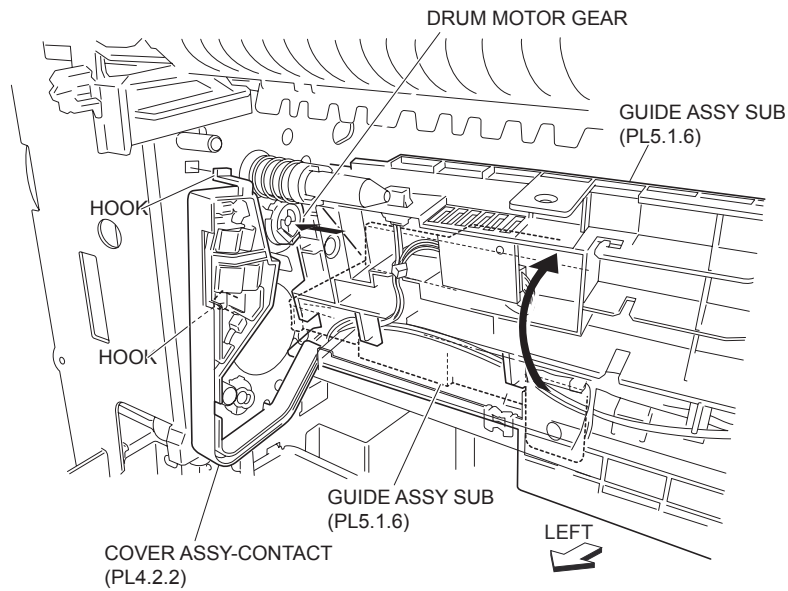
- Slide the Sub-Guide Assembly in the direction of the arrow and disconnect the connector of the Front Harness Assembly A (PL 5.1.9).



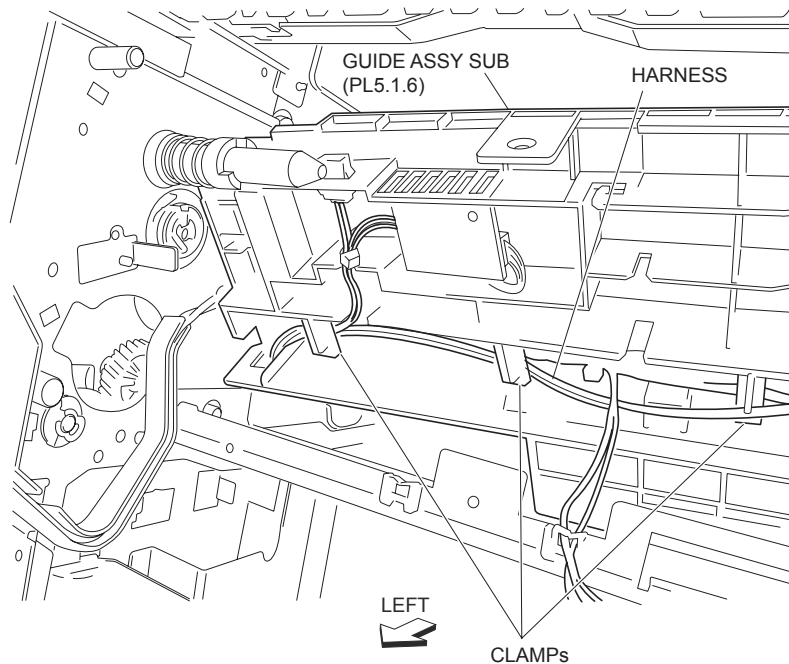
**Figure 5 Sub Guide Assembly**

- Remove the two hooks securing the Contact Cover Assembly (PL 4.2.2) to the machine .
- While pressing the drum motor gear located on the rear side of the Motor Assembly 242 (PL 7.1.7), lift the left side of the Sub-Guide Assembly upward.
- Release the Interlock Harness Assembly A and Front Harness Assembly A from the clamp on the rear side of the Sub-Guide Assembly .



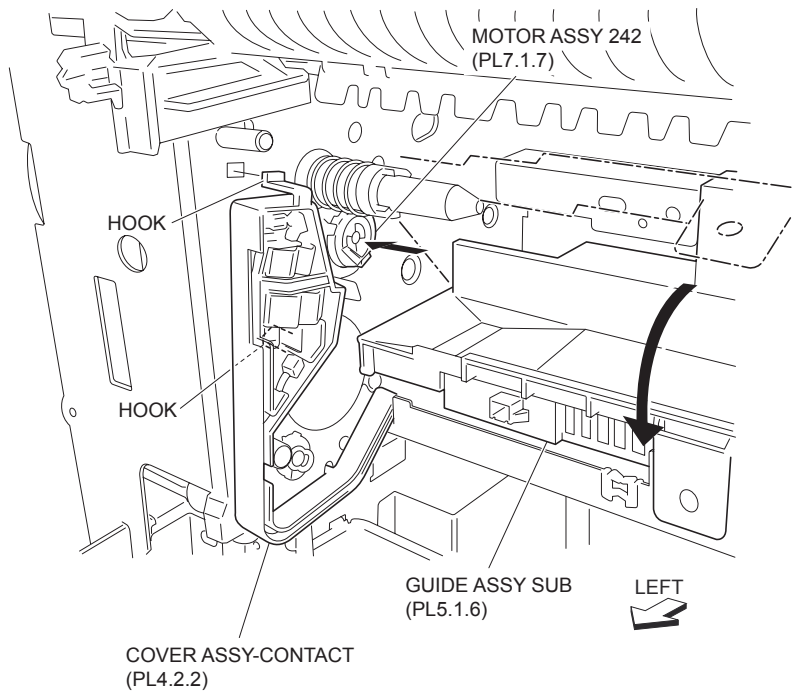


**Figure 6 Drum Motor Gear**

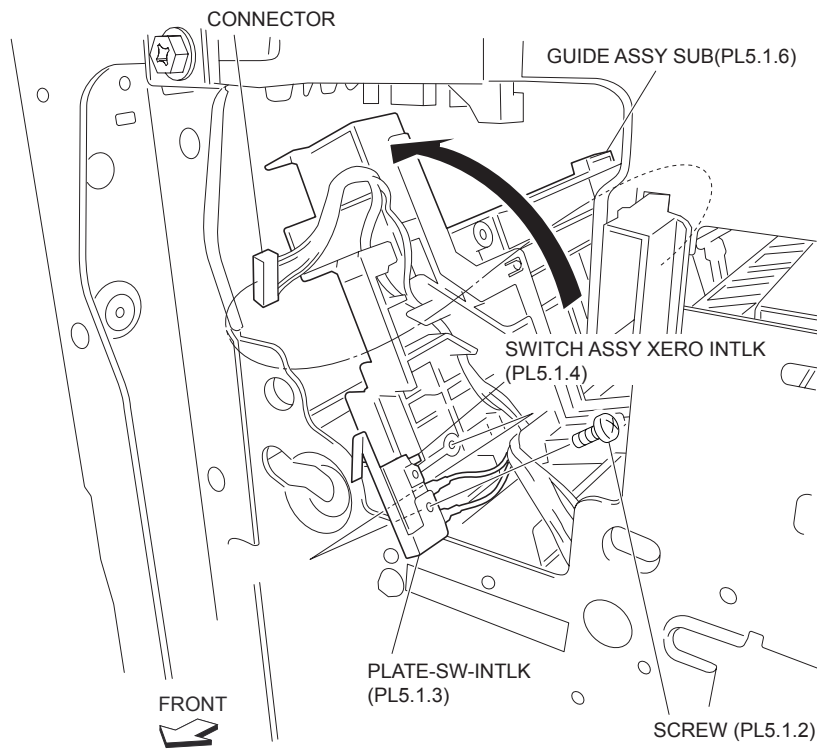


**Figure 7 Sub Guide Assembly Clamps**

24. While pressing the drum motor gear located on the rear side of Motor Assembly 242, lower the left side (left) of the Sub-Guide Assembly .
25. Lift the right side of the Sub-Guide Assembly.
26. Remove the screw (PL 5.1.2) securing the Xerographic Interlock Switch Assembly and the Interlock Switch Plate (PL 5.1.3) to the Sub-Guide Assembly .
27. Remove the Xerographic Interlock Switch Assembly together with the Interlock Switch Plate.



**Figure 8 Sub Guide Assembly**



**Figure 9 Xerographic Interlock Switch Assembly**

## Replacement

1. Install the Xerographic Interlock Switch Assembly to the Sub-Guide Assembly (PL 5.1.6) together with the Interlock Switch Plate (PL 5.1.3) using the screw (PL 5.1.2).
2. Lower in the opposite direction of the arrow of the Sub-Guide Assembly.
3. While pressing the drum motor gear located on the rear side of the Motor Assembly 242 (PL 7.1.7), lift the left side of the Sub-Guide Assembly upward and secure the Interlock Harness Assembly A (PL 8.2.10) and the Front Harness Assembly A (PL 5.1.9) to the clamps on the rear side.
4. While pressing the drum motor gear located on the rear side of the Motor Assembly 242 (PL 7.1.7), lower in the opposite direction of the arrow of the Sub-Guide Assembly.
5. Install the Contact Cover Assembly (PL 4.2.2) to the machine using the two hooks.

**NOTE Fit the bosses on the Contact Cover Assembly into the holes on the machine.**

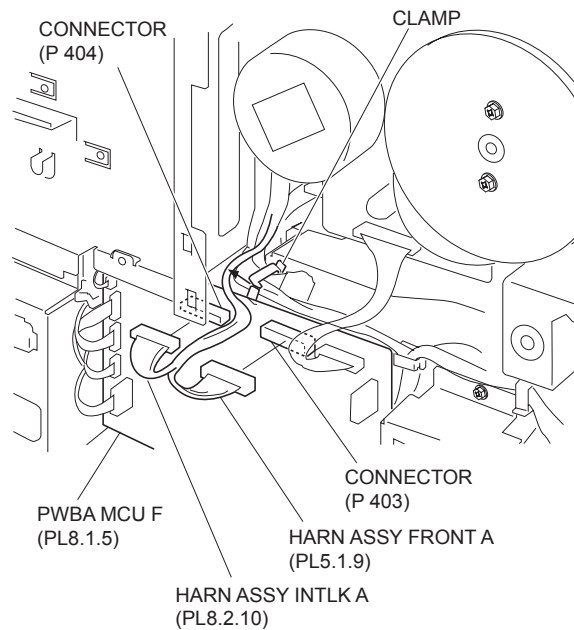
6. Slide Sub-Guide Assembly in the direction of the arrow and connect the connector of the Front Harness Assembly A (PL 5.1.9) to the CRU Switch.
7. Slide Sub-Guide Assembly in the opposite direction of the arrow and install the Sub-Guide Assembly to the machine using the four screws (Del Tite, M3x8mm).
8. Laser C Housing Assembly (PL 5.1.7) in the opposite direction of the arrow and install the Laser C Housing Assembly to the machine using the two screws (Del Tite, M3x7mm).
9. Install the Registration Transport Assembly (PL 4.5.1) .
10. Close the Left Hand Cover Assembly (PL 4.2.8).
11. Secure the CRUM B Harness Assembly to the clamp on the Laser C Housing Assembly.
12. Connect the connector (P/J126) of the CRUM B Harness Assembly to the Laser C Housing Assembly.
13. Install the Intake Duct (PL 5.1.17) .
14. Connect the connector (P/J403) of the Front Harness Assembly A (PL 5.1.9) and the connector (P/J404) of the Interlock Harness Assembly A (PL 5.1.9) to the MCU F PWBA (PL 8.1.5).
15. Secure the Interlock Harness Assembly A and the Front Harness Assembly A to the clamps on the machine.
16. Install the Lower PR Rear Cover (PL 1.2.6) .
17. Install the CTG30 Sub-Guide Assembly (PL 5.1.10) .
18. Install the High Voltage Power Supply-Y2 (PL 8.1.1) .
19. Install the Inner Cover Assembly, MN (PL 1.1.13) .
20. Install the Front Cover Assembly (PL 1.1.9) .
21. Insert the Toner Cartridge (PL 5.1.16).
22. Insert the CRU (PL 5.1.15).
23. Install the Top Cover Assembly PR (PL 1.1.8) .
24. Install the Fuser Cover (FR, PR) (PL 1.1.2) .

## Humidity & Temperature Sensor

### Removal

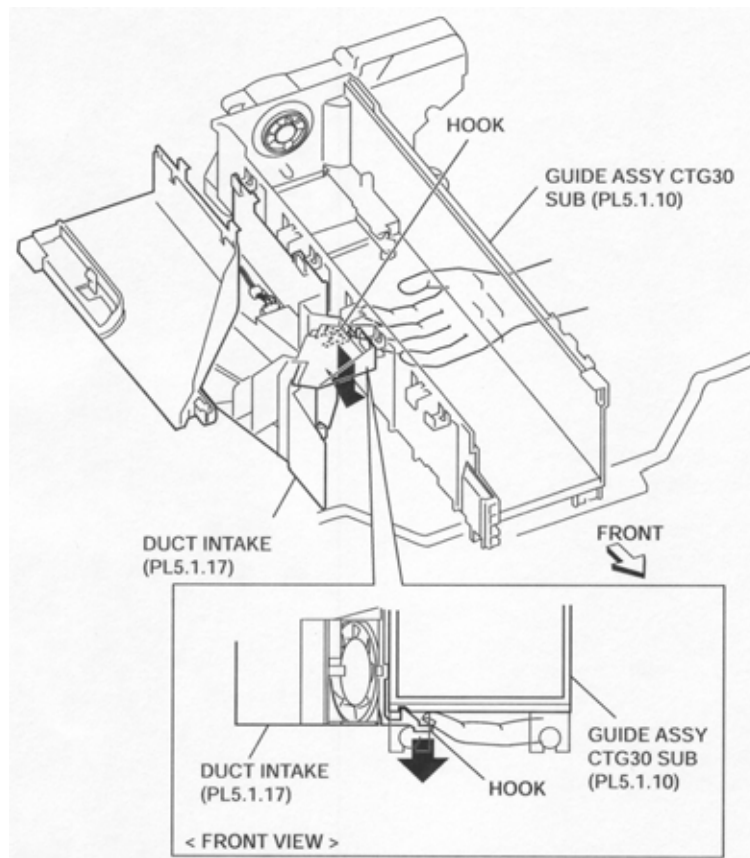
1. Remove the Left Front Cover (FR, PR) (PL 1.1.1).
2. Remove the Top Cover Assembly PR (PL 1.1.8) .
3. Pull out the CRU (PL 5.1.15).
4. Pull out the Toner Cartridge (PL 5.1.16).
5. Remove the Front Cover Assembly (PL 1.1.9) .

6. Remove the Inner Cover Assembly, MN (PL 1.1.13) .
7. Pull out the High Voltage Power Supply-Y2 (PL 8.1.1) .
8. Remove the CTG30 Sub-Guide Assembly (PL 5.1.10) .
9. Remove the Lower PR Rear Cover (PL 1.2.6) .
10. Disconnect the connector (P/J403) of the Front Harness Assembly A (PL 5.1.9) and the connector (P/J404) of the Interlock Harness Assembly A (PL 8.2.10) from the MCU F PWBA (PL 8.1.5) .



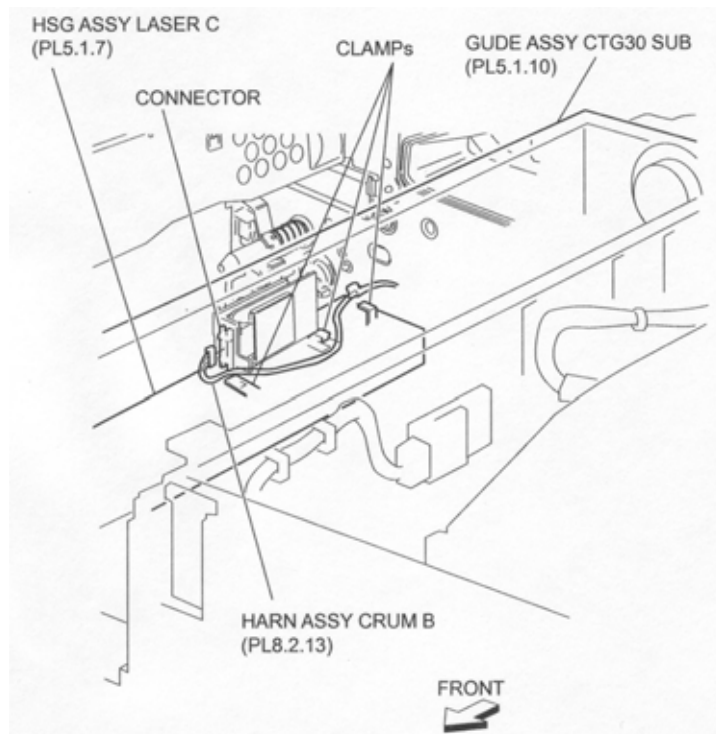
**Figure 1 Front Harness Assembly**

11. Release the Front Harness Assembly A and Interlock Harness Assembly A from the clamp on the machine.
12. Remove the Intake Duct (PL 5.1.17) .

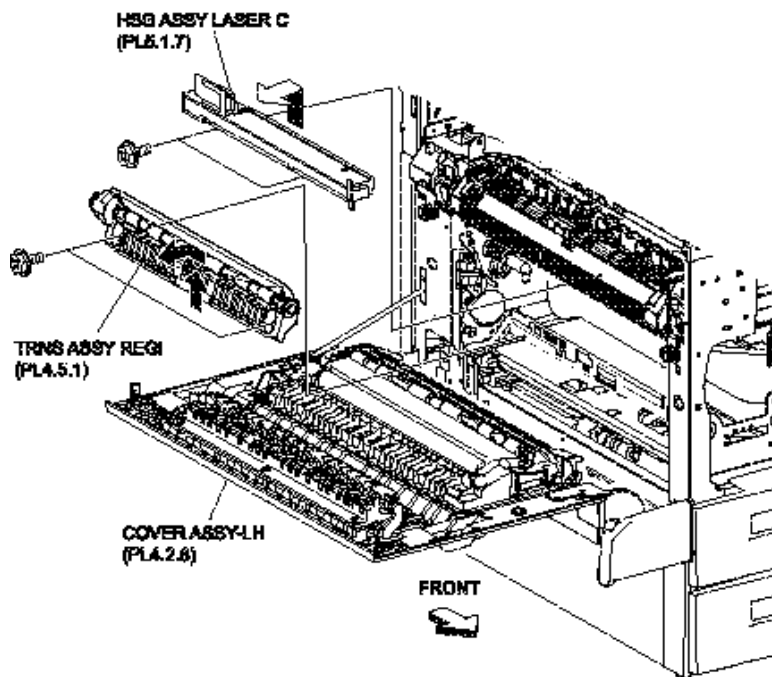


**Figure 2 Intake Duct**

13. Release the CRUM B Harness Assembly (PL 8.2.13) from the clamp on the Laser C Housing Assembly .
14. Disconnect the connector (P/J126) of the CRUM B Harness Assembly from the Laser C Housing Assembly.
15. Open the Left Hand Cover Assembly (PL 4.2.8) .
16. Remove the Registration Transport Assembly (PL 4.5.1) .
17. Remove the two screws (Del. Tite, M3x7mm) securing the Laser C Housing Assembly (PL 5.1.7) to the machine.
18. Remove the Laser C Housing Assembly by moving it in the direction of the arrow.

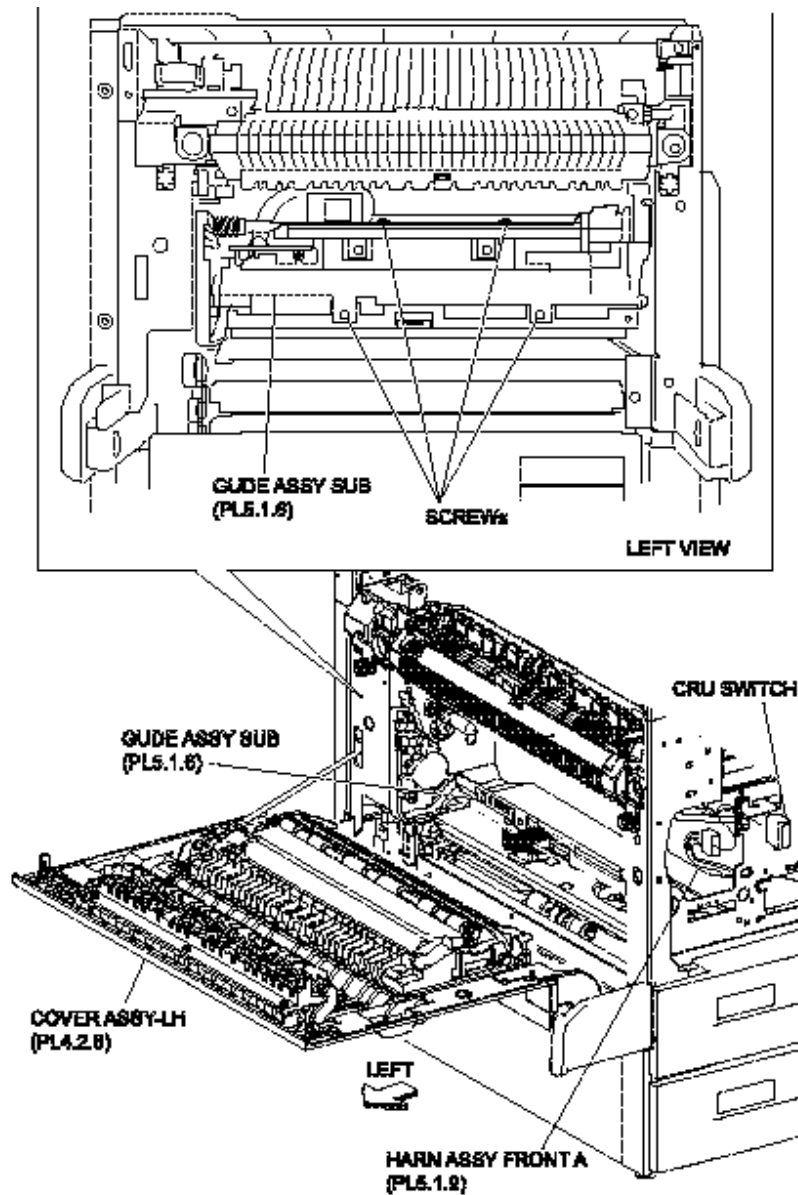


**Figure 3 CRUM Harness Assembly**



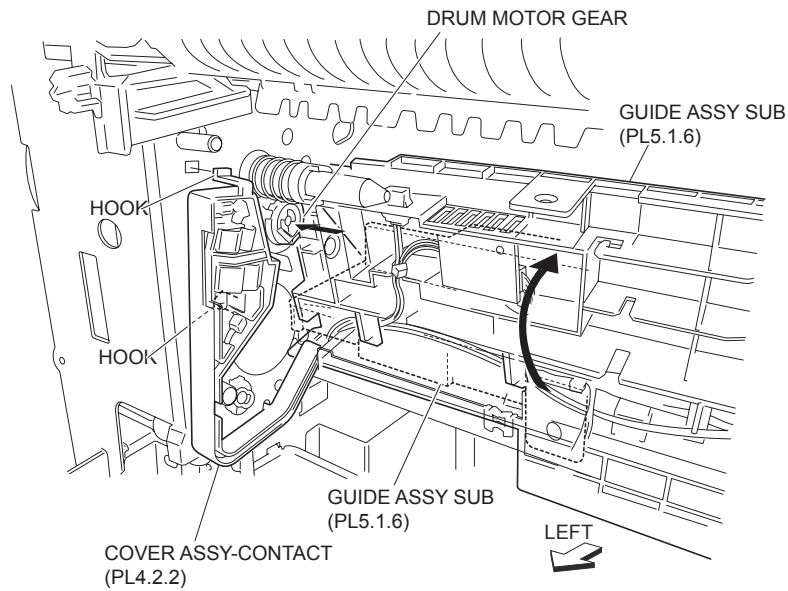
**Figure 4 Registration Transport Assembly**

19. Remove the four screws (Del Tite, M3x8mm) securing the Sub-Guide Assembly (PL 5.1.6) to the machine .
20. Slide the Sub-Guide Assembly in the direction of the arrow and disconnect the connector of the Front Harness Assembly A (PL 5.1.9).



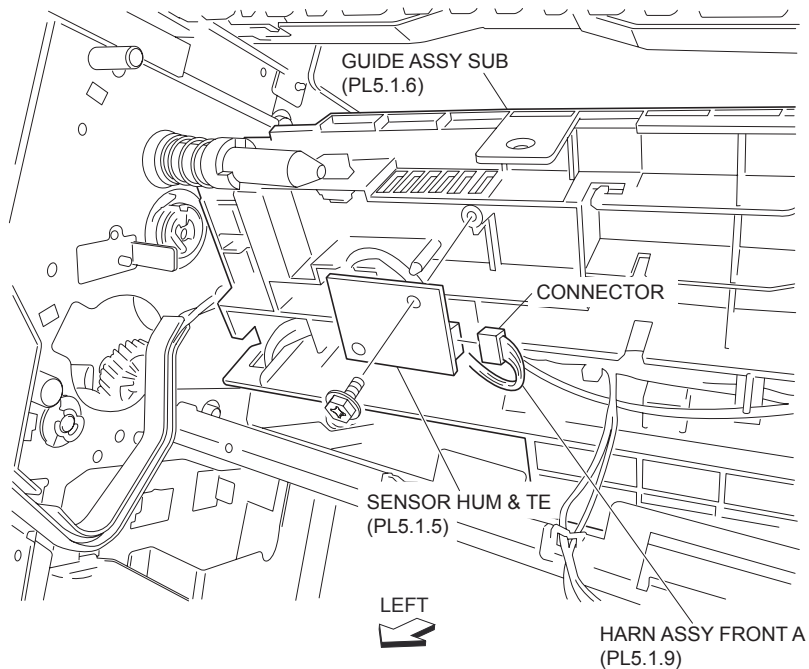
**Figure 5 Sub Guide Assembly**

21. Remove the two hooks securing the Contact Cover Assembly (PL 4.2.2) to the machine.
22. While pressing the drum motor gear located on the rear side of the Motor Assembly 242 (PL 7.1.7), lift the left side of the Sub-Guide Assembly upward .
23. Disconnect the connector (P/J150) of the Front Harness Assembly A from the Humidity & Temperature Sensor.



**Figure 6 Drum Motor Gear**

24. Remove the screw (Del Tite, M3x8mm) securing the Humidity & Temperature Sensor to the Sub-Guide Assembly .
25. Remove the Humidity & Temperature Sensor.



**Figure 7 Humidity Sensor**

## Replacement

1. Install the Humidity & Temperature Sensor to the Sub-Guide Assembly (PL 5.1.6) using the one screw (Del Tite, M3x8mm).



2. Connect the connector (P/J150) of the Front Harness Assembly A (PL.5.1.9) to the Humidity & Temperature Sensor.
3. While pressing the drum motor gear located on the rear side of the Motor Assembly 242 (PL 7.1.7), lower in the opposite direction of the arrow of the Sub-Guide Assembly.
4. Install the Contact Cover Assembly (PL 4.2.2) to the machine using the two hooks.

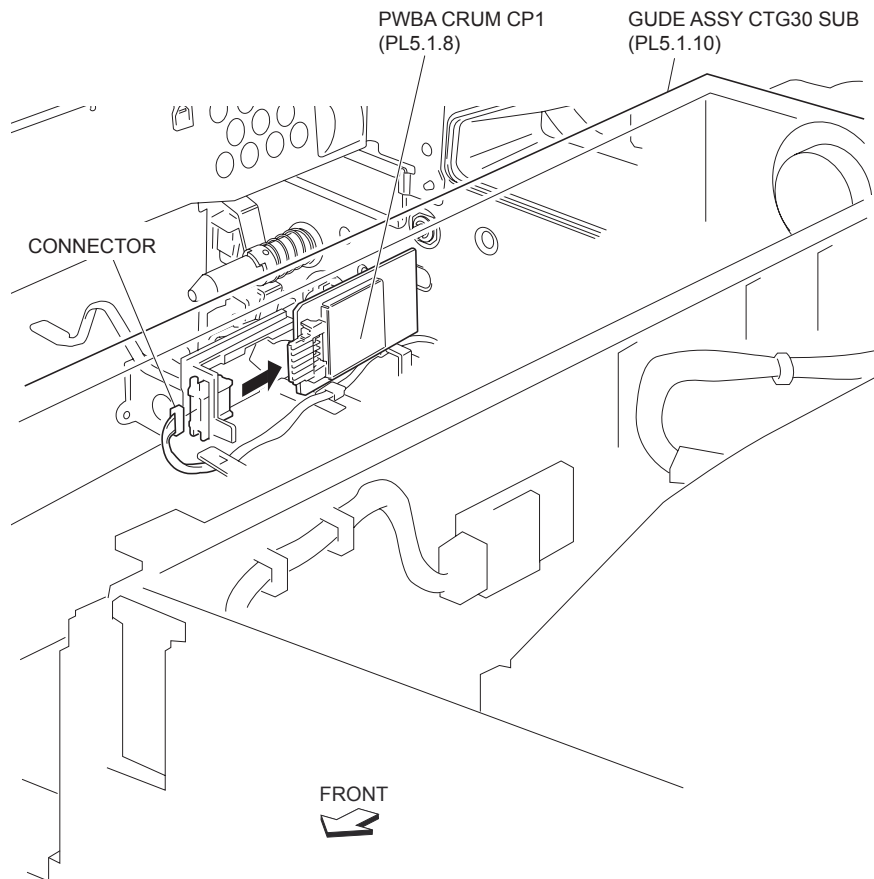
**NOTE** Fit the bosses on the Contact Cover Assembly into the holes on the machine.

5. Slide Sub-Guide Assembly in the direction of the arrow and connect the connector of the Front Harness Assembly A (PL 5.1.9) to the CRU Switch.
6. Slide Sub-Guide Assembly in the opposite direction of the arrow and install the Sub-Guide Assembly to the machine using the four screws (Del Tite, M3x8mm).
7. Laser C Housing Assembly (PL 5.1.7) in the opposite direction of the arrow and install the Laser C Housing Assembly to the machine using the two screws (Del Tite, M3x7mm).
8. Install the Registration Transport Assembly (PL 4.5.1) .
9. Close the Left Hand Cover Assembly (PL 4.2.8).
10. Secure the CRUM B Harness Assembly to the clamp on the Laser C Housing Assembly.
11. Connect the connector (P/J126) of the CRUM B Harness Assembly to the Laser C Housing Assembly.
12. Install the Intake Duct (PL 5.1.17) .
13. Connect the connector (P/J403) of the Front Harness Assembly A (PL 5.1.9) and the connector (P/J404) of the Interlock Harness Assembly A (PL 8.2.10) to the MCU F PWBA (PL 8.1.5).
14. Secure the Interlock Harness Assembly A and the Front Harness Assembly A to the clamps on the machine.
15. Install the Lower PR Rear Cover (PL 1.2.6) .
16. Install the CTG30 Sub-Guide Assembly (PL 5.1.10) .
17. Install the High Voltage Power Supply-Y2 (PL 8.1.1) .
18. Install the Inner Cover Assembly, MN (PL 1.1.13) .
19. Install the Front Cover Assembly (PL 1.1.9) .
20. Insert the Toner Cartridge (PL 5.1.16).
21. Insert the CRU (PL 5.1.15).
22. Install the Top Cover Assembly PR (PL 1.1.8) .
23. Install the Fuser Cover (FR, PR) (PL 1.1.2) .

## CP1 CRUM PWBA Housing

### Removal

1. Remove the Top Cover Assembly PR (PL 1.1.8) .
2. Remove the Intake Duct (PL 5.1.17) .
3. Disconnect the connector (P/J126) of the CRUM B Harness Assembly (PL 8.2.13) from the CP1 CRUM PWBA Housing .
4. Remove the CP1 CRUM PWBA Housing by moving it in the direction of the arrow.



**Figure 1 CRUM PWBA**

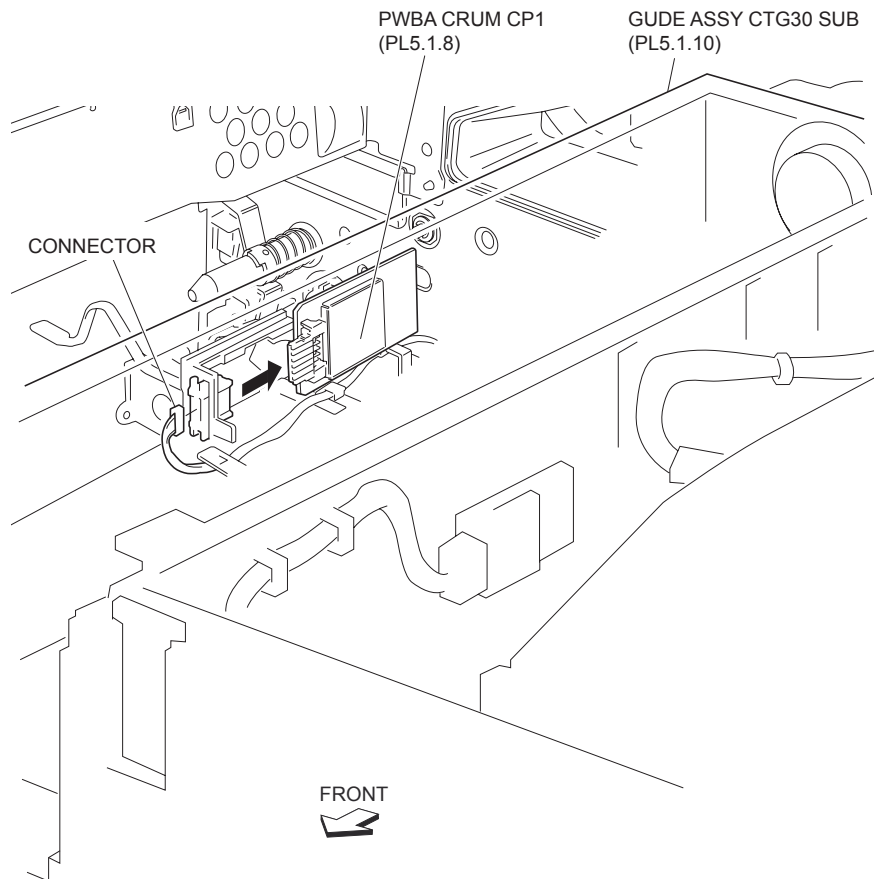
## Replacement

1. Install the CP1 CRUM PWBA Housing by moving it in the opposite direction of the arrow.
2. Connect the connector (P/J126) of the CRUM B Harness Assembly (PL 8.2.13) to the CP1 CRUM PWBA Housing.
3. Install the Intake Duct (PL 5.1.17) .
4. Install the Top Cover Assembly PR (PL 1.1.8) .

## CP1 Toner CRUM PWBA

### Removal

1. Remove Top Cover Assembly PR (PL 1.1.8) .
2. Disconnect the connector (P/J127) of the CRUM B Wire Harness Assembly (PL 8.2.13) from the PWBA CRUM CP1 .
3. Move the PWBA CRUM CP1 in the direction of the arrow to remove.



**Figure 1 CP1 CRUM PWBA**

## Replacement

1. Move the PWBA CRUM CP1 in the opposite direction of the arrow to install.
2. Connect the connector (P/J127) of the CRUM B Wire Harness Assembly (PL 8.2.13) to the PWBA CRUM CP1.
3. Install the Top Cover Assembly PR (PL 1.1.8) .

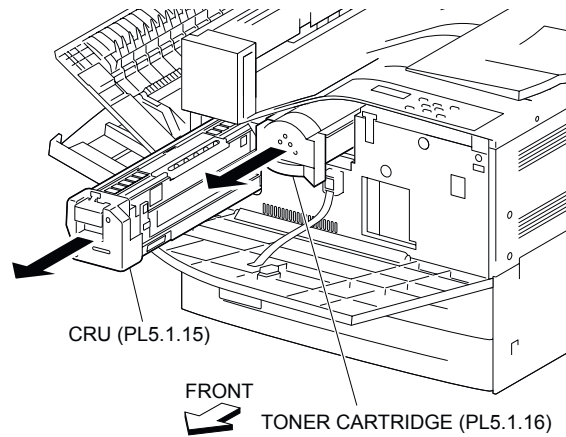
## CTG30 Sub-Guide Assembly

### Removal

1. Remove the Fuser Cover FR,PR (PL 1.1.2) .
2. Remove the Top Cover Assembly PR (PL 1.1.8) .
3. Pull out the CRU (PL 5.1.15) .
4. Pull out the Toner Cartridge (PL 5.1.16).
5. Remove the Front Cover Assembly (PL 1.1.9) .
6. Remove the Inner Cover Assembly, MN (PL 1.1.13) .
7. Remove the Intake Duct (PL 5.1.17) .
8. Release the Main Switch C Harness Assembly (PL 8.2.11) from the clamps on the rear side of the CTG30 Sub-Guide Assembly .
9. Remove the two screws (Del Tite, M3x8mm) securing the CTG30 Sub-Guide Assembly to the machine.

10. While pushing the CTG30 Sub-Guide Assembly toward the left side, remove the screw (Del Tite, M3x8mm) securing CTG30 Sub-Guide Assembly to the machine.
11. Remove the CTG30 Sub-Guide Assembly.

**NOTE** Toner comes out if the toner hose is detached. Be careful not to detach it.



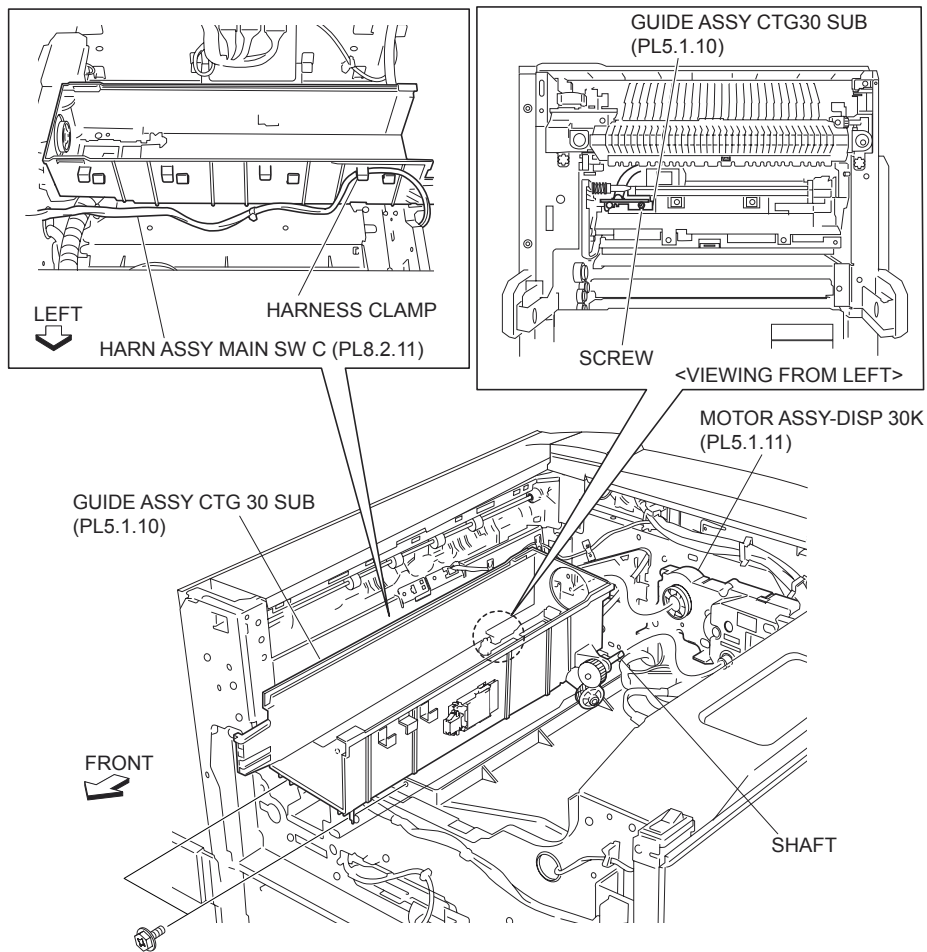
**Figure 1 CRU & Toner Cartridge**

## Replacement

1. Install the CTG30 Sub-Guide Assembly.

**NOTE** Fit the hole on the CTG30 Sub-Guide Assembly to the motor part of the Depense Motor Assembly 30K (PL 5.1.11). Also, fit the shaft into the hole on the Depense Motor Assembly 30K.

2. While pushing the CTG30 Sub-Guide Assembly toward the left side, install the CTG30 Sub-Guide Assembly to the machine using the one screw (Del Tite, M3x8mm).
3. Install the CTG30 Sub-Guide Assembly to the machine using the two screws (Del Tite, M3x8mm).
4. Secure the Main Switch C Harness Assembly (PL 8.2.11) to the clamp on the CTG30 Sub-Guide Assembly.
5. Install the Intake Duct (PL 5.1.17) .
6. Install the Inner Cover Assembly, MN (PL 1.1.13) .
7. Install the Front Cover Assembly (PL 1.1.9) .
8. Insert the Toner Cartridge (PL 5.1.16).
9. Insert the CRU (PL 5.1.15).
10. Install the Top Cover Assembly PR (PL 1.1.8) .
11. Install the Fuser Cover FR,PR (PL 1.1.2) .

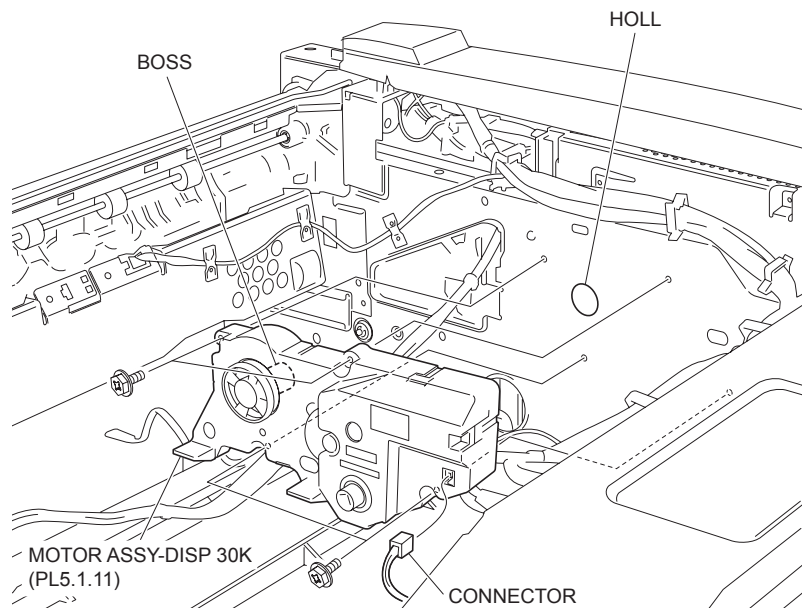


**Figure 2 Main Switch Harness**

## Depense Motor Assembly 30K

### Removal

1. Remove the Fuser Cover FR,PR (PL 1.1.2) .
2. Remove the Top Cover Assembly PR (PL 1.1.8) .
3. Pull out the CRU (PL 5.1.15).
4. Pull out the Toner Cartridge (PL 5.1.16).
5. Remove the Front Cover Assembly (PL 1.1.9) .
6. Remove the Inner Cover Assembly, MN (PL 1.1.13) .
7. Remove the Intake Duct (PL 5.1.17) .
8. Remove the CTG30 Sub-Guide Assembly (PL 5.1.10) .
9. Disconnect the connector (P/J216) of the Low Voltage Power C Harness Assembly (PL 8.2.9) from the Depense Motor Assembly 30K .
10. Remove the four screws (Del Tite, M3x8mm) securing the Depense Motor Assembly 30K to the machine.
11. Remove the Depense Motor Assembly 30K.



**Figure 1 Dispense Motor Assembly**

## Replacement

1. Install the Dispense Motor Assembly 30K to the machine using the four screws (Del Tite, M3x8mm).

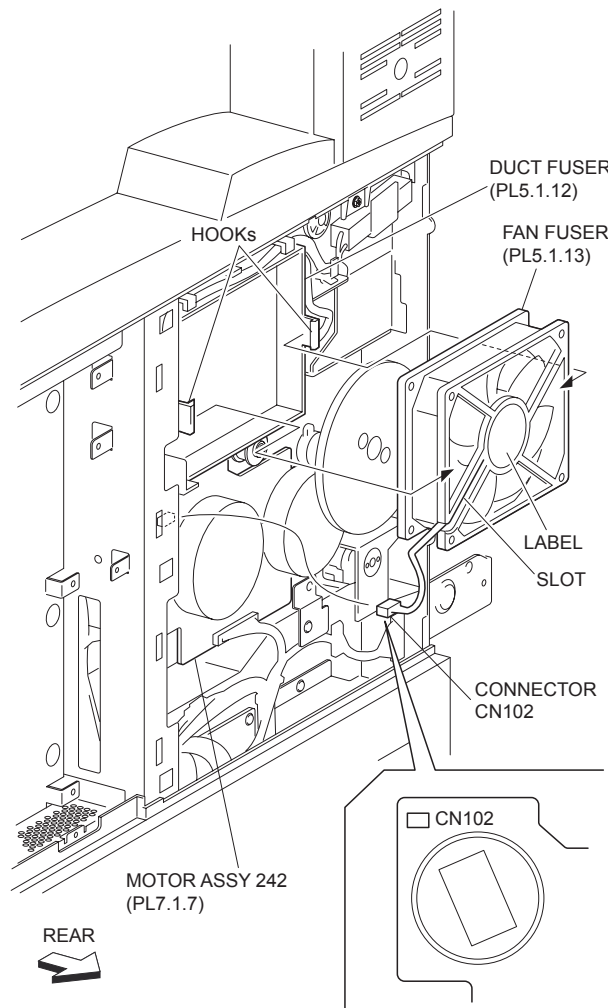
**NOTE** Fit the boss on the Dispense Motor Assembly 30K in the hole on the machine.

2. Connect the connector (P/J216) of the Low Voltage Power C Harness Assembly (PL 8.2.9) to the Dispense Motor Assembly 30K.
3. Install the CTG30 Sub-Guide Assembly (PL 5.1.10) .
4. Install the Intake Duct (PL 5.1.17) .
5. Install the Inner Cover Assembly, MN (PL 1.1.13) .
6. Install the Front Cover Assembly (PL 1.1.9) .
7. Insert the Toner Cartridge (PL 5.1.16).
8. Insert the CRU (PL 5.1.15).
9. Install the Top Cover Assembly PR (PL 1.1.8) .
10. Install the Fuser Cover FR,PR (PL 1.1.2) .

## Fuser Fan

### Removal

1. Remove the ESS Cover Assembly (PL 8.1.20) .
2. Remove the Upper Rear Cover (PL 1.2.5) .
3. Disconnect the connector (P/J102) of the harness of the Fuser Fan from the Motor Assembly 242 (PL 7.1.7) .
4. Release the hooks left and right securing the Fuser Fan to the Fuser Duct (PL 5.1.12) as shown in the figure.
5. Remove the Fuser Fan.



**Figure 1 Fuser Fan**

## Replacement

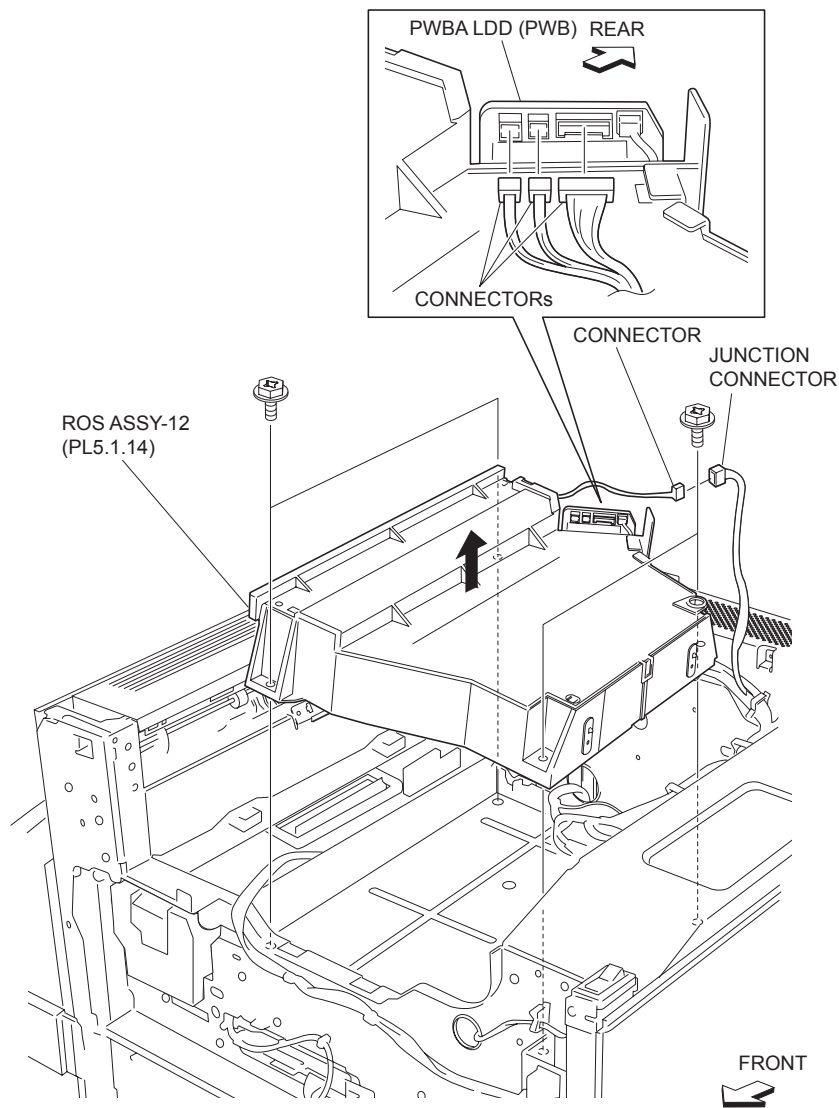
1. Install the Fuser Fan to the Fuser Duct (PL 5.1.12) using the hooks left and right.

**NOTE** Be sure to install the Fuser Fan with its label facing outward. Also, be sure to put the harness of the Fuser Fan in the slot as shown in the figure.

2. Connect the connector (P/J102) of the harness of the Fuser Fan to the Motor Assembly 242 (PL 7.1.7).
3. Install the Upper Rear Cover (PL 1.2.5) .
4. Install the ESS Cover Assembly (PL 8.1.20) .

## ROS Assembly 12

**NOTE** When performing the ROS Assembly 12 removal and/or installation, be sure to perform the operation on a level and smooth work surface desk or the like. If the operation is performed on a rough and/or inclined work top, the ROS Assembly 12 will be out of alignment. Then, applying too much force to the LDD PWBA (board) can cause a ROS alignment displacement. To avoid this, hold the board when connecting/disconnecting the connector .



**Figure 1 ROS Assembly**

## Removal

1. Remove the Top Cover Assembly PR (PL 1.1.8) .
2. Open the Front Cover Assembly (PL 1.1.9).
3. Pull out the CRU (PL 5.1.15).
4. Pull out the Toner Cartridge (PL 5.1.16).
5. Remove the Front Cover Assembly (PL 1.1.9) .
6. Remove the Inner Cover Assembly, MN (PL 1.1.13) .
7. Remove the Intake Duct (PL 5.1.17) .
8. Remove the CTG30 Sub-Guide Assembly (PL 5.1.10) .
9. Disconnect the three connectors (P/J140, P/J160 and P/J170) of the ROS C Harness Assembly (PL 8.2.5) from the ROS Assembly 12.

**NOTE** Applying too much force to the LDD PWBA (board) can cause a ROS alignment displacement. To avoid this, hold the board when connecting/disconnecting the connector.



10. Disconnect the connector (P/J620) of the ROS C Harness Assembly from the junction connector.

**NOTE** Applying too much force to the LDD PWBA (board) can cause a ROS alignment displacement. To avoid this, hold the board when connecting/disconnecting the connector.

11. Remove the four screws (Del Tite, M3x10mm) securing the ROS Assembly 12 to the machine.

**NOTE** Never impact the ROS Assembly 12 with a screwdriver or other tools

12. Remove the ROS Assembly 12 toward upward.

## Replacement

1. Install the ROS Assembly 12 to the machine using the four screws (Del Tite, M3x10mm).

**NOTE** Never impact the ROS Assembly 12 with a screwdriver or other tools

2. Connect the connector (P/J620) of the ROS C Harness Assembly to the junction connector.

**NOTE** Applying too much force to the LDD PWBA (board) can cause a ROS alignment displacement. To avoid this, hold the board when connecting/disconnecting the connector.

3. Connect the three connectors (P/J140, P/J160 and P/J170) of the ROS C Harness Assembly (PL 8.2.5) to ROS Assembly 12.

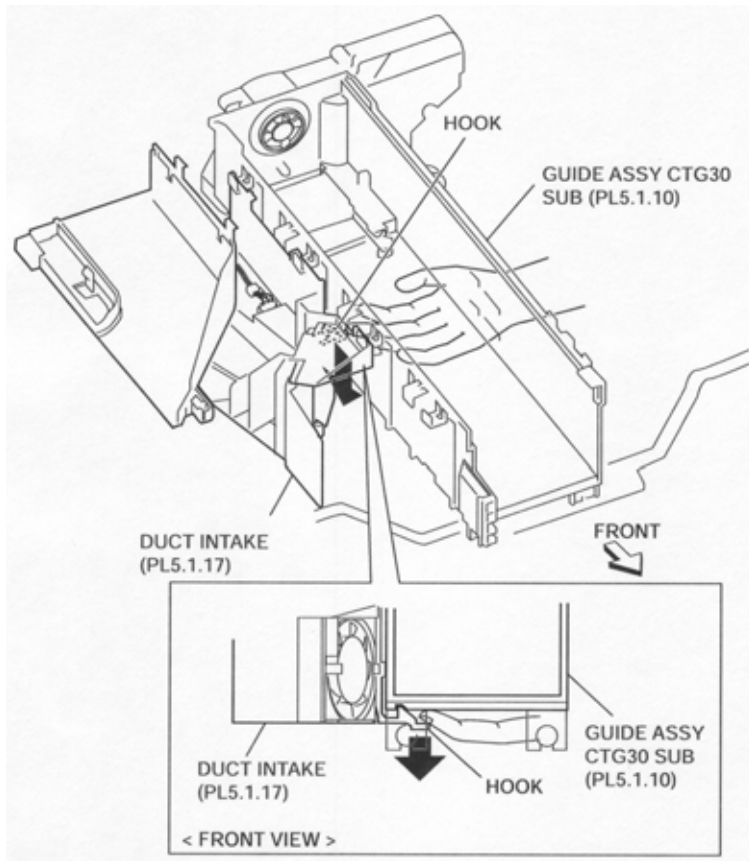
**NOTE** Applying too much force to the LDD PWBA (board) can cause a ROS alignment displacement. To avoid this, hold the board when connecting/disconnecting the connector.

4. Install the CTG30 Sub-Guide Assembly (PL 5.1.10) .
5. Install the Intake Duct (PL 5.1.17) .
6. Install the Inner Cover Assembly, MN (PL 1.1.13) .
7. Install the Front Cover Assembly (PL 1.1.9) .
8. Insert the Toner Cartridge (PL 5.1.16).
9. Insert the CRU (PL 5.1.15).
10. Close the Front Cover Assembly (PL 1.1.9).
11. Install the Top Cover Assembly PR (PL 1.1.8) .

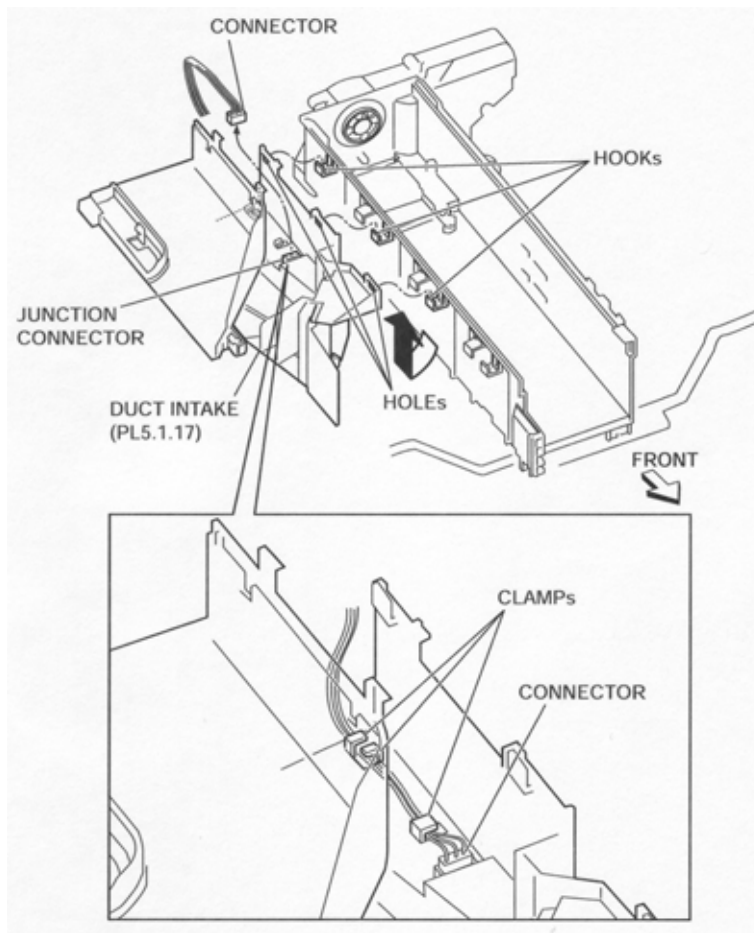
## Intake Duct

### Removal

1. Remove the Top Cover Assembly PR (PL 1.1.8) .
2. Disconnect the harness connector coming from the printer from the junction connector (P/J219) .
3. Release the harness connector connected to the printer from the clamp on the Intake Duct .
4. Release the hook securing the Intake Duct to the CTG30 Sub-Guide Assembly (PL 5.1.10).
5. Move the Intake Duct in the direction of the arrow while lifting the left side, to release the hook securing it to the CTG30 Sub-Guide Assembly (PL 5.1.10).



**Figure 1 Intake Duct**



**Figure 2 Intake Duct Connector**

## Replacement

1. Fit the three hooks on the CTG30 Sub-Guide Assembly (PL 5.1.10) to the three holes in the Intake Duct and install the Intake Duct.
2. Move the Intake Duct in the opposite direction of the arrow and secure it to the CTG30 Guide Assembly (PL 5.1.10) with the hook.
3. Secure the harness from the printer to the clamp on the Intake Duct.
4. Connect the harness connector from the printer to the junction connector (P/J219).
5. Install the Top Cover Assembly PR (PL 1.1.8) .

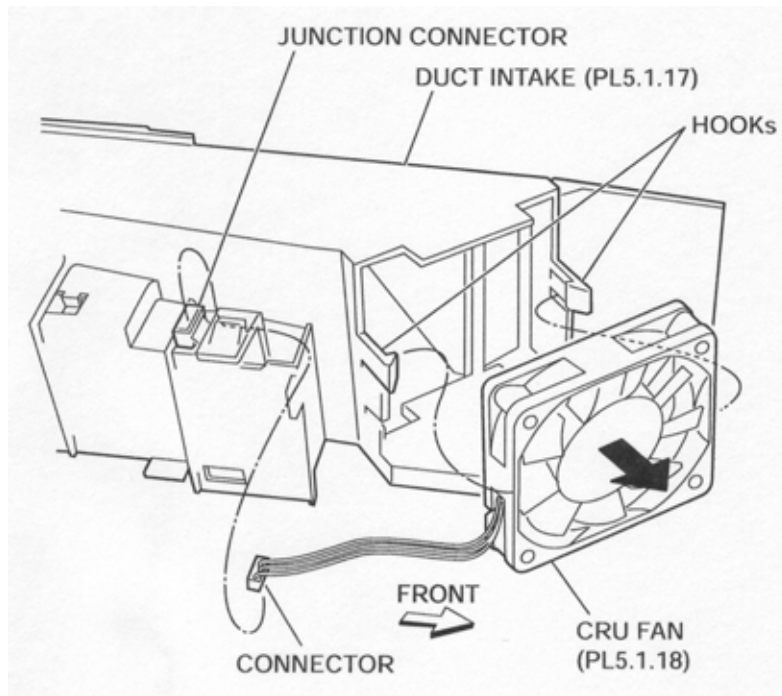
## CRU Fan

### Removal

1. Remove the Top Cover Assembly PR (PL 1.1.8) .
2. Remove the Intake Duct (PL 5.1.17) .
3. Disconnect the harness of the CRU FAN from the junction connector (P/J219).
4. Release the two hooks securing the CRU FAN to the Intake Duct as shown .

**NOTE Be careful when handling the hooks of the Intake Duct, as they are easy to break.**

5. Release the harness of the CRU FAN from the slot in the Intake Duct.
6. Remove the CRU FAN.



**Figure 1 CRU Fan**

## Replacement

1. Install the CRU FAN to the Intake Duct (PL 5.1.17) with the two hooks.

**NOTE** Install the CRU FAN with the label facing rearward.

**NOTE** Be careful when handling the hooks of the Intake Duct, as they are easy to break.

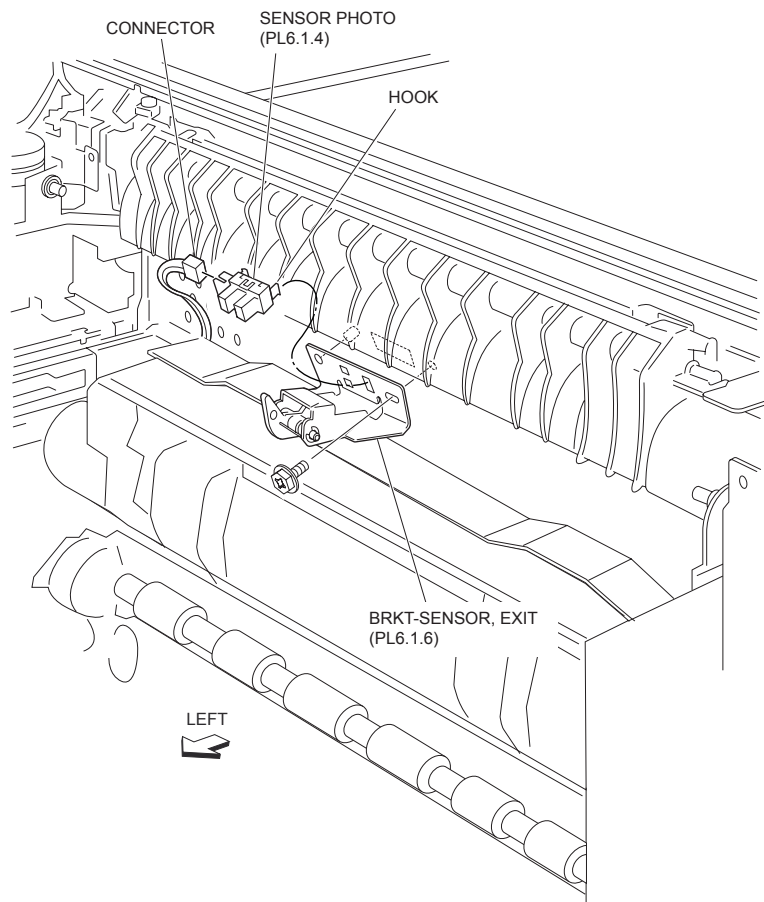
2. Secure the harness of the CRU FAN to the slot in the Intake Duct.
3. Connect the harness connector of the CRU FAN to the junction connector (P/J219).
4. Install the Intake Duct (PL 5.1.17).
5. Install the Top Cover Assembly PR (PL 1.1.8) .

## Fuser & Exit 1

### Photo Sensor

#### Removal

1. Open the Left Hand Cover Assembly (PL 4.2.8).
2. Remove the Fuser Assembly (PL 6.1.7) .
3. Disconnect the connector (P/J125) of the PH Harness Assembly C (PL 8.2.7) from the Photo Sensor .
4. Remove the screw (Del Tite, M3x6mm) securing the Exit Sensor Bracket (PL 6.1.6) to the machine.
5. Release the three hooks securing the Photo Sensor to the Exit Sensor Bracket.
6. Remove the Photo Sensor.



**Figure 1 Photo Sensor**

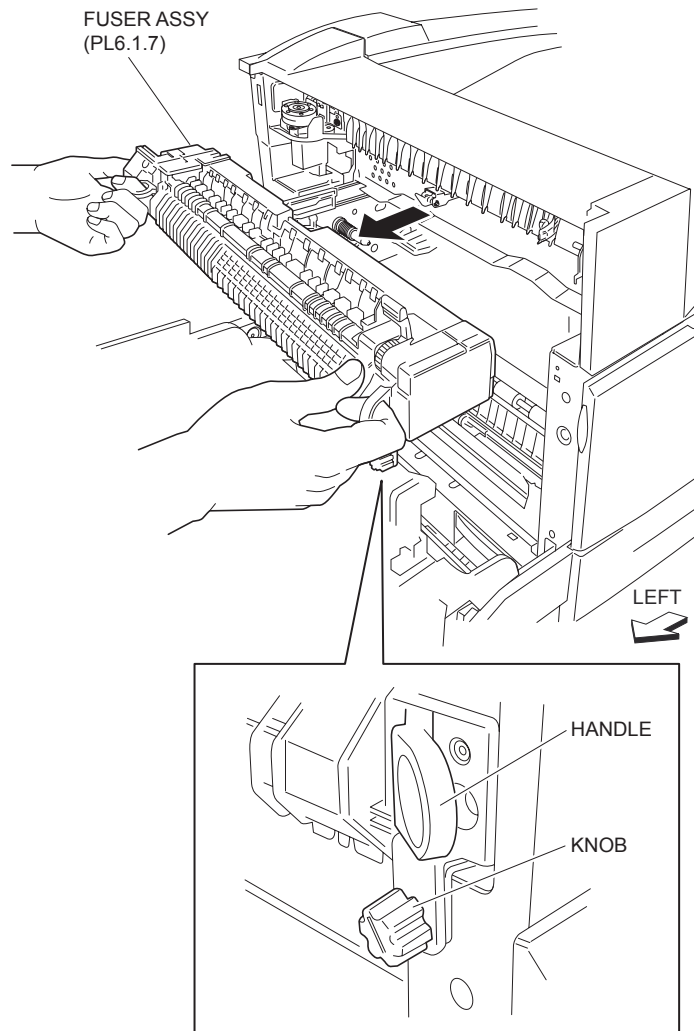
## Replacement

1. Secure the Photo Sensor to the Exit Sensor Bracket (P6.1.6) using the three hooks.
2. Install the Exit Sensor Bracket to the machine using the one screw (Del Tite, M3x6mm).
3. Connect the connector (P/J125) of the PH Harness Assembly C (PL 8.2.7) to the Photo Sensor.
4. Install the Fuser Assembly (PL 6.1.7) .
5. Close the Left Hand Cover Assembly (PL 4.2.8).

## Fuser Assembly

### Removal

1. Open the Left Hand Cover Assembly (PL 4.2.8).
2. Loosen the two knobs securing the Fuser Assembly to the machine .
3. Remove the Fuser Assembly toward you by holding the two handles left and right.



**Figure 1 Fuser Assembly**

## Replacement

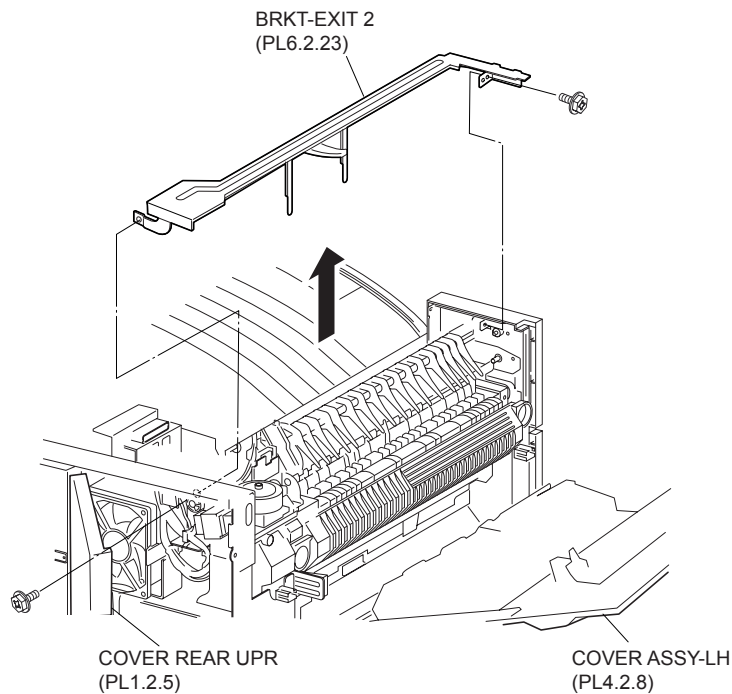
1. Install the Fuser Assembly to the machine by holding the two handles left and right.
2. Tighten the two knobs securing the Fuser Assembly to the machine.
3. Close the Left Hand Cover Assembly (PL 4.2.8).

## Exit Transport Assembly

### Removal

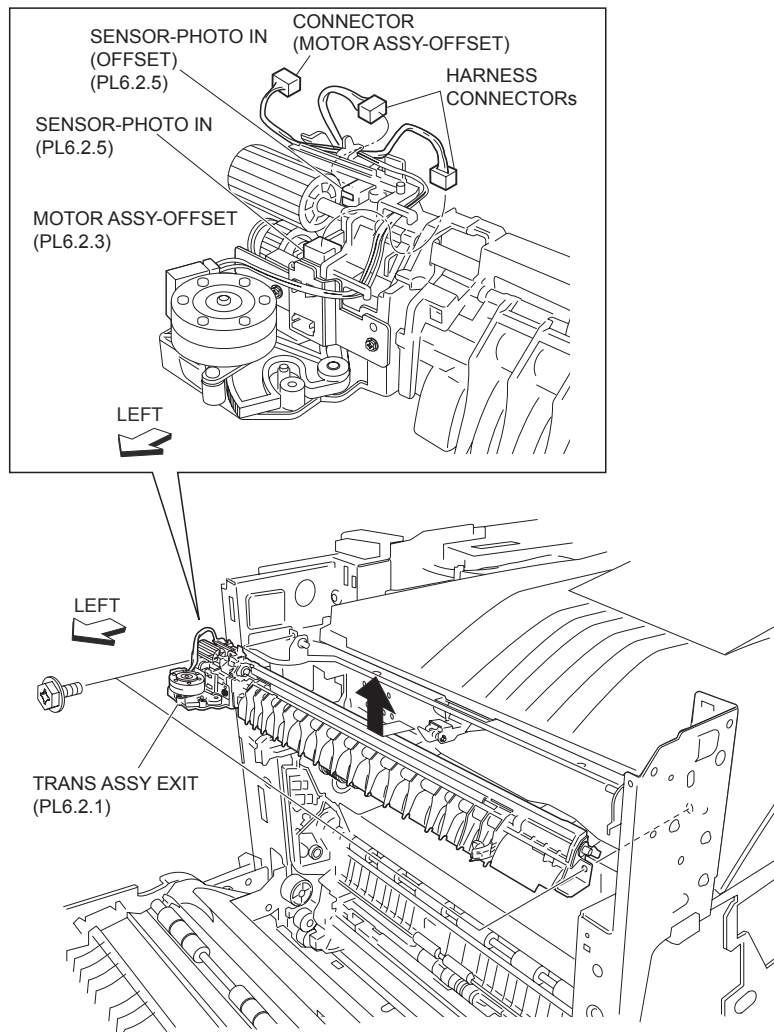
1. Remove the two screws (DeI Tite, M3x8mm) securing the Upper Rear Cover (PL 1.2.5) to the machine.
2. Open the Upper Rear Cover.
3. Remove the Top Rear Cover (PL 1.1.3) .
4. Open the Left Hand Cover Assembly (PL 4.2.8).
5. Remove the Exit 1 Top Cover (PL 6.2.22) .
6. Open the Front Cover Assembly (PL 1.1.9).
7. Remove the Fuser Cover FR,PR (PL 1.1.2) .

8. Remove the two screws (Del Tite, M3x6mm) securing the Exit 2 Bracket (PL 6.2.23) to the machine .
9. Remove the Exit 2 Bracket by moving it in the direction of the arrow.



**Figure 1 Exit Bracket 2**

10. Remove the Synchronous Ban Belt (PL 7.1.5) .
11. Disconnect the connector (P/J206) of the Exit Harness Assembly C (PL 8.2.6) in Offset Motor Assembly (PL 6.2.3) from the machine .
12. Disconnect the connector (P/J117) of the Exit Harness Assembly C from the Photo In Sensor (Offset) (PL 6.2.5).
13. Disconnect the connector (P/J118) of the Exit Harness Assembly C from the Photo In Sensor (PL 6.2.5).
14. Remove the two screws securing the Exit Transport Assembly to the machine.
15. Remove the Exit Transport Assembly toward upward.



**Figure 2 Exit Transport Assembly**

## Replacement

1. Install the Exit Transport Assembly to the machine using two screws.
2. Connect the connector (P/J206) of the Exit Harness Assembly C (PL 8.2.6) in the Offset Motor Assembly (PL 6.2.3) to the machine.
3. Connect the connector (P/J117) of the Exit Harness Assembly C to the Photo In Sensor (Offset) (PL 6.2.5)
4. Connect the connector (P/J118) of the Exit Harness Assembly C to the Photo In Sensor (PL 6.2.5)
5. Install the Synchronous Ban Belt (PL 7.1.5) .
6. Move the Exit 2 Bracket (PL 6.2.23) in the opposite direction of the arrow and install it to the machine using the two screws (Del Tite, M3x6mm).
7. Install the Fuser Cover FR,PR (PL 1.1.2) .
8. Close the Front Cover Assembly (PL 1.1.9).
9. Install the Exit 1 Top Cover (PL 6.2.22) .
10. Close the Left Hand Cover Assembly (PL 4.2.8).
11. Install the Top Rear Cover (PL 1.1.3) .
12. Close the Upper Rear Cover (PL 1.2.5).
13. Install the Upper Rear Cover to the machine using the two screws (Del Tite, M3x8mm).



# Offset Motor Assembly

## Removal

1. Remove the two screws (Del Tite, M3x8mm) securing the Upper Rear Cover (PL 1.2.5) to the machine.
2. Open the Upper Rear Cover.
3. Remove the Top Rear Cover PR (PL 1.1.3) .
4. Open the Left Hand Cover Assembly (PL 4.2.8).
5. Remove the Exit 1 Top Cover (PL 6.2.22) .
6. Open the Front Cover Assembly (PL 1.1.9).
7. Remove the Fuser Cover FR,PR (PL 1.1.2) .
8. Remove the Exit Transport Assembly (PL 6.2.1) .
9. Disconnect the connector (P/J206) of the Exit Harness Assembly C (PL 8.2.6) to the Photo In Sensor (Offset) (PL 6.2.5) from the Offset Motor Assembly .
10. Remove the two screws (Bind, M3x10mm) securing the Offset Motor Assembly to the Exit Transport Assembly (PL 6.2.1).
11. Remove the Offset Motor Assembly.

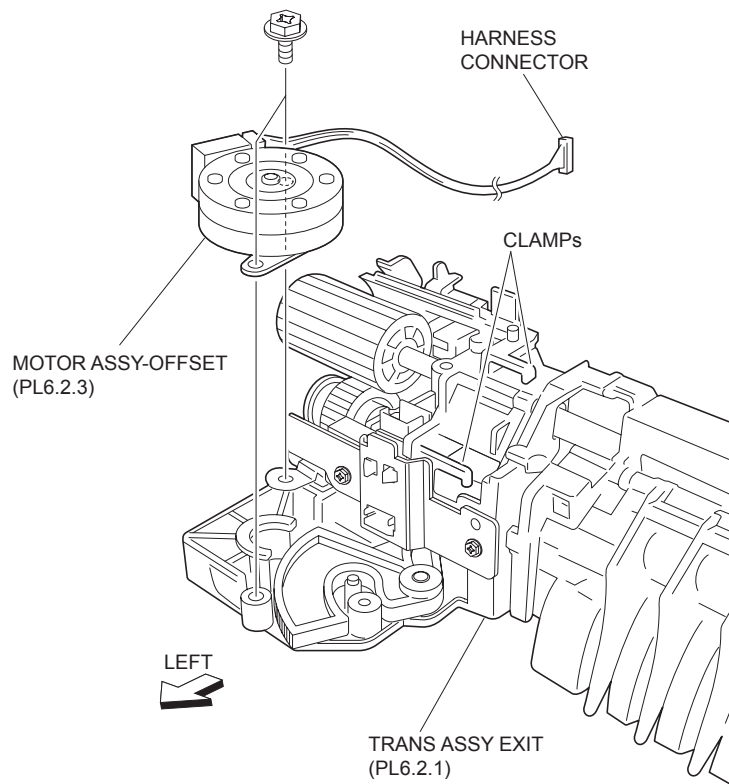


Figure 1 Offset Motor Assembly

## Replacement

1. Install the Offset Motor Assembly to the Exit Transport Assembly (PL 6.2.1) using the two screws (Bind, M3x10mm).

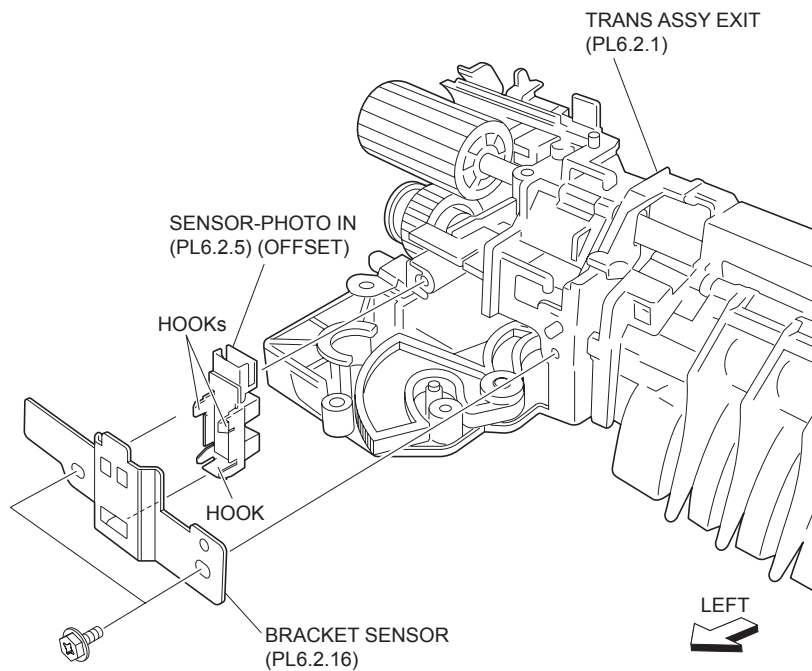
**NOTE** Be sure to secure the Exit Harness Assembly C (PL 8.2.6) to the clamp shown in the figure.

2. Connect the connector (P/J206) of the Exit Harness Assembly C to the Offset Motor Assembly.
3. Install the Exit Transport Assembly (PL 6.2.1) .
4. Install the Fuser Cover FR,PR (PL 1.1.2) .
5. Close the Front Cover Assembly (PL 1.1.9).
6. Install the Exit 1 Top Cover (PL 6.2.22) .
7. Close the Left Hand Cover Assembly (PL 4.2.8).
8. Install the Top Rear Cover PR (PL 1.1.3) .
9. Close the Upper Rear Cover (PL 1.2.5).
10. Install the Upper Rear Cover to the machine using the two screws (Del Tite, M3x8mm).

## Photo In Sensor (Offset)

### Removal

1. Remove the two screws (Del Tite, M3x8mm) securing the Upper Rear Cover (PL 1.2.5) to the machine.
2. Open the Upper Rear Cover.
3. Remove the Top Rear Cover PR (PL 1.1.3) .
4. Open the Left Hand Cover Assembly (PL 4.2.8).
5. Remove the Exit 1 Top Cover (PL 6.2.22) .
6. Open the Front Cover Assembly (PL 1.1.9).
7. Remove the Fuser Cover FR,PR (PL 1.1.2) .
8. Remove the Exit Transport Assembly (PL 6.2.1) .
9. Remove the two screws (Silver, M3x8mm) securing the Sensor Bracket (PL 6.2.16) to the Exit Transport Assembly .
10. Release the three hooks securing the Photo In Sensor (Offset) to the Sensor Bracket.
11. Remove the Photo In Sensor (Offset).



**Figure 1 Photo In Sensor**

## Replacement

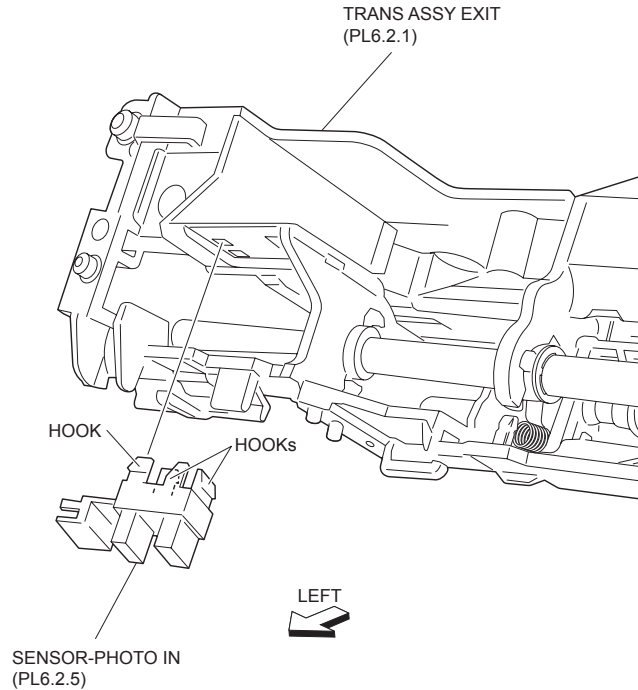
1. Secure the Photo In Sensor (Offset) to the Sensor Bracket (P6.2.16) using the three hooks.
2. Install the Sensor Bracket to the Exit Transport Assembly (PL 6.2.1) using the two screws (Silver, M3x8mm).
3. Install the Exit Transport Assembly (PL 6.2.1) .
4. Install the Fuser Cover FR,PR (PL 1.1.2) .
5. Close the Front Cover Assembly (PL 1.1.9).
6. Install the Exit 1 Top Cover (PL 6.2.22) .
7. Close the Left Hand Cover Assembly (PL 4.2.8).
8. Install the Top Rear Cover PR (PL 1.1.3) .
9. Close the Upper Rear Cover.
10. Install the Upper Rear Cover to the machine using the two screws (Del Tite, M3x8mm).

## Photo In Sensor

### Removal

1. Remove the two screws (Del Tite, M3x8mm) securing the Upper Rear Cover (PL 1.2.5) to the machine.
2. Open the Upper Rear Cover.
3. Remove the Top Rear Cover PR (PL 1.1.3) .
4. Open the Left Hand Cover Assembly (PL 4.2.8).
5. Remove the Exit 1 Top Cover (PL 6.2.22) .
6. Open the Front Cover Assembly (PL 1.1.9).
7. Remove the Fuser Cover FR,PR (PL 1.1.2) .

8. Remove the Exit Transport Assembly (PL 6.2.1) .
9. Release the three hooks securing the Photo In Sensor to the Exit Transport Assembly .
10. Remove the Photo In Sensor.



**Figure 1 Photo In Sensor**

## Replacement

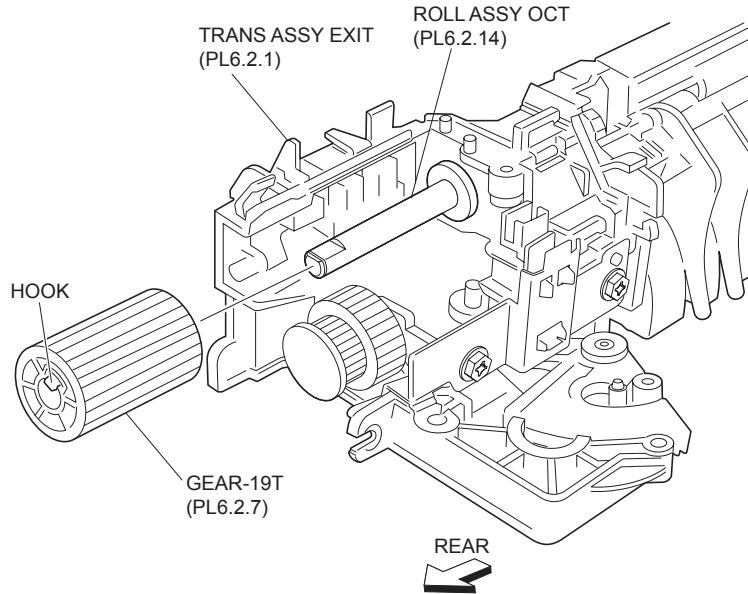
1. Secure the Photo In Sensor to the Exit Transport Assembly (PL 6.2.1) using the three hooks.
2. Install the Exit Transport Assembly (PL 6.2.1) .
3. Install the Fuser Cover FR,PR (PL 1.1.2) .
4. Close the Front Cover Assembly (PL 1.1.9).
5. Install the Exit 1 Top Cover (PL 6.2.22) .
6. Close the Left Hand Cover Assembly (PL 4.2.8).
7. Install the Top Rear Cover PR (PL 1.1.3) .
8. Close the Upper Rear Cover (PL 1.2.5).
9. Install the Upper Rear Cover to the machine using the two screws (Del Tite, M3x8mm).

## 19T Gear

### Removal

1. Remove the two screws (Del Tite, M3x8mm) securing the Upper Rear Cover (PL 1.2.5) to the machine.
2. Open the Upper Rear Cover.
3. Remove the Top Rear Cover PR (PL 1.1.3) .
4. Open the Left Hand Cover Assembly (PL 4.2.8).
5. Remove the Exit 1 Top Cover (PL 6.2.22) .
6. Open the Front Cover Assembly (PL 1.1.9).
7. Remove the Fuser Cover FR,PR (PL 1.1.2) .
8. Remove the Exit Transport Assembly (PL 6.2.1) .

9. Release the hook securing the 19T Gear to the OCT Roll Assembly (PL 6.2.14) to remove the 19T Gear .



**Figure 1 19T Gear**

## Replacement

1. Secure the 19T Gear to the OCT Roll Assembly (PL 6.2.14) using the hook.

**NOTE** Insert the 19T Gear until the hook is secured firmly.

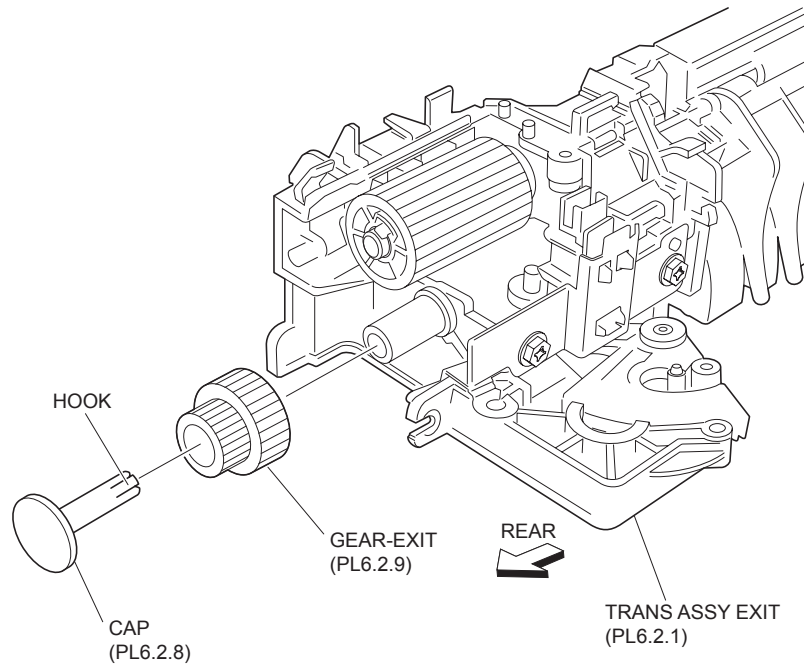
2. Install the Exit Transport Assembly (PL 6.2.1) .
3. Install the Fuser Cover FR,PR (PL 1.1.2) .
4. Close the Front Cover Assembly (PL 1.1.9).
5. Install the Exit 1 Top Cover (PL 6.2.22) .
6. Close the Left Hand Cover Assembly (PL 4.2.8).
7. Install the Top Rear Cover PR (PL 1.1.3) .
8. Close the Upper Rear Cover (PL 1.2.5).
9. Install the Upper Rear Cover to the machine using the two screws (Del Tite, M3x8mm).

## Exit Gear

### Removal

1. Remove the two screws (Del Tite, M3x8mm) securing the Upper Rear Cover (PL 1.2.5) to the machine.
2. Open the Upper Rear Cover.
3. Remove the Top Rear Cover PR (PL 1.1.3) .
4. Open the Left Hand Cover Assembly (PL 4.2.8).
5. Remove the Exit 1 Top Cover (PL 6.2.22) .
6. Open the Front Cover Assembly (PL 1.1.9).
7. Remove the Fuser Cover FR,PR (PL 1.1.2) .
8. Remove the Exit Transport Assembly (PL 6.2.1) .
9. Release the hook securing the CAP (PL 6.2.8) to the Exit Gear to remove the CAP .

10. Remove the Exit Gear.



**Figure 1 Exit Gear**

## Replacement

1. Install the Exit Gear.

**NOTE** Be sure to install the Exit Gear in the orientation shown in the figure.

2. Install the CAP (PL 6.2.8) to the Exit Gear using the hook.

**NOTE** Insert the CAP until the hook is secured firmly.

3. Install the Exit Transport Assembly (PL 6.2.1) .
4. Install the Fuser Cover FR,PR (PL 1.1.2) .
5. Close the Front Cover Assembly (PL 1.1.9).
6. Install the Exit 1 Top Cover (PL 6.2.22) .
7. Close the Left Hand Cover Assembly (PL 4.2.8).
8. Install the Top Rear Cover PR (PL 1.1.3) .
9. Close the Upper Rear Cover (PL 1.2.5).
10. Install the Upper Rear Cover to the machine using the two screws (Del Tite, M3x8mm).

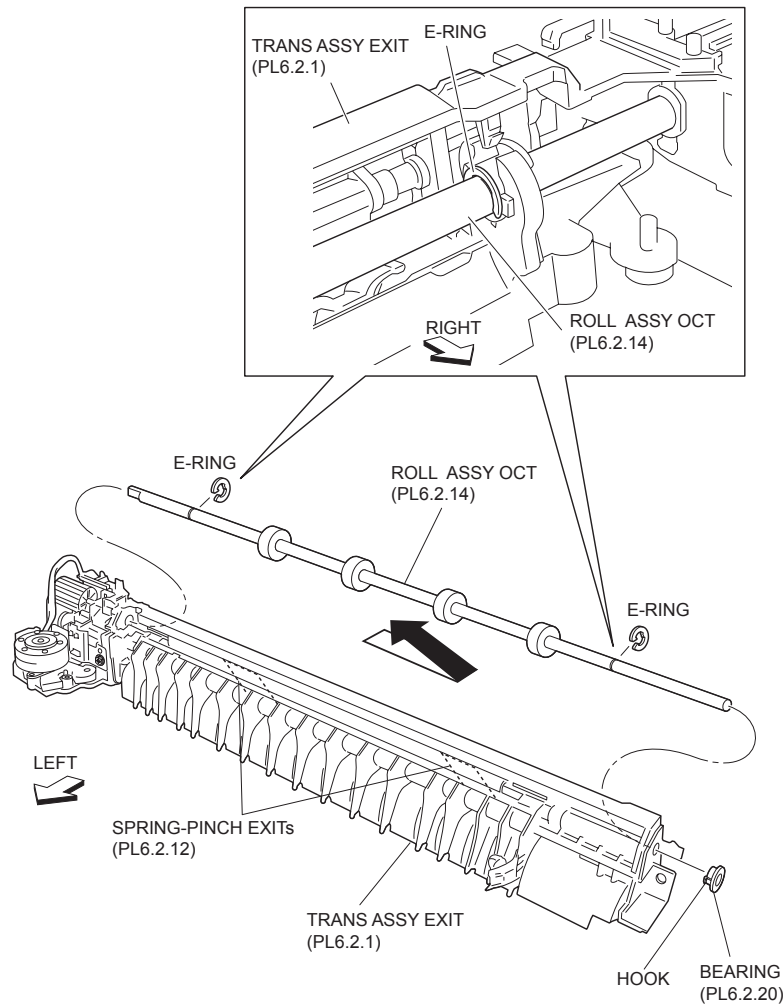
## OCT Roll Assembly

### Removal

1. Remove the two screws (Del Tite, M3x8mm) securing the Upper Rear Cover (PL 1.2.5) to the machine.
2. Open the Upper Rear Cover.
3. Remove the Top Rear Cover PR (PL 1.1.3) .
4. Open the Left Hand Cover Assembly (PL 4.2.8).
5. Remove the Exit 1 Top Cover (PL 6.2.22) .

6. Open the Front Cover Assembly (PL 1.1.9).
7. Remove the Fuser Cover FR,PR (PL 1.1.2) .
8. Remove the Exit Transport Assembly (PL 6.2.1) .
9. Remove the 19T Gear (PL 6.2.7) .
10. Remove the two E-rings left and right which secures the OCT Roll Assembly to the OCT Chute 1 (PL 6.2.11) .
11. Release the hook on the left side of the Bearing (PL 6.2.20) securing the OCT Roll Assembly to the Exit Transport Assembly to remove the Bearing.
12. Move the OCT Roll Assembly in the direction of the arrow (to the front) to remove.

**NOTE** When removing, do not hold the rubber rollers of the OCT Roll Assembly.



**Figure 1 OCT Roll Assembly**

## Replacement

1. Move the OCT Roll Assembly in the opposite direction of the arrow to install.

**NOTE** When installing, do not hold the rubber rollers of the OCT Roll Assembly.

2. Install the Bearing (PL 6.2.20) to the Out Chute 1 (PL 6.2.11) using the hook.

**NOTE** Insert the Bearing until the hook is secured firmly.

3. Install the OCT Roll Assembly to the OCT Chute 1 using the two E-rings.

**NOTE** Be careful not to bend the Exit Pinch Spring (PL 6.2.12) attached on the OCT Chute 1.

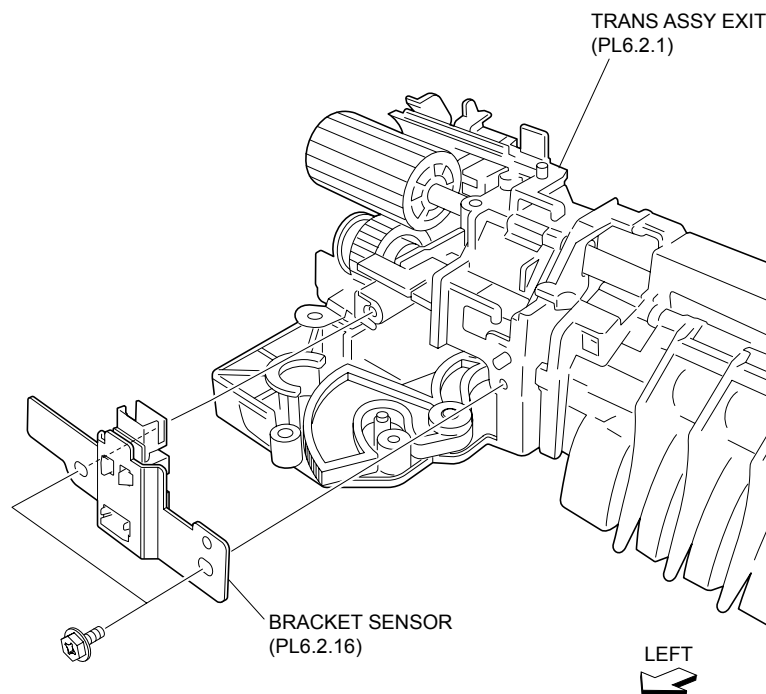
4. Install the 19T Gear (PL 6.2.7) .

5. Install the Exit Transport Assembly (PL 6.2.1) .
6. Install the Fuser Cover FR,PR (PL 1.1.2) .
7. Close the Front Cover Assembly (PL 1.1.9).
8. Install the Exit 1 Top Cover (PL 6.2.22) .
9. Close the Left Hand Cover Assembly (PL 4.2.8).
10. Install the Top Rear Cover PR (PL 1.1.3) .
11. Close the Upper Rear Cover (PL 1.2.5).
12. Install the Upper Rear Cover to the machine using the two screws (Del Tite, M3x8mm).

## Offset Gear

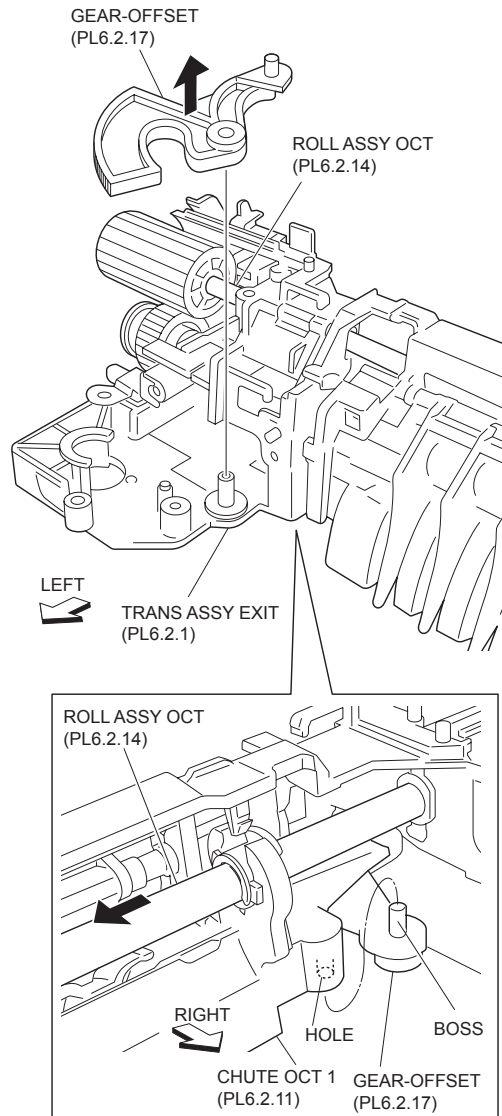
### Removal

1. Remove the two screws (Del Tite, M3x8mm) securing the Upper Rear Cover (PL 1.2.5) to the machine.
2. Open the Upper Rear Cover.
3. Remove the Top Rear Cover PR (PL 1.1.3) .
4. Open the Left Hand Cover Assembly (PL 4.2.8).
5. Remove the Exit 1 Top Cover (PL 6.2.22) .
6. Open the Front Cover Assembly (PL 1.1.9).
7. Remove the Fuser Cover FR,PR (PL 1.1.2) .
8. Remove the Exit Transport Assembly (PL 6.2.1) .
9. Remove the screw (Silver, M3x8mm) securing the Sensor Bracket (PL 6.2.16) to the Exit Transport Assembly to remove the Sensor Bracket .
10. Slide the OCT Roll Assembly (PL 6.2.14) to right (front) first, and release the Boss on the OCT Chute 1 while pressing down the Boss portion of the Offset Gear. Then, remove the Offset Gear upward .



**Figure 1 Sensor Bracket**





**Figure 2 Offset Gear**

## Replacement

1. Put the boss on the Lower Chute (PL 6.2.15) into the hole on the Offset Gear, and slide the OCT Roll Assembly (PL 6.2.14) toward the right side (front) while pressing down the boss part of the Offset Gear to engage them.
2. Install the Sensor Bracket (PL 6.2.16) to the Exit Transport Assembly using the one screw (Silver, M3x8mm).
3. Install the Exit Transport Assembly (PL 6.2.1) .
4. Install the Fuser Cover FR,PR (PL 1.1.2) .
5. Close the Front Cover Assembly (PL 1.1.9).
6. Install the Exit 1 Top Cover (PL 6.2.22) .
7. Close the Left Hand Cover Assembly (PL 4.2.8).
8. Install the Top Rear Cover PR (PL 1.1.3) .
9. Close the Upper Rear Cover.
10. Install the Upper Rear Cover (PL 1.2.5) to the machine using the two screws (Del Tite, M3x8mm).

## Exit 1 Top Cover

### Removal

1. Remove the Exit 1 Top Cover by moving it in the direction of the arrow.

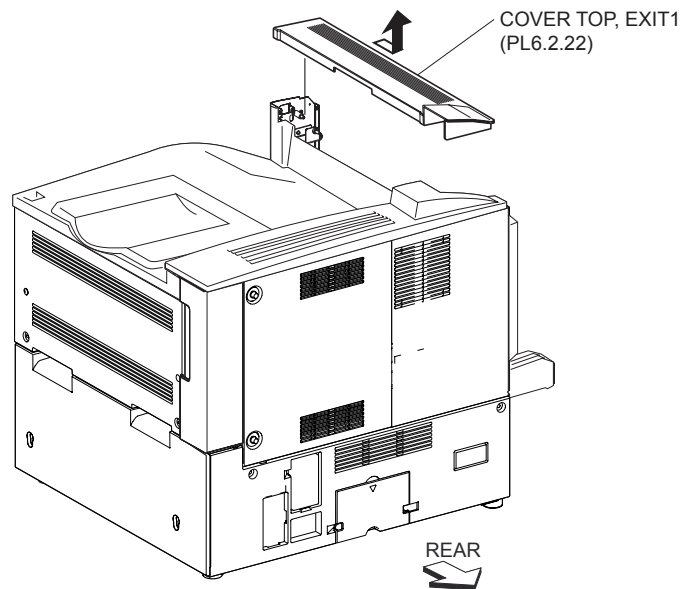


Figure 1 Exit 1 Top Cover

### Replacement

1. Install the Exit 1 Top Cover by moving it in the opposite direction of the arrow.

## Drives

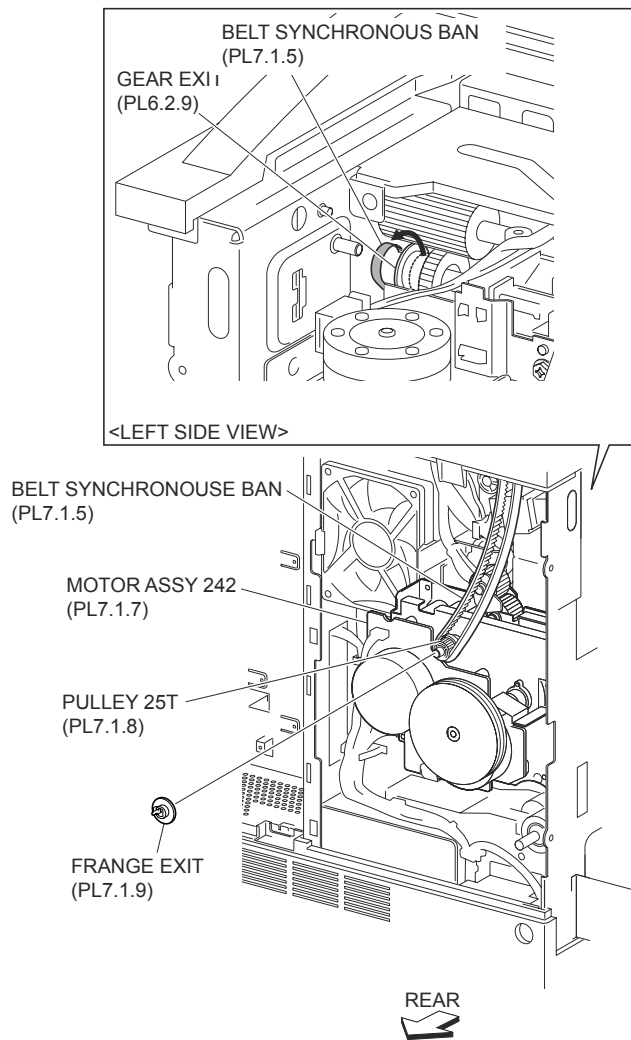
### Synchronous Ban Belt

#### Removal

1. Remove the ESS Cover Assembly (PL 8.1.20) .
2. Remove the Upper Rear Cover (PL 1.2.5) .
3. Remove the Exit 1 Top Cover (PL 6.2.22) .
4. Release the hook on the Exit Flange(PL 7.1.9) securing Synchronous Ban Belt to the Motor Assembly 242 (PL 7.1.7) to remove the Exit Flange .
5. Remove the Synchronous Ban Belt from the 25T Pulley (PL 7.1.8).

**NOTE** The 25T PULLEY is also detached. Be careful not to lose it.

6. Remove the Synchronous Ban Belt from the Exit Gear (PL 6.2.9).



**Figure 1 Synchronous Belt**

## Replacement

1. Install the 25T Pulley (PL 7.1.8) to the shaft of the Motor Assembly 242 (PL 7.1.7) shown in the figure.
2. Install the Synchronous Ban Belt onto the 25T Pulley.

**NOTE** Installing the Synchronous Ban Belt is made easy to rotate the Motor slowly by hand.

3. Install the Synchronous Ban Belt together with the 25T Pulley using the hook on the Exit Flange (PL 7.1.9).

**NOTE** Fit the flange to the D-shaped shaft, and install the flange until the hook is secured firmly.

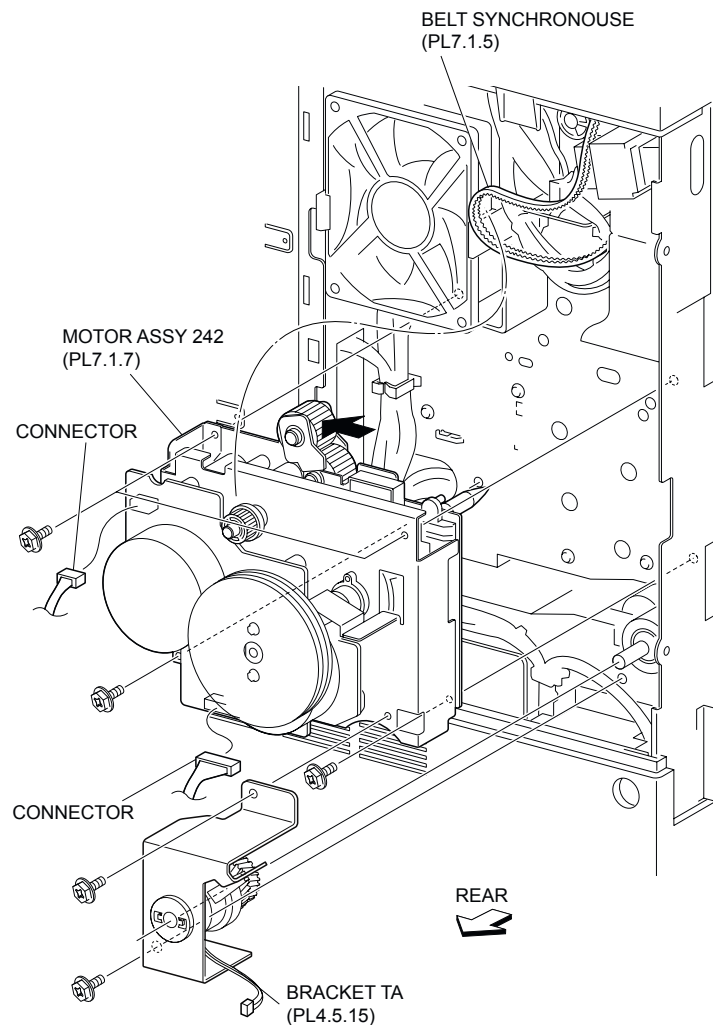
4. Install the Exit 1 Top Cover (PL 6.2.22) .
5. Install the Upper Rear Cover (PL 1.2.5) .
6. Install the ESS Cover Assembly (PL 8.1.20) .

## Motor Assembly 242

### Removal

1. Remove the ESS Cover Assembly (PL 8.1.20) .
2. Remove the Upper Rear Cover (PL 1.2.5) .
3. Remove the Exit 1 Top Cover (PL 6.2.22) .
4. Open the Front Cover Assembly (PL 1.1.9).
5. Pull out the CRU (PL 5.1.15).
6. Remove the Synchronous Ban Belt (PL 7.1.5) .
7. Disconnect the connector (P/J214) of the Drive A Harness Assembly (PL 8.2.12) and the harness connector (CN102) of the Fuser Fan from the Motor Assembly 242 .
8. Remove the two screws securing the TA Bracket (PL 4.5.15) to the machine and the Motor Assembly 242 to remove the TA Bracket.
9. Remove the four screws (Del Tite, M3x8mm) securing the Motor Assembly 242 to the machine.
10. Remove the Motor Assembly 242.

**NOTE** Be sure to remove the Gear while pushing the Gear on the upper part of the Motor in the direction of the arrow.



**Figure 1 242 Motor Assembly**

## Replacement

1. Install the Motor Assembly 242 to the machine using the four screws (Del Tite, M3x8mm).

**NOTE** Be sure to install the Gear while pushing the GEAR on the upper part of the Motor in the direction of the arrow.

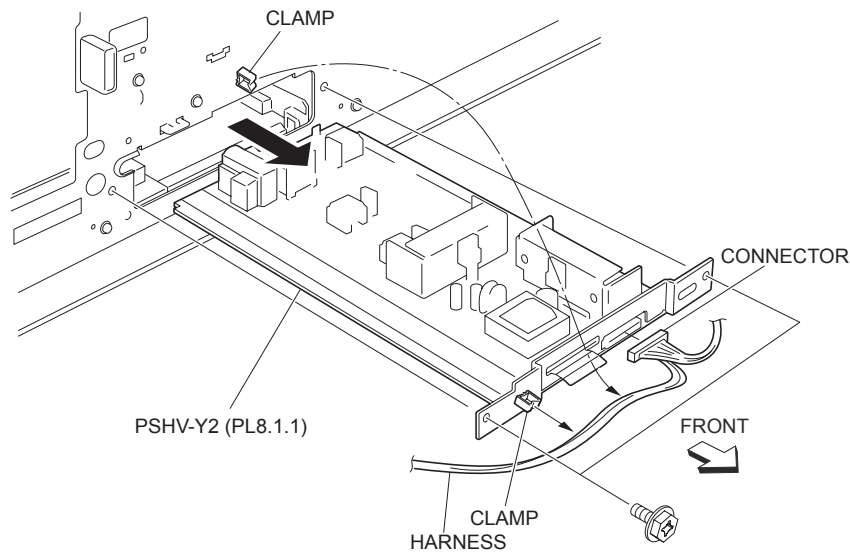
2. Install the TA Bracket (PL 4.5.15) to the machine and the Motor Assembly 242 using the two screws.
3. Connect the connector (P/J214) of the Drive A Harness Assembly (PL 8.2.12) and the harness connector (CN102) of the Fuser Fan to the Motor Assembly 242.
4. Install the Synchronous Ban Belt (PL 7.1.5) .
5. Insert the CRU (PL 5.1.15).
6. Close the Front Cover Assembly (PL 1.1.9).
7. Install the Exit 1 Top Cover (PL 6.2.22) .
8. Install the Upper Rear Cover (PL 1.2.5) .
9. Install the ESS Cover Assembly (PL 8.1.20) .

## Electrical

### High Voltage Power Supply-Y2

#### Removal

1. Remove the Fuser Cover FR,PR (PL 1.1.2) .
2. Remove the Top Cover Assembly PR (PL 1.1.8) .
3. Pull out the CRU (PL 5.1.15).
4. Remove the Front Cover Assembly (PL 1.1.9) .
5. Remove the Inner Cover Assembly, MN (PL 1.1.13) .
6. Disconnect the connector (P/J500) of the Front Harness Assembly A (PL 5.1.9) connector from the High Voltage Power Supply-Y2 .
7. Release the Front Harness Assembly A from the clamps.
8. Remove the two screws (Del Tite, M3x6mm) securing the High Voltage Power Supply-Y2 to the machine.
9. Remove the High Voltage Power Supply-Y2 by moving it in the direction of the arrow.



**Figure 1 Y2 High Voltage Power Supply**

## Replacement

1. Install the High Voltage Power Supply-Y2 by moving it in the opposite direction of the arrow.

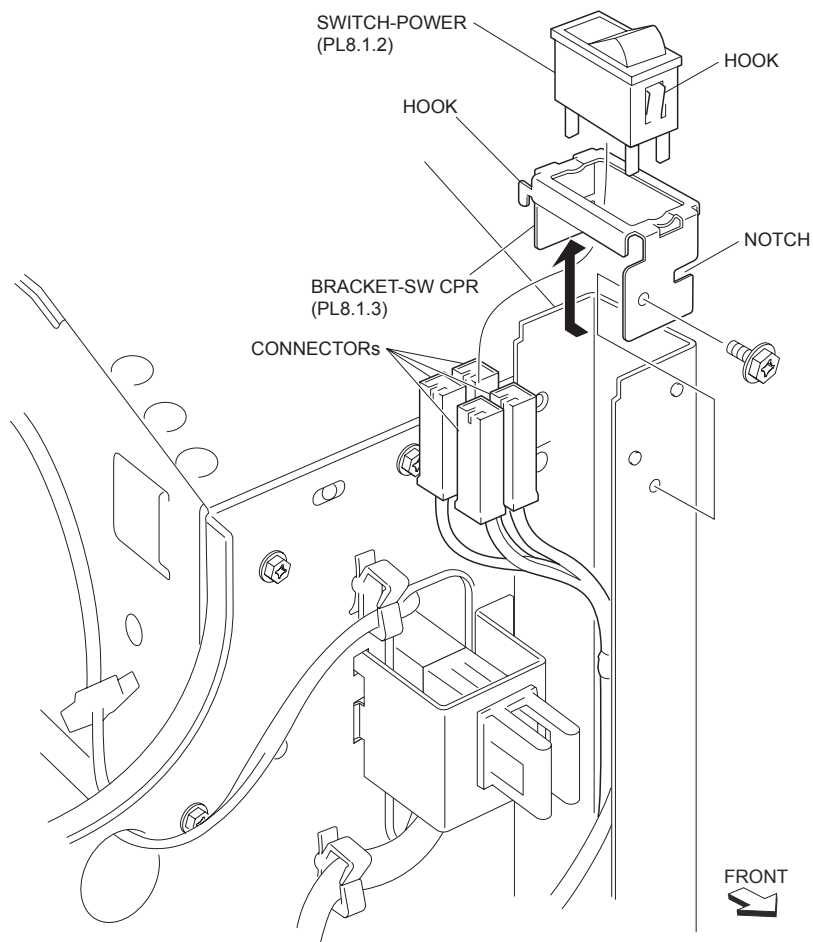
**NOTE** Be sure to put the board into the grooves on both sides.

2. Install the High Voltage Power Supply-Y2 to the machine using the two screws (Del Tite, M3x6mm).
3. Secure the Front Harness Assembly A (PL 5.1.9) to the clamps.
4. Connect the connector (P/J500) of the Front Harness Assembly A to the High Voltage Power Supply-Y2.
5. Install the Inner Cover Assembly, MN (PL 1.1.13) .
6. Install the Front Cover Assembly (PL 1.1.9) .
7. Install the CRU (PL 5.1.15).
8. Install the Top Cover Assembly PR (PL 1.1.8) .
9. Install the Fuser Cover FR,PR (PL 1.1.2) .

## Power Switch

### Removal

1. Remove the Top Cover Assembly PR (PL 1.1.8) .
2. Open the Front Cover Assembly (PL 1.1.9).
3. Remove the Upper Right Cover (PL 1.2.1) .
4. Remove the screw (Del Tite, M3x6mm) securing the CPR Switch Bracket (PL 8.1.3) to the machine .
5. Move the CPR Switch Bracket with Power Switch in the direction of the arrow (rear side) to remove.
6. Disconnect the four connectors (P/J56, P/J57, P/J68 and P/J69) of the Main Switch C Harness Assembly (PL 8.2.11) from the Power Switch.
7. Release the hooks securing the Power Switch to the CPR Switch Bracket as shown in the figure.



**Figure 1 Power Switch**

## Replacement

1. Secure the Power Switch to the CPR Switch Bracket (PL 8.1.3) using the hooks.
2. Connect the four connectors (P/J56, P/J57, P/J68 and P/J69) of the Main Switch C Harness Assembly (PL 8.2.11) to the Power Switch.
3. Install the CPR Switch Bracket together with the Power Switch to the machine using the one screw (Del Tite, M3x6mm).

**NOTE** Fit the notch on the Power Switch to the boss on the machine.

4. Install the Upper Right Cover (PL 1.2.1) .
5. Close the Front Cover Assembly (PL 1.1.9).
6. Install the Top Cover Assembly PR (PL 1.1.8) .

## Exit PWBA

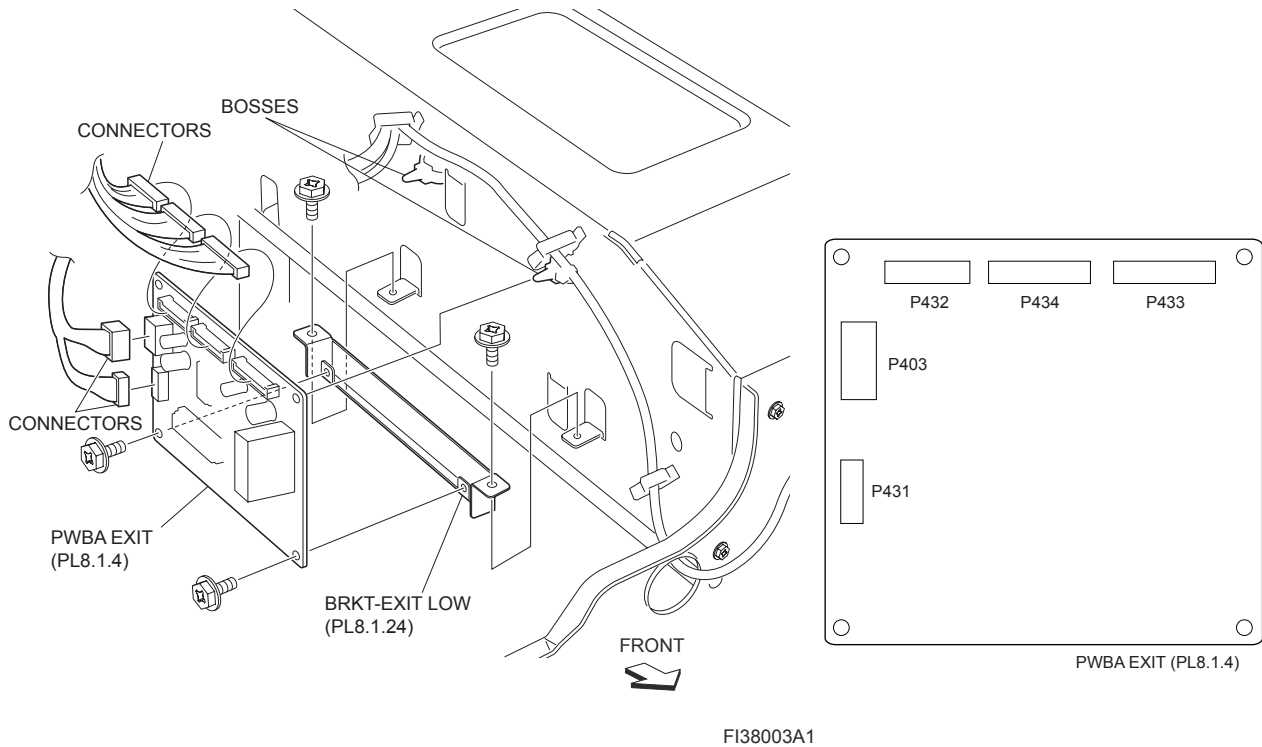
### Removal

1. Remove the Top Cover Assembly PR (PL 1.1.8) .
2. Disconnect all harness connectors from the Exit PWBA .

**NOTE** Only connector P430 has a hook. Disconnect it while pushing the hook.

3. Remove the two screws (Del Tite, M3x6mm) securing the Lower Exit Bracket (PL 8.1.24) to the machine.

4. Release the locks of the SUPPORT PCs securing the Exit PWBA to the machine as shown in the figure.
5. Remove the Exit PWB Atogether with Lower Exit Bracket from the machine.
6. Remove the two screws (Del Tite, M3x6mm) securing the Exit PWBA to the Lower Exit Bracket.
7. Remove the Exit PWBA.



**Figure 1 Exit PWBA**

## Replacement

1. Install the Exit PWBA to the Lower Exit Bracket (PL 8.1.24) using the two screws (Del Tite, M3x6mm).
2. Install the Lower Exit Bracket to the machine using the two screws (Del Tite, M3x6mm).

**NOTE** Be sure to fit the tips of the SUPPORT PCs on the machine into the holes on the Exit PWBA.

3. Connect all harness connectors to the Exit PWBA.

**NOTE** Only connector P430 has a hook. While pushing the lock of the connector, connect it until it locks firmly.

4. Install the Top Cover Assembly PR (PL 1.1.8) .

## MCU F PWBA

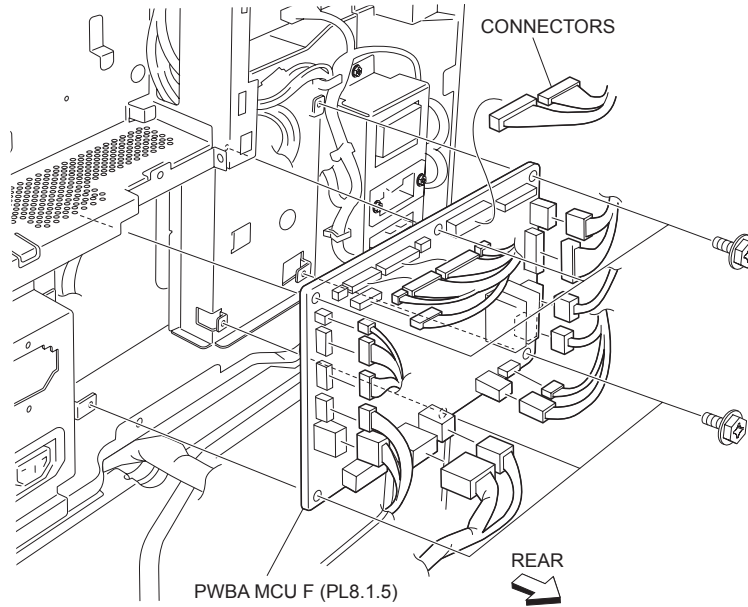
### Removal

1. Remove the ESS Cover Assembly (PL 8.1.20) .
2. Remove the Upper Rear Cover (PL 1.2.5) .
3. Remove the Lower PR Rear Cover (PL 1.2.6) .
4. Disconnect all harness connectors from the MCU F PWBA .

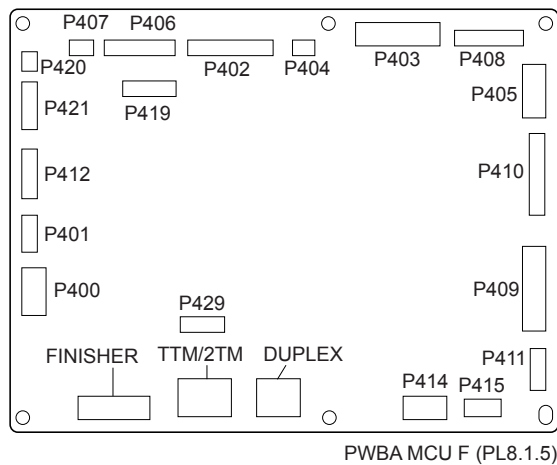


**NOTE** The connectors P/J400, P/J401, and TTM/2TM have a hook. Disconnect them while pushing the hook.

5. Remove the six screws (Del Tite, M3x6mm) securing the MCU F PWBA to the machine.
6. Remove the MCU F PWBA.



**Figure 1 MCU F PWBA**



**Figure 2 MCU PWBA**

## Replacement

1. Install the MCU F PWBA to the machine using the six screws (Del Tite, M3x6mm).
2. Connect all harness connectors to the MCU F PWBA.

**NOTE** The connectors P/J400, P/J414, P/J405, and TTM/2TM have a hook. While pushing the lock of these connectors, connect them until they lock firmly.

3. Install the Lower PR Rear Cover (PL 1.2.6) .

4. Install the Upper Rear Cover (PL 1.2.5) .
5. Install the ESS Cover Assembly (PL 8.1.20) .

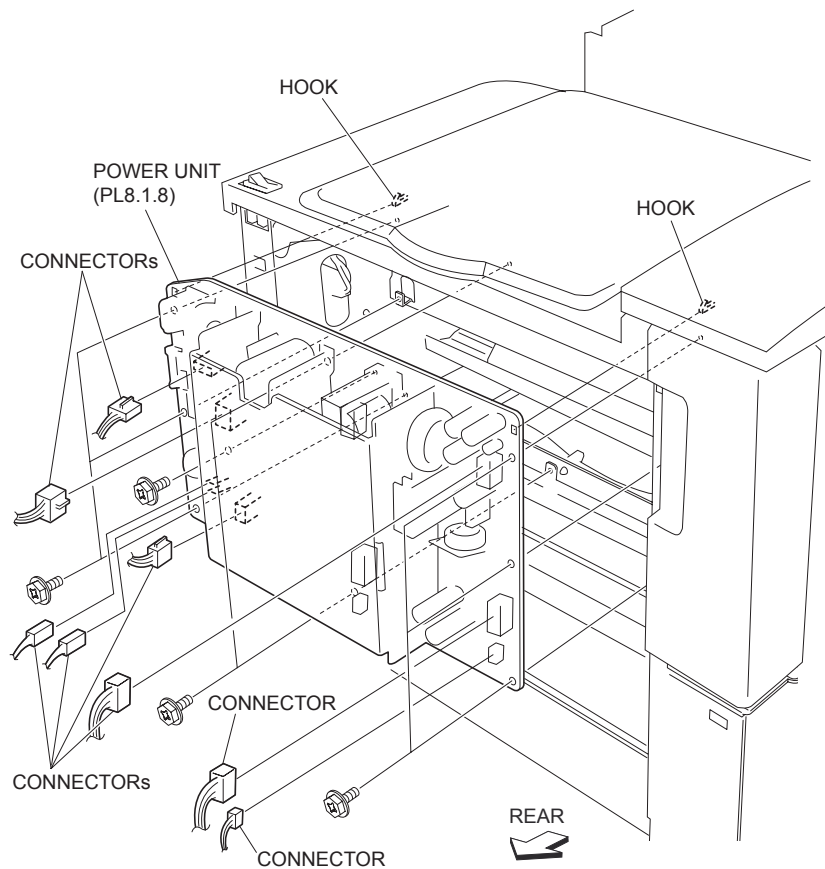
## Power Unit

### Removal

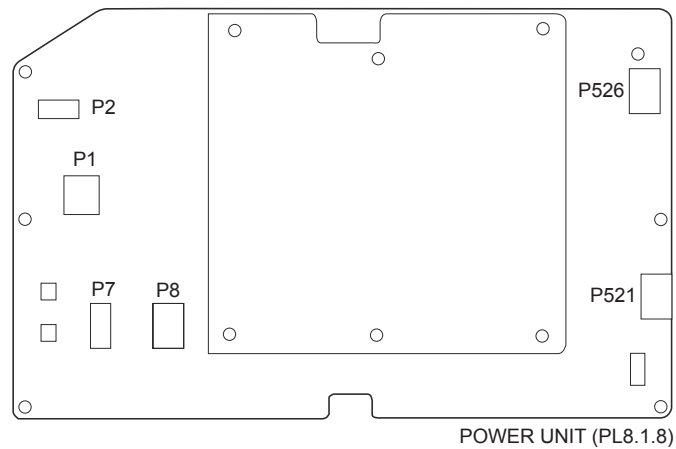
1. Remove the Upper Right Cover (PL 1.2.1) .
2. Disconnect all harness connector from the Power Unit .

**NOTE** The connectors P1, P2, P6, P521 and P526 have a hook. Disconnect then while pushing the hook .

3. Remove the nine screws (Del Tite, M3x8mm) securing the Power Unit to the machine.
4. Remove the Power Unit.



**Figure 1 Power Unit**



**Figure 2 Power Unit**

## Replacement

1. Install the Power Unit to the machine using the nine screws (Del Tite, M3x8mm).

**NOTE** Be sure to fit the holes on the board to the two bosses on the machine.

2. Connect all harness connector to the Power Unit.

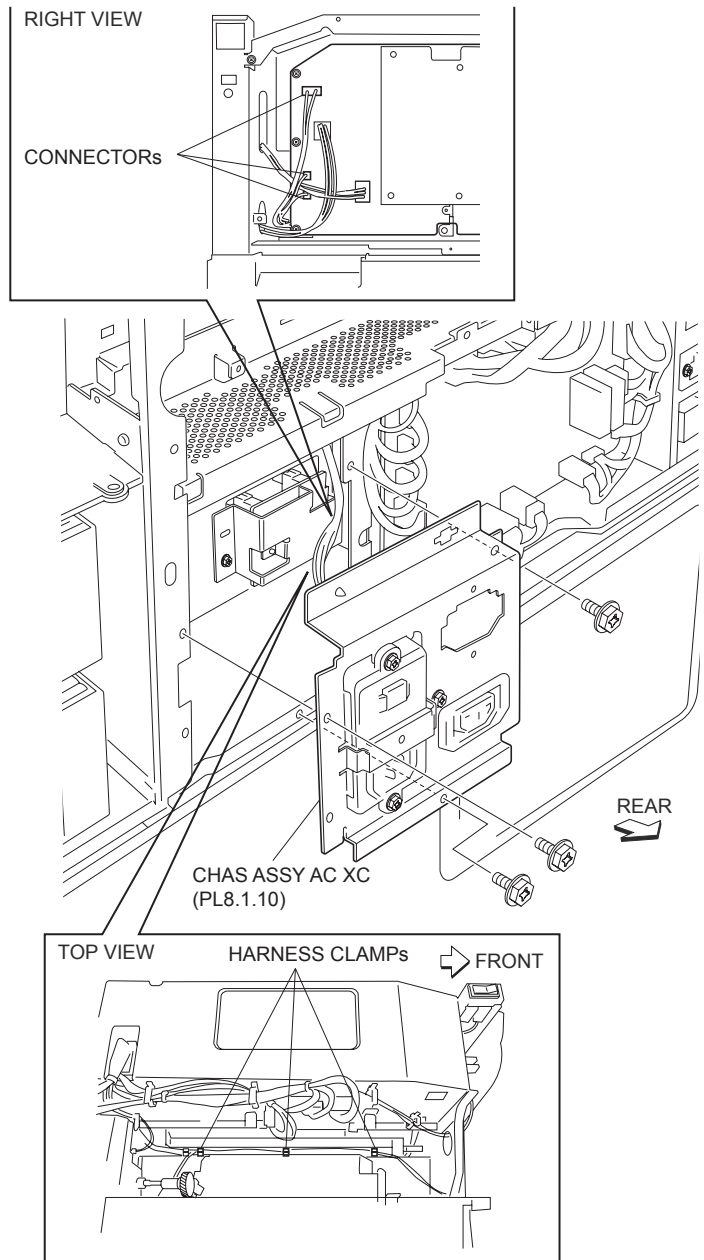
**NOTE** The connectors P1, P2, P6, P521 and P526 have a hook. Disconnect then while pushing the hook. While pushing the lock of these connectors, connect them until they lock firmly.

3. Install the Upper Right Cover (PL 1.2.1) .

## AC Chassis Assembly XC

### Removal

1. Remove the ESS Cover Assembly (PL 8.1.20) .
2. Remove the Upper Rear Cover (PL 1.2.5) .
3. Remove the Lower PR Rear Cover (PL 1.2.6) .
4. Remove the Top Cover Assembly PR (PL 1.1.8) .
5. Remove the Upper Right Cover (PL 1.2.1) .
6. Disconnect the three connectors (P2, T11 (Black), T12 (White) of the AC Harness Assembly, US, EU (PL 8.1.15) from the Power Unit .



**Figure 1 AC Chassis Assembly**

7. Release the four AC Harness Assemblies, US, EU from the three clamps.
8. Remove the three screws (Del Tite, M3x6mm) securing the AC Chassis Assembly, XC to the printer.
9. Release the AC Harness Assembly, US, EU from the clamp.
10. Remove the AC Chassis Assembly, XC.

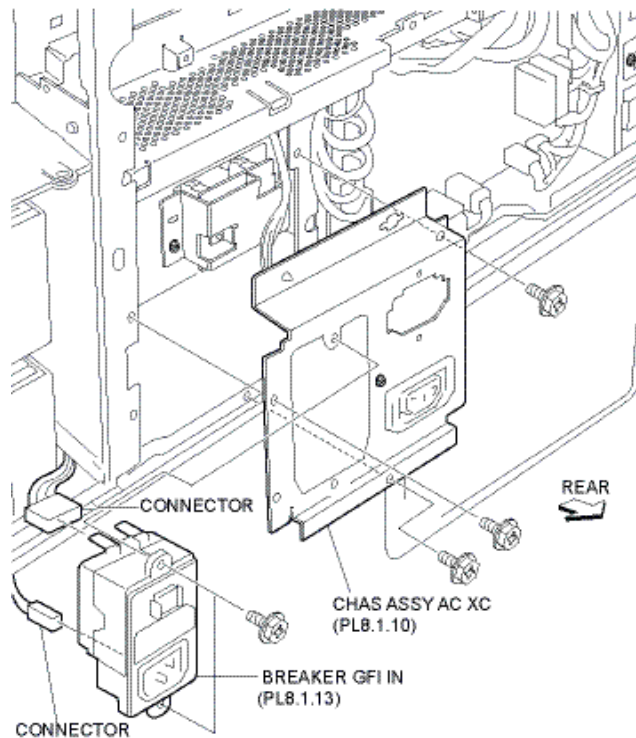
## **Replacement**

1. Connect the three Harness connectors (P2, T11 (Black), T12 (White) to the Power Unit (PL 8.1.8).
2. Secure the four AC Harness Assemblies, US, EU with three clamps.
3. Secure the AC Harness Assembly, US, EU to the clamp.
4. Install the AC Chassis Assembly, XC (PL 8.1.10) to the printer using the three screws (Del Tite, M3x6mm).
5. Install the Upper Right Cover (PL 1.2.1) .
6. Install the Top Cover Assembly PR (PL 1.1.8) .
7. Install the Lower PR Rear Cover (PL 1.2.6) .
8. Install the Upper Rear Cover (PL 1.2.5) .
9. Install the ESS Cover Assembly (PL 8.1.20) .

## **Ground Fault Breaker INL**

### **Removal**

1. Remove the ESS Cover Assembly (PL 8.1.20) .
2. Remove the Upper Rear Cover (PL 1.2.5) .
3. Remove the Lower PR Rear Cover (PL 1.2.6) .
4. Remove the three screws (Del Tite, M3x6mm) securing the AC Chassis Assembly, XC (PL 8.1.10) to the printer .
5. Disconnect the two connectors (P/J50) of the AC Harness Assembly, US, EU (PL 8.1.15) from the GIF Breaker INL.
6. Remove the two screws (M4x12mm) securing the GIF Breaker INL to the AC Chassis Assembly, XC.
7. Remove the GIF Breaker INL.



**Figure 1 Ground Fault Breaker**

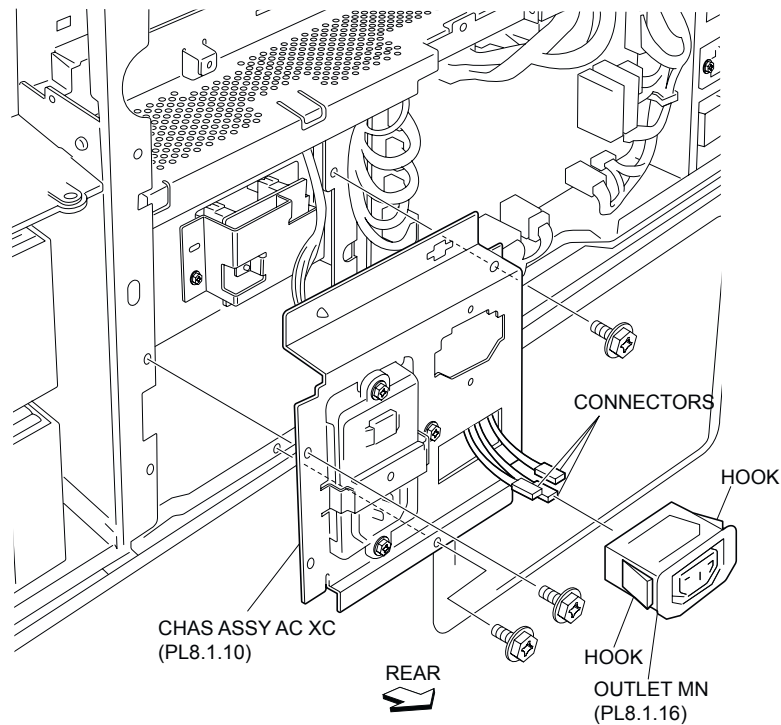
## Replacement

1. Install the GIF Breaker INL to the AC Chassis Assembly, XC (PL 8.1.10) using the two screws (M4x12mm).
2. Connect the two connectors (P/J50) of the AC Harness Assembly, US, EU (PL 8.1.15) to the GIF Breaker INL.
3. Install the AC Chassis Assembly, XC to the printer using the three screws (Del Tite, M3x6mm).
4. Install the Lower PR Rear Cover (PL 1.2.6) .
5. Install the Upper Rear Cover (PL 1.2.5) .
6. Install the ESS Cover Assembly (PL 8.1.20) .

## MN Outlet

### Removal

1. Remove the ESS Cover Assembly (PL 8.1.20) .
2. Remove the Upper Rear Cover (PL 1.2.5) .
3. Remove the Lower PR Rear Cover (PL 1.2.6) .
4. Remove the three screws (Del Tite, M3x6mm) securing the AC Chassis Assembly, XC (PL 8.1.10) to the printer .
5. Disconnect the three connectors of the AC Harness Assembly, US, EU (PL 8.1.15) from the MN Outlet (PL 8.1.16).
6. Release the two hooks securing the MN Outlet to the AC Chassis Assembly, XC.
7. Remove the MN Outlet.



**Figure 1 Outlet**

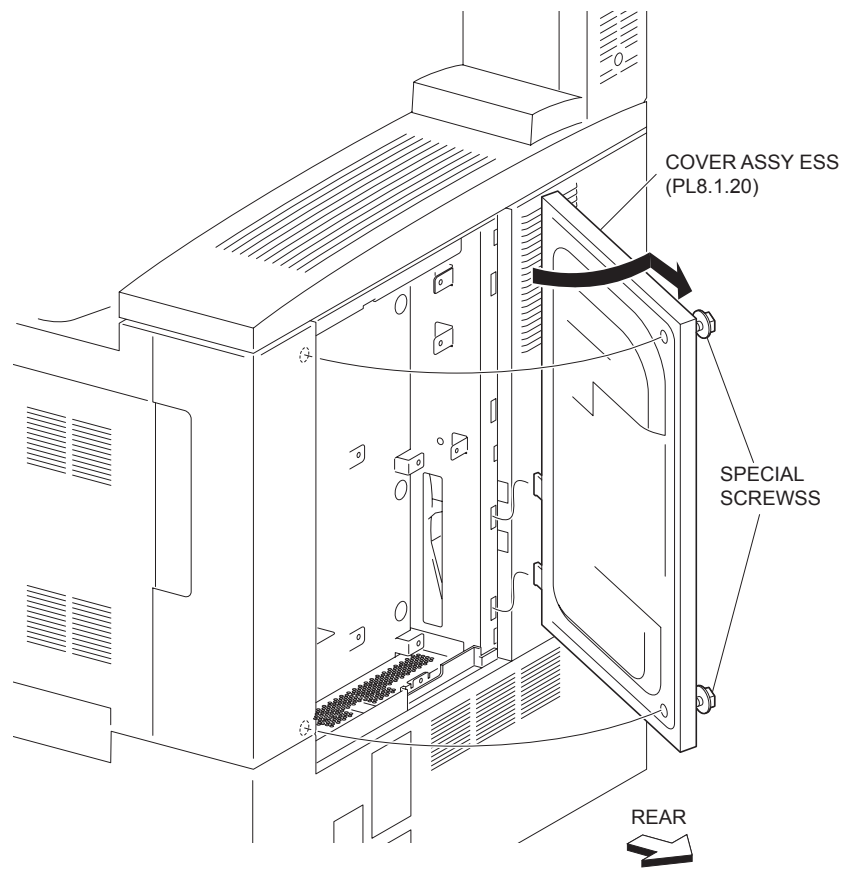
## Replacement

1. Install the MN Outlet to the AC Chassis Assembly, XC (PL 8.1.10) using the two hooks.
2. Connect the three connectors of the AC Harness Assembly, US, EU (PL 8.1.15) to the MN Outlet.
3. Install the AC Chassis Assembly, XC to the printer using the three screws (Del Tite, M3x6mm).
4. Install the Lower PR Rear Cover (PL 1.2.6) .
5. Install the Upper Rear Cover (PL 1.2.5) .
6. Install the ESS Cover Assembly (PL 8.1.20) .

## ESS Cover Assembly

### Removal

1. Loosen the two special screws securing the ESS Cover Assembly to the machine .
2. Remove the ESS Cover Assembly by moving it in the direction of the arrow.



**Figure 1 ESS Cover**

### **Replacement**

1. Install the ESS Cover Assembly in the opposite direction of the arrow using two special screws.

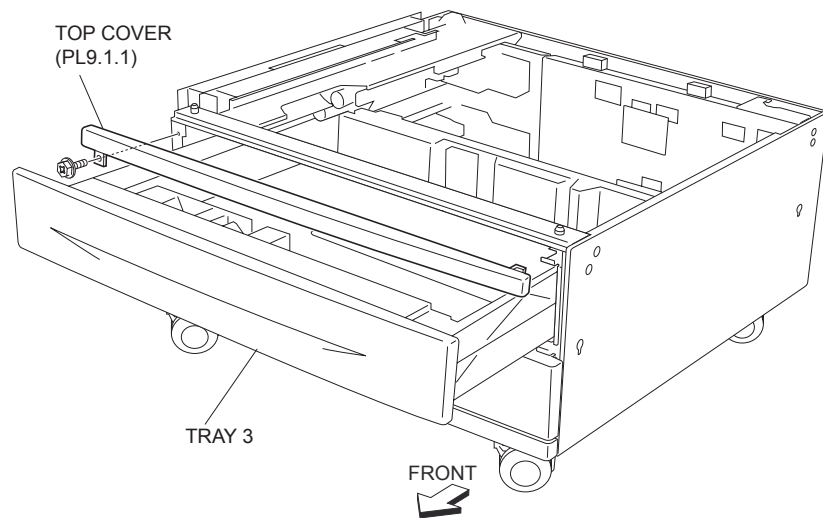
## **1000 Sheet Feeder**

### **Top Cover**

#### **Removal**

1. Pull out the Tray 3.
2. Remove the one screw (Del Tite, M3x8mm) securing the Top Cover to the machine .
3. Remove the Top Cover.





**Figure 1 Top Cover**

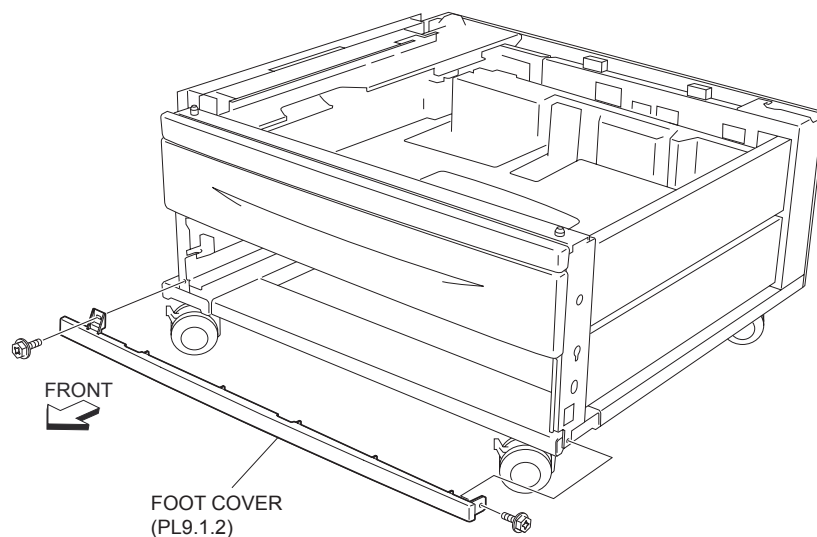
## Replacement

1. Put the Top Cover onto the frame on the right side of the machine.
2. Install the Top Cover to the machine using a screw (Del Tite, M3x8mm).
3. Push the Tray 3 in.

## Foot Cover

### Removal

1. Remove the Tray 4.
2. Remove the Right Cover (PL 9.1.3) .
3. Remove the screw (Del Tite, M3x8mm) securing the Foot Cover to the machine .
4. Remove the Foot Cover.



**Figure 1 Foot Cover**

## Replacement

1. Install the Foot Cover to the machine using the one screw (Del Tite, M3x8mm).
2. Install the Right Cover (PL 9.1.3) .
3. Install the Tray 4.

## Right Cover

### Removal

1. Remove the three screws (Del Tite, M3x8mm) securing the Right Cover to the machine .
2. Move the Right Cover in the direction of the arrow to remove.

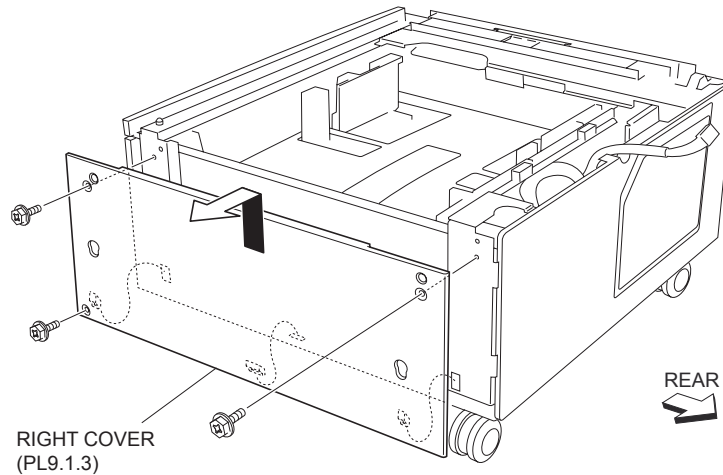


Figure 1 Right Cover

## Replacement

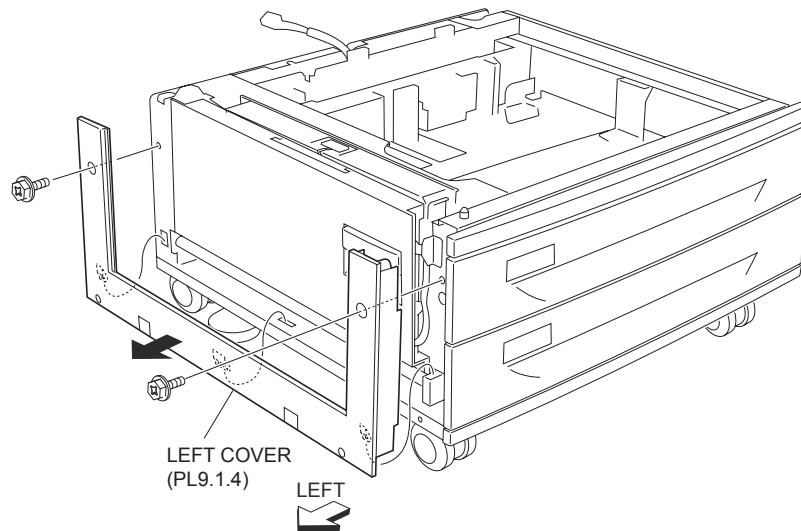
1. Install the Right Cover to the machine using three screws (Del Tite, M3x8mm).

**NOTE** Be sure to put the three hooks on the lower part of the Right Cover into the holes on the frame.

## Left Cover

### Removal

1. Remove the two screws (Del Tite, M3x8mm) securing the Left Cover to the machine .
2. Move the Left Cover in the direction of the arrow to remove.



**Figure 1 Left Cover**

## Replacement

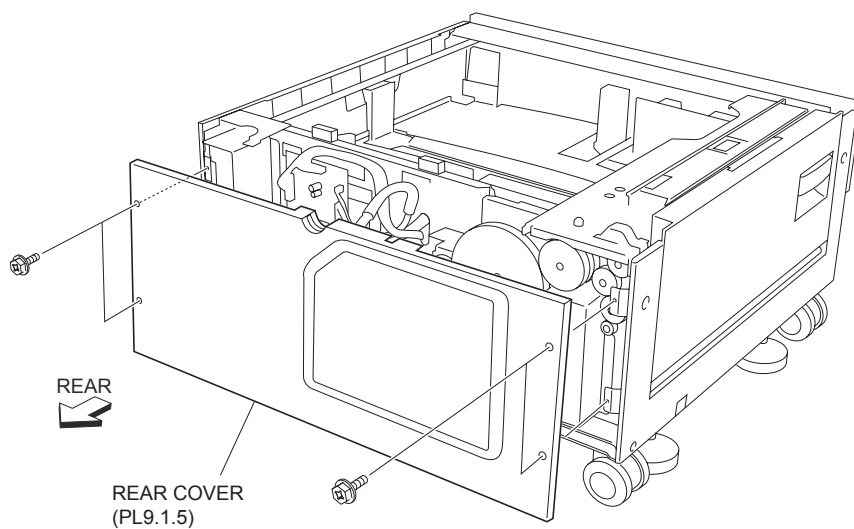
1. Install the Left Cover to the machine using two screws (Del Tite, M3x8mm).

**NOTE** Be sure to put the three hooks on the lower part of the Left Cover into the holes on the frame.

## Rear Cover

### Removal

1. Remove the four screws (Del Tite, M3x8mm) securing the Rear Cover to the machine .
2. Remove the Rear Cover.



**Figure 1 Rear Cover**

## Replacement

1. Install the Rear Cover to the machine using four screws (Del Tite, M3x8mm).

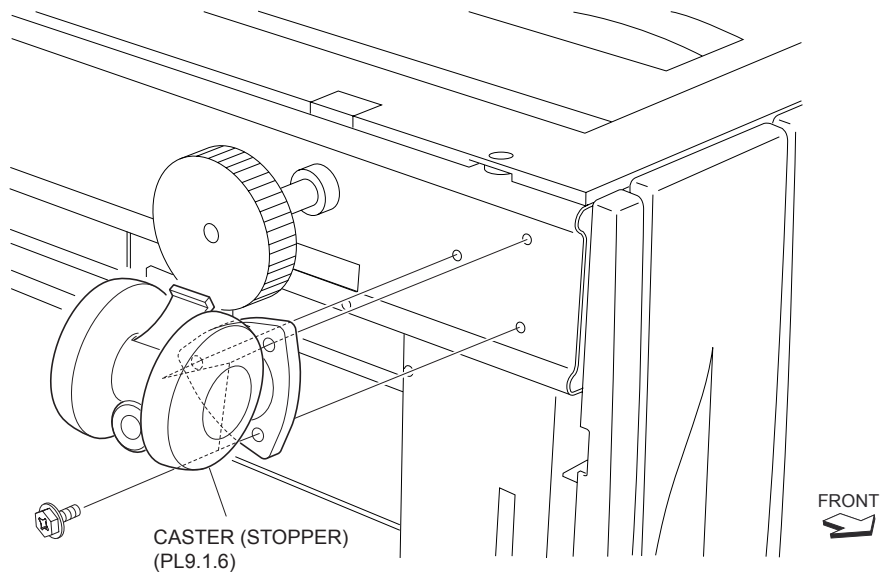
## Caster (Stopper)

### Removal

1. Remove the Tray 3.
2. Remove the Tray 4.
3. Place the machine with the right side down.

**NOTE Be careful not to damage the Right Cover (PL 9.1.3).**

4. Remove the three screws (Del Tite, M4x6mm) securing the Caster (Stopper) to the machine .
5. Remove the Caster (Stopper).



**Figure 1 Caster with Stopper**

## Replacement

1. Install the Caster (Stopper) to the machine using three screws (Del Tite, M4x6mm).
2. Install the Tray 4.
3. Install the Tray 3.

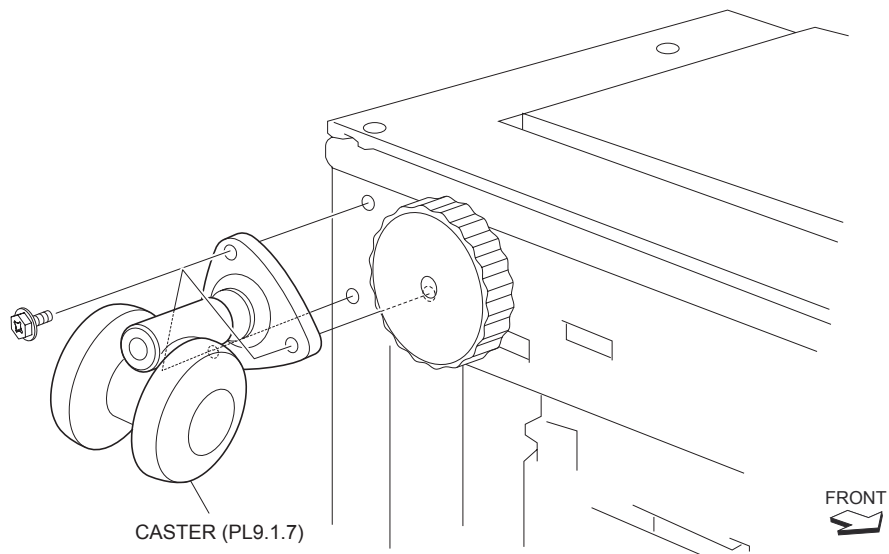
## Caster

### Removal

1. Remove the Tray 3.
2. Remove the Tray 4.
3. Place the machine with the right side down.

**NOTE Be careful not to damage the Right Cover (PL 9.1.3).**

4. Remove the three screws (Del Tite, M4x6mm) securing the Caster to the machine .
5. Remove the Caster.



**Figure 1 Castor**

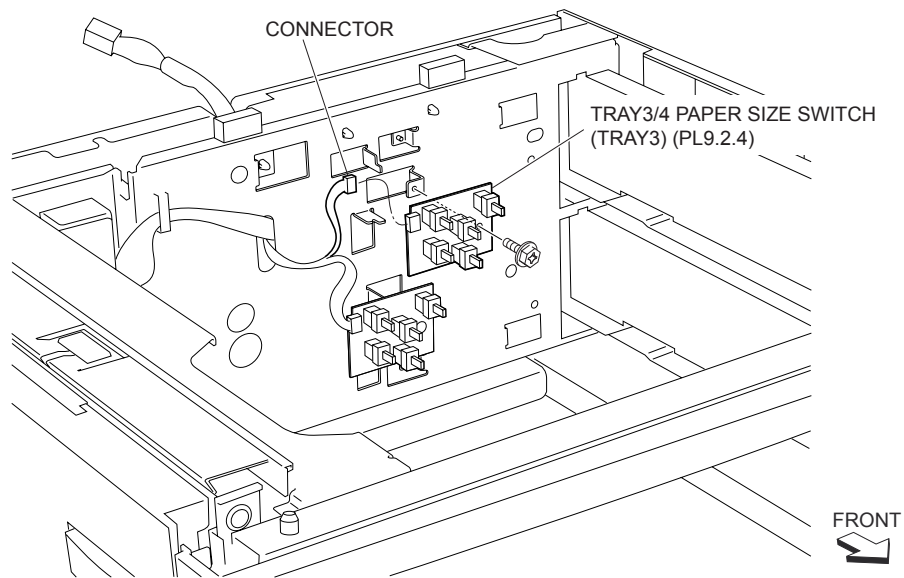
### **Replacement**

1. Install the Castor to the machine using three screws (Del Tite, M4x6mm).
2. Install the Tray 4.
3. Install the Tray 3.

### **Tray 3 Paper Size Switch**

#### **Removal**

1. Remove the Tray 3.
2. Remove the Tray 4.
3. Disconnect the connector (P/J820) of Wire Harness (PL 9.6.13) from the Tray 3 Paper Size Switch.
4. Remove the one screw securing the Tray 3 Paper Size Switch to the machine.
5. Remove the Tray 3 Paper Size Switch.



**Figure 1 Tray 3 Paper Size Switch**

### **Replacement**

1. Install the Tray 3 Paper Size Switch to the machine using the one screw.

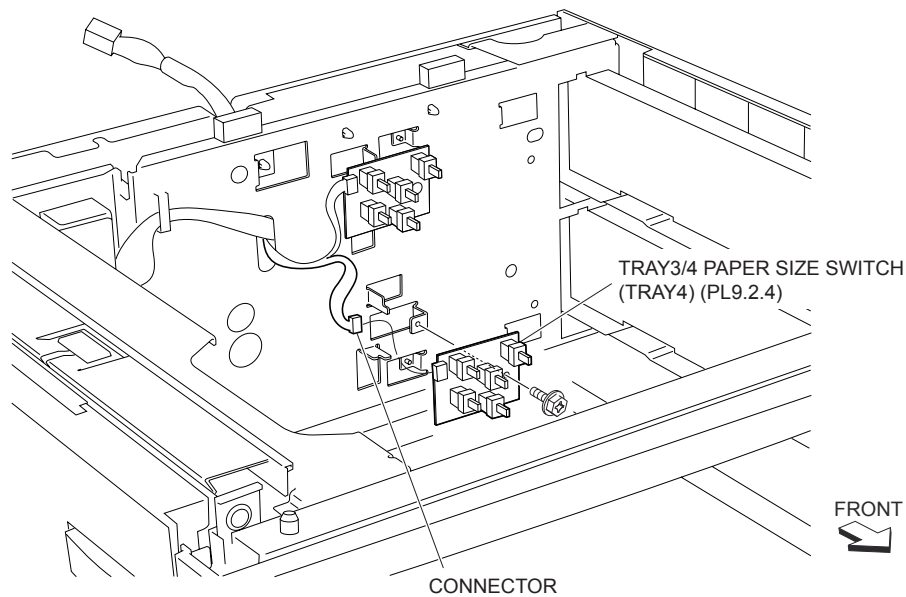
**NOTE** Be sure to fit the boss on the machine into the hole on the Tray 3 Paper Size Switch.

2. Connect the connector (P/J820) of Wire Harness (PL 9.6.13) to the Tray 3 Paper Size Switch.
3. Install the Tray 4
4. Install the Tray 3

### **Tray 4 Paper Size Switch**

#### **Removal**

1. Remove the Tray 3.
2. Remove the Tray 4.
3. Disconnect the connector (P/J824) of Wire Harness (PL 9.6.13) from the Tray 4 Paper Size Switch .
4. Remove the one screw securing the Tray 4 Paper Size Switch to the machine.
5. Remove the Tray 4 Paper Size Switch.



**Figure 1 Tray 4 Paper Size Switch**

## Replacement

1. Install the Tray 3/4 Paper Size Switch (Tray 4) to the machine using the one screw.

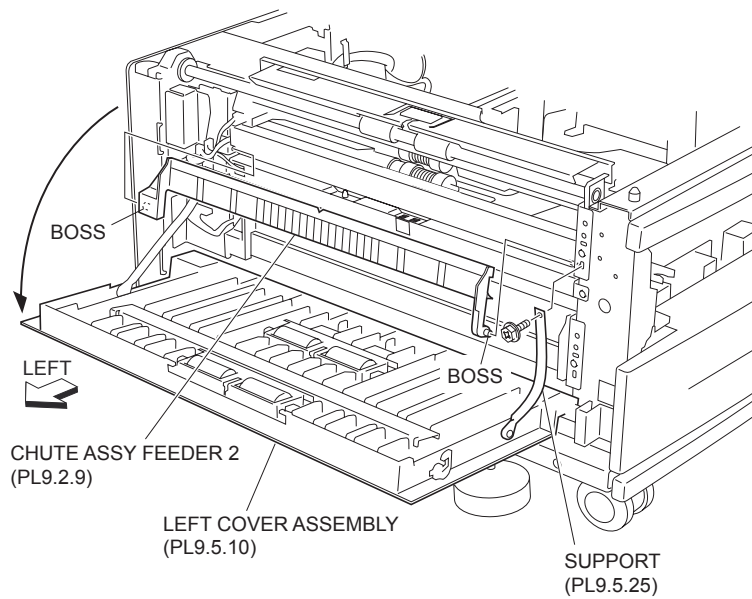
**NOTE** Be sure to fit the boss on the machine into the hole on the Tray 3/4 Paper Size Switch (Tray 4).

2. Connect the connector (P/J824) of Wire Harness (PL 9.6.13) to the Tray 3/4 Paper Size Switch (Tray 4).
3. Install the Tray 4
4. Install the Tray 3

## Tray 3 Feeder

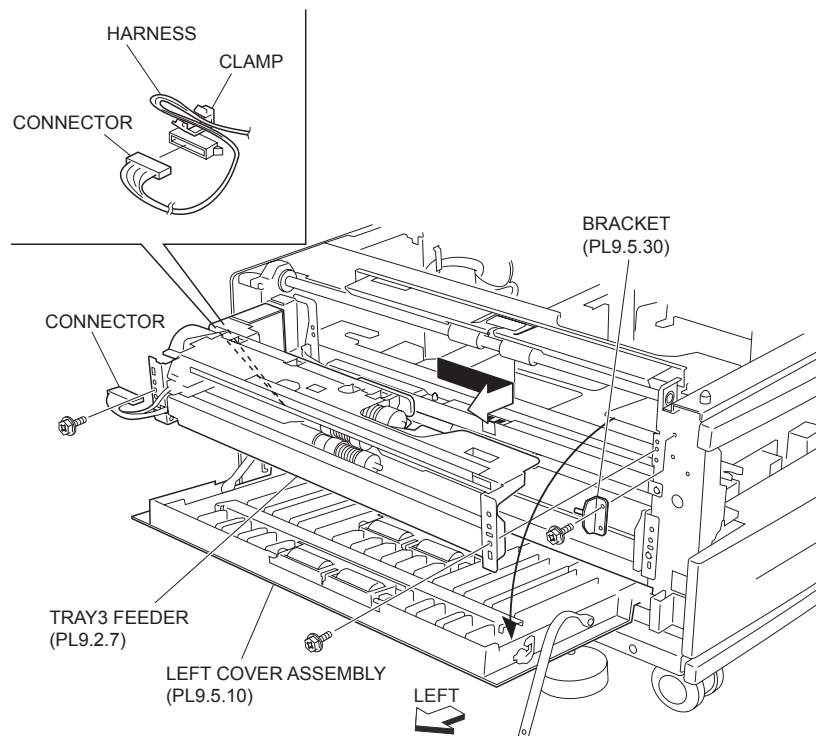
### Removal

1. Pull out the Tray 3.
2. Remove the Left Cover (PL 9.1.4) .
3. Open the Left Cover Assembly (PL 9.5.10) .
4. Remove the one screw securing the Support (PL 9.5.25) on the front to the machine.
5. Remove the bosses left and right securing the Chute Assembly Feeder 2 (PL 9.2.9) to the machine to remove the Chute Assembly Feeder 2.



**Figure 1 Left Cover Assembly**

6. Remove the one screw securing the Bracket (PL 9.5.24) to the machine to remove the Bracket .
7. Release the Wire Harness (PL 20.4.16) from the clamp.
8. Disconnect the connector (P/J661B) of the Wire Harness from the machine.
9. Remove the two screws securing the Tray 3 Feeder to the machine.
10. Move the Tray 3 Feeder in the direction of the arrow to remove.



**Figure 2 Tray 3 Feeder**



## Replacement

1. Put the Tray 3 Feeder into the machine from the rear side and install it using two screws.

**NOTE** Be sure to fit the two bosses on the machine into the two holes on the Tray 3 Feeder.

2. Connect the connector (P/J661B) of the Wire Harness (PL 9.4.16) to the machine.
3. Secure the Wire Harness to the clamp.
4. Install the Bracket (PL 9.5.24) to the machine using the one screw.

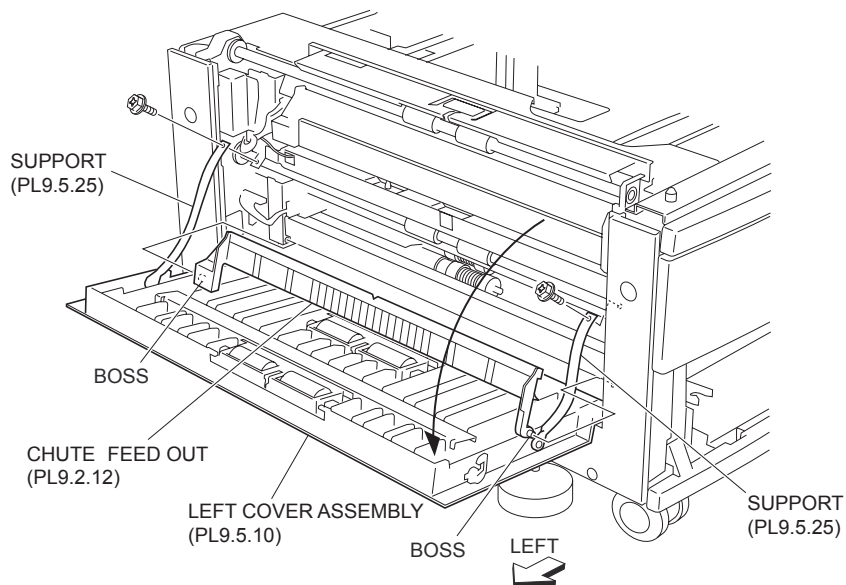
**NOTE** Be sure to fit the boss on the machine into the hole on the Bracket.

5. Install the Chute Assembly Feeder 2 (PL 9.2.9) to the machine with the bosses left and right.
6. Install the Support (PL 9.5.25) on the front to the machine using the one screw.
7. Close the Left Cover Assembly (PL 9.5.10).
8. Install the Left Cover (PL 9.1.4) .
9. Insert the Tray 3.

## Tray 4 Feeder

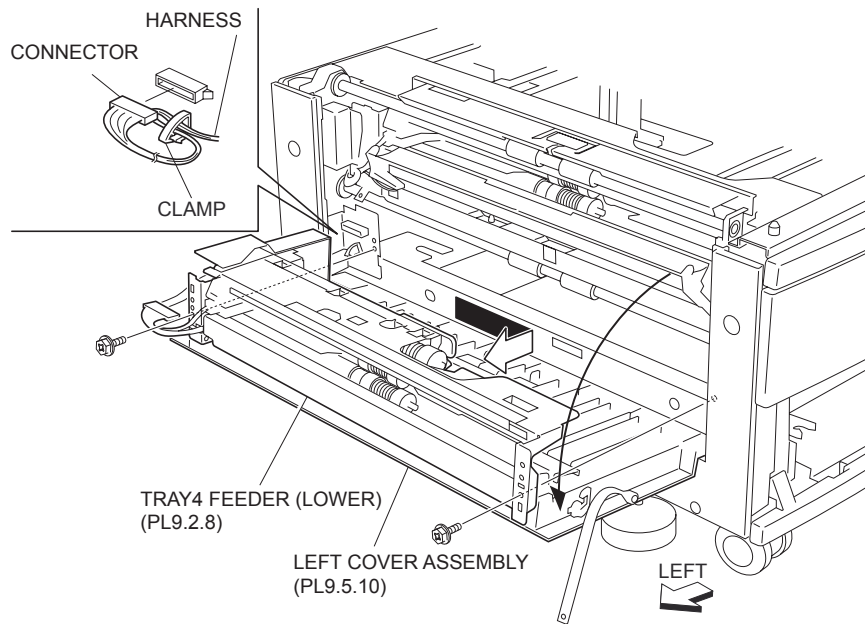
### Removal

1. Pull out the Tray 4.
2. Open the Left Cover Assembly (PL 9.5.10) .
3. Remove the one screw each on left and right Supports (PL 9.5.25) securing them to the machine.
4. Remove the bosses left and right securing the Chute Feed Out (PL 9.2.12) to the machine to remove the Chute Feed Out.



**Figure 1 Left Cover Assembly**

5. Release the Wire Harness (PL 9.4.16) from the clamp .
6. Disconnect the connector (P/J661A) of Wire Harness (PL 9.4.16) from the machine.
7. Remove the two screws securing the Tray 4 Feeder to the machine.
8. Move the Tray 4 Feeder in the direction of the arrow to remove.



**Figure 2 Tray 4 Feeder**

## Replacement

1. Put the Tray 4 Feeder into the machine from the rear side and install it using two screws.

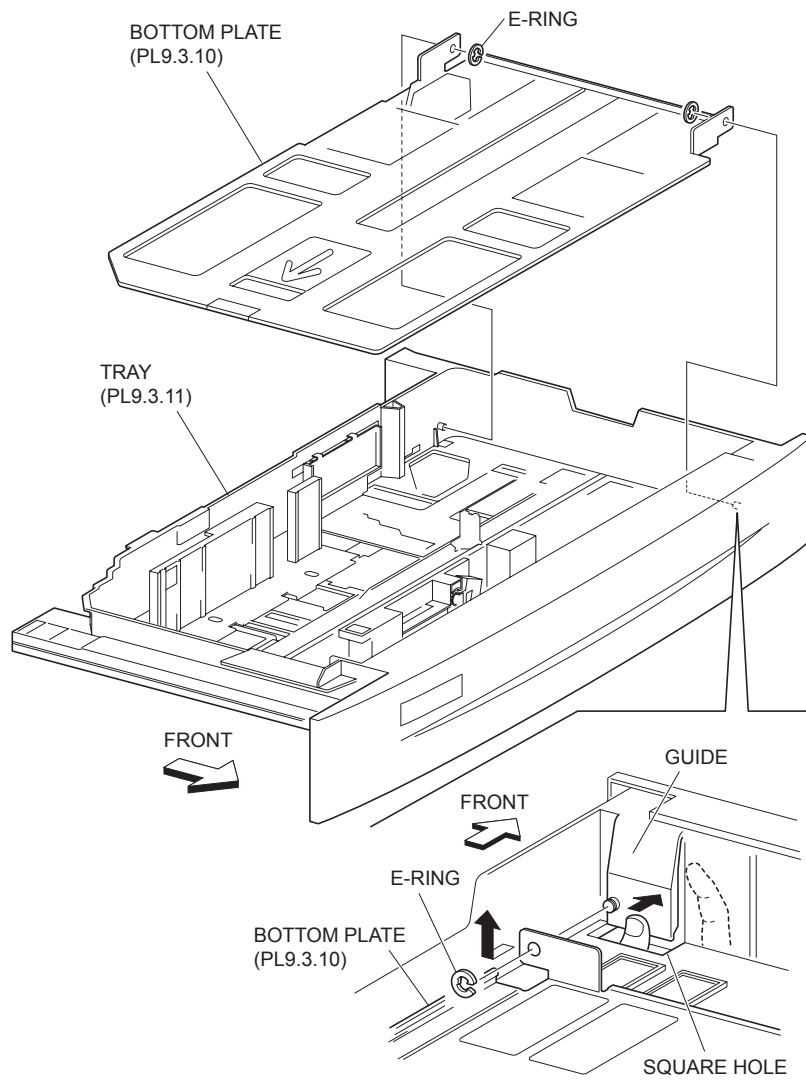
**NOTE** Be sure to fit the two bosses on the machine into the two holes on the Tray 4 Feeder.

2. Connect the connector (P/J661A) of Wire Harness (PL 9.4.16) to the machine.
3. Secure the Wire Harness (PL 9.4.16) to the clamp.
4. Install the Chute Feed Out (PL 9.2.12) to the machine with the bosses left and right.
5. Install left and right Supports (PL 9.5.25) to the machine using one screw on each.
6. Close the Left Cover Assembly (PL 9.5.10).
7. Close the Tray 4

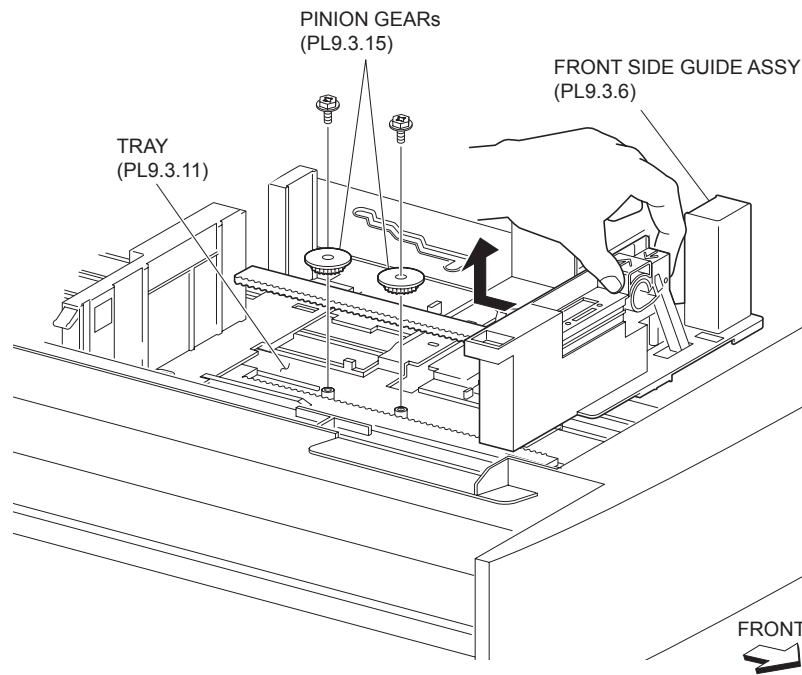
## Front Side Guide Assembly

### Removal

1. Remove the Tray Assembly (PL 9.3.1).
2. Remove E-rings on both ends (front/rear) securing the Bottom Plate (PL 9.3.10) to the Tray (PL 9.3.11) .
3. Push the guide on the front in the arrow direction shown in the figure by finger to release the boss on the Tray from the Bottom Plate.
4. Remove the Bottom Plate by moving it in the direction of the arrow.
5. Remove the one screw (Silver, M3x8mm) each securing the two Pinion Gears (PL 9.3.15) to the Tray .
6. Remove the Pinion Gears.
7. After sliding the Front Side Guide Assembly inward, remove the Front Side Guide Assembly in the direction of the arrow.



**Figure 1 Paper Tray**



**Figure 2 Front Side Guide Assembly**

## Replacement

1. Fit the bosses on the lower part of the Front Side Guide Assembly to the holes on the Tray (PL 9.3.11).
2. Slide the Front Side Guide Assembly fully outward.
3. Install the two Pinion Gears (PL 9.3.15) to the Tray using one screw (Silver, M3x8mm) each.

**NOTE** Before installing the Pinion Gears, make sure that the Front Side Guide Assembly and the Rear Side Guide (PL 9.3.9) are placed fully outward. After installing the Pinion Gears, make sure that the Front Side Guide Assembly and the Rear Side Guide slide smoothly.

4. Fit the rear guide hole on the Bottom Plate (PL 9.3.10) to the boss on the Tray.
5. Install the Bottom Plate to the Tray.

**NOTE** Be sure to fit the front guide hole on the Bottom Plate to the boss on the Tray.

6. Fix the Bottom Plate to the Tray using the two E-rings on front and rear.
7. Insert the Tray Assembly (PL 9.3.1).

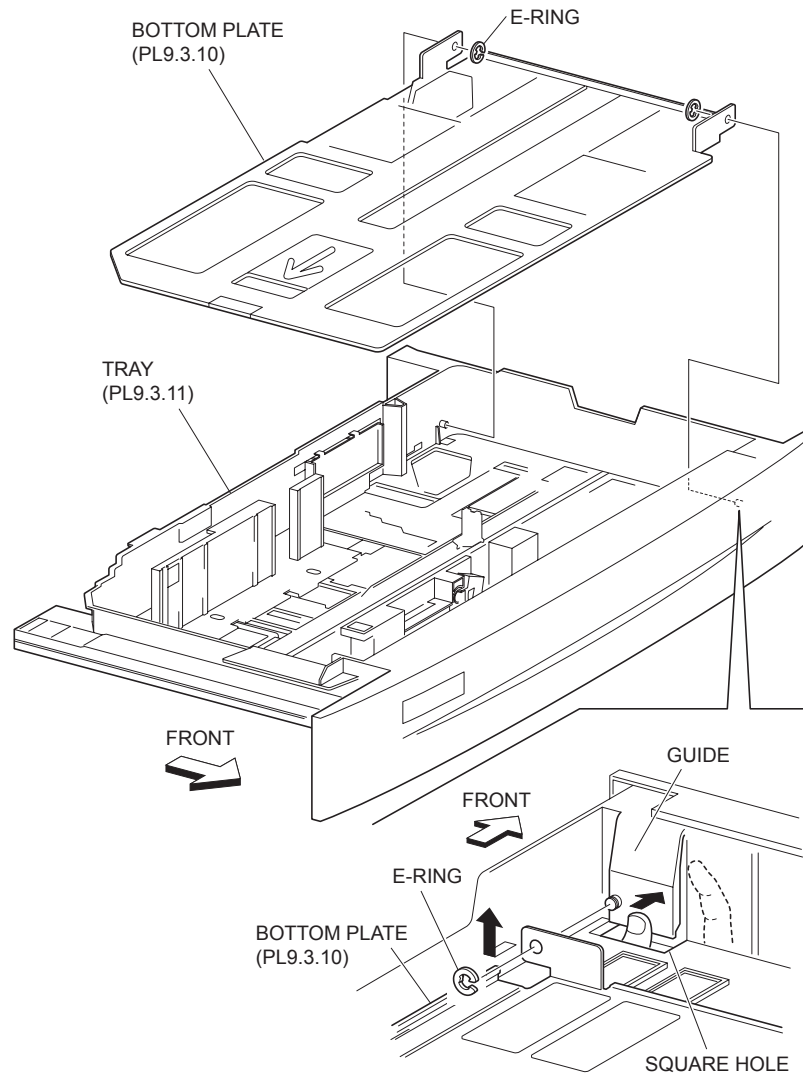
## Rear Side Guide

### Removal

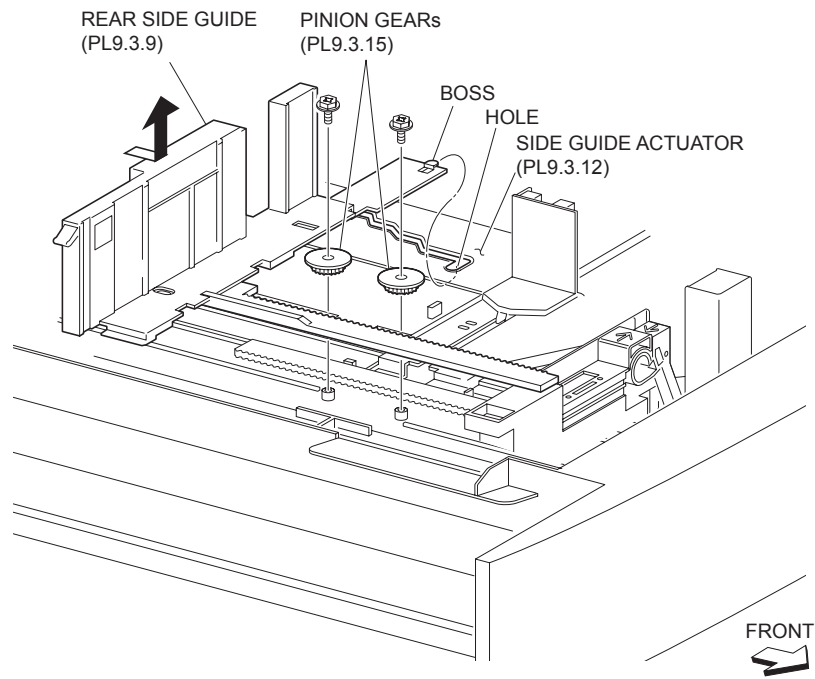
1. Remove the Tray Assembly(PL 9.3.1).
2. Remove E-rings on both ends (front/rear) securing the Bottom Plate (PL 9.3.10) to the Tray (PL 9.3.11) .
3. Push the guide on the front in the arrow direction shown in the figure by finger to release the boss on the Tray from the Bottom Plate.
4. Remove the Bottom Plate by moving it in the direction of the arrow.

5. Remove the one screw (Silver, M3x8mm) each securing the two Pinion Gears (PL 9.3.15) to the Tray .
6. Remove the Pinion Gears.
7. After sliding the Rear Side Guide inward, remove the Rear Side Guide in the direction of the arrow.

**NOTE** Be sure to release the bosses on the Rear Side Guide from the holes on the Side Guide Actuator (PL 9.3.12).



**Figure 1 Paper Tray**



**Figure 2 Rear Side Guide**

## Replacement

1. Fit the bosses on the lower part of the Rear Side Guide to the holes on the Tray (PL 9.3.11).

**NOTE** Be sure to fit the bosses on the Rear Side Guide into the holes on the Side Guide Actuator (PL 9.3.12).

2. Slide the Rear Side Guide fully outward.
3. Install the two Pinion Gears (PL 9.3.15) to the Tray using one screw (Silver, M3x8mm) each.

**NOTE** Before installing the Pinion Gears, make sure that the Rear Side Guide and the Front Side Guide Assembly (PL 9.3.6) are placed fully outward. After installing the Pinion Gears, make sure that the Front Side Guide Assembly and the Rear Side Guide slide smoothly.

4. Fit the rear guide hole on the Bottom Plate (PL 9.3.10) to the boss on the Tray.
5. Install the Bottom Plate to the Tray.

**NOTE** Be sure to fit the front guide hole on the Bottom Plate to the boss on the Tray.

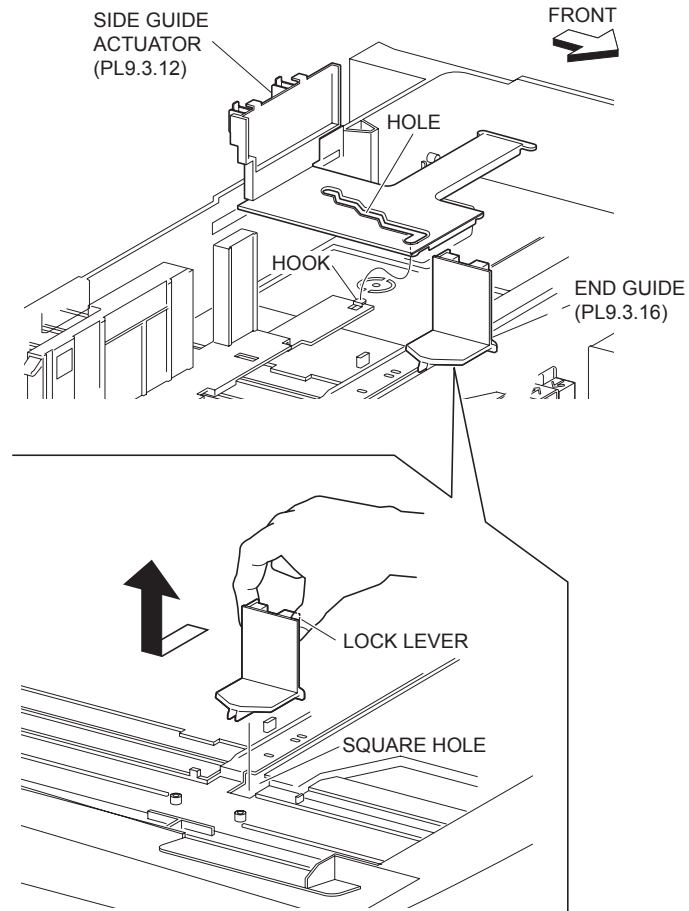
6. Fix the Bottom Plate to the Tray using the two E-rings on front and rear.
7. Insert the Tray Assembly (PL 9.3.1).

## End Guide

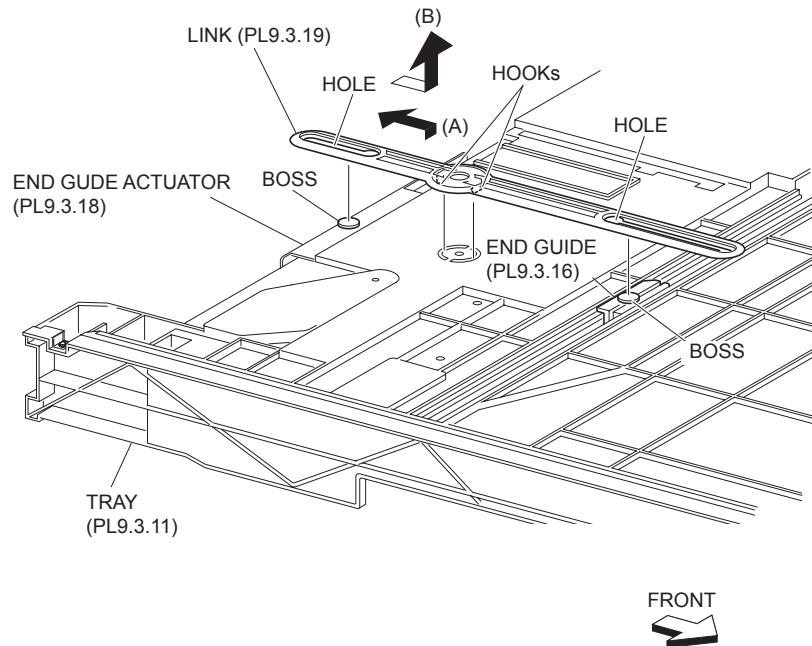
### Removal

1. Remove the Tray Assembly (PL 9.3.1).
2. Remove the Front Side Guide Assembly (PL 9.3.6) .
3. Remove the Rear Side Guide (PL 9.3.9) .
4. Remove the Side Guide Actuator (PL 9.3.12) .

5. Remove the two hooks securing the Link (PL 9.3.19) to the Tray (PL 9.3.11).
6. Release the bosses of the End Guide Actuator (PL 9.3.18) from the holes on the LINK by moving the LINK in the direction of the arrow (A), with its center slightly lifted .
7. Release the bosses on the End Guide from the holes on the Link by moving the Link in the direction of the arrow (B).
8. After sliding the End Guide inward as shown in the figure, remove it.



**Figure 1 End Guide**



**Figure 2 End Guide Actuator**

## Replacement

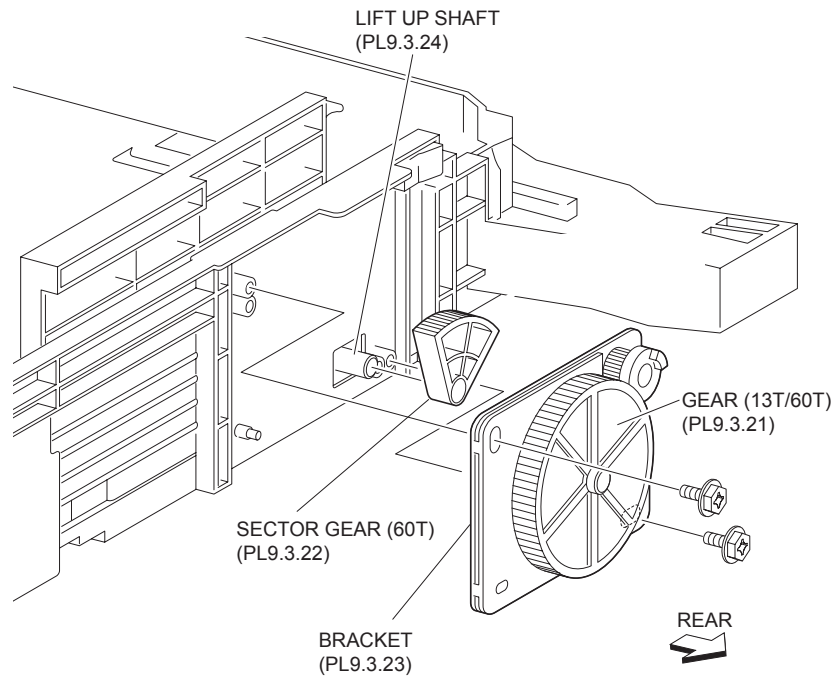
1. Fit the bosses on the lower part of the End Guide to the holes on the Tray (PL 9.3.11).
2. The Slide End Guide to around the center of the slot on the Tray.
3. Fit the bosses on the End Guide to the holes on the LINK (PL 9.3.19).
4. Fit the bosses on the End Guide Actuator (PL 9.3.18) to the holes on the LINK by moving the LINK in the direction of the arrow (A).
5. Install the LINK to the Tray using the two hooks.
6. Install the Side Guide Actuator (PL 9.3.12).
7. Install the Rear Side Guide (PL 9.3.9) .
8. Install the Front Side Guide Assembly (PL 9.3.6) .
9. Insert the Tray Assembly (PL 9.3.1).

## Sector Gear (60T)

### Removal

1. Remove the Tray Assembly (PL 9.3.1).
2. Remove the two screws (Silver, M3x8mm) securing the Bracket (PL 9.3.23) to the Tray (PL 9.3.11) to remove the bracket .
3. Remove the Sector Gear (60T).





**Figure 1 60T Sector Gear**

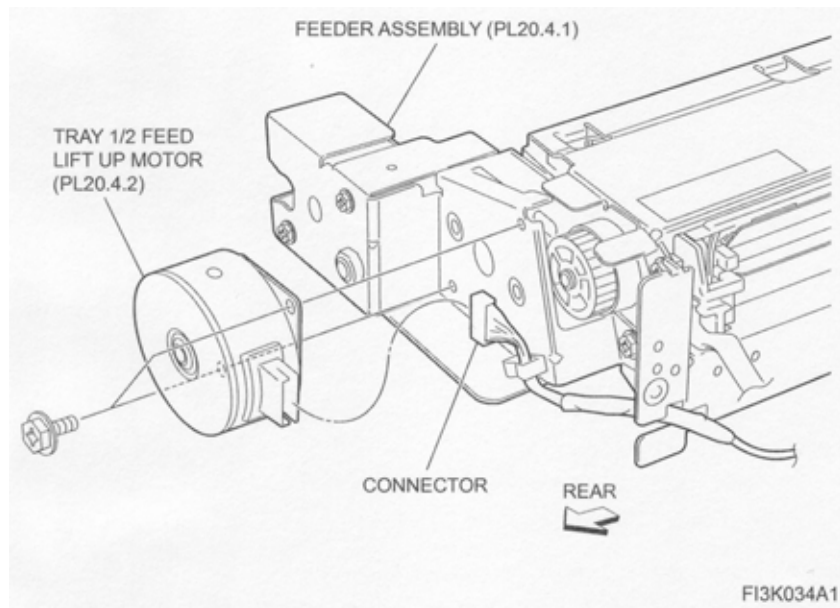
## Replacement

1. Engage the Sector Gear (60T) with the Gear (13T/60T) (PL 9.3.21).
2. With the shaft (D-shaped) of the Lift Up Shaft fitted into the holes on the Sector Gear (60T), install the Bracket (PL 9.3.23) to the Tray (PL 9.3.11) using two screws (Silver, M3x8mm).
3. Insert the Tray Assembly (PL 9.3.1).

## Tray 1/2 Feed Lift Up Motor

### Removal

1. Remove the Tray 3 Feeder (PL 9.2.7) or the Tray 4 Feeder (PL 9.2.8) or .
2. Disconnect the connector (Tray3:P/J220B, Tray4:P/J220A) of the Wire Harness (PL 9.6.13) from the Tray 1/2 Feed Lift Up Motor .
3. Remove the two screws (M3x6mm) securing the Tray 1/2 Feed Lift Up Motor to the Feeder Assembly (PL 9.4.1).
4. Remove the Tray 1/2 Feed Lift Up Motor.



**Figure 1 Lift Up Motor**

## Replacement

1. Install the Tray 1/2 Feed Lift Up Motor to the Feeder Assembly (PL 9.4.1) using two screws (M3x6mm).
2. Connect the connector (Tray3:P/J220B, Tray4:P/J220A) of the Wire Harness (PL 9.6.13) to the Tray 1/2 Feed Lift Up Motor.
3. Install the Tray 3 Feeder (PL 9.2.7) or the Tray 4 Feeder (PL 9.2.8) or .

## Spacer

### Removal

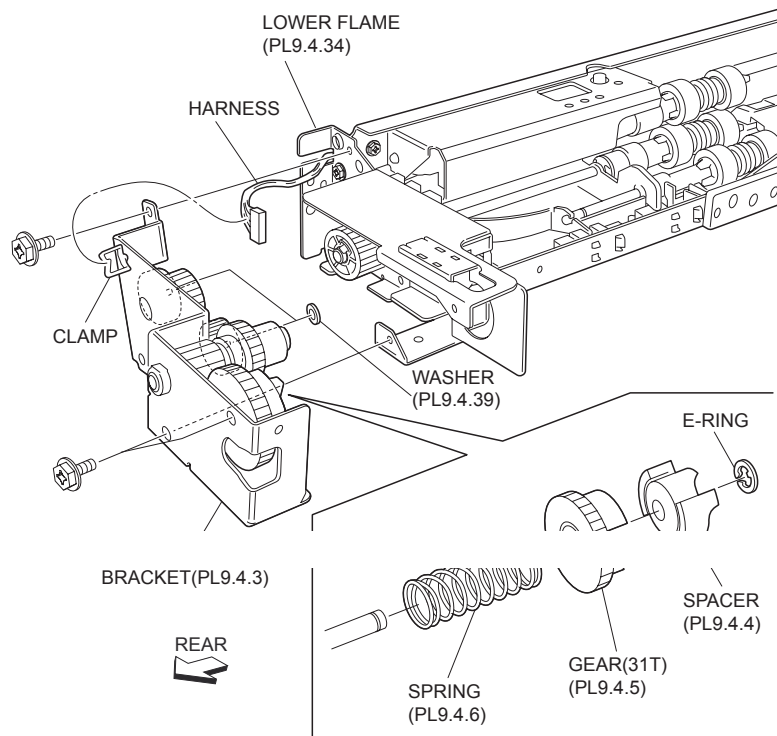
1. Remove the Tray 3 Feeder (PL 9.2.7) or the Tray 4 Feeder (PL 9.2.8) or .
2. Release the Wire Harness (PL 9.4.16) from the clamp on the Bracket (PL 9.4.3) .
3. Remove the three screws (Del Tite, M3x6mm) securing the Bracket to the Lower Frame (PL 9.4.34).

**NOTE** Note that the Gears attached on the Bracket may be detached.

4. Remove E-rings securing the Spacer, Gear (31T) (PL 9.4.5) and the Spring (PL 9.4.6) to the Bracket.

**NOTE** Note that the Spring may pop out.

5. Remove the Spacer.



**Figure 1 Lower Frame**

## Replacement

1. Install the Spacer to the Bracket (PL 9.4.3) together with the Gear (31T) (PL 9.4.5) and the Spring (PL 9.4.6), and fix them using E-ring.
2. Install the Bracket to the Lower Frame (PL 9.4.34) using the three screws (Del Tite, M3x6mm).

**NOTE** Make sure that the Gears attached on the Bracket are surely installed.

3. Secure the Wire Harness (PL 9.4.16) to the clamp on the Bracket.
4. Install the Tray 3 Feeder (PL 9.2.7) or the Tray 4 Feeder (PL 9.2.8) or .

## Gear (31T)

### Removal

1. Remove the Tray 3 Feeder (PL 9.2.7) or the Tray 4 Feeder (PL 9.2.8) or .
2. Release the Wire Harness (PL 9.4.16) from the clamp on the Bracket (PL 9.4.3) .
3. Remove the three screws (Del Tite, M3x6mm) securing the Bracket to the Lower Frame (PL 9.4.34).

**NOTE** Note that the Gears attached on the Bracket may be detached.

4. Remove E-rings securing the Gear (31T), the Spacer (PL 9.4.4) and the Spring (PL 9.4.6) to the Bracket.

**NOTE** Note that the Spring can pop out.

5. Remove the Gear (31T).

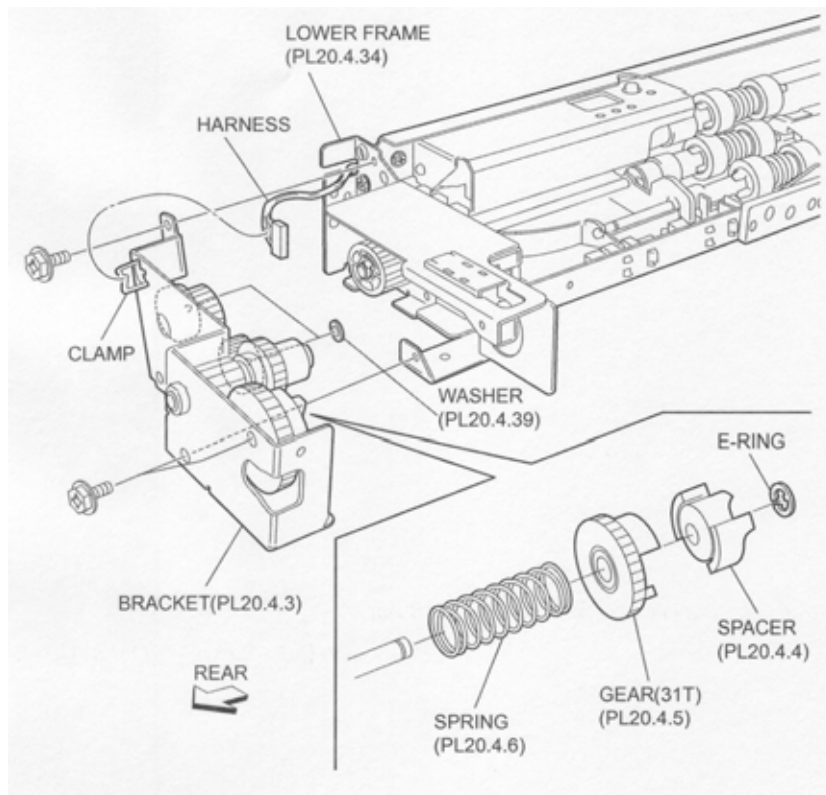


Figure 1 31T gear

## Replacement

1. Install the Gear (31T) to Bracket (PL 9.4.3), together with the Spacer (PL 9.4.4) and the Spring (PL 9.4.6), using E-rings.
2. Install the Bracket to the Lower Frame (PL 9.4.34) using the three screws (Del Tite, M3x6mm).

**NOTE** Make sure that the Gears attached on the Bracket are surely installed.

3. Secure the Wire Harness (PL 9.4.16) to the clamp on the Bracket.
4. Install the Tray 3 Feeder (PL 9.2.7) or the Tray 4 Feeder (PL 9.2.8) or .

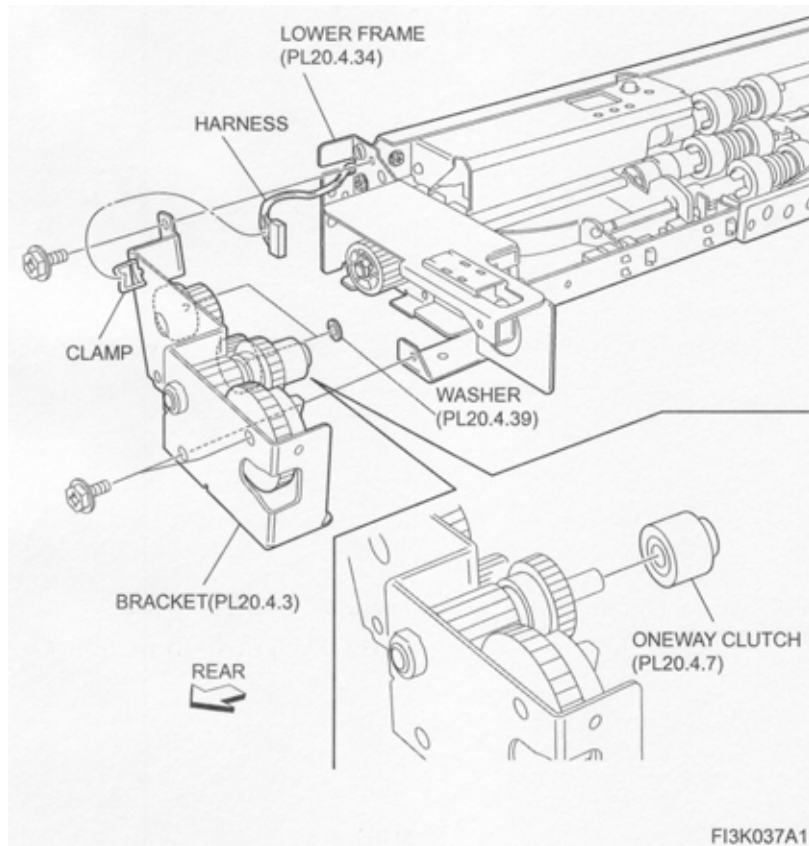
## Oneway Clutch

### Removal

1. Remove the Tray 3 Feeder (PL 9.2.7) or the Tray 4 Feeder (PL 9.2.8) or .
2. Release the Wire Harness (PL 9.4.16) from the clamp on the Bracket (PL 9.4.3) .
3. Remove the three screws (Del Tite, M3x6mm) securing the Bracket to the Lower Frame (PL 9.4.34)

**NOTE** Note that the Gears attached on the Bracket may be detached.

4. Remove the Oneway Clutch.



**Figure 1 Oneway Clutch**

## Replacement

1. Install the Oneway Clutch.
2. Install the Bracket (PL 9.4.3) to the Lower Frame (PL 9.4.34) using the three screws (Del Tite, M3x6mm).

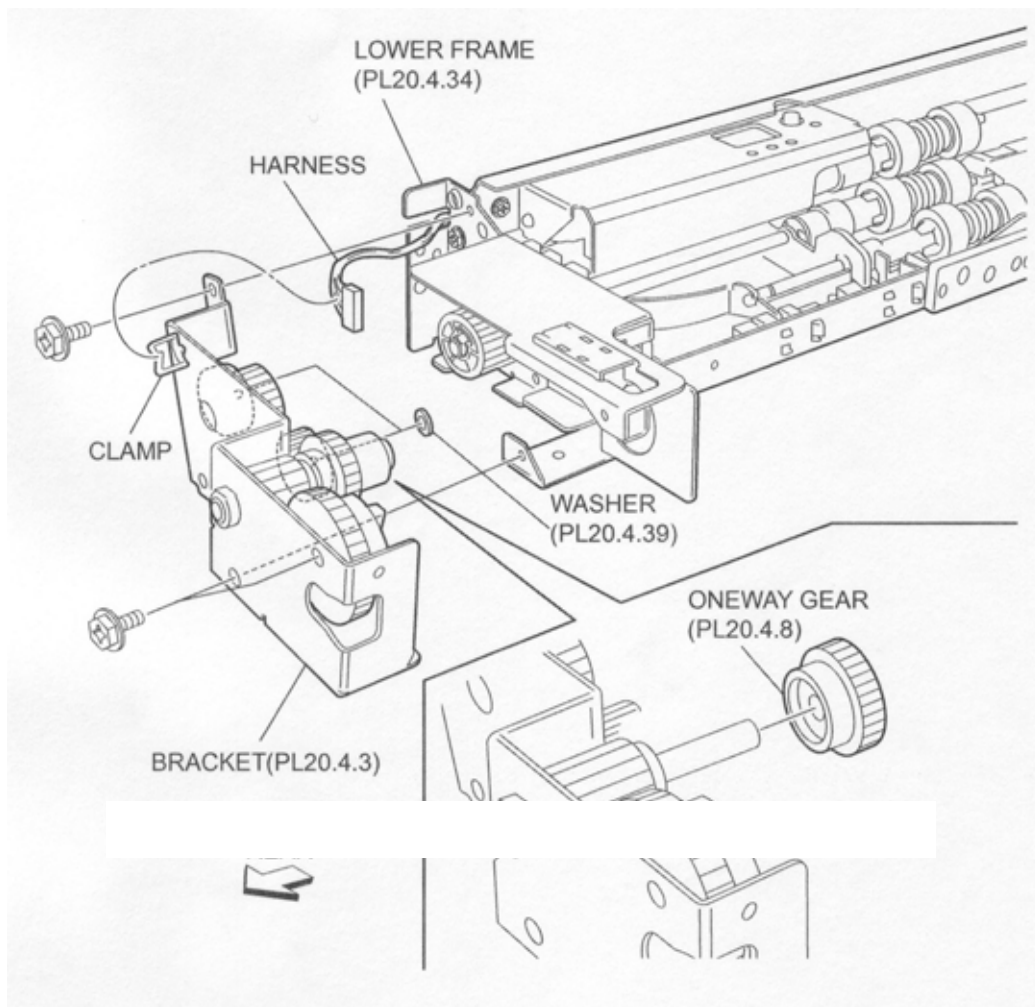
**NOTE** Make sure that the Gears attached on the Bracket are surely installed.

3. Secure the Wire Harness (PL 9.4.16) to the clamp on the Bracket.
4. Install the Tray 3 Feeder (PL 9.2.7) or the Tray 4 Feeder (PL 9.2.8) or .

## Oneway Gear

### Removal

1. Remove the Tray 3 Feeder (PL 9.2.7) or the Tray 4 Feeder (PL 9.2.8) or .
2. Remove the Oneway Clutch (PL 9.4.7) .
3. Remove the Oneway Gear .



**Figure 1 Oneway Gear**

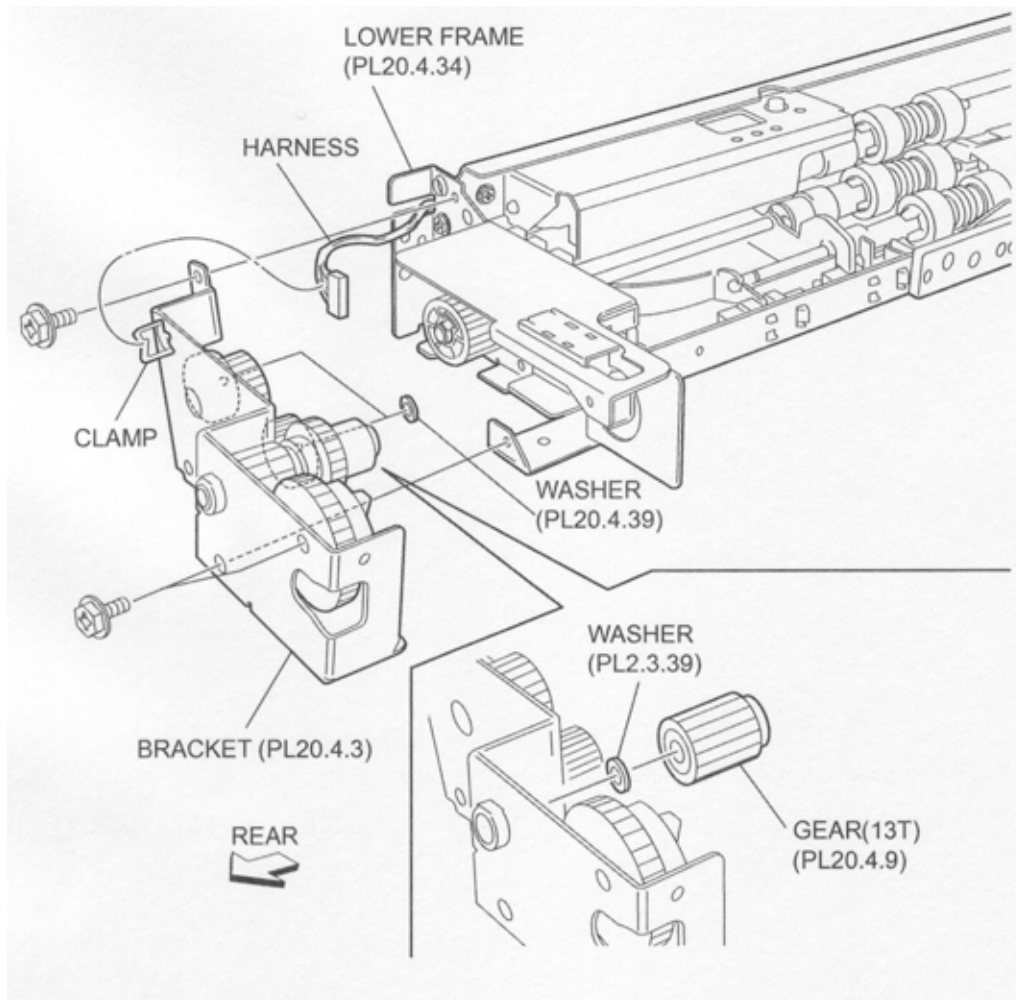
### **Replacement**

1. Install the Oneway Gear.
2. Install the Oneway Clutch (PL 9.4.7) .
3. Install the Tray 3 Feeder (PL 9.2.7) or the Tray 4 Feeder (PL 9.2.8) or .

### **Gear (13T)**

#### **Removal**

1. Remove the Tray 3 Feeder (PL 9.2.7) or the Tray 4 Feeder (PL 9.2.8) or .
2. Remove the Oneway Clutch (PL 9.4.7) .
3. Remove the Oneway Gear (PL 9.4.8) .
4. Remove the Gear (13T) .



**Figure 1 13T Gear**

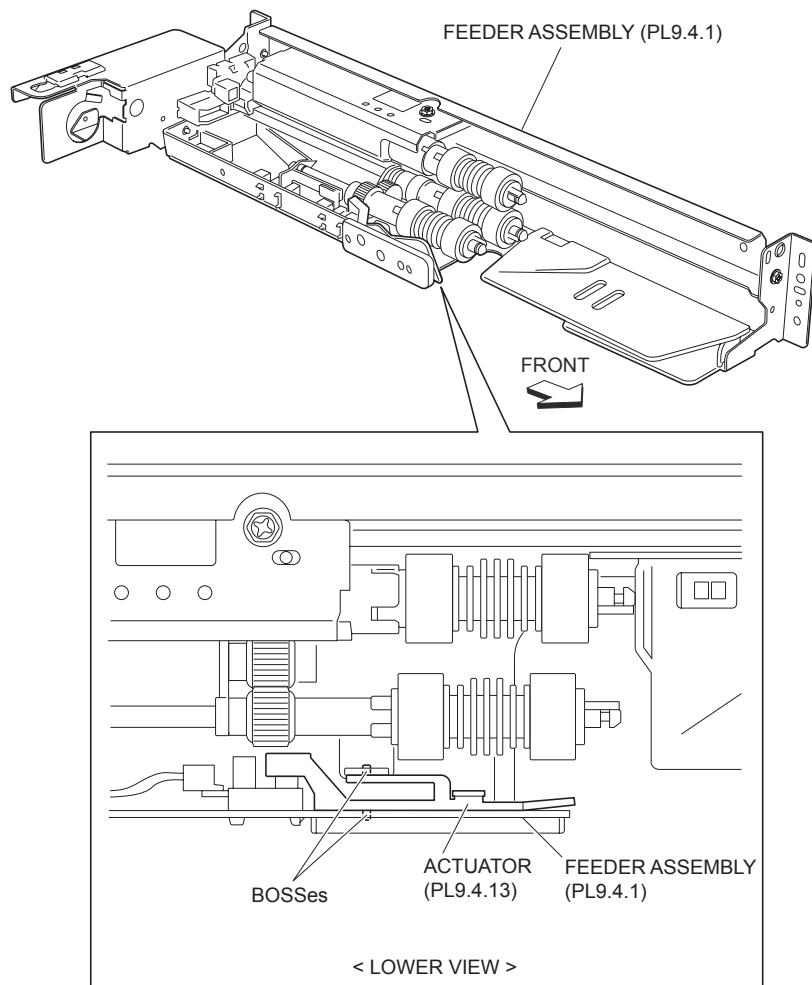
## Replacement

1. Install the Gear (13T).
2. Install the Oneway Gear (PL 9.4.8) .
3. Install the Oneway Clutch (PL 9.4.7) .
4. Install the Tray 3 Feeder (PL 9.2.7) or the Tray 4 Feeder (PL 9.2.8) or .

## Actuator

### Removal

1. Remove the Tray 3 Feeder (PL 9.2.7) or the Tray 4 Feeder (PL 9.2.8) or .
2. Remove the two bosses on the Actuator securing the Actuator to the Upper Frame (PL 9.4.40) .
3. Remove the Actuator.



FI3K040A1

**Figure 1 Actuator**

## Replacement

1. Install the Actuator.

**NOTE** Fit the bosses on the Actuator into the holes on the Upper Frame (PL 9.4.40).

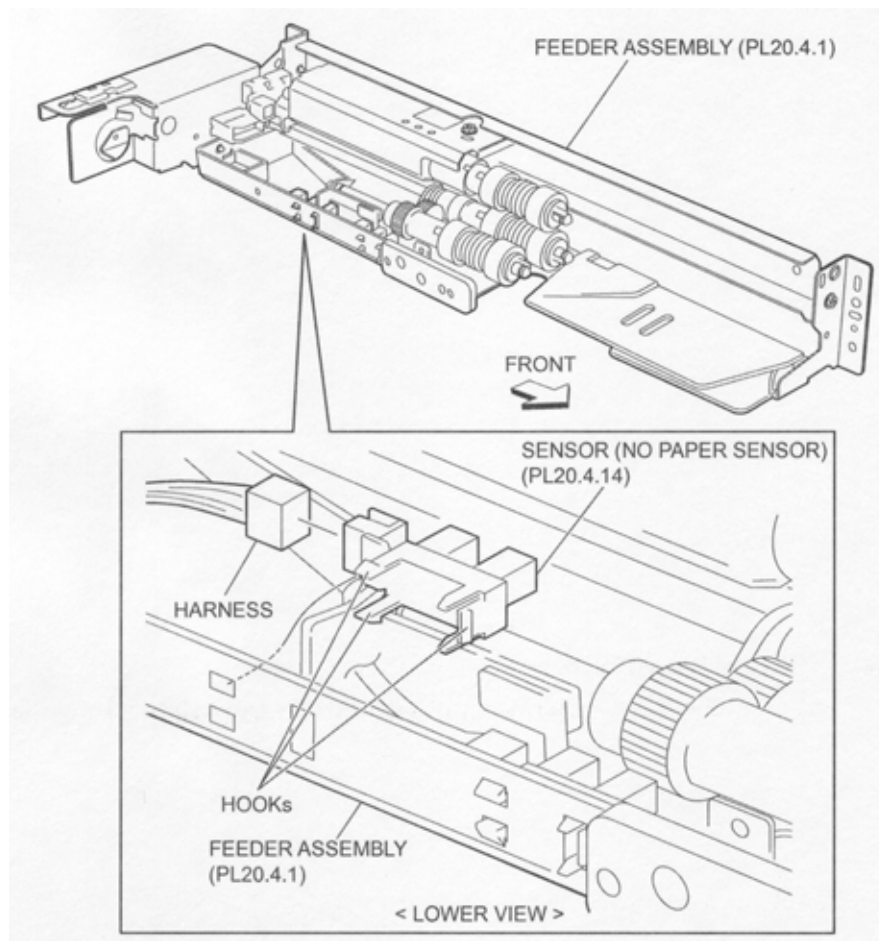
2. Install the Tray 3 Feeder (PL 9.2.7) or the Tray 4 Feeder (PL 9.2.8) or .

## No Paper Sensor

### Removal

1. Remove the Tray 3 Feeder (PL 9.2.7) or the Tray 4 Feeder (PL 9.2.8) or .
2. Disconnect the connector (Tray3:P/J102B, Tray4:P/J102A) of the Wire Harness (PL 9.4.16) from the No Paper Sensor .
3. Release the hooks securing the No Paper Sensor to the Upper Frame (PL 9.4.40) as shown in the figure.
4. Remove the No Paper Sensor.





**Figure 1 No Paper Sensor**

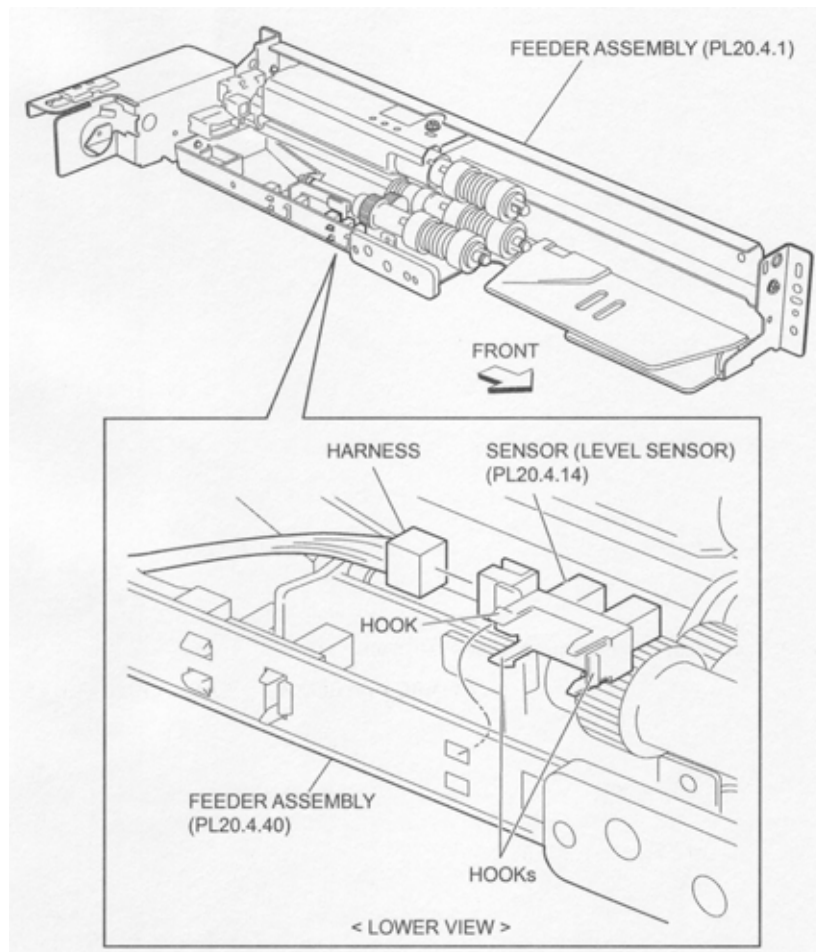
## Replacement

1. Secure the No Paper Sensor to the Upper Frame (PL 9.4.40) using the hooks.
2. Connect the connector (Tray3:P/J102B, Tray4:P/J102A) of the Wire Harness (PL 9.4.16) to the No Paper Sensor.
3. Install the Tray 3 Feeder (PL 9.2.7) or the Tray 4 Feeder (PL 9.2.8) or .

## Level Sensor

### Removal

1. Remove the Tray 3 Feeder (PL 9.2.7) or the Tray 4 Feeder (PL 9.2.8) or .
2. Remove the Actuator (PL 9.4.13) .
3. Disconnect the connector (Tray3:P/J101B, Tray4:P/J101A) of the Wire Harness (PL 9.4.16) from the Level Sensor .
4. Release the hooks securing the Level Sensor to the Upper Frame (PL 9.4.40) as shown in the figure.
5. Remove the Level Sensor.



**Figure 1 Level Sensor**

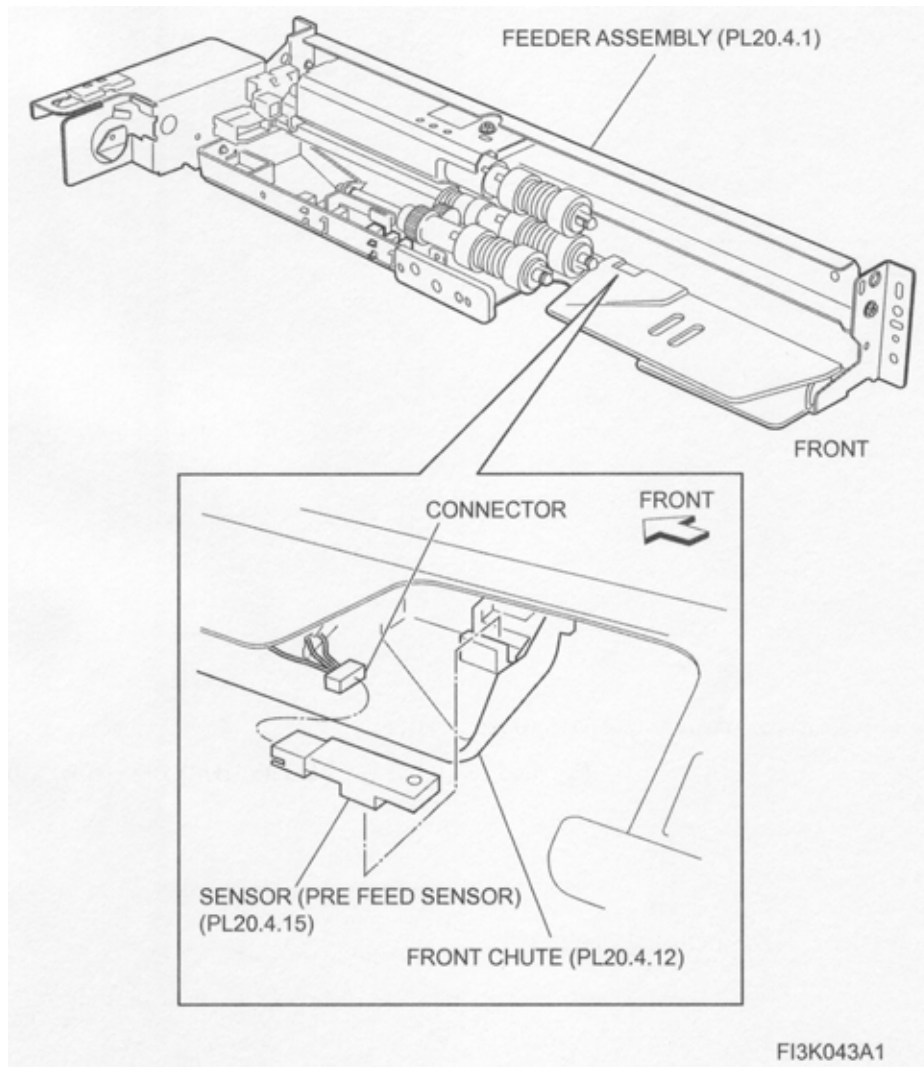
## Replacement

1. Secure the Level Sensor to the Upper Frame (PL 9.4.40) using the hooks.
2. Connect the connector (Tray3:P/J101B, Tray4:P/J101A) of the Wire Harness (PL 9.4.16) to the Level Sensor.
3. Install the Actuator (PL 9.4.13) .
4. Install the Tray 3 Feeder (PL 9.2.7) or the Tray 4 Feeder (PL 9.2.8) or .

## Pre Feed Sensor

### Removal

1. Remove the Tray 3 Feeder (PL 9.2.7) or the Tray 4 Feeder (PL 9.2.8) or .
2. Remove the Pre Feed Sensor from the Front Chute (PL 9.4.12) .
3. Disconnect the connector (Tray3:P/J103B, Tray4:P/J103A) of the Wire Harness (PL 9.4.16) from the Pre Feed Sensor.



**Figure 1 Pre feed Sensor**

## Replacement

1. Connect the connector (Tray3:P/J103B, Tray4:P/J103A) of the Wire Harness (PL 9.4.16) to the Pre Feed Sensor.
2. Install the Pre Feed Sensor to the Front Chute (PL 9.4.12).
3. Install the Tray 3 Feeder (PL 9.2.7) or the Tray 4 Feeder (PL 9.2.8) or .

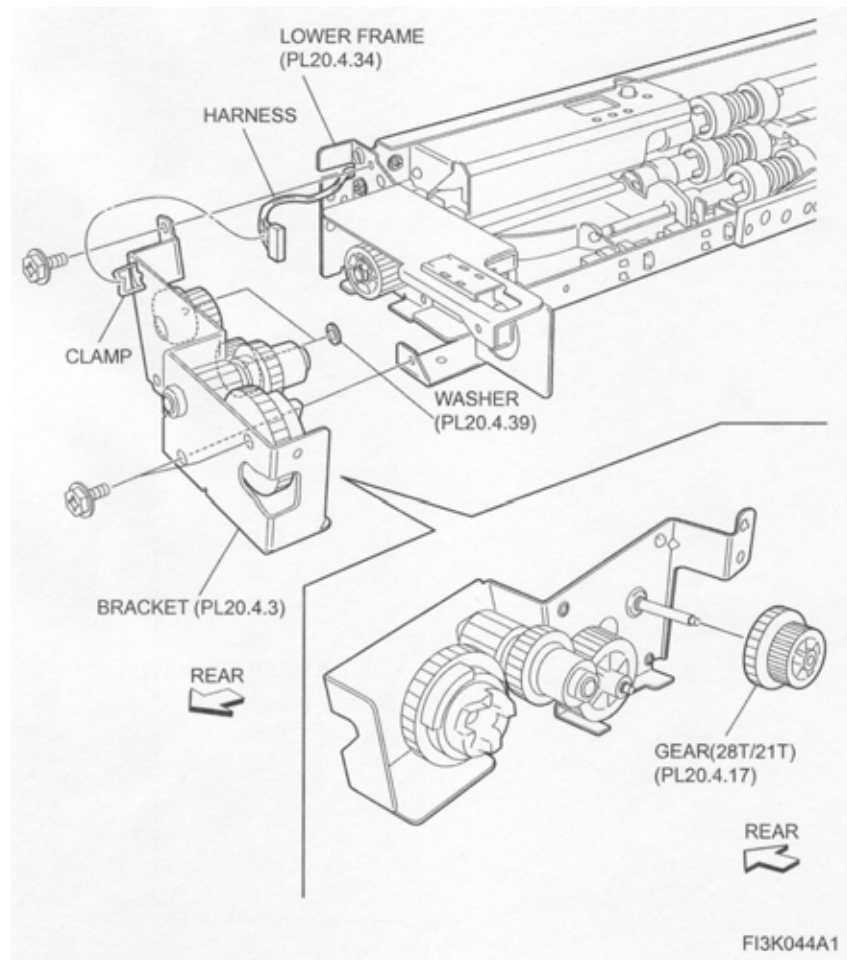
## 28T/21T Gear

### Removal

1. Remove the Tray 3 Feeder (PL 9.2.7) or the Tray 4 Feeder (PL 9.2.8) or .
2. Release the Wire Harness (PL 9.4.16) from the clamp on the Bracket (PL 9.4.3) .
3. Remove the three screws (Del Tite, M3x6mm) securing the Bracket to the Lower Frame (PL 9.4.34).

**NOTE** Note that the Gears attached on the Bracket may be detached.

4. Remove the Gear (28T/21T).



**Figure 1 Gear**

## Replacement

1. Install the Gear (28T/21T).
2. Install the Bracket (PL 9.4.3) to the Lower Frame (PL 9.4.34) using the three screws (Del Tite, M3x6mm).

**NOTE** Make sure that the Gears attached on the Bracket are surely installed.

3. Secure the Wire Harness (PL 9.4.16) to the clamp on the Bracket.
4. Install the Tray 3 Feeder (PL 9.2.7) or the Tray 4 Feeder (PL 9.2.8) or .

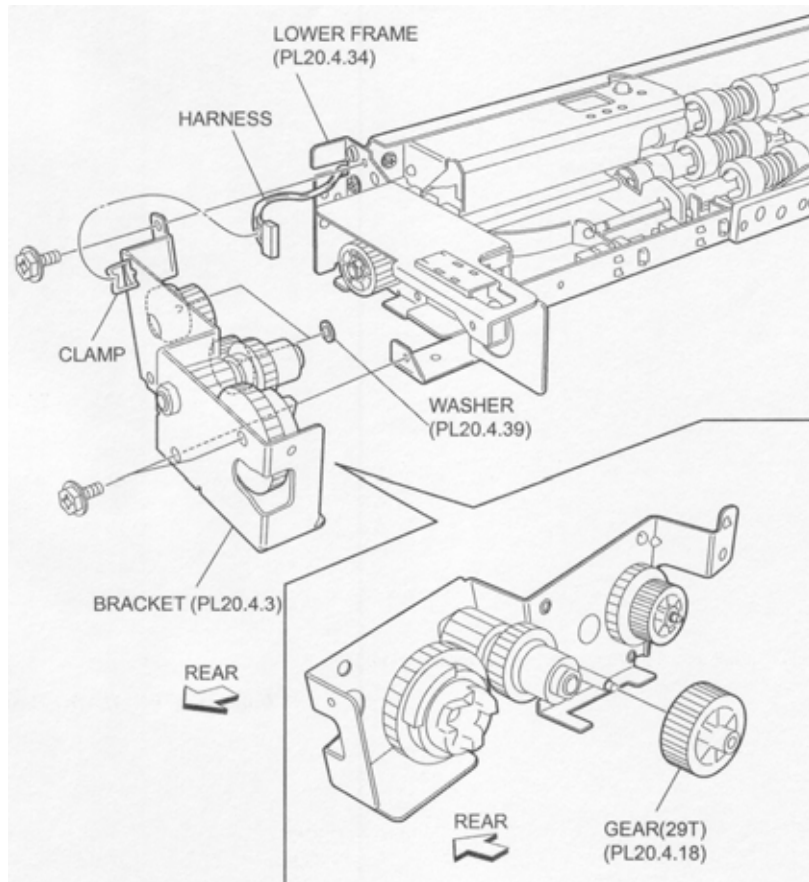
## Gear (29T)

### Removal

1. Remove the Tray 3 Feeder (PL 9.2.7) or the Tray 4 Feeder (PL 9.2.8) or .
2. Release the Wire Harness (PL 9.4.16) from the clamp on the Bracket (PL 9.4.3) .
3. Remove the three screws (Del Tite, M3x6mm) securing the Bracket to the Lower Frame (PL 9.4.34).

**NOTE** Note that the Gears attached on the Bracket may be detached.

4. Remove the Gear (29T).



## Replacement

1. Install the Gear (29T).
2. Install the Bracket (PL 9.4.3) to the Lower Frame (PL 9.4.34) using three screws (Del Tite, M3x6mm).

**NOTE** Make sure that the Gears attached on the Bracket are surely installed.

3. Secure the Wire Harness (PL 9.4.16) to the clamp on the Bracket.
4. Install the Tray 3 Feeder (PL 9.2.7) or the Tray 4 Feeder (PL 9.2.8) or .

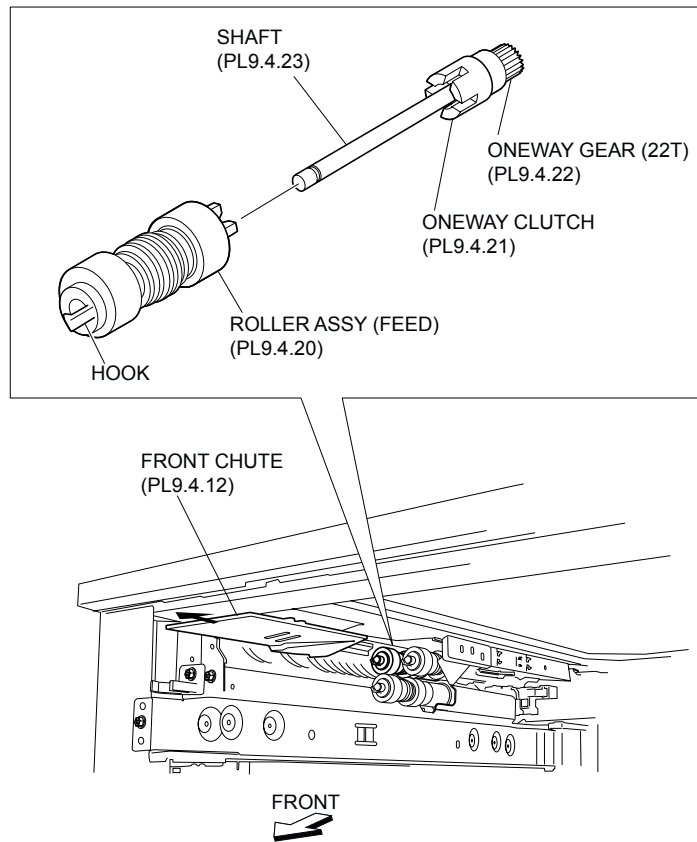
## Feed Roller Assembly

### Removal

1. Pull out the Tray3 or the Tray4.
2. Move the Front Chute (PL 9.4.12) in the direction of the arrow .
3. Release the hook securing the Feed Roller Assembly to the Shaft (PL 9.4.23) as shown in the figure.
4. Remove the Feed Roller Assembly.

**NOTE** Note that the Oneway Clutch (PL 9.4.21) and the Oneway Gear (22T) (PL 9.4.22) may be detached.

**NOTE** When removing, do not hold the rubber roller of the Feed Roller Assembly.



**Figure 1 Feed Roll Assembly**

## Replacement

1. Install the Feed Roller Assembly to the Shaft (PL 9.4.23), and fix it using hook.

**NOTE** When installing, do not hold the rubber roller of the Feed Roller Assembly.

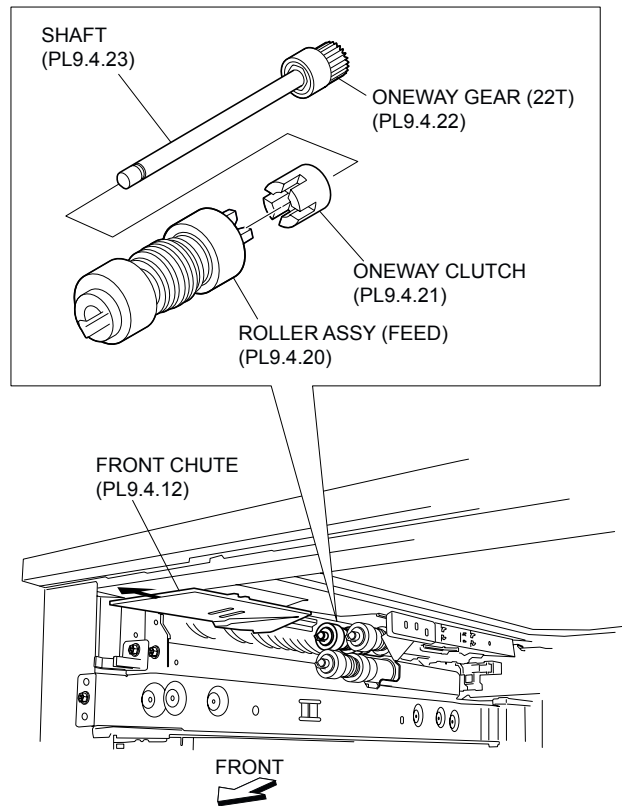
2. Move the Front Chute (PL 9.4.12) in the opposite direction of the arrow (to the rear side).
3. Insert the Tray3 or the Tray4.

## Oneway Clutch

### Removal

1. Pull out the Tray3 or the Tray4.
2. Remove the Feed Roller Assembly (PL 9.4.20) .
3. Remove the Oneway Clutch .

**NOTE** Note that Oneway Gear (22T) (PL 9.4.22) may be detached.



**Figure 1 Oneway Clutch**

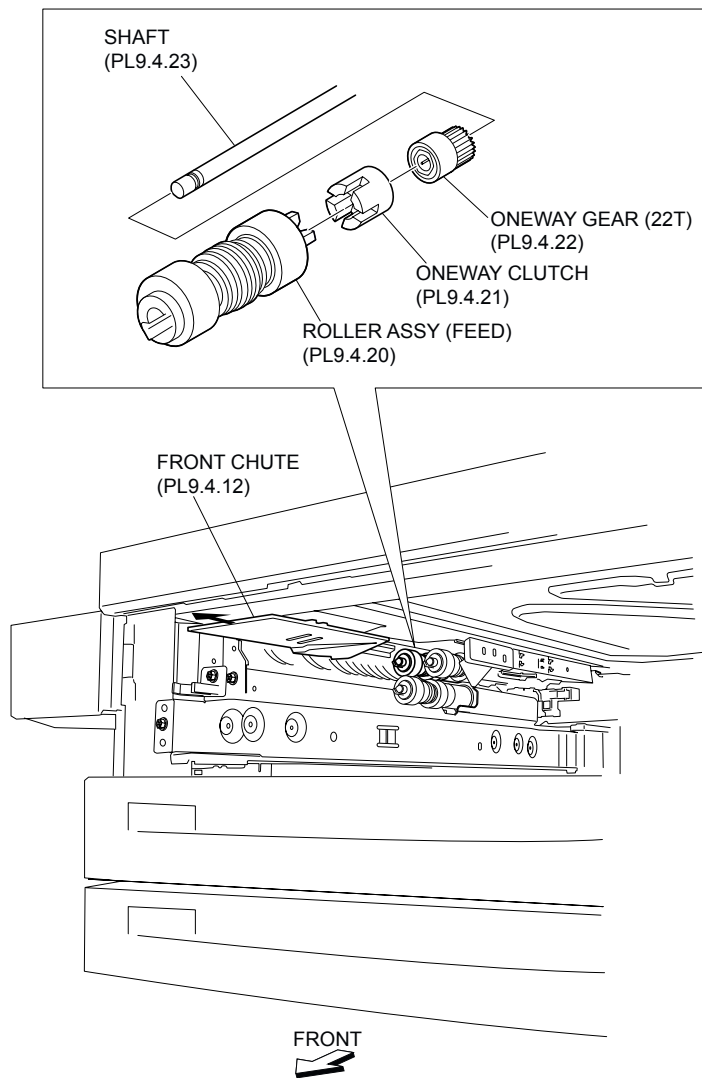
### Replacement

1. Install the Oneway Clutch.
2. Install the Feed Roller Assembly (PL 9.4.20) .
3. Insert the Tray3 or the Tray4.

### Oneway Gear (22T)

#### Removal

1. Pull out the Tray3 or the Tray4.
2. Remove the Feed Roller Assembly (PL 9.4.20) .
3. Remove the Oneway Clutch (PL 9.4.21) .
4. Remove the Oneway Gear (22T) .



**Figure 1 Oneway Gear 22T**

## Replacement

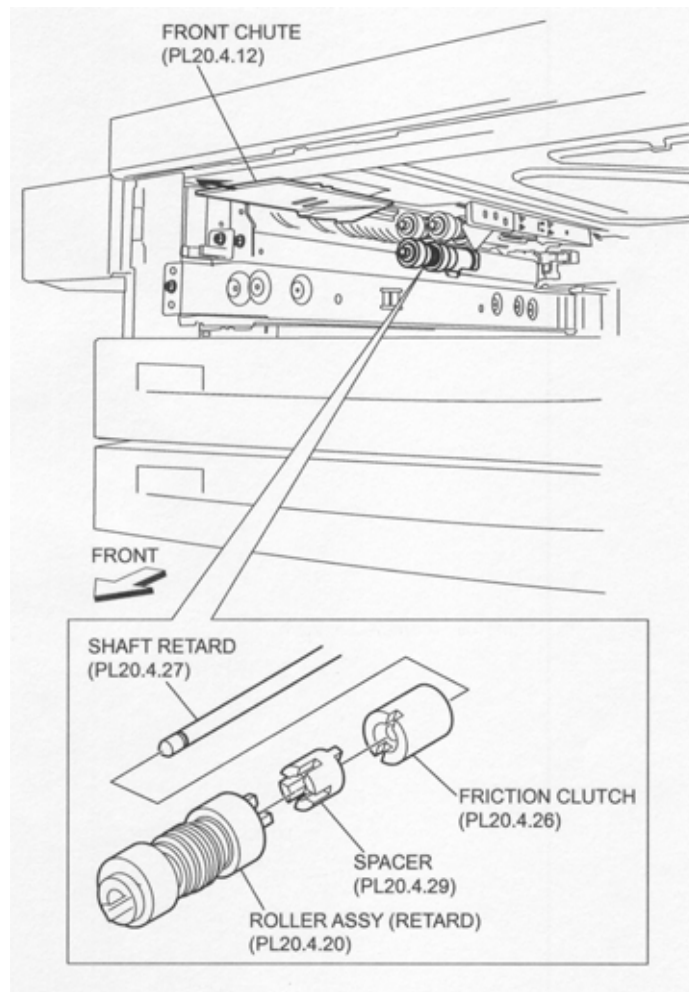
1. Install the Oneway Gear (22T).
2. Install the Oneway Clutch (PL 9.4.21) .
3. Install the Feed Roller Assembly (PL 9.4.20) .
4. Insert the Tray3 or the Tray4.

## Friction Clutch

### Removal

1. Pull out the Tray3 or the Tray4.
2. Remove the Roller Assembly (Retard) (PL 9.4.20) .
3. Remove the Spacer (PL 9.4.29) .
4. Remove the Friction Clutch .





**Figure 1 Friction Clutch**

## Replacement

1. Install the Friction Clutch.
2. Install the Spacer (PL 9.4.29) .
3. Install the Roller Assembly (Retard) (PL 9.4.20) .
4. Insert the Tray3 or the Tray4.

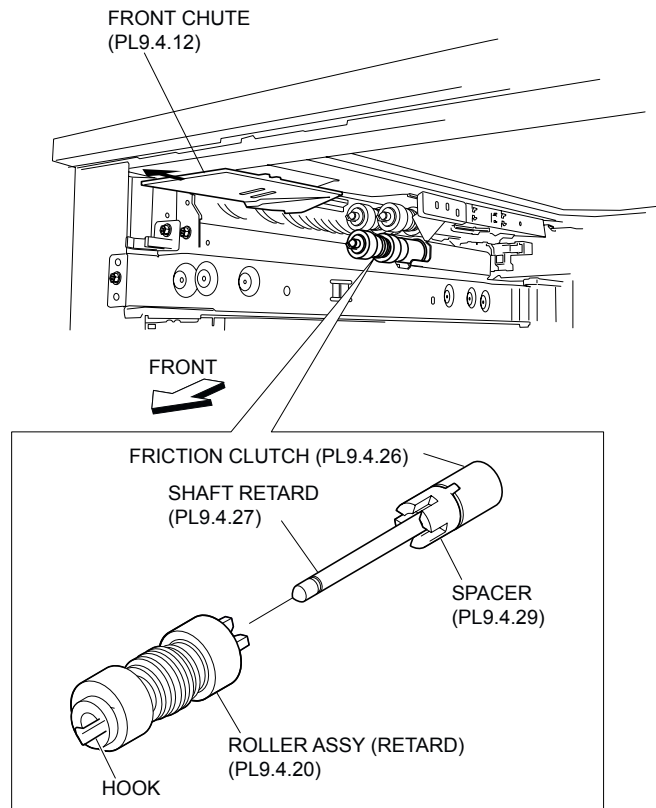
## Retard Roller Assembly

### Removal

1. Pull out the Tray3 or the Tray4.
2. Move the Front Chute (PL 9.4.12) in the direction of the arrow .
3. Release the hook securing the Retard Roller Assembly to the Shaft-Retard (PL 9.4.27) as shown in the figure.
4. Remove the Retard Roller Assembly.

**NOTE** Note that the **Spacer (PL 9.4.29)** and the **Friction Clutch (PL 9.4.26)** may be detached.

**NOTE** When removing, do not hold the rubber roller of the Retard Roller Assembly.



**Figure 1 Retard Roller Assembly**

## Replacement

1. Install the Retard Roller Assembly to the Shaft-Retard (PL 9.4.27), and fix it using the hook.

**NOTE** When installing, do not hold the rubber roller of the Retard Roller Assembly.

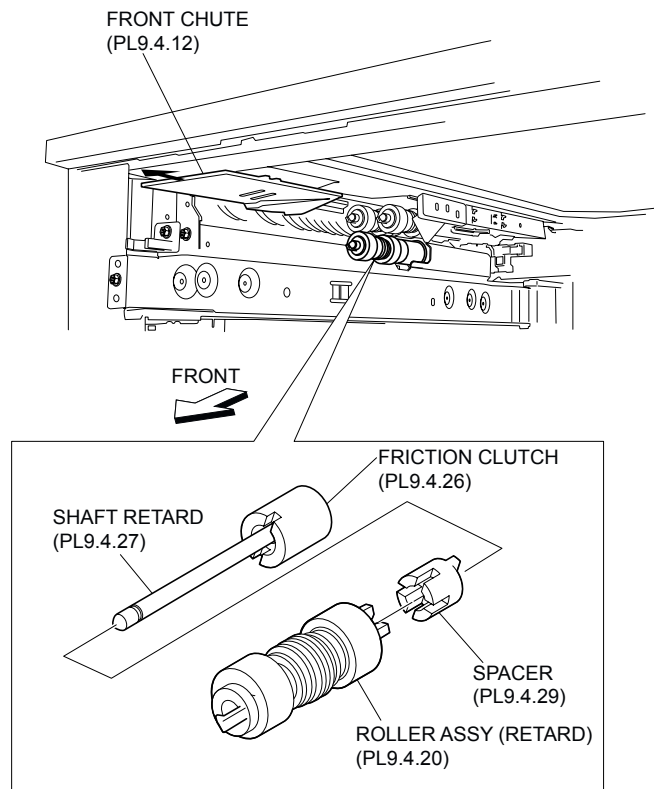
2. Move the Front Chute (PL 9.4.12) in the opposite direction of the arrow (to the rear side).
3. Insert the Tray3 or the Tray4.

## Spacer

### Removal

1. Pull out the Tray3 or the Tray4.
2. Remove the Roller Assembly (Retard) (PL 9.4.20) .
3. Remove the Spacer .

**NOTE** Note that the Friction Clutch (PL 9.4.26) may be detached.



**Figure 1 Spacer**

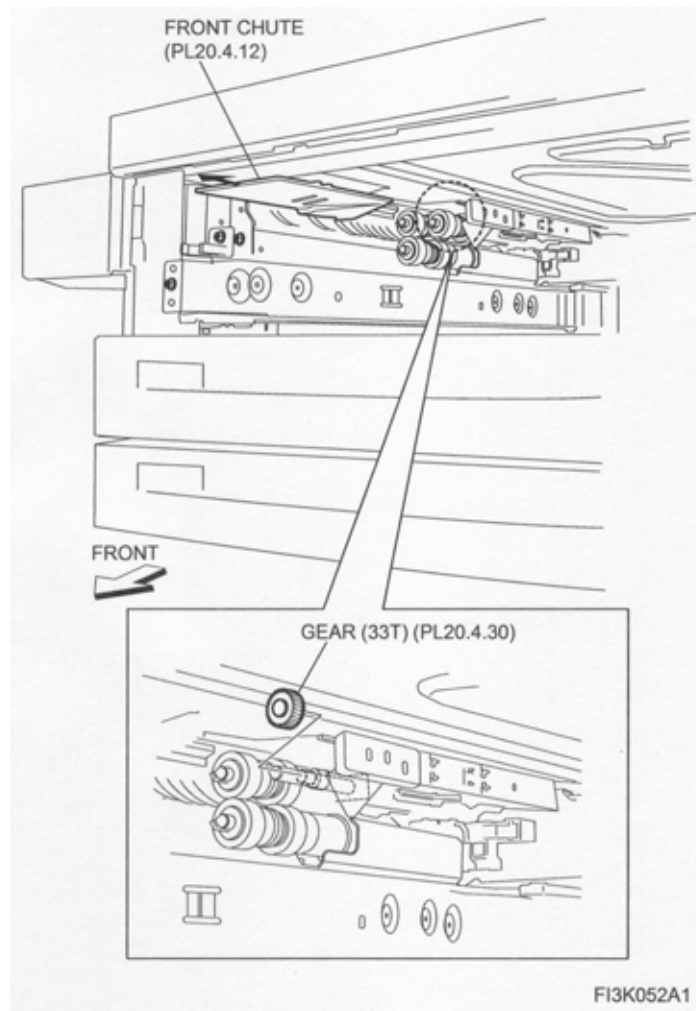
## Replacement

1. Install the Spacer.
2. Install the Roller Assembly (Retard) (PL 9.4.20) .
3. Insert the Tray3 or the Tray4.

## Gear (33T)

### Removal

1. Pull out the Tray3 or the Tray4.
2. Remove the Roller Assembly (Nudger) (PL 9.4.20) .
3. Remove the Gear (25T) (PL 9.4.33)
4. Remove the Gear (33T) .



**Figure 1 33T Gear**

## Replacement

1. Install the Gear (33T).
2. Install the Gear (25T) (PL 9.4.33) .
3. Install the Roller Assembly (Nudger) (PL 9.4.20) .
4. Insert the Tray3 or the Tray4.

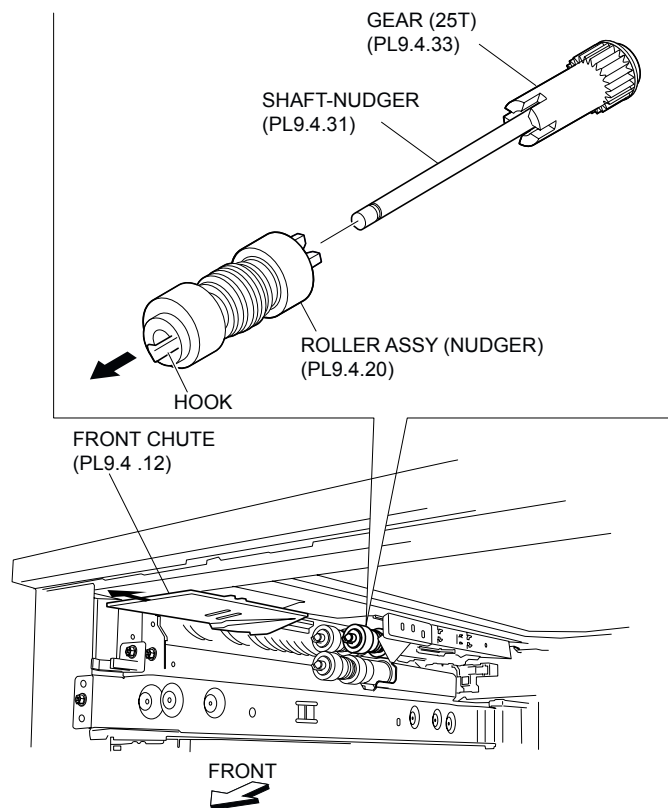
## Nudger Roller Assembly

### Removal

1. Pull out the Tray3 or the Tray4.
2. Move the Front Chute (PL 9.4.12) in the direction of the arrow .
3. Release the hook securing the Nudger Roller Assembly to the Shaft-Nudger (PL 9.4.31) as shown in the figure.
4. Remove the Nudger Roller Assembly.

**NOTE** Note that the Gear (25T) (PL 9.4.33) may be detached.

**NOTE** When removing, do not hold the rubber roller of the Nudger Roller Assembly.



**Figure 1 Nudger Roller Assembly**

## Replacement

1. Install the Nudger Roller Assembly to the Shaft-Nudger (PL 9.4.31), and fix it using the hook.

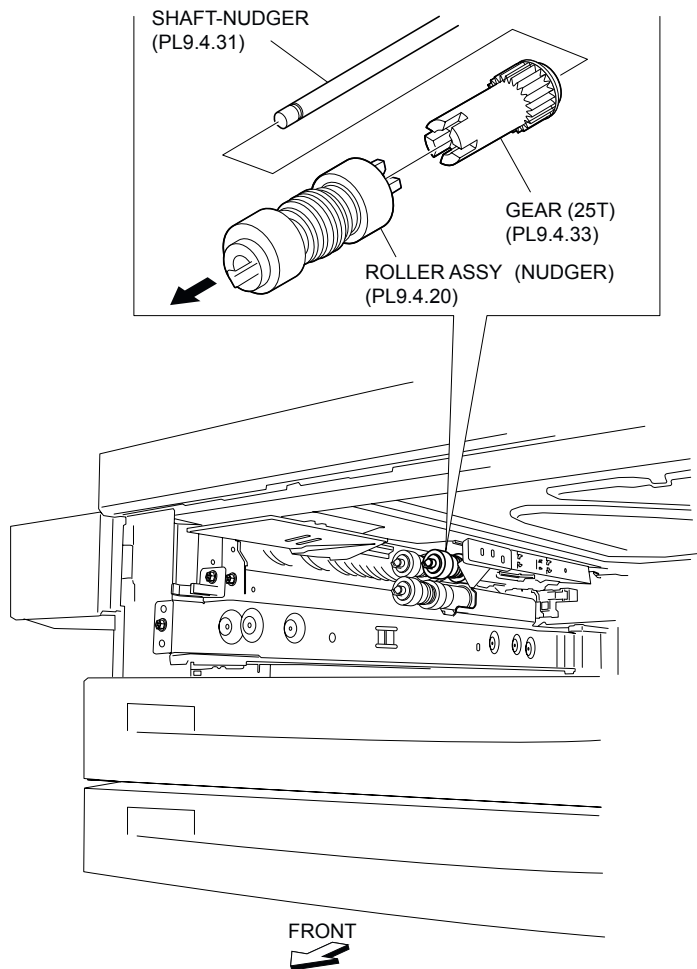
**NOTE** When installing, do not hold the rubber roller of the Nudger Roller Assembly.

2. Move the Front Chute (PL 9.4.12) in the opposite direction of the arrow (to the rear side).
3. Insert the Tray3 or the Tray4.

## Gear (25T)

### Removal

1. Pull out the Tray 3 or the Tray 4.
2. Remove the Nudger Roller Assembly (PL 9.4.20) .
3. Remove the Gear (25T) .



**Figure 1 25T Gear**

## Replacement

1. Install the Gear (25T).
2. Install the Nudger Roller Assembly (PL 9.4.20) .
3. Insert the Tray 3 or the Tray 4.

## Gear (27T)

### Removal

1. Remove the Tray 3 Feeder (PL 9.2.7) or the Tray 4 Feeder (PL 9.2.8) or .
2. Release the Wire Harness (PL 9.4.16) from the clamp on the Bracket (PL 9.4.3) .
3. Remove the three screws (Del Tite, M3x6mm) securing the Bracket to the Lower Frame (PL 9.4.34).

**NOTE** Note that the Gears attached on the Bracket may be detached.

4. Release the hook securing the Gear (27T) to the Shaft (PL 9.4.23) as shown in the figure.
5. Remove the Gear (27T).

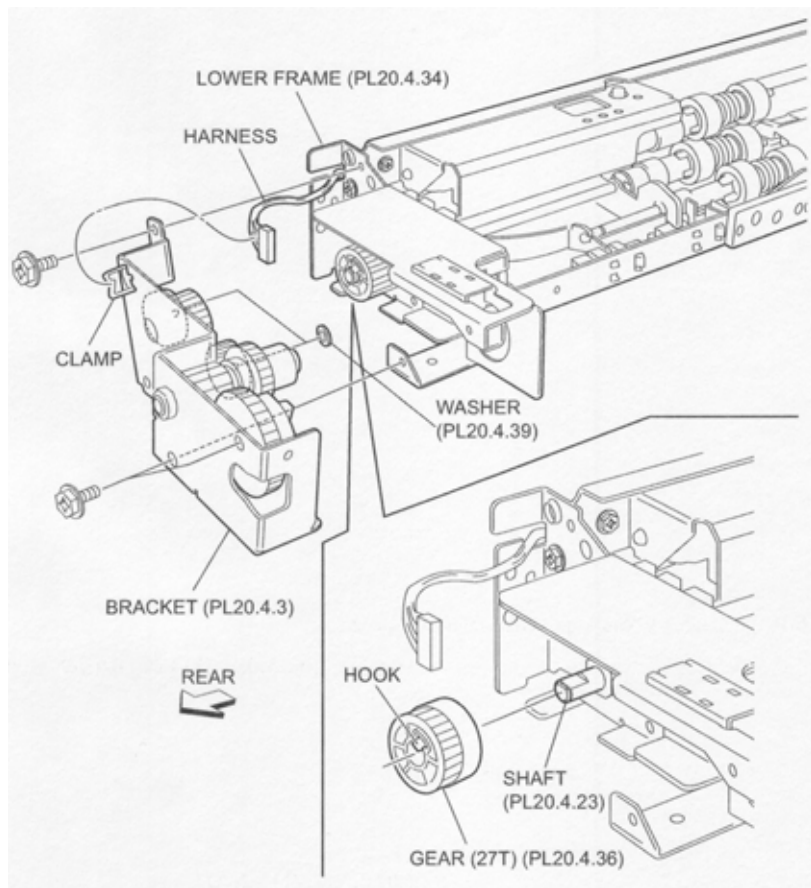


Figure 1 27T Gear

## Replacement

1. Install the Gear (27T) to the Shaft (PL 9.4.23) using the hook.
2. Install the Bracket (PL 9.4.3) to the Lower Frame (PL 9.4.34) using three screws (Del Tite, M3x6mm).

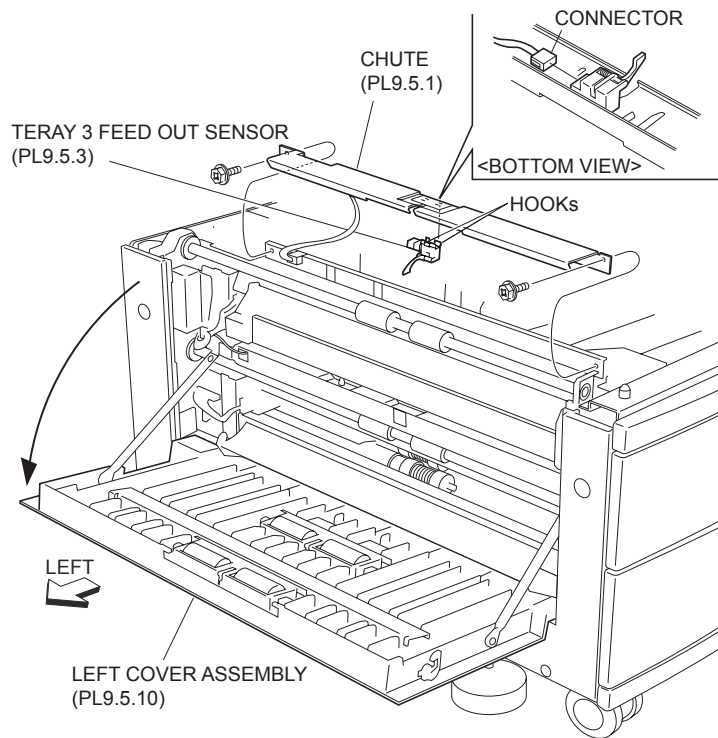
**NOTE** Make sure that the Gears attached on the Bracket are surely installed.

3. Secure the Wire Harness (PL 9.4.16) to the clamp on the Bracket.
4. Install the Tray 3 Feeder (PL 9.2.7) or the Tray 4 Feeder (PL 9.2.8) or .

## Tray 3 Feed Out Sensor

### Removal

1. Open the Left Cover Assembly (PL 9.5.10).
2. Remove the two screws (Del Tite, M3x8mm) securing the Chute (PL 9.5.1) to the machine .
3. Disconnect the connector (P/J821) of the Wire Harness (PL 9.5.4) from the Tray 3 Feed Out Sensor.
4. Release the hooks securing the Tray 3 Feed Out Sensor to the Chute as shown in the figure.



**Figure 1 Tray 3 Feed Out Sensor**

## Replacement

1. Secure the Tray 3 Feed Out Sensor to the Chute (PL 9.5.1) with the hooks.

**NOTE** Be sure to put the Actuator attached to the Tray 3 Feed Out Sensor into the hole on the Chute.

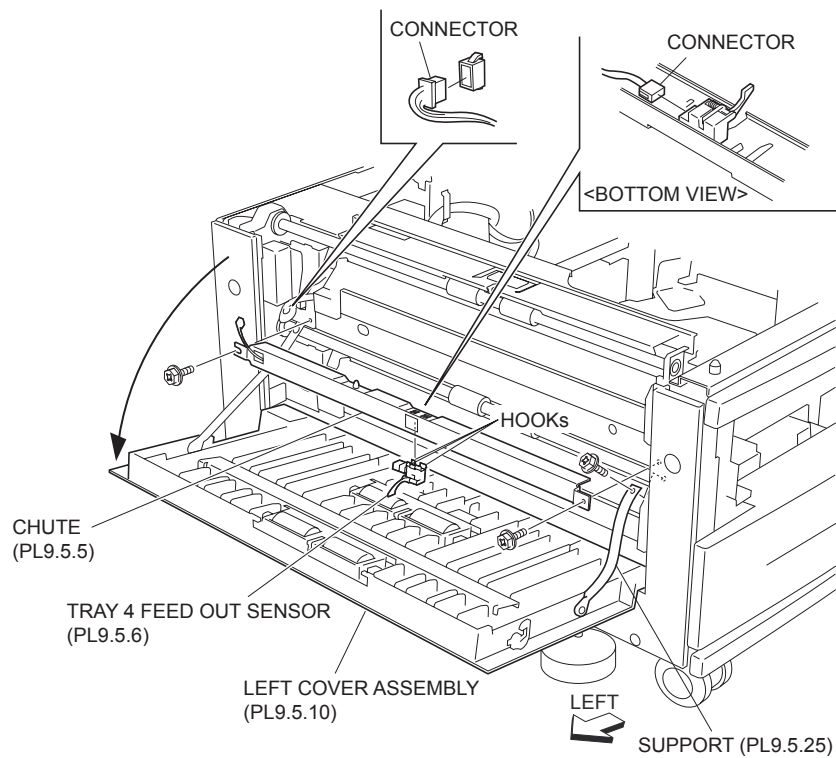
2. Connect the connector (P/J821) of the Wire Harness (PL 9.5.4) to the Tray 3 Feed Out Sensor.
3. Install the Chute to the machine using two screws (Del Tite, M3x8mm).
4. Close the Left Cover Assembly (PL 9.5.10).

## Tray 4 Feed Out Sensor

### Removal

1. Open the Left Cover Assembly (PL 9.5.10).
2. Remove the screw securing the Support (PL 9.5.25) on the front to the machine .
3. Remove the two screw (Del Tite, M3x8mm) securing the Chute (PL 9.5.5) to the machine.
4. Disconnect the connector (P/J825) of the Wire Harness (PL 9.5.7) from the Tray 4 Feed Out Sensor.
5. Release the hooks securing the Tray 4 Feed Out Sensor to the Chute as shown in the figure.





**Figure 1 Tray 4 Feed Out Sensor**

## Replacement

1. Secure the Tray 4 Feed Out Sensor to the Chute (PL 9.5.5) with the hooks.

**NOTE** Be sure to put the Actuator attached to the Tray 4 Feed Out Sensor into the hole on the Chute.

2. Connect the connector (P/J825) of the Wire Harness (PL 9.5.7) to the Tray 4 Feed Out Sensor.
3. Install the Chute to the machine using two screws (Del Tite, M3x8mm).
4. Install the Support (PL 9.5.25) on the front to the machine using the one screw.
5. Close the Left Cover Assembly (PL 9.5.10).

## Upper Takeaway Roll Assembly

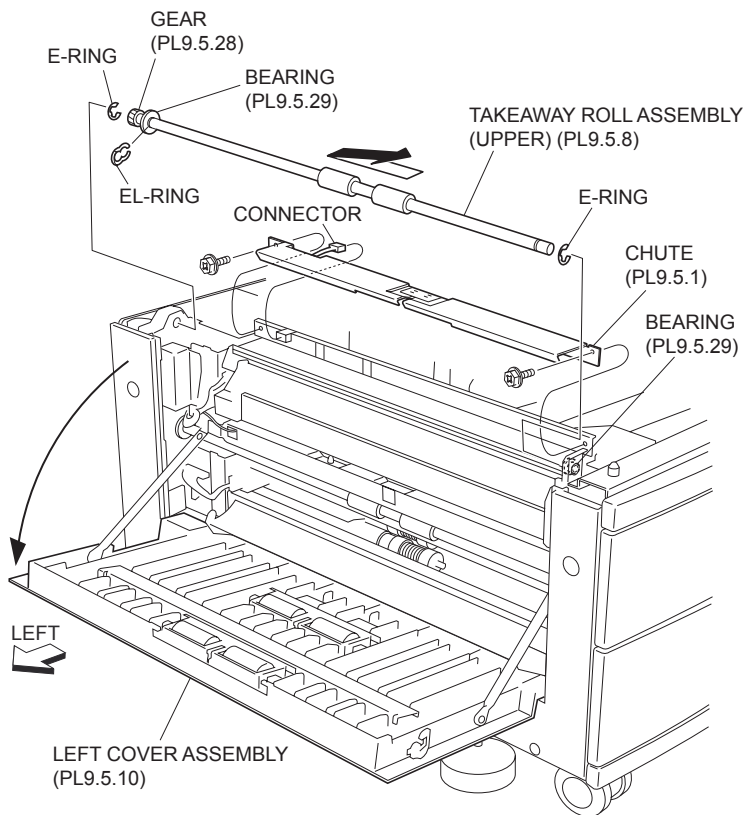
### Removal

1. Open the Left Cover Assembly (PL 9.5.10).
2. Remove the two screws (Del Tite, M3x8mm) securing the Chute (PL 9.5.1) to the machine .
3. Disconnect the connector (P/J821) of the Wire Harness (PL 9.5.4) from the machine to remove the Chute.
4. Remove the E-ring securing the Upper Takeaway Roll Assembly to the machine using a mini screwdriver or the like.
5. Remove the Bearing (PL 9.5.9) from the machine.
6. Move the Upper Takeaway Roll Assembly in the direction of the arrow to remove.

**NOTE** Note that the Bearing (PL 9.5.9) may be detached.

**NOTE** When removing, do not hold the rubber roller of the Upper Takeaway Roll Assembly.

7. Remove the left and right E-rings on the Upper Takeaway Roll Assembly, and remove the Gear and the Bearing (PL 9.5.9).



**Figure 1 Upper Takeaway Roll Assembly**

## Replacement

1. Install the Gear and the Bearing (PL 9.5.9) to the Upper Takeaway Roll Assembly, and using the E-rings on left and right.

**NOTE** Install the Gear by aligning it with the D-shape. Also, be careful not to install the Bearing in a wrong direction.

**NOTE** When installing, do not hold the rubber roller of the Upper Takeaway Roll Assembly.

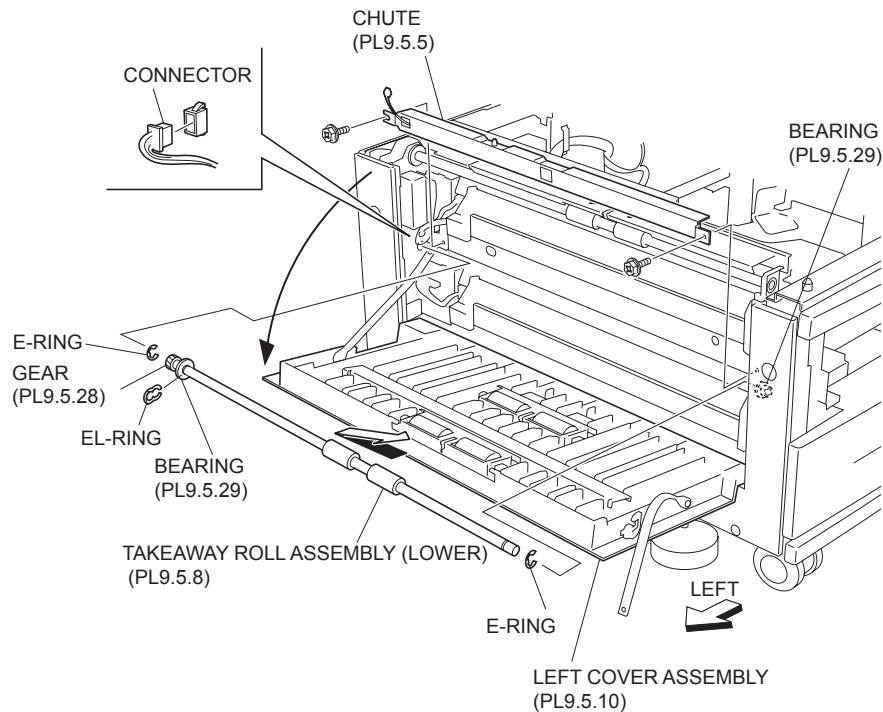
2. Move the Upper Takeaway Roll Assembly in the opposite direction of the arrow to install.
3. Install the Bearing to the machine.
4. Secure the Upper Takeaway Roll Assembly to the machine with the one E-ring.
5. Connect the connector (P/J821) of the Wire Harness (PL 9.5.4) to the machine.
6. Secure the Chute (PL 9.5.1) to the machine using two screws (Del Tite, M3x8mm).
7. Close the Left Cover Assembly (PL 9.5.10).

## Lower Takeaway Roll Assembly

### Removal

1. Open the Left Cover Assembly (PL 9.5.10).
2. Remove the two screws (Del Tite, M3x8mm) securing the Chute (PL 9.5.5) to the machine .

3. Disconnect the connector (P/J825) of the Wire Harness (PL 9.5.7) from the machine to remove the Chute.
4. Remove the E-ring securing the Lower Takeaway Roll Assembly to the machine using a mini screwdriver or the like.
5. Remove the Bearing (PL 9.5.9) from the machine.
6. Move the Lower Takeaway Roll Assembly in the direction of the arrow to remove.
7. Note that the Bearing (PL 9.5.9) may be detached.
8. When removing, do not hold the rubber roller of the Lower Takeaway Roll Assembly.
9. Remove the left and right E-rings on the Lower Takeaway Roll Assembly and remove the Gear (PL 9.5.28) and the Bearing (PL 9.5.9).



**Figure 1 Lower Takeaway Roll Assembly**

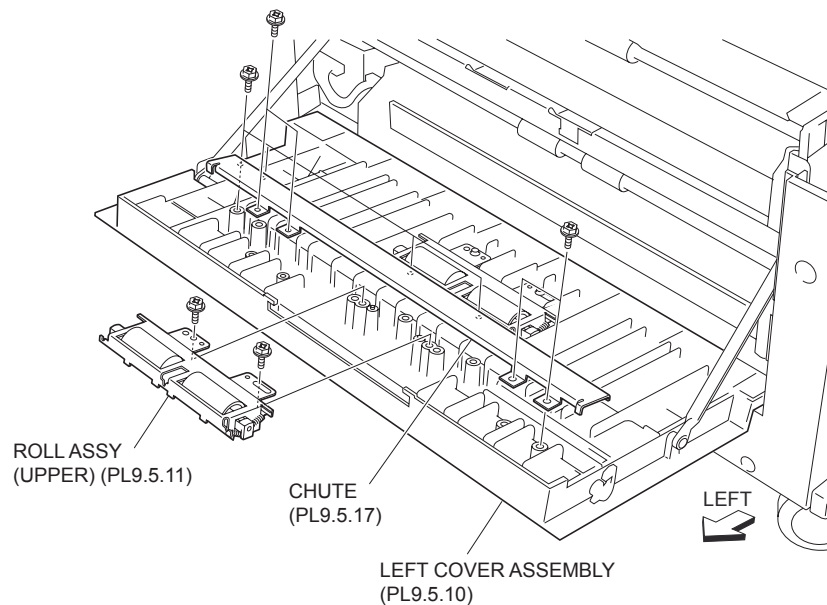
## Replacement

1. Install the Gear and the Bearing (PL 9.5.9) to the Lower Takeaway Roll Assembly, and then using the E-rings on left and right.
2. Install the Gear by aligning it with the D-shape. Also, be careful not to install the Bearing in a wrong direction.
3. When installing, do not hold the rubber roller of the Lower Takeaway Roll Assembly.
4. Move the Lower Takeaway Roll Assembly in the opposite direction of the arrow to install.
5. Install the Bearing to the machine.
6. Install the Lower Takeaway Roll Assembly to the machine with the one E-ring.
7. Connect the connector (P/J825) of the Wire Harness (PL 9.5.7) to the machine.
8. Install the Chute (PL 9.5.5) to the machine using two screws (Del Tite, M3x8mm).
9. Close the Left Cover Assembly (PL 9.5.10).

## Upper Roll Assembly

## Removal

1. Open the Left Cover Assembly (PL 9.5.10).
2. Remove the screw (Silver, M3x8mm) securing the Chute (PL 9.5.17) to the Left Cover Assembly to remove the Chute .
3. Remove the two screws (Silver, M3x8mm) securing the Upper Roll Assembly to the Left Cover Assembly.
4. Remove the Upper Roll Assembly.



**Figure 1 Upper Roll Assembly**

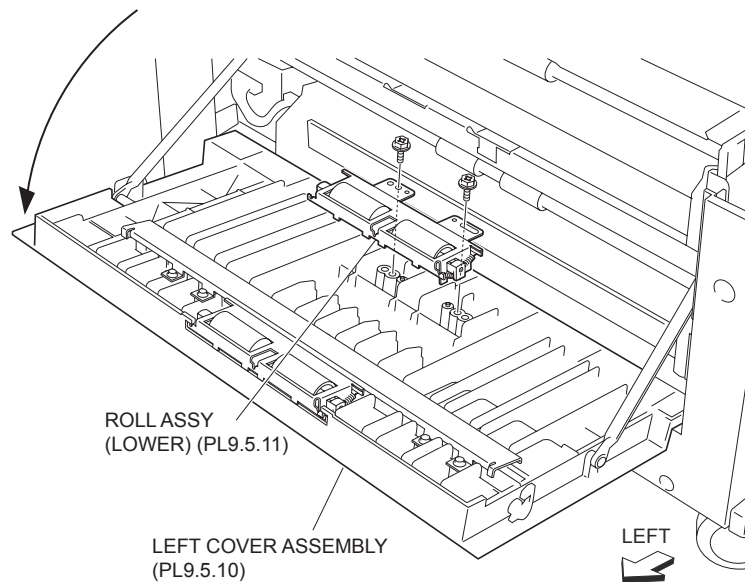
## Replacement

1. Install the Upper Roll Assembly to the Left Cover Assembly (PL 9.5.10) using two screws (Silver, M3x8mm).
2. Install the Chute (PL 9.5.17) to the Left Cover Assembly using the one screw (Silver, M3x8mm).
3. Close the Left Cover Assembly.

## Lower Roll Assembly

### Removal

1. Open the Left Cover Assembly (PL 9.5.10).
2. Remove the two screws (Silver, M3x8mm) securing the Lower Roll Assembly to the Left Cover Assembly .
3. Remove the Lower Roll Assembly.



**Figure 1 Lower Roll Assembly**

### Replacement

1. Install the Lower Roll Assembly to the Left Cover Assembly (PL 9.5.10) using two screws (Silver, M3x8mm).
2. Close the Left Cover Assembly (PL 9.5.10).

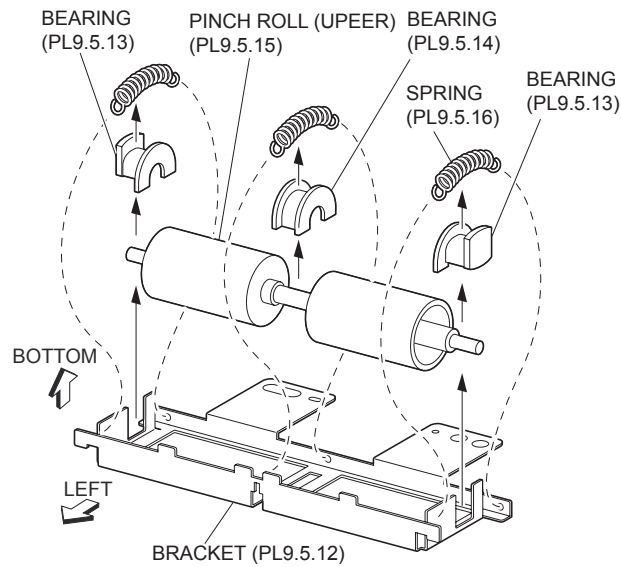
### Upper Pinch Roll

#### Removal

1. Open the Left Cover Assembly (PL 9.5.10).
2. Remove the Upper Roll Assembly (PL 9.5.11) .
3. Place the Upper Roll Assembly upside down.
4. Remove the three Springs (PL 9.5.16) from the Bracket (PL 9.5.12) .

**NOTE** When the Spring is removed, two Bearings (PL 9.5.13) and one Bearing (PL 9.5.14) are detached. Be careful not to lose them.

5. Remove the Upper Pinch Roll.



**Figure 1 Upper Pinch Roll**

## Replacement

1. Secure the Upper Pinch Roll to the Bracket (PL 9.5.12) using the three Springs (PL 9.5.16).

**NOTE** Install the Bearing (PL 9.5.14) to the center of the shaft of the Upper Pinch Roll, and the Bearings (PL 9.5.13) on both ends of the shaft in the direction shown in the figure, secure them with three Springs.

2. Install the Upper Roll Assembly .
3. Close the Left Cover Assembly (PL 9.5.10).

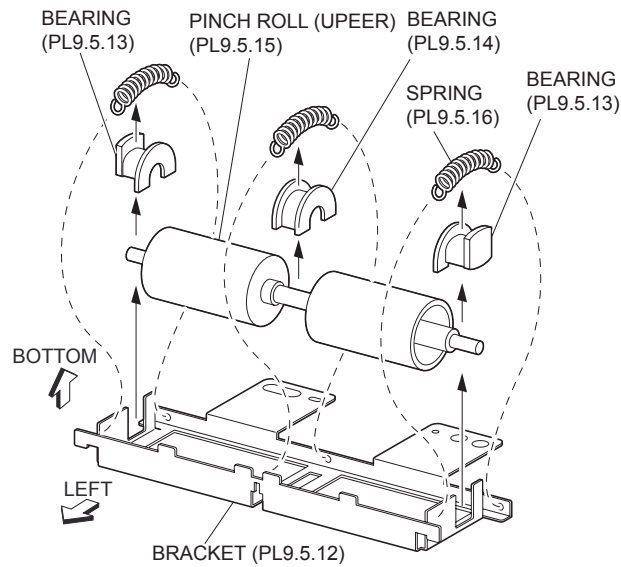
## Lower Pinch Roll

### Removal

1. Open the Left Cover Assembly (PL 9.5.10).
2. Remove the Lower Roll Assembly (PL 9.5.11) .
3. Place the Lower Roll Assembly upside down .
4. Remove the three Springs (PL 9.5.16) from the Bracket (PL 9.5.12).

**NOTE** When the Spring is removed, two Bearings (PL 9.5.13) and one Bearing (PL 9.5.14) are detached. Be careful not to lose them.

5. Remove the Lower Pinch Roll.



**Figure 1 Lower Pinch Roll**

## Replacement

1. Secure the Lower Pinch Roll to Bracket (PL 9.5.12) using the three Springs (PL 9.5.16).

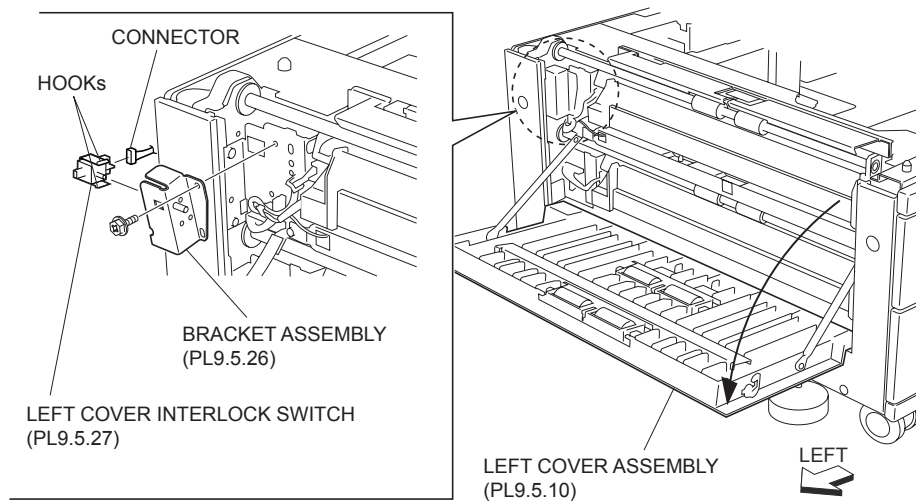
**NOTE** Install the Bearing (PL 9.5.14) to the center of the shaft of the Lower Pinch Roll, and Bearings (PL 9.5.13) on both ends of the shaft in the direction shown in the figure, secure them with three Springs.

2. Install the Lower Roll Assembly (PL 9.5.11) .
3. Close the Left Cover Assembly (PL 9.5.10).

## Left Cover Interlock Switch

### Removal

1. Open the Left Cover Assembly (PL 9.5.10).
2. Remove the one screw (Del Tite, M3x8mm) securing the Bracket Assembly (PL 9.5.26) to the machine .
3. Disconnect the connector (FS812) of the Wire Harness (PL 9.6.13) from the Left Cover Interlock Switch to remove the Bracket Assembly.
4. Release the hooks securing the Left Cover Interlock Switch to the Bracket Assembly.
5. Remove the Left Cover Interlock Switch.



**Figure 1 Left Cover Interlock Switch**

## Replacement

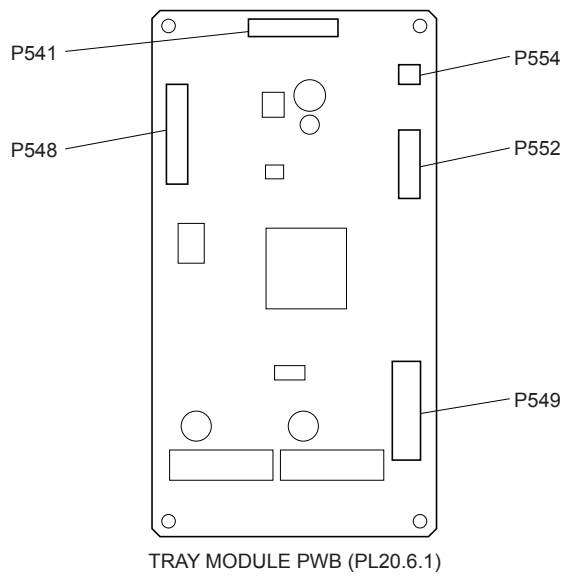
1. Secure the Left Cover Interlock Switch to the Bracket Assembly (PL 9.5.26) with the hook.
2. Connect the connector (FS812) of the Wire Harness (PL 9.6.13) to the Left Cover Interlock Switch.
3. Install the Bracket Assembly to the machine using the one screw (DeI Tite, M3x8mm).
4. Close the Left Cover Assembly (PL 9.5.10).

## Tray Module PWB

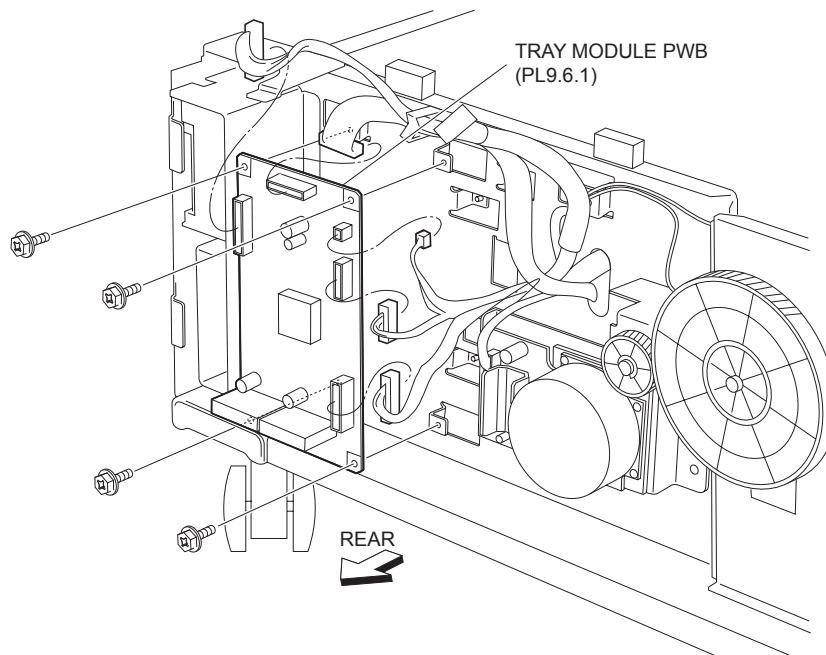
### Removal

1. Remove the Rear Cover (PL 9.1.5) .
2. Disconnect all connectors of the Wire Harness from the Tray MODULE PWB .
3. Remove the four screws securing the Tray Module PWB to the machine .
4. Remove the Tray Module PWB.





**Figure 1 Tray Module PWB**



**Figure 2 Tray Module PWB Removal**

## Replacement

1. Install the Tray Module PWB to the machine using four screws.
2. Connect all connectors of the Wire Harness to the Tray Module PWB.
3. Install the Rear Cover (PL 9.1.5) .

## Clutch

## Removal

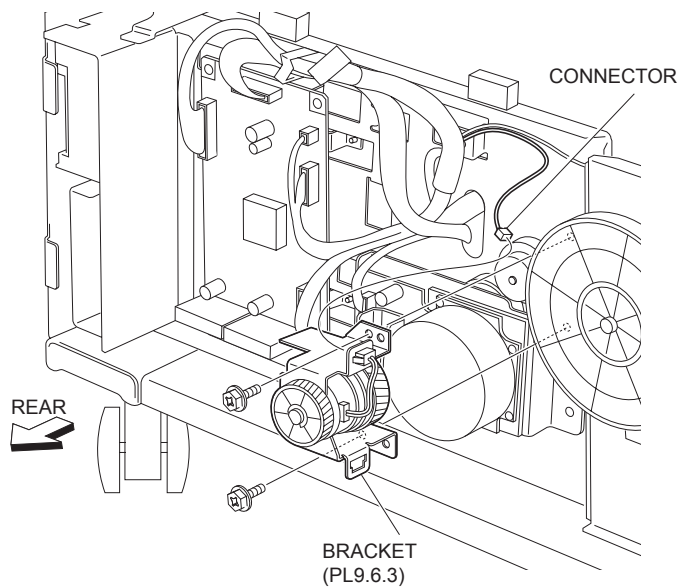
1. Remove the Rear Cover (PL 9.1.5) .
2. Disconnect the connector (P/J822) of the Wire Harness (PL 9.6.13) connected from the machine to the Bracket (PL 9.6.3) .
3. Remove the two screws (Del Tite, M3x8mm) securing the Bracket to the machine to remove the Bracket.

**NOTE** The Bearing (PL 9.6.5) and the Washer (PL 9.6.15) are detached together. Be careful not to lose them.

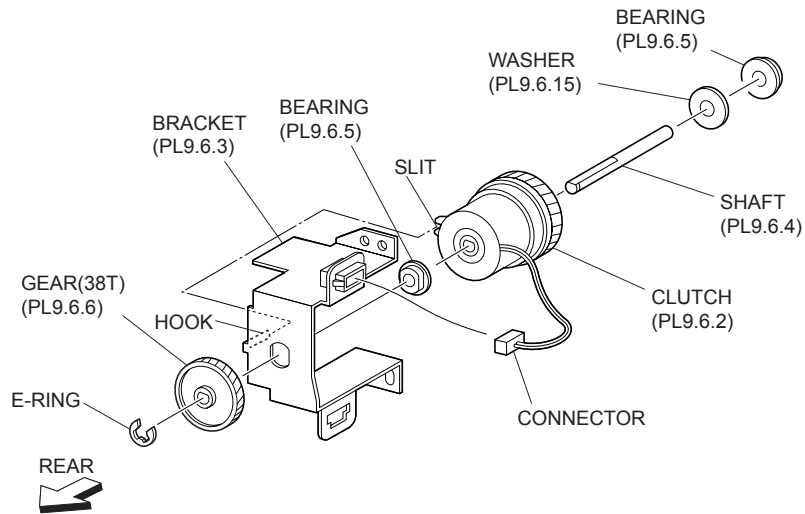
4. Remove the E-ring securing the Gear (38T) (PL 9.6.6) to the Bracket (PL 9.6.3) using a mini screwdriver or the like, and remove the Gear (38T) .

**NOTE** The Shaft (PL 9.6.4) and the Bearing are detached together. Be careful not to lose them.

5. Disconnect the harness connector of the Clutch from the Bracket by releasing the hook.
6. Remove the Clutch.



**Figure 1 Clutch Bracket**



**Figure 2 Clutch Assembly**

## Replacement

1. Secure the harness connector of the Clutch to the Bracket (PL 9.6.3) with the hook.
2. Install the Clutch together with the Gear (38T) (PL 9.6.6), the Bearing (PL 9.6.5) and the Shaft (PL 9.6.4) to the Bracket using the one E-ring.

**NOTE** Fit the Gear (38T) to the D-shaped of the Shaft. Also, Install the Bracket with its boss fit to the notch on the Clutch.

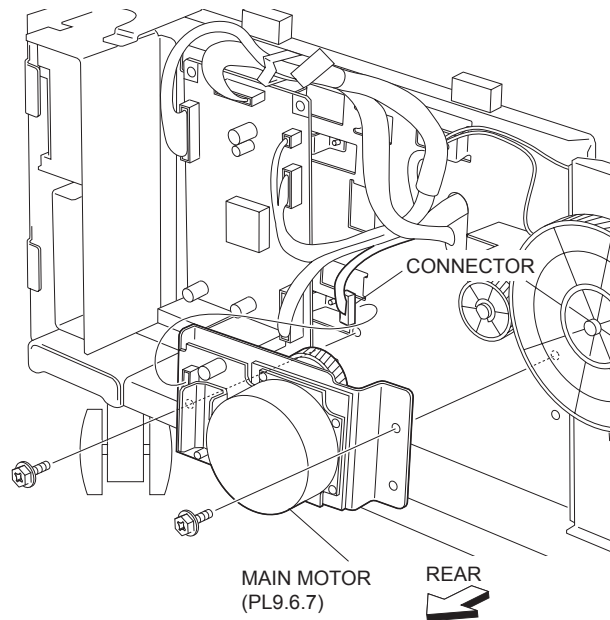
3. Install the Bracket to the machine together with the Bearing and the Washer (PL 9.6.16) using two screws (Del Tite, M3x8mm).
4. Connect the connector (P/J822) of the Wire Harness (PL 9.6.13) to the Bracket.
5. Install the Rear Cover (PL 9.1.5) .

**NOTE** After the installation, be sure that the harness connected to the Clutch does not contact the gears.

## Main Motor

### Removal

1. Remove the Rear Cover (PL 9.1.5) .
2. Disconnect the connector (P/J826) of the Wire Harness (PL 9.6.13) from the Main Motor .
3. Remove the two screws (Del Tite, M3x8mm) securing the Main Motor to the machine.
4. Remove the Main Motor.



**Figure 1 Main Motor**

## Replacement

1. Install the Main Motor to the machine using two screws (Del Tite, M3x8mm).
2. Connect the connector (P/J826) of the Wire Harness (PL 9.6.13) to the Main Motor.
3. Install the Rear Cover (PL 9.1.5) .

# Duplex Unit

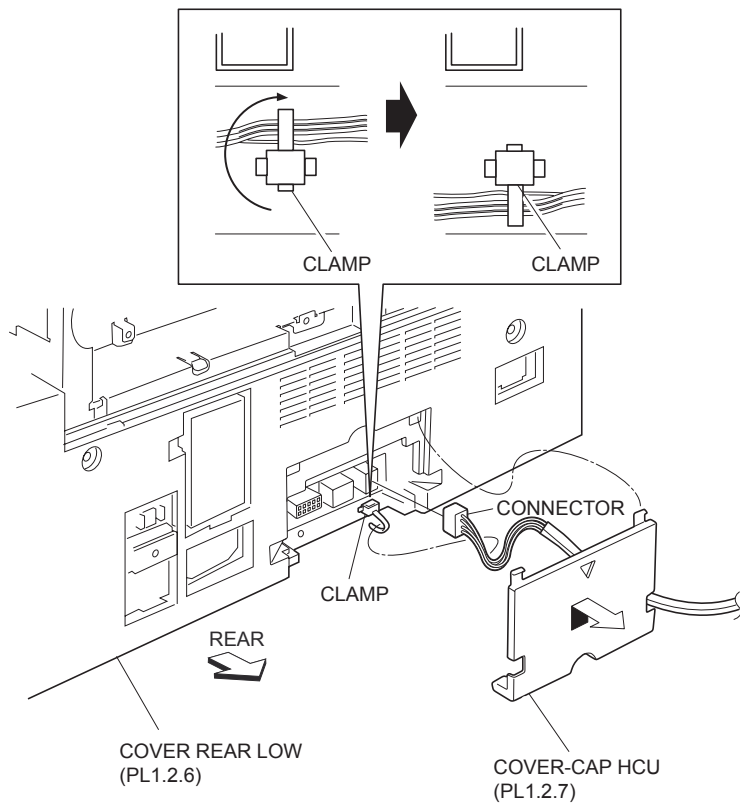
## Duplex Transport Unit

### Removal

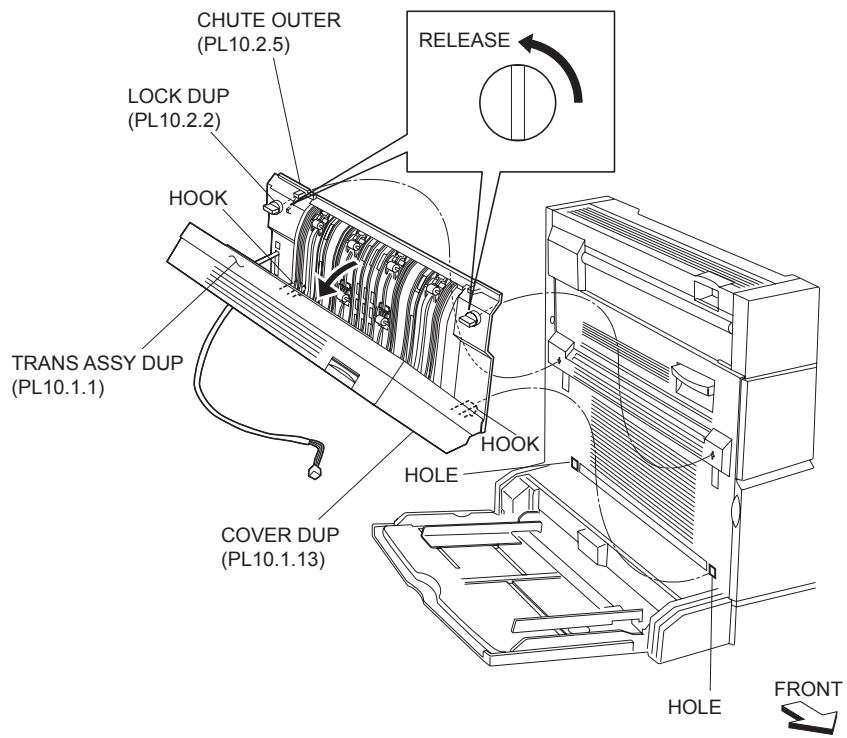
1. Move the MCU Cap Cover (PL 1.2.7) in the direction of the arrow to remove it from the Lower Rear Cover (PL 1.2.6) .
2. Disconnect the connector (Duplex) of Duplex Harness Assembly A (PL 10.1.22) from the machine.
3. Release the Duplex Harness Assembly A from the clamp.
4. Open the Duplex Cover (PL 10.1.13).
5. Turn the Duplex Locks (PL 10.2.2) left and right on the Outer Chute (PL 10.2.5) by 90 degrees as shown in the figure to release the Outer Chute from the printer .

**NOTE** When the Duplex Lock is released, the Duplex Transport Unit may fall down. Be sure to rotate the Duplex Lock until them click while holding the Duplex Transport Unit by hand.

6. Remove the Duplex Transport Unit.



**Figure 1 Cap Cover**



**Figure 2 Duplex Locks**

## Replacement

1. Connect the Duplex connector of the Duplex Harness Assembly A (PL 10.1.22) to the machine.
2. Secure the Duplex Harness Assembly A to the clamp.
3. Move the MCU Cap Cover (PL 1.2.7) in the opposite direction of the arrow to install.

**NOTE** Be careful not to pinch harness.

4. Turn the Duplex Locks (PL 10.2.2) left and right on the Outer Chute (PL 10.2.5) by 90 degrees in the opposite direction of the arrow shown in the figure to lock them.

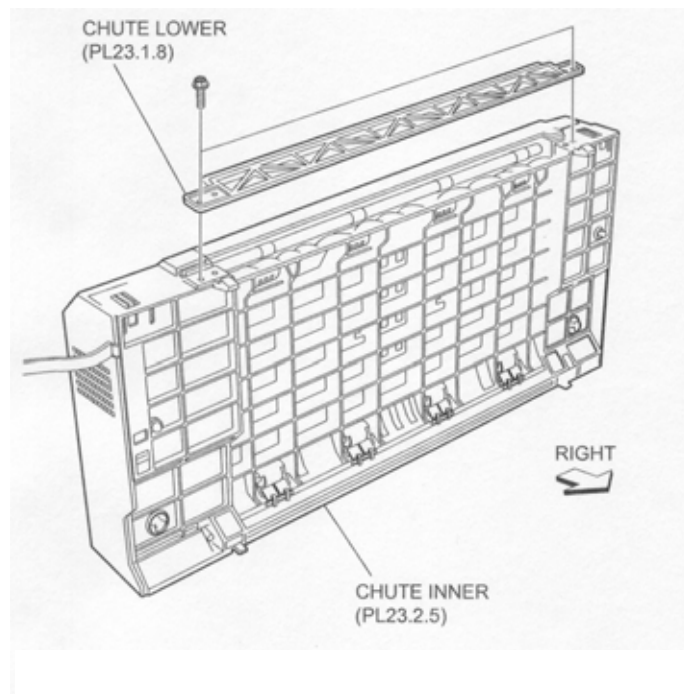
**NOTE** Fit the hooks on the lower part of the Duplex Transport Unit into the holes on the machine, and turn the Duplex Locks until they click.

5. Close the Duplex Cover (PL 10.1.13).

## Roll Gear 28

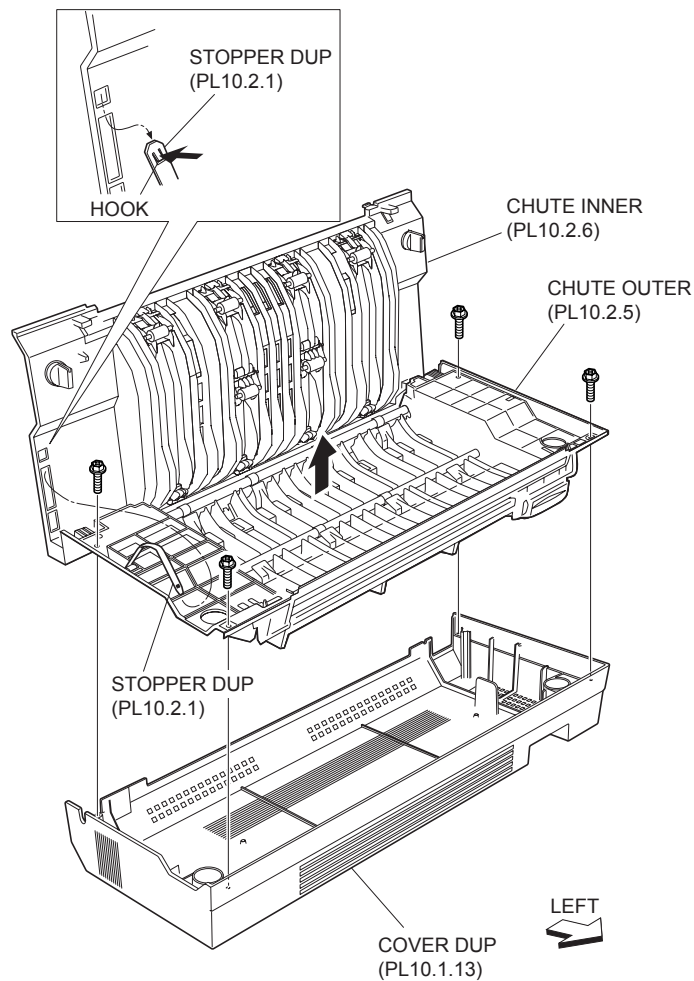
### Removal

1. Remove the Duplex Transport Unit (PL 10.1.1) .
2. Remove the two screws (Silver, M3x8mm) securing the Lower Chute (PL 10.1.8) to the Outer Chute (PL 10.2.5) to remove the Lower Chute .
3. Open the Inner Chute (PL 10.2.6).



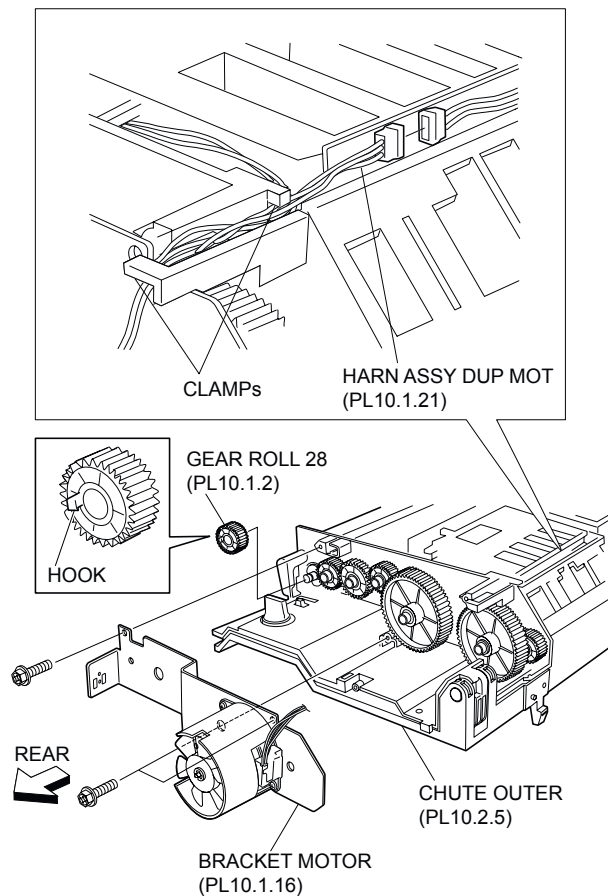
**Figure 1 Lower Chute**

4. Release the hook of the Duplex Stopper (PL 10.2.1) securing the Outer Chute to the Inner Chute .
5. Remove the four screws (Silver, M3x8mm) securing the Outer Chute and the Inner Chute to the Duplex Cover (PL 10.1.13) to remove the Outer Chute and the Inner Chute.



**Figure 2 Outer Chute**

6. Disconnect the junction connector (P/J212) of the Duplex Motor Harness Assembly (PL 10.1.21) from the Motor Harness of the Duplex Motor Assembly (PL 10.1.11) .
7. Release the Duplex Harness Assembly A from the clamps on the Outer Chute.
8. Remove the three screws (Silver, M3x8mm) securing the Motor Bracket (PL 10.1.16) to the Outer Chute and remove the Motor Bracket.
9. While releasing the hook securing the Roll Gear 28 to the Outer Chute as shown in the figure to remove the Roll Gear 28.



**Figure 3 Duplex Motor Assembly**

## Replacement

1. Install the Roll Gear 28.

**NOTE** Install the Roll Gear 28 to the Outer Chute (PL 10.2.5) until it is locked firmly.

2. Install the Motor Bracket (PL 10.1.16) to the Outer Chute using the three screws (Silver, M3x8mm).
3. Connect the junction connector (P/J212) of the Duplex Motor Harness Assembly (PL 10.1.21) to the Duplex Motor Assembly (PL 10.1.11), and secure the Duplex Harness Assembly A with the clamp on the Outer Chute.
4. Install the Outer Chute and the Inner Chute (PL 10.2.6) to the Duplex Cover (PL 10.1.13) using four screws (Silver, M3x8mm).

**NOTE** Be careful not to let the Duplex Stopper (PL 10.2.1) detach from the Outer Chute.

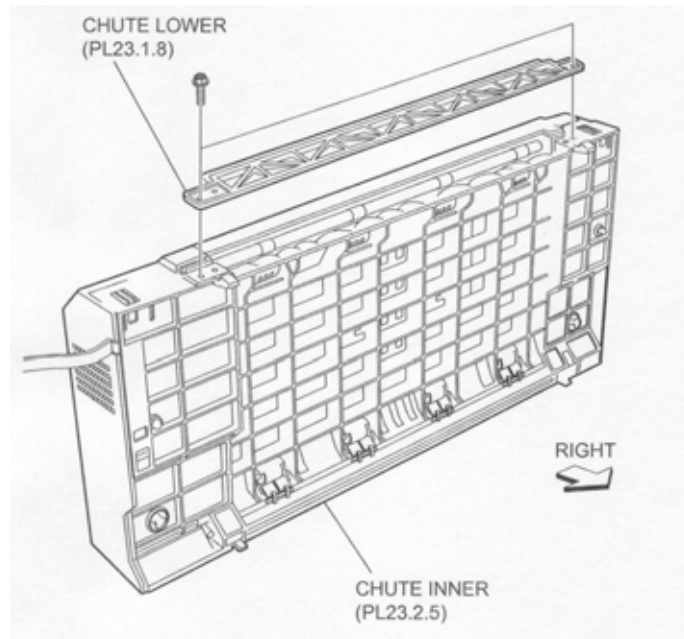
5. Install the Duplex Stopper to the Inner Chute.
6. Close the Inner Chute.
7. Install the Lower Chute (PL 10.1.8) to the Outer Chute using the two screws (Silver, M3x8mm).
8. Install the Duplex Transport Unit (PL 10.1.1) .

## Idle Gear 33 74

### Removal

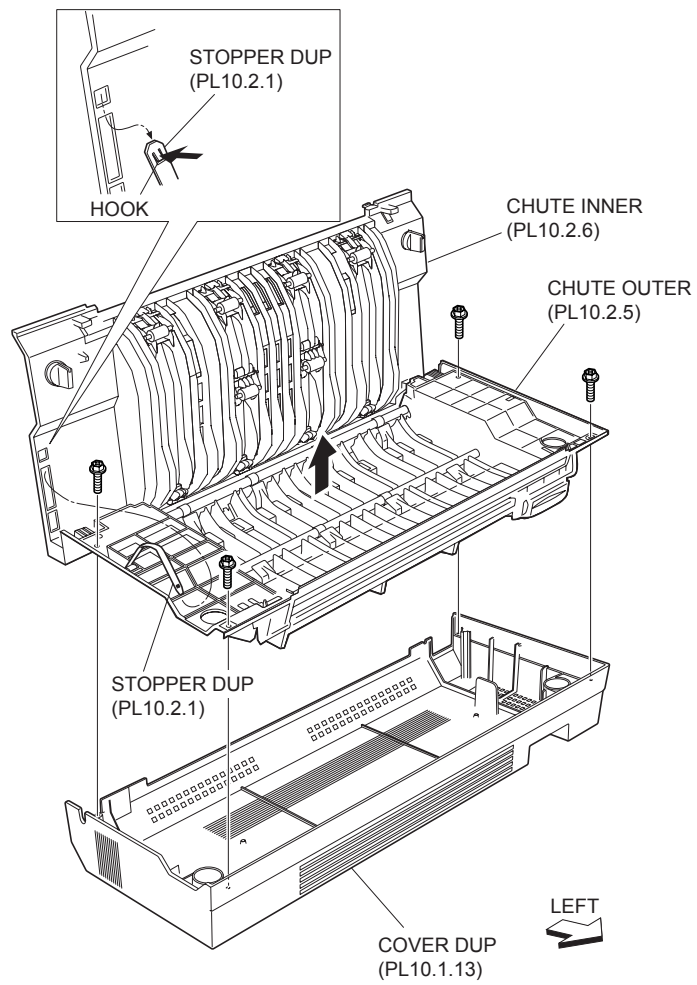


1. Remove the Duplex Transport Unit (PL 10.1.1) .
2. Remove the two screws (Silver, M3x8mm) securing the Lower Chute (PL 10.1.8) to the Outer Chute (PL 10.2.5) to remove the Lower Chute .

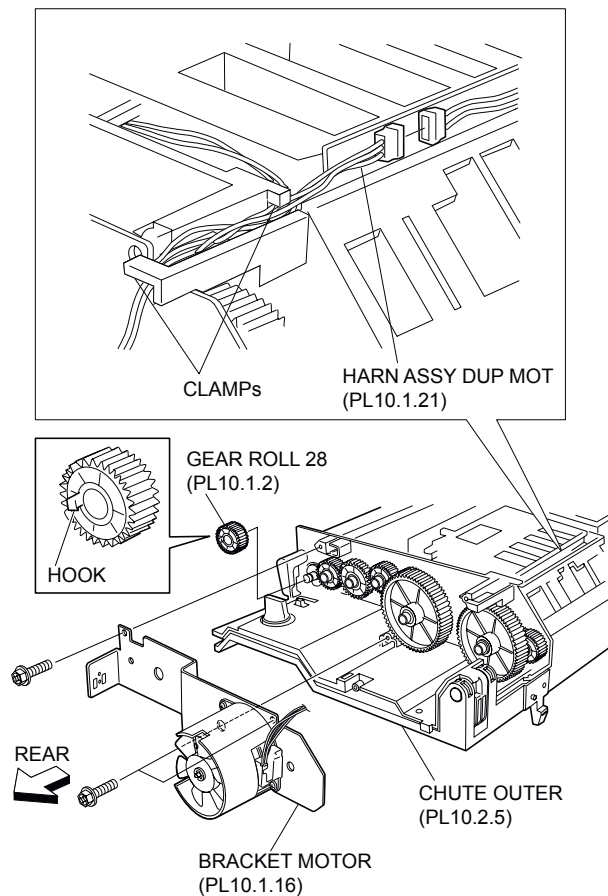


**Figure 1 Lower Chute**

3. Open the Inner Chute (PL 10.2.6).
4. Release the hook of the Duplex Stopper (PL 10.2.1) securing the Outer Chute to the Inner Chute .
5. Remove the four screws (Silver, M3x8mm) securing the Outer Chute and the Inner Chute to the Duplex Cover (PL 10.1.13) to remove the Outer Chute and the Inner Chute.
6. Disconnect the junction connector (P/J212) of the Duplex Motor Harness Assembly (PL 10.1.21) from the Motor Harness of the Duplex Motor Assembly (PL 10.1.11).
7. Release the Duplex Harness Assembly A from the clamps on the Outer Chute.
8. Remove the three screws (Silver, M3x8mm) securing the Motor Bracket (PL 10.1.16) to the Outer Chute to remove the Motor Bracket.
9. Remove the Idle Gear 33 74.



**Figure 2 Outer Chute**



**Figure 3 Duplex Motor Assembly**

## Replacement

1. Install the Idle Gear 33 74.
2. Install the Motor Bracket (PL 10.1.16) to the Outer Chute (PL 10.2.5) using the three screws (Silver, M3x8mm).
3. Connect the junction connector (P/J212) of the Duplex Motor Harness Assembly (PL 10.1.21) to the Motor Harness of the Duplex Motor Assembly (PL 10.1.11) and secure the the Duplex Harness Assembly A with the clamps on the Outer Chute.
4. Install the Outer Chute and the Inner Chute (PL 10.2.6) to the Duplex Cover (PL 10.1.13) using four screws (Silver, M3x8mm).

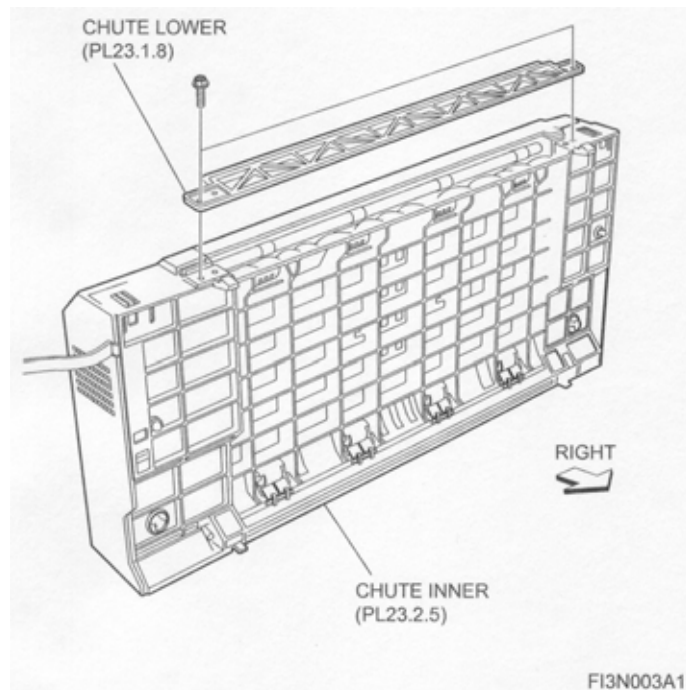
**NOTE** Be careful not to let the Duplex Stopper (PL 10.2.1) detach from the Outer Chute.

5. Install the Duplex Stopper to the Inner Chute.
6. Close the Inner Chute.
7. Install the Lower Chute (PL 10.1.8) to the Outer Chute using the two screws (Silver, M3x8mm).
8. Install the Duplex Transport Unit (PL 10.1.1) .

## Idle Gear 33

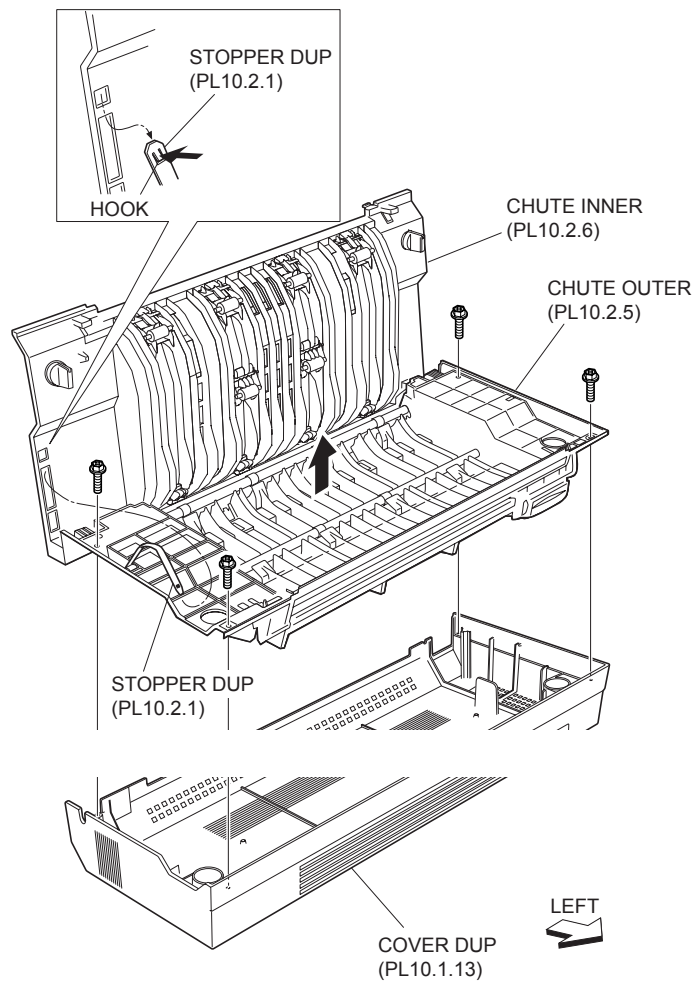
### Removal

1. Remove the Duplex Transport Unit (PL 10.1.1) .
2. Remove the two screws (Silver, M3x8mm) securing the Lower Chute (PL 10.1.8) to the Outer Chute (PL 10.2.5) to remove the Lower Chute .

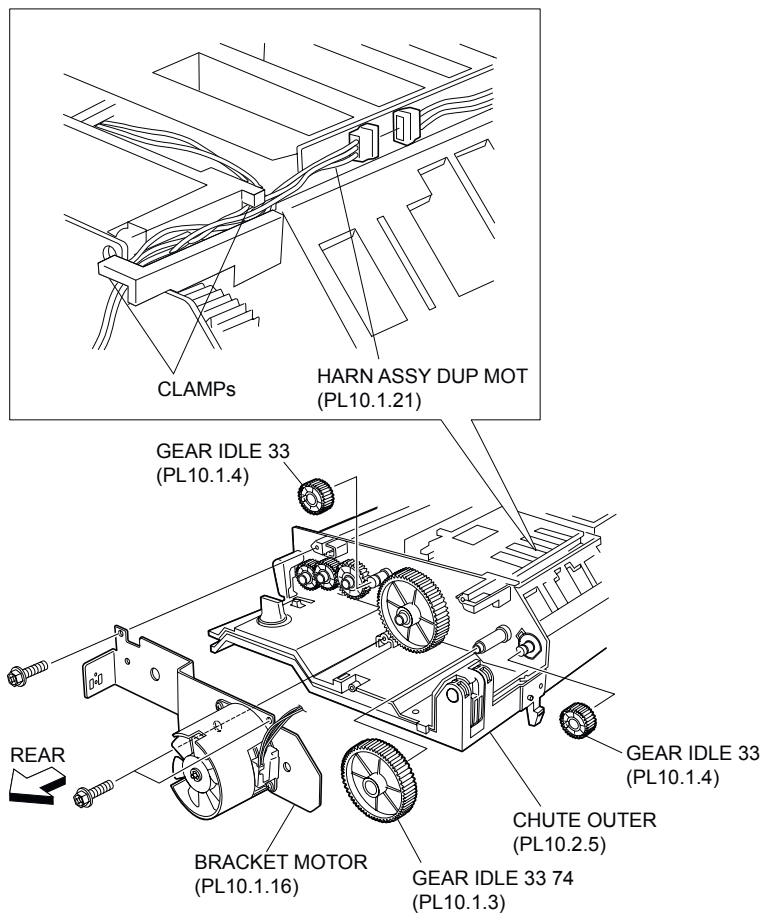


**Figure 1 Lower Chute**

3. Open the Inner Chute (PL 10.2.6).
4. Release the hook of the Duplex Stopper (PL 10.2.1) securing the Outer Chute to the Inner Chute .
5. Remove the four screws (Silver, M3x8mm) securing the Outer Chute and the Inner Chute to the Duplex Cover (PL 10.1.13) to remove the Outer Chute and the Inner Chute.
6. Disconnect the junction connector (P/J212) of the Duplex Motor Harness Assembly (PL 10.1.21) from the Motor Harness of the Duplex Motor Assembly (PL 10.1.11) .
7. Release the Duplex Harness Assembly A from the clamps on the Outer Chute.
8. Remove the three screws (Silver, M3x8mm) securing the Motor Bracket (PL 10.1.16) to the Outer Chute to remove the Motor Bracket.
9. Remove the Idle Gear 33.



**Figure 2 Outer Chute**



**Figure 3 Duplex Motor Assembly**

## Replacement

1. Install the Idle Gear 33.
2. Install the Motor Bracket (PL 10.1.16) to the Outer Chute (PL 10.2.5) using the three screws (Silver, M3x8mm).
3. Connect the junction connector (P/J212) of the Duplex Motor Harness Assembly (PL 10.1.21) to the Motor Harness of the Duplex Motor Assembly (PL 10.1.11) and secure the the Duplex Harness Assembly A with the clamps on the Outer Chute.
4. Install the Outer Chute and the Inner Chute (PL 10.2.6) to the Duplex Cover (PL 10.1.13) using four screws (Silver, M3x8mm).

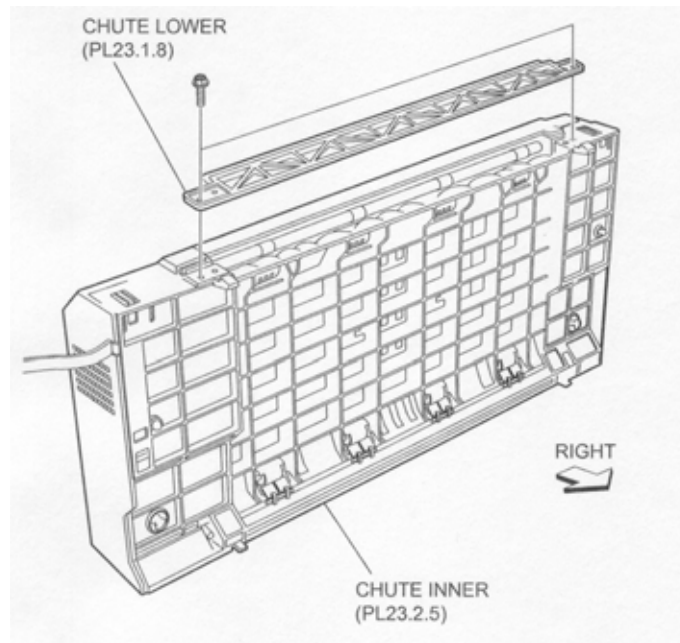
**NOTE** Be careful not to let the Duplex Stopper (PL 10.2.1) detach from the Outer Chute.

5. Install the Duplex Stopper to the Inner Chute.
6. Close the Inner Chute.
7. Install the Lower Chute (PL 10.1.8) to the Outer Chute using two screws (Silver, M3x8mm).
8. Install the Duplex Transport Unit (PL 10.1.1) .

## Idle Gear 42

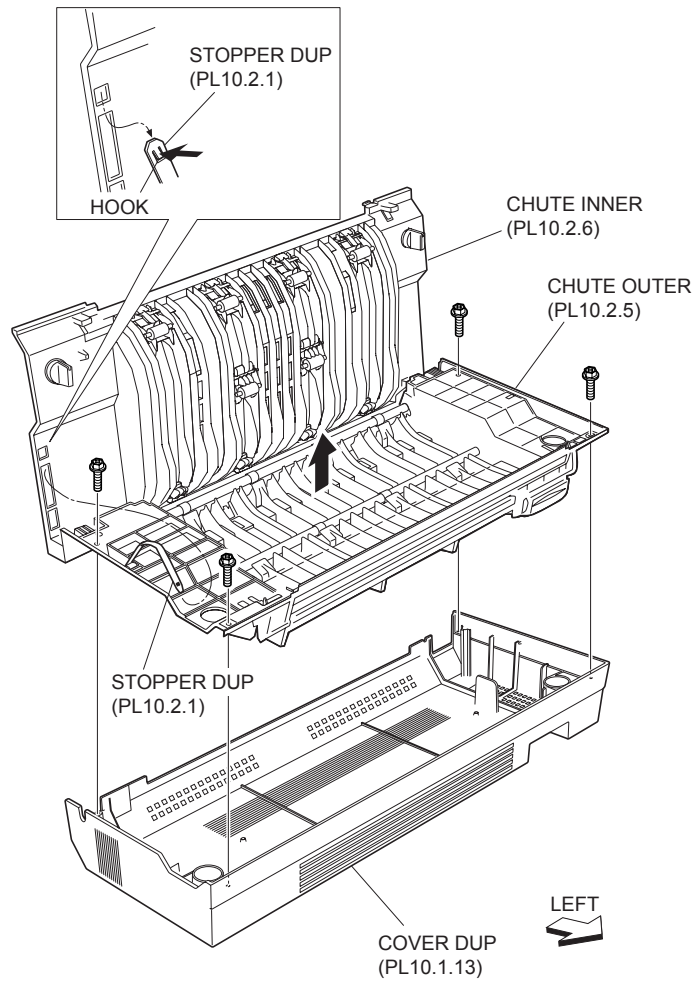
### Removal

1. Remove the Duplex Transport Unit (PL 10.1.1) .
2. Remove the two screws (Silver, M3x8mm) securing the Lower Chute (PL 10.1.8) to the Outer Chute (PL 10.2.5) to remove the Lower Chute.



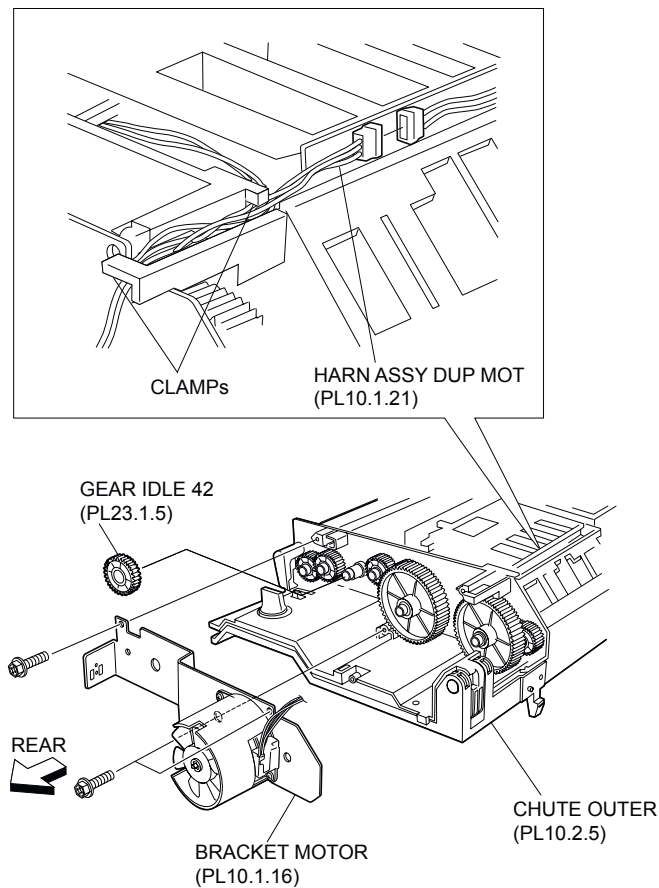
**Figure 1 Lower Chute**

3. Open the Inner Chute (PL 10.2.6).
4. Release the hook of the Duplex Stopper (PL 10.2.1) securing the Outer Chute to the Inner Chute .
5. Remove the four screws (Silver, M3x8mm) securing the Outer Chute and the Inner Chute to the Duplex Cover (PL 10.1.13) to remove the Outer Chute and the Inner Chute.
6. Disconnect the junction connector (P/J212) of the Duplex Motor Harness Assembly (PL 10.1.21) from the Motor Harness of the Duplex Motor Assembly (PL 10.1.11) .
7. Release the Duplex Harness Assembly A from the clamps on the Outer Chute.
8. Remove the three screws (Silver, M3x8mm) securing the Motor Bracket (PL 10.1.16) to the Outer Chute to remove the Motor Bracket.
9. Remove the Idle Gear 42.



**Figure 2 Outer Chute**





**Figure 3 Duplex Motor Assembly**

## Replacement

1. Install the Idle Gear 42.
2. Install the Motor Bracket (PL 10.1.16) to the Outer Chute (PL 10.2.5) using the three screws (Silver, M3x8mm).
3. Connect the junction connector (P/J212) of the Duplex Motor Harness Assembly (PL 10.1.21) to the Motor Harness of the Duplex Motor Assembly (PL 10.1.11) and secure the the Duplex Harness Assembly A with the clamps on the Outer Chute.
4. Install the Outer Chute and the Duplex Cover (PL 10.1.13) to the Inner Chute (PL 10.2.6) using four screws (Silver, M3x8mm).

**NOTE** Be careful not to let the Duplex Stopper (PL 10.2.1) detach from the Outer Chute.

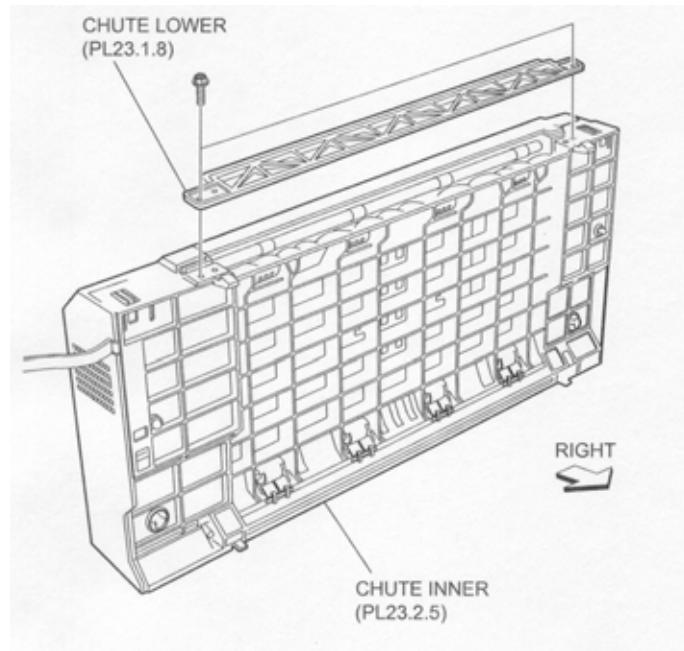
5. Install the Duplex Stopper to the Inner Chute.
6. Close the Inner Chute.
7. Install the Lower Chute (PL 10.1.8) to the Outer Chute using two screws (Silver, M3x8mm).
8. Install the Duplex Transport Unit (PL 10.1.1) .

## I/L Switch, Cab

### Removal

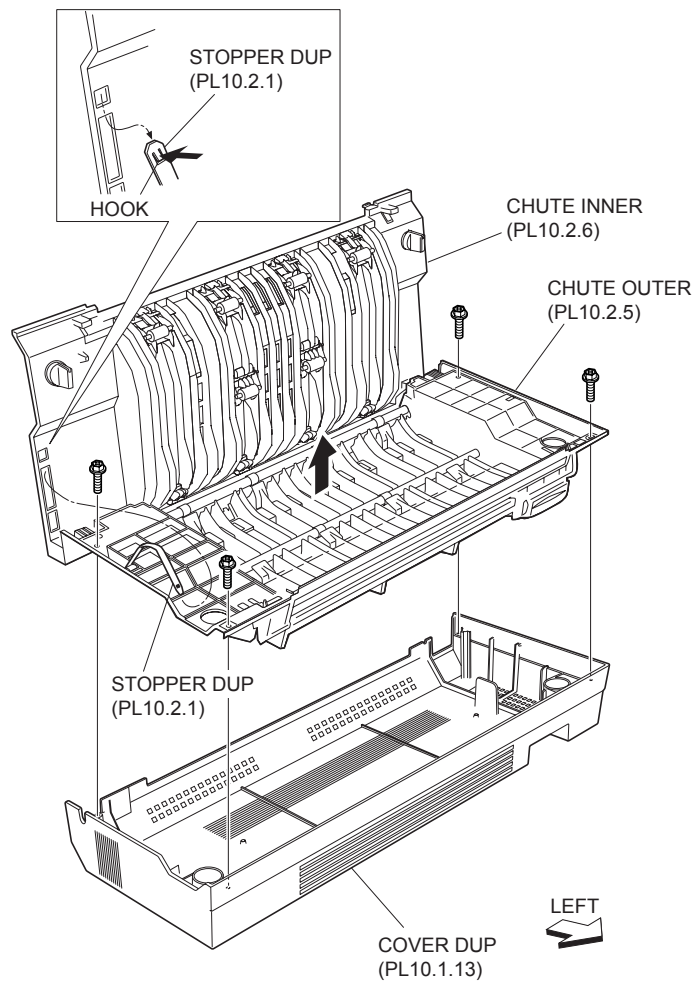
1. Remove the Duplex Transport Unit (PL 10.1.1) .

2. Remove the two screws (Silver, M3x8mm) securing the Lower Chute (PL 10.1.8) to the Outer Chute (PL 10.2.5) to remove the Lower Chute .

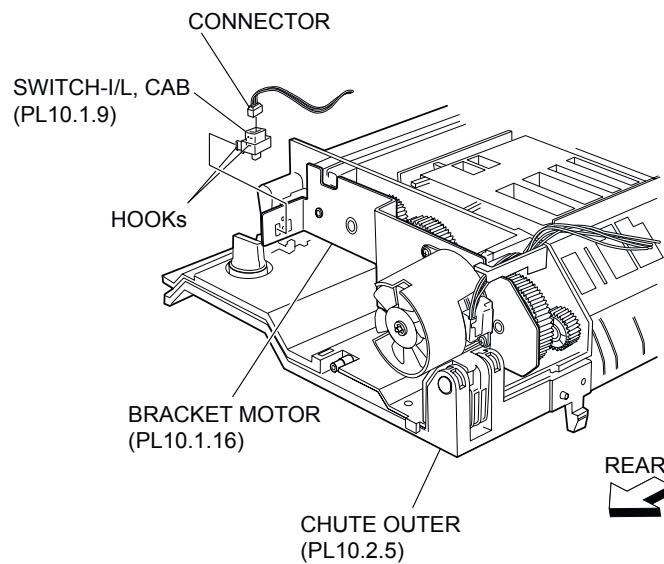


**Figure 1 Lower Chute**

3. Open the Inner Chute (PL 10.2.6).
4. Release the hook of the Duplex Stopper (PL 10.2.1) securing the Outer Chute to the Inner Chute .
5. Remove the four screws (Silver, M3x8mm) securing the Outer Chute and the Inner Chute to the Duplex Cover (PL 10.1.13) to remove the Outer Chute and the Inner Chute.
6. Disconnect the connector (P/J124) of the Duplex Sensor Harness Assembly (PL 10.1.20) from the I/L Switch, Cab.
7. Release the two hooks securing the I/L Switch, Cab to the Motor Bracket (PL 10.1.16) .
8. Remove the I/L Switch, Cab.



**Figure 2 Outer Chute**



**Figure 3 Motor Bracket**

## Replacement

1. Install the I/L Switch, Cab to the Motor Bracket (PL 10.1.16) using the two hooks.
2. Connect the connector (P/J124) of the Duplex Sensor Harness Assembly (PL 10.1.20) to the I/L Switch, Cab.
3. Install the Outer Chute (PL 10.2.5) and the Inner Chute (PL 10.2.6) to the Duplex Cover (PL 10.1.13) using four screws (Silver, M3x8mm).

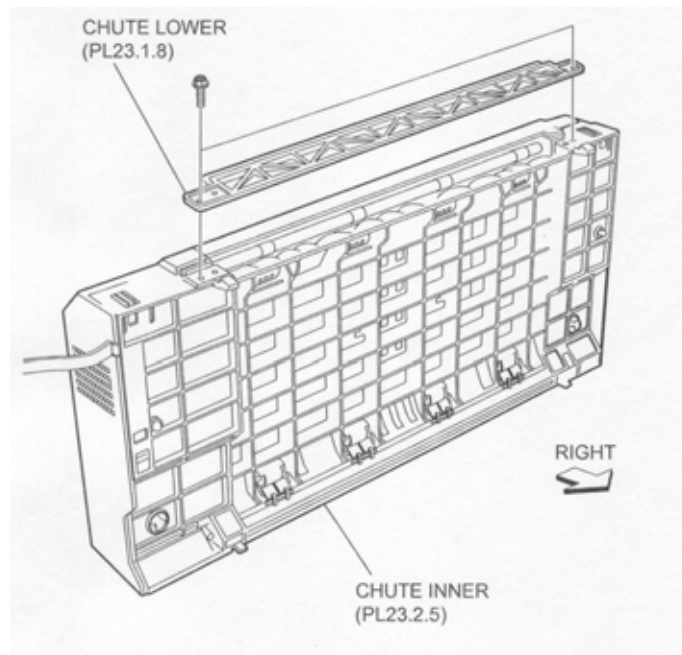
**NOTE** Be careful not to let the Duplex Stopper (PL 10.2.1) detach from the Outer Chute.

4. Install the Duplex Stopper to the Inner Chute.
5. Close the Inner Chute.
6. Install the Lower Chute (PL 10.1.8) to the Outer Chute using two screws (Silver, M3x8mm).
7. Install the Duplex Transport Unit (PL 10.1.1) .

## Duplex Actuator

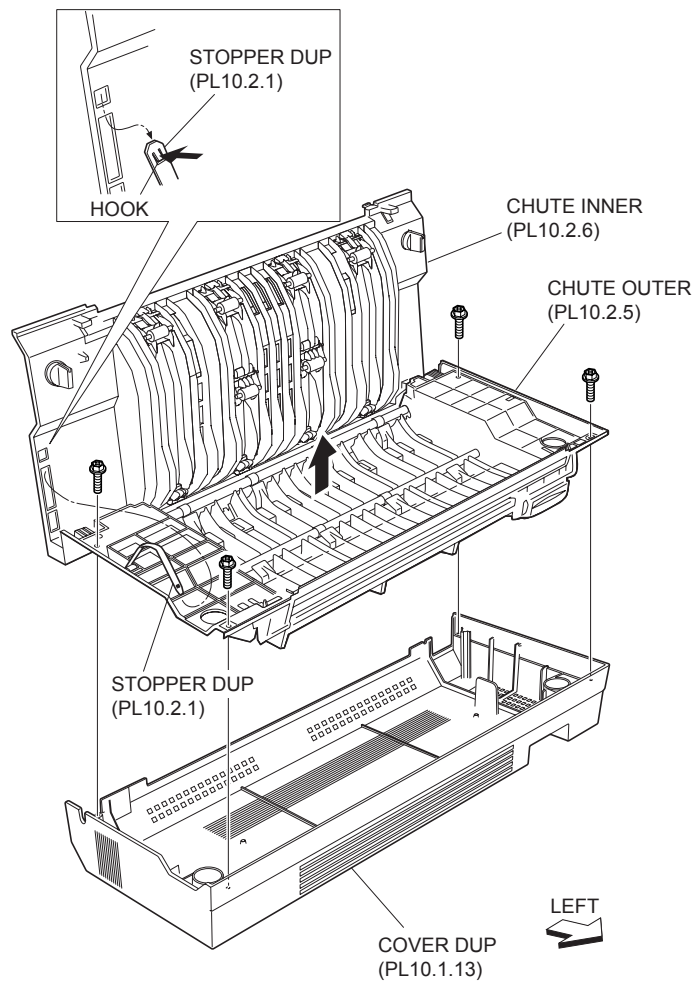
### Removal

1. Remove the Duplex Transport Unit (PL 10.1.1) .
2. Remove the two screws (Silver, M3x8mm) securing the Lower Chute (PL 10.1.8) to the Outer Chute (PL 10.2.5) to remove the Lower Chute .

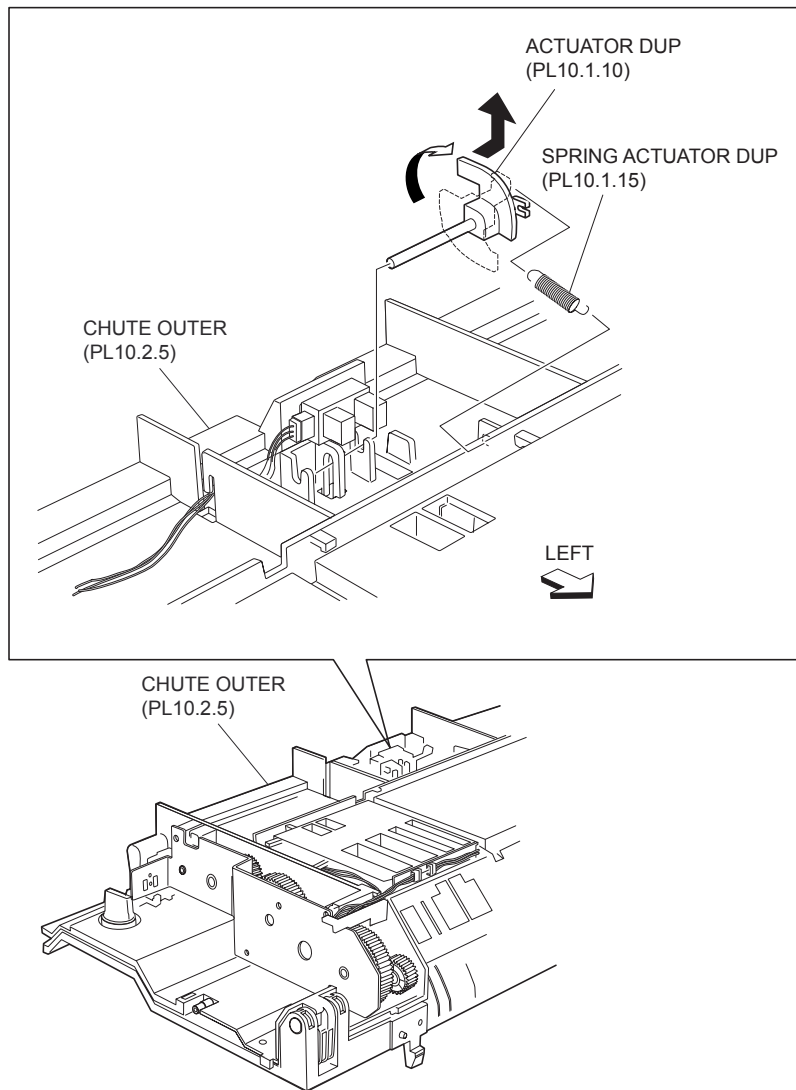


**Figure 1 Lower Chute**

3. Open the Inner Chute (PL 10.2.6).
4. Release the hook of the Duplex Stopper (PL 10.2.1) securing the Outer Chute to the Inner Chute .
5. Remove the four screws (Silver, M3x8mm) securing the Outer Chute and the Inner Chute to the Duplex Cover (PL 10.1.13) to remove the Outer Chute and the Inner Chute.
6. Remove the Duplex Actuator Spring (PL 10.1.15) from the Duplex Actuator and the Outer Chute .
7. Turn the Duplex Actuator by 180 degrees and move it in the direction of the arrow to remove.



**Figure 2 Outer Chute**



**Figure 3 Duplex Actuator**

## Replacement

1. Turn the Duplex Actuator by 180 degrees and move it in the opposite direction of the arrow to install
2. Hook the Duplex Actuator Spring (PL 10.1.15) to the Duplex Actuator and the Outer Chute.
3. Install the Outer Chute (PL 10.2.5) and the Inner Chute (PL 10.2.6) to the Duplex Cover (PL 10.1.13) using four screws (Silver, M3x8mm).

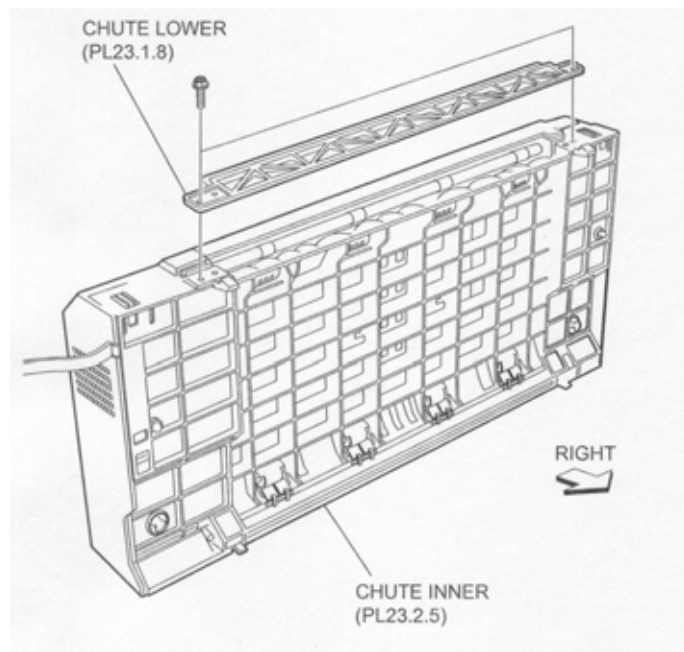
**NOTE** Be careful not to let the Duplex Stopper (PL 10.2.1) detach from the Outer Chute.

4. Install the Duplex Stopper to the Inner Chute.
5. Close the Inner Chute.
6. Install the Lower Chute (PL 10.1.8) to the Outer Chute using two screws (Silver, M3x8mm).
7. Install the Duplex Transport Unit (PL 10.1.1) .

## Duplex Motor Assembly

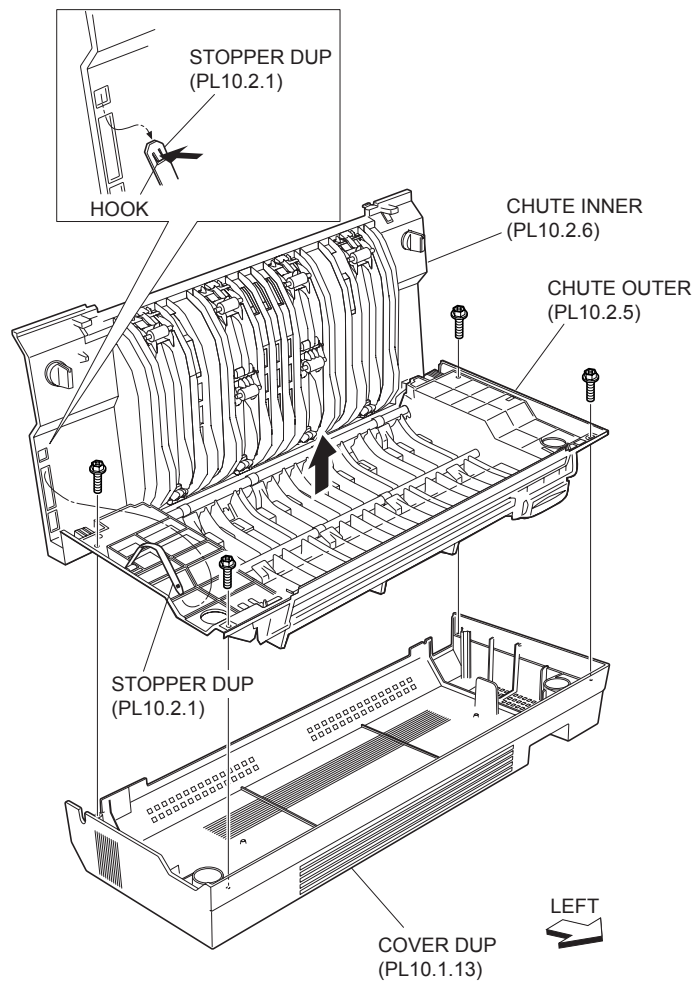
## Removal

1. Remove the Duplex Transport Unit (PL 10.1.1) .
2. Remove the two screws (Silver, M3x8mm) securing the Lower Chute (PL 10.1.8) to the Outer Chute (PL 10.2.5) to remove the Lower Chute .



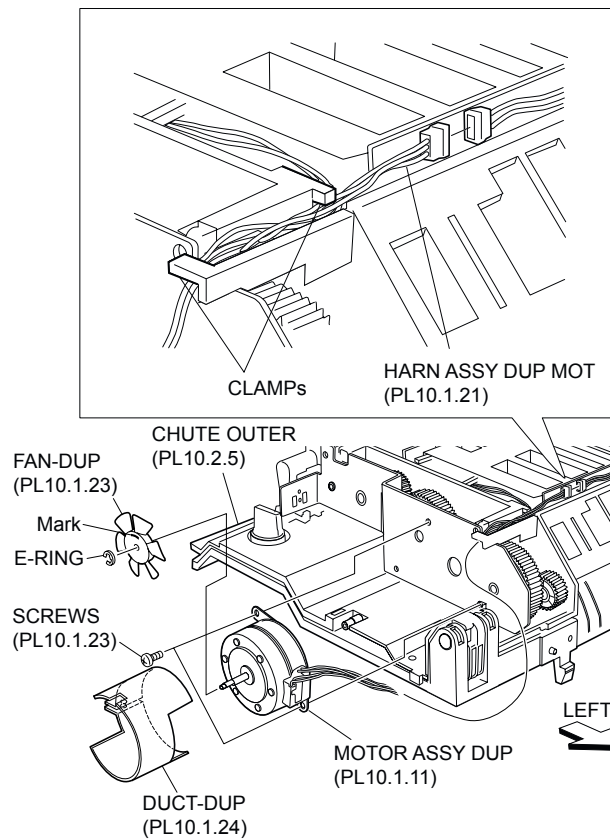
**Figure 1 Lower Chute**

3. Open the Inner Chute (PL 10.2.6).
4. Release the hook of the Duplex Stopper (PL 10.2.1) securing the Outer Chute to the Inner Chute .
5. Remove the four screws (Silver, M3x8mm) securing the Outer Chute and the Inner Chute to the Duplex Cover (PL 10.1.13) to remove the Outer Chute and the Inner Chute.
6. Disconnect the junction connector (P/J212) of the Duplex Motor Harness Assembly (PL 10.1.21) of the Duplex Motor Assembly (PL 10.1.11).
7. Release the Duplex Motor Harness Assembly from the clamps on the Outer Chute.
8. Remove the two screws (BIND, M3x6mm) securing the Duplex Motor Assembly to the Outer Chute .
9. Remove the Duplex Motor Assembly.
10. Remove the DUCT-DUP (PL 10.1.24) from the Duplex Motor Assembly.
11. Remove E-rings securing the Duplex Fan (PL 10.1.23) to the Duplex Motor Assembly, using a mini-screwdriver or the like.
12. Remove the Duplex Fan.



**Figure 2 Outer Chute**





**Figure 3 Duplex Motor Assembly**

## Replacement

1. Fit the Screw onto the shaft of the Duplex Motor Assembly and secure the screw with the E-ring.

**NOTE** Install the SCREW with the engraved mark facing outward.

2. Install the DUCT-DUP (PL 10.1.24) to the Duplex Motor Assembly.
3. Install the Duplex Motor Assembly to the Outer Chute (PL 10.2.5) using two screws (BIND, M3x6mm).
4. Connect the junction connector (P/J212) of the Duplex Motor Harness Assembly (PL 10.1.21) to the Duplex Motor Assembly (PL 10.1.11), and secure Duplex Motor Harness Assembly (PL 10.1.21) with the clamps on the Outer Chute.
5. Install the Outer Chute and the Inner Chute (PL 10.2.6) to the Duplex Cover (PL 10.1.13) using four screws (Silver, M3x8mm).

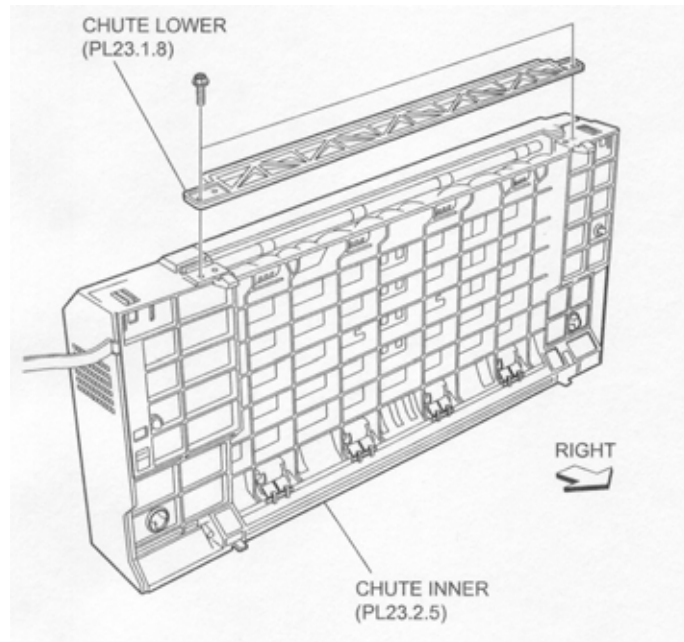
**NOTE** Be careful not to let the Duplex Stopper (PL 10.2.1) detach from the Outer Chute.

6. Install the Duplex Stopper to the Inner Chute.
7. Close the Inner Chute.
8. Install the Lower Chute (PL 10.1.8) to the Outer Chute using two screws (Silver, M3x8mm).
9. Install the Duplex Transport Unit (PL 10.1.1) .

## Duplex PWBA

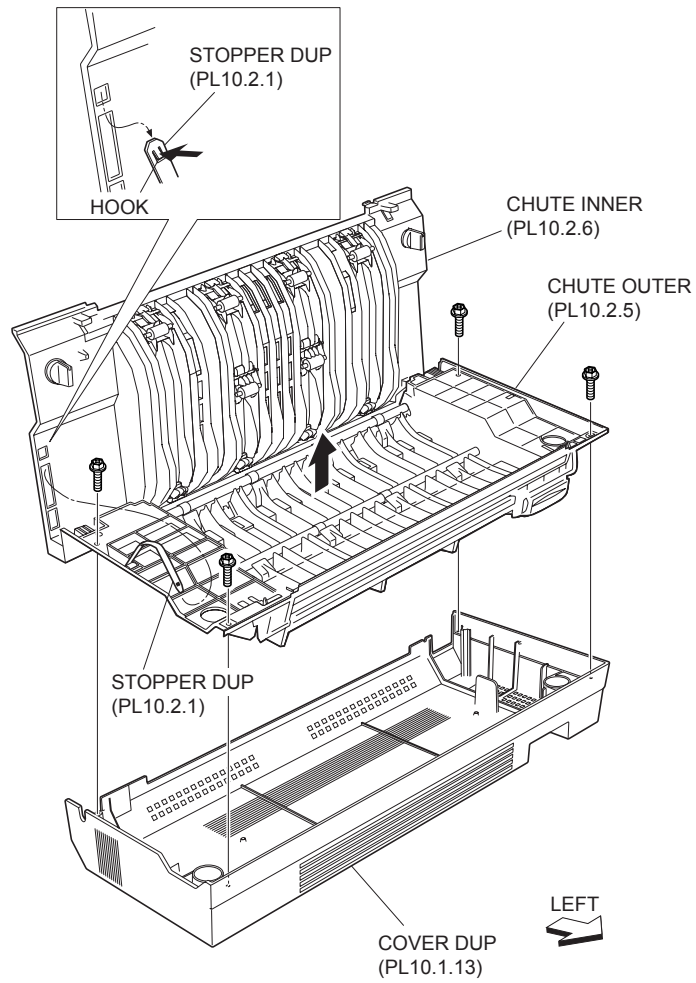
### Removal

1. Remove the Duplex Transport Unit (PL 10.1.1) .
2. Remove the two screws (Silver, M3x8mm) securing the Lower Chute (PL 10.1.8) to the Outer Chute (PL 10.2.5) to remove the Lower Chute.

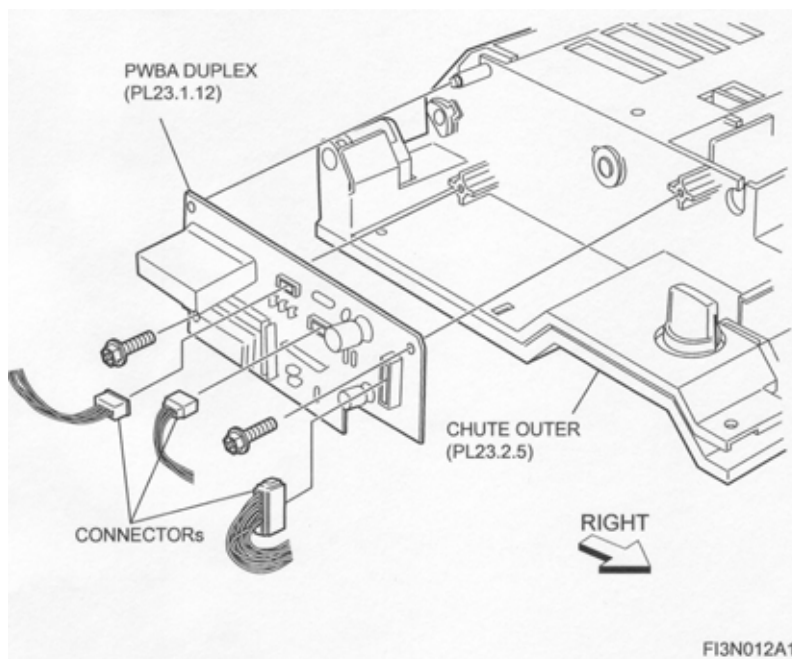


**Figure 1 Lower Chute**

3. Open the Inner Chute (PL 10.2.6).
4. Release the hook of the Duplex Stopper (PL 10.2.1) securing the Outer Chute to the Inner Chute .
5. Remove the four screws (Silver, M3x8mm) securing the Outer Chute and the Inner Chute to the Duplex Cover (PL 10.1.13) to remove the Outer Chute and the Inner Chute.
6. Disconnect the three connectors (P/J540, P/J541 and P/J542) of Duplex Harness Assembly A (PL 10.1.22) from the Duplex PWBA .
7. Remove the two screws (Silver, M3x8mm) securing the Duplex PWBA to the Outer Chute.
8. Remove the Duplex PWBA.



**Figure 2 Outer Chute**



**Figure 3 Duplex PWBA**

## Replacement

1. Install the Duplex PWBA to the Outer Chute (PL 10.2.5) using two screws (Silver, M3x8mm).
2. Connect the three connectors (P/J540, P/J541 and P/J542) of Duplex Harness Assembly A (PL 10.1.22) to the Duplex PWBA.
3. Install the Outer Chute and the Inner Chute (PL 10.2.6) to the Duplex Cover (PL 10.1.13) using four screws (Silver, M3x8mm).

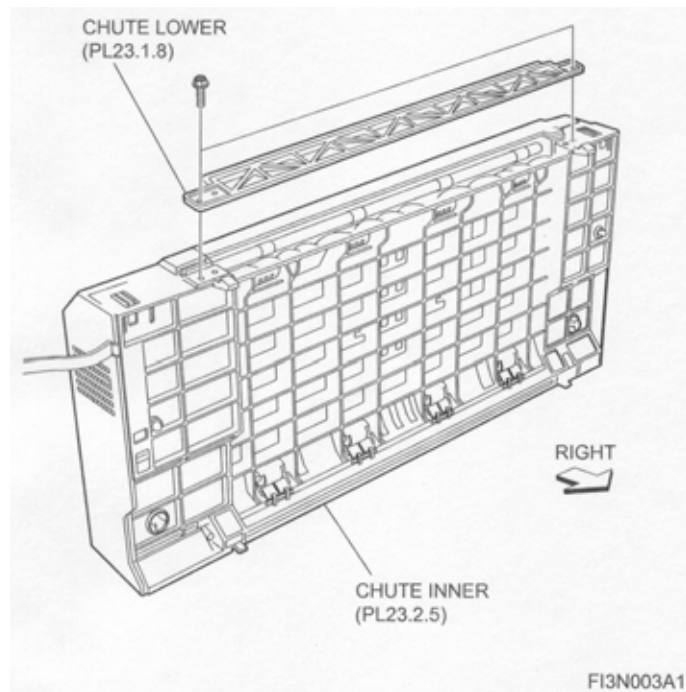
**NOTE** Be careful not to let the Duplex Stopper (PL 10.2.1) detach from the Outer Chute.

4. Install the Duplex Stopper to the Inner Chute.
5. Close the Inner Chute.
6. Install the Lower Chute (PL 10.1.8) to the Outer Chute using two screws (Silver, M3x8mm).
7. Install the Duplex Transport Unit (PL 10.1.1) .

## Photo In Sensor

### Removal

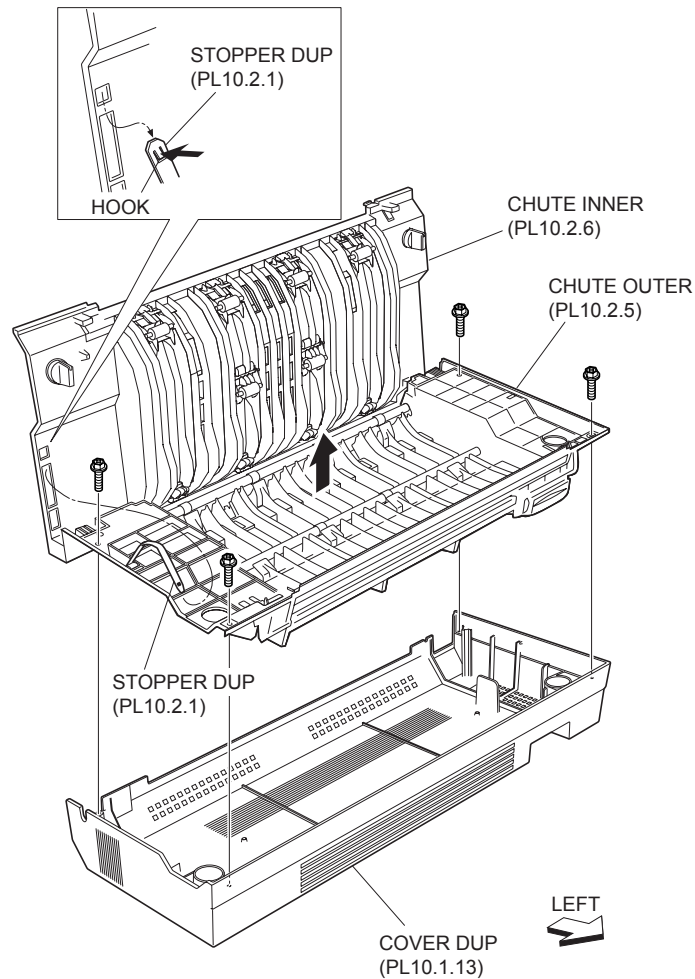
1. Remove the Duplex Transport Unit (PL 10.1.1) .
2. Remove the two screws (Silver, M3x8mm) securing the Lower Chute (PL 10.1.8) to the Outer Chute (PL 10.2.5) to remove the Lower Chute .



**Figure 1 Lower Chute**

3. Open the Inner Chute (PL 10.2.6).
4. Release the hook of the Duplex Stopper (PL 10.2.1) securing the Outer Chute to the Inner Chute .
5. Remove the four screws (Silver, M3x8mm) securing the Outer Chute and the Inner Chute to the Duplex Cover (PL 10.1.13) to remove the Outer Chute and the Inner Chute.
6. Disconnect the connector (P/J123) of the Duplex Sensor Harness Assembly (PL 10.1.20) from the Photo In Sensor .
7. Release the three hooks securing the Photo In Sensor to the Outer Chute as shown in the figure.

8. Remove the Photo In Sensor.



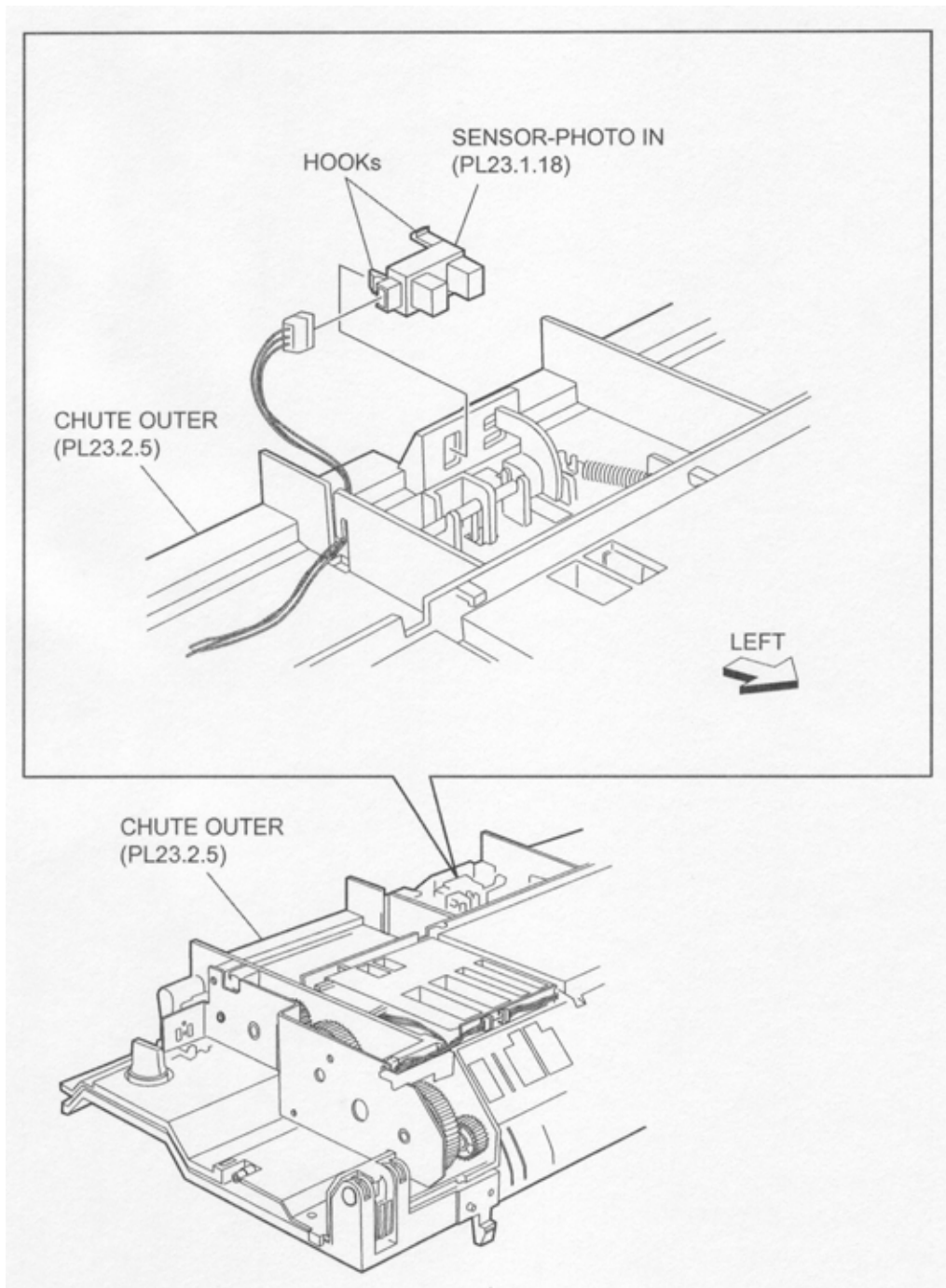
**Figure 2 Outer Chute**

## Replacement

1. Secure the Photo In Sensor to the Outer Chute (PL 10.2.5) using the three hooks.
2. Connect the connector (P/J123) of the Duplex Sensor Harness Assembly (PL 10.1.20) to the Photo In Sensor.
3. Install the Outer Chute and the Inner Chute (PL 10.2.6) to the Duplex Cover (PL 10.1.13) using f

**NOTE** Be careful not to let the Duplex Stopper (PL 10.2.1) detach from the Outer Chute.

4. Install the Duplex Stopper to the Inner Chute.
5. Close the Inner Chute.
6. Install the Lower Chute (PL 10.1.8) to the Outer Chute using two screws (Silver, M3x8mm).
7. Install the Duplex Transport Unit (PL 10.1.1) .



**Figure 3 Photo In Sensor**

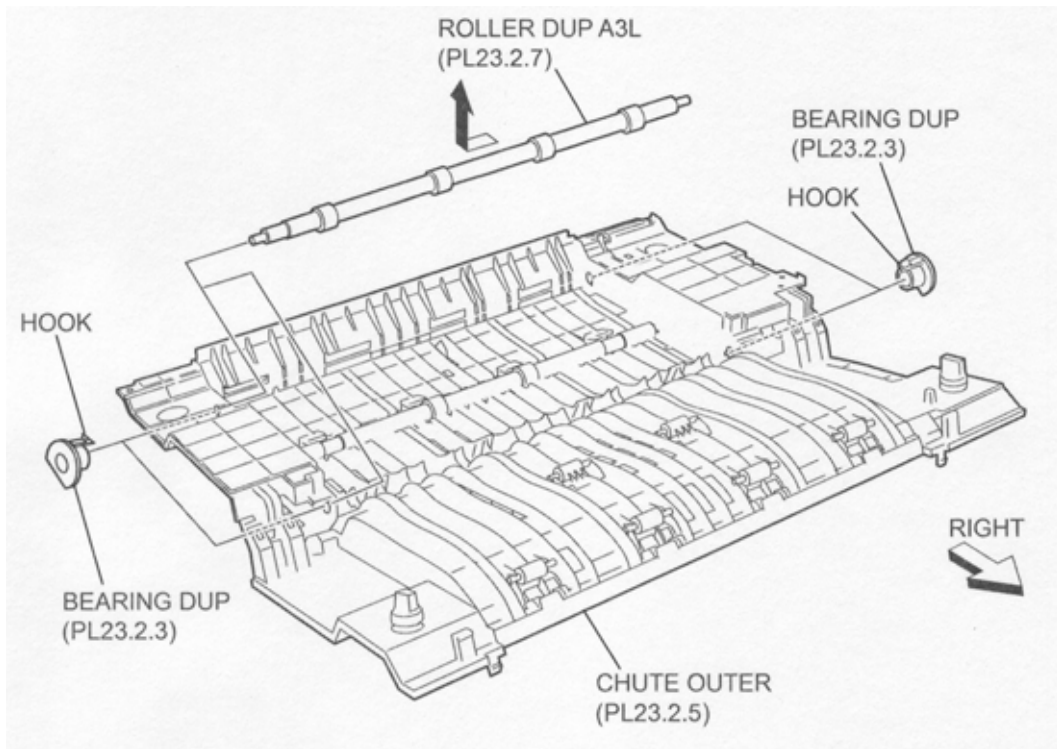
## Duplex Roller A3L

### Removal

1. Remove the Duplex Transport Unit (PL 10.1.1) .
2. Remove the Duplex PWBA (PL 10.1.12) .
3. Release the hook of the Duplex Bearing (PL 10.2.3) on the left and right to remove the Duplex Roller A3L from the Outer Chute (PL 10.2.5) .

4. Remove the Duplex Roller A3L.

**NOTE** When removing, do not hold the rubber rollers of the Duplex Roller A3L.



**Figure 1 Duplex Roller**

## Replacement

1. Install the Duplex Roller A3L to the Outer Chute (PL 10.2.5).
2. Install the Duplex Bearing (PL 10.2.3) on right and left to secure the Duplex Roller A3L to the Outer Chute.

**NOTE** Insert the Duplex Bearing to the Outer Chute until it is locked firmly.

**NOTE** When installing, do not hold the rubber rollers of the Duplex Roller A3L.

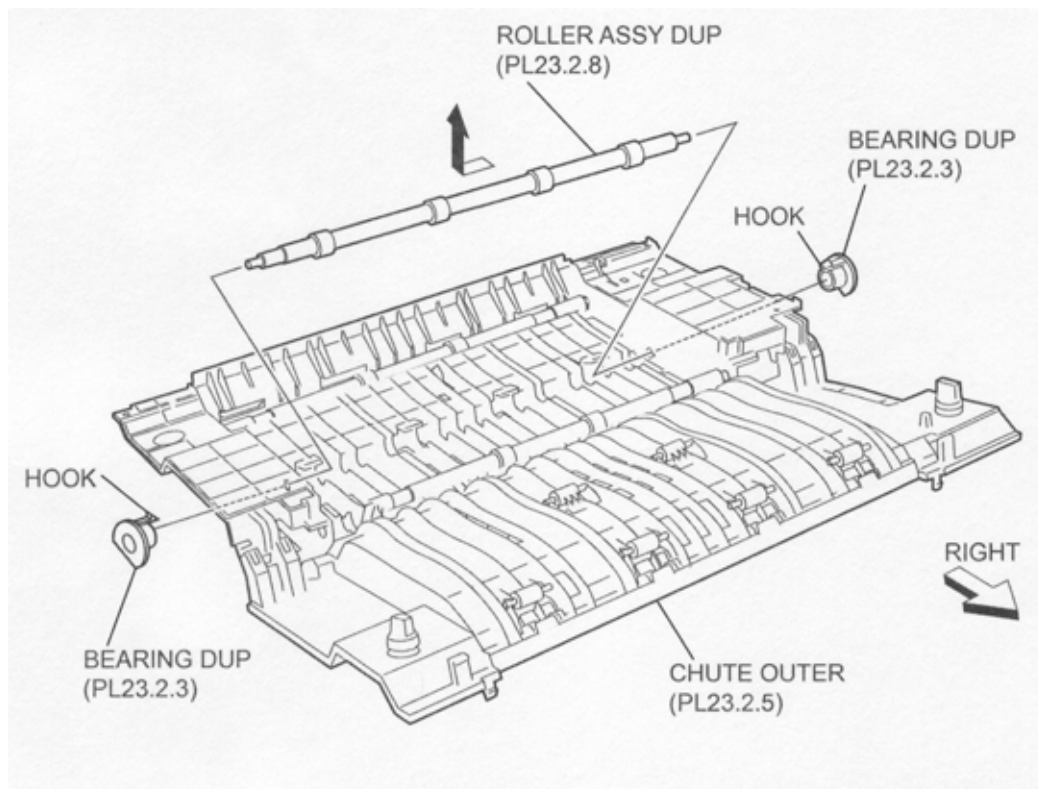
3. Install the Duplex PWBA (PL 10.1.12) .
4. Install the Duplex Transport Unit (PL 10.1.1) .

## Duplex Roller Assembly

### Removal

1. Remove the Duplex Transport Unit (PL 10.1.1) .
2. Remove the Duplex PWBA (PL 10.1.12) .
3. Release the hook of the Duplex Bearing (PL 10.2.3) on left and right to remove the Duplex Roller Assembly to the Outer Chute (PL 10.2.5) .
4. Remove the Duplex Roller Assembly.

**NOTE** When removing, do not hold the rubber rollers of the Duplex Roller Assembly.



**Figure 1 Duplex Roller Assembly**

## Replacement

1. Install the Duplex Roller Assembly to the Outer Chute (PL 10.2.5).
2. Install the Duplex Bearing (PL 10.2.3) on right and left to secure the Duplex Roller Assembly to the Outer Chute.

**NOTE** Insert the Duplex Bearings to the Outer Chute until it is locked firmly.

**NOTE** When installing, do not hold the rubber rollers of the Duplex Roller Assembly.

3. Install the Duplex PWBA (PL 10.1.12) .
4. Install the Duplex Transport Unit (PL 10.1.1) .

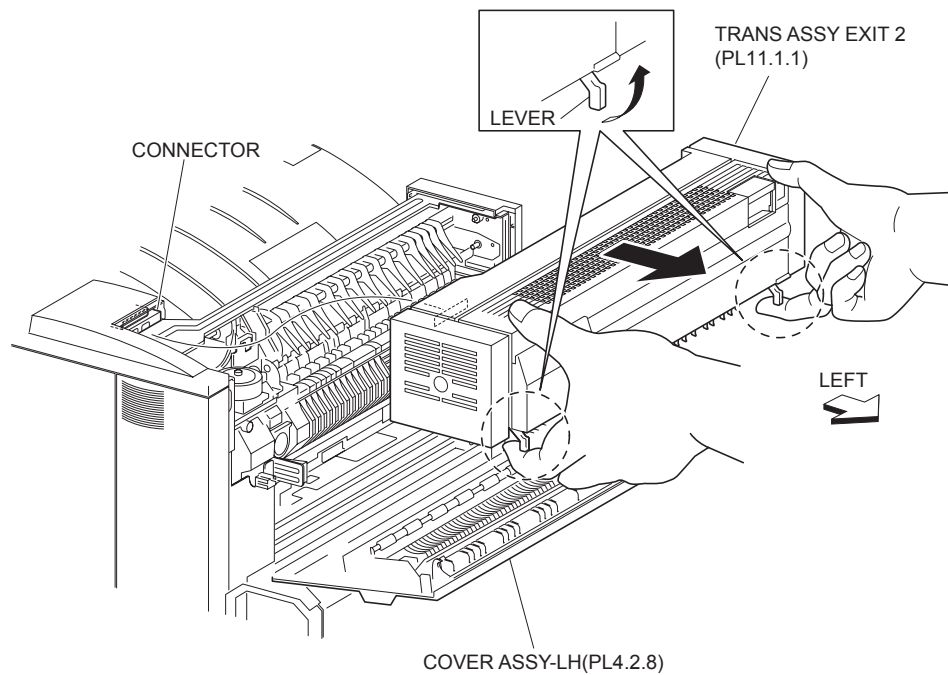
## Exit 2

### Exit 2 Transport Assembly

#### Removal

1. Open the Left Hand Cover Assembly (PL 4.2.8).
2. While lifting the levers on both sides on the Exit 2 Transport Assembly, move it in the direction of the arrow to remove it .
3. When removing the Exit 2 Transport Assembly, since its left side is connected to the machine with a connector, it may require a little stronger force to remove it.





**Figure 1 Transport Assembly**

## Replacement

1. Install the Exit 2 Transport Assembly to the printer.
2. Move the levers in the opposite direction to lock the Exit 2 Transport Assembly to the printer.
3. Install it by aligning it with the guide on the machine. Also, be sure that the left side of the Exit 2 Transport Assembly is connected to the machine with a connector securely.
4. Close the Left Hand Cover Assembly (PL 4.2.8).

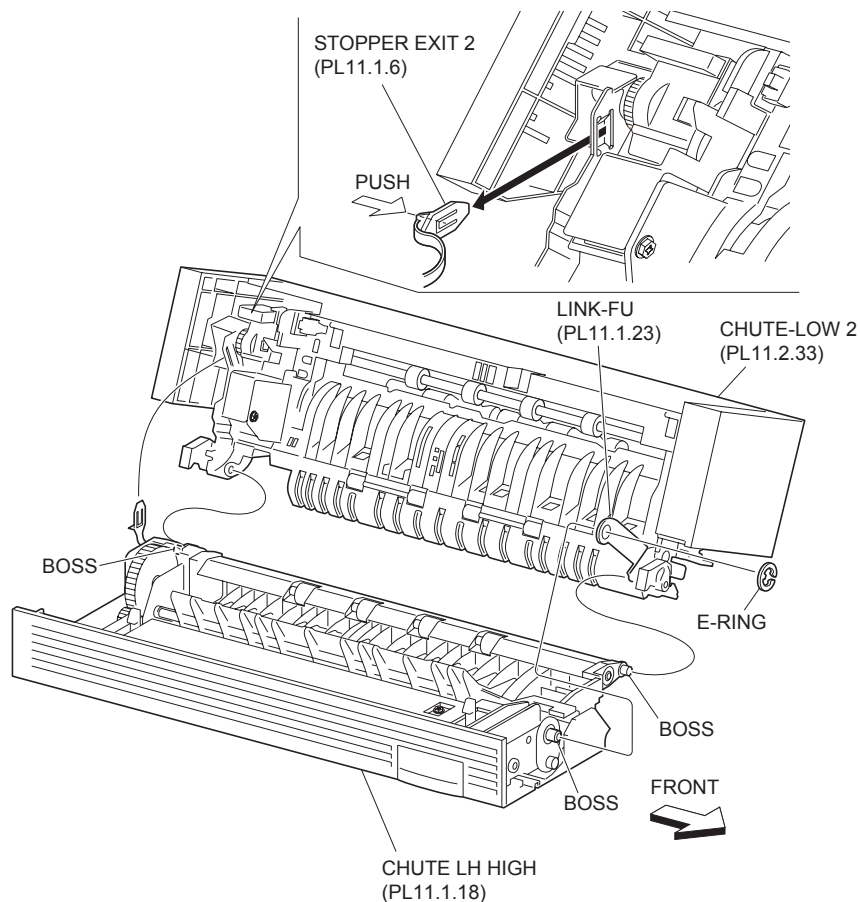
## Inverter Roll Assembly

### Removal

1. Open the Left Hand Cover Assembly (PL 4.2.8).
2. Remove the Exit 2 Transport Assembly (PL 11.1.1) .
3. Open the Exit 2 Transport Assembly.
4. Remove the hook of the Exit 2 Stopper (PL 11.1.6) .
5. Remove the E-ring securing the FU Link (PL 11.1.23) to the Left Hand High Chute (PL 11.1.18).
6. Release the boss on the right side (front) of the Left Hand High Chute from the Lower Chute 2 (PL 11.2.33).
7. Release the boss on the left side (rear) of the Left Hand High Chute from the Lower Chute 2.

**NOTE** Be sure to remove the right side (front) first, otherwise the Gear may be damaged.

8. Remove the Left Hand High Chute.

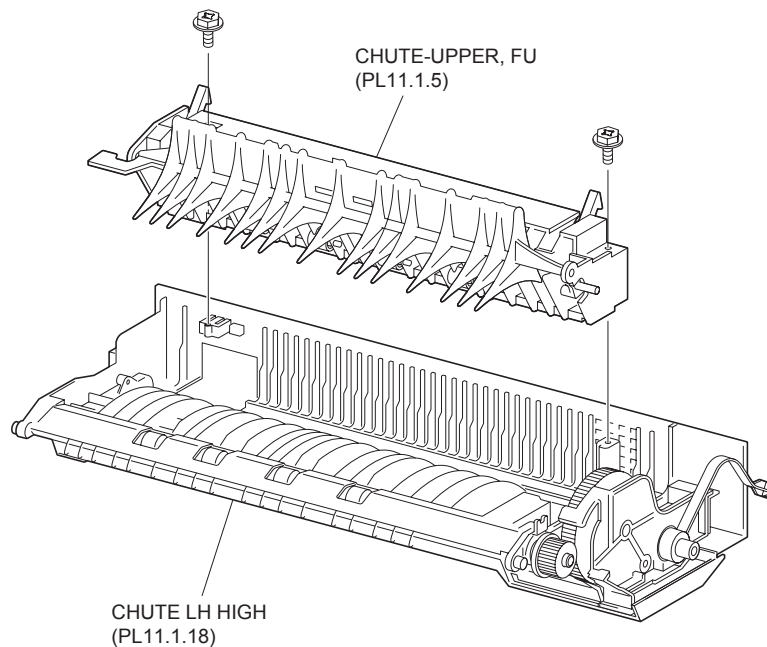


**Figure 1 Chute**

9. Remove the two screws (Silver, M3x8mm) securing the Left Hand High Chute to the Upper FU Chute (PL 11.1.5) to remove the Left Hand High Chute .
10. Remove the two screws (Silver, M3x8mm) securing the Gear Cover (PL 11.1.7) to the Left Hand High Chute to remove the Gear Cover .

**NOTE** When removing the Gear Cover, note that Exit 2 Stopper may be detached together.

11. Remove the 52Z Gear (PL 11.1.8) and the 19Z Gear (PL 11.1.9).
12. Remove the E-ring securing the Inverter Roll Assembly to the Left Hand High Chute.



**Figure 2 Upper Chute**

13. Release the hook of the Bearing (PL 11.1.16) securing the Inverter Roll Assembly to the Left Hand High Chute.

**NOTE** The hook of the Bearing is easy to be damaged, therefore be careful when removing it.

14. Move the Inverter Roll Assembly in the direction of the arrow to remove.

**NOTE** When installing, do not hold the rubber rollers of the Inverter Roll Assembly.

## Replacement

1. Move the Inverter Roll Assembly in the opposite direction of the arrow to install it.

**NOTE** When removing, do not hold the rubber rollers of the Inverter Roll Assembly.

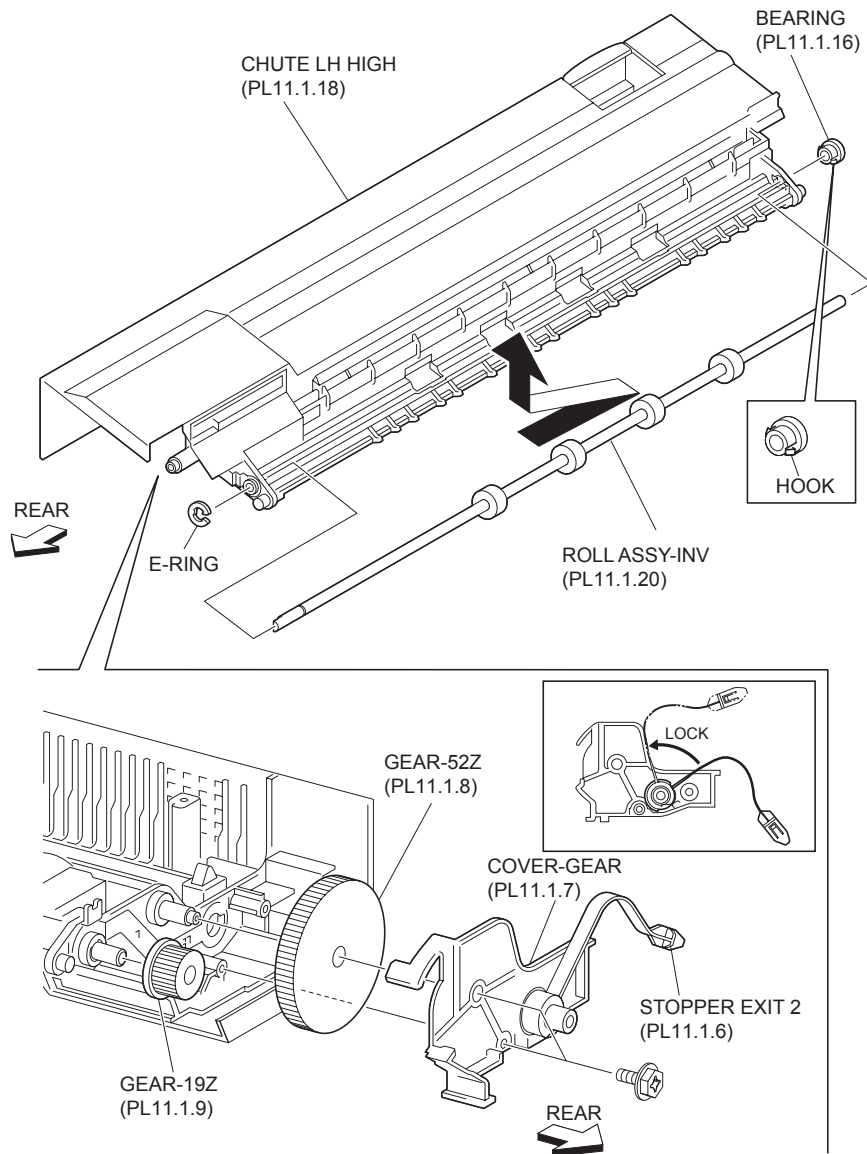
2. Secure the Inverter Roll Assembly to the Left Hand High Chute (PL 11.1.18) using the hook of the Bearing (PL 11.1.16).

**NOTE** The hook of the Bearing (PL 11.1.16) is easy to be damaged, therefore be careful when installing it.

3. Install the Inverter Roll Assembly to the Left Hand High Chute using the one E-ring.
4. Install the 19Z Gear (PL 11.1.9) to the shaft (D-shaped) of the Inverter Roll Assembly.
5. Install the Gear Cover (PL 11.1.7) to the Left Hand High Chute together with the 52Z Gear (PL 11.1.8) using two screws (Silver, M3x8mm).

**NOTE** Check that the Exit 2 Stopper (PL 11.1.6) is attached properly. When it is detached, install it by rotating the Gear Cover (PL 11.1.7) as shown in the figure.

6. Install the Left Hand High Chute to the Upper FU Chute (PL 11.1.5) using two screws (Silver, M3x8mm).
7. Fit the boss on the left side (rear) of the Left Hand High Chute into the hole on the Lower Chute 2 (PL 11.2.33).
8. Fit the boss on the right side (front) of the Left Hand High Chute into the hole on the Lower Chute 2 to install the Left Hand High Chute.



**Figure 3 Gear Cover**

9. Secure the FU Link (PL 11.1.23) to the Left Hand High Chute using the one E-ring.
10. Install the hook of the Exit 2 Stopper.
11. Close the Exit 2 Transport Assembly (PL 11.1.1).
12. Install the Exit 2 Transport Assembly .
13. Close the Left Hand Cover Assembly (PL 4.2.8).

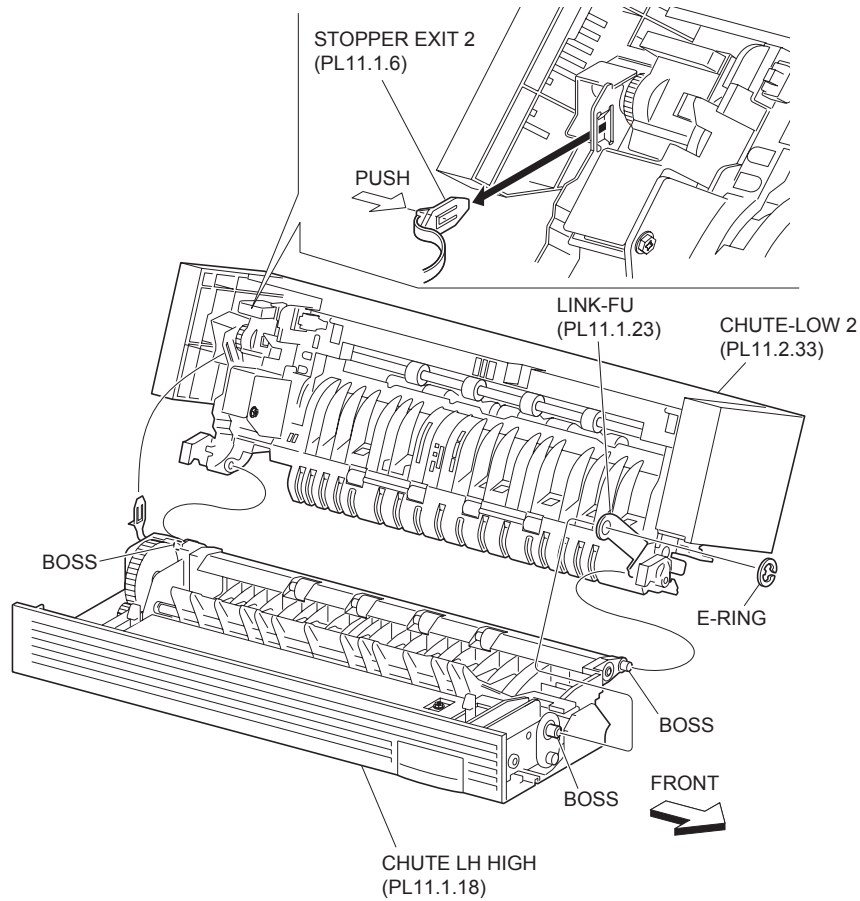
## Tray 2 Guide

### Removal

1. Open the Left Hand Cover Assembly (PL 4.2.8).
2. Remove the Exit 2 Transport Assembly (PL 11.1.1) .
3. Open the Exit 2 Transport Assembly.
4. Release the hook of the Exit 2 Stopper (PL 11.1.6) .

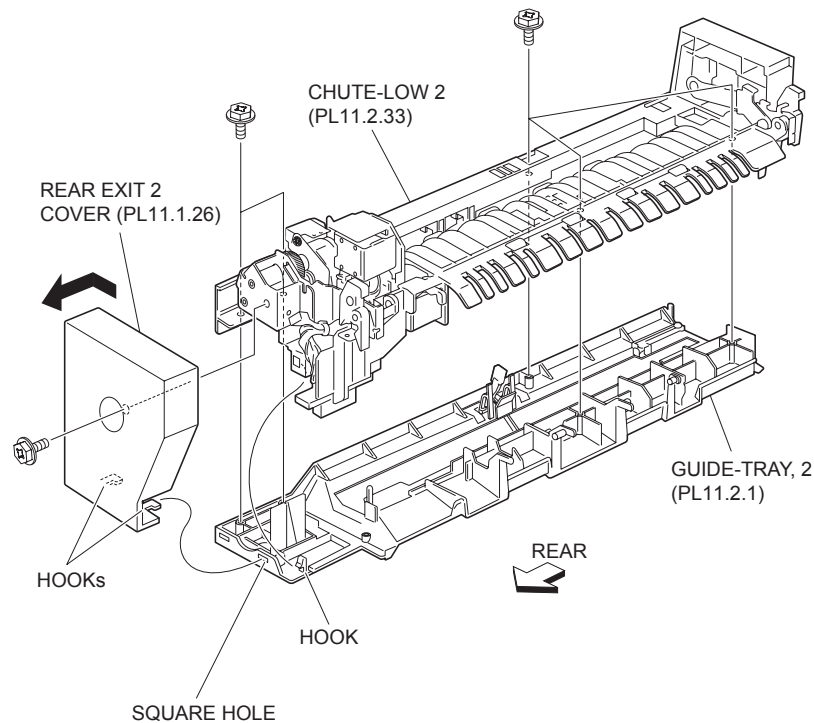
5. Remove the E-ring securing the FU Link (PL 11.1.23) to the Left Hand High Chute (PL 11.1.18).
6. Release the boss on the right side (front) of the Left Hand High Chute from the Lower Chute 2 (PL 11.2.33).
7. Release the boss on the left side (rear) of the Left Hand High Chute from the Lower Chute 2.

**NOTE** Be sure to remove the right side (front) first, otherwise the Gear may be damaged.



**Figure 1 Chute**

8. Remove the Lower Chute 2 .
9. Remove the screw (Del Tite, M3x8mm) securing the Exit 2 Rear Cover (PL 11.1.26) to the Lower Chute 2.
10. Release the hook securing the Exit 2 Rear Cover to the Lower Chute 2, as shown in the figure.
11. Move the Exit 2 Rear Cover in the direction of the arrow to remove.
12. Remove the five screws (Silver, M3x8mm) securing the Tray 2 Guide to the Lower Chute 2.
13. Release the left and right (front/rear) hooks of the Tray 2 Guide securing it to the Lower Chute 2 and remove the Tray 2 Guide.



**Figure 2 Lower Chute 2**

## Replacement

1. Secure the Tray 2 Guide to the Lower Chute 2 (PL 11.2.33) with the left and right (front/rear) hooks.
2. Install the Tray 2 Guide to the Lower Chute 2 using five screws (Silver, M3x8mm).
3. Move the Exit 2 Rear Cover (PL 11.1.26) in the opposite direction of the arrow and install it with the hook.
4. Install the Exit 2 Rear Cover to the Lower Chute 2 using the one screw (Del Tite, M3x8mm).
5. Fit the boss on the left side (rear) of the Left Hand High Chute (PL 11.1.18) into the hole on the Lower Chute 2.
6. Fit the boss on the right side (front) of the Left Hand High Chute into the hole on the Lower Chute 2 and install the Lower Chute 2.
7. Secure the FU Link (PL 11.1.23) to the Left Hand High Chute using the one E-ring.
8. Install the hook of the Exit 2 Stopper (PL 11.1.6).
9. Close the Exit 2 Transport Assembly (PL 11.1.1).
10. Install the Exit 2 Transport Assembly .
11. Close the Left Hand Cover Assembly (PL 4.2.8).

## Full B Actuator

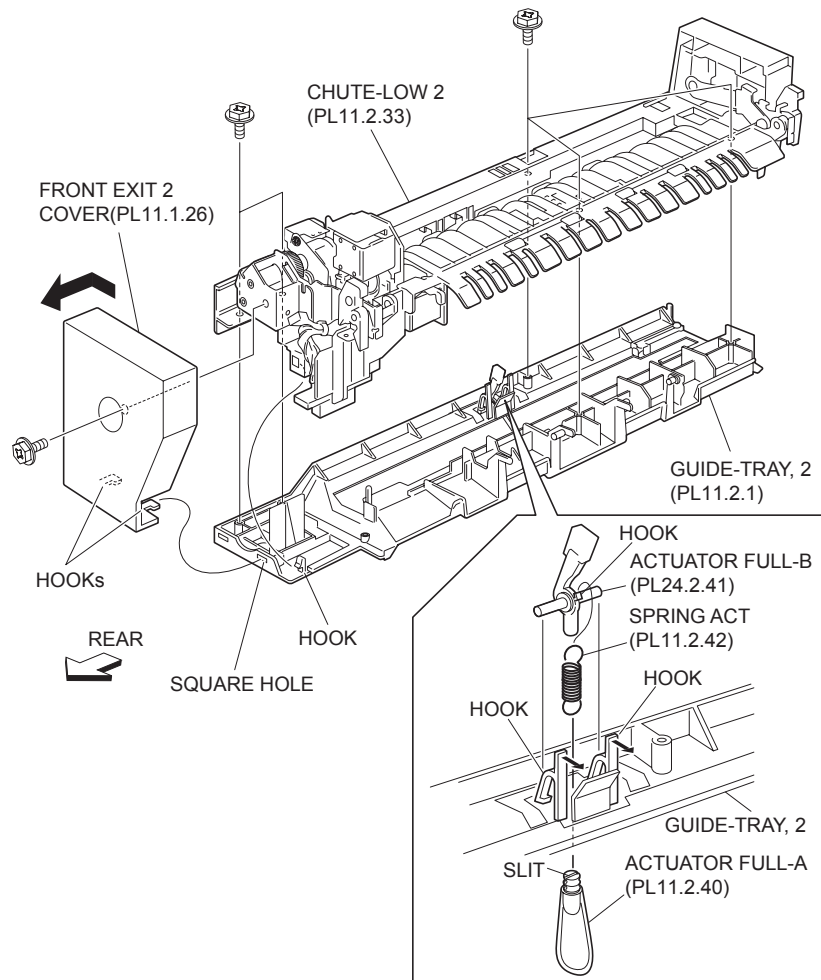
### Removal

1. Open the Left Hand Cover Assembly (PL 4.2.8).
2. Remove the Exit 2 Transport Assembly (PL 11.1.1) .
3. Open the Exit 2 Transport Assembly.

4. Remove the Tray Guide 2 (PL 11.2.1) .
5. Remove the Full A Actuator (PL 11.2.40) from the Actuator Spring (PL 11.2.42) .
6. Release the hook securing Full B Actuator to Tray 2 Guide (PL 11.2.1), as shown in the figure.

**NOTE** The hook of the Tray 2 Guide is easy to be damaged, therefore be careful when handling it.

7. Release the Actuator Spring from the hook of the Full B Actuator.



**Figure 1 Full B Actuator**

## Replacement

1. Install the Actuator Spring (PL 11.2.42) to the hook of the Full B Actuator.
2. Install the Full B Actuator to the Tray 2 Guide (PL 11.2.1) with the hook.

**NOTE** The hook of the Tray 2 Guide is easy to be damaged, therefore be careful when handling it.

3. Install the Full A Actuator (PL 11.2.40) to the Actuator Spring (PL 11.2.42).

**NOTE** When installing the Full A Actuator, fit the slit of the Full A Actuator to the Actuator Spring.

4. Install the Tray Guide 2 (PL 11.2.1) .
5. Close the Exit 2 Transport Assembly (PL 11.1.1).

6. Install the Exit 2 Transport Assembly .
7. Close the Left Hand Cover Assembly (PL 4.2.8).

## OCT Roll Assembly

### Removal

1. Open the Left Hand Cover Assembly (PL 4.2.8).
2. Remove the Exit 2 Transport Assembly (PL 11.1.1) .
3. Open the Exit 2 Transport Assembly.
4. Remove the Offset Gear 2 (PL 11.2.19) .
5. Release the hook of the 19Z Gear (PL 11.2.9) securing the OCT Roll Assembly to the Lower Chute 2 (PL 11.2.33) as shown in the figure to remove the 19Z Gear .

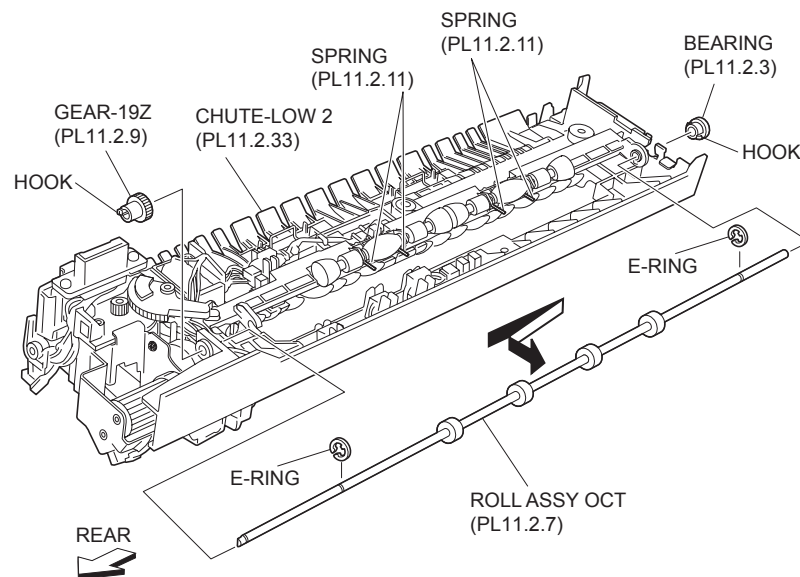
**NOTE** The hook of the 19Z Gear is easy to be damaged, therefore be careful when handling it.

6. Remove the two E-rings left and right securing the OCT Roll Assembly to the OCT Chute 2 (PL 11.2.5).
7. While releasing the hook of the Bearing (PL 11.2.3) on the left side securing the OCT Roll Assembly to the Lower Chute, remove the Bearing.

**NOTE** The hook of the Bearing is easy to be damaged, therefore be careful when handling it.

8. Move the OCT Roll Assembly in the direction of the arrow (to the front) to remove.

**NOTE** When removing, do not hold the rubber rollers of the OCT Roll Assembly.



**Figure 1 OCT Roll Assembly**

### Replacement

1. Move the OCT Roll Assembly in the opposite direction of the arrow to insert.

**NOTE** When installing, do not hold the rubber rollers of the OCT Roll Assembly.

2. Secure the Bearing (PL 11.2.3) to the Lower Chute 2 (PL 11.2.33) with the hook.

**NOTE** Insert the Bearing until the hook is firmly secured.

3. Install the OCT Roll Assembly to the OCT Chute 2 (PL 11.2.5) using the one E-ring.



**NOTE** Be careful not to bend the Spring (PL 11.2.11) installed on the OCT Chute 2.

4. Install the OCT Roll Assembly to the Lower Chute 2 with the hook of the 19Z Gear (PL 11.2.9).

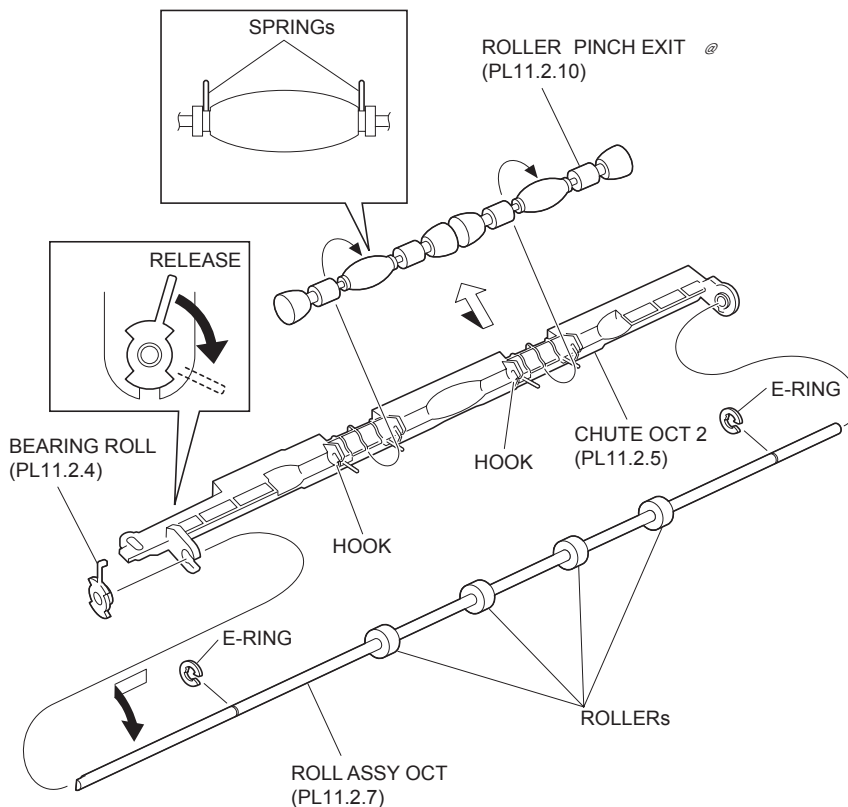
**NOTE** The hook of the 19Z Gear is easy to be damaged, therefore be careful when handling it.

5. Install the Offset Gear 2 (PL 11.2.19) .
6. Close the Exit 2 Transport Assembly (PL 11.1.1).
7. Install the Exit 2 Transport Assembly .
8. Close the Left Hand Cover Assembly (PL 4.2.8).

## Exit Pinch Roller

### Removal

1. Open the Left Hand Cover Assembly (PL 4.2.8).
2. Remove the Exit 2 Transport Assembly (PL 11.1.1) .
3. Open the Exit 2 Transport Assembly.
4. Remove the OCT Roll Assembly (PL 11.2.7) .
5. Release the hook securing the Exit Pinch Roller to the OCT Chute 2 (PL 11.2.5) .
6. Move the Exit Pinch Roller in the direction of the arrow to remove it.



**Figure 1 Exit Pinch Roller**

### Replacement

1. Move the Exit Pinch Roller in the opposite direction of the arrow and install it with the hook.
2. Install the OCT Roll Assembly (PL 11.2.7) .

3. Close the Exit 2 Transport Assembly (PL 11.1.1).
4. Install the Exit 2 Transport Assembly .
5. Close the Left Hand Cover Assembly (PL 4.2.8).

## Exit Actuator

### Removal

1. Open the Left Hand Cover Assembly (PL 4.2.8).
2. Remove the Exit 2 Transport Assembly (PL 11.1.1) .
3. Open the Exit 2 Transport Assembly.
4. Remove the Tray Guide 2 (PL 11.2.1) .
5. Release the hook of the Actuator Spring (PL 11.2.34) .
6. Place the Exit Actuator in the position shown in the figure, move it in the direction of the arrow to release the hook on the Lower Chute securing the Exit Actuator.
7. Remove the Exit Actuator.
8. Remove the Actuator Spring attached to the Exit Actuator.

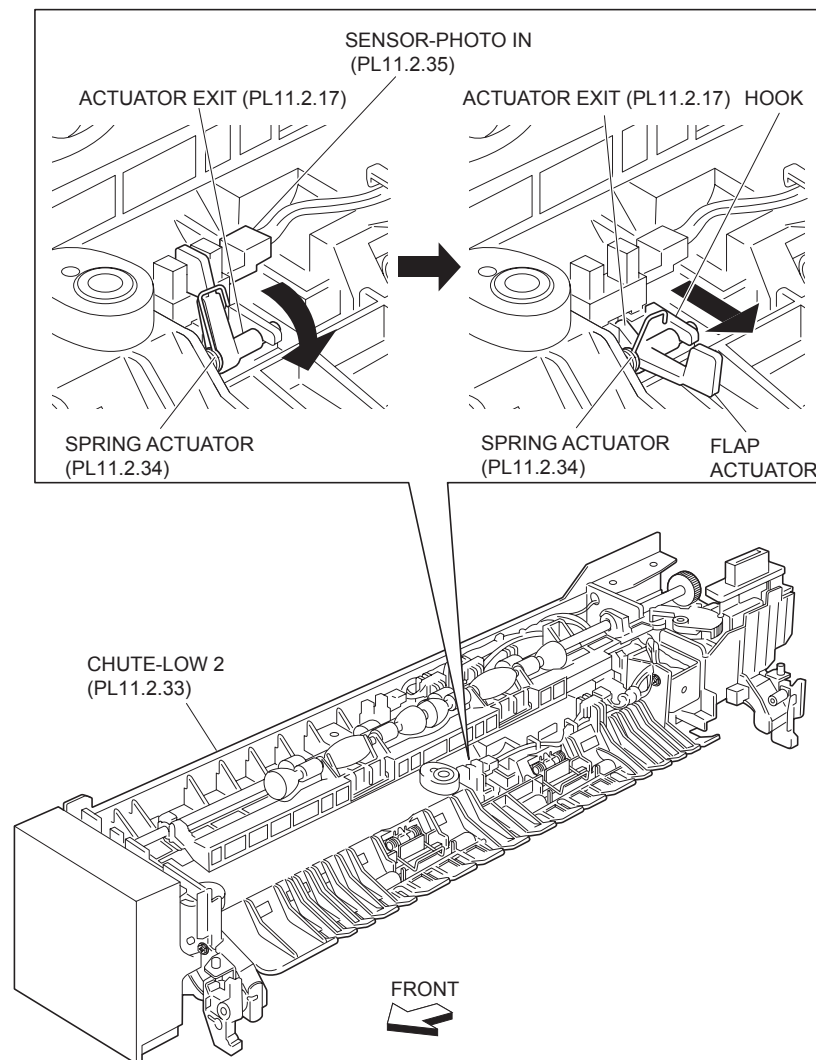


Figure 1 Exit Actuator

## Replacement

1. Install the Actuator Spring (PL 11.2.34).

**NOTE** Be sure to install the Actuator Spring in the direction shown in the figure.

2. Move the Exit Actuator in the opposite direction of the arrow to install.

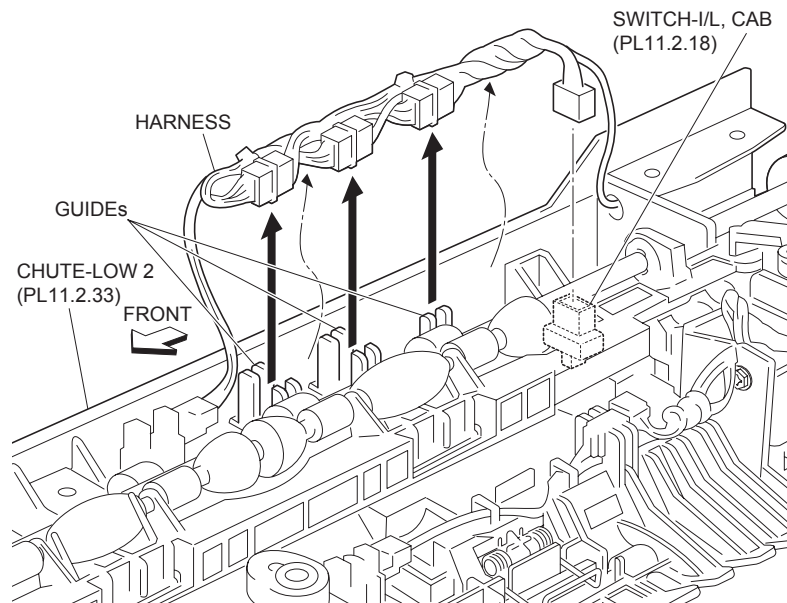
**NOTE** Check that the Exit Actuator goes into the gap (sensing area) of the Photo In Sensor (PL 11.2.35) smoothly.

3. Secure the hook of the Actuator Spring to the Exit Actuator.
4. Install the Tray Guide 2 (PL 11.2.1) .
5. Close the Exit 2 Transport Assembly (PL 11.1.1).
6. Install the Exit 2 Transport Assembly .
7. Close the Left Hand Cover Assembly (PL 4.2.8).

## I/L CAB Switch

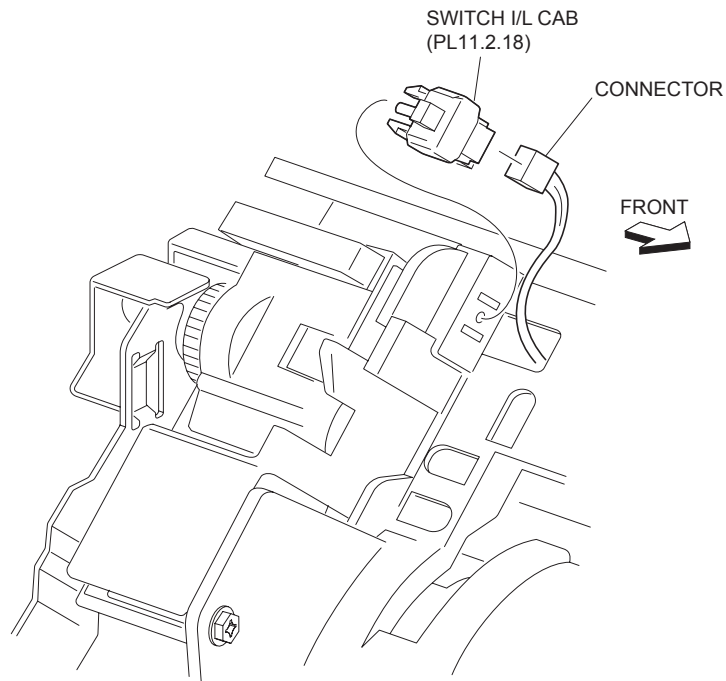
### Removal

1. Open the Left Hand Cover Assembly (PL 4.2.8).
2. Open the Exit 2 Transport Assembly (PL 11.1.1) .
3. Remove the Exit 2 Transport Assembly .
4. Remove the Tray Guide 2 (PL 11.2.1) .
5. Release the harness secured to the guide on the backside of the Lower Chute 2 (PL 11.2.33) .
6. Disconnect the connector (P/J116) of the Exit 2 C Harness Assembly (PL 11.2.36) from the I/L CAB Switch.



**Figure 1 Harness Assembly**

7. Release the hooks securing the I/L CAB Switch to the Lower Chute 2 .
8. Remove the I/L CAB Switch.



**Figure 2 I/L Cab Switch**

## Replacement

1. Secure the I/L CAB Switch to the Lower Chute 2 (PL 11.2.33) with the hooks.
2. Connect the connector (P/J116) of the Exit 2 C Harness Assembly (PL 11.2.36) to the I/L CAB Switch.
3. Secure the harness to the guide on the backside of the LOWER CHUTE.

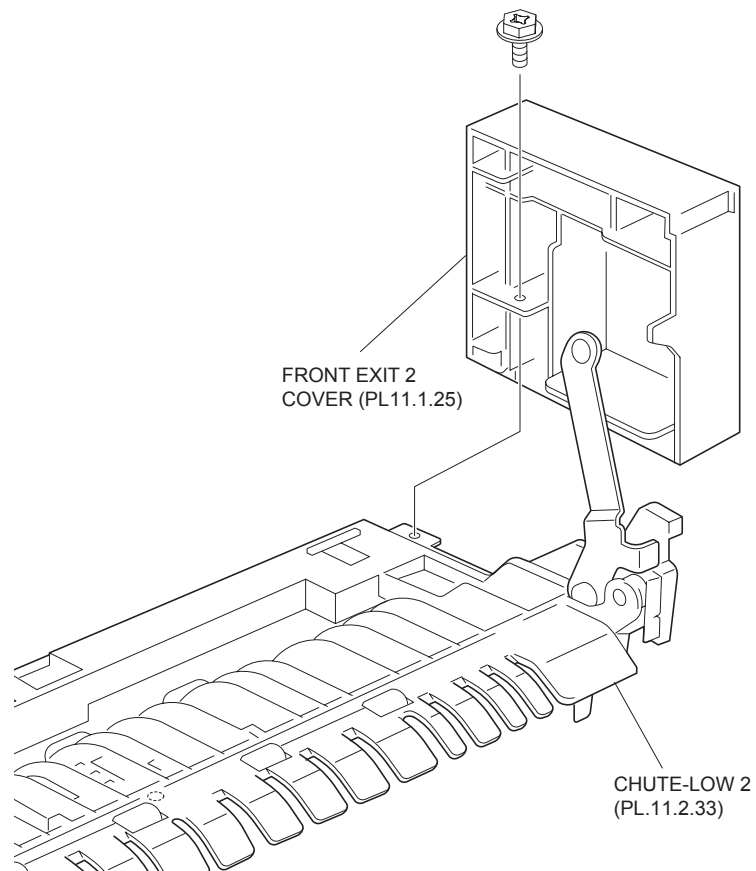
**NOTE** Be sure to put the three junction connectors into each guide.

4. Install the Tray Guide 2 (PL 11.2.1) .
5. Close the Exit 2 Transport Assembly (PL 11.1.1).
6. Install the Exit 2 Transport Assembly .
7. Close the Left Hand Cover Assembly (PL 4.2.8).

## Offset Gear 2

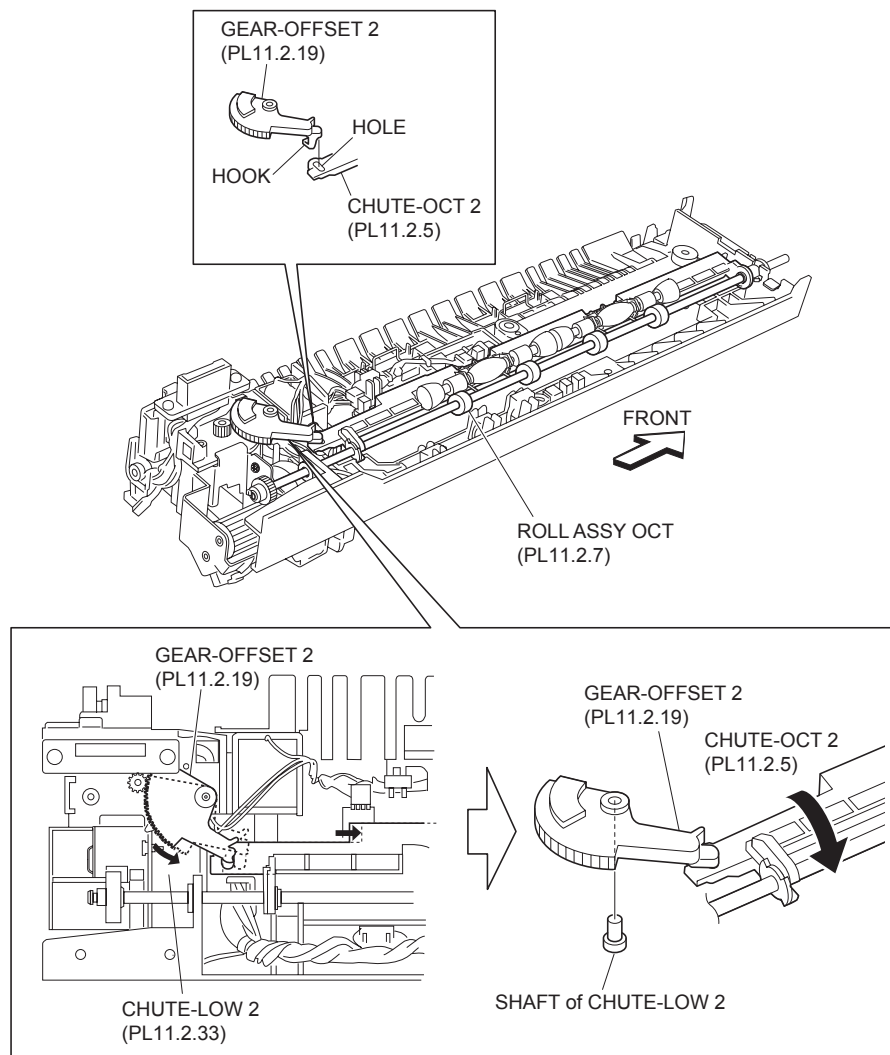
### Removal

1. Open the Left Hand Cover Assembly (PL 4.2.8).
2. Remove the Exit 2 Transport Assembly (PL 11.1.1) .
3. Open the Exit 2 Transport Assembly.
4. Remove the Tray Guide 2 (PL 11.2.1) .
5. Remove the screw (Del Tite, M3x8mm) securing the Exit 2 Front Cover (PL 11.1.25) to the Lower Chute 2 (PL 11.2.33) and remove the Exit 2 Front Cover .



**Figure 1 Exit 2 Front Cover**

6. Slide the OCT Roll Assembly (PL 11.2.7) fully to the right (Front) .
7. Move the Offset Gear 2 in the direction of the arrow to remove it from the shaft of the Lower Chute 2.
8. Remove the hook on the top of the Offset Gear 2 from the hole on the OCT Chute 2 (PL 11.2.5) to remove the Offset Gear 2.



**Figure 2 Offset Gear 2**

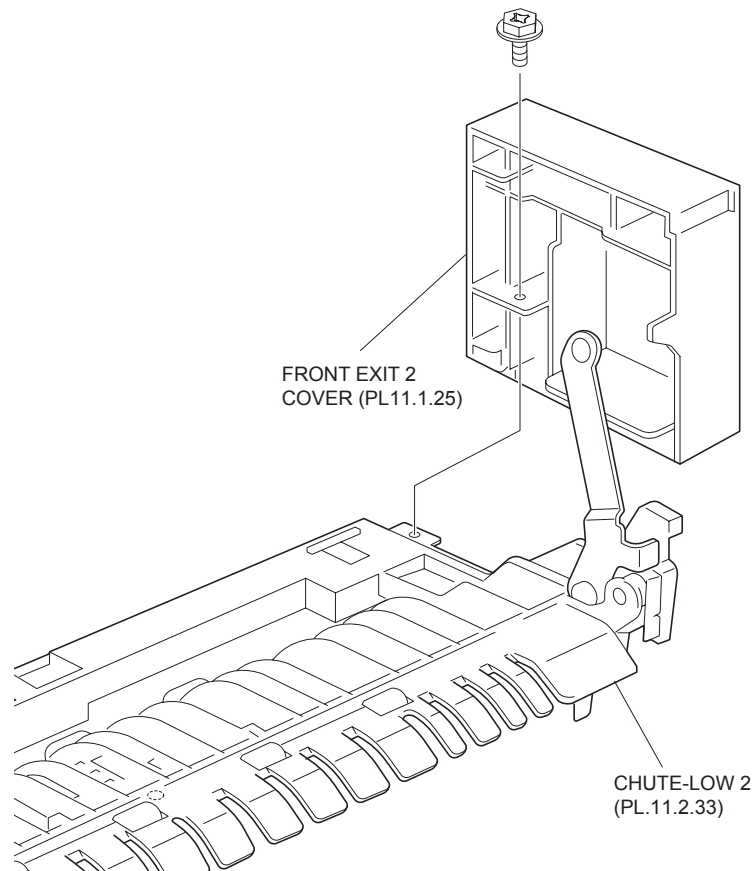
## Replacement

1. Secure the hook on the top of the Offset Gear 2 to the hole on the OCT Chute 2 (PL 11.2.5).
2. Slide the OCT Roll Assembly (PL 11.2.7) fully to the right (Front).
3. Move the Offset Gear 2 in the opposite direction of the arrow to install it to the shaft of the Lower Chute 2 (PL 11.2.33).
4. Install the Exit 2 Front Cover (Tentative PL 11.1.25) to the Lower Chute 2 (PL 11.2.33) using a screw (Del Tite, M3x8mm).
5. Install the Tray Guide 2 (PL 11.2.1) .
6. Close the Exit 2 Transport Assembly (PL 11.1.1).
7. Install the Exit 2 Transport Assembly .
8. Close the Left Hand Cover Assembly (PL 4.2.8).

## FU Solenoid Assembly

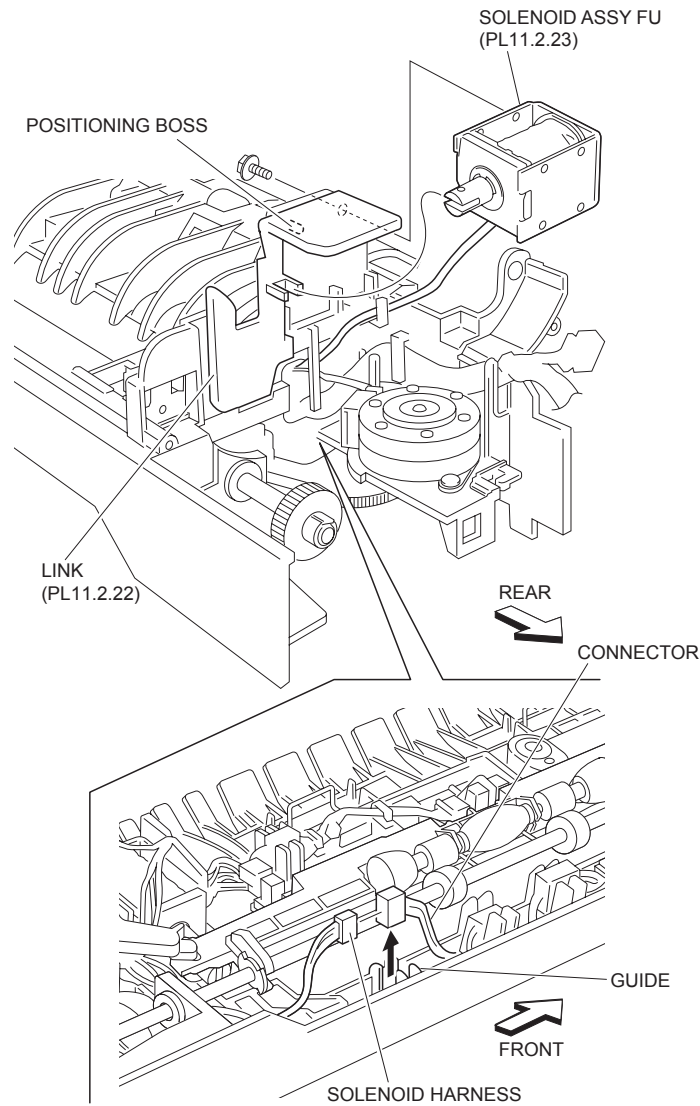
### Removal

1. Open the Left Hand Cover Assembly (PL 4.2.8).
2. Remove the Exit 2 Transport Assembly (PL 11.1.1) .
3. Open the Exit 2 Transport Assembly.
4. Remove the Tray Guide 2 (PL 11.2.1) .
5. Remove the screw (Del Tite, M3x8mm) securing the Exit 2 Front Cover (PL 11.1.25) to the Lower Chute 2 (PL 11.2.33) and remove the Exit 2 Front Cover .



**Figure 1 Exit 2 Front Cover**

6. Lift the harness and connector secured to the guide on the backside of the Lower Chute 2 .
7. Disconnect the harness connector (P/J210) of the FU Solenoid Assembly from the junction connector.
8. Remove the screw (Del Tite, M3x6mm) securing the FU Solenoid Assembly to the Lower Chute 2.
9. Remove the FU Solenoid Assembly.



**Figure 2 FU Solenoid Assembly**

## Replacement

1. Install the FU Solenoid Assembly to the Lower Chute 2 (PL 11.2.33) using a screw (Del Tite, M3x6mm).

**NOTE** Be sure to fit the iron core of the FU Solenoid Assembly to the Rear Latch Spring (PL 11.2.21) as shown in the figure. Also, put the boss on the Lower Chute 2 in to the hole on the FU Solenoid Assembly.

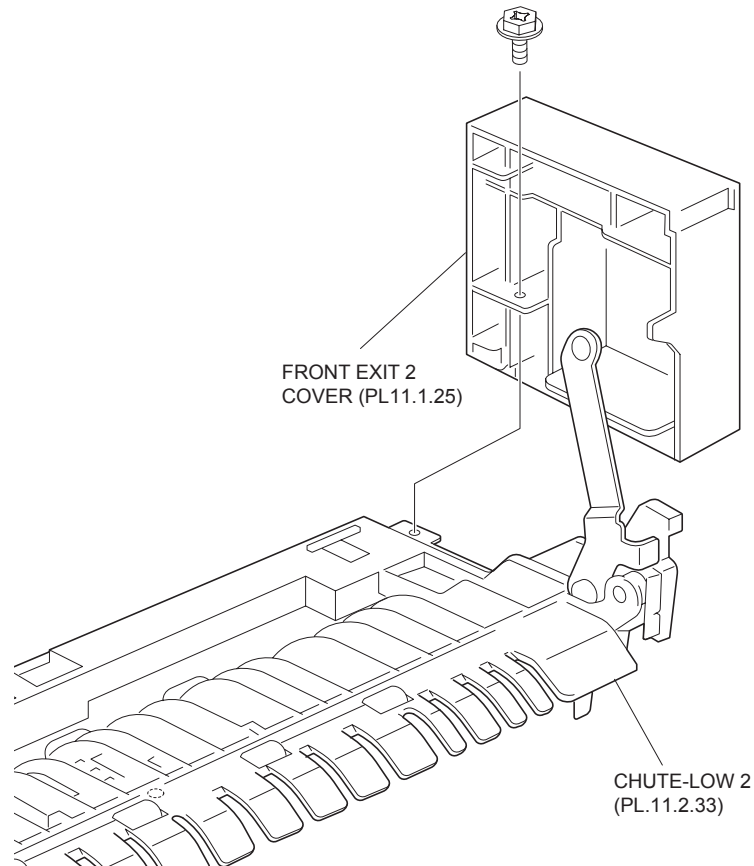
2. Connect the harness connector (P/J210) of the FU Solenoid Assembly to the junction connector.
3. Secure the harness to the guide on the backside of the Lower Chute 2.
4. Install the Exit 2 Front Cover (PL 11.1.25) to the Lower Chute 2 using a screw (Del Tite, M3x8mm).
5. Install the Tray Guide 2 (PL 11.2.1) .
6. Close the Exit 2 Transport Assembly (PL 11.1.1).
7. Install the Exit 2 Transport Assembly .
8. Close the Left Hand Cover Assembly (PL 4.2.8).



# Solenoid Assembly

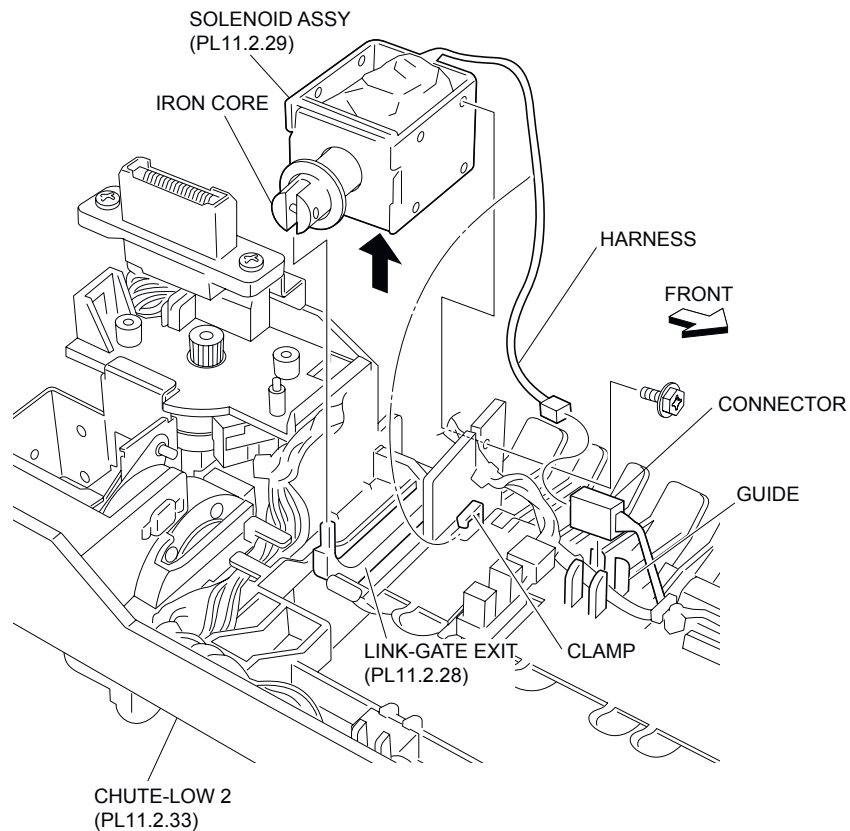
## Removal

1. Open the Left Hand Cover Assembly (PL 4.2.8).
2. Remove the Exit 2 Transport Assembly (PL 11.1.1) .
3. Open the Exit 2 Transport Assembly.
4. Remove the Tray Guide 2 (PL 11.2.1) .
5. Remove the screw (Del Tite, M3x8mm) securing the Exit 2 Front Cover (PL 11.1.25) to the Lower Chute 2 (PL 11.2.33) to remove the Exit 2 Front Cover .



**Figure 1 Exit 2 Front Cover**

6. Release the harness of the Solenoid Assembly from the guide on the Lower Chute 2 .
7. Release the harness of the Solenoid Assembly from the clamp.
8. Disconnect the harness connector (P/J209) of the Solenoid Assembly from the junction connector.
9. Remove the screw (Del Tite, M3x6mm) securing the Solenoid Assembly to the Lower Chute 2.
10. Remove the iron core of the Solenoid Assembly from the Exit Gate Link (PL 11.2.28).
11. Remove the Solenoid Assembly.



**Figure 2 Solenoid Assembly**

## Replacement

1. Install the Solenoid Assembly to the Lower Chute 2 (PL 11.2.33) using the one screw (Del Tite, M3x6mm).

**NOTE** Fit the iron core of the Solenoid Assembly to the Exit Gate Link (PL 11.2.28) as shown in the figure. Also, fit the boss on the Lower Chute 2 into the hole on the Solenoid Assembly.

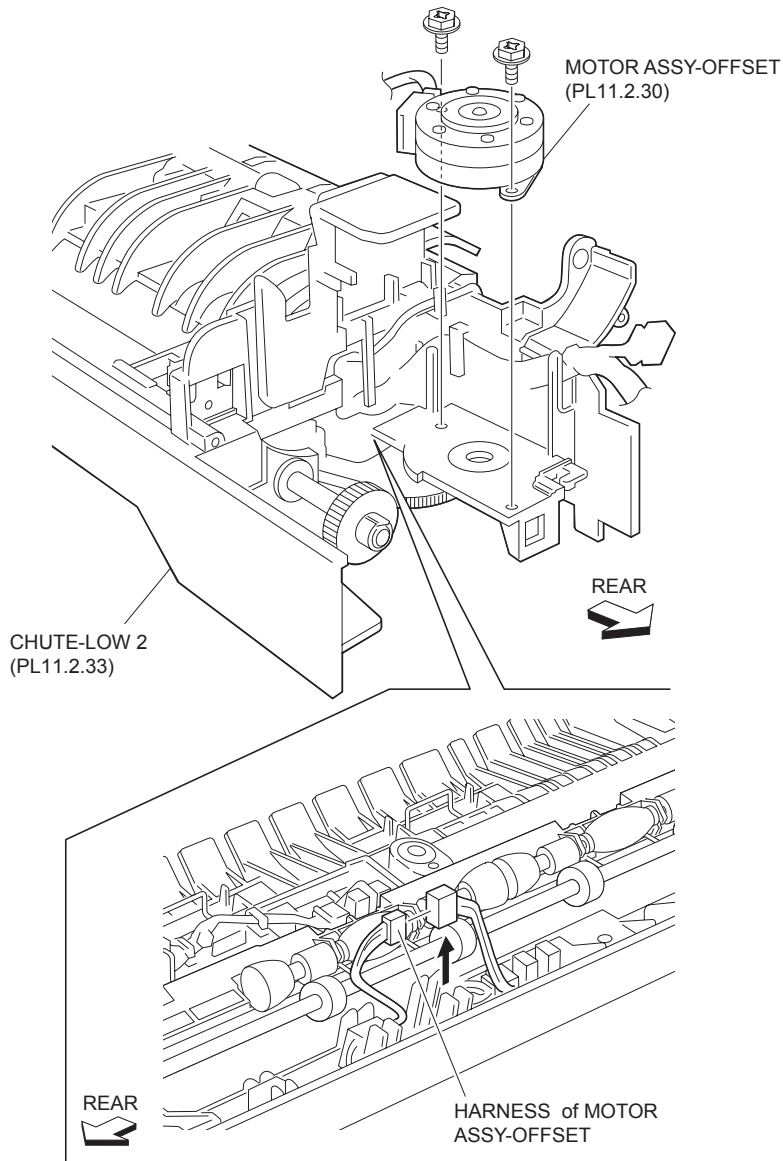
2. Connect the harness connector (P/J209) of the Solenoid Assembly to the junction connector.
3. Secure the harness of the Solenoid Assembly to the clamp.
4. Secure the harness of the Solenoid Assembly to the guide on the Lower Chute 2.
5. Install the Exit 2 Front Cover (PL 11.1.25) to the Lower Chute 2 using the one screw (Del Tite, M3x8mm).
6. Install the Tray Guide 2 (PL 11.2.1) .
7. Close the Exit 2 Transport Assembly (PL 11.1.1).
8. Install the Exit 2 Transport Assembly .
9. Close the Left Hand Cover Assembly (PL 4.2.8).

## Offset Motor Assembly

### Removal

1. Open the Left Hand Cover Assembly (PL 4.2.8).

2. Remove the Exit 2 Transport Assembly (PL 11.1.1) .
3. Open the Exit 2 Transport Assembly.
4. Remove the Tray Guide 2 (PL 11.2.1) .
5. Remove the FU Solenoid Assembly (PL 11.2.23) .
6. Disconnect the harness connector (P/J207) of the Exit 2 Motor Assembly (PL 11.2.37) from the junction connector .
7. Remove the two screws (Bind, M3x8mm) securing the Offset Motor Assembly to the Lower Chute 2 (PL 11.2.33).
8. Remove the Offset Motor Assembly.



**Figure 1 Offset Motor Assembly**

## Replacement

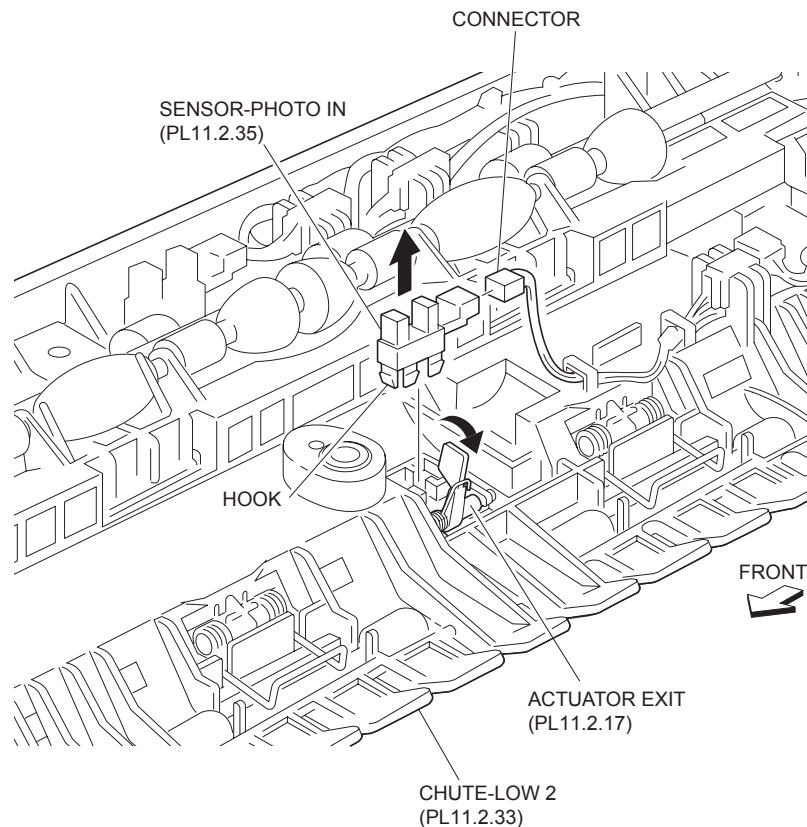
1. Secure the Offset Motor Assembly to the Lower Chute 2 (PL 11.2.33) using two screws (Bind, M3x8mm).
2. Connect the harness connector (P/J207) of the Exit 2 Motor Assembly (PL 11.2.37) to the junction connector.
3. Install the FU Solenoid Assembly (PL 11.2.23) .

4. Install the Tray Guide 2 (PL 11.2.1) .
5. Close the Exit 2 Transport Assembly (PL 11.1.1).
6. Install the Exit 2 Transport Assembly (PL 11.1.1) .
7. Close the Left Hand Cover Assembly (PL 4.2.8).

## Photo In Sensor

### Removal

1. Open the Left Hand Cover Assembly (PL 4.2.8).
2. Remove the Exit 2 Transport Assembly (PL 11.1.1) .
3. Open the Exit 2 Transport Assembly.
4. Remove the Tray Guide 2 (PL 11.2.1) .
5. Disconnect the connector (P/J112) of the Exit 2 C Harness Assembly (PL 11.2.36) connected to the Photo In Sensor .
6. While moving the Exit Actuator (PL 11.2.17) in the direction of the arrow, remove the hook securing the Photo In Sensor to the Lower Chute 2 (PL 11.2.33) as shown in the figure.
7. Remove the Photo In Sensor.



**Figure 1 Photo In Sensor**

### Replacement

1. While moving the Exit Actuator (PL 11.2.17) in the direction of the arrow, install the Photo In Sensor to the Lower Chute 2 (PL 11.2.33) with the hook.

2. Connect the connector (P/J112) of the Exit 2 C Harness Assembly (PL 11.2.36) to the Photo In Sensor.
3. Install the Tray Guide 2 (PL 11.2.1) .
4. Close the Exit 2 Transport Assembly (PL 11.1.1).
5. Install the Exit 2 Transport Assembly .
6. Close the Left Hand Cover Assembly (PL 4.2.8).

## OCT Photo In Position Sensor

### Removal

1. Open the Left Hand Cover Assembly (PL 4.2.8).
2. Remove the Exit 2 Transport Assembly (PL 11.1.1) .
3. Open the Exit 2 Transport Assembly.
4. Remove the Tray Guide 2 (PL 11.2.1) .
5. Remove the OCT Roll Assembly (PL 11.2.7) .
6. Disconnect the connector (P/J111) of the Exit 2 C Harness Assembly (PL 11.2.36) from the OCT Photo In Position Sensor .
7. Release the hook securing the OCT Photo In Position Sensor to the Lower Chute 2 (PL 11.2.33).
8. Remove the OCT Photo In Position Sensor.

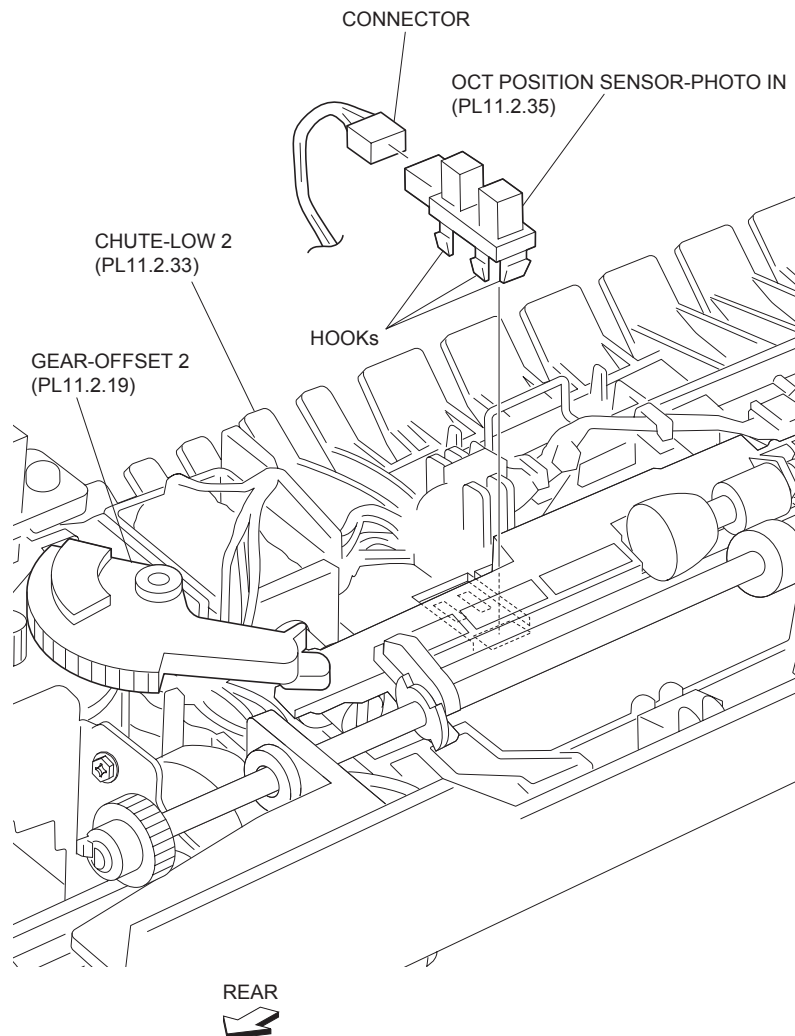


Figure 1 Position Sensor

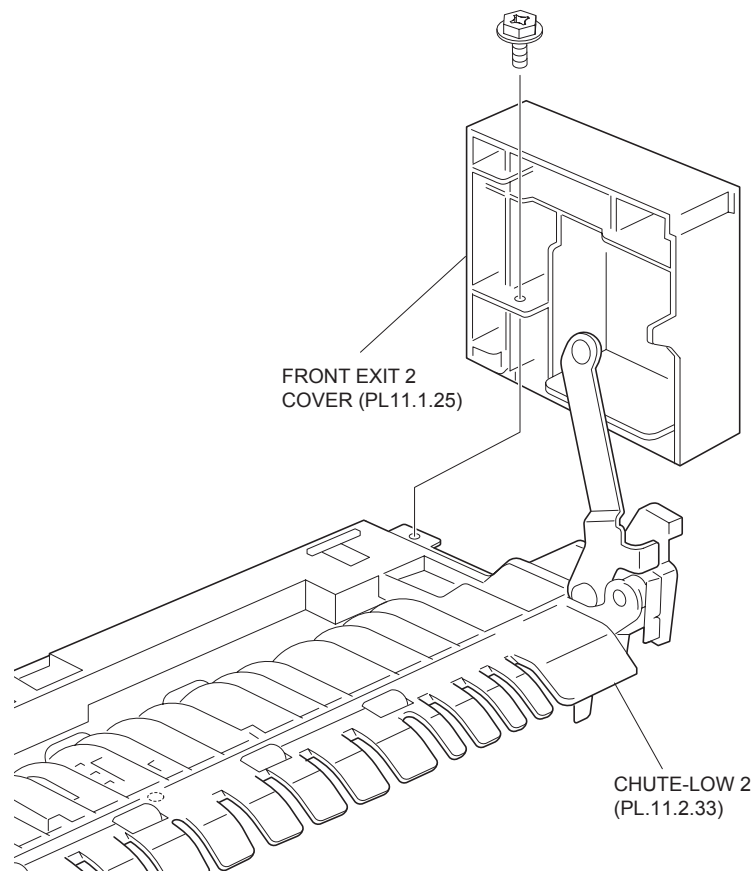
## Replacement

1. Install the OCT Photo In Position Sensor to the Lower Chute 2 (PL 11.2.33) with the hook.
2. Connect the connector (P/J111) of the Exit 2 C Harness Assembly (PL 11.2.36) to the OCT Photo In Position Sensor.
3. Install the OCT Roll Assembly (PL 11.2.7) .
4. Install the Tray Guide 2 (PL 11.2.1) .
5. Close the Exit 2 Transport Assembly (PL 11.1.1).
6. Install the Exit 2 Transport Assembly .
7. Close the Left Hand Cover Assembly (PL 4.2.8).

## Exit 2 Motor Assembly

### Removal

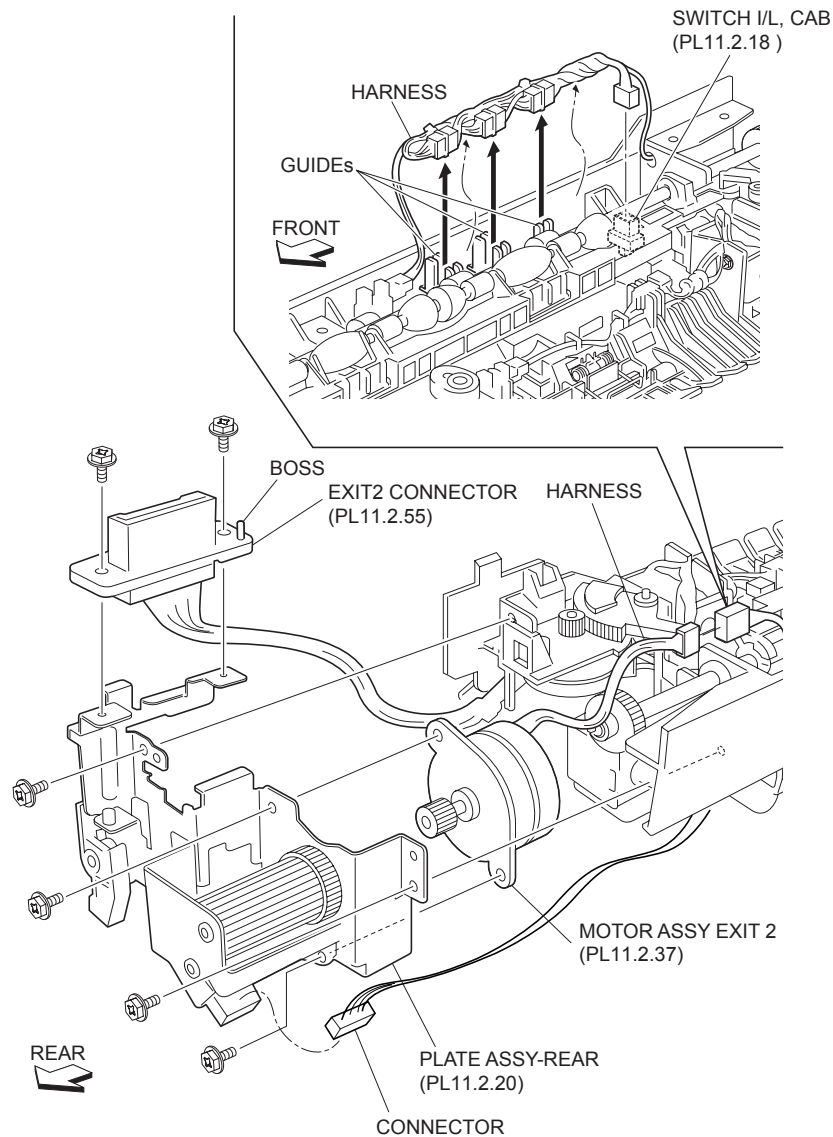
1. Open the Left Hand Cover Assembly (PL 4.2.8).
2. Remove the Exit 2 Transport Assembly (PL 11.1.1) .
3. Open the Exit 2 Transport Assembly.
4. Remove the Tray Guide 2 (PL 11.2.1) .
5. Remove the screw (Del Tite, M3x8mm) securing the Exit 2 Front Cover (PL 11.1.25) to the Lower Chute 2 (PL 11.2.33) to remove the Exit 2 Front Cover .



**Figure 1 Exit 2 Front Cover**

6. Lift the harness and connector secured to the guide on the backside of the Lower Chute 2 .

7. Disconnect the harness connector (P/J208) of the Exit 2 Motor Assembly from the junction connector.
8. Remove the Exit Fan (PL 11.2.39) .
9. Disconnect the connector (P/J112) of the Exit 2 C Harness Assembly (PL 11.2.36) from the I/L CAB Switch (PL 11.2.53).
10. Remove the two screws (Del Tite, M3x10mm) securing the Exit 2 Connector to the Rear Plate Assembly (PL 11.2.20) to remove the Exit 2 Connector.
11. Remove the two screws (Silver, M3x8mm) securing the Rear Plate Assembly to the Lower Chute 2 to remove the Rear Plate Assembly.
12. Remove the two screws (M3x6mm) securing the Exit 2 Motor Assembly to the Rear Plate Assembly.
13. Remove the Exit 2 Motor Assembly.



**Figure 2 Motor Assembly**

## Replacement

1. Install the Exit 2 Motor Assembly to the Rear Plate Assembly (PL 11.2.20) using two screws (M3x6mm).
2. Install the Rear Plate Assembly to the Lower Chute 2 (PL 11.2.33) using two screws (Silver, M3x8mm).

**NOTE** Install the Exit 2 Connector to the Rear Plate Assembly using two screws (Del Tite, M3x10mm).

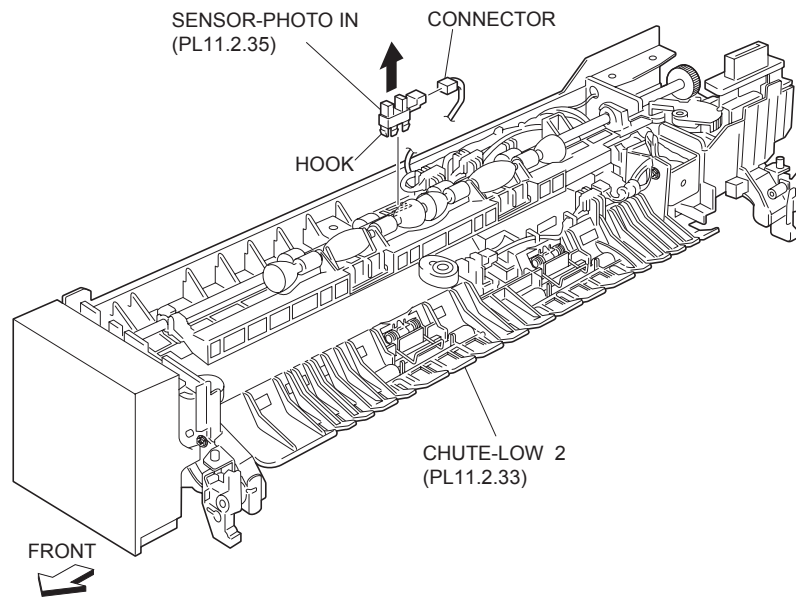
3. Install the connector with its one end having more terminals facing toward the direction shown in the figure.
4. Connect the connector (P/J112) of the Exit 2 C Harness Assembly (PL 11.2.36) to the I/L CAB Switch (PL 11.2.18).
5. Install the Exit Fan (PL 11.2.39) .
6. Connect the harness connector (P/J208) of the Exit 2 Motor Assembly to the junction connector.
7. Secure the harness to the guide on the backside of the Lower Chute 2.
8. Install the Exit 2 Front Cover (PL 11.1.25) to the Lower Chute 2 using the one screw (Del Tite, M3x8mm).
9. Install the Tray Guide 2 (PL 11.2.1) .
10. Close the Exit 2 Transport Assembly (PL 11.1.1).
11. Install the Exit 2 Transport Assembly .
12. Close the Left Hand Cover Assembly (PL 4.2.8)

## Photo In Sensor

### Removal

1. Open the Left Hand Cover Assembly (PL 4.2.8).
2. Remove the Exit 2 Transport Assembly (PL 11.1.1) .
3. Open the Exit 2 Transport Assembly.
4. Remove the Tray Guide 2 (PL 11.2.1) .
5. Disconnect the connector (P/J113) of the Exit 2 C Harness Assembly (PL 11.2.36) connected to the Photo In Sensor.
6. Release the hooks securing the Photo In Sensor to the Lower Chute 2 (PL 11.2.33) as shown in the figure.
7. Remove the Photo In Sensor.





**Figure 1 Photo In Sensor**

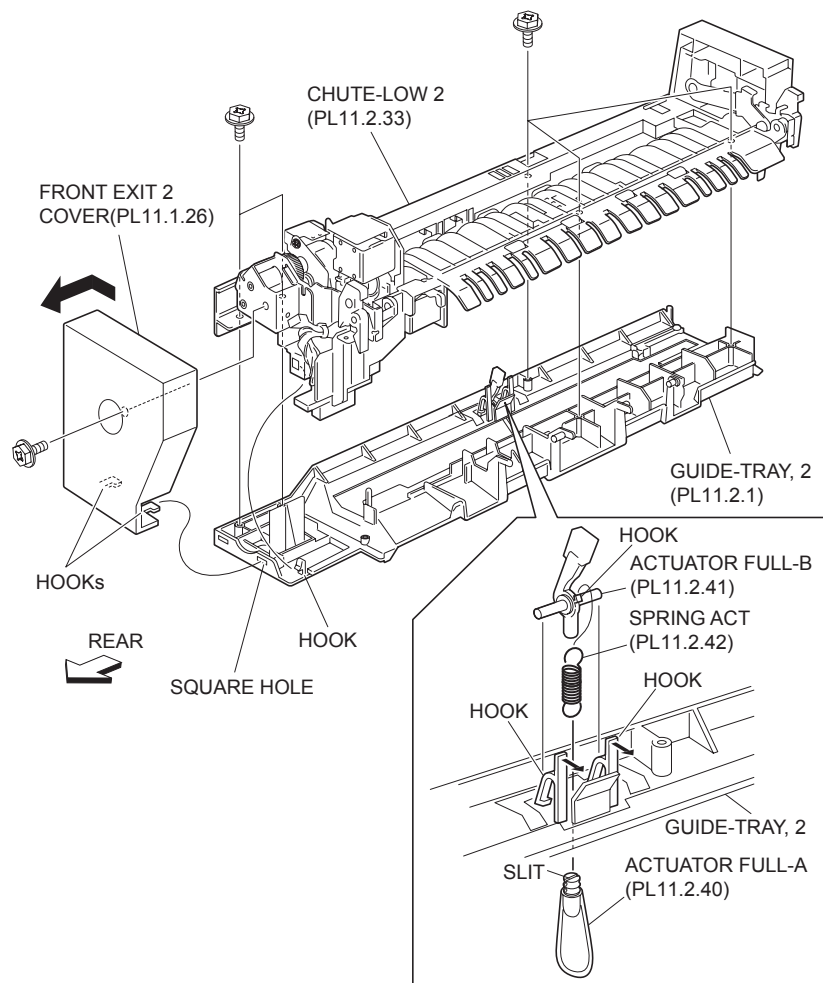
## Replacement

1. Install the Photo In Sensor to the Lower Chute 2 (PL 11.2.33) with the hook.
2. Connect the connector (P/J113) of the Exit 2 C Harness Assembly (PL 11.2.36) to the Photo In Sensor.
3. Install the Tray Guide 2 (PL 11.2.1) .
4. Close the Exit 2 Transport Assembly (PL 11.1.1).
5. Install the Exit 2 Transport Assembly .
6. Close the Left Hand Cover Assembly (PL 4.2.8).

## Exit Fan

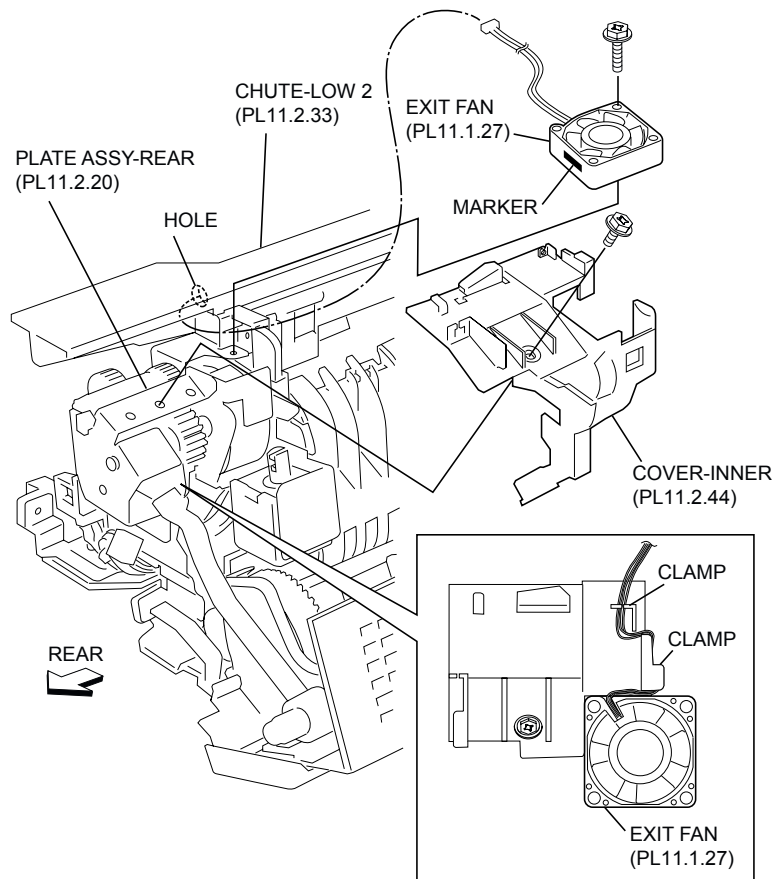
### Removal

1. Open the Left Hand Cover Assembly (PL 4.2.8).
2. Remove the Exit 2 Transport Assembly (PL 11.1.1) .
3. Open the Exit 2 Transport Assembly.
4. Remove the Tray Guide 2 (PL 11.2.1) .
5. Remove the screw (Del Tite, M3x8mm) securing the Exit 2 Front Cover (PL 11.1.25) to the Lower Chute 2 (PL 11.2.33) and remove the Exit 2 Front Cover .



**Figure 1 Exit 2 Front Cover**

6. Disconnect the harness of the Exit Fan from the junction connector (P/J606B) .
7. Remove the harness of the Exit Fan from the hole in the Lower Chute (PL 11.2.33).
8. Remove the screw (Del Tite, M3x8mm) securing the Inner Cover (PL 11.2.44) to the Rear Plate Assembly (PL 11.2.20).
9. Lift the Inner Cover in the direction of the arrow.
10. Remove the screw (Del Tite, M3x8mm) securing the Exit Fan to the Inner Cover.
11. Release the harness of the Exit Fan from the clamp on the Inner Cover.
12. Remove the Exit Fan.



**Figure 2 Exit Fan**

## Replacement

1. Put the harness of the Exit Fan through the hole in the Lower Chute (PL 11.2.33).
2. Move the Inner Cover (PL 11.2.44) in the opposite direction of the arrow to install it to the Rear Plate Assembly (PL 11.2.20).
3. Secure the harness of the Exit Fan to the clamp on the Inner Cover.
4. Install the Exit Fan to the Inner Cover with the screw (Del Tite, M3x8mm).

**NOTE** Install the Exit Fan so that the label faces downward and the printed number comes to the rear.

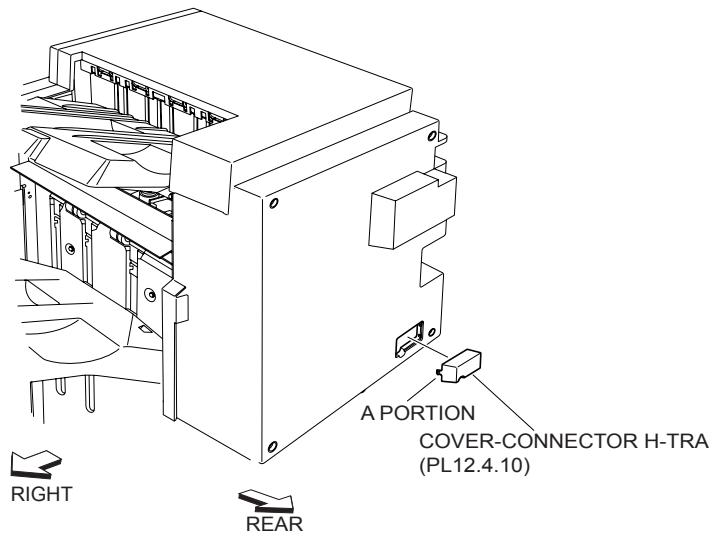
5. Connect the harness of the Exit Fan to the junction connector (P/J606B).
6. Install the Inner Cover to the Rear Plate Assembly (PL 11.2.20) with the screw (Del Tite, M3x8mm).
7. Install the Exit 2 Front Cover (PL 11.1.25) to the Lower Chute 2 (PL 11.2.33) with the screw (Del Tite, M3x8mm).
8. Install the Tray Guide 2 (PL 11.2.1) .
9. Close the Exit 2 Transport Assembly (PL 11.1.1).
10. Install the Exit 2 Transport Assembly .
11. Close the Left Hand Cover Assembly (PL 4.2.8).

# Finisher Unit

## Transport Assembly

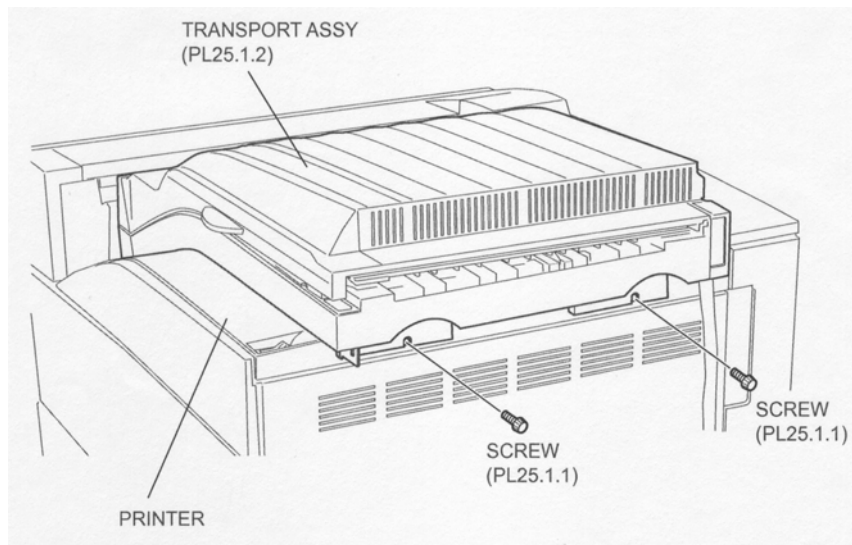
### Removal

1. Push the A portion of the H-Transport Connector Cover (PL 12.4.10) to disengage the lock from the Finisher, and remove it from the Finisher .
2. Disconnect the connection cable between the Transport Assembly and the Finisher.
3. Disengage the Finisher from the printer .



**Figure 1 Finisher**

4. Remove the two Screws (PL 12.1.1) on the right side .
5. Remove the Transport Assembly from the printer.



**Figure 2 Transport Assembly**

## Replacement

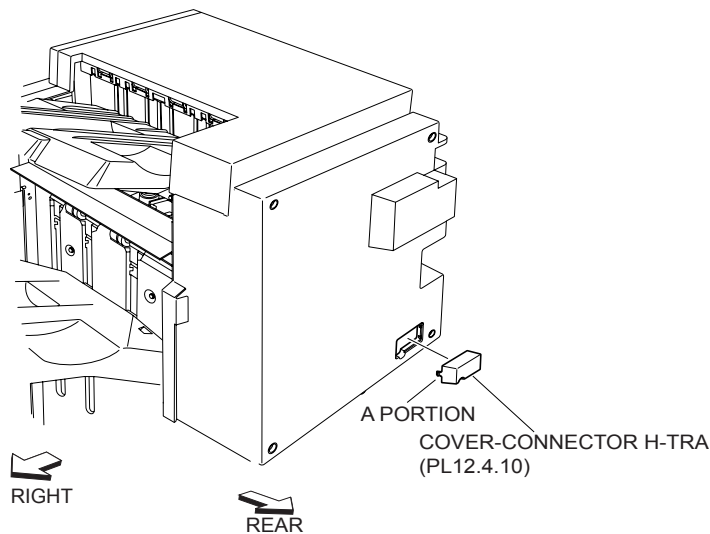
1. Place the Transport Assembly on the printer.
2. Secure the Transport Assembly to the right side of the printer using the two Screws (PL 12.1.1).
3. Move the Finisher toward the printer to engage them .
4. Connect the connection cable of the Transport Assembly to the Finisher.
5. Attach the H-Transport Connector Cover (PL 12.4.10) to the Finisher.

**NOTE** Check that the H-Transport Connector Cover is securely attached to the Finisher.

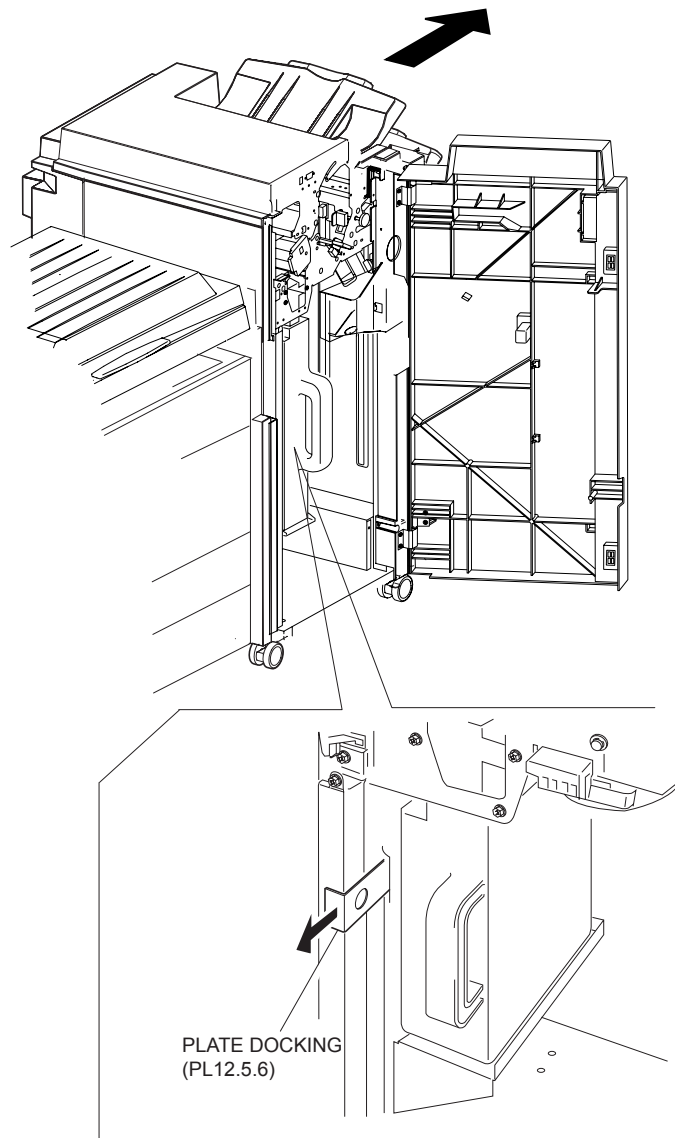
## Staple Finisher

### Removal

1. Disconnect the power cord and connection cable of the Finisher from the rear side of the printer .
2. Remove the H-Transport Connector Cover (PL 12.4.10) on the rear side of the Finisher.
3. Disconnect the cable of the Transport Assembly from the Finisher.
4. Open the Front Cover Assembly (PL 12.5.3) on the front side of the Finisher.
5. Move the Finisher to the right while pulling the Docking Plate (PL 12.5.6) toward you .
6. Close the Front Cover Assembly.



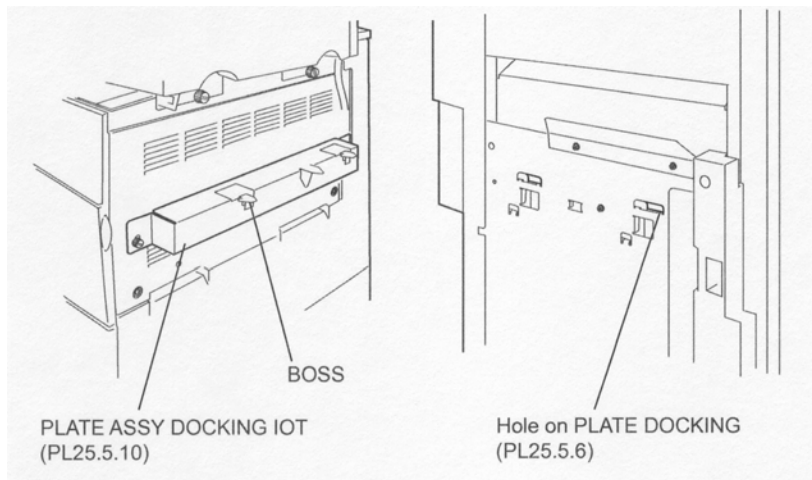
**Figure 1 Finisher**



**Figure 2 Docking Plate**

## Replacement

1. Open the Front Cover Assembly (PL 12.5.3).
2. While pulling the Docking Plate (PL 12.5.6) toward you, move the Finisher to the left so that the bosses on the IOT Docking Plate Assembly (PL 12.5.10) attached to the printer fit to the holes on the Docking Plate on the Finisher .
3. Remove your hand from the Docking Plate to engage the IOT Docking Plate Assembly with the Docking Plate.
4. Close the Front Cover Assembly.
5. Connect the cable of the Transport Assembly to the rear side of the Finisher.
6. Attach the H-Transport Connector Cover (PL 12.4.10).
7. Connect the power cord and connection cable of the Finisher to the rear side of the printer.

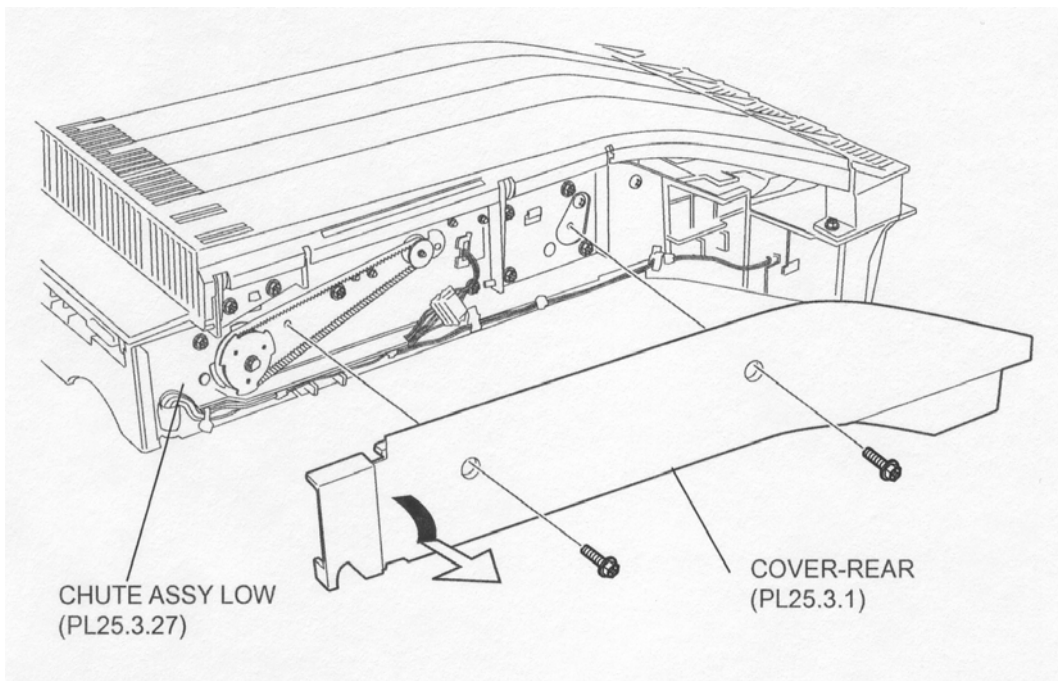


**Figure 3 Docking Plate**

## Rear Cover

### Removal

1. Remove the two Screws (TP M3 x 8) securing the Rear Cover .
2. Remove the two hooks of the Rear Cover, and move it in the direction of the arrow to remove it from the H-Transport.



**Figure 1 H Transport**

### Replacement

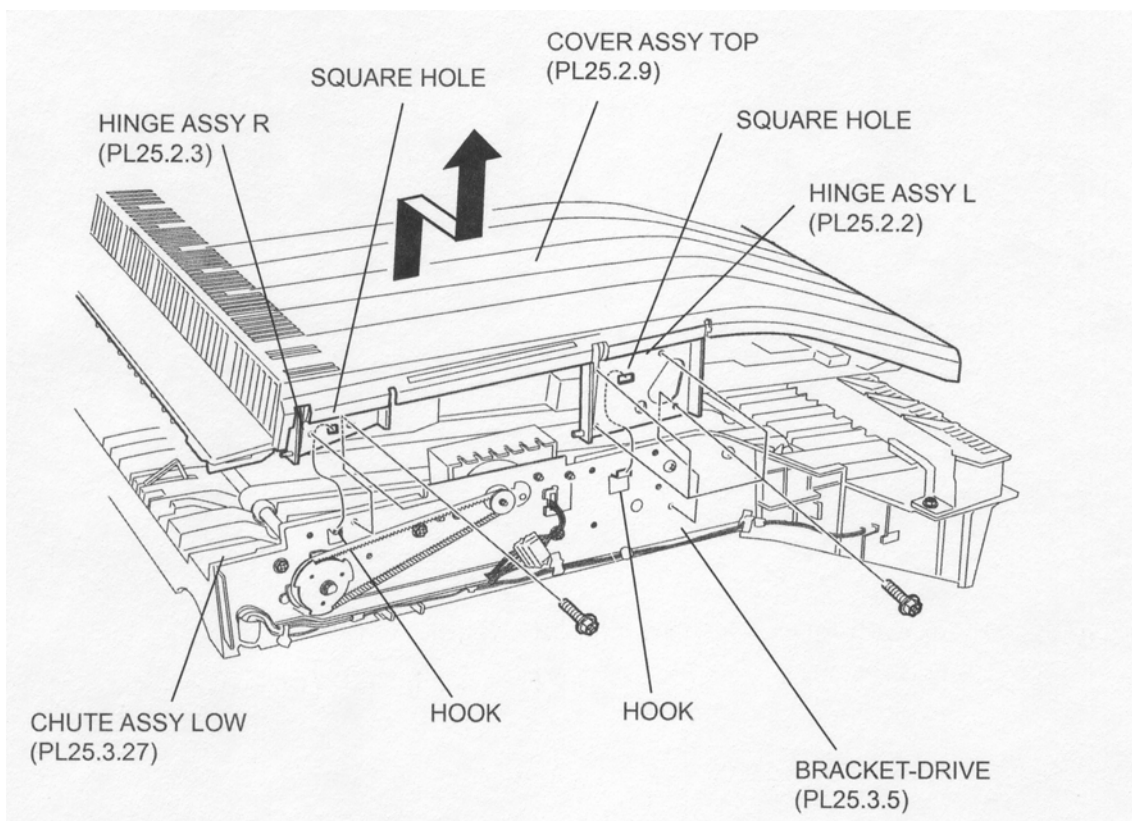
1. Move the Rear Cover in the opposite direction of the arrow to install it to the Lower Chute Assembly (PL 12.3.27) with two hooks, and secure it using two Screws (TP M3 x 8).

**NOTE** When installing the Rear Cover, be careful not to pinch the harness.

## Top Cover Assembly

### Removal

1. Remove the Rear Cover (PL 12.3.1) .
2. Open the Top Cover Assembly.
3. Remove the six Screws (TP M3 x 6) securing the Left Hinge Assembly (PL 12.2.2) and the Right Hinge Assembly (PL 12.2.3) to the Drive Bracket (PL 12.3.5) on the Lower Chute Assembly (PL 12.3.27) .
4. Remove the Top Cover Assembly in the direction of the arrow.



**Figure 1 Top Cover Assembly**

### Replacement

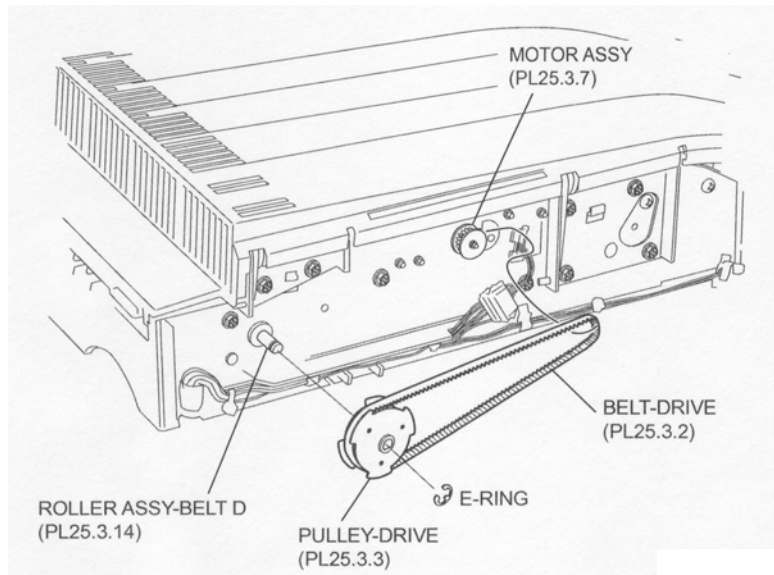
1. Install the Top Cover Assembly to the Drive Bracket (PL 12.3.5) so that the square holes on the Top Cover Assembly fit to the two hooks at left and right on the Drive Bracket.
2. Secure the Top Cover Assembly using six Screws (TP M3 x 6).
3. Close the Top Cover Assembly.
4. Install the Rear Cover (PL 12.3.1) .

## Drive Belt

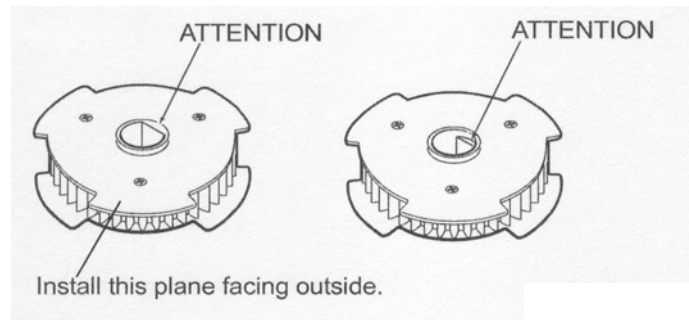
### Removal



1. Remove the Rear Cover (PL 12.3.1) .
2. Remove the E-ring securing the Drive Pulley (PL 12.3.3).
3. Remove the Drive Pulley and the Drive Belt together from the D-Belt Roller Assembly (PL 12.3.14) .



**Figure 1 Drive Belt**



**Figure 2 Drive Pulley**

## Replacement

1. Place the Drive Belt onto the Drive Pulley (PL 12.3.3) and the pulley of the Motor Assembly (PL 12.3.7), and install the Drive Pulley to the D-Belt Roller Assembly (PL 12.3.14).

**NOTE** Be sure to install the Drive Pulley to the D-Belt Roller Assembly in the direction shown in the figure.

2. Secure the Drive Pulley to the D-Belt Roller Assembly using the E-ring.
3. Install the Rear Cover (PL 12.3.1) .

## D-Belt Roller Assembly

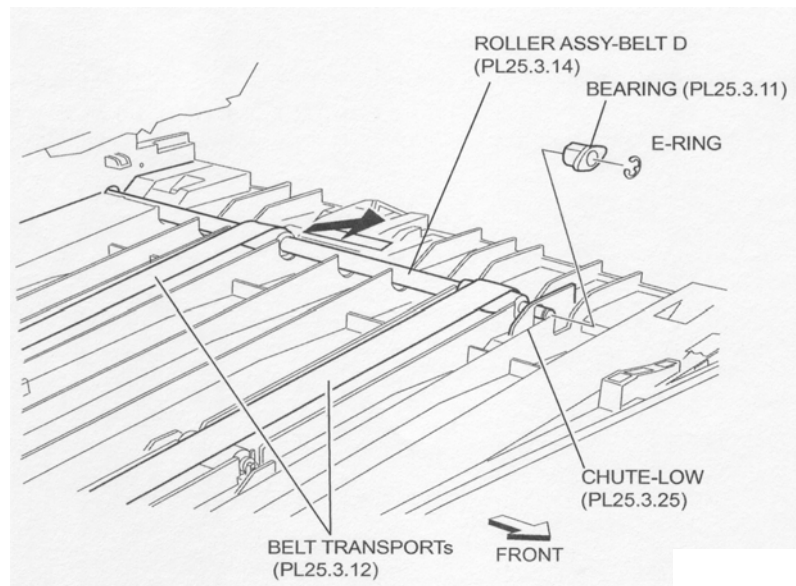
### Removal

1. Remove the Rear Cover (PL 12.3.1) .

2. Remove the Drive Belt (PL 12.3.2) and the Drive Pulley (PL 12.3.3) .
3. Remove the Bearing (PL 12.3.4) on the rear side .
4. Open the Top Cover Assembly (PL 12.2.9).
5. Remove the E-ring on the front.
6. Remove the Bearing (PL 12.3.11) on the front from the D-Belt Roller Assembly .
7. After moving the D-Belt Roller Assembly in the direction of the arrow to remove it from the hole on the Lower Chute (PL 12.3.25), and then remove D-Belt Roller Assembly from the hole on the Drive Bracket (PL 12.3.5)
8. Remove the D-Belt Roller Assembly from the two Transport Belts (PL 12.3.12).



**Figure 1 Top Cover Assembly**



**Figure 2 Belt Transport**

## Replacement

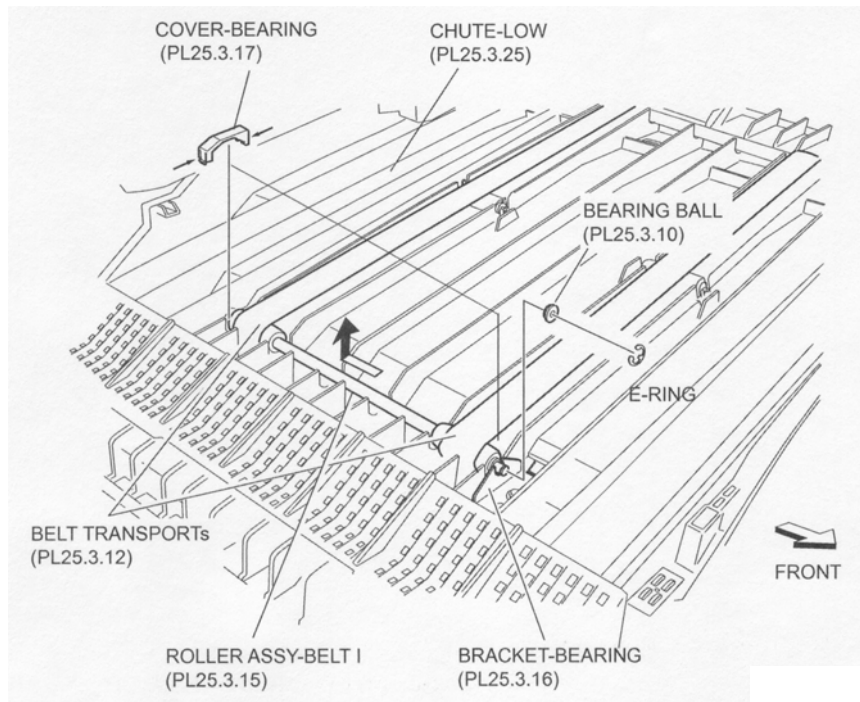
1. Put the D-Belt Roller Assembly through the two Transport Belts (PL 12.3.12).
2. Move the D-Belt Roller Assembly in the opposite direction of the arrow, and put it into the holes of the Drive Bracket (PL 12.3.5) and the Lower Chute (PL 12.3.25).

3. Install the Bearing (PL 12.3.11) to the D-Belt Roller Assembly on the front.
4. Secure the Bearing to the Lower Chute using the E-ring.
5. Install the Bearing (PL 12.3.4) to the D-Belt Roller Assembly on the rear.
6. Install the Drive Belt (PL 12.3.2) and the Drive Pulley (PL 12.3.3) .
7. Close the Top Cover Assembly (PL 12.2.9).
8. Install the Rear Cover (PL 12.3.1) .

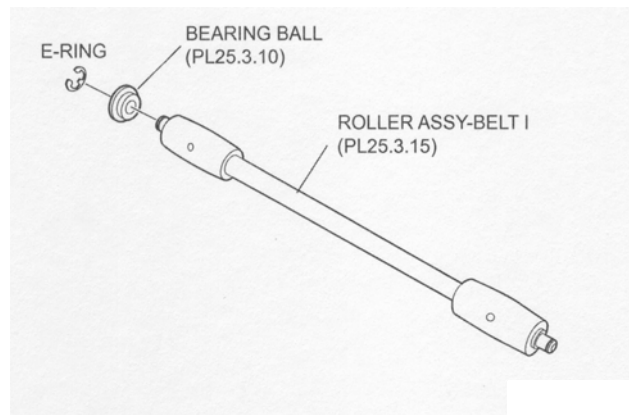
## I-Belt Roller Assembly

### Removal

1. Open the Top Cover Assembly (PL 12.2.9).
2. Push the two Cover Bearings in the direction of the arrow to release the hooks, and remove them from the Lower Chute (PL 12.3.25) .
3. Remove the E-ring on the front of the I-Belt Roller Assembly.
4. Remove the Bearing (PL 12.3.10).
5. Move the I-Belt Roller Assembly in the direction of the arrow to remove it from the Bearing Bracket (PL 12.3.16).
6. Remove the I-Belt Roller Assembly from the two Transport Belts (PL 12.3.12) .
7. Remove the E-ring attached to the I-Belt Roller Assembly, and remove the Ball Bearing (PL 12.3.10).



**Figure 1 Lower Chute**



**Figure 2 I Belt Roller Assembly**

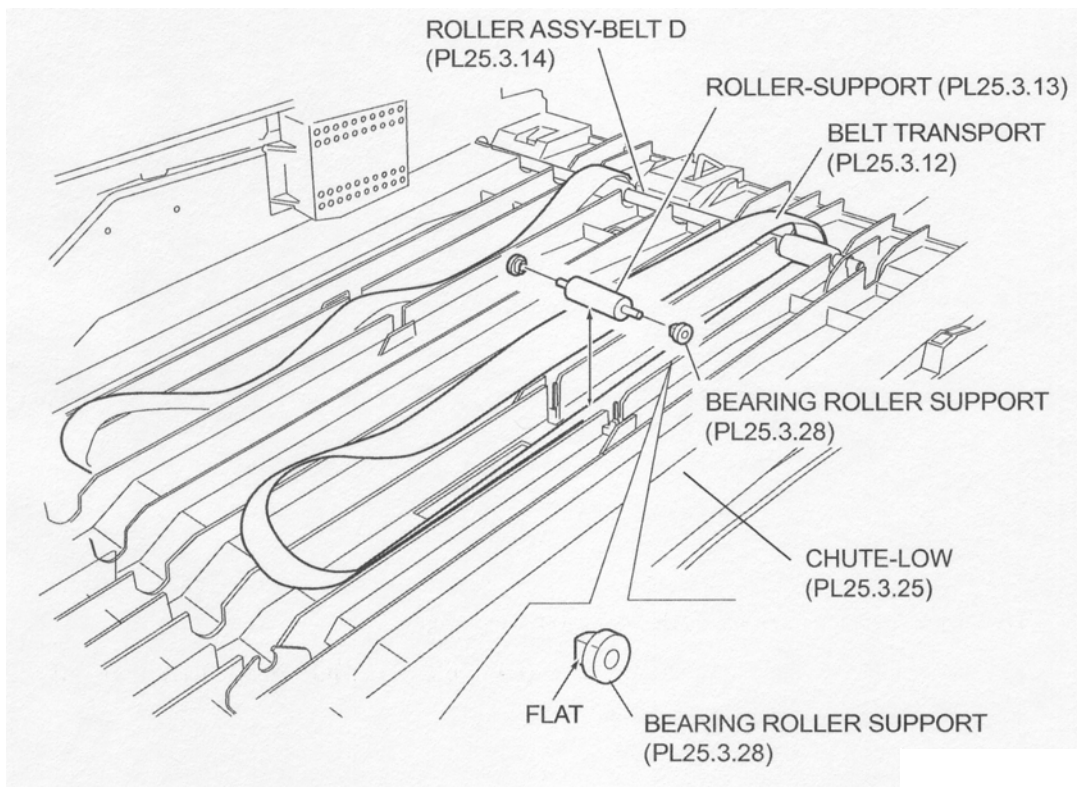
## Replacement

1. Install the Ball Bearing (PL 12.3.10) to the I-Belt Roller Assembly and secure it using the E-ring.
2. Put the I-Belt Roller Assembly through the two Transport Belts (PL 12.3.12) with the Ball Bearing facing the rear side.
3. Install the I-Belt Roller Assembly to the Bearing Bracket (PL 12.3.16) on the rear, and put the Ball Bearing into the hole of the Bearing Bracket.
4. Put the Ball Bearing through the I-Belt Roller Assembly on the front, and put it into the hole on the Bearing Bracket.
5. Secure the Ball Bearing using the E-ring.
6. Install the two Cover Bearings to the Lower Chute (PL 12.3.25), and secure them with the hooks.
7. Close the Top Cover Assembly (PL 12.2.9).

## Support Roller

### Removal

1. Open the Top Cover Assembly (PL 12.2.9).
2. Remove the D-Belt Roller Assembly (PL 12.3.14) or the I-Belt Roller Assembly (PL 12.3.15).
3. Put the Transport Belt (PL 12.3.12) aside, and lift the Support Roller up in the direction of the arrow to remove the Support Roller from the Lower Chute (PL 12.3.25) .
4. Remove the Support Roller Bearings (PL 12.3.28) from the both ends of the Support Roller.



**Figure 1 Lower Chute**

## Replacement

1. Install the Support Roller Bearings (PL 12.3.28) to both ends of the Support Roller in the direction shown in the figure.
2. Put the Transport Belt (PL 12.3.12) aside, and move the Support Roller in the opposite direction of the arrow to install it to the Lower Chute (PL 12.3.25).

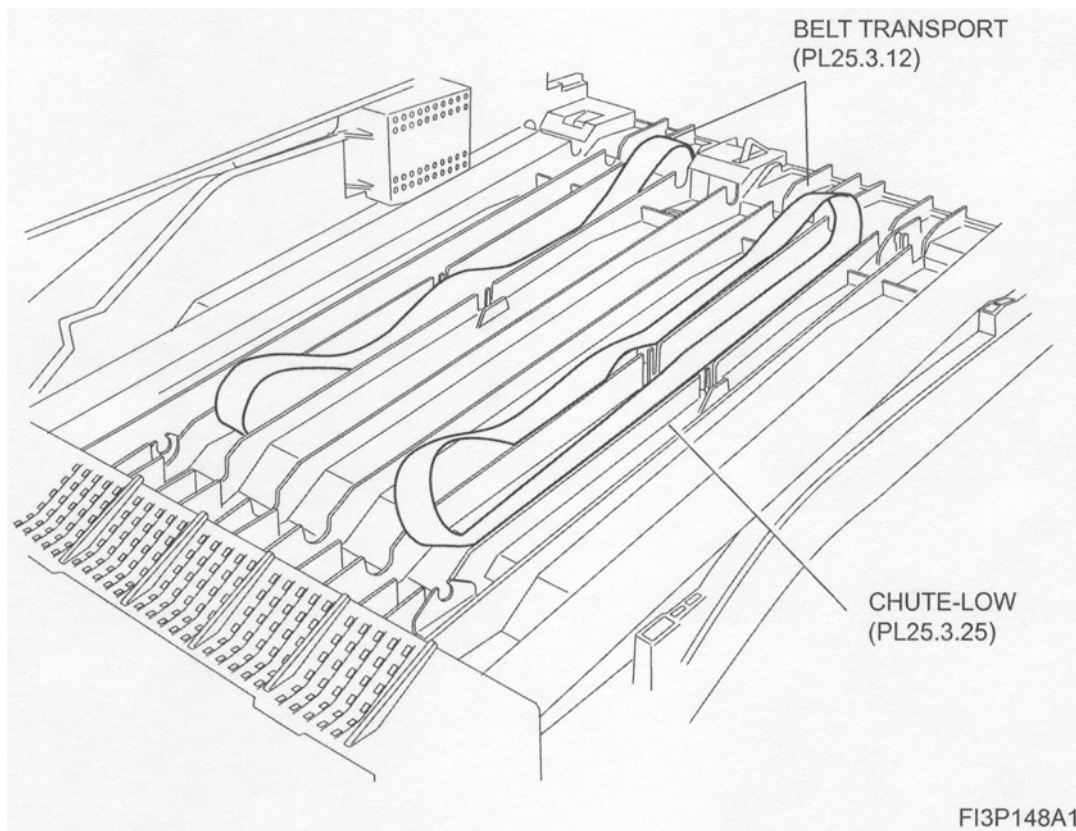
**NOTE** Install the Support Roller to the Lower Chute so that the flat surface of the Support Roller Bearing faces the direction shown in the figure.

3. Install the D-Belt Roller Assembly (PL 12.3.14) or the I-Belt Roller Assembly (PL 12.3.15).
4. Close the Top Cover Assembly (PL 12.2.9).

## Transport Belt

### Removal

1. Remove the Rear Cover (PL 12.3.1) .
2. Open the Top Cover Assembly (PL 12.2.9).
3. Remove the D-Belt Roller Assembly (PL 12.3.14) .
4. Remove the I-Belt Roller Assembly (PL 12.3.15) .
5. Remove the Support Roller (PL 12.3.13) .
6. Remove the Transport Belt from the Lower Chute (PL 12.3.25) .



**Figure 1 Lower Chute**

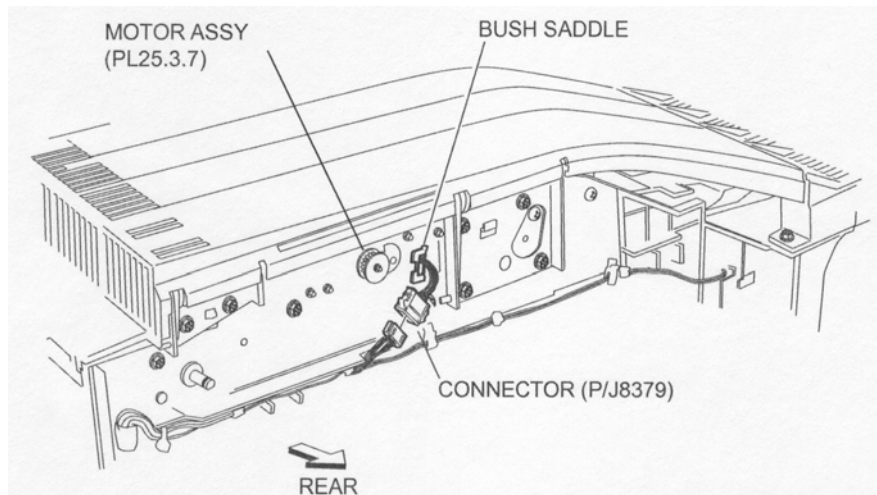
## Replacement

1. Place the Transport Belt in the position shown in the figure on the Lower Chute (PL 12.3.25).
2. Install the Support Roller (PL 12.3.13) .
3. Install the I-Belt Roller Assembly (PL 12.3.15) .
4. Install the D-Belt Roller Assembly (PL 12.3.14) .
5. Close the Top Cover Assembly (PL 12.2.9).
6. Install the Rear Cover (PL 12.3.1) .

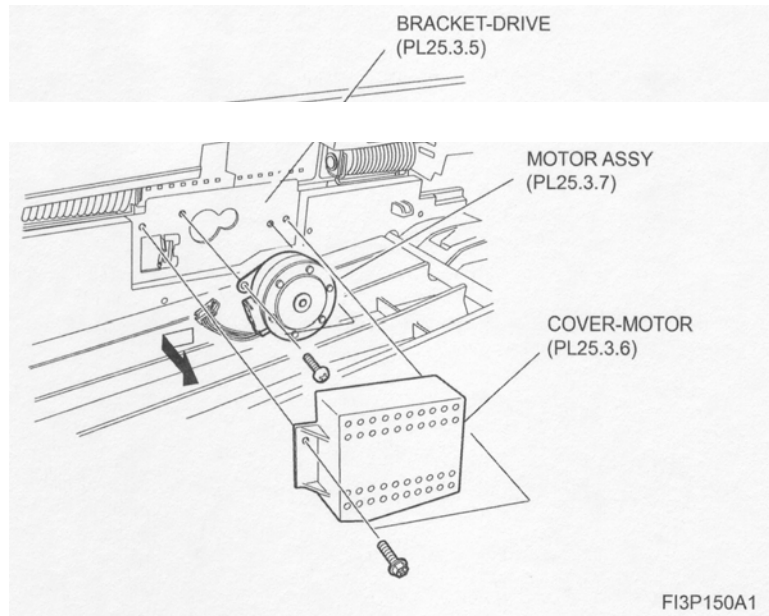
## Motor Assembly

### Removal

1. Remove the Rear Cover (PL 12.3.1) .
2. Remove the Drive Belt (PL 12.3.2) .
3. Disconnect the harness connector (P/J8379) of the Motor Assembly from the H-Transport Unit Harness Assembly (PL 12.3.26) .
4. Release the harness of the Motor Assembly from the Bush Saddle.
5. Open the Top Cover Assembly (PL 12.2.9).
6. Remove the two Screws securing the Motor Cover (PL 12.3.6) to remove the Motor Cover .
7. Remove the two Screws (+ M3 x 6) securing the Motor Assembly to the Drive Bracket, and move the Motor Assembly in the direction of the arrow to remove.



**Figure 1 H Transport**



**Figure 2 Motor Assembly**

## Replacement

1. Put the Motor Assembly into the hole of the Drive Bracket (PL 12.3.5) in the direction shown in the figure, and secure it using two Screws (+ M3 x 6) after moving it in the opposite direction of the arrow.
2. Install the Motor Cover (PL 12.3.6) using two Screws (M3 x 6).
3. Secure the harness of the Motor Assembly using the Bush Saddle.
4. Connect the harness connector (P/J8379) of the Motor Assembly to the H-Transport Unit Harness Assembly (PL 12.3.26).
5. Close the Top Cover Assembly (PL 12.2.9).
6. Install the Drive Belt (PL 12.3.2) .
7. Install the Rear Cover (PL 12.3.1) .

## Left Top Cover

### Removal

1. Remove the Rear Cover (PL 12.3.1) .
2. Open the Top Cover Assembly (PL 12.2.9).
3. Remove the two Screws (WP M3 x 8) securing the Left Top Cover to the Lower Chute (PL 12.3.25) to remove the Left Top Cover .

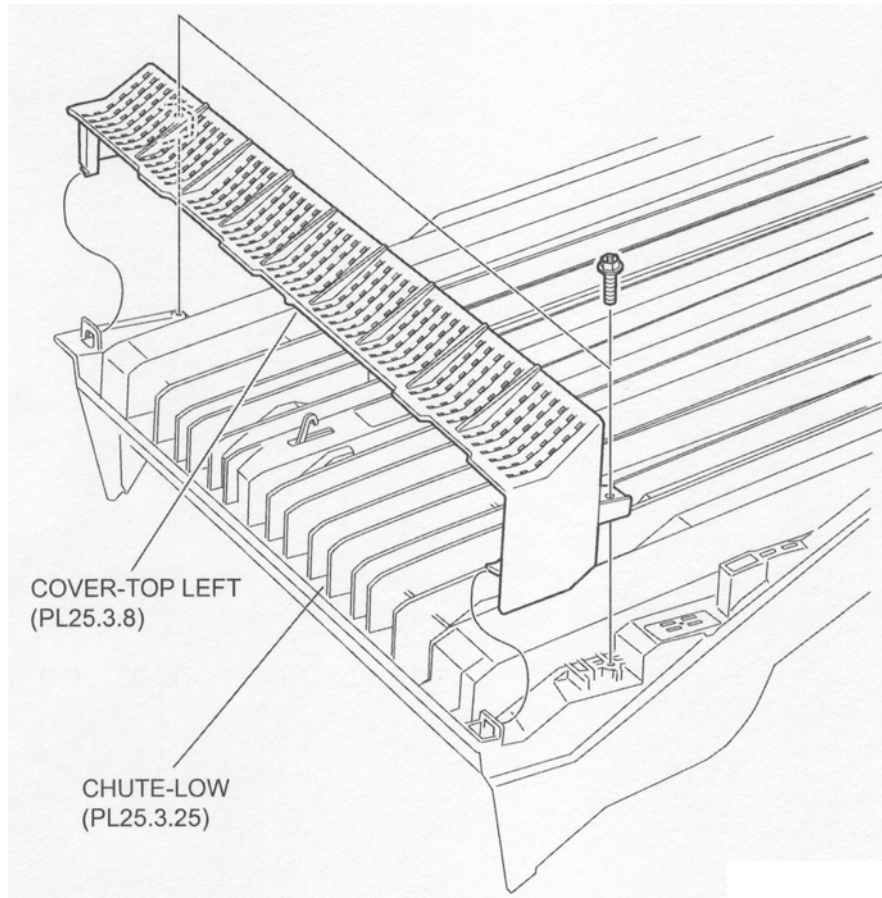


Figure 1 Left Top Cover

### Replacement

1. Install the Left Top Cover to the Lower Chute (PL 12.3.25) using two Screws (WP M3 x 8).
2. Close the Top Cover Assembly (PL 12.2.9).
3. Install the Rear Cover (PL 12.3.1) .

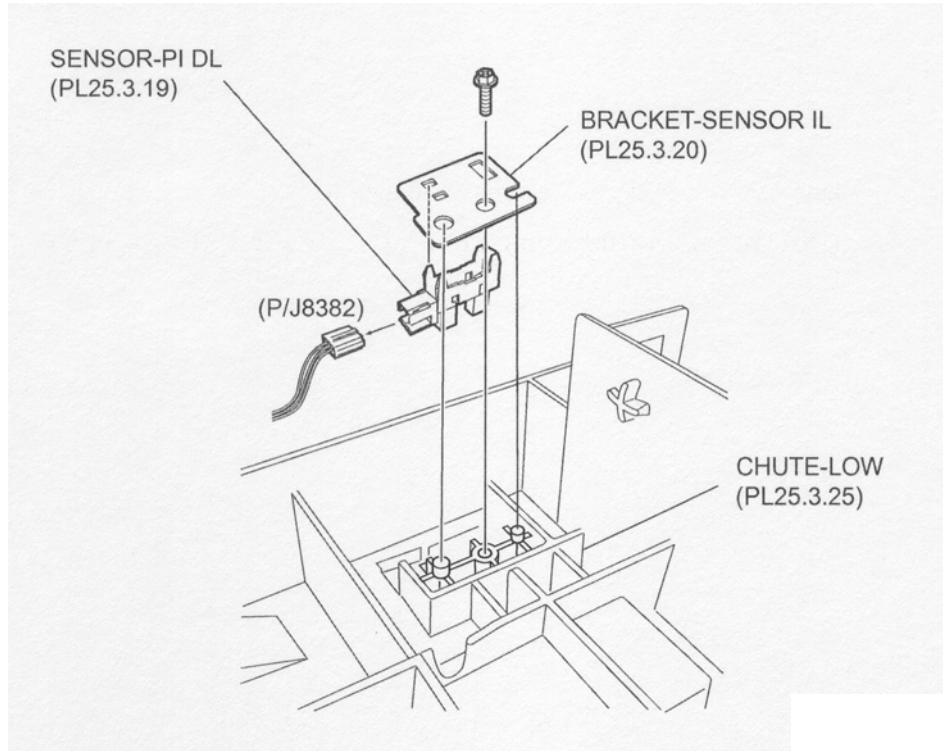
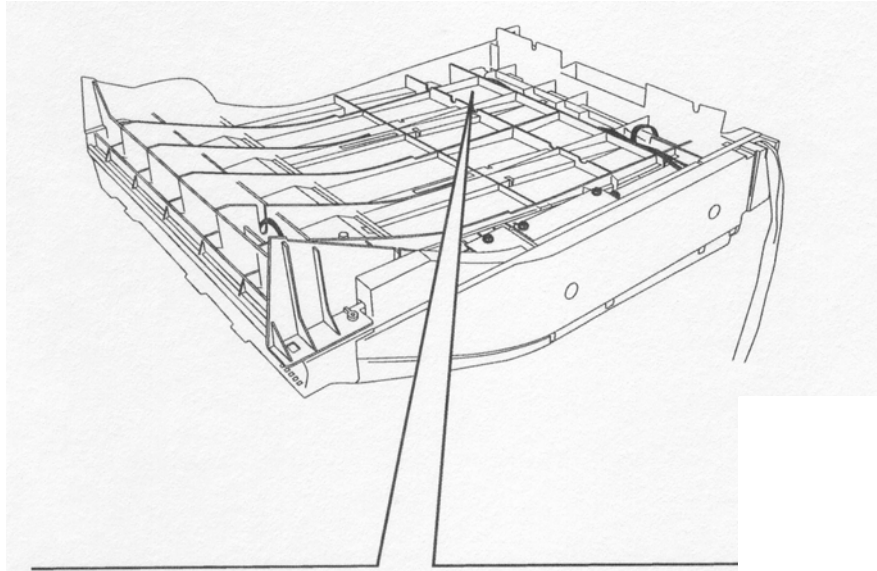
## DL PI-Sensor (H-Transport Interlock Sensor)

### Removal

1. Place the Transport Assembly (PL 12.1.2) up side down.
2. Remove the one Screw (Tapping M3 x 8) securing the IL Sensor Bracket (PL 12.3.20) to the Lower Chute (PL 12.3.25) to remove the IL Sensor Bracket .
3. Disconnect the connector (P/J8382) of the H-Transport Unit Harness Assembly (PL 12.3.26) from the DL PI-Sensor.



4. Release the hooks securing the DL PI-Sensor to the IL Sensor Bracket to remove the DL PI-Sensor.



**Figure 1 PI DL Sensor**

### **Replacement**

1. Secure the DL PI-Sensor to the IL Sensor Bracket (PL 12.3.20) using the hooks.
2. Connect the connector (P/J8382) of the H-Transport Unit Harness Assembly (PL 12.3.26) to the DL PI-Sensor.
3. Install the IL Sensor Bracket to the Lower Chute (PL 12.3.25) using one Screw (Tapping M3 x 8).
4. Place the Transport Assembly (PL 12.1.2) to the original position.

### **Sensor Assembly (H-Transport Entrance Sensor)**

## Removal

1. Place the Transport Assembly (PL 12.1.2) up side down.
2. Remove the one Screw (Tapping M3 x 8) securing the Sensor Bracket (PL 12.3.24) to the Lower Chute (PL 12.3.25) to remove the Sensor Bracket .
3. Disconnect the connector (P/J8380) of the H-Transport Unit Harness Assembly (PL 12.3.26) from the Sensor Assembly.
4. Release the hooks securing the Sensor Assembly to the Sensor Bracket to remove the Sensor Assembly.

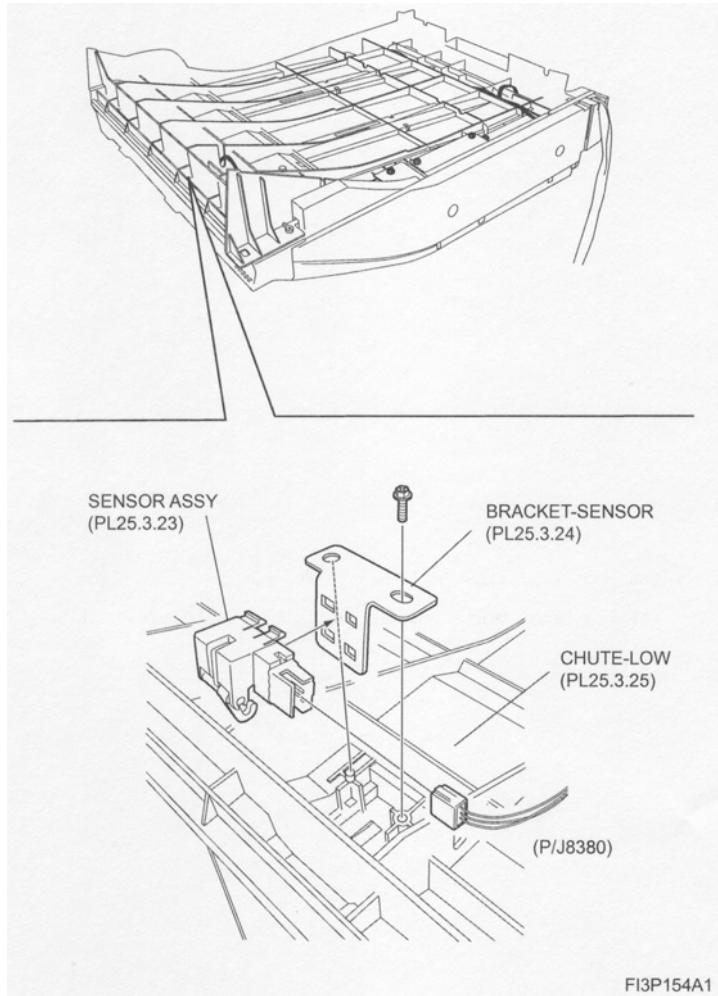


Figure 1 H Transport Sensor

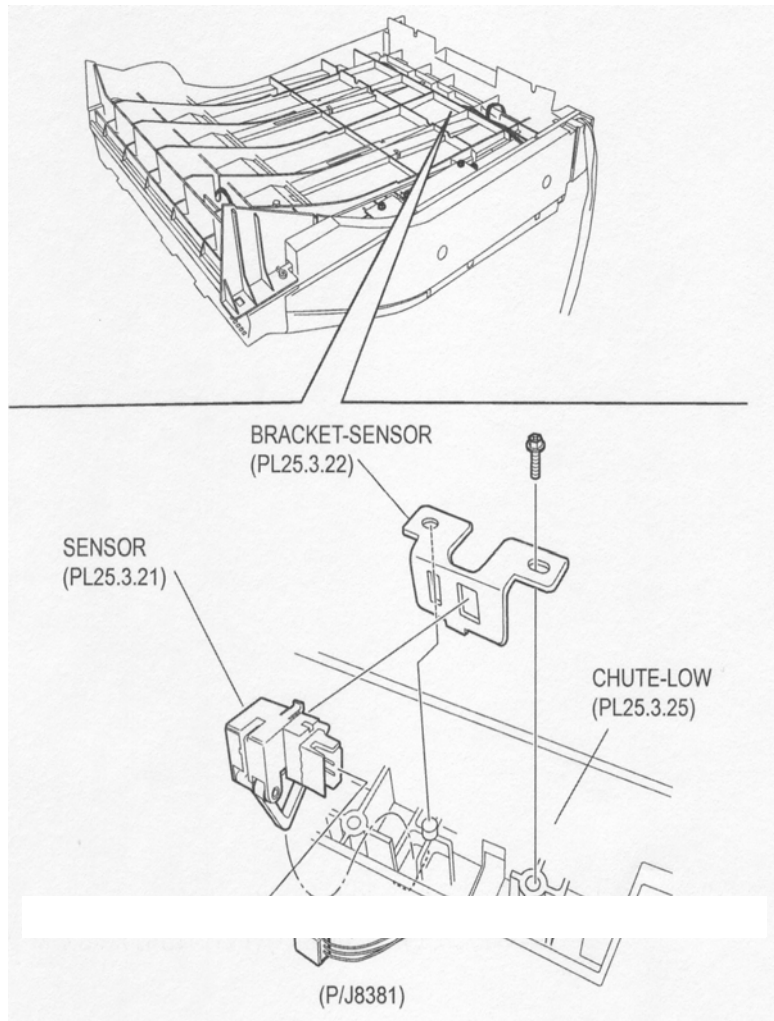
## Replacement

1. Secure the Sensor Assembly to the Sensor Bracket (PL 12.3.24) using the hooks.
2. Connect the connector (P/J8380) of the H-Transport Unit Harness Assembly (PL 12.3.26) to the Sensor Assembly.
3. Install the Sensor Bracket to the Lower Chute (PL 12.3.25) using one Screw (Tapping M3 x 8).
4. Place the Transport Assembly (PL 12.1.2) to the original position.

## Sensor (H-Transport Exit Sensor)

## Removal

1. Place the Transport Assembly (PL 12.1.2) up side down.
2. Remove the one Screw (Tapping M3 x 8) securing the Sensor Bracket (PL 12.3.22) to the Lower Chute (PL 12.3.25) to remove the Sensor Bracket .
3. Disconnect the connector (P/J8381) of the H-Transport Unit Harness Assembly (PL 12.3.26) from the Sensor.
4. Release the hooks securing the Sensor to the Sensor Bracket to remove the Sensor.



**Figure 1 Exit Sensor**

## Replacement

1. Secure the Sensor to the Sensor Bracket (PL 12.3.22) using the hooks.
2. Connect the connector (P/J8381) of the H-Transport Unit Harness Assembly (PL 12.3.26) to the Sensor.
3. Install the Sensor Bracket to the Lower Chute (PL 12.3.25) using one Screw (Tapping M3 x 8).
4. Place the Transport Assembly (PL 12.1.2) to the original position.

## Top Cover

## Removal

1. Open the Front Cover Assembly (PL 12.5.3).
2. Remove the Upper Rear Cover (PL 12.4.11) .
3. Remove the SCT Tray Assembly (PL 12.4.3) .
4. Remove the two Screws each on the front and rear securing the Top Cover to the Finisher .
5. Remove the Top Cover.

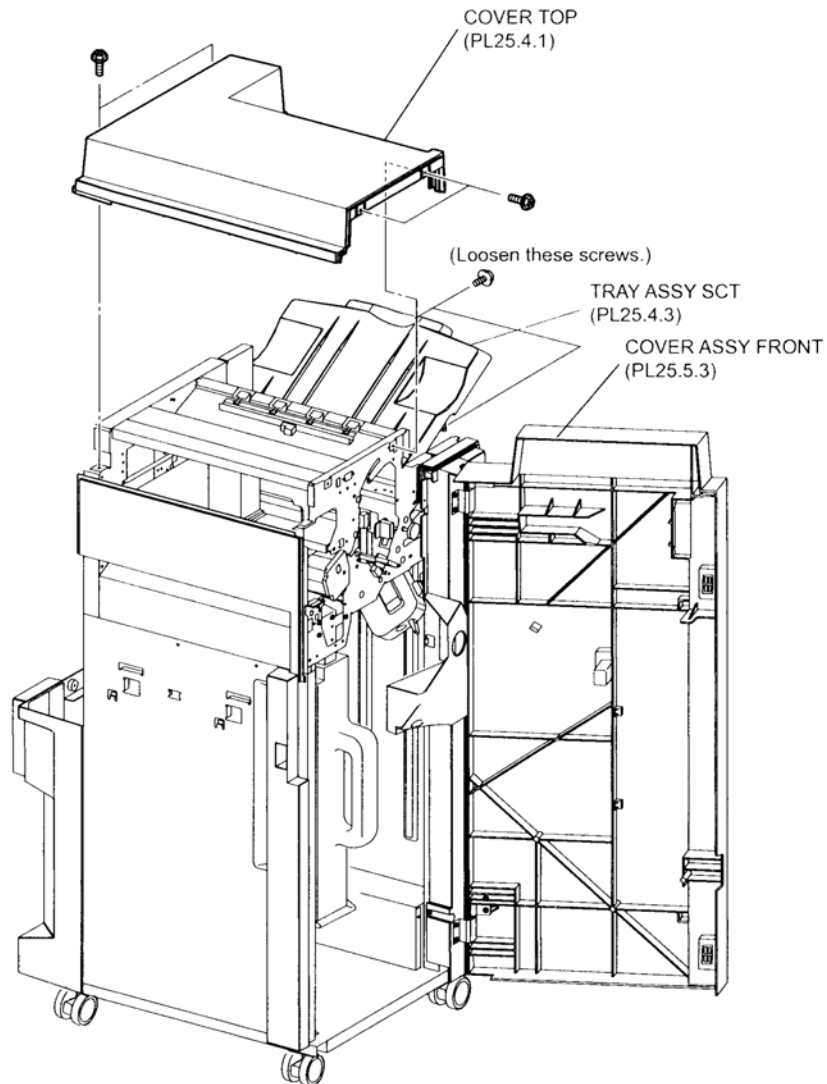


Figure 1 Top Cover

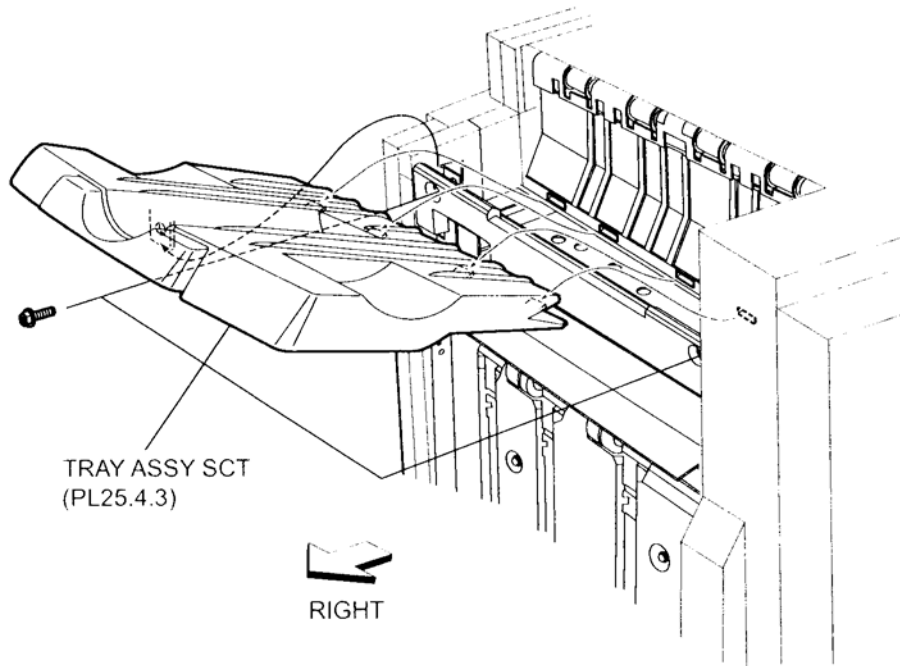
## Replacement

1. Install the Top Cover to the Finisher using four Screws.
2. Install the SCT Tray Assembly (PL 12.4.3) .
3. Install the Upper Rear Cover (PL 12.4.11) .
4. Close the Front Cover Assembly (PL 12.5.3).

## SCT Tray Assembly

### Removal

1. Loosen the two Screws (M3 x 8) securing the SCT Tray Assembly to the Finisher .
2. Lift the SCT Tray Assembly in the direction of the arrow to remove it from the Finisher.



**Figure 1 SCT Tray Assembly**

## Replacement

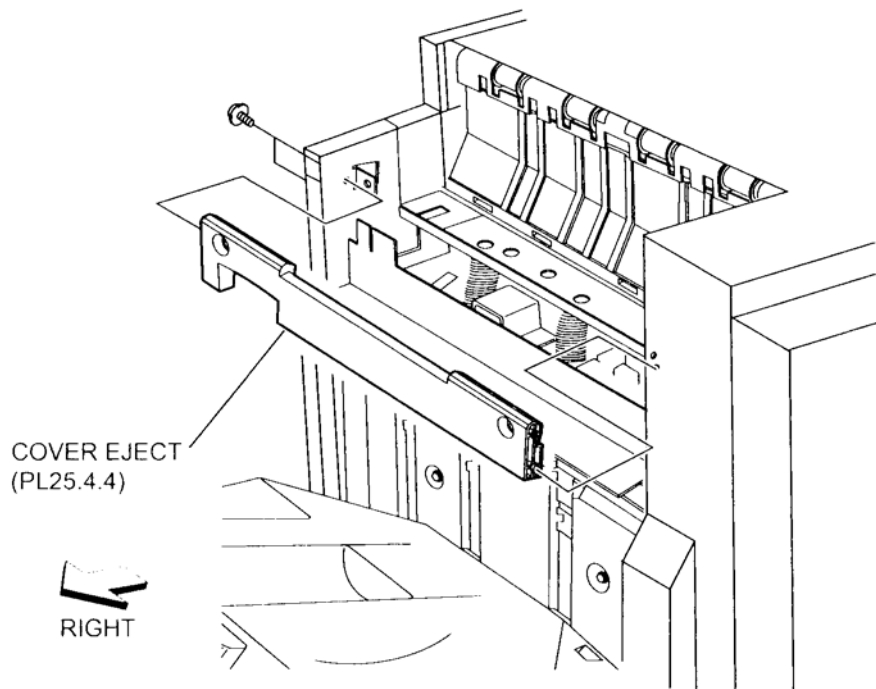
1. Put the four bosses on the top edge of the SCT Tray Assembly into the four holes on the Finisher, and move it in the opposite direction of the arrow to install.
2. Secure the SCT Tray Assembly to the Finisher using two Screws (M3 x 8).

**NOTE** Make sure that the SCT Tray Assembly moves smoothly when the SCT Tray Assembly is pushed down once and then released by hand.

## Eject Cover

### Removal

1. Remove the Front Cover Assembly (PL 12.5.3) .
2. Remove the Upper Rear Cover (PL 12.4.11) .
3. Remove the two Screws (M3 x 8) securing the Eject Cover to the Finisher .
4. Remove the Eject Cover.



**Figure 1 Eject Cover**

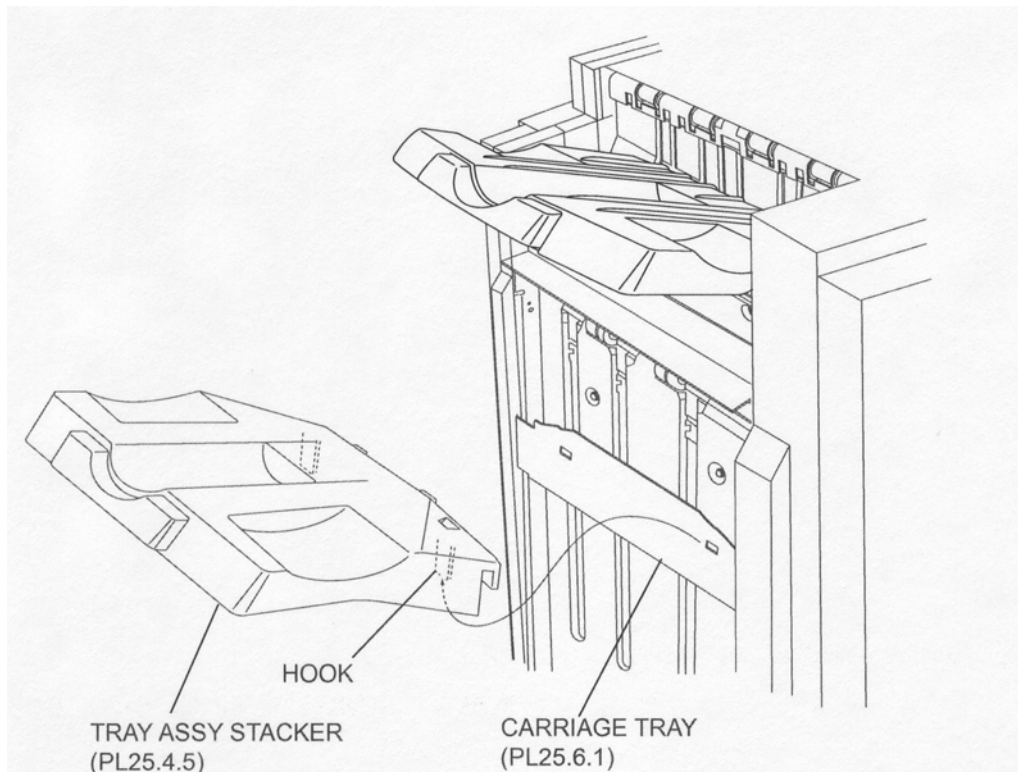
## **Replacement**

1. Install the Eject Cover to the Finisher using two Screws (M3 x 8).
2. Install the Upper Rear Cover (PL 12.4.11) .
3. Install the Front Cover Assembly (PL 12.5.3) .

## **Stacker Tray Assembly**

### **Removal**

1. Release the hooks left and right on the lower part of the Stacker Tray Assembly, and lift the Stacker Tray Assembly up to remove it from the Tray Carriage (PL 12.6.1) .



**Figure 1 Stacker Tray Assembly**

### **Replacement**

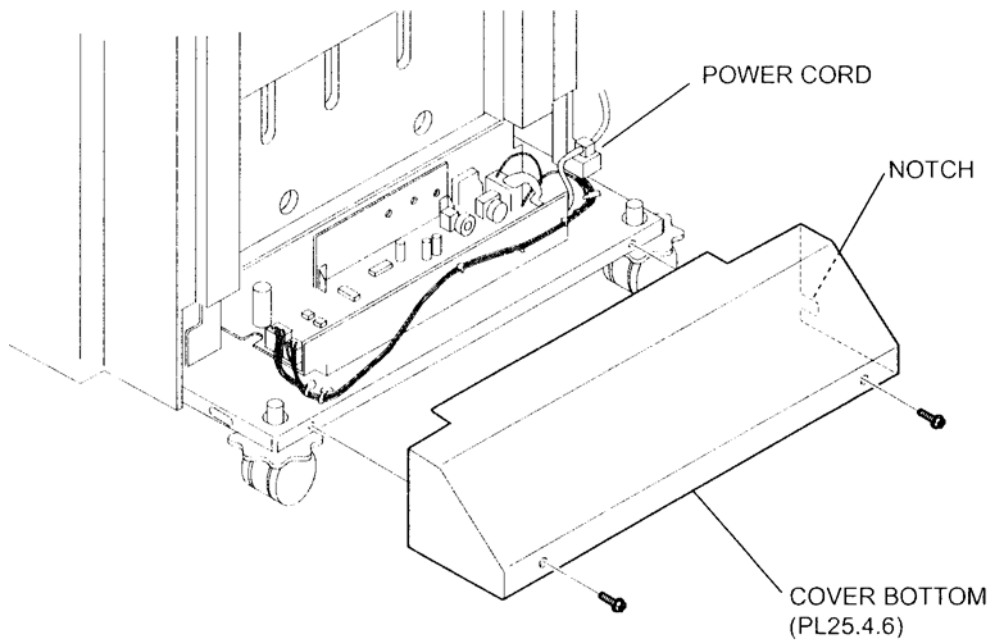
1. Move the Stacker Tray Assembly in the opposite direction of the arrow to install it to the Tray Carriage (PL 12.6.1).
2. Secure the Stacker Tray Assembly to the Tray Carriage using the hooks on left and right.

**NOTE** Make sure that the two hooks on the Stacker Tray Assembly are put into the square holes on the Tray Carriage.

### **Bottom Cover**

#### **Removal**

1. Remove the two Screws (M3 x 8) securing the Bottom Cover to the Finisher .
2. Remove the Bottom Cover.



**Figure 1 Bottom Cover**

### **Replacement**

1. Install the Bottom Cover to the Finisher using two Screws (M3 x 8).

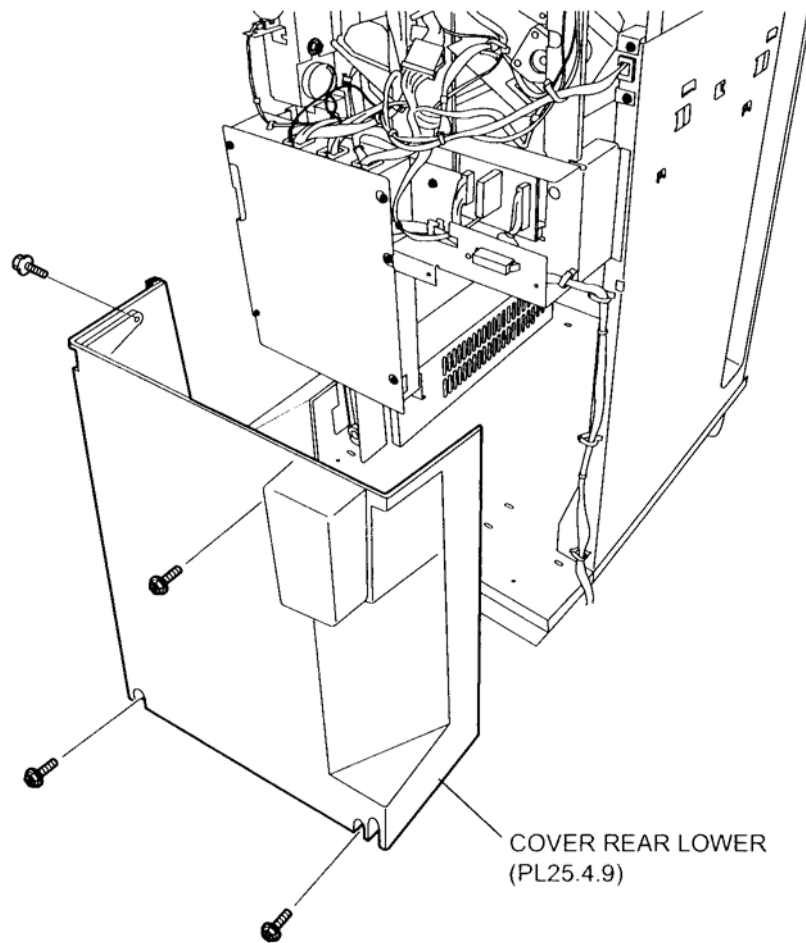
**NOTE** When installing the Bottom Cover, be sure to put the power cord into the notch on the Bottom Cover.

### **Lower Rear Cover**

#### **Removal**

1. Remove the Upper Rear Cover (PL 12.4.11) .
2. Remove the four Screws (M3 x 8) securing the Lower Rear Cover to the Finisher .
3. Remove the Lower Rear Cover.





**Figure 1 Lower Rear Cover**

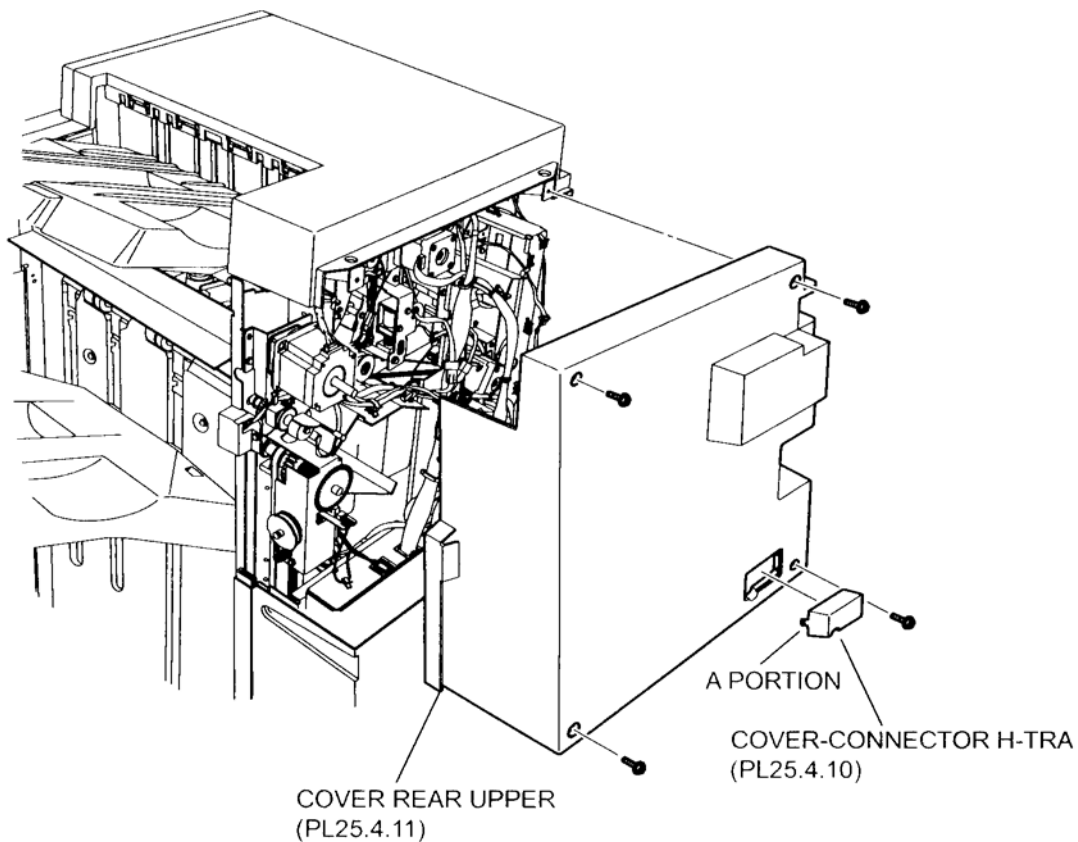
### **Replacement**

1. Install the Lower Rear Cover to the Finisher using four Screws (M3 x 8).
2. Install the Upper Rear Cover (PL 12.4.11) .

### **Upper Rear Cover**

#### **Removal**

1. Release the lock of the H-Transport Connector Cover (PL 12.4.10) by pushing the A portion to remove.
2. Disconnect the cable from the Finisher.
3. Remove the four Screws (M3 x 8) securing the Upper Rear Cover to the Finisher .
4. Remove the Upper Rear Cover from the Finisher.



**Figure 1 Upper Rear Cover**

### Replacement

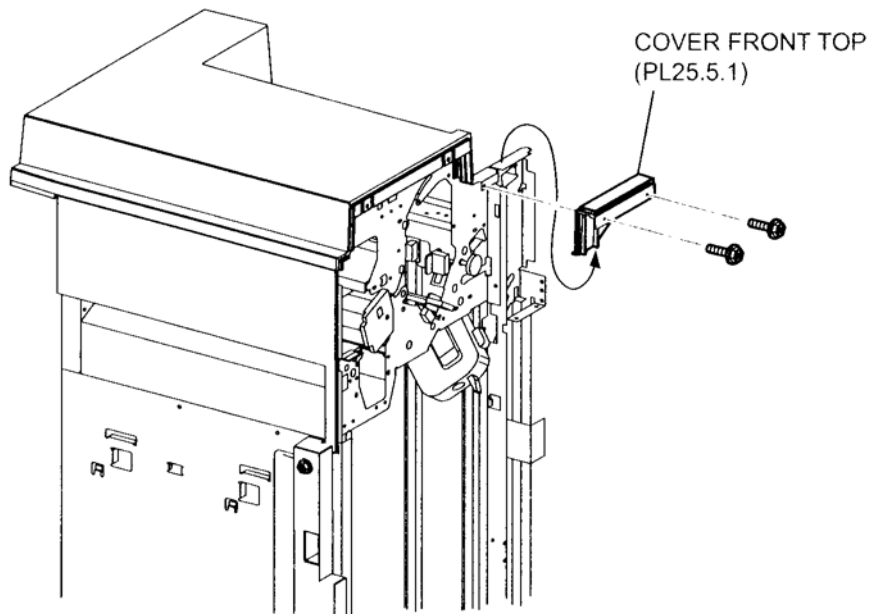
1. Install the Upper Rear Cover to the Finisher using four Screws (M3 x 8).
2. Connect the cable to the connector of the Finisher.
3. Install the H-Transport Connector Cover (PL 12.4.10).

**NOTE** Make sure that the H-Transport Connector Cover is securely locked to the Finisher.

### Top Front Cover

#### Removal

1. Remove the Front Cover Assembly (PL 12.5.3) .
2. Remove the SCT Tray Assembly (PL 12.4.3) .
3. Remove the two Screws (M3 x 8) securing the Top Front Cover to the Finisher .
4. Remove the Top Front Cover.



**Figure 1 Top Front Cover**

### Replacement

1. Install the Top Front Cover to the Finisher using two Screws (M3 x 8).
2. Install the SCT Tray Assembly (PL 12.4.3) .

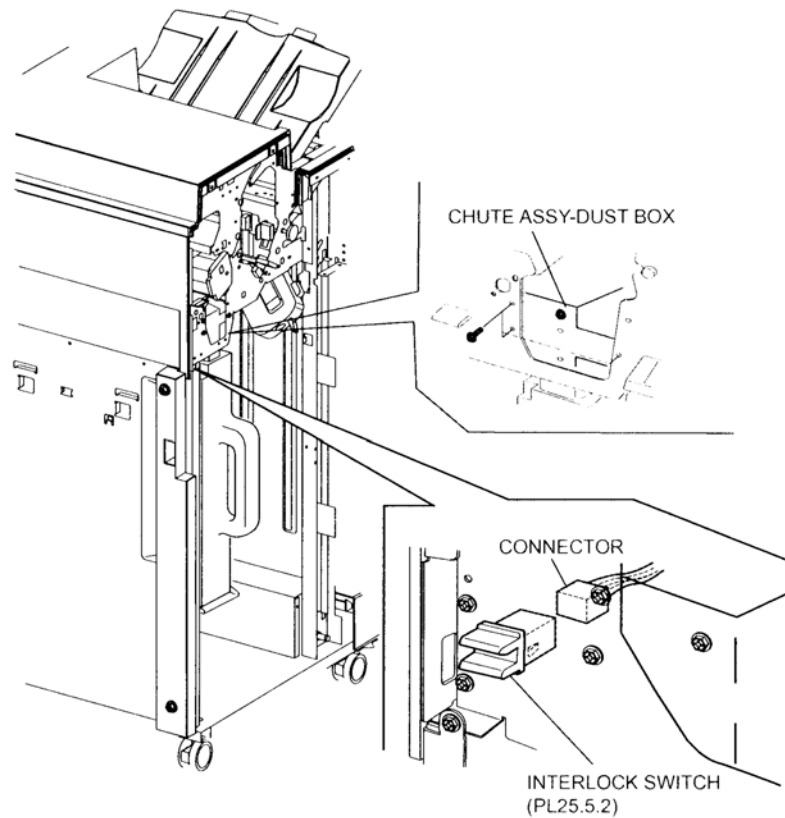
**NOTE** Make sure that the SCT Tray Assembly moves smoothly when the SCT Tray Assembly is pushed down once and then released by hand.

3. Install the Front Cover Assembly (PL 12.5.3) .

### Interlock Switch (Finisher Front Door Switch)

#### Removal

1. Open the Front Cover Assembly (PL 12.5.3).
2. Pull the Dust Box Assembly (PL 12.7.20) toward the front to remove it from the Finisher.
3. Remove the three Screws on the front side and one Screw on the rear side securing the Dust Box Chute Assembly to the Finisher to remove the Dust Box Chute Assembly .
4. Disconnect the connector (J8365) of the Interlock Harness Assembly (PL 12.12.11) from the Interlock Switch.
5. Release the hooks of the Interlock Switch to remove.



**Figure 1 Front Door Interlock Switch**

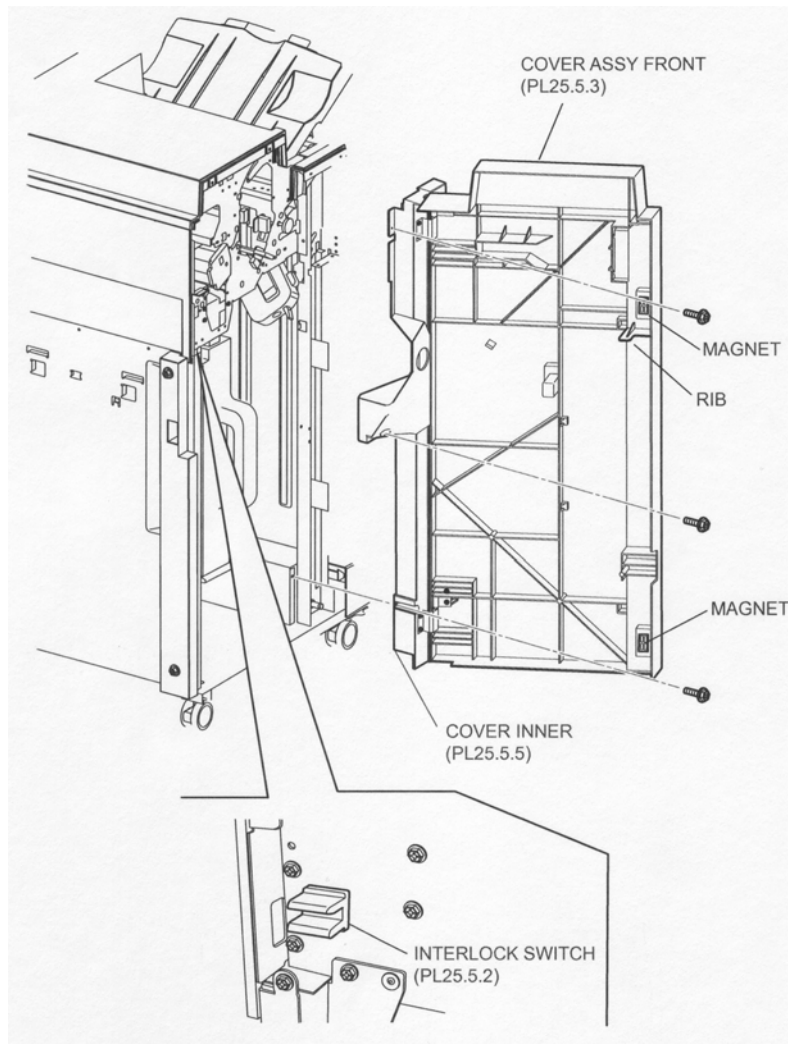
### Replacement

1. Secure the Interlock Switch to the frame using the hooks.
2. Connect the connector (J8365) of the Interlock Harness Assembly (PL 12.12.11) to the Interlock Switch.
3. Install the Dust Box Chute Assembly to the Finisher using the three Screws on the front side and one Screw on the rear side.
4. Install the Dust Box Assembly (PL 12.7.20) to the Finisher.
5. Close the Front Cover Assembly (PL 12.5.3).

### Front Cover Assembly

#### Removal

1. Open the Front Cover Assembly.
2. Remove the three Screws (M3 x 8) securing the Inner Cover (PL 12.5.5) on the Front Cover Assembly to the Finisher .
3. Remove the Front Cover Assembly.



**Figure 1 Front Cover Assembly**

## Replacement

1. Install the Inner Cover (PL 12.5.5) on the Front Cover Assembly to the Finisher using three Screws (M3 x 8).
2. Close the Front Cover Assembly.

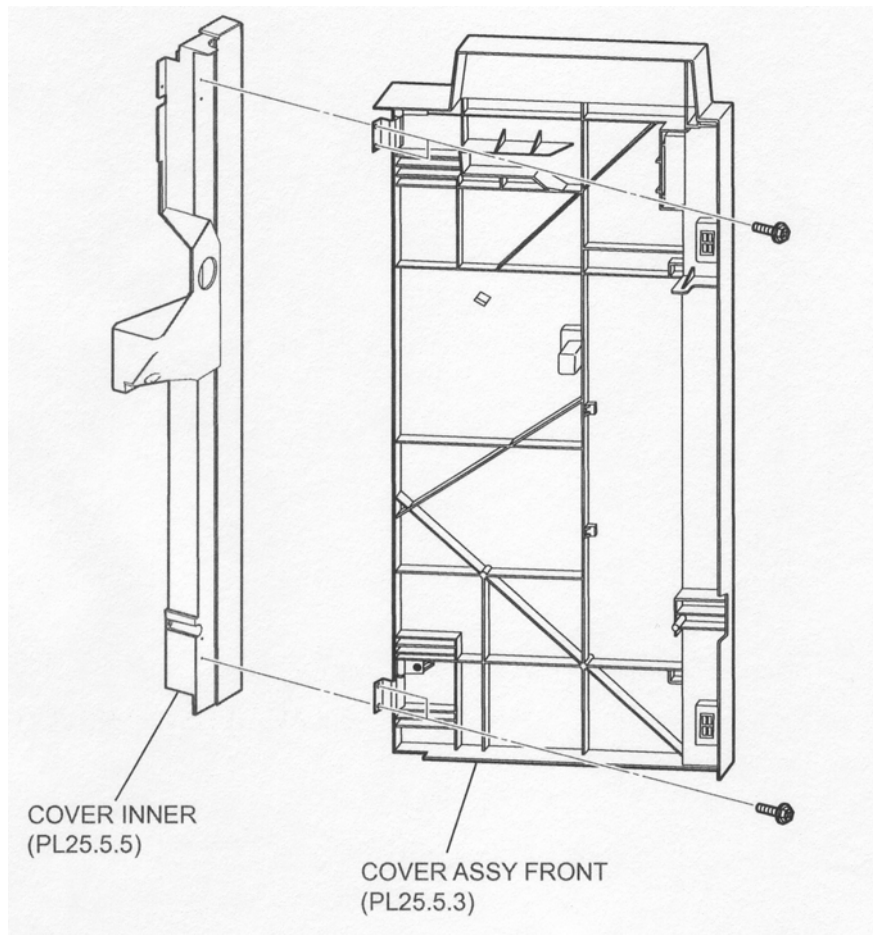
**NOTE** Make sure that the rib of the Front Cover Assembly actuates the Interlock Switch (PL 12.5.2) without contacting the bracket of the switch.

**NOTE** Make sure that the two magnets on the Front Cover Assembly are fully attracted to the Finisher.

## Inner Cover

### Removal

1. Remove the Front Cover Assembly (PL 12.5.3) .
2. Remove the four Screws (M3 x 8) securing the Inner Cover to the Front Cover Assembly .
3. Remove the Inner Cover.



**Figure 1 Inner Cover**

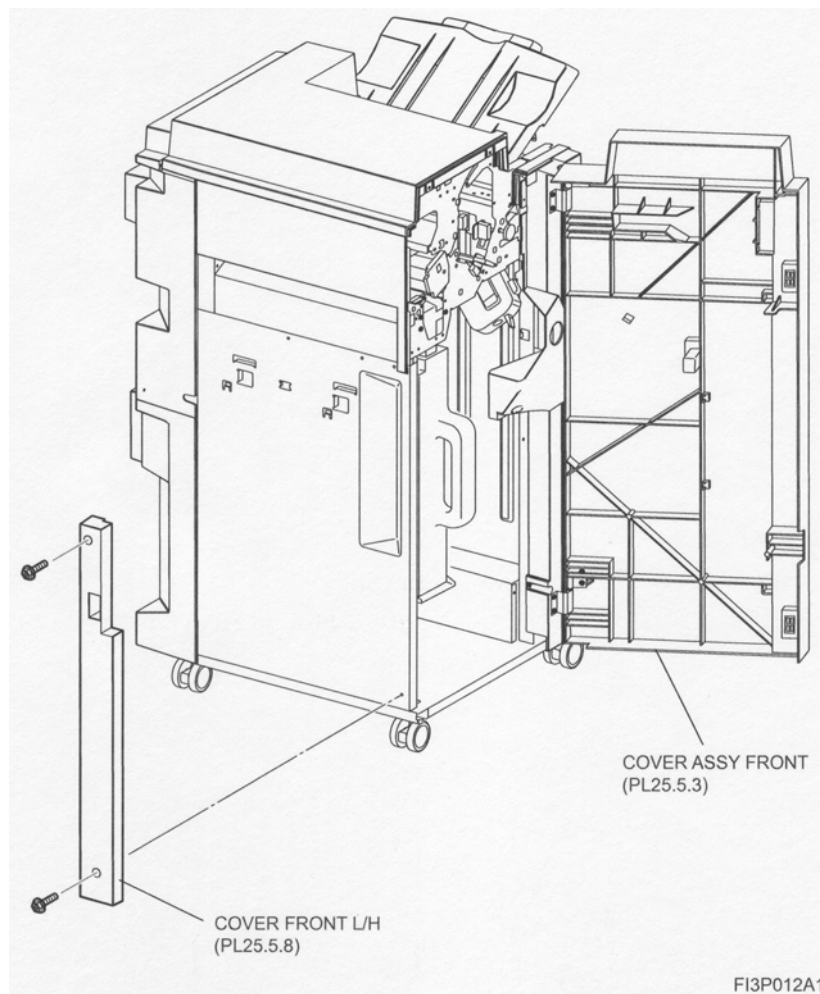
### **Replacement**

1. Install the Inner Cover to the Front Cover Assembly (PL 12.5.3) using four Screws (M3 x 8).
2. Install the Front Cover Assembly .

### **Left Hand Front Cover**

#### **Removal**

1. Open the Front Cover Assembly (PL 12.5.3).
2. Remove the two Screws (M3 x 8) securing the Left Hand Front Cover to the Finisher .
3. Remove the Left Hand Front Cover.



**Figure 1 Left Hand Front Cover**

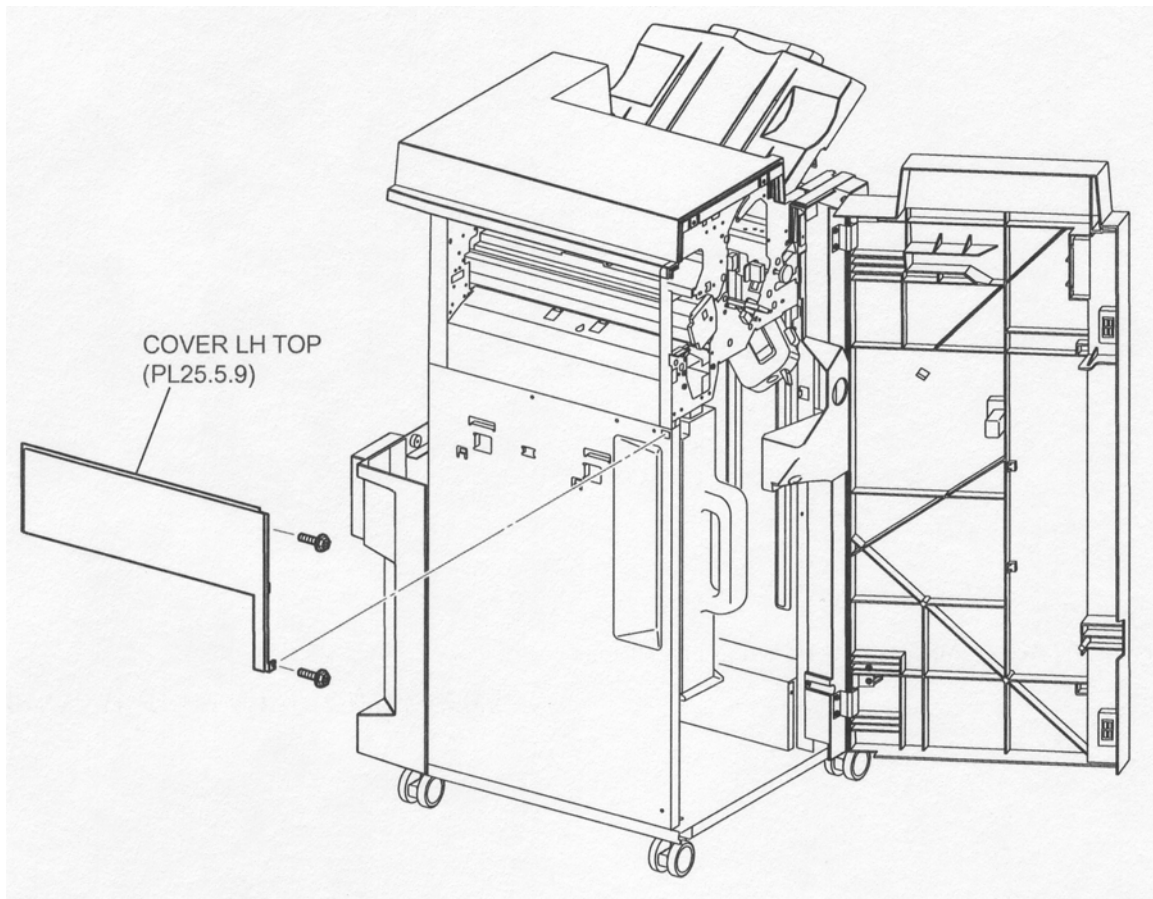
## Replacement

1. Install the Left Hand Front Cover to the Finisher using two Screws (M3 x 8).
2. Close the Front Cover Assembly (PL 12.5.3).

## Left Hand Top Cover

### Removal

1. Open the Front Cover Assembly (PL 12.5.3).
2. Remove the two Screws (M3 x 8) securing the Left Hand Top Cover to the Finisher .
3. Move the Left Hand Top Cover to the front side to remove it from the Finisher.



**Figure 1 Left Hand Top Cover**

## Replacement

1. Move the Left Hand Top Cover to the rear to put the hooks on the Left Hand Top Cover to the Finisher, and secure it using two Screws (M3 x 8).
2. Close the Front Cover Assembly (PL 12.5.3).

## Left Carriage Assembly

**NOTE** Be sure not to remove Right Carriage Assembly (Rear Side) and Left Carriage Assembly (Front Side) together. When removing them, work on one at a time. After finishing the repairing operation for one of them, work on another.

**NOTE** When removing both of them at the same time, it may cause an out of phase at the front and rear of Stacker Tray Assembly (PL 12.4.5).

## Removal

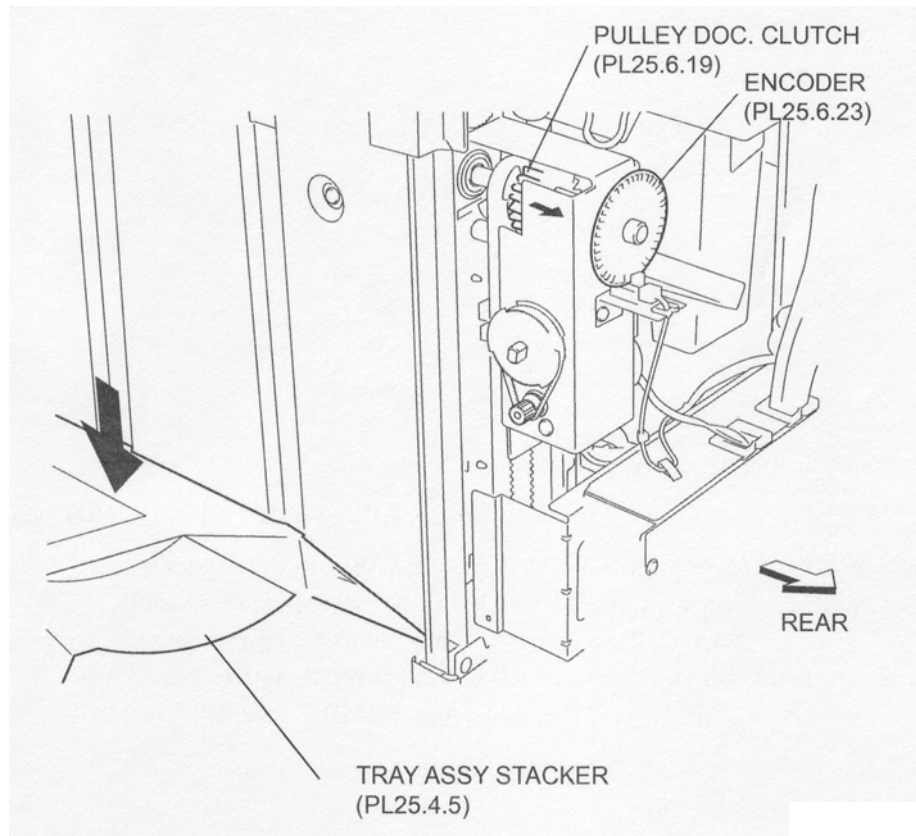
1. Remove the Upper Rear Cover (PL 12.4.11) .
2. Remove the Front Cover Assembly (PL 12.5.3) .
3. Move the Document Pulley Clutch (PL 12.6.19) on the rear side of the Finisher in the direction of the arrow by hand to move the Stacker Tray Assembly (PL 12.4.5) to its lowest position .

**NOTE** At this time, be sure not to touch the Encoder (PL 12.6.23).

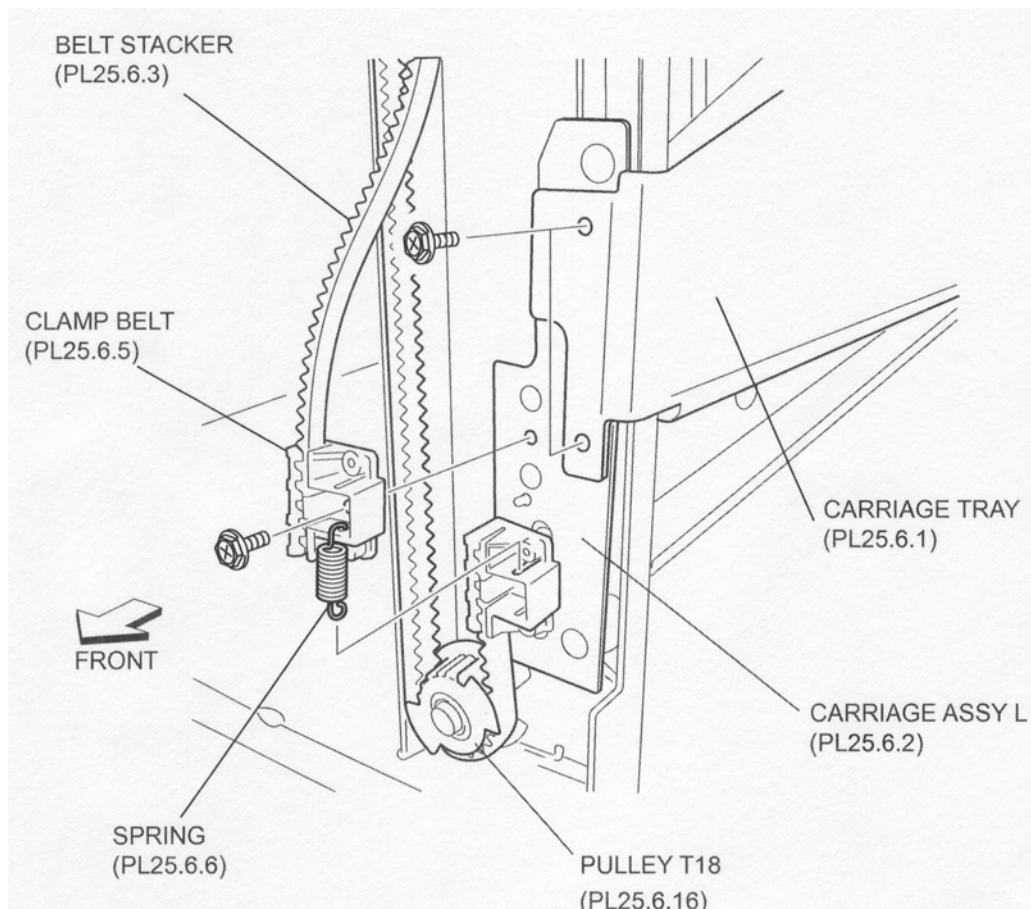
**NOTE** Be sure to move the Stacker Tray Assembly to the lowest position before performing the subsequent steps.



4. Remove the two Screws securing the Tray Carriage (PL 12.6.1) .
5. Remove the Spring (PL 12.6.6) on the Left Carriage Assembly.
6. Remove the Screw (TP M3 x 8) securing upper side of the Belt Clamp (PL 12.6.5).
7. Remove upper side of the Belt Clamp. Then, the Left Carriage Assembly with the Stacker Belt (PL 12.6.3) is detached from the Finisher.



**Figure 1 Clutch Pulley**



**Figure 2 Tray Carriage**

## Replacement

1. Put the Stacker Belt (PL 12.6.3) of the Left Carriage Assembly onto the Pulley T18s (PL 12.6.16) on the top and bottom of the Finisher.
2. Install the upper side of the Belt Clamp (PL 12.6.5) to the Left Carriage Assembly using one Screw (TP M3 x 8).

**NOTE** Be sure to put the boss on the backside of the Belt Clamp into the hole on the Left Carriage Assembly.

3. Hook the Spring (PL 12.6.6) to the upper and lower sides of the Belt Clamp.
4. Install the Tray Carriage (PL 12.6.1) using two Screws.

**NOTE** Make sure that the Stacker Tray Assembly (PL 12.4.5) is installed horizontally.

5. Install the Front Cover Assembly (PL 12.5.3) .
6. Install the Upper Rear Cover (PL 12.4.11) .

**NOTE** Make sure that the Stacker Tray Assembly moves smoothly up and down.

## Right Carriage Assembly

**NOTE** Be sure not to remove Right Carriage Assembly (Rear Side) and Left Carriage Assembly (Front Side) together. When removing them, work on one at a time. After finishing the repairing operation for one of them, work on another.

**NOTE** When removing both of them at the same time, it may cause the out of phase at the front and rear of Stacker Tray Assembly (PL 12.4.5).

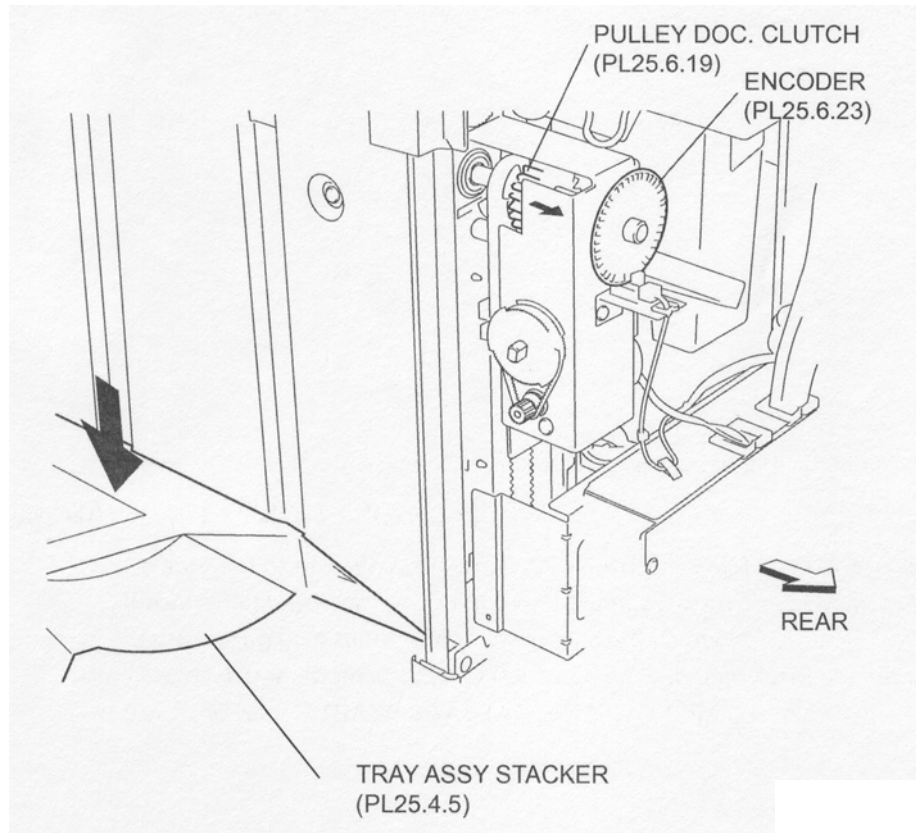
## Removal

1. Remove the Upper Rear Cover (PL 12.4.11) .
2. Remove the Lower Rear Cover (PL 12.4.9) .
3. Move the Document Pulley Clutch (PL 12.6.19) on the rear side of the Finisher in the direction of the arrow by hand to move the Stacker Tray Assembly (PL 12.4.5) to its lowest position .

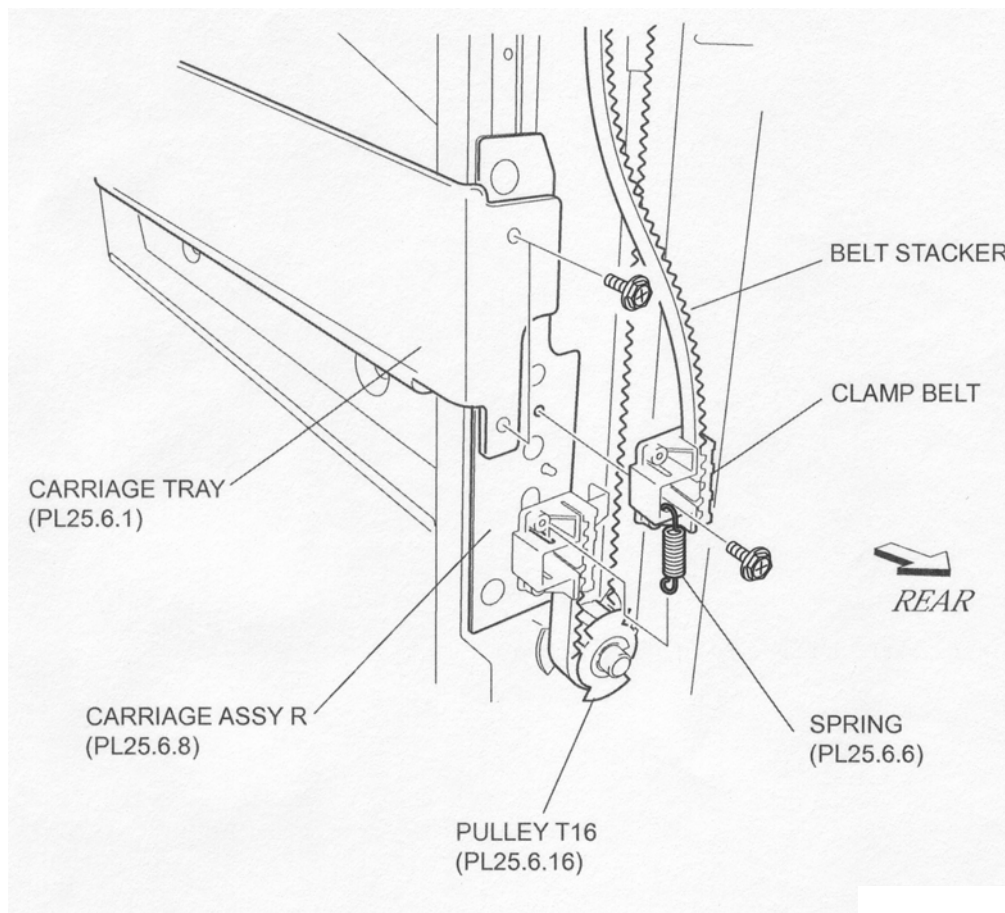
**NOTE** At this time, be sure not to touch the Encoder (PL 12.6.23).

**NOTE** Be sure to move the Stacker Tray Assembly to the lowest position before performing the subsequent steps.

4. Remove the Stacker Bracket Assembly (PL 12.6.24) .
5. Remove the two Screws securing the Tray Carriage (PL 12.6.1) .
6. Remove the Spring (PL 12.6.6) on the Right Carriage Assembly.
7. Remove the one Screw (TP M3 x 8) securing the upper side of the Belt Clamp.
8. Remove upper side of the Belt Clamp.  
Then, the Right Carriage Assembly with the Stacker Belt is detached from the Finisher.



**Figure 1 Clutch Pulley**



**Figure 2 Tray Carriage**

## Replacement

1. Put the Stacker Belt on the Right Carriage Assembly onto the Document Pulley Clutch (PL 12.6.18) and the Pulley T18 (PL 12.6.16) on the top and bottom of the Finisher.
2. Install the upper side of the Belt Clamp to the Right Carriage Assembly using one Screw (TP M3 x 8).

**NOTE** Be sure to put the boss on the backside of the Belt Clamp into the hole on the Right Carriage Assembly.

3. Hook the Spring (PL 12.6.6) to the upper and lower sides of the Belt Clamp.
4. Install the Tray Carriage (PL 12.6.1) using two Screws.

**NOTE** Make sure that the Stacker Tray Assembly (PL 12.4.5) is installed horizontally.

5. Install the Stacker Bracket Assembly (PL 12.6.24) .
6. Install the Lower Rear Cover (PL 12.4.9) .
7. Install the Upper Rear Cover (PL 12.4.11) .

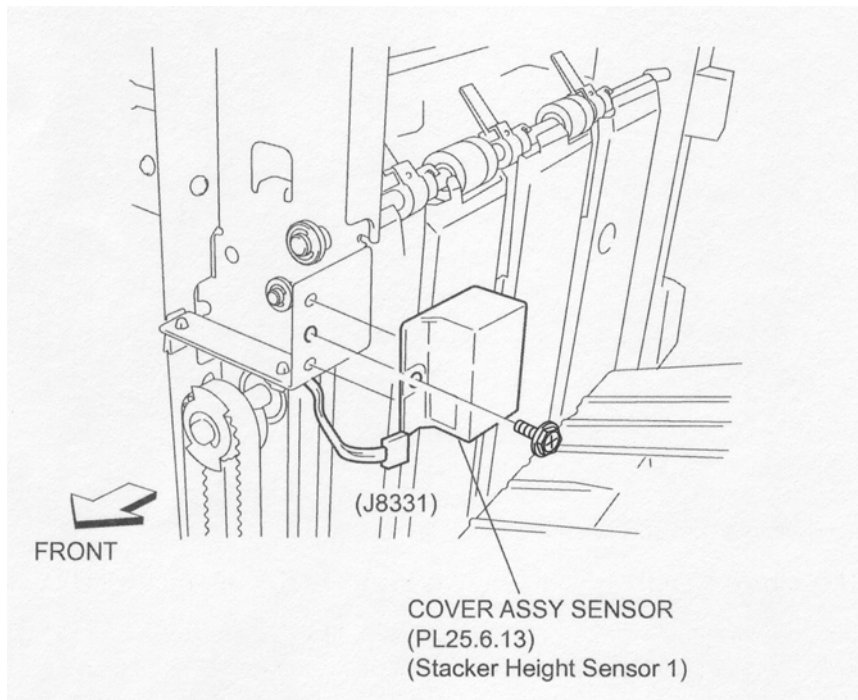
**NOTE** Make sure that the Stacker Tray Assembly moves smoothly up and down.

## Cover Assembly Sensor (Stacker Height Sensor 1)

**NOTE** Two Cover Assembly Sensors (PL 12.6.13) are installed to the Finisher, one is Stacker Height Sensor 1 attached to the front and the other is Stacker Height Sensor 2 attached to the rear. The removal and replacement procedures for Stacker Height Sensor 1 are described here.

## Removal

1. Remove the Front Cover Assembly (PL 12.5.3) .
2. Disconnect the connector (J8331) of the Main Sensor Harness Assembly from the Cover Assembly Sensor (Stacker Height Sensor 1) .
3. Remove the one Screw (M3 x 8) securing the Cover Assembly Sensor.
4. Remove the Cover Assembly Sensor.



**Figure 1 Stacker Height Sensor 1**

## Replacement

1. Install the Cover Assembly Sensor (Stacker Height Sensor 1) to the Finisher using one Screw (M3 x 8).

**NOTE** Put the two bosses on the Cover Assembly Sensor into the two holes on the frame of the Finisher.

2. Connect the connector (J8331) of the Main Sensor Harness Assembly to the Cover Assembly Sensor.
3. Install the Front Cover Assembly (PL 12.5.3) .

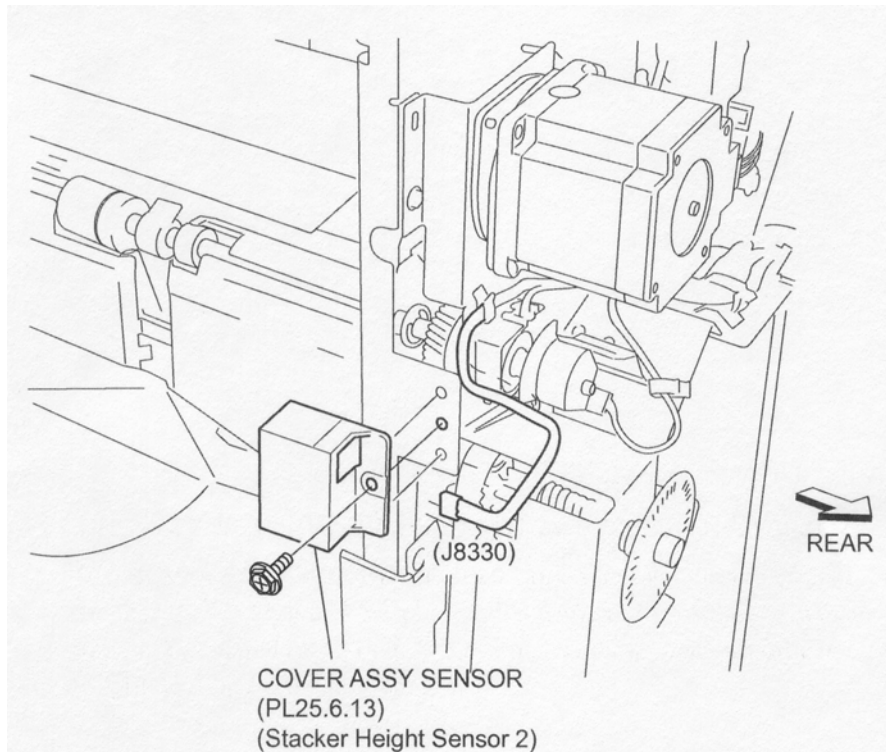
## Cover Assembly Sensor (Stacker Height Sensor 2)

**NOTE** Two Cover Assembly Sensors (PL 12.6.13) are installed to the Finisher, one is Stacker Height Sensor 1 attached to the front and the other is Stacker Height Sensor 2 attached to the rear. The removal and replacement procedures for Stacker Height Sensor 2 are described here

## Removal

1. Remove the Upper Rear Cover (PL 12.4.11) .
2. Disconnect the connector (J8330) of the Main Sensor Harness Assembly from the Cover Assembly Sensor (Stacker Height Sensor 2) .

3. Remove the one Screw (M3 x 8) securing the Cover Assembly Sensor.
4. Remove the Cover Assembly Sensor.



**Figure 1 Stacker Height Sensor 2**

## Replacement

1. Install the Cover Assembly Sensor (Stacker Height Sensor 2) to the Finisher using one Screw (M3 x 8).

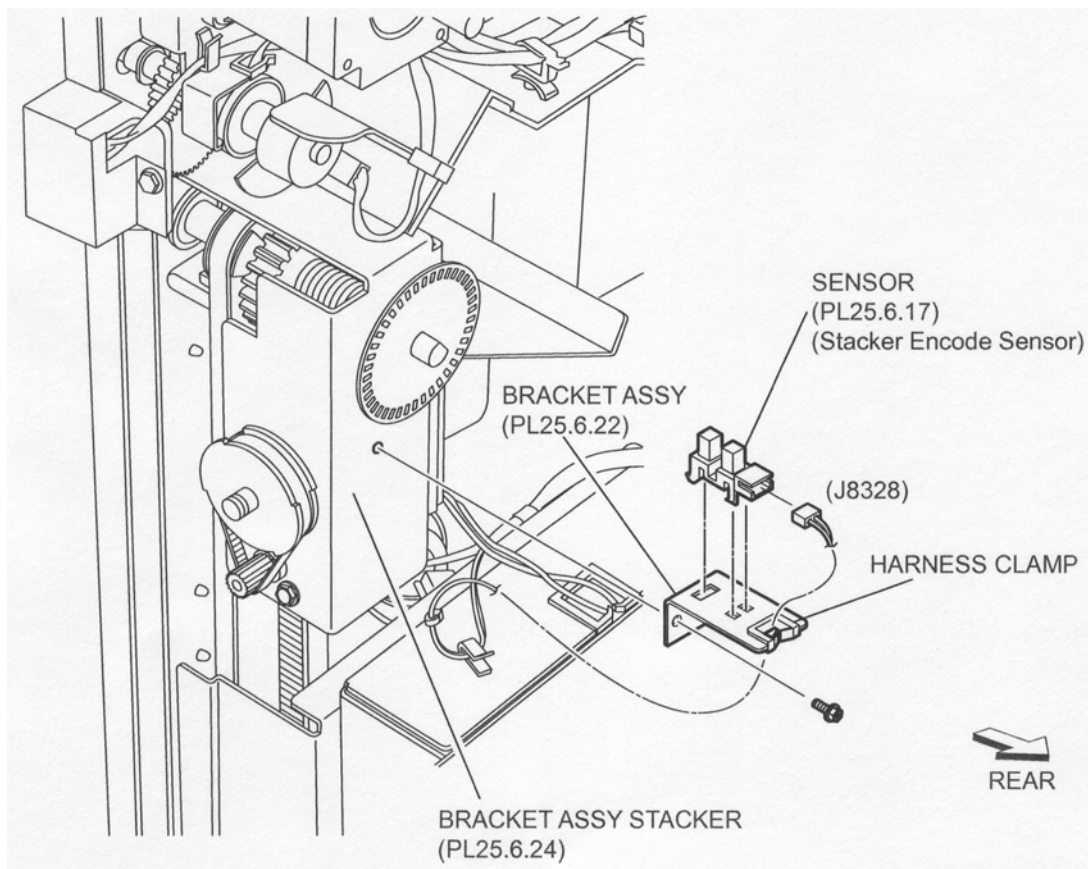
**NOTE** Put the two bosses on the Cover Assembly Sensor into the two holes on the frame of the Finisher.

2. Connect the connector (J8330) of the Main Sensor Harness Assembly to the Cover Assembly Sensor.
3. Install the Upper Rear Cover (PL 12.4.11) .

## Sensor (Stacker Encode Sensor)

### Removal

1. Remove the Upper Rear Cover (PL 12.4.11) .
2. Disconnect the connector (J8328) of the Main Sensor Harness Assembly (PL 12.15.1) from the Sensor (Stacker Encode Sensor) .
3. Release the Main Sensor Harness Assembly from the harness clamp.
4. Remove the one Screw (M3 x 6) securing the Bracket Assembly (PL 12.6.22) to remove it from the Stacker Bracket Assembly (PL 12.6.24).
5. Release the hooks of the Sensor to remove it from the Bracket Assembly.



**Figure 1 Stacker Encoder Sensor**

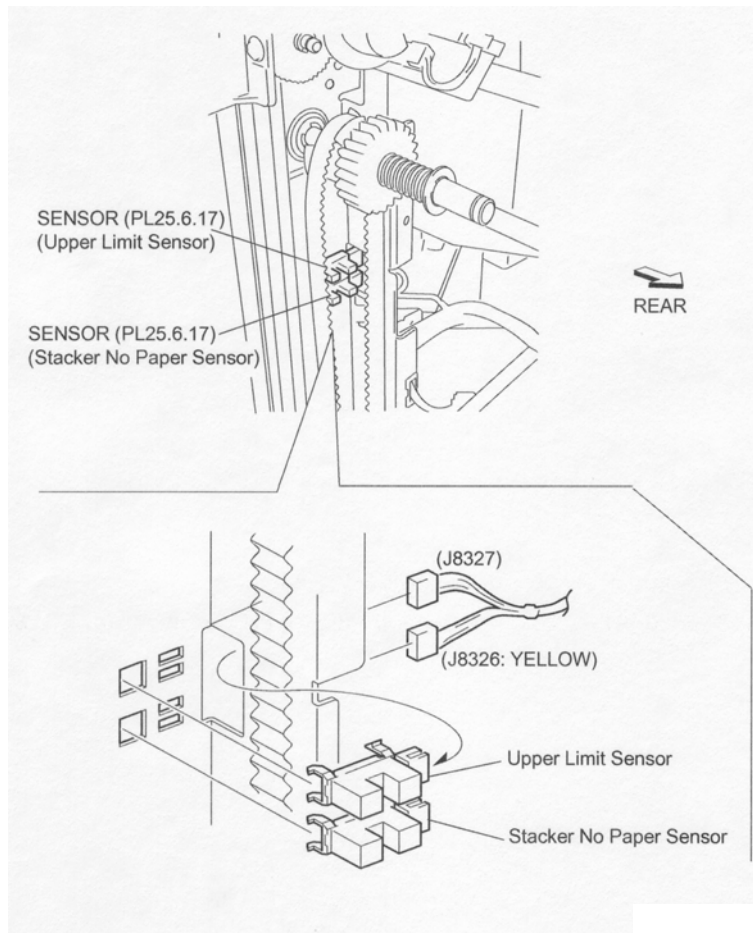
### Replacement

1. Secure the Sensor (Stacker Encode Sensor) to the Bracket Assembly (PL 12.6.22) using the hooks.
2. Install the Bracket Assembly to the Stacker Bracket Assembly (PL 12.6.24) using one Screw (M3 x 6).
3. Connect the connector (J8328) of the Main Sensor Harness Assembly (PL 12.15.1) to the Sensor.
4. Clamp the Main Sensor Harness Assembly using the harness clamp.
5. Install the Upper Rear Cover (PL 12.4.11) .

### Sensor (Upper Limit Sensor/ Stacker No Paper Sensor)

#### Removal

1. Remove the Upper Rear Cover (PL 12.4.11) .
2. Remove the Stacker Bracket Assembly (PL 12.6.24) .
3. Disconnect the connector (J8327 or J8326) of the Main Sensor Harness Assembly (PL 12.15.1) from the Sensor (Upper Limit Sensor or Stacker No Paper Sensor) .
4. Release the hooks of the Sensor.



**Figure 1 Stacker No Paper Sensor**

## Replacement

1. Secure the Sensor (Upper Limit Sensor or Stacker No Paper Sensor) to the frame using the hooks.
2. Connect the connector (J8327 or J8326) of the Main Sensor Harness Assembly (PL 12.15.1) to the Sensor.

**NOTE** Be sure to connect the yellow colored connector (J8326) to the Sensor (Stacker No Paper Sensor) on the bottom.

3. Install the Stacker Bracket Assembly (PL 12.6.24) .
4. Install the Upper Rear Cover (PL 12.4.11) .

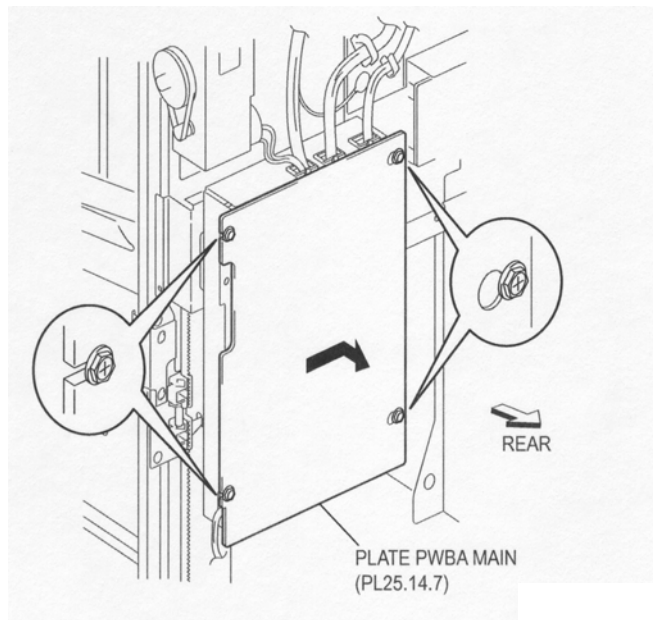
## Stacker Bracket Assembly

### Removal

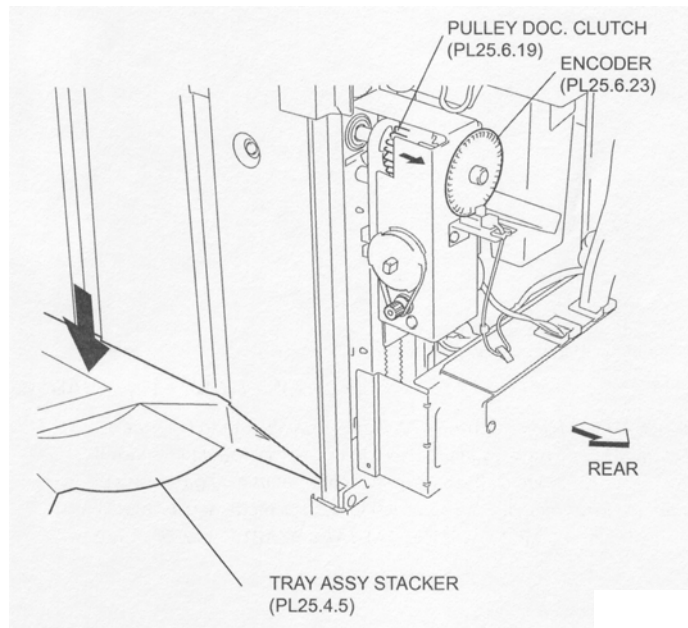
1. Remove the Upper Rear Cover (PL 12.4.11) .
2. Remove the Lower Rear Cover (PL 12.4.9) .
3. Loosen the four Screws securing the Main Plate PWBA (PL 12.14.7), and move it in the direction of the arrow to remove .
4. Move the Document Clutch Pulley (PL 12.6.19) on the rear side of the Finisher in the direction of the arrow by hand to move the Stacker Tray Assembly (PL 12.4.5) to its lowest position .

**NOTE** At this time, be sure not to touch the Encoder (PL 12.6.23).



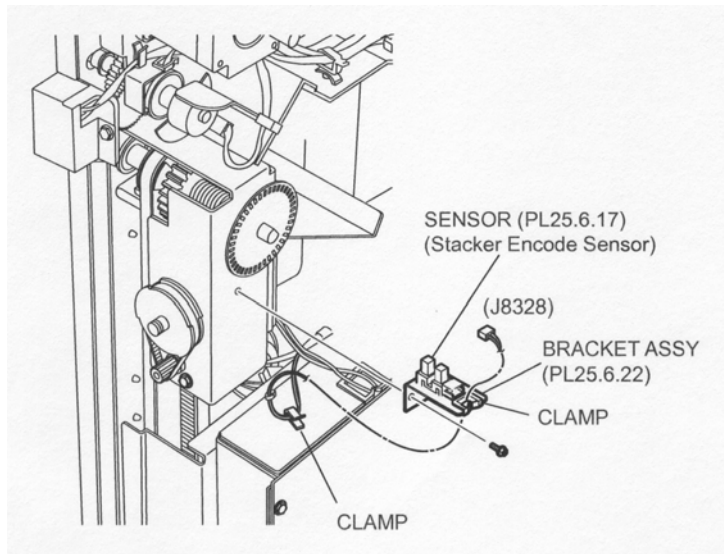


**Figure 1 Main PWBA Plate**

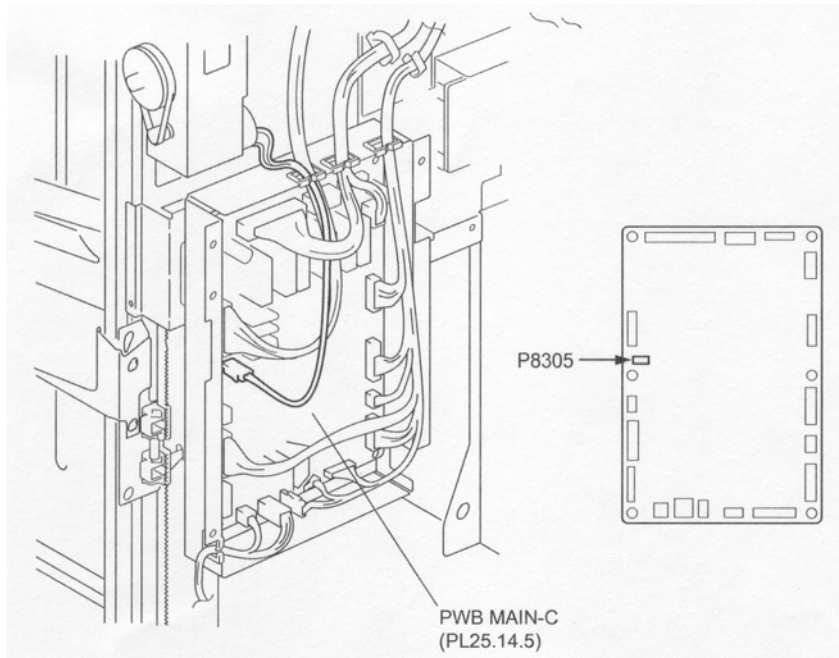


**Figure 2 Document Clutch Pulley**

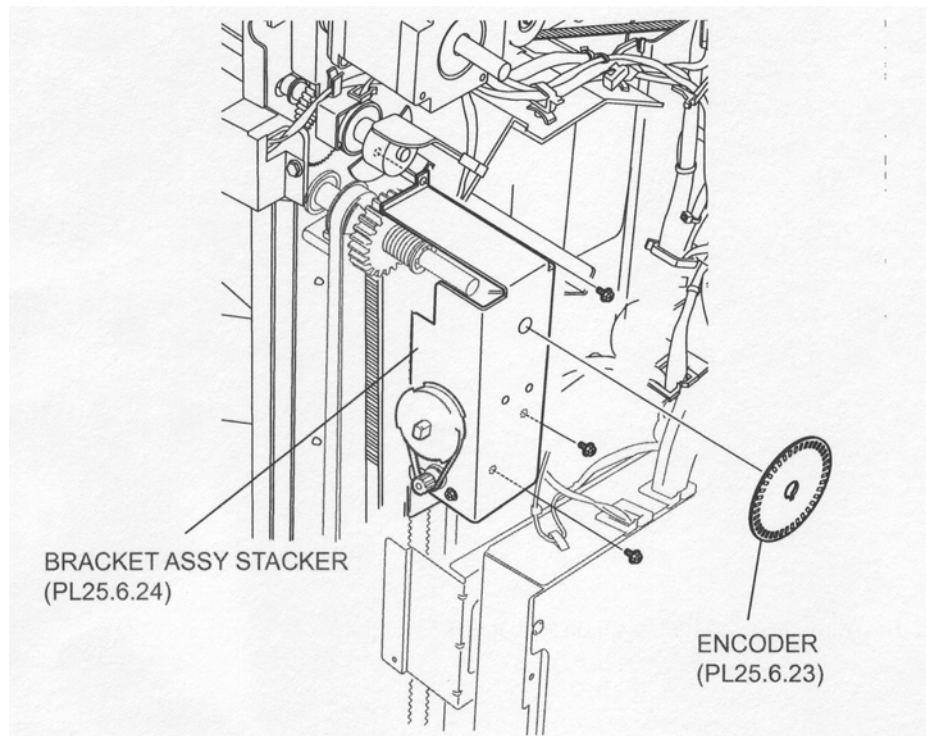
5. Disconnect the connector (J8328) of the Main Sensor Harness Assembly (PL 12.15.1) from the Sensor (PL 12.6.17) (Stacker Encode Sensor) .
6. Release the Main Sensor Harness Assembly from the two clamps.
7. Disconnect the connector of the Harness Assembly from the connector (P8305) on the Main-C PWBA (PL 12.14.5) .
8. Remove the one Screw (M3 x 6) securing the Bracket Assembly (PL 12.6.22) to remove it from the Stacker Bracket Assembly .
9. Release the hook of the Encoder (PL 12.6.23) to remove .
10. Remove the three Screws (M3 x 6) securing the Stacker Bracket Assembly.



**Figure 3 Stacker Encoder Sensor**



**Figure 4 Main C PWBA**



**Figure 5 Stacker Bracket Assembly**

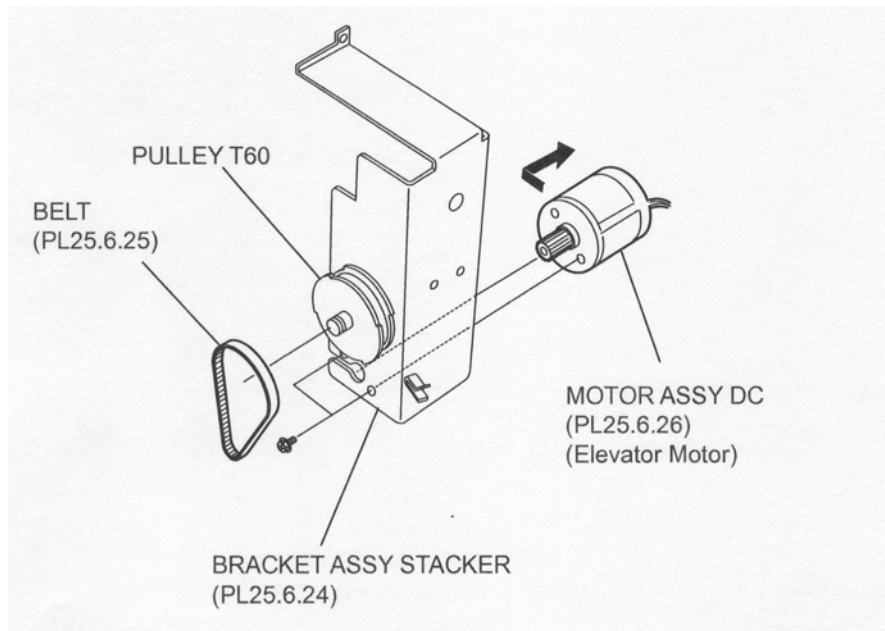
## Replacement

1. Install the Stacker Bracket Assembly to the Finisher using three Screw.
2. Install the Encoder (PL 12.6.23) and secure it using the hook.
3. Install the Bracket Assembly (PL 12.6.22) to the Stacker Bracket Assembly using one Screw (M3 x 6).
4. Connect the connector of the Harness Assembly to the connector (P8305) on the Main-C PWBA (PL 12.14.5).
5. Connect the connector (J8328) of the Main Sensor Harness Assembly (PL 12.15.1) to the Sensor (PL 12.6.17) (Stacker Encode Sensor).
6. Secure the Main Sensor Harness Assembly using two clamps.
7. Install the Main Plate PWBA (PL 12.14.7) by moving it in the opposite direction of the arrow, and secure it using four Screws.
8. Install the Lower Rear Cover (PL 12.4.9) .
9. Install the Upper Rear Cover (PL 12.4.11) .

## DC Motor Assembly (Elevator Motor)

### Removal

1. Remove the Upper Rear Cover (PL 12.4.11) .
2. Remove the Stacker Bracket Assembly (PL 12.6.24) .
3. Remove the two Screws securing the DC Motor Assembly (Elevator Motor) to the Stacker Bracket Assembly .
4. Remove the DC Motor Assembly in the direction of the arrow while removing the Belt (PL 12.6.25).



**Figure 1 DC Motor Assembly**

## Replacement

1. Put the Belt (PL 12.6.25) onto the gear of the DC Motor Assembly (Elevator Motor) and the Pulley T60, and install the DC Motor Assembly to the Stacker Bracket Assembly (PL 12.6.24) using two Screws.
2. Install the Stacker Bracket Assembly (PL 12.6.24) .
3. Install the Upper Rear Cover (PL 12.4.11) .

## Punch Frame Assembly

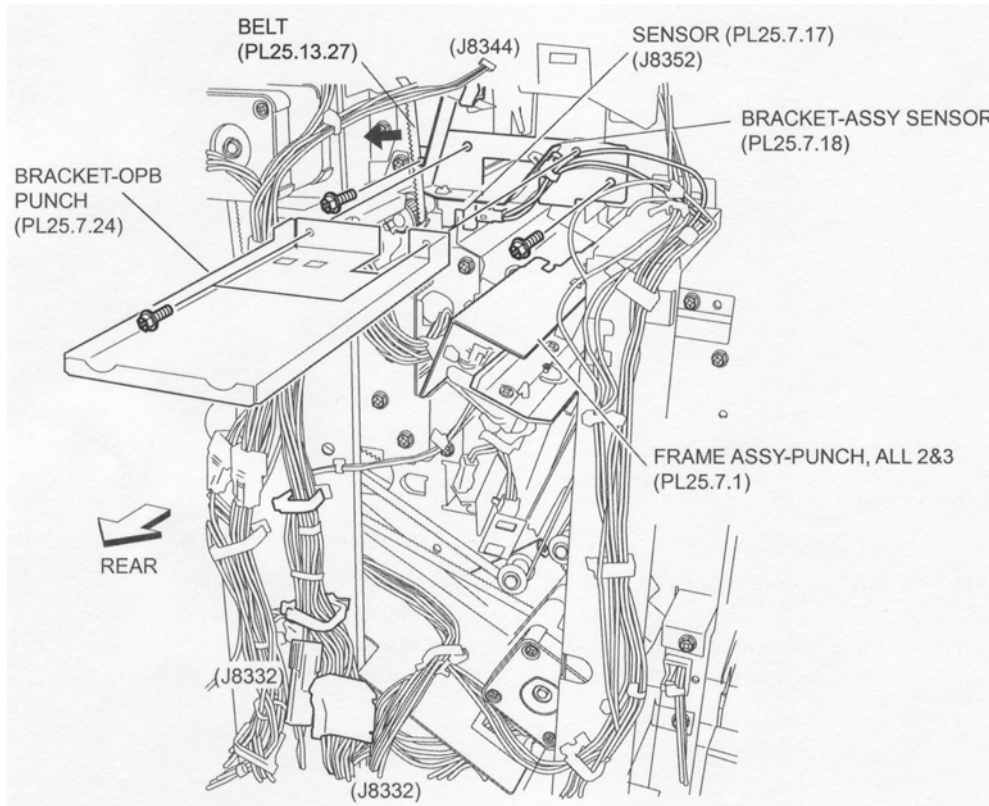
**NOTE** There are five options for the Puncher on the Finisher: 2&3-hole type, 2&4-hole type, 3-hole type, 2-hole type and punch-less type.

**NOTE** Although the following removal and replacement procedures are for the 2&3-hole type, the following procedures can also be applied for the other types.

## Removal

1. Open the Front Cover Assembly (PL 12.5.3).
2. Remove the Upper Rear Cover (PL 12.4.11) .
3. Release the two harnesses of the Punch Frame Assembly from the clamp .
4. Remove the three Screws (M3 x 6) securing the OPB Punch Bracket (PL 12.7.24) to the Punch Frame Assembly to remove the OPB Punch Bracket.
5. Release the Punch Sensor Harness Assembly (PL 12.15.9) connected to the Sensor (PL 12.7.17) (Puncher Move Home Sensor) from the clamp on the Sensor Bracket Assembly (PL 12.7.18).
6. Disconnect the connector (J8352) of the Punch Sensor Harness Assembly from the Sensor.
7. Disconnect the connector (J8344) of the Punch Drive Harness Assembly (PL 12.15.8) from the Punch Motor Bracket Assembly (PL 12.7.4).
8. Disconnect the connector (J8332) of the Punch Unit Harness Assembly (PL 12.7.2) from the Punch Drive Harness Assembly.
9. Disconnect the connector (J8333) of the Punch Unit Harness Assembly from the Punch Sensor Harness Assembly.

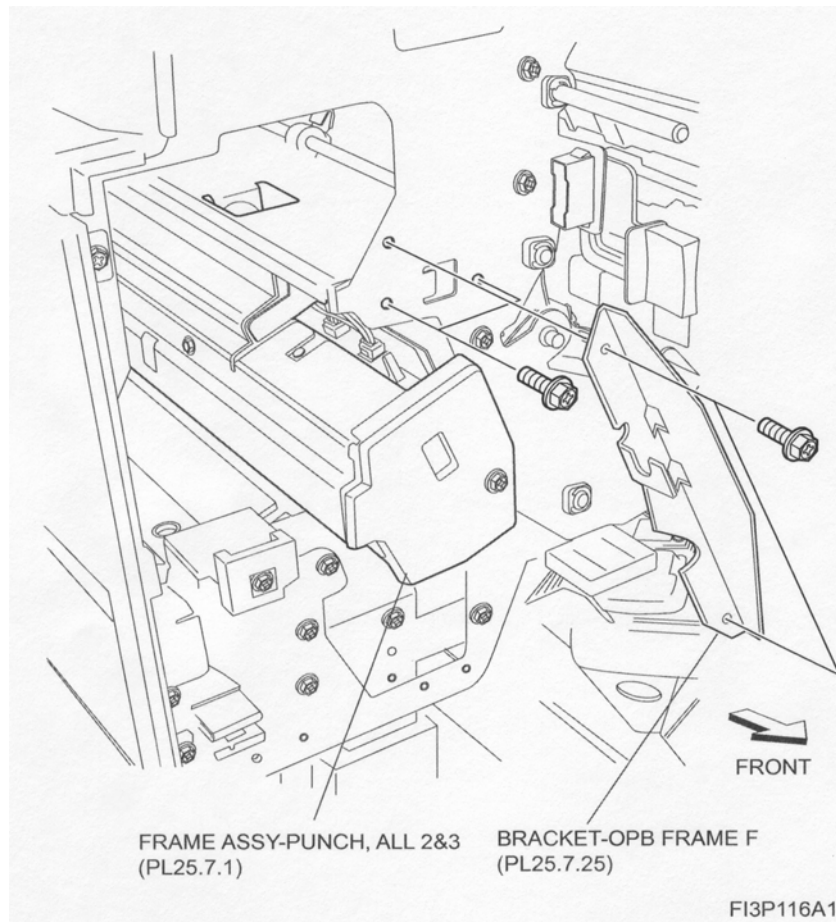
10. Remove the three Screws (M3 x 6) on the front side of the Finisher securing the OPB Frame F Bracket (PL 12.7.25) to the Finisher to remove the OPB Frame F Bracket.



**Figure 1 Punch Frame Assembly**

11. Remove the two Screws (M3 x 6) on the front side of the Finisher securing the Punch Frame Assembly to the Finisher.
12. Remove the two Screws (M3 x 6) on the rear side of the Finisher securing the Punch Frame Assembly to the Finisher.
13. While pushing the Belt (PL 12.13.27) in the arrow direction shown in the figure with finger, remove the Punch Frame Assembly to the rear.

**NOTE** Be sure to hold the Punch Frame Assembly by hand to prevent it from falling.



**Figure 2 Punch Frame Assembly**

## Replacement

1. While pushing the Belt (PL 12.13.27) on the rear in the arrow direction shown in the figure with finger, install the Punch Frame Assembly to the Finisher from the rear side.

**NOTE** Be sure to hold the Punch Frame Assembly by hand to prevent it from falling.

2. Install the Punch Frame Assembly to the Finisher from the rear side using two Screws (M3 x 6).
3. Install the Punch Frame Assembly to the Finisher from the front side using two Screws (M3 x 6).
4. Install the OPB Frame F Bracket (PL 12.7.25) to the Finisher from the front side using three Screws (M3 x 6).
5. Connect the connector (J8352) of the Punch Sensor Harness Assembly (PL 12.15.9) to the Sensor (PL 12.7.17) (Puncher Move Home Sensor).
6. Secure the harness of the Sensor (Puncher Move Home Sensor) using the two clamps.
7. Connect the connector (J8333) of the Punch Unit Harness Assembly (PL 12.7.2) to the Punch Sensor Harness Assembly.
8. Connect the connector (J8332) of the Punch Unit Harness Assembly to the Punch Drive Harness Assembly (PL 12.15.8).
9. Connect the connector (J8344) of the Punch Drive Harness Assembly to the Punch Motor Bracket Assembly (PL 12.7.4).
10. Install the OPB Punch Bracket (PL 12.7.24) to the Punch Frame Assembly from the rear side using three Screws (M3 x 6).
11. Secure the two harnesses of the Punch Frame Assembly using the clamp.

12. Install the Upper Rear Cover (PL 12.4.11) .
13. Close the Front Cover Assembly (PL 12.5.3).

## Punch Motor Bracket Assembly (Puncher Move Motor)

### Removal

1. Open the Front Cover Assembly (PL 12.5.3).
2. Remove the Upper Rear Cover (PL 12.4.11) .
3. Remove the Punch Frame Assembly (PL 12.7.1) .
4. Remove the two Screws (M3 x 6) securing the Motor Cover, Punch (PL 12.7.3) to the Punch Frame Assembly to remove the Motor Cover, Punch .
5. Remove the two Screws (M3 x 6) securing the Punch Motor Bracket Assembly to the Punch Frame Assembly to remove the Punch Motor Bracket Assembly.

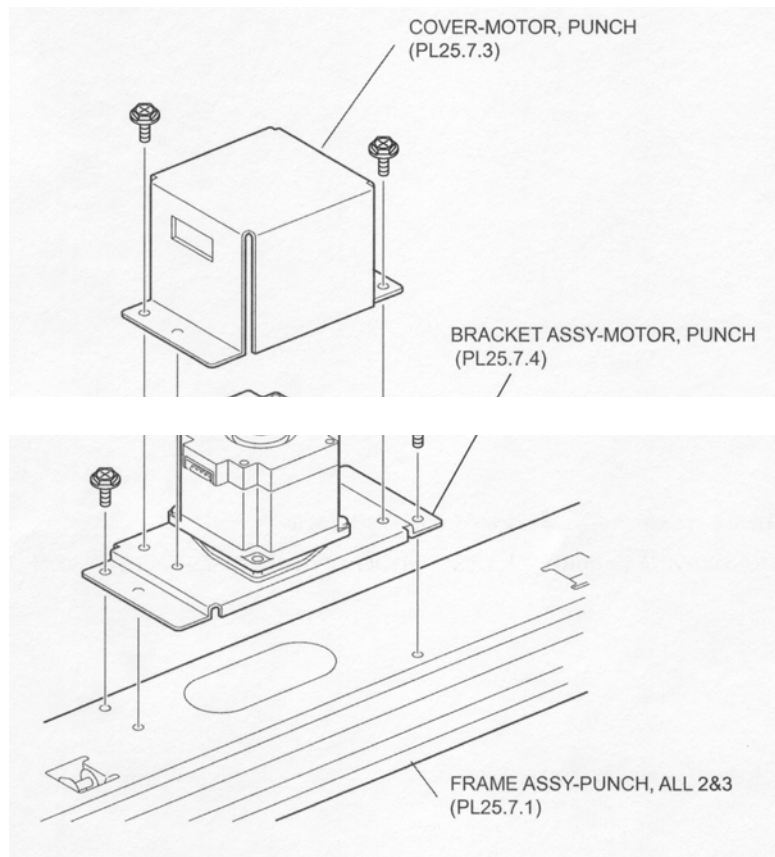


Figure 1 Puncher Move Motor

### Replacement

1. Install the Punch Motor Bracket Assembly to the Punch Frame Assembly (PL 12.7.1) using two Screws (M3 x 6).
2. Install the Motor Cover, Punch (PL 12.7.3) to the Punch Frame Assembly using two Screws (M3 x 6).
3. Install the Punch Frame Assembly .
4. Install the Upper Rear Cover (PL 12.4.11) .
5. Close the Front Cover Assembly (PL 12.5.3).

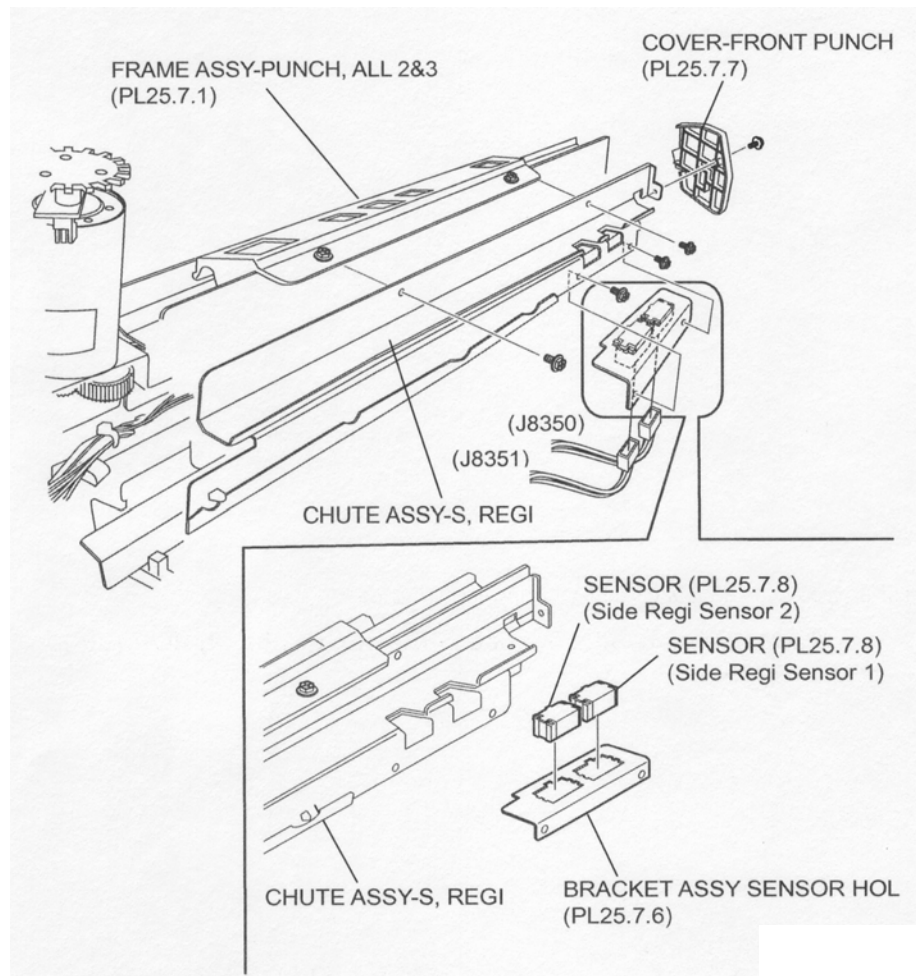
## Sensor (Side Registration Sensor 1 & 2)

## Removal

1. Open the Front Cover Assembly (PL 12.5.3).
2. Remove the Upper Rear Cover (PL 12.4.11) .
3. Remove the Punch Frame Assembly (PL 12.7.1) .
4. Remove the one Screw (TP M3 x 6) securing the Punch Front Cover (PL 12.7.7) .
5. Remove the two Screws (TP M3 x 6) securing the Registration Chute S Assembly to the Punch Frame Assembly to remove the Registration Chute S Assembly.

**NOTE** Since the harness is connected to the Registration Chute S Assembly and the Punch Frame Assembly, the Registration Chute S Assembly cannot be detached from the Punch Frame Assembly.

6. Remove the two Screws (M3 x 6) securing the Sensor Holder Bracket Assembly (PL 12.7.6) to the Registration Chute S Assembly to remove the Sensor Holder Bracket Assembly.
7. Disconnect the connector (J8350) of the Punch Unit Harness Assembly (PL 12.7.2) from the Sensor (Side Registration Sensor 1), and the connector (J8351) from the Sensor (Side Registration Sensor 2).
8. Release the hooks of the Sensor to remove it from the Sensor Holder Bracket Assembly.



**Figure 1 Side Registration Sensor 1 & 2**

## Replacement

1. Secure the Sensor to the Sensor Holder Bracket Assembly (PL 12.7.6) using the hooks.
2. Install the Sensor Holder Bracket Assembly to the Registration Chute S Assembly using two Screws (M3 x 6).



3. Connect the connector (J8350) of the Punch Unit Harness Assembly (PL 12.7.2) to the Sensor (Side Registration Sensor 1), and connect the connector (J8351) to the Sensor (Side Registration Sensor 2).
4. Install the Registration Chute S Assembly to the Punch Frame Assembly (PL 12.7.1) using two Screws (TP M3 x 6).
5. Install the Punch Front Cover (PL 12.7.7) to the Punch Frame Assembly using one Screw (TP M 3 x 6).
6. Install the Punch Frame Assembly .
7. Install the Upper Rear Cover (PL 12.4.11) .
8. Close the Front Cover Assembly (PL 12.5.3)

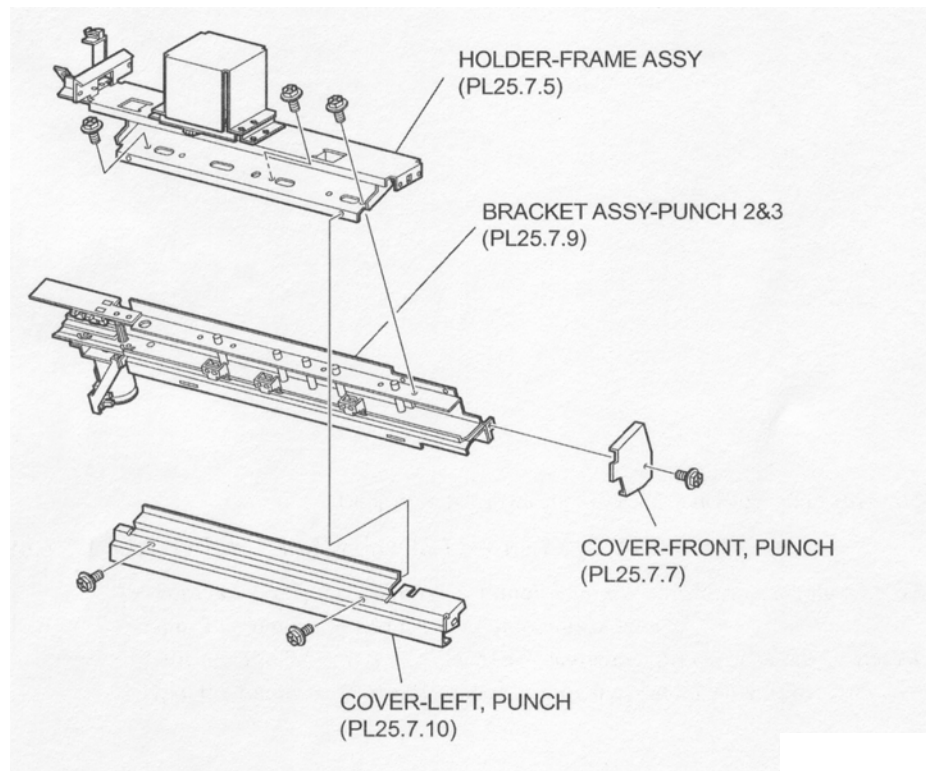
## Punch Bracket Assembly 2&3

**NOTE** There are five options for Puncher on the Finisher: 2&3-hole type, 2&4-hole type, 3-hole type, 2-hole type and punch-less type.

**NOTE** Although the following removal and replacement procedures are for the 2&3-hole type, the following procedures can also be applied for other types.

### Removal

1. Open the Front Cover Assembly (PL 12.5.3).
2. Remove the Upper Rear Cover (PL 12.4.11) .
3. Remove the Punch Frame Assembly (PL 12.7.1) .
4. Remove the one Screw (TP M3 x 8) securing the Punch Front Cover (PL 12.7.7) .
5. Remove the two Screws (M3 x 6) securing the Punch Left Cover (PL 12.7.10).
6. Remove the three Screws (TP M3 x 6) securing the Holder Frame Assembly (PL 12.7.5) to the Punch Bracket Assembly 2&3 to remove the Holder Frame Assembly.



**Figure 1 Punch Bracket Assembly**

### Replacement

1. Install the Holder Frame Assembly (PL 12.7.5) to the Punch Bracket Assembly 2&3 using three Screws (TP M3 x 6).
2. Install the Punch Left Cover (PL 12.7.10) using two Screws (M3 x 6).
3. Install the Punch Front Cover (PL 12.7.7) using one Screw (TP M3 x 8).
4. Install the Punch Frame Assembly (PL 12.7.1) .
5. Install the Upper Rear Cover (PL 12.4.11) .
6. Close the Front Cover Assembly (PL 12.5.3).

## Guide Assembly

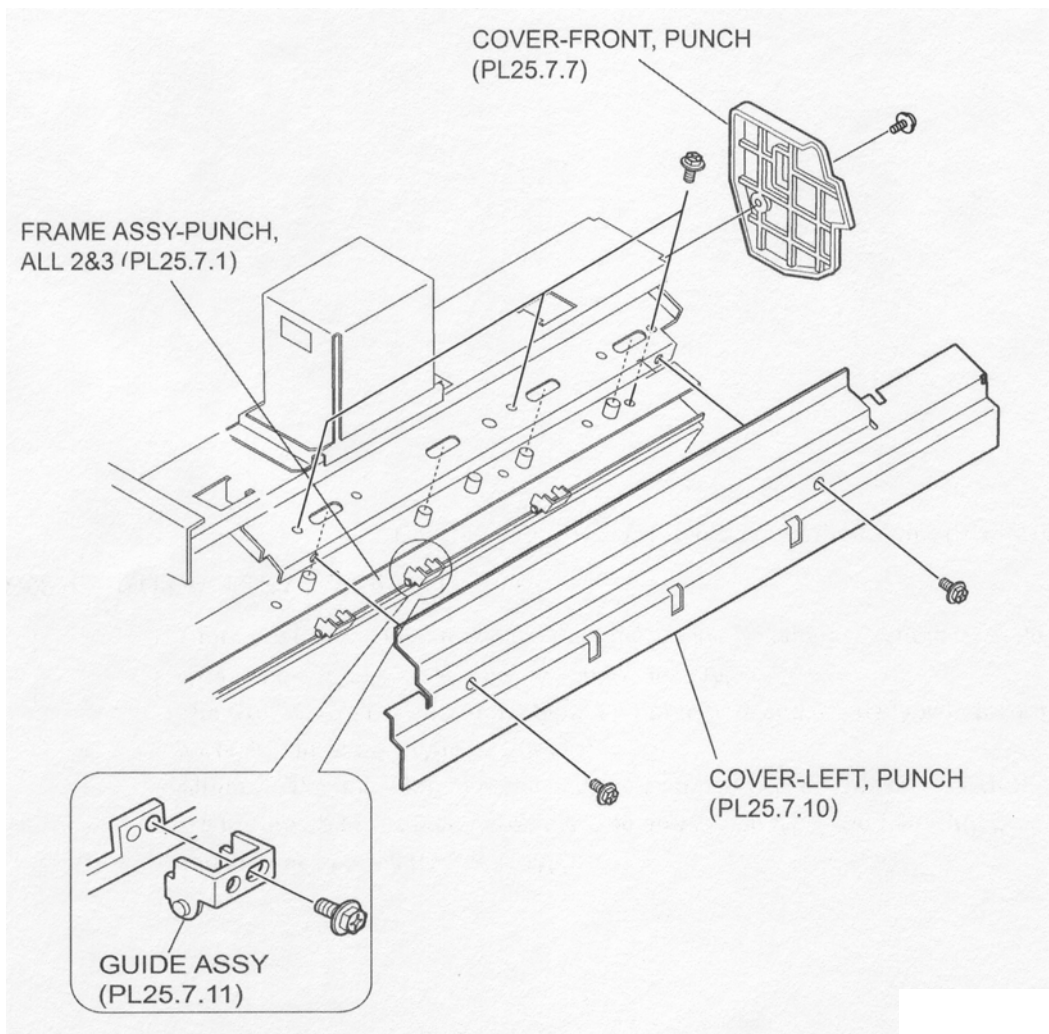
**NOTE** There are five options for the Puncher on the Finisher: 2&3-hole type, 2&4-hole type, 3-hole type, 2-hole type and punch-less type.

**NOTE** The Guide Assembly for 2&3-hole type, 2&4-hole type and 3-hole type are common parts, but the 2-hole type is different.

**NOTE** Although the following removal and replacement procedures of the Guide Assembly are for the 2&3-hole type, 2&4-hole type and 3-hole type, the following procedures can also be applied for 2-hole type.

### Removal

1. Open the Front Cover Assembly (PL 12.5.3).
2. Remove the Upper Rear Cover (PL 12.4.11) .
3. Remove the Punch Frame Assembly (PL 12.7.1) .
4. Remove the Screw (TP M3 x 8) securing the Punch Front Cover (PL 12.7.7) .
5. Remove the two Screws (M3 x 6) securing the Punch Left Cover (PL 12.7.10).
6. Remove the three Screws (TP M3 x 6) securing the Holder Frame Assembly (PL 12.7.5).
7. Remove the one Screw (TP M3 x 6) securing the Guide Assembly to Punch Frame Assembly (PL 12.7.1).
8. Remove the Guide Assembly.



**Figure 1 Guide Assembly**

## Replacement

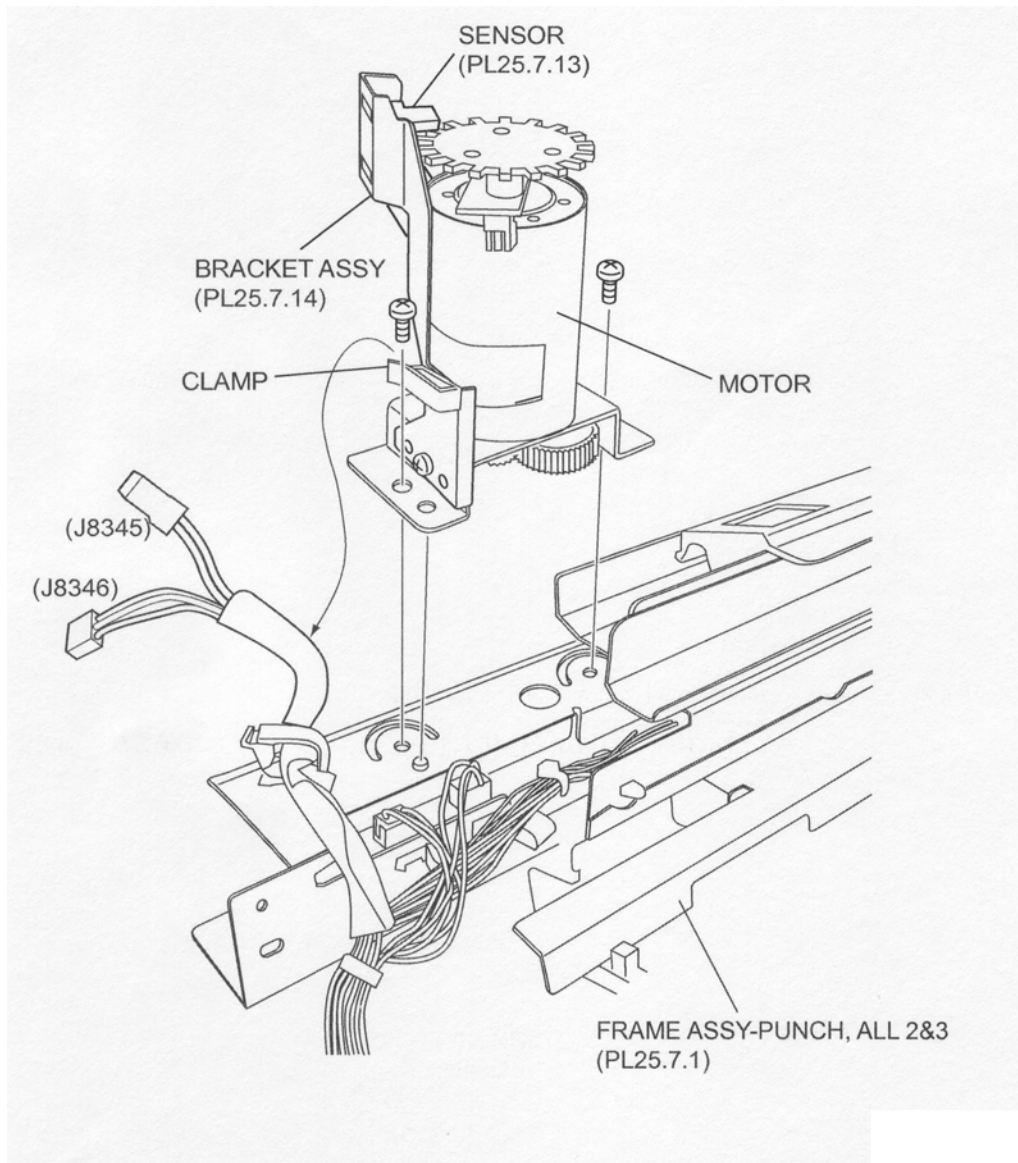
1. Install the Guide Assembly to the Punch Frame Assembly (PL 12.7.1) using one Screw (TP M3 x 6).
2. Install the Holder Frame Assembly (PL 12.7.5) to the Punch Bracket Assembly (PL 12.7.9) using three Screws (TP M3 x 6).
3. Install the Punch Left Cover (PL 12.7.10) using two Screws (M3 x 6).
4. Install the Punch Front Cover (PL 12.7.7) using one Screw (TP M3 x 8).
5. Install the Punch Frame Assembly (PL 12.7.1) .
6. Install the Upper Rear Cover (PL 12.4.11) .
7. Close the Front Cover Assembly (PL 12.5.3).

## Bracket Assembly (Puncher Motor)

### Removal

1. Open the Front Cover Assembly (PL 12.5.3).
2. Remove the Upper Rear Cover (PL 12.4.11) .
3. Remove the Punch Frame Assembly (PL 12.7.1) .
4. Disconnect the connector (J8345) of the Punch Unit Harness Assembly (PL 12.7.2) from the Motor .

5. Disconnect the connector (J8346) of the Punch Unit Harness Assembly from the Sensor (PL 12.7.13).
6. Remove the tube put on the harness connected to the Motor and the Sensor from the clamp.
7. Remove the two Screws (+B 4 x 6) securing the Bracket embly to the Punch Frame Assembly to remove the Bracket Assembly.



**Figure 1 Puncher Motor Bracketembly**

## Replacement

1. Install the Bracket Assembly to the Punch Frame Assembly (PL 12.7.1) using two Screws (+B 4 x 6).

**NOTE** Be sure to engage the gears of the Motor and the Punch Frame Assembly.

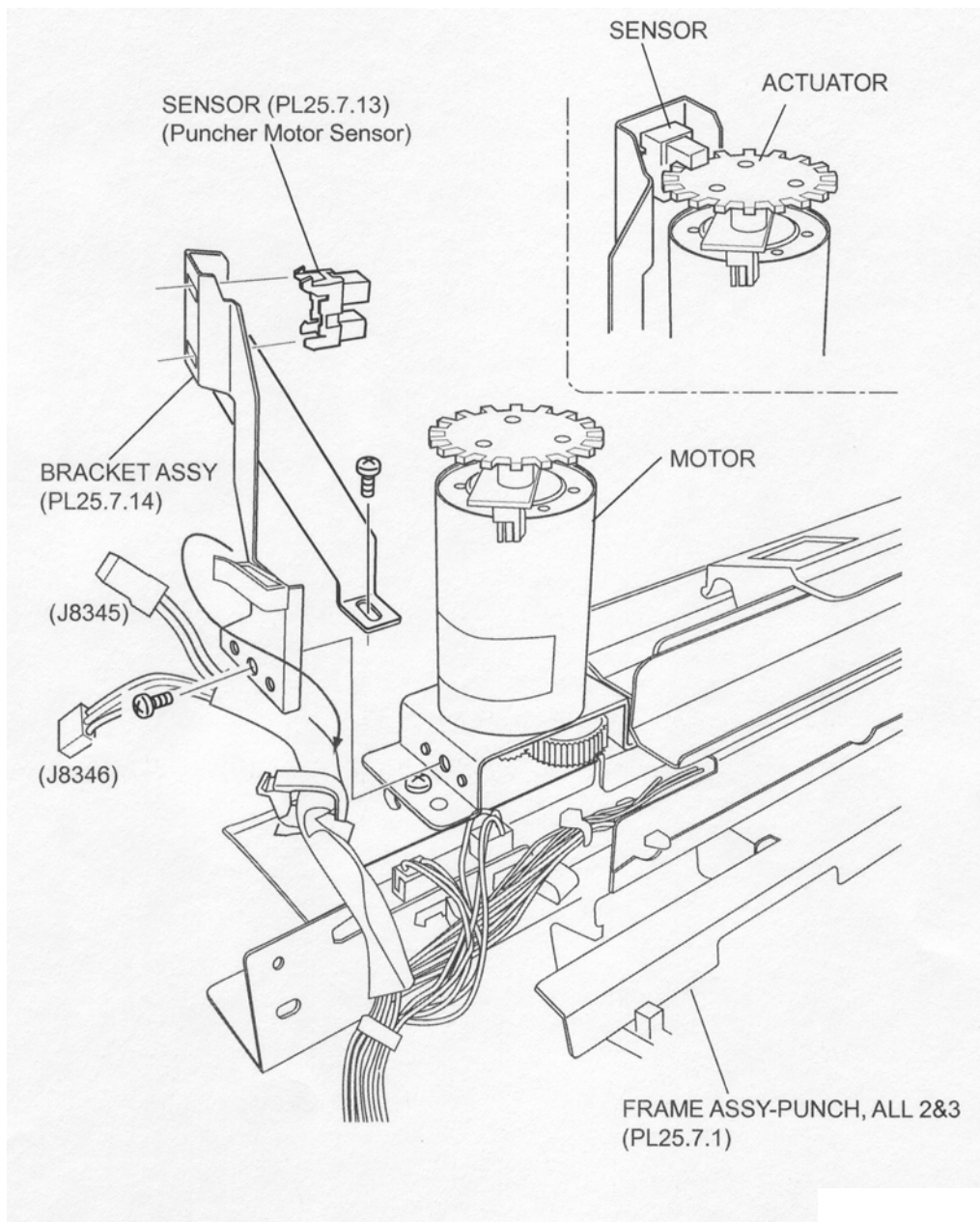
2. Connect the connector (J8346) of the Punch Unit Harness Assembly (PL 12.7.2) to the Sensor.
3. Connect the connector (J8345) of the Punch Unit Harness Assembly to the Motor.
4. Clamp the tube put on the harness connected to the Motor and the Sensor using the clamp.
5. Install the Punch Frame Assembly .
6. Install the Upper Rear Cover (PL 12.4.11) .

7. Close the Front Cover Assembly (PL 12.5.3).

## Sensor (Puncher Motor Sensor)

### Removal

1. Open the Front Cover Assembly (PL 12.5.3).
2. Remove the Upper Rear Cover (PL 12.4.11) .
3. Remove the Punch Frame Assembly (PL 12.7.1) .
4. Disconnect the connector (J8345) of the Punch Unit Harness Assembly (PL 12.7.2) from the Motor .
5. Disconnect the connector (J8346) of the Punch Unit Harness Assembly from the Sensor.
6. Release the tube put on the harness connected to the Motor and the Sensor from the clamp.
7. Remove the two Screws (+B 3 x 6) securing the Bracket Assembly (PL 12.7.14) to the Motor to remove the Bracket Assembly.
8. Release the hooks of the Sensor to remove the Sensor from the Bracket Assembly.



## Figure 1 Puncher Motor Sensor

### Replacement

1. Secure the Sensor to the Bracket Assembly (PL 12.7.14) using the hooks.
2. Install the Bracket Assembly to the Motor using two Screws (+B 3 x 6).

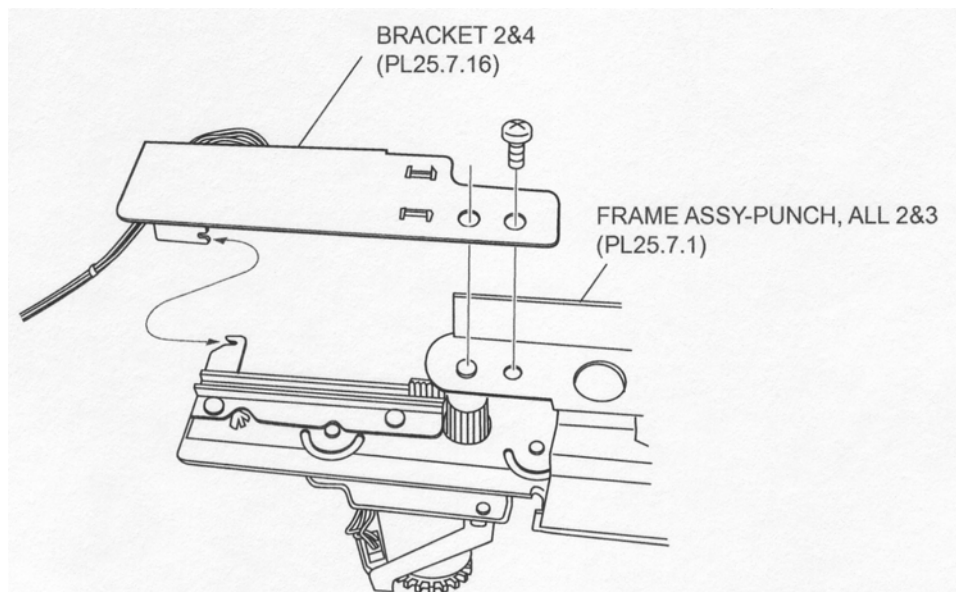
**NOTE** Be sure to put the Actuator of the Motor in the recess of the Sensor.

3. Connect the connector (J8346) of the Punch Unit Harness Assembly (PL 12.7.2) to the Sensor.
4. Connect the connector (J8345) of the Punch Unit Harness Assembly to the Motor.
5. Clamp the tube put on the harness connected to the Motor and the Sensor using the clamp.
6. Install the Punch Frame Assembly (PL 12.7.1) .
7. Install the Upper Rear Cover (PL 12.4.11) .
8. Close the Front Cover Assembly (PL 12.5.3).

## Sensor (Punch Hole Select/Puncher Front/Puncher Home)

### Removal

1. Open the Front Cover Assembly (PL 12.5.3).
2. Remove the Upper Rear Cover (PL 12.4.11) .
3. Remove the Punch Frame Assembly (PL 12.7.1) .
4. Remove the one Screw (+B 4 x 6) securing the Bracket 2&4 (PL 12.7.16) .



**Figure 1 Bracket**

5. Disconnect the connector (J8346) of the Punch Unit Harness Assembly (PL 12.7.2) from the Sensor (Punch Hole Select Sensor), connector (J8347) from the Sensor (Puncher Front Sensor), or connector (J8348) from the Sensor (Puncher Home Sensor) .
6. Release the hooks of the Sensor to remove the Sensor from the Bracket 2&4.

### Replacement

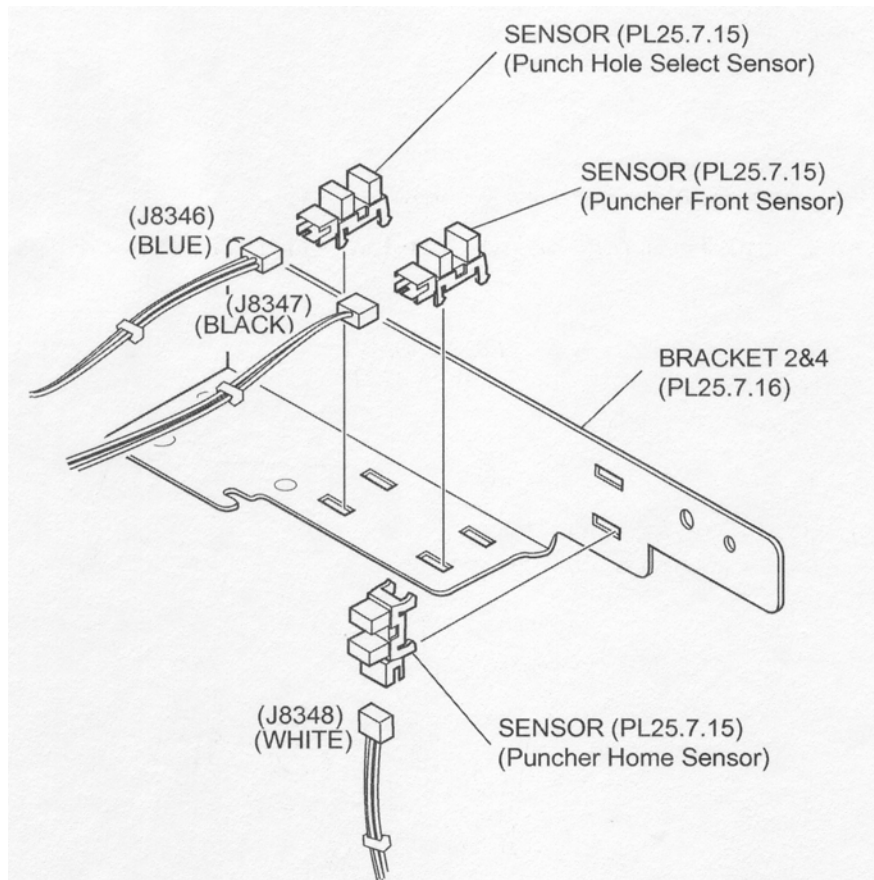
1. Secure the Sensor to the Bracket 2&4 (PL 12.7.16) using the hooks.

2. Connect the connector (J8346) (Blue) of the Punch Unit Harness Assembly (PL 12.7.2) to the Sensor (Punch Hole Select Sensor), connector (J8347) (Black) to the Sensor (Puncher Front Sensor), or connector (J8348) (White) to the Sensor (Puncher Home Sensor).
3. Install the Bracket 2&4 to the Punch Frame Assembly (PL 12.7.1) using one Screw (+B 4 x 6).

**NOTE** When installing the Bracket 2&4, engage each notch of the Bracket 2&4 and the Punch Frame Assembly, and then tighten the Screw (+B 4 x 6) while pushing the Bracket 2&4 toward the fixing Screw.

**NOTE** After tightening the Screw, make sure that both notches are engaged without extra space.

4. Install the Punch Frame Assembly .
5. Install the Upper Rear Cover (PL 12.4.11) .
6. Close the Front Cover Assembly (PL 12.5.3).

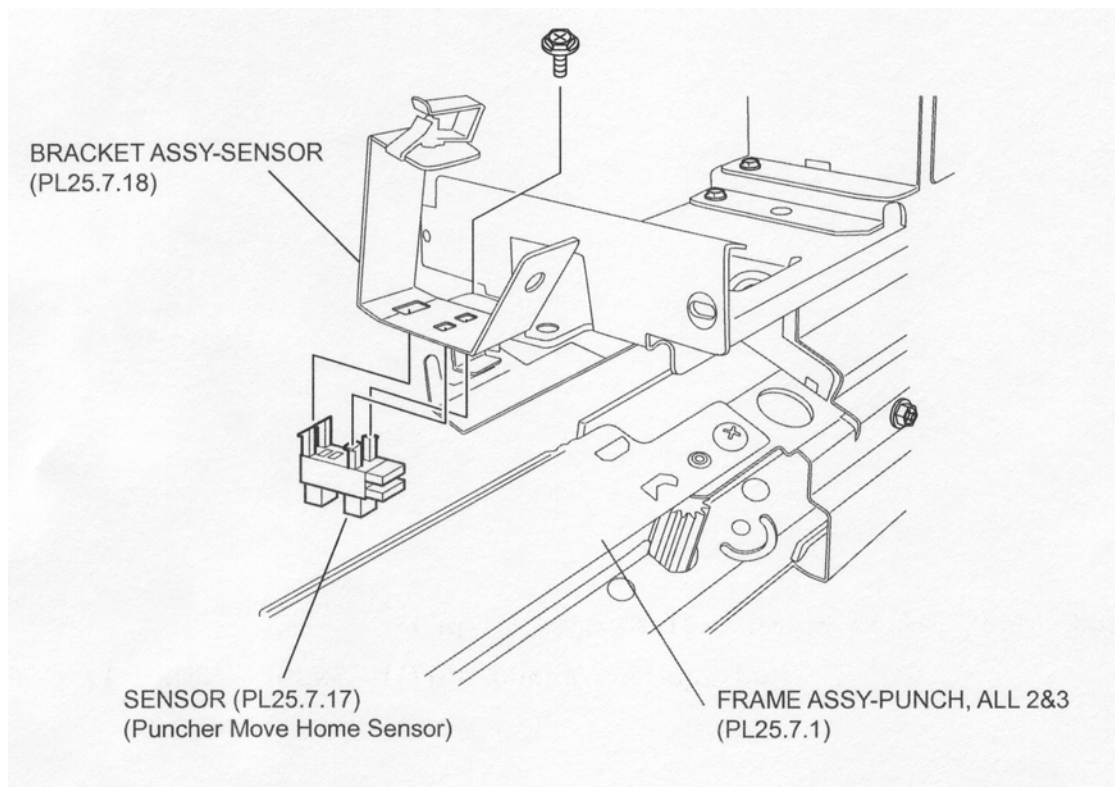


**Figure 2 Punch Sensors**

## Sensor (Puncher Move Home Sensor)

### Removal

1. Open the Front Cover Assembly (PL 12.5.3).
2. Remove the Upper Rear Cover (PL 12.4.11) .
3. Remove the Punch Frame Assembly (PL 12.7.1) .
4. Remove the one Screw (M3 x 6) securing the Sensor Bracket Assembly (PL 12.7.18) .
5. Release the hooks of the Sensor to remove the Sensor from the Sensor Bracket Assembly.



**Figure 1 Puncher Move Home Sensor**

## Replacement

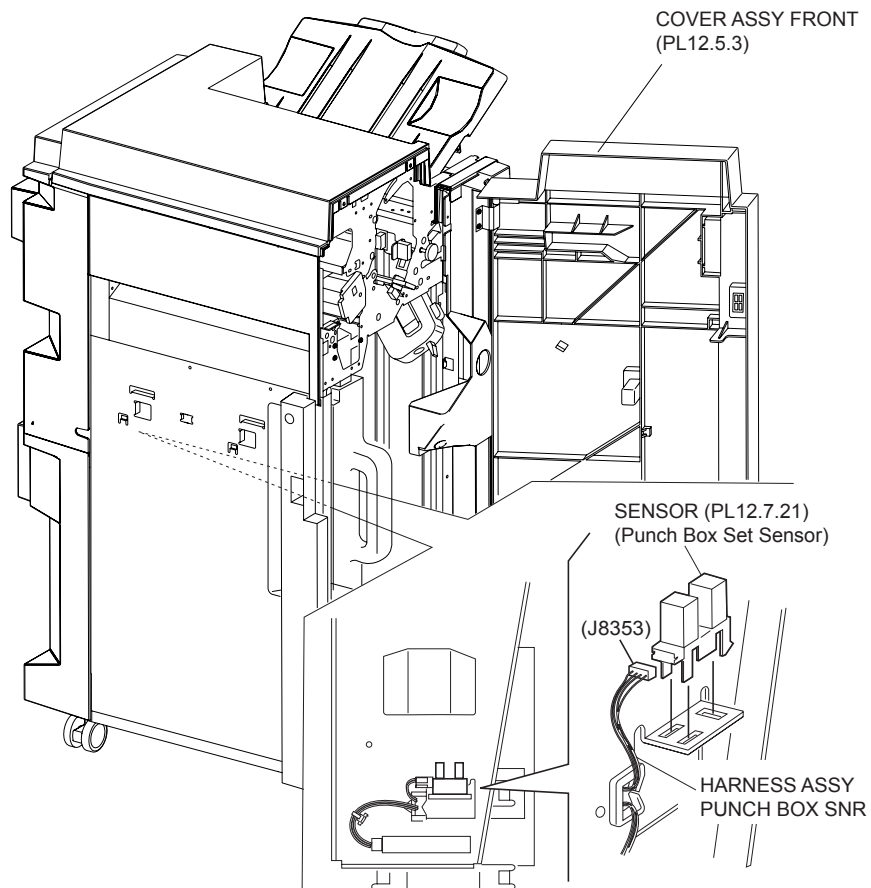
1. Secure the Sensor (Puncher Move Home Sensor) to the Sensor Bracket Assembly (PL 12.7.18) using the hooks.
2. Install the Sensor Bracket Assembly to the Punch Frame Assembly (PL 12.7.1) using one Screw (M3 x 6).
3. Install the Punch Frame Assembly .
4. Install the Upper Rear Cover (PL 12.4.11) .
5. Close the Front Cover Assembly (PL 12.5.3).

## Sensor (Punch Box Set Sensor)

### Removal

1. Open the Front Cover Assembly (PL 12.5.3).
2. Pull out the Dust Box Assembly (PL 12.7.20) from the Finisher to remove the Dust Box Assembly.
3. Disconnect the connector (J8353) of the Punch Box Sensor Harness Assembly from the Sensor (Punch Box Set Sensor) .
4. Release the hooks of the Sensor to remove the Sensor from the Bracket Assembly.





**Figure 1 Punch Box Set Sensor**

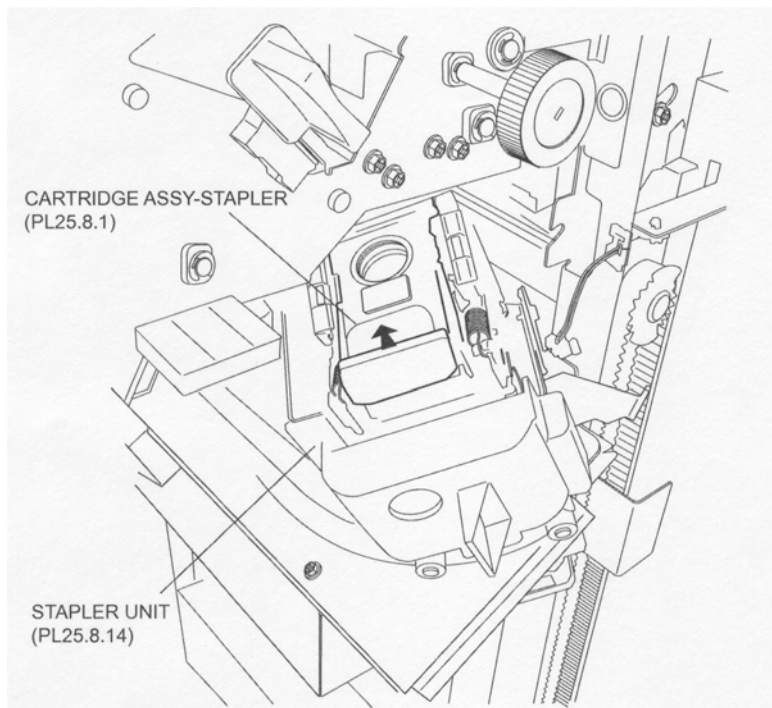
## Replacement

1. Secure the Sensor (Punch Box Set Sensor) to the Bracket Assembly using the hooks.
2. Connect the connector (J8353) of the Punch Box Sensor Harness Assembly to the Sensor.
3. Install the Dust Box Assembly (PL 12.7.20) to the Finisher.
4. Close the Front Cover Assembly (PL 12.5.3).

## Stapler Unit

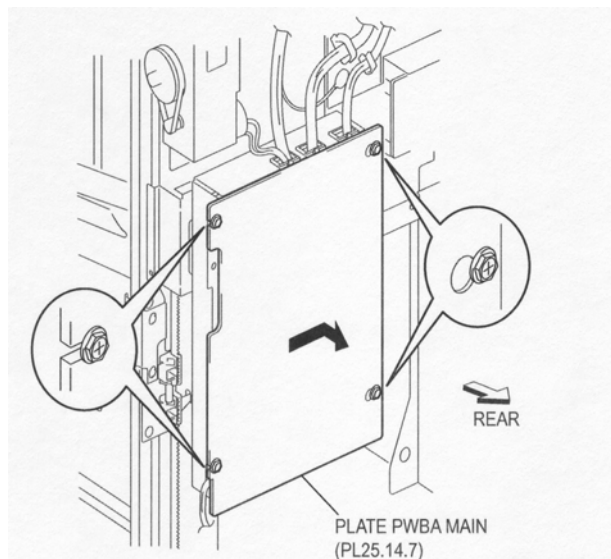
### Removal

1. Remove the Front Cover Assembly (PL 12.5.3) .
2. Remove the Stapler Cartridge Assembly (PL 12.8.1) .



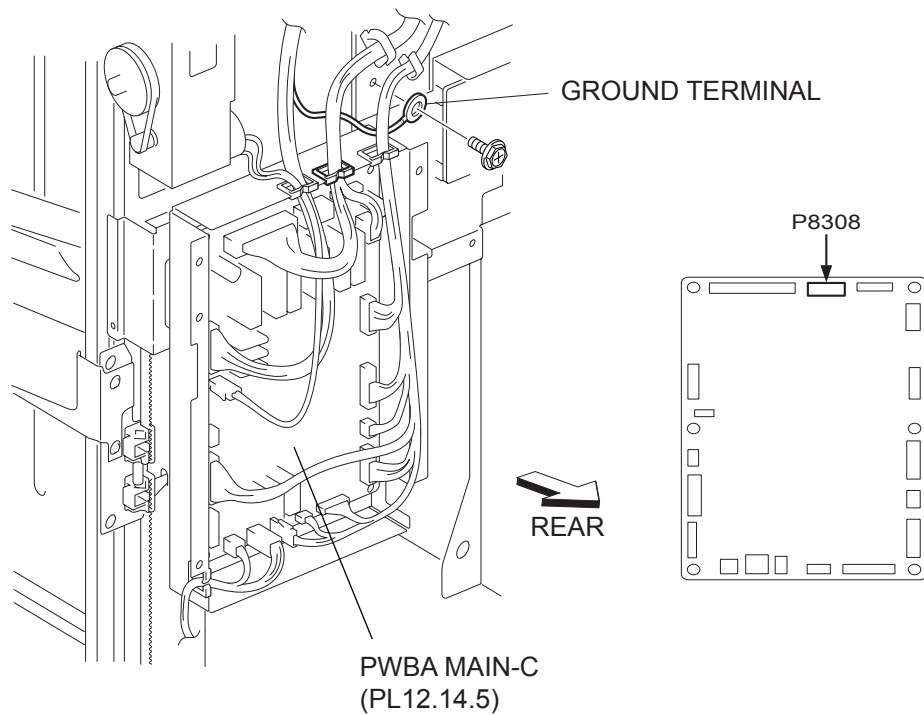
**Figure 1 Stapler Cartridge Assembly**

3. Remove the Upper Rear Cover (PL 12.4.11) .
4. Remove the Lower Rear Cover (PL 12.4.9) .
5. Loosen the four Screws securing the Main Plate PWBA (PL 12.14.7), and move it in the direction of the arrow to remove the Main Plate PWBA .



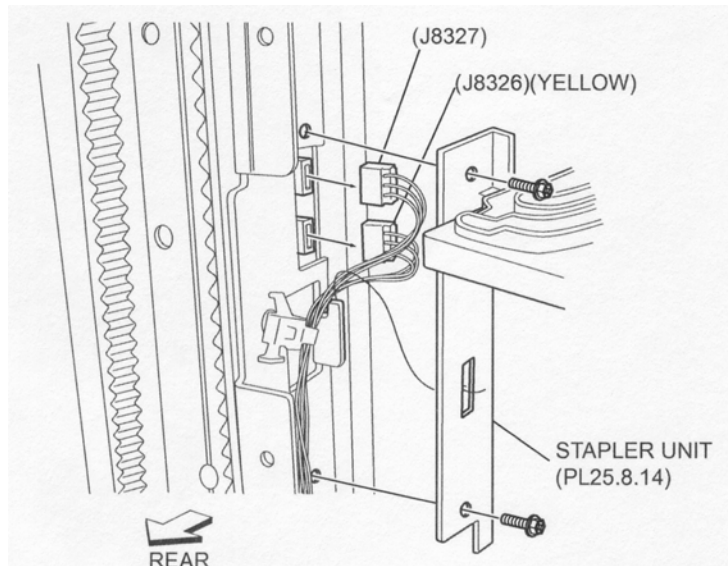
**Figure 2 Main Plate PWBA**

6. Disconnect the connector of the Staple Harness Assembly (PL 12.8.7) from the connector (P8308) on the Main-C PWBA (PL 12.14.5) .
7. Remove the one Screw securing the ground wire of the Staple Harness Assembly.



**Figure 3 Main C PWBA**

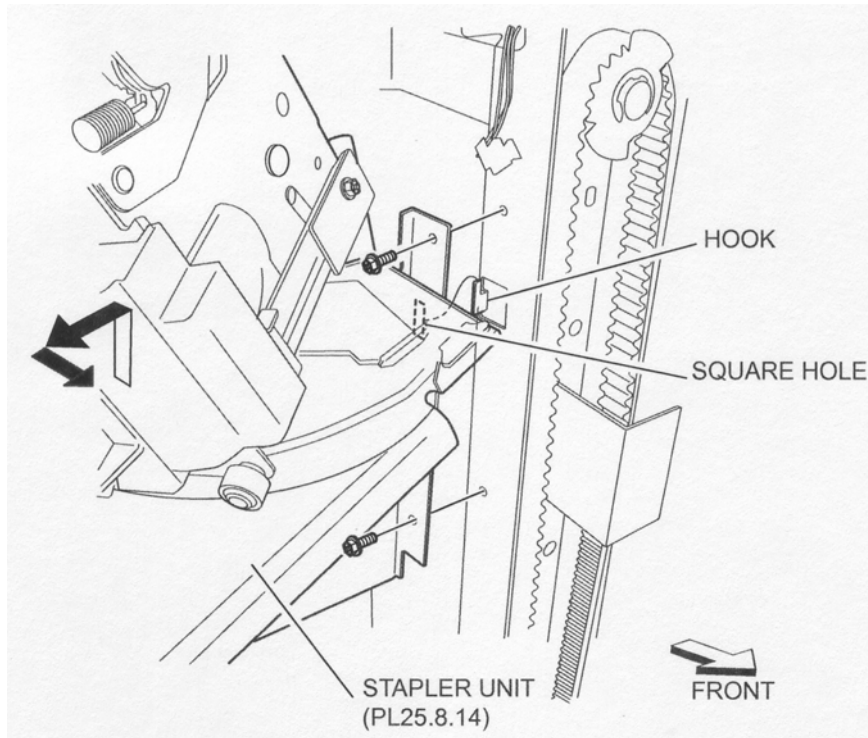
8. Release the Staple Harness Assembly from the harness clamp .
9. Remove the Stacker Bracket Assembly (PL 12.6.24) .
10. Disconnect the two connectors (J8327 and J8326 (yellow)) of the Main Sensor Harness Assembly (PL 12.15.1) from the two Sensors (PL 12.6.17) (Upper Limit Sensor and Stacker No Paper Sensor).
11. Remove the two Screws (M3 x 6) each on the front and rear securing the Stapler Unit.



**Figure 4 Main Sensor Harness**

12. Move the Stapler Unit in the direction of the arrow to disengage the hooks on the frame from the square holes on the front and rear of the Stapler Unit, and remove the Stapler Unit to the front .

**NOTE** When removing the Stapler Unit, be careful not to drop it.



**Figure 5 Stapler Unit**

## Replacement

1. Put the Stapler Unit into the Finisher from its front, and move the Stapler Unit in the opposite direction of the arrow to put the hooks on the frame into the square holes on the front and rear of the Stapler Unit.

**NOTE** When installing the Stapler Unit, be careful not to drop it.

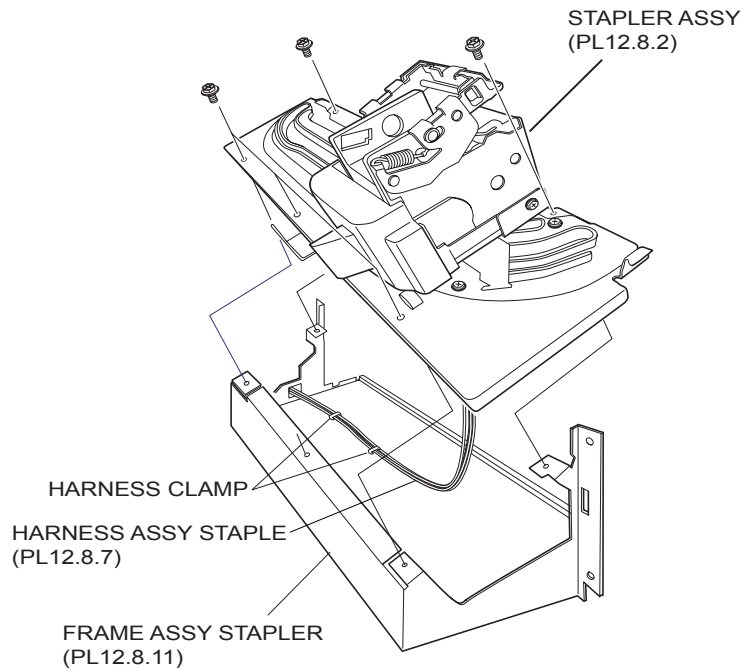
2. Secure the Stapler Unit to the frame using two Screws (M3 x 6) each on the front and rear.
3. Connect the connectors (J8327 and J8326 (yellow)) of the Main Sensor Harness Assembly (PL 12.15.1) to the connectors of the two Sensors (PL 12.6.17) (Upper Limit Sensor and Stacker No Paper Sensor).
4. Install the Stacker Bracket Assembly (PL 12.6.24) .
5. Connect the connector of the Staple Harness Assembly (PL 12.8.7) to the connector (P8308) on the Main-C PWBA (PL 12.14.5).
6. Secure the ground wire of the Staple Harness Assembly to the frame using one Screw.
7. Secure the Staple Harness Assembly using the harness clamp.
8. Install the Main Plate PWBA (PL 12.14.7) to the frame by moving it in the opposite direction of the arrow, and secure it using four Screws.
9. Install the Lower Rear Cover (PL 12.4.9) .
10. Install the Upper Rear Cover (PL 12.4.11) .
11. Install the Front Cover Assembly (PL 12.5.3) .
12. Install the Stapler Cartridge Assembly (PL 12.8.1).

## Stapler Assembly

### Removal

1. Remove the Front Cover Assembly (PL 12.5.3) .

2. Remove the Stapler Cartridge Assembly (PL 12.8.1).
3. Remove the Upper Rear Cover (PL 12.4.11) .
4. Remove the Lower Rear Cover (PL 12.4.9) .
5. Remove the Stapler Unit (PL 12.8.14) .
6. Remove the five Screws (M3 x 6) securing the Stapler Frame Assembly (PL 12.8.11) to remove the Stapler Frame Assembly .
7. Release the Staple Harness Assembly (PL 12.8.7) from the two harness clamps of the Stapler Frame Assembly.

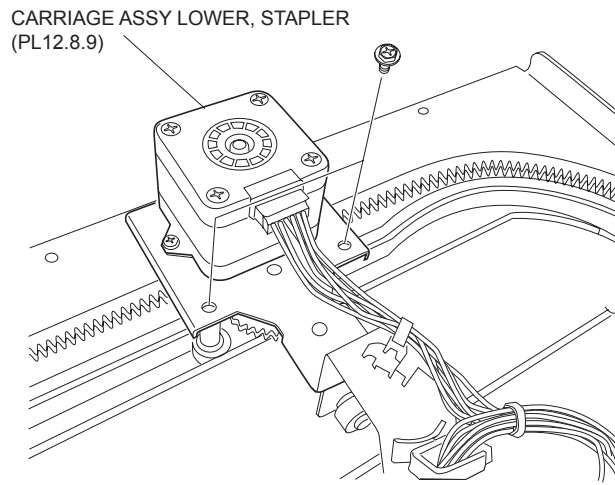


**Figure 1 Stapler Frame Assembly**

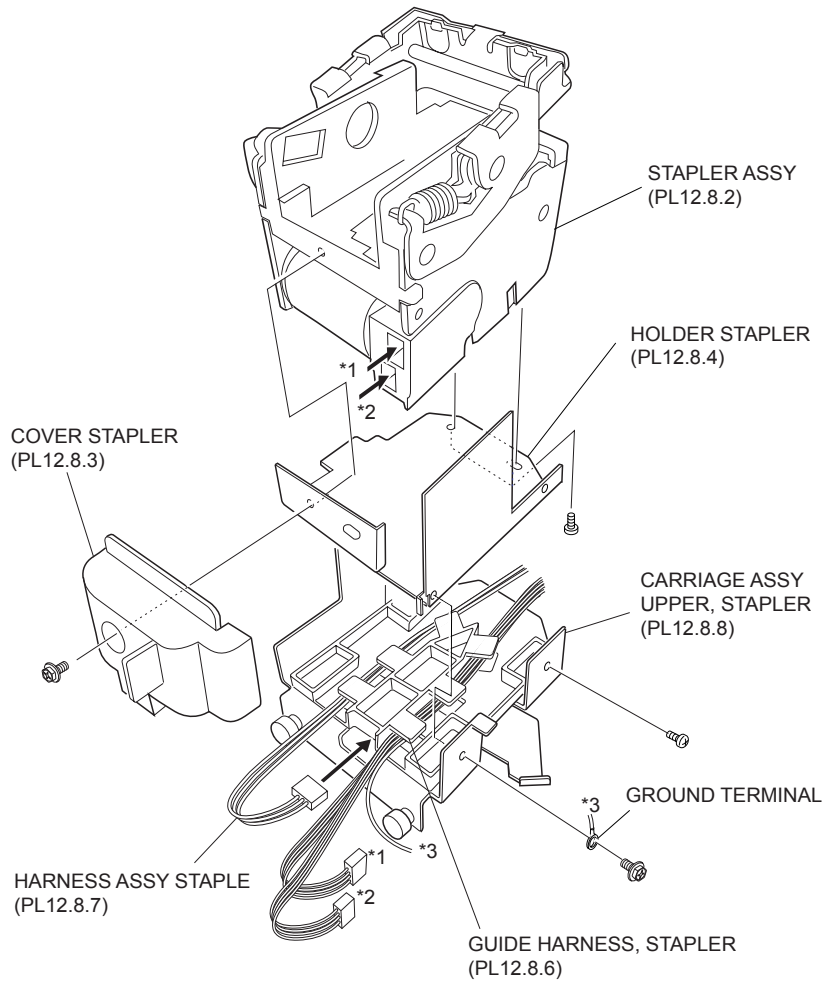
8. Remove the two Screws securing the Stapler Lower Carriage Assembly (PL 12.8.9) to remove the Stapler Lower Carriage Assembly .

**NOTE** Since the harnesses are connected to the Stapler Lower Carriage Assembly and the head of the Stapler, the Stapler Lower Carriage Assembly cannot be detached from the head of the Stapler.

9. Remove the one Screw securing the Stapler Cover (PL 12.8.3) to remove the Stapler Cover .
10. Disconnect the two connectors (J8356 and J8357) from the Stapler Assembly, and the one connector (J8354) from the Sensor.
11. Remove the two Screws on the sides on the Stapler Assembly securing the Stapler Upper Carriage Assembly (PL 12.8.8) to remove the Stapler Upper Carriage Assembly. At the same time, the ground terminal is also detached.
12. Remove the two Screws securing the Stapler Assembly to the Stapler Holder (PL 12.8.4) to remove the Stapler Assembly.



**Figure 2 Lower Stapler Carriage Assembly**



**Figure 3 Stapler Assembly**

## Replacement

1. Install the Stapler Assembly to the Stapler Holder (PL 12.8.4) using two Screws.

2. Put the Staple Harness Assembly (PL 12.8.7) under the ribs of the Stapler Guide Harness (PL 12.8.6) as shown in the figure.
3. Install the Stapler Upper Carriage Assembly (PL 12.8.8) to the Stapler Holder attached with the Stapler Assembly using two Screws.

**NOTE** Make sure that the wires of the Staple Harness Assembly are not pinched between the Stapler Upper Carriage Assembly and the Stapler Holder.

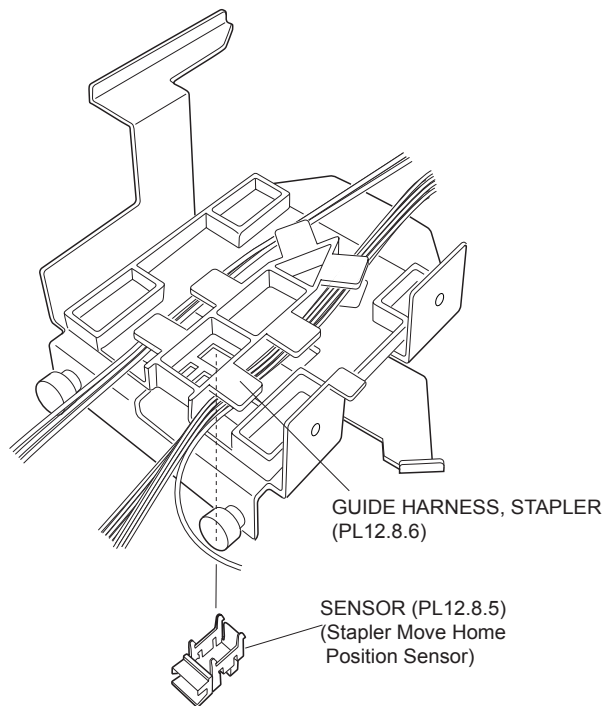
**NOTE** Secure the ground terminal in the position shown in the figure using one Screw.

4. Connect the two connectors (J8356 and J8357) of the Staple Harness Assembly to the Stapler Assembly, and the connector (J8354) to the Sensor (PL 12.8.5).
5. Install the Stapler Cover (PL 12.8.3) to the Stapler Assembly using one Screw.
6. Install the Stapler Lower Carriage Assembly (PL 12.8.9) to the head of the Stapler using two Screws.
7. Secure the Staple Harness Assembly with the two harness clamps of the Stapler Frame Assembly (PL 12.8.11).
8. Install the Stapler Frame Assembly using five Screws (M3 x 6).
9. Install the Stapler Unit (PL 12.8.14) .
10. Install the Lower Rear Cover (PL 12.4.9) .
11. Install the Upper Rear Cover (PL 12.4.11) .
12. Install the Front Cover Assembly (PL 12.5.3) .
13. Install the Stapler Cartridge Assembly (PL 12.8.1).

## Sensor (Stapler Move Home Position Sensor)

### Removal

1. Remove the Front Cover Assembly (PL 12.5.3) .
2. Remove the Stapler Cartridge Assembly (PL 12.8.1).
3. Remove the Upper Rear Cover (PL 12.4.11) .
4. Remove the Lower Rear Cover (PL 12.4.9) .
5. Remove the Stapler Unit (PL 12.8.14) .
6. Remove the Stapler Assembly (PL 12.8.2) .
7. Release the hooks of the Sensor (Stapler Move Home Position Sensor) from the Stapler Guide Harness (PL 12.8.6) to remove the Sensor.



**Figure 1 Stapler Move Home Position Sensor**

## Replacement

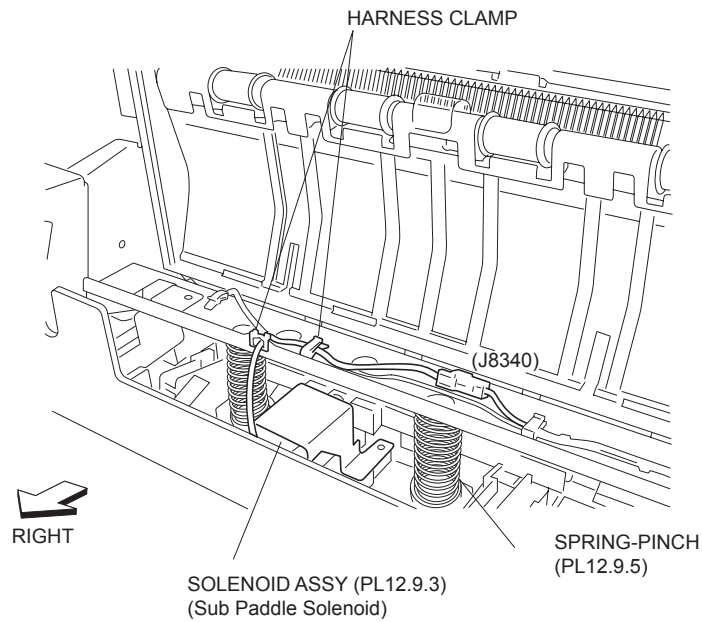
1. Secure the Sensor (Stapler Move Home Position Sensor) to the Stapler Guide Harness (PL 12.8.6) using the hooks.
2. Install the Stapler Assembly (PL 12.8.2) .
3. Install the Stapler Unit (PL 12.8.14) .
4. Install the Lower Rear Cover (PL 12.4.9) .
5. Install the Upper Rear Cover (PL 12.4.11) .
6. Install the Stapler Cartridge Assembly (PL 12.8.1).
7. Install the Front Cover Assembly (PL 12.5.3) .

## Eject Unit Chute Assembly

### Removal

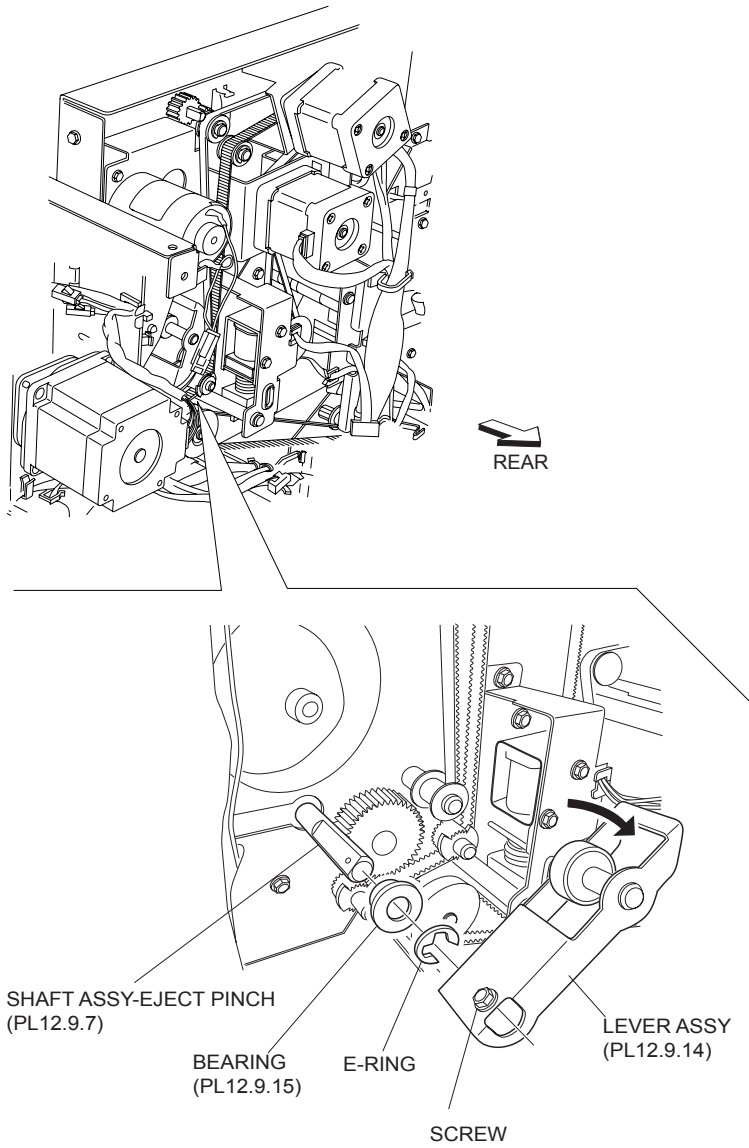
1. Remove the Front Cover Assembly (PL 12.5.3) .
2. Remove the Upper Rear Cover (PL 12.4.11) .
3. Remove the SCT Tray Assembly (PL 12.4.3) .
4. Remove the Eject Cover (PL 12.4.4) .
5. Remove the two Pinch Springs(PL 12.9.5) while pushing them downward .
6. Disconnect the harness connector (J8340) of the Solenoid Assembly (PL 12.9.3) (Sub Paddle Solenoid) from the Main Drive Harness Assembly (PL 12.15.2).
7. Release the harness of the Sub Paddle Solenoid from the two harness clamps.



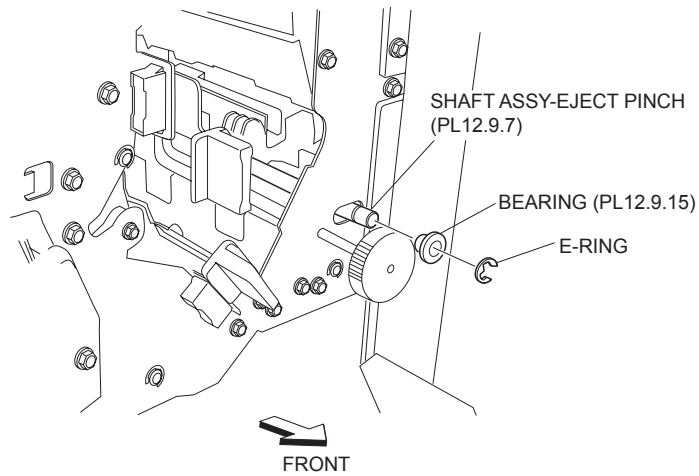


**Figure 1 Pinch Springs**

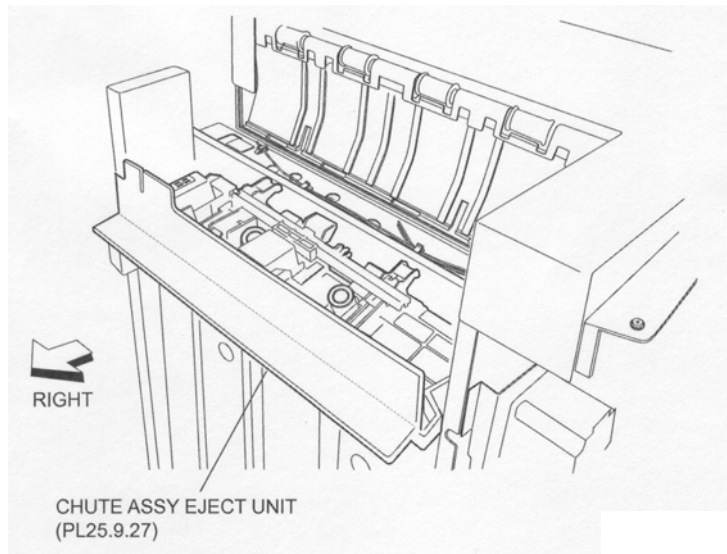
8. While pushing the Lever Assembly (PL 12.9.14) in the direction of the arrow, remove the Screw (M3 x 6) securing the Lever Assembly to the Eject Pinch Shaft Assembly to remove the Lever Assembly .
9. Remove the E-ring securing the Eject Pinch Shaft Assembly (PL 12.9.7) on the rear of the Finisher .
10. Remove the Bearing (PL 12.9.15) on the rear side.
11. Remove the E-ring securing the Eject Pinch Shaft Assembly on the front of the Finisher.
12. Remove the Bearing (PL 12.9.15) on the front side.
13. While pulling the Eject Unit Chute Assembly toward you from the right side of the Finisher, tilt it slightly to remove the front end of the Eject Pinch Shaft Assembly from the hole on the front frame .
14. Remove the Eject Unit Chute Assembly from the Finisher .



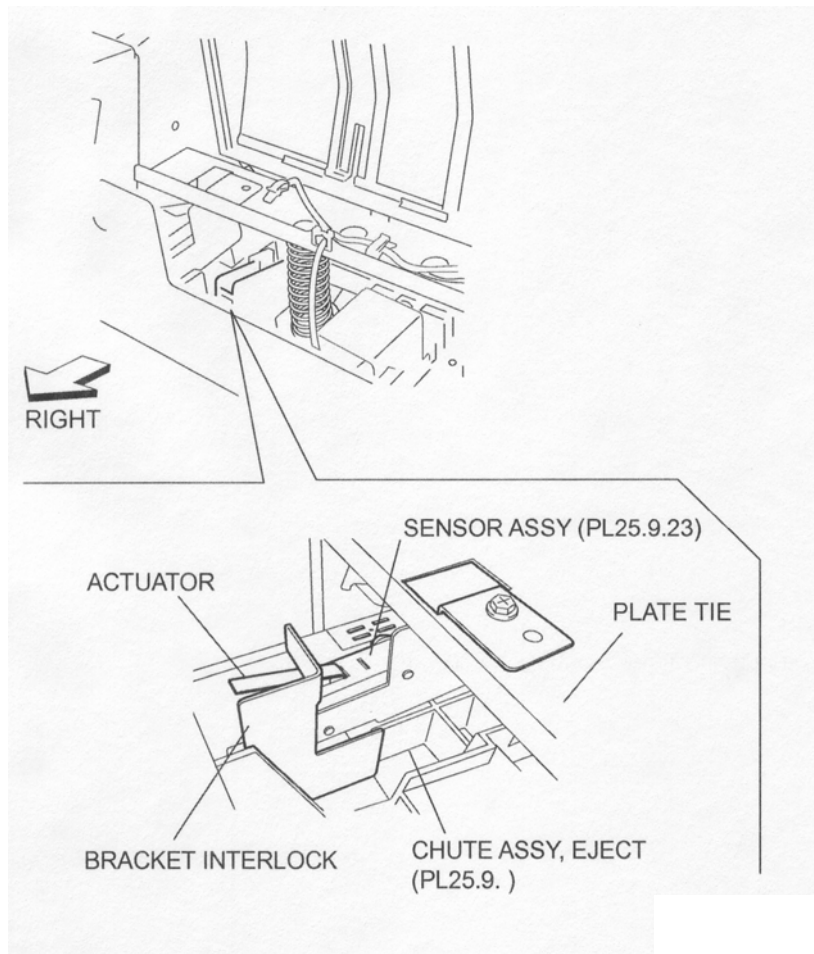
**Figure 2 Lever Assembly**



**Figure 3 Eject Pinch Shaft Assembly**



**Figure 4 Eject Unit Chute Assembly**



**Figure 5 Sensor Assembly**

## Replacement

1. Put the rear end of the Eject Pinch Shaft Assembly (PL 12.9.7) on the Eject Unit Chute Assembly into the longitudinal hole on the frame.

2. Put the front end of the Eject Pinch Shaft Assembly into the longitudinal hole on the front frame, then install the Eject Unit Chute Assembly to the Finisher.

**NOTE** When installing, be sure to install the Sensor Assembly so that the actuator of the Sensor Assembly is placed under the Interlock Bracket on Eject Unit Chute Assembly.

3. Install the Bearing (PL 12.9.15) to the Eject Pinch Shaft Assembly on the rear.

**NOTE** Install the Bearing so that its flat surfaces fits to the hole on the frame.

4. Secure the Bearing using the E-ring.
5. Install the Bearing (PL 12.9.15) to the front end of the Eject Pinch Shaft Assembly.

**NOTE** Install the Bearing with its flat surfaces fit to the hole on the frame of the Finisher.

6. Secure the Bearing using the E-ring.
7. Install the Lever Assembly (PL 12.9.14) to the Eject Pinch Shaft Assembly, and secure it to the Screw hole on the Eject Pinch Shaft Assembly using one Screw (M3 x 6).

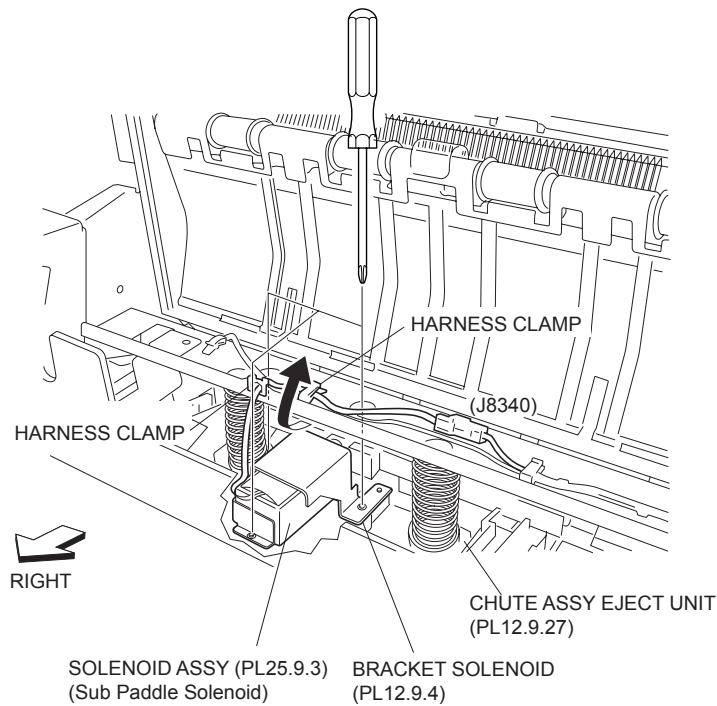
**NOTE** It is easy to tightening the Screw by pressing the Lever Assembly in the direction of the arrow.

8. Connect the harness connector (J8340) of the Solenoid Assembly (PL 12.9.3) to the Main Drive Harness Assembly (PL 12.15.2).
9. Secure the harness of the Solenoid Assembly with the two harness clamps.
10. Install the two Pinch Springs (PL 12.9.5) while pushing them downward.
11. Install the Eject Cover (PL 12.4.4) .
12. Install the SCT Tray Assembly (PL 12.4.3) .
13. Install the Upper Rear Cover (PL 12.4.11) .
14. Install the Front Cover Assembly (PL 12.5.3) .

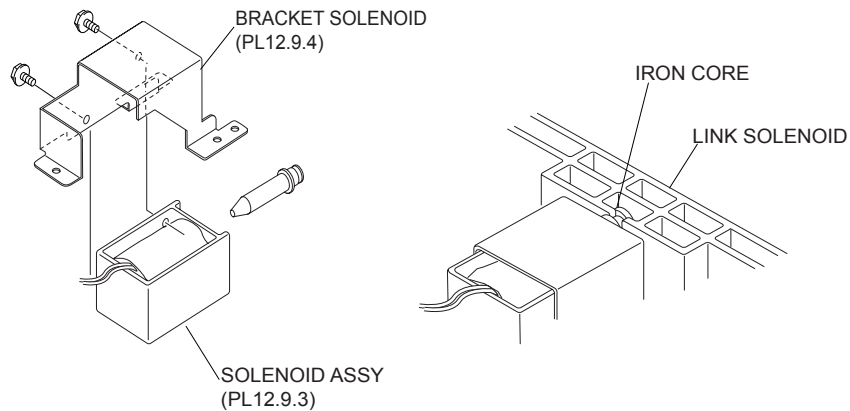
## Solenoid Assembly (Sub Paddle Solenoid)

### Removal

1. Remove the SCT Tray Assembly (PL 12.4.3) .
2. Disconnect the harness connector (J8340) of the Solenoid Assembly (Sub Paddle Solenoid) from the Main Drive Harness Assembly (PL 12.15.2) .
3. Release the harness of the Solenoid Assembly from the two harness clamps.
4. Remove the three Screws securing the Solenoid Bracket (PL 12.9.4) attached with the Solenoid Assembly to the Eject Unit Chute Assembly (PL 12.9.27), and move it in the direction of the arrow shown in the figure to remove the Solenoid Bracket.
5. Remove the two Screws securing the Solenoid Assembly to the Solenoid Bracket to remove the Solenoid Assembly .



**Figure 1 Solenoid Assembly**



**Figure 2 Solenoid Bracket**

## Replacement

1. Install the Solenoid Assembly to the Solenoid Bracket (PL 12.9.4) in the direction shown in the figure using two Screws.
2. While putting the iron core of the Solenoid Assembly into the notch of the Solenoid Link, install the Solenoid Assembly to the Eject Unit Chute Assembly (PL 12.9.27).
3. Install the Solenoid Bracket to the Eject Unit Chute Assembly using three Screws.

**NOTE** When installing, be sure to put the boss on the Eject Unit Chute Assembly into the hole on the Solenoid Bracket.

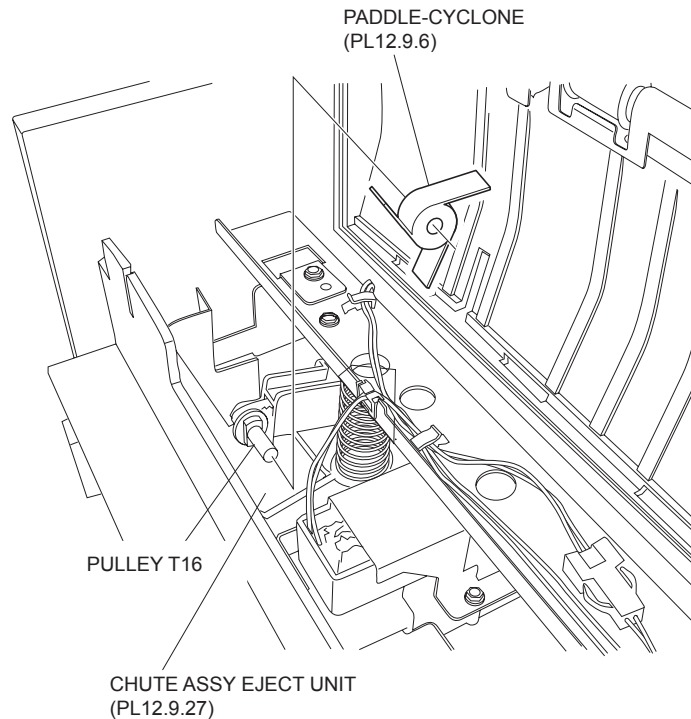
4. Connect the harness connector (J8340) of the Solenoid Assembly to the Main Drive Harness Assembly (PL 12.15.2).
5. Secure the harness of the Solenoid Assembly with the two harness clamps.
6. Install the SCT Tray Assembly (PL 12.4.3) .

## Cyclone Paddle

**NOTE** Two Cyclone Paddles are attached to the Eject Unit Chute Assembly (PL 12.9.27). Their removal and replacement procedures are the same.

### Removal

1. Remove the SCT Tray Assembly (PL 12.4.3) .
2. Remove the Cyclone Paddle from the shaft of the T16 Pulley on the Eject Unit Chute Assembly (PL 12.9.27) by hand .



**Figure 1 Cyclone Paddle**

### Replacement

1. Install the Cyclone Paddle to the shaft of the T16 Pulley on the Eject Unit Chute Assembly (PL 12.9.27) in the direction shown in the figure.

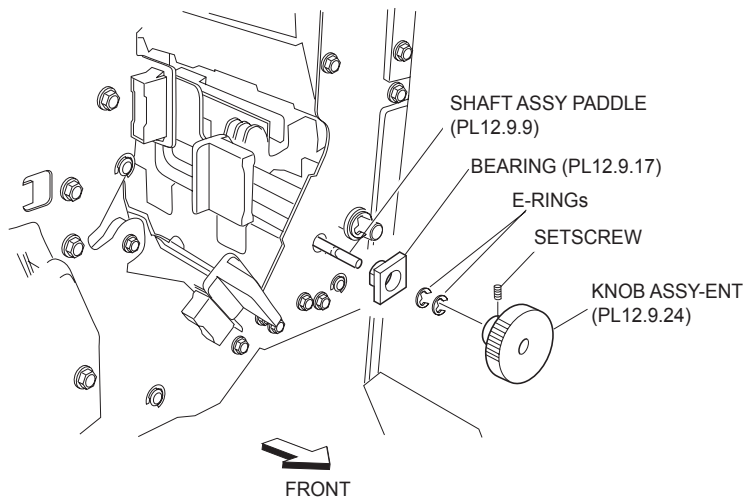
**NOTE** After installation, make sure that the Cyclone Paddle does not in contact with the Eject Unit Chute Assembly when it is rotated by hand.

2. Install the SCT Tray Assembly (PL 12.4.3) .

## Paddle Shaft Assembly

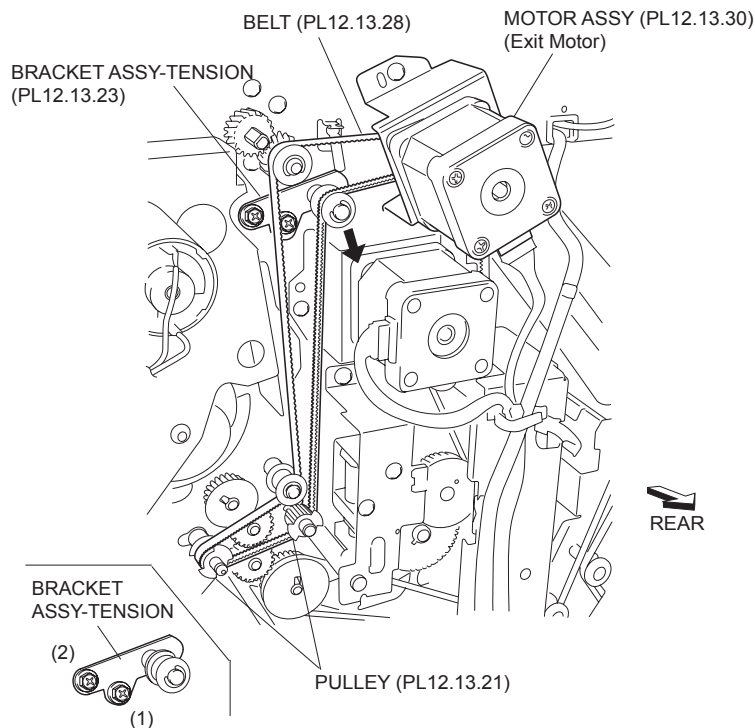
### Removal

1. Open the Front Cover Assembly.
2. Remove the Upper Rear Cover (PL 12.4.11) .
3. Loosen the setscrew securing the Entrance Knob Assembly (PL 12.9.24) on the front .
4. Pull out the Entrance Knob Assembly from the Paddle Shaft Assembly.
5. Remove the one E-ring securing the Paddle Shaft Assembly on the front.
6. Remove the Bearing (PL 12.9.17).



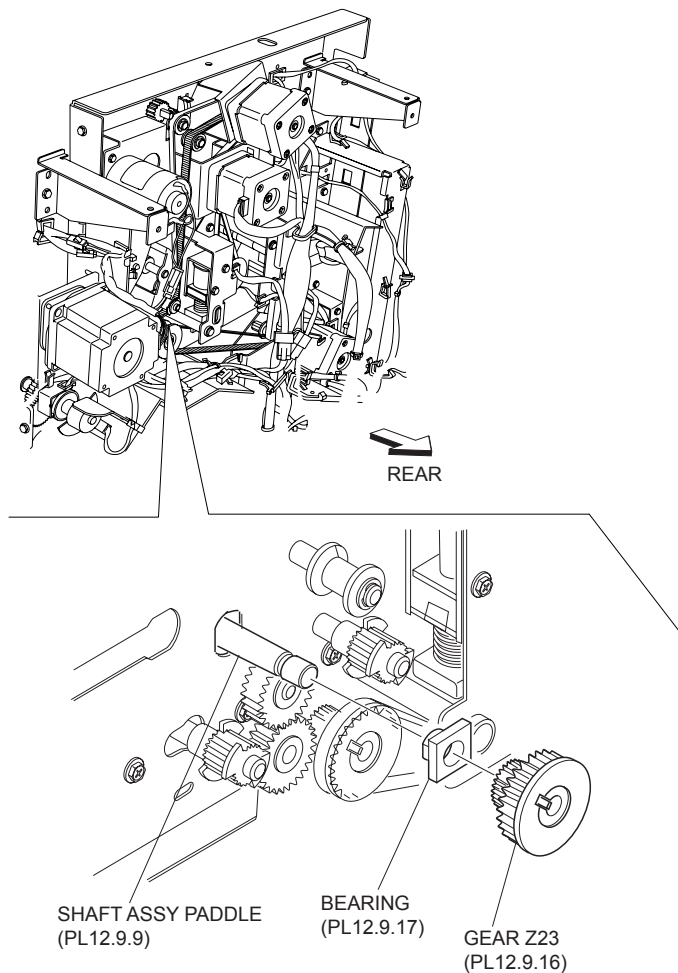
**Figure 1 Entrance Knob Assembly**

7. Loosen the two Screws securing the Tension Bracket Assembly (PL 12.13.23) on the rear so that the tension of the Belt (PL 12.13.28) decreases .



**Figure 2 Tension Bracket Assembly**

8. Release the hook of the Z23 Gear (PL 12.9.16) attached to the Paddle Shaft Assembly on the rear to remove the Z23 Gear .
9. Remove the Bearing (PL 12.9.17).
10. Move the Paddle Shaft Assembly to the rear side to remove the front end of the Paddle Shaft Assembly from the hole on the front frame, then remove the Paddle Shaft Assembly from the Finisher.



**Figure 3 Paddle Shaft Assembly**

## Replacement

1. Put the rear end of the Paddle Shaft Assembly into the hole on the rear first, then put the front end of the Paddle Shaft Assembly into the hole on the front frame.
2. Install the Bearing (PL 12.9.17) to the Paddle Shaft Assembly on the front.
3. Fix the one E-ring to the Paddle Shaft Assembly.
4. Install the Bearing (PL 12.9.17) to the Paddle Shaft Assembly on the rear.
5. Install the Z23 Gear (PL 12.9.16), and fix it to the Paddle Shaft Assembly with the hook.
6. Fix the Tension Bracket Assembly to the frame using two Screws.

**NOTE** The tension of the belt is automatically adjusted by the force of the Tension Spring (PL 12.13.24) attached to the Tension Bracket Assembly. Therefore, when tightening the two Screws, be careful not to move the Tension Bracket Assembly.

**NOTE** Tighten the two Screws in order of (1) and (2) shown in the figure.

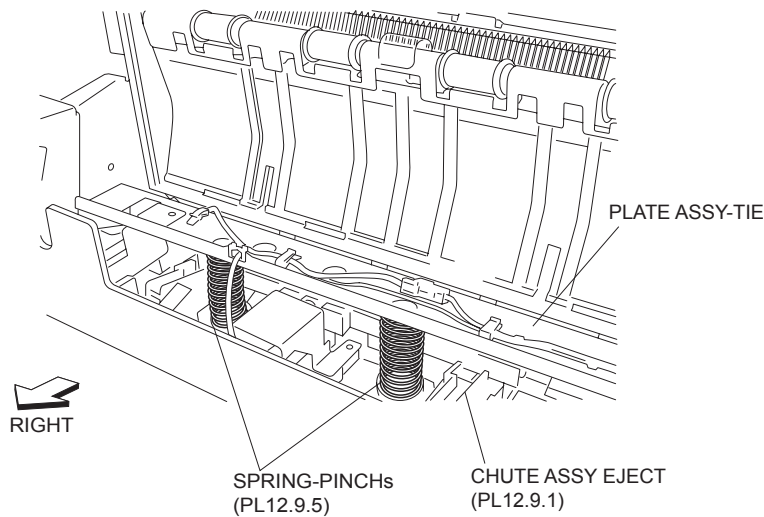
7. Install the Entrance Knob Assembly to the Paddle Shaft Assembly on the front.
8. Tighten the setScrew to secure the Entrance Knob Assembly to the Paddle Shaft Assembly.
9. Install the Upper Rear Cover (PL 12.4.11) .
10. Close the Front Cover Assembly.

## Eject Clamp Bracket Assembly



## Removal

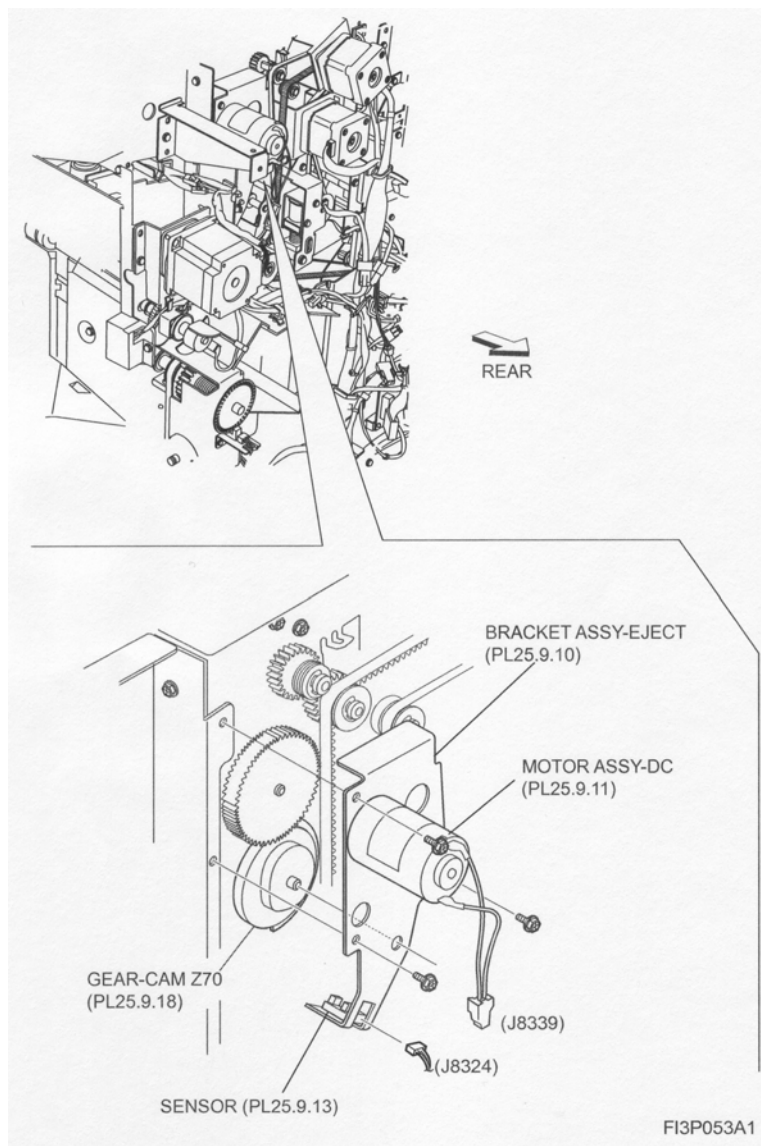
1. Remove the Upper Rear Cover (PL 12.4.11) .
2. Remove the SCT Tray Assembly (PL 12.4.3) .
3. Remove the two Pinch Springs (PL 12.9.5) attached to the Eject Chute Assembly (PL 12.9.1) while pushing them downward .



**Figure 1 Pinch Springs**

4. Disconnect the harness connector (J8339) of the DC Motor Assembly (PL 12.9.11) from the connector of the Main Drive Harness Assembly (PL 12.15.2) .
5. Disconnect the connector (J8324) of the Main Sensor Harness Assembly (PL 12.15.1) from the Sensor (PL 12.9.13).
6. Remove the three Screws (+M3 x 5) securing the Eject Clamp Bracket Assembly to the Finisher.
7. Remove the Eject Clamp Bracket Assembly.

**NOTE** When removing the Eject Clamp Bracket Assembly, rotate the Z70 Cam Gear (PL 12.9.18) with finger so that the actuator on the Eject Clamp Bracket Assembly is retracted from the recess of the sensor.



**Figure 2 Eject Bracket Assembly**

## Replacement

1. Secure the Eject Clamp Bracket Assembly to the Finisher using three Screws (+M3 x 5).

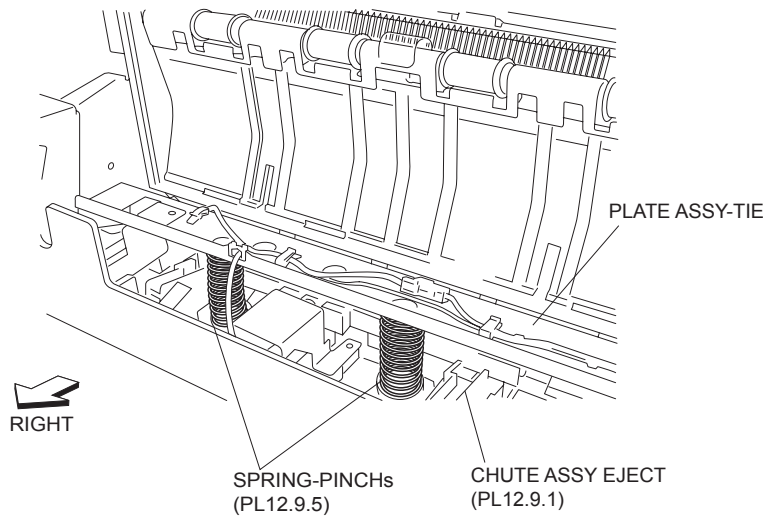
**NOTE** When installing the Eject Clamp Bracket Assembly, rotate the Z70 Cam Gear (PL 12.9.18) with finger so that the actuator on the Eject Clamp Bracket Assembly is retracted from the recess of the sensor.

2. Connect the connector (J8324) of the Main Sensor Harness Assembly (PL 12.15.1) to the Sensor (PL 12.9.13).
3. Connect the connector of the Main Drive Harness Assembly (PL 12.15.2) to the harness connector (J8339) of the DC Motor Assembly (PL 12.9.11).
4. Install the two Pinch Springs (PL 12.9.5) between the Eject Chute Assembly and the Tie Plate Assembly while pushing them downward.
5. Install the SCT Tray Assembly (PL 12.4.3) .
6. Install the Upper Rear Cover (PL 12.4.11) .

## DC Motor Assembly (Eject Clamp Motor)

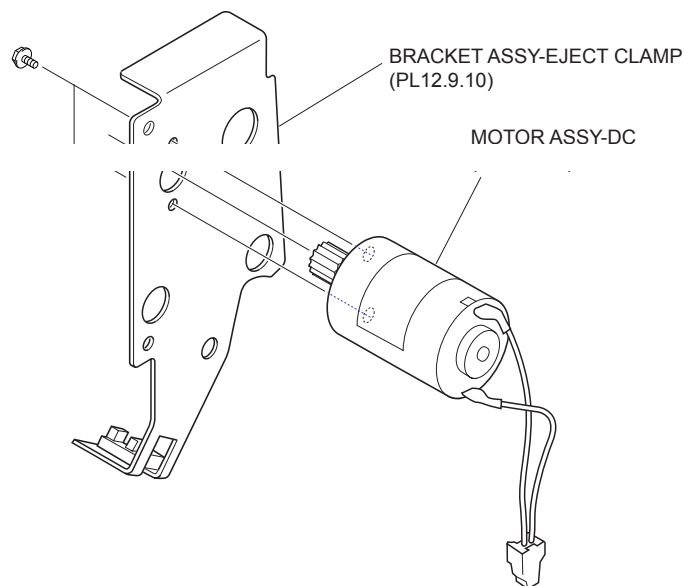
### Removal

1. Remove the Upper Rear Cover (PL 12.4.11) .
2. Remove the SCT Tray Assembly (PL 12.4.3) .
3. Remove the two Pinch Springs (PL 12.9.5) attached on the Eject Chute Assembly (PL 12.9.1) while pushing them downward .



**Figure 1 Pinch Springs**

4. Remove the Eject Clamp Bracket Assembly (PL 12.9.10) .
5. Remove the two Screws securing the DC Motor Assembly to the Eject Clamp Bracket Assembly .
6. Remove the DC Motor Assembly.



**Figure 2 Eject Clamp Bracket Assembly**

## Replacement

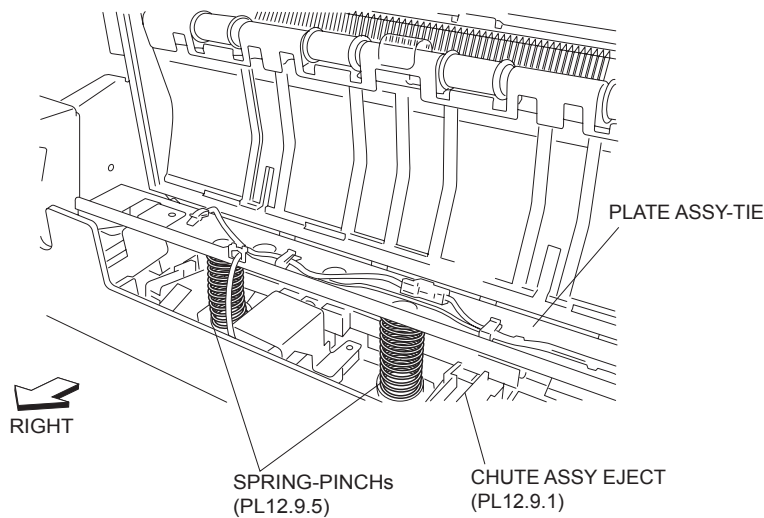
1. Install the DC Motor Assembly to the Eject Clamp Bracket Assembly (PL 12.9.10) using two Screws.
2. Install the Eject Clamp Bracket Assembly .

3. Install the two Pinch Springs between the Eject Chute Assembly (PL 12.9.1) and Tie Plate Assembly while pushing them downward.
4. Install the SCT Tray Assembly (PL 12.4.3) .
5. Install the Upper Rear Cover (PL 12.4.11) .

## Sensor (Eject Clamp Home Sensor)

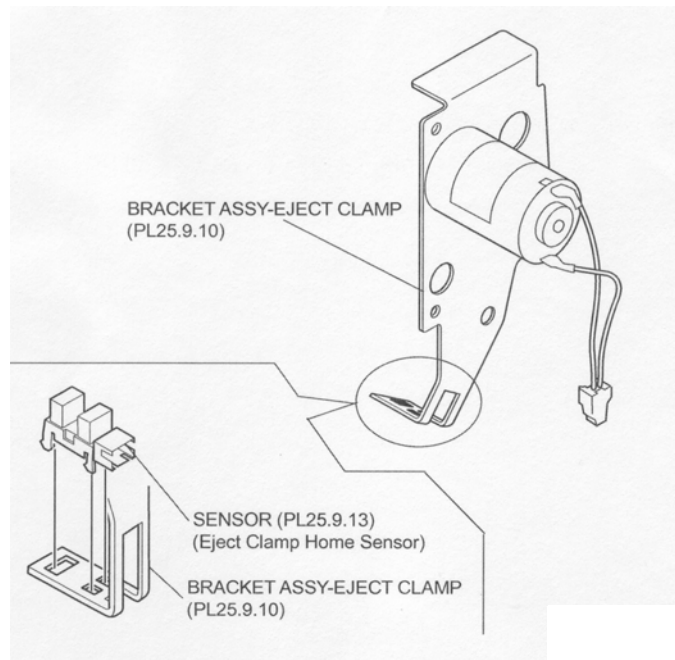
### Removal

1. Remove the Upper Rear Cover (PL 12.4.11) .
2. Remove the SCT Tray Assembly (PL 12.4.3) .
3. Remove the two Pinch Springs (PL 12.9.5) attached on the Eject Chute Assembly (PL 12.9.1) while pushing them downward .



**Figure 1 Pinch Springs**

4. Remove the Eject Clamp Bracket Assembly (PL 12.9.10) .
5. Release the hooks of the Sensor to remove the Sensor from the Eject Clamp Bracket Assembly .



**Figure 2 Eject Clamp Bracket Assembly**

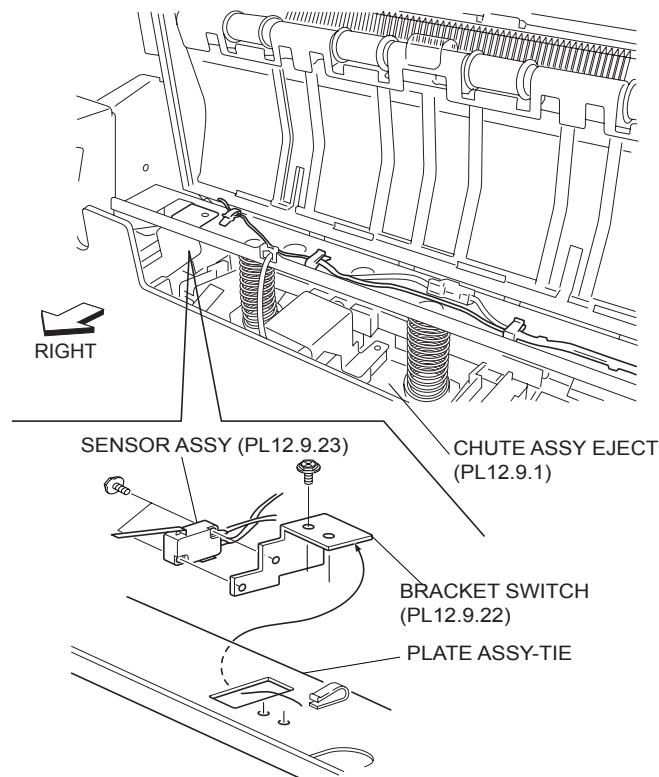
## Replacement

1. Secure the Sensor to the Eject Clamp Bracket Assembly (PL 12.9.10) using the hooks.
2. Install the Eject Clamp Bracket Assembly .
3. Install the two Pinch Springs between the Eject Chute Assembly (PL 12.9.1) and Tie Plate Assembly while pushing them downward.
4. Install the SCT Tray Assembly (PL 12.4.3) .
5. Install the Upper Rear Cover (PL 12.4.11) .

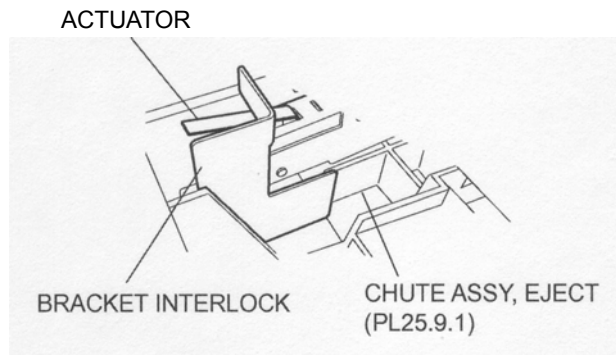
## Sensor Assembly (Eject Cover Switch)

### Removal

1. Remove the SCT Tray Assembly (PL 12.4.3) .
2. Disconnect the harness connector (J8364) of the Sensor Assembly from the connector of the Interlock Harness Assembly (PL 12.15.11) .
3. Release the harness of the Sensor Assembly from the two clamps.
4. Remove the one Screw (TP M 3 x 6) securing the Switch Bracket (PL 12.9.22) to the Tie Plate Assembly.
5. Remove the Switch Bracket attached with the Sensor Assembly from the square hole on the Tie Plate Assembly.
6. Remove the two Screws (TP M 3 x 12) securing the Sensor Assembly to the Switch Bracket.
7. Remove the Sensor Assembly from the Switch Bracket .



**Figure 1 Interlock Harness Assembly**



**Figure 2 Sensor Assembly**

## Replacement

1. Install the Sensor Assembly to the Switch Bracket (PL 12.9.22) using two Screws (TP M 3 x 12).
2. Install the Switch Bracket attached with the Sensor Assembly through the square hole on the Tie Plate Assembly.

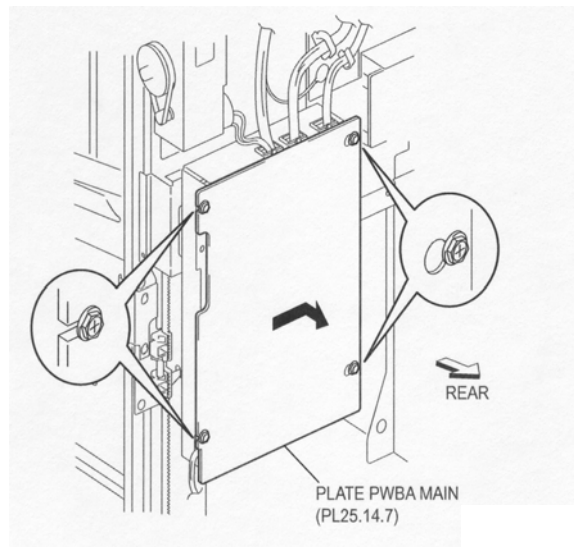
**NOTE** When installing, be sure to install the Sensor Assembly so that the actuator of the Sensor Assembly is placed under the Interlock Bracket on the Eject Chute Assembly.

3. Install the Switch Bracket to the Tie Plate Assembly using one Screw (TP M 3 x 6).
4. Connect the harness connector (J8364) of the Sensor Assembly to the connector of the Interlock Harness Assembly (PL 12.15.11).
5. Secure the harness of the Sensor Assembly with the two clamps.
6. Install the SCT Tray Assembly (PL 12.4.3) .

# Compiler Tray Assembly

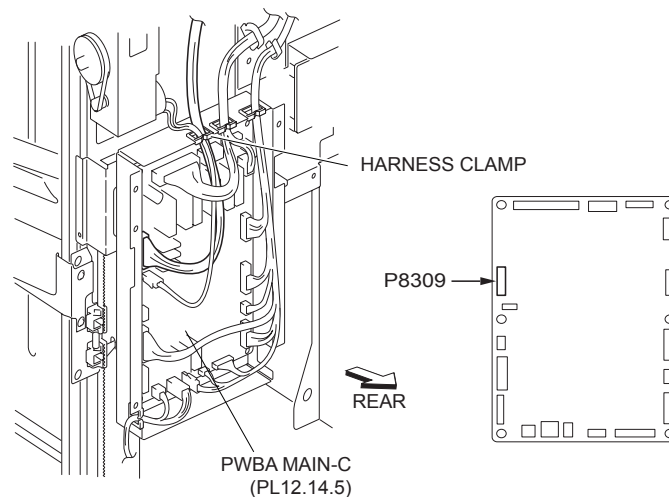
## Removal

1. Remove the Front Cover Assembly (PL 12.5.3) .
2. Remove the Upper Rear Cover (PL 12.4.11) .
3. Remove the Lower Rear Cover (PL 12.4.9) .
4. Remove the SCT Tray Assembly (PL 12.4.3) .
5. Remove the Eject Cover (PL 12.4.4) .
6. Remove the Stapler Unit (PL 12.8.14) .
7. Remove the Eject Clamp Bracket Assembly (PL 12.9.10) .
8. Remove the Eject Unit Chute Assembly (PL 12.9.27) .
9. Remove the Eject Bracket Assembly (PL 12.10.17) .
10. Loosen the four Screws securing the Main Plate PWBA (PL 12.14.7), and move it in the direction of the arrow to remove the Main Plate PWBA .



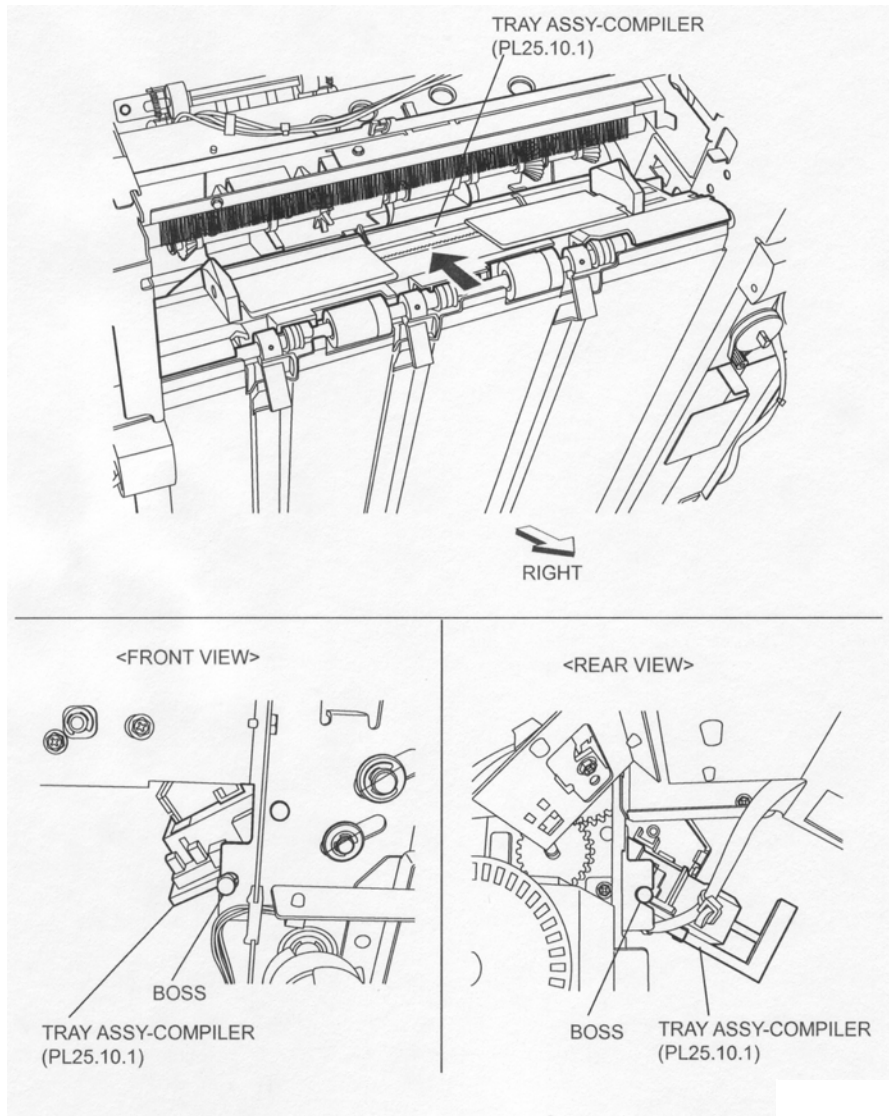
**Figure 1 Main Plate PWBA**

11. Disconnect the connector of the Compiler Harness Assembly (PL 12.10.8) from the connector (P8309) on the Main-C PWBA (PL 12.14.5) .



**Figure 2 Main C PWBA**

12. Release the Compiler Harness Assembly from the harness clamp.
13. Release the locks of the Compiler Tray Assembly by pushing the bosses on the front and rear toward the inside of the Finisher, and remove the Compiler Tray Assembly in the direction of the arrow .



**Figure 3 Compiler Tray Assembly**

## Replacement

1. Put the Compiler Tray Assembly into the Finisher from its front, move it in the opposite direction of the arrow and secure it to the frame with the bosses on the front and rear.
2. Connect the connector of the Compiler Harness Assembly (PL 12.10.8) to the connector (P8309) on the Main-C PWBA (PL 12.14.5).
3. Secure the Compiler Harness Assembly using the harness clamp.
4. Install the Main Plate PWBA (PL 12.14.7) by moving it in the opposite direction of the arrow, and secure it using four Screws.
5. Install the Eject Bracket Assembly (PL 12.10.17) .
6. Install the Eject Unit Chute Assembly (PL 12.9.27) .
7. Install the Eject Clamp Bracket Assembly (PL 12.9.10) .
8. Install the Stapler Unit (PL 12.8.14) .
9. Install the Eject Cover (PL 12.4.4) .



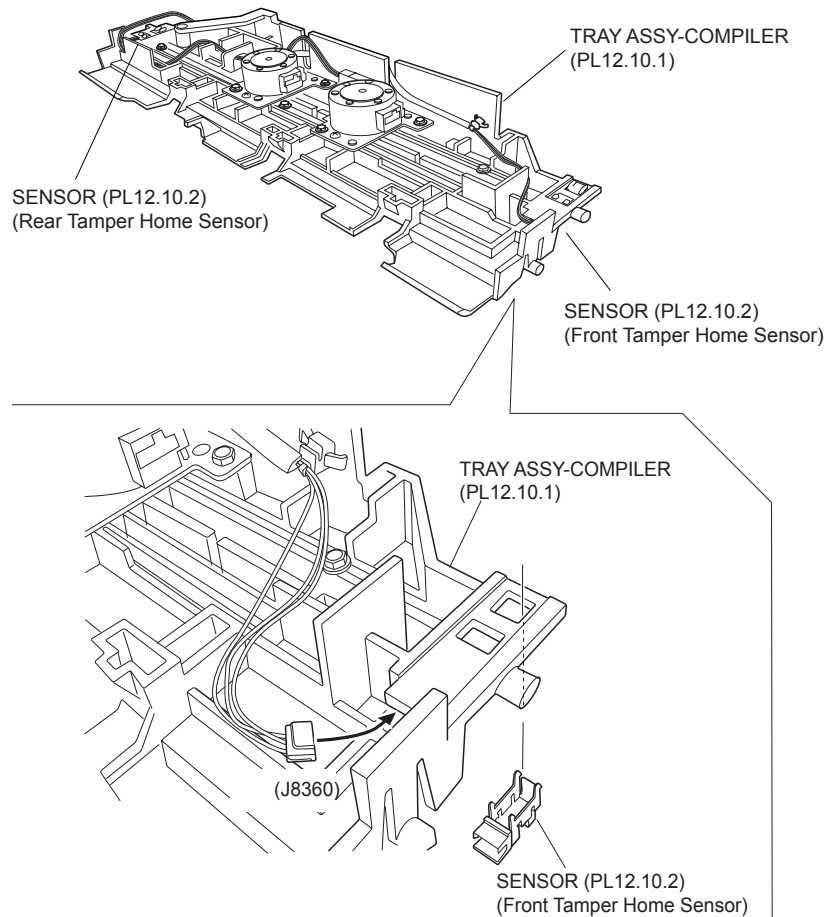
10. Install the SCT Tray Assembly (PL 12.4.3) .
11. Install the Lower Rear Cover (PL 12.4.9) .
12. Install the Upper Rear Cover (PL 12.4.11) .
13. Install the Front Cover Assembly (PL 12.5.3) .

## Front Tamper Home Sensor & Rear Tamper Home Sensor

**NOTE** The removal and replacement procedures for two Sensors (Front Tamper Home Sensor and Rear Tamper Home Sensor) are the same. The removal and replacement procedures for the Front Tamper Home Sensor are described here.

### Removal

1. Remove the Front Cover Assembly (PL 12.5.3) .
2. Remove the Upper Rear Cover (PL 12.4.11) .
3. Remove the Lower Rear Cover (PL 12.4.9) .
4. Remove the SCT Tray Assembly (PL 12.4.3) .
5. Remove the Eject Cover (PL 12.4.4) .
6. Remove the Stapler Unit (PL 12.8.14) .
7. Remove the Eject Clamp Bracket Assembly (PL 12.9.10) .
8. Remove the Eject Unit Chute Assembly (PL 12.9.27) .
9. Remove the Eject Bracket Assembly (PL 12.10.17) .
10. Remove the Compiler Tray Assembly (PL 12.10.1) .
11. Disconnect the connector (J8360) of the Compiler Harness Assembly (PL 12.10.8) from the Sensor (Front Tamper Home Sensor) .



**Figure 1 Front & Rear Tamper Sensor**

**NOTE For the Rear Tamper Home Sensor, disconnect the connector (J8361) of the Compiler Harness Assembly.**

12. Release the hooks of the Sensor to remove the Sensor from the Compiler Tray Assembly.

## Replacement

1. Secure the Sensor (Front Tamper Home Sensor) to the Compiler Tray Assembly (PL 12.10.1) with the hooks.
2. Connect the connector (J8360) of the Compiler Harness Assembly (PL 12.10.8) to the Sensor.

**NOTE For the Rear Tamper Home Sensor, connect the connector (J8361) of the Compiler Harness Assembly.**

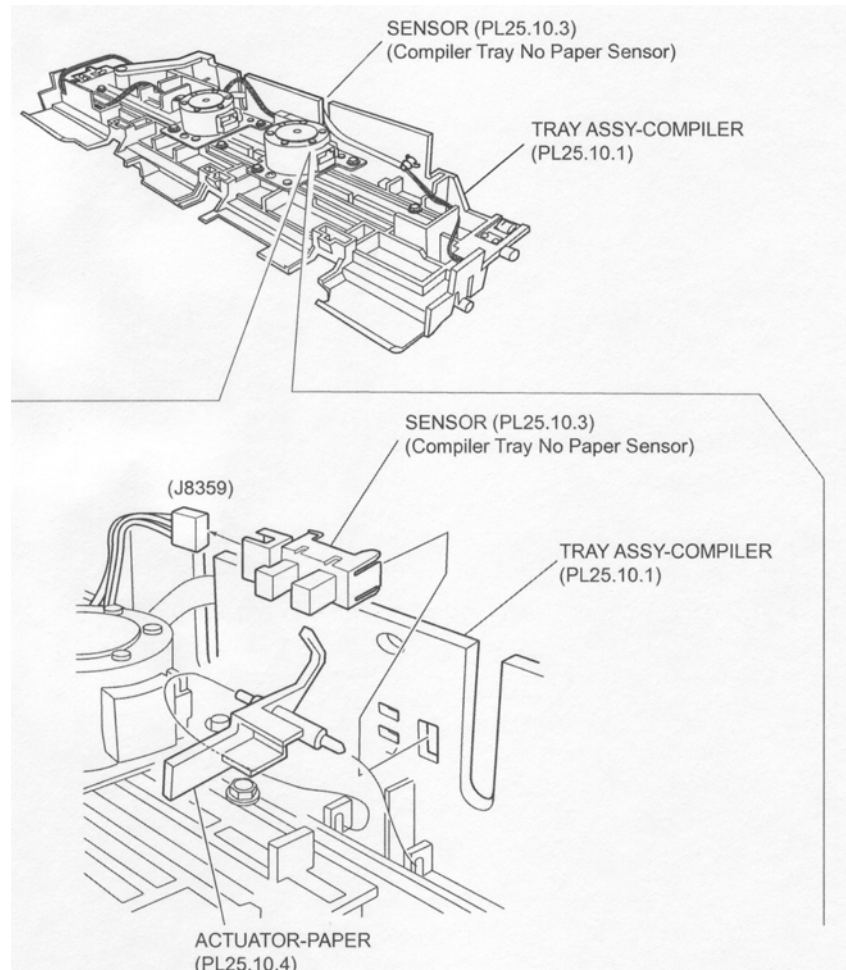
3. Install the Compiler Tray Assembly .
4. Install the Eject Bracket Assembly (PL 12.10.17) .
5. Install the Eject Unit Chute Assembly (PL 12.9.27) .
6. Install the Eject Clamp Bracket Assembly (PL 12.9.10) .
7. Install the Stapler Unit (PL 12.8.14) .
8. Install the Eject Cover (PL 12.4.4) .
9. Install the SCT Tray Assembly (PL 12.4.3) .
10. Install the Lower Rear Cover (PL 12.4.9) .

11. Install the Upper Rear Cover (PL 12.4.11) .
12. Install the Front Cover Assembly (PL 12.5.3) .

## Compiler Tray No Paper Sensor & Paper Actuator Sensor

### Removal

1. Remove the Front Cover Assembly (PL 12.5.3) .
2. Remove the Upper Rear Cover (PL 12.4.11) .
3. Remove the Lower Rear Cover (PL 12.4.9) .
4. Remove the SCT Tray Assembly (PL 12.4.3) .
5. Remove the Eject Cover (PL 12.4.4) .
6. Remove the Stapler Unit (PL 12.8.14) .
7. Remove the Eject Clamp Bracket Assembly (PL 12.9.10) .
8. Remove the Eject Unit Chute Assembly (PL 12.9.27) .
9. Remove the Eject Bracket Assembly (PL 12.10.17) .
10. Remove the Compiler Tray Assembly (PL 12.10.1) .
11. Disconnect the connector (J8359) of the Compiler Harness Assembly (PL 12.10.8) from the Sensor (Compiler Tray No Paper Sensor) .
12. Release the hooks of the Sensor to remove the Sensor from the Compiler Tray Assembly.
13. Move the Paper Actuator in the direction of the arrow to remove the Paper Actuator.



**Figure 1 No Paper Sensor Compiler Tray**

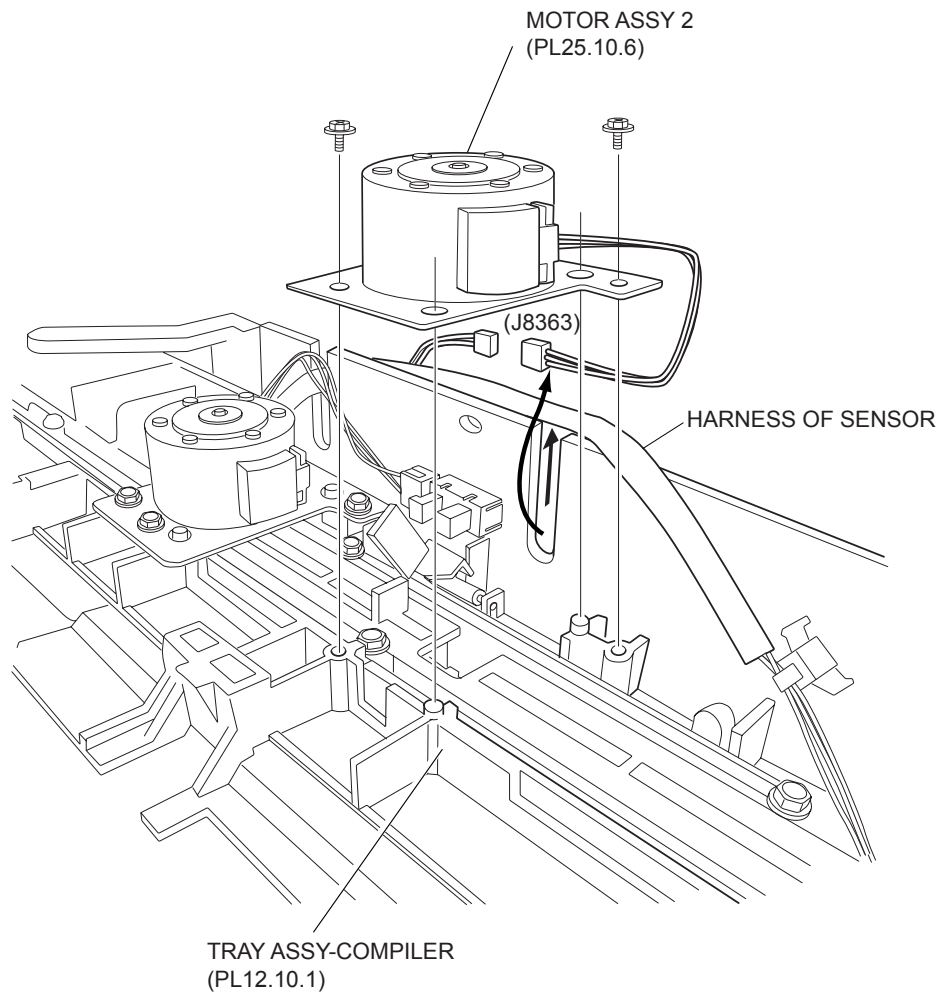
## Replacement

1. Install the Paper Actuator to the Compiler Tray Assembly (PL 12.10.1) by moving it in the opposite direction of the arrow.
2. Secure the Sensor (Compiler Tray No Paper Sensor) to the Compiler Tray Assembly with the hooks.
3. Connect the connector (J8359) of the Compiler Harness Assembly (PL 12.10.8) to the Sensor.
4. Install the Compiler Tray Assembly .
5. Install the Eject Bracket Assembly (PL 12.10.17) .
6. Install the Eject Unit Chute Assembly (PL 12.9.27) .
7. Install the Eject Clamp Bracket Assembly (PL 12.9.10) .
8. Install the Stapler Unit (PL 12.8.14) .
9. Install the Eject Cover (PL 12.4.4) .
10. Install the SCT Tray Assembly (PL 12.4.3) .
11. Install the Lower Rear Cover (PL 12.4.9) .
12. Install the Upper Rear Cover (PL 12.4.11) .
13. Install the Front Cover Assembly (PL 12.5.3) .

## Motor Assembly 2 (Front Tamper Motor)

### Removal

1. Remove the Front Cover Assembly (PL 12.5.3) .
2. Remove the Upper Rear Cover (PL 12.4.11) .
3. Remove the Lower Rear Cover (PL 12.4.9) .
4. Remove the SCT Tray Assembly (PL 12.4.3) .
5. Remove the Eject Cover (PL 12.4.4) .
6. Remove the Stapler Unit (PL 12.8.14) .
7. Remove the Eject Clamp Bracket Assembly (PL 12.9.10) .
8. Remove the Eject Unit Chute Assembly (PL 12.9.27) .
9. Remove the Eject Bracket Assembly (PL 12.10.17) .
10. Remove the Compiler Tray Assembly (PL 12.10.1) .
11. Pull out the tube put on the harness of the Sensor (Front Tamper Home Sensor) in the direction of the arrow .
12. Disconnect the connector of the Compiler Harness Assembly (PL 12.10.8) from the harness connector (J8363) of the Motor Assembly 2 (Front Tamper Motor).
13. Remove the two Screws securing the Motor Assembly 2 to the Compiler Tray Assembly to remove the Motor Assembly 2.



**Figure 1 Front Tamper Motor**

## Replacement

1. Install the Motor Assembly 2 (Front Tamper Motor) to the Compiler Tray Assembly (PL 12.10.1) using two Screws.

**NOTE** Be sure to install the Motor Assembly in the direction shown in the figure.

2. Connect the connector of the Compiler Harness Assembly (PL 12.10.8) to the harness connector (J8363) of the Motor Assembly 2.
3. Push the connected connector in the opposite direction of the arrow.
4. Push in the tube put on the harness of the Sensor (Front Tamper Home Sensor) in the opposite direction of the arrow to press the harness connector of the Motor Assembly 2.
5. Install the Compiler Tray Assembly .
6. Install the Eject Bracket Assembly (PL 12.10.17) .
7. Install the Eject Unit Chute Assembly (PL 12.9.27) .
8. Install the Eject Clamp Bracket Assembly (PL 12.9.10) .
9. Install the Stapler Unit (PL 12.8.14) .
10. Install the Eject Cover (PL 12.4.4) .
11. Install the SCT Tray Assembly (PL 12.4.3) .
12. Install the Lower Rear Cover (PL 12.4.9) .
13. Install the Upper Rear Cover (PL 12.4.11) .
14. Install the Front Cover Assembly (PL 12.5.3) .

# Motor Assembly (Rear Tamper Motor)

## Removal

1. Remove the Front Cover Assembly (PL 12.5.3) .
2. Remove the Upper Rear Cover (PL 12.4.11) .
3. Remove the Lower Rear Cover (PL 12.4.9) .
4. Remove the SCT Tray Assembly (PL 12.4.3) .
5. Remove the Eject Cover (PL 12.4.4) .
6. Remove the Stapler Unit (PL 12.8.14) .
7. Remove the Eject Clamp Bracket Assembly (PL 12.9.10) .
8. Remove the Eject Unit Chute Assembly (PL 12.9.27) .
9. Remove the Eject Bracket Assembly (PL 12.10.17) .
10. Remove the Compiler Tray Assembly (PL 12.10.1) .
11. Remove the harness connector of the Motor Assembly (Rear Tamper Motor) from underneath the rib of the Compiler Tray Assembly .
12. Disconnect the connector of the Compiler Harness Assembly (PL 12.10.8) from the harness connector (J8362) of the Motor Assembly.
13. Remove the two Screws securing the Motor Assembly to the Compiler Tray Assembly to remove the Motor Assembly.

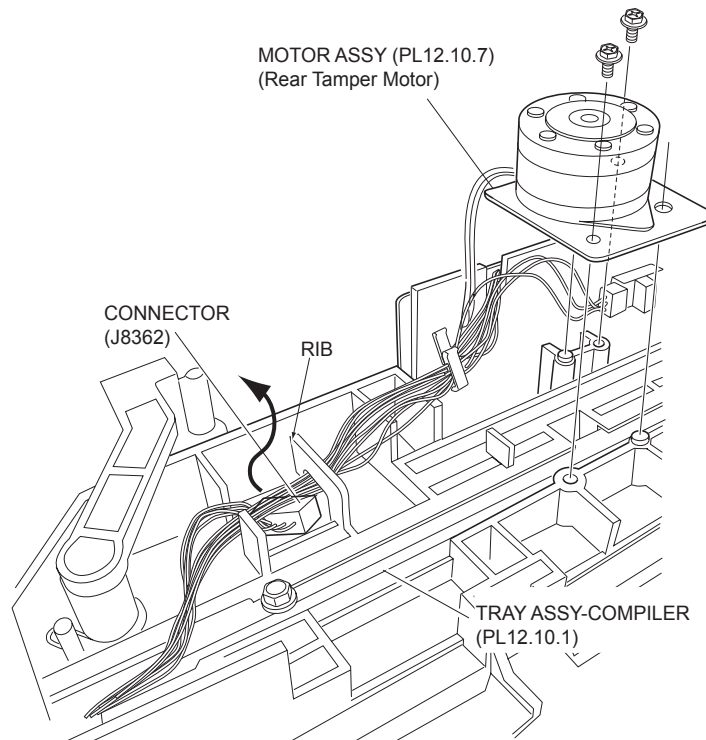


Figure 1 Rear Tamper Motor

## Replacement

1. Install the Motor Assembly (Rear Tamper Motor) to the Compiler Tray Assembly using two Screws.

**NOTE** Be sure to install the Motor Assembly in the direction shown in the figure.

2. Connect the connector of the Compiler Harness Assembly (PL 12.10.8) to the harness connector (J8362) of the Motor Assembly.

3. Put the connected connector underneath the rib of the Compiler Tray Assembly.
4. Install the Compiler Tray Assembly .
5. Install the Eject Bracket Assembly (PL 12.10.17) .
6. Install the Eject Unit Chute Assembly (PL 12.9.27) .
7. Install the Eject Clamp Bracket Assembly (PL 12.9.10) .
8. Install the Stapler Unit (PL 12.8.14) .
9. Install the Eject Cover (PL 12.4.4) .
10. Install the SCT Tray Assembly (PL 12.4.3) .
11. Install the Lower Rear Cover (PL 12.4.9) .
12. Install the Upper Rear Cover (PL 12.4.11) .
13. Install the Front Cover Assembly (PL 12.5.3) .

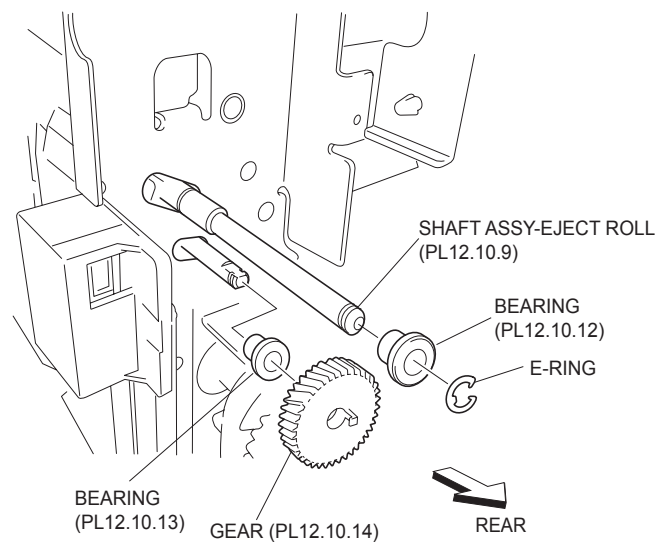
## Eject Roll Shaft Assembly

### Removal

1. Remove the Front Cover Assembly (PL 12.5.3) .
2. Remove the Upper Rear Cover (PL 12.4.11) .
3. Move the Document Pulley Clutch (PL 12.6.19) on the rear side of the Finisher in the direction of the arrow by hand to move the Stacker Tray Assembly (PL 12.4.5) to its lowest position.

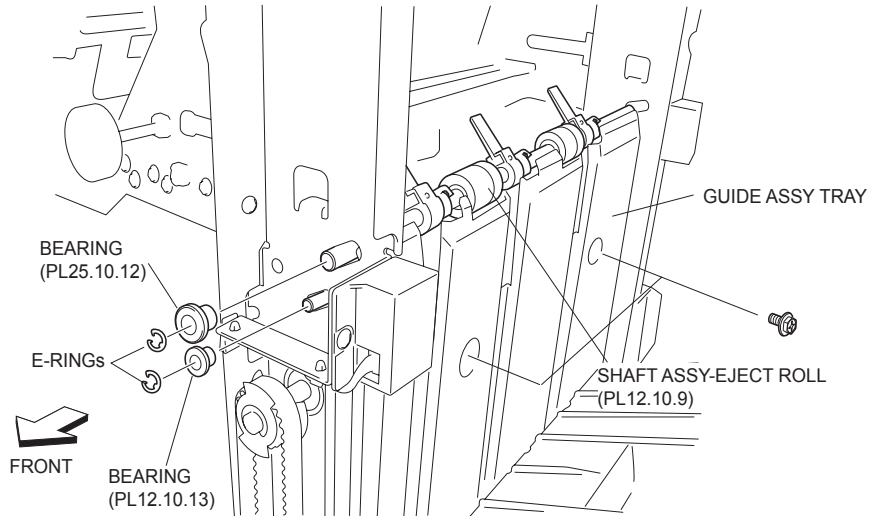
**NOTE** At this time, be sure not to touch the Encoder (PL 12.6.23).

4. Remove the Stacker Tray Assembly .
5. Remove the four Screws securing the Guide Assembly TRAY, and shift the Guide Assembly TRAY a little downward.
6. Remove the Eject Bracket Assembly (PL 12.10.17) .
7. Release the hook of the Gear (PL 12.10.14) on the rear to remove the Gear from the shaft.
8. Remove the Bearing (PL 12.10.13) .
9. Remove the E-ring on the rear.
10. Remove the Bearing (PL 12.10.12).

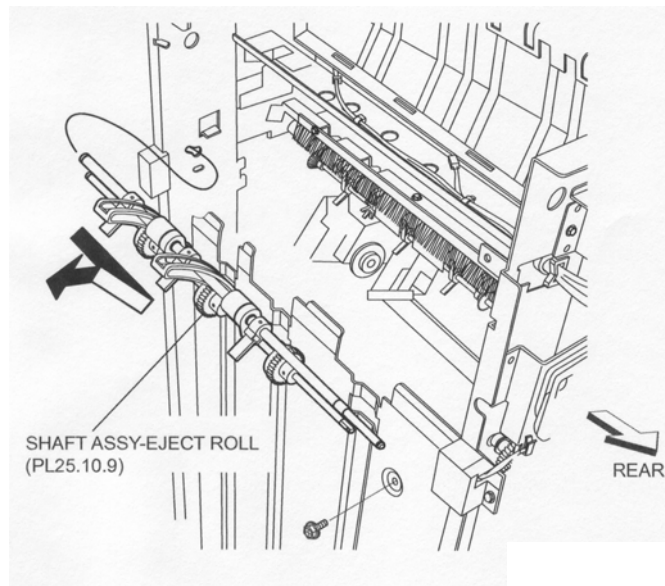


**Figure 1 Bearing**

11. Remove the two E-rings on the front securing the Eject Roll Shaft Assembly .
12. Remove the two Bearings (PL 12.10.12 and PL 12.10.13).
13. Move the Eject Roll Shaft Assembly to the rear first to remove the front end of the two shafts from the two holes on the frame, and move the Eject Roll Shaft Assembly in the direction of the arrow to remove the two shafts from the rear holes. Then, remove the Eject Roll Shaft Assembly from the Finisher .



**Figure 2 Eject Roll Shaft Assembly**



**Figure 3 Eject Roll Shaft Assembly**

## Replacement

1. Move the Eject Roll Shaft Assembly in the opposite direction of the arrow to install it to the Finisher.
2. Install the two Bearings (PL 12.10.12 and PL 12.10.13) to the two shafts on the front.
3. Secure the Bearings using two E-rings.
4. Install the two Bearings (PL 12.10.12 and PL 12.10.13) to the two shafts on the rear.



5. Secure the Bearing (PL 12.10.12) using the E-ring.
6. Install the Gear (PL 12.10.14) and secure it using the hook.
7. Install the Eject Bracket Assembly (PL 12.10.17) .
8. Install the Guide Assembly TRAY using the four Screws.
9. Install the Stacker Tray Assembly .
10. Install the Upper Rear Cover (PL 12.4.11) .
11. Install the Front Cover Assembly (PL 12.5.3) .

## Paddle-set Clamp

### Removal

1. Remove the Front Cover Assembly (PL 12.5.3) .
2. Remove the Upper Rear Cover (PL 12.4.11) .
3. Remove the Eject Roll Shaft Assembly (PL 12.10.9) .
4. Remove the Paddle-set Clamp from the Paddle Holder by hand .

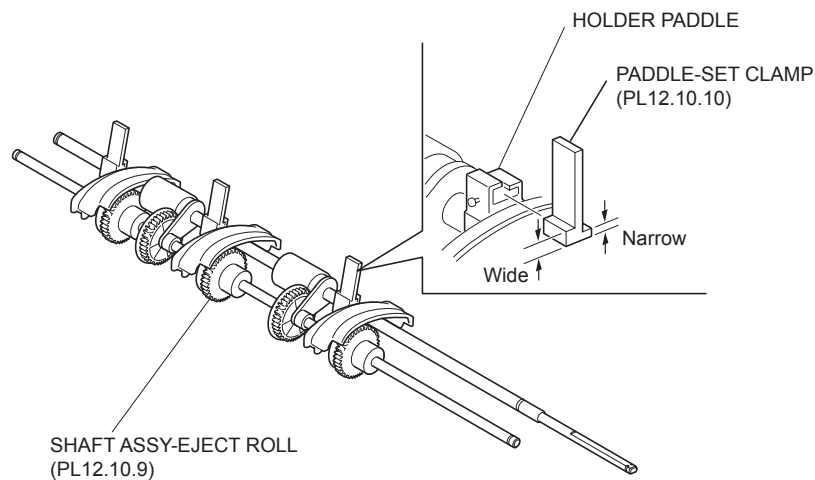


Figure 1 Paddle Set Clamp

### Replacement

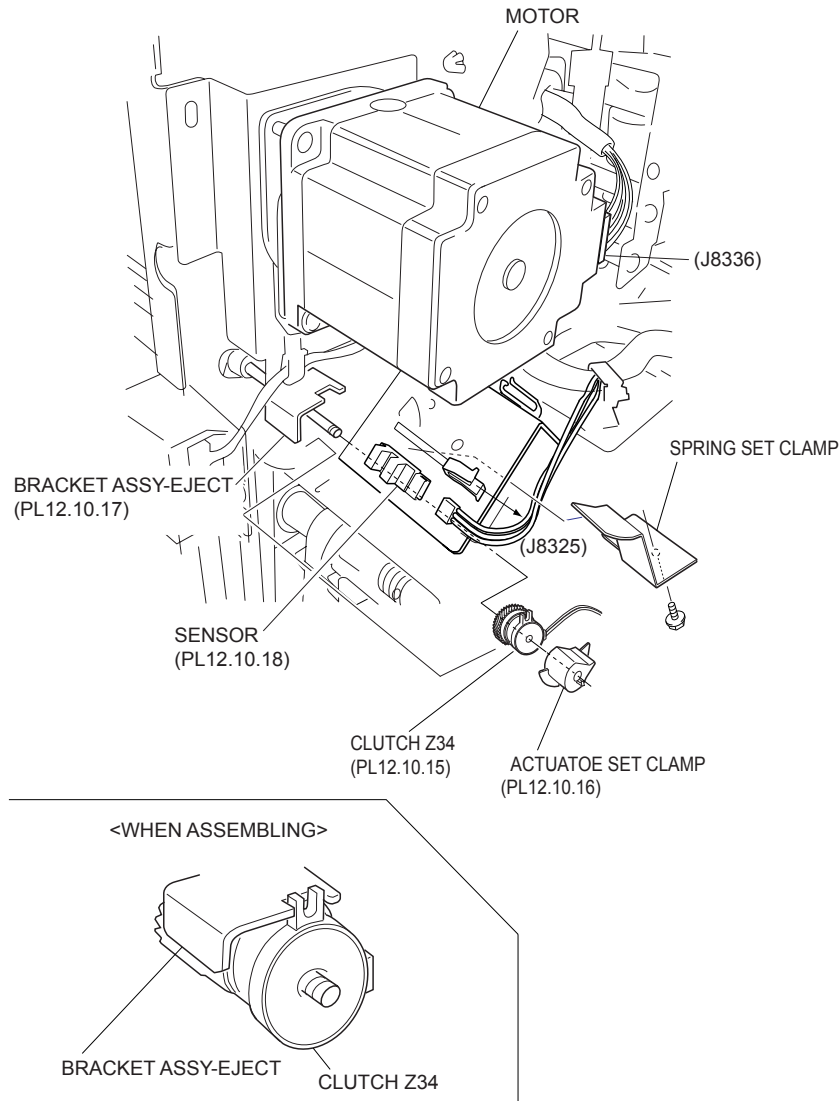
1. Install the Paddle-set Clamp to the Paddle Holder in the direction shown in the figure.
2. Install the Eject Roll Shaft Assembly (PL 12.10.9) .
3. Install the Upper Rear Cover (PL 12.4.11) .
4. Install the Front Cover Assembly (PL 12.5.3) .

## Z34 Clutch

### Removal

1. Remove the Upper Rear Cover (PL 12.4.11) .
2. Disconnect the connector (J8336) of the Main Drive Harness Assembly (PL 12.15.2) from the Motor on the Eject Bracket Assembly (PL 12.10.17).
3. Disconnect the connector (J8325) of the Main Sensor Harness Assembly (PL 12.15.1) from the Sensor (PL 12.10.18) on the Eject Bracket Assembly .
4. Release the harness from the clamp.

5. Disconnect the harness connector of the Z34 Clutch from the connector (J8338) of the Main Drive Harness Assembly.
6. Release the harness from the clamp.
7. Remove the Set Clamp Actuator (PL 12.10.16) from the shaft by releasing the hook.
8. Remove the Screw securing the Set Clamp Spring to remove the Set Clamp Spring.
9. Remove the Z34 Clutch.



**Figure 1 Z34 Clutch**

## Replacement

1. Install the Z34 Clutch to the shaft.

**NOTE** Fit the notch of the Z34 Clutch into the dented portion of the Eject Bracket Assembly (PL 12.10.17).

2. Put the tip of the Set Clamp Spring into the square hole on the Eject Bracket Assembly, and fix it using one Screw from the backside of the Eject Bracket Assembly.
3. Install the Set Clamp Actuator (PL 12.10.16) to the shaft, and secure it with the hook.
4. Connect the harness connector (J8338) of the Z34 Clutch to the Main Drive Harness Assembly (PL 12.15.2).

5. Connect the connector (J8325) of the Main Sensor Harness Assembly (PL 12.15.1) to the Sensor (PL 12.10.18).
6. Connect the connector (J8336) of the Main Drive Harness Assembly to Motor.
7. Secure the harness with the clamp.
8. Install the Upper Rear Cover (PL 12.4.11) .

## Eject Bracket Assembly

### Removal

1. Remove the Upper Rear Cover (PL 12.4.11) .
2. Remove the Z34 Clutch .
3. Remove the three Screws securing the Eject Bracket Assembly .

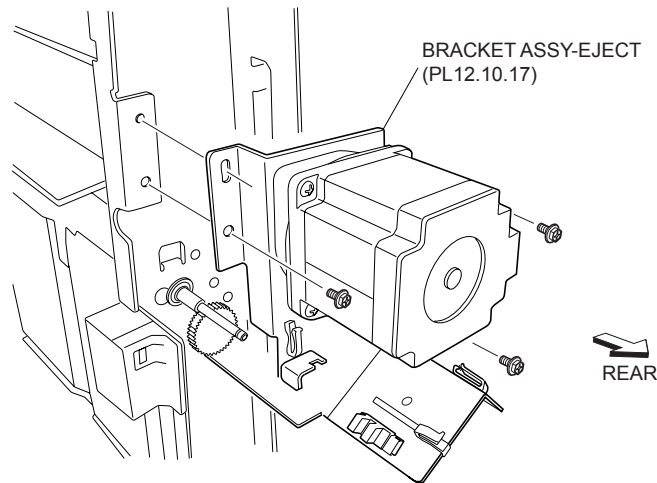


Figure 1 Eject Bracket Assembly

### Replacement

1. Install the Eject Bracket Assembly to the Finisher using three Screws.
2. Install the Z34 Clutch (PL 12.10.15) .

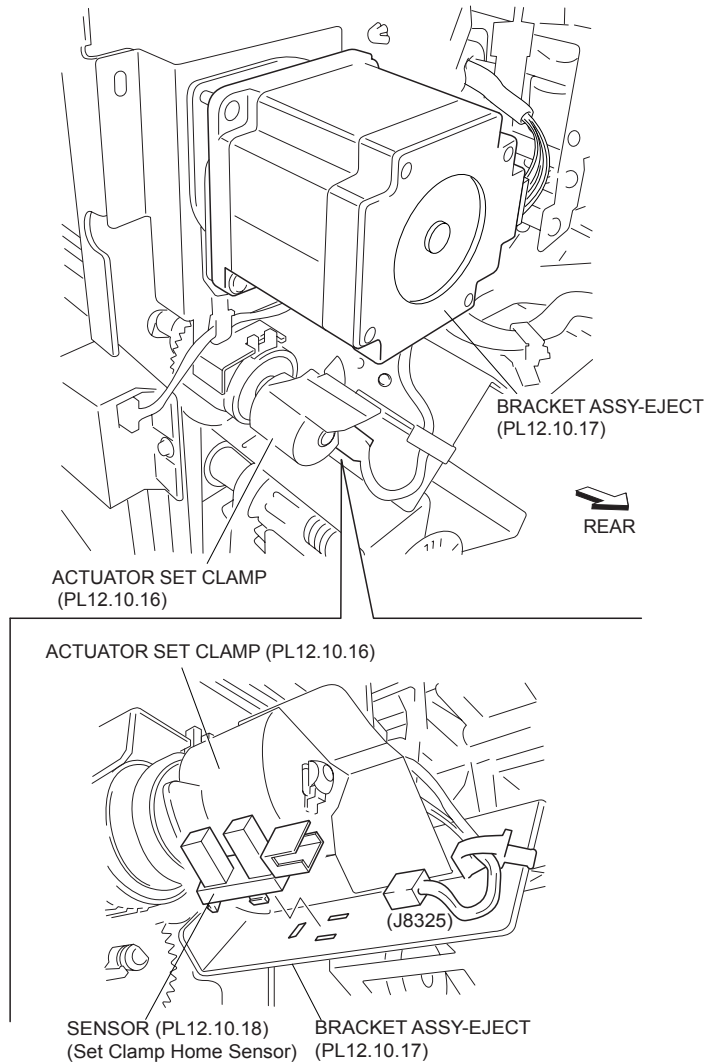
**NOTE** Put the notch of the Z34 Clutch into the dented portion of the Eject Bracket Assembly.

3. Install Upper Rear Cover (PL 12.4.11) .

## Set Clamp Home Sensor

### Removal

1. Remove the Upper Rear Cover (PL 12.4.11) .
2. Disconnect the connector (J8325) of the Main Sensor Harness Assembly (PL 12.15.1) from the Sensor (Set Clamp Home Sensor) .
3. Rotate the Set Clamp Actuator (PL 12.10.16) by hand so that the actuator of the Set Clamp Actuator is retracted from the recess of the sensor.
4. Release the hooks of the Sensor to remove it from the Eject Bracket Assembly (PL 12.10.17).



**Figure 1 Set Clamp Home Sensor**

## Replacement

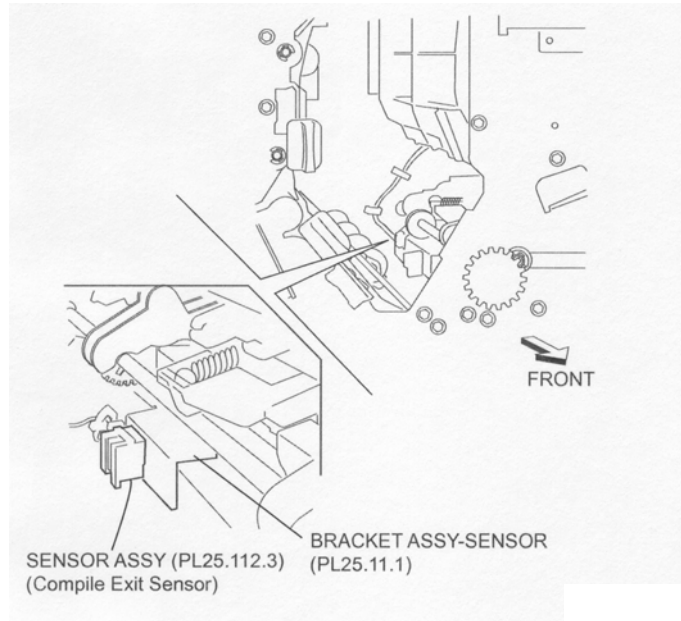
1. Secure the Sensor (Set Clamp Home Sensor) to the Eject Bracket Assembly (PL 12.10.17) using the hook.
2. Rotate the Set Clamp Actuator (PL 12.10.16) by hand and make sure that the actuator fits securely into the recess of the Sensor (Set Clamp Home Sensor).
3. Connect the connector (J8325) of the Main Sensor Harness Assembly (PL 12.15.1) to the Sensor.
4. Install the Upper Rear Cover (PL 12.4.11) .

## Sensor Assembly (Compile Exit Sensor)

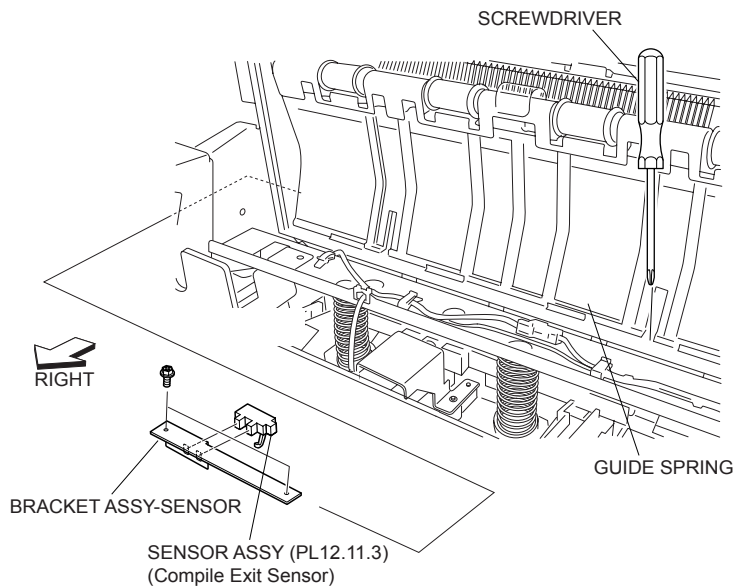
### Removal

1. Open the Front Cover Assembly (PL 12.5.3).
2. Remove the SCT Tray Assembly (PL 12.4.3) .
3. Release the harness clamp of the Compiler Sensor Harness Assembly (PL 12.11.2) from the front side of the Finisher, and disconnect the connector of the Compiler Sensor Harness Assembly from the Sensor Assembly (Compile Exit Sensor) .

4. Insert the Screwdriver into the space of the Guide Spring, and remove the two Screws securing the Sensor Bracket Assembly (PL 12.11.1) to the Finisher .
5. Remove the Sensor Bracket Assembly from the front side of the Finisher.
6. Remove the Sensor Assembly from the Sensor Bracket Assembly.



**Figure 1 Harness Assembly**



**Figure 2 Sensor Assembly**

## Replacement

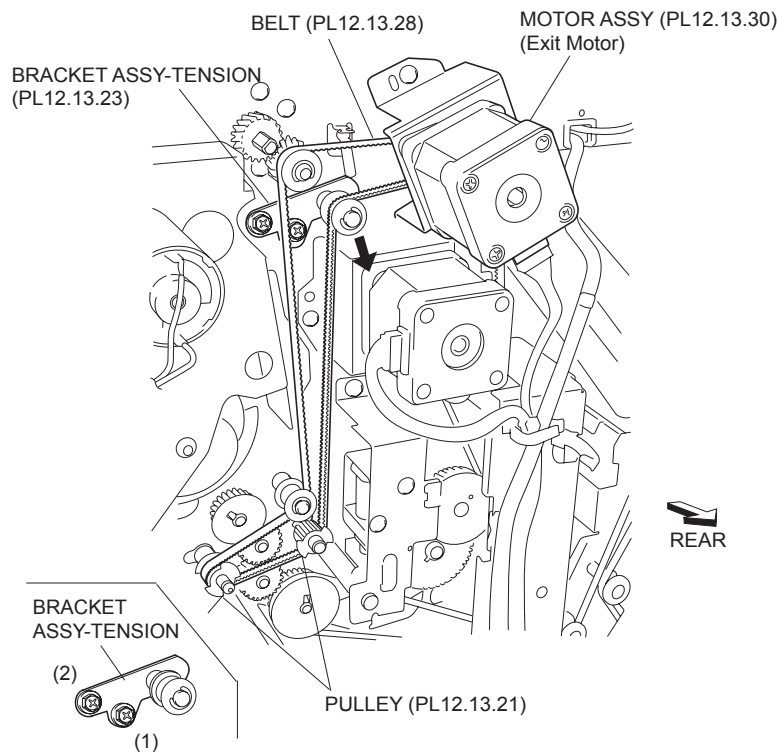
1. Secure the Sensor Assembly (Compile Exit Sensor) to the Sensor Bracket Assembly (PL 12.11.1).
2. Install the Sensor Bracket Assembly from the front side of the Finisher.
3. Insert the Screwdriver into the space of the Guide Spring, and fix the Sensor Bracket Assembly using two Screws to the Finisher.

4. Connect the connector of the Compiler Sensor Harness Assembly (PL 12.11.2) to the Sensor Assembly.
5. Install the SCT Tray Assembly (PL 12.4.3) .
6. Close the Front Cover Assembly (PL 12.5.3).

## Lower Exit Roll Assembly

### Removal

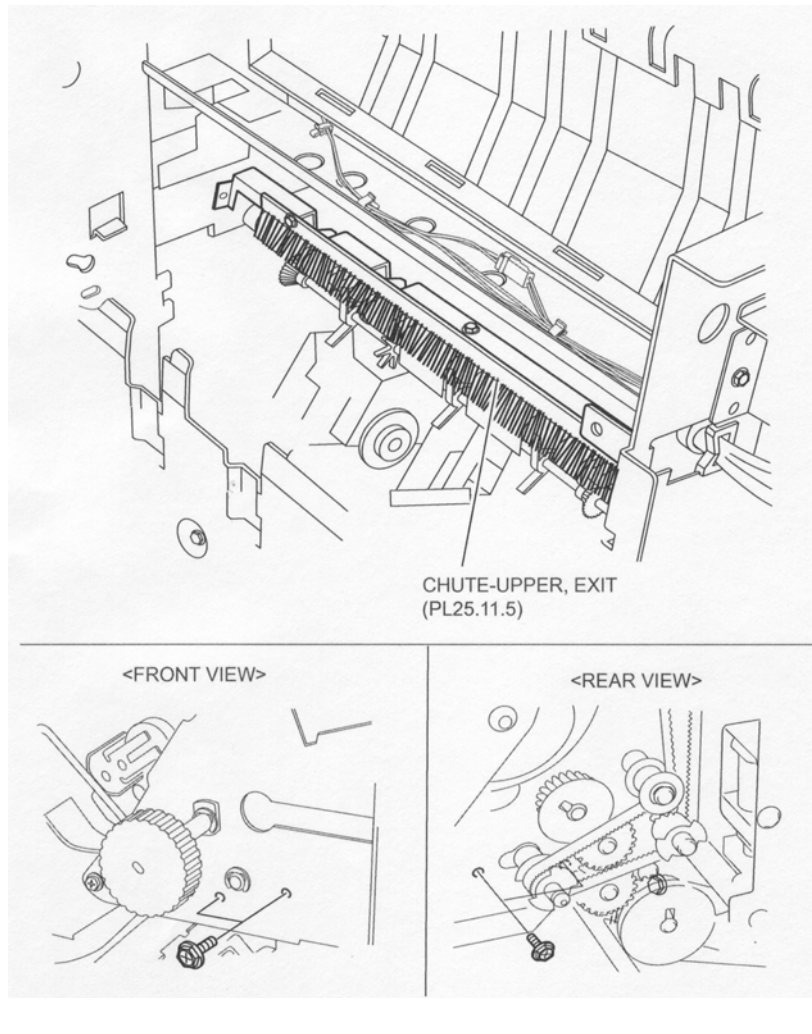
1. Remove the Front Cover Assembly (PL 12.5.3) .
2. Remove the Upper Rear Cover (PL 12.4.11) .
3. Remove the SCT Tray Assembly (PL 12.4.3) .
4. Remove the Eject Cover (PL 12.4.4) .
5. Remove the Stapler Unit (PL 12.8.14) .
6. Remove the Eject Clamp Bracket Assembly (PL 12.9.10) .
7. Remove the Eject Unit Chute Assembly (PL 12.9.27) .
8. Remove the Compiler Tray Assembly (PL 12.10.1) .
9. Remove the Eject Bracket Assembly (PL 12.10.17) .
10. Remove the Eject Roll Shaft Assembly (PL 12.10.9) .
11. Remove the Right Lower Exit Chute Assembly (PL 12.11.7) .
12. Loosen the two Screws securing the Tension Bracket Assembly (PL 12.13.23) for the Motor Assembly (PL 12.13.30) (Exit Motor) .
13. Move the Tension Bracket Assembly in the direction of the arrow so that the tension of the Belt (PL 12.13.28) decreases, and remove the Belt from each pulley.
14. Disconnect the connector of the Compiler Sensor Harness Assembly (PL 12.11.2) from the Sensor Assembly (PL 12.11.3) (Compile Exit Sensor).



**Figure 1 Tension Bracket Assembly**

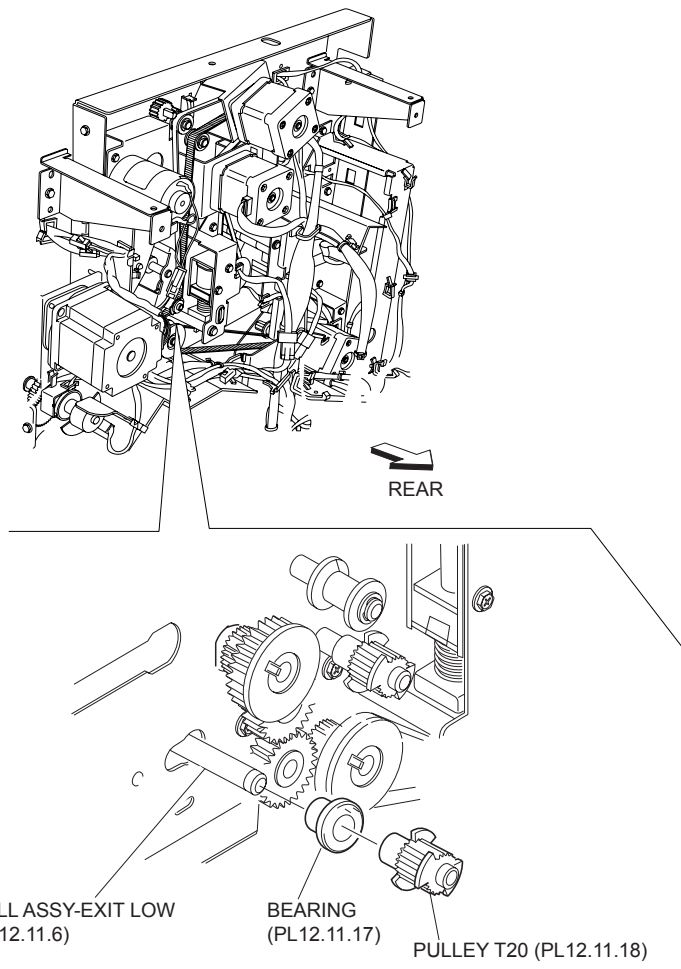
15. Remove the two Screws each on the front and rear securing the Upper Exit Chute (PL 12.11.5) .

16. Remove the Upper Exit Chute.

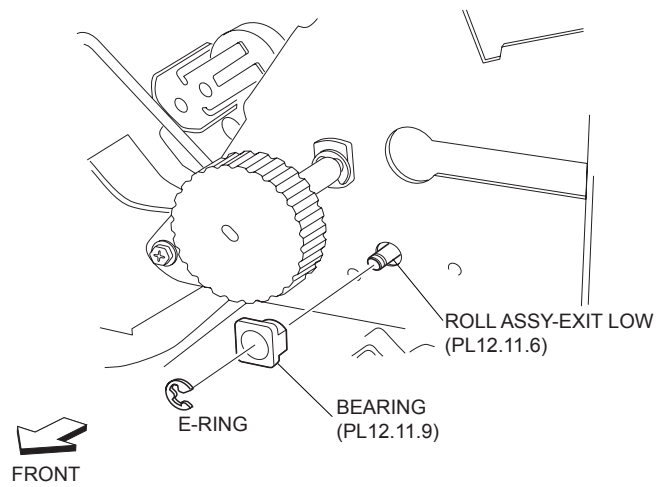


**Figure 2 Upper Exit Chute**

17. Release the hook of the T20 Pulley (PL 12.11.18) attached to the Lower Exit Roll Assembly on the rear to remove the T20 Pulley .
18. Remove the Bearing (PL 12.11.17).
19. Remove the E-ring securing the Lower Exit Roll Assembly on the front .
20. Remove the Bearing (PL 12.11.9).
21. Move the Lower Exit Roll Assembly to the rear first to remove the front end of the shaft from the hole on the frame, and remove the Lower Exit Roll Assembly from the Finisher .

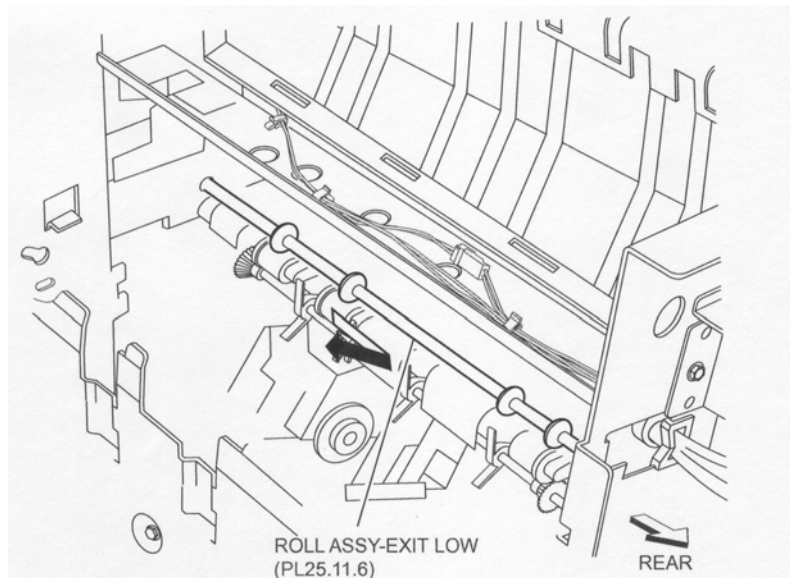


**Figure 3 T20 Pulley**



**Figure 4 Exit Roll Assembly Bearing**





**Figure 5 Lower Exit Roll Assembly**

## Replacement

1. Put the rear end of the Lower Exit Shaft Assembly into the hole on the rear first, then put the front end of the Lower Exit Shaft Assembly into the hole on the frame.
2. Install the Bearing (PL 12.11.9) to the Lower Exit Roll Assembly on the front.
3. Secure the Bearing using the E-ring.
4. Install the Bearing (PL 12.11.17) to the Lower Exit Roll Assembly on the rear.
5. Install the T20 Pulley (PL 12.11.18) and secure it using the hook.
6. Install the Upper Exit Chute (PL 12.11.5) to the frame using two Screws each on the front and rear.
7. Connect the connector of the Compiler Sensor Harness Assembly (PL 12.11.2) to the Sensor Assembly (PL 12.11.3) (Compile Exit Sensor).
8. While pushing the Tension Bracket Assembly (PL 12.13.23) in the direction of the arrow, install the Belt (PL 12.13.28) onto each pulley.
9. Fix the Tension Bracket Assembly to the frame using two Screws.

**NOTE** The tension of the belt is automatically adjusted by the force of the Tension Spring (PL 12.13.24) attached to the Tension Bracket Assembly. Therefore, when tightening the two Screws, be careful not to move the Tension Bracket Assembly.

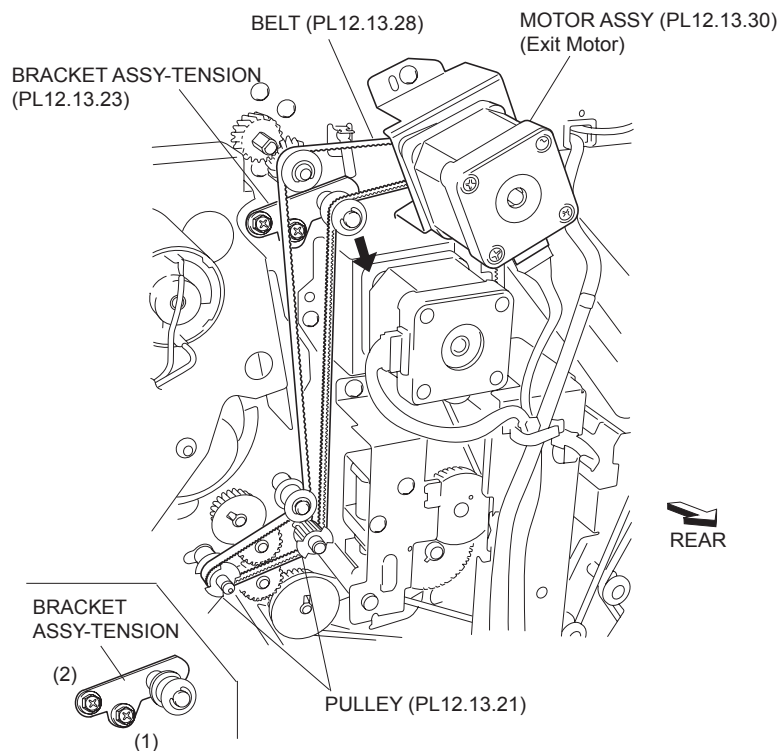
**NOTE** Tighten the two Screws in order of (1) and (2) shown in the figure.

10. Install the Right Lower Exit Chute Assembly (PL 12.11.7) .
11. Install the Eject Roll Shaft Assembly (PL 12.10.9) .
12. Install the Eject Bracket Assembly (PL 12.10.17) .
13. Install the Compiler Tray Assembly (PL 12.10.1) .
14. Install the Eject Unit Chute Assembly (PL 12.9.27) .
15. Install the Eject Clamp Bracket Assembly (PL 12.9.10) .
16. Install the Stapler Unit (PL 12.8.14) .
17. Install the Eject Cover (PL 12.4.4) .
18. Install the SCT Tray Assembly (PL 12.4.3) .
19. Install the Upper Rear Cover (PL 12.4.11) .
20. Install the Front Cover Assembly (PL 12.5.3) .

# Right Lower Exit Chute Assembly

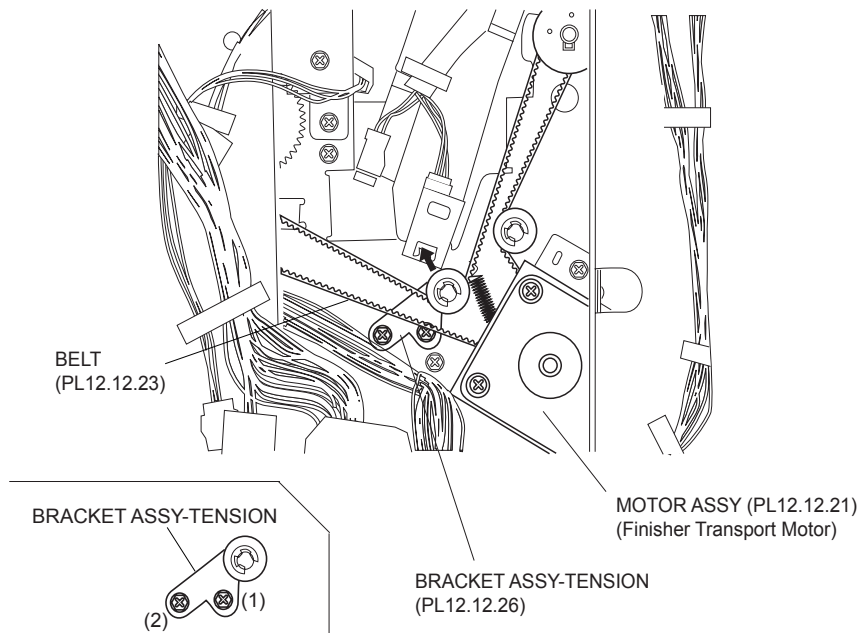
## Removal

1. Remove the Front Cover Assembly (PL 12.5.3) .
2. Remove the Upper Rear Cover (PL 12.4.11) .
3. Remove the Lower Rear Cover (PL 12.4.9) .
4. Remove the SCT Tray Assembly (PL 12.4.3) .
5. Remove the Eject Cover (PL 12.4.4) .
6. Remove the Stapler Unit (PL 12.8.14) .
7. Remove the Eject Clamp Bracket Assembly (PL 12.9.10) .
8. Remove the Eject Unit Chute Assembly (PL 12.9.27) .
9. Remove the Compiler Tray Assembly (PL 12.10.1) .
10. Remove the Eject Bracket Assembly (PL 12.10.17) .
11. Remove the Eject Roll Shaft Assembly (PL 12.10.9) .
12. Loosen the two Screws securing the Tension Bracket Assembly (PL 12.13.23) for the Motor Assembly (PL 12.13.30) (Exit Motor) .
13. Move the Tension Bracket Assembly in the direction of the arrow so that the tension of the Belt (PL 12.13.28) decreases, and remove the Belt from each pulley.



**Figure 1 Tension Bracket Assembly**

14. Loosen the two Screws securing the Tension Bracket Assembly (PL 12.12.26) for the Motor Assembly (PL 12.12.21) (Finisher Transport Motor) .
15. Move the Tension Bracket Assembly in the direction of the arrow so that the tension of the Belt (PL 12.12.23) decreases, and remove the Belt from each pulley.

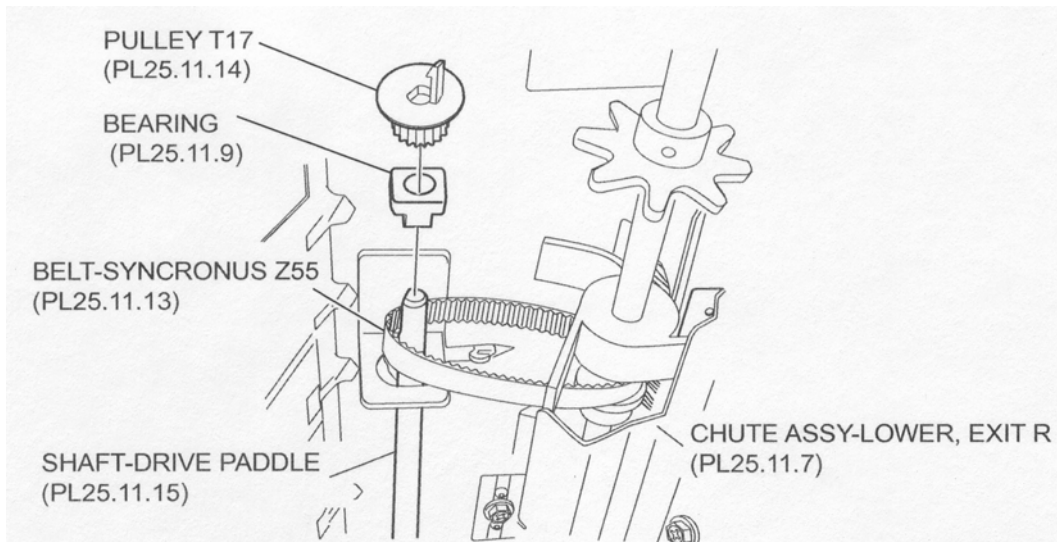


**Figure 2 Motor Assembly Tension**

16. Release the hook of the T17 Pulley (PL 12.11.14) inside the Finisher to remove the T17 Pulley. At the same time, the Z55 Synchronous Belt (PL 12.11.13) put onto the T17 Pulley is also detached .
17. Remove the Z55 Synchronous Belt from the Paddle Drive Shaft (PL 12.11.15).

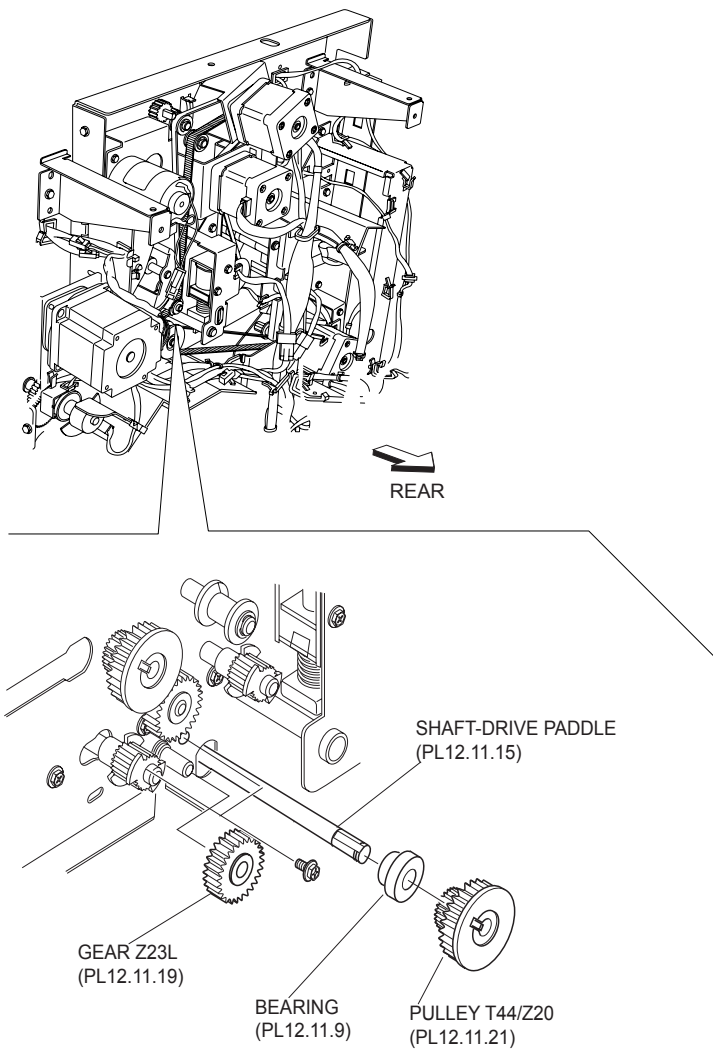
**NOTE** Since the Belt is put onto the Paddle Shaft Assembly (PL 12.11.12) on the Right Lower Exit Chute Assembly (PL 12.11.7), the Belt cannot be detached from the Finisher.

18. Remove the Bearing (PL 12.11.9) adjacent to the removed T17 Pulley.



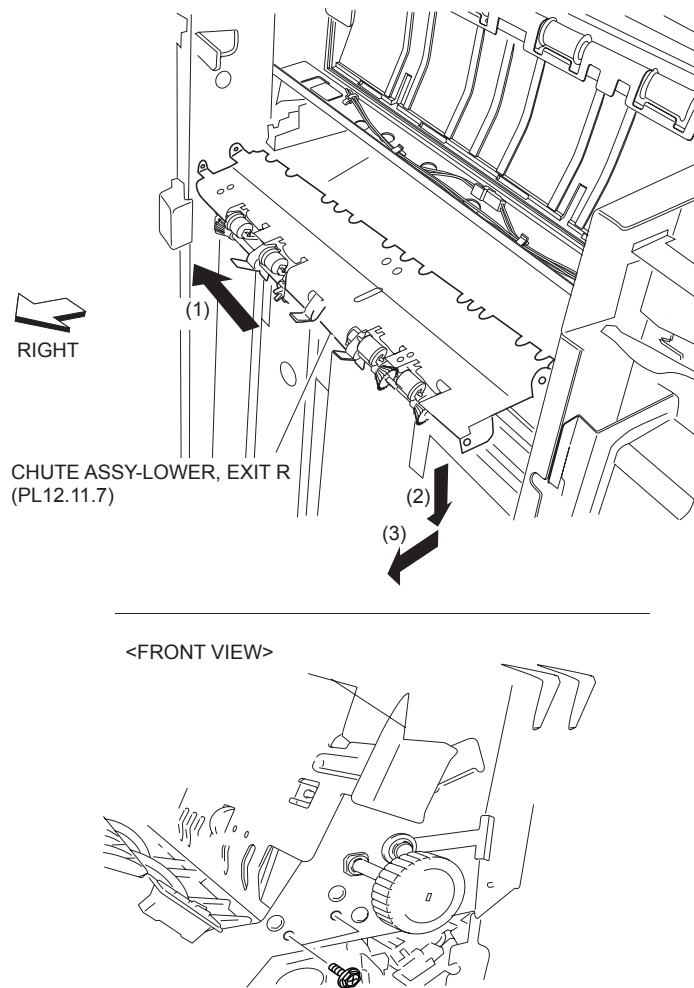
**Figure 3 T17 Pulley**

19. Release the hook of the T44/Z20 Pulley (PL 12.11.21) from the rear to remove .
20. Pull out the Paddle Drive Shaft.
21. Remove the Bearing (PL 12.11.9) from the Paddle Drive Shaft.
22. Remove the Z23 Gear (PL 12.11.19).



**Figure 4 T44/Z20 Pulley**

23. Remove the two Screws each on the front and rear securing the Right Lower Exit Chute Assembly to the Finisher .
24. While moving the Right Lower Exit Chute Assembly to the front, move the rear side of the Right Lower Exit Chute Assembly downward to remove it from the frame, and then remove the Right Lower Exit Chute Assembly from the Finisher.



**Figure 5 Lower Exit Chute Assembly**

## Replacement

1. Put the Right Lower Exit Chute Assembly into the Finisher. Move the Right Lower Exit Chute Assembly to the front first, and lift its rear side up to install it to the frame.
2. Fix the Right Lower Exit Chute to the Finisher using two Screws each on the front and rear.
3. Install the Z23L Gear (PL 12.11.19).
4. Install the Bearing (PL 12.11.9) to the frame on the rear.
5. Install the T44/Z20 Pulley (PL 12.11.21) to the Paddle Drive Shaft (PL 12.11.15), and secure it with the hook.
6. Insert the Paddle Drive Shaft into the Bearing.
7. Put the Bearing (PL 12.11.9) to the Paddle Drive Shaft inside the Finisher, and install the Bearing to the bracket.
8. Put the Z55 Synchronous Belt (PL 12.11.13) attached with the Right Lower Exit Chute Assembly onto the Paddle Drive Shaft.
9. Install the T17 Pulley (PL 12.11.14) to the Paddle Drive Shaft while installing the Belt, and secure the T17 Pulley with the hook.
10. While pushing the Tension Bracket Assembly (PL 12.12.26) for the Motor Assembly (PL 12.12.21) (Finisher Transport Motor) in the direction of the arrow, install the Belt (PL 12.12.23) onto each pulley.
11. Fix the Tension Bracket Assembly to the frame using two Screws.

**NOTE** The tension of the belt is automatically adjusted by the force of the Tension Spring attached to the Tension Bracket Assembly. Therefore, when tightening the two Screws, be careful not to move the Tension Bracket Assembly.

**NOTE** Tighten the two Screws in order of (1) and (2) shown in the figure.

12. While pushing the Tension Bracket Assembly (PL 12.13.23) for the Motor Assembly (PL 12.13.30) (Exit Motor) in the direction of the arrow, install the Belt (PL 12.13.28) onto each pulley.
13. Fix the Tension Bracket Assembly to the frame using two Screws.

**NOTE** The tension of the belt is automatically adjusted by the force of the Tension Spring attached to the Tension Bracket Assembly. Therefore, when tightening the two Screws, be careful not to move the Tension Bracket Assembly.

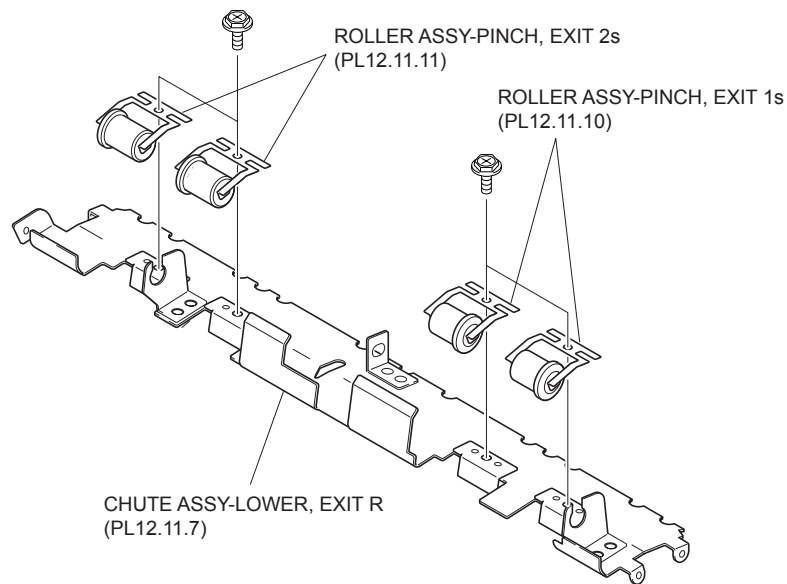
**NOTE** Tighten the two Screws in order of (1) and (2) shown in the figure.

14. Install the Eject Roll Shaft Assembly (PL 12.10.9) .
15. Install the Eject Bracket Assembly (PL 12.10.17) .
16. Install the Compiler Tray Assembly (PL 12.10.1) .
17. Install the Eject Unit Chute Assembly (PL 12.9.27) .
18. Install the Eject Clamp Bracket Assembly (PL 12.9.10) .
19. Install the Stapler Unit (PL 12.8.14) .
20. Install the Eject Cover (PL 12.4.4) .
21. Install the SCT Tray Assembly (PL 12.4.3) .
22. Install the Lower Rear Cover (PL 12.4.9) .
23. Install the Upper Rear Cover (PL 12.4.11) .
24. Install the Front Cover Assembly (PL 12.5.3) .

## Exit 1 & Exit 2 Pinch Roller Assembly

### Removal

1. Remove the Front Cover Assembly (PL 12.5.3) .
2. Remove the Upper Rear Cover (PL 12.4.11) .
3. Remove the Lower Rear Cover (PL 12.4.9) .
4. Remove the SCT Tray Assembly (PL 12.4.3) .
5. Remove the Eject Cover (PL 12.4.4) .
6. Remove the Stapler Unit (PL 12.8.14) .
7. Remove the Eject Clamp Bracket Assembly (PL 12.9.10) .
8. Remove the Eject Unit Chute Assembly (PL 12.9.27) .
9. Remove the Compiler Tray Assembly (PL 12.10.1) .
10. Remove the Eject Bracket Assembly (PL 12.10.17) .
11. Remove the Eject Roll Shaft Assembly (PL 12.10.9) .
12. Remove the Right Lower Exit Chute Assembly (PL 12.11.7) .
13. Remove the Paddle Shaft Assembly (PL 12.11.12) .
14. Remove the two Screws (M3 x 6) securing the two Exit 1 Pinch Roller Assemblies .
15. Remove the two Exit 1 Pinch Roller Assemblies.
16. Remove the two Screws (M3 x 6) securing the two Exit 2 Pinch Roller Assemblies.
17. Remove the two Exit 2 Pinch Roller Assemblies.



**Figure 1 Lower Exit Chute Assembly**

## Replacement

1. Install the two Exit 2 Pinch Roller Assemblies to the Right Lower Exit Chute Assembly (PL 12.11.7) using two Screws (M3 x 6).

**NOTE** Be careful of the installing place of the Exit 1 Pinch Roller Assembly and the Exit 2 Pinch Roller Assembly.

**NOTE** Be sure to put the bosses of the Lower Exit Chute Assembly into the two slots on the bracket of the Exit 1 Pinch Roller Assembly.

2. Install the two Exit 2 Pinch Roller Assemblies to the Right Lower Exit Chute Assembly using two Screws (M3 x 6).

**NOTE** Be sure to put the bosses of the Lower Exit Chute Assembly into the two slots on the bracket of the Exit 2 Pinch Roller Assembly.

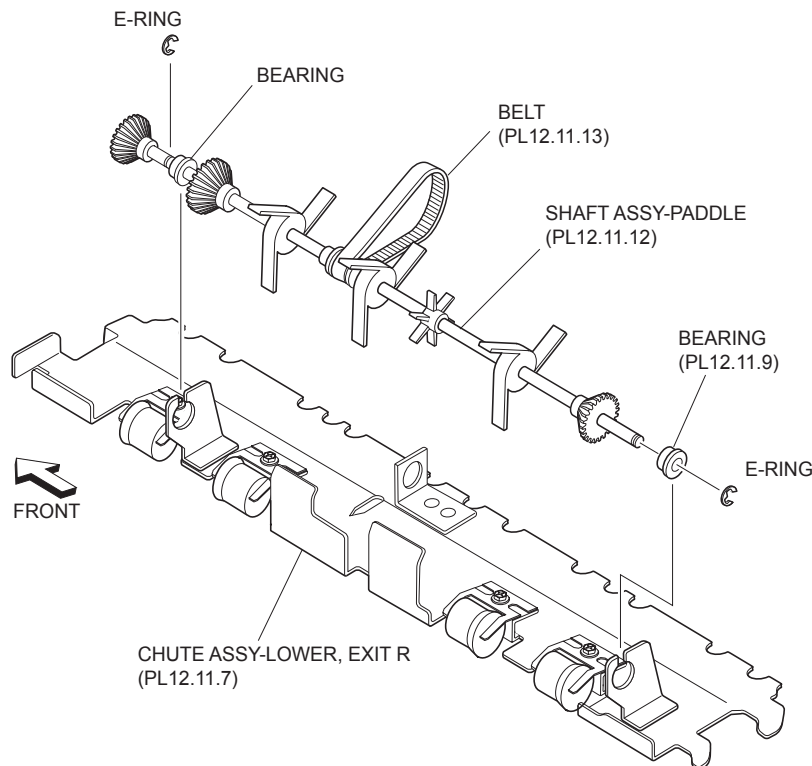
3. Install the Paddle Shaft Assembly (PL 12.11.12) .
4. Install the Right Lower Exit Chute Assembly (PL 12.11.7) .
5. Install the Eject Roll Shaft Assembly (PL 12.10.9) .
6. Install the Eject Bracket Assembly (PL 12.10.17) .
7. Install the Compiler Tray Assembly (PL 12.10.1) .
8. Install the Eject Unit Chute Assembly (PL 12.9.27) .
9. Install the Eject Clamp Bracket Assembly (PL 12.9.10) .
10. Install the Stapler Unit (PL 12.8.14) .
11. Install the Eject Cover (PL 12.4.4) .
12. Install the SCT Tray Assembly (PL 12.4.3) .
13. Install the Lower Rear Cover (PL 12.4.9) .
14. Install the Upper Rear Cover (PL 12.4.11) .
15. Install the Front Cover Assembly (PL 12.5.3) .

## Paddle Shaft Assembly

### Removal

1. Remove the Front Cover Assembly (PL 12.5.3) .

2. Remove the Upper Rear Cover (PL 12.4.11) .
3. Remove the Lower Rear Cover (PL 12.4.9) .
4. Remove the SCT Tray Assembly (PL 12.4.3) .
5. Remove the Eject Cover (PL 12.4.4) .
6. Remove the Stapler Unit (PL 12.8.14) .
7. Remove the Eject Clamp Bracket Assembly (PL 12.9.10) .
8. Remove the Eject Unit Chute Assembly (PL 12.9.27) .
9. Remove the Compiler Tray Assembly (PL 12.10.1) .
10. Remove the Eject Bracket Assembly (PL 12.10.17) .
11. Remove the Eject Roll Shaft Assembly (PL 12.10.9) .
12. Remove the Right Lower Exit Chute Assembly (PL 12.11.7) .
13. Remove the two E-rings securing the Paddle Shaft Assembly to the Right Lower Exit Chute Assembly .
14. Remove the Bearing (PL 12.11.9).
15. Move the Paddle Shaft Assembly to the front first to remove the Bearing on the front from the Right Lower Exit Chute Assembly, and then remove the Paddle Shaft Assembly from the Right Lower Exit Chute Assembly.
16. Remove the Belt (PL 12.11.13) from the Paddle Shaft Assembly.



**Figure 1 Paddle Shaft Assembly**

## Replacement

1. Install the Belt (PL 12.11.13) to the Paddle Shaft Assembly.
2. Put the Bearing attached with the Paddle Shaft Assembly into the hole of the bracket on the Right Lower Exit Chute Assembly (PL 12.11.7).
3. Install the Bearing (PL 12.11.9) to the Paddle Shaft Assembly.
4. Fix the Bearings using two E-rings.

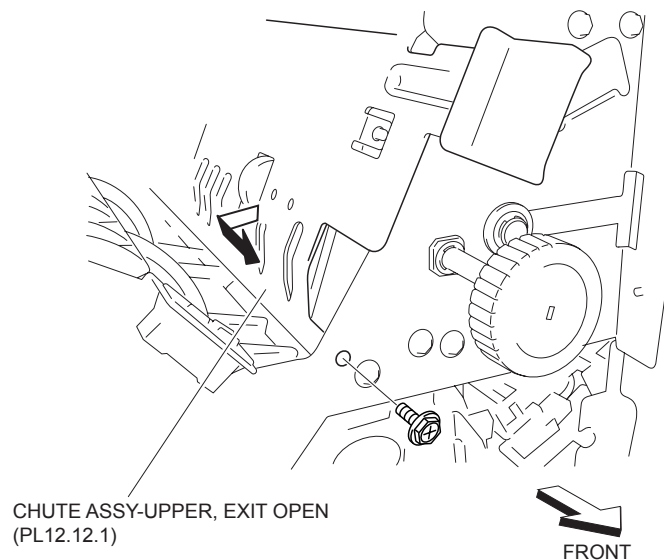


5. Install the Right Lower Exit Chute Assembly (PL 12.11.7) .
6. Install the Eject Roll Shaft Assembly (PL 12.10.9) .
7. Install the Eject Bracket Assembly (PL 12.10.17) .
8. Install the Compiler Tray Assembly (PL 12.10.1) .
9. Install the Eject Unit Chute Assembly (PL 12.9.27) .
10. Install the Eject Clamp Bracket Assembly (PL 12.9.10) .
11. Install the Stapler Unit (PL 12.8.14) .
12. Install the Eject Cover (PL 12.4.4) .
13. Install the SCT Tray Assembly (PL 12.4.3) .
14. Install the Lower Rear Cover (PL 12.4.9) .
15. Install the Upper Rear Cover (PL 12.4.11) .
16. Install the Front Cover Assembly (PL 12.5.3) .

## Upper Exit Open Chute Assembly

### Removal

1. Open the Front Cover Assembly (PL 12.5.3).
2. Open the Upper Exit Open Chute Assembly to the right by hand.
3. Remove the one Screw on the front securing the Upper Exit Open Chute Assembly to the frame .
4. Remove the Upper Exit Open Chute Assembly from the front.



**Figure 1 Upper Exit Open Chute Assembly**

### Replacement

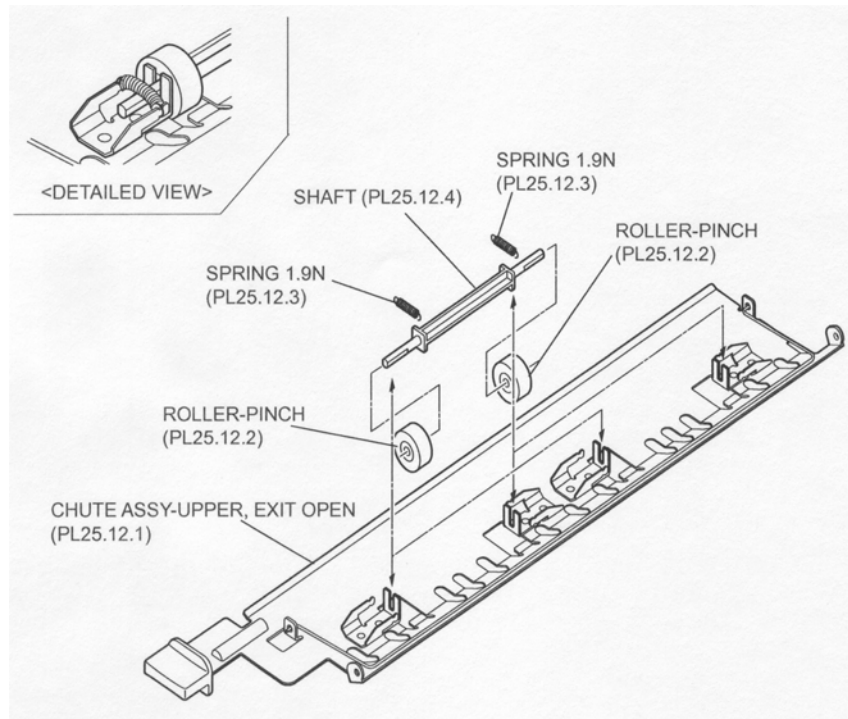
1. Put the Upper Exit Open Chute Assembly to the Finisher from the front, and put the Screw on the rear of the frame into the hole of the Upper Exit Open Chute Assembly.
2. Secure the Upper Exit Open Chute Assembly to the frame using one Screw on the front.
3. Close the Upper Exit Open Chute Assembly.
4. Close the Front Cover Assembly (PL 12.5.3).

## Pinch Roller

## Removal

1. Open the Front Cover Assembly (PL 12.5.3).
2. Remove the Upper Rear Cover (PL 12.4.11) .
3. Remove the Upper Exit Open Chute Assembly (PL 12.12.1) .
4. Remove the 1.9N Spring (PL 12.12.3) left and right, and remove the Shaft (PL 12.12.4) attached with the two Pinch Rollers .
5. Remove the two Pinch Rollers from the Shaft.

**NOTE** Remove another Pinch Roller using the same procedure.



**Figure 1 Pinch Rollers**

## Replacement

1. Install the two Pinch Rollers on both ends of the Shaft (PL 12.12.4).
2. Install the Shaft attached with two Pinch Rollers to the Upper Exit Open Chute Assembly (PL 12.12.1) using two 1.9N Springs (PL 12.12.3). (Refer to the detailed figure.)

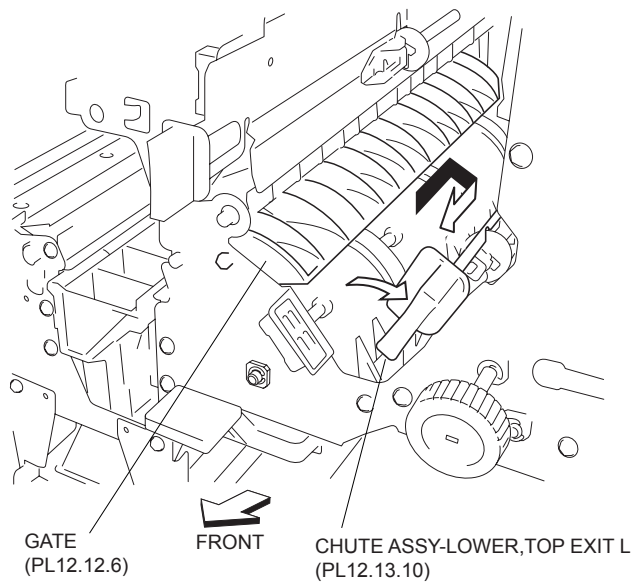
**NOTE** Install another Pinch Roller using the same procedure.

3. Install the Upper Exit Open Chute Assembly (PL 12.12.1) .
4. Install the Upper Rear Cover (PL 12.4.11) .
5. Close the Front Cover Assembly (PL 12.5.3).

## Gate

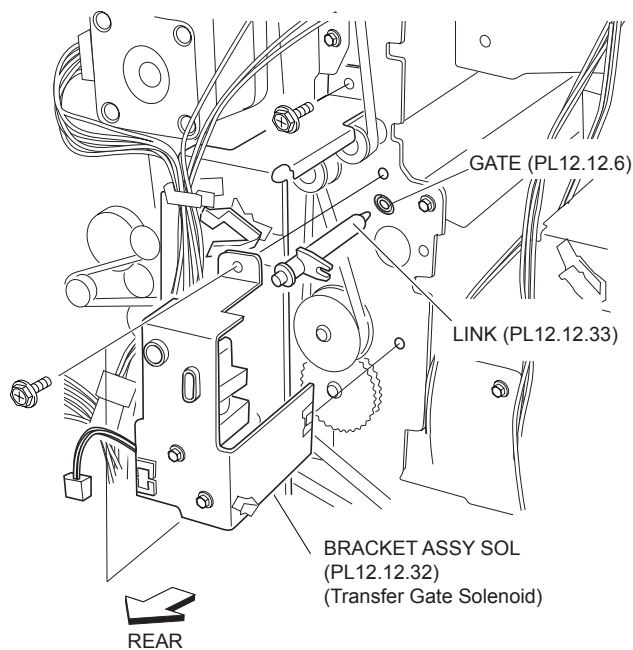
### Removal

1. Open the Front Cover Assembly (PL 12.5.3).
2. Remove the Upper Rear Cover (PL 12.4.11) .
3. Open the Lower Left Top Exit Chute Assembly (PL 12.13.10) to the right by hand .



**Figure 1 Top Exit Chute Assembly**

4. Remove the Solenoid Bracket Assembly (PL 12.12.32) (Transfer Gate Solenoid) on the rear.
5. Remove the Link (PL 12.12.33) on the rear .
6. Move the Gate in the direction of the arrow from the front to remove the Gate.



**Figure 2 Solenoid Bracket Assembly**

## Replacement

1. Move the Gate in the opposite direction of the arrow from the front, and install it to the Finisher.

**NOTE** Install the Gate with its one end with the hole facing the rear.

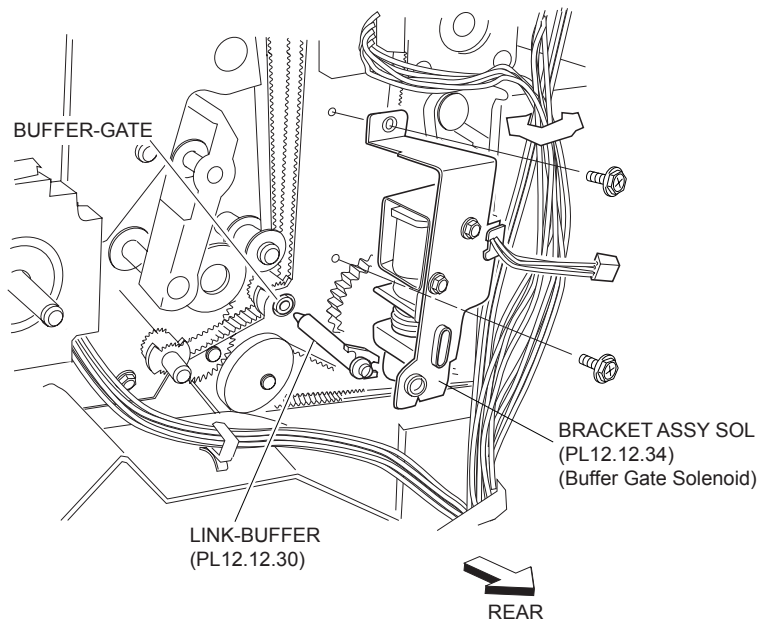
2. Put the Link (PL 12.12.33) into the hole on the Gate from the rear.

3. Install the Solenoid Bracket Assembly (PL 12.12.32) (Transport Gate Solenoid) .
4. Close the Lower Left Top Exit Chute Assembly (PL 12.13.10) to the left by hand.
5. Install the Upper Rear Cover (PL 12.4.11) .
6. Close the Front Cover Assembly (PL 12.5.3).

## Buffer Gate

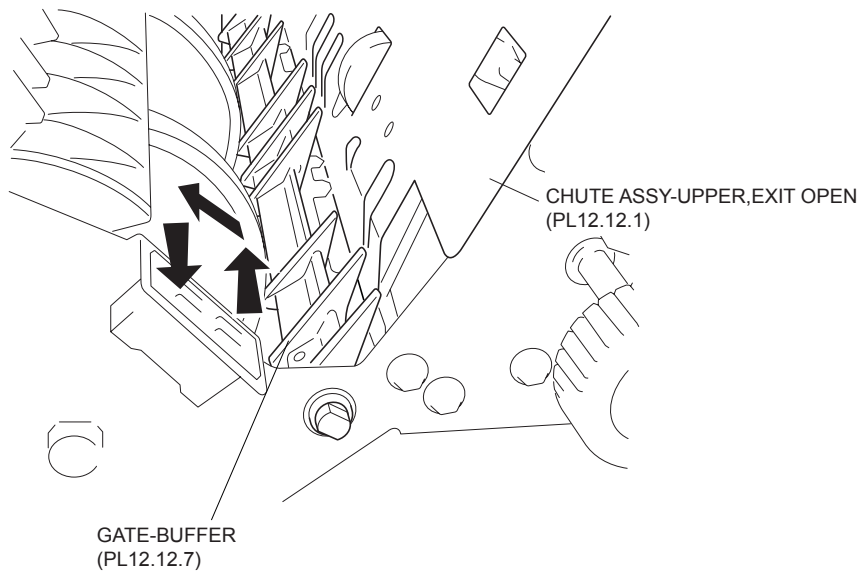
### Removal

1. Open the Front Cover Assembly (PL 12.5.3).
2. Remove the Upper Rear Cover (PL 12.4.11) .
3. Remove the Solenoid Bracket Assembly (PL 12.12.32) (Buffer Gate Solenoid) on the rear .
4. Remove the Buffer Link (PL 12.12.30) on the rear .



**Figure 1 Solenoid Bracket Assembly**

5. Open the Upper Exit Open Chute Assembly (PL 12.12.1) to the right by hand .
6. Move the Buffer Gate in the direction of the arrows from the front to remove the Buffer Gate.



**Figure 2 Upper Exit Chute Assembly**

## Replacement

1. Move the Buffer Gate in the opposite direction of the arrow from the front, and install it to the Finisher.

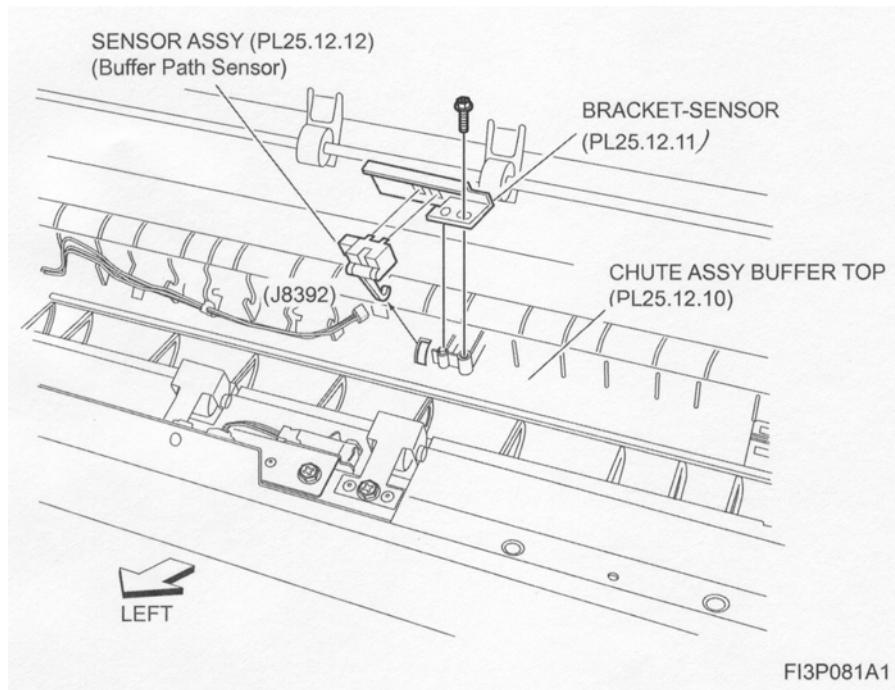
**NOTE** Install the Buffer Gate with its one end with the hole facing the rear

2. Put the Buffer Link (PL 12.12.30) into the hole on the Buffer Gate from the rear.
3. Install the Solenoid Bracket Assembly (PL 12.12.34) (Buffer Gate Solenoid) .
4. Install the Upper Rear Cover (PL 12.4.11) .
5. Close the Front Cover Assembly (PL 12.5.3).

## Buffer Path Sensor Assembly

### Removal

1. Open the Front Cover Assembly (PL 12.5.3).
2. Remove the Upper Rear Cover (PL 12.4.11) .
3. Remove the Top Cover (PL 12.4.1) .
4. Remove the Left Hand Front Cover (PL 12.5.8) .
5. Remove the Left Hand Top Cover (PL 12.5.9) .
6. Remove the Punch Frame Assembly (PL 12.7.1) .
7. Disconnect the connector (J8392) of the Buffer Sensor Harness Assembly (PL 12.15.5) from the Sensor Assembly (Buffer Path Sensor) .
8. Remove the one Screw (M3 x 8) securing the Sensor Bracket (PL 12.12.11) attached with the Sensor Assembly to the Top Buffer Chute Assembly (PL 12.12.10).
9. Remove the Sensor Bracket.
10. Release the four hooks securing the Sensor Assembly to remove the Sensor Assembly from the Sensor Bracket.



**Figure 1 Buffer Path Sensor**

## Replacement

1. Install the Sensor Assembly to the Sensor Bracket (PL 12.12.11) and secure it with the four hooks.
2. Install the Sensor Bracket to the Top Buffer Chute Assembly (PL 12.12.10) using one Screw (M3 x 8).

**NOTE** When installing the Sensor Bracket, be sure to put the actuator of the Sensor Assembly into the hole of the Top Buffer Chute Assembly.

**NOTE** Put the boss on the Top Buffer Chute Assembly into the hole of the Sensor Bracket.

3. Connect the connector (J8392) of the Buffer Sensor Harness Assembly (PL 12.15.5) to the Sensor Assembly.
4. Install the Punch Frame Assembly (PL 12.7.1) .
5. Install the Left Hand Top Cover (PL 12.5.9) .
6. Install the Left Hand Front Cover (PL 12.5.8) .
7. Install the Top Cover (PL 12.4.1) .
8. Install the Upper Rear Cover (PL 12.4.11) .
9. Close the Front Cover Assembly (PL 12.5.3).

## Buffer Roll Assembly

### Removal

1. Remove the Upper Rear Cover (PL 12.4.11) .
2. Open the Front Cover Assembly (PL 12.5.3).
3. Remove the Stapler Cartridge Assembly (PL 12.8.1).
4. Move the Stapler to the rear by hand as far as it will move.
5. Open the Upper Exit Open Chute Assembly (PL 12.12.14) to the right by hand .
6. Lift the Buffer Gate (PL 12.12.7) with finger.
7. Open the Bottom Buffer Chute Assembly (PL 12.12.1) downward by hand.

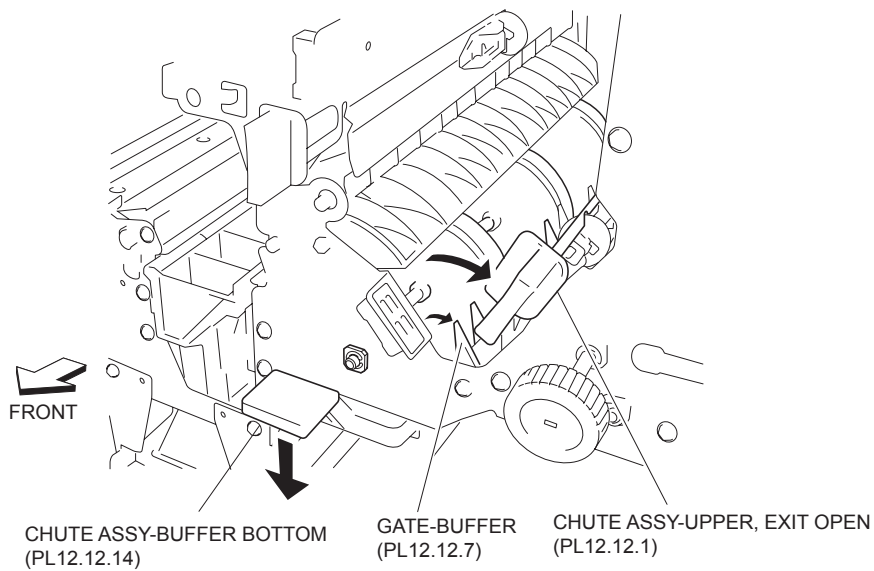


Figure 1 Gate Buffer

8. Remove the E-ring securing the shaft of the Buffer Roll Assembly on the front .
9. Remove the Bearing (PL 12.12.9).

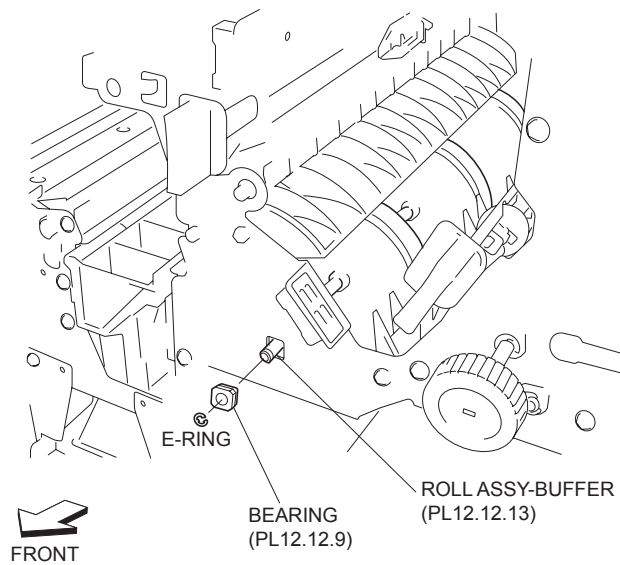
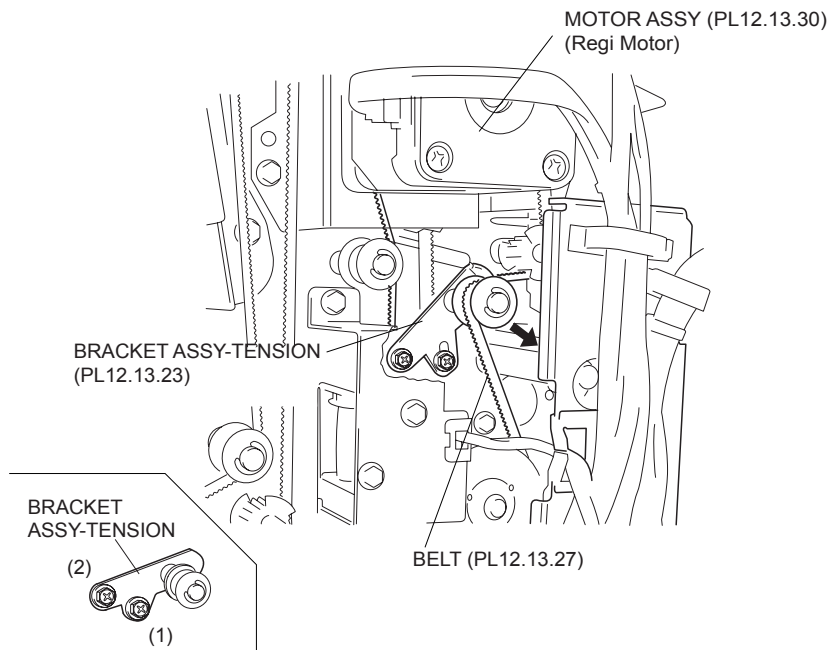


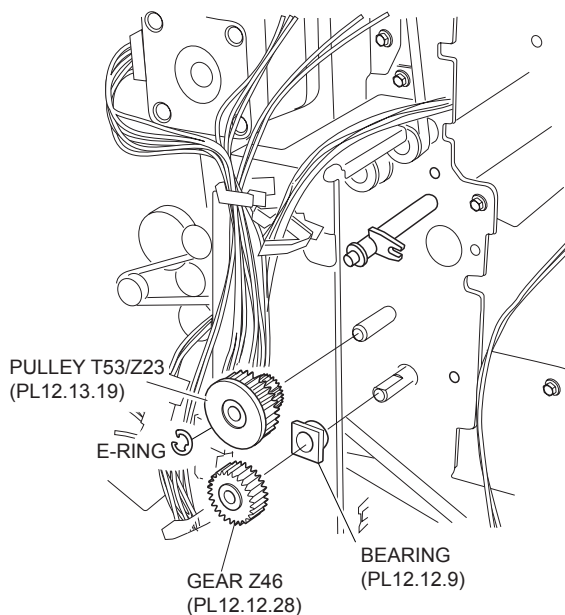
Figure 2 Buffer Roll Assembly

10. Remove the Solenoid Bracket Assembly (PL 12.12.32) (Transport Gate Solenoid) on the rear.
11. Loosen the two Screws securing the Tension Bracket Assembly (PL 12.13.23) for the Motor Assembly (PL 12.13.30) (Registration Motor) .
12. Move the Tension Bracket Assembly in the direction of the arrow so that the tension of the Belt (PL 12.13.27) decreases, and remove the Belt from each pulley.



**Figure 3 Registration Motor Tension Bracket**

13. Remove the E-ring securing the T53/Z23 Pulley (PL 12.13.19) .
14. Remove the T53/Z23 Pulley.
15. Release the hook of the Z46 Gear (PL 12.12.28) to remove the Z46 Gear from the shaft on the Buffer Roll Assembly.
16. Remove the Bearing (PL 12.12.9).

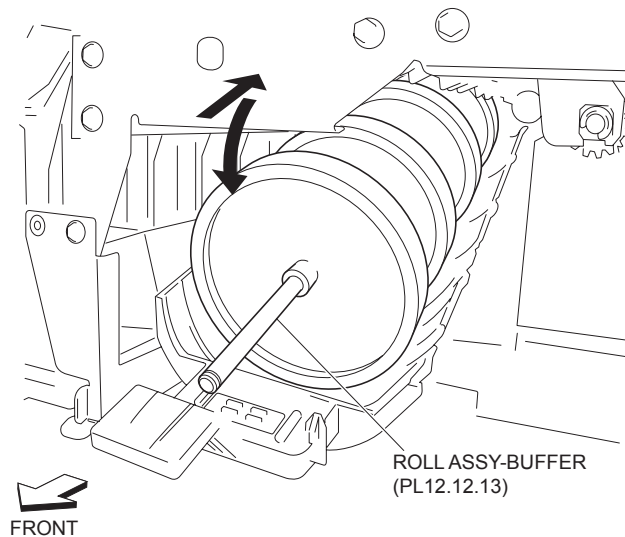


**Figure 4 T53/Z23 Pulley**

17. Move the Buffer Roll Assembly to the rear to remove the front end of the shaft from the hole on the frame .
18. Move the Buffer Roll Assembly downward first, then remove it from the Finisher.

**NOTE Do not hold the rubber roller of the Buffer Roll Assembly.**





**Figure 5 Buffer Roll Assembly**

## Replacement

1. Put the rear end of the Buffer Roll Assembly into the hole on the rear frame first, and put the front end of the shaft into the hole on the front frame.

**NOTE** Install the Buffer Roll Assembly with its one end with the flat surface facing the rear.

**NOTE** Be careful not to hold the rubber roller of the Buffer Roll Assembly.

2. Install the Bearing (PL 12.12.9) to the shaft of the Buffer Roll Assembly on the rear.
3. Install the Z46 Gear (PL 12.12.28) and secure it using its hook.
4. Install the T53/Z23 Pulley (PL 12.13.19) and secure it using the E-ring.
5. While pushing the Tension Bracket Assembly (PL 12.13.23) in the direction of the arrow, install the Belt (PL 12.13.27) onto each pulley.
6. Fix the Tension Bracket Assembly to the frame using two Screws.

**NOTE** The tension of the belt is automatically adjusted by the force of the Tension Spring (PL 12.13.24) attached to the Tension Bracket Assembly. Therefore, when tightening the two Screws, be careful not to move the Tension Bracket Assembly.

**NOTE** Tighten the two Screws in order of (1) and (2) shown in the figure.

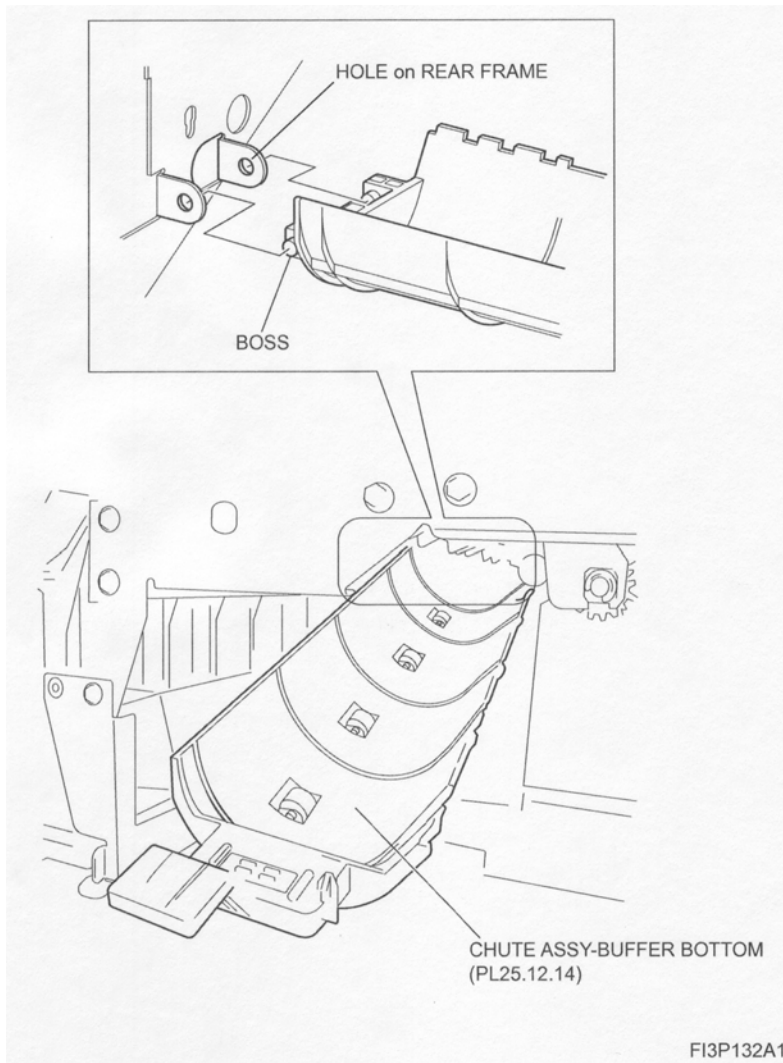
7. Install the Solenoid Bracket Assembly (PL 12.12.32) (Transport Gate Solenoid) .
8. Install the Bearing (PL 12.12.9) to the shaft on the Buffer Roll Assembly on the front, and secure it with the E-ring.
9. Lift the Bottom Buffer Chute Assembly (PL 12.12.14) by hand to close.
10. Move the Buffer Gate (PL 12.12.7) toward the Buffer Roll Assembly by hand.
11. Close the Upper Exit Open Chute Assembly (PL 12.12.1).
12. Move the Stapler to the front by hand.
13. Install the Stapler Cartridge Assembly (PL 12.8.1).
14. Close the Front Cover Assembly (PL 12.5.3).
15. Install the Upper Rear Cover (PL 12.4.11) .

## Bottom Buffer Chute Assembly

### Removal

1. Remove the Front Cover Assembly (PL 12.5.3) .

2. Remove the Upper Rear Cover (PL 12.4.11) .
3. Remove the Stapler Unit (PL 12.8.14) .
4. Remove the two bosses on the rear of the Bottom Buffer Chute Assembly from the two holes on the rear frame .



**Figure 1 Bottom Buffer Chute Assembly**

## **Replacement**

1. Install the two bosses on the rear of the Bottom Buffer Chute into the two holes on the rear frame.
2. Install the Stapler Unit (PL 12.8.14) .
3. Install the Upper Rear Cover (PL 12.4.11) .
4. Install the Front Cover Assembly (PL 12.5.3) .

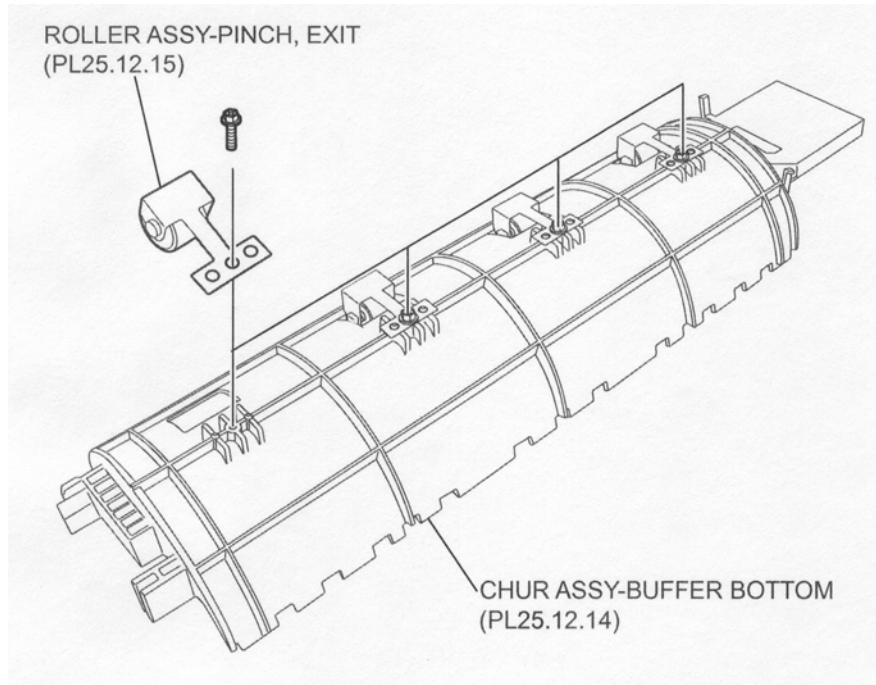
## **Exit Pinch Roller Assembly**

### **Removal**

1. Open the Front Cover Assembly.
2. Remove the Upper Rear Cover (PL 12.4.11) .
3. Remove the Buffer Roll Assembly (PL 12.12.13) .

4. Remove the Bottom Buffer Chute Assembly (PL 12.12.14) .
5. Remove the one Screw (M3 x 8) securing the Exit Pinch Roller Assembly to the Bottom Buffer Chute Assembly .

**NOTE** Remove the other three Pinch Rollers using the same procedure.



**Figure 1 Exit Pinch Roller Assembly**

## Replacement

1. Install the Exit Pinch Roller Assembly to the Bottom Buffer Chute Assembly using one Screw (M3 x 8).

**NOTE** Put the two bosses of the Bottom Buffer Chute Assembly into the two holes on the Exit Pinch Roller Assembly.

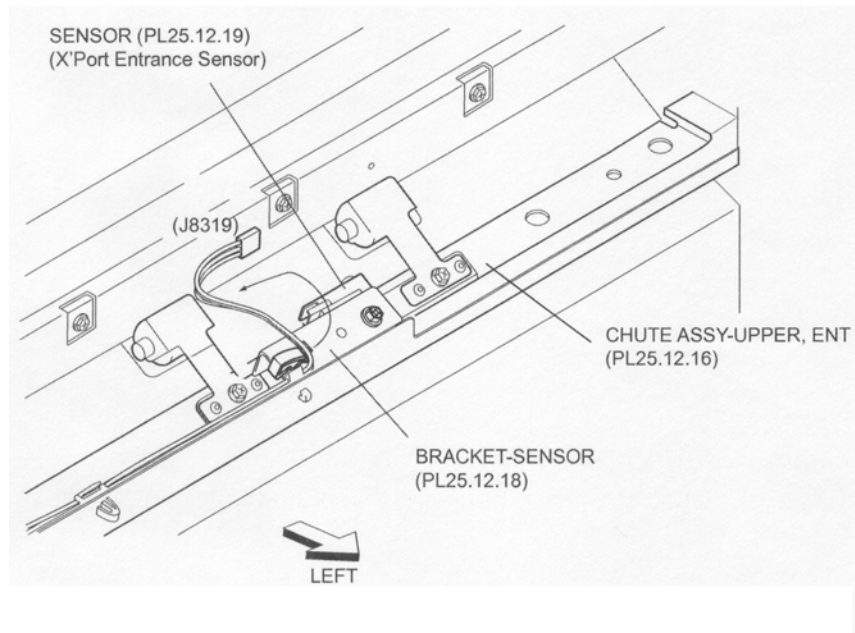
2. Ins
3. Install the Buffer Roll Assembly (PL 12.12.13) .
4. Install the Upper Rear Cover (PL 12.4.11) .
5. Close the Front Cover Assembly.

## Upper Entrance Chute Assembly

### Removal

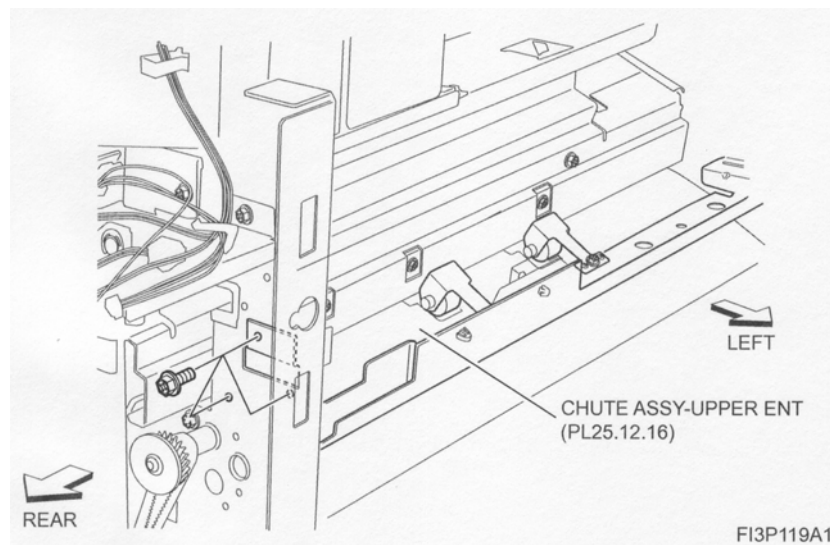
1. Open the Front Cover Assembly.
2. Remove the Upper Rear Cover (PL 12.4.11) .
3. Remove the Left Hand Front Cover (PL 12.5.8) .
4. Remove the Left Hand Top Cover (PL 12.5.9) .
5. Disconnect the connector (J8319) of the Transport Entrance Sensor Harness Assembly (PL 12.15.4) from the Sensor (PL 12.12.19) (Transport Entrance Sensor) .

- Release the Transport Entrance Sensor Harness Assembly from the clamp of the Sensor Bracket (PL 12.12.18).



**Figure 1 Transport Entrance Sensor**

- Remove the three Screws securing the Upper Entrance Chute Assembly on the rear, and remove the hinge of the Upper Entrance Chute Assembly from the square hole on the rear frame .
- Remove the Upper Entrance Chute Assembly from the front.



**Figure 2 Upper Entrance Chute Assembly**

## Replacement

- Put the Upper Entrance Chute Assembly into the Finisher from the front, put the hinge of the Upper Entrance Chute Assembly into the square hole on the rear frame.
- Install the Upper Entrance Chute Assembly at the rear using three Screws.
- Secure the Transport Entrance Sensor Harness Assembly (PL 12.15.4) with the clamp of the Sensor Bracket (PL 12.12.18).
- Connect the connector (J8319) of the Transport Entrance Sensor Harness Assembly to the Sensor (PL 12.12.19) (Transport Entrance Sensor).

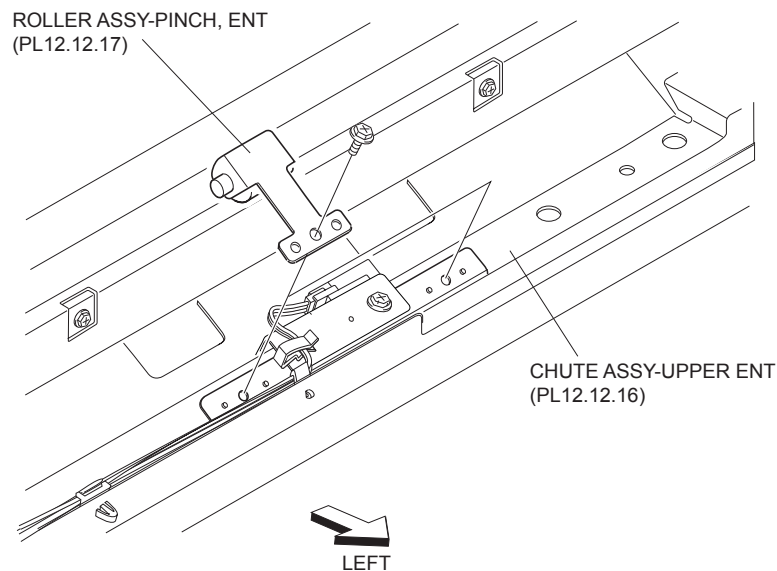
5. Install the Left Hand Top Cover (PL 12.5.9) .
6. Install the Left Hand Front Cover (PL 12.5.8) .
7. Install the Upper Rear Cover (PL 12.4.11) .
8. Close the Front Cover Assembly.

## Entrance Pinch Roller Assembly

**NOTE** Upper Entrance Chute Assembly (PL 12.12.16) has four Entrance Pinch Roller Assemblies. Their removal and replacement procedures are the same.

### Removal

1. Open the Front Cover Assembly (PL 12.5.3).
2. Remove the Upper Rear Cover (PL 12.4.11) .
3. Remove the Top Cover (PL 12.4.1) .
4. Remove the Left Hand Front Cover (PL 12.5.8) .
5. Remove the Left Hand Top Cover (PL 12.5.9) .
6. Remove the one Screw (M3 x 6) securing the Entrance Pinch Roller Assembly to the Upper Entrance Chute Assembly (PL 12.12.16) .
7. Remove the Entrance Pinch Roller Assembly.



**Figure 1 Entrance Pinch Roller Assembly**

### Replacement

1. Install the Entrance Pinch Roller Assembly to the Upper Entrance Chute Assembly (PL 12.12.16) using one Screw (M3 x 6).

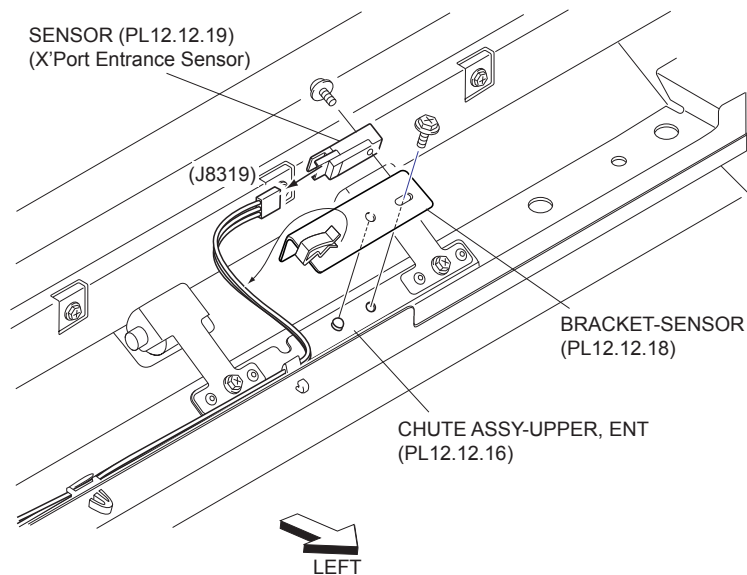
**NOTE** Be sure to put the two bosses of the Upper Entrance Chute Assembly into the two holes on the bracket of the Entrance Pinch Roller Assembly.

2. Install the Left Hand Top Cover (PL 12.5.9) .
3. Install the Left Hand Front Cover (PL 12.5.8) .
4. Install the Top Cover (PL 12.4.1) .
5. Install the Upper Rear Cover (PL 12.4.11) .
6. Close the Front Cover Assembly (PL 12.5.3).

## Transport Entrance Sensor

## Removal

1. Open the Front Cover Assembly (PL 12.5.3).
2. Remove the Upper Rear Cover (PL 12.4.11) .
3. Remove the Top Cover (PL 12.4.1) .
4. Remove the Left Hand Front Cover (PL 12.5.8) .
5. Remove the Left Hand Top Cover (PL 12.5.9) .
6. Disconnect the connector (J8319) of the Transport Entrance Sensor Harness Assembly (PL 12.15.4) from the Sensor (Transport Entrance Sensor) .
7. Release the Transport Entrance Sensor Harness Assembly from the clamp of the Sensor Bracket (PL 12.12.18).
8. Remove the one Screw (M3 x 6) securing the Sensor Bracket to the Upper Entrance Chute Assembly (PL 12.12.16).
9. Remove the Sensor Bracket.
10. Remove the one Screw (M 3 x 12) securing the Sensor (Transport Entrance Sensor) to the Sensor Bracket.
11. Remove the Sensor.



**Figure 1 Transport Entrance Sensor**

## Replacement

1. Install the Sensor (Transport Entrance Sensor) to the Sensor Bracket (PL 12.12.18) using one Screw (M3 x 12).

**NOTE** Install the Sensor in the direction shown in the figure.

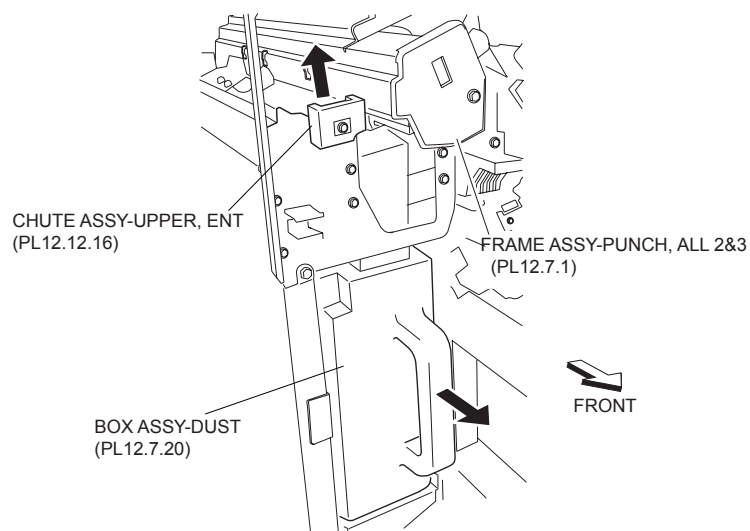
2. Install the Sensor Bracket to the Upper Entrance Chute Assembly (PL 12.12.16) using one Screw (TP M3 x 6).
3. Connect the connector (J8319) of the Transport Entrance Sensor Harness Assembly (PL 12.15.4) to the Sensor.
4. Secure the Transport Entrance Sensor Harness Assembly with the clamp of the Sensor Bracket.
5. Install the Left Hand Top Cover (PL 12.5.9) .
6. Install the Left Hand Front Cover (PL 12.5.8) .
7. Install the Top Cover (PL 12.4.1) .

8. Install the Upper Rear Cover (PL 12.4.11) .
9. Close the Front Cover Assembly (PL 12.5.3).

## Entrance Roll Assembly

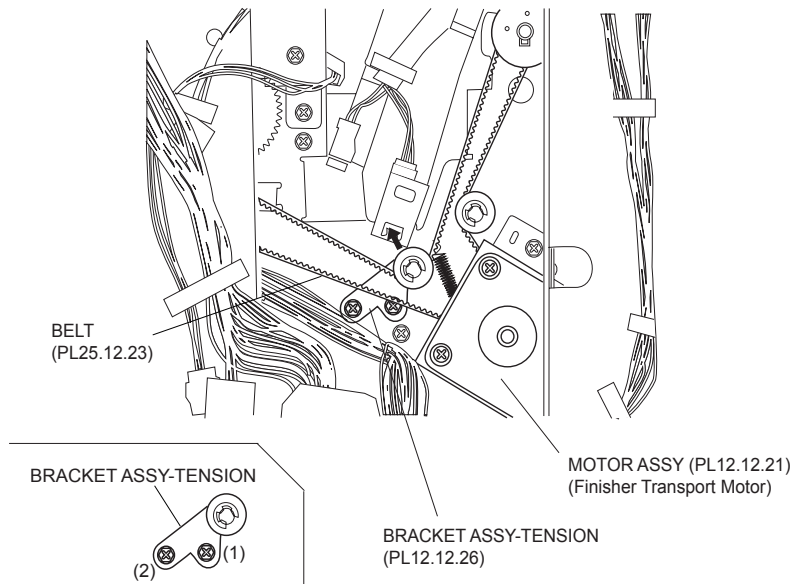
### Removal

1. Open the Front Cover Assembly (PL 12.5.3).
2. Remove the Upper Rear Cover (PL 12.4.11) .
3. Remove the Left Hand Top Cover (PL 12.5.9) .
4. Pull the Dust Box Assembly toward you to remove it from the Finisher .
5. Remove the three Screws on the front and one Screw on the rear securing the Dust Box Chute Assembly to the Finisher to remove the Dust Box Chute Assembly.
6. Open the lever of the Upper Entrance Chute Assembly (PL 12.12.16) upward by hand.
7. Remove the Punch Frame Assembly (PL 12.7.1) .



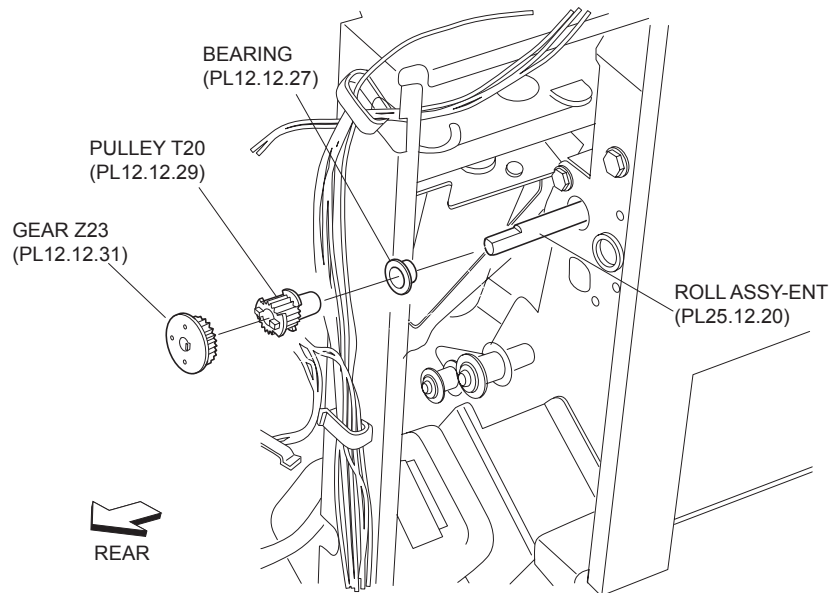
**Figure 1 Punch Frame Assembly**

8. Loosen the two Screws securing the Tension Bracket Assembly (PL 12.12.26) for the Motor Assembly (PL 12.12.21) (Finisher Transport Motor) .
9. Move the Tension Bracket Assembly in the direction of the arrow so that the tension of the Belt (PL 12.12.23) decreases, and remove the Belt from each pulley.



**Figure 2 Tension Bracket Assembly**

10. Release the hook of the Z23 Gear (PL 12.12.31) on the rear attached to the Entrance Roll Assembly to remove the Z23 Gear .
11. Remove the T20 Pulley (PL 12.12.29).
12. Remove the Bearing (PL 12.12.27).

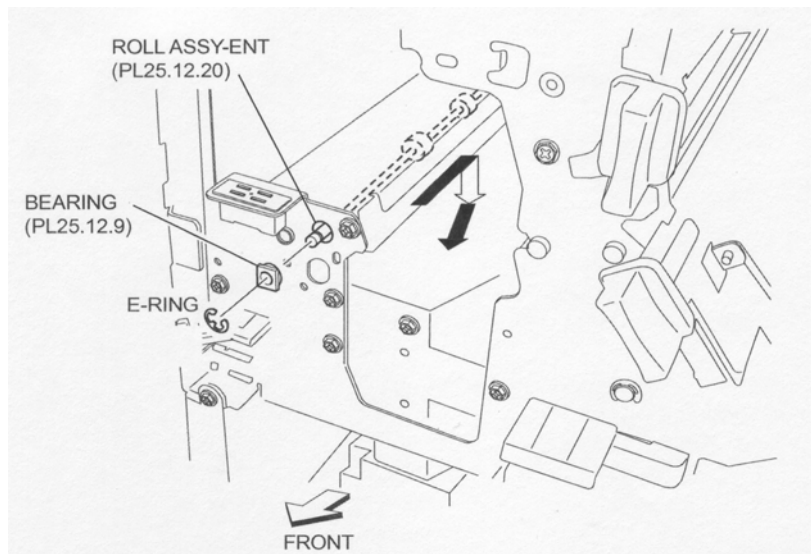


**Figure 3 Z23 Gear**

13. Remove the E-ring securing the Entrance Roll Assembly on the front .
14. Remove the Bearing (PL 12.12.9).
15. Push the Entrance Roll Assembly to the rear to remove the front end of the Entrance Roll Assembly from the hole on the frame first, and move the Entrance Roll Assembly downward to remove it from the front.

**NOTE** Be careful not to hold the rubber roller of the Entrance Roll Assembly.





**Figure 4 Entrance Roll Assembly**

## Replacement

1. Move the Entrance Roll Assembly in the opposite direction of the arrow to install it to the Finisher.

**NOTE** Install the Entrance Roll Assembly with its one end with the flat surface facing the rear.

**NOTE** Be careful not to hold the rubber roller of the Entrance Roll Assembly.

2. Install the Bearing (PL 12.12.9) to the shaft of the Entrance Roll Assembly on the front.
3. Secure the Bearing using the E-ring.
4. Install the Bearing (PL 12.12.27) to the Entrance Roll Assembly on the rear.
5. Install the T20 Pulley (PL 12.12.29) to the Entrance Roll Assembly.
6. Install the Z23 Gear (PL 12.12.31) to the Entrance Roll Assembly, and secure it using the hook.
7. While pushing the Tension Bracket Assembly (PL 12.12.26) in the direction of the arrow, install the Belt (PL 12.12.23) onto each pulley.
8. Fix the Tension Bracket Assembly to the frame using two Screws.

**NOTE** The tension of the belt is automatically adjusted by the force of the Tension Spring attached to the Tension Bracket Assembly. Therefore, when tightening the two Screws, be careful not to move the Tension Bracket Assembly.

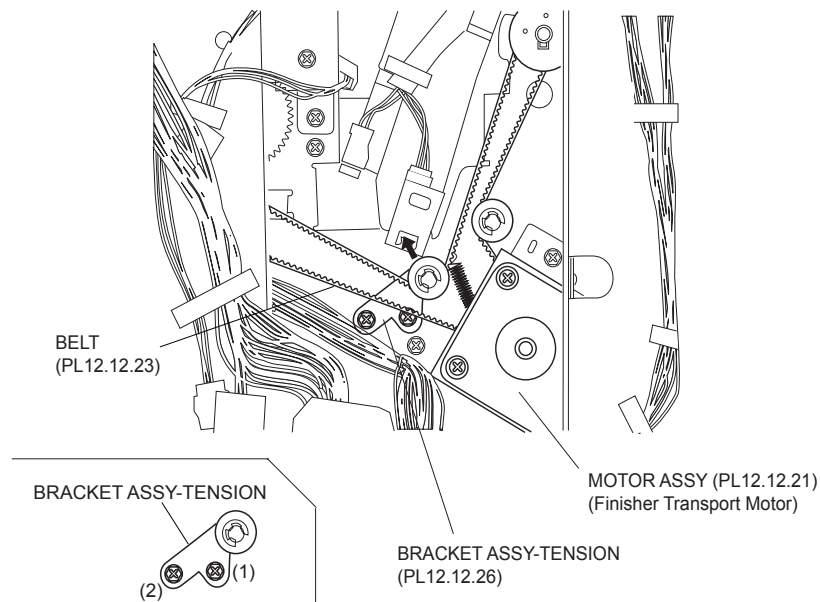
**NOTE** Tighten the two Screws in order of (1) and (2) shown in the figure.

9. Install the Dust Box Chute Assembly using the three Screws on the front and one Screw on the rear.
10. Install the Dust Box Assembly (PL 12.7.20).
11. Close the Upper Entrance Chute Assembly (PL 12.12.16).
12. Install the Punch Frame Assembly (PL 12.7.1) .
13. Install the Left Hand Top Cover (PL 12.5.9) .
14. Install the Upper Rear Cover (PL 12.4.11) .
15. Close the Front Cover Assembly (PL 12.5.3).

## Finisher Transport Motor & Belt Assembly

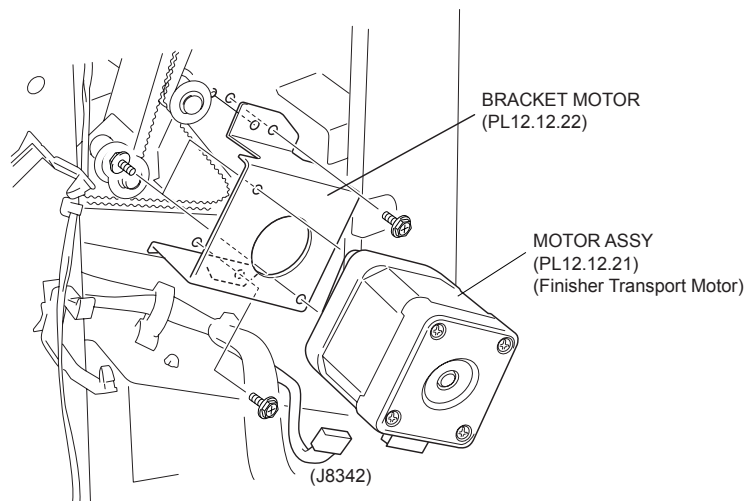
### Removal

1. Remove the Upper Rear Cover (PL 12.4.11) .
2. Loosen the two Screws (M3 x 6) securing the Tension Bracket Assembly (PL 12.12.26) for the Motor Assembly (PL 12.12.21) (Finisher Transport Motor) .
3. Move the Tension Bracket Assembly in the direction of the arrow so that the tension of the Belt (PL 12.12.23) decreases, and remove the Belt from each pulley.



**Figure 1 Tension Bracket Assembly**

4. Disconnect the connector (J8342) of the Main Drive Harness Assembly (PL 12.15.2) from the Motor Assembly.
5. Remove the two Screws (M3 x 6) securing the Motor Assembly.
6. Remove the Motor Assembly.
7. Remove the two Screws securing the Motor Assembly to the Motor Bracket (PL 12.12.22) to remove the Motor Assembly.



**Figure 2 Motor Assembly**

## Replacement

1. Install the Motor Assembly (Finisher Transport Motor) to the Motor Bracket (PL 12.12.22) in the direction shown in the figure using two Screws.
2. Install the Motor Assembly to the Finisher using two Screws (M3 x 6).

**NOTE** Be sure to put the two bosses of the chassis into the two holes on the Bracket Assembly attached with the Motor Assembly.

3. Connect the connector (J8342) of the Main Drive Harness Assembly (PL 12.15.2) to the Motor Assembly.
4. While pushing the Tension Bracket Assembly (PL 12.12.26) in the direction of the arrow, install the Belt (PL 12.12.23) onto each pulley.
5. Fix the Tension Bracket Assembly to the frame using two Screws.

**NOTE** The tension of the belt is automatically adjusted by the force of the Tension Spring (PL 12.13.24) attached to the Tension Bracket Assembly. Therefore, when tightening the two Screws, be careful not to move the Tension Bracket Assembly.

**NOTE** Tighten the two Screws in order of (1) and (2) shown in the figure.

6. Install the Upper Rear Cover (PL 12.4.11) .

## Transport Gate Solenoid Bracket Assembly

### Removal

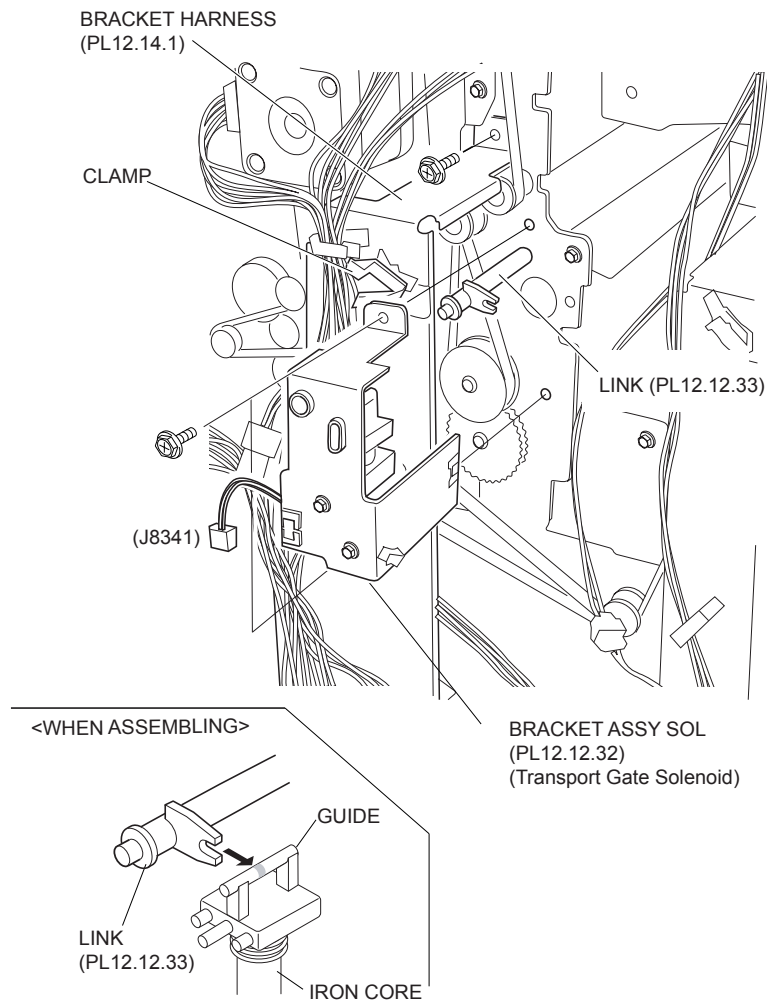
1. Open the Front Cover Assembly (PL 12.5.3).
2. Remove the Upper Rear Cover (PL 12.4.11) .
3. Disconnect the harness connector (J8341) of the Solenoid Bracket Assembly (Transport Gate Solenoid) from the Main Drive Harness Assembly (PL 12.15.2) .
4. Release the harness of the Solenoid Bracket Assembly from the clamp.
5. Remove the two Screws securing the Harness Bracket (PL 12.14.1).

**NOTE** In this procedure, remove only two Screws securing the Harness Bracket to make easier to perform the removal and replacement procedures for the Solenoid Bracket Assembly, not to remove the Harness Bracket itself from the Finisher.

6. Remove the two Screws securing the Solenoid Bracket Assembly to the Finisher.

**NOTE** When removing, Link (PL 12.12.33) may be detached together with the Solenoid Bracket Assembly or it may remain on the frame. When it remains on the frame, remove it.

**NOTE** When the Link is removed, Gate (PL 12.12.6) will be detached inside of the Finisher. If it is detached, install it referring to .



**Figure 1 Solenoid Bracket Assembly**

## Replacement

1. While holding the Gate (PL 12.12.6) from the front, put the Link (PL 12.12.33) into the hole on the Gate in the direction shown in the figure from the rear.
2. Install the Solenoid Bracket Assembly (Transport Gate Solenoid) to the Finisher while putting the GUIDE attached with the iron core of the solenoid into the notch of the Link.
3. Install the Solenoid Bracket Assembly to the Finisher using two Screws.
4. Fix the Harness Bracket (PL 12.14.1) to the Finisher using two Screws.
5. Secure the harness of the Solenoid Bracket Assembly using the clamp.
6. Connect the harness connector (J8341) of the Solenoid Bracket Assembly to the Main Drive Harness Assembly (PL 12.15.2).
7. Install the Upper Rear Cover (PL 12.4.11) .
8. Close the Front Cover Assembly (PL 12.5.3).

## Buffer Gate Solenoid Bracket Assembly

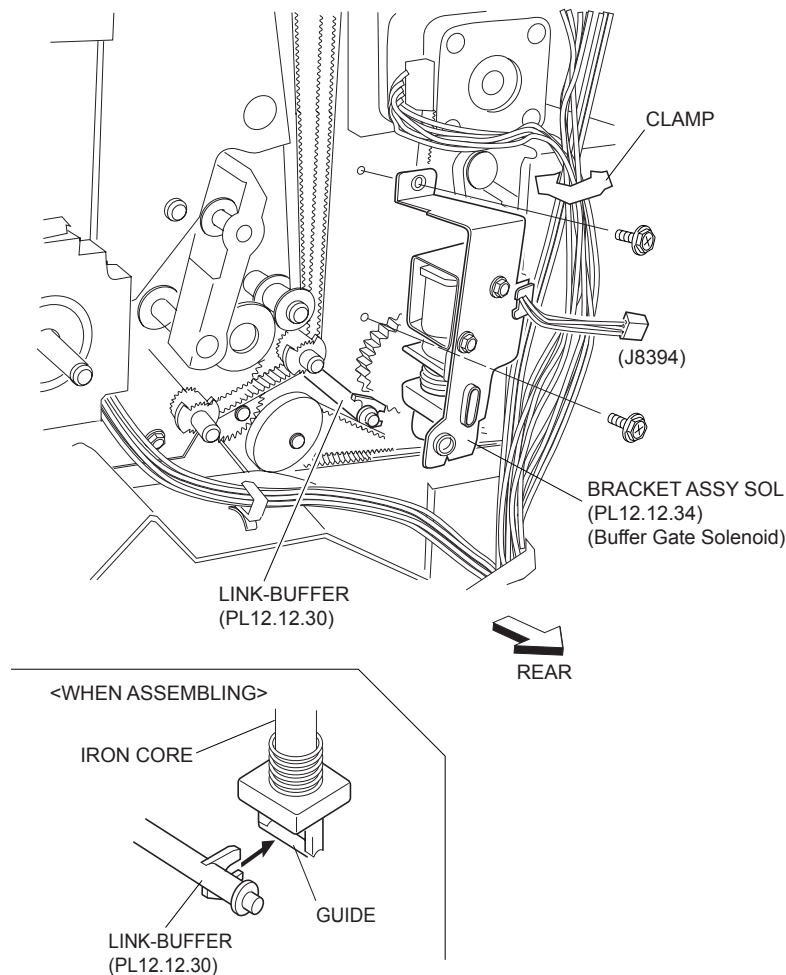
### Removal

1. Open the Front Cover Assembly (PL 12.5.3).
2. Remove the Upper Rear Cover (PL 12.4.11) .

3. Disconnect the harness connector (J8394) of the Solenoid Bracket Assembly (Buffer Gate Solenoid) from the Main Drive Harness Assembly (PL 12.15.2) .
4. Release the harness of the Solenoid Bracket Assembly from the clamp.
5. Remove the two Screws securing the Solenoid Bracket Assembly to the Finisher.
6. Remove the Solenoid Bracket Assembly.

**NOTE** When removing, Buffer Link (PL 12.12.30) may be detached together with the Solenoid Bracket Assembly or it may remain on the frame. When it remains on the frame, remove it.

**NOTE** When the Buffer Link is removed, Buffer Gate (PL 12.12.7) will be detached inside of the Finisher. If it is detached, install it referring to .



**Figure 1 Solenoid Bracket Assembly**

## Replacement

1. While holding the Buffer Gate (PL 12.12.7) from the front, put the Buffer Link (PL 12.12.30) into the hole on the Buffer Gate in the direction shown in the figure from the rear.
2. Install the Solenoid Bracket Assembly (Buffer Gate Solenoid) to the Finisher while putting the GUIDE attached with the iron core of the solenoid into the notch of the Buffer Link.
3. Install the Solenoid Bracket Assembly to the Finisher using two Screws.
4. Secure the harness of the Solenoid Bracket Assembly with the clamp.
5. Connect the harness connector (J8394) of the Solenoid Bracket Assembly to the Main Drive Harness Assembly (PL 12.15.2).
6. Install the Upper Rear Cover (PL 12.4.11) .

7. Close the Front Cover Assembly (PL 12.5.3).

## Top Tray Exit Sensor

### Removal

1. Open the Front Cover Assembly (PL 12.5.3).
2. Remove the Upper Rear Cover (PL 12.4.11) .
3. Remove the Top Cover (PL 12.4.1) .
4. Disconnect the connector (J8321) of the Top Exit Sensor Harness Assembly (PL 12.15.6) from the Sensor (Top Tray Exit Sensor) .
5. Release the hooks of the Sensor to remove the Sensor from the Upper Right Top Exit Chute Assembly (PL 12.13.1).

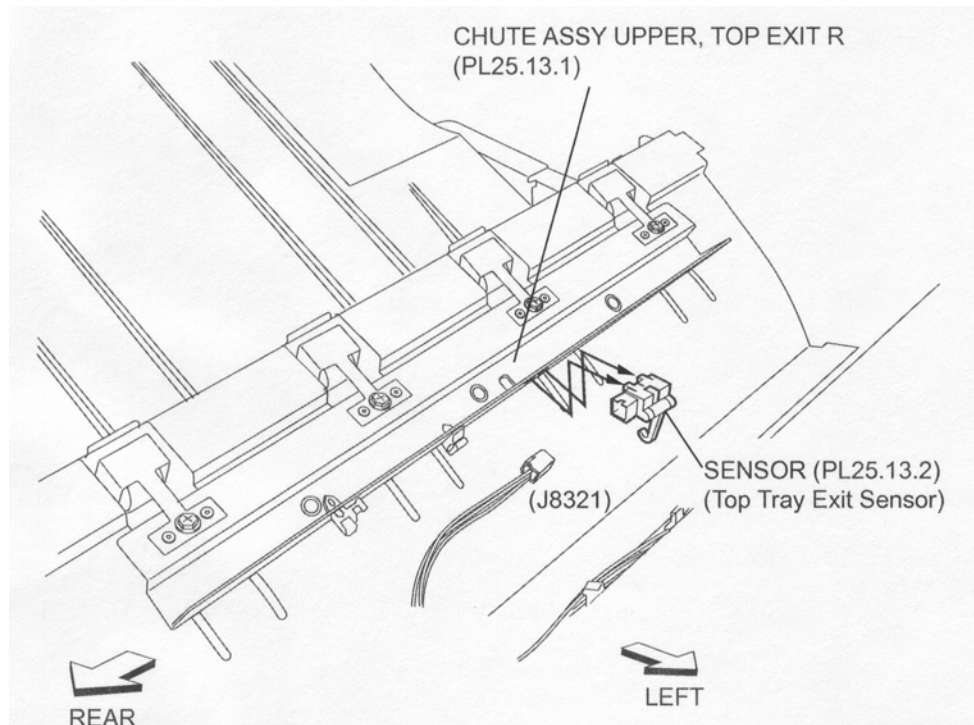


Figure 1 Top Tray Exit Sensor

### Replacement

1. Secure the Sensor (Top Tray Exit Sensor) to the Upper Right Top Exit Chute Assembly (PL 12.13.1) using the hooks.
2. Connect the connector (J8321) of the Top Exit Sensor Harness Assembly (PL 12.15.6) to the Sensor.
3. Install the Top Cover (PL 12.4.1) .
4. Install the Upper Rear Cover (PL 12.4.11) .
5. Close the Front Cover Assembly (PL 12.5.3).

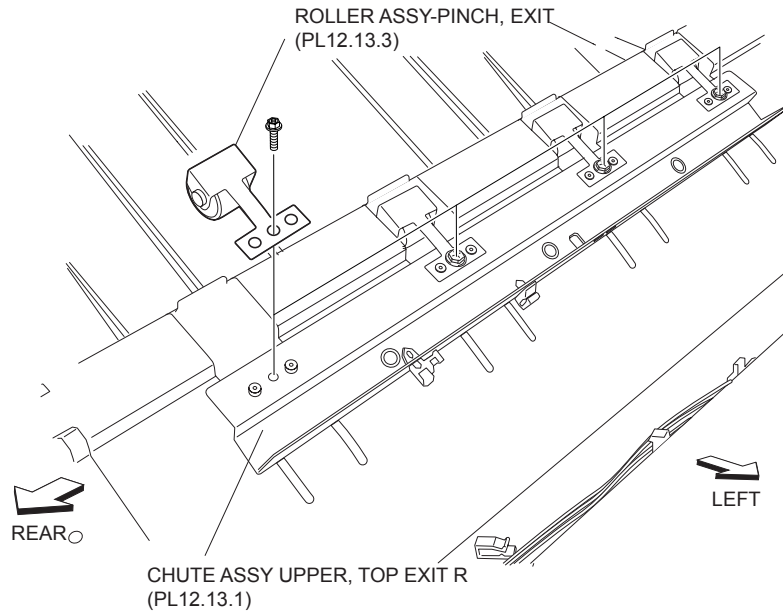
## Exit Pinch Roller Assembly

### Removal

1. Open the Front Cover Assembly (PL 12.5.3).
2. Remove the Upper Rear Cover (PL 12.4.11) .

3. Remove the Top Cover (PL 12.4.1) .
4. Remove the one Screw (M3 x 6) securing the Exit Pinch Roller Assembly to the Upper Right Top Exit Chute Assembly (PL 12.13.1) to remove .

**NOTE** Remove the other three Exit Pinch Roller Assemblies using the same procedure.



**Figure 1 Exit Pinch Roller Assembly**

## Replacement

1. Install the Exit Pinch Roller Assembly to the Upper Right Top Exit Chute Assembly (PL 12.13.1) using one Screw (M3 x 6).

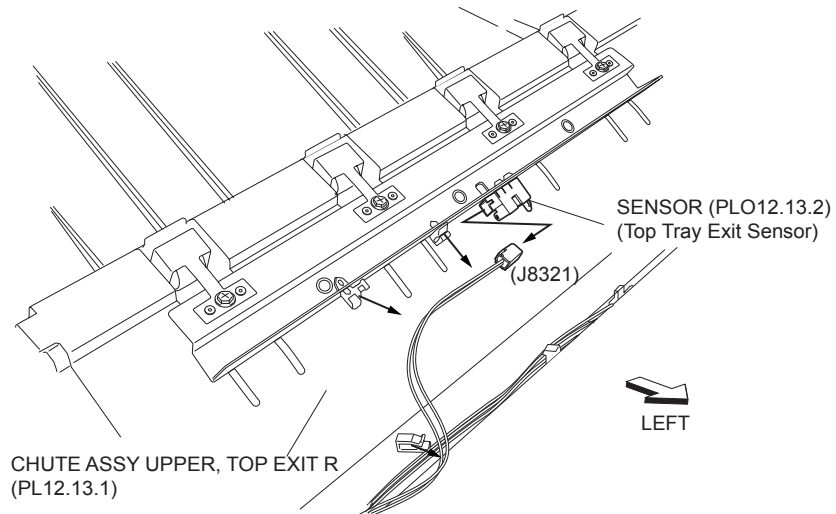
**NOTE** Be sure to put the two bosses of the Upper Right Top Exit Chute Assembly into the two holes on the Exit Pinch Roller Assembly.

2. Install the Top Cover (PL 12.4.1) .
3. Install the Upper Rear Cover (PL 12.4.11) .
4. Close the Front Cover Assembly (PL 12.5.3).

## Top Exit Roll Assembly

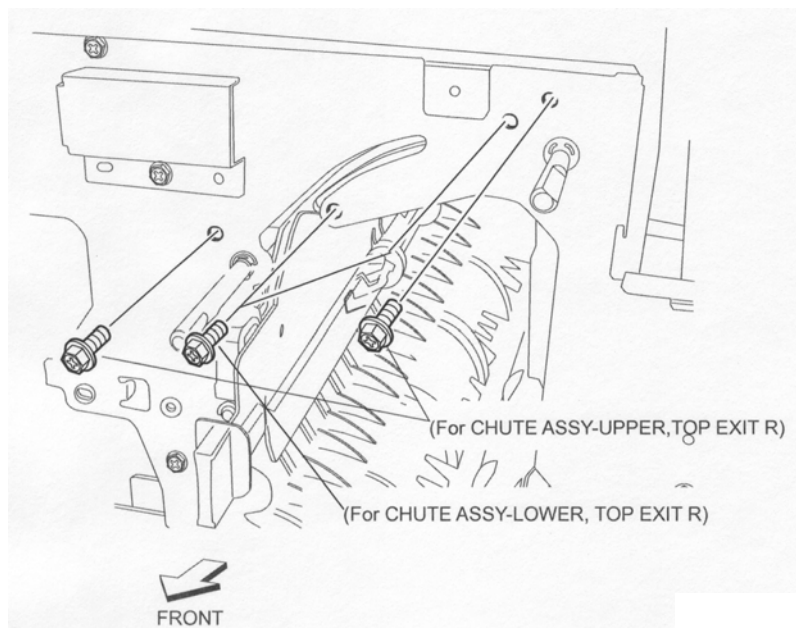
### Removal

1. Open the Front Cover Assembly (PL 12.5.3).
2. Remove the Upper Rear Cover (PL 12.4.11) .
3. Remove the Top Cover (PL 12.4.1) .
4. Remove the Motor Assembly (PL 12.13.30) (Exit Motor) .
5. Disconnect the connector (J8321) of the Top Exit Sensor Harness Assembly (PL 12.15.6) from the Sensor (PL 12.13.2) (Top Tray Exit Sensor) .
6. Release the Top Exit Sensor Harness Assembly from the harness clamps.



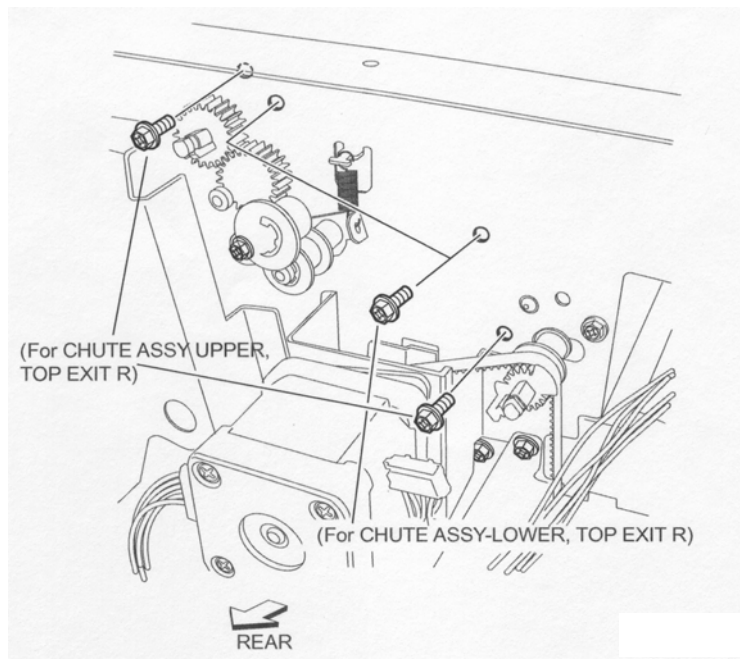
**Figure 1 Top Tray Exit Sensor**

7. Remove the two Screws each on the front and rear securing the Upper Right Top Exit Chute Assembly (PL 12.13.1) to the Finisher .
8. Remove the two Screws each on the front and rear securing the Lower Top Right Exit Chute Assembly (PL 12.13.4) to the Finisher.



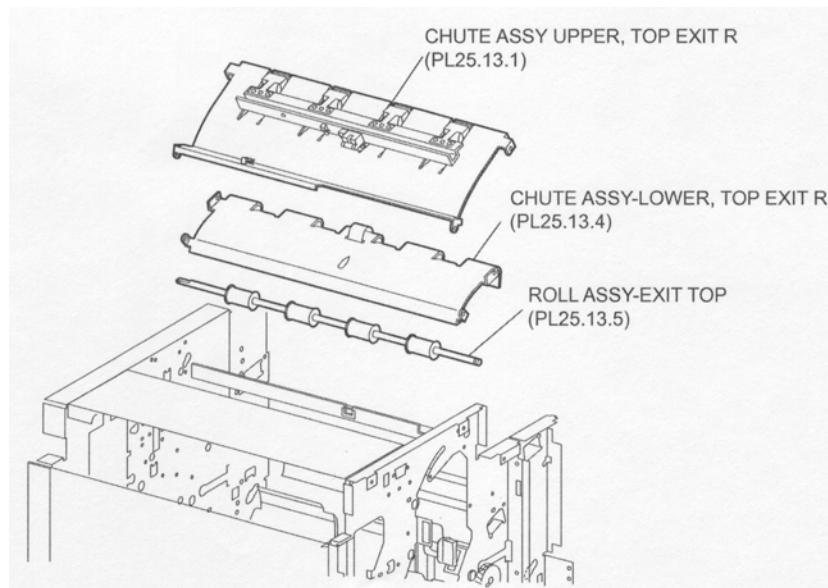
**Figure 2 Upper & Lower Top Exit Chutes**





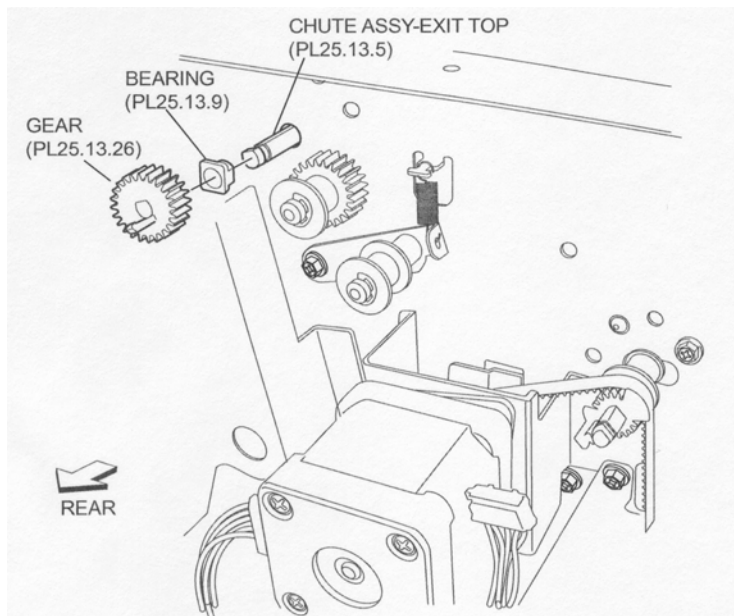
**Figure 3 Upper & Lower Top Exit Chutes**

9. Remove the Upper Right Top Exit Chute Assembly and the Lower Top Right Exit Chute Assembly .



**Figure 4 Exit Chutes**

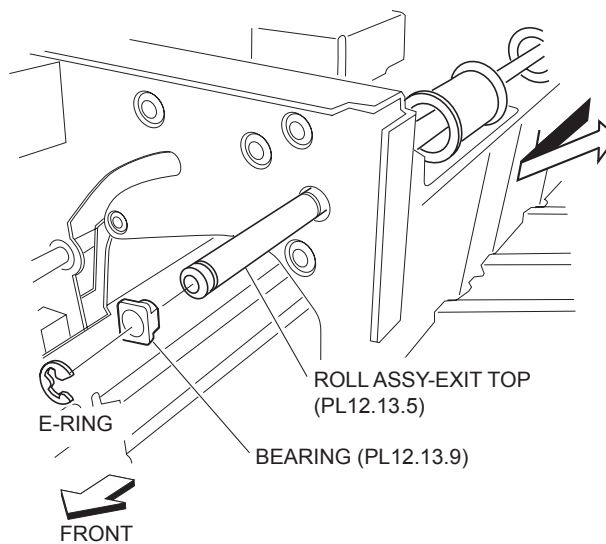
10. Release the hook of the Gear (PL 12.13.26) on the rear to remove the Gear from the Top Exit Roll Assembly .
11. Remove the Bearing (PL 12.13.9).



**Figure 5 Gear**

12. Remove the E-ring securing the Top Exit Roll Assembly on the front .
13. Remove the Bearing (PL 12.13.9).
14. Move the Top Exit Roll Assembly to the front to remove the rear end of the shaft from the rear hole on the frame, and remove the Top Exit Roll Assembly from the Finisher.

**NOTE Do not hold the rubber roller of the Top Exit Roll Assembly.**



**Figure 6 Roll Assembly Bearing**

## Replacement

1. Put the front end of the Top Exit Roll Assembly into the hole on the front frame first, and put the rear end of the shaft into the hole on the rear frame.

**NOTE Do not hold the rubber roller of the Top Exit Roll Assembly.**

**NOTE Install the Top Exit Roll Assembly with its one end with the flat surface facing the rear.**

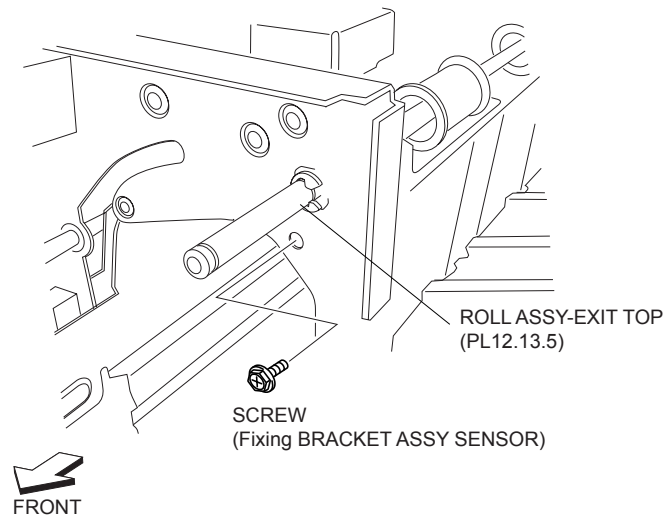
2. Install the Bearing (PL 12.13.9) to the Top Exit Roll Assembly on the front.

3. Secure the Bearing using the E-ring.
4. Install the Bearing (PL 12.13.9) to the Top Exit Roll Assembly on the rear.
5. Install the Gear (PL 12.13.26) to the Top Exit Roll Assembly on the rear, and secure it with the hook.
6. Install the Lower Top Right Exit Chute Assembly (PL 12.13.4) to the Finisher using two Screws each on the front and rear.
7. Install the Upper Right Top Exit Chute Assembly (PL 12.13.1) to the Finisher using two Screws each on the front and rear.
8. Connect the connector (J8321) of the Top Exit Sensor Harness Assembly (PL 12.15.6) to the Sensor (PL 12.13.2) (Top Tray Exit Sensor).
9. Secure the Top Exit Sensor Harness Assembly using a harness clamps.
10. Install the Motor Assembly (PL 12.13.30) (Exit Motor) .
11. Install the Top Cover (PL 12.4.1) .
12. Install the Upper Rear Cover (PL 12.4.11) .
13. Close the Front Cover Assembly (PL 12.5.3).

## Top Tray Full Sensor

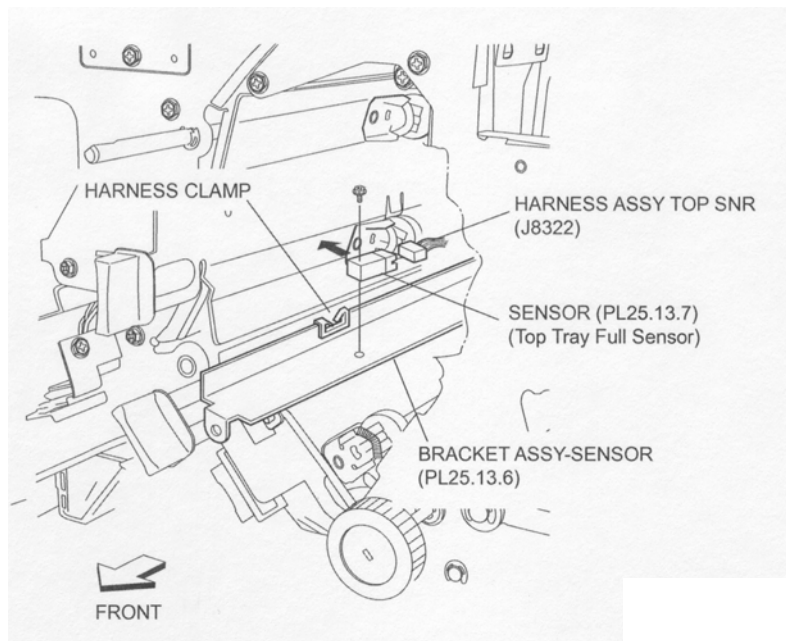
### Removal

1. Open the Front Cover Assembly (PL 12.5.3).
2. Remove the one Screw (M3 x 8) on the front side securing the Sensor Bracket Assembly (PL 12.13.6) .
3. Pull the Sensor Bracket Assembly to the front.



**Figure 1 Sensor Bracket Assembly**

4. Move the Sensor Bracket Assembly downward so that the Sensor Bracket Assembly can be seen from the front side of the Finisher .
5. Release the Top Sensor Harness Assembly (PL 12.15.7) from the clamp on the Sensor Bracket Assembly.
6. Pull the Sensor Bracket Assembly to the front, and remove the one Screw securing the Sensor (Top Tray Full Sensor).
7. Disconnect the connector (J8322) of the Top Sensor Harness Assembly from the Sensor.



**Figure 2 Top Tray Full Sensor**

## Replacement

1. Connect the connector (J8322) of the Top Sensor Harness Assembly (PL 12.15.7) to the Sensor (Top Tray Full Sensor).
2. Install the Sensor to the Sensor Bracket Assembly (PL 12.13.6) using the one Screw.

**NOTE** Install the Sensor so that the sensing portion faces to the SCT Tray Assembly (PL 12.4.3).

3. Clamp the Top Sensor Harness Assembly to the Sensor Bracket Assembly using the clamp.
4. Move the Sensor Bracket Assembly upward, and place it to the installing position on the frame.
5. Secure the Sensor Bracket Assembly to the front frame using the one Screw (M3 x 8).
6. Close the Front Cover Assembly (PL 12.5.3).

## Lower Left Top Exit Chute Assembly

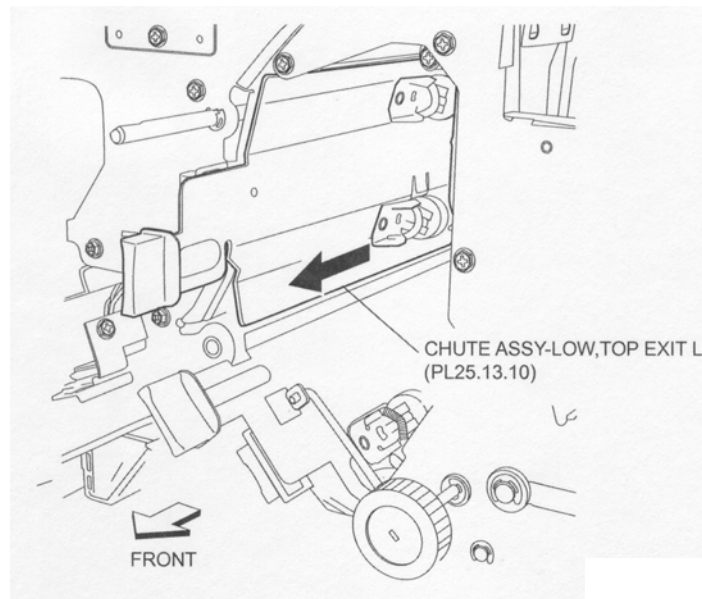
### Removal

1. Open the Front Cover Assembly (PL 12.5.3).
2. Remove the Upper Rear Cover (PL 12.4.11) .
3. Remove the Motor Assembly (PL 12.13.30) (Registration Motor) .
4. Remove the three Screws securing the hinge of the Lower Left Top Exit Chute Assembly on the rear .



**Figure 1 Top Exit Chute Assembly**

5. Remove the Lower Left Top Exit Chute Assembly from the Finisher while removing the hinge of the Lower Left Top Exit Chute Assembly from the square hole on the rear frame .



**Figure 2 Top Exit Chute Assembly**

## Replacement

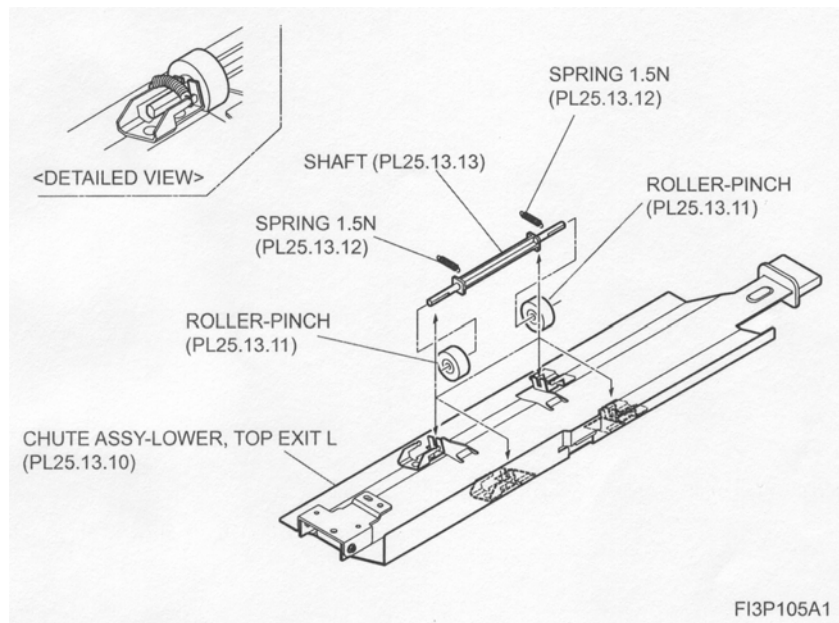
1. Put the Lower Left Top Exit Chute Assembly into the Finisher from the front, and put the hinge of the Lower Left Top Exit Chute Assembly into the square hole on the rear frame.
2. Install the hinge of the Lower Left Top Exit Chute Assembly to the rear frame using three Screws.
3. Install the Motor Assembly (PL 12.13.30) (Registration Motor) .
4. Install the Upper Rear Cover (PL 12.4.11) .
5. Close the Front Cover Assembly (PL 12.5.3).

## Pinch Roller

## Removal

1. Open the Front Cover Assembly (PL 12.5.3).
2. Remove the Upper Rear Cover (PL 12.4.11) .
3. Remove the Motor Assembly (PL 12.13.30) (Registration Motor) .
4. Remove the Lower Left Top Exit Chute Assembly (PL 12.13.10) .
5. Remove the 1.5N Spring (PL 12.13.12) left and right, and remove the Shaft (PL 12.13.13) attached with the two Pinch Rollers.
6. Remove the two Pinch Rollers from the Shaft.

**NOTE** Remove another Pinch Roller using the same procedure.



**Figure 1 Lower Left Top Exit Chute Assembly**

## Replacement

1. Install the two Pinch Rollers on both ends of the Shaft (PL 12.13.13).
2. Install the Shaft attached with the two Pinch Rollers to the Lower Left Top Exit Chute Assembly (PL 12.13.10) using the two 1.5N Springs (PL 12.13.12). (Refer to the detailed figure.)

**NOTE** Install another Pinch Roller using the same procedure.

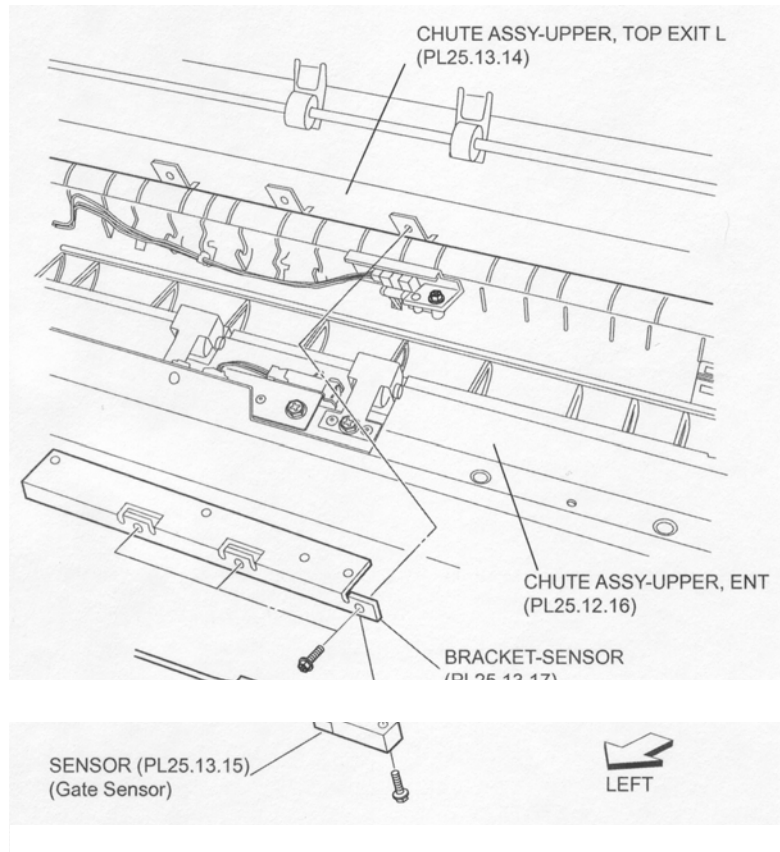
3. Install the Lower Left Top Exit Chute Assembly .
4. Install the Motor Assembly (PL 12.13.30) (Registration Motor) .
5. Install the Upper Rear Cover (PL 12.4.11) .
6. Close the Front Cover Assembly (PL 12.5.3).

## Gate Sensor

### Removal

1. Open the Front Cover Assembly (PL 12.5.3).
2. Remove the Upper Rear Cover (PL 12.4.11) .
3. Remove the Top Cover (PL 12.4.1) .
4. Remove the Left Hand Front Cover (PL 12.5.8) .
5. Remove the Left Hand Top Cover (PL 12.5.9) .

6. Remove the Punch Frame Assembly (PL 12.7.1) .
7. Open the Upper Entrance Chute Assembly (PL 12.12.16).
8. Remove the three Screws securing the Sensor Bracket (PL 12.13.17) to the Upper Left Top Exit Chute Assembly to remove.
9. Disconnect the connector of the Sensor Harness Assembly (PL 12.13.16) from the Sensor (Gate Sensor).
10. Remove the one Screw securing the Sensor (Gate Sensor) to remove it from the Sensor Bracket.



**Figure 1 Top Exit Chute Assembly**

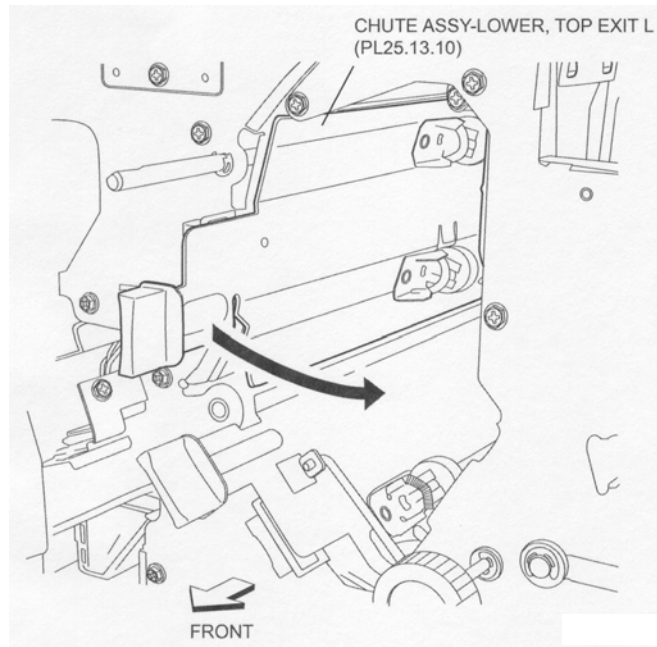
## Replacement

1. Install the Sensor (Gate Sensor) to the Sensor Bracket (PL 12.13.17) using one Screw.
2. Connect the connector of the Sensor Harness Assembly (PL 12.13.16) to the Sensor.
3. Install the Sensor Bracket to the Upper Left Top Exit Chute Assembly (PL 12.13.14) using three Screws.
4. Close the Upper Entrance Chute Assembly (PL 12.12.16).
5. Install the Punch Frame Assembly (PL 12.7.1) .
6. Install the Left Hand Top Cover (PL 12.5.9) .
7. Install the Left Hand Front Cover (PL 12.5.8) .
8. Install the Top Cover (PL 12.4.1) .
9. Install the Upper Rear Cover (PL 12.4.11) .
10. Close the Front Cover Assembly (PL 12.5.3).

## Transport Roll Assembly

### Removal

1. Open the Front Cover Assembly (PL 12.5.3).
2. Remove the Upper Rear Cover (PL 12.4.11) .
3. Remove the Top Cover (PL 12.4.1) .
4. Remove the Left Hand Front Cover (PL 12.5.8) .
5. Remove the Left Hand Top Cover (PL 12.5.9) .
6. Remove the Punch Frame Assembly (PL 12.7.1) .
7. Open the Lower Left Top Exit Chute Assembly (PL 12.13.10) to the right by hand .



**Figure 1 Lower Left Top Exit Chute Assembly**

8. Remove the two Screws securing the Upper Left Top Exit Chute Assembly (PL 12.13.14) on the front .
9. Remove the two Screws securing the Upper Left Top Exit Chute Assembly on the rear .
10. Push the Upper Left Top Exit Chute Assembly toward the paper exit side slightly.

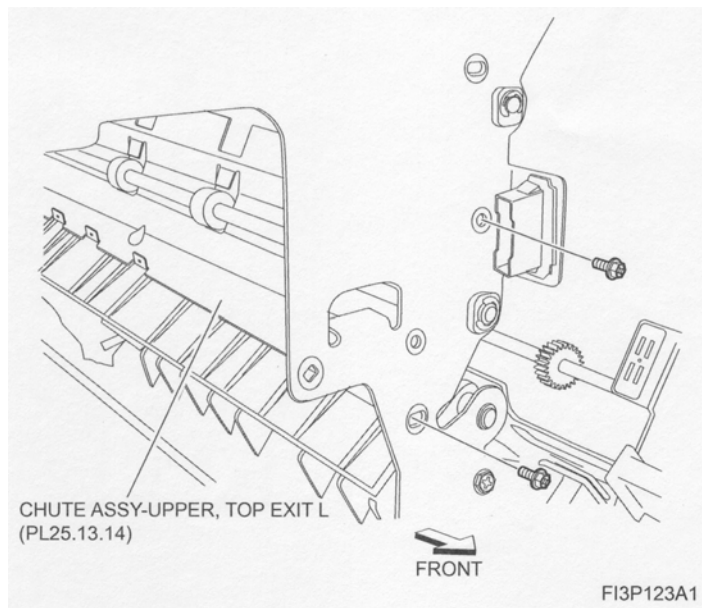
**NOTE** There is no need to remove the Upper Left Top Exit Chute Assembly from the Finisher. Move the Upper Left Top Exit Chute Assembly slightly so that the rubber roller of the Transport Roll Assembly can be easily removed from the square holes on the Upper Left Top Exit Chute Assembly.

11. Remove the two Screws securing the Harness Bracket (PL 12.14.1).

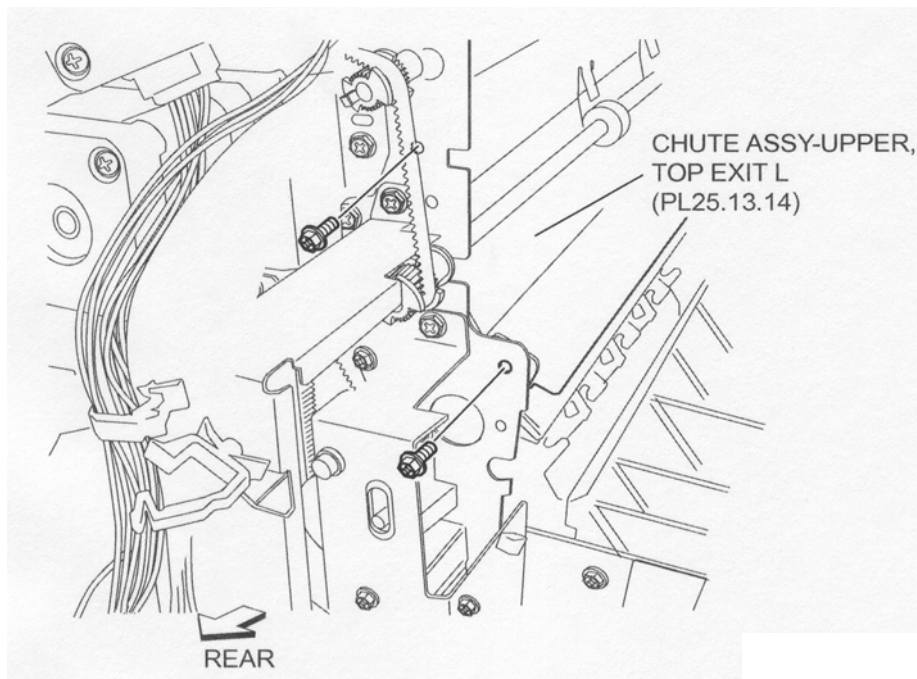
**NOTE** In this procedure, remove only two Screws securing the Harness Bracket to make easier to remove the gear from the Finisher, not to remove the Harness Bracket itself from the Finisher.

12. Loosen the two Screws securing the Tension Bracket Assembly (PL 12.13.23) for the Motor Assembly (PL 12.13.30) (Registration Motor) .
13. Move the Tension Bracket Assembly in the direction of the arrow so that the tension of the Belt (PL 12.13.27) decreases, and remove the Belt from each pulley.
14. Remove the Gear (PL 12.13.21) attached to the Transport Roll Assembly on the rear .
15. Remove the Bearing (PL 12.13.20).





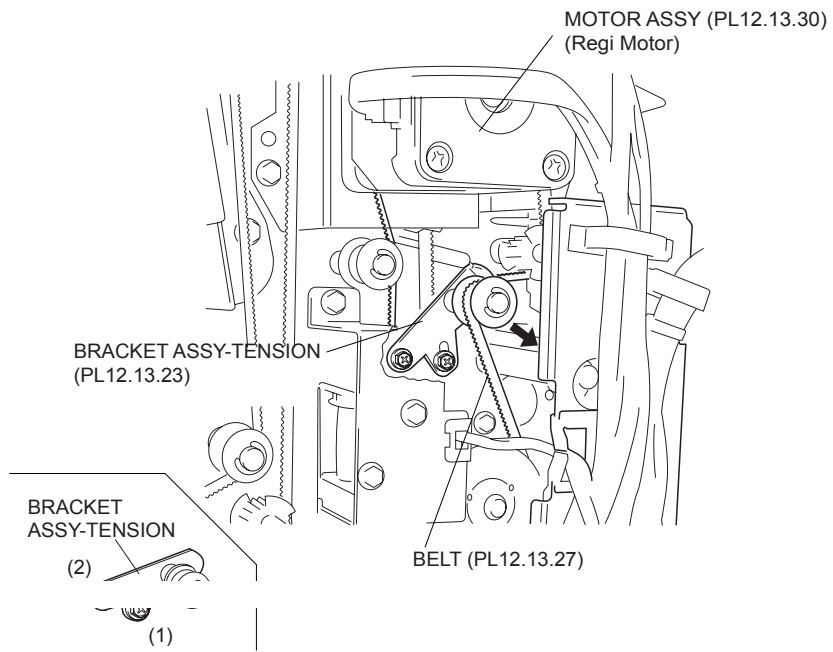
**Figure 2 Upper Left Top Exit Chute Assembly - Front**



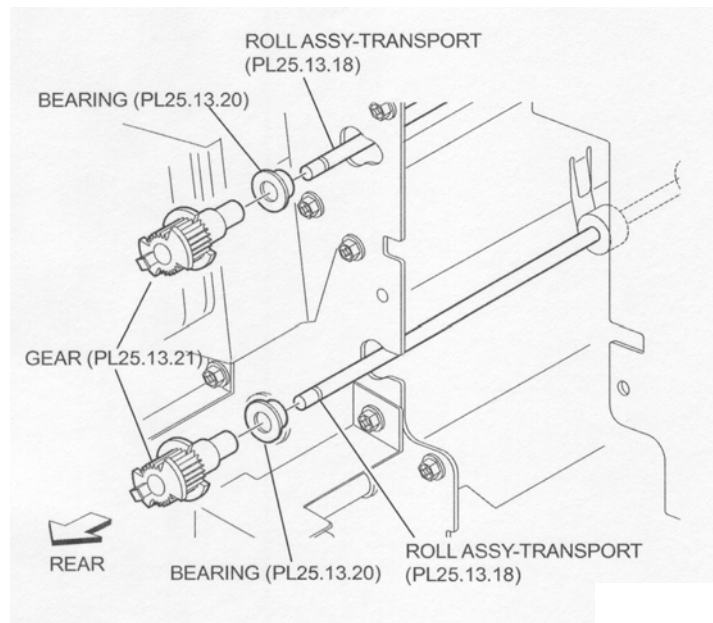
**Figure 3 Upper Left Top Exit Chute Assembly - Rear**

16. Remove the E-ring securing the Transport Roll Assembly on the front .
17. Remove the Bearing (PL 12.13.9).
18. Move the Transport Roll Assembly to the front to remove the rear end of the Transport Roll Assembly from the hole on the rear frame first, and remove it from the Finisher.

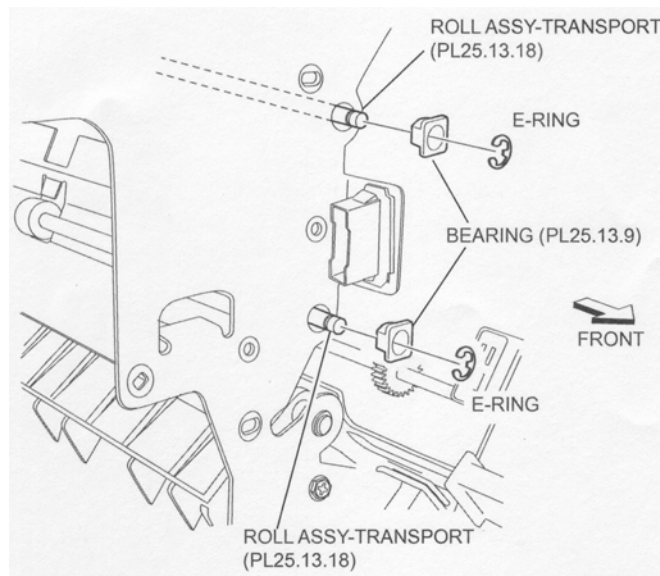
**NOTE** Do not to hold the rubber roller of the Transport Roll Assembly.



**Figure 4 Tension Bracket Assembly**



**Figure 5 Transport Roll Assembly**



**Figure 6 Transport Roll Assembly**

## Replacement

1. Put the front end of the Transport Roll Assembly into the hole on the front frame first, and put the shaft into the hole on the rear frame.

**NOTE Do not to hold the rubber roller of the Transport Roll Assembly.**

2. Install the Bearing (PL 12.13.9) to the Transport Roll Assembly on the front.
3. Secure the Bearing using the E-ring.
4. Install the Bearing (PL 12.13.20) to the Transport Roll Assembly on the rear.
5. Install the Gear (PL 12.13.21) to the shaft of the Transport Roll Assembly on the rear.
6. Install the Upper Left Top Exit Chute Assembly (PL 12.13.14) using two Screws each on the front and rear.
7. While pushing the Tension Bracket Assembly (PL 12.13.23) in the direction of the arrow, install the Belt (PL 12.13.27) onto each pulley.
8. Fix the Tension Bracket Assembly to the frame using two Screws.

**NOTE The tension of the belt is automatically adjusted by the force of the Tension Spring (PL 12.13.24) attached to the Tension Bracket Assembly. Therefore, when tightening the two Screws, be careful not to move the Tension Bracket Assembly.**

**NOTE Tighten the two Screws in order of (1) and (2) shown in the figure.**

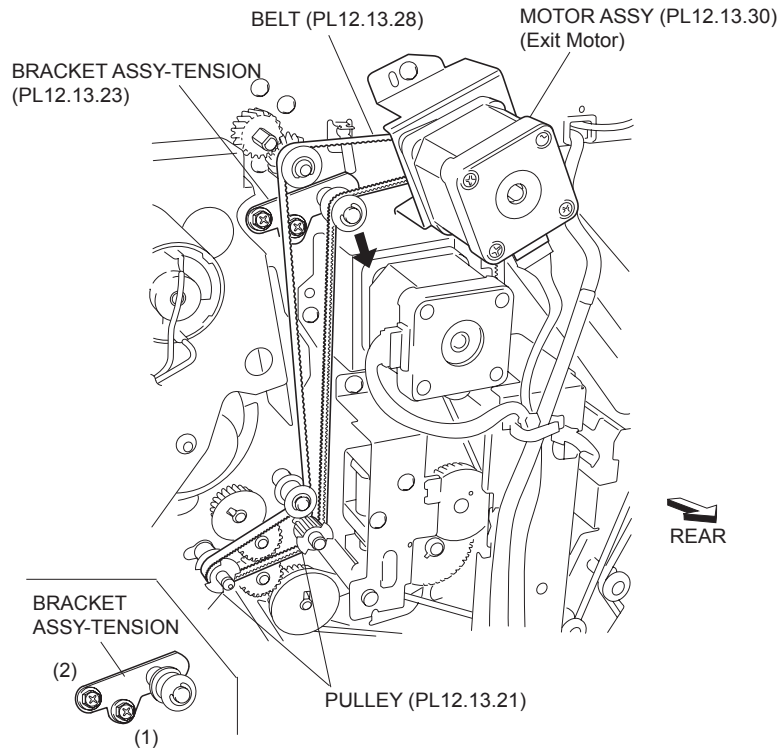
9. Secure the Harness Bracket (PL 12.14.1) using two Screws.
10. Install the Punch Frame Assembly (PL 12.7.1) .
11. Install the Left Hand Top Cover (PL 12.5.9) .
12. Install the Left Hand Front Cover (PL 12.5.8) .
13. Install the Top Cover (PL 12.4.1) .
14. Install the Upper Rear Cover (PL 12.4.11) .
15. Close the Lower Left Top Exit Chute Assembly (PL 12.13.10) to the left by hand.
16. Close the Front Cover Assembly (PL 12.5.3).

## Exit Motor Assembly & Belt

### Removal

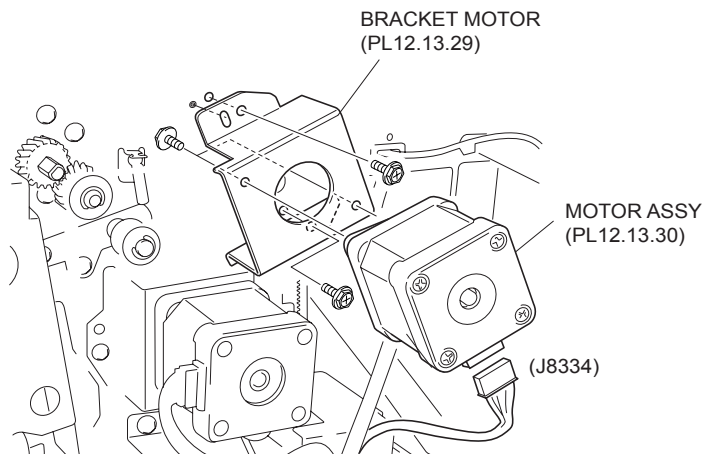
1. Remove the Upper Rear Cover (PL 12.4.11) .

2. Loosen the two Screws securing the Tension Bracket Assembly (PL 12.13.23) for the Motor Assembly (Exit Motor) .
3. Move the Tension Bracket Assembly in the direction of the arrow so that the tension of the Belt (PL 12.13.28) decreases, and remove the Belt from each pulley.



**Figure 1 Tension Bracket Assembly**

4. Disconnect the connector (J8334) of the Main Drive Harness Assembly (PL 12.15.2) from the Motor Assembly .
5. Remove the two Screws securing the Motor Assembly.
6. Remove the Motor Assembly.
7. Remove the two Screws securing the Motor Assembly to the Motor Bracket (PL 12.13.29) to remove.



**Figure 2 Exit Motor Assembly**

## Replacement

1. Install the Motor Assembly (Exit Motor) to the Motor Bracket (PL 12.13.29) in the direction shown in the figure using two Screws.
2. Install the Motor Assembly to the Finisher using two Screws.

**NOTE** Be sure to put the two bosses of chassis into the two holes on the Bracket Assembly attached with the Motor Assembly.

3. Connect the connector (J8334) of the Main Drive Harness Assembly (PL 12.15.2) to the Motor Assembly.
4. While pushing the Tension Bracket Assembly (PL 12.13.23) in the direction of the arrow, install the Belt (PL 12.13.28) onto each pulley.
5. Fix the Tension Bracket Assembly to the frame using two Screws.

**NOTE** The tension of the belt is automatically adjusted by the force of the Tension Spring (PL 12.13.24) attached to the Tension Bracket Assembly. Therefore, when tightening the two Screws, be careful not to move the Tension Bracket Assembly.

**NOTE** Tighten the two Screws in order of (1) and (2) shown in the figure.

6. Install the Upper Rear Cover (PL 12.4.11) .

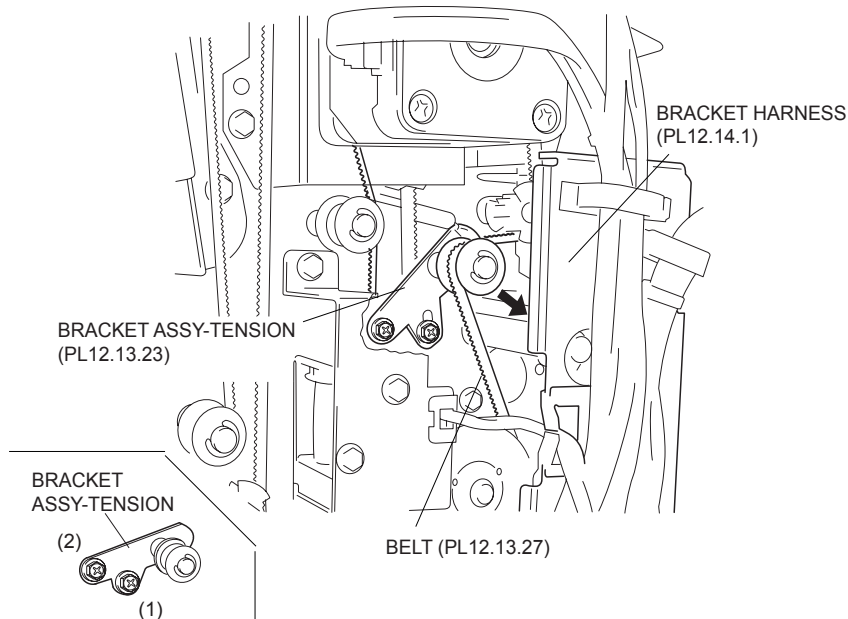
## Registration Motor Assembly & Belt

### Removal

1. Remove the Upper Rear Cover (PL 12.4.11) .
2. Remove the two Screws securing the Harness Bracket (PL 12.14.1).

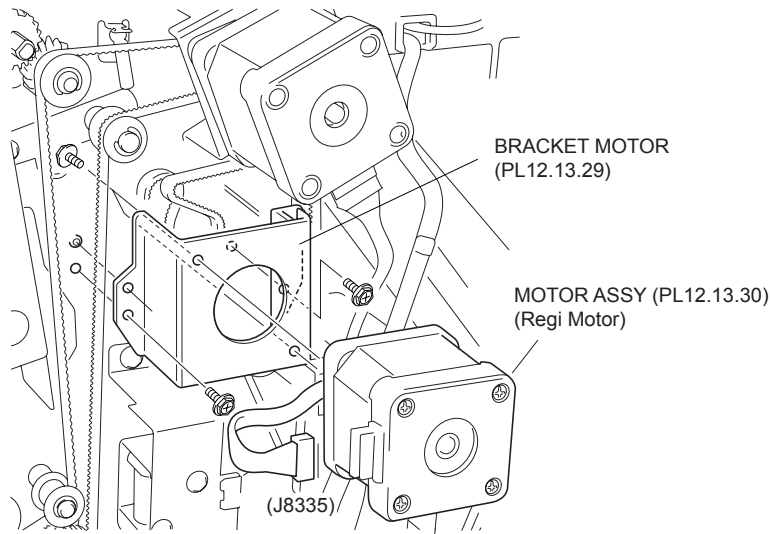
**NOTE** In this procedure, remove only two Screws securing the Harness Bracket to make easier to remove the gear or the like from the Finisher, not to remove the Harness Bracket itself from the Finisher.

3. Loosen the two Screws securing the Tension Bracket Assembly (PL 12.13.23) for the Motor Assembly (Registration Motor) .
4. Move the Tension Bracket Assembly in the direction of the arrow so that the tension of the Belt (PL 12.13.27) decreases, and remove the Belt from each pulley.



**Figure 1 Tension Bracket Assembly**

5. Disconnect the connector (J8335) of the Main Drive Harness Assembly (PL 12.15.2) from the Motor Assembly .
6. Remove the two Screws securing the Motor Assembly.
7. Remove the Motor Assembly.
8. Remove the two Screws securing the Motor Assembly to the Motor Bracket (PL 12.13.29) to remove.



**Figure 2 Motor Assembly**

## Replacement

1. Install the Motor Assembly (Registration Motor) to the Motor Bracket (PL 12.13.29) in the direction shown in the figure using two Screws.
2. Install the Motor Assembly to the Finisher using two Screws.

**NOTE** Be sure to put the two bosses of the chassis into the two holes on the Bracket Assembly attached with the Motor Assembly.

3. Connect the connector (J8335) of the Main Drive Harness Assembly (PL 12.15.2) to the Motor Assembly.
4. While pushing the Tension Bracket Assembly (PL 12.13.23) in the direction of the arrow, install the Belt (PL 12.13.27) onto each pulley.
5. Fix the Tension Bracket Assembly to the frame using two Screws.

**NOTE** The tension of the belt is automatically adjusted by the force of the Tension Spring (PL 12.13.24) attached to the Tension Bracket Assembly. Therefore, when tightening the two Screws, be careful not to move the Tension Bracket Assembly.

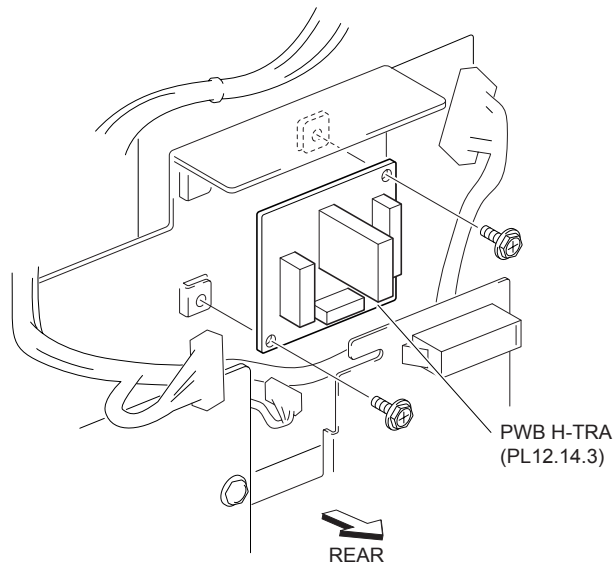
**NOTE** Tighten the two Screws in order of (1) and (2) shown in the figure.

6. Secure the Harness Bracket (PL 12.14.1) to the frame using two Screws.
7. Install the Upper Rear Cover (PL 12.4.11) .

## Horizontal Transport PWBA

### Removal

1. Remove the Upper Rear Cover (PL 12.4.11) .
2. Disconnect the three connectors on the Horizontal Transport PWBA.
3. Remove the two Screws (M3 x 6) securing the Horizontal Transport PWBA to the Finisher to remove.



**Figure 1 Horizontal Transport PWBA**

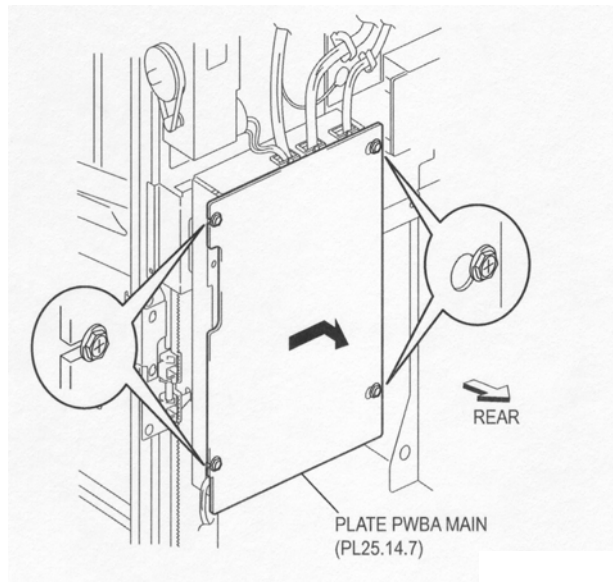
### **Replacement**

1. Install the Horizontal Transport PWBA in the direction shown in the figure, and secure it using two Screws (M3 x 6).
2. Connect the connectors (J8371) of the Horizontal Transport Harness Assembly, (J8373) of the DL Harness Assembly, and (J8372) of the Horizontal Transport Harness Assembly I/F to the H Transport PWBA.
3. Install the Upper Rear Cover (PL 12.4.11) .

### **Main-C PWBA**

#### **Removal**

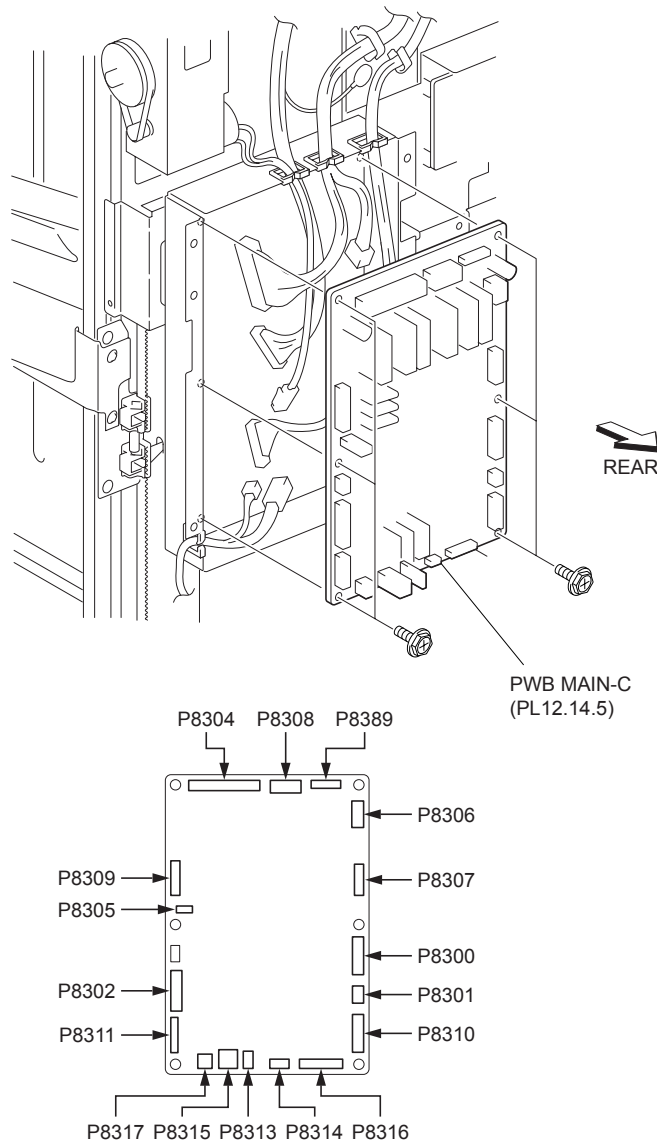
1. Remove the Upper Rear Cover (PL 12.4.11) .
2. Remove the Lower Rear Cover (PL 12.4.9) .
3. Loosen the four Screws (M3 x 6) securing the Main Plate PWBA (PL 12.14.7) .
4. Move the Main Plate PWBA in the direction of the arrow to remove.



**Figure 1 Main Plate PWBA**

5. Disconnect all the connectors on the Main-C PWBA .
6. Remove the six Screws (M3 x 6) securing the Main-C PWBA.
7. Remove the Main-C PWBA.





**Figure 2 Main C PWBA**

## Replacement

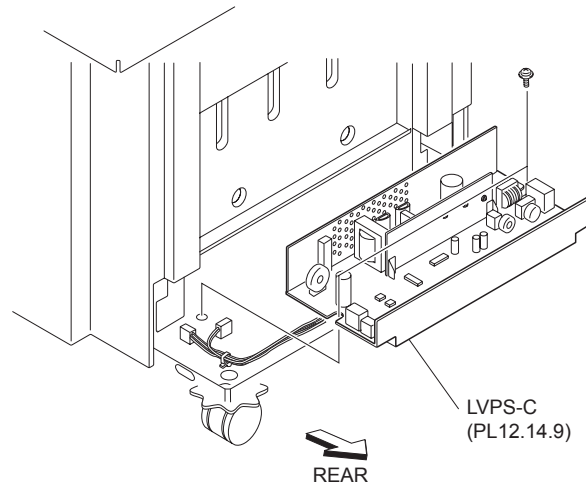
1. Install the Main-C PWBA in the direction shown in the figure, and secure it using six Screws (M3 x 6).
2. Connect the harness connectors to the Main-C PWBA.
3. Install the Main Plate PWBA (PL 12.14.7) to the frame by moving it in the opposite direction of the arrow, and secure it using four Screws (M3 x 6).
4. Install the Lower Rear Cover (PL 12.4.9) .
5. Install the Upper Rear Cover (PL 12.4.11) .

## C LVPS

### Removal

1. Remove the Bottom Cover (PL 12.4.6) .
2. Disconnect the three connectors on the C LVPS .
3. Remove the two Screws (M3 x 6) securing the C LVPS to the Finisher.

4. Remove the C LVPS.



**Figure 1 C LVPS**

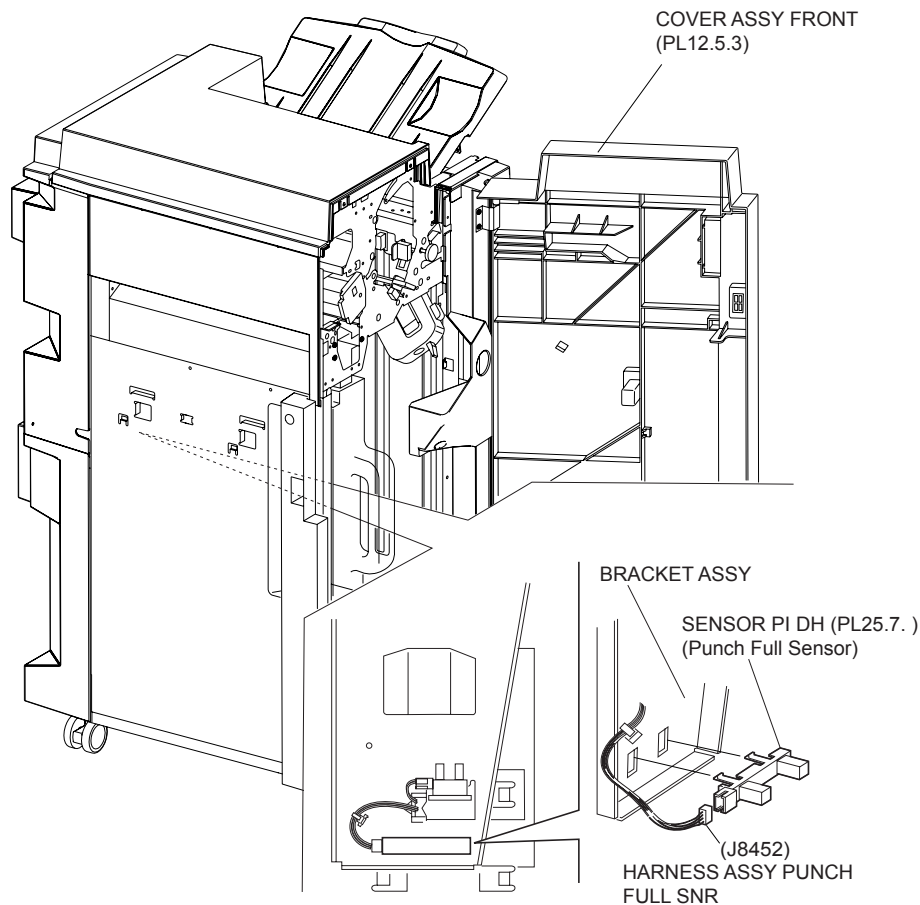
### **Replacement**

1. Install the C LVPS to the Finisher using two Screws (M3 x 6).
2. Connect the connector of the AC Inlet Harness Assembly (PL 12.14.8) to the connector (J2) on the C LVPS and connect the connector of the LVPS Harness Assembly (PL 12.15.10) to the connectors (J502 and J505).
3. Install the Bottom Cover (PL 12.4.6) .

### **Punch Full Sensor**

#### **Removal**

1. Open the Front Cover Assembly (PL 12.5.3).
2. Pull out the Dust Box Assembly (PL 12.7.20) from the Finisher to remove the Dust Box Assembly.
3. Disconnect the connector (J8452) of the Punch Full Sensor Harness Assembly from the Sensor (Punch Full Sensor) .
4. Release the hooks of the Sensor to remove the Sensor from the Bracket Assembly.



**Figure 1 Punch Full Sensor**

## Replacement

1. Secure the Sensor (Punch Full Sensor) to the Bracket Assembly using the hooks.
2. Connect the connector (J8452) of the Punch Full Sensor Harness Assembly to the Sensor.
3. Install the Dust Box Assembly (PL 12.7.20) to the Finisher.
4. Close the Front Cover Assembly (PL 12.5.3).

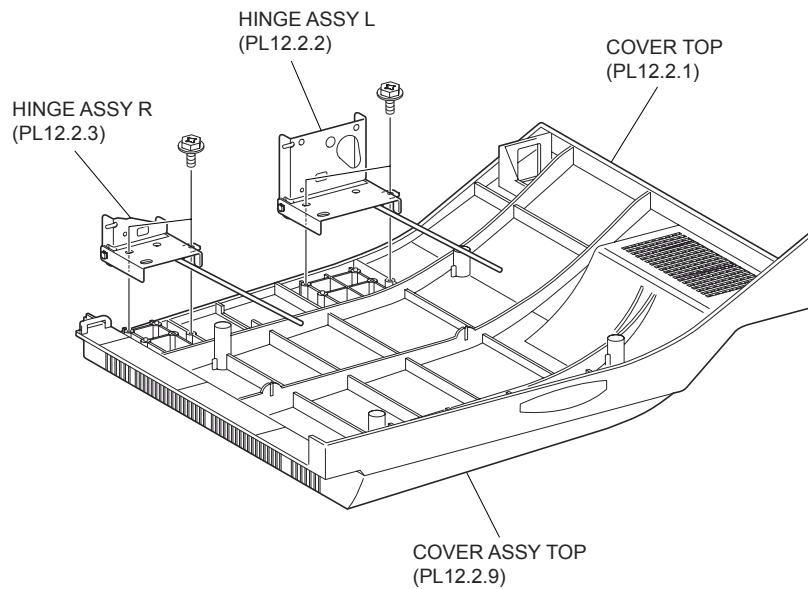
## Left Hinge Assembly/Right Hinge Assembly

**NOTE** The removal and replacement procedures for the Left Hinge Assembly and Right Hinge Assembly are the same.

**NOTE** The removal and replacement procedures for Left Hinge Assembly are described in this chapter.

## Removal

1. Remove the Rear Cover (PL 12.3.1) .
2. Remove the Top Cover Assembly (PL 12.2.9) .
3. Remove the Upper Chute Spring .
4. Remove the two Screws (M3 x 8) securing the Left Hinge Assembly to the Top Cover (PL 12.2.1) to remove the Left Hinge Assembly .



**Figure 1 Top Cover Assembly**

## Replacement

1. Secure the Left Hinge Assembly to the Top Cover (PL 12.2.1) using two Screws (M3 x 8).

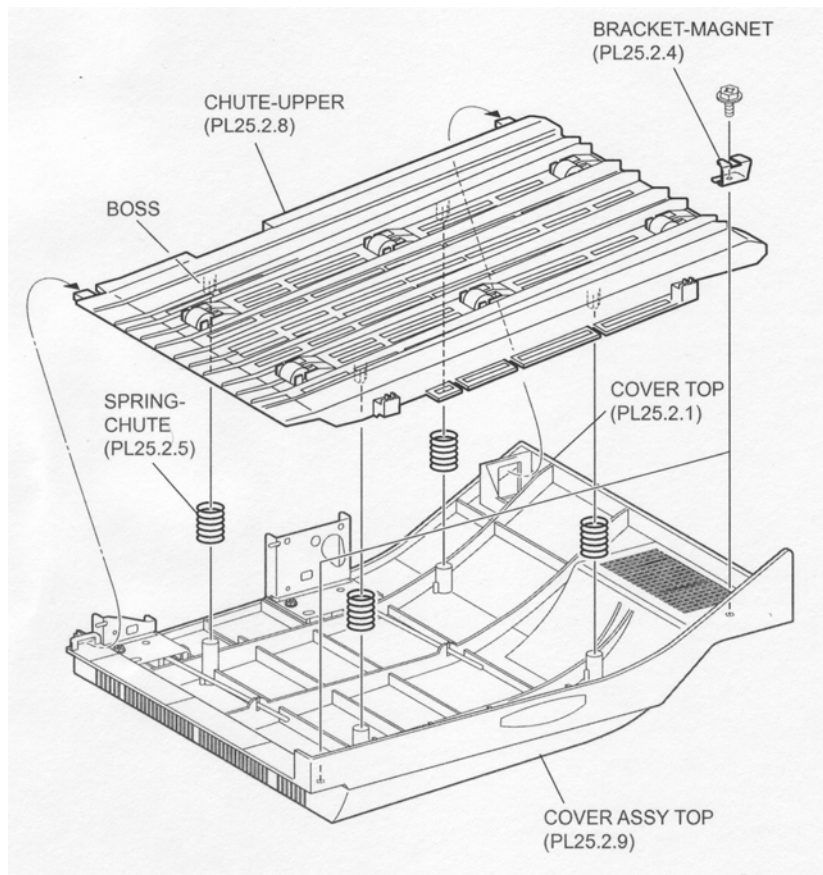
**NOTE** Be sure to install the two bosses on the Top Cover into the holes on the Left Hinge Assembly.

2. Install the Upper Chute Spring .
3. Install the Top Cover Assembly (PL 12.2.9) .
4. Install the Rear Cover (PL 12.3.1) .

## Upper Chute Spring

### Removal

1. Remove the Rear Cover (PL 12.3.1) .
2. Remove the Top Cover Assembly (PL 12.2.9) .
3. Place the Top Cover Assembly up side down.
4. Remove the two Screws (M3 x 6) securing the two Magnet Brackets (PL 12.2.4) to the Top Cover (PL 12.2.1) to remove the two Magnet Brackets .
5. Release the two hooks securing the Upper Chute to the Top Cover to remove the Upper Chute. At the same time, four Chute Spring are removed.



**Figure 1 Upper Chute**

## Replacement

1. Put the four Chute Springs into the four holes on the Top Cover (PL 12.2.1).
2. While putting the four bosses of the Upper Chute into the four Chute Springs installed on the Top Cover install the Upper Chute to the Top Cover, and then fix it to the Top Cover using two hooks.
3. Secure the two Magnet Brackets (PL 12.2.4) to the Top Cover using two Screws (M3 x 6).
4. Install the Top Cover Assembly (PL 12.2.9) .
5. Install the Rear Cover (PL 12.3.1) .

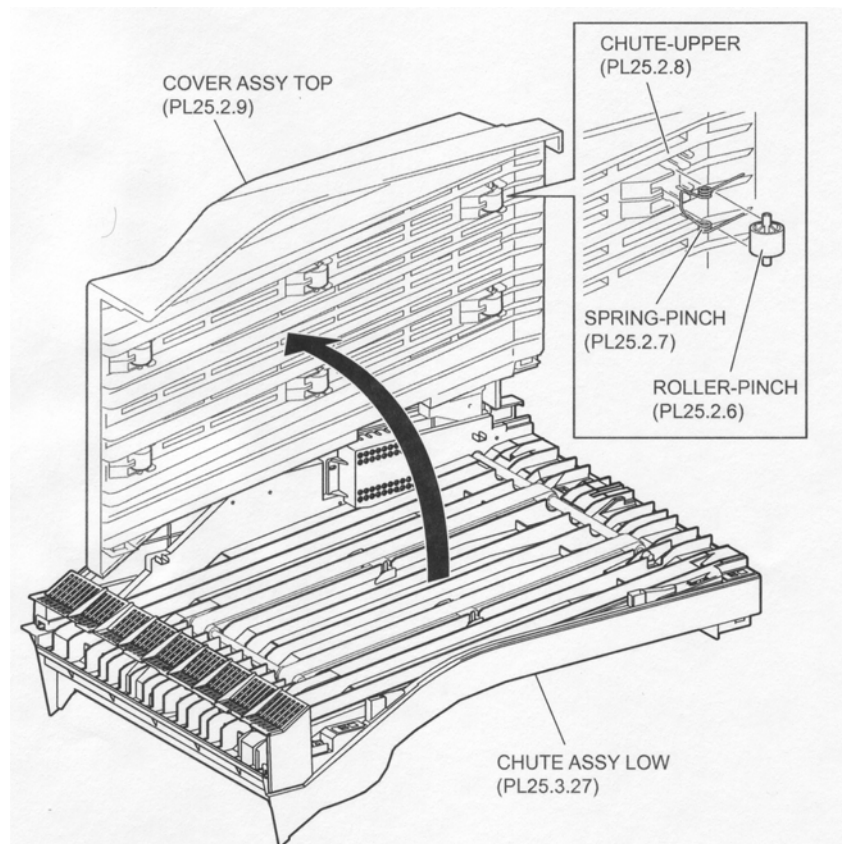
## Pinch Roller & Pinch Spring

**NOTE** The six Pinch Rollers are attached to the Upper Chute.

**NOTE** Their removal and replacement procedures are the same.

### Removal

1. Open the Top Cover Assembly (PL 12.2.9).
2. While releasing the hook of the Upper Chute (PL 12.2.8) remove the Pinch Roller from the Upper Chute .
3. Remove the Pinch Spring.



**Figure 1 Pinch Roller**

## Replacement

1. Install the Pinch Spring to the Upper Chute (PL 12.2.8) in the direction shown in the figure.
2. Install the Pinch Roller to the Upper Chute, and fix it using the hook.
3. Close the Top Cover Assembly (PL 12.2.9).

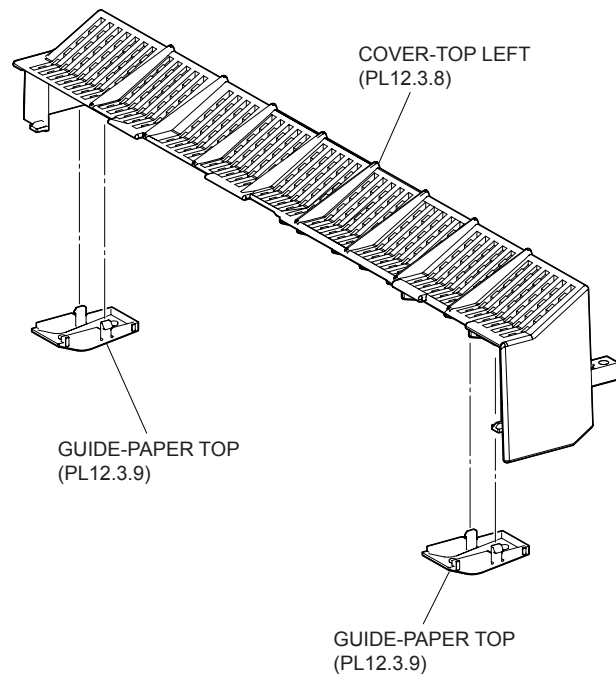
## Top Paper Guide

**NOTE** The two Top Paper Guides are attached to the Left Top Cover (PL 12.3.8).

**NOTE** Their removal and replacement procedures are the same.

## Removal

1. Remove the Rear Cover (PL 12.3.1) .
2. Open the Top Cover Assembly (PL 12.2.9).
3. Remove the Left Top Cover (PL 12.3.8) .
4. Release the two hooks securing the Top Paper Guide to the Left Top Cover to remove the Top Paper Guide .



**Figure 1 Top Left Cover**

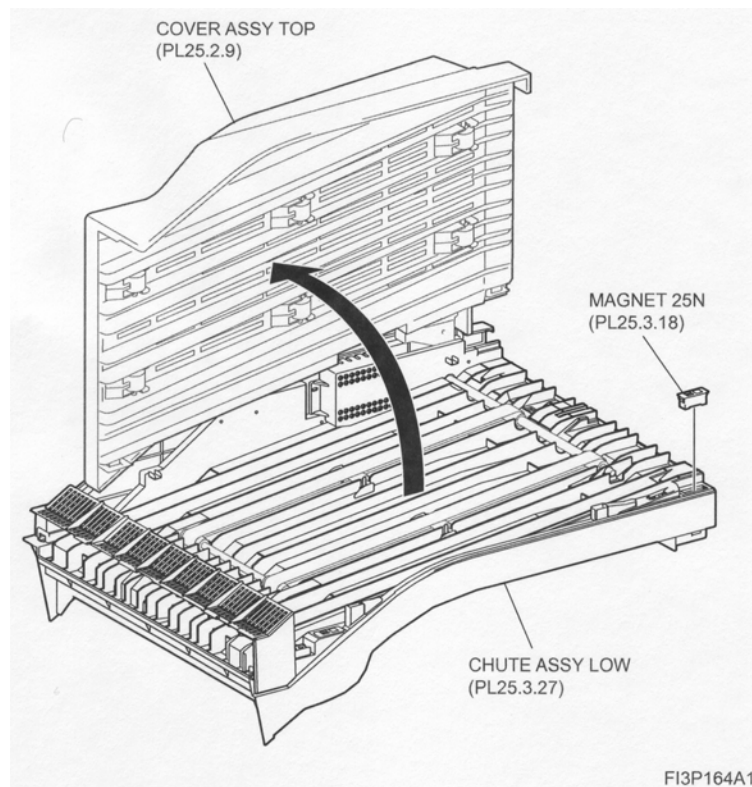
### **Replacement**

1. Install the Top Paper Guide to the Left Top Cover (PL 12.3.8) using the two hooks.
2. Install the Left Top Cover .
3. Close the Top Cover Assembly (PL 12.2.9).
4. Install the Rear Cover (PL 12.3.1) .

### **25N Magnet**

#### **Removal**

1. Open the Top Cover Assembly.
2. Release the hooks of the 25N Magnet securing the Lower Chute Assembly (PL 12.3.27) to remove the 25N Magnet .



**Figure 1 25N Magnet**

### **Replacement**

1. Install the 25N Magnet to the Lower Chute Assembly (PL 12.3.27), and secure it using the hooks.
2. Close the Top Cover Assembly.

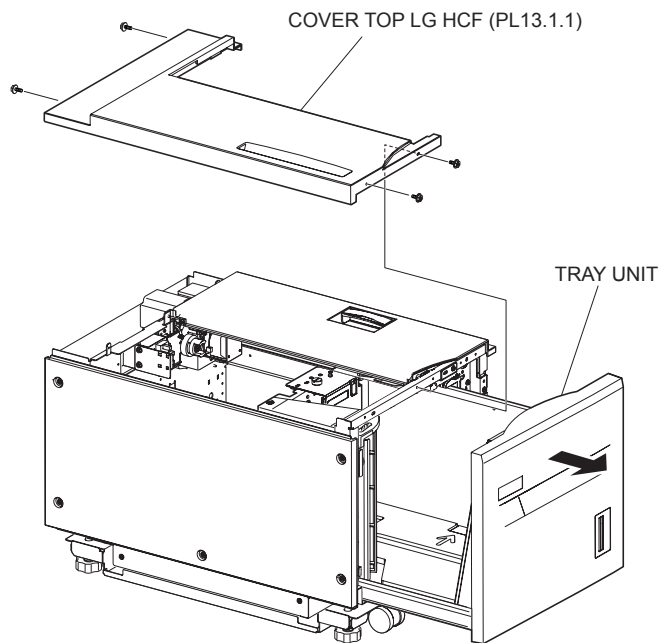
## **High Capacity Feeder (HCF)**

### **HCF Top Cover LG**

#### **Removal**

1. Pull out the Tray Unit from the machine .
2. Remove the two screws each on the front and rear securing the HCF Top Cover LG to the machine.
3. Remove the HCF Top Cover LG.





**Figure 1 Top Cover**

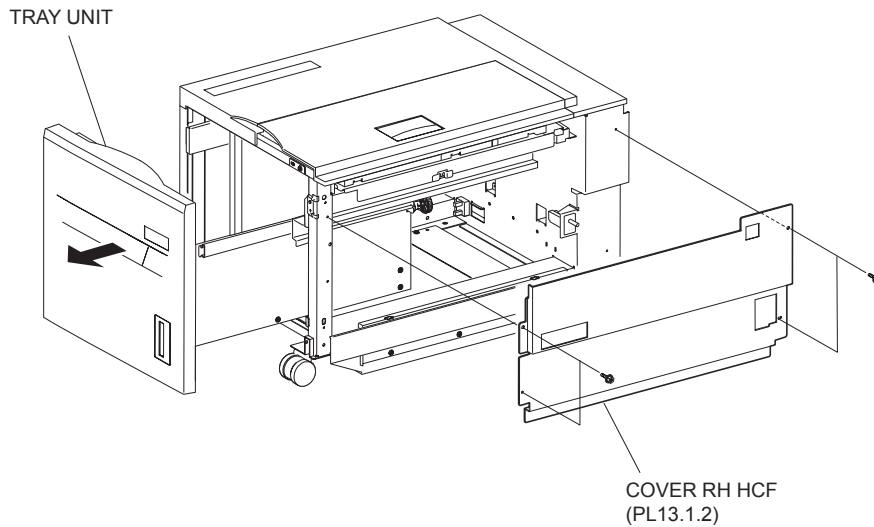
### **Replacement**

1. Install the HCF Top Cover LG to the machine and secure it using the two screws each on the front and rear.
2. Push Tray Unit into the machine.

### **HCF Right Hand Cover**

#### **Removal**

1. Pull out the Tray Unit from the machine .
2. Remove the four screws securing the HCF Right Hand Cover to the machine.
3. Remove the HCF Right Hand Cover.



**Figure 1 Right Hand Cover**

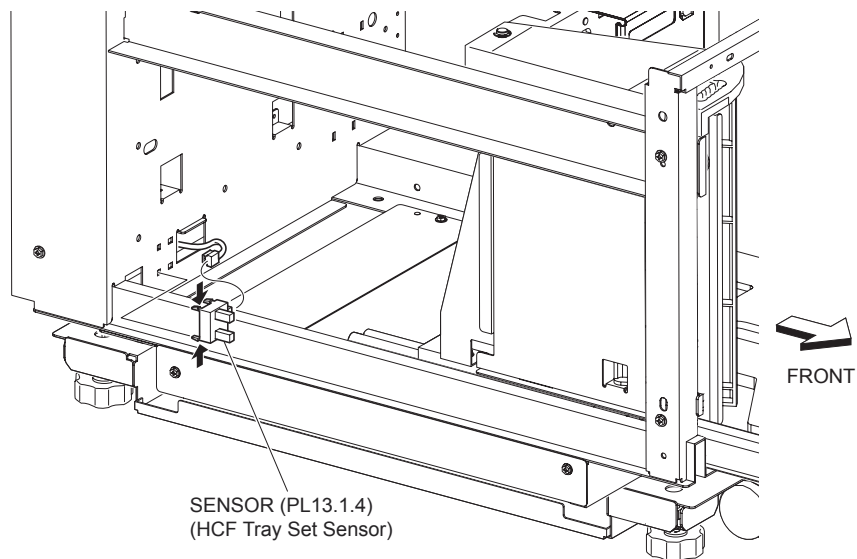
### Replacement

1. Install the HCF Right Hand Cover to the machine and secure it using the four screws.
2. Push the Tray Unit into the machine.

### HCF Tray Set Sensor

#### Removal

1. Pull out the Tray Unit from the machine.
2. Remove the HCF Left Hand Cover (PL 13.1.11) .
3. Remove the HCF Rear Cover (PL 13.1.14) .
4. Disconnect the connector (JF53) of the Main Harness Assembly (PL 13.8.2) from the HCF Tray Set Sensor .
5. Release the hooks securing the Sensor to the frame to remove the Sensor.



**Figure 1 Tray Set Sensor**

## Replacement

1. Install the HCF Tray Set Sensor to the frame and secure it using the hooks.
2. Connect the connector (JF53) of Main Harness Assembly (PL 13.8.2) to the Sensor.

**NOTE** Push the Tray Unit into the machine once and make sure that the Tray Unit shutter fits securely into the recess of the Sensor. After confirmation, pull out the Tray Unit.

3. Install the HCF Rear Cover (PL 13.1.14) .
4. Install the HCF Left Hand Cover (PL 13.1.11) .
5. Push the Tray Unit into the machine.

## HCF Size Sensor R/L

### Removal

1. Pull out the Tray Unit from the machine.
2. Remove the HCF Top Cover LG (PL 13.1.1) .
3. Remove the HCF Rear Cover (PL 13.1.14) .
4. Disconnect the connector (JF51 or JF52) of the Main Harness Assembly (PL 13.8.2) from the HCF Right or Left Size Sensor .
5. Release the hooks securing the HCF Right or Left Size Sensor to the frame, to remove the Sensor.



**Figure 1 Right & Left Size Sensor**

### Replacement

1. Install the HCF Right or Left Size Sensor to the frame and secure it using the hooks.
2. Connect the connector (JF51 or JF52) of the Main Harness Assembly (PL 13.8.2) to the Sensor.

**NOTE** Push the Tray Unit into the machine once and make sure that the Right Size Guide Assembly (PL 13.3.1) of Tray Unit fits securely into the recess of the HCF Right or Left Size Sensor. After confirmation, pull out the Tray Unit.

3. Install the HCF Rear Cover (PL 13.1.14) .
4. Install the HCF Top Cover LG (PL 13.1.1) .
5. Push the Tray Unit into the machine.

## Frame Rack Caster

**NOTE** The machine has four Frame Rack Casters. Their removal and replacement procedures are the same.

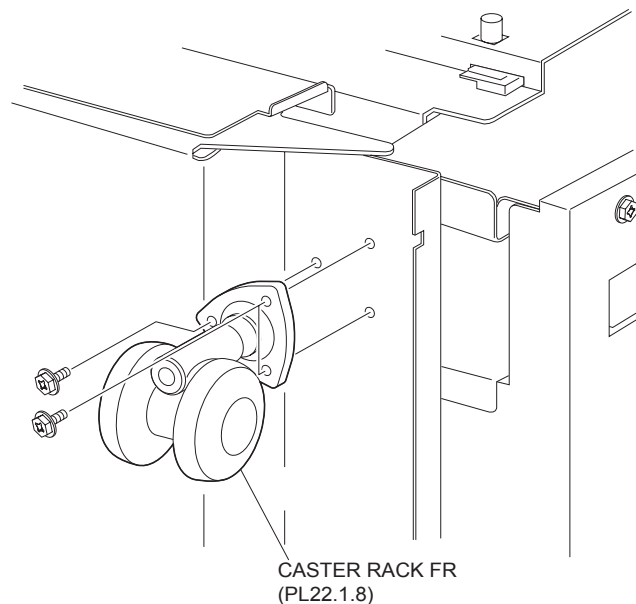
### Removal

1. Remove the Tray Unit from the machine.
2. Place the machine so that the HCF Left Hand Cover (PL 13.1.11) faces down.

**NOTE** Be careful not to scratch the HCF Left Hand Cover.

**NOTE** When placing the machine, be careful not to injure your finger with the frame.

3. Remove the three screws securing the Frame Rack Caster to the machine .
4. Remove the Frame Rack Caster.



**Figure 1 Frame Rack Caster**

### Replacement

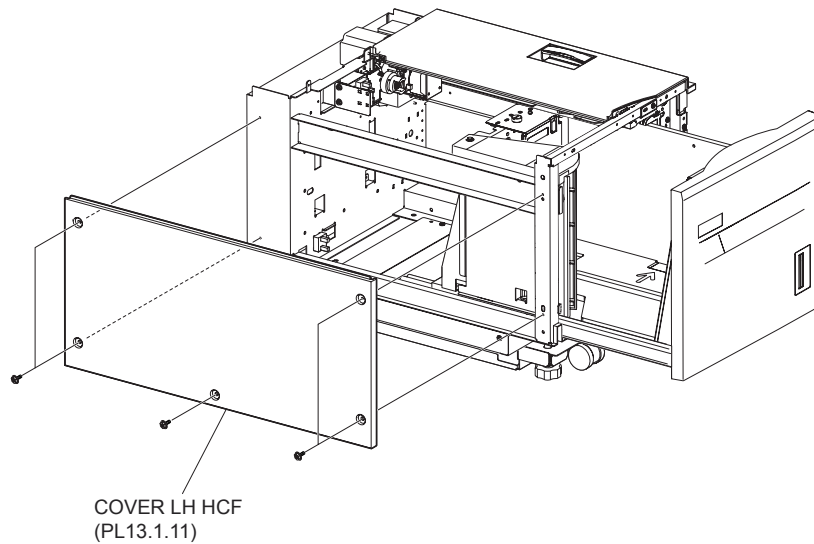
1. Install the Frame Rack Caster to the machine, and secure it with three screws.
2. Place the machine back to its original position.
3. Install the Tray Unit to the machine.

## HCF Left Hand Cover

### Removal

1. Remove the HCF Top Cover LG (PL 13.1.1) .
1. Remove the five screws securing the HCF Left Hand Cover to the machine .

2. Remove the HCF Left Hand Cover.



**Figure 1 Left Hand Cover**

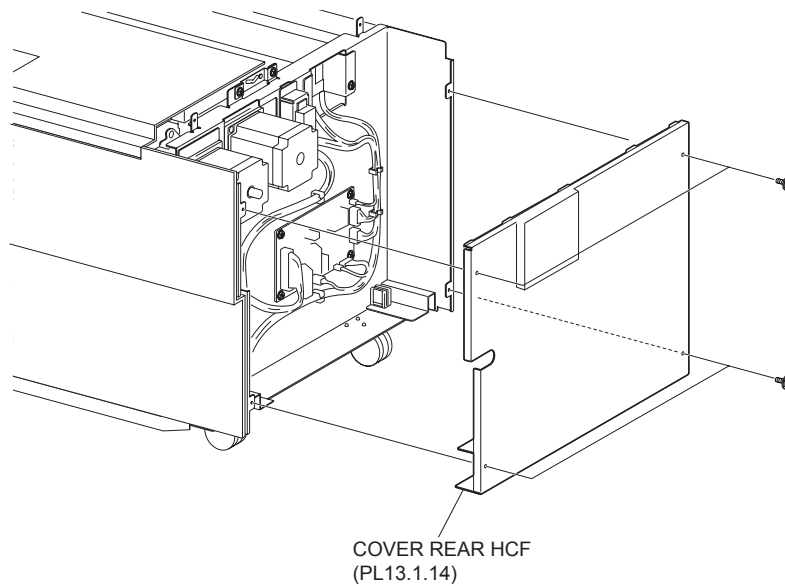
## Replacement

1. Install the HCF Left Hand Cover to the machine and secure it using the five screws.
2. Install the HCF Top Cover LG (PL 13.1.1) .

## HCF Rear Cover

### Removal

1. Remove the four screws securing the HCF Rear Cover to the machine .
2. Remove the HCF Rear Cover.



**Figure 1 Rear Cover**

## Replacement

1. Install the HCF Rear Cover to the machine and secure it using the four screws.

## Front Cover Assembly

### Removal

1. Remove the Tray Unit from the machine.
2. Remove the screws, two on the upper portion, one on the right side, and two on the left side, securing the Front Cover Assembly to the Tray Unit .
3. Remove the Front Cover Assembly.

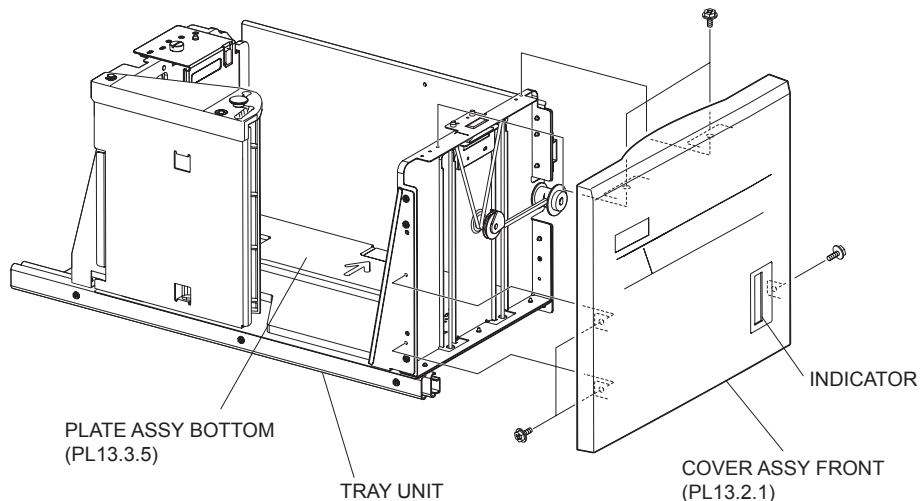


Figure 1 Front Cover Assembly

## Replacement

1. Install the Front Cover Assembly to Tray Unit using the screws, two on the upper portion, one on the right side, and two on the left side.

**NOTE** Make sure that the Front Cover Assembly indicator moves up-and-down smoothly when the Bottom Plate Assembly (PL 13.3.5) of the Tray Unit is moved by hand.

2. Install the Tray Unit to the machine.

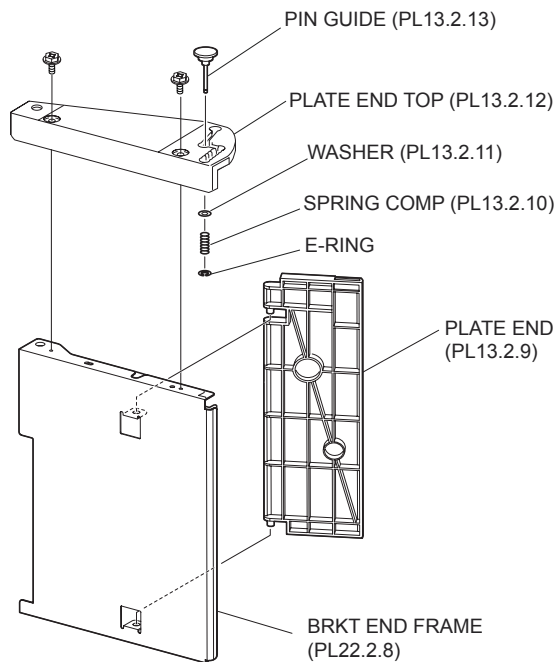
## Guide Pin / End Plate

### Removal

1. Remove the Tray Unit from the machine.
2. Remove the End Guide Assembly (PL 13.2.14) .
3. Remove the two screws securing the Top End Plate (PL 13.2.12) to the Frame End Bracket (PL 13.2.8) .
4. Remove the Top End Plate.
5. Remove the E ring securing the Guide Pin to the Top End Plate to remove the Guide Pin.

**NOTE** When the E ring is removed, the Compression Spring (PL 13.2.10) and Washer (PL 13.2.11) will be detached. Be careful not to lose them.

6. Remove the shafts at the top and bottom of the End Plate from the holes on the Frame End Bracket to remove the End Plate.



**Figure 1 End Plate and Bracket**

## Replacement

1. Fit the shafts at the top and bottom of the End Plate to the holes on the Frame End Bracket to install the End Plate.
2. Fit the Guide Pin into the hole on the Top End Plate (PL 13.2.12). Pass the Guide Pin through the Washer (PL 13.2.11) and Compression Spring (PL 13.2.10), and secure them with the E ring.
3. Install the Top End Plate to the Frame End Bracket using the two screws.
4. Install the End Guide Assembly (PL 13.2.14) .

**NOTE** Make sure that the End Plate moves smoothly when lifting the Guide Pin up and moving it to other position.

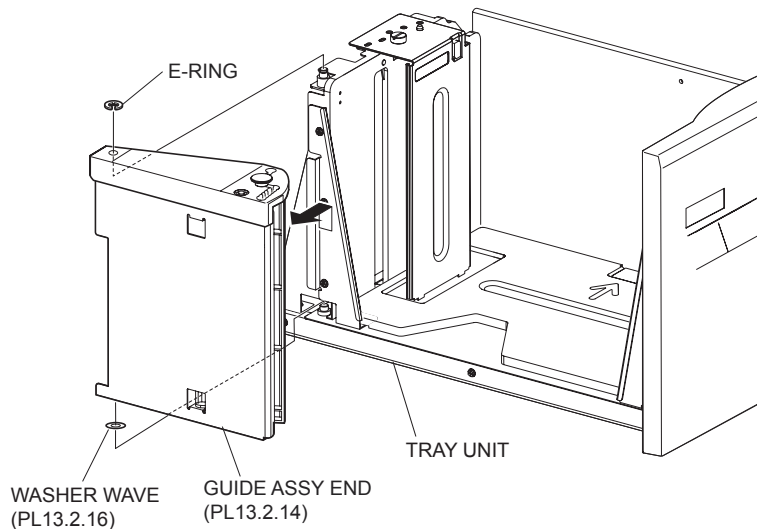
5. Install the Tray Unit to the machine.

## End Guide Assembly

### Removal

1. Remove the Tray Unit from the machine.
2. Remove the E ring securing the End Guide Assembly to the Tray Unit .
3. Lift the End Guide Assembly upward to release the holes on the End Guide Assembly from the shafts on the top and bottom of the Tray Unit to remove the End Guide Assembly.

**NOTE** When the End Guide Assembly is removed, the Wave Washer (PL 13.2.16) will be detached. Be careful not to lose it.



**Figure 1 End Guide Assembly**

## Replacement

1. Put the Wave Washer (PL 13.2.16) to the shaft on the bottom of the Tray Unit.
2. Fit the holes on the End Guide Assembly onto the shafts on the top and bottom of the Tray Unit.
3. Secure the End Guide Assembly to the Tray Unit using the E ring.
4. Install the Tray Unit to the machine.

## Cable

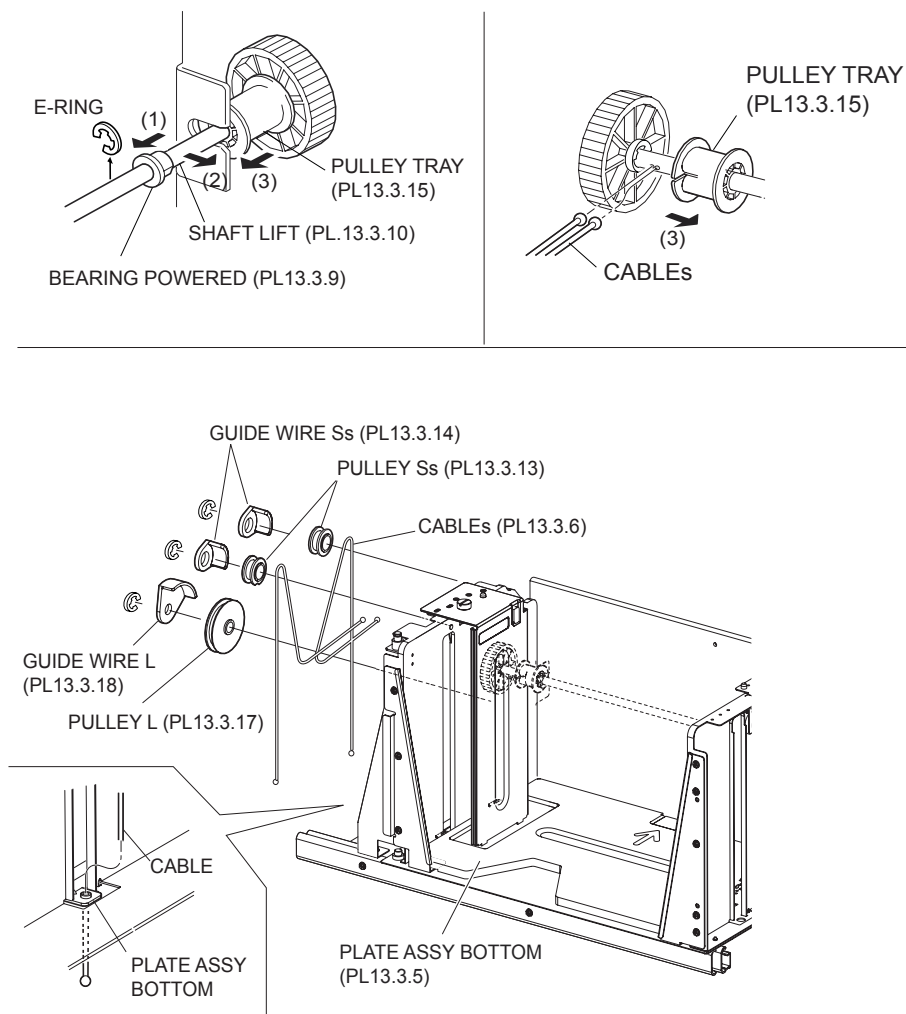
**NOTE** It is recommended to replace the Cable at front side and rear side together. When replacing the Cable, be sure to use the Tray Cable Kit (PL 13.3.99).

## Removal

1. Remove the Tray Unit from the machine.
2. Remove the Right PF2 Gear Bracket Assembly (PL 13.3.8) .
3. Remove the E ring securing the Powered Bearing (PL 13.3.9) to the Lift Shaft (PL 13.3.10) at the rear on the right side of the Tray Unit .
4. Move the Powered Bearing in the direction of the arrow (1) to remove it from the frame.
5. Move the Lift Shaft in the direction of the arrow (2) to remove it from the frame.
6. Move the Tray Pulley (PL 13.3.15) in the direction of the arrow (3). Then, the tips of the two Cables at the rear side are detached from the Lift Shaft.
7. Remove the two E rings securing the two S Pulleys (PL 13.3.13) at the upper portion on the rear side to remove the two S Wire Guide (PL 13.3.14) and two S Pulleys.
8. Remove the E ring securing the L Pulley (PL 13.3.17) at the lower portion to remove the L Wire Guide (PL 13.3.18) and L Pulley.
9. Remove the two Cables from the Bottom Plate Assembly (PL 13.3.5).



<REAR SIDE>



**Figure 1 Rear Side**

10. Remove the Cable at the front side of the Tray Unit .
11. Remove the E ring securing the Powered Bearing to the Lift Shaft at the front on the right side of the Tray Unit.
12. Move the Powered Bearing (PL 13.3.11) in the direction of the arrow (4) to remove it from the frame.
13. Move the Lift Shaft in the direction of the arrow (5) to remove it from the frame.
14. Move the Tray Pulley in the direction of the arrow (6). Then, the tips of the two Cables at the front are detached from the Lift Shaft.
15. Remove the two E rings securing the two S Pulleys at the upper portion to remove the two S Wire Guide and two S Pulleys.
16. Remove the E ring securing the L Pulley at the lower portion to remove the L Wire Guide and L Pulley.
17. Remove the tips of the two Cables from the Bottom Plate Assembly.

<FRONT SIDE>

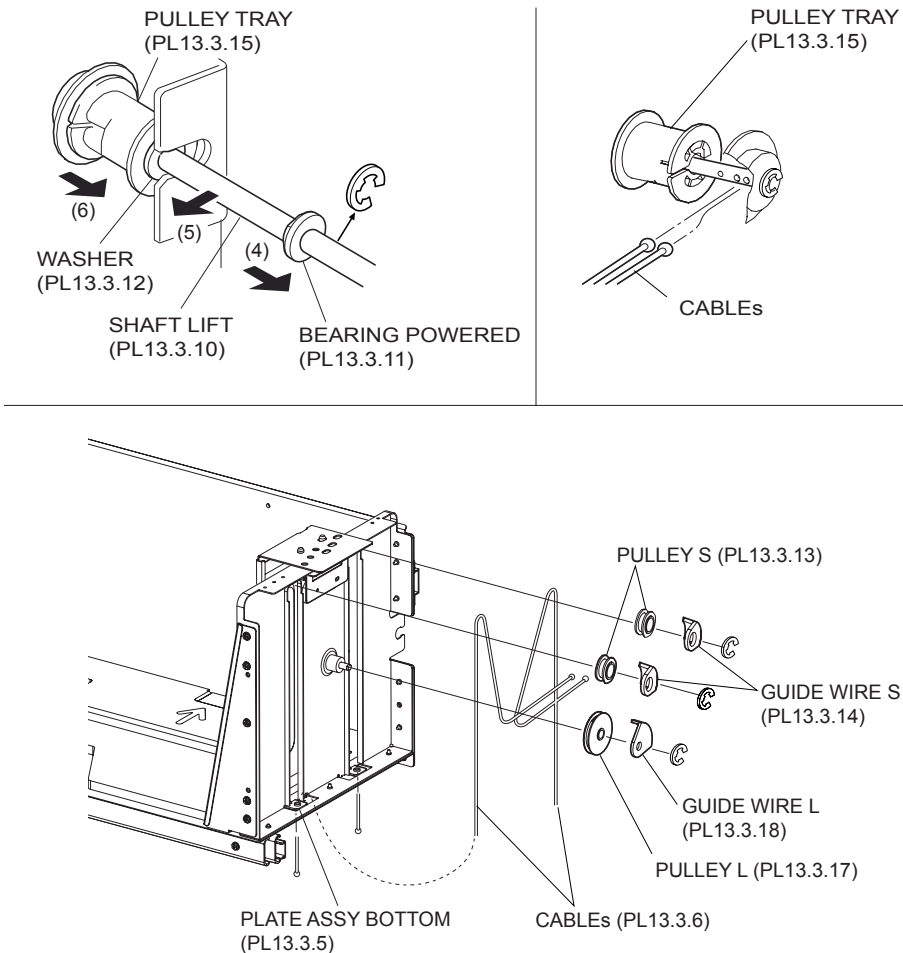


Figure 2 Front Side

## Replacement

1. Install the Cable on the front side first.
2. Fit the tips of the two Cables to the holes on the Bottom Plate Assembly (PL 13.3.5).

**NOTE** Place the Bottom Plate Assembly so that the arrow mark on it points to the direction as shown in the figure.

3. Hang the Cable onto the S Pulley (PL 13.3.13), and install the S Pulley and the S Guide Wire (PL 13.3.14) to the upper shaft. Fix them with two E rings.
4. Hang the Cable onto the L Pulley (PL 13.3.17), and install the L Pulley and the L Wire Guide (PL 13.3.18) to the lower shaft. Fix them with E ring.
5. Fit the tips of the two Cables into the two holes on the Lift Shaft (PL 13.3.10).

**NOTE** When fitting the two Cables into the holes, be careful not to twist them.

6. Press the Tray Pulley (PL 13.3.15) in the opposite direction of the arrow (6) so that the tips of the Cables are not detached from the Lift Shaft.
7. Move the Lift Shaft in the opposite direction of the arrow (5) to fit it to the notch on the frame.
8. Move the Powered Bearing in the opposite direction of the arrow (4) to install it to the frame.
9. Fix the Powered Bearing to the Lift Shaft using the E ring.
10. Install the Cable at the rear side.

11. Fit the tips of the two Cables to the holes on the Bottom Plate Assembly.
12. Hang the Cable onto the S Pulley, and install the S Pulley and the S Guide Wire to the upper shaft. Fix them with the two E rings.
13. Hang the Cable onto the L Pulley, and install the L Pulley and the L Wire Guide to the lower shaft. Fix them with the E ring.
14. Fit the tips of the two Cables into the two holes on the Lift Shaft.

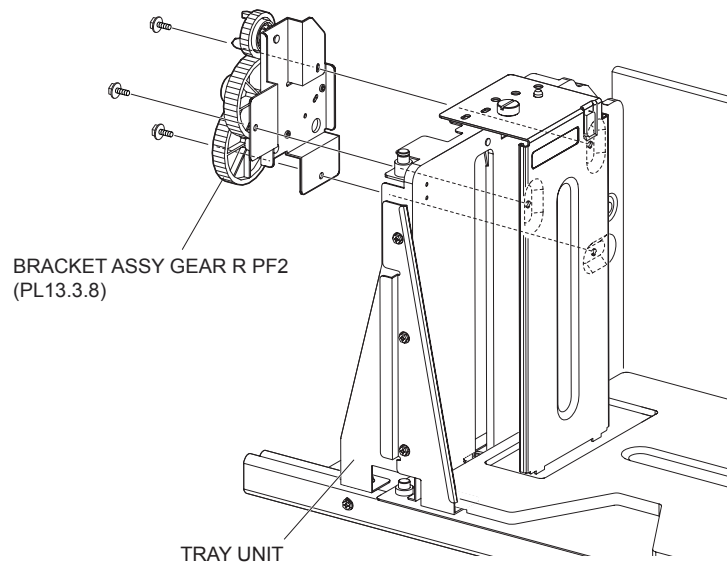
**NOTE** When fitting the two Cables into the holes, be careful not to twist them.

15. Press the Tray Pulley in the opposite direction of the arrow (3) so that the tips of the Cables are not detached from the Lift Shaft.
16. Move the Lift Shaft in the opposite direction of the arrow (2) to fit it to the notch on the frame.
17. Move the Powered Bearing in the opposite direction of the arrow (1) to install it to the frame.
18. Fix the Powered Bearing to the Lift Shaft using the E ring.
19. Install the Right PF2 Gear Bracket Assembly (PL 13.3.8) .
20. When the Lift Gear is turned by hand, make sure that the Bottom Plate Assembly moves up-and-down at the rear and front sides simultaneously.
21. Install the Tray Unit to the machine.

## Right PF2 Gear Bracket Assembly

### Removal

1. Remove the Tray Unit from the machine.
2. Remove the three screws securing the Right PF2 Gear Bracket Assembly .
3. Remove the Right PF2 Gear Bracket Assembly.



**Figure 1 Gear Bracket**

### Replacement

1. Install the Right PF2 Gear Bracket Assembly to the Tray Unit using the three screws.

**NOTE** When installing the Right PF2 Gear Bracket Assembly, engage the gears of the Right PF2 Gear Bracket Assembly and the Tray Unit.

2. Install the Tray Unit to the machine.

# Bottom Plate Assembly

## Removal

1. Remove the Tray Unit from the machine.
2. Remove the Front Cover Assembly (PL 13.2.1) .
3. Remove the Right PF2 Gear Bracket Assembly (PL 13.3.8) .
4. Remove the Cable (PL 13.3.6) .
5. Remove the Tray Guide Screw (PL 13.3.7) to remove the Right Size Guide Assembly (PL 13.3.1) .
6. Remove the Front Size Guide Assembly (PL 13.3.2).
7. Remove the Bottom Plate Assembly from the Tray Unit.

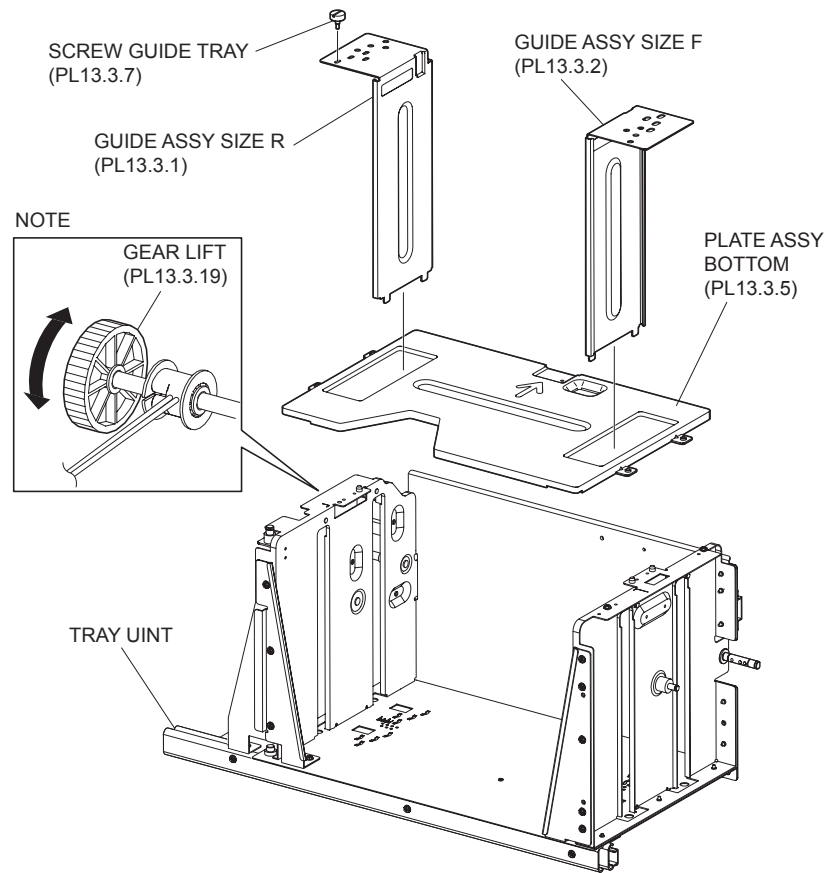


Figure 1 Bottom Plate Assembly

## Replacement

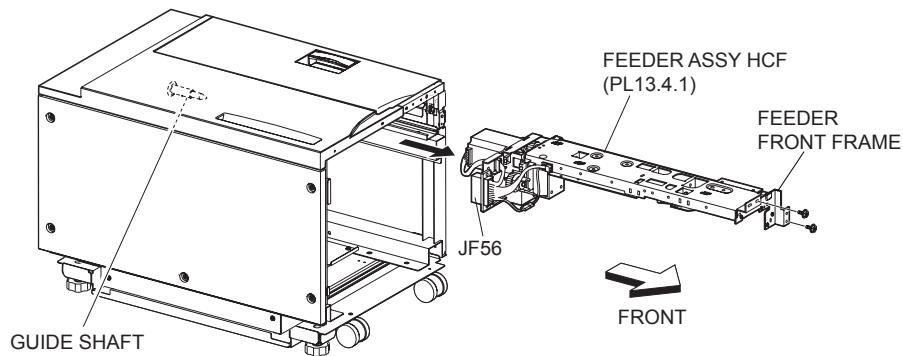
1. Install the Bottom Plate Assembly to the Tray Unit in the direction shown in the figure.
2. Install the Cable (PL 13.3.6) .
3. Install the Right PF2 Gear Bracket Assembly (PL 13.3.8) .
4. Install the Front Cover Assembly (PL 13.2.1) .
5. Install the Front Size Guide Assembly (PL 13.3.2).
6. Install the Right Size Guide Assembly (PL 13.3.1) to the Tray Unit, and fix it using the Tray Guide Screw (PL 13.3.7).
7. Install the Tray Unit to the machine.

# HCF Feeder Assembly

## Removal

1. Remove the Tray Unit from the machine.
2. Remove the two screws securing the HCF Feeder Assembly on the front side .
3. Pull the FRONT FRAME of the HCF Feeder Assembly to front until it slides out from the machine.

**NOTE** Since the connector (JF56) of the HCF Feeder Assembly is tightly fit to the connector on the frame, it may require a little stronger force to remove the HCF Feeder Assembly.



**Figure 1 Feeder Assembly**

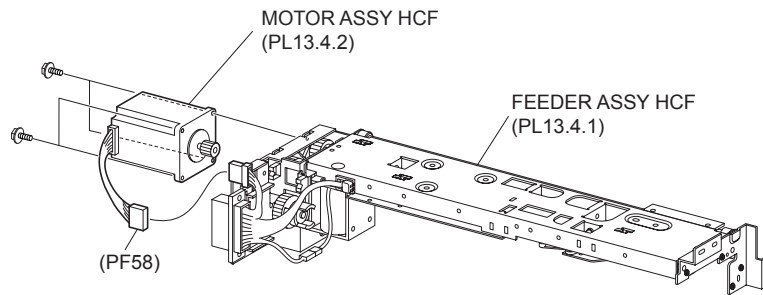
## Replacement

1. Put the HCF Feeder Assembly into the machine from the front side, and insert the guide shaft of the frame into the hole of the HCF Feeder Assembly.
2. Push the HCF Feeder Assembly towards the rear side firmly, and connect the connector (JF56) of the HCF Feeder Assembly to the connector on the frame.
3. Install the HCF Feeder Assembly to the front side of the machine using the two screws.
4. Install the Tray Unit to the machine.

# HCF Motor Assembly

## Removal

1. Remove the Tray Unit from the machine.
2. Remove the HCF Feeder Assembly (PL 13.4.1) .
3. Disconnect the connector (PF58) of the HCF Motor Assembly from the HCF Feeder Assembly .
4. Remove the four screws securing the HCF Motor Assembly to the HCF Feeder Assembly.
5. Remove the HCF Motor Assembly.



**Figure 1 Motor Assembly**

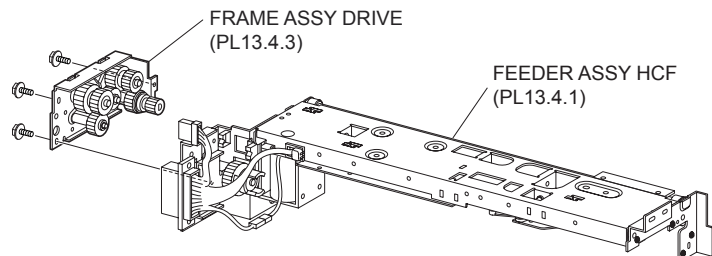
### Replacement

1. Install the HCF Motor Assembly to the HCF Feeder Assembly (PL 13.4.1) using the four screws.
2. Connect the connector (PF58) of the HCF Motor Assembly to the HCF Feeder Assembly.
3. Install the HCF Feeder Assembly .
4. Install the Tray Unit to the machine.

## Drive Frame Assembly

### Removal

1. Remove the Tray Unit from the machine.
2. Remove the HCF Feeder Assembly (PL 13.4.1) .
3. Remove the HCF Motor Assembly (PL 13.4.2) .
4. Remove the three screws securing the Drive Frame Assembly to the HCF Feeder Assembly .
5. Remove the Drive Frame Assembly.



**Figure 1 Drive Frame Assembly**

### Replacement

1. Install the Drive Frame Assembly to the HCF Feeder Assembly using the three screws.
2. Install the HCF Motor Assembly (PL 13.4.2) .
3. Install the HCF Feeder Assembly (PL 13.4.1) .
4. Install the Tray Unit to the machine.

## Solenoid Assembly

## Removal

1. Remove the Tray Unit from the machine.
2. Remove the HCF Feeder Assembly (PL 13.4.1) .
3. Remove the HCF Motor Assembly (PL 13.4.2) .
4. Remove the Drive Frame Assembly (PL 13.4.3) .
5. Remove the two screws securing the Rear Frame Assembly (PL 13.4.4) to the HCF Feeder Assembly, and remove the Rear Frame Assembly .
6. Disconnect the harness connector (PF59) of the Solenoid Assembly from the connector of Feeder Harness Assembly (PL 13.5.12).
7. Release the harness of the Solenoid Assembly from the clamp.
8. Remove the two screws securing the Solenoid Assembly to the Rear Frame Assembly.
9. Remove the Solenoid Assembly.

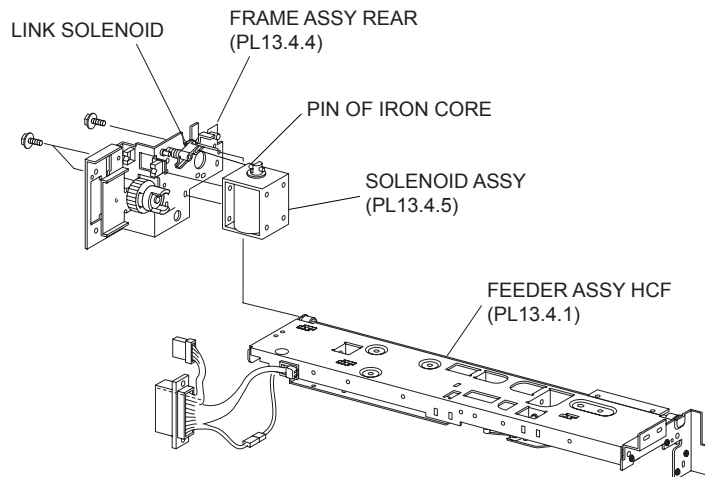


Figure 1 Solenoid Assembly

## Replacement

1. Install the Solenoid Assembly to the Rear Frame Assembly (PL 13.4.4) using the two screws.

**NOTE** When installing the Solenoid Assembly, make sure to hang the iron-core pins of the Solenoid onto the Link Solenoid of the Rear Frame Assembly.

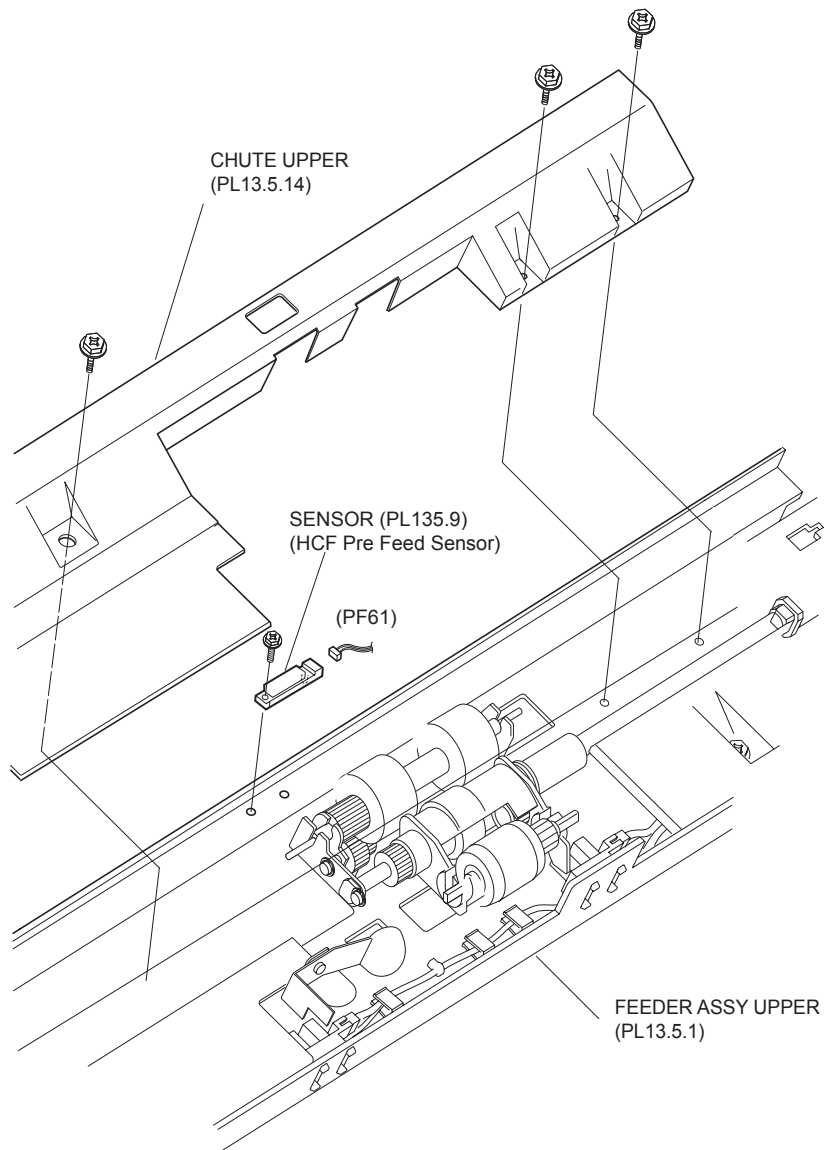
2. Install the Rear Frame Assembly (PL 13.4.4) to the HCF Feeder Assembly using the two screws.
3. Connect the harness connector (PF59) of the Solenoid Assembly to the connector of the Feeder Harness Assembly (PL 13.5.12), and secure the harness using a clamp.
4. Install the Drive Frame Assembly (PL 13.4.3) .
5. Install the HCF Motor Assembly (PL 13.4.2) .
6. Install the HCF Feeder Assembly (PL 13.4.1) .
7. Install the Tray Unit to the machine.

## HCF Pre Feed Sensor

### Removal

1. Open the Top Cover Assembly S (PL 13.7.1).
2. Open the Upper Feeder Assembly (PL 13.5.1).

3. Remove the three screws securing the Upper Chute (PL 13.5.14) to the Upper Feeder Assembly .
4. Remove the Upper Chute.
5. Remove the connector (PF61) of the Feeder Harness Assembly (PL 13.5.12) from the HCF Pre Feed Sensor.
6. Remove the one screw securing the Sensor to the Upper Feeder Assembly.
7. Remove the Sensor.



**Figure 1 Pre Feed Sensor**

## Replacement

1. Place the HCF Pre Feed Sensor so that the sensing surface faces the direction shown in the figure, and install it to the Upper Feeder Assembly (PL 13.5.1) using the one screw.
2. Connect the connector (PF61) of the Feeder Harness Assembly (PL 13.5.12) to the Sensor.
3. Install the Upper Chute (PL 13.5.14) to the Upper Feeder Assembly using the three screws.
4. Close the Upper Feeder Assembly (PL 13.5.1).
5. Close the Top Cover Assembly S (PL 13.7.1).

## Actuator



## Removal

1. Open the Top Cover Assembly S (PL 13.7.1).
2. Open the Upper Feeder Assembly (PL 13.5.1).
3. Remove the E ring securing the Actuator to the Upper Feeder Assembly .
4. Remove the Actuator.

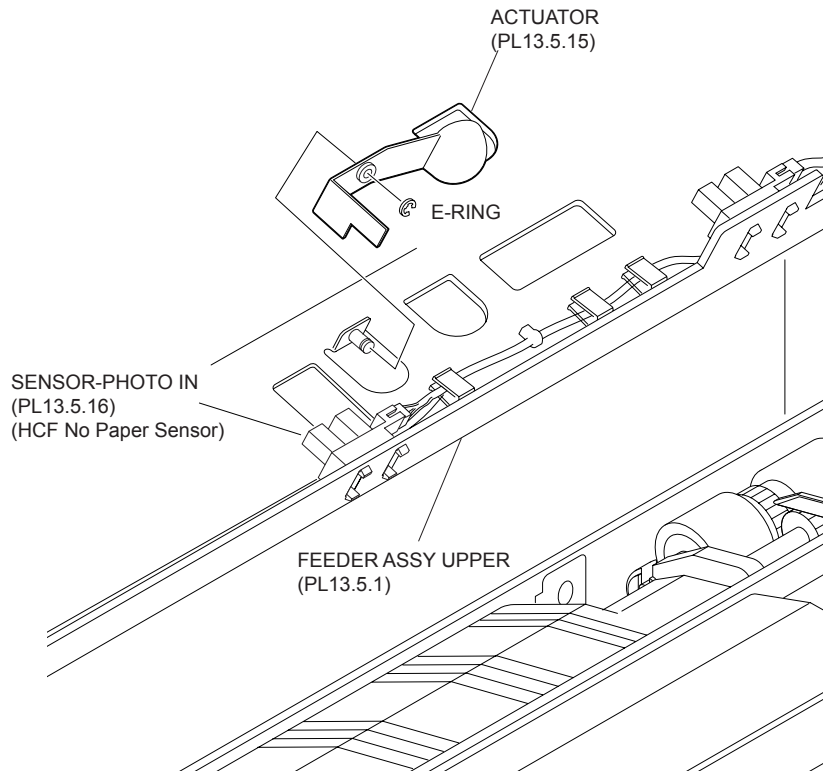


Figure 1 Actuator

## Replacement

1. Install the Actuator to the Upper Feeder Assembly, and secure it using the E-ring.

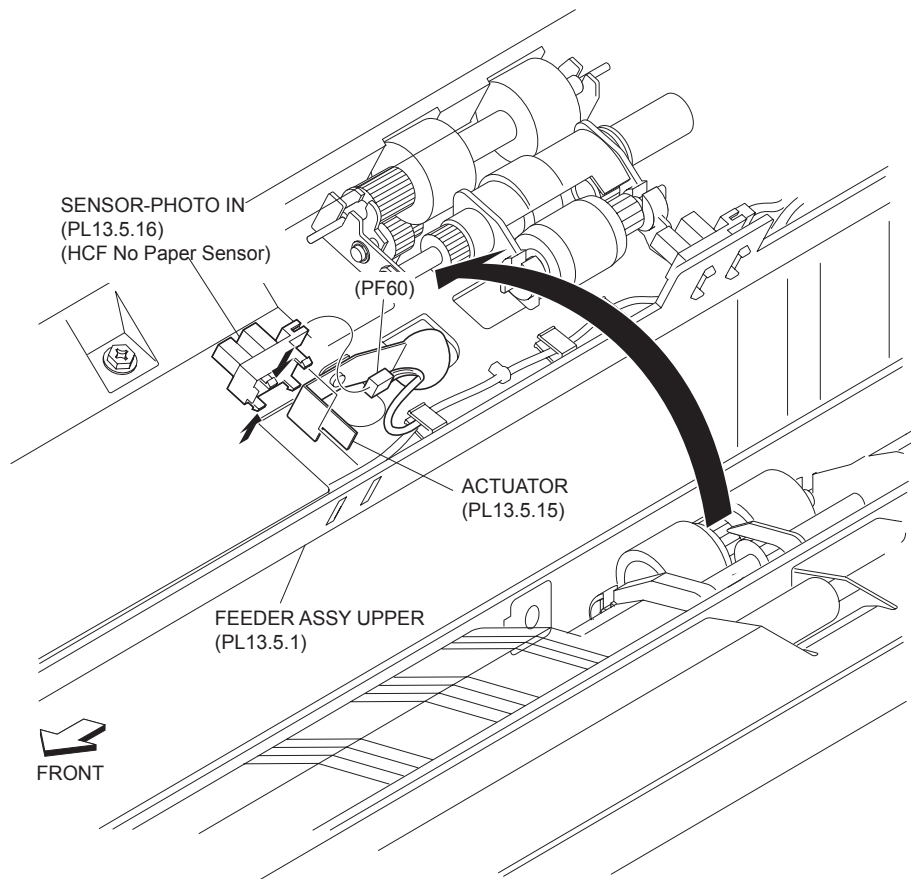
**NOTE** After installing the Actuator, make sure that it falls smoothly into the recess on the Photo In Sensor (PL 13.5.16) (HCF No Paper Sensor) when it is moved.

2. Close the Upper Feeder Assembly (PL 13.5.1).
3. Close the Top Cover Assembly S (PL 13.7.1).

## HCF Level Sensor

### Removal

1. Open the Top Cover Assembly S (PL 13.7.1).
2. Open the Upper Feeder Assembly (PL 13.5.1).
3. Disconnect the connector (PF62) of the Feeder Harness Assembly (PL 13.5.12) from the HCF Level Sensor .
4. Release the hooks securing the Photo In Sensor to the Upper Feeder Assembly to remove the Photo In Sensor.



**Figure 1 HCF Level Sensor**

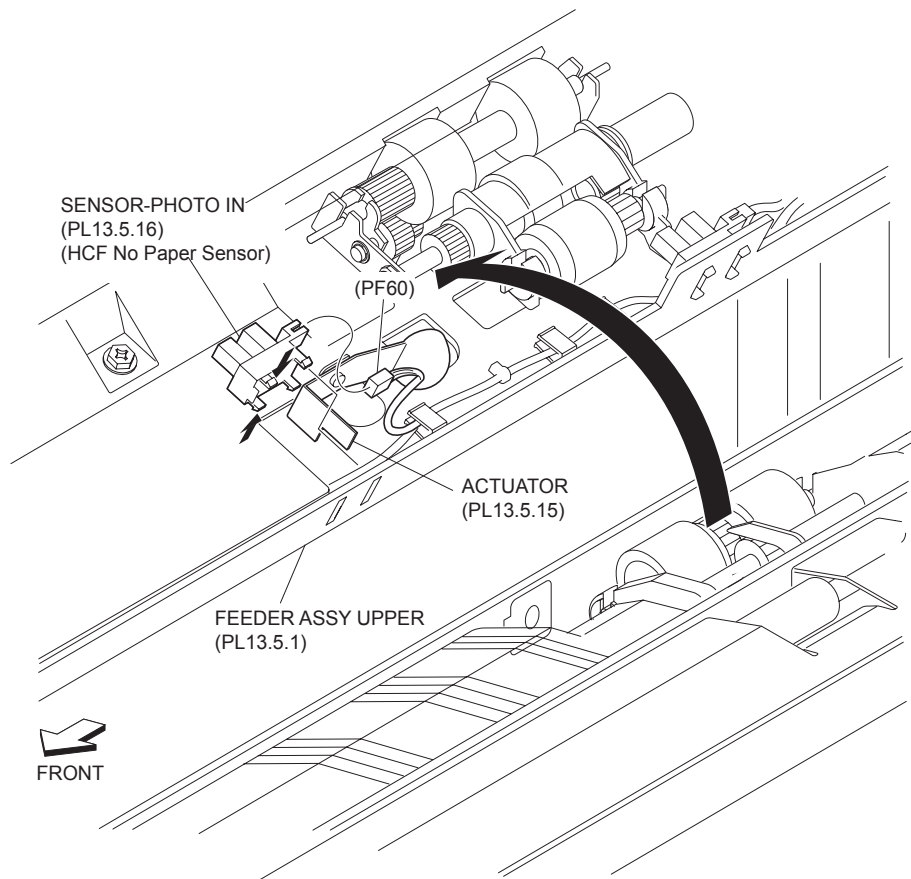
## Replacement

1. Install the HCF Level Sensor to the Upper Feeder Assembly (PL 13.5.1), and secure it with the hooks.
2. Connect the connector (PF62) of the Feeder Harness Assembly (PL 13.5.12) to the Photo In Sensor.
3. Close the Upper Feeder Assembly (PL 13.5.1).
4. Close the Top Cover Assembly S (PL 13.7.1).

## HCF No Paper Sensor

### Removal

1. Open the Top Cover Assembly S (PL 13.7.1).
2. Open the Upper Feeder Assembly (PL 13.5.1).
3. Disconnect the connector (PF60) of the Feeder Harness Assembly (PL 13.5.12) from the HCF No Paper Sensor .
4. Release the hooks securing the Photo In Sensor to the Upper Feeder Assembly to remove the Photo In Sensor.



**Figure 1 No Paper Sensor**

## Replacement

1. Install the HCF No Paper Sensor to the Upper Feeder Assembly (PL 13.5.1), and secure it with the hooks.

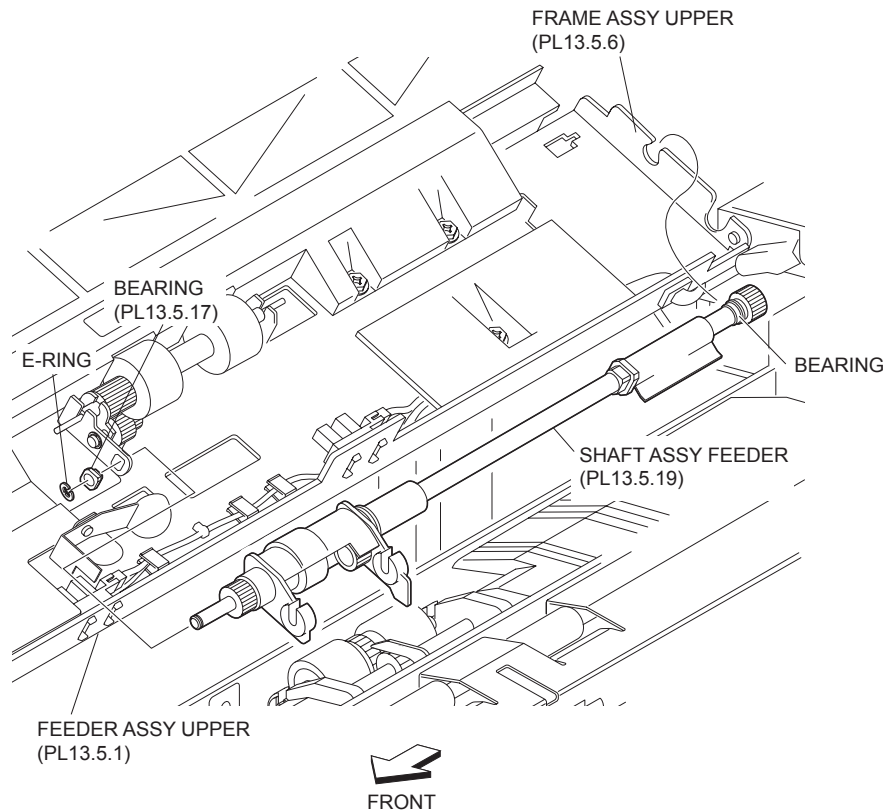
**NOTE** After installing the Photo In Sensor, make sure that the Actuator (PL 13.5.15) falls smoothly into the recess on the Photo In Sensor.

2. Connect the connector (PF60) of the Feeder Harness Assembly (PL 13.5.12) to the Photo In Sensor.
3. Close the Upper Feeder Assembly (PL 13.5.1).
4. Close the Top Cover Assembly S (PL 13.7.1).

## Feeder Shaft Assembly

### Removal

1. Open the Top Cover Assembly S (PL 13.7.1).
2. Open the Upper Feeder Assembly (PL 13.5.1).
3. Remove the Nudger Roll Assembly (PL 13.5.20) .
4. Remove the E ring securing the Feeder Shaft Assembly to the Upper Feeder Assembly .
5. Remove the Bearing (PL 13.5.17).
6. Remove the Bearing attached to the Feeder Shaft Assembly from the Upper Frame Assembly (PL 13.5.6) to remove the Feeder Shaft Assembly from the Upper Feeder Assembly.



**Figure 1 Feeder Shaft Assembly**

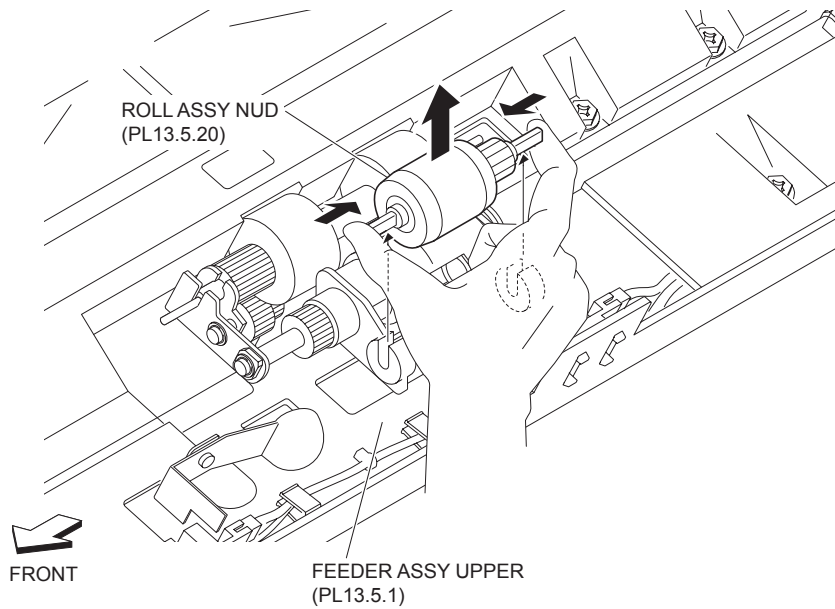
### Replacement

1. Install the Bearing attached to the Feeder Shaft Assembly to the Upper Frame Assembly (PL 13.5.6), and install the Feeder Shaft Assembly to the Upper Feeder Assembly (PL 13.5.1).
2. Install the Bearing (PL 13.5.17) to the Feeder Shaft Assembly, and secure it using the E-ring.
3. Install the Nudger Roll Assembly (PL 13.5.20) .
4. Close the Upper Feeder Assembly (PL 13.5.1).
5. Close the Top Cover Assembly S (PL 13.7.1).

### Nudger Roll Assembly

#### Removal

1. Open the Top Cover Assembly S (PL 13.7.1).
2. Open the Upper Feeder Assembly (PL 13.5.1).
3. Remove the Nudger Roll Assembly by pushing in the shaft ends with fingers .



**Figure 1 Nudger Roll Assembly**

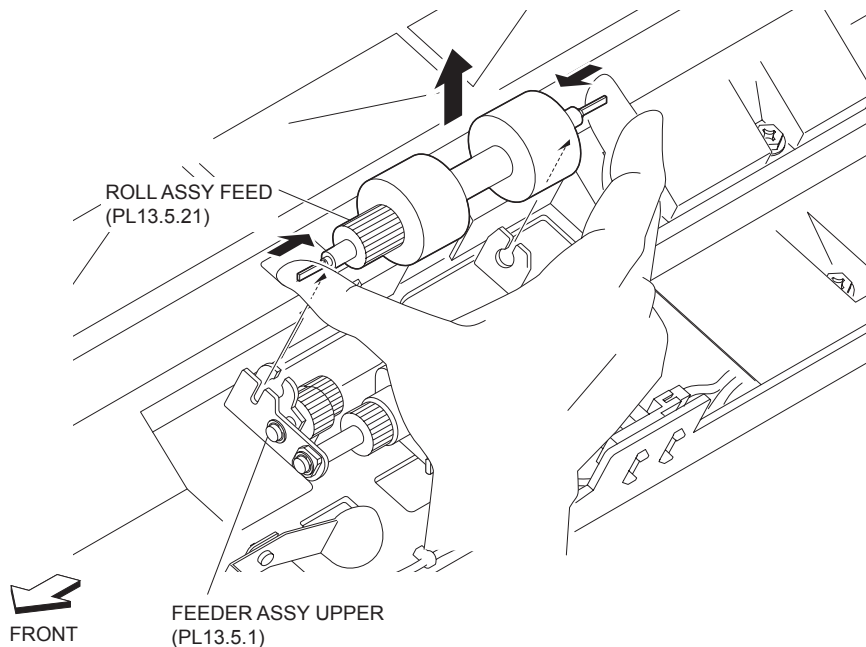
### Replacement

1. Place the Nudger Roll Assembly so that the flat surface of the shaft faces the direction shown in the figure, and install it by pushing in the shaft ends with fingers.
2. Close the Upper Feeder Assembly (PL 13.5.1).
3. Close the Top Cover Assembly S (PL 13.7.1).

### Feed Roll Assembly

#### Removal

1. Open the Top Cover Assembly S (PL 13.7.1).
2. Open the Upper Feeder Assembly (PL 13.5.1).
3. Remove the Feed Roll Assembly by pushing in the shaft ends with fingers .



**Figure 1 Feed Roll Assembly**

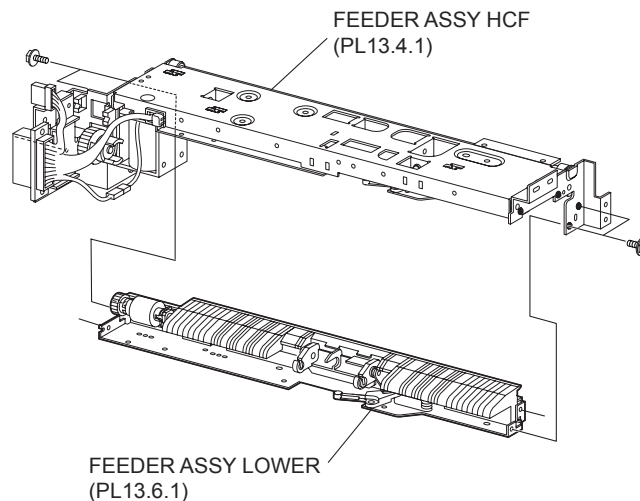
## **Replacement**

1. Place the Feed Roll Assembly so that the flat surface of the shaft faces the direction shown in the figure, and install it by pushing in the shaft ends with fingers.
2. Close the Upper Feeder Assembly (PL 13.5.1).
3. Close the Top Cover Assembly S (PL 13.7.1).

## **Lower Feeder Assembly**

### **Removal**

1. Remove the Tray Unit from the machine.
2. Remove the HCF Feeder Assembly (PL 13.4.1) .
3. Remove the HCF Motor Assembly (PL 13.4.2) .
4. Remove the Drive Frame Assembly (PL 13.4.3) .
5. Remove the Retard Roll Assembly (PL 13.6.17) .
6. Remove the two screws each on the rear and front securing the Lower Feeder Assembly to the HCF Feeder Assembly .
7. Remove the Lower Feeder Assembly.



**Figure 1 Lower Feeder Assembly**

## **Replacement**

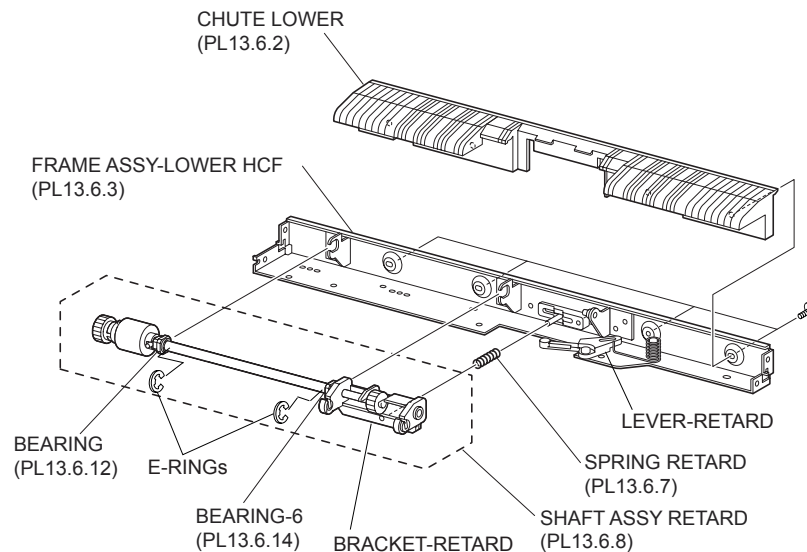
1. Install the Lower Feeder Assembly to the HCF Feeder Assembly (PL 13.4.1) using the two screws each on the rear and front.
2. Install the Retard Roll Assembly (PL 13.6.17) .
3. Install the Drive Frame Assembly (PL 13.4.3) .
4. Install the HCF Motor Assembly (PL 13.4.2) .
5. Install the HCF Feeder Assembly (PL 13.4.1) .
6. Install the Tray Unit to the machine.

## **Retard Shaft Assembly**

### **Removal**

1. Remove the Tray Unit from the machine.
2. Remove the HCF Feeder Assembly (PL 13.4.1) .
3. Remove the Retard Roll Assembly (PL 13.6.17) .
4. Remove the Lower Feeder Assembly (PL 13.6.1) .
5. Remove the four screws securing the Lower Chute (PL 13.6.2) to the HCF Lower Frame Assembly (PL 13.6.3) .
6. Remove the Lower Chute.
7. Remove the two E-rings securing the Bearing (PL 13.6.12) and Bearing-6 (PL 13.6.14), and shift them to remove them from the two brackets on the HCF Lower Frame Assembly.
8. Remove the Retard Shaft Assembly from the HCF Lower Frame Assembly.

**NOTE** When the Retard Shaft Assembly is removed, the Retard Spring (PL 13.6.7) will be detached from the shaft of the HCF Lower Frame Assembly. Be careful not to lose it.



**Figure 1 Retard Shaft Assembly**

## Replacement

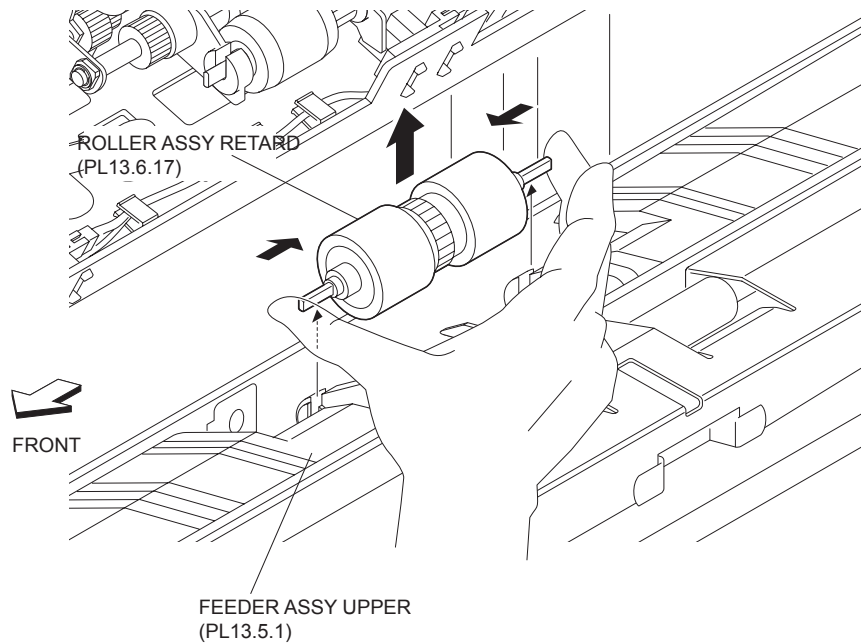
1. Install the Bearing (PL 13.6.12) and Bearing-6 (PL 13.6.14) of the Retard Shaft Assembly to the two brackets on the HCF Lower Frame Assembly (PL 13.6.3), and fix them using two E-rings.
2. Install the Retard Spring (PL 13.6.7) to the shaft of the HCF Lower Frame Assembly.
3. Turn the Retard Lever so that hold the Retard Spring with the Retard Bracket of the Retard Shaft Assembly.
4. Install the Lower Chute (PL 13.6.2) to the HCF Lower Frame Assembly using the four screws.
5. Install the Lower Feeder Assembly (PL 13.6.1) .
6. Install the Retard Roll Assembly (PL 13.6.17) .
7. Install the HCF Feeder Assembly (PL 13.4.1) .
8. Install the Tray Unit to the machine.

## Retard Roller Assembly

### Removal

1. Open the Top Cover Assembly S (PL 13.7.1).
2. Open the Upper Feeder Assembly (PL 13.5.1).

3. Remove the Retard Roller Assembly by pushing in the shaft ends with fingers .



**Figure 1 Retard Roller Assembly**

## Replacement

1. Place the Retard Roller Assembly so that the flat surface of the shaft faces the direction shown in the figure, and install it by pushing in the shaft ends with fingers.
2. Close the Upper Feeder Assembly (PL 13.5.1).
3. Close the Top Cover Assembly S (PL 13.7.1).

## Top Cover Assembly S

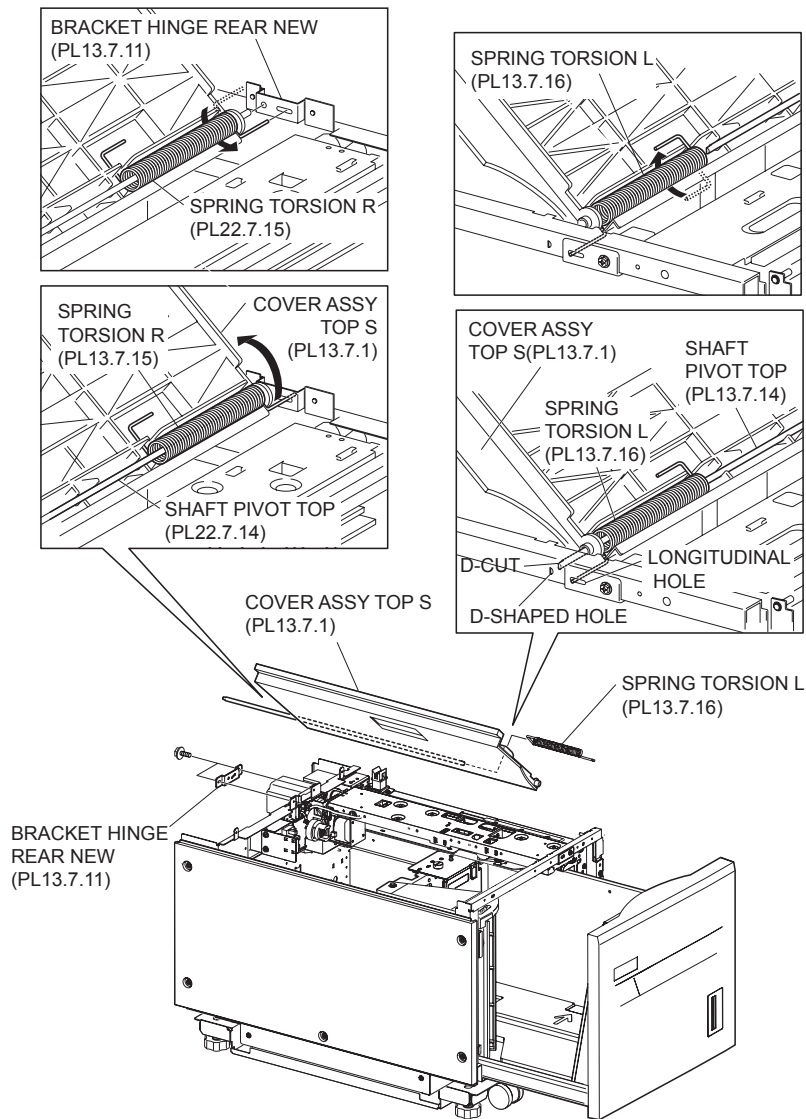
### Removal

1. Pull out the Tray Unit from the machine.
2. Remove the HCF Top Cover LG (PL 13.1.1) .
3. Remove the HCF Rear Cover (PL 13.1.14) .
4. Open the Top Cover Assembly S.
5. Remove the two screws securing the Rear Hinge Bracket New (PL 13.7.11) to the frame .
6. Remove the Rear Hinge Bracket New.

**NOTE** When removing the Hinge Bracket New, leave the Top Pivot Shaft (PL 13.7.14) and the Right Torsion Spring (PL 13.7.15) attached to the Top Cover Assembly S.

7. Lift the Top Cover Assembly S, and remove the tip on the front of the Top Pivot Shaft attached to the Top Cover Assembly S from the hole on the frame. At the same time, remove the tip of the Left Torsion Spring (PL 13.7.16) attached to the front side from the longitudinal hole of the frame.
8. Remove the Top Pivot Shaft, Right Torsion Spring and Left Torsion Spring from the Top Cover Assembly S.





**Figure 1 Top Cover Assembly**

## Replacement

1. Install the Top Pivot Shaft (PL 13.7.14), Right Torsion Spring (PL 13.7.15) and Left Torsion Spring (PL 13.7.16) to the Top Cover Assembly S as shown in the figure.

**NOTE** Install the Top Pivot Shaft so that its D-cut is positioned at the front side of the Top Cover Assembly S.

2. Put the front tip (D-cut portion) of the Top Pivot Shaft attached to the Top Cover Assembly S into the D-shaped hole on the frame.
3. Put the tip of the Left Torsion Spring into the longitudinal hole of the frame.

**NOTE** Twist the spring to install the Left Torsion Spring.

4. Fit the hole on the Rear Hinge Bracket New (PL 13.7.11) to the rear tip of the Top Pivot Shaft attached to the Top Cover Assembly S.
5. Put the tip of the Right Torsion Spring into the longitudinal hole on the Rear Hinge Bracket New.

**NOTE** Twist the spring to install the Right Torsion Spring.

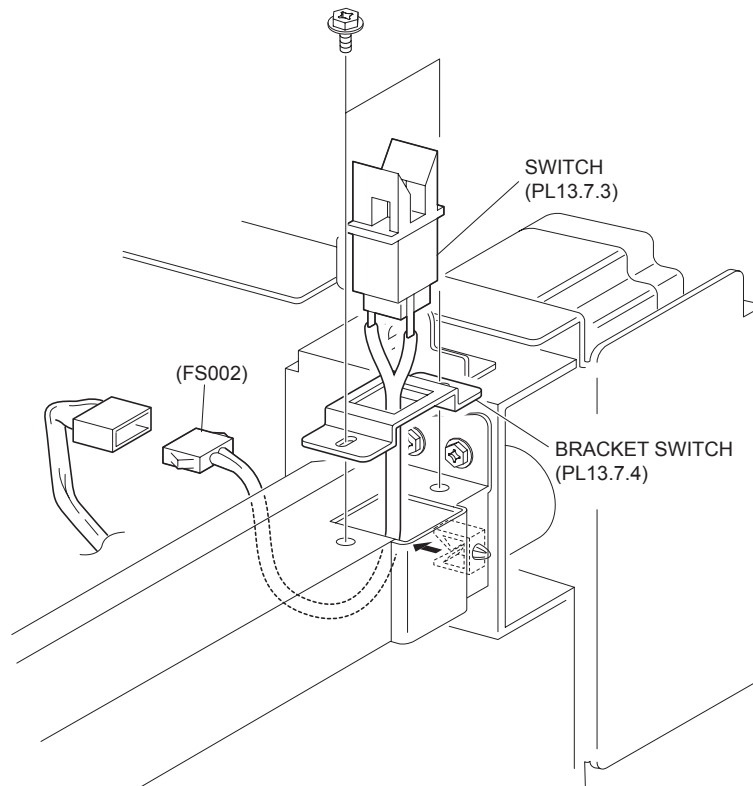
6. Install the Rear Hinge Bracket New to the frame using the two screws.

7. Open the Top Cover Assembly S fully, and make sure that the spring force is applied to retain the Top Cover Assembly S at that position.
8. Install the HCF Rear Cover (PL 13.1.14) .
9. Install the HCF Top Cover LG (PL 13.1.1) .
10. Push the Tray Unit into the machine.

## Transport Interlock Switch

### Removal

1. Pull out the Tray Unit from the machine.
2. Remove the HCF Right Hand Cover (PL 13.1.2) .
3. Open the Top Cover Assembly S (PL 13.7.1).
4. Remove the two screws securing the Switch Bracket (PL 13.7.4) attached with the Switch .
5. Remove the Switch Bracket to fitted with the Switch.
6. Disconnect the connector (FS002) of the Main Harness Assembly (PL 13.8.2) from the Switch.
7. Release the hooks securing the Switch to the Switch Bracket to remove the Switch.



**Figure 1 Transport Interlock Switch**

### Replacement

1. Install the Switch to the Switch Bracket (PL 13.7.4), and secure it with hooks.
2. Connect the connector (FS002) of the Main Harness Assembly (PL 13.8.2) to the Switch.
3. Install the Switch Bracket (PL 13.7.4) fitted with the Switch using the two screws.
4. Close the Top Cover Assembly S (PL 13.7.1).
5. Install the HCF Right Hand Cover (PL 13.1.2) .
6. Push the Tray Unit into the machine.

# HCF TA Sensor Assembly

## Removal

1. Pull out the Tray Unit from the machine.
2. Remove the HCF Right Hand Cover (PL 13.1.2) .
3. Open the Top Cover Assembly S (PL 13.7.1).
4. Remove the two screws securing the TA Sensor Bracket (PL 13.7.7) to the frame .
5. Remove the TA Sensor Bracket.
6. Disconnect the connector (JF54) of the Main Harness Assembly (PL 13.8.2) from the TA Sensor Assembly.
7. Release the hooks securing the TA Sensor Assembly to the TA Sensor Bracket to remove the TA Sensor Assembly.

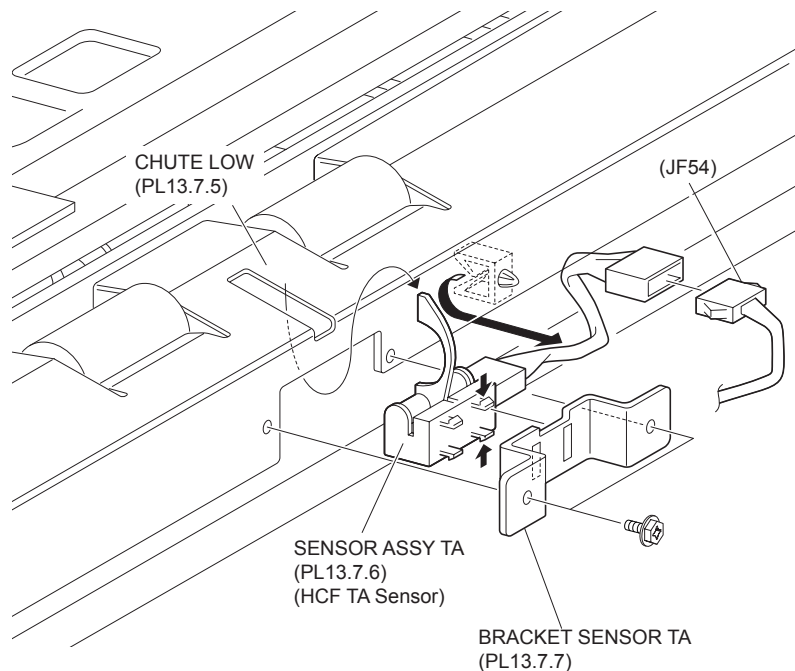


Figure 1 TA Sensor Assembly

## Replacement

1. Install the TA Sensor Assembly to the TA Sensor Bracket (PL 13.7.7) in the direction shown in the figure, and secure it with the hooks.
2. Connect the connector (JF54) of the Main Harness Assembly (PL 13.8.2) to the connector of the TA Sensor Assembly.
3. Install the TA Sensor Bracket to the Lower Chute (PL 13.7.5) using the two screws.

**NOTE** When installing the TA Sensor Assembly, put the actuator into the hole of the Lower Chute.

4. Close the Top Cover Assembly S (PL 13.7.1).
5. Install the HCF Right Hand Cover (PL 13.1.2) .
6. Push the Tray Unit into the machine.

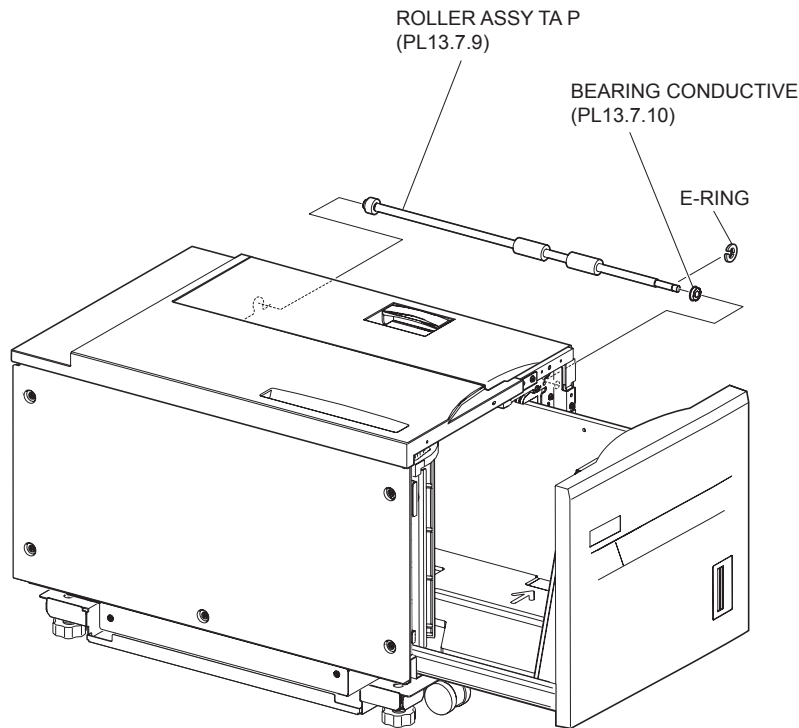
# TA Roller Assembly P

## Removal

1. Pull out the Tray Unit from the machine.
2. Remove the HCF Right Hand Cover (PL 13.1.2) .
3. Remove the E-ring on the front side securing the TA Roller Assembly P .
4. Shift the TA Roller Assembly P towards the rear side to remove the front side of the shaft from the Conductive Bearing (PL 13.7.10).

**NOTE** When removing the TA Roller Assembly P, the Conductive Bearing will be detached from the frame. Be sure not to lose it.

**NOTE** When removing TA Roller Assembly P, do not hold its rubber rollers.



**Figure 1 TA Roller Assembly P**

## Replacement

1. Install the Conductive Bearing (PL 13.7.10) into the hole of the frame.
2. After putting the TA Roller Assembly P into the hole on the rear side, put the tip of the shaft on another side into the Conductive Bearing on the front side.

**NOTE** When installing the TA Roller Assembly P, do not hold its rubber rollers.

3. Fix the E-ring to the TA Roller Assembly P on the front side.
4. Install the HCF Right Hand Cover (PL 13.1.2) .
5. Push the Tray Unit into the machine.

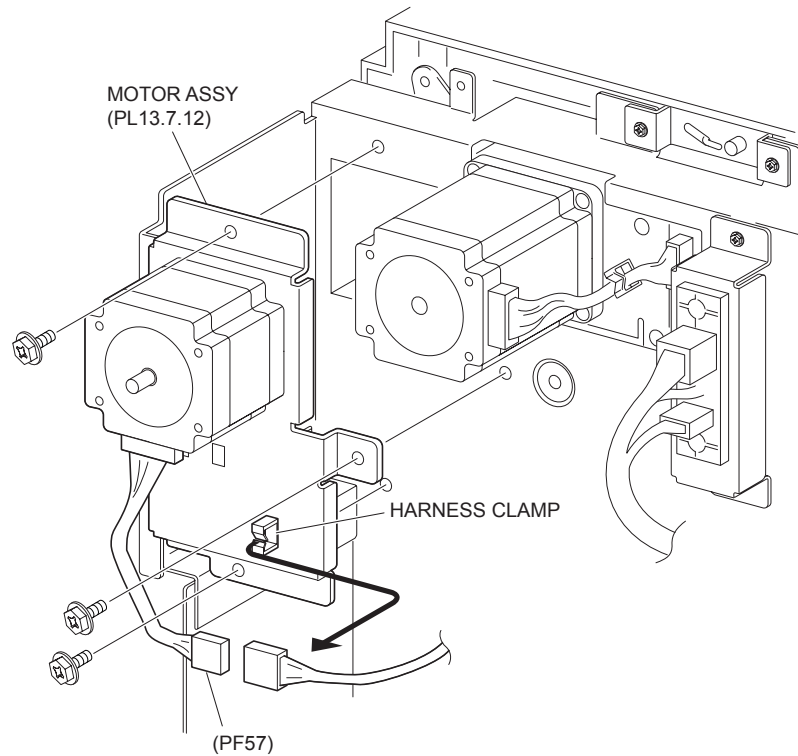
## Motor Assembly

### Removal

1. Remove the HCF Top Cover LG (PL 13.1.1) .
2. Remove the HCF Rear Cover (PL 13.1.14) .
3. Disconnect the connector (PF57) of the Main Harness Assembly (PL 13.8.2) from the Motor Assembly .

4. Release the Main Harness Assembly from the harness clamp and leave it detached.
5. Remove the three screws securing the Motor Assembly to the frame.
6. Remove the Motor Assembly.

**NOTE** Be sure not to disassemble the Motor from the Motor Assembly.



**Figure 1 Motor Assembly**

## Replacement

1. Install the Motor Assembly to the frame using the three screws.

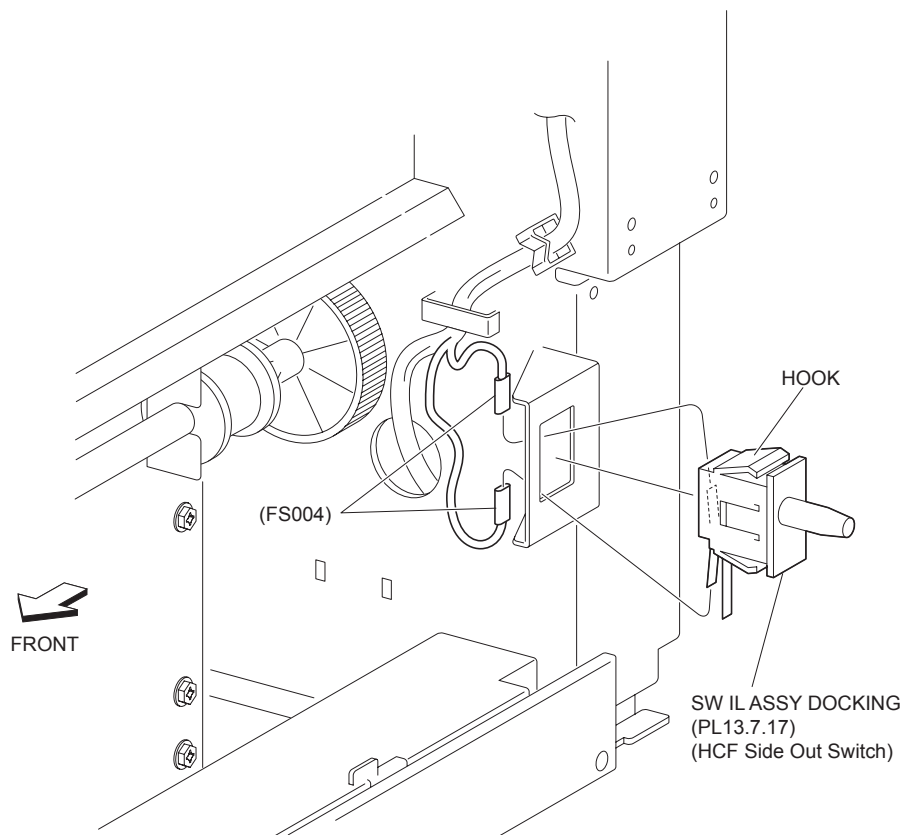
**NOTE** When installing the Motor Assembly, engage the gears of the Motor Assembly and the TA Roller Assembly P securely.

2. Connect the connector (PF57) of the Main Harness Assembly (PL 13.8.2) to the Motor Assembly.
3. Secure the Main Harness Assembly using a harness clamp.
4. Install the HCF Rear Cover (PL 13.1.14) .
5. Install the HCF Top Cover LG (PL 13.1.1) .

## Interlock Docking Switch Assembly (HCF Side Out Switch)

### Removal

1. Remove the HCF Right Hand Cover (PL 13.1.2) .
2. Remove the Tray Unit from the machine.
3. Disconnect the connector (FS004) attached to the Interlock Docking Switch Assembly (HCF Side Out Switch) from the connector of the Main Harness Assembly (PL 13.8.2) .
4. Release the hooks securing the Interlock Docking Switch Assembly to the frame to remove Interlock Docking Switch Assembly.



**Figure 1 Interlock Switch Assembly**

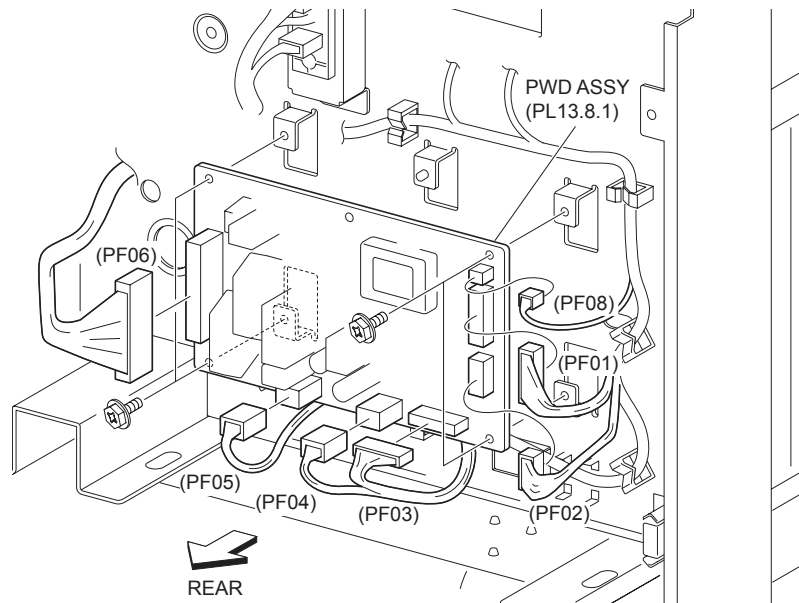
## Replacement

1. Install the Interlock Docking Switch Assembly (HCF Side Out Switch) to the frame, and secure it with the hooks.
2. Connect the connector of the Main Harness Assembly (PL 13.8.2) to the harness connector (FS004) of the Interlock Docking Switch Assembly.
3. Install the HCF Right Hand Cover (PL 13.1.2) .
4. Install the Tray Unit to the machine.

## PWB Assembly

### Removal

1. Remove the HCF Rear Cover (PL 13.1.14) .
2. Disconnect the seven connectors of Main Harness Assembly (PL 13.8.2) from the PWB Assembly .
3. Remove the four screws securing the PWB Assembly to the frame.
4. Remove the PWB Assembly.



**Figure 1 PWB Assembly**

## Replacement

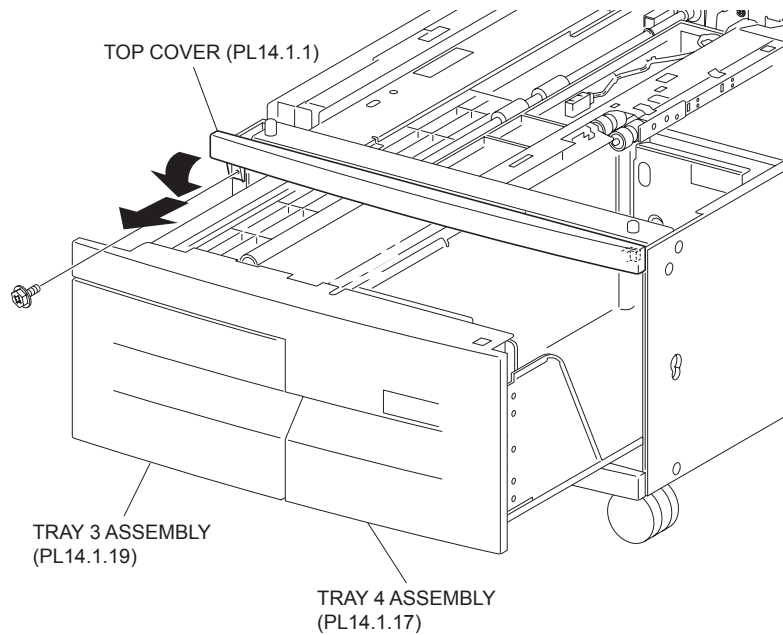
1. Install the PWB Assembly to the frame using the four screws.
2. Connect the seven connectors of the Main Harness Assembly (PL 13.8.2) to the PWB Assembly.
3. Install the HCF Rear Cover (PL 13.1.14) .

## Tandem Tray

### Top Cover

#### Removal

1. Pull out the Tray 3 Assembly (PL 14.1.19).
2. Pull out the Tray 4 Assembly (PL 14.1.17).
3. Remove the one screw (Del Tite, M3x8mm) securing the Top Cover to the machine .
4. Move the Top Cover in the direction of the arrow to remove it.



**Figure 1 Top Cover**

## Replacement

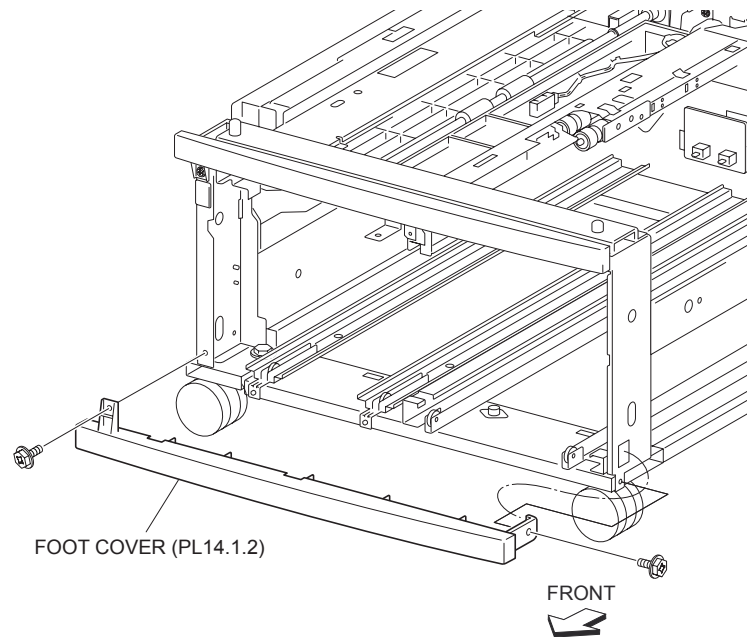
1. Move the Top Cover in the opposite direction of the arrow and put the right side of the Top Cover onto the frame.
2. Install the Top Cover to the machine using the one screw (Del Tite, M3x8mm).
3. Close the Tray 4 Assembly (PL 14.1.17).
4. Close the Tray 3 Assembly (PL 14.1.19).

## Foot Cover

### Removal

1. Remove the Tray 3 Assembly (PL 14.1.19) .
2. Remove the Tray 4 Assembly (PL 14.1.17) .
3. Remove the Right Cover (PL 14.1.3) .
4. Remove the two screws (Del Tite, M3x8mm) securing the Foot Cover to the machine .
5. Remove the Foot Cover.





**Figure 1 Foot Cover**

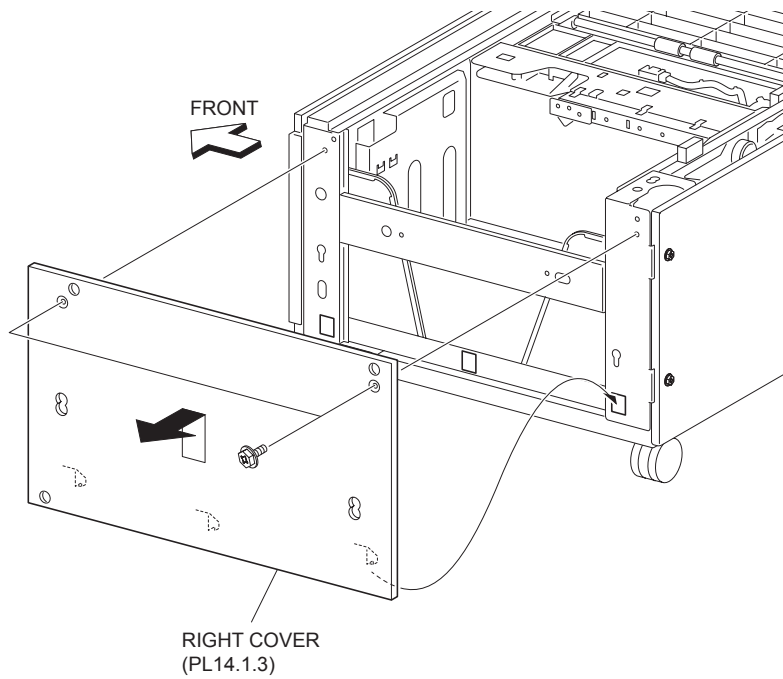
### **Replacement**

1. Install the Foot Cover to the machine using the two screws (Del Tite, M3x8mm).
2. Install the Right Cover (PL 14.1.3) .
3. Install the Tray 4 Assembly (PL 14.1.17) .
4. Install the Tray 3 Assembly (PL 14.1.19) .

### **Right Cover**

#### **Removal**

1. Remove the two screws (Del Tite, M3x8mm) securing the Right Cover to the machine .
2. Move the Right Cover in the direction of the arrow to remove it.



**Figure 1 Right Cover**

## Replacement

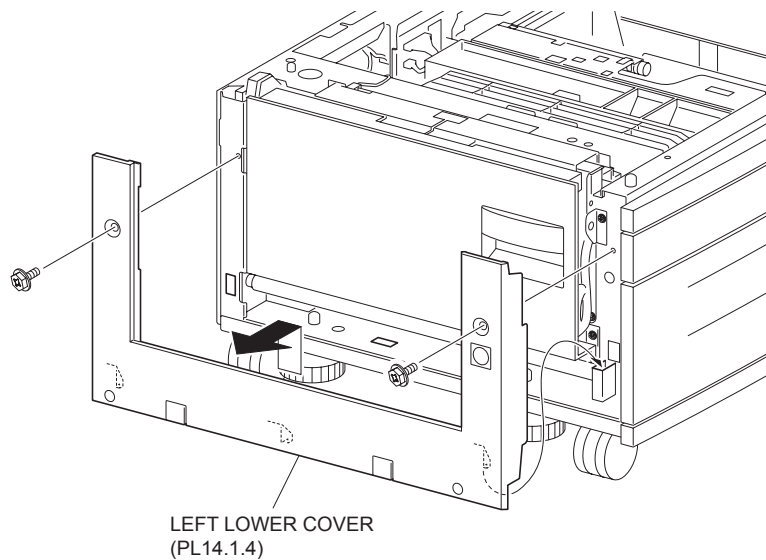
1. Install the Right Cover to the machine using the two screws (Del Tite, M3x8mm).

**NOTE** Be sure to put the three hooks on the lower part of the Right Cover into the holes on the frame.

## Left Lower Cover

### Removal

1. Remove the two screws (Del Tite, M3x8mm) securing the Left Lower Cover to the machine .
2. Move the Left Lower Cover in the direction of the arrow to remove it.



**Figure 1 Left Lower Cover**

## Replacement

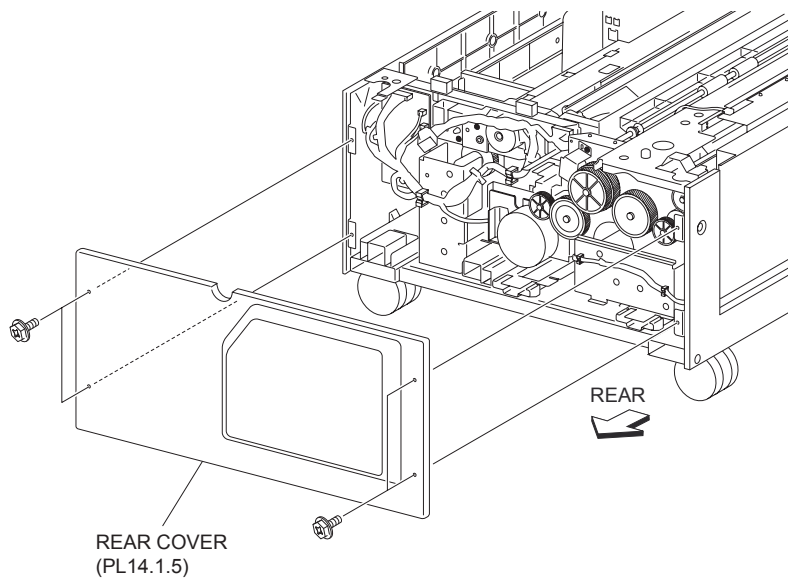
1. Install the Left Lower Cover to the machine using two screws (Del Tite, M3x8mm).

**NOTE** Be sure to put the three hooks on the lower part of the Left Lower Cover into the holes on the frame.

## Rear Cover

### Removal

1. Remove the four screws (Del Tite, M3x8mm) securing the Rear Cover to the machine .
2. Remove the Rear Cover.



**Figure 1 Rear Cover**

F15L005A 1

## Replacement

1. Install the Rear Cover to the machine using the four screws (Del Tite, M3x8mm).

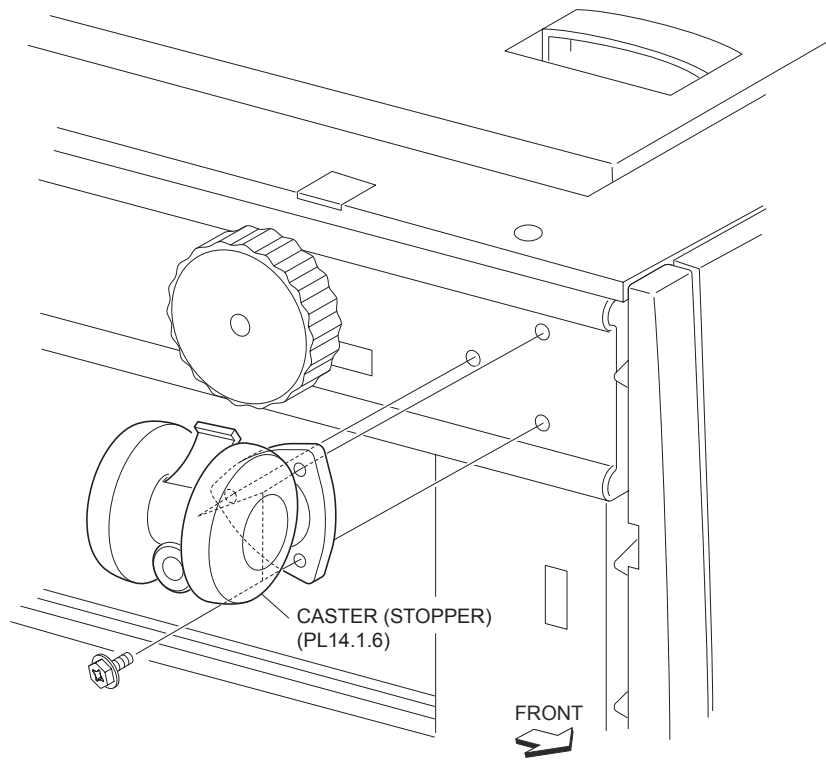
## Stopper Caster

### Removal

1. Remove the Tray 3 Assembly (PL 14.1.19) .
2. Remove the Tray 4 Assembly (PL 14.1.17) .
3. Place the machine on its right side down.

**NOTE** Be careful not to damage the Right Cover (PL 14.1.3).

4. Remove the three screws (Del Tite, M4x6mm) securing the Stopper Caster to the machine .
5. Remove the Stopper Caster.



**Figure 1 Stopper Caster**

## Replacement

1. Install the Stopper Caster to the machine using three screws (Del Tite, M4x6mm).
2. Place the machine to the original position.
3. Install the Tray 4 Assembly (PL 14.1.17) .
4. Install the Tray 3 Assembly (PL 14.1.19) .

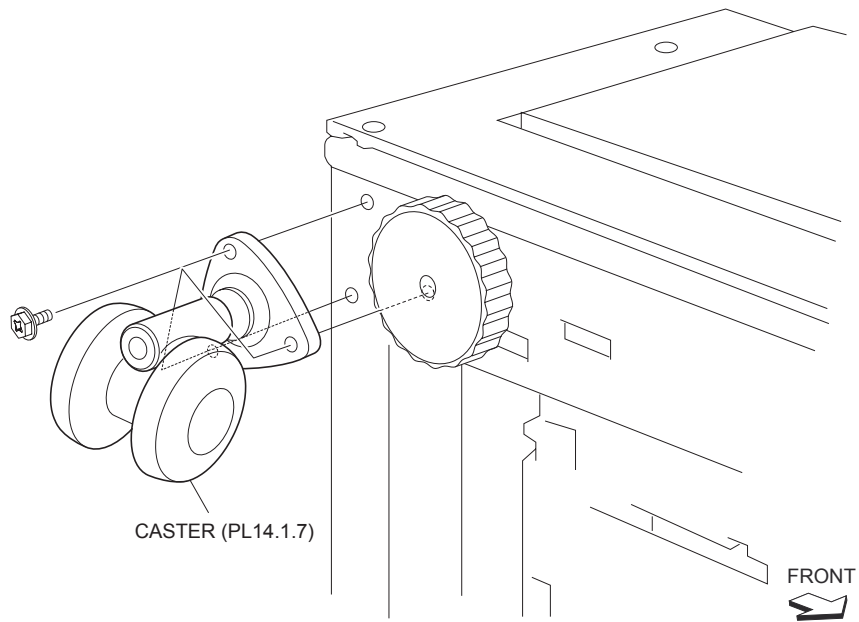
## Caster

### Removal

1. Remove the Tray 3 Assembly (PL 14.1.19) .
2. Remove the Tray 4 Assembly (PL 14.1.17) .
3. Place the machine on its right side down.

**NOTE Be careful not to damage the Right Cover (PL 14.1.3).**

4. Remove the three screws (Del Tite, M4x6mm) securing the Caster to the machine .
5. Remove the Caster.



**Figure 1 Castor**

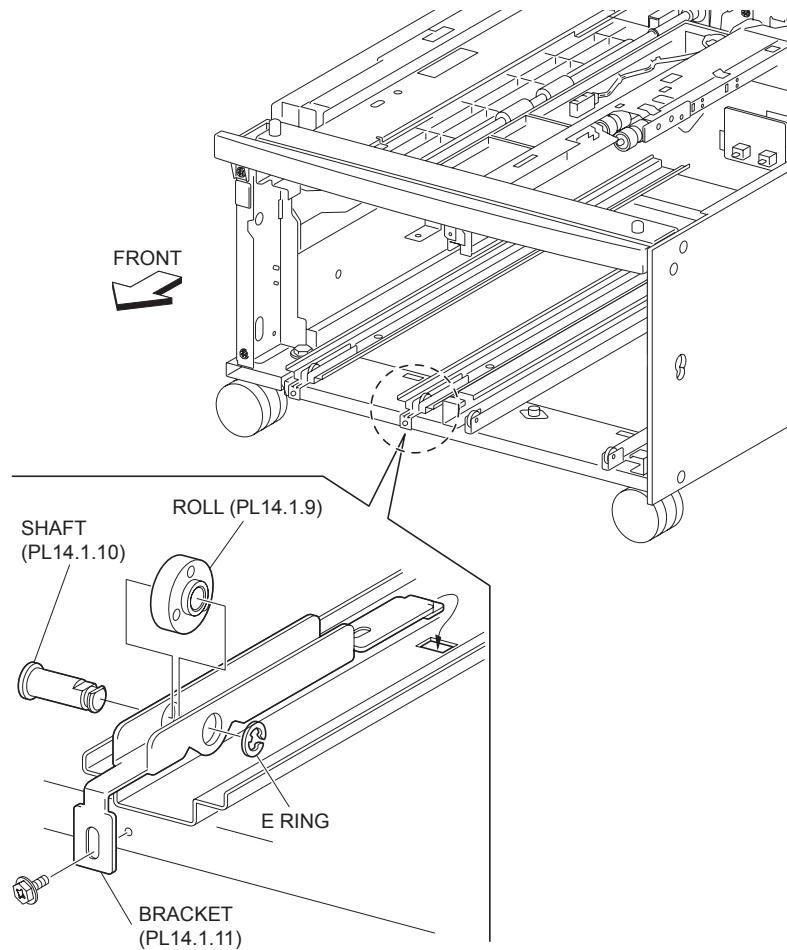
### **Replacement**

1. Install the Castor to the machine using the three screws (Del Tite, M4x6mm).
2. Place the machine to the original position.
3. Install the Tray 4 Assembly (PL 14.1.17) .
4. Install the Tray 3 Assembly (PL 14.1.19) .

### **Roll (Center)**

#### **Removal**

1. Remove the Tray 3 Assembly (PL 14.1.19) .
2. Remove the Tray 4 Assembly (PL 14.1.17) .
3. Remove the Foot Cover (PL 14.1.2) .
4. Remove the one screw securing the Bracket (PL 14.1.11) to the machine and remove the Bracket .
5. Remove the E-ring securing the Roll to Bracket.
6. Remove the Roll together with the Shaft (PL 14.1.10).



**Figure 1 Roll**

## Replacement

1. Install the Roll to Bracket together with the Shaft (PL 14.1.10) using the one E-ring.
2. Install the Bracket (PL 14.1.11) to the machine using the one screw.

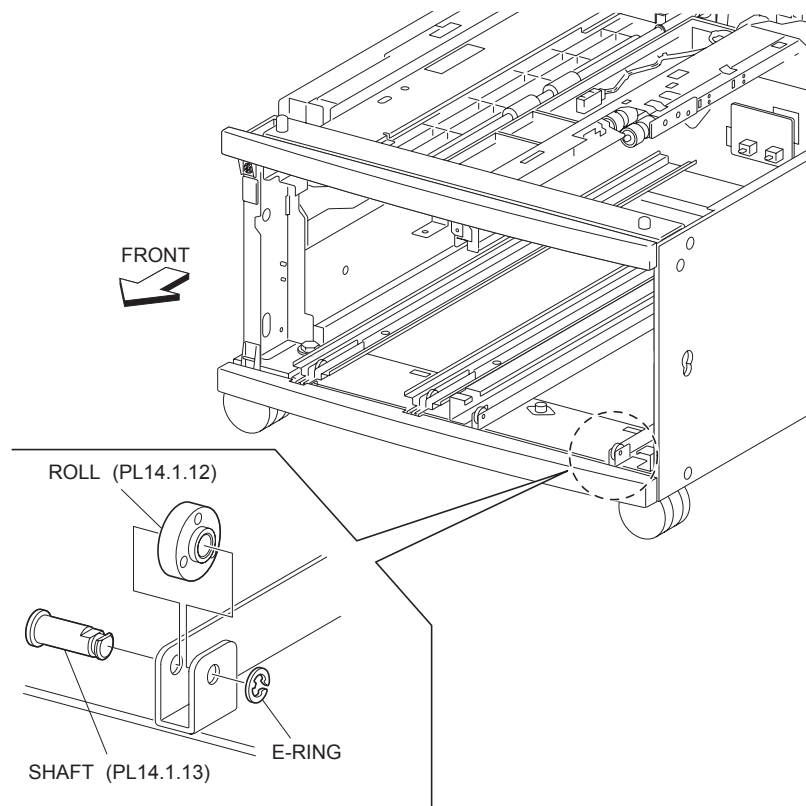
**NOTE** Be sure to put the tip of the Bracket into the hole on the machine.

3. Install the Foot Cover (PL 14.1.2) .
4. Install the Tray 4 Assembly (PL 14.1.17) .
5. Install the Tray 3 Assembly (PL 14.1.19) .

## Roll (Outboard)

### Removal

1. Remove the Tray 4 Assembly (PL 14.1.17) .
2. Remove the E-ring securing the Roll to the machine .
3. Remove the Roll together with the Shaft (PL 14.1.13).



**Figure 1 Roll**

## Replacement

1. Install the Roll to the machine together with the Shaft (PL 14.1.13) using the one E-ring.
2. Install the Tray 4 Assembly (PL 14.1.17) .

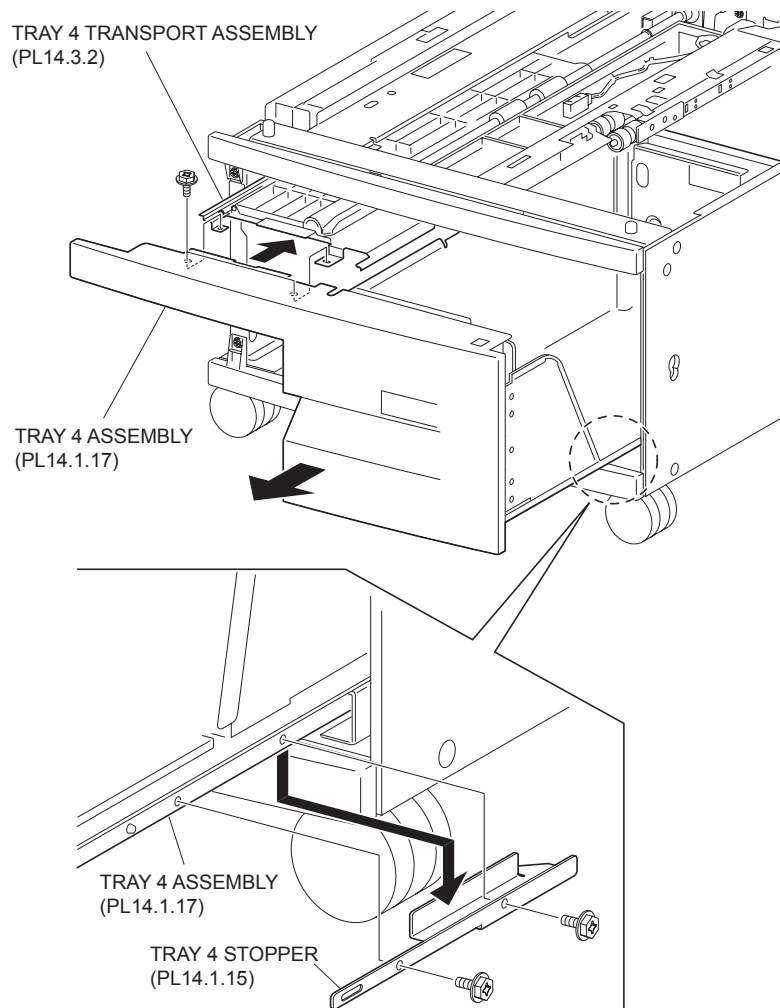
## Tray 4 Assembly

### Removal

1. Pull out the Tray 4 Assembly.
2. Remove the two screws (DeI Tite, M3x8mm) securing the Tray 4 Transport Assembly (PL 14.3.2) to the Tray 4 Assembly .
3. Push the Tray 4 Transport Assembly in the direction of the arrow until it touches the machine.

**NOTE Be careful not to push it in too forcefully or it may damage the machine.**

4. Pull out the Tray 4 Assembly fully toward you (to the front).
5. Remove the two screws securing the Tray 4 Stopper (PL 14.1.15) to the lower part of the Tray 4 Assembly to remove the Tray 4 Stopper.
6. Remove the Tray 4 Assembly.



**Figure 1 Tray 4 Assembly**

## Replacement

1. Insert the Tray 4 Assembly to the machine.
2. Secure the Tray 4 Stopper (PL 14.1.15) to the lower part of the Tray 4 Assembly using the two screws.

**NOTE** Make sure that the Tray 4 Assembly can be pulled out/pushed in smoothly in the machine, and also, it is not detached from the machine.

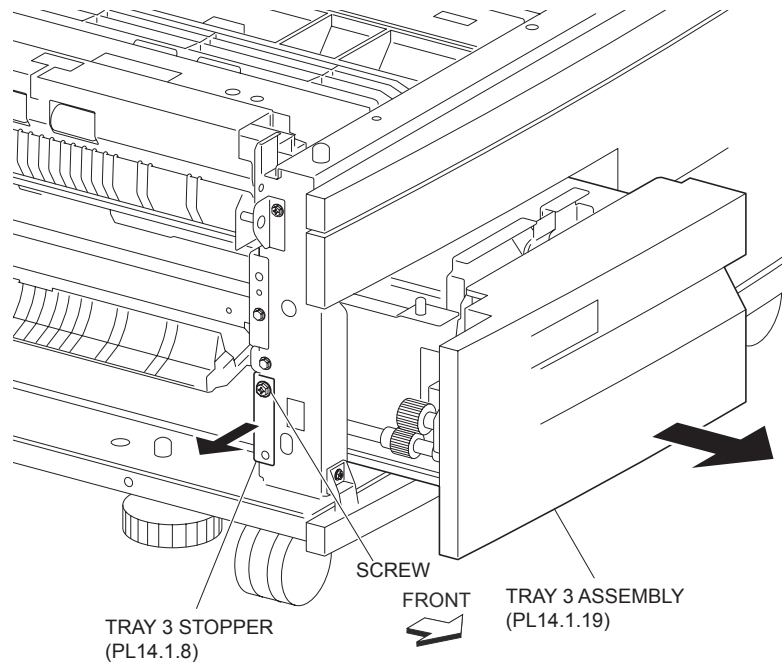
3. Pull out the Tray 4 Transport Assembly (PL 14.3.2) from the machine and install it to the Tray 4 Assembly using the two screws (Del Tite, M3x8mm).
4. Insert the Tray 4 Assembly.

## Tray 3 Assembly

### Removal

1. Remove the Left Lower Cover (PL 14.1.4) .
2. Remove the Left Cover Assembly (PL 14.7.1) .
3. Loosen the screw (Del Tite, M3x8mm) securing the Tray 3 Stopper (PL 14.1.8) to the machine .
4. Move the lower part of the Tray 3 Stopper in the direction of the arrow, and while keeping the position of it, move the Tray 3 Assembly toward you (to the front) to remove it.





**Figure 1 Tray 3 Assembly**

## Replacement

1. Move the lower part of the Tray 3 Stopper (PL 14.1.8) in the direction of the arrow, and while keeping the position of it, install the Tray 3 Assembly.

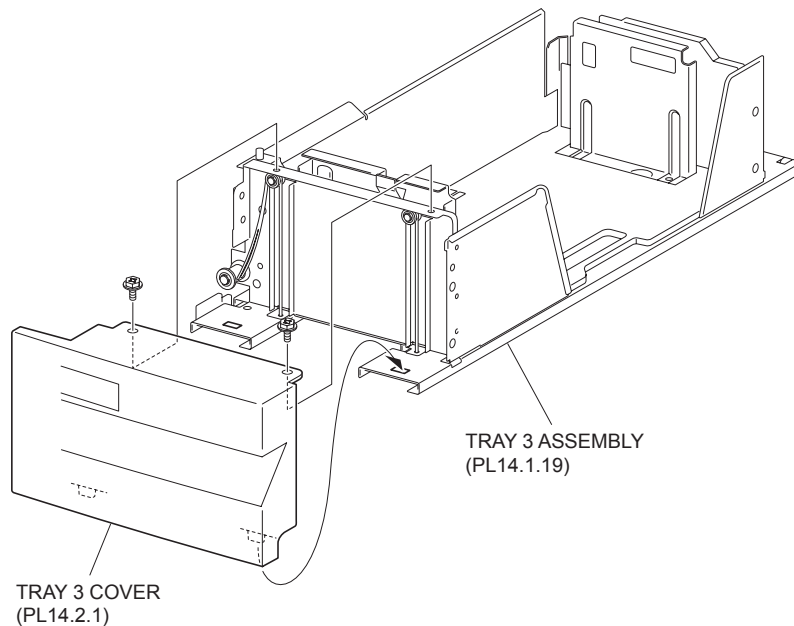
**NOTE** Make sure that the Tray 3 Assembly can be pulled out/pushed in smoothly in the machine, and also, it is not detached from the machine.

2. Install the Tray 3 Stopper (PL 14.1.8) to the machine using screw (Del Tite, M3x8mm).
3. Install the Left Cover Assembly (PL 14.7.1) .
4. Install the Left Lower Cover (PL 14.1.4) .

## Tray 3 Cover

### Removal

1. Pull out the Tray 3 Assembly (PL 14.1.19).
2. Remove the two screws (Del Tite, M3x8mm) securing the Tray 3 Cover to the Tray 3 Assembly .
3. Remove the Tray 3 Cover.



**Figure 1 Tray 3 Cover**

## Replacement

1. Install the Tray 3 Cover to the Tray 3 Assembly (PL 14.1.19) using the two screws (Del Tite, M3x8mm).

**NOTE** Be sure to fit the two bosses on the lower part of the Tray 3 Cover into the holes on the Tray 3 Assembly.

2. Push in Tray 3 Assembly.

## Rear Tray Cables

**NOTE** When replacing cables, it is recommended to replace the Rear Tray Cables and the Front Left and Right Tray Cables at the same time.

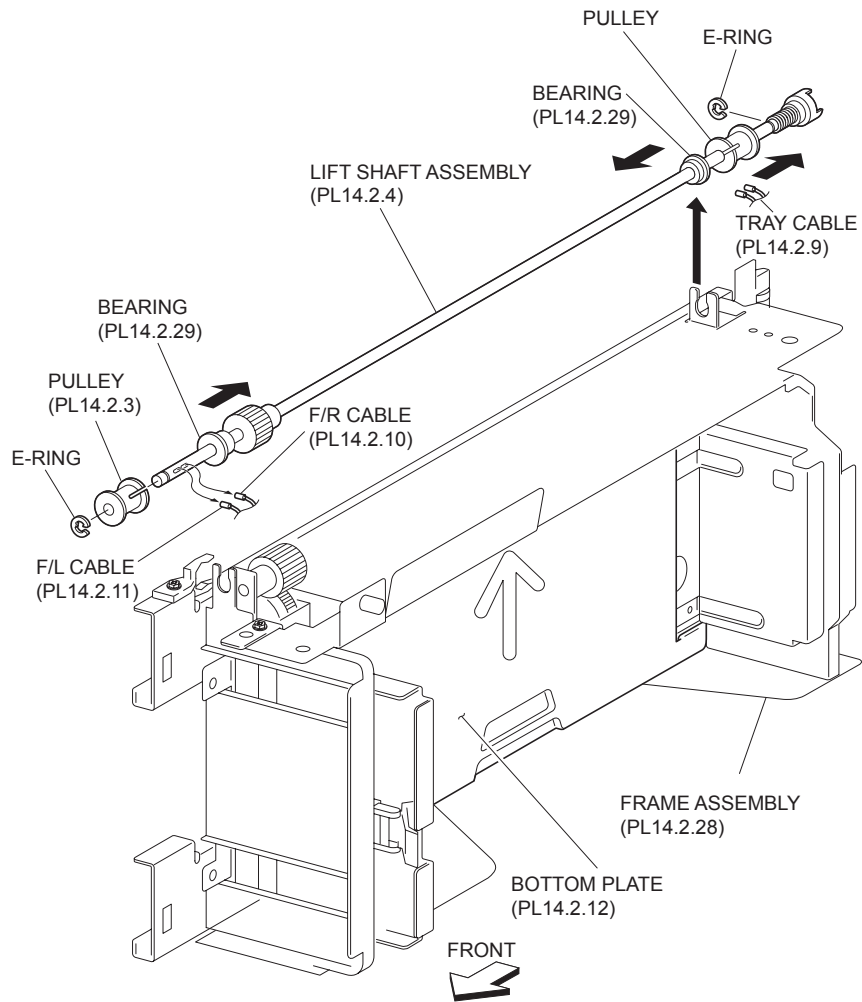
### Removal

1. Remove the Left Lower Cover (PL 14.1.4) .
2. Remove the Left Cover Assembly (PL 14.7.1) .
3. Remove the Tray 3 Assembly (PL 14.1.19) .
4. Remove the Tray 3 Cover (PL 14.2.1) .
5. Remove the two E-rings securing the Lift Shaft Assembly (PL 14.2.4) to the Frame Assembly (PL 14.2.28) and remove the Pulley (PL 14.2.3) .

**NOTE** Note that the Front Right and Left Cables are detached.

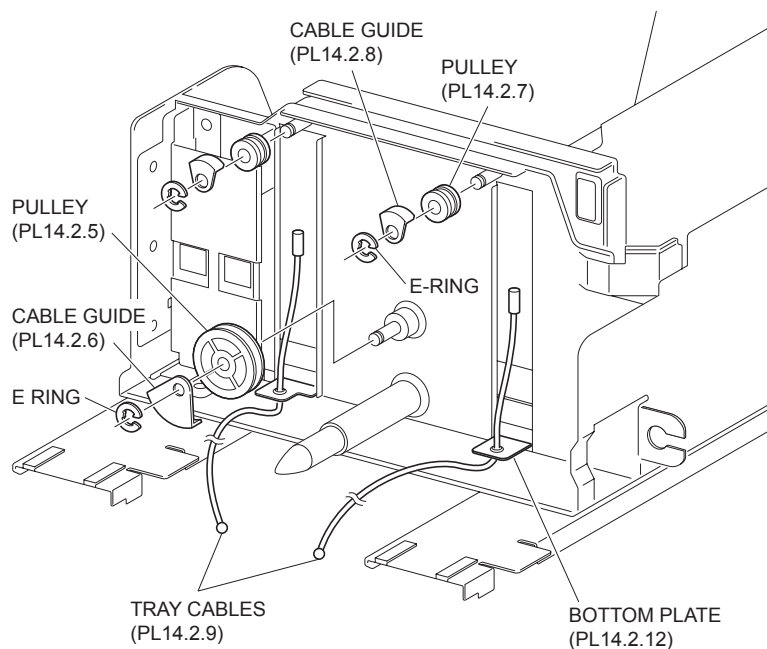
6. Move the Left and Right Bearings securing the Lift Shaft Assembly to the Frame Assembly in the direction of the arrow and remove the Lift Shaft Assembly.
7. Remove the two Rear Tray Cables from the Lift Shaft Assembly.

**NOTE** Removing the Rear Tray Cables is made easy by moving the Pulley to the rear side of the Lift Shaft Assembly.



**Figure 1 Tray Cables**

8. Remove the E-ring securing the two Pulleys (PL 14.2.7) on the rear of the Frame Assembly and remove two each of the Cable Guides (PL 14.2.8) and the Pulleys (PL 14.2.7) .
9. Remove the E-ring securing the Cable Guide (PL 14.2.6) and the Pulley (PL 14.2.5) to the Frame Assembly and remove the Pulley and the Cable Guide.
10. Remove the two Tray Cables from the Bottom Plate (PL 14.2.12).



**Figure 2 Removing Rear Tray Cables**

## Replacement

1. Fit the tips of the two Tray Cables into the holes on the Bottom Plate (PL 14.2.12) .

**NOTE** Place the Bottom Plate to the Tray 3 Assembly so that the arrow mark on the Bottom Plate points to the direction as shown in the figure.

2. Install the two Cable Guides (PL 14.2.8) on the rear to the Frame Assembly (PL 14.2.28) together with the Pulley (PL 14.2.7) using the E-rings.

**NOTE** Be sure that the two Tray Cables are put onto the two Pulleys on the rear in advance.

3. Install the Cable Guide (PL 14.2.6) to the Frame Assembly together with the Pulley (PL 14.2.5) using the one E-ring.

**NOTE** Be sure that the two Tray Cables are installed onto the Pulley in advance.

4. Fit two the Tray Cables into the hole on the Lift Shaft Assembly (PL 14.2.4).

**NOTE** When fitting the two Tray Cables into the holes, be careful not to twist them.

5. Install the Lift Shaft Assembly to the Frame Assembly by moving the left and right Bearings in the direction of the arrow.

**NOTE** Move the Pulley on the Lift Shaft Assembly to prevent the two Tray Cables from being detached.

6. Fit the Front Right Cable and Front Left Cable into the hole on the Lift Shaft Assembly.

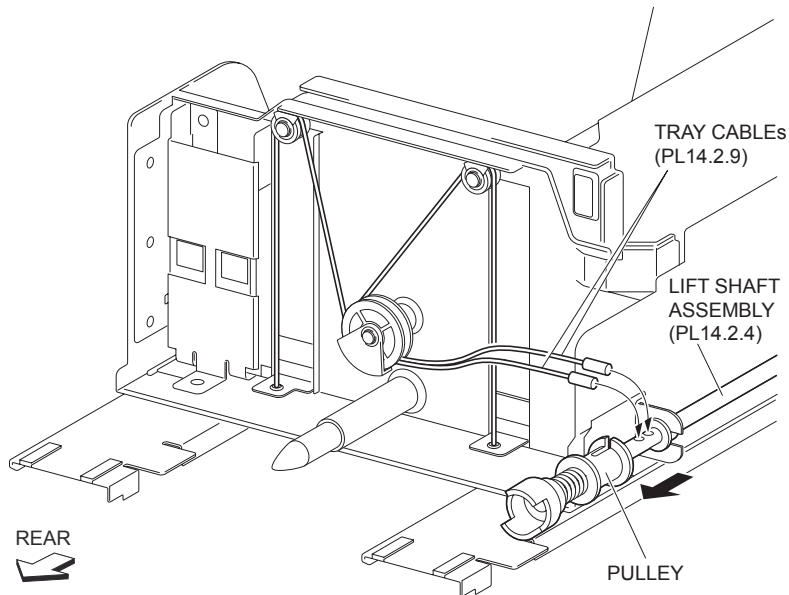
**NOTE** When fitting the Front Right Cable and Front Left Cable into the holes, be careful not to twist them.

7. Fit the Front Right Cable (PL 14.2.10) and Front Left Cable (PL 14.2.11) into the hole on the Lift Shaft Assembly (PL 14.2.4).
8. Install the Lift Shaft Assembly to the Frame Assembly together with the Pulley (PL 14.2.3) using the one E-ring.

**NOTE** Be careful not to detach the Front Right Cable and Front Left Cable from the Lift Shaft Assembly.

9. Install the Tray 3 Cover (PL 14.2.1) .
10. Install the Tray 3 Assembly (PL 14.1.19) .
11. Install the Left Cover Assembly (PL 14.7.1) .

12. Install the Left Lower Cover (PL 14.1.4) .



**Figure 3 Replacing Tray Cables**

## Front Right Tray Cable

**NOTE** When replacing cables, it is recommended to replace the Rear Tray Cables (PL 14.2.9) and the Front Left and Right Tray Cables at the same time.

### Removal

1. Remove the Left Lower Cover (PL 14.1.4) .
2. Remove the Left Cover Assembly (PL 14.7.1) .
3. Remove the Tray 3 Assembly (PL 14.1.19) .
4. Remove the Tray 3 Cover (PL 14.2.1) .
5. Remove the two E-rings securing the Lift Shaft Assembly (PL 14.2.4) to the Frame Assembly (PL 14.2.28) and remove the Pulley (PL 14.2.3) .

**NOTE** Note that the Front Left Cable is detached.

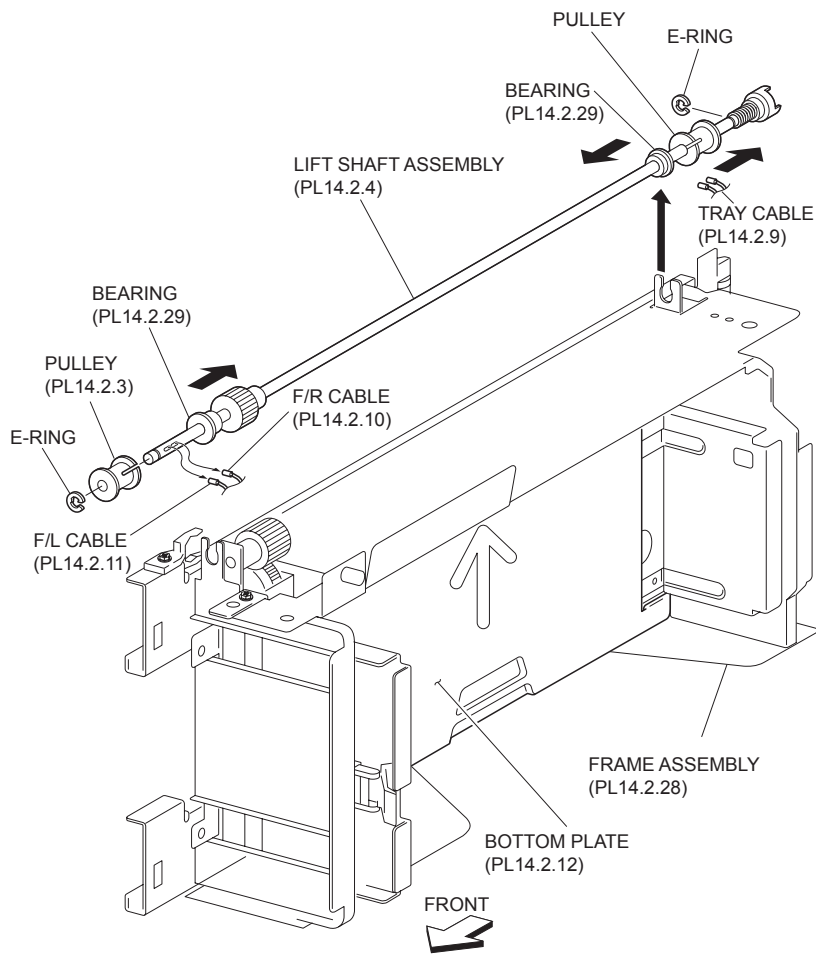
6. Move the left and right Bearings securing the Lift Shaft Assembly to the Frame Assembly in the direction of the arrow and remove the Lift Shaft Assembly.

**NOTE** Note that the Tray Cables are detached.

7. Remove the Front Right Cable from the Lift Shaft Assembly .

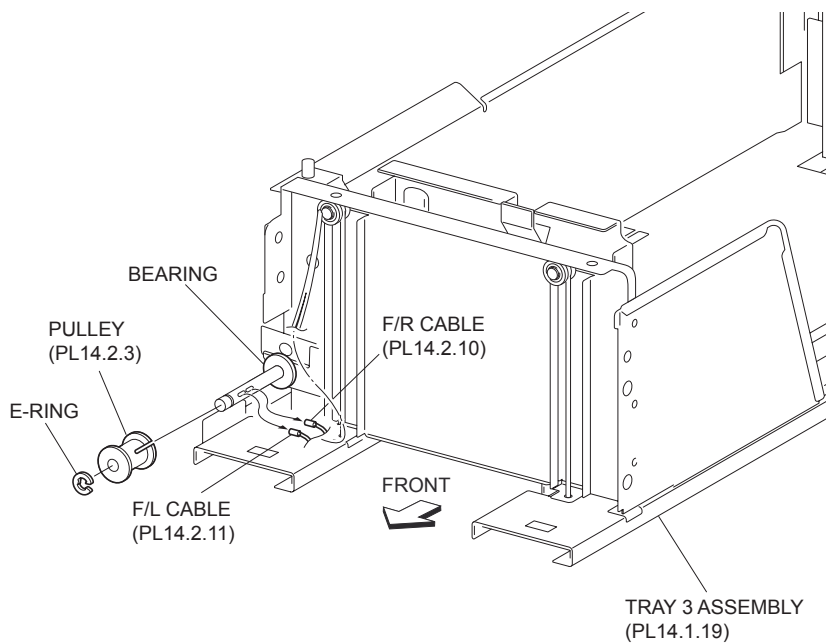
**NOTE** Removing the Front Right Tray Cable is made easy by moving the Lift Shaft Assembly.

8. Remove the E-rings securing the two Pulleys (PL 14.2.7) on the front to the Frame Assembly and remove two each of the Cable Guides (PL 14.2.8) and the Pulleys .

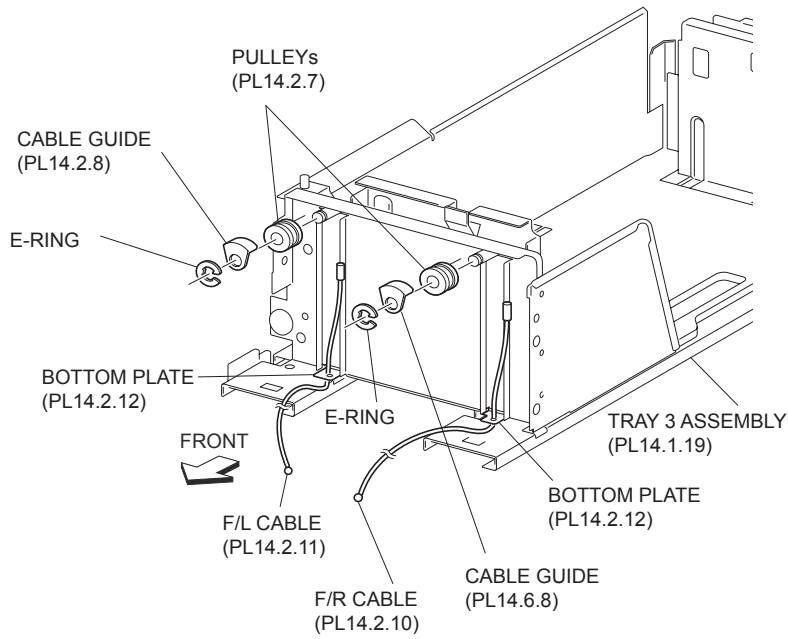


**Figure 1 Front Cables**

9. Remove the tips of the Front Right Cable from the Bottom Plate (PL 14.2.12) .



**Figure 2 Removing Front Cables**



**Figure 3 Removing Front Cables**

## Replacement

1. Fit the tip of the Front Right Cable to the hole on the Bottom Plate (PL 14.2.12).

**NOTE** Place the Bottom Plate to the Tray 3 Assembly so that the arrow mark on the Bottom Plate points to the direction as shown in the figure.

2. Install the two Cable Guides (PL 14.2.8) on the front to the Frame Assembly (PL 14.2.28) together with the Pulleys (PL 14.2.7) using the one E-rings.

**NOTE** Be sure that the Front Right Cable and Front Left Cable (PL 14.2.11) are installed onto the two Pulleys on the front in advance.

3. Fit the Front Right Cable into the hole on the Lift Shaft Assembly (PL 14.2.4).

**NOTE** When fitting the Front Right Cable and Front Left Cable into the holes, be careful not to twist them.

4. Install the Lift Shaft Assembly to the Frame Assembly by moving the left and right Bearings in the direction of the arrow.

**NOTE** Move the Pulley on the Lift Shaft Assembly to prevent the Front Right Cable and Front Left Cable from being detached.

5. Install the Lift Shaft Assembly to the Frame Assembly together with the Pulley (PL 14.2.3) using an E-ring.

**NOTE** Be careful not to let the Front Right Cable and Front Left Cable be detached.

6. Install the Tray 3 Cover (PL 14.2.1) .
7. Install the Tray 3 Assembly (PL 14.1.19) .
8. Install the Left Cover Assembly (PL 14.7.1) .
9. Install the Left Lower Cover (PL 14.1.4) .

## Front Left Tray Cable

**NOTE** When replacing cables, it is recommended to replace the Rear Tray Cables (PL 14.2.9) and the Front Left and Right Tray Cables at the same time.

## Removal

1. Remove the Left Lower Cover (PL 14.1.4) .
2. Remove the Left Cover Assembly (PL 14.7.1) .
3. Remove the Tray 3 Assembly (PL 14.1.19) .
4. Remove the Tray 3 Cover (PL 14.2.1) .
5. Remove the two E-rings securing the Lift Shaft Assembly (PL 14.2.4) to the Frame Assembly (PL 14.2.28) and remove the Pulley (PL 14.2.3) .

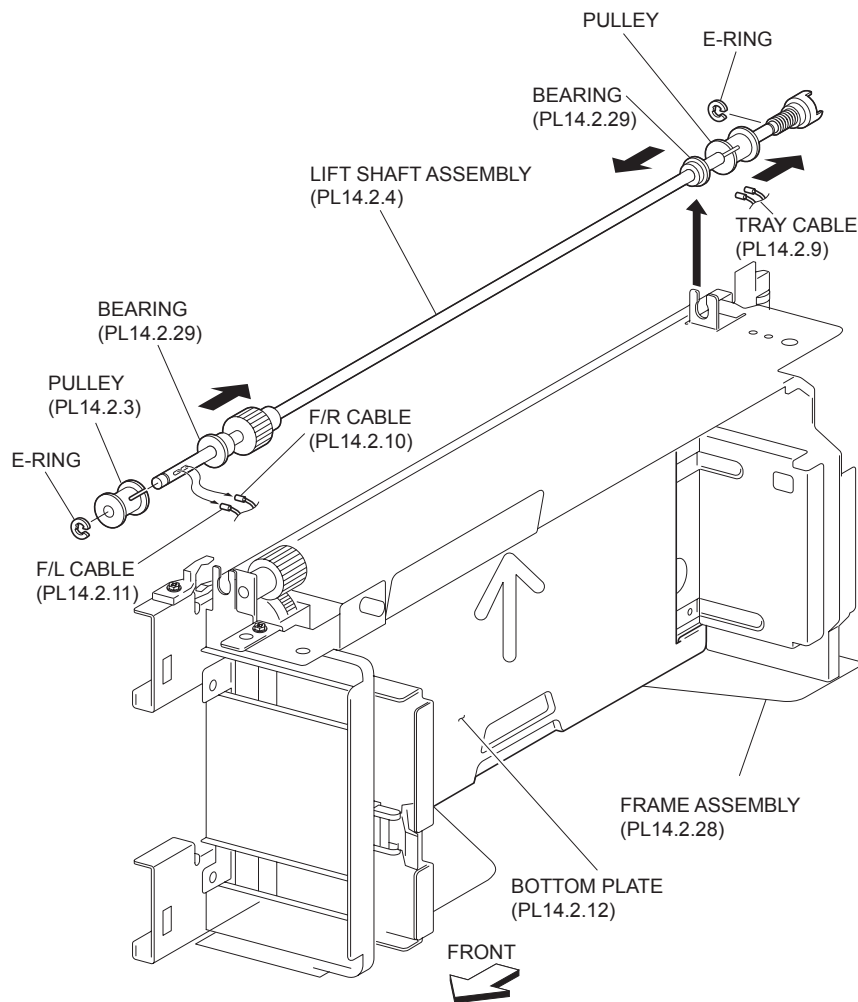
**NOTE** Note that the Front Right Cable is detached.

6. Move the left and right Bearings securing the Lift Shaft Assembly to the Frame Assembly in the direction of the arrow and remove the Lift Shaft Assembly.

**NOTE** Note that the Tray Cables are detached.

7. Remove the Front Left Cable from the Lift Shaft Assembly.

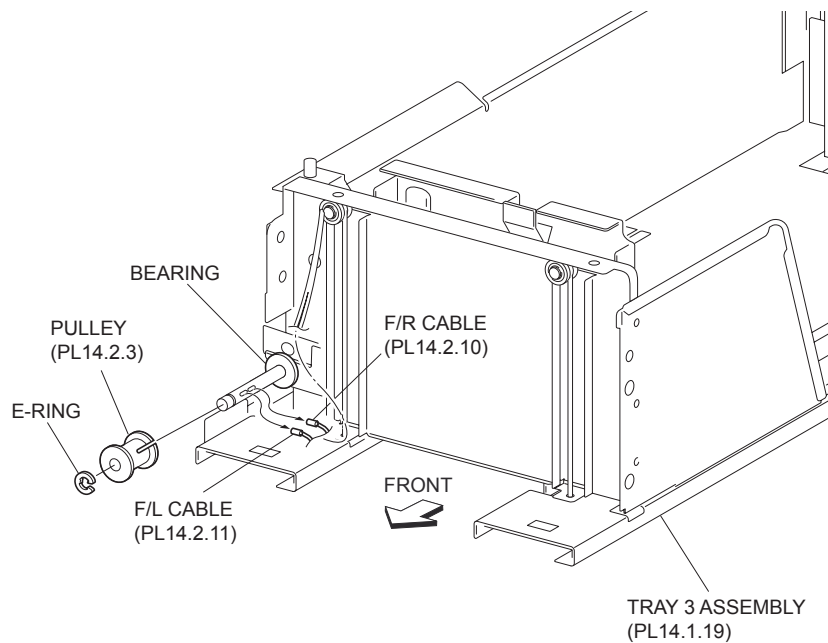
**NOTE** Removing the Front Left Tray Cable is made easy by moving the Lift Shaft Assembly.



**Figure 1 Front Left Cable**

8. Remove the E-rings securing the two Pulleys (PL 14.2.7) on the front to the Frame Assembly and remove two each of the Cable Guides (PL 14.2.8) and the Pulleys .
9. Remove the tips of the Front Left Cable from the Bottom Plate (PL 14.2.12).





**Figure 2 Removing Front Left Cable**

## Replacement

1. Fit the tip of the Front Left Cable to the hole on the Bottom Plate (PL 14.2.12).

**NOTE** Place the Bottom Plate to the Tray 3 Assembly so that the arrow mark on the Bottom Plate points to the direction as shown in the figure.

2. Install the two Cable Guides (PL 14.2.8) on the front to the Frame Assembly (PL 14.2.28) together with the Pulleys (PL 14.2.7) using the one E-rings.

**NOTE** Be sure that the Front Right Cable (PL 14.2.10) and the Front Left Cable are installed onto the two Pulleys on the front in advance.

3. Put the Front Left Cable into the hole on the Lift Shaft Assembly (PL 14.2.4).

**NOTE** When fitting the Front Right Cable and Front Left Cable into the holes, be careful not to twist them

4. Install the Lift Shaft Assembly to the Frame Assembly by moving the left and right Bearings in the direction of the arrow.

**NOTE** Move the Pulley on Lift Shaft Assembly to prevent the Front Right Cable and Front Left Cable from being detached.

5. Install Lift Shaft Assembly to Frame Assembly together with Pulley (PL 14.2.3) using an E-ring.

**NOTE** Be careful not to let Front Right Cable and Front Left Cable be detached.

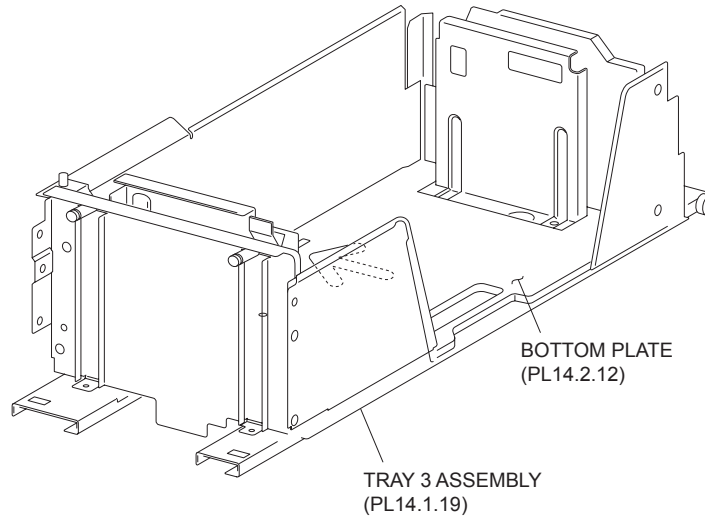
6. Install the Tray 3 Cover (PL 14.2.1) .
7. Install the Tray 3 Assembly (PL 14.1.19) .
8. Install the Left Cover Assembly (PL 14.7.1) .
9. Install the Left Lower Cover (PL 14.1.4) .

## Bottom Plate

### Removal

1. Remove the Left Lower Cover (PL 14.1.4) .
2. Remove the Left Cover Assembly (PL 14.7.1) .

3. Remove the Tray 3 Assembly (PL 14.1.19) .
4. Remove the Tray 3 Cover (PL 14.2.1) .
5. Remove the Rear Tray Cables (PL 14.2.9) .
6. Remove the Front Right Cable (PL 14.2.10) .
7. Remove the Front Left Cable (PL 14.2.11) .
8. Remove the Bottom Plate .



**Figure 1 Bottom Plate**

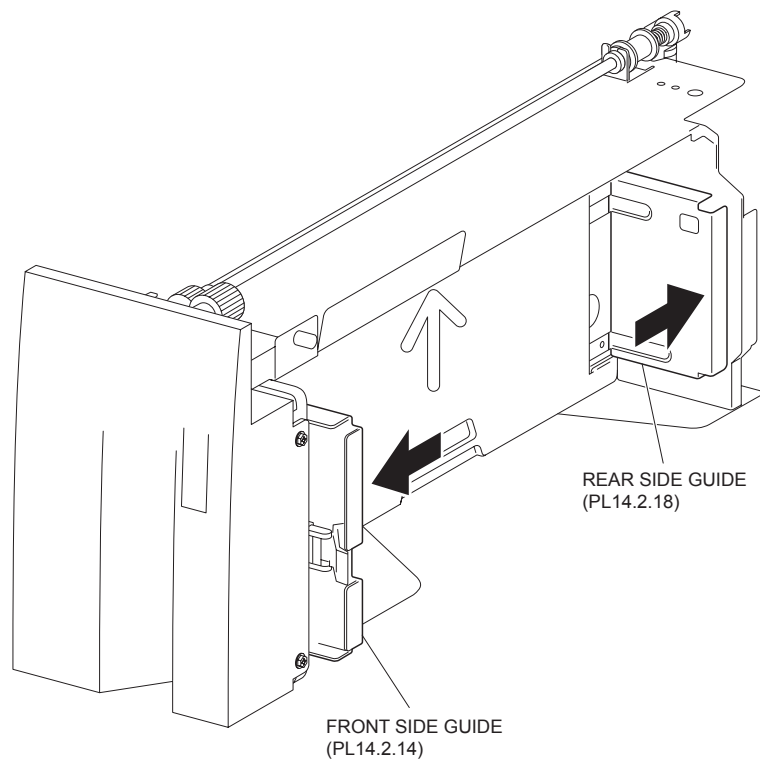
## Replacement

1. Install the Bottom Plate.
2. Install the Front Left Cable (PL 14.2.11) .
3. Install the Front Right Cable (PL 14.2.10) .
4. Install the Rear Tray Cables (PL 14.2.9) .
5. Install the Tray 3 Cover (PL 14.2.1) .
6. Install the Tray 3 Assembly (PL 14.1.19) .
7. Install the Left Cover Assembly (PL 14.7.1) .
8. Install the Left Lower Cover (PL 14.1.4) .

## Rack Gear (Tray 3)

### Removal

1. Remove the Tray 3 Assembly (PL 14.1.19) .
2. Place the Tray 3 Assembly on its right side .

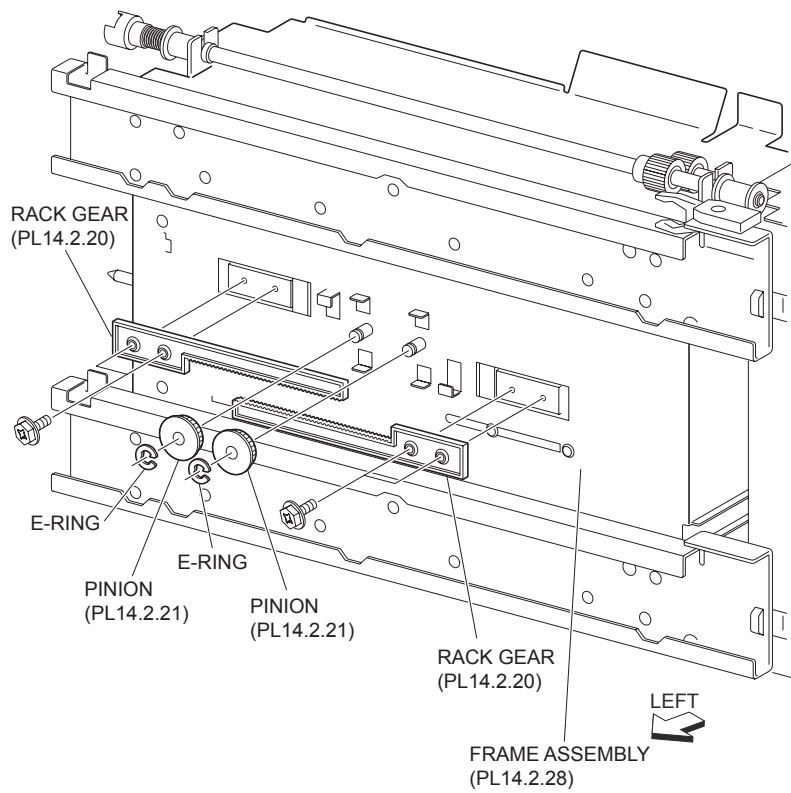


**Figure 1 Tray 3**

3. Remove the two Pinions (PL 14.2.21) .
4. Remove the four screws (Silver, M3x8mm) securing the two Rack Gears to the Frame Assembly (PL 14.2.28) .
5. Remove the two Rack Gears.

### **Replacement**

1. Move the Front Side Guide (PL 14.2.14) and the Rear Side Guide (PL 14.2.18) in the Tray 3 Assembly (PL 14.1.19) fully outward.
2. Install the two Rack Gears to the Frame Assembly (PL 14.2.28) using the two screw each (Silver, M3x8mm).
3. Install the two Pinions (PL 14.2.21) .
4. Install the Tray 3 Assembly (PL 14.1.19) .

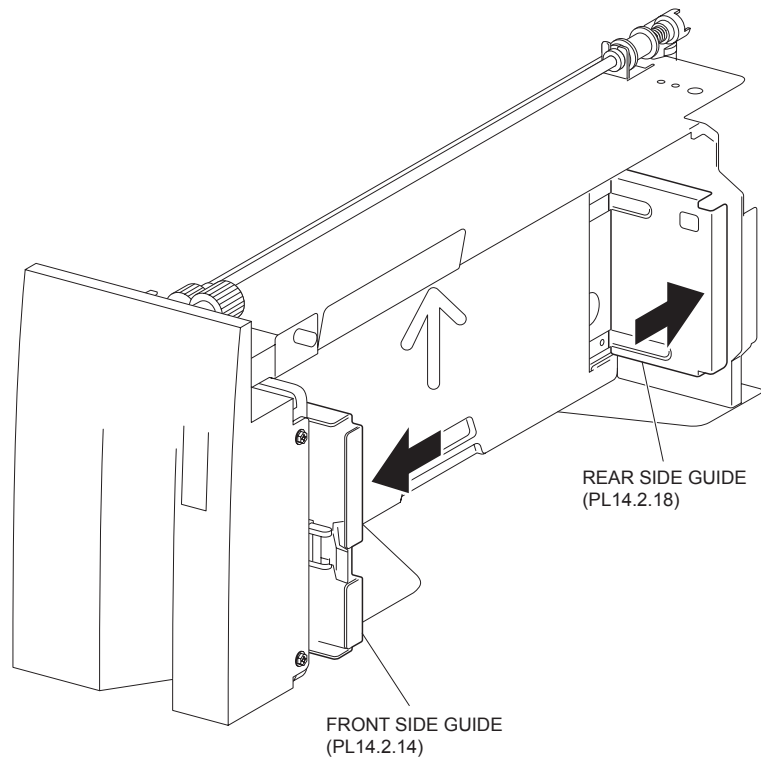


**Figure 2 Rack Gear**

## **Pinion (Tray 3)**

### **Removal**

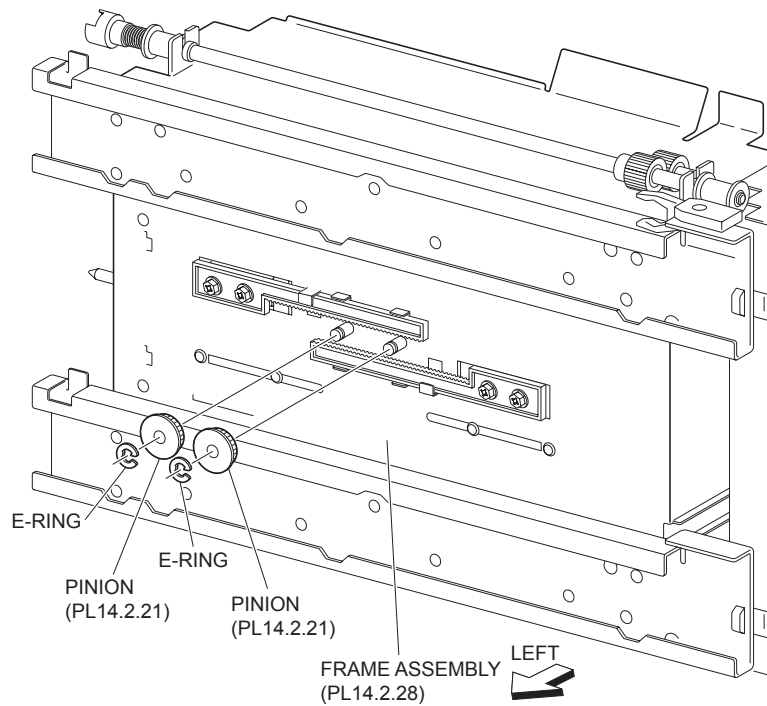
1. Remove the Tray 3 Assembly (PL 14.1.19) .
2. Place the Tray 3 Assembly on its right side .
3. Remove the two E-rings securing the two Pinions to the Frame Assembly (PL 14.2.28) to remove the two Pinions .



**Figure 1 Tray 3**

## Replacement

1. Move the Front Side Guide (PL 14.2.14) and the Rear Side Guide (PL 14.2.18) in the Tray 3 Assembly (PL 14.1.19) fully outward.
2. Install the two Pinions to the Frame Assembly (PL 14.2.28) using the one E-ring each.
3. Install the Tray 3 Assembly (PL 14.1.19) .



## Figure 2 Pinion Gears

### Tray 4 Cover

#### Removal

1. Remove the Tray 4 Assembly (PL 14.1.17) .
2. Remove the two screws (Del Tite, M3x8mm) securing the Tray 4 Cover to the Tray 4 Assembly .
3. Move the Tray 4 Cover in the direction of the arrow to remove it.

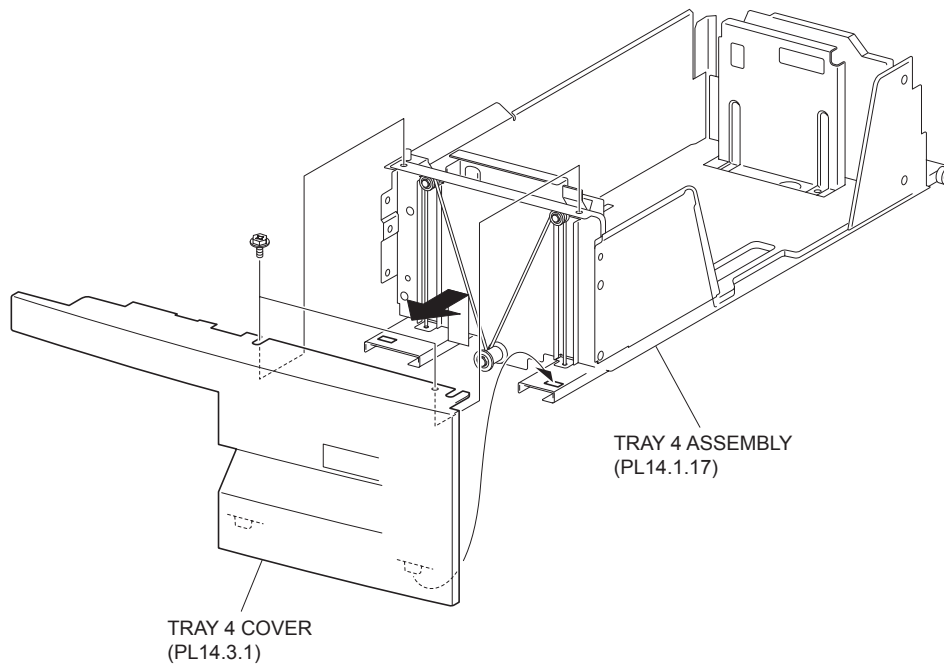


Figure 1 Tray 4 Cover

#### Replacement

1. Install the Tray 4 Cover to the Tray 4 Assembly (PL 14.1.17) using the two screws (Del Tite, M3x8mm).

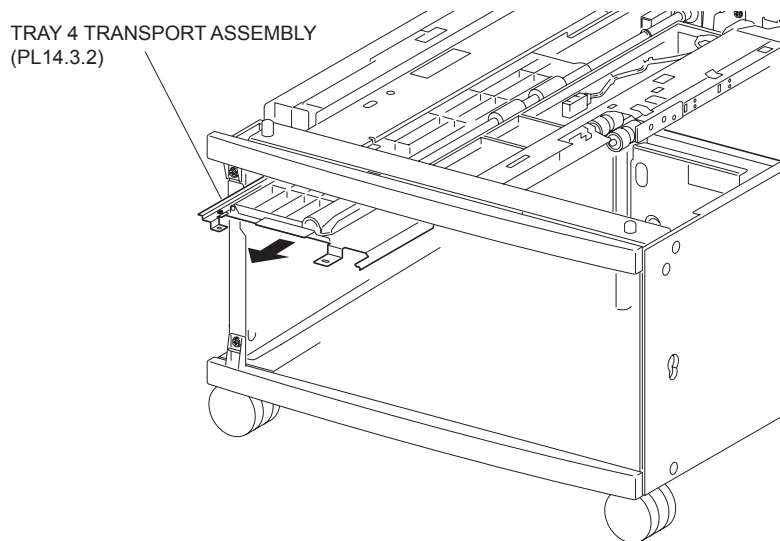
**NOTE** Be sure to fit the two bosses on the lower part of the Tray 4 Cover into the holes on the Tray 4 Assembly.

2. Install the Tray 4 Assembly (PL 14.1.17) .

### Tray 4 Transport Assembly

#### Removal

1. Remove the Tray 4 Assembly (PL 14.1.17) .
2. Remove the Tray 4 Transport Assembly .



**Figure 1 Tray 4 Transport**

## Replacement

1. Insert the Tray 4 Transport Assembly to the frame.

**NOTE** Be sure to insert the Tray 4 Transport Assembly along the guide rails of the frame.

2. Install the Tray 4 Transport Assembly to the Tray 4 Assembly using the two screws.
3. Install the Tray 4 Assembly (PL 14.1.17) .

## Rear Tray Cables (Tray 4)

**NOTE** When replacing the cable, it is recommended to replace the Front Tray Cables (PL 14.3.9) together.

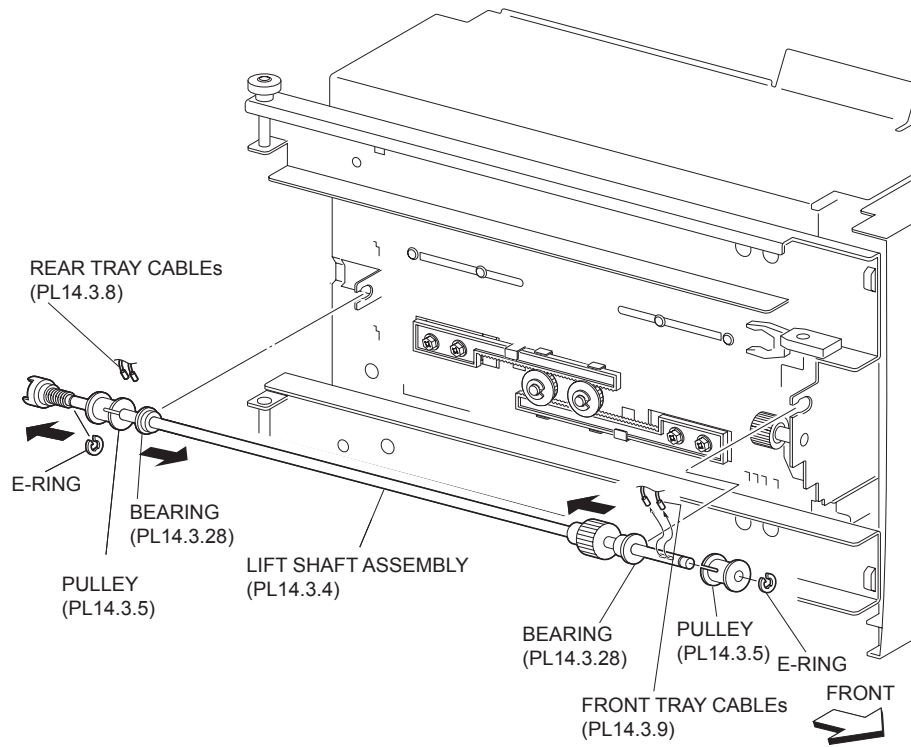
### Removal

1. Remove the Tray 4 Assembly (PL 14.1.17) .
2. Remove the Tray 4 Cover (PL 14.3.1) .
3. Place the Frame Assembly (PL 14.3.26) on its right side down .
4. Remove the two E-rings securing the Lift Shaft Assembly (PL 14.3.4) to the Frame Assembly and remove the Pulley (PL 14.3.5).

**NOTE** Note that the two Front Tray Cables are detached.

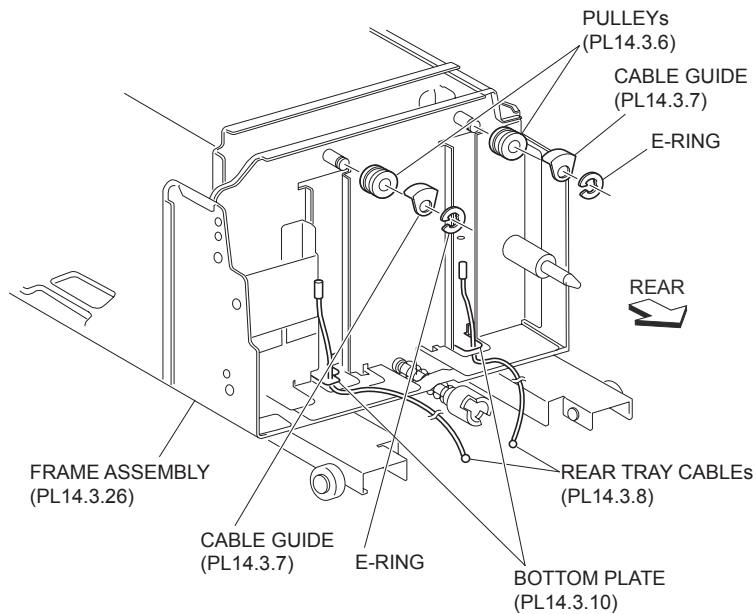
5. Move the left and right Bearings securing the Lift Shaft Assembly to the Frame Assembly in the direction of the arrow to remove the Lift Shaft Assembly.
6. Remove the two Rear Tray Cables from the Lift Shaft Assembly.

**NOTE** Removing the Rear Tray Cable is made easy by moving the Pulley to the rear side of the Lift Shaft Assembly.



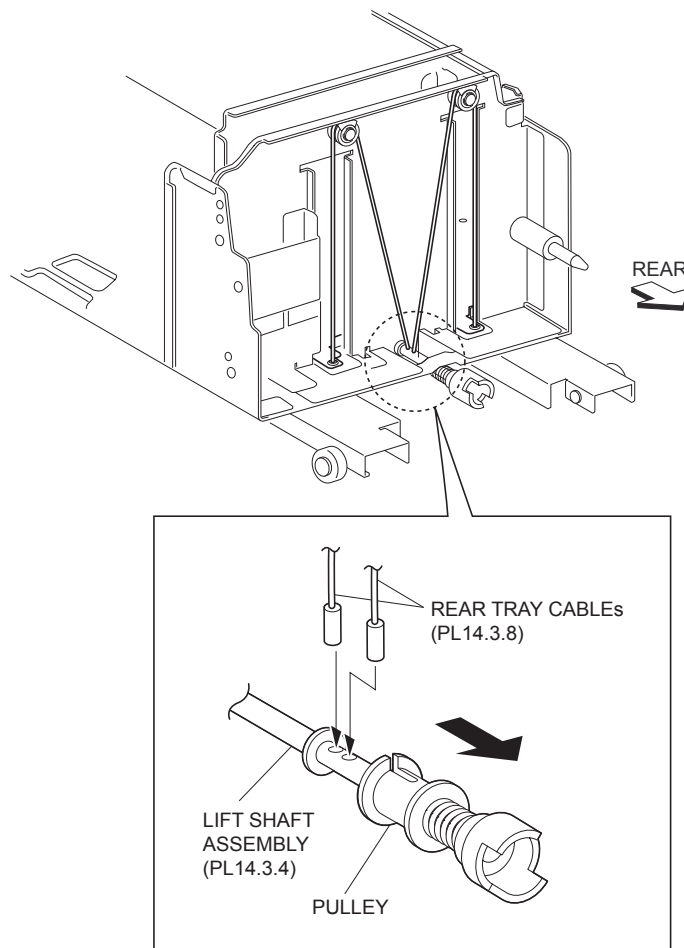
**Figure 1 Rear Tray Cables**

7. Place the Frame Assembly back to its original position .
8. Remove the E-ring securing the two Pulleys (PL 14.3.6) on the rear to the Frame Assembly and remove two each of the Cable Guide (PL 14.3.7) and the Pulley .
9. Remove the two Rear Tray Cables from the Bottom Plate (PL 14.3.10).



**Figure 2 Cable Guide**





**Figure 3 Lift Shaft Assembly**

## Replacement

1. Fit the tips of the two Rear Tray Cables into the hole on the Bottom Plate (PL 14.3.10).

**NOTE** Place the Bottom Plate to the Tray 4 Assembly so that the arrow mark on the Bottom Plate points to the direction as shown in the figure.

2. Install the two Cable Guides (PL 14.3.7) on the rear to the Frame Assembly (PL 14.3.26) together with the Pulley (PL 14.3.6) using the E-rings.

**NOTE** Be sure that the two Rear Tray Cables are installed onto the two Pulleys on the rear in advance.

3. Place the Frame Assembly on its right side down.
4. Put the two Rear Tray Cables into the hole on the Lift Shaft Assembly (PL 14.3.4).

**NOTE** When fitting the Rear Tray Cables into the holes, be careful not to twist them.

5. Move the Pulley portion of the Lift Shaft Assembly to prevent the Rear Tray Cable from coming off of the Lift Shaft Assembly.
6. Secure the Lift Shaft Assembly to the Frame Assembly by moving the left and right Bearings in the direction of the arrow.

**NOTE** Move the Pulley on the Lift Shaft Assembly to prevent the two Rear Tray Cables from being detached.

7. Put the two Front Tray Cables (PL 14.3.9) into the hole on the Lift Shaft Assembly.

**NOTE** Install the two Front Tray Cables carefully not to twist them.

8. Install the Lift Shaft Assembly to the Frame Assembly together with the Pulley (PL 14.3.5) using the two E-rings.

**NOTE** Be careful not to let the two Front Tray Cables be detached.

9. Place the Frame Assembly back to its original position.
10. Install the Tray 4 Cover (PL 14.3.1) .
11. Install the Tray 4 Assembly (PL 14.1.17) .

## Front Tray Cables (Tray 4)

**NOTE** When replacing the cable, it is recommended to replace the Rear Tray Cables together.

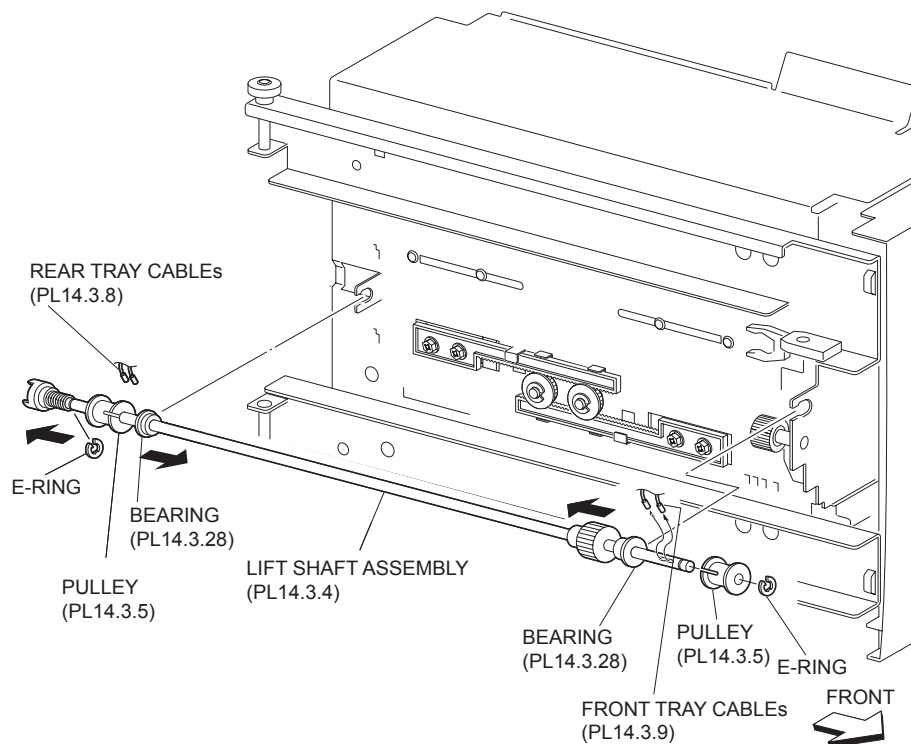
### Removal

1. Remove the Tray 4 Assembly (PL 14.1.17) .
2. Remove the Tray 4 Cover (PL 14.3.1) .
3. Place the Frame Assembly (PL 14.3.26) on its right side down .
4. Remove the two E-rings securing the Lift Shaft Assembly (PL 14.3.4) to the Frame Assembly and remove the Pulley (PL 14.3.5).

**NOTE** Note that the two Front Tray Cables are detached.

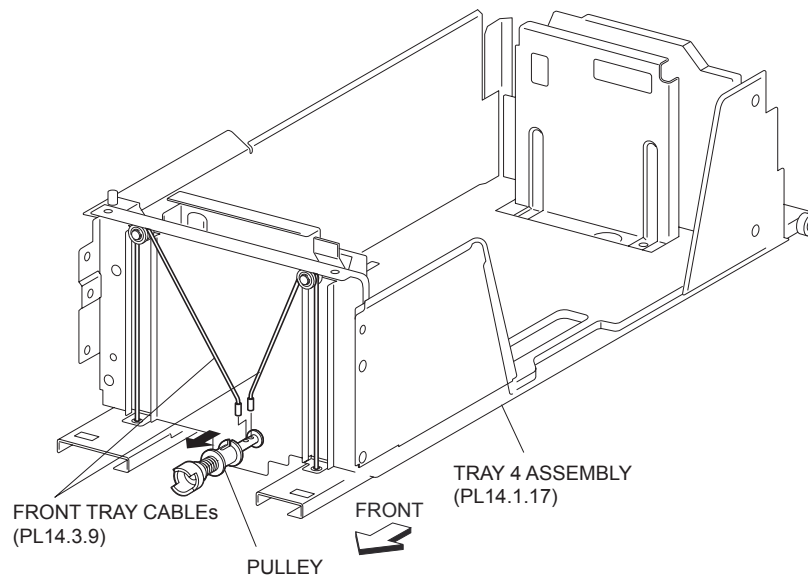
5. Move the left and right Bearings securing the Lift Shaft Assembly to the Frame Assembly in the direction of the arrow to remove the Lift Shaft Assembly.
6. Remove the two Front Tray Cables from the Lift Shaft Assembly.

**NOTE** Removing the Front Tray Cable is made easy by moving the Lift Shaft Assembly.

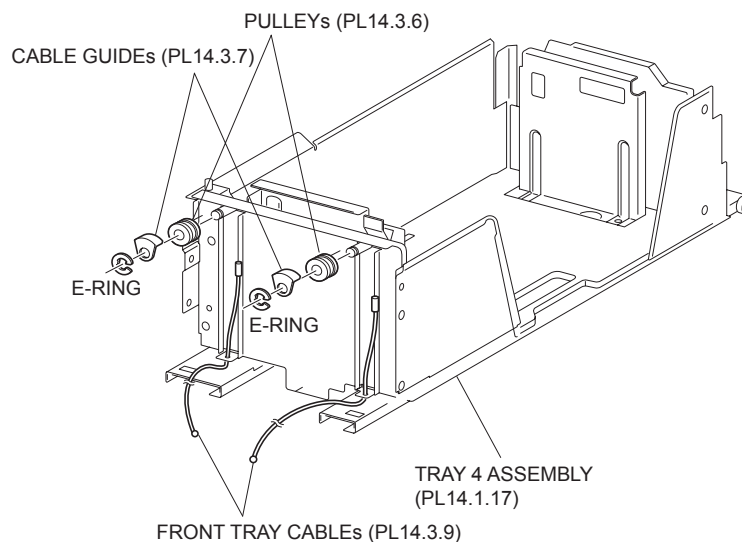


**Figure 1 Front Tray Cables**

7. Place the Frame Assembly back to its original position .
8. Remove the E-ring securing the two Pulleys (PL 14.3.6) on the front to the Frame Assembly (PL 14.2.28) and remove two each of the Cable Guide (PL 14.3.7) and the Pulley.
9. Remove the two Front Tray Cables from the Bottom Plate (PL 14.3.10) .



**Figure 2 Front Cables**



**Figure 3 Cable Pulley**

## Replacement

1. Fit the tips of the Front Tray Cables into the hole on the Bottom Plate (PL 14.3.10).

**NOTE** Place the Bottom Plate to the Tray 4 Assembly so that the arrow mark on the Bottom Plate points to the direction as shown in the figure.

2. Install the two Cable Guides (PL 14.3.7) on the front to the Frame Assembly (PL 14.3.26) together with the Pulley (PL 14.3.6) using the E-rings.

**NOTE** Be sure that each of the two Front Tray Cables is installed onto the two Pulleys on the front in advance.

3. Put the two Front Tray Cables into the hole on the Lift Shaft Assembly (PL 14.3.4).

**NOTE** When fitting the Front Tray Cables into the holes, be careful not to twist them.

4. Place the Frame Assembly on its right side down.
5. Move the Pulley of the Lift Shaft Assembly to prevent the two Front Tray Cables from coming off of the Lift Shaft Assembly.

6. Secure the Lift Shaft Assembly to the Frame Assembly by moving the left and right Bearings in the direction of the arrow.

**NOTE** Perform the service with the Pulley of the Lift Shaft Assembly pushed down, to prevent the two Front Tray Cables from being detached.

7. Install the Lift Shaft Assembly to the Frame Assembly together with the Pulley (PL 14.3.5) using the two E-rings.

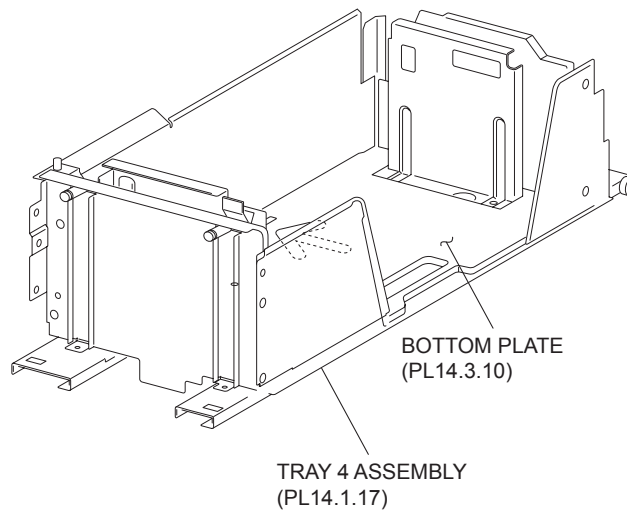
**NOTE** Be careful not to let the two Front Tray Cables be detached.

8. Place the Frame Assembly back to its original position.
9. Install the Tray 4 Cover (PL 14.3.1) .
10. Install the Tray 4 Assembly (PL 14.1.17) .

## Bottom Plate (Tray 4)

### Removal

1. Remove the Tray 4 Assembly (PL 14.1.17) .
2. Remove the Tray 4 Cover (PL 14.3.1) .
3. Remove the Rear Tray Cable (PL 14.3.8) .
4. Remove the Front Tray Cable (PL 14.3.9) .
5. Remove the Bottom Plate .



F13L025A1

**Figure 1 Bottom Plate**

### Replacement

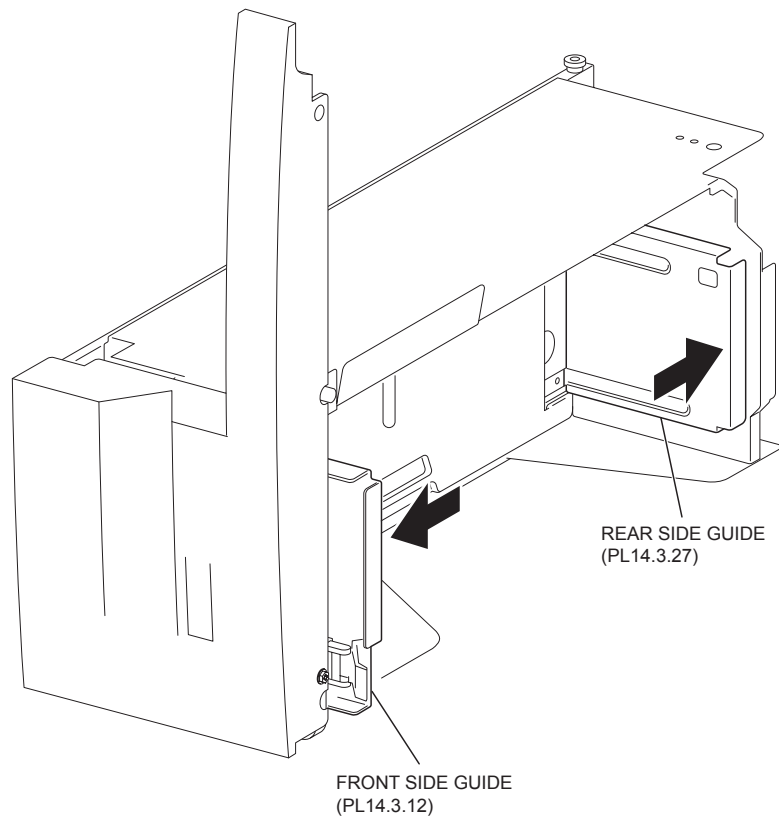
1. Install the Bottom Plate.
2. Install the Front Tray Cable (PL 14.3.9) .
3. Install the Rear Tray Cable (PL 14.3.8) .
4. Install the Tray 4 Cover (PL 14.3.1).
5. Install the Tray 4 Assembly (PL 14.1.17) .

## Rack Gear (Tray 4)

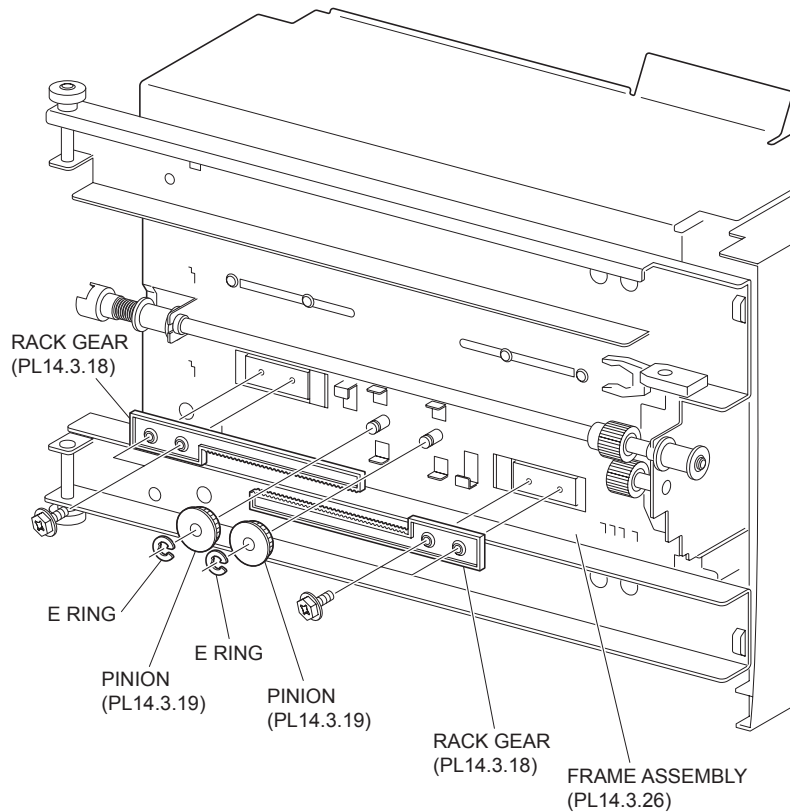
### Removal

1. Remove the Tray 4 Assembly (PL 14.1.17) .

2. Place the Tray 4 Assembly on its right side down .
3. Remove the two Pinions (PL 14.3.19) .
4. Remove the four screws (Del Tite, M3x8mm) securing the two Rack Gears to the Frame Assembly (PL 14.3.26) .
5. Remove the two Rack Gears.



**Figure 1 Tray 4**



**Figure 2 Rack Gears**

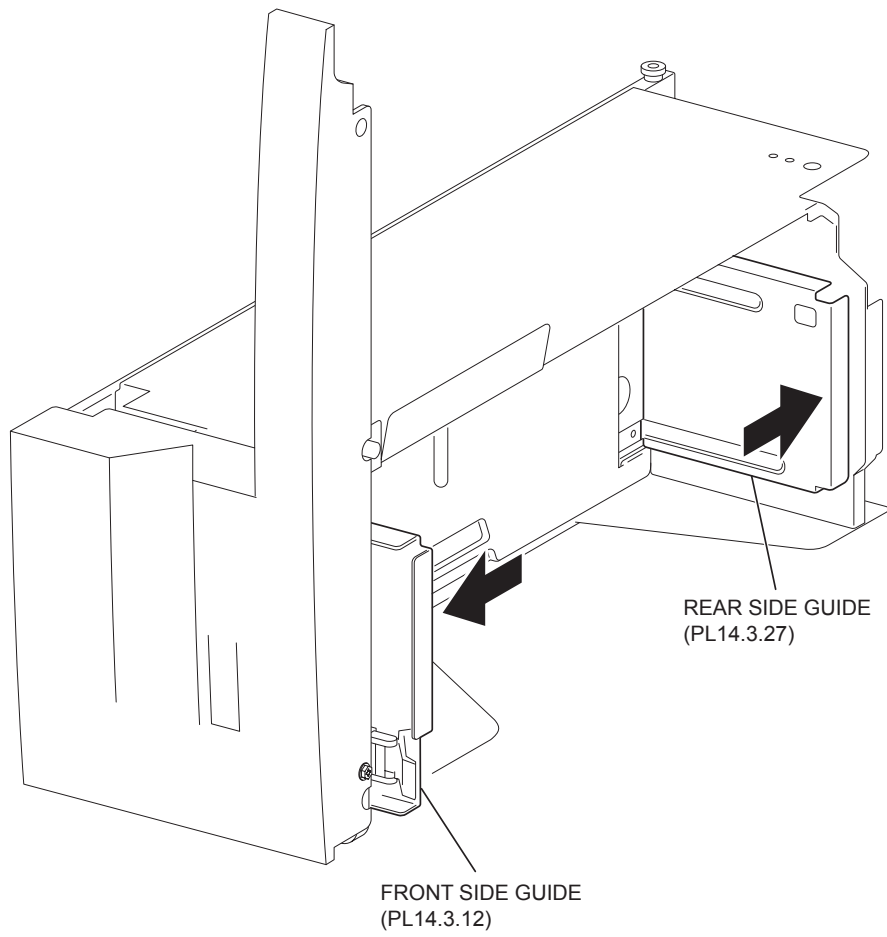
## Replacement

1. Move the Front Side Guide (PL 14.3.12) and the Rear Side Guide (PL 14.3.27) in the Tray 4 Assembly (PL 14.1.17) fully outward.
2. Install the two Rack Gears to the Frame Assembly (PL 14.3.26) using two screw each (Del Tite, M3x8mm).
3. Install the two Pinions (PL 14.3.19) .
4. Install the Tray 4 Assembly (PL 14.1.17) .

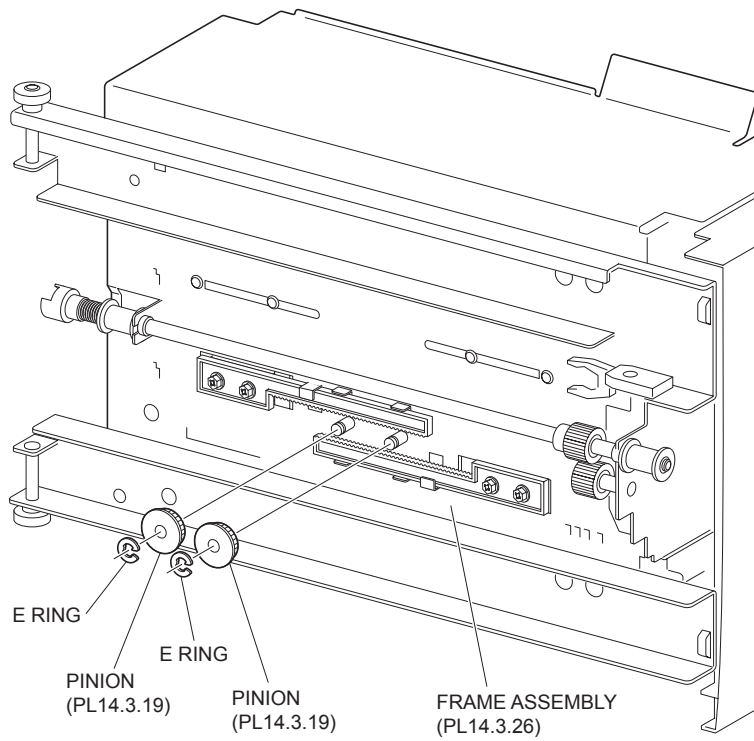
## Pinion (Tray 4)

### Removal

1. Remove the Tray 4 Assembly (PL 14.1.17) .
2. Place the Tray 4 Assembly on its right side down .
3. Remove the two E-rings securing the two Pinions to the Frame Assembly (PL 14.3.26) to remove the two Pinions .



**Figure 1 Tray 4**



**Figure 2 Pinion**

## Replacement

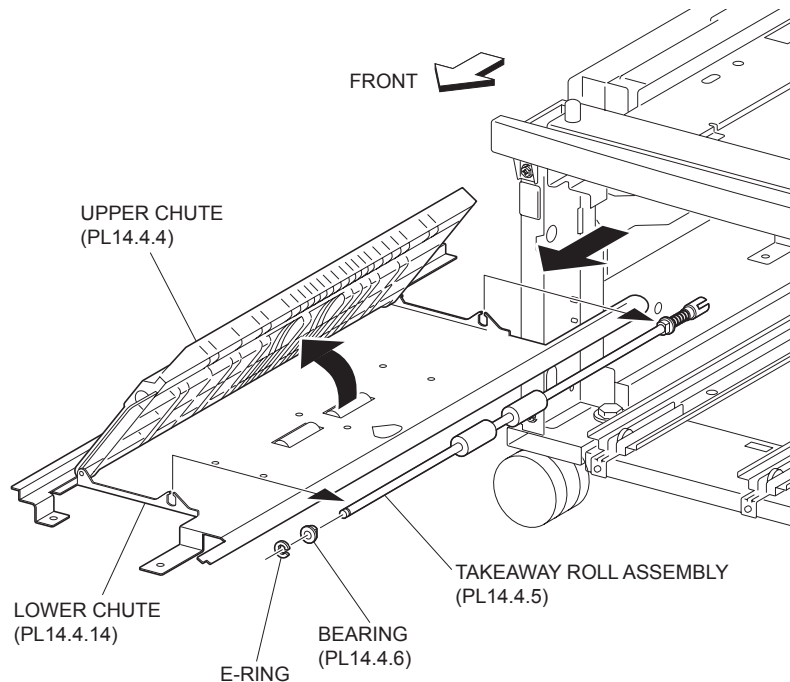
1. Move the Front Side Guide (PL 14.3.12) and the Rear Side Guide (PL 14.3.27) in the Tray 4 Assembly (PL 14.1.17) fully outward.
2. Install the two Pinions to the Frame Assembly (PL 14.3.26) using the one E-ring each.
3. Install the Tray 4 Assembly (PL 14.1.17) .

## Takeaway Roll Assembly

### Removal

1. Remove the Tray 3 Assembly (PL 14.1.19) .
2. Remove the Tray 4 Assembly (PL 14.1.17) .
3. Remove the Tray 4 Transport Assembly (PL 14.3.2) .
4. Open the Upper Chute (PL 14.4.4) .
5. Remove the E-ring securing the Takeaway Roll Assembly to the Lower Chute (PL 14.4.14) and remove the Bearing (PL 14.4.6).
6. Lift the Takeaway Roll Assembly in the direction of the arrow to remove.

**NOTE** Be careful not to hold the rubber roller part of the Takeaway Roll Assembly.



**Figure 1 Takeaway Roll**

### Replacement

1. Install the Takeaway Roll Assembly to the Lower Chute (PL 14.4.14) together with the Bearing (PL 14.4.6) using the E-ring.

**NOTE** Be careful not to hold the rubber roller of the Takeaway Roll Assembly. Also, be sure to fit the flat surface of the Bearing to the hole on the Lower Chute.

2. Close the Upper Chute (PL 14.4.4).
3. Install the Tray 4 Transport Assembly (PL 14.3.2) .
4. Install the Tray 4 Assembly (PL 14.1.17) .



5. Install the Tray 3 Assembly (PL 14.1.19) .

## Tray 4 Feeder

### Removal

1. Remove the Tray 3 Assembly (PL 14.1.19) .
2. Remove the Tray 4 Assembly (PL 14.1.17) .
3. Remove the Tray 4 Transport Assembly (PL 14.3.2) .
4. Disconnect the two connectors (P/J661A and P/J549) of the Wire Harness (PL 14.8.18) from the Tray 4 Feeder .
5. Remove the two screws securing the Tray 4 Feeder to the machine.
6. Remove the front side screw securing the Stand Bracket (PL 14.4.22) to the machine to remove the Stand Bracket.
7. Move the Tray 4 Feeder in the direction of the arrow to remove it.

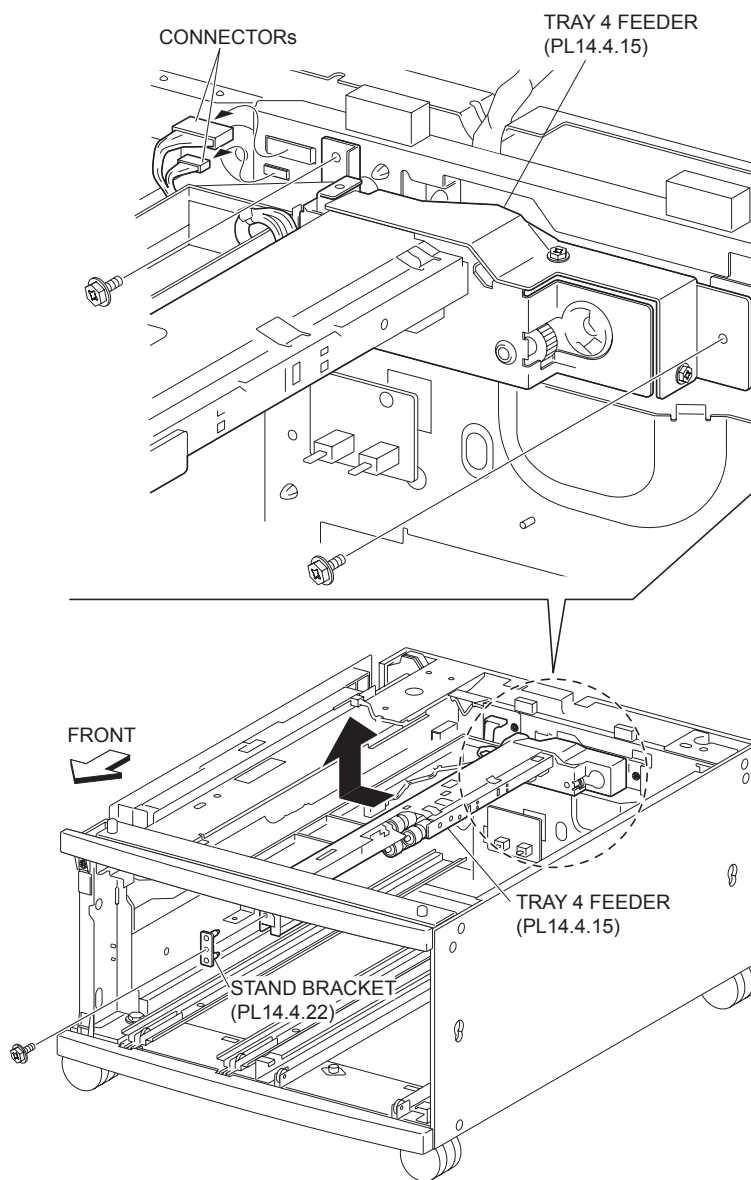
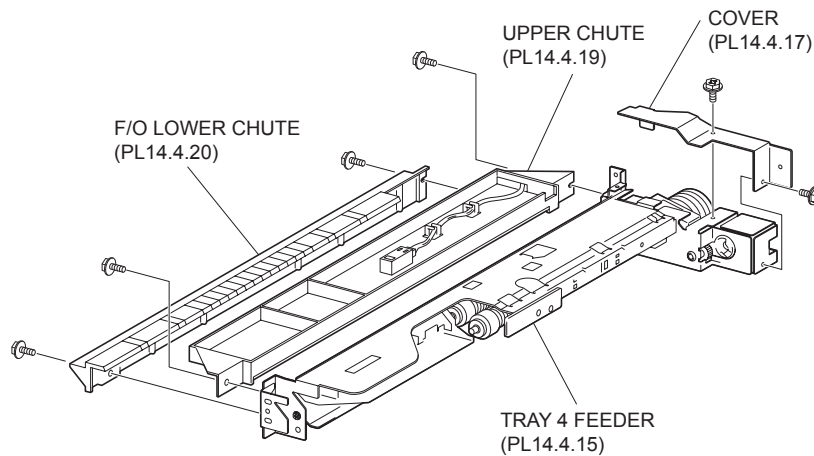


Figure 1 Tray 4 Feeder

8. Remove the two screws securing the F/O Lower Chute (PL 14.4.20) to the Tray 4 Feeder to remove the F/O Lower Chute .
9. Remove the two screws securing the Upper Chute (PL 14.4.19) to the Tray 4 Feeder to remove the Upper Chute.
10. Remove the one screw securing the Cover (PL 14.4.17) to the Tray 4 Feeder to remove Cover.



**Figure 2 Feeder Assembly**

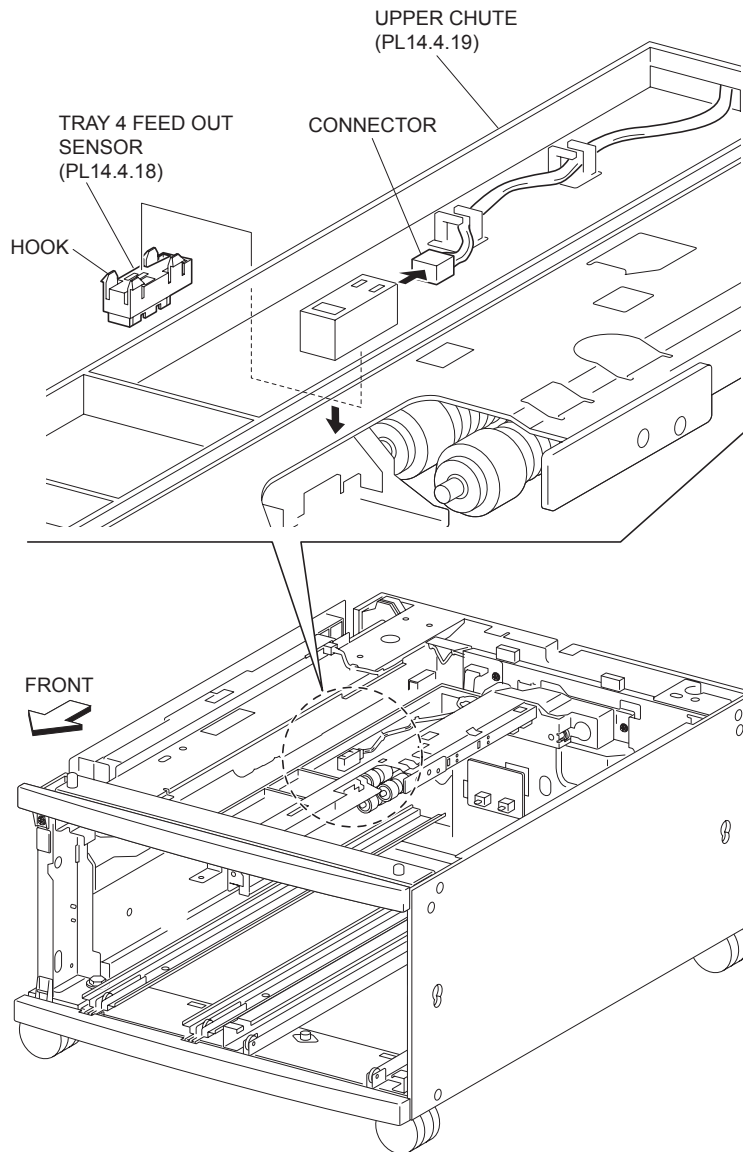
## Replacement

1. Install the Cover (PL 14.4.17) to Tray 4 Feeder using the one screw.
2. Install the Upper Chute (PL 14.4.19) to Tray 4 Feeder using the two screws.
3. Install the F/O Lower Chute (PL 14.4.20) to Tray 4 Feeder using the two screws.
4. Move the Tray 4 Feeder in the opposite direction of the arrow to install it.
5. Install the Stand Bracket (PL 14.4.22) to the machine using the one screw.
6. Connect the two connectors (P/J661A and P/J549) of the Wire Harness (PL 14.8.18) to the Tray 4 Feeder.
7. Install the Tray 4 Transport Assembly (PL 14.3.2) .
8. Install the Tray 4 Assembly (PL 14.1.17) .
9. Install the Tray 3 Assembly (PL 14.1.19) .

## Tray 4 Feed Out Sensor

### Removal

1. Remove the Tray 3 Assembly (PL 14.1.19) .
2. Remove the Tray 4 Assembly (PL 14.1.17) .
3. Disconnect the connector (P/J825) of the Wire Harness (PL 14.6.16) from the Tray 4 Feed Out Sensor .
4. Release the hooks securing the Tray 4 Feed Out Sensor to the machine as shown in the figure.
5. Move the Tray 4 Feed Out Sensor in the direction of the arrow to remove it.



**Figure 1 Feed Out Sensor**

### Replacement

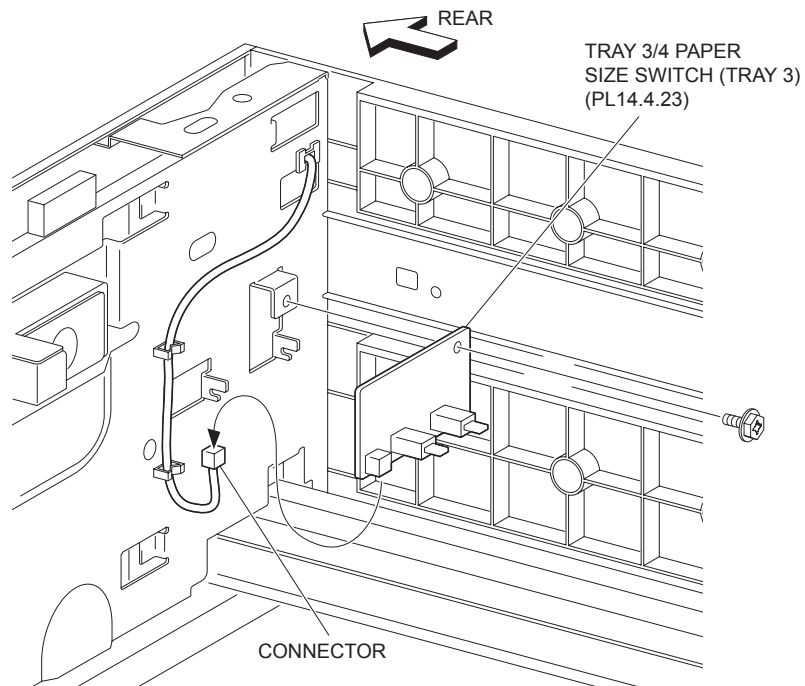
1. Move the Tray 4 Feed Out Sensor in the opposite direction of the arrow and install it with the hooks.
2. Connect the connector (P/J825) of the Wire Harness (PL 14.6.16) to the Tray 4 Feed Out Sensor.
3. Install the Tray 4 Assembly (PL 14.1.17) .
4. Install the Tray 3 Assembly (PL 14.1.19) .

### Tray 3 Paper Size Switch

#### Removal

1. Remove the Tray 3 Assembly (PL 14.1.19) .
2. Disconnect the connector (P/J820) of the Wire Harness (PL 14.8.18) from the Tray 3 Paper Size Switch .

3. Remove the screw securing the Tray 3 Paper Size Switch to the machine.
4. Remove the Tray 3 Paper Size Switch.



**Figure 1 Paper Size Switch**

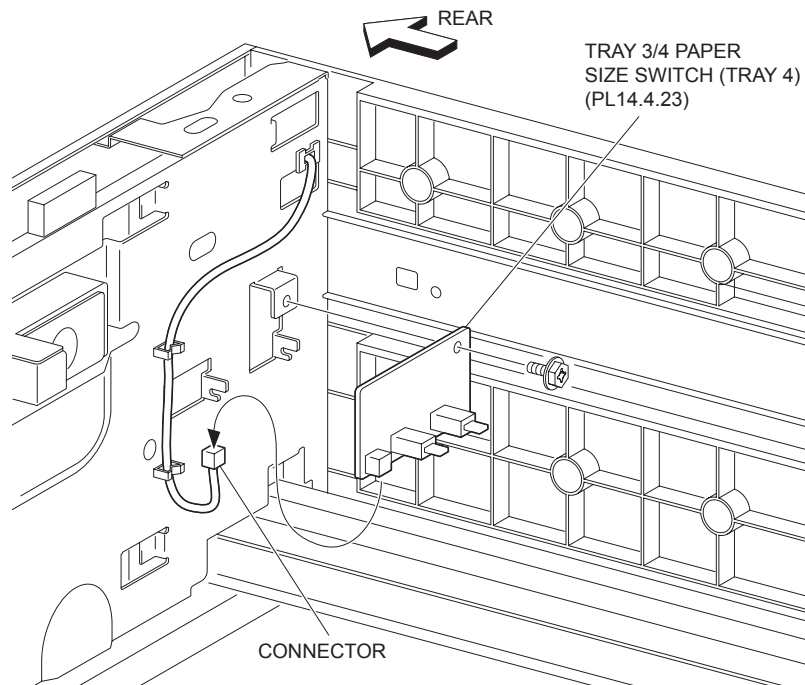
### Replacement

1. Install the Tray 3 Paper Size Switch to the machine using the one screw.
2. Be sure to fit the boss on the machine into the hole on the Tray 3 Paper Size Switch.
3. Connect the connector (P/J820) of the Wire Harness (PL 14.8.18) to the Tray 3 Paper Size Switch.
4. Install the Tray 3 Assembly (PL 14.1.19) .

### Tray 4 Paper Size Switch

#### Removal

1. Remove the Tray 4 Assembly (PL 14.1.17) .
2. Disconnect the connector (P/J824) of the Wire Harness (PL 14.8.18) from the Tray 4 Paper Size Switch .
3. Remove the screw securing the Tray 4 Paper Size Switch to the machine.
4. Remove the Tray 4 Paper Size Switch.



**Figure 1 Paper Size Switch**

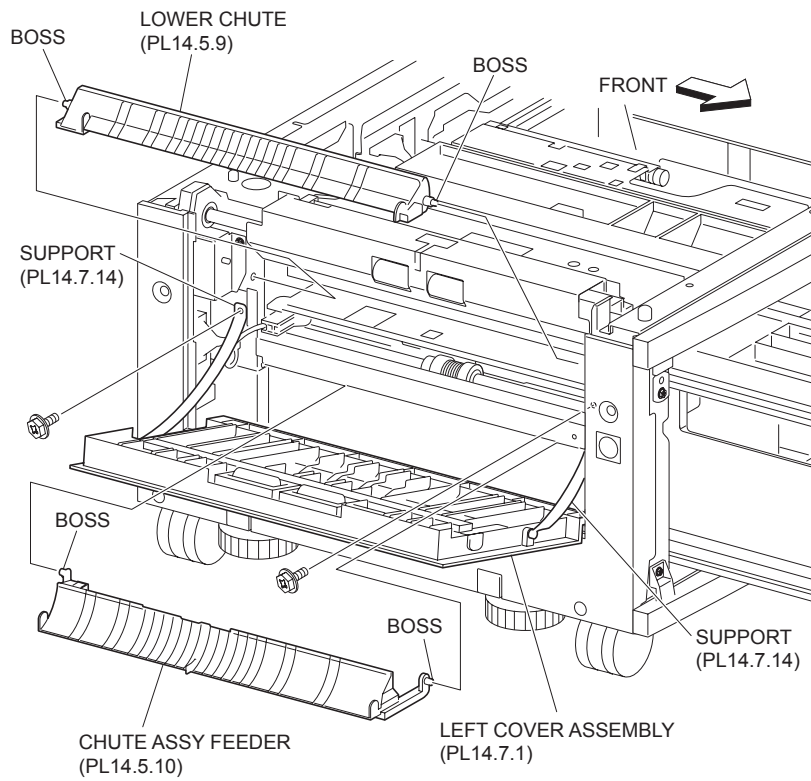
### Replacement

1. Install the Tray 4 Paper Size Switch to the machine using the one screw.
2. Be sure to fit the boss on the machine into the hole on the Tray 4 Paper Size Switch.
3. Connect the connector (P/J824) of the Wire Harness (PL 14.8.18) to the Tray 4 Paper Size Switch.
4. Install the Tray 4 Assembly (PL 14.1.17) .

### Tray 3 Feeder

#### Removal

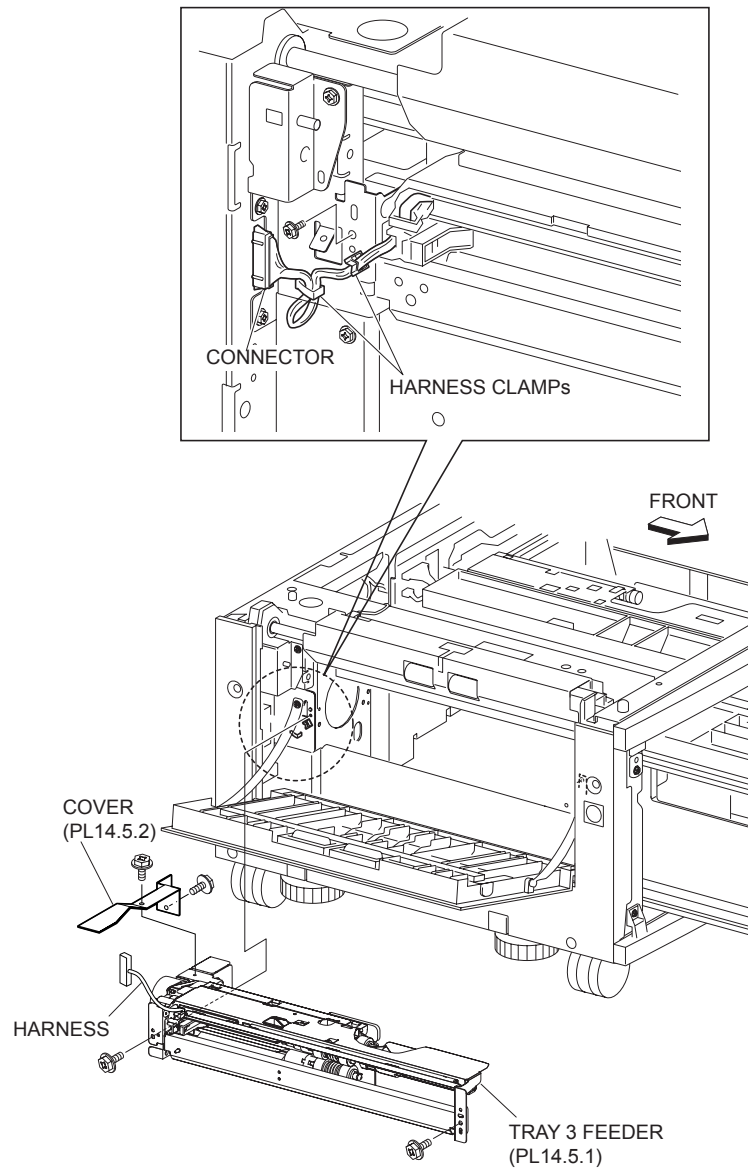
1. Pull out the Tray 3 Assembly (PL 14.1.19).
2. Pull out the Tray 4 Assembly (PL 14.1.17).
3. Open the Left Cover Assembly (PL 14.7.1).
4. Remove the screws (one each) securing the left and right Supports (PL 14.7.14) to the machine .
5. Remove the bosses left and right securing the Lower Chute (PL 14.5.9) to the machine to remove the Lower Chute.
6. Remove the bosses left and right securing the Feeder Chute Assembly (PL 14.5.10) to the Tray 3 Feeder to remove the Feeder Chute Assembly.



FI3L033A1

**Figure 1 Tray 3 Feeder**

7. Release the Wire Harness (PL 14.8.18) from the clamp on the machine .
8. Disconnect the connector (P/J661B) of the Wire Harness (PL 14.8.18) from the machine.
9. Remove the three screws securing the Tray 3 Feeder to the machine.
10. Remove the Tray 3 Feeder.
11. Remove the screw securing the Cover (PL 14.5.2) to the Tray 3 Feeder to remove the Cover.



**Figure 2 Tray 3 Feeder**

## Replacement

1. Install the Cover (PL 14.5.2) to the Tray 3 Feeder using the one screw.
2. Install the Tray 3 Feeder to the machine using three screws.
3. Connect the connector (P/J661B) of the Wire Harness (PL 14.8.18) to the machine.
4. Secure the Wire Harness (PL 14.8.18) to the clamp.
5. Install the Feeder Chute Assembly (PL 14.5.10) to the Tray 3 Feeder with the left and right bosses.

**NOTE** Fit the boss on the machine into the hole on the Feeder Chute Assembly.

6. Install the Lower Chute (PL 14.5.9) to the machine with the left and right bosses.

**NOTE** Fit the boss on the machine into the hole on the Feeder Chute Assembly.

7. Install the left and right Supports (PL 14.7.14) to the machine using one screw each.
8. Close the Left Cover Assembly (PL 14.7.1).
9. Push in Tray 4 Assembly (PL 14.1.17).
10. Push in Tray 3 Assembly (PL 14.1.19).

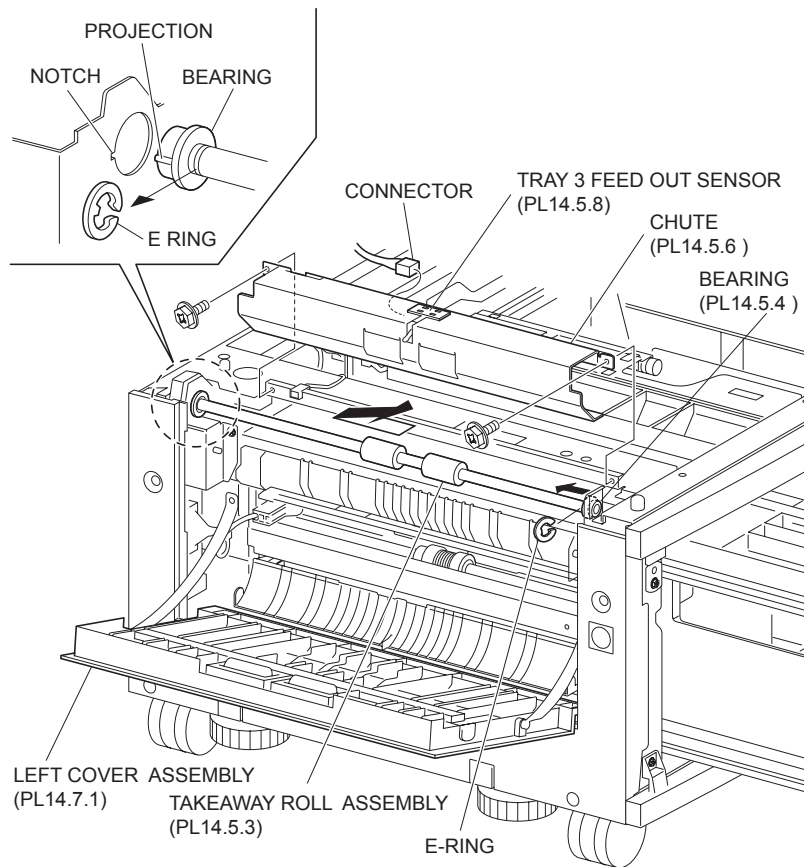
# Takeaway Roll Assembly

## Removal

1. Open the Left Cover Assembly (PL 14.7.1).
2. Remove the two screws (Del Tite, M3x8mm) securing the Chute (PL 14.5.6) to the machine .
3. Disconnect the connector (P/J821) of the Wire Harness (PL 14.5.7) connected to the Tray 3 Feed Out Sensor (PL 14.5.8).
4. Remove the Chute.
5. Remove the E-ring on the right (front) securing the Takeaway Roll Assembly to the machine.
6. Move the Takeaway Roll Assembly in the direction of the arrow and remove the Bearing (PL 14.5.4).
7. Remove the Takeaway Roll Assembly.

**NOTE** The Bearing is detached. Be careful not to lose it.

**NOTE** Be careful not to hold the rubber roller of the Takeaway Roll Assembly.



FI3L036A1

**Figure 1 Takeaway Roll**

## Replacement

1. Move the Takeaway Roll Assembly in the opposite direction of the arrow, and secure it together with the Bearing (PL 14.5.4).

**NOTE** Be sure to put the boss on the Bearing on the left of the Takeaway Roll Assembly into the notch of the hole on the machine.



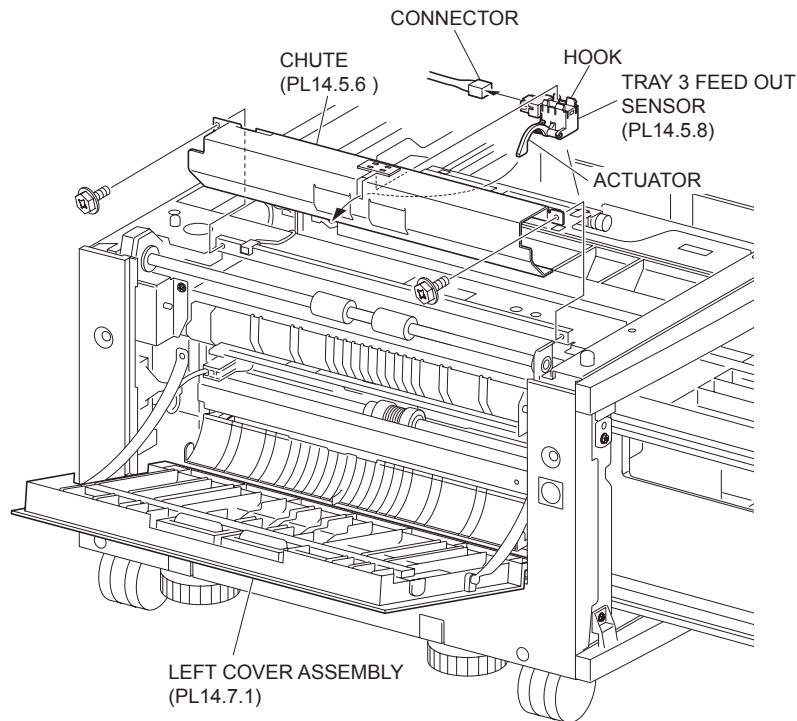
**NOTE** Be careful not to hold the rubber roller of the Takeaway Roll Assembly.

2. Install the Takeaway Roll Assembly to the machine together with the Bearing using the one E-ring.
3. Connect the connector (P/J821) of the Wire Harness (PL 14.5.7) to the Tray 3 Feed Out Sensor (PL 14.5.8).
4. Install the Chute (PL 14.5.6) to the machine using the two screws (Del Tite, M3x8mm).
5. Close the Left Cover Assembly (PL 14.7.1).

## Tray 3 Feed Out Sensor

### Removal

1. Open the Left Cover Assembly (PL 14.7.1).
2. Remove the two screws securing the Chute (PL 14.5.6) to the machine .
3. Disconnect the connector (P/J821) of the Wire Harness (PL 14.5.7) from the Tray 3 Feed Out Sensor.
4. Remove the Chute.
5. Release the hook securing the Tray 3 Feed Out Sensor to the Chute as shown in the figure.
6. Remove the Tray 3 Feed Out Sensor.



FI3L037A1

**Figure 1 Feed Out Sensor**

### Replacement

1. Install the Tray 3 Feed Out Sensor to the Chute (PL 14.5.6) with the hook.

**NOTE** Be sure to put the Actuator attached to the Tray 3 Feed Out Sensor into the hole on the Chute.

2. Connect the connector (P/J821) of the Wire Harness (PL 14.5.7) to the Tray 3 Feed Out Sensor.

3. Install the Chute to the machine using two screws.
4. Close the Left Cover Assembly (PL 14.7.1).

## Tray 3/4 Feed Lift Up Motor

### Removal

1. Remove the Tray 3 Feeder (PL 14.5.1) or Tray 4 Feeder (PL 14.4.15) .
2. Disconnect the connector (Tray 3:P/J220B, Tray 4:P/J220A) of the Wire Harness (PL 14.6.16) from the Tray 3/4 Feed Lift Up Motor .
3. Remove the two screws (M3x6mm) securing the Tray 3/4 Feed Lift Up Motor to the Tray 3 Feeder.
4. Remove the Tray 3/4 Feed Lift Up Motor.

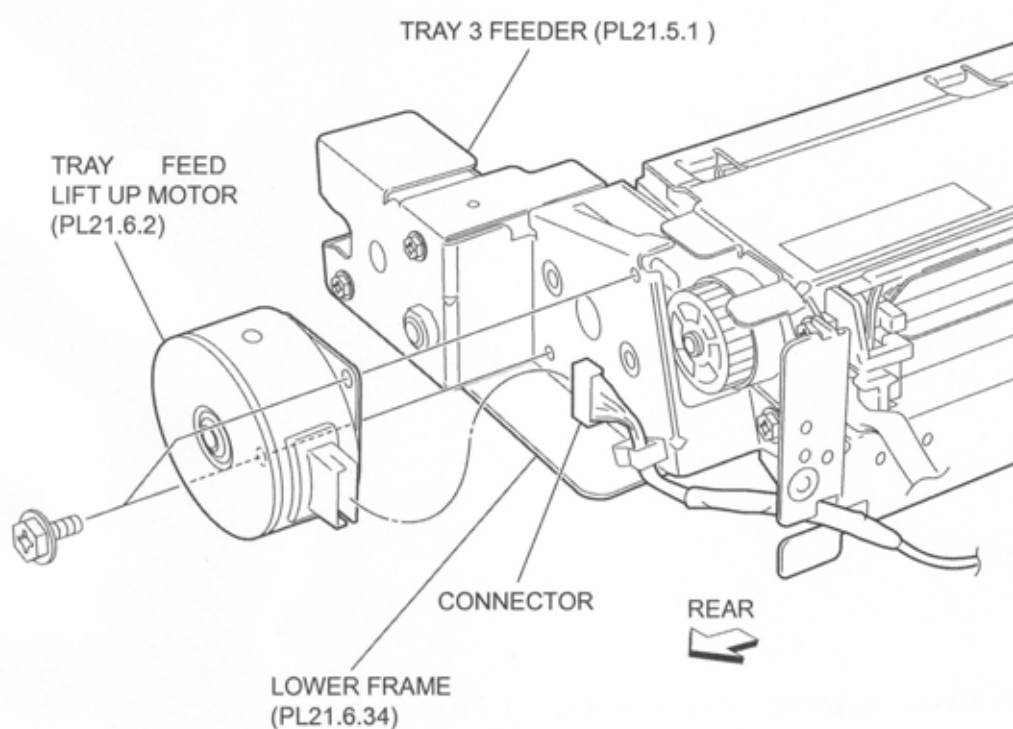


Figure 1 Feed Lift Up Motor

### Replacement

1. Install the Tray 3/4 Feed Lift Up Motor to the Tray 3 Feeder (PL 14.5.1) using the two screws (M3x6mm).
2. Connect the connector (Tray 3:P/J220B, Tray 4:P/J220A) of the Wire Harness (PL 14.6.16) to the Tray 1/2 Feed Lift Up Motor.
3. Install the Tray 3 Feeder (PL 14.5.1) or Tray 4 Feeder (PL 14.4.15) .

**NOTE** Be sure to put the Actuator attached to the Tray 3 Feed Out Sensor into the hole on the Chute.

## Spacer

### Removal

1. Remove the Tray 3 Feeder (PL 14.5.1) or Tray 4 Feeder (PL 14.4.15) .
2. Release the Wire Harness (PL 14.6.16) from the clamp on the Bracket (PL 14.6.3) .

3. Remove the three screws (Del Tite, M3x6mm) securing the Bracket to the Lower Frame (PL 14.6.34).

**NOTE** Note that the Gears attached on the Bracket may be detached.

4. Remove E-rings securing the Spacer, 31T Gear (PL 14.6.5) and the Spring (PL 14.6.6) to the Bracket, using a mini-screwdriver or the like.

**NOTE** Note that Spring may pop out.

5. Remove the Spacer.

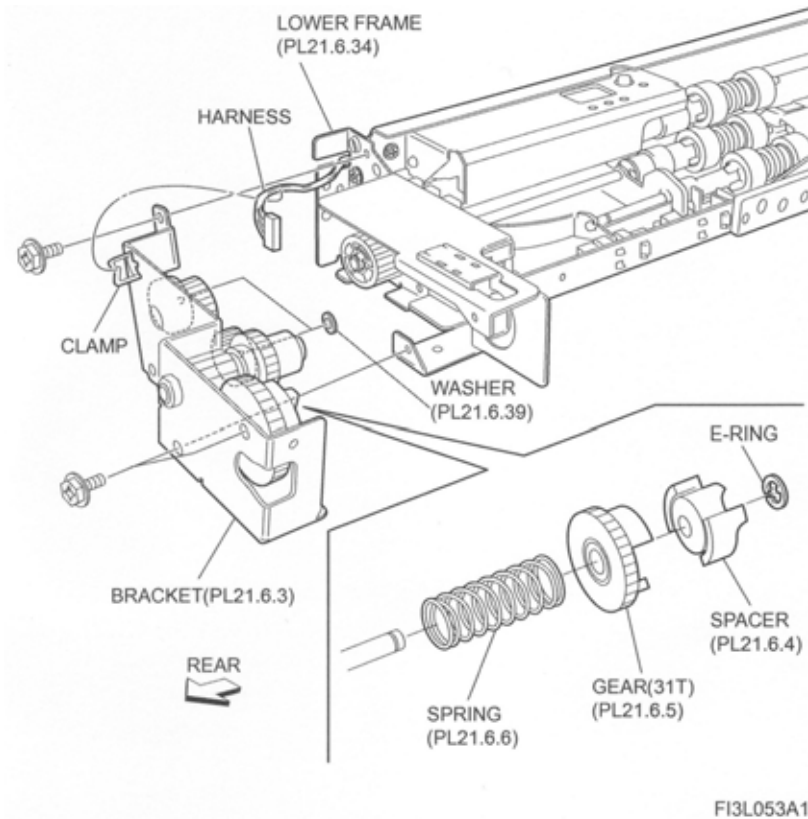


Figure 1 Spacer

## Replacement

1. Install the Spacer to the Bracket (PL 14.6.3) together with the 31T Gear (PL 14.6.5) and the Spring (PL 14.6.6), and fix them using E-ring.
2. Install the Bracket to the Lower Frame (PL 14.6.34) using the three screws (Del Tite, M3x6mm).

**NOTE** Make sure that the Gears attached on the Bracket are surely installed.

3. Secure the Wire Harness (PL 14.6.16) to the clamp on the Bracket.
4. Install the Tray 3 Feeder (PL 14.5.1) or Tray 4 Feeder (PL 14.4.15) .

## 31T Gear

### Removal

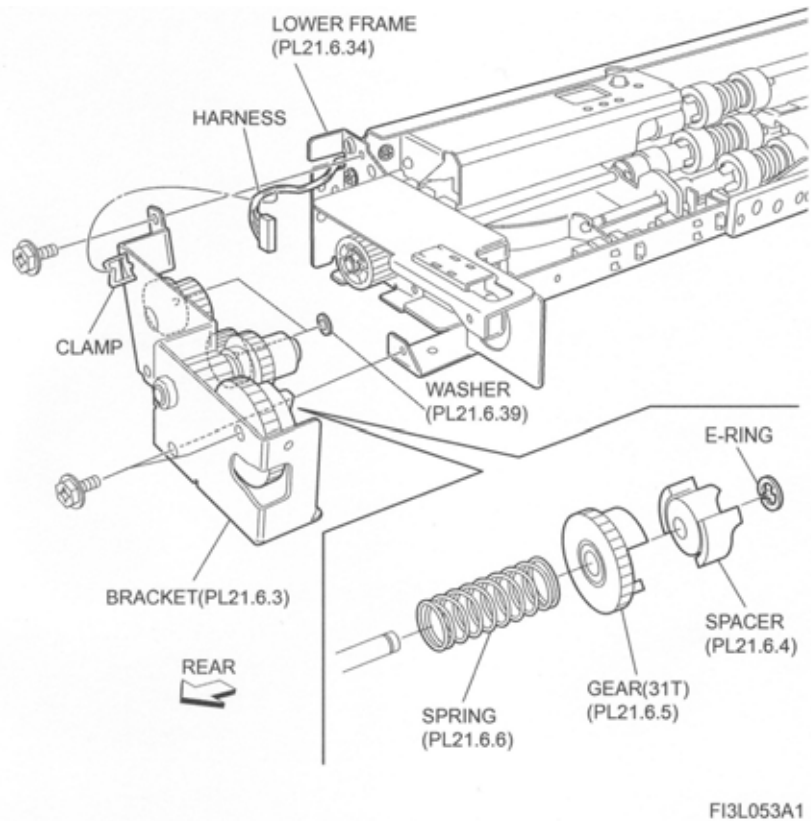
1. Remove the Tray 3 Feeder (PL 14.5.1) or Tray 4 Feeder (PL 14.4.15) .
2. Release the Wire Harness (PL 14.6.16) from the clamp on the Bracket (PL 14.6.3).
3. Remove the three screws (Del Tite, M3x6mm) securing the Bracket to the Lower Frame (PL 14.6.34).

**NOTE** Note that the Gears attached on the Bracket may be detached.

4. Remove E-rings securing 31T Gear, Spacer (PL 14.6.4) and Spring (PL 14.6.6) to Bracket.

**NOTE** Note that Spring can pop out.

5. Remove 31T Gear.



**Figure 1 31T Gear**

## Replacement

1. Install 31T Gear to Bracket (PL 14.6.3), together with Spacer (PL 14.6.4) and Spring (PL 14.6.6) using E-rings.
2. Install Bracket to Lower Frame (PL 14.6.34) using three screws (Del Tite, M3x6mm).

**NOTE** Make sure that the Gears attached on the Bracket are surely installed.

3. Secure the Wire Harness (PL 14.6.16) to the clamp on the Bracket.
4. Install the Tray 3 Feeder (PL 14.5.1) or Tray 4 Feeder (PL 14.4.15) .

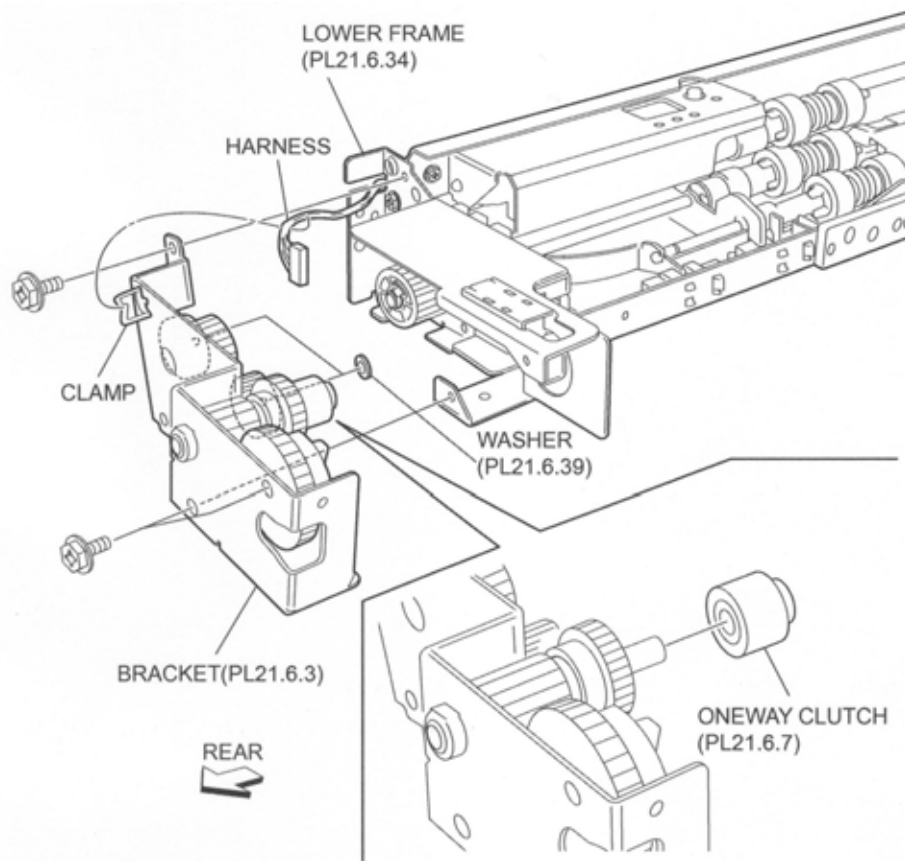
## Oneway Clutch

### Removal

1. Remove the Tray 3 Feeder (PL 14.5.1) or Tray 4 Feeder (PL 14.4.15) .
2. Release the Wire Harness (PL 14.6.16) from the clamp on the Bracket (PL 14.6.3) .
3. Remove the three screws (Del Tite, M3x6mm) securing the Bracket to the Lower Frame (PL 14.6.34)

**NOTE** Note that the Gears attached on the Bracket may be detached.

4. Remove the Oneway Clutch.



**Figure 1 Oneway Clutch**

## Replacement

1. ii
2. Install the Bracket (PL 14.6.3) to the Lower Frame (PL 14.6.34) using the three screws (Del Tite, M3x6mm).

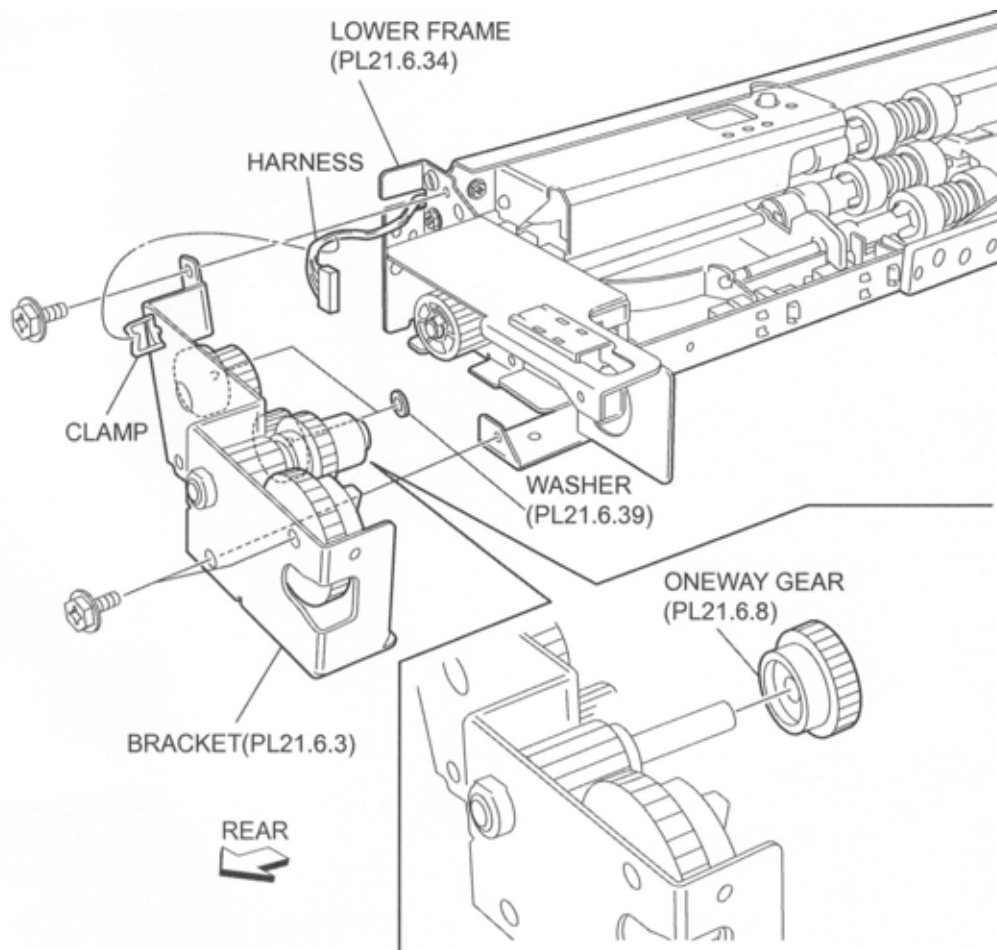
**NOTE** Make sure that the Gears attached on the Bracket are surely installed.

3. Secure the Wire Harness (PL 14.6.16) to the clamp on the Bracket.
4. Install the Tray 3 Feeder (PL 14.5.1) or Tray 4 Feeder (PL 14.4.15) .

## Oneway Gear

### Removal

1. Remove the Tray 3 Feeder (PL 14.5.1) or Tray 4 Feeder (PL 14.4.15) .
2. Remove the Oneway Clutch (PL 14.6.7) .
3. Remove the Oneway Gear.



**Figure 1 Oneway Clutch**

### Replacement

1. Install the Oneway Gear.
2. Install the Oneway Clutch (PL 14.6.7).
3. Install the Tray 3 Feeder (PL 14.5.1) or Tray 4 Feeder (PL 14.4.15) .

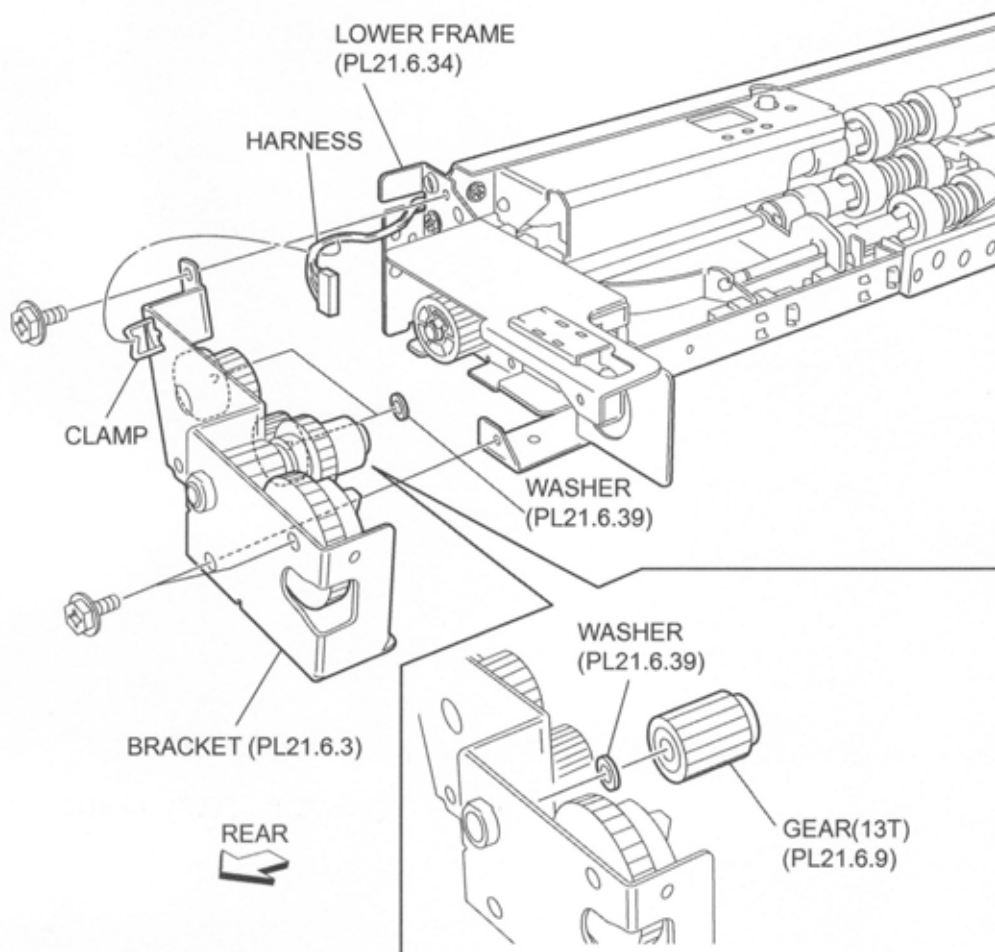
### 13T Gear

#### Removal

1. Remove the Tray 3 Feeder (PL 14.5.1) or Tray 4 Feeder (PL 14.4.15) .
2. Release the Wire Harness (PL 14.6.16) from the clamp on the Bracket (PL 14.6.3) .
3. Remove the three screws securing the Bracket to the Lower Frame (PL 14.6.34)

**NOTE** Note that the Gears attached on the Bracket may be detached.

4. Remove the 13T Gear.



**Figure 1 13T Gear**

## Replacement

1. Install the 13T Gear.
2. Install the Bracket (PL 14.6.3) to the Lower Frame (PL 14.6.34) using the three screws.

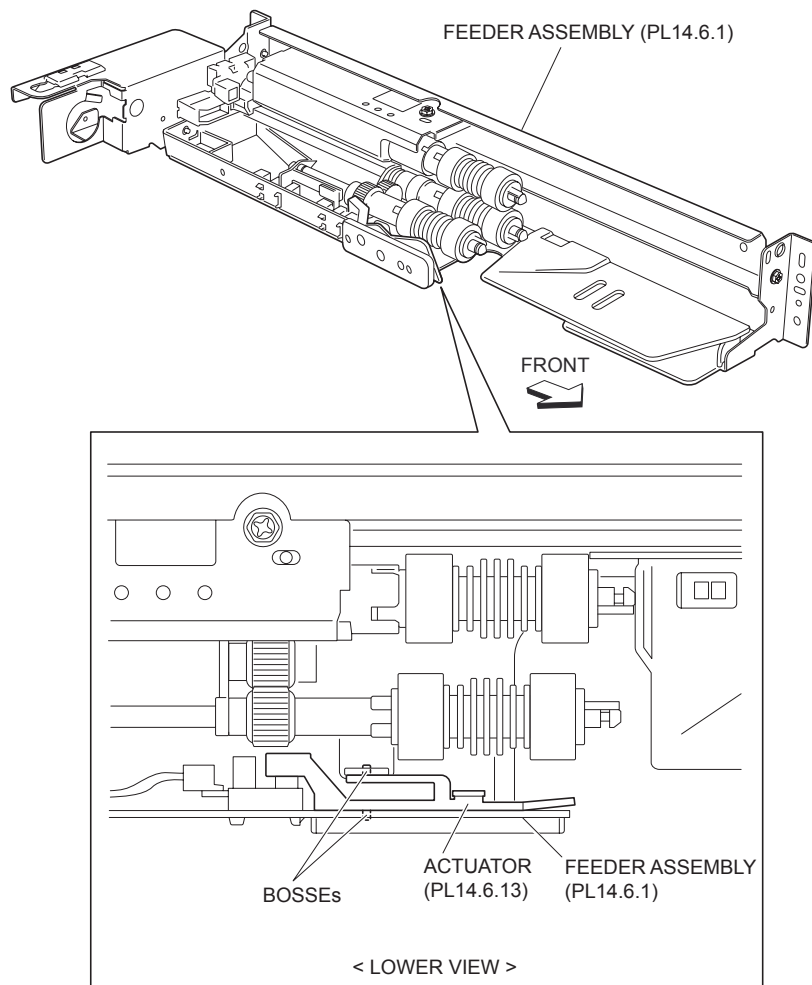
**NOTE** Make sure that the Gears attached on the Bracket are surely installed.

3. Secure the Wire Harness (PL 14.6.16) to the clamp on the Bracket.
4. Install the Tray 3 Feeder (PL 14.5.1) or Tray 4 Feeder (PL 14.4.15) .

## Actuator

### Removal

1. Remove the Tray 3 Feeder (PL 14.5.1) or Tray 4 Feeder (PL 14.4.15) .
2. Remove the two bosses on the Actuator securing the Actuator to the Upper Frame (PL 14.6.40) .
3. Remove the Actuator.



**Figure 1 Actuator**

## Replacement

1. Install Actuator.

**NOTE** Fit the bosses on the Actuator into the holes on the Upper Frame (PL 14.6.40).

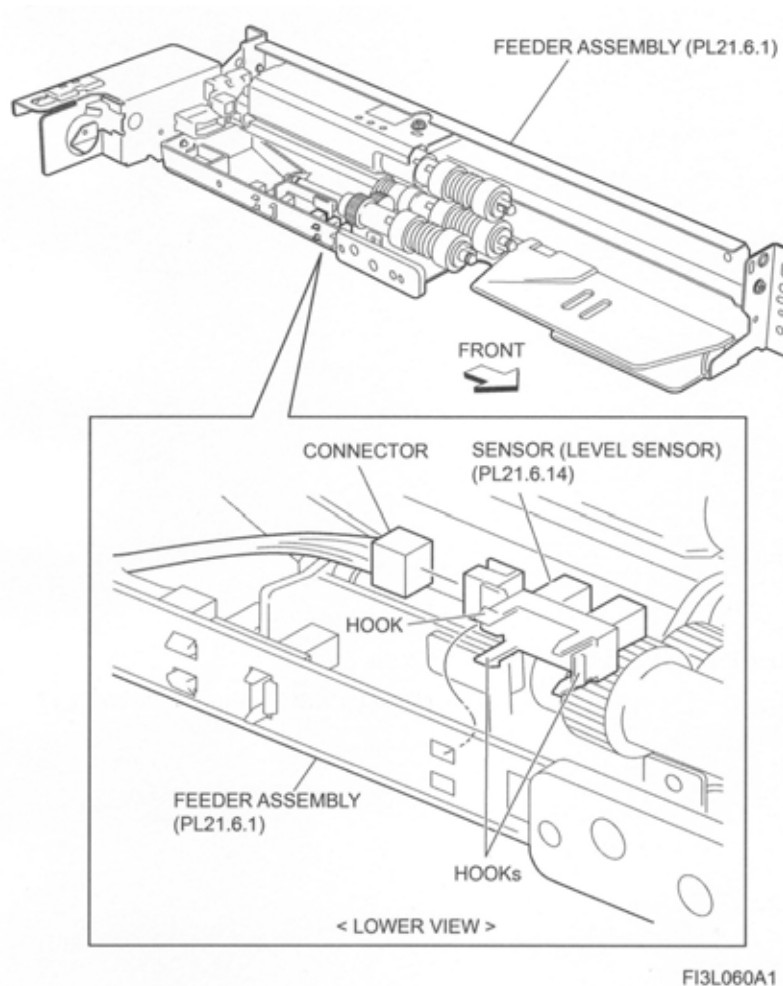
2. Install the Tray 3 Feeder (PL 14.5.1) or Tray 4 Feeder (PL 14.4.15) .

## Level Sensor

### Removal

1. Remove the Tray 3 Feeder (PL 14.5.1) or Tray 4 Feeder (PL 14.4.15) .
2. Remove the Actuator (PL 14.6.13).
3. Disconnect the connector (Tray 3:P/J102B, Tray 4:P/J102A) of the Wire Harness (PL 14.6.16) from the Level Sensor .
4. Release the hooks securing the Level Sensor to the Upper Frame (PL 14.6.40) as shown in the figure.
5. Remove the Level Sensor.





## Replacement

1. Secure the Level Sensor to the Upper Frame (PL 14.6.40) using the hooks.
2. Connect the connector (Tray 3:P/J102B, Tray 4:P/J102A) of the Wire Harness (PL 14.6.16) to the Level Sensor.
3. Install the Actuator (PL 14.6.13).
4. Install the Tray 3 Feeder (PL 14.5.1) or Tray 4 Feeder (PL 14.4.15) .

## No Paper Sensor

### Removal

1. Remove the Tray 3 Feeder (PL 14.5.1) or Tray 4 Feeder (PL 14.4.15) .
2. Disconnect the connector (Tray 3:P/J101B, Tray 4:P/J101A) of the Wire Harness (PL 14.6.16) from the No Paper Sensor .
3. Release the hooks securing the No Paper Sensor to the Upper Frame (PL 14.6.40) as shown in the figure.
4. Remove the No Paper Sensor.

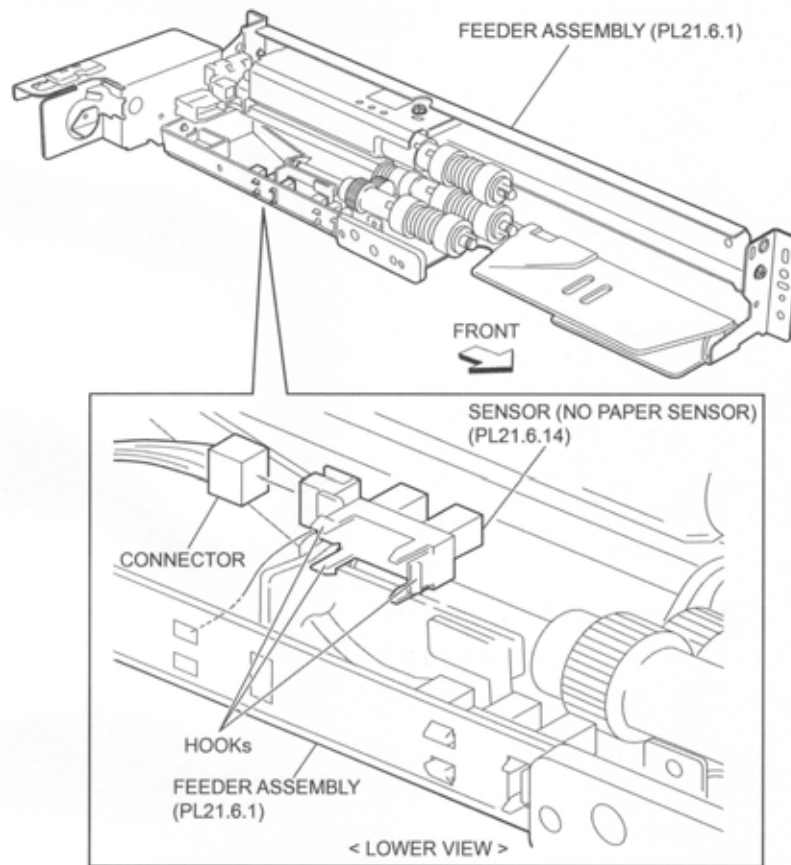


Figure 4 No Paper Sensor

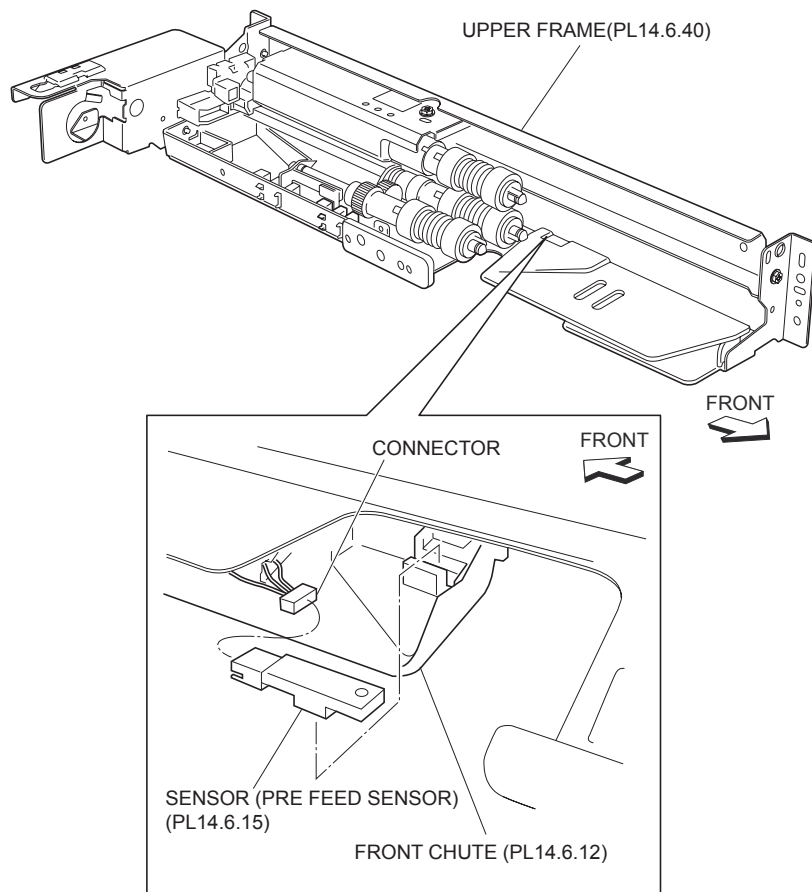
## Replacement

1. Secure the No Paper Sensor to the Upper Frame (PL 14.6.40) using the hooks.
2. Connect the connector (Tray 3:P/J101B, Tray 4:P/J101A) of the Wire Harness (PL 14.6.16) to No Paper Sensor.
3. Install the Tray 3 Feeder (PL 14.5.1) or Tray 4 Feeder (PL 14.4.15) .

## Pre Feed Sensor

### Removal

1. Remove the Tray 3 Feeder (PL 14.5.1) or Tray 4 Feeder (PL 14.4.15) .
2. Remove the Pre Feed Sensor from the Front Chute (PL 14.6.12) .
3. Disconnect the connector (Tray 3:P/J103B, Tray 4:P/J103A) of the Wire Harness (PL 14.6.16) from the Pre Feed Sensor.



**Figure 1 Pre Feed Sensor**

## Replacement

1. Connect the connector (Tray 3:P/J103B, Tray 4:P/J103A) of the Wire Harness (PL 14.6.16) to the Pre Feed Sensor.
2. Install the Pre Feed Sensor to the Front Chute (PL 14.6.12).
3. Install the Tray 3 Feeder (PL 14.5.1) or Tray 4 Feeder (PL 14.4.15) .

## 28T/21T Gear

### Removal

1. Remove the Tray 3 Feeder (PL 14.5.1) or Tray 4 Feeder (PL 14.4.15) .
2. Release the Wire Harness (PL 14.6.16) from the clamp on the Bracket (PL 14.6.3) .
3. Remove the three screws (Del Tite, M3x6mm) securing the Bracket to the Lower Frame (PL 14.6.34).

**NOTE** Note that the Gears attached on the Bracket may be detached.

4. Remove the 28T/21T Gear.

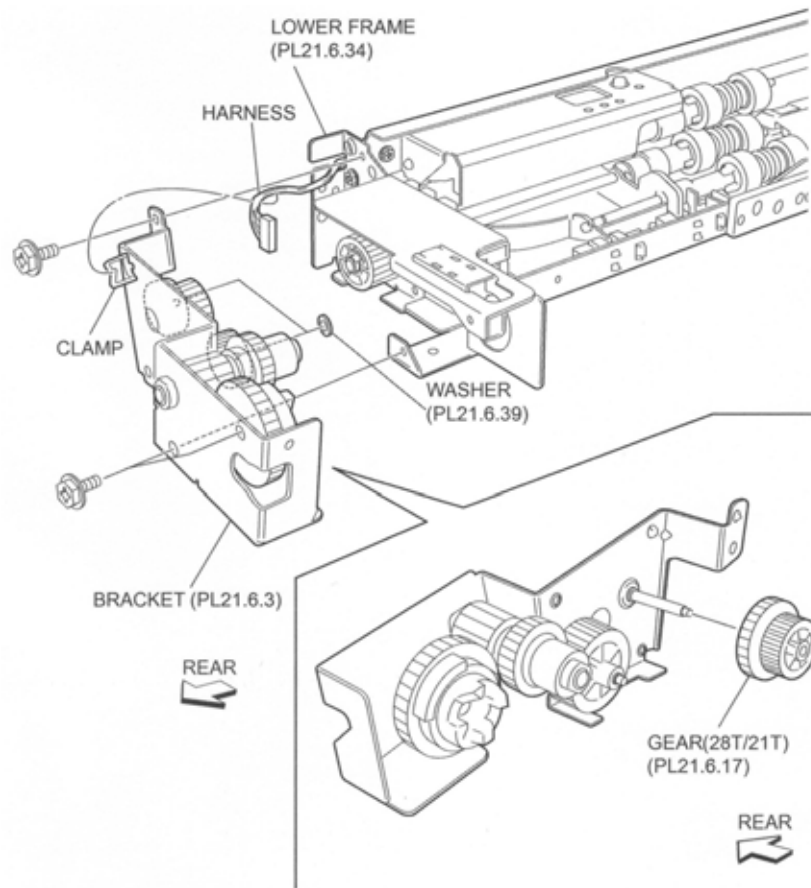


Figure 1 28T/21T Gear

## Replacement

1. Install the 28T/21T Gear.
2. Install the Bracket (PL 14.6.3) to the Lower Frame (PL 14.6.34) using the three screws (Del Tite, M3x6mm).

**NOTE** Make sure that the Gears attached on the Bracket are surely installed.

3. Secure the Wire Harness (PL 14.6.16) to the clamp on the Bracket.
4. Install the Tray 3 Feeder (PL 14.5.1) or Tray 4 Feeder (PL 14.4.15) .

## 29T Gear

### Removal

1. Remove the Tray 3 Feeder (PL 14.5.1) or Tray 4 Feeder (PL 14.4.15) .
2. Release the Wire Harness (PL 14.6.16) from the clamp on the Bracket (PL 14.6.3) .
3. Remove the three screws (Del Tite, M3x6mm) securing the Bracket to the Lower Frame (PL 14.6.34).

**NOTE** Note that the Gears attached on the Bracket may be detached.

4. Remove the 29T Gear.

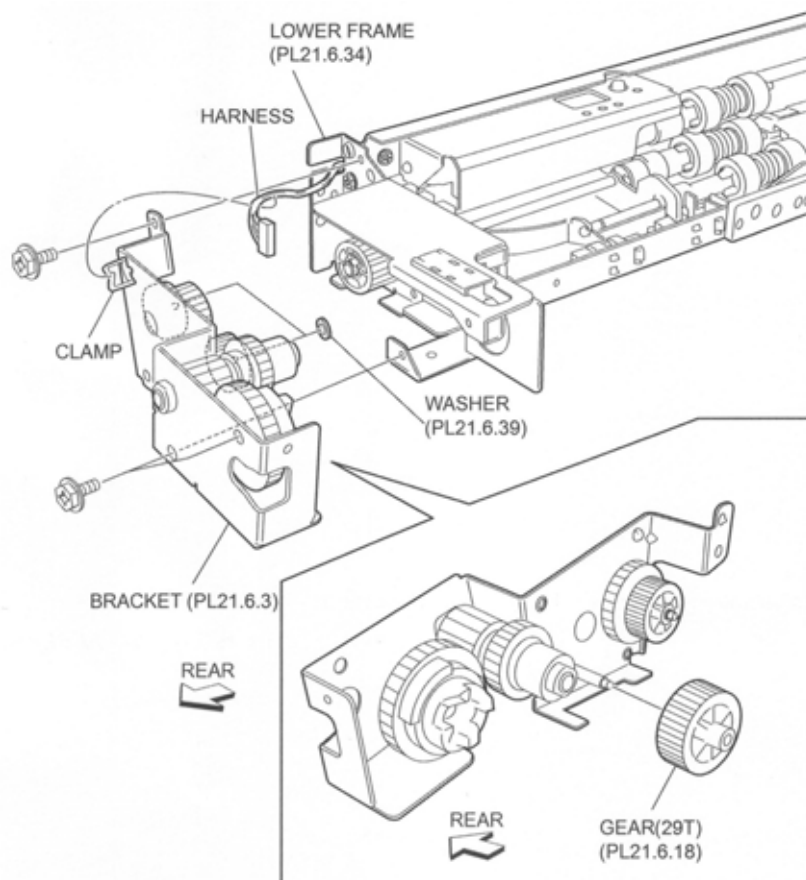


Figure 1 29T Gear

## Replacement

1. Install the 29T Gear.
2. Install the Bracket (PL 14.6.3) to the Lower Frame (PL 14.6.34) using three screws (Del Tite, M3x6mm).

**NOTE** Make sure that the Gears attached on the Bracket are surely installed.

3. Secure the Wire Harness (PL 14.6.16) to the clamp on the Bracket.
4. Install the Tray 3 Feeder (PL 14.5.1) or Tray 4 Feeder (PL 14.4.15) .

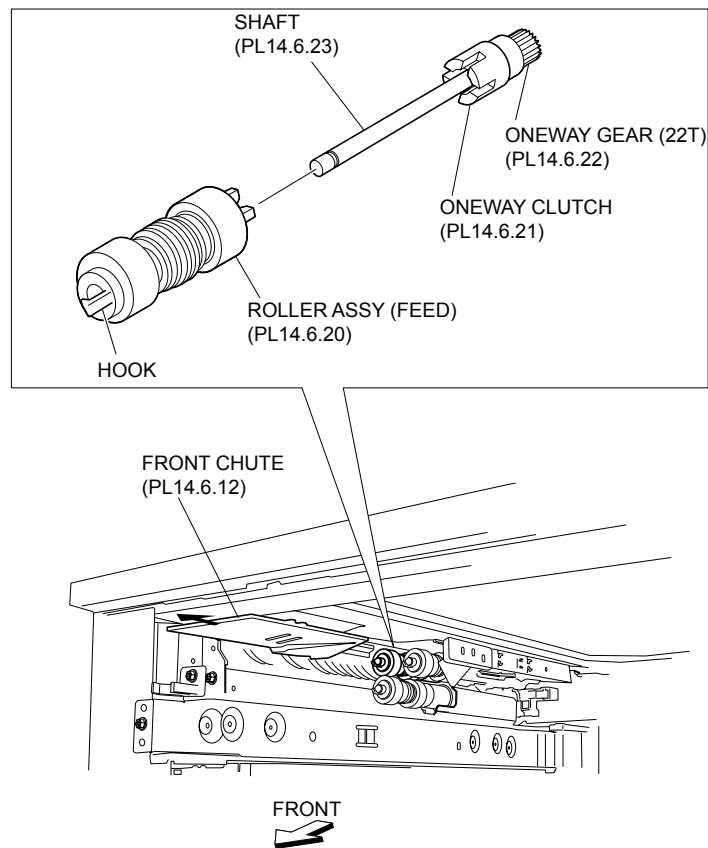
## Feed Roller Assembly

### Removal

1. Pull out the Tray 3 and Tray 4.
2. Move the Front Chute (PL 14.6.12) in the direction of the arrow .
3. Release the hook securing the Feed Roller Assembly to the Shaft (PL 14.6.23) as shown in the figure.
4. Remove the Feed Roller Assembly.

**NOTE** Note that the Oneway Clutch (PL 14.6.21) and the 22T Oneway Gear (PL 14.6.22) may be detached.

**NOTE** When removing, do not hold the rubber roller of the Feed Roller Assembly.



**Figure 1 Feed Roller**

## Replacement

1. Install the Feed Roller Assembly to the Shaft (PL 14.6.23), and fix it using hook.

**NOTE** When installing, do not hold the rubber roller of the Feed Roller Assembly.

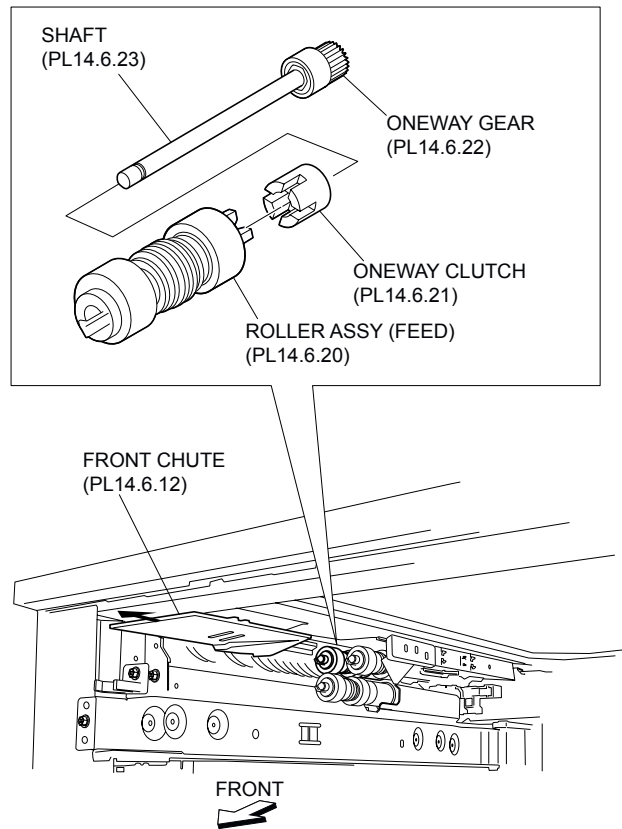
2. Move the Front Chute (PL 14.6.12) in the opposite direction of the arrow (to the rear side).
3. Insert the Tray 3 and Tray 4.

## Oneway Clutch

### Removal

1. Pull out the Tray 3 and Tray 4.
2. Remove the Feed Roller Assembly (PL 14.6.20) .
3. Remove the Oneway Clutch .

**NOTE** Note that 22T Oneway Gear (PL 14.6.22) may be detached.



**Figure 1 Oneway Clutch**

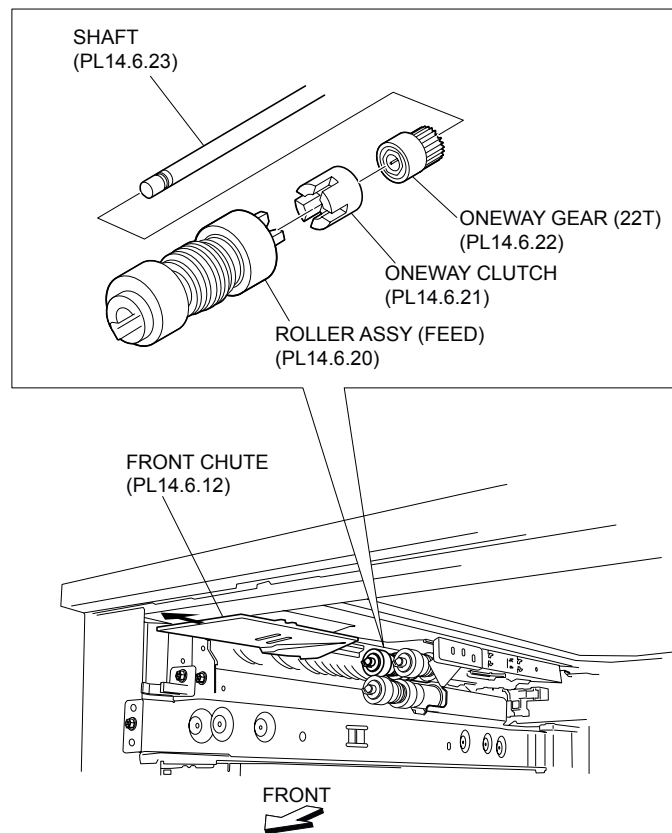
### **Replacement**

1. Install the Oneway Clutch.
2. Install the Feed Roller Assembly (PL 14.6.20) .
3. Insert the Tray 3 and Tray 4.

### **22T Oneway Gear**

#### **Removal**

1. Pull out the Tray 3 and Tray 4.
2. Remove the Feed Roller Assembly (PL 14.6.20) .
3. Remove the Oneway Clutch (PL 14.6.21) .
4. Remove the 22T Oneway Gear .



**Figure 1 Oneway Gear**

### **Replacement**

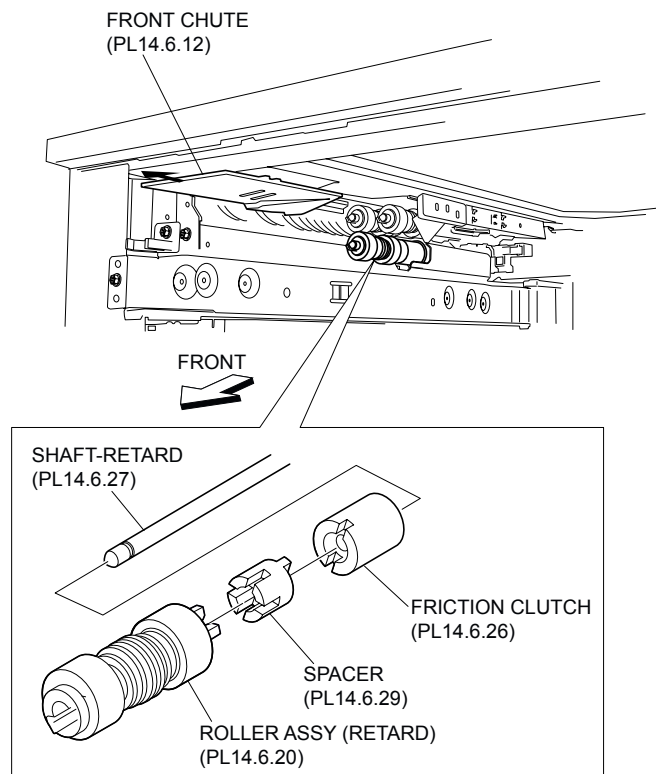
1. Install the 22T Oneway Gear.
2. Install the Oneway Clutch (PL 14.6.21) .
3. Install the Feed Roller Assembly (PL 14.6.20) .
4. Insert the Tray 3 and Tray 4.

### **Friction Clutch**

#### **Removal**

1. Pull out the Tray 3 and Tray 4.
2. Remove the Retard Roller Assembly (PL 14.6.20) .
3. Remove the Spacer (PL 14.6.29) .
4. Remove the Friction Clutch .





**Figure 1 Friction Clutch**

## Replacement

1. Install the Friction Clutch.
2. Install the Spacer (PL 14.6.29) .
3. Install the Retard Roller Assembly (PL 14.6.20) .
4. Insert the Tray 3 and Tray 4.

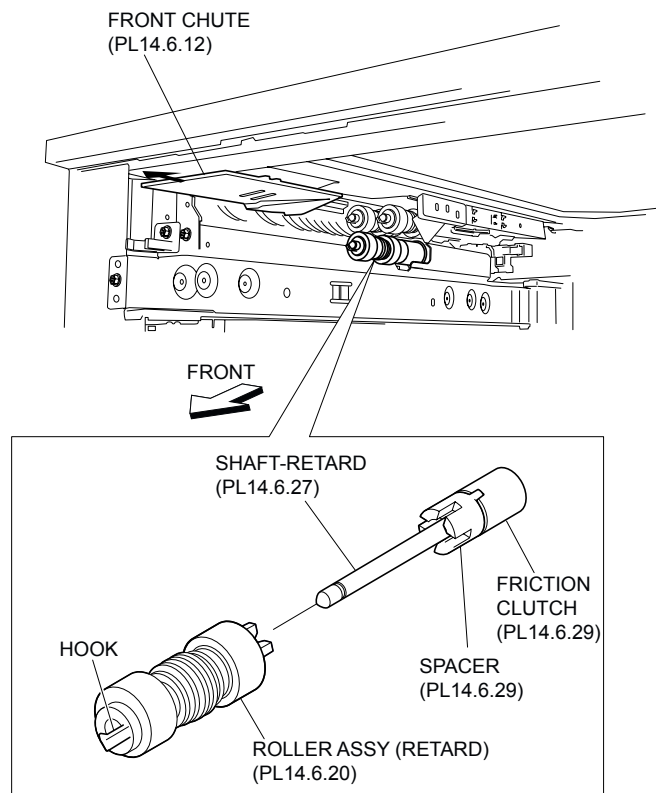
## Retard Roller Assembly

### Removal

1. Pull out the Tray 3 and Tray 4.
2. Move the Front Chute (PL 14.6.12) in the direction of the arrow .
3. Release the hook securing the Retard Roller Assembly to the Retard Shaft (PL 14.6.27) as shown in the figure.
4. Remove the Retard Roller Assembly.

**NOTE** Note that the Spacer (PL 14.6.29) and the Friction Clutch (PL 14.6.26) may be detached.

**NOTE** When removing, do not hold the rubber roller of the Retard Roller Assembly.



**Figure 1 Retard Roller**

## Replacement

1. Install the Retard Roller Assembly to the Retard Shaft (PL 14.6.27), and fix it using the hook.

**NOTE** When installing, do not hold the rubber roller of the Retard Roller Assembly.

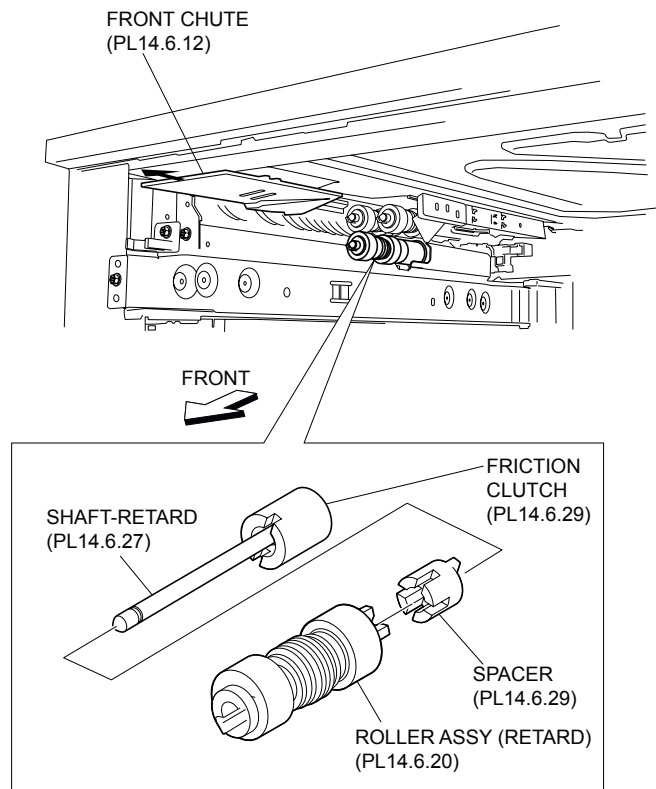
2. Move the Front Chute (PL 14.6.12) in the opposite direction of the arrow (to the rear side).
3. Insert the Tray 3 and Tray 4.

## Spacer

### Removal

1. Pull out the Tray 3 and Tray 4.
2. Remove the Retard Roller Assembly (PL 14.6.20) .
3. Remove the Spacer .

**NOTE** Note that the Friction Clutch (PL 14.6.26) may be detached.



**Figure 1 Spacer**

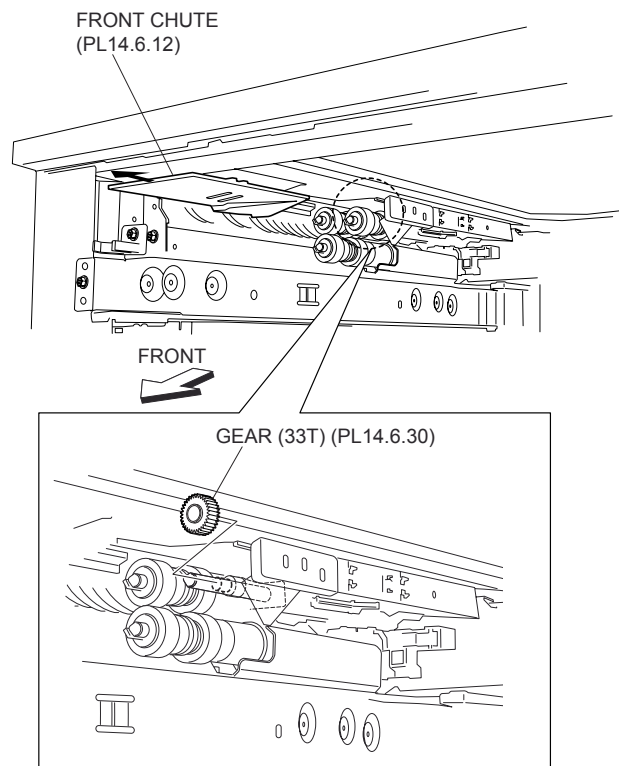
## Replacement

1. Install the Spacer.
2. Install the Retard Roller Assembly (PL 14.6.20) .
3. Insert the Tray 3 and Tray 4.

## 33T Gear

### Removal

1. Pull out the Tray 3 and Tray 4.
2. Remove the Nudger Roller Assembly (PL 14.6.20) .
3. Remove the 25T Gear (PL 14.6.33) .
4. Remove the 33T Gear .



**Figure 1 Gear**

## Replacement

1. Install the 33T Gear.
2. Install the 25T Gear (PL 14.6.33) .
3. Install the Nudger Roller Assembly (PL 14.6.20) .
4. Insert the Tray 3 and Tray 4.

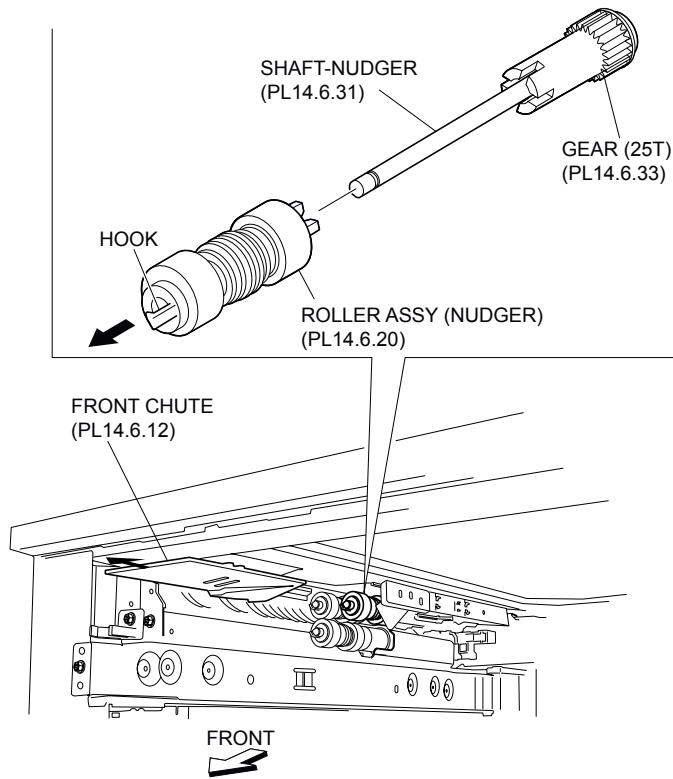
## Nudger Roller Assembly

### Removal

1. Pull out the Tray 3 and Tray 4.
2. Move the Front Chute (PL 14.6.12) in the direction of the arrow .
3. Release the hook securing the Nudger Roller Assembly to the Nudger Shaft (PL 14.6.31) as shown in the figure.
4. Remove the Nudger Roller Assembly.

**NOTE** Note that the 25T Gear (PL 14.6.33) may be detached.

**NOTE** When removing, do not hold the rubber roller of the Nudger Roller Assembly.



**Figure 1 Nudger Roller**

## Replacement

1. Install the Nudger Roller Assembly to the Nudger Shaft (PL 14.6.31), and fix it using the hook.

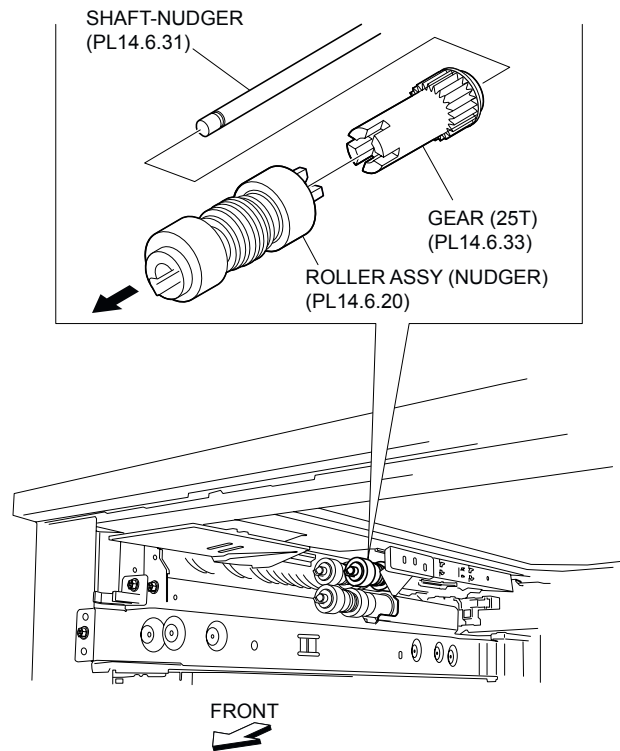
**NOTE** When installing, do not hold the rubber roller of the Nudger Roller Assembly.

2. Move the Front Chute (PL 14.6.12) in the opposite direction of the arrow (to the rear side).
3. Insert the Tray 3 and Tray 4.

## 25T Gear

### Removal

1. Pull out the Tray 3 and Tray 4.
2. Remove the Nudger Roller Assembly (PL 14.6.20) .
3. Remove the 25T Gear .



**Figure 1 25T Gear**

## Replacement

1. Install the 25T Gear.
2. Install the Nudger Roller Assembly (PL 14.6.20) .
3. Insert the Tray 3 and Tray 4.

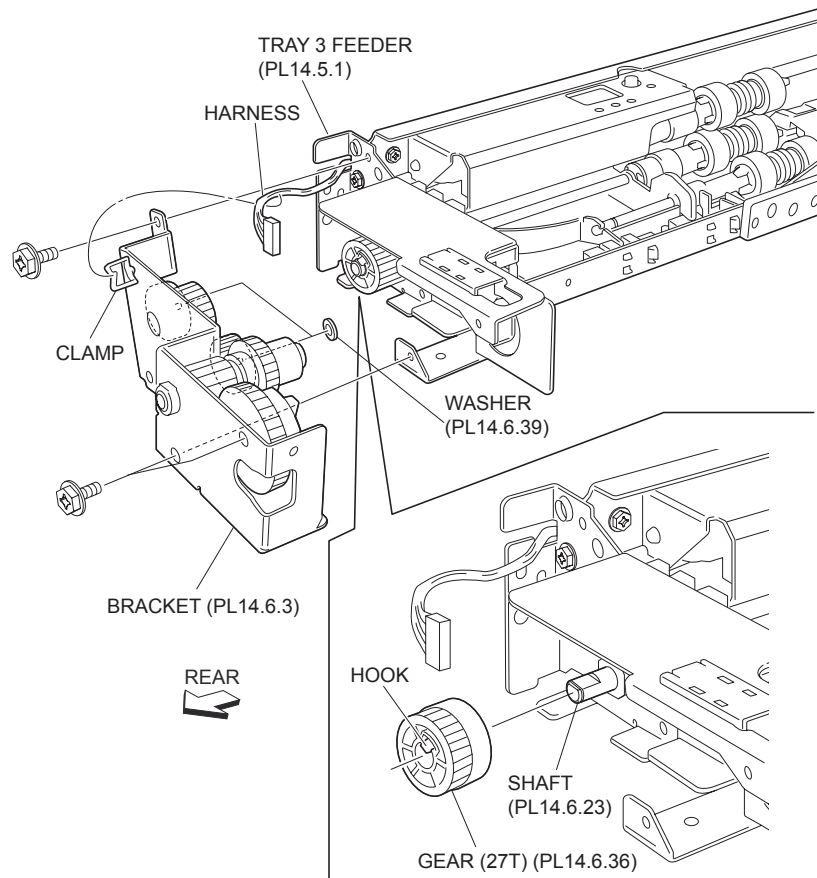
## 27T Gear

### Removal

1. Remove the Tray 3 Feeder (PL 14.5.1) or Tray 4 Feeder (PL 14.4.15) .
2. Release the Wire Harness (PL 14.6.16) from the clamp on the Bracket (PL 14.6.3) .
3. Remove the three screws (Del Tite, M3x6mm) securing the Bracket to the Lower Frame (PL 14.6.34).

**NOTE** Note that the Gears attached on the Bracket may be detached.

4. Release the hook securing the 27T Gear to the Shaft (PL 14.6.23) as shown in the figure.
5. Remove the 27T Gear.



**Figure 1 27T Gear**

## Replacement

1. Install the 27T Gear to the Shaft (PL 14.6.23) using the hook.
2. Install Bracket (PL 14.6.3) to Lower Frame (PL 14.6.34) using three screws (Del Tite, M3x6mm).

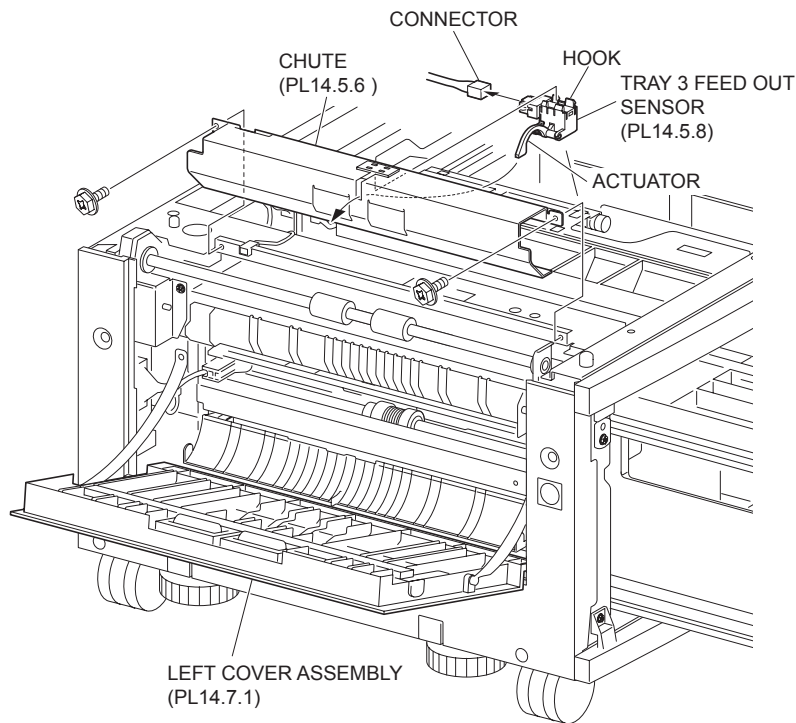
**NOTE** Make sure that the Gears attached on the Bracket are surely installed.

3. Secure the Wire Harness (PL 14.6.16) to the clamp on the Bracket.
4. Install the Tray 3 Feeder (PL 14.5.1) or Tray 4 Feeder (PL 14.4.15) .

## Left Cover Assembly

### Removal

1. Remove the Left Lower Cover (PL 14.1.4) .
2. Remove the screws (one each) securing the left and right Supports (PL 14.7.14) to the machine .
3. Remove the one screw securing the Bracket (PL 14.7.17) to the machine to remove the Bracket.
4. Move the Left Cover Assembly in the direction of the arrow to remove the shaft on the rear of the Left Cover Assembly from the hole on the frame.
5. Remove the Left Cover Assembly.



**Figure 1 Left Cover**

## Replacement

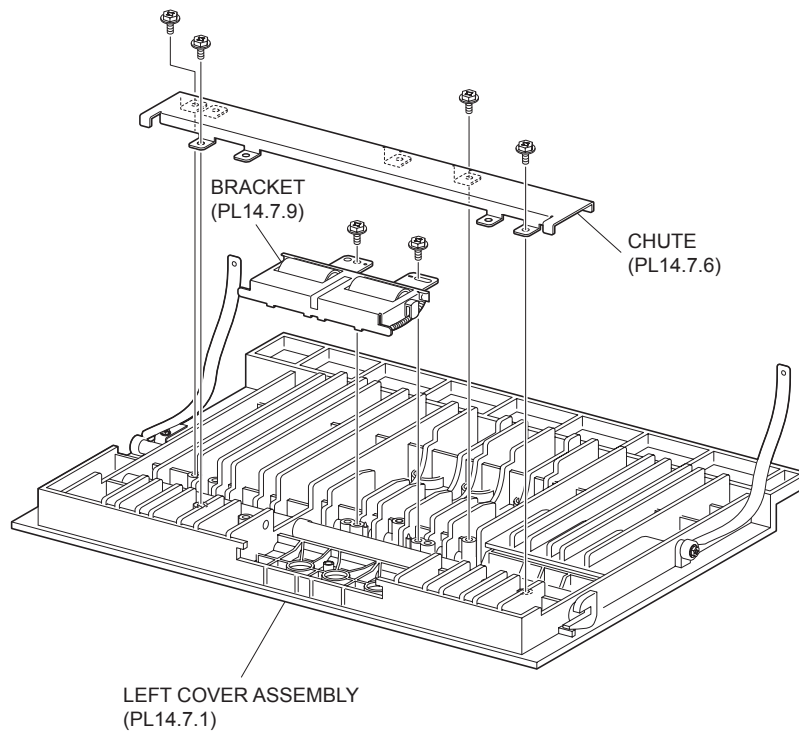
1. Move the Left Cover Assembly in the opposite direction of the arrow to put the shaft on the rear of the Left Cover Assembly into the hole on the frame.
2. Put the shaft of the Bracket (PL 14.7.17) into the hole on the front of the Left Cover Assembly, and install the Bracket to the machine together with the Left Cover Assembly using the one screw.
3. Install the left and right Supports (PL 14.7.14) to the machine using one screw each.
4. Install the Left Lower Cover (PL 14.1.4) .

## Pinch Roll

### Removal

1. Remove the Left Lower Cover (PL 14.1.4) .
2. Remove the Left Cover Assembly (PL 14.7.1) .
3. Remove the screw (Silver, M3x8mm) securing the Chute (PL 14.7.6) to the Left Cover (PL 14.7.5) to remove the Chute .
4. Remove the two screws (Silver, M3x8mm) securing the Bracket (PL 14.7.9) to the Left Cover to remove the Bracket.



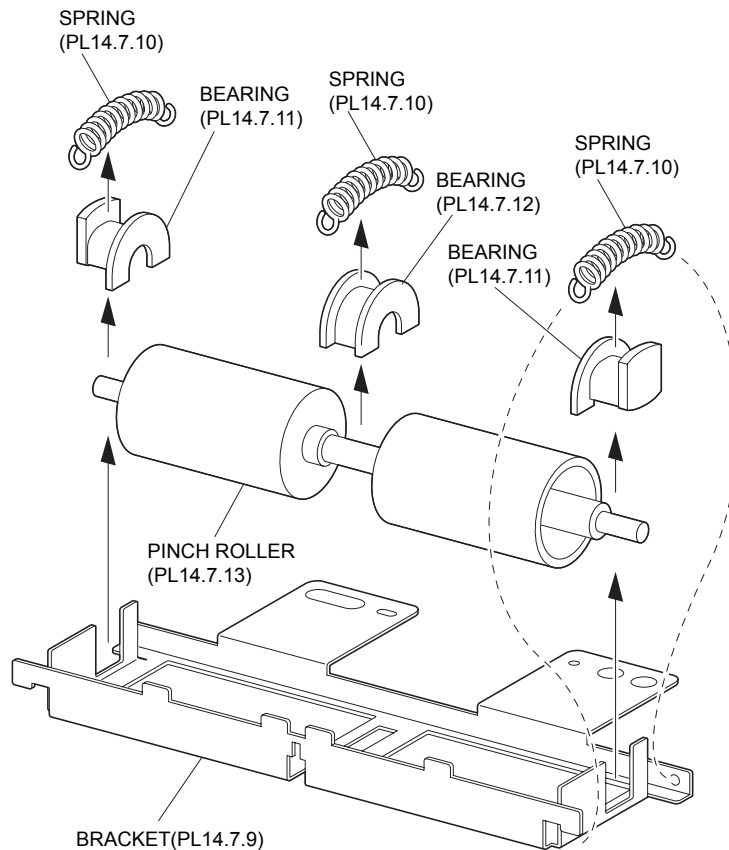


**Figure 1 Chute**

5. Turn over the removed Bracket and remove the three Springs (PL 14.7.10) .

**NOTE** When the Spring is removed, two Bearings (PL 14.7.11) and one Bearing (PL 14.7.12) are detached. Be careful not to lose them.

6. Remove the Pinch Roll.



**Figure 2 Pinch Roll**

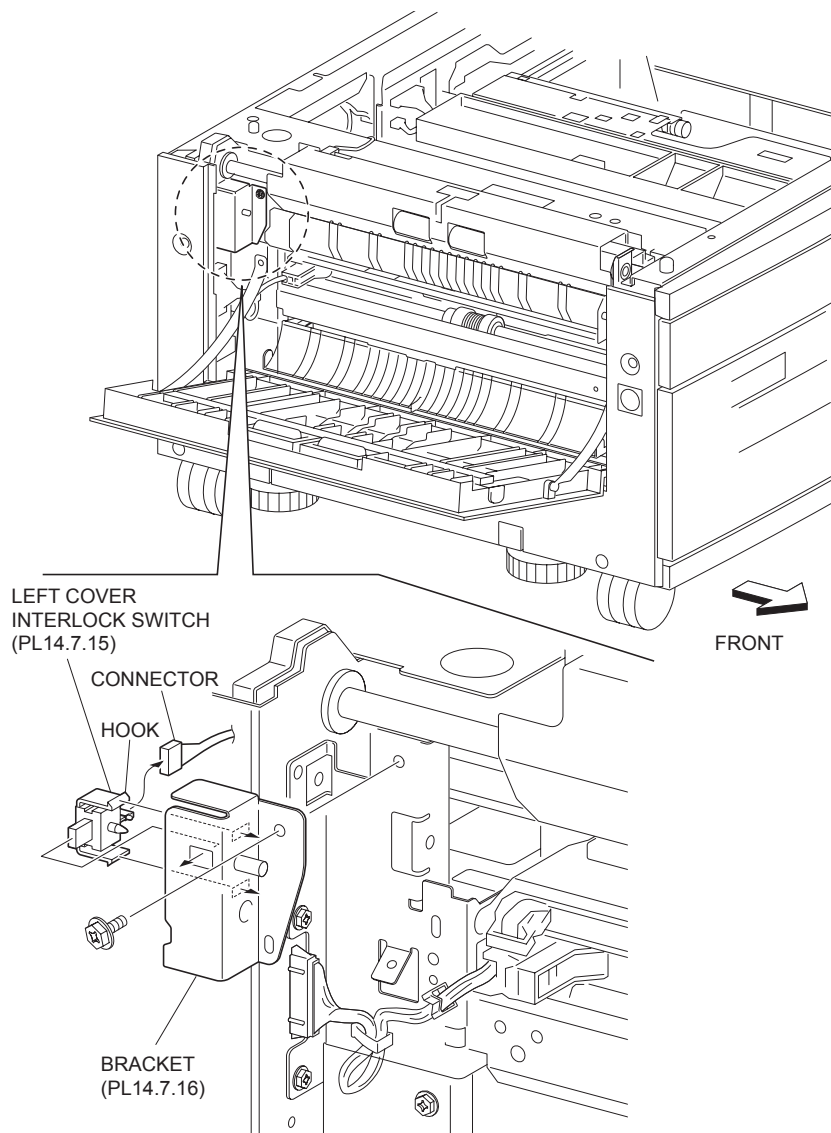
## Replacement

1. Install the Pinch Roll to the Bracket (PL 14.7.9), and install the Bearing (PL 14.7.12) to the center of the shaft of the Pinch Roll, and the Bearings (PL 14.7.11) on the left and right of the shaft in the direction shown in the figure, and secure them with the three Springs (PL 14.7.10).
2. Install the Bracket to the Left Cover (PL 14.7.5) using the two screws (Silver, M3x8mm).
3. Install the Chute (PL 14.7.6) to the Left Cover using the one screw (Silver, M3x8mm).
4. Install the Left Cover Assembly (PL 14.7.1) .
5. Install the Left Lower Cover (PL 14.1.4) .

## Left Cover Interlock Switch

### Removal

1. Open the Left Cover Assembly (PL 14.7.1).
2. Remove the screw (Del Tite, M3x8mm) securing the Bracket (PL 14.7.16) to the machine to remove the Bracket .
3. Disconnect the connector (FS812) of the Wire Harness (PL 14.8.18) from the Left Cover Interlock Switch.
4. Release the hooks securing the Left Cover Interlock Switch to the Bracket as shown in the figure.
5. Remove the Left Cover Interlock Switch.



**Figure 1 Left Cover Interlock Switch**

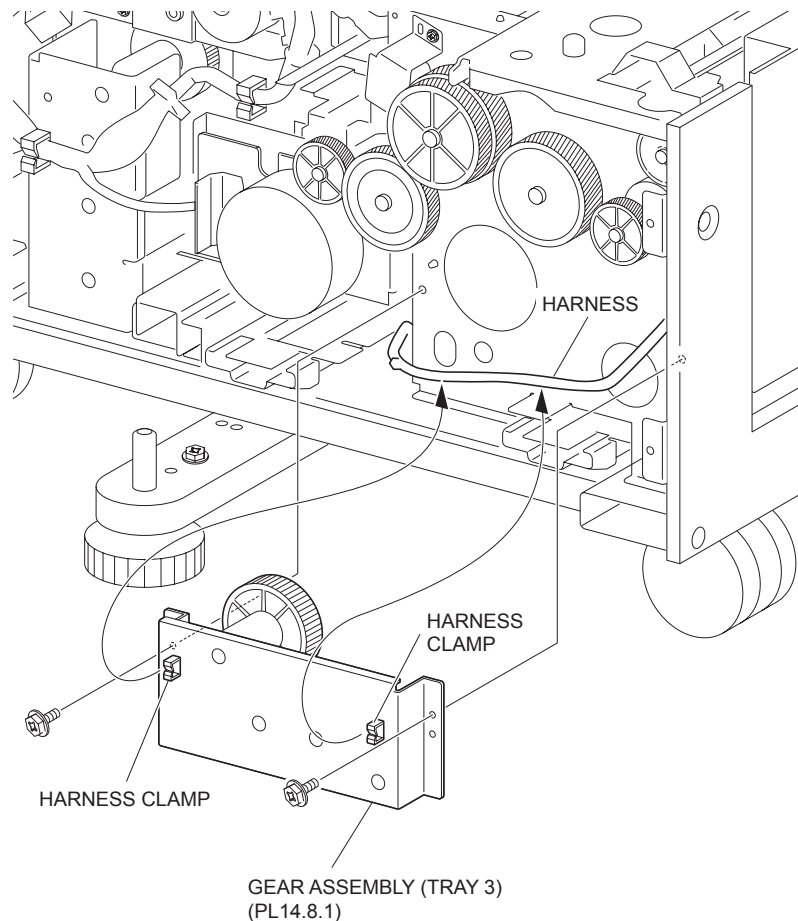
## Replacement

1. Secure the Left Cover Interlock Switch to the Bracket (PL 14.7.16) with the hooks.
2. Connect the connector (FS812) of the Wire Harness (PL 14.8.18) to the Left Cover Interlock Switch.
3. Install the Bracket to the machine using the one screw (Del Tite, M3x8mm).
4. Close the Left Cover Assembly (PL 14.7.1).

## Tray 3 Gear Assembly

### Removal

1. Remove the Rear Cover (PL 14.1.5) .
2. Remove the Tray 3 Feeder (PL 14.5.1) .
3. Release the Wire Harness (PL 14.8.18) from the clamp of the Tray 3 Gear Assembly .
4. Remove the two screws securing the Tray 3 Gear Assembly to the machine.
5. Remove the Tray 3 Gear Assembly.



**Figure 1 Tray 3 Gear Assembly**

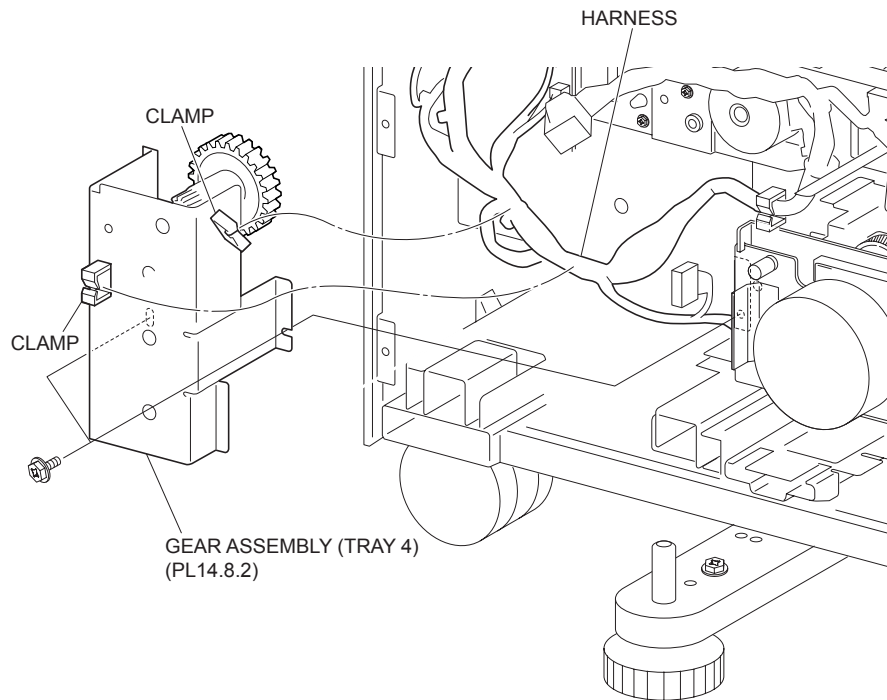
### Replacement

1. Install the Tray 3 Gear Assembly to the machine using the two screws.
2. Secure the Wire Harness (PL 14.8.18) to the clamp of the Tray 3 Gear Assembly.
3. Install the Tray 3 Feeder (PL 14.5.1) .
4. Install the Rear Cover (PL 14.1.5) .

### Tray 4 Gear Assembly

#### Removal

1. Remove the Rear Cover (PL 14.1.5) .
2. Remove the Tray Module PWB (PL 14.8.5) .
3. Release the two Wire Harnesses (PL 14.8.18) from the clamp of the Tray 4 Gear Assembly .
4. Remove the two screws securing the Tray 4 Gear Assembly to the machine.
5. Remove the Tray 4 Gear Assembly.



**Figure 1 Tray 4 Gear Assembly**

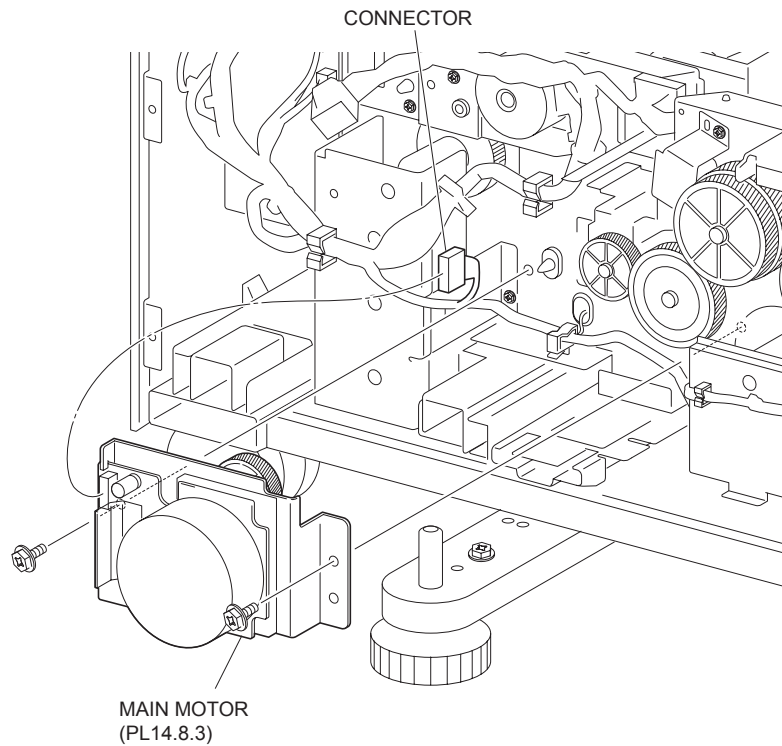
## Replacement

1. Install the Tray 4 Gear Assembly to the machine using the two screws.
2. Secure the two Wire Harnesses (PL 14.8.18) to the clamp of the Tray 4 Gear Assembly.
3. Install the Tray Module PWB (PL 14.8.5) .
4. Install the Rear Cover (PL 14.1.5) .

## Main Motor

### Removal

1. Remove the Rear Cover (PL 14.1.5) .
2. Disconnect the connector (P/J826) of the Wire Harness (PL 14.8.18) from the Main Motor .
3. Remove the two screws (Del Tite, M3x8mm) securing the Main Motor to the machine.
4. Remove the Main Motor.



**Figure 1 Main Motor**

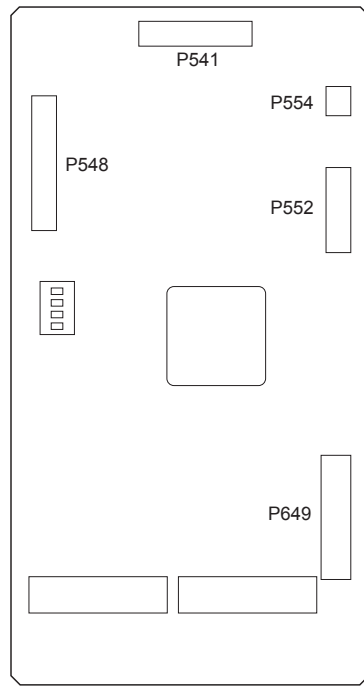
## **Replacement**

1. Install the Main Motor to the machine using the two screws (Del Tite, M3x8mm).
2. Connect the connector (P/J826) of the Wire Harness (PL 14.8.18) to the Main Motor.
3. Install the Rear Cover (PL 14.1.5) .

## **Tray Module PWB**

### **Removal**

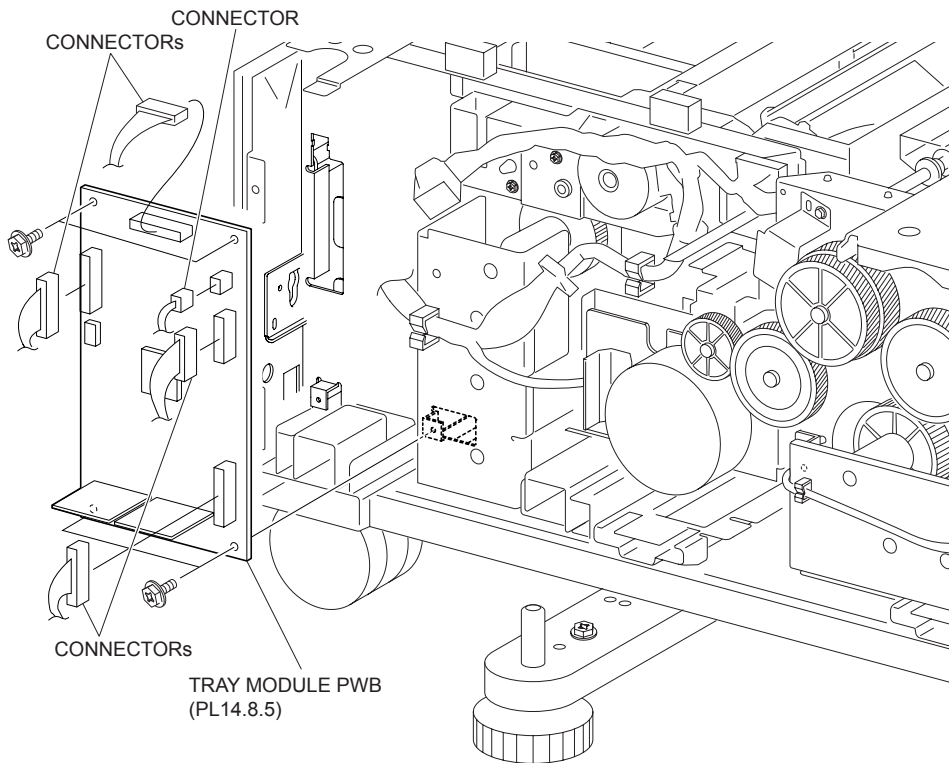
1. Remove the Rear Cover (PL 14.1.5) .
2. Disconnect all connectors of the harnesses from the Tray Module PWB .



TRAY MODULE PWB (PL21.8.5)

**Figure 1 Tray Module PWB**

3. Remove the four screws securing the Tray Module PWB to the machine .
4. Remove the Tray Module PWB.



**Figure 2 Removing Tray Module PWB**

**Replacement**

1. Install the Tray Module PWB to the machine using the four screws.
2. Connect all connectors of the harnesses to the Tray Module PWB.
3. Install the Rear Cover (PL 14.1.5) .

## Takeaway Clutch

### Removal

1. Remove the Rear Cover (PL 14.1.5) .
2. Disconnect the connector (P/J822) of the Wire Harness connected from the machine to the Bracket (PL 14.8.8) .
3. Remove the two screws (Del Tite, M3x8mm) securing the Bracket to the machine to remove the Bracket.

**NOTE** The Bearing (PL 14.8.9) and the Washer (PL 14.8.17) are detached. Be careful not to lose them.

4. Remove the E-ring securing the 38T Gear (PL 14.8.10) to the Bracket to remove the 38T Gear.
5. Disconnect the connector of the Takeaway Clutch from the Bracket by releasing the hook.

**NOTE** The Shaft (PL 14.8.11) and the Bearing are detached. Be careful not to lose them.

6. Remove the Takeaway Clutch.

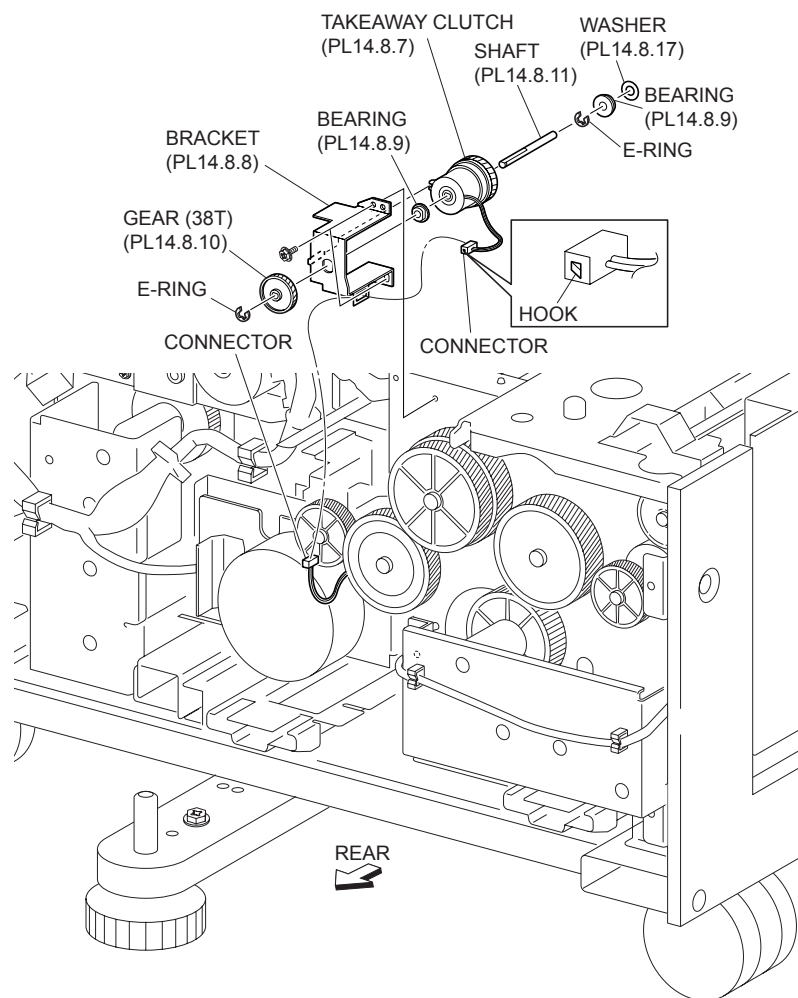


Figure 1 Takeaway Clutch

### Replacement



1. Secure the connector of the Takeaway Clutch to the Bracket (PL 14.8.8) with the hook.
2. Install the Takeaway Clutch to the Bracket together with the 38T Gear (PL 14.8.10), Bearing (PL 14.8.9) and Shaft (PL 14.8.11) using the one E-ring.

**NOTE** Fit the 38T Gear to the D-shaped of the Shaft. Also, Install the Bracket with its boss fit to the notch on the Takeaway Clutch.

3. Install the Bracket to the machine together with the Bearing and the Washer (PL 14.8.17) using the two screws (Del Tite, M3x8mm).
4. Connect the connector (P/J822) of the Wire Harness to Bracket.
5. Install the Rear Cover (PL 14.1.5) .

**NOTE** After the installation, be sure that the harness connected to the Takeaway Clutch does not contact the gears.



# Chapter 7 Troubleshooting

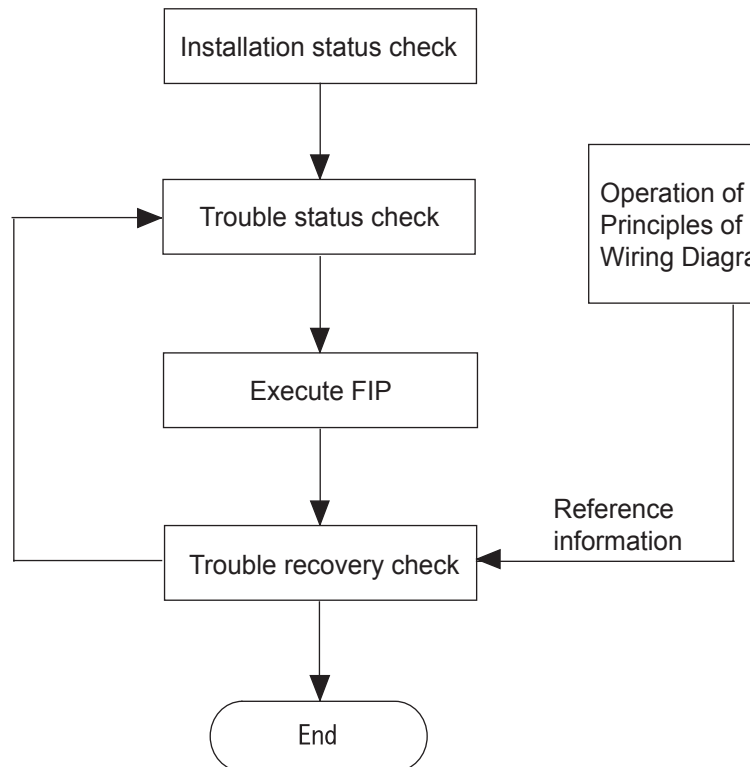
- NOTE** This manual is based on the assumption that the printer controller is working properly. When the printer controller controls operation directly or has unique specifications, the operation may be different from description in this manual.
- NOTE** Troubleshooting in this manual assumes use of Diagnostic Tools (maintenance tools). However, the troubleshooting allows for the case where the Diagnostic tools are not used. You can correct troubles according to these troubleshooting procedures.

# Progressing with the Troubleshooting

After making sure of actual condition of a trouble, proceed with the troubleshooting process efficiently making use of the Fault Isolation Procedure (FIP), Operation of Diagnostic (Chapter 2), Wiring Diagrams (Chapter 7), and Principles of Operation (Chapter 6).

## Flow of Troubleshooting

Flow of the troubleshooting is as follows:



## Preparatory Requirements

Be sure to check the following items before starting the troubleshooting procedures:

1. Voltage of the power supply is within the specifications (measure the voltage at the electric outlet).
2. Power cord is free from breakage, short-circuit, disconnected wire, or incorrect connection in the power cord.
3. The laser printer is properly grounded.
4. The laser printer is not installed at a place subjected to too high temperature, too high humidity, too low temperature, too low humidity or rapid change of temperature.
5. The laser printer is not installed close to water service, humidifier, heat generating unit, or fire, in very dusty place, or a place exposed to air flow from the air conditioning system.

6. The laser printer is not installed in a place where volatile gas or inflammable gas is generated.
7. The laser printer is not installed under direct sunbeams.
8. The laser printer is installed in a well-ventilated place.
9. The laser printer is installed on a stout and stable plane.
10. Paper used meets specifications (standard paper is recommendable).
11. The laser printer is handled properly.
12. Parts which should be periodically replaced are replaced each time when specified number of sheets have been printed.

## Cautions for Service Operations

1. Be sure to remove the power cord except when it is specifically required.



**If the printer is kept ON, never touch the conductive parts while it is not specifically required. The power switch, inlet and outlet are live even while the power supply is cut off. Never touch the live parts.**

2. When checking some parts with covers removed and with the interlock and safety and power switches ON, remove the connector (P/J140, P/J160 and P/J170) on the ROS ASSY-12 except when it is specifically required.



**When checking some parts with covers removed and with the interlock and safety and power switches ON, laser beams may be irradiated from the ROS ASSY-12. Since it is dangerous, be sure to remove the connector (P/J140, P/J160 and P/J170) while it is not required.**

3. When checking the COVER ASSY-LH removed and power ON, be sure to remove the connector (P/J500) on the PSHV-Y2 while it is not required.



**When checking the COVER ASSY-LH removed and power ON, high voltage may be applied by the PSHV-Y2. Be sure to remove the connector (P/J500) on the PSHV-Y2. When connecting the connector (P/J500) on the PSHV-Y2 according to the instructions of the FIP, never touch the HVPS and parts of high voltage.**

4. When using Diagnostic tools or other tools of high voltage, be sure to keep them covered except when otherwise specified.



**When using Diag.Tool or other tools of high voltage, never touch parts of high voltage. When using Diagnostic Tool or other tools of high voltage, be sure to follow the procedure of this manual.**

5. When operating the driving units using the Diagnostic or other tools, be sure to keep them covered unless otherwise specified.



**When operating the driving units using the Diagnostic or other tools, never touch the driving units. When operating the driving units using Diagnostic or other tools, be sure to follow the procedures in this manual.**

6. When touching hot parts, be careful not to get burnt.
7. Workers should wear a wrist band or the like to remove static electricity from their body, grounding their body while working.

## Cautions for FIP Use

1. It is assumed in the FIP that the printer controller (PWBA ESS) is normally functioning. If any trouble cannot be corrected by troubleshooting, replace the printer controller with a normal one and check for proper operation again.  
If the trouble is not still corrected, replace the major parts and then related parts in succession and confirm according to the procedure of the "Check".
2. When troubleshooting according to the FIP, normal operation of PSHV-Y2, PWBA MCU F, FUSER ASSY, and HSG ASSY-BTR may be necessary for isolation of failed parts.
3. In the initial check according to the FIP, check only items which can be simply checked.
4. In the initial check according to the FIP, check the constitutive parts of the major check parts and related parts, as well as major check parts.
5. When working with the printer, be sure to remove the power cord except when required specifically. Never touch live parts if not required, while the power cord is connected.
6. Connector condition is denoted as follows:  
 [P/J12] → Connector (P/J12) is connected.  
 [P12] → Plug side with the connector (P/J12) removed (except when attached directly to the board).  
 [J12] → Jack side with the connector (P/J12) removed (except when attached directly to the board).
7. [P/J1-2PIN <=> P/J3-4PIN] in the FIP means measurement with the plus side of the measuring instrument connected to [2PIN] of [P/J1] and the minus side to [4PIN] of [P/J3].
8. [P/J1<=> P/J2] in the FIP means measurement for all terminals corresponding between [P/J1] and [P/J2] referring to "Wiring Diagrams".
9. In [P/J1-2PIN <=> P/J3-4PIN] in the FIP where voltage is measured, [P/J3-4PIN] on the rear minus side is always at the AG (analog ground), SG (signal ground), or RTN (return).  
Therefore, after checking of proper continuity between AGs, SGs, or RTNs respectively, the rear minus side can be connected to the PIN of AG, SG or RTN instead of [P/J3-4PIN].  
However, care should be taken not to mistake since [AG], [SG], and [RTN] are not on the same level.
10. Measure the voltage of small connectors with the special tool. Handle the tool with care, as the leading edge of the tool is pointed.
11. When measuring the voltage, set the EP CARTRIDGE, HSG ASSY-BRT and paper tray, close the COVER ASSY TOP PR, and FUSER ASSY and power ON if not required specifically.
12. Numerical values in the FIP are only for standard. If numerical values are approximate, they should be considered permissible.

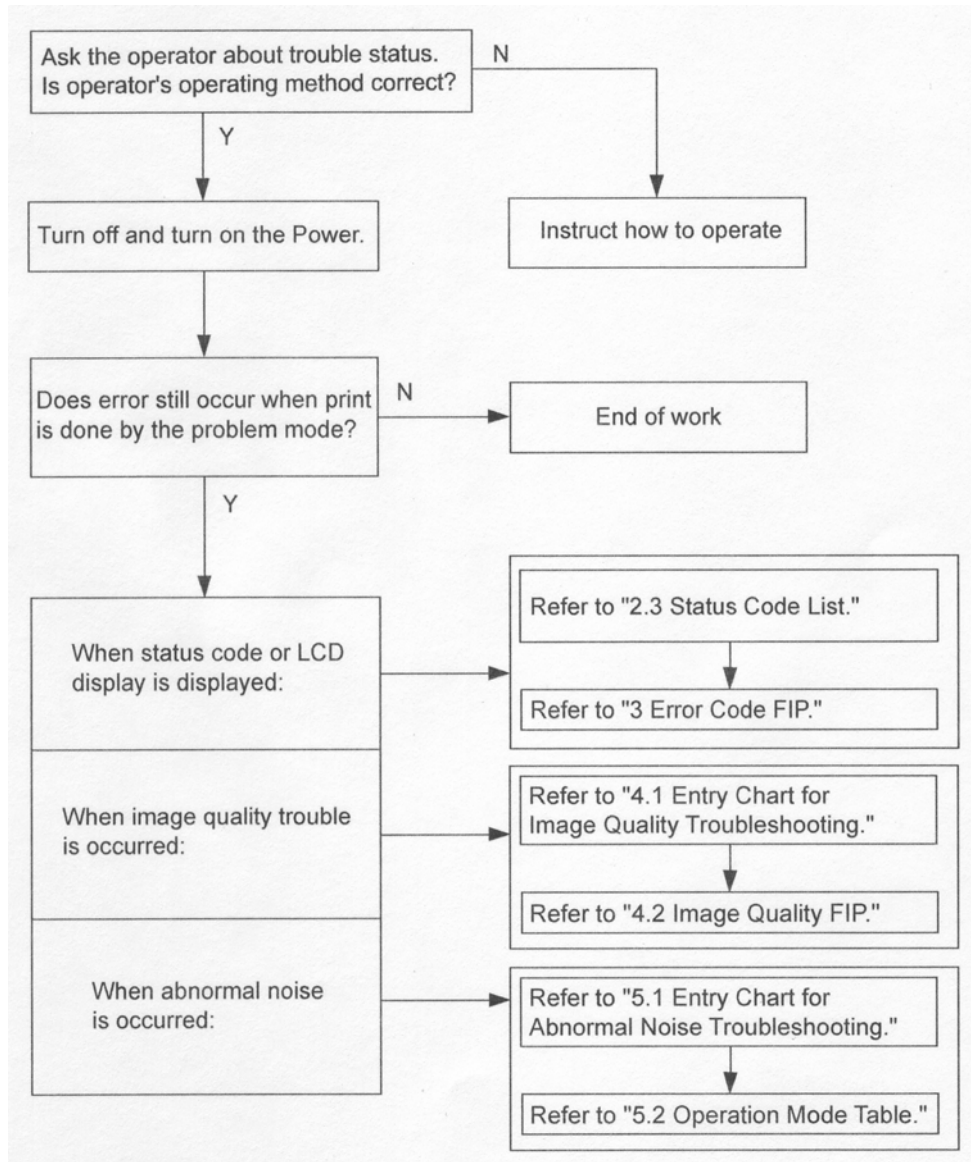
13. Parts which are always removed to check as indicated in the FIP and procedures for that purpose are not specifically referred to here. They should be handled carefully.
14. "Replacement" in the FIP indicates replacement of parts which are considered to be the source of trouble to be checked after replacing those parts, assemblies containing them (HIGH ASSY).
15. The FIP describes the first tray on the lower part of the device as "Tray 1," and the second tray as "Tray 2".
16. In the FIP, existence and non-existence of Diagnostic tools (maintenance tools) are distinguished in some cases. Correct troubles according to the instructions in the FIP.
17. In the FIP, procedures are differentiated depending on specifications. Correct troubles according to the instructions in the FIP.
18. For optional parts, some troubleshooting procedure may follow the manual for those options, of which you should take note. Keep those manuals for the optional parts when required.

# FIP

## FIP

The FIP is the first step for trouble diagnosis. The FIP isolates the presence of various troubles including error codes, and guides the troubleshooting procedure.

### Flow of FIP



### Error/Status Code List

**NOTE** For information about the following FIP items not described in "Status Code" column in the following table, refer to the manual of each Option unit.

Status Code	Error Contents	Error Description	FIP to be referred
C1-2	Prefeed SENSOR#1 on JAM (Tray 1 paper feed)	The Prefeed Sensor1 is not turned ON within the specified time after the Tray 1 Feed/Lift Motor is ON.	FIP 1.1



Status Code	Error Contents	Error Description	FIP to be referred
C1-3	Registration Sensor on JAM (Tray 1 paper feed)	The Registration Sensor is not turned ON within the specified time after the Prefeed Sensor1 is ON.	FIP 1.2
C2-1	Prefeed SENSOR#2 on JAM (Tray 2 paper feed)	The Prefeed Sensor2 is not turned ON within the specified time after the Tray 2 Feed/Lift Motor is ON.	FIP 1.3
C2-2	Tray 2 Feed Out Sensor on JAM (Tray 2 paper feed)	The Tray 2 Feed Out Sensor2 is not turned ON within the specified time after the Prefeed Sensor2 is ON.	FIP 1.4
C2-3	Registration Sensor on JAM (Tray 2 paper feed)	The Registration Sensor is not turned ON within the specified time after the Tray 2 Feed Out Sensor is ON.	FIP 1.5
C3-0	Prefeed SENSOR#3 on JAM (Tray 3 paper feed)	The Prefeed Sensor3 is not turned ON within the specified time after the Tray 3 Feed/Lift Motor is ON.	FIP 2.1 FIP 7.1
C3-1	Tray 3 Feed Out Sensor on JAM (Tray 3 paper feed)	The Tray 3 Feed Out Sensor is not turned ON within the specified time after the Prefeed Sensor3 is ON.	FIP 2.2 FIP 7.2
C3-2	Tray 2 Feed Out Sensor on JAM (Tray 3 paper feed)	The Tray 2 Feed Out Sensor is not turned ON within the specified time after the Tray 3 Feed Out Sensor is ON.	FIP 2.3 FIP 7.3
C3-3	Registration Sensor on JAM (Tray 3 paper feed)	The Registration Sensor is not turned ON within the specified time after the Tray 3 Feed Out Sensor is ON.	FIP 2.4 FIP 7.4
C4-0	Tray 4 Feed Out Sensor on JAM (Tray 4 paper feed)	The Tray 4 Feed Out Sensor is not turned ON within the specified time after the Prefeed Sensor4 is ON.	FIP 2.5 FIP 7.5
C4-1	Tray 3 Feed Out Sensor on JAM (Tray 4 paper feed)	The Tray 3 Feed Out Sensor is not turned ON within the specified time after the Tray 4 Feed Out Sensor is ON.	FIP 2.6 FIP 7.6
C4-2	Tray 2 Feed Out Sensor on JAM (Tray 3 paper feed)	The Tray 2 Feed Out Sensor is not turned ON within the specified time after the Tray 3 Feed Out Sensor is ON.	FIP 2.7 FIP 7.7
C4-3	Registration Sensor on JAM (Tray 4 paper feed)	The Registration Sensor is not turned ON within the specified time after the Tray 4 Feed Out Sensor is ON.	FIP 2.8 FIP 7.8
C4-4	Prefeed SENSOR#4 on JAM (Tray 4 paper feed)	The Prefeed Sensor4 is not turned ON within the specified time after the Tray 4 Feed/Lift Motor is ON.	FIP 2.9 FIP 7.9
C5-1	HCF F/O SENSOR On Jam	The HCF Feed Out Sensor is not turned ON within the specified time after the HCF Feed Start signal is ON.	FIP 6.1
C5-2	HCF F/O#2 SENSOR On Jam	The F/O#2 Sensor on the IOT is not turned ON within the specified time after the HCF Feed Start signal is ON.	FIP 6.2
C5-3	HCF Registration SENSOR On Jam	The Registration Sensor on the IOT is not turned ON within the specified time after the F/O#2 Sensor on the IOT is ON.	FIP 6.3
C6-1	Registration Sensor on JAM (Duplex paper feed)	Registration Sensor is not turned ON within the specified time after the Duplex Motor is ON.	FIP 3.1
C6-2	Registration Sensor on JAM (Duplex paper feed)	Registration Sensor is not turned ON within the specified time after the Duplex Sensor is ON.	FIP 3.2

Status Code	Error Contents	Error Description	FIP to be referred
C8-2	Tray 2 Feed Out Sensor Static JAM	Paper remains on the Tray 2 Feed Out Sensor.	FIP 1.6
C8-3	Tray 3 Feed Out Sensor Static JAM	Paper remains on the Tray 3 Feed Out Sensor.	FIP 2.10 FIP 7.10
C8-4	Tray 4 Feed Out Sensor Static JAM	Paper remains on the Tray 4 Feed Out Sensor.	FIP 2.11 FIP 7.11
C8-5	HCF F/O SENSOR Static Jam	Paper remains on the HCF F/O Sensor.	FIP 6.4
C8-6	Duplex Sensor Static JAM	Paper remains on the Duplex Sensor.	FIP 3.3
C9-3	Registration Sensor on JAM (MPF paper feed)	The Registration Sensor is not turned ON within the specified time after the MPF Feed Solenoid is ON.	FIP 1.7
E1-1	Registration Sensor off JAM (too long)	The Registration Sensor is not turned OFF within the specified time after the Registration Clutch is ON.	FIP 1.8
E1-1	Registration Sensor off JAM (too Short)	The Registration Sensor is turned OFF earlier than the specified time after the Registration Clutch is ON.	FIP 1.9
E1-2	Exit Sensor1 on JAM	The Exit Sensor1 is not turned ON within the specified time after the Registration Clutch is ON.	FIP 1.10
E1-6	Registration Sensor Static JAM	Paper remains on the Registration Sensor.	FIP 1.11
E3-1	Exit Sensor1 off JAM	The Exit Sensor1 is not turned OFF within the specified time after the Exit Sensor1 is ON.	FIP 1.12
E3-2	Exit Sensor1 off (too Short) JAM	The Exit Sensor1 is turned OFF earlier than the specified time after the Exit Sensor1 is ON.	FIP 1.13
E3-6	Exit Sensor1 Static JAM	Paper remains on the Exit Sensor1.	FIP 1.14
E4-1	Exit Sensor2 on JAM	The Exit Sensor2 is not turned ON within the specified time after the Exit Sensor1 is ON.	FIP 1.15
E4-3	Exit Sensor2 off JAM	The Exit Sensor2 is not turned OFF within the specified time after the Exit Sensor2 is ON.	FIP 1.16
E4-5	Exit Sensor2 ON, in FDT1/ Fin simp job	The Exit Sensor 2 was turned ON when the paper is delivered to the Exit 1 or Finisher.	FIP 4.1
E4-6	Exit Sensor2 Static JAM	Paper remains on the Exit Sensor2.	FIP 4.2
E8-2	Duplex Wait SENSOR ON JAM	The Duplex Wait SENSOR is not turned ON within the specified time after the Exit 2 MOTOR is ON.	FIP 3.4
F4-12	Finisher H-Transport Ent. SENSOR ON JAM	Finisher H-Transport Entrance Sensor is not turned ON within the specified time after the Exit Sensor in the IOT is ON.	FIP 5.1
F4-22	Finisher H-Transport Exit SENSOR ON JAM A	Finisher H-Transport Exit Sensor is not turned ON within the specified time after the Finisher H-Transport Entrance Sensor is ON. At this time, the Exit Sensor 1 in the IOT is On state.	FIP 5.2
F4-23	Finisher H-Transport Exit SENSOR ON JAM B	Finisher H-Transport Exit Sensor is not turned ON within the specified time after the Finisher H-Transport Entrance Sensor is ON. At this time, the Finisher H-Transport Entrance Sensor is On state.	FIP 5.2

Status Code	Error Contents	Error Description	FIP to be referred
F4-24	Finisher H-Transport Exit SENSOR ON JAM C	Finisher H-Transport Exit Sensor is not turned ON within the specified time after the Finisher H-Transport Entrance Sensor is ON.	FIP 5.2
F4-32	Finisher Transport Ent. SENSOR ON JAM	Finisher Transport Entrance Sensor is not turned ON within the specified time after the Finisher H-Transport Exit Sensor is ON.	FIP 5.3
F4-42	Finisher Buffer Path SENSOR ON JAM A	Finisher Buffer Path Sensor is not turned ON within the specified time after the Finisher Transport Entrance Sensor is ON.	FIP 5.4
F4-43	Finisher Buffer Path SENSOR ON JAM B	Finisher Buffer Path Sensor is not turned ON within the specified time after the Finisher Transport Entrance Sensor is ON. At this time, the Finisher Gate SENSOR is ON state.	FIP 5.4
F4-52	Finisher Compile Exit SENSOR ON JAM A	Finisher Buffer Path Sensor is not turned ON within the specified time after the Finisher Transport Entrance Sensor is ON. At this time, the Finisher H-Transport Exit Sensor is ON state.	FIP 5.5
F4-53	Finisher Compile Exit SENSOR ON JAM B	Finisher Buffer Path Sensor is not turned ON within the specified time after the Finisher Transport Entrance Sensor is ON. At this time, the Finisher Transport Entrance Sensor is ON state.	FIP 5.5
F4-54	Finisher Compile Exit SENSOR ON JAM C	Finisher Compile Exit Sensor is not turned ON within the specified time after the Finisher Buffer Path Sensor is ON.	FIP 5.5
F4-51	Finisher Compile Exit SENSOR OFF JAM A	Finisher Compile Exit Sensor is not turned OFF within the specified time after the Finisher Compile Exit Sensor is ON. At this time, the Finisher H-X'port Exit Sensor is ON state.	FIP 5.6
F4-55	Finisher Compile Exit SENSOR OFF JAM B	Finisher Compile Exit Sensor is not turned OFF within the specified time after the Finisher Compile Exit Sensor is ON. At this time, the Finisher X'port Entrance Sensor is ON state.	FIP 5.6
F4-61	Finisher Set Eject JAM	Finisher Compile No Paper Sensor is not turned ON within the specified time after the Eject Motor is ON.	FIP 5.7
F4-71	Finisher Top Tray Exit SENSOR ON JAM A	Top Tray Exit Sensor is not turned ON within the specified time after the Finisher X'port Entrance Sensor is ON. At this time, the Finisher H-X'port Exit Sensor is ON state.	FIP 5.8
F4-73	Finisher Top Tray Exit SENSOR ON JAM B	Top Tray Exit Sensor is not turned ON within the specified time after the Finisher Transport Entrance Sensor is ON. At this time, the Finisher H-Transport Exit Sensor is ON state.	FIP 5.8

Status Code	Error Contents	Error Description	FIP to be referred
F4-64	Finisher Top Tray Exit SENSOR ON JAM C	Top Tray Exit Sensor is not turned ON within the specified time after the Finisher Transport Entrance Sensor is ON. At this time, the Finisher H-Transport Exit Sensor is ON state.	FIP 5.8
F4-72	Finisher Top Tray Exit SENSOR OFF JAM A	Top Tray Exit Sensor is not turned OFF within the specified time after the Top Tray Exit Sensor is ON. At this time, the Finisher H-X'port Exit Sensor is ON state.	FIP 5.9
F4-75	Finisher Top Tray Exit SENSOR OFF JAM B	Top Tray Exit Sensor is not turned OFF within the specified time after the Top Tray Exit Sensor is ON. At this time, the Finisher H-X'port Exit Sensor is OFF state.	FIP 5.9
F4-82	Finisher Gate Sensor ON JAM	Finisher Gate Sensor is not turned ON within the specified time after the Finisher H-X'port Exit Sensor is ON.	FIP 5.10
F4-16	Finisher H-Transport Ent. SENSOR Static JAM A	Paper remains on the Finisher H-X'port Entrance Sensor.	FIP 5.11
F4-17	Finisher H-Transport Ent. SENSOR Static JAM B	Paper remains on the Finisher H-X'port Entrance Sensor.	FIP 5.11
F4-26	Finisher H-Transport Exit SENSOR Static JAM A	Paper remains on the Finisher H-X'port Exit Sensor.	FIP 5.12
F4-36	Finisher Transport Ent. SENSOR Static JAM A	Paper remains on the Finisher X'port Entrance Sensor. At this time, the Finisher H-X'port Exit Sensor is ON state.	FIP 5.13
F4-46	Finisher Buffer Path SENSOR Static JAM A	Paper remains on the Finisher Buffer Path Sensor. At this time, both Gate Sensor and X'port Exit Sensor are ON state.	FIP 5.14
F4-47	Finisher Buffer Path SENSOR Static JAM B	Paper remains on the Finisher Buffer Path Sensor. At this time, the Gate Sensor is ON state but the X'port Entrance Sensor is OFF state.	FIP 5.14
F4-48	Finisher Buffer Path SENSOR Static JAM C	Paper remains on the Finisher Buffer Path Sensor. At this time, the Gate Sensor is OFF state.	FIP 5.14
F4-56	Finisher Compile Exit SENSOR Static JAM	Paper remains on the Finisher Compile Exit Sensor.	FIP 5.15
F4-66	Finisher Compile No Paper SENSOR Static JAM	Paper remains on the Finisher Compile No Paper Sensor.	FIP 5.16
F4-76	Finisher Top Tray Exit SENSOR Static JAM A	Paper remains on the Finisher Top Tray Exit Sensor. At this time, the H-X'port Exit Sensor is ON state.	FIP 5.17
F4-77	Finisher Top Tray Exit SENSOR Static JAM B	Paper remains on the Finisher Top Tray Exit Sensor. At this time, the H-X'port Exit Sensor is OFF state but the Finisher X'port Entrance Sensor is ON state.	FIP 5.17

Status Code	Error Contents	Error Description	FIP to be referred
F4-78	Finisher Top Tray Exit SENSOR Static JAM C	Paper remains on the Finisher Top Tray Exit Sensor. At this time, both H-X'port Exit Sensor and Finisher X'port Entrance Sensor are OFF state.	FIP 5.17
F4-83	Finisher Gate SENSOR Static JAM (to Top Tray) A	Paper remains on the Gate Sensor when the Finisher is in the Top Tray exit mode. At this time, the H-X'port Exit Sensor is ON state.	FIP 5.18
F4-84	Finisher Gate SENSOR Static JAM (to Top Tray) B	Paper remains on the Gate Sensor when the Finisher is in the Top Tray exit mode. At this time, the X'port Entrance Sensor is ON state but the H-X'port Exit Sensor is OFF state.	FIP 5.18
F4-85	Finisher Gate SENSOR Static JAM (to Top Tray) C	Paper remains on the Gate Sensor when the Finisher is in the Top Tray exit mode. At this time, both X'port Entrance Sensor and H-X'port Exit Sensor are OFF state.	FIP 5.18
F4-86	Finisher Gate SENSOR Static JAM (to Stacker Tray) A	Paper remains on the Gate Sensor when the Finisher is in the Stacker Tray exit mode. At this time, the H-X'port Exit Sensor is ON state.	FIP 5.19
F4-87	Finisher Gate SENSOR Static JAM (to Stacker Tray) B	Paper remains on the Gate Sensor when the Finisher is in the Stacker Tray exit mode. At this time, the X'port Entrance Sensor is ON state but the H-X'port Exit Sensor is OFF state.	FIP 5.19
F4-88	Finisher Gate SENSOR Static JAM (to Stacker Tray) C	Paper remains on the Gate Sensor when the Finisher is in the Stacker Tray exit mode. At this time, both X'port Entrance Sensor and H-X'port Exit Sensor are OFF state.	FIP 5.19
H1-1	Tray1 Lift up /No tray fail	- The TRAY1 LEVEL SENSOR is not turned ON within the specified time after the TRAY1 LEVEL MOTOR is ON. - The TRAY1 SIZE SENSOR detected no tray.	FIP 1.17
H1-2	Tray2 Lift up /No tray fail	- The TRAY2 LEVEL SENSOR is not turned ON within the specified time after the TRAY2 FEED MOTOR is ON. - The TRAY2 SIZE SENSOR detected no tray.	FIP 1.18
H1-3	Tray3 Lift up /No tray fail	- The 2TM-TRAY3 LEVEL SENSOR is not turned ON within the specified time after the 2TM-TRAY3 FEED MOTOR is ON. - The 2TM-TRAY3 SIZE SENSOR detected no tray.	FIP 2.12 FIP 7.12
H1-4	Tray4 Lift up /No tray fail	- The 2TM-TRAY4 LEVEL SENSOR is not turned ON within the specified time after the 2TM-TRAY4 FEED MOTOR is ON. - The 2TM-TRAY4 SIZE SENSOR detected no tray.	FIP 2.13 FIP 7.13
H1-5	HCF Lift Up Fail	The HCF Level Sensor is not turned ON within the specified time after the HCF Feed Motor is ON.	FIP 6.5
H2-7	Duplex Module Communication fail	A communication error occurred between the PWBA MCU F and the Duplex Module.	FIP 3.5
H2-8	DUP MODULE Type fail	A DUP MODULE of a different specification is installed.	FIP 3.6

Status Code	Error Contents	Error Description	FIP to be referred
H3-2	OCT2 fail	The OCT2 HOME POSITION SENSOR is not turned ON within the specified time after the OCT2 Motor is ON.	FIP 4.3
H3-7	Exit Module Communication fail	A communication error occurred between the PWBA MCU F and the PWBA EXIT.	FIP 1.19
H4-1	Tray 1 cassette Size fail	Although the Tray 1 is set in the printer, the paper size is not detected correctly.	FIP 1.20
H4-2	Tray 2 cassette Size fail	Although the Tray 2 is set in the printer, the paper size is not detected correctly.	FIP 1.21
H4-3	Tray 3 cassette Size fail	Although the Tray 3 is set in the 2TM, the paper size is not detected correctly.	FIP 2.14 FIP 7.14
H4-4	Tray 4 cassette Size fail	Although the Tray 4 is set in the 2TM, the paper size is not detected correctly.	FIP 2.15 FIP 7.15
H5-11	Stacker Tray Fail	The Stacker Height Sensor is not turned ON within the specified period after the Stacker Tray starts rising.	FIP 5.20
H5-12	Stacker Tray Upper Limit Fail	The Stacker Tray abnormally rises beyond the specified upper limit position (Stacker Height).	FIP 5.21
H5-13	Stacker Tray Lower Limit Fail	The Stacker Tray abnormally lowers beyond the specified lower limit position (Full Stack).	FIP 5.22
H5-21	Front Tamper Home SENSOR ON Fail	The Front Tamper Home Sensor is not turned ON within 800 ms after the Front Tamper starts moving to the Front Tamper Home position.	FIP 5.23
H5-22	Rear Tamper Home SENSOR ON Fail	The Rear Tamper Home Sensor is not turned ON within 800 ms after the Rear Tamper starts moving to the Rear Tamper Home position.	FIP 5.24
H5-23	Front Tamper Home SENSOR OFF Fail	The Front Tamper Home Sensor is not turned OFF within the specified time after the Front Tamper starts leaving from the Front Tamper Home position. Or the Front Tamper Home Sensor is turned ON again after the Front Tamper Home Sensor is turned OFF and the Front Tamper stopped its moving.	FIP 5.25
H5-24	Rear Tamper Home SENSOR OFF Fail	The Rear Tamper Home Sensor is not turned OFF within the specified time after the Rear Tamper starts leaving from the Rear Tamper Home position. Or the Rear Tamper Home Sensor is turned ON again after the Rear Tamper Home Sensor is turned OFF and the Rear Tamper stopped its moving.	FIP 5.26
H5-31	Puncher SENSOR ON Fail	The Puncher Home Sensor is not turned ON even when the specified time passed after the Puncher Motor is ON.	FIP 5.27
H5-32	Puncher SENSOR OFF Fail	The Puncher Home Sensor is not turned OFF even when the specified time passed after the Puncher Motor is ON.	FIP 5.28

Status Code	Error Contents	Error Description	FIP to be referred
H5-33	Puncher Move Home SENSOR ON Fail	The Puncher Move Home Sensor is not turned ON even when the specified time passed after the Puncher Move Motor is ON. Or the Puncher Move Home Sensor is turned OFF again after the Puncher Move Home Sensor is turned ON and the Puncher Move Motor stopped its rotation.	FIP 5.29
H5-34	Puncher Move Home SENSOR OFF Fail	The Puncher Move Home Sensor is not turned OFF even when the specified time passed after the Puncher Move Motor is ON. Or the Puncher Move Home Sensor is turned ON again after the Puncher Move Home Sensor is turned OFF and the Puncher Move Motor stopped its rotation.	FIP 5.30
H5-81	Eject Clamp Home SENSOR ON Fail	The Eject Clamp Home Sensor is not turned ON within 500 ms after the Eject Clamp Up starts.	FIP 5.31
H5-82	Eject Clamp Home SENSOR OFF Fail	The Eject Clamp Home Sensor is not turned OFF within 200 ms after the Eject Clamp Down starts.	FIP 5.32
H5-83	Set Clamp Home SENSOR ON Fail	The Set Clamp Home Sensor is not turned ON within 200 ms after the Set Clamp starts operating.	FIP 5.33
H5-84	Set Clamp Home SENSOR OFF Fail	The Set Clamp Home Sensor is not turned OFF within the specified time after the Set Clamp ends operating.	FIP 5.34
H5-86	Side Registration Sensor OFF Fail	The Side Registration Sensor is not turned OFF within 500 ms after the Puncher Move Motor is ON. Or the Side Registration Sensor is turned ON again after the Side Registration Sensor is turned OFF and the Puncher stopped its moving. Or the Or the Side Registration Sensor1 or the Side Registration Sensor2 to be targeted is not turned OFF when the Puncher Move Motor starts operating.	FIP 5.35
H5-91	Stapler Fail	The OFF-ON status of the Stapler Home Sensor is not detected within the specified time after the Stapler Move Motor is ON (Forward operation). Or the Stapler Home Sensor is not turned ON within the specified timer after the Stapler Move Motor is ON (Reverse operation).	FIP 5.36
H5-95	Stapler Move Position SENSOR ON Fail	The Staple Move Position Sensor is not turned ON within two seconds after the Stapler starts moving toward the Staple position and also the Staple Move Position Sensor is OFF. Or the Staple Move Position Sensor is not turned ON after the Stapler was moved to the Staple position. Or the Stapler Move Position Sensor is turned OFF again after the Stapler Move Position Sensor is turned ON and the Stapler stopped its moving.	FIP 5.37

Status Code	Error Contents	Error Description	FIP to be referred
H5-96	Stapler Move Position SENSOR OFF Fail	The Staple Move Position Sensor is not turned OFF within 500 ms after Stapler starts moving to the Staple Position and Staple Move Position Sensor is OFF. Or the Staple Move Position Sensor is not turned OFF after the Stapler was moved to the Staple position. Or the Stapler Move Position Sensor is turned ON again after the Stapler Move Position Sensor is turned OFF and the Stapler stopped its moving.	FIP 5.38
H5-4	Finisher NVM R/W error	A read/write error occurred on the NVM of the PWB MAIN-C.	FIP 5.39
H5-7	MCU-Finisher comm. error	A communication error occurred between the PWBA MCU F and the Finisher.	FIP 5.40
H5-8	Finisher type error	A different type of Finisher is connected.	FIP 5.41
H6-4	HCF NVM R/W Error	A read/write error has occurred on the NVM of the HCF PWB.	FIP 6.6
H6-7	HCF NVM R/W Error	A communication error occurred between the PWBA MCU F and the HCF.	FIP 6.7
H7-3	Tray Module NVM out-of-order	A data error of the NVM on the TM PWB occurred.	FIP 2.16 FIP 7.16
H7-4	Tray Module NVM R/W error	Read/write of the NVM on the TM PWB failed.	FIP 2.17 FIP 7.17
H7-7	Tray Module Communication fail	A communication error occurred between the PWBA MCU F and the TM PWB.	FIP 2.18 FIP 7.18
H7-8	TM type error	An tray module of a different specification is connected.	FIP 2.19 FIP 7.19
H8-3	Tray3 Size sensor broken	Tray3 Size sensor is not detected.	FIP 2.20 FIP 7.20
H8-4	Tray4 Size sensor broken	Tray4 Size sensor is not detected.	FIP 2.21 FIP 7.21
J1-2	Toner Cartridge Empty fail	All toner in the Toner cartridge is consumed.	FIP 1.22
J3-1	XERO/DEVE Cartridge Set fail	The XERO/DEVE Cartridge is not installed.	FIP 1.23
J4-1	ATC Sensor fail	The ATC Sensor broke.	FIP 1.24
J6-1	XERO/DEVE Cartridge Life Over	The XERO/DEVE Cartridge needs to be replaced.	FIP 1.25
J7-1	XERO/DEVE Cartridge CRUM Communication fail	A communication error occurred between the XERO CRUM Tag in the XERO/DEVE Cartridge and the CRUM ASIC on the PWBA MCU F.	FIP 1.26
J7-2	XERO/DEVE Cartridge CRUM Data Write fail	A write error occurred on the XERO CRUM Tag in the XERO/DEVE Cartridge.	FIP 1.27
J7-3	XERO/DEVE Cartridge CRUM ID fail	A XERO/DEVE Cartridge of a different specification is attached.	FIP 1.28
J8-1	Toner Cartridge CRUM Communication fail	A communication error occurred between the Toner CRUM Tag in the Toner Cartridge and the CRUM ASIC on the PWBA MCU F.	FIP 1.29
J8-2	MCU Toner Cartridge CRUM Data Write fail	A data write error occurred on the XERO CRUM Tag in the Toner Cartridge.	FIP 1.30
J8-3	Toner Cartridge CRUM ID fail	A Toner Cartridge of a different specification is attached.	FIP 1.31



Status Code	Error Contents	Error Description	FIP to be referred
U0-1	Main Motor stop error	Due to the malfunction in the control system of the PWBA MCU F, the Main Motor does not stop when paper is not transported.	FIP 1.32
U0-2	Image Ready error	The PWBA MCU F does not receive the image-ready signal from the PWBA ESS at the specified timing.	FIP 1.33
U1-1	Main Motor fail	The Main Motor does not rotate at the specified speed.	FIP 1.34
U1-4	Drum Motor fail	The Drum Motor does not rotate at the specified speed.	FIP 1.35
U3-3	Laser Power fail	Light intensity of the LD2 is less than the specified value.	FIP 1.36
U3-5	ROS Motor fail	- Rotation speed of the ROS motor is less than the specified value even when the specified time is passed after the motor starts rotating. - Light intensity of the LD1 is less than the specified value.	FIP 1.37
U4-1	Fuser On Time fail	- During the Warm-Up period, the Control Thermistor does not detect the Ready temperature even when the specified time is passed after the Main Lamp is ON. - During the Standby period, the Control Thermistor does not detect the specified temperature even when the specified time is passed after the Main Lamp is ON. - During the Standby period, the Control Thermistor does not detect the specified temperature even when the specified time is passed after the Sub Lamp is ON. - During idling after power-on, the Control Thermistor does not detect the idling stop temperature even after the specified time is passed. - During print, the Control Thermistor does not detect the specified temperature even when the specified time is passed after the Main Lamp is ON. - During print, the Control Thermistor does not detect the specified temperature even when the specified time is passed after the Sub Lamp is ON.	FIP 1.38
U4-2	Over Heat Temp fail	- The Control Thermistor detects a temperature higher than the specified value. - The Lamp Change Thermistor detects a temperature higher than the specified value.	FIP 1.39
U4-3	Center STS fail	The Center STS broke.	FIP 1.40
U4-4	REAR STS fail	The REAR STS broke.	FIP 1.41
U4-5	P/R STS fail	The P/R STS broke.	FIP 1.42
U4-7	Cold-Sagging recovery fail	The Center STS/FS1 detects that it does not recover from Cold-Sagging after the specified time is passed.	FIP 1.43
U4-8	Hot-Sagging recovery fail	The Center STS/FS1 detects that it does not recover from Hot-Sagging after the specified time is passed.	FIP 1.44

Status Code	Error Contents	Error Description	FIP to be referred
U4-9	Fuser Fan fail	The Fuser Fan broke.	FIP 1.45
U5-1	Dispense Motor fail	The toner concentration in the XERO/DEVE Cartridge does not increase even when the Dispense Motor is turned ON for more than the specified time.	FIP 1.46
U6-2	RAM read/write Check fail	Read/write of RAM on the PWBA MCU F failed.	FIP 1.47
U6-3	NVM data defect	A data error of NVM on the PWBA MCU F occurred.	FIP 1.48
U6-4	NVM read/write cannot be executed	Read/write of the NVM on the PWBA MCU F failed.	FIP 1.49
U6-5	CPU Power to access NVM is not enough	An internal process for data write of the NVM on the PWBA MCU F failed.	FIP 1.50
U6-6	CRUM ASIC fail	The CRUM control circuit broke.	FIP 1.51
U6-7	The PPM information is defect	An incorrect NVM data is saved on the PPM.	FIP 1.52
H5-9	CRU Fan defect	A defect in the CRU FAN was detected.	FIP 1.53
H3-1	OCT1 Defect	The OCT1 HOME POSITION SENSOR is not turned ON within the specified period after the OCT1 Motor is ON.	FIP 1.54
H8-1	Tray1 Size sensor broken	Tray1 Size sensor is not detected.	FIP 1.55
H8-2	Tray1 Size sensor broken	Tray2 Size sensor is not detected.	FIP 1.56
	L/H Cover Assembly open	The L/H Cover Assembly is open.	FIP 1.57
	IOT Front Cover open	The IOT Front Cover is open.	FIP 1.58
	L/H-L Cover open	The L/H Lower Cover is open.	FIP 1.59
	L/H-H Cover Open	The CHUTE LH HIGH is open	FIP 4.4
	TM Cover open	The 2TM Cover is open.	FIP 2.22 FIP 7.22
	DUP Cover open	The Duplex Cover is open.	FIP 3.7
	Toner Cartridge was PRE-NEAR empty	Although the toner in the Toner Cartridge have only a little amount left, it can still be used.	FIP 1.60
	Drum life was near to end	The XERO/DEVE Cartridge needs to be replaced soon.	FIP 1.61
	No paper in the select paper tray	Paper is not loaded in the tray.	FIP 1.62 FIP 2.23 FIP 7.23
	Paper size mismatch in width	The paper width is inappropriate.	FIP 1.63 FIP 2.24 FIP 7.24
	Tray 1 Paper size mismatch in length	The paper length detected by the Registration Sensor after the paper is fed from the Tray 1 does not match the length detected by the Tray 1 Size Switch.	FIP 1.64
	Tray 2 Paper size mismatch in length	The paper length detected by the Registration Sensor after the paper is fed from the Tray 2, does not match the length detected by the Tray 2 Size Switch.	FIP 1.65
	Tray 3 Paper size mismatch in length	The paper length detected by the Registration Sensor after the paper is fed from the Tray 3, does not match the length detected by the Tray 3 Size Switch.	FIP 2.25 FIP 7.25

Status Code	Error Contents	Error Description	FIP to be referred
	Tray 4 Paper size mismatch in length	The paper length detected by the Registration Sensor after the paper is fed from the Tray 4, does not match the length detected by the Tray 4 Size Switch.	FIP 2.26 FIP 7.26
	Face Down Tray1 FULL	Paper in the Face Down Tray1 stacks over.	FIP 1.66
	Face Down Tray2 FULL	Paper in the Face Down Tray2 stacks over.	FIP 1.67
	Temperature SENSOR fail	The Sensor HUM & TE detected an abnormal temperature.	FIP 1.68
	Humidity SENSOR fail	The Sensor HUM & TE detected an abnormal humidity.	FIP 1.69
	Stacker Tray Full (No Mix): Finisher	When the stack of the Finisher Stacker Tray reaches the specified value (same paper size).	FIP 5.42
	Stacker Tray Full (Mix size): Finisher	When the stack of the Finisher Stacker Tray reaches the specified value (mixed paper size).	FIP 5.43
	Finisher Top Tray Full	When the stack of the Finisher Top Tray reaches the specified value.	FIP 5.44
	Staple Pin Empty	Staple Pin reaches near end. Or the cartridge is not installed.	FIP 5.45
	Staple Pin Not Ready	When the Staple Pin does not reach the Stapler head end position.	FIP 5.46
	Staple NG: Finisher	The OFF-ON status of the Staple Home Sensor is not detected within the specified time after the Stapler Move Motor is ON (Forward operation). The Staple Home Sensor is not turned ON within the specified time after the Stapler Move Motor is ON (Reverse operation).	FIP 5.47
	Stacker Lower Safety: Finisher	The Stacker No Paper Sensor is not turned ON within the specified time after the Stacker Motor is ON (lowering). The Stacker No Paper Sensor is not turned OFF within the specified time after the Stacker Motor is ON (lowering).	FIP 5.48
	Stacker Set Over Count: Finisher	When the stapled paper exceeds the specified value be able to stack on the Stacker Tray.	FIP 5.49
	Punch waste box overflow: Finisher	The Punch Dust Box is filled.	FIP 5.50
	No Punch waste Box	Punch Dust Box is open.	FIP 5.51
	Finisher Front Cover Open	he Finisher Front Cover is open.	FIP 5.52
	Finisher H-X'port Cover Open	Finisher H-X'port Cover is open.	FIP 5.53
	Finisher Eject Cover Open	The Finisher Eject Cover is open.	FIP 5.54
	HCF Top Cover Open	The HCF Top Cover is open.	FIP 6.8
	HCF Home Position S/W Open	The HCF is not placed in the Home Position.	FIP 6.9

# Error Code FIP

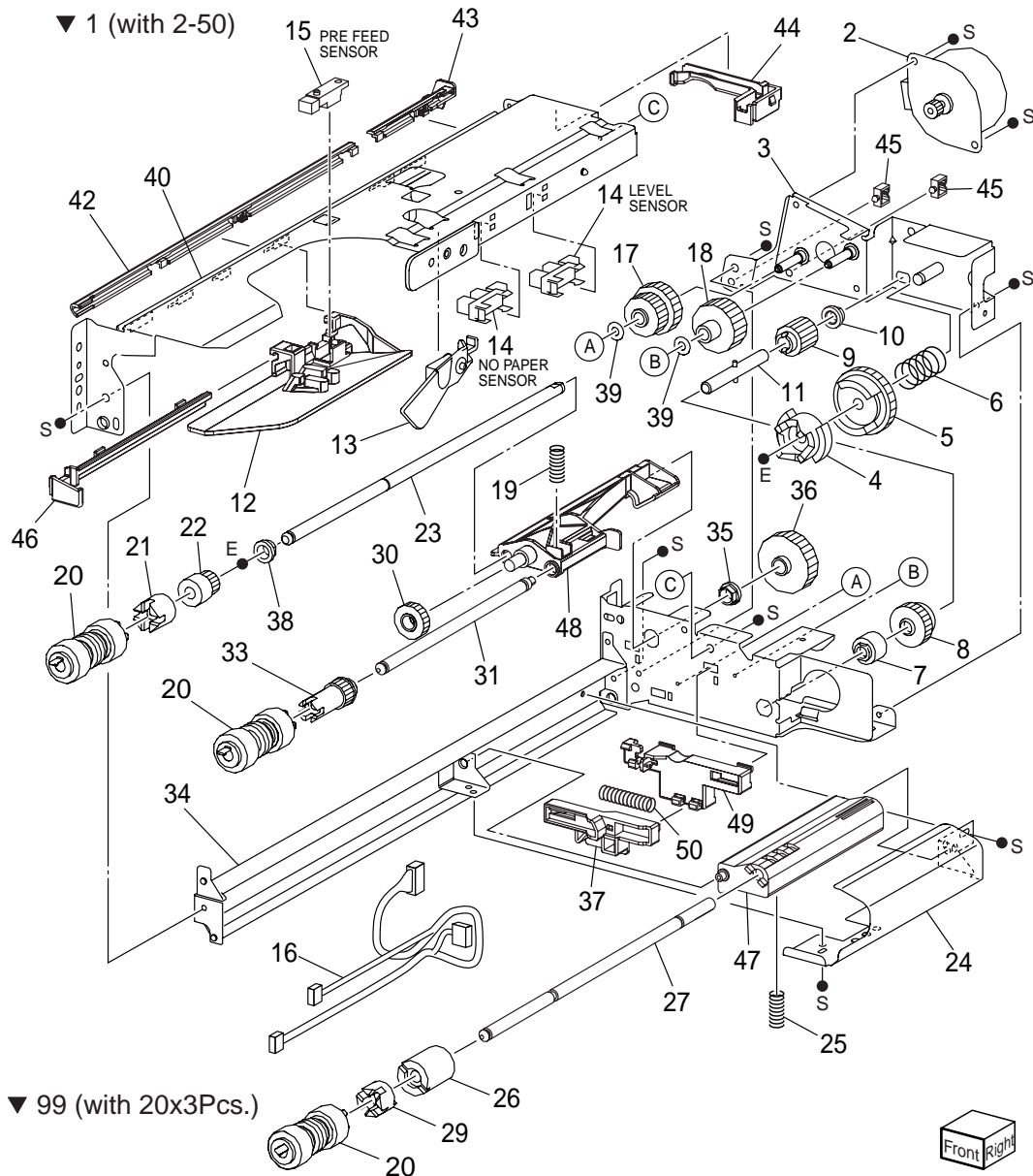
## Prefeed SENSOR #1 on JAM (Tray 1 paper feed)

Step	Check	Yes	No
	Possible causative parts: ROLLER ASSY (FEED) (PL 2.3.20) ROLLER ASSY (RETARD) (PL 2.3.28) ROLLER ASSY (NUDGER) (PL 2.3.32) TRAY 1/2 FEED LIFT UP MOTOR (PL 2.3.2) SENSOR (PRE FEED SENSOR) (PL 2.3.15) PWBA MCU F (PL 8.1.5)		
1	Checking paper condition Is the paper in the tray crumpled or damaged?	Replace the paper with a new and dry one.	Go to step 2.
2	Checking paper size setup Does the paper size in use match the size set for the TRAY1?	Go to step 3.	Replace the paper, or change the paper size setup.
3	Checking the Rollers for the TRAY1 Is the ROLLER ASSY (FEED), ROLLER ASSY (RETARD) or ROLLER ASSY (NUDGER) for transport worn and/or contaminated with paper dust? Pull out the TRAY1 and check it.	Go to step 4.	Clean or replace the ROLLER ASSY (FEED), ROLLER ASSY (RETARD) or ROLLER ASSY (NUDGER). (RRP 2.21/RRP 2.25/RRP 2.28)
4	Checking paper position Does the paper touch the SENSOR (PRE FEED SENSOR) in the FEEDER ASSY (FEEDER 1) (PL 2.1.7)? Open the COVER ASSY-LH (PL 4.2.8) and check it (visual check).	Remove the paper.	Go to step 5.
5	Checking the SENSOR (PRE FEED SENSOR) for the TRAY1 for operation Does the Input Status change from "0x0" to "0x1" each time the paper touches the SENSOR (PRE FEED SENSOR) for the TRAY1? Execute [Input 08-58 PreFEED SENSOR1] in Chapter 2 [Diagnostic]. Open the COVER ASSY-LH (PL 4.2.8) and check it.	Go to step 9.	Go to step 6.
6	Checking the SENSOR (PRE FEED SENSOR) for the TRAY1 for connection Are P/J133, P/J601 and P/J409A connected surely?	Go to step 7.	Connect P/J133, P/J601 and P/J409A surely.
7	Checking conductivity between the SENSOR (PRE FEED SENSOR) for the TRAY1 and the PWBA MCU F Is there conductivity on each wire between P/J133 <=> P/J409A?	Go to step 8.	Fix open and short circuit.

## PL 14.5 Feeder (2/3)

Item	Part Name	Remarks
1	TRAY 3 FEEDER (PL.6.1)	
2	COVER	
3	TAKEAWAY ROLL ASSEMBLY	
4	BEARING	
5	COVER	
6	CHUTE	
7	WIRE HARNESS	J821, J841
8	TRAY 3 FEED OUT SENSOR	
9	LOWER CHUTE	
10	CHUTE ASSY FEEDER 2 (with 11, 12)	
11	CHUTE FEED OUT	
12	PAD ASSY LH LOW	

## PL 14.6 Feeder (3/3) illustration



Step	Check	Yes	No
1	Checking paper condition Is the paper in the tray crumpled or damaged?	Replace the paper with a new and dry one.	Go to step 2.
2	Checking paper size setup Does the size of paper in use match the size set for the TRAY1?	Go to step 3.	Replace the paper or change the paper size setup.
3	Checking the Roll for the TRAY1 Is the ROLLER ASSY (FEED), ROLLER ASSY (RETARD) or ROLLER ASSY (NUDGER) for transport worn or contaminated with paper dust? Pull out the TRAY1 and check it.	Go to step 4.	Clean or replace the ROLLER ASSY (FEED), ROLLER ASSY (RETARD) or ROLLER ASSY (NUDGER). (RRP 2.21/RRP 2.25/RRP 2.28)
4	Checking paper position Does the paper touch the SENSOR ASSY REGI or the SENSOR (PRE FEED SENSOR) in the FEEDER ASSY (FEEDER 1) (PL 2.1.7)? Open the COVER ASSY-LH (PL 4.2.8) and check it (visual check).	Remove the paper.	Go to step 5.
5	Checking the SENSOR ASSY REGI for operation Does the Input Status change from "0x0" to "0x1" each time the paper touches the SENSOR ASSY REGI? Execute [Input 08-05 REGI SENSOR] in Chapter 2 [Diagnostic]. Open the COVER ASSY-LH (PL 4.2.8) and check it.	Go to step 9.	Go to step 6.
6	Checking the SENSOR ASSY REGI for connection Are P/J104 and P/J403B connected surely?	Go to step 7.	Connect P/J104 and P/J403B surely.
7	Checking conductivity between the SENSOR ASSY REGI and the PWBA MCU F Is there conductivity on each wire between P/J104 <=> P/J409B?	Go to step 8.	Fix open and short circuit.
8	Checking +5 VDC power supply to the SENSOR ASSY REGI Is the voltage across J104-1 (+) <=> ground +5 VDC?	Replace the SENSOR ASSY REGI. (RRP 4.13)	Replace the PWBA MCU F. (RRP 8.4)
9	Checking the SENSOR (PRE FEED SENSOR) for operation Does the Input Status change from "0x0" to "0x1" each time the paper touches the SENSOR (PRE FEED SENSOR)? Execute [Input 08-58 PreFEED SENSOR1] in Chapter 2 [Diagnostic]. Open the COVER ASSY-LH (PL 4.2.8) and check it.	Reconnect the connector on the PWBA MCU F.	Go to step 10.
10	Checking the SENSOR (PRE FEED SENSOR) for the TRAY1 for connection Are P/J133, P/J601 and P/J409A connected surely?	Go to step 11.	Connect P/J133, P/J601 and P/J409A surely.

Step	Check	Yes	No
11	Checking conductivity between the SENSOR (PRE FEED SENSOR) for the TRAY1 and the PWBA MCU F Is there conductivity on each wire between P/J133 <=> P/J409A?	Go to step 12.	Fix open and short circuit.
12	Checking +5 VDC power supply to SENSOR (PRE FEED SENSOR) for the TRAY1 Is the voltage across J133-1 (+) <=> ground +5 VDC?	Replace the SENSOR (PRE FEED SENSOR) for the TRAY1. (RRP 2.18)	Replace the PWBA MCU F. (RRP 8.4)

### Prefeed Sensor #2 on JAM (Tray 2 paper feed)

Step	Check	Yes	No
	Possible causative parts: ROLLER ASSY (FEED) (PL 2.3.20) ROLLER ASSY (RETARD) (PL 2.3.28) ROLLER ASSY (NUDGER) (PL 2.3.32) TRAY 1/2 FEED LIFT UP MOTOR (PL 2.3.2) SENSOR (PRE FEED SENSOR) (PL 2.3.15) PWBA MCU F (PL 8.1.5)		
1	Checking paper condition Is the paper in the tray crumpled or damaged?	Replace the paper with new and dry one.	Go to step 2.
2	Checking paper size setup Does the paper size in use match the size set for the TRAY2?	Go to step 3.	Replace the paper or change the paper size setup.
3	Checking the Roll for the TRAY2 Is the ROLLER ASSY (FEED), ROLLER ASSY (RETARD) or ROLLER ASSY (NUDGER) worn or contaminated with paper dust? Pull out the TRAY2 and check it.	Go to step 4.	Clean or replace the ROLLER ASSY (FEED), ROLLER ASSY (RETARD) or ROLLER ASSY (NUDGER). (RRP 2.21/RRP 2.25/RRP 2.28)
4	Checking paper position Does the paper touch the SENSOR (PRE FEED SENSOR) in the FEEDER ASSY (FEEDER 2) (PL 2.1.8)? Open the COVER ASSY-LH LOW C (PL 4.1.10) and check it (visual check).	Remove the paper.	Go to step 5.

Step	Check	Yes	No
5	Checking the SENSOR (PRE FEED SENSOR) for the TRAY2 for operation Does the Input Status change from "0x0" to "0x1" each time the paper touches the SENSOR (PRE FEED SENSOR) for the TRAY2? Execute [Input 08-59 PreFEED SENSOR2] in Chapter 2 [Diagnostic]. Open the COVER ASSY-LH LOW C (PL 4.1.10) and check it.	Go to step 9.	Go to step 6.
6	Checking the SENSOR (PRE FEED SENSOR) for the TRAY2 for connection Are P/J134, P/J602 and P/J409B connected surely?	Go to step 7.	Connect P/J134, P/J602 and P/J409B surely.
7	Checking conductivity between the SENSOR (PRE FEED SENSOR) for the TRAY2 and the PWBA MCU F Is there conductivity on each wire between P/J134 <=> P/J409B?	Go to step 8.	Fix open and short circuit.
8	Checking +5 VDC power supply to the SENSOR (PRE FEED SENSOR) for the TRAY2 Is the voltage across J134-1 (+) <=> ground +5 VDC?	Replace the SENSOR (PRE FEED SENSOR) for the TRAY2. (RRP 2.18)	Replace the PWBA MCU F. (RRP 8.4)
9	Checking the TRAY 1/2 FEED LIFT UP MOTOR for the TRAY2 for operation (1) Does the TRAY 1/2 FEED LIFT UP MOTOR for the TRAY2 operate properly? Execute [Output 08-13 TRAY2 FEED MOTOR] in Chapter 2 [Diagnostic]. Pull out the TRAY1 and check it.	Reconnect the connector on the PWBA MCU F.	Go to step 10.
10	Checking the TRAY 1/2 FEED LIFT UP MOTOR for the TRAY2 for connection Are P/J202, P/J602 and P/J409B connected surely?	Go to step 11.	Connect P/J202, P/J602 and P/J409B surely.
11	Checking the TRAY 1/2 FEED LIFT UP MOTOR for the TRAY2 for operation (2) Replace the TRAY 1/2 FEED LIFT UP MOTOR for the TRAY2 with that for the TRAY1. Does the replaced motor operate properly? Execute [Output 08-13 TRAY2 FEED MOTOR] in Chapter 2 [Diagnostic]. Pull out the TRAY2 and check it.	Reinstall the TRAY 1/2 FEED LIFT UP MOTOR for the TRAY1 as it previously was and replace the motor for the TRAY2 with a new one. (RRP 2.9)	Go to step 12.
12	Checking the TRAY 1/2 FEED LIFT UP MOTOR for the TRAY2 for conductivity Reinstall the TRAY 1/2 FEED LIFT UP MOTORS for the TRAY1 and TRAY2 as they previously were. Is there conductivity on each wire between P/J202 <=> P/J409B?	Go to step 13.	Fix open and short circuit.



Step	Check	Yes	No
13	Checking +24 VDC power supply to the TRAY 1/2 FEED LIFT UP MOTOR for the TRAY2 Is the voltage across J201-4 (+) <=> ground +24 VDC?	Replace the TRAY 1/2 FEED LIFT UP MOTOR for the TRAY2. (RRP 2.9)	Replace the PWBA MCU F. (RRP 8.4)

### Tray 2 Feed Out Sensor on JAM (Tray 2 paper feed)

Step	Check	Yes	No
	Possible causative parts: ROLLER ASSY (FEED) (PL 2.3.20) ROLLER ASSY (RETARD) (PL 2.3.28) ROLLER ASSY (NUDGER) (PL 2.3.32) SENSOR (PRE FEED SENSOR) (PL 2.3.15) SENSOR (PL 4.5.18) PWBA MCU F (PL 8.1.5)		
1	Checking paper condition Is the paper in the tray crumpled or damaged?	Replace the paper with a new and dry one.	Go to step 2.
2	Checking paper size setup Does the paper size in use match the size set for the TRAY2?	Go to step 3.	Replace the paper, or change the paper size setup.
3	Checking the Roll for the TRAY2 Is the ROLLER ASSY (FEED), ROLLER ASSY (RETARD) or ROLLER ASSY (NUDGER) for transport worn or contaminated with paper dust? Pull out the TRAY2 and check it.	Go to step 4.	Clean or replace the ROLLER ASSY (FEED), ROLLER ASSY (RETARD) or ROLLER ASSY (NUDGER). (RRP 2.21/RRP 2.25/RRP 2.28)
4	Checking paper position Does the paper touch the SENSOR or the FEEDER ASSY (FEEDER 2) (PL 2.1.8)? Open the COVER ASSY LH LOW C (PL 4.1.10) and check it (visual check).	Remove the paper.	Go to step 5.
5	Checking the SENSOR for operation Does the Input Status change from "0x0" to "0x1" each time the paper touches the SENSOR? Execute [Input 08-06 FEED OUT#2 SENSOR] in Chapter 2 [Diagnostic]. Open the COVER ASSY LH LOW C (PL 4.1.10) and check it.	Go to step 9.	Go to step 6.
6	Checking the SENSOR for connection Are P/J105, P/J608 and P/J410 connected surely?	Go to step 7.	Connect P/J105, P/J608 and P/J410 securely

Step	Check	Yes	No
7	Checking conductivity between the SENSOR and the PWBA MCU F Is there conductivity on each wire between P/J105 <=> P/J410?	Go to step 8.	Fix open and short circuit.
8	Checking +5 VDC power supply to the SENSOR Is the voltage across J105-1 (+) <=> ground +5 VDC?	Replace the SENSOR. (RRP 4.15)	Replace the PWBA MCU F. (RRP 8.4)
9	Checking the SENSOR (PRE FEED SENSOR) for the TRAY2 for operation Does the Input Status change from "0x0" to "0x1" each time the paper touches the SENSOR (PRE FEED SENSOR) for the TRAY2? Execute [Input 08-59 PreFEED SENSOR2] in Chapter 2 [Diagnostic]. Open the COVER ASSY LH LOW C (PL 4.1.10) and check it.	Reconnect the connector on the PWBA MCU F.	Go to step 10.
10	Checking the SENSOR (PRE FEED SENSOR) for the TRAY2 for connection Are P/J134, P/J602 and P/J409B connected surely?	Go to step 11.	Connect P/J134, P/J602 and P/J409B surely.
11	Checking conductivity between the SENSOR (PRE FEED SENSOR) for the TRAY2 and the PWBA MCU F Is there conductivity on each wire between P/J134 <=> P/J409B?	Go to step 12.	Fix open and short circuit.
12	Checking +5 VDC power supply to the SENSOR (PRE FEED SENSOR) for the TRAY2 Is the voltage across J134-1 (+) <=> ground +5 VDC?	Replace the SENSOR (PRE FEED SENSOR) for the TRAY2. (RRP 2.18)	Replace the PWBA MCU F. (RRP 8.4)

### Registration Sensor on JAM (Tray 2 paper feed)

Step	Check	Yes	No
	Possible causative parts: ROLLER ASSY (FEED) (PL 2.3.20) ROLLER ASSY (RETARD) (PL 2.3.28) ROLLER ASSY (NUDGER) (PL 2.3.32) SENSOR (PL 4.5.18) SENSOR ASSY REGI (PL 4.5.7) PWBA MCU F (PL 8.1.5)		
1	Checking paper condition Is the paper in the tray crumpled or damaged?	Replace the paper with a new and dry one.	Go to step 2.
2	Checking paper size setup Does the size of paper in use match the size set for the TRAY2?	Go to step 3.	Replace the paper or change the paper size setup.

Step	Check	Yes	No
3	Checking the Roll for the TRAY2 Is the ROLLER ASSY (FEED), ROLLER ASSY (RETARD) or ROLLER ASSY (NUDGER) for transport worn or contaminated with paper dust? Pull out the TRAY2 and check it.	Go to step 4.	Clean or replace the ROLLER ASSY (FEED), ROLLER ASSY (RETARD) or ROLLER ASSY (NUDGER). (RRP 2.21/RRP 2.25/RRP 2.28)
4	Checking paper position (1) Does the paper touch the SENSOR ASSY REGI? Open the COVER ASSY-LH (PL 4.2.8) and check it (visual check).	Remove the paper.	Go to step 5.
5	Checking paper position (2) Does the paper touch the SENSOR? Open the COVER ASSY LH LOW C (PL 4.1.10) and check it (visual check).	Remove the paper.	Go to step 6.
6	Checking the SENSOR ASSY REGI for operation Does the Input Status change from "0x0" to "0x1" each time the paper touches the SENSOR ASSY REGI? Execute [Input 08-05 REGI SENSOR] in Chapter 2 [Diagnostic]. Open the COVER ASSY-LH (PL 4.2.8) and check it.	Go to step 10.	Go to step 7.
7	Checking the SENSOR ASSY REGI for connection Are P/J104 and P/J403B connected surely?	Go to step 8.	Connect P/J104 and P/J403B surely.
8	Checking conductivity between the SENSOR ASSY REGI and the PWBA MCU F Is there conductivity on each wire between P/J104 <=> P/J409B?	Go to step 9.	Fix open and short circuit.
9	Checking +5 VDC power supply to the SENSOR ASSY REGI Is the voltage across J104-1 (+) <=> ground +5 VDC?	Replace the SENSOR ASSY REGI. (RRP 4.13)	Replace the PWBA MCU F. (RRP 8.4)
10	Checking the SENSOR for operation Does the Input Status change from "0x0" to "0x1" each time the paper touches the SENSOR? Execute [Input 08-06 FEED OUT#2 SENSOR] in Chapter 2 [Diagnostic]. Open the COVER ASSY LH LOW C (PL 4.1.10) and check it.	Reconnect the connector on the PWBA MCU F.	Go to step 11.
11	Checking the SENSOR for connection Are P/J105, P/J608 and P/J410 connected surely?	Go to step 12.	Connect P/J105, P/J608 and P/J410 surely.
12	Checking conductivity between the SENSOR and the PWBA MCU F Is there conductivity on each wire between P/J105 <=> P/J410?	Go to step 13.	Fix open and short circuit.

Step	Check	Yes	No
13	Checking +5 VDC power supply to the SENSOR Is the voltage across J105-1 (+) <=> ground +5 VDC?	Replace the SENSOR. (RRP 4.15)	Replace the PWBA MCU F. (RRP 8.4)

## Tray 2 Feed Out Sensor Static JAM

Step	Check	Yes	No
	Possible causative parts: SENSOR (PL 4.5.18) PWBA MCU F (PL 8.1.5)		
1	Checking paper position Does the paper touch the SENSOR? Open the COVER ASSY LH LOW C (PL 4.1.10) and check it (visual check).	Remove the paper.	Go to step 2.
2	Checking the SENSOR for operation Does the Input Status change from "0x0" to "0x1" each time the paper touches the SENSOR? Execute [Input 08-06 FEED OUT#2 SENSOR] in Chapter 2 [Diagnostic]. Open the COVER ASSY LH LOW C (PL 4.1.10) and check it.	Go to step 6.	Go to step 3.
3	Checking the SENSOR for connection Are P/J105, P/J608 and P/J410 connected surely?	Go to step 4.	Connect P/J105, P/J608 and P/J410 surely.
4	Checking conductivity between the SENSOR and the PWBA MCU F Is there conductivity on each wire between P/J105 <=> P/J410?	Go to step 5.	Fix open and short circuit.
5	Checking +5 VDC power supply to the SENSOR Is the voltage across J105-1 (+) <=> ground +5 VDC?	Replace the SENSOR. (RRP 4.15)	Replace the PWBA MCU F. (RRP 8.4)
6	Checking the TRAY Are the SECTOR GEAR (60T) of TRAY2 or the surrounding parts of it damaged?	Replace the SECTOR GEAR (60T) (RRP 2.8) or the obstacle parts.	Replace the TRAY2.

## Registration Sensor on JAM (MPF paper feed)

Step	Check	Yes	No
	Possible causative parts: ROLLER ASSY-FEED (PL 3.2.20) ROLL ASSY-DRIVE (PL 3.2.14) SENSOR ASSY REGI (PL 4.5.7) SOLENOID PICK UP (PL 3.2.15) PWBA MCU F (PL 8.1.5)		
1	Checking paper condition Is the paper in the MPF tray crumpled or damaged?	Replace the paper with a new and dry one.	Go to step 2.
2	Checking paper size setup Does the paper size in use match the size set for MPF tray?	Go to step 3.	Replace the paper or change the paper size setup.
3	Checking paper position Does the paper touch the SENSOR ASSY REGI? Open the COVER ASSY-LH (PL 4.2.8) and check it (visual check).	Remove the paper.	Go to step 4.
4	Checking the MPF guide for installation Does the MPF guide operate smoothly?	Go to step 5.	Install the MPF guide correctly.
5	Checking the MPF for installation Remove the FEEDER ASSY MPF (PL 3.1.1) and reinstall it. Does an error occur when a test print of MPF printing is carried out? Execute [Test Print] in Chapter 2 [Diagnostic].	Go to step 6.	End of work
6	Checking the Roll (1) Remove the FEEDER ASSY MPF (PL 3.1.1). Is the Roller of the ROLLER ASSY-FEED for transport worn or contaminated with paper dust?	Go to step 7.	Clean or replace the ROLLER ASSY-FEED. (RRP 3.13)
7	Checking the Roll (2) Remove the FEEDER ASSY MPF (PL 3.1.1). Is the Roller of the ROLL ASSY-DRIVE for transport worn or contaminated with paper dust?	Go to step 8.	Clean or replace the ROLLER ASSY-DRIVE. (RRP 3.10)
8	Checking the SENSOR ASSY REGI for operation Does the Input Status change from "0x0" to "0x1" each time the paper touches the SENSOR ASSY REGI? Execute [Input 08-05 REGI SENSOR] in Chapter 2 [Diagnostic]. Open the COVER ASSY-LH (PL 4.2.8) and check it.	Go to step 12.	Go to step 9.
9	Checking the SENSOR ASSY REGI for connection Are P/J104 and P/J403B connected surely?	Go to step 10.	Connect P/J104 and P/J403B surely.
10	Checking conductivity between the SENSOR ASSY REGI and the PWBA MCU F Is there conductivity on each wire between P/J104 <=> P/J403B?	Go to step 11.	Fix open and short circuit.

Step	Check	Yes	No
11	Checking +5 VDC power supply to the SENSOR ASSY REGI Is the voltage across J104-1 (+) <=> ground +5 VDC?	Replace the SENSOR ASSY REGI. (RRP 4.13)	Replace the PWBA MCU F. (RRP 8.4)
12	Checking the SOLENOID PICK UP for operation Does the SOLENOID PICK UP operate properly? Execute [Output 08-17 SMH FEED CLUTCH] in Chapter 2 [Diagnostic].	Reconnect the connector on the PWBA MCU F.	Go to step 13.
13	Checking the SOLENOID PICK UP for connection Are P/J205, P/J605 and P/J411 connected surely?	Go to step 14.	Connect P/J205, P/J605 and P/J411 surely.
14	Checking the SOLENOID PICK UP for conductivity Is there conductivity on each wire between P/J205 <=> P/J411?	Go to step 15.	Fix open and short circuit.
15	Checking the SOLENOID PICK UP for resistance Is the resistance across J205-1 and J205-2 approximately 90 ohm?	Go to step 16.	Replace the SOLENOID PICK UP. (RRP 3.11)
16	Check +24 VDC power supply to the SOLENOID PICK UP Is the voltage across P205-1 (+) <=> ground +24 VDC?	Replace the SOLENOID PICK UP. (RRP 3.11)	Replace the PWBA MCU F. (RRP 8.4)

## Registration Sensor off JAM (Too Long)

Step	Check	Yes	No
	Possible causative parts: ROLLER ASSY-TA (PL 4.1.8) SENSOR ASSY REGI (PL 4.5.7) CLUTCH ASSY REGI H (PL 4.5.2) PWBA MCU F (PL 8.1.5)		
1	Checking paper position Does the paper touch the SENSOR ASSY REGI? Open the COVER ASSY-LH (PL 4.2.8) and check it (visual check).	Remove the paper.	Go to step 2.
2	Checking the Roll Is the ROLLER ASSY-TA for transport worn or contaminated with paper dust? Open the COVER ASSY-LH (PL 4.2.8) and check it.	Go to step 3.	Clean or replace the ROLLER ASSY-TA. (RRP 4.3)
3	Checking the SENSOR ASSY REGI for operation Does the Input Status change from "0x0" to "0x1" each time the paper touches the SENSOR ASSY REGI? Execute [Input 08-05 REGI SENSOR] in Chapter 2 [Diagnostic]. Open the COVER ASSY-LH (PL 4.2.8) and check it.	Go to step 7.	Go to step 4.
4	Checking the SENSOR ASSY REGI for connection Are P/J104 and P/J403B connected surely?	Go to step 5.	Connect P/J104 and P/J403B surely.

Step	Check	Yes	No
5	Checking conductivity between the SENSOR ASSY REGI and the PWBA MCU Is there conductivity on each wire between P/J104 <=> P/J403B?	Go to step 6.	Fix open and short circuit.
6	Checking +5 VDC power supply to the SENSOR ASSY REGI Is the voltage across J104-1 (+) <=> ground +5 VDC?	Replace the SENSOR ASSY REGI. (RRP 4.13)	Replace the PWBA MCU F. (RRP 8.4)
7	Checking the CLUTCH ASSY REGI H for operation Does the CLUTCH ASSY REGI H operate properly? Execute [Output 08-10 REGI CLUTCH] in Chapter 2 [Diagnostic].	Reconnect the connector on the PWBA MCU F.	Go to step 8.
8	Checking the CLUTCH ASSY REGI H for connection Are P/J215 and P/J403B connected surely?	Go to step 9.	Connect P/J215 and P/J403B securely
9	Checking conductivity between the CLUTCH ASSY REGI H and the PWBA MCU F Is there conductivity on each wire between P/J215 <=> P/J403B?	Go to step 10.	Fix open and short circuit.
10	Checking +24 VDC power supply to the CLUTCH ASSY H Is the voltage across P215-2 (+) <=> ground +24 VDC?	Go to step 11.	Replace the PWBA MCU F. (RRP 8.4)
11	Checking the CLUTCH ASSY REGI H for resistance Is the resistance between J215-1 and J215-2 approximately 240 ohm?	Replace the PWBA MCU F. (RRP 8.4)	Replace the CLUTCH ASSY REGI H. (RRP 4.11)

### Registration Sensor off JAM (Too Short)

Step	Check	Yes	No
	Possible causative parts: ROLLER ASSY-TA (PL 4.1.8) SENSOR ASSY REGI (PL 4.5.7) CLUTCH ASSY REGI H (PL 4.5.2) PWBA MCU F (PL 8.1.5)		
1	Checking paper position Does the paper touch the SENSOR ASSY REGI? Open the COVER ASSY-LH (PL 4.2.8) and check it (visual check).	Remove the paper.	Go to step 2.
2	Checking the Roll Is the ROLLER ASSY-TA for transport worn or contaminated with paper dust? Open the COVER ASSY-LH (PL 4.2.8) and check it.	Go to step 3.	Clean or replace the ROLLER ASSY-TA. (RRP 4.3)

Step	Check	Yes	No
3	Checking the SENSOR ASSY REGI for operation Does the Input Status change from "0x0" to "0x1" each time the paper touches the SENSOR ASSY REGI? Execute [Input 08-05 REGI SENSOR] in Chapter 2 [Diagnostic]. Open the COVER ASSY-LH (PL 4.2.8) and check it.	Go to step 7.	Go to step 4.
4	Checking the SENSOR ASSY REGI for connection Are P/J104 and P/J403B connected surely?	Go to step 5.	Connect P/J104 and P/J403B surely.
5	Checking conductivity between the SENSOR ASSY REGI and the PWBA MCU Is there conductivity on each wire between P/J104 <=> P/J409B?	Go to step 6.	Fix open and short circuit.
6	Checking +5 VDC power supply to the SENSOR ASSY REGI Is the voltage across J104-1 (+) <=> ground +5 VDC?	Replace the SENSOR ASSY REGI. (RRP 4.13)	Replace the PWBA MCU F. (RRP 8.4)
7	Checking the CLUTCH ASSY REGI H for operation Does the CLUTCH ASSY REGI H operate properly? Execute [Output 08-10 REGI CLUTCH] in Chapter 2 [Diagnostic].	Reconnect the connector on the PWBA MCU F.	Go to step 8.
8	Checking the CLUTCH ASSY REGI H for connection Are P/J215 and P/J403B connected surely?	Go to step 9.	Connect P/J215 and P/J403B securely
9	Checking conductivity between the CLUTCH ASSY REGI H and the PWBA MCU F Is there conductivity on each wire between P/J215 <=> P/J403B?	Go to step 10.	Fix open and short circuit.
10	Checking +24 VDC power supply to the CLUTCH ASSY REGI H Is the voltage across P215-2 (+) <=> ground +24 VDC?	Go to step 11.	Replace the PWBA MCU F. (RRP 8.4)
11	Checking the CLUTCH ASSY REGI H for resistance Is the resistance between J215-1 and J215-2 the correct resistance?	Replace the PWBA MCU F. (RRP 8.4)	Replace the CLUTCH ASSY REGI H. (RRP 4.11)

### Exit Sensor 1 on JAM

Step	Check	Yes	No
	Possible causative parts: SENSOR PHOTO (PL 6.1.4) CLUTCH ASSY REGI H (PL 4.5.2) ROLLER ASSY-TA (PL 4.1.8) PWBA MCU F (PL 8.1.5)		



Step	Check	Yes	No
1	Checking paper position Does the paper touch the SENSOR PHOTO? Open the COVER ASSY-LH (PL 4.2.8) and check it (visual check).	Remove the paper.	Go to step 2.
2	Checking the Roll Is the ROLLER ASSY-TA for transport worn or contaminated with paper dust? Open the COVER ASSY-LH (PL 4.2.8) and check it.	Go to step 3.	Clean or replace the ROLLER ASSY-TA. (RRP 4.3)
3	Checking the SENSOR PHOTO for operation Does the Input Status change from "0x0" to "0x1" each time the paper touches the SENSOR PHOTO? Execute [Input 10-23 EXIT SENSOR] in Chapter 2 [Diagnostic]. Open the COVER ASSY-LH (PL 4.2.8) and check it.	Go to step 7.	Go to step 4.
4	Checking the SENSOR PHOTO for connection Are P/J125 and P/J410 connected surely?	Go to step 5.	Connect P/J125 and P/J410 surely.
5	Checking conductivity between the SENSOR PHOTO and the PWBA MCU F Is there conductivity on each wire between P/J125 <=> P/J410?	Go to step 6.	Fix open and short circuit.
6	Checking +5 VDC power supply to the SENSOR PHOTO Is the voltage across J125-3 (+) <=> ground +5 VDC?	Replace the SENSOR PHOTO. (RRP 6.1)	Replace the PWBA MCU F. (RRP 8.4)
7	Checking the CLUTCH ASSY REGI H for operation Does the CLUTCH ASSY REGI H operate properly? Execute [Output 08-10 REGI CLUTCH] in Chapter 2 [Diagnostic].	Reconnect the connector on the PWBA MCU F.	Go to step 8.
8	Checking the CLUTCH ASSY REGI H for connection Are P/J215 and P/J403B connected surely?	Go to step 9.	Connect P/J215 and P/J403B surely.
9	Checking conductivity between the CLUTCH ASSY REGI H and the PWBA MCU F Is there conductivity on each wire between P/J215 <=> P/J403B?	Go to step 10.	Fix open and short circuit.
10	Checking +24 VDC power supply to the CLUTCH ASSY REGI H Is the voltage across P215-2 (+) <=> ground +24 VDC?	Go to step 11.	Replace the PWBA MCU F. (RRP 8.4)
11	Checking the CLUTCH ASSY REGI H for resistance Is the resistance between J215-1 and J215-2 the correct resistance?	Replace the PWBA MCU F. (RRP 8.4)	Replace the CLUTCH ASSY REGI H. (RRP 4.11)

## Registration Sensor Static on JAM

Step	Check	Yes	No
	Possible causative parts: SENSOR ASSY REGI (PL 4.5.7) PWBA MCU F (PL 8.1.5)		
1	Checking paper position Does the paper touch the SENSOR ASSY REGI? Open the COVER ASSY-LH (PL 4.2.8) and check it (visual check).	Remove the paper.	Go to step 2.
2	Checking the SENSOR ASSY REGI for operation Does the Input Status change from "0x0" to "0x1" each time the paper touches the SENSOR ASSY REGI? Execute [Input 08-05 REGI SENSOR] in Chapter 2 [Diagnostic]. Open the COVER ASSY-LH (PL 4.2.8) and check it.	Reconnect the connector on the PWBA MCU F.	Go to step 3.
3	Checking the SENSOR ASSY REGI for connection Are P/J104 and P/J403B connected surely?	Go to step 4.	Connect P/J104 and P/J403B surely.
4	Checking conductivity between the SENSOR ASSY REGI and the PWBA MCU F Is there conductivity on each wire between P/J104 <=> P/J403B?	Go to step 5.	Fix open and short circuit.
5	Checking +5 VDC power supply to the SENSOR ASSY REGI Is the voltage across J104-1 (+) <=> ground +5 VDC?	Replace the SENSOR ASSY REGI. (RRP 4.13)	Replace the PWBA MCU F. (RRP 8.4)

## Exit Sensor 1 off JAM

Step	Check	Yes	No
	Possible causative parts: SENSOR PHOTO (PL 6.1.4) ROLLER ASSY-TA (PL 4.1.8) PWBA MCU F (PL 8.1.5)		
1	Checking paper position Does the paper touch the SENSOR PHOTO? Open the COVER ASSY-LH (PL 4.2.8) and check it (visual check).	Remove the paper.	Go to step 2.
2	Checking the Roll (2) Is the ROLLER ASSY-TA for transport worn or contaminated with paper dust? Open the COVER ASSY-LH (PL 4.2.8) and check it.	Go to step 3.	Clean or replace the ROLLER ASSY-TA. (RRP 4.3)

Step	Check	Yes	No
3	Checking the SENSOR PHOTO for operation Does the Input Status change from "0x0" to "0x1" each time the paper touches the SENSOR PHOTO? Execute [Input 10-23 EXIT SENSOR] in Chapter 2 [Diagnostic]. Open the COVER ASSY-LH (PL 4.2.8) and check it.	Reconnect the connector on the PWBA MCU F.	Go to step 4.
4	Checking the SENSOR PHOTO for connection Are P/J125 and P/J410 connected surely?	Go to step 5.	Connect P/J125 and P/J410 surely.
5	Checking conductivity between the SENSOR PHOTO and the PWBA MCU F Is there conductivity on each wire between P/J125 <=> P/J410?	Go to step 6.	Fix open and short circuit.
6	Checking +5 VDC power supply to the SENSOR PHOTO Is the voltage across J125-3 (+) <=> ground +5 VDC?	Replace the SENSOR PHOTO. (RRP 6.1)	Replace the PWBA MCU F. (RRP 8.4)

### Exit Sensor 1 off (too short) JAM

Step	Check	Yes	No
	Possible causative parts: SENSOR PHOTO (PL 6.1.4) ROLLER ASSY-TA (PL 4.1.8) FUSER ASSY (PL 6.1.7) PWBA MCU F (PL 8.1.5)		
1	Checking paper position Does the paper touch the SENSOR PHOTO? Open the COVER ASSY-LH (PL 4.2.8) and check it (visual check).	Remove the paper.	Go to step 2.
2	Checking the FUSER ASSY for paper jam Is there a paper jam in the FUSER ASSY? Open the COVER ASSY-LH (PL 4.2.8) and check it.	Go to step 3.	Remove the paper.
3	Checking the FUSER ASSY for installation Is the FUSER ASSY installed securely? Open the COVER ASSY-LH (PL 4.2.8) and check it.	Go to step 4.	Install the FUSER ASSY securely.
4	Checking the Roll Is the ROLLER ASSY-TA for transport worn or contaminated with paper dust? Open the COVER ASSY-LH (PL 4.2.8) and check it.	Go to step 5.	Clean or replace the ROLLER ASSY-TA. (RRP 4.3)
5	Checking the SENSOR PHOTO for operation Does the Input Status change from "0x0" to "0x1" each time the paper touches the SENSOR PHOTO? Execute [Input 10-23 EXIT SENSOR] in Chapter 2 [Diagnostic]. Open the COVER ASSY-LH (PL 4.2.8) and check it.	Reconnect the connector of the PWBA MCU F.	Go to step 6.

Step	Check	Yes	No
6	Checking the SENSOR PHOTO for connection Are P/J125 and P/J410 connected surely?	Go to step 7.	Connect P/J125 and P/J410 surely.
7	Checking conductivity between the SENSOR PHOTO and the PWBA MCU F Is there conductivity on each wire between P/J125 <=> P/J410?	Go to step 8.	Fix open and short circuit.
8	Checking +5 VDC power supply to the SENSOR PHOTO Is the voltage across J125-3 (+) <=> ground +5 VDC?	Replace the SENSOR PHOTO. (RRP 6.1)	Replace the PWBA MCU F. (RRP 8.4)

### Exit Sensor 1 Static JAM

Step	Check	Yes	No
	Possible causative parts: SENSOR PHOTO (PL 6.1.4) PWBA MCU F (PL 8.1.5)		
1	Checking paper position Does the paper touch the SENSOR PHOTO? Open the COVER ASSY-LH (PL 4.2.8) and check it (visual check).	Remove the paper.	Go to step 2.
2	Checking the SENSOR PHOTO for operation (1) Does the Input Status change from "0x0" to "0x1" each time the paper touches the SENSOR PHOTO? Execute [Input 10-23 EXIT SENSOR] in Chapter 2 [Diagnostic]. Open the COVER ASSY-LH (PL 4.2.8) and check it.	Reconnect the connector of the PWBA MCU F.	Go to step 3.
3	Checking the SENSOR PHOTO for connection Are P/J125 and P/J410 connected surely?	Go to step 4.	Connect P/J125 and P/J410 surely.
4	Checking conductivity between the SENSOR PHOTO and the PWBA MCU F Is there conductivity on each wire between P/J125 <=> P/J410?	Go to step 5.	Fix open and short circuit.
5	Checking +5 VDC power supply to the SENSOR PHOTO Is the voltage across J125-3 (+) <=> ground +5 VDC?	Replace the SENSOR PHOTO. (RRP 6.1)	Replace the PWBA MCU F. (RRP 8.4)

## Exit Sensor 2 on JAM

Step	Check	Yes	No
	Possible causative parts: SENSOR PHOTO (PL 6.1.4) SENSOR-PHOTO IN (PL 11.2.35) PWBA EXIT (PL 8.1.4) MOTOR ASSY EXIT 2 (PL 11.2.37) SOLENOID ASSY (PL 11.2.29)		
1	Checking paper position (1) Does the paper touch the SENSOR PHOTO? Open the COVER ASSY-LH (PL 4.2.8) and check it (visual check).	Remove the paper.	Go to step 2.
2	Checking paper position (2) Does the paper touch the SENSOR-PHOTO IN? Open the CHUTE LH HIGH (PL 11.1.18) and check it (visual check).	Remove the paper.	Go to step 3.
3	Checking the Roll Open COVER ASSY-LH (PL 4.2.8). Is the Roller of the ROLL ASSY OCT for transport worn or contaminated with paper dust?	Go to step 4.	Clean or replace the ROLL ASSY OCT. (RRP 6.9)
4	Checking the drive power transmission Do the ROLLER ASSY OCT for transport and the other gears rotate smoothly?	Go to step 5.	Replace obstacles for rotation.
5	Checking the SENSOR PHOTO for operation Does the SENSOR PHOTO operate properly? Execute [Input 10-23 EXIT SENSOR] in Chapter 2 [Diagnostic]. Open the COVER ASSY-LH (PL 4.2.8) and check it.	Go to step 9.	Go to step 6.
6	Checking the SENSOR PHOTO for connection Are P/J125 and P/J410 connected surely?	Go to step 7.	Connect P/J125 and P/J410 surely.
7	Checking conductivity between the SENSOR PHOTO and the PWBA MCU F Is there conductivity on each wire between P/J125 <=> P/J410?	Go to step 8.	Fix open and short circuit.
8	Checking +5 VDC power supply to the SENSOR PHOTO Is the voltage across P/J125-3 (+) <=> ground +5 VDC?	Replace the SENSOR PHOTO. (RRP 6.1)	Replace the PWBA MCU F. (RRP 8.4)
9	Checking the MOTOR ASSY EXIT 2 for operation Does the MOTOR ASSY EXIT 2 operate properly? Check it using "Output 10-08 EXIT DRIVE MOTOR FORWARD (Eject Paper out)" in Chapter 2, Diag.	Go to step 13.	Go to step 10.
10	Checking the MOTOR ASSY EXIT 2 for connection Are P/J208, P/J606A and P/J433 connected securely?	Go to step 11.	Connect P/J208, P/J606A and P/J433 surely.
11	Checking conductivity between the MOTOR ASSY EXIT 2 and PWBA EXIT Is there normal conductivity between P/J208 and P/J433?	Go to step 12.	Fix open and short circuit.

Step	Check	Yes	No
12	Checking the MOTOR ASSY EXIT 2 for power supply Is the voltage between P208-5 (+) and the ground (-) +24 VDC?	Replace the MOTOR ASSY EXIT 2. (RRP 11.16)	Replace the PWBA EXIT. (RRP 8.3)
13	Checking the SENSOR-PHOTO IN for operation Does the SENSOR-PHOTO IN operate properly? Execute [Input 10-52 EXIT SENSOR2] in Chapter 2 [Diagnostic].	Go to step 17.	Go to step 14.
14	Checking the SENSOR-PHOTO IN for connection Are P/J112, P/J606B and P/J434 connected surely?	Go to step 15.	Connect P/J112, P/J606B and P/J434 surely.
15	Checking conductivity between the SENSOR-PHOTO IN and the PWBA EXIT Is there conductivity on each wire between P/J112 <=> P/J434?	Go to step 16.	Fix open and short circuit.
16	Checking +5 VDC power supply to the SENSOR-PHOTO IN Is the voltage across J112-3 (+) <=> ground +5 VDC?	Replace the SENSOR-PHOTO IN. (RRP 11.14)	Go to step 13.
17	Checking the SOLENOID ASSY for operation Does the SOLENOID ASSY actuate? Check it using "Output 10-51 EXIT GATE SOLENOID" in Chapter 2, Diag.	Replace the PWBA EXIT. (RRP 8.3)	Go to step 18.
18	Checking the SOLENOID for connection Are P/J209, P/J606A and P/J433 connected securely?	Go to step 19.	Connect P/J209, P/J606A and P/J433 surely.
19	Checking the SOLENOID ASSY for conductivity Is there normal conductivity between P/J209 and P/J433?	Go to step 20.	Fix open and short circuit.
20	Checking the SOLENOID ASSY for resistance Is each pair of pins connected normally with appropriate resistance?	Go to step 21.	Replace the SOLENOID ASSY. (RRP 3.11)
21	Checking the SOLENOID ASSY for power supply Is the voltage between P209-2 (+) and the ground (-) +24 VDC?	Replace the SOLENOID ASSY. (RRP 3.11)	Replace the PWBA EXIT. (RRP 8.3)

### Exit Sensor2 off JAM

Step	Check	Yes	No
	Possible causative parts: SENSOR-PHOTO IN (PL 11.2.35) MOTOR ASSY EXIT 2(PL 11.2.37) ROLL ASSY-FU (PL 11.1.19) ROLL ASSY-INV (PL 11.1.20) ROLL ASSY OCT (PL 11.2.7) PWBA EXIT (PL 8.1.4)		

Step	Check	Yes	No
1	Checking the paper position Does the paper touch the SENSOR-PHOTO IN? Open the CHUTE LH HIGH (PL 11.1.18) and check it (visual check).	Remove the paper.	Go to step 2.
2	Checking the Roll (1) Open CHUTE LH HIGH (PL 11.1.18). Is the Roller of the ROLL ASSY-FU for transport worn or contaminated with paper dust?	Go to step 3.	Clean or replace the ROLL ASSY-FU. (RRP 11.2)
3	Checking the drive power transmission (1) Do the ROLL ASSY-FU for transport and the other gears rotate smoothly?	Go to step 4.	Replace obstacles for rotation.
4	Checking the Roll (2) Open the CHUTE LH HIGH (PL 11.1.18). Is the Roller of the ROLL ASSY-INV for transport worn or contaminated with paper dust?	Go to step 5.	Clean or replace the ROLL ASSY-INV. (RRP 11.3)
5	Checking the drive power transmission (2) Do the ROLL ASSY-INV for transport and the other gears rotate smoothly?	Go to step 6.	Replace obstacles for rotation.
6	Checking the Roll (3) Open CHUTE LH HIGH (PL 11.1.18). Is the Roller of the ROLL ASSY OCT for transport worn or contaminated with paper dust?	Go to step 7.	Clean or replace the ROLL ASSY OCT. (RRP 11.6)
7	Checking the drive power transmission (3) Do the ROLLER ASSY OCT for transport and the other gears rotate smoothly?	Go to step 8.	Replace obstacles for rotation.
8	Checking the SENSOR-PHOTO IN for operation Does the SENSOR-PHOTO IN operate properly? Execute [Input 10-52 EXIT SENSOR2] in Chapter 2 [Diagnostic].	Go to step 17.	Go to step 9.
9	Checking the SENSOR-PHOTO IN for connection Are P/J112, P/J606B and P/J434 connected surely?	Go to step 10.	Connect P/J112, P/J606B and P/J434 surely.
10	Checking conductivity between the SENSOR-PHOTO IN and the PWBA EXIT Is there conductivity on each wire between P/J112 <=> P/J434?	Go to step 11.	Fix open and short circuit.
11	Checking +5 VDC power supply to the SENSOR-PHOTO IN Is the voltage across J112-3 (+) <=> ground +5 VDC?	Replace the SENSOR-PHOTO IN. (RRP 11.14)	Replace the PWBA EXIT. (RRP 8.3)
12	Checking the MOTOR ASSY EXIT 2 for operation Does the MOTOR ASSY EXIT 2 operate properly? Execute [Output 10-09 EXIT DRIVE MOTOR REVERSE (send paper into DUP)] in Chapter 2 [Diagnostic].	Reconnect the connector of the PWBA MCU F.	Go to step 13.
13	Checking the MOTOR ASSY EXIT 2 for connection Are P/J208, P/J606A and P/J433 connected surely?	Go to step 14.	Connect P/J208, P/J606A and P/J433 surely.

Step	Check	Yes	No
14	Checking conductivity between the MOTOR ASSY EXIT 2 and PWBA EXIT Is there conductivity on each wire between P/J208 <=> P/J433?	Go to step 15.	Fix open and short circuit.
15	Checking +24 VDC power supply to the MOTOR ASSY EXIT 2 Is the voltage across P208-5 (+) <=> ground +24 VDC?	Replace the MOTOR ASSY EXIT 2. (RRP 11.16)	Replace the PWBA EXIT. (RRP 8.3)

### Tray1 Lift up /No tray fail

Step	Check	Yes	No
	Possible causative parts: SECTOR GEAR (60T) (PL 2.2.22) TRAY 1/2 FEED LIFT UP MOTOR (PL 2.3.2) SENSOR (LEVEL SENSOR) (PL 2.3.14) SWITCH ASSY P S (PL 2.1.4) PWBA MCU F (PL 8.1.5)		
1	Checking paper Is any paper loaded in the Tray1? Pull out the Tray1 to check it. (Visual check)	Go to step 2.	Load paper.
2	Checking the TRAY (1) Replace the TRAY1 with the TRAY2. Is the replaced tray lifted up?	Go to step 3.	Go to step 4.
3	Checking the TRAY (2) Are the SECTOR GEAR (60T) of TRAY1 or the surrounding parts of it damaged?	Replace the TRAY1.	Replace the SECTOR GEAR (60T) (RRP 2.8) or the obstacle parts.
4	Checking the TRAY 1/2 FEED LIFT UP MOTOR for the TRAY1 for operation (1) Does the TRAY 1/2 FEED LIFT UP MOTOR for the TRAY1 operate properly? Execute [Output 07-18 TRAY1 LIFT UP (FEED MOTOR REVERSE)] in Chapter 2 [Diagnostic]. Pull out the TRAY1 and check it.	Go to step 9.	Go to step 5.
5	Checking the TRAY 1/2 FEED LIFT UP MOTOR for the TRAY1 for connection Are P/J201, P/J601 and P/J409A connected surely?	Go to step 6.	Connect P/J201, P/J601 and P/J409A surely.



Step	Check	Yes	No
6	<p>Checking the TRAY 1/2 FEED LIFT UP MOTOR for the TRAY1 for operation (2)            Replace the TRAY 1/2 FEED LIFT UP MOTOR for the TRAY1 with that for the TRAY2.            Does the replaced motor operate properly?            Execute [Output 07-18 TRAY1 LIFT UP (FEED MOTOR REVERSE)] in Chapter 2 [Diagnostic].</p>	<p>Reinstall the TRAY 1/2 FEED LIFT UP MOTOR for the TRAY2 as it previously was and replace the TRAY 1/2 FEED LIFT UP MOTOR for the TRAY1 with a new one.            (RRP 2.9)</p>	<p>Go to step 7.</p>
7	<p>Checking the TRAY 1/2 FEED LIFT UP MOTOR for the TRAY1 for conductivity            Reinstall the TRAY 1/2 FEED LIFT UP MOTORS for the TRAY1 and TRAY2 as they previously were.            Is there conductivity on each wire between P/J201 &lt;=&gt; P/J409A?</p>	<p>Go to step 8.</p>	<p>Fix open and short circuit.</p>
8	<p>Checking +24 VDC power supply to the TRAY 1/2 FEED LIFT UP MOTOR for the TRAY 1            Is the voltage across J201-4 (+) &lt;=&gt; ground +24 VDC?</p>	<p>Replace the TRAY 1/2 FEED LIFT UP MOTOR for the TRAY1.            (RRP 2.9)</p>	<p>Replace the PWBA MCU F.            (RRP 8.4)</p>
9	<p>Checking the SENSOR (LEVEL SENSOR) for the TRAY1 for operation            Does the Input Status change from "0x0" to "0x1" each time the paper touches the SENSOR (LEVEL SENSOR) for the TRAY1?            Execute [Input 07-13 TRAY1 LEVEL SENSOR] in Chapter 2 [Diagnostic].            Open the COVER ASSY-LH (PL 4.2.8) and check it.</p>	<p>Go to step 13.</p>	<p>Go to step 10.</p>
10	<p>Checking the SENSOR (LEVEL SENSOR) for the TRAY1 for connection            Are P/J100, P/J601 and P/J409A connected surely?</p>	<p>Go to step 11.</p>	<p>Connect P/J100, P/J601 and P/J409A surely.</p>
11	<p>Checking conductivity between the SENSOR for the TRAY1 (LEVEL SENSOR) and the PWBA MCU F            Is there conductivity on each wire between P/J100 &lt;=&gt; P/J409A?</p>	<p>Go to step 12.</p>	<p>Fix open and short circuit.</p>
12	<p>Checking +5 VDC power supply to the SENSOR (LEVEL SENSOR) for the TRAY1            Is the voltage across J100-3 (+) &lt;=&gt; ground +5 VDC?</p>	<p>Replace the SENSOR (LEVEL SENSOR) for the TRAY1. (RRP 2.17)</p>	<p>Replace the PWBA MCU F.            (RRP 8.4)</p>
13	<p>Checking the SWITCH ASSY P S for the TRAY1 for operation            Does the Input Status change each time the TRAY 1 with paper loaded is pulled out or pushed in?            Execute [Input 07-01 TRAY1 SIZE SENSOR] in Chapter 2 [Diagnostic].</p>	<p>Reconnect the connector of the PWBA MCU F.</p>	<p>Go to step 14.</p>

Step	Check	Yes	No
14	Checking the SWITCH ASSY P S for the TRAY1 for connection Are P/J109 and P/J412 connected surely?	Go to step 15.	Connect P/J109 and P/J412 surely.
15	Checking conductivity between the SWITCH ASSY P S for the TRAY1 and the PWBA MCU F Is there conductivity on each wire between P/J109 <=> P/J412?	Go to step 16.	Fix open and short circuit.
16	Checking +5 VDC power supply to the SWITCH ASSY P S for the TRAY1 Is the voltage across J109-1 (+) <=> ground +5 VDC?	Replace the SWITCH ASSY P S for the TRAY1. (RRP 2.1)	Replace the PWBA MCU F. (RRP 8.4)

## Tray2 Lift up /No tray fail

Step	Check	Yes	No
	Possible causative parts: SECSTOR GEAR (60T) (PL 2.2.22) TRAY 1/2 FEED LIFT UP MOTOR (PL 2.3.2) SENSOR (LEVEL SENSOR) (PL 2.3.14) SWITCH ASSY P S (PL 2.1.4) PWBA MCU F (PL 8.1.5)		
1	Checking paper Is any paper loaded in the TRAY2? Pull out the TRAY2 to check it. (Visual check)	Go to step 2.	Load paper.
2	Checking the TRAY (1) Replace the TRAY2 with the TRAY1. Is the replaced tray lifted up?	Go to step 3.	Go to step 4.
3	Checking the TRAY (2) Are the SECTOR GEAR (60T) of TRAY2 or the surrounding parts of it damaged?	Replace the TRAY2.	Replace the SECTOR GEAR (60T) (RRP 2.8) or the obstacles.
4	Checking the TRAY 1/2 FEED LIFT UP MOTOR for the TRAY2 for operation (1) Does the TRAY 1/2 FEED LIFT UP MOTOR for the TRAY2 operate properly? Execute [Output 07-19 TRAY2 LIFT UP MOTOR (FEED MOTOR Reverse)] in Chapter 2 [Diagnostic]. Pull out the TRAY2 and check it.	Go to step 9.	Go to step 5.
5	Checking the TRAY 1/2 FEED LIFT UP MOTOR for the TRAY2 for connection Are P/J202, P/J602 and P/J409B connected surely?	Go to step 6.	Connect P/J202, P/J602 and P/J409B surely.

Step	Check	Yes	No
6	<p>Checking the TRAY 1/2 FEED LIFT UP MOTOR for the TRAY2 for operation (2)            Replace the TRAY 1/2 FEED LIFT UP MOTOR for the TRAY2 with that for the TRAY1.            Does the replaced motor operate properly?            Execute [Output 08-13 TRAY2 FEED MOTOR] in Chapter 2 [Diagnostic].</p>	<p>Reinstall the TRAY 1/2 FEED LIFT UP MOTOR for the TRAY1 as it previously was and then, replace the motor for the TRAY2 with a new one. (RRP 2.9)</p>	<p>Go to step 7.</p>
7	<p>Checking the TRAY 1/2 FEED LIFT UP MOTOR for the TRAY2 for conductivity            Reinstall the TRAY 1/2 FEED LIFT UP MOTORS for the TRAY1 and TRAY2 as they previously were.            Is there conductivity on each wire between P/J202 &lt;=&gt; P/J409B?</p>	<p>Go to step 8.</p>	<p>Fix open and short circuit.</p>
8	<p>Checking +24 VDC power supply to the TRAY 1/2 FEED LIFT UP MOTOR for the TRAY2            Is the voltage across J202-4 (+) &lt;=&gt; ground +24 VDC?</p>	<p>Replace the TRAY 1/2 FEED LIFT UP MOTOR for the TRAY2. (RRP 2.9)</p>	<p>Replace the PWBA MCU F. (RRP 8.4)</p>
9	<p>Checking the SENSOR (LEVEL SENSOR) for the TRAY2 for operation            Does the Input Status change from "0x0" to "0x1" each time the paper touches the SENSOR (LEVEL SENSOR) for the TRAY2?            Execute [Input 07-14 TRAY2 LEVEL SENSOR] in Chapter 2 [Diagnostic].            Open the COVER ASSY LH LOW C (PL 4.1.10) and check it.</p>	<p>Go to step 13.</p>	<p>Go to step 10.</p>
10	<p>Checking the SENSOR (LEVEL SENSOR) for the TRAY2 for connection            Are P/J102, P/J602 and P/J409B connected surely?</p>	<p>Go to step 11.</p>	<p>Connect P/J102, P/J602 and P/J409B surely.</p>
11	<p>Checking conductivity between the SENSOR (LEVEL SENSOR) for the TRAY2 and the PWBA MCU F            Is there conductivity on each wire between P/J102 &lt;=&gt; P/J409B?</p>	<p>Go to step 12.</p>	<p>Fix open and short circuit.</p>
12	<p>Checking +5 VDC power supply to the SENSOR (LEVEL SENSOR) for the TRAY2            Is the voltage across J102-3 (+) &lt;=&gt; ground +5 VDC?</p>	<p>Replace the SENSOR (LEVEL SENSOR) for the TRAY2. (RRP 2.17)</p>	<p>Replace the PWBA MCU F. (RRP 8.4)</p>
13	<p>Checking the SWITCH ASSY P S for the TRAY2 for operation            Does the Input Status change each time the TRAY 2 with paper loaded is pulled out or pushed in?            Execute [Input 07-02 TRAY2 SIZE SENSOR] in Chapter 2 [Diagnostic].</p>	<p>Reconnect the connector of the PWBA MCU F.</p>	<p>Go to step 14.</p>

Step	Check	Yes	No
14	Checking the SWITCH ASSY P S for the TRAY2 for connection Are P/J110 and P/J412 connected surely?	Go to step 15.	Connect P/J110 and P/J412 surely.
15	Checking conductivity between the SWITCH ASSY P S for the TRAY2 and the PWBA MCU F Is there conductivity on each wire between P/J110 <=> P/J412?	Go to step 16.	Fix open and short circuit.
16	Checking +5 VDC power supply to the SWITCH ASSY P S for the TRAY2 Is the voltage across J110-1 (+) <=> ground +5 VDC?	Replace the SWITCH ASSY P S for the TRAY2. (RRP 2.2)	Replace the PWBA MCU F. (RRP 8.4)

### Exit Module Communication fail

Step	Check	Yes	No
	Possible causative parts: PWBA EXIT (PL 8.1.4) PWBA MCU F (PL 8.1.5)		
1	Checking the PWBA EXIT for connection Are P/J431 and P/J421 connected surely?	Go to step 2.	Connect P/J431 and P/J421 surely.
2	Checking conductivity between the PWBA EXIT and the PWBA MCU F Is there conductivity on each wire between P/J431 <=> P/J421?	Go to step 3.	Fix open and short circuit.
3	Checking the connection between the PWBA EXIT and the POWER UNIT Are P/J430 and P/J526 connected surely?	Go to step 4.	Connect P/J430 and P/J526 surely.
4	Checking conductivity between the PWBA EXIT and the POWER UNIT Is there conductivity on each wire between P/J430 <=> P/J526?	Go to step 5.	Fix open and short circuit.
5	Checking +24 VDC power supply to the PWBA EXIT Is the voltage across J430-1 (+) <=> ground +24 VDC?	Replace the PWBA EXIT. (RRP 8.3)	Reconnect the connector of the POWER UNIT.

## Tray 1 cassette Size fail

Step	Check	Yes	No
	Possible causative parts: SWITCH ASSY P S (PL 2.1.4) FRONT SIDE GUIDE (PL 2.2.6) REAR SIDE GUIDE (PL 2.2.9) END GUIDE (PL 2.2.16) PWBA MCU F (PL 8.1.5)		
1	Checking the paper (1) Is paper loaded in the Tray1 properly? Pull out the Tray1 to check it. (Visual check)	Go to step 2.	Load paper properly.
2	Checking the paper (2) Are the FRONT SIDE GUIDE, REAR SIDE GUIDE and END GUIDE of the TRAY1 set correctly? Pull out the Tray1 to check it. (Visual check)	Go to step 3.	Set the parts properly.
3	Checking the SWITCH ASSY P S for the TRAY1 for installation Is the SWITCH ASSY P S for the TRAY1 installed correctly? Pull out the TRAY1 to check it. (Visual check)	Go to step 4.	Install the SWITCH ASSY P S for the TRAY1 correctly. (RRP 2.1)
4	Checking the SWITCH ASSY P S for the TRAY1 for operation Does the Input Status change each time the TRAY 1 with paper loaded is pulled out or pushed in? Execute [Input 07-01 TRAY1 SIZE SENSOR] in Chapter 2 [Diagnostic].	Reconnect the connector of the PWBA MCU F.	Go to step 5.
5	Checking the SWITCH ASSY P S for the TRAY1 for connection Are P/J109 and P/J412 connected surely?	Go to step 6.	Connect P/J109 and P/J412 surely.
6	Checking conductivity between the SWITCH ASSY P S for the TRAY1 and the PWBA MCU F Is there conductivity on each wire between P/J109 <=> P/J412?	Go to step 7.	Fix open and short circuit.
7	Checking +5 VDC power supply to the SWITCH ASSY P S for the TRAY1 Is the voltage across J109-1 (+) <=> ground +5 VDC?	Replace the SWITCH ASSY P S for the TRAY1. (RRP 2.1)	Replace the PWBA MCU F. (RRP 8.4)

## Tray 2 cassette Size fail

Step	Check	Yes	No
	Possible causative parts: SWITCH ASSY P S (PL 2.1.4) FRONT SIDE GUIDE (PL 2.2.6) REAR SIDE GUIDE (PL 2.2.9) END GUIDE (PL 2.2.16) PWBA MCU F (PL 8.1.5)		
1	Checking the paper (1) Is paper loaded in the TRAY2 properly? Pull out the TRAY2 to check it. (Visual check)	Go to step 2.	Load paper properly.
2	Checking the paper (2) Are the FRONT SIDE GUIDE, REAR SIDE GUIDE and END GUIDE of the TRAY2 set correctly? Pull out the TRAY2 to check it. (Visual check)	Go to step 3.	Set the parts properly.
3	Checking the SWITCH ASSY P S for the TRAY2 for installation Is the SWITCH ASSY P S for the TRAY2 installed correctly? Pull out the TRAY2 to check it. (Visual check)	Go to step 4.	Install the SWITCH ASSY P S for the TRAY2 correctly. (RRP 2.2)
4	Checking the SWITCH ASSY P S for the TRAY2 for operation Does the Input Status change each time the TRAY 2 with paper loaded is pulled out or pushed in? Execute [Input 07-02 TRAY2 SIZE SENSOR] in Chapter 2 [Diagnostic].	Reconnect the connector of the PWBA MCU F.	Go to step 5.
5	Checking the SWITCH ASSY P S for the TRAY2 for connection Are P/J110 and P/J412 connected surely?	Go to step 6.	Connect P/J110 and P/J412 surely.
6	Checking conductivity between the SWITCH ASSY P S for the TRAY2 and the PWBA MCU F Is there conductivity on each wire between P/J110 <=> P/J412?	Go to step 7.	Fix open and short circuit.
7	Checking +5 VDC power supply to the SWITCH ASSY P S for the TRAY2 Is the voltage across J110-1 (+) <=> ground +5 VDC?	Replace the SWITCH ASSY P S for the TRAY2. (RRP 2.2)	Replace the PWBA MCU F. (RRP 8.4)

## Toner Cartridge Empty fail

Step	Check	Yes	No
	Possible causative parts: TONER CARTRIDGE (PL 5.1.16) GUIDE ASSY CTG30 SUB (PL 5.1.10) MOTOR ASSY-DISP 30K (PL 5.1.11) PWBA CRUM CP1 (TONER) (PL 5.1.8) PWBA MCU F (PL 8.1.5)		
1	Checking remaining toner Does the TONER CARTRIDGE contain sufficient toner?	Go to step 2.	Replace the TONER CARTRIDGE.
2	Checking the TRAY CARTRIDGE for installation Remove the TONER CARTRIDGE and reinstall it. Does it operate properly?	End of work	Go to step 3.
3	Checking the gear drive of the GUIDE ASSY CTG30 SUB Does the gear located at the lower part of the GUIDE ASSY CTG30 SUB rotate smoothly?	Go to step 4.	Replace the obstacles for rotation.
4	Checking the GUIDE ASSY CTG30 SUB for pipe clogging Is the pipe located at the lower part of the GUIDE ASSY CTG30 SUB clogged?	Go to step 5.	Clean the pipe.
5	Checking the PWBA CRUM CP1 (TONER) for installation Is the PWBA CRUM CP1 (TONER) installed correctly?	Go to step 6.	Install the PWBA CRUM CP1 (TONER) correctly.
6	Checking the PWBA CRUM CP1 (TONER) for connection Are P/J127 and P/J419 connected surely?	Go to step 7.	Connect P/J127 and P/J419 surely.
7	Checking conductivity between the PWBA CRUM CP1 (TONER) and the PWBA MCU F Is there conductivity on each wire between P/J127 <=> P/J419?	Go to step 8.	Fix open and short circuit.
8	Checking +5 VDC power supply to the PWBA CRUM CP1 (TONER) Is the voltage across P127-1 (+) <=> ground +5 VDC?	Go to step 9.	Replace the PWBA MCU F. (RRP 8.4)
9	Checking the MOTOR ASSY-DISP 30K for operation Execute [Output 15-63 Dispense Motor] in Chapter 2 [Diagnostic].	Reconnect the connector of the PWBA MCU F.	Go to step 10.
10	Checking the MOTOR ASSY-DISP 30K for connection Are P/J216 and P/J420 connected surely?	Go to step 11.	Connect P/J216 and P/J420 surely.
11	Checking conductivity between the MOTOR ASSY-DISP 30K and the PWBA MCU F Is there conductivity on each wire between P/J216 <=> P/J420?	Go to step 12.	Fix open and short circuit.
12	Checking +24 VDC power supply to the MOTOR ASSY-DISP 30K Is the voltage across J216-1 (+) <=> ground +24 VDC?	Replace the MOTOR ASSY-DISP 30K. (RRP 5.6)	Replace the PWBA MCU F. (RRP 8.4)

## XERO/DEVE Cartridge Set fail

Step	Check	Yes	No
	Possible causative parts: CRU (PL 5.1.15) SWITCH ASSY XERO INTLK (PL 5.1.4) PWBA MCU F (PL 8.1.5)		
1	Checking the CRU for installation Is the CRU installed surely?	Go to step 2.	Install the CRU surely.
2	Checking the harness for connection Is P/J403B connected securely?	Go to step 3.	Connect P/J403B surely.
3	Checking the power supply Is the voltage between P401-1 (+) and the ground (-) +0 VDC when the CRU is installed?	Replace the CRU.	Go to step 4.
4	Checking conductivity between the ATC SENSOR and the PWBA MCU F (1) Is there normal conductivity between P403B-11 and P610 when the CRU is installed?	Go to step 5.	Fix open and short circuit.
5	Checking conductivity between the ATC SENSOR and the PWBA MCU F (2) Is there normal conductivity between P610-3 and P610-7 when the CRU is installed?	Go to step 6.	Fix open and short circuit.
6	Checking conductivity between the ATC SENSOR and the PWBA MCU F (3) Is there normal conductivity between P610-7 and P403-B when the CRU is installed?	Go to step 7.	Fix open and short circuit.
7	Checking the SWITCH ASSY XERO INTLK for operation Does the Input Status change from "0x0" to "0x1" each time the CRU is installed or removed? Execute [Input 09-02 DRUM DETECT] in Chapter 2 [Diagnostic]. Open COVER ASSY FRONT (PL 1.1.9) and check it.	Reconnect the connector of the PWBA MCU F.	Go to step 8.
8	Checking the SWITCH ASSY XERO INTLK for connection Is P/J404 connected surely?	Go to step 9.	Connect P/J404 surely.
9	Checking the SWITCH ASSY XERO INTLK for conductivity Is there conductivity between P/J404-1 <=> P/J404-3 when the CRU is installed?	Go to step 10.	Fix open and short circuit.
10	Checking +5 VDC power supply to the SWITCH ASSY XERO INTLK Is the voltage across P404-3 (+) <=> ground +5 VDC?	Replace the SWITCH ASSY XERO INTLK. (RRP 5.1)	Replace the PWBA MCU F. (RRP 8.4)



## ATC Sensor fail

Step	Check	Yes	No
	Possible causative parts: CRU (PL 5.1.15) HARN ASSY FRONT A (PL 5.1.9) SWITCH ASSY XERO INTLK (PL 5.1.4) PWBA MCU F (PL 8.1.5)		
1	Checking the CRU for installation Is the CRU installed surely?	Go to step 2.	Install the CRU surely.
2	Checking the harness for connection Is P/J403B connected securely?	Go to step 3.	Connect P/J403B surely.
3	Checking the ATC SENSOR for operation Does the Input Status change each time the CRU is installed or removed? Execute [Input 15-62 ATC Sensor] in Chapter 2 [Diagnostic]. Open COVER ASSY FRONT (PL 1.1.9) and check it.	Reconnect the connector of the PWBA MCU F.	Go to step 4.
4	Checking the SWITCH ASSY XERO INTLK for connection Is P/J404 connected surely?	Go to step 5.	Connect P/J404 surely.
5	Checking the SWITCH ASSY XERO INTLK for conductivity Is there conductivity between P/J404-1 <=> P/J404-3 when the CRU is installed?	Go to step 6.	Fix open and short circuit.
6	Checking +5 VDC power supply to the SWITCH ASSY XERO INTLK Is the voltage across P404-3 (+) <=> ground +5 VDC?	Replace the CRU.	Replace the PWBA MCU F. (RRP 8.4)

## XERO/DEVE Cartridge Life Over

Step	Check	Yes	No
	Possible causative parts: CRU (PL 5.1.15) PWBA CRUM CP1 (HSG) (PL 5.1.8) PWBA MCU F (PL 8.1.5)		
1	Checking the CRU for installation Is the CRU installed surely?	Go to step 2.	Install the CRU surely.
2	Checking the PWBA CRUM CP1 (HSG) for installation Is the PWBA CRUM CP1 (HSG) installed correctly?	Go to step 3.	Install the PWBA CRUM CP1 (HSG) correctly.
3	Checking the PWBA CRUM CP1 (HSG) for connection Are P/J126 and P/J419 connected surely?	Go to step 4.	Connect P/J126 and P/J419 surely.

Step	Check	Yes	No
4	Checking conductivity between the PWBA CRUM CP1 (HSG) and the PWBA MCU F Is there conductivity on each wire between P/J126 <=> P/J419?	Go to step 5.	Fix open and short circuit.
5	Checking +5 VDC power supply to the PWBA CRUM CP1 (HSG) Is the voltage across P126-6 (+) <=> ground +5 VDC?	Replace the PWBA CRUM CP1 (HSG). (RRP 5.3)	Replace the PWBA MCU F. (RRP 8.4)

### **XERO/DEVE Cartridge CRUM Communication fail**

Step	Check	Yes	No
	Possible causative parts: CRU (PL 5.1.15) PWBA CRUM CP1 (HSG) (PL 5.1.8) PWBA MCU F (PL 8.1.5)		
1	Checking the CRU for installation Is the CRU installed surely?	Go to step 2.	Install the CRU surely.
2	Checking the PWBA CRUM CP1 (HSG) for installation Is the PWBA CRUM CP1 (HSG) installed correctly?	Go to step 3.	Install the PWBA CRUM CP1 (HSG) correctly.
3	Checking the PWBA CRUM CP1 (HSG) for connection Are P/J126 and P/J419 connected surely?	Go to step 4.	Connect P/J126 and P/J419 surely.
4	Checking conductivity between the PWBA CRUM CP1 (HSG) and the PWBA MCU F Is there conductivity on each wire between P/J126 <=> P/J419?	Go to step 5.	Fix open and short circuit.
5	Checking +5 VDC power supply to the PWBA CRUM CP1 (HSG) Is the voltage across P126-6 (+) <=> ground +5 VDC?	Replace the PWBA CRUM CP1 (HSG). (RRP 5.3)	Replace the PWBA MCU F. (RRP 8.4)

### **XERO/DEVE Cartridge CRUM Data Write fail**

Step	Check	Yes	No
	Possible causative parts: CRU (PL 5.1.15) PWBA CRUM CP1 (HSG) (PL 5.1.8) PWBA MCU F (PL 8.1.5)		
1	Checking the CRU for installation Is the CRU installed surely?	Go to step 2.	Install the CRU surely.

Step	Check	Yes	No
2	Checking the PWBA CRUM CP1 (HSG) for installation Is the PWBA CRUM CP1 (TONER) installed correctly?	Go to step 3.	Install the PWBA CRUM CP1 (TONER) correctly.
3	Checking the PWBA CRUM CP1 (HSG) for connection Are P/J126 and P/J419 connected surely?	Go to step 4.	Connect P/J126 and P/J419 surely.
4	Checking conductivity between the PWBA CRUM CP1 (HSG) and the PWBA MCU F Is there conductivity on each wire between P/J126 <=> P/J419?	Go to step 5.	Fix open and short circuit.
5	Checking +5 VDC power supply to the PWBA CRUM CP1 (HSG) Is the voltage across P126-6 (+) <=> ground +5 VDC?	Replace the PWBA CRUM CP1 (HSG). (RRP 5.3)	Replace the PWBA MCU F. (RRP 8.4)

### **XERO/DEVE Cartridge CRUM ID fail**

Step	Check	Yes	No
	Possible causative parts: CRU (PL 5.1.15) PWBA CRUM CP1 (HSG) (PL 5.1.8) PWBA MCU F (PL 8.1.5)		
1	Checking the CRU for installation Is the CRU installed surely?	Go to step 2.	Install the CRU surely.
2	Checking the PWBA CRUM CP1 (HSG) for installation Is the PWBA CRUM CP1 (HSG) installed correctly?	Go to step 3.	Install the PWBA CRUM CP1 (HSG) correctly.
3	Checking the PWBA CRUM CP1 (HSG) for connection Are P/J126 and P/J419 connected surely?	Go to step 4.	Connect P/J126 and P/J419 surely.
4	Checking conductivity between the PWBA CRUM CP1 (HSG) and the PWBA MCU F Is there conductivity on each wire between P/J126 <=> P/J419?	Go to step 5.	Fix open and short circuit.
5	Checking +5 VDC power supply to the PWBA CRUM CP1 (HSG) Is the voltage across P126-6 (+) <=> ground +5 VDC?	Replace the PWBA CRUM CP1 (HSG). (RRP 5.3)	Replace the PWBA MCU F. (RRP 8.4)

## Toner Cartridge CRUM Communication fail

Step	Check	Yes	No
	Possible causative parts: CRU (PL 5.1.15) PWBA CRUM CP1 (TONER) (PL 5.1.8) PWBA MCU F (PL 8.1.5)		
1	Checking the CRU for installation Is the CRU installed surely?	Go to step 2.	Install the CRU surely.
2	Checking the PWBA CRUM CP1 (TONER) for installation Is the PWBA CRUM CP1 (TONER) installed correctly?	Go to step 3.	Install the PWBA CRUM CP1 (TONER) correctly.
3	Checking the PWBA CRUM CP1 (TONER) for connection Are P/J127 and P/J419 connected surely?	Go to step 4.	Connect P/J127 and P/J419 surely.
4	Checking conductivity between the PWBA CRUM CP1 (TONER) and the PWBA MCU F Is there conductivity on each wire between P/J127 <=> P/J419?	Go to step 5.	Fix open and short circuit.
5	Checking +5 VDC power supply to the PWBA CRUM CP1 (TONER) Is the voltage across P127-6 (+) <=> ground +5 VDC?	Replace the PWBA CRUM CP1 (TONER). (RRP 5.4)	Replace the PWBA MCU F. (RRP 8.4)

## MCU Toner Cartridge CRUM Data Write fail

Step	Check	Yes	No
	Possible causative parts: CRU (PL 5.1.15) PWBA CRUM CP1 (TONER) (PL 5.1.8) PWBA MCU F (PL 8.1.5)		
1	Checking the CRU for installation Is the CRU installed surely?	Go to step 2.	Install the CRU surely.
2	Checking the PWBA CRUM CP1 (TONER) for installation Is the PWBA CRUM CP1 (TONER) installed correctly?	Go to step 3.	Install the PWBA CRUM CP1 (TONER) correctly.
3	Checking the PWBA CRUM CP1 (TONER) for connection Are P/J127 and P/J419 connected surely?	Go to step 4.	Connect P/J127 and P/J419 surely.
4	Checking conductivity between the PWBA CRUM CP1 (TONER) and the PWBA MCU F Is there conductivity on each wire between P/J127 <=> P/J419?	Go to step 5.	Fix open and short circuit.

Step	Check	Yes	No
5	Checking +5 VDC power supply to the PWBA CRUM CP1 (TONER) Is the voltage across P127-6 (+) <=> ground +5 VDC?	Replace the PWBA CRUM CP1 (TONER). (RRP 5.4)	Replace the PWBA MCU F. (RRP 8.4)

### Toner Cartridge CRUM ID fail

Step	Check	Yes	No
	Possible causative parts: CRU (PL 5.1.15) PWBA CRUM CP1 (TONER) (PL 5.1.8) PWBA MCU F (PL 8.1.5)		
1	Checking the CRU for installation Is the CRU installed surely?	Go to step 2.	Install the CRU surely.
2	Checking the PWBA CRUM CP1 (TONER) for installation Is the PWBA CRUM CP1 (TONER) installed correctly?	Go to step 3.	Install the PWBA CRUM CP1 (TONER) correctly.
3	Checking the PWBA CRUM CP1 (TONER) for connection Are P/J127 and P/J419 connected surely?	Go to step 4.	Connect P/J127 and P/J419 surely.
4	Checking conductivity between the PWBA CRUM CP1 (TONER) and the PWBA MCU F Is there conductivity on each wire between P/J127 <=> P/J419?	Go to step 5.	Fix open and short circuit.
5	Checking +5 VDC power supply to the PWBA CRUM CP1 (TONER) Is the voltage across P127-6 (+) <=> ground +5 VDC?	Replace the PWBA CRUM CP1 (TONER). (RRP 5.4)	Replace the PWBA MCU F. (RRP 8.4)

### Main Motor stop error

Step	Check	Yes	No
	Possible causative parts: MOTOR ASSY 242 (PL 7.1.7) PWBA MCU F (PL 8.1.5)		
1	Checking the MOTOR ASSY 242 for installation Is the MOTOR ASSY 242 installed surely? Open the COVER REAR UPR (PL 1.2.5) and check it.	Go to step 2.	Install the CRU surely.

Step	Check	Yes	No
2	Checking the MOTOR ASSY 242 for operation Execute [Output 04-01 MAIN MOTOR ON] in Chapter 2 [Diagnostic]. Open the COVER REAR UPR (PL 1.2.5) and check it.	Go to step 6.	Go to step 3.
3	Checking the MOTOR ASSY 242 for connection Are P/J214 and P/J408 connected surely?	Go to step 4.	Connect P/J214 and P/J408 surely.
4	Checking conductivity between the MOTOR ASSY 242 and the PWBA MCU F Is there conductivity on each wire between P/J214 <=> P/J408?	Go to step 5.	Fix open and short circuit.
5	Checking +24 VDC power supply to the MOTOR ASSY 242 Are the voltages across P/J214-1/-2 (+) <=> ground +24 VDC?	Replace the MOTOR ASSY 242. (RRP 7.2)	Replace the PWBA MCU F. (RRP 8.4)
6	Checking the ROM version Check the ROM version. Is the ROM version latest?	Replace the PWBA MCU F. (RRP)	Upgrade the ROM to the latest version.

### Image Ready error

Step	Check	Yes	No
	Possible causative parts: PWBA ESS (PL 8.1.25) PWBA MCU F (PL 8.1.5)		
1	Checking the ROM version Check the ROM version. Is the ROM version latest?	Go to step 2.	Upgrade the ROM to the latest version.
2	Checking the PWBA ESS for connection. Are P/J402 and P/J301 connected surely?	Go to step 3.	Connect P/J402 and P/J301 surely.
3	Checking the PWBA ESS for operation Disconnect all the connectors from the PWBA ESS and reconnect them. Does the error still occur?	Replace the PWBA ESS.	Replace the PWBA MCU F. (RRP 8.4)

### Main Motor fail

Step	Check	Yes	No
	Possible causative parts: MOTOR ASSY 242 (PL 7.1.7) PWBA MCU F (PL 8.1.5)		

Step	Check	Yes	No
1	Checking the MOTOR ASSY 242 for operation (1) Does the MOTOR ASSY 242 operate properly? Execute [Output 04-01 MAIN MOTOR ON] in Chapter 2 [Diagnostic]. Open the COVER REAR UPR (PL 1.2.5) and check it.	Go to step 2.	Go to step 3.
2	Checking the MOTOR ASSY 242 for installation Is the MOTOR ASSY 242 installed securely? Open the COVER REAR UPR (PL 1.2.5) and check it.	Reconnect the connector of the PWBA MCU F.	Install the MOTOR ASSY 242 securely.
3	Checking the rotation of the rotor of the MOTOR ASSY 242 Can the rotor be rotated by hand without excessive load? Open the COVER REAR UPR (PL 1.2.5) and check it.	Go to step 4.	Install the MOTOR ASSY 242 surely.
4	Checking the MOTOR ASSY 242 for connection Are P/J214 and P/J408 connected surely?	Go to step 5.	Connect P/J214 and P/J408 surely.
5	Checking conductivity between the MOTOR ASSY 242 and the PWBA MCU F Is there conductivity on each wire between P/J214 <=> P/J408?	Go to step 6.	Fix open and short circuit.
6	Checking +24 VDC power supply to the MOTOR ASSY 242 Are the voltages across P214-1/-2 (+) <=> ground +24 VDC?	Replace the MOTOR ASSY 242. (RRP 7.2)	Replace the PWBA MCU F. (RRP 8.4)

## Drum Motor fail

Step	Check	Yes	No
	Possible causative parts: CRU (PL 5.1.15) MOTOR ASSY 242 (PL 7.1.7) PWBA MCU F (PL 8.1.5)		
1	Checking the CRU for installation Is the CRU installed securely?	Go to step 2.	Install the CRU securely.
2	Checking the MOTOR ASSY 242 for operation (1) Does the MOTOR ASSY 242 operate properly? Execute [Output 08-04 DRUM MOTOR ON] in Chapter 2 [Diagnostic]. Open the COVER REAR UPR (PL 1.2.5) and check it.	Go to step 3.	Go to step 4.
3	Checking the MOTOR ASSY 242 for installation Is the MOTOR ASSY 242 installed securely? Open the COVER REAR UPR (PL 1.2.5) and check it.	Reconnect the connector of the PWBA MCU F.	Install the MOTOR ASSY 242 securely.
4	Checking the rotation of the rotor of the MOTOR ASSY 242 Can the rotor be rotated by hand without excessive load? Open the COVER REAR UPR (PL 1.2.5) and check it.	Go to step 5.	Install the MOTOR ASSY 242 securely.

Step	Check	Yes	No
5	Checking the MOTOR ASSY 242 for connection Are P/J214 and P/J408 connected surely?	Go to step 6.	Connect P/J214 and P/J408 surely.
6	Checking conductivity between the MOTOR ASSY 242 and the PWBA MCU F Is there conductivity on each wire between P/J214 <=> P/J408?	Go to step 7.	Fix open and short circuit.
7	Checking +24 VDC power supply to the MOTOR ASSY 242 Are the voltages across P214-1/-2 (+) <=> ground +24 VDC?	Replace the MOTOR ASSY 242. (RRP 7.2)	Replace the PWBA MCU F. (RRP 8.4)

### Laser Power fail

Step	Check	Yes	No
	Possible causative parts: ROS ASSY-12 (PL 5.1.14) PWBA MCU F (PL 8.1.5)		
1	Checking the ROSS ASSY -12 for installation Is the ROSS ASSY-12 installed securely?	Go to step 2.	Install the ROS ASSY-12 securely.
2	Checking the ROSS ASSY-12 for connection Are P/J140 and P/J406 connected surely?	Go to step 3.	Connect P/J140 and P/J406 surely.
3	Checking conductivity between the ROS ASSY-12 and the PWBA MCU F Is there conductivity on each wire between P/J140 <=> P/J406?	Go to step 4.	Fix open and short circuit.
4	Checking +5 VDC power supply to the ROS ASSY-12 Is the voltage across P140-8 (+) <=> ground +5 VDC?	Replace the ROS ASSY-12. (RRP 5.8)	Replace the PWBA MCU F. (RRP 8.4)

### ROS Motor fail

Step	Check	Yes	No
	Possible causative parts: MOTOR ASSY-DISP 30K (PL 5.1.11) ROS ASSY-12 (PL 5.1.14) PWBA MCU F (PL 8.1.5)		



Step	Check	Yes	No
1	Checking the MOTOR ASSY-DISP 30K for operation Does the MOTOR ASSY-DISP 30K operate properly? Execute [Output 06-15 ROS MOTOR ON] in Chapter 2 [Diagnostic].	Go to step 4.	Go to step 2.
2	Checking the MOTOR ASSY-DISP 30K for connection Are P/J216 and P/J420 connected surely?	Go to step 3.	Connect P/J216 and P/J420 surely.
3	Checking +24 VDC power supply to the MOTOR ASSY-DISP 30K Is the voltage across J216-1 (+) <=> ground +24 VDC?	Replace the MOTOR ASSY-DISP 30K. (RRP 5.6)	Replace the PWBA MCU F. (RRP 8.4)
4	Checking the ROSS ASSY -12 for installation Is the ROSS ASSY-12 installed securely?	Go to step 5.	Install the ROSS ASSY-12 securely.
5	Checking the ROSS ASSY-12 for connection Are P/J130, P/J620 and P/J406 connected surely?	Go to step 6.	Connect P/J130, P/J620 and P/J406 surely.
6	Checking conductivity between the ROS ASSY-12 and the PWBA MCU F Is there conductivity on each wire between P/J130 <=> P/J406?	Go to step 7.	Fix open and short circuit.
7	Checking +24 VDC power supply to the ROS ASSY-12 Is the voltage across J130-5 (+) <=> ground +24 VDC?	Replace the ROS ASSY-12. (RRP 5.8)	Replace the PWBA MCU F. (RRP 8.4)

## Fuser On Time fail

Step	Check	Yes	No
	Possible causative parts: FUSER ASSY (PL 6.1.7) PWBA MCU F (PL 8.1.5)		
1	Checking the FUSER ASSY for paper jam Is there a paper jam in the FUSER ASSY? Open the COVER ASSY-LH (PL 4.2.8) and check it.	Remove the paper.	Go to step 2.
2	Checking the FUSER ASSY for installation Is the FUSER ASSY installed securely? Open the COVER ASSY-LH (PL 4.2.8) and check it.	Go to step 3.	Install the FUSER ASSY securely.
3	Checking conductivity between the junction connector pins of the FUSER ASSY Is there conductivity on each pin between the junction connector pins? Remove the FUSER ASSY and check it. <b>WARNING! Start the operation after the FUSER ASSY has cooled down.</b>	Go to step 4.	Replace the FUSER ASSY. (RRP 6.2)

Step	Check	Yes	No
4	Checking the resistance of the FUSER ASSY (1) Is the resistance of the MAIN LAMP across P/J600-1 and P/J600-11 less than or equal to 100 ohm?	Go to step 5.	Replace the FUSER ASSY. (RRP 6.2)
5	Checking the resistance of the FUSER ASSY (2) Is the resistance of the SUB LAMP1 across P/J600-4 and P/J600-11 less than or equal to 100 ohm?	Go to step 6.	Replace the FUSER ASSY. (RRP 6.2)
6	Checking the resistance of the FUSER ASSY (3) Is the resistance of the SUB LAMP2 across P/J600-7 and P/J600-11 less than or equal to 100 ohm?	Go to step 7	Replace the FUSER ASSY. (RRP 6.2)
7	Checking the resistance of the FUSER ASSY (4) Is there a disconnection in the Center STS between P/J131-1 and P/J131-2? Is the resistance of the Center STS across P/J131-1 and P/J131-2 more than or equal to 3 k-ohm?	Go to step 8.	Replace the FUSER ASSY. (RRP 6.2)
8	Checking the resistance of the FUSER ASSY (5) Is there a disconnection in the 2nd STS between P/J132-1 and P/J132-2? Is the resistance of the 2nd STS more than or equal to 3 k-ohm?	Go to step 9.	Replace the FUSER ASSY. (RRP 6.2)
9	Checking the resistance of the FUSER ASSY (6) Is there a disconnection in the Rear STS between P/J133-1 and P/J133-2? Is the resistance of the Rear STS across P/J133-1 and P/J133-2 more than or equal to 3 k-ohm?	Go to step 10.	Replace the FUSER ASSY. (RRP 6.2)
10	Checking the FUSER ASSY for connection Is P/J6 connected surely?	Go to step 11.	Connect P/J6 surely.
11	Checking conductivity between the FUSER ASSY and the POWER UNIT Is there conductivity on each wire between P/J600 <=> P/J6?	Go to step 12.	Fix open and short circuit.
12	Checking power supply to the FUSER ASSY Is a voltage equivalent to the power voltage applied between the following pins? P6-1 <=> P6-2 P6-1 <=> P6-3 P6-1 <=> P6-4	Replace the FUSER ASSY. (RRP 6.2)	Go to step 13.
13	Checking between the Power Unit and the PWBA MCU F for connection. Are P/J401 and P/J525 connected securely?	Replace the PWBA MCU F. (RRP 8.8)	Connect P/J401 and P/J525 Securely

## Over Heat Temp fail

Step	Check	Yes	No
	Possible causative parts: FUSER ASSY (PL 6.1.7) PWBA MCU F (PL 8.1.5)		

Step	Check	Yes	No
1	Checking the FUSER ASSY for installation Is the FUSER ASSY installed securely? Open the COVER ASSY-LH (PL 4.2.8) and check it.	Go to step 2.	Install the FUSER ASSY securely.
2	Checking the resistance of the FUSER ASSY (1) Is there a disconnection in the Center STS between J131-1 and J131-2? Is the resistance of the Center STS across J131-1 and J131-2 more than or equal to 3 k-ohm?	Go to step 3.	Replace the FUSER ASSY. (RRP 6.2)
3	Checking the resistance of the FUSER ASSY (2) Is there a disconnection in the 2nd STS between J132-1 and J132-2? Is the resistance of the 2nd STS across J132-1 and J132-2 more than or equal to 3 k-ohm?	Go to step 4.	Replace the FUSER ASSY. (RRP 6.2)
4	Checking the resistance of the FUSER ASSY (3) Is there a disconnection in the Rear STS between J133-1 and J133-2? Is the resistance of the Rear STS across J133-1 and J133-2 more than or equal to 3 k-ohm?	Go to step 5.	Replace the FUSER ASSY. (RRP 6.2)
5	Checking the FUSER ASSY for connection (1) Is P/J6 connected surely?	Go to step 6.	Connect P/J6 surely.
6	Checking the FUSER ASSY for connection (2) Are P/J410, P/J607, P/J600, P131, P132 and P133 connected surely?	Go to step 7.	Connect P/J410, P/J607, P/J600, P131, P132 and P133 surely
7	Checking conductivity between the FUSER ASSY and the POWER UNIT Is there conductivity on each wire between P/J600 <=> P/J6?	Go to step 8.	Fix open and short circuit.
8	Checking power supply to the FUSER ASSY Is a voltage equivalent to the power voltage applied between the following pins? P6-1 <=> P6-2 P6-1 <=> P6-3 P6-1 <=> P6-4	Replace the FUSER ASSY. (RRP 6.2)	Go to step 9.
9	Checking connection between the POWER UNIT and the PWBA MCU F Are P/J401 and P/J525 connected surely?	Replace the PWBA MCU F. (RRP 8.4)	Connect P/J401 and P/J525 surely.

## Center STS fail

Step	Check	Yes	No
	Possible causative parts: FUSER ASSY (PL 6.1.7) PWBA MCU F (PL 8.1.5)		

Step	Check	Yes	No
1	Checking the FUSER ASSY for installation Is the FUSER ASSY installed securely? Open the COVER ASSY-LH (PL 4.2.8) and check it.	Go to step 2.	Install the FUSER ASSY securely.
2	Checking the FUSER CONTROL SENSOR (FS1) for operation Does the Input Status change each time the FUSER ASSY is installed or removed? Execute [Input 10-20 FUSER CONTROL SENSOR (FS1)] in Chapter 2 [Diagnostic].	Go to step 4.	Go to step 3.
3	Checking the resistance of the FUSER ASSY Is there a disconnection in the Center STS between J131-1 and J131-2? Is the resistance of the Center STS across J131-1 and J131-2 more than or equal to 3 k-ohm?	Go to step 4.	Replace the FUSER ASSY. (RRP 6.2)
4	Checking the FUSER ASSY for connection Are P/J410, P/J607, P/J600, P131, P132 and P133 connected surely?	Replace the PWBA MCU F. (RRP 8.4)	Connect P/J410, P/J607, P/J600, P131, P132 and P133 surely.

## REAR STS fail

Step	Check	Yes	No
	Possible causative parts: FUSER ASSY (PL 6.1.7) PWBA MCU F (PL 8.1.5)		
1	Checking the FUSER ASSY for installation Is the FUSER ASSY installed securely? Open the COVER ASSY-LH (PL 4.2.8) and check it.	Go to step 2.	Install the FUSER ASSY securely.
2	Checking the FUSER CONTROL SENSOR (FS2) for operation Does the Input Status change each time the FUSER ASSY is installed or removed? Execute [Input 10-21 FUSER CONTROL SENSOR (FS2)] in Chapter 2 [Diagnostic].	Go to step 4.	Go to step 3.
3	Checking the resistance of the FUSER ASSY Is there a disconnection in the REAR STS between J132-1 and J132-2? Is the resistance of the REAR STS across J132-1 and J132-2 more than or equal to 3 k-ohm?	Go to step 4.	Replace the FUSER ASSY. (RRP 6.2)
4	Checking the FUSER ASSY for connection Are P/J410, P/J607, P/J600 and P132 connected surely?	Replace the PWBA MCU F. (RRP 8.4)	Connect P/J410, P/J607, P/J600 and P132 surely.

## P/R STS fail

Step	Check	Yes	No
	Possible causative parts: FUSER ASSY (PL 6.1.7) PWBA MCU F (PL 8.1.5)		
1	Checking the FUSER ASSY for installation Is the FUSER ASSY installed securely? Open the COVER ASSY-LH (PL 4.2.8) and check it.	Go to step 2.	Install the FUSER ASSY securely.
2	Checking the FUSER CONTROL SENSOR (PR) for operation Does the Input Status change each time the FUSER ASSY is installed or removed? Execute [Input 10-22 FUSER CONTROL SENSOR (PR)] in Chapter 2 [Diagnostic].	Go to step 4.	Go to step 3.
3	Checking the resistance of the FUSER ASSY Is there a disconnection in the P/R STS between J133-1 and J133-2? Is the resistance of the P/R STS across J133-1 and J133-2 more than or equal to 3 k-ohm?	Go to step 4.	Replace the FUSER ASSY. (RRP 6.2)
4	Checking the FUSER ASSY for connection Are P/J410, P/J607, P/J600 and P133 connected surely?	Replace the PWBA MCU F. (RRP 8.4)	Connect P/J410, P/J607, P/J600 and P133 surely.

## Cold-Sagging recovery fail

Step	Check	Yes	No
	Possible causative parts: FUSER ASSY (PL 6.1.7) POWER UNIT (PL 8.1.8) PWBA MCU F (PL 8.1.5)		
1	Checking the FUSER ASSY for paper jam Is there a paper jam in the FUSER ASSY? Open the COVER ASSY-LH (PL 4.2.8) and check it.	Go to step 2.	Remove the paper.
2	Checking the FUSER ASSY for installation Is the FUSER ASSY installed securely? Open the COVER ASSY-LH (PL 4.2.8) and check it.	Go to step 3.	Install the FUSER ASSY securely.
3	Checking the FUSER CONTROL SENSOR (FS1) for operation Does the Input Status change each time the FUSER ASSY is installed or removed? Execute [Input 10-20 FUSER CONTROL SENSOR (FS1)] in Chapter 2 [Diagnostic].	Go to step 5.	Go to step 4.

Step	Check	Yes	No
4	Checking the resistance of the FUSER ASSY Is there a disconnection in the Center STS between J131-1 and J131-2? Is the resistance of the Rear STS across J131-1 and J131-2 more than or equal to 3 k-ohm?	Go to step 7.	Replace the FUSER ASSY. (RRP 6.2)
5	Checking the FUSER CONTROL SENSOR (PR) for operation Does the Input Status change each time the FUSER ASSY is installed or removed? Execute [Input 10-22 FUSER CONTROL SENSOR (PR)] in Chapter 2 [Diagnostic].	Go to step 7.	Go to step 6.
6	Checking the resistance of the FUSER ASSY Is there a disconnection in the P/R STS between J133-1 and J133-2? Is the resistance of the P/R STS across J133-1 and J133-2 more than or equal to 3 k-ohm?	Go to step 7.	Replace the FUSER ASSY. (RRP 6.2)
7	Checking the FUSER ASSY for connection (1) Is P/J6 connected surely?	Go to step 8.	Connect P/J6 surely.
8	Checking the FUSER ASSY for connection (2) Are P/J410, P/J607, P/J600, P131 and P133 connected surely?	Replace the PWBA MCU F. (RRP 8.4)	Connect P/J410, P/J607, P/J600, P131 and P133 surely.

## Hot-Sagging recovery fail

Step	Check	Yes	No
	Possible causative parts: FUSER ASSY (PL 6.1.7) POWER UNIT (PL 8.1.8) PWBA MCU F (PL 8.1.5)		
1	Checking the FUSER ASSY for paper jam Is there a paper jam in the FUSER ASSY? Open the COVER ASSY-LH (PL 4.2.8) and check it.	Go to step 2.	Remove the paper.
2	Checking the FUSER ASSY for installation Is the FUSER ASSY installed securely? Open the COVER ASSY-LH (PL 4.2.8) and check it.	Go to step 3.	Install the FUSER ASSY securely.
3	Checking the FUSER CONTROL SENSOR (FS1) for operation Does the Input Status change each time the FUSER ASSY is installed or removed? Execute [Input 10-20 FUSER CONTROL SENSOR (FS1)] in Chapter 2 [Diagnostic].	Go to step 5.	Go to step 4.

Step	Check	Yes	No
4	Checking the resistance of the FUSER ASSY Is there a disconnection in the Center STS between J131-1 and J131-2? Is the resistance of the Rear STS across J131-1 and J131-2 more than or equal to 3 k-ohm?	Go to step 7.	Replace the FUSER ASSY. (RRP 6.2)
5	Checking the FUSER CONTROL SENSOR (PR) for operation Does the Input Status change each time the FUSER ASSY is installed or removed? Execute [Input 10-22 FUSER CONTROL SENSOR (PR)] in Chapter 2 [Diagnostic].	Go to step 7.	Go to step 6.
6	Checking the resistance of the FUSER ASSY Is there a disconnection in the P/R STS between J133-1 and J133-2? Is the resistance of the P/R STS across J133-1 and J133-2 more than or equal to 3 k-ohm?	Go to step 7.	Replace the FUSER ASSY. (RRP 6.2)
7	Checking the FUSER ASSY for connection (1) Is P/J6 connected surely?	Go to step 8.	Connect P/J6 surely.
8	Checking the FUSER ASSY for connection (2) Are P/J410, P/J607, P/J600, P131 and P133 connected surely?	Replace the PWBA MCU F. (RRP 8.4)	Connect P/J410, P/J607, P/J600, P131 and P133 surely.

## Fuser Fan fail

Step	Check	Yes	No
	Possible causative parts: FAN FUSER (PL 5.1.13) MOTOR ASSY 242 (PL 7.1.7) PWBA MCU F (PL 8.1.5)		
1	Checking the FAN FUSER for installation Is the FAN FUSER installed securely?	Go to step 2.	Install the FAN FUSER securely.
2	Checking the FAN FUSER for rotation Does the FAN FUSER rotate? (Visual check)	Go to step 7.	Go to step 3.
3	Checking the FAN FUSER for operation (1) Does the FAN FUSER operate properly? Execute [Output 04-02 FUSER FAN MOTOR (HIGH SPEED)] in Chapter 2 [Diagnostic].	Go to step 7.	Go to step 4.
4	Checking the FAN FUSER for operation (2) Is CN102 connected surely?	Go to step 5.	Connect CN102 surely.
5	Checking conductivity between the MOTOR ASSY 242 and the PWBA MCU F Is there conductivity on each wire between P/J214 <=> P/J408?	Go to step 6.	Fix open and short circuit.

Step	Check	Yes	No
6	Checking +24 VDC power supply to the FAN FUSER Is the voltage across P/J214-1 (+) <=> ground +24 VDC?	Go to step 7.	Replace the PWBA MCU F. (RRP 8.4)
7	Checking the FAN FUSER for operation (1) Does the FAN FUSER receive the signal? Execute [Input 10-60 FUSER FAN MOTOR SIGNAL] in Chapter 2 [Diagnostic].	Replace the FAN FUSER. (RRP 5.7)	Replace the PWBA MCU F. (RRP 8.4)

## Dispense Motor fail

Step	Check	Yes	No
	Possible causative parts: TONER CARTRIDGE (PL 5.1.16) GUIDE ASSY CTG30 SUB (PL 5.1.10) MOTOR ASSY-DISP 30K (PL 5.1.11) PWBA MCU F (PL 8.1.5)		
1	Checking the TRAY CARTRIDGE for installation Remove the TONER CARTRIDGE and reinstall it. Does it operate properly?	End of work	Go to step 2.
2	Checking the rotation of the gear of the GUIDE ASSY CTG30 SUB Does the gear located at the lower part of the GUIDE ASSY CTG30 SUB rotate smoothly?	Go to step 3.	Replace the obstacle part for rotation.
3	Checking the GUIDE ASSY CTG30 SUB for pipe clogging Is the pipe located at the lower part of the GUIDE ASSY CTG30 SUB clogged?	Go to step45.	Clean the pipe.
4	Checking the MOTOR ASSY-DISP 30K for operation Is the MOTOR ASSY-DISP 30K operated? Execute [Output 15-63 Dispense Motor] in Chapter 2 [Diagnostic].	Reconnect the connector of the PWBA MCU F.	Go to step 5.
5	Checking the MOTOR ASSY-DISP 30K for connection Are P/J216 and P/J420 connected surely?	Go to step 6.	Connect P/J216 and P/J420 securely
6	Checking conductivity between the MOTOR ASSY-DISP 30K and the PWBA MCU F Is there conductivity on each wire between P/J216 <=> P/J420?	Go to step 7.	Fix open and short circuit.
7	Checking +24 VDC power supply to the MOTOR ASSY-DISP 30K Is the voltage across J216-1 (+) <=> ground +24 VDC?	Replace the MOTOR ASSY-DISP 30K. (RRP 5.6)	Replace the PWBA MCU F. (RRP 8.4)



## RAM read/write Check fail

Step	Check	Yes	No
	Possible causative parts: PWBA MCU F (PL 8.1.5)		
1	Does an error occur when the power is turned OFF/ON?	Go to step 2.	End of work
2	Does an error occur when the power is turned ON again?	Replace the PWBA MCU F. (RRP 8.4)	End of work

## NVM data defect

Step	Check	Yes	No
	Possible causative parts: PWBA MCU F (PL 8.1.5)		
1	Does an error occur when the power is turned ON again?	Go to step 3.	Go to step 2.
2	Does the error still occur after the power is turned ON/OFF repeatedly several times?	Go to step 3.	End of work
3	Checking data on the NVRAM (1) Is data on the NVRAM accessible? Execute [NVM Edit] in Chapter 2 [Diagnostic].	Go to step 4.	Contact a Techni- cal Engineer
4	Checking data on the NVRAM (2) Change NVRAM data to the correct setup value, and then turn the power ON again. Does the error still occur?	Replace the PWBA MCU F. (RRP 8.4)	End of work

## NVM read/write cannot be executed

Step	Check	Yes	No
	Possible causative parts: PWBA MCU F (PL 8.1.5)		
1	Does an error occur when the power is turned ON again?	Go to step 3.	Go to step 2.
2	Does the error still occur after the power is turned ON/OFF repeatedly several times?	Go to step 3.	End of work
3	Checking data on the NVRAM (1) Is data on the NVRAM accessible? Execute [NVM Edit] in Chapter 2 [Diagnostic].	Go to step 4.	Contact a Techni- cal Engineer
4	Checking data on the NVRAM (2) Change NVRAM data to the correct setup value, and then turn the power ON again. Does the error still occur?	Replace the PWBA MCU F. (RRP 8.4)	End of work

## CPU Power to access NVM is not enough

Step	Check	Yes	No
	Possible causative parts: PWBA MCU F (PL 8.1.5)		
1	Does the error occur when the power is turned ON again?	Go to step 3.	Go to step 2.
2	Does the error still occur after the power is turned ON/OFF repeatedly several times?	Go to step 3.	End of work
3	Checking data on the NVRAM (1) Is data on the NVRAM accessible? Execute [NVM Edit] in Chapter 2 [Diagnostic].	Go to step 4.	Go to step 5.
4	Checking data on the NVRAM (2) Change NVRAM data to the correct setup value, and then turn the power ON again. Does the error still occur?	Replace the PWBA MCU F. (RRP 8.4)	End of work
5	Checking the ROM version Check the ROM version. Is the ROM version latest?	Replace the PWBA MCU F. (RRP 8.4)	Upgrade the ROM to the latest ver- sion.

## CRUM ASIC fail

Step	Check	Yes	No
	Possible causative parts: PWBA MCU F (PL 8.1.5)		
1	Does an error occur when the power is turned OFF/ON?	Go to step 2.	End of work
2	Checking the PWBA MCU F for connection Are P/J419, P/J126 and P/J127 connected surely?	Go to step 3.	Connect P/J419, P/J126 and P/ J127 surely.
3	Does the error occur when the power is turned ON again?	Replace the PWBA MCU F. (RRP 8.4)	End of work

## The PPM information is defect

Step	Check	Yes	No
	Possible causative parts: PWBA MCU F (PL 8.1.5)		
1	Does the error occur when the power is turned ON again?	Go to step 3.	Go to step 2.
2	Does the error still occur after the power is turned ON/OFF repeatedly several times?	Go to step 3.	End of work

Step	Check	Yes	No
3	Checking data on the NVRAM (1) Is data on the NVRAM accessible? Execute [NVM Edit] in Chapter 2 [Diagnostic].	Go to step 4.	Go to step 5.
4	Checking data on the NVRAM (2) Change NVRAM data to the correct setup value, and then turn the power ON again. Does the error still occur?	Replace the PWBA MCU F. (RRP 8.4)	End of work
5	Checking the ROM version Check the ROM version. Is the ROM version latest?	Replace the PWBA MCU F. (RRP 8.4)	Upgrade the ROM to the latest version.

## CRU Fan defect

Step	Check	Yes	No
	Possible causative parts: CRU FAN (PL 5.1.18) PWBA MCU F (PL 8.1.5)		
1	Checking the CRU FAN for rotation Is the CRU FAN FUSER rotating? (Visual check)	Go to step 7.	Go to step 2.
2	Checking the CRU FAN Is there any object blocking CRU FAN rotation?	Remove the object blocking the rotation.	Go to step 3.
3	Checking the CRU FAN for operation Does the CRU FAN operate properly? Check it using [Output 04-03 CRU FAN MOTOR ON] in Chapter 2, Diag.	Reconnect the connector of the PWBA MCU F.	Go to step 4.
4	Checking the CRU FAN for connection Is the harness connector of the CRU FAN connected to the junction connector P/J221 securely?	Go to step 5.	Connect the harness connector of the CRU FAN surely.
5	Checking the PWBA MCU F for connection Is P407 connected surely?	Go to step 6.	Connect P407 surely
6	Checking conductivity between the PWBA MCU F and the junction connector P/J221 Is there conductivity on each wire between P407 <=> P/J221?	Go to step 7.	Fix open and short circuit.
7	Checking +24 VDC power supply to the CRU FAN Is the voltage across J407-1 (+) <=> ground +24 VDC?	Replace the CRU FAN. (RRP 5.10)	Replace the PWBA MCU F. (RRP 8.4)

## OCT1 Defect

Step	Check	Yes	No
	Possible causative parts: SENSOR-PHOTO IN (PL 6.2.5) MOTOR ASSY-OFFSET (PL 6.2.3) PWBA EXIT (PL 8.1.4)		
1	Checking the SENSOR-PHOTO IN for operation Does the Input Status change from "0x0" to "0x1" each time the paper touches the SENSOR-PHOTO? Check it using [Input 07-033 OCT1 HOME POSITION SENSOR] in Chapter 2 [Diagnostic].	Go to step 5.	Go to step 2.
2	Checking the SENSOR-PHOTO IN for connection Are P/J117, P/J613 and P/J432 connected surely?	Go to step 3.	Connect P/J117, P/J613 and P/J432 securely
3	Checking conductivity between the SENSOR-PHOTO IN and the PWBA EXIT Is there conductivity on each wire between P/J117 <=> P/J432?	Go to step 4.	Fix open and short circuit.
4	Checking +5 VDC power supply to the SENSOR-PHOTO IN Is the voltage across J117-3 (+) <=> ground +5 VDC?	Replace the SENSOR-PHOTO IN. (RRP 6.5)	Replace the PWBA EXIT. (RRP 8.3)
5	Checking the MOTOR ASSY-OFFSET for operation Does the MOTOR ASSY-OFFSET operate properly? Check it using [Output 10-07 OFFSET MOTOR1 REVERSE ROTATION] in Chapter 2, Diag. Note: Continuous operation check is allowed up to twice for each direction.	Reconnect the connector of the PWBA MCU F.	Go to step 6.
6	Checking the PWBA MCU F for connection Are P/J206 and P/J432 connected surely?	Go to step 7.	Connect P/J206 and P/J432 securely
7	Checking conductivity between the MOTOR ASSY-OFFSET and the PWBA EXIT Is there conductivity on each wire between P/J206 <=> P/J432?	Go to step 8.	Fix open and short circuit.
8	Checking +24 VDC power supply to the CRU FAN Is the voltage across P206-5 (+) <=> ground +24 VDC?	Replace the MOTOR ASSY-OFFSET. (RRP 6.4)	Replace the PWBA EXIT. (RRP 8.3)

## Tray1 Size sensor broken

Step	Check	Yes	No
	Possible causative parts: SWITCH ASSY P S (PL 2.1.4) PWBA MCU F (PL 8.1.5)		

Step	Check	Yes	No
1	Checking the paper Is paper loaded in the Tray1 properly? Pull out the Tray1 to check it. (Visual check)	Go to step 2.	Load paper properly.
2	Checking the SWITCH ASSY P S for the TRAY1 for installation Is the SWITCH ASSY P S for the TRAY1 installed correctly? Pull out the TRAY1 to check it. (Visual check)	Go to step 3.	Reinstall the SWITCH ASSY P S for TRAY1.
3	Checking the SWITCH ASSY P S for the TRAY1 for operation Does the Input Status change each time the TRAY1 with paper loaded is pulled out and pushed in? Check it using [Input 07-01 TRAY1 SIZE SENSOR] in Chapter 2, Diag.	Reconnect the connector of the PWBA MCU F.	Go to step 4.
4	Checking the TRAY1 SWITCH ASSY P S for connection Are P/J109 and P/J412 connected surely?	Go to step 5.	Connect P/J109 and P/J412 securely
5	Checking conductivity between the TRAY1 SWITCH ASSY P S and the PWBA MCU F Is there conductivity on each wire between P/J109 <=> P/P/J412?	Go to step 6.	Fix open and short circuit.
6	Checking +5 VDC power supply to the TRAY1 SWITCH ASSY P S Is the voltage across J109-1 (+) <=> ground +5 VDC?	Replace the SWITCH ASSY P S for TRAY1. (RRP 2.1)	Replace the PWBA MCU F. (RRP 8.4)

## Tray2 Size sensor broken

Step	Check	Yes	No
	Possible causative parts: SWITCH ASSY P S (PL 2.1.4) PWBA MCU F (PL 8.1.5)		
1	Checking the paper Is paper loaded in the Tray2 properly? Pull out the Tray2 to check it. (Visual check)	Go to step 2.	Load paper properly.
2	Checking the SWITCH ASSY P S for the TRAY2 for installation Is the SWITCH ASSY P S for the TRAY2 installed correctly? Pull out the TRAY2 to check it. (Visual check)	Go to step 3.	Reinstall the SWITCH ASSY P S for TRAY2.
3	Checking the SWITCH ASSY P S for the TRAY2 for operation Does the Input Status change each time the TRAY2 with paper loaded is pulled out and pushed in? Check it using [Input 07-02 TRAY2 SIZE SENSOR] in Chapter 2, Diag.	Reconnect the connector of the PWBA MCU F.	Go to step 4.

Step	Check	Yes	No
4	Checking the SWITCH ASSY P S for TRAY2 for connection Are P/J110 and P/J412 connected surely?	Go to step 5.	Connect P/J110 and P/J412 securely
5	Checking conductivity between the SWITCH ASSY P S for TRAY2 and the PWBA MCU F Is there conductivity on each wire between P/J110 <=> P/J412?	Go to step 6.	Fix open and short circuit.
6	Checking +5 VDC power supply to the SWITCH ASSY P S for TRAY2 Is the voltage across J110-1 (+) <=> ground +5 VDC?	Replace the SWITCH ASSY P S for TRAY2. (RRP 2.2)	Replace the PWBA MCU F. (RRP 8.4)

### L/H Cover Assembly open

Step	Check	Yes	No
	Possible causative parts: SWITCH (PL 4.2.4) PWBA MCU F (PL 8.1.5)		
1	Checking the COVER ASSY-LH (PL 4.2.8) for opening and closing Does the COVER ASSY-LH (PL 4.2.8) open or close normally?	Go to step 2.	Check the COVER ASSY-LH for deformation and reinstall it.
2	Checking the SWITCH for operation Does the Input Status change from "0x0" to "0x1" each time the SWITCH is pressed? Execute [Input 01-01 L/H COVER] in Chapter 2 [Diagnostic]. Open the COVER ASSY-LH (PL 4.2.8) and check it.	Reconnect the connector of the PWBA MCU F.	Go to step 3.
3	Checking the SWITCH for connection Are P/J120 and P/J405 connected surely?	Go to step 4.	Connect P/J120 and P/J405 surely.
4	Checking conductivity between the SWITCH and the PWBA MCU F Is there conductivity on each wire between P/J120 <=> P/J405?	Go to step 5.	Fix open and short circuit.
5	Checking +24 VDC power supply to the SWITCH Is the voltage across J120-B1 (+) <=> ground +24 VDC?	Replace the SWITCH.	Replace the PWBA MCU F. (RRP 8.4)

## IOT Front Cover open

Step	Check	Yes	No
	Possible causative parts: SWITCH (PL 1.1.5) PWBA MCU F (PL 8.1.5)		
1	Checking the COVER ASSY FRONT (PL 1.1.9) for opening and closing Does the COVER ASSY FRONT (PL 1.1.9) open or close normally?	Go to step 2.	Check the COVER ASSY FRONT for deformation and re-install it.
2	Checking the SWITCH for operation Does the Input Status change from "0x0" to "0x1" each time the SWITCH is pressed? Execute [Input 01-12 FRONT COVER] in Chapter 2 [Diagnostic]. Open the COVER ASSY FRONT (PL 1.1.9) and check it.	Reconnect the connector of the PWBA MCU F.	Go to step 3.
3	Checking the SWITCH for connection Are P/J121 and P/J405 connected surely?	Go to step 4.	Connect P/J121 and P/J405 surely.
4	Checking conductivity between the SWITCH and the PWBA MCU F Is there conductivity on each wire between P/J121 <=> P/J405?	Go to step 5.	Fix open and short circuit.
5	Checking +24 VDC power supply to the SWITCH Is the voltage across J121-B1 (+) <=> ground +24 VDC?	Replace the SWITCH. (RRP 1.3)	Replace the PWBA MCU F. (RRP 8.4)

## L/H-L Cover open

Step	Check	Yes	No
	Possible causative parts: SWITCH-I/L, CAB (PL 4.1.3) PWBA MCU F (PL 8.1.5)		
1	Checking the COVER ASSY LH LOW C (PL 4.1.10) for opening and closing Does the COVER ASSY LH LOW C (PL 4.1.10) open or close normally?	Go to step 2.	Check the COVER ASSY LH LOW C for deformation and re-install it.
2	Checking the SWITCH-I/L, CAB for operation Does the Input Status change from "0x0" to "0x1" each time the SWITCH-I/L, CAB is pressed? Execute [Input 01-11 L/H Low COVER] in Chapter 2 [Diagnostic]. Open the COVER ASSY LH LOW C (PL 4.1.10) and check it.	Reconnect the connector of the PWBA MCU F.	Go to step 3.

Step	Check	Yes	No
3	Checking the SWITCH-I/L, CAB for connection Are P/J106 and P/J410 connected surely?	Go to step 4.	Connect P/J106 and P/J410 surely.
4	Checking conductivity between the SWITCH-I/L, CAB and the PWBA MCU F Is there conductivity on each wire between P/J106 <=> P/J410?	Go to step 5.	Fix open and short circuit.
5	Checking +5 VDC power supply to the SWITCH-I/L, CAB Is the voltage across J106-2 (+) <=> ground +5 VDC?	Replace the SWITCH-I/L, CAB. (RRP 4.2)	Replace the PWBA MCU F. (RRP 8.4)

### Toner Cartridge was PRENEAR empty

Step	Check	Yes	No
	Possible causative parts: TONER CARTRIDGE (PL 5.1.16) GUIDE ASSY CTG30 SUB (PL 5.1.10) MOTOR ASSY-DISP 30K (PL 5.1.11) PWBA CRUM CP1 (TONER) (PL 5.1.8) PWBA MCU F (PL 8.1.5)		
1	Checking remaining toner Does the TONER CARTRIDGE contain sufficient toner?	Go to step 2.	Replace the TONER CARTRIDGE.
2	Checking the TRAY CARTRIDGE for installation Remove the TONER CARTRIDGE and reinstall it. Does it operate properly?	End of work	Go to step 3.
3	Checking the rotation of the gear of the GUIDE ASSY CTG30 SUB Does the gear located at the lower part of the GUIDE ASSY CTG30 SUB rotate smoothly?	Go to step 4.	Replace the obstacle part for rotation.
4	Checking the GUIDE ASSY CTG30 SUB for pipe clogging Is the pipe located at the lower part of the GUIDE ASSY CTG30 SUB clogged?	Go to step 5.	Clean the pipe.
5	Checking the MOTOR ASSY-DISP 30K for operation Is he MOTOR ASSY-DISP 30K operated? Execute [Output 15-63 Dispense Motor] in Chapter 2 [Diagnostic].	Reconnect the connector of the PWBA MCU F.	Go to step 6.
6	Checking the MOTOR ASSY-DISP 30K for connection Are P/J216 and P/J420 connected surely?	Go to step 7.	Connect P/J216 and P/J420 surely.
7	Checking conductivity between the MOTOR ASSY-DISP 30K and the PWBA MCU F Is there conductivity on each wire between P/J216 <=> P/J420?	Go to step 8.	Fix open and short circuit.



Step	Check	Yes	No
8	Checking +24 VDC power supply to the MOTOR ASSY-DISP 30K Is the voltage across J216-1 (+) <=> ground +24 VDC?	Replace the MOTOR ASSY-DISP 30K. (RRP 5.6)	Replace the PWBA MCU F. (RRP 8.4)

### Drum life was near to end

Step	Check	Yes	No
	Possible causative parts: CRU (PL 5.1.15) PWBA CRUM CP1 (HSG) (PL 5.1.8) PWBA MCU F (PL 8.1.5)		
1	Checking the CRU for installation Is the CRU installed securely?	Go to step 2.	Install the CRU securely.
2	Checking the PWBA CRUM CP1 (HSG) for installation Is the PWBA CRUM CP1 (HSG) installed correctly?	Go to step 3.	Install the PWBA CRUM CP1 (HSG) correctly.
3	Checking the PWBA CRUM CP1 (HSG) for connection Are P/J126 and P/J419 connected surely?	Go to step 4.	Connect P/J126 and P/J419 surely.
4	Checking conductivity between the PWBA CRUM CP1 (HSG) and the PWBA MCU F Is there conductivity on each wire between P/J126 <=> P/J419?	Go to step 5.	Fix open and short circuit.
5	Checking +5 VDC power supply to the PWBA CRUM CP1 (HSG) Is the voltage across J126-1 (+) <=> ground +5 VDC?	Replace the PWBA CRUM CP1 (HSG). (RRP 5.3)	Replace the PWBA MCU F. (RRP 8.4)

### No paper in the select paper tray

Step	Check	Yes	No
	Possible causative parts: SENSOR (NO PAPER SENSOR) (PL 2.3.14) PWBA MCU F (PL 8.1.5)		
1	Checking paper Is Paper loaded in the selected TRAY?	Go to step 2.	Load paper.

Step	Check	Yes	No
2	<p>Checking the SENSOR (NO PAPER SENSOR) for operation Does the Input Status change from "0x0" to "0x1" each time the TRAY with paper loaded is pulled out or pushed in?</p> <p>For TRAY1: Execute [Input 07-07 TRAY1 NO PAPER SENSOR] in Chapter 2 [Diagnostic].</p> <p>For TRAY2: Execute [Input 07-08 TRAY2 NO PAPER SENSOR] in Chapter 2 [Diagnostic].</p>	Reconnect the connector of the PWBA MCU F.	Go to step 3.
3	<p>Checking the SENSOR (NO PAPER SENSOR) for connection</p> <p>For TRAY1: Are P/J101 and P/J409A connected surely?</p> <p>For TRAY2: Are P/J103 and P/J409B connected surely?</p>	Go to step 4.	Connect the connectors surely.
4	<p>Checking conductivity between the SENSOR (NO PAPER SENSOR) and the PWBA MCU F</p> <p>For TRAY1: Is there conductivity on each wire between P/J101 &lt;=&gt; P/J409A?</p> <p>For TRAY2: Is there conductivity on each wire between P/J103 &lt;=&gt; P/J409B?</p>	Go to step 5.	Fix open and short circuit.
5	<p>Checking +5 VDC power supply to the SENSOR (NO PAPER SENSOR)</p> <p>For TRAY1: Is the voltage across J101-3 (+) &lt;=&gt; ground +5 VDC?</p> <p>For TRAY2: Is the voltage across J103-3 (+) &lt;=&gt; ground +5 VDC?</p>	Replace the SENSOR (NO PAPER SENSOR) for the TRAY. (RRP 2.16)	Replace the PWBA MCU F. (RRP 8.4)

## Paper size mismatch in width

Step	Check	Yes	No
	<p>Possible causative parts: SWITCH ASSY P S (PL 2.1.4) FRONT SIDE GUIDE (PL 2.2.6) REAR SIDE GUIDE (PL 2.2.9) END GUIDE (PL 2.2.16) PWBA MCU F (PL 8.1.5)</p>		
1	<p>Checking the paper (1) Is paper loaded in the Tray properly? Pull out the TRAY to check it. (Visual check)</p>	Go to step 2.	Load paper properly.
2	<p>Checking the paper (2) Are the FRONT SIDE GUIDE, REAR SIDE GUIDE and END GUIDE of the TRAY1 or TRAY2 set correctly? Pull out the TRAY to check it. (Visual check)</p>	Go to step 3.	Set the parts properly.

Step	Check	Yes	No
3	Checking the SWITCH ASSY P S for installation Is the SWITCH ASSY P S for the TRAY1 or TRAY2 installed correctly? Pull out the TRAY to check it. (Visual check)	Go to step 4.	Install the SWITCH ASSY P S for each TRAY correctly. (RRP 2.1/RRP 2.2)
4	Checking the SWITCH ASSY P S for operation Does the Input Status change each time the TRAY 1 with paper loaded is pulled out or pushed in? For TRAY1: Execute [Input 07-01 TRAY1 SIZE SENSOR] in Chapter 2 [Diagnostic]. For TRAY2: Execute [Input 07-02 TRAY2 SIZE SENSOR] in Chapter 2 [Diagnostic].	Reconnect the connector of the PWBA MCU F.	Go to step 5.
5	Checking the SWITCH ASSY P S for connection For TRAY1: Are P/J109 and P/J412 connected surely? For TRAY2 Are P/J110 and P/J412 connected surely?	Go to step 6.	Connect P/J109, P/J110 and P/J412 surely.
6	Checking conductivity between the SWITCH ASSY P S and the PWBA MCU F For TRAY1: Is there conductivity on each wire between P/J109 <=> P/J412? For TRAY2 Is there conductivity on each wire between P/J110 <=> P/J412?	Go to step 7.	Fix open and short circuit.
7	Checking +5 VDC power supply to the SWITCH ASSY P S For TRAY1: Is the voltage across J109-1 (+) <=> ground +5 VDC? For TRAY2 Is the voltage across J110-1 (+) <=> ground +5 VDC?	Replace the SWITCH ASSY P S for the TRAY. (RRP 2.1/RRP 2.2)	Replace the PWBA MCU F. (RRP 8.4)

## Tray 1 Paper size mismatch in length

Step	Check	Yes	No
	Possible causative parts: SWITCH ASSY P S (PL 2.1.4) FRONT SIDE GUIDE (PL 2.2.6) REAR SIDE GUIDE (PL 2.2.9) END GUIDE (PL 2.2.16) ROLLER ASSY-TA (PL 4.1.8) SENSOR ASSY REGI (PL 4.5.7) CLUTCH ASSY REGI (PL 4.5.5) PWBA MCU F (PL 8.1.5)		
1	Checking the paper (1) Is paper loaded in the Tray1 properly? Pull out the Tray1 to check it. (Visual check)	Go to step 2.	Load paper properly.

Step	Check	Yes	No
2	Checking the paper (2) Are the FRONT SIDE GUIDE, REAR SIDE GUIDE and END GUIDE of the TRAY1 set correctly? Pull out the TRAY1 to check it. (Visual check)	Go to step 3.	Set the parts properly.
3	Checking the SWITCH ASSY P S for the TRAY1 for installation Is the SWITCH ASSY P S for the TRAY1 installed correctly? Pull out the TRAY1 to check it. (Visual check)	Go to step 4.	Install the SWITCH ASSY P S for the TRAY1 correctly. (RRP 2.1)
4	Checking the SWITCH ASSY P S for the TRAY1 for operation Does the Input Status change each time the TRAY 1 with paper loaded is pulled out or pushed in? Execute [Input 07-01 TRAY1 SIZE SENSOR] in Chapter 2 [Diagnostic].	Go to step 8.	Go to step 5.
5	Checking the SWITCH ASSY P S for the TRAY1 for connection Are P/J109 and P/J412 connected surely?	Go to step 6.	Connect P/J109 and P/J412 surely.
6	Checking conductivity between the SWITCH ASSY P S for the TRAY1 and the PWBA MCU F Is there conductivity on each wire between P/J109 <=> P/J412?	Go to step 7.	Fix open and short circuit.
7	Checking +5 VDC power supply to the SWITCH ASSY P S for the TRAY1 Is the voltage across J109-1 (+) <=> ground +5 VDC?	Replace the SWITCH ASSY P S for the STRAY1. (RRP 2.1)	Replace the PWBA MCU F. (RRP 8.4)
8	Checking the Roll for the TRAY1 Is the ROLLER ASSY (FEED), ROLLER ASSY (RETARD) or ROLLER ASSY (NUDGER) for transport worn or contaminated with paper dust? Pull out the TRAY1 and check it.	Go to step 9.	Clean or replace the ROLLER ASSY (FEED), ROLLER ASSY (RETARD) or ROLLER ASSY (NUDGER). (RRP 2.21/RRP 2.25/RRP 2.28)
9	Checking paper position Does the paper touch the SENSOR ASSY REGI? Open the COVER ASSY-LH (PL 4.2.8) and check it (visual check).	Remove the paper.	Go to step 10.
10	Checking the Roll (1) Is the ROLLER ASSY-TA for transport worn or contaminated with paper dust? Open the COVER ASSY-LH (PL 4.2.8) and check it.	Go to step 11.	Clean or replace the ROLLER ASSY-TA. (RRP 4.3)
11	Checking the Roll (2) Is the ROLLER of the TRANS ASSY REGI for transport (PL 4.5.1) worn or contaminated with paper dust? Open the COVER ASSY-LH (PL 4.2.8) and check it.	Go to step 12.	Clean or replace the TRANS ASSY REGI. (RRP 4.10)

Step	Check	Yes	No
12	Checking the SENSOR ASSY REGI for operation Does the Input Status change from "0x0" to "0x1" each time the paper touches the SENSOR ASSY REGI? Execute [Input 08-05 REGI SENSOR] in Chapter 2 [Diagnostic]. Open the COVER ASSY-LH (PL 4.2.8) and check it.	Go to step 16.	Go to step 13.
13	Checking the SENSOR ASSY REGI for connection Are P/J104 and P/J403B connected surely?	Go to step 14.	Connect P/J104 and P/J403B surely.
14	Checking conductivity between the SENSOR ASSY REGI and the PWBA MCU Is there conductivity on each wire between P/J104 <=> P/J403B?	Go to step 15.	Fix open and short circuit.
15	Checking +5 VDC power supply to the SENSOR ASSY REGI Is the voltage across J104-1 (+) <=> ground +5 VDC?	Replace the SENSOR ASSY REGI. (RRP 4.13)	Replace the PWBA MCU F. (RRP 8.4)
16	Checking the CLUTCH ASSY REGI H for operation Does the CLUTCH ASSY REGI H operate properly? Execute [Output 08-10 REGI CLUTCH] in Chapter 2 [Diagnostic].	Reconnect the connector of the PWBA MCU F.	Go to step 17.
17	Checking the CLUTCH ASSY REGI H for connection Are P/J215 and P/J403B connected surely?	Go to step 18.	Connect P/J215 and P/J403B surely.
18	Checking conductivity between the CLUTCH ASSY REGI H and the PWBA MCU Is there conductivity on each wire between P/J215 <=> P/J403B?	Go to step 19.	Fix open and short circuit.
19	Checking +24 VDC power supply to the CLUTCH ASSY REGI H Is the voltage across P215-2 (+) <=> ground +24 VDC?	Go to step 20.	Replace the PWBA MCU F. (RRP 8.4)
20	Checking the resistance of the CLUTCH ASSY REGI H Is the resistance across J215-1 and J215-2 approximately 240 ohm?	Replace the PWBA MCU F. (RRP 8.4)	Replace the CLUTCH ASSY REGI H. (RRP 4.11)

## Tray 2 Paper size mismatch in length

Step	Check	Yes	No
	Possible causative parts: SWITCH ASSY P S (PL 2.1.4) FRONT SIDE GUIDE (PL 2.2.6) REAR SIDE GUIDE (PL 2.2.9) END GUIDE (PL 2.2.16) SENSOR ASSY REGI (PL 4.5.7) CLUTCH ASSY REGI (PL 4.5.5) PWBA MCU F (PL 8.1.5)		

Step	Check	Yes	No
1	Checking the paper (1) Is paper loaded in the TRAY2 properly? Pull out the TRAY2 to check it. (Visual check)	Go to step 2.	Load paper properly.
2	Checking the paper (2) Are the FRONT SIDE GUIDE, REAR SIDE GUIDE and END GUIDE of the TRAY2 set correctly? Pull out the TRAY2 to check it. (Visual check)	Go to step 3.	Set the parts properly.
3	Checking the SWITCH ASSY P S for the TRAY2 for installation Is the SWITCH ASSY P S for the TRAY2 installed correctly? Pull out the TRAY2 to check it. (Visual check)	Go to step 4.	Install the SWITCH ASSY P S for the TRAY2 correctly. (RRP 2.2)
4	Checking the SWITCH ASSY P S for the TRAY2 for operation Does the Input Status change each time the TRAY 2 with paper loaded is pulled out or pushed in? Execute [Input 07-02 TRAY2 SIZE SENSOR] in Chapter 2 [Diagnostic].	Go to step 8.	Go to step 5.
5	Checking the SWITCH ASSY P S for the TRAY2 for connection Are P/J110 and P/J412 connected surely?	Go to step 6.	Connect P/J110 and P/J412 surely.
6	Checking conductivity between the SWITCH ASSY P S for the TRAY2 and the PWBA MCU F Is there conductivity on each wire between P/J110 <=> P/J412?	Go to step 7.	Fix open and short circuit.
7	Checking +5 VDC power supply to the SWITCH ASSY P S for the TRAY2 Is the voltage across J110-1 (+) <=> ground +5 VDC?	Replace the SWITCH ASSY P S for the TRAY2. (RRP 2.2)	Replace the PWBA MCU F. (RRP 8.4)
8	Checking the Roll for the TRAY2 Is the ROLLER ASSY (FEED), ROLLER ASSY (RETARD) or ROLLER ASSY (NUDGER) for transport worn or contaminated with paper dust? Pull out the TRAY2 and check it.	Go to step 9.	Clean or replace the ROLLER ASSY (FEED), ROLLER ASSY (RETARD) or ROLLER ASSY (NUDGER). (RRP 2.21/RRP 2.25/RRP 2.28)
9	Checking paper position Does the paper touch the SENSOR ASSY REGI? Open the COVER ASSY-LH (PL 4.2.8) and check it (visual check).	Remove the paper.	Go to step 10.
10	Checking the Roll (1) Is the ROLLER ASSY-TA for transport worn or contaminated with paper dust? Open the COVER ASSY-LH (PL 4.2.8) and check it.	Go to step 11.	Clean or replace the ROLLER ASSY-TA. (RRP 4.3)

Step	Check	Yes	No
11	Checking the Roll (2) Is the ROLLER of the TRANS ASSY REGI for transport (PL 4.5.1) worn or contaminated with paper dust? Open the COVER ASSY-LH (PL 4.2.8) and check it.	Go to step 12.	Clean or replace the TRANS ASSY REGI. (RRP 4.10)
12	Checking the SENSOR ASSY REGI for operation Does the Input Status change from "0x0" to "0x1" each time the paper touches the SENSOR ASSY REGI? Execute [Input 08-05 REGI SENSOR] in Chapter 2 [Diagnostic]. Open the COVER ASSY-LH (PL 4.2.8) and check it.	Go to step 16.	Go to step 13.
13	Checking the SENSOR ASSY REGI for connection Are P/J104 and P/J403B connected surely?	Go to step 14.	Connect P/J104 and P/J403B surely.
14	Checking conductivity between the SENSOR ASSY REGI and the PWBA MCU Is there conductivity on each wire between P/J104 <=> P/J403B?	Go to step 15.	Fix open and short circuit.
15	Checking +5 VDC power supply to the SENSOR ASSY REGI Is the voltage across J104-1 (+) <=> ground +5 VDC?	Replace the SENSOR ASSY REGI. (RRP 4.13)	Replace the PWBA MCU F. (RRP 8.4)
16	Checking the CLUTCH ASSY REGI H for operation Does the CLUTCH ASSY REGI H operate properly? Execute Output 08-10 REGI CLUTCH] in Chapter 2 [Diagnostic].	Reconnect the connector of the PWBA MCU F.	Go to step 17.
17	Checking the CLUTCH ASSY REGI H for connection Are P/J215 and P/J403B connected surely?	Go to step 18.	Connect P/J215 and P/J403B surely.
18	Checking conductivity between the CLUTCH ASSY REGI H and the PWBA MCU Is there conductivity on each wire between P/J215 <=> P/J403B?	Go to step 19.	Fix open and short circuit.
19	Checking +24 VDC power supply to the CLUTCH ASSY REGI H Is the voltage across P215-2 (+) <=> ground +24 VDC?	Go to step 20.	Replace the PWBA MCU F. (RRP 8.4)
20	Checking the resistance of the CLUTCH ASSY REGI H Is the resistance across J215-1 and J215-2 approximately 240 ohm?	Replace the PWBA MCU F. (RRP 8.4)	Replace the CLUTCH ASSY REGI H. (RRP 4.11)

## Face Down Tray1 FULL

Step	Check	Yes	No
	Possible causative parts: ACTUATOR FULLSTACK (PL 6.2.26) ACTUATOR (PL 6.2.27) SENSOR-PHOTO IN (PL 6.2.5) PWBA EXIT (PL 8.1.4) PWBA MCU F (PL 8.1.5)		
1	Checking the actuator for movement Does the ACTUATOR move up and down normally?	Go to step 2.	Reinstall the ACTUATOR and ACTUATOR FULLSTACK.
2	Checking the SENSOR-PHOTO IN for operation Does the Input Status change from "0x0" to "0x1" each time the paper touches the SENSOR-PHOTO IN? Execute [Input 07-30 FACE DOWN TRAY1 FULL STACK SENSOR] in Chapter 2 [Diagnostic].	Reconnect the connector of the PWBA MCU F.	Go to step 3.
3	Checking the SENSOR-PHOTO IN for connection Are P/J118, P/J613 and P/J432 connected surely?	Go to step 4.	Connect P/J118, P/J613 and P/J432 surely.
4	Checking conductivity between the SENSOR-PHOTO IN and the PWBA EXIT Is there conductivity on each wire between P/J118 <=> P/J432?	Go to step 5.	Fix open and short circuit.
5	Checking +5 VDC power supply to the SENSOR-PHOTO IN Is the voltage across J118-3 (+) <=> ground +5 VDC?	Replace the SENSOR-PHOTO IN. (RRP 6.5)	Go to step 6.
6	Checking the PWBA EXIT for connection Are P/J421 and P/J431 connected surely?	Go to step 7.	Connect P/J421 and P/J431 surely.
7	Checking conductivity between the PWBA EXIT and the PWBA MCU F Is there conductivity on each wire between P/J421 <=> P/J431?	Go to step 8.	Fix open and short circuit.
8	Checking +5 VDC power supply to the PWBA EXIT Is the voltage across J421-8 (+) <=> ground +5 VDC?	Replace the PWBA EXIT. (RRP 8.3)	Replace the PWBA MCU F. (RRP 8.4)

## Face Down Tray2 FULL

Step	Check	Yes	No
	Possible causative parts: WEIGHT ASSY-PAPER (PL 11.2.6) SENSOR (PL 11.2.52) PWBA EXIT (PL 8.1.4)		



Step	Check	Yes	No
1	Checking the actuator for movement Does the WEIGHT ASSY-PAPER move up and down normally?	Go to step 2.	Reinstall the WEIGHT ASSY-PAPER.
2	Checking the SENSOR for operation Does the Input Status change from "0x0" to "0x1" each time the paper touches the SENSOR? Execute [Input 07-31 FACE DOWN TRAY2 FULL STACK SENSOR] in Chapter 2 [Diagnostic].	Reconnect the connector of the PWBA MCU F.	Go to step 3.
3	Checking the SENSOR for connection Are P/J113, P/J606B and P/J434 connected surely?	Go to step 4.	Connect P/J113, P/J606B and P/J434 surely.
4	Checking conductivity between the SENSOR and the PWBA EXIT Is there conductivity on each wire between P/J113 <=> P/J434?	Go to step 5.	Fix open and short circuit.
5	Checking +5 VDC power supply to the SENSOR Is the voltage across J113-3 (+) <=> ground +5 VDC?	Replace the SENSOR. (RRP 11.17)	Go to step 6.
6	Checking the PWBA EXIT for connection Are P/J421 and P/J431 connected surely?	Go to step 7.	Connect P/J421 and P/J431 surely.
7	Checking conductivity between the PWBA EXIT and the PWBA MCU F Is there conductivity on each wire between P/J421 <=> P/J431?	Go to step 8.	Fix open and short circuit.
8	Checking +5 VDC power supply to the PWBA EXIT Is the voltage across J421-8 (+) <=> ground +5 VDC?	Replace the PWBA EXIT. (RRP 8.3)	Replace the PWBA MCU F. (RRP 8.4)

## Temperature SENSOR fail

Step	Check	Yes	No
	Possible causative parts: SENSOR HUM & TE (PL 5.1.5) PWBA MCU F (PL 8.1.5)		
1	Does the error still occur after the power is turned ON/OFF?	Go to step 2.	End of work
2	Checking the SENSOR HUM & TE for operation Does the Input Status of the SENSOR HUM & TE change when the COVER ASSY-LH (PL 4.2.8) is opened? Execute [Input 15-60 Temp Sensor] in Chapter 2 [Diagnostic].	Reconnect the connector on the PWBA MCU F.	Go to step 3.
3	Checking the SENSOR HUM & TE for connection Are P/J150 and P/J403B connected surely?	Go to step 4.	Connect P/J150 and P/J403B surely.

Step	Check	Yes	No
4	Checking conductivity between the SENSOR HUM & TE and the PWBA MCU F Is there conductivity on each wire between P/J150 <=> P/J403B?	Go to step 5.	Fix open or short circuit.
5	Checking +5 VDC power supply to the SENSOR HUM & TE Is the voltage across J150-1 (+) <=> ground (-) +5 VDC?	Replace the SENSOR HUM & TE. (RRP 5.2)	Replace the PWBA MCU F. (RRP 8.4)

## Humidity Sensor fail

Step	Check	Yes	No
	Possible causative parts: SENSOR HUM & TE (PL 5.1.5) PWBA MCU F (PL 8.1.5)		
1	Does the error still occur after the power is turned ON/OFF?	Go to step 2.	End of work
2	Checking the SENSOR HUM & TE for operation Does the Input Status of the SENSOR HUM & TE change when the COVER ASSY-LH (PL 4.2.8) is opened? Execute [Input 15-61 Hum Sensor] in Chapter 2 [Diagnostic].	Reconnect the connector on the PWBA MCU F.	Go to step 3.
3	Checking the SENSOR HUM & TE for connection Are P/J150 and P/J403B connected surely?	Go to step 4.	Connect P/J150 and P/J403B surely.
4	Checking conductivity between the SENSOR HUM & TE and the PWBA MCU F Is there conductivity on each wire between P/J150 <=> P/J403B?	Go to step 5.	Fix open or short circuit.
5	Checking +5 VDC power supply to the SENSOR HUM & TE Is the voltage across J150-1 (+) <=> ground (-) +5 VDC?	Replace the SENSOR HUM & TE. (RRP 5.2)	Replace the PWBA MCU F. (RRP 8.4)

## Prefeed Sensor #3 on JAM (Tray3 paper feed)

Step	Check	Yes	No
	Possible causative parts: ROLLER ASSY (FEED) (PL 9.4.20) ROLLER ASSY (RETARD) (PL 9.4.28) ROLLER ASSY (NUDGER) (PL 9.4.32) TRAY 1/2 FEED LIFT UP MOTOR (PL 9.4.2) SENSOR (PRE FEED SENSOR) (PL 9.4.15) TRAY MODULE PWB (PL 9.6.5) PWBA MCU F (PL 8.1.5)		
1	Checking paper condition Is the paper in the tray crumpled or damaged?	Replace the paper with a new and dry one.	Go to step 2.
2	Checking paper size setup Does the paper size in use match the size set for the TRAY3?	Go to step 3.	Replace the paper, or change the paper size setup.
3	Checking the Roll for the TRAY3 Is the ROLLER ASSY (FEED), ROLLER ASSY (RETARD) or ROLLER ASSY (NUDGER) for transport worn or contaminated with paper dust? Pull out the TRAY3 and check it.	Go to step 4.	Clean or replace the ROLLER ASSY (FEED), ROLLER ASSY (RETARD) or ROLLER ASSY (NUDGER). (RRP 9.28/RRP 9.32/RRP 9.35)
4	Checking paper position Does the paper touch the SENSOR (PRE FEED SENSOR) of the TRAY3 FEEDER (PL 9.2.7)? Open the LEFT COVER ASSEMBLY (PL 9.5.10) and check it (visual check).	Remove the paper.	Go to step 5.
5	Checking the SENSOR (PRE FEED SENSOR) for the TRAY3 for operation Does the Input Status change from "0x0" to "0x1" each time the paper touches the SENSOR (PRE FEED SENSOR) for the TRAY3? Execute [Input 08-20 PreFEED SENSOR3] in Chapter 2 [Diagnostic].	Go to step 12.	Go to step 6.
6	Checking the SENSOR (PRE FEED SENSOR) for the TRAY3 for connection Are P/J103, P/J661B and P/J549B connected surely?	Go to step 7.	Connect P/J103, P/J661 and P/J549B surely.
7	Checking conductivity between the SENSOR (PRE FEED SENSOR) for the TRAY3 and the TRAY MODULE PWB Is there conductivity on each wire between P/J103B <=> P/J549B?	Go to step 8.	Fix open and short circuit.
8	Checking +5 VDC power supply to the SENSOR (PRE FEED SENSOR) for the TRAY3 Is the voltage across P/J103B-1 (+) <=> ground +5 VDC?	Replace the SENSOR (PRE FEED SENSOR) for the TRAY3. (RRP 9.25)	Go to step 9.

Step	Check	Yes	No
9	Checking connection between the TRAY MODULE PWB and the PWBA MCU F Are P/J541 and P/J413 connected surely?	Go to step 10.	Connect P/J541 and P/J413B surely.
10	Checking conductivity between the TRAY MODULE PWB and the PWBA MCU F Is there conductivity on each wire between P/J541 <=> P/J413?	Go to step 11.	Fix open and short circuit.
11	Checking +24 VDC power supply to the TRAY MODULE PWB Is the voltage across P/J541-8 (+) <=> ground +24 VDC?	Replace the TRAY MODULE PWB. (RRP 9.47)	Replace the PWBA MCU F. (RRP 8.4)
12	Checking the TRAY 1/2 FEED LIFT UP MOTOR for the TRAY3 for operation Does the TRAY 1/2 FEED LIFT UP MOTOR for the TRAY3 operate properly? Execute [Output 08-14 TRAY3 FEED MOTOR] in Chapter 2 [Diagnostic].	Replace the PWBA MCU F. (RRP 8.4)	Go to step 13.
13	Checking the TRAY 1/2 FEED LIFT UP MOTOR for the TRAY3 for connection Are P/J220B, P/J661B and P/J549B connected surely?	Go to step 14.	Connect P/J220, P/J661B and P/J549B surely.
14	Checking the TRAY 1/2 FEED LIFT UP MOTOR for the TRAY3 for operation (3) Replace the TRAY 1/2 FEED LIFT UP MOTOR for the TRAY3 with that for the TRAY4. Does the replaced motor operate properly? Execute [Output 08-14 TRAY3 FEED MOTOR] in Chapter 2 [Diagnostic].	Reinstall the TRAY 1/2 FEED LIFT UP MOTOR for the TRAY4 as it previously was and replace the motor for the TRAY3 with a new one. (RRP 9.16)	Go to step 15.
15	Checking conductivity the TRAY 1/2 FEED LIFT UP MOTOR for the TRAY3 Reinstall the TRAY 1/2 FEED LIFT UP MOTORS for the TRAY3 and TRAY4 as they previously were. Check the conductivity between the TRAY 1/2 FEED LIFT UP MOTOR for the TRAY3 and the TRAY MODULE PWB. Is there conductivity on each wire between P/J220B <=> P/J549B?	Go to step 16.	Fix open and short circuit.
16	Checking +24 VDC power supply to the TRAY 1/2 FEED LIFT UP MOTOR for the TRAY3 Is the voltage across P/J220B-3 (+) <=> ground +24 VDC?	Replace the TRAY 1/2 FEED LIFT UP MOTOR for the TRAY3. (RRP 9.16)	Go to step 9.

## Tray 3 Feed Out Sensor on JAM (Tray 3 paper feed)

Step	Check	Yes	No
	Possible causative parts: ROLLER ASSY (FEED) (PL 9.4.20) ROLLER ASSY (RETARD) (PL 9.4.28) ROLLER ASSY (NUDGER) (PL 9.4.32) SENSOR (PRE FEED SENSOR) (PL 9.4.15) TRAY 3 FEED OUT SENSOR (PL 9.5.3) TRAY MODULE PWB (PL 9.6.1) PWBA MCU F (PL 8.1.5)		
1	Checking paper condition Is the paper in the tray crumpled or damaged?	Replace the paper with a new and dry one.	Go to step 2.
2	Checking paper size setup Does the size of paper in use match the size set for the TRAY3?	Go to step 3.	Replace the paper or change the paper size setup.
3	Checking the Roll for the TRAY3 Is the ROLLER ASSY (FEED), ROLLER ASSY (RETARD) or ROLLER ASSY (NUDGER) for transport worn or contaminated with paper dust? Pull out the TRAY3 and check it.	Go to step 4.	Clean or replace the ROLLER ASSY (FEED), ROLLER ASSY (RETARD) or ROLLER ASSY (NUDGER). (RRP 9.28/RRP 9.32/ RRP 9.35)
4	Checking paper position Does the paper touch the SENSOR (PRE FEED SENSOR) of the TRAY3 FEED OUT SENSOR or the TRAY 3 FEEDER (PL 9.2.7)? Open the LEFT COVER ASSEMBLY (PL 9.5.10) and check it (visual check).	Remove the paper.	Go to step 5.
5	Checking the TRAY 3 FEED OUT SENSOR for operation Does the Input Status change from "0x0" to "0x1" each time the paper touches the TRAY 3 FEED OUT SENSOR? Execute [Input 08-08 T/A F/03 SENSOR] in Chapter 2 [Diagnostic]. Open the LEFT COVER ASSEMBLY (PL 9.5.10) and check it.	Go to step 12.	Go to step 6.
6	Checking the TRAY 3 FEED OUT SENSOR for connection Are P/J821, P/J841 and P/J548 connected surely?	Go to step 7.	Connect P/J821, P/J841 and P/J548 surely.
7	Checking conductivity between the TRAY 3 FEED OUT SENSOR and the TRAY MODULE PWB Is there conductivity on each wire between P/J821 <=> P/J548?	Go to step 8.	Fix open and short circuit.
8	Checking +5 VDC power supply to the TRAY 3 FEED OUT SENSOR Is the voltage across P/J821-3 (+) <=> ground +5 VDC?	Replace the TRAY 3 FEED OUT SNESOR. (RRP 9.39)	Go to step 9.

Step	Check	Yes	No
9	Checking connection between the TRAY MODULE PWB and the PWBA MCU F (1) Are P/J541 and P/J413 connected surely?	Go to step 10.	Connect P/J541 and P/J413 surely.
10	Checking conductivity between the TRAY MODULE and the PWBA MCU F Is there conductivity on each wire between P/J541 <=> P/J413?	Go to step 11.	Fix open and short circuit.
11	Checking +24 VDC power supply to the TRAY MODULE PWB Is the voltage across P/J541-8 (+) <=> ground +24 VDC?	Replace the TRAY MODULE PWB. (RRP 9.47)	Replace the PWBA MCU F. (RRP 8.4)
12	Checking the SENSOR (PRE FEED SENSOR) for the TRAY3 for operation Does the Input Status change from "0x0" to "0x1" each time the paper touches the SENSOR (PRE FEED SENSOR) for the TRAY3? Execute [Input 08-20 PreFEED SENSOR3] in Chapter 2 [Diagnostic]. Open the LEFT COVER ASSEMBLY (PL 9.5.10) and check it.	Replace the PWBA MCU F. (RRP 8.4)	Go to step 13.
13	Checking the SENSOR (PRE FEED SENSOR) for the TRAY3 for connection Are P/J103B, P/J661B and P/J549B connected surely?	Go to step 14.	Connect P/J103B, P/J661B and P/J549B surely.
14	Checking conductivity between the SENSOR (PRE FEED SENSOR) for the TRAY3 and the TRAY MODULE PWB Is there conductivity on each wire between P/J103B <=> P/J549B?	Go to step 15.	Fix open and short circuit.
15	Checking +5 VDC power supply to the SENSOR (PRE FEED SENSOR) for the TRAY2 Is the voltage across P/J103B-1 (+) <=> ground +5 VDC?	Replace the SENSOR (PRE FEED SENSOR). (RRP 9.25)	Go to step 16.
16	Checking connection between the TRAY MODULE PWB and the PWBA MCU F Are P/J541 and P/J413 connected surely?	Go to step 17.	Connect P/J541 and P/J413 surely.
17	Checking conductivity between the TRAY MODULE and the PWBA MCU F Is there conductivity on each wire between P/J541 <=> P/J413?	Go to step 18.	Fix open and short circuit.
18	Checking +24 VDC power supply to the TRAY MODULE PWB Is the voltage across P/J541-8 (+) <=> ground +24 VDC?	Replace the TRAY MODULE PWB. (RRP 9.47)	Replace the PWBA MCU F. (RRP 8.4)

## Tray 2 Feed Out Sensor on JAM (Tray 3 paper feed)

Step	Check	Yes	No
	Possible causative parts: ROLLER ASSY (FEED) (PL 9.4.20) ROLLER ASSY (RETARD) (PL 9.4.28) ROLLER ASSY (NUDGER) (PL 9.4.32) SENSOR (PL 4.5.18) TRAY 3 FEED OUT SENSOR (PL 9.5.3) TRAY MODULE PWB (PL 9.6.1) PWBA MCU F (PL 8.1.5)		
1	Checking paper condition Is the paper in the tray crumpled or damaged?	Replace the paper with a new and dry one.	Go to step 2.
2	Checking the paper size setup Does the paper size in use match the size set for the TRAY3?	Go to step 3.	Replace the paper or change the paper size setup.
3	Checking the Roll for the TRAY3 Is the ROLLER ASSY (FEED), ROLLER ASSY (RETARD) or ROLLER ASSY (NUDGER) for transport worn or contaminated with paper dust? Pull out the TRAY3 and check it.	Go to step 4.	Clean or replace the ROLLER ASSY (FEED), ROLLER ASSY (RETARD) or ROLLER ASSY (NUDGER). (RRP 9.28/RRP 9.32/ RRP 9.35)
4	Checking paper position (1) Does the paper touch the SENSOR? Open the COVER ASSY LH LOW C (PL 4.1.10) and check it (visual check).	Remove the paper.	Go to step 5.
5	Checking paper position (2) Does the paper touch the TRAY 3 FEED SENSOR? Open the LEFT COVER ASSEMBLY (PL 9.5.10) and check it (visual check).	Remove the paper.	Go to step 6.
6	Checking the SENSOR for operation Does the Input Status change from "0x0" to "0x1" each time the paper touches the SENSOR? Execute [Input 08-06 FEED OUT#2 SENSOR] in Chapter 2 [Diagnostic]. Open the COVER ASSY LH LOW C (PL 4.1.10) and check it.	Go to step 10.	Go to step 7.
7	Checking the SENSOR for connection Are P/J105, P/J608 and P/J410 connected surely?	Go to step 8.	Connect P/J105, P/J608 and P/J410 surely.
8	Checking conductivity between the SENSOR and the PWBA MCU F Is there conductivity on each wire between P/J105 <=> P/J410?	Go to step 9.	Fix open and short circuit.

Step	Check	Yes	No
9	Checking +5 VDC power supply to the SENSOR Is the voltage across P/J105-1 (+) <=> ground +5 VDC?	Replace the SENSOR. (RRP 4.15)	Replace the PWBA MCU F. (RRP 8.4)
10	Checking the TRAY 3 FEED OUT SENSOR for the TRAY3 for operation Does the Input Status change from "0x0" to "0x1" each time the paper touches the TRAY 3 FEED OUT SENSOR for the TRAY3? Execute [Input 08-20 PreFEED SENSOR3] in Chapter 2 [Diagnostic]. Open the LEFT COVER ASSEMBLY (PL 9.5.10) and check it.	Replace the PWBA MCU F. (RRP 8.4)	Go to step 11.
11	Checking the TRAY 3 FEED OUT SENSOR for connection Are P/J821, P/J841 and P/J548 connected surely?	Go to step 12.	Connect P/J821, P/J841 and P/J548 surely.
12	Checking conductivity between the TRAY 3 FEED OUT SENSOR and the TRAY MODULE PWB Is there conductivity on each wire between P/J821 <=> P/J548?	Go to step 13.	Fix open and short circuit.
13	Checking +5 VDC power supply to the TRAY 3 FEED OUT SENSOR Is the voltage across P/J821-3 (+) <=> ground +5 VDC?	Replace the TRAY 3 FEED OUT SNESOR. (RRP 9.39)	Go to step 14.
14	Checking connection between the TRAY MODULE PWB and the PWBA MCU F Are P/J541 and P/J413 connected surely?	Go to step 15.	Connect P/J541 and P/J413 surely.
15	Checking conductivity between the TRAY MODULE and the PWBA MCU F Is there conductivity on each wire between P/J541 <=> P/J413?	Go to step 16.	Fix open and short circuit.
16	Checking +24 VDC power supply to the TRAY MODULE PWB Is the voltage across P/J541-8 (+) <=> ground +24 VDC?	Replace the TRAY MODULE PWB. (RRP 9.47)	Replace the PWBA MCU F. (RRP 8.4)

### Registration Sensor on JAM (Tray3 paper feed)

Step	Check	Yes	No
	Possible causative parts: ROLLER ASSY (FEED) (PL 9.4.20) ROLLER ASSY (RETARD) (PL 9.4.28) ROLLER ASSY (NUDGER) (PL 9.4.32) SENSOR ASSY REGI (PL 4.5.7) TRAY 3 FEED OUT SENSOR (PL 9.5.3) TRAY MODULE PWB (PL 9.6.1) PWBA MCU F (PL 8.1.5)		
1	Checking paper condition Is the paper in the tray crumpled or damaged?	Replace the paper with a new and dry one.	Go to step 2.



Step	Check	Yes	No
2	Checking the paper size setup Does the paper size in use match the size set for the TRAY3?	Go to step 3.	Replace the paper or change the paper size setup.
3	Checking the Roll for the TRAY3 Is the ROLLER ASSY (FEED), ROLLER ASSY (RETARD) or ROLLER ASSY (NUDGER) for transport worn or contaminated with paper dust? Pull out the TRAY3 and check it.	Go to step 4.	Clean or replace the ROLLER ASSY (FEED), ROLLER ASSY (RETARD) or ROLLER ASSY (NUDGER). (RRP 9.28/RRP 9.32/RRP 9.35)
4	Checking paper position (1) Does the paper touch the SENSOR ASSY REGI? Open the COVER ASSY-LH (PL 4.2.8) and check it (visual check).	Remove the paper.	Go to step 5.
5	Checking paper position (2) Does the paper touch the TRAY 3 FEED SENSOR? Open the LEFT COVER ASSEMBLY (PL 9.5.10) and check it (visual check).	Remove the paper.	Go to step 6.
6	Checking the SENSOR ASSY REGI for operation Does the Input Status change from "0x0" to "0x1" each time the paper touches the SENSOR ASSY REGI? Execute [Input 08-05 REGI SENSOR] in Chapter 2 [Diagnostic]. Open the COVER ASSY-LH (PL 4.2.8) and check it.	Go to step 10.	Go to step 7.
7	Checking the SENSOR ASSY REGI for connection Are P/J104 and P/J403B connected surely?	Go to step 8.	Connect P/J104 and P/J403B surely.
8	Checking conductivity between the SENSOR ASSY REGI and the PWB A MCU F Is there conductivity on each wire between P/J104 <=> P/J409B?	Go to step 9.	Fix open and short circuit.
9	Checking +5 VDC power supply to the SENSOR ASSY REGI Is the voltage across P/J104-1 (+) <=> ground +5 VDC?	Replace the SENSOR ASSY REGI. (RRP 4.13)	Replace the PWBA MCU F. (RRP 8.4)
10	Checking the TRAY 3 FEED OUT SENSOR for operation Does the Input Status change from "0x0" to "0x1" each time the paper touches the TRAY 3 FEED OUT SENSOR? Execute [Input 08-08 T/A F/03 SENSOR] in Chapter 2 [Diagnostic]. Open the LEFT COVER ASSEMBLY (PL 9.5.10) and check it.	Replace the PWBA MCU F. (RRP 8.4)	Go to step 11.
11	Checking the TRAY 3 FEED OUT SENSOR for connection Are P/J821, P/J841 and P/J548 connected surely?	Go to step 12.	Connect P/J821, P/J841 and P/J548 surely.

Step	Check	Yes	No
12	Checking conductivity between the TRAY 3 FEED OUT SENSOR and the TRAY MODULE PWB Is there conductivity on each wire between P/J821 <=> P/J548?	Go to step 13.	Fix open and short circuit.
13	Checking +5 VDC power supply to the TRAY 3 FEED OUT SENSOR Is the voltage across P/J821-3 (+) <=> ground +5 VDC?	Replace the TRAY 3 FEED OUT SNESOR. (RRP 9.39)	Go to step 14.
14	Checking connection between the TRAY MODULE PWB and the PWBA MCU F Are P/J541 and P/J413 connected surely?	Go to step 15.	Connect P/J541 and P/J413 surely.
15	Checking conductivity between the TRAY MODULE and the PWBA MCU F Is there conductivity on each wire between P/J541 <=> P/J413?	Go to step 16.	Fix open and short circuit.
16	Checking +24 VDC power supply to the TRAY MODULE PWB Is the voltage across P/J541-8 (+) <=> ground +24 VDC?	Replace the TRAY MODULE PWB. (RRP 9.47)	Replace the PWBA MCU F. (RRP 8.4)

### Tray 4 Feed Out Sensor on JAM (Tray 4 paper feed)

Step	Check	Yes	No
	Possible causative parts: ROLLER ASSY (FEED) (PL 9.4.20) ROLLER ASSY (RETARD) (PL 9.4.28) ROLLER ASSY (NUDGER) (PL 9.4.32) SENSOR (PRE FEED SENSOR) (PL 9.4.15) TRAY 4 FEED OUT SENSOR (PL 9.5.6) TRAY MODULE PWB (PL 9.6.1) PWBA MCU F (PL 8.1.5)		
1	Checking paper condition Is the paper in the tray crumpled or damaged?	Replace the paper with a new and dry one.	Go to step 2.
2	Checking the paper size setup Does the paper size in use match the size set for the TRAY4?	Go to step 3.	Replace the paper or change the paper size setup.
3	Checking the Roll for the TRAY4 Is the ROLLER ASSY (FEED), ROLLER ASSY (RETARD) or ROLLER ASSY (NUDGER) for transport worn or contaminated with paper dust? Pull out the TRAY4 and check it.	Go to step 4.	Clean or replace the ROLLER ASSY (FEED), ROLLER ASSY (RETARD) or ROLLER ASSY (NUDGER). (RRP 9.28/RRP 9.32/ RRP 9.35)

Step	Check	Yes	No
4	Checking the paper position Does the paper touch the SENSOR (PRE FEED SENSOR) of the TRAY 4 FEEDER (PL 9.2.8) or the TRAY4 FEED OUT SENSOR? Open the LEFT COVER ASSEMBLY (PL 9.5.10) and check it (visual check).	Remove the paper.	Go to step 5.
5	Checking the SENSOR (PRE FEED SENSOR) for the TRAY4 for operation Does the Input Status change from "0x0" to "0x1" each time the paper touches the SENSOR (PRE FEED SENSOR) for the TRAY4? Execute [Input 08-21 PreFEED SENSOR4] in Chapter 2 [Diagnostic]. Open the LEFT COVER ASSEMBLY (PL 9.5.10) and check it.	Go to step 12.	Go to step 6.
6	Checking the SENSOR (PRE FEED SENSOR) for the TRAY4 for connection Are P/J103A, P/J661A and P/J549A connected surely?	Go to step 7.	Connect P/J103A, P/J661A and P/J549A surely.
7	Checking conductivity between the SENSOR (PRE FEED SENSOR) for the TRAY4 and the TRAY MODULE PWB Is there conductivity on each wire between P/J103A <=> P/J549A?	Go to step 8.	Fix open and short circuit.
8	Checking +5 VDC power supply to the SENSOR (PRE FEED SENSOR) for the TRAY4 Is the voltage across P/J103A-1 (+) <=> ground +5 VDC?	Replace the SENSOR (PRE FEED SENSOR). (RRP 9.25)	Go to step 9.
9	Checking connection between the TRAY MODULE PWB and the PWBA MCU F (1) Are P/J541 and P/J413 connected surely?	Go to step 10.	Connect P/J541 and P/J413 surely.
10	Checking conductivity between the TRAY MODULE and the PWBA MCU F Is there conductivity on each wire between P/J541 <=> P/J413?	Go to step 11.	Fix open and short circuit.
11	Checking +24 VDC power supply to the TRAY MODULE PWB Is the voltage across P/J541-8 (+) <=> ground +24 VDC?	Replace the TRAY MODULE PWB. (RRP 9.47)	Replace the PWBA MCU F. (RRP 8.4)
12	Checking the TRAY 4 FEED OUT SENSOR for operation Does the Input Status change from "0x0" to "0x1" each time the paper touches the TRAY 4 FEED OUT SENSOR? Execute [Input 08-09 T/A F/04 SENSOR] in Chapter 2 [Diagnostic]. Open the LEFT COVER ASSEMBLY (PL 9.5.10) and check it.	Replace the PWBA MCU F. (RRP 8.4)	Go to step 13.
13	Checking the TRAY 4 FEED OUT SENSOR for connection Are P/J825, P/J842 and P/J548 connected surely?	Go to step 14.	Connect P/J825, P/J842 and P/J548 surely.

Step	Check	Yes	No
14	Checking conductivity between the TRAY 4 FEED OUT SENSOR and the TRAY MODULE PWB Is there conductivity on each wire between P/J825 <=> P/J548?	Go to step 15.	Fix open and short circuit.
15	Checking +5 VDC power supply to the TRAY 4 FEED OUT SENSOR Is the voltage across P/J825-3 (+) <=> ground +5 VDC?	Replace the TRAY 4 FEED OUT SNESOR. (RRP 9.38)	Go to step 16.
16	Checking connection between the TRAY MODULE PWB and the PWBA MCU F Are P/J541 and P/J413 connected surely?	Go to step 17.	Connect P/J541 and P/J413 surely.
17	Checking conductivity between the TRAY MODULE and the PWBA MCU F Is there conductivity on each wire between P/J541 <=> P/J413?	Go to step 18.	Fix open and short circuit.
18	Checking +24 VDC power supply to the TRAY MODULE PWB Is the voltage across P/J541-8 (+) <=> ground +24 VDC?	Replace the TRAY MODULE PWB. (RRP 9.47)	Replace the PWBA MCU F. (RRP 8.4)

### Tray 3 Feed Out Sensor on JAM (Tray 4 paper feed)

Step	Check	Yes	No
	Possible causative parts: ROLLER ASSY (FEED) (PL 9.4.20) ROLLER ASSY (RETARD) (PL 9.4.28) ROLLER ASSY (NUDGER) (PL 9.4.32) TRAY 3 FEED OUT SENSOR (PL 9.5.3) TRAY 4 FEED OUT SENSOR (PL 9.5.6) TRAY MODULE PWB (PL 9.6.1) PWBA MCU F (PL 8.1.5)		
1	Checking paper condition Is the paper in the tray crumpled or damaged?	Replace the paper with a new and dry one.	Go to step 2.
2	Checking paper size setup Does the paper size in use match the size set for the TRAY4?	Go to step 3.	Replace the paper or change the paper size setup.
3	Checking the Roll for the TRAY4 Is the ROLLER ASSY (FEED), ROLLER ASSY (RETARD) or ROLLER ASSY (NUDGER) for transport worn or contaminated with paper dust? Pull out the TRAY4 and check it.	Go to step 4.	Clean or replace the ROLLER ASSY (FEED), ROLLER ASSY (RETARD) or ROLLER ASSY (NUDGER). (RRP 9.28/RRP 9.32/RRP 9.35)

Step	Check	Yes	No
4	Checking paper position Does the paper touch the TRAY 3 FEED OUT SENSOR or the TRAY 4 FEED OUT SENSOR? Open the LEFT COVER ASSEMBLY (PL 9.5.10) and check it (visual check).	Remove the paper.	Go to step 5.
5	Checking the TRAY 4 FEED OUT SENSOR for operation Does the Input Status change from "0x0" to "0x1" each time the paper touches the TRAY 4 FEED OUT SENSOR? Execute [Input 08-09 T/A F/04 SENSOR] in Chapter 2 [Diagnostic].	Go to step 12.	Go to step 6.
6	Checking the TRAY 4 FEED OUT SENSOR for connection Are P/J825, P/J842 and P/J548 connected surely?	Go to step 7.	Connect P/J825, P/J842 and P/J548 surely.
7	Checking conductivity between the TRAY 4 FEED OUT SENSOR and the TRAY MODULE PWB Is there conductivity on each wire between P/J825 <=> P/J548?	Go to step 8.	Fix open and short circuit.
8	Checking +5 VDC power supply to the TRAY 4 FEED OUT SENSOR Is the voltage across P/J825-3 (+) <=> ground +5 VDC?	Replace the TRAY 4 FEED OUT SNESOR. (RRP 9.38)	Go to step 9.
9	Checking connection between the TRAY MODULE PWB and the PWBA MCU F Are P/J541 and P/J413 connected surely?	Go to step 10.	Connect P/J541 and P/J413 surely.
10	Checking conductivity between the TRAY MODULE and the PWBA MCU F Is there conductivity on each wire between P/J541 <=> P/J413?	Go to step 11.	Fix open and short circuit.
11	Checking +24 VDC power supply to the TRAY MODULE PWB Is the voltage across P/J541-8 (+) <=> ground +24 VDC?	Replace the TRAY MODULE PWB. (RRP 9.47)	Replace the PWBA MCU F. (RRP 8.4)
12	Checking the TRAY 3 FEED OUT SENSOR for operation Does the Input Status change from "0x0" to "0x1" each time the paper touches the TRAY 3 FEED OUT SENSOR? Execute [Input 08-08 T/A F/03 SENSOR] in Chapter 2 [Diagnostic]. Open the LEFT COVER ASSEMBLY (PL 9.5.10) and check it.	Replace the PWBA MCU F. (RRP 8.4)	Go to step 13.
13	Checking the TRAY 3 FEED OUT SENSOR for connection Are P/J821, P/J841 and P/J548 connected surely?	Go to step 14.	Connect P/J821, P/J841 and P/J548 surely.
14	Checking conductivity between the TRAY 3 FEED OUT SENSOR and the TRAY MODULE PWB Is there conductivity on each wire between P/J821 <=> P/J548?	Go to step 15.	Fix open and short circuit.

Step	Check	Yes	No
15	Checking +5 VDC power supply to the TRAY 3 FEED OUT SENSOR Is the voltage across P/J821-3 (+) <=> ground +5 VDC?	Replace the TRAY 3 FEED OUT SNESOR. (RRP 9.39)	Go to step 16.
16	Checking connection between the TRAY MODULE PWB and the PWBA MCU F Are P/J541 and P/J413 connected surely?	Go to step 17.	Connect P/J541 and P/J413 surely.
17	Checking conductivity between the TRAY MODULE and the PWBA MCU F Is there conductivity on each wire between P/J541 <=> P/J413?	Go to step 18.	Fix open and short circuit.
18	Checking +24 VDC power supply to the TRAY MODULE PWB Is the voltage across P/J541-8 (+) <=> ground +24 VDC?	Replace the TRAY MODULE PWB. (RRP 9.47)	Replace the PWBA MCU F. (RRP 8.4)

### Tray 2 Feed Out Sensor on JAM (Tray 3 paper feed)

Step	Check	Yes	No
	Possible causative parts: ROLLER ASSY (FEED) (PL 9.4.20) ROLLER ASSY (RETARD) (PL 9.4.28) ROLLER ASSY (NUDGER) (PL 9.4.32) SENSOR (PL 4.5.18) TRAY 3 FEED OUT SENSOR (PL 9.5.3) TRAY MODULE PWB (PL 9.6.1) PWBA MCU F (PL 8.1.5)		
1	Checking paper condition Is the paper in the tray crumpled or damaged?	Replace the paper with a new and dry one.	Go to step 2.
2	Checking paper size setup Does the paper size in use match the size set for the TRAY3?	Go to step 3.	Replace the paper or change the paper size setup.
3	Checking the Roll for the TRAY3 Is the ROLLER ASSY (FEED), ROLLER ASSY (RETARD) or ROLLER ASSY (NUDGER) for transport worn or contaminated with paper dust? Pull out the TRAY3 and check it.	Go to step 4.	Clean or replace the ROLLER ASSY (FEED), ROLLER ASSY (RETARD) or ROLLER ASSY (NUDGER). (RRP 9.28/RRP 9.32/RRP 9.35)
4	Checking paper position (1) Does the paper touch the SENSOR? Open the COVER ASSY LH LOW C (PL 4.1.10) and check it (visual check).	Remove the paper.	Go to step 5.

Step	Check	Yes	No
5	Checking paper position (2) Does the paper touch the TRAY 3 FEED SENSOR? Open the LEFT COVER ASSEMBLY (PL 9.5.10) and check it (visual check).	Remove the paper.	Go to step 6.
6	Checking the SENSOR for operation Does the Input Status change from "0x0" to "0x1" each time the paper touches the SENSOR? Execute [Input 08-06 FEED OUT#2 SENSOR] in Chapter 2 [Diagnostic]. Open the COVER ASSY LH LOW C (PL 4.1.10) and check it.	Go to step 10.	Go to step 7.
7	Checking the SENSOR for connection Are P/J105, P/J608 and P/J410 connected surely?	Go to step 8.	Connect P/J105, P/J608 and P/J410 surely.
8	Checking conductivity between the SENSOR and the PWBA MCU F Is there conductivity on each wire between P/J105 <=> P/J410?	Go to step 9.	Fix open and short circuit.
9	Checking +5 VDC power supply to the SENSOR Is the voltage across P/J105-1 (+) <=> ground +5 VDC?	Replace the SENSOR. (RRP 4.15)	Replace the PWBA MCU F. (RRP 8.4)
10	Checking the TRAY 3 FEED OUT SENSOR for operation Does the Input Status change from "0x0" to "0x1" each time the paper touches the TRAY 3 FEED OUT SENSOR? Execute [Input 08-20 PreFEED SENSOR3] in Chapter 2 [Diagnostic]. Open the LEFT COVER ASSEMBLY (PL 9.5.10) and check it.	Replace the PWBA MCU F. (RRP 8.4)	Go to step 11.
11	Checking the TRAY 3 FEED OUT SENSOR for connection Are P/J821, P/J841 and P/J548 connected surely?	Go to step 12.	Connect P/J821, P/J841 and P/J548 surely.
12	Checking conductivity between the TRAY 3 FEED OUT SENSOR and the TRAY MODULE PWB Is there conductivity on each wire between P/J821 <=> P/J548?	Go to step 13.	Fix open and short circuit.
13	Checking +5 VDC power supply to the TRAY 3 FEED OUT SENSOR Is the voltage across P/J821-3 (+) <=> ground +5 VDC?	Replace the TRAY 3 FEED OUT SNESOR. (RRP 9.39)	Go to step 14.
14	Checking connection between the TRAY MODULE PWB and the PWBA MCU F Are P/J541 and P/J413 connected surely?	Go to step 15.	Connect P/J541 and P/J413 surely.
15	Checking conductivity between the TRAY MODULE and the PWBA MCU F Is there conductivity on each wire between P/J541 <=> P/J413?	Go to step 16.	Fix open and short circuit.

Step	Check	Yes	No
16	Checking +24 VDC power supply to the TRAY MODULE PWB Is the voltage across P/J541-8 (+) <=> ground +24 VDC?	Replace the TRAY MODULE PWB. (RRP 9.47)	Replace the PWBA MCU F. (RRP 8.4)

### Registration Sensor on JAM (Tray 4 paper feed)

Step	Check	Yes	No
	Possible causative parts: ROLLER ASSY (FEED) (PL 9.4.20) ROLLER ASSY (RETARD) (PL 9.4.28) ROLLER ASSY (NUDGER) (PL 9.4.32) SENSOR ASSY REGI (PL 4.5.7) TRAY 4 FEED OUT SENSOR (PL 9.5.6) TRAY MODULE PWB (PL 9.6.1) PWBA MCU F (PL 8.1.5)		
1	Checking paper condition Is the paper in the tray crumpled or damaged?	Replace the paper with a new and dry one.	Go to step 2.
2	Checking paper size setup Does the paper size in use match the size set for the TRAY4?	Go to step 3.	Replace the paper or change the paper size setup.
3	Checking the Roll for the TRAY4 Is the ROLLER ASSY (FEED), ROLLER ASSY (RETARD) or ROLLER ASSY (NUDGER) for transport worn or contaminated with paper dust? Pull out the TRAY4 and check it.	Go to step 4.	Clean or replace the ROLLER ASSY (FEED), ROLLER ASSY (RETARD) or ROLLER ASSY (NUDGER). (RRP 9.28/RRP 9.32/ RRP 9.35)
4	Checking paper position (1) Does the paper touch the SENSOR ASSY REGI? Open the COVER ASSY-LH (PL 4.2.8) and check it (visual check).	Remove the paper.	Go to step 5.
5	Checking paper position (2) Does the paper touch the TRAY 4 FEED SENSOR? Open the LEFT COVER ASSEMBLY (PL 9.5.10) and check it (visual check).	Remove the paper.	Go to step 6.
6	Checking the SENSOR ASSY REGI for operation Does the Input Status change from "0x0" to "0x1" each time the paper touches the SENSOR ASSY REGI? Execute [Input 08-05 REGI SENSOR] in Chapter 2 [Diagnostic]. Open the COVER ASSY-LH (PL 4.2.8) and check it.	Go to step 10.	Go to step 7.
7	Checking the SENSOR ASSY REGI for connection Are P/J104 and P/J403B connected surely?	Go to step 8.	Connect P/J104 and P/J403B surely.



Step	Check	Yes	No
8	Checking conductivity between the SENSOR ASSY REGI and the PWB A MCU Is there conductivity on each wire between P/J104 <=> P/J409B?	Go to step 9.	Fix open and short circuit.
9	Checking +5 VDC power supply to the SENSOR ASSY REGI Is the voltage across P/J104-1 (+) <=> ground +5 VDC?	Replace the SENSOR ASSY REGI. (RRP 4.13)	Replace the PWBA MCU F. (RRP 8.4)
10	Checking the TRAY 4 FEED OUT SENSOR for operation Does the Input Status change from "0x0" to "0x1" each time the paper touches the TRAY 4 FEED OUT SENSOR? Execute [Input 08-08 T/A F/04 SENSOR] in Chapter 2 [Diagnostic]. Open the LEFT COVER ASSEMBLY (PL 9.5.10) and check it.	Replace the PWBA MCU F. (RRP 8.4)	Go to step 11.
11	Checking the TRAY 4 FEED OUT SENSOR for connection Are P/J825, P/J842 and P/J548 connected surely?	Go to step 12.	Connect P/J825, P/J842 and P/J548 surely.
12	Checking conductivity between the TRAY 4 FEED OUT SENSOR and the TRAY MODULE PWB Is there conductivity on each wire between P/J825 <=> P/J548?	Go to step 13.	Fix open and short circuit.
13	Checking +5 VDC power supply to the TRAY 4 FEED OUT SENSOR Is the voltage across P/J821-3 (+) <=> ground +5 VDC?	Replace the TRAY 4 FEED OUT SNESOR. (RRP 9.38)	Go to step 14.
14	Checking connection between the TRAY MODULE PWB and the PWBA MCU F Are P/J541 and P/J413 connected surely?	Go to step 15.	Connect P/J541 and P/J413 surely.
15	Checking conductivity between the TRAY MODULE and the PWBA MCU F Is there conductivity on each wire between P/J541 <=> P/J413?	Go to step 16.	Fix open and short circuit.
16	Checking +24 VDC power supply to the TRAY MODULE PWB Is the voltage across P/J541-8 (+) <=> ground +24 VDC?	Replace the TRAY MODULE PWB. (RRP 9.47)	Replace the PWBA MCU F. (RRP 8.4)

### Prefeed Sensor #4 on JAM (Tray4 paper feed)

Step	Check	Yes	No
	Possible causative parts: ROLLER ASSY (FEED) (PL 9.4.20) ROLLER ASSY (RETARD) (PL 9.4.28) ROLLER ASSY (NUDGER) (PL 9.4.32) TRAY 1/2 FEED LIFT UP MOTOR (PL 9.4.2) SENSOR (PRE FEED SENSOR) (PL 9.4.15) TRAY MODULE PWB (PL 9.6.1) PWBA MCU F (PL 8.1.5)		

Step	Check	Yes	No
1	Checking paper condition Is the paper in the tray crumpled or damaged?	Replace the paper with a new and dry one.	Go to step 2.
2	Checking paper size setup Does the paper size in use match the size set for the TRAY4?	Go to step 3.	Replace the paper or change the paper size setup.
3	Checking the Roll for the TRAY4 Is the ROLLER ASSY (FEED), ROLLER ASSY (RETARD) or ROLLER ASSY (NUDGER) for transport worn or contaminated with paper dust? Pull out the TRAY4 and check it.	Go to step 4.	Clean or replace the ROLLER ASSY (FEED), ROLLER ASSY (RETARD) or ROLLER ASSY (NUDGER). (RRP 9.28/RRP 9.32/RRP 9.35)
4	Checking paper position Does the paper touch the SENSOR (PRE FEED SENSOR) of the TRAY4 FEEDER (PL 9.2.8)?	Remove the paper.	Go to step 5.
5	Checking the SENSOR (PRE FEED SENSOR) for the TRAY4 for operation Does the Input Status change from "0x0" to "0x1" each time the paper touches the SENSOR (PRE FEED SENSOR) for the TRAY4? Execute [Input 08-21 PreFEED SENSOR4] in Chapter 2 [Diagnostic].	Go to step 12.	Go to step 6.
6	Checking the SENSOR (PRE FEED SENSOR) for the TRAY4 for connection Are P/J103A, P/J661A and P/J549A connected surely?	Go to step 7.	Connect P/J103A, P/J661A and P/J549A surely.
7	Checking conductivity between the SENSOR (PRE FEED SENSOR) for the TRAY4 and the TRAY MODULE PWB Is there conductivity on each wire between P/J103A <=> P/J549A?	Go to step 8.	Fix open and short circuit.
8	Checking +5 VDC power supply to the SENSOR (PRE FEED SENSOR) for the TRAY4 Is the voltage across P/J103A-1 (+) <=> ground +5 VDC?	Replace the SENSOR for the TRAY4 (PRE FEED SENSOR). (RRP 9.25)	Go to step 9.
9	Checking connection between the TRAY MODULE PWB and the PWBA MCU F Are P/J541 and P/J413 connected surely?	Go to step 10.	Connect P/J541 and P/J413 surely.
10	Checking conductivity between the TRAY MODULE PWB and the PWBA MCU F Is there conductivity on each wire between P/J541 <=> P/J413?	Go to step 11.	Fix open and short circuit.
11	Checking +24 VDC power supply to the TRAY MODULE PWB Is the voltage across P/J541-8 (+) <=> ground +24 VDC?	Replace the TRAY MODULE PWB. (RRP 9.47)	Replace the PWBA MCU F. (RRP 8.4)

Step	Check	Yes	No
12	Checking the TRAY 1/2 FEED LIFT UP MOTOR for the TRAY4 for operation Does the TRAY 1/2 FEED LIFT UP MOTOR for the TRAY4 operate properly? Execute [Output 08-15 TRAY4 FEED MOTOR] in Chapter 2 [Diagnostic].	Replace the PWBA MCU F. (RRP 8.4)	Go to step 13.
13	Checking the TRAY 1/2 FEED LIFT UP MOTOR for the TRAY4 for connection Are P/J220A, P/J661A and P/J549A connected surely?	Go to step 14.	Connect P/J220A, P/J661A and P/J549A surely.
14	Checking the TRAY 1/2 FEED LIFT UP MOTOR for the TRAY4 for operation (3) Replace the TRAY 1/2 FEED LIFT UP MOTOR for the TRAY4 with that for the TRAY3. Does the replaced motor operate properly? Execute [Output 08-15 TRAY4 FEED MOTOR] in Chapter 2 [Diagnostic].	Reinstall the TRAY 1/2 FEED LIFT UP MOTOR for the TRAY3 as it previously was and then, replace the motor for the TRAY4 with a new one. (RRP 9.16)	Go to step 15.
15	Checking the TRAY 1/2 FEED LIFT UP MOTOR for the TRAY4 for operation (4) Reinstall the TRAY 1/2 FEED LIFT UP MOTORS for the TRAY3 and TRAY4 as they previously were. Checking conductivity between the TRAY 1/2 FEED LIFT UP MOTOR for the TRAY3 and the TRAY MODULE PWB. Is there conductivity on each wire between P/J220A <=> P/J549A?	Go to step 16.	Fix open and short circuit.
16	Checking connection between the TRAY MODULE PWB and the PWBA MCU F Are P/J541 and P/J413 connected surely?	Go to step 17.	Connect P/J541 and P/J413 surely.
17	Checking conductivity between the TRAY MODULE PWB and the PWBA MCU F Is there conductivity on each wire between P/J541 <=> P/J413?	Go to step 18.	Fix open and short circuit.
18	Checking +24 VDC power supply to the TRAY 1/2 FEED LIFT UP MOTOR for the TRAY4 Is the voltage across P/J220B-3 (+) <=> ground +24 VDC?	Replace the TRAY 1/2 FEED LIFT UP MOTOR for the TRAY4. (RRP 9.16)	Replace the PWBA MCU F. (RRP 8.4)

### Tray 3 Feed Out Sensor Static JAM

Step	Check	Yes	No
	Possible causative parts: TRAY 3 FEED OUT SENSOR (PL 9.5.3) TRAY MODULE PWB (PL 9.6.1) PWBA MCU F (PL 8.1.5)		

Step	Check	Yes	No
1	Checking paper position Does the paper touch the TRAY 3 FEED OUT SENSOR? Open the LEFT COVER ASSEMBLY (PL 9.5.10) and check it (visual check).	Remove the paper.	Go to step 2.
2	Checking the TRAY 3 FEED OUT SENSOR for operation Does the Input Status change from "0x0" to "0x1" each time the paper touches the TRAY 3 FEED OUT SENSOR? Execute [Input 08-08 T/A F/03 SENSOR] in Chapter 2 [Diagnostic]. Open the LEFT COVER ASSEMBLY (PL 9.5.10) and check it.	Replace the PWBA MCU F. (RRP 8.4)	Go to step 3.
3	Checking the TRAY 3 FEED OUT SENSOR for connection Are P/J821, P/J841 and P/J548 connected surely?	Go to step 4.	Connect P/J821, P/J841 and P/J548 surely.
4	Checking conductivity between the TRAY 3 FEED OUT SENSOR and the TRAY MODULE PWB Is there conductivity on each wire between P/J821 <=> P/J548?	Go to step 5.	Fix open and short circuit.
5	Checking conductivity between the TRAY MODULE and the PWBA MCU F Is there conductivity on each wire between P/J541 <=> P/J413?	Go to step 6.	Fix open and short circuit.
6	Checking +5 VDC power supply to the TRAY 3 FEED OUT SENSOR Is the voltage across P/J821-3 (+) <=> ground +5 VDC?	Replace the TRAY 3 FEED OUT SNESOR. (RRP 9.39)	Go to step 7.
7	Checking +5 VDC power supply to the TRAY MODULE PWB Is the voltage across P/J541-5 (+) <=> ground +5 VDC?	Replace the TRAY MODULE PWB. (RRP 9.47)	Replace the PWBA MCU F. (RRP 8.4)

### Tray 4 Feed Out Sensor Static JAM

Step	Check	Yes	No
	Possible causative parts: TRAY 4 FEED OUT SENSOR (PL 9.5.6) TRAY MODULE PWB (PL 9.6.1) PWBA MCU F (PL 8.1.5)		
1	Checking paper position Does the paper touch the TRAY 4 FEED OUT SENSOR? Open the LEFT COVER ASSEMBLY (PL 9.5.10) and check it (visual check).	Remove the paper.	Go to step 2.
2	Checking the TRAY 4 FEED OUT SENSOR for operation Does the Input Status change from "0x0" to "0x1" each time the paper touches the TRAY 4 FEED OUT SENSOR? Execute [Input 08-09 T/A F/04 SENSOR] in Chapter 2 [Diagnostic]. Open the LEFT COVER ASSEMBLY (PL 9.5.10) and check it.	Replace the PWBA MCU F. (RRP 8.4)	Go to step 3.

Step	Check	Yes	No
3	Checking the TRAY 4 FEED OUT SENSOR for connection Are P/J825, P/J842 and P/J548 connected surely?	Go to step 4.	Connect P/J825, P/J842 and P/J548 surely.
4	Checking conductivity between the TRAY 4 FEED OUT SENSOR and the TRAY MODULE PWB Is there conductivity on each wire between P/J825 <=> P/J548?	Go to step 5.	Fix open and short circuit.
5	Checking conductivity between the TRAY MODULE and the PWBA MCU F Is there conductivity on each wire between P/J541 <=> P/J413?	Go to step 6.	Fix open and short circuit.
6	Checking +5 VDC power supply to the TRAY 4 FEED OUT SENSOR Is the voltage across P/J825-3 (+) <=> ground +5 VDC?	Replace the TRAY 4 FEED OUT SNESOR. (RRP 9.38)	Go to step 7.
7	Checking +5 VDC power supply to the TRAY MODULE PWB Is the voltage across P/J545-8 (+) <=> ground +5 VDC?	Replace the TRAY MODULE PWB. (RRP 9.47)	Replace the PWBA MCU F. (RRP 8.4)

### Tray 3 Lift up /No tray fail

Step	Check	Yes	No
	Possible causative parts: SECTOR GEAR (60T) (PL 9.3.22) TRAY 1/2 FEED LIFT UP MOTOR (PL 9.4.2) SENSOR (LEVEL SENSOR) (PL 9.4.14) TRAY 3/4 PAPER SIZE SWITCH (PL 9.2.4) TRAY MODULE PWB (PL 9.6.1) PWBA MCU F (PL 8.1.5)		
1	Checking paper Is any paper loaded in the Tray3? Pull out the Tray3 to check it. (Visual check)	Go to step 2.	Load paper.
2	Checking the TRAY Are the SECTOR GEAR (60T) of TRAY2 or the surrounding parts of it damaged?	Go to step 3.	Replace the SECTOR GEAR (60T) (RRP 9.15) or the obstacles.
3	Checking the TRAY 1/2 FEED LIFT UP MOTOR for the TRAY3 for operation (1) Does the TRAY 1/2 FEED LIFT UP MOTOR for the TRAY3 operate properly? Execute [Output 08-14 TRAY3 FEED MOTOR] in Chapter 2 [Diagnostic].	Go to step 11.	Go to step 4.
4	Checking the TRAY 1/2 FEED LIFT UP MOTOR for the TRAY3 for connection Are P/J220B, P/J661B and P/J549B connected surely?	Go to step 5.	Connect P/J220B, P/J661B and P/J549B surely.

Step	Check	Yes	No
5	<p>Checking the TRAY 1/2 FEED LIFT UP MOTOR for the TRAY3 for operation (2)</p> <p>Replace the TRAY 1/2 FEED LIFT UP MOTOR for the TRAY3 with that for the TRAY4.</p> <p>Does the replaced motor operate properly?</p> <p>Execute [Output 08-14 TRAY3 FEED MOTOR] in Chapter 2 [Diagnostic].</p>	<p>Reinstall the TRAY 1/2 FEED LIFT UP MOTOR for the TRAY4 as it previously was and replace the motor for the TRAY3 with a new one. (RRP 9.16)</p>	<p>Go to step 6.</p>
6	<p>Checking the TRAY 1/2 FEED LIFT UP MOTOR for the TRAY3 for operation (3)</p> <p>Reinstall the TRAY 1/2 FEED LIFT UP MOTORS for the TRAY3 and TRAY4 as they previously were.</p> <p>Checking conductivity between the TRAY 1/2 FEED LIFT UP MOTOR for the TRAY3 and the TRAY MODULE PWB.</p> <p>Is there conductivity on each wire between P/J220B &lt;=&gt; P/J549B?</p>	<p>Go to step 7.</p>	<p>Fix open and short circuit.</p>
7	<p>Checking +24 VDC power supply to the TRAY 1/2 FEED LIFT UP MOTOR for the TRAY3</p> <p>Is the voltage across P/J220B-3 (+) &lt;=&gt; ground +24 VDC?</p>	<p>Replace the TRAY 1/2 FEED LIFT UP MOTOR for the TRAY3. (RRP 9.16)</p>	<p>Go to step 8.</p>
8	<p>Checking the TRAY MODULE PWB for connection</p> <p>Are P/J413 and P/J541 connected surely?</p>	<p>Go to step 9.</p>	<p>Connect P/J413 and P/541 surely.</p>
9	<p>Checking conductivity between the TRAY MODULE PWB and the PWBA MCU F</p> <p>Is there conductivity on each wire between P/J413 &lt;=&gt; P/J541?</p>	<p>Go to step 10.</p>	<p>Fix open and short circuit.</p>
10	<p>Checking +24 VDC power supply to the TRAY MODULE PWB</p> <p>Is the voltage across P/J413-B2 (+) &lt;=&gt; ground +24 VDC?</p>	<p>Replace the TRAY MODULE PWB. (RRP 9.47)</p>	<p>Replace the PWBA MCU F. (RRP 8.4)</p>
11	<p>Checking the SENSOR (LEVEL SENSOR) for the TRAY3 for operation</p> <p>Does the Input Status change from "0x0" to "0x1" each time the paper touches the SENSOR (LEVEL SENSOR) for the TRAY3?</p> <p>Execute [Input 07-15 TRAY3 LEVEL SENSOR] in Chapter 2 [Diagnostic].</p> <p>Open the LEFT COVER ASSEMBLY (PL 9.5.10) and check it.</p>	<p>Go to step 18.</p>	<p>Go to step 12.</p>
12	<p>Checking the SENSOR (LEVEL SENSOR) for the TRAY3 for connection</p> <p>Are P/J101B, P/J661B and P/J549B connected surely?</p>	<p>Go to step 13.</p>	<p>Connect P/J101B, P/J661B and P/J549B surely.</p>
13	<p>Checking conductivity between the SENSOR (LEVEL SENSOR) for the TRAY3 and the TRAY MODULE PWB</p> <p>Is there conductivity on each wire between P/J101B &lt;=&gt; P/J549B?</p>	<p>Go to step 14.</p>	<p>Fix open and short circuit.</p>

Step	Check	Yes	No
14	Checking +5 VDC power supply to the SENSOR (LEVEL SENSOR) for the TRAY3 Is the voltage across P/J101B-3 (+) <=> ground +5 VDC?	Replace the SENSOR (LEVEL SENSOR) for the TRAY3. (RRP 9.24)	Go to step 16.
15	Checking the TRAY MODULE PWB for connection Are P/J413 and P/J541 connected surely?	Go to step 16.	Connect P/J413 and P/541 surely.
16	Checking conductivity between the TRAY MODULE PWB and the PWBA MCU F Is there conductivity on each wire between P/J413 <=> P/J541?	Go to step 17.	Fix open and short circuit.
17	Checking +5 VDC power supply to the TRAY MODULE PWB Is the voltage across P/J413-A5 (+) <=> ground +5 VDC?	Replace the TRAY MODULE PWB. (RRP 9.47)	Replace the PWBA MCU F. (RRP 8.4)
18	Checking the TRAY 3/4 PAPER SIZE SWITCH for the TRAY 3 for operation Does the Input Status change from "0x0" to "0x1" each time the TRAY3 with paper loaded is pulled out or pushed in? Execute [Input 07-03 TRAY3 SIZE SENSOR] in Chapter 2 [Diagnostic].	Replace the PWBA MCU F. (RRP 8.4)	Go to step 19.
19	Checking the TRAY 3/4 PAPER SIZE SWITCH for the TRAY 3 for connection Are P/J820 and P/J548 connected surely?	Go to step 20.	Connect P/J820 and P/J548 surely.
20	Checking conductivity between the TRAY 3/4 PAPER SIZE SWITCH for the TRAY3 and the PWBA MCU F Is there conductivity on each wire between P/J820 <=> P/J548?	Go to step 21.	Fix open and short circuit.
21	Checking +3.3 VDC power supply to the TRAY 3/4 PAPER SIZE SWITCH for the TRAY3 Is the voltage across P/J820-1 (+) <=> ground +3.3 VDC?	Replace the TRAY 3/4 PAPER SIZE SWITCH for the TRAY3. (RRP 9.8)	Go to step 22.
22	Checking the TRAY MODULE PWB for connection Are P/J413 and P/J541 connected surely?	Go to step 23.	Connect P/J413 and P/541 surely.
23	Checking conductivity between the TRAY MODULE PWB and the PWBA MCU F Is there conductivity on each wire between P/J413 <=> P/J541?	Go to step 24.	Fix open and short circuit.
24	Checking +5 VDC power supply to the TRAY MODULE PWB Is the voltage across P/J413-A5 (+) <=> ground +5 VDC?	Replace the TRAY MODULE PWB. (RRP 9.47)	Replace the PWBA MCU F. (RRP 8.4)

## Tray 4 Lift up /No tray fail

Step	Check	Yes	No
	Possible causative parts: SECTOR GEAR (60T) (PL 9.3.22) TRAY 1/2 FEED LIFT UP MOTOR (PL 9.4.2) SENSOR (LEVEL SENSOR) (PL 9.4.14) TRAY 3/4 PAPER SIZE SWITCH (PL 9.2.4) TRAY MODULE PWB (PL 9.6.1) PWBA MCU F (PL 8.1.5)		
1	Checking paper Is any paper loaded in the Tray4? Pull out the Tray4 to check it. (Visual check)	Go to step 2.	Load paper.
2	Checking the TRAY Are the SECTOR GEAR (60T) of TRAY4 or the surrounding parts of it damaged?	Go to step 3.	Replace the SECTOR GEAR (60T) (RRP 9.15) or the obstacles.
3	Checking the TRAY 1/2 FEED LIFT UP MOTOR for the TRAY4 for operation Does the TRAY 1/2 FEED LIFT UP MOTOR for the TRAY4 operate properly? Execute [Output 08-15 TRAY4 FEED MOTOR] in Chapter 2 [Diagnostic].	Go to step 11.	Go to step 4.
4	Checking the TRAY 1/2 FEED LIFT UP MOTOR for the TRAY4 for connection Are P/J220A, P/J661A and P/J549A connected surely?	Go to step 5.	Connect P/J220A, P/J661A and P/J549A surely.
5	Checking the TRAY 1/2 FEED LIFT UP MOTOR for the TRAY4 for operation (3) Replace the TRAY 1/2 FEED LIFT UP MOTOR for the TRAY4 with that for the TRAY3. Does the replaced motor operate properly? Execute [Output 08-15 TRAY4 FEED MOTOR] in Chapter 2 [Diagnostic].	Reinstall the TRAY 1/2 FEED LIFT UP MOTOR for the TRAY3 as it previously was and then, replace the motor for the TRAY4 with a new one. (RRP 9.16)	Go to step 6.
6	Checking the TRAY 1/2 FEED LIFT UP MOTOR for the TRAY4 for operation (4) Reinstall the TRAY 1/2 FEED LIFT UP MOTORS for the TRAY3 and TRAY4 as they previously were. Checking conductivity between the TRAY 1/2 FEED LIFT UP MOTOR for the TRAY3 and the TRAY MODULE PWB. Is there conductivity on each wire between P/J220A <=> P/J549A?	Go to step 7.	Fix open and short circuit.
7	Checking +24 VDC power supply to the TRAY 1/2 FEED LIFT UP MOTOR for the TRAY4 Is the voltage across P/J220A-3 (+) <=> ground +24 VDC?	Replace the TRAY 1/2 FEED LIFT UP MOTOR for the TRAY4. (RRP 9.16)	Go to step 8.



Step	Check	Yes	No
8	Checking the TRAY MODULE PWB for connection Are P/J413 and P/J541 connected surely?	Go to step 9.	Connect P/J413 and P/541 surely.
9	Checking conductivity between the TRAY MODULE PWB and the PWBA MCU F Is there conductivity on each wire between P/J413 <=> P/J541?	Go to step 10.	Fix open and short circuit.
10	Checking +24 VDC power supply to the TRAY MODULE PWB Is the voltage across P/J413-B2 (+) <=> ground +24 VDC?	Replace the TRAY MODULE PWB. (RRP 9.47)	Replace the PWBA MCU F. (RRP 8.4)
11	Checking the SENSOR (LEVEL SENSOR) for the TRAY4 for operation Does the Input Status change from "0x0" to "0x1" each time the paper touches the SENSOR (LEVEL SENSOR) for the TRAY4? Execute [Input 07-16 TRAY4 LEVEL SENSOR] in Chapter 2 [Diagnostic]. Open the LEFT COVER ASSEMBLY (PL 9.5.10) and check it.	Go to step 18.	Go to step 12.
12	Checking the SENSOR (LEVEL SENSOR) for the TRAY4 for connection Are P/J101A, P/J661A and P/J549A connected surely?	Go to step 13.	Connect P/J101A, P/J661A and P/J549A surely.
13	Checking conductivity between the SENSOR (LEVEL SENSOR) for the TRAY4 and the TRAY MODULE PWB Is there conductivity on each wire between P/J101A <=> P/J549A?	Go to step 14.	Fix open and short circuit.
14	Checking +5 VDC power supply to the SENSOR (LEVEL SENSOR) for the TRAY4 Is the voltage across P/J101A-3 (+) <=> ground +5 VDC?	Replace the SENSOR (LEVEL SENSOR) for the TRAY4. (RRP 9.24)	Go to step 15.
15	Checking the TRAY MODULE PWB for connection Are P/J413 and P/J541 connected surely?	Go to step 16.	Connect P/J413 and P/541 surely.
16	Checking +5 VDC power supply to the TRAY MODULE PWB Is the voltage across P/J413-A5 (+) <=> ground +5 VDC?	Go to step 17.	Fix open and short circuit.
17	Checking +24 VDC power supply to the TRAY MODULE PWB Is the voltage across P/J413-B2 (+) <=> ground +24 VDC?	Replace the TRAY MODULE PWB. (RRP 9.47)	Replace the PWBA MCU F. (RRP 8.4)
18	Checking the TRAY 3/4 PAPER SIZE SWITCH for the TRAY4 for operation Does the Input Status change from "0x0" to "0x1" each time the TRAY4 with paper loaded is pulled out or pushed in? Execute [Input 07-04 TRAY4 SIZE SENSOR] in Chapter 2 [Diagnostic].	Replace the PWBA MCU F. (RRP 8.4)	Go to step 19.
19	Checking the TRAY 3/4 PAPER SIZE SWITCH for the TRAY4 for connection Are P/J824 and P/J548 connected surely?	Go to step 20.	Connect P/J824 and P/J548 surely.

Step	Check	Yes	No
20	Checking conductivity between the TRAY 3/4 PAPER SIZE SWITCH for the TRAY4 and the PWBA MCU F Is there conductivity on each wire between P/J824 <=> P/J548?	Go to step 21.	Fix open and short circuit.
21	Checking +3.3 VDC power supply to the TRAY 3/4 PAPER SIZE SWITCH for the TRAY4 Is the voltage across P/J824-1 (+) <=> ground +3.3 VDC?	Replace the TRAY 3/4 PAPER SIZE SWITCH for the TRAY4. (RRP 9.9)	Go to step 22.
22	Checking the TRAY MODULE PWB for connection Are P/J413 and P/J541 connected surely?	Go to step 23.	Connect P/J413 and P/541 surely.
23	Checking conductivity between the TRAY MODULE PWB and the PWBA MCU F Is there conductivity on each wire between P/J413 <=> P/J541?	Go to step 24.	Fix open and short circuit.
24	Checking +5 VDC power supply to the TRAY MODULE PWB Is the voltage across P/J413-A5 (+) <=> ground +5 VDC?	Replace the TRAY MODULE PWB. (RRP 9.47)	Replace the PWBA MCU F. (RRP 8.4)

### Tray 3 cassette Size fail

Step	Check	Yes	No
	Possible causative parts: TRAY 3/4 PAPER SIZE SWITCH (PL 9.2.4) FRONT SIDE GUIDE (PL 9.3.6) REAR SIDE GUIDE (PL 9.3.9) TRAY MODULE PWB (PL 9.6.1) PWBA MCU F (PL 8.1.5)		
1	Checking the paper (1) Is paper loaded in the TRAY3 properly? Pull out the TRAY3 to check it. (Visual check)	Go to step 2.	Load paper properly.
2	Checking the paper (2) Are the FRONT SIDE GUIDE and REAR SIDE GUIDE of the TRAY3 set correctly? Pull out the TRAY3 to check it. (Visual check)	Go to step 3.	Set the parts properly.
3	Checking the TRAY 3/4 PAPER SIZE SWITCH for the TRAY3 for operation Is the TRAY 3/4 PAPER SIZE SWITCH for the TRAY3 installed properly? Pull out the TRAY3 to check it. (Visual check)	Go to step 4.	Install the TRAY 3/4 PAPER SIZE SWITCH for the TRAY3 correctly. (RRP 9.8)
4	Checking the TRAY 3/4 PAPER SIZE SWITCH for operation Does the Input Status change from "0x0" to "0x1" each time the TRAY3 with paper loaded is pulled out or pushed in? Execute [Input 07-03 TRAY3 SIZE SENSOR] in Chapter 2 [Diagnostic].	Replace the PWBA MCU F. (RRP 8.4)	Go to step 5.

Step	Check	Yes	No
5	Checking the TRAY 3/4 PAPER SIZE SWITCH for connection Are P/J820 and P/J548 connected surely?	Go to step 6.	Connect P/J820 and P/J548 surely.
6	Checking conductivity between the TRAY 3/4 PAPER SIZE SWITCH for the TRAY3 and the PWBA MCU F Is there conductivity on each wire between P/J820 <=> P/J548?	Go to step 7.	Fix open and short circuit.
7	Checking +3.3 VDC power supply to the TRAY 3/4 PAPER SIZE SWITCH for the TRAY3 Is the voltage across P/J820-1 (+) <=> ground +3.3 VDC?	Replace the TRAY 3/4 PAPER SIZE SWITCH for the TRAY3. (RRP 9.8)	Go to step 8.
8	Checking the TRAY MODULE PWB for connection Are P/J413 and P/J541 connected surely?	Go to step 9.	Connect P/J413 and P/541 surely.
9	Checking conductivity between the TRAY MODULE PWB and the PWBA MCU F Is there conductivity on each wire between P/J413 <=> P/J541?	Go to step 10.	Fix open and short circuit.
10	Checking +5 VDC power supply to the TRAY MODULE PWB Is the voltage across P/J413-A5 (+) <=> ground +5 VDC?	Replace the TRAY MODULE PWB. (RRP 9.47)	Replace the PWBA MCU F. (RRP 8.4)

### Tray 4 cassette Size fail

Step	Check	Yes	No
	Possible causative parts: TRAY 3/4 PAPER SIZE SWITCH (PL 9.2.4) FRONT SIDE GUIDE PL 9.3.6) REAR SIDE GUIDE PL 9.3.9) TRAY MODULE PWB (PL 9.6.1) PWBA MCU F (PL 8.1.5)		
1	Checking the paper (1) Is paper loaded in the TRAY4 properly? Pull out the TRAY4 to check it. (Visual check)	Go to step 2.	Load paper properly.
2	Checking the paper (2) Are the FRONT SIDE GUIDE and REAR SIDE GUIDE of the TRAY4 set correctly? Pull out the TRAY4 to check it. (Visual check)	Go to step 3.	Set the parts properly.
3	Checking the TRAY 3/4 PAPER SIZE SWITCH for the TRAY4 for installation Is the TRAY 3/4 PAPER SIZE SWITCH for the TRAY4 installed properly? Pull out the TRAY4 to check it. (Visual check)	Go to step 4.	Install the TRAY 3/4 PAPER SIZE SWITCH for the TRAY4 correctly. (RRP 9.9)

Step	Check	Yes	No
4	Checking the TRAY 3/4 PAPER SIZE SWITCH for the TRAY4 for operation Does the Input Status change from "0x0" to "0x1" each time the TRAY4 with paper loaded is pulled out or pushed in? Execute [Input 07-04 TRAY4 SIZE SENSOR] in Chapter 2 [Diagnostic].	Replace the PWBA MCU F. (RRP 8.4)	Go to step 5.
5	Checking the TRAY 3/4 PAPER SIZE SWITCH for the TRAY4 for connection Are P/J824 and P/J548 connected surely?	Go to step 6.	Connect P/J824 and P/J548 surely.
6	Checking conductivity between the TRAY 3/4 PAPER SIZE SWITCH for the TRAY4 and the PWBA MCU F Is there conductivity on each wire between P/J824 <=> P/J548?	Go to step 7.	Fix open and short circuit.
7	Checking +3.3 VDC power supply to the TRAY 3/4 PAPER SIZE SWITCH for the TRAY4 Is the voltage across P/J824-1 (+) <=> ground +3.3 VDC?	Replace the TRAY 3/4 PAPER SIZE SWITCH for the TRAY4. (RRP 9.9)	Go to step 8.
8	Checking the TRAY MODULE PWB for connection Are P/J413 and P/J541 connected surely?	Go to step 9.	Connect P/J413 and P/J541 surely.
9	Checking conductivity between the TRAY MODULE PWB and the PWBA MCU F Is there conductivity on each wire between P/J413 <=> P/J541?	Go to step 10.	Fix open and short circuit.
10	Checking +5 VDC power supply to the TRAY MODULE PWB Is the voltage across P/J413-A5 (+) <=> ground +5 VDC?	Replace the TRAY MODULE PWB. (RRP 9.47)	Replace the PWBA MCU F. (RRP 8.4)

### Tray Module NVM out-of-order

Step	Check	Yes	No
	Possible causative parts: TRAY MODULE PWB (PL 9.6.1) PWBA MCU F (PL 8.1.5)		
1	Does the error occur when the power is turned ON again?	Go to step 3.	Go to step 2.
2	Does the error still occur after the power is turned ON/OFF repeatedly several times?	Go to step 3.	End of work *1
3	Checking data on the NVRAM (1) Is data on the NVRAM accessible? Execute [NVM Edit] in Chapter 2 [Diagnostic].	Go to step 4.	Go to step 5.
4	Checking data on the NVRAM (2) Change NVRAM data to the correct setup value, and then turn the power ON again. Does the error still occur?	Go to step 5.	End of work

Step	Check	Yes	No
5	Checking the TRAY MODULE PWB Are P/J413 and P/J541 connected surely?	Go to step 6.	Connect P/J413 and P/541 surely.
6	Checking conductivity between the TRAY MODULE PWB and the PWBA MCU F Is there conductivity on each wire between P/J413 <=> P/J541?	Go to step 7.	Fix open and short circuit.
7	Checking +5 VDC power supply to the TRAY MODULE PWB Is the voltage across P/J413-A5 (+) <=> ground +5 VDC?	Replace the TRAY MODULE PWB. (RRP 9.47)	Replace the PWBA MCU F. (RRP 8.4)

\*1: External noise is considered to be the cause, proceed to Procedure 5.1.

## Tray Module NVM R/W error

Step	Check	Yes	No
	Possible causative parts: TRAY MODULE PWB (PL 9.6.1) PWBA MCU F (PL 8.1.5)		
1	Does the error still occur when the power is turned ON again?	Go to step 3.	Go to step 2.
2	Does the error still occur after the power is turned ON/OFF repeatedly several times?	Go to step 3.	End of work *1
3	Checking data on the NVRAM (1) Is data on the NVRAM accessible? Execute [NVM Edit] in Chapter 2 [Diagnostic].	Go to step 4.	Go to step 5.
4	Checking data on the NVRAM (2) Change NVRAM data to the correct setup value, and then turn the power ON again. Does the error still occur?	Go to step 5.	End of work
5	Checking the TRAY MODULE PWB Are P/J413 and P/J541 connected surely?	Go to step 6.	Connect P/J413 and P/541 surely.
6	Checking conductivity between the TRAY MODULE PWB and the PWBA MCU F Is there conductivity on each wire between P/J413 <=> P/J541?	Go to step 7.	Fix open and short circuit.
7	Checking +5 VDC power supply to the TRAY MODULE PWB Is the voltage across P/J413-A5 (+) <=> ground +5 VDC?	Replace the TRAY MODULE PWB. (RRP 9.47)	Replace the PWBA MCU F. (RRP 8.4)

## Tray Module Communication fail

Step	Check	Yes	No
	Possible causative parts: TRAY MODULE PWB (PL 9.6.1) PWBA MCU F (PL 8.1.5)		
1	Checking the TRAY MODULE for installation Disconnect the connector P/J541 of the TRAY MODULE and reconnect it. Does the tray module operate properly?	End of work	Go to step 2.
2	Checking the TRAY MODULE PWB for connection Is P/J413 connected surely?	Go to step 3.	Connect P/J413 surely.
3	Checking conductivity between the TRAY MODULE PWB and the PWBA MCU F Is there conductivity on each wire between P/J413 <=> P/J541?	Go to step 4.	Fix open and short circuit.
4	Checking +5 VDC power supply to the TRAY MODULE PWB Is the voltage across P/J413-A5 (+) <=> ground +5 VDC?	Replace the TRAY MODULE PWB. (RRP 9.47)	Replace the PWBA MCU F. (RRP 8.4)

## TM type error

Step	Check	Yes	No
	Possible causative parts: TRAY MODULE PWB (PL 9.6.1) PWBA MCU F (PL 8.1.5)		
1	Checking the TRAY MODULE for installation Disconnect the connector P/J541 of the TRAY MODULE and reconnect it. Does the tray module operate properly?	End of work	Go to step 2.
2	Checking the TRAY MODULE PWB for connection Is P/J413 connected surely?	Go to step 3.	Connect P/J413 surely.
3	Checking conductivity between the TRAY MODULE PWB and the PWBA MCU F Is there conductivity on each wire between P/J413 <=> P/J541?	Go to step 4.	Fix open and short circuit.
4	Checking +5 VDC power supply to the TRAY MODULE PWB Is the voltage across P/J413-A5 (+) <=> ground +5 VDC?	Replace the TRAY MODULE PWB. (RRP 9.47)	Replace the PWBA MCU F. (RRP 8.4)

## Tray 3 Size sensor broken

Step	Check	Yes	No
	Possible causative parts: TRAY 3/4 PAPER SIZE SWITCH (PL 9.2.4) TRAY MODULE PWB (PL 9.6.1) PWBA MCU F (PL 8.1.5)		
1	Checking paper Is paper loaded in the TRAY3 properly? Pull out the TRAY3 to check it. (Visual check)	Go to step 2.	Load paper properly.
2	Checking the TRAY 3/4 PAPER SIZE SWITCH for the TRAY3 for installation Is the TRAY 3/4 PAPER SIZE SWITCH for the TRAY3 installed properly? Pull out the TRAY3 to check it. (Visual check)	Go to step 3.	Install the TRAY 3/4 PAPER SIZE SWITCH for the TRAY3 correctly. (RRP 9.8)
3	Checking the TRAY 3/4 PAPER SIZE SWITCH for operation Does the Input Status change from "0x0" to "0x1" each time the TRAY3 with paper loaded is pulled out or pushed in? Check it using [Input 07-03 TRAY3 SIZE SENSOR] in Chapter 2, Diag.	Reconnect the connector of the PWBA MCU F.	Go to step 4.
4	Checking the TRAY 3/4 PAPER SIZE SWITCH for TRAY3 for connection Are P/J820 and P/J548 connected securely?	Go to step 5.	Connect P/J820 and P/J548 securely.
5	Checking conductivity between the TRAY 3/4 PAPER SIZE SWITCH for the TRAY3 and the PWBA MCU F Is there normal conductivity between P/J820 and P/J548?	Go to step 6.	Fix open or short circuit.
6	Checking the TRAY 3/4 PAPER SIZE SWITCH for the TRAY3 for power supply Is the voltage between J820-1 (+) and the ground (-) +3.3 VDC?	Replace the TRAY 3/4 PAPER SIZE SWITCH for the TRAY3. (RRP 9.8)	Go to step 7.
7	Checking the TRAY MODULE PWB for connection Are P/J413 and P/J541 connected securely?	Go to step 8.	Connect P/J413 and P/541 securely.
8	Checking conductivity between the TRAY MODULE PWB and the PWBA MCU F Is there normal conductivity between P/J541 and P/J413?	Go to step 9.	Fix open or short circuit.
9	Checking the TRAY MODULE PWB for power supply Is the voltage between J413-A5 (+) and the ground (-) +5 VDC?	Replace the TRAY MODULE PWB. (RRP 9.47)	Replace the PWBA MCU F. (RRP 8.4)

## Tray4 Size sensor broken

Step	Check	Yes	No
	Possible causative parts: TRAY 3/4 PAPER SIZE SWITCH (PL 9.2.4) TRAY MODULE PWB (PL 9.6.1) PWBA MCU F (PL 8.1.5)		
1	Checking paper Is paper loaded in the TRAY4 properly? Pull out the TRAY4 to check it. (Visual check)	Go to step 2.	Load paper properly.
2	Checking the TRAY 3/4 PAPER SIZE SWITCH for the TRAY4 for installation Is the TRAY 3/4 PAPER SIZE SWITCH for the TRAY4 installed properly? Pull out the TRAY4 to check it. (Visual check)	Go to step 3.	Install the TRAY 3/4 PAPER SIZE SWITCH for the TRAY4 correctly. (RRP 9.9)
3	Checking the TRAY 3/4 PAPER SIZE SWITCH for the TRAY4 for operation Does the Input Status change from "0x0" to "0x1" each time the TRAY4 with paper loaded is pulled out or pushed in? Check it using [Input 07-04 TRAY4 SIZE SENSOR] in Chapter 2, Diag.	Reconnect the connector of the PWBA MCU F.	Go to step 4.
4	Checking the TRAY 3/4 PAPER SIZE SWITCH for TRAY4 for connection Are P/J824 and P/J548 connected securely?	Go to step 5.	Connect P/J824 and P/J548 securely.
5	Checking conductivity between the TRAY 3/4 PAPER SIZE SWITCH for the TRAY4 and the PWBA MCU F Is there normal conductivity between P/J824 and P/J548?	Go to step 6.	Fix open or short circuit.
6	Checking the TRAY 3/4 PAPER SIZE SWITCH for the TRAY4 for power supply Is the voltage between J824-1 (+) and the ground (-) +3.3 VDC?	Replace the TRAY 3/4 PAPER SIZE SWITCH for the TRAY4. (RRP 9.9)	Go to step 7.
7	Checking the TRAY MODULE PWB for connection Are P/J413 and P/J541 connected securely?	Go to step 8.	Connect P/J413 and P/541 securely.
8	Checking conductivity between the TRAY MODULE PWB and the PWBA MCU F Is there normal conductivity between P/J541 and P/J413?	Go to step 9.	Fix open or short circuit.
9	Checking the TRAY MODULE PWB for power supply Is the voltage between J413-A5 (+) and the ground (-) +5 VDC?	Replace the TRAY MODULE PWB. (RRP 9.47)	Replace the PWBA MCU F. (RRP 8.4)



## TM Cover open

Step	Check	Yes	No
	Possible causative parts: LEFT COVER INTERLOCK SWITCH (PL 9.5.27) PWBA MCU F (PL 8.1.5)		
1	Checking the LEFT COVER ASSEMBLY (PL 9.5.10) for opening and closing Does the LEFT COVER ASSEMBLY (PL 9.5.10) open or close normally?	Go to step 2.	Check the LEFT COVER ASSEMBLY for deformation and reinstall it.
2	Checking the LEFT COVER INTERLOCK SWITCH for operation Does the Input Status change from "0x0" to "0x1" each time the LEFT COVER INTERLOCK SWITCH is pressed? Execute [Input 01-10 TRAY MODULE COVER] in Chapter 2 [Diagnostic]. Open the LEFT COVER ASSEMBLY (PL 9.5.10) and check it.	Replace the PWBA MCU F. (RRP 8.4)	Go to step 3.
3	Checking the LEFT COVER INTERLOCK SWITCH for connection Are FS812, FS813 and P/J554 connected surely?	Go to step 4.	Connect FS812, FS813 and P/J554 surely.
4	Checking conductivity between the LEFT COVER INTERLOCK SWITCH and the TRAY MODULE PWB Is there conductivity on each wire between FS812 <=> P/J554? Is there conductivity on each wire between FS813 <=> P/J554?	Go to step 5.	Fix open and short circuit.
5	Checking +24 VDC power supply to the LEFT COVER INTERLOCK SWITCH Is the voltage across FS813 <=> ground +24 VDC?	Replace the LEFT COVER INTERLOCK SWITCH. (RRP 9.46)	Go to step 6.
6	Checking the TRAY MODULE PWB for connection Are P/J541 and P/J413 connected surely?	Go to step 7.	Connect P/J541 and P/J413 surely.
7	Checking conductivity between the TRAY MODULE PWB and the PWBA MCU F Is there conductivity on each wire between P/J541 <=> P/J413?	Go to step 8.	Fix open and short circuit.
8	Checking +24 VDC power supply to the TRAY MODULE PWB Is the voltage across P/J541-8 (+) <=> ground +24 VDC?	Replace the TRAY MODULE PWB. (RRP 9.47)	Replace the PWBA MCU F. (RRP 8.4)

## No paper in the select paper tray

Step	Check	Yes	No
	Possible causative parts: SENSOR (NO PAPER SENSOR) (PL 9.4.14) TRAY MODULE PWB (PL 9.6.1) PWBA MCU F (PL 8.1.5)		
1	Checking paper Is Paper loaded in the selected TRAY?	Go to step 2.	Load paper.
2	Checking the SENSOR (NO PAPER SENSOR) for operation Does the Input Status change from "0x0" to "0x1" each time the TRAY with paper loaded is pulled out or pushed in? For TRAY3: Execute [Input 07-09 TRAY3 NO PAPER SENSOR] in Chapter 2 [Diagnostic]. For TRAY4: Execute [Input 07-10 TRAY4 NO PAPER SENSOR] in Chapter 2 [Diagnostic].	Replace the PWBA MCU F. (RRP 8.4)	Go to step 3.
3	Checking the SENSOR (NO PAPER SENSOR) for connection For TRAY3: Are P/J102B, P/J661B and P/J549B connected surely? For TRAY4: Are P/J102A, P/J661A and P/J549A connected surely?	Go to step 4.	Connect the connectors surely.
4	Checking conductivity between the SENSOR (NO PAPER SENSOR) and the PWBA MCU F For TRAY3: Is there conductivity on each wire between P/J102B <=> P/J549B? For TRAY4: Is there conductivity on each wire between P/J102A <=> P/J549A?	Go to step 5.	Fix open and short circuit.
5	Checking +5 VDC power supply to the SENSOR (NO PAPER SENSOR) For TRAY3: Is the voltage across P/J102B-3 (+) <=> ground +5 VDC? For TRAY4: Is the voltage across P/J102A-3 (+) <=> ground +5 VDC?	Replace the SENSOR (NO PAPER SENSOR) for the TRAY. (RRP 9.23)	Go to step 6.
6	Checking the TRAY MODULE PWB for connection Are P/J413 and P/J541 connected surely?	Go to step 7.	Connect P/J413 and P/541 surely.
7	Checking conductivity between the TRAY MODULE PWB and the PWBA MCU F Is there conductivity on each wire between P/J413 <=> P/J541?	Go to step 8.	Fix open and short circuit.
8	Checking +5 VDC power supply to the TRAY MODULE PWB Is the voltage across P/J413-A5 (+) <=> ground +5 VDC?	Replace the TRAY MODULE PWB. (RRP 9.47)	Replace the PWBA MCU F. (RRP 8.4)

## Paper size mismatch in width

Step	Check	Yes	No
	Possible causative parts: TRAY 3/4 PAPER SIZE SWITCH (PL 9.2.4) FRONT SIDE GUIDE (PL 9.3.6) REAR SIDE GUIDE (PL 9.3.9) TRAY MODULE PWB (PL 9.6.1) PWBA MCU F (PL 8.1.5)		
1	Checking the paper (1) Is paper loaded in the Tray properly? Pull out the TRAY to check it. (Visual check)	Go to step 2.	Load paper properly.
2	Checking the paper (2) Are the FRONT SIDE GUIDE and REAR SIDE GUIDE of the TRAY3 and TRAY4 set correctly? Pull out each TRAY to check it. (Visual check)	Go to step 3.	Set the parts properly.
3	Checking the TRAY 3/4 PAPER SIZE SWITCH for installation Are the TRAY 3/4 PAPER SIZE SWITCH for the TRAY3 and TRAY4 installed properly? Pull out each TRAY to check it. (Visual check)	Go to step 4.	Install the TRAY 3/4 PAPER SIZE SWITCH for each TRAY correctly. (RRP 9.8/RRP 9.9)
4	Checking the TRAY 3/4 PAPER SIZE SWITCH for operation Does the Input Status change from "0x0" to "0x1" each time the TRAY with paper loaded is pulled out or pushed in? For TRAY3: Execute [Input 07-03 TRAY3 SIZE SENSOR] in Chapter 2 [Diagnostic]. For TRAY4: Execute [Input 07-04 TRAY4 SIZE SENSOR] in Chapter 2 [Diagnostic].	Replace the PWBA MCU F. (RRP 8.4)	Go to step 5.
5	Checking the TRAY 3/4 PAPER SIZE SWITCH for connection For TRAY3: Are P/J820 and P/J548 connected surely? For TRAY4 Are P/J824 and P/J548 connected surely?	Go to step 6.	Connect the connectors surely.
6	Checking conductivity between the TRAY 3/4 PAPER SIZE SWITCH and the TRAY MODULE PWB For TRAY3: Is there conductivity on each wire between P/J820 <=> P/J548? For TRAY4 Is there conductivity on each wire between P/J824 <=> P/J548?	Go to step 7.	Fix open and short circuit.

Step	Check	Yes	No
7	Checking +3.3 VDC power supply to the TRAY 3/4 PAPER SIZE SWITCH For TRAY3: Is the voltage across P/J820-1 (+) <=> ground +3.3 VDC? For TRAY4 Is the voltage across P/J824-1 (+) <=> ground +3.3 VDC?	Replace the SWITCH ASSY P S for the TRAY. (RRP 9.8/RRP 9.9)	Go to step 8.
8	Checking the TRAY MODULE PWB for connection Are P/J413 and P/J541 connected surely?	Go to step 9.	Connect P/J413 and P/541 surely.
9	Checking conductivity between the TRAY MODULE PWB and the PWBA MCU F Is there conductivity on each wire between P/J413 <=> P/J541?	Go to step 10.	Fix open and short circuit.
10	Checking +5 VDC power supply to the TRAY MODULE PWB Is the voltage across P/J413-A5 (+) <=> ground +5 VDC?	Replace the TRAY MODULE PWB. (RRP 9.47)	Replace the PWBA MCU F. (RRP 8.4)

### Tray 3 Paper size mismatch in length

Step	Check	Yes	No
	Possible causative parts: TRAY 3/4 PAPER SIZE SWITCH (PL 9.2.4) FRONT SIDE GUIDE (PL 9.3.6) REAR SIDE GUIDE (PL 9.3.9) SENSOR ASSY REGI (PL 4.5.7) CLUTCH ASSY REGI (PL 4.5.5) TRAY MODULE PWB (PL 9.6.1) PWBA MCU F (PL 8.1.5)		
1	Checking the paper (1) Is paper loaded in the TRAY3 properly? Pull out the TRAY3 to check it. (Visual check)	Go to step 2.	Load paper properly.
2	Checking the paper (2) Are the FRONT SIDE GUIDE and REAR SIDE GUIDE of the TRAY3 set correctly? Pull out the TRAY3 to check it. (Visual check)	Go to step 3.	Set the parts properly.
3	Checking the TRAY 3/4 PAPER SIZE SWITCH for the TRAY3 for installation Is the TRAY 3/4 PAPER SIZE SWITCH for the TRAY3 installed properly? Pull out the TRAY3 to check it. (Visual check)	Go to step 4.	Install the TRAY 3/4 PAPER SIZE SWITCH for the TRAY3 correctly. (RRP 9.8)
4	Checking the TRAY 3/4 PAPER SIZE SWITCH for operation Does the Input Status change from "0x0" to "0x1" each time the TRAY3 with paper loaded is pulled out or pushed in? Execute [Input 07-03 TRAY3 SIZE SENSOR] in Chapter 2 [Diagnostic].	Go to step 11.	Go to step 5.

Step	Check	Yes	No
5	Checking the TRAY 3/4 PAPER SIZE SWITCH for connection Are P/J820 and P/J548 connected surely?	Go to step 6.	Connect P/J820 and P/J548 surely.
6	Checking conductivity between the TRAY 3/4 PAPER SIZE SWITCH for the TRAY3 and the TRAY MODULE PWB Is there conductivity on each wire between P/J820 <=> P/J548?	Go to step 7.	Fix open and short circuit.
7	Checking +3.3 VDC power supply to the TRAY 3/4 PAPER SIZE SWITCH for the TRAY3 Is the voltage across P/J820-1 (+) <=> ground +3.3 VDC?	Replace the SWITCH ASSY P S for the TRAY3. (RRP 9.8)	Go to step 8.
8	Checking the TRAY MODULE PWB for connection Are P/J413 and P/J541 connected surely?	Go to step 9.	Connect P/J413 and P/541 surely.
9	Checking conductivity between the TRAY MODULE PWB and the PWBA MCU F Is there conductivity on each wire between P/J413 <=> P/J541?	Go to step 10.	Fix open and short circuit.
10	Checking +5 VDC power supply to the TRAY MODULE PWB Is the voltage across P/J413-A5 (+) <=> ground +5 VDC?	Replace the TRAY MODULE PWB. (RRP 9.47)	Replace the PWBA MCU F. (RRP 8.4)
11	Checking the Roll for the TRAY3 Is the ROLLER ASSY (FEED), ROLLER ASSY (RETARD) or ROLLER ASSY (NUDGER) for transport worn or contaminated with paper dust? Pull out the TRAY3 and check it.	Go to step 12.	Clean or replace the ROLLER ASSY (FEED), ROLLER ASSY (RETARD) or ROLLER ASSY (NUDGER). (RRP 9.28/RRP 9.32/ RRP 9.35))
12	Checking paper position Does the paper touch the SENSOR ASSY REGI? Open the COVER ASSY-LH (PL 4.2.8) and check it (visual check).	Remove the paper.	Go to step 13.
13	Checking the Roll (1) Is the ROLLER ASSY-TA for transport worn or contaminated with paper dust? Open the COVER ASSY-LH (PL 4.2.8) and check it.	Go to step 14.	Clean or replace the ROLLER ASSY-TA. (RRP 4.3)
14	Checking the Roll (2) Is the ROLLER of the TRANS ASSY REGI for transport (PL 4.5.1) worn or contaminated with paper dust? Open the COVER ASSY-LH (PL 4.2.8) and check it.	Go to step 15.	Clean or replace the rolls.
15	Checking the SENSOR ASSY REGI for operation Does the Input Status change from "0x0" to "0x1" each time the paper touches the SENSOR ASSY REGI? Execute [Input 08-05 REGI SENSOR] in Chapter 2 [Diagnostic]. Open the COVER ASSY-LH (PL 4.2.8) and check it.	Go to step 19.	Go to step 16.

Step	Check	Yes	No
16	Checking the SENSOR ASSY REGI for connection Are P/J104 and P/J403B connected surely?	Go to step 17.	Connect P/J104 and P/J403B surely.
17	Checking conductivity between the SENSOR ASSY REGI and the PWB A MCU Is there conductivity on each wire between P/J104 <=> P/J403B?	Go to step 18.	Fix open and short circuit.
18	Checking +5 VDC power supply to the SENSOR ASSY REGI Is the voltage across P/J104-1 (+) <=> ground +5 VDC?	Replace the SENSOR ASSY REGI. (RRP 4.13)	Replace the PWBA MCU F. (RRP 8.4)
19	Checking the CLUTCH ASSY REGI H for operation Does the CLUTCH ASSY REGI H operate properly? Execute [Output 08-39 REGI CLUTCH (EXIT)] in Chapter 2 [Diagnostic].	Replace the PWBA MCU F. (RRP 8.4)	Go to step 20.
20	Checking the CLUTCH ASSY REGI H for connection Are P/J215 and P/J403B connected surely?	Go to step 21.	Connect P/J215 and P/J403B surely.
21	Checking conductivity between the CLUTCH ASSY REGI H and the PWB A MCU Is there conductivity on each wire between P/J215 <=> P/J403B?	Go to step 22.	Fix open and short circuit.
22	Checking +24 VDC power supply to the CLUTCH ASSY H Is the voltage across P215-2 (+) <=> ground +24 VDC?	Go to step 23.	Replace the PWBA MCU F. (RRP 8.4)
23	Checking the resistance of the CLUTCH ASSY REGI H Is the resistance across J215-1 and J215-2 approximately 240 ohm?	Replace the PWBA MCU F. (RRP 8.4)	Replace the CLUTCH ASSY REGI H. (RRP 4.11)

### Tray 4 Paper size mismatch in length

Step	Check	Yes	No
	Possible causative parts: TRAY 3/4 PAPER SIZE SWITCH (PL 9.2.4) FRONT SIDE GUIDE (PL 9.3.6) REAR SIDE GUIDE (PL 9.3.9) SENSOR ASSY REGI (PL 4.5.7) CLUTCH ASSY REGI (PL 4.5.5) TRAY MODULE PWB (PL 9.6.1) PWBA MCU F (PL 8.1.5)		
1	Checking the paper (1) Is paper loaded in the TRAY4 properly? Pull out the TRAY4 to check it. (Visual check)	Go to step 2.	Load paper properly.
2	Checking the paper (2) Are the FRONT SIDE GUIDE and REAR SIDE GUIDE of the TRAY4 set correctly? Pull out the TRAY4 to check it. (Visual check)	Go to step 3.	Set the parts properly.

Step	Check	Yes	No
3	Checking the TRAY 3/4 PAPER SIZE SWITCH for the TRAY4 for installation Is the TRAY 3/4 PAPER SIZE SWITCH for the TRAY4 installed properly? Pull out the TRAY4 to check it. (Visual check)	Go to step 4.	Install the TRAY 3/4 PAPER SIZE SWITCH for the TRAY4 correctly. (RRP 9.9)
4	Checking the TRAY 3/4 PAPER SIZE SWITCH for the TRAY4 for operation Does the Input Status change from "0x0" to "0x1" each time the TRAY3 is pulled out or pushed in, when the TRAY4 is loaded with paper? Execute [Input 07-04 TRAY4 SIZE SENSOR] in Chapter 2 [Diagnostic].	Go to step 11.	Go to step 5.
5	Checking the TRAY 3/4 PAPER SIZE SWITCH for the TRAY4 for connection Are P/J824 and P/J548 connected surely?	Go to step 6.	Connect P/J820 and P/J548 surely.
6	Checking conductivity between the TRAY 3/4 PAPER SIZE SWITCH for the TRAY4 and the TRAY MODULE PWB Is there conductivity on each wire between P/J824 <=> P/J548?	Go to step 7.	Fix open and short circuit.
7	Checking +3.3 VDC power supply to the TRAY 3/4 PAPER SIZE SWITCH for the TRAY4 Is the voltage across P/J824-1 (+) <=> ground +3.3 VDC?	Replace the TRAY 3/4 PAPER SIZE SWITCH for the TRAY4. (RRP 9.9)	Go to step 8.
8	Checking the TRAY MODULE PWB for connection Are P/J413 and P/J541 connected surely?	Go to step 9.	Connect P/J413 and P/J541 surely.
9	Checking conductivity between the TRAY MODULE PWB and the PWBA MCU F Is there conductivity on each wire between P/J413 <=> P/J541?	Go to step 10.	Fix open and short circuit.
10	Checking +5 VDC power supply to the TRAY MODULE PWB Is the voltage across P/J413-A5 (+) <=> ground +5 VDC?	Replace the TRAY MODULE PWB. (RRP 9.47)	Replace the PWBA MCU F. (RRP 8.4)
11	Checking the Roll for the TRAY4 Is the ROLLER ASSY (FEED), ROLLER ASSY (RETARD) or ROLLER ASSY (NUDGER) for transport worn or contaminated with paper dust? Pull out the TRAY4 and check it.	Go to step 12.	Clean or replace the ROLLER ASSY (FEED), ROLLER ASSY (RETARD) or ROLLER ASSY (NUDGER). (RRP 9.28/RRP 9.32/RRP 9.35)
12	Checking paper position Does the paper touch the SENSOR ASSY REGI? Open the COVER ASSY-LH (PL 4.2.8) and check it (visual check).	Remove the paper.	Go to step 13.

Step	Check	Yes	No
13	Checking the Roll (1) Is the ROLLER ASSY-TA for transport worn or contaminated with paper dust? Open the COVER ASSY-LH (PL 4.2.8) and check it.	Go to step 14.	Clean or replace the ROLLER ASSY-TA. (RRP 4.3)
14	Checking the Roll (2) Is the ROLLER of the TRANS ASSY REGI for transport (PL 4.5.1) worn or contaminated with paper dust? Open the COVER ASSY-LH (PL 4.2.8) and check it.	Go to step 15.	Clean or replace the XXX.
15	Checking the SENSOR ASSY REGI for operation Does the Input Status change from "0x0" to "0x1" each time the paper touches the SENSOR ASSY REGI? Execute [Input 08-05 REGI SENSOR] in Chapter 2 [Diagnostic]. Open the COVER ASSY-LH (PL 4.2.8) and check it.	Go to step 19.	Go to step 16.
16	Checking the SENSOR ASSY REGI for connection Are P/J104 and P/J403B connected surely?	Go to step 17.	Connect P/J104 and P/J403B surely.
17	Checking conductivity between the SENSOR ASSY REGI and the PWB A MCU Is there conductivity on each wire between P/J104 <=> P/J403B?	Go to step 18.	Fix open and short circuit.
18	Checking +5 VDC power supply to the SENSOR ASSY REGI Is the voltage across P/J104-1 (+) <=> ground +5 VDC?	Replace the SENSOR ASSY REGI. (RRP 4.13)	Replace the PWBA MCU F. (RRP 8.4)
19	Checking the CLUTCH ASSY REGI H for operation Does the CLUTCH ASSY REGI H operate properly? Execute [Output 08-39 REGI CLUTCH] in Chapter 2 [Diagnostic].	Replace the PWBA MCU F. (RRP)8.4	Go to step 20.
20	Checking the CLUTCH ASSY REGI H for connection Are P/J215 and P/J403B connected surely?	Go to step 21.	Connect P/J215 and P/J403B surely.
21	Checking conductivity between the CLUTCH ASSY REGI H and the PWB A MCU Is there conductivity on each wire between P/J215 <=> P/J403B?	Go to step 22.	Fix open and short circuit.
22	Checking +24 VDC power supply to the CLUTCH ASSY REGI H Is the voltage across P215-2 (+) <=> ground +24 VDC?	Go to step 23.	Replace the PWBA MCU F. (RRP 8.4)
23	Checking the resistance of the CLUTCH ASSY REGI H Is the resistance across J215-1 and J215-2 approximately 240 ohm?	Replace the PWBA MCU F. (RRP 8.4)	Replace the CLUTCH ASSY REGI H. (RRP 4.11)



## Registration Sensor on JAM (Duplex paper feed)

Step	Check	Yes	No
	Possible causative parts: ROLLER DUP A3L (PL 10.2.7) ROLLER ASSY DUP (PL 10.2.8) MOTOR ASSY DUP (PL 10.1.11) PWBA DUPLEX (PL 10.1.12)		
1	Checking paper position Does the paper touch the SENSOR ASSY REGI? Open the COVER ASSY-LH (PL 4.2.8) and check it (visual check).	Remove the paper.	Go to step 2.
2	Checking the Duplex for installation Remove TRANS ASSY DUP (PL 10.1.1) and reinstall it. Does the error occur again when a test print of duplex printing is carried out? Execute [Test Print] in Chapter 2 [Diagnostic].	Go to step 3.	End of work
3	Checking the Roll (1) Open the COVER DUP (PL 10.1.13). Is the Roller of the ROLLER DUP A3L worn or contaminated with paper dust?	Go to step 4.	Clean or replace the ROLLER DUP A3L. (RRP 10.11)
4	Checking the drive power transmission (1) Open the COVER DUP (PL 10.1.13). Do the ROLLER DUP A3L and the other gears rotate smoothly?	Go to step 5.	Replace the obstacles.
5	Checking the Roll (2) Open the COVER DUP (PL 10.1.13). Is the Roller of the ROLLER ASSY DUP worn or contaminated with paper dust?	Go to step 6.	Clean or replace the ROLLER ASSY DUP. (RRP 10.8)
6	Checking the drive power transmission (2) Open the COVER DUP (PL 10.1.13). Do the ROLLER ASSY DUP and the other gears rotate smoothly?	Go to step 7.	Replace the obstacles.
7	Checking the MOTOR ASSY DUP for operation Does the MOTOR ASSY DUP operate properly? Execute [Output 08-38 DUP MOTOR] in Chapter 2 [Diagnostic].	Go to step 15.	Go to step 8.
8	Checking the MOTOR ASSY DUP for connection Are P/J212 and P/J542 connected surely?	Go to step 9.	Connect P/J212 and P/J542 surely
9	Checking the MOTOR ASSY DUP for conductivity Is there conductivity on each wire between P/J212 <=> P/J542?	Go to step 10.	Fix open and short circuit.
10	Checking +24 VDC power supply to the MOTOR ASSY DUP Is the voltage across P542-1 (+) <=> ground +24 VDC?	Go to step 14.	Go to step 11.
11	Checking the PWBA Duplex for connection Are P/J540 and P/J417 connected surely?	Go to step 12.	Connect P/J540 and P/J417 surely.

Step	Check	Yes	No
12	Checking conductivity between the PWBA DUPLEX and the PWBA MCU F Is there conductivity on each wire between P/J540 <=> P/J417?	Replace the PWBA DUPLEX. (RRP 10.9)	Fix open and short circuit.

### Registration Sensor on JAM (Duplex paper feed)

Step	Check	Yes	No
	Possible causative parts: ROLLER DUP A3L (PL 10.2.7) ROLLER ASSY DUP (PL 10.2.8) MOTOR ASSY DUP (PL 10.1.11) SENSOR-PHOTO IN (PL 10.1.18) PWBA DUPLEX (10.1.12)		
1	Checking paper position Does the paper touch the SENSOR ASSY REGI? Open the COVER ASSY-LH (PL 4.2.8) and check it (visual check).	Remove the paper.	Go to step 2.
2	Checking paper position Does the paper touch the SENSOR-PHOTO IN? Open the COVER DUP (PL 10.1.13) and check it (visual check).	Remove the paper.	Go to step 3.
3	Checking the Duplex for installation Remove TRANS ASSY DUP (PL 10.1.1) and reinstall it. Does the error occur again when a test print of duplex printing is carried out? Execute [Test Print] in Chapter 2 [Diagnostic].	Go to step 4.	End of work
4	Checking the Roll (1) Open the COVER DUP (PL 10.1.13). Is the Roller of the ROLLER DUP A3L worn or contaminated with paper dust?	Go to step 5.	Clean or replace the ROLLER DUP A3L. (RRP 10.11)
5	Checking the drive power transmission (1) Do the ROLLER DUP A3L and the other gears rotate smoothly? Remove COVER DUP (PL 10.1.13).	Go to step 6.	Replace the obstacles.
6	Checking the Roll (2) Open the COVER DUP (PL 10.1.13). Is the Roller of the ROLLER ASSY DUP for transport worn or contaminated with paper dust?	Go to step 7.	Clean or replace the ROLLER ASSY DUP. (RRP 10.8)
7	Checking the drive power transmission (2) Do the ROLLER ASSY DUP and the other gears rotate smoothly? Remove COVER DUP (PL 10.1.13).	Go to step 8.	Replace the obstacles.

Step	Check	Yes	No
8	Checking the SENSOR-PHOTO IN for operation Does the Input Status change from "0x0" to "0x1" each time the paper touches the SENSOR-PHOTO IN? Execute [Input 08-31 DUP WAIT SENSOR] in Chapter 2 [Diagnostic]. Open the COVER DUP (PL 10.1.13) and check it (visual check).	Go to step 14.	Go to step 9.
9	Checking the SENSOR-PHOTO IN for connection Are P/J123 and P/J541 connected surely?	Go to step 10.	Connect P/J123 and P/J541 surely.
10	Checking conductivity between the SENSOR-PHOTO IN and the PWBA DUPLEX Is there conductivity on each wire between P/J123 <=> P/J541?	Go to step 11.	Fix open and short circuit.
11	Checking +5 VDC power supply to the SENSOR-PHOTO IN Is the voltage across J123-3 (+) <=> ground +5 VDC?	Replace the SENSOR-PHOTO IN. (RRP 10.10)	Go to step 12.
12	Checking conductivity between the PWBA DUPLEX and the PWBA MCU F Is there conductivity on each wire between P/J540 <=> P/J417?	Replace the PWBA DUPLEX. (RRP 10.9)	Fix open and short circuit.
13	Checking the MOTOR ASSY DUP for operation Does the MOTOR ASSY DUP operate properly? Execute [Output 08-38 DUP MOTOR] in Chapter 2 [Diagnostic].	Replace the PWBA DUPLEX. (RRP 10.9)	Go to step 14.
14	Checking the MOTOR ASSY DUP for connection Are P/J212 and P/J542 connected surely?	Go to step 15.	Connect P/J212 and P/J542 surely.
15	Checking the MOTOR ASSY DUP for conductivity Is there conductivity on each wire between P/J212 <=> P/J542?	Go to step 16.	Fix open and short circuit.
16	Checking +24 VDC power supply to the MOTOR ASSY DUP Is the voltage across P212-5 (+) <=> ground +24 VDC?	Replace the MOTOR ASSY DUP. (RRP 10.8)	Go to step 17.
17	Checking the PWBA DUPLEX for connection Are P/J540 and P/J417 connected surely?	Replace the PWBA DUPLEX. (RRP 10.9)	Connect P/J540 and P/J417 surely.

### Duplex Sensor Static JAM

Step	Check	Yes	No
	Possible causative parts: SENSOR-PHOTO IN (PL 10.1.18) PWBA DUPLEX (10.1.12)		

Step	Check	Yes	No
1	Checking paper position Does the paper touch the SENSOR-PHOTO IN? Open the COVER DUP (PL 10.1.13) and check it (visual check).	Remove the paper.	Go to step 2.
2	Checking the SENSOR-PHOTO IN for operation Does the Input Status change from "0x0" to "0x1" each time the paper touches the SENSOR-PHOTO IN? Execute [Input 08-31 DUP WAIT SENSOR] in Chapter 2 [Diagnostic]. Open the COVER DUP (PL 10.1.13) and check it (visual check).	Reconnect the connector on the PWBA MCU F. (RRP 8.4)	Go to step 3.
3	Checking the SENSOR-PHOTO IN for connection Are P/J123 and P/J541 connected surely?	Go to step 4.	Connect P/J123 and P/J541 surely.
4	Checking conductivity between the SENSOR-PHOTO IN and the PWBA DUPLEX Is there conductivity on each wire between P/J123 <=> P/J541?	Go to step 5.	Fix open and short circuit.
5	Checking +5 VDC power supply to the SENSOR-PHOTO IN Is the voltage across J123-3 (+) <=> ground +5 VDC?	Replace the SENSOR-PHOTO IN. (RRP 10.10)	Go to step 6.
6	Checking conductivity between the PWBA DUPLEX and the PWBA MCU F Is there conductivity on each wire between P/J540 <=> P/J417?	Go to step 7.	Fix open and short circuit.
7	Checking +5 VDC power supply to the PWBA DUPLEX Is the voltage across P/J541-2 (+) <=> ground +5 VDC?	Replace the PWBA DUPLEX. (RRP 10.9)	Replace the PWBA MCU F. (RRP 8.4)

### FIP 3.1 Duplex Wait SENSOR ON JAM

Step	Check	Yes	No
	Possible causative parts: ROLL ASSY-FU (PL 11.1.19) ROLL ASSY-INV (PL 11.1.20) ROLL ASSY OCT (PL 11.2.7) MOTOR ASSY EXIT 2 (PL 11.2.37) PWBA EXIT (PL 8.1.4) SENSOR-PHOTO IN (PL 10.1.18) PWBA DUPLEX (PL10.1.12)		
1	Checking paper position Does the paper remain in the EXIT 2? Open the CHUTE LH HIGH (PL 11.1.18) and check it (visual check).	Remove the paper.	Go to step 2.
2	Checking the Roll (1) Open CHUTE LH HIGH (PL 11.1.18). Is the Roller of the ROLL ASSY-FU worn or contaminated with paper dust?	Go to step 3.	Clean or replace the ROLL ASSY-FU. (RRP 11.2)
3	Checking the drive power transmission (1) Do the ROLL ASSY-FU and the other gears rotate smoothly?	Go to step 4.	Replace the obstacles.
4	Checking the Roll (2) Open CHUTE LH HIGH (PL 11.1.18). Is the Roller of the ROLL ASSY-INV worn or contaminated with paper dust?	Go to step 5.	Clean or replace the ROLL ASSY-INV. (RRP 11.3)
5	Checking the drive power transmission (2) Do the ROLL ASSY-INV and the other gears rotate smoothly?	Go to step 6.	Replace the obstacles.
6	Checking the Roll (3) Open CHUTE LH HIGH (PL 11.1.18). Is the Roller of the ROLL ASSY OCT worn or contaminated with paper dust?	Go to step 7.	Clean or replace the ROLL ASSY OCT. (RRP 11.6)
7	Checking the drive power transmission (3) Do the ROLLER ASSY OCT and the other gears rotate smoothly?	Go to step 8.	Replace the obstacles.
8	Checking the MOTOR ASSY EXIT 2 for operation Does the MOTOR ASSY EXIT 2 operate properly? Execute [Output 10-09 EXIT DRIVE MOTOR REVERSE (send paper into Duplex)] in Chapter 2 [Diagnostic].	Go to step 17.	Go to step 9.
9	Checking the MOTOR ASSY EXIT 2 for connection Are P/J208, P/J606A and P/J433 connected surely?	Go to step 10.	Connect P/J208, P/J606A and P/J433 surely.
10	Checking conductivity between the MOTOR ASSY EXIT 2 and PWBA EXIT Is there conductivity on each wire between P/J208 <=> P/J433?	Go to step 11.	Fix open and short circuit.

Step	Check	Yes	No
11	Checking +24 VDC power supply to the MOTOR ASSY EXIT 2 Is the voltage across P208-5 (+) <=> ground +24 VDC?	Replace the MOTOR ASSY EXIT 2. (RRP 11.16)	Go to step 12.
12	Checking the connection between the PWBA EXIT and the PWBA MCU F Are P/J431 and P/J421 connected surely?	Go to step 13.	Connect P/J431 and P/J421 surely.
13	Checking conductivity between the PWBA EXIT and the PWBA MCU F Is there conductivity on each wire between P/J431 <=> P/J421?	Replace the PWBA EXIT. (RRP 8.3)	Fix open and short circuit.
14	Checking the SENSOR-PHOTO IN for operation Does the Input Status change from "0x0" to "0x1" each time the paper touches the SENSOR-PHOTO IN? Execute [Input 08-31 DUP WAIT SENSOR] in Chapter 2 [Diagnostic]. Open the COVER DUP (PL 10.1.13) and check it (visual check).	Reconnect the connector on the PWBA MCU F.	Go to step 15.
15	Checking the SENSOR-PHOTO IN for connection Are P/J123 and P/J541 connected surely?	Go to step 16.	Connect P/J123 and P/J541 surely.
16	Checking conductivity between the SENSOR-PHOTO IN and the PWBA DUPLEX Is there conductivity on each wire between P/J123 <=> P/J541?	Go to step 17.	Fix open and short circuit.
17	Checking +5 VDC power supply to the SENSOR-PHOTO IN Is the voltage across J123-3 (+) <=> ground +5 VDC?	Replace the SENSOR-PHOTO IN. (RRP 10.10)	Replace the PWBA DUPLEX. (RRP 10.9)

## Duplex Module Communication fail

Step	Check	Yes	No
	Possible causative parts: PWBA DUPLEX (PL10.1.12) PWBA MCU F (PL 8.1.5)		
1	Checking the DUPLEX UNIT for installation Remove the TRANS ASSY DUP (PL 10.1.1) and reinstall it. Does it operate properly?	End of work	Go to step 2.
2	Checking the PWBA DUPLEX for connection Are P/J540 and P/J417 connected surely?	Go to step 3.	Connect P/J540 and P/J417 surely.
3	Checking conductivity between the PWBA DUPLEX and the PWBA MCU F Is there conductivity on each wire between P/J540 <=> P/J417?	Go to step 4.	Fix open and short circuit.

Step	Check	Yes	No
4	Checking +24 VDC power supply to the PWBA DUPLEX Is the voltage across P540-2 (+) <=> ground +24 VDC?	Replace the PWBA DUPLEX. (RRP 10.9)	Replace the PWBA MCU F. (RRP 8.4)

### DUP MODULE Type fail

Step	Check	Yes	No
	Possible causative parts: PWBA DUPLEX (PL10.1.12)		
1	Checking the DUPLEX UNIT for installation Remove the TRANS ASSY DUP (PL 10.1.1) and reinstall it. Does it operate properly?	End of work	Go to step 2.
2	Checking +24 VDC power supply to the PWBA DUPLEX Is the voltage across P540-2 (+) <=> ground +24 VDC?	Replace the PWBA DUPLEX. (RRP 10.9)	Reconnect the connector on the PWBA MCU F. (RRP 8.4)

### DUP Cover open

Step	Check	Yes	No
	Possible causative parts: SWITCH-I/L, CAB (PL 10.1.9) PWBA DUPLEX (PL 10.1.)		
1	Checking the COVER DUP (PL 10.1.13) for opening and closing. Does the COVER DUP (PL 10.1.13) open or close normally?	Go to step 2.	Check the COVER DUP for deformation and reinstall it
2	Checking the SWITCH-I/L, CAB for operation Does the Input Status change from "0x0" to "0x1" each time the SWITCH-I/L, CAB is pressed? Execute [Input 08-33 DUP INTERLOCK] in Chapter 2 [Diagnostic]. Open the COVER DUP (PL 10.1.13) and check it (visual check).	Reconnect the connector on the PWBA MCU F. (RRP 8.4)	Go to step 3.
3	Checking the SWITCH-I/L, CAB for connection Are P/J124 and P/J541 connected surely?	Go to step 4.	Connect P/J124 and P/J541 surely.
4	Checking conductivity between the SWITCH-I/L, CAB and the PWBA DUPLEX Is there conductivity on each wire between P/J124 <=> P/J541?	Go to step 5.	Fix open and short circuit.
5	Checking +5 VDC power supply to the SWITCH-I/L, CAB Is the voltage across J124-2 (+) <=> ground +5 VDC?	Replace the SWITCH-I/L, CAB. (RRP 10.6)	Go to step 6.

Step	Check	Yes	No
6	Checking the PWBA Duplex for connection Are P/J540 and P/J417 connected surely?	Go to step 7.	Connect P/J540 and P/J417 surely.
7	Checking conductivity between the PWBA DUPLEX and the PWBA MCU F Is there conductivity on each wire between P/J540 <=> P/J417?	Go to step 8.	Fix open and short circuit.
8	Checking +5 VDC power supply to the PWBA DUPLEX Is the voltage across P540-1 (+) <=> ground +5 VDC?	Replace the PWBA DUPLEX. (RRP 10.9)	Connect the connector on the PWBA MCU F. (RRP 8.4)

### Exit Sensor2 ON, in FDT1/Fin simp job

Step	Check	Yes	No
	Possible causative parts: SOLENOID ASSY FU(PL 11.2.23) SENSOR-PHOTO IN (PL 11.2.35) PWBA EXIT (PL 8.1.4)		
1	Checking the position of the SOLENOID ASSY FU Is SOLENOID ASSY FU facing toward the Exit1?	Go to step 2.	Go to step 4.
2	Checking the GATE SENSOR for operation Does the GATE-EXIT, 2 move smoothly?	Go to step 4.	Go to step 3.
3	Checking the GATE EXIT, 2 for foreign particle Are there any foreign particles near the GATE-EXIT, 2?	Reinstall the GATE-EXIT, 2.	Remove foreign particles.
4	Checking the SOLENOID ASSY FU for operation Does the SOLENOID ASSY FU operate properly? Check it using input 10-53 FACE UP GATE Solenoid in Chapter 2, Diagnostics.	Go to step 8.	Go to step 5.
5	Checking the SOLENOID ASSY FU for connection Are P/J210, P/J606A and P/J433 connected securely?	Go to step 6.	Connect P/J210, P/J606A and P/J433 securely.
6	Checking conductivity between the SOLENOID ASSY FU and PWBA EXIT Is there normal conductivity between P/J210 and P/J433?	Go to step 7.	Fix open and short circuit.
7	Checking the SOLENOID ASSY FU for power supply Is the voltage between P210-2 (+) and the ground (-) +24 VDC?	Replace the SOLENOID ASSY FU. (RRP 11.11)	Replace the PWBA EXIT. (RRP 8.3)
8	Checking paper position Does the paper touch the SENSOR-PHOTO IN? Open the CHUTE LH HIGH (PL 11.1.18) and check it (visual check).	Remove the paper.	Go to step 9.



Step	Check	Yes	No
9	Checking the SENSOR-PHOTO IN for operation Does the SENSOR-PHOTO IN operate properly? Check it using input 10-52 EXIT SENSOR2î in Chapter 2, Diagnostics.	Reconnect the connector on the PWBA MCU F.	Go to step 10.
10	Checking the SENSOR-PHOTO IN for connection Are P/J112, P/J606B and P/J434 connected securely?	Go to step 11.	Connect P/J112, P/J606B and P/J434 securely.
11	Checking conductivity between the SENSOR-PHOTO IN and the PWBA EXIT Is there normal conductivity between P/J112 and P/J434?	Go to step 12.	Fix open and short circuit.
12	Checking the SENSOR-PHOTO IN for power supply Is the voltage between P/J112-3 (+) and the ground (-) +5 VDC?	Replace the SENSOR-PHOTO IN. (RRP 11.14)	Replace the PWBA EXIT. (RRP 8.3)

### Exit Sensor 2 Static JAM

Step	Check	Yes	No
	Possible causative parts: SENSOR-PHOTO IN (PL 11.2.35) PWBA EXIT (PL 8.1.4)		
1	Checking paper position Does the paper touch the SENSOR-PHOTO IN? Open the CHUTE LH HIGH (PL 11.1.18) and check it (visual check).	Remove the paper.	Go to step 2.
2	Checking the SENSOR-PHOTO IN for operation (1) Execute [Input 10-52 EXIT SENSOR2] in Chapter 2 [Diagnostic]. Does the Input Status change from "0x0" to "0x1" each time the ACTUATOR EXIT (PL 11.2.17) of the SENSOR-PHOTO IN is operated?	Reconnect the connector on the PWBA MCU F. (RRP 8.4)	Go to step 3.
3	Checking the SENSOR-PHOTO IN for connection (2) Are P/J112, P/J606B and P/J434 connected surely?	Go to step 4.	Connect P/J112, P/J606B and P/J434 surely.
4	Checking conductivity between the SENSOR-PHOTO IN and the PWBA EXIT Is there conductivity on each wire between P/J112 <=> P/J434?	Go to step 5.	Fix open and short circuit.
5	Checking +5 VDC power supply to the SENSOR-PHOTO IN Is the voltage across J112-3 (+) <=> ground +5 VDC?	Replace the SENSOR-PHOTO IN. (RRP 11.14)	Replace the PWBA EXIT. (RRP 8.3)

## OCT2 fail

Step	Check	Yes	No
	Possible causative parts: OCT POSITION SENSOR-PHOTO IN (PL 11.2.54) MOTOR ASSY-OFFSET (PL 11.2.30) PWBA EXIT (PL 8.1.4)		
1	Checking the OCT POSITION SENSOR-PHOTO IN for operation (1) Execute [Input 07-34 OCT2 HOME POSITION SENSOR] in Chapter 2 [Diagnostic]. Open the TRANS ASSY EXIT 2 (PL 11.1.1).	Go to step 5.	Go to step 2.
2	Checking the OCT POSITION SENSOR-PHOTO IN for connection Are P/J111, P/J606B and P/J434 connected surely?	Go to step 3.	Connect P/J111, P/J606B and P/J434 surely.
3	Checking conductivity between the OCT POSITION SENSOR-PHOTO IN and the PWBA EXIT Is there conductivity on each wire between P/J111 <=> P/J434?	Go to step 4.	Fix open and short circuit.
4	Checking +5 VDC power supply to the OCT POSITION SENSOR-PHOTO IN Is the voltage across J111-3 (+) <=> ground +5 VDC?	Replace the OCT POSITION SENSOR-PHOTO IN. (RRP 11.15)	Replace the PWBA EXIT. (RRP 8.3)
5	Checking the MOTOR ASSY-OFFSET for operation (1) Does the MOTOR ASSY-OFFSET operate properly? Execute [Output 10-25 OFFSET MOTOR2 REVERSE ROTATION] in Chapter 2 [Diagnostic].	Reconnect the connector on the PWBA MCU F.	Go to step 11.
6	Checking the MOTOR ASSY-OFFSET for connection Are P/J207, P/J606A and P/J433 connected surely?	Go to step 7.	Connect P/J207, P/J606A and P/J433 surely.
7	Checking conductivity between the MOTOR ASSY-OFFSET and PWBA EXIT Is there conductivity on each wire between P/J207 <=> P/J433?	Go to step 8.	Fix open and short circuit.
8	Checking +24 VDC power supply to the MOTOR ASSY-OFFSET Is the voltage across P207-5 (+) <=> ground +24 VDC?	Replace the MOTOR ASSY-OFFSET. (RRP 11.13)	Replace the PWBA EXIT. (RRP 8.3)

## L/H-H Cover open

Step	Check	Yes	No
	Possible causative parts: SWITCH-I/L, CAB (PL 11.1.18) PWBA EXIT (PL 8.1.4)		

Step	Check	Yes	No
1	Checking the CHUTE LH HIGH (PL 11.1.18) for opening and closing Does the CHUTE LH HIGH (PL 11.1.18) open or close normally?	Go to step 2.	Check the CHUTE LH HIGH for deformation, and then reinstall it.
2	Checking the SWITCH-I/L, CAB for operation Does the Input Status change from "0x0" to "0x1" each time the SWITCH-I/L, CAB is pressed? Check it using [Input 01-13 L/H High COVER] in Chapter 2, Diagnostics. Open the CHUTE LH HIGH (PL 11.1.18) and check it.	Reconnect the connector of the PWBA MCU F.	Go to step 3.
3	Checking the SWITCH-I/L, CAB for connection Are P/J116, P/J606B and P/J434 connected securely?	Go to step 4.	Connect P/J116, P/J606B and P/J434 securely.
4	Checking conductivity between the SWITCH-I/L, CAB and the PWBA EXIT Is there normal conductivity between P/J116 and P/J434?	Go to step 5.	Fix open or short circuit.
5	Checking the SWITCH-I/L, CAB for power supply Is the voltage between P/J116-2 (+) and the ground (-) +5 VDC?	Replace the SWITCH-I/L, CAB. (RRP 11.9)	Replace the PWBA EXIT. (RRP 8.3)

#### F4-12 Finisher H-Transport Entrance Sensor On Jam

Step	Check	Yes	No
	Possible causative parts: BELT (PL 12.3.12) PINCH ROLL (PL 12.2.6) WIRE HARNESS (PL 12.3.26) PWB H-TRA (PL 12.14.3) H-TRANSPORT ENTRANCE SENSOR (PL 12.3.23) H-TRANSPORT MOTOR (PL 12.3.7) PWB MAIN-C (PL 12.14.5) PWBA MCU F (PL 8.1.5)		
1	Checking the paper path Open the COVER ASSY TOP (PL 12.2.9) of the H-TRANSPORT ASSEMBLY (PL 12.1.2). Are two BELTs (PL 12.3.12) and the PINCH ROLL (PL 12.2.6) attached on the COVER ASSY TOP installed correctly? Also, are they not contaminated or damaged, and rotated smoothly? Check these items by turning them with your fingers. Are there any stains such as paper dust on the paper path?	Go to step 2.	Clean or replace the BELTs and PINCH ROLL, and clean the paper path.

Step	Check	Yes	No
2	Checking the H-TRANSPORT ENTRANCE SENSOR (Finisher H-Transport Entrance Sensor) for operation Execute [Input 12-28 H-Transport Ent.SENSOR] in [Diagnosis]. Does the display on the screen change, every time the actuator of the H-TRANSPORT ENTRANCE SENSOR is operated?	Go to step 8.	Go to step 3.
3	Checking the WIRE HARNESS (PL 12.3.26) connection Are the connectors of the WIRE HARNESS connected to the H-TRANSPORT ENTRANCE SENSOR and H-TRA of the Finisher connected correctly?	Go to step 5.	After reconnecting, go to step 4.
4	Execute [Test Print] in [Diagnosis]. Does the error still occur?	Go to step 5.	End of work.
5	Checking the WIRE HARNESS for conductivity Disconnect J8380 of the H-TRANSPORT ENTRANCE SENSOR, and P8372 connected to the PWB H-TRA of the Finisher. Check for conductivity at the following: P8372-7 <=> J8380-3 P8372-8 <=> J8380-2 P8372-9 <=> J8380-1	Go to step 6.	Replace the WIRE HARNESS.
6	Checking +5 VDC power supply to the H-TRANSPORT ENTRANCE SENSOR Is the voltage across J8372-9 <=> J8372-7 on the PWB H-TRA of the Finisher +5 VDC?	Go to step 7.	Replace the PWB H-TRA. (RRP 12.97)
7	Checking the H-TRANSPORT ENTRANCE SENSOR for operation Does the voltage across J8372-8 <=> J8372-7 on the PWB H-TRA of the Finisher change, every time the actuator of the H-TRANSPORT ENTRANCE SENSOR is operated?	Replace the PWB H-TRA. (RRP 12.97)	Replace the H-TRANSPORT ENTRANCE SENSOR. (RRP 12.13)
8	Checking the H-TRANSPORT MOTOR for operation Execute [Output 12-01 H XPORT Motor 145 ON/OFF] in [Diagnosis]. Does the H-TRANSPORT MOTOR rotate normally?	Replace the PWB H-TRA. (RRP 12.97)	Go to step 9.
9	Checking the WIRE HARNESS connection Are the connectors of the WIRE HARNESS connected to the H-TRANSPORT MOTOR and H-TRA of the Finisher connected correctly?	Go to step 11.	After reconnecting, go to step 10.
10	Execute [Test Print] in [Diagnosis]. Does the error still occur?	Go to step 11.	End of work.

Step	Check	Yes	No
11	Checking the WIRE HARNESS for conductivity Disconnect P/J8379 of the H-TRANSPORT MOTOR, and P8372 on the PWB H-TRA of the Finisher. Check for conductivity at the following: P8372-13 <=> J8379-6 P8372-12 <=> J8379-4 P8372-11 <=> J8379-1 P8372-10 <=> J8379-3 P8372-15 <=> J8379-2 P8372-14 <=> J8379-5	Go to step 12.	Replace the WIRE HARNESS.
12	Checking the resistance of the H-TRANSPORT MOTOR Are there any resistances without disconnection across P8379-2/5(COM) and P8379-1/3/4/6 of the H-TRANSPORT MOTOR?	Go to step 13.	Replace the H-TRANSPORT MOTOR. (RRP 12.10)
13	Checking +24 VDC power supply to the H-TRANSPORT MOTOR Is the voltage across J8372-15 <=> J8372-7, and J8372-14 <=> J8372-7 on the PWB H-TRA of the Finisher +24 VDC?	Go to step 14.	Replace the PWB H-TRA. (RRP 12.97)
14	Checking after replacing the H-TRANSPORT MOTOR Replaced the H-TRANSPORT MOTOR. (RRP 12.10) Execute [Test Print] in [Diagnosis]. Does the error still occur?	Go to step 15.	End of work.
15	Checking after replacing the PWB H-TRA Replace the PWB H-TRA. (RRP 12.97) Execute [Test Print] in [Diagnosis]. Does the error still occur?	Go to step 16.	End of work.
16	Checking after replacing the PWB MAIN-C Replace the PWB MAIN-C. (RRP 12.98) Execute [Test Print] in [Diagnosis]. Does the error still occur?	Replace the PWBA MCU F. (RRP 8.4)	End of work.

## F4-22 Finisher H-Transport Exit Sensor On Jam A

**NOTE** This FIP can also be applied for the followings.

**NOTE** F4-23 Finisher H-Transport Exit Sensor On Jam B

**NOTE** F4-24 Finisher H-Transport Exit Sensor On Jam C

Step	Check	Yes	No
	Possible causative parts: BELT (PL 12.3.12) PINCH ROLL (PL 12.2.6) WIRE HARNESS (PL 12.3.26) PWB H-TRA (PL 12.14.3) H-TRANSPORT EXIT SENSOR (PL 12.3.21) H-TRANSPORT MOTOR (PL 12.3.7) PWB MAIN-C (PL 12.14.5) PWBA MCU F (PL 8.1.5)		

Step	Check	Yes	No
1	<p>Checking the paper path Open the COVER ASSY TOP (PL 12.2.9) of the H-TRANSPORT ASSEMBLY (PL 12.1.2). Are two BELTs (PL 12.3.12) and the PINCH ROLL (PL 12.2.6) attached on the COVER ASSY TOP installed correctly? Also, are they not contaminated or damaged, and rotated smoothly? Check these items by turning them with your fingers. Are there any stains such as paper dust on the paper path?</p>	Go to step 2.	Clean or replace the BELTs and PINCH ROLL, and clean the paper path.
2	<p>Checking the H-TRANSPORT EXIT SENSOR (Finisher H-Transport Exit Sensor) for operation Execute [Input 12-29 H-Transport Exit SENSOR] in [Diagnosis]. Does the display on the screen change, every time the actuator of the H-TRANSPORT EXIT SENSOR is operated?</p>	Go to step 8.	Go to step 3.
3	<p>Checking the WIRE HARNESS (PL 12.3.26) connection Are the connectors of the WIRE HARNESS connected to the H-TRANSPORT EXIT SENSOR and the PWB H-TRA of the Finisher connected correctly?</p>	Go to step 5.	After reconnecting, go to step 4.
4	<p>Execute [Test Print] in [Diagnosis]. Does the error still occur?</p>	Go to step 5.	End of work.
5	<p>Checking the WIRE HARNESS for conductivity Disconnect J8381 of the H-TRANSPORT EXIT SENSOR, and P/J8372 on the PWB H-TRA of the Finisher. Check for conductivity at the following: P8372-4 &lt;=&gt; J8381-3 P8372-5 &lt;=&gt; J8381-2 P8372-6 &lt;=&gt; J8381-1</p>	Go to step 6.	Replace the WIRE HARNESS.
6	<p>Checking +5 VDC power supply to the H-TRANSPORT EXIT SENSOR Is the voltage across J8372-6 &lt;=&gt; J8372-4 on the PWB H-TRA of the Finisher +5 VDC?</p>	Go to step 7.	Replace the PWB H-TRA. (RRP 12.97)
7	<p>Checking the H-TRANSPORT EXIT SENSOR for operation Does the voltage across J8372-5 &lt;=&gt; J8372-4 on the PWB H-TRA of the Finisher change, every time the actuator of the H-TRANSPORT EXIT SENSOR is operated?</p>	Replace the PWB H-TRA. (RRP 12.97)	Replace the H-TRANSPORT EXIT SENSOR. (RRP 12.14)
8	<p>Checking the H-TRANSPORT MOTOR for operation Execute [Output 12-01 H XPORT Motor 145 ON/OFF] in [Diagnosis] Does the H-TRANSPORT MOTOR rotate normally?</p>	Replace the PWB H-TRA. (RRP 12.97)	Go to step 9.
9	<p>Checking the WIRE HARNESS connection Are the connectors of the WIRE HARNESS connected to the H-TRANSPORT MOTOR and the H-TRA of the Finisher connected correctly?</p>	Go to step 11.	After reconnecting, go to step 10.

Step	Check	Yes	No
10	Execute [Test Print] in [Diagnosis]. Does the error still occur?	Go to step 11.	End of work.
11	Checking the WIRE HARNESS for conductivity Disconnect P/J8379 of the H-TRANSPORT MOTOR, and P8372 on the PWB H-TRA of the Finisher. Check for conductivity at the following: P8372-13 <=> J8379-6 P8372-12 <=> J8379-4 P8372-11 <=> J8379-1 P8372-10 <=> J8379-3 P8372-15 <=> J8379-2 P8372-14 <=> J8379-5	Go to step 12.	Replace the WIRE HARNESS.
12	Checking the resistance of the H-TRANSPORT MOTOR Are there any resistances without disconnection across P8379-2/5(COM) and P8379-1/3/4/6 of the H-TRANSPORT MOTOR?	Go to step 13.	Replace the H-TRANSPORT MOTOR. (RRP 12.10)
13	Checking +24 VDC power supply to the H-TRANSPORT MOTOR Is the voltage across J8372-15 <=> J8372-7, and J8372-14 <=> J8372-7 on the PWB H-TRA of the Finisher +24 VDC?	Go to step 14.	Replace the PWB H-TRA. (RRP 12.97)
14	Checking after replacing the H-TRANSPORT MOTOR Replace the H-TRANSPORT MOTOR. (RRP 12.10) Execute [Test Print] in [Diagnosis]. Does the error still occur?	Go to step 15.	End of work.
15	Checking after replacing the PWB H-TRA Replace the PWB H-TRA. (RRP 12.97) Execute [Test Print] in [Diagnosis]. Does the error still occur?	Go to step 16.	End of work.
16	Checking after replacing the PWB MAIN-C Replace the PWB MAIN-C. (RRP 12.98) Execute [Test Print] in [Diagnosis]. Does the error still occur?	Replace the PWBA MCU F. (RRP 8.4)	End of work.

## F4-32 Finisher Transport Entrance Sensor On Jam

Step	Check	Yes	No
	<p>Possible causative parts:</p> <p>BELT (PL 12.3.12)</p> <p>PINCH ROLL (PL 12.2.6)</p> <p>WIRE HARNESS (PL 12.3.26)</p> <p>PWB H-TRA (PL 12.14.3)</p> <p>H-TRANSPORT EXIT SENSOR (PL 12.3.21)</p> <p>H-TRANSPORT MOTOR (PL 12.3.7)</p> <p>HARNESS ASSY X'PORT ENT SENSOR (PL 12.15.4)</p> <p>HARNESS ASSY MAIN SENSOR (PL 12.15.1)</p> <p>SENSOR (PL 12.12.19)</p> <p>PWB MAIN-C (PL 12.14.5)</p>		
1	<p>Checking the paper path</p> <p>Open the COVER ASSY TOP (PL 12.2.9) of the H-TRANSPORT ASSEMBLY (PL 12.1.2).</p> <p>Are two BELTs (PL 12.3.12) and the PINCH ROLL (PL 12.2.6) attached on the COVER ASSY TOP installed correctly?</p> <p>Also, are they not contaminated or damaged, and rotated smoothly?</p> <p>Check these items by turning them with your fingers.</p> <p>Are there any stains such as paper dust on the paper path?</p>	Go to step 2.	Clean or replace the BELTs and PINCH ROLL, and clean the paper path.
2	<p>Checking H-TRANSPORT EXIT SENSOR (Finisher H-Transport Exit Sensor) for operation</p> <p>Execute [Input 12-29 H-Transport Exit SENSOR] in [Diagnosis].</p> <p>Does the display on the screen change, every time the actuator of the H-TRANSPORT EXIT SENSOR is operated?</p>	Go to step 8.	Go to step 3.
3	<p>Checking the WIRE HARNESS (PL 12.3.26) connection</p> <p>Are the connectors of the WIRE HARNESS connected to the H-TRANSPORT EXIT SENSOR and the H-TRA of the Finisher connected correctly?</p>	Go to step 5.	After reconnecting, go to step 4.
4	<p>Execute [Test Print] in [Diagnosis].</p> <p>Does the error still occur?</p>	Go to step 5.	End of work.
5	<p>Checking the WIRE HARNESS for conductivity</p> <p>Disconnect J8381 of the H-TRANSPORT EXIT SENSOR, and P8372 on the PWB H-TRA of the Finisher.</p> <p>Check for conductivity at the following:</p> <p>P8372-4 &lt;=&gt; J8381-3</p> <p>P8372-5 &lt;=&gt; J8381-2</p> <p>P8372-6 &lt;=&gt; J8381-1</p>	Go to step 6.	Replace the WIRE HARNESS.
6	<p>Checking +5 VDC power supply to the H-TRANSPORT EXIT SENSOR</p> <p>Is the voltage across J8372-6 &lt;=&gt; J8372-4 on the PWB H-TRA of the Finisher +5 VDC?</p>	Go to step 7.	Replace the PWB H-TRA. (RRP 12.97)



Step	Check	Yes	No
7	Checking the H-TRANSPORT EXIT SENSOR for operation Does the voltage across J8372-5 <=> J8372-4 on the PWB H-TRA of the Finisher change, every time the actuator of the H-TRANSPORT EXIT SENSOR is operated?	Replace the PWB H-TRA. (RRP 12.97)	Replace the H-TRANSPORT EXIT SENSOR. (RRP 12.14)
8	Checking the H-TRANSPORT MOTOR for operation Execute [Output 12-01 H XPORT Motor 145 ON/OFF] in [Diagnosis]. Does the H-TRANSPORT MOTOR rotate normally?	Go to step 16.	Go to step 9.
9	Checking the WIRE HARNESS connection Are the connectors of the WIRE HARNESS connected to the H-TRANSPORT MOTOR and the H-TRA of the Finisher connected correctly?	Go to step 11.	After reconnecting, go to step 10.
10	Execute [Test Print] in [Diagnosis]. Does the error still occur?	Go to step 11.	End of work.
11	Checking the WIRE HARNESS for conductivity Disconnect P/J8379 of the H-TRANSPORT MOTOR, and P8372 on the PWB H-TRA of the Finisher. Check for conductivity at the following: P8372-13 <=> J8379-6 P8372-12 <=> J8379-4 P8372-11 <=> J8379-1 P8372-10 <=> J8379-3 P8372-15 <=> J8379-2 P8372-14 <=> J8379-5	Go to step 12.	Replace the WIRE HARNESS.
12	Checking the resistance of the H-TRANSPORT MOTOR Are there any resistances without disconnection across P8379-2/5(COM) and P8379-1/3/4/6 of the H-TRANSPORT MOTOR?	Go to step 13.	Replace the H-TRANSPORT MOTOR. (RRP 12.10)
13	Checking +24 VDC power supply to the H-TRANSPORT MOTOR Is the voltage across J8372-15 <=> J8372-7, and J8372-14 <=> J8372-7 on the PWB H-TRA of the Finisher +24 VDC?	Go to step 14.	Replace the PWB H-TRA. (RRP 12.97)
14	Checking after replacing the H-TRANSPORT MOTOR Replace the H-TRANSPORT MOTOR. (RRP 12.10) Execute [Test Print] in [Diagnosis]. Does the error still occur?	Go to step 15.	End of work.
15	Checking after replacing the PWB H-TRA Replace the PWB H-TRA. (RRP 12.97) Execute [Test Print] in [Diagnosis]. Does the error still occur?	Replace the PWB MAIN-C. (RRP 12.98)	End of work.
16	Checking the SENSOR (Transport Entrance Sensor) for operation Execute [Input 12-30 Transport Entrance SENSOR] in [Diagnosis]. Does the display on the screen change, every time a piece of white paper is placed over the sensing area of the SENSOR (Transport Entrance Sensor)?	Replace the PWB MAIN-C. (RRP 12.98)	Go to step 17.

Step	Check	Yes	No
17	Checking the HARNESS ASSY connection Are P/J8319 and P/J8303 of the HARNESS ASSY X'PORT ENT SENSOR, and P/J8302A of the HARNESS ASSY MAIN SENSOR connected surely?	Go to step 19.	After reconnecting, go to step 18.
18	Execute [Test Print] in [Diagnosis]. Does the error still occur?	Go to step 19.	End of work.
19	Checking the HARNESS ASSY X'PORT ENT SENSOR for conductivity Disconnect P/J8319 and P/J8303 of the HARNESS ASSY X'PORT ENT SENSOR. Check for conductivity at the following: J8319-3 <=> J8303B-1 J8319-2 <=> J8303B-2 J8319-1 <=> J8303B-3	Go to step 20.	Replace the HARNESS ASSY X'PORT ENT SENSOR.
20	Checking the HARNESS ASSY MAIN SENSOR for conductivity Disconnect P/J8303 of the HARNESS ASSY MAIN SENSOR, and P/J8302A on the PWB MAIN-C. Check for conductivity at the following: J8303A-3 <=> J8302A-1 J8303A-2 <=> J8302A-2 J8303A-1 <=> J8302A-3	Go to step 21.	Replace the HARNESS ASSY MAIN SENSOR.
21	Checking +5 VDC power supply to the SENSOR (Transport Entrance Sensor) Is the voltage across J8302A-3 <=> J8302A-1 on the PWB MAIN-C +5 VDC?	Go to step 22.	Replace the WB MAIN-C. (RRP 12.98)
22	Checking the SENSOR (Transport Entrance Sensor) for operation Does the voltage across P8302A-2 <=> P8302A-1 on the PWB MAIN-C change, every time a piece of white paper is placed over the sensing area of the SENSOR (X'port Entrance Sensor)?	Replace the PWB MAIN-C. (RRP 12.98)	Replace the SENSOR. (RRP 12.82)

## F4-42 Finisher Buffer Path Sensor On Jam A

**NOTE** This FIP can also be applied for the following.

**NOTE** F4-43 Finisher Buffer Path Sensor On Jam B

Step	Check	Yes	No
	Possible causative parts: ROLL ASSY-ENT (PL 12.12.20) ROLLER ASSY-PINCH, ENT (PL 12.12.17) ROLL ASSY-BUFFER (PL 12.12.13) ROLLER-PINCH (PL 12.12.2) HARNESS ASSY X'PORT ENT SENSOR (PL 12.15.4) HARNESS ASSY MAIN SENSOR (PL 12.15.1) PWB MAIN-C (PL 12.14.5) SENSOR (PL 12.12.19) HARNESS ASSY MAIN DRIVE (PL 12.15.2) SENSOR (PL 12.13.15) HARNESS ASSY-SENSOR (PL 12.13.16) BRACKET ASSY SOL (PL 12.12.34) MOTOR ASSY (PL 12.13.30) HARNESS ASSY BUFFER SENSOR (PL 12.15.5) SENSOR ASSY (PL 12.12.12)		
1	Checking the paper path Open the COVER ASSY FRONT (PL 12.5.3) of the Finisher. Remove the COVER TOP (PL 12.4.1) and COVER LH TOP (PL 12.5.9). Open the CHUTE ASSY-UPPER, ENT (PL 12.12.16) to upward. Are the ROLL ASSY-ENT (PL 12.12.20) and the ROLLER ASSY-PINCH, ENT (PL 12.12.17) attached on the CHUTE ASSY-UPPER, ENT installed correctly? Also, are they not contaminated or damaged, and rotated smoothly? Check these items by turning them with your fingers. Are there any stains such as paper dust on the paper path?	Go to step 2.	Clean or replace the appropriate ROLLER, and clean the paper path.
2	Checking the paper path Open the COVER ASSY FRONT (PL 12.5.3) of the Finisher. Remove the COVER TOP (PL 12.4.1) and COVER LH TOP (PL 12.5.9). Open the CHUTE ASSY-UPPER, EXIT OPEN (PL 12.12.1) to right. Are the ROLL ASSY-BUFFER (PL 12.12.13) and the ROLLER-PINCH (PL 12.12.2) attached on the CHUTE ASSY-UPPER, EXIT OPEN installed correctly? Also, are they not contaminated or damaged, and rotated smoothly? Check these items by turning them with your fingers. Are there any stains such as paper dust on the paper path?	Go to step 3.	After cleaning or replacing the appropriate ROLLER, go to step 3.
3	Checking the SENSOR (Gate Sensor) for operation Execute [Input 12-51 Gate SENSOR] in [Diagnosis] Does the display on the screen change, every time a piece of white paper is placed over the sensing area of the SENSOR (Gate Sensor)?	Go to step 9.	Go to step 4.

Step	Check	Yes	No
4	Checking the HARNESS ASSY-SENSOR connection Is the connector of the HARNESS ASSY-SENSOR connected correctly?	Go to step 6.	After reconnecting, go to step 5.
5	Execute [Test Print] in [Diagnosis]. Does the error still occur?	Go to step 6.	End of work.
6	Checking the HARNESS ASSY-SENSOR for conductivity Disconnect P/J8432 and P/J8376 of the HARNESS ASSY-SENSOR. Check for conductivity at the following: J8432-3 <=> J8376-1 J8432-2 <=> J8376-2 J8432-1 <=> J8376-3	Go to step 7.	Replace the HARNESS ASSY-SENSOR.
7	Checking +5 VDC power supply to the SENSOR (Gate Sensor) Is the voltage across P8376-3 <=> P8376-1 on the PWB MAIN-C +5 VDC?	Go to step 8.	Replace the PWB MAIN-C. (RRP 12.98)
8	Checking the SENSOR (Gate Sensor) for operation Does the voltage across P8376-2 <=> P8376-1 on the PWB MAIN-C change, every time a piece of white paper is placed over the sensing area of the SENSOR (Gate Sensor)?	Replace the PWB MAIN-C. (RRP 12.98)	Replace the SENSOR. (RRP 12.93)
9	Checking the BRACKET ASSY SOL (Buffer Gate Solenoid) for operation Execute [Output 12-25 Buffer Gate SOL BUF] in [Diagnosis]. Does the GATE-BUFFER (PL 12.12.7) open upward?	Go to step 15.	Go to step 10.
10	Checking the HARNESS ASSY MAIN DRIVE connection Are P/J8394 and P/J8304 of the HARNESS ASSY MAIN DRIVE connected surely?	Go to step 12.	After reconnecting, go to step 11.
11	Execute [Test Print] in [Diagnosis]. Does the error still occur?	Go to step 12.	End of work.
12	Checking the HARNESS ASSY MAIN DRIVE for conductivity Disconnect P/J8394 and P/J8304 of the HARNESS ASSY MAIN DRIVE. Check for conductivity at the following: J8394-1 <=> J8304-35 J8394-2 <=> J8304-34 J8394-3 <=> J8304-36	Go to step 13.	Replace the HARNESS ASSY MAIN DRIVE.
13	Checking +24 VDC power supply to the BRACKET ASSY SOL (Buffer Gate Solenoid) Is the voltage across J8304-34 <=> J8304-36 on the PWB MAIN-C +24 VDC?	Go to step 14.	Replace the PWB MAIN-C. (RRP 12.98)
14	Checking after replacing the BRACKET ASSY SOL (Buffer Gate Solenoid) Replace the BRACKET ASSY SOL (Buffer Gate Solenoid). (RRP 12.86) Execute [Test Print] in [Diagnosis]. Does the error still occur?	Replace the PWB MAIN-C. (RRP 12.98)	End of work.

Step	Check	Yes	No
15	Checking the MOTOR ASSY (Registration Motor) for operation Execute [Output 12-05 Registration Motor 285F ON/OFF] in [Diagnosis] Does the MOTOR ASSY (Registration Motor) rotate normally?	Go to step 16.	Go to step 18.
16	Checking the MOTOR ASSY (Registration Motor) for power transmission Execute [Output 12-05 Registration Motor 285F ON/OFF] in [Diagnosis]. Does the rotation of the MOTOR ASSY transmit to the ROLL ASSY-BUFFER (PL 12.12.13) through the BELT (PL 12.13.27)?	Go to step 24.	After reinstalling the MOTOR ASSY and BELT, go to step 33. (RRP 12.96)
17	Execute [Test Print] in [Diagnosis]. Does the error still occur?	Go to step 24.	End of work.
18	Checking the HARNESS ASSY MAIN DRIVE connection Are P/J8335 and P/J8304 of the HARNESS ASSY MAIN DRIVE connected surely?	Go to step 20.	After reconnecting, go to step 19.
19	Execute [Test Print] in [Diagnosis]. Does the error still occur?	Go to step 20.	End of work.
20	Checking the HARNESS ASSY MAIN DRIVE for conductivity Disconnect P/J8335 and P/J8304 of the HARNESS ASSY MAIN DRIVE. Check for conductivity at the following: J8335-1 <=> J8304-7 J8335-2 <=> J8304-8 J8335-3 <=> J8304-9 J8335-4 <=> J8304-11 J8335-5 <=> J8304-10 J8335-6 <=> J8304-13	Go to step 21.	Replace the HARNESS ASSY MAIN DRIVE.
21	Checking the resistance of the MOTOR ASSY Are there any resistances without disconnection cross P8335-2/5(COM) and P8335-1/3/4/6 of the MOTOR ASSY?	Go to step 22	Replace the MOTOR ASSY. (RRP 12.96)
22	Checking +24 VDC power supply to the MOTOR ASSY Are the voltages across J8304-8 <=> FRAME CHASSIS and J8304-10 <=> FRAME CHASSIS on the PWB MAIN-C +24 VDC?	Go to step 23.	Replace the PWB MAIN-C. (RRP 12.98)
23	Checking after replacing the MOTOR ASSY (Registration Motor) Replace the MOTOR ASSY (Registration Motor). (RRP 12.96) Execute [Test Print] in [Diagnosis]. Does the error still occur?	Replace the PWB MAIN-C. (RRP 12.98)	End of work.

Step	Check	Yes	No
24	Checking the SENSOR ASSY (Buffer Path Sensor) for operation Execute [Input 12-31 Buffer Path SENSOR] in [Diagnosis]. Does the display on the screen change, every time the actuator of the SENSOR ASSY (Buffer Path Sensor) is operated?	Replace the PWB MAIN-C. (RRP 12.98)	Go to step 26.
25	Checking the HARNESS ASSY BUFFER SENSOR connection Are P/J8392 and P/J8318 of the HARNESS ASSY BUFFER SENSOR connected surely?	Go to step 27.	After reconnecting, go to step 26.
26	Execute [Test Print] in [Diagnosis]. Does the error still occur?	Go to step 27.	End of work.
27	Checking the HARNESS ASSY MAIN SENSOR connection Are P/J8318 and P/J8302A of the HARNESS ASSY MAIN SENSOR connected surely?	Go to step 29.	After reconnecting, go to step 28.
28	Execute [Test Print] in [Diagnosis]. Does the error still occur?	Go to step 29.	End of work.
29	Checking the HARNESS ASSY BUFFER SENSOR for conductivity Disconnect P/J8392 and P/J8318 of the HARNESS ASSY BUFFER SENSOR. Check for conductivity at the following: J8392-3 <=> J8318B-1 J8392-2 <=> J8318B-2 J8392-1 <=> J8318B-3	Go to step 30.	Replace the HARNESS ASSY BUFFER SENSOR.
30	Checking the HARNESS ASSY MAIN SENSOR for conductivity Disconnect P/J8318 of the HARNESS ASSY MAIN SENSOR, and P/J8302A on the PWB MAIN-C. Check for conductivity at the following: J8318A-3 <=> J8302A-13 J8318A-2 <=> J8302A-14 J8318A-1 <=> J8302A-15	Go to step 31.	Replace the HARNESS ASSY MAIN SENSOR.
31	Checking +5 VDC power supply to the SENSOR ASSY (Buffer Path Sensor) Is the voltage across J8302A-15 <=> J8302A-13 on the PWB MAIN-C +5 VDC?	Go to step 32.	Replace the PWB MAIN-C. (RRP 12.98)
32	Checking the SENSOR ASSY (Buffer Path Sensor) for operation Does the voltage across P8302A-14 <=> P8302A-13 on the PWB MAIN-C change, every time the actuator of the SENSOR ASSY (Buffer Path Sensor) is operated?	Replace the PWB MAIN-C. (RRP 12.98)	Replace the SENSOR ASSY (Buffer Path Sensor). (RRP 12.76)

## F4-52 Finisher Compile Exit Sensor On Jam A

**NOTE** This FIP can also be applied for the followings.

**NOTE** F4-53 Finisher Compile Exit Sensor On Jam B

**NOTE F4-54 Finisher Compile Exit Sensor On Jam C**

Step	Check	Yes	No
	<p>Possible causative parts:            ROLL ASSY-BUFFER (PL 12.12.13)            ROLLER-PINCH (PL 12.12.2)            ROLLER ASSY-PINCH, EXIT (PL 12.12.15)            HARNESS ASSY BUFFER SENSOR (PL 12.15.5)            HARNESS ASSY MAIN SENSOR (PL 12.15.1)            PWB MAIN-C (PL 12.14.5)            SENSOR ASSY (PL 12.12.12)            SENSOR (PL 12.13.16)            HARNESS ASSY MAIN DRIVE (PL 12.15.2)            MOTOR ASSY (PL 12.13.30)            HARNESS ASSY COMPILER (PL 12.10.8)            SENSOR ASSY (PL 12.11.3)</p>		
1	<p>Checking the paper path            Open the COVER ASSY FRONT (PL 12.5.3) of the Finisher.            Open the CHUTE ASSY-UPPER, EXIT OPEN (PL 12.12.1) to right.            Open the CHUTE ASSY-BUFFER BOTTOM (PL 12.12.14) top downward.            Are the ROLL ASSY-BUFFER (PL 12.12.13), the ROLLER-PINCH (PL 12.12.2) attached on the CHUTE ASSY-UPPER, EXIT OPEN, and the ROLLER ASSY-PINCH, EXIT (PL 12.12.15) attached on the CHUTE ASSY-BUFFER BOTTOM installed correctly?            Also, are they not contaminated or damaged, and rotated smoothly?            Check these items by turning them with your fingers.            Are there any stains such as paper dust on the paper path?</p>	Go to step 2.	Clean or replace the appropriate ROLLER, and clean the paper path.
2	<p>Checking the SENSOR ASSY (Buffer Path Sensor) for operation            Execute [Input 12-31 Buffer Path SENSOR] in [Diagnosis].            Does the display on the screen change, every time the actuator of the SENSOR ASSY (Buffer Path Sensor) is operated?</p>	Go to step 11.	Go to step 3.
3	<p>Checking the HARNESS ASSY BUFFER SENSOR connection            Are P/J8392 and P/J8318 of the HARNESS ASSY BUFFER SENSOR connected surely?</p>	Go to step 5.	After reconnecting, go to step 4.
4	<p>Execute [Test Print] in [Diagnosis].            Does the error still occur?</p>	Go to step 5.	End of work.
5	<p>Checking the HARNESS ASSY MAIN SENSOR connection            Are P/J8318 and P/J8302A of the HARNESS ASSY MAIN SENSOR connected surely?</p>	Go to step 7.	After reconnecting, go to step 6.
6	<p>Execute [Test Print] in [Diagnosis].            Does the error still occur?</p>	Go to step 7.	End of work.

Step	Check	Yes	No
7	Checking the HARNESS ASSY BUFFER SENSOR for conductivity Disconnect P/J8392 and P/J8318 of the HARNESS ASSY BUFFER SENSOR. Check for conductivity at the following: J8392-3 <=> J8318B-1 J8392-2 <=> J8318B-2 J8392-1 <=> J8318B-3	Go to step 8.	Replace the HARNESS ASSY BUFFER SENSOR.
8	Checking the HARNESS ASSY MAIN SENSOR for conductivity Disconnect P/J8318 of the HARNESS ASSY BUFFER SENSOR, and P/J8302A on the PWB MAIN-C. Check for conductivity at the following: J8318A-3 <=> J8302A-13 J8318A-2 <=> J8302A-14 J8318A-1 <=> J8302A-15	Go to step 9.	Replace the HARNESS ASSY MAIN SENSOR.
9	Checking +5 VDC power supply to the SENSOR ASSY (Buffer Path Sensor) Is the voltage across J8302A-15 <=> J8302A-13 on the PWB MAIN-C +5 VDC?	Go to step 10.	Replace the PWB MAIN-C. (RRP 12.98)
10	Checking the ENSOR ASSY (Buffer Path Sensor) for operation Does the voltage across P8302A-14 <=> P8302A-13 on the PWB MAIN-C change, every time the actuator of the SENSOR ASSY (Buffer Path Sensor) is operated?	Replace the PWB MAIN-C. (RRP 12.98)	Replace the SENSOR ASSY (Buffer Path Sensor). (RRP 12.76)
11	Checking the MOTOR ASSY (Registration Motor) for operation Execute [Output 12-05 Registration Motor 285F ON/OFF] in [Diagnosis]. Does the MOTOR ASSY (Registration Motor) rotate normally?	Go to step 20.	Go to step 12.
12	Checking the MOTOR ASSY (Registration Motor) for power transmission Execute [Output 12-05 Registration Motor 285F ON/OFF] in [Diagnosis]. Does the rotation of the MOTOR ASSY transmit to the ROLL ASSY-BUFFER (PL 12.12.13) through the BELT (PL 12.13.27)?	Go to step 14.	After reinstalling the MOTOR ASSY and BELT, go to step 13. (RRP 12.96)
13	Execute [Test Print] in [Diagnosis]. Does the error still occur?	Go to step 14.	End of work.
14	Checking the HARNESS ASSY MAIN DRIVE connection Are P/J8335 and P/J8304 of the HARNESS ASSY MAIN DRIVE connected surely?	Go to step 16.	After reconnecting, go to step 15.
15	Execute [Test Print] in [Diagnosis]. Does the error still occur?	Go to step 16.	End of work.



Step	Check	Yes	No
16	<p>Checking the HARNESS ASSY MAIN DRIVE for conductivity Disconnect P/J8335 and P/J8304 of the HARNESS ASSY MAIN DRIVE. Check for conductivity at the following: J8335-1 &lt;=&gt; J8304-7 J8335-2 &lt;=&gt; J8304-8 J8335-3 &lt;=&gt; J8304-9 J8335-4 &lt;=&gt; J8304-11 J8335-5 &lt;=&gt; J8304-10 J8335-6 &lt;=&gt; J8304-13</p>	Go to step 17.	Replace the HARNESS ASSY MAIN DRIVE.
17	<p>Checking the resistance of the Motor Assembly. Are there any resistances without disconnection across P8335-2/5 COM and P8335-1/3/4/6 of the motor assembly</p>	Go to step 18.	Replace the Motor Assembly (RRP 12.96).
18	<p>Checking +24 VDC power supply to the MOTOR ASSY Are the voltages across J8304-8 &lt;=&gt; FRAME CHASSIS, and J8304-10 &lt;=&gt; FRAME CHASSIS on the PWB MAIN-C, +24 VDC?</p>	Go to step 19.	Replace the PWB MAIN-C. (RRP 12.98)
19	<p>Checking after replacing the MOTOR ASSY (Registration Motor) Replace the MOTOR ASSY (Registration Motor). (RRP 12.96) Execute [Test Print] in [Diagnosis]. Does the error still occur?</p>	Replace the PWB MAIN-C. (RRP 12.98)	End of work.
20	<p>Checking the SENSOR (Gate Sensor) for operation Perform [Input 12-51 Gate SENSOR] in Chapter 2, Diagnostics. Does the screen display change each time a piece of paper is placed at the front of the SENSOR (Gate Sensor)?</p>	Go to step 26.	Go to step 21.
21	<p>Checking the HARNESS ASSY-SENSOR for connection Are the connectors of the HARNESS ASSY-SENSOR connected securely?</p>	Go to step 23.	After reconnecting, go to step 22.
22	<p>Perform [Test Print] in Chapter 2, Diagnostics. Does the error still occur?</p>	Go to step 23.	End of work.
23	<p>Checking the HARNESS ASSY-SENSOR for conductivity Disconnect P/J8342 and P/J 8376 of the HARNESS ASSY-SENSOR. Check for conductivity at the following: J8432-3 &lt;=&gt; J8376-1 J8432-2 &lt;=&gt; J8376-2 J8432-1 &lt;=&gt; J8376-3</p>	Go to step 24.	Replace the HARNESS ASSY-SENSOR.
24	<p>Checking the SENSOR (Gate Sensor) for +5 VDC power supply Is the voltage between J8376-3 and J8376-1 of the PWB MAIN-C +5 VDC?</p>	Go to step 24.	Replace the PWB MAIN-C. (RRP 12.98)

Step	Check	Yes	No
25	Checking the SENSOR (Gate Sensor) for operation Does the voltage between P8376-2 and P8376-1 of the PWB MAIN-C change each time a piece of paper is placed at the front of the sensor?	Replace the PWB MAIN-C. (RRP 12.98)	Replace the SENSOR. (RRP 12.93)
26	Checking the SENSOR ASSY (Compile Exit Sensor) for operation Execute [Input 12-34 Compile Exit SENSOR] in [Diagnosis]. Does the display on the screen change, every time the actuator of the SENSOR ASSY (Compile Exit Sensor) is operated?	Replace the PWB MAIN-C. (RRP 12.98)	Go to step 27.
27	Checking the HARNESS ASSY COMPILER connection Are P/J8320 and P/J8391 of the HARNESS ASSY COMPILER connected surely?	Go to step 29.	After reconnecting, go to step 28.
28	Execute [Test Print] in [Diagnosis]. Does the error still occur?	Go to step 29.	End of work.
29	Checking the HARNESS ASSY MAIN SENSOR connection Are P/J8391 and P/J8302A of the HARNESS ASSY MAIN SENSOR connected surely?	Go to step 31.	After reconnecting, go to step 30.
30	Execute [Test Print] in [Diagnosis]. Does the error still occur?	Go to step 31.	End of work.
31	Checking the HARNESS ASSY COMPILER for conductivity Disconnect P/J8320 and P/J8391 of the HARNESS ASSY COMPILER. Check for conductivity at the following: J8320-3 <=> J8391B-1 J8320-2 <=> J8391B-2 J8320-1 <=> J8391B-3	Go to step 32.	Replace the HARNESS ASSY COMPILER.
32	Checking the HARNESS ASSY MAIN SENSOR for conductivity Disconnect P/J8391 of the HARNESS ASSY MAIN SENSOR, and P/J8302A on the PWB MAIN-C. Check for conductivity at the following: J8391A-3 <=> J8302A-4 J8391A-2 <=> J8302A-5 J8391A-1 <=> J8302A-6	Go to step 33.	Replace the HARNESS ASSY MAIN SENSOR.
33	Checking +5 VDC power supply to the SENSOR ASSY (Compile Exit Sensor) Is the voltage across J8302A-6 <=> J8302A-4 on the PWB MAIN-C +5 VDC?	Go to step 34.	Replace the PWB MAIN-C. (RRP 12.98)
34	Checking the SENSOR ASSY (Compile Exit Sensor) for operation Does the voltage across P8302A-5 <=> P8302A-4 on the PWB MAIN-C change, every time the actuator of the SENSOR ASSY (Compile Exit Sensor) is operated?	Replace the PWB MAIN-C. (RRP 12.98)	Replace the SENSOR ASSY (Compile Exit Sensor). (RRP 12.67)

## F4-51 Finisher Compile Exit Sensor Off Jam A

**NOTE This FIP can also be applied for the following.**

**NOTE F4-55 Finisher Compile Exit Sensor Off Jam B**

Step	Check	Yes	No
	Possible causative parts: ROLL ASSY-EXIT LOW (PL 12.11.6) HARNESS ASSY COMPILER (PL 12.10.8) HARNESS ASSY MAIN SENSOR (PL 12.15.1) PWB MAIN-C (PL 12.14.5) SENSOR ASSY (PL 12.11.3) HARNESS ASSY MAIN DRIVE (PL 12.15.2) MOTOR ASSY (PL 12.13.30)		
1	Checking the paper path Open the COVER ASSY FRONT (PL 12.5.3) of the Finisher. Is the ROLL ASSY-EXIT LOW (PL 12.11.6) installed correctly? Also, is it not contaminated or damaged, and rotated smoothly? Check this item by turning it with your fingers. Are there any stains such as paper dust on the paper path?	Go to step 2.	Clean or replace the ROLL ASSY-EXIT LOW, and clean the paper path.
2	Checking the SENSOR ASSY (Compile Exit Sensor) for operation Execute [Input 12-34 Compile Exit SENSOR] in [Diagnosis]. Does the display on the screen change, every time the actuator of the SENSOR ASSY (Compile Exit Sensor) is operated?	Go to step 11.	Go to step 3.
3	Checking the HARNESS ASSY COMPILER connection Are P/J8320 and P/J8391 of the HARNESS ASSY COMPILER connected surely?	Go to step 5.	After reconnecting, go to step 4.
4	Execute [Test Print] in [Diagnosis]. Does the error still occur?	Go to step 5.	End of work.
5	Checking the HARNESS ASSY MAIN SENSOR connection Are P/J8391 and P/J8302A of the HARNESS ASSY MAIN SENSOR connected surely?	Go to step 7.	After reconnecting, go to step 6.
6	Execute [Test Print] in [Diagnosis]. Does the error still occur?	Go to step 7.	End of work.
7	Checking the HARNESS ASSY COMPILER for conductivity Disconnect P/J8320 and P/J8391 of the HARNESS ASSY COMPILER. Check for conductivity at the following: J8320-3 <=> J8391B-1 J8320-2 <=> J8391B-2 J8320-1 <=> J8391B-3	Go to step 8.	Replace the HARNESS ASSY COMPILER.

Step	Check	Yes	No
8	Checking the HARNESS ASSY MAIN SENSOR for conductivity Disconnect P/J8391 of the HARNESS ASSY MAIN SENSOR, and P/J8302A on the PWB MAIN-C. Check for conductivity at the following: J8391A-3 <=> J8302A-4 J8391A-2 <=> J8302A-5 J8391A-1 <=> J8302A-6	Go to step 9.	Replace the HARNESS ASSY MAIN SENSOR.
9	Checking +5 VDC power supply to the SENSOR ASSY (Compile Exit Sensor) Is the voltage across J8302A-6 <=> J8302A-4 on the PWB MAIN-C +5 VDC?	Go to step 10.	Replace the PWB MAIN-C. (RRP 12.98)
10	Checking the SENSOR ASSY (Compile Exit Sensor) for operation Does the voltage across P8302A-5 <=> P8302A-4 on the PWB MAIN-C change, every time the actuator of the SENSOR ASSY (Compile Exit Sensor) is operated?	Replace the PWB MAIN-C. (RRP 12.98)	Replace the SENSOR ASSY (Compile Exit Sensor). (RRP 12.67)
11	Checking the MOTOR ASSY (Exit Motor) for operation Execute [Output 12-09 Exit Motor 285F ON/OFF] in [Diagnosis] Does the MOTOR ASSY (Exit Motor) rotate normally?	Replace the PWB MAIN-C. (RRP 12.98)	Go to step 12.
12	Checking the MOTOR ASSY (Exit Motor) for power transmission Execute [Output 12-09 Exit Motor 285F ON/OFF] in [Diagnosis]. Does the rotation of the MOTOR ASSY transmit to the ROLL ASSY-EXIT LOW (PL 12.11.6) through the BELT (PL 12.13.28)?	Go to step 14.	After reinstalling the MOTOR ASSY and BELT, go to step 13. (RRP 12.95)
13	Execute [Test Print] in [Diagnosis]. Does the error still occur?	Go to step 14.	End of work.
14	Checking the HARNESS ASSY MAIN DRIVE connection Are P/J8334 and P/J8304 of the HARNESS ASSY MAIN DRIVE connected surely?	Go to step 16.	After reconnecting, go to step 15.
15	Execute [Test Print] in [Diagnosis]. Does the error still occur?	Go to step 16.	End of work.
16	Checking the HARNESS ASSY MAIN DRIVE for conductivity Disconnect P/J8334 and P/J8304 of the HARNESS ASSY MAIN DRIVE. Check for conductivity at the following: J8334-1 <=> J8304-2 J8334-2 <=> J8304-4 J8334-3 <=> J8304-1 J8334-4 <=> J8304-3 J8334-5 <=> J8304-6 J8334-6 <=> J8304-5	Go to step 17.	Replace the HARNESS ASSY MAIN DRIVE.

Step	Check	Yes	No
17	Checking the resistance of the MOTOR ASSY Are there any resistances without disconnection across P8334-2/5(COM) and P8334-1/3/4/6 of the MOTOR ASSY?	Go to step 18.	Replace the MOTOR ASSY. (RRP 12.95)
18	Checking +24 VDC power supply to the MOTOR ASSY Are the voltages across J8304-4 <=> FRAME CHASSIS, and J8304-6 <=> FRAME CHASSIS on the PWB MAIN-C, +24 VDC?	Go to step 19.	Replace the PWB MAIN-C. (RRP 12.98)
19	Checking after replacing the MOTOR ASSY (Exit Motor) Replace the MOTOR ASSY (Exit Motor). (RRP 12.95) Execute [Test Print] in [Diagnosis]. Does the error still occur?	Replace the PWB MAIN-C. (RRP 12.98)	End of work.

### F4-61 Finisher Set Eject Jam

Step	Check	Yes	No
	Possible causative parts: SHAFT ASSY-EJECT ROLL (PL 12.10.9) HARNESS ASSY MAIN DRIVE (PL 12.15.2) MOTOR ASSY-DC (PL 12.9.11) BRACKET ASSY-EJECT (PL 12.10.17) PWB MAIN-C (PL 12.14.5) HARNESS ASSY COMPILER (PL 12.10.8) HARNESS ASSY MAIN SENSOR (PL 12.15.1) ACTUATOR-PAPER (PL 12.10.4) SENSOR (PL 12.10.3)		
1	Checking the paper path Is the SHAFT ASSY-EJECT ROLL (PL 12.10.9) installed correctly? Does it rotate smoothly without contaminated or damaged? Check this item by turning it with your fingers. Are there any stains such as paper dust on the paper path?	Go to step 2.	Clean or replace the ROLLER and clean the paper path.
2	Checking the MOTOR ASSY-DC (Eject Clamp Motor) for rotation Execute [Output 12-18 Eject Clamp Motor UP ON/OFF] and [Output 12-19 Eject Clamp Motor DOWN ON/OFF] in [Diagnosis]. Does the MOTOR ASSY-DC (Eject Clamp Motor) rotate properly?	Go to step 7.	Go to step 3.
3	Checking the HARNESS ASSY MAIN DRIVE connection Are P/J8339 and P/J 8304 of HARNESS ASSY MAIN DRIVE connected surely?	Go to step 5.	Reconnect them and go to step 4.
4	Does the error still occur? Execute [Test Print] in [Diagnosis].	Go to step 5.	End of work.

Step	Check	Yes	No
5	Checking the HARNESS ASSY MAIN DRIVE for conductivity Disconnect P/J8339 and P/J 8304 of the HARNESS ASSY MAIN DRIVE. Check for conductivity at the following: J8339-1 <=> J8304-33 J8339-2 <=> J8304-31	Go to step 6.	Replace the HARNESS ASSY MAIN DRIVE.
6	Checking after replacing the MOTOR ASSY-DC (Eject Clamp Motor) Replace the MOTOR ASSY-DC (Eject Clamp Motor) (RRP 12.54). Execute [Test Print] in [Diagnosis]. Does the error still occur?	Replace the PWB MAIN-C. (PL 12.98)	End of work.
7	Checking the BRACKET ASSY-EJECT (Eject Motor) for rotation Execute [Output 12-20 Eject Motor Low FORWARD ON/OFF] and [Output 12-22 Eject Motor Low REVERSE ON/OFF] in [Diagnosis] alternately. Does the BRACKET ASSY-EJECT (Eject Motor) rotate in the forward and reverse directions alternately?	Go to step 14.	Go to step 8.
8	Checking the HARNESS ASSY MAIN DRIVE connection Are P/J8336 and P/J 8304 of the HARNESS ASSY MAIN DRIVE connected surely?	Go to step 10.	Reconnect them and go to step 9.
9	Does the error still occur? Execute [Test Print] in [Diagnosis].	Go to step 10.	End of work.
10	Checking the HARNESS ASSY MAIN DRIVE for conductivity Disconnect P/J8336 and P/J 8304 of the HARNESS ASSY MAIN DRIVE. Check for conductivity at the following: J8336-1 <=> J8304-15 J8336-2 <=> J8304-12 J8336-3 <=> J8304-17 J8336-4 <=> J8304-19 J8336-5 <=> J8304-14 J8336-6 <=> J8304-21	Go to step 11.	Replace the HARNESS ASSY MAIN DRIVE.
11	Checking the resistance of the BRACKET ASSY-EJECT (Eject Motor) Are there any resistances without disconnection across P8336-2/5(COM) <=> P8336-1/3/4/6 of the BRACKET ASSY-EJECT (Eject Motor)?	Go to step 12.	Replace the BRACKET ASSY-EJECT. (RRP 12.65)
12	Checking +24 VDC power supply to the BRACKET ASSY-EJECT (Eject Motor) Are the voltages across J8304-12 <=> FRAME CHASSIS, and J8304-14 <=> FRAME CHASSIS on the PWB MAIN-C, +24 VDC?	Go to step 13.	Replace the PWB MAIN-C. (RRP 12.98)

Step	Check	Yes	No
13	Checking after replacing the BRACKET ASSY-EJECT (Eject Motor) Replace the BRACKET ASSY-EJECT (Eject Motor). (RRP 12.65) Does the error still occur? Execute [Test Print] in [Diagnosis].	Replace the PWB MAIN-C. (RRP 12.98)	End of work.
14	Checking the ACTUATOR-PAPER for operation Is the ACTUATOR-PAPER operated correctly?	Go to step 15.	Reinstall the ACTUATOR-PAPER.
15	Checking the SENSOR (Compile Tray No Paper Sensor) for operation Execute [Input 12-35 Compile Tray No Paper SENSOR] in [Diagnosis]. Does the display on the screen change, every time the ACTUATOR-PAPER (PL 12.10.4) of the SENSOR is operated?	Replace the PWB MAIN-C. (RRP 12.98)	Go to step 16.
16	Checking the HARNESS ASSY COMPILER connection Are P/J8359 and P/J8309 of the HARNESS ASSY COMPILER connected surely?	Go to step 18.	After reconnecting, go to step 17.
17	Execute [Test Print] in [Diagnosis]. Does the error still occur?	Go to step 18.	End of work.
18	Checking the HARNESS ASSY COMPILER for conductivity Disconnect P/J8359 and P/J8309 of the HARNESS ASSY COMPILER. Check for conductivity at the following: J8359-3 <=> J8309-1 J8359-2 <=> J8309-2 J8359-1 <=> J8309-3	Go to step 19.	Replace the HARNESS ASSY COMPILER.
19	Checking +5 VDC power supply to the SENSOR (Compile Tray No Paper Sensor) Is the voltage across J8309-3 <=> J8309-1 on the PWB MAIN-C +5 VDC?	Go to step 20.	Replace the PWB MAIN-C. (RRP 12.98)
20	Checking the SENSOR (Compile Tray No Paper Sensor) for operation Does the voltage across P8309-2 <=> P8309-1 on the PWB MAIN-C change, every time the ACTUATOR-PAPER (PL 12.10.4) of the SENSOR (Compile Tray No Paper Sensor) is operated?	Replace the PWB MAIN-C. (RRP 12.98)	Replace the SENSOR (Compile Tray No Paper Sensor). (RRP 12.59)

## F4-71 Finisher Top Tray Exit Sensor On Jam A

**NOTE** This FIP can also be applied for the followings.

**NOTE** F4-73 Finisher Top Tray Exit Sensor On Jam B

**NOTE F4-74 Finisher Top Tray Exit Sensor On Jam C**

Step	Check	Yes	No
	<p>Possible causative parts:            ROLL ASSY-ENT (PL 12.12.20)            ROLLER ASSY-PINCH, ENT (PL 12.12.17)            ROLL ASSY-TRANSPORT (PL 12.13.18)            ROLLER-PINCH (PL 12.13.11)            MOTOR ASSY (PL 12.13.30)            HARNESS ASSY MAIN DRIVE (PL 12.15.2)            PWB MAIN-C (PL 12.14.5)            HARNESS ASSY TOP EXIT SENSOR (PL 12.15.6)            HARNESS ASSY MAIN SENSOR (PL 12.15.1)            SENSOR (PL 12.13.2)</p>		
1	<p>Checking the paper path            Open the COVER ASSY FRONT (PL 12.5.3) of the Finisher.            Remove the COVER TOP (PL 12.4.1) and COVER LH TOP (PL 12.5.9).            Open the CHUTE ASSY-UPPER, ENT (PL 12.12.16) to upward.            Are the ROLLER ASSY-PINCH, ENT (PL 12.12.17) of the CHUTE ASSY-UPPER, ENT and ROLL ASSY-ENT (PL 12.12.20) installed correctly?            Also, are they not contaminated or damaged, and rotated smoothly?            Check these items by turning them with your fingers.            Are there any stains such as paper dust on the paper path?</p>	Go to step 2.	Clean or replace the appropriate ROLLER, and clean the paper path.
2	<p>Checking the paper path            Open the CHUTE ASSY-LOWER, TOP EXIT L (PL 12.13.10) to right.            Are the ROLLER-PINCH (PL 12.13.11) of the CHUTE ASSY-LOWER, TOP EXIT L and two ROLL ASSY-TRANSPORTS (PL 12.13.18) installed correctly?            Also, are they not contaminated or damaged, and rotated smoothly?            Check these items by turning them with your fingers.</p>	Go to step 3.	Clean or replace the appropriate ROLLER, and clean the paper path.
3	<p>Checking the MOTOR ASSY (Registration Motor) for rotation            Perform [Output 12-05 Registration Motor 285F ON/OFF] in Chapter 2, Diagnostics.            Does the MOTOR ASSY (Registration Motor) rotate properly?</p>	Go to step 12.	Go to step 4.
4	<p>Checking the MOTOR ASSY (Registration Motor) for power transmission            Perform [Output 12-05 Registration Motor 285F ON/OFF] in Chapter 2, Diagnostics.            Does the rotation of the MOTOR ASSY transmit to the ROLL ASSY-BUFFER (PL 12.12.13) via the BELT (PL 12.13.27)?</p>	Go to step 6.	Reinstall the MOTOR ASSY and the BELT, and then go to step 5. (RRP 12.96)
5	<p>Perform [Test Print] in Chapter 2, Diagnostics.            Does the error still occur?</p>	Go to step 6.	End of work.



Step	Check	Yes	No
6	Checking the HARNESS ASSY MAIN DRIVE for connection Are P/J8335 and P/J 8304 of the HARNESS ASSY MAIN DRIVE connected securely?	Go to step 8.	After reconnecting, go to step 7.
7	Perform [Test Print] in Chapter 2, Diagnostics. Does the error still occur?	Go to step 8.	End of work.
8	Checking the HARNESS ASSY MAIN DRIVE for conductivity Disconnect P/J8335 and P/J 8304 of the HARNESS ASSY MAIN DRIVE. Check for conductivity at the following: J8335-1 <=> J8304-7 J8335-2 <=> J8304-8 J8335-3 <=> J8304-9 J8335-4 <=> J8304-11 J8335-5 <=> J8304-10 J8335-6 <=> J8304-13	Go to step 9.	Replace the HARNESS ASSY MAIN DRIVE.
9	Checking the resistance of the MOTOR ASSY Are there any resistances without disconnection across P8335-2/5(COM) and P8335-/3/4/6 of the MOTOR ASSY?	Go to step 10.	Replace the MOTOR ASSY. (RRP 12.96)
10	Checking the MOTOR ASSY for +24 VDC power supply Is the voltage between J8304-8 and the FRAME CHASSIS, and J8304-10 and the FRAME CHASSIS of the PWB MAIN-C, +24VDC?	Go to step 11.	Replace the PWB MAIN-C. (RRP 12.98)
11	Checking the MOTOR ASSY (Registration Motor) after the replacement Replace the MOTOR ASSY (Registration Motor). (RRP 12.96) Perform [Test Print] in Chapter 2, Diagnostics. Does the error still occur?	Replace the PWB MAIN-C. (RRP 12.98)	End of work.
12	Checking the SENSOR (Top Tray Exit Sensor) for operation Execute [Input 12-32 Top Tray Exit SENSOR] in [Diagnosis]. Does the display on the screen change, every time the actuator of the SENSOR is operated?	Replace the PWB MAIN-C. (RRP 12.98)	Go to step 13.
13	Checking the HARNESS ASSY TOP EXIT SENSOR and HARNESS ASSY MAIN SENSOR connections Are P/J8321 and P/J8312 of the HARNESS ASSY TOP EXIT SENSOR, and P/J8312 and P/J8302 of the HARNESS ASSY MAIN SENSOR connected surely?	Go to step 15.	After reconnecting, go to step 14.
14	Execute [Test Print] in [Diagnosis]. Does the error still occur?	Go to step 15.	End of work.

Step	Check	Yes	No
15	Checking the HARNESS ASSY TOP EXIT SENSOR for conductivity Disconnect P/J8321 and P/J8312 of the HARNESS ASSY TOP EXIT SENSOR. Check for conductivity at the following: J8321-3 <=> J8312B-1 J8321-2 <=> J8312B-2 J8321-1 <=> J8312B-3	Go to step 16.	Replace the HARNESS ASSY TOP EXIT SENSOR.
16	Checking the HARNESS ASSY MAIN SENSOR for conductivity Disconnect P/J8312 of the HARNESS ASSY MAIN SENSOR, and P/J8302A on the PWB MAIN-C. Check for conductivity at the following: J8312A-3 <=> J8302A-7 J8312A-2 <=> J8302A-8 J8312A-1 <=> J8302A-9	Go to step 17.	Replace the HARNESS ASSY MAIN SENSOR.
17	Checking +5 VDC power supply to the SENSOR (Top Tray Exit Sensor) Is the voltage across J8302A-9 <=> J8302A-7 on the PWB MAIN-C +5 VDC?	Go to step 18.	Replace the PWB MAIN-C. (RRP 12.98)
18	Checking the SENSOR (Top Tray Exit Sensor) for operation Does the voltage across P8302A-8 <=> P8302A-7 on the PWB MAIN-C change, every time a piece of white paper is placed over the sensing area of the SENSOR (Top Tray Exit Sensor)?	Replace the PWB MAIN-C. (RRP 12.98)	Replace the SENSOR (Top Tray Exit Sensor). (RRP 12.87)

### F4-72 Finisher Top Tray Exit Sensor Off Jam A

**NOTE** This FIP can also be applied for the following.

**NOTE** F4-75 Finisher Top Tray Exit Sensor Off Jam B

Step	Check	Yes	No
	Possible causative parts: ROLL ASSY-TRANSPORT (PL 12.13.18) ROLLER-PINCH (PL 12.13.11) MOTOR ASSY (PL 12.12.21) HARNESS ASSY MAIN DRIVE (PL 12.15.2) PWB MAIN-C (PL 12.14.5) HARNESS ASSY TOP EXIT SENSOR (PL 12.15.6) HARNESS ASSY MAIN SENSOR (PL 12.15.1) SENSOR (PL 12.13.2) PWB MAIN-C (PL 12.14.5) SENSOR (PL 12.13.2)		

Step	Check	Yes	No
1	<p>Checking the paper path Open the CHUTE ASSY-LOWER, TOP EXIT L (PL 12.13.10) to right. Are the ROLLER-PINCH (PL 12.13.11) on the CHUTE ASSY-LOWER, TOP EXIT L and two ROLL ASSY-TRANSPORTS (PL 12.13.18) installed correctly? Also, are they not contaminated or damaged, and rotated smoothly? Check these items by turning them with your fingers. Are there any stains such as paper dust on the paper path?</p>	Go to step 2.	Clean or replace the appropriate ROLLER, and clean the paper path.
2	<p>Checking the MOTOR ASSY (Registration Motor) for rotation Perform [Output 12-05 Registration Motor 285F ON/OFF] in Chapter 2, Diagnostics. Does the MOTOR ASSY (Registration Motor) rotate properly?</p>	Go to step 11.	Go to step 3.
3	<p>Checking the MOTOR ASSY (Registration Motor) for power transmission Perform [Output 12-05 Registration Motor 285F ON/OFF] in Chapter 2, Diagnostics. Does the rotation of the MOTOR ASSY transmit to the ROLL ASSY-BUFFER (PL 12.12.13) via the BELT (PL 12.13.27)?</p>	Go to step 5.	After reconnecting, go to step 4.
4	<p>Perform [Test Print] in Chapter 2, Diagnostics. Does the error still occur?</p>	Go to step 6.	End of work.
5	<p>Checking the HARNESS ASSY MAIN DRIVE for connection Are P/J8335 and P/J 8304 of the HARNESS ASSY MAIN DRIVE connected securely?</p>	Go to step 8.	After reconnecting, go to step 7.
6	<p>Perform [Test Print] in Chapter 2, Diagnostics. Does the error still occur?</p>	Go to step 8.	End of work.
7	<p>Checking the HARNESS ASSY MAIN DRIVE for conductivity Disconnect P/J8335 and P/J 8304 of the HARNESS ASSY MAIN DRIVE. Check for conductivity at the following: J8335-1 &lt;=&gt; J8304-7 J8335-2 &lt;=&gt; J8304-8 J8335-3 &lt;=&gt; J8304-9 J8335-4 &lt;=&gt; J8304-11 J8335-5 &lt;=&gt; J8304-10 J8335-6 &lt;=&gt; J8304-13</p>	Go to step 8.	Replace the HARNESS ASSY MAIN DRIVE.
8	<p>Checking the resistance of the MOTOR ASSY Are there any resistances without disconnection across P8335-2/5(COM) and P8335-/3/4/6 of the MOTOR ASSY?</p>	Go to step 9.	Replace the MOTOR ASSY. (RRP 12.96)

Step	Check	Yes	No
9	Checking the MOTOR ASSY for +24 VDC power supply Is the voltage between J8304-8 and the FRAME CHASSIS, and J8304-10 and the FRAME CHASSIS of the PWB MAIN-C, +24VDC?	Go to step 10.	Replace the PWB MAIN-C. (RRP 12.98)
10	Checking the MOTOR ASSY (Registration Motor) after the replacement Replace the MOTOR ASSY (Registration Motor). (RRP 12.96) Perform [Test Print] in Chapter 2, Diagnostics. Does the error still occur?	Replace the PWB MAIN-C. (RRP 12.98)	End of work.
11	Checking the MOTOR ASSY (Exit Motor) for operation Execute [Output 12-09 Exit Motor 285F ON/OFF] in [Diagnosis] Does the MOTOR ASSY (Exit Motor) rotate normally?	Replace the PWB MAIN-C. (RRP 12.98)	Go to step 12.
12	Checking the MOTOR ASSY (Exit Motor) for power transmission Execute [Output 12-09 Exit Motor 285F ON/OFF] in [Diagnosis]. Does the rotation of the MOTOR ASSY transmit to the ROLL ASSY-EXIT LOW (PL 12.11.6) through the BELT (PL 12.13.28)?	Go to step 20.	After reinstalling the MOTOR ASSY and BELT, go to step 13. (RRP 12.95)
13	Execute [Test Print] in [Diagnosis]. Does the error still occur?	Go to step 14.	End of work.
14	Checking the HARNESS ASSY MAIN DRIVE connection Are P/J8334 and P/J8304 of the HARNESS ASSY MAIN DRIVE connected surely?	Go to step 16.	After reconnecting, go to step 15.
15	Execute [Test Print] in [Diagnosis]. Does the error still occur?	Go to step 16.	End of work.
16	Checking the HARNESS ASSY MAIN DRIVE for conductivity Disconnect P/J8334 and P/J8304 of the HARNESS ASSY MAIN DRIVE. Check for conductivity at the following: J8334-1 <=> J8304-2 J8334-2 <=> J8304-4 J8334-3 <=> J8304-1 J8334-4 <=> J8304-3 J8334-5 <=> J8304-6 J8334-6 <=> J8304-5	Go to step 17.	Replace the HARNESS ASSY MAIN DRIVE.
17	<b>Checking the resistance of the</b> MOTOR ASSY Are there any resistances without disconnection across P8334-2/5(COM) and P8334-1/3/4/6 of the MOTOR ASSY?	Go to step 18.	Replace the MOTOR ASSY. (RRP 12.95)
18	Checking +24 VDC power supply to the MOTOR ASSY Are the voltages across J8304-4 <=> FRAME CHASSIS, and J8304-6 <=> FRAME CHASSIS on the PWB MAIN-C, +24 VDC?	Go to step 19.	Replace the PWB MAIN-C. (RRP 12.98)

Step	Check	Yes	No
19	Checking after replacing the MOTOR ASSY (Exit Motor) Replace the MOTOR ASSY (Exit Motor). (RRP 12.95) Execute [Test Print] in [Diagnosis]. Does the error still occur?	Replace the PWB MAIN-C. (RRP 12.98)	End of work.
20	Checking the SENSOR (Top Tray Exit Sensor) for operation Execute [Input 12-32 Top Tray Exit SENSOR] in [Diagnosis]. Does the display on the screen change, every time the actuator of the SENSOR is operated?	Replace the PWB MAIN-C. (RRP 12.98)	Go to step 21.
21	Checking the HARNESS ASSY TOP EXIT SENSOR and HARNESS ASSY MAIN SENSOR connections Are P/J8321 and P/J8312 of the HARNESS ASSY TOP EXIT SENSOR, and P/J8312 and P/J8302 of the HARNESS ASSY MAIN SENSOR connected surely?	Go to step 23.	After reconnecting, go to step 22.
22	Execute [Test Print] in [Diagnosis]. Does the error still occur?	Go to step 23.	End of work.
23	Checking the HARNESS ASSY TOP EXIT SENSOR for conductivity Disconnect P/J8321 and P/J8312 of the HARNESS ASSY TOP EXIT SENSOR. Check for conductivity at the following: J8321-3 <=> J8312B-1 J8321-2 <=> J8312B-2 J8321-1 <=> J8312B-3	Go to step 24.	Replace the HARNESS ASSY TOP EXIT SENSOR.
24	Checking the HARNESS ASSY MAIN SENSOR for conductivity Disconnect P/J8312 of the HARNESS ASSY MAIN SENSOR, and P/J8302A on the PWB MAIN-C. Check for conductivity at the following: J8312A-3 <=> J8302A-7 J8312A-2 <=> J8302A-8 J8312A-1 <=> J8302A-9	Go to step 25.	Replace the HARNESS ASSY MAIN SENSOR.
25	Checking +5 VDC power supply to the SENSOR (Top Tray Exit Sensor) Is the voltage across J8302A-9 <=> J8302A-7 on the PWB MAIN-C +5 VDC?	Go to step 26.	Replace the PWB MAIN-C. (RRP 12.98)
26	Checking the SENSOR (Top Tray Exit Sensor) for operation Does the voltage across P8302A-8 <=> P8302A-7 on the PWB MAIN-C change, every time a piece of white paper is placed over the sensing area of the SENSOR (Top Tray Exit Sensor)?	Replace the PWB MAIN-C. (RRP 12.98)	Replace the SENSOR (Top Tray Exit Sensor). (RRP 12.87)

## F4-82 Finisher Gate Sensor On Jam

Step	Check	Yes	No
	<p>Possible causative parts:</p> <ul style="list-style-type: none"> <li>BELT (PL 12.3.12)</li> <li>PINCH ROLL (PL 12.2.6)</li> <li>ROLL ASSY-ENT (PL 12.12.20)</li> <li>ROLLER ASSY-PINCH, ENT (PL 12.12.17)</li> <li>H-TRANSPORT EXIT SENSOR (PL 12.3.21)</li> <li>WIRE HARNESS (PL 12.3.26)</li> <li>PWB H-TRA (PL 12.14.3)</li> <li>SENSOR (PL 12.12.19)</li> <li>HARNESS ASSY X'PORT ENT SENSOR (PL 12.15.4)</li> <li>HARNESS ASSY MAIN SENSOR (PL 12.15.1)</li> <li>PWB MAIN-C (PL 12.14.5)</li> <li>MOTOR ASSY (PL 12.12.21)</li> <li>HARNESS ASSY MAIN DRIVE (PL 12.15.2)</li> <li>SENSOR (PL 12.13.15)</li> <li>HARNESS ASSY-SENSOR (PL 12.13.16)</li> </ul>		
1	<p>Checking the paper path</p> <p>Open the COVER ASSY TOP (PL 12.2.9) of the H-TRANSPORT ASSEMBLY (PL 12.1.2).</p> <p>Are the PINCH ROLL (PL 12.2.6) on the COVER ASSY TOP and two BELTs (PL 12.3.12) installed correctly? Also, are they not contaminated or damaged, and rotated smoothly?</p> <p>Check these items by turning them with your fingers.</p> <p>Are there any stains such as paper dust on the paper path?</p>	Go to step 2.	Clean or replace the appropriate BELTs and PINCH ROLL, and clean the paper path.
2	<p>Checking the paper path</p> <p>Open the COVER ASSY FRONT (PL 12.5.3) of the Finisher.</p> <p>Remove the COVER TOP (PL 12.4.1) and COVER LH TOP (PL 12.5.9).</p> <p>Open the CHUTE ASSY-UPPER, ENT (PL 12.12.16) to upward.</p> <p>Are the ROLLER ASSY-PINCH, ENT (PL 12.12.17) on the CHUTE ASSY-UPPER, ENT and ROLL ASSY-ENT (PL 12.12.20) installed correctly? Also, are they not contaminated or damaged, and rotated smoothly?</p> <p>Check these items by turning them with your fingers.</p> <p>Are there any stains such as paper dust on the paper path?</p>	Go to step 3.	Clean or replace the appropriate ROLLER, and clean the paper path.
3	<p>Checking the H-TRANSPORT EXIT SENSOR (Finisher H-Transport Exit Sensor) for operation</p> <p>Execute [Input 12-29 H-Transport Exit SENSOR] in [Diagnosis].</p> <p>Does the display on the screen change, every time the actuator of the H-TRANSPORT EXIT SENSOR is operated?</p>	Go to step 9.	Go to step 4.

Step	Check	Yes	No
4	Checking the WIRE HARNESS (PL 12.3.26) connection Are the connectors of the WIRE HARNESS connected to the H-TRANSPORT EXIT SENSOR and the PBW H-TRA of the Finisher connected surely?	Go to step 6.	After reconnecting, go to step 5.
5	Execute [Test Print] in [Diagnosis]. Does the error still occur?	Go to step 6.	End of work.
6	Checking the WIRE HARNESS for conductivity Disconnect J8381 of the H-TRANSPORT EXIT SENSOR, and P/J8372 on the PWB H-TRA of the Finisher. Check for conductivity at the following: J8372-4 <=> J8381-3 J8372-5 <=> J8381-2 J8372-6 <=> J8381-1	Go to step 7.	Replace the WIRE HARNESS.
7	Checking +5 VDC power supply to the H-TRANSPORT EXIT SENSOR Is the voltage across J8372-6 <=> J8372-4 on the PWB H-TRA of the Finisher +5 VDC?	Go to step 8.	Replace the PWB H-TRA. (RRP 12.97)
8	Checking the H-TRANSPORT EXIT SENSOR for operation Does the voltage across J8372-5 <=> J8372-4 on the PWB H-TRA of the Finisher change, every time the actuator of the SENSOR is operated?	Replace the PWB H-TRA. (RRP 12.97)	Replace the H-TRANSPORT EXIT SENSOR. (RRP 12.14)
9	Checking the SENSOR (Transport Entrance Sensor) for operation Execute [Input 12-30 Transport Ent. SENSOR] in [Diagnosis]. Does the display change, every time a piece of white paper is placed over the SENSOR (X'port Entrance Sensor)?	Go to step 16.	Go to step 10.
10	Checking the HARNESS ASSY connection Are P/J8319 and P/J8303 of the HARNESS ASSY X'PORT ENT SENSOR, and P/J8302A of the HARNESS ASSY MAIN SENSOR connected surely?	Go to step 12.	After reconnecting, go to step 11.
11	Execute [Test Print] in [Diagnosis]. Does the error still occur?	Go to step 12.	End of work.
12	Checking the HARNESS ASSY X'PORT ENT SENSOR for conductivity Disconnect P/J8319 and P/J8303 of the HARNESS ASSY X'PORT ENT SENSOR. Check for conductivity at the following: J8319-3 <=> J8303B-1 J8319-2 <=> J8303B-2 J8319-1 <=> J8303B-3	Go to step 13.	Replace the HARNESS ASSY X'PORT ENT SENSOR.

Step	Check	Yes	No
13	Checking the HARNESS ASSY MAIN SENSOR for conductivity Disconnect P/J8303 of the HARNESS ASSY MAIN SENSOR, and P/J8302A on the PWB MAIN-C. Check for conductivity at the following: J8303A-3 <=> J8302A-1 J8303A-2 <=> J8302A-2 J8303A-1 <=> J8302A-3	Go to step 14.	Replace the HARNESS ASSY MAIN SENSOR.
14	Checking +5 VDC power supply to the SENSOR (Transport Entrance Sensor) Is the voltage across J8302A-3 <=> J8302A-1 on the PWB MAIN-C +5 VDC?	Go to step 15.	Replace the PWB MAIN-C. (RRP 12.98)
15	Checking the SENSOR (Transport Entrance Sensor) for operation Does the voltage across P8302A-2 <=> P8302A-1 on the PWB MAIN-C change, every time a piece of white paper is placed over the sensing area of the SENSOR (X'port Entrance Sensor)?	Replace the PWB MAIN-C. (RRP 12.98)	Replace the SENSOR. (RRP 12.82)
16	Checking the MOTOR ASSY (Finisher Transport Motor) for operation Execute [Output 12-03 Fin Transport Motor 350 ON/OFF] in [Diagnosis]. Does the MOTOR ASSY (Finisher Transport Motor) rotate normally?	Go to step 25.	Go to step 17.
17	Checking the MOTOR ASSY (Finisher Transport Motor) for power transmission Execute [Output 12-03 Fin Transport Motor 350 ON/OFF] in [Diagnosis]. Does the rotation of the MOTOR ASSY transmit to the ROLL ASSY-ENT (PL 12.12.10) through the BELT (PL 12.12.23)?	Go to step 19.	After reinstalling the MOTOR ASSY and BELT, go to step 18. (RRP 12.84)
18	Execute [Test Print] in [Diagnosis]. Does the error still occur?	Go to step 19.	End of work.
19	Checking the HARNESS ASSY MAIN DRIVE connection Are P/J8342 and P/J8304 of the HARNESS ASSY MAIN DRIVE connected surely?	Go to step 21.	After reconnecting, go to step 20.
20	Execute [Test Print] in [Diagnosis]. Does the error still occur?	Go to step 21.	End of work.
21	Checking the HARNESS ASSY MAIN DRIVE for conductivity Disconnect P/J8342 and P/J8304 of the HARNESS ASSY MAIN DRIVE. Check for conductivity at the following: J8342-1 <=> J8304-23 J8342-2 <=> J8304-16 J8342-3 <=> J8304-25 J8342-4 <=> J8304-27 J8342-5 <=> J8304-18 J8342-6 <=> J8304-29	Go to step 22.	Replace the HARNESS ASSY MAIN DRIVE.



Step	Check	Yes	No
22	Checking the resistance of the MOTOR ASSY Are there any resistances without disconnection across P8342-2/5(COM) and P8342-1/3/4/6 of the MOTOR ASSY?	Go to step 23.	Replace the MOTOR ASSY. (RRP 12.84)
23	Checking +24 VDC power supply to MOTOR ASSY Are the voltages across J8304-16 <=> FRAME CHASSIS, and J8304-18 <=> FRAME CHASSIS on the PWB MAIN-C, +24 VDC?	Go to step 24.	Replace the PWB MAIN-C. (RRP 12.98)
24	Checking after replacing the MOTOR ASSY Replace the MOTOR ASSY.(RRP 12.84) Execute [Test Print] in [Diagnosis]. Does the error still occur?	Replace the PWB MAIN-C. (RRP 12.98)	End of work.
25	Checking the SENSOR (Gate Sensor) for operation Execute [Input 12-51 Gate SENSOR] in [Diagnosis]. Does the display on the screen change, every time a piece of white paper is placed over the sensing area of the SENSOR (Gate Sensor)?	Replace the PWB MAIN-C. (RRP 12.98)	Go to step 26.
26	Checking the HARNESS ASSY-SENSOR connection Are the connectors of the HARNESS ASSY-SENSOR connected surely?	Go to step 28.	After reconnecting, go to step 27.
27	Execute [Test Print] in [Diagnosis]. Does the error still occur?	Go to step 28.	End of work.
28	Checking the HARNESS ASSY-SENSOR for conductivity Disconnect P/J8432 and P/J8376 of the HARNESS ASSY-SENSOR. Check for conductivity at the following: J8432-3 <=> J8376-1 J8432-2 <=> J8376-2 J8432-1 <=> J8376-3	Go to step 29.	Replace the HARNESS ASSY-SENSOR.
29	Checking +5 VDC power supply to the SENSOR (Gate Sensor) Is the voltage across P8376-3 <=> P8376-1 on the PWB MAIN-C +5 VDC?	Go to step 30.	Replace the PWB MAIN-C. (RRP 12.98)
30	Checking the SENSOR (Gate Sensor) for operation Does the voltage across P8376-2 <=> P8376-1 on the PWB MAIN-C change, every time a piece of white paper is placed over the SENSOR (Gate Sensor)?	Replace the PWB MAIN-C. (RRP 12.98)	Replace the SENSOR. (RRP 12.93)

## F4-16 Finisher H-Transport Entrance Sensor Static Jam A

**NOTE** This FIP can also be applied for the following.

**NOTE** F4-17 Finisher H-Transport Entrance Sensor Static Jam B

Step	Check	Yes	No
	Possible causative parts: WIRE HARNESS (PL 12.3.26) PWB H-TRA (PL 12.14.3) H-TRANSPORT ENTRANCE SENSOR (PL 12.3.23) H-TRANSPORT MOTOR (PL 12.3.7)		
1	Checking the H-TRANSPORT ENTRANCE SENSOR (Finisher H-Transport Entrance Sensor) for operation Execute [Input 12-28 H-Transport Ent.SENSOR] in [Diagnosis]. Does the display on the screen change, every time the actuator of the H-TRANSPORT ENTRANCE SENSOR is operated?	Go to step 7.	Go to step 2.
2	Checking the WIRE HARNESS (PL 12.3.26) connection Are the connectors of the WIRE HARNESS connected to the H-TRANSPORT ENTRANCE SENSOR and PBW H-TRA of the Finisher connected surely?	Go to step 4.	After reconnecting, go to step 3.
3	Execute [Test Print] in [Diagnosis]. Does the error still occur?	Go to step 4.	End of work.
4	Checking the WIRE HARNESS for conductivity Disconnect J8380 of the H-TRANSPORT ENTRANCE SENSOR, and P8372 on the PWB H-TRA of the Finisher. Check for conductivity at the following: P8372-7 <=> J8380-3 P8372-8 <=> J8380-2 P8372-9 <=> J8380-1	Go to step 5.	Replace the WIRE HARNESS.
5	Checking +5 VDC power supply to the H-TRANSPORT ENTRANCE SENSOR Is the voltage across J8372-9 <=> J8372-7 on the PWB H-TRA of the Finisher +5 VDC?	Go to step 6.	Replace the PWB H-TRA. (RRP 12.97)
6	Checking the H-TRANSPORT ENTRANCE SENSOR for operation Does the voltage across J8372-8 <=> J8372-7 on the PWB H-TRA of the Finisher change, every time the actuator of the H-TRANSPORT ENTRANCE SENSOR is operated?	Replace the PWB H-TRA. (RRP 12.97)	Replace the H-TRANSPORT ENTRANCE SENSOR. (RRP 12.13)
7	Checking the H-TRANSPORT MOTOR for operation Execute [Output 12-01 H XPORT Motor 145 ON/OFF] in [Diagnosis]. Does the H-TRANSPORT MOTOR rotate normally?	Replace the PWB H-TRA. (RRP 12.97)	Go to step 8.
8	Checking the WIRE HARNESS connection Are the connectors of the WIRE HARNESS connected to the H-TRANSPORT MOTOR and PBW H-TRA of the Finisher connected surely?	Go to step 10.	After reconnecting, go to step 9.
9	Execute [Test Print] in [Diagnosis]. Does the error still occur?	Go to step 10.	End of work.

Step	Check	Yes	No
10	Checking the WIRE HARNESS for conductivity Disconnect P/J8379 of the H-TRANSPORT MOTOR, and P8372 on the PWB H-TRA of the Finisher. Check for conductivity at the following: P8372-13 <=> J8379-6 P8372-12 <=> J8379-4 P8372-11 <=> J8379-1 P8372-10 <=> J8379-3 P8372-15 <=> J8379-2 P8372-14 <=> J8379-5	Go to step 11.	Replace the WIRE HARNESS.
11	Checking the resistance of the H-TRANSPORT MOTOR Are there any resistances without disconnection across P8379-2/5(COM) and P8379-1/3/4/6 of the H-TRANSPORT MOTOR?	Go to step 12.	Replace the H-TRANSPORT MOTOR. (RRP 12.10)
12	Checking +24 VDC power supply to the H-TRANSPORT MOTOR Are the voltages across J8372-15 <=> J8372-7, and J8372-14 <=> J8372-7 on the PWB H-TRA of the Finisher, +24 VDC?	Go to step 13.	Replace the PWB H-TRA. (RRP 12.97)
13	Checking after replacing the H-TRANSPORT MOTOR Replace the H-TRANSPORT MOTOR. (RRP 12.10) Execute [Test Print] in [Diagnosis]. Does the error still occur?	Replace the PWB H-TRA. (RRP 12.97)	End of work.

#### F4-26 Finisher H-Transport Exit Sensor Static Jam

Step	Check	Yes	No
	Possible causative parts: WIRE HARNESS (PL 12.3.26) PWB H-TRA (PL 12.14.3) H-TRANSPORT EXIT SENSOR (PL 12.3.21) H-TRANSPORT MOTOR (PL 12.3.7)		
1	Checking the H-TRANSPORT EXIT SENSOR (Finisher H-Transport Exit Sensor) for operation Execute [Input 12-29 H-Transport Exit SENSOR] in [Diagnosis]. Does the display on the screen change, every time the actuator of the H-TRANSPORT Exit SENSOR is operated?	Go to step 7.	Go to step 2.
2	Checking the WIRE HARNESS (PL 12.3.26) connection Are the connectors of the WIRE HARNESS connected to the H-TRANSPORT EXIT SENSOR and PBW H-TRA of the Finisher connected surely?	Go to step 4.	After reconnecting, go to step 3.
3	Execute [Test Print] in [Diagnosis]. Does the error still occur?	Go to step 4.	End of work.

Step	Check	Yes	No
4	Checking the WIRE HARNESS for conductivity Disconnect J8381 of the H-TRANSPORT EXIT SENSOR, and P8372 on the PWB H-TRA of the Finisher. Check for conductivity at the following: P8372-4 <=> J8381-3 P8372-5 <=> J8381-2 P8372-6 <=> J8381-1	Go to step 5.	Replace the WIRE HARNESS.
5	Checking +5 VDC power supply to the H-TRANSPORT EXIT SENSOR Is the voltage across J8372-6 <=> J8372-4 on the PWB H-TRA of the Finisher +5 VDC?	Go to step 6.	Replace the PWB H-TRA. (RRP 12.97)
6	Checking the H-TRANSPORT EXIT SENSOR for operation Does the voltage across J8372-5 <=> J8372-4 on the PWB H-TRA of the Finisher change, every time the actuator of the H-TRANSPORT EXIT SENSOR is operated?	Replace the PWB H-TRA. (RRP 12.97)	Replace the H-TRANSPORT EXIT SENSOR. (RRP 12.14)
7	Checking the H-TRANSPORT MOTOR for operation Execute [Output 12-01 H XPORT Motor 145 ON/OFF] in [Diagnosis]. Does the H-TRANSPORT MOTOR rotate normally?	Replace the PWB H-TRA. (RRP 12.97)	Go to step 8.
8	Checking the WIRE HARNESS connection Are the connectors of the WIRE HARNESS connected to the H-TRANSPORT MOTOR and PBW H-TRA of the Finisher connected surely?	Go to step 10.	After reconnecting, go to step 9.
9	Execute [Test Print] in [Diagnosis]. Does the error still occur?	Go to step 10.	End of work.
10	Checking the WIRE HARNESS for conductivity Disconnect P/J8379 of the H-TRANSPORT MOTOR, and P8372 on the PWB H-TRA of the Finisher. Check for conductivity at the following: P8372-13 <=> J8379-6 P8372-12 <=> J8379-4 P8372-11 <=> J8379-1 P8372-10 <=> J8379-3 P8372-15 <=> J8379-2 P8372-14 <=> J8379-5	Go to step 11.	Replace the WIRE HARNESS.
11	Checking the resistance of the H-TRANSPORT MOTOR Are there any resistances without disconnection across P8379-2/5(COM) and P8379-1/3/4/6 of the H-TRANSPORT MOTOR?	Go to step 12.	Replace the H-TRANSPORT MOTOR. (RRP 12.10)
12	Checking +24 VDC power supply to the H-TRANSPORT MOTOR Are the voltages across J8372-15 <=> J8372-7, and J8372-14 <=> J8372-7 on the PWB H-TRA of the Finisher, +24 VDC?	Go to step 13.	Replace the PWB H-TRA. (RRP 12.97)
13	Checking after replacing the H-TRANSPORT MOTOR Replace the H-TRANSPORT MOTOR. (RRP 12.10) Execute [Test Print] in [Diagnosis]. Does the error still occur?	Replace the PWB H-TRA. (RRP 12.97)	End of work.

## F4-36 Finisher Transport Entrance Sensor Static Jam

Step	Check	Yes	No
	Possible causative parts: SENSOR (PL 12.12.19) HARNESS ASSY TRANSPORT ENT SENSOR (PL 12.15.4) HARNESS ASSY MAIN SENSOR (PL 12.15.1) PWB MAIN-C (PL 12.14.5) MOTOR ASSY (PL 12.12.21) HARNESS ASSY MAIN DRIVE (PL 12.15.2)		
1	Checking the SENSOR (Transport Entrance Sensor) for operation Execute [Input 12-30 Transport Ent. SENSOR] in [Diagnosis]. Does the display change, every time a piece of white paper is placed over the SENSOR (Transport Entrance Sensor)?	Go to step 8.	Go to step 2.
2	Checking the HARNESS ASSY connection Are P/J8319 and P/J8303 of the HARNESS ASSY X'PORT ENT SENSOR, and P/J8302A of the HARNESS ASSY MAIN SENSOR connected surely?	Go to step 4.	After reconnecting, go to step 3.
3	Execute [Test Print] in [Diagnosis]. Does the error still occur?	Go to step 4.	End of work.
4	Checking the HARNESS ASSY X'PORT ENT SENSOR for conductivity Disconnect P/J8319 and P/J8303 of the HARNESS ASSY X'PORT ENT SENSOR. Check for conductivity at the following: J8319-3 <=> J8303B-1 J8319-2 <=> J8303B-2 J8319-1 <=> J8303B-3	Go to step 5.	Replace the HARNESS ASSY X'PORT ENT SENSOR.
5	Checking the HARNESS ASSY MAIN SENSOR for conductivity Disconnect P/J8303 of the HARNESS ASSY MAIN SENSOR, and P/J8302A on the PWB MAIN-C. Check for conductivity at the following: J8303A-3 <=> J8302A-1 J8303A-2 <=> J8302A-2 J8303A-1 <=> J8302A-3	Go to step 6.	Replace the HARNESS ASSY MAIN SENSOR.
6	Checking +5 VDC power supply to the SENSOR (Transport Entrance Sensor) Is the voltage across J8302A-3 <=> J8302A-1 on the PWB MAIN-C +5 VDC?	Go to step 7.	Replace the PWB MAIN-C. (RRP 12.98)
7	Checking the SENSOR (Transport Entrance Sensor) for operation Does the voltage across P8302A-2 <=> P8302A-1 on the PWB MAIN-C change, every time a piece of white paper is placed over the SENSOR (X'port Entrance Sensor)?	Replace the PWB MAIN-C. (RRP 12.98)	Replace the SENSOR. (RRP 12.82)

Step	Check	Yes	No
8	Checking the MOTOR ASSY (Finisher Transport Motor) for operation Execute [Output 12-03 Fin Transport Motor 350 ON/OFF] in [Diagnosis]. Does the MOTOR ASSY (Finisher Transport Motor) rotate normally?	Go to step 9.	Go to step 10.
9	Checking the MOTOR ASSY (Finisher Transport Motor) for power transmission Execute [Output 12-03 Fin Transport Motor 350 ON/OFF] in [Diagnosis]. Does the rotation of the MOTOR ASSY transmit to the ROLL ASSY-ENT through the BELT (PL 12.12.23)?	Replace the PWB MAIN-C. (RRP 12.98)	Reinstall the MOTOR ASSY and BELT. (RRP 12.84)
10	Checking the HARNESS ASSY MAIN DRIVE connection Are P/J8342 and P/J8304 of the HARNESS ASSY MAIN DRIVE connected surely?	Go to step 12.	After reconnecting, go to step 11.
11	Execute [Test Print] in [Diagnosis]. Does the error still occur?	Go to step 12.	End of work.
12	Checking the HARNESS ASSY MAIN DRIVE for conductivity Disconnect P/J8342 and P/J8304 of the HARNESS ASSY MAIN DRIVE. Check for conductivity at the following: J8342-1 <=> J8304-23 J8342-2 <=> J8304-16 J8342-3 <=> J8304-25 J8342-4 <=> J8304-27 J8342-5 <=> J8304-18 J8342-6 <=> J8304-29	Go to step 13.	Replace the HARNESS ASSY MAIN DRIVE.
13	Checking the resistance of the MOTOR ASSY Are there any resistances without disconnection across P8342-2/5(COM) and P8342-1/3/4/6 of the MOTOR ASSY?	Go to step 14.	Replace the MOTOR ASSY. (RRP 12.84)
14	Checking +24 VDC power supply to the MOTOR ASSY Are the voltages across J8304-16 <=> FRAME CHASSIS, AND J8304-18 <=> FRAME CHASSIS on the PWB MAIN-C, +24 VDC?	Go to step 15.	Replace the PWB MAIN-C. (RRP 12.98)
15	Checking after replacing the MOTOR ASSY Replace the MOTOR ASSY. (RRP 12.84) Execute [Test Print] in [Diagnosis]. Does the error still occur?	Replace the PWB MAIN-C. (RRP 12.98)	End of work.

## F4-46 Finisher Buffer Path Sensor Static Jam A

**NOTE** This FIP can also be applied for the followings.

**NOTE** F4-47 Finisher Buffer Path Sensor Static Jam B

**NOTE F4-48 Finisher Buffer Path Sensor Static Jam C**

Step	Check	Yes	No
	Possible causative parts: SENSOR ASSY (PL 12.12.12) HARNESS ASSY BUFFER SENSOR (PL 12.15.5) HARNESS ASSY MAIN SENSOR (PL 12.15.1) PWB MAIN-C (PL 12.14.5) HARNESS ASSY MAIN DRIVE (PL 12.15.2) MOTOR ASSY (PL 12.13.30)		
1	Checking the SENSOR ASSY (Buffer Path Sensor) for operation Execute [Input 12-31 Buffer Path SENSOR] in [Diagnosis]. Does the display on the screen change, every time the actuator of the SENSOR ASSY (Buffer Path Sensor) R is operated?	Go to step 10.	Go to step 2.
2	Checking the HARNESS ASSY BUFFER SENSOR connection Are P/J8392 and P/J8318 of the HARNESS ASSY BUFFER SENSOR connected surely?	Go to step 4.	After reconnecting, go to step 3.
3	Execute [Test Print] in [Diagnosis]. Does the error still occur?	Go to step 4.	End of work.
4	Checking the HARNESS ASSY MAIN SENSOR connection Are P/J8318 and P/J8302A of the HARNESS ASSY MAIN SENSOR connected surely?	Go to step 6.	After reconnecting, go to step 5.
5	Execute [Test Print] in [Diagnosis]. Does the error still occur?	Go to step 6.	End of work.
6	Checking the HARNESS ASSY BUFFER SENSOR for conductivity Disconnect P/J8392 and P/J8318 of the HARNESS ASSY BUFFER SENSOR. Check for conductivity at the following: J8392-3 <=> J8318B-1 J8392-2 <=> J8318B-2 J8392-1 <=> J8318B-3	Go to step 7.	Replace the HARNESS ASSY BUFFER SENSOR.
7	Checking the HARNESS ASSY MAIN SENSOR for conductivity Disconnect P/J8318 of the HARNESS ASSY MAIN SENSOR, and P/J8302A on the PWB MAIN-C. Check for conductivity at the following: J8318A-3 <=> J8302A-13 J8318A-2 <=> J8302A-14 J8318A-1 <=> J8302A-15	Go to step 8.	Replace the HARNESS ASSY MAIN SENSOR.
8	Checking +5 VDC power supply to the SENSOR ASSY (Buffer Path Sensor) Is the voltage across J8302A-15 <=> J8302A-13 on the PWB MAIN-C +5 VDC?	Go to step 9.	Replace the PWB MAIN-C. (RRP 12.98)

Step	Check	Yes	No
9	Checking the SENSOR ASSY (Buffer Path Sensor) for operation Does the voltage across P8302A-14 <=> P8302A-13 on the PWB MAIN-C change, every time the actuator of the SENSOR ASSY (Buffer Path Sensor) is operated?	Replace the PWB MAIN-C. (RRP 12.98)	Replace the SENSOR ASSY (Buffer Path Sensor). (RRP 12.76)
10	Checking the MOTOR ASSY (Registration Motor) for operation Execute [Output 12-05 Registration Motor 285F ON/OFF] in [Diagnosis]. Does the MOTOR ASSY (Registration Motor) rotate normally?	Replace the PWB MAIN-C. (RRP 12.98)	Go to step 11.
11	Checking the MOTOR ASSY (Registration Motor) for power transmission Execute [Output 12-05 Registration Motor 285F ON/OFF] in [Diagnosis]. Does the rotation of the MOTOR ASSY transmit to the ROLL ASSY-BUFFER (PL 12.12.13) through the BELT (PL 12.13.27)?	Go to step 13.	After reinstalling the MOTOR ASSY and BELT, go to step 12. (RRP 12.96)
12	Execute [Test Print] in [Diagnosis]. Does the error still occur?	Go to step 13.	End of work.
13	Checking the HARNESS ASSY MAIN DRIVE connection Are P/J8335 and P/J8304 of the HARNESS ASSY MAIN DRIVE connected surely?	Go to step 15.	After reconnecting, go to step 14.
14	Execute [Test Print] in [Diagnosis]. Does the error still occur?	Go to step 15.	End of work.
15	Checking the HARNESS ASSY MAIN DRIVE for conductivity Disconnect P/J8335 and P/J8304 of the HARNESS ASSY MAIN DRIVE. Check for conductivity at the following: J8335-1 <=> J8304-7 J8335-2 <=> J8304-8 J8335-3 <=> J8304-9 J8335-4 <=> J8304-11 J8335-5 <=> J8304-10 J8335-6 <=> J8304-13	Go to step 16.	Replace the HARNESS ASSY MAIN DRIVE.
16	Checking the resistance of the MOTOR ASSY Are there any resistances without disconnection across P8335-2/5(COM) and P8335-1/3/4/6 of the MOTOR ASSY?	Go to step 17.	Replace the MOTOR ASSY. (RRP 12.96)
17	Checking +24 VDC power supply to the MOTOR ASSY Are the voltages across J8304-8 <=> FRAME CHASSIS, and J8304-10 <=> FRAME CHASSIS on the PWB MAIN-C, +24 VDC?	Go to step 18.	Replace the PWB MAIN-C. (RRP 12.98)



Step	Check	Yes	No
18	<p>Checking after replacing the MOTOR ASSY (Registration Motor)</p> <p>Replace the MOTOR ASSY (Registration Motor). (RRP 12.96)</p> <p>Execute [Test Print] in [Diagnosis].</p> <p>Does the error still occur?</p>	<p>Replace the PWB MAIN-C. (RRP 12.98)</p>	<p>End of work.</p>

#### F4-56 Finisher Compile Exit Sensor Static Jam

Step	Check	Yes	No
	<p>Possible causative parts:</p> <p>SENSOR ASSY (PL 12.11.3)</p> <p>HARNESS ASSY COMPILER (PL 12.10.8)</p> <p>HARNESS ASSY MAIN SENSOR (PL 12.15.1)</p> <p>PWB MAIN-C (PL 12.14.5)</p> <p>HARNESS ASSY MAIN DRIVE (PL 12.15.2)</p> <p>MOTOR ASSY (PL 12.13.30)</p> <p>BRACKET ASSY SOL (PL 12.12.34)</p>		
1	<p>Checking the SENSOR ASSY (Compile Exit Sensor) for operation</p> <p>Execute [Input 12-34 Compile Exit SENSOR] in [Diagnosis].</p> <p>Does the display on the screen change, every time the actuator of the SENSOR ASSY (Compile Exit Sensor) is operated?</p>	<p>Go to step 10.</p>	<p>Go to step 2.</p>
2	<p>Checking the HARNESS ASSY COMPILER connection</p> <p>Are P/J8320 and P/J8391 of the HARNESS ASSY COMPILER connected surely?</p>	<p>Go to step 4.</p>	<p>After reconnecting, go to step 3.</p>
3	<p>Execute [Test Print] in [Diagnosis].</p> <p>Does the error still occur?</p>	<p>Go to step 4.</p>	<p>End of work.</p>
4	<p>Checking the HARNESS ASSY MAIN SENSOR connection</p> <p>Are P/J8391 and P/J8302A of the HARNESS ASSY MAIN SENSORE connected surely?</p>	<p>Go to step 6.</p>	<p>After reconnecting, go to step 5.</p>
5	<p>Execute [Test Print] in [Diagnosis].</p> <p>Does the error still occur?</p>	<p>Go to step 6.</p>	<p>End of work.</p>
6	<p>Checking the HARNESS ASSY COMPILER for conductivity</p> <p>Disconnect P/J8320 and P/J8391 of the HARNESS ASSY COMPILER.</p> <p>Check for conductivity at the following:</p> <p>J8320-3 &lt;=&gt; J8391B-1</p> <p>J8320-2 &lt;=&gt; J8391B-2</p> <p>J8320-1 &lt;=&gt; J8391B-3</p>	<p>Go to step 7.</p>	<p>Replace the HARNESS ASSY COMPILER.</p>

Step	Check	Yes	No
7	Checking the HARNESS ASSY MAIN SENSOR for conductivity Disconnect P/J8391 of the HARNESS ASSY MAIN SENSOR, and P/J8302A on the PWB MAIN-C. Check for conductivity at the following: J8391A-3 <=> J8302A-4 J8391A-2 <=> J8302A-5 J8391A-1 <=> J8302A-6	Go to step 8.	Replace the HARNESS ASSY MAIN SENSOR.
8	Checking +5 VDC power supply to the SENSOR ASSY (Compile Exit Sensor) Is the voltage across J8302A-6 <=> J8302A-4 on the PWB MAIN-C +5 VDC?	Go to step 9.	Replace the PWB MAIN-C. (RRP 12.98)
9	Checking the SENSOR ASSY (Compile Exit Sensor) for operation Does the voltage across P8302A-5 <=> P8302A-4 on the PWB MAIN-C change, every time the actuator of the SENSOR ASSY (Compile Exit Sensor) is operated?	Replace the PWB MAIN-C. (RRP 12.98)	Replace the SENSOR ASSY (Compile Exit Sensor). (RRP 12.67)
10	Checking the MOTOR ASSY (Exit Motor) for operation Execute [Output 12-09 Exit Motor 285F ON/OFF] in [Diagnosis]. Does the MOTOR ASSY (Exit Motor) rotate normally?	Go to step 19.	Go to step 11.
11	Checking the MOTOR ASSY (Exit Motor) for power transmission Execute [Output 12-09 Exit Motor 285F ON/OFF] in [Diagnosis]. Does the rotation of the MOTOR ASSY transmit to the ROLL ASSY-ENT (PL 12.12.10) and the two ROLL ASSY-EXIT LOWs (PL 12.11.6) through the BELT (PL 12.13.28)?	Go to step 13.	After reinstalling the MOTOR ASSY and BELT, go to step 12. (RRP 12.95)
12	Execute [Test Print] in [Diagnosis]. Does the error still occur?	Go to step 13.	End of work.
13	Checking the HARNESS ASSY MAIN DRIVE connection Are P/J8334 and P/J8304 of the HARNESS ASSY MAIN DRIVE connected surely?	Go to step 15.	After reconnecting, go to step 14.
14	Execute [Test Print] in [Diagnosis]. Does the error still occur?	Go to step 15.	End of work.
15	Checking the HARNESS ASSY MAIN DRIVE for conductivity Disconnect P/J8334 and P/J8304 of the HARNESS ASSY MAIN DRIVE. Check for conductivity at the following: J8334-1 <=> J8304-2 J8334-2 <=> J8304-4 J8334-3 <=> J8304-1 J8334-4 <=> J8304-3 J8334-5 <=> J8304-6 J8334-6 <=> J8304-5	Go to step 16.	Replace the HARNESS ASSY MAIN DRIVE.

Step	Check	Yes	No
16	Checking the resistance of the MOTOR ASSY Are there any resistances without disconnection across P8334-2/5(COM)and P8334-1/3/4/6 of the MOTOR ASSY?	Go to step 17.	Replace the MOTOR ASSY. (RRP 12.95)
17	Checking +24 VDC power supply to the MOTOR ASSY Are the voltages across J8304-4 <=> FRAME CHASSIS and J8304-6 <=> FRAME CHASSIS on the PWB MAIN-C, +24 VDC?	Go to step 18.	Replace the PWB MAIN-C. (RRP 12.98)
18	Checking after replacing the MOTOR ASSY (Exit Motor) Replace the MOTOR ASSY (Exit Motor). (RRP 12.95) Execute [Test Print] in [Diagnosis]. Does the error still occur?	Replace the PWB MAIN-C. (RRP 12.98)	End of work.
19	Checking the BRACKET ASSY SOL (Buffer Gate Solenoid) for operation Perform [Input 12-25 Buffer Gate SOL BUF] in Chapter 2, Diagnostics. Does the GATE-BUFFER (PL 12.12.7) open upward?	Replace the PWB MAIN-C. (RRP 12.98)	Go to step 20.
20	Checking the HARNESS ASSY MAIN DRIVE connection Are P/J8394 and P/J8304 of the HARNESS ASSY MAIN DRIVE connected surely?	Go to step 22.	After reconnecting, go to step 21.
21	Execute [Test Print] in [Diagnosis]. Does the error still occur?	Go to step 22.	End of work.
22	Checking the HARNESS ASSY MAIN DRIVE for conductivity Disconnect P/J8394 and P/J8304 of the HARNESS ASSY MAIN DRIVE. Check for conductivity at the following: J8394-1 <=> J8304-35 J8394-2 <=> J8304-34 J8394-3 <=> J8304-36	Go to step 23.	Replace the HARNESS ASSY MAIN DRIVE.
23	Checking +24 VDC power supply to the BRACKET ASSY SOL (Buffer Gate Solenoid) Is the voltage across J8304-34 <=> J8304-36 on the PWB MAIN-C +24 VDC?	Go to step 24.	Replace the PWB MAIN-C. (RRP 12.98)
24	Checking after replacing the BRACKET ASSY SOL (Buffer Gate Solenoid) Replace the BRACKET ASSY SOL (Buffer Gate Solenoid). (RRP 12.86) Execute [Test Print] in [Diagnosis]. Does the error still occur?	Replace the PWB MAIN-C. (RRP 12.98)	End of work.

## F4-66 Finisher Compile No Paper Sensor Static Jam

Step	Check	Yes	No
	Possible causative parts: MOTOR ASSY-DC (PL 12.9.11) HARNESS ASSY MAIN DRIVE (PL 12.15.2) BRACKET ASSY-EJECT (PL 12.10.17) PWB MAIN-C (PL 12.14.5) SENSOR (PL 12.10.3) HARNESS ASSY COMPILER (PL 12.10.8)		
1	Checking the MOTOR ASSY-DC (Eject Clamp Motor) for operation Execute [Output 12-18 Eject Clamp Motor UP ON/OFF] and [Output 12-19 Eject Clamp Motor DOWN ON/OFF] in [Diagnosis]. Does the MOTOR ASSY-DC (Eject Clamp Motor) rotate normally?	Go to step 6.	Go to step 2.
2	Checking the HARNESS ASSY MAIN DRIVE connection Are P/J8339 and P/J 8304 of the HARNESS ASSY MAIN DRIVE connected surely?	Go to step 4.	After reconnecting, go to step 3.
3	Execute [Test Print] in [Diagnosis]. Does the error still occur?	Go to step 4.	End of work.
4	Checking the HARNESS ASSY MAIN DRIVE for conductivity Disconnect P/J8339 and P/J8304 of the HARNESS ASSY MAIN DRIVE. Check for conductivity at the following: J8339-1 <=> J8304-33 J8339-2 <=> J8304-31	Go to step 5.	Replace the HARNESS ASSY MAIN DRIVE.
5	Checking after replacing the MOTOR ASSY-DC (Eject Clamp Motor) Replace the MOTOR ASSY-DC (Eject Clamp Motor). (RRP 12.54) Execute [Test Print] in [Diagnosis]. Does the error still occur?	Replace the PWB MAIN-C. (RRP 12.98)	End of work.
6	Checking the BRACKET ASSY-EJECT (Eject Motor) for operation Execute [Output 12-20 Eject Motor Low FORWARD ON/OFF] in [Diagnosis]. Does the BRACKET ASSY-EJECT (Eject Motor) rotate in the FORWARD direction normally?	Go to step 13.	Go to step 7.
7	Checking the HARNESS ASSY MAIN DRIVE connection Are P/J8336 and P/J8304 of the HARNESS ASSY MAIN DRIVE connected surely?	Go to step 9.	After reconnecting, go to step 8.
8	Execute [Test Print] in [Diagnosis]. Does the error still occur?	Go to step 9.	End of work.

Step	Check	Yes	No
9	<p>Checking the HARNESS ASSY MAIN DRIVE for conductivity Disconnect P/J8336 and P/J8304 of the HARNESS ASSY MAIN DRIVE. Check for conductivity at the following: J8336-1 &lt;=&gt; J8304-15 J8336-2 &lt;=&gt; J8304-12 J8336-3 &lt;=&gt; J8304-17 J8336-4 &lt;=&gt; J8304-19 J8336-5 &lt;=&gt; J8304-14 J8336-6 &lt;=&gt; J8304-21</p>	Go to step 10.	Replace the HARNESS ASSY MAIN DRIVE.
10	<p>Checking the resistance of the MOTOR ASSY Are there any resistances without disconnection across P8336-2/5(COM) and P8336-1/3/4/6 of the MOTOR ASSY?</p>	Go to step 11.	Replace the BRACKET ASSY-EJECT. (RRP 12.65)
11	<p>Checking +24 VDC power supply to the MOTOR ASSY Are the voltages across J8304-12 &lt;=&gt; FRAME CHASSIS, and J8304-14 &lt;=&gt; FRAME CHASSIS on the PWB MAIN-C, +24 VDC?</p>	Go to step 12.	Replace the PWB MAIN-C. (RRP 12.98)
12	<p>Checking after replacing the BRACKET ASSY-EJECT (Eject Motor) Replace the BRACKET ASSY-EJECT (Eject Motor). (RRP 12.65) Execute [Test Print] in [Diagnosis]. Does the error still occur?</p>	Replace the PWB MAIN-C. (RRP 12.98)	End of work.
13	<p>Checking the SENSOR (Compile Tray No Paper Sensor) for operation Execute [Input 12-35 Compile Tray No Paper SENSOR] in [Diagnosis]. Does the display on the screen change, every time the ACTUATOR-PAPER (PL 12.10.4) of the SENSOR is operated?</p>	Replace the PWB MAIN-C. (RRP 12.98)	Go to step 14.
14	<p>Checking the HARNESS ASSY COMPILER connection Are P/J8359 and P/J8309 of the HARNESS ASSY COMPILER connected surely?</p>	Go to step 16.	After reconnecting, go to step 15.
15	<p>Execute [Test Print] in [Diagnosis]. Does the error still occur?</p>	Go to step 16.	End of work.
16	<p>Checking the HARNESS ASSY COMPILER for conductivity Disconnect P/J8359 and P/J8309 of the HARNESS ASSY COMPILER. Check for conductivity at the following: J8359-3 &lt;=&gt; J8309-1 J8359-2 &lt;=&gt; J8309-2 J8359-1 &lt;=&gt; J8309-3</p>	Go to step 17.	Replace the HARNESS ASSY COMPILER.
17	<p>Checking +5 VDC power supply to the SENSOR (Compile Tray No Paper Sensor) Is the voltage across J8309-3 &lt;=&gt; J8309-1 on the PWB MAIN-C +5 VDC?</p>	Go to step 18.	Replace the PWB MAIN-C. (RRP 12.98)

Step	Check	Yes	No
18	<p>Checking the SENSOR (Compile Tray No Paper Sensor) for operation</p> <p>Does the voltage across P8309-2 &lt;=&gt; P8309-1 on the PWB MAIN-C change, every time the ACTUATOR-PAPER (PL 12.10.4) of the SENSOR (Compile Tray No Paper Sensor) is operated?</p>	Replace the PWB MAIN-C. (RRP 12.98)	Replace the SENSOR (Compile Tray No Paper Sensor). (RRP 12.59)

## F4-76 Finisher Top Tray Exit Sensor Static Jam A

**NOTE** This FIP can also be applied for the followings.

**NOTE** F4-77 Finisher Top Tray Exit Sensor Static Jam B

**NOTE** F4-78 Finisher Top Tray Exit Sensor Static Jam C

Step	Check	Yes	No
	<p>Possible causative parts:</p> <p>SENSOR (PL 12.13.2)</p> <p>HARNESS ASSY TOP EXIT SENSOR (PL 12.15.6)</p> <p>HARNESS ASSY MAIN SENSOR (PL 12.15.1)</p> <p>PWB MAIN-C (PL 12.14.5)</p> <p>MOTOR ASSY (PL 12.13.30)</p> <p>HARNESS ASSY MAIN DRIVE (PL 12.15.2)</p>		
1	<p>Checking the SENSOR (Top Tray Exit Sensor) for operation</p> <p>Execute [Input 12-32 Top Tray Exit SENSOR] in [Diagnosis].</p> <p>Does the display on the screen change, every time the actuator of the SENSOR is operated?</p>	Go to step 8.	Go to step 2.
2	<p>Checking the HARNESS ASSY TOP EXIT SENSOR and HARNESS ASSY MAIN SENSOR connection</p> <p>Are P/J8321 and P/J8312 of the HARNESS ASSY TOP EXIT SENSOR, and P/J8312 and P/J8302 of the HARNESS ASSY MAIN SENSOR connected surely?</p>	Go to step 4.	After reconnecting, go to step 3.
3	<p>Execute [Test Print] in [Diagnosis].</p> <p>Does the error still occur?</p>	Go to step 4.	End of work.
4	<p>Checking the HARNESS ASSY TOP EXIT SENSOR for conductivity</p> <p>Disconnect P/J8321 and P/J8312 of the HARNESS ASSY TOP EXIT SENSOR.</p> <p>Check for conductivity at the following:</p> <p>J8321-3 &lt;=&gt; J8312B-1</p> <p>J8321-2 &lt;=&gt; J8312B-2</p> <p>J8321-1 &lt;=&gt; J8312B-3</p>	Go to step 5.	Replace the HARNESS ASSY TOP EXIT SENSOR.

Step	Check	Yes	No
5	Checking the HARNESS ASSY MAIN SENSOR for conductivity Disconnect P/J8312 of the HARNESS ASSY MAIN SENSOR, and P/J8302A on the PWB MAIN-C. Check for conductivity at the following: J8312A-3 <=> J8302A-7 J8312A-2 <=> J8302A-8 J8312A-1 <=> J8302A-9	Go to step 6.	Replace the HARNESS ASSY MAIN SENSOR.
6	Checking +5 VDC power supply to the SENSOR (Top Tray Exit Sensor) Is the voltage across J8302A-9 <=> J8302A-7 on the PWB MAIN-C +5 VDC?	Go to step 7.	Replace the PWB MAIN-C. (RRP 12.98)
7	Checking the SENSOR (Top Tray Exit Sensor) for operation Does the voltage across P8302A-8 <=> P8302A-7 on the PWB MAIN-C change, every time a piece of white paper is placed over the sensing area of the SENSOR (Top Tray Exit Sensor)?	Replace the PWB MAIN-C. (RRP 12.98)	Replace the SENSOR (Top Tray Exit Sensor). (RRP 12.87)
8	Checking the MOTOR ASSY (Registration Motor) for operation Execute [Output 12-05 Registration Motor 285F ON/OFF] in [Diagnosis]. Does the MOTOR ASSY (Registration Motor) rotate normally?	Replace the PWB MAIN-C. (RRP 12.98)	Go to step 9.
9	Checking the MOTOR ASSY (Registration Motor) for power transmission Execute [Output 12-05 Registration Motor 285F ON/OFF] in [Diagnosis]. Does the rotation of the MOTOR ASSY transmit to the ROLL ASSY-BUFFER (PL 12.12.13) through the BELT (PL 12.13.27)?	Go to step 11.	After reinstalling the MOTOR ASSY and BELT, go to step 10. (RRP 12.96)
10	Execute [Test Print] in [Diagnosis]. Does the error still occur?	Go to step 11.	End of work.
11	Checking the HARNESS ASSY MAIN DRIVE connection Are P/J8335 and P/J8304 of the HARNESS ASSY MAIN DRIVE connected surely?	Go to step 13.	After reconnecting, go to step 12.
12	Execute [Test Print] in [Diagnosis]. Does the error still occur?	Go to step 13.	End of work.
13	Checking the HARNESS ASSY MAIN DRIVE for conductivity Disconnect P/J8335 and P/J8304 of the HARNESS ASSY MAIN DRIVE. Check for conductivity at the following: J8335-1 <=> J8304-7 J8335-2 <=> J8304-8 J8335-3 <=> J8304-9 J8335-4 <=> J8304-11 J8335-5 <=> J8304-10 J8335-6 <=> J8304-13	Go to step 14.	Replace the HARNESS ASSY MAIN DRIVE.

Step	Check	Yes	No
14	Checking the resistance of the MOTOR ASSY Are there any resistances without disconnection across P8335-2/5(COM) and P8335-1/3/4/6 of the MOTOR ASSY?	Go to step 15.	Replace the MOTOR ASSY. (RRP 12.96)
15	Checking +24 VDC power supply to the MOTOR ASSY Are the voltages across J8304-8 <=> FRAME CHASSIS, and J8304-10 <=> FRAME CHASSIS on the PWB MAIN-C, +24 VDC?	Go to step 16.	Replace the PWB MAIN-C. (RRP 12.98)
16	Checking after replacing the MOTOR ASSY (Registration Motor) Replace the MOTOR ASSY (Registration Motor). (RRP 12.96) Execute [Test Print] in [Diagnosis]. Does the error still occur?	Replace the PWB MAIN-C. (RRP 12.98)	End of work.

### F4-83 Finisher Gate Sensor Static Jam (to Top Tray) A

**NOTE** This FIP can also be applied for the followings.

**NOTE** F4-84 Finisher Gate Sensor Static Jam (to Top Tray) B

**NOTE** F4-85 Finisher Gate Sensor Static Jam (to Top Tray) C

Step	Check	Yes	No
	Possible causative parts: MOTOR ASSY (PL 12.12.21) HARNESS ASSY MAIN DRIVE (PL 12.15.2) PWB MAIN-C (PL 12.14.5) SENSOR (PL 12.13.15) HARNESS ASSY-SENSOR (PL 12.13.16)		
1	Checking the MOTOR ASSY (Finisher Transport Motor) for operation Execute [Output 12-03 Fin Transport Motor 350 ON/OFF] in [Diagnosis]. Does the MOTOR ASSY (Finisher Transport Motor) rotate normally?	Go to step 2.	Go to step 3.
2	Checking the MOTOR ASSY (Finisher Transport Motor) for power transmission Execute [Output 12-03 Fin Transport Motor 350 ON/OFF] in [Diagnosis]. Does the rotation of the MOTOR ASSY transmit to the ROLL ASSY-ENT (PL 12.12.10) and two ROLL ASSY-TRANSPORTs (PL 12.13.18) through the BELT (PL 12.12.23)?	Go to step 9.	Reinstall the MOTOR ASSY and BELT. (RRP 12.84)
3	Checking the HARNESS ASSY MAIN DRIVE connection Are P/J8342 and P/J8304 of the HARNESS ASSY MAIN DRIVE connected surely?	Go to step 5.	After reconnecting, go to step 4.
4	Execute [Test Print] in [Diagnosis]. Does the error still occur?	Go to step 5.	End of work.



Step	Check	Yes	No
5	Checking the HARNESS ASSY MAIN DRIVE for conductivity Disconnect P/J8342 and P/J8304 of the HARNESS ASSY MAIN DRIVE. Check for conductivity at the following: J8342-1 <=> J8304-23 J8342-2 <=> J8304-16 J8342-3 <=> J8304-25 J8342-4 <=> J8304-27 J8342-5 <=> J8304-18 J8342-6 <=> J8304-29	Go to step 6.	Replace the HARNESS ASSY MAIN DRIVE.
6	Checking the resistance of the MOTOR ASSY (Finisher Transport Motor) Are there any resistances without disconnection across P8342-2/5(COM) and P8342-1/3/4/6 of the MOTOR ASSY (Finisher Transport Motor)?	Go to step 7.	Replace the MOTOR ASSY (Finisher Transport Motor). (RRP 12.84)
7	Checking +24 VDC power supply to the MOTOR ASSY (Finisher Transport Motor) Are the voltages across J8304-16 <=> FRAME CHASSIS, and J8304-18 <=> FRAME CHASSIS on the PWB MAIN-C, +24 VDC?	Go to step 8.	Replace the PWB MAIN-C (RRP 12.98)
8	Checking after replacing the MOTOR ASSY (Finisher Transport Motor) Replace the MOTOR ASSY (Finisher Transport Motor). (RRP 12.84) Execute [Test Print] in [Diagnosis]. Does the error still occur?	Replace the PWB MAIN-C. (RRP 12.98)	End of work.
9	Checking the SENSOR (Gate Sensor) for operation Execute [Input 12-51 Gate SENSOR] in [Diagnosis]. Does the display on the screen change, every time a piece of white paper is placed over the sensing area of the SENSOR (Gate Sensor)?	Replace the PWB MAIN-C. (RRP 12.98)	Go to step 10.
10	Checking the HARNESS ASSY-SENSOR connection Are the connectors of the HARNESS ASSY-SENSOR connected surely?	Go to step 12.	After reconnecting, go to step 11.
11	Execute [Test Print] in [Diagnosis]. Does the error still occur?	Go to step 12.	End of work.
12	Checking the HARNESS ASSY-SENSOR for conductivity Disconnect P/J8432 and P/J8376 of the HARNESS ASSY-SENSOR. Check for conductivity at the following: J8432-3 <=> J8376-1 J8432-2 <=> J8376-2 J8432-1 <=> J8376-3	Go to step 13.	Replace the HARNESS ASSY-SENSOR.
13	Checking +5 VDC power supply to the SENSOR (Gate Sensor) Is the voltage across P8376-3 <=> P8376-1 on the PWB MAIN-C +5 VDC?	Go to step 14.	Replace the PWB MAIN-C. (RRP 12.98)

Step	Check	Yes	No
14	Checking the SENSOR (Gate Sensor) for operation Does the voltage across P8376-2 <=> P8376-1 on the PWB MAIN-C change, every time a piece of white paper is placed over the sensing area of the SENSOR (Gate Sensor)?	Replace the PWB MAIN-C. (RRP 12.98)	Replace the SENSOR. (RRP 12.93)

### F4-86 Finisher Gate Sensor Static Jam (to Stacker Tray) A

**NOTE** This FIP can also be applied for the followings.

**NOTE** F4-87 Finisher Gate Sensor Static Jam (to Stacker Tray) B

**NOTE** F4-88 Finisher Gate Sensor Static Jam (to Stacker Tray) C

Step	Check	Yes	No
	Possible causative parts: MOTOR ASSY (PL 12.12.21) HARNESS ASSY MAIN DRIVE (PL 12.15.2) PWB MAIN-C (PL 12.14.5) SENSOR (PL 12.13.15) HARNESS ASSY-SENSOR (PL 12.13.16)		
1	Checking the MOTOR ASSY (Finisher Transport Motor) for operation Execute [Output 12-03 Fin Transport Motor 350 ON/OFF] in [Diagnosis]. Does the MOTOR ASSY (Finisher Transport Motor) rotate normally?	Go to step 2.	Go to step 3.
2	Checking the MOTOR ASSY (Finisher Transport Motor) for power transmission Execute [Output 12-03 Fin Transport Motor 350 ON/OFF] in [Diagnosis]. Does the rotation of the MOTOR ASSY transmit to the ROLL ASSY-ENT (PL 12.12.10) and two ROLL ASSY-TRANSPORTs (PL 12.13.18) through the BELT (PL 12.12.23)?	Go to step 9.	Reinstall the MOTOR ASSY and BELT. (RRP 12.84)
3	Checking the HARNESS ASSY MAIN DRIVE connection Are P/J8342 and P/J8304 of the HARNESS ASSY MAIN DRIVE connected surely?	Go to step 5.	After reconnecting, go to step 4.
4	Execute [Test Print] in [Diagnosis]. Does the error still occur?	Go to step 5.	End of work.

Step	Check	Yes	No
5	<p>Checking the HARNESS ASSY MAIN DRIVE for conductivity</p> <p>Disconnect P/J8342 and P/J8304 of the HARNESS ASSY MAIN DRIVE.</p> <p>Check for conductivity at the following:</p> <p>J8342-1 &lt;=&gt; J8304-23  J8342-2 &lt;=&gt; J8304-16  J8342-3 &lt;=&gt; J8304-25  J8342-4 &lt;=&gt; J8304-27  J8342-5 &lt;=&gt; J8304-18  J8342-6 &lt;=&gt; J8304-29</p>	Go to step 6.	Replace the HARNESS ASSY MAIN DRIVE.
6	<p>Checking the resistance of the MOTOR ASSY (Finisher Transport Motor)</p> <p>Are there any resistances without disconnection across P8342-2/5(COM) and P8342-1/3/4/6 of the MOTOR ASSY (Finisher Transport Motor)?</p>	Go to step 7.	Replace the MOTOR ASSY (Finisher Transport Motor). (RRP 12.84)
7	<p>Checking +24 VDC power supply to the MOTOR ASSY (Finisher Transport Motor)</p> <p>are the voltages across J8304-16 &lt;=&gt; FRAME CHASSIS, and J8304-18 &lt;=&gt; FRAME CHASSIS on the PWB MAIN-C, +24 VDC?</p>	Go to step 8.	Replace the PWB MAIN-C. (RRP 12.98)
8	<p>Checking after replacing the MOTOR ASSY (Finisher Transport Motor)</p> <p>Replace the MOTOR ASSY (Finisher Transport Motor). (RRP 12.84)</p> <p>Execute [Test Print] in [Diagnosis].</p> <p>Does the error still occur?</p>	Replace the PWB MAIN-C. (RRP 12.98)	End of work.
9	<p>Checking the SENSOR (Gate Sensor) for operation</p> <p>Execute [Input 12-51 Gate SENSOR] in [Diagnosis].</p> <p>Does the display on the screen change, every time a piece of white paper is placed over the sensing area of the SENSOR (Gate Sensor)?</p>	Replace the PWB MAIN-C. (RRP 12.98)	Go to step 10.
10	<p>Checking the HARNESS ASSY-SENSOR connection</p> <p>Are the connectors of the HARNESS ASSY-SENSOR connected surely?</p>	Go to step 12.	After reconnecting, go to step 11.
11	<p>Execute [Test Print] in [Diagnosis].</p> <p>Does the error still occur?</p>	Go to step 12.	End of work.
12	<p>Checking the HARNESS ASSY-SENSOR for conductivity</p> <p>Disconnect P/J8432 and P/J8376 of the HARNESS ASSY-SENSOR.</p> <p>Check for conductivity at the following:</p> <p>J8432-3 &lt;=&gt; J8376-1  J8432-2 &lt;=&gt; J8376-2  J8432-1 &lt;=&gt; J8376-3</p>	Go to step 13.	Replace the HARNESS ASSY-SENSOR.
13	<p>Checking +5 VDC power supply to the SENSOR (Gate Sensor)</p> <p>Is the voltage across P8376-3 &lt;=&gt; P8376-1 on the PWB MAIN-C +5 VDC?</p>	Go to step 14.	Replace the PWB MAIN-C. (RRP 12.98)

Step	Check	Yes	No
14	Checking the SENSOR (Gate Sensor) for operation Does the voltage across P8376-2 <=> P8376-1 on the PWB MAIN-C change, every time a piece of white paper is placed over the sensing area of the SENSOR (Gate Sensor)?	Replace the PWB MAIN-C. (RRP 12.98)	Replace the SENSOR. (RRP 12.93)

## H5-11 Stacker Tray Fail

Step	Check	Yes	No
	Possible causative parts: COVER ASSY SENSOR (PL 12.6.13) HARNESS ASSY MAIN SENSOR (PL 12.15.1) PWB MAIN-C (PL 12.14.5) MOTOR ASSY DC (PL 12.6.26) PWBA MCU F (PL 8.1.5)		
1	Checking the vertical transport mechanism of the Stacker Tray for obstacles and deformation Are there any obstacles in the vertical transport mechanism of the Stacker Tray? Is there any deformation in the vertical transport mechanism of the Stacker Tray?	Remove obstacles/replace deformed part.	Go to step 2.
2	Checking the COVER ASSY SENSOR (PL 12.6.13) (Stacker Height Sensor 1) for operation Execute [Input 13-50 Stack Height SENSOR 1] in [Diagnosis]. Does the display on the screen change, every time the sensing area of the SENSOR is blocked by putting a piece of paper?	Go to step 8.	Go to step 3.
3	Checking the HARNESS ASSY MAIN SENSOR connection Are P/J8331 and P/J8302B of the HARNESS ASSY MAIN SENSOR connected surely?	Go to step 5.	After reconnecting, go to step 4.
4	Execute [Test Print] in [Diagnosis]. Does the error still occur?	Go to step 5.	End of work.
5	Checking the HARNESS ASSY MAIN SENSOR for conductivity Disconnect P/J8331 of the HARNESS ASSY MAIN SENSOR, and P/J8302B on the PWB MAIN-C. Check for conductivity at the following: J8331-5 <=> J8302B-1 J8331-4 <=> J8302B-2 J8331-3 <=> J8302B-3 J8331-2 <=> J8302B-4 J8331-1 <=> J8302B-5	Go to step 6.	Replace the HARNESS ASSY MAIN SENSOR.
6	Checking +5 VDC power supply to the COVER ASSY SENSOR (Stacker Height Sensor 1) Is the voltage across J8302B-3 <=> J8302B-1 on the PWB MAIN-C +5 VDC?	Go to step 7.	Replace the PWB MAIN-C. (RRP 12.98)

Step	Check	Yes	No
7	Checking the COVER ASSY SENSOR (Stacker Height Sensor 1) for operation Does the voltage across P8302B-2 <=> P8302B-1 on the PWB MAIN-C change, every time the sensing area of the SENSOR is blocked by putting a piece of paper?	Replace the PWB MAIN-C. (RRP 12.98)	Replace the COVER ASSY SENSOR (Stacker Height Sensor 1). (RRP 12.30)
8	Checking the COVER ASSY SENSOR (PL 12.6.13) (Stacker Height Sensor 2) for operation Execute [Input 13-51 Stack Height SENSOR 2] in [Diagnosis]. Does the display on the screen change, every time the sensing area of the SENSOR is blocked by putting a piece of paper?	Go to step 14.	Go to step 9.
9	Checking the HARNESS ASSY MAIN SENSOR connection Are P/J8330 and P/J8302A of the HARNESS ASSY MAIN SENSOR connected surely?	Go to step 11.	After reconnecting, go to step 10.
10	Execute [Test Print] in [Diagnosis]. Does the error still occur?	Go to step 11.	End of work.
11	Checking the HARNESS ASSY MAIN SENSOR for conductivity Disconnect P/J8330 of the HARNESS ASSY MAIN SENSOR, and P/J8302A on the PWB MAIN-C. Check for conductivity at the following: J8330-5 <=> J8302A-16 J8330-4 <=> J8302A-17 J8330-3 <=> J8302A-18 J8330-2 <=> J8302A-19 J8330-1 <=> J8302A-20	Go to step 12.	Replace the HARNESS ASSY MAIN SENSOR.
12	Checking +5 VDC power supply to the COVER ASSY SENSOR (Stacker Height Sensor 2) Is the voltage across J8302A-18 <=> J8302A-16 on the PWB MAIN-C +5 VDC?	Go to step 13.	Replace the PWB MAIN-C. (RRP 12.98)
13	Checking the COVER ASSY SENSOR (Stacker Height Sensor 2) for operation Does the voltage across P8302A-17 <=> P8302A-16 on the PWB MAIN-C change, every time the sensing area of the SENSOR is blocked by putting a piece of paper?	Replace the PWB MAIN-C. (RRP 12.98)	Replace the COVER ASSY SENSOR (Stacker Height Sensor 2). (RRP 12.31)
14	Checking the MOTOR ASSY DC (Elevator Motor) for operation Execute [Output 13-31 Stacker Motor UP ON/OFF] and [Output 13-32 Stacker Motor DOWN ON/OFF] in [Diagnosis] alternately. Does the MOTOR ASSY DC (Elevator Motor) rotate normally in Forward/Reverse directions?	Replace the PWB MAIN-C. (RRP 12.98)	Go to step 16.
15	Checking the MOTOR ASSY DC (Elevator Motor) connection Is P/J8305 of the MOTOR ASSY DC (Elevator Motor) connected to the PWB MAIN-C surely?	Go to step 17.	After reconnecting, go to step 16.

Step	Check	Yes	No
16	Execute [Test Print] in [Diagnosis]. Does the error still occur?	Go to step 17.	End of work.
17	Checking after replacing the MOTOR ASSY DC (Elevator Motor) Replace the MOTOR ASSY DC (Elevator Motor). (RRP 12.35) Execute [Test Print] in [Diagnosis]. Does the error still occur?	Go to step 18.	End of work.
18	Checking after replacing the PWB MAIN-C Replace the PWB MAIN-C. (RRP 12.98) Does the error still occur when the power is turned ON?	Replace the PWB A MAIN F.	End of work.

### H5-12 Stacker Tray Upper Limit Fail

Step	Check	Yes	No
	Possible causative parts: ACTUATOR (PL 12.6.12) COVER ASSY SENSOR (PL 12.6.13) HARNESS ASSY MAIN SENSOR (PL 12.15.1) PWB MAIN-C (PL 12.14.5) SENSOR (PL 12.6.17) MOTOR ASSY DC (PL 12.6.26) PWBA MCU F (PL 8.1.5)		
1	Checking the COVER ASSY SENSOR (PL 12.6.13) (Stacker Height Sensor 1) for operation Execute [Input 13-50 Stack Height SENSOR 1] in [Diagnosis]. Does the display on the screen change, every time the sensing area of the SENSOR is blocked by putting a piece of paper?	Go to step 7.	Go to step 2.
2	Checking the HARNESS ASSY MAIN SENSOR connection Are P/J8331 and P/J8302B of the HARNESS ASSY MAIN SENSOR connected surely?	Go to step 4.	After reconnecting, go to step 3.
3	Execute [Test Print] in [Diagnosis]. Does the error still occur?	Go to step 4.	End of work.
4	Checking the HARNESS ASSY MAIN SENSOR for conductivity Disconnect P/J8331 of the HARNESS ASSY MAIN SENSOR, and P/J8302B on the PWB MAIN-C. Check for conductivity at the following: J8331-5 <=> J8302B-1 J8331-4 <=> J8302B-2 J8331-3 <=> J8302B-3 J8331-2 <=> J8302B-4 J8331-1 <=> J8302B-5	Go to step 5.	Replace the HARNESS ASSY MAIN SENSOR.

Step	Check	Yes	No
5	Checking +5 VDC power supply to the COVER ASSY SENSOR (Stacker Height Sensor 1) Is the voltage across J8302B-3 <=> J8302B-1 on the PWB MAIN-C +5 VDC?	Go to step 6.	Replace the PWB MAIN-C. (RRP 12.98)
6	Checking the COVER ASSY SENSOR (Stacker Height Sensor 1) for operation Does the voltage across P8302B-2 <=> P8302B-1 on the PWB MAIN-C change, every time the sensing area of the SENSOR is blocked by putting a piece of paper?	Replace the PWB MAIN-C. (RRP 12.98)	Replace the COVER ASSY SENSOR (Stacker Height Sensor 1). (RRP 12.30)
7	Checking the COVER ASSY SENSOR (PL 12.6.13) (Stacker Height Sensor 2) for operation Execute [Input 13-51 Stack Height SENSOR 2] in [Diagnosis]. Does the display on the screen change, every time the sensing area of the SENSOR is blocked by putting a piece of paper?	Go to step 13.	Go to step 8.
8	Checking the HARNESS ASSY MAIN SENSOR connection Are P/J8330 and P/J8302A of the HARNESS ASSY MAIN SENSOR connected surely?	Go to step 10.	After reconnecting, go to step 9.
9	Execute [Test Print] in [Diagnosis]. Does the error still occur?	Go to step 10.	End of work.
10	Checking the HARNESS ASSY MAIN SENSOR for conductivity Disconnect P/J8330 of the HARNESS ASSY MAIN SENSOR, and P/J8302A on the PWB MAIN-C. Check for conductivity at the following: J8330-5 <=> J8302A-16 J8330-4 <=> J8302A-17 J8330-3 <=> J8302A-18 J8330-2 <=> J8302A-19 J8330-1 <=> J8302A-20	Go to step 11.	Replace the HARNESS ASSY MAIN SENSOR.
11	Checking +5 VDC power supply to the COVER ASSY SENSOR (Stacker Height Sensor 2) Is the voltage across J8302A-18 <=> J8302A-16 on the PWB MAIN-C +5 VDC?	Go to step 12.	Replace the PWB MAIN-C. (RRP 12.98)
12	Checking the COVER ASSY SENSOR (Stacker Height Sensor 2) for operation Does the voltage across P8302A-17 <=> P8302A-16 on the PWB MAIN-C change, every time the sensing area of the SENSOR is blocked by putting a piece of paper?	Replace the PWB MAIN-C. (RRP 12.98)	Replace the COVER ASSY SENSOR (Stacker Height Sensor 2). (RRP 12.31)
13	Checking the ACTUATOR (PL 12.6.12) for operation Is the ACTUATOR installed correctly? Does it enter the sensing area of the SENSOR (Upper Limit Sensor)?	Go to step 14.	Replace the ACTUATOR.

Step	Check	Yes	No
14	Checking the SENSOR (Upper Limit Sensor) for operation Execute [Input 13-46 Upper Limit SENSOR] in [Diagnosis]. Does the display on the screen change, every time the sensing area of the SENSOR is blocked by putting a piece of paper?	Replace the PWB MAIN-C. (RRP 12.98)	Go to step 15.
15	Checking the HARNESS ASSY MAIN SENSOR connection Are P/J8327 and P/J8302B of the HARNESS ASSY MAIN SENSOR connected surely?	Go to step 17.	After reconnecting, go to step 16.
16	Execute [Test Print] in [Diagnosis]. Does the error still occur?	Go to step 17.	End of work.
17	Checking the HARNESS ASSY MAIN SENSOR for conductivity Disconnect P/J8327 of the HARNESS ASSY MAIN SENSOR, and P/J8302B on the PWB MAIN-C. Check for conductivity at the following: J8327-3 <=> J8302B-18 J8327-2 <=> J8302B-19 J8327-1 <=> J8302B-20	Go to step 18.	Replace the HARNESS ASSY MAIN SENSOR.
18	Checking +5 VDC power supply to the SENSOR (Upper Limit Sensor) Is the voltage across J8302B-20 <=> J8302B-18 on the PWB MAIN-C +5 VDC?	Go to step 19.	Replace the PWB MAIN-C. (RRP 12.98)
19	Checking the SENSOR (Upper Limit Sensor) for operation Does the voltage across P8302B-19 <=> P8302B-18 on the PWB MAIN-C change, every time the sensing area of the SENSOR is blocked by putting a piece of paper?	Replace the PWB MAIN-C. (RRP 12.98)	Replace the SENSOR (Upper Limit Sensor). (RRP 12.33)
20	Checking the MOTOR ASSY DC (Elevator Motor) for operation Execute [Output 13-31 Stacker Motor UP ON/OFF] and [Output 13-32 Stacker Motor DOWN ON/OFF] in [Diagnosis] alternately. Does the MOTOR ASSY DC (Elevator Motor) rotate normally in Forward/Reverse directions?	Replace the PWB MAIN-C. (RRP 12.98)	Go to step 21.
21	Checking the MOTOR ASSY DC (Elevator Motor) connection Is P/J8305 of the MOTOR ASSY DC (Elevator Motor) connected to the PWB MAIN-C securely?	Go to step 23.	After reconnecting, go to step 22.
22	Execute [Test Print] in [Diagnosis]. Does the error still occur?	Go to step 23.	End of work.
23	Checking after replacing the MOTOR ASSY DC (Elevator Motor) Replace the MOTOR ASSY DC (Elevator Motor). (RRP 12.35) Execute [Test Print] in [Diagnosis]. Does the error still occur?	Go to step 24.	End of work.



Step	Check	Yes	No
24	Checking after replacing the PWB MAIN-C Replace the PWB MAIN-C. (RRP 12.98) Does the error still occur when the power is turned ON?	Replace the PWBA MCU F. (RRP 8.4)	End of work.

### H5-13 Stacker Tray Lower Limit Fail

Step	Check	Yes	No
	Possible causative parts: ACTUATOR (PL 12.6.12) COVER ASSY SENSOR (PL 12.6.13) HARNESS ASSY MAIN SENSOR (PL 12.15.1) PWB MAIN-C (PL 12.14.5) SENSOR (PL 12.6.17) MOTOR ASSY DC (PL 12.6.26)		
1	Checking the ACTUATOR for operation Is the ACTUATOR installed correctly? Does it enter the sensing area of the SENSOR (Upper Limit Sensor)?	Go to step 2.	Replace the ACTUATOR.
2	Checking the SENSOR (Stacker No Paper Sensor) for operation Execute [Input 13-48 Stacker No Paper SENSOR] in [Diagnosis]. Does the display on the screen change, every time the sensing area of the SENSOR is blocked by putting a piece of paper?	Go to step 8.	Go to step 3.
3	Checking the HARNESS ASSY MAIN SENSOR connection Are P/J8326 and P/J8302B of the HARNESS ASSY MAIN SENSOR connected surely?	Go to step 5.	After reconnecting, go to step 4.
4	Execute [Test Print] in [Diagnosis]. Does the error still occur?	Go to step 5.	End of work.
5	Checking the HARNESS ASSY MAIN SENSOR for conductivity Disconnect P/J8326 of the HARNESS ASSY MAIN SENSOR, and P/J8302B on the PWB MAIN-C. Check for conductivity at the following: J8326-3 <=> J8302B-15 J8326-2 <=> J8302B-16 J8326-1 <=> J8302B-17	Go to step 6.	Replace the HARNESS ASSY MAIN SENSOR.
6	Checking +5 VDC power supply to the SENSOR (Stacker No Paper Sensor) Is the voltage across J8302B-17 <=> J8302B-15 on the PWB MAIN-C +5 VDC?	Go to step 7.	Replace the PWB MAIN-C. (RRP 12.98)

Step	Check	Yes	No
7	Checking the SENSOR (Stacker No Paper Sensor) for operation Does the voltage across P8302B-16 <=> P8302B-15 on the PWB MAIN-C change, every time the sensing area of the SENSOR is blocked by putting a piece of paper?	Replace the PWB MAIN-C. (RRP 12.98)	Replace the SENSOR (Stacker No Paper Sensor). (RRP 12.33)
8	Checking the COVER ASSY SENSOR (PL 12.6.13) (Stacker Height Sensor 1) for operation Execute [Input 13-50 Stack Height SENSOR 1] in [Diagnosis]. Does the display on the screen change, every time the sensing area of the SENSOR is blocked by putting a piece of paper?	Go to step 14.	Go to step 9.
9	Checking the HARNESS ASSY MAIN SENSOR connection Are P/J8331 and P/J8302B of the HARNESS ASSY MAIN SENSOR connected surely?	Go to step 11.	After reconnecting, go to step 10.
10	Execute [Test Print] in [Diagnosis]. Does the error still occur?	Go to step 11.	End of work.
11	Checking the HARNESS ASSY MAIN SENSOR for conductivity Disconnect P/J8331 of the HARNESS ASSY MAIN SENSOR, and P/J8302B on the PWB MAIN-C. Check for conductivity at the following: J8331-5 <=> J8302B-1 J8331-4 <=> J8302B-2 J8331-3 <=> J8302B-3 J8331-2 <=> J8302B-4 J8331-1 <=> J8302B-5	Go to step 12.	Replace the HARNESS ASSY MAIN SENSOR.
12	Checking +5 VDC power supply to the COVER ASSY SENSOR (Stacker Height Sensor 1) Is the voltage across J8302B-3 <=> J8302B-1 on the PWB MAIN-C +5 VDC?	Go to step 13.	Replace the PWB MAIN-C. (RRP 12.98)
13	Checking the COVER ASSY SENSOR (Stacker Height Sensor 1) for operation Does the voltage across P8302B-2 <=> P8302B-1 on the PWB MAIN-C change, every time the sensing area of the SENSOR is blocked by putting a piece of paper?	Replace the PWB MAIN-C. (RRP 12.98)	Replace the COVER ASSY SENSOR (Stacker Height Sensor 1). (RRP 12.30)
14	Checking the COVER ASSY SENSOR (PL 12.6.13) (Stacker Height Sensor 2) for operation Execute [Input 13-51 Stack Height SENSOR 2] in [Diagnosis]. Does the display on the screen change, every time the sensing area of the SENSOR is blocked by putting a piece of paper?	Go to step 20.	Go to step 15.
15	Checking the HARNESS ASSY MAIN SENSOR connection Are P/J8330 and P/J8302A of the HARNESS ASSY MAIN SENSOR connected surely?	Go to step 17.	After reconnecting, go to step 16.

Step	Check	Yes	No
16	Execute [Test Print] in [Diagnosis]. Does the error still occur?	Go to step 17.	End of work.
17	Checking the HARNESS ASSY MAIN SENSOR for conductivity Disconnect P/J8330 of the HARNESS ASSY MAIN SENSOR, and P/J8302A on the PWB MAIN-C. Check for conductivity at the following: J8330-5 <=> J8302A-16 J8330-4 <=> J8302A-17 J8330-3 <=> J8302A-18 J8330-2 <=> J8302A-19 J8330-1 <=> J8302A-20	Go to step 18.	Replace the HARNESS ASSY MAIN SENSOR.
18	Checking +5 VDC power supply to the COVER ASSY SENSOR (Stacker Height Sensor 2) Is the voltage across J8302A-18 <=> J8302A-16 on the PWB MAIN-C +5 VDC?	Go to step 19.	Replace the PWB MAIN-C. (RRP 12.98)
19	Checking the COVER ASSY SENSOR (Stacker Height Sensor 2) for operation Does the voltage across P8302A-17 <=> P8302A-16 on the PWB MAIN-C change, every time the sensing area of the SENSOR is blocked by putting a piece of paper?	Replace the PWB MAIN-C. (RRP 12.98)	Replace the COVER ASSY SENSOR (Stacker Height Sensor 2). (RRP 12.31)
20	Checking the SENSOR (Stacker Encode Sensor) for operation Execute [Input 13-49 Stack Encoder SENSOR] in [Diagnosis]. Does the display on the screen change when the BELT (PL 12.6.25) of the MOTOR ASSY-DC (PL 12.6.26) is moved by hand (when the ENCODER (PL 12.6.23) is rotated)?	Go to step 26.	Go to step 21.
21	Checking the HARNESS ASSY MAIN SENSOR connection Are P/J8328 and P/J8302B of HARNESS ASSY MAIN SENSOR connected surely?	Go to step 23.	After reconnecting, go to step 22.
22	Execute [Test Print] in [Diagnosis]. Does the error still occur?	Go to step 23.	End of work.
23	Checking the HARNESS ASSY MAIN SENSOR for conductivity Disconnect P/J8328 of the HARNESS ASSY MAIN SENSOR, and P/J8302B on the PWB MAIN-C. Check for conductivity at the following: J8328-3 <=> J8302B-12 J8328-2 <=> J8302B-13 J8328-1 <=> J8302B-14	Go to step 24.	Replace the HARNESS ASSY MAIN SENSOR.
24	Checking +5 VDC power supply to the SENSOR (Stacker Encode Sensor) Is the voltage across J8302B-14 <=> J8302B-12 on the PWB MAIN-C +5 VDC?	Go to step 25.	Replace the PWB MAIN-C. (RRP 12.98)

Step	Check	Yes	No
25	Checking the SENSOR (Stacker Encode Sensor) for operation Does the voltage across P8302B-13 and P8302B-12 of the PWB MAIN-C change, every time the detection point of the SENSOR is blocked or opened?	Replace the PWB MAIN-C. (RRP 12.98)	Replace the SENSOR (Stacker Encode Sensor). (RRP 12.32)
26	Checking the MOTOR ASSY DC (Elevator Motor) for operation Execute [Output 13-31 Stacker Motor UP ON/OFF] and [Output 13-32 Stacker Motor DOWN ON/OFF] in [Diagnosis] alternately. Does the MOTOR ASSY DC (Elevator Motor) rotate normally in Forward/reverse directions?	Replace the PWB MAIN-C. (RRP 12.98)	Go to step 27.
27	Checking the MOTOR ASSY DC (Elevator Motor) connection Is P/J8305 of the MOTOR ASSY DC (Elevator Motor) connected to the PWB MAIN-C surely?	Go to step 28.	After reconnecting, go to step 28.
28	Execute [Test Print] in [Diagnosis]. Does the error still occur?	Go to step 29.	End of work.
29	Checking after replacing the MOTOR ASSY DC (Elevator Motor) Replace the MOTOR ASSY DC (Elevator Motor). (RRP 12.35) Execute [Test Print] in [Diagnosis]. Does the error still occur?	Replace the PWB MAIN-C. (RRP 12.98)	End of work.

## H5-21 Front Tamper Home Sensor On Fail

Step	Check	Yes	No
	Possible causative parts: SENSOR (PL 12.10.2) TRAY ASSY-COMPILER (PL 12.10.1) HARNESS ASSY COMPILER (PL 12.10.8) PWB MAIN-C (PL 12.14.5) MOTOR ASSY 2 (PL 12.10.6)		
1	Checking the Tamper mechanism for operation Does the tamper mechanism operate smoothly? Check this item by moving it with your fingers.	Go to step 2.	Replace the TRAY ASSY-COMPILER. (RRP 12.57)
2	Checking the SENSOR (Front Tamper Home Sensor) for operation Execute [Input 13-39 Front Tamper Home SENSOR] in [Diagnosis]. Does the display on the screen change, every time a piece of white paper is inserted into the sensing area of the SENSOR?	Go to step 8.	Go to step 3.
3	Checking the HARNESS ASSY COMPILER connection Are P/J8360 and P/J8309 of the HARNESS ASSY COMPILER connected surely?	Go to step 5.	After reconnecting, go to step 4.

Step	Check	Yes	No
4	Execute [Test Print] in [Diagnosis]. Does the error still occur?	Go to step 5.	End of work.
5	Checking the HARNESS ASSY COMPILER for conductivity Disconnect P/J8360 of the HARNESS ASSY COMPILER, and P/J8309 on the PWB MAIN-C. Check for conductivity at the following: J8360-3 <=> J8309-4 J8360-2 <=> J8309-5 J8360-1 <=> J8309-6	Go to step 6.	Replace the HARNESS ASSY COMPILER.
6	Checking +5 VDC power supply to the SENSOR (Front Tamper Home Sensor) Is the voltage across J8309-6 <=> J8309-4 on the PWB MAIN-C +5 VDC?	Go to step 7.	Replace the PWB MAIN-C. (RRP 12.98)
7	Checking the SENSOR (Front Tamper Home Sensor) for operation Does the voltage across P8309-5 <=> P8309-4 on the PWB MAIN-C change, every time a piece of white paper is inserted into the sensing area of the SENSOR?	Replace the PWB MAIN-C. (RRP 12.98)	Replace the SENSOR (Front Tamper Home Sensor). (RRP 12.58)
8	Checking the MOTOR ASSY 2 (Front Tamper Motor) for operation Execute [Output 13-11 Front Tamper Mot Low FRONT ON/OFF] and [Output 13-14 Front Tamper Mot Low REAR ON/OFF] in [Diagnosis] alternately. Does the MOTOR ASSY 2 (Front Tamper Motor) rotate, and does the tamper move front and rear?	Replace the PWB MAIN-C. (RRP 12.98)	Go to step 9.
9	Checking the HARNESS ASSY COMPILER connection Are P/J8363 and P/J8309 of the HARNESS ASSY COMPILER connected surely?	Go to step 11.	After reconnecting, go to step 10.
10	Execute [Test Print] in [Diagnosis]. Does the error still occur?	Go to step 11.	End of work.
11	Checking the HARNESS ASSY COMPILER for conductivity Disconnect P/J8363 and P/J8309 of the HARNESS ASSY COMPILER. Check for conductivity at the following: J8363-6 <=> J8309-10 J8363-5 <=> J8309-11 J8363-4 <=> J8309-12 J8363-3 <=> J8309-13 J8363-2 <=> Non connection J8363-1 <=> J8309-14	Go to step 12.	Replace the HARNESS ASSY COMPILER.
12	Checking +24 VDC power supply to the MOTOR ASSY 2 (Front Tamper Motor) Is the voltage across J8309-11 <=> FRAME CHASSIS on the PWB MAIN-C +24 VDC?	Go to step 13.	Replace the PWB MAIN-C. (RRP 12.98)

Step	Check	Yes	No
13	<p>Checking after replacing the MOTOR ASSY 2 (Front Tamper Motor)</p> <p>Replace the MOTOR ASSY 2 (Front Tamper Motor). (RRP 12.60)</p> <p>Execute [Test Print] in [Diagnosis].</p> <p>Does the error still occur?</p>	<p>Replace the PWB MAIN-C. (RRP 12.98)</p>	<p>End of work.</p>

## H5-22 Rear Tamper Home Sensor On Fail

Step	Check	Yes	No
	<p>Possible causative parts:</p> <p>TRAY ASSY-COMPILER (PL 12.10.1)</p> <p>SENSOR (PL 12.10.2)</p> <p>HARNESS ASSY COMPILER (PL 12.10.8)</p> <p>PWB MAIN-C (PL 12.14.5)</p> <p>MOTOR ASSY (PL 12.10.7)</p>		
1	<p>Checking the Tamper mechanism for operation</p> <p>Does the tamper mechanism operate smoothly?</p> <p>Check this item by moving it with your fingers.</p>	<p>Go to step 2.</p>	<p>Replace the TRAY ASSY-COMPILER. (RRP 12.57)</p>
2	<p>Checking the SENSOR (Rear Tamper Home Sensor) for operation</p> <p>Execute [Input 13-40 Rear Tamper Home SENSOR] in [Diagnosis].</p> <p>Does the display on the screen change, every time a piece of white paper is inserted into the sensing area of the SENSOR?</p>	<p>Go to step 8.</p>	<p>Go to step 3.</p>
3	<p>Checking the HARNESS ASSY COMPILER connection</p> <p>Are P/J8361 and P/J8309 of the HARNESS ASSY COMPILER connected surely?</p>	<p>Go to step 5.</p>	<p>After reconnecting, go to step 4.</p>
4	<p>Execute [Test Print] in [Diagnosis].</p> <p>Does the error still occur?</p>	<p>Go to step 5.</p>	<p>End of work.</p>
5	<p>Checking the HARNESS ASSY COMPILER for conductivity</p> <p>Disconnect P/J8361 of the HARNESS ASSY COMPILER, and P/J8309 on the PWB MAIN-C.</p> <p>Check for conductivity at the following:</p> <p>J8361-3 &lt;=&gt; J8309-7</p> <p>J8361-2 &lt;=&gt; J8309-8</p> <p>J8361-1 &lt;=&gt; J8309-9</p>	<p>Go to step 6.</p>	<p>Replace the HARNESS ASSY COMPILER.</p>
6	<p>Checking +5 VDC power supply to the SENSOR (Rear Tamper Home Sensor)</p> <p>Is the voltage across J8309-9 &lt;=&gt; J8309-7 on the PWB MAIN-C +5 VDC?</p>	<p>Go to step 7.</p>	<p>Replace the PWB MAIN-C. (RRP 12.98)</p>

Step	Check	Yes	No
7	Checking the SENSOR (Rear Tamper Home Sensor) for operation Does the voltage across P8309-8 <=> P8309-7 on the PWB MAIN-C change, every time a piece of white paper is inserted into the sensing area of the SENSOR?	Replace the PWB MAIN-C. (RRP 12.98)	Replace the SENSOR (Rear Tamper Home Sensor). (RRP 12.58)
8	Checking the MOTOR ASSY (Rear Tamper Motor) for operation Execute [Output 13-17 Rear Tamper Mot Low FRONT ON/OFF] and [Output 13-20 Rear Tamper Mot Low REAR ON/OFF] in [Diagnosis] alternately. Does the MOTOR ASSY (Rear Tamper Motor) rotate, and does the tamper move front and rear?	Replace the PWB MAIN-C. (RRP 12.98)	Go to step 9.
9	Checking the HARNESS ASSY COMPILER connection Are P/J8362 and P/J8309 of the HARNESS ASSY COMPILER connected surely?	Go to step 11.	After reconnecting, go to step 10.
10	Execute [Test Print] in [Diagnosis]. Does the error still occur?	Go to step 11.	End of work.
11	Checking the HARNESS ASSY COMPILER for conductivity Disconnect P/J8362 and P/J8309 of the HARNESS ASSY COMPILER. Check for conductivity at the following: J8362-6 <=> J8309-15 J8362-5 <=> J8309-16 J8362-4 <=> J8309-17 J8362-3 <=> J8309-18 J8362-2 <=> Non connection J8362-1 <=> J8309-19	Go to step 12.	Replace the HARNESS ASSY COMPILER.
12	Checking +24 VDC power supply to the MOTOR ASSY (Rear Tamper Motor) Is the voltage across J8309-16 <=> FRAME CHASSIS on the PWB MAIN-C +24 VDC?	Go to step 13.	Replace the PWB MAIN-C. (RRP 12.98)
13	Checking after replacing the MOTOR ASSY (Rear Tamper Motor) Replace the MOTOR ASSY (Rear Tamper Motor). (RRP 12.61) Execute [Test Print] in [Diagnosis]. Does the error still occur?	Replace the PWB MAIN-C. (RRP 12.98)	End of work.

### H5-23 Front Tamper Home Sensor Off Fail

Step	Check	Yes	No
	Possible causative parts: TRAY ASSY-COMPILER (PL 12.10.1) SENSOR (PL 12.10.2) HARNESS ASSY COMPILER (PL 12.10.8) PWB MAIN-C (PL 12.14.5) MOTOR ASSY 2 (PL 12.10.6)		

Step	Check	Yes	No
1	Checking the Tamper mechanism for operation Does the tamper mechanism operate smoothly? Check this item by moving it with your fingers.	Go to step 2.	Replace the TRAY ASSY-COMPILE. (RRP 12.57)
2	Checking the SENSOR (Front Tamper Home Sensor) for operation Execute [Input 13-39 Front Tamper Home SENSOR] in [Diagnosis]. Does the display on the screen change, every time a piece of white paper is inserted into the sensing area of the SENSOR?	Go to step 8.	Go to step 3.
3	Checking the HARNESS ASSY COMPILER connection Are P/J8360 and P/J8309 of the HARNESS ASSY COMPILER connected surely?	Go to step 5.	After reconnecting, go to step 4.
4	Execute [Test Print] in [Diagnosis]. Does the error still occur?	Go to step 5.	End of work.
5	Checking the HARNESS ASSY COMPILER for conductivity Disconnect P/J8360 of the HARNESS ASSY COMPILER, and P/J8309 on the PWB MAIN-C. Check for conductivity at the following: J8360-3 <=> J8309-4 J8360-2 <=> J8309-5 J8360-1 <=> J8309-6	Go to step 6.	Replace the HARNESS ASSY COMPILER.
6	Checking +5 VDC power supply to the SENSOR (Front Tamper Home Sensor) Is the voltage across J8309-6 <=> J8309-4 on the PWB MAIN-C +5 VDC?	Go to step 7.	Replace the PWB MAIN-C. (RRP 12.98)
7	Checking the SENSOR (Front Tamper Home Sensor) for operation Does the voltage across P8309-5 <=> P8309-4 on the PWB MAIN-C change, every time a piece of white paper is inserted into the sensing area of the SENSOR?	Replace the PWB MAIN-C. (RRP 12.98)	Replace the SENSOR (Front Tamper Home Sensor). (RRP 12.58)
8	Checking the MOTOR ASSY 2 (Front Tamper Motor) for operation Execute [Output 13-11 Front Tamper Mot Low FRONT ON/OFF] and [Output 13-14 Front Tamper Mot Low REAR ON/OFF] in [Diagnosis] alternately. Does the MOTOR ASSY 2 (Front Tamper Motor) rotate, and does the tamper move front and rear?	Replace the PWB MAIN-C. (RRP 12.98)	Go to step 9.
9	Checking the HARNESS ASSY COMPILER connection Are P/J8363 and P/J8309 of the HARNESS ASSY COMPILER connected surely?	Go to step 11.	After reconnecting, go to step 10.
10	Execute [Test Print] in [Diagnosis]. Does the error still occur?	Go to step 11.	End of work.



Step	Check	Yes	No
11	<p>Checking the HARNESS ASSY COMPILER for conductivity</p> <p>Disconnect P/J8363 and P/J8309 of the HARNESS ASSY COMPILER.</p> <p>Check for conductivity at the following:</p> <p>J8363-6 &lt;=&gt; J8309-10</p> <p>J8363-5 &lt;=&gt; J8309-11</p> <p>J8363-4 &lt;=&gt; J8309-12</p> <p>J8363-3 &lt;=&gt; J8309-13</p> <p>J8363-2 &lt;=&gt; Non connection</p> <p>J8363-1 &lt;=&gt; J8309-14</p>	Go to step 12.	Replace the HARNESS ASSY COMPILER.
12	<p>Checking +24 VDC power supply to the MOTOR ASSY 2 (Front Tamper Motor)</p> <p>Is the voltage across J8309-11 &lt;=&gt; FRAME CHASSIS on the PWB MAIN-C +24 VDC?</p>	Go to step 13.	Replace the PWB MAIN-C. (RRP 12.98)
13	<p>Checking after replacing the MOTOR ASSY 2 (Front Tamper Motor)</p> <p>Replace the MOTOR ASSY 2 (Front Tamper Motor). (RRP 12.60)</p> <p>Execute [Test Print] in [Diagnosis].</p> <p>Does the error still occur?</p>	Replace the PWB MAIN-C. (RRP 12.98)	End of work.

## H5-24 Rear Tamper Home Sensor Off Fail

Step	Check	Yes	No
	<p>Possible causative parts:</p> <p>TRAY ASSY-COMPILER (PL 12.10.1)</p> <p>SENSOR (PL 12.10.2)</p> <p>HARNESS ASSY COMPILER (PL 12.10.8)</p> <p>PWB MAIN-C (PL 12.14.5)</p> <p>MOTOR ASSY (PL 12.10.7)</p>		
1	<p>Checking the Tamper mechanism for operation</p> <p>Does the tamper mechanism operate smoothly?</p> <p>Check this item by moving it with your fingers.</p>	Go to step 2.	Replace the TRAY ASSY-COMPILER. (RRP 12.57)
2	<p>Checking the SENSOR (Rear Tamper Home Sensor) for operation</p> <p>Execute [Input 13-40 Rear Tamper Home SENSOR] in [Diagnosis].</p> <p>Does the display on the screen change, every time a piece of white paper is inserted into the sensing area of the SENSOR?</p>	Go to step 8.	Go to step 3.
3	<p>Checking the HARNESS ASSY COMPILER connection</p> <p>Are P/J8361 and P/J8309 of the HARNESS ASSY COMPILER connected surely?</p>	Go to step 5.	After reconnecting, go to step 4.
4	<p>Execute [Test Print] in [Diagnosis].</p> <p>Does the error still occur?</p>	Go to step 5.	End of work.

Step	Check	Yes	No
5	Checking the HARNESS ASSY COMPILER for conductivity Disconnect P/J8361 of the HARNESS ASSY COMPILER, and P/J8309 on the PWB MAIN-C. Check for conductivity at the following: J8361-3 <=> J8309-7 J8361-2 <=> J8309-8 J8361-1 <=> J8309-9	Go to step 6.	Replace the HARNESS ASSY COMPILER.
6	Checking +5 VDC power supply to the SENSOR (Rear Tamper Home Sensor) Is the voltage across J8309-9 <=> J8309-7 on the PWB MAIN-C +5 VDC?	Go to step 7.	Replace the PWB MAIN-C. (RRP 12.98)
7	Checking the SENSOR (Rear Tamper Home Sensor) for operation Does the voltage across P8309-8 <=> P8309-7 on the PWB MAIN-C change, every time a piece of white paper is inserted into the sensing area of the SENSOR?	Replace the PWB MAIN-C. (RRP 12.98)	Replace the SENSOR (Rear Tamper Home Sensor). (RRP 12.58)
8	Checking the MOTOR ASSY (Rear Tamper Motor) for operation Execute [Output 13-17 Rear Tamper Mot Low FRONT ON/OFF] and [Output 13-20 Rear Tamper Mot Low REAR ON/OFF] in [Diagnosis] alternately. Does the MOTOR ASSY (Rear Tamper Motor) rotate, and does the tamper move front and rear?	Replace the PWB MAIN-C. (RRP 12.98)	Go to step 9.
9	Checking the HARNESS ASSY COMPILER connection Are P/J8362 and P/J8309 of the HARNESS ASSY COMPILER connected surely?	Go to step 11.	After reconnecting, go to step 10.
10	Execute [Test Print] in [Diagnosis]. Does the error still occur?	Go to step 11.	End of work.
11	Checking the HARNESS ASSY COMPILER for conductivity Disconnect P/J8362 and P/J8309 of the HARNESS ASSY COMPILER. Check for conductivity at the following: J8362-6 <=> J8309-15 J8362-5 <=> J8309-16 J8362-4 <=> J8309-17 J8362-3 <=> J8309-18 J8362-2 <=> Non connection J8362-1 <=> J8309-19	Go to step 12.	Replace the HARNESS ASSY COMPILER.
12	Checking +24 VDC power supply to the MOTOR ASSY (Rear Tamper Motor) Is the voltage across J8309-16 <=> FRAME CHASSIS on the PWB MAIN-C +24 VDC?	Go to step 13.	Replace the PWB MAIN-C. (RRP 12.98)
13	Checking after replacing the MOTOR ASSY (Rear Tamper Motor) Replace the MOTOR ASSY (Rear Tamper Motor). (RRP 12.61) Execute [Test Print] in [Diagnosis]. Does the error still occur?	Replace the PWB MAIN-C. (RRP 12.98)	End of work.

## H5-31 Puncher Sensor On Fail

Step	Check	Yes	No
	Possible causative parts: SENSOR (PL 12.7.15) HARNESS ASSY PUNCH UNIT (PL 12.7.2) HARNESS ASSY PUNCH SENSOR (PL 12.15.9) PWB MAIN-C (PL 12.14.5) MOTOR ASSY (PL 12.7.12) HARNESS ASSY PUNCH DRIVE (PL 12.15.8)		
1	Checking the Puncher for operation Does the puncher move smoothly? Check this item by moving it with your fingers.	Go to step 2.	Remove obstacles.
2	Checking the SENSOR (Puncher Home Sensor) for operation Execute [Input 13-34 Puncher Home SENSOR] in [Diagnosis]. Does the display on the screen change, every time a piece of white paper is inserted into the sensing area of the SENSOR?	Go to step 9.	Go to step 3.
3	Checking the HARNESS ASSY PUNCH UNIT and HARNESS ASSY PUNCH SENSOR connection Are P/J8348 and P/J8333 of the HARNESS ASSY PUNCH UNIT, and P/J8333 and P/J8307 of the HARNESS ASSY PUNCH SENSOR connected surely?	Go to step 5.	After reconnecting, go to step 4.
4	Execute [Test Print] in [Diagnosis]. Does the error still occur?	Go to step 5.	End of work.
5	Checking the HARNESS ASSY PUNCH UNIT for conductivity Disconnect P/J8348 and P/J8333 of the HARNESS ASSY PUNCH UNIT. Check for conductivity at the following: J8348-3 <=> P8333-7 J8348-2 <=> P8333-8 J8348-1 <=> P8333-9	Go to step 6.	Replace the HARNESS ASSY PUNCH UNIT.
6	Checking the HARNESS ASSY PUNCH SENSOR for conductivity Disconnect P/J8333 and P/J8307 of the HARNESS ASSY PUNCH SENSOR. Check for conductivity at the following: J8333-7 <=> J8307-B6 J8333-8 <=> J8307-B5 J8333-9 <=> J8307-B4	Go to step 7.	Replace the HARNESS ASSY PUNCH SENSOR.
7	Checking +5 VDC power supply to the SENSOR (Puncher Home Sensor) Is the voltage across J8307-B6 <=> J8307-B5 on the PWB MAIN-C +5 VDC?	Go to step 8.	Replace the PWB MAIN-C. (RRP 12.98)

Step	Check	Yes	No
8	Checking the SENSOR (Puncher Home Sensor) for operation Does the voltage across P8307-B4 <=> P8307-B5 on the PWB MAIN-C change, every time a piece of white paper is inserted into the sensing area of the SENSOR?	Replace the PWB MAIN-C. (RRP 12.98)	Replace the SENSOR (Puncher Home Sensor). (RRP 12.43)
9	Checking the MOTOR ASSY (Puncher Motor) for operation Execute [Output 13-XX Puncher Mot XX Hole Home Move] in [Diagnosis]. (Where XX varies depending on the number of punch holes) (2 holes: 13-05, 3 Holes: 13-06 and 4 Holes: 13-07) Does the MOTOR ASSY (Puncher Motor) rotate?	Replace the PWB MAIN-C. (RRP 12.98)	Go to step 10.
10	Checking the HARNESS ASSY PUNCH UNIT and HARNESS ASSY PUNCH DRIVE connection Are P/J8345 and P/J8332 of the HARNESS ASSY PUNCH UNIT, and P/J83325 and P/J8306 of the HARNESS ASSY PUNCH DRIVE connected surely?	Go to step 12.	After reconnecting, go to step 11.
11	Execute [Test Print] in [Diagnosis]. Does the error still occur?	Go to step 12.	End of work.
12	Checking the HARNESS ASSY PUNCH UNIT for conductivity Disconnect P/J8345 and P/J8332 of the HARNESS ASSY PUNCH UNIT. Check for conductivity at the following: J8345-2 <=> P8332-2 J8345-1 <=> P8332-1	Go to step 13.	Replace the HARNESS ASSY PUNCH UNIT.
13	Checking the HARNESS ASSY PUNCH DRIVE for conductivity Disconnect P/J8332 and P/J8306 of the HARNESS ASSY PUNCH DRIVE. Check for conductivity at the following: J8332-2 <=> J8306-8 J8332-1 <=> J8306-4	Go to step 14.	Replace the HARNESS ASSY PUNCH DRIVE.
14	Checking after replacing the MOTOR ASSY (Puncher Motor) Replace the MOTOR ASSY (Puncher Motor). (RRP 12.41) Execute [Test Print] in [Diagnosis]. Does the error still occur?	Replace the PWB MAIN-C. (RRP 12.98)	End of work.

## H5-32 Puncher Sensor Off Fail

Step	Check	Yes	No
	Possible causative parts: SENSOR (PL 12.7.15) HARNESS ASSY PUNCH UNIT (PL 12.7.2) HARNESS ASSY PUNCH SENSOR (PL 12.15.9) PWB MAIN-C (PL 12.14.5) MOTOR ASSY (PL 12.7.12) HARNESS ASSY PUNCH DRIVE (PL 12.15.8)		
1	Checking the Puncher for operation Does the puncher move smoothly? Check this item by moving it with your fingers.	Go to step 2.	Remove obstacles.
2	Checking the SENSOR (Puncher Home Sensor) for operation Execute [Input 13-34 Puncher Home SENSOR] in [Diagnosis]. Does the display on the screen change, every time a piece of white paper is inserted into the sensing area of the SENSOR?	Go to step 9.	Go to step 3.
3	Checking the HARNESS ASSY PUNCH UNIT and HARNESS ASSY PUNCH SENSOR connection Are P/J8348 and P/J8333 of the HARNESS ASSY PUNCH UNIT, and P/J8333 and P/J8307 of the HARNESS ASSY PUNCH SENSOR connected surely?	Go to step 5.	After reconnecting, go to step 4.
4	Execute [Test Print] in [Diagnosis]. Does the error still occur?	Go to step 5.	End of work.
5	Checking the HARNESS ASSY PUNCH UNIT for conductivity Disconnect P/J8348 and P/J8333 of the HARNESS ASSY PUNCH UNIT. Check for conductivity at the following: J8348-3 <=> P8333-7 J8348-2 <=> P8333-8 J8348-1 <=> P8333-9	Go to step 6.	Replace the HARNESS ASSY PUNCH UNIT.
6	Checking the HARNESS ASSY PUNCH SENSOR for conductivity Disconnect P/J8333 and P/J8307 of the HARNESS ASSY PUNCH SENSOR. Check for conductivity at the following: J8333-7 <=> J8307-B6 J8333-8 <=> J8307-B5 J8333-9 <=> J8307-B4	Go to step 7.	Replace the HARNESS ASSY PUNCH SENSOR.
7	Checking +5 VDC power supply to the SENSOR (Puncher Home Sensor) Is the voltage across J8307-B6 <=> J8307-B5 on the PWB MAIN-C +5 VDC?	Go to step 8.	Replace the PWB MAIN-C. (RRP 12.98)

Step	Check	Yes	No
8	Checking the SENSOR (Puncher Home Sensor) for operation Does the voltage across P8307-B4 <=> P8307-B on the PWB MAIN-C change, every time a piece of white paper is inserted into the sensing area of the SENSOR?	Replace the PWB MAIN-C. (RRP 12.98)	Replace the SENSOR (Puncher Home Sensor). (RRP 12.43)
9	Checking the MOTOR ASSY (Puncher Motor) for operation Execute [Output 13-XX Puncher Mot XX Hole Home Move] in [Diagnosis]. (Where XX varies depending on the number of punch holes) (2 holes: 13-05, 3 Holes: 13-06 and 4 Holes: 13-07) Does the MOTOR ASSY (Puncher Motor) rotate?	Replace the PWB MAIN-C. (RRP 12.98)	Go to step 10.
10	Checking the HARNESS ASSY PUNCH UNIT and HARNESS ASSY PUNCH DRIVE connection Are P/J8345 and P/J8332 of the HARNESS ASSY PUNCH UNIT, and P/J8332 and P/J8306 of the HARNESS ASSY PUNCH DRIVE connected surely?	Go to step 12.	After reconnecting, go to step 11.
11	Execute [Test Print] in [Diagnosis]. Does the error still occur?	Go to step 12.	End of work.
12	Checking the HARNESS ASSY PUNCH UNIT for conductivity Disconnect P/J8345 and P/J8332 of the HARNESS ASSY PUNCH UNIT. Check for conductivity at the following: J8345-2 <=> P8332-2 J8345-1 <=> P8332-1	Go to step 13.	Replace the HARNESS ASSY PUNCH UNIT.
13	Checking the HARNESS ASSY PUNCH DRIVE for conductivity Disconnect P/J8332 and P/J8306 of the HARNESS ASSY PUNCH DRIVE. Check for conductivity at the following: J8332-2 <=> J8306-8 J8332-1 <=> J8306-4	Go to step 14.	Replace the HARNESS ASSY PUNCH DRIVE.
14	Checking after replacing the MOTOR ASSY (Puncher Motor) Replace the MOTOR ASSY (Puncher Motor). (RRP 12.41) Execute [Test Print] in [Diagnosis]. Does the error still occur?	Replace the PWB MAIN-C. (RRP 12.98)	End of work.

## H5-33 Puncher Move Home Sensor On Fail

Step	Check	Yes	No
	Possible causative parts: SENSOR (PL 12.7.17) HARNESS ASSY PUNCH SENSOR (PL 12.15.9) PWB MAIN-C (PL 12.14.5) BRACKET ASSY-MOTOR, PUNCH (PL 12.7.4) HARNESS ASSY PUNCH DRIVE (PL 12.15.8) PWBA MCU F (PL 8.1.5)		
1	Checking the Puncher for operation Does the puncher move front and rear smoothly? Check this item by moving it with your fingers.	Go to step 2.	Remove obstacles.
2	Checking the SENSOR (Puncher Move Home Sensor) for operation Execute [Input 13-33 Puncher Move Home SENSOR] in [Diagnosis]. Does the display on the screen change, every time a piece of white paper is inserted into the sensing area of the SENSOR?	Go to step 8.	Go to step 3.
3	Checking the HARNESS ASSY PUNCH SENSORE connection Are P/J8352 and P/J8307 of the HARNESS ASSY PUNCH SENSOR connected surely?	Go to step 5.	After reconnecting, go to step 4.
4	Execute [Test Print] in [Diagnosis]. Does the error still occur?	Go to step 5.	End of work.
5	Checking the HARNESS ASSY PUNCH SENSOR for conductivity Disconnect P/J8352 and P/J8307 of the HARNESS ASSY PUNCH SENSOR. Check for conductivity at the following: J8352-3 <=> J8307-A6 J8352-2 <=> J8307-A5 J8352-1 <=> J8307-A4	Go to step 6.	Replace the HARNESS ASSY PUNCH SENSOR.
6	Checking +5 VDC power supply to the SENSOR (Puncher Move Home Sensor) Is the voltage across J8307-A4 <=> J8307-A6 on the PWB MAIN-C +5 VDC?	Go to step 7.	Replace the PWB MAIN-C. (RRP 12.98)
7	Checking the SENSOR (Puncher Move Home Sensor) for operation Does the voltage across P8307-A5 <=> P8307-A6 on the PWB MAIN-C change, every time a piece of white paper is inserted into the sensing area of the SENSOR?	Replace the PWB MAIN-C. (RRP 12.98)	Replace the SENSOR (Puncher Move Home Sensor). (RRP 12.44)
8	Checking the Bracket Assembly-Motor, Punch (Puncher Move Motor) for operation Execute [Output 13-01 Puncher Move Motor Low Front ON/OFF] and [Output 13-03 Puncher Move Motor Low Rear ON/OFF] in [Diagnosis]. Does the Bracket Assembly-Motor, Punch (Puncher Move Motor) rotate, and does the Holder-Frame Assembly move front and rear?	Replace the PWB MAIN-C. (RRP 12.98)	Go to step 9.

Step	Check	Yes	No
9	Checking the HARNESS ASSY PUNCH DRIVE connection Are P/J8344 and P/J8306 of the HARNESS ASSY PUNCH DRIVE connected surely?	Go to step 11.	After reconnecting, go to step 10.
10	Execute [Test Print] in [Diagnosis]. Does the error still occur?	Go to step 11.	End of work.
11	Checking the HARNESS ASSY PUNCH DRIVE for conductivity Disconnect P/J8344 and P/J8306 of the HARNESS ASSY PUNCH DRIVE. Check for conductivity at the following: J8344-1 <=> J8306-7 J8344-2 <=> J8306-3 J8344-3 <=> J8306-6 J8344-4 <=> J8306-5 J8344-5 <=> J8306-2 J8344-6 <=> J8306-1	Go to step 12.	Replace the HARNESS ASSY PUNCH DRIVE.
12	Checking after replacing the Bracket Assembly-Motor, Punch (Puncher Move Motor) Replace the Bracket Assembly-Motor, Punch (Puncher Move Motor). (RRP 12.37) Execute [Test Print] in [Diagnosis]. Does the error still occur?	Go to step 13.	End of work.
13	Checking after replacing the PWB MAIN-C Replace the PWB MAIN-C. (RRP 12.98) Does the error still occur when the power is turned ON?	Replace the PWBA MCU F. (RRP 8.4)	End of work.

### H5-34 Puncher Move Home Sensor OFF Fail

Step	Check	Yes	No
	Possible causative parts: SENSOR (PL 12.7.17) HARNESS ASSY PUNCH SENSOR (PL 12.15.9) PWB MAIN-C (PL 12.14.5) Bracket Assembly-Motor, Punch (PL 12.7.4) HARNESS ASSY PUNCH DRIVE (PL 12.15.8) PWBA MCU F (PL 8.1.5)		
1	Checking the Puncher for operation Does the puncher move front and rear smoothly? Check this item by moving it with your fingers.	Go to step 2.	Remove obstacles.
2	Checking the SENSOR (Puncher Move Home Sensor) for operation Execute [Input 13-33 Puncher Move Home SENSOR] in [Diagnosis]. Does the display on the screen change, every time a piece of white paper is inserted into the sensing area of the SENSOR?	Go to step 8.	Go to step 3.



Step	Check	Yes	No
3	Checking the HARNESS ASSY PUNCH SENSOR connection Are P/J8352 and P/J8307 of the HARNESS ASSY PUNCH SENSOR connected surely?	Go to step 5.	After reconnecting, go to step 4.
4	Execute [Test Print] in [Diagnosis]. Does the error still occur?	Go to step 5.	End of work.
5	Checking the HARNESS ASSY PUNCH SENSOR for conductivity Disconnect P/J8352 and P/J8307 of the HARNESS ASSY PUNCH SENSOR. Check for conductivity at the following: J8352-3 <=> J8307-A6 J8352-2 <=> J8307-A5 J8352-1 <=> J8307-A4	Go to step 6.	Replace the HARNESS ASSY PUNCH SENSOR.
6	Checking +5 VDC power supply to the SENSOR (Puncher Move Home Sensor) Is the voltage across J8307-A4 <=> J8307-A6 on the PWB MAIN-C +5 VDC?	Go to step 7.	Replace the PWB MAIN-C. (RRP 12.98)
7	Checking the SENSOR (Puncher Move Home Sensor) for operation Does the voltage across P8307-A5 <=> P8307-A6 on the PWB MAIN-C change, every time a piece of white paper is inserted into the sensing area of the SENSOR?	Replace the PWB MAIN-C. (RRP 12.98)	Replace the SENSOR (Puncher Move Home Sensor). (RRP 12.44)
8	Checking the Bracket Assembly-Motor, Punch (Puncher Move Motor) for operation Execute [Output 13-01 Puncher Move Motor Low Front ON/OFF] and [Output 13-03 Puncher Move Motor Low Rear ON/OFF] in [Diagnosis]. Does the Bracket Assembly-Motor, Punch (Puncher Move Motor) rotate, and does the Holder-Frame Assembly move front and rear?	Replace the PWB MAIN-C. (RRP 12.98)	Go to step 9.
9	Checking the HARNESS ASSY PUNCH DRIVE connection Are P/J8352 and P/J8306 of the HARNESS ASSY PUNCH DRIVE connected surely?	Go to step 11.	After reconnecting, go to step 10.
10	Execute [Test Print] in [Diagnosis]. Does the error still occur?	Go to step 11.	End of work.
11	Checking the HARNESS ASSY PUNCH DRIVE for conductivity Disconnect P/J8344 and P/J8306 of the HARNESS ASSY PUNCH DRIVE. Check for conductivity at the following: J8344-1 <=> J8306-7 J8344-2 <=> J8306-3 J8344-3 <=> J8306-6 J8344-4 <=> J8306-5 J8344-5 <=> J8306-2 J8344-6 <=> J8306-1	Go to step 12.	Replace the HARNESS ASSY PUNCH DRIVE.

Step	Check	Yes	No
12	Checking after replacing the Bracket Assembly-Motor, Punch (Puncher Move Motor) Replace the Bracket Assembly-Motor, Punch (Puncher Move Motor). (RRP 12.37) Execute [Test Print] in [Diagnosis]. Does the error still occur?	Go to step 13.	End of work.
13	Checking after replacing the PWB MAIN-C Replace the PWB MAIN-C. (RRP 12.98) Does the error still occur when the power is turned ON?	Replace the PWBA MCU F. (RRP 8.4)	End of work.

## H5-81 Eject Clamp Home Sensor On Fail

Step	Check	Yes	No
	Possible causative parts: SENSOR (PL 12.9.13) HARNESS ASSY MAIN SENSOR (PL 12.15.1) PWB MAIN-C (PL 12.14.5) MOTOR ASSY-DC (PL 12.9.11) HARNESS ASSY MAIN DRIVE (PL 12.15.2)		
1	Checking the Eject clamp for operation Does the eject clamp mechanism move smoothly? Check this item by moving it with your fingers.	Go to step 2.	Remove obstacles.
2	Checking the SENSOR (Eject Clamp Home Sensor) for operation Execute [Input 12-38 Eject Clamp Home SENSOR] in [Diagnosis]. Does the display on the screen change, every time a piece of white paper is inserted into the sensing area of the SENSOR?	Go to step 8.	Go to step 3.
3	Checking the HARNESS ASSY MAIN SENSOR connection Are P/J8324 and P/J8302B of the HARNESS ASSY MAIN SENSOR connected surely?	Go to step 5.	After reconnecting, go to step 4.
4	Execute [Test Print] in [Diagnosis]. Does the error still occur?	Go to step 5.	End of work.
5	Checking the HARNESS ASSY MAIN SENSOR for conductivity Disconnect P/J8324 and P/J8302B of the HARNESS ASSY MAIN SENSOR. Check for conductivity at the following: J8324-3 <=> P8302B-6 J8324-2 <=> P8302B-7 J8324-1 <=> P8302B-8	Go to step 6.	Replace the HARNESS ASSY MAIN SENSOR.
6	Checking +5 VDC power supply to the SENSOR (Eject Clamp Home Sensor) Is the voltage across J8302B-8 <=> J8302B-6 on the PWB MAIN-C +5 VDC?	Go to step 7.	Replace the PWB MAIN-C. (RRP 12.98)

Step	Check	Yes	No
7	Checking the SENSOR (Eject Clamp Home Sensor) for operation Does the voltage across P8302B-7 <=> P8302B-6 on the PWB MAIN-C change, every time a piece of white paper is inserted into the sensing area of the SENSOR?	Replace the PWB MAIN-C. (RRP 12.98)	Replace the SENSOR (Eject Clamp Home Sensor). (RRP 12.55)
8	Checking the MOTOR ASSY-DC (Eject Clamp Motor) for operation Execute [Output 12-18 Eject Clamp Motor UP ON/OFF] and [Output 12-19 Eject Clamp Motor DOWN ON/OFF] in [Diagnosis]. Does the MOTOR ASSY-DC (Eject Clamp Motor) rotate normally?	Replace the PWB MAIN-C. (RRP 12.98)	Go to step 9.
9	Checking the HARNESS ASSY MAIN DRIVE connection Are P/J8339 and P/J8304B of the HARNESS ASSY MAIN DRIVE connected surely?	Go to step 11.	After reconnecting, go to step 10.
10	Execute [Test Print] in [Diagnosis]. Does the error still occur?	Go to step 11.	End of work.
11	Checking the HARNESS ASSY MAIN DRIVE for conductivity Disconnect P/J8339 and P/J8304 of the HARNESS ASSY MAIN DRIVE. Check for conductivity at the following: J8339-1 <=> J8304-33 J8339-2 <=> J8304-31	Go to step 12.	Replace the HARNESS ASSY MAIN DRIVE.
12	Checking after replacing the MOTOR ASSY-DC (Eject Clamp Motor) Replace the MOTOR ASSY-DC (Eject Clamp Motor). (RRP 12.54) Execute [Test Print] in [Diagnosis]. Does the error still occur?	Replace the PWB MAIN-C. (RRP 12.98)	End of work.

## H5-82 Eject Clamp Home Sensor Off Fail

Step	Check	Yes	No
	Possible causative parts: SENSOR (PL 12.9.13) HARNESS ASSY MAIN SENSOR (PL 12.15.1) PWB MAIN-C (PL 12.14.5) MOTOR ASSY-DC (PL 12.9.11) HARNESS ASSY MAIN DRIVE (PL 12.15.2)		
1	Checking the Eject clamp block for operation Does the eject clamp mechanism move smoothly? Check this item by moving it with your fingers.	Go to step 2.	Remove obstacles.

Step	Check	Yes	No
2	Checking the SENSOR (Eject Clamp Home Sensor) for operation Execute [Input 12-38 Eject Clamp Home SENSOR] in [Diagnosis]. Does the display on the screen change, every time a piece of white paper is inserted into the sensing area of the SENSOR?	Go to step 8.	Go to step 3.
3	Checking the HARNESS ASSY MAIN SENSOR connection Are P/J8324 and P/J8302B of the HARNESS ASSY MAIN SENSOR connected surely?	Go to step 5.	After reconnecting, go to step 4.
4	Execute [Test Print] in [Diagnosis]. Does the error still occur?	Go to step 5.	End of work.
5	Checking the HARNESS ASSY MAIN SENSOR for conductivity Disconnect P/J8324 and P/J8302B of the HARNESS ASSY MAIN SENSOR. Check for conductivity at the following: J8324-3 <=> P8302B-6 J8324-2 <=> P8302B-7 J8324-1 <=> P8302B-8	Go to step 6.	Replace the HARNESS ASSY MAIN SENSOR.
6	Checking +5 VDC power supply to the SENSOR (Eject Clamp Home Sensor) Is the voltage across J8302B-8 <=> J8302B-6 on the PWB MAIN-C +5 VDC?	Go to step 7.	Replace the PWB MAIN-C. (RRP 12.98)
7	Checking the SENSOR (Eject Clamp Home Sensor) for operation Does the voltage across P8302B-7 <=> P8302B-6 on the PWB MAIN-C change, every time a piece of white paper is inserted into the sensing area of the SENSOR?	Replace the PWB MAIN-C. (RRP 12.98)	Replace the SENSOR (Eject Clamp Home Sensor). (RRP 12.55)
8	Checking the MOTOR ASSY-DC (Eject Clamp Motor) for operation Execute [Output 12-18 Eject Clamp Motor UP ON/OFF] and [Output 12-19 Eject Clamp Motor DOWN ON/OFF] in [Diagnosis]. Does the MOTOR ASSY-DC (Eject Clamp Motor) rotate normally?	Replace the PWB MAIN-C. (RRP 12.98)	Go to step 9.
9	Checking the HARNESS ASSY MAIN DRIVE connection Are P/J8339 and P/J8304 of the HARNESS ASSY MAIN DRIVE connected surely?	Go to step 11.	After reconnecting, go to step 10.
10	Execute [Test Print] in [Diagnosis]. Does the error still occur?	Go to step 11.	End of work.
11	Checking the HARNESS ASSY MAIN DRIVE for conductivity Disconnect P/J8339 and P/J8304 of the HARNESS ASSY MAIN DRIVE. Check for conductivity at the following: J8339-1 <=> J8304-33 J8339-2 <=> J8304-31	Go to step 12.	Replace the HARNESS ASSY MAIN DRIVE.

Step	Check	Yes	No
12	<p>Checking after replacing the MOTOR ASSY-DC (Eject Clamp Motor)</p> <p>Replace the MOTOR ASSY-DC (Eject Clamp Motor). (RRP 12.54)</p> <p>Execute [Test Print] in [Diagnosis].</p> <p>Does the error still occur?</p>	<p>Replace the PWB MAIN-C. (RRP 12.98)</p>	<p>End of work.</p>

### H5-83 Set Clamp Home Sensor On Fail

Step	Check	Yes	No
	<p>Possible causative parts:</p> <p>SENSOR (PL 12.10.18)</p> <p>HARNESS ASSY MAIN SENSOR (PL 12.15.1)</p> <p>PWB MAIN-C (PL 12.14.5)</p> <p>BRACKET ASSY-EJECT (PL 12.10.17)</p> <p>HARNESS ASSY MAIN DRIVE (PL 12.15.2)</p> <p>CLUTCH Z34 (PL 12.10.15)</p>		
1	<p>Checking the Eject clamp block for operation</p> <p>Does the eject clamp mechanism move smoothly?</p> <p>Check this item by moving it with your fingers.</p>	<p>Go to step 2.</p>	<p>Remove obstacles.</p>
2	<p>Checking the SENSOR (Set Clamp Home Sensor) for operation</p> <p>Execute [Input 12-39 Set Clamp Home SENSOR] in [Diagnosis].</p> <p>Does the display on the screen change, every time a piece of white paper is inserted into the sensing area of the SENSOR?</p>	<p>Go to step 8.</p>	<p>Go to step 3.</p>
3	<p>Checking the HARNESS ASSY MAIN SENSOR connection</p> <p>Are P/J8325 and P/J8302B of the HARNESS ASSY MAIN SENSOR connected surely?</p>	<p>Go to step 5.</p>	<p>After reconnecting, go to step 4.</p>
4	<p>Execute [Test Print] in [Diagnosis].</p> <p>Does the error still occur?</p>	<p>Go to step 5.</p>	<p>End of work.</p>
5	<p>Checking the HARNESS ASSY MAIN SENSOR for conductivity</p> <p>Disconnect P/J8325 and P/J8302B of the HARNESS ASSY MAIN SENSOR.</p> <p>Check for conductivity at the following:</p> <p>J8325-3 &lt;=&gt; P8302B-9</p> <p>J8325-2 &lt;=&gt; P8302B-10</p> <p>J8325-1 &lt;=&gt; P8302B-11</p>	<p>Go to step 6.</p>	<p>Replace the HARNESS ASSY MAIN SENSOR.</p>
6	<p>Checking +5 VDC power supply to the SENSOR (Set Clamp Home Sensor)</p> <p>Is the voltage across J8302B-11 &lt;=&gt; J8302B-94 on the PWB MAIN-C +5 VDC?</p>	<p>Go to step 7.</p>	<p>Replace the PWB MAIN-C. (RRP 12.98)</p>

Step	Check	Yes	No
7	Checking the SENSOR (Set Clamp Home Sensor) for operation Does the voltage across P8302B-10 <=> P8302B-9 on the PWB MAIN-C change, every time a piece of white paper is inserted into the sensing area of the SENSOR?	Replace the PWB MAIN-C. (RRP 12.98)	Replace the SENSOR (Set Clamp Home Sensor). (RRP 12.66)
8	Checking the BRACKET ASSY-EJECT (Eject Motor) for operation Execute [Output 12-20 Eject Motor Low FORWARD ON/OFF] and [Output 12-22 Eject Motor Low REVERSE ON/OFF] in [Diagnosis] alternately. Does the BRACKET ASSY-EJECT (Eject Motor) rotate normally in Forward/Reverse directions alternately?	Go to step 15.	Go to step 9.
9	Checking the HARNESS ASSY MAIN DRIVE connection Are P/J8336 and P/J8304 of the HARNESS ASSY MAIN DRIVE connected surely?	Go to step 11.	After reconnecting, go to step 10.
10	Execute [Test Print] in [Diagnosis]. Does the error still occur?	Go to step 11.	End of work.
11	Checking the HARNESS ASSY MAIN DRIVE for conductivity Disconnect P/J8336 and P/J8304 of the HARNESS ASSY MAIN DRIVE. Check for conductivity at the following: J8336-1 <=> J8304-15 J8336-2 <=> J8304-12 J8336-3 <=> J8304-17 J8336-4 <=> J8304-19 J8336-5 <=> J8304-14 J8336-6 <=> J8304-21	Go to step 12.	Replace the HARNESS ASSY MAIN DRIVE.
12	Checking the resistance of the MOTOR ASSY Are there any resistances without disconnection across P8336-2/5(COM) and P8336-1/3/4/6 of the MOTOR ASSY?	Go to step 13.	Replace the BRACKET ASSY-EJECT. (RRP 12.65)
13	Checking +24 VDC power supply to the MOTOR ASSY Are the voltages across J8304-12 <=> FRAME CHASSIS, and J8304-14 <=> FRAME CHASSIS on the PWB MAIN-C, +24 VDC?	Go to step 14.	Replace the PWB MAIN-C. (RRP 12.98)
14	Checking after replacing the BRACKET ASSY-EJECT (Eject Motor) Replace the BRACKET ASSY-EJECT (Eject Motor). (RRP 12.65) Execute [Test Print] in [Diagnosis]. Does the error still occur?	Replace the PWB MAIN-C. (RRP 12.98)	End of work.
15	Checking the CLUTCH Z34 (Set Clamp Clutch) for operation Execute [Output 12-16 Set Clamp CLUTCH ON/OFF] in [Diagnosis]. Does the CLUTCH Z34 (Set Clam Clutch) operate?	Replace the PWB MAIN-C. (RRP 12.98)	Go to step 16.

Step	Check	Yes	No
16	Checking the HARNESS ASSY MAIN DRIVE connection Are P/J8338 and P/J8304 of the HARNESS ASSY MAIN DRIVE connected surely?	Go to step 18.	After reconnecting, go to step 17.
17	Execute [Test Print] in [Diagnosis]. Does the error still occur?	Go to step 18.	End of work.
18	Checking the HARNESS ASSY MAIN DRIVE for conductivity Disconnect P/J8338 and P/J8304 of the HARNESS ASSY MAIN DRIVE. Check for conductivity at the following: J8338B-1 <=> J8304-20 J8338B-2 <=> J8304-22	Go to step 19.	Replace the HARNESS ASSY MAIN DRIVE.
19	Checking +24 VDC power supply to the CLUTCH Z34 (Set Clamp Clutch) Is the voltage across J8304-22 <=> FRAME CHASSIS on the PWB MAIN-C +24 VDC?	Go to step 20.	Replace the PWB MAIN-C. (RRP 12.98)
20	Checking after replacing the CLUTCH Z34 (Set Clamp Clutch) Replace the CLUTCH Z34 (Set Clamp Clutch). (RRP 12.64) Execute [Test Print] in [Diagnosis]. Does the error still occur?	Replace the PWB MAIN-C. (RRP 12.98)	End of work.

### H5-84 Set Clamp Home Sensor Off Fail

Step	Check	Yes	No
	Possible causative parts: SENSOR (PL 12.10.18) HARNESS ASSY MAIN SENSOR (PL 12.15.1) BRACKET ASSY-EJECT (PL 12.10.17) HARNESS ASSY MAIN DRIVE (PL 12.15.2) CLUTCH Z34 (PL 12.10.15) PWB MAIN-C (PL 12.14.5)		
1	Checking the Eject clamp block for operation Does the eject clamp mechanism move smoothly? Check this item by moving it with your fingers.	Go to step 2.	Remove obstacles.
2	Checking the SENSOR (Set Clamp Home Sensor) for operation Execute [Input 12-39 Set Clamp Home SENSOR] in [Diagnosis]. Does the display on the screen change, every time a piece of white paper is inserted into the sensing area of the SENSOR?	Go to step 8.	Go to step 3.
3	Checking the HARNESS ASSY MAIN SENSOR connection Are P/J8325 and P/J8302B of the HARNESS ASSY MAIN SENSOR connected surely?	Go to step 5.	After reconnecting, go to step 14.

Step	Check	Yes	No
4	Execute [Test Print] in [Diagnosis]. Does the error still occur?	Go to step 5.	End of work.
5	Checking the HARNESS ASSY MAIN SENSOR for conductivity Disconnect P/J8325 and P/J8302B of the HARNESS ASSY MAIN SENSOR. Check for conductivity at the following: J8325-3 <=> P8302B-9 J8325-2 <=> P8302B-10 J8325-1 <=> P8302B-11	Go to step 6.	Replace the HARNESS ASSY MAIN SENSOR.
6	Checking +5 VDC power supply to the SENSOR (Set Clamp Home Sensor) Is the voltage across J8302B-11 <=> J8302B-9 on the PWB MAIN-C +5 VDC?	Go to step 7.	Replace the PWB MAIN-C. (RRP 12.98)
7	Checking the SENSOR (Set Clamp Home Sensor) for operation Does the voltage across P8302B-10 <=> P8302B-9 on the PWB MAIN-C change, every time a piece of white paper is inserted into the sensing area of the SENSOR?	Replace the PWB MAIN-C. (RRP 12.98)	Replace the SENSOR (Set Clamp Home Sensor). (RRP 12.66)
8	Checking the BRACKET ASSY-EJECT (Eject Motor) for operation Execute [Output 12-20 Eject Motor Low FORWARD ON/OFF] and [Output 12-22 Eject Motor Low REVERSE ON/OFF] in [Diagnosis] alternately. Does the BRACKET ASSY-EJECT (Eject Motor) rotate normally in Forward/Reverse directions alternately?	Go to step 15.	Go to step 9.
9	Checking the HARNESS ASSY MAIN DRIVE connection Are P/J8336 and P/J8304 of the HARNESS ASSY MAIN DRIVE connected surely?	Go to step 11.	After reconnecting, go to step 10.
10	Execute [Test Print] in [Diagnosis]. Does the error still occur?	Go to step 11.	End of work.
11	Checking the HARNESS ASSY MAIN DRIVE for conductivity Disconnect P/J8336 and P/J8304 of the HARNESS ASSY MAIN DRIVE. Check for conductivity at the following: J8336-1 <=> J8304-15 J8336-2 <=> J8304-12 J8336-3 <=> J8304-17 J8336-4 <=> J8304-19 J8336-5 <=> J8304-14 J8336-6 <=> J8304-21	Go to step 12.	Replace the HARNESS ASSY MAIN DRIVE.
12	Checking the resistance of the MOTOR ASSY Are there any resistances without disconnection across P8336-2/5(COM) and P8336-1/3/4/6 of the MOTOR ASSY?	Go to step 13.	Replace the BRACKET ASSY-EJECT. (RRP 12.65)



Step	Check	Yes	No
13	Checking +24 VDC power supply to the MOTOR ASSY Are the voltages across J8304-12 <=> FRAME CHASSIS, and J8304-14 <=> FRAME CHASSIS on the PWB MAIN-C, +24 VDC?	Go to step 14.	Replace the PWB MAIN-C. (RRP 12.98)
14	Checking after replacing the BRACKET ASSY-EJECT (Eject Motor) Replace the BRACKET ASSY-EJECT (Eject Motor). (RRP 12.65) Execute [Test Print] in [Diagnosis]. Does the error still occur?	Replace the PWB MAIN-C. (RRP 12.98)	End of work.
15	Checking the CLUTCH Z34 (Set Clamp Clutch) for operation Execute [Output 12-16 Set Clamp CLUTCH ON/OFF] in [Diagnosis]. Does the CLUTCH Z34 (Set Clam Clutch) operate?	Replace the PWB MAIN-C. (RRP 12.98)	Go to step 16.
16	Checking the HARNESS ASSY MAIN DRIVE connection Are P/J8338 and P/J8304 of the HARNESS ASSY MAIN DRIVE connected surely?	Go to step 18.	After reconnecting, go to step 17.
17	Execute [Test Print] in [Diagnosis]. Does the error still occur?	Go to step 18.	End of work.
18	Checking the HARNESS ASSY MAIN DRIVE for conductivity Disconnect P/J8338 and P/J8304 of the HARNESS ASSY MAIN DRIVE. Check for conductivity at the following: J8338B-1 <=> J8304-20 J8338B-2 <=> J8304-22	Go to step 19.	Replace the HARNESS ASSY MAIN DRIVE.
19	Checking +24 VDC power supply to the CLUTCH Z34 (Set Clamp Clutch) Is the voltage across J8304-22 <=> FRAME CHASSIS on the PWB MAIN-C +24 VDC?	Go to step 20.	Replace the PWB MAIN-C. (RRP 12.98)
20	Checking after replacing the CLUTCH Z34 (Set Clamp Clutch) Replace the CLUTCH Z34 (Set Clamp Clutch). (RRP 12.64) Execute [Test Print] in [Diagnosis]. Does the error still occur?	Replace the PWB MAIN-C. (RRP 12.98)	End of work.

## H5-86 Side Registration Sensor Off Fail

Step	Check	Yes	No
	Possible causative parts: Bracket Assembly-Motor, Punch (PL 12.7.4) HARNESS ASSY PUNCH DRIVE (PL 12.15.8) PWB MAIN-C (PL 12.14.5) PWBA MCU F (PL 8.1.5) SENSOR (PL 12.7.8) HARNESS ASSY PUNCH SENSOR (PL 12.15.9) HARNESS ASSY PUNCH UNIT (PL 12.7.2)		
1	Checking the Puncher for operation Does the puncher move front and rear smoothly? Check this item by moving it with your fingers.	Go to step 2.	Remove obstacles.
2	Checking the Bracket Assembly-Motor, Punch (Puncher Move Motor) for operation Execute [Output 13-01 Puncher Move Motor Low Front ON/OFF] and [Output 13-03 Puncher Move Motor Low Rear ON/OFF] in [Diagnosis]. Does the Bracket Assembly-Motor, Punch (Puncher Move Motor) rotate, and does the Holder-Frame Assembly move front and rear?	Go to step 8.	Go to step 3.
3	Checking the HARNESS ASSY PUNCH DRIVE connection Are P/J8344 and P/J8306 of the HARNESS ASSY PUNCH DRIVE connected surely?	Go to step 5.	After reconnecting, go to step 4.
4	Execute [Test Print] in [Diagnosis]. Does the error still occur?	Go to step 5.	End of work.
5	Checking the HARNESS ASSY PUNCH DRIVE for conductivity Disconnect P/J8344 and P/J8306 of the HARNESS ASSY PUNCH DRIVE. Check for conductivity at the following: J8344-1 <=> J8306-7 J8344-2 <=> J8306-3 J8344-3 <=> J8306-6 J8344-4 <=> J8306-5 J8344-5 <=> J8306-2 J8344-6 <=> J8306-1	Go to step 6.	Replace the HARNESS ASSY PUNCH DRIVE.
6	Checking after replacing the Bracket Assembly-Motor, Punch (Puncher Move Motor) Replace the Bracket Assembly-Motor, Punch (Puncher Move Motor). (RRP 12.37) Execute [Test Print] in [Diagnosis]. Does the error still occur?	Go to step 7.	End of work.
7	Checking after replacing the PWB MAIN-C Replace the PWB MAIN-C. (RRP 12.98) Does the error still occur when the power is turned ON?	Replace the PWB A MAIN F.	End of work.

Step	Check	Yes	No
8	Checking the SENSOR (Side Registration Sensor 1) for operation Execute [Input 12-36 Side Registration SENSOR 1] in [Diagnosis]. Does the display on the screen change, every time a piece of white paper is placed over the sensing area of the SENSOR (Side Registration Sensor 1)?	Replace the PWB MAIN-C. (RRP 12.98)	Go to step 9.
9	Checking the SENSOR (Side Registration Sensor 2) for operation Execute [Input 12-37 Side Registration SENSOR 2] in [Diagnosis]. Does the display on the screen change, every time a piece of white paper is placed over the sensing area of the SENSOR (Side Registration Sensor 2)?	Replace the PWB MAIN-C. (RRP 12.98)	Go to step 10.
10	Checking the HARNESS ASSY PUNCH SENSOR and HARNESS ASSY PUNCH UNIT connection Are P/J8307, P/J8333 and P/J8350 (for Side Registration Sensor 1), and P/L8351 (for Side Registration Sensor 2) of the HARNESS ASSY PUNCH SENSOR and HARNESS ASSY PUNCH UNIT connected surely?	Go to step 12.	After reconnecting, go to step 11.
11	Execute [Test Print] in [Diagnosis]. Does the error still occur?	Go to step 12.	End of work.
12	Checking the HARNESS ASSY PUNCH SENSOR for conductivity Disconnect P/J8307 and P/J8333 of the HARNESS ASSY PUNCH SENSOR. Is there conductivity on each wire between J8307 <=> J8333?	Go to step 13.	Replace the HARNESS ASSY PUNCH SENSOR.
13	Checking the HARNESS ASSY PUNCH UNIT for conductivity Disconnect P/J8333, P/J8350 (Side Registration Sensor 1), and P/J8351 (Side Registration Sensor 2) of the HARNESS ASSY PUNCH UNIT. Check for conductivity at the following: P8333-13 <=> J8350-3 P8333-14 <=> J8350-2 P8333-15 <=> J8350-1 P8333-16 <=> J8351-3 P8333-17 <=> J8351-2 P8333-18 <=> J8351-1	Go to step 14.	Replace the HARNESS ASSY PUNCH UNIT.
14	Checking after replacing the SENSOR (Side Registration Sensor 1) Replace the SENSOR (Side Registration Sensor 1). (RRP 12.38) Execute [Test Print] in [Diagnosis]. Does the error still occur?	Go to step 15.	End of work.

Step	Check	Yes	No
15	Checking after replacing the SENSOR (Side Registration Sensor 2) Replace the SENSOR (Side Registration Sensor 2). (RRP 12.38) Execute [Test Print] in [Diagnosis]. Does the error still occur?	Go to step 16.	End of work.
16	Checking after replacing the PWB MAIN-C Replace the PWB MAIN-C. (RRP 12.98) Does the error still occur when the power is turned ON?	Replace the PWBA MCU F. (RRP 8.4)	End of work.

## H5-91 Stapler Fail

Step	Check	Yes	No
	Possible causative parts: STAPLER ASSY (PL 12.8.2) HARNESS ASSY STAPLE (PL 12.8.7) PWB MAIN-C (PL 12.14.5) PWBA MCU F (PL 8.1.5)		
1	Checking the STAPLER ASSY (PL 12.8.2) for operation Execute [Output 13-29 Stapler Motor Forward ON/OFF] and [Output 13-30 Stapler Motor Reverse ON/OFF] in [Diagnosis]. Does the MOTOR in the STAPLER ASSY (PL 12.8.2) rotate normally?	Go to step 5.	Go to step 2.
2	Checking the HARNESS ASSY STAPLE connection Are P/J8357 and P/J8308 of the HARNESS ASSY STAPLE connected surely?	Go to step 4.	After reconnecting, go to step 3.
3	Execute [Test Print] in [Diagnosis]. Does the error still occur?	Go to step 4.	End of work.
4	Checking the HARNESS ASSY STAPLE for conductivity Disconnect P/J8357 and P/J8308 of the HARNESS ASSY STAPLE. Check for conductivity at the following: J8357-1 <=> J8308-10 J8357-2 <=> J8308-9 J8357-3 <=> J8308-8 J8357-4 <=> J8308-7	Go to step 9.	Replace the HARNESS ASSY STAPLE.
5	Checking the Staple Home Sensor for operation Execute [Input 13-45 Stapler Home SENSOR] in [Diagnosis], and then execute [Output 13-29 Staple Motor FORWARD ON/OFF] and [Output 13-30 Staple Motor REVERSE ON/OFF] in [Diagnosis] alternately. Does the display on the screen change, every time the Diagnosis is executed?	Replace the PWB MAIN-C. (RRP 12.98)	Go to step 6.
6	Checking the HARNESS ASSY STAPLE connection Are P/J8358 and P/J8308 of the HARNESS ASSY STAPLE connected surely?	Go to step 8.	After reconnecting, go to step 7.

Step	Check	Yes	No
7	Execute [Test Print] in [Diagnosis]. Does the error still occur?	Go to step 8.	End of work.
8	Checking the HARNESS ASSY STAPLE for conductivity Disconnect P/J8358 and P/J8308 of the HARNESS ASSY STAPLE. Check for conductivity at the following: J8358-1 <=> J8308-15 J8358-2 <=> J8308-14 J8358-3 <=> J8308-13 J8358-4 <=> J8308-12 J8358-5 <=> J8308-11	Go to step 9.	Replace the HARNESS ASSY STAPLE.
9	Checking after replacing the STAPLER ASSY (PL 12.8.2) Replace the STAPLER ASSY (PL 12.8.2). (RRP 12.47) Execute [Test Print] in [Diagnosis]. Does the error still occur?	Go to step 10.	End of work.
10	Checking after replacing the PWB MAIN-C Replace the PWB MAIN-C. (RRP 12.98) Does the error still occur when the power is turned ON?	Replace the PWBA MCU F. (RRP 8.4)	End of work.

### H5-95 Stapler Move Position Sensor On Fail

Step	Check	Yes	No
	Possible causative parts: CARRIAGE ASSY LOWER, STAPLER (PL 12.8.9) HARNESS ASSY STAPLE (PL 12.8.7) PWB MAIN-C (PL 12.14.5) SENSOR (PL 12.8.5)		
1	Checking the Stapler for operation Does the Stapler move smoothly? Check this item by moving it with your fingers.	Go to step 2.	Remove obstacles.
2	Checking the CARRIAGE ASSY LOWER, STAPLER (PL 12.8.9) (Stapler Move Motor) for operation Execute [Output 13-23 Stapler Move Mot Low FRONT ON/OFF] and [Output 13-26 Stapler Move Mot Low REAR ON/OFF] in [Diagnosis]. Does the CARRIAGE ASSY LOWER, STAPLER (PL 12.8.9) (Stapler Move Motor) rotate normally?	Go to step 7.	Go to step 3.
3	Checking the HARNESS ASSY STAPLE connection Are P/J8358 and P/J8308 of the HARNESS ASSY STAPLE connected surely?	Go to step 5.	After reconnecting, go to step 4.
4	Execute [Test Print] in [Diagnosis]. Does the error still occur?	Go to step 5.	End of work.

Step	Check	Yes	No
5	<p>Checking the HARNESS ASSY STAPLE for conductivity Disconnect P/J8358 and P/J8308 of the HARNESS ASSY STAPLE.</p> <p>Check for conductivity at the following: J8358-1 &lt;=&gt; J8308-3 J8358-2 &lt;=&gt; J8308-6 J8358-3 &lt;=&gt; J8308-5 J8358-4 &lt;=&gt; J8308-1 J8358-5 &lt;=&gt; J8308-4 J8358-6 &lt;=&gt; J8308-2</p>	Go to step 6.	Replace the HARNESS ASSY STAPLE.
6	<p>Checking after replacing the CARRIAGE ASSY LOWER, STAPLER (PL 12.8.9) (Stapler Move Motor) Replace the CARRIAGE ASSY LOWER, STAPLER (PL 12.8.9) (Stapler Move Motor). (RRP 12.47) Execute [Test Print] in [Diagnosis]. Does the error still occur?</p>	Replace the PWB MAIN-C. (RRP 12.98)	End of work.
7	<p>Checking the SENSOR (Stapler Move Home Position Sensor) for operation Execute [Output 13-42 Staple Move Position SENSOR] in [Diagnosis], and then execute [Output 13-23 Stapler Move Mot Low FRONT ON/OFF] and [Output 13-26 Stapler Move Mot Low REAR ON/OFF] in [Diagnosis] alternately. Does the display on the screen change?</p>	Replace the PWB MAIN-C. (RRP 12.98)	Go to step 8.
8	<p>Checking the HARNESS ASSY STAPLE connection Are P/J8354 and P/J8308 of the HARNESS ASSY STAPLE connected surely?</p>	Go to step 10.	After reconnecting, go to step 9.
9	<p>Execute [Test Print] in [Diagnosis]. Does the error still occur?</p>	Go to step 10.	End of work.
10	<p>Checking the HARNESS ASSY STAPLE for conductivity Disconnect P/J8354 and P/J8308 of the HARNESS ASSY STAPLE.</p> <p>Check for conductivity at the following: J8354-1 &lt;=&gt; P8308-18 J8354-2 &lt;=&gt; P8308-17 J8354-3 &lt;=&gt; P8308-16</p>	Go to step 11.	Replace the HARNESS ASSY STAPLE.
11	<p>Checking +5 VDC power supply to the SENSOR (Stapler Move Home Position Sensor) Is the voltage across J8308-18 &lt;=&gt; J8308-16 on the PWB MAIN-C +5 VDC?</p>	Go to step 12.	Replace the PWB MAIN-C. (RRP 12.98)
12	<p>Checking the SENSOR (Stapler Move Home Position Sensor) for operation Does the voltage across J8308-17 &lt;=&gt; J8308-16 on the PWB MAIN-C change, every time the sensing area of the SENSOR is placed to the protrusion of the RAIL-UPPER (PL 12.8.10) by moving the stapler by hand.</p>	Replace the PWB MAIN-C. (RRP 12.98)	Replace the SENSOR (Stapler Move Home Position Sensor). (RRP 12.48)

## H5-96 Stapler Move Position Sensor OFF Fail

Step	Check	Yes	No
	Possible causative parts: CARRIAGE ASSY LOWER, STAPLER (PL 12.8.9) HARNESS ASSY STAPLE (PL 12.8.7) PWB MAIN-C (PL 12.14.5) SENSOR (PL 12.8.5)		
1	Checking the Stapler for operation Does the Stapler move smoothly? Check this item by moving it with your fingers.	Go to step 2.	Remove obstacles.
2	Checking the CARRIAGE ASSY LOWER, STAPLER (PL 12.8.9) (Stapler Move Motor) for operation Execute [Output 13-23 Stapler Move Mot Low FRONT ON/OFF] and [Output 13-26 Stapler Move Mot Low REAR ON/OFF] in [Diagnosis]. Does the CARRIAGE ASSY LOWER, STAPLER (PL 12.8.9) (Stapler Move Motor) rotate normally?	Go to step 7.	Go to step 3.
3	Checking the HARNESS ASSY STAPLE connection Are P/J8358 and P/J8308 of the HARNESS ASSY STAPLE connected surely?	Go to step 5.	After reconnecting, go to step 4.
4	Execute [Test Print] in [Diagnosis]. Does the error still occur?	Go to step 5.	End of work.
5	Checking the HARNESS ASSY STAPLE for conductivity Disconnect P/J8358 and P/J8308 of the HARNESS ASSY STAPLE. Check for conductivity at the following: J8358-1 <=> J8308-3 J8358-2 <=> J8308-6 J8358-3 <=> J8308-5 J8358-4 <=> J8308-1 J8358-5 <=> J8308-4 J8358-6 <=> J8308-2	Go to step 6.	Replace the HARNESS ASSY STAPLE.
6	Checking after replacing the CARRIAGE ASSY LOWER, STAPLER (PL 12.8.9) (Stapler Move Motor) Replace the CARRIAGE ASSY LOWER, STAPLER (PL 12.8.9) (Stapler Move Motor). (RRP 12.47) Execute [Test Print] in [Diagnosis]. Does the error still occur?	Replace the PWB MAIN-C. (RRP 12.98)	End of work.
7	Checking the SENSOR (Stapler Move Home Position Sensor) for operation Execute [Output 13-42 Staple Move Position SENSOR] in [Diagnosis], and then execute [Output 13-23 Stapler Move Mot Low FRONT ON/OFF] and [Output 13-26 Stapler Move Mot Low REAR ON/OFF] in [Diagnosis] alternately. Does the display on the screen change?	Replace the PWB MAIN-C. (RRP 12.98)	Go to step 8.
8	Checking the HARNESS ASSY STAPLE connection Are P/J8354 and P/J8308 of the HARNESS ASSY STAPLE connected surely?	Go to step 10.	After reconnecting, go to step 9.

Step	Check	Yes	No
9	Execute [Test Print] in [Diagnosis]. Does the error still occur?	Go to step 10.	End of work.
10	Checking the HARNESS ASSY STAPLE for conductivity Disconnect P/J8354 and P/J8308 of the HARNESS ASSY STAPLE. Check for conductivity at the following: J8354-1 <=> P8308-18 J8354-2 <=> P8308-17 J8354-3 <=> P8308-16	Go to step 11.	Replace the HARNESS ASSY STAPLE.
11	Checking +5 VDC power supply to the SENSOR (Stapler Move Home Position Sensor) Is the voltage across J8308-18 <=> J8308-16 on the PWB MAIN-C +5 VDC?	Go to step 12.	Replace the PWB MAIN-C. (RRP 12.98)
12	Checking the SENSOR (Stapler Move Home Position Sensor) for operation Does the voltage across J8308-17 <=> J8308-16 on the PWB MAIN-C change, every time the protrusion of the RAIL-UPPER (PL 12.8.10) is inserted into the sensing area of the SENSOR (Stapler Move Home Position Sensor) by moving the Stapler by hand?	Replace the PWB MAIN-C. (RRP 12.98)	Replace the SENSOR (Stapler Move Home Position Sensor). (RRP 12.48)

#### H5-4 Finisher NVM R/W error

Step	Check	Yes	No
	Possible causative parts: PWB MAIN-C (PL 12.14.5) PWBA MCU F (PL 8.1.5)		
1	Turn off/on several times. Does the error still occur when the power is on?	Go to step 2.	End of work.
2	Checking data on the NVRAM (1) Is data on the NVRAM accessible? Check it using [NVM Edit] in Chapter 2, Diag.	Go to step 3.	Go to step 4.
3	Checking data on the NVRAM (2) Change NVRAM data to the correct setup value, and then turn the power ON again. Does the error still occur?	Go to step 4.	End of work.
4	Checking the PWB MAIN-C for connection Are P/J8300 and P416 of the PWB MAIN-C connected surely?	Go to step 5.	Connect P/J8300 and P416 surely.
5	Checking conductivity between the PWB MAIN-C and PWBA MCU F Is there conductivity on each wire between P/J8300 <=> P416?	Go to step 6.	Fix open and short circuit.
6	Checking +24 VDC power supply to the PWB MAIN-C Is the voltage across J416-6 (+) <=> ground +24 VDC?	Replace the PWB MAIN-C. (RRP 12.98)	Replace the PWBA MCU F (RRP 8.4)



## H5-7 MCU-Finisher comm. error

Step	Check	Yes	No
	Possible causative parts: PWB MAIN-C (PL 12.14.5) PWBA MCU F (PL 8.1.5)		
1	Checking the IOT and Finisher installation Is the Finisher installed to the printer correctly?	Go to step 2.	After reinstalling, go to step 2.
2	Turn ON/OFF the power. Does the error still occur when the power is on?	Go to step 3.	End of work.
3	Checking the PWB MAIN-C for connection Are P/J8300 and P416 of the PWB MAIN-C connected surely?	Go to step 4.	Connect P/J8300 and P416 surely.
4	Checking conductivity between the PWB MAIN-C and PWBA MCU F Is there conductivity on each wire between P/J8300 <=> P416?	Go to step 5.	Fix open and short circuit.
5	Checking +24 VDC power supply to the PWB MAIN-C Is the voltage across J416-6 (+) <=> ground +24 VDC?	Replace the PWB MAIN-C. (RRP 12.98)	Replace the PWBA MCU F (RRP 8.4)

## H5-8 Finisher type error

Step	Check	Yes	No
	Possible causative parts: PWB MAIN-C (PL 12.14.5) PWBA MCU F (PL 8.1.5)		
1	Checking the IOT and Finisher installation (1). Is the Finisher installed to the printer correctly?	Go to step 2.	Reinstall the Finisher
2	Checking the IOT and Finisher installation (2). Is the Finisher for FIO printer installed?	Go to step 3.	Reinstall the Finisher for FIO printer.
3	Turn ON/OFF the power. Does the error still occur when the power is on?	Go to step 4.	End of work.
4	Checking the PWB MAIN-C for connection Are P/J8300 and P416 of the PWB MAIN-C connected surely?	Go to step 5.	Connect P/J8300 and P416 surely.
5	Checking conductivity between the PWB MAIN-C and PWBA MCU F Is there conductivity on each wire between P/J8300 <=> P416?	Go to step 6.	Fix open and short circuit.
6	Checking +24 VDC power supply to the PWB MAIN-C Is the voltage across J416-6 (+) <=> ground +24 VDC?	Replace the PWB MAIN-C. (RRP 12.98)	Replace the PWBA MCU F (RRP 8.4)

## Stacker Tray Full (No Mix): Finisher

Step	Check	Yes	No
	Possible causative parts: SENSOR (PL 12.6.17) COVER ASSY SENSOR (PL 12.6.13) HARNESS ASSY MAIN SENSOR (PL 12.15.1) PWB MAIN-C (PL 12.14.5) MOTOR ASSY DC (PL 12.6.26)		
1	Checking the Stacker Tray for obstacles Are there any obstacles on the upper and lower parts of the Stacker Tray?	Remove the obstacles.	Go to step 2.
2	Checking the COVER ASSY SENSOR (PL 12.6.13) (Stacker Height Sensor 1) for operation Execute [Input 13-50 Stack Height SENSOR 1] in [Diagnosis]. Does the display on the screen change, every time the sensing area of the SENSOR is blocked by putting a piece of paper?	Go to step 8.	Go to step 3.
3	Checking the HARNESS ASSY MAIN SENSOR connection Are P/J8331 and P/J8302B of the HARNESS ASSY MAIN SENSOR connected surely?	Go to step 5.	After reconnecting, go to step 4.
4	Execute [Test Print] in [Diagnosis]. Does the error still occur?	Go to step 5.	End of work.
5	Checking the HARNESS ASSY MAIN SENSOR for conductivity Disconnect P/J8331 of the HARNESS ASSY MAIN SENSOR, and P/J8302B on the PWB MAIN-C. Check for conductivity at the following: J8331-5 <=> J8302B-1 J8331-4 <=> J8302B-2 J8331-3 <=> J8302B-3 J8331-2 <=> J8302B-4 J8331-1 <=> J8302B-5	Go to step 6.	Replace the HARNESS ASSY MAIN SENSOR.
6	Checking +5 VDC power supply to the COVER ASSY SENSOR (Stacker Height Sensor 1) Is the voltage across J8302B-3 <=> J8302B-1 on the PWB MAIN-C +5 VDC?	Go to step 7.	Replace the PWB MAIN-C. (RRP 12.98)
7	Checking the COVER ASSY SENSOR (Stacker Height Sensor 1) for operation Does the voltage across P8302B-2 <=> P8302B-1 on the PWB MAIN-C change, every time the sensing area of the SENSOR is blocked by putting a piece of paper?	Replace the PWB MAIN-C. (RRP 12.98)	Replace the COVER ASSY SENSOR (Stacker Height Sensor 1). (RRP 12.30)

Step	Check	Yes	No
8	Checking the COVER ASSY SENSOR (PL 12.6.13) (Stacker Height Sensor 2) for operation Execute [Input 13-51 Stack Height SENSOR 2] in [Diagnosis]. Does the display on the screen change, every time the sensing area of the SENSOR is blocked by putting a piece of paper?	Go to step 14.	Go to step 9.
9	Checking the HARNESS ASSY MAIN SENSOR connection Are P/J8330 and P/J8302A of the HARNESS ASSY MAIN SENSOR connected surely?	Go to step 11.	After reconnecting, go to step 10.
10	Execute [Test Print] in [Diagnosis]. Does the error still occur?	Go to step 11.	End of work.
11	Checking the HARNESS ASSY MAIN SENSOR for conductivity Disconnect P/J8330 of the HARNESS ASSY MAIN SENSOR, and P/J8302A on the PWB MAIN-C. Check for conductivity at the following: J8330-5 <=> J8302A-16 J8330-4 <=> J8302A-17 J8330-3 <=> J8302A-18 J8330-2 <=> J8302A-19 J8330-1 <=> J8302A-20	Go to step 12.	Replace the HARNESS ASSY MAIN SENSOR.
12	Checking +5 VDC power supply to the COVER ASSY SENSOR (Stacker Height Sensor 2) Is the voltage across J8302A-18 <=> J8302A-16 on the PWB MAIN-C +5 VDC?	Go to step 13.	Replace the PWB MAIN-C. (RRP 12.98)
13	Checking the COVER ASSY SENSOR (Stacker Height Sensor 2) for operation Does the voltage across P8302A-17 <=> P8302A-16 on the PWB MAIN-C change, every time the sensing area of the SENSOR is blocked by putting a piece of paper?	Replace the PWB MAIN-C. (RRP 12.98)	Replace the COVER ASSY SENSOR (Stacker Height Sensor 2). (RRP 12.31)
14	Checking the ENCODER (PL 12.6.23) of the SENSOR (Stacker Encode Sensor) installation. Is the ENCODER installed correctly? Does it enter the detection point of the SENSOR?	Go to step 16.	After reinstalling, go to step 15.
15	Checking the SENSOR (Stacker Encode Sensor) for operation Execute [Input 13-49 Stack Encoder SENSOR] in [Diagnosis]. Does the screen display change when the BELT (PL 12.6.25) of the MOTOR ASSY-DC (PL 12.6.26) is moved by hand (when the ENCODER (PL 12.6.23) is rotated)?	Go to step 21.	Go to step 16.
16	Checking the HARNESS ASSY MAIN SENSOR connection Are P/J8328 and P/J8302B of the HARNESS ASSY MAIN SENSOR connected surely?	Go to step 18.	After reconnecting, go to step 17.

Step	Check	Yes	No
17	Execute [Test Print] in [Diagnosis]. Does the error still occur?	Go to step 18.	End of work.
18	Checking the HARNESS ASSY MAIN SENSOR for conductivity Disconnect P/J8328 of the HARNESS ASSY MAIN SENSOR, and P/J8302B on the PWB MAIN-C. Check for conductivity at the following: J8328-3 <=> J8302B-12 J8328-2 <=> J8302B-13 J8328-1 <=> J8302B-14	Go to step 19.	Replace the HARNESS ASSY MAIN SENSOR.
19	Checking +5 VDC power supply to the SENSOR (Stacker Encode Sensor) Is the voltage across J8302B-14 <=> J8302B-12 on the PWB MAIN-C +5 VDC?	Go to step 20.	Replace the PWB MAIN-C. (RRP 12.98)
20	Checking the SENSOR (Stacker Encode Sensor) for operation Does the voltage across P8302B-13 <=> P8302B-12 on the PWB MAIN-C change, every time the detection point of the SENSOR is blocked by putting a piece of paper?	Replace the PWB MAIN-C. (RRP 12.98)	Replace the SENSOR (Stacker Encode Sensor). (RRP 12.32)
21	Checking the MOTOR ASSY DC (Elevator Motor) for operation Execute [Output 13-31 Stacker Motor UP ON/OFF] and [Output 13-32 Stacker Motor DOWN ON/OFF] in [Diagnosis] alternately. Does the MOTOR ASSY DC (Elevator Motor) rotate normally in Forward /Reverse directions?	Replace the PWB MAIN-C. (RRP 12.98)	Go to step 22.
22	Checking the MOTOR ASSY DC (Elevator Motor) connection Is P/J8305 of the MOTOR ASSY DC (Elevator Motor) connected to the PWB MAIN-C surely?	Go to step 24.	After reconnecting, go to step 23.
23	Execute [Test Print] in [Diagnosis]. Does the error still occur?	Go to step 24.	End of work.
24	Checking after replacing the MOTOR ASSY DC (Elevator Motor) Replace the MOTOR ASSY DC (Elevator Motor). (RRP 12.35) Execute [Test Print] in [Diagnosis]. Does the error still occur?	Replace the PWB MAIN-C. (RRP 12.98)	End of work.

### Stacker Tray Full (Mix Size): Finisher

Step	Check	Yes	No
	Possible causative parts: SENSOR (PL 12.6.17) COVER ASSY SENSOR (PL 12.6.13) HARNESS ASSY MAIN SENSOR (PL 12.15.1) PWB MAIN-C (PL 12.14.5) MOTOR ASSY DC (PL 12.6.26)		

Step	Check	Yes	No
1	Checking the Stacker Tray for obstacles Are there any obstacles on the upper and lower parts of the Stacker Tray?	Remove the obstacles.	Go to step 2.
2	Checking the COVER ASSY SENSOR (PL 12.6.13) (Stacker Height Sensor 1) for operation Execute [Input 13-50 Stack Height SENSOR 1] in [Diagnosis]. Does the display on the screen change, every time the sensing area of the SENSOR is blocked by putting a piece of paper?	Go to step 8.	Go to step 3.
3	Checking the HARNESS ASSY MAIN SENSOR connection Are P/J8331 and P/J8302B of the HARNESS ASSY MAIN SENSOR connected surely?	Go to step 5.	After reconnecting, go to step 4.
4	Execute [Test Print] in [Diagnosis]. Does the error still occur?	Go to step 5.	End of work.
5	Checking the HARNESS ASSY MAIN SENSOR for conductivity Disconnect P/J8331 of the HARNESS ASSY MAIN SENSOR, and P/J8302B on the PWB MAIN-C. Check for conductivity at the following: J8331-5 <=> J8302B-1 J8331-4 <=> J8302B-2 J8331-3 <=> J8302B-3 J8331-2 <=> J8302B-4 J8331-1 <=> J8302B-5	Go to step 6.	Replace the HARNESS ASSY MAIN SENSOR.
6	Checking +5 VDC power supply to the COVER ASSY SENSOR (Stacker Height Sensor 1) Is the voltage across J8302B-3 <=> J8302B-1 on the PWB MAIN-C +5 VDC?	Go to step 7.	Replace the PWB MAIN-C. (RRP 12.98)
7	Checking the COVER ASSY SENSOR (Stacker Height Sensor 1) for operation Does the voltage across P8302B-2 <=> P8302B-1 on the PWB MAIN-C change, every time the sensing area of the SENSOR is blocked by putting a piece of paper?	Replace the PWB MAIN-C. (RRP 12.98)	Replace the COVER ASSY SENSOR (Stacker Height Sensor 1). (RRP 12.30)
8	Checking the COVER ASSY SENSOR (PL 12.6.13) (Stacker Height Sensor 2) for operation Execute [Input 13-51 Stack Height SENSOR 2] in [Diagnosis]. Does the display on the screen change, every time the sensing area of the SENSOR is blocked by putting a piece of paper?	Go to step 14.	Go to step 9.
9	Checking the HARNESS ASSY MAIN SENSOR connection Are P/J8330 and P/J8302A of the HARNESS ASSY MAIN SENSOR connected surely?	Go to step 11.	After reconnecting, go to step 10.
10	Execute [Test Print] in [Diagnosis]. Does the error still occur?	Go to step 11.	End of work.

Step	Check	Yes	No
11	<p>Checking the HARNESS ASSY MAIN SENSOR for conductivity</p> <p>Disconnect P/J8330 of the HARNESS ASSY MAIN SENSOR, and P/J8302A on the PWB MAIN-C.</p> <p>Check for conductivity at the following:</p> <p>J8330-5 &lt;=&gt; J8302A-16</p> <p>J8330-4 &lt;=&gt; J8302A-17</p> <p>J8330-3 &lt;=&gt; J8302A-18</p> <p>J8330-2 &lt;=&gt; J8302A-19</p> <p>J8330-1 &lt;=&gt; J8302A-20</p>	Go to step 12.	Replace the HARNESS ASSY MAIN SENSOR.
12	<p>Checking +5 VDC power supply to the COVER ASSY SENSOR (Stacker Height Sensor 2)</p> <p>Is the voltage across J8302A-18 &lt;=&gt; J8302A-16 on the PWB MAIN-C +5 VDC?</p>	Go to step 13.	Replace the PWB MAIN-C. (RRP 12.98)
13	<p>Checking the COVER ASSY SENSOR (Stacker Height Sensor 2) for operation</p> <p>Does the voltage across P8302A-17 &lt;=&gt; P8302A-16 on the PWB MAIN-C change, every time the sensing area of the SENSOR is blocked by putting a piece of paper?</p>	Replace the PWB MAIN-C. (RRP 12.98)	Replace the COVER ASSY SENSOR (Stacker Height Sensor 2). (RRP 12.31)
14	<p>Checking the ENCODER (PL 12.6.23) of the SENSOR (Stacker Encode Sensor) installation.</p> <p>Is the ENCODER installed correctly?</p> <p>Does it enter the detection point of the SENSOR?</p>	Go to step 15.	After reinstalling, go to step 15.
15	<p>Checking the SENSOR (Stacker Encode Sensor) for operation</p> <p>Execute [Input 13-49 Stack Encoder SENSOR] in [Diagnosis].</p> <p>Does the screen display change when the BELT (PL 12.6.25) of the MOTOR ASSY-DC (PL 12.6.26) is moved by hand (when the ENCODER (PL 12.6.23) is rotated)?</p>	Go to step 21.	Go to step 16.
16	<p>Checking the HARNESS ASSY MAIN SENSOR connection</p> <p>Are P/J8328 and P/J8302B of the HARNESS ASSY MAIN SENSOR connected surely?</p>	Go to step 18.	After reconnecting, go to step 17.
17	<p>Execute [Test Print] in [Diagnosis].</p> <p>Does the error still occur?</p>	Go to step 18.	End of work.
18	<p>Checking the HARNESS ASSY MAIN SENSOR for conductivity</p> <p>Disconnect P/J8328 of the HARNESS ASSY MAIN SENSOR, and P/J8302B on the PWB MAIN-C.</p> <p>Check for conductivity at the following:</p> <p>J8328-3 &lt;=&gt; J8302B-12</p> <p>J8328-2 &lt;=&gt; J8302B-13</p> <p>J8328-1 &lt;=&gt; J8302B-14</p>	Go to step 19.	Replace the HARNESS ASSY MAIN SENSOR.
19	<p>Checking +5 VDC power supply to the SENSOR (Stacker Encode Sensor)</p> <p>Is the voltage across J8302B-14 &lt;=&gt; J8302B-12 on the PWB MAIN-C +5 VDC?</p>	Go to step 20.	Replace the PWB MAIN-C. (RRP 12.98)

Step	Check	Yes	No
20	Checking the SENSOR (Stacker Encode Sensor) for operation Does the voltage across P8302B-13 <=> P8302B-12 on the PWB MAIN-C change, every time the detection point of the SENSOR is blocked by putting a piece of paper?	Replace the PWB MAIN-C. (RRP 12.98)	Replace the SENSOR (Stacker Encode Sensor). (RRP 12.32)
21	Checking the MOTOR ASSY DC (Elevator Motor) for operation Execute [Output 13-31 Stacker Motor UP ON/OFF] and [Output 13-32 Stacker Motor DOWN ON/OFF] in [Diagnosis] alternately. Does the MOTOR ASSY DC (Elevator Motor) rotate normally in Forward/Reverse directions?	Replace the PWB MAIN-C. (RRP 12.98)	Go to step 22.
22	Checking the MOTOR ASSY DC (Elevator Motor) connection Is P/J8305 of the MOTOR ASSY DC (Elevator Motor) connected to the PWB MAIN-C surely?	Go to step 24.	After reconnecting, go to step 23.
23	Execute [Test Print] in [Diagnosis]. Does the error still occur?	Go to step 24.	End of work.
24	Checking after replacing the MOTOR ASSY DC (Elevator Motor) Replace the MOTOR ASSY DC (Elevator Motor). (RRP 12.35) Execute [Test Print] in [Diagnosis]. Does the error still occur?	Replace the PWB MAIN-C. (RRP 12.98)	End of work.

### Finisher Top Tray Full

Step	Check	Yes	No
	Possible causative parts: SENSOR (PL 12.13.7) HARNESS ASSY TOP SENSOR (PL 12.15.7) HARNESS ASSY MAIN SENSOR (PL 12.15.1) PWB MAIN-C (PL 12.14.5)		
1	Checking the SENSOR (Top Tray Full Sensor) for operation Execute [Input 12-33 Top Tray Full SENSOR] in [Diagnosis]. Does the display of the screen change, every time a piece of white paper is placed over the sensing area of the SENSOR (Top Tray Full Sensor)?	Replace the PWB MAIN-C. (RRP 12.98)	Go to step 2.
2	Checking the HARNESS ASSY TOP SENSOR and HARNESS ASSY MAIN SENSOR connection Are P/J8322 and P/J8393 of the HARNESS ASSY TOP SENSOR, and P/J8393 and P/J8302A of the HARNESS ASSY MAIN SENSOR connected surely?	Go to step 4.	After reconnecting, go to step 3.
3	Execute [Test Print] in [Diagnosis]. Does the error still occur?	Go to step 4.	End of work.

Step	Check	Yes	No
4	Checking the HARNESS ASSY TOP SENSOR for conductivity Disconnect P/J8322 and P/J8393 of the HARNESS ASSY TOP SENSOR. Check for conductivity at the following: J8322-3 <=> J8393B-1 J8322-2 <=> J8393B-2 J8322-1 <=> J8393B-3	Go to step 5.	Replace the HARNESS ASSY TOP SENSOR.
5	Checking the HARNESS ASSY MAIN SENSOR for conductivity Disconnect P/J8393 and P/J8302A of the HARNESS ASSY MAIN SENSOR. Check for conductivity at the following: J8393A-3 <=> J8302A-10 J8393A-2 <=> J8302A-11 J8393A-1 <=> J8302A-12	Go to step 6.	Replace the HARNESS ASSY MAIN SENSOR.
6	Checking +5 VDC power supply to the SENSOR (Top Tray Full Sensor) Is the voltage across J8302A-12 <=> J8302A-10 on the PWB MAIN-C +5 VDC?	Go to step 7.	Replace the PWB MAIN-C. (RRP 12.98)
7	Checking the SENSOR (Top Tray Full Sensor) for operation Does the voltage across P8302A-11 <=> P8302A-10 on the PWB MAIN-C change, every time a piece of white paper is placed over the sensing area of the SENSOR (Top Tray Full Sensor)?	Replace the PWB MAIN-C. (RRP 12.98)	Replace the SENSOR (Top Tray Full Sensor). (RRP 12.90)

## Staple Pin Empty

Step	Check	Yes	No
	Possible causative parts: STAPLER ASSY (PL 12.8.2) HARNESS ASSY STAPLE (PL 12.8.7) PWB MAIN-C (PL 12.14.5) PWBA MCU F (PL 8.1.5)		
1	Checking the Low Staple Sensor in the Staple Cartridge for operation Execute [Input 13-43 Low Staple SENSOR] in [Diagnosis]. Does the display on the screen change, every time the Staple Cartridge that stores the Staple pin is removed or installed?	Go to step 9.	Go to step 2.
2	Checking the mounting position of the Staple Cartridge on the STAPLER ASSY (PL 12.8.2) for faulty parts and foreign particles. Is the component part damaged? Or are there any foreign particles?	Replace faulty parts or remove foreign articles and/or clean.	Go to step 3.



Step	Check	Yes	No
3	Checking the HARNESS ASSY STAPLE connection Are P/J8356 and P/J8308 of the HARNESS ASSY STAPLE connected surely?	Go to step 5.	After reconnecting, go to step 4.
4	Does the error still occur when the power is turned ON?	Go to step 5.	End of work.
5	Checking the HARNESS ASSY STAPLE for conductivity Disconnect P/J8356 and P/J8308 of the HARNESS ASSY STAPLE. Check for conductivity at the following: J8356-1 <=> J8308-15 J8356-2 <=> J8308-14 J8356-3 <=> J8308-13 J8356-4 <=> J8308-12 J8356-5 <=> J8308-11	Go to step 6.	Replace the HARNESS ASSY STAPLE.
6	Checking +5 VDC power supply to the Low Staple Sensor in the Staple Cartridge Is the voltage across J8308-11 <=> J8308-15 on the PWB MAIN-C +5 VDC?	Go to step 7.	Replace the PWB MAIN-C. (RRP 12.98)
7	Checking the Low Staple Sensor in the Staple Cartridge for operation Does the voltage across P8308-14 <=> P8308-15 on the PWB MAIN-C change, every time the Staple Cartridge is installed or removed?	Go to step 8.	Replace the PWB MAIN-C. (RRP 12.98)
8	Checking after replacing the STAPLER ASSY Replace the STAPLER ASSY. (RRP 12.47) Does the error still occur when the power is turned ON?	Go to step 9.	End of work.
9	Checking after replacing the PWB MAIN-C Replace the PWB MAIN-C. (RRP 12.98) Does the error still occur when the power is turned ON?	Replace the PWBA MCU F. (RRP 8.4)	End of work.

## Staple Pin Not Ready

Step	Check	Yes	No
	Possible causative parts: STAPLER ASSY (PL 12.8.2) HARNESS ASSY STAPLE (PL 12.8.7) PWB MAIN-C (PL 12.14.5) PWBA MCU F (PL 8.1.5)		
1	Checking the Self Priming Sensor in the Staple Cartridge for operation Execute [Input 13-44 Self Priming SENSOR] in [Diagnosis]. Does the display on the screen change, every time the Staple Cartridge is installed or removed?	Go to step 11.	Go to step 2.
2	Checking the Staple Cartridge and the STAPLER ASSY for Staple Pin JAM Is there Staple pin Jam in the Staple Cartridge or the STAPLER ASSY.	Go to step 4.	After removing, go to step 3.

Step	Check	Yes	No
3	Does the error still occur when the power is turned ON?	Go to step 4.	End of work.
4	Checking the mounting position of the Staple Cartridge on the STAPLER ASSY (PL 12.8.2) for faulty parts and foreign particles. Is the component part damaged? Or are there any foreign particles?	Replace faulty parts or remove foreign articles and/or clean.	Go to step 5.
5	Checking the HARNESS ASSY STAPLE connection Are P/J8356 and P/J8308 of the HARNESS ASSY STAPLE connected surely?	Go to step 7.	After reconnecting, go to step 6.
6	Does the error still occur when the power is turned ON?	Go to step 7.	End of work.
7	Checking the HARNESS ASSY STAPLE for conductivity Disconnect P/J8356 and P/J8308 of the HARNESS ASSY STAPLE. Check for conductivity at the following: J8356-1 <=> J8308-15 J8356-2 <=> J8308-14 J8356-3 <=> J8308-13 J8356-4 <=> J8308-12 J8356-5 <=> J8308-11	Go to step 8.	Replace the HARNESS ASSY STAPLE.
8	Checking +5 VDC power supply to the Self Priming Sensor in the Staple Cartridge Is the voltage across J8308-11 <=> J8308-15 on the PWB MAIN-C +5 VDC?	Go to step 9.	Replace the PWB MAIN-C. (RRP 12.98)
9	Checking the Self Priming Sensor in the Staple Cartridge for operation Does the voltage across P8308-14 <=> P8308-15 on the PWB MAIN-C change, every time the Staple Cartridge is installed or removed?	Go to step 10.	Replace the PWB MAIN-C. (RRP 12.98)
10	Checking after replacing the STAPLER ASSY Replace the STAPLER ASSY. (RRP 12.47) Does the error still occur when the power is turned ON?	Go to step 11.	End of work.
11	Checking after replacing the PWB MAIN-C Replace the PWB MAIN-C. (RRP 12.98) Does the error still occur when the power is turned ON?	Replace the PWBA MCU F. (RRP 8.4)	End of work.

### Staple NG: Finisher

Step	Check	Yes	No
	Possible causative parts: HARNESS ASSY STAPLE (PL 12.8.7) PWB MAIN-C (PL 12.14.5) STAPLER ASSY (PL 12.8.2) PWBA MCU F (PL 8.1.5)		
1	Checking the Compile Tray for foreign particle Are there any foreign particles in the Compile Tray?	Remove the obstacles.	Go to step 2.

Step	Check	Yes	No
2	Checking the Staple Motor in the Staple Cartridge for operation Execute [Output 13-29 Staple Motor FORWARD ON/OFF] and [Output 13-30 Staple Motor REVERSE ON/OFF] in [Diagnosis] alternately. Does the Motor in the Staple Cartridge rotate? Check by rotating sound of the Motor.	Go to step 6.	Go to step 3.
3	Checking the HARNESS ASSY STAPLE connection Are P/J8357 and P/J8308 of the HARNESS ASSY STAPLE connected surely?	Go to step 5.	After reconnecting, go to step 4.
4	Does the error still occur when the power is turned ON?	Go to step 5.	End of work.
5	Checking the HARNESS ASSY STAPLE for conductivity Disconnect P/J8357 and P/J8308 of the HARNESS ASSY STAPLE. Check for conductivity at the following: J8357-1 <=> J8308-10 J8357-2 <=> J8308-9 J8357-3 <=> J8308-8 J8357-4 <=> J8308-7	Go to step 11.	Replace the HARNESS ASSY STAPLE.
6	Execute [Input 13-45 Staple Home SENSOR] in [Diagnosis], and then execute [Output 13-29 Staple Motor FORWARD ON/OFF] and [Output 13-30 Staple Motor REVERSE ON/OFF] in [Diagnosis] alternately. Does the display on the screen change, every time the Diagnosis is operated?	Go to step 12.	Go to step 7.
7	Checking the HARNESS ASSY STAPLE connection Are P/J8356 and P/J8308 of the HARNESS ASSY STAPLE connected surely?	Go to step 9.	After reconnecting, go to step 8.
8	Does the error still occur when the power is turned ON?	Go to step 9.	End of work.
9	Checking the HARNESS ASSY STAPLE for conductivity Disconnect P/J8356 and P/J8308 of the HARNESS ASSY STAPLE. Check for conductivity at the following: J8356-1 <=> J8308-15 J8356-2 <=> J8308-14 J8356-3 <=> J8308-13 J8356-4 <=> J8308-12 J8356-5 <=> J8308-11	Go to step 10.	Replace the HARNESS ASSY STAPLE.
10	Checking +5 VDC power supply to the Low Staple Sensor in the Staple Cartridge Is the voltage across J8308-11 <=> J8308-15 on the PWB MAIN-C +5 VDC?	Go to step 11.	Replace the PWB MAIN-C. (RRP 12.98)
11	Checking after replacing the STAPLER ASSY Replace the STAPLER ASSY. (RRP 12.47) Does the error still occur when the power is turned ON?	Go to step 12.	End of work.
12	Checking after replacing the PWB MAIN-C Replace the PWB MAIN-C. (RRP 12.98) Does the error still occur when the power is turned ON?	Replace the PWBA MCU F. (RRP 8.4)	End of work.

## Stacker Lower Safety: Finisher

Step	Check	Yes	No
	Possible causative parts: COVER ASSY SENSOR (PL 12.6.13) HARNESS ASSY MAIN SENSOR (PL 12.15.1) PWB MAIN-C (PL 12.14.5) MOTOR ASSY DC (PL 12.6.26) PWBA MCU F (PL 8.1.5)		
1	Checking the vertical transport mechanism of the Stacker Tray for obstacles and deformation Are there any obstacles in the vertical transport mechanism of the Stacker Tray? Is there any deformation in the vertical transport mechanism of the Stacker Tray?	Remove obstacles/replace deformed part.	Go to step 2.
2	Checking the COVER ASSY SENSOR (PL 12.6.13) (Stacker Height Sensor 1) for operation Execute [Input 13-50 Stack Height SENSOR 1] in [Diagnosis]. Does the display on the screen change, every time the sensing area of the SENSOR is blocked by putting a piece of paper?	Go to step 8.	Go to step 3.
3	Checking the HARNESS ASSY MAIN SENSOR connection Are P/J8331 and P/J8302B of the HARNESS ASSY MAIN SENSOR connected surely?	Go to step 5.	After reconnecting, go to step 4.
4	Execute [Test Print] in [Diagnosis]. Does the error still occur?	Go to step 5.	End of work.
5	Checking the HARNESS ASSY MAIN SENSOR for conductivity Disconnect P/J8331 of the HARNESS ASSY MAIN SENSOR, and P/J8302B on the PWB MAIN-C. Check for conductivity at the following: J8331-5 <=> J8302B-1 J8331-4 <=> J8302B-2 J8331-3 <=> J8302B-3 J8331-2 <=> J8302B-4 J8331-1 <=> J8302B-5	Go to step 6.	Replace the HARNESS ASSY MAIN SENSOR.
6	Checking +5 VDC power supply to the COVER ASSY SENSOR (Stacker Height Sensor 1) Is the voltage across J8302B-3 <=> J8302B-1 on the PWB MAIN-C +5 VDC?	Go to step 7.	Replace the PWB MAIN-C. (RRP 12.98)
7	Checking the COVER ASSY SENSOR (Stacker Height Sensor 1) for operation Does the voltage across P8302B-2 <=> P8302B-1 on the PWB MAIN-C change, every time the sensing area of the SENSOR is blocked by putting a piece of paper?	Replace the PWB MAIN-C. (RRP 12.98)	Replace the COVER ASSY SENSOR (Stacker Height Sensor 1). (RRP 12.30)

Step	Check	Yes	No
8	Checking the COVER ASSY SENSOR (PL 12.6.13) (Stacker Height Sensor 2) for operation Execute [Input 13-51 Stack Height SENSOR 2] in [Diagnosis]. Does the display on the screen change, every time the sensing area of the SENSOR is blocked by putting a piece of paper?	Go to step 14.	Go to step 9.
9	Checking the HARNESS ASSY MAIN SENSOR connection Are P/J8330 and P/J8302A of the HARNESS ASSY MAIN SENSOR connected surely?	Go to step 11.	After reconnecting, go to step 10.
10	Execute [Test Print] in [Diagnosis]. Does the error still occur?	Go to step 11.	End of work.
11	Checking the HARNESS ASSY MAIN SENSOR for conductivity Disconnect P/J8330 of the HARNESS ASSY MAIN SENSOR, and P/J8302A on the PWB MAIN-C. Check for conductivity at the following: J8330-5 <=> J8302A-16 J8330-4 <=> J8302A-17 J8330-3 <=> J8302A-18 J8330-2 <=> J8302A-19 J8330-1 <=> J8302A-20	Go to step 12.	Replace the HARNESS ASSY MAIN SENSOR.
12	Checking +5 VDC power supply to the COVER ASSY SENSOR (Stacker Height Sensor 2) Is the voltage across J8302A-18 <=> J8302A-16 on the PWB MAIN-C +5 VDC?	Go to step 13.	Replace the PWB MAIN-C. (RRP 12.98)
13	Checking the COVER ASSY SENSOR (Stacker Height Sensor 2) for operation Does the voltage across P8302A-17 <=> P8302A-16 on the PWB MAIN-C change, every time the sensing area of the SENSOR is blocked by putting a piece of paper?	Replace the PWB MAIN-C. (RRP 12.98)	Replace the COVER ASSY SENSOR (Stacker Height Sensor 2). (RRP 12.31)
14	Checking the MOTOR ASSY DC (Elevator Motor) for operation Execute [Output 13-31 Stacker Motor UP ON/OFF] and [Output 13-321 Stacker Motor DOWN ON/OFF] in [Diagnosis] alternately. Does the MOTOR ASSY DC (Elevator Motor) rotate normally in Forward/reverse directions?	Go to step 18.	Go to step 15.
15	Checking the MOTOR ASSY DC (Elevator Motor) connection Is P/J8305 of the MOTOR ASSY DC (Elevator Motor) connected to the PWB MAIN-C surely?	Go to step 17.	After reconnecting, go to step 16.
16	Execute [Test Print] in [Diagnosis]. Does the error still occur?	Go to step 17.	End of work.

Step	Check	Yes	No
17	Checking after replacing the MOTOR ASSY DC (Elevator Motor) Replace the MOTOR ASSY DC (Elevator Motor). (RRP 12.35) Execute [Test Print] in [Diagnosis]. Does the error still occur?	Go to step 18.	End of work.
18	Checking after replacing the PWB MAIN-C Replace the PWB MAIN-C. (RRP 12.98) Does the error still occur when the power is turned ON?	Replace the PWB A MAIN F.	End of work.

### Stacker Set Over Count: Finisher

Step	Check	Yes	No
	Possible causative parts: PWB MAIN-C (PL 12.14.5) PWBA MCU F (PL 8.1.5)		
1	Checking connectors of the PWB MAIN-C connection Are all the connectors connected to the PWB MAIN-C connected surely?	Go to step 3.	After reconnecting, go to step 2.
2	Does the error still occur when the power is turned ON?	Go to step 3.	End of work.
3	Checking after replacing the PWB MAIN-C Replace the PWB MAIN-C. (RRP 12.98) Does the error still occur when the power is turned ON?	Replace the PWBA MCU F. (RRP 8.4)	End of work.

### Punch Waste Box Overflow: Finisher

Step	Check	Yes	No
	Possible causative parts: SENSOR PI DH (PL 12.7. ) HARNESS ASSY PUNCH FULL SENSOR PWB H-TRA (PL 12.14.3) PWB MAIN-C (PL 12.14.5) PWBA MCU F (PL 8.1.5)		
1	Checking the HARNESS ASSY PUNCH FULL SENSOR connection Are P/J8452 and P/J8500 of the HARNESS ASSY PUNCH FULL SENSOR connected surely?	Go to step 3.	After reconnecting, go to step 2.
2	Does the error still occur when the power is turned ON?	Go to step 3.	End of work.

Step	Check	Yes	No
3	Checking the HARNESS ASSY PUNCH FULL SENSOR for conductivity Disconnect P/J8452 and P/J8500 of the HARNESS ASSY PUNCH FULL SENSOR. Check for conductivity at the following: J8452-3 <=> J8500-1 J8452-2 <=> J8500-2 J8452-1 <=> J8500-3	Go to step 4.	Replace the HARNESS ASSY PUNCH FULL SENSOR.
4	Checking +5 VDC power supply to the SENSOR PI DH (Punch Full Sensor) Is the voltage across P8500-3 <=> P8500-1 on the PWB H-TRA +5 VDC?	Go to step 7.	Go to step 5.
5	Checking +5 VDC power supply to the PWB H-TRA Is the voltage across P8371-17 <=> P8371-18 on the PWB H-TRA +5 VDC?	Replace the PWB H-TRA. (RRP 12.97)	Go to step 6.
6	Checking the HARNESS between PWB MAIN-C and PWB H-TRA for conductivity Disconnect P/J8310 on the PWB MAIN-C and P/J8371 on the PWB H-TRA. Check for conductivity at the following: J8371B-3 <=> J8310A-13 J8371B-2 <=> J8310A-14 J8371A-10 <=> J8310B-6	Replace the PWB MAIN-C. (RRP 12.98)	Fix open and short circuit.
7	Checking the SENSOR PI DH (Punch Full Sensor) for operation Does the voltage across P8500-2 <=> P8500-1 on the PWB MAIN-C change, every time the detection point of the SENSOR PI DH is blocked by putting a piece of paper?	Go to step 8.	Replace the SENSOR PI DH (Punch Full Sensor). (RRP 12.100)
8	Checking after replacing the PWB MAIN-C Replace the PWB MAIN-C. (RRP 12.98) Does the error still occur when the power is turned ON?	Replace the PWBA MCU F. (RRP 8.4)	End of work.

## No Punch Waste Box

Step	Check	Yes	No
	Possible causative parts: SENSOR (PL 12.7.21) HARNESS PUNCH BOX SENSOR HARNESS ASSY PUNCH SENSOR (PL 12.15.9) PWB MAIN-C (PL 12.14.5) PWBA MCU (PL 8.1.5)		

Step	Check	Yes	No
1	Checking the SENSOR (Punch Box Set Sensor) for operation Remove the Dust Box (PL 12.7.20). Execute [Input 13-38 Punch Box Set SENSOR] in [Diagnosis]. Does the display on the screen change, every time the detection point of the SENSOR is blocked by putting a piece of paper?	Go to step 8.	Go to step 2.
2	Checking the HARNESS PUNCH BOX SENSOR and HARNESS ASSY PUNCH SENSOR connection Are P/J8353 and P/J8355 of the HARNESS PUNCH BOX SENSOR, and P/J8355 and P/J8307 of the HARNESS ASSY PUNCH SENSOR connected surely?	Go to step 4.	After reconnecting, go to step 3.
3	Does the error still occur when the power is turned ON?	Go to step 4.	End of work.
4	Checking the HARNESS PUNCH BOX SENSOR for conductivity Disconnect P/J8353 and P/J8355 of the HARNESS PUNCH BOX SENSOR. Check for conductivity at the following: J8353-3 <=> P8355-3 J8353-2 <=> P8355-2 J8353-1 <=> P8355-1	Go to step 5.	Fix open and short circuit.
5	Checking the HARNESS ASSY PUNCH SENSOR for conductivity Disconnect P/J8355 and P/J8307 of the HARNESS ASSY PUNCH SENSOR. Check for conductivity at the following: J8355-3 <=> J8307-A3 J8355-2 <=> J8307-A2 J8355-1 <=> J8307-A1	Go to step 6.	Replace the HARNESS ASSY PUNCH SENSOR.
6	Checking +5 VDC power supply to the SENSOR (Punch Box Set Sensor) Is the voltage across J8307-A1 <=> J8307-A3 on the PWB MAIN-C +5 VDC?	Go to step 7.	Replace the PWB MAIN-C. (RRP 12.98)
7	Checking the SENSOR (Punch Box Set Sensor) for operation Does the voltage across P8307-A2 <=> P8307-A3 on the PWB MAIN-C change, every time the detection point of the SENSOR is blocked by putting a piece of paper?	Replace the PWB MAIN-C. (RRP 12.98)	Replace the SENSOR (Punch Box Set Sensor). (RRP 12.45)
8	Checking after replacing the PWB MAIN-C Replace the PWB MAIN-C. (RRP 12.98) Does the error still occur when the power is turned ON?	Replace the PWBA MCU F. (RRP 8.4)	End of work.



## Finisher Front Cover Open

Step	Check	Yes	No
	Possible causative parts: COVER ASSY FRONT (PL 12.5.3) INTERLOCK SWITCH (PL 12.5.2) HARNESS ASSY INTERLOCK (PL 12.15.11) PWB MAIN-C (PL 12.14.5) SENSOR ASSY (PL 12.9.23) PWBA MCU (PL 8.1.5)		
1	Checking the COVER ASSY FRONT for opening and closing Open and close the COVER ASSY FRONT (PL 12.5.3). Does it open or close smoothly?	Go to step 2.	Check the COVER ASSY FRONT for installation, correct deformations, or replace it.
2	Checking the INTERLOCK SWITCH (Finisher Front Door SW) installation Is the INTERLOCK SWITCH (PL 12.5.2) installed correctly?	Go to step 3.	Check the INTERLOCK SWITCH for installation or replace it.
3	Checking the INTERLOCK SWITCH (Finisher Front Door SW) for operation Execute [Input 13-54 Finisher Front Cover SW] in [Diagnosis]. Does the display on the screen change, every time the detection point of the INTERLOCK SWITCH is pressed by the tip of the screwdriver?	Go to step 9.	Go to step 4.
4	Checking the HARNESS ASSY INTERLOCK connection Are P/J8365 of the HARNESS ASSY INTERLOCK, P/J8364 of the Eject Cover SW, and P/J8388 and P/J8314 on the PWB MAIN-C connected surely?	Go to step 6.	After reconnecting, go to step 5.
5	Does the error still occur when the power is turned ON?	Go to step 6.	End of work.
6	Checking the HARNESS ASSY INTERLOCK for conductivity Disconnect P/J8365 of the HARNESS ASSY INTERLOCK, P/J8364 of the Eject Cover SW, and P/J8388 and P/J8314 on the PWB MAIN-C. Check for conductivity at the following: J8365-1A <=> J8388-2 J8365-1B <=> J8364-2 J8365-2A <=> J8314-3 J8365-2B <=> J8314-2 J8364-1 <=> J8388-1 J8364-3 <=> J8314-1	Go to step 7.	Replace the HARNESS ASSY INTERLOCK.
7	Checking +5/+24 VDC power supply to the INTERLOCK SWITCH (Finisher Front Door SW) Is the voltage across J8314-2 <=> FRAME CHASSIS on the PWB MAIN-C +5 VDC? Is the voltage across J8388-1 <=> FRAME CHASSIS on the PWB MAIN-C +24 VDC?	Go to step 8.	Replace the PWB MAIN-C. (RRP 12.98)

Step	Check	Yes	No
8	Checking the INTERLOCK SWITCH (Finisher Front Door SW) for operation Does the voltage across J8314-2 <=> J8314-3 on the PWB MAIN-C change, every time the sensing area of the INTERLOCK SWITCH (Finisher Front Door SW) is pushed by the tip of the screwdriver?	Replace the PWB MAIN-C. (RRP 12.98)	Replace the INTERLOCK SWITCH (Finisher Front Door SW). (RRP 12.23)
9	Checking the SENSOR ASSY (Eject Cover SW) for operation Does the voltage across J8365-1B <=> FRAME CHASSIS of the HARNESS ASSY INTERLOCK change, every time the actuator of the SENSOR ASSY (Eject Cover SW) is pushed?	Go to step 10.	Replace the SENSOR ASSY (Eject Cover SW). (RRP 12.56)
10	Checking the INTERLOCK SWITCH (Finisher Front Door SW) for operation Does the voltage across J8388-2 <=> FRAME CHASSIS on the PWB MAIN-C change, every time the actuator of the Eject Cover SW and the sensing area of the INTERLOCK SWITCH (Finisher Front Door SW) are pushed simultaneously by the tip of the screwdriver?	Go to step 11.	Replace the INTERLOCK SWITCH (Finisher Front Door SW). (RRP 12.23)
11	Checking after replacing the PWB MAIN-C Replace the PWB MAIN-C. (RRP 12.98) Does the error still occur when the power is turned ON?	Replace the PWBA MCU F. (RRP 8.4)	End of work.

## Finisher H-Transport Cover Open

Step	Check	Yes	No
	Possible causative parts: COVER ASSY TOP (PL 12.2.9) T-TRANSPORT INTERLOCK SENSOR (PL 12.3.19) WIRE HARNESS (PL 12.3.26) PWB MAIN-C (PL 12.14.5) PWBA MCU F (PL 8.1.5)		
1	Checking the COVER ASSY TOP on the H-TRA for opening and closing Open and close the COVER ASSY TOP (PL 12.2.9). Does it open or close smoothly?	Go to step 2.	Check the COVER ASSY TOP for installation, correct deformations, or replace it.
2	Checking the COVER ASSY TOP on the H-TRA for shape and operation Is the actuator of the COVER ASSY TOP that enters the T-TRANSPORT INTERLOCK SENSOR damaged?	Replace the COVER ASSY TOP.	Go to step 3.
3	Checking the T-TRANSPORT INTERLOCK SENSOR installation Is the T-TRANSPORT INTERLOCK SENSOR (PL 12.3.19) installed correctly?	Go to step 4.	Check the T-TRANSPORT INTERLOCK SENSOR for installation, or replace it.

Step	Check	Yes	No
4	Checking the T-TRANSPORT INTERLOCK SENSOR for operation Execute [Input 13-53 H-Transport Interlock SENSOR] in [Diagnosis]. Does the display on the screen change, every time the detection point of the T-TRANSPORT INTERLOCK SENSOR is blocked by putting a piece of paper?	Go to step 11.	Go to step 5.
5	Checking the WIRE HARNESS connection Are P/J8382 of the WIRE HARNESS, and P/J8372 on the PWB H-TRA of the Finisher connected surely?	Go to step 7.	After reconnecting, go to step 6.
6	Does the error still occur when the power is turned ON?	Go to step 7.	End of work.
7	Checking the WIRE HARNESS for conductivity Disconnect P/J8382 of the WIRE HARNESS, and P/J8372 connected to the PWB H-TRA of the Finisher. Check for conductivity at the following: J8382-3 <=> J8372-1 J8382-2 <=> J8372-2 J8382-1 <=> J8372-3	Go to step 8.	Replace the WIRE HARNESS.
8	Checking +5 VDC power supply to the T-TRANSPORT INTERLOCK SENSOR Is the voltage across J8372-3 <=> J8372-1 on the PWB H-TRA +5 VDC?	Go to step 9.	Replace the PWB MAIN-C. (RRP 12.98)
9	Checking the T-TRANSPORT INTERLOCK SENSOR for operation Does the voltage across J8372-3 <=> J8372-1 on the H-TRA change, every time the sensing area of the T-TRANSPORT INTERLOCK SENSOR is blocked by putting a piece of paper?	Go to step 10.	Replace the T-TRANSPORT INTERLOCK SENSOR. (RRP 12.12)
10	Checking after replacing the T-TRANSPORT INTERLOCK SENSOR Replace the T-TRANSPORT INTERLOCK SENSOR. (RRP 12.12) Does the error still occur when the power is turned ON?	Go to step 11.	End of work.
11	Checking after replacing the PWB MAIN-C Replace the PWB MAIN-C. (RRP 12.98) Does the error still occur when the power is turned ON?	Replace the PWBA MCU F. (RRP 8.4)	End of work.

## Finisher Eject Cover Open

Step	Check	Yes	No
	Possible causative parts: COVER ASSY FRONT (PL 12.5.3) SENSOR ASSY (PL 12.9.23) HARNESS ASSY INTERLOCK (PL 12.15.11) INTERLOCK SWITCH (PL 12.5.2) PWB MAIN-C (PL 12.14.5) PWBA MCU F (PL 8.1.5)		

Step	Check	Yes	No
1	Checking the COVER ASSY FRONT for opening and closing Open and close the COVER ASSY FRONT (PL 12.5.3). Does it open or close smoothly?	Go to step 2.	Check the COVER ASSY TOP for installation, correct deformations, or replace it.
2	Checking the SENSOR ASSY (Eject Cover SW) installation Is the SENSOR ASSY (PL 12.9.23) installed correctly?	Go to step 3.	Check the SENSOR ASSY (Eject Cover SW) for installation, or replace it.
3	Checking the HARNESS ASSY INTERLOCK connection Are P/J8365 of the HARNESS ASSY INTERLOCK, and P/J8364 of the Eject Cover SW, and P/J8388 and P/J8314 on the PWB MAIN-C connected surely?	Go to step 5.	After reconnecting, go to step 4.
4	Does the error still occur when the power is turned ON?	Go to step 5.	End of work.
5	Checking the HARNESS ASSY INTERLOCK for conductivity Disconnect P/J8365 of the HARNESS ASSY INTERLOCK, P/J8364 of the Eject Cover SW, and P/J8388 and P/J8314 on the PWB MAIN-C. Check for conductivity at the following: J8365-1A <=> J8388-2 J8365-1B <=> J8364-2 J8365-2A <=> J8314-3 J8365-2B <=> J8314-2 J8364-1 <=> J8388-1 J8364-3 <=> J8314-1	Go to step 6.	Replace the HARNESS ASSY INTERLOCK.
6	Checking +5/+24 VDC power supply to the INTERLOCK SWITCH (Finisher Front Door SW) Is the voltage across J8314-2 <=> FRAME CHASSIS on the PWB MAIN-C +5 VDC? Is the voltage across J8388-1 <=> FRAME CHASSIS on the PWB MAIN-C +24 VDC?	Go to step 7.	Replace the PWB MAIN-C. (RRP 12.98)
7	Checking the INTERLOCK SWITCH (Finisher Front Door SW) for operation Does the voltage across J8314-2 <=> J8314-3 on the PWB MAIN-C change, every time the sensing area of the INTERLOCK SWITCH (Finisher Front Door SW) is pushed by the tip of the screwdriver?	Go to step 8.	Replace the INTERLOCK SWITCH (Finisher Front Door SW). (RRP 12.23)
8	Checking the SENSOR ASSY (Eject Cover SW) for operation Does the voltage across J8365-1B <=> FRAME CHASSIS on the HARNESS ASSY INTERLOCK change, every time the actuator of the Eject Cover SW is operated?	Go to step 9.	Replace the SENSOR ASSY (Eject Cover SW). (RRP 12.56)

Step	Check	Yes	No
9	Checking the INTERLOCK SWITCH (Finisher Front Door SW) for operation Does the voltage across J8388-2 <=> FRAME CHASSIS on the PWB MAIN-C change, every time the actuator of the Eject Cover SW, and the sensing area of the INTERLOCK SWITCH (Finisher Front Door SW) is pushed simultaneously by the tip of the screwdriver?	Go to step 10.	Replace the INTERLOCK SWITCH (Finisher Front Door SW). (RRP 12.23)
10	Checking after replacing the PWB MAIN-C Replace the PWB MAIN-C. (RRP 12.98) Does the error still occur when the power is turned ON?	Replace the PWBA MCU F. (RRP 8.4)	End of work.

### C5-1 HCF F/O Sensor On Jam (HCF T/A Sensor On Jam)

Step	Check	Yes	No
	Possible causative parts: ROLL ASSY NUD (PL 13.5.20) ROLL ASSY FEED (PL 13.5.21) ROLLER ASSY RETARD (PL 13.6.17) ROLLER ASSY TA P (PL 13.7.9) COVER ASSY TOP S (PL 13.7.1) SENSOR ASSY TA (PL 13.7.6) HARNESS ASSY FEEDER (PL 13.5.12) HARNESS ASSY MAIN (PL 13.8.2) PWB ASSY (PL 13.8.1) SENSOR ASSY (PL 13.5.9) MOTOR ASSY HCF (PL 13.4.2) SOLENOID ASSY (PL 13.4.5) PWBA MCU F (PL 8.1.5)		
1	Checking the paper path Open the COVER ASSY TOP S (PL 13.7.1). Open the FEEDER ASSY UPPER (PL 13.5.1). Are the ROLLER ASSY NUD (PL 12.12.20), ROLL ASSY FEED (PL 13.5.21), ROLLER ASSY RETARD (PL 13.6.17), ROLLER ASSY TA P (PL 13.7.9), and Roller attached on the COVER ASSY TOP S installed correctly? Does they rotate smoothly without wear or/and paper dust? Check these items by turning them with your fingers. Are there any stains such as paper dust on the paper path?	Go to step 2.	Clean or replace the appropriate ROLLER, and clean the paper path.
2	Checking the SENSOR ASSY (HCF Pre Feed Sensor) for operation Execute [Input 08-22 HCF PreFEED SENSOR] in [Diagnosis]. Open the COVER ASSY TOP S (PL 13.7.1). Open the FEEDER ASSY UPPER (PL 13.5.1). Does the display on the screen change, every time a piece of white paper is placed over the sensing area of the SENSOR ASSY (HCF Pre Feed Sensor)?	Go to step 10.	Go to step 3.

Step	Check	Yes	No
3	Checking the HARNESS ASSY FEEDER for connection Are PF61 and PF56B of the HARNESS ASSY FEEDER connected surely?	Go to step 4.	After reconnecting, go to step 4.
4	Checking the HARNESS ASSY MAIN for connection Are PF56B and JF02 of the HARNESS ASSY MAIN connected surely?	Go to step 6.	After reconnecting, go to step 5.
5	Execute [Test Print] in [Diagnosis]. Does the error still occur?	Go to step 6.	End of work.
6	Checking the HARNESS ASSY FEEDER for conductivity Disconnect PF61 and PF56B of the HARNESS ASSY FEEDER. Check for conductivity at the following: PF61-1 <=> JF56B-3 PF61-2 <=> JF56B-2 PF61-3 <=> JF56B-1	Go to step 7.	Replace the HARNESS ASSY FEEDER.
7	Checking the HARNESS ASSY MAIN for conductivity Disconnect PF56B and JF02 of the HARNESS ASSY MAIN. Check for conductivity at the following: PF56B-4 <=> JF02-6 PF56B-5 <=> JF02-5 PF56B-6 <=> JF02-4	Go to step 8.	Replace the HARNESS ASSY MAIN.
8	Checking +5 VDC power supply to the SENSOR ASSY (HCF Pre Feed Sensor) Is the voltage across PF02-6 <=> PF02-4 on the PWB ASSY +5 VDC?	Go to step 9.	Replace the PWB ASSY. RRP 13.34)
9	Checking the SENSOR ASSY (HCF Pre Feed Sensor) for operation Does the voltage across PF02-5 <=> PF02-4 on the PWB ASSY change, every time a piece of white paper is placed over the sensing area of the SENSOR ASSY (HCF Pre Feed Sensor)?	Go to step 35.	Replace the SENSOR ASSY. RRP 13.18)
10	Checking the SENSOR ASSY TA (HCF TA Sensor) for operation Execute [Input 08-23 HCF F/O SENSOR] in [Diagnosis]. Does the display on the screen change, every time the actuator of the SENSOR ASSY TA (HCF TA Sensor) is operated?	Go to step 18.	Go to step 11.
11	Checking the HARNESS ASSY for connection Are PF67 and JF54 of the HARNESS ASSY connected to the SENSOR ASSY TA (HCF TA Sensor) connected surely?	Go to step 12.	After reconnecting, go to step 12.
12	Checking the HARNESS ASSY MAIN (PL 13.8.2) for connection Are PF54 and JF01 of the HARNESS ASSY MAIN connected surely?	Go to step 14.	After reconnecting, go to step 13.
13	Execute [Test Print] in [Diagnosis]. Does the error still occur?	Go to step 14.	End of work.

Step	Check	Yes	No
14	Checking the HARNESS ASSY for conductivity Disconnect PF67 and JF54 of the HARNESS ASSY. Check for conductivity at the following: PF67-1 <=> JF54-3 PF67-2 <=> JF54-2 PF67-3 <=> JF54-1	Go to step 15.	Replace the HARNESS ASSY.
15	Checking the HARNESS ASSY MAIN for conductivity Disconnect PF54 and JF01 of the HARNESS ASSY MAIN. Check for conductivity at the following: PF54-1 <=> JF01-3 PF54-2 <=> JF01-2 PF54-3 <=> JF01-1	Go to step 16.	Replace the HARNESS ASSY MAIN.
16	Checking +5 VDC power supply to the SENSOR ASSY TA (HCF TA Sensor) Is the voltage across PF01-3 <=> PF01-1 on the PWB ASSY +5 VDC?	Go to step 17.	Replace the PWB ASSY. RRP 13.34)
17	Checking the SENSOR ASSY TA (HCF TA Sensor) for operation Does the voltage across PF01-2 <=> PF01-1 on the PWB ASSY change, every time the actuator of the SENSOR ASSY TA (HCF TA Sensor) is operated?	Go to step 35.	Replace the SENSOR ASSY. RRP 13.30)
18	Checking the MOTOR ASSY HCF (Feed Sensor) for operation Execute [Output 08-16 HCF FEED MOTOR] in [Diagnosis]. Does the MOTOR ASSY HCF (Feed Sensor) rotate normally?	Go to step 26.	Go to step 19.
19	Checking the HARNESS ASSY FEEDER and HARNESS ASSY MAIN for connection Are the connectors PF58 and PF56 of the HARNESS ASSY FEEDER and HARNESS ASSY MAIN, and JF06 on the PWB ASSY connected surely?	Go to step 21.	After reconnecting, go to step 20.
20	Execute [Test Print] in [Diagnosis]. Does the error still occur?	Go to step 21.	End of work.
21	Checking the HARNESS ASSY FEEDER for conductivity Disconnect PF58 and JF56 of the HARNESS ASSY FEEDER. Check for conductivity at the following: PF58-1 <=> JF56-1 PF58-2 <=> JF56-2 PF58-3 <=> JF56-3 PF58-4 <=> JF56-4 PF58-5 <=> JF56-5 PF58-6 <=> JF56-6	Go to step 22.	Replace the HARNESS ASSY FEEDER.

Step	Check	Yes	No
22	<p>Checking the HARNESS ASSY MAIN for conductivity Disconnect PF56 and JF06 of the HARNRESS ASSY MAIN.</p> <p>Check for conductivity at the following: PF56-1 &lt;=&gt; JF06-1 PF56-2 &lt;=&gt; JF06-3 PF56-3 &lt;=&gt; JF06-2 PF56-4 &lt;=&gt; JF06-6 PF56-5 &lt;=&gt; JF06-4 PF56-6 &lt;=&gt; JF06-5</p>	Go to step 23.	Replace the HARNESS ASSY MAIN.
23	<p>Checking the conductivity (resistance) of the MOTOR ASSY HCF (Feed Motor) Are the conductivity across PF58-2/5 (COM) and PF58-1/3/4/6 of the MOTOR ASSY HCF (Feed Motor) normal, or are there any resistance without disconnection?</p>	Go to step 24.	Replace the MOTOR ASSY HCF. RRP 13.15)
24	<p>Checking +24 VDC power supply to the MOTOR ASSY HCF (Feed Motor) Are the voltages across PF06-3 &lt;=&gt; GND and PF06-4 &lt;=&gt; GND on the PWB ASSY, +24 VDC?</p>	Go to step 25.	Replace the PWB ASSY. RRP 13.34)
25	<p>Checking after replacing the MOTOR ASSY HCF (Feed Motor) Replace the MOTOR ASSY HCF (Feed Motor). RRP 13.15) Execute [Test Print] in [Diagnosis]. Does the error still occur?</p>	Go to step 35.	End of work.
26	<p>Checking the SOLENOID ASSY (Nudger Solenoid) for operation Execute [Output 08-41 HCF Nudger Solenoid (High Power)] in [Diagnosis]. Does the SOLENOID ASSY activates?</p>	Go to step 35.	Go to step 27.
27	<p>Checking the HARNESS ASSY FEEDER and HARNESS ASSY MAIN for connection Are the connectors PF59 and PF56 of the HARNRESS ASSY FEEDER and HARNESS ASSY MAIN, and JF06 on the PWB ASSY connected surely?</p>	Go to step 29.	After reconnecting, go to step 28.
28	<p>Execute [Test Print] in [Diagnosis]. Does the error still occur?</p>	Go to step 29.	End of work.
29	<p>Checking the HARNESS ASSY FEEDER for conductivity Disconnect PF59 and JF56A of the HARNESS ASSY FEEDER. Check for conductivity at the following: PF59-2 &lt;=&gt; JF56A-1 PF59-1 &lt;=&gt; JF56A-2</p>	Go to step 30.	Replace the HARNESS ASSY FEEDER.
30	<p>Checking the HARNESS ASSY MAIN for conductivity Disconnect PF56A and JF06 of the HARNESS ASSY MAIN. Check for conductivity at the following: PF56A-6 &lt;=&gt; JF06-13 PF56A-5 &lt;=&gt; JF06-14</p>	Go to step 31.	Replace the HARNESS ASSY MAIN.



Step	Check	Yes	No
31	Checking the conductivity (resistance) of the SOLENOID ASSY (Nudger Solenoid) Is the conductivity across PF59-1 and PF59-2 of the SOLENOID ASSY (Nudger Solenoid) normal, or is there any resistance without disconnection?	Go to step 32.	Replace the SOLENOID ASSY. RRP 13.17)
32	Checking +24.5 VDC power supply to the SOLENOID ASSY (Nudger Solenoid) Execute [Output 08-41 HCF Nudger Solenoid (High Power)] in [Diagnosis]. Is the voltage across PF06-13 <=> PF06-14 on the PWB ASSY +24.5 VDC?	Go to step 33.	Replace the PWB ASSY. RRP 13.34)
33	Checking +13.8 VDC power supply to the SOLENOID ASSY (Nudger Solenoid) Execute [Output 08-51 HCF Nudger Solenoid (Low Power)] in [Diagnosis]. Is the voltage across PF06-13 <=> PF06-14 on the PWB ASSY +13.8 VDC?	Go to step 34.	Replace the PWB ASSY. RRP 13.34)
34	Checking after replacing the SOLENOID ASSY (Nudger Solenoid) Replace the SOLENOID ASSY (Nudger Solenoid). RRP 13.17) Execute [Test Print] in [Diagnosis]. Does the error still occur?	Go to step 35.	End of work.
35	Checking after replacing the PWB ASSY Replace the PWB ASSY. RRP 13.34) Execute [Test Print] in [Diagnosis]. Does the error still occur?	Replace the PWBA MCU F.	End of work.

### C5-2 HCF F/O#2 Sensor On Jam

Step	Check	Yes	No
	Possible causative parts: ROLL ASSY NUD (PL 13.5.20) ROLL ASSY FEED (PL 13.5.21) ROLLER ASSY RETARD (PL 13.6.17) ROLLER ASSY TA P (PL 13.7.9) COVER ASSY TOP S (PL 13.7.1) HARNESS ASSY MAIN (PL 13.8.2) PWB ASSY (PL 13.8.1) MOTOR ASSY (PL 13.7.12) PWBA MCU F (PL 8.1.5)		

Step	Check	Yes	No
1	<p>Checking the paper path  Open the COVER ASSY TOP S (PL 13.7.1).  Open the FEEDER ASSY UPPER (PL 13.5.1).  Are the ROLLER ASSY NUD (PL 12.12.20), ROLL ASSY FEED (PL 13.5.21) ,ROLLER ASSY RETARD (PL 13.6.17), ROLLER ASSY TA P (PL 13.7.9), and Roller attached on the COVER ASSY TOP S installed correctly?  Does they rotate smoothly without wear or/and paper dust?  Check these items by turning them with your fingers.  Are there any stains such as paper dust on the paper path?</p>	Go to step 2.	Clean or replace the appropriate ROLLER, and clean the paper path.
2	<p>Checking the SENSOR (IOT Feed Out#2 Sensor) on the IOT for operation  Execute [Input 08-06 FEED OUT#2 SENSOR] in [Diagnosis].  Open the COVER ASSY LH LOW C (PL 4.1.10).  Does the display on the screen change, every time the SENSOR is operated?</p>	Go to step 7.	Go to step 3.
3	<p>Checking the SENSOR for connection  Are P/J105, P/J608 and P/J410 of the HARNESS connected to the SENSOR connected surely?</p>	Go to step 5.	After reconnecting, go to step 4.
4	<p>Execute [Test Print] in [Diagnosis].  Does the error still occur?</p>	Go to step 5.	End of work.
5	<p>Checking the HARNESS between SENSOR and PWBA MCU F for conductivity  Is there conductivity on each wire between P/J105 &lt;=&gt; P/J410?</p>	Go to step 6.	Replace the HARNESS.
6	<p>Checking +5 VDC power supply to the SENSOR  Is the voltage across P/J105-1 &lt;=&gt; GND on the PWBA MCU F +5 VDC?</p>	Replace the SENSOR. (RRP 4.15)	Replace the PWBA MCU F. (RRP 8.4)
7	<p>Checking the MOTOR ASSY (T/A Motor) for operation  Execute [Output 08-11 HCF T/A Motor(242mm/s)] in [Diagnosis].  Does the MOTOR ASSY (T/A Motor) rotate normally?</p>	Go to step 14.	Go to step 8.
8	<p>Checking the HARNESS ASSY MAIN for connection  Are PF57 and JF06 of the HARNESS ASSY MAIN connected surely?</p>	Go to step 10.	After reconnecting, go to step 9.
9	<p>Execute [Test Print] in [Diagnosis].  Does the error still occur?</p>	Go to step 10.	End of work.
10	<p>Checking the HARNESS ASSY MAIN for conductivity  Disconnect PF57 and JF06 of the HARNESS ASSY MAIN.  Check for conductivity at the following:  PF57-7 &lt;=&gt; JF06-11  PF57-6 &lt;=&gt; JF06-8  PF57-5 &lt;=&gt; JF06-9  PF57-4 &lt;=&gt; JF06-10  PF57-3 &lt;=&gt; JF06-12  PF57-2 &lt;=&gt; JF06-7</p>	Go to step 11.	Replace the HARNESS ASSY MAIN.

Step	Check	Yes	No
11	Checking the conductivity (resistance) of the MOTOR ASSY (T/A Motor) Are the conductivity across JF57-3/4(COM) and JF57-1/2/5/6 of the MOTOR ASSY (T/A Motor) normal, or are there any resistance without disconnection?	Go to step 12.	Replace the MOTOR ASSY. RRP 13.32)
12	Checking +24 VDC power supply to the MOTOR ASSY (T/A Motor) Are the voltages across PF06-9 <=> PF04-3, and PF06-10 <=> PF04-3 on the PWB ASSY, +24 VDC?	Go to step 13.	Replace the PWB ASSY. RRP 13.34)
13	Checking after replacing the MOTOR ASSY (T/A Motor) Replace the MOTOR ASSY (T/A Motor). RRP 13.32) Execute [Test Print] in [Diagnosis]. Does the error still occur?	Go to step 14.	End of work.
14	Checking after replacing the PWB ASSY Replace the PWB ASSY. RRP 13.34) Execute [Test Print] in [Diagnosis]. Does the error still occur?	Replace the PWBA MCU F. (RRP 8.4)	End of work.

### C5-3 HCF Registration Sensor On Jam

Step	Check	Yes	No
	Possible causative parts: ROLLER ASSY TA P (PL 13.7.9) COVER ASSY TOP S (PL 13.7.1) SENSOR ASSY REGI (PL 4.5.7) HARNESS ASSY FRONT A (PL 5.1.9) PWBA MCU F (PL 8.1.5) MOTOR ASSY (PL 13.7.12) PWB ASSY (PL 13.8.1) HARNESS ASSY MAIN (PL 13.8.2)		
1	Checking the paper path Open the COVER ASSY TOP S (PL 13.7.1). Are the ROLLER ASSY TA P (PL 13.7.9) and Roller attached on the COVER ASSY TOP S installed correctly? Does they rotate smoothly without wear or/and paper dust? Check these items by turning them with your fingers. Are there any stains such as paper dust on the paper path?	Go to step 2.	Clean or replace the appropriate ROLLER, and clean the paper path.
2	Checking the paper path of the IOT Open the COVER ASSY-LH (PL 4.2.8). Are there any stains such as paper dust on the paper path?	Go to step 3.	Clean the paper path.

Step	Check	Yes	No
3	Checking the SENSOR ASSY REGI (Registration Sensor) in the IOT for operation Execute [Input 08-05 REGI SENSOR] in [Diagnosis]. Open the COVER ASSY-LH (PL 4.2.8). Does the display on the screen change, every time the actuator of the SENSOR ASSY REGI (Registration Sensor) is operated?	Go to step 9.	Go to step 4.
4	Checking the HARNESS ASSY FRONT A on the IOT for connection Are P/J104 and P/J403 of the HARNESS ASSY FRONT A connected to the SENSOR ASSY REGI connected surely?	Go to step 6.	After reconnecting, go to step 5.
5	Execute [Test Print] in [Diagnosis]. Does the error still occur?	Go to step 6.	End of work.
6	Checking the HARNESS ASSY FRONT A on the IOT for conductivity Disconnect P/J104 and P/J403 of the HARNESS ASSY FRONT A. Check for conductivity at the following: J104-3 <=> J403B-3 J104-2 <=> J403B-8 J104-1 <=> J403B-13	Go to step 7.	Replace the HARNESS ASSY FRONT A.
7	Checking +5 VDC power supply to the SENSOR ASSY REG2 (Registration Sensor) on the IOT Is the voltage across P403-13 <=> P403-3 on the PWBA MCU F +5 VDC?	Go to step 8.	Replace the PWBA MCU F. (RRP 8.4)
8	Checking the SENSOR ASSY REG2 (Registration Sensor) on the IOT for operation Does the voltage across P403-8 <=> P403-3 on the PWBA MCU F change, every time the actuator of the SENSOR ASSY REG2 (Registration Sensor) is operated?	Go to step 16.	Replace the SENSOR ASSY REGI. (RRP 4.13)
9	Checking the MOTOR ASSY (T/A Motor) for operation Execute [Output 08-11 HCF T/A Motor (242mm/s)] in [Diagnosis]. Does the MOTOR ASSY (T/A Motor) rotate normally?	Go to step 16.	Go to step 10.
10	Checking the HARNESS ASSY MAIN for connection Are PF57 and JF06 of the HARNESS ASSY MAIN connected surely?	Go to step 12.	After reconnecting, go to step 11.
11	Execute [Test Print] in [Diagnosis]. Does the error still occur?	Go to step 12.	End of work.
12	Checking the HARNESS ASSY MAIN for conductivity Disconnect PF57 and JF06 of the HARNESS ASSY MAIN. Check for conductivity at the following: PF57-7 <=> JF06-11 PF57-6 <=> JF06-8 PF57-5 <=> JF06-9 PF57-4 <=> JF06-10 PF57-3 <=> JF06-12 PF57-2 <=> JF06-7	Go to step 13.	Replace the HARNESS ASSY MAIN.

Step	Check	Yes	No
13	Checking the conductivity (resistance) of the MOTOR ASSY (T/A Motor) Are the conductivity across JF57-3/4(COM) and JF57-1/2/5/6 of the MOTOR ASSY (T/A Motor) normal, or are there any resistance without disconnection?	Go to step 14.	Replace the MOTOR ASSY. RRP 13.32)
14	Checking +24 VDC power supply to the MOTOR ASSY (T/A Motor) Are the voltages across PF06-9 <=> PF04-3, and PF06-10 <=> PF04-3 on the PWB ASSY, +24 VDC?	Go to step 15.	Replace the PWB ASSY. RRP 13.34)
15	Checking after replacing the MOTOR ASSY (T/A Motor) Replace the MOTOR ASSY (T/A Motor). RRP 13.32) Execute [Test Print] in [Diagnosis]. Does the error still occur?	Go to step 16.	End of work.
16	Checking after replacing the PWB ASSY Replace the PWB ASSY. RRP 13.34) Execute [Test Print] in [Diagnosis]. Does the error still occur?	Replace the PWBA MCU F. (RRP 8.4)	End of work.

### C8-5 HCF F/O Sensor Static Jam

Step	Check	Yes	No
	Possible causative parts: ROLL ASSY FEED (PL 13.5.21) ROLLER ASSY RETARD (PL 13.6.17) ROLLER ASSY TA P (PL 13.7.9) COVER ASSY TOP S (PL 13.7.1) SENSOR ASSY TA (PL 13.7.6) HARNESS ASSY FEEDER (PL 13.5.12) HARNESS ASSY MAIN (PL 13.8.2) HARNESS ASSY XXXX (PL 13.XXX) MOTOR ASSY (PL 13.7.12) MOTOR ASSY HCF (PL 13.4.2) PWB ASSY (PL 13.8.1) PWBA MCU F (PL 8.1.5)		
1	Checking the paper path Open the COVER ASSY TOP S (PL 13.7.1). Open the FEEDER ASSY UPPER (PL 13.5.1). Are the ROLLER ASSY FEED (PL 13.5.21), ROLLER ASSY RETARD (PL 13.6.17), ROLLER ASSY TA P (PL 13.7.9) and Roller attached on the COVER ASSY TOP S installed correctly? Does they rotate smoothly without wear or/and paper dust? Check these items by turning them with your fingers. Are there any stains such as paper dust on the paper path?	Go to step 2.	Clean or replace the appropriate ROLLER, and clean the paper path.

Step	Check	Yes	No
2	Checking the SENSOR ASSY TA (HCF TA Sensor) for operation Execute [Input 08-23 HCF F/O SENSOR] in [Diagnosis]. Open the COVER ASSY TOP S (PL 13.7.1). Does the display on the screen change, every time the actuator of the SENSOR ASSY TA (HCF TA Sensor) is operated?	Go to step 10.	Go to step 3.
3	Checking the HARNESS ASSY for connection Are PF67 and PF54 of the HARNESS ASSY connected to the SENSOR ASSY TA (HCF TA Sensor) connected surely?	Go to step 4.	After reconnecting, go to step 4.
4	Checking the HARNESS ASSY MAIN for connection Are PF54 and JF01 of the HARNESS ASSY MAIN connected surely?	Go to step 6.	After reconnecting, go to step 5.
5	Execute [Test Print] in [Diagnosis]. Does the error still occur?	Go to step 6.	End of work.
6	Checking the HARNESS ASSY for conductivity Disconnect PF67 and JF54 of the HARNESS ASSY. Check for conductivity at the following: PF67-1 <=> JF54-3 PF67-2 <=> JF54-2 PF67-3 <=> JF54-1	Go to step 7.	Replace the HARNESS ASSY.
7	Checking the HARNESS ASSY MAIN for conductivity Disconnect PF54 and JF01 of the HARNESS ASSY MAIN. Check for conductivity at the following: PF54-1 <=> JF01-3 PF54-2 <=> JF01-2 PF54-3 <=> JF01-1	Go to step 8.	Replace the HARNESS ASSY MAIN.
8	Checking +5 VDC power supply to the SENSOR ASSY TA (HCF TA Sensor) Is the voltage across PF01-3 <=> PF01-1 on the PWB ASSY +5 VDC?	Go to step 9.	Replace the PWB ASSY. (RRP 13.34)
9	Checking the SENSOR ASSY TA (HCF TA Sensor) for operation Does the voltage across PF01-2 <=> PF01-1 on the PWB ASSY change, every time the actuator of the SENSOR ASSY TA (HCF TA Sensor) is operated?	Go to step 25.	Replace the SENSOR ASSY. (RRP 13.30)
10	Checking the MOTOR ASSY HCF (Feed Motor) for operation Execute [Output 08-16 HCF FEED MOTOR] in [Diagnosis]. Does the MOTOR ASSY HCF (Feed Motor) rotate normally?	Go to step 18.	Go to step 11.
11	Checking the HARNESS ASSY FEEDER and HARNESS ASSY MAIN for connection Are PF58 and PF56 of the HARNESS ASSY FEEDER and HARNESS ASSY MAIN, and JF06 on the PWB ASSY connected surely?	Go to step 13.	After reconnecting, go to step 12.

Step	Check	Yes	No
12	Execute [Test Print] in [Diagnosis]. Does the error still occur?	Go to step 13.	End of work.
13	Checking the HARNRESS ASSY FEEDER for conductivity Disconnect PF58 and JF56 of the HARNRESS ASSY FEEDER. Check for conductivity at the following: PF58-1 <=> JF56-1 PF58-2 <=> JF56-2 PF58-3 <=> JF56-3 PF58-4 <=> JF56-4 PF58-5 <=> JF56-5 PF58-6 <=> JF56-6	Go to step 14.	Replace the HARNRESS ASSY FEEDER.
14	Checking the HARNRESS ASSY MAIN for conductivity Disconnect PF56 and JF06 of the HARNRESS ASSY MAIN. Check for conductivity at the following: PF56-1 <=> JF06-1 PF56-2 <=> JF06-3 PF56-3 <=> JF06-2 PF56-4 <=> JF06-6 PF56-5 <=> JF06-4 PF56-6 <=> JF06-5	Go to step 15.	Replace the HARNRESS ASSY MAIN.
15	Checking the conductivity (resistance) of the MOTOR ASSY HCF (Feed Motor) Are the conductivity across PF58-2/5(COM) and PF58-1/3/4/6 of the MOTOR ASSY HCF (Feed Motor) normal, or are there any resistance without disconnection?	Go to step 16.	Replace the MOTOR ASSY HCF. RRP 13.15)
16	Checking +24 VDC power supply to the MOTOR ASSY HCF (Feed Motor) Are the voltages across PF06-3 <=> GND, and PF06-4 <=> GND on the PWB ASSY +24 VDC?	Go to step 17.	Replace the PWB ASSY. RRP 13.34)
17	Checking after replacing the MOTOR ASSY HCF (Feed Motor) Replace the MOTOR ASSY HCF (Feed Motor). RRP 13.15) Execute [Test Print] in [Diagnosis]. Does the error still occur?	Go to step 25.	End of work.
18	Checking the MOTOR ASSY (T/A Motor) for operation Execute [Output 08-11 HCF T/A Motor (242mm/s)] in [Diagnosis]. Does the MOTOR ASSY (T/A Motor) rotate normally?	Go to step 25.	Go to step 19.
19	Checking the HARNRESS ASSY MAIN for connection Are PF57 and JF06 of the HARNRESS ASSY MAIN connected surely?	Go to step 21.	After reconnecting, go to step 20.
20	Execute [Test Print] in [Diagnosis]. Does the error still occur?	Go to step 21.	End of work.

Step	Check	Yes	No
21	Checking the HARNESS ASSY MAIN for conductivity Disconnect PF57 and JF06 of the HARNESS ASSY MAIN. Check for conductivity at the following: PF57-7 <=> JF06-11 PF57-6 <=> JF06-8 PF57-5 <=> JF06-9 PF57-4 <=> JF06-10 PF57-3 <=> JF06-12 PF57-2 <=> JF06-7	Go to step 22.	Replace the HARNESS ASSY MAIN.
22	Checking the conductivity (resistance) of the MOTOR ASSY (T/A Motor) Are the conductivity across JF57-3/4(COM) and JF57-1/2/5/6 of the MOTOR ASSY (T/A Motor) normal, or are there any resistance without disconnection?	Go to step 23.	Replace the MOTOR ASSY. RRP 13.32)
23	Checking +24 VDC power supply to the MOTOR ASSY (T/A Motor) Are the voltages across PF06-9 <=> GND, and PF06-10 <=> GND on the PWB ASSY +24 VDC?	Go to step 24.	Replace the PWB ASSY. RRP 13.34)
24	Checking after replacing the MOTOR ASSY (T/A Motor) Replace the MOTOR ASSY (T/A Motor). RRP 13.32) Execute [Test Print] in [Diagnosis]. Does the error still occur?	Go to step 25.	End of work.
25	Checking after replacing the PWB ASSY Replace the PWB ASSY. RRP 13.34) Execute [Test Print] in [Diagnosis]. Does the error still occur?	Replace the PWBA MCU F. (RRP 8.4)	End of work.

## H1-5 HCF Lift Up Fail

Step	Check	Yes	No
	Possible causative parts: SENSOR (PL 13.1.4) HARNESS ASSY MAIN (PL 13.8.2) HARNESS ASSY FEEDER (PL 13.5.12) PWB ASSY (PL 13.8.1) KIT CABLE TRAY (PL 13.3.99) SENSOR-PHOTO IN (PL 13.5.16) SOLENOID ASSY (PL 13.4.5) PWBA MCU F (PL 8.1.5) MOTOR ASSY HCF (PL 13.4.2)		
1	Checking the SENSOR-PHOTO IN (HCF Level Sensor) for operation Execute [Input 07-17 HCF LEVEL SENSOR] in [Diagnosis]. At the same time, execute [Output 08-41 HCF Nudger Solenoid (High Power)] in [Diagnosis]. Does the display on the screen change, every time [Output 08-41 HCF Nudger Solenoid (High Power)] in [Diagnosis] is operated?	Go to step 9.	Go to step 2.



Step	Check	Yes	No
2	Checking the HARNESS ASSY FEEDER for connection Are PF62 and PF56B of the HARNESS ASSY FEEDER connected securely?	Go to step 3.	After reconnecting, go to step 3.
3	Checking the HARNESS ASSY MAIN for connection Are PF56B and JF02 of the HARNESS ASSY MAIN connected securely?	Go to step 5.	After reconnecting, go to step 4.
4	Does the error still occur when the power is on?	Go to step 5.	End of work.
5	Checking the HARNESS ASSY FEEDER for conductivity Disconnect PF62 and JF56B of the HARNESS ASSY FEEDER. Check for conductivity at the following: PF62-1 <=> JF56B-6 PF62-2 <=> JF56B-5 PF62-3 <=> JF56B-4	Go to step 6.	Replace the HARNESS ASSY FEEDER.
6	Checking the HARNESS ASSY MAIN for conductivity Disconnect PF56B and JF02 of the HARNESS ASSY MAIN. Check for conductivity at the following: JF56B-1 <=> JF02-3 JF56B-2 <=> JF02-2 JF56B-3 <=> JF02-1	Go to step 7.	Replace the HARNESS ASSY MAIN.
7	Checking +5 VDC power supply to the SENSOR-PHOTO IN (HCF Level Sensor) Is the voltage across PF02-3 <=> PF02-1 on the PWB ASSY +5 VDC?	Go to step 8.	Replace the PWB ASSY. RRP 13.34)
8	Checking the SENSOR-PHOTO IN (HCF Level Sensor) for operation Open the COVER ASSY TOP S (PL 13.7.1). Open the FEEDER ASSY UPPER (PL 13.5.1). Does the voltage across PF02-2 <=> PF02-1 on the PWB ASSY change, every time a piece of paper is placed into the detection area of the SENSOR-PHOTO IN (HCF Level Sensor)?	Go to step 26.	Replace the SENSOR-PHOTO IN. RRP 13.20)
9	Checking the SOLENOID ASSY (Nudger Solenoid) for operation Execute [Output 08-41 HCF Nudger Solenoid (High Power)] in [Diagnosis]. Does the SOLENOID ASSY activates?	Go to step 18.	Go to step 10.
10	Checking the HARNESS ASSY FEEDER and HARNESS ASSY MAIN for connection Are PF59 and PF56 of the HARNESS ASSY FEEDER and HARNESS ASSY MAIN, and JF06 on the PWB ASSY connected surely?	Go to step 12.	After reconnecting, go to step 11.
11	Does the error still occur when the power is on?	Go to step 12.	End of work.

Step	Check	Yes	No
12	Checking the HARNESS ASSY FEEDER for conductivity Disconnect PF59 and JF56A of the HARNESS ASSY FEEDER. Check for conductivity at the following: PF59-2 <=> JF56A-1 PF59-1 <=> JF56A-2	Go to step 13.	Replace the HARNESS ASSY FEEDER.
13	Checking the HARNESS ASSY MAIN for conductivity Disconnect PF56A and JF06 of the HARNESS ASSY MAIN. Check for conductivity at the following: PF56A-6 <=> JF06-13 PF56A-5 <=> JF06-14	Go to step 14.	Replace the HARNESS ASSY MAIN.
14	Checking the conductivity (resistance) of the SOLENOID ASSY (Nudger Solenoid) Is the conductivity across PF59-1 and PF59-2 of the SOLENOID ASSY (Nudger Solenoid) normal, or is there any resistance without disconnection?	Go to step 15.	Replace the SOLENOID ASSY. RRP 13.17)
15	Checking +24.5 VDC power supply to the SOLENOID ASSY (Nudger Solenoid) Execute [Output 08-41 HCF Nudger Solenoid (High Power)] in [Diagnosis]. Is the voltage across PF06-13 <=> PF06-14 on the PWB ASSY +24.5 VDC?	Go to step 16.	Replace the PWB ASSY. RRP 13.34)
16	Checking +13.8 VDC power supply to the SOLENOID ASSY (Nudger Solenoid) Execute [Output 08-51 HCF Nudger Solenoid (Low Power)] in [Diagnosis]. Is the voltage across PF06-13 <=> PF06-14 on the PWB ASSY +13.8 VDC?	Go to step 17.	Replace the PWB ASSY. RRP 13.34)
17	Checking after replacing the SOLENOID ASSY (Nudger Solenoid) Replace the SOLENOID ASSY (Nudger Solenoid). RRP 13.17) Does the error still occur when the power is on?	Go to step 26.	End of work.
18	Checking the MOTOR ASSY HCF (Feed Motor) for operation Execute [Output 07-22 HCF LIFTER UP (FEED MOTOR REVERSE)] in [Diagnosis]. Does the Feed Motor rotate reversely and the Tray raise?	Go to step 26.	Go to step 19.
19	Checking the HARNESS ASSY FEEDER and HARNESS ASSY MAIN for connection Are PF58 and PF56 of the HARNESS ASSY FEEDER and HARNESS ASSY MAIN, and JF06 on the PWB ASSY connected surely?	Go to step 21.	After reconnecting, go to step 20.
20	Does the error still occur when the power is on?	Go to step 21.	End of work.

Step	Check	Yes	No
21	<p>Checking the HARNESS ASSY FEEDER for conductivity Disconnect PF58 and JF56 of the HARNESS ASSY FEEDER.</p> <p>Check for conductivity at the following: PF58-1 &lt;=&gt; JF56-1 PF58-2 &lt;=&gt; JF56-2 PF58-3 &lt;=&gt; JF56-3 PF58-4 &lt;=&gt; JF56-4 PF58-5 &lt;=&gt; JF56-5 PF58-6 &lt;=&gt; JF56-6</p>	Go to step 22.	Replace the HARNESS ASSY FEEDER.
22	<p>Checking the HARNESS ASSY MAIN for conductivity Disconnect PF56 and JF06 of the HARNESS ASSY MAIN.</p> <p>Check for conductivity at the following: PF56-1 &lt;=&gt; JF06-1 PF56-2 &lt;=&gt; JF06-3 PF56-3 &lt;=&gt; JF06-2 PF56-4 &lt;=&gt; JF06-6 PF56-5 &lt;=&gt; JF06-4 PF56-6 &lt;=&gt; JF06-5</p>	Go to step 23.	Replace the HARNESS ASSY MAIN.
23	<p>Checking the conductivity (resistance) of the MOTOR ASSY HCF (Feed Motor)</p> <p>Are the conductivity across PF58-2/5(COM) and PF58-1/3/4/6 of the MOTOR ASSY HCF (Feed Motor) normal, or are there any resistance without disconnection?</p>	Go to step 24.	Replace the MOTOR ASSY HCF. RRP 13.15)
24	<p>Checking +24 VDC power supply to the MOTOR ASSY HCF (Feed Motor)</p> <p>Are the voltages across PF06-3 &lt;=&gt; GND, and PF06-4 &lt;=&gt; GND on the PWB ASSY +24 VDC?</p>	Go to step 25.	Replace the PWB ASSY. RRP 13.34)
25	<p>Checking after replacing the MOTOR ASSY HCF (Feed Motor)</p> <p>Replace the MOTOR ASSY HCF (Feed Motor). RRP 13.15)</p> <p>Does the error still occur when the power is on?</p>	Go to step 26.	End of work.
26	<p>Checking after replacing the PWB ASSY</p> <p>Replace the PWB ASSY. RRP 13.34)</p> <p>Does the error still occur when the power is on?</p>	Replace the PWBA MCU F. (RRP 8.4)	End of work.

## H6-4 HCF NVM R/W Error

Step	Check	Yes	No
	Possible causative parts: PWB ASSY (PL 13.8.1)		
1	<p>Turn off/on several times.</p> <p>Does the error still occur when the power is on?</p>	Go to step 2.	End of work.
2	<p>Checking the PWB ASSY for connection</p> <p>Are the connectors connected to the PWB ASSY surely?</p>	Go to step 4.	After reconnecting the connectors, go to step 3.

Step	Check	Yes	No
3	Does the error still occur when the power is on?	Go to step 4.	End of work.
4	Reconnect the connectors on the PWB ASSY. Disconnect all the connectors connected to the PWB ASSY and reconnect them. Does the error still occur when the power is on?	Replace the PWB ASSY. RRP 13.34)	End of work.

### HCF Communication fail

Step	Check	Yes	No
	Possible causative parts:		
1	Checking the HCF for installation Is the HCF installed to the printer correctly?	Go to step 2.	After reinstalling, go to step 2.
2	Turn ON/OFF the power. Does the error still occur when the power is on?	Go to step 3.	End of work.
3	Checking the HCF for connection Are P/J800A, P/J800B, P/J800 and P/J414 connected securely?	Go to step 4.	Connect P/J800A, P/J800B, P/J800 and P/J414 surely.
4	Checking conductivity between the PWB ASSY and the PWBA MCU F Is there normal conductivity at the following? P/J800A <=> P/J415 P/J800B <=> P/J415 P/J800 <=> P/J414	Go to step 5.	Fix open and short circuit.
5	Checking the PWB ASSY for power supply Is the voltage between P800-4 (+) and the ground (-) +24 VDC?	Replace the PWB ASSY. RRP 13.34)	Replace the PWBA MCU F. (RRP 8.4)

### HCF Top Cover Open

Step	Check	Yes	No
	Possible causative parts: PWB ASSY (PL 13.8.1) SWITCH (PL 13.7.3) HARNESS ASSY MAIN (PL 13.8.2) COVER ASSY TOP S (PL 13.7.1) PWBA MCU F (PL 8.1.5)		
1	Checking the COVER ASSY TOP S for shape Is the actuator of the COVER ASSY TOP enters the sensing area of the SWITCH (PL 13.7.3) (Transport Cover Interlock Switch) damaged?	Go to step 2.	Replace the COVER ASSY TOP S. RRP 13.28)

Step	Check	Yes	No
2	Checking the SWITCH (Transport Cover Interlock Switch) for operation Execute [Input 07-23 HCF COVER] in [Diagnosis]. Does the display on the screen change, every time the COVER ASSY TOP S is opened/closed?	Go to step 9.	Go to step 3.
3	Checking the HARNESS ASSY MAIN for connection Are FS001, FS002 and JF05 of the HARNESS ASSY MAIN connected securely?	Go to step 5.	After reconnecting, go to step 4.
4	Does the error still occur when the power is on?	Go to step 5.	End of work.
5	Checking the HARNESS ASSY MAIN for conductivity Disconnect FS001, FS002 and JF05 of the HARNESS ASSY MAIN. Check for conductivity at the following: FS002 <=> JF05-2 FS001 <=> JF05-1	Go to step 6.	Replace the HARNESS ASSY MAIN.
6	Checking +24 VDC power supply to the SWITCH (Transport Cover Interlock Switch) Is the voltage across PF05-2 <=> PF04-3 on the PWB ASSY +24 VDC?	Go to step 7.	Replace the PWB ASSY. RRP 13.34)
7	Checking the SWITCH (Transport Cover Interlock Switch) for operation Does the voltage across PF05-1 <=> PF04-3 on the PWB ASSY change, every time the COVER ASSY TOP S (PL 13.7.1) is opened/closed?	Go to step 8.	Replace the SWITCH. RRP 13.29)
8	Checking after replacing the SWITCH (Transport Cover Interlock Switch) Replace the SWITCH (Transport Cover Interlock Switch). RRP 13.29) Does the error still occur when the power is on?	Go to step 9.	End of work.
9	Checking after replacing the PWB ASSY Replace the PWB ASSY. RRP 13.34) Does the error still occur when the power is on?	Replace the PWBA MCU F. (RRP 8.4)	End of work.

## HCF Home Position S/W Open

Step	Check	Yes	No
	Possible causative parts: PWB ASSY (PL 13.8.1) SW IL ASSY DOCKING (PL 13.7.17) HARNESS ASSY MAIN (PL 13.8.2) PWBA MCU F (PL 8.1.5)		
1	Checking the HCF for installation Is the HCF installed to the printer correctly?	Go to step 2.	After reinstalling, go to step 2.

Step	Check	Yes	No
2	Checking the SW IL ASSY DOCKING (HCF Home Position Switch) for shape Is the SW IL ASSY DOCKING (HCF Home Position Switch) damaged?	Go to step 3.	Replace the SW IL ASSY DOCKING. RRP 13.33)
3	Checking the SW IL ASSY DOCKING (HCF Home Position Switch) for operation Execute [Input 08-57 HCF SIDE OUT SW] in [Diagnosis]. Does the display on the screen change, every time the SWITCH (Transport Cover Interlock Switch) is pushed/released?	Go to step 10.	Go to step 4.
4	Checking the HARNESS ASSY MAIN for connection Are FS003, FS004 and JF08 of the HARNESS ASSY MAIN connected securely?	Go to step 6.	After reconnecting, go to step 5.
5	Does the error still occur when the power is on?	Go to step 6.	End of work.
6	Checking the HARNESS ASSY MAIN for conductivity Disconnect FS003, FS004 and JF08 of the HARNESS ASSY MAIN. Check for conductivity at the following: FS003 <=> JF08-1 FS004 <=> JF08-2	Go to step 7.	Replace the HARNESS ASSY MAIN.
7	Checking +5 VDC power supply to the SW IL ASSY DOCKING (HCF Home Position Switch) Is the voltage across PF08-1 <=> PF04-2 on the PWB ASSY +0 VDC?	Go to step 8.	Replace the PWB ASSY. RRP 13.34)
8	Checking the SW IL ASSY DOCKING (HCF Home Position Switch) for operation Does the voltage across PF08-2 <=> PF04-3 on the PWB ASSY change, every time the SW IL ASSY DOCKING is pushed?	Go to step 9.	Replace the SW IL ASSY DOCKING. RRP 13.33)
9	Checking after replacing the SW IL ASSY DOCKING (HCF Home Position Switch) Replace the SW IL ASSY DOCKING (HCF Home Position Switch). RRP 13.33) Does the error still occur when the power is on?	Go to step 10.	End of work.
10	Checking after replacing the PWB ASSY Replace the PWB ASSY. RRP 13.34) Does the error still occur when the power is on?	Replace the PWBA MCU F. (RRP 8.4)	End of work.

## Prefeed SENSOR#3 on JAM (Tray3 paper feed)

Step	Check	Yes	No
	Possible causative parts: ROLLER ASSY (FEED) (PL 14.6.20) ROLLER ASSY (RETARD) (PL 14.6.28) ROLLER ASSY (NUDGER) (PL 14.6.32) TRAY 1/2 FEED LIFT UP MOTOR (PL 14.6.2) SENSOR (PRE FEED SENSOR) (PL 14.6.15) TRAY MODULE PWB (PL 14.8.5) PWBA MCU F (PL 8.1.5)		
1	Checking paper condition Is the paper in the tray crumpled or damaged?	Replace the paper with a new and dry one.	Go to step 2.
2	Checking paper size setup Does the paper size in use match the size set for the TRAY3?	Go to step 3.	Replace the paper, or change the paper size setup.
3	Checking the Roll for the TRAY3 Is the ROLLER ASSY (FEED), ROLLER ASSY (RETARD) or ROLLER ASSY (NUDGER) for transport worn or contaminated with paper dust? Pull out the TRAY3 and check it.	Go to step 4.	Clean or replace the ROLLER ASSY (FEED), ROLLER ASSY (RETARD) or ROLLER ASSY (NUDGER). (RRP 14.46/RRP 14.50/RRP 14.53)
4	Checking paper position Does the paper touch the SENSOR (PRE FEED SENSOR) of the TRAY3 FEEDER (PL 14.5.1)? Open the LEFT COVER ASSEMBLY (PL 14.7.1) and check it (visual check).	Remove the paper.	Go to step 5.
5	Checking the SENSOR (PRE FEED SENSOR) for the TRAY3 for operation Does the Input Status change from "0x0" to "0x1" each time the paper touches the SENSOR (PRE FEED SENSOR) for the TRAY3? Execute [Input 08-20 PreFEED SENSOR3] in Chapter 2 [Diagnostic].	Go to step 12.	Go to step 6.
6	Checking the SENSOR (PRE FEED SENSOR) for the TRAY3 for connection Are P/J103, P/J661B and P/J549B connected surely?	Go to step 7.	Connect P/J103, P/J661B and P/J549B surely.
7	Checking conductivity between the SENSOR (PRE FEED SENSOR) for the TRAY3 and the TRAY MODULE PWB Is there conductivity on each wire between P/J103B <=> P/J549B?	Go to step 8.	Fix open and short circuit.
8	Checking +5 VDC power supply to the SENSOR (PRE FEED SENSOR) for the TRAY2 Is the voltage across J103B-1 (+) <=> ground +5 VDC?	Replace the SENSOR (PRE FEED SENSOR) for the TRAY3. (RRP 14.43)	Go to step 9.

Step	Check	Yes	No
9	Checking connection between the TRAY MODULE PWB and the PWBA MCU F Are P/J541 and P/J413 connected surely?	Go to step 10.	Connect P/J541 and P/J413 surely.
10	Checking conductivity between the TRAY MODULE PWB and the PWBA MCU F Is there conductivity on each wire between P/J541 <=> P/J413?	Go to step 11.	Fix open and short circuit.
11	Checking +24 VDC power supply to the TRAY MODULE PWB Is the voltage across J541-8 (+) <=> ground +24 VDC?	Replace the TRAY MODULE PWB. (RRP 14.62)	Replace the PWBA MCU F. (RRP 8.4)
12	Checking the TRAY 1/2 FEED LIFT UP MOTOR for the TRAY3 for operation Does the TRAY 1/2 FEED LIFT UP MOTOR for the TRAY3 operate properly? Execute [Output 08-14 TRAY3 FEED MOTOR] in Chapter 2 [Diagnostic].	Reconnect the connector on the PWBA MCU F.	Go to step 13.
13	Checking the TRAY 1/2 FEED LIFT UP MOTOR for the TRAY3 for connection Are P/J220B, P/J661B and P/J549B connected surely?	Go to step 14.	Connect P/J220B, P/J661B and P/J549B surely.
14	Checking the TRAY 1/2 FEED LIFT UP MOTOR for the TRAY3 for operation (3) Replace the TRAY 1/2 FEED LIFT UP MOTOR for the TRAY3 with that for the TRAY4. Does the replaced motor operate properly? Execute [Output 08-14 TRAY3 FEED MOTOR] in Chapter 2 [Diagnostic].	Reinstall the TRAY 1/2 FEED LIFT UP MOTOR for the TRAY4 as it previously was and replace the motor for the TRAY3 with a new one. (RRP 14.34)	Go to step 15.
15	Checking the TRAY 1/2 FEED LIFT UP MOTOR for the TRAY3 for operation (4) Reinstall the TRAY 1/2 FEED LIFT UP MOTORS for the TRAY3 and TRAY4 as they previously were. Checking conductivity between the TRAY 1/2 FEED LIFT UP MOTOR for the TRAY3 and the TRAY MODULE PWB. Is there conductivity on each wire between P/J220B <=> P/J549B?	Go to step 16.	Fix open and short circuit.
16	Checking +24 VDC power supply to the TRAY 1/2 FEED LIFT UP MOTOR for the TRAY3 Is the voltage across J220-3 (+) <=> ground +24 VDC?	Replace the TRAY 1/2 FEED LIFT UP MOTOR for the TRAY3. (RRP 14.34)	Go to step 9.



## Tray 3 Feed Out Sensor on JAM (Tray 3 paper feed)

Step	Check	Yes	No
	Possible causative parts: ROLLER ASSY (FEED) (PL 14.6.20) ROLLER ASSY (RETARD) (PL 14.6.28) ROLLER ASSY (NUDGER) (PL 14.6.32) SENSOR (PRE FEED SENSOR) (PL 14.6.15) TRAY 3 FEED OUT SENSOR (PL 14.5.8) TRAY MODULE PWB (PL 14.8.5) PWBA MCU F (PL 8.1.5)		
1	Checking paper condition Is the paper in the tray crumpled or damaged?	Replace the paper with a new and dry one.	Go to step 2.
2	Checking paper size setup Does the paper size in use match the size set for the TRAY3?	Go to step 3.	Replace the paper or change the paper size setup.
3	Checking the Roll for the TRAY3 Is the ROLLER ASSY (FEED), ROLLER ASSY (RETARD) or ROLLER ASSY (NUDGER) for transport worn or contaminated with paper dust? Pull out the TRAY3 and check it.	Go to step 4.	Clean or replace the ROLLER ASSY (FEED), ROLLER ASSY (RETARD) or ROLLER ASSY (NUDGER). (RRP 14.46/RRP 14.50/RRP 14.53)
4	Checking paper position Does the paper touch the TRAY3 FEED OUT SENSOR or the SENSOR (PRE FEED SENSOR) of the TRAY 3 FEEDER (PL 14.5.1)? Open the LEFT COVER ASSEMBLY (PL 14.7.1) and check it (visual check).	Remove the paper.	Go to step 5.
5	Checking the TRAY 3 FEED OUT SENSOR for operation Does the Input Status change from "0x0" to "0x1" each time the paper touches the TRAY 3 FEED OUT SENSOR? Execute [Input 08-08 T/A F/03 SENSOR] in Chapter 2 [Diagnostic]. Open the LEFT COVER ASSEMBLY (PL 14.7.1) and check it.	Go to step 12.	Go to step 6.
6	Checking the TRAY 3 FEED OUT SENSOR for connection Are P/J821, P/J841 and P/J548 connected surely?	Go to step 7.	Connect P/J821, P/J841 and P/J548 surely.
7	Checking conductivity between the TRAY 3 FEED OUT SENSOR and the TRAY MODULE PWB Is there conductivity on each wire between P/J821 <=> P/J548?	Go to step 8.	Fix open and short circuit.
8	Checking +5 VDC power supply to the TRAY 3 FEED OUT SENSOR Is the voltage across J821-3 (+) <=> ground +5 VDC?	Replace the TRAY 3 FEED OUT SNESOR. (RRP 14.33)	Go to step 9.

Step	Check	Yes	No
9	Checking connection between the TRAY MODULE PWB and the PWBA MCU F (1) Are P/J541 and P/J413 connected surely?	Go to step 10.	Connect P/J541 and P/J413 surely.
10	Checking conductivity between the TRAY MODULE and the PWBA MCU F Is there conductivity on each wire between P/J541 <=> P/J413?	Go to step 11.	Fix open and short circuit.
11	Checking +24 VDC power supply to the TRAY MODULE PWB Is the voltage across J541-8 (+) <=> ground +24 VDC?	Replace the TRAY MODULE PWB. (RRP 14.62)	Replace the PWBA MCU F. (RRP 8.4)
12	Checking the SENSOR (PRE FEED SENSOR) for the TRAY3 for operation Does the Input Status change from "0x0" to "0x1" each time the paper touches the SENSOR (PRE FEED SENSOR) for the TRAY3? Execute [Input 08-20 PreFEED SENSOR3] in Chapter 2 [Diagnostic]. Open the LEFT COVER ASSEMBLY (PL 14.7.1) and check it.	Reconnect the connector on the PWBA MCU F.	Go to step 13.
13	Checking the SENSOR (PRE FEED SENSOR) for the TRAY3 for connection Are P/J103B, P/J661B and P/J549B connected surely?	Go to step 14.	Connect P/J103B, P/J661B and P/J549B surely.
14	Checking conductivity between the SENSOR (PRE FEED SENSOR) for the TRAY3 and the TRAY MODULE PWB Is there conductivity on each wire between P/J103B <=> P/J549B?	Go to step 15.	Fix open and short circuit.
15	Checking +5 VDC power supply to the SENSOR for the TRAY2 (PRE FEED SENSOR) Is the voltage across J103B-1 (+) <=> ground +5 VDC?	Replace the SENSOR (PRE FEED SENSOR). (RRP 14.43)	Go to step 16.
16	Checking connection between the TRAY MODULE PWB and the PWBA MCU F Are P/J541 and P/J413 connected surely?	Go to step 17.	Connect P/J541 and P/J413 surely.
17	Checking conductivity between the TRAY MODULE and the PWBA MCU F Is there conductivity on each wire between P/J541 <=> P/J413?	Go to step 18.	Fix open and short circuit.
18	Checking +24 VDC power supply to the TRAY MODULE PWB Is the voltage across J541-8 (+) <=> ground +24 VDC?	Replace the TRAY MODULE PWB. (RRP 14.62)	Replace the PWBA MCU F. (RRP 8.4)

## Tray 2 Feed Out Sensor on JAM (Tray 3 paper feed)

Step	Check	Yes	No
	Possible causative parts: ROLLER ASSY (FEED) (PL 14.6.20) ROLLER ASSY (RETARD) (PL 14.6.28) ROLLER ASSY (NUDGER) (PL 14.6.32) SENSOR (PL 4.5.18) TRAY 3 FEED OUT SENSOR (PL 14.5.8) TRAY MODULE PWB (PL 14.8.5) PWBA MCU F (PL 8.1.5)		
1	Checking paper condition Is the paper in the tray crumpled or damaged?	Replace the paper with a new and dry one.	Go to step 2.
2	Checking paper size setup Does the paper size in use match the size set for the TRAY3?	Go to step 3.	Replace the paper or change the paper size setup.
3	Checking the Roll for the TRAY3 Is the ROLLER ASSY (FEED), ROLLER ASSY (RETARD) or ROLLER ASSY (NUDGER) for transport worn or contaminated with paper dust? Pull out the TRAY3 and check it.	Go to step 4.	Clean or replace the ROLLER ASSY (FEED), ROLLER ASSY (RETARD) or ROLLER ASSY (NUDGER). (RRP 14.46/RRP 14.50/RRP 14.53)
4	Checking paper position (1) Does the paper touch the SENSOR? Open the COVER ASSY LH LOW C (PL 4.1.10) and check it (visual check).	Remove the paper.	Go to step 5.
5	Checking paper position (2) Does the paper touch the TRAY 3 FEED SENSOR? Open the LEFT COVER ASSEMBLY (PL 14.7.1) and check it (visual check).	Remove the paper.	Go to step 6.
6	Checking the SENSOR for operation Does the Input Status change from "0x0" to "0x1" each time the paper touches SENSOR? Execute [Input 08-06 FEED OUT#2 SENSOR] in Chapter 2 [Diagnostic]. Open the COVER ASSY LH LOW C (PL 4.1.10) and check it.	Go to step 10.	Go to step 7.
7	Checking the SENSOR for connection Are P/J105, P/J608 and P/J410 connected surely?	Go to step 8.	Connect P/J105, P/J608 and P/J410 surely.
8	Checking conductivity between the SENSOR and the PWBA MCU F Is there conductivity on each wire between P/J105 <=> P/J410?	Go to step 9.	Fix open and short circuit.

Step	Check	Yes	No
9	Checking +5 VDC power supply to the SENSOR Is the voltage across J105-1 (+) <=> ground +5 VDC?	Replace the SENSOR. (RRP 4.15)	Replace the PWBA MCU F. (RRP 8.4)
10	Checking the TRAY 3 FEED OUT SENSOR for operation Does the Input Status change from "0x0" to "0x1" each time the paper touches the TRAY 3 FEED OUT SENSOR? Execute [Input 08-20 PreFEED SENSOR3] in Chapter 2 [Diagnostic]. Open the LEFT COVER ASSEMBLY (PL 14.7.1) and check it.	Reconnect the connector on the PWBA MCU F.	Go to step 11.
11	Checking the TRAY 3 FEED OUT SENSOR for connection Are P/J821, P/J841 and P/J548 connected surely?	Go to step 12.	Connect P/J821, P/J841 and P/J548 surely.
12	Checking conductivity between the TRAY 3 FEED OUT SENSOR and the TRAY MODULE PWB Is there conductivity on each wire between P/J821 <=> P/J548?	Go to step 13.	Fix open and short circuit.
13	Checking +5 VDC power supply to the TRAY 3 FEED OUT SENSOR Is the voltage across J821-3 (+) <=> ground +5 VDC?	Replace the TRAY 3 FEED OUT SNESOR. (RRP 14.33)	Go to step 14.
14	Checking connection between the TRAY MODULE PWB and the PWBA MCU F Are P/J541 and P/J413 connected surely?	Go to step 15.	Connect P/J541 and P/J413 surely.
15	Checking conductivity between the TRAY MODULE and the PWBA MCU F Is there conductivity on each wire between P/J541 <=> P/J413?	Go to step 16.	Fix open and short circuit.
16	Checking +24 VDC power supply to the TRAY MODULE PWB Is the voltage across J541-8 (+) <=> ground +24 VDC?	Replace the TRAY MODULE PWB. (RRP 14.62)	Replace the PWBA MCU F. (RRP 8.4)

### Registration Sensor on JAM (Tray3 paper feed)

Step	Check	Yes	No
	Possible causative parts: ROLLER ASSY (FEED) (PL 14.6.20) ROLLER ASSY (RETARD) (PL 14.6.28) ROLLER ASSY (NUDGER) (PL 14.6.32) SENSOR ASSY REGI (PL 4.5.7) TRAY 3 FEED OUT SENSOR (PL 14.5.8) TRAY MODULE PWB (PL 14.8.5) PWBA MCU F (PL 8.1.5)		
1	Checking paper condition Is the paper in the tray crumpled or damaged?	Replace the paper with a new and dry one.	Go to step 2.

Step	Check	Yes	No
2	Checking the paper size setup Does the paper size in use match the size set for the TRAY3?	Go to step 3.	Replace the paper or change the paper size setup.
3	Checking the Roll for the TRAY3 Is the ROLLER ASSY (FEED), ROLLER ASSY (RETARD) or ROLLER ASSY (NUDGER) for transport worn or contaminated with paper dust? Pull out the TRAY3 and check it.	Go to step 4.	Clean or replace the ROLLER ASSY (FEED), ROLLER ASSY (RETARD) or ROLLER ASSY (NUDGER). (RRP 14.46/RRP 14.50/RRP 14.53)
4	Checking paper position (1) Does the paper touch the SENSOR ASSY REGI? Open the COVER ASSY-LH (PL 4.2.8) and check it (visual check).	Remove the paper.	Go to step 5.
5	Checking paper position (2) Does the paper touch the TRAY 3 FEED SENSOR? Open the LEFT COVER ASSEMBLY (PL 14.7.1) and check it (visual check).	Remove the paper.	Go to step 6.
6	Checking the SENSOR ASSY REGI for operation Does the Input Status change from "0x0" to "0x1" each time the paper touches the SENSOR ASSY REGI? Execute [Input 08-05 REGI SENSOR] in Chapter 2 [Diagnostic]. Open the COVER ASSY-LH (PL 4.2.8) and check it.	Go to step 10.	Go to step 7.
7	Checking the SENSOR ASSY REGI for connection Are P/J104 and P/J403B connected surely?	Go to step 8.	Connect P/J104 and P/J403B surely.
8	Checking conductivity between the SENSOR ASSY REGI and the PWB A MCU F Is there conductivity on each wire between P/J104 <=> P/J409B?	Go to step 9.	Fix open and short circuit.
9	Checking +5 VDC power supply to the SENSOR ASSY REGI Is the voltage across J104-1 (+) <=> ground +5 VDC?	Replace the SENSOR ASSY REGI. (RRP 4.13)	Replace the PWBA MCU F. (RRP 8.4)
10	Checking the TRAY 3 FEED OUT SENSOR for operation Does the Input Status change from "0x0" to "0x1" each time the paper touches the TRAY 3 FEED OUT SENSOR? Execute [Input 08-08 T/A F/03 SENSOR] in Chapter 2 [Diagnostic]. Open the LEFT COVER ASSEMBLY (PL 14.7.1) and check it.	Reconnect the connector on the PWBA MCU F.	Go to step 11.
11	Checking the TRAY 3 FEED OUT SENSOR for connection Are P/J821, P/J841 and P/J548 connected surely?	Go to step 12.	Connect P/J821, P/J841 and P/J548 surely.

Step	Check	Yes	No
12	Checking conductivity between the TRAY 3 FEED OUT SENSOR and the TRAY MODULE PWB Is there conductivity on each wire between P/J821 <=> P/J548?	Go to step 13.	Fix open and short circuit.
13	Checking +5 VDC power supply to the TRAY 3 FEED OUT SENSOR Is the voltage across J821-3 (+) <=> ground +5 VDC?	Replace the TRAY 3 FEED OUT SNESOR. (RRP 14.33)	Go to step 14.
14	Checking connection between the TRAY MODULE PWB and the PWBA MCU F Are P/J541 and P/J413 connected surely?	Go to step 15.	Connect P/J541 and P/J413 surely.
15	Checking conductivity between the TRAY MODULE and the PWBA MCU F Is there conductivity on each wire between P/J541 <=> P/J413?	Go to step 16.	Fix open and short circuit.
16	Checking +24 VDC power supply to the TRAY MODULE PWB Is the voltage across J541-8 (+) <=> ground +24 VDC?	Replace the TRAY MODULE PWB. (RRP 14.62)	Replace the PWBA MCU F. (RRP 8.4)

### Tray 4 Feed Out Sensor on JAM (Tray 4 paper feed)

Step	Check	Yes	No
	Possible causative parts: ROLLER ASSY (FEED) (PL 14.6.20) ROLLER ASSY (RETARD) (PL 14.6.28) ROLLER ASSY (NUDGER) (PL 14.6.32) SENSOR (PRE FEED SENSOR) (PL 14.6.15) TRAY 4 FEED OUT SENSOR (PL 14.4.18) TRAY MODULE PWB (PL 14.8.5) PWBA MCU F (PL 8.1.5)		
1	Checking paper condition Is the paper in the tray crumpled or damaged?	Replace the paper with a new and dry one.	Go to step 2.
2	Checking the paper size setup Does the paper size in use match the size set for the TRAY4?	Go to step 3.	Replace the paper or change the paper size setup.
3	Checking the Roll for the TRAY4 Is the ROLLER ASSY (FEED), ROLLER ASSY (RETARD) or ROLLER ASSY (NUDGER) for transport worn or contaminated with paper dust? Pull out the TRAY4 and check it.	Go to step 4.	Clean or replace the ROLLER ASSY (FEED), ROLLER ASSY (RETARD) or ROLLER ASSY (NUDGER). (RRP 14.46/RRP 14.50/RRP 14.53)

Step	Check	Yes	No
4	Checking paper position Does the paper touch the SENSOR (PRE FEED SENSOR) of the TRAY 4 FEEDER (PL 14.5.1) or the TRAY4 FEED OUT SENSOR? Open the LEFT COVER ASSEMBLY (PL 14.7.1) and check it (visual check).	Remove the paper.	Go to step 5.
5	Checking the SENSOR (PRE FEED SENSOR) for the TRAY4 for operation Does the Input Status change from "0x0" to "0x1" each time the paper touches the SENSOR (PRE FEED SENSOR) for the TRAY4? Execute [Input 08-21 PreFEED SENSOR4] in Chapter 2 [Diagnostic]. Open the LEFT COVER ASSEMBLY (PL 14.7.1) and check it.	Go to step 12.	Go to step 6.
6	Checking the SENSOR (PRE FEED SENSOR) for the TRAY4 for connection Are P/J103A, P/J661A and P/J549A connected surely?	Go to step 7.	Connect P/J103A, P/J661A and P/J549A surely.
7	Checking conductivity between the SENSOR (PRE FEED SENSOR) for the TRAY4 and the TRAY MODULE PWB Is there conductivity on each wire between P/J103A <=> P/J549A?	Go to step 8.	Fix open and short circuit.
8	Checking +5 VDC power supply to the SENSOR (PRE FEED SENSOR) for the TRAY4 Is the voltage across J103A-1 (+) <=> ground +5 VDC?	Replace the SENSOR (PRE FEED SENSOR). (RRP 14.43)	Go to step 9.
9	Checking connection between the TRAY MODULE PWB and the PWBA MCU F (1) Are P/J541 and P/J413 connected surely?	Go to step 10.	Connect P/J541 and P/J413 surely.
10	Checking conductivity between the TRAY MODULE and the PWBA MCU F Is there conductivity on each wire between P/J541 <=> P/J413?	Go to step 11.	Fix open and short circuit.
11	Checking +24 VDC power supply to the TRAY MODULE PWB Is the voltage across J541-8 (+) <=> ground +24 VDC?	Replace the TRAY MODULE PWB. (RRP 14.62)	Replace the PWBA MCU F. (RRP 8.4)
12	Checking the TRAY 4 FEED OUT SENSOR for operation Does the Input Status change from "0x0" to "0x1" each time the paper touches the TRAY 4 FEED OUT SENSOR? Execute [Input 08-09 T/A F/04 SENSOR] in Chapter 2 [Diagnostic]. Open the LEFT COVER ASSEMBLY (PL 14.7.1) and check it.	Reconnect the connector on the PWBA MCU F.	Go to step 13.
13	Checking the TRAY 4 FEED OUT SENSOR for connection Are P/J825, P/J842 and P/J548 connected surely?	Go to step 14.	Connect P/J825, P/J842 and P/J548 surely.

Step	Check	Yes	No
14	Checking conductivity between the TRAY 4 FEED OUT SENSOR and the TRAY MODULE PWB Is there conductivity on each wire between P/J825 <=> P/J548?	Go to step 15.	Fix open and short circuit.
15	Checking +5 VDC power supply to the TRAY 4 FEED OUT SENSOR Is the voltage across J825-3 (+) <=> ground +5 VDC?	Replace the TRAY 4 FEED OUT SNESOR. (RRP 14.28)	Go to step 16.
16	Checking connection between the TRAY MODULE PWB and the PWBA MCU F Are P/J541 and P/J413 connected surely?	Go to step 17.	Connect P/J541 and P/J413 surely.
17	Checking conductivity between the TRAY MODULE and the PWBA MCU F Is there conductivity on each wire between P/J541 <=> P/J413?	Go to step 18.	Fix open and short circuit.
18	Checking +24 VDC power supply to the TRAY MODULE PWB Is the voltage across J541-8 (+) <=> ground +24 VDC?	Replace the TRAY MODULE PWB. (RRP 14.62)	Replace the PWBA MCU F. (RRP 8.4)

### Tray 3 Feed Out Sensor on JAM (Tray 4 paper feed)

Step	Check	Yes	No
	Possible causative parts: ROLLER ASSY (FEED) (PL 14.6.20) ROLLER ASSY (RETARD) (PL 14.6.28) ROLLER ASSY (NUDGER) (PL 14.6.32) TRAY 3 FEED OUT SENSOR (PL 14.5.8) TRAY 4 FEED OUT SENSOR (PL 14.4.18) TRAY MODULE PWB (PL 14.8.5) PWBA MCU F (PL 8.1.5)		
1	Checking paper condition Is the paper in the tray crumpled or damaged?	Replace the paper with a new and dry one.	Go to step 2.
2	Checking paper size setup Does the paper size in use match the size set for the TRAY4?	Go to step 3.	Replace the paper or change the paper size setup.
3	Checking the Roll for the TRAY4 Is the ROLLER ASSY (FEED), ROLLER ASSY (RETARD) or ROLLER ASSY (NUDGER) for transport worn or contaminated with paper dust? Pull out the TRAY4 and check it.	Go to step 4.	Clean or replace the ROLLER ASSY (FEED), ROLLER ASSY (RETARD) or ROLLER ASSY (NUDGER). (RRP 14.46/RRP 14.50/RRP 14.53)



Step	Check	Yes	No
4	Checking paper position Does the paper touch the TRAY 3 FEED OUT SENSOR or the TRAY 4 FEED OUT SENSOR? Open the LEFT COVER ASSEMBLY (PL 14.7.1) and check it (visual check).	Remove the paper.	Go to step 5.
5	Checking the TRAY 4 FEED OUT SENSOR for operation Does the Input Status change from "0x0" to "0x1" each time the paper touches the TRAY 4 FEED OUT SENSOR? Execute [Input 08-09 T/A F/04 SENSOR] in Chapter 2 [Diagnostic].	Go to step 12.	Go to step 6.
6	Checking the TRAY 4 FEED OUT SENSOR for connection Are P/J825, P/J842 and P/J548 connected surely?	Go to step 7.	Connect P/J825, P/J842 and P/J548 surely.
7	Checking conductivity between the TRAY 4 FEED OUT SENSOR and the TRAY MODULE PWB Is there conductivity on each wire between P/J825 <=> P/J548?	Go to step 8.	Fix open and short circuit.
8	Checking +5 VDC power supply to the TRAY 4 FEED OUT SENSOR Is the voltage across J825-3 (+) <=> ground +5 VDC?	Replace the TRAY 4 FEED OUT SNESOR. (RRP 14.28)	Go to step 9.
9	Checking connection between the TRAY MODULE PWB and the PWBA MCU F Are P/J541 and P/J413 connected surely?	Go to step 10.	Connect P/J541 and P/J413 surely.
10	Checking conductivity between the TRAY MODULE and the PWBA MCU F Is there conductivity on each wire between P/J541 <=> P/J413?	Go to step 11.	Fix open and short circuit.
11	Checking +24 VDC power supply to the TRAY MODULE PWB Is the voltage across J541-8 (+) <=> ground +24 VDC?	Replace the TRAY MODULE PWB. (RRP 14.62)	Replace the PWBA MCU F. (RRP 8.4)
12	Checking the TRAY 3 FEED OUT SENSOR for operation Does the Input Status change from "0x0" to "0x1" each time the paper touches the TRAY 3 FEED OUT SENSOR? Execute [Input 08-08 T/A F/03 SENSOR] in Chapter 2 [Diagnostic]. Open the LEFT COVER ASSEMBLY (PL 14.7.1) and check it.	Reconnect the connector on the PWBA MCU F.	Go to step 13.
13	Checking the TRAY 3 FEED OUT SENSOR for connection Are P/J821, P/J841 and P/J548 connected surely?	Go to step 14.	Connect P/J821, P/J841 and P/J548 surely.
14	Checking conductivity between the TRAY 3 FEED OUT SENSOR and the TRAY MODULE PWB Is there conductivity on each wire between P/J821 <=> P/J548?	Go to step 15.	Fix open and short circuit.

Step	Check	Yes	No
15	Checking +5 VDC power supply to the TRAY 3 FEED OUT SENSOR Is the voltage across J821-3 (+) <=> ground +5 VDC?	Replace the TRAY 3 FEED OUT SNESOR. (RRP 14.33)	Go to step 16.
16	Checking connection between the TRAY MODULE PWB and the PWBA MCU F Are P/J541 and P/J413 connected surely?	Go to step 17.	Connect P/J541 and P/J413 surely.
17	Checking conductivity between the TRAY MODULE and the PWBA MCU F Is there conductivity on each wire between P/J541 <=> P/J413?	Go to step 18.	Fix open and short circuit.
18	Checking +24 VDC power supply to the TRAY MODULE PWB Is the voltage across J541-8 (+) <=> ground +24 VDC?	Replace the TRAY MODULE PWB. (RRP 14.62)	Replace the PWBA MCU F. (RRP 8.4)

### Tray 2 Feed Out Sensor on JAM (Tray 3 paper feed) TTM

Step	Check	Yes	No
	Possible causative parts: ROLLER ASSY (FEED) (PL 14.6.20) ROLLER ASSY (RETARD) (PL 14.6.28) ROLLER ASSY (NUDGER) (PL 14.6.32) SENSOR (PL 4.5.18) TRAY 3 FEED OUT SENSOR (PL 14.5.8) TRAY MODULE PWB (PL 14.8.5) PWBA MCU F (PL 8.1.5)		
1	Checking paper condition Is the paper in the tray crumpled or damaged?	Replace the paper with a new and dry one.	Go to step 2.
2	Checking the paper size setup Does the paper size in use match the size set for the TRAY3?	Go to step 3.	Replace the paper or change the paper size setup.
3	Checking the Roll for the TRAY3 Is the ROLLER ASSY (FEED), ROLLER ASSY (RETARD) or ROLLER ASSY (NUDGER) for transport worn or contaminated with paper dust? Pull out the TRAY3 and check it.	Go to step 4.	Clean or replace the ROLLER ASSY (FEED), ROLLER ASSY (RETARD) or ROLLER ASSY (NUDGER). (RRP 14.46/RRP 14.50/RRP 14.53)
4	Checking paper position (1) Does the paper touch the SENSOR? Open the COVER ASSY LH LOW C (PL 4.1.10) and check it (visual check).	Remove the paper.	Go to step 5.

Step	Check	Yes	No
5	Checking paper position (2) Does the paper touch the TRAY 3 FEED OUT SENSOR? Open the LEFT COVER ASSEMBLY (PL 14.7.1) and check it (visual check).	Remove the paper.	Go to step 6.
6	Checking the SENSOR for operation Does the Input Status change from "0x0" to "0x1" each time the paper touches the SENSOR? Execute [Input 08-06 FEED OUT#2 SENSOR] in Chapter 2 [Diagnostic]. Open the COVER ASSY LH LOW C (PL 4.1.10) and check it.	Go to step 10.	Go to step 7.
7	Checking the SENSOR for connection Are P/J105, P/J608 and P/J410 connected surely?	Go to step 8.	Connect P/J105, P/J608 and P/J410 surely.
8	Checking conductivity between the SENSOR and the PWBA MCU F Is there conductivity on each wire between P/J105 <=> P/J410?	Go to step 9.	Fix open and short circuit.
9	Checking +5 VDC power supply to the SENSOR Is the voltage across J105-1 (+) <=> ground +5 VDC?	Replace the SENSOR. (RRP 4.15)	Replace the PWBA MCU F. (RRP 8.4)
10	Checking the TRAY 3 FEED OUT SENSOR for the TRAY3 for operation Does the Input Status change from "0x0" to "0x1" each time the paper touches the TRAY 3 FEED OUT SENSOR for the TRAY3? Execute [Input 08-20 PreFEED SENSOR3] in Chapter 2 [Diagnostic]. Open the LEFT COVER ASSEMBLY (PL 14.7.1) and check it.	Reconnect the connector on the PWBA MCU F.	Go to step 11.
11	Checking the TRAY 3 FEED OUT SENSOR for connection Are P/J821, P/J841 and P/J548 connected surely?	Go to step 12.	Connect P/J821, P/J841 and P/J548 surely.
12	Checking conductivity between the TRAY 3 FEED OUT SENSOR and the TRAY MODULE PWB Is there conductivity on each wire between P/J821 <=> P/J548?	Go to step 13.	Fix open and short circuit.
13	Checking +5 VDC power supply to the TRAY 3 FEED OUT SENSOR Is the voltage across J821-3 (+) <=> ground +5 VDC?	Replace the TRAY 3 FEED OUT SNESOR. (RRP 14.33)	Go to step 14.
14	Checking connection between the TRAY MODULE PWB and the PWBA MCU F Are P/J541 and P/J413 connected surely?	Go to step 15.	Connect P/J541 and P/J413 surely?
15	Checking conductivity between the TRAY MODULE and the PWBA MCU F Is there conductivity on each wire between P/J541 <=> P/J413?	Go to step 16.	Fix open and short circuit.

Step	Check	Yes	No
16	Checking +24 VDC power supply to the TRAY MODULE PWB Is the voltage across J541-8 (+) <=> ground +24 VDC?	Replace the TRAY MODULE PWB. (RRP 14.62)	Replace the PWBA MCU F. (RRP 8.4)

### Registration Sensor on JAM (Tray4 paper feed)

Step	Check	Yes	No
	Possible causative parts: ROLLER ASSY (FEED) (PL 14.6.20) ROLLER ASSY (RETARD) (PL 14.6.28) ROLLER ASSY (NUDGER) (PL 14.6.32) SENSOR ASSY REGI (PL 4.5.7) TRAY 4 FEED OUT SENSOR (PL 14.4.18) TRAY MODULE PWB (PL 14.8.5) PWBA MCU F (PL 8.1.5)		
1	Checking paper condition Is the paper in the tray crumpled or damaged?	Replace the paper with a new and dry one.	Go to step 2.
2	Checking paper size setup Does the paper size in use match the size set for the TRAY4?	Go to step 3.	Replace the paper or change the paper size setup.
3	Checking the Roll for the TRAY4 Is the ROLLER ASSY (FEED), ROLLER ASSY (RETARD) or ROLLER ASSY (NUDGER) for transport worn or contaminated with paper dust? Pull out the TRAY4 and check it.	Go to step 4.	Clean or replace the ROLLER ASSY (FEED), ROLLER ASSY (RETARD) or ROLLER ASSY (NUDGER). (RRP 14.46/RRP 14.50/RRP 14.53)
4	Checking paper position (1) Does the paper touch the SENSOR ASSY REGI? Open the COVER ASSY-LH (PL 4.2.8) and check it (visual check).	Remove the paper.	Go to step 5.
5	Checking paper position (2) Does the paper touch the TRAY 4 FEED OUT SENSOR? Open the LEFT COVER ASSEMBLY (PL 14.7.1) and check it (visual check).	Remove the paper.	Go to step 6.
6	Checking the SENSOR ASSY REGI for operation Does the Input Status change from "0x0" to "0x1" each time the paper touches the SENSOR ASSY REGI? Execute [Input 08-05 REGI SENSOR] in Chapter 2 [Diagnostic]. Open the COVER ASSY-LH (PL 4.2.8) and check it.	Go to step 10.	Go to step 7.

Step	Check	Yes	No
7	Checking the SENSOR ASSY REGI for connection Are P/J104 and P/J403B connected surely?	Go to step 8.	Connect P/J104 and P/J403B surely.
8	Checking conductivity between the SENSOR ASSY REGI and the PWB A MCU F Is there conductivity on each wire between P/J104 <=> P/J403B?	Go to step 9.	Fix open and short circuit.
9	Checking +5 VDC power supply to the SENSOR ASSY REGI Is the voltage across J104-1 (+) <=> ground +5 VDC?	Replace the SENSOR ASSY REGI. (RRP 4.13)	Replace the PWBA MCU F. (RRP 8.4)
10	Checking the TRAY 4 FEED OUT SENSOR for operation Does the Input Status change from "0x0" to "0x1" each time the paper touches the TRAY 4 FEED OUT SENSOR? Execute [Input 08-08 T/A F/04 SENSOR] in Chapter 2 [Diagnostic]. Open the LEFT COVER ASSEMBLY (PL 14.7.1) and check it.	Reconnect the connector on the PWBA MCU F.	Go to step 11.
11	Checking the TRAY 4 FEED OUT SENSOR for connection Are P/J825, P/J842 and P/J548 connected surely?	Go to step 12.	Connect P/J825, P/J842 and P/J548 surely.
12	Checking conductivity between the TRAY 4 FEED OUT SENSOR and the TRAY MODULE PWB Is there conductivity on each wire between P/J825 <=> P/J548?	Go to step 13.	Fix open and short circuit.
13	Checking +5 VDC power supply to the TRAY 4 FEED OUT SENSOR Is the voltage across J821-3 (+) <=> ground +5 VDC?	Replace the TRAY 4 FEED OUT SNESOR. (RRP 14.28)	Go to step 14.
14	Checking connection between the TRAY MODULE PWB and the PWBA MCU F Are P/J541 and P/J413 connected surely?	Go to step 15.	Connect P/J541 and P/J413 surely.
15	Checking conductivity between the TRAY MODULE and the PWBA MCU F Is there conductivity on each wire between P/J541 <=> P/J413?	Go to step 16.	Fix open and short circuit.
16	Checking +24 VDC power supply to the TRAY MODULE PWB Is the voltage across J541-8 (+) <=> ground +24 VDC?	Replace the TRAY MODULE PWB. (RRP 14.62)	Replace the PWBA MCU F. (RRP 8.4)

## Prefeed Sensor #4 on JAM (Tray4 paper feed)

Step	Check	Yes	No
	Possible causative parts: ROLLER ASSY (FEED) (PL 14.6.20) ROLLER ASSY (RETARD) (PL 14.6.28) ROLLER ASSY (NUDGER) (PL 14.6.32) TRAY 1/2 FEED LIFT UP MOTOR (PL 14.6.2) SENSOR (PRE FEED SENSOR) (PL 14.6.15) TRAY MODULE PWB (PL 14.8.5) PWBA MCU F (PL 8.1.5)		
1	Checking paper condition Is the paper in the tray crumpled or damaged?	Replace the paper with a new and dry one.	Go to step 2.
2	Checking paper size setup Does the paper size in use match the size set for the TRAY4?	Go to step 3.	Replace the paper or change the paper size setup.
3	Checking the Roll for the TRAY4 Is the ROLLER ASSY (FEED), ROLLER ASSY (RETARD) or ROLLER ASSY (NUDGER) for transport worn or contaminated with paper dust? Pull out the TRAY4 and check it.	Go to step 4.	Clean or replace the ROLLER ASSY (FEED), ROLLER ASSY (RETARD) or ROLLER ASSY (NUDGER). (RRP 14.46/RRP 14.50/RRP 14.53)
4	Checking paper position Does the paper touch the SENSOR (PRE FEED SENSOR) of the TRAY4 FEEDER (PL 14.4.15)?	Remove the paper.	Go to step 5.
5	Checking the SENSOR (PRE FEED SENSOR) for the TRAY4 for operation Does the Input Status change from "0x0" to "0x1" each time the paper touches the SENSOR (PRE FEED SENSOR) for the TRAY4? Execute [Input 08-21 PreFEED SENSOR4] in Chapter 2 [Diagnostic].	Go to step 12.	Go to step 6.
6	Checking the SENSOR (PRE FEED SENSOR) for the TRAY4 for connection Are P/J103A, P/J661A and P/J549A connected surely?	Go to step 7.	Connect P/J103A, P/J661A and P/J549A surely.
7	Checking conductivity between the SENSOR (PRE FEED SENSOR) for the TRAY4 and the TRAY MODULE PWB Is there conductivity on each wire between P/J103A <=> P/J549A?	Go to step 8.	Fix open and short circuit.
8	Checking +5 VDC power supply to the SENSOR (PRE FEED SENSOR) for the TRAY4 Is the voltage across J103A-1 (+) <=> ground +5 VDC?	Replace the SENSOR (PRE FEED SENSOR) for the TRAY4. (RRP 14.43)	Go to step 9.

Step	Check	Yes	No
9	Checking connection between the TRAY MODULE PWB and the PWBA MCU F Are P/J541 and P/J413 connected surely?	Go to step 10.	Connect P/J541 and P/J413 surely.
10	Checking conductivity between the TRAY MODULE PWB and the PWBA MCU F Is there conductivity on each wire between P/J541 <=> P/J413?	Go to step 11.	Fix open and short circuit.
11	Checking +24 VDC power supply to the TRAY MODULE PWB Is the voltage across J541-8 (+) <=> ground +24 VDC?	Replace the TRAY MODULE PWB. (RRP 14.62)	Replace the PWBA MCU F. (RRP 8.4)
12	Checking the TRAY 1/2 FEED LIFT UP MOTOR for the TRAY4 for operation Does the TRAY 1/2 FEED LIFT UP MOTOR for the TRAY4 operate properly? Execute [Output 08-15 TRAY4 FEED MOTOR] in Chapter 2 [Diagnostic].	Reconnect the connector on the PWBA MCU F.	Go to step 13.
13	Checking the TRAY 1/2 FEED LIFT UP MOTOR for the TRAY4 for connection Are P/J220A, P/J661A and P/J549A connected surely?	Go to step 14.	Connect P/J220A, P/J661A and P/J549A surely.
14	Checking the TRAY 1/2 FEED LIFT UP MOTOR for the TRAY4 for operation (3) Replace the TRAY 1/2 FEED LIFT UP MOTOR for the TRAY4 with that for the TRAY3. Does the replaced motor operate properly? Execute [Output 08-15 TRAY4 FEED MOTOR] in Chapter 2 [Diagnostic].	Reinstall the TRAY 1/2 FEED LIFT UP MOTOR for the TRAY3 as it previously was and then, replace the motor for the TRAY4 with a new one. (RRP 14.34)	Go to step 15.
15	Checking the TRAY 1/2 FEED LIFT UP MOTOR for the TRAY4 for operation (4) Reinstall the TRAY 1/2 FEED LIFT UP MOTORS for the TRAY3 and TRAY4 as they previously were. Checking conductivity between the TRAY 1/2 FEED LIFT UP MOTOR for the TRAY3 and the TRAY MODULE PWB. Is there conductivity on each wire between P/J220A <=> P/J549A?	Go to step 16.	Fix open and short circuit.
16	Checking connection between the TRAY MODULE PWB and the PWBA MCU F Are P/J541 and P/J413 connected surely?	Go to step 17.	Connect P/J541 and P/J413 surely.
17	Checking conductivity between the TRAY MODULE PWB and the PWBA MCU F Is there conductivity on each wire between P/J541 <=> P/J413?	Go to step 18.	Fix open and short circuit.
18	Checking +24 VDC power supply to the TRAY 1/2 FEED LIFT UP MOTOR for the TRAY4 Is the voltage across J220A-3 (+) <=> ground +24 VDC?	Replace the TRAY 1/2 FEED LIFT UP MOTOR for the TRAY4. (RRP 14.34)	Replace the PWBA MCU F. (RRP 8.4)

## Tray 3 Feed Out Sensor Static JAM

Step	Check	Yes	No
	Possible causative parts: TRAY 3 FEED OUT SENSOR (PL 14.5.8) TRAY MODULE PWB (PL 14.8.5) PWBA MCU F (PL 8.1.5)		
1	Checking paper position Does the paper touch the TRAY 3 FEED SENSOR? Open the LEFT COVER ASSEMBLY (PL 14.7.1) and check it (visual check).	Remove the paper.	Go to step 2.
2	Checking the TRAY 3 FEED OUT SENSOR for operation Does the Input Status change from "0x0" to "0x1" each time the paper touches the TRAY 3 FEED OUT SENSOR? Execute [Input 08-08 T/A F/03 SENSOR] in Chapter 2 [Diagnostic]. Open the LEFT COVER ASSEMBLY (PL 14.7.1) and check it.	Reconnect the connector on the PWBA MCU F.	Go to step 3.
3	Checking the TRAY 3 FEED OUT SENSOR for connection Are P/J821, P/J841 and P/J548 connected surely?	Go to step 4.	Connect P/J821, P/J841 and P/J548 surely.
4	Checking conductivity between the TRAY 3 FEED OUT SENSOR and the TRAY MODULE PWB Is there conductivity on each wire between P/J821 <=> P/J548?	Go to step 5.	Fix open and short circuit.
5	Checking conductivity between the TRAY MODULE and the PWBA MCU F Is there conductivity on each wire between P/J541 <=> P/J413?	Go to step 6.	Fix open and short circuit.
6	Checking +5 VDC power supply to the TRAY 3 FEED OUT SENSOR Is the voltage across J821-3 (+) <=> ground +5 VDC?	Replace the TRAY 3 FEED OUT SNESOR. (RRP 14.43)	Go to step 7.
7	Checking +5 VDC power supply to the TRAY MODULE PWB Is the voltage across J541-5 (+) <=> ground +5 VDC?	Replace the TRAY MODULE PWB. (RRP 14.62)	Replace the PWBA MCU F. (RRP 8.4)

## Tray 4 Feed Out Sensor Static JAM

Step	Check	Yes	No
	Possible causative parts: TRAY 4 FEED OUT SENSOR (PL 14.4.18) TRAY MODULE PWB (PL 14.8.5) PWBA MCU F (PL 8.1.5)		



Step	Check	Yes	No
1	Checking paper position Does the paper touch the TRAY 4 FEED OUT SENSOR? Open the LEFT COVER ASSEMBLY (PL 14.7.1) and check it (visual check).	Remove the paper.	Go to step 2.
2	Checking the TRAY 4 FEED OUT SENSOR for operation Does the Input Status change from "0x0" to "0x1" each time the paper touches the TRAY 4 FEED OUT SENSOR? Execute [Input 08-09 T/A F/04 SENSOR] in Chapter 2 [Diagnostic]. Open the LEFT COVER ASSEMBLY (PL 14.7.1) and check it.	Reconnect the connector on the PWBA MCU F.	Go to step 3.
3	Checking the TRAY 4 FEED OUT SENSOR for connection Are P/J825, P/J842 and P/J548 connected surely?	Go to step 4.	Connect P/J825, P/J842 and P/J548 surely.
4	Checking conductivity between the TRAY 4 FEED OUT SENSOR and the TRAY MODULE PWB Is there conductivity on each wire between P/J825 <=> P/J548?	Go to step 5.	Fix open and short circuit.
5	Checking conductivity between the TRAY MODULE and the PWBA MCU F Is there conductivity on each wire between P/J541 <=> P/J413?	Go to step 6.	Fix open and short circuit.
6	Checking +5 VDC power supply to the TRAY 4 FEED OUT SENSOR Is the voltage across J821-5 (+) <=> ground +5 VDC?	Replace the TRAY 4 FEED OUT SNESOR. (RRP 14.28)	Go to step 7.
7	Checking +5 VDC power supply to the TRAY MODULE PWB Is the voltage across J541-5 (+) <=> ground +5 VDC?	Replace the TRAY MODULE PWB. (RRP 14.62)	Replace the PWBA MCU F. (RRP 8.4)

### Tray3 Lift up /No tray fail

Step	Check	Yes	No
	Possible causative parts: GEAR ASSEMBLY (TRAY 3) (PL 14.8.1) TRAY 1/2 FEED LIFT UP MOTOR (PL 14.6.2) SENSOR (LEVEL SENSOR) (PL 14.6.14) TRAY 3/4 PAPER SIZE SWITCH (PL 14.4.23) TRAY MODULE PWB (PL 14.8.5) PWBA MCU F (PL 8.1.5)		
1	Checking paper Is any paper loaded in the Tray3? Pull out the Tray3 to check it. (Visual check)	Go to step 2.	Load paper.

Step	Check	Yes	No
2	Checking the TRAY Are the GEAR ASSEMBLY (TRAY 3) of TRAY3 or the surrounding parts of it damaged?	Go to step 3.	Replace the GEAR ASSEMBLY (TRAY 3) (RRP 14.59) or the obstacles.
3	Checking the TRAY 1/2 FEED LIFT UP MOTOR for the TRAY3 for operation (1) Does the TRAY 1/2 FEED LIFT UP MOTOR for the TRAY3 operate properly? Execute [Output 08-14 TRAY3 FEED MOTOR] in Chapter 2 [Diagnostic].	Go to step 11.	Go to step 4.
4	Checking the TRAY 1/2 FEED LIFT UP MOTOR for the TRAY3 for connection Are P/J220B, P/J661B and P/J549B connected surely?	Go to step 5.	Connect P/J220B, P/J661B and P/J549B surely.
5	Checking the TRAY 1/2 FEED LIFT UP MOTOR for the TRAY3 for operation (2) Replace the TRAY 1/2 FEED LIFT UP MOTOR for the TRAY3 with that for the TRAY4. Does the replaced motor operate properly? Execute [Output 08-14 TRAY3 FEED MOTOR] in Chapter 2 [Diagnostic].	Reinstall the TRAY 1/2 FEED LIFT UP MOTOR for the TRAY4 as it previously was and replace the motor for the TRAY3 with a new one. (RRP 14.34)	Go to step 6.
6	Checking the TRAY 1/2 FEED LIFT UP MOTOR for the TRAY3 for operation (3) Reinstall the TRAY 1/2 FEED LIFT UP MOTORS for the TRAY3 and TRAY4 as they previously were. Checking conductivity between the TRAY 1/2 FEED LIFT UP MOTOR for the TRAY3 and the TRAY MODULE PWB. Is there conductivity on each wire between P/J220B <=> P/J549B?	Go to step 7.	Fix open and short circuit.
7	Checking +24 VDC power supply to the TRAY 1/2 FEED LIFT UP MOTOR for the TRAY3 Is the voltage across J220-3 (+) <=> ground +24 VDC?	Replace the TRAY 1/2 FEED LIFT UP MOTOR for the TRAY3. (RRP 14.34)	Go to step 8.
8	Checking the TRAY MODULE PWB for connection Are P/J413 and P/J541 connected surely?	Go to step 9.	Connect P/J413 and P/541 surely.
9	Checking conductivity between the TRAY MODULE PWB and the PWBA MCU F Is there conductivity on each wire between P/J413 <=> P/J541?	Go to step 10.	Fix open and short circuit.
10	Checking +24 VDC power supply to the TRAY MODULE PWB Is the voltage across J413-B2 (+) <=> ground +24 VDC?	Replace the TRAY MODULE PWB. (RRP 14.62)	Replace the PWBA MCU F. (RRP 8.4)

Step	Check	Yes	No
11	Checking the SENSOR (LEVEL SENSOR) for the TRAY3 for operation Does the Input Status change from "0x0" to "0x1" each time the paper touches the SENSOR (LEVEL SENSOR) for the TRAY3? Execute [Input 07-15 TRAY3 LEVEL SENSOR] in Chapter 2 [Diagnostic]. Open the LEFT COVER ASSEMBLY (PL 14.7.1) and check it.	Go to step 18.	Go to step 12.
12	Checking the SENSOR (LEVEL SENSOR) for the TRAY3 for connection Are P/J101B, P/J661B and P/J549B connected surely?	Go to step 13.	Connect P/J101B, P/J661B and P/J549B surely.
13	Checking conductivity between the SENSOR (LEVEL SENSOR) for the TRAY3 and the TRAY MODULE PWB Is there conductivity on each wire between P/J101B <=> P/J549B?	Go to step 14.	Fix open and short circuit.
14	Checking +5 VDC power supply to the SENSOR (LEVEL SENSOR) for the TRAY3 Is the voltage across J101B-3 (+) <=> ground +5 VDC?	Replace the SENSOR (LEVEL SENSOR) for the TRAY3. (RRP 14.41)	Go to step 15.
15	Checking the TRAY MODULE PWB for connection Are P/J413 and P/J541 connected surely?	Go to step 16.	Connect P/J413 and P/J541 surely.
16	Checking conductivity between the TRAY MODULE PWB and the PWBA MCU F Is there conductivity on each wire between P/J413 <=> P/J541?	Go to step 17.	Fix open and short circuit.
17	Checking +5 VDC power supply to the TRAY MODULE PWB Is the voltage across J413-A5 (+) <=> ground +5 VDC?	Replace the TRAY MODULE PWB. (RRP 14.62)	Replace the PWBA MCU F. (RRP 8.4)
18	Checking the TRAY 3/4 PAPER SIZE SWITCH for the TRAY3 for operation Does the Input Status change from "0x0" to "0x1" each time the TRAY3 with paper loaded is pulled out or pushed in? Execute [Input 07-03 TRAY3 SIZE SENSOR] in Chapter 2 [Diagnostic].	Reconnect the connector on the PWBA MCU F.	Go to step 19.
19	Checking the TRAY 3/4 PAPER SIZE SWITCH for the TRAY3 for connection Are P/J820 and P/J548 connected surely?	Go to step 20.	Connect P/J820 and P/J548 surely.
20	Checking conductivity between the TRAY 3/4 PAPER SIZE SWITCH for the TRAY3 and the PWBA MCU F Is there conductivity on each wire between P/J820 <=> P/J548?	Go to step 21.	Fix open and short circuit.

Step	Check	Yes	No
21	Checking +3.3 VDC power supply to the TRAY 3/4 PAPER SIZE SWITCH for the TRAY3 Is the voltage across J820-1 (+) <=> ground +3.3 VDC?	Replace the TRAY 3/4 PAPER SIZE SWITCH for the TRAY3. (RRP 14.29)	Go to step 22.
22	Checking the TRAY MODULE PWB for connection Are P/J413 and P/J541 connected surely?	Go to step 23.	Connect P/J413 and P/541 surely.
23	Checking conductivity between the TRAY MODULE PWB and the PWBA MCU F Is there conductivity on each wire between P/J413 <=> P/J541?	Go to step 24.	Fix open and short circuit.
24	Checking +5 VDC power supply to the TRAY MODULE PWB Is the voltage across J413-A5 (+) <=> ground +5 VDC?	Replace the TRAY MODULE PWB. (RRP 14.62)	Replace the PWBA MCU F. (RRP 8.4)

### Tray4 Lift up /No tray fail

Step	Check	Yes	No
	Possible causative parts: GEAR ASSEMBLY (TRAY 4) (PL 14.8.2) TRAY 1/2 FEED LIFT UP MOTOR (PL 14.6.2) SENSOR (LEVEL SENSOR) (PL 14.6.14) TRAY 3/4 PAPER SIZE SWITCH (PL 14.4.23) TRAY MODULE PWB (PL 14.8.5) PWBA MCU F (PL 8.1.5)		
1	Checking paper Is any paper loaded in the Tray4? Pull out the Tray4 to check it. (Visual check)	Go to step 2.	Load paper.
2	Checking the TRAY Are the GEAR ASSEMBLY (TRAY 4) of TRAY4 or the surrounding parts of it damaged?	Go to step 3.	Replace the GEAR ASSEMBLY (TRAY 4) (RRP 14.60) or the obstacles.
3	Checking the TRAY 1/2 FEED LIFT UP MOTOR for the TRAY4 for operation Does the TRAY 1/2 FEED LIFT UP MOTOR for the TRAY4 operate properly? Execute [Output 08-15 TRAY4 FEED MOTOR] in Chapter 2 [Diagnostic].	Go to step 11.	Go to step 4.
4	Checking the TRAY 1/2 FEED LIFT UP MOTOR for the TRAY4 for connection Are P/J220A, P/J661A and P/J549A connected surely?	Go to step 5.	Connect P/J220A, P/J661A and P/J549A surely.

Step	Check	Yes	No
5	<p>Checking the TRAY 1/2 FEED LIFT UP MOTOR for the TRAY4 for operation (3)</p> <p>Replace the TRAY 1/2 FEED LIFT UP MOTOR for the TRAY4 with that for the TRAY3.</p> <p>Does the replaced motor operate properly?</p> <p>Execute [Output 08-15 TRAY4 FEED MOTOR] in Chapter 2 [Diagnostic].</p>	<p>Reinstall the TRAY 1/2 FEED LIFT UP MOTOR for the TRAY3 as it previously was and then, replace the motor for the TRAY4 with a new one. (RRP 14.34)</p>	<p>Go to step 6.</p>
6	<p>Checking the TRAY 1/2 FEED LIFT UP MOTOR for the TRAY4 for operation (4)</p> <p>Reinstall the TRAY 1/2 FEED LIFT UP MOTORS for the TRAY3 and TRAY4 as they previously were.</p> <p>Checking conductivity between the TRAY 1/2 FEED LIFT UP MOTOR for the TRAY3 and the TRAY MODULE PWB.</p> <p>Is there conductivity on each wire between P/J220A &lt;=&gt; P/J549A?</p>	<p>Go to step 7.</p>	<p>Fix open and short circuit.</p>
7	<p>Checking +24 VDC power supply to the TRAY 1/2 FEED LIFT UP MOTOR for the TRAY4</p> <p>Is the voltage across J220A-3 (+) &lt;=&gt; ground +24 VDC?</p>	<p>Replace the TRAY 1/2 FEED LIFT UP MOTOR for the TRAY4. (RRP 14.34)</p>	<p>Go to step 8.</p>
8	<p>Checking the TRAY MODULE PWB for connection</p> <p>Are P/J413 and P/J541 connected surely?</p>	<p>Go to step 9.</p>	<p>Connect P/J413 and P/541 surely.</p>
9	<p>Checking conductivity between the TRAY MODULE PWB and the PWBA MCU F</p> <p>Is there conductivity on each wire between P/J413 &lt;=&gt; P/J541?</p>	<p>Go to step 10.</p>	<p>Fix open and short circuit.</p>
10	<p>Checking +24 VDC power supply to the TRAY MODULE PWB</p> <p>Is the voltage across J413-B2 (+) &lt;=&gt; ground +24 VDC?</p>	<p>Replace the TRAY MODULE PWB. (RRP 14.62)</p>	<p>Replace the PWBA MCU F. (RRP 8.4)</p>
11	<p>Checking the SENSOR (LEVEL SENSOR) for the TRAY4 for operation</p> <p>Does the Input Status change from "0x0" to "0x1" each time the paper touches the SENSOR (LEVEL SENSOR) for the TRAY4?</p> <p>Execute [Input 07-16 TRAY4 LEVEL SENSOR] in Chapter 2 [Diagnostic].</p> <p>Open the LEFT COVER ASSEMBLY (PL 14.7.1) and check it.</p>	<p>Go to step 18.</p>	<p>Go to step 12.</p>
12	<p>Checking the SENSOR (LEVEL SENSOR) for the TRAY4 for connection</p> <p>Are P/J101A, P/J661A and P/J549A connected surely?</p>	<p>Go to step 13.</p>	<p>Connect P/J101A, P/J661A and P/J549A surely.</p>
13	<p>Checking conductivity between the SENSOR (LEVEL SENSOR) for the TRAY4 and the TRAY MODULE PWB</p> <p>Is there conductivity on each wire between P/J101A &lt;=&gt; P/J549A?</p>	<p>Go to step 14.</p>	<p>Fix open and short circuit.</p>

Step	Check	Yes	No
14	Checking +5 VDC power supply to the SENSOR (LEVEL SENSOR) for the TRAY4 Is the voltage across J101A-3 (+) <=> ground +5 VDC?	Replace the SENSOR (LEVEL SENSOR) for the TRAY4. (RRP 14.41)	Go to step 15.
15	Checking the TRAY MODULE PWB for connection Are P/J413 and P/J541 connected surely?	Go to step 16.	Connect P/J413 and P/541 surely.
16	Checking conductivity between the TRAY MODULE PWB and the PWBA MCU F Is there conductivity on each wire between P/J413 <=> P/J541?	Go to step 17.	Fix open and short circuit.
17	Checking +5 VDC power supply to the TRAY MODULE PWB Is the voltage across J413-A5 (+) <=> ground +5 VDC?	Replace the TRAY MODULE PWB. (RRP 14.62)	Replace the PWBA MCU F. (RRP 8.4)
18	Checking the TRAY 3/4 PAPER SIZE SWITCH for the TRAY4 for operation Does the Input Status change from "0x0" to "0x1" each time the TRAY4 with paper loaded is pulled out or pushed in? Execute [Input 07-04 TRAY4 SIZE SENSOR] in Chapter 2 [Diagnostic].	Reconnect the connector on the PWBA MCU F.	Go to step 19.
19	Checking the TRAY 3/4 PAPER SIZE SWITCH for the TRAY4 for connection Are P/J824 and P/J548 connected surely	Go to step 20.	Connect P/J824 and P/J548 surely.
20	Checking conductivity between the TRAY 3/4 PAPER SIZE SWITCH for the TRAY4 and the PWBA MCU F Is there conductivity on each wire between P/J824 <=> P/J548?	Go to step 21.	Fix open and short circuit.
21	Checking +3.3 V DC power supply to the TRAY 3/4 PAPER SIZE SWITCH for the TRAY4 Is the voltage across J824-1 (+) <=> ground +3.3 VDC?	Replace the TRAY 3/4 PAPER SIZE SWITCH for the TRAY4. (RRP 14.30)	Go to step 22.
22	Checking the TRAY MODULE PWB for connection Are P/J413 and P/J541 connected surely?	Go to step 23.	Connect P/J413 and P/541 surely.
23	Checking conductivity between the TRAY MODULE PWB and the PWBA MCU F Is there conductivity on each wire between P/J413 <=> P/J541?	Go to step 24.	Fix open and short circuit.
24	Checking +5 VDC power supply to the TRAY MODULE PWB Is the voltage across J413-A5 (+) <=> ground +5 VDC?	Replace the TRAY MODULE PWB. (RRP 14.62)	Replace the PWBA MCU F. (RRP 8.4)

## Tray 3 cassette Size fail

Step	Check	Yes	No
	Possible causative parts: TRAY 3/4 PAPER SIZE SWITCH (PL 14.4.23) FRONT SIDE GUIDE (PL 14.2.14) REAR SIDE GUIDE (PL 14.2.18) TRAY MODULE PWB (PL 14.8.5) PWBA MCU F (PL 8.1.5)		
1	Checking the paper (1) Is paper loaded in the TRAY3 properly? Pull out the TRAY3 to check it. (Visual check)	Go to step 2.	Load paper properly.
2	Checking the paper (2) Are the FRONT SIDE GUIDE and REAR SIDE GUIDE of the TRAY3 set correctly? Pull out the TRAY3 to check it. (Visual check)	Go to step 3.	Set the parts properly.
3	Checking the TRAY 3/4 PAPER SIZE SWITCH for the TRAY3 for installation Is the TRAY 3/4 PAPER SIZE SWITCH for the TRAY3 installed properly? Pull out the TRAY3 to check it. (Visual check)	Go to step 4.	Install the TRAY 3/4 PAPER SIZE SWITCH for the TRAY3 correctly. (RRP 14.29)
4	Checking the TRAY 3/4 PAPER SIZE SWITCH for the TRAY3 for operation Does the Input Status change from "0x0" to "0x1" each time the TRAY3 with paper loaded is pulled out or pushed in? Execute [Input 07-03 TRAY3 SIZE SENSOR] in Chapter 2 [Diagnostic].	Reconnect the connector on the PWBA MCU F.	Go to step 5.
5	Checking the TRAY 3/4 PAPER SIZE SWITCH for the TRAY3 for connection Are P/J820 and P/J548 connected surely?	Go to step 6.	Connect P/J820 and P/J548 surely.
6	Checking conductivity between the TRAY 3/4 PAPER SIZE SWITCH for the TRAY3 and the PWBA MCU F Is there conductivity on each wire between P/J820 <=> P/J548?	Go to step 7.	Fix open and short circuit.
7	Checking +3.3 VDC power supply to the TRAY 3/4 PAPER SIZE SWITCH for the TRAY3 Is the voltage across J820-1 (+) <=> ground +3.3 VDC?	Replace the TRAY 3/4 PAPER SIZE SWITCH for the TRAY3. (RRP 14.29)	Go to step 8.
8	Checking the TRAY MODULE PWB for connection Are P/J413 and P/J541 connected surely?	Go to step 9.	Connect P/J413 and P/J541 surely.
9	Checking conductivity between the TRAY MODULE PWB and the PWBA MCU F Is there conductivity on each wire between P/J413 <=> P/J541?	Go to step 10.	Fix open and short circuit.
10	Checking +5 VDC power supply to the TRAY MODULE PWB Is the voltage across J413-A5 (+) <=> ground +5 VDC?	Replace the TRAY MODULE PWB. (RRP 14.62)	Replace the PWBA MCU F. (RRP 8.4)

## Tray 4 cassette Size fail

Step	Check	Yes	No
	Possible causative parts: TRAY 3/4 PAPER SIZE SWITCH (PL 14.4.23) FRONT SIDE GUIDE (PL 14.3.12) REAR SIDE GUIDE (PL 14.3.27) TRAY MODULE PWB (PL 14.8.5) PWBA MCU F (PL 8.1.5)		
1	Checking the paper (1) Is paper loaded in the TRAY4 properly? Pull out the TRAY4 to check it. (Visual check)	Go to step 2.	Load paper properly.
2	Checking the paper (2) Are the FRONT SIDE GUIDE and REAR SIDE GUIDE of the TRAY4 set correctly? Pull out the TRAY4 to check it. (Visual check)	Go to step 3.	Set the parts properly.
3	Checking the TRAY 3/4 PAPER SIZE SWITCH for the TRAY4 for installation Is the TRAY 3/4 PAPER SIZE SWITCH for the TRAY4 installed properly? Pull out the TRAY4 to check it. (RRP) (Visual check)	Go to step 4.	Install the TRAY 3/4 PAPER SIZE SWITCH for the TRAY4 correctly (RRP 14.30)
4	Checking the TRAY 3/4 PAPER SIZE SWITCH for the TRAY4 for operation Does the Input Status change from "0x0" to "0x1" each time the TRAY4 with paper loaded is pulled out or pushed in? Execute [Input 07-04 TRAY4 SIZE SENSOR] in Chapter 2 [Diagnostic].	Reconnect the connector on the PWBA MCU F.	Go to step 5.
5	Checking the TRAY 3/4 PAPER SIZE SWITCH for the TRAY4 for connection Are P/J824 and P/J548 connected surely?	Go to step 6.	Connect P/J824 and P/J548 surely.
6	Checking conductivity between the TRAY 3/4 PAPER SIZE SWITCH for the TRAY4 and the PWBA MCU F Is there conductivity on each wire between P/J824 <=> P/J548?	Go to step 7.	Fix open and short circuit.
7	Checking +3.3 VDC power supply to the TRAY 3/4 PAPER SIZE SWITCH for the TRAY4 Is the voltage across J824-1 (+) <=> ground +3.3 VDC?	Replace the TRAY 3/4 PAPER SIZE SWITCH for the TRAY4. (RRP 14.30)	Go to step 8.
8	Checking the TRAY MODULE PWB for connection Are P/J413 and P/J541 connected surely?	Go to step 9.	Connect P/J413 and P/J541 surely.
9	Checking conductivity between the TRAY MODULE PWB and the PWBA MCU F Is there conductivity on each wire between P/J413 <=> P/J541?	Go to step 10.	Fix open and short circuit.
10	Checking +5 VDC power supply to the TRAY MODULE PWB Is the voltage across J413-A5 (+) <=> ground +5 VDC?	Replace the TRAY MODULE PWB. (RRP 14.62)	Replace the PWBA MCU F. (RRP 8.4)



## Tray Module NVM out-of-order

Step	Check	Yes	No
	Possible causative parts: TRAY MODULE PWB (PL 14.8.5) PWBA MCU F (PL 8.1.5)		
1	Does Error occur when the power is turned ON?	Go to step 3.	Go to step 2.
2	Does the error still occur after the power is turned ON/OFF repeatedly several times?	Go to step 3.	End of work *1
3	Checking data on the NVRAM (1) Is data on the NVRAM accessible? Execute [NVM Edit] in Chapter 2 [Diagnostic].	Go to step 4.	Go to step 5.
4	Checking data on the NVRAM (2) Change NVRAM data to the correct setup value, and then turn the power ON again. Does an error still occur?	Go to step 5.	End of work
5	Checking the TRAY MODULE PWB for connection Are P/J413 and P/J541 connected surely?	Go to step 6.	Connect P/J413 and P/J541 surely.
6	Checking conductivity between the TRAY MODULE PWB and the PWBA MCU F Is there conductivity on each wire between P/J413 <=> P/J541?	Go to step 7.	Fix open and short circuit.
7	Checking +5 VDC power supply to the TRAY MODULE PWB Is the voltage across J413-A5 (+) <=> ground +5 VDC?	Replace the TRAY MODULE PWB. (RRP 14.62)	Replace the PWBA MCU F. (RRP 8.4)

\*1: External noise is considered to be the cause. Proceed to Procedure 5.1.

## Tray Module NVM R/W error

Step	Check	Yes	No
	Possible causative parts: TRAY MODULE PWB (PL 14.8.5) PWBA MCU F (PL 8.1.5)		
1	Does the error still occur when the power is turned ON again?	Go to step 3.	Go to step 2.
2	Does the error still occur after the power is turned ON/OFF repeatedly several times?	Go to step 3.	End of work *1
3	Checking data on the NVRAM (1) Is data on the NVRAM accessible? Execute [NVM Edit] in Chapter 2 [Diagnostic].	Go to step 4.	Go to step 5.
4	Checking data on the NVRAM (2) Change NVRAM data to the correct setup value, and then turn the power ON again. Does the error still occur?	Go to step 5.	End of work

Step	Check	Yes	No
5	Checking the TRAY MODULE PWB for connection Are P/J413 and P/J541 connected surely?	Go to step 6.	Connect P/J413 and P/J541 surely.
6	Checking conductivity between the TRAY MODULE PWB and the PWBA MCU F Is there conductivity on each wire between P/J413 <=> P/J541?	Go to step 7.	Fix open and short circuit.
7	Checking +5 VDC power supply to the TRAY MODULE PWB Is the voltage across J413-A5 (+) <=> ground +5 VDC?	Replace the TRAY MODULE PWB. (RRP 14.62)	Replace the PWBA MCU F. (RRP 8.4)

### Tray Module Communication fail

Step	Check	Yes	No
	Possible causative parts: TRAY MODULE PWB (PL 14.8.5) PWBA MCU F (PL 8.1.5)		
1	Checking the TRAY MODULE for installation Disconnect the connector P/J541 of the TRAY MODULE and reconnect it. Does the tray module operate properly?	End of work	Go to step 2.
2	Checking the TRAY MODULE PWB for connection Is P/J413 connected surely?	Go to step 3.	Connect P/J413 surely.
3	Checking conductivity between the TRAY MODULE PWB and the PWBA MCU F Is there conductivity on each wire between P/J413 <=> P/J541?	Go to step 4.	Fix open and short circuit.
4	Checking +5 VDC power supply to the TRAY MODULE PWB Is the voltage across J413-A5 (+) <=> ground +5 VDC?	Replace the TRAY MODULE PWB. (RRP 14.62)	Replace the PWBA MCU F. (RRP 8.4)

### TM type error

Step	Check	Yes	No
	Possible causative parts: TRAY MODULE PWB (PL 14.8.5) PWBA MCU F (PL 8.1.5)		
1	Checking the TRAY MODULE for installation Disconnect the connector P/J541 of the TRAY MODULE and reconnect it. Does the tray module operate properly?	End of work	Go to step 2.

Step	Check	Yes	No
2	Checking the TRAY MODULE PWB for connection Is P/J413 connected surely?	Go to step 3.	Connect P/J413 surely.
3	Checking conductivity between the TRAY MODULE PWB and the PWBA MCU F Is there conductivity on each wire between P/J413 <=> P/J541?	Go to step 4.	Fix open and short circuit.
4	Checking +5 VDC power supply to the TRAY MODULE PWB Is the voltage across J413-A5 (+) <=> ground +5 VDC?	Replace the TRAY MODULE PWB. (RRP 14.62)	Replace the PWBA MCU F. (RRP 8.4)

### Tray3 Size sensor broken

Step	Check	Yes	No
	Possible causative parts: TRAY 3/4 PAPER SIZE SWITCH (PL 14.4.23) TRAY MODULE PWB (PL 14.8.5) PWBA MCU F (PL 8.1.5)		
1	Checking the paper Is paper loaded in the Tray3 properly? Pull out the Tray3 to check it. (Visual check)	Go to step 2.	Load paper properly.
2	Checking the TRAY 3/4 PAPER SIZE SWITCH for the TRAY3 for installation Is the TRAY 3/4 PAPER SIZE SWITCH for the TRAY3 installed correctly? Pull out the TRAY3 to check it. (Visual check)	Go to step 3.	Reinstall the TRAY 3/4 PAPER SIZE SWITCH for TRAY3.
3	Checking the TRAY 3/4 PAPER SIZE SWITCH for the TRAY3 for operation Does the Input Status change each time the TRAY3 with paper loaded is pulled out and pushed in? Check it using [Input 07-03 TRAY3 SIZE SENSOR] in Chapter 2, Diag.	Reconnect the connector of the PWBA MCU F.	Go to step 4.
4	Checking the TRAY 3/4 PAPER SIZE SWITCH for TRAY3 for connection Are P/J820 and P/J548 connected surely?	Go to step 5.	Connect P/J820 and P/J548 securely
5	Checking conductivity between the TRAY 3/4 PAPER SIZE SWITCH for TRAY3 and the PWBA MCU F Is there conductivity on each wire between P/J820 <=> P/P/J548?	Go to step 6.	Fix open and short circuit.
6	Checking +5 VDC power supply to the TRAY 3/4 PAPER SIZE SWITCH for TRAY3 Is the voltage across J820-1 (+) <=> ground +5 VDC?	Replace the TRAY 3/4 PAPER SIZE SWITCH for TRAY3. (RRP 14.29)	Go to step 7.
7	Checking the TRAY MODULE PWB for connection Are P/J413 and P/J541 connected surely?	Go to step 8.	Connect P/J413 and P/J541 surely.

Step	Check	Yes	No
8	Checking conductivity between the TRAY MODULE PWB and the PWBA MCU F Is there conductivity on each wire between P/J413 <=> P/J541?	Go to step 9.	Fix open and short circuit.
9	Checking +5 VDC power supply to the TRAY MODULE PWB Is the voltage across J413-A5 (+) <=> ground +5 VDC?	Replace the TRAY MODULE PWB. (RRP 14.62)	Replace the PWBA MCU F. (RRP 8.4)

### Tray4 Size sensor broken

Step	Check	Yes	No
	Possible causative parts: SWITCH ASSY P S (PL 2.1.4) PWBA MCU F (PL 8.1.5)		
1	Checking the paper Is paper loaded in the Tray4 properly? Pull out the Tray4 to check it. (Visual check)	Go to step 2.	Load paper properly.
2	Checking the TRAY 3/4 PAPER SIZE SWITCH for the TRAY4 for installation Is the TRAY 3/4 PAPER SIZE SWITCH for the TRAY4 installed correctly? Pull out the TRAY4 to check it. (Visual check)	Go to step 3.	Reinstall the TRAY 3/4 PAPER SIZE SWITCH for TRAY4.
3	Checking the TRAY 3/4 PAPER SIZE SWITCH for the TRAY4 for operation Does the Input Status change each time the TRAY4 with paper loaded is pulled out and pushed in? Check it using [Input 07-04 TRAY4 SIZE SENSOR] in Chapter 2, Diag.	Reconnect the connector of the PWBA MCU F.	Go to step 4.
4	Checking the TRAY 3/4 PAPER SIZE SWITCH for TRAY4 for connection Are P/J824 and P/J548 connected surely?	Go to step 5.	Connect P/J824 and P/J548 securely
5	Checking conductivity between the TRAY 3/4 PAPER SIZE SWITCH for TRAY4 and the PWBA MCU F Is there conductivity on each wire between P/J824 <=> P/P/J548?	Go to step 6.	Fix open and short circuit.
6	Checking +5 VDC power supply to the TRAY 3/4 PAPER SIZE SWITCH for TRAY4 Is the voltage across J824-1 (+) <=> ground +5 VDC?	Replace the TRAY 3/4 PAPER SIZE SWITCH for TRAY4. (RRP 14.30)	Go to step 7.
7	Checking the TRAY MODULE PWB for connection Are P/J413 and P/J541 connected surely?	Go to step 8.	Connect P/J413 and P/J541 surely.

Step	Check	Yes	No
8	Checking conductivity between the TRAY MODULE PWB and the PWBA MCU F Is there conductivity on each wire between P/J413 <=> P/J541?	Go to step 9.	Fix open and short circuit.
9	Checking +5 VDC power supply to the TRAY MODULE PWB Is the voltage across J413-A5 (+) <=> ground +5 VDC?	Replace the TRAY MODULE PWB. (RRP 14.62)	Replace the PWBA MCU F. (RRP 8.4)

## TM Cover open

Step	Check	Yes	No
	Possible causative parts: LEFT COVER INTERLOCK SWITCH (PL 14.7.15) PWBA MCU F (PL 8.1.5)		
1	Checking the LEFT COVER ASSEMBLY (PL 14.7.1) for opening and closing Does the LEFT COVER ASSEMBLY (PL 14.7.1) open or close normally?	Go to step 2.	Check the LEFT COVER ASSM-BLY for deformation and reinstall it.
2	Checking the LEFT COVER INTERLOCK SWITCH for operation Does the Input Status change from "0x0" to "0x1" each time the LEFT COVER INTERLOCK SWITCH is pressed? Execute [Input 01-10 TRAY MODULE COVER] in Chapter 2 [Diagnostic]. Open the LEFT COVER ASSEMBLY (PL 14.7.1) and check it.	Reconnect the connector on the PWBA MCU F.	Go to step 3.
3	Checking the LEFT COVER INTERLOCK SWITCH for connection Are FS812, FS813 and P/J554 connected surely?	Go to step 4.	Connect FS812, FS813 and P/J554 surely.
4	Checking conductivity between the LEFT COVER INTERLOCK SWITCH and the TRAY MODULE PWB Is there conductivity on each wire between FS812 <=> P/J554? Is there conductivity on each wire between FS813 <=> P/J554?	Go to step 5.	Fix open and short circuit.
5	Checking +24 VDC power supply to the LEFT COVER INTERLOCK SWITCH Is the voltage across J813-1 (+) <=> ground +24 VDC?	Replace the LEFT COVER INTERLOCK SWITCH. (RRP 14.58)	Go to step 6.
6	Checking the TRAY MODULE PWB for connection Are P/J541 and P/J413 connected surely?	Go to step 7.	Connect P/J541 and P/J413 surely.
7	Checking conductivity between the TRAY MODULE PWB and the PWBA MCU F Is there conductivity on each wire between P/J541 <=> P/J413?	Go to step 8.	Fix open and short circuit.

Step	Check	Yes	No
8	Checking +24 VDC power supply to the TRAY MODULE PWB Is the voltage across J541-8 (+) <=> ground +24 VDC?	Replace the TRAY MODULE PWB. (RRP 14.62)	Replace the PWBA MCU F. (RRP 8.4)

### No paper in the select paper tray

Step	Check	Yes	No
	Possible causative parts: SENSOR (NO PAPER SENSOR) (PL 14.6.14) TRAY MODULE PWB (PL 14.8.5) PWBA MCU F (PL 8.1.5)		
1	Checking paper Is Paper loaded in the selected TRAY?	Go to step 2.	Load paper.
2	Checking the SENSOR (NO PAPER SENSOR) for operation Does the Input Status change from "0x0" to "0x1" each time the TRAY with paper loaded is pulled out or pushed in? For TRAY3: Execute [Input 07-09 TRAY3 NO PAPER SENSOR] in Chapter 2 [Diagnostic]. For TRAY4: Execute [Input 07-10 TRAY4 NO PAPER SENSOR] in Chapter 2 [Diagnostic].	Reconnect the connector on the PWBA MCU F.	Go to step 3.
3	Checking the SENSOR (NO PAPER SENSOR) for connection For TRAY3: Are P/J102B, P/J661B and P/J549B connected surely? For TRAY4: Are P/J102A, P/J661A and P/J549A connected surely?	Go to step 4.	Connect the connectors surely.
4	Checking conductivity between the SENSOR (NO PAPER SENSOR) and the PWBA MCU F For TRAY3: Is there conductivity on each wire between P/J102B <=> P/J549B? For TRAY4: Is there conductivity on each wire between P/J102A <=> P/J549A?	Go to step 5.	Fix open and short circuit.
5	Checking +5 VDC power supply to the SENSOR (NO PAPER SENSOR) For TRAY3: Is the voltage across J102B-3 (+) <=> ground +5 VDC? For TRAY4: Is the voltage across J102A-3 (+) <=> ground +5 VDC?	Replace the SENSOR (NO PAPER SENSOR) for the TRAY. (RRP 14.42)	Go to step 6.
6	Checking the TRAY MODULE PWB for connection Are P/J413 and P/J541 connected surely?	Go to step 7.	Connect P/J413 and P/541 surely.

Step	Check	Yes	No
7	Checking conductivity between the TRAY MODULE PWB and the PWBA MCU F Is there conductivity on each wire between P/J413 <=> P/J541?	Go to step 8.	Fix open and short circuit.
8	Checking +5 VDC power supply to the TRAY MODULE PWB Is the voltage across J413-A5 (+) <=> ground +5 VDC?	Replace the TRAY MODULE PWB. (RRP 14.62)	Replace the PWBA MCU F. (RRP 8.4)

## Paper size mismatch in width

Step	Check	Yes	No
	Possible causative parts: TRAY 3/4 PAPER SIZE SWITCH (PL 14.4.23) FRONT SIDE GUIDE (PL 14.2.14) REAR SIDE GUIDE (PL 14.2.18) TRAY MODULE PWB (PL 14.8.5) PWBA MCU F (PL 8.1.5)		
1	Checking the paper (1) Is paper loaded in the Tray properly? Pull out the TRAY to check it. (Visual check)	Go to step 2.	Load paper properly.
2	Checking the paper (2) Are the FRONT SIDE GUIDE and REAR SIDE GUIDE of the TRAY3 or TRAY4 set correctly? Pull out the TRAYS to check it. (Visual check)	Go to step 3.	Set the parts correctly.
3	Checking the TRAY 3/4 PAPER SIZE SWITCH for installation Is the TRAY 3/4 PAPER SIZE SWITCH for the TRAY3 or TRAY4 installed properly? Pull out the TRAY to check it. (Visual check)	Go to step 4.	Install the TRAY 3/4 PAPER SIZE SWITCH for each TRAY correctly. (RRP 14.29/RRP 14.30)
4	Checking the TRAY 3/4 PAPER SIZE SWITCH for operation Does the Input Status change from "0x0" to "0x1" each time the TRAY with paper loaded is pulled out or pushed in? For TRAY3: Execute [Input 07-03 TRAY3 SIZE SENSOR] in Chapter 2 [Diagnostic]. For TRAY4: Execute [Input 07-04 TRAY4 SIZE SENSOR] in Chapter 2 [Diagnostic].	Reconnect the connector on the PWBA MCU F.	Go to step 5.
5	Checking the TRAY 3/4 PAPER SIZE SWITCH for connection For TRAY3: Are P/J820 and P/J548 connected surely? For TRAY4 Are P/J824 and P/J548 connected surely?	Go to step 6.	Connect the connectors surely.

Step	Check	Yes	No
6	Checking conductivity between the TRAY 3/4 PAPER SIZE SWITCH and the TRAY MODULE PWB For TRAY3: Is there conductivity on each wire between P/J820 <=> P/J548? For TRAY4 Is there conductivity on each wire between P/J824 <=> P/J548?	Go to step 7.	Fix open and short circuit.
7	Checking +3.3 VDC power supply to the TRAY 3/4 PAPER SIZE SWITCH For TRAY3: Is the voltage across J820-1 (+) <=> ground +3.3 VDC? For TRAY4 Is the voltage across J824-1 (+) <=> ground +3.3 VDC?	Replace the TRAY 3/4 PAPER SIZE SWITCH for the TRAY. (RRP 14.29/RRP 14.30)	Go to step 8.
8	Checking the TRAY MODULE PWB for connection Are P/J413 and P/J541 connected surely?	Go to step 9.	Connect P/J413 and P/541 surely.
9	Checking conductivity between the TRAY MODULE PWB and the PWBA MCU F Is there conductivity on each wire between P/J413 <=> P/J541?	Go to step 10.	Fix open and short circuit.
10	Checking +5 VDC power supply to the TRAY MODULE PWB Is the voltage across J413-A5 (+) <=> ground +5 VDC?	Replace the TRAY MODULE PWB. (RRP 14.62)	Replace the PWBA MCU F. (RRP 8.4)

### Tray 3 Paper size mismatch in length

Step	Check	Yes	No
	Possible causative parts: TRAY 3/4 PAPER SIZE SWITCH (PL 14.4.23) FRONT SIDE GUIDE (PL 14.2.14) REAR SIDE GUIDE (PL 14.2.18) SENSOR ASSY REGI (PL 4.5.7) CLUTCH ASSY REGI (PL 4.5.5) TRAY MODULE PWB (PL 14.8.5) PWBA MCU F (PL 8.1.5)		
1	Checking the paper (1) Is paper loaded in the TRAY3 properly? Pull out the TRAY3 to check it. (Visual check)	Go to step 2.	Load paper properly.
2	Checking the paper (2) Are the FRONT SIDE GUIDE and REAR SIDE GUIDE of the TRAY3 set correctly? Pull out the TRAY3 to check it. (Visual check)	Go to step 3.	Set the parts properly.
3	Checking the TRAY 3/4 PAPER SIZE SWITCH for the TRAY3 for operation Is the TRAY 3/4 PAPER SIZE SWITCH for the TRAY3 installed properly? Pull out the TRAY3 to check it. (Visual check)	Go to step 4.	Install the TRAY 3/4 PAPER SIZE SWITCH for the TRAY3 correctly. (RRP 14.29)



Step	Check	Yes	No
4	Checking the TRAY 3/4 PAPER SIZE SWITCH for operation Does the Input Status change from "0x0" to "0x1" each time the TRAY3 with paper loaded is pulled out or pushed in? Execute [Input 07-03 TRAY3 SIZE SENSOR] in Chapter 2 [Diagnostic].	Go to step 11.	Go to step 5.
5	Checking the TRAY 3/4 PAPER SIZE SWITCH for the TRAY3 for connection Are P/J820 and P/J548 connected surely?	Go to step 6.	Connect P/J820 and P/J548 surely.
6	Checking conductivity between the TRAY 3/4 PAPER SIZE SWITCH for the TRAY3 and the TRAY MODULE PWB Is there conductivity on each wire between P/J820 <=> P/J548?	Go to step 7.	Fix open and short circuit.
7	Checking +3.3 VDC power supply to the TRAY 3/4 PAPER SIZE SWITCH for the TRAY3 Is the voltage across J820-1 (+) <=> ground +3.3 VDC?	Replace the TRAY 3/4 PAPER SIZE SWITCH for the TRAY3. (RRP 14.29)	Go to step 8.
8	Checking the TRAY MODULE PWB for connection Are P/J413 and P/J541 connected surely?	Go to step 9.	Connect P/J413 and P/541 surely.
9	Checking conductivity between the TRAY MODULE PWB and the PWBA MCU F Is there conductivity on each wire between P/J413 <=> P/J541?	Go to step 10.	Fix open and short circuit.
10	Checking +5 VDC power supply to the TRAY MODULE PWB Is the voltage across J413-A5 (+) <=> ground +5 VDC?	Replace the TRAY MODULE PWB. (RRP 14.62)	Replace the PWBA MCU F. (RRP 8.4)
11	Checking the Roll for the TRAY3 Is the ROLLER ASSY (FEED), ROLLER ASSY (RETARD) or ROLLER ASSY (NUDGER) for transport worn or contaminated with paper dust? Pull out the TRAY3 and check it.	Go to step 12.	Clean or replace the ROLLER ASSY (FEED), ROLLER ASSY (RETARD) or ROLLER ASSY (NUDGER). (RRP 14.46/RRP 14.50/RRP 14.53)
12	Checking paper position Does the paper touch the SENSOR ASSY REGI? Open the COVER ASSY-LH (PL 4.2.8) and check it (visual check).	Remove the paper.	Go to step 13.
13	Checking the Roll (1) Is the ROLLER ASSY-TA for transport worn or contaminated with paper dust? Open the COVER ASSY-LH (PL 4.2.8) and check it.	Go to step 14.	Clean or replace the ROLLER ASSY-TA. (RRP 4.3)

Step	Check	Yes	No
14	Checking the Roll (2) Is the ROLLER of the TRANS ASSY REGI for transport (PL 4.5.1) worn or contaminated with paper dust? Open the COVER ASSY-LH (PL 4.2.8) and check it.	Go to step 15.	Clean or replace the TRANS ASSY REGI. (RRP 4.10)
15	Checking the SENSOR ASSY REGI for operation Does the Input Status change from "0x0" to "0x1" each time the paper touches the SENSOR ASSY REGI? Execute [Input 08-05 REGI SENSOR] in Chapter 2 [Diagnostic]. Open the COVER ASSY-LH (PL 4.2.8) and check it.	Go to step 19.	Go to step 16.
16	Checking the SENSOR ASSY REGI for connection Are P/J104 and P/J403B connected surely?	Go to step 17.	Connect P/J104 and P/J403B surely.
17	Checking conductivity between the SENSOR ASSY REGI and the PWB A MCU Is there conductivity on each wire between P/J104 <=> P/J403B?	Go to step 18.	Fix open and short circuit.
18	Checking +5 VDC power supply to the SENSOR ASSY REGI Is the voltage across J104-1 (+) <=> ground +5 VDC?	Replace the SENSOR ASSY REGI. (RRP 4.13)	Replace the PWBA MCU F. (RRP 8.4)
19	Checking the CLUTCH ASSY REGI H for operation Does the CLUTCH ASSY REGI H operate properly? Execute [Output 08-39 REGI CLUTCH (EXIT)] in Chapter 2 [Diagnostic].	Reconnect the connector on the PWBA MCU F.	Go to step 20.
20	Checking the CLUTCH ASSY REGI H for connection Are P/J215 and P/J403B connected surely?	Go to step 21.	Connect P/J215 and P/J403B surely.
21	Checking conductivity between the CLUTCH ASSY REGI H and the PWB A MCU F Is there conductivity on each wire between P/J215 <=> P/J403B?	Go to step 22.	Fix open and short circuit.
22	Checking +24 VDC power supply to the CLUTCH ASSY REGI H Is the voltage across P215-2 (+) <=> ground +24 VDC?	Go to step 23.	Replace the PWBA MCU F. (RRP 8.4)
23	Checking the resistance of the CLUTCH ASSY REGI H Is the resistance across J215-1 <=> J215-2 approximately 240 ohm?	Replace the PWBA MCU F. (RRP 8.4)	Replace the CLUTCH ASSY REGI H. (RRP 4.11)

## Tray 4 Paper size mismatch in length

Step	Check	Yes	No
	Possible causative parts: TRAY 3/4 PAPER SIZE SWITCH (PL 14.4.23) FRONT SIDE GUIDE (PL 14.2.14) REAR SIDE GUIDE (PL 14.2.18) SENSOR ASSY REGI (PL 4.5.7) CLUTCH ASSY REGI (PL 4.5.5) TRAY MODULE PWB (PL 14.8.5) PWBA MCU F (PL 8.1.5)		
1	Checking the paper (1) Is paper loaded in the TRAY4 properly? Pull out the TRAY4 to check it. (Visual check)	Go to step 2.	Load paper properly.
2	Checking the paper (2) Are the FRONT SIDE GUIDE and REAR SIDE GUIDE of the TRAY4 set correctly? Pull out the TRAY4 to check it. (Visual check)	Go to step 3.	Set the parts properly.
3	Checking the TRAY 3/4 PAPER SIZE SWITCH for the TRAY4 for installation Is the TRAY 3/4 PAPER SIZE SWITCH for the TRAY4 installed properly? Pull out the TRAY4 to check it. (Visual check)	Go to step 4.	Install the TRAY 3/4 PAPER SIZE SWITCH for the TRAY4 correctly. (RRP 14.30)
4	Checking the TRAY 3/4 PAPER SIZE SWITCH for the TRAY4 for operation Does the Input Status change from "0x0" to "0x1" each time the TRAY4 is pulled out or pushed in, when the TRAY4 is loaded with paper? Execute [Input 07-04 TRAY4 SIZE SENSOR] in Chapter 2 [Diagnostic].	Go to step 11.	Go to step 5.
5	Checking the TRAY 3/4 PAPER SIZE SWITCH for the TRAY4 for connection Are P/J824 and P/J548 connected surely?	Go to step 6.	Connect P/J824 and P/J548 surely.
6	Checking conductivity between the TRAY 3/4 PAPER SIZE SWITCH for the TRAY4 and the TRAY MODULE PWB Is there conductivity on each wire between P/J824 <=> P/J548?	Go to step 7.	Fix open and short circuit.
7	Checking +3.3 VDC power supply to the TRAY 3/4 PAPER SIZE SWITCH for the TRAY4 Is the voltage across J824-1 (+) <=> ground +3.3 VDC?	Replace the TRAY 3/4 PAPER SIZE SWITCH for the STRAY4. (RRP 14.30)	Go to step 8.
8	Checking the TRAY MODULE PWB for connection Are P/J413 and P/J541 connected surely?	Go to step 9.	Connect P/J413 and P/541 surely.
9	Checking conductivity between the TRAY MODULE PWB and the PWBA MCU F Is there conductivity on each wire between P/J413 <=> P/J541?	Go to step 10.	Fix open and short circuit.

Step	Check	Yes	No
10	Checking +5 VDC power supply to the TRAY MODULE PWB Is the voltage across J413-A5 (+) <=> ground +5 VDC?	Replace the TRAY MODULE PWB. (RRP 14.62)	Replace the PWBA MCU F. (RRP 8.4)
11	Checking the Roll for the TRAY4 Is the ROLLER ASSY (FEED), ROLLER ASSY (RETARD) or ROLLER ASSY (NUDGER) for transport worn or contaminated with paper dust? Pull out the TRAY4 and check it.	Go to step 12.	Clean or replace the ROLLER ASSY (FEED), ROLLER ASSY (RETARD) or ROLLER ASSY (NUDGER). (RRP 14.46/RRP 14.50/RRP 14.53))
12	Checking paper position Does the paper touch the SENSOR ASSY REGI? Open the COVER ASSY-LH (PL 4.2.8) and check it (visual check).	Remove the paper.	Go to step 13.
13	Checking the Roll (1) Is the ROLLER ASSY-TA for transport worn or contaminated with paper dust? Open the COVER ASSY-LH (PL 4.2.8) and check it.	Go to step 14.	Clean or replace the ROLLER ASSY-TA. (RRP 4.3)
14	Checking the Roll (2) Is the ROLLER of the TRANS ASSY REGI for transport (PL 4.5.1) worn or contaminated with paper dust? Open the COVER ASSY-LH (PL 4.2.8) and check it.	Go to step 15.	Clean or replace the TRANS ASSY REGI. (RRP 4.10)
15	Checking the SENSOR ASSY REGI for operation Does the Input Status change from "0x0" to "0x1" each time the paper touches the SENSOR ASSY REGI? Execute [Input 08-05 REGI SENSOR] in Chapter 2 [Diagnostic]. Open the COVER ASSY-LH (PL 4.2.8) and check it.	Go to step 19.	Go to step 16.
16	Checking the SENSOR ASSY REGI for connection Are P/J104 and P/J403B connected surely?	Go to step 17.	Connect P/J104 and P/J403B surely.
17	Checking conductivity between the SENSOR ASSY REGI and the PWB A MCU Is there conductivity on each wire between P/J104 <=> P/J403B?	Go to step 18.	Fix open and short circuit.
18	Checking +5 VDC power supply to the SENSOR ASSY REGI Is the voltage across J104-1 (+) <=> ground +5 VDC?	Replace the SENSOR ASSY REGI. (RRP 4.13)	Replace the PWBA MCU F. (RRP 8.4)
19	Checking the CLUTCH ASSY REGI H for operation Does the CLUTCH ASSY REGI H operate properly? Execute [Output 08-39 REGI CLUTCH (EXIT)] in Chapter 2 [Diagnostic].	Reconnect the connector on the PWBA MCU F.	Go to step 20.
20	Checking the CLUTCH ASSY REGI H for connection Are P/J215 and P/J403B connected surely?	Go to step 21.	Connect P/J215 and P/J403B surely.

Step	Check	Yes	No
21	Checking conductivity between the CLUTCH ASSY REGI H and the PWB A MCU Is there conductivity on each wire between P/J215 <=> P/J403B?	Go to step 22.	Fix open and short circuit.
22	Checking +24 VDC power supply to the CLUTCH ASSY REGI H Is the voltage across P215-2 (+) <=> ground +24 VDC?	Go to step 23.	Replace the PWBA MCU F. (RRP 8.4)
23	Checking the resistance of the CLUTCH ASSY REGI H Is the resistance across J215-1 and J215-2 approximately 240 ohm?	Replace the PWBA MCU F. (RRP 8.4)	Replace the CLUTCH ASSY REGI H. (RRP 4.11)

# Image Quality Trouble

## Entry Chart for Image Quality Troubleshooting

**NOTE** By printing a test print with the engine only, isolating problems between the Printer Controller or the engine can usually be diagnosed easily.

- Test print result with the engine only is normal. ---> Malfunction on Printer Controller side
  - Test print result with the engine only is also abnormal. ---> Malfunction on the engine side
- When it is the case of [Malfunction on Printer Controller side], replace with normal Printer Controller and normal Interface Cable, and check.

When the trouble still occurs after replacement, check the host side, and then perform troubleshooting using the following image quality FIP according to each phenomenon.

When the image quality trouble of print occurs, get a print to judge, understand and treat the trouble substance precisely and appropriately, and then troubleshoot efficiently, using the image quality FIP table according to each phenomenon.

When trouble restoration with image quality FIP is not possible, check again with the image quality FIP, and then replace [ESS and possible causative parts] in order and check, and operate Troubleshooting, using [Chapter 2 Diagnostic].

Image quality FIP states regarding the typical image quality trouble, as follows.

- FIP-1.P1 Faint print (Low contrast)
- FIP-1.P2 Blank print (No print)
- FIP-1.P3 Solid black
- FIP-1.P4 Vertical blank lines (White stripes in paper transport direction)
- FIP-1.P5 Horizontal band cross out
- FIP-1.P6 Vertical stripes
- FIP-1.P7 Horizontal stripes
- FIP-1.P8 Partial lack
- FIP-1.P9 Spots
- FIP-1.P10 Afterimage
- FIP-1.P11 Background (Fog)
- FIP-1.P12 Skew
- FIP-1.P13 Paper damage
- FIP-1.P14 No fix

**NOTE** When horizontal lines and/or spots occur periodically, it is possibly caused by a particular roll. In this case, measure the interval on the test print, and check the relation to the rolls in the machine. The interval does not necessarily match circumference of the roll. The trouble may be solved easily by the check.

## 18.1 Image Quality FIP

### Faint print (Low contrast)



Trouble substance

The density of the image is entirely too faint.

Possible causative parts

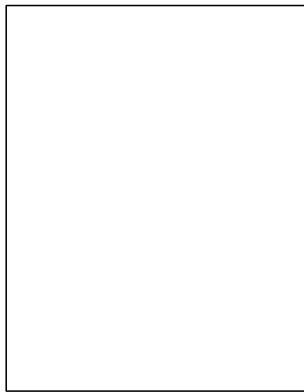
- CRU (PL 5.1.15)
- TONER CARTRIDGE (PL 5.1.16)
- PWBA MCU F (PL 8.1.5)
- HSG ASSY-BTR (PL 4.2.1)
- PSHV-Y2 (PL 8.1.1)
- PWBA ESS (PL 8.1.25)

Before starting troubleshooting, check the paper transfer route. Check that there is no foreign article, such as staples, paper clips and paper scraps, in the route.

Step	Check	Yes	No
1	Checking paper condition Load new, dry recommended paper, and perform Test Print. Is the density of the image normal?	End of work	Go to step 2.
2	Checking the TONER CARTRIDGE Install a new TONER CARTRIDGE. Re-print the defective image. Is the image density normal?	End of work	Go to step 3.
3	Checking the HSG ASSY-BTR Remove the HSG ASSY-BTR. (RRP 4.7) Check the HSG ASSY-BTR for contamination and wear. Is there any contamination or wear on the HSG ASSY-BTR?	Go to step 4.	Replace the HSG ASSY-BTR (RRP 4.7).
4	Checking the CRU installation condition Remove the CRU. Check the CRU SWITCH on the printer side. Check the CRU SWITCH pins for contamination or deformation.	Go to step 5.	Correct and clean defective pins or replace the switch.
5	Checking the CRU ground Remove the CRU. Check the Earth Plate located behind the CRU. Is the Earth Plate contaminated or deformed?	Go to step 6.	Correct and clean Earth Plate or replace the CRU.
6	Checking image development process Perform Test Print, and turn off the power of the printer while printing. Carefully remove the TONER CARTRIDGE, and check the toner image formed on the drum right before the transfer unit (BTR). Is the image completely formed on the drum? Is the area clear and black, and easy to read?	Go to step 7.	Go to step 9.

Step	Check	Yes	No
7	Checking image transfer process Check the toner image formed on the drum, right after the transfer unit (BTR). Is the toner image completely transferred on the paper?	Go to step 8.	Go to step 9.
8	Checking the PSHV-Y2 Replace the PSHV-Y2 (RRP 8.1). Perform Test Print. Is the trouble rectified?	End of work	Go to step 9.
9	Checking the PWBA MCU F Replace the PWBA MCU F (RRP 8.4). Perform Test Print. Is the trouble rectified?	End of work	Replace the PWBA ESS.

## Blank print (No print)



### Trouble substance

The entire paper is printed pure white.

### Possible causative parts

- ROS ASSY-12 (PL 5.1.14)
- CRU (PL 5.1.15)
- TONER CARTRIDGE (PL 5.1.16)
- PWBA MCU F (PL 8.1.5)
- HSG ASSY-BTR (PL 4.2.1)
- PSHV-Y2 (PL 8.1.1)
- PWBA ESS (PL 8.1.25)

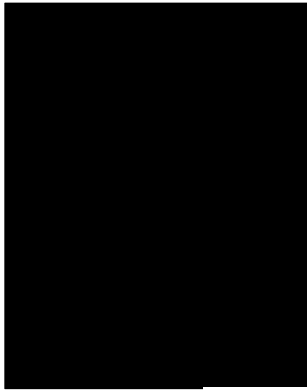
Before commencing troubleshooting, check the paper transfer course. Make sure there is no foreign articles on the transfer course, such as staples, paper clips, scraps of paper and so on.

Step	Check	Yes	No
1	Checking the TONER CARTRIDGE Install a new TONER CARTRIDGE. Re-print the defective image. Is the image density normal?	End of work	Go to step 2.
2	Checking the HSG ASSY-BTR Remove the HSG ASSY-BTR (RRP 4.7). Check the HSG ASSY-BTR for contamination and wear. Is there any contamination or wear on the HSG ASSY-BTR?	Go to step 3.	Replace the HSG ASSY-BTR (RRP 4.7).
3	Checking the CRU installation condition Remove the CRU. Check the CRU SWITCH on the printer side. Check the CRU SWITCH pins for contamination or deformation.	Go to step 4.	Correct and clean defective pins or replace the switch.



Step	Check	Yes	No
4	Checking the CRU ground Remove the CRU. Check the Earth Plate located behind the CRU. Is the Earth Plate contaminated or deformed?	Go to step 5.	Correct and clean the Earth Plate or replace the CRU.
5	Checking laser beam route Check that there is no obstacle between the ROS ASSY-12 and the Drum. Check the ROS ASSY-12 window for contamination. Is there any obstacle on the laser beam route? Is the ROS ASSY-12 window normal?	Go to step 6.	Remove obstacles or clean the ROS ASSY-12 window.
6	Checking the ROS ASSY-12 installation (1) Is the ROS ASSY-12 installed securely with four screws?	Go to step 8.	Go to step 7.
7	Checking the ROS ASSY-12 installation (2) Install the ROS ASSY-12 securely and then perform Test Print. Is the trouble rectified?	End of work	Go to step 8.
8	Checking the ROSS ASSY-12 for connection Are P/J130, P/J620 and P/J406 connected surely? Warning! Be careful not to apply too much force to the board when checking it or it can cause a ROS alignment displacement.	Go to step 9.	Connect P/J130, P/J620 and P/J406 surely.
9	Checking image development process Perform Test Print, and turn off the power of the printer while printing. Carefully remove the TONER CARTRIDGE, and check the toner image formed on the drum right before the transfer unit (BTR). Carefully remove the TONER CARTRIDGE, and check the toner image formed on the drum right before the transfer unit (BTR). Is the image completely formed on the drum? Is the area clear and black, and easy to read?	Go to step 10.	Go to step 11.
10	Checking image transfer process Check the toner image formed on the drum right after the transfer unit (BTR). Is the toner image completely transferred on the paper?	Go to step 11.	Go to step 12.
11	Checking the PSHV-Y2 Replace the PSHV-Y2 (RRP 8.1). Perform Test Print. Is the trouble rectified?	End of work	Go to step 12.
12	Checking the PWBA MCU F Replace the PWBA MCU F (RRP 8.4). Perform Test Print. Is the trouble rectified?	End of work	Replace the PWBA ESS.

## Solid black



**Trouble substance**

The entire paper is printed jet-black.

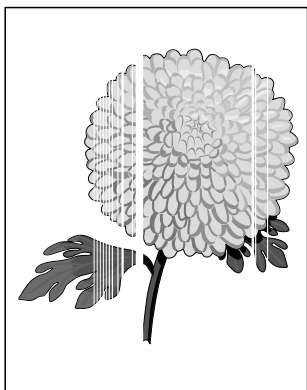
**Possible causative parts**

- TONER CARTRIDGE (PL 5.1.16)
- PSHV-Y2 (PL 8.1.1)
- PWBA MCU F (PL 8.1.5)
- PWBA ESS (PL 8.1.25)

Before commencing troubleshooting, check the paper transfer course. Make sure there is no foreign articles on the transfer course, such as staples, paper clips, scraps of paper and so on.

Step	Check	Yes	No
1	Checking the TONER CARTRIDGE Install a new TONER CARTRIDGE. Re-print the defective image. Is the image density normal?	End of work	Go to step 2.
2	Checking the PSHV-Y2 Replace the PSHV-Y2 (RRP 8.1). Perform Test Print. Is the trouble rectified?	End of work	Go to step 3.
3	Checking the PWBA MCU F Replace the PWBA MCU F (RRP 8.4). Perform Test Print. Is the trouble rectified?	End of work	Replace the PWBA ESS.

**Vertical blank lines (White stripes in paper transport direction)**



**Trouble substance**

There are some extremely faint or completely non-printed parts. Those non-printed parts cover a wide area vertically, along the paper feeding direction.

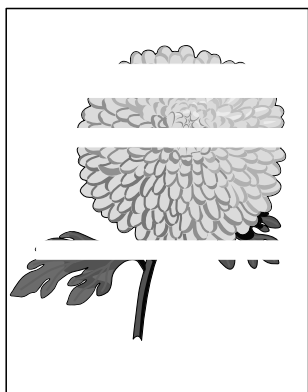
**Possible causative parts**

- TONER CARTRIDGE (PL 5.1.16)
- HSG ASSY-BTR (PL 4.2.1)
- ROS ASSY-12 (PL 5.1.14)
- FUSER ASSY (PL 6.1.7)
- PWBA MCU F (PL 8.1.5)
- PWBA ESS (PL 8.1.25)

Before commencing troubleshooting, check the paper transfer course. Make sure there is no foreign articles on the transfer course, such as staples, paper clips, scraps of paper and so on.

Step	Check	Yes	No
1	Checking paper condition Load new and dry recommended paper. Re-print the defective image. Is the problem still occurs?	Go to step 2.	End of work
2	Checking paper transfer route Check the paper router for contamination or obstacles. Is there any obstacle on the paper route?	Go to step 3.	Remove obstacles or contamination.
3	Checking laser beam route Check that there is no obstacle between the ROS ASSY-12 and the Drum. Check the ROS ASSY-12 window for contamination. Is there any obstacle on the laser beam route? Is the ROS ASSY-12 window normal?	Go to step 4.	Remove obstacles or clean the ROS ASSY-12 window.
4	Checking the ROS ASSY-12 installation (1) Is the ROS ASSY-12 installed securely with four screws?	Go to step 6.	Go to step 5.
5	Checking the ROS ASSY-12 installation (2) Install the ROS ASSY-12 securely and then perform Test Print. Is the trouble rectified?	End of work	Go to step 6.
6	Checking the TONER CARTRIDGE Install a new TONER CARTRIDGE. Re-print the defective image. Is the image density normal?	End of work	Go to step 7.
7	Checking the HSG ASSY-BTR Remove the HSG ASSY-BTR (RRP 4.7). Check the HSG ASSY-BTR for contamination and wear. Is there any contamination or wear on the HSG ASSY-BTR?	Go to step 8.	Replace the HSG ASSY-BTR (RRP 4.7).
8	Checking the Heat Roll and Pressure Roll Remove the FUSER ASSY (RRP 6.2). WARNING! Start the operation after the FUSER ASSY has cooled down. Is there any contamination or crack on Heat Roll or Pressure Roll?	Replace the FUSER ASSY (RRP 6.2).	Go to step 9.
9	Checking the PWBA MCU F Replace the PWBA MCU F (RRP 8.4). Perform Test Print. Is the trouble rectified?	End of work	Go to step 10.
10	Checking the ROSS ASSY-12 for connection Are P/J130, P/J620 and P/J406 connected surely? Warning! Be careful not to apply too much force to the board when checking it or it can cause a ROS alignment displacement.	Replace the PWBA ESS.	Connect P/J130, P/J620 and P/J406 surely.

## Horizontal band cross out



### Trouble substance

There are some extremely faint or completely non-printed parts. The non-printed parts cover a wide area perpendicular to the paper feed direction.

### Possible causative parts

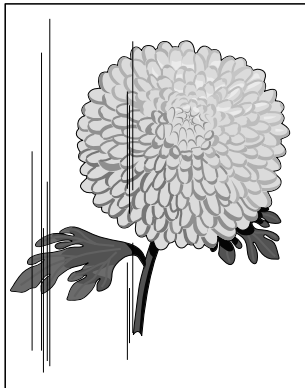
- CRU (PL 5.1.15)
- TONER CARTRIDGE (PL 5.1.16)
- HSG ASSY-BTR (PL 4.2.1)
- ROS ASSY-12 (PL 5.1.14)
- FUSER ASSY (PL 6.1.7)
- PWBA MCU F (PL 8.1.5)
- PWBA ESS (PL 8.1.25)

Before commencing troubleshooting, check the paper transfer course. Make sure there is no foreign articles on the transfer course, such as staples, paper clips, scraps of paper and so on.

Step	Check	Yes	No
1	Checking paper condition Load new and dry recommended paper. Re-print the defective image. Is the problem still occurs?	Go to step 2.	End of work
2	Checking paper transfer route Check the paper router for contamination or obstacles. Is there any obstacle on the paper route?	Go to step 3.	Remove obstacles or contamination.
3	Checking the TONER CARTRIDGE Install a new TONER CARTRIDGE. Re-print the defective image. Is the image density normal?	End of work	Go to step 4.
4	Checking the HSG ASSY-BTR Remove the HSG ASSY-BTR (RRP 4.7). Check the HSG ASSY-BTR for contamination and wear. Is there any contamination or wear on the HSG ASSY-BTR?	Go to step 5.	Replace the HSG ASSY-BTR (RRP 4.7).
5	Checking white-band pitch Is the white-band pitch approximately. 78 mm (Heat Roll circumference)?	Go to step 9.	Go to step 6.
6	Checking the Heat Roll and Pressure Roll Remove the FUSER ASSY (RRP 6.2). WARNING! Start the operation after the FUSER ASSY has cooled down.the Is there any contamination or crack on Heat Roll and/or the Pressure Roll?	Replace the FUSER ASSY (RRP 6.2).	Go to step 7.

Step	Check	Yes	No
7	<p>Checking image development process</p> <p>Perform Test Print, and turn off the power of the printer while printing.</p> <p>Carefully remove the TONER CARTRIDGE, and check the toner image formed on the drum right before the transfer unit (BTR).</p> <p>Is the image completely formed on the drum? Is the area clear and black, and easy to read?</p>	Go to step 8.	Go to step 9.
8	<p>Checking image transfer process</p> <p>Check the toner image formed on the drum just after the transfer unit (BTR) passed.</p> <p>Is the toner image completely transferred on the paper?</p>	Go to step 9.	Go to step 10.
9	<p>Checking the PSHV-Y2</p> <p>Replace the PSHV-Y2 (RRP 8.1).</p> <p>Perform Test Print.</p> <p>Is the trouble rectified?</p>	End of work	Go to step 10.
10	<p>Checking the PWBA MCU F</p> <p>Replace the PWBA MCU F (RRP 8.4).</p> <p>Perform Test Print.</p> <p>Is the trouble rectified?</p>	End of work	Replace the PWBA ESS.

## Vertical stripes



### Trouble substance

There are vertical black stripes along the longer side of the paper.

### Possible causative parts

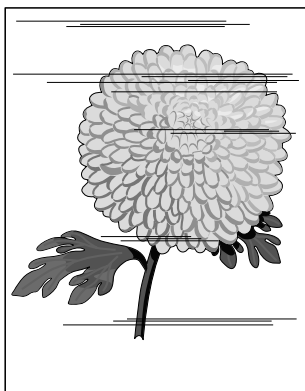
- TONER CARTRIDGE (PL 5.1.16)
- HSG ASSY-BTR (PL 4.2.1)
- ROS ASSY-12 (PL 5.1.14)
- FUSER ASSY (PL 6.1.7)
- PWBA MCU F (PL 8.1.5)
- PWBA ESS (PL 8.1.25)

Before commencing troubleshooting, check the paper transfer course. Make sure there is no foreign articles on the transfer course, such as staples, paper clips, scraps of paper and so on.

Step	Check	Yes	No
1	<p>Checking paper condition</p> <p>Load new and dry recommended paper.</p> <p>Re-print the defective image.</p> <p>Is the problem still occurs?</p>	Go to step 2.	End of work
2	<p>Checking paper transfer route</p> <p>Check the paper router for contamination or obstacles.</p> <p>Is there any obstacle on the paper route?</p>	Go to step 3.	Remove obstacles or contamination.

Step	Check	Yes	No
3	Checking the TONER CARTRIDGE Install a new TONER CARTRIDGE. Re-print the defective image. Is the image density normal?	End of work	Go to step 4.
4	Checking the HSG ASSY-BTR Remove the HSG ASSY-BTR (RRP 4.7). Check the HSG ASSY-BTR for contamination and wear. Is there any contamination or wear on the HSG ASSY-BTR?	Go to step 5.	Replace the HSG ASSY-BTR (RRP 4.7).
5	Checking the CRU installation condition Remove the CRU. Check the CRU SWITCH on the printer side. Check the CRU SWITCH pins for contamination or deformation.	Go to step 5.	Correct and clean defective pins or replace the switch.
6	Checking the CRU ground Remove the CRU. Check the Earth Plate located behind the CRU. Is the Earth Plate contaminated or deformed?	Go to step 6.	Correct and clean Earth Plate or replace the CRU.
7	Checking laser beam route Check that there is no obstacle between the ROS ASSY-12 and the Drum. Check the ROS ASSY-12 window for contamination. Is there any obstacle on the laser beam route? Is the ROS ASSY-12 window normal?	Go to step 4.	Remove obstacles or clean the ROS ASSY-12 window.
8	Checking the Heat Roll and Pressure Roll Remove the FUSER ASSY (RRP 6.2). WARNING! Start the operation after the FUSER ASSY has cooled down. Is there any contamination or crack on Heat Roll and/or Pressure Roll?	Replace the FUSER ASSY (RRP 6.2).	Go to step 9.
9	Checking the PWBA MCU F Replace the PWBA MCU F (RRP 8.4). Perform Test Print. Is the trouble rectified?	End of work	Replace the PWBA ESS.

## Horizontal stripes



Trouble substance

There are horizontal black stripes along the shorter side of the paper.

Possible causative parts

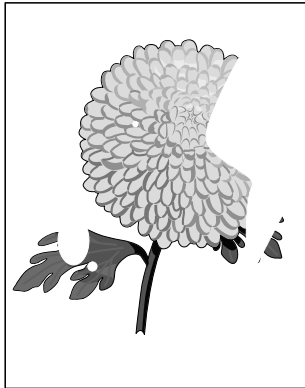
- CRU ((PL 5.1.15)
- TONER CARTRIDGE (PL 5.1.16)
- HSG ASSY-BTR (PL 4.2.1)
- ROS ASSY-12 (PL 5.1.14)
- FUSER ASSY (PL 6.1.7)
- PWBA MCU F (PL 8.1.5)
- PWBA ESS (PL 8.1.25)

Before commencing troubleshooting, check the paper transfer course. Make sure there is no foreign articles on the transfer course, such as staples, paper clips, scraps of paper and so on.

Step	Check	Yes	No
1	Checking paper condition Load new and dry recommended paper. Re-print the defective image. Is the problem still occurs?	Go to step 2.	End of work
2	Checking paper transfer route Check the paper router for contamination or obstacles. Is there any obstacle on the paper route?	Go to step 3.	Remove obstacles or contamination.
3	Checking the TONER CARTRIDGE Install a new TONER CARTRIDGE. Re-print the defective image. Is the image density normal?	End of work	Go to step 4.
4	Checking the HSG ASSY-BTR Remove the HSG ASSY-BTR (RRP 4.7). Check the HSG ASSY-BTR for contamination and wear. Is there any contamination or wear on the HSG ASSY-BTR?	Go to step 5.	Replace the HSG ASSY-BTR (RRP 4.7).
5	Checking white-band pitch Is the white-band pitch approximately. 78 mm (Heat Roll circumference)?	Go to step 9.	Go to step 6.
6	Checking the Heat Roll and Pressure Roll Remove the FUSER ASSY (RRP 6.2). WARNING! Start the operation after the FUSER ASSY has cooled down. Is there any contamination or crack on Heat Roll and/or Pressure Roll?	Replace the FUSER ASSY (RRP 6.2).	Go to step 7.
7	Checking image development process Perform Test Print, and turn off the power of the printer while printing. Carefully remove the TONER CARTRIDGE, and check the toner image formed on the drum just before the transfer unit (BTR). Is the image completely formed on the drum? Is the area clear and black, and easy to read?	Go to step 8.	Go to step 9.
8	Checking image transfer process Check the toner image formed on the drum just after the transfer unit (BTR) passed. Is the toner image completely transferred on the paper?	Go to step 9.	Go to step 10.
9	Checking the PSHV-Y2 Replace the PSHV-Y2 (RRP 8.1). Perform Test Print. Is the trouble rectified?	End of work	Go to step 10.
10	Checking the PWBA MCU F Replace the PWBA MCU F (RRP 8.4). Perform Test Print. Is the trouble rectified?	End of work	Go to step 11.

Step	Check	Yes	No
11	Checking the ROSS ASSY-12 for connection Are P/J130, P/J620 and P/J406 connected surely? Warning! Be careful not to apply too much force to the board when checking it or it can cause a ROS alignment displacement.	Replace the PWBA ESS.	Connect P/J130, P/J620 and P/J406 surely.

## Partial lack of Image



### Trouble substance

There are some extremely faint or completely missing parts. Those missing parts are dotted in a limited area on the paper.

### Possible causative parts

- TONER CARTRIDGE (PL 5.1.16)
- HSG ASSY-BTR (PL 4.2.1)
- FUSER ASSY (PL 6.1.7)
- PWBA MCU F (PL 8.1.5)
- PWBA ESS (PL 8.1.25)

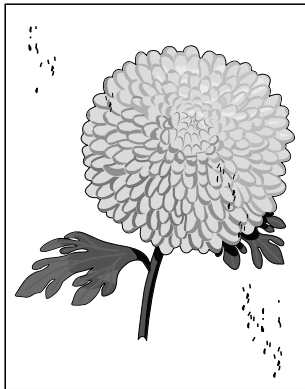
Before commencing troubleshooting, check the paper transfer course. Make sure there is no foreign articles on the transfer course, such as staples, paper clips, scraps of paper and so on.

Step	Check	Yes	No
1	Checking paper condition Load new and dry recommended paper. Re-print the defective image. Is the problem still occurs?	Go to step 2.	End of work
2	Checking paper transfer route Check the paper router for contamination or obstacles. Is there any obstacle on the paper route?	Go to step 3.	Remove obstacles or contamination.
3	Checking the TONER CARTRIDGE Install a new TONER CARTRIDGE. Re-print the defective image. Is the image density normal?	End of work	Go to step 4.
4	Checking the HSG ASSY-BTR Remove the HSG ASSY-BTR (RRP 4.7). Check the HSG ASSY-BTR for contamination and wear. Is there any contamination or wear on the HSG ASSY-BTR?	Go to step 5.	Replace the HSG ASSY-BTR (RRP 4.7).



Step	Check	Yes	No
5	Checking the Heat Roll and the Pressure Roll Remove the FUSER ASSY (RRP 6.2). WARNING! Start the operation after the FUSER ASSY has cooled down. Is there any contamination or crack on the Heat Roll and/or the Pressure Roll?	Replace the FUSER ASSY (RRP 6.2).	Go to step 6.
6	Checking the PWBA MCU F Replace the PWBA MCU F (RRP 8.4). Perform Test Print. Is the trouble rectified?	End of work	Replace the PWBA ESS.

## Spots



Trouble substance

There are toner spots all over the paper disorderedly.

Possible causative parts

- TONER CARTRIDGE (PL 5.1.16)
- HSG ASSY-BTR (PL 4.2.1)
- FUSER ASSY (PL 6.1.7)
- PWBA MCU F (PL 8.1.5)
- PWBA ESS (PL 8.1.25)

Before commencing troubleshooting, check the paper transfer course. Make sure there is no foreign articles on the transfer course, such as staples, paper clips, scraps of paper and so on.

Step	Check	Yes	No
1	Checking paper condition Load new and dry recommended paper. Re-print the defective image. Is the problem still occurs?	Go to step 2.	End of work
2	Checking paper transfer route Check the paper router for contamination or obstacles. Is there any obstacle on the paper route?	Go to step 3.	Remove obstacles or contamination.
3	Checking the TONER CARTRIDGE Install a new TONER CARTRIDGE. Re-print the defective image. Is the image density normal?	End of work	Go to step 4.
4	Checking the HSG ASSY-BTR Remove the HSG ASSY-BTR (RRP 4.7). Check the HSG ASSY-BTR for contamination and wear. Is there any contamination or wear on the HSG ASSY-BTR?	Go to step 5.	Replace the HSG ASSY-BTR (RRP 4.7).

Step	Check	Yes	No
5	Checking the Heat Roll and the Pressure Roll Remove the FUSER ASSY (RRP 6.2). WARNING! Start the operation after the FUSER ASSY has cooled down. Is there any contamination or crack on the Heat Roll and/or the Pressure Roll?	Replace the FUSER ASSY (RRP 6.2).	Go to step 6.
6	Checking the PWBA MCU F Replace the PWBA MCU F (RRP 8.4). Perform Test Print. Is the trouble rectified?	End of work	Replace the PWBA ESS.

## Afterimage



### Trouble substance

The ghost appears on the paper. The ghost may be the image of the previous page, or a part of the page currently printing.

### Possible causative parts

- TONER CARTRIDGE (PL 5.1.16)
- FUSER ASSY (PL 6.1.7)
- PWBA MCU F (PL 8.1.5)
- PWBA ESS (PL 8.1.25)

Before commencing troubleshooting, check the paper transfer course. Make sure there is no foreign articles on the transfer course, such as staples, paper clips, scraps of paper and so on.

Step	Check	Yes	No
1	Checking repeated printing Check the afterimage. Is the client printing a copy of the same image in large quantity?	Go to step 2.	Go to step 3.
2	Print 30 pages of every kind of image. Does the afterimage still appear?	Go to step 3.	End of work (Do not make a copy of the same image in large quantity.)
3	Checking paper condition Load new and dry recommended paper. Re-print the defective image. Is the problem still occurs?	Go to step 4.	End of work
4	Checking the TONER CARTRIDGE Install a new TONER CARTRIDGE. Re-print the defective image. Is the image density normal?	End of work	Go to step 5.

Step	Check	Yes	No
5	Checking the Heat Roll and the Pressure Roll Remove the FUSER ASSY (RRP 6.2). WARNING! Start the operation after the FUSER ASSY has cooled down. Is there any contamination or crack on Heat Roll and/or Pressure Roll?	Replace the FUSER ASSY (RRP 6.2).	Go to step 6.
6	Checking the PWBA MCU F Replace the PWBA MCU F (RRP 8.4). Perform Test Print. Is the trouble rectified?	End of work	Replace the PWBA ESS.

## Background (Fog)



### Trouble substance

There is toner stain all over or a part of the page. The stain appears as very bright gray stain.

### Possible causative parts

- TONER CARTRIDGE (PL 5.1.16)
- HSG ASSY-BTR (PL 4.2.1)
- PSHV-Y2 (PL 8.1.1)
- PWBA MCU F (PL 8.1.5)
- PWBA ESS (PL 8.1.25)

Before commencing troubleshooting, check the paper transfer course. Make sure there is no foreign articles on the transfer course, such as staples, paper clips, scraps of paper and so on.

Step	Check	Yes	No
1	Checking paper condition Load new and dry recommended paper. Re-print the defective image. Is the problem still occurs?	Go to step 2.	End of work
2	Checking paper transfer route Check the paper router for contamination or obstacles. Is there any obstacle on the paper route?	Go to step 3.	Remove obstacles or contamination.
3	Checking the TONER CARTRIDGE Install a new TONER CARTRIDGE. Re-print the defective image. Is the image density normal?	End of work	Go to step 4.
4	Checking the HSG ASSY-BTR Remove the HSG ASSY-BTR (RRP 4.7). Check the HSG ASSY-BTR for contamination and wear. Is there any contamination or wear on the HSG ASSY-BTR?	Go to step 5.	Replace the HSG ASSY-BTR (RRP 4.7).

Step	Check	Yes	No
5	<p>Checking image development process</p> <p>Perform Test Print, and turn off the power of the printer while printing.</p> <p>Carefully remove the TONER CARTRIDGE, and check the toner image formed on the drum just before the transfer unit (BTR).</p> <p>Is the image completely formed on the drum?</p> <p>Is the area clear and black, and easy to read?</p>	Go to step 6.	Go to step 7.
6	<p>Checking image transfer process</p> <p>Check the toner image formed on the drum just after the transfer unit (BTR) passed.</p> <p>Is the toner image completely transferred on the paper?</p>	Go to step 7.	Go to step 8.
7	<p>Checking the PSHV-Y2</p> <p>Replace the PSHV-Y2 (RRP 8.1).</p> <p>Perform Test Print.</p> <p>Is the trouble rectified?</p>	End of work	Go to step 8.
8	<p>Checking the PWBA MCU F</p> <p>Replace the PWBA MCU F (RRP 8.4).</p> <p>Perform Test Print.</p> <p>Is the trouble rectified?</p>	End of work	Replace the PWBA ESS.

## Skew



### Trouble substance

The printed image is not paralleled with both sides of the paper.

### Possible causative parts

- CRU ((PL 5.1.15)
- TONER CARTRIDGE (PL 5.1.16)
- PWBA MCU F (PL 8.1.5)
- PWBA ESS (PL 8.1.25)
- TRAY ASSY (PL 2.1.3)

Before commencing troubleshooting, check the paper transfer course. Make sure there is no foreign articles on the transfer course, such as staples, paper clips, scraps of paper and so on.

Step	Check	Yes	No
1	<p>Checking installation place</p> <p>Check the installation surface for irregularities.</p> <p>Check for any missing Foot.</p> <p>Is the setup surface normal?</p>	Go to step 2.	Correct the installation place.

Step	Check	Yes	No
2	Load paper on the TRAY ASSY properly. Install the TRAY ASSY properly to the printer. Re-print the defective image. Does the problem still occur?	Go to step 3.	End of work
3	Checking paper transfer route Check the paper router for contamination or obstacles. Is there any obstacle on the paper route?	Go to step 4.	Remove obstacles or contamination.
4	Checking rollers on the paper transfer route Check all rollers on the entire route for contamination, wear or damage. Check whether pinch rollers rotate freely and spring pressure is applied evenly. Is there any contamination, wear or damage on the rollers?	Go to step 5.	Replace defective rollers. (Refer to applicable RRP's for replacement.)
5	Checking the PWBA MCU F Replace the PWBA MCU F (RRP 8.4). Perform Test Print. Is the trouble rectified?	End of work	Replace the PWBA ESS.

## Paper damage



### Trouble substance

The paper comes out from the printer crumpled, folded or worn-out.

### Possible causative parts

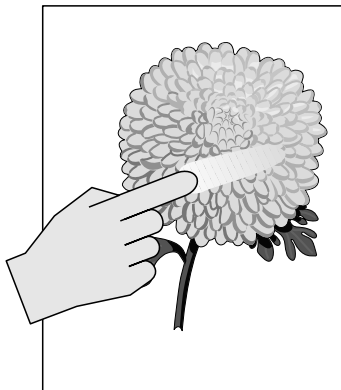
- FUSER ASSY (PL 6.1.7)
- TRAY ASSY (PL 2.1.3)

Before commencing troubleshooting, check the paper transfer course. Make sure there is no foreign articles on the transfer course, such as staples, paper clips, scraps of paper and so on.

Step	Check	Yes	No
1	Checking installation place Check the installation surface for irregularities. Check for any missing Foot. Is the setup surface normal?	Go to step 2.	Correct the installation place.
2	Checking paper feeding Remove the TRAY ASSY. Load paper on the TRAY ASSY properly. Install the TRAY ASSY properly to the printer. Re-print the defective image. Does the problem still occur?	Go to step 3.	End of work

Step	Check	Yes	No
3	Checking paper condition Load new and dry recommended paper. Re-print the defective image. Is the problem still occurs?	Go to step 4.	End of work
4	Checking paper transfer route Check the paper router for contamination or obstacles. Is there any obstacle on the paper route?	Go to step 5.	Remove obstacles or contamination.
5	Checking rollers on the paper transfer route Check all rollers on the entire route for contamination, wear or damage. Check whether pinch rollers rotate freely and spring pressure is applied evenly. Is there any contamination, wear or damage on the rollers?	Go to step 6.	Replace defective rollers.
6	Checking the Heat Roll and the Pressure Roll Remove the FUSER ASSY (RRP 6.2). <b>WARNING! Start the operation after the FUSER ASSY has cooled down.</b> Is there any contamination or crack on the Heat Roll and/or the Pressure Roll?	Replace the FUSER ASSY (RRP 6.2).	Contact the Technical Engineer.

## No fix



### Trouble substance

The printed image is not fixed on the paper properly. The image easily comes off when rubbed.

### Possible causative parts

- FUSER ASSY (PL 6.1.7)
- PSHV-Y2 (PL 8.1.1)
- PWBA MCU F (PL 8.1.5)
- PWBA ESS (PL 8.1.25)

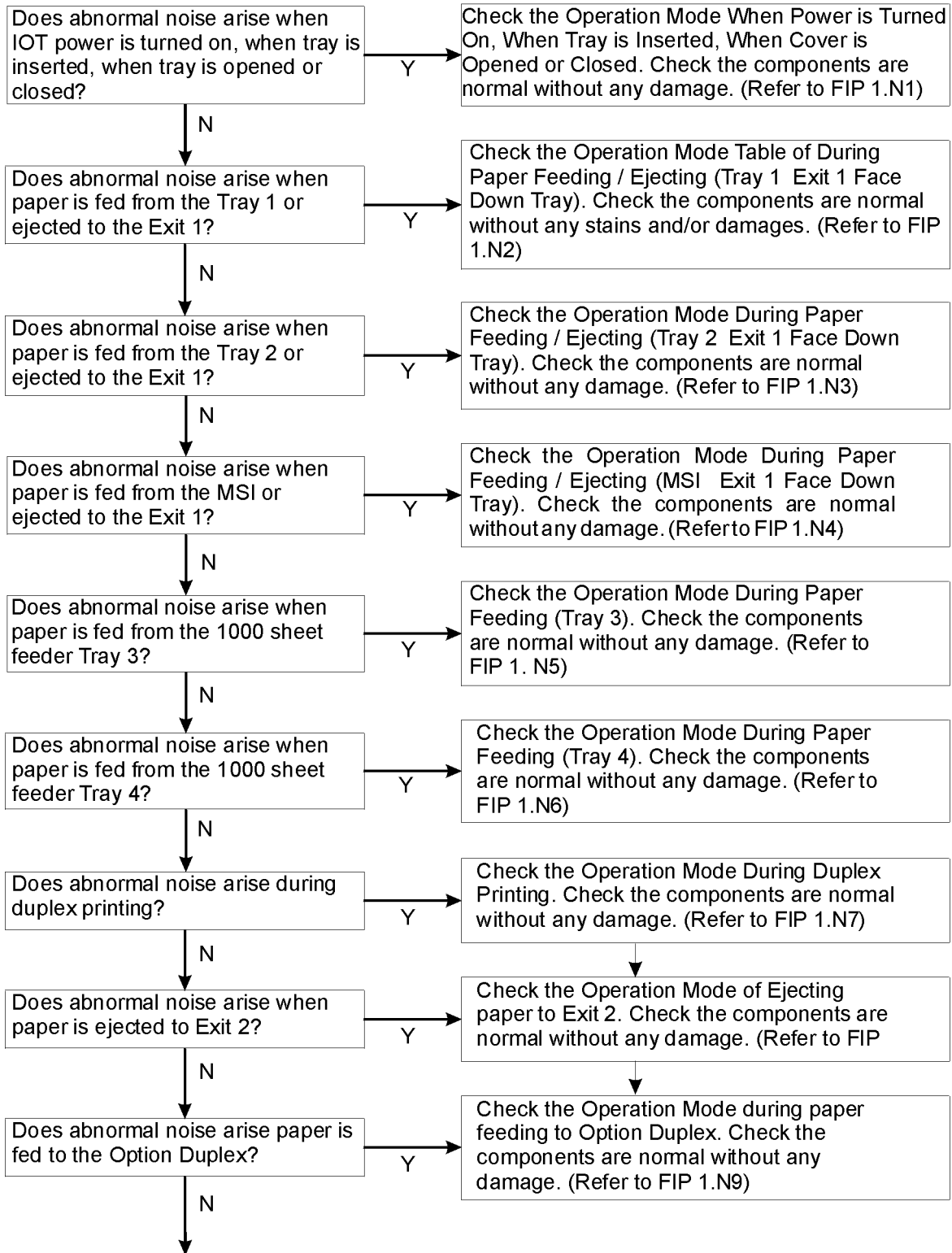
Before commencing troubleshooting, check the paper transfer course. Make sure there is no foreign articles on the transfer course, such as staples, paper clips, scraps of paper and so on.

Step	Check	Yes	No
1	Checking the FUSER ASSY installation Check that the levers on both sides of the FUSER ASSY are pushed down. Re-print the defective image. Does the problem still occur?	Go to step 2.	End of work
2	Checking paper condition Load new and dry recommended paper. Re-print the defective image. Is the problem still occurs?	Go to step 3.	End of work

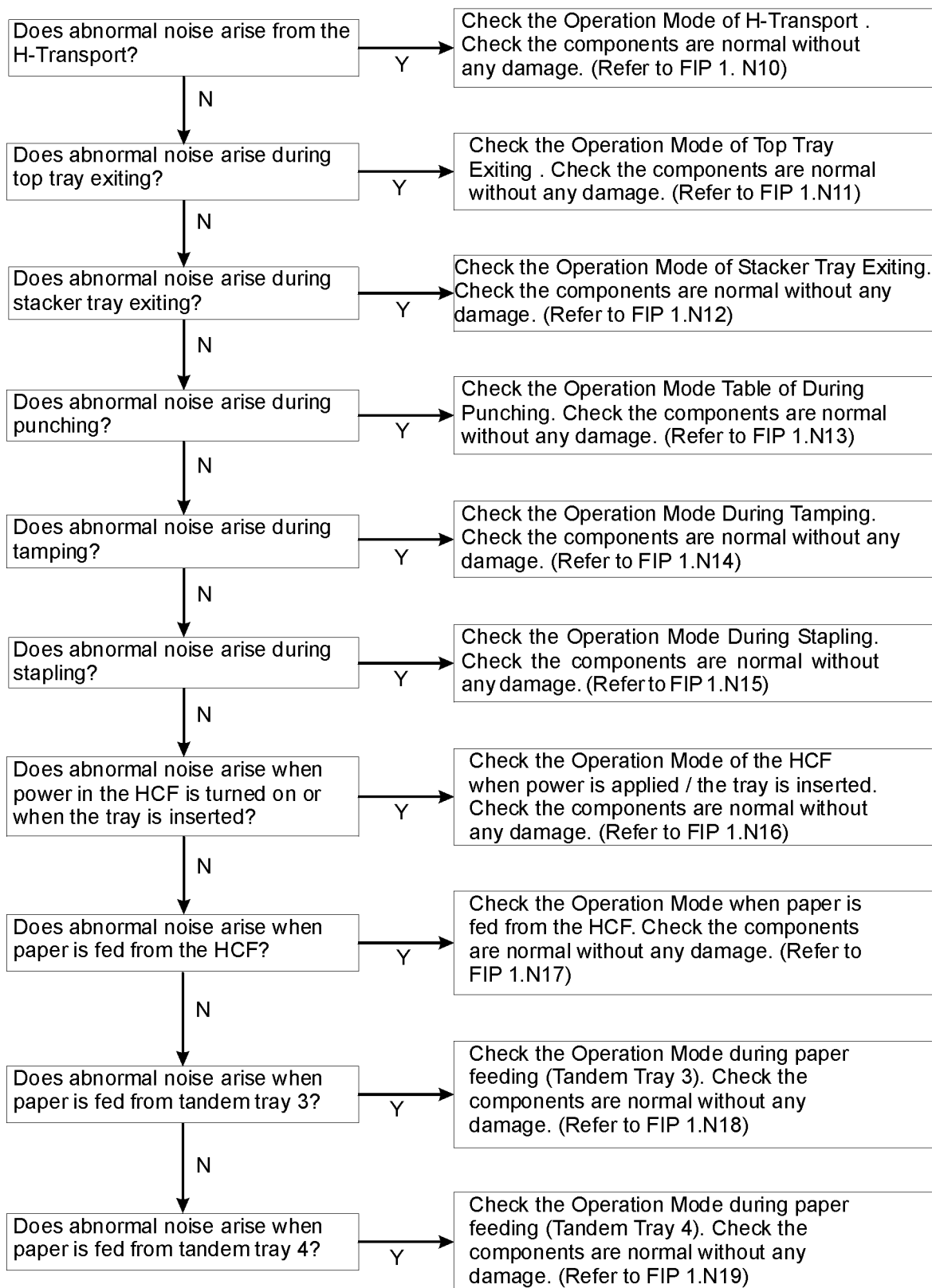
Step	Check	Yes	No
3	Checking the Heat Roll and the Pressure Roll Remove the FUSER ASSY (RRP 6.2). <b>WARNING! Start the operation after the FUSER ASSY has cooled down.</b> Is there any contamination or crack on the Heat Roll and/or the Pressure Roll?	Replace the FUSER ASSY (RRP 6.2).	Go to step 4.
4	Checking image development process Perform Test Print, and turn off the power of the printer while printing. Carefully remove the TONER CARTRIDGE, and check the toner image formed on the drum just before the transfer unit (BTR). Is the image completely formed on the drum? Is the area clear and black, and easy to read?	Go to step 5.	Go to step 7.
5	Checking image transfer process Check the toner image formed on the drum just after the transfer unit (BTR) passed. Is the toner image completely transferred on the paper?	Go to step 6.	Go to step 7.
6	Checking the PSHV-Y2 Replace the PSHV-Y2 (RRP 8.1). Perform Test Print. Is the trouble rectified?	End of work	Go to step 7.
7	Checking the PWBA MCU F Replace the PWBA MCU F (RRP 8.4). Perform Test Print. Is the trouble rectified?	End of work	Replace the PWBA ESS.

# Abnormal Noise Trouble

## Entry Chart for Abnormal Noise Troubleshooting







## Operation Mode Tables

### Normal Operation

When Power is Turned On / When Tray is Inserted/ When Cover is Opened or Closed.

Step	Check	Yes	No
	Possible causative parts MOTOR ASSY 242 (PL 7.1.7) BELT-SYNCHRONOUS BAN (PL 7.1.5) PULLEY 25T (PL 7.1.8) FUSER ASSY (PL 6.1.7) HSG ASSY-BTR (PL 4.2.1) ROLL ASSY OCT (PL 6.2.14) FAN FUSER (PL 5.1.13) SPACER (PL 2.3.4) GEAR (31T) (PL 2.3.5) SPRING (PL 2.3.6) TRAY 1/2 FEED LIFT UP MOTOR (PL 2.3.2) GEAR (13T/60T) SECTOR GEAR (60T) (PL 2.2.22) LIFT UP SHAFT (PL 2.2.24) FEEDER ASSY (FEEDER 1) (PL 2.1.7) FEEDER ASSY (FEEDER 2) (PL 2.1.8) TRAY ASSY (PL 2.1.3)		
1	Does noise arise from the MOTOR ASSY 242?	Go to step 2.	Go to step 7.
2	Is the MOTOR ASSY 242 fastened securely with the four screws?	Go to step 4.	Go to step 3.
3	Does noise arise after the MOTOR ASSY 242 is fastened with the four screws?	Go to step 4.	End of work.
4	Does noise arise from the PULLEY 25T or BELT-SYNCHRONOUS BAN?	Go to step 6.	Go to step 5.
5	Does noise arise after the gears of the MOTOR ASSY 242 are cleaned, and obstacles are removed?	Replace the MOTOR ASSY 242. (RRP 7.2)	End of work.
6	Does noise arise after the PULLEY 25T and BELT-SYNCHRONOUS BAN of the MOTOR ASSY 242 are cleaned, and obstacles are removed?	Replace the PULLEY 25T and BELT-SYNCHRONOUS BAN. (RRP 7.1)	End of work.
7	Does noise arise from the FUSER ASSY?	Go to step 8.	Go to step 10.
8	Does noise arise from the HSG ASSY-BTR?	Go to step 9.	Replace the FUSER ASSY. (RRP 6.2)
9	Does noise arise after the rollers of the HSG ASSY-BTR are cleaned, and obstacles are removed?	Replace the HSG ASSY-BTR. (RRP 4.7)	End of work.
10	Does noise arise from the ROLL ASSY OCT?	Clean or replace the ROLL ASSY OCT. (RRP 6.9)	Go to step 11.
11	Does noise arise from the Tray 1?	Go to step 12.	Go to step 24.
12	Does noise arise from the FEEDER ASSY (FEEDER 1)?	Go to step 13.	Go to step 17.

Step	Check	Yes	No
13	Is the FEEDER ASSY (FEEDER 1) fastened securely with the two screws?	Go to step 15.	Go to step 14.
14	Does noise arise after the FEEDER ASSY (FEEDER 1) is fastened with the two screws?	Go to step 15.	End of work.
15	Are the SPACER, GEAR (31T) and the SPRING installed in the correct orientation and order?	Go to step 16.	Reinstall the SPACER, GEAR (31T) and the SPRING in the correct orientation and order. (RRP 2.10/RRP 2.11)
16	Does noise arise from the TRAY 1/2 FEED LIFT UP MOTOR?	Replace the TRAY 1/2 FEED LIFT UP MOTOR. (RRP 2.9)	Go to step 22.
17	Does noise arise from the GEAR (13T/60T)?	Clean or replace the GEAR (13T/60T).	Go to step 18.
18	Does noise arise from the SECTOR GEAR (60T)?	Clean or replace the SECTOR GEAR (60T). (RRP 2.8)	Go to step 19.
19	Is the LIFT UP SHAFT deformed?	Replace the LIFT UP SHAFT.	Go to step 20.
20	Are there any obstacles around the LIFT UP SHAFT?	Go to step 21.	Go to step 23.
21	Does noise arise after obstacles are removed?	Go to step 23.	End of work.
22	Does noise arise after the FEEDER ASSY (FEEDER 1) is replaced (RRP 2.3)?	Contact a Technical Engineer.	End of work.
23	Does noise arise after the TRAY ASSY is replaced?	Contact a Technical Engineer.	End of work.
24	Does noise arise from the Tray 2?	Go to step 25.	Contact a Technical Engineer.
25	Does noise arise from the FEEDER ASSY (FEEDER 2)?	Go to step 26.	Go to step 30.
26	Is the FEEDER ASSY (FEEDER 2) fastened securely with the two screws?	Go to step 28.	Go to step 27.
27	Does noise arise after the FEEDER ASSY (FEEDER 2) is fastened with the two screws?	Go to step 28.	End of work.

Step	Check	Yes	No
28	Are the SPACER, GEAR (31T) and the SPRING installed in the correct orientation and order?	Go to step 29.	Reinstall the SPACER, GEAR (31T) and the SPRING in the correct orientation and order. (RRP)
29	Does noise arise from the TRAY 1/2 FEED LIFT UP MOTOR?	Replace the TRAY 1/2 FEED LIFT UP MOTOR. (RRP 2.9)	Go to step 35.
30	Does noise arise from the GEAR (13T/60T)?	Clean or replace the GEAR (13T/60T).	Go to step 31.
31	Does noise arise from the SECTOR GEAR (60T)?	Clean or replace the SECTOR GEAR (60T). (RRP 2.8)	Go to step 32.
32	Is the LIFT UP SHAFT deformed?	Replace the LIFT UP SHAFT.	Go to step 33.
33	Are there any obstacles around the LIFT UP SHAFT?	Go to step 34.	Go to step 36.
34	Does noise arise after obstacles are removed?	Go to step 36.	End of work.
35	Does noise arise after the FEEDER ASSY (FEEDER 2) is replaced (RRP 2.4)?	Contact a Technical Engineer.	End of work.
36	Does noise arise after the TRAY ASSY is replaced?	Contact a Technical Engineer.	End of work.

### During Paper Feeding/Ejecting (Tray 1 - Exit1 Face Down Tray)

Step	Check	Yes	No
	Possible causative parts FEEDER ASSY (FEEDER 1) (PL 2.1.7) ROLLER ASSY (FEED) (PL 2.3.20) ROLLER ASSY (RETARD) (PL 2.3.28) ROLLER ASSY (NUDGER) (PL 2.3.32) TRAY 1/2 FEED LIFT UP MOTOR (PL 2.3.2) MOTOR ASSY 242 (PL 7.1.7) PULLEY 25T (PL 7.1.8) BELT-SYNCHRONOUS BAN (PL 7.1.5) ROLLER ASSY REGI (4.5.5) BRKT ASSY TA (PL 4.1.1) FUSER ASSY (PL 6.1.7) HSG ASSY-BTR (PL 4.2.1) ROLL ASSY OCT (PL 6.2.14)		

Step	Check	Yes	No
1	Does noise arise from the Tray 1?	Go to step 2.	Go to step 10.
2	Does noise arise from the FEEDER ASSY (FEEDER 1)?	Go to step 3.	Contact a Technical Engineer.
3	Is the FEEDER ASSY (FEEDER 1) fastened securely with the two screws?	Go to step 5.	Go to step 4.
4	Does noise arise after the FEEDER ASSY (FEEDER 1) is fastened with the two screws?	Go to step 5.	End of work.
5	Does noise arise from the ROLLER ASSY (FEED)?	Clean or replace the ROLLER ASSY (FEED). (RRP 2.21)	Go to step 6.
6	Does noise arise from the ROLLER ASSY (RETARD)?	Clean or replace the ROLLER ASSY (RETARD). (RRP 2.25)	Go to step 7.
7	Does noise arise from the ROLLER ASSY (NUDGER)?	Clean or replace the ROLLER ASSY (NUDGER). (RRP 2.28)	Go to step 8.
8	Does noise arise from the TRAY 1/2 FEED LIFT UP MOTOR?	Replace the TRAY 1/2 FEED LIFT UP MOTOR. (RRP 2.9)	Go to step 9.
9	Does noise arise after the FEEDER ASSY (FEEDER 1) is replaced (RRP 2.3)?	Contact a Technical Engineer.	End of work.
10	Does noise arise from the MOTOR ASSY 242?	Go to step 11.	Go to step 16.
11	Is the MOTOR ASSY 242 fastened securely with the four screws?	Go to step 13.	Go to step 12.
12	Does noise arise after the MOTOR ASSY 242 is fastened with the four screws?	Go to step 13.	End of work.
13	Does noise arise from the PULLEY 25T or BELT-SYNCHRONOUS BAN?	Go to step 15.	Go to step 14.
14	Does noise arise after the gears of the MOTOR ASSY 242 are cleaned, and obstacles are removed?	Replace the MOTOR ASSY 242. (RRP 7.2)	End of work.
15	Does noise arise after the PULLEY 25T and BELT-SYNCHRONOUS BAN of the MOTOR ASSY 242 are cleaned, and obstacles are removed?	Replace the PULLEY 25T and BELT-SYNCHRONOUS BAN. (RRP 7.1)	End of work.

Step	Check	Yes	No
16	Does noise arise from the ROLLER ASSY REGI?	Clean or replace the ROLLER ASSY REGI. (RRP 4.12)	Go to step 17.
17	Does noise arise from the BRKT ASSY TA?	Clean or replace the BRKT ASSY TA. (RRP 4.1)	Go to step 18.
18	Does noise arise from the FUSER ASSY?	Go to step 19.	Go to step 21.
19	Does noise arise from the HSG ASSY-BTR?	Go to step 20.	Replace the FUSER ASSY. (RRP 6.2)
20	Does noise arise after the rollers of the HSG ASSY-BTR are cleaned, and obstacles are removed?	Replace the HSG ASSY-BTR. (RRP 4.7)	End of work.
21	Does noise arise from the ROLL ASSY OCT?	Clean or replace the ROLL ASSY OCT. (RRP 6.9)	Contact a Technical Engineer.

### During Paper Feeding/Ejecting (Tray 2 - Exit 1 Face Down Tray)

Step	Check	Yes	No
	Possible causative parts FEEDER ASSY (FEEDER 2) (PL 2.1.8) ROLLER ASSY (FEED) (PL 2.3.20) ROLLER ASSY (RETARD) (PL 2.3.28) ROLLER ASSY (NUDGER) (PL 2.3.32) TRAY 1/2 FEED LIFT UP MOTOR (PL 2.3.2) MOTOR ASSY 242 (PL 7.1.7) PULLEY 25T (PL 7.1.8) BELT-SYNCHRONOUS BAN (PL 7.1.5) ROLLER ASSY-TA (PL 4.1.8) ROLLER ASSY REGI (4.5.5) BRKT ASSY TA (PL 4.1.1) FUSER ASSY (PL 6.1.7) HSG ASSY-BTR (PL 4.2.1) ROLLER ASSY OCT (PL 6.2.14)		
1	Does noise arise from the Tray 2?	Go to step 2.	Go to step 10.
2	Does noise arise from the FEEDER ASSY (FEEDER 2)?	Go to step 3.	Contact a Technical Engineer.
3	Is the FEEDER ASSY (FEEDER 2) fastened securely with the two screws?	Go to step 5.	Go to step 4.
4	Does noise arise after the FEEDER ASSY (FEEDER 2) is fastened with the two screws?	Go to step 5.	End of work.

Step	Check	Yes	No
5	Does noise arise from the ROLLER ASSY (FEED)?	Clean or replace the ROLLER ASSY (FEED). (RRP 2.21)	Go to step 6.
6	Does noise arise from the ROLLER ASSY (RETARD)?	Clean or replace the ROLLER ASSY (RETARD). (RRP 2.25)	Go to step 7.
7	Does noise arise from the ROLLER ASSY (NUDGER)?	Clean or replace the ROLLER ASSY (NUDGER). (RRP 2.28)	Go to step 8.
8	Does noise arise from the TRAY 1/2 FEED LIFT UP MOTOR?	Replace the TRAY 1/2 FEED LIFT UP MOTOR. (RRP 2.9)	Go to step 9.
9	Does noise arise after the FEEDER ASSY (FEEDER 2) is replaced (RRP 2.4)?	Contact a Technical Engineer.	End of work.
10	Does noise arise from the MOTOR ASSY 242?	Go to step 11.	Go to step 16.
11	Is the MOTOR ASSY 242 fastened securely with the four screws?	Go to step 13.	Go to step 12.
12	Does noise arise after the MOTOR ASSY 242 is fastened with the four screws?	Go to step 13.	End of work.
13	Does noise arise from the PULLEY 25T or BELT-SYNCHRONOUS BAN?	Go to step 15.	Go to step 14.
14	Does noise arise after the gears of the MOTOR ASSY 242 are cleaned, and obstacles are removed?	Replace the MOTOR ASSY 242. (RRP 7.1)	End of work.
15	Does noise arise after the PULLEY 25T and BELT-SYNCHRONOUS BAN of the MOTOR ASSY 242 are cleaned, and obstacles are removed?	Replace the PULLEY 25T and BELT-SYNCHRONOUS BAN. (RRP 7.2)	End of work.
16	Does noise arise from the BRKT ASSY TA?	Clean or replace the BRKT ASSY TA. (RRP 4.1)	Go to step 17.
17	Does noise arise from the ROLLER ASSY REGI?	Clean or replace the ROLLER ASSY REGI. (RRP 4.12)	Go to step 18.
18	Does noise arise from the BRKT ASSY TA?	Clean or replace the BRKT ASSY TA. (RRP 4.1)	Go to step 19.

Step	Check	Yes	No
19	Does noise arise from the FUSER ASSY?	Go to step 20.	Go to step 22.
20	Does noise arise from the HSG ASSY-BTR?	Go to step 21.	Replace the FUSER ASSY. (RRP 6.2)
21	Does noise arise after the rollers of the HSG ASSY-BTR are cleaned, and obstacles are removed?	Replace the HSG ASSY-BTR. (RRP 4.7)	End of work.
22	Does noise arise from the ROLL ASSY OCT?	Clean or replace the ROLL ASSY OCT. (RRP 6.9)	Contact a Technical Engineer.

### During Paper Feeding/Ejecting (MPF - Exit 1 Face Down Tray)

Step	Check	Yes	No
	Possible causative parts ROLLER ASSY-FEED (PL 3.2.20) GEAR PICK UP (PL 3.2.6) GEAR CAM (PL 3.2.22) MOTOR ASSY 242 (PL 7.1.7) PULLEY 25T (PL 7.1.8) BELT-SYNCHRONOUS BAN (PL 7.1.5) ROLLER ASSY REGI (4.5.5) BRKT ASSY TA (PL 4.1.1) FUSER ASSY (PL 6.1.7) HSG ASSY-BTR (PL 4.2.1) ROLL ASSY OCT (PL 6.2.14)		
1	Does noise arise from the MPF?	Go to step 2.	Go to step 6.
2	Is the MPF fastened securely with the two screws?	Go to step 4.	Go to step 3.
3	Does noise arise after the MPF is fastened with the four screws?	Go to step 4.	End of work.
4	Does noise arise from the GEAR PICK UP?	Clean or replace the GEAR PICK UP. (RRP 3.7)	Go to step 5.
5	Does noise arise from the GEAR CAM?	Clean or replace the GEAR CAM. (RRP 3.14)	Go to step 6.
6	Does noise arise from the ROLLER ASSY-FEED?	Clean or replace the ROLLER ASSY-FEED. (RRP 3.13)	Go to step 7.
7	Does noise arise from the MOTOR ASSY 242?	Go to step 8.	Go to step 13.
8	Is the MOTOR ASSY 242 fastened securely with the four screws?	Go to step 10.	Go to step 9.



Step	Check	Yes	No
9	Does noise arise after the MOTOR ASSY 242 is fastened with the four screws?	Go to step 10.	End of work.
10	Does noise arise from the PULLEY 25T or BELT-SYNCHRONOUS BAN?	Go to step 12.	Go to step 11.
11	Does noise arise after the gears of the MOTOR ASSY 242 are cleaned, and obstacles are removed?	Replace the MOTOR ASSY 242. (RRP 7.2)	End of work.
12	Does noise arise after the PULLEY 25T and BELT-SYNCHRONOUS BAN of the MOTOR ASSY 242 are cleaned, and obstacles are removed?	Replace the PULLEY 25T and BELT-SYNCHRONOUS BAN. (RRP 7.1)	End of work.
13	Does noise arise from the ROLLER ASSY REGI?	Clean or replace the ROLLER ASSY REGI. (RRP 4.12)	Go to step 14.
14	Does noise arise from the BRKT ASSY TA?	Clean or replace the BRKT ASSY TA. (RRP 4.1)	Go to step 15.
15	Does noise arise from the ROLLER ASSY REGI?	Clean or replace the ROLLER ASSY REGI. (RRP 4.12)	Go to step 16.
16	Does noise arise from the BRKT ASSY TA?	Clean or replace the BRKT ASSY TA. (RRP 4.1)	Go to step 17.
17	Does noise arise from the FUSER ASSY?	Go to step 18.	Go to step 20.
18	Does noise arise from the HSG ASSY-BTR?	Go to step 19.	Replace the FUSER ASSY. (RRP 6.2)
19	Does noise arise after the rollers of the HSG ASSY-BTR are cleaned, and obstacles are removed?	Replace the HSG ASSY-BTR. (RRP 4.7)	End of work.
20	Does noise arise from the ROLLER ASSY OCT?	Clean or replace the ROLL ASSY OCT. (RRP 6.9)	Contact a Technical Engineer.

### During Paper Feeding (Tray 3)

Step	Check	Yes	No
	Possible causative parts TRAY 3 FEEDER (PL 9.2.7) SPACER (PL 9.4.4) GEAR (31T) (PL 9.4.5) SPRING (PL 9.4.6) TRAY 1/2 FEED LIFT UP MOTOR (PL 9.4.2) GEAR (13T/60T) (PL 9.3.21) SECTOR GEAR (60T) (PL 9.3.22) LIFT UP SHAFT (PL 9.3.24) MAIN MOTOR (PL 9.6.7) GEAR (126T) (PL 9.6.9) GEAR (60T) (PL 9.6.10) GEAR (37T) (PL 9.6.12) TAKEAWAY ROLL ASSEMBLY (UPPER) (PL 9.5.8) ROLL ASSY (UPPER) (PL 9.5.11)		
1	Is the 2 TRAY MODULE fastened securely with the two screws?	Go to step 3.	Go to step 2.
2	Does noise still arise after the 2 TRAY MODULE is fastened with the two screws?	Go to step 3.	End of work.
3	Does noise arise from the Tray 3?	Go to step 4.	Go to step 16.
4	Does noise arise from the TRAY 3 FEEDER?	Go to step 5.	Go to step 9.
5	Is the TRAY 3 FEEDER fastened securely with the two screws?	Go to step 7.	Go to step 6.
6	Does noise still arise after the TRAY 3 FEEDER is fastened with the two screws?	Go to step 7.	End of work.
7	Are the SPACER, GEAR (31T) and the SPRING installed in the correct orientation and order?	Go to step 8.	Reinstall the SPACER, GEAR (31T) and the SPRING in the correct orientation and order. (RRP 9.17/RRP 9.18)
8	Does noise arise from the TRAY 1/2 FEED LIFT UP MOTOR?	Replace the TRAY 1/2 FEED LIFT UP MOTOR. (RRP 9.16)	Go to step 9.
9	Does noise arise from the GEAR (13T/60T)?	Clean or replace the GEAR (13T/60T).	Go to step 10.
10	Does noise arise from the SECTOR GEAR (60T)?	Clean or replace the SECTOR GEAR (60T). (RRP 9.15)	Go to step 11.

Step	Check	Yes	No
11	Is the LIFT UP SHAFT deformed?	Replace the LIFT UP SHAFT.	Go to step 12.
12	Are there any obstacles around the LIFT UP SHAFT?	Go to step 13.	Go to step 15.
13	Does noise still arise after obstacles are removed?	Go to step 14.	End of work.
14	Does noise still arise after the TRAY 3 FEEDER is replaced (RRP 9.10)?	Contact a Technical Engineer	End of work.
15	Does noise still arise after the TRAY ASSY is replaced?	Contact a Technical Engineer.	End of work.
16	Does noise arise from the MAIN MOTOR?	Replace the MAIN MOTOR.	Go to step 17.
17	Does noise arise from the GEAR (126T)?	Clean or replace the GEAR (126T).	Go to step 18.
18	Does noise arise from the GEAR (60T)?	Clean or replace the GEAR (60T).	Go to step 19.
19	Does noise arise from the GEAR (37T)?	Clean or replace the GEAR (37T).	Go to step 20.
20	Does noise arise from the GEAR (32T)?	Clean or replace the GEAR (32T).	Go to step 21.
21	Does noise arise from the TAKEAWAY ROLL ASSEMBLY (UPPER)?	Clean or replace the TAKEAWAY ROLL ASSEMBLY (UPPER). (RRP 9.40)	Go to step 22.
22	Does noise arise from the ROLL ASSY (UPPER)?	Clean or replace the ROLL ASSY (UPPER). (RRP 9.44)	Contact a Technical Engineer.

## During Paper Feeding (Tray 4)

Step	Check	Yes	No
	Possible causative parts TRAY 4 FEEDER (PL 9.2.8) SPACER (PL 9.4.4) GEAR (31T) (PL 9.4.5) SPRING (PL 9.4.6) TRAY 1/2 FEED LIFT UP MOTOR (PL 9.4.2) GEAR (13T/60T) (PL 9.3.21) SECTOR GEAR (60T) (PL 9.3.22) LIFT UP SHAFT (PL 9.3.24) MAIN MOTOR (PL 9.6.7) GEAR (126T) (PL 9.6.9) GEAR (60T) (PL 9.6.10) GEAR (37T) (PL 9.6.12) TAKEAWAY ROLL ASSEMBLY (UPPER) (PL 9.5.8) TAKEAWAY ROLL ASSEMBLY (LOWER) (PL 9.5.8) ROLL ASSY (UPPER) (PL 9.5.11) ROLL ASSY (LOWER) (PL 9.5.11)		
1	Is the 2 TRAY MODULE fastened securely with the two screws?	Go to step 3.	Go to step 2.
2	Does noise still arise after the 2 TRAY MODULE is fastened with the two screws?	Go to step 3.	End of work.
3	Does noise arise from the Tray 4?	Go to step 4.	Go to step 16.
4	Does noise arise from the TRAY 4 FEEDER?	Go to step 5.	Go to step 9.
5	Is the TRAY 4 FEEDER fastened securely with the two screws?	Go to step 7.	Go to step 6.
6	Does noise still arise after the TRAY 4 FEEDER is fastened with the two screws?	Go to step 7.	End of work.
7	Are the SPACER, GEAR (31T) and the SPRING installed in the correct orientation and order?	Go to step 8.	Reinstall the SPACER, GEAR (31T) and the SPRING in the correct orientation and order. (RRP 9.17/RRP 9.18)
8	Does noise arise from the TRAY 1/2 FEED LIFT UP MOTOR?	Replace the TRAY 1/2 FEED LIFT UP MOTOR. (RRP 9.16)	Go to step 9.
9	Does noise arise from the GEAR (13T/60T)?	Clean or replace the GEAR (13T/60T).	Go to step 10.
10	Does noise arise from the SECTOR GEAR (60T)?	Clean or replace the SECTOR GEAR (60T). (RRP 9.15)	Go to step 11.

Step	Check	Yes	No
11	Is the LIFT UP SHAFT deformed?	Replace the LIFT UP SHAFT.	Go to step 12.
12	Are there any obstacles around the LIFT UP SHAFT?	Go to step 13.	Go to step 15.
13	Does noise still arise after obstacles are removed?	Go to step 14.	End of work.
14	Does noise still arise after the TRAY 4 FEEDER is replaced (RRP 9.11)?	Contact a Technical Engineer.	End of work.
15	Does noise still arise after the TRAY ASSY is replaced?	Contact a Technical Engineer.	End of work.
16	Does noise arise from the MAIN MOTOR?	Replace the MAIN MOTOR.	Go to step 17.
17	Does noise arise from the GEAR (126T)?	Clean or replace the GEAR (126T).	Go to step 18.
18	Does noise arise from the GEAR (60T)?	Clean or replace the GEAR (60T).	Go to step 19.
19	Does noise arise from the GEAR (37T)?	Clean or replace the GEAR (37T).	Go to step 20.
20	Does noise arise from the GEAR (32T)?	Clean or replace the GEAR (32T).	Go to step 21.
21	Does noise arise from the TAKEAWAY ROLL ASSEMBLY (LOWER)?	Clean or replace the TAKEAWAY ROLL ASSEMBLY (LOWER). (RRP 9.41)	Go to step 22.
22	Does noise arise from the TAKEAWAY ROLL ASSEMBLY (UPPER)?	Clean or replace the TAKEAWAY ROLL ASSEMBLY (UPPER). (RRP 9.40)	Go to step 23.
23	Does noise arise from the ROLL ASSY (LOWER)?	Clean or replace the ROLL ASSY (LOWER). (RRP 9.43)	Go to step 24.
24	Does noise arise from the ROLL ASSY (UPPER)?	Clean or replace the ROLL ASSY (UPPER). (RRP 9.44)	Contact a Technical Engineer.

## During Duplex Printing

Step	Check	Yes	No
	Possible causative parts TRANS ASSY DUP (PL 10.1.1) MOTOR ASSY 242 (PL 7.1.7) PULLEY 25T (PL 7.1.8) BELT-SYNCHRONOUS BAN (PL 7.1.5) ROLL ASSY OCT (PL 6.2.14) MOTOR ASSY EXIT 2 (PL 11.2.37) ROLL ASSY-FU (PL 11.1.19) ROLL ASSY-INV (PL 11.1.20) MOTOR ASSY DUP (PL 10.1.11) GEAR ROLL 28 (PL 10.1.2) GEAR IDLE 33 74 (PL 10.1.3) GEAR IDLE 33 (PL 10.1.4) GEAR IDLE 42 (PL 10.1.5) ROLLER DUP A3L (PL 10.2.7) ROLLER ASSY DUP (PL 10.2.8)		
1	Is the TRANS ASSY DUP fastened to the printer securely?	Go to step 3.	Go to step 2.
2	Does noise still arise after the TRANS ASSY DUP is replaced?	Go to step 3.	End of work.
3	Does noise arise from the MOTOR ASSY 242?	Go to step 4.	Go to step 9.
4	Is the MOTOR ASSY 242 fastened securely with the four screws?	Go to step 6.	Go to step 5.
5	Does noise still arise after the MOTOR ASSY 242 is fastened with the four screws?	Go to step 6.	End of work.
6	Does noise arise from the PULLEY 25T or BELT-SYNCHRONOUS BAN?	Go to step 8.	Go to step 7.
7	Does noise still arise after the gears of the MOTOR ASSY 242 are cleaned and obstacles are removed?	Replace the MOTOR ASSY 242. (RRP 7.2)	End of work.
8	Does noise still arise after the PULLEY 25T and BELT-SYNCHRONOUS BAN of the MOTOR ASSY 242 are cleaned and obstacles are removed?	Replace the PULLEY 25T and BELT-SYNCHRONOUS BAN. (RRP 7.1)	End of work.
9	Does noise arise from the ROLL ASSY OCT?	Clean or replace the ROLL ASSY OCT. (RRP 6.9)	Go to step 10.
10	Does noise arise from the MOTOR ASSY EXIT 2?	Replace the MOTOR ASSY EXIT 2. (RRP 11.16)	Go to step 11.
11	Does noise arise from the ROLL ASSY-FU?	Clean or replace the ROLL ASSY-FU. (RRP 11.2)	Go to step 12.

Step	Check	Yes	No
12	Does noise arise from the ROLL ASSY-IN?	Clean or replace the ROLL ASSY-INV. (RRP 11.3)	Go to step 13.
13	Does noise arise from the MOTOR ASSY DUP?	Replace the MOTOR ASSY DUP. (RRP 10.8)	Go to step 14.
14	Does noise arise from the GEAR ROLL 28?	Clean or replace the GEAR ROLL 28. (RRP 10.2)	Go to step 15.
15	Does noise arise from the GEAR IDLE 33 74?	Clean or replace the GEAR IDLE 33 74. (RRP 10.3)	Go to step 16.
16	Does noise arise from the GEAR IDLE 33?	Clean or replace the GEAR IDLE 33. (RRP 10.4)	Go to step 17.
17	Does noise arise from the GEAR IDLE 42?	Clean or replace the GEAR IDLE 42. (RRP 10.5)	Go to step 18.
18	Does noise arise from the ROLLER DUP A3L?	Clean or replace the ROLLER DUP A3L. (RRP 10.11)	Go to step 19.
19	Does noise arise from the ROLLER ASSY DUP?	Clean or replace the ROLLER ASSY DUP. (RRP 10.12)	Contact a Technical Engineer.

### When Ejecting Paper to Exit 2

Step	Check	Yes	No
	Possible causative parts TRANS ASSY EXIT (PL 11.1.1) MOTOR ASSY 242 (PL 7.1.7) PULLEY 25T (PL 7.1.8) BELT-SYNCHRONOUS BAN (PL 7.1.5) ROLL ASSY OCT (PL 6.2.14) MOTOR ASSY EXIT 2 (PL 11.2.37) ROLL ASSY OCT (PL 11.2.7) ROLL ASSY-FU (PL 11.1.19) ROLL ASSY-INV (PL 11.1.20)		
1	Is the TRANS ASSY EXIT fastened to the printer securely?	Go to step 3.	Go to step 2.
2	Does noise still arise after the TRANS ASSY EXIT is replaced?	Go to step 3.	End of work.

Step	Check	Yes	No
3	Does noise arise from the MOTOR ASSY 242?	Go to step 4.	Go to step 9.
4	Is the MOTOR ASSY 242 fastened securely with the four screws?	Go to step 6.	Go to step 5.
5	Does noise still arise after the MOTOR ASSY 242 is fastened with the four screws?	Go to step 6.	End of work.
6	Does noise arise from the PULLEY 25T or BELT-SYNCHRONOUS BAN?	Go to step 8.	Go to step 7.
7	Does noise still arise after the gears of the MOTOR ASSY 242 are cleaned and obstacles are removed?	Replace the MOTOR ASSY 242. (RRP 7.2)	End of work.
8	Does noise still arise after the PULLEY 25T and BELT-SYNCHRONOUS BAN of the MOTOR ASSY 242 are cleaned and obstacles are removed?	Replace the PULLEY 25T and BELT-SYNCHRONOUS BAN. (RRP 7.1)	End of work.
9	Does noise arise from the ROLL ASSY OCT (PL 6.2.14)?	Clean or replace the ROLL ASSY OCT. (RRP 6.9)	Go to step 10.
10	Does noise arise from the MOTOR ASSY EXIT 2?	Replace the MOTOR ASSY EXIT 2. (RRP 11.16)	Go to step 11.
11	Does noise arise from the ROLL ASSY OCT (PL 11.2.7)?	Clean or replace the ROLL ASSY OCT. (RRP 11.6)	Go to step 12.
12	Does noise arise from the ROLL ASSY-FU?	Clean or replace the ROLL ASSY-FU. (RRP 11.2)	Go to step 13.
13	Does noise arise from the ROLL ASSY-INV?	Clean or replace the ROLL ASSY-INV. (RRP 11.3)	Contact a Technical Engineer.

**During Paper Feeding (to Option DUPLEX)**

Step	Check	Yes	No
	Possible causative parts TRANS ASSY EXIT (PL 11.1.1) MOTOR ASSY 242 (PL 7.1.7) PULLEY 25T (PL 7.1.8) BELT-SYNCHRONOUS BAN (PL 7.1.5) ROLL ASSY OCT (PL 6.2.14) MOTOR ASSY EXIT 2 (PL 11.2.37) ROLL ASSY OCT (PL 11.2.7) ROLL ASSY-FU (PL 11.1.19) ROLL ASSY-INV (PL 11.1.20)		



Step	Check	Yes	No
1	Is the TRANS ASSY EXIT fastened to the printer securely?	Go to step 3.	Go to step 2.
2	Does noise still arise after the TRANS ASSY EXIT is replaced?	Go to step 3.	End of work.
3	Does noise arise from the MOTOR ASSY 242?	Go to step 4.	Go to step 9.
4	Is the MOTOR ASSY 242 fastened securely with the four screws?	Go to step 6.	Go to step 5.
5	Does noise still arise after the MOTOR ASSY 242 is fastened with the four screws?	Go to step 6.	End of work.
6	Does noise arise from the PULLEY 25T or BELT-SYNCHRONOUS BAN?	Go to step 8.	Go to step 7.
7	Does noise still arise after the gears of the MOTOR ASSY 242 are cleaned and obstacles are removed?	Replace the MOTOR ASSY 242. (RRP 7.2)	End of work.
8	Does noise still arise after the PULLEY 25T and BELT-SYNCHRONOUS BAN of the MOTOR ASSY 242 are cleaned and obstacles are removed?	Replace the PULLEY 25T and BELT-SYNCHRONOUS BAN. (RRP 7.1)	End of work.
9	Does noise arise from the ROLL ASSY OCT (PL 6.2.14)?	Clean or replace the ROLL ASSY OCT. (RRP 6.9)	Go to step 10.
10	Does noise arise from the MOTOR ASSY EXIT 2?	Replace the MOTOR ASSY EXIT 2. (RRP 11.16)	Go to step 11.
11	Does noise arise from the ROLL ASSY OCT (PL 11.2.7)?	Clean or replace the ROLL ASSY OCT. (RRP 11.6)	Go to step 12.
12	Does noise arise from the ROLL ASSY-FU?	Clean or replace the ROLL ASSY-FU. (RRP 11.2)	Go to step 13.
13	Does noise arise from the ROLL ASSY-INV?	Clean or replace the ROLL ASSY-INV. (RRP 11.3)	Contact a Technical Engineer.

## H-TRANSPORT

Step	Check	Yes	No
	Possible causative parts: H-TRANSPORT MOTOR (PL 12.3.7) SHAFT ASSEMBLY (RIGHT) (PL 12.3.14) BEARING (PL 12.3.11) BEARING (PL 12.3.4) SHAFT ASSEMBLY (LEFT) (PL 12.3.15) BEARING (PL 12.3.10) BELT (PL 12.3.12) PINCH ROLL (PL 12.2.6)		
1	Is the H-TRANSPORT secured surely to the printer with the two screws?	Go to step 2.	Secure the H-TRANSPORT using two screws.
2	Does noise arise from the H-TRANSPORT MOTOR?	Replace the H-TRANSPORT MOTOR.	Go to step 3.
3	Does noise arise from the SHAFT ASSEMBLY (RIGHT) actuated by the H-TRANSPORT MOTOR or from the BEARINGS (PL 12.3.11/PL 12.3.4) on its both ends?	Clean/replace the SHAFT ASSEMBLY (RIGHT), or replace the BEARINGS.	Go to step 4.
4	Does noise arise from the SHAFT ASSEMBLY (LEFT) actuated by the H-TRANSPORT MOTOR or from the BEARINGS (PL 12.3.10) on its both ends?	Clean/replace the SHAFT ASSEMBLY (LEFT), or replace the BEARINGS.	Go to step 5.
5	Does noise arise from the two BELTs or ROLL (PL 12.3.13)?	Clean/replace the BELTs or ROLL.	Go to step 6.
6	Does noise arise from the PINCH ROLL of the COVER ASSY TOP?	Clean/replace the PINCH ROLL.	Go to step 7.
7	Checking the IOT and Finisher installation Do the Finisher and the IOT keep an appropriate distance from each other?	Consult Technical Engineer in your area.	Reinstall.

## Top Tray Exiting

Step	Check	Yes	No
	Possible causative parts: MOTOR ASSY (PL 12.12.21) BELT (PL 12.12.23) ROLL ASSY-ENT (PL 12.12.20) ROLLER ASSY-PINCH, ENT (PL 12.12.17) BEARING (PL 12.12.9) BEARING (PL 12.12.27) MOTOR ASSY (PL 12.13.30) BELT (PL 12.13.27) ROLL ASSY-TRANSPORT (PL 12.13.18) ROLLER-PINCH (PL 12.13.11) SHAFT (PL 12.13.13) MOTOR ASSY (PL 12.13.30) BELT (PL 12.13.28) ROLL ASSY-EXIT TOP (PL 12.13.5) BEARING (PL 12.13.9) BEARING (PL 12.13.20) ROLLER ASSY-PINCH, EXIT (PL 12.13.3)		
1	Clean the paper path. Does noise still arise after cleaning?	Go to step 2.	End of work.
2	Does noise arise from the FINISHER TRANSPORT MOTOR (PL 12.12.21)?	Replace the MOTOR ASSY.	Go to step 3.
3	Does noise arise from the BELT or GEAR actuated from the FINISHER TRANSPORT MOTOR?	Clean/replace the BELT and GEAR.	Go to step 4.
4	Does noise arise from the ROLL ASSY-ENT (PL 12.12.20) or the BEARINGS (PL 12.12.9/PL 12.12.27) on its both ends?	Clean/replace the ROLL ASSY-ENT, or replace the BEARINGS.	Go to step 5.
5	Does noise arise from the ROLLER ASSY-PINCH, ENT (PL 12.12.17) opposing to the ROLL ASSY-ENT?	Clean/replace the ROLLER ASSY-PINCH, ENT.	Go to step 6.
6	Does noise arise from the REGI MOTOR?	Replace the MOTOR ASSY.	Go to step 7.
7	Does noise arise from the BELT or GEAR actuated from the REGI MOTOR?	Clean/replace the BELT and GEAR.	Go to step 8.
8	Does noise arise from the two ROLL ASSY-TRANSPORTS (PL 12.13.18) or the BEARINGS (PL 12.13.9/PL 12.13.20) on its both ends?	Clean/replace the ROLL ASSY-TRANSPORT, or replace the BEARINGS.	Go to step 9.
9	Does noise arise from the four ROLLER-PINCHs (PL 12.13.11) on the CHUTE ASSY-LOWER and TOP EXIT L (PL 12.13.10) opposing to the ROLL ASSY-TRANSPORT, and the SHAFT (PL 12.13.13)?	Clean/replace the ROLLER-PINCH and the SHAFT.	Go to step 10.
10	Does noise arise from the EXIT MOTOR?	Replace the MOTOR ASSY.	Go to step 11.

Step	Check	Yes	No
11	Does noise arise from the BELT or GEAR actuated from the EXIT MOTOR?	Clean/replace the BELT and GEAR.	Go to step 12.
12	Does noise arise from the ROLL ASSY-EXIT TOP (PL 12.13.5) or the BEARING (PL 12.13.9) on its both ends?	Clean/replace the ROLL ASSY-EXIT TOP, or replace the BEARING.	Go to step 13.
13	Does noise arise from the ROLLER ASSY-PINCH, EXIT (PL 12.13.3) opposing to the ROLL ASSY-EXIT TOP?	Clean/replace the ROLLER ASSY-PINCH, EXIT.	Consult Technical Engineer in your area.

## Stacker Tray Exiting

Step	Check	Yes	No
	Possible causative parts: MOTOR ASSY (PL 12.12.21) BELT (PL 12.12.23) ROLL ASSY-ENT (PL 12.12.20) ROLLER ASSY-PINCH, ENT (PL 12.12.17) BEARING (PL 12.12.9) BEARING (PL 12.12.27) REGI MOTOR (PL 12.13.30) BELT (PL 12.13.27) ROLL ASSY-BUFFER (PL 12.12.13j) ROLLER ASSY-PINCH, EXIT (PL 12.12.15) ROLLER-PINCH (PL 12.12.2) SHAFT (PL 12.12.4) EXIT MOTOR (PL 12.13.30) BELT (PL 12.13.28) ROLL ASSY-EXIT LOW (PL 12.11.6) BEARING (PL 12.11.9) BEARING (PL 12.11.17) ROLLER ASSY-PINCH,EXIT1 (PL 12.11.10) ROLLER ASSY-PINCH,EXIT2 (PL 12.11.11) MOTOR ASSY-DC (PL 12.9.11) BRACKET ASSY-EJECT (PL 12.10.17) SHAFT ASSY-EJECT ROLL (PL 12.10.9) BEARING (PL 12.10.13) BEARING (PL 12.10.12) SHAFT ASSY-PADDLE (PL 12.11.12) BEARING (PL 12.11.9) BELT-SYNCRONUS Z55 (PL 12.11.13) SHAFT-DRIVE PADDLE (PL 12.11.15) SHAFT ASSY PADDLE (PL 12.9.9) BEARING (PL 12.9.17) PADDLE-CYCLONE (PL 12.9.6) SHAFT ASSY-EJECT PINCH (PL 12.9.7) BELT (PL 12.6.25) MOTOR ASSY DC (PL 12.6.26) SHAFT-ELEV (PL 12.6.14) BEARING (PL 12.6.15) BELT STACKER (PL 12.6.3) BELT STACKER (PL 12.6.9)		
1	Clean the paper path. Does noise still arise after cleaning?	Go to step 2.	End of work.
2	Does noise arise from the FINISHER TRANSPORT MOTOR?	Replace the MOTOR ASSY.	Go to step 3.
3	Does noise arise from the BELT or GEAR actuated from the FINISHER TRANSPORT MOTOR?	Clean/replace the BELT and GEAR.	Go to step 4.
4	Does noise arise from the ROLL ASSY-ENT (PL 12.12.20) or the BEARINGS (PL 12.12.9/PL 12.12.27) on its both ends?	Clean/replace the ROLL ASSY-ENT, or replace the BEARINGS.	Go to step 5.

Step	Check	Yes	No
5	Does noise arise from the ROLLER ASSY-PINCH, ENT (PL 12.12.17) opposing to the ROLL ASSY-ENT?	Clean/replace the ROLLER ASSY-PINCH, ENT.	Go to step 6.
6	Does noise arise from the REGI MOTOR?	Replace the MOTOR ASSY.	Go to step 7.
7	Does noise arise from the BELT or GEAR actuated from the REGI MOTOR?	Clean/replace the BELT and GEAR.	Go to step 8.
8	Does noise arise from the ROLL ASSY-BUFFER (PL 12.12.13) or the BEARING (PL 12.12.9) on its both ends?	Clean/replace the ROLL ASSY-BUFFER, or replace the BEARING.	Go to step 9.
9	Does noise arise from the ROLLER ASSY-PINCH, EXIT (PL 12.12.15) opposing to the ROLL ASSY-BUFFER, or from the four ROLLER-PINCHs (PL 12.12.2) on the CHUTE ASSY-UPPER,EXIT OPEN (PL 12.12.1), and SHAFT (PL 12.12.4)?	Clean/replace the ROLLER ASSY-PINCH, EXIT, ROLLER-PINCH and SHAFT.	Go to step 10.
10	Does noise arise from the EXIT MOTOR?	Replace the MOTOR ASSY.	Go to step 11.
11	Does noise arise from the BELT or GEAR actuated from the EXIT MOTOR?	Clean/replace the BELT and GEAR.	Go to step 12.
12	Does noise arise from the ROLL ASSY-EXIT LOW (PL 12.11.6) or the BEARINGs (PL 12.11.9/PL 12.11.17) on its both ends?	Clean/replace the ROLL ASSY-EXIT LOW, or replace the BEARING.	Go to step 13.
13	Does noise arise from the two ROLLER ASSY-PINCH,EXIT1s (PL 12.11.10) and/or two ROLLER ASSY-PINCH,EXIT2s (PL 12.11.11) on the ROLLER ASSY-LOWER EXIT R (PL 12.11.7) opposing to the ROLL ASSY-EXIT LOW?	Clean/replace the ROLLER ASSY-PINCH,EXIT1 and ROLLER ASSY-PINCH,EXIT2.	Go to step 14.
14	Does noise arise from the BELT or GEAR actuated from the EJECT CLAMP MOTOR (PL 12.9.11)?	Replace the MOTOR ASSY-DC.	Go to step 15.
15	Does noise arise from the BELT or GEAR actuated from the EJECT MOTOR (PL 12.10.17)?	Replace the BRACKET ASSY-EJECT.	Go to step 16.
16	Does noise arise from the four ROLLER-PINCHs (PL 12.13.11) on the CHUTE ASSY-LOWER and TOP EXIT L (PL 12.13.10) opposing to the ROLL ASSY-TRANSPOR, or the SHAFT (PL 12.13.13)?	Clean/replace the SHAFT ASSY-EJECT ROLL, or replace the BEARING.	Go to step 17.
17	Does noise arise from the SHAFT ASSY-PADDLE (PL 12.11.12)?	Clean/replace the SHAFT ASSY-PADDLE.	Go to step 18.

Step	Check	Yes	No
18	Does noise arise from the BELT-SYNCRONUS Z55 (PL 12.11.13)?	Clean/replace the BELT-SYNCRONUS Z55.	Go to step 19.
19	Does noise arise from the SHAFT ASSY-EJECT ROLL (PL 12.10.9) or the BEARINGS (PL 12.10.12) on its both ends?	Clean/replace the SHAFT ASSY-EJECT ROLL or replace the BEARINGS.	Go to step 20.
20	Does the PADDLE on the SHAFT ASSY-PADDLE (PL 12.11.12) contact with the surrounding parts when rotating?	Replace the SHAFT ASSY-PADDLE.	Go to step 21.
21	Does noise arise from the SHAFT ASSY PADDLE (PL 12.9.9) or the BEARING (PL 12.9.17) on its both ends?	Clean/replace the SHAFT ASSY PADDLE, or replace the BEARING.	Go to step 22.
22	Does the PADDLE-CYCLONE (PL 12.9.6) actuated from the SHAFT ASSY PADDLE (PL 12.9.9) contact with the surrounding parts when rotating?	Reinstall the PADDLE-CYCLONE.	Go to step 26.
23	Does noise arise from the SHAFT ASSY-EJECT PINCH (PL 12.9.7)?	Clean/replace the SHAFT ASSY-EJECT PINCH.	Go to step 24.
24	Does noise arise from the BELT (PL 12.6.25)?	Clean/replace the BELT.	Go to step 25.
25	Does noise arise from the SHAFT-ELEV (PL 12.6.14) or the BEARINGS (PL 12.6.15) on its both ends?	Clean/replace the SHAFT-ELEV or replace the BEARINGS.	Go to step 26.
26	Does noise arise from the ELEVATOR MOTOR when rotating it?	Replace the MOTOR ASSY DC.	Go to step 27.
27	Are the BELT STACKERS (PL 12.6.3/PL 12.6.9) installed correctly on the front and rear of the STACKER TRAY?	Consult Technical Engineer in your area.	Reinstall it.

### During Punching

Step	Check	Yes	No
	Possible causative parts: BRACKET ASSY-MOTOR, PUNCH (PL 12.7.4) MOTOR ASSY (PL 12.7.12) BRACKET ASSY-PUNCH (PL 12.7.9)		

Step	Check	Yes	No
1	When travelling the BRACKET ASSY-PUNCH, does the contacting noise, which contact the BRACKET ASSY-PUNCH with the component parts such as harness and sensor inside of the Finisher, arise from the inside of the Finisher?	Reinstall the component part.	Go to step 2.
2	Clean the paper path of the FRAME ASSY-PUNCH, ALL 2&3. Does noise still arise after cleaning?	Go to step 3.	End of work.
3	Does noise arise from the BRACKET ASSY-MOTOR, PUNCH (PL 12.7.4)?	Replace the BRACKET ASSY-MOTOR, PUNCH.	Go to step 4.
4	Does noise arise from the MOTOR ASSY (PL 12.7.12)?	Replace the MOTOR ASSY.	Go to step 5.
5	Does noise arise from the inside of the BRACKET ASSY-PUNCH?	Replace the BRACKET ASSY-PUNCH.	Consult Technical Engineer in your area.

### During Tamping

Step	Check	Yes	No
	Possible causative parts: MOTOR ASSY 2 (PL 12.10.6) MOTOR ASSY (PL 12.10.7) TRAY ASSY-COMPILER (PL 12.10.1)		
1	Does noise (rotating noise) arise from the compile tray when front-tamping?	Replace the MOTOR ASSY 2.	Go to step 2.
2	Does noise (scraping noise) arise from the compile tray when front-tamping?	Replace the TRAY ASSY-COMPILER.	Go to step 3.
3	Does noise (rotating noise) arise from the compile tray when rear-tamping?	Replace the MOTOR ASSY.	Go to step 4.
4	Does noise (scraping noise) arise from the compile tray when rear-tamping?	Replace the TRAY ASSY-COMPILER.	Go to step 5.
5	Does noise (rotating noise) arise from the compile tray when center-tamping?	Replace the MOTOR ASSY 2 and MOTOR ASSY.	Go to step 6.
6	Does noise (scraping noise) arise from the compile tray when center-tamping?	Replace the TRAY ASSY-COMPILER.	Consult Technical Engineer in your area.



## During Stapling

Step	Check	Yes	No
	Possible causative parts: CARRIAGE ASSY UPPER, STAPLE (PL 12.8.8) CARRIAGE ASSY LOWER, STAPLE (PL 12.8.9) CARRIAGE ASSY-STAPLER (PL 12.8.1) STAPLE ASSY (PL 12.8.2)		
1	Does noise arise from the STAPLE UNIT when traveling it to the front or rear?	Go to step 2.	Go to step 3.
2	Clean the surfaces of the RAIL-UPPER (PL 12.8.10) which travelling the STAPLE UNIT. Does noise still arise after cleaning?	Replace the CARRIAGE ASSY UPPER, STAPLE, or the CARRIAGE ASSY LOWER, STAPLE.	End of work.
3	Replace the CARRIAGE ASSY-STAPLER (PL 12.8.1). Does noise still arise after replacing?	Go to step 4.	End of work.
4	Replace the CSTAPLE ASSY (PL 12.8.2). Does noise still arise after replacing?	Consult Technical Engineer in your area.	End of work.

## When Power is Turned On / When Tray is Inserted

Step	Check	Yes	No
	Possible causative parts: FEEDER ASSY HCF (PL 13.4.1) MOTOR ASSY HCF (PL 13.4.2) BRKT ASSY GEAR R PF2 (PL 13.3.8)		
1	Is the FEEDER ASSY HCF is fastened to the front side of the frame securely using the two screws?	Go to step 2.	Refastened.
2	Does noise arise from the MOTOR ASSY HCF in the FEEDER ASSY HCF?	Replace the MOTOR ASSY HCF. RRP 13.15)	Go to step 3.
3	Does noise arise from the BRKT ASSY GEAR R PF2 on the rear side of the Tray activated by the MOTOR ASSY HCF?	replace the BRKT ASSY GEAR R PF2. RRP 13.12)	Go to step 4.
4	Does noise arise from the Tray?	Replace defective parts or reassemble the Tray.	Consult Technical Engineer in your area.

## During Paper Feeding

Step	Check	Yes	No
	Possible causative parts: MOTOR ASSY HCF (PL 13.4.2) ROLL ASSY NUD (PL 13.5.20) ROLL ASSY FEED (PL 13.5.21) ROLLER ASSY RETARD (PL 13.6.17) MOTOR ASSY (PL 13.7.12) ROLLER ASSY TA P (PL 13.7.9)		
1	Does noise arise from the MOTOR ASSY HCF in the FEEDER ASSY HCF?	Replace the MOTOR ASSY HCF. RRP 13.15)	Go to step 2.
2	Does noise arise from the ROLL ASSY NUD activated by the MOTOR ASSY HCF?	Replace the ROLL ASSY NUD. RRP 13.23)	Go to step 3.
3	Does noise arise from the ROLL ASSY FEED activated by the MOTOR ASSY HCF?	Replace the ROLL ASSY FEED. RRP 13.24)	Go to step 4.
4	Does noise arise from the ROLLER ASSY RETARD activated by the MOTOR ASSY HCF?	Replace the ROLLER ASSY RETARD. RRP 13.27)	Go to step 5.
5	Does noise arise from the MOTOR ASSY (T/A Motor)?	Replace the MOTOR ASSY. RRP 13.32)	Go to step 6.
6	Does noise arise from the ROLLER ASSY TA P activated by the MOTOR ASSY (T/A Motor)?	Replace the ROLLER ASSY TA P. RRP 13.31)	Consult Technical Engineer in your area.

### During Paper Feeding (Tray 3)

Step	Check	Yes	No
	Possible causative parts TRAY 3 FEEDER (PL 14.5.1) SPACER (PL 14.6.4) GEAR (31T) (PL 14.6.5) SPRING (PL 14.6.6) TRAY 1/2 FEED LIFT UP MOTOR (PL 14.6.2) LIFT SHAFT ASSEMBLY (PL 14.2.4) PULLEY (PL 14.2.5) TRAY CABLE (PL 14.2.9) F/R CABLE (PL 14.2.10) F/L CABLE (PL 14.2.11) MAIN MOTOR (PL 14.8.3) GEAR (37T) (PL 14.8.12) GEAR (32T) (PL 14.8.13) GEAR (60T) (PL 14.8.14) GEAR (60T) (PL 14.8.15) GEAR ASSEMBLY (TRAY 3) (PL 14.8.1) TAKEAWAY ROLL ASSEMBLY (PL 14.5.3) PINCH ROLL (PL 14.7.13)		
1	Is the TANDEM TRAYMODULE fastened securely with the two screws?	Go to step 3.	Go to step 2.
2	Does noise still arise after the TANDEM TRAY MODULE is fastened with the two screws?	Go to step 3.	End of work.
3	Does noise arise from the Tray 3?	Go to step 4.	Go to step 16.
4	Does noise arise from the TRAY 3 FEEDER?	Go to step 5.	Go to step 9.
5	Is the TRAY 3 FEEDER fastened securely with the two screws?	Go to step 7.	Go to step 6.
6	Does noise still arise after the TRAY 3 FEEDER is fastened with the two screws?	Go to step 7.	End of work.
7	Are the SPACER, GEAR (31T) and the SPRING installed in the correct orientation and order?	Go to step 8.	Reinstall the SPACER, GEAR (31T) and the SPRING in the correct orientation and order. (RRP 14.35/RRP 14.36)
8	Does noise arise from the TRAY 1/2 FEED LIFT UP MOTOR?	Replace the TRAY 1/2 FEED LIFT UP MOTOR. (RRP 14.34)	Go to step 14.
9	Does noise arise from the LIFT SHAFT ASSEMBLY?	Clean or replace the LIFT SHAFT ASSEMBLY.	Go to step 10.
10	Does noise arise from the PULLEY?	Clean or replace the PULLEY.	Go to step 11.

Step	Check	Yes	No
11	Is the TRAY CABLE installed properly?	Go to step 12.	Reinstall the TRAY CABLE properly or replace it. (RRP 14.13)
12	Is the F/R CABLE installed properly?	Go to step 13.	Reinstall the F/R CABLE properly or replace it. (RRP 14.14)
13	Is the F/L CABLE installed properly?	Go to step 15.	Reinstall the F/L CABLE properly or replace it. (RRP 14.15)
14	Does noise still arise after the TRAY 3 TRANSPORT ASSEMBLY is replaced (RRP 14.20)?	Contact a Technical Engineer.	End of work.
15	Does noise still arise after the TRAY ASSY is replaced?	Contact a Technical Engineer.	End of work.
16	Does noise arise from the MAIN MOTOR?	Replace the MAIN MOTOR. (RRP 14.61)	Go to step 17.
17	Does noise arise from the GEAR (37T)?	Clean or replace the GEAR (37T).	Go to step 18.
18	Does noise arise from the GEAR (32T)?	Clean or replace the GEAR (32T).	Go to step 19.
19	Does noise arise from the GEAR (60T)?	Clean or replace the GEAR (60T).	Go to step 20.
20	Does noise arise from the GEAR (60T)?	Clean or replace the GEAR (60T).	Go to step 21.
21	Does noise arise from the GEAR ASSEMBLY (TRAY 3)?	Clean or replace the GEAR ASSEMBLY (TRAY 3). (RRP 14.59)	Go to step 22.
22	Does noise arise from the TAKEAWAY ROLL ASSEMBLY?	Clean or replace the TAKEAWAY ROLL ASSEMBLY. (RRP 14.32)	Go to step 23.
23	Does noise arise from the PINCH ROLL?	Clean or replace the ROLL ASSY. (RRP 14.57)	Contact a Technical Engineer.

## During Paper Feeding (Tray 4)

Step	Check	Yes	No
	Possible causative parts TRAY 4 FEEDER (PL 14.4.15) SPACER (PL 14.6.4) GEAR (31T) (PL 14.6.5) SPRING (PL 14.6.6) TRAY 1/2 FEED LIFT UP MOTOR (PL 14.6.2) LIFT SHAFT ASSEMBLY (PL 14.2.4) PULLEY (PL 14.2.5) REAR TRAY CABLE (PL 14.3.8) FRONT TRAY CABLE (PL 14.3.9) MAIN MOTOR (PL 14.8.3) GEAR (22/40) (PL 14.8.4) GEAR ASSEMBLY (TRAY 4) (PL 14.8.2) TAKEAWAY ROLL ASSEMBLY (PL 14.4.5) TAKEAWAY ROLL ASSEMBLY (PL 14.5.3) PINCH ROLL (PL 14.4.8) PINCH ROLL (PL 14.7.13)		
1	Is the TANDEM TRAYMODULE fastened securely with the two screws?	Go to step 3.	Go to step 2.
2	Does noise still arise after the TANDEM TRAY MODULE is fastened with the two screws?	Go to step 3.	End of work.
3	Does noise arise from the Tray 4?	Go to step 4.	Go to step 15.
4	Does noise still arise from the TRAY 4 FEEDER?	Go to step 5.	Go to step 9.
5	Is the TRAY 4 FEEDER fastened securely with the two screws?	Go to step 7.	Go to step 6.
6	Does noise still arise after the TRAY 4 FEEDER is fastened with the two screws?	Go to step 7.	End of work.
7	Are the SPACER, GEAR (31T) and the SPRING installed in the correct orientation and order?	Go to step 8.	Reinstall the SPACER, GEAR (31T) and the SPRING in the correct orientation and order. (RRP 14.35/RRP 14.36)
8	Does noise arise from the TRAY 1/2 FEED LIFT UP MOTOR?	Replace the TRAY 1/2 FEED LIFT UP MOTOR. (RRP 14.34)	Go to step 13.
9	Does noise arise from the LIFT SHAFT ASSEMBLY?	Clean or replace the LIFT SHAFT ASSEMBLY.	Go to step 10.
10	Does noise arise from the PULLEY?	Clean or replace the PULLEY.	Go to step 11.

Step	Check	Yes	No
11	Is the REAR TRAY CABLE installed properly?	Go to step 12.	Reinstall the REAR TRAY CABLE properly or replace it. (RRP 14.21)
12	Is the FRONT TRAY CABLE installed properly?	Go to step 13.	Reinstall the FRONT TRAY CABLE properly or replace it. (RRP 14.22)
13	Does noise still arise after the TRAY 4 FEEDER is replaced (RRP 14.27)?	Contact a Technical Engineer.	End of work.
14	Does noise still arise after the TRAY 4 TRANSPORT ASSEMBLY is replaced?	Contact a Technical Engineer.	End of work.
15	Does noise arise from the MAIN MOTOR?	Replace the MAIN MOTOR. (RRP 14.61)	Go to step 16.
16	Does noise arise from the GEAR (37T) or GEAR (22/40)?	Clean or replace the GEAR (37T) or GEAR (22/40).	Go to step 17.
17	Does noise arise from the GEAR ASSEMBLY (TRAY 4)?	Clean or replace the GEAR ASSEMBLY (TRAY 4). (RRP 14.60)	Go to step 18.
18	Does noise arise from the TAKEAWAY ROLL ASSEMBLY (PL 14.4.5)?	Clean or replace the TAKEAWAY ROLL ASSEMBLY (PL 14.4.5). (RRP 14.26)	Go to step 19.
19	Does noise arise from the TAKEAWAY ROLL ASSEMBLY (PL 14.5.3)?	Clean or replace the TAKEAWAY ROLL ASSEMBLY (PL 14.5.3). (RRP 14.32)	Go to step 20.
20	Does noise arise from the PINCH ROLL (PL 14.4.8)?	Clean or replace the PINCH ROLL.	Go to step 21.
21	Does noise arise from the PINCH ROLL (PL 14.7.13)?	Clean or replace the PINCH ROLL. (RRP 14.57)	Contact a Technical Engineer.

# Judgment of Print Consistency

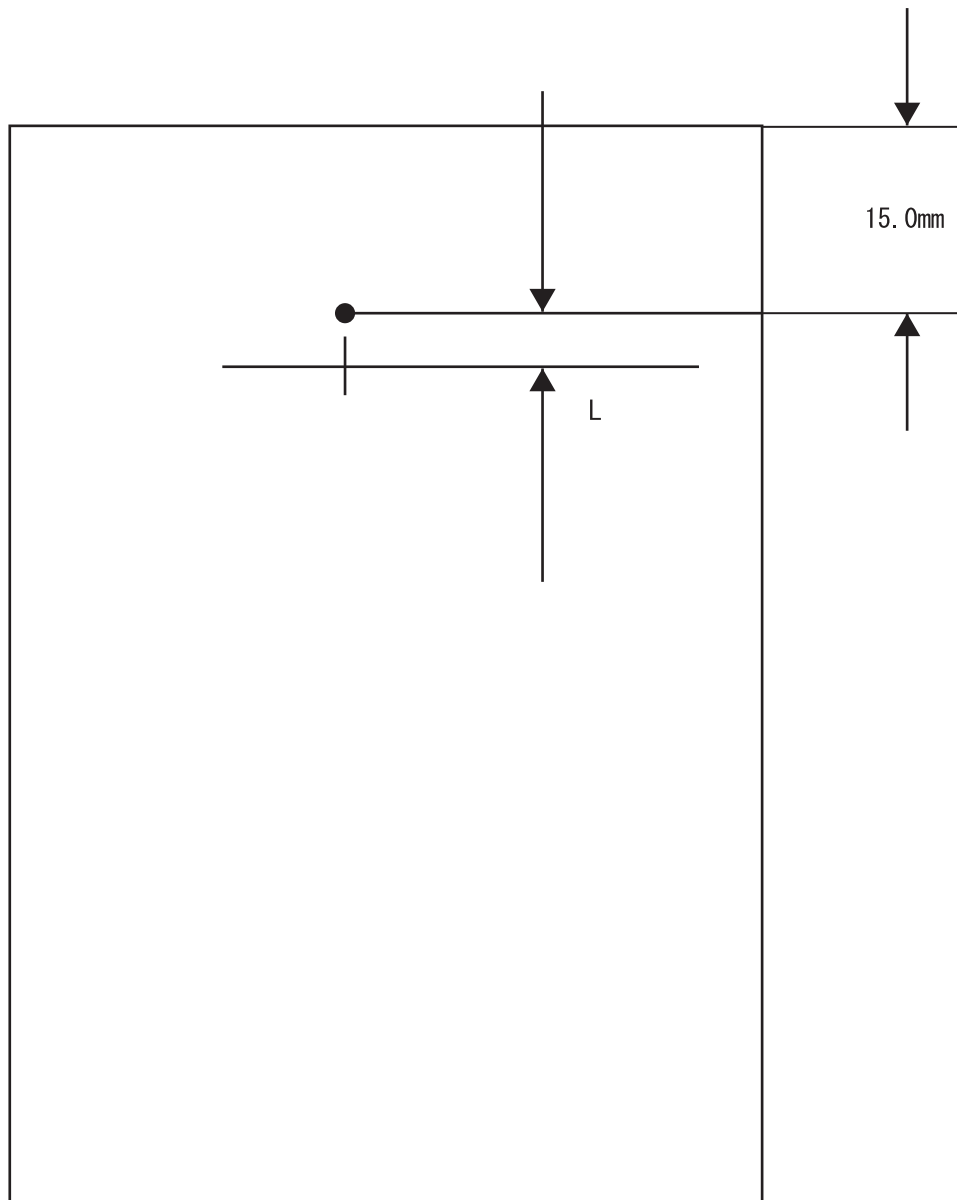
These instructions are used to judge print consistency printing with the standard paper (letter size).

Keep the paper packaged in the operating environment for 12 hours, and then use the paper fresh from the packaged.

**NOTE** The image quality cannot be evaluated when the machine is faulty.

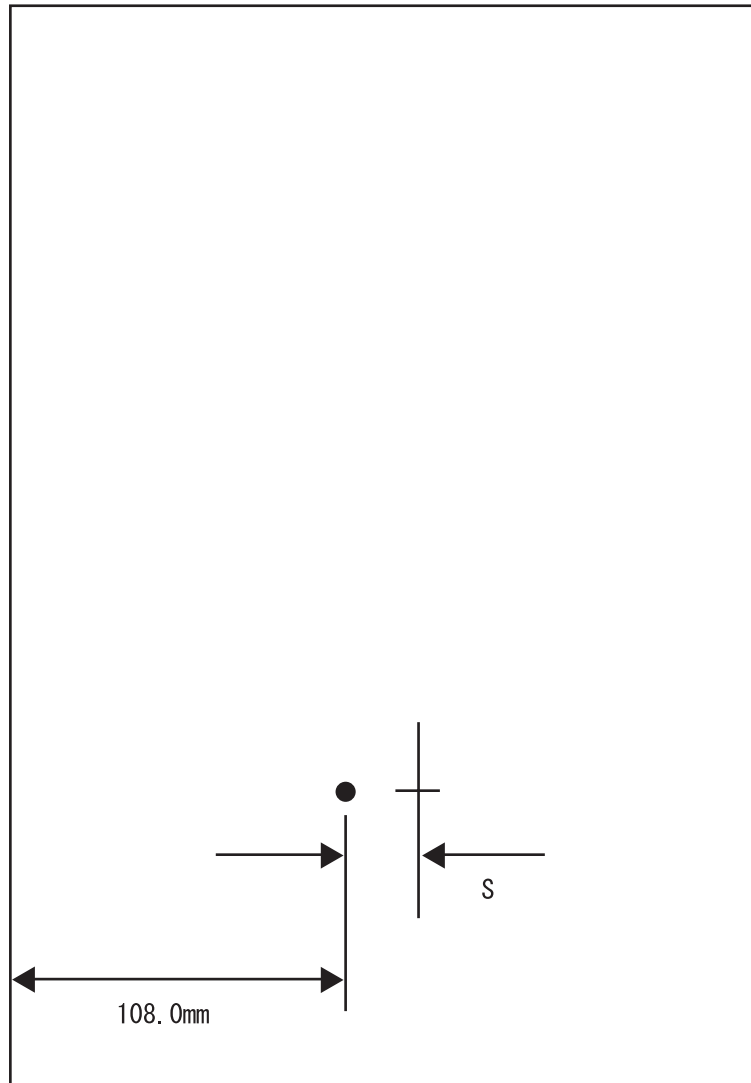
Leading edge registration

- Measurement of the amount of print shift from the ideal position on the paper
- Measure the amount of shift from the ideal point 15 mm away from the front end at center of right-and-left of the paper.
- Reference: less than +/-2.0 mm



Side edge registration

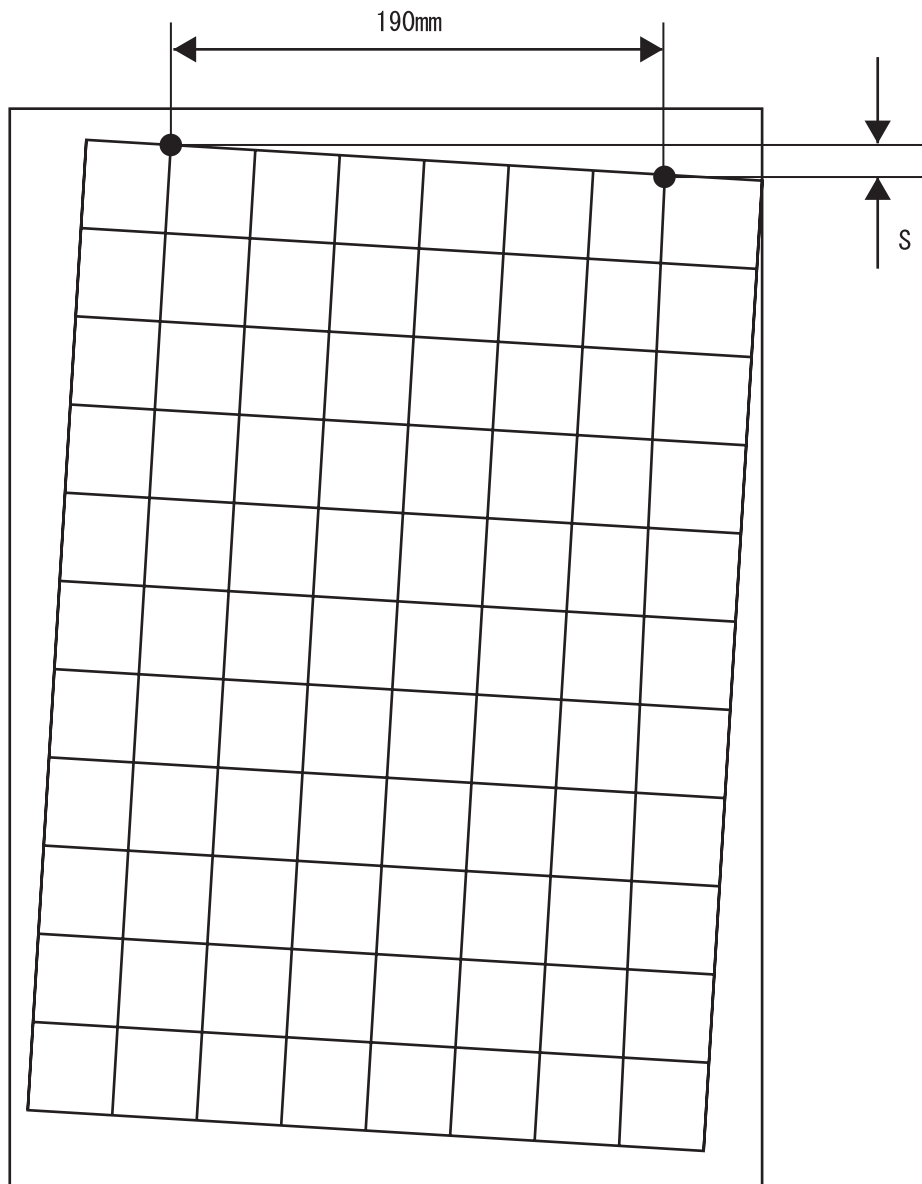
- Measure the amount of shift from the ideal point 108.0 mm away from the left end at center of front-and-back of the paper.
- Reference: less than +/-2.5 mm





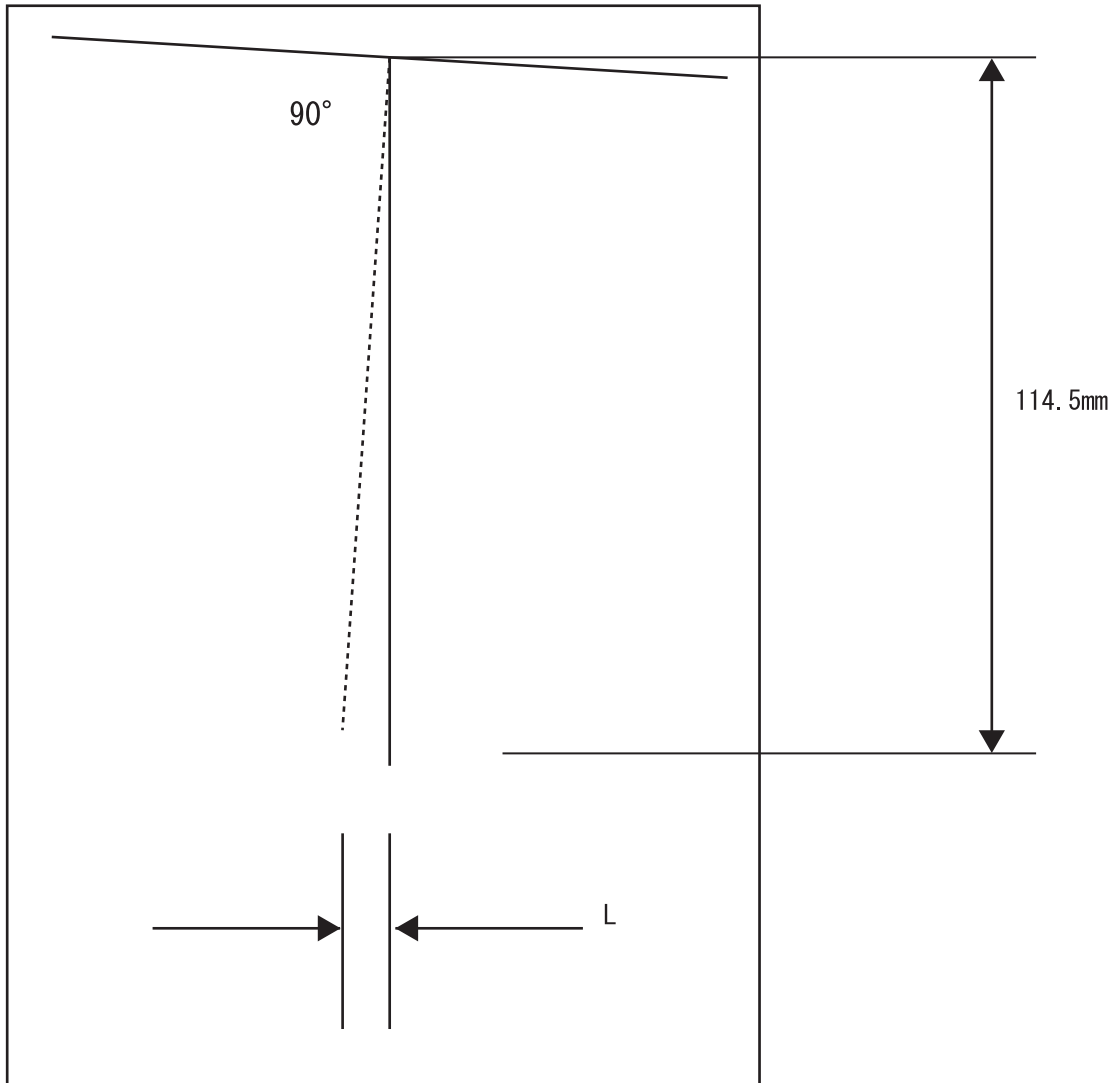
### Skew

- Measurement of the inclined paper feeding
- Measure the vertical distance of two points 190 mm away each other on the top horizontal line.
- Reference: less than  $\pm 1.2$  mm



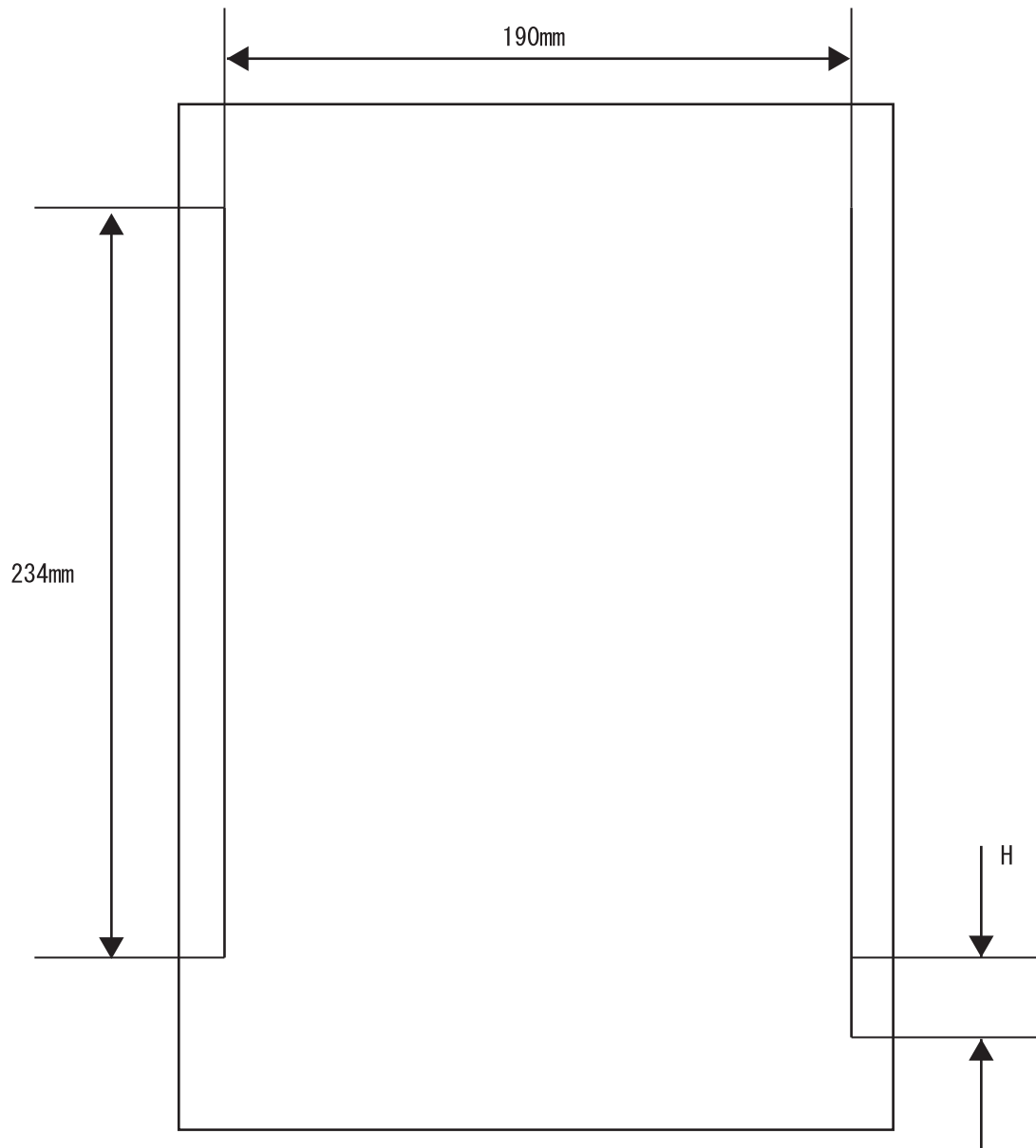
### Perpendicularity

- Measurement of the perpendicularity for suppressing inclines of ROS and OPC
- Check the perpendicular line to the horizontal line to measure the horizontal distance at the point 114.5 mm away vertically from center of top horizontal line.
- Reference: less than +/-0.8 mm



### Parallelism

- The parallelism is difference of feeding speed between left and right sides of the paper.
- Measure the difference of length between two 234 mm long vertical lines 190 mm away each other.
- Reference: less than  $\pm 1.2$  mm



# Preventive maintenance

When visiting the customer, perform the maintenance work other than the original purpose to avoid any trouble that may arise.

Procedure for preventive maintenance

1. Check how the customer is using the machine.
2. Write down the cumulative print count.

**NOTE Use the cumulative print count as a guide of replacing periodic replacement parts.**

**NOTE Replace the periodic replacement parts as required.**

3. Perform some printings to check that there is no problem.
4. Remove foreign articles on the BTR ASSY, FUSER ASSY and paper transfer rolls, and clean stains with a brush and dry waste cloth.

**NOTE When stains are heavy, clean with dampened cloth, and then clean with dry cloth.**

**NOTE Be careful not to damage the parts to be cleaned.**

5. Cleaning the fan exhaust  
Remove the COVER REAR, and clean the dust on the MAIN FAN with a brush.  
Remove the COVER FRONT, and clean the dust on the FAN SUB.

**NOTE The clogged exhaust and fan cause a temperature rise inside and failures.**

6. Perform some printings again to check that there is no problem.

# Chapter 8 Diagnostics

This section provides procedures for performing various diagnostic functions including the following actions: display the accumulated print count, run input tests to check the function of sensors and switches, run output tests to check the operation and function of printer's components.

## Entering the Diagnostic Mode

To enter the diagnostic mode, hold down the MENU and Right Arrow control panel pushbuttons while turning the printer on. Continue to hold the buttons down until the control panel displays the text "Input Test" on the first line of the display. The diagnostic mode allows you to access various diagnostic menus and submenus. Pressing the Down Arrow button on the control panel repeatedly will cycle through the diagnostic menus in the following order:

- Input Tests
- Output Tests
- Alignment
- Maintenance Info
- Operator Panel
- Test Print
- Print Summary

### MENU STRUCTURE

#### Input Tests

#### Output Tests

#### Alignment

##### Chain 6

- Function 20
- Function 21
- Function 22
- Function 23
- Function 24
- Function 25
- Function 26
- Function 28
- Function 29
- Function 30
- Function 31
- Function 32
- Function 33
- Function 34

##### Chain 20

- Function 1
- Function 41
- Function 42
- Function 43
- Function 45

#### Maintenance Info

Image Counter  
Sheet Counter  
Toner Page Count  
Tray 1 Counter  
Tray 2 Counter  
Tray 3 Counter  
Tray 4 Counter  
Tray 5 Counter  
Tray 6 Counter  
Serial Number  
Asset Tag  
Reset Error Log  
Power Saver 0  
Sleep Mode 0

## Operator Panel Print Summary

LED Test  
LCD Test  
Key Test

## Test Print

Default Source  
Duplex  
Grid Page  
Blank Page  
Black Page  
Test Page

## Flash Summary

## Print Summary

## Input Tests

### NOTES AND WARNINGS

- NOTE** When the power is on, do not touch energized parts unless absolutely necessary. Note that the wiring inside the power switch/inlet unit remains energized as long as the power cord is connected to the AC outlet, even when the switch is off.
- NOTE** Never work in the vicinity of drive units and operating units while executing tests that activate motors.
- NOTE** Never touch the high-voltage parts of the printer while executing tests that activate high voltage outputs. Always follow the procedures given in this manual.
- NOTE** Never touch drive units while the drive system is operating.
- NOTE** Never touch the fan while it is in operation.
- NOTE** Never test the interlock switch with the front cover open since there is a risk of activating the laser beam.

The Input Tests menu provides access to the diagnostic input tests. Use the following procedure to enter this menu:

**NOTE** PL20 = PL9; PL21 = PL14; PL22 = PL13; PL23 = PL10; PL24 = PL11; PL25 = PL12

1. Enter Diagnostic Mode.

2. Navigate through the Input Tests menu structure to select Chain and Function.

Chain-Function	Title	Function	Mode
01-01	L/H COVER	Checking open/close of the COVER ASSY-LH (PL4.2.8).	INPUT
01-10	TRAY MODULE COVER	Checking open/close of the LEFT COVER ASSEMBLY (2TM:PL20.5.10/TTM:PL21.7.1).	INPUT
01-11	L/H Low COVER	Checking open/close of the COVER ASSY LH LOW C (PL4.1.10).	INPUT
01-12	FRONT COVER	Checking open/close of the COVER ASSY FRONT (PL1.1.9).	INPUT
01-13	L/H High COVER	Checking open/close of the CHUTE LH HIGH (EXIT2:PL24.1.18).	INPUT
07-01	TRAY1 SIZE SENSOR	Checking operation of the TRAY1 Size Sensor (SWITCH ASSY P S) (PL2.1.4).	INPUT
07-02	TRAY2 SIZE SENSOR	Checking operation of the TRAY2 Size Sensor (SWITCH ASSY P S) (PL2.1.4).	INPUT
07-03	TRAY3 SIZE SENSOR	Checking operation of the optional TRAY MODULE TRAY3 Size Sensor (TRAY 3/4 PAPER SIZE SWITCH) (2TM:PL20.2.4/TTM:21.4.23).	INPUT
07-04	TRAY4 SIZE SENSOR	Checking operation of the optional TRAY MODULE TRAY4 Size Sensor (TRAY 3/4 PAPER SIZE SWITCH) (2TM:PL20.2.4/TTM:21.4.23).	INPUT
07-05	TRAY4 SIZE digital SENSOR	Checking operation of the TRAY4 Size Sensor (TRAY 3/4 PAPER SIZE SWITCH) (2TM:PL20.2.4/TTM:21.4.23).	INPUT

07-06	MSI SIZE SENSOR	Checking operation of the MSI Size Sensor (SENSOR ASSY-MSI) (PL3.3.10).	INPUT
07-07	TRAY1 NO PAPER SENSOR	Checking operation of the TRAY1 No Paper Sensor (SENSOR) (NO PAPER SENSOR) (PL2.3.14).	INPUT
07-08	TRAY2 NO PAPER SENSOR	Checking operation of the TRAY2 No Paper Sensor (SENSOR) (NO PAPER SENSOR) (PL2.3.14).	INPUT
07-09	TRAY3 NO PAPER SENSOR	Checking operation of the TRAY3 No Paper Sensor (SENSOR) (NO PAPER SENSOR) (2TM:PL20.4.14/ TTM:21.6.14).	INPUT
07-10	TRAY4 NO PAPER SENSOR	Checking operation of the TRAY4 No Paper Sensor (SENSOR) (NO PAPER SENSOR) (2TM:PL20.4.14/ TTM:21.6.14).	INPUT
07-11	HCF NO PAPER SENSOR	Checking operation of the optional HCF No Paper Sensor (SENSOR-PHOTO IN (HCF NO PAPER SENSOR)) (PL22.5.16).	INPUT
07-12	SMH/ENV NO PAPER SENSOR	Checking operation of the MSI No Paper Sensor (SENSOR- PHOTO IN) (PL3.1.4).	INPUT
07-13	TRAY1 LEVEL SENSOR	Checking operation of the TRAY1 Level Sensor (SENSOR (LEVEL SENSOR)) (PL2.3.14).	INPUT
07-14	TRAY2 LEVEL SENSOR	Checking operation of the TRAY2 Level Sensor (SENSOR (LEVEL SENSOR)) (PL2.3.14).	INPUT
07-15	TRAY3 LEVEL SENSOR	Checking operation of the TRAY3 Level Sensor (SENSOR (LEVEL SENSOR)) (2TM:PL20.4.14/ TTM:21.6.14).	INPUT
07-16	TRAY4 LEVEL SENSOR	Checking operation of the TRAY4 Level Sensor (SENSOR (LEVEL SENSOR)) (2TM:PL20.4.14/ TTM:21.6.14).	INPUT
07-17	HCF LEVEL SENSOR	Checking operation of the optional HCF Level Sensor (SENSOR-PHOTO IN (HCF LEVEL SENSOR)) (PL22.5.16).	INPUT



07-23	HCF COVER	Checking open/close of the optional HCF COVER ASSY TOP S (PL22.7.1).	INPUT
07-24	FACE UP TRAY DETECTED	Checking whether the FACE UP TRAY is installed.	INPUT
07-25	OCT2 DETECTED	Checking whether the optional EXIT2 is installed.	INPUT
07-26	TRAY1 SIZE digital SENSOR	Checking operation of the TRAY1 No Paper Sensor (SENSOR) (NO PAPER SENSOR) (PL2.3.14).	INPUT
07-27	TRAY2 SIZE digital SENSOR	Checking operation of the TRAY2 No Paper Sensor (SENSOR) (NO PAPER SENSOR) (PL2.3.14).	INPUT
07-28	TRAY3 SIZE digital SENSOR	Checking operation of the TRAY3 No Paper Sensor (SENSOR) (NO PAPER SENSOR) (2TM:PL20.4.14/ TTM:21.6.14).	INPUT
07-30	FACE DOWN TRAY1 FULL STACK SENSOR	Checking operation of the EXIT1 Full Stack Sensor (SENSOR-PHOTO IN) (PL6.2.5).	INPUT
07-31	FACE DOWN TRAY2 FULL STACK SENSOR	Checking operation of the optional EXIT2 Full Stack Sensor (SENSOR) (PL24.2.52).	INPUT
07-32	FACE UP TRAY FULL STACK SENSOR	Checking operation of the FACE UP TRAY full stack sensor.	INPUT
07-33	OCT1 HOME POSITION SENSOR	Checking operation of the EXIT1 Home Position Sensor (SENSOR-PHOTO IN) (PL6.2.5).	INPUT
07-34	OCT2 HOME POSITION SENSOR	Checking operation of the optional EXIT2 Home Position Sensor (OCT POSITION SENSOR) (PL24.2.54).	INPUT
08-05	REGI SENSOR	Checking operation of the REGI Sensor (SNR ASSY REGI) (PL4.5.7).	INPUT
08-06	FEED OUT#2 SENSOR	Checking operation of the FEED OUT SENSOR 2 (SENSOR) (PL4.5.18).	INPUT
08-08	T/A F/O3 SENSOR	Checking operation of the FEED OUT SENSOR 3 (TRAY 3 FEED OUT SENSOR) (2TM:PL20.5.3/ TTM:21.5.8).	INPUT
08-09	T/A F/O4 SENSOR	Checking operation of the FEED OUT SENSOR 4 (TRAY 4 FEED OUT SENSOR) (2TM:PL20.5.6/ TTM:21.4.18).	INPUT
08-20	PreFEED SENSOR3	Checking operation of the TRAY3 Pre Feed Sensor (SENSOR (PRE FEED SENSOR)) (2TM:PL20.4.15/ TTM:PL21.6.15).	INPUT
08-21	PreFEED SENSOR4	Checking operation of the TRAY4 Pre Feed Sensor (SENSOR (PRE FEED SENSOR)) (2TM:PL20.4.15/ TTM:PL21.6.15).	INPUT
08-22	HCF PreFEED SENSOR	Checking operation of the optional HCF Pre Feed Sensor (SENSOR ASSY (HCF PRE FEED SENSOR)) (PL22.5.9).	INPUT

08-23	HCF F/O SENSOR	Checking operation of the optional HCF FEED OUT SENSOR (HCF TA SENSOR) (PL22.7.6).	INPUT
08-31	DUP WAIT SENSOR	Checking operation of the optional DUPEX Wait Sensor (SENSOR-PHOTO IN) (PL23.1.18).	INPUT
08-32	REGI SENSOR (DM)	Checking operation of the optional DUPLEX REGI Sensor (SNR ASSY REGI) (PL4.5.7).	INPUT
08-33	DUP INTERLOCK	Checking open/close of the optional DUPLEX COVER DUP (PL23.1.13).	INPUT
08-35	REGI CLUTCH (DM)	Checking operation of the optional DUPLEX REGI Clutch (CLUTCH ASSY REGI H) (PL4.5.2).	INPUT
08-39	REGI CLUTCH (EXIT)	Checking operation of the EXIT REGI Clutch (CLUTCH ASSY REGI H) (PL4.5.2).	INPUT
08-47	FEED READY SIGNAL	Checking the FEED READY signal.	INPUT
08-48	T/A F/O3 SENSOR	Checking operation of the FEED OUT SENSOR 3 (TRAY 3 FEED OUT SENSOR)(2TM:PL20.5.3/ TTM:21.5.8).	INPUT
08-49	T/A F/O4 SENSOR	Checking operation of the FEED OUT SENSOR 4 (TRAY 4 FEED OUT SENSOR) (2TM:PL20.5.6/ TTM:21.4.18).	INPUT
08-52	HCF NO PAPER SENSOR(Hot Line)	Checking hot-line operation of the optional HCF No Paper Sensor (HCF NO PAPER SENSOR) (PL22.5.16).	INPUT
08-53	HCF SIZE SENSOR A	Checking operation of the optional HCF Size Sensor (HCF SIZE SENSOR) (PL22.1.4).	INPUT
08-54	HCF SIZE SENSOR B	Checking operation of the optional HCF Size Sensor (HCF SIZE SENSOR) (PL22.1.4).	INPUT
08-55	HCF TRAY IN SENSOR	Checking operation of the optional HCF Tray Set Sensor (HCF TRAY SET SENSOR) (PL22.1.4).	INPUT
08-57	HCF SIDE OUT SW	Checking the HCF SIDE OUT switch (SW IL ASSY DOCKING) (PL22.7.17).	INPUT
08-58	PreFEED SENSOR1	Checking operation of the TRAY1 Pre Feed Sensor (SENSOR) (PRE FEED SENSOR) (PL2.3.15).	INPUT
08-59	PreFEED SENSOR2	Checking operation of the TRAY2 Pre Feed Sensor (SENSOR) (PRE FEED SENSOR) (PL2.3.15).	INPUT
09-02	DRUM DETECT	Checking operation of the CRU (PL5.1.15) Detect Sensor (SWITCH ASSY XERO INTLK (PL5.1.4).	INPUT
09-30	BTR MONITOR VOLTAGE INPUT	Checking BTR voltage.	INPUT

10-20	FUSER CONTROL SENSOR (FS1)	Checking forward rotation of the MOTOR ASSY-OFFSET (PL24.2.30).	INPUT
10-21	FUSER CONTROL SENSOR (FS2)	Checking operation of the FUSER temperature sensor (FS1).	INPUT
10-22	FUSER CONTROL SENSOR (PR)	Checking operation of the FUSER temperature sensor (FS2).	INPUT
10-23	EXIT SENSOR	Checking operation of the SENSOR PHOTO (PL6.1.4).	INPUT
10-26	EXIT SENSOR1(EXIT)	Checking operation of the SENSOR PHOTO (PL6.1.4).	INPUT
10-60	FUSER FAN FAIL MONITOR SIGNAL	Checking signals to FAN FUSER (PL5.1.13) from the MOTOR ASSY 242 (PL7.1.7).	INPUT
12-27	IOT Exit SNR	Checking operation of the SENSOR PHOTO (PL6.1.4).	INPUT
12-28	H-Xport Ent. SNR	Checking operation of the optional FINISHER H-TRANSPORT ENTRANCE SENSOR (PL25.3.23).	INPUT
12-29	H-Xport Exit SNR	Checking operation of the optional FINISHER H-TRANSPORT EXIT SENSOR (PL25.3.21).	INPUT
12-30	Xport Ent. SNR	Checking operation of the optional FINISHER SENSOR (PL25.12.19).	INPUT
12-31	Buffer Path SNR	Checking operation of the optional FINISHER SENSOR ASSY (PL25.12.12).	INPUT
12-32	Top Tray Exit SNR	Checking operation of the optional FINISHER SENSOR (PL25.13.2).	INPUT
12-33	Top Tray Full SNR	Checking operation of the optional FINISHER SENSOR (PL25.13.7).	INPUT
12-34	Compile Exit SNR	Checking operation of the optional FINISHER SENSOR ASSY (PL25.11.3).	INPUT
12-35	Compile Tray No Paper SNR	Checking operation of the optional FINISHER SENSOR (PL25.10.3).	INPUT
12-36	Side Regi SNR 1	Checking the optional FINISHER Side Regi sensor (SIDE REGI SENSOR) (PL25.7.8).	INPUT
12-37	Side Regi SNR 2	Checking operation of the optional FINISHER SENSOR (PL25.7.8).	INPUT
12-38	Eject Clamp Home SNR	Checking operation of the optional FINISHER SENSOR (PL25.9.13).	INPUT
12-39	Set Clamp Home SNR	Checking operation of the optional FINISHER SENSOR (PL25.10.18).	INPUT
12-51	Gate SNR	Checking operation of the optional FINISHER GATE SENSOR (SENSOR) (PL25.13.15).	INPUT

13-33	Puncher Move Home SNR	Checking operation of the optional FINISHER SENSOR (PL25.7.17).	INPUT
13-34	Puncher Home SNR	Checking operation of the optional FINISHER SENSOR (PL25.7.15 right)	INPUT
13-35	Puncher Front SNR	Checking operation of the optional FINISHER SENSOR (PL25.7.15 center)	INPUT
13-36	Punch Hole Select SNR	Checking operation of the optional FINISHER SENSOR (PL25.7.15 left).	INPUT
13-37	Puncher Motor SNR	Checking operation of the optional FINISHER SENSOR (PL25.7.13).	INPUT
13-38	Punch Box Set SNR	Check whether the optional FINISHER PUNCH BOX SENSOR (SENSOR) (PL25.7.21) is installed.	INPUT
13-39	Front Tamper Home SNR	Checking operation of the optional FINISHER SENSOR (PL25.10.2 right).	INPUT
13-40	Rear Tamper Home SNR	Checking operation of the optional FINISHER SENSOR (PL25.10.2 left).	INPUT
13-42	Stapler Move Position SNR	Checking operation of the optional FINISHER SENSOR (PL25.8.5).	INPUT
13-43	Low Staple SNR	Checking operation of the optional FINISHER Low Staple SNR.	INPUT
13-44	Self Priming SNR	Checking operation of the optional FINISHER Self Priming SNR.	INPUT
13-45	Staple Home SNR	Checking operation of the optional FINISHER Staple Home SNR.	INPUT
13-46	Upper Limit SNR	Checking operation of the optional FINISHER SENSOR (PL25.6.17 upper).	INPUT
13-48	Stacker No Paper SNR	Checking operation of the optional FINISHER SENSOR (PL25.6.17 lower).	INPUT
13-49	Stack Encoder SNR	Checking operation of the optional FINISHER SENSOR (PL25.6.17).	INPUT
13-50	Stack Hight SNR 1	Checking operation of the optional FINISHER Stack Hight SNR 1.	INPUT
13-51	Stack Hight SNR 2	Checking operation of the optional FINISHER Stack Hight SNR 2.	INPUT
13-53	H-Xport Interlock SNR	Checking open/close of the optional FINISHER COVER TOP,C (PL25.2.1).	INPUT
13-54	Finisher Front Cover SW	Checking open/close of the optional FINISHER COVER ASSY FRONT (PL25.5.3).	INPUT
13-55	Eject Cover SW	Checking open/close of the optional FINISHER EJECT COVER (SENSOR ASSY) (PL25.9.23).	INPUT
15-60	Temp Sensor	Checking operation of the Temperature Sensor (SENSOR HUM&TE) (PL5.1.5).	INPUT
15-61	Hum Sensor	Checking operation of the Temperature Sensor (SENSOR HUM&TE) (PL5.1.5).	INPUT
15-62	ATC Sensor	Checking operation of the ATC Sensor.	INPUT

# Output Tests

## NOTES AND WARNINGS

**NOTE** When the power is on, do not touch energized parts unless absolutely necessary. Note that the wiring inside the power switch/inlet unit remains energized as long as the power cord is connected to the AC outlet, even when the switch is off.

**NOTE** Never use any procedure other than the one specified for testing the operation of the LD switch in the CRU sensor assembly as there is a risk of activating the laser beam.

**NOTE** Never work in the vicinity of drive units and operating units while executing tests that activate motors.

**NOTE** Never touch the high-voltage parts of the printer while executing tests that activate high voltage outputs. Always follow the procedures given in this manual.

**NOTE** Never touch drive units while the drive system is operating.

**NOTE** Never touch the fan while it is in operation.

**NOTE** **PL20 = PL9; PL21 = PL14; PL22 = PL13; PL23 = PL10; PL24 = PL11; PL25 = PL12**

The Output Tests menu provides access to the diagnostic output tests. Use the following procedure to enter this menu:

1. Enter Diagnostic Mode.
2. Navigate through the Output Tests menu structure to select Chain and Function.

Chain-Function	Title	Function	Mode
04-01	MAIN MOTOR ON	Checking operation of the MAIN Motor (MOTOR ASSY 242) (PL7.1.7).	OUTPUT
04-02	FUSER FAN MOTOR (HIGH SPEED)	Checking high-speed rotation of the FAN Motor (FAN FUSER) (PL5.1.13).	OUTPUT
06-15	ROS MOTOR ON	Checking operation of the ROS Motor (MOTOR ASSY-DISP 30K) (PL5.1.11).	OUTPUT
07-18	TRAY1 LIFTER UP (FEED MOTOR Reverse)	Checking reverse rotation of the TRAY1 Motor (TRAY1/2 FEED LIFT UP MOTOR) (PL2.3.2).	OUTPUT
07-19	TRAY2 LIFTER UP (FEED MOTOR Reverse)	Checking reverse rotation of the TRAY2 Motor (TRAY1/2 FEED LIFT UP MOTOR) (PL2.3.2).	OUTPUT
07-20	TRAY3 LIFTER UP (FEED MOTOR Reverse)	Checking reverse rotation of the optional TRAY MODULE TRAY3 Motor (TRAY1/2 FEED LIFT UP MOTOR) (2TM:PL20.4.2/ TTM:PL21.6.2).	OUTPUT
07-21	TRAY4 LIFTER UP (FEED MOTOR Reverse)	Checking reverse rotation of the optional TRAY MODULE TRAY4 Motor (TRAY1/2 FEED LIFT UP MOTOR) (2TM:PL20.4.2/ TTM:PL21.6.2).	OUTPUT
07-22	HCF LIFTER UP (FEED MOTOR Reverse)	Checking reverse rotation of the optional HCF Tray Motor (MOTOR ASSY HCF) (PL22.4.2).	OUTPUT

08-10	REGI CLUTCH	Checking operation of the REGI Clutch (CLUTCH ASSY REGI H) (PL4.5.2).	OUTPUT
08-11	HCF T/A MOTOR (242mm/s)	Checking low-speed rotation of the optional HCF T/A Motor (MOTOR ASSY) (PL22.7.12).	OUTPUT
08-12	TRAY1 FEED MOTOR	Checking forward rotation of the TRAY1 Motor (TRAY1/2 FEED LIFT UP MOTOR) (PL2.3.2).	OUTPUT
08-13	TRAY2 FEED MOTOR	Checking forward rotation of the TRAY2 Motor (TRAY1/2 FEED LIFT UP MOTOR) (PL2.3.2).	OUTPUT
08-14	TRAY3 FEED MOTOR	Checking forward rotation of the optional TRAY MODULE TRAY3 Motor (TRAY1/2 FEED LIFT UP MOTOR) (2TM:PL20.4.2/ TTM:PL21.6.2).	OUTPUT
08-15	TRAY4 FEED MOTOR	Checking forward rotation of the optional TRAY MODULE TRAY4 Motor (TRAY1/2 FEED LIFT UP MOTOR) (2TM:PL20.4.2/ TTM:PL21.6.2).	OUTPUT
08-16	HCF FEED MOTOR	Checking forward rotation of the optional HCF Tray Motor (MOTOR ASSY HCF) (PL22.4.2).	OUTPUT
08-17	SMH FEED CLUTCH	Checking operation of the MSI FEED Clutch (SOLENOID PICKUP) (PL3.2.15).	OUTPUT
08-18	TM T/A CL	Checking operation of the optional TRAY MODULE T/A Clutch (2TM:CLUTCH (PL20.6.2)/ TTM:TAKEAWAY CLUTCH (PL21.8.7)).	OUTPUT
08-38	DUP MOTOR	Checking operation of the optional DUPLEX Motor (MOTOR ASSY DUP) (PL23.1.11).	OUTPUT
08-41	HCF Nudger Solenoid ( High Power)	Checking high-power operation of the optional HCF Solenoid (SOLENOID ASSY) (PL22.4.5).	OUTPUT
08-42	HOT-LINE CHECK with alternative signal	Switching between the FEED and STOP signal.	OUTPUT
08-44	TRAY3 FEED MOTOR (Hot-Line)	Checking hot-line of the optional TRAY MODULE TRAY3 Motor (TRAY1/2 FEED LIFT UP MOTOR) (2TM:PL20.4.2/TTM:PL21.6.2).	OUTPUT
08-45	TRAY4 FEED MOTOR (Hot-Line)	Checking hot-line of the optional TRAY MODULE TRAY4 Motor (TRAY1/2 FEED LIFT UP MOTOR) (2TM:PL20.4.2/TTM:PL21.6.2).	OUTPUT

08-50	DUP MOTOR Rotate for sending paper out to regi	Checking operation of the optional DUPLEX Motor (MOTOR ASSY DUP) (PL23.1.11).	OUTPUT
08-51	HCF Nudger Solenoid( Low Power)	Checking low-power operation of the optional HCF Solenoid (SOLENOID ASSY) (PL22.4.5).	OUTPUT
08-56	HCF T/A MOTOR (500mm/s)	Checking high-speed rotation of the optional HCF T/A Motor (MOTOR ASSY) (PL22.7.12).	OUTPUT
09-01	MAIN MOTOR ON	Checking operation of the MAIN Motor (MOTOR ASSY 242) (PL7.1.7).	OUTPUT
09-03	DRUM MOTOR ON	Checking operation of the DRUM Motor (MOTOR ASSY 242) (PL7.1.7).	OUTPUT
09-23	BCR AC BIAS	Checking AC BIAS of the MAIN Motor (MOTOR ASSY 242) (PL7.1.7).	OUTPUT
09-24	BCR DC BIAS	Checking DC BIAS of the MAIN Motor (MOTOR ASSY 242) (PL7.1.7).	OUTPUT
09-27	DTS	Checking DTS of the MAIN Motor (MOTOR ASSY 242) (PL7.1.7).	OUTPUT
09-29	BTR(+) BIAS	Checking BTR(+) BIAS of the MAIN Motor (MOTOR ASSY 242) (PL7.1.7).	OUTPUT
09-33	Deve DC BIAS	Checking Deve DC BIAS of the MAIN Motor (MOTOR ASSY 242) (PL7.1.7).	OUTPUT
09-36	BTR(-) BIAS	Checking BTR(-) BIAS of the MAIN Motor (MOTOR ASSY 242) (PL7.1.7).	OUTPUT
10-01	MAIN MOTOR	Checking operation of the MAIN Motor (MOTOR ASSY 242) (PL7.1.7).	OUTPUT
10-04	FUSER FAN MOTOR(HIGH SPEED)	Checking high-speed rotation of the FAN FUSER (PL5.1.13).	OUTPUT
10-06	OFFSET MOTOR1 FORWARD ROTATION	Checking forward rotation of the MOTOR ASSY-OFFSET (PL6.2.3).	OUTPUT
10-07	OFFSET MOTOR1 REVERSE ROTATION	Checking reverse rotation of the MOTOR ASSY-OFFSET (PL6.2.3).	OUTPUT
10-08	EXIT DRIVE MOTOR FORWARD (Eject Paper out)	Checking forward rotation of the MOTOR ASSY EXIT 2 (PL24.2.37).	OUTPUT
10-09	EXIT DRIVE MOTOR REVERSE (send paper into Dup)	Checking reverse rotation of the MOTOR ASSY EXIT 2 (PL24.2.37).	OUTPUT

10-24	OFFSET MOTOR2 FORWARD ROTATION	Checking forward rotation of the MOTOR ASSY-OFFSET (PL24.2.30).	OUTPUT
10-25	OFFSET MOTOR2 REVERSE ROTATION	Checking reverse rotation of the MOTOR ASSY-OFFSET (PL24.2.30).	OUTPUT
10-51	EXIT GATE SOLENOID	Checking operation of the SOLENOID ASSY (PL24.2.29).	OUTPUT
10-53	FACE UP GATE SOLENOID	Checking operation of the SOLENOID ASSY FU (PL24.2.23).	OUTPUT
12-01	H XPORT Motor 145 ON/OFF	Checking low-speed rotation of the optional FINISHER H-TRANSPORT MOTOR (PL25.3.7).	OUTPUT
12-02	H XPORT Motor 242 ON/OFF	Checking high-speed rotation of the optional FINISHER H-TRANSPORT MOTOR (PL25.3.7).	OUTPUT
12-03	Fin Transport Motor 350 ON/OFF	Checking low-speed rotation of the optional FINISHER MOTOR ASSY-DC (PL25.9.11).	OUTPUT
12-04	Fin Transport Motor 600 ON/OFF	Checking high-speed rotation of the optional FINISHER MOTOR ASSY-DC (PL25.9.11).	OUTPUT



12-05	Regi Motor 285F ON/OFF	Checking low-speed forward rotation of the optional FINISHER MOTOR ASSY (LEFT) (PL25.13.30).	OUTPUT
12-06	Regi Motor 350F ON/OFF	Checking medium-speed forward rotation of the optional FINISHER MOTOR ASSY (LEFT) (PL25.13.30).	OUTPUT
12-07	Regi Motor 600F ON/OFF	Checking high-speed forward rotation of the optional FINISHER MOTOR ASSY (LEFT) (PL25.13.30).	OUTPUT
12-08	Regi Motor 285R ON/OFF	Checking low-speed reverse rotation of the optional FINISHER MOTOR ASSY (LEFT) (PL25.13.30).	OUTPUT
12-09	Exit Motor 285F ON/OFF	Checking low-speed forward rotation of the optional FINISHER MOTOR ASSY (RIGHT) (PL25.13.30).	OUTPUT
12-10	Exit Motor 350F ON/OFF	Checking medium-speed forward rotation of the optional FINISHER MOTOR ASSY (RIGHT) (PL25.13.30).	OUTPUT
12-11	Exit Motor 600F ON/OFF	Checking high-speed forward rotation of the optional FINISHER MOTOR ASSY (RIGHT) (PL25.13.30).	OUTPUT
12-12	Exit Motor 285R ON/OFF	Checking low-speed forward rotation of the optional FINISHER MOTOR ASSY (RIGHT) (PL25.13.30).	OUTPUT
12-13	Transpoort Gate Solenoid TOP	Checking ON operation of the optional FINISHER BRACKET ASSY SOL (PL25.12.32).	OUTPUT
12-14	Transpoort Gate Solenoid STACKER	Checking OFF operation of the optional FINISHER BRACKET ASSY SOL (PL25.12.32).	OUTPUT
12-15	Sub Paddle Solenoid ON/OFF	Checking operation of the optional FINISHER SOLENOID ASSY (PL25.9.3).	OUTPUT
12-16	Set Clamp CLUTCH ON/OFF	Checking operation of the optional FINISHER Set Clamp CLUTCH.	OUTPUT
12-18	Eject Clamp Motor UP ON/OFF	Checking UP operation of the optional FINISHER MOTOR ASSY-DC (PL25.9.11).	OUTPUT
12-19	Eject Clamp Motor DOWN ON/OFF	Checking DOWN operation of the optional FINISHER MOTOR ASSY-DC (PL25.9.11).	OUTPUT
12-20	Eject Motor Low FORWARD ON/OFF	Checking low-speed forward rotation of the optional FINISHER BRACKET ASSY-EJECT (PL25.10.17).	OUTPUT
12-21	Eject Motor High FORWARD ON/OFF	Checking high-speed forward rotation of the optional FINISHER BRACKET ASSY-EJECT (PL25.10.17).	OUTPUT
12-22	Eject Motor Low REVERSE ON/OFF	Checking low-speed reverse rotation of the optional FINISHER BRACKET ASSY-EJECT (PL25.10.17).	OUTPUT

12-23	Eject Motor High REVERSE ON/OFF	Checking high-speed reverse rotation of the optional FINISHER BRACKET ASSY-EJECT (PL25.10.17).	OUTPUT
12-24	Buffer Gate SOL STK	Checking OFF operation of the optional FINISHER BRACKET ASSY SOL (PL25.12.34).	OUTPUT
12-25	Buffer Gate SOL BUF	Checking ON operation of the optional FINISHER BRACKET ASSY SOL (PL25.12.34).	OUTPUT
13-01	Puncher Move Motor Low FRONT ON/OFF	Checking low-speed rotation (FRONT) of the optional FINISHER MOTOR ASSY (PL25.7.12).	OUTPUT
13-02	Puncher Move Motor High FRONT ON/OFF	Checking high-speed rotation (FRONT) of the optional FINISHER MOTOR ASSY (PL25.7.12).	OUTPUT
13-03	Puncher Move Motor Low REAR ON/OFF	Checking low-speed rotation (REAR) of the optional FINISHER MOTOR ASSY (PL25.7.12).	OUTPUT

13-04	Puncher Move Motor High REAR ON/OFF	Checking high-speed rotation (REAR) of the optional FINISHER MOTOR ASSY (PL25.7.12).	OUTPUT
13-05	Puncher Mot 2Hole Home Move	Move the optional FINISHER PUNCHER MOTOR (MOTOR ASSY) (PL25.7.12) to the 2Hole Home.	OUTPUT
13-06	Puncher Mot 3Hole Home Move	Move the optional FINISHER PUNCHER MOTOR (MOTOR ASSY) (PL25.7.12) to the 3Hole Home.	OUTPUT
13-07	Puncher Mot 4Hole Home Move	Move the optional FINISHER PUNCHER MOTOR (MOTOR ASSY) (PL25.7.12) to the 4Hole Home.	OUTPUT
13-08	Punch (2Hole)	Checking operation of the Motor (BRACKET ASSY-MOTOR,PUNCH) (PL25.7.4) for driving the optional FINISHER BRACKET ASSY PUNCH2&3 (PL25.7.9).	OUTPUT
13-09	Punch (3Hole)	Checking operation of the Motor (BRACKET ASSY-MOTOR,PUNCH) (PL25.7.4) for driving the optional FINISHER BRACKET ASSY PUNCH2&3 (PL25.7.9).	OUTPUT
13-10	Punch (4Hole)	Checking operation of the Motor (BRACKET ASSY-MOTOR,PUNCH) (PL25.7.4) for driving the optional FINISHER BRACKET ASSY PUNCH (PL25.7.9).	OUTPUT
13-11	Front Tamper Mot Low FRONT ON/OFF	Checking low-speed rotation (FRONT) of the optional FINISHER MOTOR ASSY 2 (PL25.10.6).	OUTPUT
13-12	Front Tamper Mot Middle FRONT ON/OFF	Checking medium-speed rotation (FRONT) of the optional FINISHER MOTOR ASSY 2 (PL25.10.6).	OUTPUT
13-13	Front Tamper Mot High FRONT ON/OFF	Checking high-speed rotation (FRONT) of the optional FINISHER MOTOR ASSY 2 (PL25.10.6).	OUTPUT
13-14	Front Tamper Mot Low REAR ON/OFF	Checking low-speed rotation (REAR) of the optional FINISHER MOTOR ASSY 2 (PL25.10.6).	OUTPUT
13-15	Front Tamper Mot Middle REAR ON/OFF	Checking medium-speed rotation (REAR) of the optional FINISHER MOTOR ASSY 2 (PL25.10.6).	OUTPUT
13-16	Front Tamper Mot High REAR ON/OFF	Checking high-speed rotation (REAR) of the optional FINISHER MOTOR ASSY 2 (PL25.10.6).	OUTPUT
13-17	Rear Tamper Mot Low FRONT ON/OFF	Checking low-speed rotation (FRONT) of the optional FINISHER MOTOR ASSY (PL25.10.7).	OUTPUT
13-18	Rear Tamper Mot Middle FRONT ON/OFF	Checking medium-speed rotation (FRONT) of the optional FINISHER MOTOR ASSY (PL25.10.7).	OUTPUT
13-19	Rear Tamper Mot High FRONT ON/OFF	Checking high-speed rotation (FRONT) of the optional FINISHER MOTOR ASSY (PL25.10.7).	OUTPUT

13-20	Rear Tamper Mot Low REAR ON/OFF	Checking low-speed rotation (REAR) of the optional FINISHER MOTOR ASSY (PL25.10.7).	OUTPUT
13-21	Rear Tamper Mot Middle REAR ON/OFF	Checking medium-speed rotation (REAR) of the optional FINISHER MOTOR ASSY (PL25.10.7).	OUTPUT
13-22	Rear Tamper Mot High REAR ON/OFF	Checking high-speed rotation (REAR) of the optional FINISHER MOTOR ASSY (PL25.10.7).	OUTPUT
13-23	Stapler Move Mot Low FRONT ON/OFF	Checking low-speed rotation (FRONT) of optional FINISHER CARRIAGE ASSY LOWER, STAPLER (PL25.8.9) Motor.	OUTPUT
13-24	Stapler Move Mot Middle FRONT ON/OFF	Checking medium-speed rotation (FRONT) of the optional FINISHER CARRIAGE ASSY LOWER, STAPLER (PL25.8.9) Motor.	OUTPUT
13-25	Stapler Move Mot High FRONT ON/OFF	Checking high-speed rotation (FRONT) of the optional FINISHER CARRIAGE ASSY LOWER, STAPLER (PL25.8.9) Motor.	OUTPUT
13-26	Stapler Move Mot Low REAR ON/OFF	Checking low-speed rotation (REAR) of the optional FINISHER CARRIAGE ASSY LOWER, STAPLER (PL25.8.9) Motor.	OUTPUT
13-27	Stapler Move Mot Middle REAR ON/OFF	Checking medium-speed rotation (REAR) of the optional FINISHER CARRIAGE ASSY LOWER, STAPLER (PL25.8.9) Motor.	OUTPUT
13-28	Stapler Move Mot High REAR ON/OFF	Checking high-speed rotation (REAR) of the optional FINISHER CARRIAGE ASSY LOWER, STAPLER (PL25.8.9) Motor.	OUTPUT
13-29	Staple Motor FORWARD ON/OFF	Checking forward rotation of the optional FINISHER STAPLER ASSY (PL25.8.2) Motor.	OUTPUT
13-30	Staple Motor REVERSE ON/OFF	Checking reverse rotation of the optional FINISHER STAPLER ASSY (PL25.8.2) Motor.	OUTPUT
13-31	Stacker Motor UP ON/OFF	Checking Motor UP operation of the optional FINISHER MOTOR ASSY DC (PL25.6.26).	OUTPUT
13-32	Stacker Motor DOWN ON/OFF	Checking Motor DOWN operation of the optional FINISHER MOTOR ASSY DC (PL25.6.26).	OUTPUT
15-63	Dispense Motor	Checking operation of the Dispense Motor (Motor ASSY-DISP 30K) (PL5.1.11).	OUTPUT

## Alignment

The Alignment menu provides access to the diagnostic alignments. Use the following procedure to enter this menu:

1. Enter Diagnostic Mode.
2. Navigate through the Alignment menu structure to select specific alignment tests.

Chain Function	Name	Value		Initial Value	1 Count
		Min.	Max.		
06-20	ALL TRAY-LASER SIDE REGI ADJUSTMENT	1	99	50	0.254mm
06-21	TRAY1-LASER SIDE REGI ADJUSTMENT	1	99	50	0.254mm
06-22	TRAY2-LASER SIDE REGI ADJUSTMENT	1	99	50	0.254mm
06-23	TRAY3-LASER SIDE REGI ADJUSTMENT	1	99	50	0.254mm
06-24	TRAY4-LASER SIDE REGI ADJUSTMENT	1	99	50	0.254mm
06-25	HCF-LASER SIDE REGI ADJUSTMENT	1	99	50	0.254mm
06-26	MSI-LASER SIDE REGI ADJUSTMENT	1	99	50	0.254mm
06-28	DUP ALL TRAY-LASER SIDE REGI ADJUSTMENT	1	99	50	0.254mm
06-29	DUP TRAY1-LASER SIDE REGI ADJUSTMENT	1	99	50	0.254mm
06-30	DUP TRAY2-LASER SIDE REGI ADJUSTMENT	1	99	50	0.254mm
06-31	DUP TRAY3-LASER SIDE REGI ADJUSTMENT	1	99	50	0.254mm
06-32	DUP TRAY4-LASER SIDE REGI ADJUSTMENT	1	99	50	0.254mm
06-33	DUP HCF-LASER SIDE REGI ADJUSTMENT	1	99	50	0.254mm
06-34	DUP MSI-LASER SIDE REGI ADJUSTMENT	1	99	50	0.254mm
20-01	LEAD REGI ADJUSTMENT - ALL TRAY	0	66	33	0.363mm
20-41	TRAY1 for Normal Paper - LEAD REGI ADJUSTMENT	0	66	33	0.363mm
20-42	"TRAY2-4,HCF for Normal Paper - LEAD REGI ADJUSTMENT"	0	66	33	0.363mm
20-43	SMH for Normal Paper - LEAD REGI	0	66	33	0.363mm

## Maintenance Info

The Maintenance Info menu provides access to the diagnostic maintenance information. Use the following procedure to enter this menu:

1. Enter Diagnostic Mode.
2. Navigate through the Maintenance menu structure to view information.
  - Image Counter displays the total number of images printed.
  - Sheet Counter displays the total number of sheets used.
  - Toner Page Count Displays the total number of sheets printed with current toner cartridge.
  - Tray 1 Counter displays the total number of sheets printed from Tray 1.
  - Tray 2 Counter displays the total number of sheets printed from Tray 2.
  - Tray 3 Counter displays the total number of sheets printed from Tray 3.
  - Tray 4 Counter displays the total number of sheets printed from Tray 4.
  - Tray 5 Counter displays the total number of sheets printed from Tray 5.
  - Tray 6 Counter displays the total number of sheets printed from Tray 6.

- Serial Number displays printer serial number.
- Asset Tag displays and sets printer serial number.
- Reset Error Log resets error log.
- Power Saver 0 – setting to ON allows disabling Power Saver Mode
- Sleep Mode 0 - setting to ON allows disabling Sleep Mode.

## Operator Panel

The Operator Panel menu provides access to the diagnostic operator panel tests. Use the following procedure to enter this menu:

1. Enter Diagnostic Mode.
2. Navigate through the Operator Panel menu structure to move through the available tests.
3. Use the procedures in the following table to execute specific operator panel tests:

Operator Panel Tests	Function	Procedure
LED Test	Lights the operator panel LEDs in various sequences and combinations to verify that all are functioning correctly.	<ol style="list-style-type: none"> <li>1. Press SELECT to execute the LED Test.</li> <li>2. Press CANCEL to stop the LED Test.</li> <li>3. Press RETURN to return to the Operator Panel menu.</li> </ol>
LCD Test	Displays the operator panel character set.	<ol style="list-style-type: none"> <li>1. Press SELECT to view the operator panel character set.</li> <li>2. Press NEXT or PREVIOUS to scroll through the characters.</li> <li>3. Press RETURN to return to the Operator Panel menu.</li> </ol>
Key Test	Displays indicators that verify if the operator panel buttons are functioning.	<ol style="list-style-type: none"> <li>1. Press SELECT to view the indicators.</li> <li>2. Press each button and verify that the indicator changes as the button is pressed.</li> <li>3. Press RETURN to return to the Operator Panel menu.</li> </ol>

## Test Print

The Operator Panel menu provides access to the diagnostic operator panel tests. Use the following procedure to enter this menu:

1. Enter Diagnostic Mode.
2. Navigate through the Test Print menu structure to move through the available tests.
  - Grid Page prints a grid page to assist in adjusting alignment.
  - Blank Page prints a blank page.
  - Black Page prints a black page.
  - Test Page prints a basic test page.

## Flash Summary

The Flash Summary menu prints Code and User Flash Summary. Use the following procedure to enter this menu:

1. Enter Diagnostic Mode.
2. Navigate through the Test Print menu structure to print Code and User Flash Summary

# Print Summary

The Print Summary menu prints Counter values from Maintenance Menu and Alignment Values from Alignment Menu. Use the following procedure to enter this menu:

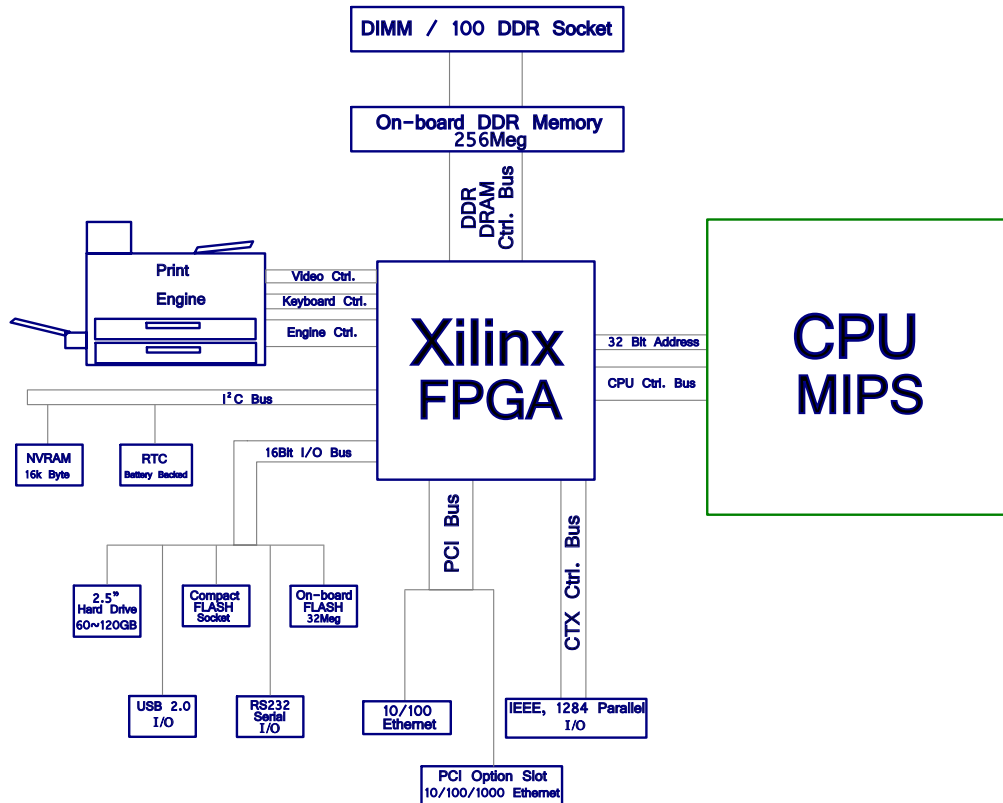
1. Enter Diagnostic Mode.
2. Navigate through the Test Print menu structure to print Counter values from Maintenance Menu and Alignment Values from Alignment Menu.





# Chapter 9 Controller/ESS

## 50PPM Controller Architecture

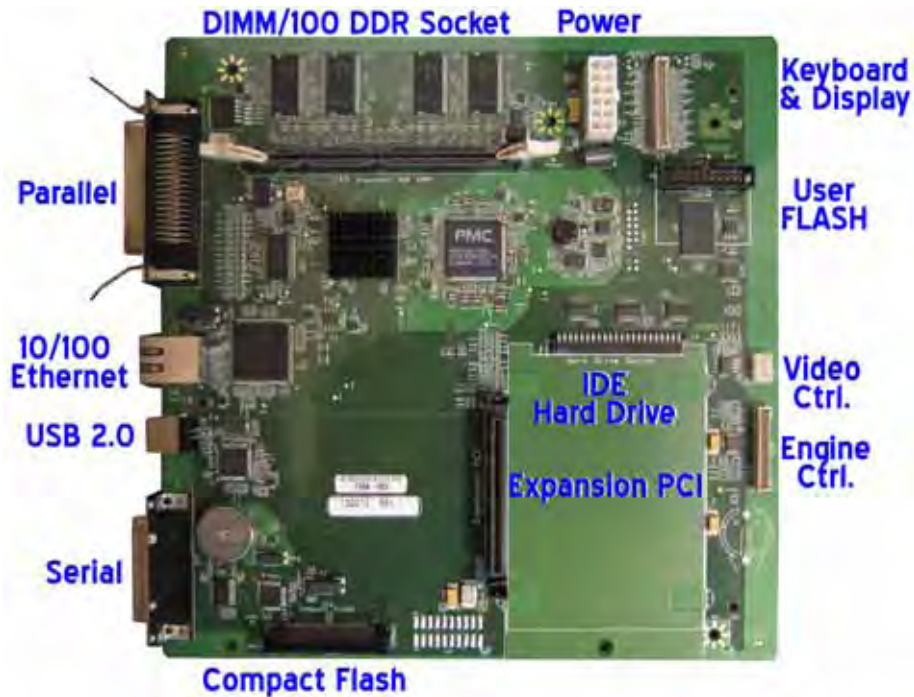


This Controller is based on the standard Intelliprint architecture, with a MIPS RM7035C / 600Mhz PMC Processor. The Field Programmable Gate Array chip, a Xilinx (XC3S1000) which implements various core devices and controllers required by the Intelliprint architecture, such as:

DDR Memory Controller, Dual Video Channels, PCI and 16 bit Bus Interfaces, IDE Interface, IEEE-1284 Interface, Programmable Engine Interface, and I2C Interface. USB, Ethernet, and Serial RS232 are stand alone controller chips peripheral to the Gate Array device.

This Controller has 256MBytes standard on-board memory, with a DIMM/100 DDR memory expansion slot for memory upgrade modules ranging from 128MB to 512MB. The Video Channels deliver a dual laser differential video output signal to the engine's ROS unit, while the Programmable Engine Interface provides control for Keyboard, LCD Display and engine status. The onboard NVRAM device stores data ranging from User configuration to Page counts, LAN settings and miscellaneous internal information. There is also a Real Time Clock (RTC) feature that gives the user the ability to provide date indexing and Job accounting. There are a number of data storage devices available to the user ranging from a 12MB User Flash partition in the onboard Flash module, to the optional Compact Flash Module and an optional 2.5" IDE Hard Drive. The Compact Flash is available in a broad range of sizes, however, Compact Micro Drives are Not supported. The IDE Hard Drive is the largest supported User Storage device option. Also supported, is a User Upgradeable I/O Option via the Expansion PCI slot.

# Actual Controller Layout (PN 101K54690)



## Connector Identification Chart

J1	Power Connector
J2	Keyboard & LCD Display
J3	Parallel
J5	USB 2.0
J6	10/100 Ethernet
J7	Video Control (Laser)
J8	Expansion PCI
J10	Engine Control
J11	Serial RS232
J12	Compact Flash
J45	DIMM/100 DDR Socket
JF1	Flash Expansion ( <i>Allows Service Technician to perform Firmware capture or Code upgrades</i> )

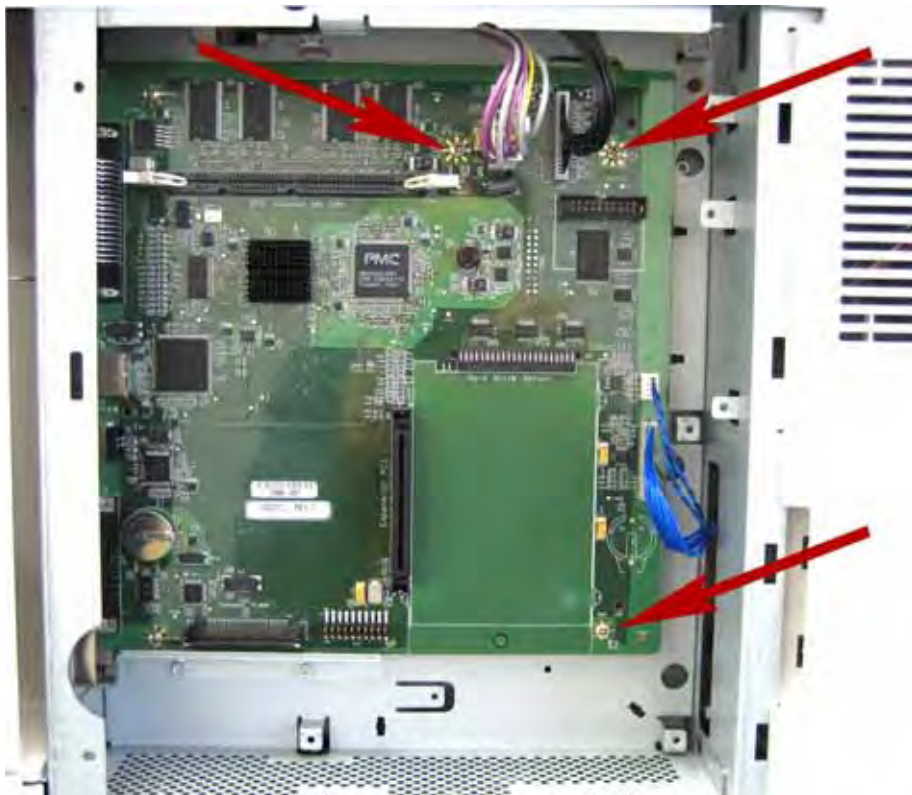
## Removal / Installation process

1. Turn off power to the unit and remove the power cord.

2. Remove 2 Thumbscrews to release Back Cover



3. Release four internal engine connector cables from the controller J1, J2, J7 & J10.
4. Remove three Phillips Pan Head Screws to release Controller from internal chassis mounts



5. Remove any external I/O Cables from the Controller

6. Remove the final two Phillips Screws from I/O Plate to release the controller & I/O Bracket Assembly from the Engine



## Typical reasons for Controller removal

- No LCD display No panel LED's

**NOTE** *Note: Deep Sleep Mode will interrupt +5V Power to the LCD, resulting in "No Display" this loss of +5V during Deep Sleep Mode will not disrupt power to the LED's. And should not be mistaken for a "Dead Controller"*

**NOTE** *Note: Deep Sleep Mode will also affect any peripheral devices connected to the Centronics Connection that requires +5V Power to be supplied to it via J3 pin 18.*

- Any Hard Fault Service Error reporting "Call Service" barring any issues with consumables.
- Obvious damage to the controller from misuse or abuse.
- Dysfunction of any I/O feature, from known good User I/O source.
- Engine not responding properly to Controller commands.
- Intermittent dysfunction relative to temperature differentials.

# Chapter 10 Parts Identification

- The Item Numbers in the illustrations have the corresponding Item Numbers in the list.
- The notation of PL "X.Y.Z" is composed of the plate (PL), item "X.Y", and parts "Z".
- The alphabet characters in the illustrations represent screws and clips as follows:  
"S": screw, "E": E-ring, "KL": KL clip, "C": C-ring, and "N": nut
- "▼" mark in the illustrations are attached to items indicating assembly parts in the illustrations.
- Encircled alphabetical figures in the illustrations indicate interrupted leader lines. Same characters in the illustrations represent lines to be connected.
- The mark "(with 2-5)" attached to assembly parts on the illustrations and lists represents that the items "2, 3, 4, and 5" of that plate are contained and the mark "(with 2-5, PL6.1.1)" represent that the item "2, 3, 4, and 5" of that plate and the item "1" of the plate "6.1" are contained.
- The mark "[Same PLX.Y.Z]" attached to parts in the illustrations and lists represents that the parts is the same as the parts of the item "Z" of the plate "X.Y".
- The mark "\*" attached to parts in the list represents "Note" or "Reference" about parts that are contained in the same page.
- "HIGH ASSY" in the list represent the high level assembly containing a specific part/s.
- PL numbers in this document correspond to the part numbers in the accompanying Excel Parts List spreadsheet.

**NOTE** For spare parts, refer to the "Spare parts list" which is issued separately.

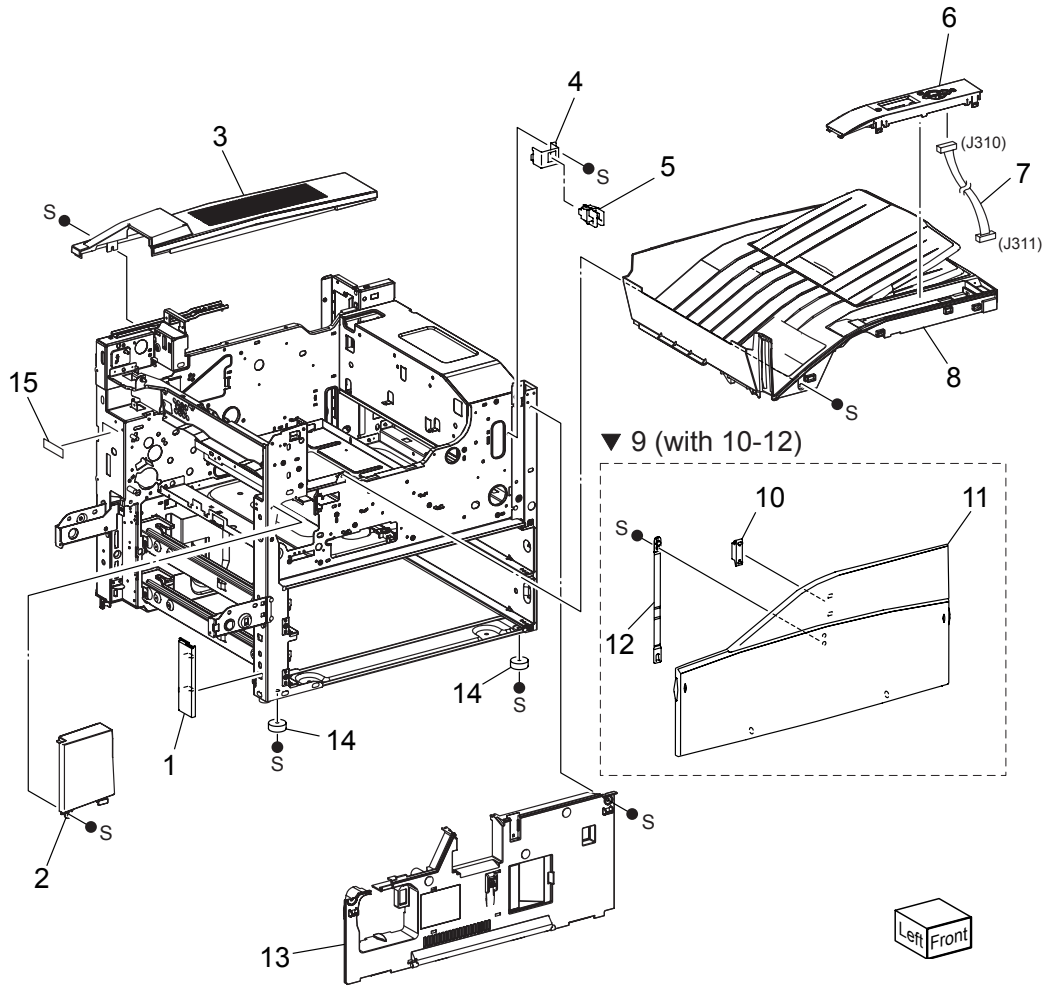
**NOTE** For the connector (P/J), parts such as harness, wire, etc. in the list, refer to "Chapter 7, Electric wiring"

**NOTE** It should be noted that configuration of parts may be different or some parts are not used depending on specifications of OEM.

# Engine

## 1 Covers

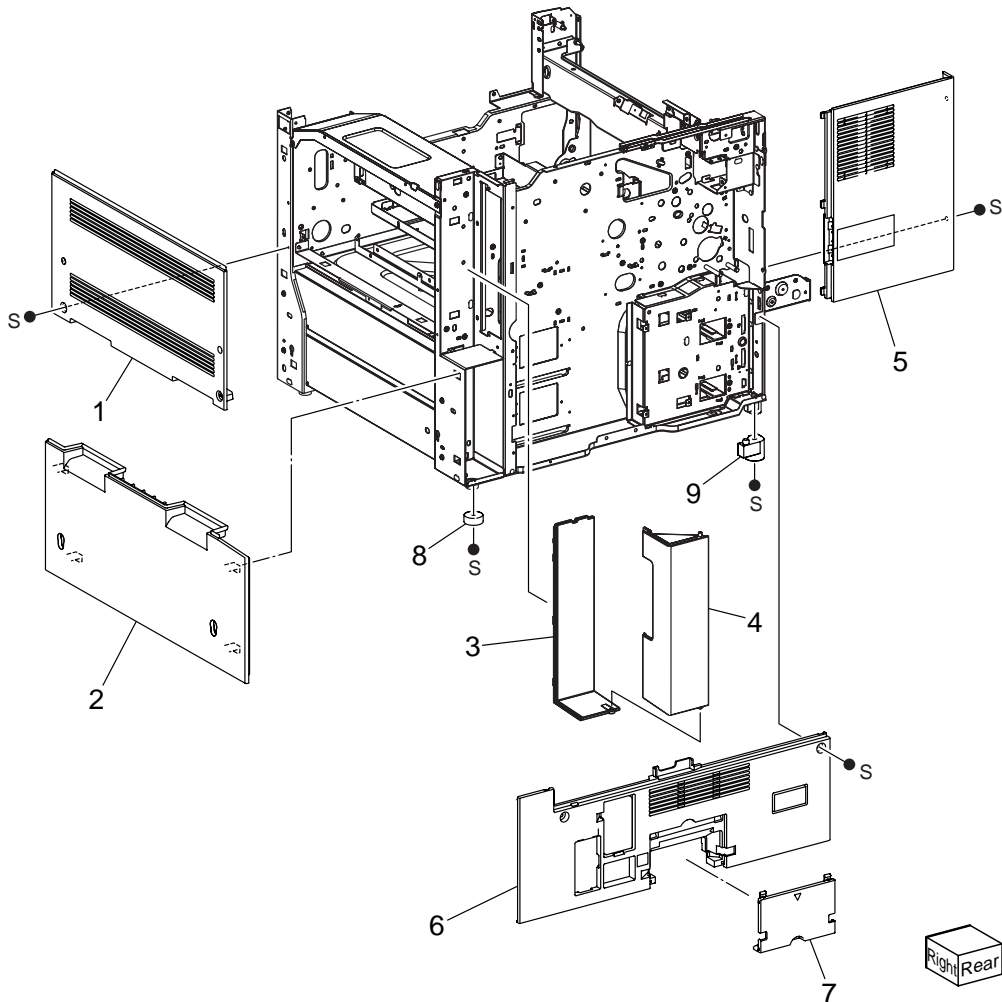
### PL 1.1 Covers (illustration 1 of 2)



## PL 1.1 Covers (1 of 2)

Item	Part Name	Remarks	Part Number
1	COVER LEFT FR.....		53090910
2	COVER-FSR FR,PR.....		53091072
3	COVER-TOP RR,PR		
4	BRACKET ILSW		
5	SWITCH		
6	CONSOLE PANEL .....		50134410
7	HARN ASSY CONPANEL		
8	COVER ASSY TOP PR		
9	COVER ASSY FRONT (with 10-12)		
10	MAGNET CATCH 24N.....		50813960
11	COVER-FRONT		
12	STRIP.....		53091051
13	COVER ASSY INNER,MN.....		53091170
14	FOOT FRONT.....		50813810
15	PLATE SER		

## PL 1.2 Covers (illustration 2 of 2)



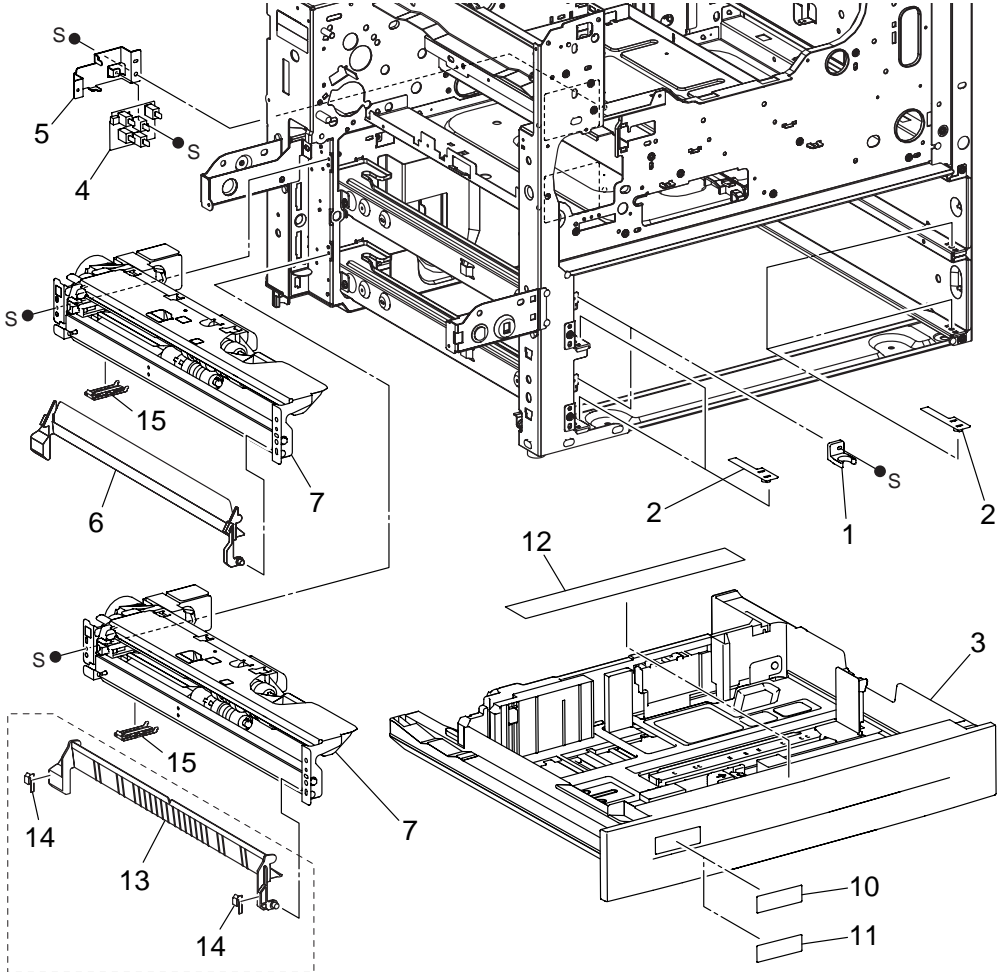
## PL 1.2 Covers (2 of 2)

Item	Part Name	Remarks	Part Number
1	COVER RIGHT UPR		
2	COVER RIGHT LOW		
3	COVER ESS RH.....		53091261
4	COVER-ESS CAP,PR.....		53091082
5	COVER REAR UPR		
6	COVER REAR LOW PR		
7	COVER-CAP MCU		
8	FOOT FRONT.....		50813810
9	FOOT REAR LEFT		
10	--		
11	--		

## 2 Tray & Feeder



**PL 2.1 Tray (1/2) & Feeder (1/2) illustrations**



▼ 9 (with 13,14)

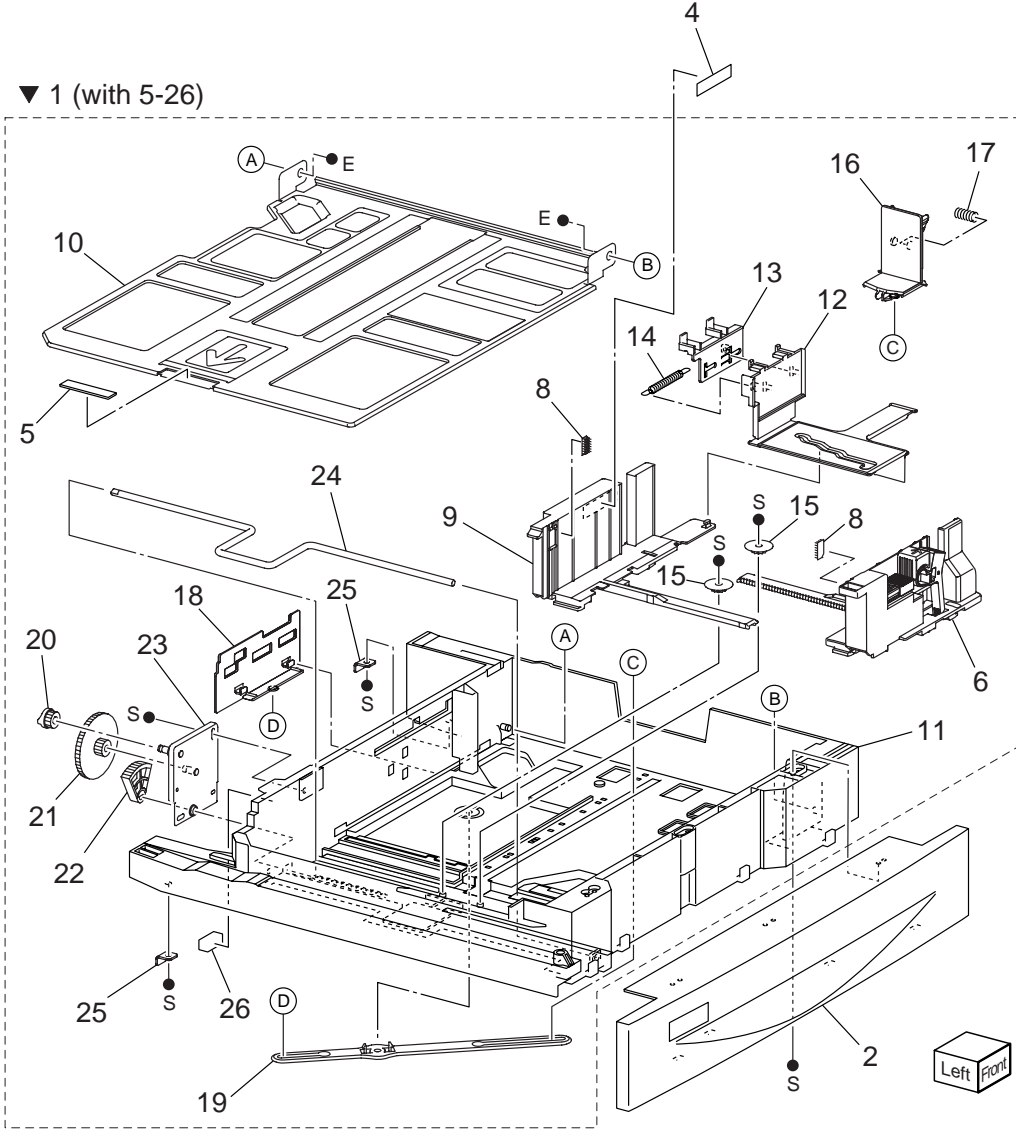
▼ 99 (with 3, 10, 11, 12, PL20.2.2, PL20.2.3)



## PL 2.1 Tray (1/2) & Feeder (1/2)

Item	Part Name	Remarks	Part Number
1	STOPPER-TRAY,FR		
2	SPACER TRAY G		
3	TRAY ASSY (PL2.2)		
4	SWITCH ASSY P S.....		56215801
5	BRACKET-SW		
6	CHUTE ASSY FEEDER.....		53359991
7	FEEDER ASSY (PL2.3.1).....		50238801
8	--		
9	CHUTE ASSY FEEDER 2 (with 13, 14)		
10	LABEL TRAY NO1		
11	LABEL TRAY NO2		
12	LABEL INST,M/N		
13	CHUTE FEED OUT		
14	PAD ASSY LH LOW		
15	COVER SENSOR		
98	KIT LABEL (Labels for trays 1, 2, 3 & 4).....		50236880
99	KIT TRAY (with 3, 10, 11, 12, PL20.2.2, PL20.2.3) .....		50238701

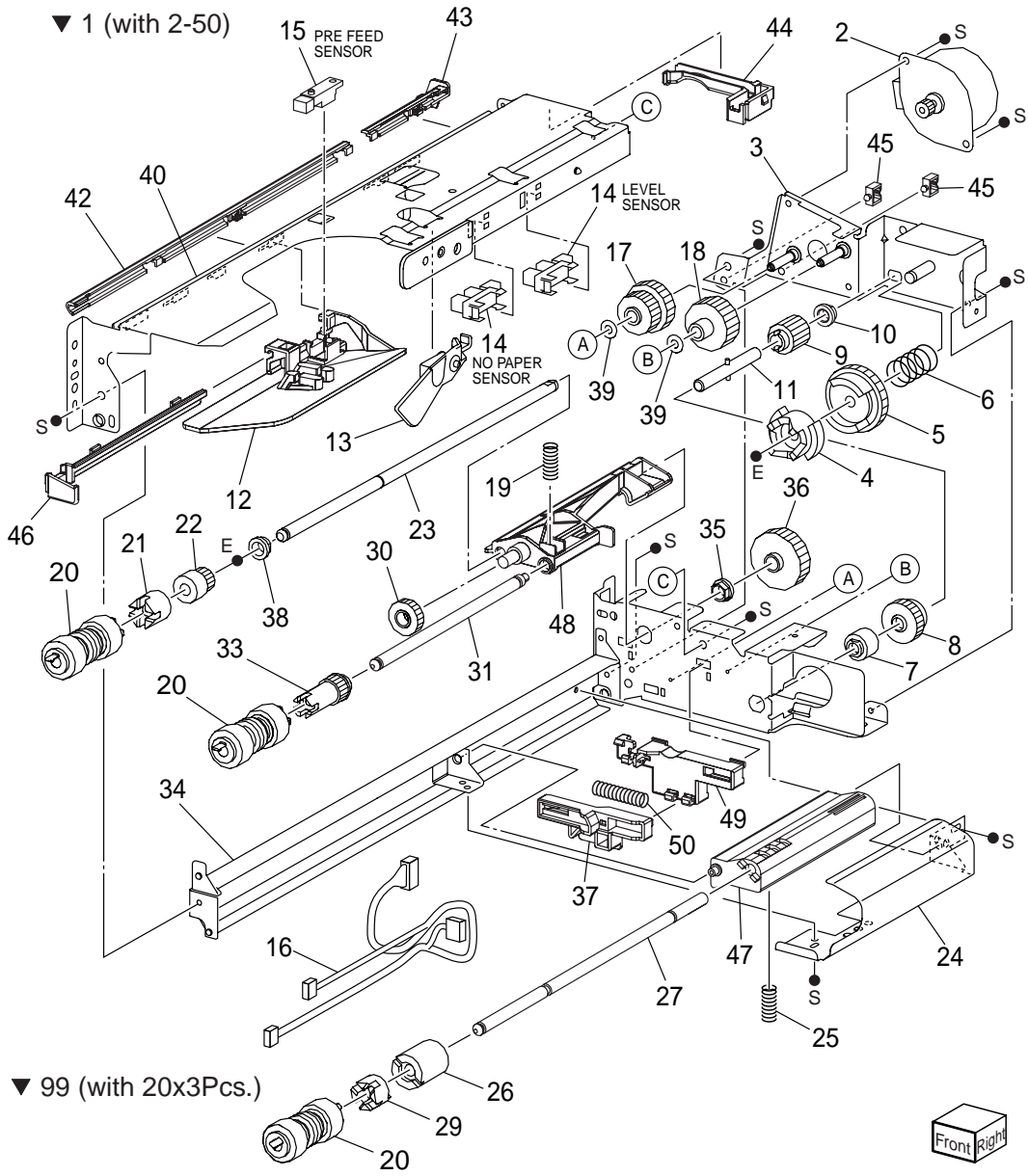
PL 2.2 Tray (2/2) illustration



## PL 2.2 Tray (2/2)

Item	Part Name	Remarks	Part Number
1	TRAY ASSEMBLY (with 5-26)		
2	TRAY COVER.....		53091320
3	--		
4	LABEL (MAX)		
5	BOTTOM PAD.....		50519351
6	FRONT SIDE GUIDE ASSY		
7	--		
8	TRAY PAD		
9	REAR SIDE GUIDE		
10	BOTTOM PLATE		
11	TRAY		
12	SIDE GUIDE ACTUATOR		
13	GUIDE ACTUATOR		
14	SPRING		
15	PINION GEAR		
16	END GUIDE		
17	SPRING		
18	END GUIDE ACTUATOR		
19	LINK		
20	COUPLING GEAR (13T)		
21	GEAR (13T/60T)		
22	SECTOR GEAR (60T)		
23	BRACKET		
24	IFT UP SHAFT		
25	STOPPER		
26	SEAL		

# PL 2.3 Feeder (2/2) illustration



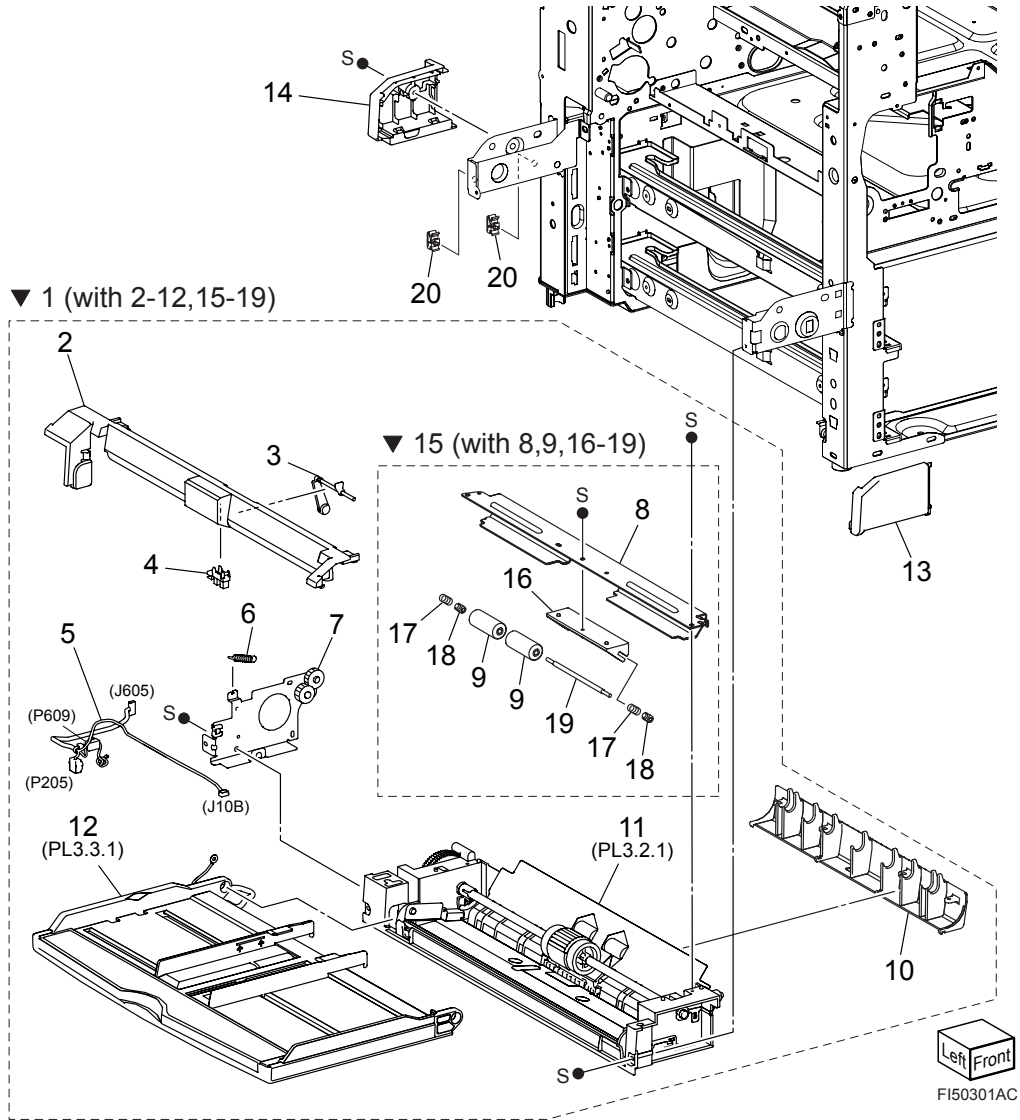
## PL 2.3 Feeder (2/2)

Item	Part Name	Remarks	Part Number
1	FEEDER ASSEMBLY (with 2-50)		50236880
2	TRAY 1/2 FEED LIFT UP MOTOR		56523471
3	BRACKET		
4	SPACE		
5	GEAR (31T)		
6	SPRING		
7	ONEWAY CLUTCH		
8	ONEWAY GEAR		
9	GEAR (13T)		
10	BEARING		
11	SHAFT		
12	FRONT CHUTE		
13	ACTUATOR		53360781
14	SENSOR		50422213
15	SENSOR		50422311
16	WIRE HARNESS	J101, J102, J103, J220, J661	
17	GEAR (28T/21T)		
18	GEAR (29T)		51256301
19	SPRING		
20	ROLLER ASSY	Periodical replacement parts (per 300k print)	See # 99
21	ONEWAY CLUTCH		51402590
22	ONEWAY GEAR (22T)		
23	SHAFT		
24	CHUTE		
25	SPRING		
26	FRICTION CLUTCH		51402610
27	SHAFT-RETARD		
28	--		
29	SPACER		
30	GEAR (33T)		
31	SHAFT-NUDGER		
32	--		
33	GEAR (25T)		
34	LOWER FRAME		
35	BEARING		
36	GEAR (27T)		
37	LEVER		
38	BEARING		
39	WASHER		
40	UPPER FRAME		
41	--		
42	HOLDER HARNESS CTR		
43	HOLDER HARNESS REAR		
44	HOLDER HARNESS UPPER		

45	HOLDER HARNESS PS1	ALT
	CLAMP MINI-SADDLE	ALT
46	RAIL	
47	SUPPORT RETARD	
48	SUPPORT NUDGER	
49	HOLDER	
50	SPRING	
99	KIT ROLLS (with 20x3Pcs.) Periodical replacement parts (per 300k print).....53361030	

### 3 MPF Assembly

PL 3.1 MPF Assembly illustration



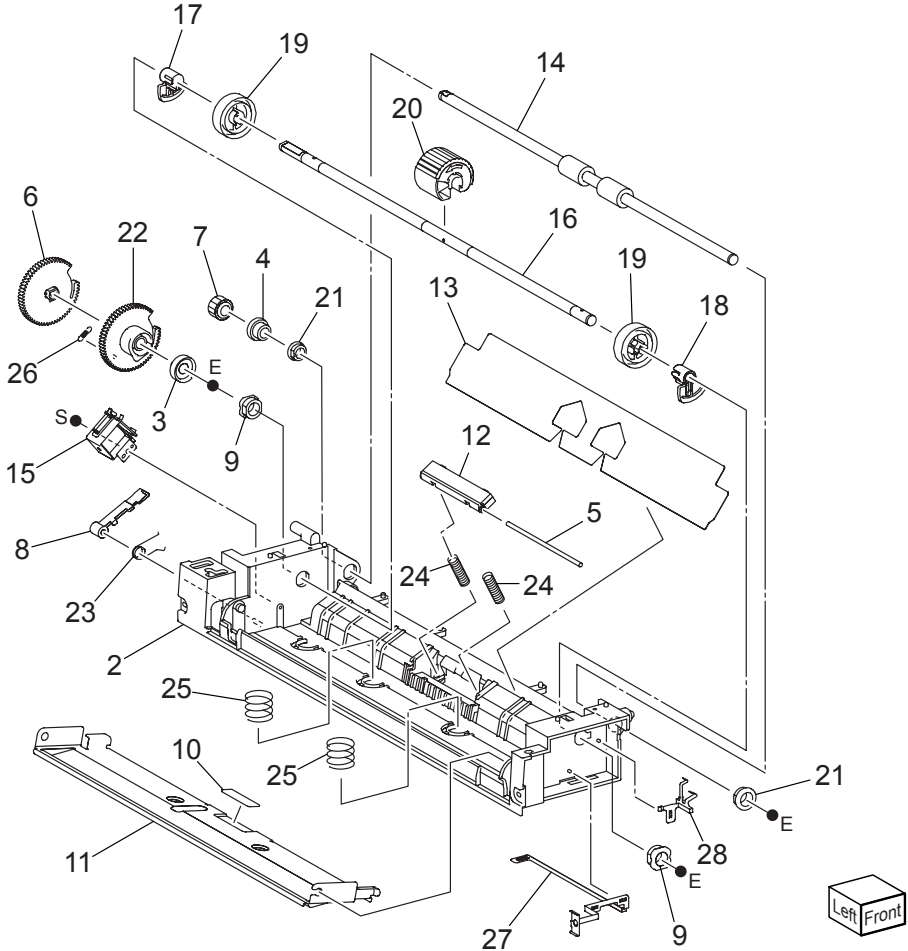
## PL 3.1 MPF Assembly

Item	Part Name	Remarks	Part Number
1	FEEDER ASSY MPF (with 2-12, 15-19)		
2	FRAME UPPER		
3	ACTUATOR.....		53360831
4	SENSOR-PHOTO IN.....		50422213
5	HARNESS ASSY MPF	J10B, J605, P205, P609	
6	SPRING MPF		
7	BRKT ASSY-GEAR		
8	CHUTE PINCH		
9	ROLL ASSY-PINCH		
10	CHUTE LOW		
11	FRAME ASSY LOWER (PL3.2.1).....		53361164
12	TRAY ASSY-MPF (PL3.3.1)		
13	COVER-MPF FR		
14	COVER-MPF RR		
15	CHUTE ASSY PINCH		
16	GUIDE PINCH		
17	SPRING PINCH		
18	SPACER SPRING PINCH		
19	SHAFT PINCH		
20	WIRE SADDLE		



**PL 3.2 MPF Lower Frame Assembly illustration**

▼ 1 (with 2-28)

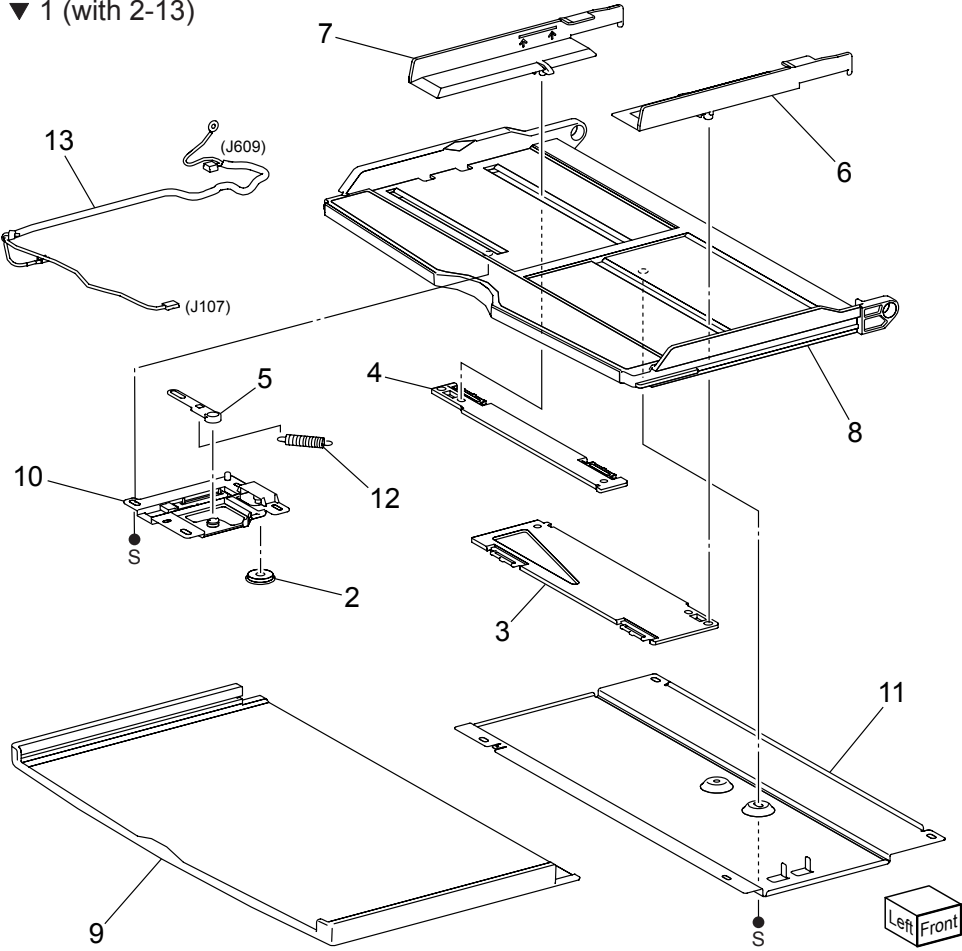


## PL 3.2 MPF Lower Frame Assembly

Item	Part Name	Remarks	Part Number
1	FRAME ASSY LOWER (with 2-28).....		53361164
2	FRAME LOWER MPF		
3	STOPPER LEVER		
4	COLLAR		
5	SHAFT-RETARD		
6	GEAR PICK UP		
7	GEAR 18T.....		51256570
8	LEVER-GEAR		
9	BEARING 8		
10	PAD BOTTOM.....		50519351
11	PLATE BOTTOM		
12	PAD ASSY RETARD.....		50519420
13	GUIDE PAPER MPF.....		51032561
14	ROLL ASSY-DRIVE		
15	SOLENOID PICK UP		
16	SHAFT ASSY-PICK UP		
17	CAM PICK UP 2		
18	CAM PICK UP FRONT		
19	ROLL CORE		
20	ROLLER ASSY-FEED.....		50422454
21	BEARING SLEEVE		
22	GEAR CAM		
23	SPRING LEVER GE		
24	SPRING PAD.....		50937550
25	SPRING N F		
26	SPRING-GEAR CAM		
27	PLATE EARTH BOTTOM		
28	PLATE EARTH FRONT		

# PL 3.3 MPF Tray Assembly illustration

▼ 1 (with 2-13)

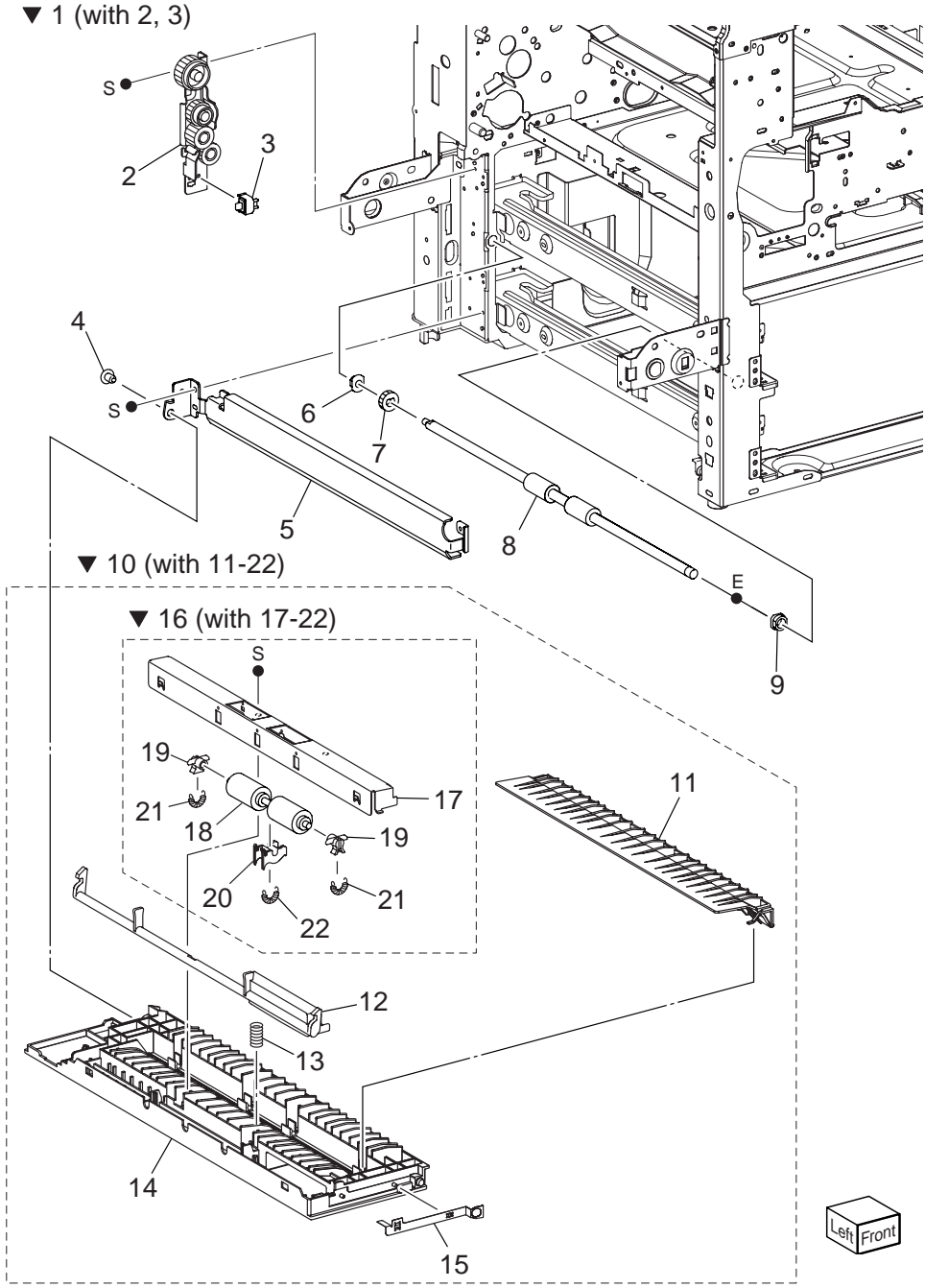


### PL 3.3 MPF Tray Assembly

Item	Part Name	Remarks
1	TRAY ASSY-MPF (with 2-13)	
2	GEAR-PINION	
3	RACK-FRONT	
4	RACK-REAR	
5	LINK-SENSOR	
6	GUIDE-SIDE FRONT	
7	GUIDE-SIDE REAR	
8	TRAY MPF	
9	TRAY EXT	
10	SENSOR ASSY-MPF	
11	COVER TRAY	
12	SPRING-SENSOR	
13	HARNESS ASSY SIZE	J107, J609

#### 4 L/H Lower

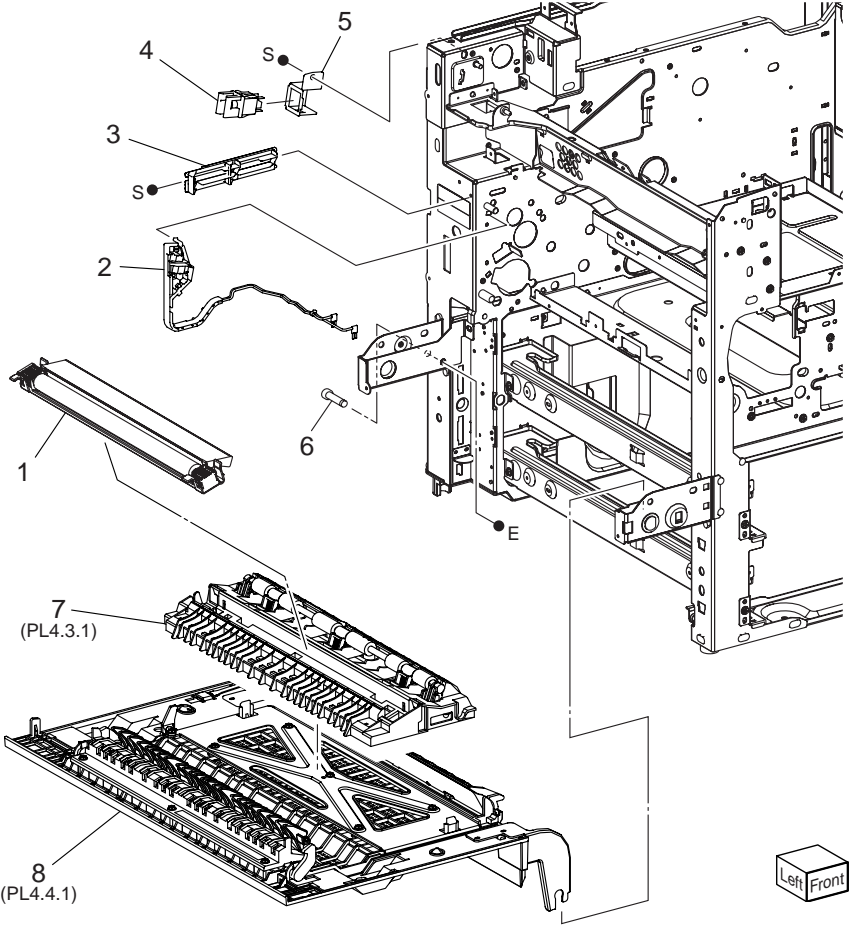
**PL 4.1 L/H Lower illustration**



## PL 4.1 L/H Lower

Item	Part Name	Remarks	Part Number
1	BRKT ASSY TA (with 2, 3).....		51713710
2	BRACKET ASSY IDLER		
3	SWITCH-I/L,CAB.....		56215980
4	RIVET		
5	CHUTE-LOWER		
6	BEARING TA		
7	GEAR-18T.....		51256570
8	ROLLER ASSY-TA		
9	BEARING SLEEVE.....		51613359
10	COVER ASSY LH LOW C (with 11-22).....		53091484
11	CHUTE LH LOW C		
12	HANDLE LH LOW		
13	SPRING-COMP LH LOW.....		50937660
14	COVER LH LOW C		
15	PLATE-EARTH		
16	BRKT ASSY LH LOW C (with 17-22)		
17	BRKT LH LOW		
18	ROLLER-TA PINCH		
19	BEARING-OUT		
20	BEARING-IN		
21	SPRING LH LOW		
22	SPRING		

**PL 4.2 L/H Upper illustration**

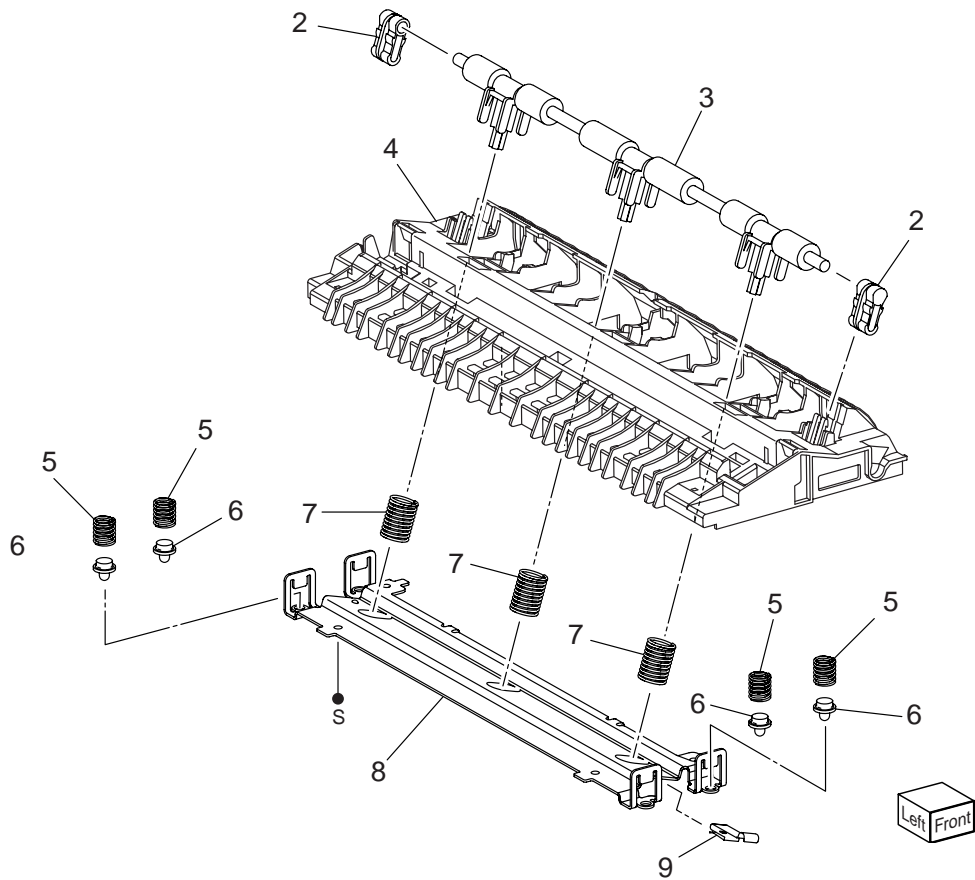


## PL 4.2 L/H Upper

Item	Part Name	Remarks	Part Number
1	HSG ASSY-BTR	Periodical Replacement parts (per 300k print).....	50237095
2	COVER ASSY-CONTACT.....		53091540
3	LINK ASSY-SHUTTER.....		56216241
4	SWITCH		
5	BRACKET ILSW		
6	STUD		
7	CHUTE ASSY LH (PL4.3.1).....		53359955
8	COVER ASSY-LH (PL4.4.1).....		53091622

### PL 4.3 L/H Chute Assembly illustration

▼ 1 (with 2-9)

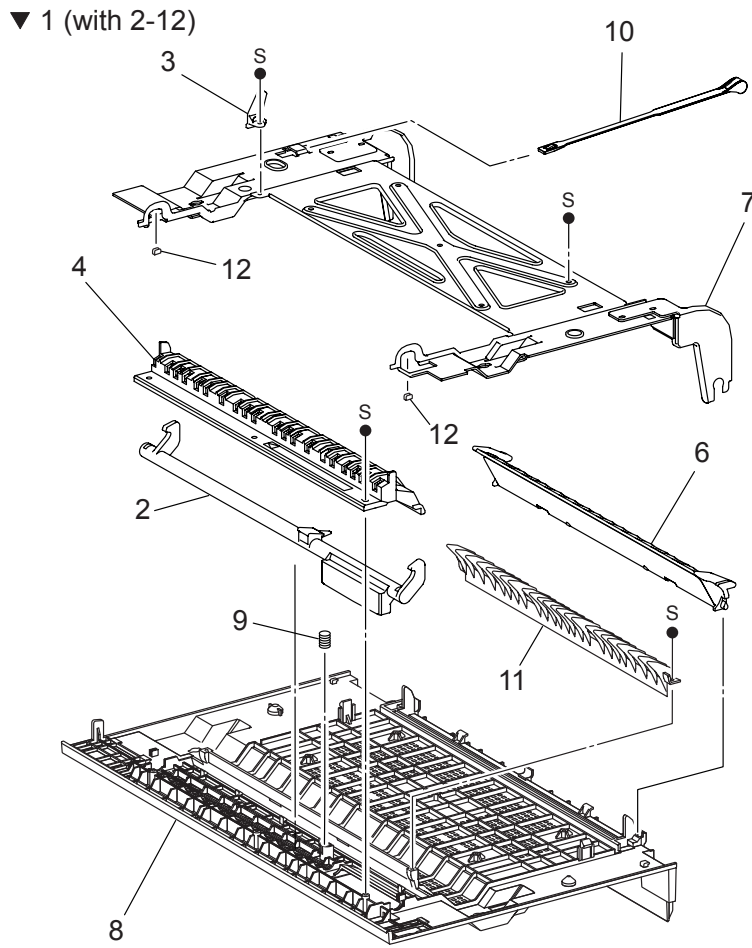




## PL 4.3 L/H Chute Assembly

Item	Part Name	Remarks	Part Number
1	CHUTE ASSY LH (with 2-9).....		53359955
2	BEARING-PINCH OUT		
3	ROLLER ASSY-REGI-P.....		50422531
4	CHUTE-ASSY		
5	SPRING COMP FL		
6	GUIDE		
7	SPRING COMP PINCH		
8	PLATE-TIE		
9	PLATE-EARTH		

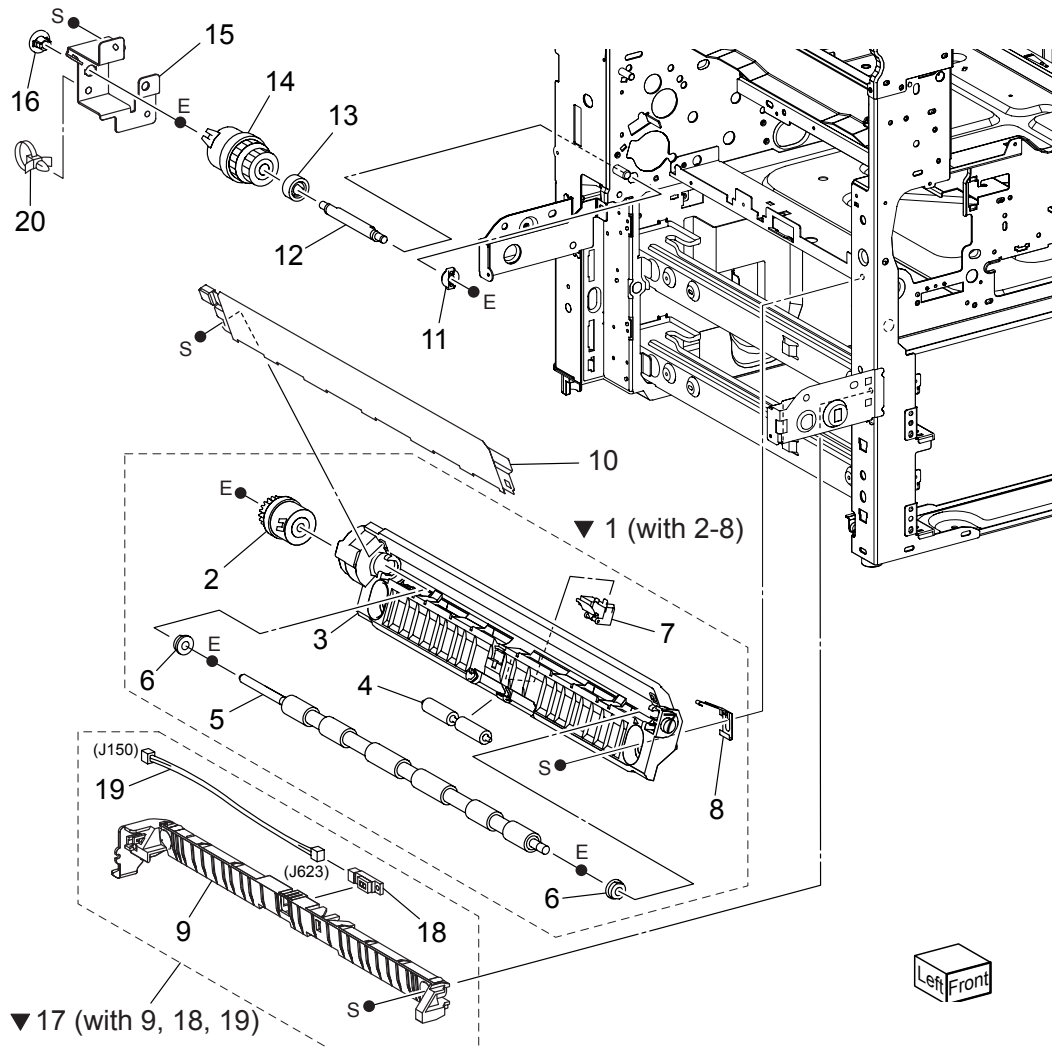
## PL 4.4 L/H Cover Assembly illustration



## PL 4.4 L/H Cover Assembly

Item	Part Name	Remarks	Part Number
1	COVER ASSY-LH (with 2-12).....		53091622
2	HANDLE-LH.....		51903233
3	ROD CRU SHUTTER		
4	CHUTE LHCOV.....		53360050
5	--		
6	CHUTE ASSY-DUP.....		53359960
7	FRAME ASSY LH.....		53091622
8	COVER LH		
9	SPRING COMP LH.....		50937660
10	SUPPORT-LHCOVER		
11	CHUTE-EXIT		
12	GUIDE HANDLE LH		

## PL 4.5 Registration illustration

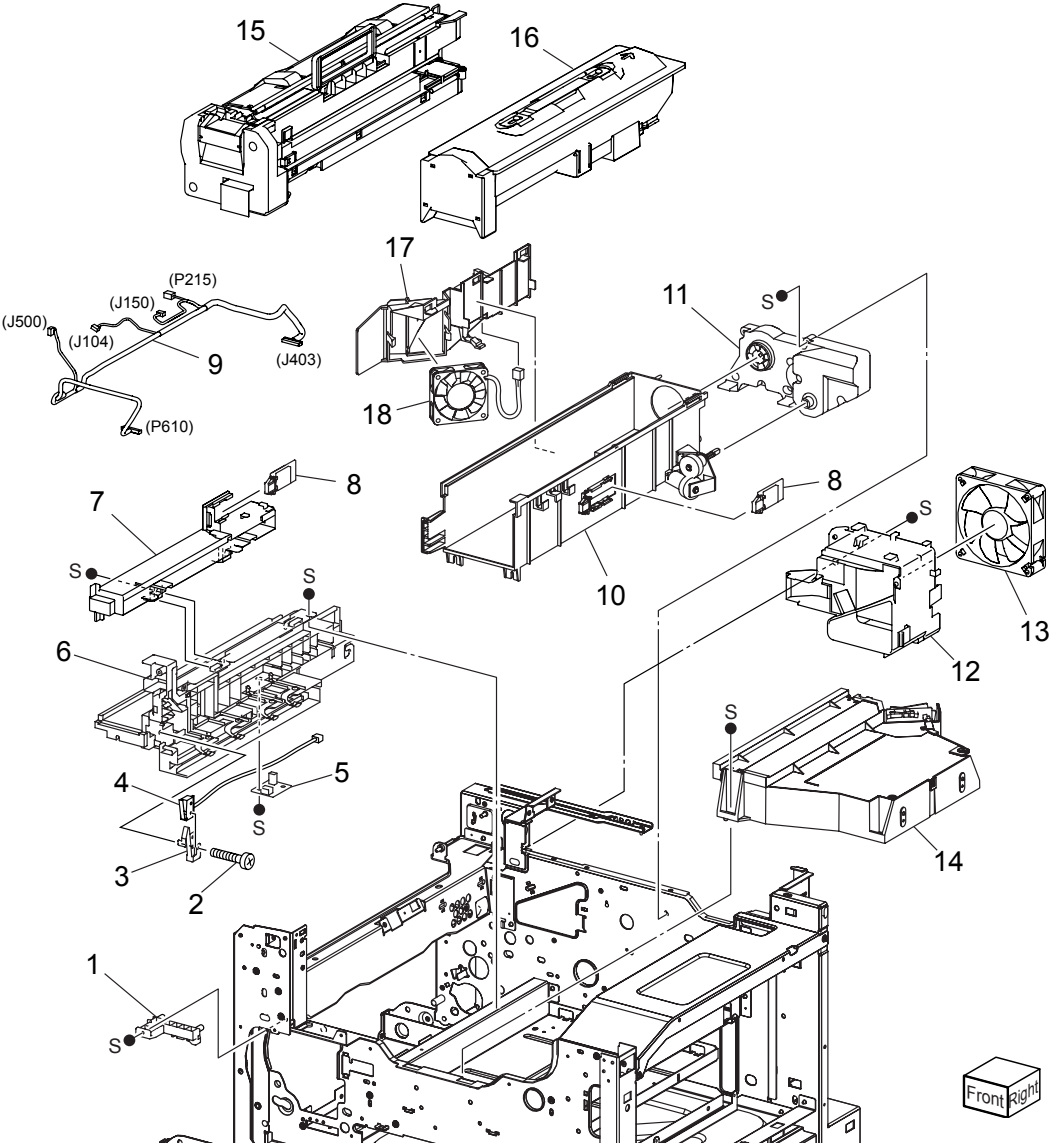


## PL 4.5 Registration

Item	Part Number	Remarks	Part Number
1	TRNS ASSY REGI (with 2-8).....		50237160
2	CLUTCH ASSY REGI H		
3	CHUTE-REGI		
4	ROLLER REGI IDLER		
5	ROLLER ASSY REGI		
6	BEARING REGI E		
7	SNR ASSY REGI		
8	PLATE-EARTH FG		
9	CHUTE-TA		
10	CHUTE ASSY-R.....		53360140
11	BEARING		
12	SHAFT TA		
13	GEAR-19T.....		51256420
14	CLUTCH ASSY-TA.....		51402730
15	BRACKET TA		
16	BEARING		
17	CHUTE-TA ASSY (with 9, 18, 19).....		53359980
18	SENSOR.....		50422311
19	HARNES	J150, J623	
20	PUSH TIE		

## 5 ROS, CRU & Toner Dispense

**PL 5.1 ROS, CRU & Toner Dispense illustrations**

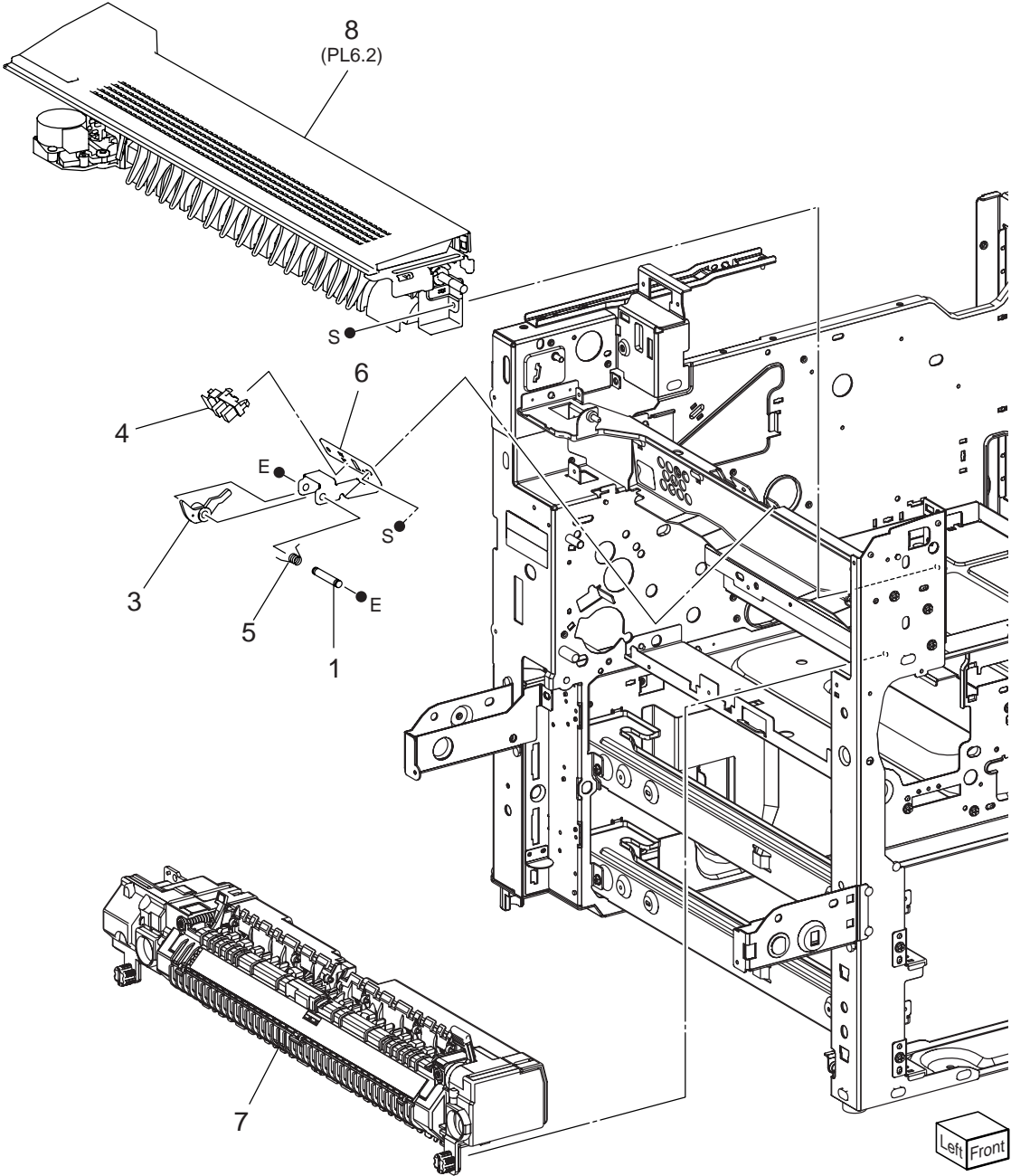


## PL 5.1 ROS, CRU & Toner Dispense

Item	Part Name	Remarks	Part Number
1	BLOCK STOPPER CRU.....		53361333
2	SCREW		
3	PLATE-SW-IN TLK .....		53361230
4	SWITCH ASSY XERO INTLK.....		56215010
5	SENSOR HUM & TE.....		50422680
6	GUIDE ASSY SUB.....		51032610
7	HSG ASSY LASER C.....		50237290
8	PWBA CRUM CP1.....		50237331
9	HARN ASSY FRONT A	J104, J150, J403, J500, P215, P610	
10	GUIDE ASSY CTG30 SUB		
11	MOTOR ASSY-DISP 30K		
12	DUCT FUSER		
13	FAN FUSER		
14	ROS ASSY-12.....		50237415
15	CRU		
16	TONER CARTRIDGE		
17	DUCT INTAKE		
18	CRU FAN		

## 6 Fuser & Exit 1 Unit

**PL 6.1 Fuser & Exit 1 Unit illustrations**

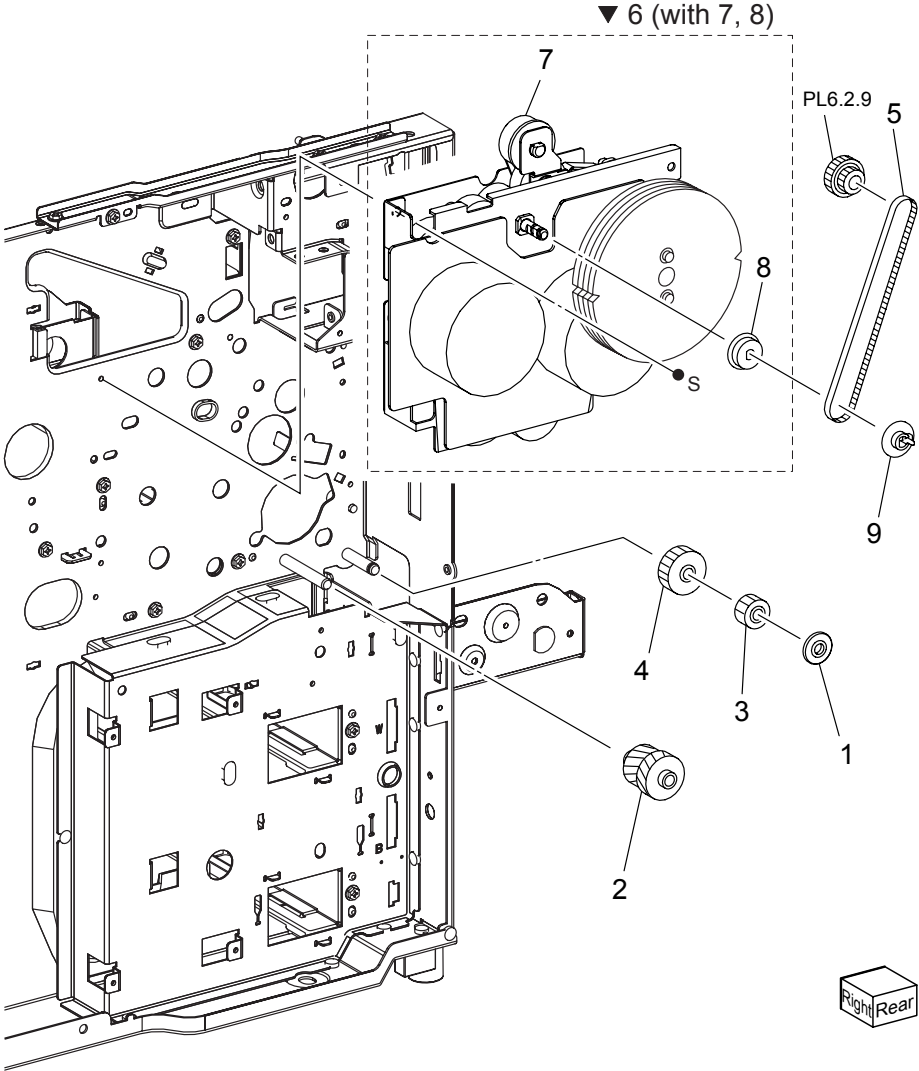








PL 7.1 Drive illustration

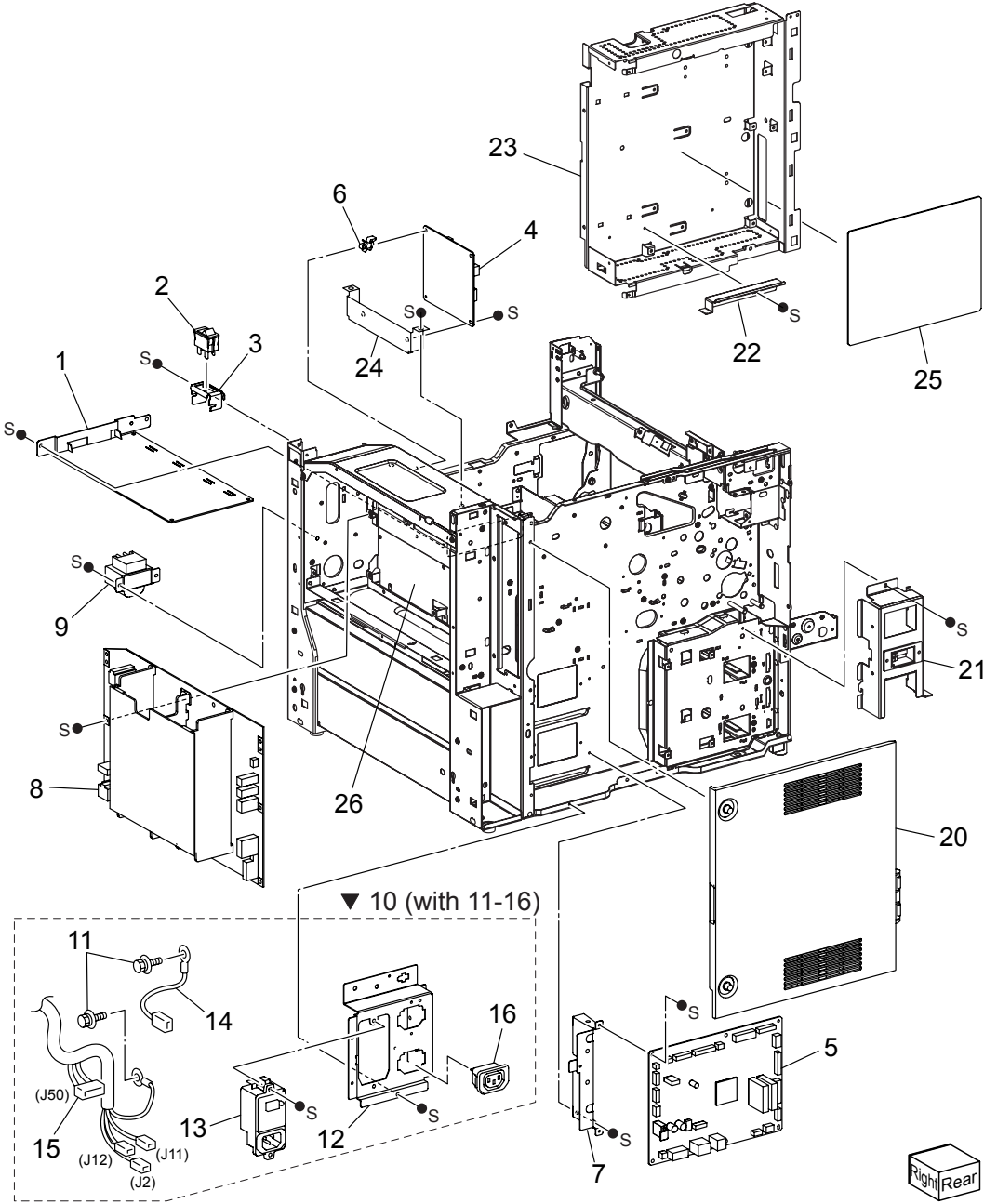


## PL 7.1 Drive

Item	Part Name	Part Number
1	COLLAR	
2	GEAR 21/21T MPF.....	51256560
3	GEAR 18T MPF	
4	GEAR 28T TA.....	51256580
5	BELT-SYNCHRONOUS BAN	
6	DRIVE ASSY 242 (with 7, 8)	
7	MOTOR ASSY 242	
8	PULLEY 25T	
9	FLANGE EXIT	
99	KIT: GEAR DRIVE (with 1, 2, 3 & 4).....	51256670

## 8 Electrical

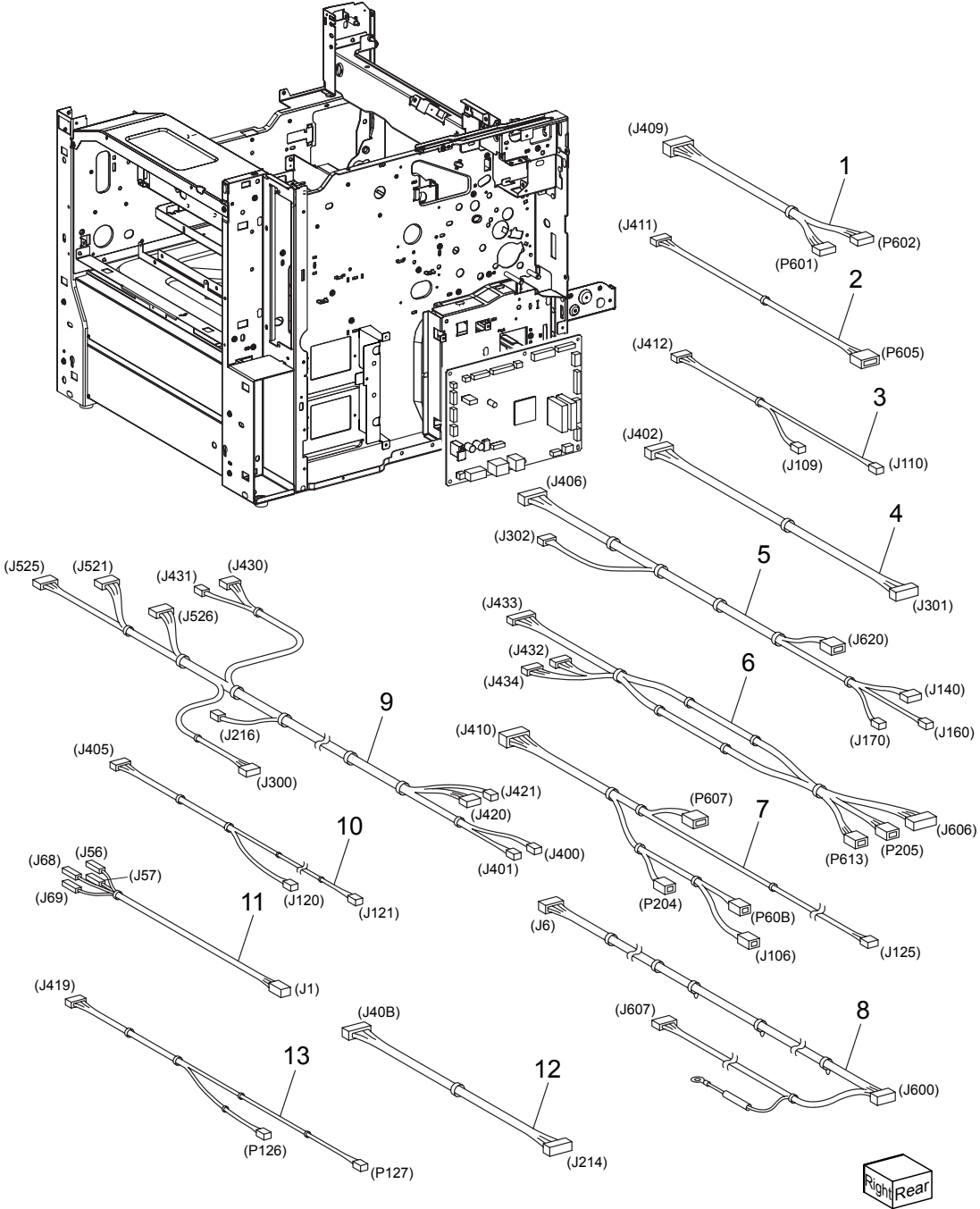
**PL 8.1 Electrical (1/2) illustration**



## PL 8.1 Electrical (1/2)

Item	Part Name	Remarks	Part Number
1	PSHV-Y2		
2	SWITCH-POWER		
3	BRACKET-SW CPR		
4	PWBA EXIT		
5	PWBA MCU F – New - .....		55107501
5	PWBA MCU F – Refurb - .....		55107551
6	PWB SUPP EDGE		
7	BRACKET MCU		
8	POWER UNIT-C1 (100/127).....		56420891
	POWER UNIT C1H (200/240).....		56420901
9	CHOKE COIL (220/240)		
10	CHAS ASSY AC XC (with 11-16)		
11	SCREW		
12	BRACKET-CONN AC		
13	BREAKER GFI INL		
14	HARNESS ASSY F/G,E		
15	HARN ASSY AC US EU	J2, J11, J12, J50	
16	OUTLET MN		
17	--		
18	--		
19	--		
20	COVER ASSY ESS		
21	PANEL ASSY CONN HCF		
22	BRKT GUIDE PRX		
23	CHASSIS ASSY ESS PRX		
24	BRKT-EXIT LOW		
25	PWBA ESS.....		55954090
25	PWBA ESS MPS930b Only – New Board .....		55119501
25	PWBA ESS MPS930b Only – Refurb Board .....		55119551
26	PLATE ASSY LVPS		

# PL 8.2 Electrical (2/2) illustration



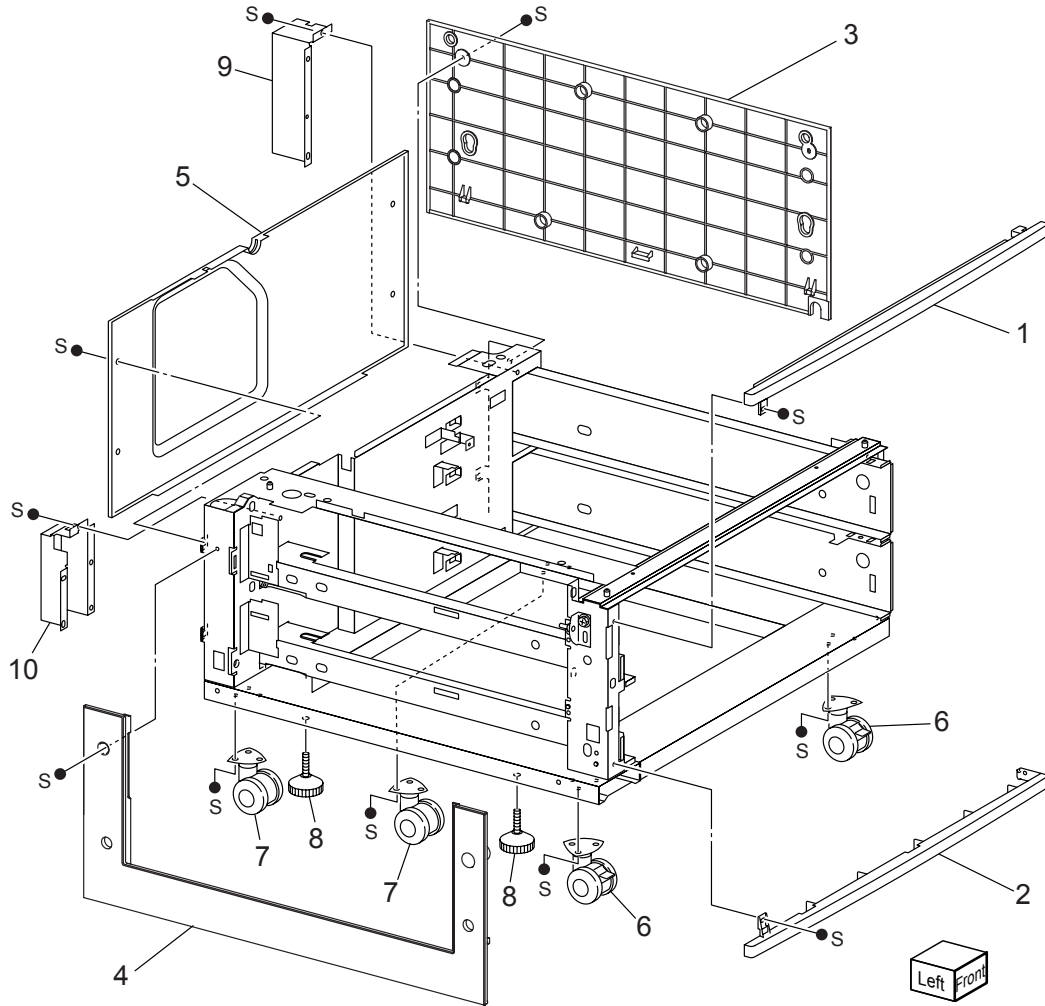
## PL 8.2 Electrical (2/2)

Item	Part Name	Remarks	Part Number
1	HARN ASSY FEEDER C	J409, P601, P602.....	56745140
2	HARN ASSY MPF A	J411, P605	
3	HARN ASSY SIZE A	J412, J109, J110	
4	HARN ASSY ESS C	J402, J301.....	56745291
5	HARN ASSY ROS C	J406, J302, J140, J160, J170, J620.....	56745131
6	HARN ASSY EXIT C	J432, J433, J434, J606, P205, P613.....	56745192
7	HARN ASSY PH C	J410, J106, J125, P60B, P607, P204.....	56745231
8	HARN ASSY FUSER AC C	J6, J600, J607	
9	HARN ASSY LV PWR C	J400, J401, J420, J421, J216, J300, J430, J431, J521, J525, J526	
10	HARN ASSY INTLK A	J120, J121, J405	
11	HARN ASSY MAIN SW C	J1, J56, J57, J68, J69	
12	HARN ASSY DRIVE A	J40B, J214.....	56745090
13	WIRE HARNESS CRUM B	J419, P126, P127.....	56745120

# 1000 Sheet Feeder

## PL 9 Covers

### PL 9.1 Covers illustration

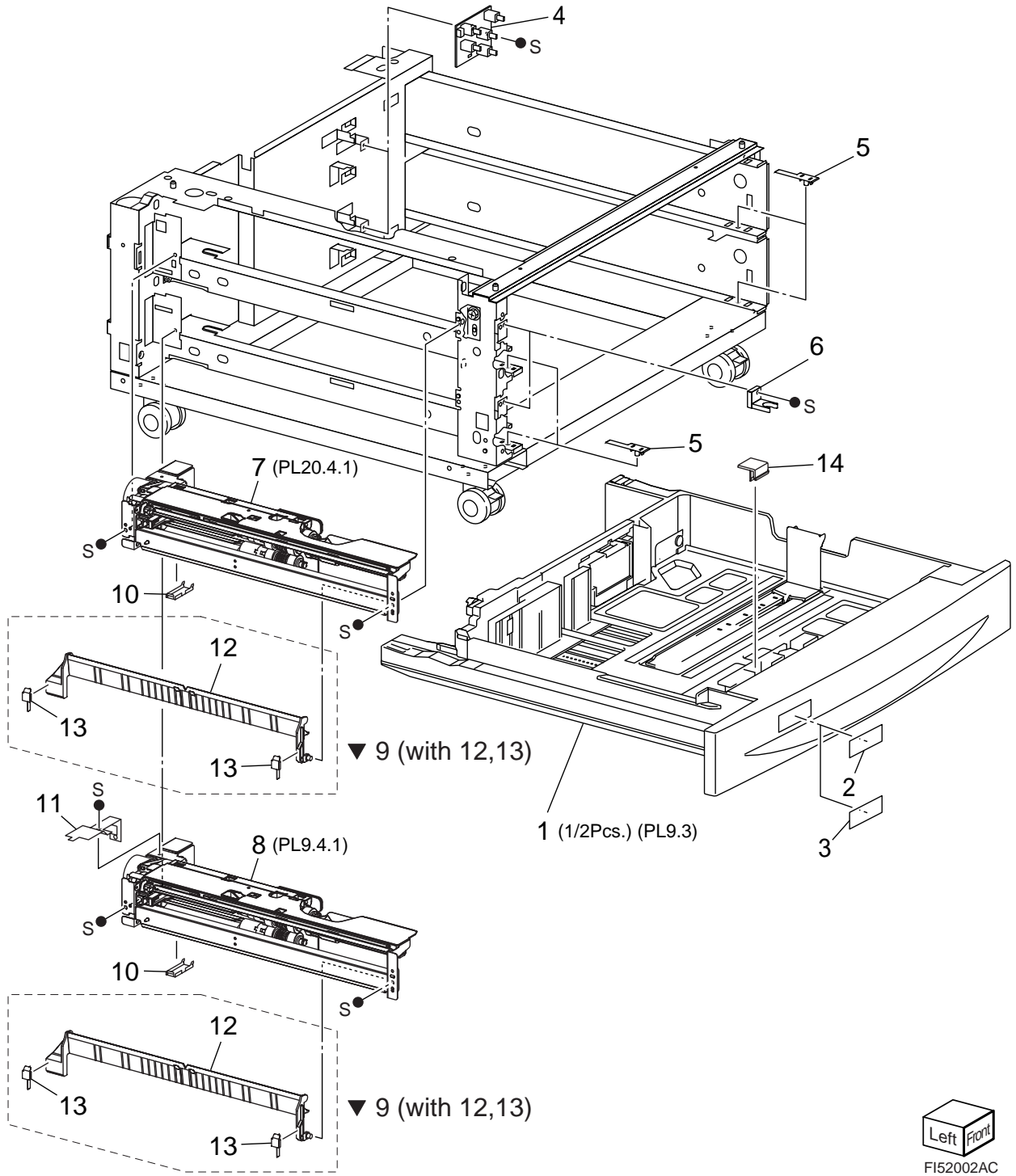


## PL 9.1 Cover

Item	Parts name	Remark	Part Number
1	TOP COVER		
2	FOOT COVER		
3	RIGHT COVER		
4	LEFT COVER		
5	REAR COVER		
6	CASTER (STOPPER)		
7	CASTER.....		50610321
8	FOOT ADJUSTER.....		50813791
9	BRACKET REAR RH 2T.....		51713510
10	BRACKET REAR LH 2T.....		51713500
	KIT: GEAR 2T SP.....		50242305
	CLUTCH.....		51402701
	PCB: TRAY MODULE PWB.....		55954101
	MOTOR: MAIN.....		56523501



PL 9.2 Tray (1/2) & Feeder (1/2)



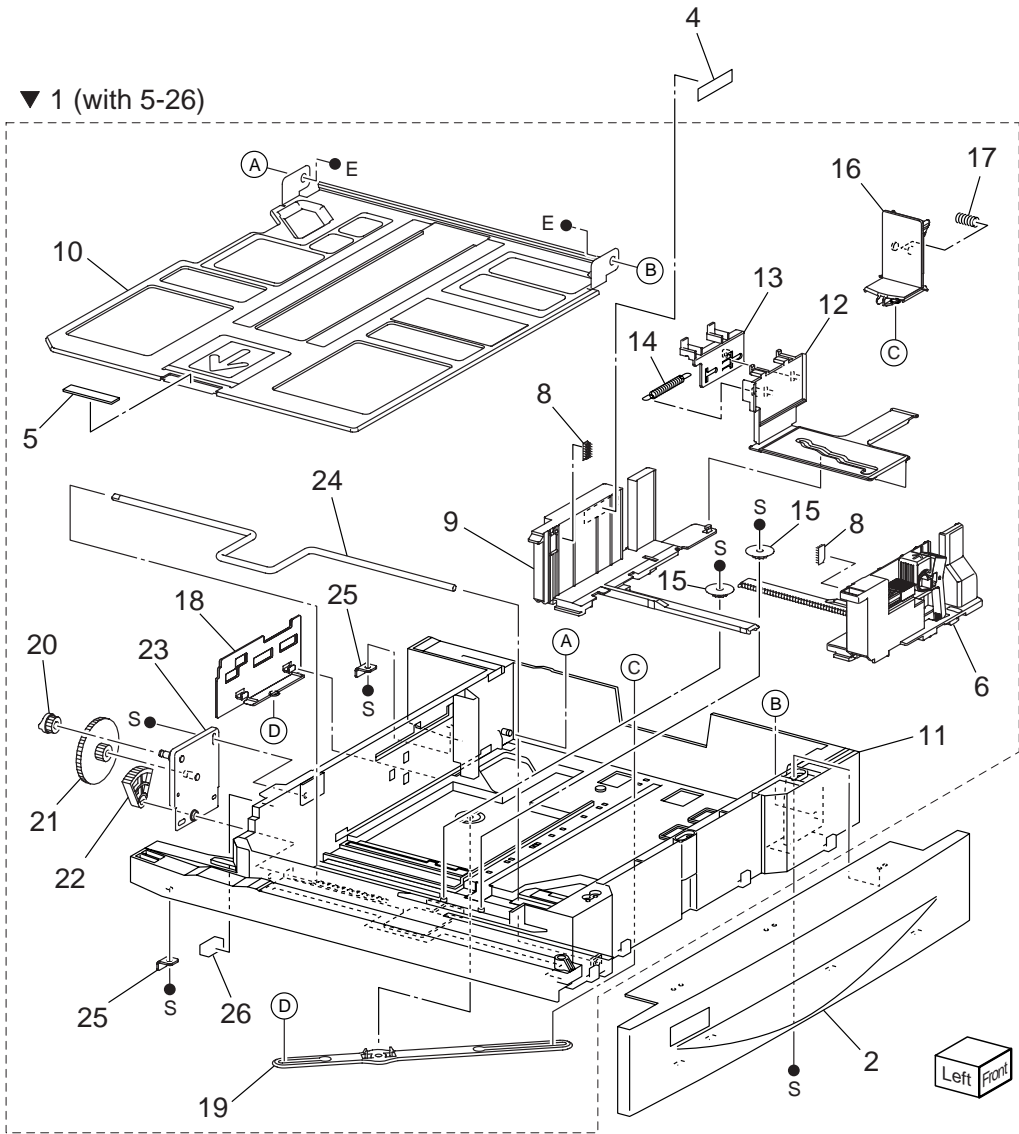
▼ 99 (with 2, 3, PL2.1.3, PL2.1.10, PL2.1.11, PL2.1.12)



## PL 9.2 Tray (1/2) & Feeder (1/2)

Item	Part Name	Remarks	Part Number
1	TRAY 3/4 ASSEMBLY (PL20.3)		
2	LABEL (No.3)		
3	LABEL (No.4)		
4	TRAY 3/4 PAPER SIZE SWITCH		
5	TRAY SPACER		
6	TRAY STOPPER		
7	TRAY 3 FEEDER (PL20.4.1)		
8	TRAY 4 FEEDER (PL20.4.1)		
9	CHUTE ASSY FEEDER 2 (with 12, 13).....		53360220
10	COVER SENSOR		
11	COVER FDR		
12	CHUTE FEED OUT		
13	PAD ASSY LH LOW (Use Kit 10.2.09).....		53360220
14	BLOCK SLIDE LOCK		
99	KIT TRAY (with 2, 3, PL2.1.3, PL2.1.10, PL2.1.11, PL2.1.12)		

PL 9.3 Tray (2/2) illustration



## PL 9.3 Tray (2/2)

Item	Part Number	Part Number
1	TRAY ASSEMBLY (with 5-26)	
2	TRAY COVER.....	53091320
3	--	
4	LABEL (MAX)	
5	BOTTOM PAD.....	50519351
6	FRONT SIDE GUIDE ASSY	
7	--	
8	TRAY PAD	
9	REAR SIDE GUIDE	
10	BOTTOM PLATE	
11	TRAY	
12	SIDE GUIDE ACTUATOR	
13	GUIDE ACTUATOR	
14	SPRING	
15	PINION GEAR	
16	END GUIDE	
17	SPRING	
18	END GUIDE ACTUATOR	
19	LINK	
20	COUPLING GEAR (13T)	
21	GEAR (13T/60T)	
22	SECTOR GEAR (60T)	
23	BRACKET	
24	LIFT UP SHAFT	
25	STOPPER	
26	SEAL	

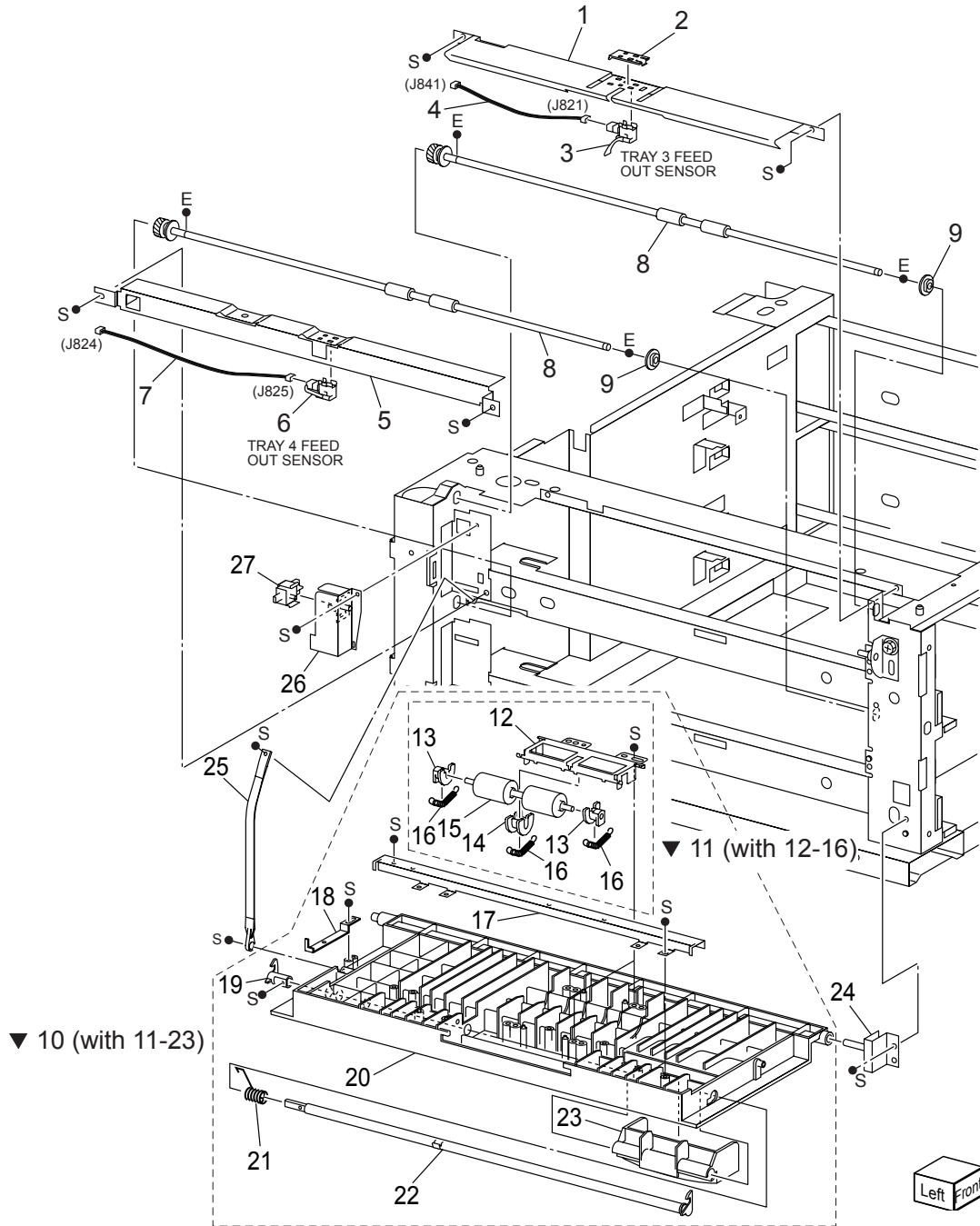


## PL 9.4 Feeder (2/2)

Item	Part Name	Remarks	Part Number
1	FEEDER ASSEMBLY (with 2-50)		
2	TRAY 1/2 FEED LIFT UP MOTOR.....		56523471
3	BRACKET		
4	SPACER		
5	GEAR (31T)		
6	SPRING		
7	ONEWAY CLUTCH		
8	ONEWAY GEAR		
9	GEAR (13T)		
10	BEARING		
11	SHAFT		
12	FRONT CHUTE		
13	ACTUATOR		
14	SENSOR		
15	SENSOR		
16	WIRE HARNESS	J101, J102, J103, J220, J661	
17	GEAR (28T/21T)		
18	GEAR (29T)		
19	SPRING		
20	ROLLER ASSY	Periodical replacement parts (per 300k print) See # 99	
21	ONEWAY CLUTCH.....		51402590
22	ONEWAY GEAR (22T)		
23	SHAFT		
24	CHUTE		
25	SPRING		
26	FRICTION CLUTCH.....		51402610
27	SHAFT-RETARD		
28	--		
29	SPACER		
30	GEAR (33T)		
31	SHAFT-NUDGER		
32	--		
33	GEAR (25T)		
34	LOWER FRAME		
35	BEARING		
36	GEAR (27T)		
37	LEVER		
38	BEARING		
39	WASHER		
40	UPPER FRAME		
41	--		
42	HOLDER HARNESS CTR		
43	HOLDER HARNESS REAR		
44	HOLDER HARNESS UPPER		

- 45      HOLDER HARNESS PS1                      ALT
- CLAMP MINI-SADDLE                     ALT
- 46      RAIL
- 47      SUPPORT RETARD
- 48      SUPPORT NUDGER
- 49      HOLDER
- 50      SPRING
- 99      KIT ROLLS (with 20x3Pcs.) Periodical replacement parts (per 300k print).....53361030

**PL 9.5 Transportation illustration**

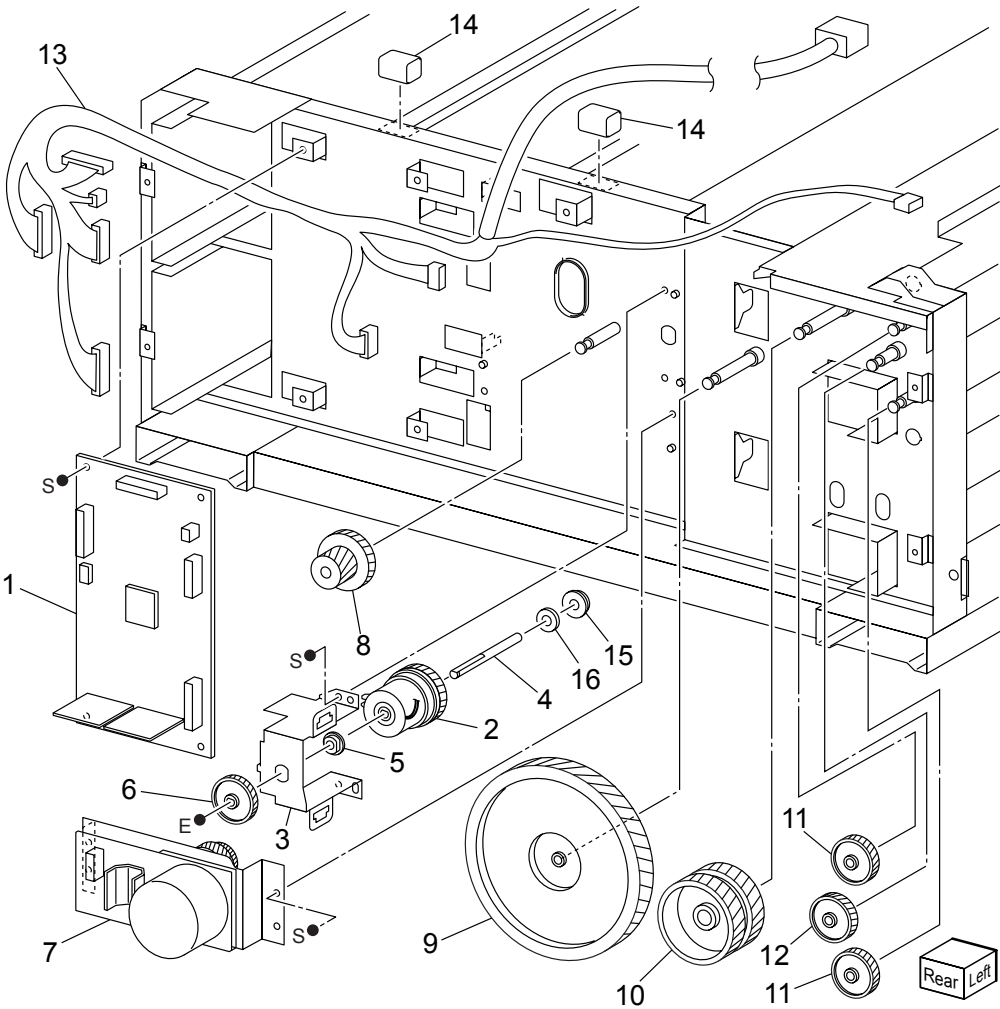


## PL 9.5 Transportation

Item	Part Name	Remarks	Part Number
1	CHUTE		
2	COVER		
3	TRAY 3 FEED OUT SENSOR.....		50423821
4	WIRE HARNESS	J821, J841.....	56745371
5	CHUTE.....		53360351
6	TRAY 4 FEED OUT SENSOR.....		50423971
7	WIRE HARNESS	J825, J842.....	56745401
8	TAKEAWAY ROLL ASSEMBLY.....		50424050
9	BEARING		
10	LEFT COVER ASSEMBLY (with 11-23).....		53091754
11	ROLL ASSY (with 12-16)		
12	BRACKET (Assy. only).....		53091754
13	BEARING (Assy. only).....		53091754
14	BEARING		
15	PINCH ROLL (Assy. only).....		53091754
16	SPRING (Assy. only).....		53091754
17	CHUTE		
18	ACTUATOR		
19	HOOK		
20	LEFT COVER		
21	SPRING (Assy. only).....		53091754
22	LATCH (Assy. only).....		53091754
23	HANDLE (Assy. only).....		53091754
24	BRACKET		
25	SUPPORT		
26	BRACKET ASSEMBLY		
27	LEFT COVER INTERLOCK SWITCH		



**PL 9.6 Drive & Electrical illustration**



## PL 9.6 Drive & Electrical

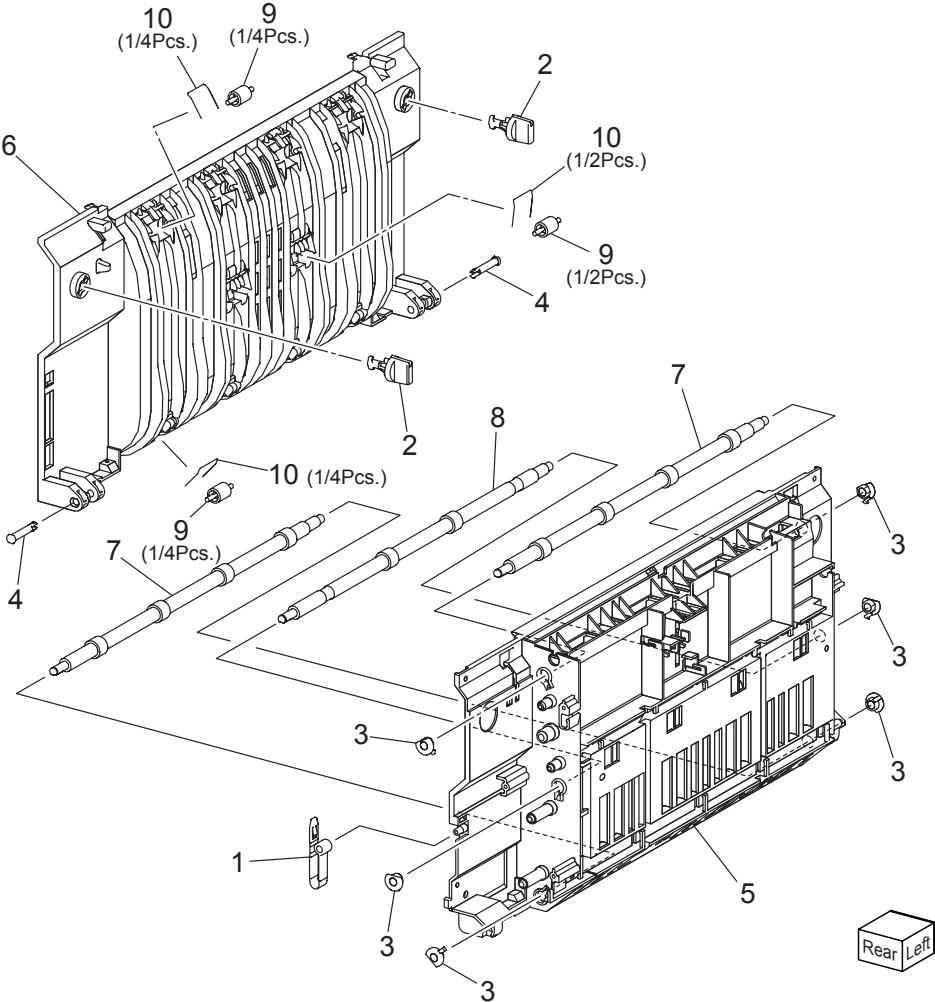
Item	Part Name	Remarks	Part Number
1	TRAY MODULE PWB		
2	CLUTCH		
3	BRACKET		
4	SHAFT		
5	BEARING		
6	GEAR (38T)		
7	MAIN MOTOR		
8	GEAR (22T/40T)		
9	GEAR (126T)		
10	GEAR (60T)		
11	GEAR (37T)		
12	GEAR (32T)		
13	WIRE HARNESS	541, J552, J554, J549, J548, J826, J820, J824, P661, P822, P841, P842, FS812, FS813	
14	GASKET		
15	BEARING		
16	WASHER-PLAIN,NYN		
98	KIT: GEAR 2 TRAY (With 6, 8 - 12).....		51256681



## PL 10.1 Duplex Unit

Item	Part Name	Remarks	Part Number
1	TRANS ASSY DUP (with 2-24).....		50237530
2	GEAR ROLL 28.....		51256890
3	GEAR IDLE 33 74.....		51256901
4	GEAR IDLE 33.....		51256920
5	GEAR IDLE 42.....		51256930
6	LEVER LATCH RR		
7	LEVER LATCH FR		
8	CHUTE LOWER		
9	SWITCH-I/L,CAB.....		56215980
10	ACTUATOR DUP		
11	MOTOR ASSY DUP		
12	PWBA DUPLEX		
13	COVER DUP		
14	SPRING LATCH		
15	SPRING ACTUATOR DUP		
16	BRACKET MOTOR		
17	PLATE LATCH		
18	SENSOR-PHOTO IN.....		50422213
19	INNER CHUTE ASSEMBLY (PL23.2)		
20	HARN ASSY DUP SNR	J123, J124, J541.....	56745270
21	HARN ASSY DUP MOT	J542, P212	
22	HARN ASSY DUP A	J417, J540	
23	FAN-DUP		
24	DUCT-DUP		

# PL 10.2 Inner Chute Assembly illustration



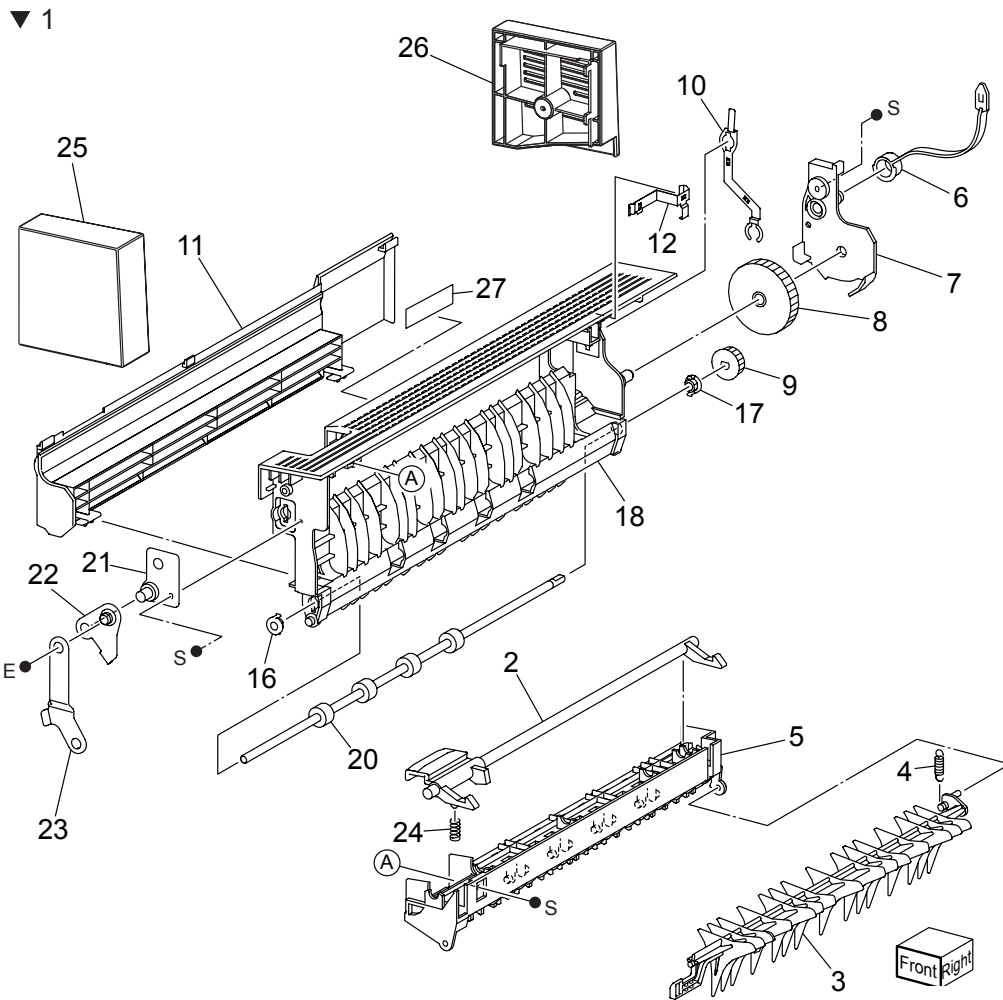
## PL 10.2 Inner Chute Assembly

Item	Part Name	Remarks
1	STOPPER DUP	
2	LOCK DUP	
3	BEARING DUP	
4	PIN DUP	
5	CHUTE OUTER	
6	CHUTE INNER	
7	ROLLER DUP A3L	
8	ROLLER ASSY DUP	
9	ROLLER PINCH DUP	
10	SPRING PINCH DUP	

# Exit 2

## 11 Exit 2

### PL 11.1 L/H Upper Chute Assembly illustration

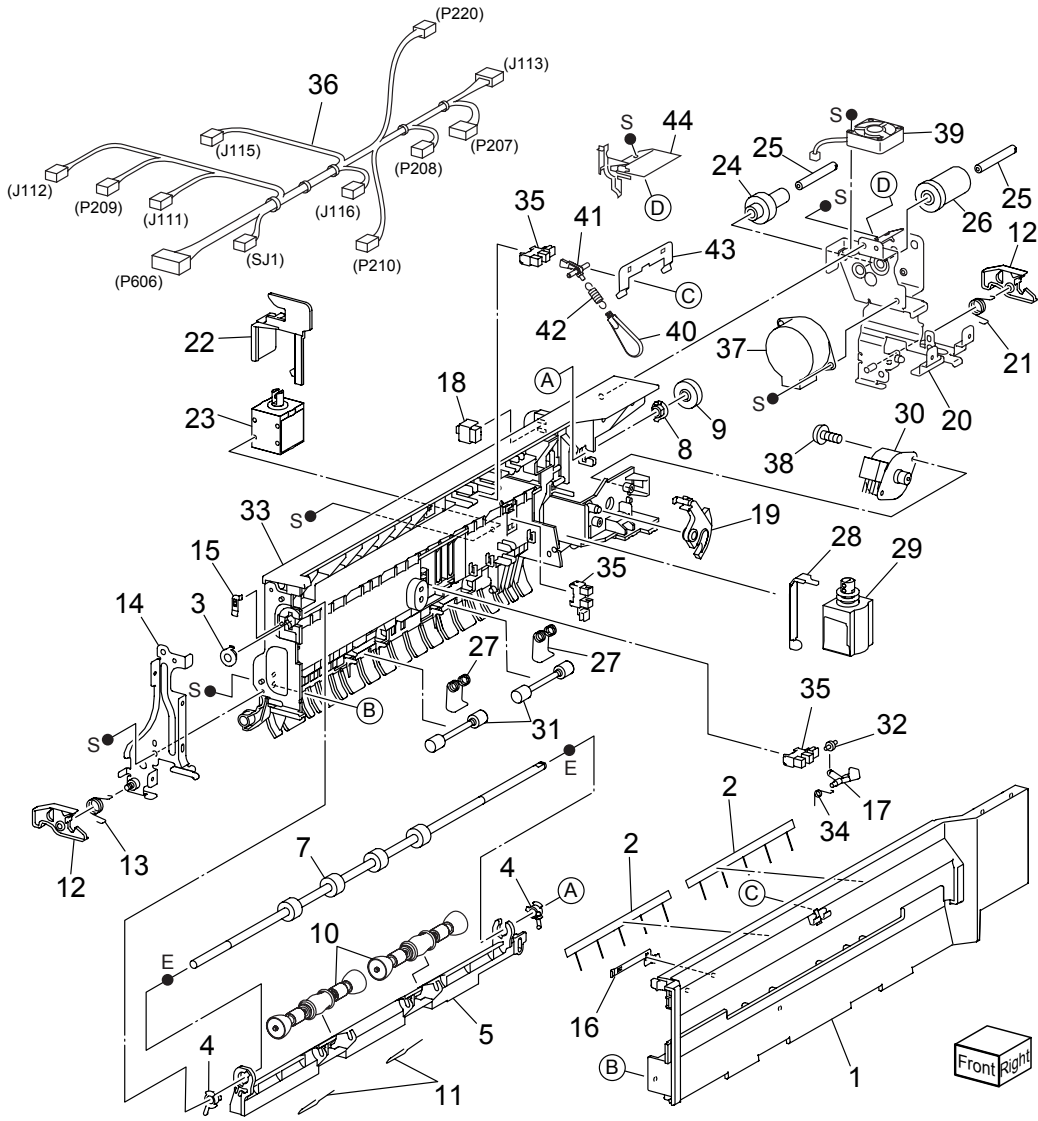


## PL 11.1 L/H Upper Chute Assembly

Item	Part Name	Remarks
1	TRANS ASSY EXIT2 (with 2-27, PL24.2)	
2	HANDLE LATCH	
3	GATE-EXIT,2	
4	SPRING-GATE 2	
5	CHUTE-UPPER,FU	
6	STOPPER EXIT2	
7	COVER-GEAR	
8	GEAR-52Z	
9	GEAR-19Z	
10	PLATE-EARTH INV	
11	COVER FUP EXIT	
12	PLATE-EARTH FU	
13	--	
14	--	
15	--	
16	BEARING	
17	BEARING	
18	CHUTE LH HIGH	
19	--	
20	ROLL ASSY-INV	
21	BRKT ASSY TRAY	
22	BRKT ASSY LINK	
23	LINK-FU	
24	SPRING LATCH	
25	FRONT EXIT 2 COVER	
26	REAR EXIT 2 COVER	
27	LABEL-LH-HIGH	



# PL 11.2 Tray Guide Assembly illustration



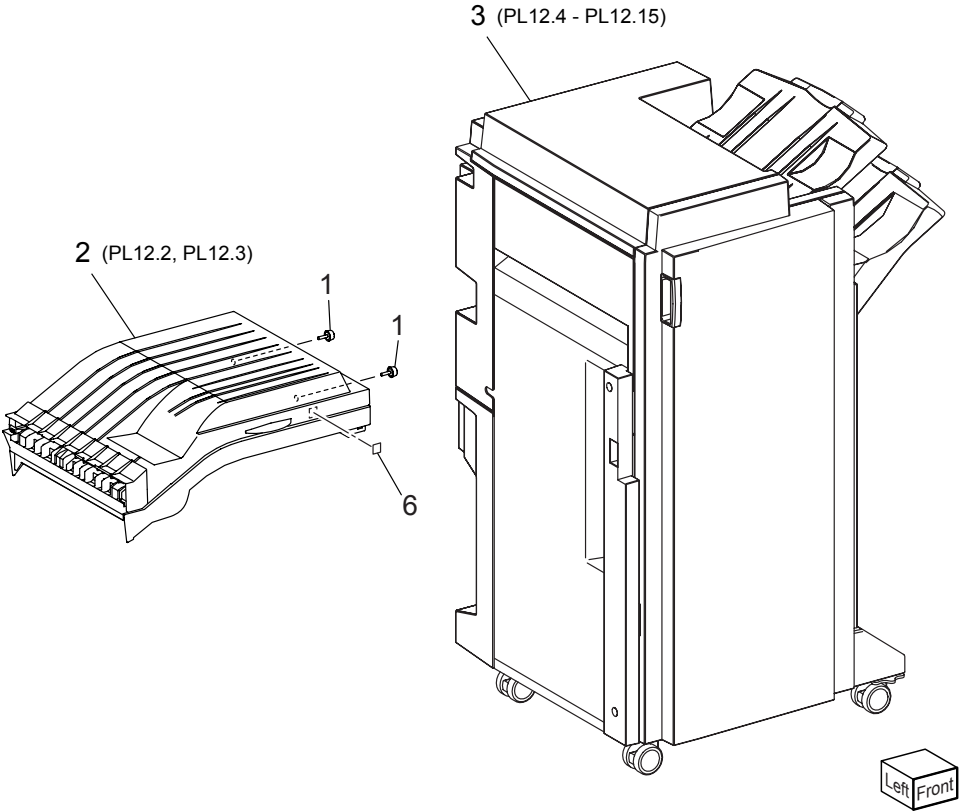
## PL 11.2 Tray Guide Assembly

Item	Part Name	Remarks	Part Number
1	GUIDE-TRAY,2		
2	ELIMINATOR EXIT		
3	BEARING		
4	BEARING ROLL		
5	CHUTE-OCT 2.....		53360531
6	--		
7	ROLL ASSY OCT		
8	BEARING		
9	GEAR-19Z		
10	ROLLER PINCH EXIT		
11	SPRING PINCH EXIT		
12	LATCH		
13	SPRING LATCH FRONT		
14	PLATE ASSY-FRONT		
15	PLATE-EARTH 2		
16	PLATE EARTH 3		
17	ACTUATOR EXIT		
18	SWITCH-I/L,CAB.....		56215980
19	GEAR-OFFSET 2		
20	PLATE ASSY-REAR		
21	SPRING-LATCH REAR.....		50938301
22	LINK-SOL FU.....		56216380
23	SOLENOID ASSY FU.....		56523670
24	GEAR-20Z		
25	SHAFT-GEAR		
26	GEAR-19Z/44Z		
27	SPRING PINCH INV		
28	LINK-GATE EXIT		
29	SOLENOID ASSY.....		56523710
30	MOTOR ASSY-OFFSET		
31	ROLL-PINCH,INV.....		50423001
32	ROLLER ACTUATOR.....		50423180
33	CHUTE-LOW 2		
34	SPRING ACTUATOR		
35	SENSOR-PHOTO IN.....		50422213
36	HARN ASSY EXIT2 C	J111, J112, J113, J115, J116, P207, P208, P209, P210, P220, P606, SJ1	
37	MOTOR ASSY EXIT 2.....		56523862
38	SCREW		
39	EXIT FAN		
40	ACTUATOR FULL-A		
41	ACTUATOR FULL-B		
42	SPRING ACT		
43	PLATE EARTH 4		
44	COVER-INNER		

# Finisher Unit

## 12 Finisher Unit

PL 12.1 Finisher Unit illustration

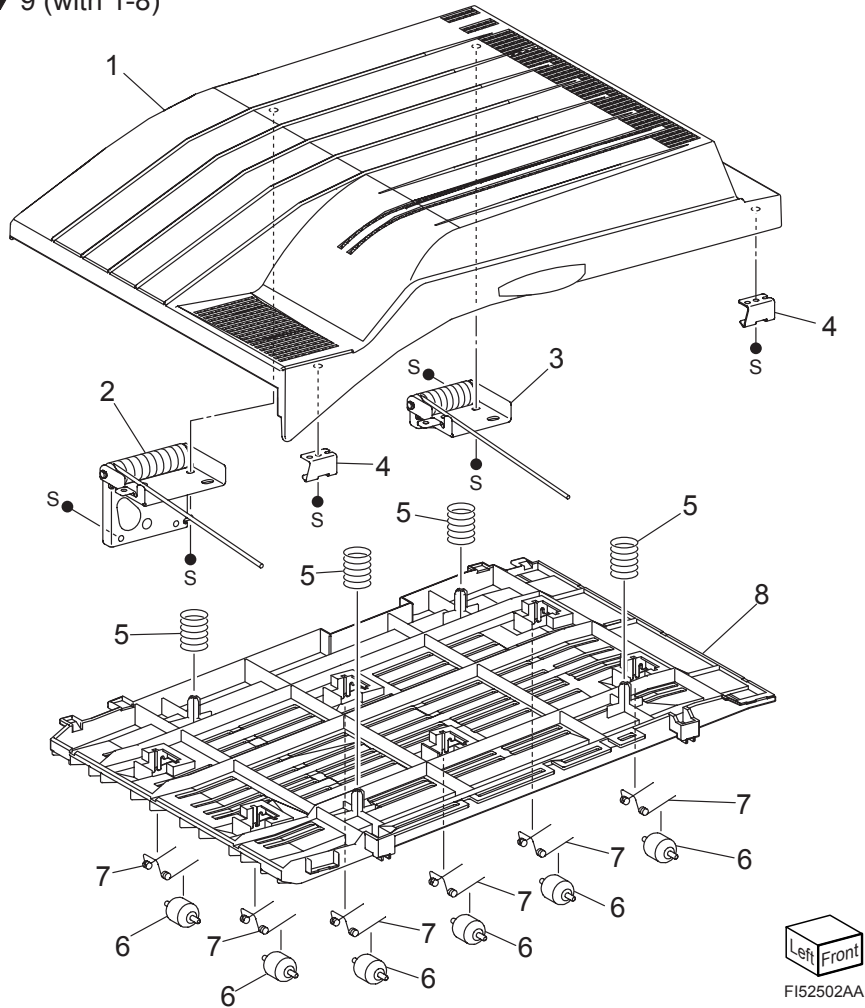


## PL 12.1 Finisher Unit

Item	Part Name	Remarks
1	SCREW	
2	H-TRANSPORT ASSEMBLY (PL12.2, PL12.3)	
3	STAPLE FINISHER (PL12.4-PL12.15)	
4	--	
5	--	
6	LABEL	

### PL 12.2 H-Transport Assembly (1/2) illustration

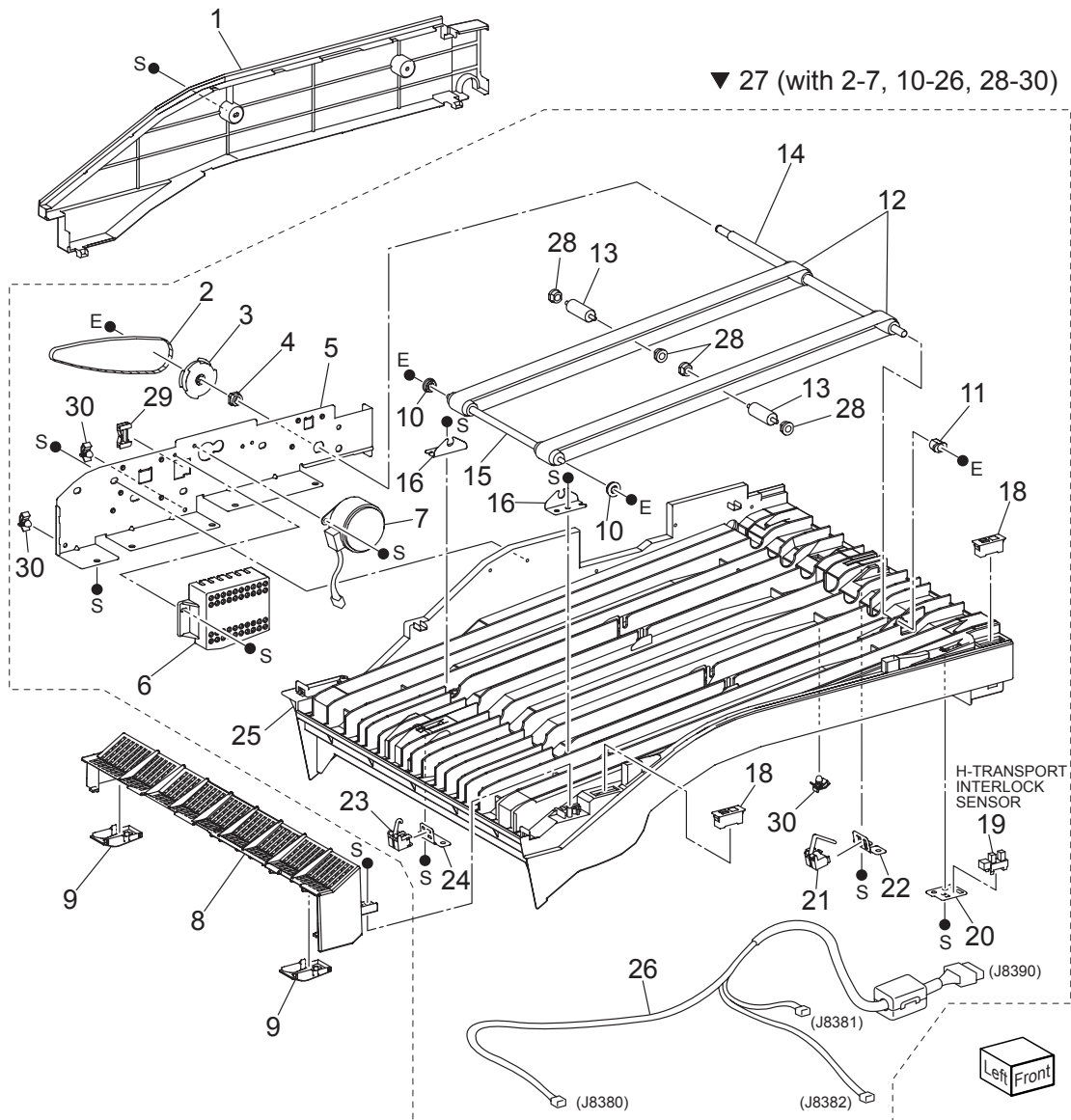
▼ 9 (with 1-8)



## PL 12.2 H-Transport Assembly (1/2)

Item	Part Name	Remarks	Part Number
1	COVER TOP, C.....		53091922
2	HINGE ASSEMBLY (LEFT).....		50814490
3	HINGE ASSEMBLY (RIGHT).....		50814480
4	BRACKET-MAGNET.....		51713620
5	SPRING-CHUTE		
6	PINCH ROLL		
7	SPRING-PINCH		
8	UPPER CHUTE.....		53360411
9	COVER ASSY TOP (with 1-8)		

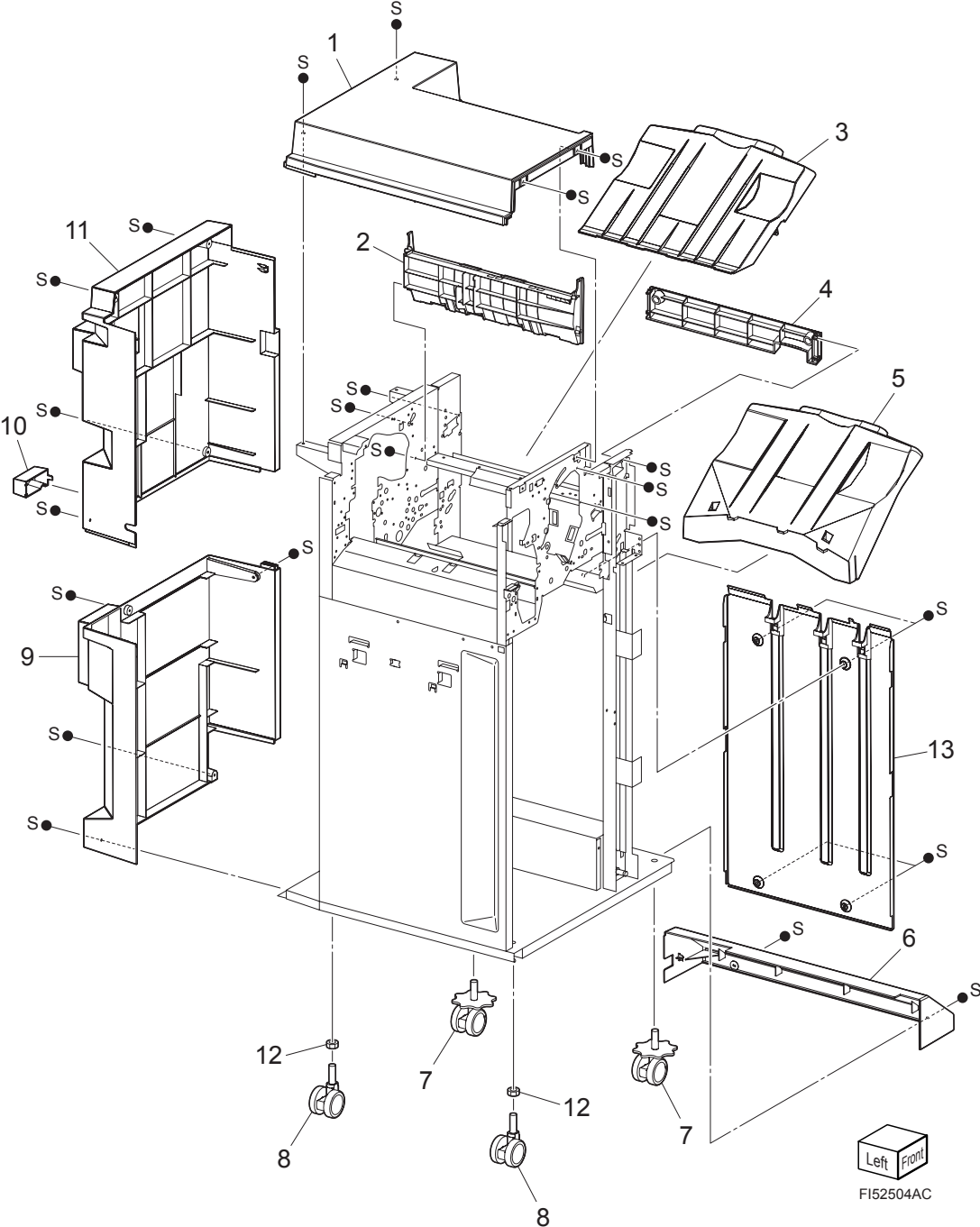
## PL 12.3 H-Transport Assembly (2/2) illustration



## PL 12.3 H-Transport Assembly (2/2)

Item	Part Name	Remarks	Part Number
1	REAR COVER.....		53091940
2	BELT-DRIVE.....		51311580
3	PULLEY		
4	BEARING		
5	BRACKET-DRIVE		
6	COVER-MOTOR		
7	H-TRANSPORT MOTOR		
8	TOP COVER		
9	PAPER GUIDE		
10	BEARING		
11	BEARING		
12	BELT		
13	ROLL		
14	SHAFT ASSEMBLY (RIGHT)		
15	SHAFT ASSEMBLY (LEFT)		
16	BRACKET-BEARING		
17	--		
18	MAGNET.....		50814520
19	H-TRANSPORT INTERLOCK SENSOR.....		50423280
20	BRACKET		
21	H-TRANSPORT EXIT SENSOR.....		50424381
22	BRACKET		
23	H-TRANSPORT ENTRANCE SENSOR.....		50423290
24	BRACKET		
25	LOWER CHUTE		
26	WIRE HARNESS	J8380, J8381, J8382, P8390	
27	CHUTE ASSY LOW (with 2-7, 10-26, 28-30)		
28	BEARING ROLLER SUPPORT		
29	BUSH SADDLE		
30	CLAMP MINI-CLAMP		

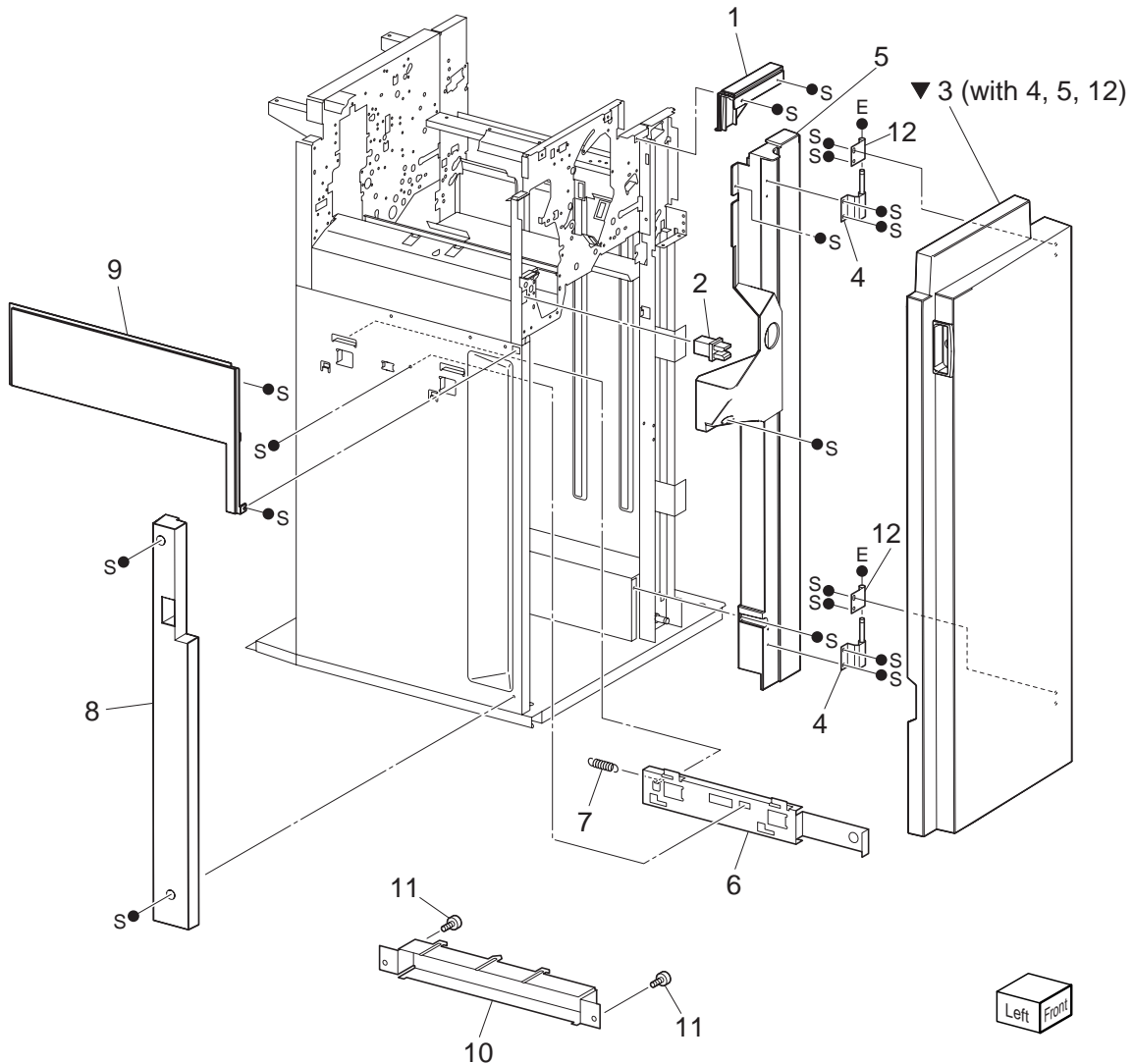
**PL 12.4 Finisher Cover (1/2) illustration**



## PL 12.4 Finisher Cover (1/2)

Item	Part Name	Remarks	Part Number
1	COVER TOP		
2	GUIDE TRAY SPRING		
3	TRAY ASSY SCT.....		50238170
4	COVER EJECT.....		53092090
5	TRAY ASSY STACKER.....		50238180
6	COVER BOTTOM.....		53092110
7	CASTER		
8	CASTER		
9	COVER REAR LOWER		
10	COVER-CONNECTOR H-TRA		
11	COVER REAR UPPER		
12	NUT M12X1.25		
13	PLATE COVER		

## PL 12.5 Finisher Cover (2/2) illustration

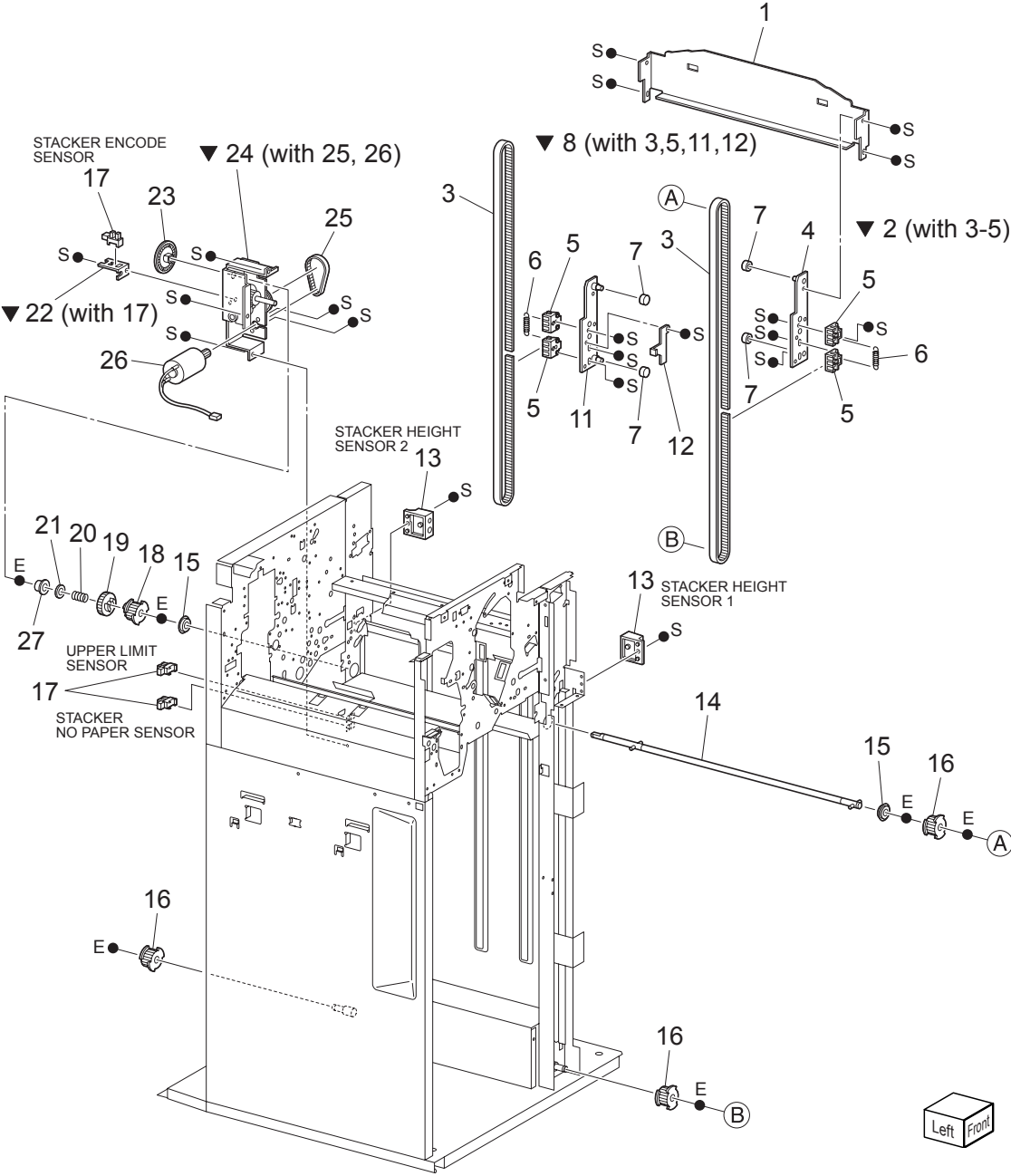




## PL 12.5 Finisher Cover (2/2)

Item	Part Name	Remarks	Part Number
1	COVER FRONT TOP.....		53092180
2	INTERLOCK SWITCH.....		56216090
3	COVER ASSY FRONT (with 4, 5, 12).....		53092230
4	BRACKET ASSY HINGE		
5	COVER INNER		
6	PLATE DOCKING		
7	SPRING.....		50938410
8	COVER FRONT L/H.....		53092160
9	COVER LH TOP		
10	PLATE ASSY DOCKING IOT		
11	SCREW		
12	BRACKET-COVER		

# PL 12.6 Finisher Stack illustration

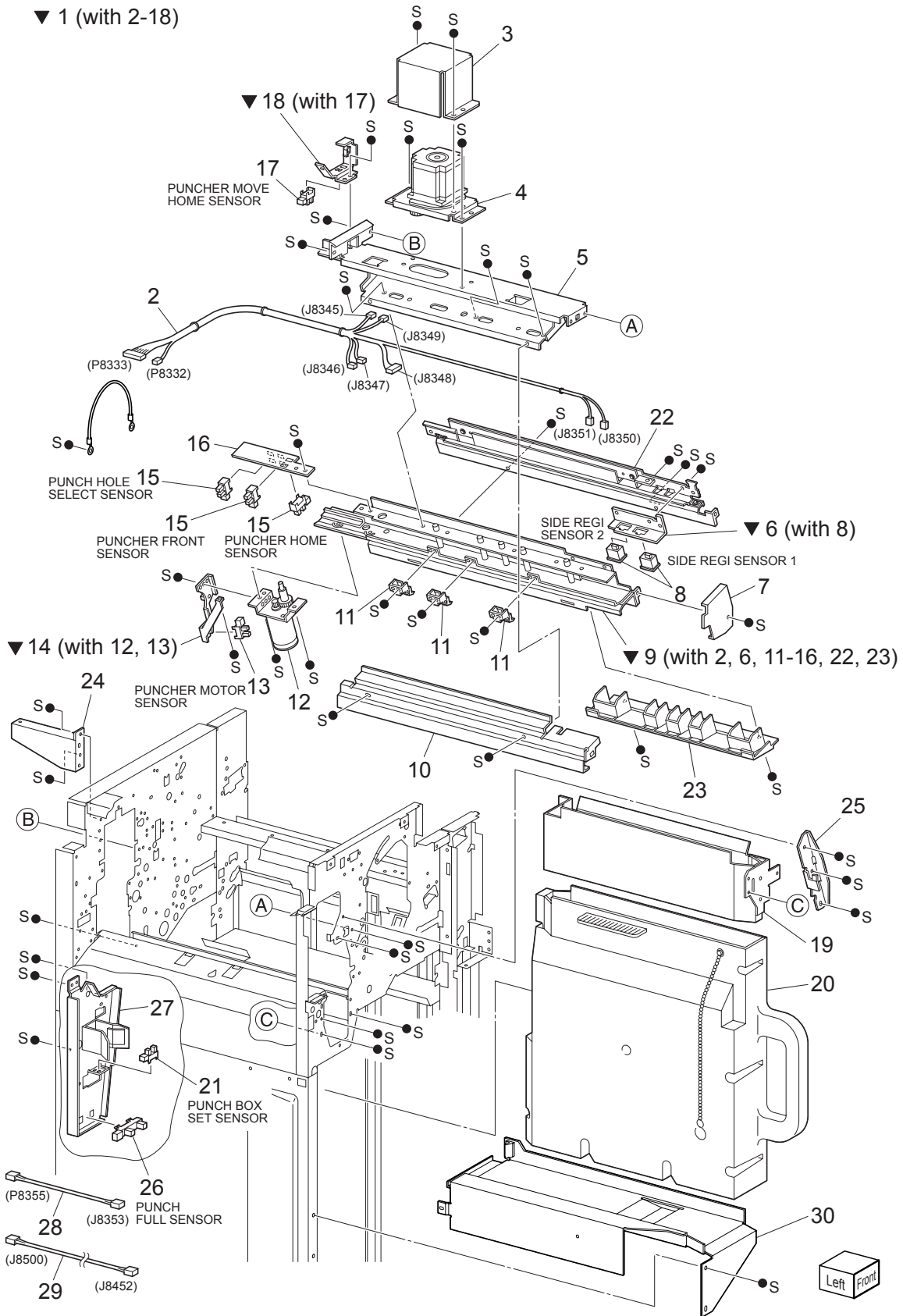


## PL 12.6 Finisher Stack

Item	Part Name	Remarks	Part Number
1	CARRIAGE TRAY		
2	CARRIAGE ASSY L (with 3-5)		
3	BELT STACKER.....		51311620
4	CARRIAGE ASSY L		
5	CLAMP BELT.....		50711460
6	SPRING.....		50938550
7	BEARING CARRIAGE		
8	CARRIAGE ASSY R (with 3, 5, 11, 12)		
9	--		
10	--		
11	CARRIAGE ASSY R		
12	ACTUATOR		
13	COVER ASSY SENSOR		
14	SHAFT-ELEV		
15	BEARING		
16	PULLEY T18		
17	SENSOR.....		50423270
18	PULLEY DOC. CLUTCH		
19	GEAR DOC. CLUTCH.....		51257030
20	SPRING DOC.....		50938560
21	WASHER		
22	BRACKET ASSY (with 17)		
23	ENCODER.....		50424470
24	BRACKET ASSY STACKER (with 25, 26)		
25	BELT.....		51311454
26	MOTOR ASSY DC.....		56524000
27	BEARING 10x6		

# PL 12.7 Finisher Punch illustration

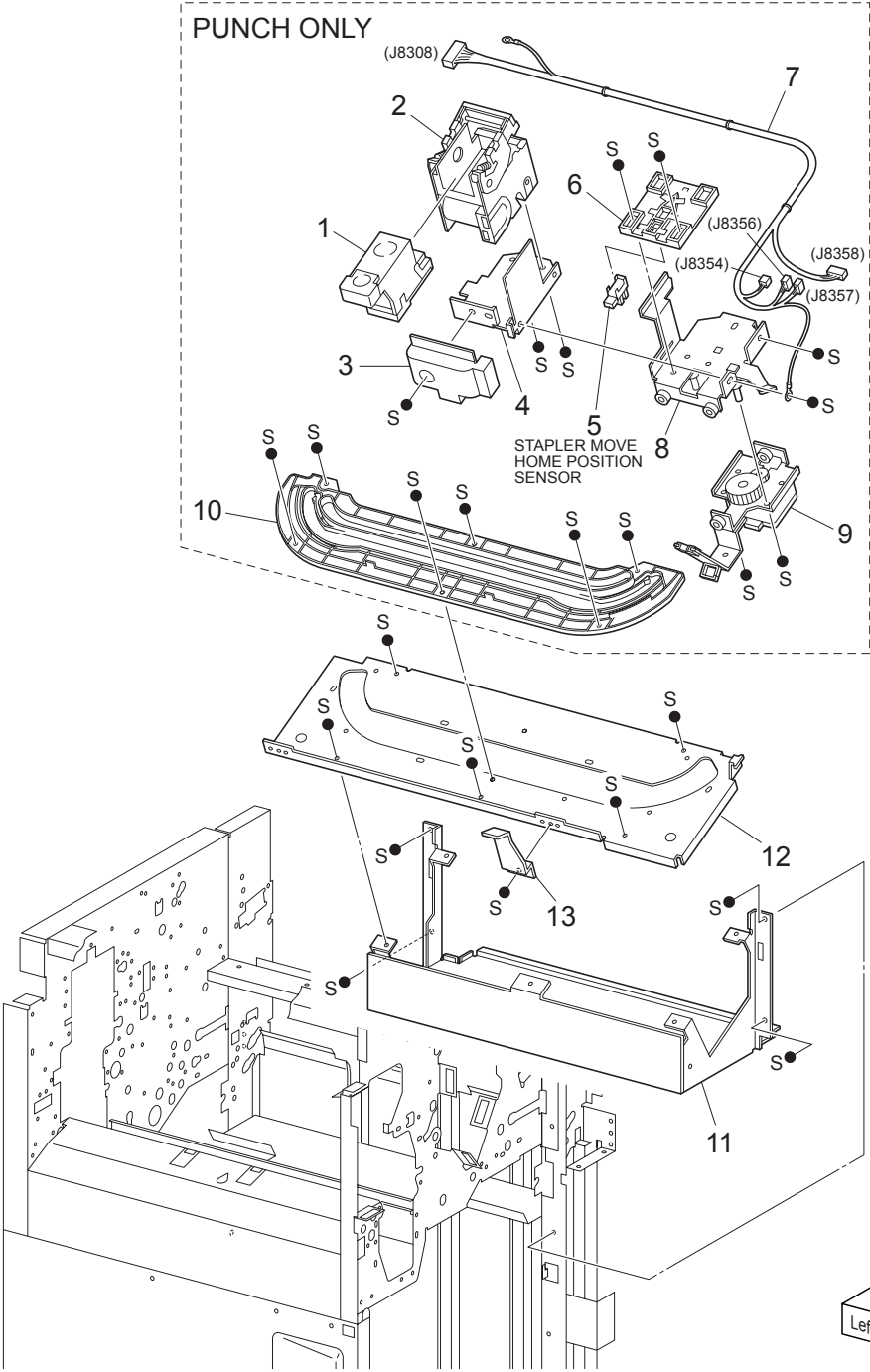
▼ 1 (with 2-18)



## PL 12.7 Finisher Punch

Item	Part Name	Remarks	Part Number
1A	FRAME ASSY-PUNCH ALL 2 & 3 (with 2-18).....		53361481
1B	FRAME ASSY-PUNCH ALL 3 HOLE (with 2-18).....		53361561
1C	FRAME ASSY-PUNCH ALL 2 & 4 HOLE (with 2 - 18).....		53361571
1D	FRAME ASSY-PUNCH ALL 2 HOLE (with 2 - 18).....		53361581
2	HARNESS ASSY PUNCH UNIT	J8345, J8346, J8347, J8348, J8349, J8350,.....	56745650
		J8351, P8332, P8333	
3	COVER-MOTOR, PUNCH		
4	BRACKET ASSY-MOTOR, PUNCH.....		51713880
5	HOLDER-FRAME ASSY		
6	BRACKET ASSY SENSOR HOL (with 8).....		51713840
7	COVER-FRONT, PUNCH		
8	SENSOR		
9	BRACKET ASSY-PUNCH (with 2, 6, 11-16, 22, 23)		
10	COVER-LEFT, PUNCH		
11	IDE ASSY		
12	MOTOR ASSY		
13	SENSOR		
14	BRACKET ASSY (with 12, 13)		
15	SENSOR.....		50423380
16	BRACKET 2&4 (REF ONLY)		
17	SENSOR.....		50423270
18	BRACKET ASSY-SENSOR (with 17)		
19	CHUTE ASSY DUST BOX		
20	DUST BOX.....		50238390
21	SENSOR.....		50423270
22	CHUTE ASSY-S REGI		
23	GUIDE BOX		
24	BRACKET-OPB PUNCH		
25	BRACKET-OPB FRAME F		
26	SENSOR		
27	BRACKET		
28	HARNESS ASSY PUNCH BOX SET		
29	HARNESS ASSY PUNCH FULL SNRJ8353, P8355		
30	BRACKET ASSY DUST BOX	J8452, J8500	

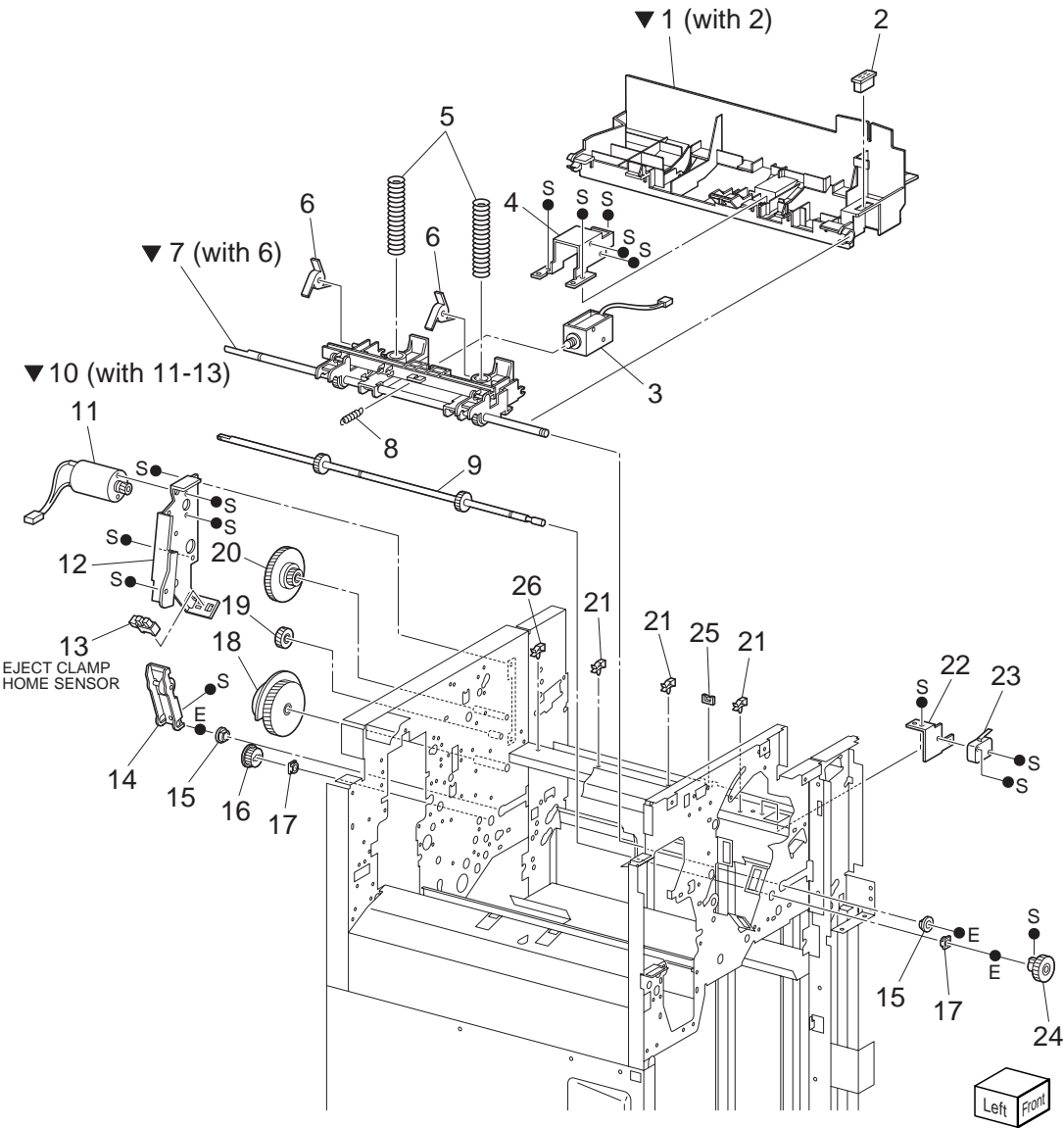
# PL 12.8 Finisher Staple illustration



## PL 12.8 Finisher Staple

Item	Part Name	Remarks	Part Number
1	CARTRIDGE ASSY-STAPLES.....		50238470
2	STAPLER ASSY.....		50238500
3	COVER STAPLER.....		53092050
4	HOLDER STAPLER		
5	SENSOR.....		50423270
6	GUIDE HARNES, STAPLER		
7	HARNES ASSY STAPLE	J8308, J8354, J8356, J8357, J8358.....	56745661
8	CARRIAGE ASSY UPPER, STAPLER		
9	CARRIAGE ASSY LOWER, STAPLER.....		53361650
10	RAIL-UPPER.....		53361740
11	FRAME ASSY STAPLER		
12	BASE-RAIL (REF ONLY)		
13	STOPPER-CHUTE (REF ONLY)		
14	STAPLER UNIT (with 1-10) (REF ONLY)		

**PL 12.9 Finisher Eject (1/3) illustration**

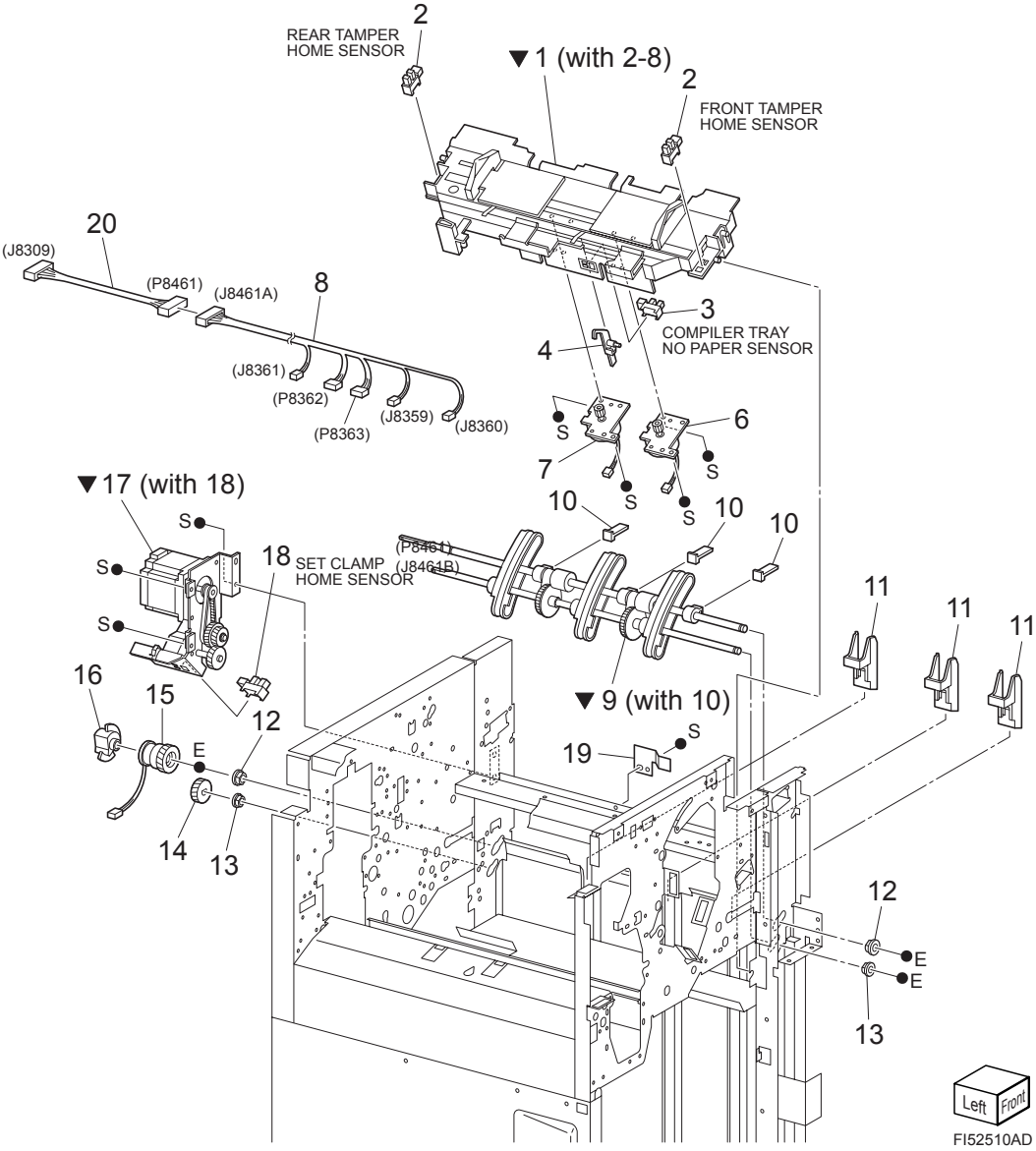




## PL 12.9 Finisher Eject (1/3)

Item	Part Name	Remarks	Part Number
1	CHUTE ASSY EJECT (with 2)		
2	MAGNET 25N		
3	SOLENOID ASSY.....		51402920
4	BRACKET SOLENOID		
5	SPRING-PINCH		
6	PADDLE-CYCLONE		
7	SHAFT ASSY-EJECT PINCH (with 6)		
8	SPRING SOLENOID.....		50938580
9	SHAFT ASSY PADDLE		
10	BRACKET ASSY-EJECT CLAMP (with 11-13)		
11	MOTOR ASSY-DC.....		56523990
12	BRACKET-EJECT CLAMP		
13	SENSOR.....		50423280
14	LEVER ASSY		
15	BEARING		
16	GEAR Z23		
17	BEARING		
18	GEAR-CAM Z70		
19	GEAR Z23L		
20	GEAR Z68L/Z20L		
21	CLAMP		
22	BRACKET SWITCH		
23	SENSOR ASSY.....		56215990
24	KNOB ASSY-ENT		
25	EDGE SADDLE		
26	CLAMP		
27	CHUTE ASSY EJECT UNIT (with 1-7) (REF ONLY)		

**PL 12.10 Finisher Eject (2/3) illustration**



## PL 12.10 Finisher Eject (2/3)

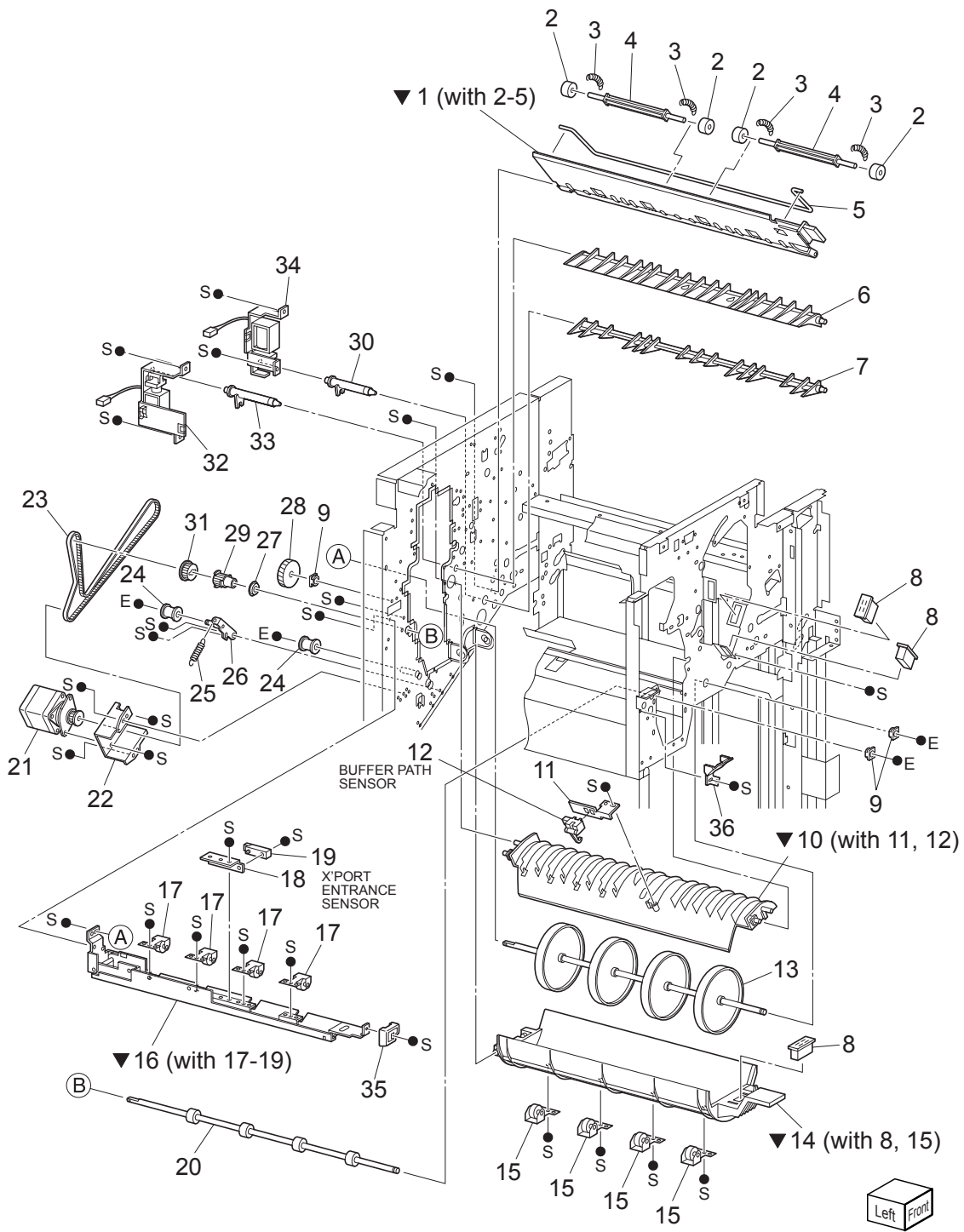
Item	Part Name	Remarks	Part Number
1	TRAY ASSY-COMPILER (with 2-8).....		50238651
2	SENSOR.....		50423270
3	SENSOR.....		50423280
4	ACTUATOR-PAPER		
5	--		
6	MOTOR ASSY 2		
7	MOTOR ASSY.....		56523970
8	HARNESS ASSY COMPILER 2	J8359, J8360, J8361, J8461A, P8362, P8363	
9	SHAFT ASSY-EJECT ROLL (with 10)		
10	PADDLE-SET CLAMP		
11	GUIDE-PADDLE		
12	BEARING		
13	BEARING		
14	GEAR		
15	CLUTCH Z34.....		51402931
16	ACTUATOR SET CLAMP		
17	BRACKET ASSY-EJECT (with 18).....		51713850
18	SENSOR.....		50423280
19	PLATE		
20	HARNESS ASSY COMPILER 1	J8309, J8461B	



## PL 12.11 Finisher Eject (3/3)

Item	Part Name	Remarks	Part Number
1	BRACKET ASSY-SENSOR (with 2, 3).....		51713801
2	HARNESS ASSY COMP SNR	J8320, P8391	
3	SENSOR ASSY.....		50422990
4	ELIMINATOR .....		50238200
5	CHUTE-UPPER, EXIT		
6	ROLL ASSY-EXIT LOW.....		50423440
7	CHUTE ASSY-LOWER, EXIT R (with 8-13)		
8	CHUTE ASSY-LOWER, EXIT R		
9	BEARING		
10	ROLLER ASSY-PINCH, EXIT 1		
11	ROLLER ASSY-PINCH, EXIT 2		
12	SHAFT ASSY-PADDLE		
13	BELT-SYNCRONUS Z55.....		51311354
14	PULLEY T17.....		51257630
15	SHAGT-DRIVE PADDLE		
16	PULLEY.....		51257640
17	BEARING		
18	PULLEY T20		
19	GEAR Z23L		
20	PULLEY T20		
21	PULLEY T44/Z20		
22	GEAR Z23R		

# PL 12.12 Finisher Transport (1/2) illustration



## PL 12.12 Finisher Transport (1/2)

Item	Part Name	Remarks	Part Number
1	CHUTE ASSY-UPPER, EXIT OPEN (with 2-5).....		53360640
2	ROLLER-PINCH		
3	SPRING 1.9N		
4	SHAFT		
5	SPRING-TORSION		
6	GATE		
7	GATE-BUFFER		
8	MAGNET 25N		
9	BEARING		
10	CHUTE ASSY BUFFER TOP (with 11, 12)		
11	BRACKET-SENSOR		
12	SENSOR ASSY.....		50422990
13	ROLL ASSY-BUFFER		
14	CHUTE ASSY-BUFFER BOTTOM (with 8, 15).....		53360660
15	ROLLER ASSY-PINCH, EXIT		
16	CHUTE ASSY-UPPER, ENT (with 17-19).....		53360611
17	ROLLER ASSY-PINCH, ENT		
18	BRACKET-SENSOR		
19	SENSOR.....		50423370
20	ROLL ASSY-ENT		
21	MOTOR ASSY.....		56523981
22	BRACKET MOTOR		
23	BELT.....		51311254
24	PULLEY.....		51257640
25	SPRING-TENSION		
26	BRACKET ASSY-TENSION		
27	BEARING		
28	GEAR Z46		
29	PULLEY T20		
30	LINK-BUFFER		
31	GEAR Z23		
32	BRACKET ASSY SOL		
33	LINK		
34	BRACKET ASSY SOL		
35	KNOB		
36	BRACKET STOPPER		

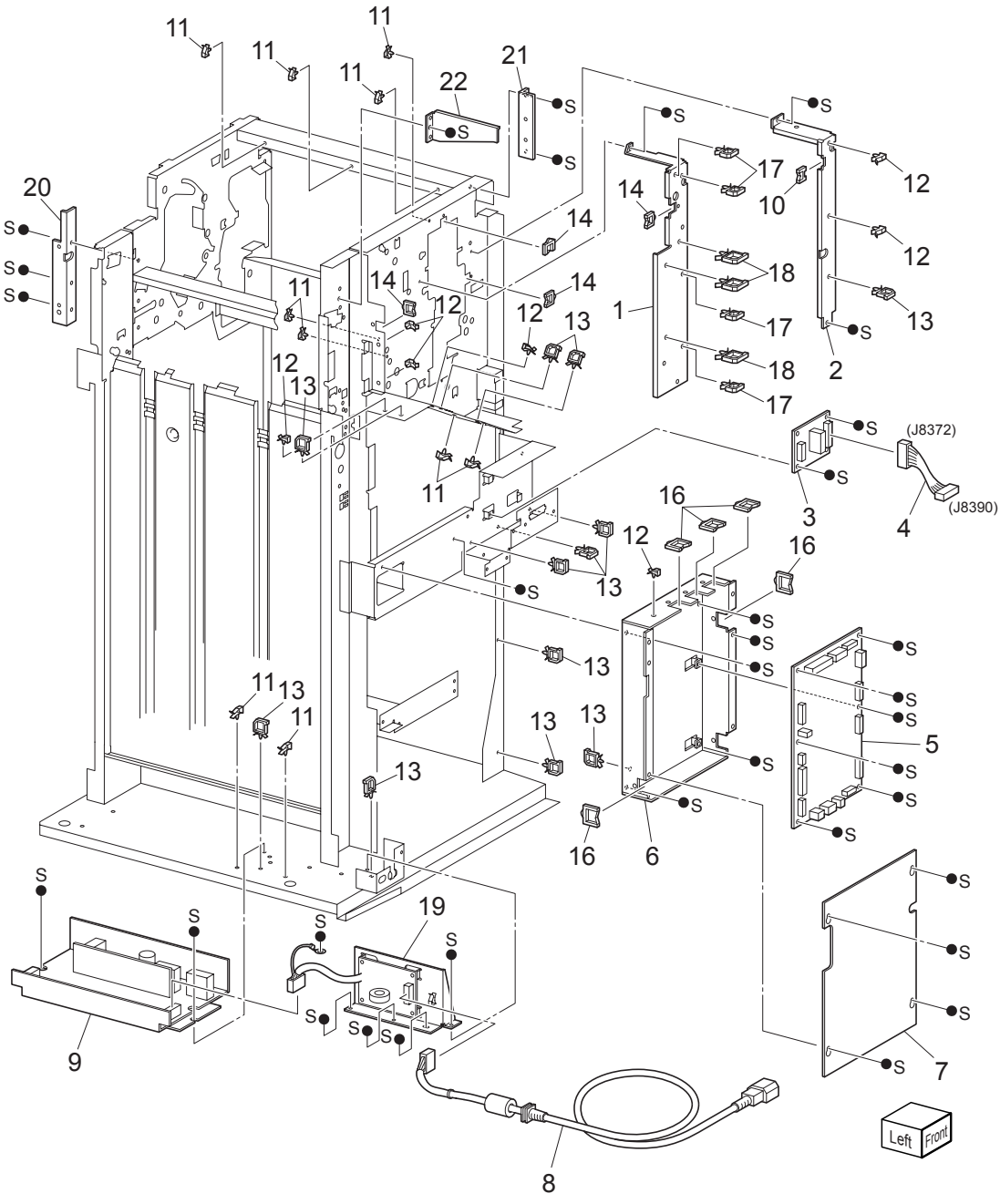




## PL 12.13 Finisher Transport (2/2)

Item	Part Name	Remarks	Part Number
1	CHUTE ASSY UPPER, TOP EXIT R (with 2, 3).....		53360691
2	SENSOR.....		50422990
3	ROLLER ASSY-PINCH, EXIT		
4	CHUTE ASSY-LOWER, TOP EXIT R		
5	ROLL ASSY-EXIT TOP.....		50423420
6	BRACKET ASSY-SENSOR (with 7)		
7	SENSOR.....		50423370
8	MAGNET 25N		
9	BEARING		
10	CHUTE ASSY-LOWER, TOP EXIT L (with 11-13).....		53360620
11	ROLLER-PINCH		
12	SPRING 1.5N		
13	SHAFT		
14	CHUTE ASSY-UPPER, TOP EXIT L (with 15-17)		
15	SENSOR.....		50423510
16	HARNES ASSY-SNR	J8432, J8434B	
17	BRACKET-SENSOR		
18	ROLL ASSY-TRANSPORT		
19	PULLEY T53/Z23		
20	BEARING		
21	PULLEY		
22	PULLEY.....		51257640
23	BRACKET ASSY-TENSION		
24	SPRING-TENSION		
25	PULLEY T20/Z20.....		51257600
26	GEAR.....		51257020
27	BELT.....		51311154
28	BELT		
29	BRACKET MOTOR		
30	MOTOR ASSY.....		56523981
31	HARNES ASSY GATE SNR	J8376, J8434A	

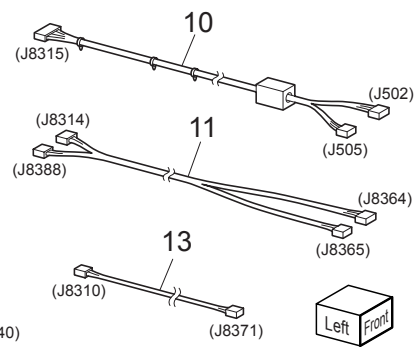
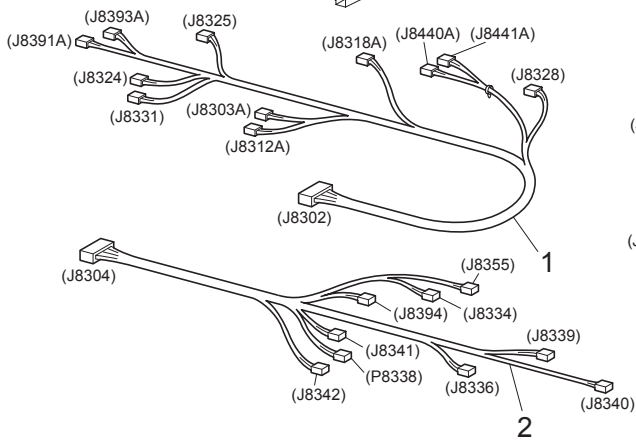
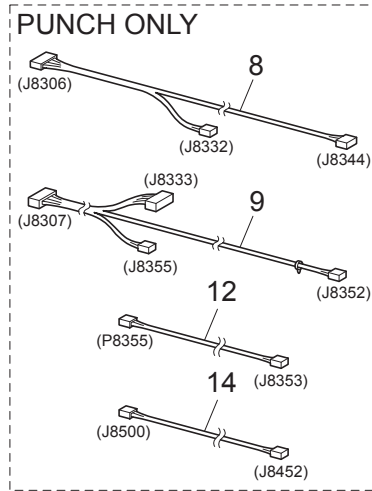
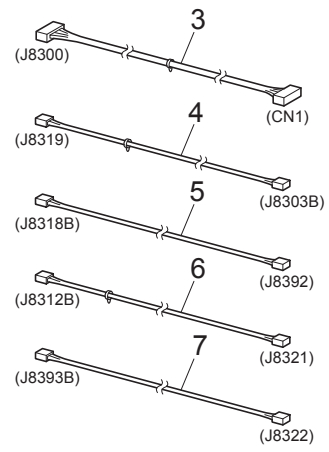
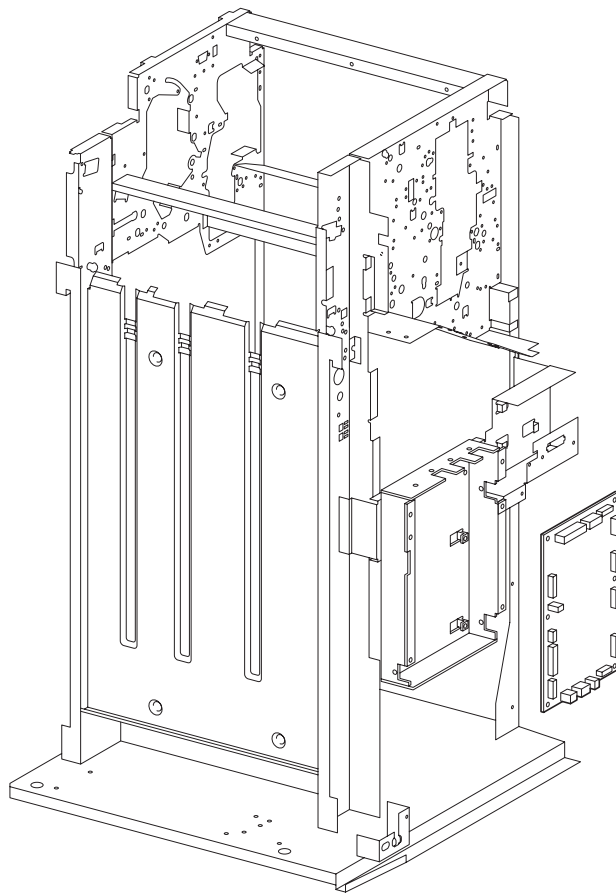
**PL 12.14 Finisher Electrical illustration**



## PL 12.14 Finisher Electrical

Item	Part Name	Remarks	Part Number
1	BRACKET HARNESS		
2	BRACKET HARNESS L/H		
3	PWB H-TRA J8372, J8390.....		55954130
4	HARNESS ASSY H-TRA I/F		
5	PWB MAIN-C		
6	BRACKET-PWBA MAIN.....		55954252
7	PLATE PWBA MAIN		
8	HARNESS ASSY AC INLET.....		56745740
9	LVPS-C.....		55954381
10	EDGE SADDLE		
11	CLAMP		
12	CLAMP		
13	CLAMP		
14	EDGE SADDLE		
15	--		
16	EDGE SADDLE		
17	CLAMP		
18	CLAMP		
19	BRACKET ASSY AC FILTER		
20	PLATE FRAME FRONT	XOG ONLY	
21	BRACKET-OPB COVER L	XOG ONLY	
22	BRACKET-OPB COVER R	XOG ONLY	

# PL 12.15 Finisher Harness illustration



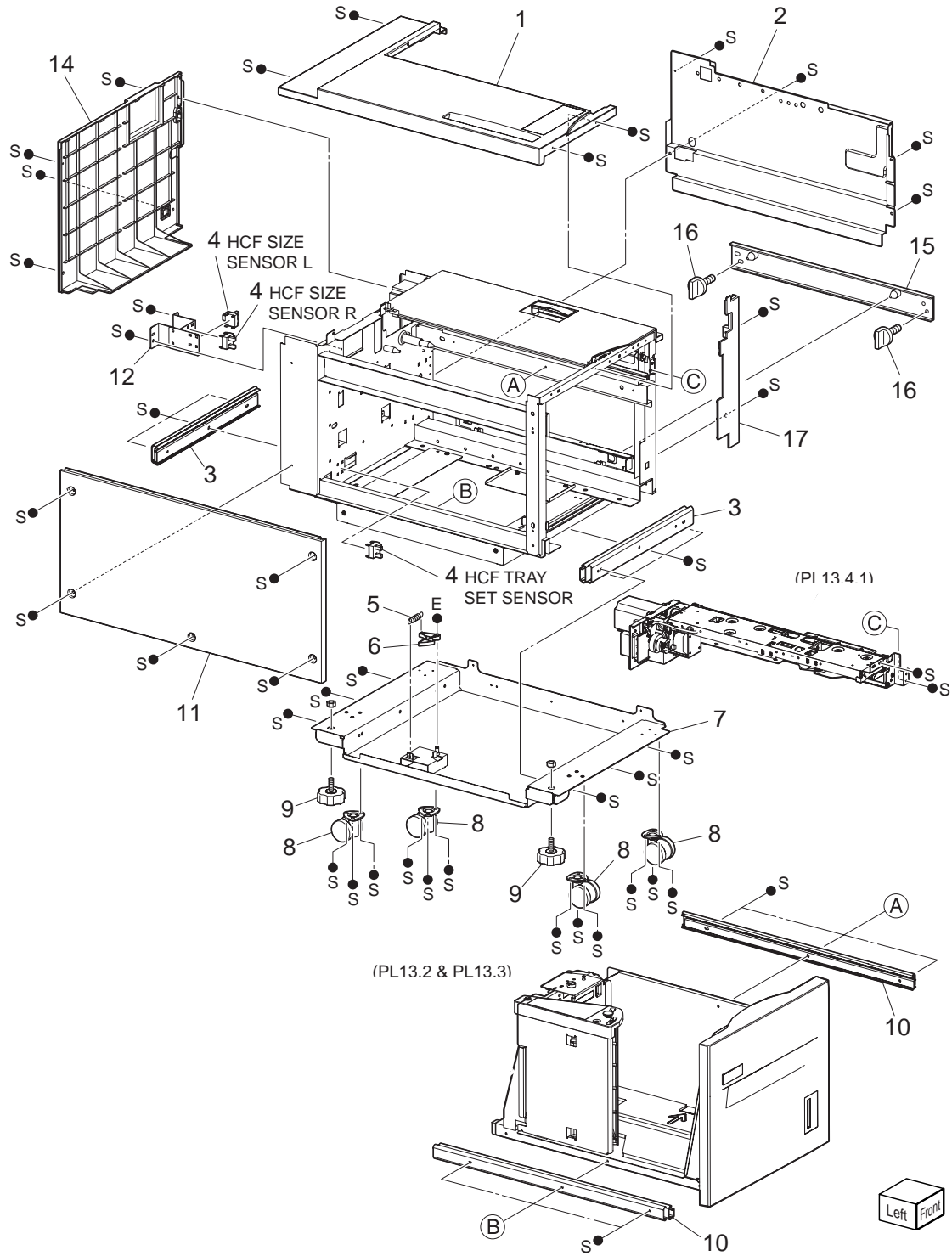
## PL 12.15 Finisher Harness

Item	Part Name	Remarks
1	HARNESS ASSY MAIN SNR	J8302, J8303A, J8312A, J8318A, J8328, J8391A, J8393A, J8440A, J8441A, J8324, J8325, J8331
2	HARNESS ASSY MAIN DRIVE	J8304, J8334, J8335, J8336, J8339, J8340, J8341, J8342, J8394, P8338
3	HARNESS ASSY I/F	J8300, CN1
4	HARNESS ASSY X'PORT ENT SNR	J8319, J8303B
5	HARNESS ASSY BUFFER SNR	J8318B, J8392
6	HARNESS ASSY TOP EXIT SNR	J8312B, J8321
7	HARNESS ASSY TOP SNR	J8393B, J8322
8	HARNESS ASSY PUNCH DRIVE	PUNCH ONLY J8306, J8332, J8344
9	HARNESS ASSY PUNCH SNR	PUNCH ONLY J8307, J8333, J8352, J8355
10	HARNESS ASSY LVPS	J8315, J502, J505
11	HARNESS ASSY INTERLOCK	J8314, J8364, J8365, J8388
12	HARNESS ASSY PUNCH BOX SET	PUNCH ONLY J8353, P8355
13	HARNESS ASSY M-HTRA	J8310, J8371
14	HARNESS ASSY PUNCH FULL SNR	PUNCH ONLY J8500, J8452

# HCF

## 13 HCF

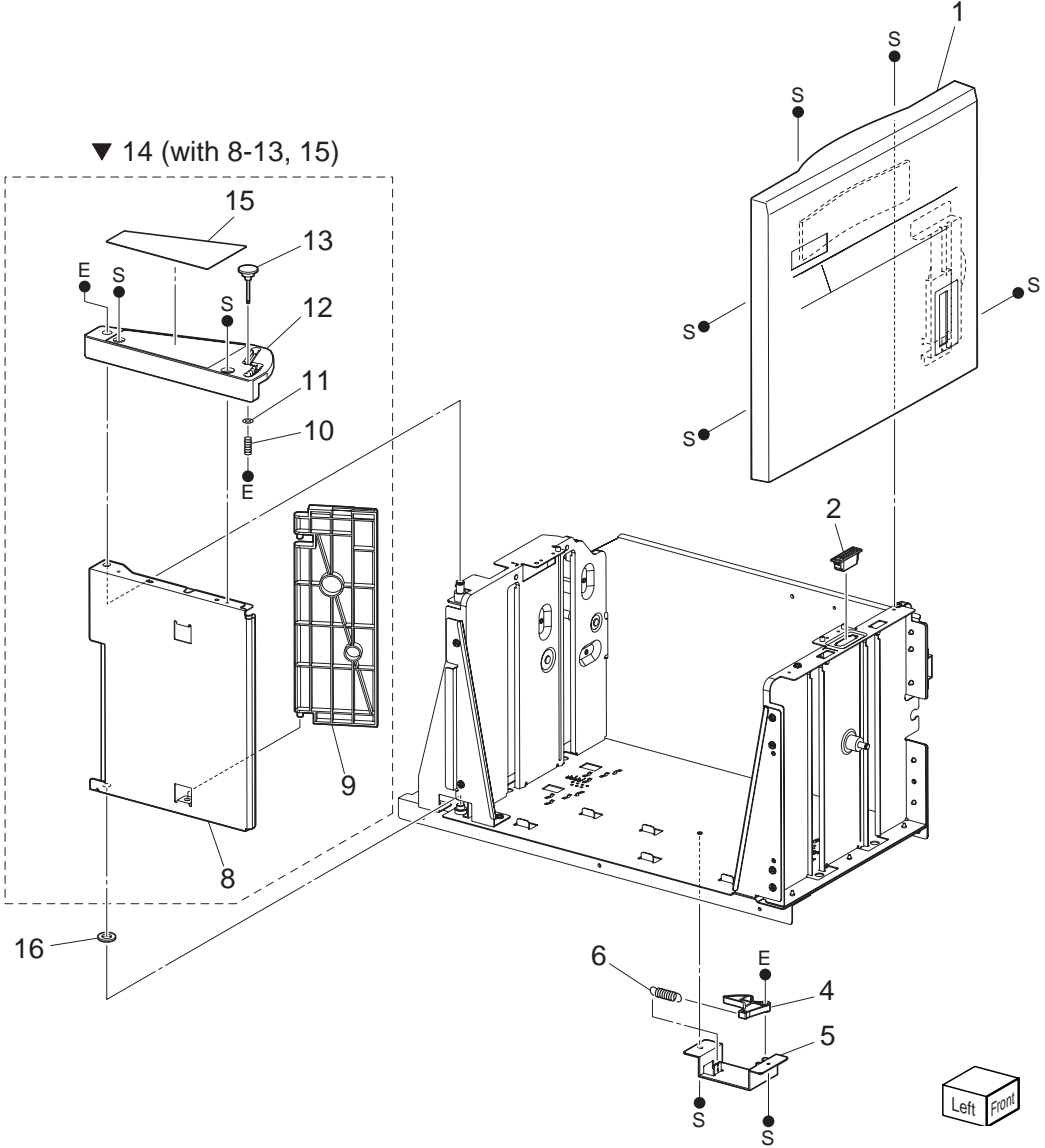
### PL 13.1 Cover illustration



## PL 13.1 Cover

Item	Part Name	Remarks	Part Number
1	COVER TOP LG HCF.....		53091850
2	COVER RH HCF		
3	RAIL ASSY SLIDE		
4	SENSOR.....		50422790
5	SPRING.....		50937990
6	LEVER LATCH.....		50814000
7	PLATE ASSY CASTER W		
8	CASTER RACK FR		
9	FOOT ADJUSTER		
10	RAIL ASSY TRAY		
11	COVER LH HCF		
12	BRKT ASSY-SNR		
13	--		
14	COVER REAR HCF		
15	JOINT BRACKET		
16	SCREW		
17	COVER FRONT SIDE		

**PL 13.2 Tray (1/2) illustration**

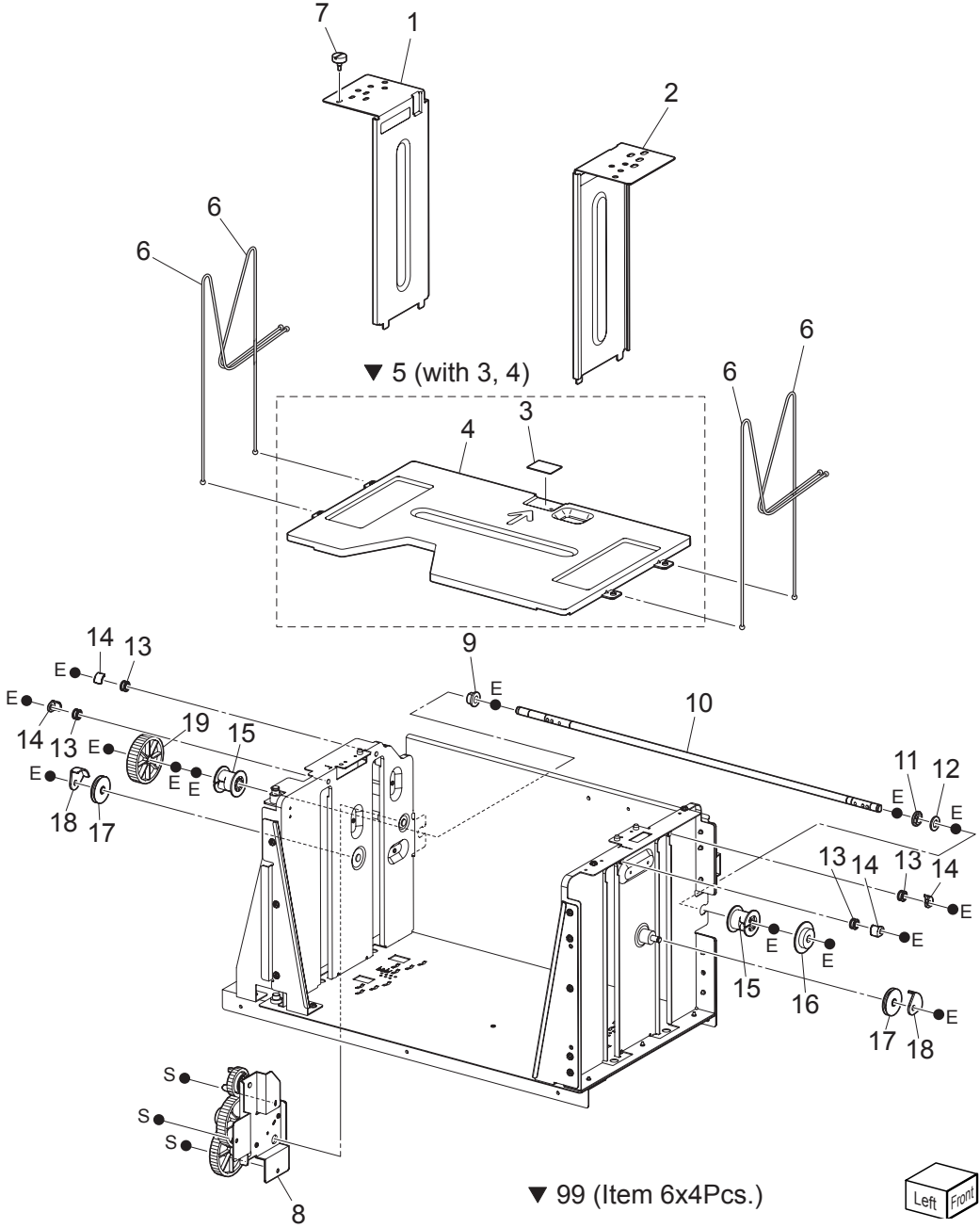




## PL 13.2 Tray (1/2)

Item	Part Name	Remarks	Part Number
1	COVER ASSY FRONT.....		53091861
2	MAGNET CATCH TRAY		
3	--		
4	LEVER LATCH		
5	LATCH ASSY TRAY STD		
6	SPRING		
7	--		
8	BRKT END FRAME		
9	PLATE END		
10	SPRING COMP		
11	WASHR		
12	PLATE END TOP		
13	PIN GUIDE		
14	GUIDE ASSY END (with 8-13, 15).....		51032850
15	LABEL END TOP		
16	WASHR WAVE		

**PL 13.3 Tray (2/2) illustration**

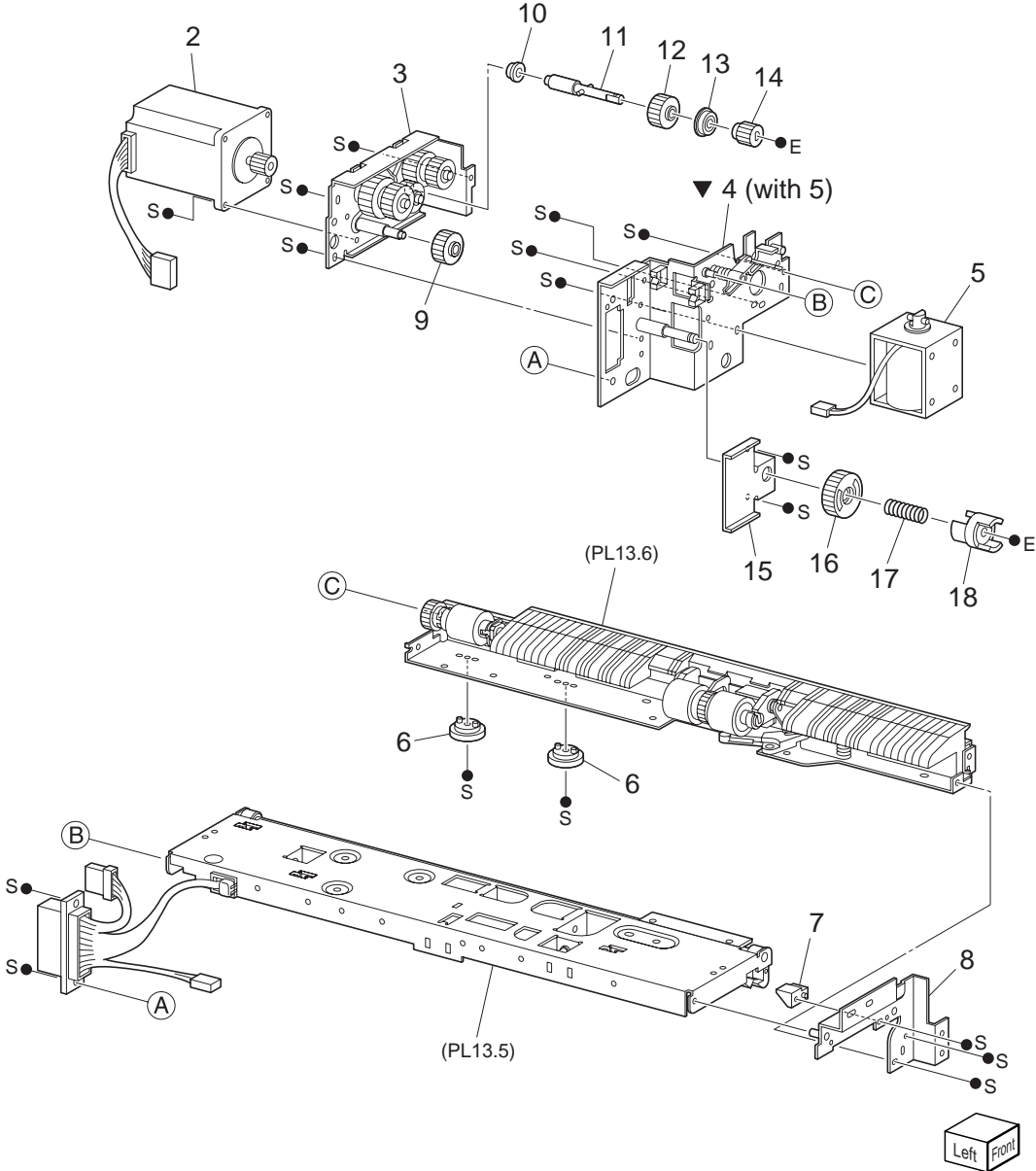


## PL 13.3 Tray (2/2)

Item	Part Name	Part Number
1	GUIDE ASSY SIDE R	
2	GUIDE ASSY SIDE F	
3	PAD BOTTOM.....	50519351
4	PLATE BOTTOM	
5	PLATE ASSY BOTTOM (with 3, 4)	
6	CABLE	
7	SCREW GUIDE TRAY	
8	BRKT ASSY GEAR R PF2	
9	BEARING POWERD	
10	SHAFT LIFT	
11	BEARING POWERD	
12	WASHER	
13	PULLEY S	
14	GUIDE WIRE S	
15	PULLEY TRAY.....	51257520
16	GEAR FRONT TRAY.....	51256730
17	PULLEY L.....	51257530
18	GUIDE WIRE L.....	51032710
19	GEAR LIFT	
99	KIT CABLE TRAY (Item 6x4Pcs.)	

**PL 13.4 Feeder (1/3) illustration**

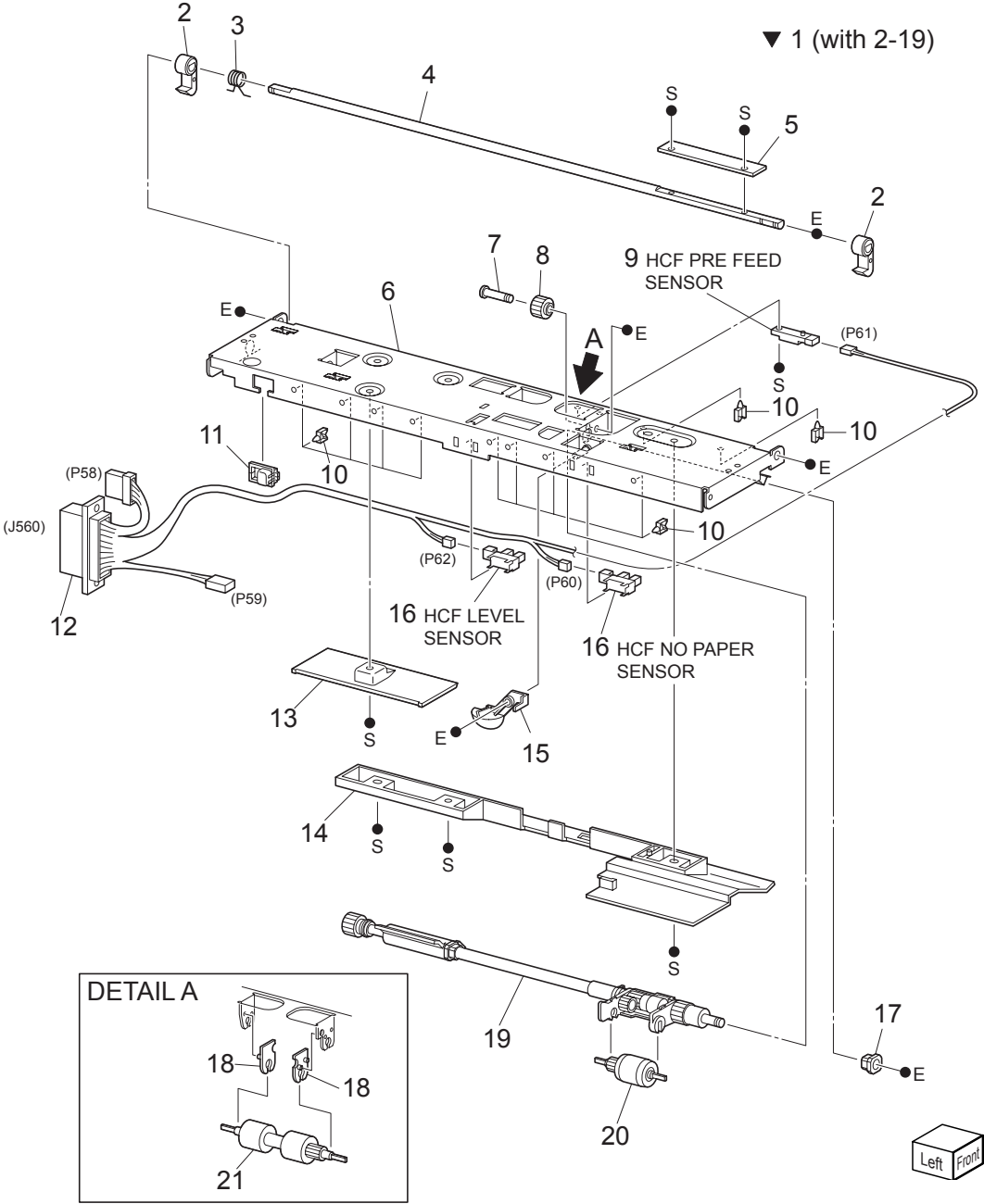
▼ 1 (with 2-18, PL22.5, PL22.6)



## PL 13.4 Feeder (1/3)

Item	Part Name	Remarks	Part Number
1	FEEDER ASSY HCF (with 2-18, PL13.5, PL13.6).....		50237853
2	MOTOR ASSY HCF		
3	FRAME ASSY DRIVE		
4	FRAME ASSY REAR (with 5)		
5	SOLENOID ASSY		
6	HOLDER		
7	BLOCK		
8	FRAME ASSY FRONT		
9	GEAR-25		
10	BEARING		
11	SHAFT ASSY		
12	GEAR-25		
13	BEARING		
14	GEAR-19		
15	BRACKET		
16	GEAR-40		
17	SPRING SPACER		
18	SPACER		

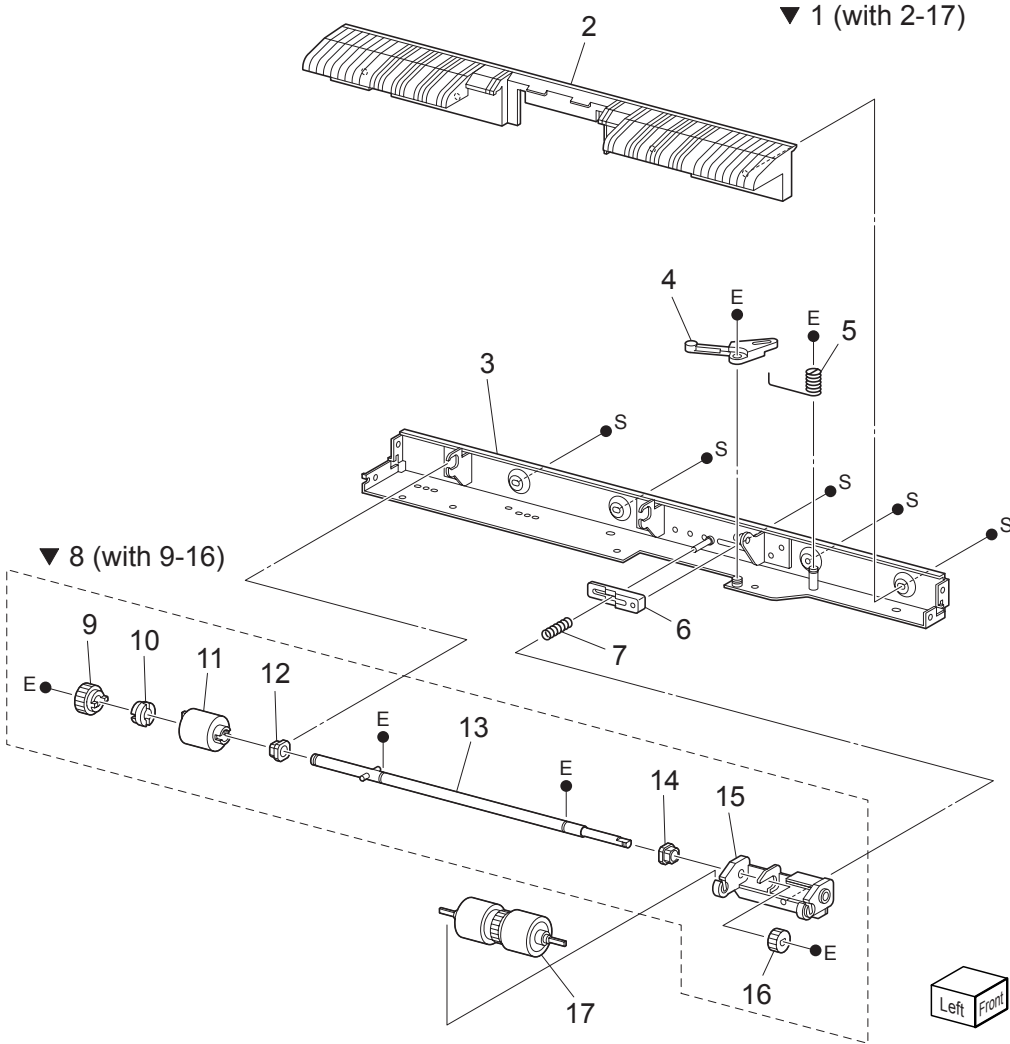
**PL 13.5 Feeder (2/3) illustration**



## PL 13.5 Feeder (2/3)

Item	Part Name	Remarks	Part Number
1	FEEDER ASSY UPPER (with 2-19)		
2	LATCH.....		50814270
3	SPRING LATCH.....		50938080
4	SHAFT LATCH		
5	LEVER.....		50814140
6	FRAME ASSY UPPER		
7	PIN DRIVE		
8	GEAR 25 FEED		
9	SENSOR ASSY		
10	CLAMP MINI-SADDLE HOLDER HARNESS PS1		
11	GUIDE		
12	HARN ASSY FEEDER	J560, P58, P59, P60, P61, P62	
13	CHUTE UPPER REAR		
14	CHUTE UPPER		
15	ACTUATOR		
16	SENSOR-PHOTO IN.....		50422812
17	BEARING		
18	SPACER		
19	SHAFT ASSY FEEDER		
20	ROLL ASSY NUD		
21	ROLL ASSY FEED		
99	KIT: FEED ROLL (HFC) (with 13.5.20, 13.5.21, 13.6.17).....		50423660

PL 13.6 Feeder (3/3) illustration

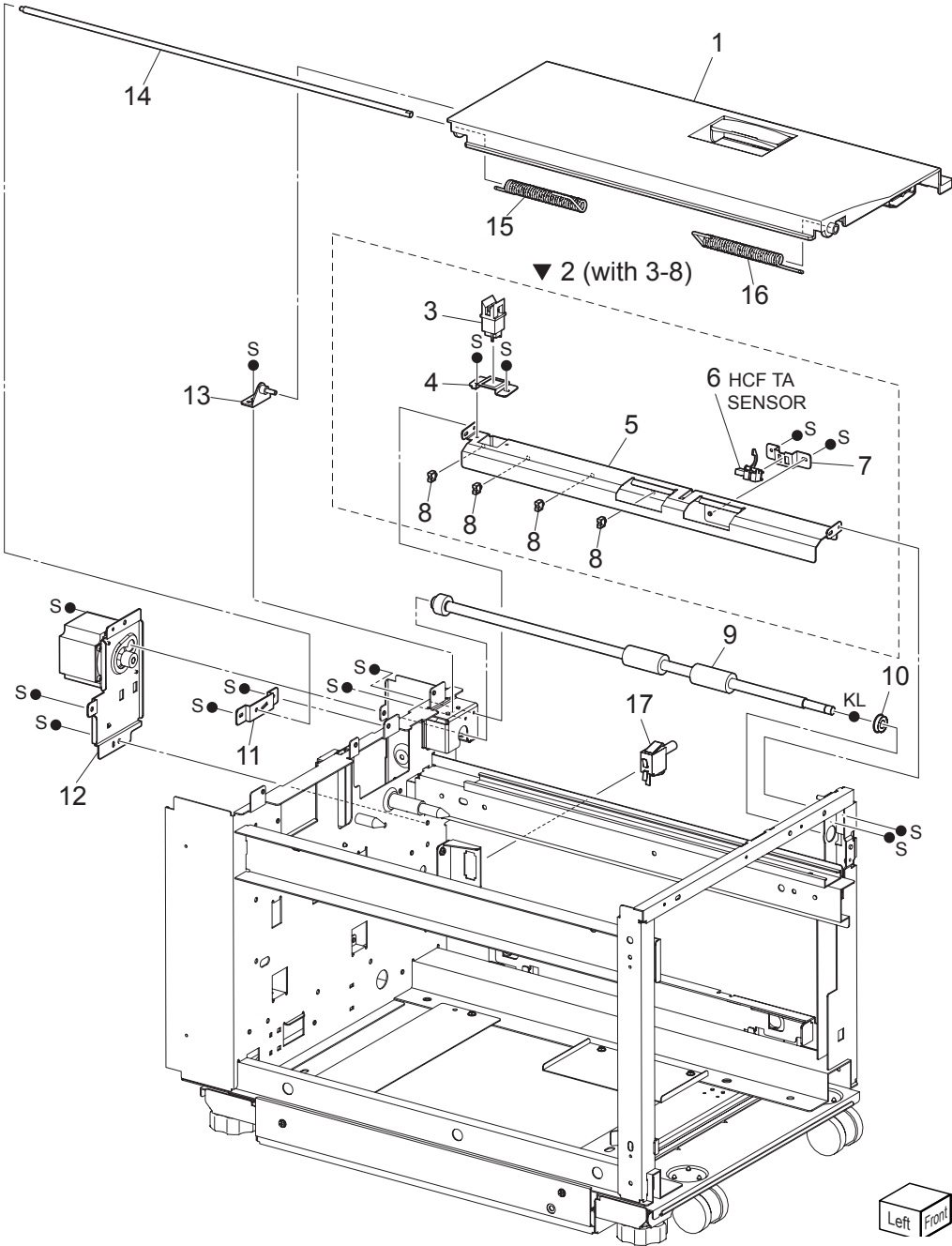




## PL 13.6 Feeder (3/3)

Item	Part Name	Remarks	Part Number
1	FEEDER ASSY LOWER (with 2-17)		
2	CHUTE LOWER		
3	FRAME ASSY-LOWER HCF		
4	LEVER RETARD.....		50814301
5	SPRING RET DOWN		
6	SLIDE RETARD		
7	SPRING RETARD.....		50938121
8	SHAFT ASSY RETARD (with 9-16)		
9	GEAR 22		
10	COLLAR		
11	CLUTCH ASSY-FRICTION.....		51402801
12	BEARING		
13	SHAFT ASSY-RET		
14	BEARING-6		
15	BRACKET-ASSY RETARD		
16	GEAR 15		
17	ROLLER ASSY RETARD		
99	KIT: FEED ROLL (HFC) (with 13.5.20, 13.5.21, 13.6.17).....		50423660

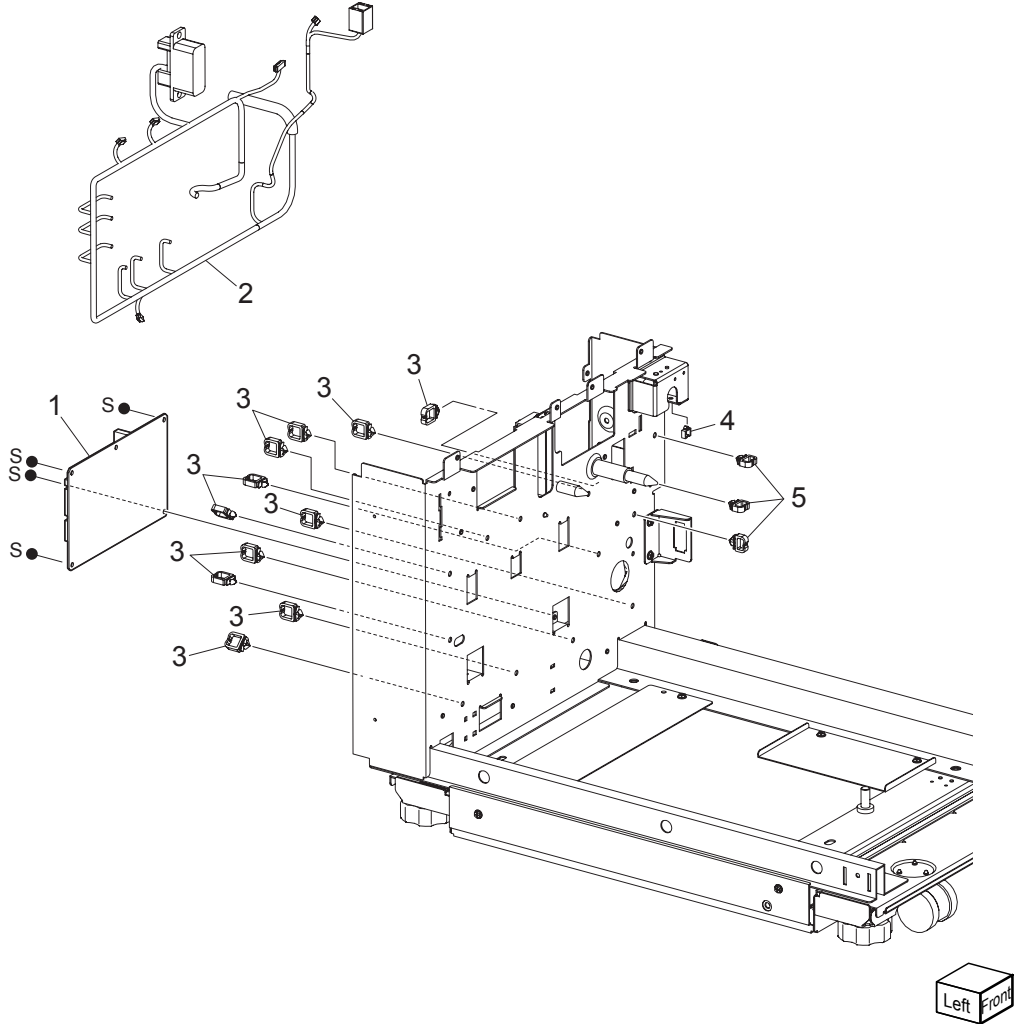
**PL 13.7 Drive & Transportation illustration**



## PL 13.7 Drive & Transportation

Item	Part Name	Remarks	Part Number
1	COVER ASSY TOP S		
2	CHUTE ASSY LOW (with 3-8)		
3	SWITCH		
4	BRACKET SWITCH		
5	CHUTE LOW.....		53360480
6	SENSOR ASSY TA.....		50422950
7	BRACKET SENSOR TA		
8	CLAMP MINI-SADDLE	ALT	
	HOLDER HARNESS PS1	ALT	
9	ROLLER ASSY TA P.....		50923760
10	BEARING CONDUCTIVE		
11	BRACKET HINGE REAR NEW		
12	MOTOR ASSY.....		56523551
13	BRACKET ASSY PIVOT		
14	SHAFT PIVOT TOP		
15	SPRING TOSION R.....		50938280
16	SPRING TOSION L.....		50938290
17	SW IL ASSY DOCKING.....		50237980

PL 13.8 Electrical illustration



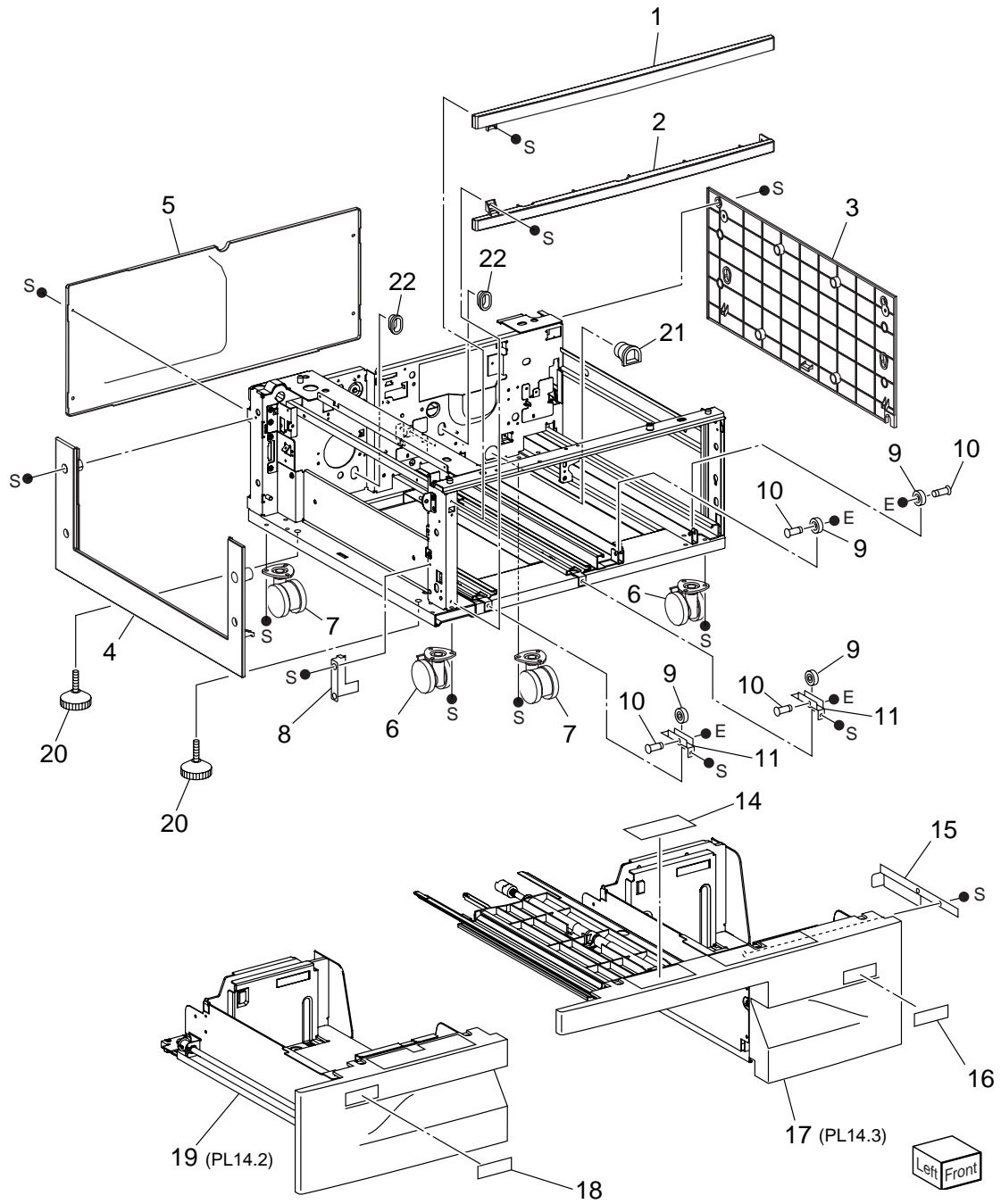
## PL 13.8 Electrical

Item	Part Name	Remarks	Part Number
1	PWB ASSY (B930 HFC).....		50238030
2	HARNESS ASSY MAIN J1, J2, J3, J4, J5, J6, J8, P51, P52, P53, P54, P55,.....		56745590
		P56, P57, P58, P800, FS1, FS2, FS3, FS4	
3	CLAMP WS-2N		
4	CLAMP MINI-SADDLE	ALT	
	HOLDER HARNESS PS1	ALT	
5	WS-1N		
6	--		

# Tandem Tray

## 14 Tandem Tray

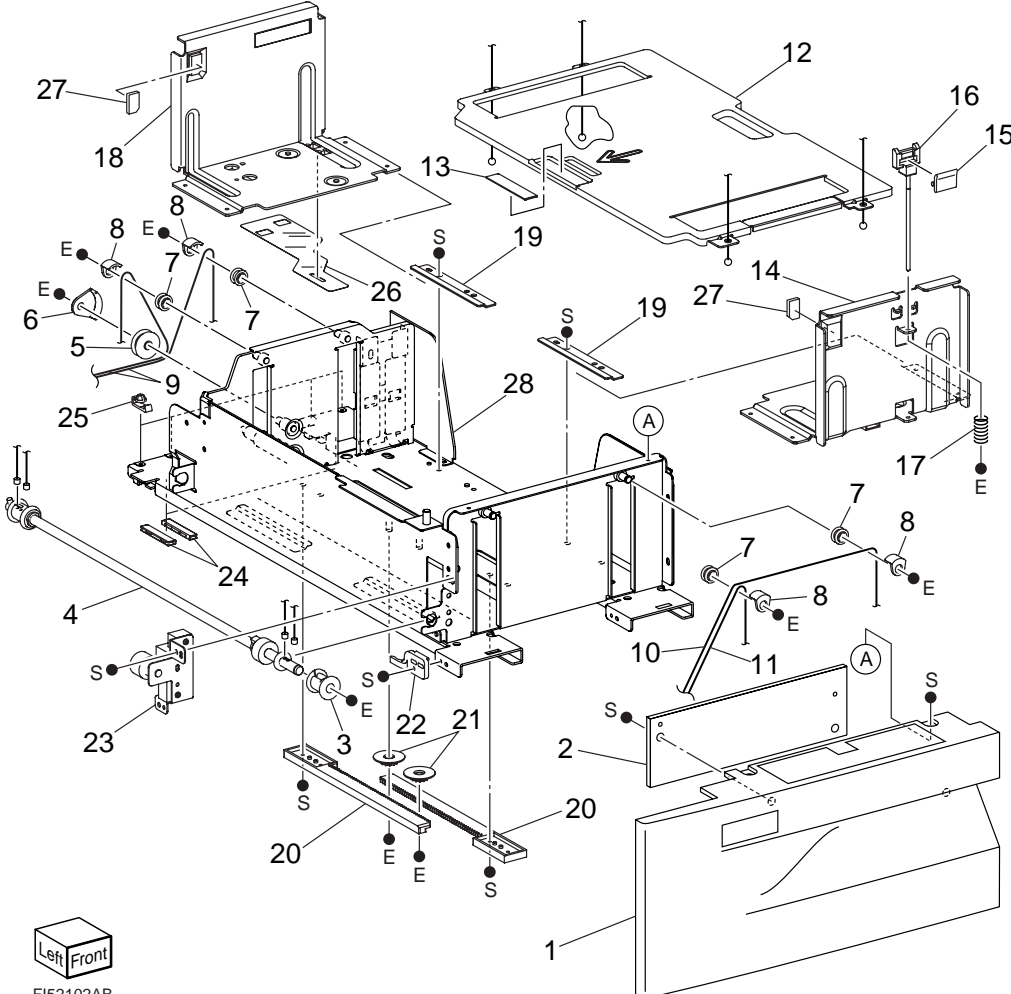
### PL 14.1 Cover illustration



## PL 14.1 Cover

Item	Part Name	Remarks
1	TOP COVER	
2	FOOT COVER	
3	RIGHT COVER	
4	LEFT LOWER COVER	
5	REAR COVER	
6	CASTER (STOPPER)	
7	CASTER	
8	TRAY 3 STOPPER	
9	ROLL	
10	SHAFT	
11	BRACKET	
12	--	
13	--	
14	LABEL	
15	TRAY 4 STOPPER (P/O ITEM 3)	
16	LABEL (4)	
17	TRAY 4 ASSEMBLY (PL14.3)	
18	LABEL (3)	
19	TRAY 3 ASSEMBLY (PL14.2)	
20	FOOT ADJUSTER	
21	COVER JOINT	
22	GUIDE TRAY	
23	--	

PL 14.2 Tray 3 illustration



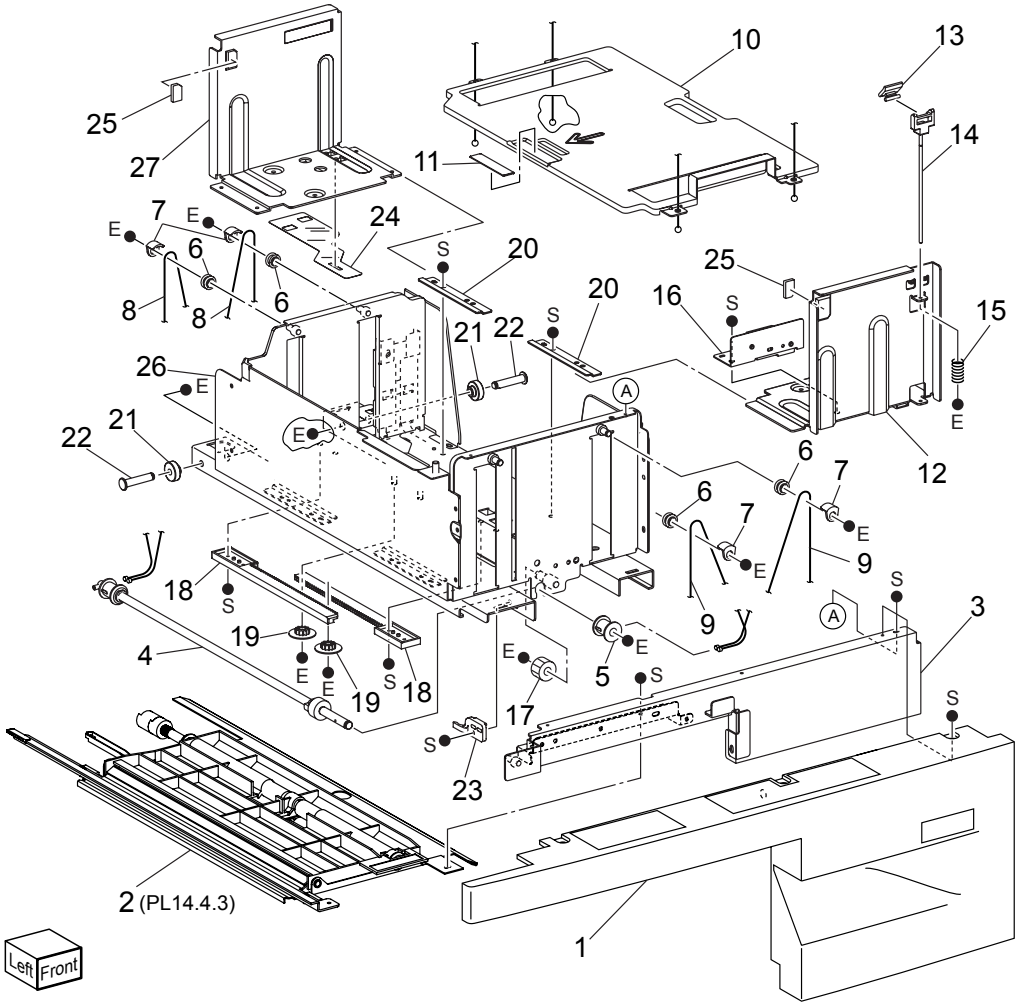
Left Front  
FI52102AB



## PL 14.2 Tray 3

Item	Part Name	Part Number
1	TRAY 3 COVER	
2	HANDLE TRAY	
3	PULLEY.....	51257221
4	LIFT SHAFT ASSEMBLY	
5	PULLEY.....	51257360
6	CABLE GUIDE.....	56643290
7	PULLEY	
8	CABLE GUIDE.....	56643350
9	TRAY CABLE.....	56643401
10	F/R CABLE.....	56643422
11	F/L CABLE	
12	BOTTOM PLATE	
13	PAD.....	50519351
14	FRONT SIDE GUIDE	
15	KNOB	
16	KNOB ASSEMBLY	
17	SPRING.....	50937870
18	REAR SIDE GUIDE	
19	BRACKET	
20	RACK GEAR.....	51257870
21	PINION.....	58257990
22	STOPPER.....	50610661
23	BRAKE BRACKET	
24	RAIL SPACER	
25	SPACER	
26	ACTUATOR	
27	PAD	
28	FRAME ASSEMBLY	

**PL 14.3 Tray 4 illustration**

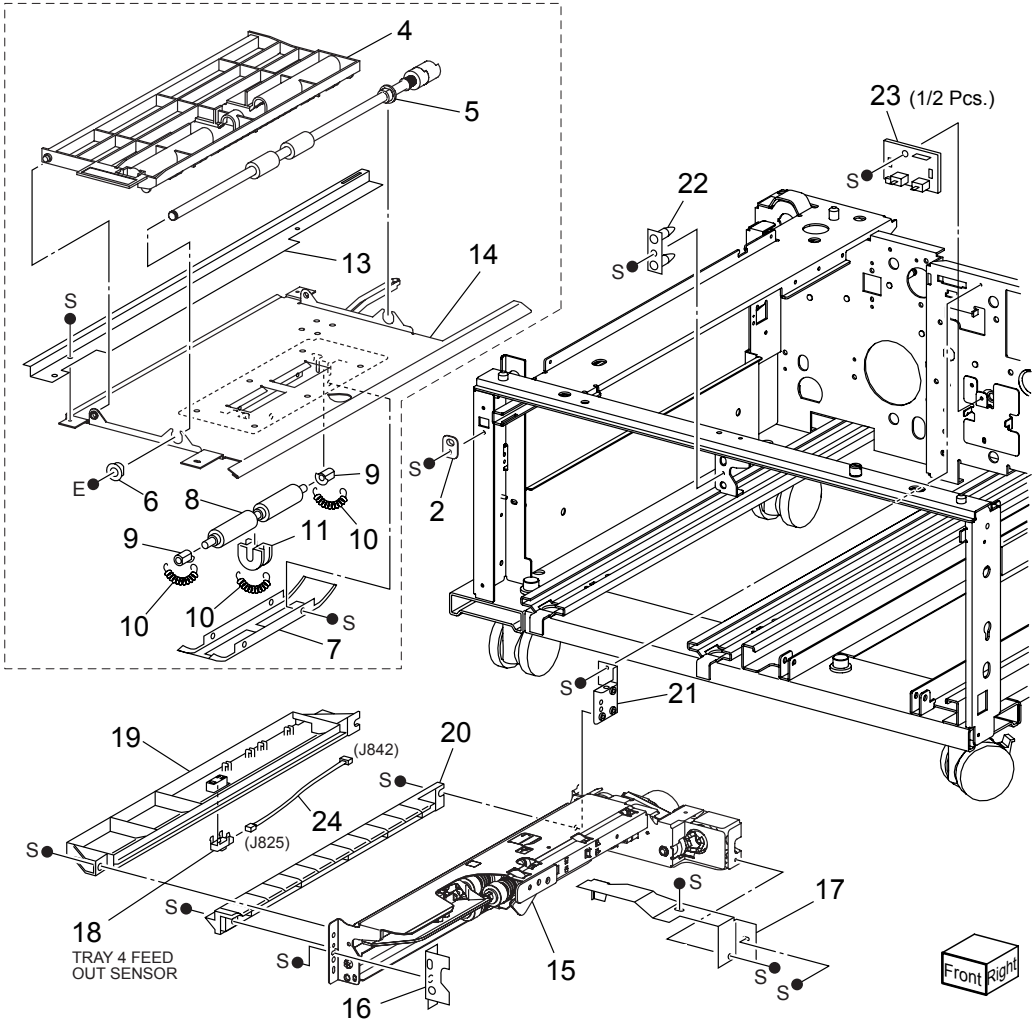


## PL 14.3 Tray 4

Item	Part Name	Part Number
1	TRAY 4 COVER	
2	TRAY 4 TRANSPORT ASSEMBLY (PL14.4.3)	
3	FRAME ASSEMBLY	
4	LIFT SHAFT ASSEMBLY	
5	PULLEY	
6	PULLEY	
7	CABLE GUIDE	
8	REAR TRAY CABLE	
9	FRONT TRAY CABLE	
10	BOTTOM PLATE	
11	PAD.....	50519351
12	FRONT SIDE GUIDE	
13	KNOB	
14	KNOB ASSEMBLY	
15	SPRING	
16	BRAKE BRACKET	
17	GEAR	
18	RACK GEAR	
19	PINION	
20	BRACKET	
21	RAIL ROLL	
22	SHAFT	
23	STOPPER	
24	ACTUATOR	
25	PAD	
26	FRAME ASSEMBLY	
27	REAR SIDE GUIDE	

# PL 14.4 Feeder (1/3) illustration

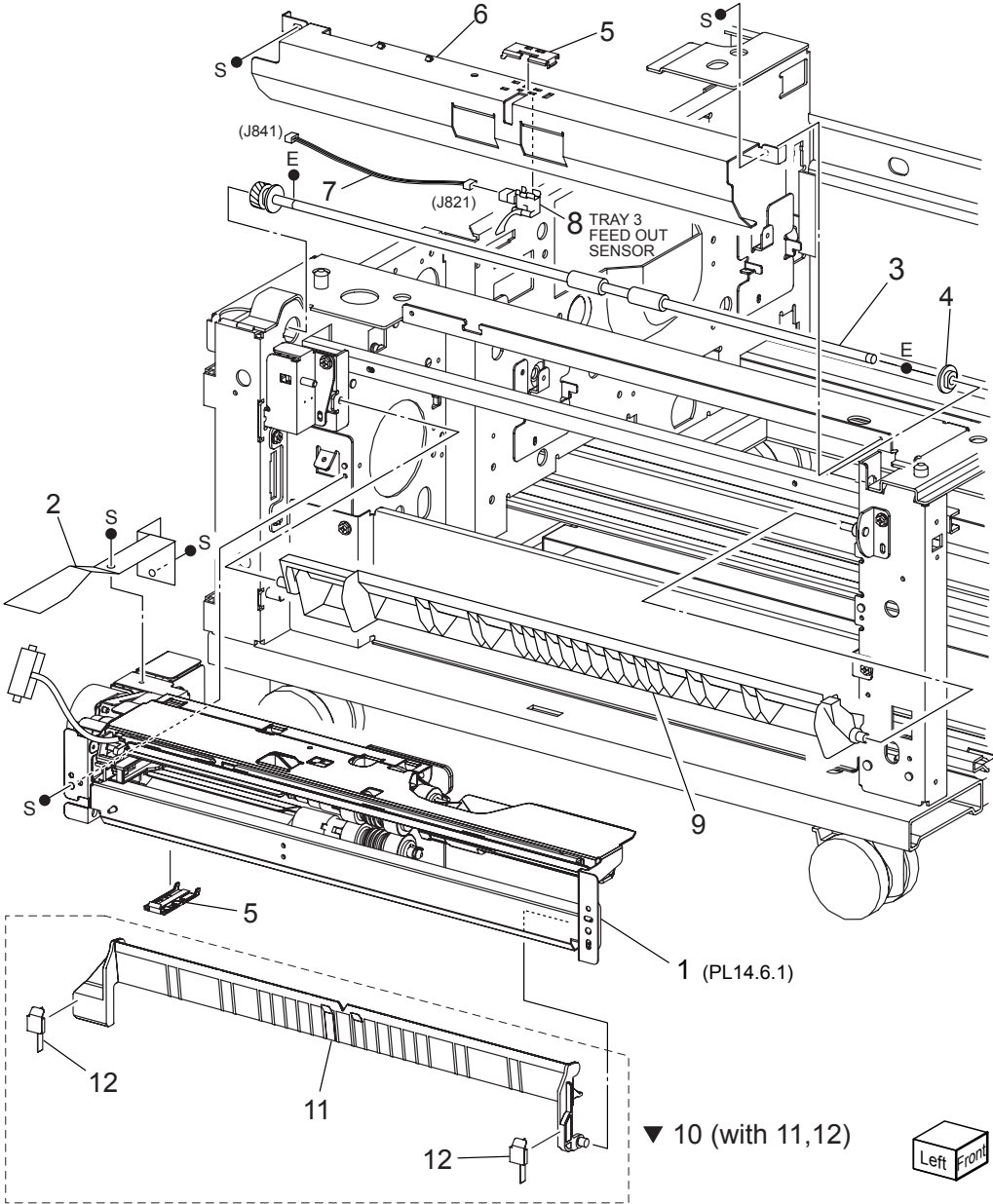
▼ 3 (with 4-14)



## PL 14.4 Feeder (1/3)

Item	Part Name	Remarks
1	--	
2	GUIDE	
3	TRAY 4 TRANSPORT ASSEMBLY (with 4-14)	
4	UPPER CHUTE	
5	TAKEAWAY ROLL ASSEMBLY	
6	BEARING	
7	COVER	
8	PINCH ROLL	
9	BEARING	
10	SPRING	
11	BEARING	
12	--	
13	TRANSPORT RAIL	
14	LOWER CHUTE	
15	TRAY 4 FEEDER (PL14.6.1)	
16	BRACKET	
17	COVER	
18	TRAY 4 FEED OUT SENSOR	
19	UPPER CHUTE	
20	F/O LOWER CHUTE	
21	BRACKET	
22	STAND BRACKET	
23	TRAY 3/4 PAPER SIZE SWITCH	
24	WIRE HARNESS	J825, J842

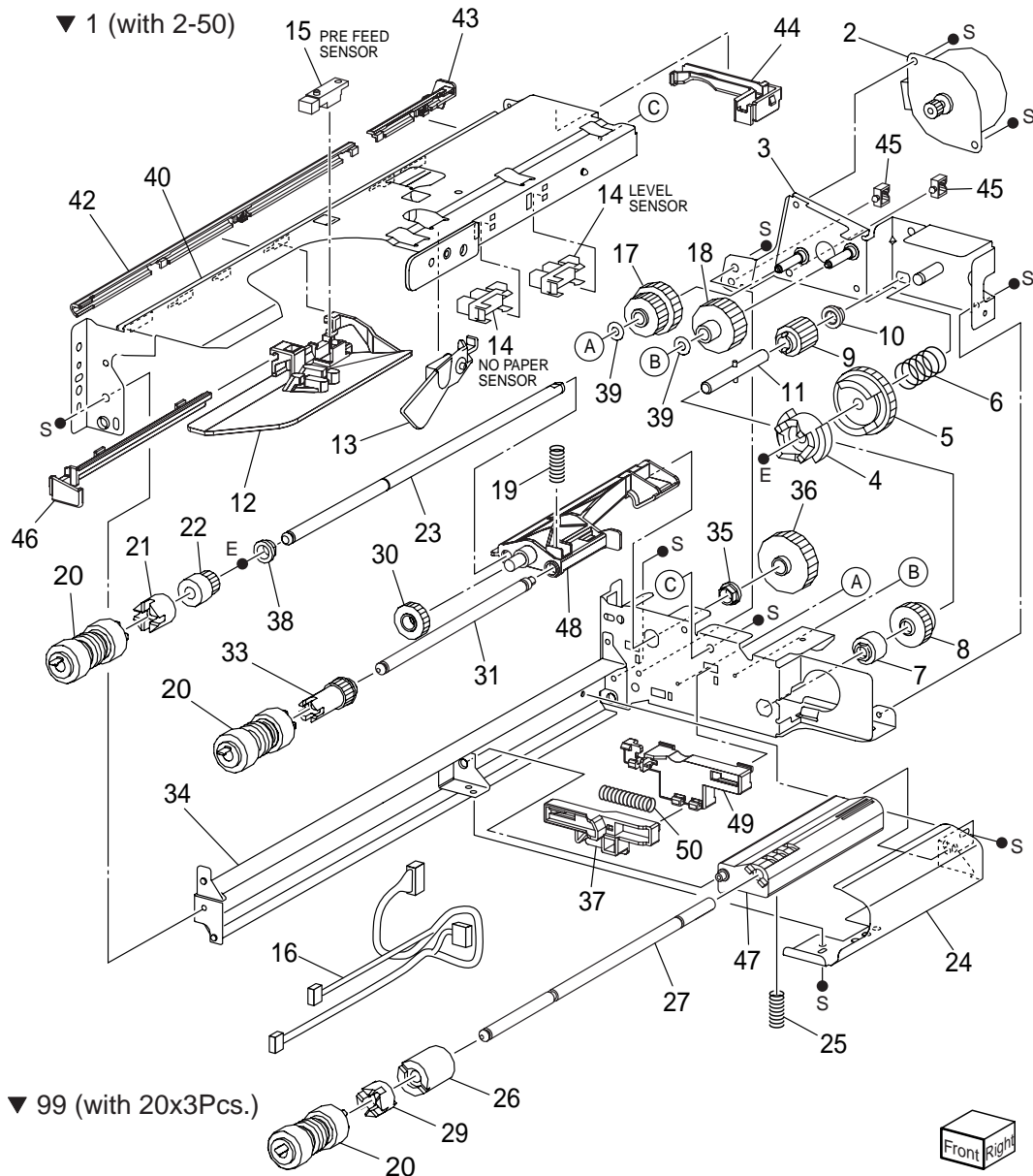
**PL 14.5 Feeder (2/3) illustration**



## PL 14.5 Feeder (2/3)

Item	Part Name	Remarks
1	TRAY 3 FEEDER (PL14.6.1)	
2	COVER	
3	TAKEAWAY ROLL ASSEMBLY	
4	BEARING	
5	COVER	
6	CHUTE	
7	WIRE HARNESS	J821, J841
8	TRAY 3 FEED OUT SENSOR	
9	LOWER CHUTE	
10	CHUTE ASSY FEEDER 2 (with 11, 12)	
11	CHUTE FEED OUT	
12	PAD ASSY LH LOW	

## PL 14.6 Feeder (3/3) illustration



## PL 14.6 Feeder (3/3)

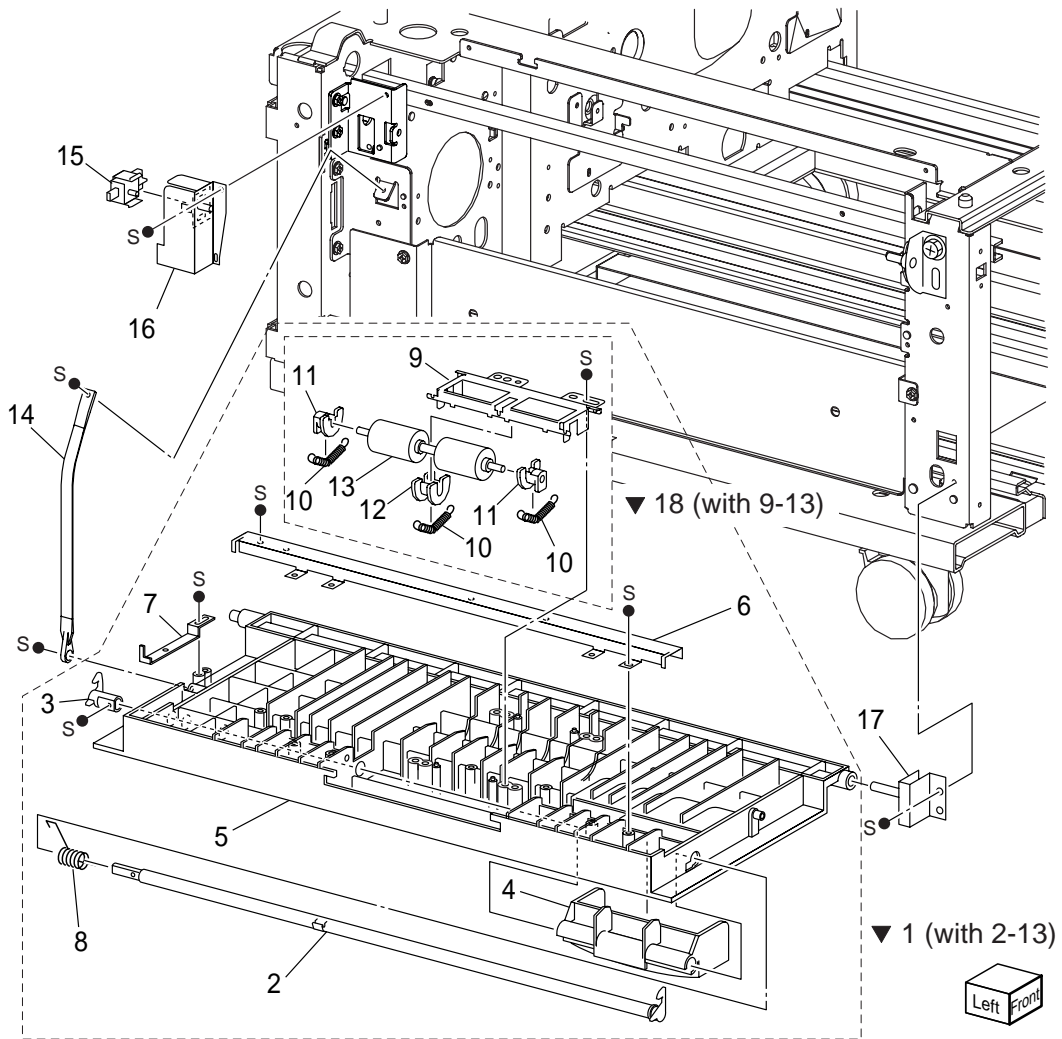
Item	Part Name	Remarks	Part Number
1	FEEDER ASSEMBLY (with 2-50)		
2	TRAY 1/2 FEED LIFT UP MOTOR		
3	BRACKET		
4	SPACER		
5	GEAR (31T)		
6	SPRING		
7	ONEWAY CLUTCH		
8	ONEWAY GEAR		
9	GEAR (13T)		
10	BEARING		
11	SHAFT		
12	FRONT CHUTE		
13	ACTUATOR		
14	SENSOR		
15	SENSOR		
16	WIRE HARNESS	J101, J102, J103, J220, J661	
17	GEAR (28T/21T)		
18	GEAR (29T).....		51256301
19	SPRING		
20	ROLLER ASSY	Periodical replacement parts (per 300k print) See # 99	
21	ONEWAY CLUTCH.....		51402590
22	ONEWAY GEAR (22T)		
23	SHAFT		
24	CHUTE		
25	SPRING		
26	FRICTION CLUTCH.....		51402610
27	SHAFT-RETARD		
28	--		
29	SPACER		
30	GEAR (33T)		
31	SHAFT-NUDGER		
32	--		
33	GEAR (25T)		
34	LOWER FRAME		
35	BEARING		
36	GEAR (27T)		
37	LEVER		
38	BEARING		
39	WASHER		
40	UPPER FRAME		
41	--		
42	HOLDER HARNESS CTR		
43	HOLDER HARNESS REAR		
44	HOLDER HARNESS UPPER		



- 45      HOLDER HARNESS PS1      ALT
- CLAMP MINI-SADDLE      ALT
- 46      RAIL
- 47      SUPPORT RETARD
- 48      SUPPORT NUDGER
- 49      HOLDER
- 50      SPRING

99      KIT ROLLS (with 20x3Pcs.)      Periodical replacement parts (per 300k print).....53361030

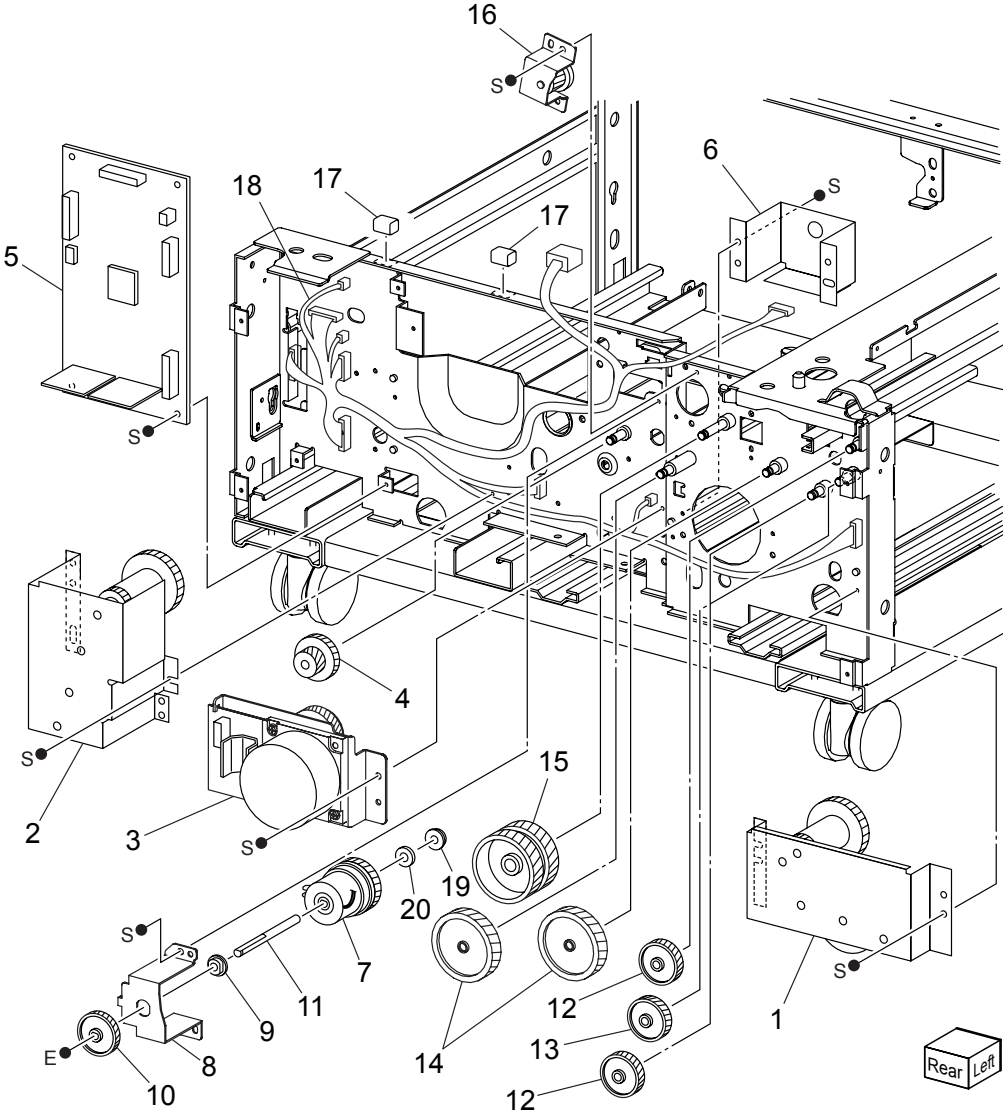
**PL 14.7 Transportation illustration**



## PL 14.7 Transportation

Item	Part Name	Remarks
1	LEFT COVER ASSEMBLY (with 2-13)	
2	LATCH	
3	HOOK	
4	HANDLE	
5	LEFT COVER	
6	CHUTE	
7	ACTUATOR	
8	SPRING	
9	BRACKET	
10	SPRING	
11	BEARING	
12	BEARING	
13	PINCH ROLL	
14	SUPPORT	
15	LEFT COVER INTERLOCK SWITCH	
16	BRACKET	
17	BRACKET	
18	ROLL ASSY (with 9-13)	

PL 14.8 Drive & Electrical illustration



## PL 14.8 Drive & Electrical

Item	Part Name	Remarks
1	GEAR ASSEMBLY (Tray 3)	
2	GEAR ASSEMBLY (Tray 4)	
3	MAIN MOTOR	
4	GEAR (22/40)	
5	TRAY MODULE PWB	
6	BRACKET	
7	TAKEAWAY CLUTCH	
8	BRACKET	
9	BEARING	
10	GEAR (38T)	
11	SHAFT	
12	GEAR (37T)	
13	GEAR (32T)	
14	GEAR (60T)	
15	GEAR (60T)	
16	BRACKET ASSEMBLY	
17	GASKET	
18	WIRE HARNESS	J541, J552, J554, J549, J548, J826, J820, J824, P661, P822, P841, P842, FS812, FS813
19	BEARING	
20	WASHER-PLAIN,NYN	

