

B83MB

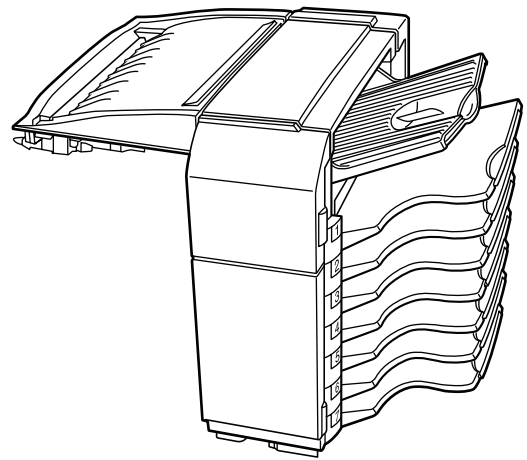

## LASER PRINTER OPTION

**MAIL BIN STACKER - B83MB**

---

# Table of Contents

---

<b>[1] PRODUCT OUTLINE</b>	<b>1</b>
CONFIGURATION.....	1
<b>[2] SPECIFICATIONS</b>	<b>1</b>
Basic.....	1
<b>[3] UNPACKING AND INSTALLATION</b>	<b>1</b>
	<i>Before installation 1</i>
<b>[4] EXTERNAL VIEWS AND INTERNAL STRUCTURES</b>	<b>1</b>
External view.....	1
Internal structure.....	1
Sensor.....	2
Motor, clutch, PWB.....	3
<b>[5] MACHINE OPERATION</b>	<b>1</b>
Printer driver setting.....	1
Specifying a mail bin.....	1
<b>[6] DISASSEMBLY AND ASSEMBLY, MAINTENANCE</b>	<b>1</b>
Maintenance System Table.....	1
Disassembly and assembly.....	1
Unit transit.....	1
External cabinet.....	2
Transport unit.....	2
Gate solenoid.....	2
Transport roller.....	2
Upper open/close sensor.....	3
Upper cover.....	3
Paper entry sensor.....	3
Transport roller.....	3
Inside of the unit.....	4
Transport sensor.....	4
Transport sensor.....	4
Paper guide.....	4
Front side of the unit.....	5
Front door open/close sensor.....	5
Rear side of the unit.....	5
Main PWB/Main motor.....	5
Paper exit full sensor.....	6
Upper side of the unit.....	6
Paper guide.....	6
Paper transport sensor/Paper exit full sensor.....	6
Gate solenoid.....	6
Transport roller.....	6
Right side of the unit (Paper exit side).....	7
Paper transport sensor.....	7
Paper exit tray unit.....	7
Gate tray.....	7
Paper exit full sensor.....	7

# [1] PRODUCT OUTLINE

This unit allows selection of two or more paper exit trays (mail bins) when installed.

## 1. CONFIGURATION

1. Before installation of this unit, the multi-purpose tray (B83MB), the large capacity paper feed desk (B83LT), or the 3-stage paper feed desk (B83TT) must be installed.
2. When installing this unit together with the B83MP, it may be required to install the optional power unit (B83PS) together.
3. This unit cannot be installed together with the finisher (B83F) or the paper exit extension tray .

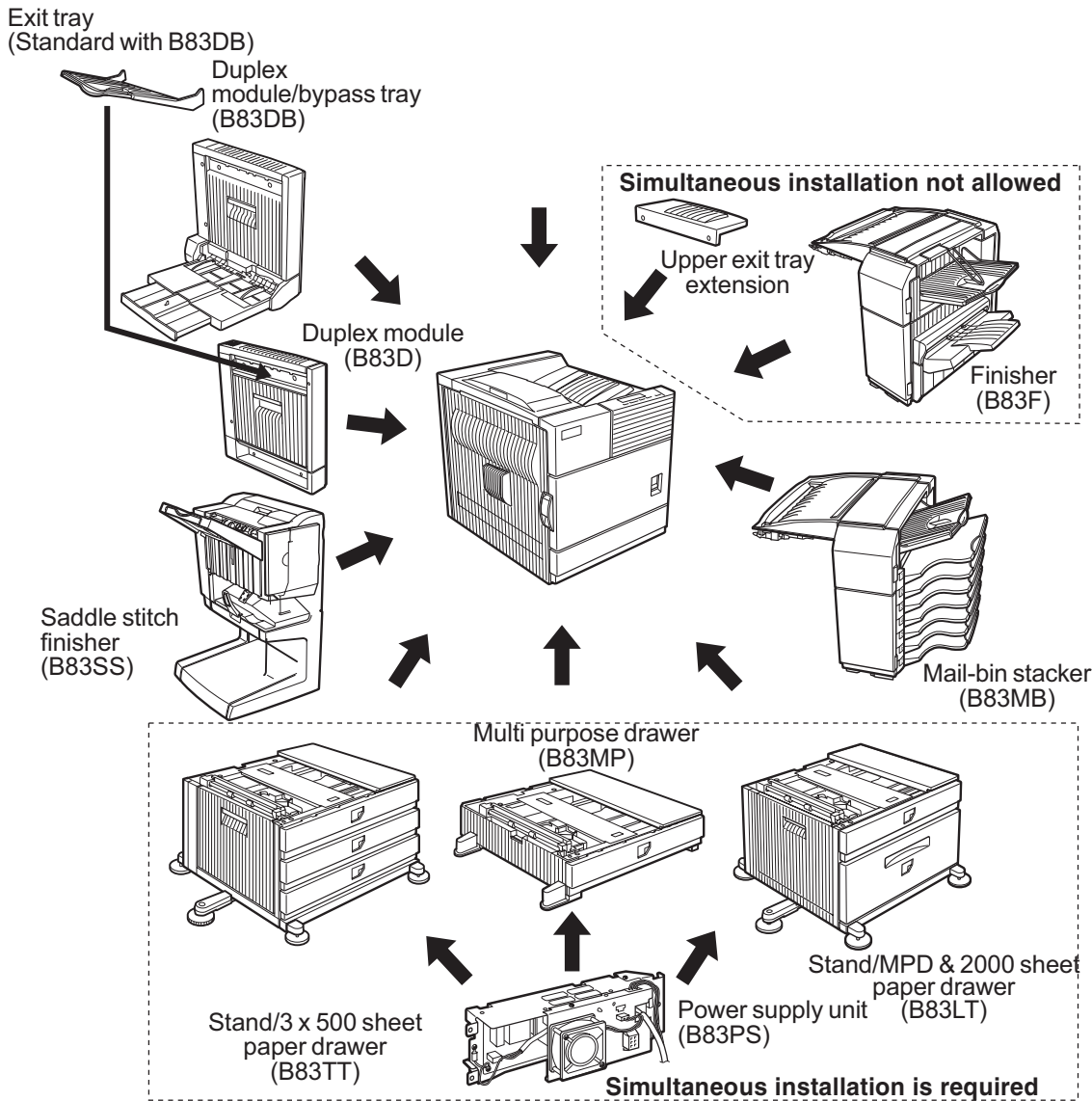

Output unit		Multi purpose drawer	Stand/3 x 500 sheet paper drawer	Stand/MPD & 2000 sheet	Duplex module/bypass tray	Duplex module	Saddle stitch finisher	Finisher	Mail-bin stacker	Exit tray	Upper exit tray extension	Punch unit	Print server card	PS3 expansion kit	Power supply unit	Hard disk drive
Mail-bin stacker	B83MB	○ <sup>*1</sup>						X	—						○	

○<sup>\*1</sup> = Any of the units must be installed together.

# [2] SPECIFICATIONS

## 1. Basic

Type	Desktop type mail bin stacker with 8-exit-tray	
Transport speed	To support 35-45 sheet/minute	
Transport alignment	Center alignment	
Tray type (No. of tray)	Upper tray	EXIT tray
	Lower Tray	Mail bin tray (7 stages)
Output paper capacity	Upper tray	250 sheets (A4 / 8.5"x11", 80g/m <sup>2</sup> / 21.22lbs)
	Lower Tray	100 sheets/bin (A4 / 8.5"x11", 80g/m <sup>2</sup> / 21.22lbs)
Output paper delivery	Face-down	
Output paper size	Upper tray	A3, B4, A4, A4R, B5, B5R, A5R 11"x17", 8.5"x14", 8.5"x13", 8.5"x11", 8.5"x11"R, 5.5"x8.5"R, Executive, Japanese post card, Monarch (98x191), Com-10 (105x241), DL (110x220), C5 (162x229), ISO B5 (176x250)
	Lower Tray	A3, B4, A4, A4R, B5, B5R 11"x17", 8.5"x14", 8.5"x13", 8.5"x11", 8.5"x11"R, Executive
Spec of media for paper output	Upper tray	Tracing paper: 52-59g/m <sup>2</sup> / 14-15lbs Plain paper: 60-128g/m <sup>2</sup> / 16-34lbs Index paper: 176g/m <sup>2</sup> / 47lbs Cover paper: 205g/m <sup>2</sup> / 54-55lbs Transparency
	Lower Tray	Plain 60-105g/m <sup>2</sup> / 16-28lbs
Remaining paper detection	Upper tray	Not Provided
	Lower Tray	Not Provided
Exit tray full detection	Upper tray	Provided
	Lower tray	Provided
Power consumption	Less than about 20.2W	
Power source	Supplied from the optional power source (DC24V 0.8A / DC5V 0.2A)	
External dimensions (WxDxH)	18.31"x20.87"x20" (inches)	
	465x530x508 (mm)	
Occupied dimensions (WxD)	18.31"x20.87" (inches)	
	465x530 (mm)	
Weight	Approx. 19kg / 41.89lbs	

Note: The meaning of "R" in paper size indications

- Some paper sizes can be placed in the printer so that it feeds either long edge first or short edge first.
- To differentiate between the two sizes in the various tables, the short edge first size indication will contain an "R". These are indicated as 8½ x 11R, 5½ x 8½R, A4R, B5R, etc.
- Sizes that can be placed only in the landscape orientation (11 x 17, 8½ x 14, 8½ x 13, A3, B4) do not contain the "R" in their size indication.

# [3] UNPACKING AND INSTALLATION

## Before installation

- Start installation after checking that the DATA and COMMUNICATION indicators on the operation panel are neither lit nor blinking.
- For installation of B83MB, an optional stand/paper drawer (stand/MPD & 2000 sheet paper drawer, stand/3 x 500 sheet paper drawer or multi purpose drawer) must have been installed.
- Also if a multi purpose drawer has been installed, a power supply unit (B83PS) is needed additionally.

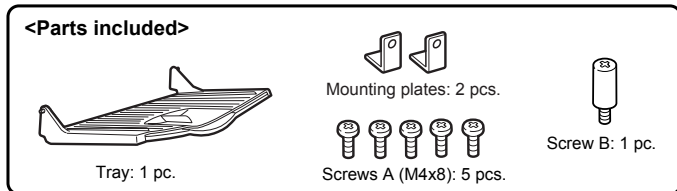
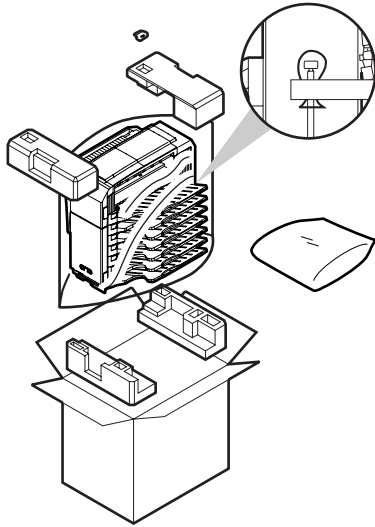

1. Turn the main switch located on the front side of the main unit to the "OFF" position. Then, remove the power plug of the main unit from the outlet.

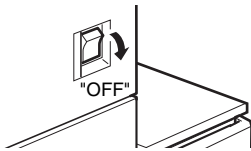

2. Remove the upper cabinet of the stand/paper drawer.

- a. Pull out the paper tray of the stand/paper drawer. Remove the four screws of the cabinet attached to the right side of the main unit of the printer and remove the cabinet.

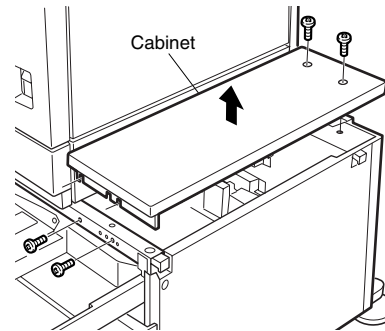

- b. Mount screw B to the position shown in the illustration.

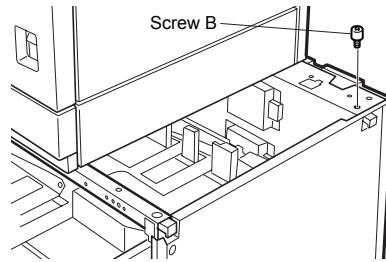

3. Attach the mail-bin stacker.

- a. Remove the paper exit actuator from the main unit of the printer.

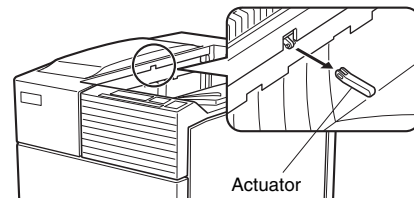

- b. Raise the relay unit at the side of the mail-bin stacker.

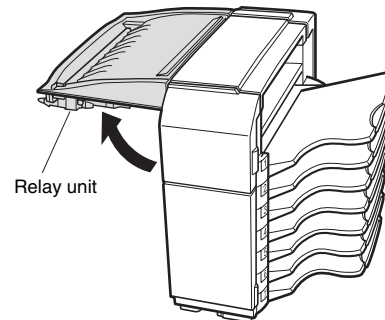

*Caution: Do not press on the relay unit while it is raised. Doing so may deform or damage the unit.*

- c. Hold the grip of the mail-bin stacker and place the mail-bin stacker on the stand/paper drawer temporarily.
- d. Push the lower part to attach the mail-bin stacker by sliding it toward the exit tray of the main unit. At this

time, align the mail-bin stacker with the exterior line of the stand/paper drawer.

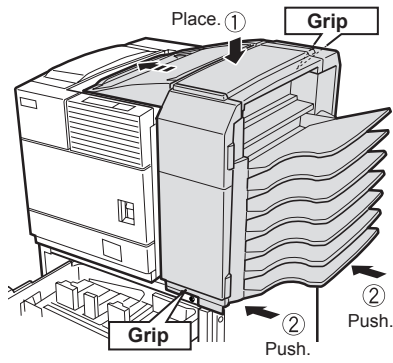

- e. Open the front cover of the mail-bin stacker and fix the stacker with three screws A at the positions shown in the illustration.
- f. Then, close the front cover and close the paper tray of the stand/paper drawer.

(Front side)

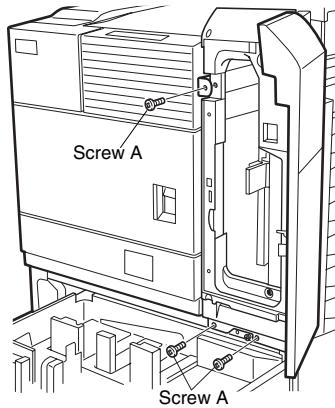

- g. Attach the mounting plates to the positions shown in the illustration and fix them with screws A.

(Rear side)

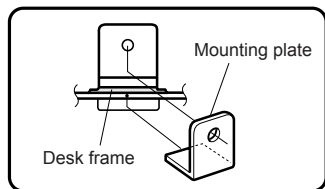
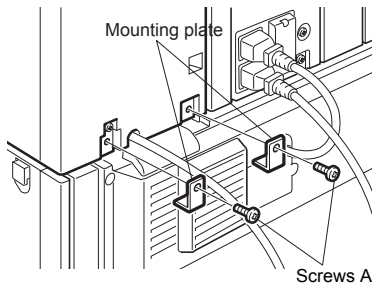

*Caution: Insert the mounting plate under the desk frame.*

- 4. Attach the tray.

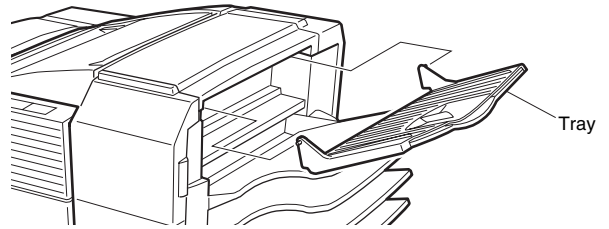

Steps 5) and after are the procedure to be carried out when a multi purpose drawer has been installed. If a stand/MPD & 2000 sheet paper drawer or a stand/3 x 500 sheet paper drawer has been installed, carry out steps 8) and after.

- 5. Remove the AC inlet cover attached to the rear cabinet of the stand/paper drawer.
  - a. Remove the two screws that secure the rear cabinet and remove the rear cabinet.
  - b. Remove the screw that fixes the AC inlet cover and then remove the AC inlet cover, as shown in the illustration.

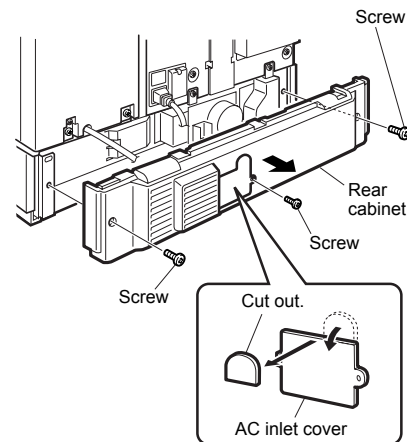

- 6. Attach the power supply unit to the hanging portions and secure it using the supplied three screws.

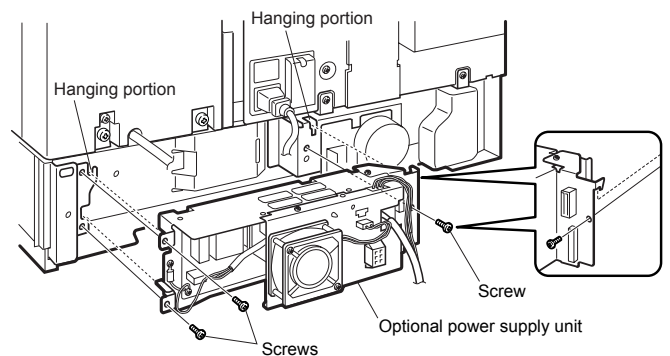

7. Connect the power supply unit harness to the PCU PWB of the main unit of the printer.

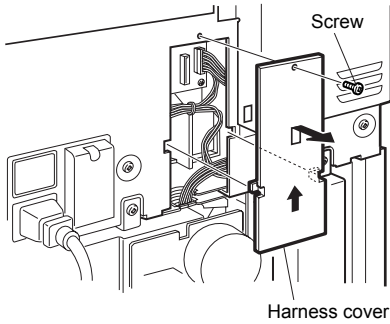

- a. Connect the power supply unit harness connector to CN11 (red connector) of the PCU PWB of the main unit of the printer.

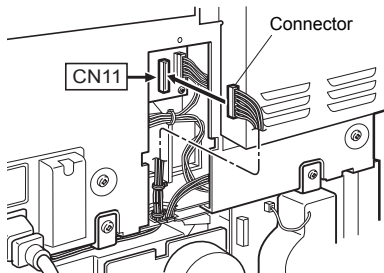

- b. Reattach the harness cover to its original position and fix it with the removed screw. At this time, ensure that the power supply unit harness is arranged as shown in the illustration.
- c. Fix the harness securely to the wire saddle.

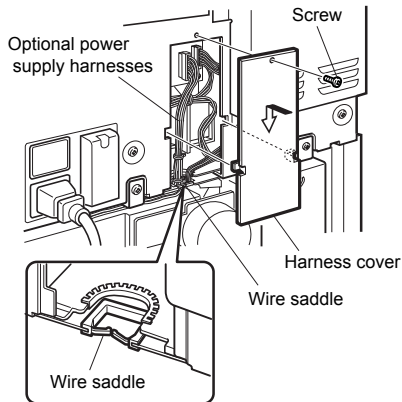

8. Remove the AC inlet cover and then remove the rear cabinet of the stand/paper drawer.

- a. Remove the screw that fixes the AC inlet cover and then remove the AC inlet cover.

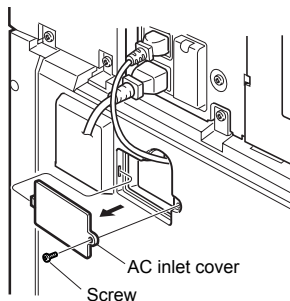

(\* Similar work for the multi purpose drawer)

- b. Remove the AC cord of the power supply unit from the inlet connector of the main unit of the printer. Remove the four screws that fix the rear cabinet and then remove the rear cabinet.

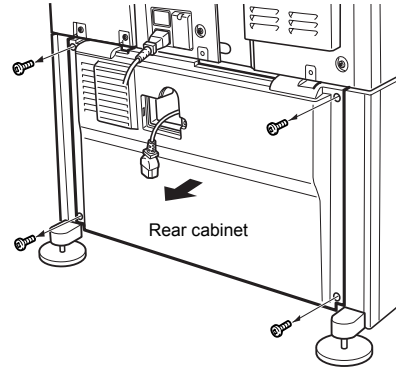

(\* Similar work for the multi purpose drawer)

9. Arrange the harness of the mail-bin staker.

- a. Pass the harness of the mail-bin staker between the power supply unit and the frame of the stand/paper drawer and connect it to the connector of the power supply unit.
- b. Fit the snap band attached to the mail-bin staker at the position shown in the illustration to fix the harness.

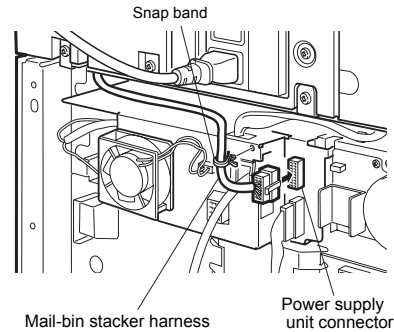

(\* Similar work for the multi purpose drawer)

10. Attach the rear cabinet of the stand/paper drawer.

- a. Pass the AC cord of the power supply unit as shown in the illustration and fix the rear cabinet of the stand/paper drawer with the screws.

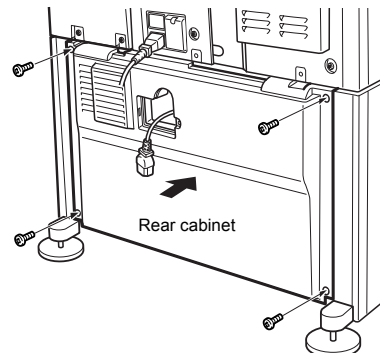

(\* Similar work for the multi purpose drawer)

- b. Attach the AC inlet cover to the rear cabinet of the stand/  
paper drawer and fix it with the removed screw.

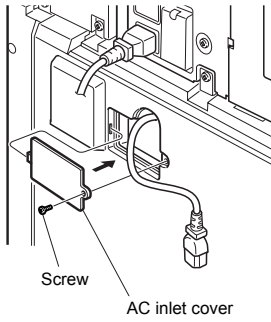

(\* Similar work for the multi purpose drawer)

11. Connect the AC cord of the optional power supply unit  
to the main unit of the printer at the location shown.

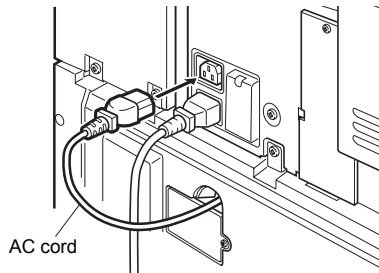

(\* Similar work for the multi purpose drawer)



# [4] EXTERNAL VIEWS AND INTERNAL STRUCTURES

## A. External view

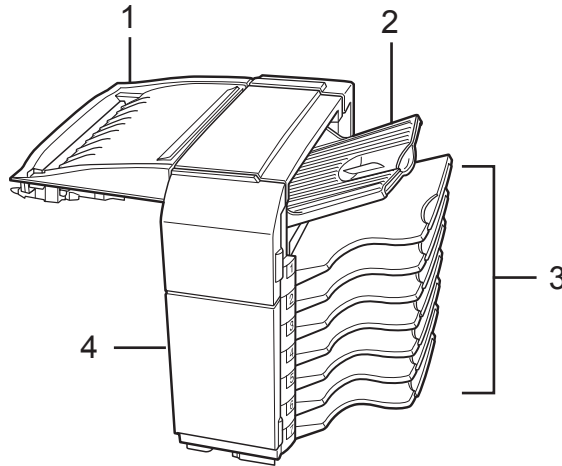

1	Top cover	2	Top stage tray	3	Male bin tray
4	Front cover				

## B. Internal structure

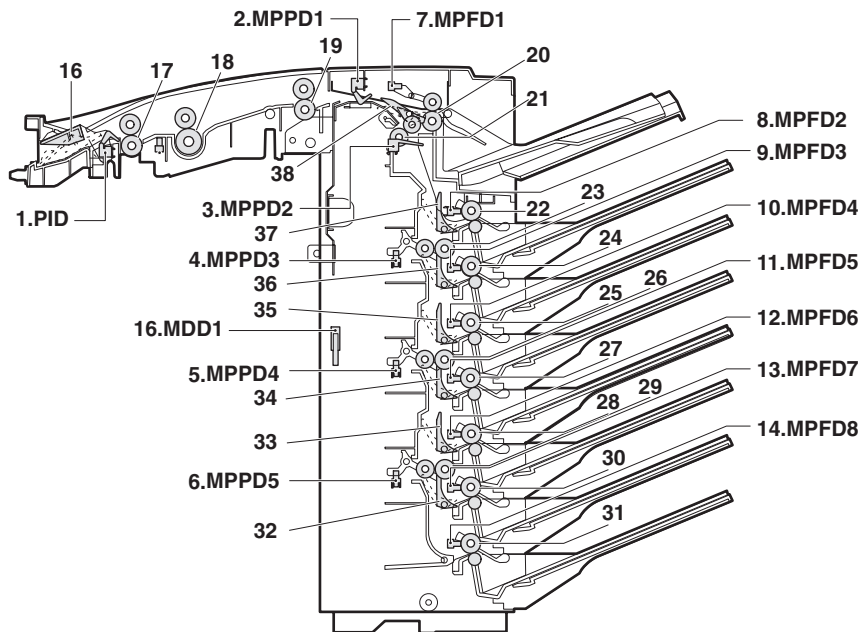

1	Paper entry sensor (PID)	15		29	Paper transport roller 7
2	Transport sensor (MPPD1)	16	Switchback (paper entry) gate	30	Male bin tray 6 paper exit roller
3	Transport sensor (MPPD2)	17	Paper transport roller 1	31	Male bin tray 7 paper exit roller
4	Transport sensor (MPPD3)	18	Paper transport roller 2	32	Tray select gate 6
5	Transport sensor (MPPD4)	19	Paper transport roller 3	33	Tray select gate 5
6	Transport sensor (MPPD5)	20	Upper stage tray paper exit roller	34	Tray select gate 4
7	Paper exit full detection 1 (MPFD1)	21	Paper transport roller 4	35	Tray select gate 3
8	Paper exit full detection 2 (MPFD2)	22	Male bin tray 1 paper exit roller	36	Tray select gate 2
9	Paper exit full detection 3 (MPFD3)	23	Paper transport roller 5	37	Tray select gate 1
10	Paper exit full detection 4 (MPFD4)	24	Male bin tray 2 paper exit roller	38	Upper stage tray select gate
11	Paper exit full detection 5 (MPFD5)	25	Male bin tray 3 paper exit roller		
12	Paper exit full detection 6 (MPFD6)	26	Paper transport roller 6		
13	Paper exit full detection 7 (MPFD7)	27	Male bin tray 4 paper exit roller		
14	Paper exit full detection 8 (MPFD8)	28	Male bin tray 5 paper exit roller		

## C. Sensor

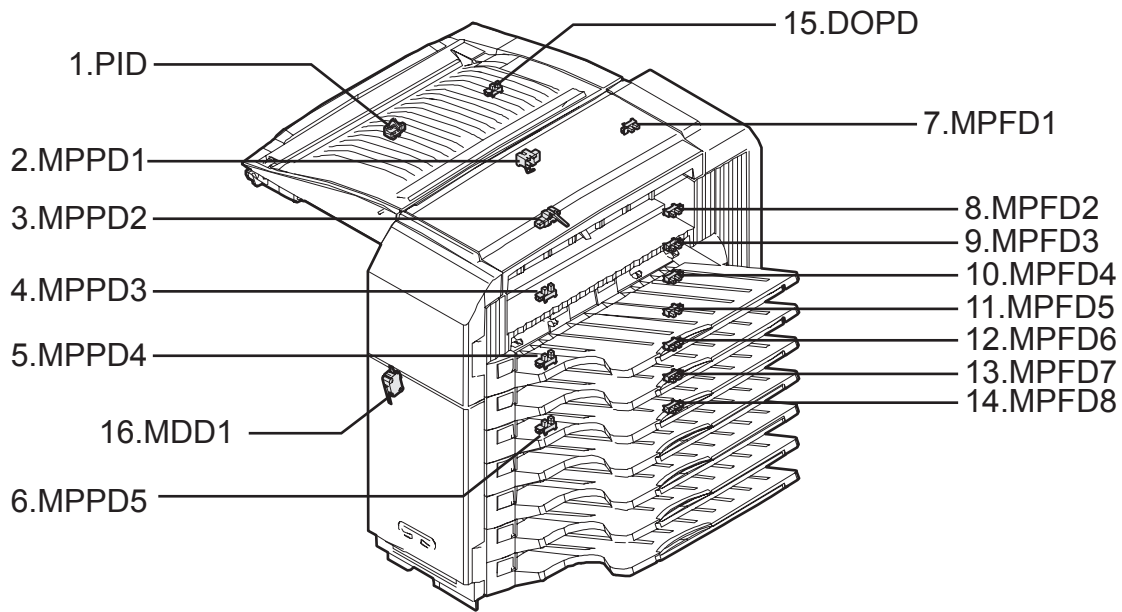

	Code	Name	Function	Active condition	Remark
1	PID	Paper entry sensor	Detection of paper entry into the interface transport section	L: Paper loaded (sensor ON)	
2	MPPD1	Transport sensor 1	Paper transport detection	L: Paper loaded (sensor ON)	
3	MPPD2	Transport sensor 2	Paper transport detection	L: Paper loaded (sensor ON)	
4	MPPD3	Transport sensor 3	Paper transport detection	L: Paper loaded	
5	MPPD4	Transport sensor 4	Paper transport detection	L: Paper loaded	
6	MPPD5	Transport sensor 5	Paper transport detection	L: Paper loaded	
7	MPFD1	Paper exit full sensor 1	Top tray full detection	L: Paper full detected	
8	MPFD2	Paper exit full sensor 2	No. 1 bin tray full detection	H: Paper full detected	
9	MPFD3	Paper exit full sensor 3	No. 2 bin tray full detection	H: Paper full detected	
10	MPFD4	Paper exit full sensor 4	No. 3 bin tray full detection	H: Paper full detected	
11	MPFD5	Paper exit full sensor 5	No. 4 bin tray full detection	H: Paper full detected	
12	MPFD6	Paper exit full sensor 6	No. 5 bin tray full detection	H: Paper full detected	
13	MPFD7	Paper exit full sensor 7	No. 6 bin tray full detection	H: Paper full detected	
14	MPFD8	Paper exit full sensor 8	No. 7 bin tray full detection	H: Paper full detected	
15	DOPD	Top cover open/close sensor	Top cover open/close detection	L: Upper cover open	
16	MDD1	Front cover open/close sensor	Front cover open/close detection	L: Front cover open	

## D. Motor, clutch, PWB

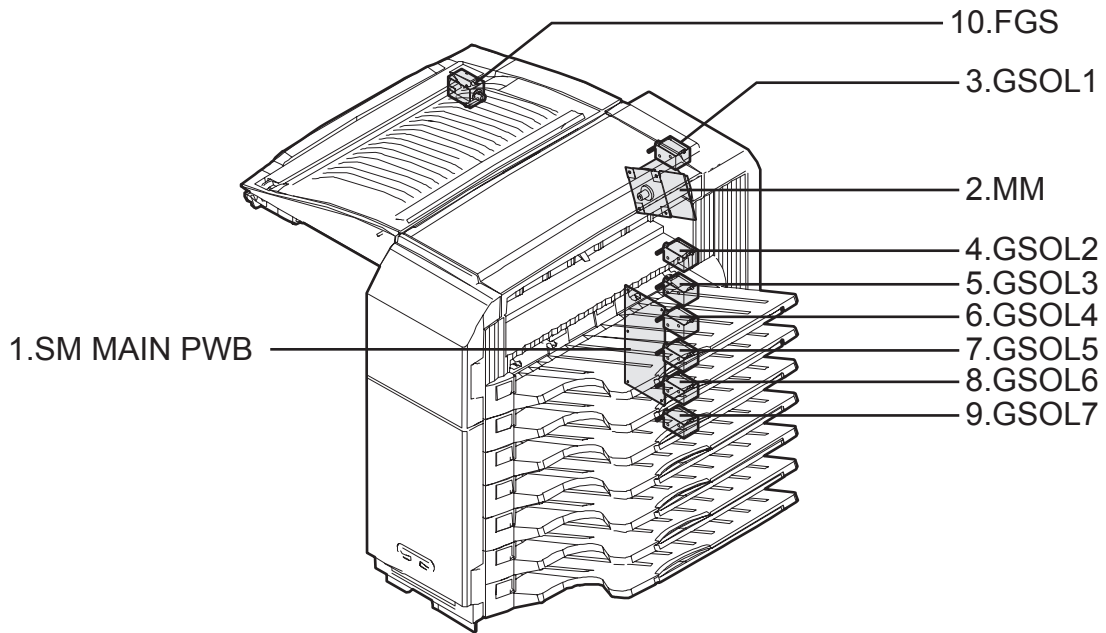

	<b>Code</b>	<b>Name</b>	<b>Function</b>	<b>Remark</b>
1	SM MAIN PWB	Male bin control PWB	Communication with the machine, operation and control of the machine	
2	MM	Transport motor	Drives rollers.	
3	GSOL1	No. 1 gate solenoid	No. 1 gate select	
4	GSOL2	No. 2 gate solenoid	No. 2 gate select	
5	GSOL3	No. 3 gate solenoid	No. 3 gate select	
6	GSOL4	No. 4 gate solenoid	No. 4 gate select	
7	GSOL5	No. 5 gate solenoid	No. 5 gate select	
8	GSOL6	No. 6 gate solenoid	No. 6 gate select	
9	GSOL7	No. 7 gate solenoid	No. 7 gate select	
10	FGS	Paper entry gate solenoid	Paper entry gate select	

# [5] MACHINE OPERATION

## 1. Printer driver setting

To specify a mail bin when printing, select "Properties" in the printer driver setting screen and set as follows.

### A. Specifying a mail bin

Open the "Paper" tab and select a mail bin for delivery in the "Output" drop down. (The top tray can be selected if active.)

Note:

- The settings screens above will appear only if the devices have been set properly in the printer driver configuration.
- The combination of paper selection and other functions may not be compatible. For instance, if heavy paper, envelopes, label stock, etc. are selected, it will not be possible to select duplex, offset tray, saddle stitch, etc. For details, see printer driver help.

The illustration below shows a sample screen for a PCL printer driver in the Windows 98 environment.

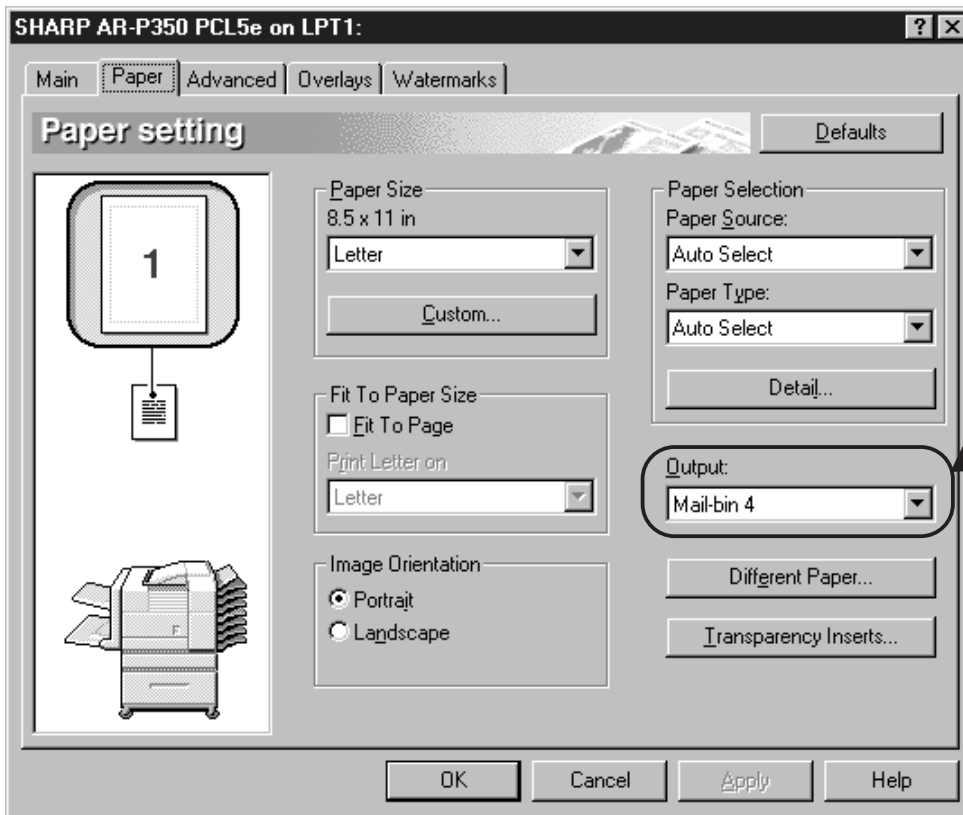

# [6] DISASSEMBLY AND ASSEMBLY, MAINTENANCE

## 1. Maintenance System Table

× Check (Clean, replace, or adjust as necessary.)    ○ Clean    ▲ Replace    △ Adjust    ☆ Lubricate    □ Move position

Unit name	Part name	When calling	50K	100K	150K	200K	250K	300K	350K	400K	Remark
Transport section	Transport rollers	○		○		○		○		○	
	Transport paper guides	○		○		○		○		○	
Drive section	Gears	☆		☆		☆		☆		☆	(Specified position)
	Belts							×			
Other	Sensors	×		×		×		×		×	
	Discharge brushes	×		×		×		×		×	

## 2. Disassembly and assembly

### A. Unit transit

Note: When carrying the Mail bin stacker unit removed from the printer, fold the transport unit as described below. If not, the frame may be bent, causing a breakdown of the machine.

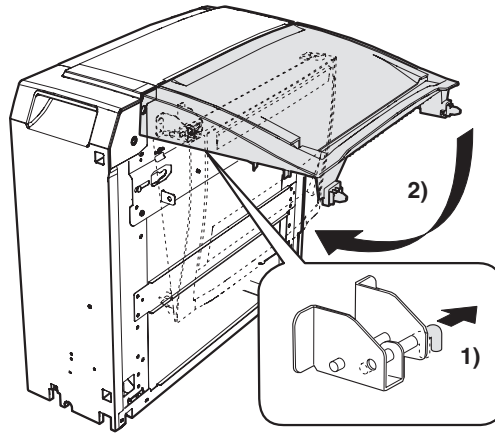

Note: The numbers in illustrations reflect the sequence required for disassembly/assembly.

## B. External cabinet

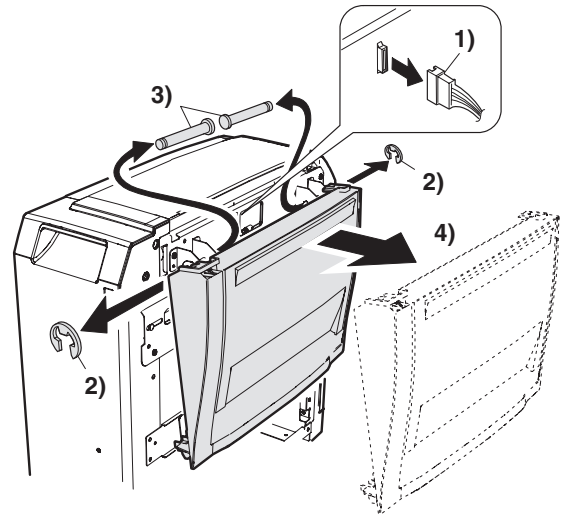
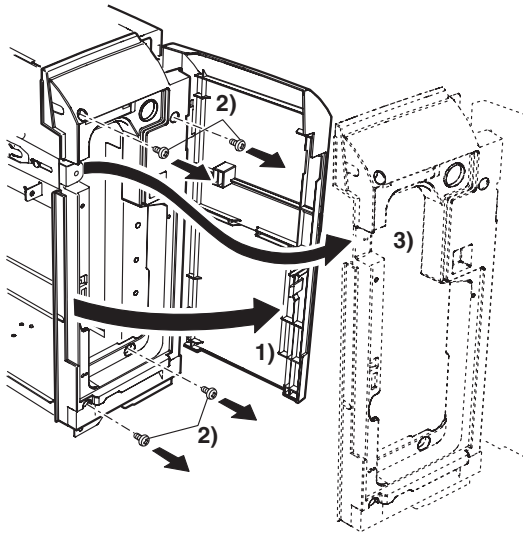

## Gate solenoid

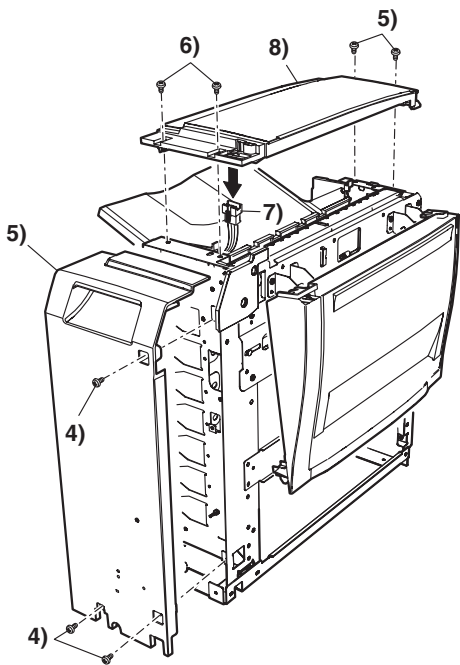
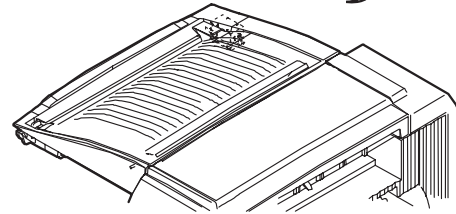
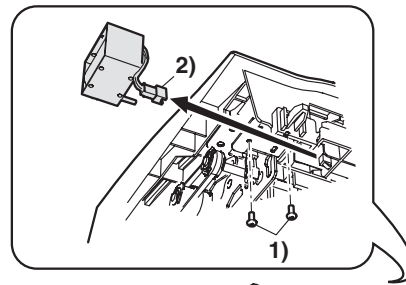

## Transport roller

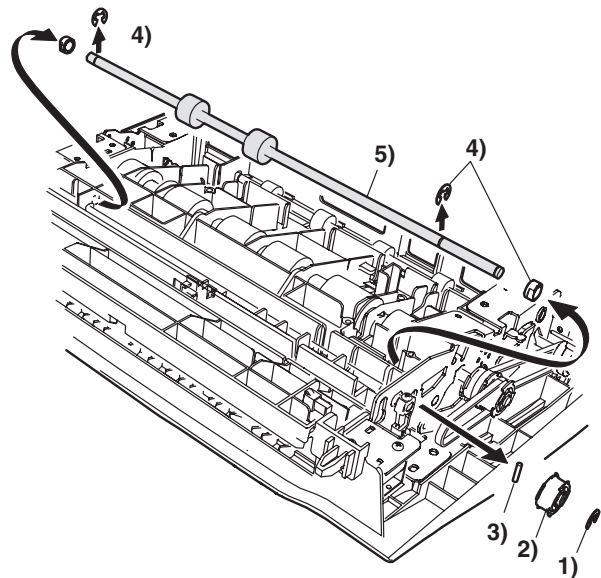

## C. Transport unit

Parts name	Job item	cycle
Transport rollers	Clean	100K
Transport paper guide	Clean	100K
Gears	Lubricate	100K
Belts	Check	300K

Note: The numbers in illustrations reflect the sequence required for disassembly/assembly.

### Upper open/close sensor

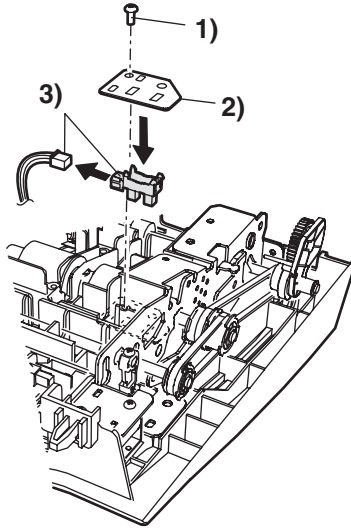

### Transport roller

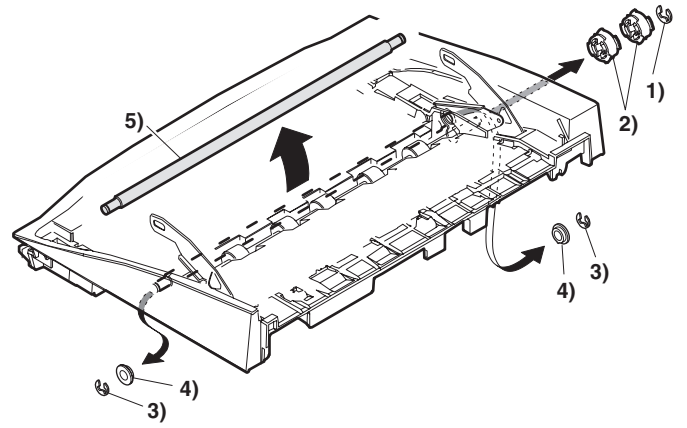

### Upper cover

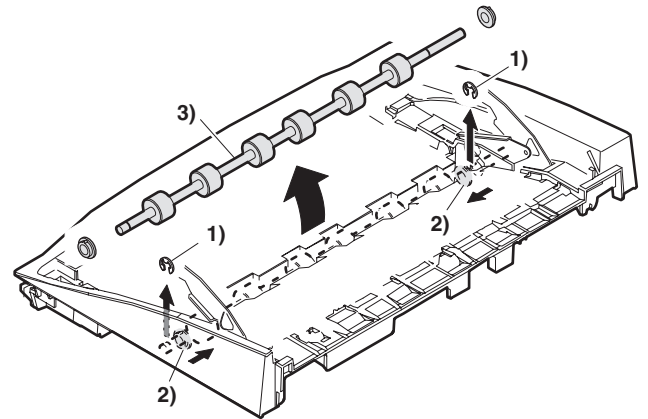
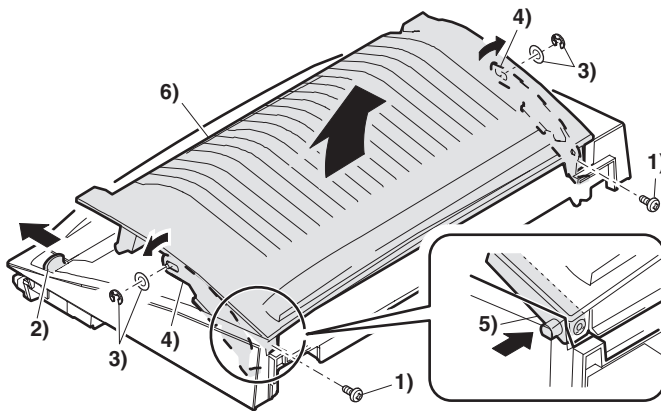

### Paper entry sensor

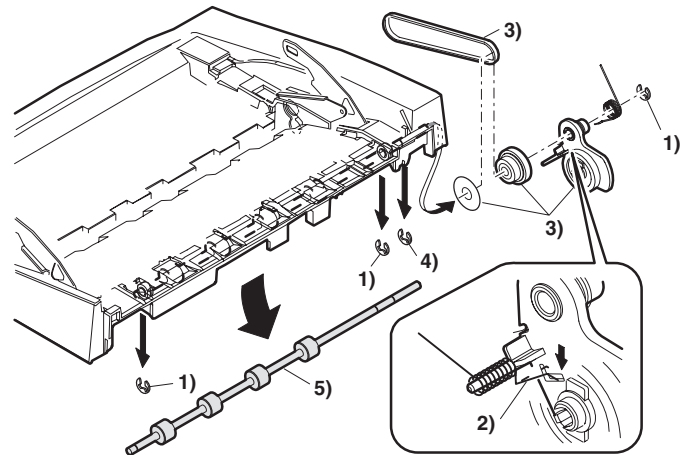
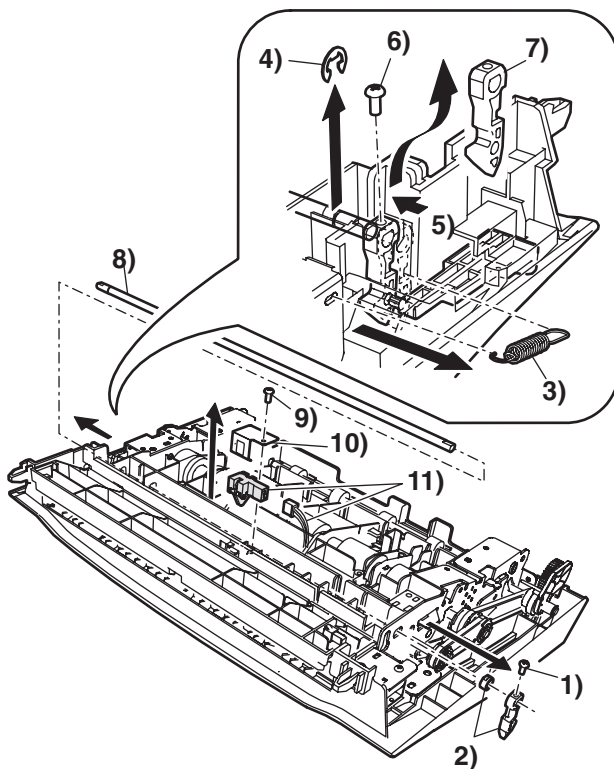

Note: The numbers in illustrations reflect the sequence required for disassembly/assembly.

## D. Inside of the unit

Parts name	Job item	cycle
Sensors	Clean	100K
Transport paper guides	Clean	100K

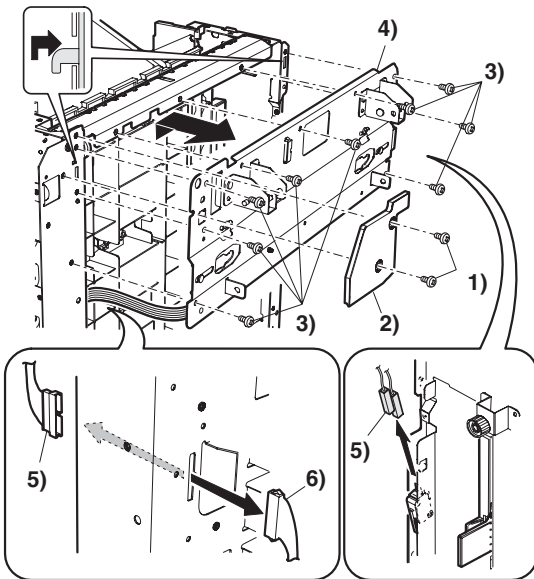
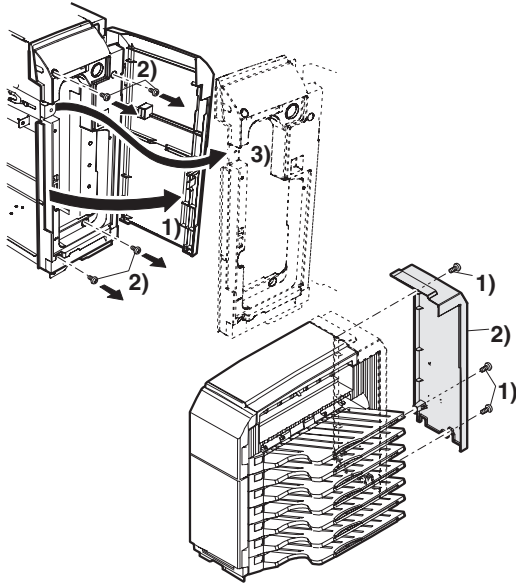

## Transport sensor

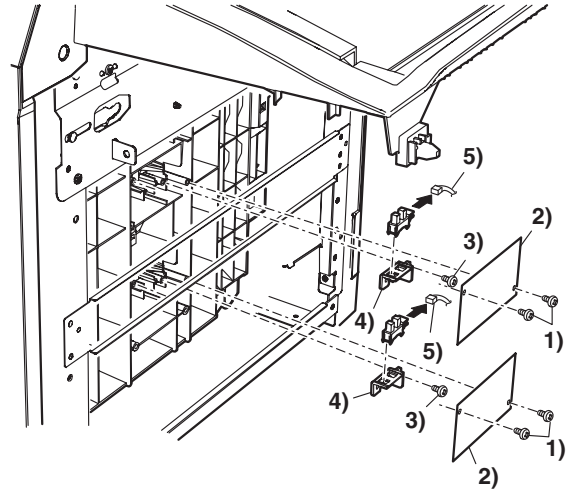

## Transport sensor

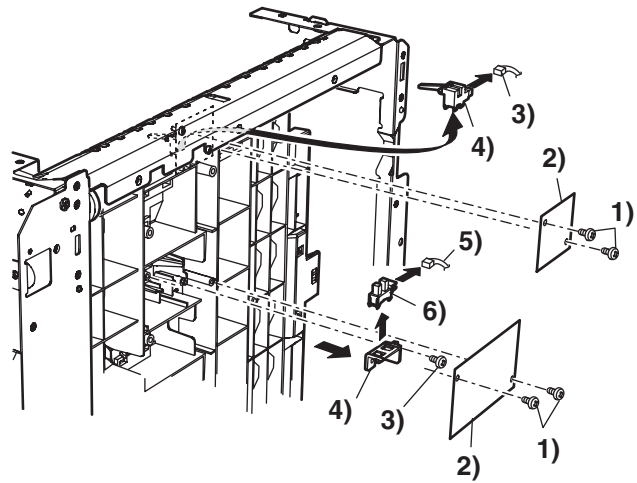

## Paper guide

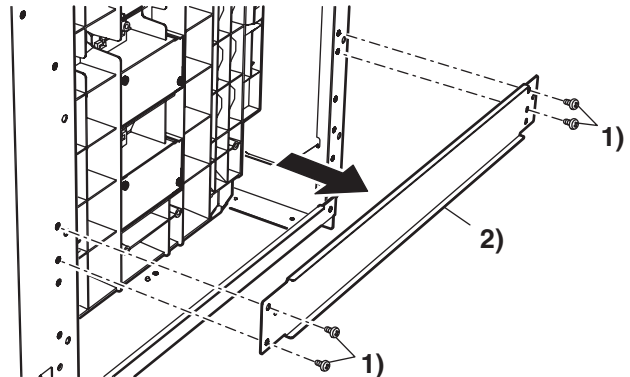

Note: The numbers in illustrations reflect the sequence required for disassembly/assembly.



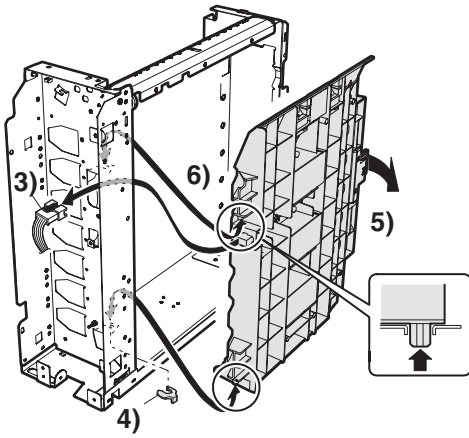

Note: When assembling the paper guide, check to insure that the paper guide boss is securely inserted into the mounting hole.

### E. Front side of the unit

Parts name	Job item	cycle
Sensors	Clean	100K

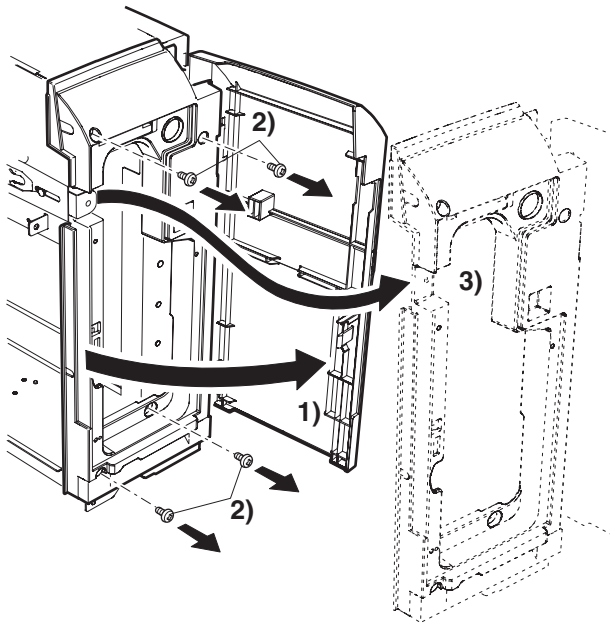

### Front door open/close sensor

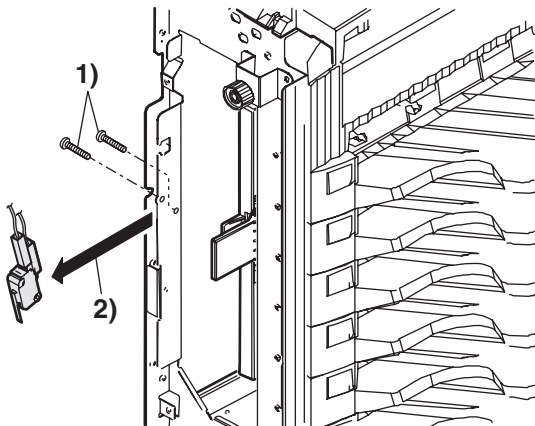

### F. Rear side of the unit

Parts name	Job item	cycle
Sensors	Clean	100K

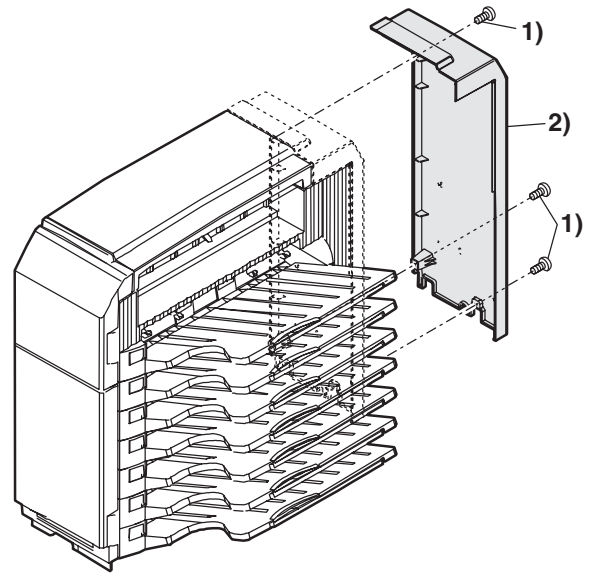

### Main PWB/Main motor

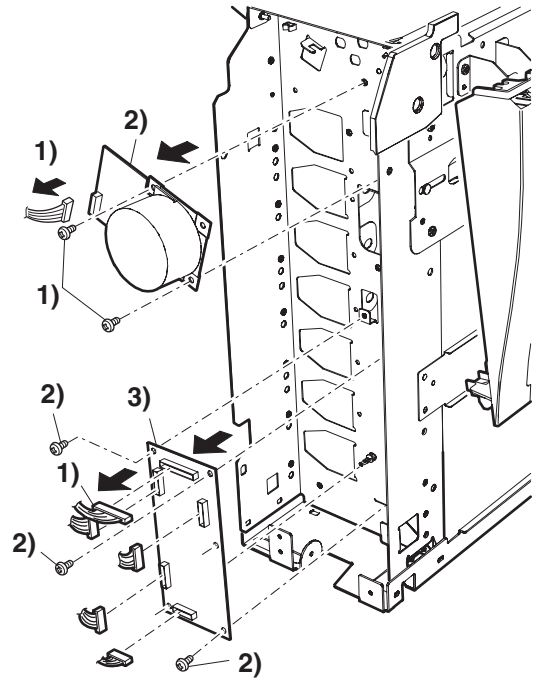

Note: The numbers in illustrations reflect the sequence required for disassembly/assembly.

## Paper exit full sensor

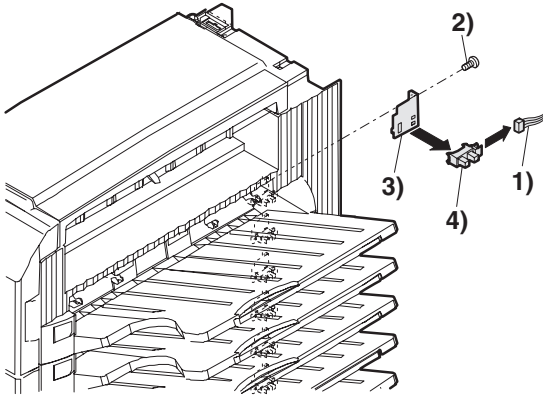

## Paper transport sensor/Paper exit full sensor

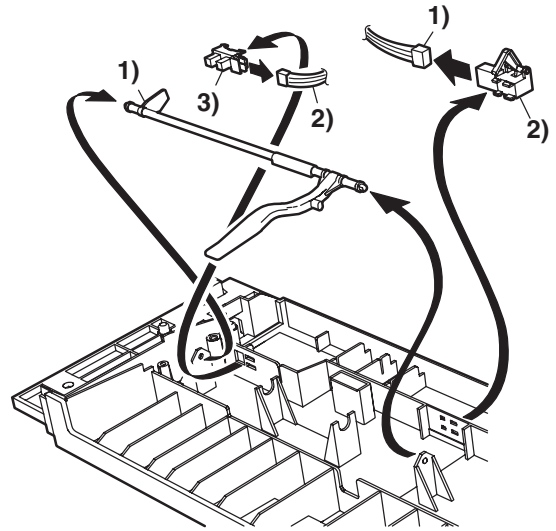

## G. Upper side of the unit

Parts name	Job item	cycle
Sensors	Check	100K
Discharge brushes	Lubricate	100K
Transport rollers	Clean	100K

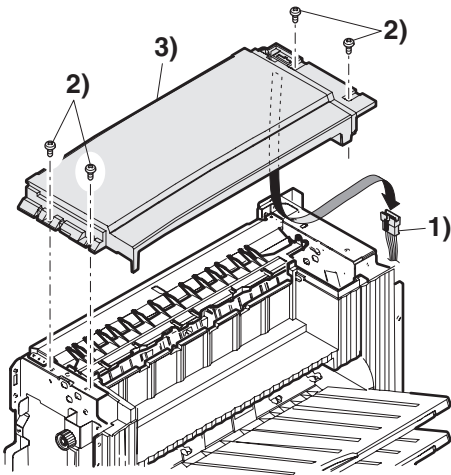

## Gate solenoid

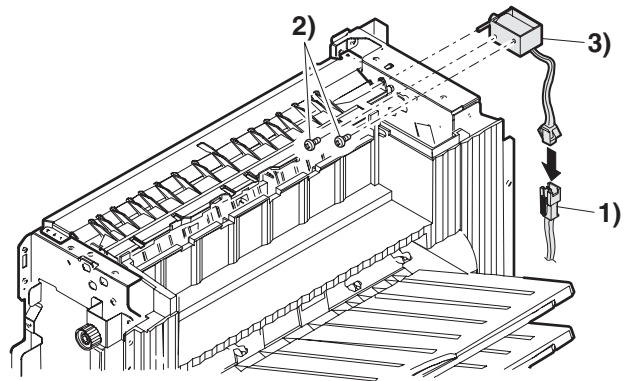

## Paper guide

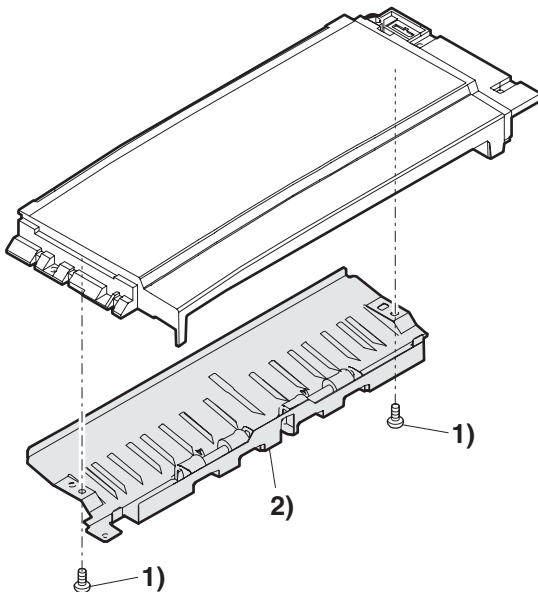

## Transport roller

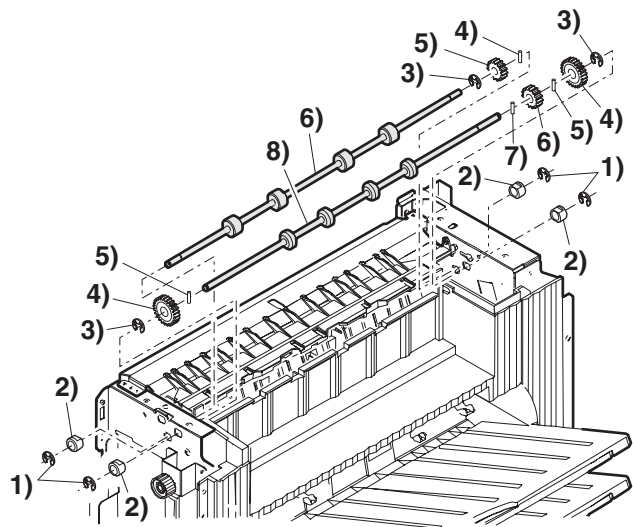

Note: The numbers in illustrations reflect the sequence required for disassembly/assembly.

## H. Right side of the unit (Paper exit side)

Parts name	Job item	cycle
Sensors	Check	100K
Discharge brushes	Lubricate	100K
Transport rollers	Clean	100K

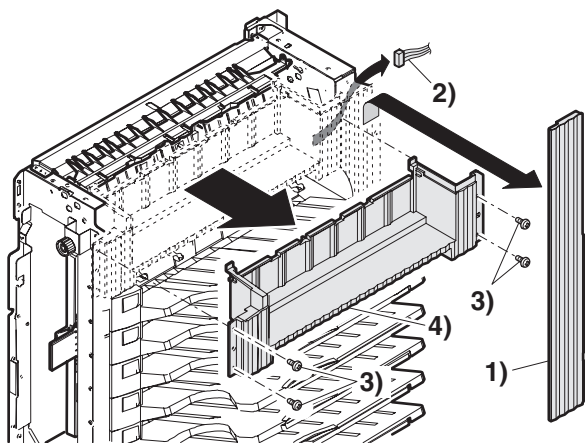

### Paper transport sensor

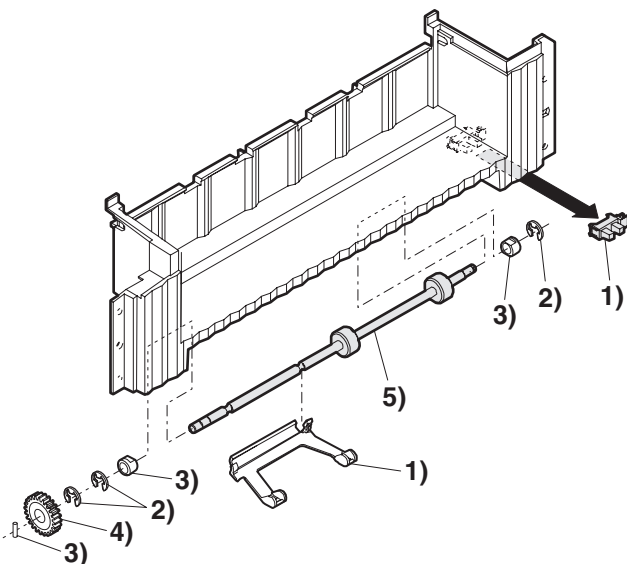

## I. Paper exit tray unit

Parts name	Job item	cycle
Sensors	Clean	100K
Transport paper guides	Clean	100K

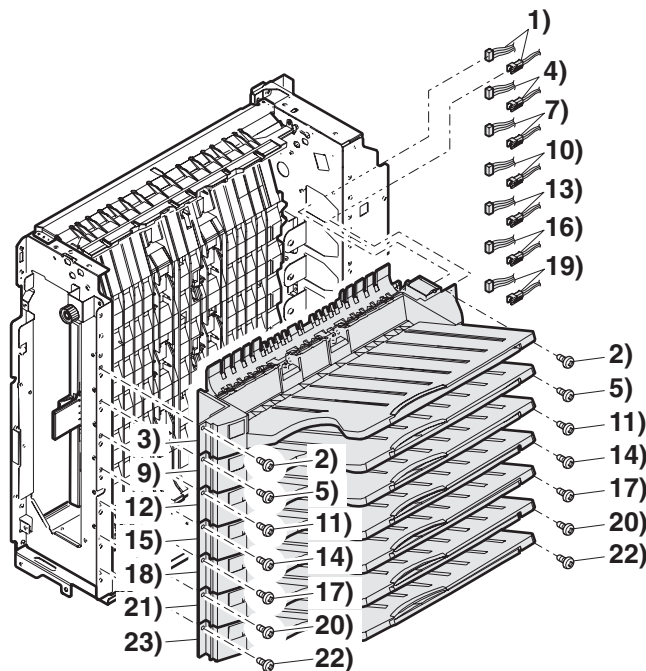

### Gate tray

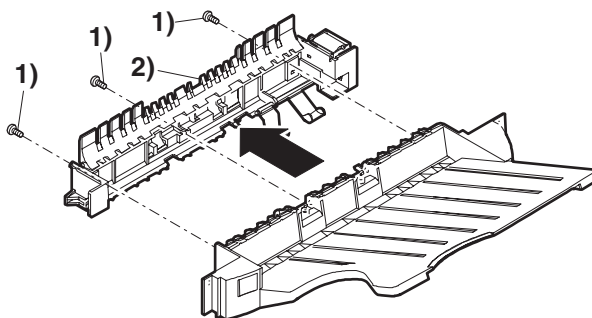

### Paper exit full sensor

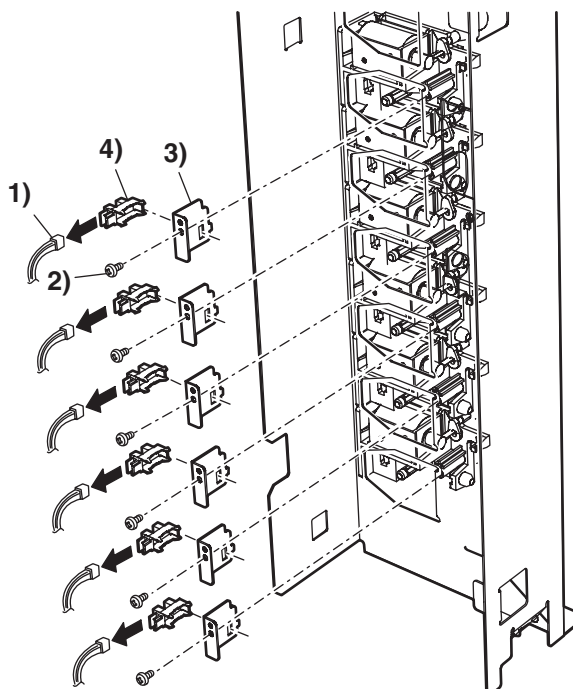

Note: The numbers in illustrations reflect the sequence required for disassembly/assembly.