

User's Guide

Contents

Basic Operations	10
Front View	10
Rear View	11
Internal View	12
Control Panel Buttons	13
Control Panel Display/Lights	14
The LCD Display	14
Print Mode	14
Menu Mode	14
Power Save Mode	15
Exiting the Power Save Mode	15
Cancelling a Print Job	15
At the Printer	15
At the Computer	15
AirPrint®	16
Setup Requirements	16
Printing from your Apple iOS Device	16
Security	16
User Controls	17
Print Media	18
Paper Exit Paths	18
Top Exit Path	18
The Rear Exit Path	19
Loading Standard Paper	20
Usable Media	24
Custom Sizes	25
Configuring Custom Sizes	26
Special Media Types	27
Transparencies	28
Loading Transparencies	28
Envelopes	32
Loading envelopes	33
Labels	36
Unusable Media	40
Automatic Tray Selection	41
Advanced Media Control	42
Auto Tray Change	42
Media Check	42
Express Print	42
Storing and Handling Media	43
To Prevent Paper Curling when Printing	43
Menu Mode	44
Navigating the Printer Menu	44
Printing a Menu Map	44

Basic Menu Structure	45
Explanation of Menu Items	46
USB Drive Menu	46
Print Jobs Menu	46
Configuration\ Page Counts Menu	47
Configuration\ Supplies Life Menu	47
Configuration\ Network Menu	47
Configuration\ System Menu	48
Information Menu	48
Menus\ Tray Configuration Menu	49
Menus\ Sys Config Menu	52
Admin Menus	53
Admin\ Network Menu	54
Admin\ Wireless Setup	55
Admin\ Print Menu	56
Admin\ PCL Emulation Menu	57
Admin\ FX Emulation Menu	58
Admin\ Parallel Menu	58
Admin\ Serial Menu	59
Admin\ USB Menu	60
Admin\ Date & Time Menu	60
Admin\ User Flash Menu	61
Admin\ Disk Menu	62
Admin\ Compact Flash Menu	63
Admin\ Spooling Menu	63
Admin\ Job Accounting Menu	64
Admin\ Change Password Menu	64
Admin\ Maintenance Menu	64
Print Features	65
Printing PDF Files From a USB Flash Drive	65
Printing a Job Stored in Memory	67
Storing a Job in the Printer	68
Retrieving a Document for Printing	68
Deleting a Stored Document	69
Printing on Banners	70
Loading Banner Paper	70
Direct Printing of PDF Files	73
Printing a PDF File	73
Printing via Electronic Mail /	
E-mail Printing	74
Environment Settings for E-mail Printing	74
Attachments That Can Be Sent	75
Sending E-mails	75
Points to Note When Sending E-mails	76
Barcode Printing	77
Internal Bar Codes	77
Supported Software-Generated Bar Codes	77

Driver-Set Print Features	78
Manual Feed from Tray 1	78
Collating	78
2-Sided Printing/Duplex	79
Cover Sheet	79
Fit to Page	79
N-up Printing (Multiple Pages to a Single Sheet)	80
Finishing	80
Poster Printing	80
Job Offset	81
Print Quality	81
Font Substitution	81
Watermark	82
The Embedded Web Server (EWS)	83
Accessing the Embedded Web Server	83
Troubleshooting.	85
Paper Jams	85
Paper Jams Inside Cover A	86
Removing Jams Inside the Paper Tray(s)	90
Paper Jams Inside Cover B	93
Paper Jams Inside Cover C: Duplex Unit	95
Paper Jams Inside Cover D: Offset Catch Tray	97
When Problems Occur	98
When the Print Quality is Poor	104
Error Messages (alphabetical order)	107
Network Related Problems	112
Using TCP/IP	112
For Windows NT 4. 0/Windows 2000/Windows XP	114
Using Printer Web Page	115
E-Mail Related Problems	117
Routine Maintenance.	118
Replacing the Drum/Toner Cartridge	118
Replacing the Drum/Toner Cartridge	119
Printing Reports/Lists	124
Checking the Printer Status via E-mail	125
About Mail Notice Service	125
Settings for Mail Notice Service	125
Setting the E-mail Environment (at this Printer)	126
Cleaning the Printer's Exterior	127
Cleaning the Printer's Interior	129
Cleaning the Feed Rollers	129
Procedure for Removing and Cleaning the Feed Rollers	130
First, Clean the Rollers Inside of Printer	131
Next, Clean the Tray Rollers	134
If you have Optional Tray(s) installed, Clean the Tray Module Roller(s)	136
When Moving the Printer	138

Appendix A **141**
PCL Emulation Symbol Sets 141

Copyright Information ---

Copyright © 2013 by Oki Data. All Rights Reserved

Document Information

B710, B720, B730 User's Guide

P/N 59322001, Revision 1.3

August, 2013

Disclaimer

Every effort has been made to ensure that the information in this document is complete, accurate, and up-to-date. The manufacturer assumes no responsibility for the results of errors beyond its control. The manufacturer also cannot guarantee that changes in software and equipment made by other manufacturers and referred to in this guide will not affect the applicability of the information in it. Mention of software products manufactured by other companies does not necessarily constitute endorsement by the manufacturer.

While all reasonable efforts have been made to make this document as accurate and helpful as possible, we make no warranty of any kind, expressed or implied, as to the accuracy or completeness of the information contained herein.

Parts of this guide are subject to change without prior notice.

The most up-to-date drivers and manuals are available from the web site: <http://www.okidata.com>

Trademark Information

Oki and Microline are registered trademarks of Oki Electric Industry Company Ltd.

Adobe, PostScript and PostScript 3 are trademarks of Adobe Systems Incorporated.

Apple, AirPrint, the AirPrint logo, EtherTalk, iPad, iPhone, iPod touch, Max, OS X, TrueType, are trademarks of Apple Inc.

Microsoft, MS-DOS, Windows NT and Windows Server are either registered trademarks or trademarks of Microsoft Corporation in the United States and/or other countries.

Other product names and brand names are registered trademarks or trademarks of their proprietors.

Precautions

Data Loss in Hard Disk/Compact Flash Disk

Saved data may be lost if the hard disk/compact flash in the printer breaks down due to external shocks or if the power is accidentally cut off in a manner not following the methods listed in this guide or other documentation. Oki is not responsible for such data loss and any consequence caused by such data loss.

Damage Related to Computer Virus

Oki is not responsible for any breakdown of units due to infection of computer virus.

Class I Laser System

This product is a "Class I Laser System" that does not emit dangerous laser beam.

- Operate the printer according to the instructions in this guide.
- Do not carry out any operation not mentioned in the guide. Otherwise, it may lead to unforeseen accident or printer breakdown.

Important!

- **Never attempt any procedure on the printer that is not specifically described in this guide.**
 - **Unauthorized operation can cause faults or accidents.**
 - **OKI is not liable for any problems resulting from unauthorized operation of the equipment.**
-

General Conventions _____

- “Computer” refers to both the personal computer and workstation.
- []
Indicates items displayed on the computer and the printer control panel. Also indicates the title of printed reports/lists from the printer.
- < >
Indicates items such as hard buttons and indicators on the keyboard and printer.

Important!, Notes, Cautions, Warnings

Important!

Indicates important information which you should read.

Note

Indicates additional information on operations or features.

Caution

Indicates instructions which you should follow to avoid damage to the printer.

WARNING

Indicates instructions which you should follow to avoid possible injury.

Illegal Copies and Printouts _____

Copying or printing certain documents may be illegal in your country. Penalties of fines or imprisonment may be imposed on those found guilty. The following are examples of items that may be illegal to copy or print in your country.

- Currency
- Bank notes and checks
- Bank and government bonds and securities
- Passports and identification cards
- Copyright material or trademarks without the consent of the owner
- Postage stamps and other negotiable instruments

This list is not inclusive and no liability is assumed for either its completeness or accuracy. In case of doubt, contact your legal counsel.

Basic Operations

Front View

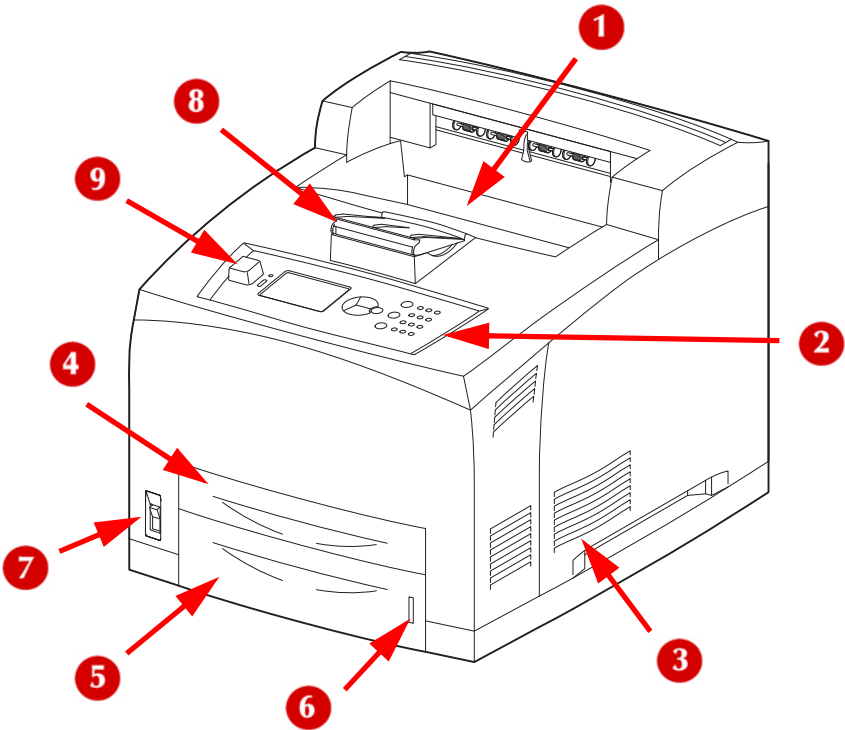

1	Default output tray (pages exit print side down)
2	Control panel
3	Ventilation hole (do not block)
4	Tray 1, 150 sheets
5	Tray 2, 550 sheets
6	Paper meter (amount of paper left in Tray 2)
7	Power switch
8	Paper stopper for letter or A4 paper
9	Host USB Port

Rear View

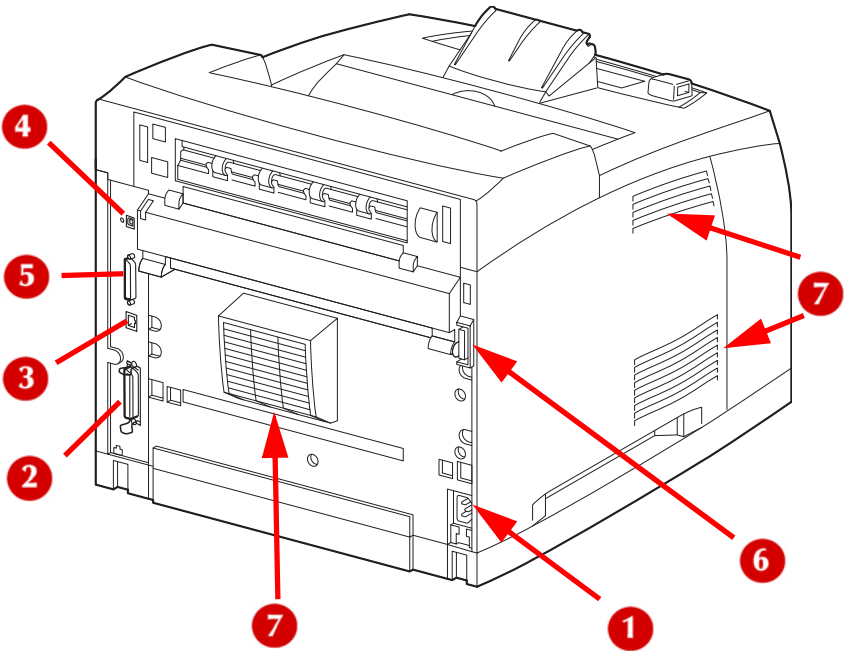

1	Power cord connector
2	Parallel connector
3	Network connector
4	USB connector
5	Serial connector
6	Duplex unit connector
7	Ventilation holes

Internal View

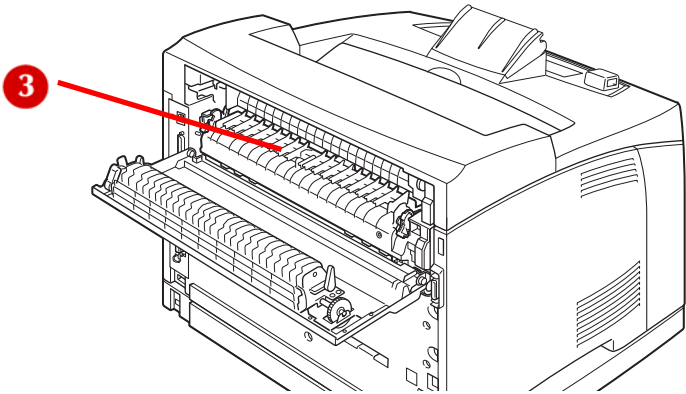
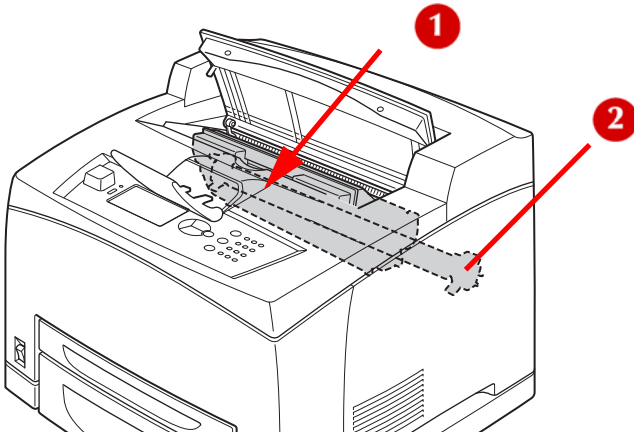

1	Drum/toner cartridge	Contains the toner and the photosensitive drum.
2	Transfer roll cartridge	Transfers the toner image on the surface of the photosensitive drum to the paper.
3	Fuser unit	Fixes the toner on the paper. Do not touch this when using the printer as it is hot.

Control Panel Buttons

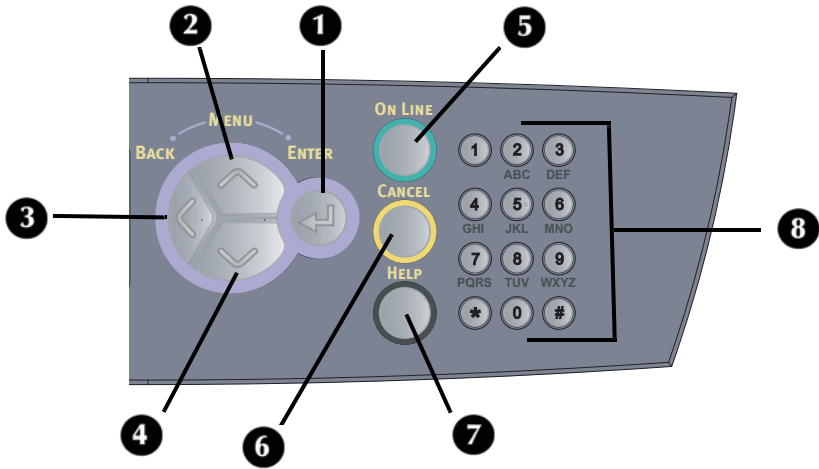

No.	Button	Description
1	<Enter>	Print mode: press to enter the menu mode. Menu mode: press to select the currently displayed menu item.
2	Up Arrow	Print mode: press to enter the menu mode. Menu mode: Press to navigate up in the menu screen listings
3	<Back>	Menu mode: press to go up one level in the menu, or press repeatedly to exit the menu.
4	Down Arrow	Menu mode: press to navigate down in the menu screen listings.
5	<On Line>	Press to switch back and forth between on-line (Ready to Print) and Off-line status. When Off-line, the machine cannot receive data or process printing.
6	<Cancel>	Print mode: press to cancel printing. Menu mode: press to exit Menu Mode.
7	<Help>	Press for more information regarding error messages on line 5 of the display.
8		Keypad, for making alphanumeric entries.

Control Panel Display/Lights

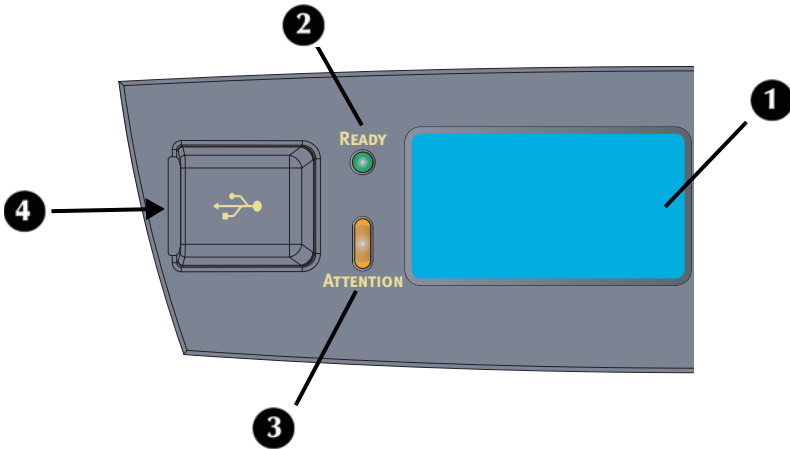

No.	Name	Description
1	LCD display	Displays the setting items, machine status, and messages.
2	<READY> light	When lit, the printer is ready to receive data.
3	<ATTENTION> light	When lit, operator intervention is required.
4	Host USB Port	For printing from an optional USB Flash Drive

The LCD Display

Print Mode

The following contents are shown on the screen in print mode.

- Current printer status
- Port receiving data (USB, Net, LPT or Serial)
- Driver (PCL, PS or XL)
- Toner Status bar.

Menu Mode

For configuring settings related to the printer.

This screen appears when you press the <Enter> button.

For more information on the menu mode, see page 44.

Power Save Mode

This printer is equipped with a Power Save mode to reduce power consumption when it is left idle. The default time from last print activity until the printer enters Power Save mode is 5 minutes. This time can be changed using the printer menu (see page 52).

A message appears on the operator panel indicating Power Save Mode. Power consumption during Power Save mode is 10 Watts or less.

Exiting the Power Save Mode

The printer automatically exits from Power Save mode once it receives data or if any key on the operator panel is pressed.

The time required to exit from Power Save mode to a print-ready status is about 10 seconds.

Cancelling a Print Job

At the Printer

Press <CANCEL>, then press <ON LINE>.

Note

Pages being printed at the moment will continue to be printed.

At the Computer

Double-click the printer icon  at the bottom right of the taskbar in Windows.

In the window which appears, click the document name that you wish to delete, and press <Delete> on your keyboard.

AirPrint®



AirPrint is a wireless technology that allows you to print from your iPhone®, iPod touch®, iPad®, or other iOS device without installing a printer driver. AirPrint can be used with Apple® devices running iOS 4.2 or later.

Your OKI printer comes with AirPrint configured ON and ready to work once it is connected to your network.

Setup Requirements

To use AirPrint from your mobile device, you must be connected using Wi-Fi to the network your printer is connected to. Your printer can be connected to the wireless access point using either a wireless or wired connection.

Printing from your Apple iOS Device

Most applications on your iOS device that allow printing will allow you to use AirPrint. For example, if you would like to print the currently displayed web page using Safari, press the Action button and then the Print button. You will see the Printer Options dialog. Press the Printer button to select the desired printer from the list of AirPrint printers that were automatically discovered by your device. Then press the Print button to print the desired page.

Depending on features supported by the selected printer, you may also see options for selecting the number of copies or double-sided printing.

Security

If you attempt to print a page and you receive a notification that says "Password required for...", this means your network administrator has configured the printer to require a User ID and password in order to use this printer. Enter your User ID and password and press OK to print your document. Both User ID and password are case sensitive. After you have entered a correct User ID and password, your device will remember them so you will not have to enter them again for additional prints.

User Controls

Your administrator may have established a list of authorized users for printing. Only these users will be allowed to print. If this feature is not in use and thus there are no authorized users, then the printer will allow any user to print as it does prior to the addition of the AirPrint User Control feature. Further, the printer's admin website will allow the admin to enable/disable the User Control feature.

Print Media

Paper Exit Paths

Before sending a job to the printer, make sure you have the correct exit path engaged.

Top Exit Path

The default path is the top exit bin (1).

Printed pages exit face down.

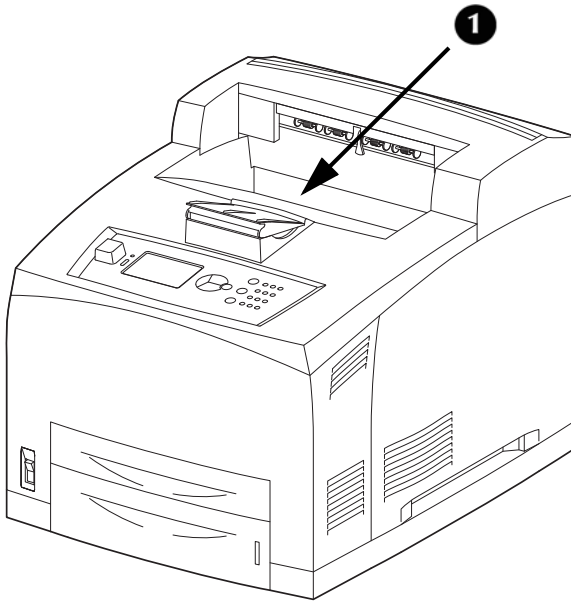

The Rear Exit Path

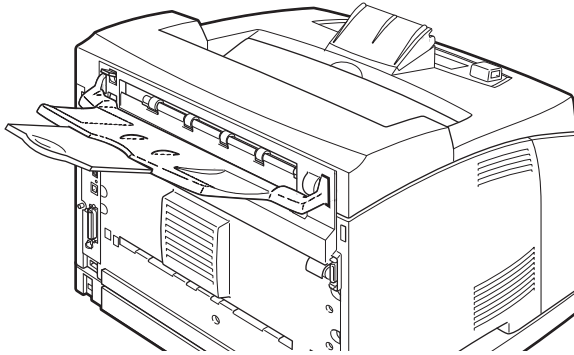

Always use the rear exit path for special media such as labels, card stock, envelopes, etc. This provides the straight-through path needed to prevent curling and jams.

Printed documents exit face up.

To use the rear exit, be sure the exit lever (1) is pushed up and the extension tray (2) is pulled out.

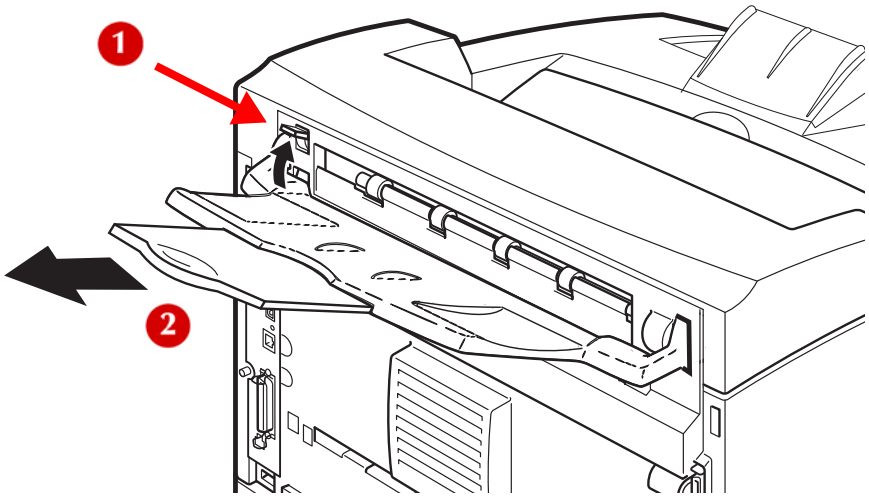

See page 27 for more information.

Loading Standard Paper

Examples of paper which works well with this product:

Paper name	Weight	Paper type
FX P	17 lb. US Bond (64 g/m ²)	Plain
Xerox 4024	20 lb. US Bond (75 g/m ² , or 80 g/m ²)	Plain
Xerox 4200	20 lb. US Bond (75 g/m ²)	Plain

1. Pull the tray out and place it on a flat surface.

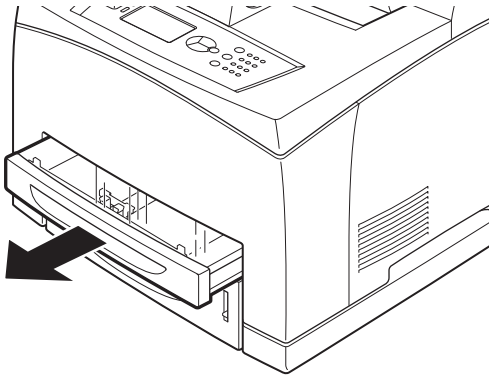

2. If installed, remove the lid.

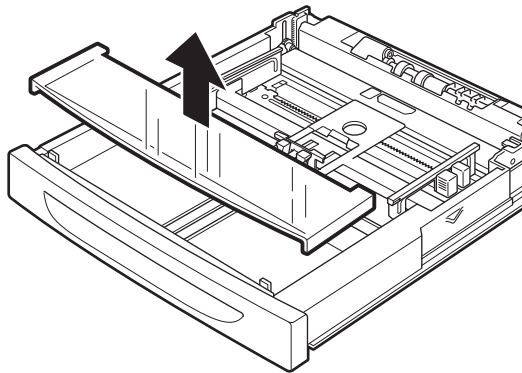

3. If the base plate of the paper tray is raised, push it down.

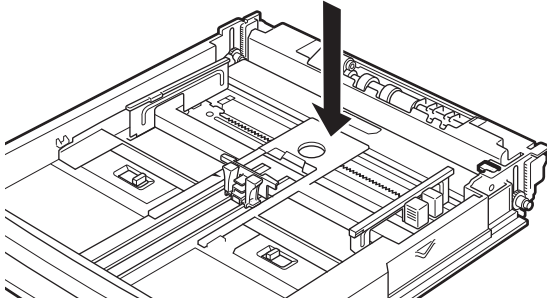

4. When loading paper longer than A4 size, slide the left and right lock tabs in the paper tray outwards to unlock them.

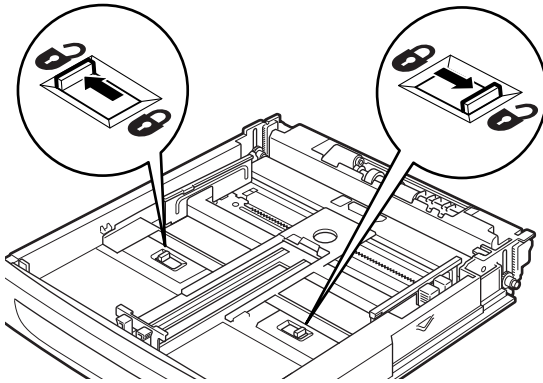

5. Hold the grip of the paper tray and pull its extendable part to the front until it reaches its maximum.

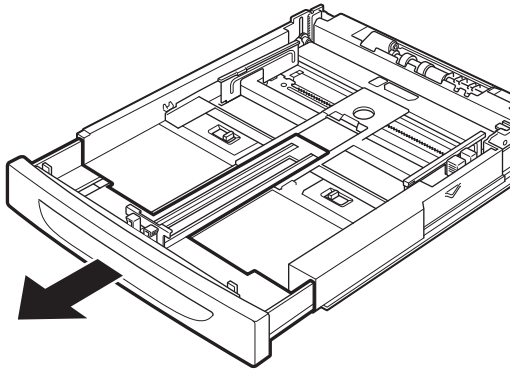

6. Squeeze the length guide and slide it to the desired paper size (1). Squeeze the right width guide and slide it to the desired paper size (2).

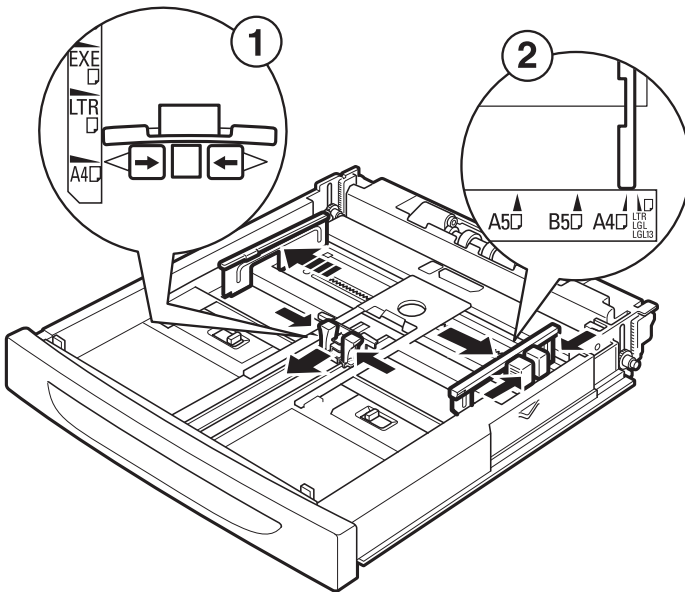

7. Load the paper with the side to be printed facing up and with all four corners aligned.

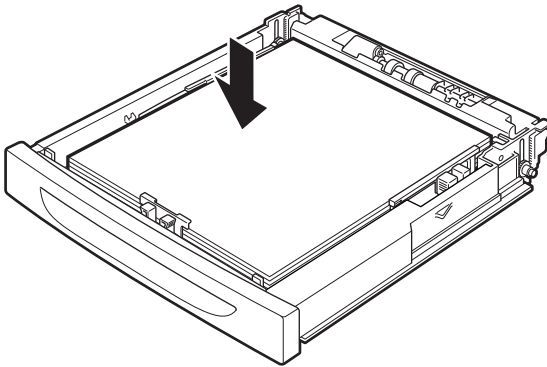

Important!

- **Align the right width guide with the paper width correctly. If the right width guide is not in place, this may cause paper jams.**
- **Do not load paper exceeding the maximum fill line or the maximum capacity allowed.**

-
8. Firmly close the lid of the paper tray and push the tray completely into the printer.

Important!

If the lid is not firmly closed, the paper can become misaligned.

Usable Media

Tray	Media Sizes	Weight	Capacity
Tray 1	<p>Standard sizes that can be automatically detected: A5, B5, A4, Executive (7.25 × 10.5"), Letter (8.5 × 11"), Legal (8.5 × 13"), Legal (8.5 × 14")</p> <p>Other sizes: A6*1, Statement Envelopes*1: COM-10, Monarch, DL, C5</p> <p>Custom Sizes*2 <i>Minimum:</i> 3 x 5 inches (76 x 127 mm) <i>Maximum:</i> 8.5 x 35.4 inches (216 to 900*3 mm)</p>	16-58 lb US Bond (60-216 g/m ²)	150 sheets 20-lb US Bond (75 g/m ²)
Tray 2 and optional Trays 3 and 4	<p>Same as above, but custom sizes are restricted to</p> <p><i>Minimum:</i> 3.9 x 5.8 inches (98 x 148 mm) <i>Maximum:</i> 8.5 x 14 inches (216 x 356 mm)</p>	Same as above	550 sheets 20-lb. US Bond (75 g/m ²)

*1: Requires the paper size settings be done on the control panel.

*2: Requires the paper size settings be done on the control panel and the printer driver.

*3: Print quality on the part of the paper that extends beyond 14 inches (356 mm) cannot be guaranteed.

Important!

- **To avoid paper jams, select the correct paper size, type, and tray.**
 - **The printed image may fade due to moisture such as water, rain or vapor. For details, contact service.**
-

Custom Sizes

Custom size paper can be printed from any tray. It must meet the following guidelines.

- All Custom sizes must be fed print side up and short edge first.
- Tray 1
 - Minimum: 3 x 5 inches (76 x 127 mm).
 - Maximum: 8.5 x 34.4 inches (216 x 900 mm).
- Tray 2 or optional trays 3 and 4
 - Minimum: 3.9 x 5.8 inches (98 x 148 mm)
 - Maximum: 8.5 x 14 inches (216 x 356 mm).
- Minimum for duplexing or output to Offset Catch Tray: 3.5 x 5.5 inches (89 x 140 mm).

Configuring Custom Sizes

To print on custom size paper loaded in trays 1 to 4, you must set the paper size on the control panel. Use the Menu to set Auto-Sense OFF and then set Custom Size for the intended tray.

You may also need to set it in the printer driver, depending on the paper size. See the description of Express Print for an easy way to print on various Custom Sizes.

Caution!

When setting the paper size in the printer driver and control panel, be sure to specify the same size as the actual paper used. *Setting the wrong size for printing will cause printer failure.* This is especially true if you configure a bigger size when using a narrow width paper.

Note

To return to standard paper size settings, select [Auto]. The printer will automatically detect the size and orientation of the loaded paper.

Special Media Types

Media	Fuser Setting*	Exit Path
Transparency*+	Transparency	Rear only
Pre-Punched	Normal	Top or Rear
Letter Head or Pre-Printed	Normal	Top or Rear
Labels*	Thick1**	Rear only
Cardstock*	Thick2** (43-58 lb. US Bond, 160-216 g/m ²)	Rear only
Postcards	Thick1** (28-43 lb. US Bond, 106-159 g/m ²)	Rear only
Envelopes* +	Thick3	Rear only
Thin	Thin	Top or Rear

*No duplexing

+ Half speed

** If you do not get satisfactory results using Thick1 or Thick2, try using Thick3 for better results.

Note:

The fuser temperature progression (lowest to highest) is:

Transparency > Thin > Thick3 > Normal > Thick1 > Thick2

Transparencies

Caution!

Only use transparencies that are designed to withstand the heat required for laser printing. It is possible to damage your printer by using unsupported transparencies.

Examples of transparencies which work well with this printer.

Transparency	Size
Xerox 3R2780	Letter
Xerox 3R98202	A4
3M CG3300	Letter

Note:

Transparencies with white frames and full-color transparencies cannot be used.

Loading Transparencies

1. Make sure the rear exit (1) is open and selected.

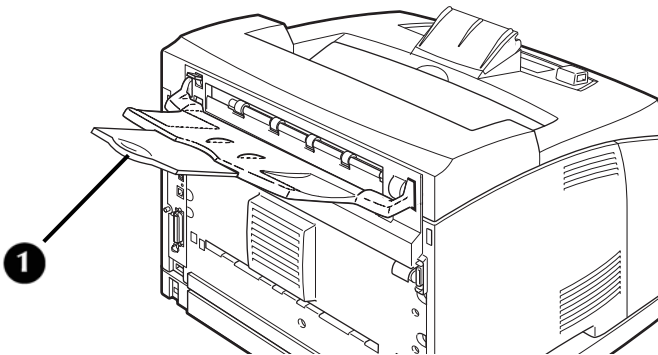

2. Remove the tray from the printer.

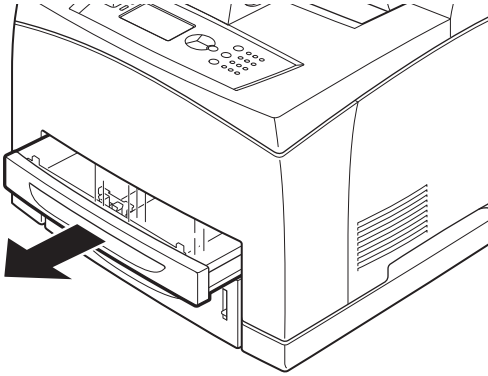

3. If installed, remove the lid.

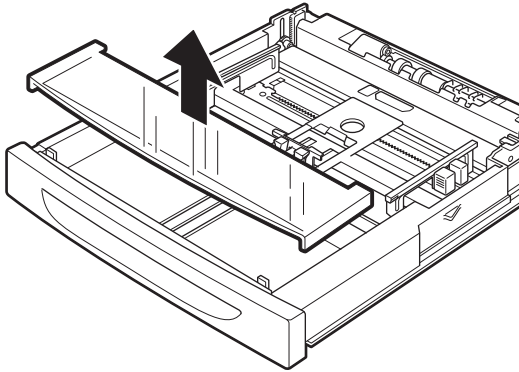

4. Remove all paper from a tray before loading transparencies.

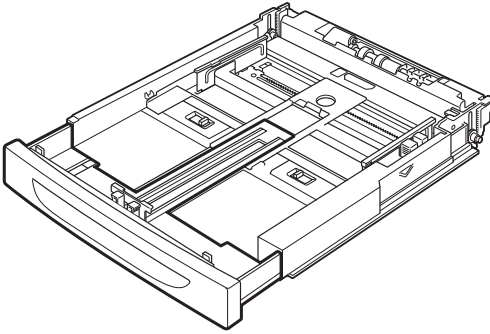

5. Fan the stack of new transparencies before putting them in the tray.

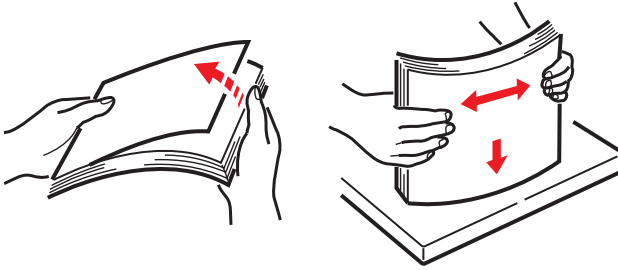

6. Adjust the paper guides to fit the transparencies.

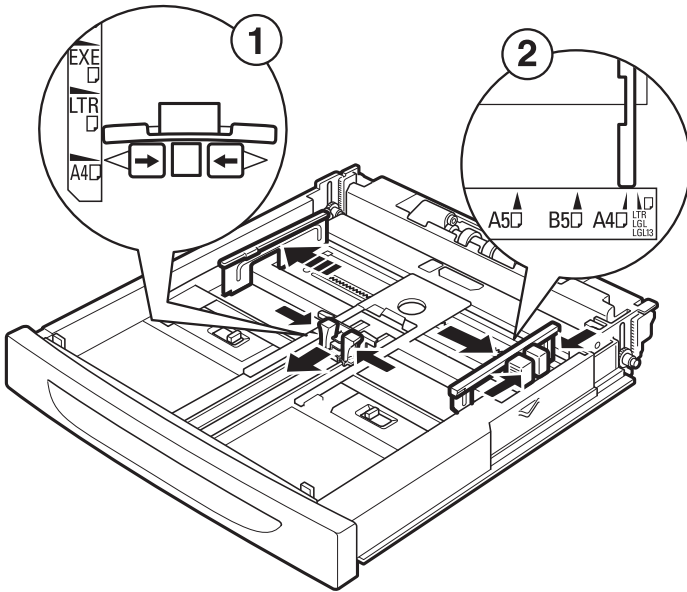

7. Insert the transparencies into the tray.

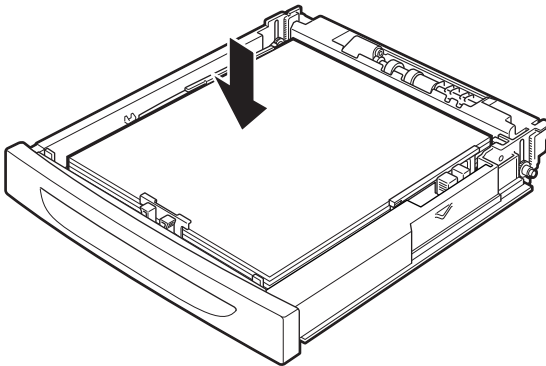

Important!

- Place the transparencies in the tray with the side to be printed facing up.
 - Load no more than 100 transparencies in a tray.
 - Handle transparencies by the edges with both hands to avoid getting fingerprints and creases on them.
-

8. Insert the tray firmly into the printer.
9. Using the Operator Panel or Embedded Web Server (see page 83), select the Transparency Media Type and correct Media Size for the tray to be used.
10. In the printer driver or the computer application program, select Transparency as the media type you wish to use.

Important!

To prevent output transparencies from sticking together, remove them from the output tray after about 20 sheets, and then fan them to lower their temperature.

Envelopes

Envelopes that are supported by this printer.

Paper name	Size	Paper type
Columbia 3B1183	COM10	Envelope
Monroe 3B1039	Monarch	Envelope
River Series 3B1041	C5	Envelope
River Series 3B1042	DL	Envelope

Caution!

Only use envelopes designed for use in laser printers. The heat from the fuser can melt some adhesives and possibly damage your printer.

Envelopes can be printed from all trays.

Usable standard sizes:

- COM10
- COM9
- C5
- Monarch
- DL

All other envelope sizes must be defined as custom size.

Loading envelopes

1. Make sure the rear exit (1) is open and selected.

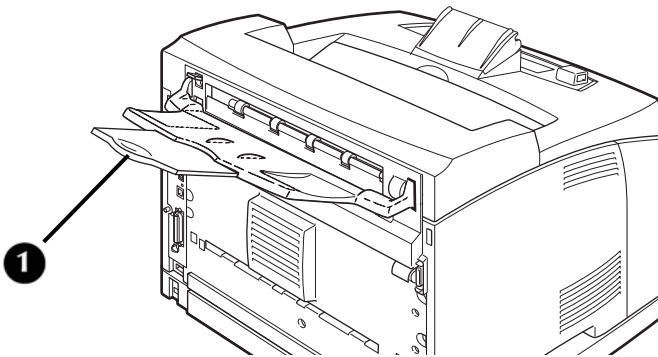

2. Remove the tray from the printer.

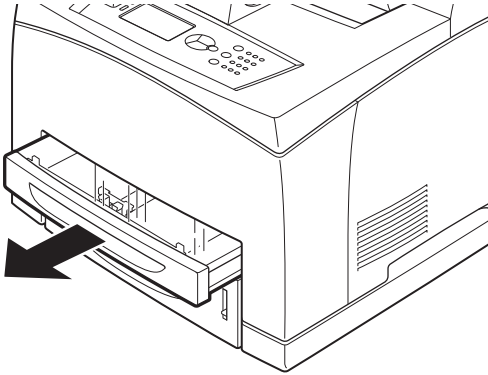

3. If installed, remove the lid.

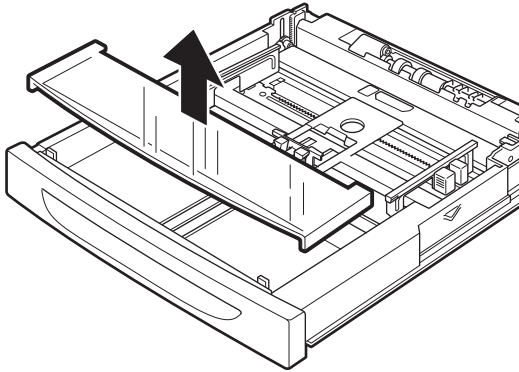

4. Remove all paper from a tray.

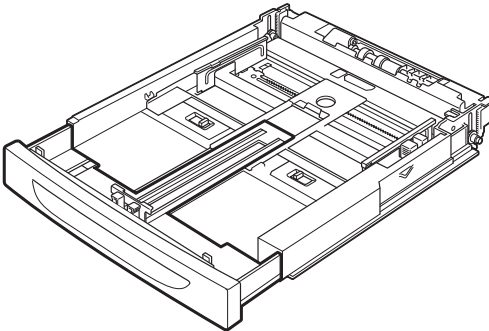

5. Adjust the guides to fit the envelopes and place the envelopes face up in the center of the tray as shown.

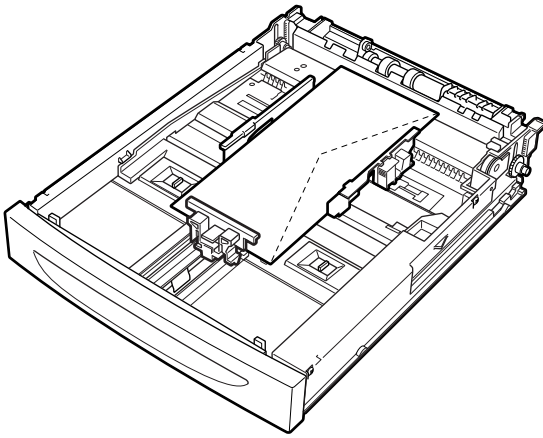

Important!

- Place envelopes in the tray with the printing side up (flap side down).
- All envelope sizes except C5 should be placed with the top toward the right side of the printer.
- C5 envelopes are available in two configurations. C5 with the flap on the long edge must be placed with the flap toward the right side of the printer. C5 with the flap on the short edge must be placed with the flap edge feeding into the printer.
- Do not load more than 15 envelopes in Tray 1 or more than 80 in Trays 2 through 4.

-
6. Reinstall the lid and insert the tray firmly into the printer.
 7. Using the Operator Panel or Embedded Web Server, select the Envelope Media Type and correct Media Size for the tray to be used.
 8. In the printer driver or the computer application program, select Envelope as the paper type you wish to use, and select the size and orientation of the image to be printed.

Note:

The reverse side of the envelope cannot be printed.

Labels

Common brands of labels that are supported by this printer.

Label	Size	Paper type
Xerox 3R97408	A4	Label
Xerox 3R96178	A4	Label
Xerox V860	A4	Label
Avery 5160	Letter	Label

- Labels can be printed from any tray.

Caution!

Use labels that were designed for use in laser printers. The heat from the fuser can melt some adhesives and possibly damage your printer.

1. Make sure the rear exit (1) is open and selected.

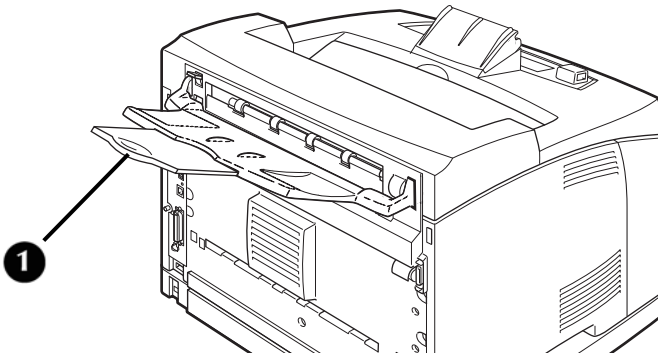

2. Remove the tray from the printer.

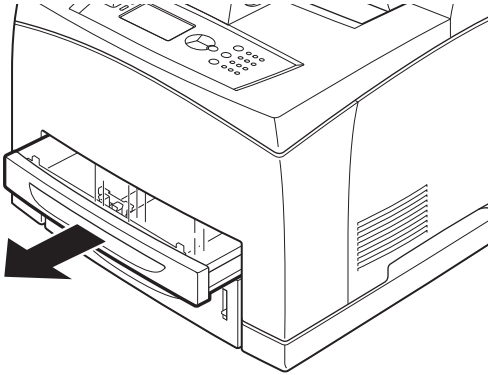

3. If installed, remove the lid.

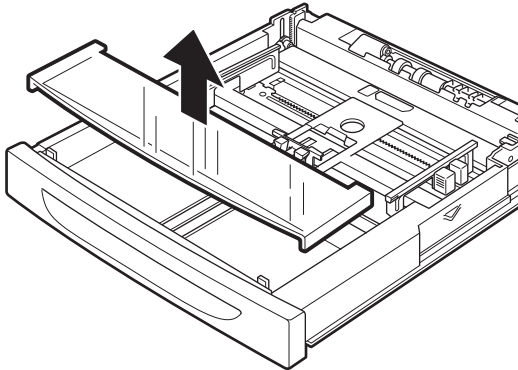

4. Remove all paper from the tray before loading labels.

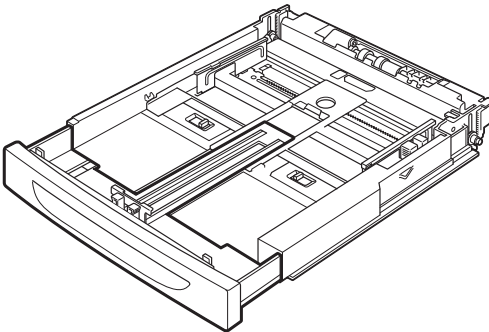

5. If needed, adjust the guides to fit the label sheets.

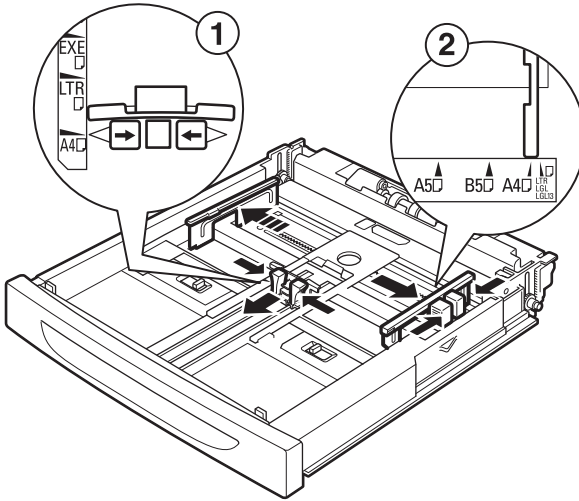

6. Insert the label sheets in the tray.

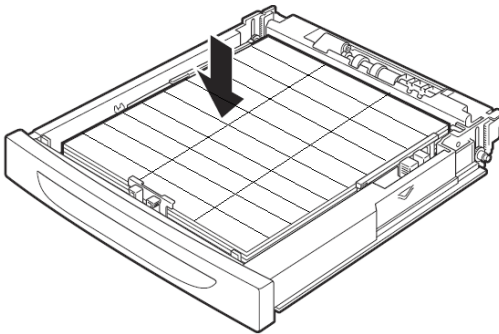

Important!

- **Place the side to be printed facing up and the top of the sheets to be fed into the printer first.**
- **Do not load more than 100 label sheets in Tray 1 or more than 290 sheets in Tray 2 and optional trays 3 and 4.**
- **Do not fill any tray above the fill line marked inside the tray.**

-
7. Reinstall the lid and insert the tray firmly into the printer.
 8. Use the Operator Panel Menu to select the Label Media Type and size for the tray in use. Then use your computer's application software to print the labels.

Unusable Media

CaUTION!

Using the following types of media might cause paper jams, malfunctions or damage to the printer. Do not use them.

- Fuji Xerox full-color transparencies (example: V556, V558, V302)
- Paper exclusively for ink-jet printer use
- Paper that is too thick or thin
- Paper that has been printed on before (including color printing)
- Wrinkled, folded or torn paper
- Wet paper
- Curled paper
- Paper with static electricity
- Adhesive paper
- Paper with special coatings
- Treated colored paper
- Paper using ink that will run at a temperature of 302°F (150°C).
- Thermal paper
- Carbon paper
- Paper with staples, paper clips, ribbons or tape
- Paper with rough surfaces such as pulp paper or fibrous paper
- If acid paper is used, the characters might appear fuzzy. Replace it with alkaline paper.
- Labels that do not fully cover the adhesive backing

Automatic Tray Selection

From the properties dialog box in the printer driver, select

- paper size
- Media Type
- [Automatically Select] for [Paper Source].

The printer will first automatically detect paper trays loaded with the selected media type, then the tray that matches the document.

If there are multiple trays that match the criteria for automatic tray selection, a tray is selected based on the printer's Tray Priority as set using the printer's web pages.

Note:

If there are no input trays that match the automatic tray selection, the display will prompt you to load the media.

If you prefer, you can configure the printer to automatically select a tray with media of the nearest or larger size instead. To do this, enable Auto Resize in the printer menu under Admin Setup > Print Menu.

Advanced Media Control

Auto Tray Change

When an input tray runs out of paper, auto tray changing enables the printer to switch to another available tray that contains the same Media size and type.

Media Check

Controls whether or not the paper size and media type specified in the print job must be used to satisfy the print request.

When both Auto Resize and Media Check are enabled, Auto Resize overrides Media Check in regard to paper size.

To force a specific paper size, disable Auto Resize in the printer menu (under Admin Setup > Print Menu).

Express Print

To use Express Print, you must disable Media Check. You can use the driver to do this.

When the printer is in Express Print mode, you can leave the default media settings as is in the printer, and it will assume the paper you put in the tray and selected in your driver is the correct size and type for the print job.

This allows you to switch between paper sizes easily without configuring custom paper sizes at the printer. It is up to you to load the correct media in the designated tray.

Storing and Handling Media

To help prevent paper jams, poor print quality and printer breakdown, it is important to observe the following recommendations when storing paper:

- Store paper
 - at a temperature of 50 to 86°F (10 to 30°C)
 - at relative humidity of 30 to 65%
 - away from direct sunlight
 - flat, not on its edge, bent or curled
 - preferably in a cabinet
- After opening a ream of paper, use the original cover sheets to wrap up the paper not used.

To Prevent Paper Curling when Printing

it is important to follow the manufactures orientation instruction to "Print this side first ▼"

Example:



Menu Mode

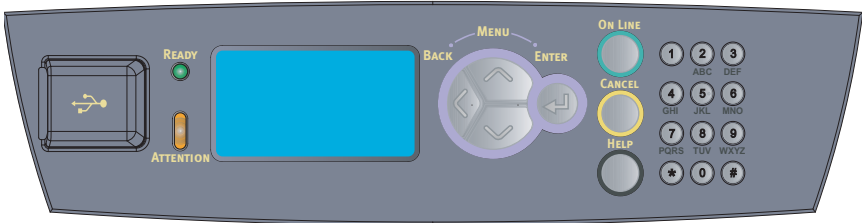

Navigating the Printer Menu

- To enter the printer menu, press <Enter>.
- To scroll through the menu entries, press the Up and Down Arrow buttons repeatedly.
- To go up a level in the menu, or to exit the menu, press <Back>.
- To enter passwords, use the keypad.
- To enable the highlighted setting, press <Enter>.

Note

Menus and submenus may or may not be displayed, depending on the options installed.

Printing a Menu Map

The Menu Map provides a listing of all the current settings in the printer menu.

1. Press <Enter> to go into the menu mode.
2. Press the Down Arrow button until Information Menu is highlighted.
3. Press <Enter>.
4. Press the Down Arrow button until Print Menu Map is highlighted.
5. Press <Enter> twice.

The Menu Map prints.

Basic Menu Structure

USB Drive Menu

Note

This Menu item will only appear if a USB Flash drive is installed in the Host USB connector on the operator panel.

Print Jobs Menu

Configuration

- Page Counts
- Supplies Life
- Network
- Wireless
- System

Information Menus

Menus

- Tray Configuration
- Sys Config Menu

Admin Setup

- Network Menu
- Wireless Setup
- Print Menu
- PCL Emulation
- FX Emulation
- Parallel Menu
- Serial Menu
- USB Menu
- Date/Time Menu
- Flash Menu
- Disk Menu
- Compact Flash Menu
- Spooling Menu
- Job Accounting
- Change Password
- Maintenance Menu

Explanation of Menu Items

USB Drive Menu

Note

This Menu item will only appear if a USB Flash drive is installed in the Host USB connector on the operator panel.

The [**USB Drive**] menu allows the user to print a selected file from the installed USB Flash Drive. The file selected for printing must be one of the following formats:

- Supported PDF
- PCL5, PCL6, FX80 or PostScript
- Generic text (such as a .txt file)

Size of PDF files to be printed is limited by available space in standard user flash memory unless a Compact Flash or Hard Disk option is installed.

To print a PDF file from a USB flash drive, see page 65.

Print Jobs Menu

This menu is used to access print jobs stored in the printer.

For information on printing stored jobs, see page 67.

Configuration\ Page Counts Menu

Provides access to certain counters inside the printer.

Submenus	Example	Resettable?
Usage Counter	123456	Yes
Page Counter	123456	No
Toner Page Count	123456	Yes
Fuser Count	123456	Yes Note: Images larger than either A4 or Letter are counted as 2 images.

Configuration\ Supplies Life Menu

Provides access to the printer supply levels.

Submenus	Available Settings
Tray1 Level	OK, Low, Empty
Tray2 Level	OK, Low, Empty
Tray3 Level	OK, Low, Empty
Tray4 Level	OK, Low, Empty
Toner	0% to 100% (percentage of toner remaining.)

Configuration\ Network Menu

For setting printer network parameters.

- Printer Name
- IP Address
- Subnet Mask
- Gateway Address
- Network Address
- Network Version

Configuration\ System Menu

Provides printer system settings.

- Serial Number (current Printer Serial Number)
- CU Version (Controller firmware)
- PU Version (Print Engine firmware)
- Installed memory (DRAM)
- User Flash (flash memory installed)
- Disk (if hard disk drive is installed)
- Compact Flash (if compact flash is installed)

Information Menu

Provides printouts of printer settings for various printing functions.

Submenus	Description
Print Usage Report	Prints a report of printer usage.
Print Menu Map	Prints the menu map.
Network Summary	Prints a report of the current Network settings.
Print PCL Fonts	Prints the PCL font list.
Print PS Fonts	Prints the Postscript font list.
Print FX Fonts	Prints the FX80 font list.

Menus\ Tray Configuration Menu

Default settings are in **bold face** type.

Submenus	Available Settings
Paper Feed	Tray 1 , Tray 2, Tray 3, Tray 4
Auto Tray Switch	On , Off
Output Tray	Face Down Tray , Offset Tray
Output Linking	On , Off
Unit Of Measure	inch , Millimeter
Tray1 Auto-Sense	On , Off
Tray1 Paper size	Letter , B5, A5, A6, Statement, Executive, C5 Envelope DL Envelope, Com10 Envelope, Monarch Envelope, Com9 Envelope, Oficio, Legal13, Legal14, A4, Custom Note: Tray1 Auto-Sense must be off to use this feature.
Tray1 Media Type	Plain , Transparency, Pre-punched, Letterhead, Colored, Preprinted, Bond, Label, Card Stock, Postcard, Envelope, Thick 1, Thick 2, Thick 3, Thin, Other
Tray1 X Dimen	3.00 - 8.50 inches (76 - 216 mm) Tray1 Paper Size must be set to Custom to use this feature
Tray1 Y Dimen	5.00 - 48.00 inches (127 - 1219 mm); default = 11.00 inch, 279 mm) Tray1 Paper Size must be set to Custom to use this feature.
Tray2 Auto-sense	ON , OFF
Tray2 Paper size	Letter , B5, A5, A6, Statement, Executive, C5 Envelope DL Envelope, Com10 Envelope, Monarch Envelope, Com9 Envelope, Oficio, Legal13, Legal14, A4, Custom Note: Tray2 Auto-Sense must be off to use this feature.

Submenus	Available Settings
Tray2 Media Type	Plain , Transparency, Prepunched, Letterhead, Colored, Preprinted, Bond, Label, Card Stock, Postcard, Envelope, Thick 1, Thick 2, Thick 3, Thin, Other
Tray2 X Dimen	3.88 - 8.50 inches (99 - 216 mm) Note: Tray2 Paper Size must set to Custom to use this feature.
Tray2 Y Dimen	5.83 - 14.00 inches (148 - 356 mm); Default is 11.00 inches Note: Tray2 Paper Size must set to Custom to use this feature
Tray3 Auto-sense	On Off
Tray3 Papersize	Letter , B5, A5, A6, Statement, Executive, C5 Envelope DL Envelope, Com10 Envelope, Monarch Envelope, Com9 Envelope, Oficio, Legal13, Legal14, A4, Custom Note: Tray3 Auto-Sense must be off to use this feature.
Tray3 Media Type	Plain , Transparency, Prepunched, Letterhead, Colored, Preprinted, Bond, Label, Card Stock, Postcard, Envelope, Thick 1, Thick 2, Thick 3, Thin, Other
Tray3 X Dimen	3.88 - 8.50 inches (99 - 216 mm) Note: Tray3 Paper Size must set to Custom to use this feature.
Tray3 Y Dimen	5.83 - 11.00 - 14.00 inches (148 - 356 mm) Note: Tray3 Paper Size must set to Custom to use this feature
Tray4 Auto-sense	On Off

Submenus	Available Settings
Tray4 Papersize	<p>Letter, B5, A5, A6, Statement, Executive, C5 Envelope DL Envelope, Com10 Envelope, Monarch Envelope, Com9 Envelope, Oficio, Legal13, Legal14, A4, Custom</p> <p>Note: Tray4 Auto-Sense must be off to use this feature.</p>
Tray4 Media Type	<p>Plain, Transparency, Prepunched, Letterhead, Colored, Preprinted, Bond, Label, Card Stock, Postcard, Envelope, Thick 1, Thick 2, Thick 3, Thin, Other</p>
Tray4 X Dimen	<p>3.88 - 8.50 inches (99 - 216 mm)</p> <p>Note: Tray4 Paper Size must set to Custom to use this feature</p>
Tray4 Y Dimen	<p>5.83 - 11.00 - 14.00 inches (148 - 356 mm)</p> <p>Note: Tray4 Paper Size must set to Custom to use this feature</p>

Menus \ Sys Config Menu

Provides access to the system settings.

Default settings are in **bold face** type.

Submenus	Available Settings
Power Save Time	5 , 15, 30, 60, 120
Wait Timeout	5 - 9999 seconds Default is 20
Toner Low	Continue, Stop
Jam Recovery	On , Off
Language	English , and other supported languages
Display Contrast	1 to 5 Default is 3
Print PS Errors	On, Off
Print Density	1 to 7, Default is 4
Tray1 X Adjust	0 to 15, Default is 8
Tray1 Y Adjust	0 to 15, Default is 8
Tray2 X Adjust	0 to 15, Default is 8
Tray2 Y Adjust	0 to 15, Default is 8
Tray3 X Adjust	0 to 15, Default is 8
Tray3 Y Adjust	0 to 15, Default is 8
Tray4 X Adjust	0 to 15, Default is 8
Tray4 Y Adjust	0 to 15, Default is 8
Duplex X Adjust	0 to 15, Default is 8
Duplex Y Adjust	0 to 15, Default is 8
Hex Dump	Enable, Disable

Admin Menus

The following menus are all located inside the Admin Menu. A password is needed to enter these menus.

Note

The factory default password is "aaaaaa".

The password (1 to 12 characters) should be entered using one of two methods:

Method 1

For each character in the password, press the Up or Down Arrow buttons to scroll between a – z and 0 – 9. When the desired character is displayed, press <Enter> to advance to the next character position. To go back a digit, press <Back>. When all desired characters have been entered, press <Enter>.

Method 2

For each character in the password, use the alpha-numeric buttons on the numeric keypad. For example, to enter a "c", press the numeric <2> button 3 times in rapid succession. To enter a "2", press the numeric <2> button 4 times in rapid succession. To go back a digit, press <Back>. When all desired characters have been entered, press <Enter>.

Admin\ Network Menu

Default settings are in **bold face** type.

Submenus	Available Settings
TCP/IP	Enable , Disable
IPv6	Enable , Disable
IPSec	Enable, Disable
802.1X	Enable, Disable
Netware	Enable, Disable
Ethertalk	Enable , Disable
IP Address Set	Automatic , Manual
IP Address	(user-specified)
Subnet Mask	(user-specified)
Gateway Address	(user-specified)
Factory Default	Execute
DNS	Enable, Disable
WINS	Enable , Disable
Web	Enable , Disable
SNMP	Disable, SNMP v1/v2 , SNMP v1/v2/v3, SNMP v3
FTP Print	Enable, Disable
Hub Link Setting	Auto Negotiate , 10 Base-T Full, 10 Base-T Half, 100 Base-T Full, 100 Base-T Half, 1000 Base-T Full, 1000 Base-T Half
PS Protocol	ASCII, RAW
HTTP Port	1 - 9999, Default is 80
Netware Frame	Auto-Sense, 802.3, Ethernet II, 802.2 SNAP, 802.2

Admin\ Wireless Setup

Note

Settings made in the printer driver when printing a job will override these settings.

Default settings are in **bold face** type.

Submenus	Available Settings
WPS PIN Connect	Enter PIN on Access Point
WPS PBC Connect	Push WPS Button on Access Point
Select Network	Choose from list of discovered nets
Remove Network	Choose from list of remembered nets
IP Address Set	Manual, * Automatic
IP Address	IP Address Displayed
Subnet Mask	Display of Subnet Mask
Gateway Address	Display of Gateway Address
Factory Default	Set Wireless Factory Defaults

Admin\ Print Menu

Note

Settings made in the printer driver when printing a job will override these settings.

Default settings are in **bold face** type.

Submenus	Available Settings
Personality	Auto Emulation , PCL, PostScript 3, FX
Copies	1 - 999
Duplex	On, Off
Duplex Bind	Long Edge , Short Edge
Auto Resize	Enable , Disable
Media Check	Enable , Disable
Resolution	600 dpi , 1200 dpi
Toner Save Mode	ON, OFF
Orientation	Portrait , Landscape
Lines Per Page	5 to 128, Default is 60
Separator Page	Off , Tray 1, Tray 2, Tray 3, Tray 4
White Page Skip	Enable, Disable

Admin\ PCL Emulation Menu

Default settings are in **bold face** type.

Submenus	Available Settings
Font Source	Internal , Compact Flash, User Flash, Disk Drive
Font No.	Available Fonts, Default is No. 50
Font Pitch	0.08 - 100.00, Default is 10.00
Symbol Set	Default is PC-8, see Appendix A for a complete list of all the available symbol sets
CR Function	CR , CR+LF
LF function	LF , LF+CR
A4 Print Width	78 Columns , 80 Columns
Print Area	Normal , Expanded
PCL Tray1 ID#	0000 to 9999, Default is 0001
PCL Tray2 ID#	0000 to 9999, Default is 0004
PCL Tray3 ID#	0000 to 9999, Default is 0005
PCL Tray4 ID#	0000 to 9999, Default is 0006
PCL Auto ID#	0000 to 9999, Default is 0007

Admin\ FX Emulation Menu

Default settings are in **bold face** type.

Submenus	Available Settings
Character Pitch	10 cpi , 12 cpi, 17.1 cpi, 20 cpi, Proportional
Character Set	Set-1, Set-2
Symbol Set	Default is PC-8. Available Symbol Sets
Zero Char	Slashed, Normal
Line Pitch	6 LPI , 8 LPI
CR Function	CR , CR+LF
Line Length	80 Column , 130 Column
Form Length	11 inch, 11.7 inch, 12 inch
TOF Position	0 inch , 0.1 inch, 0.2 inch ...1.0 inch
Left Margin	0 inch , 0.1 inch, 0.2 inch ...1.0 inch
Fit To Letter	Disable , Enable
Text Height	Same , Diff

Admin\ Parallel Menu

Default settings are in **bold face** type.

Submenus	Available Settings
Parallel	Enable , Disable
Bi-Direction	Enable , Disable
PS Protocol	ASCII , RAW

Admin\ Serial Menu

Default settings are in **bold face** type.

Submenus	Available Settings
Serial	Enable , Disable
Baud Rate	1200, 2400, 4800, 9600 , 19200, 38400, 57600, 115200
Data Bits	8 , 7
Stop Bits	1 , 2
Parity	None , Even, Odd
DTR Ready/Busy	Off , On
DTR On/Off	Off , On
DTR Error	Off , On
RTS Ready/Busy	Off , On
RTS On/Off	Off , On
RTS Error	Off , On
XON Ready/Busy	Off, On
XON On/Off	Off, On
XON Error	Off , On
DTR Polarity	High , Low
RTS Polarity	High , Low
Robust XON	Off , On
PS Protocol	ASCII , RAW

Admin\ USB Menu

Default settings are in **bold face** type.

Submenus	Available Settings
USB	Enabled , Disabled
PS Protocol	ASCII , RAW

Admin\ Date & Time Menu

Default settings are in **bold face** type.

Submenus	Available Settings
Month	January thru December, Default is current month
Day	1 to 31, Default is current day
Year	2000 - 2099, Default is current year
Hour	Midnight, 1 AM to 11 AM, Noon, 1 PM to 11 PM, Default is current hour
Minute	0 - 59, Default is current minute
Second	0 - 59
GMT Offset/Hours	-12 through + 12, Default is 0
GMT Offset/Mins	0 , 30
Daylight Savings	On, Off

Admin\ User Flash Menu

Default settings are in **bold face** type.

Submenus	Description	
Data Security	On, Off	When set to ON, as data is deleted, the location where the data was stored, is overwritten by random data. When set to OFF, the data is deleted.
Print	Reads and prints the selected file from User Flash.	
Delete	Deletes the selected file or directory from the User Flash.	
Format Usr Flash	Reformats the User Flash.	
Flash Summary	Prints a page containing information about the installed User Flash.	

Important!

All files on the User Flash will be deleted if the Format User Flash function is selected.

Admin\ Disk Menu

Note

This menu appears only when the optional hard disk drive is installed.

Submenus	Description
Data Security	When set to ON, as data is deleted, the location where the data was stored is overwritten by random data. When set to OFF, the data is deleted.
Print	Reads and prints the selected file from hard disk.
Delete	Deletes the selected disk file or directory from the hard disk.
Format Disk	This selection will reformat the hard disk.
Disk Summary	Prints a page containing information about the installed hard disk.

Important!

All files on the hard disk will be deleted if the Format Disk function is selected.

Admin\ Compact Flash Menu

The **Comp Flash Menu** provides access to the compact flash settings.

Submenus	Description
Data Security	When set to ON, as data is deleted, the location where the data was stored, is overwritten by random data. When set to OFF, the data is deleted.
Print	Reads and prints the selected file from Compact Flash.
Delete	This selection will delete the selected file or directory from the Compact Flash.
Format Cmp Flash	Reformats the Compact Flash.
CFlash Summary	Prints a page containing information about the installed Compact Flash.

Important!

All files on the compact flash will be deleted if the Format Cmp Flash function is selected.

Admin\ Spooling Menu

Default settings are in **bold face** type.

SubMenu	Available Settings
Start Spooling	Spool and Print, Spool Only, Off
Stop Spooling	Yes, No
Playback	USB, Parallel, Serial, Network
Delete	User Flash, Disk, Compact Flash
Destination	User Flash, Disk, Compact Flash

Admin\ Job Accounting Menu

Default settings are in **bold face** type.

SubMenu	Available Settings
Enabled	Yes, No
Print Info	Execute

Admin\ Change Password Menu

Used to change the Operator Panel Password that is used to gain access to the "Admin Setup" menus. For more information, see page 53.

Admin\ Maintenance Menu

Default settings are in **bold face** type.

Submenus	Available Settings	Description
Menu Reset	Execute	Restore the panel settings to Factory Default.
Save Menu	Execute	Saves the current menu setup for recall at a later time.
Restore Menu	Execute	Restores the saved Menu setting
Panel Security	Enable, Disable	If enabled, all configuration changes require the password.
USB Drive	Enable , Disable	If enabled, gives the printer the ability to read and print files from a connected USB drive.

Print Features

- **Printing Files from a USB Flash Drive** (see below)
- **Printing Jobs stored in the printer's memory** (see page 67)
- **Printing Banners** (see page 70)
- **Printing a PDF file directly from your computer** (see page 73)
- **E-mail printing** (see page 74)
- **Barcodes** (see page 77)

Printing PDF Files From a USB Flash Drive

You can print PDF files up to PDF Version 1.6 directly from a standard USB flash drive without any connection to a host computer. The size of PDF files to be printed is limited by available space in the printer's standard user flash memory unless a Compact Flash or Hard Disk option is installed.

The Host USB Port connection is located on the top left side of the control panel.

1. Put the PDF to be printed on any USB flash drive in either the root directory or a subdirectory.
2. Press <On Line> to make sure the printer is not in "Power Save" mode.
3. Plug the flash drive into the Host USB connector on the operator panel.

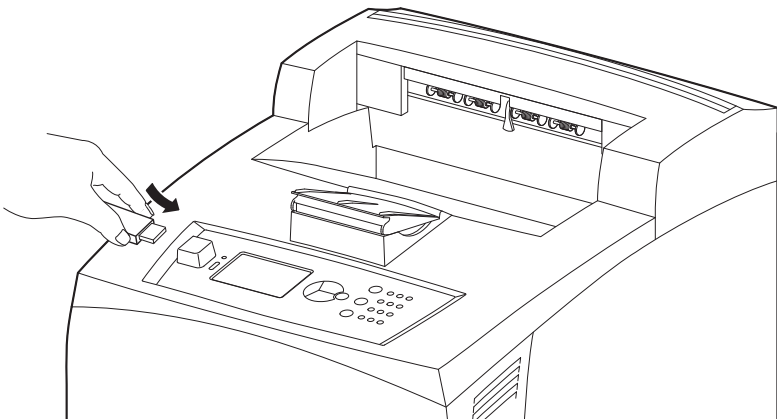

4. When the flash drive is recognized by the printer, you will hear a brief tone. The printer will then automatically go to the [USB Drive] menu.
 5. Select the [Print] submenu.
You will see the list of files on the USB drive.
 6. Select the desired file.
-

Note

The <BACK> button may be used to return from a sub-directory to the parent directory to exit the Print option.

7. You will be prompted to enter the number of Copies for the print request (the default value is 1). To enter a different number of copies, use the numeric keypad.
8. When ready, press <ENTER> to process the file for printing.
9. After printing is complete, the printer will return to the [Ready to Print] state and you may remove the USB flash drive.

Printing a Job Stored in Memory

Note

If you will be using this feature, it is recommended that you purchase the optional Hard Disk Drive or the Compact Flash option to provide the memory required for storing the documents.

When you print a job, instead of printing it out directly, you can use the driver to store the job in the printer along with a 6-digit password for accessing it.

Choose from the following options:

- **Stored**

These documents are stored in the printer for future printing. For example you might use this to store a frequently used form. The document will remain there until the expiration date you specify or until you delete it.

- **Secure Print**

For printing confidential documents. Store the password-protected print file in the printer, then go to the printer and use your password to retrieve it for printing.

- **Proof and Print**

Use this to test print a document before printing it in large quantities.

- **Timed Job**

Used to store a document in the printer for printing at a later time which you specify.

See the Help screens in the printer driver for information on using it to store documents in the printer.

Storing a Job in the Printer

Important!

The Hard Disk Drive or Compact Flash could become damaged and erase important data saved on it. We recommend you back up your data.

1. From your application, select File > Print.
2. Select the printer, then click Preferences (or Properties or Setup).
3. Select the Job Options tab.
4. Under Job Type, select Stored, Secure Print, Proof and Print, or Timed Jobs.
5. *For Timed Jobs:* set the time for the job to print. Other wise, skip this step.
6. Under Job Name, type in a name for the job.
7. Under Job PIN, enter your 6-digit password and click OK.
8. *For Stored, Secure Print and Proof and Print:* enter the job expiration date (use zero if you do not wish the job to expire) and click OK. Otherwise, skip this step.
9. Click Print.

Retrieving a Document for Printing

1. Press <ENTER> to access the printer menu.
2. With Print Jobs Menu highlighted, press <ENTER>.
Enter PIN displays.
3. Use the printer's keypad to enter your 6-digit password. As each digit is entered the display will automatically advance to the next digit. To go back a digit, press <BACK> (left arrow). When all 6 digits have been entered, "Select Jobs" displays.

Stored jobs associated with the PIN value appear on the display.

Note

If there are no stored jobs associated with the PIN value entered, the display will read "Select Jobs PIN has no jobs".

4. Use the up and down arrow keys to scroll through the list of jobs until you locate the one you wish to print.
5. With the job to be printed highlighted, press <Enter>.
6. You will be prompted to enter the number of copies to print. For one copy, press <Enter>. To print more copies, use the keypad to enter the number of copies, then press <Enter>.

Stored Jobs: The printer processes the job and returns to the Ready to Print state.

Secure Print Jobs: The printer processes the job, prompts you to delete it, then returns to the Ready to Print state.

Proof and Print Jobs: The printer prints one copy of the job for you to check, then prompts you to print further copies or to delete it. Once done, the printer returns to the Ready to Print state.

Deleting a Stored Document

Note

Secure Print and Proof and Print documents are automatically deleted after they have successfully printed.

1. Press <Enter> to access the printer menu.
2. With Print Jobs Menu highlighted, press <Enter>.
3. Use the printer's keypad to enter your 6-digit password.
4. Press <Enter>.
5. Use the up and down arrow keys to highlight the job you wish to delete.
6. Press <Cancel>.

*The display changes to:
Delete the Job
Enter and Cancel.*

7. Press <Enter> delete the job, or press <Cancel> to abort the delete.

Printing on Banners

Banners up to 35.4 inches (900 mm) long by up to 8.5 inches (216 mm) wide can be printed from Tray 1.

Loading Banner Paper

1. Pull out Tray 1 and place it on a flat surface.

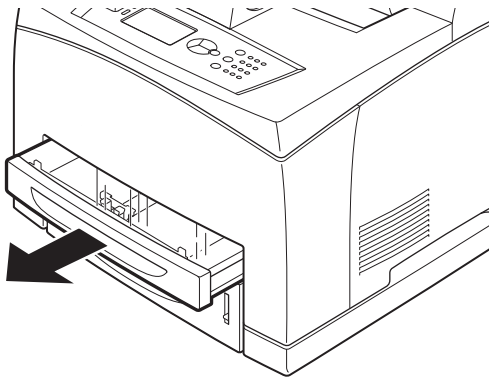

2. If installed, remove the lid.

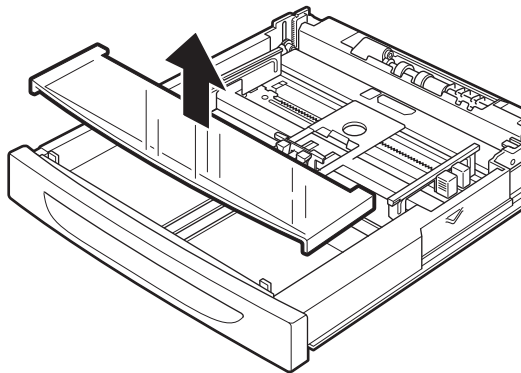

3. If the base plate of the paper tray is raised, push it down.

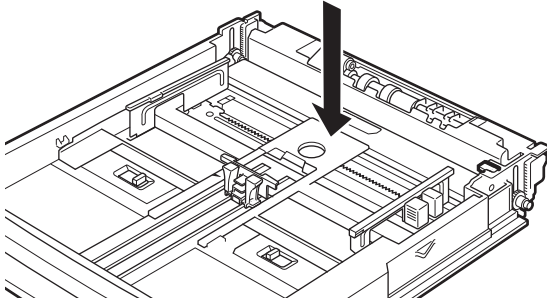

4. Slide the left and right lock tabs in the paper tray outwards to unlock them.

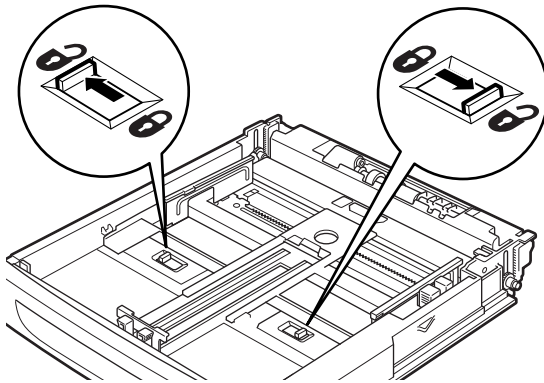

5. Hold the grip of the paper tray and pull its extendable part to the front until it reaches its maximum.

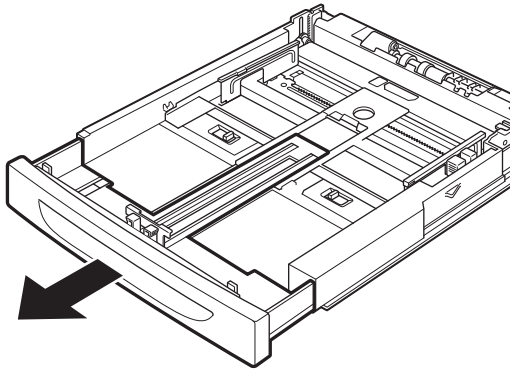

6. Squeeze the right width guide (1) and slide it to the banner width.

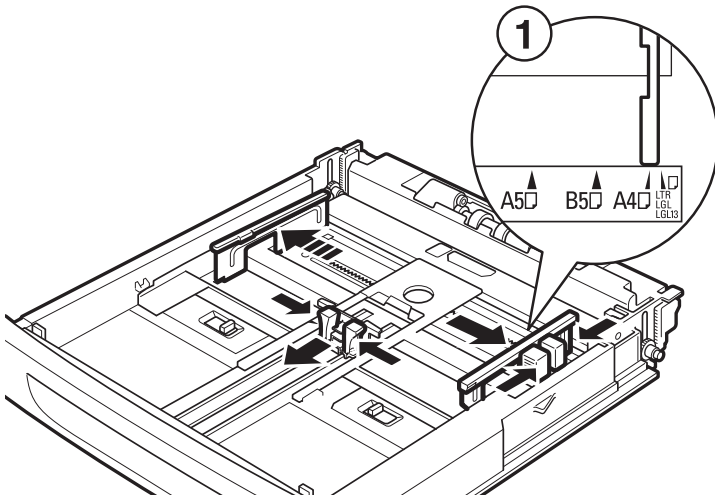

7. Load the paper with the side to be printed facing up. Roll up the back end of the paper so that it will not fall from the tray.

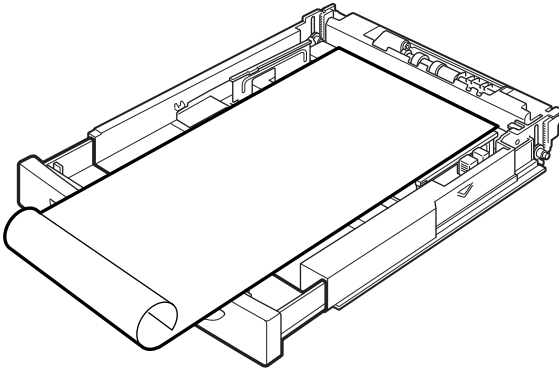

8. Push the paper tray completely into the printer.
9. Send the print job from your application.

Direct Printing of PDF Files

You can send a PDF file directly to the printer for printing without using the printer driver. The size of PDF you can print is limited by the amount of available space in the printer's memory. If you are printing large files, you may need to install either the optional Compact Flash or Hard Disk option.

Note

You may not be able to print some PDF files directly by the printer due to the way they were created. When this happens, open the PDF files and use the printer driver to print them.

Printing a PDF File

To print PDF files directly, you can send the PDF using any method of file transmission such as DOS Copy or using a utility to send it directly to Port 9100 on a TCP connected printer. You can also use the Oki PC based utility for printing PDF files directly to the printer.

When sending the PDF file to the printer using the lpr command, printing will be done with the defaults set at the control panel, including the defaults set for

- Copies
- Duplex
- Print mode
- Paper size
- Paper feed

Note

When the lpr command is used, you must specify the number of copies using the lpr command. The [Quantity] setting on the control panel will become disabled. If the number of copies is not specified by the lpr command, it will be treated as one copy.

Printing via Electronic Mail / E-mail Printing

Models with the optional Hard Disk Drive or Compact Flash installed can receive and print e-mails sent directly from your computer via TCP/IP communication, including e-mail contents and TIFF or PDF attachments.

This feature is known as E-mail Printing.

Environment Settings for E-mail Printing

To use the E-mail Printing feature, you need to configure server settings (such as SMTP and POP3 servers) on your network environment.

Note

Wrong e-mail environment settings may cause disruptions in your network. Always ask your network administrator to configure e-mail environment settings.

Attachments That Can Be Sent

The following files can be sent as an attachment.

- PDF file created by Adobe Acrobat.
- TIFF file

Note

The PDF files sent will be printed by using the PostScript feature and according to the [PDF] setting on the control panel. For details refer to "Direct Printing of PDF Files" on page 73.

Sending E-mails

This section explains how to send e-mails from the computer to the printer using Outlook Express as an example.

1. Create mail contents using your mailing software and attach any TIFF or PDF files.

Important!

Only text format can be used for the mail contents. Set the format of the e-mail content to text format in your mailing software.

Note

- > If the extension of the attached file is not "tif" or "pdf", it may not print correctly.
 - > A maximum 31 documents can be attached.
-

2. Enter the printer's e-mail address in the address column.
3. Send the e-mail. The printer will print the e-mail automatically after receiving it.

Points to Note When Sending E-mails

Security Issues

E-mails are sent via the Internet, connecting computers from all over the world. As a result, precautions must be taken relating to security issues such that information is not easily seen or altered by third parties.

Therefore, we recommend that you use methods to ensure that important information is secured. You are also advised not to reveal the e-mail address of this printer to third parties to avoid receiving spam.

Caution Regarding Internet Provider and E-mail Features

- In the case where a flat-rate contract with the Internet provider exists and the user is not always connected to the network, a telephone charge will be incurred every time this printer retrieves data regularly from the mail server.
- Connect the printer to an private IP address. Functionality of this printer is not guaranteed when it is assigned public IP addresses.
- When receiving e-mails via POP, always apply an exclusive e-mail account for the printer. Using a common e-mail account shared with other users will result in errors.
- When the internet connection speed is slow, it takes time to receive large amounts of data such as image data.
- There are also providers that allow reception of e-mails via SMTP. Detailed adjustments with the provider are required in such cases.
- When setting up the e-mail configuration in an environment where MTA support is set up in private segments, match the operating configuration.

Barcode Printing

Bar Codes are supported for PCL5.

Internal Bar Codes

- Code 128
- Code 3 of 9
- Interleaved 2 of 5
- UPC/EAN
- Postnet

Supported Software-Generated Bar Codes

- UPC/EAN
- Code 128
- EAN/UCC 128
- PostNet
- Interleaved 2 of 5
- Code 39
- Codabar
- Code93.

Driver-Set Print Features ---

Use the print driver Printer Properties dialog box to configure these features.

Some of these features may also be configured in the printer menu or using the Embedded Web Server.

Manual Feed from Tray 1

Tray 1 can be set for manual feed in the Printer Properties in the driver. When Tray 1 is set to Manual mode, you must press <ENTER> to print each sheet.

Collating

When you are printing multiple copies of a multi-page document, the printer is set by default to automatically collate the pages; i.e., all pages of the document will print before the second copy of the document begins printing.

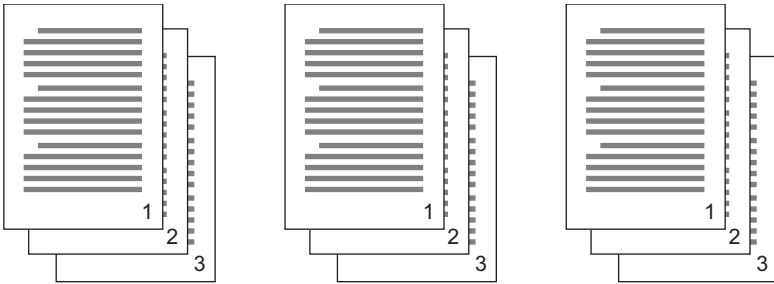

Without collating selected, the unit will print the total number of copies of each page before proceeding to the next page.

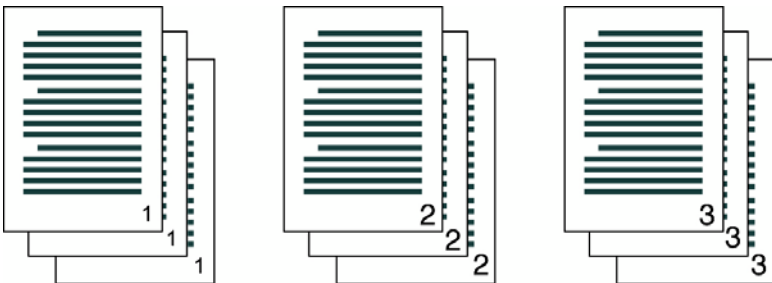

2-Sided Printing/Duplex

The printer can automatically print on both sides of the paper for the models which include the duplex unit (standard on Models B710dn, B720dn and B730dn; optional on Models B710n, B720n and B730n). You can use two-sided printing to produce a document in the form of a small book.

Cover Sheet

The printer enables you to choose a different paper source for the cover sheet of a document. This allows you to use a different stock and/or color paper for the first page while sending the document as a single print job.

Note

The cover sheet must be the same size as the rest of the document.

Fit to Page

This allows you to scale the document to fit the paper size being used.

Note

This setting is unavailable if you have chosen a document style of N-Up or Pamphlet.

N-up Printing (Multiple Pages to a Single Sheet)

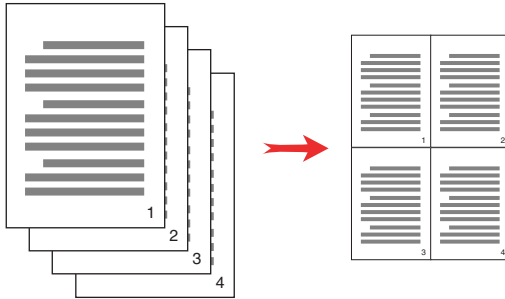

You can print multiple pages on a single sheet when printing a multi-page document. This can save paper and is handy for draft reviews. You can print one, two, four, six, eight, nine, or sixteen pages per sheet.

Finishing

You can add room on a page to allow for binding without modifying the document in the authoring application.

Poster Printing

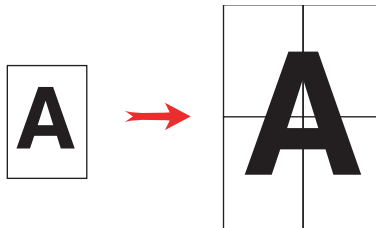

If you have a large page image that can not be printed on the available paper sizes, you can print the document in poster printing mode. Poster Print prints the document to the edges of the paper with no border and breaks the document up into multiple pages. The pages can then be placed together, edge-to-edge, to create a large version of the printed page.

Job Offset

Note

Requires the optional Offset Catch Tray.

This feature places sheets in alternate positions to separate one print job from another. After the final sheet of a print job is printed, the next job is offset (shifted a bit) to keep it separate from the previous print job.

The Offset Catch Tray must be installed to use this feature. Once installed, this feature is enabled by default.

Print Quality

You can adjust quality settings, including:

- Resolution: Select 600 dpi for normal printing or 1200 dpi for high quality mode.
- Toner Save: This prints everything with less print density.

Font Substitution

This feature allows you to substitute TrueType fonts with printer fonts. You can also set the TrueType font output type.

Watermark

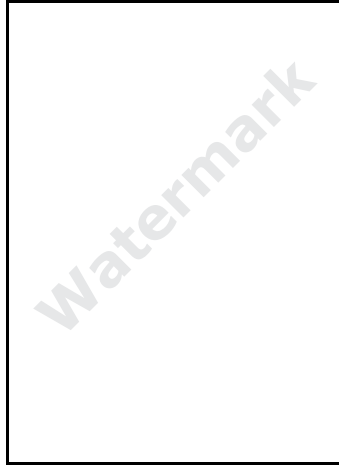

A Watermark is faded text that appears in your choice of the background of all pages or only the first page. Predefined COPY, DRAFT, and CONFIDENTIAL watermarks are provided in the driver. You can view these by clicking on their name in the Watermark Pane of the Watermark Window. You can edit their settings or the settings of any configured watermark by clicking the Edit button.

The Embedded Web Server (EWS)

The printer's Embedded Web Server (EWS) provides access to printer features over the network as HTML web pages. Changes made via the EWS change the printer settings in the same manner as changes made through the operator panel.

To change settings for specific documents, use your Printer Properties options within the driver.

Note

- Any setting you make in the application from which you are printing will override settings in the Embedded Web Server or the printer menu.
 - The EWS is only available when the printer is connected to the network.
-

Accessing the Embedded Web Server

To access the EWS, you need the printer's IP address. The IP address is located in the Menu Map on the first page under the heading "Network" (to print a Menu Map, see page 44).

The EWS home page for the Model B730 printer is shown below. The various functions are accessed through the menu on the left side of the page.

OKI
PRINTING SOLUTIONS

B730n

Status

- Printer Status
- Printer Summary
- Network Summary
- Usage Report
- Print Jobs
- Links
- Send File

Administrator Login

Power Save

Refresh Cancel Job

Toner Remain :
Black: ██████████ 99%

Toner Coverage Average :
Black: ██████████ 54461.60%

Printer Alert Information

WARNING Paper Out Tray 1

Printer Information

IP Address	10.5.1.158
System Contact	
System Name	B730n 030054
System Location	
Printer Serial Number	
Printer Asset Number	
Tray 1	Letter
Tray 2	Letter
Duplex	Installed
Offset Tray	Not Installed
Hard Disk	Not Installed
Compact FLASH	Installed
Memory	128 MB

Print Service Enabled

TCP/IP	●
Ethertalk	●
Netware	○

Setting Service Enabled

Web	●
IPv6	●

Version Information

CU Firmware	6.0 T1
PU Firmware	0.45.0
Network Firmware	10/100 Ethernet Rev 3.5 (id 0020)
PostScript Version	3016.103

Troubleshooting

Paper Jams

Caution!

When removing jammed paper, make sure that no pieces of torn paper are left in the printer. A piece of paper remaining in the printer can cause a fire.

If a sheet of paper is wrapped around the heat roller, or when clearing a jammed sheet that is difficult or impossible to see, do not try to remove it by yourself. Doing so can cause injuries or burns. Turn off the printer immediately, and contact your dealer for service.

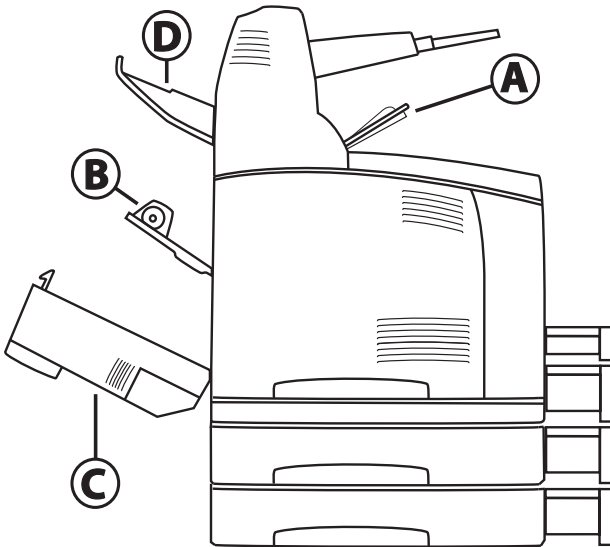

- A Top Cover
- B Back Cover
- C (Optional) Duplex Unit Cover
- D (Optional) Offset Catch Tray Cover

Paper Jams Inside Cover A

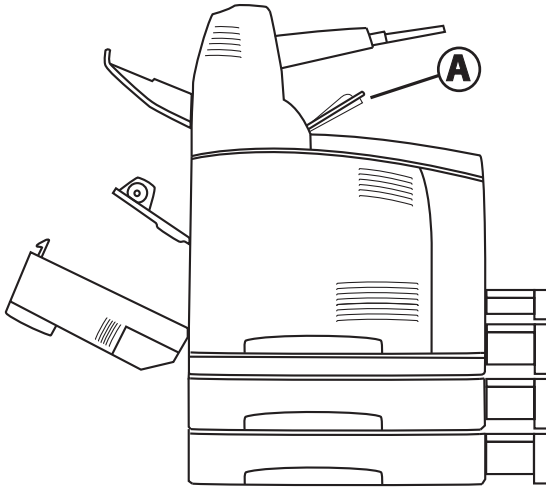

1. If the optional offset catch tray is installed, lift it out of the way.

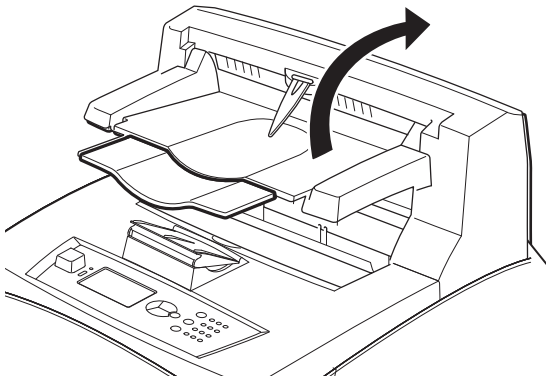

2. Open Cover A.

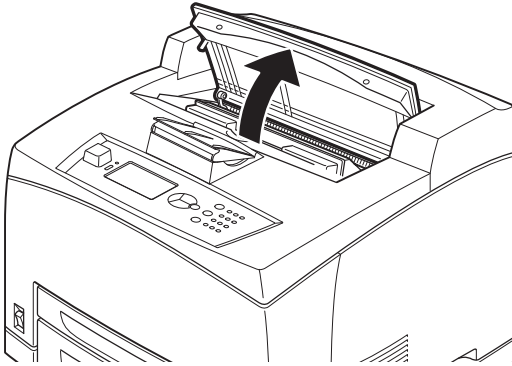

3. Holding the drum/toner cartridge by the grip, remove it from the printer (1).

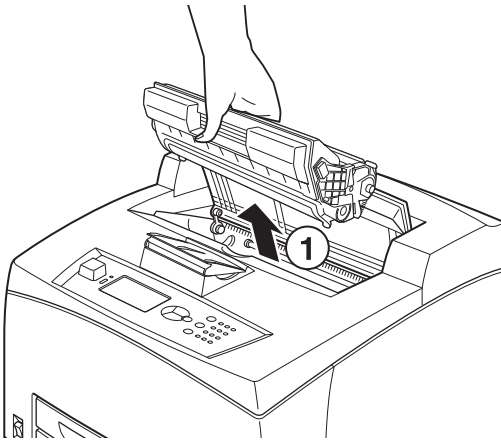

4. Turn the roll (2) and remove any jammed paper inside.

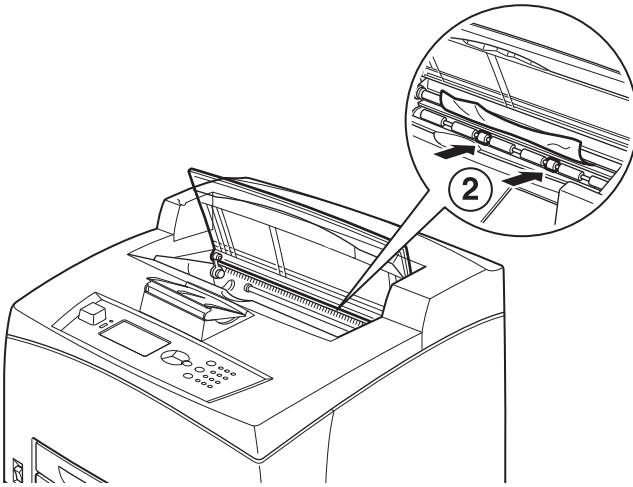

5. Put the drum/toner cartridge back in the printer.

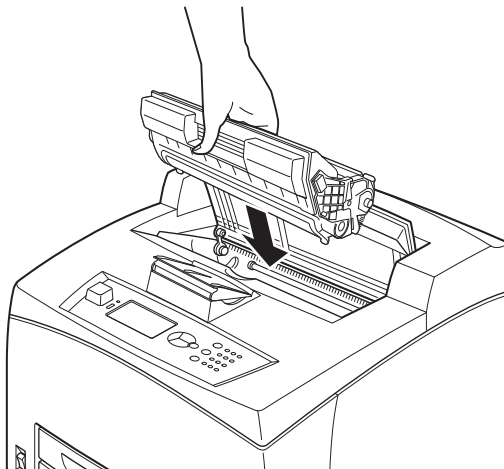

6. Close Cover A.

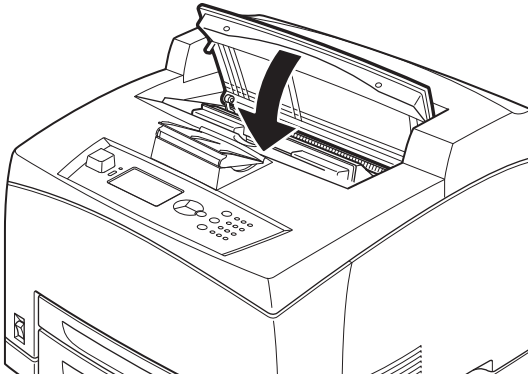

7. If installed, lower the offset catch tray to its original position.

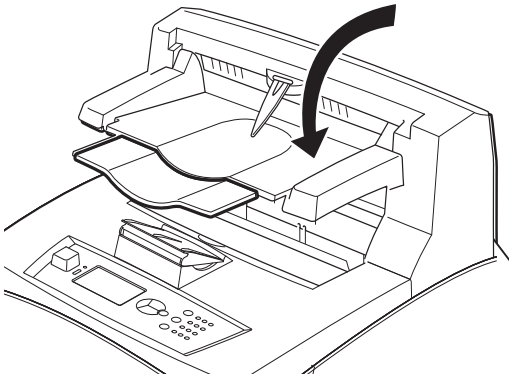

Caution

If you continue to print with the offset catch tray folded, this may cause a paper jam. Always use the printer with the tray open.

Removing Jams Inside the Paper Tray(s)

1. Pull out all paper trays and remove any wrinkled paper.

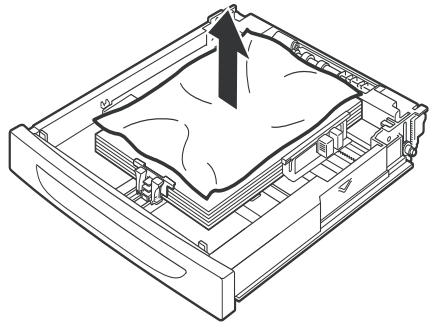
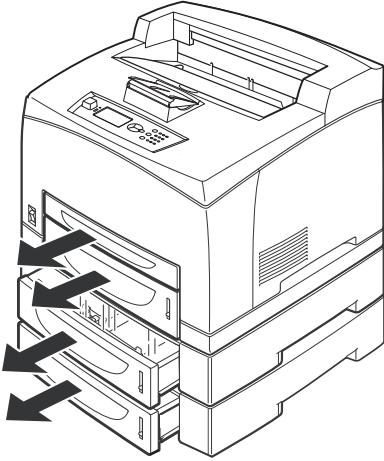

2. Examine the inside of the printer and remove any jammed pieces of paper.

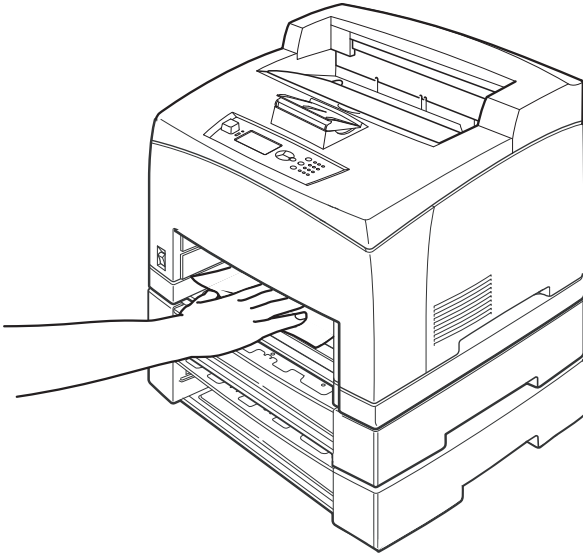

3. Push the paper tray(s) completely back into the printer.

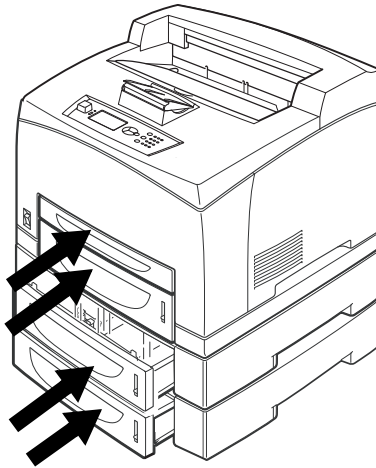

4. Open and close cover A. Doing this will clear the error message.

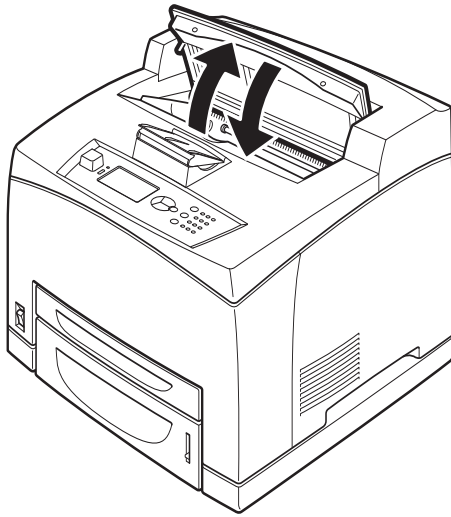

Paper Jams Inside Cover B

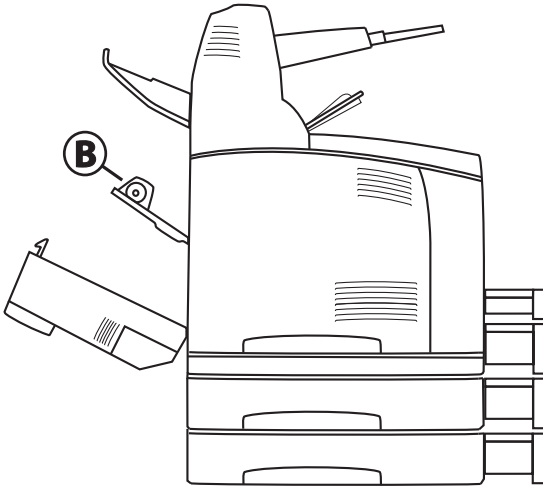

1. Remove the rear tray.

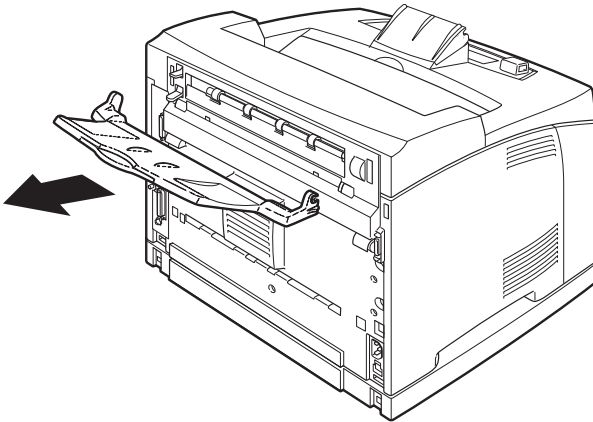

WARNING!

The fuser unit is hot. You may get burned if you touch it directly.

2. Raise the lever as shown in the diagram and open the cover B (1). Then open the cover of the fuser unit (2), indicated by a small green label with a black star, and remove any jammed paper.

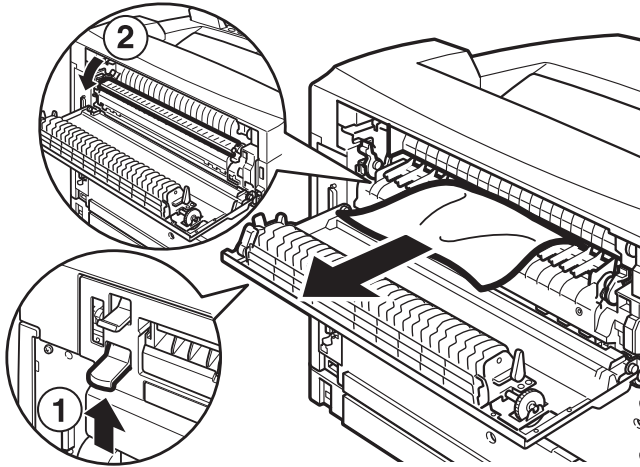

3. Close the fuser unit and Cover B.
4. Replace the rear tray.

Paper Jams Inside Cover C: Duplex Unit

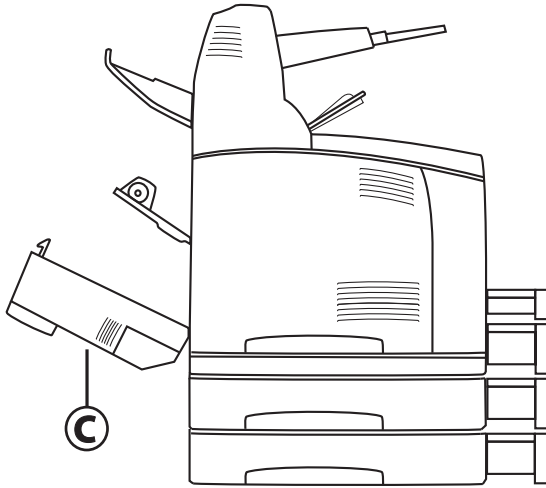

1. Remove the rear tray.

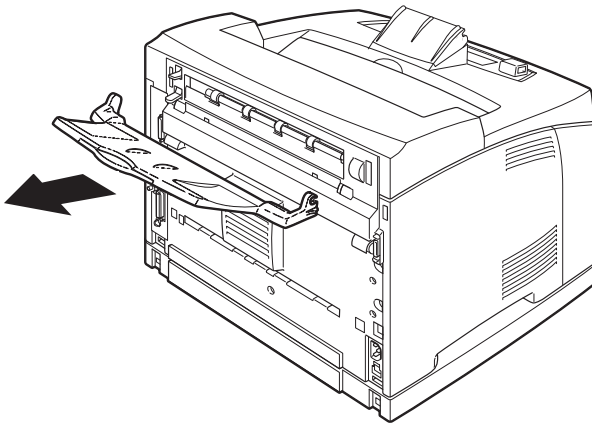

2. Push up the lever shown in the diagram to open the cover. Then remove the jammed paper.

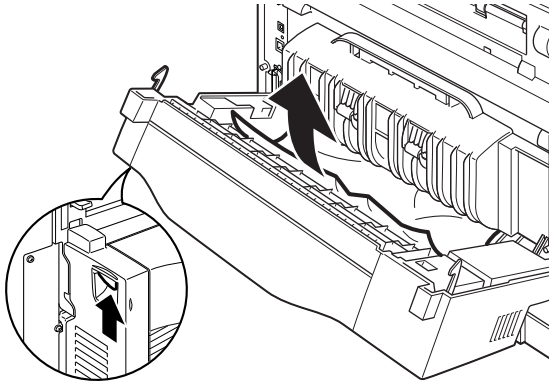

3. Close the cover and replace the rear tray.

Paper Jams Inside Cover D: Offset Catch Tray

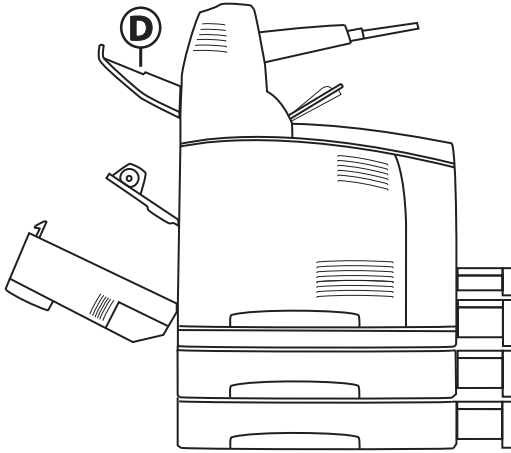

1. Open the Offset Catch Tray cover and pull out the jammed paper.

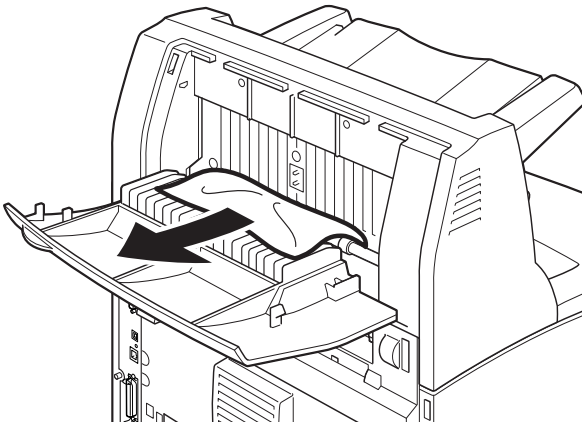

2. Close the cover.

When Problems Occur

Before treating the problem as a printer breakdown, refer to the following table and check the printer condition again.

WARNING

- **Never open or remove printer covers that are secured with screws unless specifically instructed in the user guide. A high voltage component can cause electric shock.**
 - **Do not try to alter the printer configuration, or modify any parts. An unauthorized modification can cause smoke or fire.**
-

Note

Limitations of the printer and incorrect settings at the printer, computer and server corresponding to your network environment may also result in printing problems.

Symptom	Explanation	Action
No power.	The printer is turned off.	Turn on the power.
	The power cord is disconnected or not securely connected.	Turn off the printer and reconnect the power cord to the power outlet. Then, turn on the printer.
	The power cord is connected to a power outlet with incorrect voltage.	Connect the printer to a power outlet with a suitable voltage and current rating. See the label on the printer.

Symptom	Explanation	Action
Cannot print.	Is the READY light off? If so, this printer is off-line or in menu setting mode.	Check the control panel display: "Off-line" Press <On Line> Others Press the Back Arrow button to exit the menu setting mode.
	Is there a message displayed on the control panel?	Follow the message to rectify the problem. See page 107
	When a parallel cable is used for connection, are you using a computer that supports bidirectional communication?	By default, the printer's bidirectional communication setting is set to [Enable]. If the computer is not responding to bidirectional communication, printing cannot be done. Turn the bidirectional communication setting to [Disable] on the control panel and then print again.
	The printer has insufficient memory to print the job.	If the printer driver is set to [1200dpi] on the [Graphics] tab, change it to [600dpi]. Install additional memory (optional) in the printer. Reduce the complexity of the print job.
Print job is sent, but the READY light is not on.	The interface cable may be disconnected.	Turn off the power and check the connection of the interface cable.
	Is the interface configured?	Check the port status of the interface.
	The computer environment is not correctly set up.	Check the computer environment, such as the printer driver.

Symptom	Explanation	Action
The ATTENTION light is on.	Is there an error message displayed on the control panel?	Check the displayed message and rectify the error. See page 107
ATTENTION light is blinking.	An error that you cannot rectify yourself has occurred.	Record the displayed error message or error code, turn off the power, pull out the power plug from the outlet, and then call for service.
Although no print job is sent, the message "Printing" appears on the control panel (when using the parallel interface).	You turned on the computer <i>after</i> turning on the printer?	Press <Cancel>. In the future, be sure to turn on the computer power <i>before</i> turning on the printer.
Poor print quality.	There may be a problem with the image.	Refer to " When the Print Quality is Poor" (page 104)
The correct characters are not printed (printing garbage).	This printer is printing with nonstandard built-in fonts.	Check the fonts used in the application. Download the necessary fonts when using PostScript.
The printout is different from what is displayed on the screen.	Did you change the TrueType font settings to printer fonts?	Change to TrueType font printing for [Font Substitution] on the [Setup] tab of the printer driver. See the Online Help for the printer driver

Symptom	Explanation	Action
<p>"Waiting" is displayed but nothing is being printed.</p>	<p>Printer is waiting for data from the host computer and is in the midst of a job. Sometimes a job is sent without normal job termination characters.</p>	<p>Press and hold <On Line> for 3 seconds until the printer flushes the job buffers and completes the printing of this job.</p> <p>Alternatively, you can simply wait for a timeout to occur which will automatically flush the buffers and complete the printing of the job. This default timeout is normally 20 seconds and can be adjusted with a control panel command</p>
<p>Printing is taking up a lot of time.</p>	<p>The receive buffer is insufficient.</p>	<p>When printing documents of high resolution, reduce the memory capacity of items not in use.</p> <p>It is recommended to disable ports not in use, and channel the memory to other purposes.</p>
	<p>Is the printer driver set to [1200dpi] on the [Graphics] tab?</p>	<p>Changing the setting to [600dpi] will shorten the print time.</p> <p>See the Online Help for the printer driver.</p>
	<p>Printing with TrueType fonts may take up printing time.</p>	<p>Change the printing method for TrueType fonts in [Specify Font] on the [Detailed Settings] tab of the printer driver.</p> <p>See the Online Help for the printer driver.</p>
<p>Top section of printed document is missing. Text is reduced.</p>	<p>Are the paper tray guides set in the correct positions?</p>	<p>Set the length guide and the right width guide in the correct positions.</p> <p>See page 22.</p>

Symptom	Explanation	Action
<p>Paper cannot be fed. Paper jam. Multiple pages are fed. Paper is fed at an angle. Paper is wrinkled.</p>	<p>Is the paper correctly set?</p>	<p>Load the paper correctly. For labels, transparencies or envelopes, fan them well first to allow air to enter between each sheet before loading. See pages 20, ff.</p>
	<p>Is the paper damp?</p>	<p>Replace with paper from a new ream.</p>
	<p>Is the correct type of paper used?</p>	<p>Load the correct type of paper. See page 24.</p>
	<p>Is the paper tray set correctly?</p>	<p>Push the paper tray completely into the printer.</p>
	<p>Is the printer placed on a flat location?</p>	<p>Place the printer on a stable surface.</p>
	<p>Are the paper tray guides set in the correct positions?</p>	<p>Set the length guide and right width guide in the correct positions. See page 22.</p>
	<p>Have you used any picture papers?</p>	<p>Clean the feed roll. See page 129.</p>
	<p>Paper is fed in more than 1 sheet at a time.</p>	<p>Remove the paper in the feed tray, fan it, then load it again. Replenish paper only when all the sheets in the tray are used up.</p>

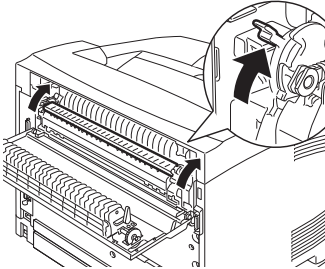
Symptom	Explanation	Action
Envelope is wrinkled.	Envelopes can get wrinkled depending on the type used.	<p>Open cover B of this printer and lift up the levers at both ends of the fuser unit. The wrinkles can be reduced.</p>  <p>Important! After printing the envelope, remember to return the levers to their original positions.</p>
Strange noise.	Is the printer placed on a flat location?	Place the printer on a stable surface.
	Is cover A open?	Close cover A securely.
	Is the paper tray set correctly?	Push the paper tray completely into the printer.
	Are there foreign objects inside the printer?	<p>Turn off the power and remove any foreign objects inside the printer.</p> <p>If the object cannot be removed unless the printer is disassembled, contact service.</p>

When the Print Quality is Poor

When the print quality is poor, select the closest symptom from the following table to rectify the problem.

If the print quality does not improve after carrying out the appropriate action, contact service.

Symptom	Reason/Action
Printing is light. (faded, blurred).	The paper is damp. Replace with paper from a new ream. See page 40.
	The drum/toner cartridge is defective/damaged or there is no more toner inside the cartridge. Replace with a new drum/toner cartridge. See page 119.
	The Toner Saving feature is on. Un-check the [Toner Saving] check box on the [Graphics] tab of the printer driver. See the Online Help for the printer driver
	Levers on both sides of the fuser unit are raised. Open cover B of this printer and push down the levers at both ends of the fuser unit. <div data-bbox="444 889 849 1156" style="text-align: center;"> </div>
Black spots or streaks are printed.	The drum/toner cartridge is defective or damaged. Replace with a new drum/toner cartridge. See page 119.
Toner appears at equal intervals.	The paper feed rout contains excess toner. Print a few pages to remove the excess toner.
	The drum/toner cartridge is defective or damaged. Replace with a new drum/toner cartridge. See page 119.

Symptom	Reason/Action
White dots appear in black filled areas.	The paper used is not suitable. Load the correct type of paper. See pages 24 and 40.
	The drum/toner cartridge is defective or damaged. Replace with a new drum/toner cartridge. See page 119.
Printed image smudges when rubbed with your finger. The toner is not fixed on the paper. Paper is smeared with toner.	The paper loaded in the paper tray does not match the paper type set on the control panel. Make sure the paper loaded in the tray matches the type set using the control panel.
	The paper is damp. Replace with paper from a new ream.
	The paper used is not suitable. Load the correct type of paper. See pages 24 and 40.
The whole sheet is printed black.	The drum/toner cartridge is defective or damaged. Replace with a new drum/toner cartridge. See page 119.
	This may be due to breakdown of high voltage power. Contact service.
Nothing is printed.	The drum/toner cartridge is defective/damaged or there is no more toner inside the cartridge. Replace with a new drum/toner cartridge. See page 119.
Spots of missing text.	This may be due to breakdown of high voltage power. Contact service.
	The paper is damp. Replace with paper from a new ream.
	The paper used is not suitable. Load the correct type of paper. See pages 24 and 40.

Symptom	Reason/Action
Text is blurred.	The paper used is not suitable. Load the correct type of paper. See pages 24 and 40.
	The paper is damp. Replace with paper from a new ream.
Missing characters throughout the length of the paper.	The drum/toner cartridge is defective/damaged or there is no more toner inside the cartridge. Replace with a new drum/toner cartridge. See page 119.
Text or images are printed at an angle.	The paper tray guides are not set in the correct positions. Set the length guide and the right width guide in the correct positions. See page 22.
Transparencies and envelopes are not printed clearly.	The type of transparency or envelope loaded cannot be used in this printer. Load the correct type. See pages 28 and 32.
	Check that the paper type on the printer driver or the control panel is correctly set.

Error Messages (alphabetical order)

Message	Condition/Reason/Action
Bad Action	Format error.
Bad Action Str	Missing or bad action defined for job.
Bad BUFSIZE Cmd	Format error on BUFSIZE command.
Bad COLUMN Cmd	Format error on COLUMN command.
Bad FEntry CMD	Unrecognized Form Entry command.
Bad FORMLINES	Format error on FORMLINES command.
Bad Header Cmd	Unrecognized Header command.
Bad LINE Cmd	Format error on LINE command.
Bad PAGE Cmd	Format error on PAGE command.
Bad PORT Cmd	Format error on PORT command.
Bad Target Str	TARGET string format error.
Bad TEntry CMD	Unrecognized Target Entry command.
Call Service	Help message used for service-type errors.
Cancel Job	Confirmation prompt used when CANCEL is pressed.
Canceling Job	An operator-requested Cancel is in progress.
Clock Not Set	Real Time Clock has not been initialized.
Close Duplexer	Recovery message displayed when duplex door is open.
Close Rear Cover	Recovery message displayed when rear cover is open.
Close Top Cover	Recovery message displayed when top cover is open.
Code FLASH Error	Defective Code Flash - user forced into Firmware Upgrade.
Command Format	Bad command format.
Completed	Display for the files status.
Cover Open	Recovery action displayed when cover is open

Message	Condition/Reason/Action
Disk Unformatted	Error message displayed when unformatted disk is detected.
Drive Full Error	The storage device that you are trying to copy to is full.
Duplex Failure	Duplex Unit Failure.
Engine NV Fail	Call for service.
Exit Jam	Paper jam detected
Face Up Failure	Error message displayed for Face-Up tray unit failure.
Fan Failure	Error message displayed for Fan Failure.
File Error	Status display for "File Error xx" (where xx is error code).
File Not Found	Could not find a filter configuration file.
Filter Error	Displayed on line 1, detail of error on line 2.
Firmware Upgrade	Indicates "Firmware Upgrade" mode is active.
Format Error	Failure during attempted format of flash.
Formatting	Status display for file status.
Fuser Failure	Error message for Fuser Failure.
ID Mismatch	Displayed for OEM ID Mismatch on EP Cartridge.
Incompatible Duplexer	Incompatible Duplex Option Installed
Incompatible OCT	Incompatible Offset Catch Tray Option Installed
Incompatible Tray 3	Incompatible Tray 3 Option Installed
Incompatible Tray 4	Incompatible Tray 4 Option Installed
Initializing	Displayed during Power-on Initialization.
Insert Tray	Recovery action displayed when tray needs to be inserted
Install/Reset	Recovery message displayed for ROS failure. Call for service.
Load Paper	Un-specific "Load Paper" prompt.
Load Paper Tray 1	A user prompt that paper needs to be put into Tray 1.

Message	Condition/Reason/Action
Load Paper Tray 2	A user prompt that paper needs to be put into Tray 2.
Load Paper Tray 3	A user prompt that paper needs to be put into Tray 3.
Load Paper Tray 4	A user prompt that paper needs to be put into Tray 4.
Lower Switch	Face Up Tray Failure.
Main Motor Fail	Displayed for Main Motor Failure.
Maintenance Req'd	Used for error/warning when Maintenance is required (replace fuser/rollers/etc.)
Misfeed Jam	Paper jam detected inside the printer.
Net Comm Error	Error Message used to report Network Interface Communication Failure.
Net: Error	Used for display of Network Interface error code (Net1: Error yy)
NVRAM Failure	NVRAM failure message.
Offset Tray	Optional face-down output tray (offset-capable)
Offset Tray Fail	Error message displayed for Offset Tray Unit Failure.
Offset Tray Full	Error message displayed when optional output bin is full
Offset Tray Jam	Paper jam detected. Error message displayed for Offset Tray Jam
Out of Memory	Error displayed when there is insufficient memory to print a page or job.
Output Tray Full	Error message displayed when output tray is full
Paper Low Tray 1	Tray 1 is low on paper.
Paper Low Tray 2	Tray 2 is low on paper.
Paper Low Tray 3	Tray 3 is low on paper.
Paper Low Tray 4	Tray 4 is low on paper.
Paper Out Tray 1	Tray 1 has no paper
Paper Out Tray 2	Tray 2 has no paper
Paper Out Tray 3	Tray 3 has no paper

Message	Condition/Reason/Action
Paper Out Tray 4	Tray 4 has no paper
PDF Format Error	The PDF file being printed has an unsupported PDF format later than V1.6
Power Save	Displayed when printer is in Power Save mode.
Press <OnLine>	Prompts the user to press <OnLine>.
Processing	Printer is actively processing job data.
Receive	Status display for file status "Receive xx" (where xx is percentage received).
Remove Paper	A help message to remove paper
Replace EP Cart	Replace the image drum.
SELECT to Format	User prompt displayed when unformatted disk detected.
Service Error	Report Service errors ("Service Error xx").
Toner Low	Toner cartridge is low
Toner Missing	Error message displayed when Toner cartridge is missing.
Toner Out	Toner Out message.
Too Many Filters	Too many filters defined.
Tray 1 Missing	Warning message displayed when Tray 1 is missing
Tray 2 Missing	Warning message displayed when Tray 2 is missing
Tray 3 Missing	Warning message displayed when Tray 3 is missing
Tray 4 Missing	Warning message displayed when Tray 4 is missing
USB Drive / Device Not Supported	Installed USB Flash Device is not supported
USB Drive / Format Not Supported	The file format used on the installed USB Flash Drive is not supported.
User FLASH	String used to describe FLASH used for USER storage.
Waiting	Printer has completed processing data, but has not detected end-of-job.

Message	Condition/Reason/Action
Warming Up	Displayed when printer is "Warming Up".
Write	Status display for file status "Write xx" (where xx is percentage received).

Network Related Problems

Using TCP/IP

This section explains how to fix the printer status when “Unable to print (xxxx Error)” appears in the window displayed by clicking [Start] > [Printers].

Cause	Verification	Action
The printer and the computer are connected to different networks.	Check with your network system administrator to verify that the network connecting the computer and that connecting the printer are linked by a router or a gateway.	Connect this printer directly to the network connecting the computer.
An error has occurred in the network between the computer and the printer. Connection cannot be established.	“Unable to print (NetworkError)” is displayed.	Ask your network system administrator to check the network for errors.
The printer is turned off after a print instruction has been sent from a computer. Or the print instruction is sent to the printer which is turned off.	“Unable to print (NetworkError)” is displayed. Check whether the printer is turned on.	Turn on the printer.
Print instructions from multiple computers are sent to the printer at the same time.	“Unable to print (NetworkError)” is displayed.	None (Printing will be resumed automatically).

Cause	Verification	Action
<p>Printing files cannot be spooled due to insufficient disk capacity of the computer.</p>	<p>“Unable to print (SpoolError)” is displayed. Double-click [My Computer] and right-click the disk (example: C drive) with Windows< Select [Properties] from the menu displayed and then check available free space.</p>	<p>After deleting unnecessary files to increase the free space available, select [Pause] from the [Documents] menu of the [Printers] window to enable printing to restart.</p>

For Windows NT 4. 0/Windows 2000/Windows XP

The printer is not printing

Cause	Verification	Action
Incorrect IP address.	Ask your network administrator to check that the IP address is correct.	Specify the correct IP address for the printer.
When [LPD Spool] is set to [Memory], the print data sent from a computer in a single print instruction has exceeded the upper limit of the receiving capacity.	Check the memory capacity of [LPD Spool] and compare it with the print data which was sent in the single print instruction.	1. If a single file of print data has exceeded the upper limit of the memory capacity, divide the file into smaller ones and try again.
		2. If multiple files have exceeded the upper limit of memory capacity, reduce the number of files to be sent at one time.
An irrecoverable error has occurred during printing.	Check if an error is displayed on the control panel.	Turn the printer off, then on.
The transport protocol is different from that of the computer.	Check the selected transport protocol.	Select the same transport protocol as that of the computer.

Using Printer Web Page

Symptom	Reason/Action
Cannot access the Printer Web Page.	<p>Is the printer working correctly? Check if the power of the printer is turned on.</p>
	<p>Is Printer Web Page enabled? Print out the [System Settings List] to check.</p>
	<p>Is the URL correctly entered? Check the URL again. If connection fails, enter the IP address to connect.</p>
	<p>Is a proxy server being used? Some proxy servers do not allow this feature. Try connection without using the proxy server. Refer to: • Online Help for the web browser</p>
The "Please wait" message is displayed throughout the Web browser.	<p>Wait for a while as instructed. If the problem persists, refresh the Web browser. If nothing happens, check if the printer is working properly.</p>
The [Refresh] button is not working.	Are you using the supported OS and Web browser?
Selecting the left frame menu does not change the display	Check whether the OS and web browser you are using are supported
The screen display is distorted.	Change the window size of the web browser.
The latest information is not displayed.	Click [Refresh].
The new settings were not reflected by clicking the [Submit] button.	<p>Is the entered value correct? If an invalid value is entered, it will be automatically changed to a value within the range.</p>

Symptom	Reason/Action
Clicking the [Submit] button prompts messages such as “no data” or “the server has returned invalid or unrecognizable response”.	Are the user name and password correct? Enter the correct user name and password.
	Turn the printer off, then on. g

E-Mail Related Problems

This section explains how to troubleshoot problems when the mail notification services and E-mail Printing features are used.

Symptom	Reason/Action
<p>Cannot perform E-mail printing.</p>	<p>Check the following settings:</p> <ul style="list-style-type: none"> • Is the printer e-mail address specified? • Is [Enable] set for [Receive E-mail]? • Are the SMTP server IP address and POP3 server IP address (if [POP3] is selected as the receive protocol) specified correctly? • Are the POP user name and password specified correctly?
	<p>Are the SMTP server and POP server working correctly?</p> <p>Check with your network administrator.</p>
<p>During E-mail printing, the attached PDF file was not printed.</p>	<p>If the memory capacity is insufficient, it may not be printed. If you print big attachments frequently, we recommend adding memory.</p>
<p>During mail notification services, the printer status was not notified by e-mail.</p>	<p>Check the following settings:</p> <ul style="list-style-type: none"> • Is the printer e-mail address specified? • Is [Enable] set for [Mail Notice Service]? • Are the SMTP server IP address and POP3 server IP address (if [POP3] is selected as the receive protocol) specified correctly? • Are the POP user name and password specified correctly? • Are the items to be notified set correctly? • Are the destination e-mail addresses entered correctly?
	<p>Are the SMTP server and POP server working correctly?</p> <p>Check with your network administrator.</p>

Routine Maintenance _____

Replacing the Drum/Toner Cartridge

The drum/toner cartridge includes the toner and the photosensitive drum. When it is about time to replace the drum/toner cartridge, the following message will appear on the control panel.

Ready to print
Repl. Drum/Toner

After this message displays, you can continue to print about 100 more sheets. Make sure you have a new drum/toner cartridge on hand.

When the following message displays, printing stops and you must replace the drum/toner cartridge.

Replace Drum/
Toner Cartridge

Note

- If you continue to print with a worn-out drum/toner cartridge, it may affect the functions of this printer, such as the print quality.
 - You can set whether to stop printing when the drum/toner cartridge is due for replacement.
-

Cautions on Handling the Drum/Toner Cartridge

When handling the drum/toner cartridge, take note of the Do not subject it to direct sunlight or strong light.

- When installing the drum/toner cartridge, select a location away from strong light and try to finish the installation within 5 minutes.
- Do not touch the surface of the photosensitive drum. Do not let the drum/toner cartridge stand or place it upside down. The drum might be damaged.
- A drum shutter protects the photosensitive drum from light. Do not open the drum shutter.
- Although the toner is not harmful to the body, wash it off with cool water immediately if your hands or clothes are stained with it.
- It is recommended to use the drum/toner cartridge within 1 year after opening it.

Replacing the Drum/Toner Cartridge

1. If the optional offset catch tray is installed, lift it out of the way.

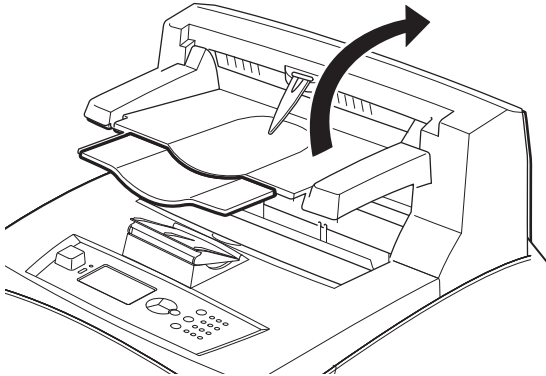

2. Turn the printer off.

3. Remove any output paper and open cover A.

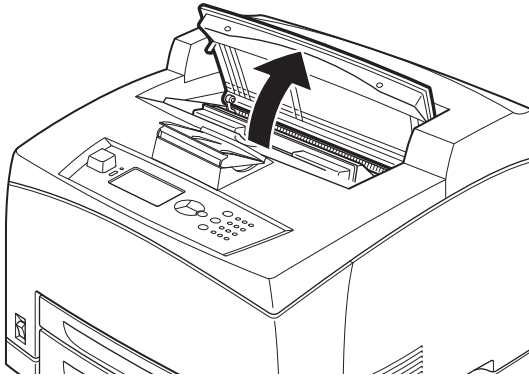

Caution!

Do not touch any parts inside the printer.

4. Hold the drum/toner cartridge by the grip and pull it out slowly. Discard it in accordance with local regulations.

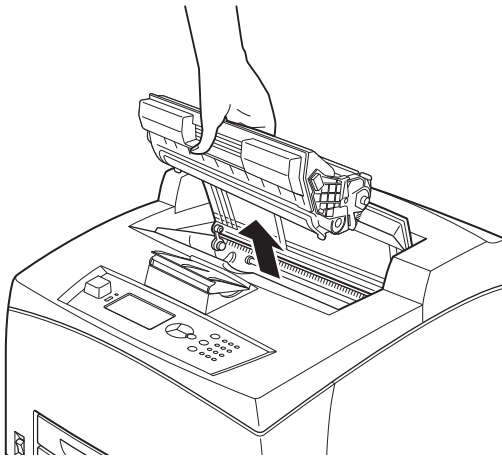

WARNING

Never throw a drum/toner cartridge into an open flame. It can cause an explosion and you can get burned.

5. Take the new drum/toner cartridge out of the packaging box and shake it 7 or 8 times as shown in the diagram.

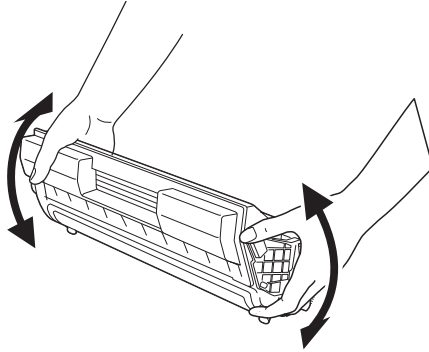

Important!

- If the toner is not evenly spread out, the print quality may be reduced. Also, there may be operating noise or the interior of the cartridge may be damaged during operation.
 - Do not touch the surface of the photosensitive drum.
-

6. Place the drum/toner cartridge on a flat surface and pull out the seal horizontally.

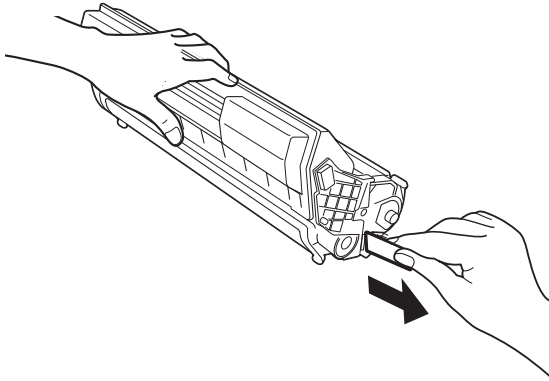

Important!

- Pull out the seal horizontally. The tape might break if it is pulled out diagonally.
 - After the seal has been pulled out, do not shake or bump the drum/toner cartridge.
-

7. Hold the drum/toner cartridge by the grip and insert it into the slot inside the printer.

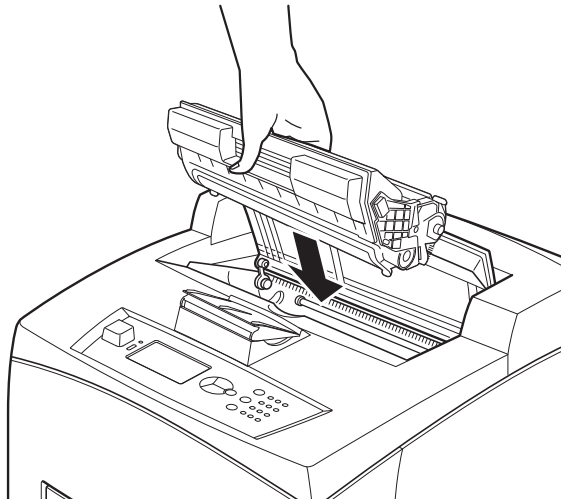

Important!

- Do not touch any parts inside the printer.
 - Ensure that the drum/toner cartridge is firmly set.
 - After opening cover A, remove any dust or stains inside the printer with a dry clean cloth.
-

8. Close cover A securely.
9. If installed, lower the offset catch tray to its original position.

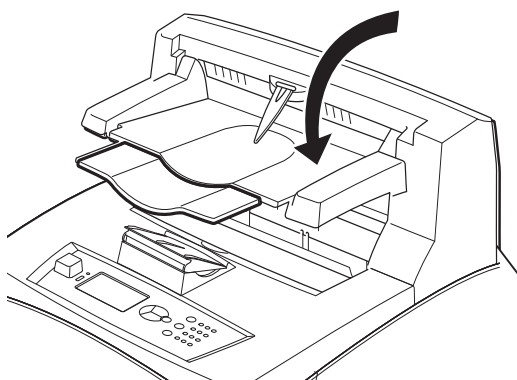

Caution

If you continue to print with the offset catch tray up, this may cause a paper jam. Always use the printer with the tray down.

10. Turn the printer back on.

Printing Reports/Lists

To print out reports:

1. Press <Enter>.
2. Use the up and down arrow buttons to highlight Information Menu, then press <Enter>.
3. Use the up and down arrow buttons to select:
 - Print Usage Rep
 - Print Menu Map
 - Network Summary
 - Print PCL Fonts
 - Print PS Fonts
 - Print FX Fonts
4. With the report highlighted, press <Enter>.
Execute appears.
5. Press <Enter> to print the report.
The printer returns to the Ready to Print state.

Checking the Printer Status via E-mail

When connected to a network environment where sending and receiving of e-mails is possible, this printer can send an e-mail with the following report to a specified e-mail address: completed print jobs from the computer, error history, list of rejected print jobs/e-mails.

This feature is known as Mail Notice Service.

About Mail Notice Service

The types of information that can be sent through Mail Notice Service are listed below.

Types of information	Description
Job Completion	Notifies the status of print jobs (completed, cancelled or confirm) from the computer (set in driver).
Printer status is set through the printers Web Server	Off-line Consumable message Toner low / toner out Paper low / paper out Paper Jam Cover open Stacker error Mass storage error Recoverable error Service call required

Settings for Mail Notice Service

To use the Mail Notice Service, settings on the network and e-mail environment are required. Check with your network administrator whether these settings are completed.

Setting the E-mail Environment (at this Printer)

Activate the Printer Web Page and set Port Status, Printer E-Mail Address, TCP/IP environment and mail server.

Configure the following items according to your e-mail environment under [Network], [Email].

Note

After configuring the settings, always click [Submit] and switch off/on the printer to reboot.

Item	Item to be set	Description
Maintenance > Services Option	Mail Notice Service	Select [Enable].
Network > General Settings	Administrator E-mail Address (recommended setting), Printer E-mail Address	For details, refer to "Environment Settings for E-mail Printing" on page 74.
Network > TCP/IP	Host Name, Get DNS Address, DNS Address 1 to 3, DNS Name	For details, refer to "Environment Settings for E-mail Printing" on page 74.
Network > E-mail Settings	Receiving Protocol, POP3 Server Address, POP3 Server Check Interval, POP User Name, POP User Password, SMTP Sending Authentication, SMTP Server Address	For details, refer to "Environment Settings for E-mail Printing" on page 74.

Item	Item to be set	Description
Network > Mail Notice Settings	Mail Notice Settings	Select appropriate settings for mail notification.
	Mail Recipient Settings	Up to 128 alphanumeric characters can be entered for the recipient e-mail address, including the ASCII characters for "@" (at mark), "." (full stop), "-" (hyphen) and "_" (underscore).

Cleaning the Printer's Exterior

Clean the exterior of the printer about once a month.

Important!

- **Do not spray the detergent directly on the printer. The liquid detergent may enter the printer through a gap and cause problems.**
 - **Never use cleaning agents other than water or neutral detergent.**
-

1. Wipe the parts with a wet but well-wrung soft cloth, then wipe it dry with another soft cloth.

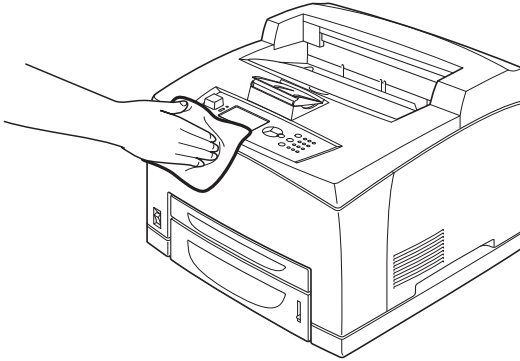

2. For stubborn stains, moisten a soft cloth with a small amount of neutral detergent, and gently wipe the stain off.

Cleaning the Printer's Interior

WARNING

Be sure to switch off and unplug the printer before accessing the interior of the printer for cleaning, maintenance, or fault clearance. Access to a live printer's interior can cause electric shock.

After clearing paper jams or replacing the drum/toner cartridge, inspect the inside of the printer before closing cover A.

WARNING

- Never touch a labelled area found on or near the heat roller. You can get burned.
 - If a sheet of paper is wrapped around the heat roller, do not try to remove it by yourself. To avoid injuries or burns, switch off the printer immediately, and contact service.
-

- Remove any remaining pieces of paper.
- Remove any dust or stains with a clean *dry* cloth.

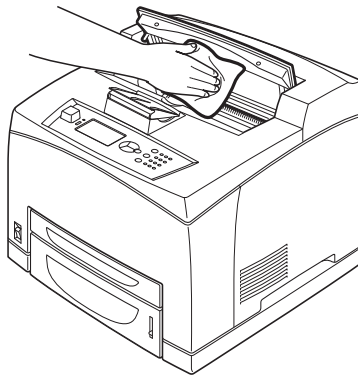

Cleaning the Feed Rollers

If you start to encounter difficulties with paper feed, you should clean the feed rollers. Generally, this should be done about every 100,000 impressions, but may need to be done more often if you are using paper which gives off a lot of paper dust.

Procedure for Removing and Cleaning the Feed Rollers

Follow this for each of the roller locations given below.

1. While pushing down on the right end of the shaft (1), widen the tab on the feed roll to loosen it (2) and then slowly remove the feed roll from the shaft (3).

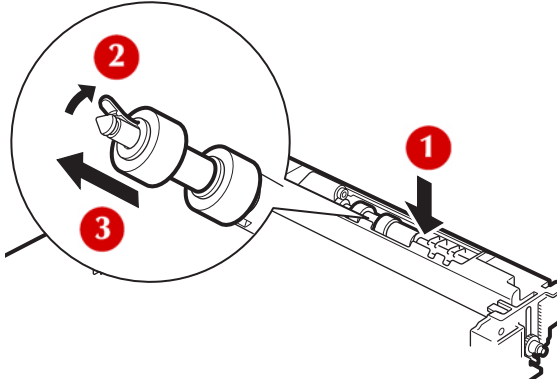

2. Wipe the rubber parts with a wet but well-wrung soft cloth.

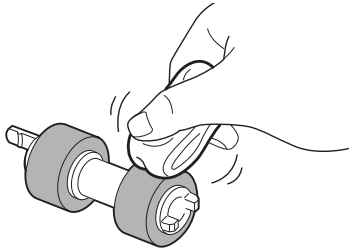

3. Hold the roller with the short tab (1) to the right and slowly push it back onto the shaft.

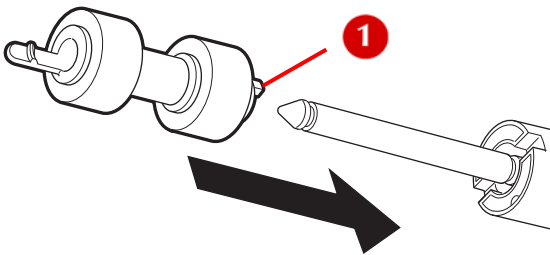

4. Align the slot of the feed roll with that of the shaft, and push the feed roll completely in so that the short tab fits into the slot of the shaft.

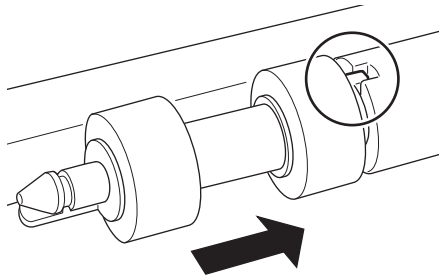

First, Clean the Rollers Inside of Printer

1. If the optional offset catch tray is installed, lift it out of the way.

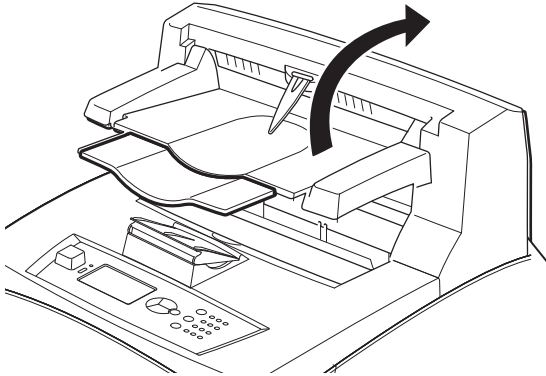

2. Turn the printer off.

3. Open Cover A.

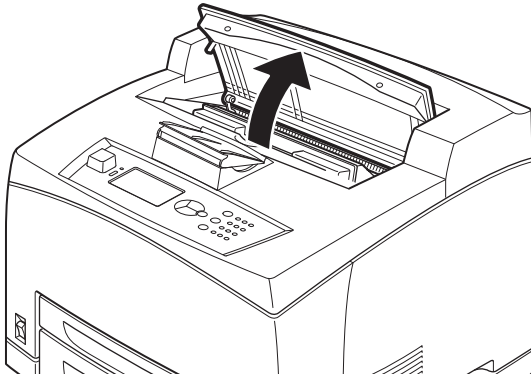

4. Hold the drum/toner cartridge by the grip and remove it. Set it on a piece of paper to keep it from dirtying the tabletop.

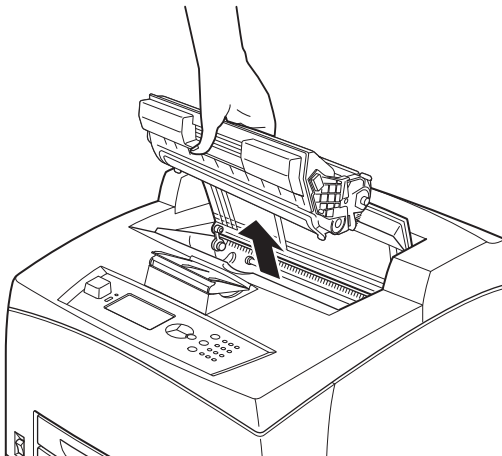

5. Locate and clean the feed rollers (see cleaning procedure on page 130).

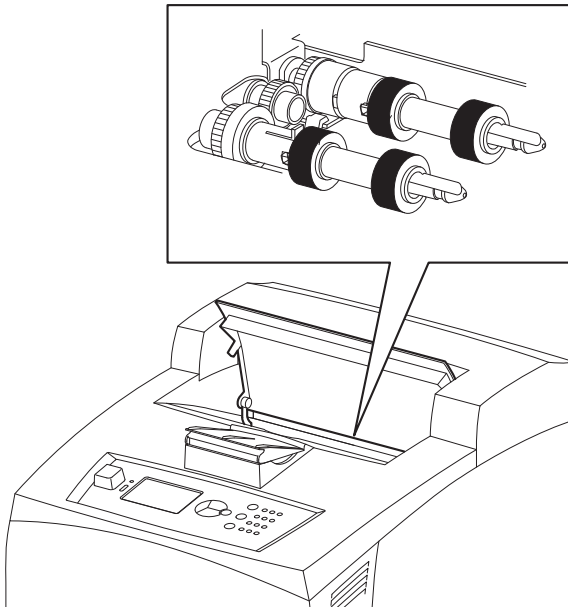

6. Hold the drum/toner cartridge by the grip and insert it into the printer.

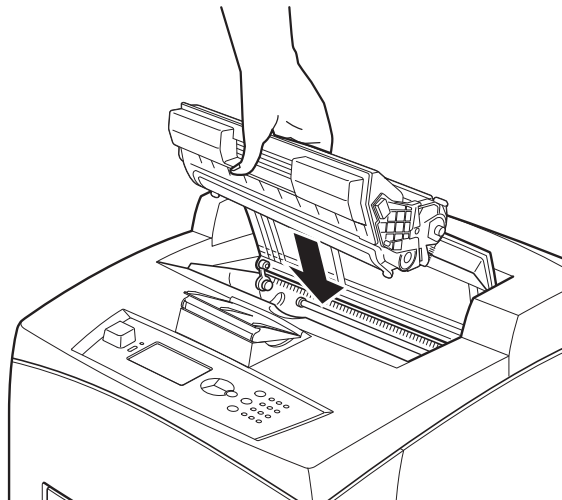

7. Close cover A securely.
8. If installed, lower the offset catch tray to its original position.

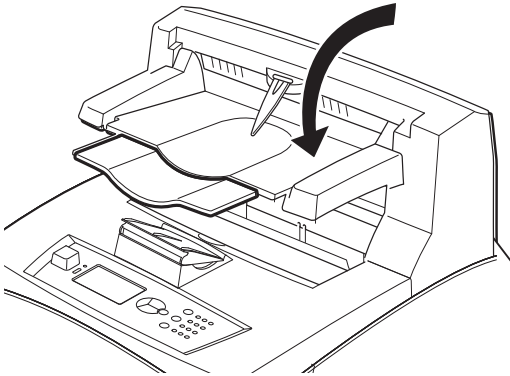

Next, Clean the Tray Rollers

1. Pull the paper trays out of the printer.

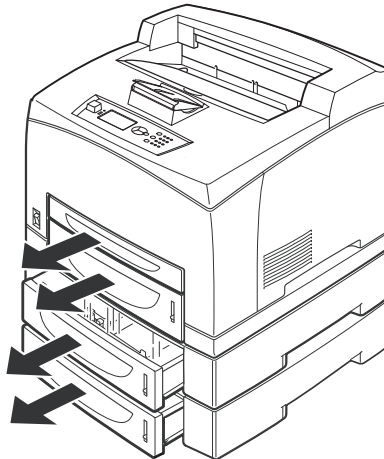

2. Remove, clean and replace the rollers at the back of each tray (see cleaning procedure on page 130).

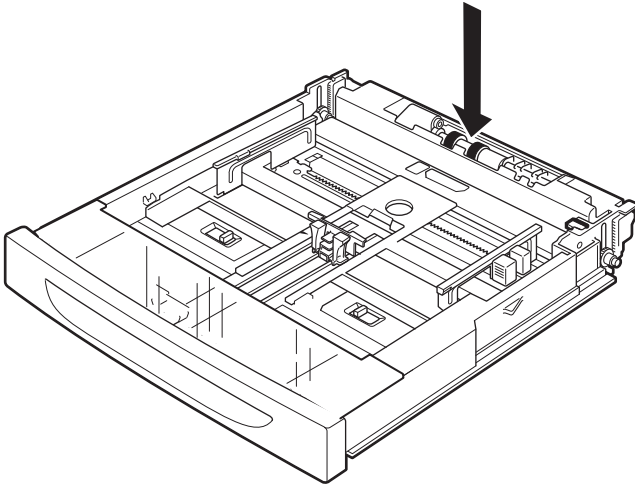

3. If you have optional paper trays installed, leave the trays outside the printer and proceed to the next section.
4. *If you do NOT have any optional paper trays installed*, push the paper trays back into the printer and turn the printer back on.

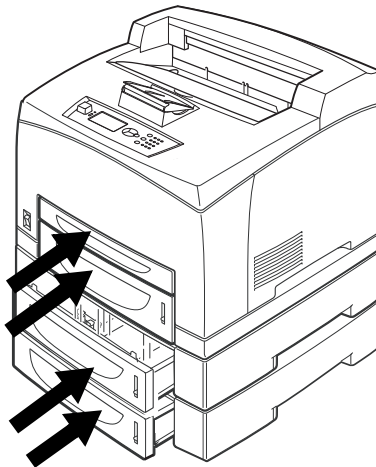

If you have Optional Tray(s) installed, Clean the Tray Module Roller(s)

1. With the paper trays removed, reach inside the printer to access the tray module rollers (at the back) for cleaning. Illustration 1 below is a view of the optional tray module removed from the printer to illustrate the location of the feed rollers.

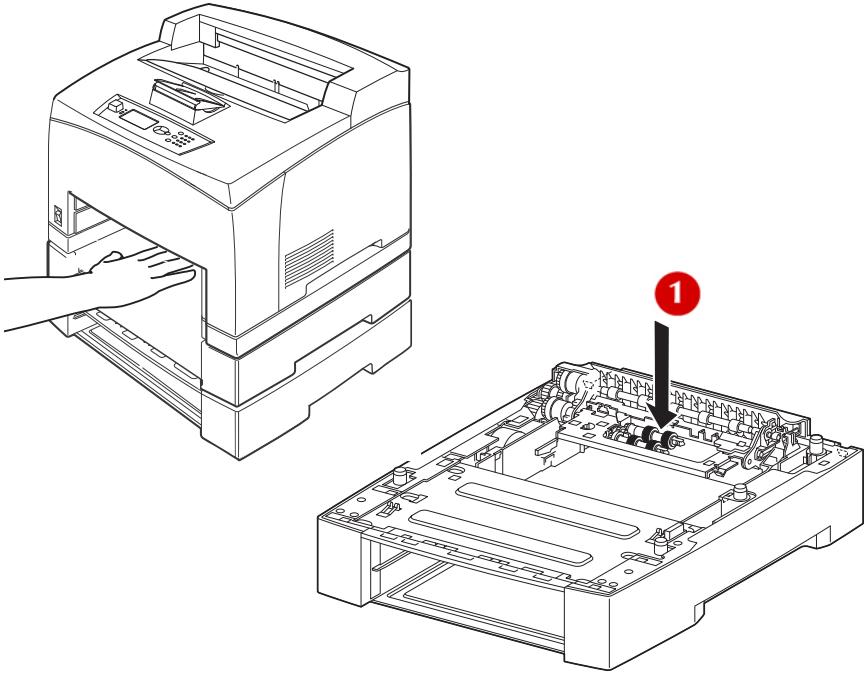

2. Follow the procedure on page 130 to remove and clean the feed roller for each optional tray installed.

3. Push the paper trays back into the printer and turn the printer back on.

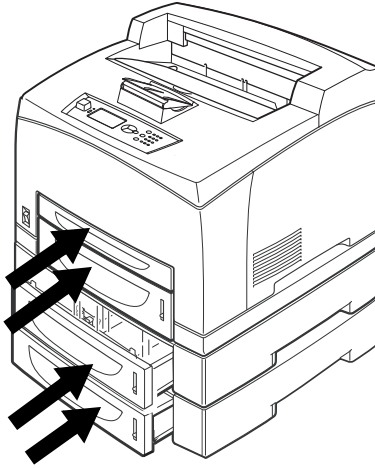

When Moving the Printer

WARNING



- The printer, *without* the optional accessories, paper trays, consumables and paper, weighs 41.4 lb. (18.8 kg).
- When lifting the printer, be sure to observe the following points, failure to do so may cause the printer to fall and result in injuries.
 - > 2 persons, one facing the front of the printer (control panel) and the other facing the back, should firmly grip the recessed areas on the bottom part of both sides of the printer. Never try to lift the printer by gripping any other areas.

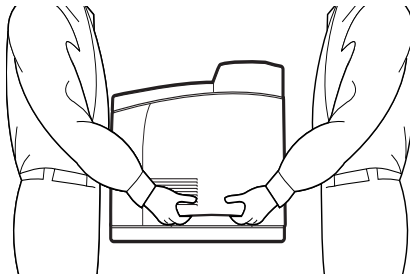

- > Bend your knees to avoid possible injuries to your back.
 - > Do not tilt the printer more than 10 degrees.
-
-

WARNING

If the optional duplex unit or optional A4 universal tray is installed, uninstall it before moving the printer. If these are not fixed securely to the printer, they may fall to the ground and cause injuries.

1. Press the power switch of this printer to the <O> position to switch the power off.

2. Remove all cords, such as the power cord and interface cables.
3. Remove any paper in the center output tray and return the paper stopper to its original position if it's raised.
4. Pull out the paper tray from the printer and remove any paper in the tray.

Note

Keep the paper wrapped and away from humidity and dirt.

5. Push the paper tray completely into the printer.
6. Open cover A.

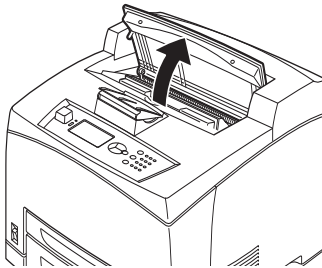

Important!

Do not touch parts inside the printer.

7. Hold the drum/toner cartridge by the grip and pull it out slowly.

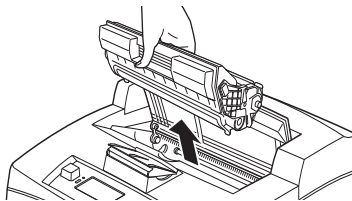

Important!

- **It is necessary to remove the drum/toner cartridge. If you move the printer with the drum/toner cartridge installed, the toner may spill inside of the printer.**
 - **Do not shake the drum/toner cartridge after removing it from the printer. The toner will spill.**
 - **While it is out of the printer, put the drum/toner cartridge back into its original bag or wrap it with a thick cloth to prevent it from being exposed to strong light.**
-

8. Close cover A securely.
 9. Lift the printer and move it gently.
-

Note

If the printer is to be moved over a long distance, pack it inside a box.

Appendix A

PCL Emulation Symbol Sets

10U:PC-8 CP437	6S:ISO85 SPANISH	2024Z:GREEK-437
11U:PC-8 D/N	OG: GERMAN	2025Z:GRK-437CY
12U:PC-850	1S: SPANISH	2026Z:GREEK 928
17U:PC-852	90D: ISO DUTCH	2018Z:SERCROAT 2
9T:PC-Turkish	0E:ROMAN EXT	2017Z:UKRAINIAN
19U:WIN Latin1	91S: ISO SWEDISH 1	2016Z:BULGARIAN
9E:WIN Latin2	92S: ISO SWEDISH 2	00:OCR-A
5T:WIN Latin5	93S: ISO SWEDISH 3	10:OCR-B
7J:Desk Top	2038Z:IBM-437	10L:DINGBATS
10J:PS Text	2039Z:IBM-850	9J:PC-1004
13J:Ventura Int	2037Z:IBM-860	19L:WIN BALTIC
14J:Ventura US	2036Z:IBM-863	26U:PC-775
6J:Microsoft Pub	2035Z:IBM-865	2010Z:SERCROAT 1
8M:Math-8	8Q:PC SET 1	9N:ISO L9
5M:PSMath	9Q:PC EXT US	2009Z:GREEK-737
6M:Ventura Math	2033Z:PCEXT D/N	2008Z:ARABIC 864
15U:Pi Font	2034Z:PCSET2 US	8U:Roman 8
1U: Legal	2032Z:PCSET2 DN	0N:ISO 8859-1
1E: ISO4 UK	12J:MC TEXT	2N:ISO 8859-2
0U:ISO6 ASCII	2044Z:CWI HUNG	5N:ISO 8859-5
0S:ISO11 Swedish	2040Z:PC-857 TK	
0I:ISO15 Italian	2022Z:KAMENICKY	
2S:ISO17 Spanish	2020Z:HEBREW NC	
1G:ISO21 German	2021Z:HEBREW OC	
0D:ISO60 Norweg	2023Z:PLSKA MAZ	
1F:ISO69 French	6N:ISO L6	
9U:WIN3.0 Latin1	2019Z:WIN3.1 HEB	
2U:ISO2 IRV	15Y:HP ZIP	
3S:ISO10 S/F	9R:WIN3.1 CYR	
0K:ISO14 JASCII	3R:PC-866	
4S:ISO16 PORTUG	2042Z:WIN3.1GRK	
0F:ISO25 FRENCH	2041Z:PC-869	
2K:ISO57 CHINESE	2031Z:PC-855	
1D:ISO61 NOR.V2	579L:WINGDINGS	
5S:ISO84 PORTUG	19M:SYMBOL	