

B6500

Maintenance Manual

010808B

Cautions For Operation

Contents of this document may be subjected to modification without previous notice. Oki Data

will not assume any responsibilities for accidental or incidental damages resulting from technical or editorial errors or omission in this manual, issue of this manual, execution of description in this manual, or use of this manual.

This document is protected by copyright. It is not forgiven to photocopy or duplicate any part of this document in any form without previous permission in writing from Oki Data, Americas, Inc.

I. About This Manual

This manual is a standard service manual containing information required for maintenance of this laser printer (standard specifications).

II. Cautions, Warnings and Notes

Maintenance operations requiring special cautions or additional information for procedures in this manual are presented as "Warning", "Caution", or "Note", according to their nature.



If instructions are not observed, death or serious injury may be caused.



If instructions are not observed, personal injury or physical damage to assets (including this laser printer) may result.

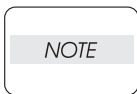

Particularly important essentials for procedures, steps, rules, etc.

Reference Incidental information to descriptions.

III. Related documents

▼ Instruction manuals (standard manuals)

Describe operation and handling of this laser printer.

▼ Performance specifications

Describe in detail various specifications of this laser printer.

(In the event of discrepancy between this manual and the performance specifications, the performance specifications shall take preference.)

▼ Video interface specifications

Detailed video interface specifications for this laser printer

▼ Spare parts list

Information on maintenance parts (spare parts) for this laser printer

IV. Safety

To prevent possible accidents during maintenance activities, you must pay attention to the "Warning" and "Caution" information in this manual.

Performing any dangerous operations, or procedures not included in this manual, should be avoided.

Occasionally, it may be required to perform some procedures not covered by this manual. These procedures should be performed carefully, always giving attention to safety.

Power source

Keep the power supply off during maintenance activities to prevent electric shock, burns and equipment damage. Keep the power plug disconnected during the maintenance operation. If it is necessary for the machine power to be switched ON for voltage measurements or other similar reasons, sufficient care should be given to prevent electric shock, by following the procedures in this manual.

While the printer is ON, never touch live components.



Power is supplied to the power unit (LVPS ASSY) even while the printer is off. Never touch its live components.



Do not touch live components unless otherwise specified.

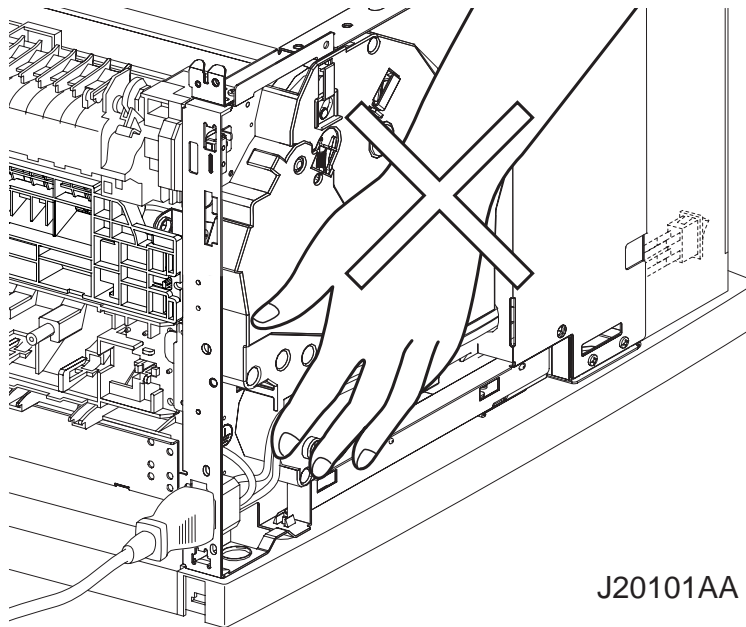

J20101AA

Drive units

When servicing gears or other drive units, be sure to turn them OFF and disconnect the power plug from the receptacle. Whenever possible, drive them manually.



Never touch the gears or other moving parts while the printer is running.

High-temperature units

When servicing high-temperature units (removal, replacement, adjustment, etc.), be sure to turn them OFF to prevent burns, injuries and an electrical hazard. Remove the power plug from the receptacle and allow the unit to cool down before servicing.



Fusing units retain their heat after the power is removed. Wait at least 30 minutes after removing power before servicing.

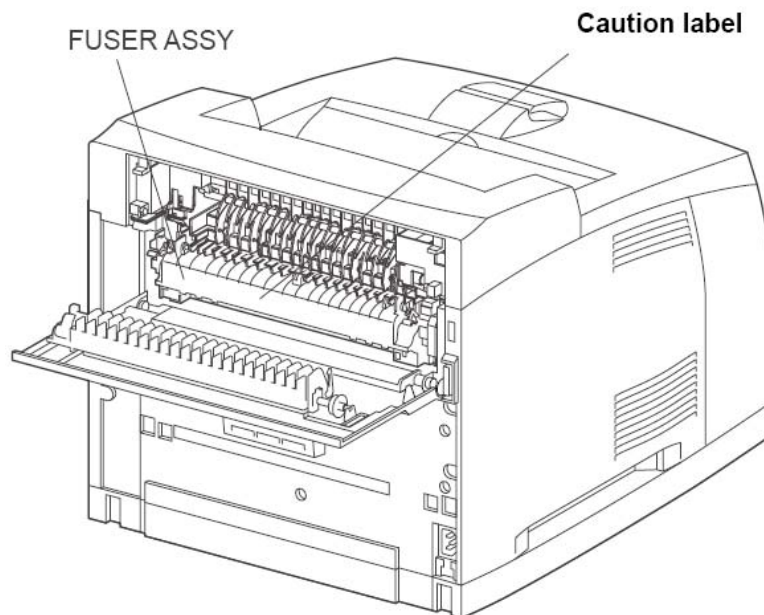

J20105AA

Laser beams



- **Direct exposure to a laser beam can damage the eyes and cause blindness.**
- **Never open a cover that has a laser warning label attached.**
- **Before disassembling and reassembling this laser printer, be sure to turn the printer power OFF.**
- **When servicing this laser printer while it is running, be sure to follow the procedures specified in this manual.**
- **You should understand and exercise all safety precautions to prevent injuries when servicing equipment that uses a laser. Carefully follow procedures to prevent anyone in the area from exposure to the laser beam.**

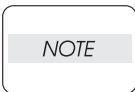

Laser beams have the following characteristics:

- **Frequencies are higher than other beams (sun and electric bulbs) and phases are uniform so that high monochromatic and convergence performance can be obtained and thin beams of light can reach places at a long distance.**
- **Due to the high convergence, beams are highly concentrated in density and temperature, which is dangerous to human body.**

Reference: *The frequency of the Laser used in this laser printer produces beams that are invisible.*

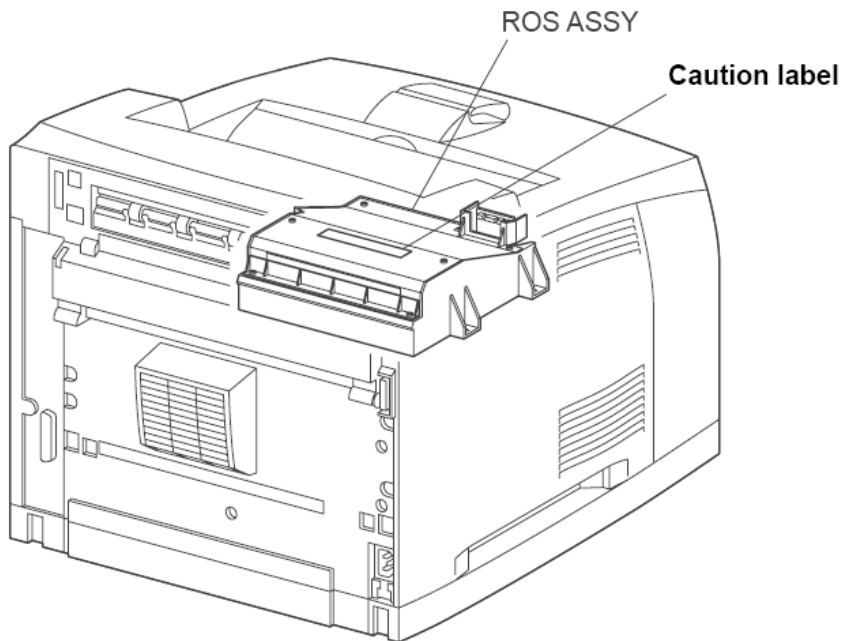

J20104AA

Warning/caution labels

Warning labels and caution labels are attached to this laser printer to prevent accidents. These labels should be clear and easy to read. Check the labels for any damage such as peeling or stains when servicing the printer.

Caution label for high-temperature units



Hi Temp Label

Caution label for laser beams

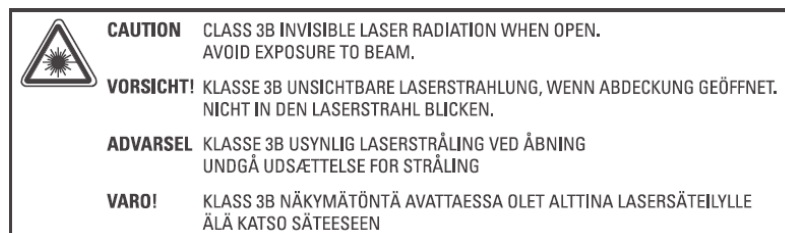

Laser Beam Label

V. Installation

Power source

Do not plug too many leads into a single socket. Use a dedicated electric outlet and confirm that the power is within specifications.



Connect the single power cord to an electric outlet capable of supplying more power than the maximum power consumption of this laser printer.

Ground



Be sure the laser printer is properly grounded.

Be sure to connect the ground of this laser printer with one of the following:

- Grounding terminal of an electric outlet
- Copper or the like which is embedded 650 mm or deeper in the ground
- Grounding terminal for which the grounding work has been carried out



Be sure not to establish a ground with the following:

- Gas pipe
- Ground for telephone
- Water pipe which is partially made from plastic



When establishing a ground, be sure not to use the 2pin - 3pin conversion plug.

Installation location

- Ensure that there is adequate space for operating this printer.
- Install where the temperature and the humidity meet the following environmental specifications:

During operation:

5 to 35 degree C / 15 to 85% RH (70% RH at 35 degree C, 85% RH at 32 degree C).

No condensation

Not in operation:

-20 to 40 degree C / 5 to 85%

RH (A place with no condensation)

- Install in a flat place with the angle of 5 degrees or less.
- Install in a place with the illumination of 3000 Lux or less. (Avoid direct sunlight.)
- Avoid placing near a water system, a humidifier or fire, a dusty place, or a place which gets direct air from air conditioning.
- Avoid where volatile or flammable gas is generated.
- Avoid a poor ventilated place.
- Avoid an unstable and non-durable place.

Unpacking

Unpacking laser printer



The printer must be carried horizontally with two or more persons.



Extreme care must be taken to avoid personal injuries.

Unpack the carton and confirm that the part numbers of the laser printer and all components are correct. Ensure that all components are without damage.

- 1) Laser Printer main unit
- 2) 150 Paper Cassette
- 3) 550 Paper Cassette
- 4) EP CARTRIDGE
- 5) Power Cord
- 6) Instruction Manual

Unpacking Option Duplex

Unpack the carton and confirm that the part numbers of the Duplex Transport and all components are correct. Ensure that all components are undamaged.

- 1) Option Duplex main unit

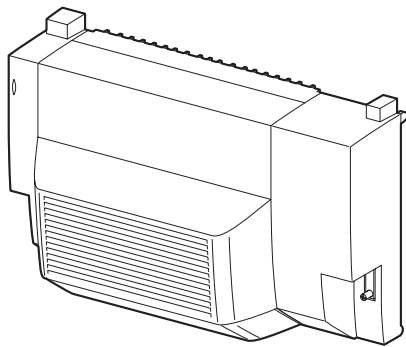

J20009AA

Unpacking Option Face Up Tray

Unpack the carton and confirm that the part numbers of the Face Up Tray and all components are correct. Ensure that all components are undamaged.

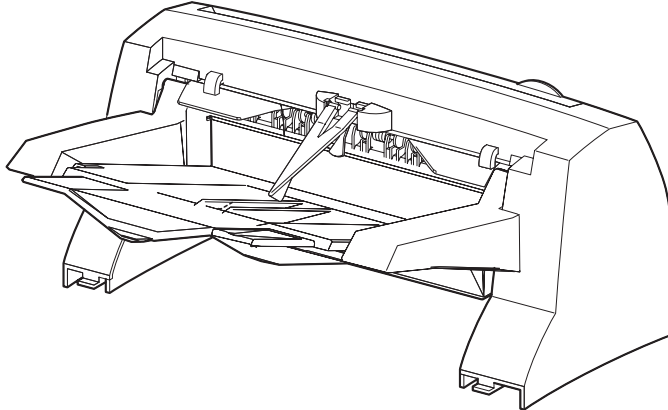

JG0008AA

Unpacking Option 550 Paper Feeder

Unpack the carton and confirm that the part numbers of the Option 550 Paper Feeder and all components are correct. Ensure that all components are undamaged.

- 1) Option 550 Paper Feeder main unit
- 2) Option 550 Paper Cassette
- 3) JOINT FEEDER (four pieces)

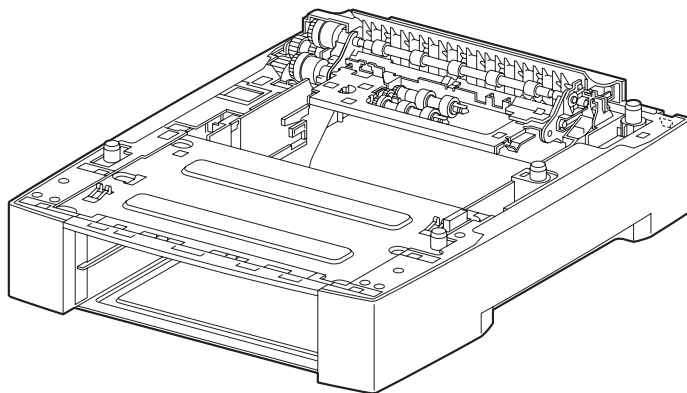

J20007AA

Installation Procedures

Installing laser printer

For details, refer to the Instruction Manual supplied with the main unit.



When holding up the later printer, be sure to grasp the handles with both hands. Grasping a part other than the handles result in fall or damage of the laser printer.



When holding up the later printer, bend your knees thoroughly to prevent lower back strain.



The protection sheets and the fixing materials, which are removed before the installation, are re-used when the later printer is moved to another place. Be sure to keep them.

- 1) Unpack the laser printer, and place it in an installation location after removing cushioning materials.
- 2) Confirm the attachments.
- 3) Peel off fixing tapes applied to the later printer.
- 4) Unpack the EP CARTRIDGE, then be sure to shake it seven to eight times holding both sides.

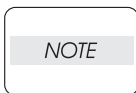

When removing the toner seal, draw it out straight and horizontally. After removal, be careful not to shake or give a shock to the EP CARTRIDGE.

- 5) Open the COVER OPEN, and install the EP CARTRIDGE.
- 6) Close the COVER OPEN.
- 7) Draw the paper tray, and press down the PLATE ASSY BTM to lock.
- 8) Place papers into the paper tray.

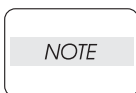

When placing papers into the paper tray, be careful for the followings:

- **Align four corners of papers to place.**
- **Adjust the paper guide to the paper size.**
- **Do not place papers over the capacity or over the upper-limit line of the paper tray.**

- 9) Push the paper tray into the laser printer to install.
- 10) Connect the power cord.
- 11) Turn on the power switch of the laser printer.
- 12) Try some test printings with each paper-feed trays to confirm that there is no problem.

Installing Option Duplex

For details, refer to the Instruction Manual supplied with the main unit or Chapter 3 RRP 21.1 Option Duplex.



Before the installation, turn off the power and plug off the power cord.

- 1) Unpack the Option Duplex, remove cushioning materials, and confirm that all attachments are available.
- 2) Remove the COVER DUP and CONNECTOR COVER on rear of the laser printer.

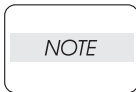

Keep the removed COVER DUP and CONNECTOR COVER carefully.

- 3) Fit the hooks on the lower part of the Option Duplex with the holes on the rear of the laser printer to install.
- 4) Tighten the screws (two) on the lower part of the Option Duplex to fix securely.
- 5) Connect the power cord.
- 6) Turn on the power switch of the laser printer.
- 7) Try some test duplex-printings to confirm that there is no problem.

Installing Option Face Up Tray

For details, refer to the Instruction Manual supplied with the main unit.



Before the installation, turn off the power and plug off the power cord.

- 1) Unpack the Option Face Up Tray, remove cushioning materials, and confirm that all attachments are available.
- 2) Insert the front edge of the Option Face Up Tray into the slot on the upper-rear of the laser printer to install.
- 3) Connect the power cord.
- 4) Turn on the power switch of the laser printer.
- 5) Try running some test prints to eject onto the Option Face Up Tray and confirm that there are no problems.

Installing Option 550 Paper Feeder

For details, refer to the Instruction Manual supplied with the main unit or Chapter 3 RRP 20.1 Option 550 Paper Feeder.



Before the installation, turn off the power, plug off the power cord, and remove the paper tray from the laser printer.

- 1) Unpack the Option 550 Paper Feeder, remove cushioning materials, and confirm that all attachments are available.
- 2) Place the Option 550 Paper Feeder in an installation location.
- 3) Fit the holes on the bottom of the laser printer with the four positioning bosses of the Option 550 Paper Feeder, and place the laser printer on the Option 550 Paper Feeder.
- 4) Fix the laser printer and the Option 550 Paper Feeder securely with the JOINT FEEDERS (four pieces).
- 5) Push the paper tray into the laser printer completely to install.
- 6) Connect the power cord.
- 7) Turn on the power switch of the laser printer.
- 8) Try some test printings with the newly installed paper-feed tray to confirm that there is no problem.

VI. Dismantlement

Dismantlement procedures

Dismantling laser printer and option units

For details, refer to the Instruction Manual or Chapter 3 Removal and Replacement Procedures.

The dismantlement process is performed by following installation procedures in reverse sequence.



When holding up the later printer, be sure to grasp the handles with both hands. Grasping a part other than the handles results in fall or damage of the laser printer.



When lifting the later printer, bend your knees thoroughly to prevent lower back strain.

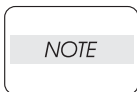

Be sure to remove the EP CARTRIDGE from the laser printer and put it into a plastic bag.

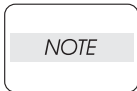

Be sure to re-use the protection sheets and fixing materials, which are removed during the installation.

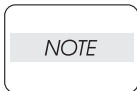

Confirm that no attachment is missing.

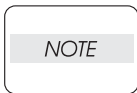

Be sure to use the cushioning materials properly.

Contents

Chapter 1 Removal and Replacement Procedures	1 - 1
Chapter 2 Print Engine Plug/Jack Connector Locations.....	2 - 1
Chapter 3 Principles of Operation	3 - 1
Chapter 4 Wiring.....	4 - 1
Chapter 5 Printer Specifications	5 - 1
Chapter 6 ESS Options	6 - 1

Chapter 1 Removal and Replacement Procedures (RRPs) CONTENTS

RRP1. COVERS.....	1 - 4
RRP1.1 COVER REAR (PL 1.1).....	1 - 4
RRP1.2 COVER RIGHT (PL 1.1).....	1 - 5
RRP1.3 COVER LEFT (PL 1.1).....	1 - 6
RRP1.4 COVER TOP (PL 1.1), OPERATION PANEL (PL 1.1).....	1 - 7
RRP1.5 COVER FRONT (PL 1.1).....	1 - 9
RRP2. 150 PAPER CASSETTE.....	1 - 10
RRP2.1 ROLL ASSEMBLY RETARD (PL 2.1.2).....	1 - 11
RRP2.2 RACK SIZE (PL 2.1).....	1 - 13
RRP2.3 GEAR SECTOR (PL 2.1).....	1 - 17
RRP2.4 GUIDE ASSEMBLY END 150 (PL 2.1).....	1 - 20
RRP2.5 PLATE ASSEMBLY BTM (PL 2.1).....	1 - 23
RRP2.6 GEAR LEVER LOCK (PL 2.1.25), LEVER BTM LOCK (PL 2.1).....	1 - 26
RRP2.7 HANDLE EXTENSION 150 (PL 2.1).....	1 - 28
RRP3. 550 PAPER CASSETTE.....	1 - 29
RRP3.1 ROLL ASSEMBLY RETARD (PL 3.1).....	1 - 30
RRP3.2 RACK SIZE (PL 4.1.40).....	1 - 32
RRP3.3 GEAR SECTOR (PL 3.1).....	1 - 36
RRP3.4 GUIDE ASSEMBLY END 550 (PL 3.1).....	1 - 39
RRP3.5 PLATE ASSEMBLY BTM.....	1 - 42
RRP3.6 GEAR LEVER LOCK (PL 3.1.26), LEVER BTM LOCK (PL 3.1).....	1 - 46
RRP3.7 HANDLE EXTENSION 550 (PL 3.1).....	1 - 49
RRP3.8 GUIDE INDICATOR 3 (PL 3.1.36).....	1 - 50
RRP3.9 GUIDE INDICATOR 2 (PL 3.1.35).....	1 - 51
RRP3.10 LOW IND FRONT (PL 3.1).....	1 - 55
RRP4. 150 paper Feeder.....	1 - 56
RRP4.1 150 FEEDER ASSEMBLY (PL 4.1).....	1 - 57
RRP4.2 ROLL ASSEMBLY NUDGER (PL 4.1), ROLL ASSEMBLY FEED (PL 4.1).....	1 - 59
RRP4.3 CLUTCH ONEWAY NUDGER (PL 4.1).....	1 - 60
RRP4.4 GEAR NUDGER (PL 4.1).....	1 - 61
RRP4.5 ROLL REGI RUBBER (PL 4.1.12).....	1 - 63
RRP4.6 CLUTCH ASSEMBLY PH (PL 4.1.21), CLUTCH REGI (PL 4.1).....	1 - 65
RRP4.7 SENSOR REGI (PL 4.1.30).....	1 - 67
RRP4.8 SENSOR NO PAPER (PL 4.1.38).....	1 - 68
RRP4.9 SENSOR TONER (PL 4.1.46).....	1 - 70
RRP4.10 ACTUATOR NO PAPER (PL 4.1).....	1 - 71
RRP5. 550 Paper Feeder.....	1 - 73
RRP5.1 550 FEEDER ASSEMBLY (PL 5.1).....	1 - 74
RRP5.2 ROLL ASSEMBLY NUDGER (PL 5.1), ROLL ASSEMBLY FEED (PL 5.1).....	1 - 76
RRP5.3 CLUTCH ONEWAY NUDGER (PL 5.1.27).....	1 - 78
RRP5.4 GEAR NUDGER (PL 5.1.18).....	1 - 80

Chapter 1 Removal and Replacement Procedures (RRPs) CONTENTS

RRP5.5 CLUTCH ASSEMBLY PH (PL 5.1.20).....	1 - 82
RRP5.6 SENSOR NO PAPER (PL 5.1.38).....	1 - 84
RRP5.7 GUIDE TRAY RIGHT (PL 5.1)	1 - 86
RRP5.8 GUIDE TRAY LEFT (PL 7.1).....	1 - 88
RRP5.9 SENSOR LOW PAPER (PL 5.1.4).....	1 - 90
RRP5.10 ACTUATOR NO PAPER (PL 5.1)	1 - 91
RRP6. Xerographics.....	1 - 93
RRP6.1 ROS ASSEMBLY (PL 6.1)	1 - 94
RRP6.2 DUCT FRONT (PL 6.1), FAN SUB (PL 6.1).....	1 - 96
RRP6.3 SHIELD PLATE ROS (PL 6.1)	1 - 98
RRP6.4 GUIDE CRU LEFT (PL 6.1).....	1 - 100
RRP6.5 INTERLOCK S/W 24V, INTERLOCK S/W 5V (PL 6.1).....	1 - 103
RRP6.6 LEVER GUIDE (PL 6.1.14)	1 - 105
RRP6.7 HARNESS ASSEMBLY FUSER (PL 6.1).....	1 - 107
RRP6.8 FUSER ASSEMBLY (PL 6.1).....	1 - 109
RRP6.9 BTR ASSEMBLY (PL 6.1)].....	1 - 110
RRP6.10 CHUTE TRANSFER (PL 6.1).....	1 - 111
RRP6.11 PWBA ASSEMBLY ANT (PL 6.1.23)	1 - 112
RRP6.12 GUIDE ASSEMBLY CRU R (PL 6.1)	1 - 114
RRP6.13 LEVER LINK (PL 6.1.29), LINK GEAR 3(PL 6.1.30).....	1 - 116
RRP7. 500 Paper Exit	1 - 118
RRP7.1 COVER EXIT 500 (PL 1.1).....	1 - 119
RRP7.2 500 EXIT ASSEMBLY	1 - 120
RRP7.3 CHUTE UP EXIT, CHUTE LOW EXIT (PL 7.1).....	1 - 122
RRP7.4 ROLL EXIT (PL 7.1.)	1 - 124
RRP7.5 MOTOR ASSEMBLY EXIT (PL 7.1.15).....	1 - 126
RRP7.6 SENSOR FACE UP OPEN (PL 7.1).....	1 - 127
RRP7.7 SENSOR FULL STACK (PL 7.1.26).....	1 - 128
RRP7.8 ACTUATOR FULL STACK (PL 7.1.10).....	1 - 129
RRP7.9 COVER REAR 500 (PL 7.1).....	1 - 130
RRP7.10 FUSER ROLL (FU) (PL 7.2).....	1 - 131
RRP7.11 LEVER GATE HOLDER, SPRING LEVER GATE, LEVER GATE FU (PL 7.2)	1 - 132
RRP7.12 LEVER LATCH LEFT, SPRING LATCH FU, LEVER LATCH RIGHT (PL 7.2)	1 - 133
RRP7.13 ROLL PINCH FUSER, SPRING PINCH FUSER (PL 7.2).....	1 - 135
RRP7.14 GATE FUSER (PL 7.2).....	1 - 136
RRP7.15 GATE OCT EXIT (PL 7.1)	1 - 137
RRP8. Frame & Drive.....	1 - 138
RRP8.1 MOTOR COVER (PL 8.1)	1 - 139
RRP8.2 MAIN MOTOR (PL 8.1.2)	1 - 141
RRP8.3 GEAR ASSEMBLY HOUSING (PL 8.1.3)	1 - 143
RRP8.4 GEAR ASSEMBLY PLATE (PL 8.1.10), GEAR 9 (PL 8.1.9).....	1 - 145

Chapter 1 Removal and Replacement Procedures (RRPs) CONTENTS

RRP9. Electrical	1 - 147
RRP9.1 SHIELD PLATE LVPS (PL 9.1)	1 - 148
RRP9.2 PWBA EXIT MOTOR (PL 9.1.4).....	1 - 149
RRP9.3 LVPS (PL 9.1.5)	1 - 150
RRP9.4 POWER SWITCH (PL 9.1.6), HARNESS ASSEMBLY AC100V/AC200V (PL 9.1.8)	1 - 152
RRP9.5 INTERLOCK S/W REAR (PL 9.1.7)	1 - 154
RRP9.6 FAN MAIN (PL 1.1.14)	1 - 156
RRP9.7 SHIELD ASSEMBLY ESS (PL 9.1)	1 - 157
RRP9.8 SHIELD ASSEMBLY WINDOW (PL 9.1)	1 - 158
RRP9.9 SHIELD PLATE HVPS (PL 12.1.18)	1 - 159
RRP9.10 HVPS/MCU (PL 9.1.19).....	1 - 160
RRP10. Duplex Option	1 - 163
RRP10.1 Duplex Option.....	1 - 163
RRP10.2 HSG UPPER ASSY (PL10.1).....	1 - 165
RRP10.3 HSG LOWER DUP (PL10.1)	1 - 166
RRP10.4 COVER TOP (PL10.1)	1 - 168
RRP10.5 PWBA DUPLEX (PL10.1).....	1 - 169
RRP10.6 COVER REAR (PL10.1), FAN DUPLEX (PL10.1)	1 - 171
RRP10.7 SENSOR DUP (PL10.1).....	1 - 173
RRP10.8 ROLL DUP (PL10.1).....	1 - 174
RRP10.9 COVER LEFT (PL10.1)	1 - 176
RRP10.10 COVER RIGHT (PL10.1).....	1 - 177
RRP10.11 MOTOR DUPLEX (PL10.1).....	1 - 178
RRP10.12 SWITCH DUPLEX (PL10.1)	1 - 181
RRP10.13 COVER HARNESS (PL10.1), HARNESS ASSY DUP (PL10.1)	1 - 183
RRP11. OCT Option.....	1 - 184
RRP11.1 OCT Option	1 - 184
RRP11.2 COVER REAR (PL11.1).....	1 - 187
RRP11.3 TRAY ASSY OCT (PL11.1).....	1 - 188
RRP11.4 COVER OCT (PL11.1)	1 - 189
RRP11.5 COVER FRONT (PL11.1)	1 - 192
RRP11.6 ACTUATOR FULL STACK (PL11.1).....	1 - 195
RRP11.7 PWBA OCT (PL11.1)	1 - 198
RRP11.8 MOTOR ASSY OFFSET (PL11.1)	1 - 201
RRP11.9 SOLENOID ASSY GATE (PL11.1).....	1 - 202
RRP11.10 SENSOR OCT (PL11.1).....	1 - 203
RRP11.11 ROLL OCT LOWER (PL11.1)	1 - 206
RRP11.12 ROLL OCT UPPER (PL11.1)	1 - 209
RRP11.13 MOTOR ASSY OCT (PL11.1).....	1 - 212
RRP12. 550 Paper Feeder Option	1 - 213
RRP12.1 550 Paper Feeder Option.....	1 - 213
RRP12.2 COVER RIGHT PLATE (PL12.1)	1 - 215

Chapter 1 Removal and Replacement Procedures (RRPs) CONTENTS

RRP12.3 COVER LEFT PLATE (PL12.1).....	1 - 216
RRP12.4 OPT ASSY SIZE (PL12.1).....	1 - 217
RRP12.5 DRIVE ASSY OPT FDR (PL12.1)	1 - 218
RRP12.6 MOTOR FEEDER (PL12.1).....	1 - 220
RRP12.7 SENSOR LOW PAPER (PL12.1)	1 - 221
RRP12.8 PWBA FEEDER 550 (PL12.1)	1 - 222
RRP12.9 550 FEEDER OPTION (PL12.2)	1 - 224
RRP12.10 ROLL ASSY NUDGER (PL12.2), ROLL ASSY FEED (PL12.2).....	1 - 227
RRP12.11 CLUTCH ONEWAY NUDGER (PL12.2)	1 - 229
RRP12.12 GEAR NUDGER (PL12.2).....	1 - 230
RRP12.13 ROLL ASSY TURN (PL12.2).....	1 - 233
RRP12.14 CLUTCH ASSY PH (PL12.2)	1 - 234
RRP12.15 CLUTCH PR-REGI (PL12.2)	1 - 236
RRP12.16 SENSOR NO PAPER (PL12.2).....	1 - 237
RRP12.17 ROLL ASSY RETARD (PL12.2).....	1 - 238
RRP12.18 RACK SIZE (PL12.3).....	1 - 241
RRP12.19 GEAR SECTOR (PL12.3)	1 - 247
RRP12.20 GUIDE ASSY END 550 (PL12.3).....	1 - 250
RRP12.21 PLATE ASSY BTM (PL12.3)	1 - 253
RRP12.22 GEAR LEVER LOCK (PL12.3), LEVER BTM LOCK (PL12.3).....	1 - 257
RRP12.23 HANDLE EXTENSION 550 (PL12.1)	1 - 261
RRP12.24 GUIDE INDICATOR 3 (PL12.3)	1 - 262
RRP12.25 GUIDE INDICATOR 2 (PL12.3)	1 - 264
RRP12.26 LOW IND FRONT (PL12.3).....	1 - 267
RRP12.27 SPRING EARTH TOP (PL12.2)	1 - 269

Removal and Replacement Procedures

1. Removal and Replacement Procedures (RRPs)

Removal and replacement procedures are described for the 9 major sections of the parts listings, plus the 3 optional components.

RRP 1	COVERS
RRP 2	150 PAPER CASSETTE
RRP 3	500 PAPER CASSETTE
RRP 4	150 PAPER FEEDER
RRP 5	500 PAPER FEEDER
RRP 6	XEROGRAPHICS
RRP 7	550 PAPER EXIT
RRP 8	FRAME & DRIVE
RRP 9	ELECTRICAL
OPTIONS	
RRP 10	DUPLEX
RRP 11	OCT
RRP 12	550 PAPER FEEDER

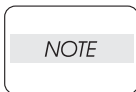

Parts are controlled as spare parts. When servicing parts that have no procedures, carefully observe their assembly detail before starting the service.

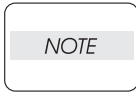

Refer to the manual for optional parts.

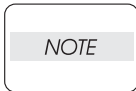

Unless necessary, optional parts should not be removed when performing a service operation.

1.1 Before starting service work

- ◆ Turn the printer power OFF and remove the power cord from the outlet before beginning a procedure.
- ◆ When working on, or around the FUSER ASSEMBLY, ensure the temperature has cooled sufficiently.
- ◆ Applying unreasonable force to the parts or hardware while servicing the printer may cause them to break or compromise their performance.
- ◆ Be sure to use the correct screw for the application. Different screws are used for plastic and sheet metal. Incorrect use of the screw type may result in damage to the screw threads or other hardware.

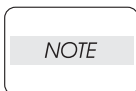

Locations on the frame where the character "TAP" is stamped, should use the screws designated for plastic.

- ◆ Remove the 150 Sheet Paper Cassette, 550 Sheet Paper Cassette and the EP Cartridge. Place the components in a safe place during servicing.
- ◆ Damage to sensitive electronic components should be avoided by grounding the body using a wrist band or other suitable Electrostatic Discharge (ESD) tools.

1.2 Prohibited matter

Do not remove the frame components shown in the figure below. Removing any of these components will make the laser printer go out of alignment. If the frame components are removed or their screws loosened by mistake, be sure to replace them again on a stable and firm horizontal work surface.

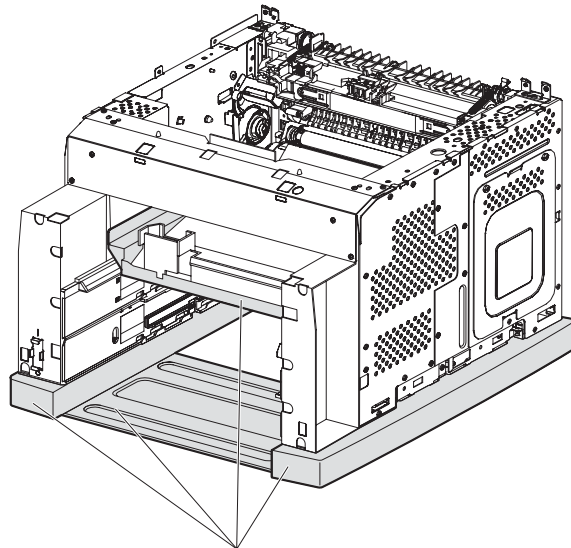

✘ Never disassemble these parts

JG3172AA

1.3 Confirmation after service

After a service, confirm that the COVER OPEN and the LEVER LINK are connected properly, and confirm the operation of the COVER OPEN by opening and closing it.

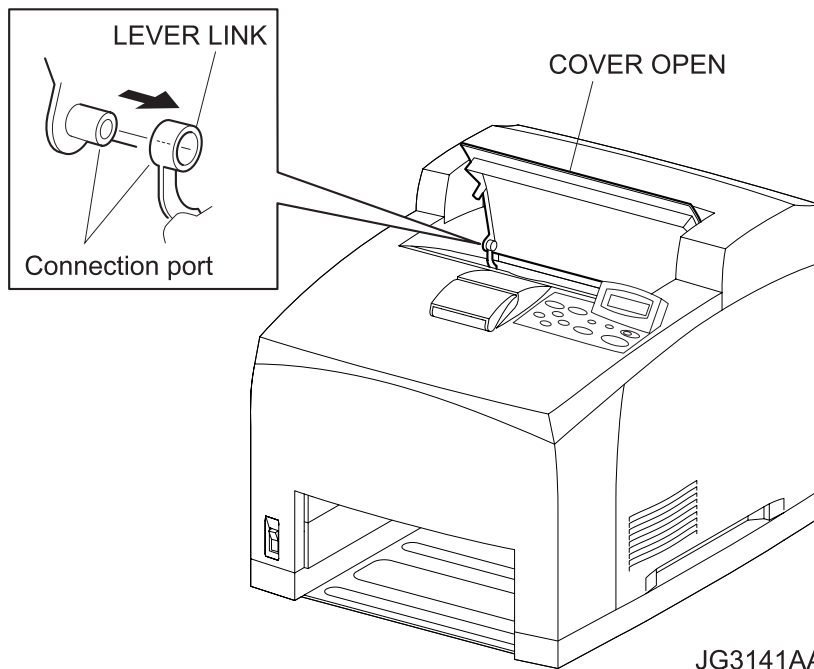

JG3141AA

1.4 Description of procedures

- ❑ "RRP X,Y "AAAAA" at the top of procedures represent the part name AAAAA are to be removed and replaced.
- ❑ "(PL X.Y.Z)" following the parts name in procedures represent that the parts are those of the plate (PL) "X.Y", item "Z" in Chapter 5, Parts List. Their forms, replacing position or other conditions can be seen in Chapter 5, Parts List.
- ❑ In the procedures, directions are represented as follows.
 - Front: Front when you are facing the front of this laser printer.
 - Rear: Inner direction when you are facing the front of this laser printer.
 - Left: Left hand when you are facing the front of this laser printer.
 - Right: Right hand when you are facing the front of this laser printer.

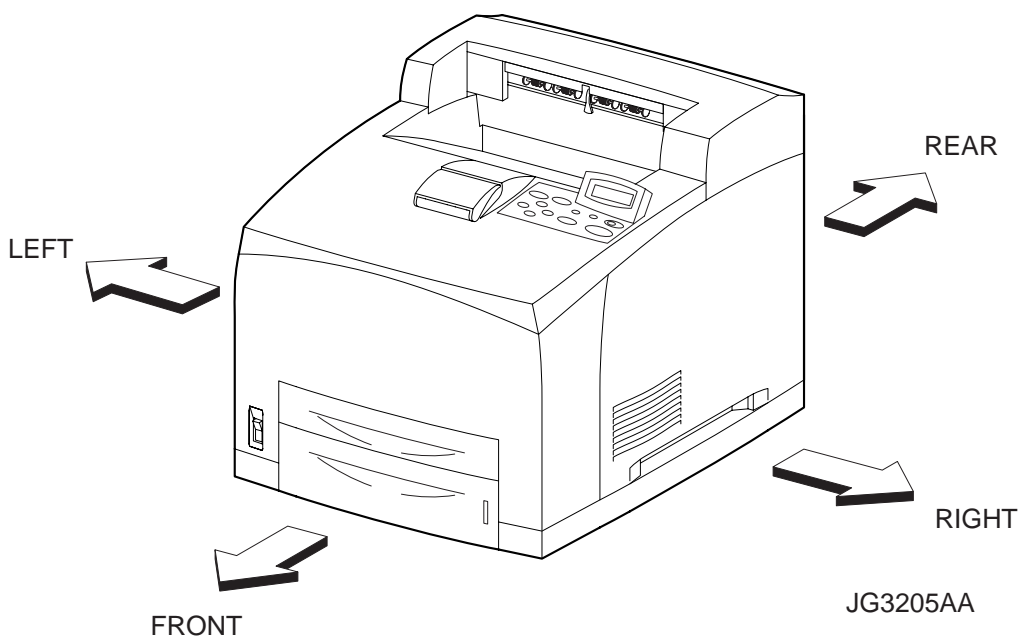

- ❑ The screws in procedures are expressed with their replacing position, color, characteristics and nominal length, etc.
- ❑ "In case of _____ specifications" in the procedures indicate that service operation should be provided only to laser printer of specified specifications (service operation should not be provided for laser printer of specifications not covered).
- ❑ "RRP X.Y" in the midst or at the end of sentences in the procedures indicate that work procedures related with the "RRP X.Y" are described.
- ❑ "Figure X.Y" at the end of the sentences of procedures indicate that illustrations instructive for the "RRP X.Y" are included.
- ❑ "Z)" in the illustrations correspond to "Z)" of the service procedures.
- ❑ The screws in the illustrations should be removed using a plus (+) screwdriver unless otherwise specified.
- ❑ A black arrow in the illustrations indicate movement in the arrow mark direction. Numbered black arrows indicate movement in the order of the numbers.
- ❑ White arrows (FRONT) in the illustrations indicate the front direction.
- ❑ For the positions of the connectors (P/J), refer to Chapter 7, Electric wiring.

RRP1. COVERS

RRP1.1 COVER REAR (PL 1.1)

Removal

- 1) Remove the 500 COVER REAR (PL 7.1) (RRP7.9)
- 2) Remove the 5 screws (silver with flange, 8mm x 2, gold tapping, 8mm x 3) securing the COVER REAR to the printer (Figure 1).
- 3) Open the COVER REAR in the direction of the arrow. Release the 3 hooks securing the COVER REAR to the printer, and remove it from the printer.
- 4) Disconnect the connector (P/J244).

Replacement

- 1) Connect the connector (P/J244).
- 2) Insert the 3 hooks on the left side of the COVER REAR into the 3 holes of the printer (Figure 1).
- 3) Secure the COVER REAR to the printer using the 5 screws (silver with flange, 8mm x 2, gold tapping, 8mm x 3).

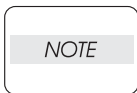

There are 2 kinds of screws, make sure they are installed correctly.

When tightening the screws be careful not to pinch the harness between the board and frame.

- 4) Install the 500 COVER REAR (PL 7.1.21). (RRP7.9)

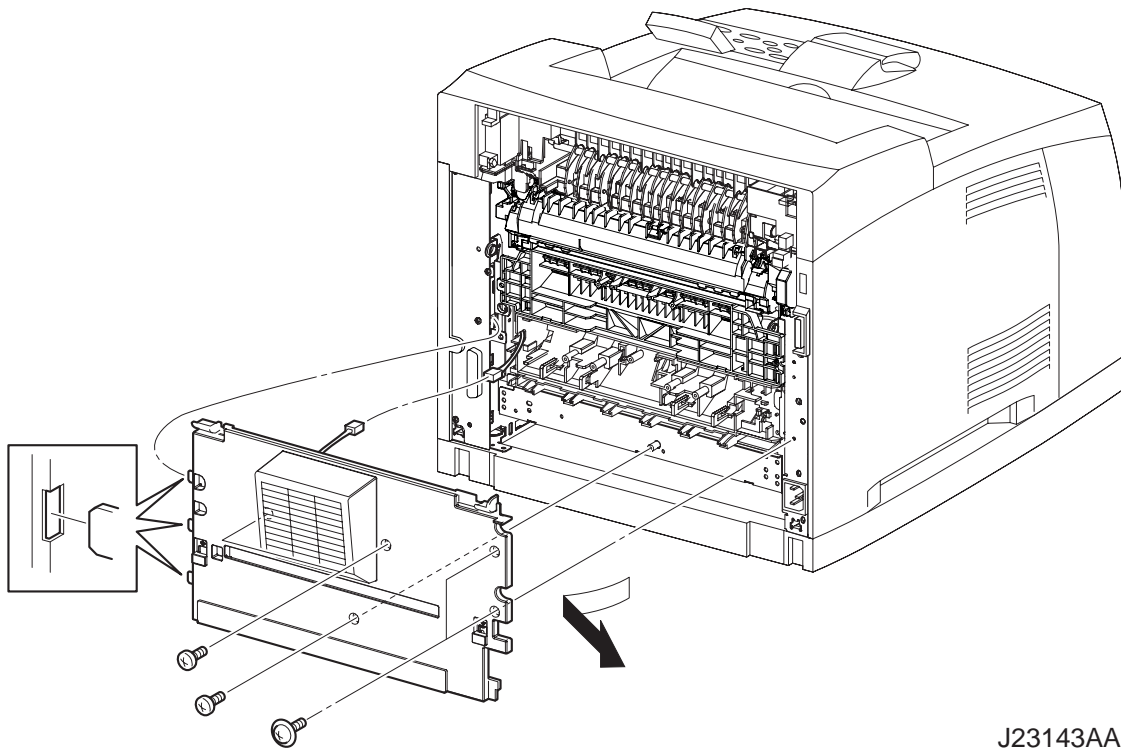

J23143AA

Figure 1. Cover Rear

RRP1.2 COVER RIGHT (PL 1.1)**Removal**

- 1) Loosen the screw securing the COVER RIGHT to the rear side of the printer (Figure 1).
- 2) Shift the COVER RIGHT in the direction of the arrow to release the 4 hooks, two below, one in front and one on rear, securing the cover to the printer.
- 3) Shift the COVER RIGHT downward to release the 3 hooks securing the top of it, and remove the COVER RIGHT from the printer.

Replacement

- 1) Shift the COVER RIGHT upward to lock the 3 hooks to the printer (Figure 1).
- 2) Shift the COVER RIGHT frontward to secure the 4 hooks, two below, one in front and one on rear, to the printer.
- 3) Secure the COVER RIGHT to the printer using the screw on the rear side of the printer.

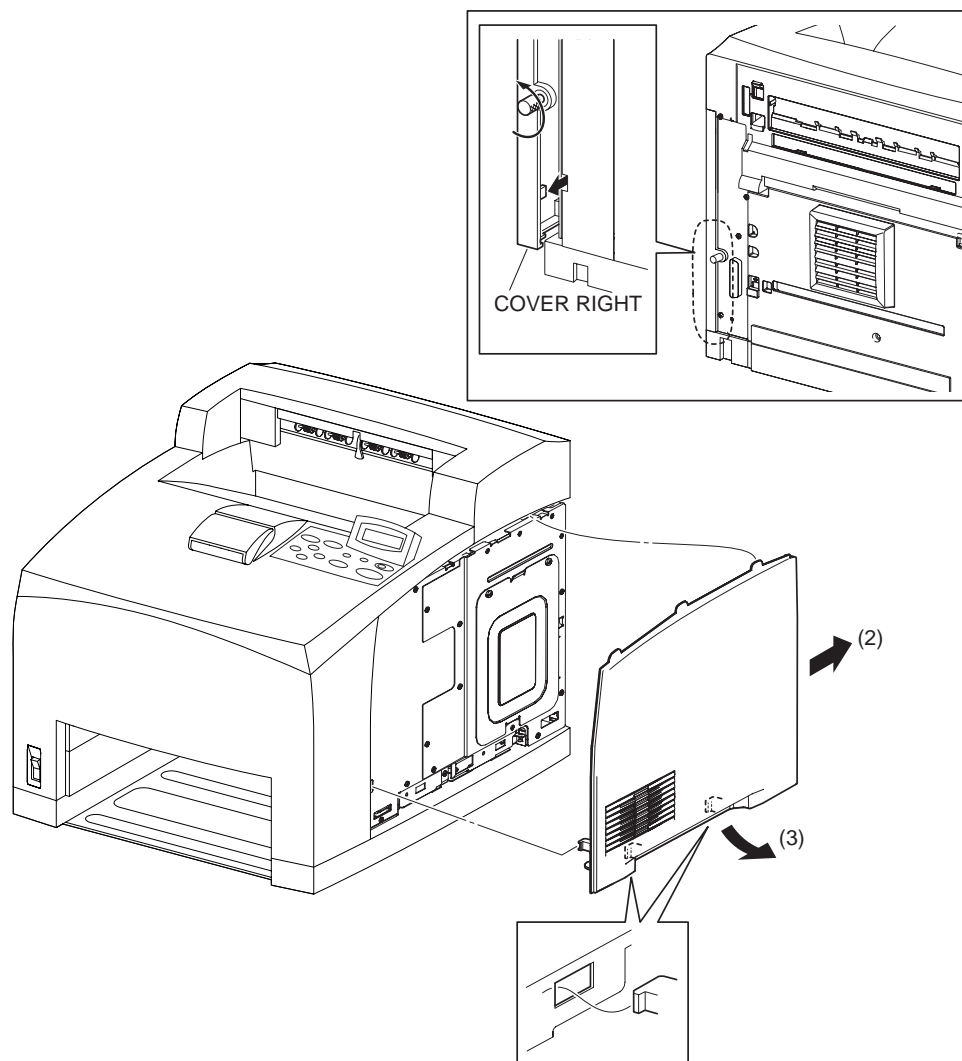
**Figure 1. Cover Right**

RRP1.3 COVER LEFT (PL 1.1)**Removal**

- 1) Remove the 500 COVER REAR (PL 7.1.21) (RRP7.9).
- 2) Remove the COVER REAR (PL 1.1) (RRP1.1).
- 3) Shift the COVER LEFT in the direction of the arrow to release the 4 hooks, two below and two on rear, securing the cover to the printer (Figure 1).
- 4) Shift the COVER LEFT downward to release the 3 hooks securing the top of it, and remove the COVER LEFT from the printer.

Replacement

- 1) Shift the COVER LEFT upward to lock the 3 hooks to the printer.
- 2) Shift the COVER LEFT frontward to lock the 4 hooks, two below and two on rear, to the printer.
- 3) Install the COVER REAR (PL 1.1) (RRP1.1).

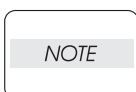

There are 2 kinds of screws, make sure they are installed correctly.

- 4) Install the COVER REAR 500 (PL 7.1) (RRP7.9).

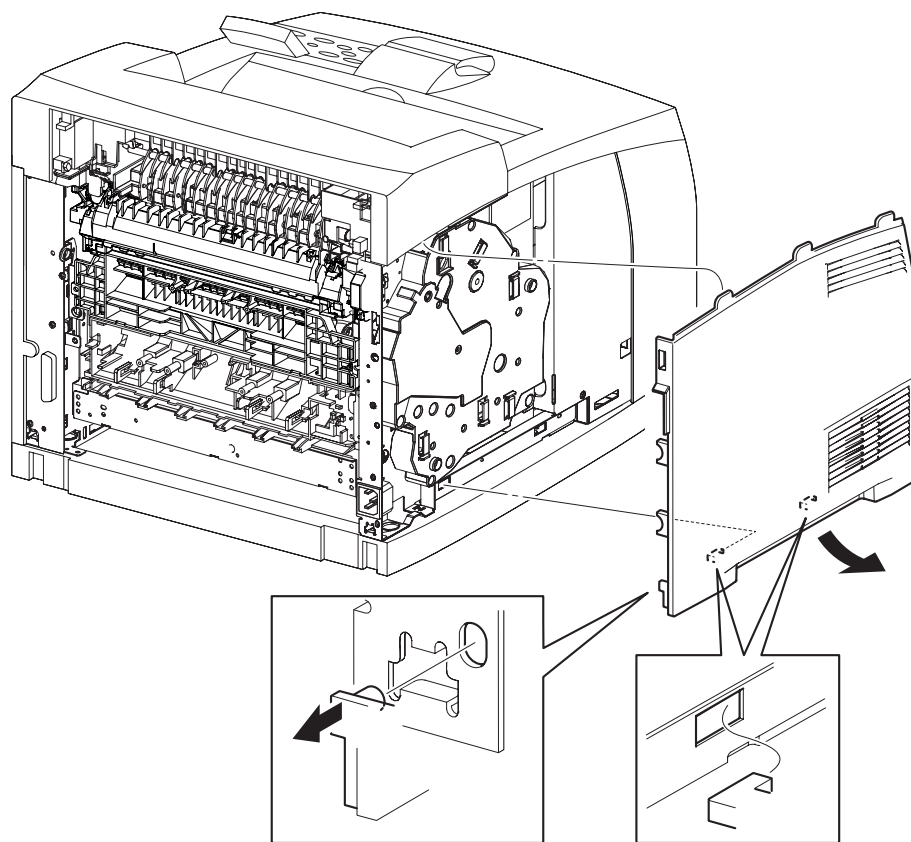

J23145AA

Figure 1. Cover Left

RRP1.4 COVER TOP (PL 1.1), OPERATION PANEL (PL 1.1)**Removal**

- 1) Remove the COVER REAR 500 (PL 7.1) (RRP7.9).
- 2) Remove the COVER REAR (PL 1.1) (RRP1.1).
- 3) Remove the COVER RIGHT (PL 1.1) (RRP1.2).
- 4) Remove the COVER LEFT (PL 1.1) (RRP1.3).
- 5) Remove the COVER EXIT 500 (PL 1.1) (RRP7.1)
- 6) Remove the 500 EXIT ASSEMBLY (PL 7.1) (RRP7.2).
- 7) Remove the 2 screws (silver with flange, 8mm) securing the COVER TOP to the printer (Figure 1).
- 8) Remove the LEVER LINK (PL 6.1) from the boss of the COVER OPEN (PL 1.1) (Figure 1).

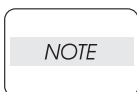

When removing the LEVER LINK from the boss of the COVER OPEN, the cover is opened, and the LEVER LINK is extended (Figure 1).

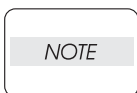

In the following steps, do not separate the COVER TOP too far from the printer, since the OPERATION PANEL (PL 1.1) attached to the COVER TOP is connected to the printer.

- 9) Release the 2 hooks securing the front of the COVER TOP to the COVER FRONT (PL 1.1), and pull out the COVER TOP slightly away from the printer.
- 10) Disconnect the connector (P/J1) of the OPERATION PANEL.
- 11) Release the harness clamps of the OPERATION PANEL.
- 12) Remove the COVER TOP.
- 13) Release the 2 hooks securing the OPERATION PANEL to the COVER TOP, and remove the OPERATION PANEL.

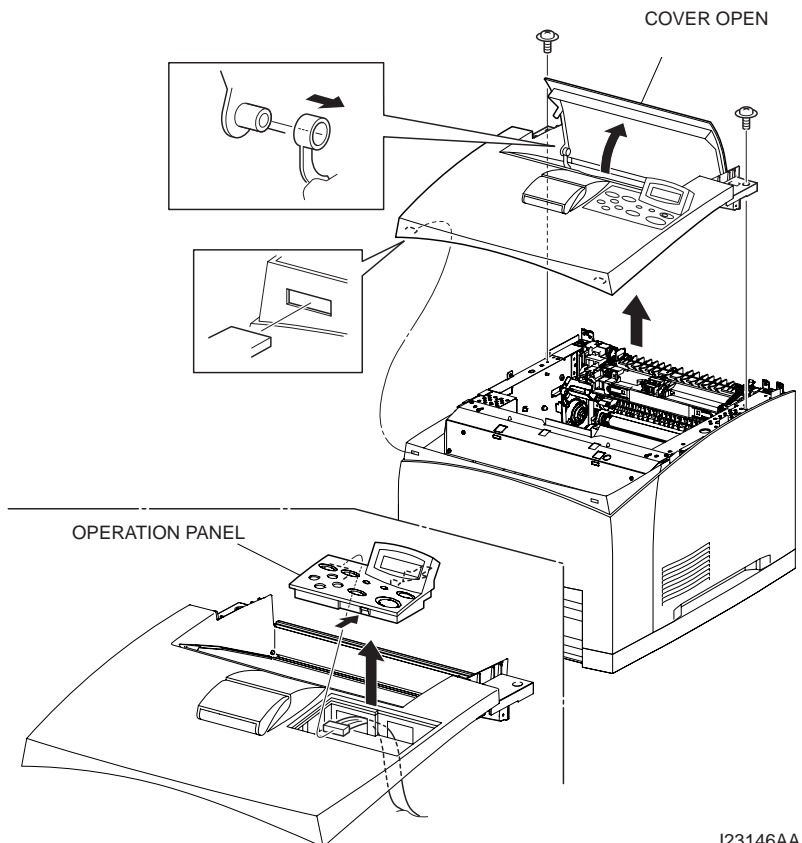

Figure 1. Top Cover & Operation Panel

Replacement

- 1) Install the OPERATION PANEL to the COVER TOP, and secure it using the 2 hooks.
- 2) Connect P/J1 of the OPERATION PANEL.
- 3) Secure the harnesses with the 2 clamps on the OPERATION PANEL.
- 4) Install the COVER TOP to the printer, and secure it to the COVER FRONT (PL 1.1) using the 2 hooks at the front of the COVER TOP.
- 5) Put the boss of the COVER OPEN (PL 1.1) into the hole of the LEVER LINK (PL 6.1.29).

NOTE

When putting the boss of the COVER OPEN into the hole of the LEVER LINK, the cover should be opened, and the LEVER LINK should be extended.

- 6) Secure the COVER TOP to the printer using the 2 screws (silver with flange, 8mm).
- 7) Install the 500 EXIT ASSEMBLY (PL 7.1) (RRP7.2).

NOTE

When installing, put the harnesses of the MOTOR ASSEMBLY EXIT and HARNESS ASSEMBLY EXIT SNR1 into the square hole of the frame.

- 8) Install the COVER EXIT 500 (PL 1.1) (RRP7.1).
- 9) Install the COVER LEFT (PL 1.1) (RRP1.3).
- 10) Install the COVER RIGHT (PL 1.1) (RRP1.2).
- 11) Install the COVER REAR (PL 1.1) (RRP1.1).
- 12) Install the COVER REAR 500 (PL 7.1) (RRP7.9).

RRP1.5 COVER FRONT (PL 1.1)**Removal**

- 1) Remove the COVER REAR 500 (PL 7.1) (RRP7.9)
- 2) Remove the COVER REAR (PL 1.1) (RRP1.1)
- 3) Remove the COVER LEFT (PL 1.1) (RRP1.3)
- 4) Remove the COVER RIGHT (PL 1.1) (RRP1.2)
- 5) Remove the COVER EXIT 500 (PL 1.1) (RRP7.1)
- 6) Remove the 500 EXIT ASSEMBLY (PL 7.1) (RRP7.2).
- 7) Remove the COVER TOP (PL 1.1) (RRP1.4)
- 8) Release the 2 hooks of the COVER FRONT securing it to the printer by pressing down the 2 hooks at the upper portion of the cover, and open it to the front (arrow 1) (Figure 1).
- 9) Shift the COVER FRONT in the direction of the arrow 2 (Figure 1). Remove the cover from the printer by releasing the 2 hooks at the lower portion of the cover (Figure 1).

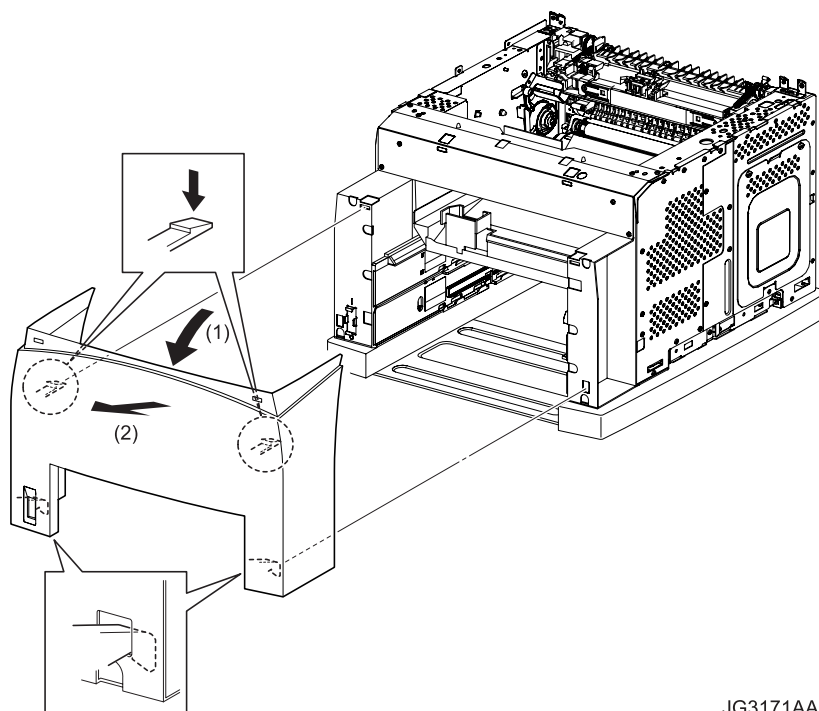

JG3171AA

Figure 1. Cover Front**Replacement**

- 1) Hang the 2 hooks at the lower portion of the COVER FRONT to the printer (Figure 1).
- 2) Lock the 2 hooks at the upper portion of the COVER FRONT to the printer, and secure it to the printer (Figure 1).
- 3) Install the COVER TOP (PL 1.1) (RRP1.4).
- 4) Install the 500 EXIT ASSEMBLY (PL 7.1) (RRP7.2).

NOTE

When installing, put the harnesses of the MOTOR ASSEMBLY EXIT and HARNESS ASSEMBLY EXIT SNR1 into the square hole of the frame.

- 5) Install the COVER EXIT 500 (PL 1.1) (RRP7.1).
- 6) Install the COVER RIGHT (PL 1.1) (RRP1.2).
- 7) Install the COVER LEFT (PL 1.1) (RRP1.3).
- 8) Install the COVER REAR (PL 1.1) (RRP1.1).
- 9) Install the COVER REAR 500 (PL 7.1) (RRP7.9).

RRP2. 150 PAPER CASSETTE

RRP2.1 ROLL ASSEMBLY RETARD (PL 2.1.2)

Removal

- 1) Pull out the 150 PAPER CASSETTE from the printer.
- 2) Release the hooks securing the HOLDER RETARD (PL 2.1) to the 150 PAPER CASSETTE using a screwdriver (Figure 1).
- 3) Lift up the HOLDER RETARD in the direction of the arrow, and remove it.
- 4) Release the hook securing the RETARD ROLL ASSEMBLY, and pull it out from the SHAFT RETARD (PL 2.1).

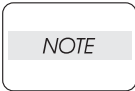

When removing, do not touch the roller surface of the ROLL ASSEMBLY RETARD.

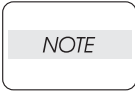

When removing HOLDER RETARD, be careful not to lose the SPRING RETARD.

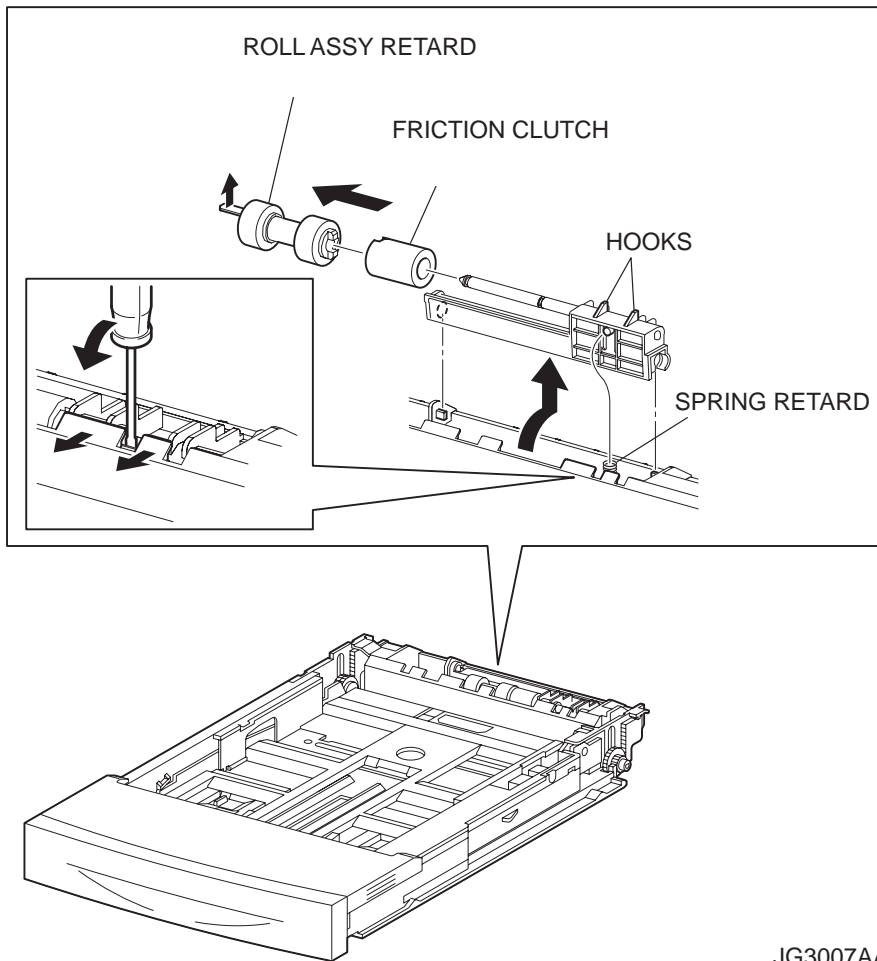
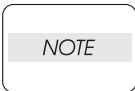

Figure 1. 150 Paper Cassette

Replacement

- 1) Install the ROLL ASSEMBLY RETARD to the SHAFT RETARD (PL 2.1), and secure the ROLL ASSEMBLY RETARD with the hook.



When installing, do not touch the roller surface of the ROLL ASSEMBLY RETARD.

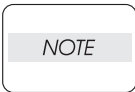

Be sure to install the hook of the ROLL ASSEMBLY RETARD in the groove of the SHAFT RETARD.

- 2) Move the HOLDER RETARD (PL 2.1) in the opposite direction of the arrow, and install it to the 150 PAPER CASSETTE.

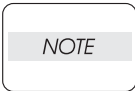

After installing, make sure the HOLDER RETARD comes back to the former position with the spring force of the SPRING RETARD (PL 2.1), when pushing down the HOLDER RETARD and then release the finger from it.

- 3) Install the 150 PAPER CASSETTE to the printer.

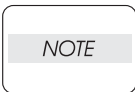

Other than the procedure above, it is possible to remove the ROLL ASSEMBLY RETARD by pushing down the HOLDER RETARD (Figure 2).

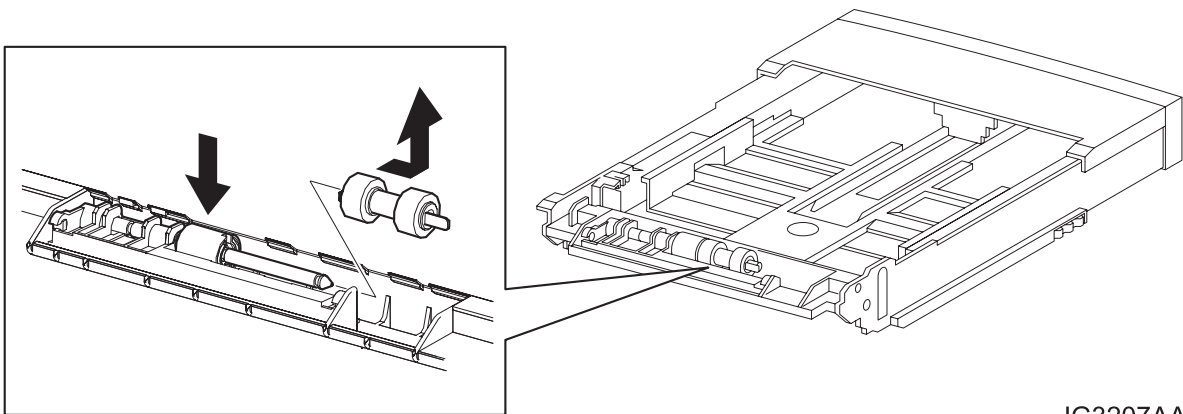

JG3207AA

Figure 2. Roll Assembly Retard

RRP2.2 RACK SIZE (PL 2.1)

Removal

- 1) Remove the COVER CST (PL 2.1) from the 150 PAPER CASSETTE.
- 2) Release the lock of the LOCK EXTENSION, and pull out the cassette extension as far as it will go.
- 3) Release the hooks securing the GEAR PINION (PL 2.1) to the HOUSING TOP 150 (PL 2.1), and remove the PINION GEAR (Figure 1).
- 4) While pressing down the lock of the STOPPER GEAR (PL 2.1), release the lock of the LEVER BTM LOCK (PL 2.1) to lift up the PLATE ASSEMBLY BTM (PL 2.1) (Figure 1).
- 5) Slide the GUIDE ASSEMBLY SD L150 (PL 2.1) inward, and remove it from the HOUSING TOP 150 by pressing down the hook of the HOUSING TOP 150.
- 6) Slide the GUIDE ASSEMBLY SD R150 (PL 2.1) inward, and remove it from the HOUSING TOP 150 by pressing down the hook of the HOUSING TOP 150.

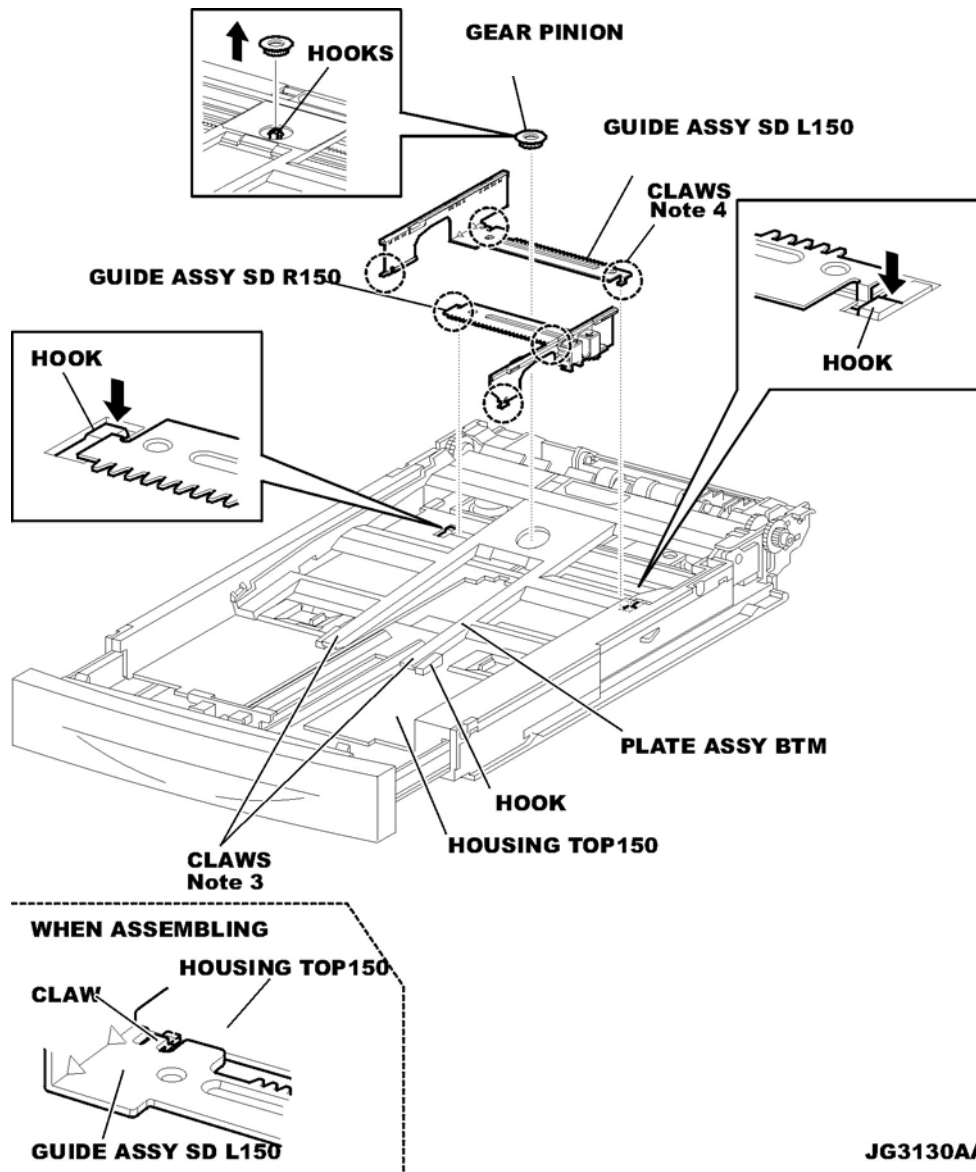

JG3130AA

Figure 1. 150 Paper Cassette

- 7) Remove the 2 screws (gold tapping, 8mm) from both right and left side, as well as the 6 screws (gold tapping, 8mm) on the back, that secure the HOUSING TOP 150 (PL 2.1) to the HOUSING BASE 150 (PL 2.1) (Figure 2).
- 8) Release the 4 hooks of the HOUSING TOP 150, and remove the HOUSING TOP 150 and HOUSING EXTENSION 150 (PL 2.1) from the HOUSING BASE 150 (Figure 2).
- 9) Remove the 4 screws (gold tapping, 6mm) securing the COVER EXTENSION (PL 2.1) to the HOUSING EXTENSION 150.
- 10) Remove the COVER EXTENSION from the HOUSING EXTENSION 150.

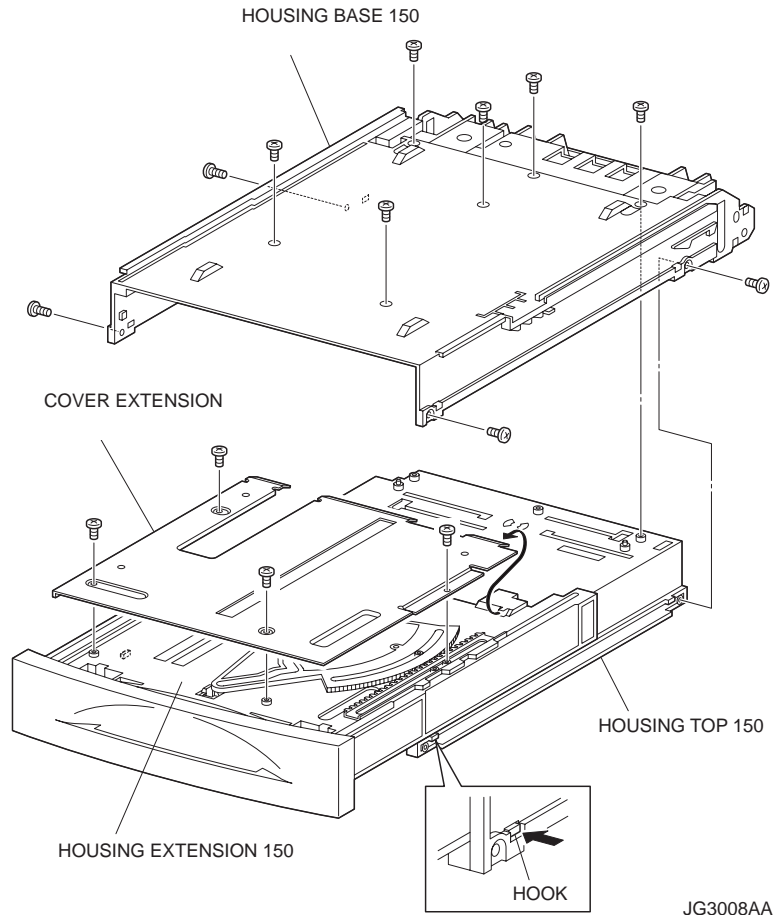

Figure 2. 150 Paper Cassette Base

- 11) Lift the front of the RACK SIZE (PL 2.1) a little, and turn it in the direction of the arrow to remove it from the HOUSING EXTENSION 150 (Figure 3).

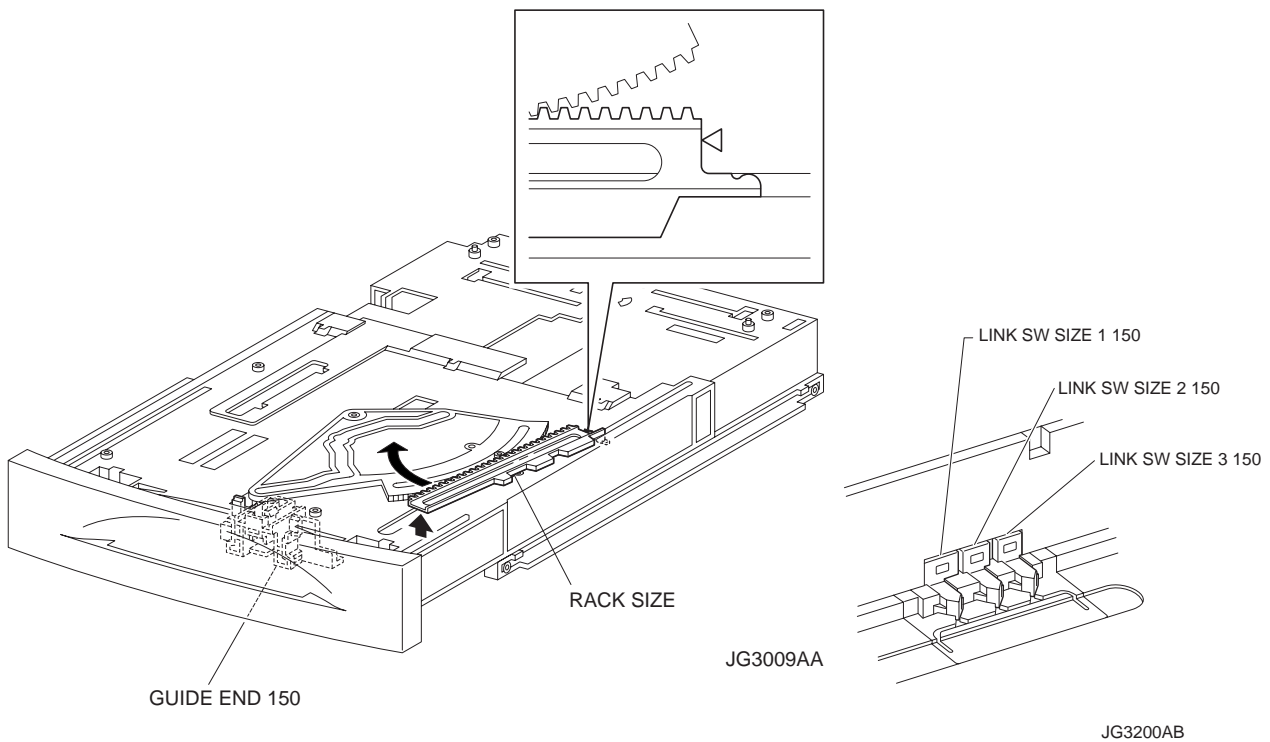

Figure 3. Size Rack

Replacement

- 1) Put the hook of the tip of the RACK SIZE (PL 2.1) into the groove of the HOUSING EXTENSION 150, and turn it in the opposite direction of the arrow.
- 2) Align the end of the RACK SIZE with the triangle mark printed on the HOUSING EXTENSION 150 as shown in the figure, and install the RACK SIZE to the HOUSING EXTENSION 150.

NOTE

When installing the RACK SIZE, be sure to pull out the GUIDE ASSEMBLY END 150 (PL 2.1) as far as it will go. (NOTE 1) (Figure 3).

- 3) Install the COVER EXTENSION (PL 2.1) to the HOUSING EXTENSION 150 using the 4 screws (gold tapping, 6mm).

NOTE

When installing, make sure the COVER EXTENSION is inserted under 3 claws of the HOUSING EXTENSION 150. (NOTE 2) (Figure 2).

NOTE

Use 6mm size of fixed screw. If 8mm size of screw is used, HOUSING EXTENSION 150 doesn't operate smoothly and LOCK EXTENSION 150 doesn't operate correctly.

- 4) Install the HOUSING EXTENSION 150 and HOUSING TOP 150 (PL 2.1) to the HOUSING BASE 150 (PL 2.1) while pushing the LINK SW SIZE1-150 (PL 2.1), LINK SW SIZE2-150 (PL 2.1) and LINK SW SIZE3-150 (PL) of the HOUSING BASE 150 outward as shown in the figure (Figure 3).

NOTE

Be sure to put 2 claws on the top of the PLATE ASSEMBLY BTM under the hooks on the HOUSING TOP 150. (NOTE 3) (Figure 1).

- 5) After assembling the HOUSING TOP 150 to 150 BASE HOUSING using the 4 hooks, secure them using the 2 screws (gold tapping, 8mm) on both right and left sides, as well as the 6 screws (gold tapping, 8mm) on the back.

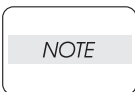

After tightening the screws, move the GUIDE ASSEMBLY END 150 back and forth, and make sure that the LINK SW SIZES operate smoothly.

- 6) While pressing down the hook of the HOUSING TOP 150, install the GUIDE ASSEMBLY SD R150 (PL 2.1) to the HOUSING TOP 150.

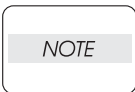

After installing, make sure that the 3 claws of the GUIDE ASSEMBLY SD R150 sit correctly in the grooves of the HOUSING TOP 150. (NOTE 4) (Figure 1).

- 7) While pressing down the hook of the HOUSING TOP 150, install the GUIDE ASSEMBLY SD L150 (PL 2.1) to the HOUSING TOP 150.

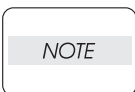

After installing, make sure that the 3 claws of the GUIDE ASSEMBLY SD L150 sit correctly in the grooves of the HOUSING TOP 150. (NOTE 4) (Figure 1).

- 8) Push the PLATE ASSEMBLY BTM downward to lock.
- 9) With completely opened GUIDE ASSEMBLY SD L150 (PL 2.1) and GUIDE ASSEMBLY SD R150 (PL 2.1) to the both sides, install the GEAR PINION (PL 2.1) to the HOUSING TOP 150.

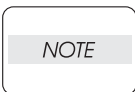

When installing the GEAR PINION, make sure the GUIDE ASSEMBLY SD R150 and GUIDE ASSEMBLY SD L150 are completely opened. If not, the side register may be misaligned.

- 10) Install the COVER CST (PL 2.1) to the 150 PAPER CASSETTE.

RRP2.3 GEAR SECTOR (PL 2.1)**Removal**

- 1) Remove the COVER CST (PL 2.1) from the 150 PAPER CASSETTE.
- 2) Release the lock of the LOCK EXTENSION, and pull out the cassette extension as far as it will go.
- 3) Release the hooks securing the GEAR PINION (PL 2.1) to the HOUSING TOP 150 (PL 2.1), and remove the GEAR PINION.
- 4) While pressing down the lock of the STOPPER GEAR (PL 2.1), release the lock of the LEVER BTM LOCK (PL 2.1) to lift up the PLATE ASSY BTM (PL 2.1).
- 5) Slide the GUIDE ASSY SD L150 (PL 2.1) inward, and remove it from the HOUSING TOP 150 by pressing down the hook of the HOUSING TOP 150.
- 6) Slide the GUIDE ASSY SD R150 (PL 2.1) inward, and remove it from the HOUSING TOP 150 by pressing down the hook of the HOUSING TOP 150.
- 7) Remove the 2 screws (gold tapping, 8mm) from both right and left sides, as well as the 6 screws (gold tapping, 8mm) on the back, that secure the HOUSING TOP 150 (PL 2.1) to the HOUSING BASE 150 (PL 2.1).
- 8) Release the 4 hooks of the HOUSING TOP 150, and remove the HOUSING TOP 150 and HOUSING EXTENSION 150 (PL 2.1) from the HOUSING BASE 150.
- 9) Remove the 4 screws (gold tapping, 6mm) securing the COVER EXTENSION (PL 2.1) to the HOUSING EXTENSION 150.
- 10) Remove the COVER EXTENSION from the HOUSING EXTENSION 150.
- 11) Remove the RACK SIZE (PL 2.1) (RRP2.2).
- 12) Remove the screw (black with flange, 8mm) securing the GEAR SECTOR.
- 13) Remove the GEAR SECTOR from the HOUSING EXTENSION 150.

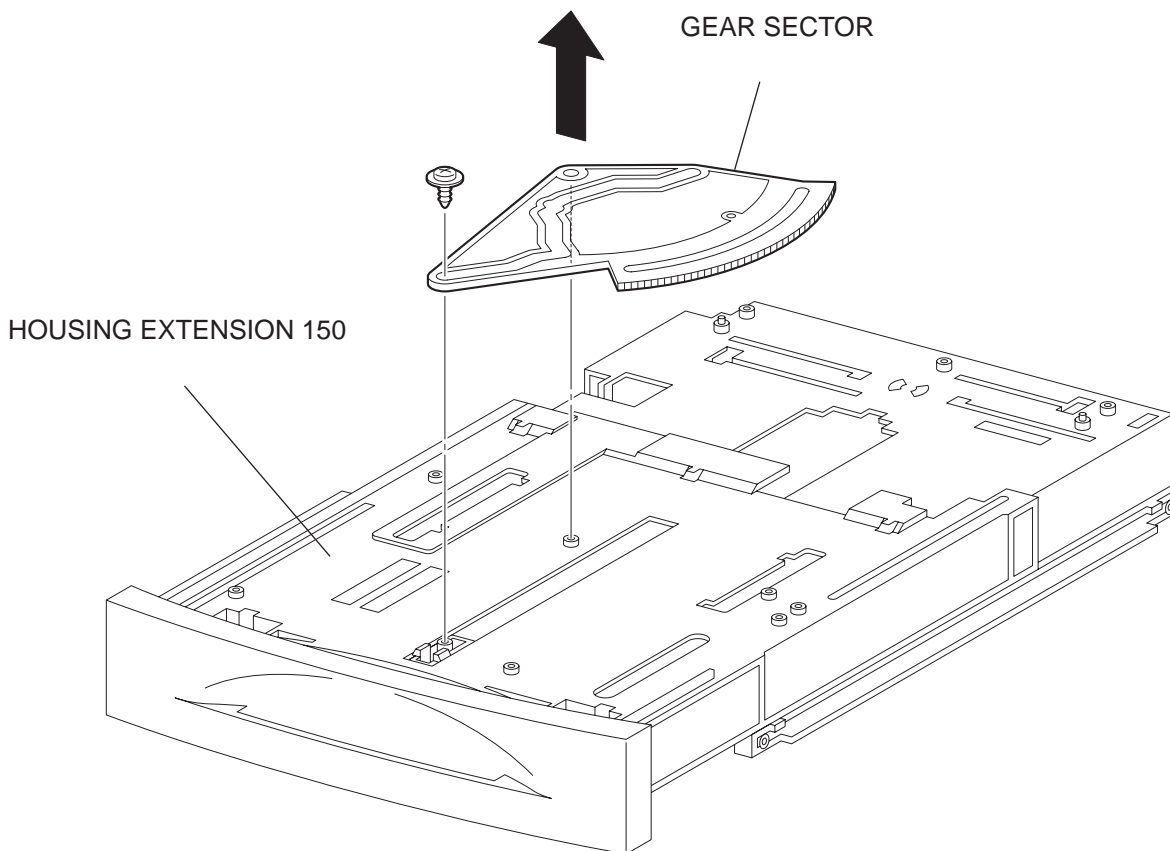

JG3118AA

Figure 1. Gear Sector

Replacement

- 1) Install the GEAR SECTOR to the HOUSING EXTENSION 150 (PL 2.1) (Figure 1).
- 2) Secure the GEAR SECTOR using the screw (black with flange, 8mm).
- 3) Install the RACK SIZE 150 (PL 2.1) (RRP2.2).
- 4) Install the COVER EXTENSION (PL 2.1) to the HOUSING EXTENSION 150 using the 4 screws (gold tapping, 6mm).

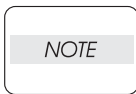

When installing, make sure the COVER EXTENSION is inserted under 3 claws of the HOUSING EXTENSION 150.

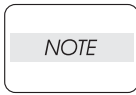

Use 6mm size of fixed screw. If 8mm size of screw is used, HOUSING EXTENSION 150 doesn't operate smoothly and LOCK EXTENSION 150 doesn't operate correctly.

- 5) Install the HOUSING EXTENSION 150 and HOUSING TOP 150 (PL 2.1) to the HOUSING BASE 150 (PL 2.1) while pushing the LINK SW SIZE1-150 (PL 2.1), LINK SW SIZE2-150 (PL 2.1) and LINK SW SIZE3-150 (PL 2.1) of the HOUSING BASE 150 outward as shown (Figure 2).

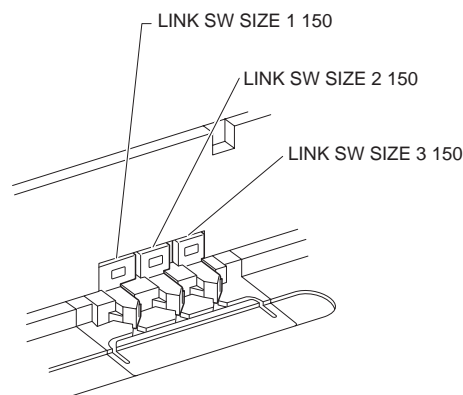

JG3200AB

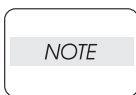
Figure 2. Link Size

Be sure to put 2 claws on the top of the PLATE ASSEMBLY BTM under the hooks on the HOUSING TOP 150.

- 6) After assembling the HOUSING TOP 150 to HOUSING BASE 150 using the 4 hooks, secure them using the 2 screws (gold tapping, 8mm) on both right and left sides, as well as the 6 screws (gold tapping, 8mm) on the back.

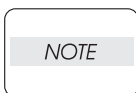

After tightening the screws, move the GUIDE ASSEMBLY END 150 back and forth, and make sure that the LINK SW SIZES operate smoothly.

- 7) While pressing down the hook of the HOUSING TOP 150, install the GUIDE ASSEMBLY SD R150 (PL 2.1) to the HOUSING TOP 150.

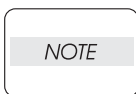

After installing, make sure that the 3 claws of the GUIDE ASSEMBLY SD R150 sit correctly in the grooves of the HOUSING TOP 150.

- 8) While pressing down the hook of the HOUSING TOP 150, install the GUIDE ASSEMBLY SD L150 (PL 2.1) to the HOUSING TOP 150.

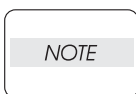

After installing, make sure that the 3 claws of the GUIDE ASSEMBLY SD L150 sit correctly in the grooves of the HOUSING TOP 150.

- 9) Push the PLATE ASSEMBLY BTM downward to lock.

Removal and Replacement Procedures (RRPs)

- 10) With completely opened GUIDE ASSEMBLY SD L150 (PL 2.1) and GUIDE ASSEMBLY SD R150 (PL 2.1), install the GEAR PINION (PL 2.1) to the HOUSING TOP 150.

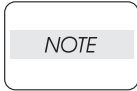

When installing the GEAR PINION, make sure the GUIDE ASSEMBLY SD R150 and GUIDE ASSEMBLY SD L150 are completely opened. If not, the side register may be misaligned.

- 11) Install the COVER CST (PL 2.1) to the 150 PAPER CASSETTE.

RRP2.4 GUIDE ASSEMBLY END 150 (PL 2.1)**Removal**

- 1) Remove the COVER CST (PL 2.1) from the 150 PAPER CASSETTE.
- 2) Release the lock of the LOCK EXTENSION, and pull out the cassette extension as far as it will go.
- 3) Release the hooks securing the GEAR PINION (PL 2.1) to the HOUSING TOP 150 (PL 2.1), and remove the GEAR PINION.
- 4) While pressing down the lock of the STOPPER GEAR (PL 2.1), release the lock of the LEVER BTM LOCK (PL 2.1) to lift up the PLATE ASSY BTM (PL 2.1) (Figure 1).

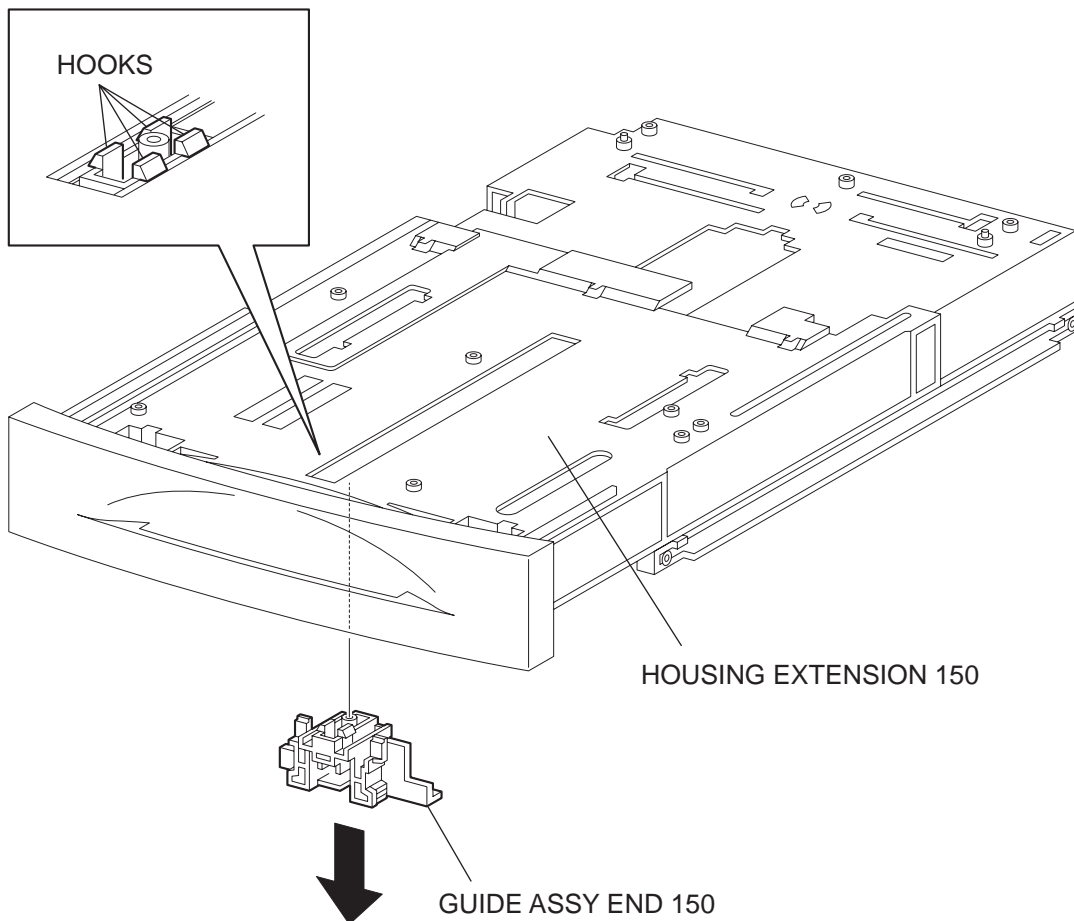

JG3011AA

Figure 1. Guide Assembly End

- 5) Slide the GUIDE ASSY SD L150 (PL 2.1) inward, and remove it from the HOUSING TOP 150 by pressing down the hook of the HOUSING TOP 150.
- 6) Slide the GUIDE ASSY SD R150 (PL 2.1) inward, and remove it from the HOUSING TOP 150 by pressing down the hook of the HOUSING TOP 150.
- 7) Remove the 2 screws (gold tapping, 8mm) from both right and left sides, as well as the 6 screws (gold tapping, 8mm) on the back, that secure the HOUSING TOP 150 (PL 2.1) to the HOUSING BASE 150 (PL 2.1).
- 8) Release the 4 hooks of the HOUSING TOP 150, and remove the HOUSING TOP 150 and HOUSING EXTENSION 150 (PL 2.1) from the HOUSING BASE 150.
- 9) Remove the 4 screws (gold tapping, 6mm) securing the COVER EXTENSION (PL 2.1) to the HOUSING EXTENSION 150.
- 10) Remove the COVER EXTENSION from the HOUSING EXTENSION 150.

- 11) Remove the RACK SIZE (PL 2.1) (RRP2.2).
- 12) Remove the GEAR SECTOR (PL 2.1) (RRP2.3).
- 13) Release the hooks securing the GUIDE ASSY END 150 to the HOUSING EXTENSION 150.

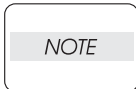

Be careful handling the hooks of the GUIDE ASSY END150. They are fragile and could break if given excessive force.

- 14) Remove the GUIDE ASSY END 150 from the HOUSING EXTENSION 150.

Replacement

- 1) Secure the GUIDE ASSEMBLY END 150 to the HOUSING EXTENSION 150 (PL 2.1) using the 4 hooks (Figure 1).
- 2) Install the GEAR SECTOR (PL 2.1) (RRP2.3)
- 3) Install the RACK SIZE (PL 2.1) (RRP2.2)
- 4) Install the COVER EXTENSION (PL 2.1) to the HOUSING EXTENSION 150 using the 4 screws (gold tapping, 6mm).

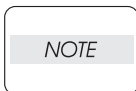

When installing, make sure the COVER EXTENSION is inserted under 3 claws of the HOUSING EXTENSION 150.

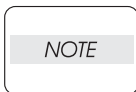

Use 6mm size of fixed screw. If 8mm size of screw is used, HOUSING EXTENSION 150 doesn't operate smoothly and LOCK EXTENSION 150 doesn't operate correctly.

- 5) Install the HOUSING EXTENSION 150 and HOUSING TOP 150 (PL 2.1) to the HOUSING BASE 150 (PL 2.1) while pushing the LINK SW SIZE1-150 (PL 2.1), LINK SW SIZE2-150 (PL 2.1) and LINK SW SIZE3-150 (PL 2.1) of the HOUSING BASE 150 outward as shown (Figure 3) (RRP2.2).

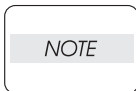

Be sure to put 2 claws that on the top of the PLATE ASSEMBLY BTM under the hooks on the HOUSING TOP 150.

- 6) After assembling the HOUSING TOP 150 to the HOUSING BASE 150 using the 4 hooks, secure them using the 2 screws (gold tapping, 8mm) on both right and left sides, as well as the 6 screws (gold tapping, 8mm) on the back.

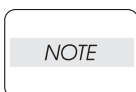

After tightening the screws, move the GUIDE ASSEMBLY END 150 back and forth, and make sure that the LINK SW SIZES operate smoothly.

- 7) While pressing down the hook of the HOUSING TOP 150, install the GUIDE ASSEMBLY SD R150 (PL 2.1) to the HOUSING TOP 150.

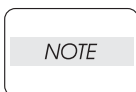

After installing, make sure that the 3 claws of the GUIDE ASSEMBLY SD R150 sit correctly in the grooves of the HOUSING TOP 150.

- 8) While pressing down the hook of the HOUSING TOP 150, install the GUIDE ASSEMBLY SD L150 (PL 2.1) to the HOUSING TOP 150.

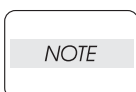

After installing, make sure that the 3 claws of the GUIDE ASSEMBLY SD L150 sit correctly in the grooves of the HOUSING TOP 150.

- 9) Push the PLATE ASSEMBLY BTM downward to lock.
- 10) With completely opened GUIDE ASSEMBLY SD L150 (PL 2.1) and GUIDE ASSEMBLY SD R150 (PL 2.1) to the both sides, install the GEAR PINION (PL 2.1) to the HOUSING TOP 150.

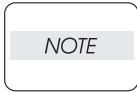

When installing the GEAR PINION, make sure the GUIDE ASSEMBLY SD R150 and GUIDE ASSEMBLY SD L150 are completely opened. If not, the side register may be misaligned.

- 11) Install the COVER CST (PL 2.1) to the 150 PAPER CASSETTE.

RRP2.5 PLATE ASSEMBLY BTM (PL 2.1)

Removal

- 1) Remove the COVER CST (PL 2.1) from the 150 PAPER CASSETTE (Figure 1).
- 2) Release the lock of the LOCK EXTENSION, and pull out the cassette extension as far as it will go (Figure 1).
- 3) Release the hooks securing the GEAR PINION (PL 2.1) to the HOUSING TOP 150 (PL 2.1), and remove the GEAR PINION.
- 4) While pressing down the lock of the STOPPER GEAR (PL 2.1), release the lock of the LEVER BTM LOCK (PL 2.1) to lift up the PLATE ASSEMBLY BTM (PL 2.1).
- 5) Slide the GUIDE ASSEMBLY SD L150 (PL 2.1) inward, and remove it from the HOUSING TOP 150 by pressing down the hook of the HOUSING TOP 150.
- 6) Slide the GUIDE ASSEMBLY SD R150 (PL 2.1) inward, and remove it from the HOUSING TOP 150 by pressing down the hook of the HOUSING TOP 150.

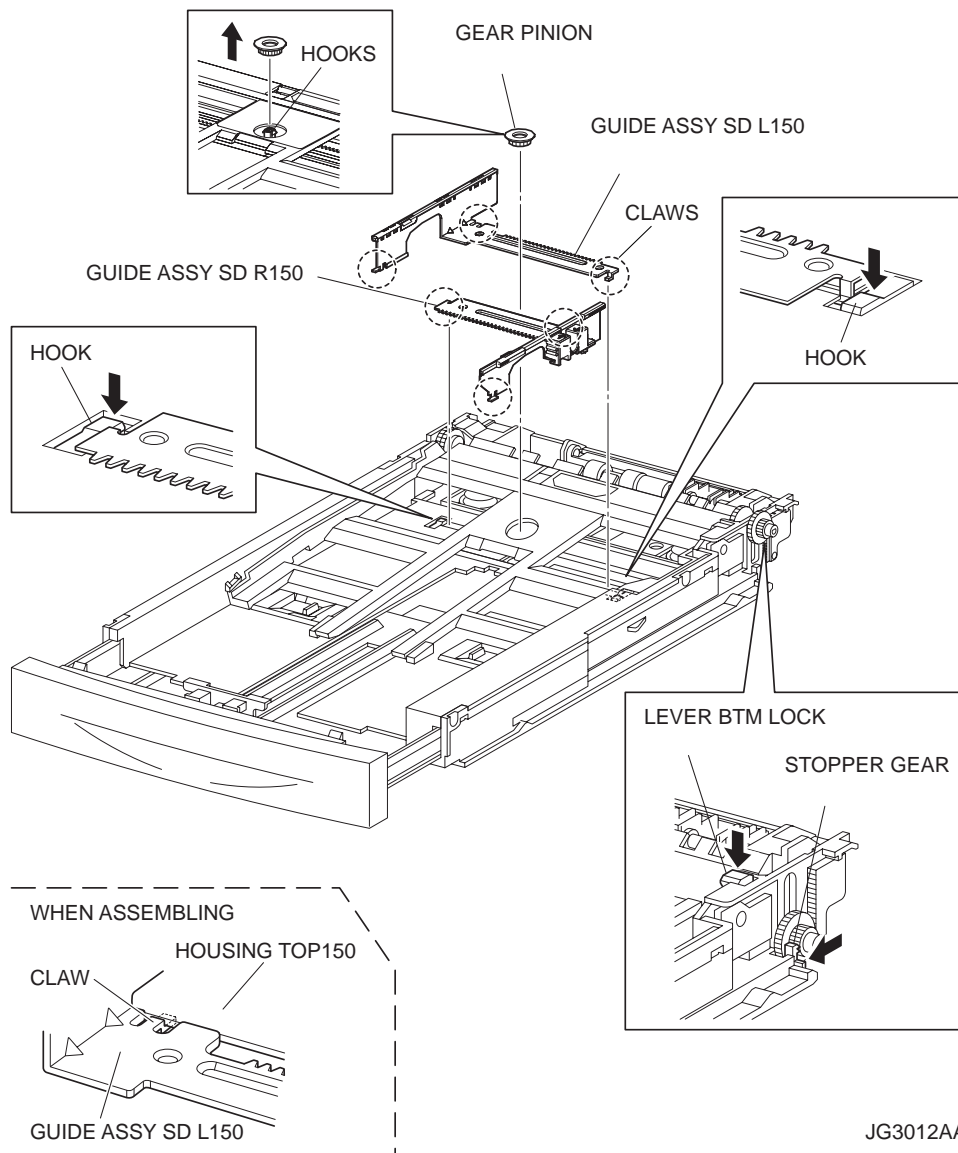

JG3012AA

Figure 1. Plate Assembly BTM

NOTE

In the following steps, the GEAR PB L (PL 2.1), GEAR BTM DMP ONEWAY (PL 2.1) and GEAR BTM LOCK ONEWAY (PL 2.1) will be detached. Be careful not to lose these gears (Figure 2).

- 7) Release the hook of the GEAR PB R (PL 2.1), and remove it from the SHAFT PB (PL 2.1) (Figure 2).

NOTE

It is hard to remove GEAR PB R. When removing it, be careful not to break it.

- 8) Disengage the GEAR PB L from the PLATE GEAR LOCK 150 while bending the HOUSING BASE 150 in the direction of the arrows. Remove the PLATE ASSEMBLY BTM together with the SHAFT PB, GEAR PB L, GEAR BTM DMP ONEWAY, and GEAR BTM LOCK ONEWAY from the HOUSING TOP 150.
- 9) Pull out the SHAFT PB from the PLATE ASSEMBLY BTM, and remove the GEAR PB L, GEAR BTM DMP ONEWAY and GEAR BTM LOCK ONEWAY.

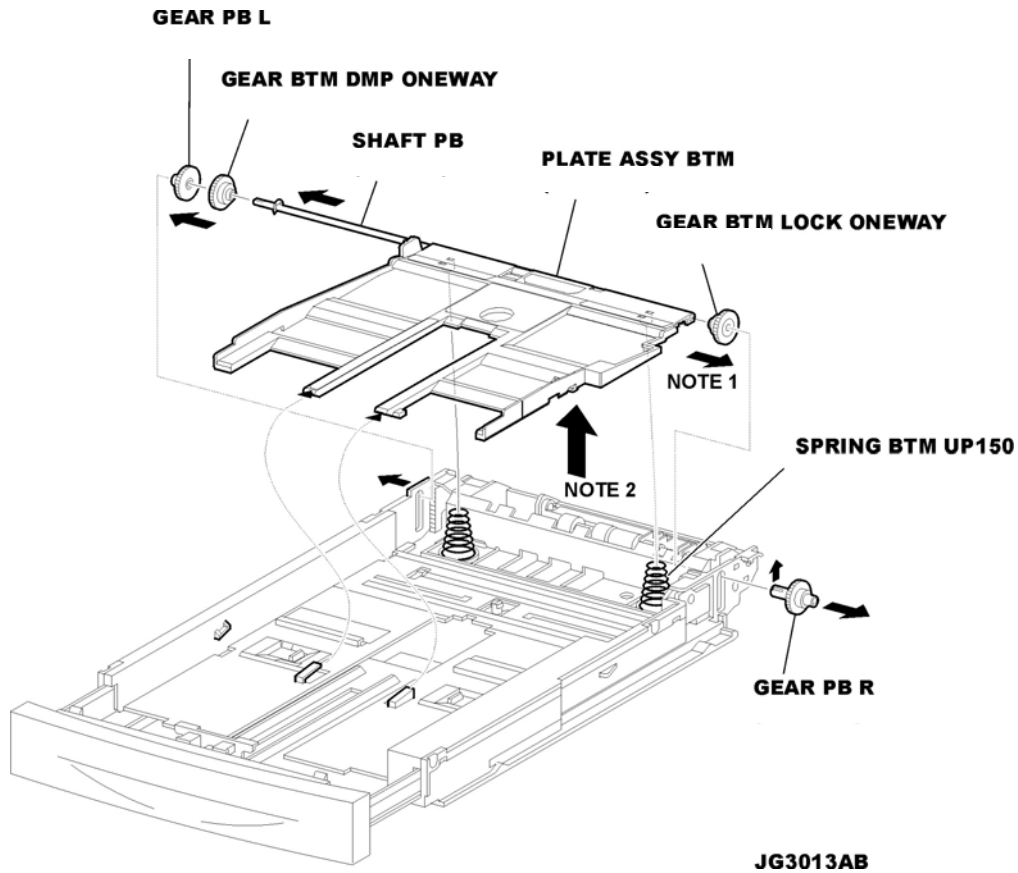
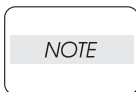

Figure 2. Plate Assembly

Replacement

- 1) Insert the SHAFT PB (PL 2.1) into the PLATE ASSEMBLY BTM, and insert the GEAR BTM DMP ONEWAY (PL 2.1), GEAR PB L (PL 2.1), and GEAR BTM LOCK ONEWAY (PL 2.1) to the SHAFT PB (Figure 2).
- 2) While disengaging the GEAR PB L, install the assembled PLATE ASSEMBLY BTM to the HOUSING TOP 150 (PL 2.1).



When installing the PLATE ASSEMBLY BTM, be sure to put 2 SPRING BTM UP 150s (PL 2.1) into the bosses on the back of the PLATE ASSEMBLY BTM (NOTE 1) (Figure 2).

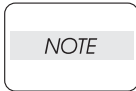

Be sure to put 2 claws on the top of the PLATE ASSEMBLY BTM under the hooks on the HOUSING TOP 150.(NOTE 2) (Figure 2).

- 3) Install the GEAR PB R (PL 2.1) to the SHAFT PB, and secure it with the hook.

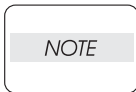

Be sure to install the hook of the GEAR PB R into the groove of the SHAFT PB.

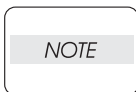

When installing the GEAR PB R, be sure to lift up the PLATE ASSEMBLY BTM. If the PLATE ASSEMBLY BTM is inclined, a paper skew or jam may occur. Check after the installation is completed.

- 4) While pressing down the hook of the HOUSING TOP 150, install the GUIDE ASSEMBLY SD R150 (PL 2.1) to the HOUSING TOP 150.

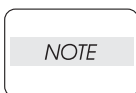

After installing, make sure that the 3 claws of the GUIDE ASSEMBLY SD R150 sit correctly in the grooves of the HOUSING TOP 150.

- 5) While pressing down the hook of the HOUSING TOP 150, install the GUIDE ASSEMBLY SD L150 (PL 2.1) to the HOUSING TOP 150

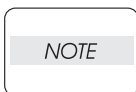

After installing, make sure that the 3 claws of the GUIDE ASSEMBLY SD L150 sit correctly in the grooves of the HOUSING TOP 150.

- 6) Push the PLATE ASSEMBLY BTM downward to lock.

- 7) Install the GEAR PINION (PL 2.1) to the HOUSING TOP 150.

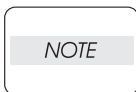

When installing the GEAR PINION, make sure the GUIDE ASSEMBLY SD R150 and GUIDE ASSEMBLY SD L150 are completely opened. If not, the side register may be misaligned.

- 8) Install the COVER CST (PL 2.1) to the 150 PAPER CASSETTE.

RRP2.6 GEAR LEVER LOCK (PL 2.1.25), LEVER BTM LOCK (PL 2.1)

Removal

- 1) Remove the COVER CST (PL 2.1) from the 150 PAPER CASSETTE.
- 2) Release the lock of the LOCK EXTENSION, and pull out the cassette extension as far as it will go.
- 3) While pressing down the lock of the STOPPER GEAR (PL 2.1), release the lock of LEVER BTM LOCK (PL 2.1) to lift up the PLATE ASSEMBLY BTM (PL 2.1) (Figure 1).
- 4) Remove the screw (gold tapping, 8mm) securing the PLATE GEAR LOCK 150 (PL 2.1) at the GEAR PB R (PL 2.1) side (Figure 1).
- 5) Release the hook of the PLATE GEAR LOCK 150, and remove it from the HOUSING BASE 150 (PL 2.1).
- 6) Release the hook of the GEAR PB R, and remove it from the SHAFT PB (PL 2.1).
- 7) Remove the screw (gold tapping, 6mm) securing the COVER BTM UP 150 (PL 2.1), and remove it from the HOUSING BASE 150.
- 8) Remove the GEAR BTM LOCK PINION (PL 2.1) from the HOUSING BASE 150.
- 9) Remove the RACK BTM LOCK 150 (PL 2.1) together with the SPRING BTM LOCK (PL 2.1) from the HOUSING BASE 150.
- 10) Remove the GEAR LEVER LOCK from the HOUSING BASE 150.
- 11) Remove the 2 screws (gold tapping, 6mm) securing the STOPPER GEAR (PL 2.1), and remove the STOPPER GEAR and SPRING STOPPER GEAR (PL 2.1) from the HOUSING BASE 150.

NOTE

When removing the STOPPER GEAR, be careful not to lose the SPRING STOPPER GEAR.

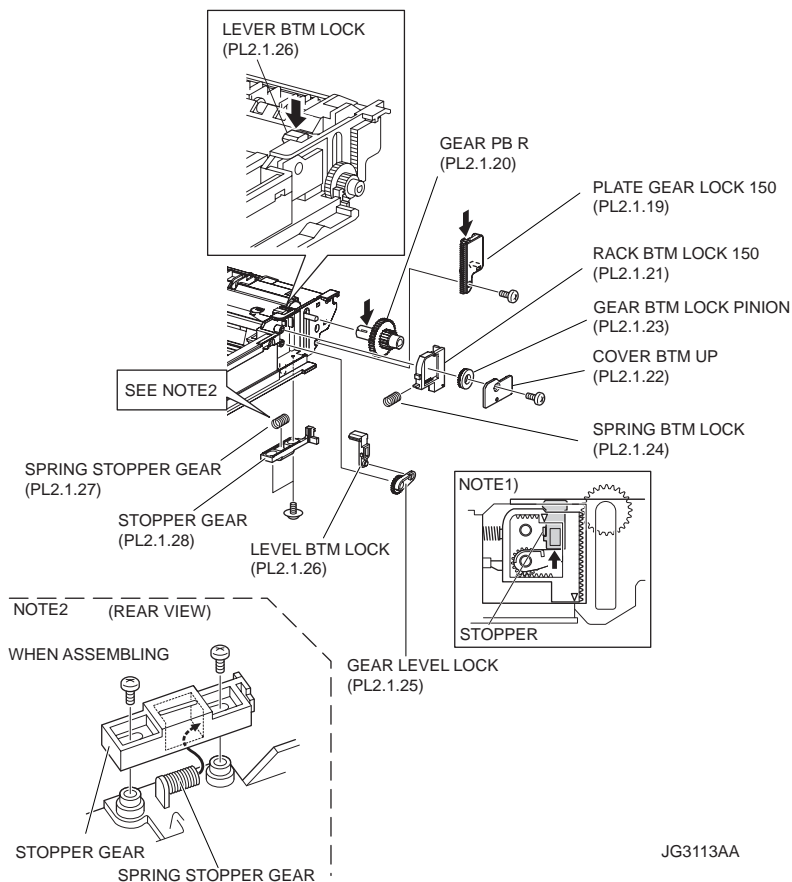

JG3113AA

Figure 1. Gear Lever Lock

Replacement**NOTE**

When installing, be sure to lift up the PLATE ASSEMBLY BTM. If the PLATE ASSEMBLY BTM is inclined, a paper skew or jam may occur. Check after the installation is completed.

- 1) Put the SPRING STOPPER GEAR (PL 2.1) into the STOPPER GEAR (PL 2.1), and secure the STOPPER GEAR to the HOUSING BASE 150 (PL 2.1) using the 2 screws (gold tapping, 6mm).

NOTE

When installing the STOPPER GEAR, be careful not to lose the SPRING STOPPER GEAR.

NOTE

Install the STOPPER GEAR so that one end of the SPRING STOPPER GEAR is in contact with the plate located on the back of the HOUSING BASE 150 as shown (NOTE 2) (Figure 1)

- 2) Install the GEAR LEVER LOCK (PL 2.1.25) to the HOUSING BASE 150.
- 3) Install the SPRING BTM LOCK (PL 2.1) to the projection of the RACK BTM LOCK 150 (PL 2.1), and install them to the HOUSING BASE 150.

NOTE

When installing the RACK BTM LOCK 150, be sure to install it with the LEVER BTM LOCK lifted up. After installing, push down the LEVER BTM LOCK and then release, check that the projection of the LEVER BTM LOCK hits the stopper of the HOUSING BASE 150 and the triangle mark is placed above the stopper.

- 4) Install the GEAR BTM LOCK PINION (PL 2.1) to the HOUSING BASE 150, and engage the gear.
- 5) Secure the COVER BTM UP 150 (PL 2.1) to the HOUSING BASE 150 using the screw (gold tapping, 6mm).
- 6) Install the GEAR PB R (PL 2.1) to the SHAFT PB (PL 2.1), and secure it with the hook.

NOTE

Be sure to install the hook of the GEAR PB R into the groove of the SHAFT PB.

- 7) Install the PLATE GEAR LOCK 150 (PL 2.1) to the HOUSING BASE 150, and secure it with the hook.
- 8) Secure the PLATE GEAR LOCK 150 using the screw (gold tapping, 8mm).
- 9) Push the PLATE ASSEMBLY BTM (PL 2.1) downward to lock.

RRP2.7 HANDLE EXTENSION 150 (PL 2.1)

Removal

- 1) Remove the COVER CST (PL2.1.1) from the 150 PAPER CASSETTE.
- 2) Remove the 2 screws on the back side of the HANDLE EXTENSION 150 (PL 2.1) (Figure 1).
- 3) Release the 5 hooks at the upper side and the 2 hooks at the lower side of the HANDLE EXTENSION 150 (PL 2.1), then, remove the HANDLE EXTENSION 150 (PL 2.1) from the HOUSING EXTENSION 150 (PL 2.1) (Figure 1).

Replacement

- 1) Put the 5 hooks on the upper side and 2 hooks on the lower side of the HANDLE EXTENSION 150 (PL 2.1) to the HOUSING EXTENSION 150 (PL 2.1).
- 2) Secure the HANDLE EXTENSION 150 (PL 2.1) to the HOUSING EXTENSION 150 (PL 2.1) using the 2 screws.
- 3) Install the COVER CST (PL 2.1) to the 150 PAPER CASSETTE.

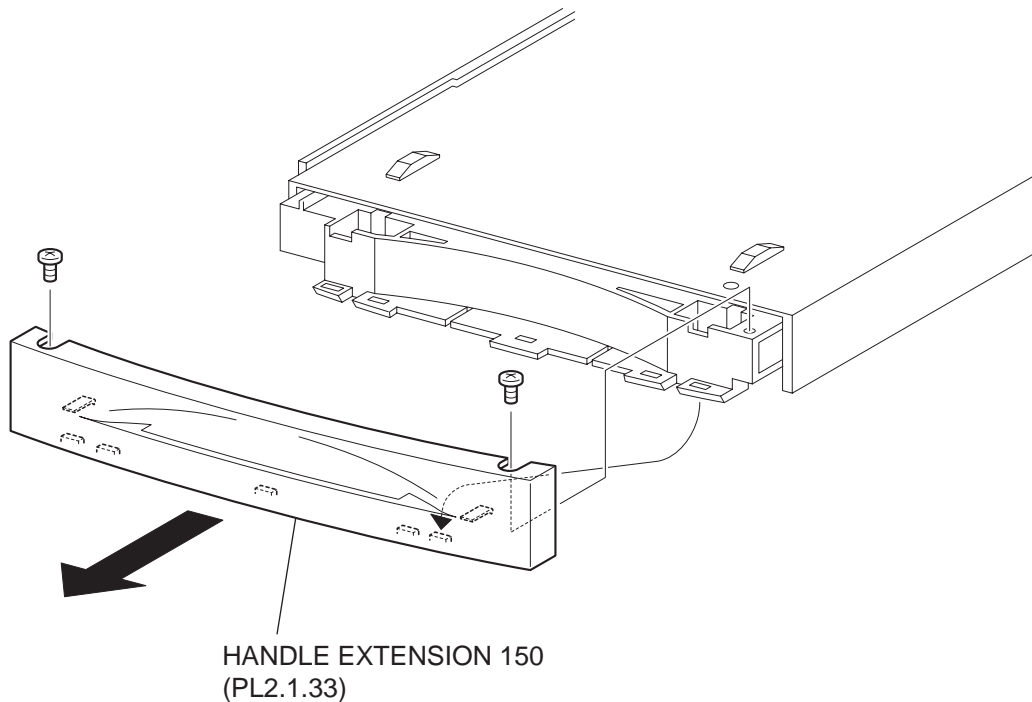

JG3301AA

Figure 1. Handle Extension

RRP3. 550 PAPER CASSETTE

RRP3.1 ROLL ASSEMBLY RETARD (PL 3.1)

Removal

- 1) Pull out the 550 PAPER CASSETTE from the printer.
- 2) Release the hooks securing the HOLDER RETARD (PL 3.1) to the 550 PAPER CASSETTE using a screwdriver (Figure 1).
- 3) Lift up the HOLDER RETARD in the direction of the arrow, and remove it (Figure 1).
- 4) Release the hook securing the ROLL ASSEMBLY RETARD, and pull it out from the SHAFT RETARD (PL 3.1).

NOTE

When removing, do not touch the roller surface of the ROLL ASSEMBLY RETARD.

NOTE

When removing HOLDER RETARD, be careful not to lose SPRING RETARD.

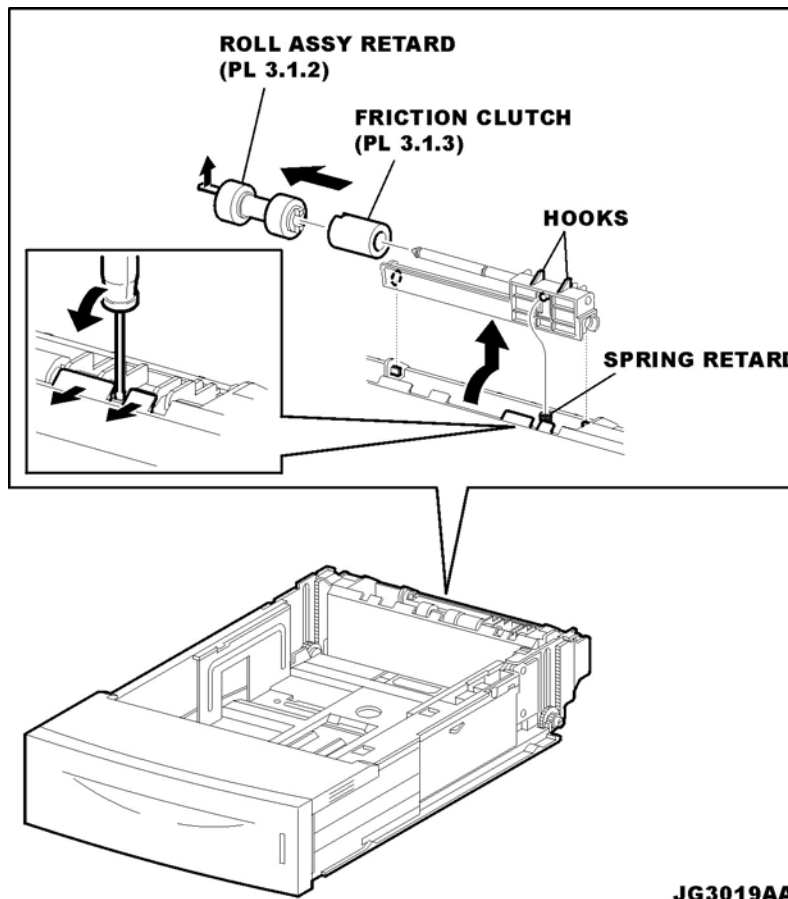

JG3019AA

Figure 1. Retard Roll Assembly

NOTE

It is also possible to remove the ROLL ASSEMBLY RETARD by pushing the HOLDER RETARD down (Figure 2).

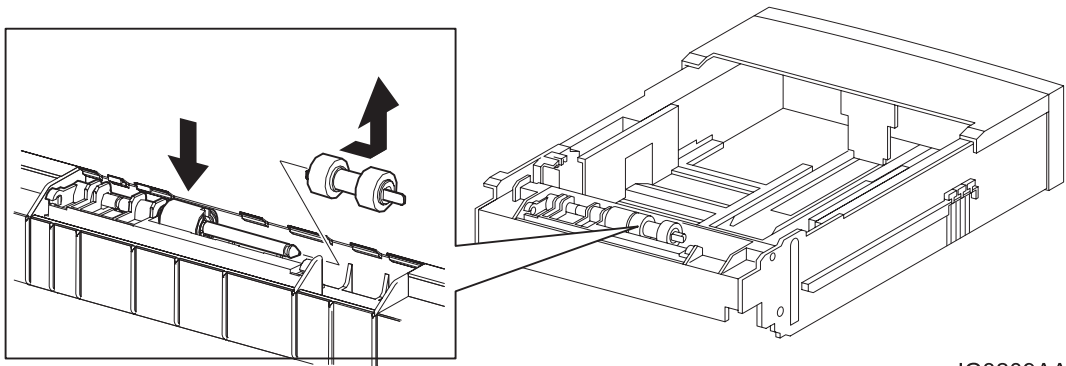

JG3209AA

Figure 2. Holder Retard

Replacement

- 1) Install the ROLL ASSEMBLY RETARD to the SHAFT RETARD (PL 12.3), and secure the ROLL ASSEMBLY RETARD with the hook.

NOTE

When installing, do not touch the roller surface of the ROLL ASSEMBLY RETARD.

NOTE

Be sure to install the hook of the ROLL ASSEMBLY RETARD into the groove of the SHAFT RETARD.

- 2) Move the HOLDER RETARD (PL 3.1) in the opposite direction of the arrow, and install it to the 550 PAPER CASSETTE.

NOTE

After installing, make sure the HOLDER RETARD comes back to the former position with the spring force of the SPRING RETARD (PL 12.3), when pushing down the HOLDER RETARD and then release the finger from it.

- 3) Install the 550 PAPER CASSETTE to the printer.

RRP3.2 RACK SIZE (PL 4.1.40)

Removal

- 1) Remove the COVER CST (PL 12.3) from the 550 PAPER CASSETTE.
- 2) Release the lock of the LOCK EXTENSION, and pull out the cassette extension as far as it will go.
- 3) Release the hooks securing the GEAR PINION (PL 12.3) to the HOUSING TOP 550 (PL 12.3), and remove the GEAR PINION (Figure 1).
- 4) While pressing down the lock of the STOPPER GEAR (PL 12.3), release the lock of the LEVER BTM LOCK (PL 3.1) to lift up the PLATE ASSEMBLY BTM (Figure 1).
- 5) Slide the GUIDE ASSEMBLY SD L550 (PL 12.3) inward, and remove it from the HOUSING TOP 550 by pressing down the hook of the HOUSING TOP 550 (Figure 1).
- 6) Slide the GUIDE ASSEMBLY SD R550 (PL 12.3) inward, and remove it from the HOUSING TOP 550 by pressing down the hook of the HOUSING TOP 550.

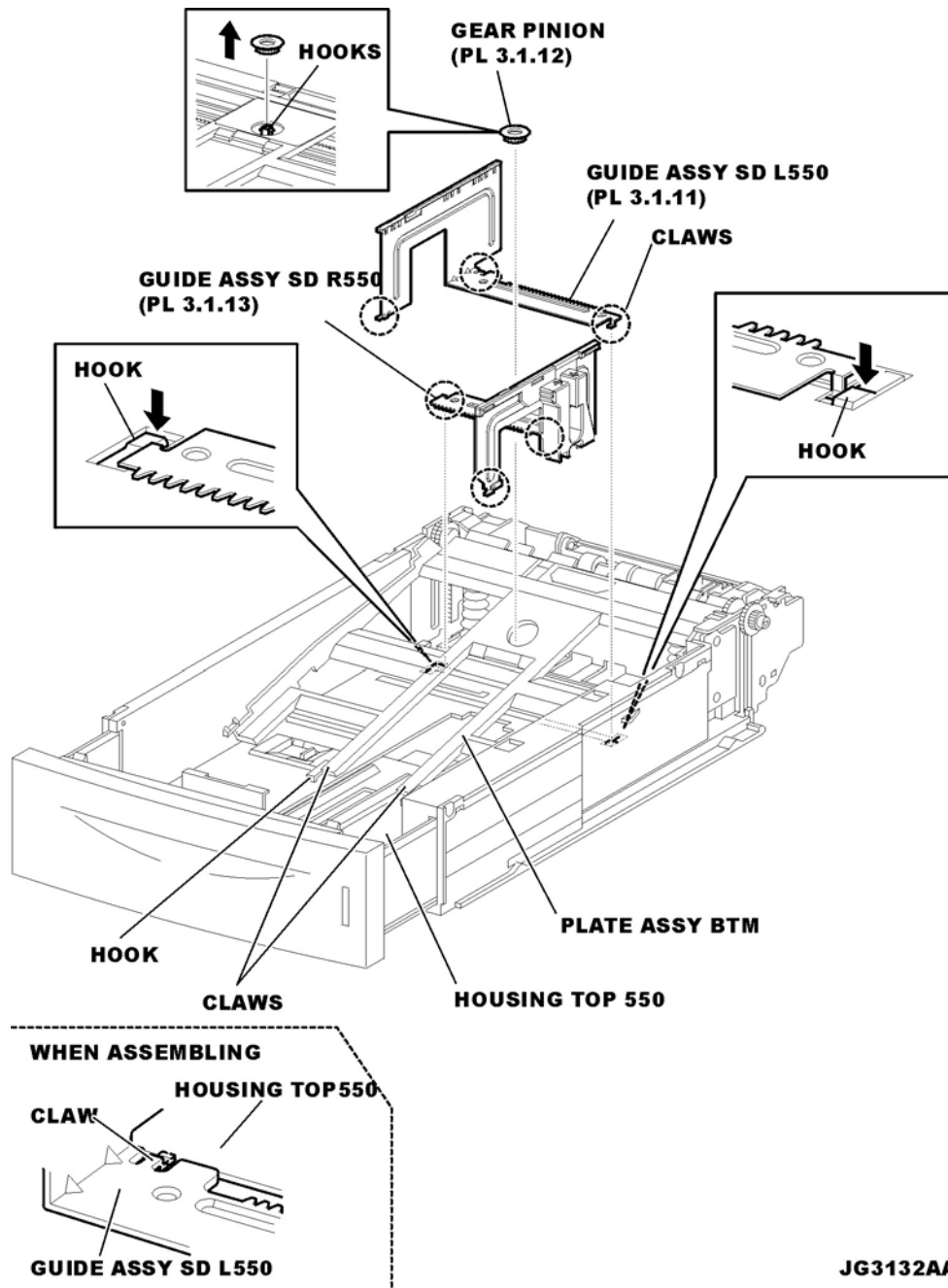

JG3132AA

Figure 1. Rack Size

Removal and Replacement Procedures (RRPs)

- 7) Remove the 2 screws (gold tapping, 8mm) from both right and left sides, as well as the 6 screws (gold tapping, 8mm) on the back (Figure 2), that secure the HOUSING TOP 550 to the HOUSING BASE 550 (PL 3.1).
- 8) Release the 4 hooks of the HOUSING TOP 550, and remove the HOUSING TOP 550 together with the HOUSING EXTENSION 550 (PL 3.1), from the HOUSING BASE 550 (Figure 2).
- 9) Remove the 4 screws (gold tapping, 6mm) securing the COVER EXTENSION (PL 3.1) to the HOUSING EXTENSION 550.
- 10) Remove the COVER EXTENSION from the HOUSING EXTENSION 550.

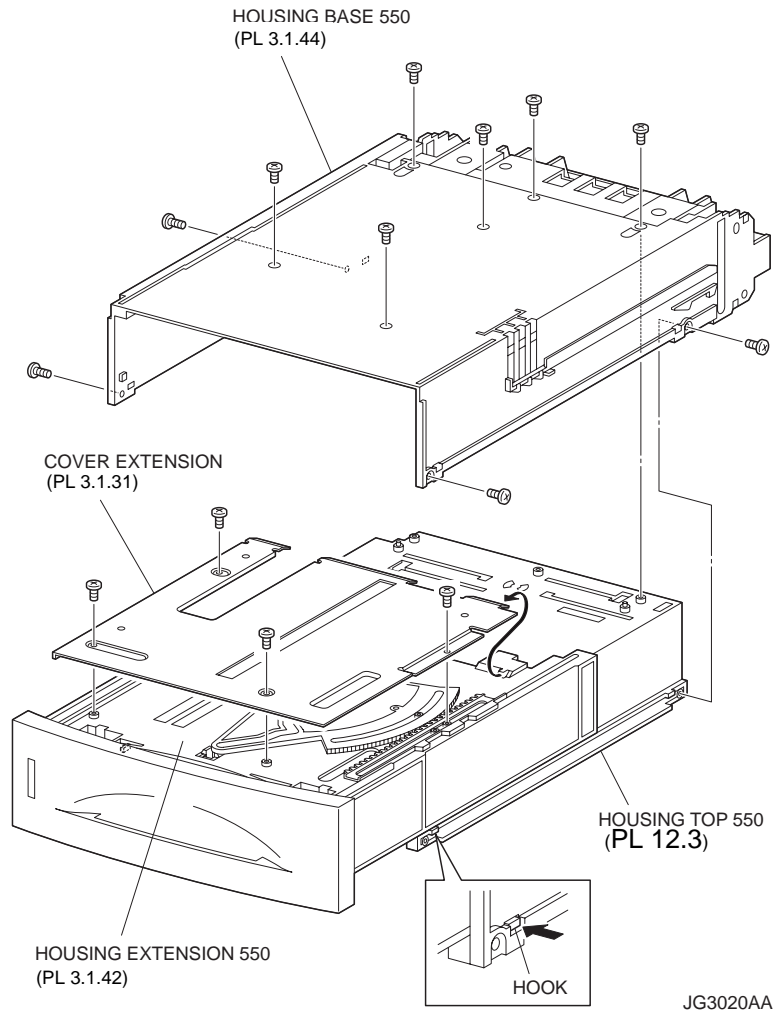

Figure 2. Housing

- 11) Lift the front of the RACK SIZE (PL 3.1) a little, and turn it in the direction of the arrow to remove it from the HOUSING EXTENSION 550 (Figure 3).

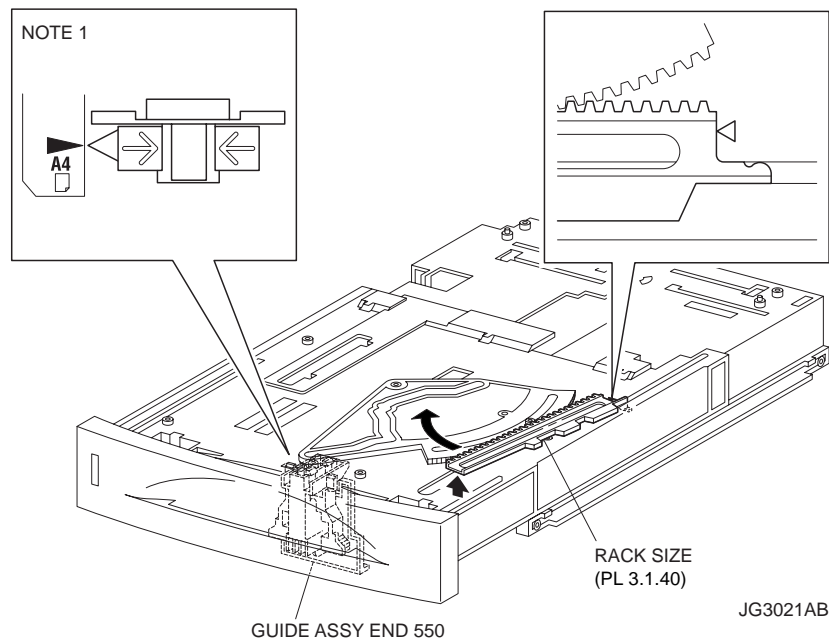
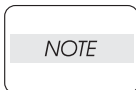

Figure 3. Size Rack

Replacement

- 1) Put the hook on top of the RACK SIZE into the groove of the HOUSING EXTENSION 550 (PL 3.1), and turn it in the opposite direction of the arrow.
- 2) Align the end of the RACK SIZE with the triangle mark printed on the HOUSING EXTENSION 550 (Figure 3), and install the RACK SIZE to the HOUSING EXTENSION 550.



When installing the RACK SIZE, be sure to pull out the GUIDE ASSEMBLY END 550 (PL 3.1) as far as it will go (NOTE 1) (Figure 3).

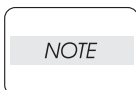

Use 6mm size of fixed screw. If 8mm size of screw is used, HOUSING EXTENSION 550 doesn't operate smoothly and LOCK EXTENSION 550 doesn't operate correctly.

- 3) Install the COVER EXTENSION (PL 3.1) to the HOUSING EXTENSION 550 using the 4 screws (gold tapping, 6mm).

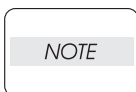

When installing, make sure the COVER EXTENSION is inserted under 3 claws of the HOUSING EXTENSION 550 (NOTE 2) (Figure 2).

- 4) Install the HOUSING EXTENSION 550 and HOUSING TOP 550 (PL 12.3) to the HOUSING BASE 550 while pushing the LINK SW SIZE1-550 (PL 3.1), LINK SW SIZE2-550 (PL 3.1) and LINK SW SIZE3-550 (PL 3.1) of the HOUSING BASE 550 outward (Figure 4).

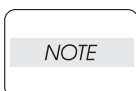

Be sure to put 2 claws that on the top of the PLATE ASSEMBLY BTM under the hooks on the HOUSING TOP 550 (NOTE 3) (Figure 1).

- 5) After assembling the HOUSING TOP 550 to the HOUSING BASE 550 using the 4 hooks, secure them using the 2 screws (gold tapping, 8mm) on both right and left sides, as well as the 6 screws (gold tapping, 8mm) on the back.

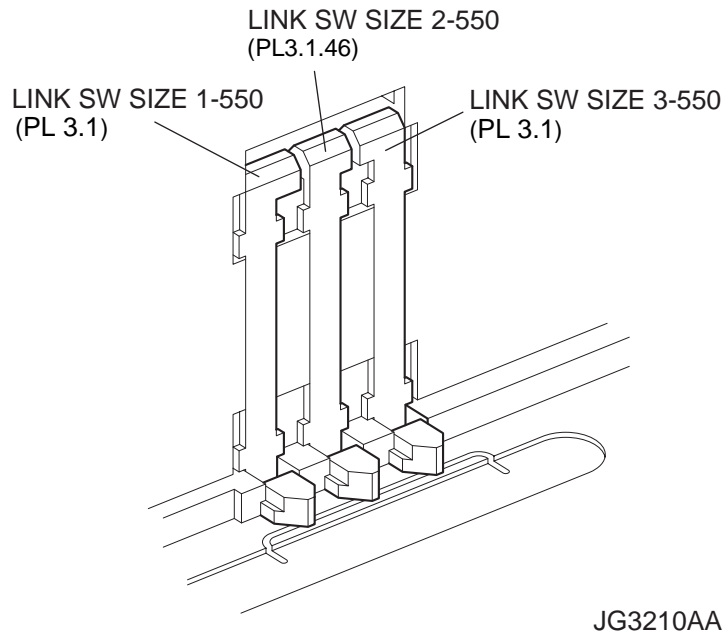

Figure 4. Link Size Switches

NOTE

After tightening the screws, move the GUIDE ASSEMBLY END 550 back and forth, and make sure that the LINK SW SIZES operate smoothly.

- 6) Insert the link lever of the GUIDE INDICATOR 1 (PL 3.1) into the hole of the PLATE ASSEMBLY BTM.
- 7) While pressing down the hook of the HOUSING TOP 550, install the GUIDE ASSEMBLY SD R550 (PL 12.3) to the HOUSING TOP 550.

NOTE

After installing, make sure that the 3 claws of the GUIDE ASSEMBLY SD R550 sit correctly in the grooves of the HOUSING TOP 550 (NOTE4) (Figure 1).

- 8) While pressing down the hook of the HOUSING TOP 550, install the GUIDE ASSEMBLY SD L550 (PL 12.3) to the HOUSING TOP 550.

NOTE

After installing, make sure that the 3 claws of the GUIDE ASSEMBLY SD L550 sit correctly in the grooves of the HOUSING TOP 550 (NOTE4) (Figure 1).

- 9) Push the PLATE ASSEMBLY BTM downward to lock.
- 10) Completely opened GUIDE ASSEMBLY SD L550 (PL 12.3) and GUIDE ASSEMBLY SD R550 (PL 12.3), install the GEAR PINION (PL 12.3) to the HOUSING TOP 550.

NOTE

When installing the GEAR PINION, make sure the GUIDE ASSEMBLY SD R550 and GUIDE ASSEMBLY SD L550 are completely opened. If not, the side register may be misaligned.

- 11) Install the COVER CST (PL 12.3) to the 550 PAPER CASSETTE.

NOTE

After assembling, make sure that the LOW IND FRONT moves up-and-down in conjunction with the up-and-down movement of the PLATE ASSEMBLY BTM.

RRP3.3 GEAR SECTOR (PL 3.1)**Removal**

- 1) Remove the COVER CST (PL 12.3) from the 550 PAPER CASSETTE.
- 2) Release the lock of the LOCK EXTENSION, and pull out the cassette extension as far as it will go.
- 3) Release the hooks securing the GEAR PINION (PL 12.3) to the HOUSING TOP 550 (PL 12.3), and remove the GEAR PINION.
- 4) While pressing down the lock of the STOPPER GEAR (PL 12.3), release the lock of the LEVER BTM LOCK (PL 3.1) to lift up the PLATE ASSEMBLY BTM. (Figure 4.5)
- 5) Slide the GUIDE ASSEMBLY SD L550 (PL 12.3) inward, and remove it from the HOUSING TOP 550 by pressing down the hook of the HOUSING TOP 550.
- 6) Slide the GUIDE ASSEMBLY SD R550 (PL 12.3) inward, and remove it from the HOUSING TOP 550 by pressing down the hook of the HOUSING TOP 550.
- 7) Remove the 2 screws (gold tapping, 8mm) from both right and left sides, as well as the 6 screws (gold tapping, 8mm) on the back, that secure the HOUSING TOP 550 to the HOUSING BASE 550 (PL 3.1).
- 8) Release the 4 hooks of the HOUSING TOP 550, and remove the HOUSING TOP 550 together with the HOUSING EXTENSION 550 (PL 3.1) from the HOUSING BASE 550.
- 9) Remove the 4 screws (gold tapping, 6mm) securing the COVER EXTENSION (PL 3.1) to the HOUSING EXTENSION 550.
- 10) Remove the COVER EXTENSION from the HOUSING EXTENSION 550.
- 11) Remove the RACK SIZE (PL 3.1) (RRP3.2)
- 12) Remove the screw (black with flange, 8mm) securing the GEAR SECTOR.
- 13) Remove the GEAR SECTOR from the HOUSING EXTENSION 550 (PL 3.1).

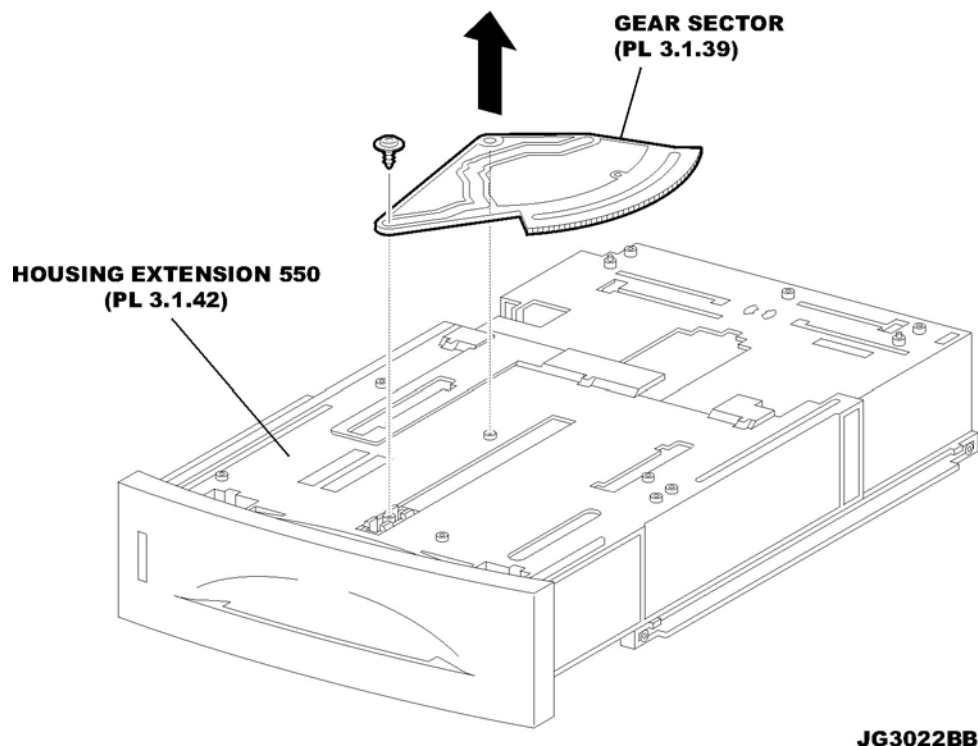
**Figure 1. Gear Sector**

Replacement

- 1) Install the GEAR SECTOR to the HOUSING EXTENSION 550 (PL 3.1).
- 2) Secure the GEAR SECTOR using the screw (black with flange, 8mm).
- 3) Install the RACK SIZE (PL 3.1) (RRP3.2).
- 4) Install the COVER EXTENSION (PL 3.1) to the HOUSING EXTENSION 550 using the 4 screws (gold tapping, 6mm).

NOTE

When installing, make sure the COVER EXTENSION is inserted under 3 claws of the HOUSING EXTENSION 550.

- 5) Install the HOUSING EXTENSION 550 and HOUSING TOP 550 (PL 12.3) on the HOUSING BASE 550 while pushing the LINK SW SIZE1-550 (PL 3.1), LINK SW SIZE2-550 (PL 3.1) and LINK SW SIZE3-550 (PL 3.1) of the HOUSING BASE 550 outward as shown in figure 4 of procedure (RRP3.2).

NOTE

Be sure to put 2 claws on the top of the PLATE ASSEMBLY BTM under the hooks on the HOUSING TOP 550.

NOTE

Use 6mm size of fixed screw. If 8mm size of screw is used, HOUSING EXTENSION 550 doesn't operate smoothly and LOCK EXTENSION 550 doesn't operate correctly.

- 6) After assembling the HOUSING TOP 550 to the HOUSING BASE 550 using the 4 hooks, secure them using the 2 screws (gold tapping, 8mm) on both right and left sides, as well as the 6 screws (gold tapping, 8mm) on the back.

NOTE

After tightening the screws, move the GUIDE ASSEMBLY END 550 back and forth, and make sure that the LINK SW SIZES operate smoothly.

- 7) Insert the link lever of the GUIDE INDICATOR 1 (PL 3.1) into the hole of the PLATE ASSEMBLY BTM (Figure 2).

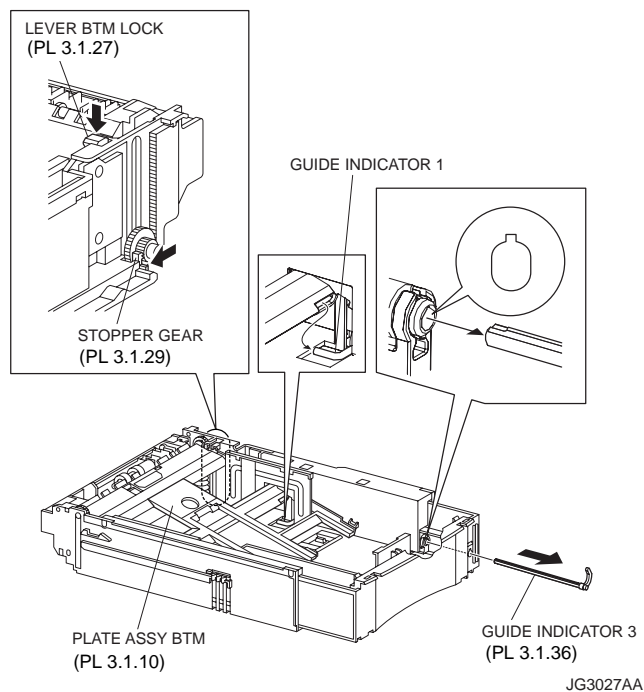
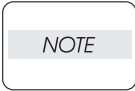

Figure 2 Guide Indicator

- 8) While pressing down the hook of the HOUSING TOP 550, install the GUIDE ASSEMBLY SD R550 (PL 12.3) to the HOUSING TOP 550.



After installing, make sure that the 3 claws of the GUIDE ASSEMBLY SD R550 sit correctly in the grooves of the HOUSING TOP 550.

- 9) While pressing down the hook of the HOUSING TOP 550, install the GUIDE ASSEMBLY SD L550 (PL 12.3) to the HOUSING TOP 550.

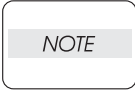

After installing, make sure that the 3 claws of the GUIDE ASSEMBLY SD L550 sit correctly in the grooves of the HOUSING TOP 550.

- 10) Push the PLATE ASSEMBLY BTM downward to lock.

- 11) Completely opened GUIDE ASSEMBLY SD L550 (PL 12.3) and GUIDE ASSEMBLY SD R550 (PL 12.3), install the GEAR PINION (PL 12.3) to the HOUSING TOP 550.

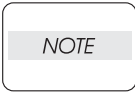

When installing the GEAR PINION, make sure the GUIDE ASSEMBLY SD R550 and GUIDE ASSEMBLY SD L550 are completely opened. If not, the side register may be misaligned.

- 12) Install the COVER CST (PL 12.3) to the 550 PAPER CASSETTE.

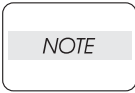

After assembling, make sure that the LOW IND FRONT moves up-and-down in conjunction with the up-and-down movement of the PLATE ASSEMBLY BTM.

RRP3.4 GUIDE ASSEMBLY END 550 (PL 3.1)**Removal**

- 1) Remove the COVER CST (PL 12.3) from the 550 PAPER CASSETTE.
- 2) Release the lock of the LOCK EXTENSION, and pull out the cassette extension as far as it will go.
- 3) Release the hooks securing the GEAR PINION (PL 12.3) to the HOUSING TOP 550 (PL 12.3), and remove the GEAR PINION.
- 4) While pressing down the lock of the STOPPER GEAR (PL 12.3), release the lock of the LEVER BTM LOCK (PL 3.1) to lift up the PLATE ASSEMBLY BTM (Figure 1).

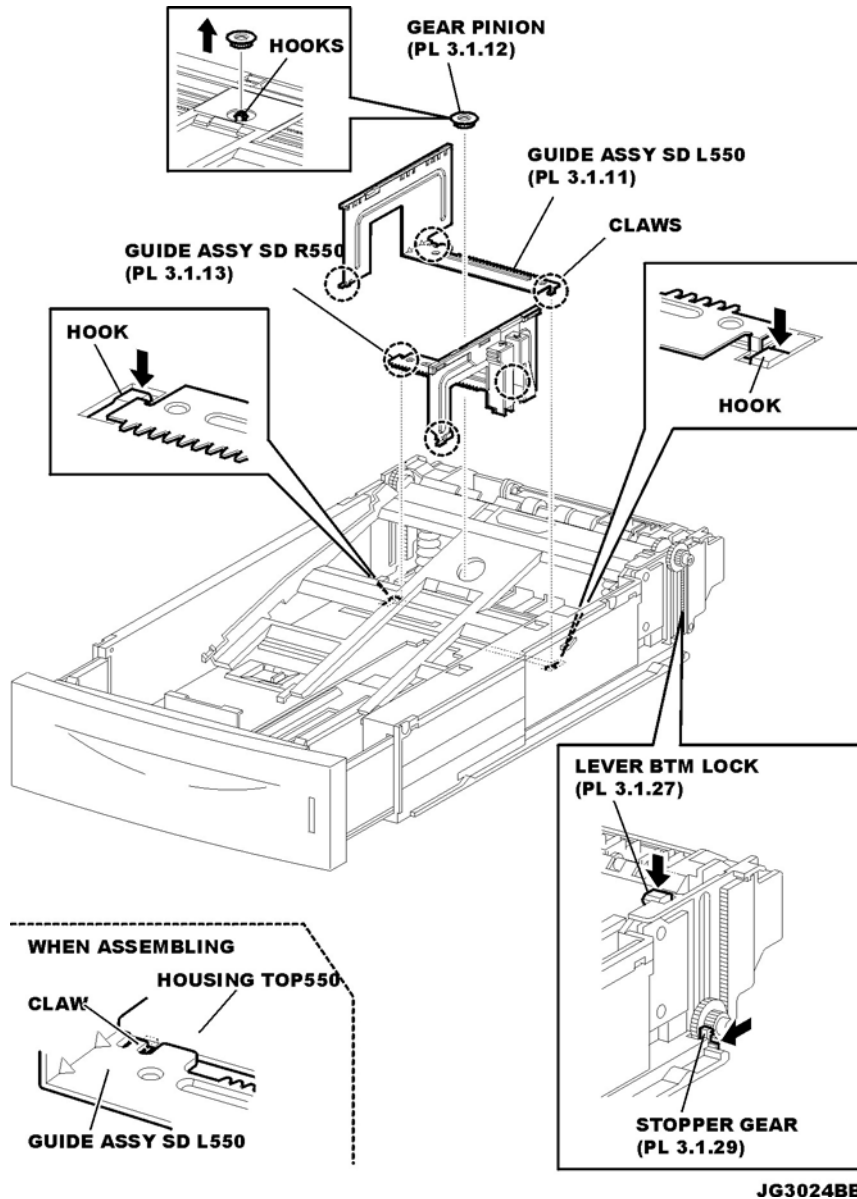
**Figure 1. Plate Assembly BTM**

- 5) Slide the GUIDE ASSEMBLY SD L550 (PL 12.3) inward, and remove it from the HOUSING TOP 550 by pressing down the hook of the HOUSING TOP 550.
- 6) Slide the GUIDE ASSEMBLY SD R550 (PL 12.3) inward, and remove it from the HOUSING TOP 550 by pressing down the hook of the HOUSING TOP 550.
- 7) Remove the 2 screws (gold tapping, 8mm) from both right and left sides, as well as the 6 screws (gold tapping, 8mm) on the back, that secure the HOUSING TOP 550 to the HOUSING BASE 550 (PL 3.1).

- 8) Release the 4 hooks of the HOUSING TOP 550, and remove the HOUSING TOP 550 together with the HOUSING EXTENSION 550 (PL 3.1) from the HOUSING BASE 550.
- 9) Remove the 4 screws (gold tapping, 6mm) securing the COVER EXTENSION (PL 3.1) to the HOUSING EXTENSION 550.
- 10) Remove the COVER EXTENSION from the HOUSING EXTENSION 550.
- 11) Remove the RACK SIZE (PL 3.1) (RRP3.2)
- 12) Remove the GEAR SECTOR (PL 3.1) (RRP3.3).
- 13) Release the hooks securing the GUIDE ASSEMBLY END 550 to the HOUSING EXTENSION 550 (PL 3.1) (Figure 2).

NOTE

Be careful handling the hooks of the GUIDE ASSEMBLY END 550. They are fragile and could break if given excessive force.

- 14) Remove the GUIDE ASSEMBLY END 550 from the HOUSING EXTENSION 550.

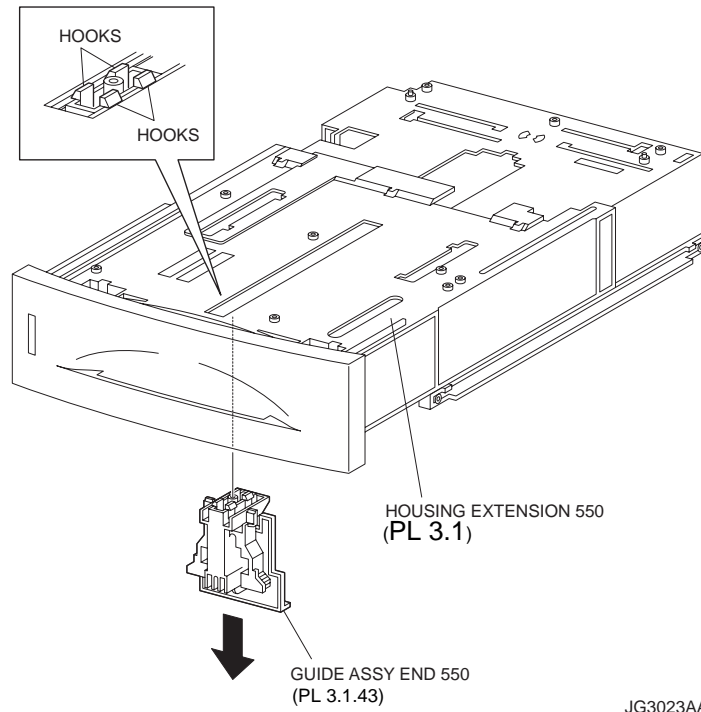

Figure 2. Guide Assembly End 550

Replacement

- 1) Secure the GUIDE ASSEMBLY END 550 to the HOUSING EXTENSION 550 (PL 3.1) using the 4 hooks.
- 2) Install the GEAR SECTOR (PL 3.1) (RRP3.3)
- 3) Install the RACK SIZE (PL 3.1) (RRP3.2)
- 4) Install the COVER EXTENSION (PL 3.1) to the HOUSING EXTENSION 550 using the four screws (gold tapping, 6mm).

NOTE

When installing, make sure the COVER EXTENSION is inserted under 3 claws of the HOUSING EXTENSION 550.

NOTE

Use 6mm size of fixed screw. If 8mm size of screw is used, HOUSING EXTENSION 550 doesn't operate smoothly and LOCK EXTENSION 550 doesn't operate correctly.

- 5) Install the HOUSING EXTENSION 550 and HOUSING TOP 550 (PL 12.3) to the HOUSING BASE 550 while pushing the LINK SW SIZE1-550 (PL 3.1), LINK SW SIZE2-550 (PL 3.1) and LINK SW SIZE3-550 (PL 3.1) of the HOUSING BASE 550 outward (RRP3.2).

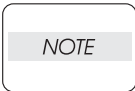

Be sure to put 2 claws on the top of the PLATE ASSEMBLY BTM under the hooks on the HOUSING TOP 550.

- 6) After assembling the HOUSING TOP 550 to the HOUSING BASE 550 using the four hooks, secure them using the two screws (gold tapping, 8mm) on both right and left sides, as well as the six screws (gold tapping, 8mm) on the back.

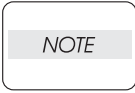

After tightening the screws, move the GUIDE ASSEMBLY END 550 back and forth, and make sure that the LINK SW SIZEs operate smoothly.

- 7) Insert the link lever of the GUIDE INDICATOR 1 (PL 3.1) into the hole of the PLATE ASSEMBLY BTM.
- 8) While pressing down the hook of the HOUSING TOP 550, install the GUIDE ASSEMBLY SD R550 (PL 12.3) to the HOUSING TOP 550.

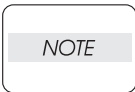

After installing, make sure that the 3 claws of the GUIDE ASSEMBLY SD R550 sit correctly in the grooves of the HOUSING TOP 550.

- 9) While pressing down the hook of the HOUSING TOP 550, install the GUIDE ASSEMBLY SD L550 (PL 12.3) to the HOUSING TOP 550.

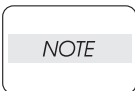

After installing, make sure that the 3 claws of the GUIDE ASSEMBLY SD L550 sit correctly in the grooves of the HOUSING TOP 550.

- 10) Push the PLATE ASSEMBLY BTM downward to lock.
- 11) Completely opened GUIDE ASSEMBLY SD L550 (PL 12.3) and GUIDE ASSEMBLY SD R550 (PL 12.3), install the GEAR PINION (PL 12.3) to the HOUSING TOP 550.

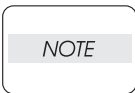

When installing the GEAR PINION, make sure the GUIDE ASSEMBLY SD R550 and GUIDE ASSEMBLY SD L550 are completely opened. If not, the side register may be misaligned.

- 12) Install the COVER CST (PL 12.3) to the 550 PAPER CASSETTE.

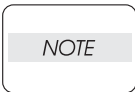

After assembling, make sure that the LOW IND FRONT moves up-and-down in conjunction with the up-and-down movement of the PLATE ASSEMBLY BTM.

RRP3.5 PLATE ASSEMBLY BTM

Removal

- 1) Remove the COVER CST (PL 12.3) from the 550 PAPER CASSETTE.
- 2) Release the lock of the LOCK EXTENSION, and pull out the cassette extension as far as it will go.
- 3) Release the hooks securing the GEAR PINION (PL 12.3) to the HOUSING TOP 550 (PL 12.3), and remove the GEAR PINION (Figure 1).
- 4) While pressing down the lock of the STOPPER GEAR (PL 12.3), release the lock of the LEVER BTM LOCK (PL 3.1) to lift up the PLATE ASSEMBLY BTM (Figure 1).
- 5) Slide the GUIDE ASSEMBLY SD L550 (PL 12.3) inward, and remove it from the HOUSING TOP 550 by pressing down the hook of the HOUSING TOP 550.
- 6) Slide the GUIDE ASSEMBLY SD R550 (PL 12.3) inward, and remove it from the HOUSING TOP 550 by pressing down the hook of the HOUSING TOP 550

NOTE

In the following steps, the GEAR PB L (PL 3.1), GEAR BTM DMP ONEWAY (PL 3.1) and GEAR BTM LOCK ONEWAY (PL 3.1) will be detached (Figure 2). Be careful not to lose these gears.

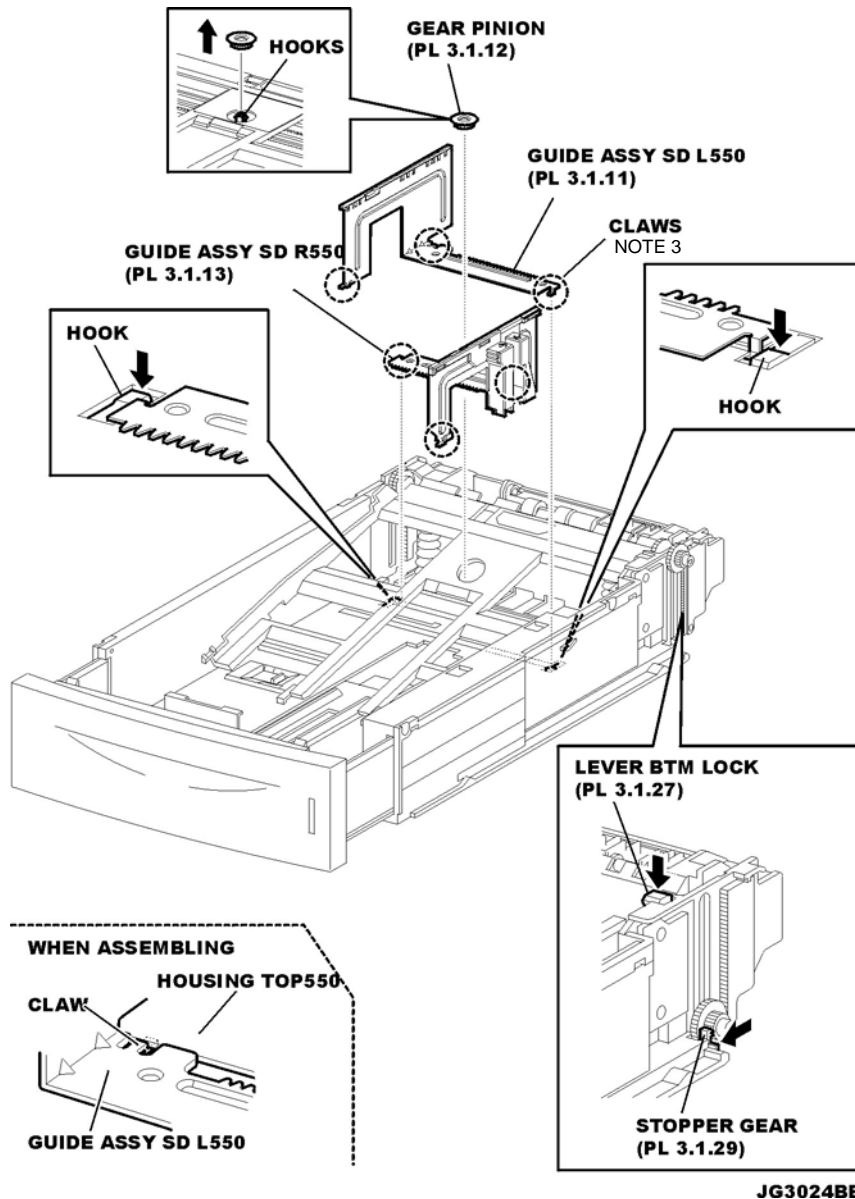

Figure 1. Plate Assembly BTM

- 7) Release the hook of the GEAR PB R (PL 3.1), and remove the GEAR PB R from the SHAFT PB (PL 3.1) (Figure 2).

NOTE

It is hard to remove GEAR PB R. When removing it, be careful not to break it (Figure 2).

- 8) Disengage the GEAR PB L from the PLATE GEAR LOCK 550 while bending the HOUSING BASE 550 in the direction of the arrows. Remove the PLATE ASSEMBLY BTM together with the SHAFT PB, GEAR PB L, GEAR BTM DMP ONEWAY, and GEAR BTM LOCK ONEWAY from the HOUSING TOP 550.
- 9) Pull out the SHAFT PB from the PLATE ASSEMBLY BTM, and remove the GEAR PB L, GEAR BTM DMP ONEWAY and GEAR BTM LOCK ONEWAY.

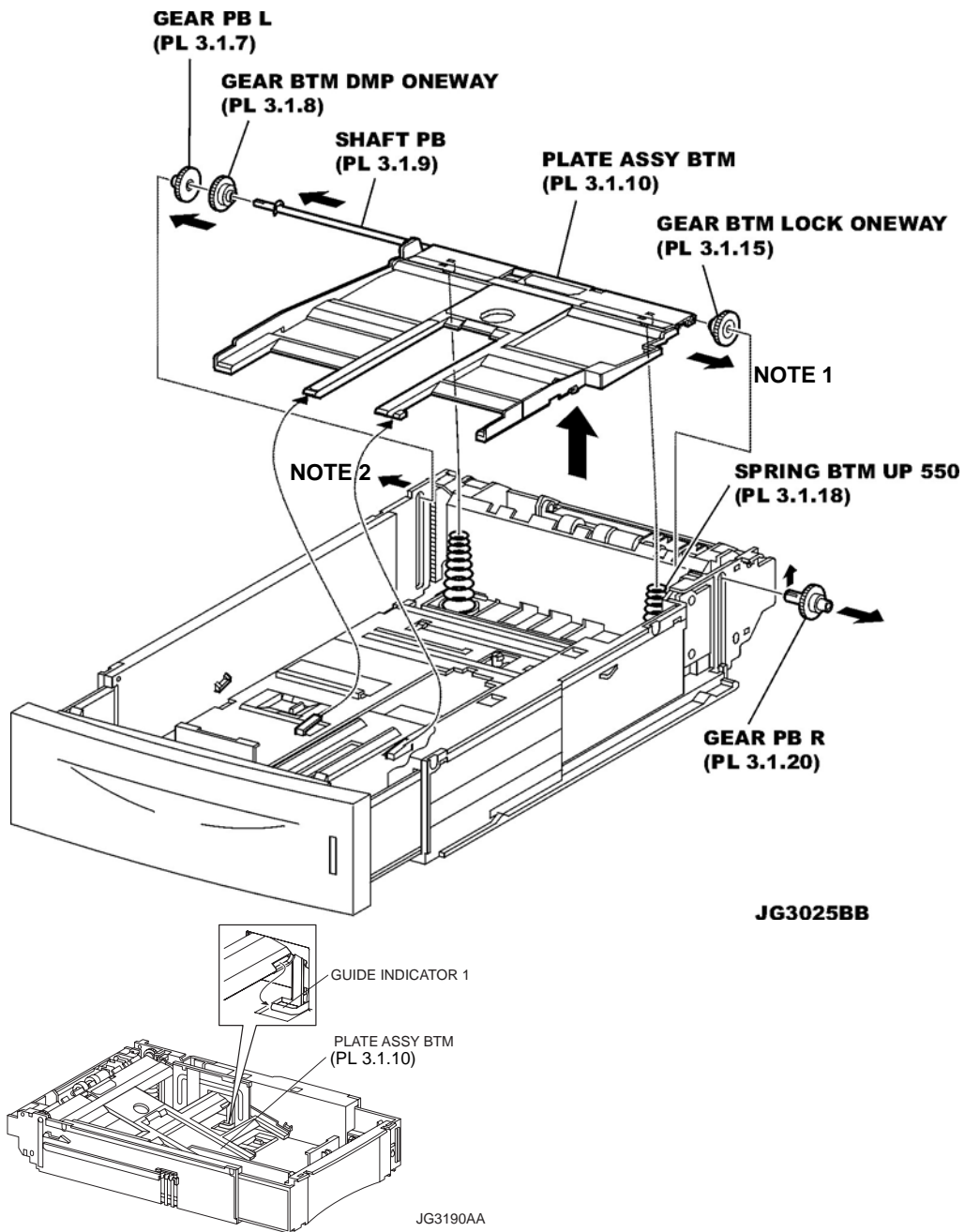

Figure 2 Tray Plate Assembly

Replacement

- 1) Insert the SHAFT PB (PL 3.1) into the PLATE ASSEMBLY BTM, and insert the GEAR BTM DMP ONEWAY, GEAR PB L and GEAR BTM LOCK ONEWAY to the SHAFT PB.
- 2) While disengaging the GEAR PB L, install the assembled PLATE ASSEMBLY BTM to the HOUSING TOP 550 (PL 12.3).

NOTE

When installing the PLATE ASSEMBLY BTM, be sure to put 2 SPRING BTM UP 550s (PL 3.1.18) into the bosses on the back of the PLATE ASSEMBLY BTM (NOTE 1) (Figure 2).

NOTE

Be sure to put 2 claws on the top of the PLATE ASSEMBLY BTM under the hooks on the HOUSING TOP 550.(NOTE 2) (Figure 2).

- 3) Insert the link lever of the GUIDE INDICATOR 1 (PL 3.1) (Figure 2) into the hole of the PLATE ASSEMBLY BTM (Figure 3).

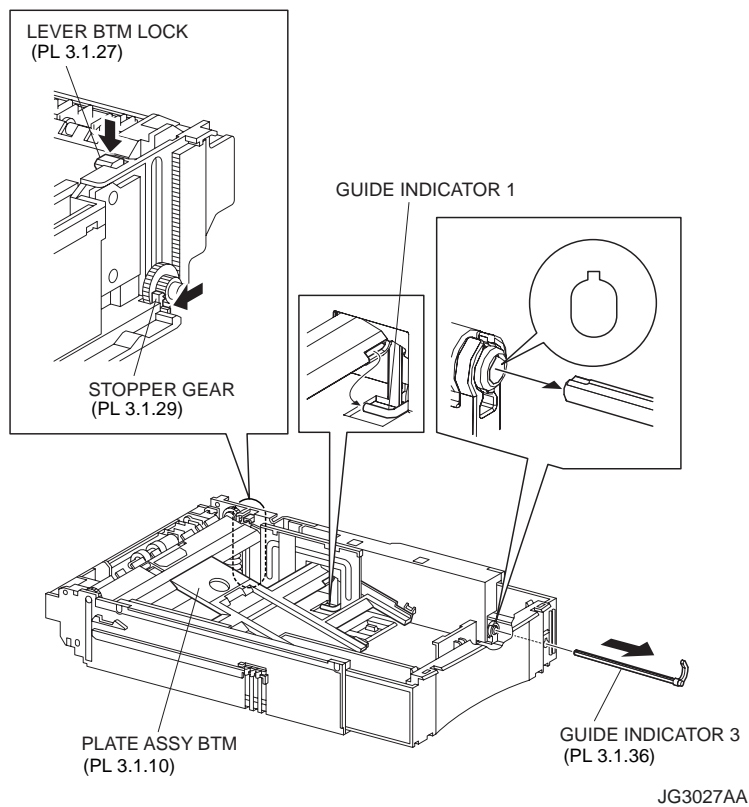

Figure 3. Guide Indicator 3

- 4) Install the GEAR PB R (PL4.1.20) to the SHAFT PB (PL4.1.9), and secure it with the hook.

NOTE

Be sure to install the hook of the GEAR PB R into the groove of the SHAFT PB.

NOTE

When installing the PLATE GEAR LOCK 550, be sure to lift up the PLATE ASSEMBLY BTM. If the PLATE ASSEMBLY BTM is inclined, a paper skew or jam may occur. Check after the installation is completed.

- 5) While pressing down the hook of the HOUSING TOP 550, install the GUIDE ASSEMBLY SD R550 (PL 12.3) to the HOUSING TOP 550.

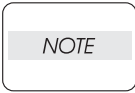

After installing, make sure that the 3 claws of the GUIDE ASSEMBLY SD R550 sit correctly in the grooves of the HOUSING TOP 550 (NOTE 3) (Figure 1).

- 6) While pressing down the hook of the HOUSING TOP 550, install the GUIDE ASSEMBLY SD L550 (PL 12.3) to the HOUSING TOP 550.

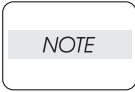

After installing, make sure that the 3 claws of the GUIDE ASSEMBLY SD L550 sit correctly in the grooves of the HOUSING TOP 550.

- 7) Push the PLATE ASSEMBLY BTM downward to lock.
- 8) Install the GEAR PINION (PL 12.3) to the HOUSING TOP 550.

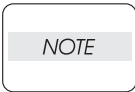

When installing the GEAR PINION, make sure the GUIDE ASSEMBLY SD R550 and GUIDE ASSEMBLY SD L550 are completely opened. If not, the side register may be misaligned.

- 9) Install the COVER CST (PL 12.3) to the 550 PAPER CASSETTE.

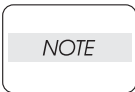

After assembling, make sure that the LOW IND FRONT moves up-and-down in conjunction with the up-and-down movement of the PLATE ASSEMBLY BTM.

RRP3.6 GEAR LEVER LOCK (PL 3.1.26), LEVER BTM LOCK (PL 3.1)**Removal**

- 1) Remove the COVER CST (PL 12.3) from the 550 PAPER CASSETTE.
- 2) Release the lock of the LOCK EXTENSION, and pull out the cassette extension as far as it will go.
- 3) While pressing down the lock of the STOPPER GEAR (PL 12.3), release the lock of LEVER BTM LOCK (PL 3.1) to lift up the PLATE ASSEMBLY BTM (PL 3.1).
- 4) Remove the screw (gold tapping, 8mm) securing the PLATE GEAR LOCK 550 (PL 3.1) at the GEAR PB R (PL 3.1) side.
- 5) Release the hook of the PLATE GEAR LOCK 550, and remove it from the HOUSING BASE 550 (PL 3.1).
- 6) Release the hook of the GEAR PB R, and remove the GEAR PB R from the SHAFT PB (PL 3.1).
- 7) Remove the 2 screws (gold tapping, 6mm) securing the COVER BTM UP 550 (PL 3.1), and remove it from the HOUSING BASE 550.
- 8) Remove 2 GEAR LOCK PINIONS (PL 3.1) from the HOUSING BASE 550 (Figure 1).
- 9) Remove the RACK BTM LOCK 550 (PL 3.1) together with the SPRING BTM LOCK (PL 3.1) from the HOUSING BASE 550 (Figure 1).

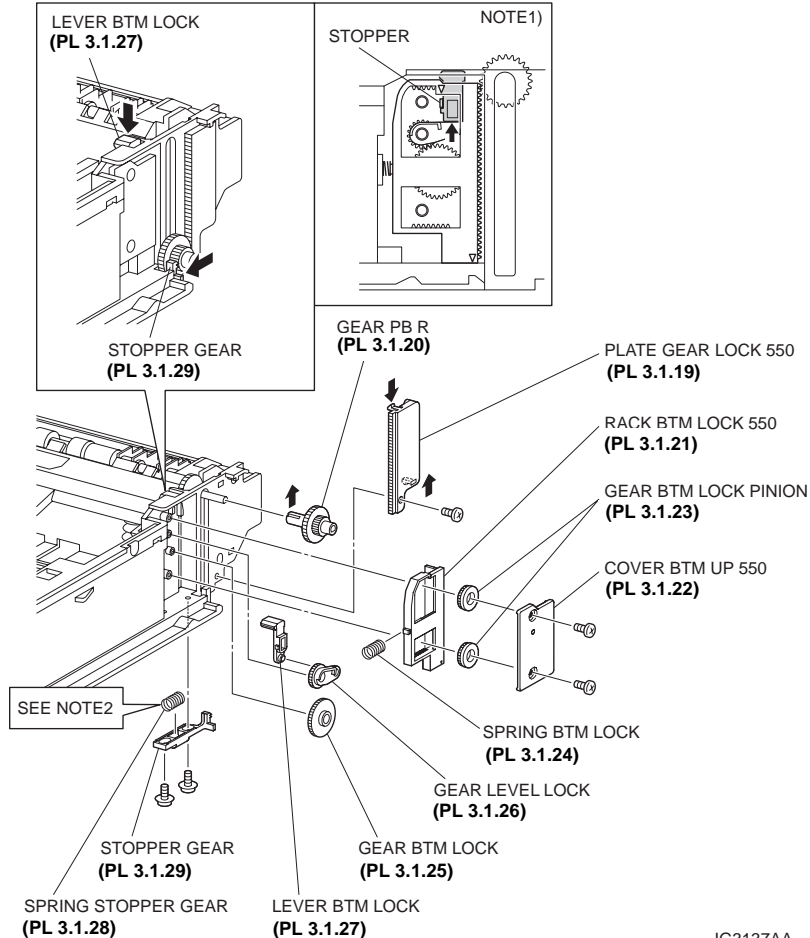
**Figure 1. Gear Lever & Lever BTM Lock**

- 10) Remove the GEAR BTM LOCK (PL 3.1) from the HOUSING BASE 550.
- 11) Remove the GEAR LEVER LOCK from the HOUSING BASE 550.
- 12) Remove the 2 screws (gold tapping, 6mm) securing the STOPPER GEAR (PL 12.3), and remove the STOPPER GEAR and SPRING STOPPER GEAR (PL 3.1) from the HOUSING BASE 550.

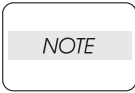

When removing the STOPPER GEAR, be careful not to lose the SPRING STOPPER GEAR.

Replacement

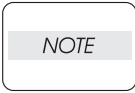

When installing, be sure to lift up the PLATE ASSEMBLY BTM. If the PLATE ASSEMBLY BTM is inclined, a paper skew or jam may occur. Check after the installation is completed.

- 1) Put the SPRING STOPPER GEAR (PL 3.1) into the STOPPER GEAR (PL 12.3), and secure the STOPPER GEAR to the HOUSING BASE 550 (PL 3.1) using the 2 screws (gold tapping, 6mm).

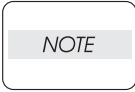

When installing the STOPPER GEAR, be careful not to lose the SPRING STOPPER GEAR.

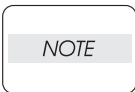

Install the STOPPER GEAR so that one end of the SPRING STOPPER GEAR is in contact with the plate located on the back of the HOUSING BASE 550 as shown in NOTE 2 (Figure 2).

- 2) Install the GEAR LEVER LOCK to the HOUSING BASE 550.
- 3) Install the GEAR BTM LOCK (PL 3.1) to the HOUSING BASE 550.
- 4) Install the SPRING BTM LOCK (PL 3.1) to the projection of the RACK BTM LOCK 550 (PL 3.1), and install them to the HOUSING BASE 550.

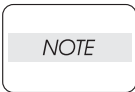

When installing the RACK BTM LOCK 550, be sure to install it with the LEVER BTM LOCK lifted up. After installing, push down the LEVER BTM LOCK and then release the finger from it, check that the projection of the LEVER BTM LOCK is hit the stopper of the HOUSING BASE 550 and the triangle mark is placed above the stopper.

- 5) Install 2 GEAR LOCK PINIONS (PL 3.1) to the HOUSING BASE 550, and engage the gear.

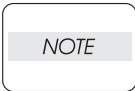

Install the lower GEAR BTM PINION after installing the upper GEAR BTM LOCK PINION. When installing the lower GEAR BTM PINION, press RACK BTM LOCK 550 in the direction of arrow until it bumps into the edge (NOTE 1) (Figure 1).

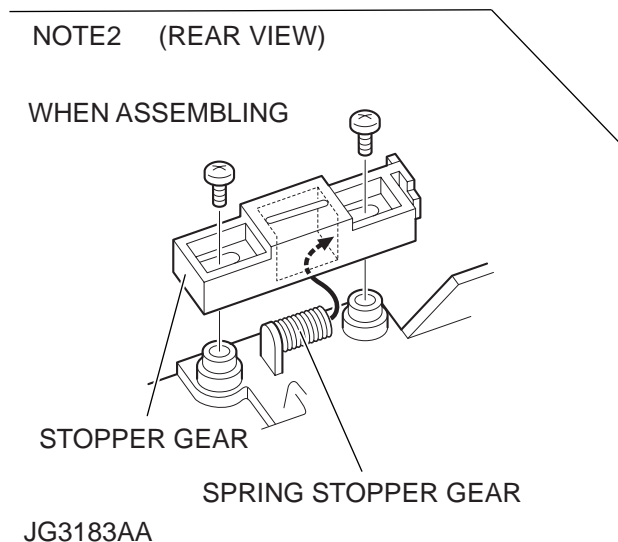

Figure 2. Stopper Gear

- 6) Secure the COVER BTM UP 550 (PL 3.1) to the HOUSING BASE 550 using the screw (gold tapping, 6mm).
- 7) Install the GEAR PB R (PL 3.1) to the SHAFT PB (PL 3.1), and secure it with the hook.

NOTE

Be sure to install the hook of the GEAR PB R into the groove of the SHAFT PB.

- 8) Install the PLATE GEAR LOCK 550 (PL 3.1) to the HOUSING BASE 550, and secure it with the hook.
- 9) Secure the PLATE GEAR LOCK 550 using the screw (gold tapping, 8mm).
- 10) Push the PLATE ASSEMBLY BTM (PL 3.1) downward to lock.

NOTE

Confirm that there is no space between RACK BTM LOCK 550 and HOUSING BASE 550 when pressing the center of RACK BTM LOCK 550 against HOUSING BASE 550 (Figure 3).

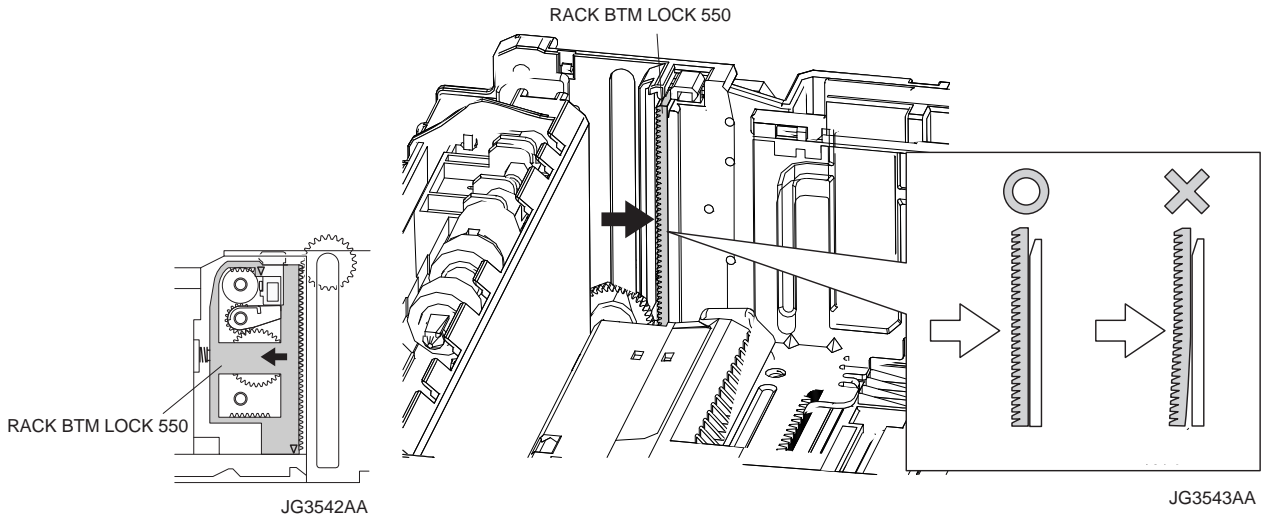
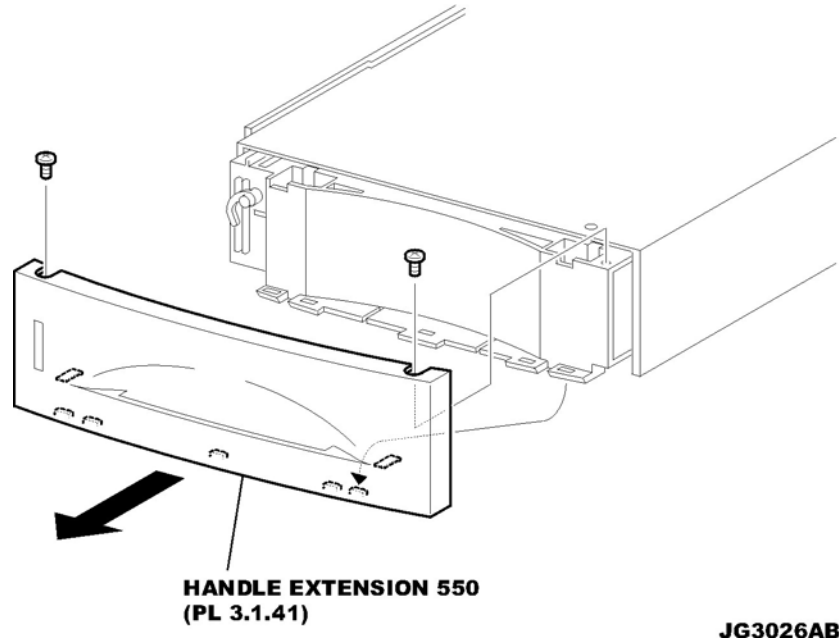
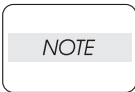

Figure 3. Rack BTM Lock 550

RRP3.7 HANDLE EXTENSION 550 (PL 3.1)**Removal**

- 1) Remove the COVER CST (PL 12.3) from the 550 PAPER CASSETTE.
- 2) Remove the 2 screws on the back side of the HANDLE EXTENSION 550.
- 3) Release the 5 hooks at the upper side and 2 hooks at the lower side of the HANDLE EXTENSION 550, then, remove the HANDLE EXTENSION 550 from the HOUSING EXTENSION 550 (PL 3.1) (Figure 1).

**Figure 1. Handle Extension**

When removing the HANDLE EXTENSION 550, the LOW INDICATOR (PL 3.1) and LOW IND FRONT (PL 3.1) will be detached. Be careful not to lose them.

Replacement

- 1) Install the LOW INDICATOR (PL 3.1) and LOW IND FRONT (PL 3.1) (RRP3.10)
- 2) Put the 5 hooks on the top portion and 2 hooks on the lower side of the HANDLE EXTENSION 550 to the HOUSING EXTENSION 550 (PL 3.1).
- 3) Secure the HANDLE EXTENSION 550 (PL 3.1) to the HOUSING EXTENSION 550 using the 2 screws (Figure 1).
- 4) Install the COVER CST (PL 12.3) to the 550 PAPER CASSETTE.

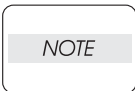

After assembling, make sure that the LOW IND FRONT moves up-and-down in conjunction with the up-and-down movement of the PLATE ASSEMBLY BTM.

RRP3.8 GUIDE INDICATOR 3 (PL 3.1.36)**Removal**

- 1) Remove the COVER CST (PL 12.3) from the 550 PAPER CASSETTE.
- 2) Remove the HANDLE EXTENSION 550 (PL 3.1) (RRP3.7).

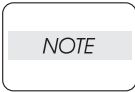

When removing the HANDLE EXTENSION 550, the LOW INDICATOR (PL 3.1) and LOW IND FRONT (PL 3.1) will be detached. Be careful not to lose them.

- 3) While pressing down the lock of the STOPPER GEAR (PL 12.3), release the lock of the LEVER BTM LOCK (PL 3.1) to lift up the PLATE ASSEMBLY BTM (PL 3.1).
- 4) Remove the link lever of the GUIDE INDICATOR 1 (PL 3.1) from the hole of the PLATE ASSEMBLY BTM (Figure 1).
- 5) While pressing the link lever down to the bottom side of the 550 PAPER CASSETTE, slowly but firmly pull the GUIDE INDICATOR 3 out from the front side of the HOUSING EXTENSION 550 (PL 3.1).

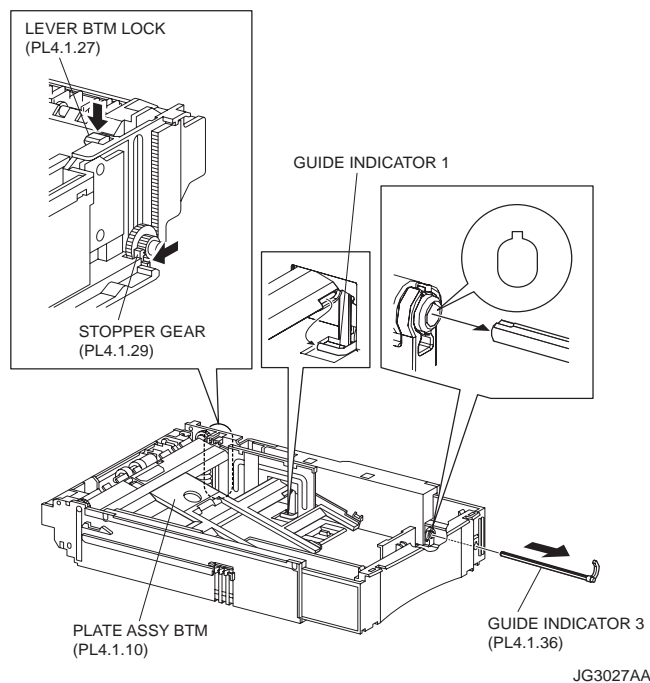
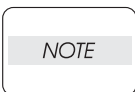

Figure 1. Guide Indicator

Replacement

- 1) While pressing the link lever down to the bottom side of the 550 PAPER CASSETTE, insert the GUIDE INDICATOR 3 to the HOUSING EXTENSION 550 (PL 3.1) from the front side.



Be sure to align the groove of the GUIDE INDICATOR 1 and the projection of the GUIDE INDICATOR 3.

- 2) Insert the link lever of the GUIDE INDICATOR 1 (PL 3.1) to the hole of the PLATE ASSEMBLY BTM.
- 3) Install the LOW INDICATOR (PL 3.1) and LOW IND FRONT (PL 3.1) (RRP3.10).
- 4) Install the HANDLE EXTENSION 550 (PL 3.1) (RRP3.7)
- 5) Install the COVER CST (PL 12.3) to the 550 PAPER CASSETTE.

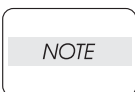

After assembling, make sure that the LOW IND FRONT moves up-and-down in conjunction with the up-and-down movement of the PLATE ASSEMBLY BTM

RRP3.9 GUIDE INDICATOR 2 (PL 3.1.35)**Removal**

- 1) Remove the COVER CST (PL 12.3) from the 550 PAPER CASSETTE.
- 2) Release the lock of the LOCK EXTENSION, and pull out the cassette extension as far as it will go.
- 3) Release the hooks securing the GEAR PINION (PL 12.3) to the HOUSING TOP 550 (PL 12.3), and remove the GEAR PINION (Figure 1).

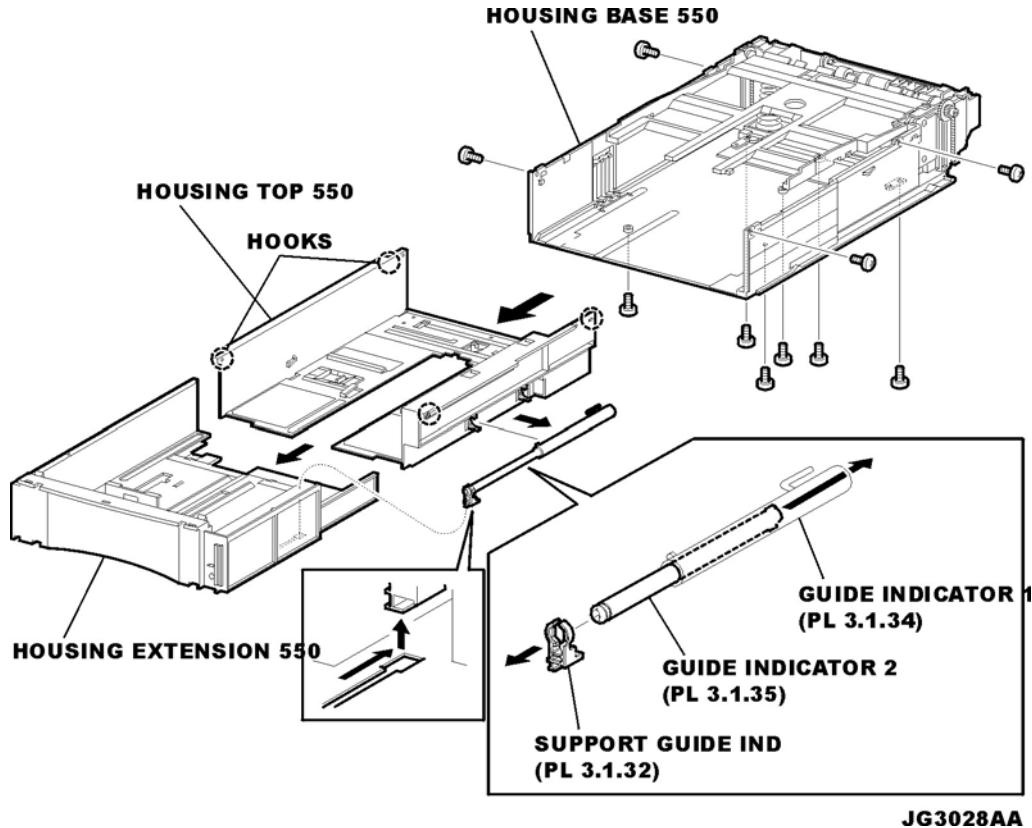
**Figure 1. Pinion Gear**

- 4) While pressing down the lock of the STOPPER GEAR (PL 3.1), release the lock of the LEVER BTM LOCK (PL 3.1) to lift up the PLATE ASSEMBLY BTM (Figure 2).
- 5) Slide the GUIDE ASSEMBLY SD L550 (PL 12.3) inward, and remove it from the HOUSING TOP 550 by pressing down the hook of the HOUSING TOP 550.
- 6) Slide the GUIDE ASSEMBLY SD R550 (PL 12.3) inward, and remove it from the HOUSING TOP 550 by pressing down the hook of the HOUSING TOP 550.
- 7) Remove the 2 screws (gold tapping, 8mm) from both right and left sides, as well as the 6 screws (gold tapping, 8mm) on the back, that secure the HOUSING TOP 550 (PL 12.3) to the HOUSING BASE 550 (PL 3.1).
- 8) Turn the 550 PAPER CASSETTE over, and pull out the HOUSING TOP 550 frontward about 20 mm to release the claws on the top of the PLATE ASSEMBLY BTM from the hooks of the HOUSING TOP 550.
- 9) Release the 4 hooks of the HOUSING TOP 550, and remove the HOUSING TOP 550 and HOUSING EXTENSION 550 (PL 3.1) from the HOUSING BASE 550 (Figure 1).
- 10) Slide the SUPPORT GUIDE IND (PL 3.1), and remove it from the groove of the HOUSING EXTENSION 550. Then, separate the HOUSING TOP 550 and HOUSING EXTENSION 550.

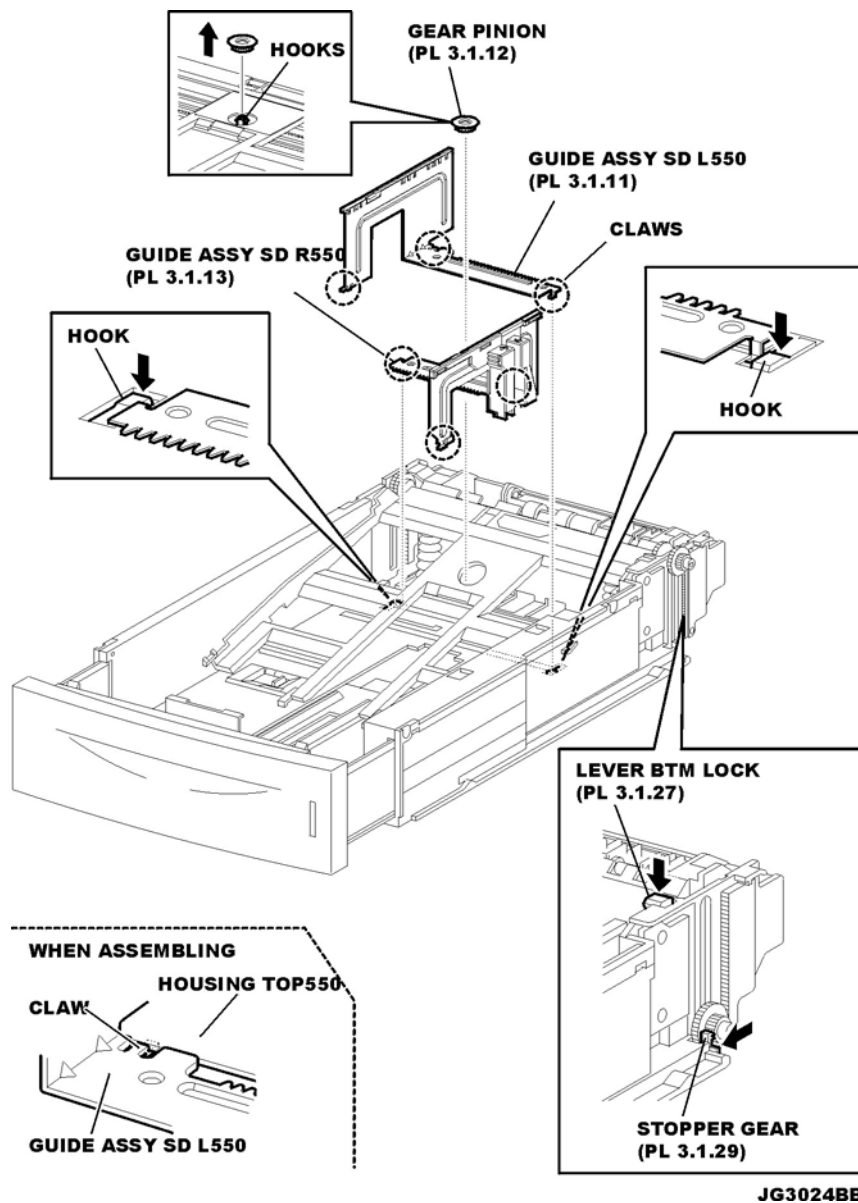

Figure 2. Lever BTM Lock

- 11) Remove the GUIDE INDICATOR 1 (PL 3.1) from the hooks of the HOUSING TOP 550, and remove the SUPPORT GUIDE IND together with the GUIDE INDICATOR 1 and GUIDE INDICATOR 2 from the HOUSING TOP 550.
- 12) Release the hook of the SUPPORT GUIDE IND, and remove the SUPPORT GUIDE IND from the GUIDE INDICATOR 2.
- 13) Extract the GUIDE INDICATOR 2 from the back side of the GUIDE INDICATOR 1.

Replacement

- 1) Insert the GUIDE INDICATOR 2 into the hole of the GUIDE INDICATOR 1 (PL 3.1) from back.
- 2) Install the SUPPORT GUIDE IND (PL 3.1) to the GUIDE INDICATOR 2, and secure it with the hook.

NOTE

Install the SUPPORT GUIDE IND to the GUIDE INDICATOR 2 in the direction shown in the figure.

- 3) Install the SUPPORT GUIDE IND together with the GUIDE INDICATOR 1 and GUIDE INDICATOR 2 to the HOUSING TOP 550 (PL 12.3), and secure the GUIDE INDICATOR 1 using the 2 hooks of the HOUSING TOP 550.
- 4) Slide the SUPPORT GUIDE IND (PL 3.1) along the groove of the HOUSING EXTENSION 550 to install, and assemble the HOUSING TOP 550 and HOUSING EXTENSION 550 into 1 unit.
- 5) Install the HOUSING EXTENSION 550 and HOUSING TOP 550 (PL 12.3) to the HOUSING BASE 550 while pushing the LINK SW SIZE1-550 (PL 3.1), LINK SW SIZE2-550 (PL 3.1) and LINK SW SIZE3-550 (PL 3.1) of the HOUSING BASE 550 outward as shown (Figure 3).

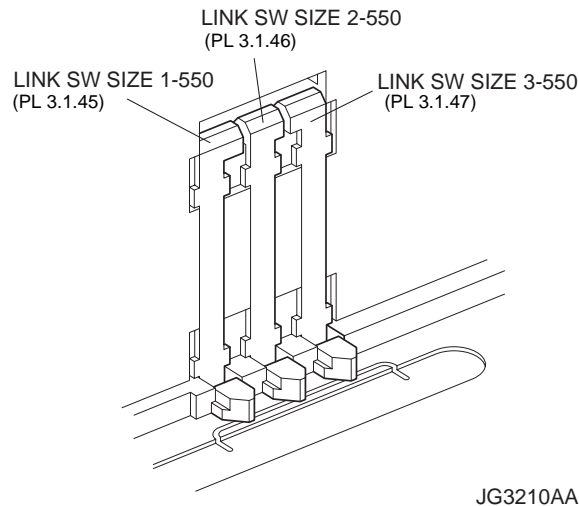
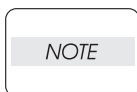
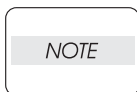

Figure 3. Link Size Switches



Be sure to put 2 claws on the top of the PLATE ASSEMBLY BTM under the hooks on the HOUSING TOP 550.

- 6) After assembling the HOUSING TOP 550 to the HOUSING BASE 550 using the 4 hooks, secure them using the 2 screws (gold tapping, 8mm) on both right and left sides, as well as the 6 screws (gold tapping, 8mm) on the back.



After tightening the screws, move the GUIDE ASSEMBLY END 550 back and forth, and make sure that the LINK SW SIZES operate smoothly.

- 7) Insert the link lever of the GUIDE INDICATOR 1 (PL 3.1) into the hole of the PLATE ASSEMBLY BTM.
- 8) While pressing down the hook of the HOUSING TOP 550, install the GUIDE ASSEMBLY SD R550 (PL 12.3) to the HOUSING TOP 550.

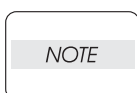

After installing, make sure that the 3 claws of the GUIDE ASSEMBLY SD R550 sit correctly in the grooves of the HOUSING TOP 550.

- 9) While pressing down the hook of the HOUSING TOP 550, install the GUIDE ASSEMBLY SD L550 (PL 12.3) to the HOUSING TOP 550.

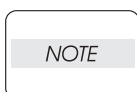

After installing, make sure that the 3 claws of the GUIDE ASSEMBLY SD L550 sit correctly in the grooves of the HOUSING TOP 550.

- 10) Push the PLATE ASSEMBLY BTM downward to lock.
- 11) Install the GEAR PINION (PL 12.3) to the HOUSING TOP 550.

Removal and Replacement Procedures (RRPs)

NOTE

When installing the GEAR PINION, make sure the GUIDE ASSEMBLY SD R550 and GUIDE ASSEMBLY SD L550 are completely opened. If not, the side register may be misaligned.

12) Install the COVER CST (PL 12.3) to the 550 PAPER CASSETTE.

NOTE

After assembling, make sure that the LOW IND FRONT moves up-and-down in conjunction with the up-and-down movement of the PLATE ASSEMBLY BTM

RRP3.10 LOW IND FRONT (PL 3.1)**Removal**

- 1) Remove the COVER CST (PL 12.3) from the 550 PAPER CASSETTE.
- 2) Remove the HANDLE EXTENSION 550 (PL 3.1) (RRP3.7).
- 3) Turn the LOW INDICATOR (PL 3.1) by 90 degrees, and remove it together with the LOW IND FRONT from the HANDLE EXTENSION 550 (Figure 1).
- 4) Release the hook on the one side of the LOW IND FRONT, and remove the LOW IND FRONT from the LOW INDICATOR.

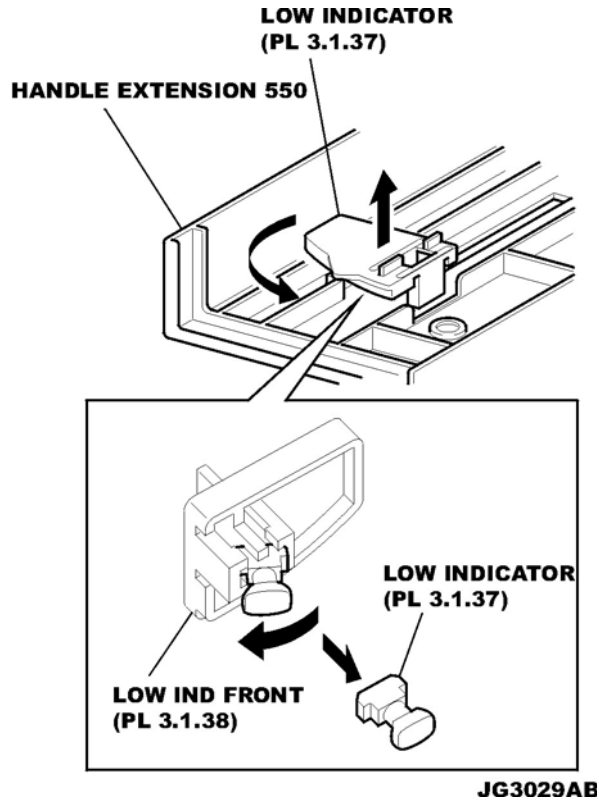
**Figure 1. Low Indicator****Replacement**

- 1) Install the LOW IND FRONT to the LOW INDICATOR (PL 3.1).

NOTE

When installing the LOW IND FRONT to the LOW INDICATOR, be careful in the installing direction of the LOW IND FRONT.

- 2) Turn the LOW INDICATOR by 90 degrees in the opposite direction of the arrow, and install it together with the LOW IND FRONT to the HANDLE EXTENSION 550 (Figure 1).
- 3) Install the HANDLE EXTENSION 550 (PL 3.1) (RRP3.7)
- 4) Install the COVER CST (PL 12.3) to the 550 PAPER CASSETTE.

NOTE

After assembling, make sure that the LOW IND FRONT moves up-and-down in conjunction with the up-and-down movement of the PLATE ASSEMBLY BTM

RRP4. 150 paper Feeder

RRP4.1 150 FEEDER ASSEMBLY (PL 4.1)**Removal**

- 1) Remove the COVER REAR 500 (PL 7.1) (RRP7.9).
- 2) Remove the FUSER ASSEMBLY (PL 6.1) (RRP6.8).
- 3) Remove the COVER REAR (PL 1.1) (RRP1.1).
- 4) Remove the CHUTE TRANSFER (PL 6.1) together with the BTR ASSEMBLY (RRP6.9).
- 5) Disconnect the connector (P/J245) of the HARNESS ASSEMBLY TRAY 1 (PL 4.1) from the HARNESS ASSEMBLY CHUTE (PL 9.1) (Figure 1).
- 6) Disconnect the connector (P/J221) of the HARNESS ASSEMBLY TONER 1 (PL 4.1) from the HARNESS ASSEMBLY TONER 2 (PL 9.1.28) (Figure 1).
- 7) Remove the 5 screws (silver with flange, 8mm) securing the 150 FEEDER ASSEMBLY to the printer (Figure 1).
- 8) Shift the 150 FEEDER ASSEMBLY backward, and remove the right boss of the 150 FEEDER ASSEMBLY from the frame.
- 9) Lift up the 150 FEEDER ASSEMBLY in the direction of the arrow (A), and remove the left boss of the 150 FEEDER ASSEMBLY.

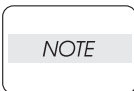

The 150 FEEDER ASSEMBLY clicks into a notch when lifted to the half way point, push the assembly past the notch.

Remove the 150 FEEDER ASSEMBLY from the printer.

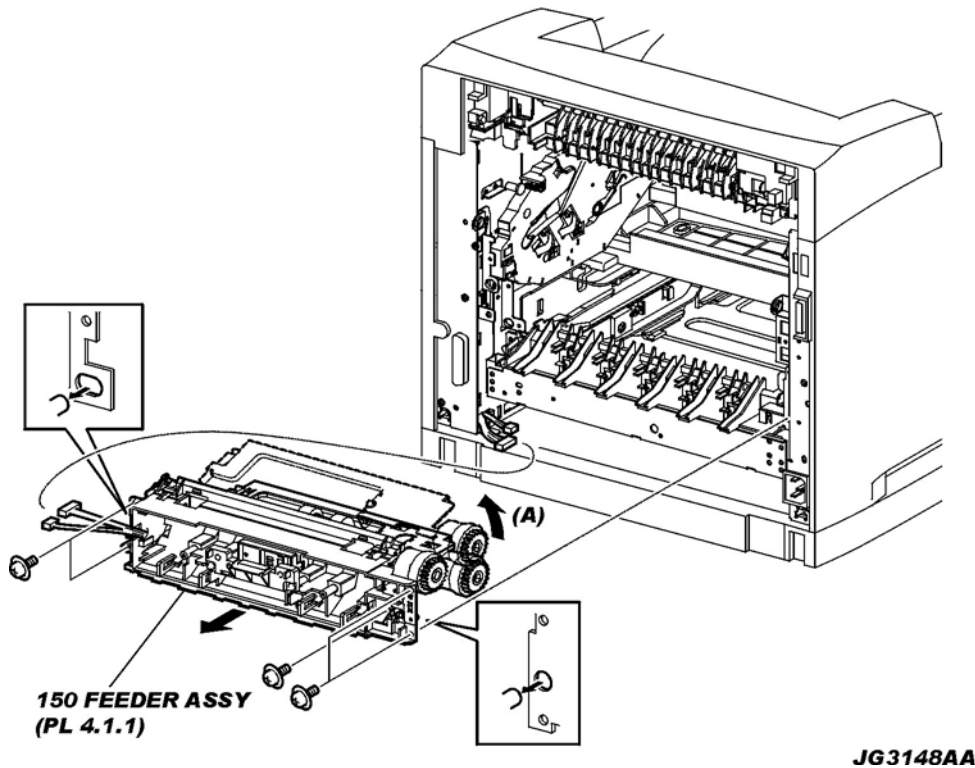

Figure 1. Feeder Assembly

Replacement

- 1) While lifting up the 150 FEEDER ASSEMBLY in the direction of the arrow (A), and install it to the printer. Then, put the bosses at right and left of the 150 FEEDER ASSEMBLY into the holes of the printer.
- 2) Secure the 150 FEEDER ASSEMBLY to the printer using the 5 screws (silver with flange, 8mm).

NOTE

One of the screws that secure the 150 FEEDER ASSEMBLY is tightened together with the EARTH PLATE BASE (PL 4.1.27).

- 3) Connect the connector (P/J221) of the HARNESS ASSEMBLY TONER 1 (PL 4.1) to the HARNESS ASSEMBLY TONER 2 (PL 9.1.28).
- 4) Connect the connector (P/J 245) of the HARNESS ASSEMBLY TRAY 1 (PL 4.1) to the HARNESS ASSEMBLY CHUTE (PL 9.1).
- 5) Install the CHUTE TRANSFER (PL 6.1) together with the BTR ASSEMBLY to the printer (RRP6.9).

NOTE

Do not tighten the screw to the left side hole of the CHUTE TRANSFER.

- 6) Install the COVER REAR (PL 1.1) (RRP1.1).

NOTE

There are 2 kinds of screws, make sure they are installed correctly.

- 7) Install the FUSER ASSEMBLY (PL 6.1) (RRP6.8).
- 8) Install the COVER REAR 500 (PL 7.1) (RRP7.9).

RRP4.2 ROLL ASSEMBLY NUDGER (PL 4.1), ROLL ASSEMBLY FEED (PL 4.1)**Removal**

- 1) Open the COVER OPEN (PL 1.1).
- 2) Release the hook securing the ROLL ASSEMBLY NUDGER, and pull the ROLL ASSEMBLY NUDGER out from the SHAFT NUDGER (PL 4.1) (Figure 1).
- 3) Release the hook securing the ROLL ASSEMBLY FEED, and pull the ROLL ASSEMBLY FEED out from the SHAFT FEED (PL 4.1) (Figure 1).

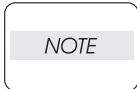

When removing, do not touch the roller surface of the ROLL ASSEMBLY NUDGER and ROLL ASSEMBLY FEED.

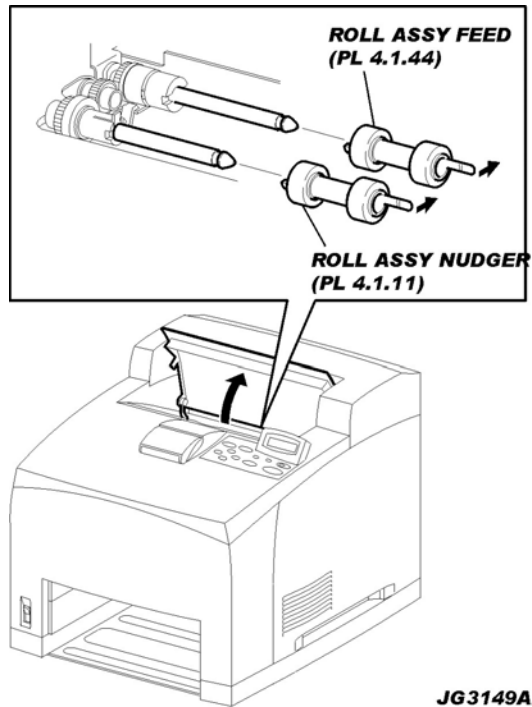

JG3149AA

Figure 1. Roll Feed Assembly

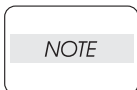
Replacement

The ROLL ASSEMBLY FEED and ROLL ASSEMBLY NUDGER are the same parts, although the names differ.

- 1) Install the ROLL ASSEMBLY FEED to the SHAFT FEED (PL 4.1), and secure the ROLL ASSEMBLY FEED with the hook.

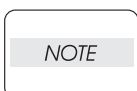

Be sure to install the hook of the ROLL ASSEMBLY FEED into the groove of the SHAFT FEED.

- 2) Install the ROLL ASSEMBLY NUDGER to the SHAFT NUDGER (PL 4.1), and secure the ROLL ASSEMBLY NUDGER with the hook.

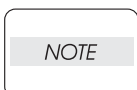

Be sure to install the hook of the ROLL ASSEMBLY NUDGER into the groove of the SHAFT NUDGER.

- 3) Close the COVER OPEN (PL 1.1).

RRP4.3 CLUTCH ONEWAY NUDGER (PL 4.1)**Removal**

- 1) Open the COVER OPEN (PL 1.1).
- 2) Remove the ROLL ASSEMBLY FEED (PL 4.1) (RRP4.2).

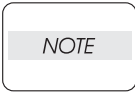

When removing, do not touch the roller surface of the ROLL ASSEMBLY FEED.

- 3) Pull out the CLUTCH ONEWAY FEED (PL 4.1) from the SHAFT FEED (PL 4.1) (Figure 1).
- 4) Remove the E-ring securing the CLUTCH ONEWAY NUDGER (PL 4.1) to the SHAFT FEED (Figure 1).
- 5) Pull out the CLUTCH ONEWAY NUDGER from the SHAFT FEED (Figure 1).

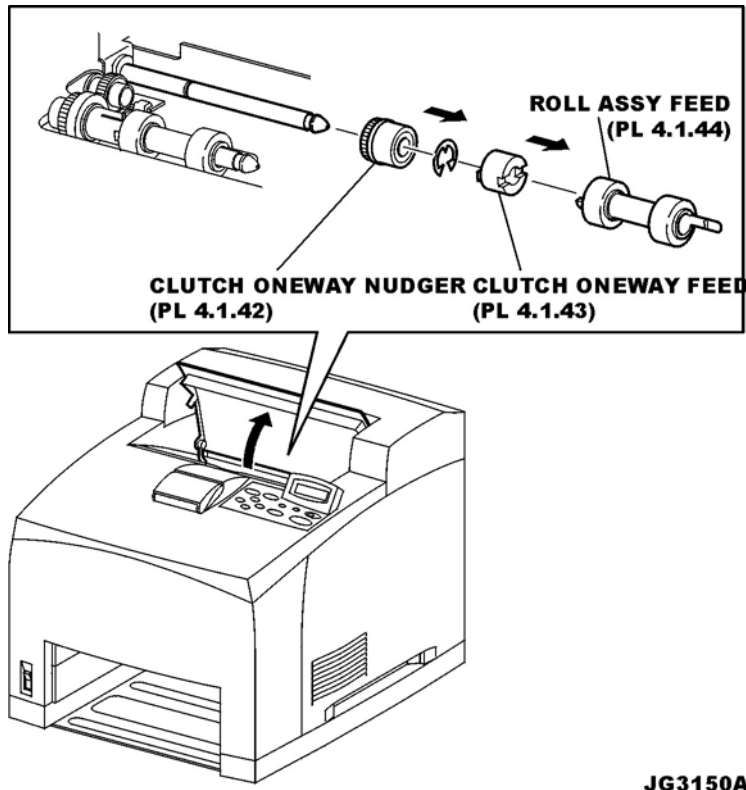
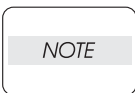

Figure 1. One-way Nudger Clutch

Replacement

- 1) Install the CLUTCH ONEWAY NUDGER (PL 4.1) to the SHAFT FEED (PL 4.1).
- 2) Clip the E-ring to the SHAFT FEED to secure the CLUTCH ONEWAY NUDGER.
- 3) Install the CLUTCH ONEWAY FEED (PL 4.1) to the SHAFT FEED.
- 4) Install the ROLL ASSEMBLY FEED (PL 4.1) to the SHAFT FEED, and secure it with the hook (RRP4.2).



Be sure to install the hook of the ROLL ASSEMBLY FEED into the groove of the SHAFT FEED.

- 5) Close the COVER OPEN (PL 1.1).

RRP4.4 GEAR NUDGER (PL 4.1)**Removal**

- 1) Open the COVER OPEN (PL 1.1).
- 2) While pressing down the boss of the HOLDER LEFT (PL 4.1) at the back of the 150 FEEDER ASSEMBLY, shift the HOLDER LEFT in the direction of the arrow to remove the 3 hooks (Figure 1).
- 3) Remove the HOLDER LEFT from the SUPPORT NUDGER (PL 12.3). At the same time, the ACTUATOR NO PAPER (PL 4.1) is removed.
- 4) Release the hook of the ROLL ASSEMBLY NUDGER (PL 4.1), and pull the ROLL ASSEMBLY NUDGER out from the SHAFT NUDGER (PL 4.1).
- 5) Release the hook of the GEAR NUDGER, and pull the GEAR NUDGER out from the SHAFT NUDGER.

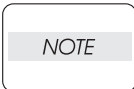

When removing, do not touch the roller surface of the ROLL ASSEMBLY NUDGER and GEAR NUDGER.

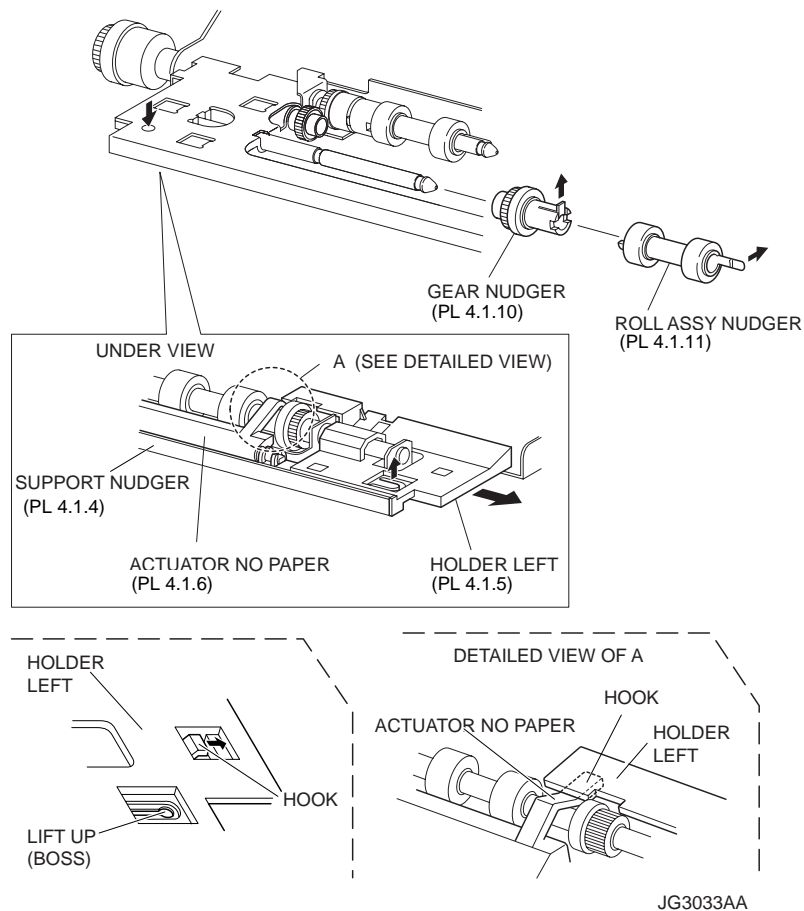
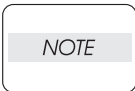

Figure 1. Nudger Gear

Replacement

- 1) Install the GEAR NUDGER to the SHAFT NUDGER (PL 4.1), and secure the GEAR NUDGER with the hook.



When installing, do not touch the roller surface of the ROLL ASSEMBLY NUDGER and GEAR NUDGER.

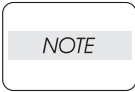

Be sure to install the hook of the GEAR NUDGER into the groove of the SHAFT NUDGER.

- 2) Install the ROLL ASSEMBLY NUDGER (PL 4.1) to the SHAFT NUDGER, and secure the ROLL ASSEMBLY NUDGER with the hook.

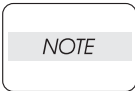

Be sure to install the hook of the ROLL ASSEMBLY NUDGER into the groove of the SHAFT NUDGER.

- 3) Install the HOLDER LEFT (PL 4.1) and ACTUATOR NO PAPER (PL 4.1) to the SUPPORT NUDGER (PL 12.3).

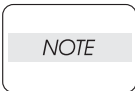

Be sure to install the shafts on both ends of the ACTUATOR NO PAPER into the HOLDER LEFT and SUPPORT NUDGER.

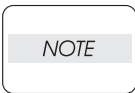

Assemble the hook of the ACTUATOR NO PAPER to the HOLDER LEFT as shown (Figure 1).

- 4) Move the HOLDER LEFT (PL 4.1) in the opposite direction of the arrow, and secure it to the 150 FEEDER ASSEMBLY with the 3 hooks.

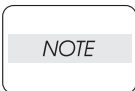

After installing, move the ACTUATOR NO PAPER with a finger, and make sure that the ACTUATOR NO PAPER operates smoothly.

RRP4.5 ROLL REGI RUBBER (PL 4.1.12)**Removal**

- 1) Remove the COVER REAR 500 (PL 7.1) (RRP7.9).
- 2) Remove the FUSER ASSEMBLY (PL 6.1) (RRP6.8).
- 3) Remove the COVER REAR (PL 1.1) (RRP1.1)
- 4) Remove the CHUTE TRANSFER (PL 6.1) together with the BTR ASSEMBLY (RRP6.9).
- 5) Remove the 150 FEEDER ASSEMBLY (PL 4.1) (RRP4.1).
- 6) Remove 2 SPRING REGIs (PL 4.1) hanging to the CHUTE REGI (PL 4.1) and ROLL REGI RUBBER (PL 4.1.12) on both sides of the 150 FEEDER ASSEMBLY (Figure 1).
- 7) Remove the E-ring securing the GEAR REGI RUBBER (PL 4.1) to the ROLL REGI RUBBER, and remove the GEAR REGI RUBBER from the ROLL REGI RUBBER (Figure 1).
- 8) Remove the E-ring securing the BEARING REGI LEFT (PL 4.1) to the ROLL REGI RUBBER.
- 9) Pull the BEARING REGI LEFT, and turn it in the direction of the arrow shown in the figure, and remove the notch of the BEARING REGI LEFT from the protrusion of the CHUTE REGI (NOTE 1).
- 10) Pull the BEARING REGI LEFT out from the ROLL REGI RUBBER.
- 11) Remove the E-ring securing the CLUTCH REGI (PL 4.1), and remove the CLUTCH REGI.
- 12) Pull the BEARING REGI RIGHT (PL 4.1), and turn it in the direction of the arrow shown in the figure, and remove the notch of the BEARING REGI RIGHT from the protrusion of the CHUTE REGI (NOTE 1).
- 13) Pull the BEARING REGI RIGHT out from the ROLL REGI RUBBER.
- 14) Shift the ROLL REGI RUBBER left, and extract the right of the ROLL REGI RUBBER from the hole of the CHUTE REGI, and then extract the ROLL REGI RUBBER upward.

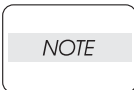

When removing, do not touch the roller surface of the ROLL REGI RUBBER.

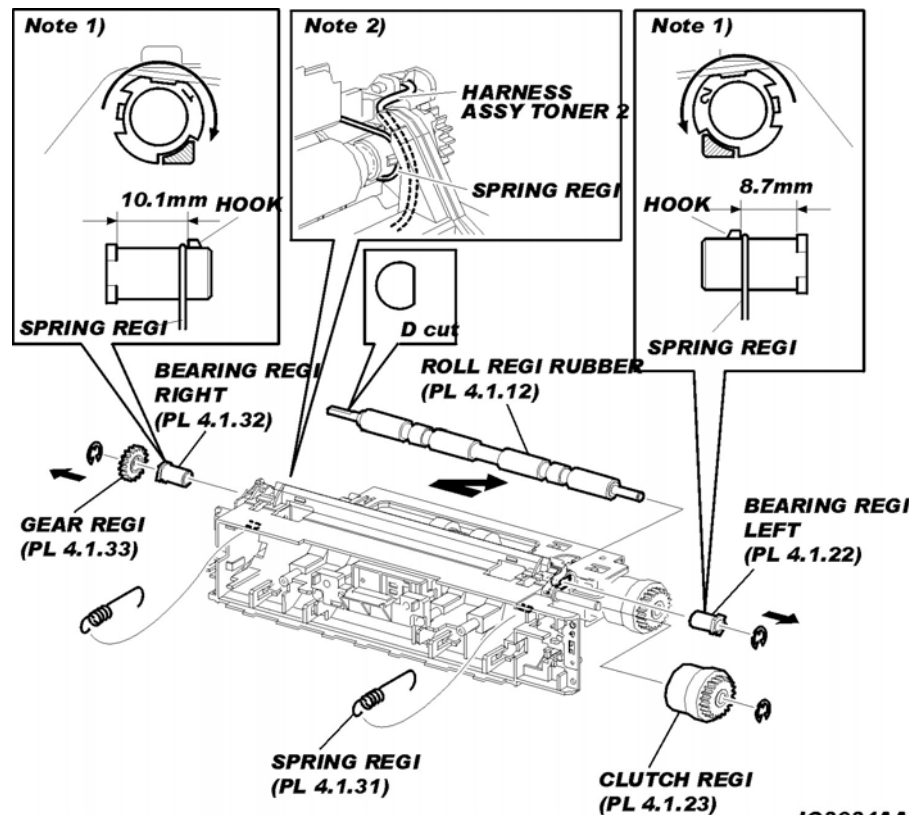
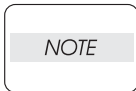

Figure 1. Rubber Registration Roller

Replacement

- 1) Shift the ROLL REGI RUBBER in the opposite direction of the arrow, and install it to the 150 FEEDER ASSEMBLY.



When installing, do not touch the roller surface of the ROLL REGI RUBBER.

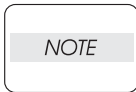

Install the ROLL REGI RUBBER so that its D-cut is positioned at the BEARING REGI RIGHT side.

- 2) Install the BEARING REGI RIGHT (PL 4.1) to the ROLL REGI RUBBER.

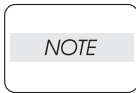

The shapes of the flange and the positions of the hook are different on the BEARING REGI RIGHT (white) and BEARING REGI LEFT (black).

- 3) Turn the BEARING REGI RIGHT in the opposite direction of the arrow, and install it to the CHUTE REGI.

- 4) Install the BEARING REGI LEFT (PL 4.1) to the ROLL REGI RUBBER.

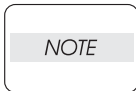

The shapes of the flange and the positions of the hook are different on the BEARING REGI RIGHT (white) and BEARING REGI LEFT (black).

- 5) Turn the BEARING REGI LEFT in the opposite direction of the arrow, and install it to the CHUTE REGI.

- 6) Clip the E-ring to the ROLL REGI RUBBER to secure the BEARING REGI LEFT.

- 7) Install the GEAR REGI RUBBER (PL 4.1) to the ROLL REGI RUBBER, and secure it using the E-ring.

- 8) Hang 2 SPRING REGIs (PL 4.1) to the CHUTE REGI (PL 4.1) and BEARING REGI RUBBER.

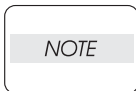

When hanging the SPRING REGIs, make sure that the SPRING REGIs are hung to the boss of the CHUTE REGI, and to the inside of the hooks of the BEARING REGI LEFT and BEARING REGI RIGHT.

After hanging the SPRING REGIs, make sure the SPRING REGIs have not pinched the HARNESS ASSEMBLY TONER 2 (NOTE 2) (Figure 1).

- 9) Install the CLUTCH REGI (PL 4.1) (RRP4.6).

- 10) Install the 150 FEEDER ASSEMBLY (PL 4.1) (RRP4.1).

- 11) Install the CHUTE TRANSFER (PL 6.1) together with the BTR ASSEMBLY (RRP6.9).

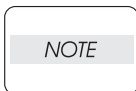

Do not tighten the screw to the left side hole of the CHUTE TRANSFER.

- 12) Install the COVER REAR (PL 1.1) (RRP1.1).

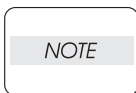

There are 2 kinds of screws, make sure they are installed correctly.

- 13) Install the FUSER ASSEMBLY (PL 6.1) (RRP6.8).

- 14) Install the COVER REAR 500 (PL 7.1) (RRP7.9).

RRP4.6 CLUTCH ASSEMBLY PH (PL 4.1.21), CLUTCH REGI (PL 4.1)**Removal**

- 1) Remove the COVER REAR 500 (PL 7.1) (RRP7.9).
- 2) Remove the FUSER ASSEMBLY (PL 6.1) (RRP6.8).
- 3) Remove the COVER REAR (PL 1.1) (RRP1.1).
- 4) Remove the CHUTE TRANSFER (PL 6.1) together with the BTR ASSEMBLY (RRP6.9).
- 5) Remove the 150 FEEDER ASSEMBLY (PL 4.1) (RRP4.1).
- 6) Disconnect the connector (P/J242) of the CLUTCH ASSEMBLY PH from the HARNESS ASSEMBLY TRAY 1 (PL 4.1) (Figure 1).
- 7) Remove the E-ring securing the CLUTCH ASSEMBLY PH, and remove the CLUTCH ASSEMBLY PH from the SHAFT FEED (PL 4.1) (Figure 1).
- 8) Disconnect the connector (P/J243) of the CLUTCH REGI from the HARNESS ASSEMBLY TRAY 1.
- 9) Remove the E-ring securing the CLUTCH REGI, and remove the CLUTCH REGI from the ROLL REGI METAL (PL 4.1).

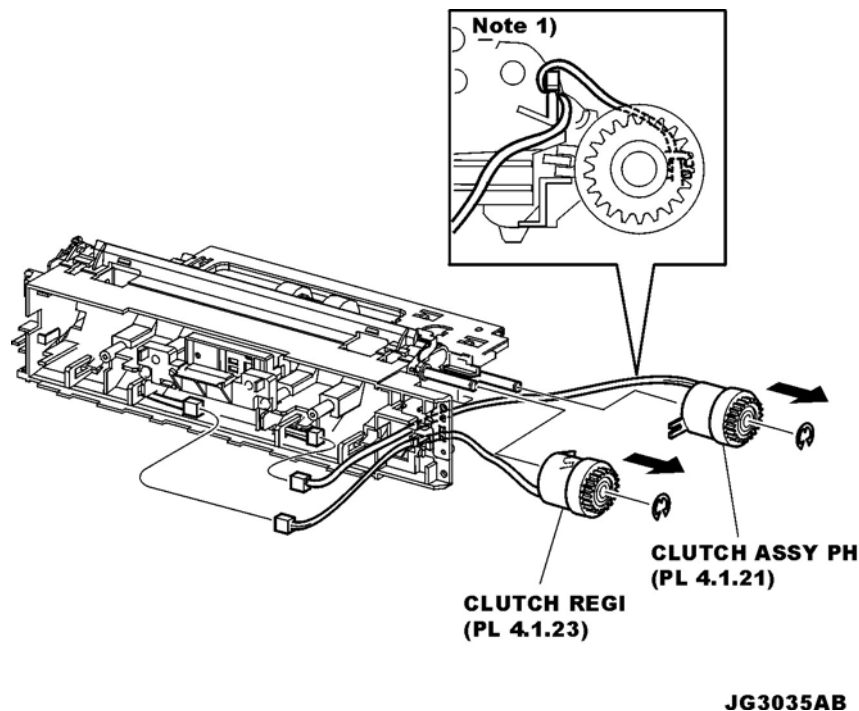
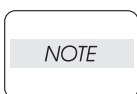
**Figure 1. Registration & PH Clutches****Replacement**

The part names differ with the CLUTCH ASSEMBLY PH and CLUTCH REGI, but they are the same parts.

- 1) Install the CLUTCH REGI to the ROLL REGI METAL (PL 4.1), and secure it using the E-ring.

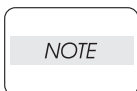

When installing, make sure that the notch of the CLUTCH REGI is combined with the boss of the CHUTE REGI.

- 2) Connect the connector (P/J243) of the CLUTCH REGI (PL 4.1) to the HARNESS ASSEMBLY TRAY 1 (PL 4.1).
- 3) Install the CLUTCH ASSEMBLY PH to the SAHFT FEED, and secure it using the E-ring.

Removal and Replacement Procedures (RRPs)

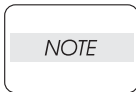

When installing, make sure that the notch of the CLUTCH ASSEMBLY PH is combined with the boss of the CHUTE REGI.

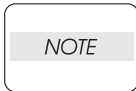

The harness of the CLUTCH ASY PH should be routed around the portion of the CHUTE REGI as shown (Figure 1).

- 4) Connect the connector (P/J242) of the CLUTCH ASSEMBLY PH to the HARNESS ASSEMBLY TRAY 1.
- 5) Install the 150 FEEDER ASSEMBLY (PL 4.1) (RRP4.1).
- 6) Install the CHUTE TRANSFER (PL 6.1) together with the BTR ASSEMBLY (RRP6.9).

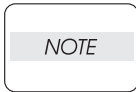

Do not tighten the screw to the left side hole of the CHUTE TRANSFER.

- 7) Install the COVER REAR (PL 1.1) (RRP1.1).

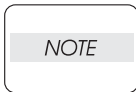

There are 2 kinds of screws, make sure they are installed correctly.

- 8) Install the FUSER ASSEMBLY (PL 6.1) (RRP6.8).
- 9) Install the COVER REAR 500 (PL 7.1) (RRP7.9).

RRP4.7 SENSOR REGI (PL 4.1.30)**Removal**

- 1) Remove the COVER REAR 500 (PL 7.1) (RRP7.9).
- 2) Remove the COVER REAR (PL 1.1) (RRP1.1).
- 3) Release the hooks securing the COVER SENSOR (PL 4.1), and remove the COVER SENSOR from the CHUTE ASSEMBLY REGI (Figure 1).
- 4) Release the hooks securing the SENSOR REGI, and remove the SENSOR REGI from the COVER SENSOR (Figure 1).
- 5) Disconnect the connector (P/J241) of the HARNESS ASSEMBLY TRAY 1 (PL 4.1) from the SENSOR REGI.

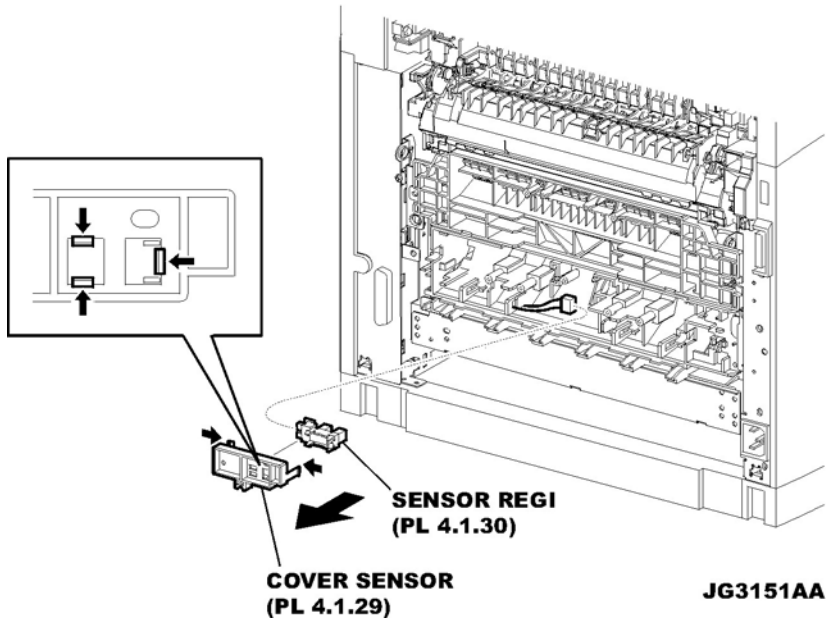
**Figure 1. Registration Sensor****Replacement**

- 1) Connect the connector (P/J241) of the HARNESS ASSEMBLY TRAY 1 (PL 4.1) to the SENSOR REGI.
- 2) Install the SENSOR REGI to the COVER SENSOR (PL 4.1), and secure it using hooks (Figure 1).
- 3) Install the COVER SENSOR to the CHUTE ASSEMBLY REGI, and secure it using hooks (Figure 1).
- 4) Install the COVER REAR (PL 1.1) (RRP1.1)

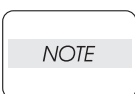

There are 2 kinds of screws, make sure they are installed correctly.

- 5) Install the COVER REAR 500 (PL 7.1) (RRP7.9).

RRP4.8 SENSOR NO PAPER (PL 4.1.38)**Removal**

- 1) Open the COVER OPEN (PL 1.1).
- 2) Remove the COVER REAR 500 (PL 7.1) (RRP7.9).
- 3) Remove the FUSER ASSEMBLY (PL 6.1) (RRP6.8).
- 4) Lift up the 150 FEEDER ASSEMBLY a little, insert a screwdriver through the space left by the FUSER ASSEMBLY, and remove the screw (gold, 8mm) securing the HOLDER NO PAPER SENSOR (PL 4.1) (Figure 1).
- 5) Remove the HOLDER NO PAPER SENSOR from the 150 FEEDER ASSEMBLY.
- 6) Release the hooks securing the SENSOR NO PAPER to the HOLDER NO PAPER SENSOR, and remove the SENSOR NO PAPER (Figure 1).
- 7) Disconnect the HARNESS ASSEMBLY TRAY 1 (PL 4.1) from the connector (P/J240) of the SENSOR NO PAPER (Figure 1).

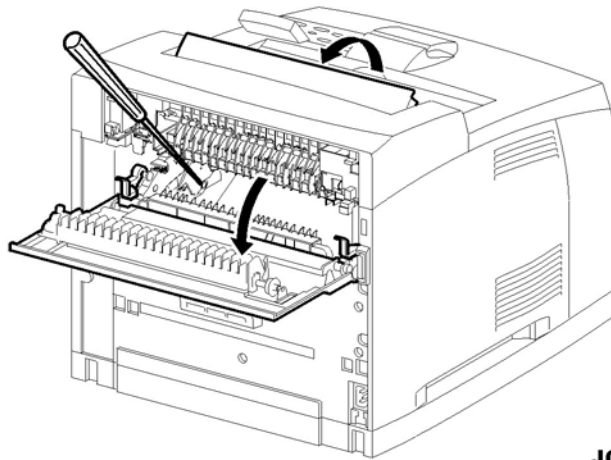
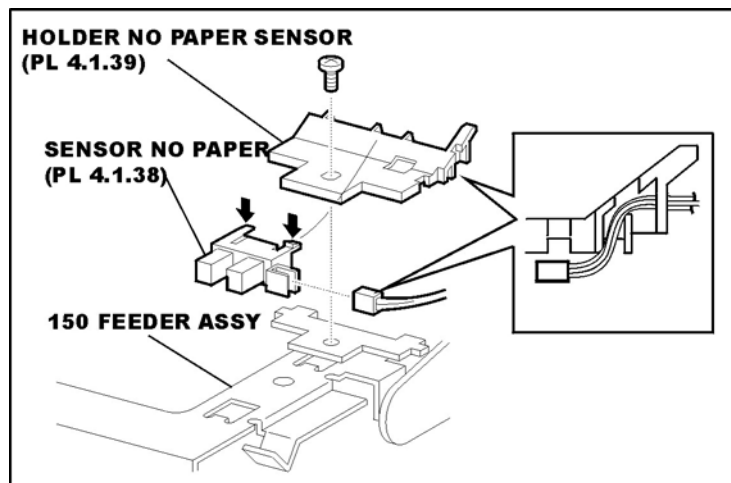
**JG3152AA****Figure 1. No Paper Sensor****Replacement**

- 1) Connect the connector (P/J240) of the HARNESS ASSEMBLY TRAY 1 (PL 4.1) to the connector of the SENSOR NO PAPER.
- 2) Install the SENSOR NO PAPER to the HOLDER NO PAPER SENSOR (PL 4.1), and secure it using hooks (Figure 1).

Removal and Replacement Procedures (RRPs)

- 3) Put the wires of the HARNESS ASSEMBLY TRAY 1 into the notch of the HOLDER NO PAPER SENSOR as shown (Figure 1).
- 4) Insert a screwdriver through the space left by the FUSER ASSEMBLY, and install the HOLDER NO PAPER SENSOR to the 150 FEEDER ASSEMBLY using the screw (gold, 8mm).

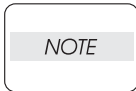

After tightening the screw, make sure that the wires of the HARNESS ASSEMBLY TRAY 1 have not been pinched.

- 5) Install the FUSER ASSEMBLY (PL 6.1) (RRP6.8).
- 6) Install the COVER REAR 500 (PL 7.1) (RRP7.9).
- 7) Close the COVER OPEN (PL 1.1).

RRP4.9 SENSOR TONER (PL 4.1.46)**Removal**

- 1) Open the COVER OPEN (PL 1.1).
- 2) Disconnect the connector (P/J220) of the SENSOR TONER from the HARNESS ASSEMBLY TONER 1 (PL 4.1) (Figure 1).
- 3) Release the holdings of the harness of the SENSOR TONER from 2 clamps.
- 4) Release 2 hooks of the HOLDER-D (PL 4.1), and remove the SENSOR TONER from the HOLDER-D by turning it in the direction of the arrow (Figure 1).

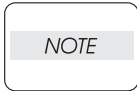

When removing the SENSOR TONER, be careful not to lose the SPRING TONER (PL 4.1.48) (Figure 1).

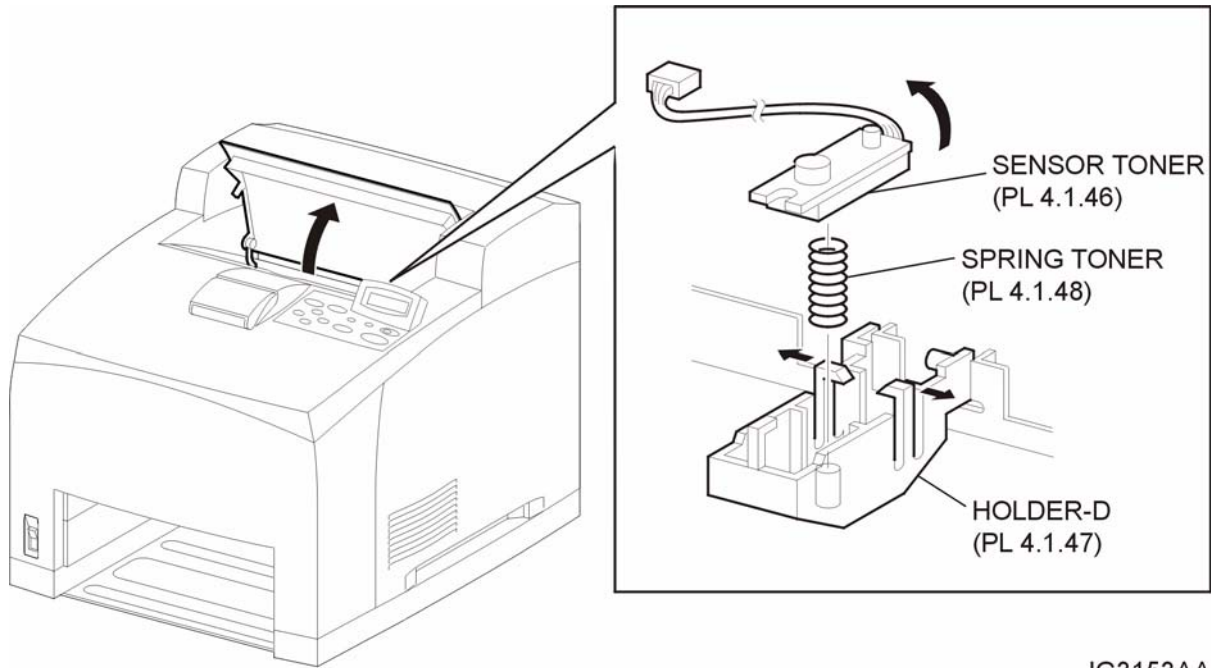

JG3153AA

Figure 1. Toner Sensor**Replacement**

- 1) Install the SENSOR TONER to the HOLDER-D (PL 4.1) by turning it in the opposite direction of the arrow, and secure it using 2 hooks (Figure 1).

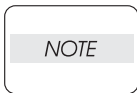

When installing the SENSOR TONER, put the SPRING TONER on the boss of the HOLDER-D, and then install the SENSOR TONER on it.

- 2) Secure the harness of the SENSOR TONER using the 2 clamps.
- 3) Connect the connector (P/J220) of the SENSOR TONER to the HARNESS ASSEMBLY TRAY 1 (PL 4.1).
- 4) Close the COVER OPEN (PL 1.1).

RRP4.10 ACTUATOR NO PAPER (PL 4.1)

Removal

- 1) Remove the COVER REAR 500 (PL 7.1) (RRP7.9).
- 2) Remove the FUSER ASSEMBLY (PL 6.1) (RRP6.8).
- 3) Place the printer down on its left side.

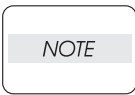

Be careful not to scratch the cover, and do not drop the printer.

- 4) Open the COVER OPEN (PL 1.1).
- 5) While lifting up the boss of the HOLDER LEFT (PL 4.1) at the back of the 150 FEEDER ASSEMBLY, shift the HOLDER LEFT in the direction of the arrow to remove 3 hooks (Figure 1).
- 6) Remove the HOLDER LEFT from the SUPPORT NUDGER (PL 12.3). At the same time, the ACTUATOR NO PAPER (PL 4.1) is removed (Figure 1).

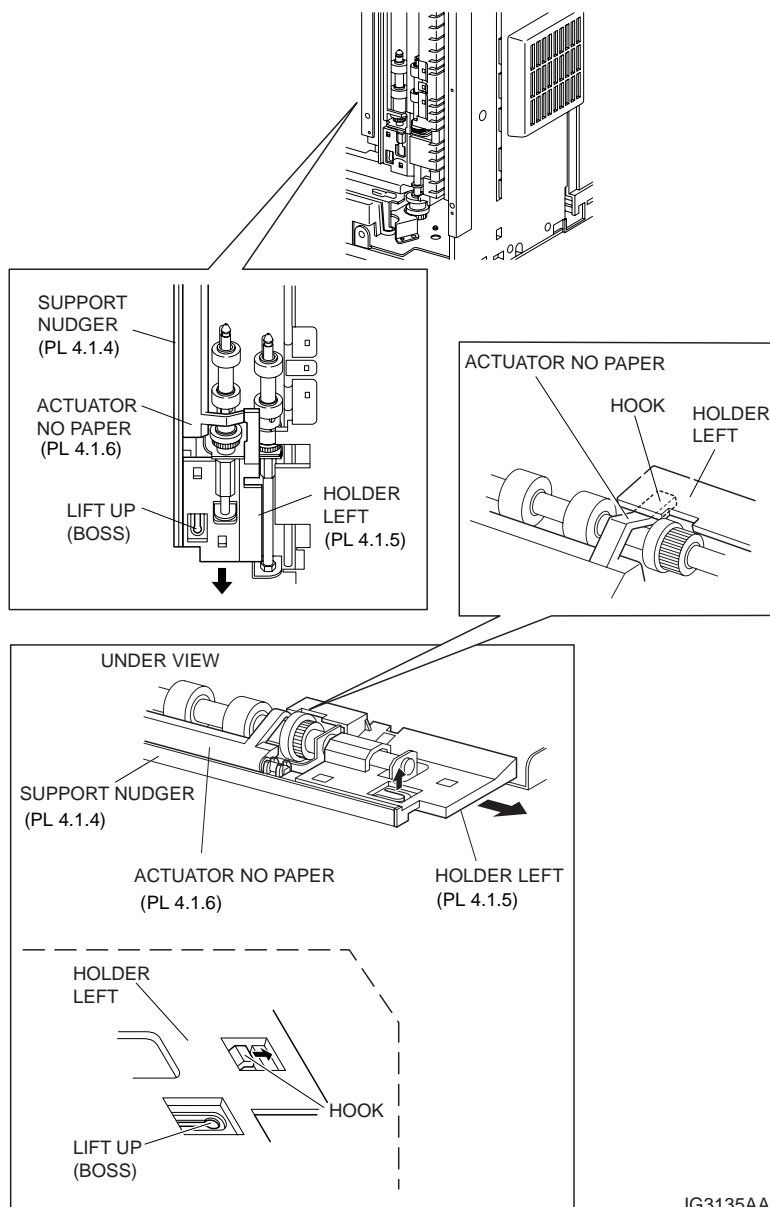

JG3135AA

Figure 1. No Paper Actuator

Replacement

- 1) Install the HOLDER LEFT (PL 4.1) and ACTUATOR NO PAPER (PL 4.1) to the SUPPORT NUDGER (PL 12.2).

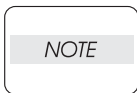

Be sure to install the shafts on both ends of the ACTUATOR NO PAPER into the HOLDER LEFT and SUPPORT NUDGER.

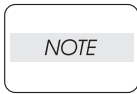

Assemble the hook of the ACTUATOR NO PAPER to the HOLDER LEFT as shown (Figure 1).

- 2) Move the HOLDER LEFT (PL 4.1) in the opposite direction of the arrow, and secure it to the 150 FEEDER ASSEMBLY with 3 hooks.

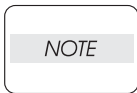

After installing, move the ACTUATOR NO PAPER with a finger, and make sure that the ACTUATOR NO PAPER operates smoothly.

- 3) Return the printer to the normal use state.
- 4) Install the FUSER ASSEMBLY (PL 6.1) (RRP6.8)
- 5) Install the COVER REAR 500 (PL 7.1) (RRP7.9).

RRP5. 550 Paper Feeder

RRP5.1 550 FEEDER ASSEMBLY (PL 5.1)

Removal

- 1) Remove the COVER REAR 500 (PL 7.1) (RRP7.9).
- 2) Remove the FUSER ASSEMBLY (PL 6.1) (RRP6.8).
- 3) Remove the COVER REAR (PL 1.1) (RRP1.1).
- 4) Remove the CHUTE TRANSFER (PL 6.1) together with the BTR ASSEMBLY (RRP6.9).
- 5) Remove the 150 FEEDER ASSEMBLY (PL 4.1) (RRP4.1).
- 6) Disconnect the connector (P/J248) of the HARNESS ASSEMBLY TRAY 2 (PL 5.1) from the HARNESS ASSEMBLY CHUTE (PL 9.1) (Figure 1).
- 7) Release the holdings of the harness from 2 clamps on the PLATE TIE (PL 5.1) (Figure 2).
- 8) Remove the 4 screws (silver with flange, and spring washer 8mm) securing the PLATE TIE to the frame (Figure 1).
- 9) Remove the 2 screws (silver with flange, and spring washer 8mm) securing the CHUTE OUT (PL 5.1) to the frame (Figure 1).
- 10) Remove the 550 FEEDER ASSEMBLY from the frame.

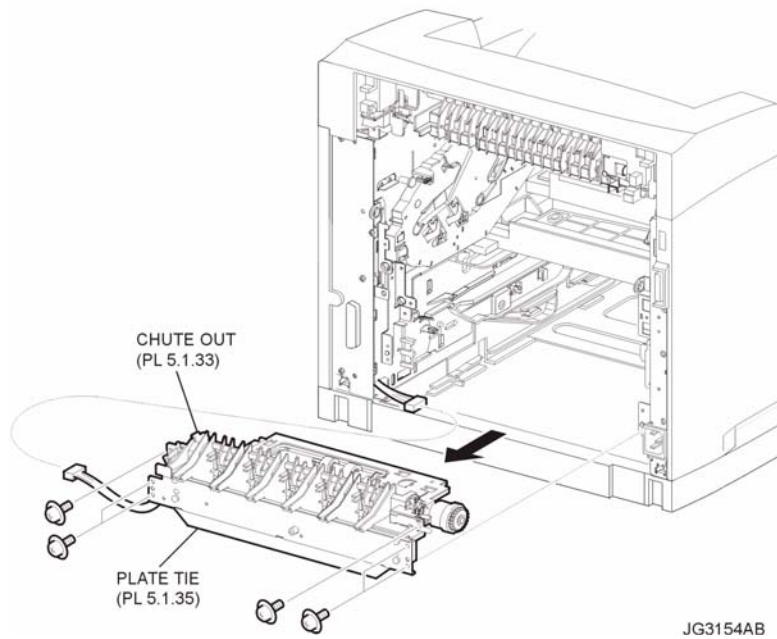

Figure 1. 550 Feeder Assembly

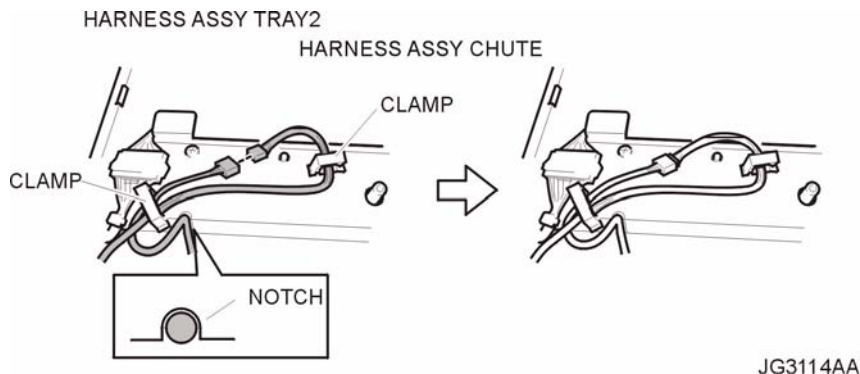

Figure 2. Harness Clamps

Replacement

Removal and Replacement Procedures (RRPs)

- 1) Install the 550 FEEDER ASSEMBLY to the frame.
- 2) Secure the CHUTE OUT (PL 5.1) to the frame using the 2 screws (silver with flange, and spring washer 8mm) (Figure 1).

NOTE

One of the screws that secure the CHUTE OUT to the frame is tightened together with the SPRING EARTH (PL 5.1.31).

- 3) Install the PLATE TIE (PL 5.1) to the frame using the 4 screws (silver with flange, and spring washer 8mm).
- 4) Secure the harness using the 2 clamps on the PLATE TIE. (Refer to figures.)

NOTE

When installing, put the harness into the notch on the PLATE TIE, and arrange it as shown (Figure 1).

- 5) Connect the connector (P/J248) of the HARNESS ASSEMBLY TRAY 2 (PL 5.1) to the HARNESS ASSEMBLY CHUTE (PL 9.1).
- 6) Install the 150 FEEDER ASSEMBLY (PL 4.1) (RRP4.1).
- 7) Install the CHUTE TRANSFER (PL 6.1) together with the BTR ASSEMBLY (RRP6.9).

NOTE

Do not tighten the screw to the left side hole of the CHUTE TRANSFER.

- 8) Install the COVER REAR (PL 1.1) (RRP1.1).

NOTE

There are 2 kinds of screws, make sure they are installed correctly.

- 9) Install the FUSER ASSEMBLY (PL 6.1) (RRP6.8).
- 10) Install the COVER REAR 500 (PL 7.1) (RRP7.9).

RRP5.2 ROLL ASSEMBLY NUDGER (PL 5.1), ROLL ASSEMBLY FEED (PL 5.1)**Removal**

- 1) Open the COVER OPEN (PL 1.1) so that the removing operation can be checked visually.
- 2) Remove Tray 1 and Tray 2 Paper Cassettes.
- 3) Lift up the 150 FEEDER ASSEMBLY (PL 4.1).

NOTE

The 150 FEEDER ASSEMBLY clicks into a notch when lifted to the half way point, push the assembly past the notch.

- 4) While holding the 150 FEEDER ASSEMBLY, release the hook securing the ROLL ASSEMBLY NUDGER by hand which is inserted through the space left by the Paper Cassettes, and pull it out from the SHAFT NUDGER (PL 5.1) (Figure 1).
- 5) Release the hook securing the ROLL ASSEMBLY FEED by using the same procedures of step 4 above, and pull it out from the SHAFT FEED (PL 5.1) (Figure 1).

NOTE

When removing, do not touch the roller surface of the ROLL ASSEMBLY NUDGER and ROLL ASSEMBLY FEED.

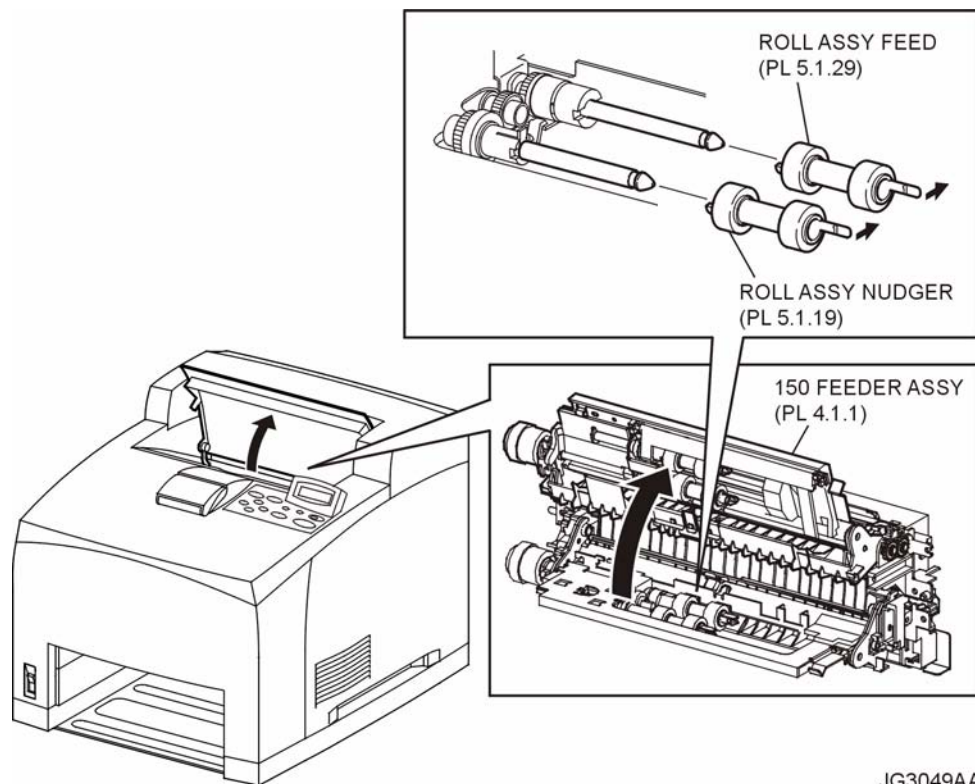

JG3049AA

Figure 1. Nudger & Feed Roll Assembly**Replacement**

- 1) While holding the 150 FEEDER ASSEMBLY, install the ROLL ASSEMBLY FEED to the SHAFT FEED (PL 5.1), and secure the ROLL ASSEMBLY FEED with the hook by using the same procedures of step 4 of removal (Figure 1).

NOTE

Be sure to install the hook of the ROLL ASSEMBLY FEED into the groove of the SHAFT FEED.

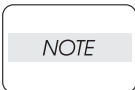

When installing, do not touch the roller surface of the ROLL ASSEMBLY NUDGER and ROLL ASSEMBLY FEED.

- 2) Install the ROLL ASSEMBLY NUDGER to the SHAFT NUDGER (PL 5.1), and secure the ROLL ASSEMBLY NUDGER with the hook.

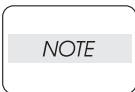

Be sure to install the hook of the ROLL ASSEMBLY NUDGER into the groove of the SHAFT NUDGER.

- 3) Press the 150 FEEDER ASSEMBLY (PL 4.1) down so that it returns to the original position.
- 4) Install the Paper Cassettes to the Tray 1 and Tray 2.
- 5) Close the COVER OPEN (PL 1.1).

RRP5.3 CLUTCH ONEWAY NUDGER (PL 5.1.27)**Removal**

- 1) Open the COVER OPEN (PL 1.1) so that the removing operation can be checked visually.
- 2) Remove the Paper Cassettes of the Tray 1 and Tray 2.
- 3) Lift up the 150 FEEDER ASSEMBLY (PL 4.1).

NOTE

The 150 FEEDER ASSEMBLY clicks into a notch when lifted to the half way point, push the assembly past the notch.

- 4) While holding the 150 FEEDER ASSEMBLY, remove the ROLL ASSEMBLY FEED (PL 5.1.29) by hand which is inserted through the space left by the Paper Cassettes (RRP5.2) (Figure 1).

NOTE

When removing, do not touch the roller surface of the ROLL ASSEMBLY FEED.

- 5) Pull out the CLUTCH ONEWAY FEED (PL 5.1.28) from the SHAFT FEED (PL 5.1) (Figure 1).
- 6) Remove the E-ring securing the CLUTCH ONEWAY NUDGER to the SHAFT FEED.
- 7) Pull out the CLUTCH ONEWAY NUDGER from the SHAFT FEED (Figure 1).

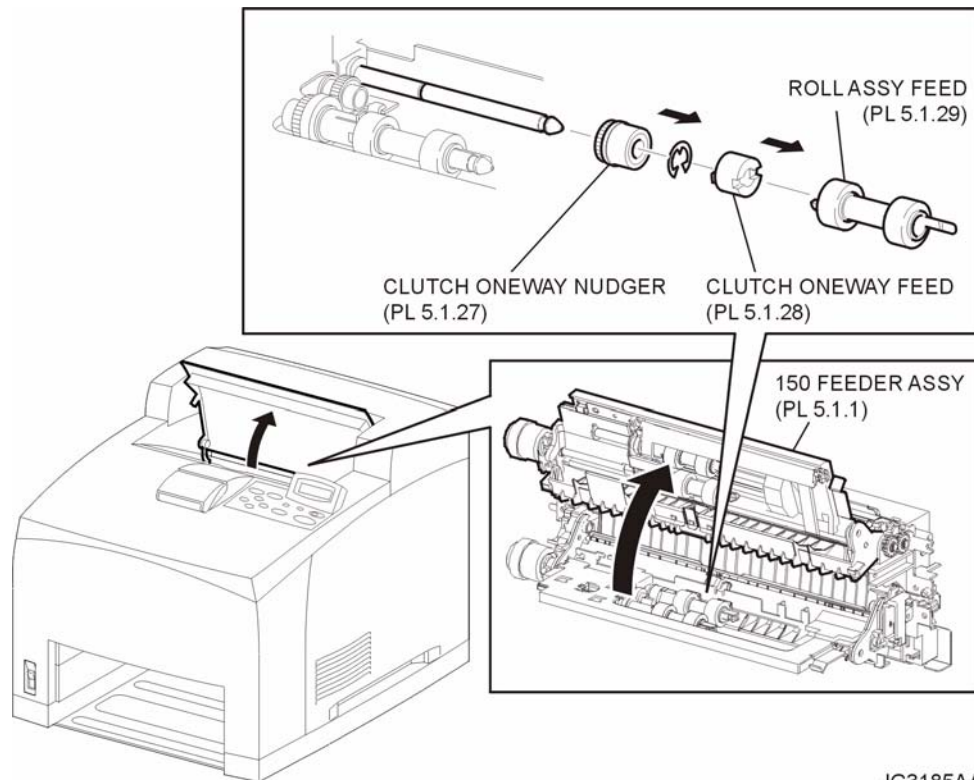

JG3185AA

Figure 1. Nudger One-way Clutch**Replacement**

- 1) Install the CLUTCH ONEWAY NUDGER to the SHAFT FEED (PL 5.1), and secure it using the E-ring (Figure 1).
- 2) Install the CLUTCH ONEWAY FEED (PL 5.1.28) to the SHAFT FEED (Figure 1).
- 3) Install the ROLL ASSEMBLY FEED (PL 5.1.29) to the SHAFT FEED, and secure it with the hook. (RRP5.2) (Figure 1).

Removal and Replacement Procedures (RRPs)

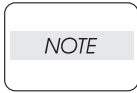

Be sure to install the hook of the ROLL ASSEMBLY FEED into the groove of the SHAFT FEED.

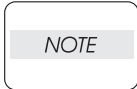

When installing, do not touch the roller surface of the ROLL ASSEMBLY FEED.

- 4) Press the 150 FEEDER ASSEMBLY (PL 4.1) down so that it returns to the original position.
- 5) Close the COVER OPEN (PL 1.1).

RRP5.4 GEAR NUDGER (PL 5.1.18)

Removal

- 1) Remove the COVER REAR 500 (PL 7.1) (RRP7.9).
- 2) Remove the FUSER ASSEMBLY (PL 6.1) (RRP6.8).
- 3) Place the printer down on its left side.

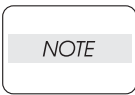

Be careful not to scratch the cover, and do not drop the printer.

- 4) Open the COVER OPEN (PL 1.1).
- 5) While lifting up the boss of the HOLDER LEFT (PL 5.1) at the back of the 550 FEEDER ASSEMBLY, shift the HOLDER LEFT in the direction of the arrow to remove 3 hooks (Figure 1).
- 6) Remove the HOLDER LEFT from the SUPPORT NUDGER (PL 5.1). At the same time, the ACTUATOR NO PAPER (PL 5.1) is removed (Figure 1).
- 7) Release the hook securing the ROLL ASSEMBLY NUDGER (PL 5.1), and pull it out from the SHAFT NUDGER (PL 5.1) (Figure 1).

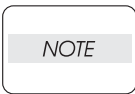

When removing, do not touch the roller surface of the ROLL ASSEMBLY NUDGER.

- 8) Release the hook securing the GEAR NUDGER, and pull it out from the SHAFT NUDGER.

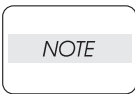

When removing, do not touch the roller surface of the GEAR NUDGER.

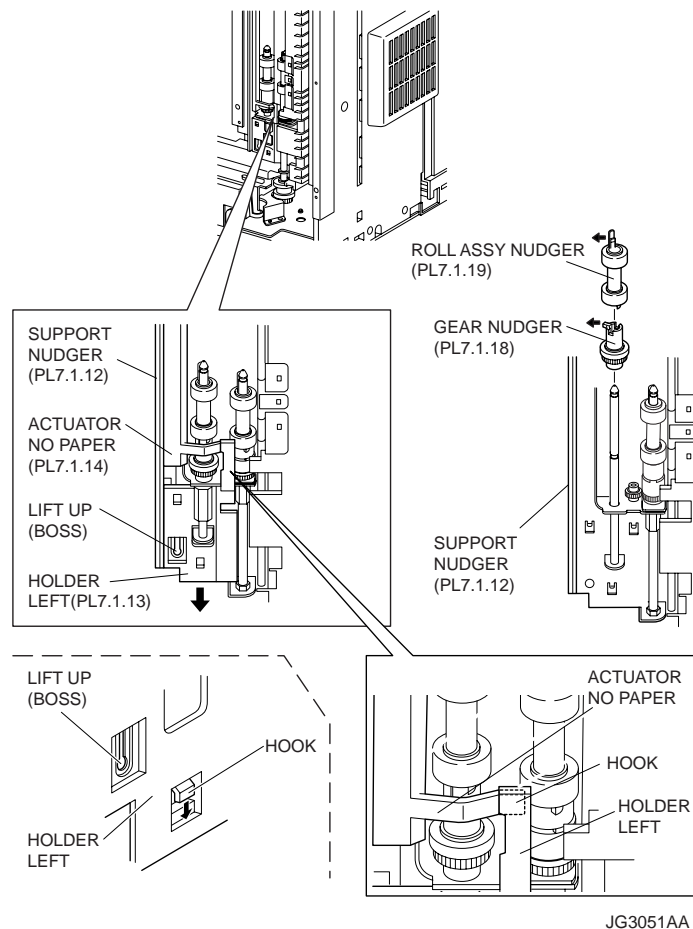
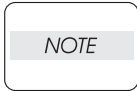

Figure 1. Nudger Gear

Replacement

- 1) Install the GEAR NUDGER to the SHAFT NUDGER (PL 5.1), and secure it with the hook.



When installing, do not touch the roller surface of the GEAR NUDGER.

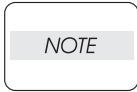

Be sure to install the hook of the GEAR NUDGER into the groove of the SHAFT NUDGER.

- 2) Install the ROLL ASSEMBLY NUDGER (PL 5.1) to the SHAFT NUDGER, and secure it with the hook.

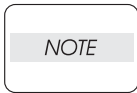

When installing, do not touch the roller surface of the ROLL ASSEMBLY NUDGER.

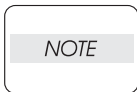

Be sure to install the hook of the ROLL ASSEMBLY NUDGER into the groove of the SHAFT NUDGER.

- 3) Install the HOLDER LEFT (PL 5.1) and ACTUATOR NO PAPER (PL 5.1) to the SUPPORT NUDGER (PL 5.1).

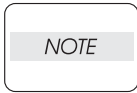

Be sure to install the shafts on both ends of the ACTUATOR NO PAPER into the HOLDER LEFT and SUPPORT NUDGER.

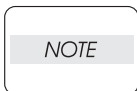

Assemble the hook of the ACTUATOR NO PAPER to the HOLDER LEFT as shown (Figure 1).

- 4) Move the HOLDER LEFT in the opposite direction of the arrow, and secure it to the 550 FEEDER ASSEMBLY with the 3 hooks.

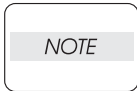

After installing, move the ACTUATOR NO PAPER with a finger, and make sure that the ACTUATOR NO PAPER operates smoothly.

- 5) Return the printer to the normal use state.
- 6) Install the FUSER ASSEMBLY (PL 6.1) (RRP6.8).
- 7) Install the COVER REAR 500 (PL 7.1) (RRP7.9).

RRP5.5 CLUTCH ASSEMBLY PH (PL 5.1.20)**Removal**

- 1) Remove the COVER REAR 500 (PL 7.1) (RRP7.9).
- 2) Remove the FUSER ASSEMBLY (PL 6.1) (RRP6.8).
- 3) Remove the COVER REAR (PL 1.1) (RRP1.1).
- 4) Remove the CHUTE TRANSFER (PL 6.1) together with the BTR ASSEMBLY (RRP6.9).
- 5) Remove the 150 FEEDER ASSEMBLY (PL 4.1) (RRP4.1).
- 6) Remove the 550 FEEDER ASSEMBLY (PL 5.1) (RRP5.1).
- 7) Remove the 6 screws (gold tapping, 8mm) securing the PLATE TIE (PL 5.1) to the CHUTE OUT (PL 5.1), and remove the PLATE TIE from the CHUTE OUT (Figure 1).
- 8) Disconnect the connector (P/J247) of the CLUTCH ASSEMBLY PH from the HARNESS ASSEMBLY TRAY 2 (PL 5.1) (Figure 1).
- 9) Remove the E-ring securing the CLUTCH ASSEMBLY PH, and remove the CLUTCH ASSEMBLY PH from the SHAFT FEED (PL 5.1) (Figure 1).

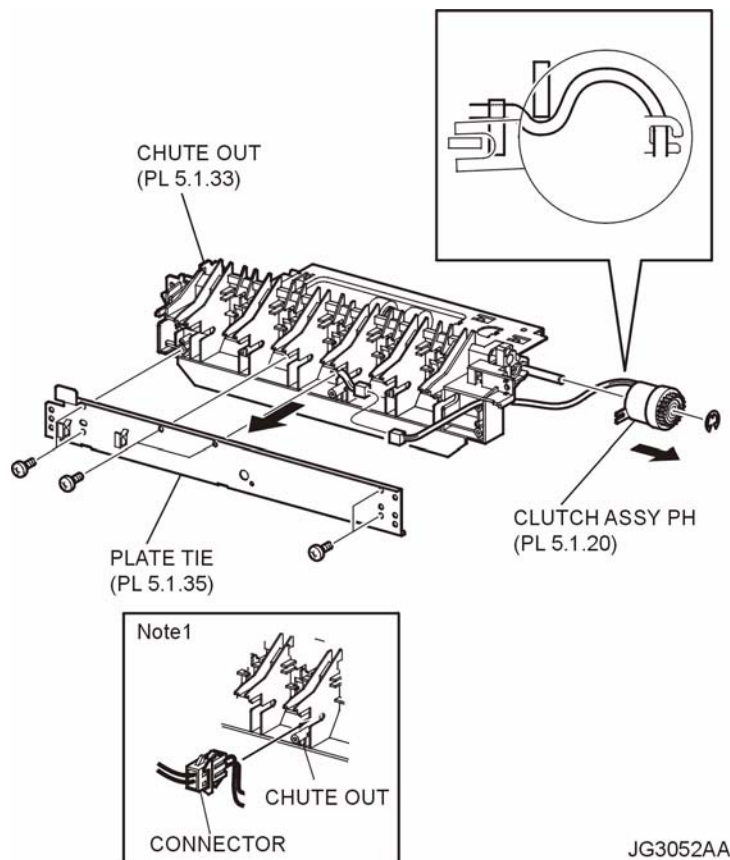
**Figure 1. PH Clutch Assembly****Replacement**

- 1) Install the CLUTCH ASSEMBLY PH to the SHAFT FEED (PL 5.1), and secure it using the E-ring.

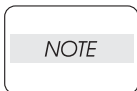

When installing, make sure that the notch of the CLUTCH ASSEMBLY PH is combined with the boss of the CHUTE OUT.

- 2) Connect P/J247 of the CLUTCH ASSEMBLY PH to the HARNESS ASSEMBLY TRAY 2 (PL 5.1). After connecting, put the connector into the space between the ribs of the CHUTE OUT (Figure 1).

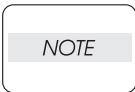

Be careful of the arranging of the harness of the CLUTCH ASSEMBLY PH.

- 3) Install the PLATE TIE (PL 5.1) to the CHUTE OUT (PL 5.1) using the 6 screws (gold tapping, 8mm) (Figure 1).
- 4) Install the 550 FEEDER ASSEMBLY (PL 5.1) (RRP5.1).
- 5) Install the 150 FEEDER ASSEMBLY (PL 4.1) (RRP4.1).
- 6) Install the CHUTE TRANSFER (PL 6.1) (RRP6.9).

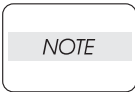

Do not tighten the screw to the left side hole of the CHUTE TRANSFER.

- 7) Install the COVER REAR (PL 1.1) (RRP1.1).

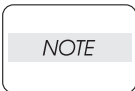

There are 2 kinds of screws, make sure they are installed correctly.

- 8) Install the FUSER ASSEMBLY (PL 6.1) (RRP6.8).
- 9) Install the COVER REAR 500 (PL 7.1) (RRP7.9).

RRP5.6 SENSOR NO PAPER (PL 5.1.38)**Removal**

- 1) Remove the COVER REAR 500 (PL 7.1) (RRP7.9).
- 2) Remove the FUSER ASSEMBLY (PL 6.1) (RRP6.8).
- 3) Remove the COVER REAR (PL 1.1) (RRP1.1).
- 4) Remove the CHUTE TRANSFER (PL 6.1) together with the BTR ASSEMBLY (RRP6.9).
- 5) Remove the 150 FEEDER ASSEMBLY (PL 4.1) (RRP4.1).
- 6) Remove the screw (gold, 6mm) securing the HOLDER NO PAPER SENSOR (PL 4.1) (Figure 1).
- 7) Remove the HOLDER NO PAPER SENSOR from the 550 FEEDER ASSEMBLY.
- 8) Release the hooks securing the SENSOR NO PAPER to the HOLDER NO PAPER SENSOR, and remove the SENSOR NO PAPER (Figure 1).
- 9) Disconnect the HARNESS ASSEMBLY TRAY 2 (PL 5.1) from the connector (P/J246) of the SENSOR NO PAPER.

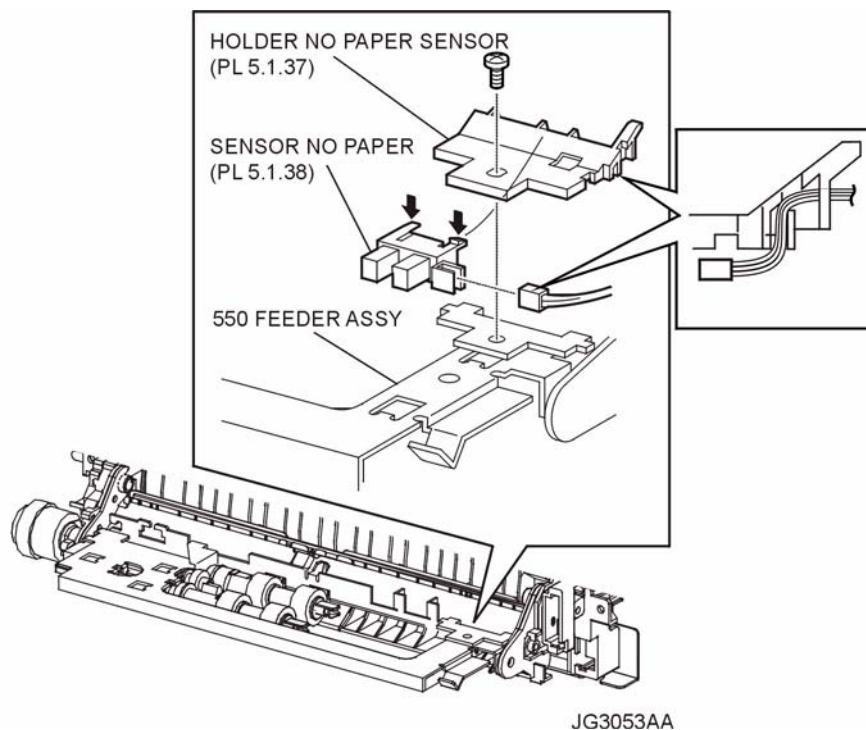
**Figure 1. No Paper Sensor****Replacement**

- 1) Connect the HARNESS ASSEMBLY TRAY 2 (PL 5.1) to the connector (P/J246) of the SENSOR NO PAPER.
- 2) Install the SENSOR NO PAPER to the HOLDER NO PAPER SENSOR (PL 4.1), and secure it using hooks (Figure 1).
- 3) Put the wires of the HARNESS ASSEMBLY TRAY 2 to the notch of the HOLDER NO PAPER SENSOR as shown in the figure.
- 4) Install the HOLDER NO PAPER SENSOR to the 550 FEEDER ASSEMBLY using the screw (gold, 6mm).

NOTE

After tightening the screw, make sure that the wires of the HARNESS ASSEMBLY TRAY 2 are not pinched.

- 5) Install the 150 FEEDER ASSEMBLY (PL 4.1) (RRP4.1).

- 6) Install the CHUTE TRANSFER (PL 6.1) (RRP6.9).

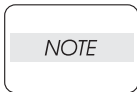

Do not tighten the screw to the left side hole of the CHUTE TRANSFER.

- 7) Install the COVER REAR (PL 1.1) (RRP1.1).

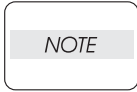

There are 2 kinds of screws, make sure they are installed correctly.

- 8) Install the FUSER ASSEMBLY (PL 6.1) (RRP6.8).

- 9) Install the COVER REAR 500 (PL 7.1) (RRP7.9).

RRP5.7 GUIDE TRAY RIGHT (PL 5.1)**Removal**

- 1) Remove the EP CARTRIDGE and Paper Cassettes.
- 2) Remove the COVER REAR 500 (PL 7.1) (RRP7.9).
- 3) Remove the COVER REAR (PL 1.1) (RRP1.1).
- 4) Remove the FUSER ASSEMBLY (PL 6.1) (RRP6.8).
- 5) Remove the COVER LEFT (PL 1.1) (RRP1.3).
- 6) Remove the COVER RIGHT (PL 1.1) (RRP1.2).
- 7) Remove the COVER EXIT 500 (PL 1.1). (RRP7.1)
- 8) Remove the 500 EXIT ASSEMBLY (PL 7.1) (RRP7.2).
- 9) Remove the COVER TOP (PL 1.1) (RRP1.4).
- 10) Remove the COVER FRONT (PL 1.1) (RRP1.5).
- 11) Place the printer down on its right side.
- 12) Disconnect the connector (P/J260) of the HARNESS ASSEMBLY LOW PAPER SNR from the GUIDE TRAY RIGHT (Figure 1).
- 13) Remove the screw (silver, 6mm) securing the GUIDE TRAY RIGHT to the frame (Figure 1).
- 14) Lift up the hook of the GUIDE TRAY RIGHT, and shift it in the direction of the arrow. Then, remove the GUIDE TRAY RIGHT from the frame (Figure 1).

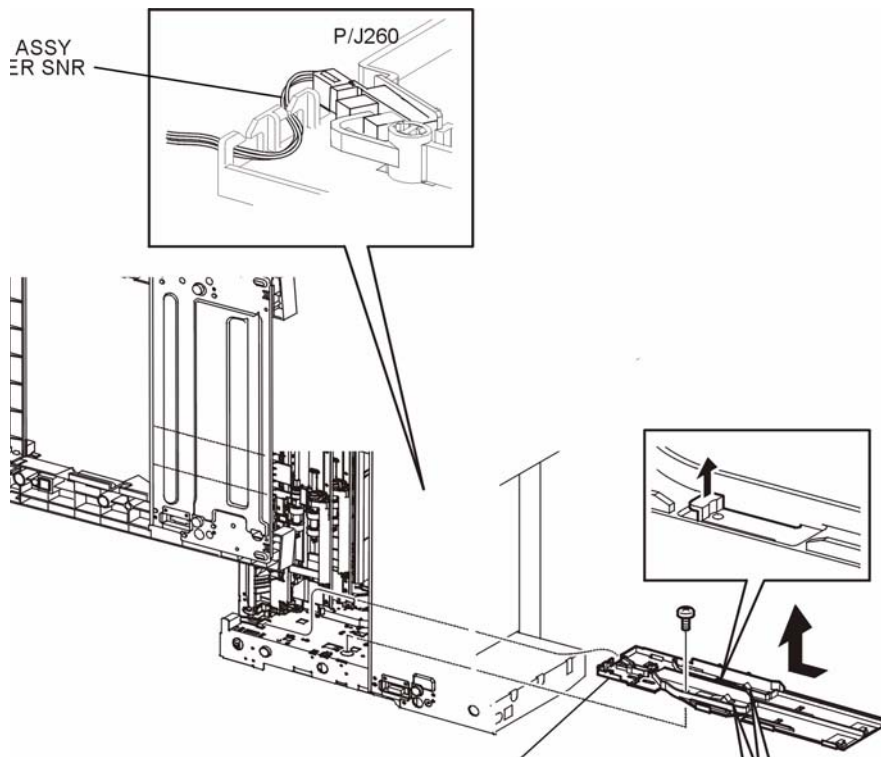
**Figure 1. Right Tray Guide**

Replacement

- 1) Shift the GUIDE TRAY RIGHT in the opposite direction of the arrow to install it to the frame, and secure it using the screw (silver, 6mm).

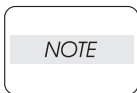

When installing the GUIDE TRAY RIGHT, make sure the installing position of the PLATE CST LOCK (PL 5.1) is in the position shown (Figure 1) (NOTE).

- 2) Connect the connector (P/J260) of the HARNESS ASSEMBLY LOW PAPER SNR to the GUIDE TRAY RIGHT (Figure 1).
- 3) Return the printer to the normal use state.
- 4) Install the COVER FRONT (PL 1.1) (RRP1.5).
- 5) Install the COVER TOP (PL 1.1) (RRP1.4).
- 6) Install the 500 EXIT ASSEMBLY (PL 7.1) (RRP7.2).
- 7) Install the COVER EXIT 500 (PL 1.1) (RRP7.1).
- 8) Install the COVER RIGHT (PL 1.1) (RRP1.2).
- 9) Install the COVER LEFT (PL 1.1) (RRP1.3).
- 10) Install the FUSER ASSEMBLY (PL 6.1) (RRP6.8).
- 11) Install the COVER REAR (PL 1.1) (RRP1.1).

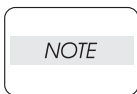

There are 2 kinds of screws, make sure they are installed correctly.

- 12) Install the COVER REAR 500 (PL 7.1) (RRP7.9).
- 13) Install the EP CARTRIDGE and Paper Cassettes.

RRP5.8 GUIDE TRAY LEFT (PL 7.1)**Removal**

- 1) Remove the EP CARTRIDGE and Paper Cassettes.
- 2) Remove the COVER REAR 500 (PL 7.1) (RRP7.9).
- 3) Remove the COVER REAR (PL 1.1) (RRP1.1).
- 4) Remove the FUSER ASSEMBLY (PL 6.1) (RRP6.8).
- 5) Remove the COVER LEFT (PL 1.1) (RRP1.3).
- 6) Remove the COVER RIGHT (PL 1.1) (RRP1.2).
- 7) Remove the COVER EXIT 500 (PL 1.1) (RRP7.1).
- 8) Remove the 500 EXIT ASSEMBLY (PL 7.1) (RRP7.2).
- 9) Remove the COVER TOP (PL 1.1) (RRP1.4).
- 10) Remove the COVER FRONT (PL 1.1) (RRP1.5).
- 11) Place the printer down on its left side.
- 12) Disconnect the HARNESS ASSEMBLY LVPS (PL 9.1) from the connector (P/J1821) of the GUIDE TRAY LEFT (Figure 1).
- 13) Remove the 6 screws (gold tapping, 8mm x 1, gold, 6mm x 5) securing the GUIDE TRAY LEFT to the frame (Figure 1).
- 14) Shift the GUIDE TRAY LEFT in the direction of the arrows (A) and (B), and remove it from the frame (Figure 1).

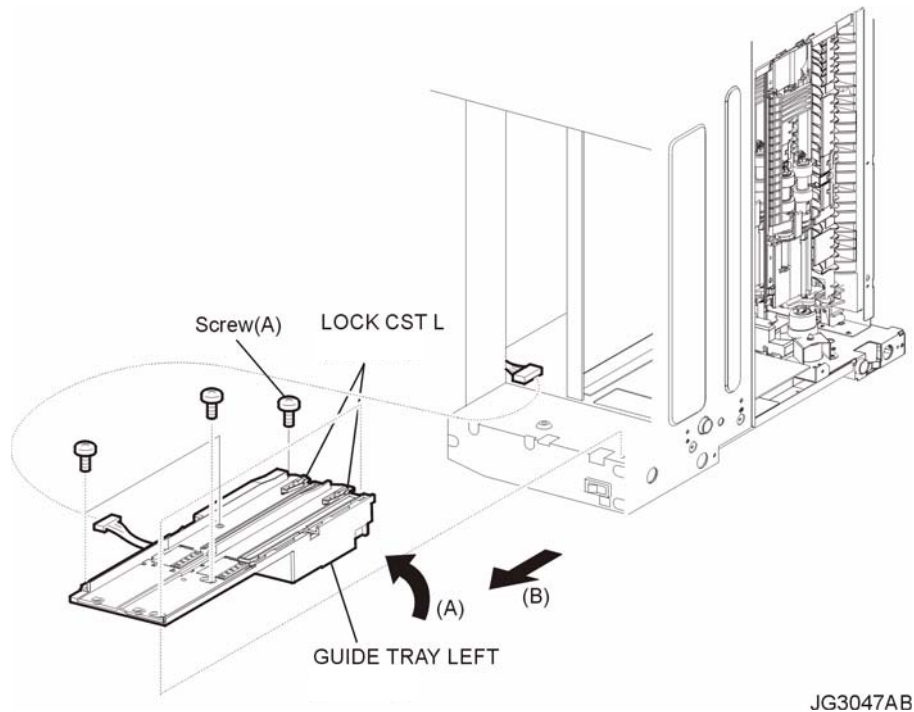
**Figure 1. Left Tray Guide****Replacement**

- 1) Shift the GUIDE TRAY LEFT in the opposite direction of the arrows (A) and (B), and install it to the frame.
- 2) Install the GUIDE TRAY LEFT using the 6 screws (gold tapping, 8mm x 1, gold, 6mm x 5).

NOTE

Be sure to tighten the screw (gold tapping, 8mm) shown as "Screw (A)" (Figure 1).

- 3) Connect the connector (P/J1821) of the GUIDE TRAY LEFT to the HARNESS ASSEMBLY LVPS (PL 9.1) (Figure 1).
- 4) Return the printer to the normal use state.
- 5) Install the COVER FRONT (PL 1.1) (RRP1.5).
- 6) Install the COVER TOP (PL 1.1) (RRP1.4).
- 7) Install the 500 EXIT ASSEMBLY (PL 7.1) (RRP7.2).
- 8) Install the COVER EXIT 500 (PL 1.1) (RRP7.1).
- 9) Install the COVER RIGHT (PL 1.1) (RRP1.2).
- 10) Install the COVER LEFT (PL 1.1) (RRP1.3).
- 11) Install the FUSER ASSEMBLY (PL 6.1) (RRP6.8).
- 12) Install the COVER REAR (PL 1.1) (RRP1.1).

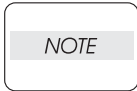

There are 2 kinds of screws, make sure they are installed correctly.

- 13) Install the COVER REAR 500 (PL 7.1) (RRP7.9).
- 14) Install the EP CARTRIDGE and Paper Cassettes.

RRP5.9 SENSOR LOW PAPER (PL 5.1.4)**Removal**

- 1) Remove the EP CARTRIDGE and Paper Cassettes.
- 2) Remove the COVER REAR 500 (PL 7.1) (RRP7.9).
- 3) Remove the FUSER ASSEMBLY (PL 6.1) (RRP6.8).
- 4) Place the printer down on its right side.

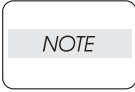

Be careful not to scratch the cover, and do not drop the printer.

- 5) Disconnect the connector (P/J260) of the HARNESS ASSEMBLY LOW 1 (PL 5.1) from the SENSOR (Figure 1).
- 6) Release the hooks of the SENSOR, and remove it from the GUIDE TRAY RIGHT (PL 5.1) (Figure 1).

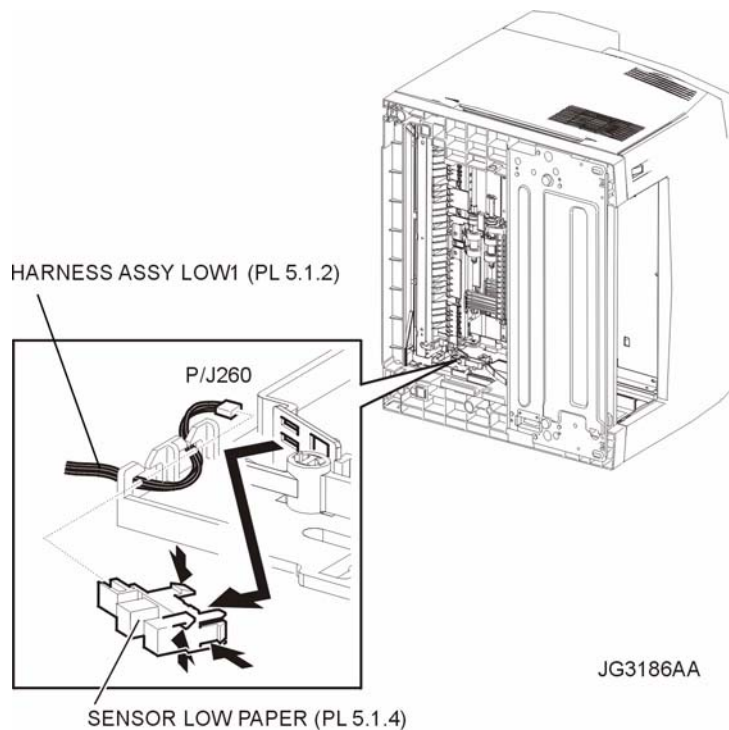

Figure 1. Low Paper Sensor

Replacement

- 1) Install the SENSOR LOW PAPER to the GUIDE TRAY RIGHT (PL 5.1), and secure it with hooks (Figure 1).
- 2) Connect the connector (P/J260) of the HARNESS ASSEMBLY LOW 1 (PL 5.1) to the SENSOR (Figure 1).
- 3) Return the printer to the normal use state.
- 4) Install the FUSER ASSEMBLY (PL 6.1) (RRP6.8).
- 5) Install the COVER REAR 500 (PL 7.1) (RRP7.9).
- 6) Install the EP CARTRIDGE and Paper Cassettes.

RRP5.10 ACTUATOR NO PAPER (PL 5.1)

Removal

- 1) Remove the COVER REAR 500 (PL 7.1) (RRP7.9).
- 2) Remove the FUSER ASSEMBLY (PL 6.1) (RRP6.8).
- 3) Place the printer down on its left side.

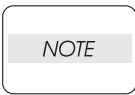

Be careful not to scratch the cover, and do not drop the printer.

- 4) Open the COVER OPEN (PL 1.1).
- 5) While lifting up the boss of the HOLDER LEFT (PL 5.1) at the back of the 550 FEEDER ASSEMBLY, shift the HOLDER LEFT in the direction of the arrow to remove 3 hooks (Figure 1).
- 6) Remove the HOLDER LEFT from the SUPPORT NUDGER (PL 5.1) (Figure 1). At the same time, the ACTUATOR NO PAPER is removed.

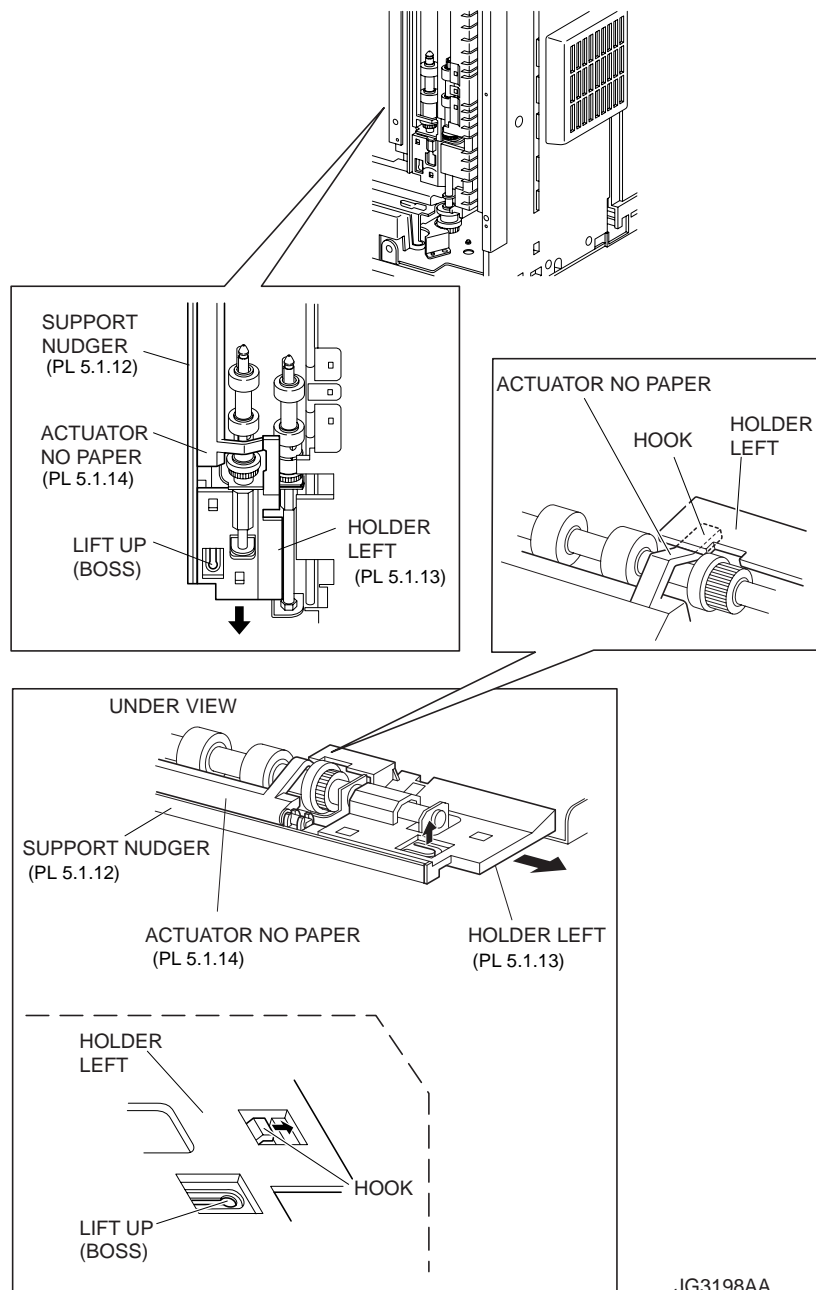

JG3198AA

Figure 1. No Paper Actuator

Replacement

- 1) Install the HOLDER LEFT (PL 5.1) and ACTUATOR NO PAPER to the SUPPORT NUDGER (PL 5.1).

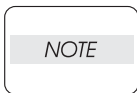

Be sure to install the shafts on both ends of the ACTUATOR NO PAPER into the HOLDER LEFT and SUPPORT NUDGER.

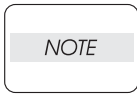

Assemble the hook of the ACTUATOR NO PAPER to the HOLDER LEFT as shown (Figure 1).

- 2) Move the HOLDER LEFT in the opposite direction of the arrow, and secure it to the 550 FEEDER ASSEMBLY with the 3 hooks (Figure 1).

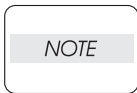

After installing, move the ACTUATOR NO PAPER with a finger, and make sure that the ACTUATOR NO PAPER operates smoothly.

- 3) Return the printer to the normal use state.
- 4) Install the FUSER ASSEMBLY (PL 6.1) (RRP6.8).
- 5) Install the COVER REAR 500 (PL 7.1) (RRP7.9).

RRP6. Xerographics

RRP6.1 ROS ASSEMBLY (PL 6.1)**NOTE**

When performing the ROS ASSEMBLY removal and/or installation, be sure to perform the operation on a level and smooth work surface. If the operation is performed on a rough and/or inclined surface, the ROS ASSEMBLY will be out of alignment.

Removal

- 1) Remove the COVER REAR 500 (PL 7.2) (RRP7.9).
- 2) Remove the COVER REAR (PL 1.1) (RRP1.1).
- 3) Remove the COVER LEFT (PL 1.1) (RRP1.3).
- 4) Remove the COVER RIGHT (PL 1.1) (RRP1.2).
- 5) Remove the COVER EXIT 500 (PL 1.1) (RRP7.1).
- 6) Remove the 500 EXIT ASSEMBLY (PL 7.1) (RRP7.2).
- 7) Remove the COVER TOP (PL 1.1) (RRP1.4).
- 8) Remove the COVER FRONT (PL 1.1) (RRP1.5).
- 9) Remove the DUCT FRONT (PL 6.1) (RRP6.2).
- 10) Remove the 3 screws (silver with flange, 8mm) securing the DUCT HIGH (PL 9.1), and remove the DUCT HIGH (Figure 1).
- 11) Remove the screw (silver with flange, 8mm) securing the DUCT VACUUM L/R (PL 6.1), and release the hooks of the DUCT VACUUM L/R, and remove the DUCT VACUUM L/R.
- 12) Release the 2 clamps holding the harnesses, from the PLATE TIE FRONT (PL 9.1) (Figure 1).
- 13) Remove the 8 screws (silver, 6mm) securing the PLATE TIE FRONT to the frame, and remove the PLATE TIE FRONT (Figure 1).
- 14) Release the 2 clamps holding the harnesses, from the ROS ASSEMBLY (Figure 1).
- 15) Disconnect 4 connectors of the HARNESS ASSEMBLY ROS (PL 6.1) (Figure 1).

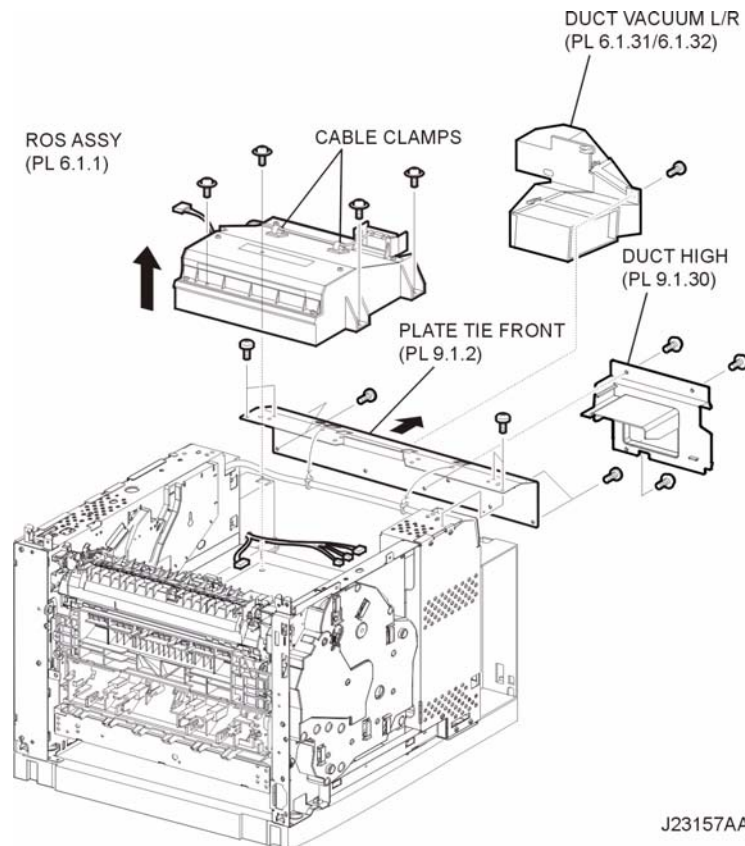

J23157AA

Figure 1. ROS Assembly

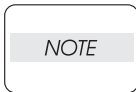

The printed circuit board on the ROS ASSEMBLY is fragile, therefore, be sure to hold it when disconnecting the connectors (Figure 1).

- 16) Remove the 4 screws (black with flange, 8mm) securing the ROS ASSEMBLY to the frame.

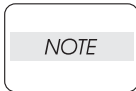

Be careful not to drop or strike the ROS Assembly with any tools or other objects.

- 17) Remove the ROS ASSEMBLY.

Replacement

- 1) Install the ROS ASSEMBLY to the frame using the 4 screws (black with flange, 8mm).

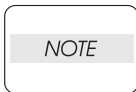

Be careful not to drop or strike the ROS Assembly with any tools or other objects.

- 2) Connect the connectors of the HARNESS ASSEMBLY ROS to the printed circuit board on the ROS ASSEMBLY.

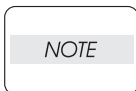

The printed circuit board on the ROS ASSEMBLY is fragile, then, be sure to hold it with hand when connecting the connectors.

- 3) Secure the harness with the 2 cable clamps on the ROS ASSEMBLY.
- 4) Install the PLATE TIE FRONT (PL 9.1) to the frame using the 8 screws (silver, 6mm) and tighten firmly.

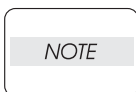

Be sure to perform this operation on a level and smooth work space.

- 5) Secure the harness to the PLATE TIE FRONT using the 2 clamps.
- 6) Secure the DUCT VACUUM L/R (PL 6.1/PL 8.1.31) using the screw (silver with flange, 8mm).
- 7) Secure the DUCT HIGH (PL 9.1) using the 3 screws (silver with flange, 8mm).
- 8) Install the DUCT FRONT (PL 6.1) (RRP6.2).
- 9) Install the COVER FRONT (PL 1.1) (RRP1.5).
- 10) Install the COVER TOP (PL 1.1) (RRP1.4).
- 11) Install the 500 EXIT ASSEMBLY (PL 7.1) (RRP7.2).
- 12) Install the COVER EXIT 500 (PL 1.1) (RRP7.1).
- 13) Install the COVER RIGHT (PL 1.1) (RRP1.2).
- 14) Install the COVER LEFT (PL 1.1) (RRP1.3).
- 15) Install the COVER REAR (PL 1.1) (RRP1.1).

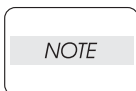

There are 2 kinds of screws, make sure they are installed correctly.

- 16) Install the COVER REAR 500 (PL 7.1) (RRP7.9).

RRP6.2 DUCT FRONT (PL 6.1), FAN SUB (PL 6.1)**Removal**

- 1) Remove the COVER REAR 500 (PL 7.1) (RRP7.9).
- 2) Remove the COVER REAR (PL 1.1) (RRP1.1).
- 3) Remove the COVER LEFT (PL 1.1) (RRP1.3).
- 4) Remove the COVER RIGHT (PL 1.1) (RRP1.2).
- 5) Remove the COVER EXIT 500 (PL 1.1) (RRP7.1).
- 6) Remove the 500 EXIT ASSEMBLY (PL 7.1) (RRP7.2).
- 7) Remove the COVER TOP (PL 1.1) (RRP1.4).
- 8) Remove the COVER FRONT (PL 1.1) (RRP1.5).
- 9) Disconnect the connector (P/J270) of the FAN SUB from the HARNESS ASSEMBLY LVPS (PL 9.1) (Figure 1).
- 10) Remove the 3 screws (silver tapping with flange, 8mm x 1, gold tapping, 8mm x 2) securing the DUCT FRONT (Figure 1).
- 11) Remove the DUCT FRONT attached with the FAN SUB from the frame by moving it in the direction of the arrow (Figure 1).
- 12) Release the hook securing the FAN SUB to the DUCT FRONT, and remove the FAN SUB.

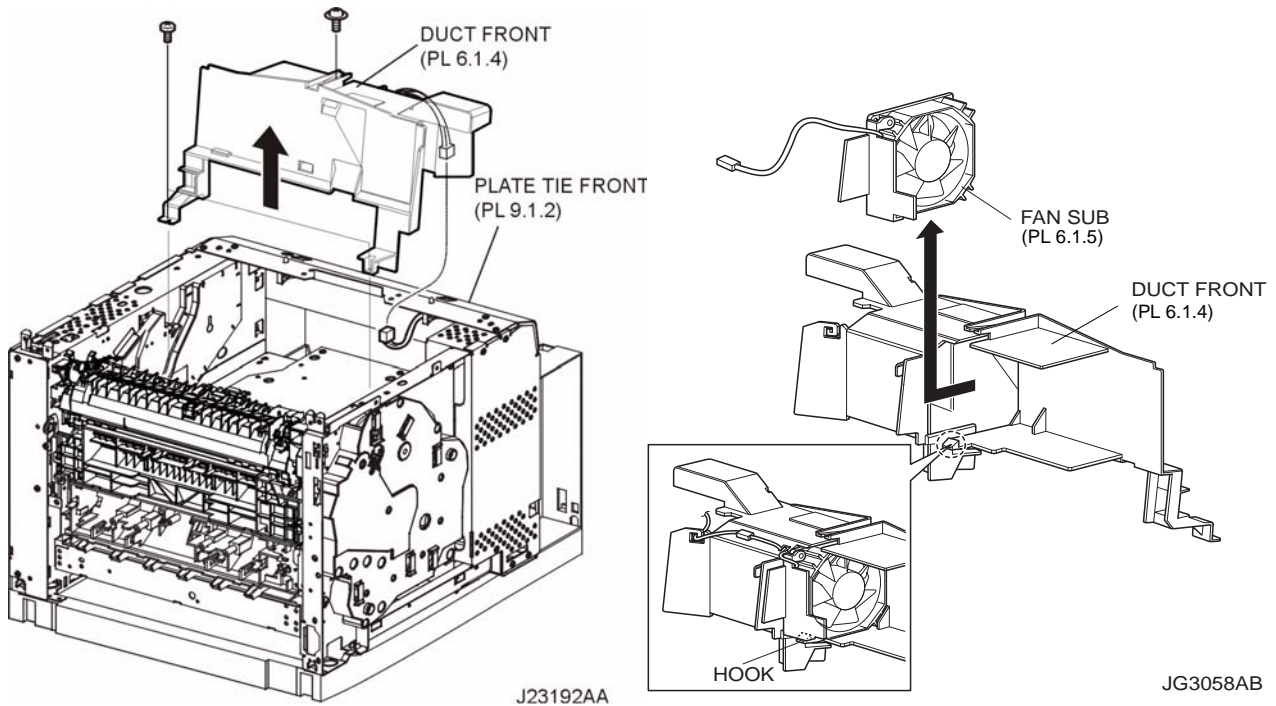
**Figure 1. Front Duct & Sub Fan****Replacement**

- 1) Install the FAN SUB to the DUCT FRONT, and secure it with the hook.

NOTE

When installing the FAN SUB to the DUCT FRONT, be sure to install the FAN SUB so that the label is facing inside and the harness is in the place shown (Figure 1).

- 2) Install the DUCT FRONT attached with the FAN SUB to the frame by moving the opposite direction of the arrow shown (Figure 1).
- 3) Install the DUCT FRONT to the frame using the 3 screws (silver tapping with flange, 8mm x1, gold tapping, 8mm x 2) (Figure 1).

Removal and Replacement Procedures (RRPs)

- 4) Connect the connector (P/J270) of the FAN SUB to the HARNESS ASSEMBLY LVPS (PL 9.1).
- 5) Install the COVER FRONT (PL 1.1) (RRP1.5).
- 6) Install the COVER TOP (PL 1.1) (RRP1.4).
- 7) Install the 500 EXIT ASSEMBLY (PL 7.1) (RRP7.2).
- 8) Install the COVER EXIT 500 (PL 1.1) (RRP7.1).
- 9) Install the COVER RIGHT (PL 1.1) (RRP1.2).
- 10) Install the COVER LEFT (PL 1.1) (RRP1.3).
- 11) Install the COVER REAR (PL 1.1) (RRP1.1).

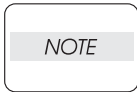

There are 2 kinds of screws, make sure they are installed correctly.

- 12) Install the COVER REAR 500 (PL 7.2) (RRP7.9).

RRP6.3 SHIELD PLATE ROS (PL 6.1)**Removal**

- 1) Remove the COVER REAR 500 (PL 7.1) (RRP7.9).
- 2) Remove the COVER REAR (PL 1.1) (RRP1.1).
- 3) Remove the COVER LEFT (PL 1.1) (RRP1.3).
- 4) Remove the COVER RIGHT (PL 1.1) (RRP1.2).
- 5) Remove the COVER EXIT 500 (PL 1.1) (RRP7.1).
- 6) Remove the 500 EXIT ASSEMBLY (PL 7.1) (RRP7.2).
- 7) Remove the COVER TOP (PL 1.1) (RRP1.4).
- 8) Remove the COVER FRONT (PL 1.1) (RRP1.5).
- 9) Remove the DUCT FRONT (PL 6.1) (RRP6.2).
- 10) Remove the FUSER ASSEMBLY (PL 6.1) (RRP6.8).
- 11) Remove the ROS ASSEMBLY (PL 6.1) (RRP6.1)

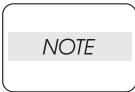

Be careful not to drop or strike the ROS Assembly with any tools or other objects.

- 12) Remove the 2 screws (black with flange, 8mm) securing the SHIELD PLATE ROS to the frame (Figure 1).
- 13) Move the SHIELD PLATE ROS in the direction of the arrows to remove (Figure 1).

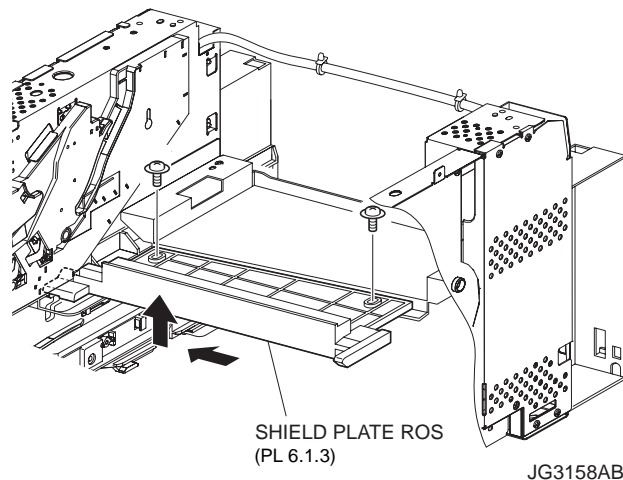
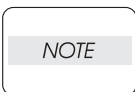

Figure 1. ROS Shield Plate

Replacement

- 1) Install the SHIELD PLATE ROS by moving it in the opposite direction of the arrows (Figure 1).
- 2) Secure the SHIELD PLATE ROS using the 2 screws (black with flange, 8mm) to the frame (Figure 1).
- 3) Install the ROS ASSEMBLY (PL 6.1) (RRP6.1).



Be careful not to drop or strike the ROS Assembly with any tools or other objects.

- 4) Install the FUSER ASSEMBLY (PL 6.1) (RRP6.8).
- 5) Install the DUCT FRONT (PL 6.1) (RRP6.2).
- 6) Install the COVER FRONT (PL 1.1) (RRP1.5).
- 7) Install the COVER TOP (PL 1.1) (RRP1.4).
- 8) Install the 500 EXIT ASSEMBLY (PL 7.1) (RRP7.2).

9) Install the COVER EXIT 500 (PL 1.1) (RRP7.1).

10) Install the COVER RIGHT (PL 1.1) (RRP1.2).

11) Install the COVER LEFT (PL 1.1) (RRP1.3).

12) Install the COVER REAR (PL 1.1) (RRP1.1).

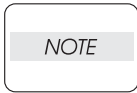

There are 2 kinds of screws, make sure they are installed correctly.

13) Install the COVER REAR 500 (PL 7.1) (RRP7.9).

RRP6.4 GUIDE CRU LEFT (PL 6.1)**Removal**

- 1) Remove the COVER REAR 500 (PL 7.1) (RRP7.9).
- 2) Remove the COVER REAR (PL 1.1) (RRP1.1).
- 3) Remove the COVER LEFT (PL 1.1) (RRP1.3).
- 4) Remove the COVER RIGHT (PL 1.1) (RRP1.2).
- 5) Remove the COVER EXIT 500 (PL 1.1) (RRP7.1).
- 6) Remove the 500 EXIT ASSEMBLY (PL 7.1) (RRP7.2).
- 7) Remove the COVER TOP (PL 1.1) (RRP1.4).
- 8) Remove the COVER FRONT (PL 1.1) (RRP1.5).
- 9) Remove the FUSER ASSEMBLY (PL 6.1) (RRP6.8).
- 10) Remove the BTR ASSEMBLY (PL 6.1) (RRP6.9).
- 11) Remove the GUIDE TRAY LEFT (PL 5.1) (RRP5.8).
- 12) Remove the DUCT FRONT (PL 6.1) (RRP6.2).
- 13) Remove the ROS ASSEMBLY (PL 6.1) (RRP6.1).

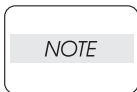

Be careful not to drop or strike the ROS Assembly with any tools or other objects.

- 14) Remove the SHIELD PLATE ROS (PL 6.1) (RRP6.3).
- 15) While lifting up the 150 FEEDER ASSEMBLY, remove the MOTOR COVER (PL 8.1) (RRP8.1).
- 16) Remove the SHIELD PLATE LVPS (PL 9.1) (RRP9.1).
- 17) Remove the connector (P/J46 and P/J47) of the HARNESS ASSEMBLY FUSER (PL 6.1) from the frame (Figure 1).
- 18) Remove the harness clamp holding the HARNESS ASSEMBLY FUSER attached to the GUIDE CRU LEFT to the frame (Figure 1).

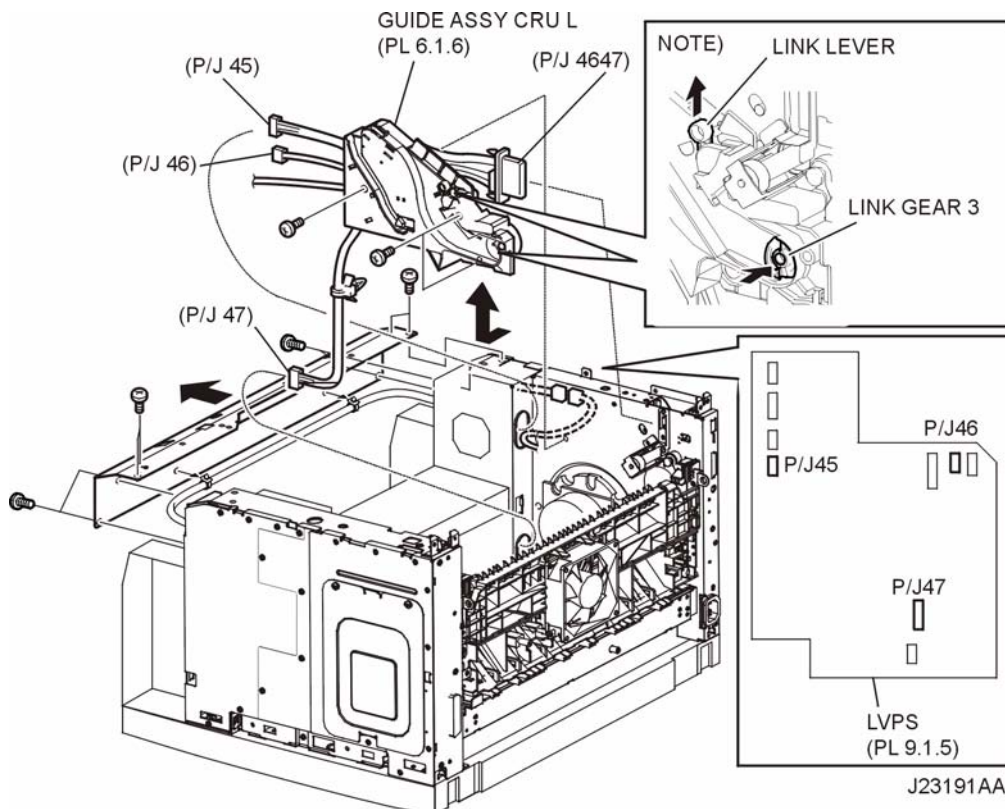
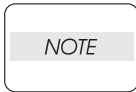

Figure 1. Left CRU Guide

- 19) Disconnect the connector (P/J141) of the INTERLOCK S/W 5V from the HARNESS ASSEMBLY LVPS (PL 9.1) (Figure 1).
- 20) Disconnect the connector (P/J45) of the INTERLOCK S/W 24V from the LVPS (PL 9.1.5) (Figure 1).
- 21) Disconnect the connectors (P/J46 and P/J47) of the HARNESS ASSEMBLY FUSER from the LVPS (Figure 1).
- 22) Remove the 3 screws (gold, 6mm) securing the GUIDE CRU LEFT to the frame (Figure 1).
- 23) Remove the GUIDE CRU LEFT from the frame.



When removing GUIDE CRU LEFT, pressing LINK GEAR 3 in the direction of the arrow helps to remove GUIDE CRU LEFT easily.

Replacement

- 1) Install the GUIDE CRU LEFT to the frame.

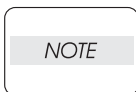

When installing, make sure that the LEVER LINK (PL 6.1) is attached to the GUIDE CRU LEFT (Figure 1).

- 2) Install the GUIDE CRU LEFT to the frame using the 3 screws (gold, 6mm).

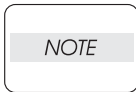

After installing the GUIDE CRU LEFT, touch the LINK GEAR 3 with your finger. Make sure that your finger can feel the LINK GEAR 3 move inward, when the LEVER LINK is pulled up.

- 3) Connect the connectors (P/J46 and P/J47) of the HARNESS ASSEMBLY FUSER to the LVPS (PL 9.1.5).
- 4) Connect the connector (P/J45) of the INTERLOCK S/W 24V to the LVPS.
- 5) Connect the connector (P/J141) of the INTERLOCK S/W 5V to the HARNESS ASSEMBLY LVPS (PL 9.1).
- 6) Secure the HARNESS ASSEMBLY FUSER (PL 6.1) attached to the GUIDE CRU LEFT to the frame using harness clamp.
- 7) Install the connector (P/J46 and P/J47) of the HARNESS ASSEMBLY FUSER to the frame.
- 8) Install the SHIELD PLATE LVPS (PL 9.1) (RRP8.1).
- 9) While lifting up the 150 FEEDER ASSEMBLY, install the MOTOR COVER (PL 8.1) (RRP8.1).
- 10) Install the SHIELD PLATE ROS (PL 6.1) (RRP6.3).
- 11) Install the ROS ASSEMBLY (PL 6.1) (RRP6.1).

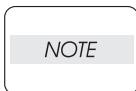

Be careful not to drop or strike the ROS Assembly with any tools or other objects.

- 12) Install the DUCT FRONT (PL 6.1) (RRP6.2).
- 13) Install the GUIDE TRAY LEFT (PL 5.1) (RRP5.8).
- 14) Install the BTR ASSEMBLY (PL 6.1) (RRP6.9).
- 15) Install the FUSER ASSEMBLY (PL 6.1) (RRP6.8).
- 16) Install the COVER FRONT (PL 1.1) (RRP1.5).
- 17) Install the COVER TOP (PL 1.1) (RRP1.4).
- 18) Install the 500 EXIT ASSEMBLY (PL 7.1) (RRP7.2).
- 19) Install the COVER EXIT 500 (PL 1.1) (RRP7.1).
- 20) Install the COVER RIGHT (PL 1.1) (RRP1.2).
- 21) Install the COVER LEFT (PL 1.1) (RRP1.3).
- 22) Install the COVER REAR (PL 1.1) (RRP1.1).

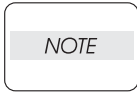

There are 2 kinds of screws, make sure they are installed correctly.

23) Install the COVER REAR 500 (PL 7.1) (RRP7.9).

RRP6.5 INTERLOCK S/W 24V, INTERLOCK S/W 5V (PL 6.1)**Removal**

- 1) Remove the COVER REAR 500 (PL 7.1) (RRP7.9).
- 2) Remove the COVER REAR (PL 1.1) (RRP1.1).
- 3) Remove the FUSER ASSEMBLY (PL 6.1) (RRP6.8).
- 4) Remove the COVER LEFT (PL 1.1) (RRP1.3).
- 5) Remove the COVER RIGHT (PL 1.1) (RRP1.2).
- 6) Remove the COVER EXIT 500 (PL 1.1) (RRP7.1).
- 7) Remove the 500 EXIT ASSEMBLY (PL 7.1) (RRP7.2).
- 8) Remove the COVER TOP (PL 1.1) (RRP1.4).
- 9) Remove the COVER FRONT (PL 1.1) (RRP1.5).
- 10) Remove the BTR ASSEMBLY (PL 6.1) (RRP6.9).
- 11) Remove the DUCT FRONT (PL 6.1) (RRP6.2).
- 12) Remove the ROS ASSEMBLY (PL 6.1) (RRP6.1).

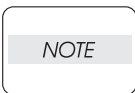

Be careful not to drop or strike the ROS Assembly with any tools or other objects.

- 13) Remove the SHIELD PLATE ROS (PL 6.1) (RRP6.3).
- 14) Remove the GUIDE TRAY LEFT (PL 5.1) (RRP5.8).
- 15) Remove the MOTOR COVER (PL 8.1) (RRP8.1).
- 16) Remove the SHIELD PLATE LVPS (PL 9.1) (RRP8.1).
- 17) Remove the GUIDE CRU LEFT (PL 6.1) (RRP6.4).
- 18) Remove the COVER GUIDE CRU (PL 6.1) and HARNESS ASSEMBLY FUSER (PL 6.1) from the GUIDE CRU LEFT (RRP6.7).
- 19) Remove the 2 screws (gold tapping, 6mm) securing the HOLDER I/L SW2 (PL 6.1) to the GUIDE CRU LEFT (Figure 1).
- 20) Remove the HOLDER I/L SW2 (Figure 1).
- 21) Release the hook of the HOLDER I/L SW1 (PL 6.1), and remove the INTERLOCK S/W 24V and INTERLOCK S/W 5V (Figure 1).

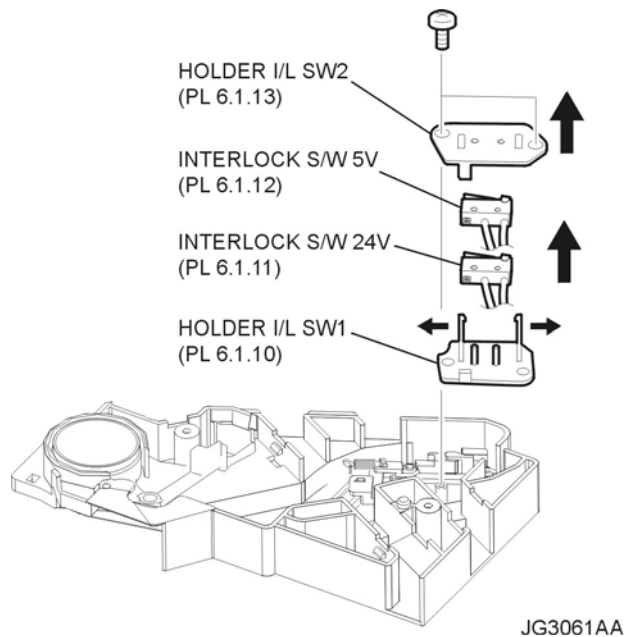

JG3061AA

Figure 1. 5 Volt & 24 Volt Interlock

Replacement

- 1) Install the INTERLOCK S/W 24V and INTERLOCK S/W 5V to the HOLDER I/L SW1 (PL 6.1) and secure them with hooks (Figure 1).
- 2) Install the HOLDER I/L SW2 (PL 6.1) to the GUIDE CRU LEFT (PL 6.1) using the 2 screws (gold tapping, 6mm) (Figure 1).
- 3) Install the COVER GUIDE CRU (PL 6.1) and HARNESS ASSEMBLY FUSER (PL 6.1) to the GUIDE CRU LEFT.
- 4) Install the GUIDE CRU LEFT (RRP6.4).

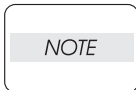

When installing, make sure that the LEVER LINK (PL 6.1.29) is attached to the GUIDE CRU LEFT.

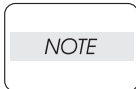

After installing the GUIDE CRU LEFT, touch the LINK GEAR 3 with your finger. Make sure that your finger can feel the LINK GEAR 3 move inward, when the LEVER LINK is pulled up.

- 5) Install the SHIELD PLATE LVPS (PL 9.1) (RRP8.1).
- 6) Install the MOTOR COVER (PL 8.1) (RRP1.1).
- 7) Install the GUIDE TRAY LEFT (PL 5.1) (RRP5.8).
- 8) Install the SHIELD PLATE ROS (PL 6.1) (RRP6.3).
- 9) Install the ROS ASSEMBLY (PL 6.1) (RRP6.1).

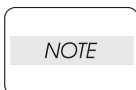

Be careful not to drop or strike the ROS Assembly with any tools or other objects.

- 10) Install the DUCT FRONT (PL 6.1) (RRP6.2).
- 11) Install the COVER FRONT (PL 1.1) (RRP1.5).
- 12) Install the COVER TOP (PL 1.1) (RRP1.4).
- 13) Install the 500 EXIT ASSEMBLY (PL 7.1) (RRP7.2).
- 14) Install the COVER EXIT 500 (PL 1.1) (RRP7.1).
- 15) Install the COVER RIGHT (PL 1.1) (RRP1.2).
- 16) Install the COVER LEFT (PL 1.1) (RRP1.3).
- 17) Install the FUSER ASSEMBLY (PL 6.1) (RRP6.8).
- 18) Install the COVER REAR (PL 1.1) (RRP1.1).

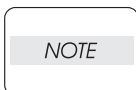

There are 2 kinds of screws, make sure they are installed correctly.

- 19) Install the COVER REAR 500 (PL 7.1) (RRP7.9).
- 20) Install the BTR ASSEMBLY (PL 6.1) (RRP6.9).

RRP6.6 LEVER GUIDE (PL 6.1.14)**Removal**

- 1) Remove the COVER REAR 500 (PL 7.1) (RRP7.9).
- 2) Remove the COVER REAR (PL 1.1) (RRP1.1).
- 3) Remove the FUSER ASSEMBLY (PL 6.1) (RRP6.8).
- 4) Remove the COVER LEFT (PL 1.1) (RRP1.3).
- 5) Remove the COVER RIGHT (PL 1.1) (RRP1.2).
- 6) Remove the COVER EXIT 500 (PL 1.1) (RRP7.1).
- 7) Remove the 500 EXIT ASSEMBLY (PL 7.1) (RRP7.2).
- 8) Remove the COVER TOP (PL 1.1) (RRP1.4).
- 9) Remove the COVER FRONT (PL 1.1) (RRP1.5).
- 10) Remove the BTR ASSEMBLY (PL 6.1) (RRP6.9).
- 11) Remove the DUCT FRONT (PL 6.1) (RRP6.2).
- 12) Remove the ROS ASSEMBLY (PL 6.1) (RRP6.1).

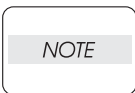

Be careful not to drop or strike the ROS Assembly with any tools or other objects.

- 13) Remove the SHIELD PLATE ROS (PL 6.1) (RRP6.3).
- 14) Remove the GUIDE TRAY LEFT (PL 5.1) (RRP5.8).
- 15) Remove the MOTOR COVER (PL 8.1) (RRP8.1).
- 16) Remove the SHIELD PLATE LVPS (PL 9.1) (RRP8.1).
- 17) Remove the GUIDE CRU LEFT (PL 6.1) (RRP6.4).
- 18) Remove the COVER GUIDE CRU (PL 6.1) and HARNESS ASSEMBLY FUSER (PL 6.1) from the GUIDE CRU LEFT (RRP6.7).
- 19) Remove the INTERLOCK S/W 24V (PL 6.1) and INTERLOCK S/W 5V (PL 6.1) (RRP6.5).
- 20) Remove the SPRING SL (PL 6.1) from the GUIDE CRU LEFT (Figure 1).
- 21) Remove the SPACER SS (PL 6.1) from the GUIDE CRU LEFT (Figure 1).
- 22) Remove the GUIDE SL (PL 6.1) from the GUIDE CRU LEFT (Figure 1).
- 23) Remove the LEVER GUIDE from the GUIDE CRU LEFT (Figure 1).

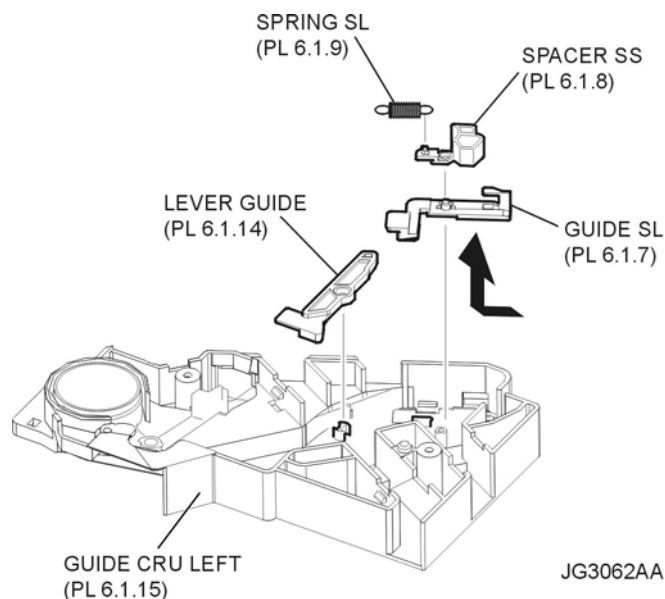
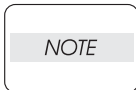

Figure 1. Guide Lever

Replacement

- 1) Install the LEVER GUIDE to the GUIDE CRU LEFT (PL 6.1) (Figure 1).
- 2) Install the GUIDE SL (PL 6.1) to the GUIDE CRU LEFT.
- 3) Install the SPACER SS (PL 6.1) to the GUIDE CRU LEFT.
- 4) Install the SPRING SL (PL 6.1) to the GUIDE CRU LEFT.
- 5) Install the INTERLOCK S/W 24V (PL 6.1) and INTERLOCK S/W 5V (PL 6.1) (RRP6.5).
- 6) Install the COVER GUIDE CRU (PL 6.1) and HARNESS ASSEMBLY FUSER (PL 6.1) (RRP6.7).
- 7) Install the GUIDE CRU LEFT (PL 6.1) (RRP6.4).



When installing, make sure that the LEVER LINK (PL 6.1.29) is attached to the GUIDE CRU LEFT.

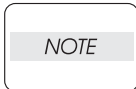

After installing the GUIDE CRU LEFT, touch the LINK GEAR 3 with your finger. Make sure that your finger can feel the LINK GEAR 3 move inward, when the LEVER LINK is pulled up.

- 8) Install the SHIELD PLATE LVPS (PL 9.1) (RRP8.1).
- 9) Install the MOTOR COVER (PL 8.1) (RRP8.1).
- 10) Install the GUIDE TRAY LEFT (PL 5.1) (RRP5.8).
- 11) Install the SHIELD PLATE ROS (PL 6.1) (RRP6.3).
- 12) Install the ROS ASSEMBLY (PL 6.1) (RRP6.1).

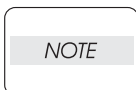

Be careful not to drop or strike the ROS Assembly with any tools or other objects.

- 13) Install the DUCT FRONT (PL 6.1) (RRP6.2).
- 14) Install the COVER FRONT (PL 1.1) (RRP1.5).
- 15) Install the COVER TOP (PL 1.1) (RRP1.4).
- 16) Install the 500 EXIT ASSEMBLY (PL 7.1) (RRP7.2).
- 17) Install the COVER EXIT 500 (PL 1.1) (RRP7.1).
- 18) Install the COVER RIGHT (PL 1.1) (RRP1.2).
- 19) Install the COVER LEFT (PL 1.1) (RRP1.3).
- 20) Install the FUSER ASSEMBLY (PL 6.1) (RRP6.8).
- 21) Install the COVER REAR (PL 1.1) (RRP1.1).

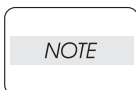

There are 2 kinds of screws, make sure they are installed correctly.

- 22) Install the COVER REAR 500 (PL 7.1) (RRP7.9).
- 23) Install the BTR ASSEMBLY (PL 6.1) (RRP6.9).

RRP6.7 HARNESS ASSEMBLY FUSER (PL 6.1)**Removal**

- 1) Remove the COVER REAR 500 (PL 7.1) (RRP7.9).
- 2) Remove the COVER REAR (PL 1.1) (RRP1.1).
- 3) Remove the FUSER ASSEMBLY (PL 6.1) (RRP6.8).
- 4) Remove the COVER LEFT (PL 1.1) (RRP1.3).
- 5) Remove the COVER RIGHT (PL 1.1) (RRP1.2).
- 6) Remove the COVER EXIT 500 (PL 1.1) (RRP7.1).
- 7) Remove the 500 EXIT ASSEMBLY (PL 7.1) (RRP7.2).
- 8) Remove the COVER TOP (PL 1.1) (RRP1.4).
- 9) Remove the COVER FRONT (PL 1.1) (RRP1.5).
- 10) Remove the BTR ASSEMBLY (PL 6.1) (RRP6.9).
- 11) Remove the DUCT FRONT (PL 6.1) (RRP6.2).
- 12) Remove the ROS ASSEMBLY (PL 6.1) (RRP6.1).

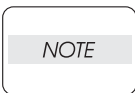

Be careful not to drop or strike the ROS Assembly with any tools or other objects.

- 13) Remove the SHIELD PLATE ROS (PL 6.1) (RRP6.3).
- 14) Remove the GUIDE TRAY LEFT (PL 5.1) (RRP5.8).
- 15) Remove the MOTOR COVER (PL 8.1) (RRP8.1).
- 16) Remove the SHIELD PLATE LVPS (PL 9.1) (RRP8.1).
- 17) Remove the GUIDE CRU LEFT (PL 6.1) (RRP6.4).
- 18) Release the hooks securing the COVER GUIDE CRU (PL 6.1) to the GUIDE CRU LEFT, and remove the COVER GUIDE CRU together with the HARNESS ASSEMBLY FUSER (Figure 1).

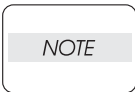

Be careful handling the hooks of the GUIDE CRU LEFT. They are fragile and could break if widen to much.

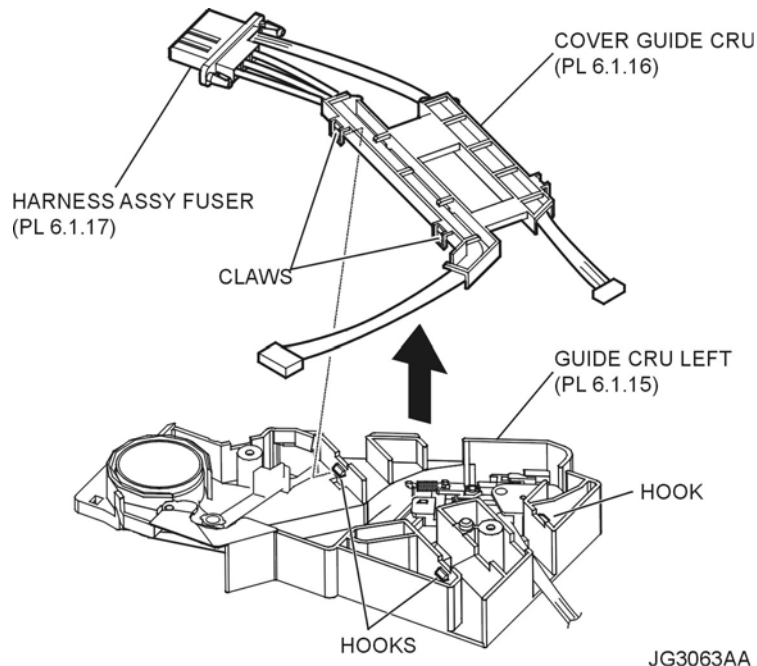

Figure 1. Fuser Harness Assembly

Replacement

- 1) Install the COVER GUIDE CRU (PL 6.1) together with the HARNESS ASSEMBLY FUSER to the GUIDE CRU LEFT (PL 6.1) (Figure 1).
- 2) Install the GUIDE CRU LEFT (PL 6.1) (RRP6.4).



When installing, make sure that the LEVER LINK (PL 6.1.29) is attached to the GUIDE CRU LEFT.

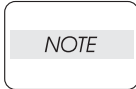

After installing the GUIDE CRU LEFT, touch the LINK GEAR 3 with your finger. Make sure that the LINK GEAR 3 moves inward, when the LEVER LINK is pulled up.

- 3) Install the SHIELD PLATE LVPS (PL 9.1) (RRP8.1).
- 4) Install the MOTOR COVER (PL 8.1) (RRP8.1).
- 5) Install the GUIDE TRAY LEFT (PL 5.1) (RRP5.8).
- 6) Install the SHIELD PLATE ROS (PL 6.1) (RRP6.3).
- 7) Install the ROS ASSEMBLY (PL 6.1) (RRP6.1).

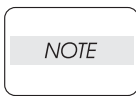

Be careful not to drop or strike the ROS Assembly with any tools or other objects.

- 8) Install the DUCT FRONT (PL 6.1) (RRP6.2).
- 9) Install the COVER FRONT (PL 1.1) (RRP1.5).
- 10) Install the COVER TOP (PL 1.1) (RRP1.4).
- 11) Install the 500 EXIT ASSEMBLY (PL 7.1) (RRP7.2).
- 12) Install the COVER EXIT 500 (PL 1.1) (RRP7.1).
- 13) Install the COVER RIGHT (PL 1.1) (RRP1.2).
- 14) Install the COVER LEFT (PL 1.1) (RRP1.3).
- 15) Install the FUSER ASSEMBLY (PL 6.1) (RRP6.8).
- 16) Install the COVER REAR (PL 1.1) (RRP1.1).

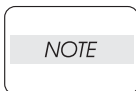

There are 2 kinds of screws, make sure they are installed correctly.

- 17) Install the COVER REAR 500 (PL 7.1) (RRP7.9).
- 18) Install the BTR ASSEMBLY (PL 6.1) (RRP6.9).

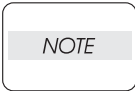
RRP6.8 FUSER ASSEMBLY (PL 6.1)**Removal**

Before performing the following procedures, make sure that the FUSER ASSEMBLY has cooled.

- 1) Open the COVER REAR 500 (PL 7.1).
- 2) Push down the LEVER FUSER LH (PL 6.1) and LEVER FUSER RH (PL 6.1) in the direction of the arrow to release the lock of the FUSER ASSEMBLY (Figure 1).
- 3) Shift the FUSER ASSEMBLY in the direction of the arrow, and remove it from the printer (Figure 1).

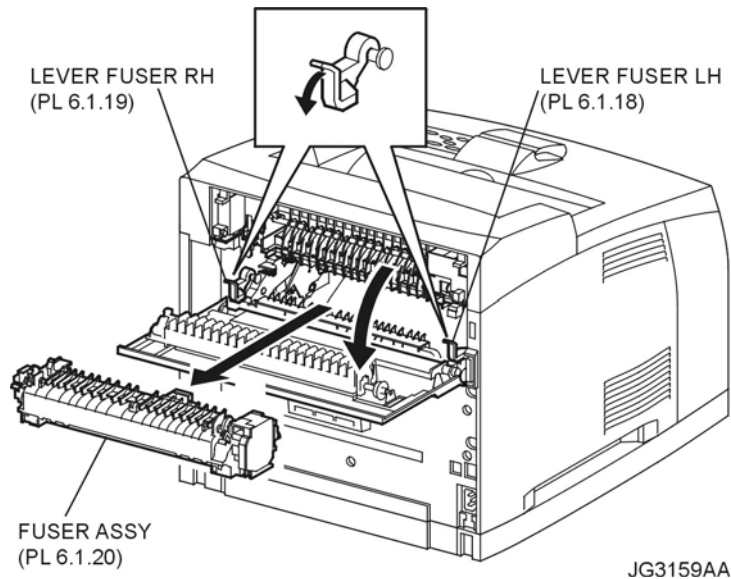

Figure 1. Fuser Assembly

Replacement

- 1) Shift the FUSER ASSEMBLY in the opposite direction of the arrow, and install it to the printer (Figure 1).
- 2) Lock the FUSER ASSEMBLY by pulling up the LEVER FUSER LH (PL 6.1) and LEVER FUSER RH (PL 6.1) (Figure 1).
- 3) Close the COVER REAR 500 (PL 7.1).

RRP6.9 BTR ASSEMBLY (PL 6.1)]

Removal

- 1) Open the COVER OPEN (PL 1.1).
- 2) Pinch the hooks of both ends of the BTR ASSEMBLY, and remove it from the printer (Figure 1).

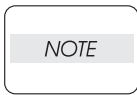

Use extreme care in handling of the BTR ASSEMBLY, do not touch or damage the BTR surface.

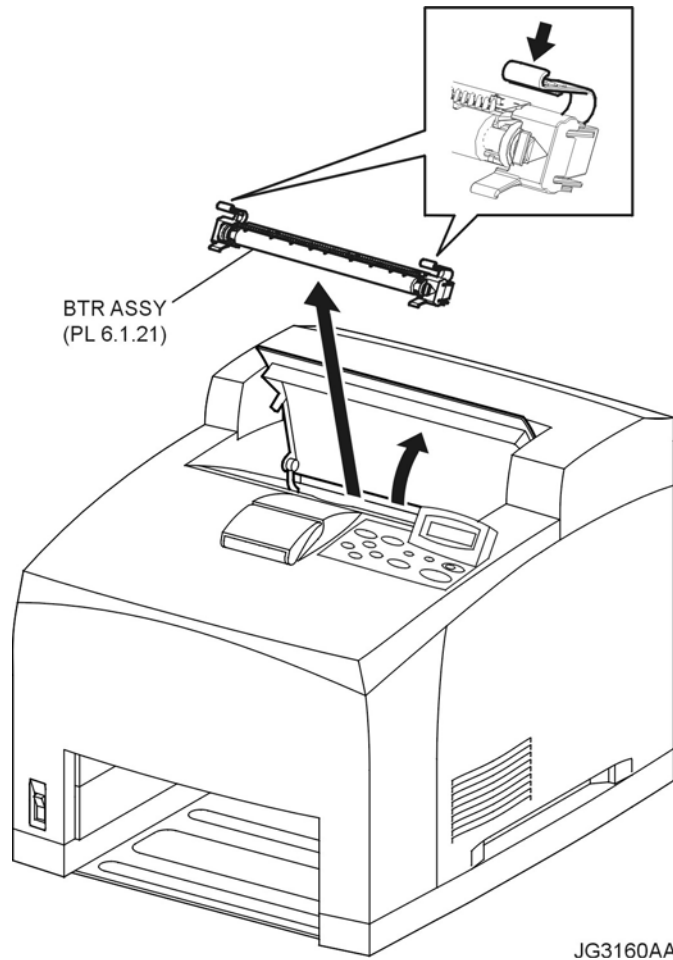

Figure 1. BTR Assembly

Replacement

- 1) Pinch the hooks of both ends of the BTR ASSEMBLY, and install it to the printer (Figure 1).
- 2) Close the COVER OPEN (PL 1.1).

RRP6.10 CHUTE TRANSFER (PL 6.1)**Removal**

- 1) Remove the COVER REAR 500 (PL 7.1) (RRP7.9).
- 2) Remove the COVER REAR (PL 1.1) (RRP1.1).
- 3) Remove the FUSER ASSEMBLY (PL 6.1) (RRP6.8).
- 4) Remove the BTR ASSEMBLY (PL 6.1) (RRP6.9).
- 5) Release the hook of the CHUTE TRANSFER (Figure 1).
- 6) Shift the CHUTE TRANSFER in the direction of the arrow, and remove it from the frame (Figure 1).

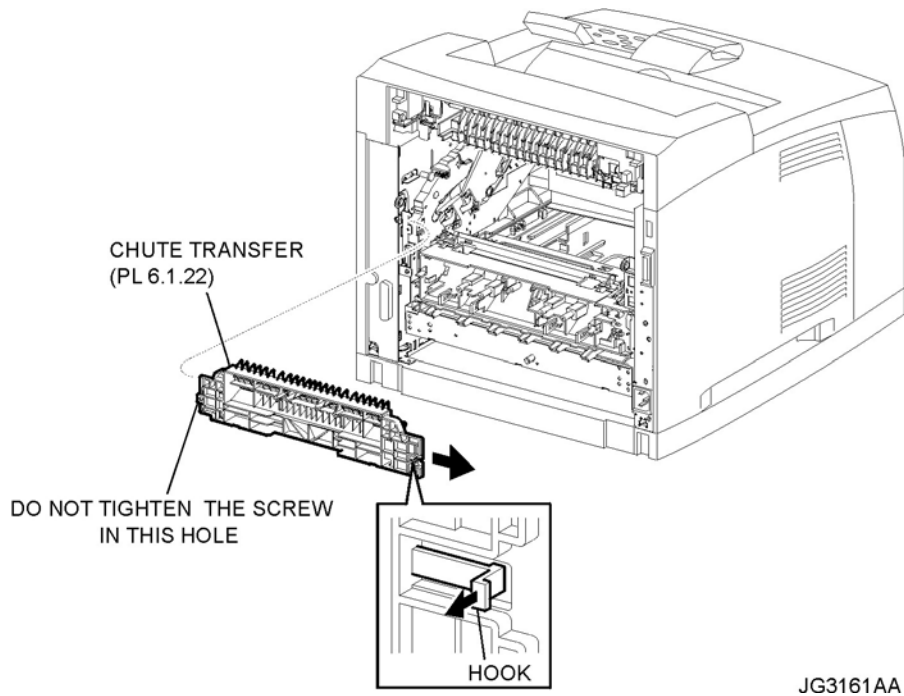
**Figure 1. Transfer Chute****Replacement**

- 1) Shift the CHUTE TRANSFER in the opposite direction of the arrow to install the frame, and secure it using a hook (Figure 1).

NOTE

Do not tighten the screw on the left side of the CHUTE TRANSFER.

- 2) Install the BTR ASSEMBLY (PL 6.1) (RRP6.9).
- 3) Install the FUSER ASSEMBLY (PL 6.1) (RRP6.8).
- 4) Install the COVER REAR (PL 1.1) (RRP1.1).

NOTE

There are 2 kinds of screws, make sure they are installed correctly.

- 5) Install the COVER REAR 500 (PL 7.1) (RRP7.9).

RRP6.11 PWBA ASSEMBLY ANT (PL 6.1.23)**Removal**

- 1) Remove the COVER REAR 500 (PL 7.1) (RRP7.9).
- 2) Remove the COVER REAR (PL 1.1) (RRP1.1).
- 3) Remove the FUSER ASSEMBLY (PL 6.1) (RRP6.8).
- 4) Remove the COVER LEFT (PL 1.1) (RRP1.3).
- 5) Remove the COVER RIGHT (PL 1.1) (RRP1.2).
- 6) Remove the COVER EXIT 500 (PL 1.1) (RRP7.1).
- 7) Remove the 500 EXIT ASSEMBLY (PL 7.1) (RRP7.2).
- 8) Remove the COVER TOP (PL 1.1) (RRP1.4).
- 9) Remove the COVER FRONT (PL 1.1) (RRP1.5).
- 10) Remove the BTR ASSEMBLY (PL 6.1) (RRP6.9).
- 11) Remove the DUCT FRONT (PL 6.1) (RRP6.2).
- 12) Remove the GUIDE ASSEMBLY CRU R (PL 6.1) (RRP6.12)
- 13) Remove the 2 screws (gold tapping, 6mm) securing the PWBA ASSEMBLY ANT to the GUIDE ASSEMBLY CRU R (Figure 1).
- 14) Remove the PWBA ASSEMBLY ANT (Figure 1).
- 15) Disconnect the harness connector from the connector (P/J150) on the PWBA ASSEMBLY ANT (Figure 1).

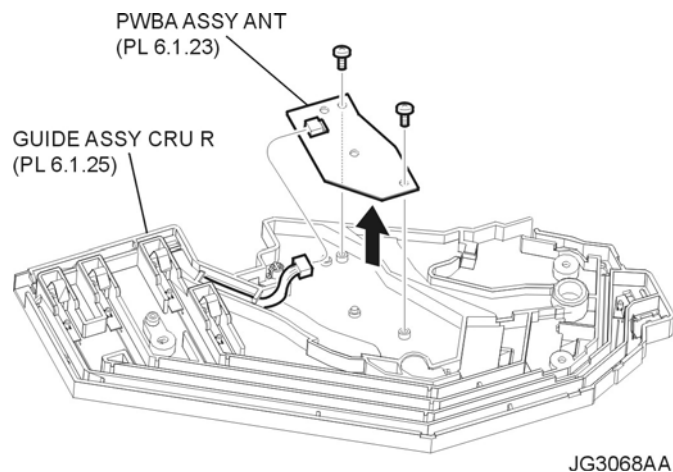
**Figure 1. ANT PWBA Assembly****Replacement**

- 1) Connect the harness connector to the connector (P/J150) on the PWBA ASSEMBLY ANT (Figure 1).
- 2) Install the PWBA ASSEMBLY ANT to the GUIDE ASSEMBLY CRU R (PL 6.1) using the 2 screws (gold tapping, 6mm) (Figure 1).
- 3) Install the GUIDE ASSEMBLY CRU R (PL 6.1) (RRP6.12).
- 4) Install the DUCT FRONT (PL 6.1) (RRP6.2).
- 5) Install the COVER FRONT (PL 1.1) (RRP1.5).
- 6) Install the COVER TOP (PL 1.1) (RRP1.4).
- 7) Install the 500 EXIT ASSEMBLY (PL 7.1) (RRP7.2).
- 8) Install the COVER EXIT 500 (PL 1.1) (RRP7.1).
- 9) Install the COVER RIGHT (PL 1.1) (RRP1.2).
- 10) Install the COVER LEFT (PL 1.1) (RRP1.3).

11) Install the FUSER ASSEMBLY (PL 6.1) (RRP6.8).

12) Install the COVER REAR (PL 1.1) (RRP1.1).

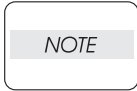

There are 2 kinds of screws, make sure they are installed correctly.

13) Install the COVER REAR 500 (PL 7.1) (RRP7.9).

14) Install the BTR ASSEMBLY (PL 6.1) (RRP6.9).

RRP6.12 GUIDE ASSEMBLY CRU R (PL 6.1)**Removal**

- 1) Remove the COVER REAR 500 (PL 7.1) (RRP7.9).
- 2) Remove the COVER REAR (PL 1.1) (RRP1.1).
- 3) Remove the FUSER ASSEMBLY (PL 6.1) (RRP6.8).
- 4) Remove the COVER LEFT (PL 1.1) (RRP1.3).
- 5) Remove the COVER RIGHT (PL 1.1) (RRP1.2).
- 6) Remove the COVER EXIT 500 (PL 1.1) (RRP7.1).
- 7) Remove the 500 EXIT ASSEMBLY (PL 7.1) (RRP7.2).
- 8) Remove the COVER TOP (PL 1.1) (RRP1.4).
- 9) Remove the COVER FRONT (PL 1.1) (RRP1.5).
- 10) Remove the BTR ASSEMBLY (PL 6.1) (RRP6.9).
- 11) Remove the SHIELD ASSEMBLY ESS (PL 9.1) (RRP9.7).
- 12) Remove the SHIELD PLATE HVPS (PL 9.1) (RRP9.9)
- 13) Remove the DUCT FRONT (PL 6.1) (RRP6.2).
- 14) Disconnect the connector (P/J31) of the GUIDE ASSEMBLY CRU R from the HVPS/MCU (PL 9.1.19) (Figure 1).
- 15) Disconnect the connector (P/J15) of the HARNESS ASSEMBLY ANT from the HVPS/MCU (Figure 1).
- 16) Remove the 3 screws (silver, 6mm) securing the GUIDE ASSEMBLY CRU R to the frame (Figure 1).
- 17) Pull out the harness of the GUIDE ASSEMBLY CRU R from the frame (Figure 1).
- 18) Remove the GUIDE ASSEMBLY CRU R.

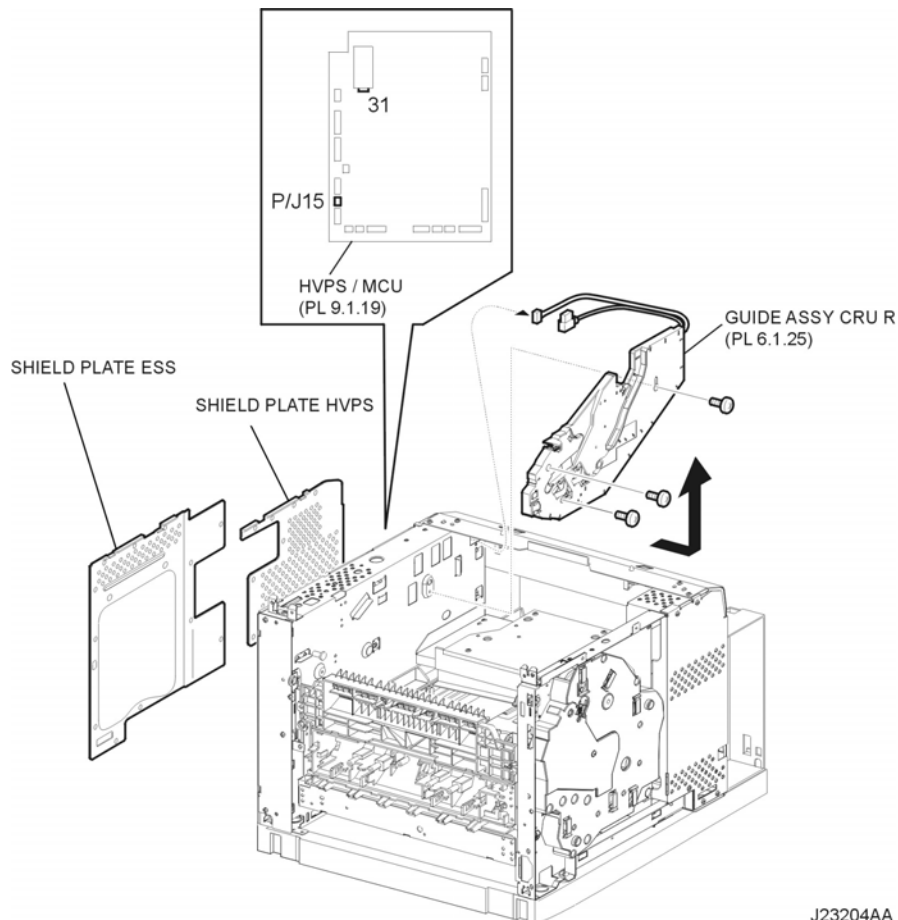
**Figure 1. Right CRU Guide Assembly**

Replacement

- 1) Install the GUIDE ASSEMBLY CRU R.
- 2) Put the harness of the GUIDE ASSEMBLY CRU R to the hole of the frame (Figure 1).
- 3) Install the GUIDE ASSEMBLY CRU R to the frame using the 3 screws (silver, 6mm) (Figure 1).
- 4) Connect the connector (P/J15) of the HARNESS ASSEMBLY ANT to the HVPS/MCU (PL 9.1.19).
- 5) Connect the connector (P/J31) of the GUIDE ASSEMBLY CRU R to the HVPS/MCU.
- 6) Install the DUCT FRONT (PL 6.1) (RRP6.2).
- 7) Install the SHIELD PLATE HVPS (PL 9.1) (RRP9.9).
- 8) Install the SHIELD ASSEMBLY ESS (PL 9.1) (RRP9.7).
- 9) Install the COVER FRONT (PL 1.1) (RRP1.5).
- 10) Install the COVER TOP (PL 1.1) (RRP1.4).
- 11) Install the 500 EXIT ASSEMBLY (PL 7.1) (RRP7.2).
- 12) Install the COVER EXIT 500 (PL 1.1) (RRP7.1).
- 13) Install the COVER RIGHT (PL 1.1) (RRP1.2).
- 14) Install the COVER LEFT (PL 1.1) (RRP1.3).
- 15) Install the FUSER ASSEMBLY (PL 6.1) (RRP6.8).
- 16) Install the COVER REAR (PL 1.1) (RRP1.1).

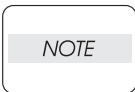

There are 2 kinds of screws, make sure they are installed correctly.

- 17) Install the COVER REAR 500 (PL 7.1) (RRP7.9).
- 18) Install the BTR ASSEMBLY (PL 6.1) (RRP6.9).

RRP6.13 LEVER LINK (PL 6.1.29), LINK GEAR 3(PL 6.1.30)**Removal**

- 1) Remove the COVER REAR 500 (PL 7.1) (RRP7.9).
- 2) Remove the COVER REAR (PL 1.1) (RRP1.1).
- 3) Remove the FUSER ASSEMBLY (PL 6.1) (RRP6.8).
- 4) Remove the COVER LEFT (PL 1.1) (RRP1.3).
- 5) Remove the COVER RIGHT (PL 1.1) (RRP1.2).
- 6) Remove the COVER EXIT 500 (PL 1.1) (RRP7.1).
- 7) Remove the 500 EXIT ASSEMBLY (PL 7.1) (RRP7.2).
- 8) Remove the COVER TOP (PL 1.1) (RRP1.4).
- 9) Remove the COVER FRONT (PL 1.1) (RRP1.5).
- 10) Remove the BTR ASSEMBLY (PL 6.1) (RRP6.9).
- 11) Remove the DUCT FRONT (PL 6.1) (RRP6.2).
- 12) Remove the ROS ASSEMBLY (PL 6.1) (RRP6.1).

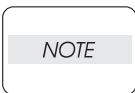

Be careful not to drop or strike the ROS Assembly with any tools or other objects.

- 13) Remove the SHIELD PLATE ROS (PL 6.1) (RRP6.3).
- 14) Remove the GUIDE TRAY LEFT (PL 5.1) (RRP5.8).
- 15) Remove the MOTOR COVER (PL 8.1) (RRP8.1).
- 16) Remove the SHIELD PLATE LVPS (PL 9.1) (RRP8.1).
- 17) Remove the GUIDE CRU LEFT (PL 6.1) (RRP6.4).
- 18) Remove the COVER GUIDE CRU (PL 6.1) and HARNESS ASSEMBLY FUSER (PL 6.1) from the GUIDE CRU LEFT (RRP6.7).
- 19) Remove the LEVER LINK and LINK GEAR 3 (Figure 1).

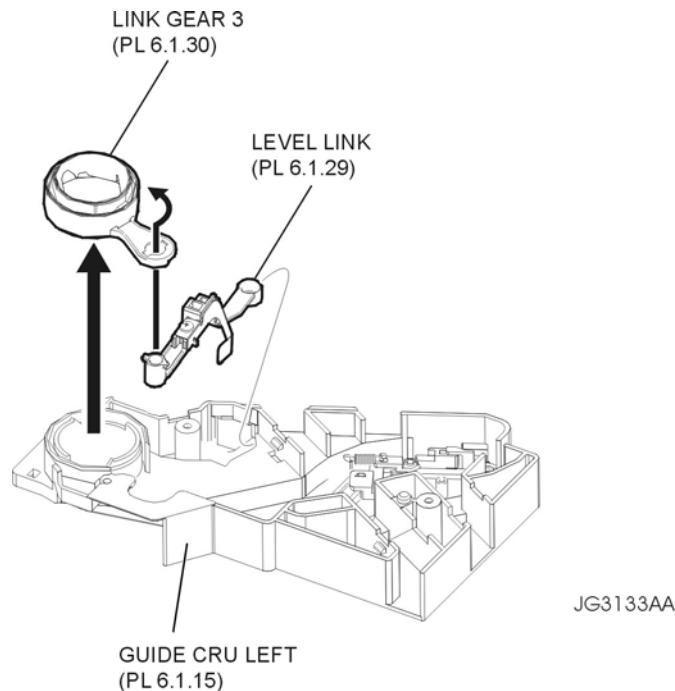
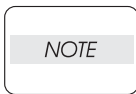

Figure 1. Link Lever & Link Gear

Replacement

- 1) Assemble the LEVER LINK and LINK GEAR 3 as shown in the figure, and install them to the GUIDE CRU LEFT (PL 6.1) (Figure 1).
- 2) Install the COVER GUIDE CRU (PL 6.1) and HARNESS ASSEMBLY FUSER (PL 6.1) to the GUIDE CRU LEFT (RRP6.7).
- 3) Install the GUIDE CRU LEFT (RRP6.4).



When installing, make sure that the LEVER LINK (PL 6.1.29) is attached to the GUIDE CRU LEFT.

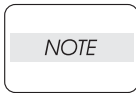

After installing the GUIDE CRU LEFT, touch the LINK GEAR 3 with your finger. Make sure the LINK GEAR 3 moves inward, when the LEVER LINK is pulled up.

- 4) Install the SHIELD PLATE LVPS (PL 9.1) (RRP8.1).
- 5) Install the MOTOR COVER (PL 8.1) (RRP8.1).
- 6) Install the GUIDE TRAY LEFT (PL 5.1) (RRP5.8).
- 7) Install the SHIELD PLATE ROS (PL 6.1) (RRP6.3).
- 8) Install the ROS ASSEMBLY (PL 6.1) (RRP6.1).

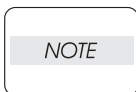

Be careful not to drop or strike the ROS Assembly with any tools or other objects.

- 9) Install the DUCT FRONT (PL 6.1) (RRP6.2).
- 10) Install the COVER FRONT (PL 1.1) (RRP1.5).
- 11) Install the COVER TOP (PL 1.1) (RRP1.4).
- 12) Install the 500 EXIT ASSEMBLY (PL 7.1) (RRP7.2).
- 13) Install the COVER EXIT 500 (PL 1.1) (RRP7.1).
- 14) Install the COVER RIGHT (PL 1.1) (RRP1.2).
- 15) Install the COVER LEFT (PL 1.1) (RRP1.3).
- 16) Install the FUSER ASSEMBLY (PL 6.1) (RRP6.8).
- 17) Install the COVER REAR (PL 1.1) (RRP1.1).

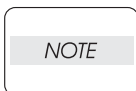

There are 2 kinds of screws, make sure they are installed correctly.

- 18) Install the COVER REAR 500 (PL 7.1) (RRP7.9).
- 19) Install the BTR ASSEMBLY (PL 6.1) (RRP6.9).

RRP7. 500 Paper Exit

RRP7.1 COVER EXIT 500 (PL 1.1)

Removal

- 1) Open the COVER REAR 500 (PL 7.1).
- 2) Remove the 2 screws securing the COVER EXIT 500, and remove from the printer (Figure 1).

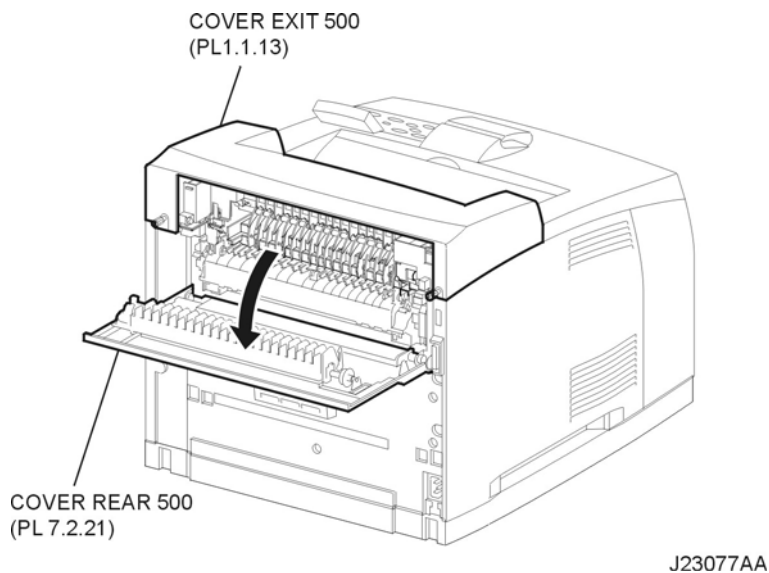

Figure 1. 500 Exit Cover

Replacement

- 1) Install the COVER EXIT 500 to the printer, and secure it with the 2 screws (Figure 1).
- 2) Close the COVER REAR 500 (PL 7.1).

RRP7.2 500 EXIT ASSEMBLY**Removal**

- 1) Remove the COVER REAR 500 (PL 7.1) (RRP7.9).
- 2) Remove the COVER REAR (PL 1.1) (RRP1.1).
- 3) Remove the COVER LEFT (PL 1.1) (RRP1.3).
- 4) Remove the COVER RIGHT (PL 1.1) (RRP1.2).
- 5) Remove the COVER EXIT 500 (PL 1.1) (RRP7.1).
- 6) Remove the SHIELD ASSEMBLY ESS (PL 9.1) (RRP9.7)
- 7) Disconnect the connector (P/J29) of the HARNESS ASSEMBLY EXIT SNR from the HVPS/MCU (PL 9.1.19) (Figure 1).
- 8) Disconnect the connector (P/J103) of the MOTOR ASSEMBLY EXIT from the PWBA EXIT MOTOR (PL 9.1.4) (Figure 1).
- 9) Remove the 5 screws (gold with spring washer,10mm,x4,silver 6mm,x1)securing the 500 EXIT ASSEMBLY to the printer (Figure 1).
- 10) Remove the 500 EXIT ASSEMBLY.

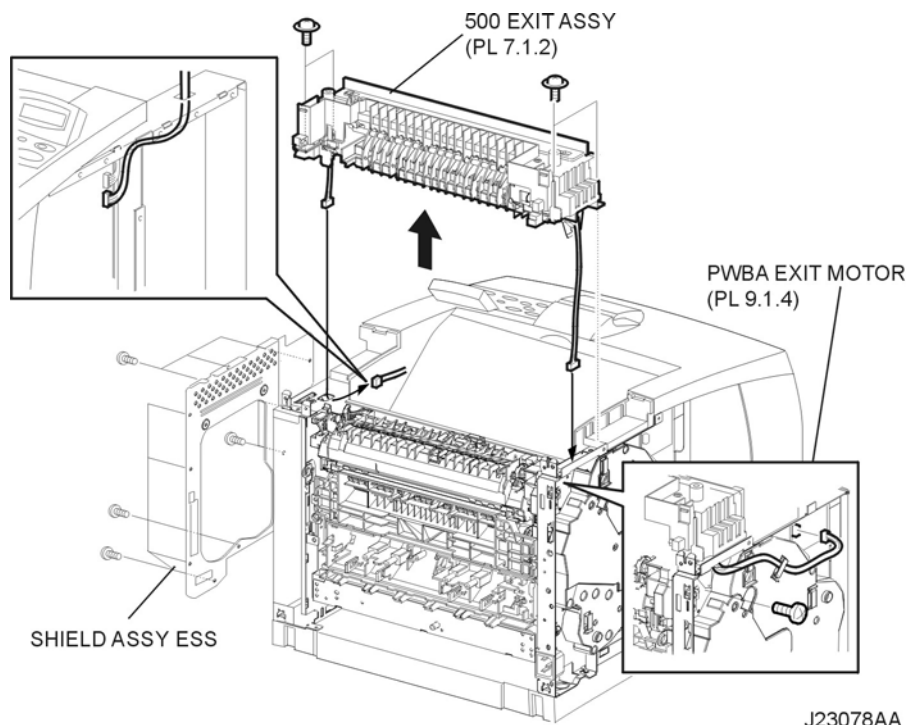
**Figure 1. 500 Exit Assembly****Replacement**

- 1) Put the harnesses of the MOTOR ASSEMBLY EXIT and SENSOR into the hole on the frame (Figure 1).
- 2) Install the 500 EXIT ASSEMBLY using the 5 screws (gold with spring washer,10mm,x4,silver 6mm,x1) (Figure 1).
- 3) Connect the connector (P/J103) of the MOTOR ASSEMBLY EXIT to the PWBA EXIT MOTOR (PL 9.1.4) (Figure 1).
- 4) Connect the connector (P/J29) of the HARNESS ASSEMBLY EXIT SNR to the HVPS/MCU (PL 9.1.19) (Figure 1).
- 5) Install the SHIELD ASSEMBLY ESS (PL 9.1) (RRP9.7).
- 6) Install the COVER EXIT 500 (PL 1.1) (RRP7.1).

- 7) Install the COVER RIGHT (PL 1.1) (RRP1.2).
- 8) Install the COVER LEFT (PL 1.1) (RRP1.3).
- 9) Install the COVER REAR (PL 1.1) (RRP1.1).

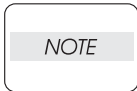

There are 2 kinds of screws, make sure they are installed correctly.

- 10) Install the COVER REAR 500 (PL 7.1) (RRP7.9).

RRP7.3 CHUTE UP EXIT, CHUTE LOW EXIT (PL 7.1)

Removal

- 1) Remove the COVER REAR 500 (PL 7.1) (RRP7.9).
- 2) Remove the COVER REAR (PL 1.1) (RRP1.1).
- 3) Remove the COVER LEFT (PL 1.1) (RRP1.3).
- 4) Remove the COVER RIGHT (PL 1.1) (RRP1.2).
- 5) Remove the COVER EXIT 500 (PL 1.1) (RRP7.1).
- 6) Remove the 500 EXIT ASSEMBLY (PL 7.1) (RRP7.2).
- 7) Remove the 2 screws (gold tapping, 8mm) securing the CHUTE UP EXIT to the CHUTE LOW EXIT (Figure 1).
- 8) Separate the CHUTE UP EXIT and CHUTE LOW EXIT (Figure 1).

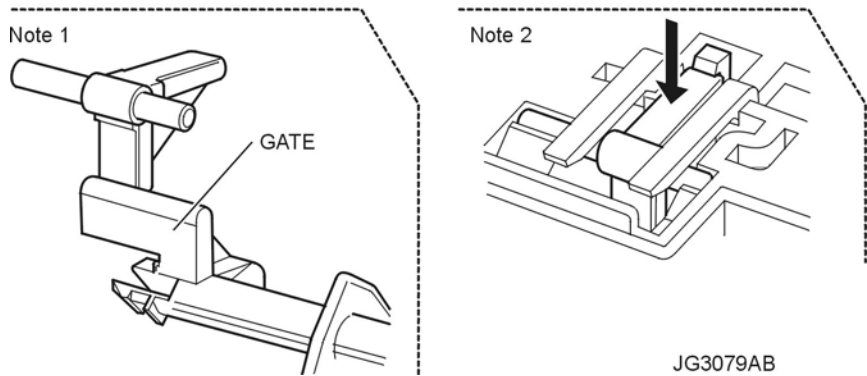
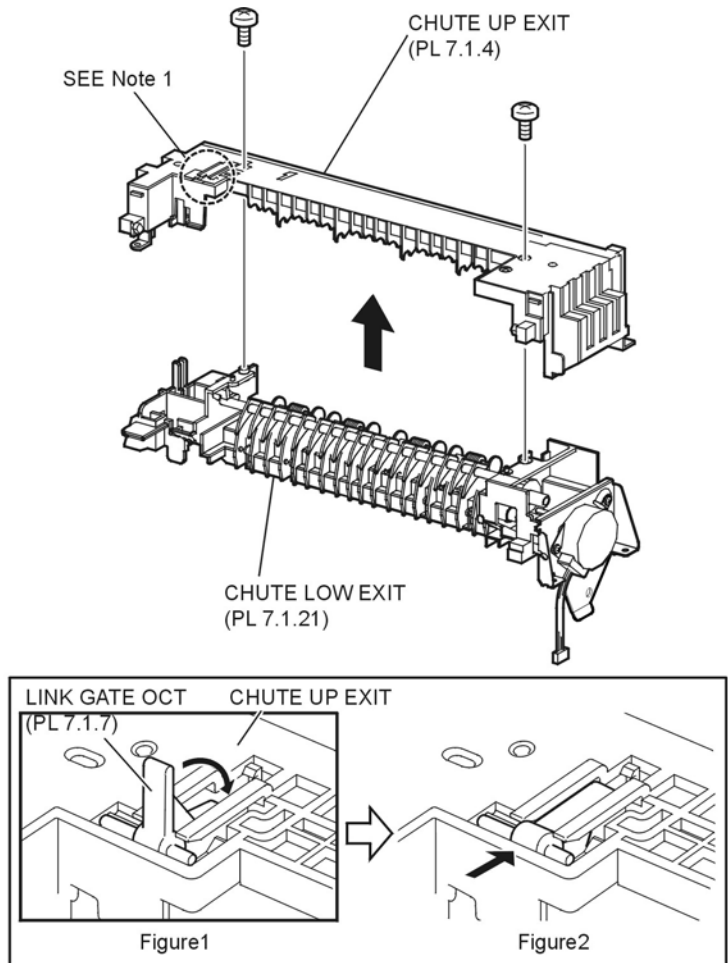

JG3079AB

Figure 1. Chute Up & Low Exit

Replacement

- 1) Remove the LINK GATE OCT (PL 7.1) assembled into the removed CHUTE UP EXIT (Figure 1).
- 2) Secure the CHUTE UP EXIT to the CHUTE LOW EXIT using the 2 screws (gold tapping, 8mm) (Figure 1).
- 3) Put the LINK GATE OCT under the 2 arms of the CHUTE UP EXIT as shown (Figure 1), and turn it in the direction of the arrow.
- 4) Push the LINK GATE OCT in the direction of the arrow (shown in the area labeled figure 2) as far as it will go.

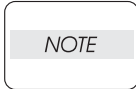

After installing, make sure that the LINK GATE OCT is placed at the back side of the GATE. (Note1) (Figure 1)

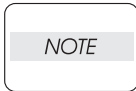

After installing, make sure that the tip of the LINK GATE OCT is placed under the hook of the CHUTE LOW EXIT. (Note2) (Figure 1).

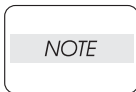

After installing, make sure that the GATE moves when the LINK GATE OCT is pushed in the direction of the arrow. (Note2) (Figure 1)

- 5) Install the 500 EXIT ASSEMBLY (PL 7.1) (RRP7.2).
- 6) Install the COVER EXIT 500 (PL 1.1) (RRP7.1).
- 7) Install the COVER RIGHT (PL 1.1) (RRP1.2).
- 8) Install the COVER LEFT (PL 1.1) (RRP1.3).
- 9) Install the COVER REAR (PL 1.1) (RRP1.1).

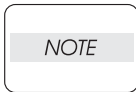

There are 2 kinds of screws, make sure they are installed correctly.

- 10) Install the COVER REAR 500 (PL 7.1) (RRP7.9).

RRP7.4 ROLL EXIT (PL 7.1.)**Removal**

- 1) Remove the COVER REAR 500 (PL 7.1) (RRP7.9).
- 2) Remove the COVER REAR (PL 1.1) (RRP1.1).
- 3) Remove the COVER LEFT (PL 1.1) (RRP1.3).
- 4) Remove the COVER RIGHT (PL 1.1) (RRP1.2).
- 5) Remove the COVER EXIT 500 (PL 1.1) (RRP7.1).
- 6) Remove the CHUTE UP EXIT (PL 7.1) (RRP7.3)
- 7) Release the hook of the GEAR 21 (PL 7.1), and remove it from the ROLL EXIT (Figure 1).
- 8) Release the hook of the BEARING EXIT (PL 7.1.11) on the GEAR 21 side, and lift up the ROLL EXIT, then, remove the BEARING EXIT from the ROLL EXIT (Figure 1).

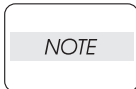

Be careful handling the hook of the BEARING EXIT. It is fragile and could break if given excessive force.

- 9) Remove the ROLL EXIT from the other side of the BEARING EXIT by shifting the ROLL EXIT in the direction of the arrow as shown (Figure 1).

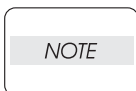

When removing, do not touch the roller surface of the ROLL EXIT.

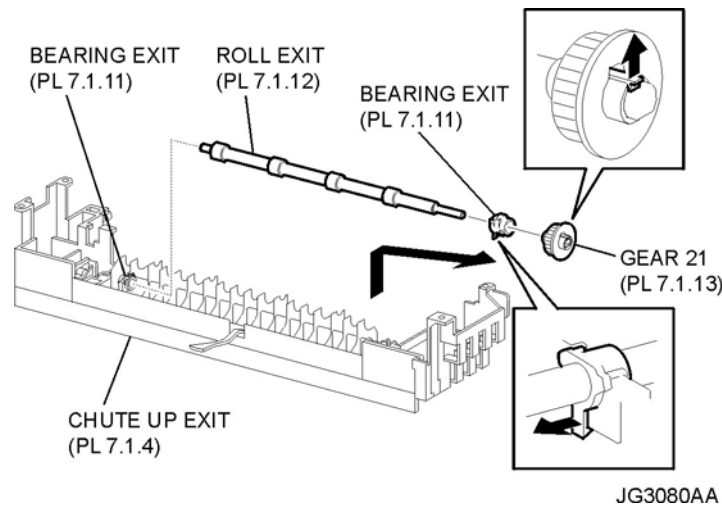
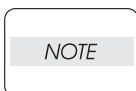

Figure 1. Exit Roll

Replacement

- 1) Install the ROLL EXIT to the BEARING EXIT (PL 7.1.11) by shifting the ROLL EXIT in the opposite direction of the arrow (Figure 1).



When installing, do not touch the roller surface of the ROLL EXIT.

- 2) Put the BEARING EXIT to the ROLL EXIT on the GEAR 21 side, and install the BEARING EXIT to the CHUTE UP EXIT (PL 7.1), and then secure it with the hook (Figure 1).
- 3) Install the GEAR 21 (PL 7.1) to the ROLL EXIT, and secure it with the hook (Figure 1).
- 4) Install the CHUTE UP EXIT (RRP7.3).
- 5) Install the COVER EXIT 500 (PL 1.1) (RRP7.1).
- 6) Install the COVER RIGHT (PL 1.1) (RRP1.2).

7) Install the COVER LEFT (PL 1.1) (RRP1.3).

8) Install the COVER REAR (PL 1.1) (RRP1.1).

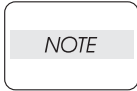

There are 2 kinds of screws, make sure they are installed correctly.

9) Install the COVER REAR 500 (PL 7.1) (RRP7.9).

RRP7.5 MOTOR ASSEMBLY EXIT (PL 7.1.15)**Removal**

- 1) Remove the COVER REAR 500 (PL 7.1) (RRP7.9).
- 2) Remove the COVER REAR (PL 1.1) (RRP1.1).
- 3) Remove the COVER LEFT (PL 1.1) (RRP1.3).
- 4) Remove the COVER RIGHT (PL 1.1) (RRP1.2).
- 5) Remove the COVER EXIT 500 (PL 1.1) (RRP7.1).
- 6) Remove the 500 EXIT ASSEMBLY (PL 7.1) (RRP7.2).
- 7) Remove the CHUTE LOW EXIT (PL 7.11) (RRP7.3).
- 8) Remove the 2 screws (silver, 6mm) securing the MOTOR ASSEMBLY EXIT to the BRACKET MOTOR EXIT (PL 7.1) (Figure 1).
- 9) Remove the MOTOR ASSEMBLY EXIT (Figure 1).

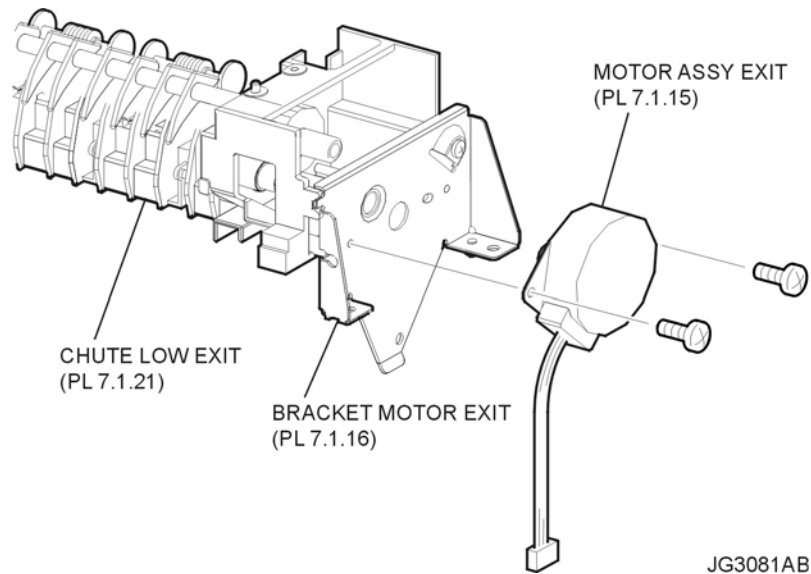
**Figure 1. Exit Motor Assembly****Replacement**

- 1) Secure the MOTOR ASSEMBLY EXIT to the BRACKET MOTOR EXIT (PL 7.1) using the 2 screws (silver, 8mm) (Figure 1).
- 2) Install the CHUTE LOW EXIT (PL 7.11) (RRP7.3).
- 3) Install the 500 EXIT ASSEMBLY (PL 7.1) (RRP7.2).
- 4) Install the COVER EXIT 500 (PL 1.1) (RRP7.1).
- 5) Install the COVER RIGHT (PL 1.1) (RRP1.2).
- 6) Install the COVER LEFT (PL 1.1) (RRP1.3).
- 7) Install the COVER REAR (PL 1.1) (RRP1.1).

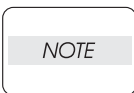

There are 2 kinds of screws, make sure they are installed correctly.

- 8) Install the COVER REAR 500 (PL 7.1) (RRP7.9).

RRP7.6 SENSOR FACE UP OPEN (PL 7.1)**Removal**

- 1) Remove the COVER REAR 500 (PL 7.1) (RRP7.9).
- 2) Remove the COVER REAR (PL 1.1) (RRP1.1).
- 3) Remove the COVER LEFT (PL 1.1) (RRP1.3).
- 4) Remove the COVER RIGHT (PL 1.1) (RRP1.2).
- 5) Remove the COVER EXIT 500 (PL 1.1) (RRP7.1).
- 6) Remove the CHUTE UP EXIT (PL 7.1) (RRP7.3).
- 7) Disconnect the connector (P/J291) of the HARNESS ASSEMBLY EXIT SNR (PL 7.1.27) from the SENSOR FACE UP OPEN (Figure 1).
- 8) Lift up the CHUTE LOW EXIT (PL 7.1), and release the hooks of the SENSOR FACE UP OPEN, then, remove the SENSOR FACE UP OPEN from the CHUTE LOW EXIT (Figure 1).

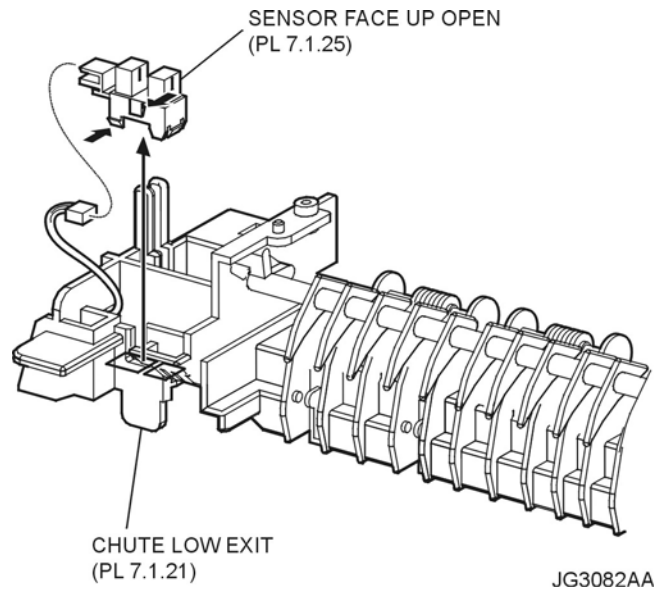
**Figure 1. Face Up open Sensor****Replacement**

- 1) Install the SENSOR FACE UP OPEN to the CHUTE LOW EXIT (PL 7.1) (Figure 1).
- 2) Connect the connector (P/J291) of the HARNESS ASSEMBLY EXIT SNR (PL 7.1.27) to the SENSOR FACE UP OPEN (Figure 1).
- 3) Install the CHUTE UP EXIT (PL 7.1) (RRP7.3).
- 4) Install the COVER EXIT 500 (PL 1.1) (RRP7.1).
- 5) Install the COVER RIGHT (PL 1.1) (RRP1.2).
- 6) Install the COVER LEFT (PL 1.1) (RRP1.3).
- 7) Install the COVER REAR (PL 1.1) (RRP1.1).

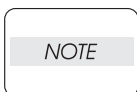

There are 2 kinds of screws, make sure they are installed correctly.

- 8) Install the COVER REAR 500 (PL 7.1) (RRP7.9).

RRP7.7 SENSOR FULL STACK (PL 7.1.26)**Removal**

- 1) Remove the COVER REAR 500 (PL 7.1) (RRP7.9).
- 2) Remove the COVER REAR (PL 1.1) (RRP1.1).
- 3) Remove the COVER LEFT (PL 1.1) (RRP1.3).
- 4) Remove the COVER RIGHT (PL 1.1) (RRP1.2).
- 5) Remove the COVER EXIT 500 (PL 1.1) (RRP7.1).
- 6) Remove the CHUTE UP EXIT (PL 7.1) (RRP7.3).
- 7) Disconnect the connector (P/J290) of the HARNESS ASSEMBLY EXIT SNR (PL 7.1.27) from the SENSOR FULL STACK (Figure 1).
- 8) Release the hooks of the SENSOR FULL STACK, and remove the SENSOR FULL STACK from the CHUTE LOW EXIT (PL 7.1) (Figure 1).

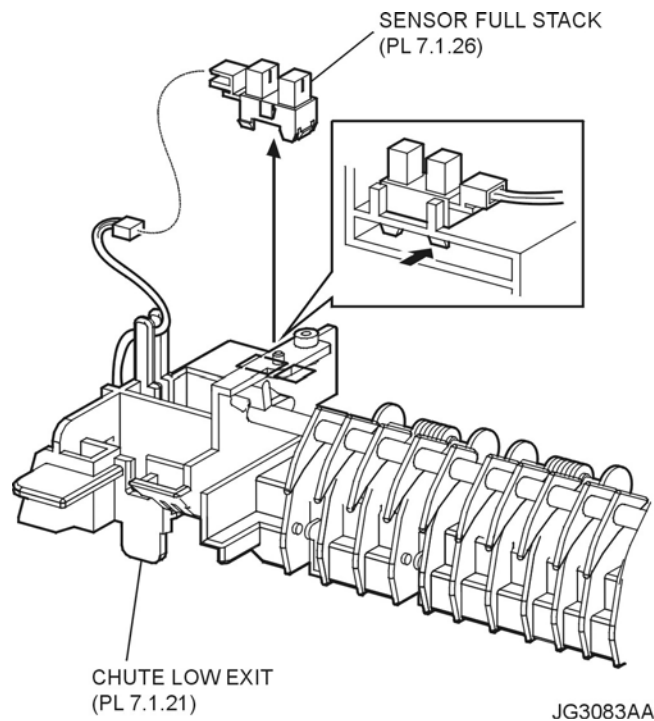
**Figure 1. Full Stack Sensor****Replacement**

- 1) Install the SENSOR FULL STACK to the CHUTE LOW EXIT (PL 7.1) (Figure 1).
- 2) Connect the connector (P/J290) of the HARNESS ASSEMBLY SNR (PL 7.1.27) to the SENSOR FULL STACK (Figure 1).
- 3) Install the CHUTE UP EXIT (PL 7.1) (RRP7.3).
- 4) Install the COVER EXIT 500 (PL 1.1) (RRP7.1).
- 5) Install the COVER RIGHT (PL 1.1) (RRP1.2).
- 6) Install the COVER LEFT (PL 1.1) (RRP1.3).
- 7) Install the COVER REAR (PL 1.1) (RRP1.1).

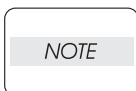

There are 2 kinds of screws, make sure they are installed correctly.

- 8) Install the COVER REAR 500 (PL 7.1) (RRP7.9).

RRP7.8 ACTUATOR FULL STACK (PL 7.1.10)**Removal**

- 1) Remove the COVER REAR 500 (PL 7.1) (RRP7.9).
- 2) Remove the COVER REAR (PL 1.1) (RRP1.1).
- 3) Remove the COVER LEFT (PL 1.1) (RRP1.3).
- 4) Remove the COVER RIGHT (PL 1.1) (RRP1.2).
- 5) Remove the COVER EXIT 500 (PL 1.1) (RRP7.1).
- 6) Remove the CHUTE UP EXIT (PL 7.1) (RRP7.3).
- 7) Remove the ACTUATOR FULL STACK from the CHUTE UP EXIT by moving it in the direction of the arrow (Figure 1).

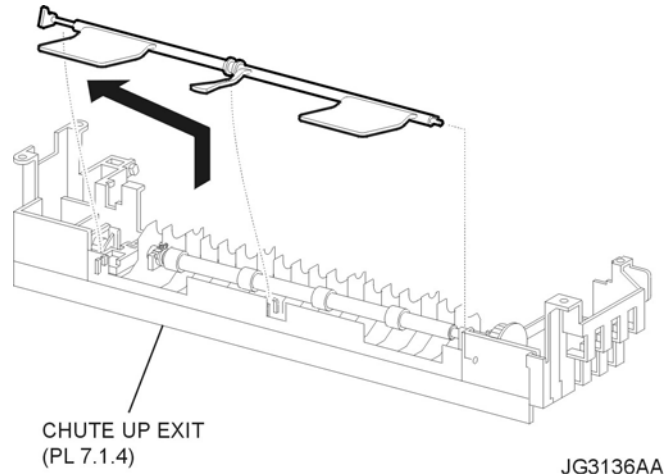
**Figure 1. Full Stack Actuator****Replacement**

- 1) Install the ACTUATOR FULL STACK to the CHUTE UP EXIT (PL 10.1.4) by moving it in the opposite direction of the arrow (Figure 1).
- 2) Install the CHUTE UP EXIT (RRP7.3)
- 3) Install the COVER EXIT 500 (PL 1.1) (RRP7.1).
- 4) Install the COVER RIGHT (PL 1.1) (RRP1.2).
- 5) Install the COVER LEFT (PL 1.1) (RRP1.3).
- 6) Install the COVER REAR (PL 1.1) (RRP1.1).

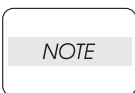

There are 2 kinds of screws, make sure they are installed correctly.

- 7) Install the COVER REAR 500 (PL 7.1) (RRP7.9).

RRP7.9 COVER REAR 500 (PL 7.1)**Removal**

- 1) Pinch the lever to release the lock, and open the COVER REAR 500 (Figure 1).
- 2) Move the STOPPER FSR in the arrow direction to remove (Figure 1).
- 3) Release the hook of the right side boss of the COVER REAR 500, and shift the COVER REAR 500 in the direction of the arrow to remove from the printer (Figure 1).

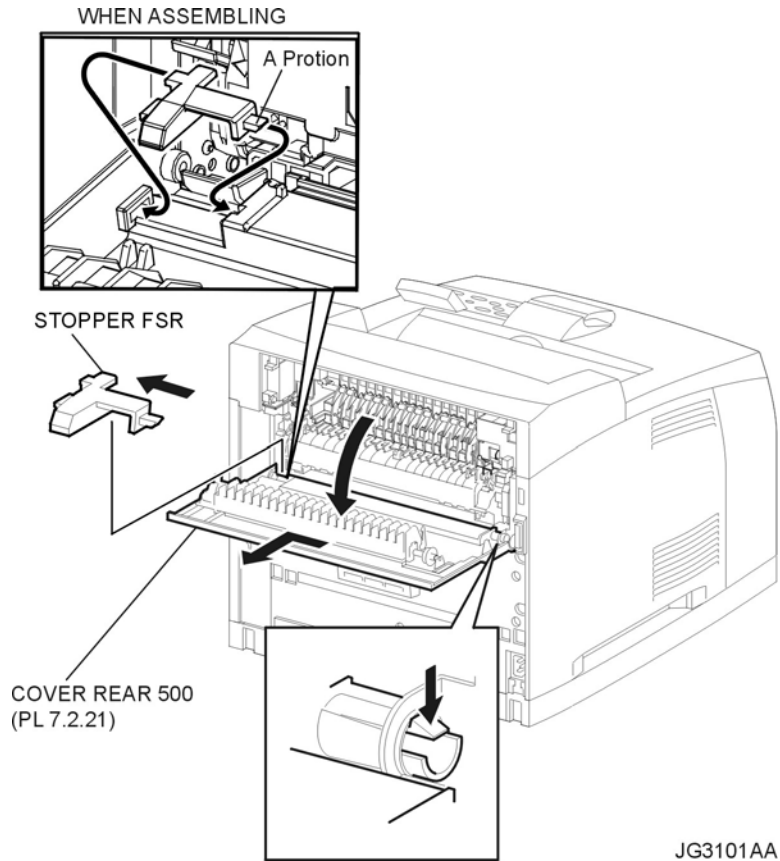
**Figure 1. 500 Rear Cover****Replacement**

- 1) Shift the COVER REAR 500 in the opposite direction of the arrow to install, and secure it with the hook (Figure 1).
- 2) Insert the A portion of the STOPPER FSR into the COVER REAR 500 first, and then insert the opposite side (Figure 1).
- 3) Close the COVER REAR 500.

RRP7.10 FUSER ROLL (FU) (PL 7.2)**Removal**

- 1) Remove the COVER REAR 500 (PL 7.1) (RRP7.9).
- 2) Remove the 5 screws (gold tapping, 8mm) securing the CHUTE LOW FU (PL 7.2) to the COVER REAR 500 (Figure 1).
- 3) Release the hooks of the COVER REAR 550, and remove the CHUTE LOW FU from the COVER REAR 500 (Figure 1).
- 4) Release the hook of the GEAR 21 (PL 7.2), and remove it from the ROLL FU (Figure 1).
- 5) Release the hook of the BEARING EXIT (PL 7.2), and remove it from the CHUTE LOW FU (Figure 1).

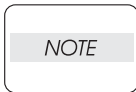

Be careful handling the hook of the BEARING EXIT. It is fragile and could break if given excessive force.

- 6) Remove the ROLL FU in the direction of the arrow (Figure 1).

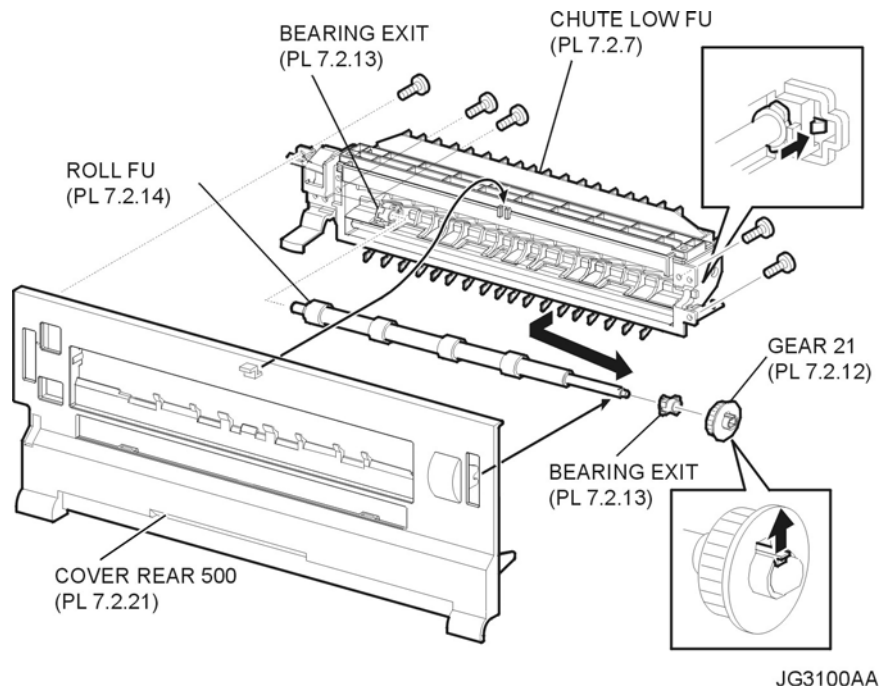
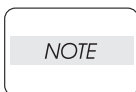

Figure 1. Fuser Roll

Replacement

- 1) Install the ROLL FU to the BEARING EXIT (PL 7.2) on the opposite side of the GEAR 21 (PL 7.2) by shifting the ROLL FU in the opposite direction of the arrow (Figure 1).
- 2) Install the BEARING EXIT to the CHUTE LOW FU (PL 7.2) (Figure 1).
- 3) Install the GEAR 21 to the ROLL FU, and secure it with the hook (Figure 1).



Be sure to install the hook of the GEAR 21 into the groove of the ROLL FU.

- 4) Install the CHUTE LOW FU to the COVER REAR 550, and secure it with the hook (Figure 1).
- 5) Secure the CHUTE LOW FU to the COVER REAR 550 using the 5 screws (gold tapping, 8mm).
- 6) Install the COVER REAR 500 (PL 7.1) (RRP7.9).

RRP7.11 LEVER GATE HOLDER, SPRING LEVER GATE, LEVER GATE FU (PL 7.2)**Removal**

- 1) Remove the COVER REAR 500 (PL 7.1) (RRP7.9).
- 2) Remove the 5 screws (gold tapping, 6mm) securing the CHUTE LOW FU (PL 7.2) to the COVER REAR 550.
- 3) Release the hooks of the COVER REAR 550, and remove the CHUTE LOW FU from the COVER REAR 550.
- 4) Remove the ROLL FU (PL 7.2) (RRP7.10).
- 5) Remove the LEVER GATE FU (PL 7.2) by rotating (Figure 1).

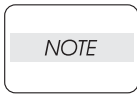

LEVER GATE HOLDER (PL 7.2), SPRING LEVER GATE (PL 7.2), and LEVER GATE FU (PL 7.2) are removed at the same time.

- 6) Bend LEVER GATE FU (PL 7.2), and remove it from LEVER GATE HOLDER (PL 7.2) (Figure 1).

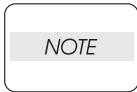

SPRING LEVER GATE (PL 7.2) remains on the side of LEVER GATE HOLDER (PL 7.2) (Figure 1).

- 7) Remove the SPRING LEVER GATE (PL 7.2) (Figure 1).

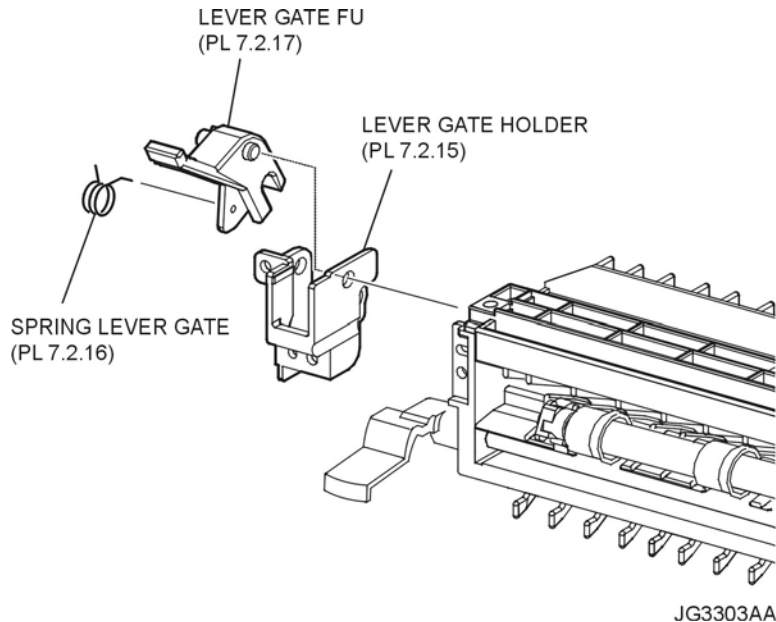

Figure 1. Lever Gate Holder & Spring

Replacement

- 1) Install the ROLL FU to the BEARING EXIT (PL 7.2) on the opposite side of the GEAR 21 (PL 7.2) by shifting the ROLL FU in the opposite direction of the arrow (Figure 1).
- 2) Install the BEARING EXIT to the CHUTE LOW FU (PL 7.2).
- 3) Install the GEAR 21 to the ROLL FU, and secure it with the hook.
- 4) Install the ROLL FU (PL 7.2) (RRP7.10).
- 5) Install the CHUTE LOW FU to the COVER REAR 550, and secure it with the hook.
- 6) Secure the CHUTE LOW FU to the COVER REAR 550 using the 5 screws (gold tapping, 6mm).
- 7) Install the COVER REAR 500 (PL 7.1) (RRP7.9).

RRP7.12 LEVER LATCH LEFT, SPRING LATCH FU, LEVER LATCH RIGHT (PL 7.2)**Removal**

- 1) Remove the COVER REAR 500 (PL 7.1) (RRP7.9).
- 2) Remove the 5 screws (gold tapping, 6mm) securing the CHUTE LOW FU (PL 7.2) to the COVER REAR 550.
- 3) Release the hooks of the COVER REAR 550, and remove the CHUTE LOW FU from the COVER REAR 550.
- 4) Remove the ROLL FU (PL 7.2) (RRP7.10).
- 5) Remove the LEVER GATE HOLDER (PL 7.2), SPRING LEVER GATE (PL 7.2), LEVER GATE FU (PL 7.2) (RRP7.11).
- 6) Rotate LEVER LATCH LEFT (PL 7.2) in the direction of the arrow, and remove it (Figure 1).

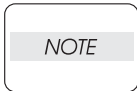

Completely insert the internal projection of LEVER LATCH LEFT (PL 7.2) into the notch of CHUTE LOW FU (PL 7.2).

- 7) Rotate LEVER LATCH RIGHT (PL 7.2) in the direction of the arrow, and remove it (Figure 1).

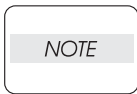

Completely insert the internal projection of LEVER LATCH RIGHT (PL 7.2) and the notch of CHUTE LOW FU (PL 7.2).

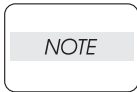

PIPE LATCH FU (PL 7.2) is also removed.

- 8) Remove the SPRING LATCH (PL 7.2) (Figure 1).

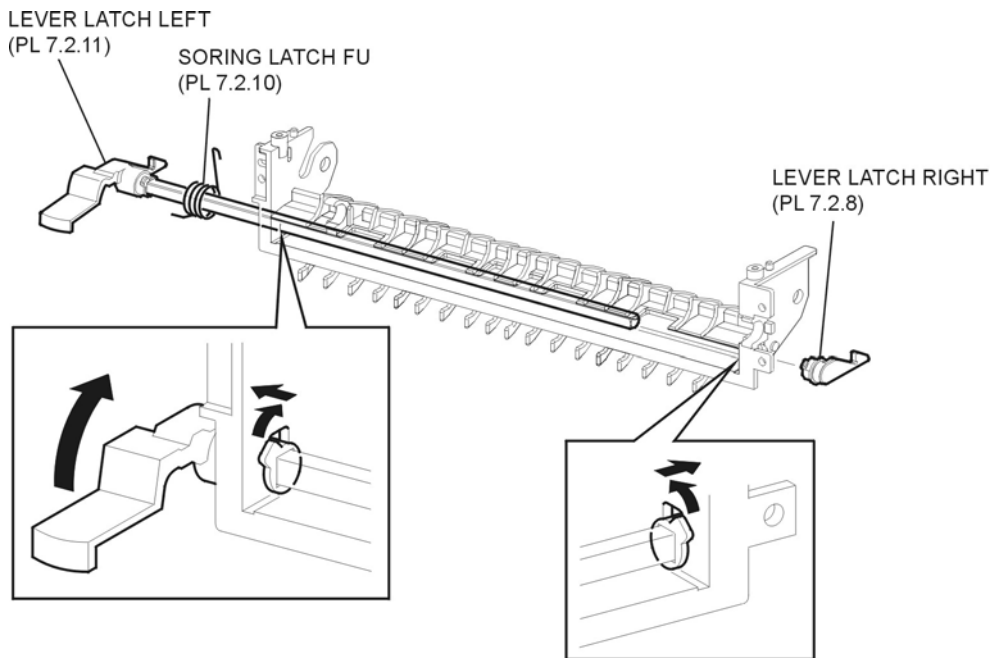

JG3304AA

Figure 1. Left Lever Latch & Spring

Replacement

- 1) Install the SPRING LATCH (PL 7.2) (Figure 1).
- 2) Install the LEVER LATCH LEFT (PL 7.2) to PIPE LATCH FU (PL 7.2), then install them to CHUTE LOW FU (PL 7.2) (Figure 1).
- 3) Install the LEVER LATCH RIGHT (PL 7.2) to PIPE LATCH FU (PL 7.2) (Figure 1).
- 4) Insert the projections of both the LEVER LATCH RIGHT (PL 7.2) and LEVER LATCH LEFT (PL 7.2) into the notch of the CHUTE LOW FU (PL 7.2), and install by rotating in the opposite direction of the arrow (Figure 1).
- 5) Install LEVER GATE HOLDER (PL 7.2), SPRING LEVER GATE (PL 7.2), and LEVER GATE FU (PL 7.2) (Figure 1).
- 6) Install the ROLL FU (PL 7.2) (RRP7.10).
- 7) Install the CHUTE LOW FU to the COVER REAR 550, and secure it with the hook.
- 8) Secure the CHUTE LOW FU to the COVER REAR 550 using the 5 screws (gold tapping, 6mm).
- 9) Install the COVER REAR 500 (PL 7.1) (RRP7.9).

RRP7.13 ROLL PINCH FUSER, SPRING PINCH FUSER (PL 7.2)**Removal**

- 1) Remove the COVER REAR 500 (PL 7.1) (RRP7.9).
- 2) Remove the 5 screws (gold tapping, 6mm) securing the CHUTE LOW FU (PL 7.2) to the COVER REAR 550.
- 3) Release the hooks of the COVER REAR 550, and remove the CHUTE LOW FU from the COVER REAR 550.
- 4) Remove the 2 screws (gold tapping, 6mm) securing the CHUTE UP FU (PL 7.2).
- 5) Insert a screwdriver between ROLL PINCH FU (PL 7.2) and CHUTE UP FU (PL 7.2), and remove ROLL PINCH FU (PL 7.2) (Figure 1).
- 6) Remove the SPRING PINCH FU (PL 7.2) (Figure 1).

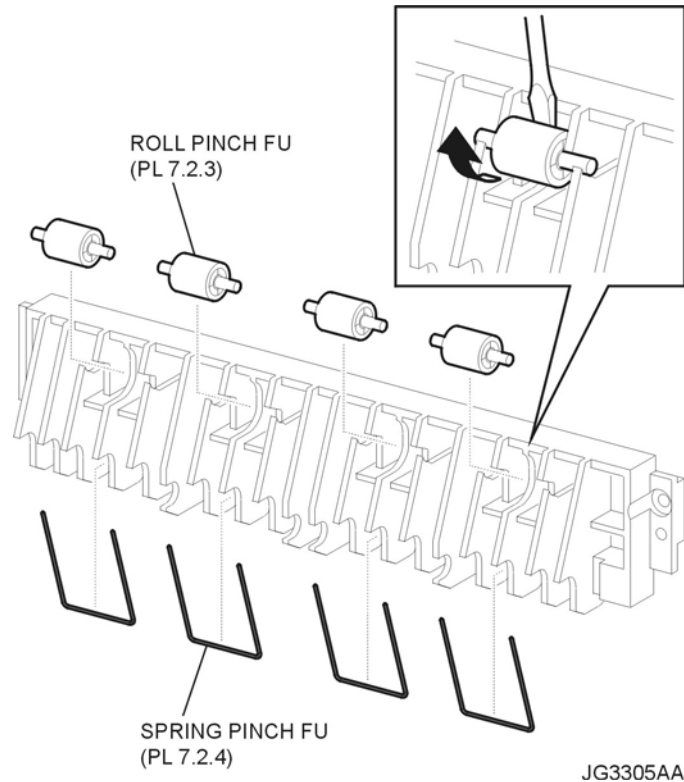
**Figure 1. Fuser Pinch Roll & Spring****Replacement**

- 1) Install the SPRING PINCH FU (PL 7.2) (Figure 1).
- 2) Install the ROLL PINCH FU (PL 7.2) (Figure 1).
- 3) Install the CHUTE UP FU (PL 7.2) to the CHUTE LOW FU (PL 7.2) using the 4 screws (gold tapping, 6mm).
- 4) Install the CHUTE LOW FU to the COVER REAR 550, and secure it with the hook.
- 5) Secure the CHUTE LOW FU to the COVER REAR 550 using the 5 screws (gold tapping, 6mm).
- 6) Install the COVER REAR 500 (PL 7.1) (RRP7.9).

RRP7.14 GATE FUSER (PL 7.2)**Removal**

- 1) Remove the COVER REAR 500 (PL 7.1) (RRP7.9).
- 2) Remove the 5 screws (gold tapping, 6mm) securing the CHUTE LOW FU (PL 7.2) to the COVER REAR 550.
- 3) Release the hooks of the COVER REAR 550, and remove the CHUTE LOW FU from the COVER REAR 550.
- 4) Remove the LEVER GATE HOLDER (PL 7.2), SPRING LEVER GATE (PL 7.2), and LEVER GATE FU (PL 7.2) (RRP7.11).
- 5) Remove the 2 screws (gold tapping, 6mm) securing the CHUTE UP FU (PL 7.2).
- 6) Remove the GATE FU (PL 7.2) from CHUTE LOW FU (PL 7.2) by bending GATE FU (PL 7.2) (Figure 1).

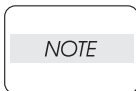

Be careful handling the GATE FU. It is fragile and could break if given excessive force.

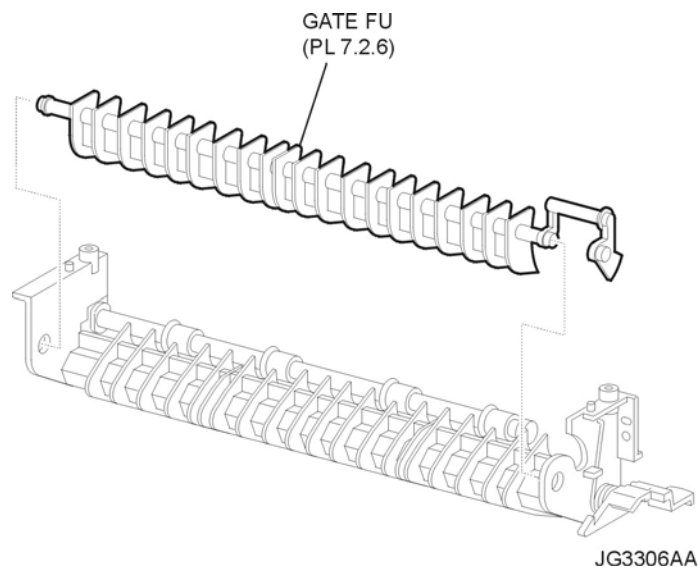

Figure 1. Fuser Gate

Replacement

- 1) Install the GATE FU (PL 7.2) to CHUTE LOW FU (PL 7.2) (Figure 1).
- 2) Secure the CHUTE UP FU using the 5 screws (gold tapping, 6mm).
- 3) Install the LEVER GATE HOLDER (PL 7.2), SPRING LEVER GATE (PL 7.2), and LEVER GATE FU (PL 7.2) (RRP7.11).
- 4) Install the ROLL FU to the BEARING EXIT (PL 7.2) on the opposite side of the GEAR 21 (PL 7.2) by shifting the ROLL FU in the opposite direction of the arrow.
- 5) Install the CHUTE LOW FU to the COVER REAR 550, and secure it with the hook.
- 6) Secure the CHUTE LOW FU to the COVER REAR 550 using the 5 screws (gold tapping, 6mm).
- 7) Install the COVER REAR 500 (PL 7.1) (RRP7.9).

RRP7.15 GATE OCT EXIT (PL 7.1)**Removal**

- 1) Remove the COVER REAR 500 (PL 7.1) (RRP7.9).
- 2) Remove the COVER REAR (PL 1.1) (RRP1.1).
- 3) Remove the COVER LEFT (PL 1.1) (RRP1.3).
- 4) Remove the COVER RIGHT (PL 1.1) (RRP1.2).
- 5) Remove the COVER EXIT 500 (PL 1.1) (RRP7.1).
- 6) Remove the 500 EXIT ASSEMBLY (PL 7.1) (RRP7.2).
- 7) Remove the CHUTE LOW EXIT (PL 7.1) (RRP7.3).
- 8) Remove the SPRING GATE OCT (PL 7.1) (Figure 1).
- 9) Bend GATE OCT EXIT (PL 7.1), and remove the it from CHUTE LOW EXIT (Figure 1).

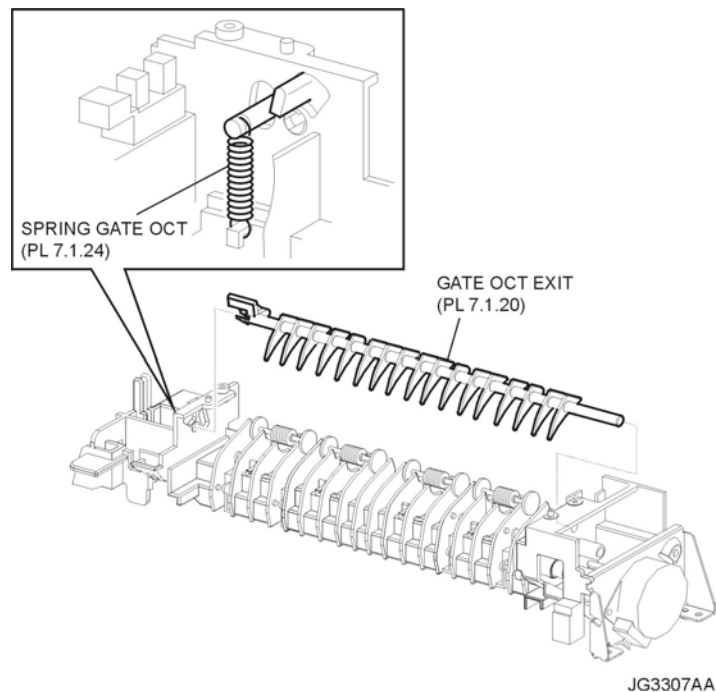
**Figure 1. OCT Exit Gate****Replacement**

- 1) Install the GATE OCT EXIT (PL 7.1) (Figure 1).
- 2) Install the SPRING GATE OCT (PL 7.1) (Figure 1).
- 3) Install the CHUTE LOW EXIT (PL 7.1) (RRP7.3).
- 4) Install the 500 EXIT ASSEMBLY (PL 7.1) (RRP7.2).
- 5) Install the COVER EXIT 500 (PL 1.1) (RRP7.1).
- 6) Install the COVER RIGHT (PL 1.1) (RRP1.2).
- 7) Install the COVER LEFT (PL 1.1) (RRP1.3).
- 8) Install the COVER REAR (PL 1.1) (RRP1.1).

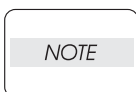

There are 2 kinds of screws, make sure they are installed correctly.

- 9) Install the COVER REAR 500 (PL 7.1) (RRP7.9).

RRP8. Frame & Drive

RRP8.1 MOTOR COVER (PL 8.1)**Removal**

- 1) Remove the COVER REAR 500 (PL 7.1) (RRP7.9).
- 2) Remove the COVER REAR (PL 1.1) (RRP1.1).
- 3) Remove the FUSER ASSEMBLY (PL 6.1) (RRP6.8).
- 4) Remove the COVER LEFT (PL 1.1) (RRP1.3).
- 5) Remove the COVER RIGHT (PL 1.1) (RRP1.2).
- 6) Remove the COVER EXIT 500 (PL 1.1) (RRP7.1).
- 7) Remove the 500 EXIT ASSEMBLY (PL 7.1) (RRP7.2).
- 8) Remove the COVER TOP (PL 1.1) (RRP1.4).
- 9) Remove the COVER FRONT (PL 1.1) (RRP1.5).
- 10) Remove the BTR ASSEMBLY (PL 6.1) (RRP6.9).
- 11) Remove the GUIDE TRAY LEFT (PL 5.1) (RRP5.8).
- 12) Remove the DUCT FRONT (PL 6.1) (RRP6.2).
- 13) Remove the ROS ASSEMBLY (PL 6.1) (RRP6.1).

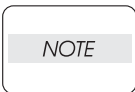

Be careful not to drop or strike the ROS Assembly with any tools or other objects.

- 14) Remove the SHIELD PLATE ROS (PL 6.1) (RRP6.3).
- 15) While lifting up the 150 FEEDER ASSEMBLY, remove the screw (silver, 6mm) securing the MOTOR COVER to the frame (Figure 1).
- 16) Remove the harness connector of MAIN MOTOR (Figure 1).
- 17) Remove the MOTOR COVER (Figure 1).

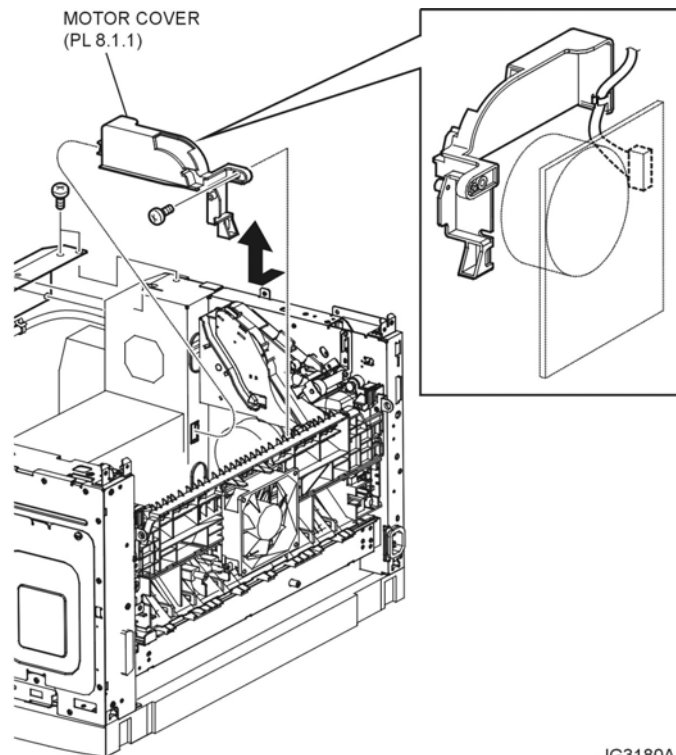

JG3180AB

Figure 1. Motor Cover

Replacement

- 1) Install the MOTOR COVER to the frame using the screw (silver, 6mm) (Figure 1).
- 2) Install the harness connector of MAIN MOTOR(Figure 1).
- 3) Install the SHIELD PLATE ROS (PL 6.1) (RRP6.3).
- 4) Install the ROS ASSEMBLY (PL 6.1) (RRP6.1).

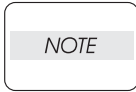

Be careful not to drop or strike the ROS Assembly with any tools or other objects.

- 5) Install the DUCT FRONT (PL 6.1) (RRP6.2).
- 6) Install the GUIDE TRAY LEFT (PL 5.1) (RRP5.8).
- 7) Install the COVER FRONT (PL 1.1) (RRP1.5).
- 8) Install the COVER TOP (PL 1.1) (RRP1.4).
- 9) Install the 500 EXIT ASSEMBLY (PL 7.1) (RRP7.2).
- 10) Install the COVER EXIT 500 (PL 1.1) (RRP7.1).
- 11) Install the COVER RIGHT (PL 1.1) (RRP1.2).
- 12) Install the COVER LEFT (PL 1.1) (RRP1.3).
- 13) Install the FUSER ASSEMBLY (PL 6.1) (RRP6.8).
- 14) Install the COVER REAR (PL 1.1) (RRP1.1).

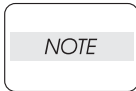

There are 2 kinds of screws, make sure they are installed correctly.

- 15) Install the COVER REAR 500 (PL 7.1) (RRP7.9).
- 16) Install the BTR ASSEMBLY (PL 6.1) (RRP6.9).

RRP8.2 MAIN MOTOR (PL 8.1.2)**Removal**

- 1) Remove the COVER REAR 500 (PL 7.1) (RRP7.9).
- 2) Remove the COVER REAR (PL 1.1) (RRP1.1).
- 3) Remove the FUSER ASSEMBLY (PL 6.1) (RRP6.8).
- 4) Remove the COVER LEFT (PL 1.1) (RRP1.3).
- 5) Remove the COVER RIGHT (PL 1.1) (RRP1.2).
- 6) Remove the COVER EXIT 500 (PL 1.1) (RRP7.1).
- 7) Remove the 500 EXIT ASSEMBLY (PL 7.1) (RRP7.2).
- 8) Remove the COVER TOP (PL 1.1) (RRP1.4).
- 9) Remove the COVER FRONT (PL 1.1) (RRP1.5).
- 10) Remove the BTR ASSEMBLY (PL 6.1) (RRP6.9).
- 11) Remove the DUCT FRONT (PL 6.1) (RRP6.2).
- 12) Remove the ROS ASSEMBLY (PL 6.1) (RRP6.1).

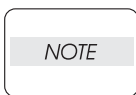

Be careful not to drop or strike the ROS Assembly with any tools or other objects.

- 13) Remove the SHIELD PLATE ROS (PL 6.1) (RRP6.3).
- 14) Remove the GUIDE TRAY LEFT (PL 5.1) (RRP5.8).
- 15) Remove the MOTOR COVER (PL 8.1) (RRP8.1).
- 16) Remove the SHIELD PLATE LVPS (PL 9.1) (RRP8.1).
- 17) Disconnect the connector (P/J43) of the MAIN MOTOR from the LVPS (PL 9.1.5) and disconnect the connector (P/J271) (Figure 1).
- 18) Lift up the 150 FEEDER ASSEMBLY (PL 4.1) (Figure 1).

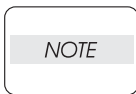

The 150 FEEDER ASSEMBLY clicks into a notch when lifted to the half way point, push the assembly past the notch.

- 19) Remove the 3 screws (gold, 6mm) securing the MAIN MOTOR to the frame (Figure 1).
- 20) Remove the MAIN MOTOR (Figure 1).

Replacement

- 1) Install the MAIN MOTOR to the frame using the 3 screws (gold, 6mm) (Figure 1).
- 2) Connect the connector (P/J43) of the MAIN MOTOR to the LVPS (PL 9.1.5) and connect the connector (P/J271) (Figure 1).
- 3) Install the SHIELD PLATE LVPS (PL 9.1) (RRP8.1).
- 4) Install the MOTOR COVER (PL 8.1) (RRP8.1).
- 5) Install the GUIDE TRAY LEFT (PL 5.1) (RRP5.8).
- 6) Install the SHIELD PLATE ROS (PL 6.1) (RRP6.3).
- 7) Install the ROS ASSEMBLY (PL 6.1) (RRP6.1).

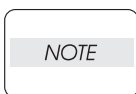

Be careful not to drop or strike the ROS Assembly with any tools or other objects.

- 8) Install the DUCT FRONT (PL 6.1) (RRP6.2).
- 9) Install the COVER FRONT (PL 1.1) (RRP1.5).
- 10) Install the COVER TOP (PL 1.1) (RRP1.4).
- 11) Install the 500 EXIT ASSEMBLY (PL 7.1) (RRP7.2).
- 12) Install the COVER EXIT 500 (PL 1.1) (RRP7.1).

- 13) Install the COVER RIGHT (PL 1.1) (RRP1.2).
- 14) Install the COVER LEFT (PL 1.1) (RRP1.3).
- 15) Install the FUSER ASSEMBLY (PL 6.1) (RRP6.8).
- 16) Install the COVER REAR (PL 1.1) (RRP1.1).

NOTE

There are 2 kinds of screws, make sure they are installed correctly.

- 17) Install the COVER REAR 500 (PL 7.1) (RRP7.9).
- 18) Install the BTR ASSEMBLY (PL 6.1) (RRP6.9).

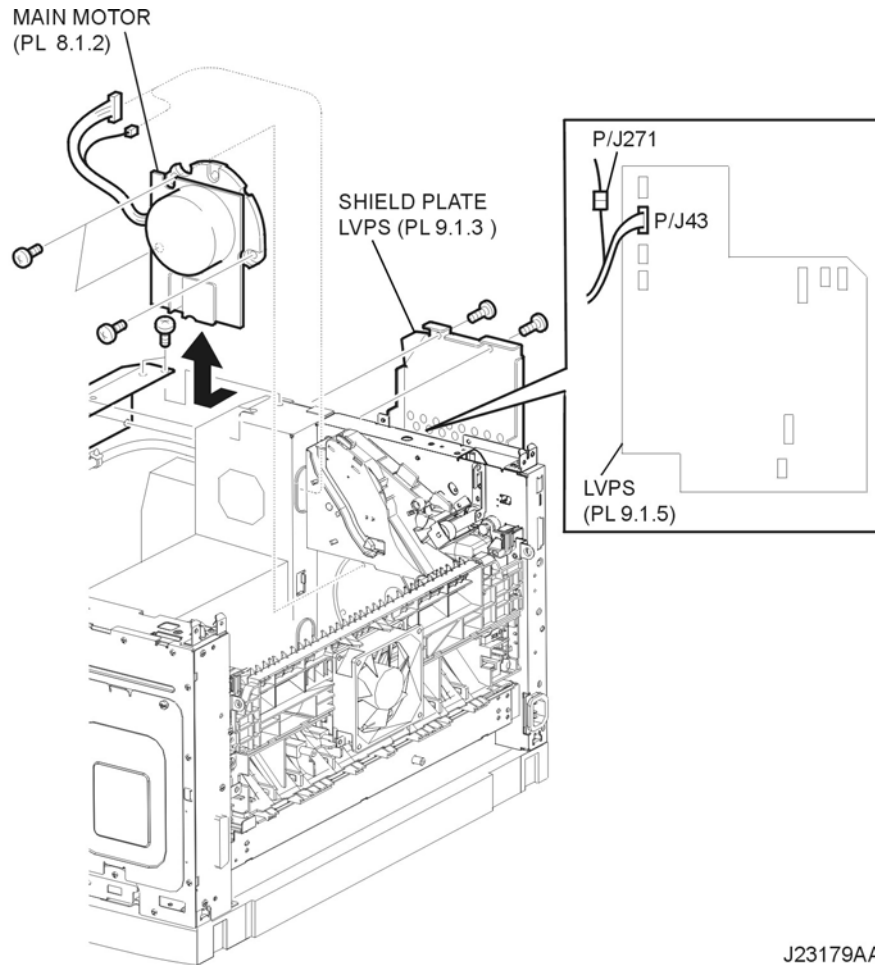

J23179AA

Figure 1. Main Motor

RRP8.3 GEAR ASSEMBLY HOUSING (PL 8.1.3)**Removal**

- 1) Remove the COVER REAR 500 (PL 7.1) (RRP7.9).
- 2) Remove the COVER REAR (PL 1.1) (RRP1.1).
- 3) Remove the COVER LEFT (PL 1.1) (RRP1.3).
- 4) Release the holding of the HARNESS ASSEMBLY INTERLOCK2 and HARNESS ASSEMBLY LVPS from the clamps on the GEAR ASSEMBLY HOUSING.
- 5) Remove the 6 screws (silver, 6mm x 5, gold, 6mm x 1) securing the GEAR ASSEMBLY HOUSING to the frame (Figure 1).
- 6) Release the hooks of the GEAR ASSEMBLY HOUSING, and remove it from the frame (Figure 1).

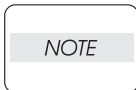

When removing the GEAR ASSEMBLY HOUSING, two of the gears that are installed to the GEAR ASSEMBLY HOUSING are not fixed and they may come off. Be careful not to drop them.

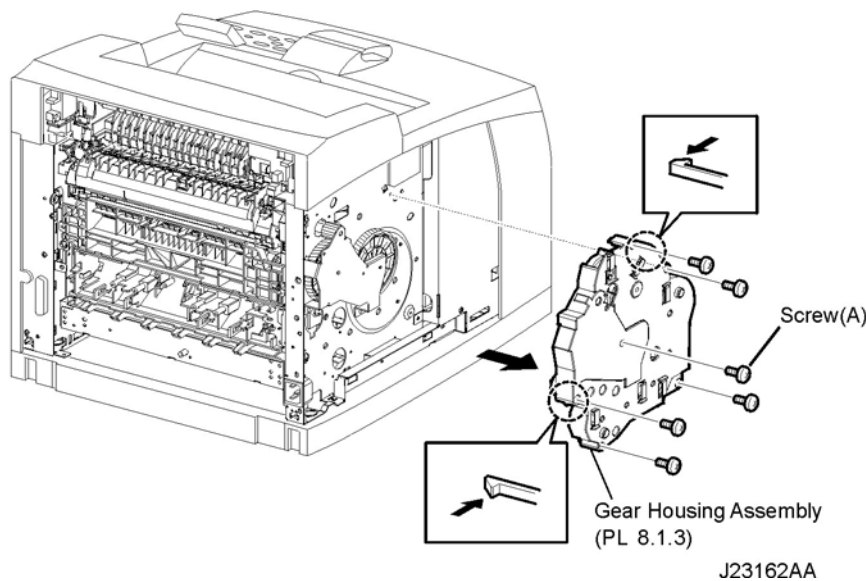
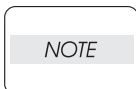

Figure 1. Gear Housing Assembly

Replacement

- 1) Install the GEAR ASSEMBLY HOUSING to the frame (Figure 1).



When installing, two of the gears that are installed to the GEAR ASSEMBLY HOUSING are not fixed and they may come off. Be careful not to drop them.

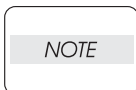

When installing, engage the gears of the GEAR ASSEMBLY HOUSING, MAIN MOTOR, and GEAR ASSEMBLY PLATE. After assembling, check the engagement of the gears. The gears will engage easily when they are assembled, by rotating the MAIN MOTOR with hand.

- 2) Install the GEAR ASSEMBLY HOUSING to the frame using the 6 screws (silver, 6mm x 5, gold, 6mm x 1) (Figure 1).

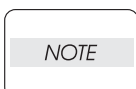

Be sure to tighten the screw (gold, 8mm) shown as "Screw (A)" (Figure 1).

- 3) Secure the HARNESS ASSEMBLY INTERLOCK 2 and HARNESS ASSEMBLY LVPS (PL 9.1) using the clamps on the GEAR ASSEMBLY HOUSING (Figure 1).

4) Install the COVER LEFT (PL 1.1) (RRP1.3).

5) Install the COVER REAR (PL 1.1) (RRP1.1).

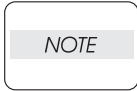

There are 2 kinds of screws, make sure they are installed correctly.

6) Install the COVER REAR 500 (PL 7.1) (RRP7.9).

RRP8.4 GEAR ASSEMBLY PLATE (PL 8.1.10), GEAR 9 (PL 8.1.9)**Removal**

- 1) Remove the COVER REAR 500 (PL 7.1) (RRP7.9).
- 2) Remove the COVER REAR (PL 1.1) (RRP1.1).
- 3) Remove the FUSER ASSEMBLY (PL 6.1) (RRP6.8).
- 4) Remove the COVER LEFT (PL 1.1) (RRP1.3).
- 5) Remove the GEAR ASSEMBLY HOUSING (PL 8.1.3) (RRP8.3).
- 6) Remove the 4 screws (silver, 6mm) securing the GEAR ASSEMBLY PLATE to the frame (Figure 1).
- 7) Remove the GEAR ASSEMBLY PLATE (Figure 1).
- 8) Remove the boss of the bottom side of the connector of the HARNESS ASSEMBLY FUSER from the frame (Figure 1).
- 9) Remove the GEAR 9 (PL 8.1.9) from the shaft on the frame (Figure 1).

NOTE When removing the GEAR ASSEMBLY PLATE, one of the gears installed to the GEAR ASSEMBLY PLATE is not fixed and it may come off. Be careful not to drop it.

NOTE There is a SPRING inside of the GEAR that is not fixed to the GEAR ASSEMBLY PLATE. Be careful not to drop this SPRING.

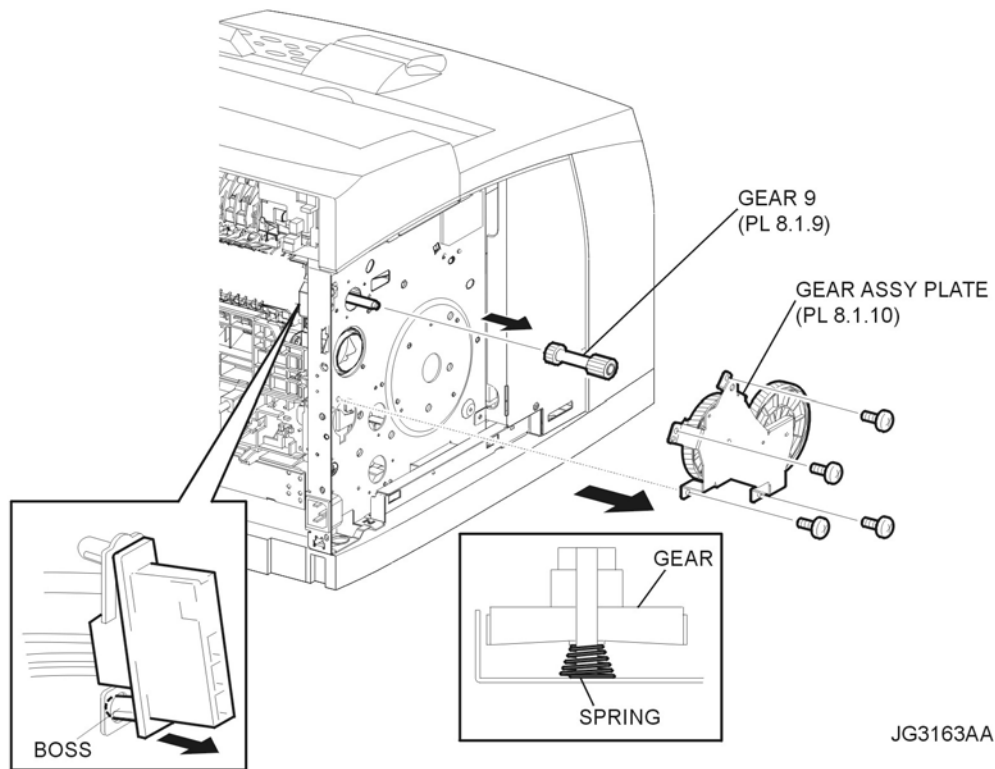
**Figure 1. Gear 9 & Gear Plate Assembly****Replacement**

- 1) Install the GEAR 9 (PL 8.1.9) to the shaft on the frame (Figure 1).

NOTE When installing the GEAR 9, be sure to install the narrow end of the GEAR inside.

2) Install the boss which is under the connector of HARNESS ASSEMBLY FUSER to the frame (Figure 1).

3) Install the GEAR ASSEMBLY PLATE to the frame using the 4 screws (silver, 6mm) (Figure 1).

NOTE

When installing, if the GEAR or the SPRING that are not fixed to the GEAR ASSEMBLY PLATE come off, re-install them in the direction shown in the figure.

4) Install the GEAR ASSEMBLY HOUSING (PL 8.1.3) (RRP8.3).

NOTE

When installing, two of the gears that are installed to the GEAR ASSEMBLY HOUSING are not fixed and they may come off. Be careful not to drop them.

NOTE

When installing, engage the gears of the GEAR ASSEMBLY HOUSING, MAIN MOTOR, and GEAR ASSEMBLY PLATE. After assembling, check the engagement of the gears. The gears will engage easily when they are assembled, by rotating the MAIN MOTOR with hand.

5) Insert the boss of the bottom side of the connector of the HARNESS ASSEMBLY FUSER to the frame.

6) Install the COVER LEFT (PL 1.1) (RRP1.3).

7) Install the FUSER ASSEMBLY (PL 6.1) (RRP6.8).

8) Install the COVER REAR (PL 1.1) (RRP1.1).

NOTE

There are 2 kinds of screws, make sure they are installed correctly.

9) Install the COVER REAR 500 (PL 7.1) (RRP7.9).

RRP9. Electrical

RRP9.1 SHIELD PLATE LVPS (PL 9.1)**Removal**

- 1) Remove the COVER REAR 500 (PL 7.1) (RRP7.9).
- 2) Remove the COVER REAR (PL 1.1) (RRP1.1).
- 3) Remove the COVER LEFT (PL 1.1) (RRP1.3).
- 4) Remove the COVER RIGHT (PL 1.1) (RRP1.2).
- 5) Remove the COVER EXIT 500 (PL 1.1) (RRP7.1).
- 6) Remove the 500 EXIT ASSEMBLY (PL 7.1) (RRP7.2).
- 7) Remove the COVER TOP (PL 1.1) (RRP1.4).
- 8) Remove the COVER FRONT (PL 1.1) (RRP1.5).
- 9) Remove the 8 screws (silver, 6mm) securing the SHIELD PLATE LVPS to the frame (Figure 1).
- 10) Remove the SHIELD PLATE LVPS (Figure 1).

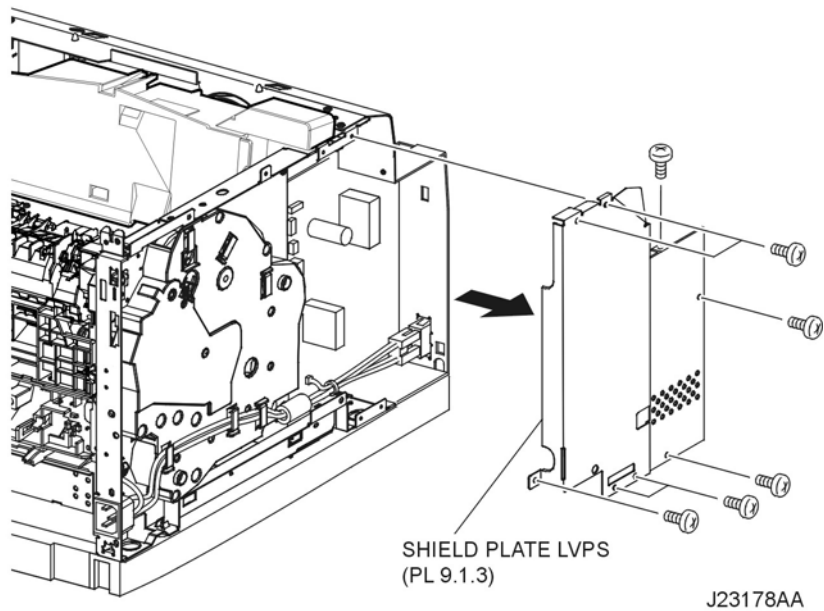
**Figure 1. LVPS Shield Plate****Replacement**

- 1) Install the SHIELD PLATE LVPS to the frame using the 8 screws (silver, 6mm) (Figure 1).
- 2) Install the COVER FRONT (PL 1.1) (RRP1.5).
- 3) Install the COVER TOP (PL 1.1) (RRP1.4).
- 4) Install the 500 EXIT ASSEMBLY (PL 7.1) (RRP7.2).

NOTE

When installing, pull the CHUTE EXIT FUSER lever.

- 5) Install the COVER EXIT 500 (PL 1.1) (RRP7.1).
- 6) Install the COVER RIGHT (PL 1.1) (RRP1.2).
- 7) Install the COVER LEFT (PL 1.1) (RRP1.3).
- 8) Install the COVER REAR (PL 1.1) (RRP1.1).

NOTE

There are 2 kinds of screws, make sure they are installed correctly.

- 9) Install the COVER REAR 500 (PL 7.1) (RRP7.9).

RRP9.2 PWBA EXIT MOTOR (PL 9.1.4)**Removal**

- 1) Remove the COVER REAR 500 (PL 7.1) (RRP7.9).
- 2) Remove the COVER REAR (PL 1.1) (RRP1.1).
- 3) Remove the COVER LEFT (PL 1.1) (RRP1.3).
- 4) Disconnect the harnesses from the connectors (P/J101, P/J102 and P/J103) on the PWBA EXIT MOTOR (Figure 1).
- 5) Remove the 2 screws (silver, 6mm) securing the PWBA EXIT MOTOR to the frame (Figure 1).
- 6) Remove the PWBA EXIT MOTOR (Figure 1).

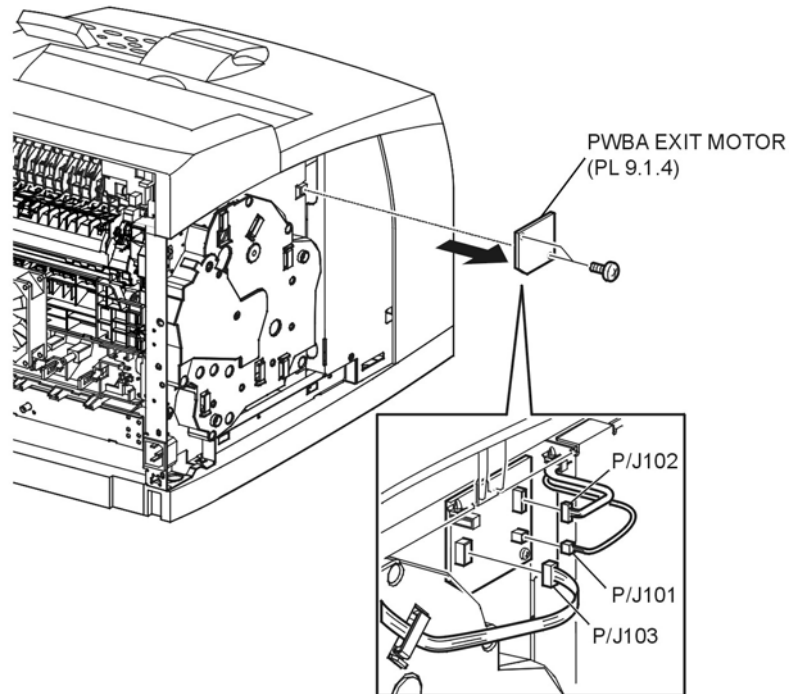

JG3164AA

Figure 1. Exit Motor PWBA**Replacement**

- 1) Install the PWBA EXIT MOTOR to the frame using the 2 screws (silver, 6mm) (Figure 1).
- 2) Connect the harness connectors to the connectors (P/J101, P/J102 and P/J103) on the PWBA EXIT MOTOR (Figure 1).
- 3) Install the COVER LEFT (PL 1.1) (RRP1.3).
- 4) Install the COVER REAR (PL 1.1) (RRP1.1).

NOTE

There are 2 kinds of screws, make sure they are installed correctly.

- 5) Install the COVER REAR 500 (PL 7.1) (RRP7.9).

RRP9.3 LVPS (PL 9.1.5)**Removal**

- 1) Remove the COVER REAR 500 (PL 7.1) (RRP7.9).
- 2) Remove the COVER REAR (PL 1.1) (RRP1.1).
- 3) Remove the COVER LEFT (PL 1.1) (RRP1.3).
- 4) Remove the COVER RIGHT (PL 1.1) (RRP1.2).
- 5) Remove the COVER EXIT 500 (PL 1.1) (RRP7.1).
- 6) Remove the 500 EXIT ASSEMBLY (PL 7.1) (RRP7.2).
- 7) Remove the COVER TOP (PL 1.1) (RRP1.4).
- 8) Remove the COVER FRONT (PL 1.1) (RRP1.5).
- 9) Remove the SHIELD PLATE LVPS (PL 9.1) (RRP8.1).
- 10) Disconnect the harness connector from the connector (P/J101) on the PWBA EXIT MOTOR (PL 9.1.4) (Figure 1).
- 11) Disconnect the harness connectors from the connectors (P/J40, P/J41, P/J42, P/J43, P/J44, P/J45, P/J46, P/J47 and P/J48) on the LVPS (Figure 1).
- 12) Remove the 5 screws (silver, 6mm) securing the LVPS to the frame (Figure 1).
- 13) Remove the LVPS.

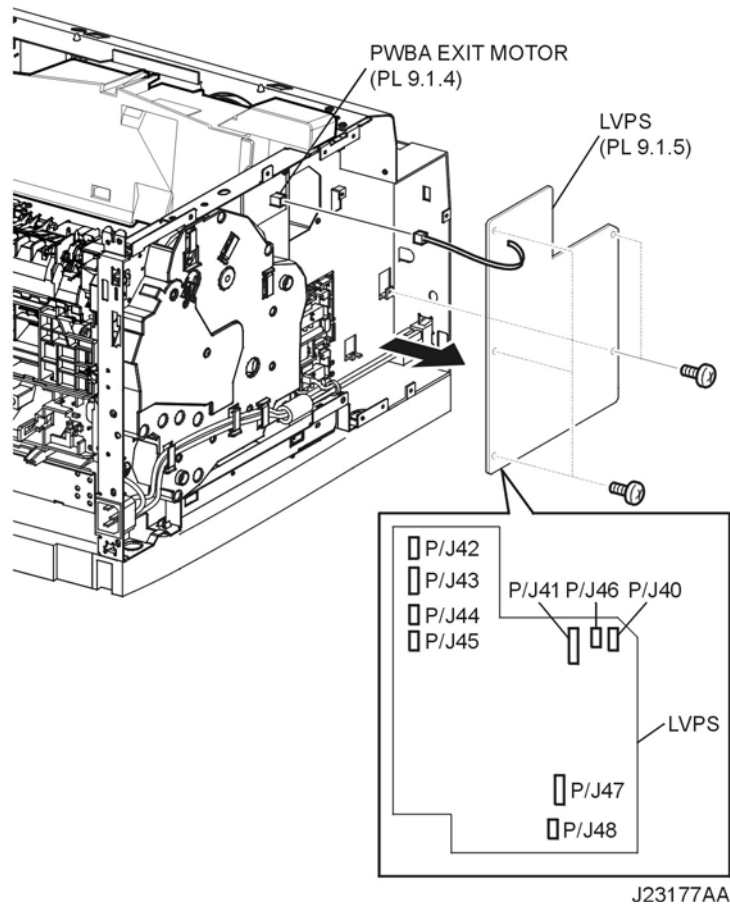
**Figure 1. Low Voltage Power Supply (LVPS)**

Replacement

- 1) Install the LVPS to the frame using the 5 screws (silver, 6mm) (Figure 1).
- 2) Connect the harness connectors to the connectors (P/J40, P/J41, P/J42, P/J43, P/J44, P/J45, P/J46, P/J47 and P/J48) on the LVPS (Figure 1).
- 3) Connect the connector of the harness LVPS to the connector (P/J101) on the PWBA EXIT MOTOR (PL 12.1.4) (Figure 1).
- 4) Install the SHIELD PLATE LVPS (PL 9.1) (RRP8.1).
- 5) Install the COVER FRONT (PL 1.1) (RRP1.5).
- 6) Install the COVER TOP (PL 1.1) (RRP1.4).
- 7) Install the 500 EXIT ASSEMBLY (PL 7.1) (RRP7.2).
- 8) Install the COVER EXIT 500 (PL 1.1) (RRP7.1).

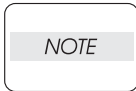

When installing, pull the CHUTE EXIT FUSER lever.

- 9) Install the COVER RIGHT (PL 1.1) (RRP1.2).
- 10) Install the COVER LEFT (PL 1.1) (RRP1.3).
- 11) Install the COVER REAR (PL 1.1) (RRP1.1).

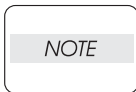

There are 2 kinds of screws, make sure they are installed correctly.

- 12) Install the COVER REAR 500 (PL 7.1) (RRP7.9).

RRP9.4 POWER SWITCH (PL 9.1.6), HARNESS ASSEMBLY AC100V/AC200V (PL 9.1.8)

Removal

- 1) Remove the COVER REAR 500 (PL 7.1) (RRP7.9).
- 2) Remove the COVER REAR (PL 1.1) (RRP1.1).
- 3) Remove the COVER LEFT (PL 1.1) (RRP1.3).
- 4) Remove the COVER RIGHT (PL 1.1) (RRP1.2).
- 5) Remove the COVER EXIT 500 (PL 1.1) (RRP7.1).
- 6) Remove the 500 EXIT ASSEMBLY (PL 7.1) (RRP7.2).
- 7) Remove the COVER TOP (PL 1.1) (RRP1.4).
- 8) Remove the COVER FRONT (PL 1.1) (RRP1.5).
- 9) Remove the SHIELD PLATE LVPS (PL 9.1) (RRP8.1).
- 10) Release the clamp of the HARNESS ASSEMBLY AC100V/AC200V from the clamps on the GEAR ASSEMBLY HOUSING (PL 8.1.3) (Figure 1).
- 11) Disconnect the connector (P/J480) of the HARNESS ASSEMBLY AC100V/AC200V from the POWER SWITCH (Figure 1).
- 12) Disconnect the connector (P/J48) of the HARNESS ASSEMBLY AC100V/AC200V from the LVPS (PL 9.1.5) (Figure 1).
- 13) Release the clamp of the HARNESS ASSEMBLY AC100V/AC200V (Figure 1).
- 14) Remove the screw (silver with toothed washer, 6mm) securing the ground terminal of the HARNESS ASSEMBLY AC100V/AC200V to the frame (Figure 1).
- 15) Pull out the HARNESS ASSEMBLY AC100V/AC200V from the hole at the rear of the frame (Figure 1).
- 16) Remove the POWER SWITCH from the frame.

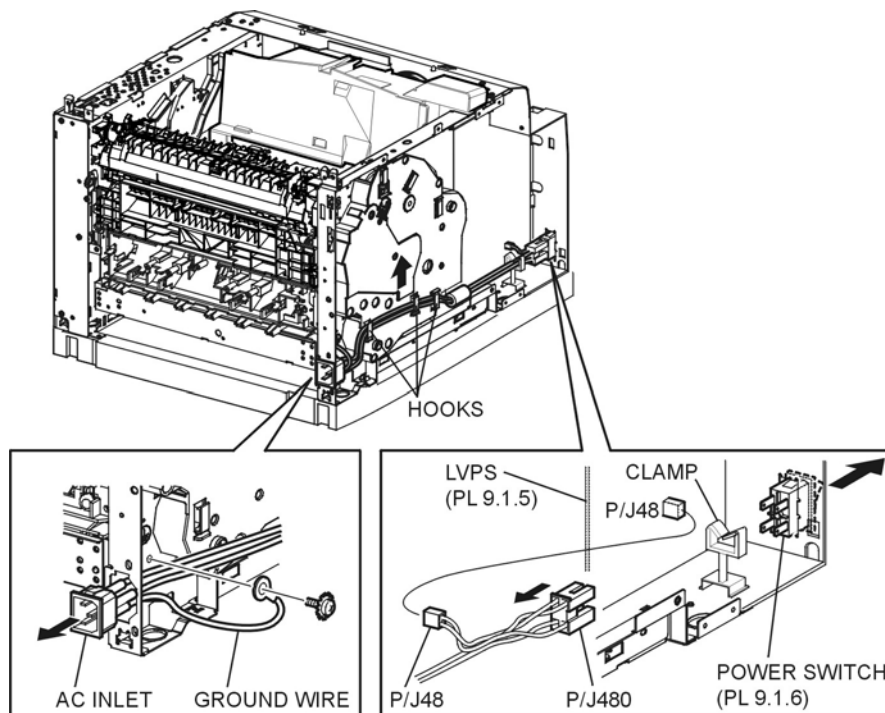

J23176AA

Figure 1. Power Switch & Harness Assembly

Replacement

- 1) Install the POWER SWITCH to the frame (Figure 1).
- 2) Install the HARNESS ASSEMBLY AC100V/AC200V to the hole at the rear of the frame (Figure 1).
- 3) Secure the ground terminal of the HARNESS ASSEMBLY AC100V/AC200V to the frame using the screw (silver with toothed washer, 6mm) (Figure 1).
- 4) Secure the HARNESS ASSEMBLY AC100V/AC200V.
- 5) Connect the connector (P/J48) of the HARNESS ASSEMBLY AC100V/AC200V to the LVPS (PL 9.1.5).
- 6) Connect the connector (P/J480) of the HARNESS ASSEMBLY AC100V/AC200V to the POWER SWITCH.
- 7) Secure the HARNESS ASSEMBLY AC100V/AC200V using the clamps of the GEAR ASSEMBLY HOUSING (PL 8.1.3).
- 8) Install the SHIELD PLATE LVPS (PL 9.1) (RRP8.1).
- 9) Install the COVER FRONT (PL 1.1) (RRP1.5).
- 10) Install the COVER TOP (PL 1.1) (RRP1.4).
- 11) Install the 500 EXIT ASSEMBLY (PL 7.1) (RRP7.2).

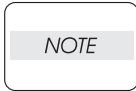

When installing, pull the CHUTE EXIT FUSER lever.

- 12) Install the COVER EXIT 500 (PL 1.1) (RRP7.1).
- 13) Install the COVER RIGHT (PL 1.1) (RRP1.2).
- 14) Install the COVER LEFT (PL 1.1) (RRP1.3).
- 15) Install the COVER REAR (PL 1.1) (RRP1.1).

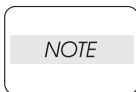

There are 2 kinds of screws, make sure they are installed correctly.

- 16) Install the COVER REAR 500 (PL 7.1) (RRP7.9).

RRP9.5 INTERLOCK S/W REAR (PL 9.1.7)**Removal**

- 1) Remove the COVER REAR 500 (PL 7.1) (RRP7.9).
- 2) Remove the COVER REAR (PL 1.1) (RRP1.1).
- 3) Remove the COVER LEFT (PL 1.1) (RRP1.3).
- 4) Remove the COVER RIGHT (PL 1.1) (RRP1.2).
- 5) Remove the COVER EXIT 500 (PL 1.1) (RRP7.1).
- 6) Remove the 500 EXIT ASSEMBLY (PL 7.1) (RRP7.2).
- 7) Remove the COVER TOP (PL 1.1) (RRP1.4).
- 8) Remove the COVER FRONT (PL 1.1) (RRP1.5).
- 9) Remove the SHIELD PLATE LVPS (PL 9.1) (RRP8.1).
- 10) Disconnect the connector (P/J44) of the INTERLOCK S/W REAR from the LVPS (PL 9.1.5) (Figure 1).
- 11) Release the clamps of the HARNESS ASSEMBLY INTERLOCK 2 of the INTERLOCK S/W REAR from the clamps on the GEAR ASSEMBLY HOUSING (PL 8.1.3) (Figure 1).
- 12) Remove the screw (silver, 6mm) securing the INTERLOCK S/W REAR to the frame (Figure 1).
- 13) Remove the INTERLOCK S/W REAR.

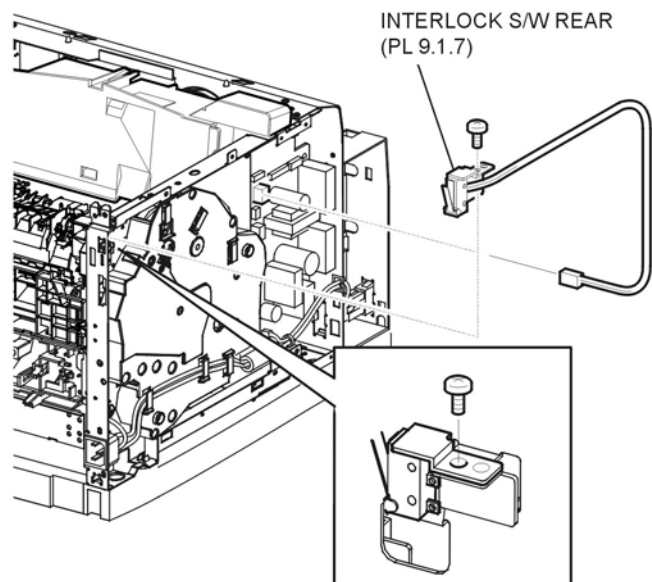

JG3175AA

Figure 1. Rear Interlock Switch**Replacement**

- 1) Install the INTERLOCK S/W REAR to the frame using the screw (silver, 6mm) (Figure 1).
- 2) Secure the HARNESS ASSEMBLY INTERLOCK 2 of the INTERLOCK S/W REAR to the clamps on the GEAR ASSEMBLY HOUSING (PL 8.1.3) (Figure 1).
- 3) Connect the connector (P/J44) of the INTERLOCK S/W REAR to the LVPS (PL 9.1.5) (Figure 1).
- 4) Install the SHIELD PLATE LVPS (PL 9.1) (RRP8.1).
- 5) Install the COVER FRONT (PL 1.1) (RRP1.5).
- 6) Install the COVER TOP (PL 1.1) (RRP1.4).
- 7) Install the 500 EXIT ASSEMBLY (PL 7.1) (RRP7.2).

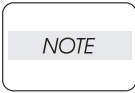

When installing, pull the CHUTE EXIT FUSER lever.

- 8) Install the COVER EXIT 500 (PL 1.1) (RRP7.1).
- 9) Install the COVER RIGHT (PL 1.1) (RRP1.2).
- 10) Install the COVER LEFT (PL 1.1) (RRP1.3).
- 11) Install the COVER REAR (PL 1.1) (RRP1.1).

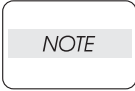

There are 2 kinds of screws, make sure they are installed correctly.

- 12) Install the COVER REAR 500 (PL 7.1) (RRP7.9).

RRP9.6 FAN MAIN (PL 1.1.14)**Removal**

- 1) Remove the COVER REAR 500 (PL 7.1) (RRP7.9).
- 2) Remove the COVER REAR (PL 1.1) (RRP1.1).
- 3) Release the harness clamps of the FAN MAIN (Figure 1).
- 4) Remove the 2 screws (silver tapping, 8mm) securing the FAN MAIN to the COVER REAR, and remove the FAN MAIN (Figure 1).

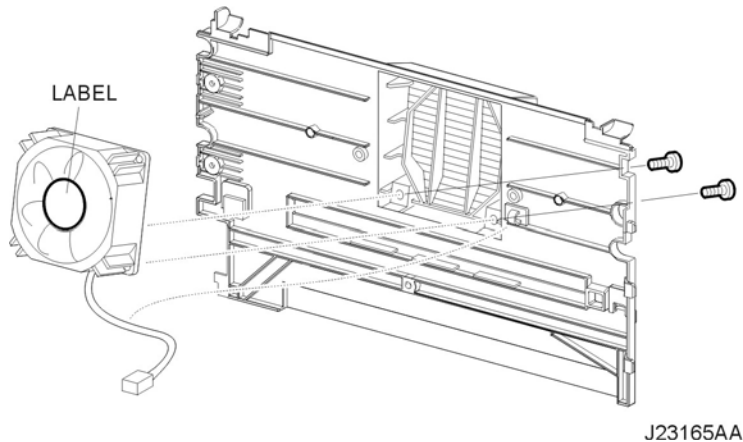
**Figure 1. Main Fan****Replacement**

- 1) Install the FAN MAIN to the COVER REAR using the 2 screws (silver tapping, 8mm) (Figure 1).

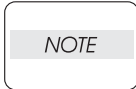

When installing, be sure to install the FAN MAIN so that the label is facing outside.

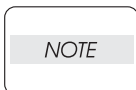

When installing, make sure the harness is not pinched between the FAN MAIN and the COVER REAR.

- 2) Attach the harness of the FAN MAIN with the clamp (Figure 1).
- 3) Install the COVER REAR (PL 1.1) (RRP1.1).

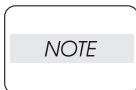

There are 2 kinds of screws, make sure they are installed correctly.

- 4) Install the COVER REAR 500 (PL 7.1) (RRP7.9).

RRP9.7 SHIELD ASSEMBLY ESS (PL 9.1)

Removal

- 1) Remove the COVER RIGHT (PL 1.1) (RRP1.2).
- 2) Remove the 12 screws (silver, 6mm) securing the SHIELD ASSEMBLY ESS to the frame (Figure 1).
- 3) Remove the SHIELD ASSEMBLY ESS.

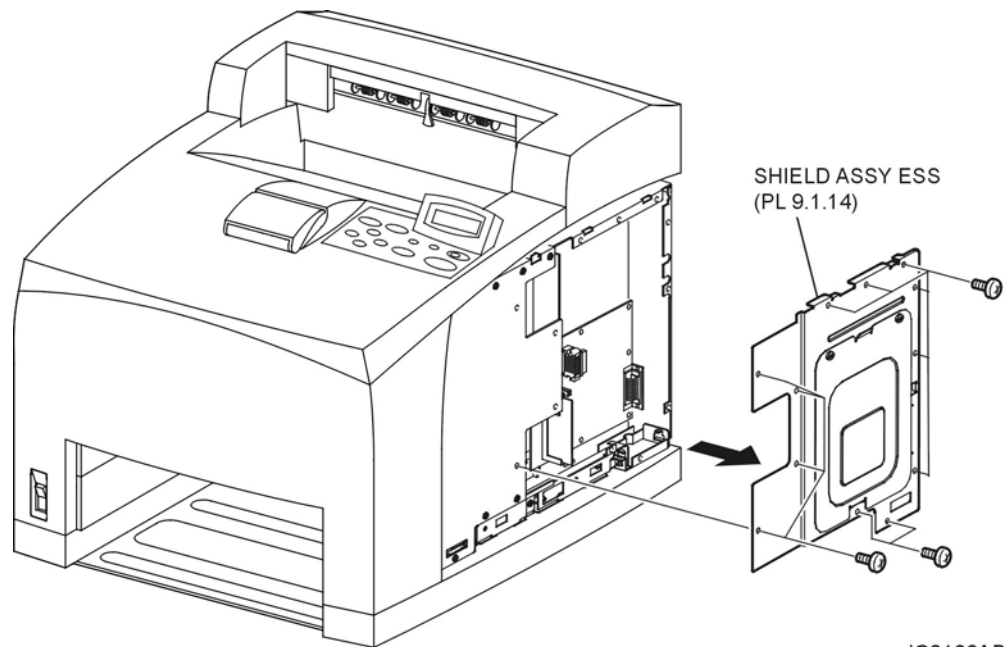

Figure 1. ESS Shield Assembly

Replacement

- 1) Install the SHIELD ASSEMBLY ESS to the frame using the 12 screws (silver, 6mm) (Figure 1).
- 2) Install the COVER RIGHT (PL 1.1) (RRP1.2).

RRP9.8 SHIELD ASSEMBLY WINDOW (PL 9.1)

Removal

- 1) Remove the COVER RIGHT (PL 1.1) (RRP1.2).
- 2) Remove the 2 screws securing the SHIELD ASSEMBLY WINDOW to the frame (Figure 1).
- 3) Remove the SHIELD ASSEMBLY WINDOW.

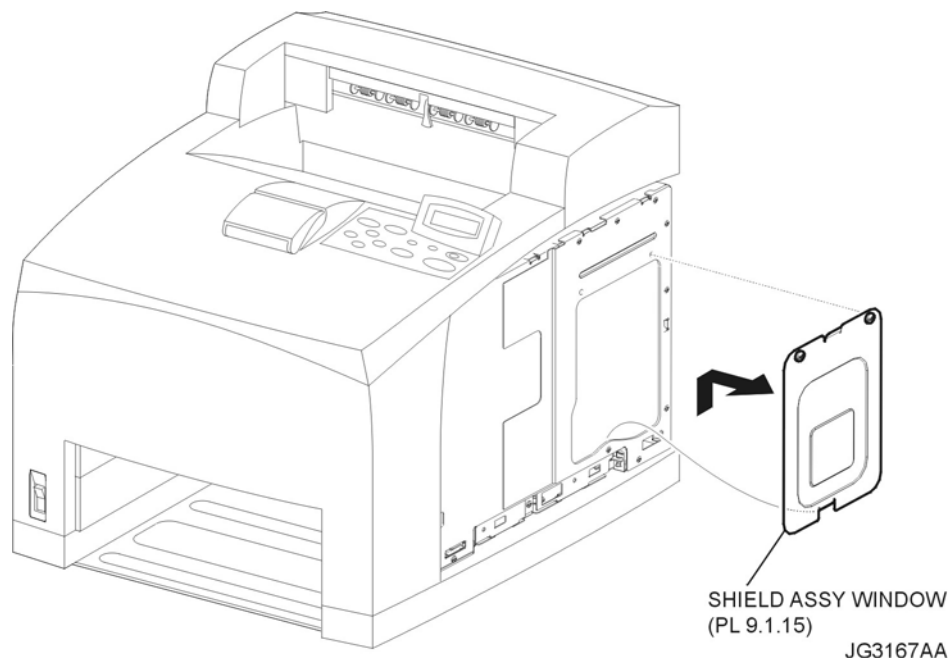

Figure 1. Window Shield Assembly

Replacement

- 1) Install the SHIELD ASSEMBLY WINDOW to the frame using the 2 screws (Figure 1).
- 2) Install the COVER RIGHT (PL 1.1) (RRP1.2).

RRP9.9 SHIELD PLATE HVPS (PL 12.1.18)

Removal

- 1) Remove the COVER RIGHT (PL 1.1) (RRP1.2).
- 2) Remove the SHIELD ASSEMBLY ESS (PL 9.1) (RRP9.7).
- 3) Remove the 10 screws (silver, 6mm) securing the SHIELD PLATE HVPS to the frame (Figure 1).
- 4) Remove the SHIELD PLATE HVPS.

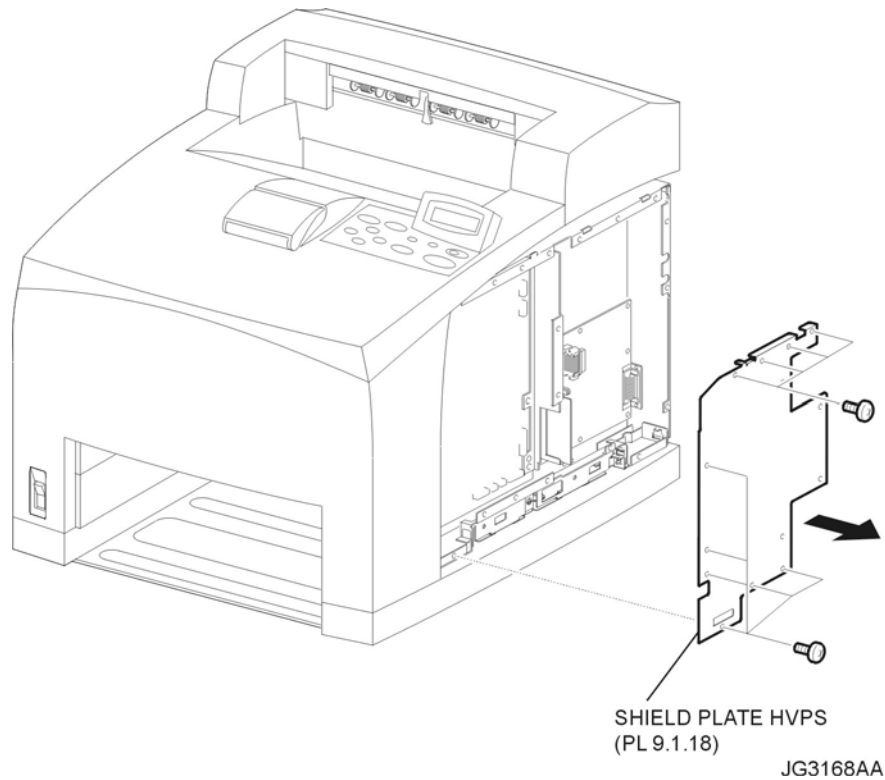

Figure 1. HVPS Shield Plate

Replacement

- 1) Install the SHIELD PLATE HVPS to the frame using the 10 screws (silver, 6mm) (Figure 1).
- 2) Install the SHIELD ASSEMBLY ESS (PL 9.1) (RRP9.7).
- 3) Install the COVER RIGHT (PL 1.1) (RRP1.2).

RRP9.10 HVPS/MCU (PL 9.1.19)**Removal**

- 1) Remove the COVER RIGHT (PL 1.1) (RRP1.2).
- 2) Remove the SHIELD ASSEMBLY ESS (PL 9.1) (RRP9.7).
- 3) Remove the SHIELD PLATE HVPS (PL 9.1) (RRP9.9).
- 4) Remove the screw (silver, 6mm) securing the BRACKET HANDLE R (PL 9.1.12) to the frame.
- 5) Remove the BRACKET HANDLE R from the frame.
- 6) Disconnect the harness connectors from the connectors (P/J10, P/J11, P/J13, P/J14, P/J15, P/J16, P/J17, P/J18, P/J20, P/J22, P/J24, P/J26, P/J 27, P/J 28, P/J29, P/J30, and P/J31) on the HVPS/MCU (Figure 1).
- 7) Remove the 3 screws (silver, 6mm) securing the BRACKET SHIELD HVPS (PL 9.1) to the frame (Figure 1).
- 8) Remove the 4 screws (silver, 6mm) securing the HVPS/MCU (PL 9.1) to the frame (Figure 1).
- 9) Carefully remove the HVPS/MCU from the 2 mounting tabs on the right side of the frame and slide the unit down slightly to release it from the frame hook (Figure 1).

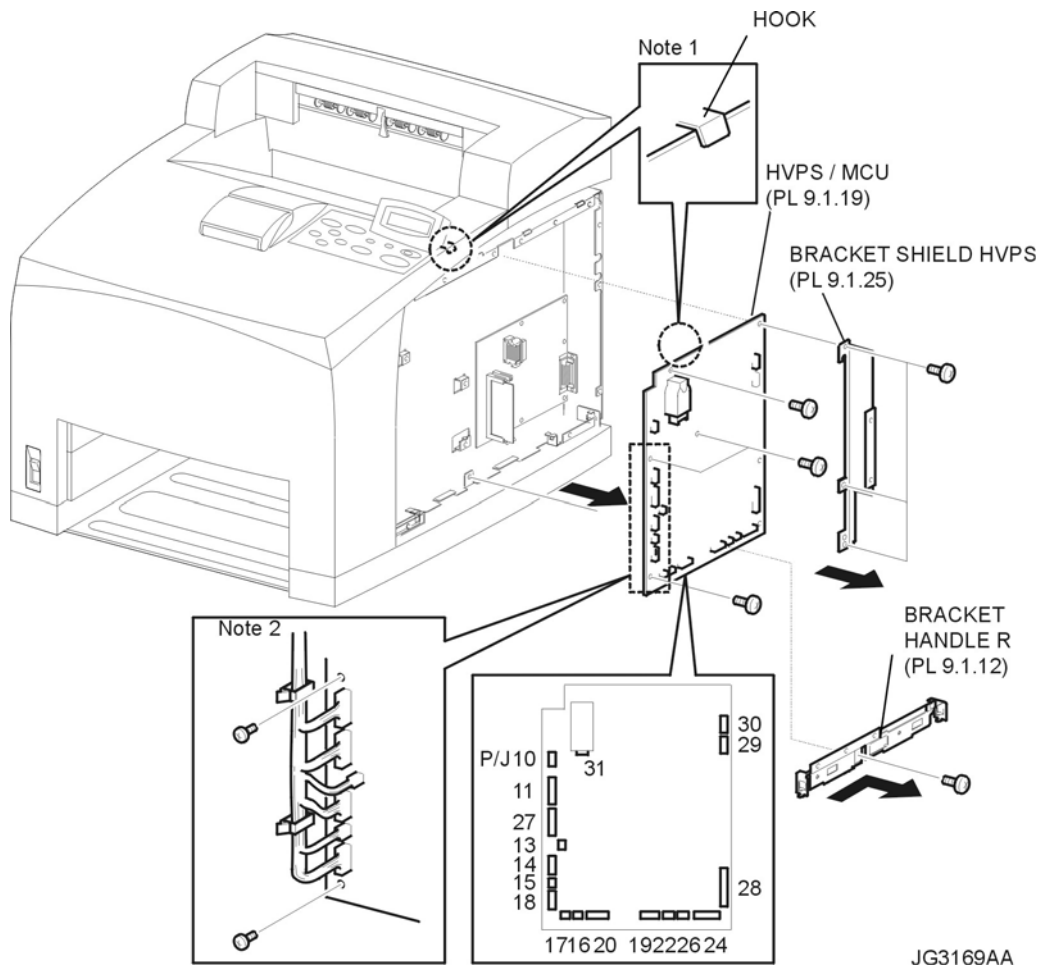
**Figure 1. HVPS/MCU****Replacement**

- 1) Carefully slide the unit under the frame hook and seat it on the 2 mounting tabs on the right side of the frame (Figure 1).
- 2) Replace the 4 screws (silver, 6mm) securing the HVPS/MCU (PL 9.1) to the frame (Figure 1).

Removal and Replacement Procedures (RRPs)

- 3) Replace the BRACKET SHIELD HVPS (PL 9.1) to the frame and secure with 3 screws (silver, 6mm) (Figure 1).
- 4) Reconnect the harness connectors: (P/J10, P/J11, P/J13, P/J14, P/J15, P/J16, P/J17, P/J18, P/J20, P/J22, P/J24, P/J26, P/J 27, P/J 28, P/J29, P/J30, and P/J31) on the HVPS/MCU (Figure 1).
- 5) Replace the BRACKET HANDLE R on the frame.
- 6) Replace the screw (silver, 6mm) securing the BRACKET HANDLE R (PL 9.1.12) to the frame.
- 7) Replace the SHIELD PLATE HVPS (PL 9.1) (RRP9.9).
- 8) Replace the SHIELD ASSEMBLY ESS (PL 9.1) (RRP9.7).
- 9) Replace the COVER RIGHT (PL 1.1) (RRP1.2).

Duplex Option

Description of procedure

- ❑ [RRP X.Y “AAAAA”] attached at the front of the procedure shows that the name of parts to be assembled/disassembled is “AAAAA”.
- ❑ “(PL X.Y.Z)” attached at the end of parts name in the procedure shows that the parts corresponds to the plate (PL) “X.Y”, item “Z” of [Chapter 5 Parts list], and their shape and fitting position can be checked in [Chapter 5 parts list].
- ❑ The printer orientation used in the procedures is defined as follows:
 - Front : Front direction when facing the front of device.
 - Rear : Rear direction when facing the front of device.
 - Left : Left direction when facing the front of device.
 - Right : Right direction when facing the front of device.

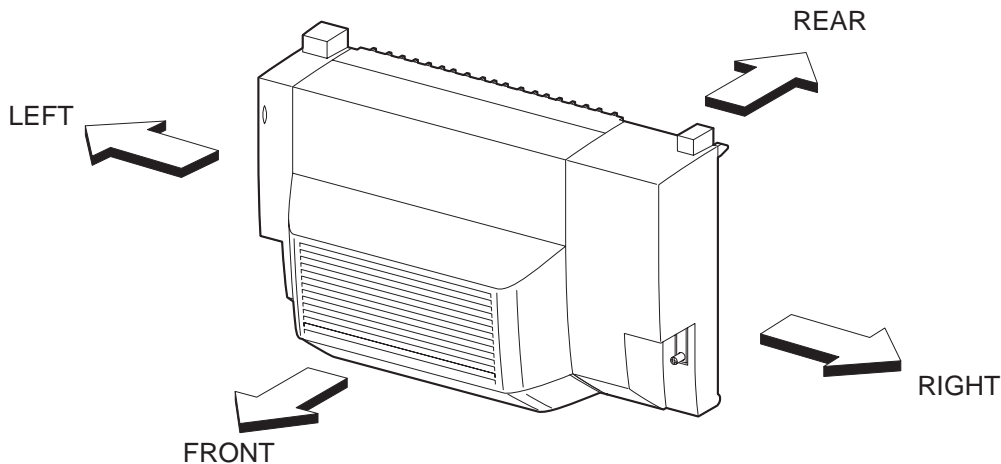

J23619AA

- ❑ The screws in procedures are expressed with their replacing position, color, characteristics and nominal length, etc.
- ❑ In case of _____ specifications" in the procedures indicate that service operation should be provided only to Duplex Option of specified specifications (service operation should not be provided for Duplex Option of specifications not covered).
- ❑ "RRP X.Y" in the midst or at the end of sentences in the procedures indicate that work procedures related with the "RRP X.Y" are described.
- ❑ "Figure X.Y" at the end of the sentences of procedures indicate that illustrations instructive for the "RRP X.Y" are included.
- ❑ "Z)" in the illustrations correspond to "Z)" of the service procedures.
- ❑ The screws in the illustrations should be removed using a plus (+) screwdriver unless otherwise specified.
- ❑ A black arrow in the illustrations indicate movement in the arrow mark direction. Numbered black arrows indicate movement in the order of the numbers.
- ❑ White arrows (FRONT) in the illustrations indicate the front direction.
- ❑ For the positions of the connectors (P/J), refer to Chapter 7, Electric wiring.

RRP10.Duplex Option

RRP10.1 Duplex Option

Removal

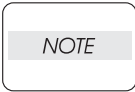

When removing the Duplex Option, be careful not to drop the Duplex unit.

- 1) Loosen the 2 SCREW THUMBs (PL 10.1) securing the Duplex Option to the printer.
- 2) Push up the LEVER LATCH RIGHT (PL 10.1), and release the hooks of the LEVER LATCH RIGHT and LEVER LATCH LEFT (PL 10.1).
- 3) Position the Duplex Option forward, disconnect the connector (P/J2750) of the HARNESS ASSY DUP (PL 10.1) from the printer.
- 4) Remove 2 bosses on both sides of the HSG LOWER DUP (PL 10.1).
- 5) Release the 2 bottom hooks of the HSG LOWER DUP, and remove the Duplex Option from the printer.

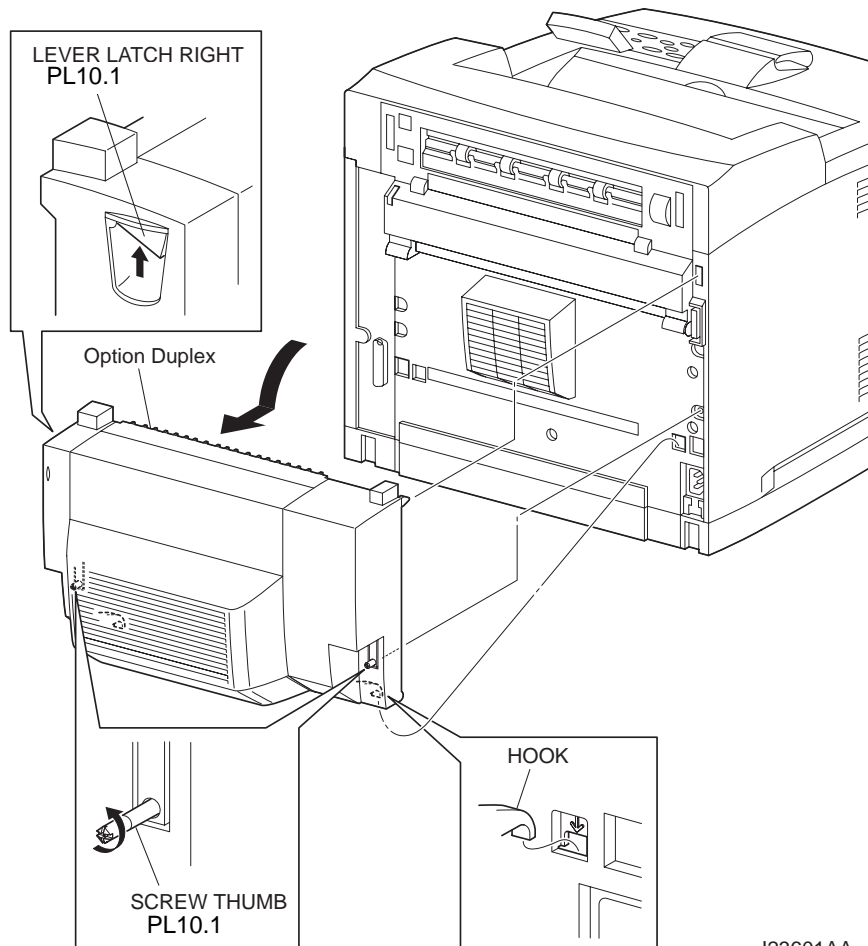

J23601AA

Replacement

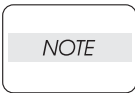

When installing the Duplex Option, be careful not to drop the unit.

- 1) Insert the 2 bottom hooks of the HSG LOWER DUP (PL 10.1) into the holes of the printer.

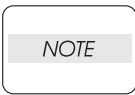

When installing, be sure to install the bottom hooks of the Duplex Option into the holes of the printer.

- 2) Push the Duplex Option to the printer, and connect the connector (P/J2750) of the HARNESS ASSY DUP (PL 10.1) to the printer. At this time, the Duplex Option is locked to the printer with the LEVER LATCH RIGHT (PL 10.1) and LEVER LATCH LEFT (PL 10.1).
- 3) Secure the Duplex Option to the printer by tightening the 2 SCREW THUMBs (PL 10.1).

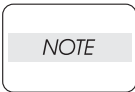

The SCREW THUMBs should be completely tightened to fasten the unit.

RRP10.2 HSG UPPER ASSY (PL10.1)

Removal

- 1) Remove the 4 screws (gold tapping, 8mm) securing the HSG UPPER ASSY to the Option Duplex.
- 2) Remove the HSG UPPER ASSY from the COVER HSG DUP (PL 10.1).

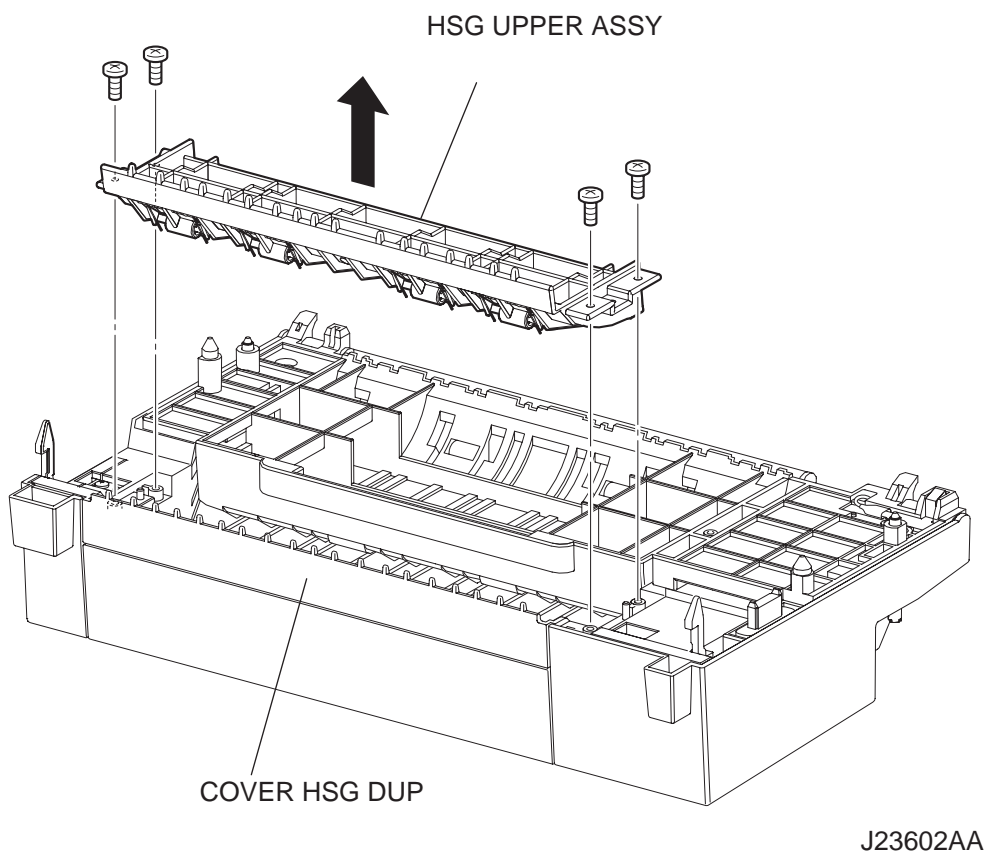

Replacement

- 1) Install the HSG UPPER ASSY to the COVER HSG DUP (PL 10.1) using the 4 screws (gold tapping, 8mm).

RRP10.3 HSG LOWER DUP (PL10.1)

Removal

- 1) Remove the COVER LEFT (PL 10.1). (RRP10.9)
- 2) Remove the COVER RIGHT (PL 10.1). (RRP10.10)
- 3) Disconnect the connector (P/J50) of the HARNESS ASSY DUP (PL 10.1) from the PWBA DUPLEX (PL 10.1).
- 4) Remove the screw (silver, 6mm) securing the HARNESS ASSY DUP EARTH (PL 10.1).
- 5) Release the HARNESS ASSY DUP from the harness clamp.
- 6) Remove the SCREW TAPPING (PL 10.1) securing the SPRING DUMPER (PL 10.1).
- 7) Remove the 2 SCREW HINGEs (PL 10.1) securing the HSG LOWER DUP, and remove the HSG LOWER DUP from the COVER HSG DUP (PL 10.1).

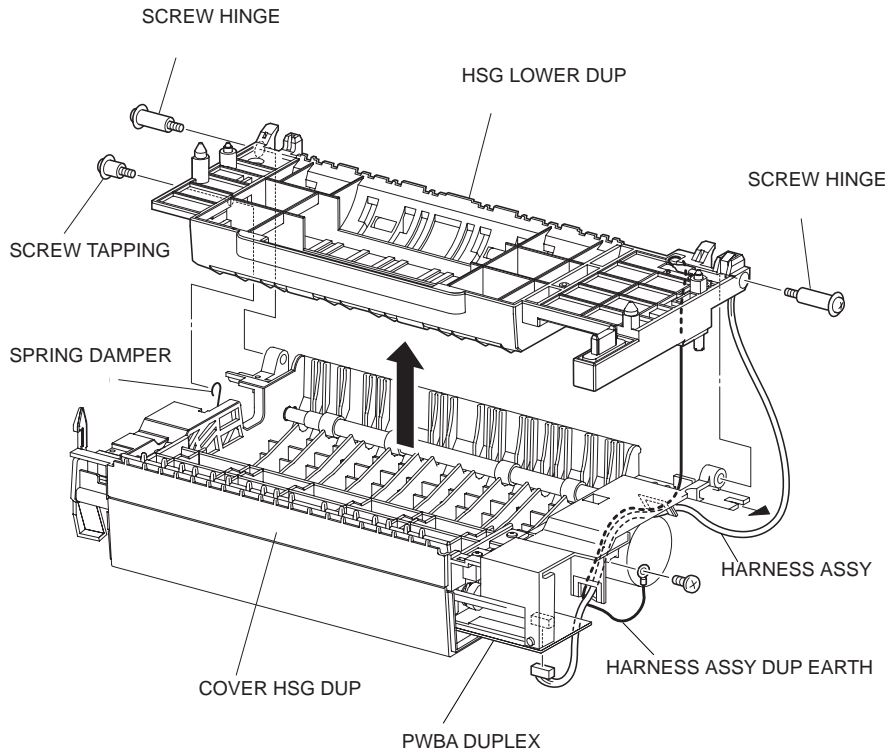

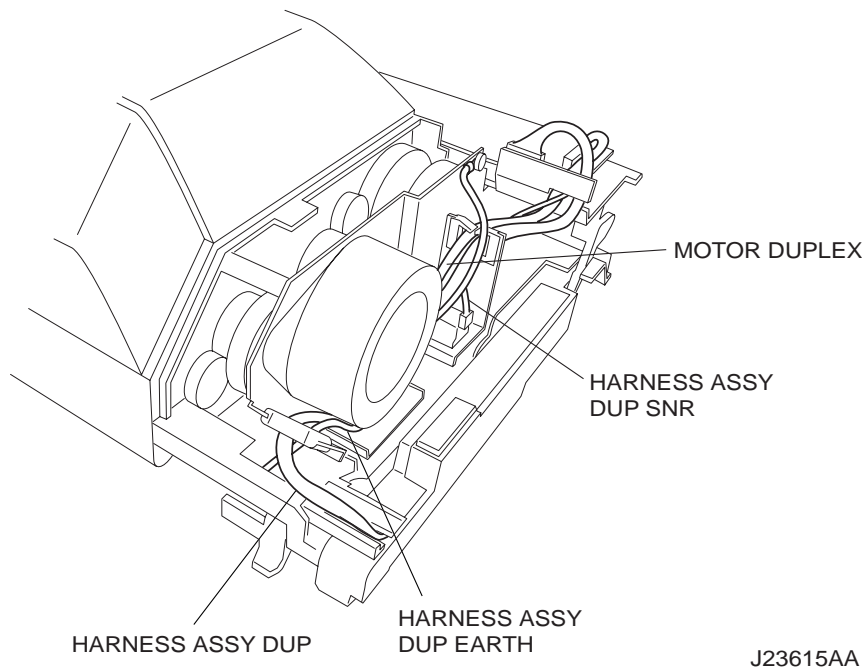

Replacement

- 1) Install the HSG LOWER DUP to the COVER HSG DUP (PL 10.1) using the 2 SCREW HINGEs (PL 10.1).
- 2) Install the SPRING DAMPER (PL 10.1) to the COVER HSG DUP using the SCREW TAPPING (PL 10.1).
- 3) Secure the HARNESS ASSY DUP (PL 10.1) using harness clamps as shown in the figure.
- 4) Secure the HARNESS ASSY DUP EARTH using the screw (silver, 6mm).
- 5) Connect the connector (P/J50) of the HARNESS ASSY DUP to the PWBA DUPLEX (PL 10.1).
- 6) Install the COVER RIGHT (PL 10.1). (RRP10.10)

NOTE When installing, be sure to fit the positioning holes on the COVER RIGHT to the bosses on the COVER HSG DUP.

- 7) Install the COVER LEFT (PL 10.1). (RRP10.9)

NOTE When installing, be sure to fit the positioning holes on the COVER LEFT to the bosses on the COVER HSG DUP.

RRP10.4 COVER TOP (PL10.1)**Removal**

- 1) Remove the COVER RIGHT (PL 10.1). (RRP10.10)
- 2) Remove the screw (gold tapping, 8mm) securing the COVER TOP to the COVER HSG DUP (PL 10.1).
- 3) Shift the COVER TOP in the direction of the arrow to release the 4 hooks, and remove the COVER TOP from the COVER HSG DUP.

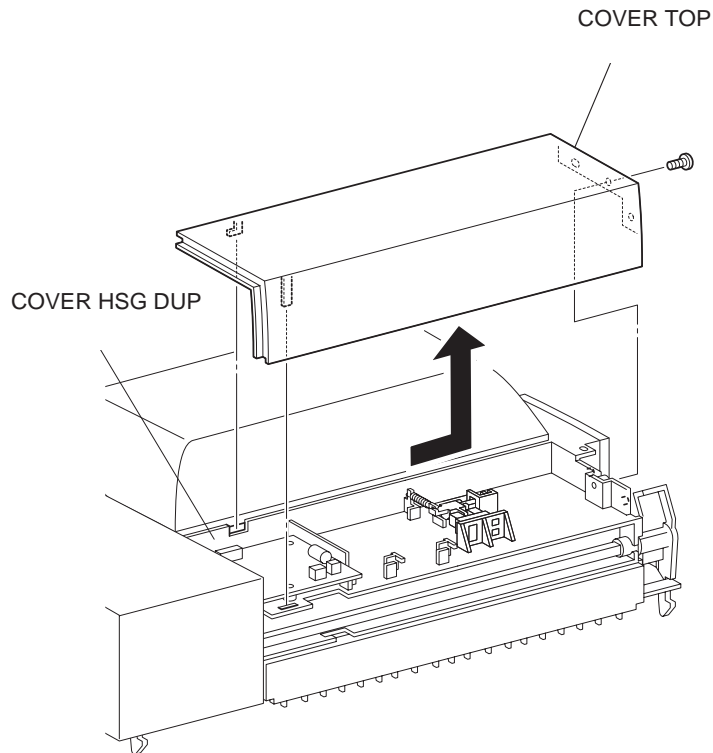

J23604AA

Replacement

- 1) Shift the COVER TOP in the opposite direction of the arrow to install it to the COVER HSG DUP (PL 10.1), and secure it using the 4 hooks.

NOTE

When installing, be sure to fit the positioning holes on the COVER TOP to the bosses on the COVER HSG DUP.

- 2) Install the COVER TOP to the COVER HSG DUP using the screw (gold tapping, 8mm).
- 3) Install the COVER RIGHT (PL 10.1). (RRP10.10)

NOTE

When installing, be sure to fit the positioning holes on the COVER RIGHT to the bosses on the COVER HSG DUP.

RRP10.5 PWBA DUPLEX (PL10.1)

Removal

- 1) Remove the COVER LEFT (PL 10.1). (RRP10.9)
- 2) Remove the COVER RIGHT (PL 10.1). (RRP10.10)
- 3) Remove the COVER TOP (PL 10.1). (RRP10.4)
- 4) Disconnect the harness connectors from the connectors (P/J50, P/J51, P/J52, P/J53 and P/J54) on the PWBA DUPLEX.
- 5) Remove the 2 screws (gold tapping, 8mm x 1, gold, 6mm x 1) securing the PWBA DUPLEX to the COVER HSG DUP (PL 10.1).
- 6) Remove the PWA DUPLEX.

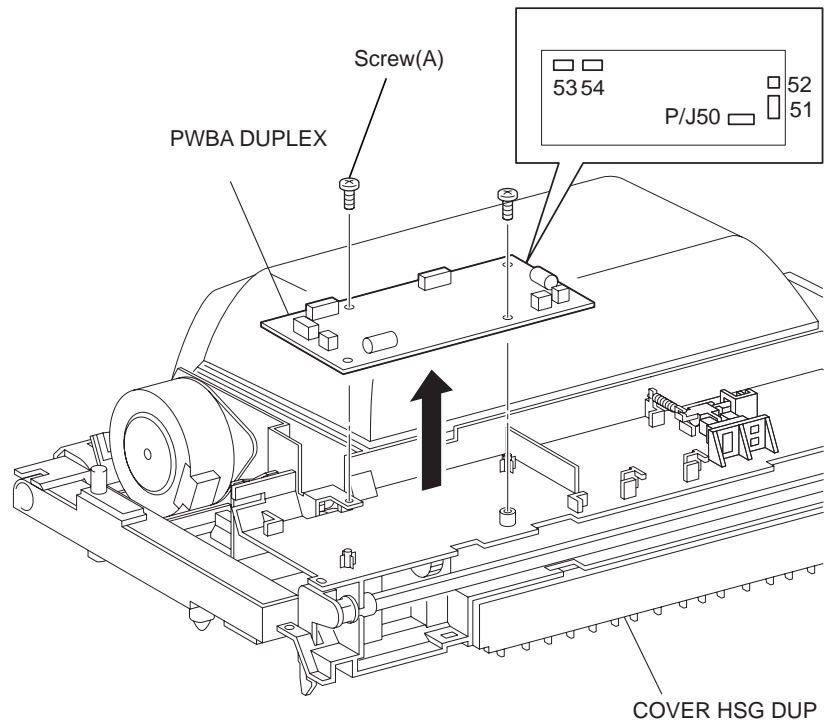

J23605AA

Replacement

- 1) Install the PWBA DUPLEX to the COVER DUPLEX (PL 10.1) using the 2 screws (gold tapping, 8mm x 1, gold, 6mm x 1).

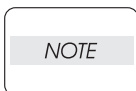

Install the PWA DUPLEX to the COVER DUPLEX in the direction shown in the figure.

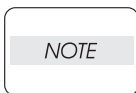

Be sure to tighten the screw (gold, 6mm) shown as Screw (A) in the figure.

- 2) Connect the harness connectors to the connectors (P/J50, P/J51, P/J52, P/J53 and P/J54) on the PWBA DUPLEX.
- 3) Install the COVER TOP (PL 10.1). (RRP10.4)

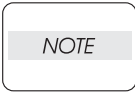

When installing, be sure to fit the positioning holes on the COVER TOP to the bosses on the COVER HSG DUP.

- 4) Install the COVER RIGHT (PL 10.1). (RRP10.10)

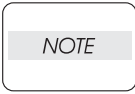

When installing, be sure to fit the positioning holes on the COVER RIGHT to the bosses on the COVER HSG DUP.

- 5) Install the COVER LEFT (PL 10.1). (RRP10.9)

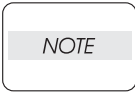

When installing, be sure to fit the positioning holes on the COVER LEFT to the bosses on the COVER HSG DUP.

RRP10.6 COVER REAR (PL10.1), FAN DUPLEX (PL10.1)

Removal

- 1) Remove the COVER RIGHT (PL 10.1). (RRP10.10)
- 2) Remove the COVER TOP (PL 10.1). (RRP10.4)
- 3) Disconnect the harness connector from the connector (P/J54) on the PWBA DUPLEX (PL 10.1).
- 4) Release the harness of the FAN DUPLEX from the hook on the COVER HSG DUP (PL 10.1).
- 5) Remove the 4 screws securing the COVER REAR to the COVER HSG DUP and remove the COVER REAR.
- 6) Remove the 2 screws (gold tapping, 22mm) securing the FAN DUPLEX to the COVER REAR and remove the FAN DUPLEX.

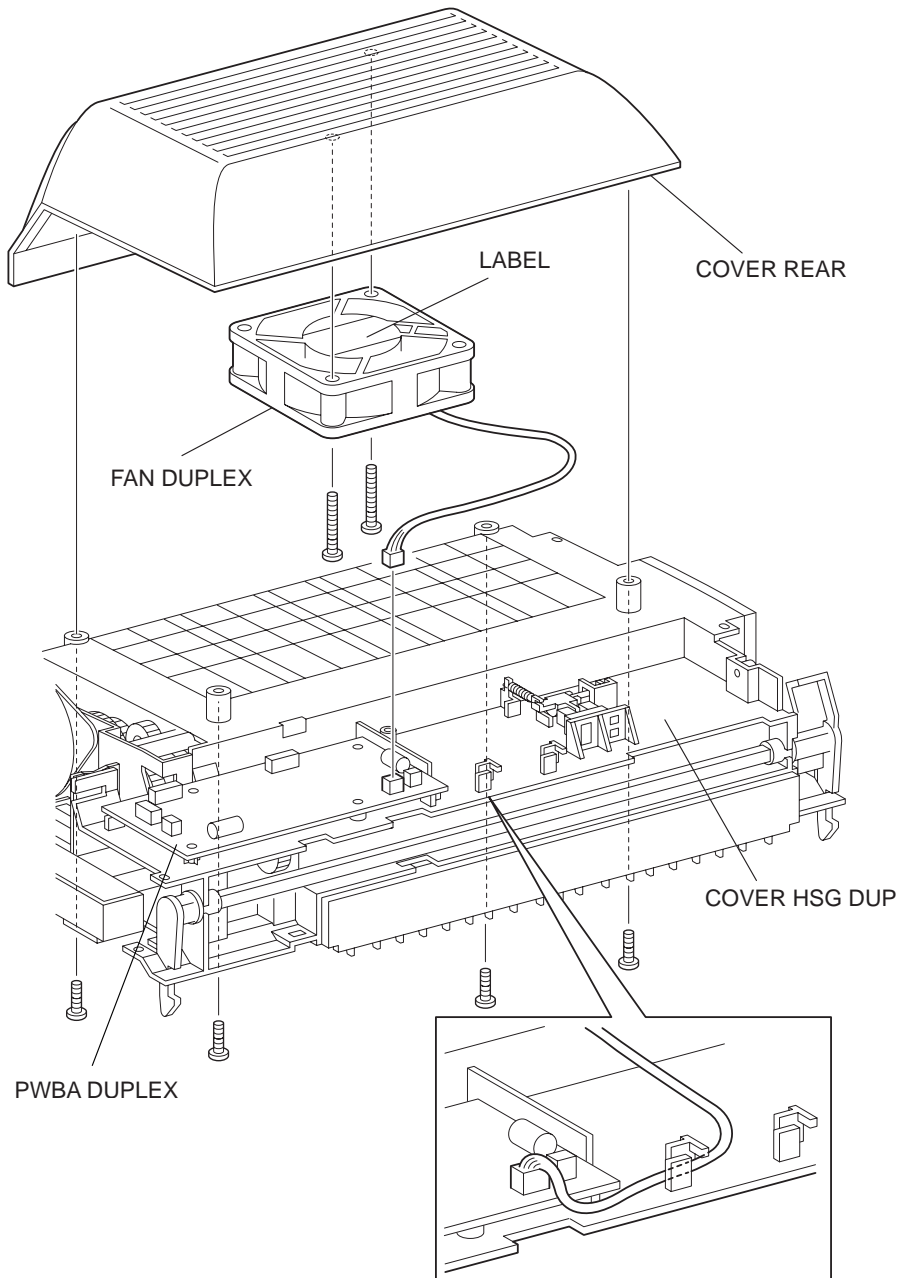

J23606AA

Replacement

- 1) 1) Install the FAN DUPLEX to the COVER REAR using the 2 screws (gold tapping, 22mm).

NOTE

When installing, be sure to install the FAN DUPLEX so that the label is facing outside.

- 2) Install the COVER REAR to the COVER HSG DUP using the 4 screws
- 3) Secure the harness of the FAN DUPLEX to the hook on the COVER HSG DUP.
- 4) Connect the harness connector to the connector (P/J54) on the PWBA DUPLEX (PL 10.1).
- 5) Install the COVER TOP (PL 10.1). (RRP10.4)

NOTE

When installing, be sure to fit the positioning holes on the COVER TOP to the bosses on the COVER HSG DUP.

- 6) Install the COVER RIGHT (PL 10.1). (RRP10.10)

NOTE

When installing, be sure to fit the positioning holes on the COVER RIGHT to the bosses on the COVER HSG DUP.

RRP10.7 SENSOR DUP (PL10.1)**Removal**

- 1) Remove the COVER RIGHT (PL 10.1). (RRP10.10)
- 2) Remove the COVER TOP (PL 10.1). (RRP10.4)
- 3) Release the hooks of the SENSOR DUP, and remove it from the COVER HSG DUP (PL 10.1).
- 4) Disconnect the connector (P/J530) of the HARNESS ASSY DUP SNR (PL 10.1) from the SENSOR DUP.

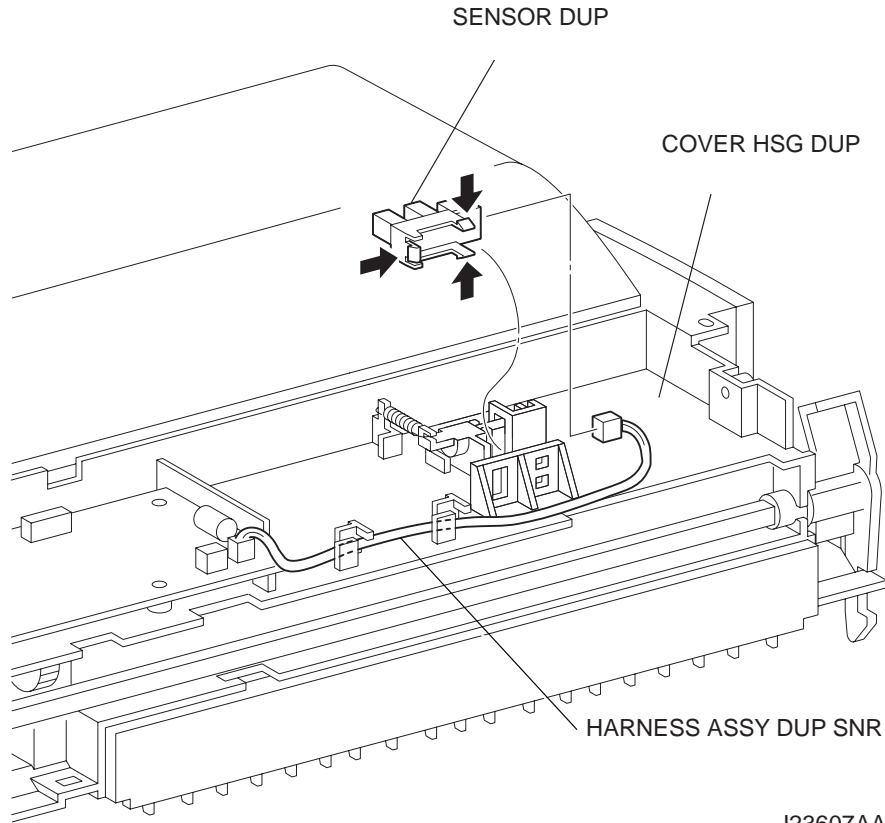

J23607AA

Replacement

- 1) Connect the connector (P/J 530) of the HARNESS ASSY DUP SNR (PL 10.1) to the SENSOR DUP.
- 2) Install the SENSOR DUP to the COVER HSG DUP (PL 10.1), and secure it with the hooks.
- 3) Install the COVER TOP (PL 10.1). (RRP10.4)

NOTE

When installing, be sure to fit the positioning holes on the COVER TOP to the bosses on the COVER HSG DUP.

- 4) Install the COVER RIGHT (PL 10.1). (RRP10.10)

NOTE

When installing, be sure to fit the positioning holes on the COVER RIGHT to the bosses on the COVER HSG DUP.

RRP10.8 ROLL DUP (PL10.1)

Removal

- 1) Remove the COVER LEFT (PL 10.1). (RRP10.9)
- 2) Remove the COVER RIGHT (PL 10.1). (RRP10.10)
- 3) Remove the HSG UPPER ASSY (PL 10.1). (RRP10.2)
- 4) Remove the HSG LOWER DUP (PL 10.1). (RRP10.3)
- 5) Remove the 2 screws (gold tapping, 8mm) and the SCREW TAPPING (PL 10.1) securing the COVER DAMPER (PL 10.1) to the COVER HSG DUP (PL 10.1).
- 6) Remove the COVER DAMPER (PL 10.1) and SPRING DAMPER (PL 10.1) from the COVER HSG DUP.

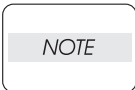

For the following step, be careful not to lose any gear, as the working space is limited.

- 7) Release the hooks of 3 BEARING DUPs (PL 10.1) on the other side of the GEAR ROLL from the inside, and remove 3 BEARING DUPs from the COVER HSG DUP.
- 8) Release the hooks of 3 GEAR ROLLS (PL 10.1), and remove them from the ROLL DUP.
- 9) Remove 3 ROLL DUPs by moving them in the direction of the arrow.

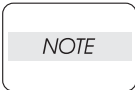

To avoid contamination when removing the ROLL DUP, do not touch the rubber rollers.

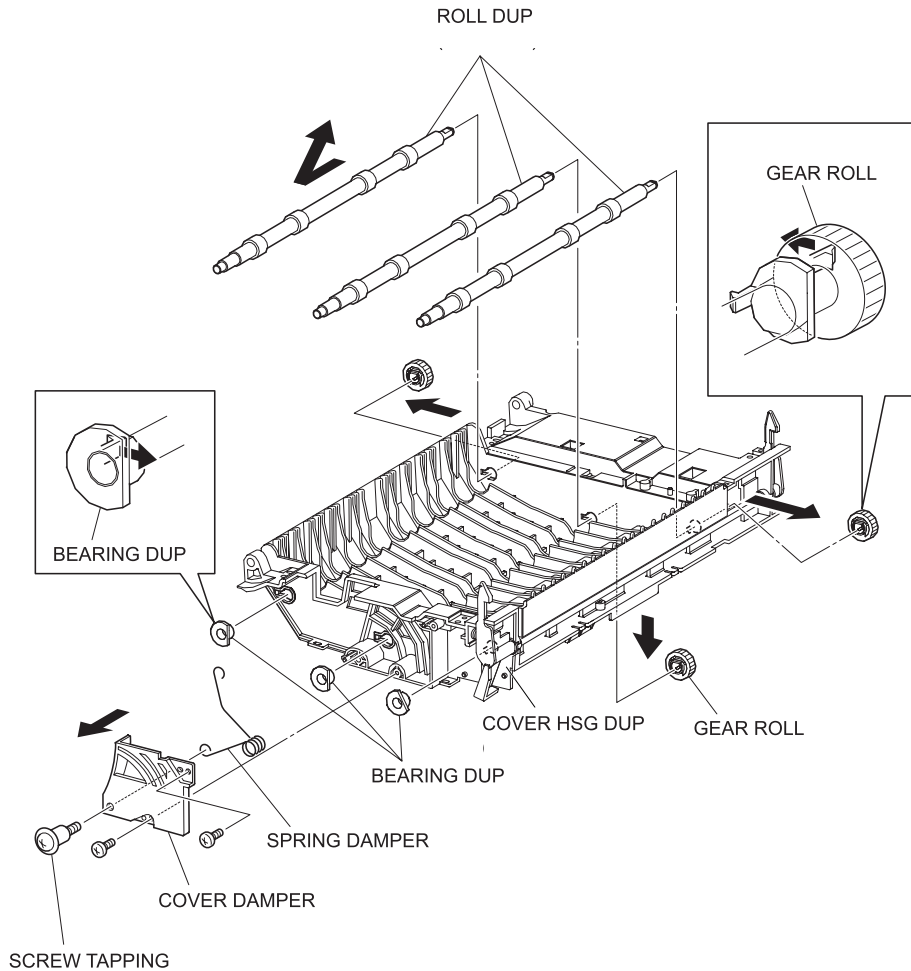

JG3608AB

Replacement

- 1) Move 3 ROLL DUPs in the opposite direction of the arrow, and install them to the BEARING DUP (PL 10.1) on the GEAR ROLL (PL 10.1) side

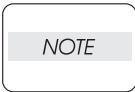

To avoid contamination when installing the ROLL DUP, do not touch the rubber rollers.

- 2) Put the BEARING DUP into the ROLL DUP on the opposite side of the GEAR ROLL, and insert it into the hole on the COVER HSG DUP (PL12.1.18), and then secure it with the hook.
- 3) Lock 3 GEAR ROLLs to the ROLL DUP with hook.
- 4) Install the COVER DAMPER (PL 10.1) and SPRING DAMPER (PL 10.1) to the COVER HSG DUP using the 2 screws (gold tapping, 8mm) and the SCREW TAPPING (PL 10.1).

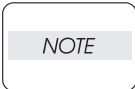

The SCREW TAPPING securing the COVER DAMPER is tightened together with the SPRING DAMPER.

- 5) Install the HSG LOWER DUP (PL 10.1). (RRP10.3)
- 6) Install the HSG UPPER ASSY (PL 10.1). (RRP10.2)
- 7) Install the COVER RIGHT (PL 10.1). (RRP10.10)

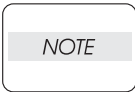

When installing, be sure to fit the positioning holes on the COVER RIGHT to the bosses on the COVER HSG DUP.

- 8) Install the COVER LEFT (PL 10.1). (RRP10.9)

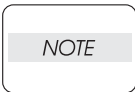

When installing, be sure to fit the positioning holes on the COVER LEFT to the bosses on the COVER HSG DUP.

RRP10.9 COVER LEFT (PL10.1)

Removal

- 1) Remove the 2 screws (gold tapping, 8mm) securing the COVER LEFT.
- 2) Remove the COVER LEFT from the COVER HSG DUP (PL 10.1).

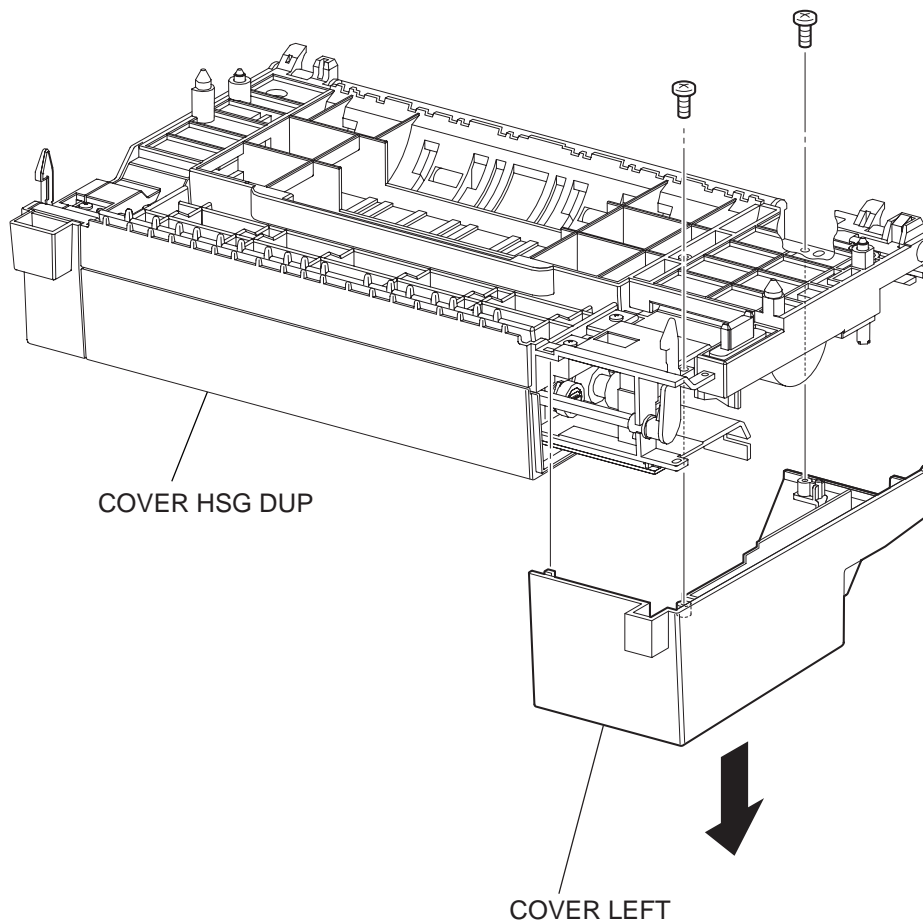

J23609AA

Replacement

- 1) Install the COVER LEFT to the COVER HSG DUP (PL 10.1) using the 2 screws (gold tapping, 8mm).

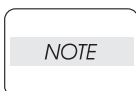

When installing, be sure to fit the positioning holes on the COVER LEFT to the bosses on the COVER HSG DUP.

RRP10.10 COVER RIGHT (PL10.1)

Removal

- 1) Remove the 2 screws (gold tapping, 8mm) securing the COVER RIGHT.
- 2) 2) Remove the COVER RIGHT from the COVER HSG DUP (PL 10.1).

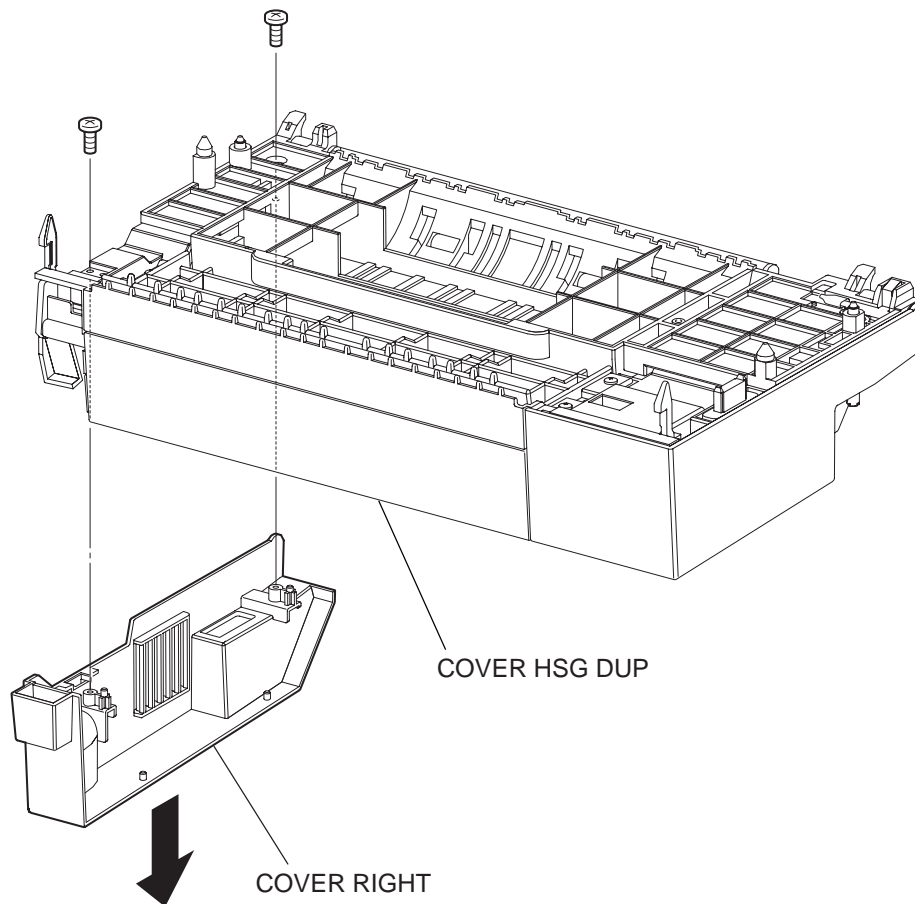

J23610AA

Replacement

- 1) Install the COVER RIGHT to the COVER HSG DUP (PL 10.1) using the 2 screws (gold tapping, 8mm).

NOTE

When installing, be sure to fit the positioning holes on the COVER RIGHT to the bosses on the COVER HSG DUP.

RRP10.11 MOTOR DUPLEX (PL10.1)

Removal

- 1) Remove the COVER LEFT (PL 10.1). (RRP10.9)
- 2) Remove the COVER TOP (PL 10.1). (RRP10.4)
- 3) Remove the PWBA DUPLEX (PL 10.1). (RRP10.5)
- 4) Remove the screw (silver, 6mm) securing the HARNESS ASSY DUP EARTH (PL 10.1)
- 5) Remove the 3 screws (gold tapping, 8mm) securing the BRACKET MOTOR (PL 10.1) to the COVER HSG DUP (PL 10.1).
- 6) Remove the SPRING LATCH (PL 10.1) between the LEVER LATCH LEFT (PL 10.1) and BRACKET MOTOR (PL 10.1).
- 7) Remove the BRACKET MOTOR together with the MOTOR DUPLEX and SWITCH DUPLEX (PL 10.1).

NOTE

When removing the BRACKET MOTOR, be careful not to lose the gears attached to the COVER HSG DUP.

- 8) Remove the 2 screws (gold, 6mm) securing the MOTOR DUPLEX to the BRACKET MOTOR.
- 9) Remove the MOTOR DUPLEX.

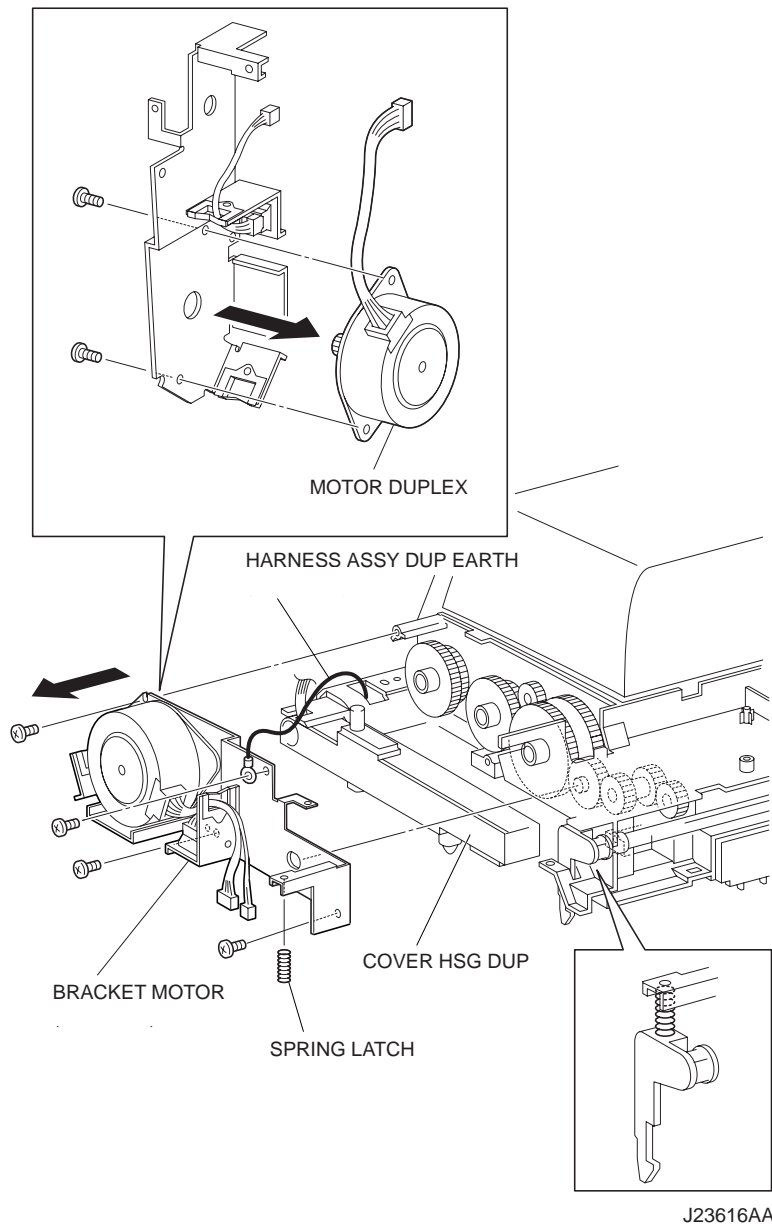

Replacement

- 1) Install the MOTOR DUPLEX to the BRACKET MOTOR using the 2 screws (gold, 6mm).

NOTE

When installing the MOTOR DUPLEX, be careful in the installing direction.

- 2) Install the BRACKET MOTOR to the COVER HSG DUP (PL 10.1) using the 3 screws (gold tapping, 8mm).

NOTE

When installing the BRACKET MOTOR, be careful not to lose the gears.

- 3) Install the SPRING LATCH (PL 10.1) between the LEVER LATCH LEFT (PL 10.1) and BRACKET MOTOR.
- 4) Install the HARNESS ASSY DUP EARTH (PL 10.1) using the screw (silver, 6mm).
- 5) Install the PWBA DUPLEX (PL 10.1). (RRP10.5)

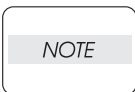

When installing, be careful in the installing direction.

- 6) Install the COVER TOP (PL 10.1). (RRP10.4)

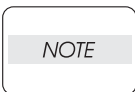

When installing, be sure to fit the positioning holes on the COVER TOP to the bosses on the COVER HSG DUP.

- 7) Install the COVER LEFT (PL 10.1). (RRP10.9)

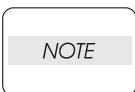

When installing, be sure to fit the positioning holes on the COVER LEFT to the bosses on the COVER HSG DUP.

RRP10.12 SWITCH DUPLEX (PL10.1)**Removal**

- 1) Remove the COVER LEFT (PL 10.1). (RRP10.9)
- 2) Remove the COVER TOP (PL 10.1). (RRP10.4)
- 3) Remove the PWBA DUPLEX (PL 10.1). (RRP10.5)
- 4) Remove the screw (silver, 6mm) securing the HARNESS ASSY DUP EARTH (PL 10.1).
- 5) Remove the 3 screws (gold tapping, 8mm) securing the BRACKET MOTOR (PL 10.1) to the COVER HSG DUP (PL 10.1).
- 6) Remove the SPRING LATCH (PL 10.1) between the LEVER LATCH LEFT (PL 10.1) and BRACKET MOTOR.
- 7) Remove the BRACKET MOTOR together with the MOTOR DUPLEX (PL 10.1) and SWITCH DUPLEX.

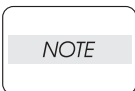

When removing the BRACKET MOTOR, be careful not to lose the gears attached to the COVER HSG DUP.

- 8) Disconnect the connector of the HARNESS ASSY DUP COVER (PL 10.1) from the connector (P/J52) of the SWITCH DUPLEX.
- 9) Release the hooks of the SWITCH DUPLEX, and remove it from the BRACKET MOTOR.

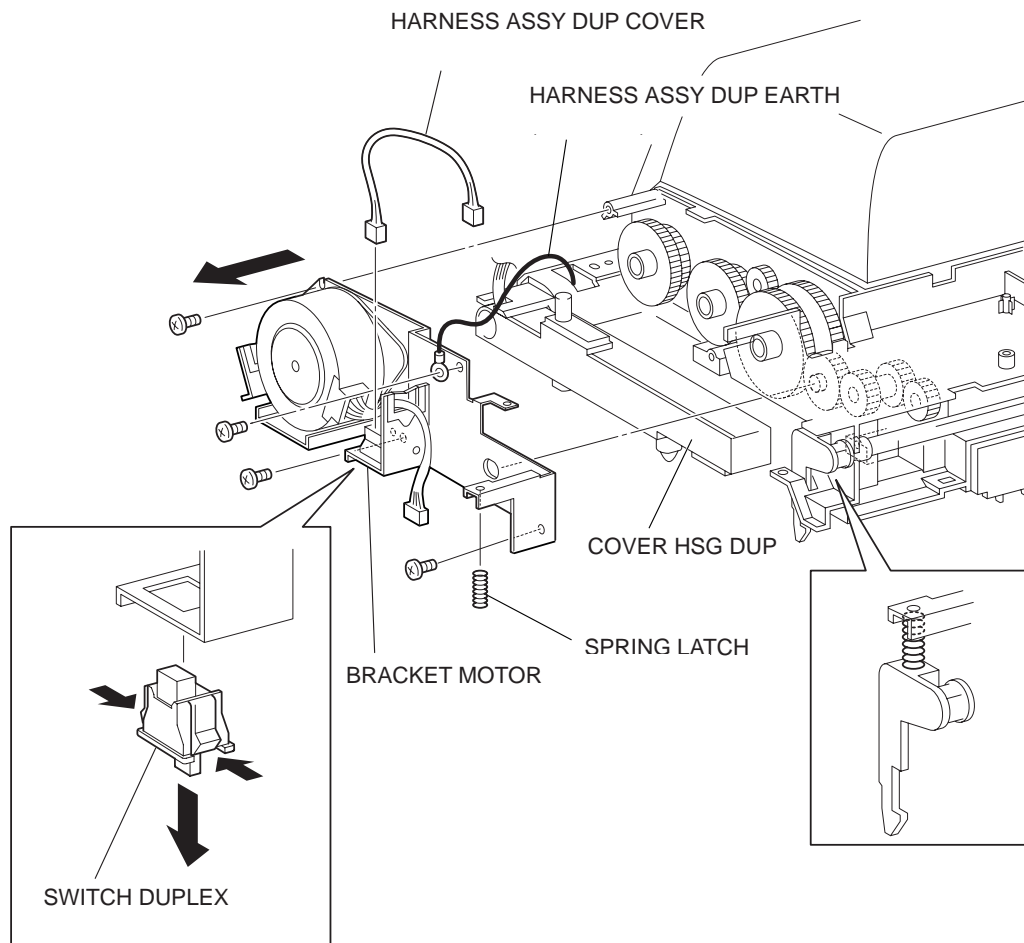

J23617AA

Replacement

- 1) Install the SWITCH DUPLEX to the BRACKET MOTOR with hooks.

Removal and Replacement Procedures (RRPs)

- 2) Connect the connector of the HARNESS ASSY DUP COVER (PL 10.1) to the connector (P/J52) of the SWITCH DUPLEX.
- 3) Install the BRACKET MOTOR to the COVER HSG DUP (PL 10.1) using the 3 screws (gold tapping, 8mm).

NOTE

When installing the BRACKET MOTOR, be careful not to lose the gears.

- 4) Install the SPRING LATCH (PL 10.1) between the LEVER LATCH LEFT (PL 10.1) and BRACKET MOTOR.
- 5) Install the HARNESS ASSY DUP EARTH (PL 10.1) using the screw (silver, 6mm).
- 6) Install the PWBA DUPLEX (PL 10.1). (RRP10.5)

NOTE

When installing the PWBA DUPLEX, be careful in the installing direction.

- 7) Install the COVER TOP (PL 10.1). (RRP10.4)

NOTE

When installing, be sure to fit the positioning holes on the COVER TOP to the bosses on the COVER HSG DUP.

- 8) Install the COVER LEFT (PL 10.1). (RRP10.9)

NOTE

When installing, be sure to fit the positioning holes on the COVER LEFT to the bosses on the COVER HSG DUP.

RRP10.13 COVER HARNESS (PL10.1), HARNESS ASSY DUP (PL10.1)

Removal

- 1) Remove the COVER LEFT (PL 10.1). (RRP10.9)
- 2) Remove the COVER RIGHT (PL 10.1). (RRP10.10)
- 3) Remove the HSG LOWER DUP (PL 10.1). (RRP10.3)
- 4) Remove the screw (gold tapping, 8mm) securing the COVER HARNESS R.
- 5) Release the 2 hooks of the COVER HARNESS, and remove it from the HSG LOWER DUP.
- 6) Disconnect the connector of the HARNESS ASSY DUP (PL 10.1) from the HSG LOWER DUP (PL 10.1), and remove the HARNESS ASSY DUP (PL 10.1).

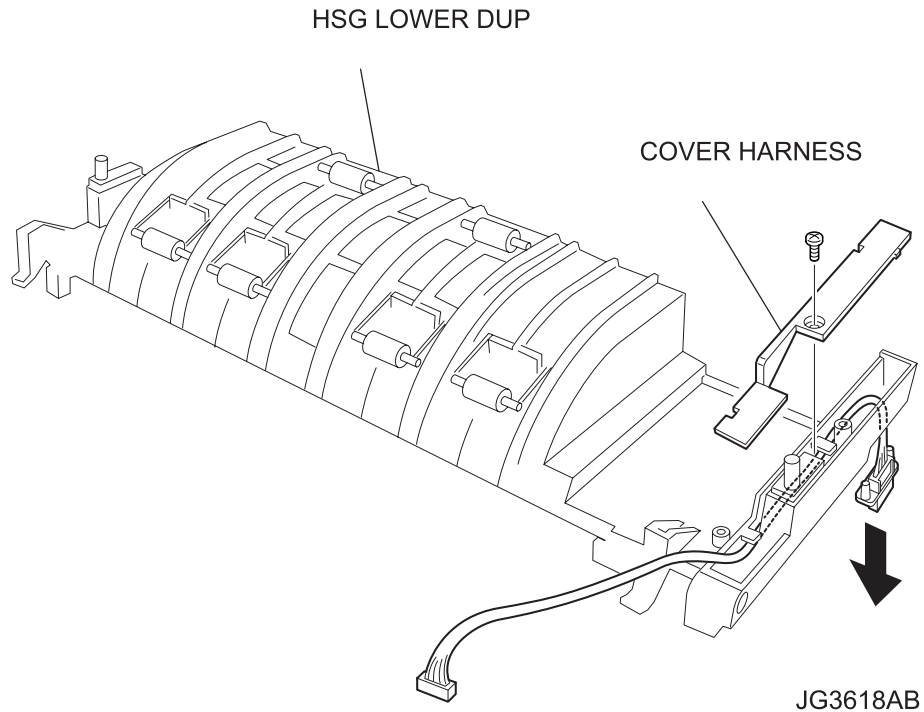

Replacement

- 1) Connect the connector of the HARNESS ASSY DUP (PL 10.1) to the HSG LOWER DUP (PL 10.1).
- 2) Install the COVER HARNESS to the HSG LOWER DUP, and fix it with the 2 hooks.
- 3) Secure the COVER HARNESS with the screw (gold tapping, 8mm).
- 4) Install the HSG LOWER DUP (PL 10.1). (RRP10.3)
- 5) Install the COVER RIGHT (PL 10.1). (RRP10.10)
- 6) Install the COVER LEFT (PL 10.1). (RRP10.9)

RRP11.OCT Option

RRP11.1 OCT Option

Removal

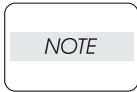

When removing the Option OCT, be careful not to drop the assembly.

- 1) Loosen the 2 SCREW THUNBs (PL 11.1) securing the OCT to the printer.
- 2) Lift up the OCT, and disconnect the connector (P/J3070) of the HARNESS ASSY OCT2 (PL 11.1) from the printer,
- 3) Release the 2 hooks at the bottom side of the COVER OCT (PL 11.1) from the printer, and remove the OCT.

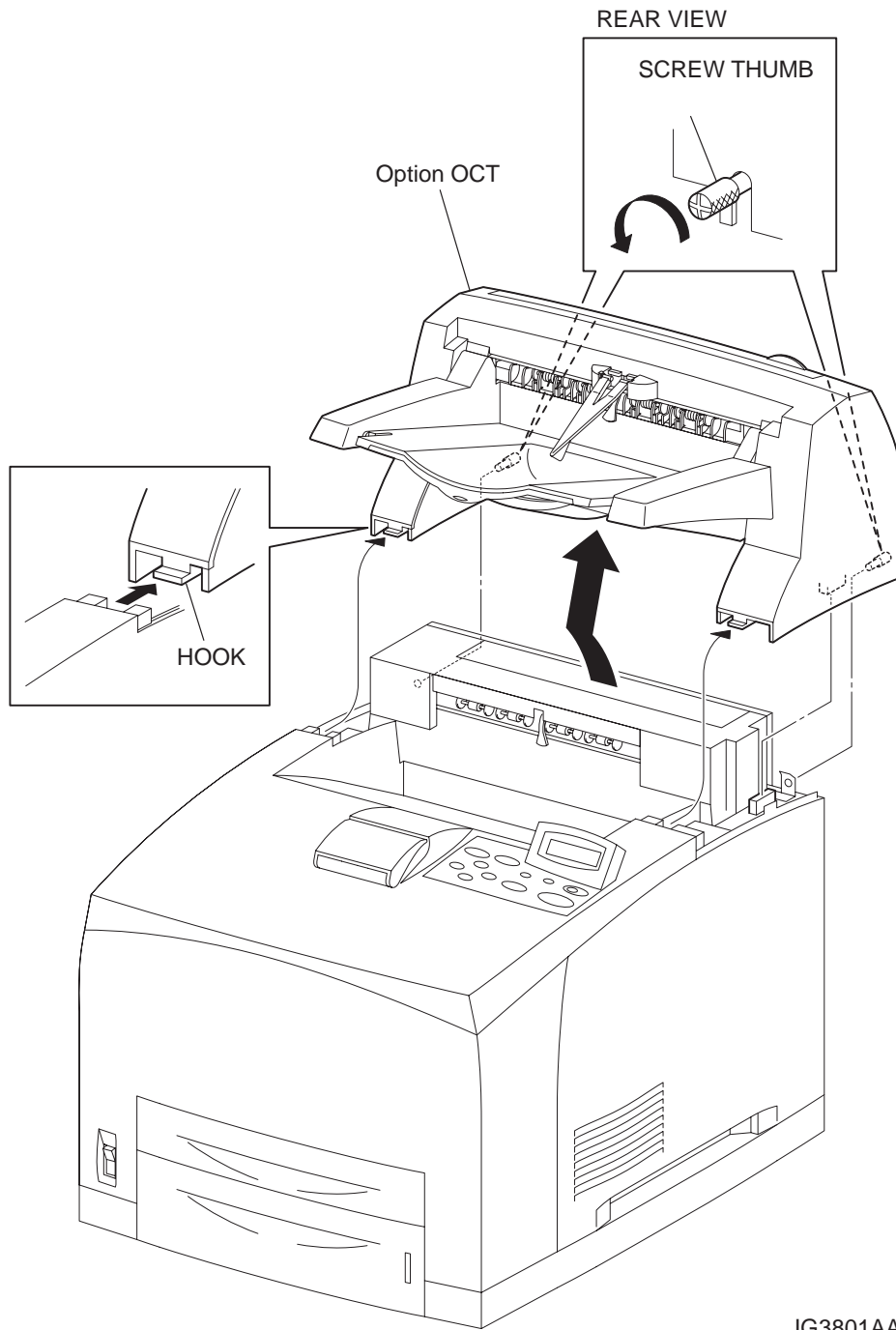

JG3801AA

Replacement

NOTE

When installing the OCT, be careful not to drop the assembly.

- 1) Insert the 2 hooks at the bottom side of the COVER OCT (PL 11.1) into the holes of the printer, and place the Option OCT on the printer. Then, connect the connector (P/J3070) of the HARNESS ASSY OCT2 (PL 11.1) to the printer.

NOTE

When installing, be sure to install the hooks at the bottom side of the Option OCT into the holes of the printer.

- 2) Fasten the Option OCT to the printer by tightening the 2 SCREW THUMBS (PL 11.1).

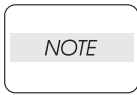

The SCREW THUMB should be completely tightened to fasten the Option OCT.

RRP11.2 COVER REAR (PL11.1)

Removal

- 1) Move the COVER REAR in the direction of the arrows, and remove the bosses on both sides of the COVER REAR from the COVER OCT (PL 11.1), and then remove the COVER REAR.

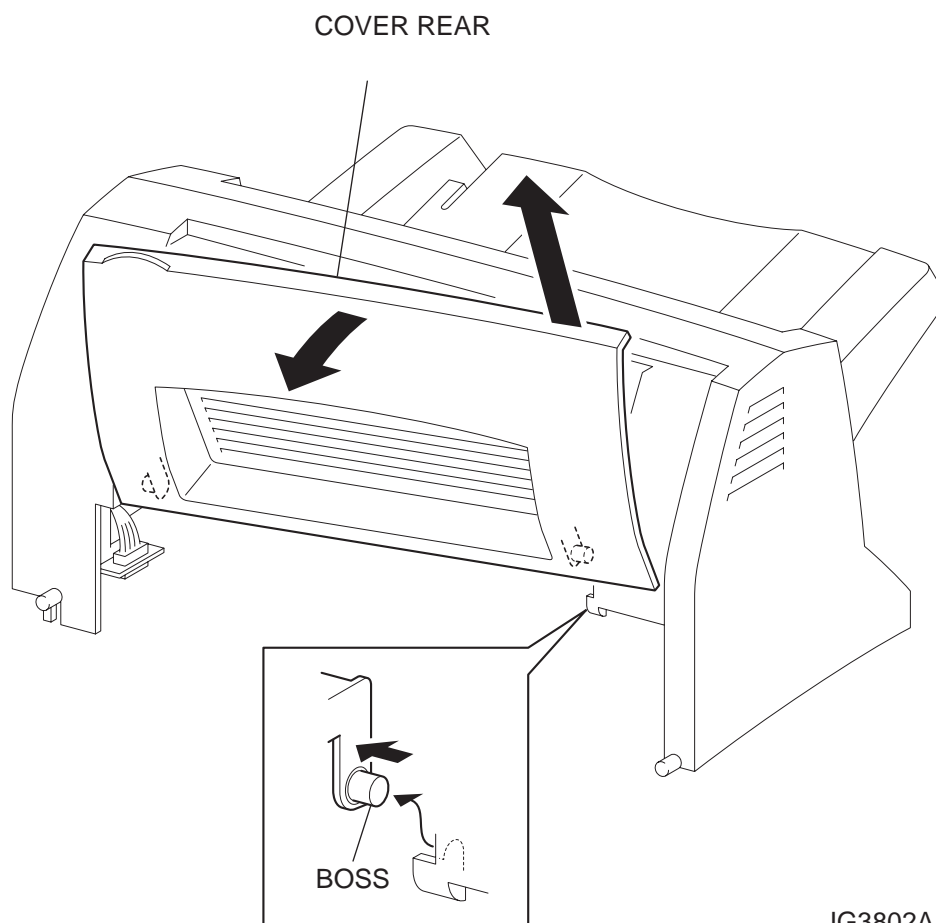

JG3802AA

Replacement

- 1) Move the COVER REAR in the opposite direction of the arrows, and insert the bosses on both side of the COVER REAR to the COVER OCT (PL 11.1)

RRP11.3 TRAY ASSY OCT (PL11.1)

Removal

- 1) Remove the COVER REAR (PL 11.1). (RRP11.2)
- 2) Remove the COVER OCT (PL 11.1). (RRP11.4)
- 3) Remove the 2 screws (gold tapping, 8mm) on both sides securing the TRAY ASSY OCT to the removed COVER OCT, and remove the TRAY ASSY OCT from the COVER OCT.

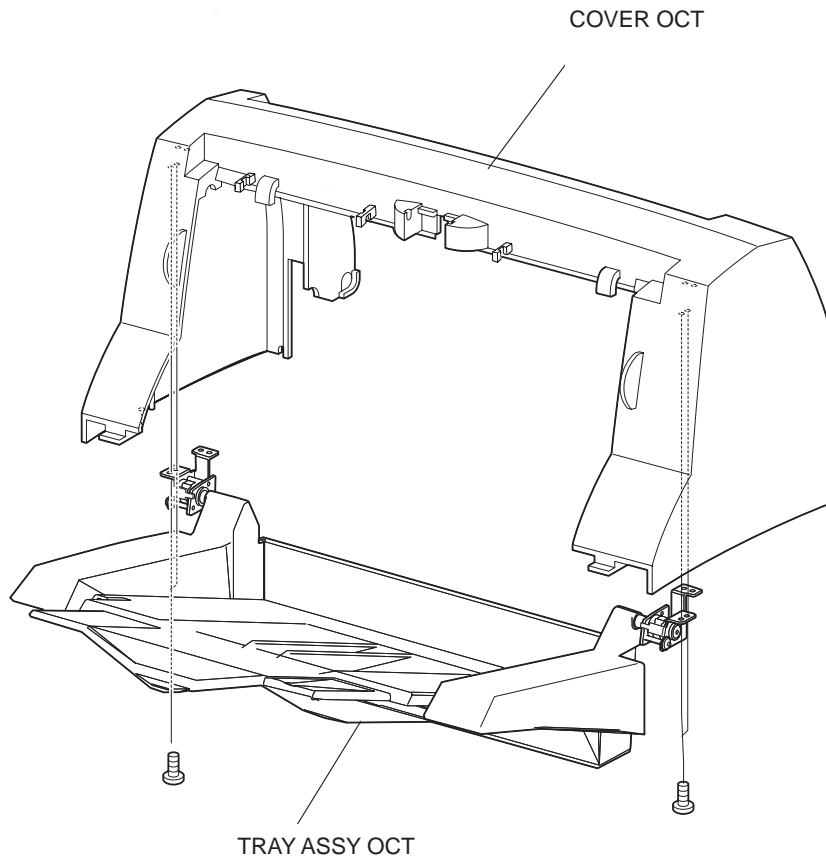

JG3819AA

Replacement

- 1) Install the TRAY ASSY OCT to the COVER OCT (PL 11.1) using the 2 screws (gold tapping, 8mm) on both sides.
- 2) Install the COVER OCT. (RRP11.4)
- 3) Install the COVER REAR (PL 11.1). (RRP11.2)

RRP11.4 COVER OCT (PL11.1)

Removal

- 1) Remove the COVER REAR (PL 11.1). (RRP11.2)
- 2) Remove the WEIGHT (PL 11.1).
- 3) Remove the hinges on both sides of the FLAPPER L (PL 11.1) from the COVER OCT (PL 11.1).
- 4) Remove the LINK (PL 11.1) attached to the FLAPPER L from the SHAFT FULL STACK (PL 11.1).
- 5) Remove the hinges on both sides of the FLAPPER R (PL 11.1) from the COVER OCT.
- 6) Remove the LINK attached to the FLAPPER R from the ACTUATOR FULL STACK (PL 11.1).
- 7) Remove the 2 screws (gold tapping, 8mm) at the rear side of the Option OCT securing the COVER OCT to the Option OCT.
- 8) Remove the 2 screws (gold tapping, 8mm) at the bottom side of the Option OCT securing the COVER OCT to the Option OCT.
- 9) Open TRAY ASSY OCT (PL 11.1) to almost 90 degrees, lift COVER OCT with being set to TRAY ASSY OCT, and remove from the body.

NOTE

When lifting COVER OCT, be careful not to break ACTUATOR FULL STACK by TRAY ASSY OCT.

Removal and Replacement Procedures (RRPs)

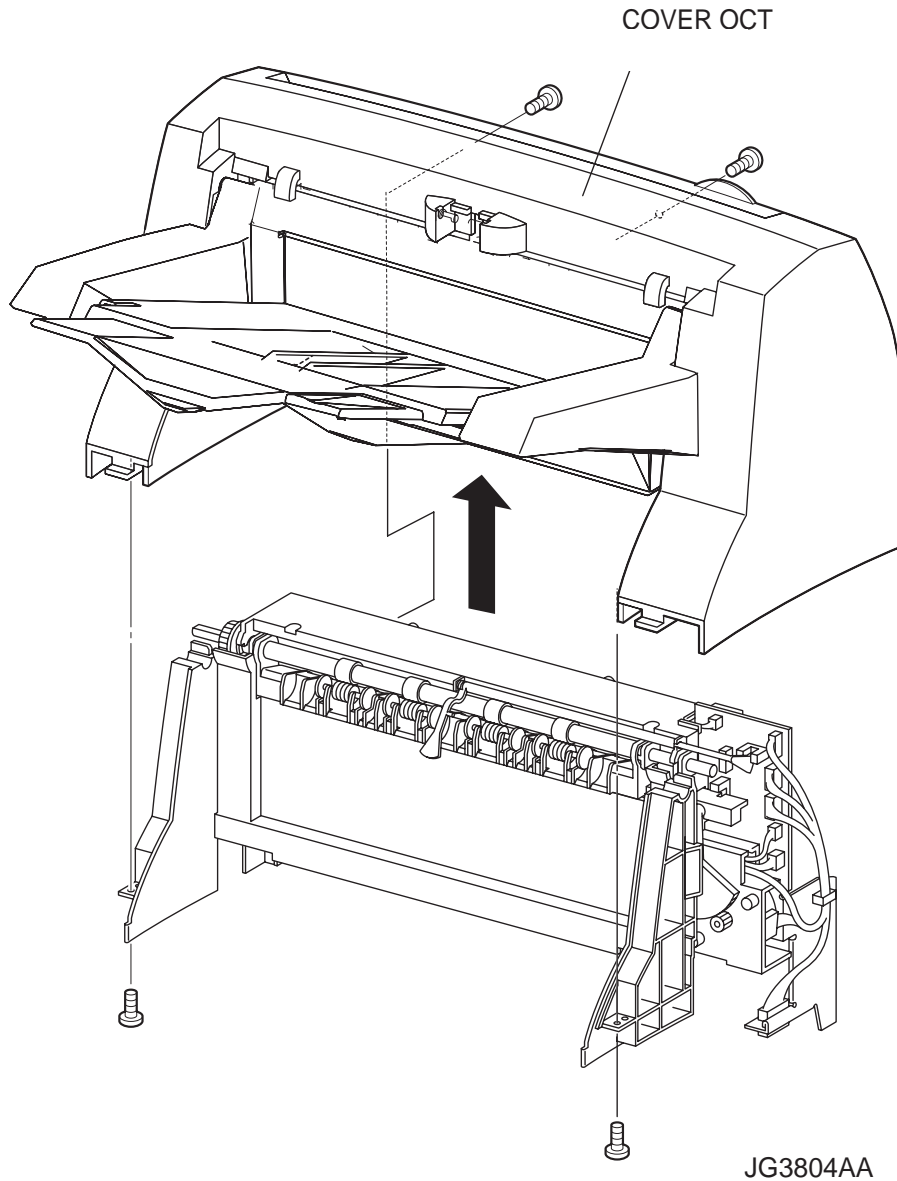
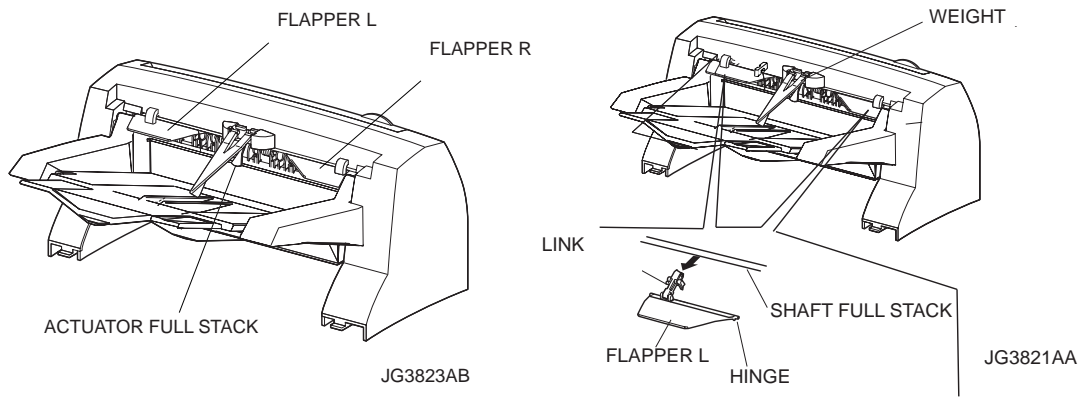

Replacement

- 1) Install the COVER OCT to the Option OCT.
- 2) Secure the COVER OCT to the Option OCT using the 2 screws (gold tapping, 8mm) at the bottom.

Removal and Replacement Procedures (RRPs)

- 3) Secure the COVER OCT to the Option OCT using the 2 screws (gold tapping, 8mm) at the rear.
- 4) Install the LINK (PL 11.1) attached with the FLAPPER R (PL 11.1) to the ACTUATOR FULL STACK (PL 11.1) from under slanting direction, and install the hinges on both sides of the FLAPPER R to the COVER OCT.
- 5) Similarly, install the LINK attached with the FLAPPER L (PL 11.1) to the SHAFT FULL STACK (PL 11.1) from under slanting direction, and install the hinges on both sides of the FLAPPER L to the COVER OCT.
- 6) Install the WEIGHT (PL 11.1).
- 7) Install the COVER REAR (PL 11.1). (RRP11.2)

NOTE

After installation, when the FLAPPER L is moved with a finger, make sure that the ACTUATOR FULL STACK moves together with the FLAPPER L. Also make sure that FLAPPER R operates smoothly.

RRP11.5 COVER FRONT (PL11.1)

Removal

- 1) Remove the COVER REAR (PL 11.1). (RRP11.2)
- 2) Remove the COVER OCT (PL 11.1). (RRP11.4)
- 3) Remove the 3 screws (gold tapping, 8mm) securing the COVER FRONT to the Option OCT and remove the COVER FRONT.

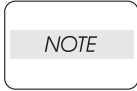

When removing the COVER FRONT, the GEAR CAM (PL 11.1) comes off. Be careful not to lose it.

Removal and Replacement Procedures (RRPs)

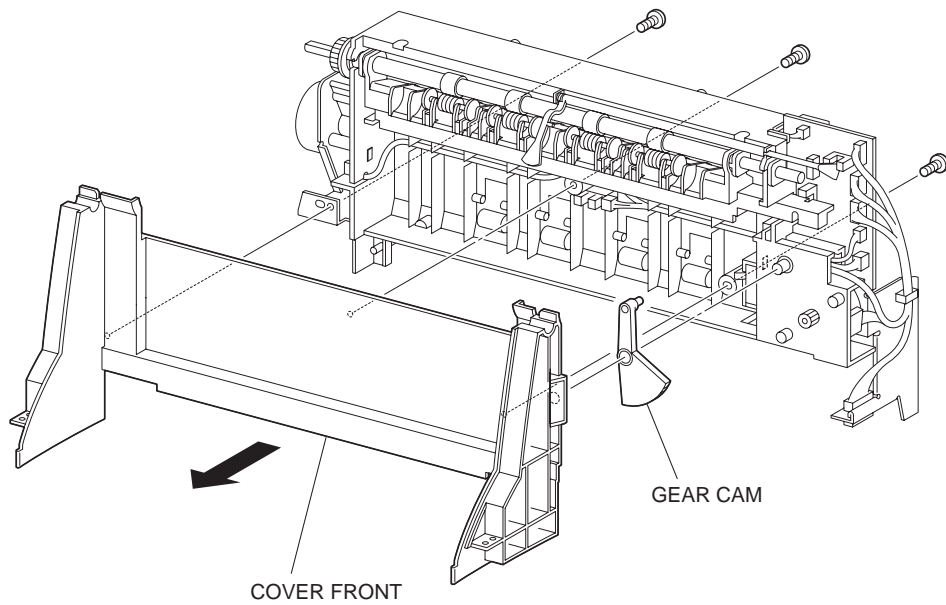

JG3805AC

CHUTE OFFSET

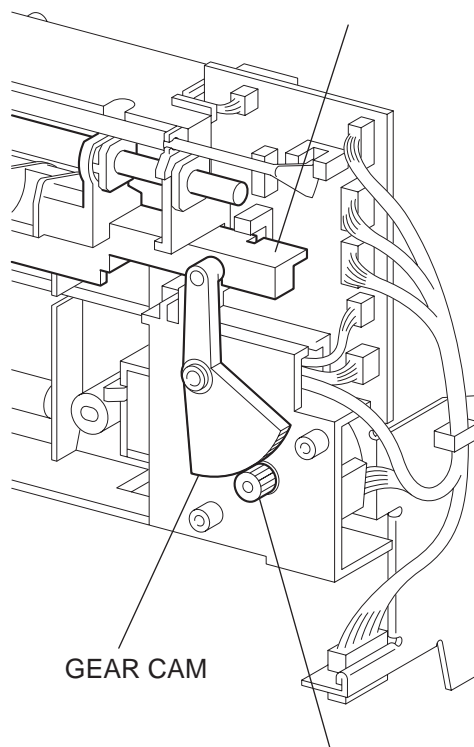

GEAR OF MOTOR ASSY OFFSET

JG3806AA

Replacement

- 1) Make sure that the GEAR CAM (PL 11.1) and the GEAR of the MOTOR ASSY OFFSET (PL 11.1) are engaged, and the boss of the GEAR CAM is in the groove of the CHUTE OFFSET (PL 11.1).
- 2) Secure the COVER FRONT to the Option OCT using the 3 screws (gold tapping, 8mm).

Removal and Replacement Procedures (RRPs)

- 3) Install the COVER OCT (PL 11.1). (RRP11.4)
- 4) Install the COVER REAR (PL 11.1). (RRP11.2)

RRP11.6 ACTUATOR FULL STACK (PL11.1)

Removal

- 1) Remove the COVER REAR (PL 11.1). (RRP11.2)
- 2) 2) Remove the COVER OCT (PL 11.1). (RRP11.4)
- 3) 3) After lifting up the flap of the ACTUATOR FULL STACK in the direction of the arrow (1), remove the hook first, and then move it in the direction of the arrow (2) to remove from the Option OCT.

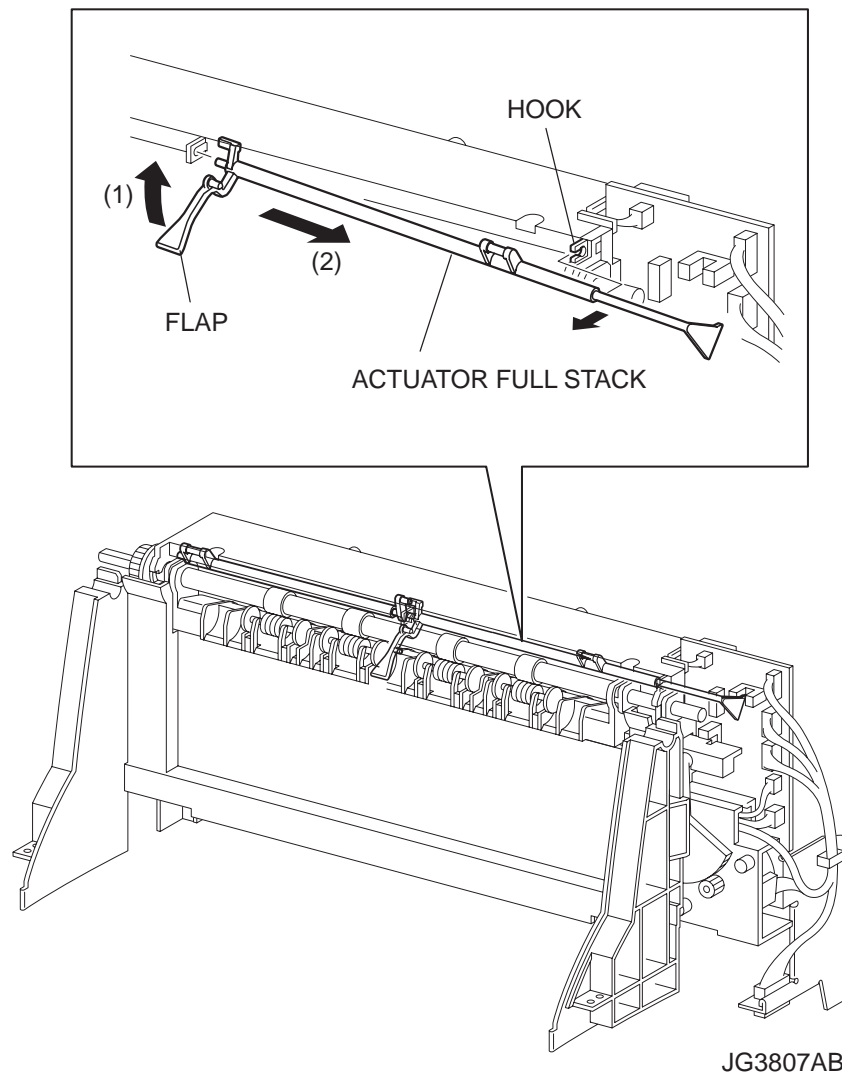

JG3807AB

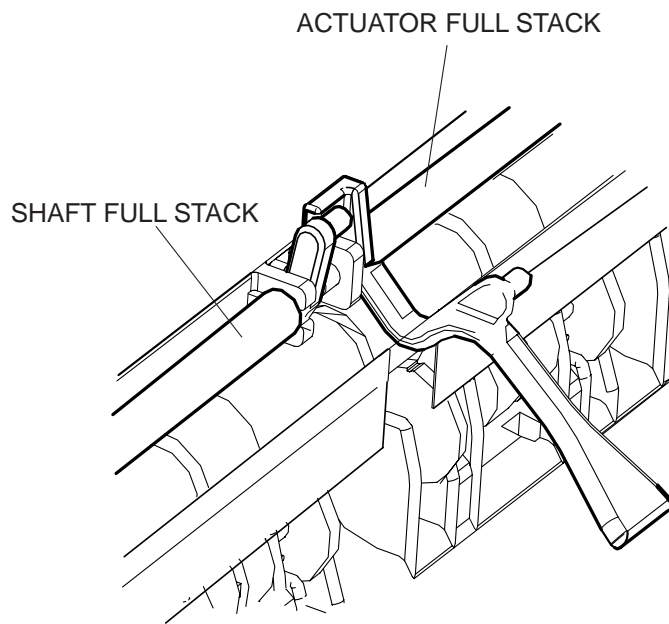

JG3822AA

Replacement

- 1) Lift up the ACTUATOR FULL STACK in the direction of the arrow (1), and insert it to the hook. Move the ACTUATOR FULL STACK in the opposite direction of the arrow (2) to install.

Removal and Replacement Procedures (RRPs)

NOTE

When installing the ACTUATOR FULL STACK to the Option OCT, combine it with the SHAFT FULL STACK as shown in the figure.

- 2) Install the COVER OCT (PL 11.1). (RRP11.4)
- 3) Install the COVER REAR (PL 11.1). (RRP11.2)

NOTE

After installation, when the FLAPPER L is moved with a finger, make sure that the ACTUATOR FULL STACK moves together with the FLAPPER L. Also make sure that FLAPPER R operates smoothly.

RRP11.7 PWBA OCT (PL11.1)

Removal

- 1) Remove the COVER REAR (PL 11.1). (RRP11.2)
- 2) Remove the COVER OCT (PL 11.1). (RRP11.4)
- 3) Remove the ACTATOR FULL STACK in order to prevent from breaking ACTUATOR FULL STACK (PL 11.1).
- 4) Release the harness connected to the S/W REAR COVER (PL 11.1) from the clamp.

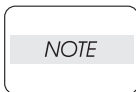

When disconnecting a harness connector from PWBA OCT shown below, disconnect it by securing PWBA OCT with your hand.

- 5) Disconnect the harness connectors from the connectors (P/J70, P/J71, P/J72, P/J73, P/J74 and P/J75) on the PWBA OCT.
- 6) Remove 2 screws (gold tapping, 8mm) securing the PWBA OCT unit to the HOUSING OCT (PL 11.1).
- 7) Remove the PWBA OCT unit.
- 8) Remove the screw (silver, 6mm) securing the PWBA OCT to the SUPPORT OCT RIGHT (PL 11.1) of the PWBA OCT unit.
- 9) Remove the PWBA OCT.

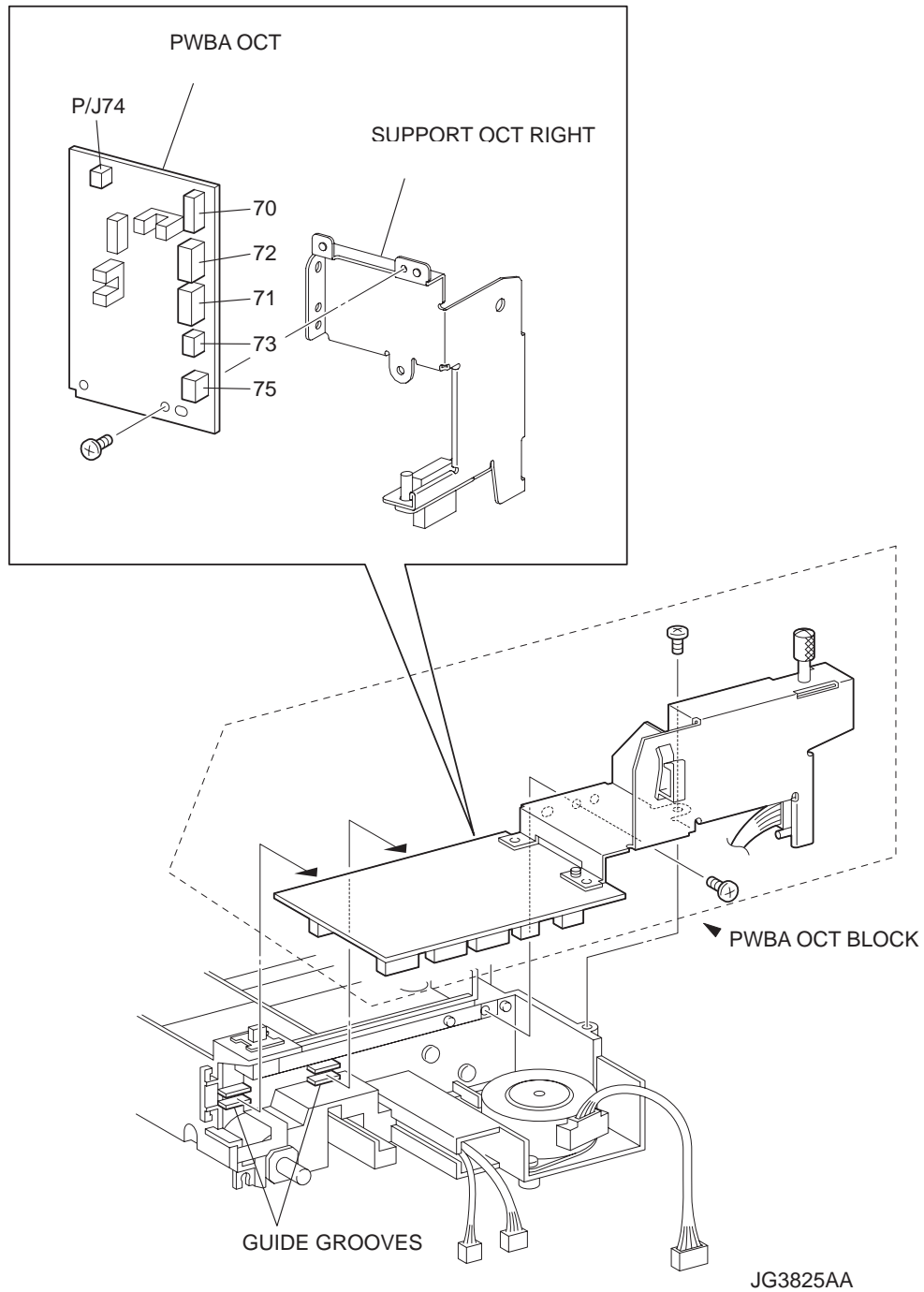

Replacement

- 1) Install the PWBA OCT to the SUPPORT OCT RIGHT (PL 11.1) using the screw (silver, 6mm).
- 2) Install the SUPPORT OCT RIGHT attached with the PWBA OCT to the Option OCT using 2 screws (gold tapping, 8mm).

NOTE

When installing, be sure to install the PWBA OCT into the two guiding ditches of the Option OCT.

NOTE

When installing, be sure to install the SHUTTER portion of the ACTUATOR FULL STACK (PL 11.1) into the photo interrupter on the PWBA OCT.

Removal and Replacement Procedures (RRPs)

- 3) Connect the harness connectors to the connectors (P/J70, P/J71, P/J72, P/J73, P/J74 and P/J75) on the PWBA OCT.

NOTE

When connecting a harness connector, connect it by securing PWBA OCT with your hand.

- 4) Secure the harness connected to the S/W REAR COVER (PL 11.1) using clamp.
- 5) Install the COVER FRONT (PL 11.1). (RRP11.5)
- 6) Install the COVER OCT (PL 11.1). (RRP11.4)
- 7) Install the COVER REAR (PL 11.1). (RRP11.2)

RRP11.8 MOTOR ASSY OFFSET (PL11.1)

Removal

- 1) Remove the COVER REAR (PL 11.1). (RRP11.2)
- 2) Remove the COVER OCT (PL 11.1). (RRP11.4)
- 3) Remove the PWBA OCT (PL 11.1). (RRP11.7)
- 4) Remove the 2 screws (gold tapping, 8mm) securing the MOTOR ASSY OFFSET to the Option OCT.
- 5) Remove the MOTOR ASSY OFFSET.

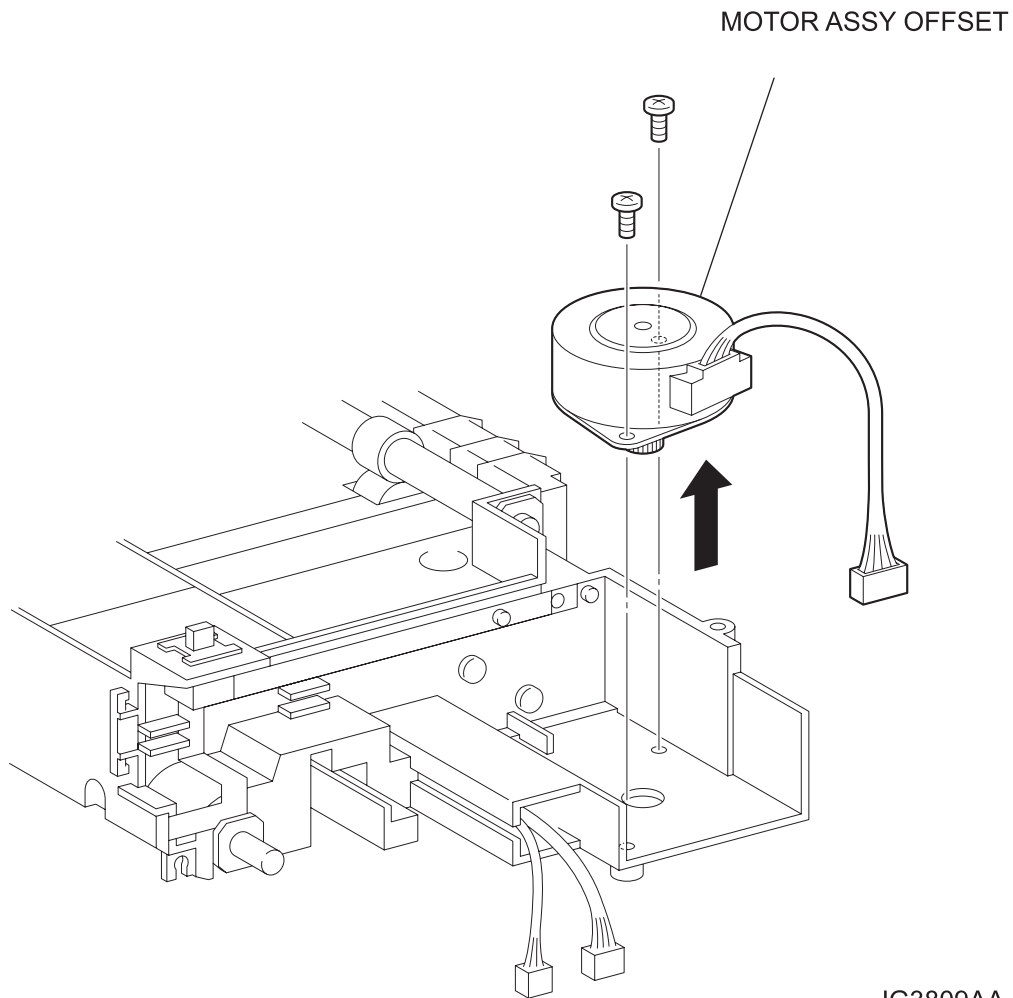

Replacement

- 1) Install the MOTOR ASSY OFFSET to the Option OCT using the 2 screws (gold tapping, 8mm).
- 2) Install the PWBA OCT (PL 11.1). (RRP11.7)
- 3) Install the COVER OCT (PL 11.1). (RRP11.4)
- 4) Install the COVER REAR (PL 11.1). (RRP11.2)

RRP11.9 SOLENOID ASSY GATE (PL11.1)

Removal

- 1) Remove the COVER REAR (PL 11.1). (RRP11.2)
- 2) Remove the COVER OCT (PL 11.1). (RRP11.4)
- 3) Remove the COVER FRONT (PL 11.1). (RRP11.5)
- 4) Remove the PWBA OCT (PL 11.1). (RRP11.7)
- 5) Remove the MOTOR ASSY OFSET (PL 11.1). (RRP11.8)
- 6) Remove the 2 screws (gold, 6mm) securing the SOLENOID ASSY GATE to the Option OCT.
- 7) Release the hook securing the SOLENOID ASSY GATE, and remove the SOLENOID ASSY GATE.

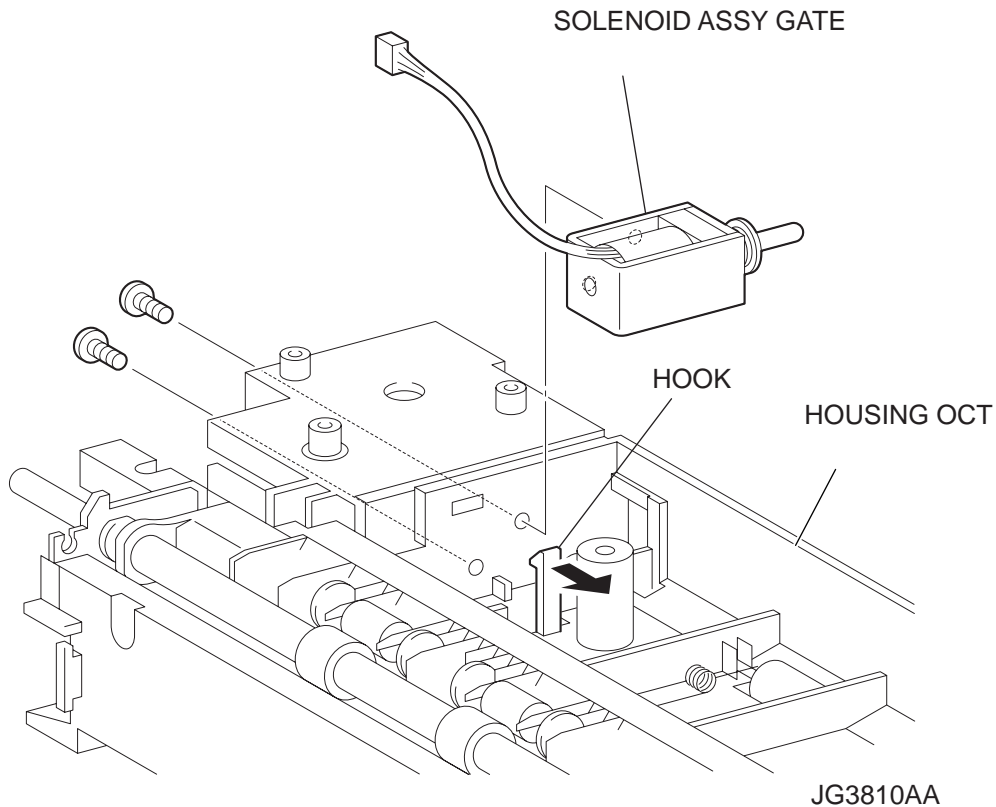

Replacement

- 1) Secure the SOLENOID ASSY GATE with the hook, and secure it using the 2 screws (gold, 6mm).
- 2) Install the MOTOR ASSY OFFSET (PL 11.1). (RRP11.8)
- 3) Install the PWBA OCT (PL 11.1). (RRP11.7)
- 4) Install the COVER FRONT (PL 11.1). (RRP11.5)
- 5) Install the COVER OCT (PL 11.1). (RRP11.4)
- 6) Install the COVER REAR (PL 11.1). (RRP11.2)

RRP11.10 SENSOR OCT (PL11.1)

Removal

- 1) Remove the COVER REAR (PL 11.1). (RRP10.6)
- 2) Remove the COVER OCT (PL 11.1). (RRP11.4)
- 3) Remove the COVER FRONT (PL 11.1). (RRP11.5)
- 4) Release the HARNESS ASSY OCT SNR (PL 11.1) from the hooks.
- 5) Disconnect the connector (P/J730) of the HARNESS ASSY OCT SNR from the SENSOR OCT.
- 6) Remove the SPRING ACTUATOR (PL 11.1).
- 7) Shift the ACTUATOR OCT (PL 11.1) in the direction of the arrows to remove it from the hooks on both sides .
- 8) Release the hooks of the SENSOR OCT, and remove it from the HOUSING OCT (PL 11.1).

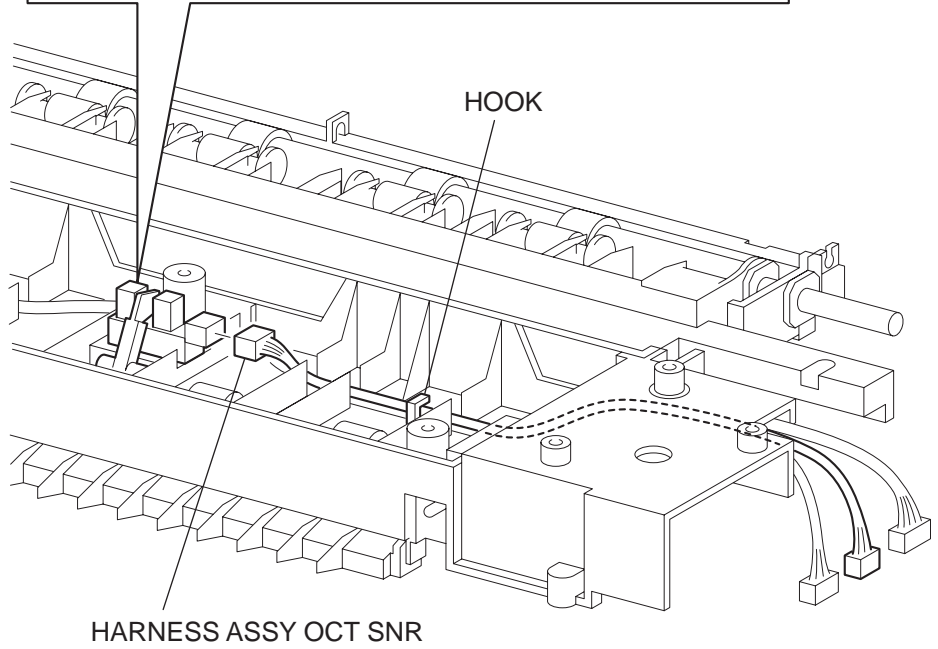
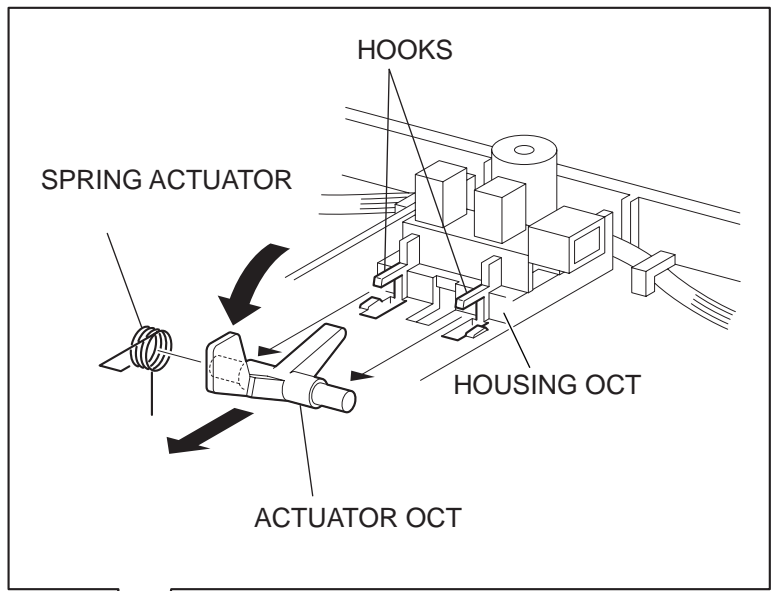

JG3811AA

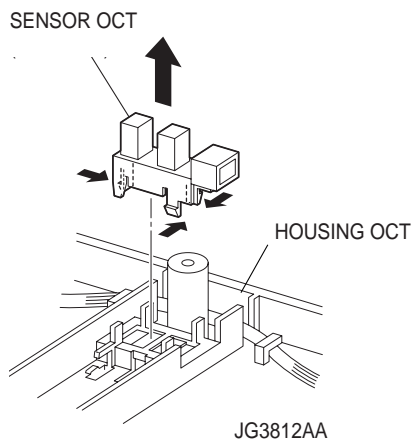

JG3812AA

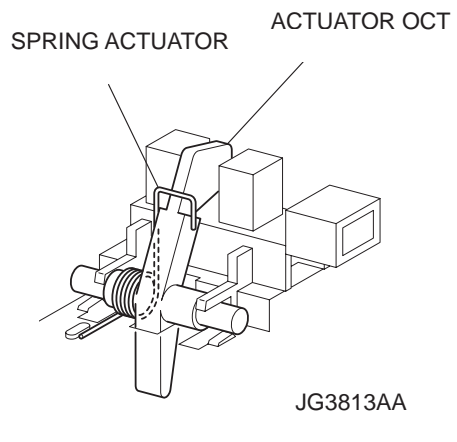

JG3813AA

Replacement

- 1) Install the SENSOR OCT to the HOUSING OCT (PL 11.1), and secure it with the hooks.
- 2) Move the ACTUATOR OCT in the opposite direction of the arrows, and secure it with the hooks.
- 3) Install the SPRING ACTUATOR (PL 11.1).

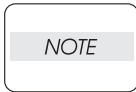

Install the SPRING ACTUATOR to the ACTUATOR OCT as shown in the figure.

- 4) Connect the connector (P/J730) of the HARNESS ASSY OCR SNR (PL 11.1) to the SENSOR OCT.
- 5) Secure the HARNESS ASSY OCT SNR with the hooks.
- 6) Install the COVER FRONT (PL 11.1). (RRP11.5)
- 7) Install the COVER OCT (PL 11.1). (RRP11.4)
- 8) Install the COVER REAR (PL 11.1). (RRP11.2)

RRP11.11 ROLL OCT LOWER (PL11.1)

Removal

- 1) Remove the COVER REAR (PL 11.1). (RRP11.2)
- 2) Remove the COVER OCT (PL 11.1). (RRP11.4)
- 3) Remove the 2 screws (gold tapping, 8mm, gold 6mm) securing the SUPPORT OCT LEFT (PL 11.1).
- 4) Remove the 2 screws (gold tapping, 8mm) securing the BRACKET MOTOR OCT (PL 11.1).
- 5) Disconnect the harness conector of the MOTOR ASSY OCT , and remove the BRACKET MOTOR OCT together with the MOTOR ASSY OCT (PL 11.1).
- 6) Remove the GEAR 45 (PL 11.1), GEAR 19/37 (PL 11.1) and GEAR 19 (PL 11.1).
- 7) Release the hook of the BEARING ROLL (PL 11.1) on the side of GEAR 19 , and remove it from the HOUSING OCT (PL 11.1).

NOTE

Be careful handling the hook of the BEARING ROLL. It is fragile and could break if given excessive force.

- 8) Shift the ROLL OCT LOWER in the direction of the arrow to remove.

NOTE

When removing, do not hold the rubber rollers of the ROLL OCT LOWER.

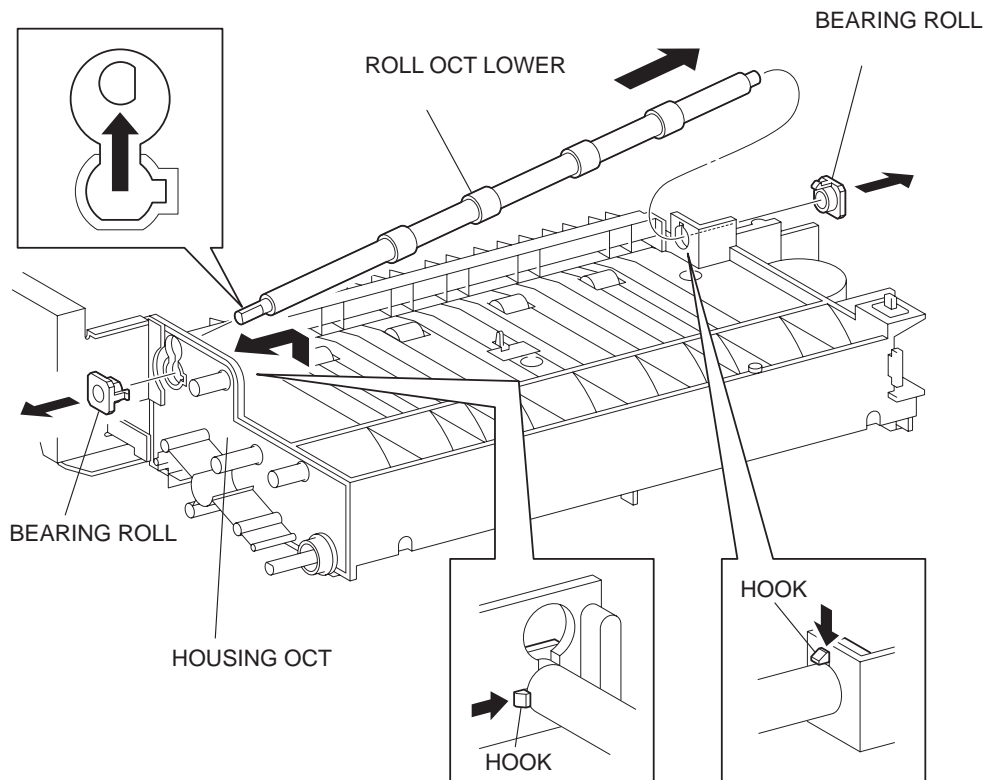
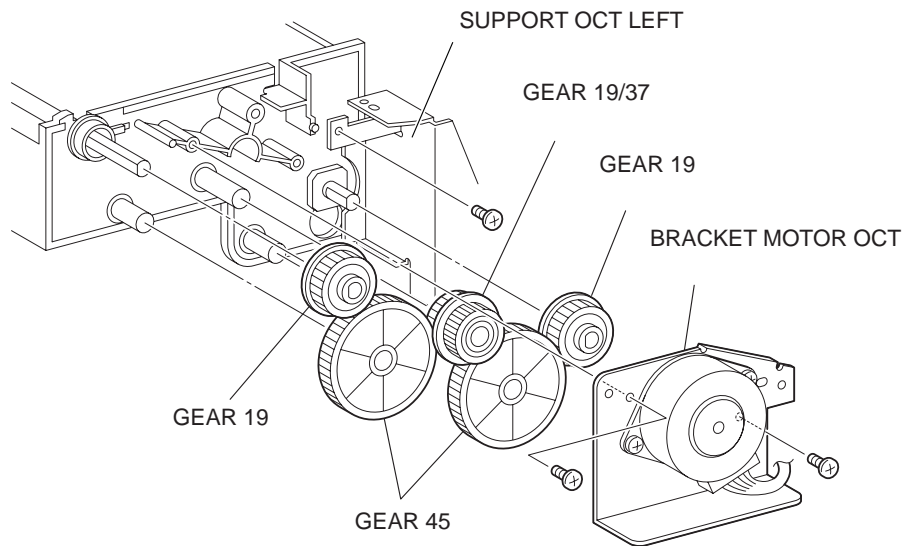

JG3814AA

Replacement

- 1) Shift the ROLL OCT LOWER in the opposite direction of the arrow to install.

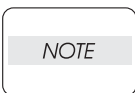

When installing, do not hold the rubber rollers of the ROLL OCT LOWER.

- 2) Install the BEARING ROLL to the HOUSING OCT at the GEAR 19 side.
- 3) Install the GEAR 19 (PL 11.1), GEAR 45 (PL 11.1) and GEAR 19/37 (PL 11.1) in order.

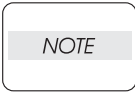

When installing the GEAR 19, be careful in the installing direction.

- 4) Install the BRACKET MOTOR OCT (PL 11.1) using the 2 screws (gold tapping, 8mm).
- 5) Install the SUPPORT OCT LEFT using the 2 screws (gold tapping, 8mm, gold 6mm).
- 6) Install the COVER OCT (PL 11.1). (RRP11.4)
- 7) Install the COVER REAR (PL 11.1). (RRP11.2)

RRP11.12 ROLL OCT UPPER (PL11.1)

Removal

- 1) Remove the COVER REAR (PL 11.1). (RRP11.2)
- 2) Remove the COVER OCT (PL 11.1). (RRP11.4)
- 3) Remove the COVER FRONT (PL 11.1). (RRP11.5)
- 4) Remove the GEAR CAM (PL 11.1).
- 5) Remove the 2 screws (gold tapping, 8mm, gold 6mm) securing the SUPPORT OCT LEFT (PL 11.1).
- 6) Remove the 2 screws (gold tapping, 8mm) securing the BRACKET MOTOR OCT (PL 11.1).
- 7) Disconnect the harness connector of the MOTOR ASSY, and remove the BRACKET MOTOR OCT together with the MOTOR ASSY OCT (PL 11.1).
- 8) Remove the GEAR 45 (PL 11.1), GEAR 19/37 (PL 11.1) and GEAR 19 (PL 11.1).
- 9) Release the hook of the BEARING OFFSET (PL 11.1), and turn it in the direction of the arrow. Remove the BEARING OFFSET from the HOUSING OCT (PL 11.1).
- 10) Release the hook of the BEARING ROLL (PL 11.1) on the other side, and remove it. Remove the CHUTE OFFSET ASSY (PL 11.1).
- 11) Release the hook of the 2 BEARING ROLLS (PL 11.1) on one side, and remove them.
- 12) Remove the ROLL OCT UPPER from the CHUTE OFFSET ASSY.

Removal and Replacement Procedures (RRPs)

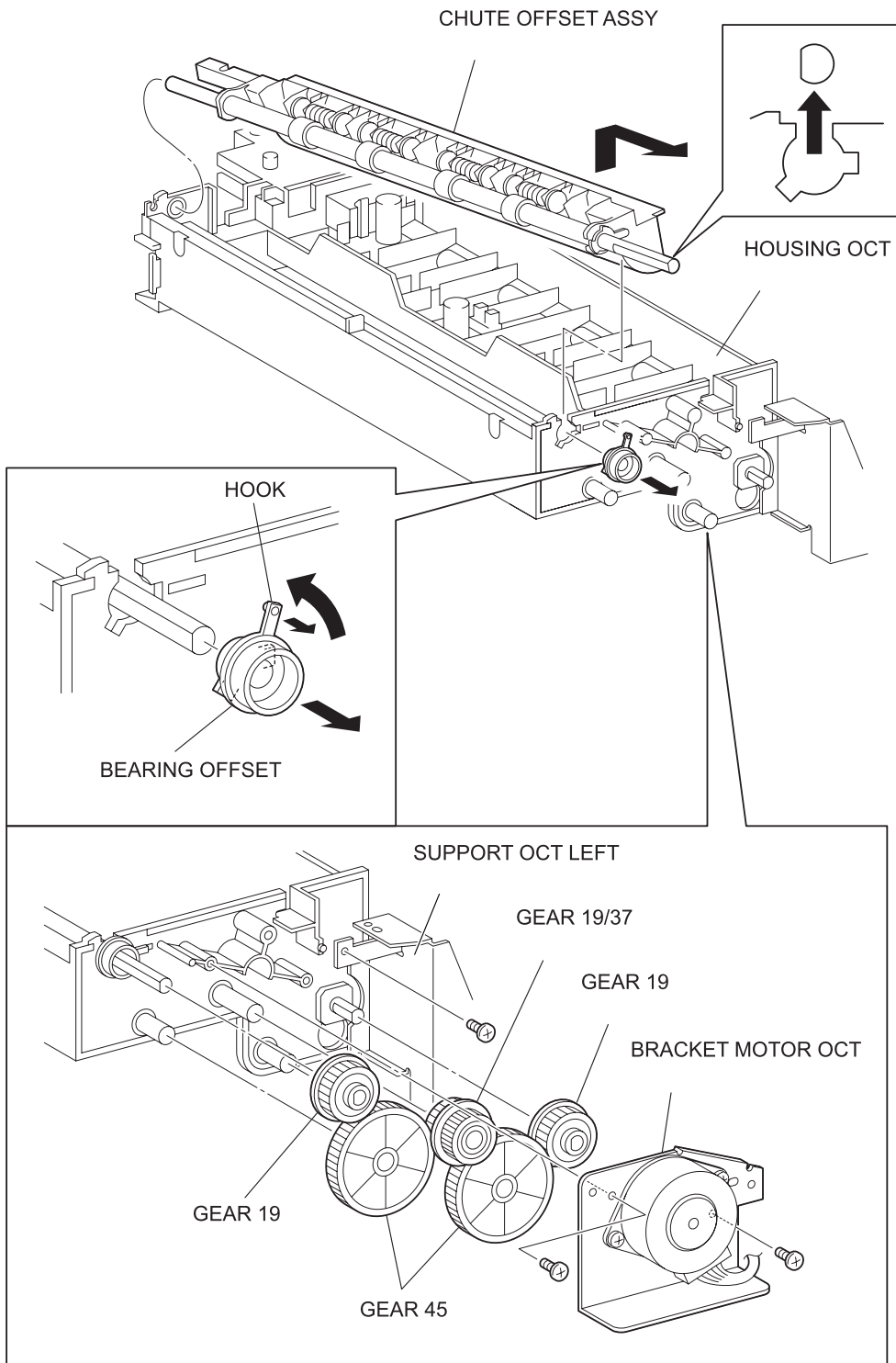

JG3815AB

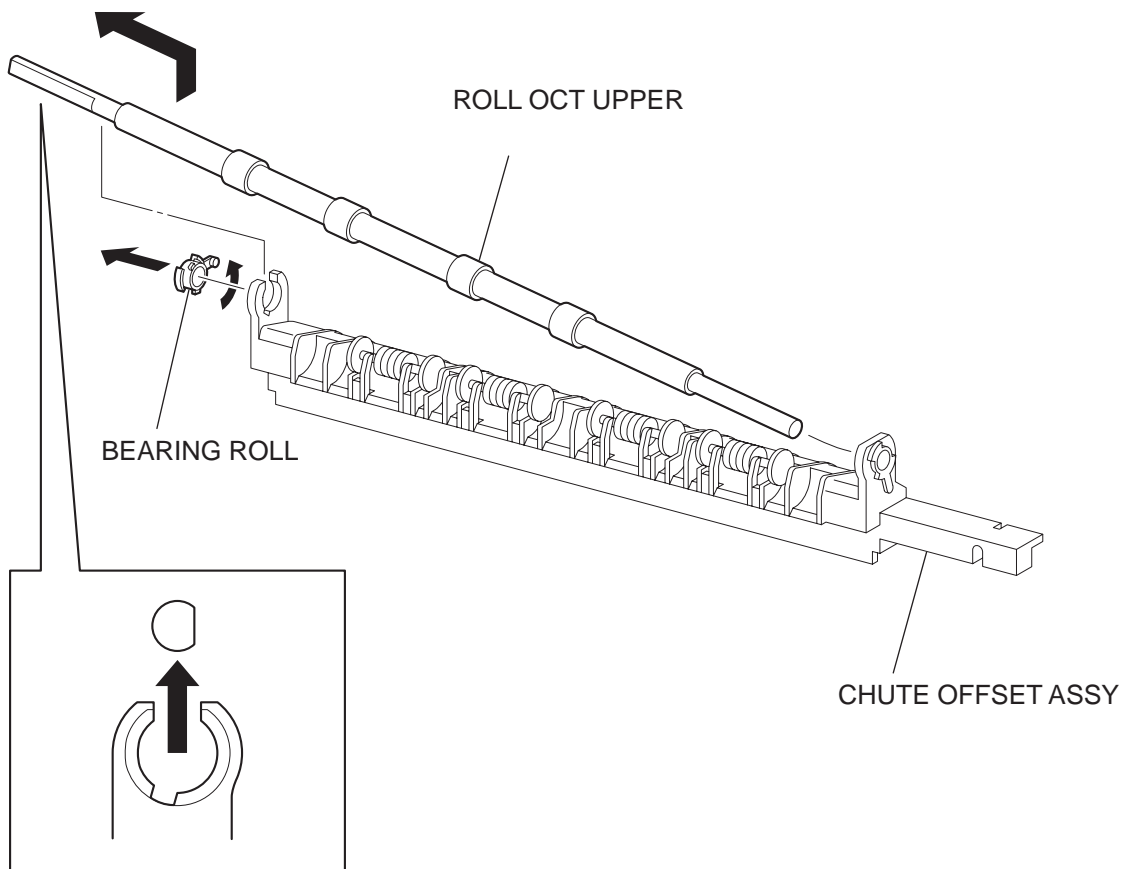

JG3816AB

Replacement

- 1) Install the ROLL OCT UPPER to the CHUTE OFFSET ASSY (PL 11.1).
- 2) Install the 2 BEARING ROLLS (PL 11.1) to the CHUTE OFFSET ASSY.
- 3) Install the BEARING ROLL (PL 11.1) to the HOUSING OCT (PL 11.1).
- 4) Install the CHUTE OFFSET ASSY to the HOUSING OCT. Install the BEARING OFFSET (PL 11.1), and secure it with the hook.
- 5) Install the GEAR 19 (PL 11.1), GEAR 45 (PL 11.1) and GEAR 19/37 (PL 11.1) in order.

NOTE

When installing the GEAR 19, be careful in the installing direction.

- 6) Install the BRACKET MOTOR OCT (PL 11.1) using the 2 screws (gold tapping, 8mm).
- 7) Install the SUPPORT OCT LEFT using the 2 screws (gold tapping, 8mm, gold 6mm).
- 8) Install the GEAR CAM (PL 11.1). (Figure 23.5)
- 9) Install the COVER FRONT (PL 11.1). (RRP11.5)
- 10) Install the COVER OCT (PL 11.1). (RRP11.4)
- 11) Install the COVER REAR (PL 11.1). (RRP11.2)

RRP11.13 MOTOR ASSY OCT (PL11.1)

Removal

- 1) Remove the COVER REAR (PL 11.1). (RRP11.2)
- 2) Remove the COVER OCT (PL 11.1). (RRP11.4)
- 3) Disconnect the connector of the MOTOR ASSY OCT from the HARNESS ASSY OCT MOT (PL 11.1).
- 4) Remove the 2 screws (gold, 8mm) securing the MOTOR ASSY OCT, and remove the MOTOR ASSY OCT.

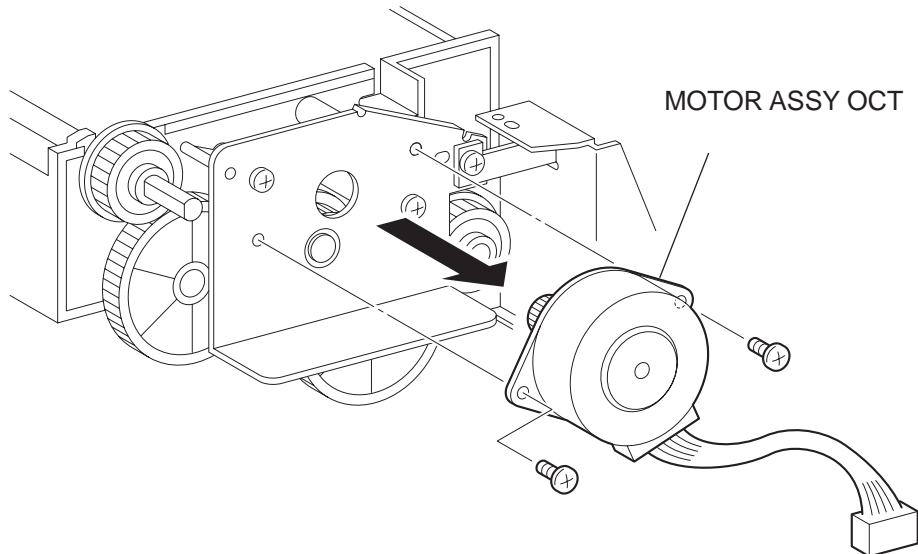

JG3817AA

Replacement

- 1) Secure the MOTOR ASSY OCT using the 2 screws (gold, 8mm).
- 2) Connect the connector of the MOTOR ASSY OCT to the HARNESS ASSY OCT MOT (PL 11.1).
- 3) Install the COVER FRONT (PL 11.1). (RRP11.5)
- 4) Install the COVER OCT (PL 11.1). (RRP11.4)
- 5) Install the COVER REAR (PL 11.1). (RRP11.2)

RRP12.550 Paper Feeder Option

RRP12.1 550 Paper Feeder Option

Removal

- 1) Remove the EP CARTRIDGE.
- 2) Pull out the 250 PAPER CASSETTE or 550 PAPER CASSETTE from the 2nd tray of the printer.
- 3) Remove the 550 PAPER CASSETTE from the Option 550 Paper Feeder.
- 4) Remove 2 JOINT FEEDERS (PL 12.1) at the rear of the printer securing the printer and the Option 550 Paper Feeder.
- 5) Remove 2 JOINT FEEDERS inside the tray insertion space.
- 6) Lift and remove the printer from the Option 550 Paper Feeder, and put it aside.

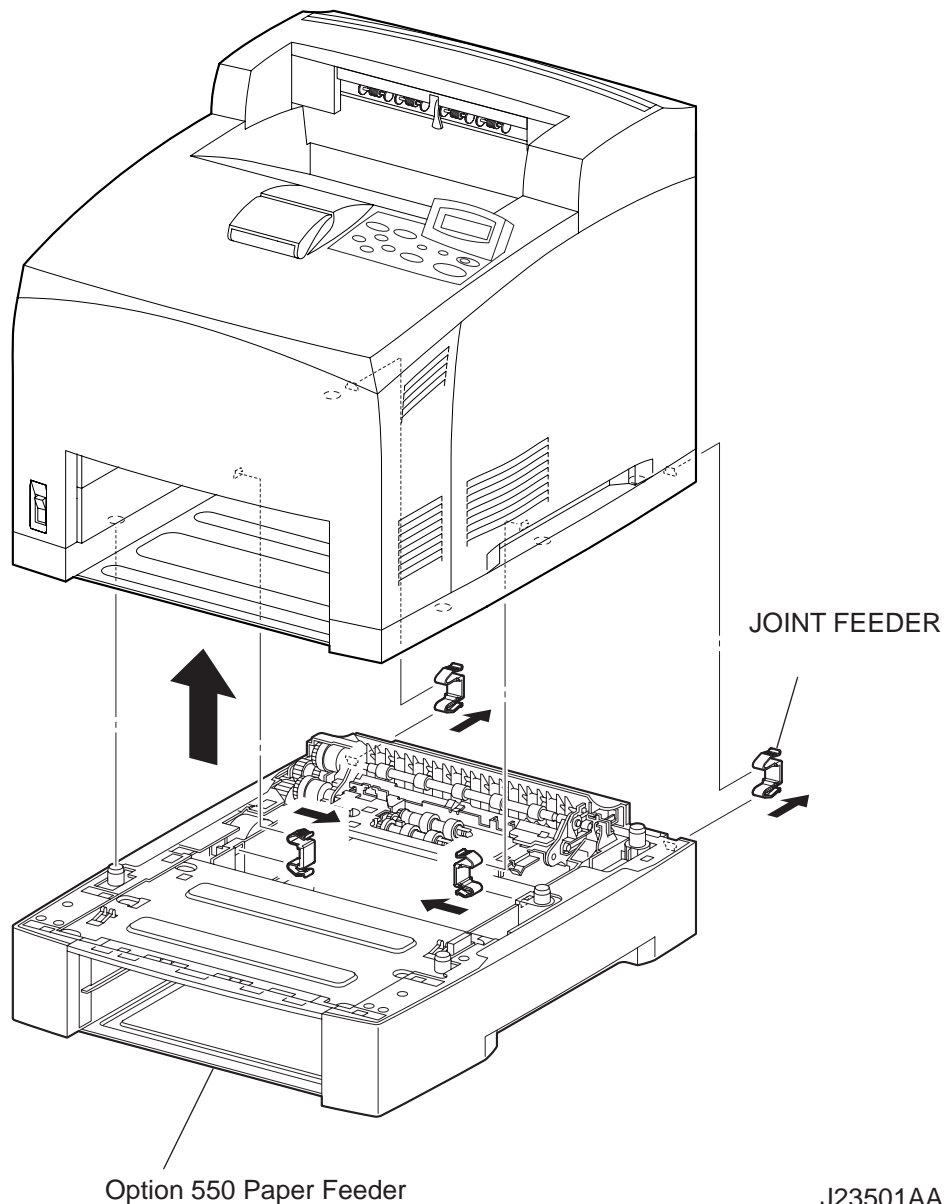

J23501AA

Replacement

- 1) Install the printer on the Option 550 Paper Feeder.

NOTE

When installing, align the holes and the bosses of the printer and Option 550 Paper Feeder, and fix them using 4 JOINT FEEDERs firmly.

- 2) Secure the printer and Option 550 Paper Feeder using 2 JOINT FEEDERs (PL 12.1) inside the tray insertion space.
- 3) INstall 2 JOINT FEEDERs at the rear of the printer.
- 4) Set the 550 PAPER CASSETTE to the Option 550 Paper Feeder.
- 5) Set the 250 PAPER CASSETTE or 550 PAPER CASSETTE to the 2nd tray of the printer.
- 6) Install the EP CARTRIDGE.

RRP12.2 COVER RIGHT PLATE (PL12.1)**Removal**

- 1) Remove the screw (gold tapping, 8mm) securing the COVER RIGHT PLATE to the frame.
- 2) Lift up the COVER RIGHT PLATE just above the boss of the FRAME CVR R550 (PL 12.1) a little to release.
- 3) Shift the COVER RIGHT PLATE in the direction of the arrow to release the 4 hooks of the FRAME CVR R550, and remove the COVER RIGHT PLATE from the Option 550 Paper Feeder.

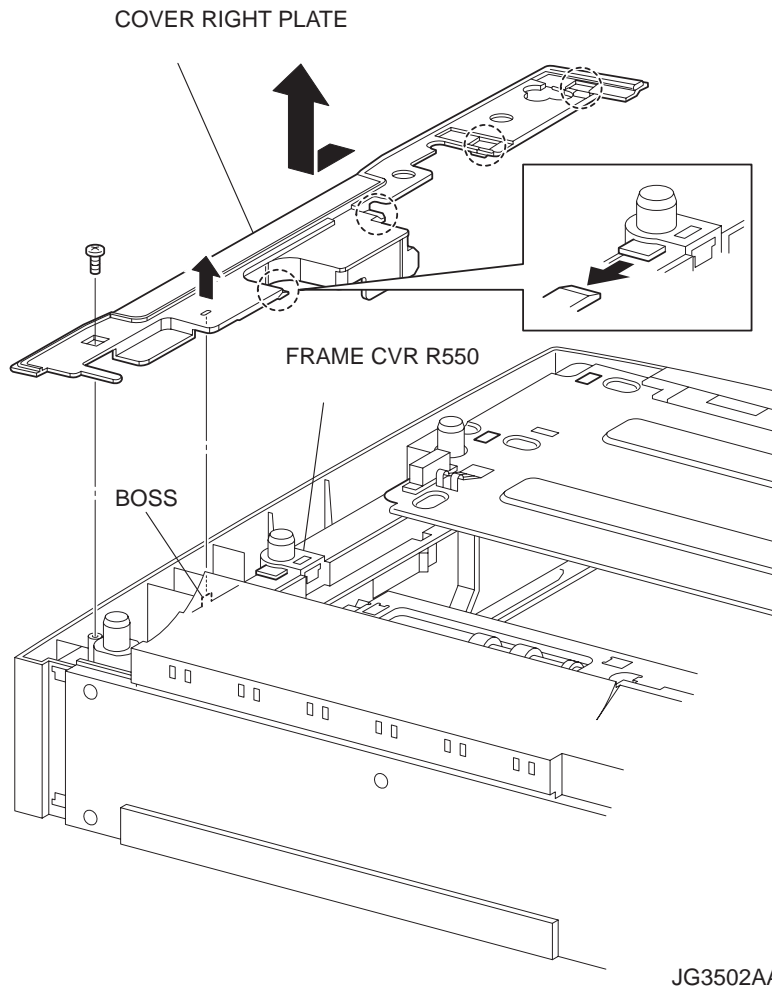
**Replacement**

- 1) Shift the COVER RIGHT PLATE in the opposite direction of the arrow to engage the 4 hooks of the FRAME CVR R550 (PL 12.1) with the COVER RIGHT PLATE.
- 2) Put the boss of the FRAME CVR R550 into the hole of the COVER RIGHT PLATE.
- 3) Secure the COVER RIGHT PLATE to the frame using the screw (gold tapping, 8mm).

RRP12.3 COVER LEFT PLATE (PL12.1)**Removal**

- 1) Remove the 2 screws (gold tapping, 8mm) securing the EARTH PLATE (PL 12.1) to the frame.
- 2) Remove the EARTH PLATE.
- 3) Lift up the COVER LEFT PLATE just above the boss of the FRAME CVR L550 (PL 12.1) a little to release them.
- 4) Shift the COVER LEFT PLATE in the direction of the arrow to release the 4 hooks of the FRAME CVR L550, and remove the COVER LEFT PLATE from the Option 550 Paper Feeder.

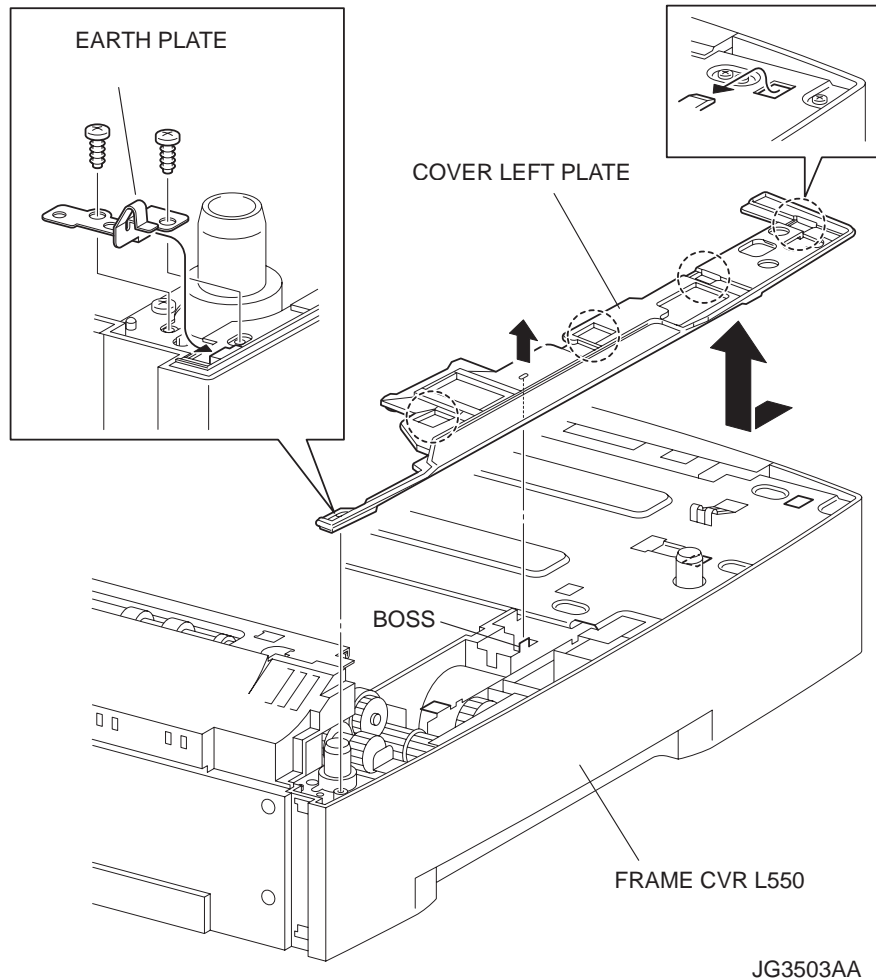
**Replacement**

- 1) Shift the COVER LEFT PLATE in the opposite direction of the arrow to engage the 4 hooks of the FRAME CVR L550 (PL 12.1) with the COVER LEFT PLATE.
- 2) Put the boss of the FRAME CVR L550 into the hole of the COVER LEFT PLATE.
- 3) Secure the EARTH PLATE (PL 12.1) to the frame using the 2 screws (gold tapping, 8mm).

NOTE

When installing the EARTH PLATE, be sure to install the tip of the EARTH PLATE under the COVER LEFT PLATE.

RRP12.4 OPT ASSY SIZE (PL12.1)**Removal**

- 1) Release the HARNESS ASSY SIZE FDR1 (PL 12.1) from the hooks of the FRAME CVR L550 (PL 12.1).
- 2) Remove the 2 screws (gold tapping, 8mm) securing the OPT ASSY SIZE to the FRAME CVR L550.
- 3) Shift the OPT ASSY SIZE in the direction of the arrow to release the bosses, and remove it from the FRAME CVR L550.
- 4) Disconnect the connector (P/J802) of the the HARNESS ASSY SIZE FDR1 from the connector of the OPT ASSY SIZE.

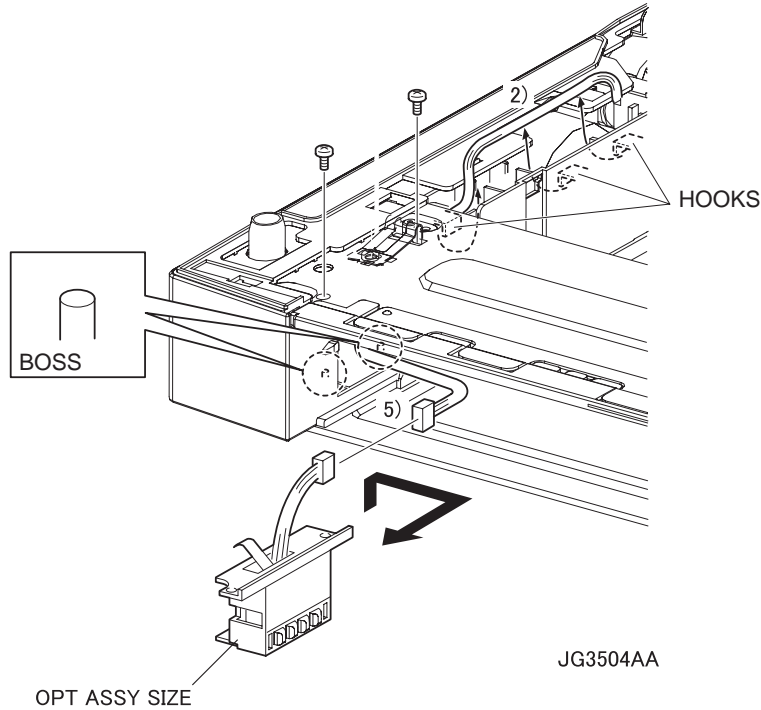
**Replacement**

- 1) Shift the OPT ASSY SIZE in the opposite direction of the arrow, and install it to the FRAME CVR L550 (PL 12.1) using the 2 screws (gold tapping, 8mm).
- 2) Connect the connector (P/J802) of the HARNESS ASSY SIZE FDR1 (PL 12.1) to the connector of the OPT ASSY SIZE.
- 3) Secure the HARNESS ASSY SIZE FDR1 to the FRAME CVR L550 using hooks.

RRP12.5 DRIVE ASSY OPT FDR (PL12.1)**Removal**

- 1) Remove the 550 FEEDER OPTION (PL 12.2). (RRP12.1)
- 2) Remove the COVER LEFT PLATE (PL 12.1.3). (RRP12.3)
- 3) Disconnect the connector (P/J820) of the MOTOR FEEDER (PL 12.1.17) attached to the DRIVE ASSY OPT FDR from the HARNESS ASSY FDR MOT (PL 12.1.37).
- 4) Remove the 3 screws (gold tapping, 8mm x 2, silver, 6mm x 1) securing the DRIVE ASSY OPT FDR to the FRAME CVR L550 (PL 12.1).
- 5) Remove the DRIVE ASSY OPT FDR.

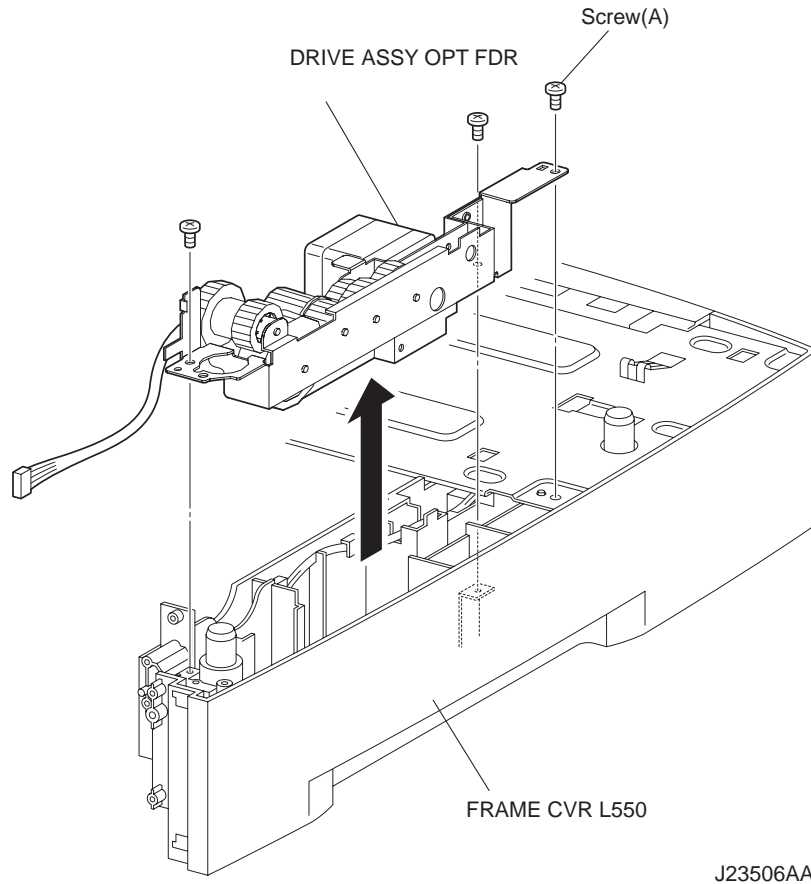
**Replacement**

- 1) Install the DRIVE ASSY OPT FDR to the FRAME CVR L550 (PL 12.1) using the 3 screws (gold tapping, 8mm x 2, silver, 8mm x 1).

NOTE

Be sure to tighten the screw (silver, 6mm) shown as Screw (A) in the figure. When tightening the screws, be careful not to pinch the harness between the board and frame.

- 2) Connect the connector (P/J820) of the MOTOR FEEDER (PL 12.1.17) attached to the DRIVE ASSY OPT FDR to the HARNESS ASSY FDR MOT (PL 12.1.37).
- 3) Install the COVER LEFT PLATE (PL 12.1.3). (RRP12.3)

NOTE

When installing the EARTH PLATE, be sure to install the tip of the EARTH PLATE under the COVER LEFT PLATE.

- 4) Install the 550 FEEDER OPTION (PL 12.2). (RRP12.1)

RRP12.6 MOTOR FEEDER (PL12.1)

Removal

- 1) Remove the 550 FEEDER OPTION (PL 12.2). (RRP12.1)
- 2) Remove the COVER LEFT PLATE (PL 12.1.3). (RRP12.3)
- 3) Remove the DRIVE ASSY OPT FDR (PL 12.1.8). (RRP12.5)
- 4) Remove the 2 screws (gold, 6mm) securing the MOTOR FEEDER to the DRIVE ASSY OPT FDR.
- 5) Remove the MOTOR FEEDER.

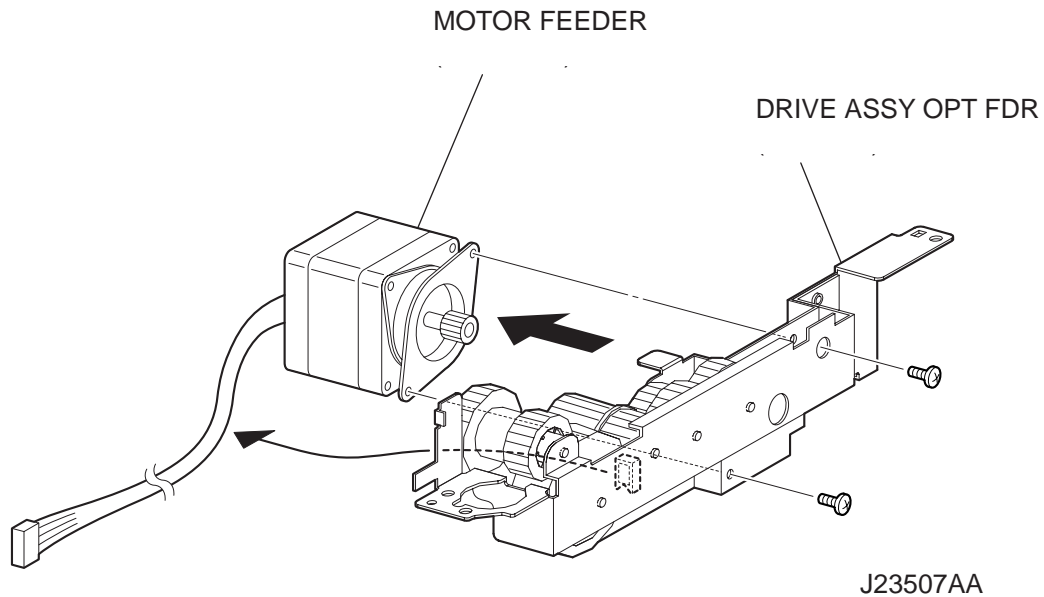

Replacement

- 1) Install the MOTOR FEEDER to the DRIVE ASSY OPT FDR (PL 12.1.8) using the 2 screws (gold, 6mm).
- 2) Install the DRIVE ASSY OPT FDR. (RRP12.5)
- 3) Install the COVER LEFT PLATE (PL 12.1.3). (RRP12.3)

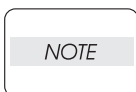

When installing the EARTH PLATE, be sure to install the tip of the EARTH PLATE under the COVER LEFT PLATE.

- 4) Install the 550 FEEDER OPTION (PL 12.2). (RRP12.1)

RRP12.7 SENSOR LOW PAPER (PL12.1)

Removal

- 1) Remove the COVER RIGHT PLATE (PL 12.1.1). (RRP12.2)
- 2) Remove the 2 screws securing the HLD LOW PAPER ASSY (PL 12.1.29) to the FRAME CVR R550 (PL 12.1).
- 3) Disconnect the connector (P/J810) of the HARNESS LOW PAPER (PL 12.1.33) from the SENSOR LOW PAPER of the HLD LOW PAPER ASSY.
- 4) Remove the HLD LOW PAPER ASSY.
- 5) Release the hooks of the SENSOR LOW PAPER, and remove it from the HLD LOW PAPER ASSY.

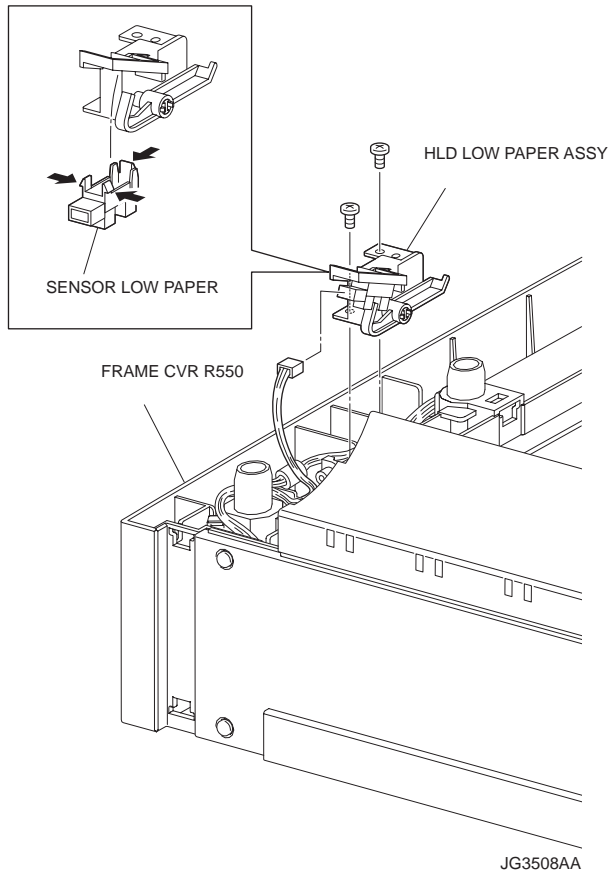

Replacement

- 1) Install the SENSOR LOW PAPER to the HLD LOW PAPER ASSY (PL 12.1.29).
- 2) Connect the connector (P/J810) of the HARNESS LOW PAPER (PL 12.1.33) to the SENSOR LOW PAPER of the HLD LOW PAPER ASSY.
- 3) Install the HLD LOW PAPER ASSY to the FRAME CVR R550 (PL 12.1) using the 2 screws.
- 4) Install the COVER RIGHT PLATE (PL 12.1.1). (RRP12.2)

RRP12.8 PWBA FEEDER 550 (PL12.1)

Removal

- 1) Remove the COVER RIGHT PLATE (PL 12.1.1). (RRP12.2)
- 2) Disconnect the harness connectors from the connectors (P/J80, P/J81, P/J82, P/J83, P/J84 and P/ J85) on the PWBA FEEDER 550.
- 3) Remove the 2 screws (gold tapping, 8mm) securing the PWBA FEEDER 550 to the frame.
- 4) Remove the PWBA FEEDER 550.

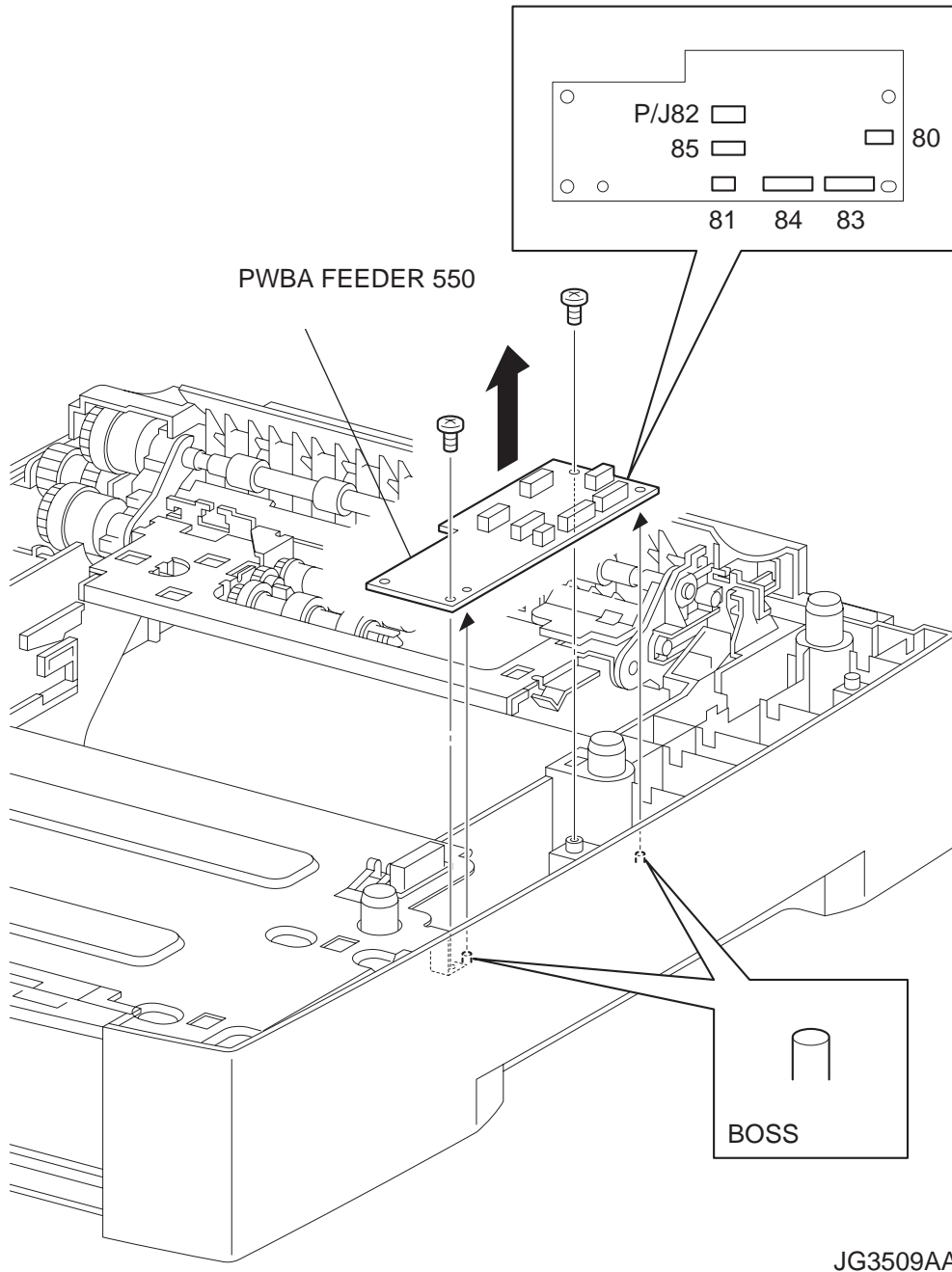

JG3509AA

Replacement

- 1) Install the PWBA FEEDER 550 to the frame using the 2 screws (gold tapping, 8mm).

Removal and Replacement Procedures (RRPs)

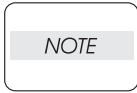

One of the screws that secure the PWBA FEEDER 550 is tightened together with the FRAME TOP ASSY.

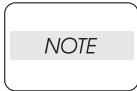

When installing, align the hole of the PWBA FEEDER 550 with the boss of the FRAME CVR R550.

- 2) Connect the connectors (P/J80, P/J81, P/J82, P/J83, P/J84 and P/J85) on the PWBA FEEDER 550 to the harness connectors.
- 3) Install the COVER RIGHT PLATE (PL 12.1.1). (RRP12.2)

RRP12.9 550 FEEDER OPTION (PL12.2)

Removal

- 1) Remove the 5 screws (gold tapping, 8mm) securing the COVER RE550 (PL 12.1.25) to the frame.
- 2) Remove the COVER RE550.
- 3) Disconnect the connector (P/J855) of the HARNESS ASSY CLSNR1 (PL 12.1.31) from the HARNESS ASSY CLSNR2 (PL 12.1.36).
- 4) Disconnect the connector (P/J820) of the MOTOR FEEDER (PL 12.1.17) from the HARNESS ASSY FDR MOT (PL 12.1.37).
- 5) Disconnect the connector (P/J801) of the HARNESS ASSY SIZE FDR1 (PL 12.1) from the HARNESS ASSY SIZE FDR2 (PL 12.1.35).
- 6) Release the clamp of the HARNESS ASSY FDR MOT and HARNESS ASSY SIZE FDR2 from the clamps.
- 7) Remove the 6 screws (gold tapping, 8mm) securing the 550 FEEDER OPTION to the frame.
- 8) Remove the 550 FEEDER OPTION from the frame.

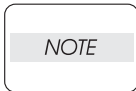

The following step is performed, if necessary.

- 9) Remove the 3 screws (silver, 6mm) securing the CHUTE 550 LOWER (PL 12.2.34) to the 550 FEEDER OPTION, and remove the CHUTE 550 LOWER from the 550 FEEDER OPTION.

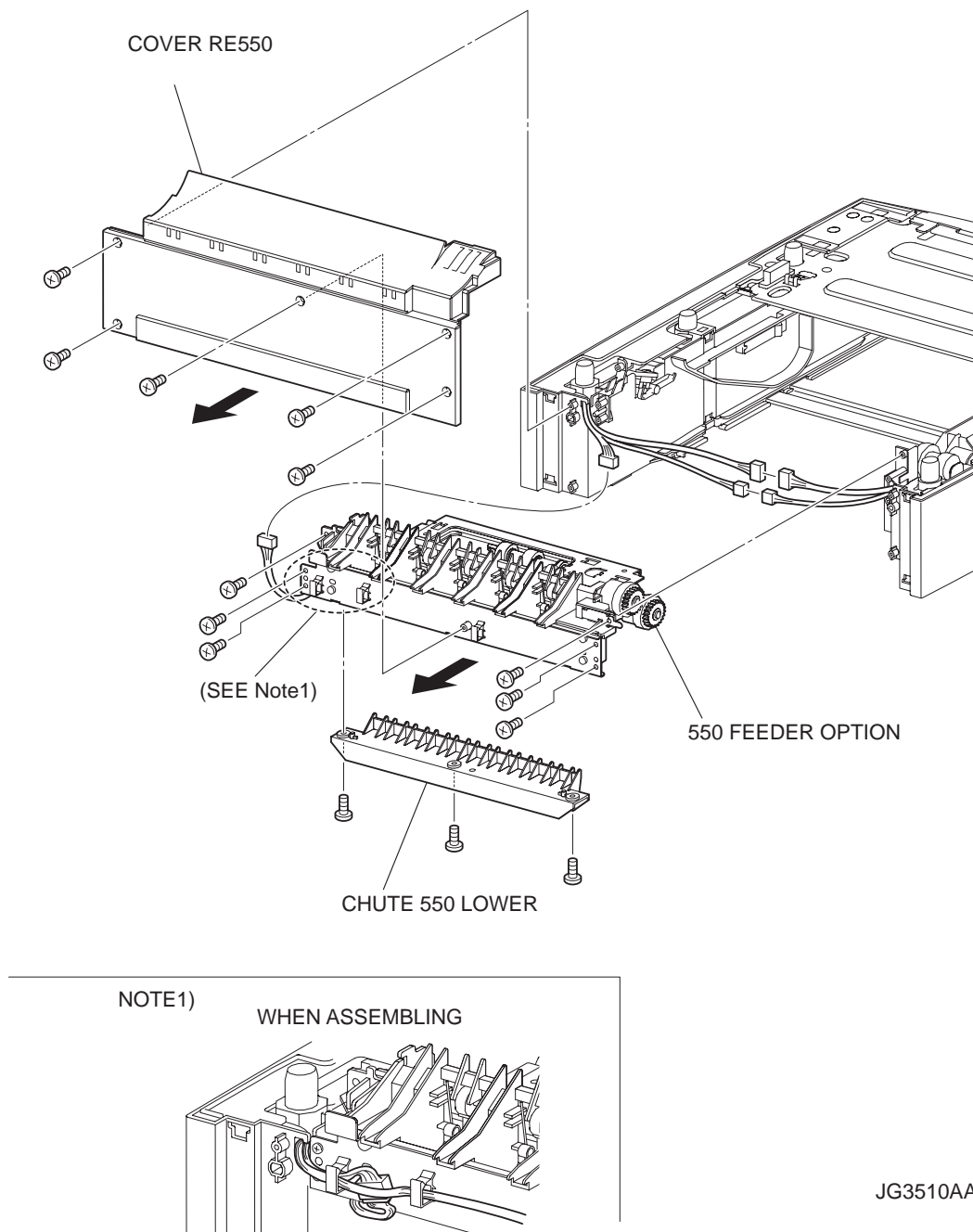

Replacement

- 1) Install the CHUTE 550 LOWER (PL 12.2.34) to the 550 FEEDER OPTION using the 3 screws (silver, 6mm).
- 2) Install the 550 FEEDER OPTION to the frame using the 6 screws (gold tapping, 8mm).
- 3) Secure the HARNESS ASSY FDR MOT (PL 12.1.37) and HARNESS ASSY SIZE FDR2 (PL 12.1.35) using clamps.
- 4) Connect the connector (P/J801) of the HARNESS ASSY SIZE FDR1 (PL 12.1) to the HARNESS ASSY SIZE FDR2.
- 5) Connect the connector (P/J820) of the MOTOR FEEDER (PL 12.1.17) to the HARNESS ASSY FDR MOT.

Removal and Replacement Procedures (RRPs)

- 6) Connect the connector (P/J855) of the HARNESS ASSY CLSNR1 (PL 12.2.31) to the HARNESS ASSY CLSNR2 (PL 12.1.36).

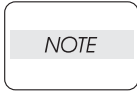

After connecting the connector, put the connector under the harness.

- 7) Install the COVER RE550 (PL 12.1.25) to the frame using the 5 screws (gold tapping, 8mm).

RRP12.10 ROLL ASSY NUDGER (PL12.2), ROLL ASSY FEED (PL12.2)

Removal

- 1) Release the hook securing the ROLL ASSY NUDGER, and pull it out from the SHAFT NUDGER (PL 12.2.9).
- 2) Release the hook securing the ROLL ASSY FEED, and pull it out from the SHAFT FEED (PL 12.2.16).

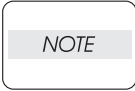

When removing, do not hold the rubber rollers of the ROLL ASSY NUDGER and ROLL ASSY FEED.

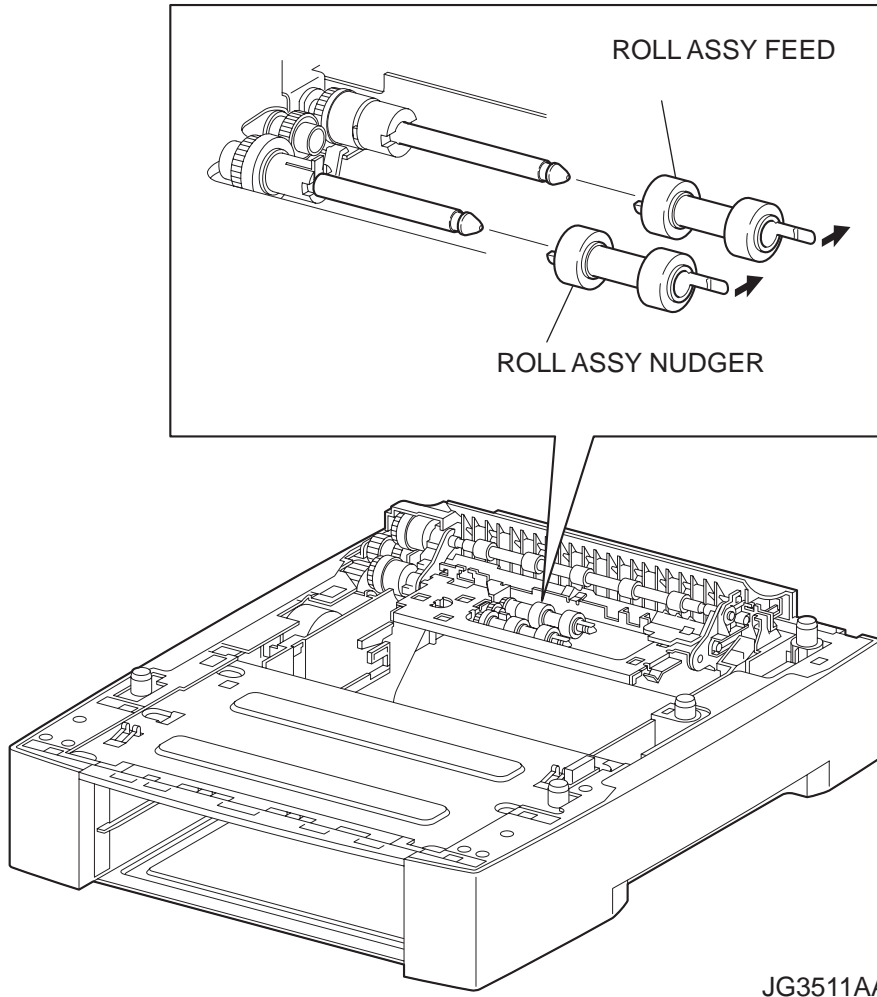

JG3511AA

Replacement

The ROLL ASSY FEED and ROLL ASSY NUDGER are the same parts, although the names differ.

- 1) Install the ROLL ASSY FEED to the SHFT FEED (PL 12.2.16), and secure the ROLL ASSY FEED with the hook.

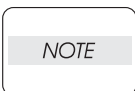

Be sure to install the hook of the ROLL ASSY FEED into the groove of the SHAFT FEED.

Removal and Replacement Procedures (RRPs)

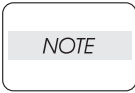

When installing, do not hold the rubber rollers of the ROLL ASSY FEED.

- 2) Install the ROLL ASSY NUDGER to the SHFT NUDGER (PL 12.2.9), and secure the ROLL ASSY NUDGER with the hook.

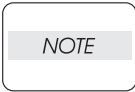

Be sure to install the hook of the ROLL ASSY NUDGER into the groove of the SHAFT NUDGER.

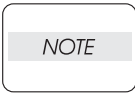

When installing, do not hold the rubber rollers of the ROLL ASSY NUDGER.

RRP12.11 CLUTCH ONEWAY NUDGER (PL12.2)**Removal**

- 1) Remove the ROLL ASSY FEED (PL 12.2.12). (RRP12.10)
- 2) Pull out the CLUTCH ONEWAY FEED (PL 12.2.13) from the SHAFT FEED (PL 12.2.16).
- 3) Remove the E-ring securing the CLUTCH ONEWAY NUDGER to the SHAFT FEED.
- 4) Pull out the CLUTCH ONEWAY NUDGER from the SHAFT FEED.

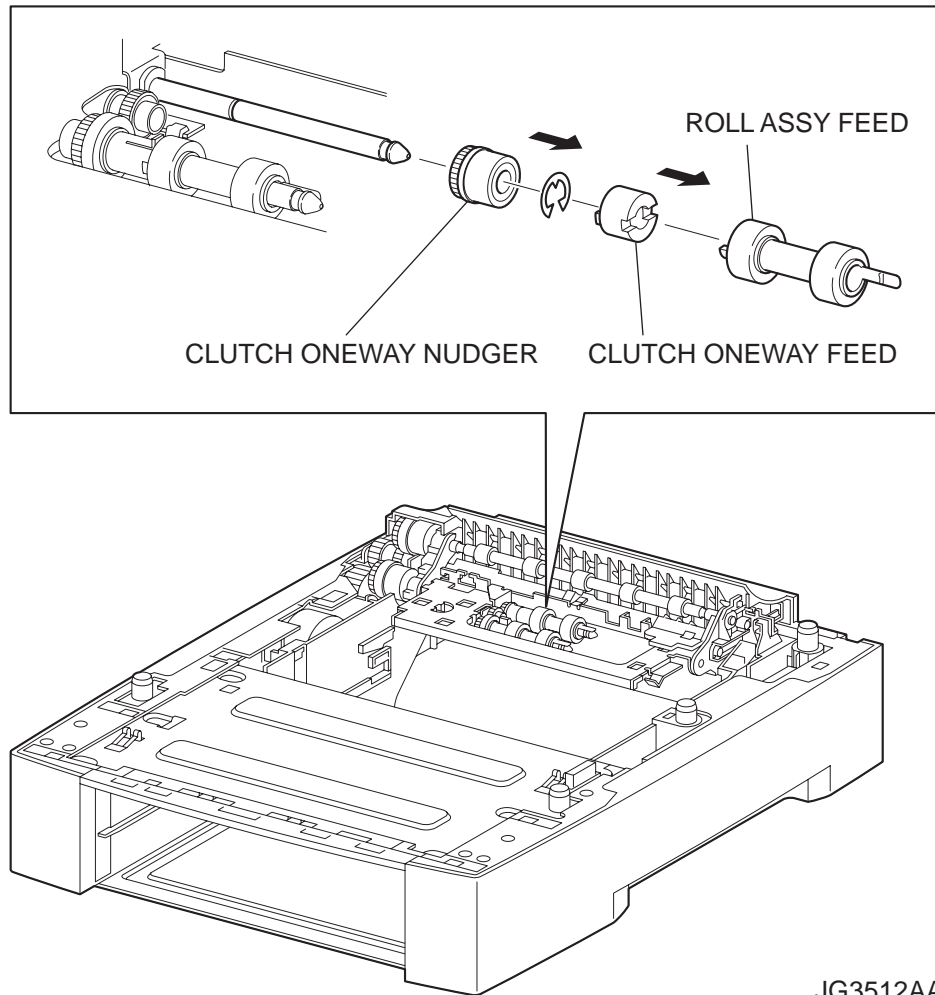

JG3512AA

Replacement

- 1) Install the CLUTCH ONEWAY NUDGER to the SHAFT FEED (PL 12.2.16).
- 2) Clip the E-ring to the SHAFT FEED to secure the CLUTCH ONEWAY NUDGER.
- 3) Install the CLUTCH ONEWAY FEED (PL 12.2.13) to the SHAFT FEED.
- 4) Install the ROLL ASSY FEED (PL 12.2.12). (RRP12.10)

NOTE

Be sure to install the hook of the ROLL ASSY FEED into the groove of the SHAFT FEED.

RRP12.12 GEAR NUDGER (PL12.2)

Removal

- 1) While lifting up the boss of the HOLDER LEFT (PL 12.2.5) at the back of the 550 FEEDER OPTION, shift the HOLDER LEFT in the direction of the arrow to remove the 3 hooks.
- 2) Remove the HOLDER LEFT from the SUPPORT NUDGER (PL 12.2.4). At the same time, the ACTUATOR NO PAPER (PL 12.2.6) is removed.
- 3) Release the hook of the ROLL ASSY NUDGER (PL 12.2.11), and pull it out from the SHAFT NUDGER (PL 12.2.9).
- 4) Release the hook of the GEAR NUDGER, and pull it out from the SHAFT NUDGER.

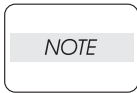

When removing, do not hold the rubber rollers of the ROLL ASSY NUDGER and GEAR NUDGER.

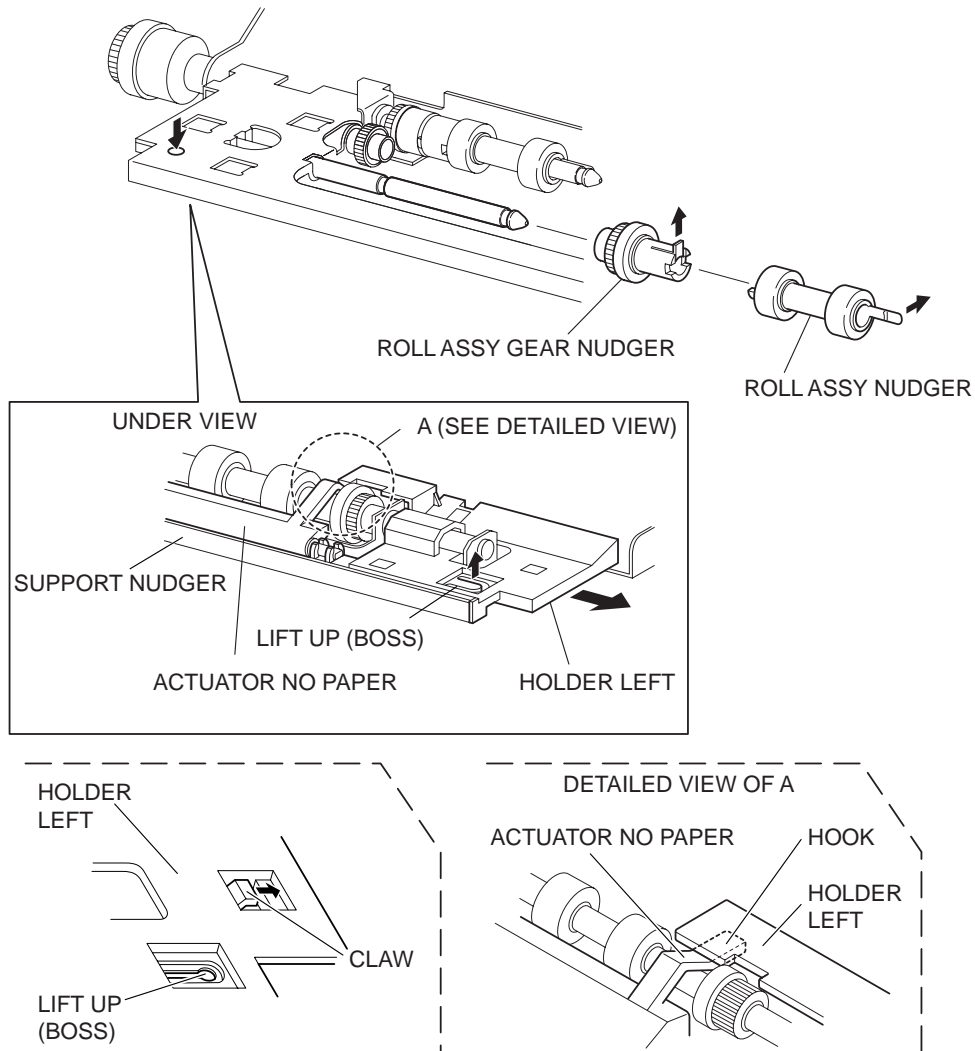

JG3513AA

Replacement

- 1) Install the GEAR NUDGER to the SHFT NUDGER (PL 12.2.9), and secure it with the hook.

NOTE

Be sure to install the hook of the GEAR NUDGER into the groove of the SHAFT NUDGER.

NOTE

When installing, do not hold the rubber rollers of the GEAR NUDGER.

- 2) Install the ROLL ASSY NUDGER (PL 12.2.11) to the SHFT NUDGER, and secure it with the hook.

NOTE

Be sure to install the hook of the ROLL ASSY NUDGER into the groove of the SHAFT NUDGER.

NOTE

When installing, do not hold the rubber rollers of the ROLL ASSY NUDGER.

- 3) Install the ACTUATOR NO PAPER (PL 12.2.6) and HOLDER LEFT (PL 12.2.5) to the SUPPORT NUDGER (PL 12.2.4).

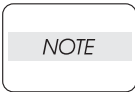

Be sure to install the shafts on both ends of the ACTUATOR NO PAPER into the HOLDER LEFT and SUPPORT NUDGER.

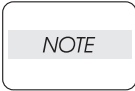

Assemble the hook of the ACTUATOR NO PAPER with the HOLDER LEFT as shown in the figure.

- 4) Move the HOLDER LEFT in the opposite direction of the arrow, and secure it to the 550 FEEDER OPTION with the 3 hooks.

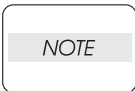

After installing, move the ACTUATOR NO PAPER with a finger, and make sure that the ACTUATOR NO PAPER operates smoothly.

RRP12.13 ROLL ASSY TURN (PL12.2)

Removal

- 1) Remove the 550 FEEDER OPTION (PL 12.2). (RRP12.1)
- 2) Remove the CLUTCH PR-REGI (PL 12.2.22). (RRP12.15)
- 3) Remove 2 E-rings on both ends of the ROLL ASSY TURN securing the BEARING FEEDER (PL 12.2.23).
- 4) Remove the BEARING FEEDERS from the CHUTE OUT (PL 12.2.25).
- 5) Shift the ROLL ASSY TURN in the direction of the arrow, and remove it from the CHUTE OUT (PL 12.2.18)

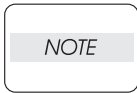

When removing, do not hold the rubber rollers of the ROLL ASSY TURN.

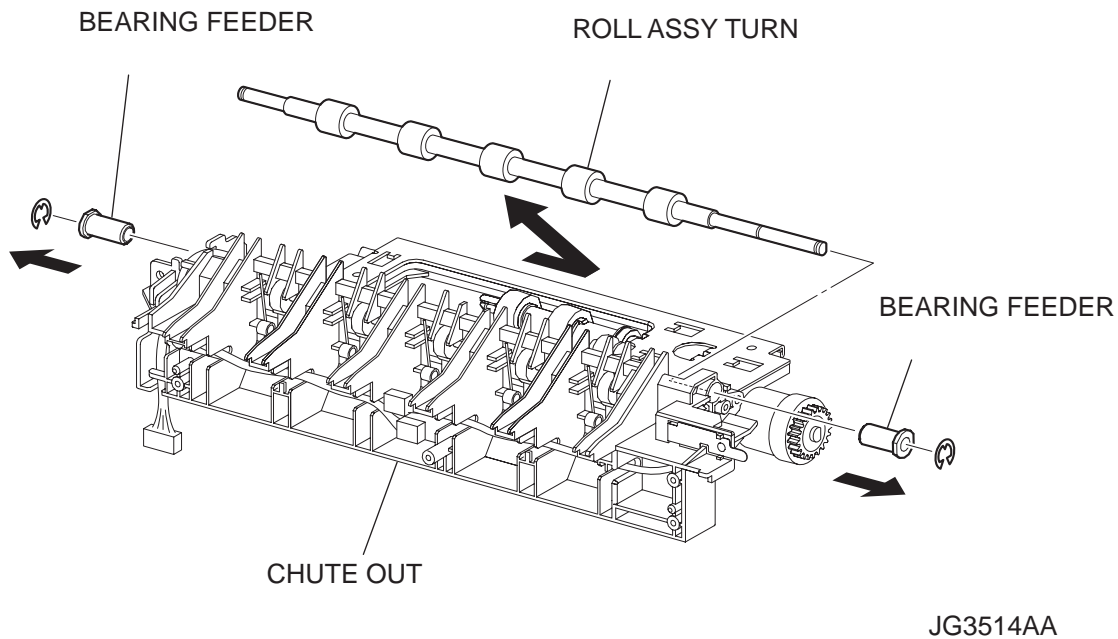

Replacement

- 1) Move the ROLL ASSY TURN in the opposite direction of the arrow, and install it to the CHUTE OUT (PL 12.2.25)

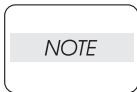

When installing, do not hold the rubber rollers of the ROLL ASSY TURN.

- 2) Install the BEARING FEEDERS (PL 12.2.23) to the CHUTE OUT.
- 3) Clip 2 E-rings on both ends of the ROLL ASSY TURN to secure the BEARING FEEDERS.
- 4) Install the CLUTCH PR-REGI (PL 12.2.22). (RRP12.15)

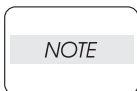

When installing, make sure that the notch of the CLUTCH PR-REGI is combined with the boss of the CHUTE OUT.

- 5) Install the 550 FEEDER OPTION (PL 12.2 .1). (RRP12.1)

RRP12.14 CLUTCH ASSY PH (PL12.2)

Removal

- 1) Remove the 550 FEEDER OPTION (PL 12.2). (RRP12.1)
- 2) Remove the 6 screws (gold taping, 8mm) securing the PLATE TIE (PL 12.2.29).
- 3) Remove the PLATE TIE from the CHUTE OUT (PL 12.2.25).
- 4) Disconnect the connector (P/J853) of the CLUTCH ASSY PH from the HARNESS ASSY CLSNR1 (PL 12.2.31).
- 5) Remove the E-ring securing the CLUTCH ASSY PH, and remove the CLUTCH ASSY PH from the SHAFT FEED (PL 12.2.16).

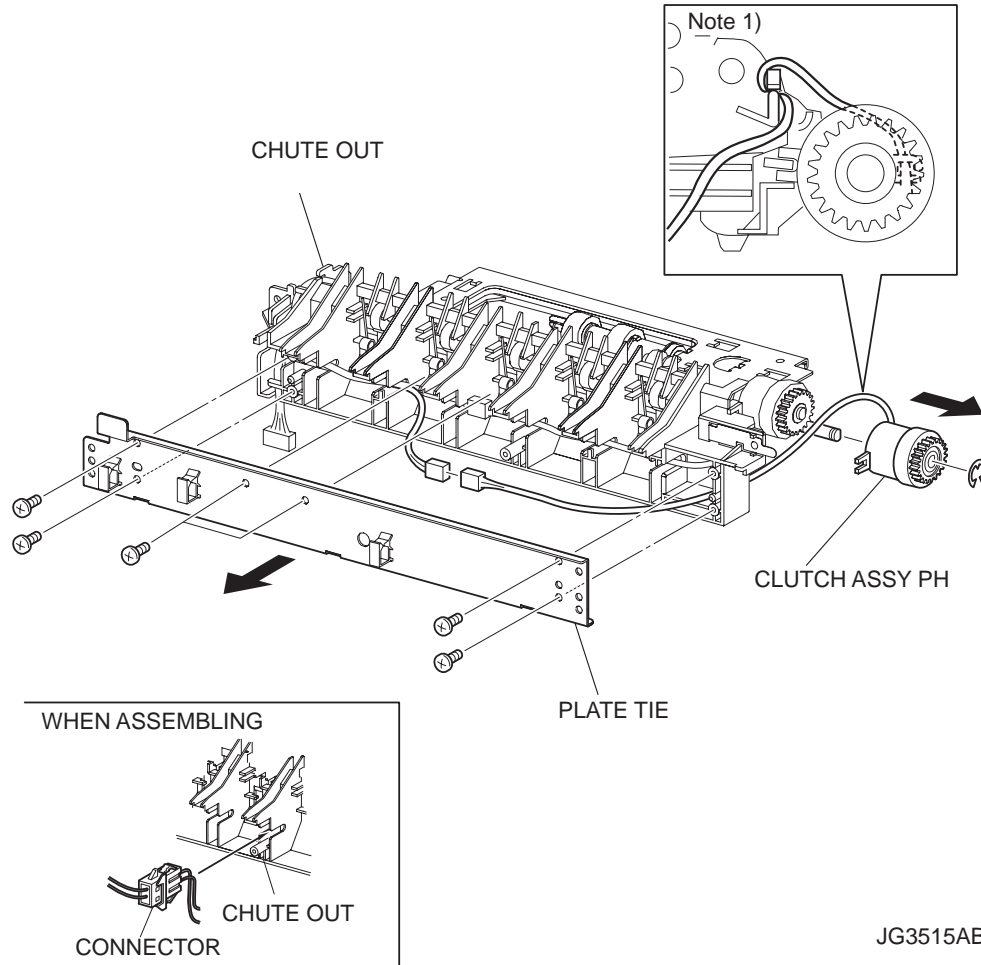

Replacement

- 1) Install the CLUTCH ASSY PH to the SHAFT FEED (PL 12.2.16), and secure it with the E-ring.

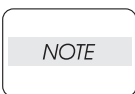

When installing, make sure that the notch of the CLUTCH PH is combined with the boss of the CHUTE OUT.

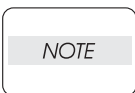

Be careful of the arranging of the harness of the CLUTCH ASSY PH.

Removal and Replacement Procedures (RRPs)

- 2) Connect the connector (P/J853) of the CLUTCH ASSY PH to the HARNESS ASSY CLSNR1 (PL 12.2.31). After connecting the connector, put the connector into the space between two ribs of the CHUTE OUT (PL 12.2.25).
- 3) Install the 550 FEEDER OPTION (PL 12.2). (RRP12.1)

RRP12.15 CLUTCH PR-REGI (PL12.2)**Removal**

- 1) Remove the 550 FEEDER OPTION (PL 12.2). (RRP12.1)
- 2) Remove the 6 screws (gold tapping, 8mm) securing the PLATE TIE (PL 12.2.29).
- 3) Remove the PLATE TIE from the CHUTE OUT (PL 12.2.25).
- 4) Disconnect the connector (P/J854) of the CLUTCH PR-REGI from the HARNESS ASSY CLSNR1 (PL 12.2.31).
- 5) Remove the E-ring securing the CLUTCH PR-REGI, and remove the CLUTCH PR-REGI from the ROLL ASSY TURN (PL 12.2.14).

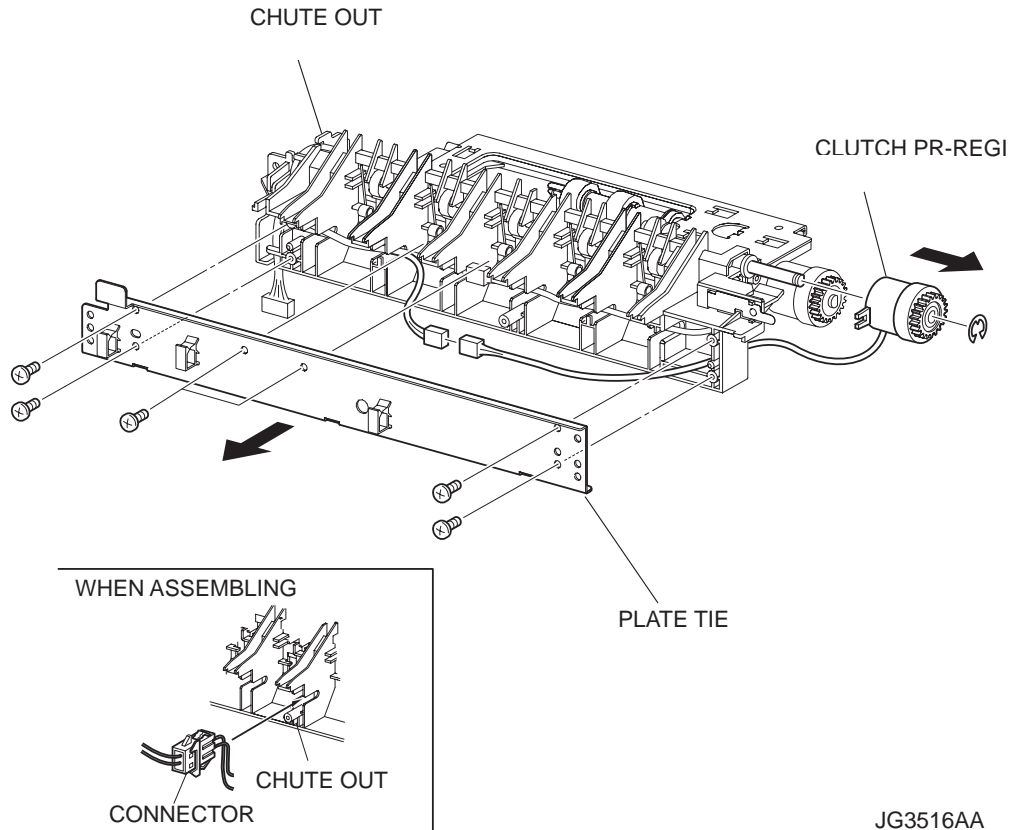
**Replacement**

- 1) Install the CLUTCH PR-REGI to the ROLL ASSY TURN (PL 12.2.14), and secure it with the E-ring.

NOTE

When installing, make sure that the notch of the CLUTCH PR-REGI is combined with the boss of the CHUTE OUT.

- 2) Connect the connector (P/J854) of the CLUTCH PR-REGI to the HARNESS ASSY CLSNR1 (PL 12.2.31). After connecting the connector, put the connector into the space between two ribs of the CHUTE OUT (PL 12.2.25).
- 3) Install the PLATE TIE (PL 12.2.29) to the CHUTE OUT using the 6 screws (gold tapping, 8mm).
- 4) Install the 550 FEEDER OPTION (PL 12.2). (RRP12.1)

RRP12.16 SENSOR NO PAPER (PL12.2)**Removal**

- 1) Remove the screw securing the HOLDER NO PAPER SENSOR (PL 12.2.32).
- 2) Remove the HOLDER NO PAPER SENSOR from the Option 550 Paper Feeder.
- 3) Release the 2 hooks of the SENSOR NO PAPER, and remove the SENSOR NO PAPER from the HOLDER NO PAPER SENSOR.
- 4) Disconnect the connector of the HARNESS ASSY CLSNR1 (PL 12.2.31) from the connector (P/ J852) of the SENSOR NO PAPER.

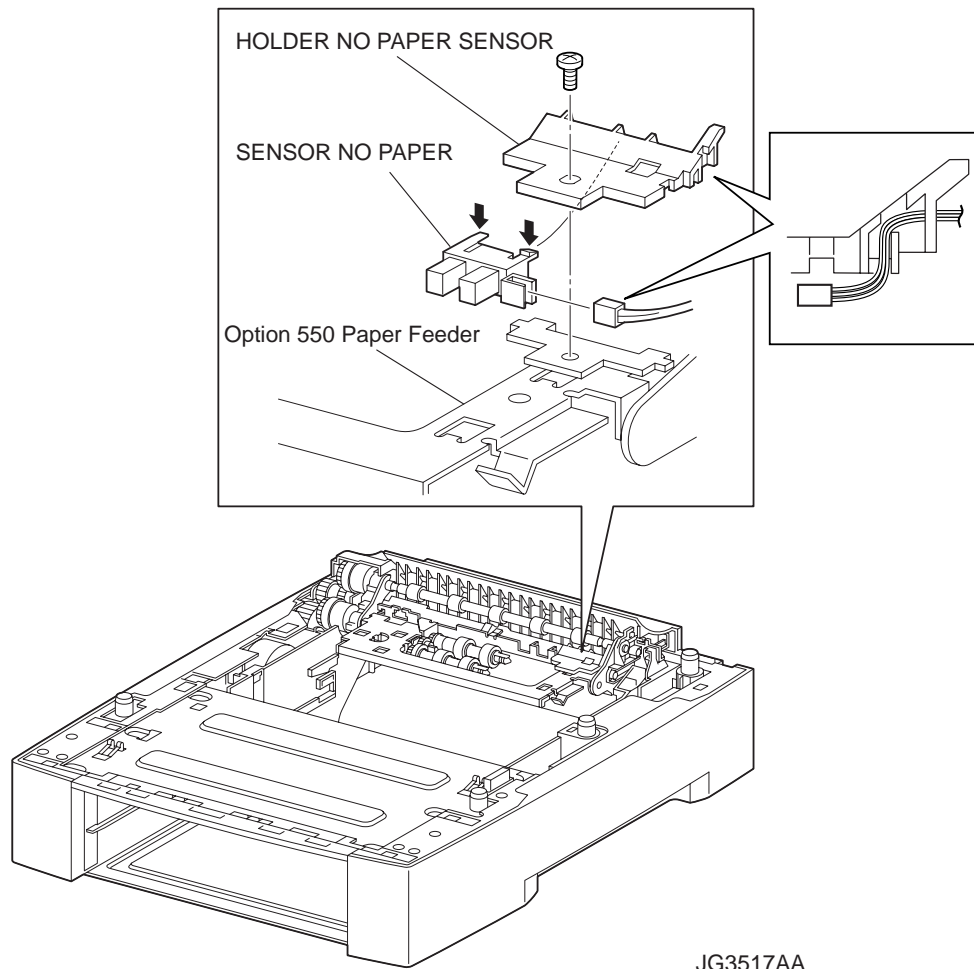
**Replacement**

- 1) Connect the connector (P/J852) of the SENSOR NO PAPER to the connector of the HARNESS ASSY CLSNR1 (PL 12.2.31).
- 2) Install the SENSOR NO PAPER to the HOLDER NO PAPER SENSOR (PL 12.2.32).
- 3) Install the HOLDER NO PAPER SENSOR to the Option 550 Paper Feeder using the screw.

NOTE

After installation, make sure that the HARNESS ASSY CLSNR1 have not pinched between the HOLDER NO PAPER SENSOR and frame.

RRP12.17 ROLL ASSY RETARD (PL12.2)

Removal

- 1) Pull out the 550 PAPER CASSETTE (PL 12.3) from the Option 550 Paper Feeder.
- 2) Release the hooks securing the HOLDER RETARD (PL 12.3.5) to the 550 PAPER CASSETTE using a screwdriver or the like.
- 3) Lift the HOLDER RETARD up in the direction of the arrow, and remove it.
- 4) Release the hook securing the ROLL ASSY RETARD, and pull it out from the SHAFT RETARD (PL 12.3.4).

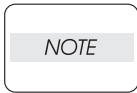

When removing, do not hold the rubber rollers of the ROLL ASSY RETARD.

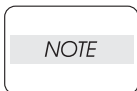

When removing HOLDER RETARD, be careful not to lose SPRING RETARD.

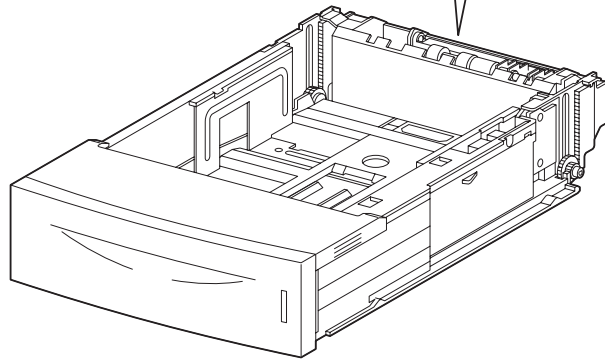
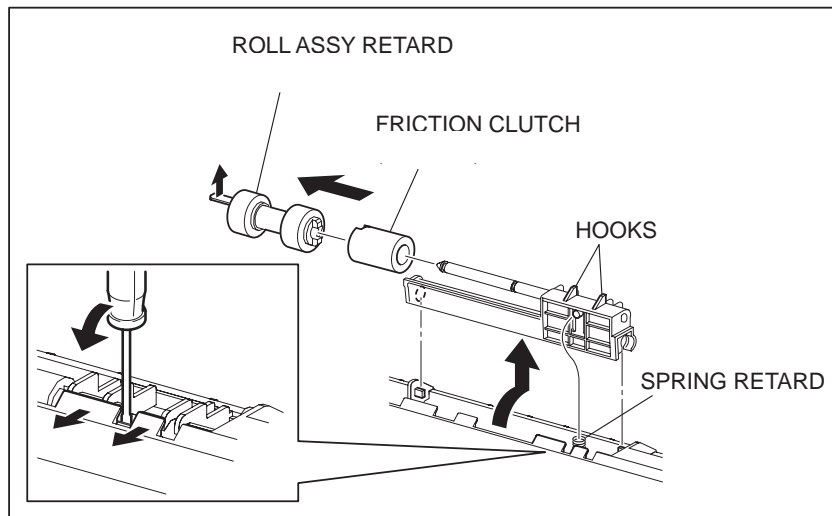

JG3518AA

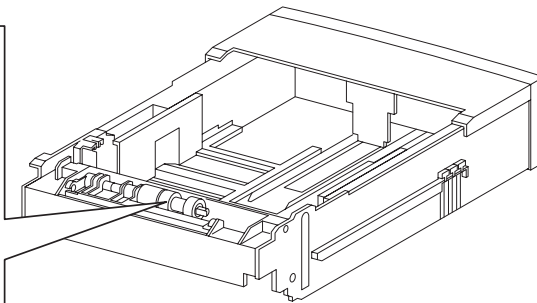
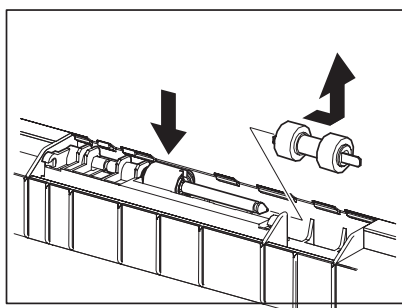

JG3209AA

Replacement

- 1) Install the ROLL ASSY RETARD to the SHFT RETARD (PL 12.3.4), and secure the ROLL ASSY RETARD with the hook.

NOTE

When installing, do not hold the rubber rollers of the ROLL ASSY RETARD.

NOTE

Be sure to install the hook of the ROLL ASSY RETARD into the groove of the SHAFT RETARD.

- 2) Move the HOLDER RETARD (PL 12.3.5) in the opposite direction of the arrow, and install it to the 550 PAPER CASSETTE (PL 12.3).

Removal and Replacement Procedures (RRPs)

NOTE

After installing, make sure the HOLDER RETARD comes back to the former position with the spring force of the SPRING RETARD (PL 12.3.6), when pushing down the HOLDER RETARD and then release the finger from it.

- 3) Install the 550 PAPER CASSETTE to the Option 550 Paper Feeder.

RRP12.18 RACK SIZE (PL12.3)

Removal

- 1) Remove the COVER CST (PL 12.3.1) from the 550 PAPER CASSETTE (PL 12.3.50).
- 2) Release the lock of the LOCK EXTENSION, and draw out the cassette extension as far as it will go.
- 3) Release the hooks securing the GEAR PINION (PL 12.3.12) to the HOUSING TOP 550 (PL 12.3.16), and remove the GEAR PINION.
- 4) While pressing down the lock of the STOPPER GEAR (PL 12.3.29), release the lock of the LEVER BTM LOCK (PL 12.3.27) to lift up the PLATE ASSY BTM. (Figure 20.21)
- 5) Slide the GUIDE ASSY SD L550 (PL 12.3.11) inward, and remove it from the HOUSING TOP 550 by pressing down the hook of the HOUSING TOP 550.
- 6) Slide the GUIDE ASSY SD R550 (PL 12.3.13) inward, and remove it from the HOUSING TOP 550 by pressing down the hook of the HOUSING TOP 550.
- 7) Remove the 2 screws (gold tapping, 8mm) from both right and left sides, as well as the 6 screws (gold tapping, 8mm) on back, that secure the HOUSING TOP 550 to the HOUSING BASE 550 (PL 12.3.44).
- 8) Release the 4 hooks of the HOUSING TOP 550, and remove the HOUSING TOP 550 together with the HOUSING EXTENSION 550 (PL 12.3.42) from the HOUSING BASE 550.
- 9) Remove the 4 screws (gold tapping, 6mm) securing the COVER EXTENSION (PL 12.3.31) to the HOUSING EXTENSION 550.
- 10) Remove the COVER EXTENSION from the HOUSING EXTENSION 550.
- 11) Lift the front end of the RACK SIZE a little, and turn it in the direction of the arrow to remove it from the HOUSING EXTENSION 550.

Removal and Replacement Procedures (RRPs)

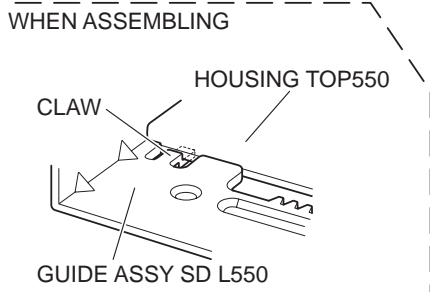
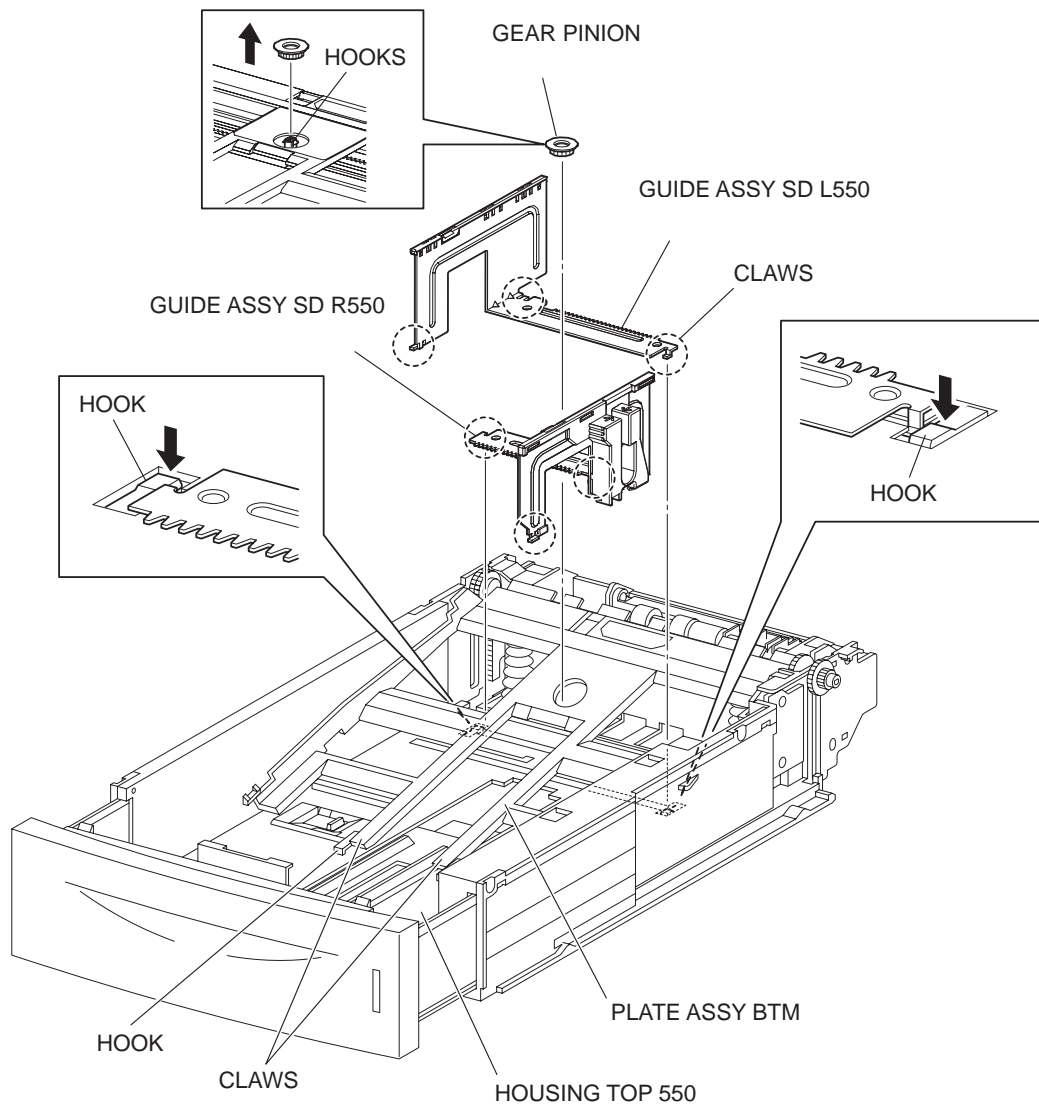

JG3521AA

Removal and Replacement Procedures (RRPs)

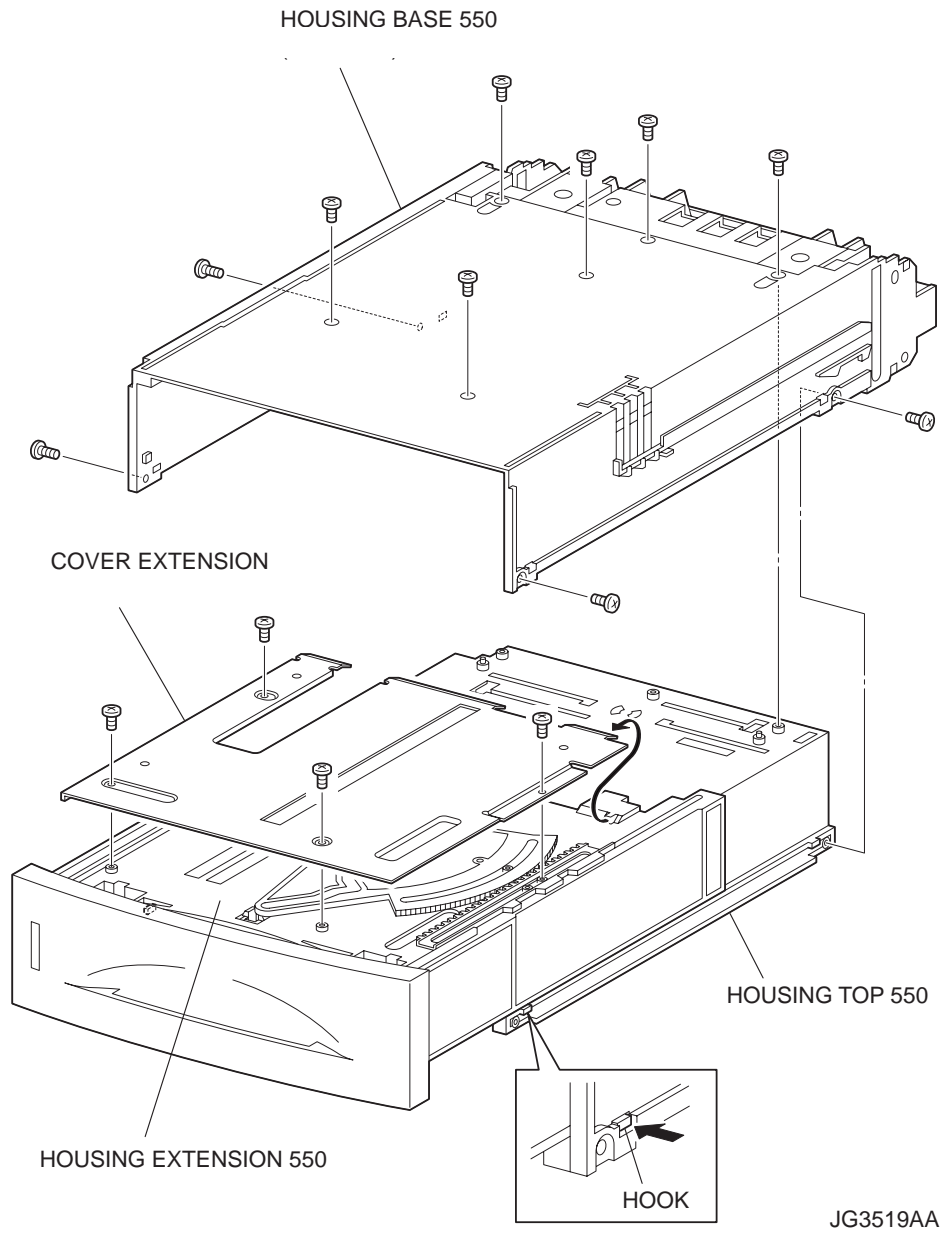

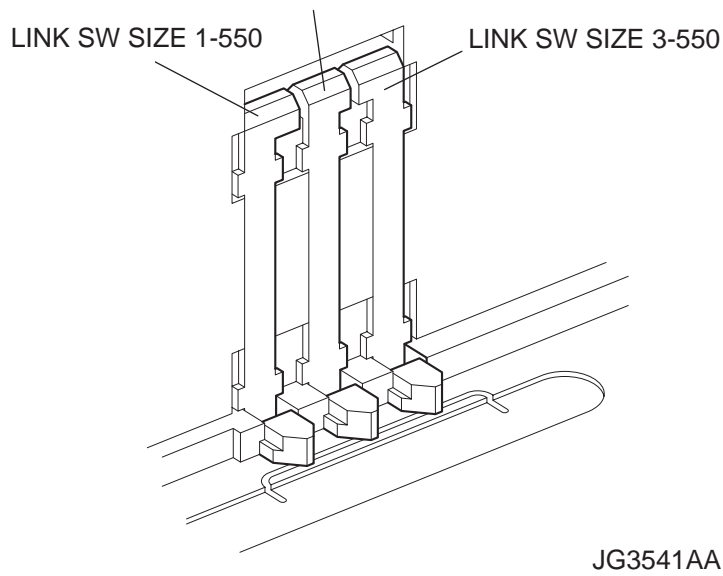
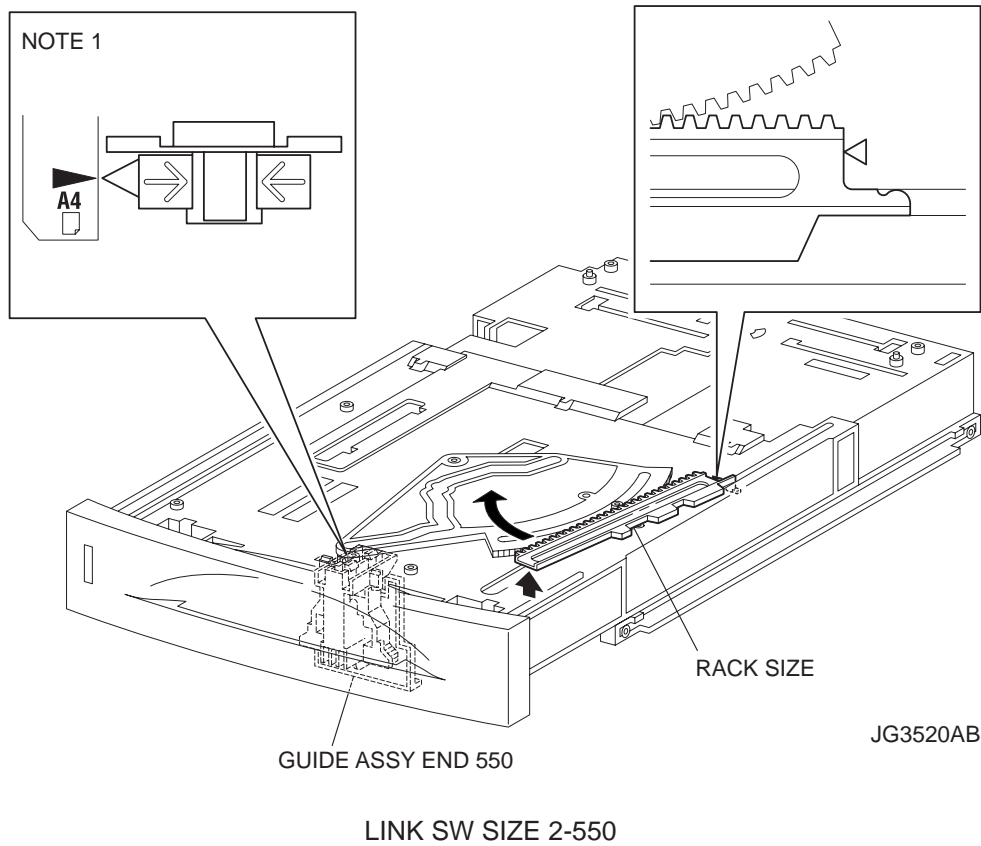

Replacement

- 1) Put the hook on the tip of the RACK SIZE into the groove of the HOUSING EXTENSION 550 (PL 12.3.42), and turn it in the opposite direction of the arrow.
- 2) Align the end of the RACK SIZE with the triangle mark printed on the HOUSING EXTENSION 550 as shown in the figure, and install the RACK SIZE to the HOUSING EXTENSION 550.

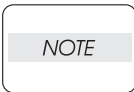

When installing the RACK SIZE, be sure to draw out the GUIDE ASSY END 550 (PL 12.3.43) as far as it will go.(NOTE 1).

- 3) Install the COVER EXTENSION (PL 12.3.31) to the HOUSING EXTENSION 550 using the 4 screws (gold tapping, 6mm).

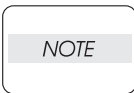

When installing, make sure the COVER EXTENSION is inserted under 3 claws of the HOUSING EXTENSION 550.(NOTE2).

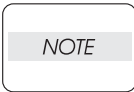

Use 6mm size of fixed screw. If 8mm size of screw is used, HOUSING EXTENSION 550 doesn't operate smoothly and LOCK EXTENSION 550 doesn't operate correctly.

- 4) Install the HOUSING EXTENSION 550 and HOUSING TOP 550 (PL 12.3.16) to the HOUSING BASE 550 while pushing the LINK SW SIZE1-550 (PL 12.3.45), LINK SW SIZE2-550 (PL 12.3.46) and LINK SW SIZE3-550 (PL 12.3.47) of the HOUSING BASE 550 outward as shown in the figure.

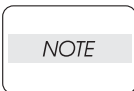

Be sure to put 2 claws at the tip of the PLATE ASSY BTM under the hooks on the HOUSING TOP 550.(NOTE3).

- 5) After assembling the HOUSING TOP 550 with HOUSING BASE 550 using the 4 hooks, secure them using the 2 screws (gold tapping, 8mm) from both right and left sides, as well as the 6 screws (gold tapping, 8mm) on back.

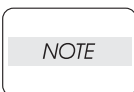

After tightening the screws, move the GUIDE ASSY END 550 back and forth, and make sure that the LINK SW SIZES operate smoothly.

- 6) Insert the link lever of the GUIDE INDICATOR1 (PL 12.3.34) into the hole of the PLATE ASSY BTM. (Figure 20.21)
- 7) While pressing down the hook of the HOUSING TOP 550, install the GUIDE ASSY SD R550 (PL 12.3.13) to the HOUSING TOP 550.(NOTE4).

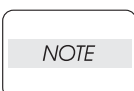

After installing, make sure that the 3 claws of the GUIDE ASSY SD R550 sit correctly in the grooves of the HOUSING TOP 550.

- 8) While pressing down the hook of the HOUSING TOP 550, install the GUIDE ASSY SD L550 (PL 12.3.11) to the HOUSING TOP 550.

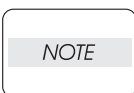

After installing, make sure that the 3 claws of the GUIDE ASSY SD L550 sit correctly in the grooves of the HOUSING TOP 550.(NOTE4).

- 9) Push the PLATE ASSY BTM downward to lock.
- 10) With completely opened GUIDE ASSY SD L550 and GUIDE ASSY SD R550 to the both sides, Install the GEAR PINION (PL 12.3.12) to the HOUSING TOP 550.

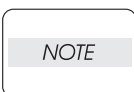

When installing the GEAR PINION, make sure the GUIDE ASSY SD R550 and GUIDE ASSY SD L550 are completely opened. If not, the side register may be misaligned.

- 11) Install the COVER CST (PL 12.3.1) to the 550 PAPER CASSETTE.

Removal and Replacement Procedures (RRPs)

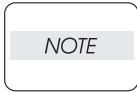

After assembling, make sure that the LOW IND FRONT moves up-and-down in conjunction with the up-and-down movement of the PLATE ASSY BTM.

RRP12.19 GEAR SECTOR (PL12.3)

Removal

- 1) Remove the COVER CST (PL 12.3.1) from the 550 PAPER CASSETTE (PL 12.3.50).
- 2) Release the lock of the LOCK EXTENSION, and draw out the cassette extension as far as it will go.
- 3) Release the hooks securing the GEAR PINION (PL 12.3.12) to the HOUSING TOP 550 (PL 12.3.16), and remove the GEAR PINION.
- 4) While pressing down the lock of the STOPPER GEAR (PL 12.3.29), release the lock of the LEVER BTM LOCK (PL 12.3.27) to lift up the PLATE ASSY BTM. (Figure 20.21)
- 5) Slide the GUIDE ASSY SD L550 (PL 12.3.11) inward, and remove it from the HOUSING TOP 550 by pressing down the hook of the HOUSING TOP 550.
- 6) Slide the GUIDE ASSY SD R550 (PL 12.3.13) inward, and remove it from the HOUSING TOP 550 by pressing down the hook of the HOUSING TOP 550.
- 7) Remove the 2 screws (gold tapping, 8mm) from both right and left sides, as well as the 6 screws (gold tapping, 8mm) on back, that secure the HOUSING TOP 550 to the HOUSING BASE 550 (PL 12.3.44).
- 8) Release the 4 hooks of the HOUSING TOP 550, and remove the HOUSING TOP 550 together with the HOUSING EXTENSION 550 (PL 12.3.42) from the HOUSING BASE 550.
- 9) Remove the 4 screws (gold tapping, 6mm) securing the COVER EXTENSION (PL 12.3.31) to the HOUSING EXTENSION 550.
- 10) Remove the COVER EXTENSION from the HOUSING EXTENSION 550.
- 11) Remove the RACK SIZE (PL 12.3.40). (RRP12.18)
- 12) Remove the screw (black with flange, 8mm) securing the GEAR SECTOR.
- 13) Remove the GEAR SECTOR from the HOUSING EXTENSION 550.

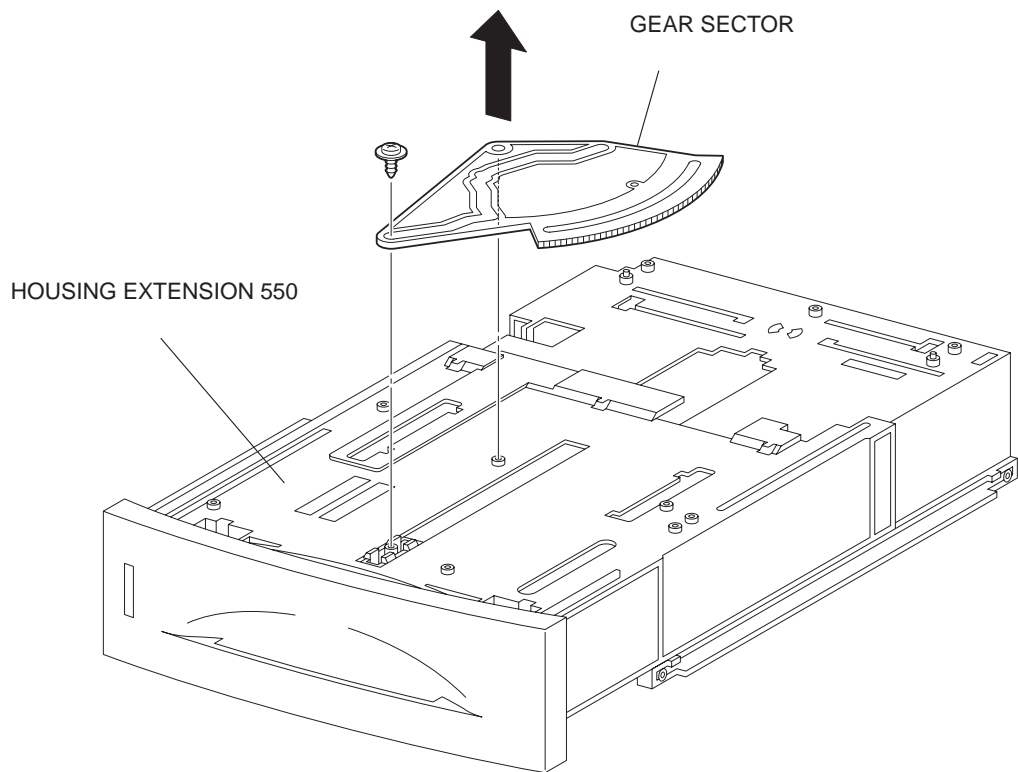

JG3522AA

Replacement

- 1) Install the GEAR SECTOR to the HOUSING EXTENSION 550 (PL 12.3.42).
- 2) Secure the GEAR SECTOR using the screw (black with flange, 8mm).
- 3) Install the RACK SIZE (PL 12.3.40). (RRP12.18)
- 4) Install the COVER EXTENSION (PL 12.3.31) to the HOUSING EXTENSION 550 using the 4 screws (gold tapping, 6mm).

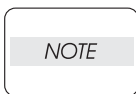

When installing, make sure the COVER EXTENSION is inserted under 3 claws of the HOUSING EXTENSION 550.

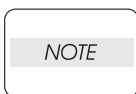

Use 6mm size of fixed screw. If 8mm size of screw is used, HOUSING EXTENSION 550 doesn't operate smoothly and LOCK EXTENSION 550 doesn't operate correctly.

- 5) Install the HOUSING EXTENSION 550 and HOUSING TOP 550 (PL 12.3.16) to the HOUSING BASE 550 while pushing the LINK SW SIZE1-550 (PL 12.3.45), LINK SW SIZE2-550 (PL 12.3.46) and LINK SW SIZE3-550 (PL 12.3.47) of the HOUSING BASE 550 outward as shown in the figure. (Figure 20.18)

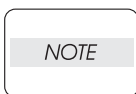

Be sure to put 2 claws at the tip of the PLATE ASSY BTM under the hooks on the HOUSING TOP 550.

- 6) After assembling the HOUSING TOP 550 with HOUSING BASE 550 using the 4 hooks, secure them using the 2 screws (gold tapping, 8mm) from both right and left sides, as well as the 6 screws (gold tapping, 8mm) on back.

Removal and Replacement Procedures (RRPs)

NOTE

After tightening the screws, move the GUIDE ASSY END 550 back and forth, and make sure that the LINK SW SIZES operate smoothly.

- 7) Insert the link lever of the GUIDE INDICATOR1 (PL 12.3.34) into the hole of the PLATE ASSY BTM. (Figure20.24)
- 8) While pressing down the hook of the HOUSING TOP 550, install the GUIDE ASSY SD R550 (PL 12.3.13) to the HOUSING TOP 550.

NOTE

After installing, make sure that the 3 claws of the GUIDE ASSY SD R550 sit correctly in the grooves of the HOUSING TOP 550.

- 9) While pressing down the hook of the HOUSING TOP 550, install the GUIDE ASSY SD L550 (PL 12.3.11) to the HOUSING TOP 550.

NOTE

After installing, make sure that the 3 claws of the GUIDE ASSY SD L550 sit correctly in the grooves of the HOUSING TOP 550.

- 10) Push the PLATE ASSY BTM downward to lock.
- 11) With completely opened GUIDE ASSY SD L550 and GUIDE ASSY SD R550 to the both sides, install the GEAR PINION (PL 12.3.12) to the HOUSING TOP 550.

NOTE

When installing the GEAR PINION, make sure the GUIDE ASSY SD R550 and GUIDE ASSY SD L550 are completely opened. If not, the side register may be misaligned.

- 12) Install the COVER CST (PL 12.3.1) to the 550 PAPER CASSETTE.

NOTE

After assembling, make sure that the LOW IND FRONT moves up-and-down in conjunction with the up-and-down movement of the PLATE ASSY BTM.

RRP12.20 GUIDE ASSY END 550 (PL12.3)**Removal**

- 1) Remove the COVER CST (PL 12.3.1) from the 550 PAPER CASSETTE (PL 12.3.50).
- 2) Release the lock of the LOCK EXTENSION, and draw out the cassette extension as far as it will go.
- 3) Release the hooks securing the GEAR PINION (PL 12.3.12) to the HOUSING TOP 550 (PL 12.3.16), and remove the GEAR PINION.
- 4) While pressing down the lock of the STOPPER GEAR (PL 12.3.29), release the lock of the LEVER BTM LOCK (PL 12.3.27) to lift up the PLATE ASSY BTM.
- 5) Slide the GUIDE ASSY SD L550 (PL 12.3.11) inward, and remove it from the HOUSING TOP 550 by pressing down the hook of the HOUSING TOP 550.
- 6) Slide the GUIDE ASSY SD R550 (PL 12.3.13) inward, and remove it from the HOUSING TOP 550 by pressing down the hook of the HOUSING TOP 550.
- 7) Remove the 2 screws (gold tapping, 8mm) from both right and left sides, as well as the 6 screws (gold tapping, 8mm) on back, that secure the HOUSING TOP 550 to the HOUSING BASE 550 (PL 12.3.44).
- 8) Release the 4 hooks of the HOUSING TOP 550, and remove the HOUSING TOP 550 together with the HOUSING EXTENSION 550 (PL 12.3.42) from the HOUSING BASE 550.
- 9) Remove the 4 screws (gold tapping, 6mm) securing the COVER EXTENSION (PL 12.3.31) to the HOUSING EXTENSION 550.
- 10) Remove the COVER EXTENSION from the HOUSING EXTENSION 550.
- 11) Remove the RACK SIZE (PL 12.3.40). (RRP12.18)
- 12) Remove the GEAR SECTOR (PL 12.3.39) (RRP12.19)
- 13) Release the hooks securing the GUIDE ASSY END 550 to the HOUSING EXTENSION 550 (PL 12.3.42).

NOTE

Be careful handling the hooks of the GUIDE ASSY END 550. They are fragile and could break if given excessive force.

- 14) Remove the GUIDE ASSY END 550 from the HOUSING EXTENSION 550.

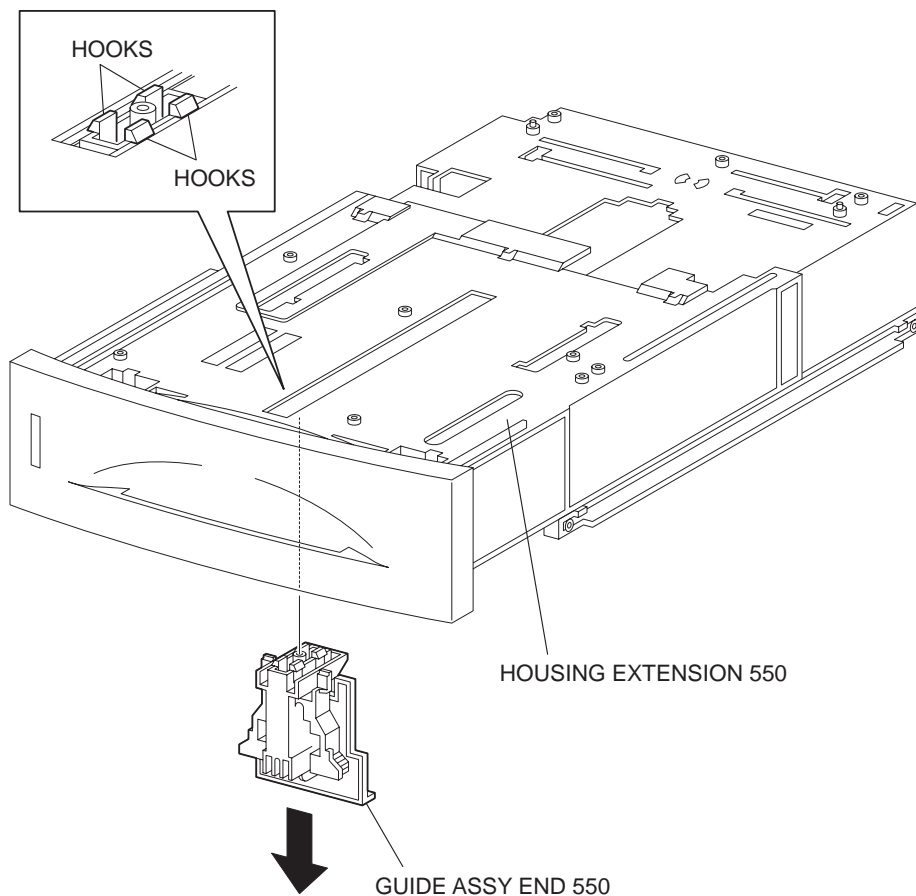

JG3523AA

Replacement

- 1) Secure the GUIDE ASSY END 550 to the HOUSING EXTENSION 550 (PL 12.3.42) using the 4 hooks.
- 2) Install the GEAR SECTOR (PL 12.3.39). (RRP12.19)
- 3) Install the RACK SIZE (PL 12.3.40). (RRP12.18)
- 4) Install the COVER EXTENSION (PL 12.3.31) to the HOUSING EXTENSION 550 using the 4 screws (gold tapping, 6mm).

NOTE When installing, make sure the COVER EXTENSION is inserted under 3 claws of the HOUSING EXTENSION 550.

NOTE Use 6mm size of fixed screw. If 8mm size of screw is used, HOUSING EXTENSION 550 doesn't operate smoothly and LOCK EXTENSION 550 doesn't operate correctly.

- 5) Install the HOUSING EXTENSION 550 and HOUSING TOP 550 (PL 12.3.16) to the HOUSING BASE 550 while pushing the LINK SW SIZE1-550 (PL 12.3.45), LINK SW SIZE2-550 (PL 12.3.46) and LINK SW SIZE3-550 (PL 12.3.47) of the HOUSING BASE 550 outward as shown in the figure. (Figure 20.18)

NOTE Be sure to put 2 claws at the tip of the PLATE ASSY BTM under the hooks on the HOUSING TOP 550.

Removal and Replacement Procedures (RRPs)

- 6) After assembling the HOUSING TOP 550 with HOUSING BASE 550 using the 4 hooks, secure them using the 2 screws (gold tapping, 8mm) from both right and left sides, as well as the 6 screws (gold tapping, 8mm) on back.

NOTE

After tightening the screws, move the GUIDE ASSY END 550 back and forth, and make sure that the LINK SW SIZES operate smoothly.

- 7) Insert the link lever of the GUIDE INDICATOR1 into the hole of the PLATE ASSY BTM.
- 8) While pressing down the hook of the HOUSING TOP 550, install the GUIDE ASSY SD R550 (PL 12.3.13) to the HOUSING TOP 550.

NOTE

After installing, make sure that the 3 claws of the GUIDE ASSY SD R550 sit correctly in the grooves of the HOUSING TOP 550.

- 9) While pressing down the hook of the HOUSING TOP 550, install the GUIDE ASSY SD L550 (PL 12.3.11) to the HOUSING TOP 550.

NOTE

After installing, make sure that the 3 claws of the GUIDE ASSY SD L550 sit correctly in the grooves of the HOUSING TOP 550.

- 10) Push the PLATE ASSY BTM downward to lock.
- 11) With completely opened GUIDE ASSY SD L550 and GUIDE ASSY SD R550 to the both sides, install the GEAR PINION (PL 12.3.12) to the HOUSING TOP 550.

NOTE

When installing the GEAR PINION, make sure the GUIDE ASSY SD R550 and GUIDE ASSY SD L550 are completely opened. If not, the side register may be misaligned.

- 12) Install the COVER CST (PL 12.3.1) to the 550 PAPER CASSETTE.

NOTE

After assembling, make sure that the LOW IND FRONT moves up-and-down in conjunction with the up-and-down movement of the PLATE ASSY BTM.

RRP12.21 PLATE ASSY BTM (PL12.3)**Removal**

- 1) Remove the COVER CST (PL 12.3.1) from the 550 PAPER CASSETTE (PL 12.3.50).
- 2) Release the lock of the LOCK EXTENSION, and draw out the cassette extension as far as it will go.
- 3) Release the hooks securing the GEAR PINION (PL 12.3.12) to the HOUSING TOP 550 (PL 12.3.16), and remove the GEAR PINION.
- 4) While pressing down the lock of the STOPPER GEAR (PL 12.3.29), release the lock of the LEVER BTM LOCK (PL 12.3.27) to lift up the PLATE ASSY BTM.
- 5) Slide the GUIDE ASSY SD L550 (PL 12.3.11) inward, and remove it from the HOUSING TOP 550 by pressing down the hook of the HOUSING TOP 550.
- 6) Slide the GUIDE ASSY SD R550 (PL 12.3.13) inward, and remove it from the HOUSING TOP 550 by pressing down the hook of the HOUSING TOP 550.

NOTE

In the following steps, the GEAR PB L (PL 12.3.7), GEAR BTM DMP ONEWAY (PL 12.3.8) and GEAR BTM LOCK ONEWAY (PL 12.3.15) will be detached, and be careful not to lose these gears.

- 7) Release the hook of the GEAR PB R (PL 12.3.20), and remove the GEAR PB R from the SHAFT PB (PL 12.3.9).

NOTE

It is hard to remove GEAR PB R. When removing it, be careful not to break it.

- 8) Disengage the GEAR PB L from the PLATE GEAR LOCK 550 while bending the HOUSING BASE 550 in the direction of the arrow, and remove the PLATE ASSY BTM together with the SHAFT PB, GEAR PB L, GEAR BTM DMP ONEWAY and GEAR BTM LOCK ONEWAY from the HOUSING TOP 550.
- 9) Pull out the SHAFT PB from the PLATE ASSY BTM, and remove the GEAR PB L, GEAR BTM DMP ONEWAY and GEAR BTM LOCK ONEWAY.

Removal and Replacement Procedures (RRPs)

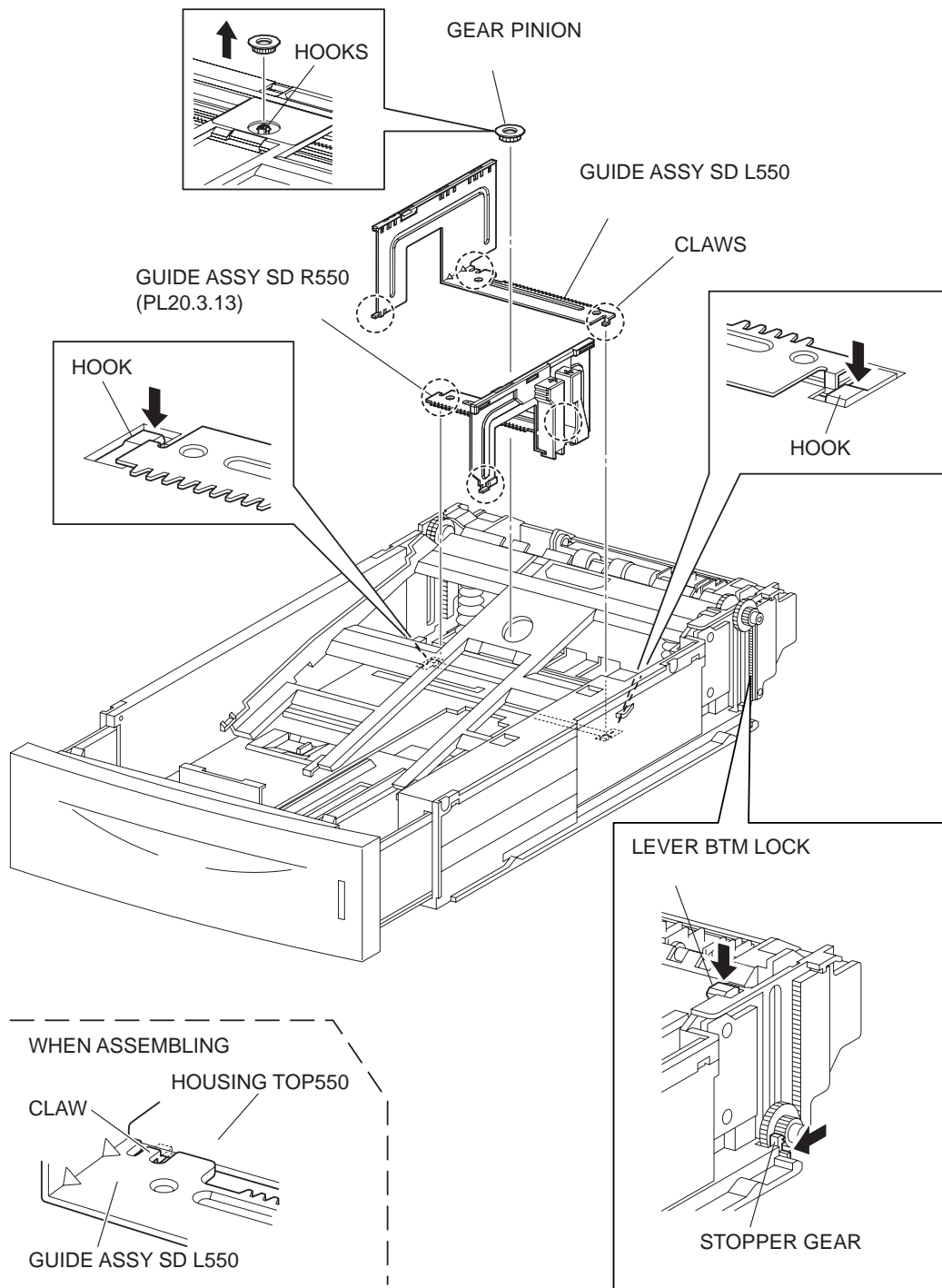

JG3524AA

Removal and Replacement Procedures (RRPs)

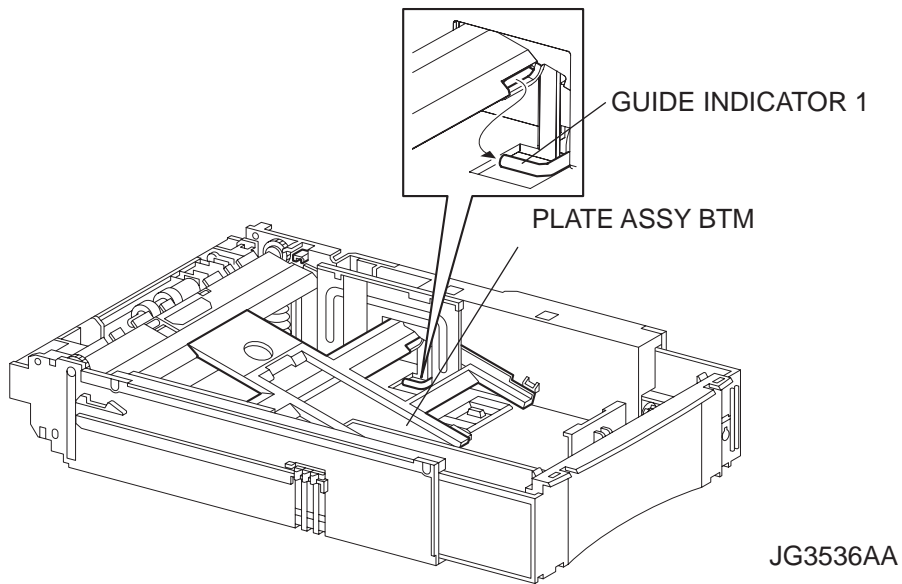
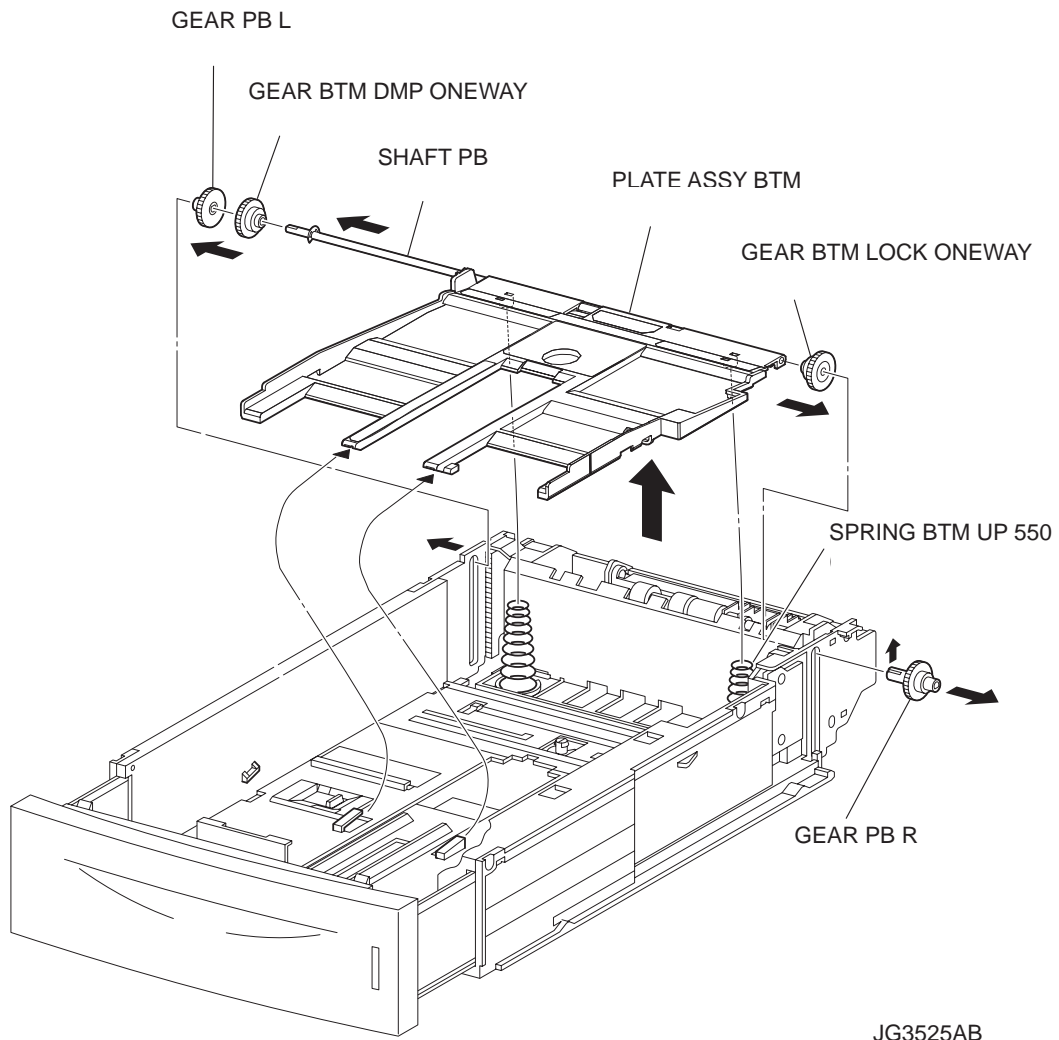

Replacement

- 1) Insert the SHAFT PB (PL 12.3.9) into the PLATE ASSY BTM, and insert the GEAR BTM DMP ONEWAY, GEAR PB L and GEAR BTM LOCK ONEWAY to the SHAFT PB.
- 2) While disengaging the GEAR PB L, install the assembled PLATE ASSY BTM to the HOUSING TOP 550 (PL 12.3.16).

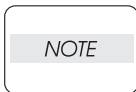

When installing the PLATE ASSY BTM, be sure to put 2 SPRING BTM UP 550s (PL 12.3.18) into the bosses on the back of the PLATE ASSY BTM.(NOTE1).

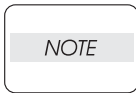

Be sure to put 2 claws at the tip of the PLATE ASSY BTM under the hooks on the HOUSING TOP 550.(NOTE2).

- 3) Insert the link lever of the GUIDE INDICATOR1 (PL 12.3.34) into the hole of the PLATE ASSY BTM.
- 4) Install the GEAR PB R (PL 12.3.20) to the SHAFT PB, and secure it with the hook.

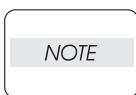

Be sure to install the hook of the GEAR PB R into the groove of the SHAFT PB. (NOTE3).

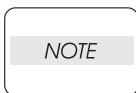

When installing the PLATE GEAR LOCK 550, be sure to lift up the PLATE ASSY BTM. If the PLATE ASSY BTM is inclined, a paper skew or jam may occur. Check after the installation is completed.

- 5) While pressing down the hook of the HOUSING TOP 550, install the GUIDE ASSY SD R550 (PL 12.3.13) to the HOUSING TOP 550.

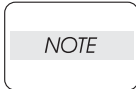

After installing, make sure that the 3 claws of the GUIDE ASSY SD R550 sit correctly in the grooves of the HOUSING TOP 550.

- 6) While pressing down the hook of the HOUSING TOP 550, install the GUIDE ASSY SD L550 (PL 12.3.11) to the HOUSING TOP 550.

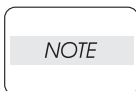

After installing, make sure that the 3 claws of the GUIDE ASSY SD L550 sit correctly in the grooves of the HOUSING TOP 550.

- 7) Push the PLATE ASSY BTM downward to lock.
- 8) Install the GEAR PINION (PL 12.3.12) to the HOUSING TOP 550.

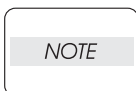

When installing the GEAR PINION, make sure the GUIDE ASSY SD R550 and GUIDE ASSY SD L550 are completely opened. If not, the side register may be misaligned.

- 9) Install the COVER CST (PL 12.3.1) to the 550 PAPER CASSETTE.

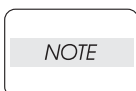

After assembling, make sure that the LOW IND FRONT moves up-and-down in conjunction with the up-and-down movement of the PLATE ASSY BTM.

RRP12.22 GEAR LEVER LOCK (PL12.3), LEVER BTM LOCK (PL12.3)**Removal**

- 1) Remove the COVER CST (PL 12.3.1) from the 550 PAPER CASSETTE (PL 12.3.50).
- 2) Release the lock of the LOCK EXTENSION, and draw out the cassette extension as far as it will go.
- 3) While pressing down the lock of the STOPPER GEAR (PL 12.3.29), release the lock of LEVER BTM LOCK (PL 12.3.27) to lift up the PLATE ASSY BTM (PL 12.3.10).
- 4) Remove the screw (gold tapping, 8mm) securing the PLATE GEAR LOCK 550 (PL 12.3.19) at the GEAR PB R (PL 12.3.20) side.
- 5) Release the hook of the PLATE GEAR LOCK 550, and remove it from the HOUSING BASE 550 (PL 12.3.44).
- 6) Release the hook of the GEAR PB R, and remove the GEAR PB R from the SHAFT PB (PL 12.3.9).
- 7) Remove the 2 screws (gold tapping, 6mm) securing the COVER BTM UP 550 (PL 12.3.22), and remove it from the HOUSING BASE 550.
- 8) Remove 2 GEAR LOCK PINIONS (PL 12.3.23) from the HOUSING BASE 550.
- 9) Remove the RACK BTM LOCK 550 (PL 12.3.21) together with the SPRING BTM LOCK (PL 12.3.24) from the HOUSING BASE 550.
- 10) Remove the GEAR BTM LOCK (PL 20.3.25) from the HOUSING BASE 550.
- 11) Remove the GEAR LEVER LOCK from the HOUSING BASE 550.
- 12) Remove the 2 screws (gold tapping, 6mm) securing the STOPPER GEAR (PL 12.3.29), and remove the STOPPER GEAR and SPRING STOPPER GEAR (PL 12.3.28) from the HOUSING BASE 550.

NOTE

When removing the STOPPER GEAR, be careful not to lose the SPRING STOPPER GEAR.

Removal and Replacement Procedures (RRPs)

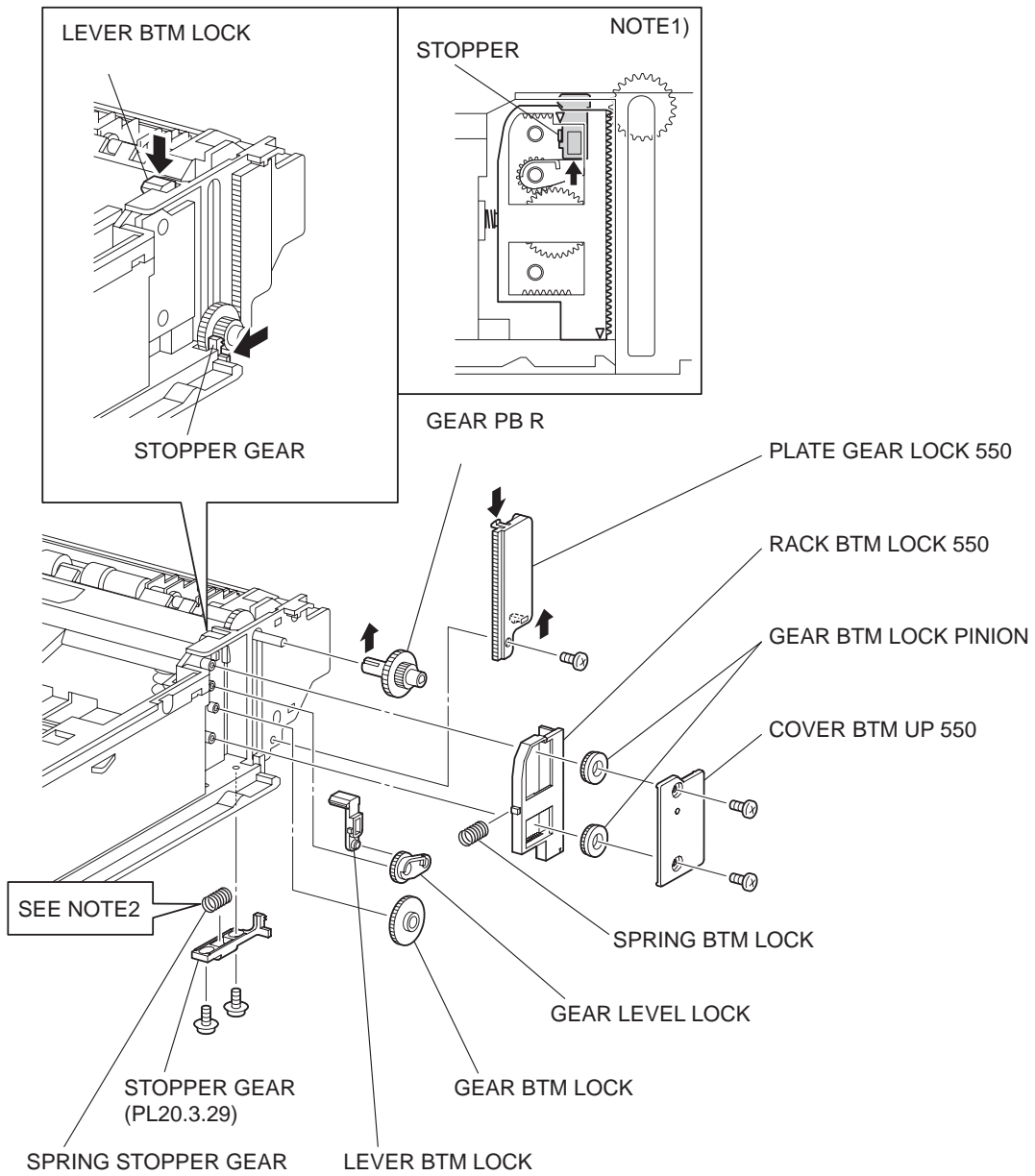

JG3535AB

NOTE2 (REAR VIEW)

WHEN ASSEMBLING

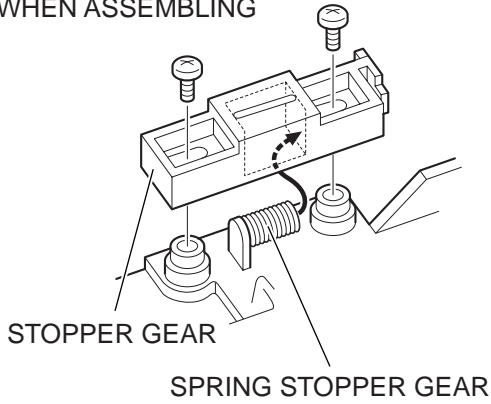

JG3183AA

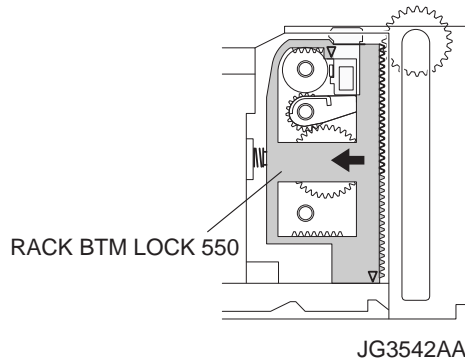

JG3542AA

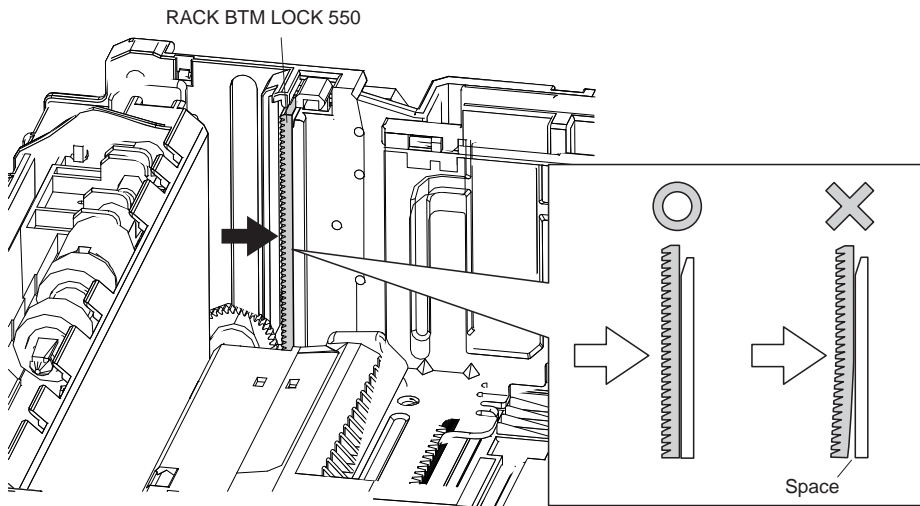

JG3544AA

Replacement

NOTE

When installing, be sure to lift up the PLATE ASSY BTM. If the PLATE ASSY BTM is inclined, a paper skew or jam may occur. Check after the installation is completed.

Removal and Replacement Procedures (RRPs)

- 1) Put the SPRING STOPPER GEAR (PL 12.3.28) into the STOPPER GEAR (PL 12.3.29), and secure the STOPPER GEAR to the HOUSING BASE 550 (PL 12.3.44) using the 2 screws (gold tapping, 6mm).

NOTE

When installing the STOPPER GEAR, be careful not to lose the SPRING STOPPER GEAR.

NOTE

Install the STOPPER GEAR so that one end of the SPRING STOPPER GEAR is in contact with the plate located on the back of the HOUSING BASE 550 as shown in the figure.

(NOTE 2)

- 2) Install the GEAR LEVER LOCK to the HOUSING BASE 550.
- 3) Install the GEAR BTM LOCK (PL 12.3.25) to the HOUSING BASE 550.
- 4) Install the SPRING BTM LOCK (PL 12.3.24) to the projection of the RACK BTM LOCK 550 (PL 12.3.21), and install them to the HOUSING BASE 550.

NOTE

When installing the RACK BTM LOCK 550, be sure to install it with the LEVER BTM LOCK lifted up. After installing, check that the projection of the LEVER BTM LOCK hits the stopper of the HOUSING BASE 550 and the triangle mark is placed above the stopper, when pushing down the LEVER BTM LOCK and then release the finger from it.

(NOTE1)

5) Install 2 GEAR LOCK PINIONS (PL 12.3.23) to the HOUSING BASE 550, and put them into the state of being in gear.

NOTE

Install the lower GEAR BTM PINION after installing the upper GEAR BTM LOCK PINION. When installing the lower GEAR BTM PINION, press RACK BTM LOCK 550 in the direction of arrow until it bumps into the edge. (NOTE3)

- 6) Secure the COVER BTM UP 550 (PL 12.3.22) to the HOUSING BASE 550 using the screw (gold tapping, 6mm).
- 7) Install the GEAR PB R (PL 12.3.20) to the SHAFT PB (PL 12.3.9), and secure it with the hook.

NOTE

Be sure to install the hook of the GEAR PB R into the groove of the SHAFT PB.

- 8) Install the PLATE GEAR LOCK 550 (PL 12.3.19) to the HOUSING BASE 550, and secure it with the hook.
- 9) Secure the PLATE GEAR LOCK 550 using the screw (gold tapping, 8mm).
- 10) Push the PLATE ASSY BTM (PL 12.3.10) downward to lock.

NOTE

Confirm that there is no space between RACK BTM LOCK 550 and HOUSING BASE 550 when pressing the center of RACK BTM LOCK 550 against HOUSING BASE 550.

RRP12.23 HANDLE EXTENSION 550 (PL12.1)**Removal**

- 1) Remove the COVER CST (PL 12.3.1) from the 550 PAPER CASSETTE (PL 12.3.50).
- 2) Remove the 2 screws on the back side of the HANDLE EXTENSION 550 (PL 12.3.41).
- 3) Release the 5 hooks at the upper side and the 2 hooks at the lower side of the HANDLE EXTENSION 550 (PL 12.3.41). then, remove the HANDLE EXTENSION 550 from the HOUSING EXTENSION 550 (PL 12.3.42).

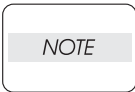

When removing the HANDLE EXTENSION 550, the LOW INDICATOR (PL 12.3.37) and LOW IND FRONT (PL 12.3.38) will be detached, and be careful not to lose them.

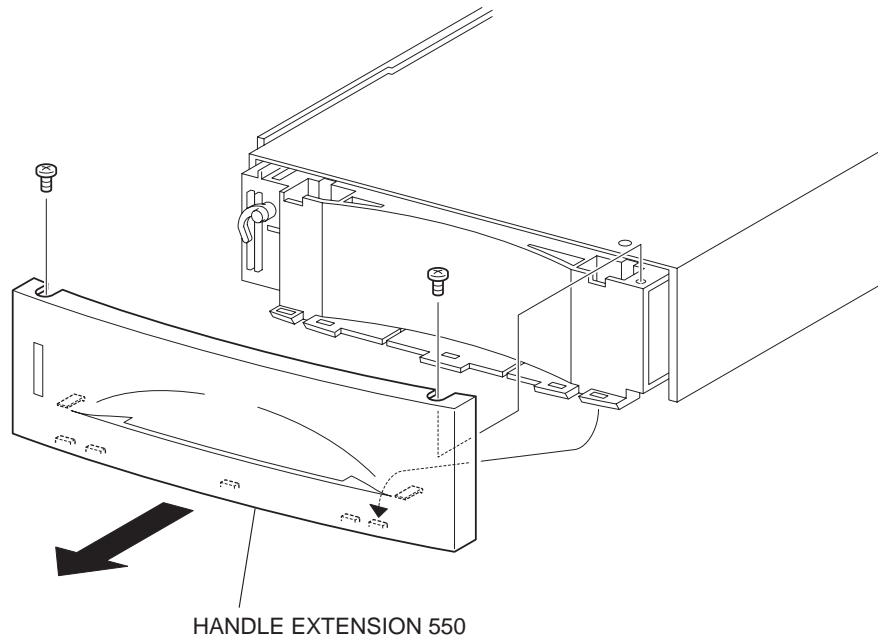

JG3540AA

Replacement

- 1) Install the LOW INDICATOR (PL 12.3.37) and LOW IND FRONT (PL 12.3.38). (RRP12.26)
- 2) Put the 5 hooks on the upper side and 2 hooks on the lower side of the HANDLE EXTENSION 550 to the HOUSING EXTENSION 550 (PL 12.3.42),
- 3) Secure the HANDLE EXTENSION 550 (PL 12.3.41) to the HOUSING EXTENSION 550 (PL 12.3.42) using the 2 screws.
- 4) Install the COVER CST (PL 12.3.1) to the 550 PAPER CASSETTE.

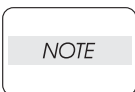

After assembling, make sure that the LOW IND FRONT moves up-and-down in conjunction with the up-and-down movement of the PLATE ASSY BTM.

RRP12.24 GUIDE INDICATOR 3 (PL12.3)**Removal**

- 1) Remove the COVER CST (PL 12.3.1) from the 550 PAPER CASSETTE (PL 12.3.50).
- 2) Remove the HANDLE EXTENSION 550 (PL 12.3.41). (RRP12.23)

NOTE

When removing the HANDLE EXTENSION 550, the LOW INDICATOR (PL 12.3.37) and LOW IND FRONT (PL 12.3.38) will be detached. Be careful not to lose them.

- 3) While pressing down the lock of the STOPPER GEAR (PL 12.3.29), release the lock of the LEVER BTM LOCK (PL 12.3.27) and lift up the PLATE ASSY BTM (PL 12.3.10).
- 4) Remove the link lever of the GUIDE INDICATOR 1 (PL 12.3.34) from the hole of the PLATE ASSY BTM.
- 5) While pressing the link lever down to the bottom side of the 550 PAPER CASSETTE, slowly but firmly draw the GUIDE INDICATOR 3 out from the front side of the HOUSING EXTENSION 550 (PL 12.3.42).

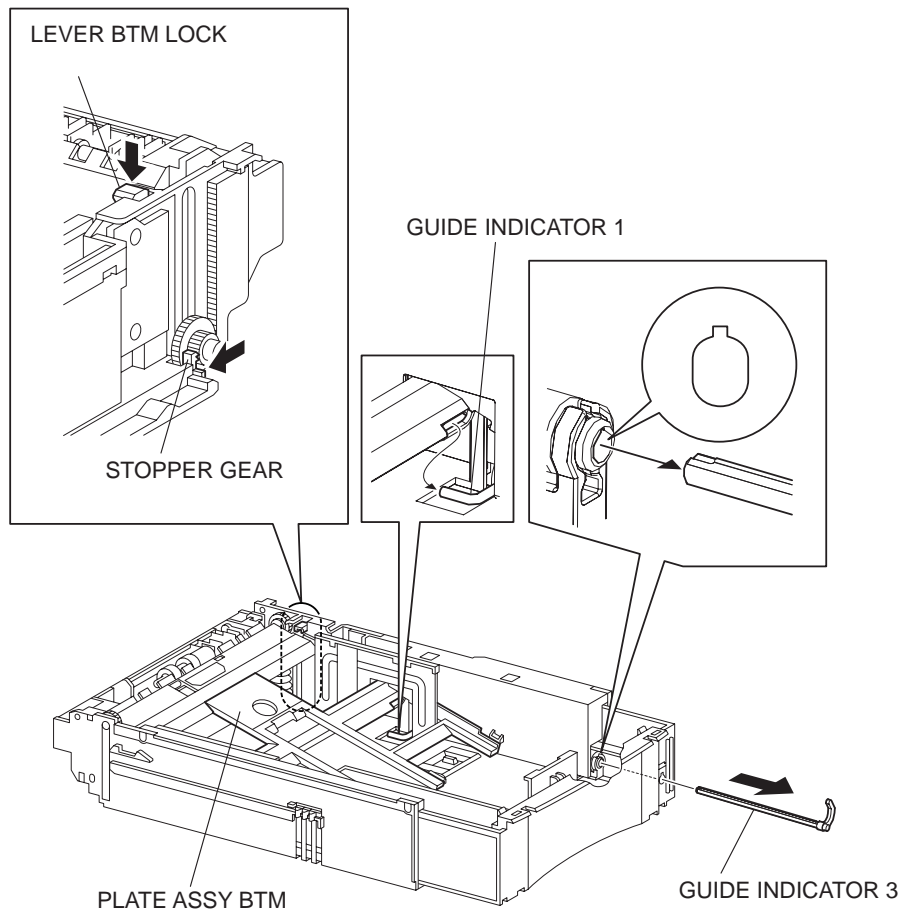

JG3527AA

Replacement

- 1) While pressing the link lever down to the bottom side of the 550 PAPER CASSETTE, insert the GUIDE INDICATOR 3 to the HOUSING EXTENSION 550 (PL 12.3.42) from the front side.

NOTE

Be sure to align the groove of the GUIDE INDICATOR 1 and the projection of the GUIDE INDICATOR 3.

- 2) Insert the link lever of the GUIDE INDICATOR 1 (PL 12.3.34) to the hole of the PLATE ASSY BTM.
- 3) Install the LOW INDICATOR (PL 12.3.37) and LOW IND FRONT (PL 12.3.38). (RRP12.26)
- 4) Install the HANDLE EXTENSION 550 (PL 12.3.41). (RRP12.23)
- 5) Install the COVER CST (PL 12.3.1) to the 5550 PAPER CASSETTE.

NOTE

After assembling, make sure that the LOW IND FRONT moves up-and-down in conjunction with the up-and-down movement of the PLATE ASSY BTM

RRP12.25 GUIDE INDICATOR 2 (PL12.3)**Removal**

- 1) Remove the COVER CST (PL 12.3.1) from the 550 PAPER CASSETTE (PL 12.3.50).
- 2) Release the lock of the LOCK EXTENSION, and draw out the cassette extension as far as it will go.
- 3) Release the hooks securing the GEAR PINION (PL 12.3.12) to the HOUSING TOP 550 (PL 12.3.16), and remove the GEAR PINION.
- 4) While pressing down the lock of the STOPPER GEAR (PL 12.3.29), release the lock of the LEVER BTM LOCK (PL 12.31.27) to lift up the PLATE ASSY BTM. (Figure 20.24)
- 5) Slide the GUIDE ASSY SD L550 (PL 12.3.11) inward, and remove it from the HOUSING TOP 550 by pressing down the hook of the HOUSING TOP 550.
- 6) Slide the GUIDE ASSY SD R550 (PL 12.3.13) inward, and remove it from the HOUSING TOP 550 by pressing down the hook of the HOUSING TOP 550.
- 7) Remove the 2 screws (gold tapping, 8mm) from both right and left sides, as well as the 6 screws (gold tapping, 8mm) on back, that secure the HOUSING TOP 550 to the HOUSING BASE 550 (PL 12.3.44).
- 8) Turn the 550 PAPER CASSETTE over, and pull out the HOUSING TOP 550 forward about 20 mm to release the claws at the tip of the PLATE ASSY BTM from the hooks of the HOUSING TOP 550.
- 9) Release the 4 hooks of the HOUSING TOP 550, and remove the HOUSING TOP 550 and HOUSING EXTENSION 550 (PL 12.3.42) from the HOUSING BASE 550.
- 10) Slide the SUPPORT GUIDE IND (PL 12.3.32), and remove it from the groove of the HOUSING EXTENSION 550. Then, separate the HOUSING TOP 550 and HOUSING EXTENSION 550.
- 11) Remove the GUIDE INDICATOR 1 (PL 12.3.34) from the hooks of the HOUSING TOP 550, and remove the SUPPORT GUIDE IND together with the GUIDE INDICATOR 1 and GUIDE INDICATOR 2 from the HOUSING TOP 550.
- 12) Release the hook of the SUPPORT GUIDE IND, and remove the SUPPORT GUIDE IND from the GUIDE INDICATOR 2.
- 13) Extract the GUIDE INDICATOR 2 from the back side of the GUIDE INDICATOR 1.

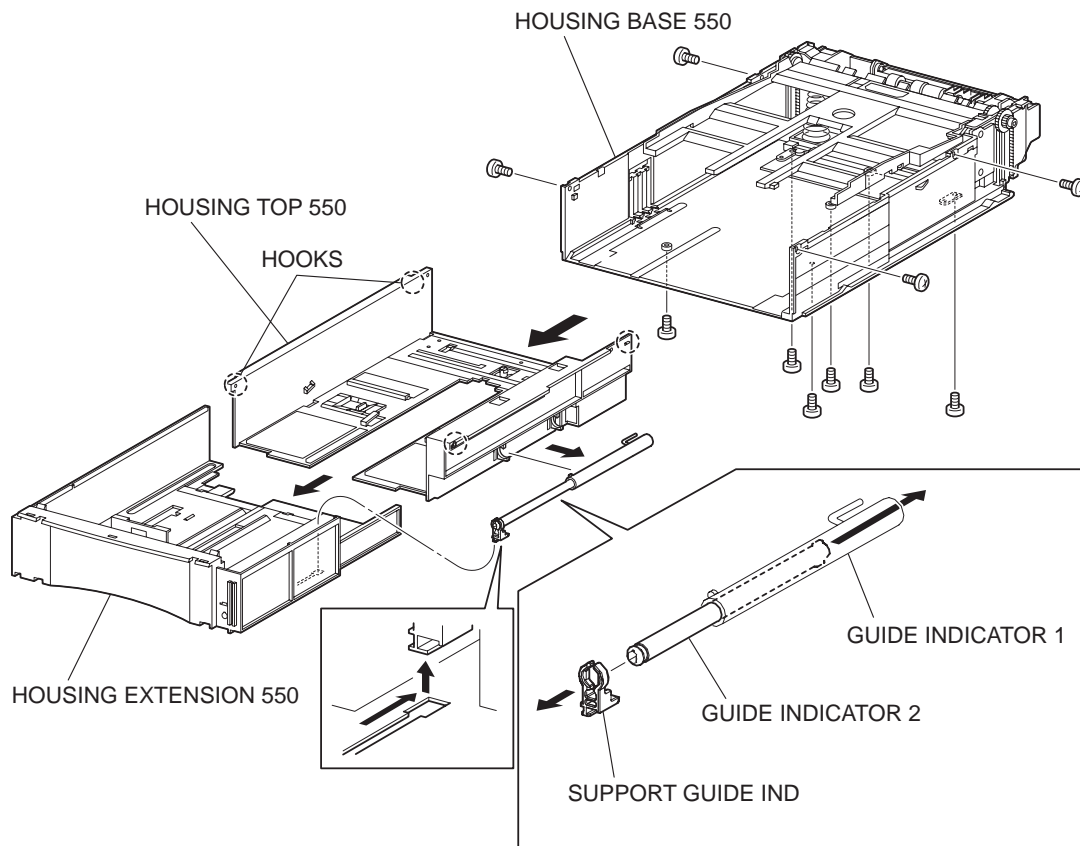

JG3528AA

Replacement

- 1) Insert the GUIDE INDICATOR 2 into the hole of the GUIDE INDICATOR 1 (PL 12.3.34) from back.
- 2) Install the SUPPORT GUIDE IND (PL 12.3.32) to the GUIDE INDICATOR 2, and secure it with the hook.

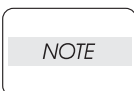

Install the SUPPORT GUIDE IND to the GUIDE INDICATOR 2 in the direction shown in the figure.

- 3) Install the SUPPORT GUIDE IND together with the GUIDE INDICATOR 1 and GUIDE INDICATOR 2 to the HOUSING TOP 550 (PL 12.3.16), and secure the GUIDE INDICATOR 1 using the 2 hooks of the HOUSING TOP 550.
- 4) Slide the SUPPORT GUIDE IND along the groove of the HOUSING EXTENSION 550 to install, and assemble the HOUSING TOP 550 and HOUSING EXTENSION 550 into 1 unit.
- 5) Install the HOUSING EXTENSION 550 and HOUSING TOP 550 (PL 12.3.16) to the HOUSING BASE 550 while pushing the LINK SW SIZE1-550 (PL 12.3.45), LINK SW SIZE2-550 (PL 12.3.46) and LINK SW SIZE3-550 (PL 12.3.47) of the HOUSING BASE 550 outward as shown in the figure.(Figure 20.18)

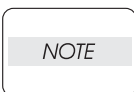

Be sure to put 2 claws at the tip of the PLATE ASSY BTM under the hooks on the HOUSING TOP 550.

- 6) After assembling the HOUSING TOP 550 with HOUSING BASE 550 using the 4 hooks, secure them using the 2 screws (gold tapping, 8mm) from both right and left sides, as well as the 6 screws (gold tapping, 8mm) on back.

Removal and Replacement Procedures (RRPs)

NOTE

After tightening the screws, move the GUIDE ASSY END 550 back and forth, and make sure that the LINK SW SIZES operate smoothly.

- 7) Insert the link lever of the GUIDE INDICATOR1 (PL 12.3.34) into the hole of the PLATE ASSY BTM.
- 8) While pressing down the hook of the HOUSING TOP 550, install the GUIDE ASSY SD R550 (PL 12.3.13) to the HOUSING TOP 550.

NOTE

After installing, make sure that the 3 claws of the GUIDE ASSY SD R550 sit correctly in the grooves of the HOUSING TOP 550.

- 9) While pressing down the hook of the HOUSING TOP 550, install the GUIDE ASSY SD L550 (PL 12.3.11) to the HOUSING TOP 550.

NOTE

After installing, make sure that the 3 claws of the GUIDE ASSY SD L550 sit correctly in the grooves of the HOUSING TOP 550.

- 10) Push the PLATE ASSY BTM downward to lock.
- 11) Install the GEAR PINION (PL 12.31.12) to the HOUSING TOP 550.

NOTE

When installing the GEAR PINION, make sure the GUIDE ASSY SD R550 and GUIDE ASSY SD L550 are completely opened. If not, the side register may be misaligned.

- 12) Install the COVER CST (PL 12.3.1) to the 550 PAPER CASSETTE.

NOTE

After assembling, make sure that the LOW IND FRONT moves up-and-down in conjunction with the up-and-down movement of the PLATE ASSY BTM

RRP12.26 LOW IND FRONT (PL12.3)**Removal**

- 1) Remove the COVER CST (PL 12.3.1) from the 550 PAPER CASSETTE (PL 12.3.50).
- 2) Remove the HANDLE EXTENSION 550 (PL 12.3.41). (RRP12.23)
- 3) Turn the LOW INDICATOR (PL 12.3.37) by 90 degrees, and remove it together with the LOW IND FRONT from the HANDLE EXTENSION 550.
- 4) Release the hook on the one side of the LOW IND FRONT, and remove the LOW IND FRONT from the LOW INDICATOR.

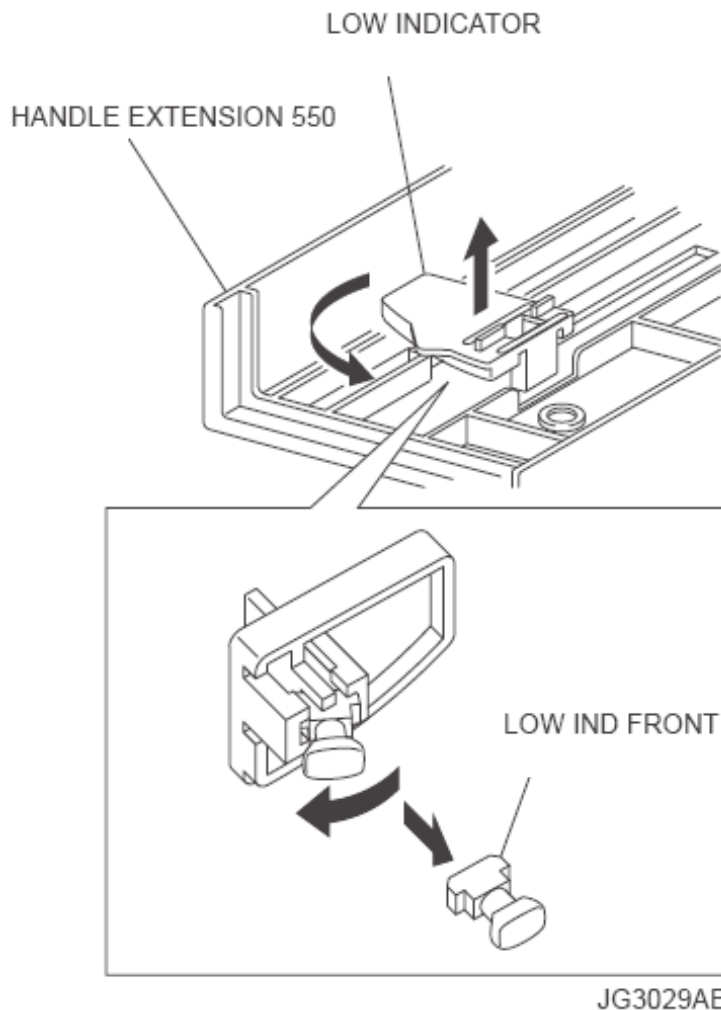
**Replacement**

- 1) Install the LOW INDICATOR (PL 12.3.37) to the LOW INDICATOR.

NOTE

When installing the LOW IND FRONT to the LOW INDICATOR, be careful in the installing direction of the LOW IND FRONT.

- 2) Turn the LOW INDICATOR by 90 degrees in the opposite direction of the arrow, and install it together with the LOW IND FRONT to the HANDLE EXTENSION 550.
- 3) Install the HANDLE EXTENSION 550 (PL 12.3.41). (RRP12.23)
- 4) Install the COVER CST (PL 12.3.1) to the 550 PAPER CASSETTE (PL 12.3.50).

Removal and Replacement Procedures (RRPs)

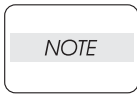

After assembling, make sure that the LOW IND FRONT moves up-and-down in conjunction with the up-and-down movement of the PLATE ASSY BTM

RRP12.27 SPRING EARTH TOP (PL12.2)

Removal

- 1) Remove the screw (silver, 6mm) securing the SPRING EARTH TOP to the FRAME TOP ASSY (PL 12.1.7).
- 2) Remove the SPRING EARTH TOP.

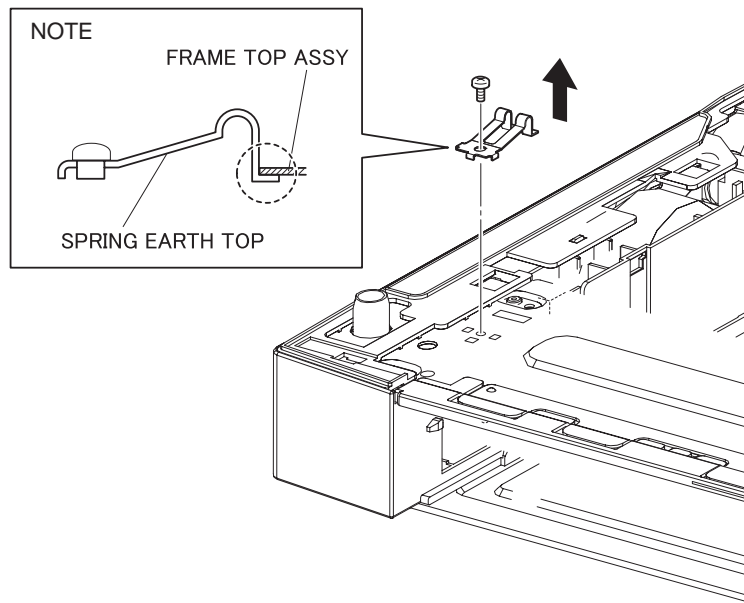

JG3538AA

Replacement

- 1) Put the tip of the SPRING EARTH TOP into the hole of the FRAME TOP ASSY (PL 12.1.7), and secure it using the screw (silver, 6mm).

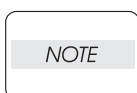

The tip of the SPRING EARTH TOP should be put into the hole and should not be on the FRAME TOP ASSY

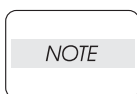

After installation, when the top of the SPRING EARTH TOP is depressed, make sure that it moves downward.

Chapter 2 Plug/Jack(P/J) Connector Locations CONTENTS

Chapter 2 Print Engine Plug/Jack Connector Locations.....2 - 1

1. Connector [P (plug) / J (jack)].....2 - 1

 1.1 List of P/J 2 - 1

 1.2 Print Engine P/J Diagram (1 of 2) 2 - 4

 1.3 Print Engine P/J Diagram (2 of 2)2 - 5

Duplex Transport Option

2. Connector [P (plug) / J (jack)].....2 - 6

 2.1 List of P/J2 - 6

 2.2 Duplex Transport Option P/J Diagram2 - 7

OCT Option

3. Connector [P (plug) / J (jack)].....2 - 8

 3.1 List of P/J2 - 8

 3.2 OCT Option P/J Diagram2 - 9

550 Sheet Feeder

4. Connector [P (plug) / J (jack)].....2 - 10

 4.1 List of P/J 2 - 10

 4.2 550 Sheet Feeder P/J Diagram2 - 11

Chapter 2 Print Engine Plug/Jack Connector Locations

1. Connector [P (plug) / J (jack)]

1.1 List of P/J

P/J	Coordinates	Remarks
1	G-104	Connects OPERATION PANEL and HARNESS ASSY PANEL
10	B-111	Connects HARNESS ASSY LVPS and HVPS/MCU
11	D-111	Connects HARNESS ASSY LVPS and HVPS/MCU
13	E-111	Connects HARNESS ASSY ROS and HVPS/MCU
14	E-112	Connects HARNESS ASSY ROS and HVPS/MCU
15	F-112	Connects HARNESS ASSY ANT and HVPS/MCU
16	G-111	Connects HARNESS ASSY ROS and HVPS/MCU
17	G-111	Connects HARNESS ASSY ROS and HVPS/MCU
18	F-112	Connects HARNESS ASSY LVPS and HVPS/MCU
20	H-111	Connects HARNESS ASSY FDR1 and HVPS/MCU
22	I-110	Connects HARNESS ASSY TONER1 and HVPS/MCU
24	J-110	Connects HARNESS ASSY CHUTE and HVPS/MCU
26	I-110	Connects HARNESS ASSY LOW PAPER SNR and HVPS/MCU
27	D-111	Connects HARNESS ASSY LVPS and HVPS/MCU
28	K-110	Connects FFC ASSY ESS and HVPS/MCU
29	K-108	Connects HARNESS ASSY EXIT SNR1 and HVPS/MCU
30	K-107	Connects HARNESS ASSY OCT1 and HVPS/MCU
31	C-111	Connects GUIDE ASSY CRU and HVPS/MCU
40	X-121	Connects HARNESS ASSY LVPS and LVPS
41	X-122	Connects HARNESS ASSY LVPS and LVPS
42	W-122	Connects HARNESS ASSY LVPS and LVPS
43	X-122	Connects MAIN MOTOR and LVPS
44	X-123	Connects INTERLOCK SW REAR and LVPS
45	X-123	Connects INTERLOCK SW 24V and LVPS
46	X-120	Connects HARNESS ASSY FUSER and LVPS
47	U-126	Connects HARNESS ASSY FUSER and LVPS
48	U-125	Connects HARNESS ASSY 100V and LVPS
101	V-120	Connects LVPS and PWBA EXIT MOTOR
102	U-120	Connects HARNESS ASSY LVPS and PWBA EXIT MOTOR
103	S-119	Connects MOTOR ASSY EXIT and PWBA EXIT MOTOR
131	B-111	Connects ROS ASSY and HARNESS ASSY ROS

Plug/Jack(P/J) Connector Locations

P/J	Coordinates	Remarks
140	A-108	Connects ROS ASSY and HARNESS ASSY ROS
141	R-119	Connects HARNESS ASSY LVPS and INTERLOCK SW 5V
150	M-121	Connects PWBA ASSY ANT and HARNESS ASSY ANT
160	A-108	Connects ROS ASSY and HARNESS ASSY ROS
170	A-107	Connects ROS ASSY and HARNESS ASSY ROS
180	A-109	Connects SIZE1 Tray and HARNESS ASSY LVPS
210	A-110	Connects SIZE2 Tray and HARNESS ASSY LVPS
220	R-127	Connects SENSOR TONER and HARNESS ASSY TONER1
221	M-124	Connects HARNESS ASSY TONER1 and HARNESS ASSY TONER2
240	M-122	Connects SENSOR NO PAPER and HARNESS ASSY TRAY1
241	O-126	Connects SENSOR REGI and HARNESS ASSY TRAY1
242	Q-126	Connects CLUTCH ASSY PH and HARNESS ASSY TRAY1
243	P-126	Connects CLUTCH REGI and HARNESS ASSY TRAY1
244	M-124	Connects FAN MAIN and HARNESS ASSY TRAY1
245	M-125	Connects HARNESS ASSY TRAY1 and HARNESS ASSY CHUTE
246	M-123	Connects SENSOR NO PAPER and HARNESS ASSY TRAY2
247	Q-126	Connects CLUTCH ASSY PH and HARNESS ASSY TRAY2
248	M-126	Connects HARNESS ASSY TRAY2 and HARNESS ASSY CHUTE
260	N-126	Connects SENSOR LOW PAPER and HARNESS ASSY LOW PAPER SNR
270	T-119	Connects FAN SUB and HARNESS ASSY LVPS
271	U-120	Connects HARNESS ASSY LVPS and MAIN MOTOR
290	M-120	Connects SENSOR FULL STACK and HARNESS ASSY EXIT SNR1
291	M-120	Connects SENSOR FACE UP OPEN and HARNESS ASSY EXIT SNR1
310	M-122	Connects EP CARTRIGE and GUIDE ASSY CRU
480	W-125	Connects HARNESS ASSY 100V and POWER SWITCH
1821	A-109	Connects GUIDE TRAY L ASSY and HARNESS ASSY LVPS
2083	H-111	Connects HARNESS ASSY FDR1 and HARNESS ASSY FDR2
2750	S-126	Connects HARNESS ASSY LVPS and HARNESS ASSY DUP
3070	M-121	Connects HARNESS ASSY OCT1 and HARNESS ASSY OCT2
4647	T-126	Connects HARNESS ASSY FUSER and FUSER ASSY

Blank Page

1.2 Print Engine P/J Diagram (1 of 2)

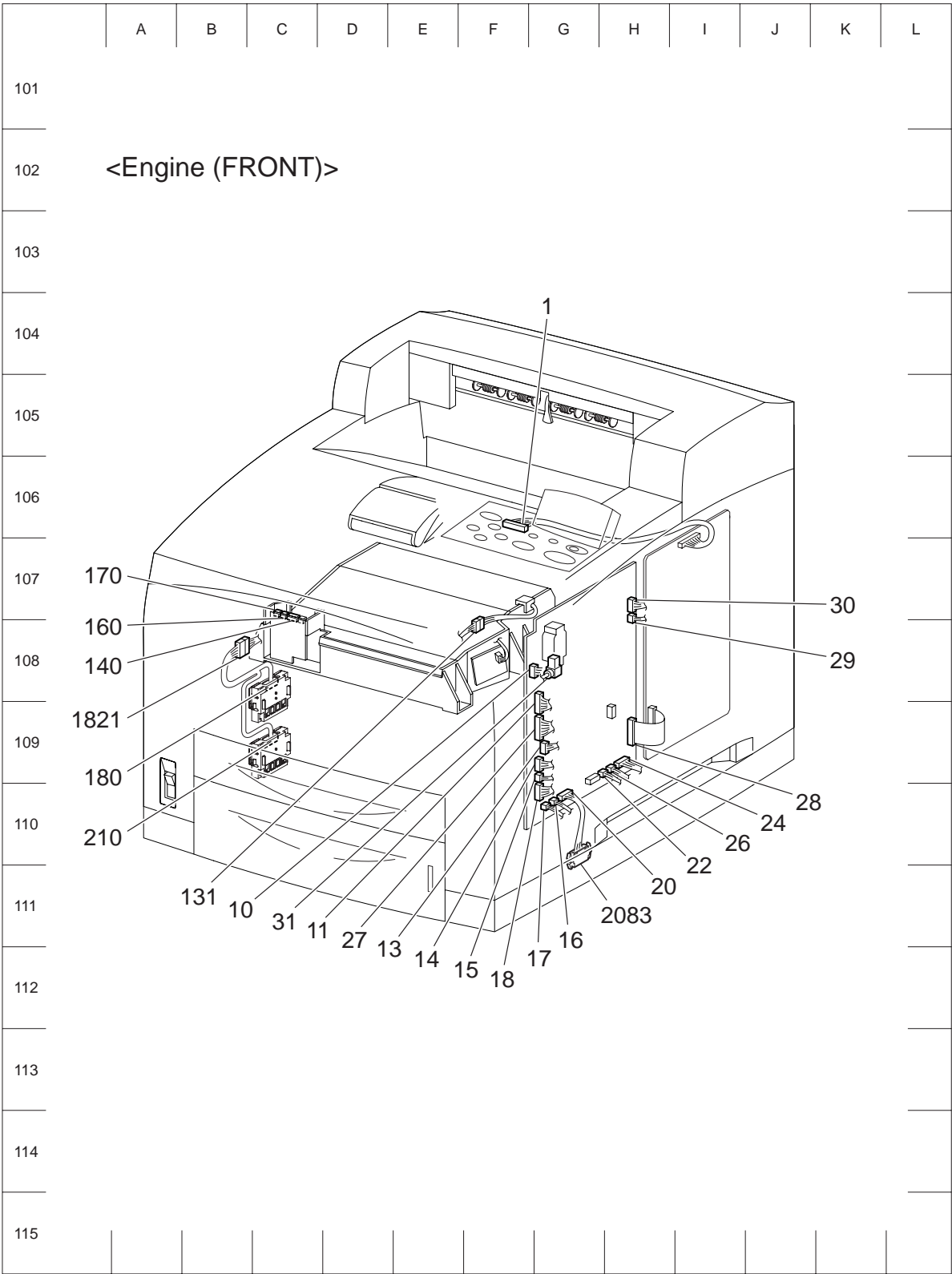

J24101AA

1.3 Print Engine P/J Diagram (2 of 2)

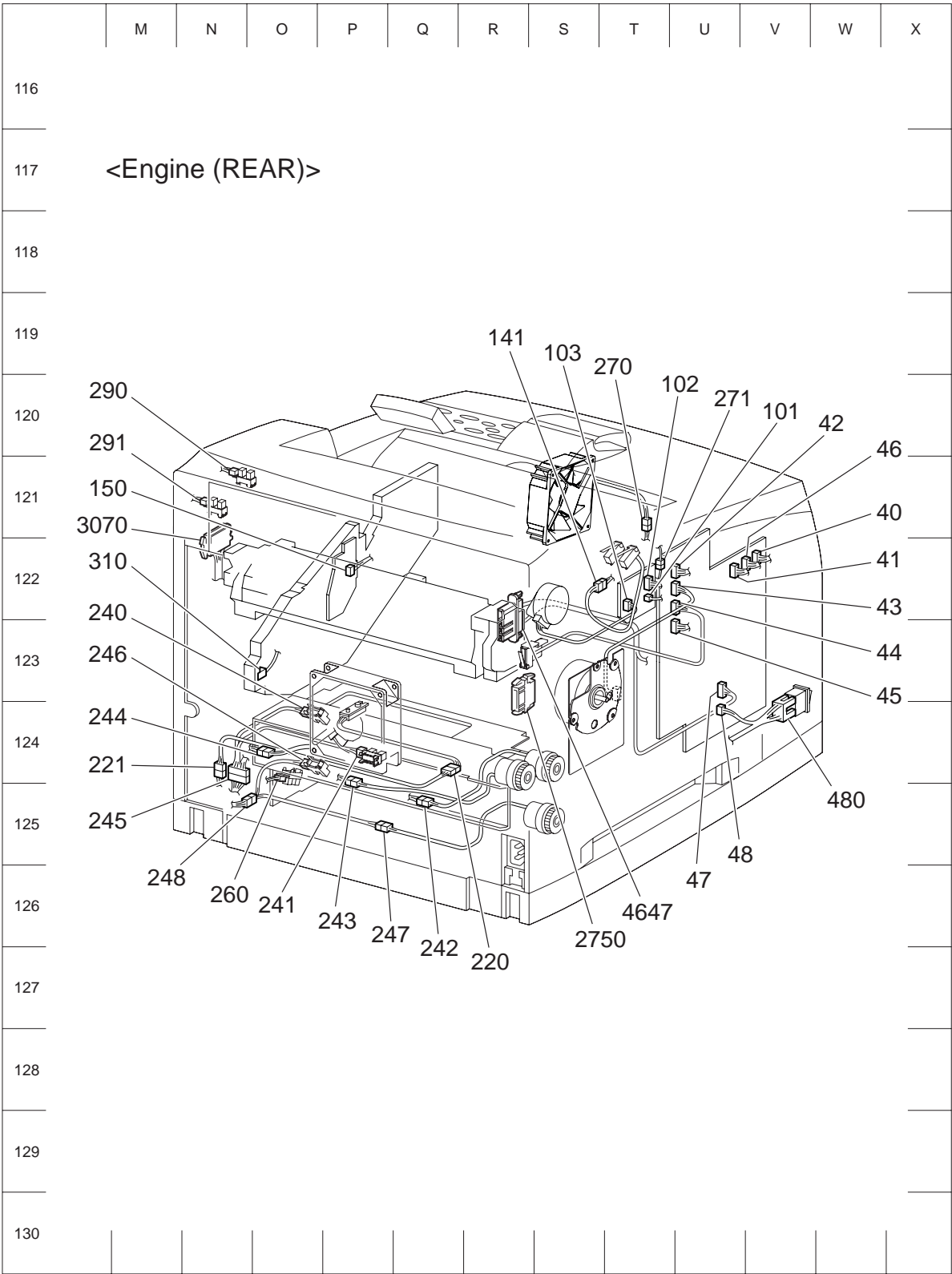

J24102AA

Duplex Transport Option

2. Connector [P (plug) / J (jack)]

2.1 List of P/J

P/J	Coordinates	Remarks
50	H-308	Connects HARNESS ASSY DUP and PWBA DUPLEX
51	H-308	Connects MOTOR DUPLEX and PWBA DUPLEX
52	H-308	Connects HARNESS ASSY DUP COVER and PWBA DUPLEX
53	F-307	Connects HARNESS ASSY DUP SNR and PWBA DUPLEX
54	F-307	Connects FAN DUPLEX and PWBA DUPLEX
56	H-309	Connects HARNESS ASSY DUP EARTH and PWBA DUPLEX
520	I-309	Connects SWITCH DUPLEX and HARNESS ASSY DUP
530	C-306	Connects SENSOR DUP and HARNESS ASSY DUP SNR
560	I-311	Connects HARNESS ASSY DUP EARTH and EARTH ASSY PLATE
2750	I-308	Connects HARNESS ASSY DUP and HARNESS ASSY LVPS

2.2 Duplex Transport Option P/J Diagram

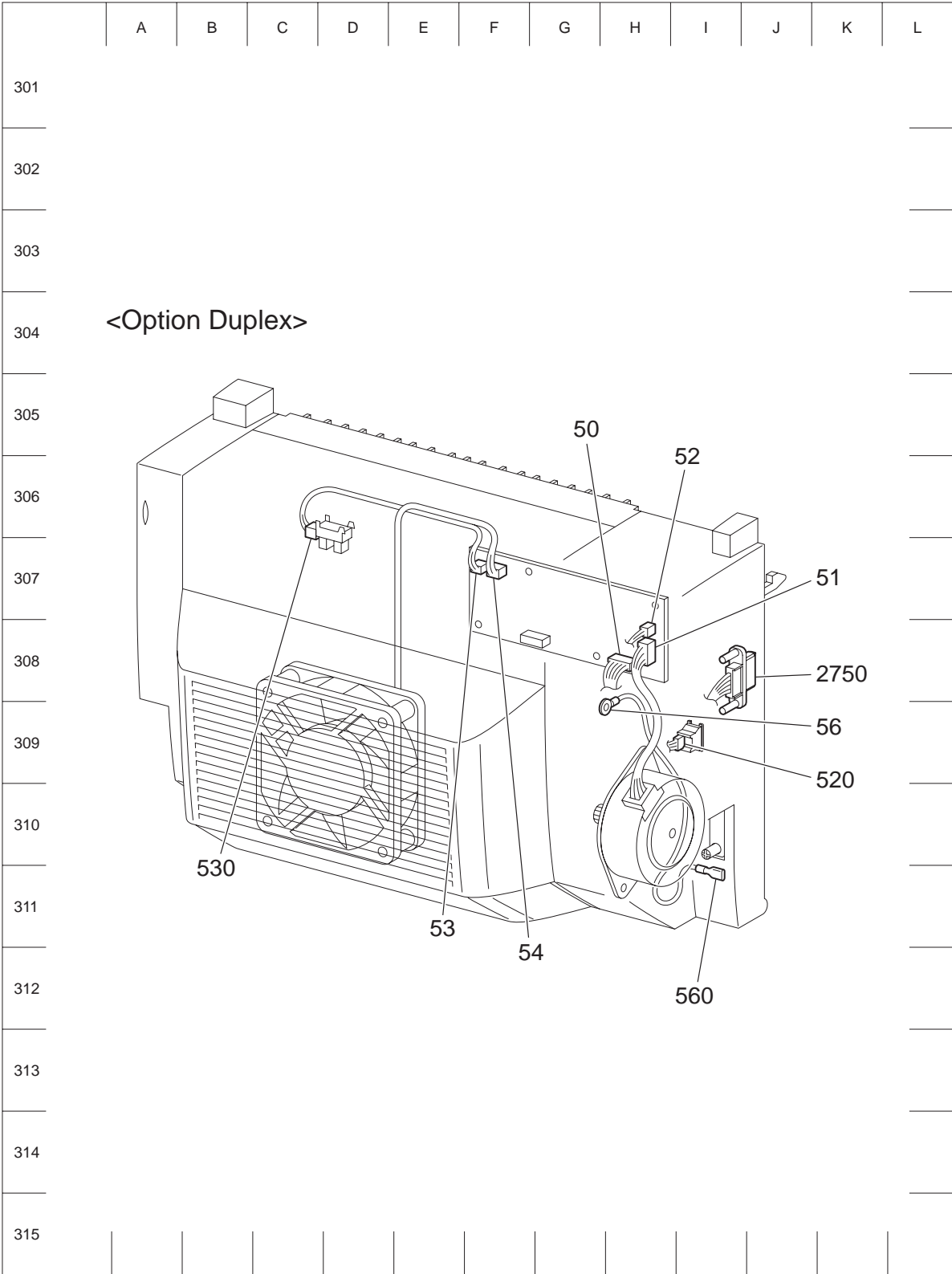

J24611AA

OCT Option**3. Connector [P (plug) / J (jack)]****3.1 List of P/J**

P/J	Coordinates	Remarks
70	J-407	Connects HARNESS ASSY OCT2 and PWBA OCT
71	J-408	Connects MOTOR ASSY OCT and PWBA OCT
72	J-407	Connects MOTOR ASSY OFFSET and PWBA OCT
73	J-408	Connects HARNESS ASSY OCT SNR and PWBA OCT
74	I-407	Connects HARNESS ASSY REAR COVER and PWBA OCT
75	J-408	Connects SOLENOID ASSY GATE and PWBA OCT
710	F-405	Connects HARNESS ASSY OCT MOT and MOTOR ASSY OCT
730	F-408	Connects SENSOR OCT and HARNESS ASSY OCT SNR
740	I-407	Connects SWITCH REAR COVER and HARNESS ASSY REAR COVER
3070	J-410	Connects HARNESS ASSY OCT2 and HARNESS ASSY OCT1

3.2 OCT Option P/J Diagram

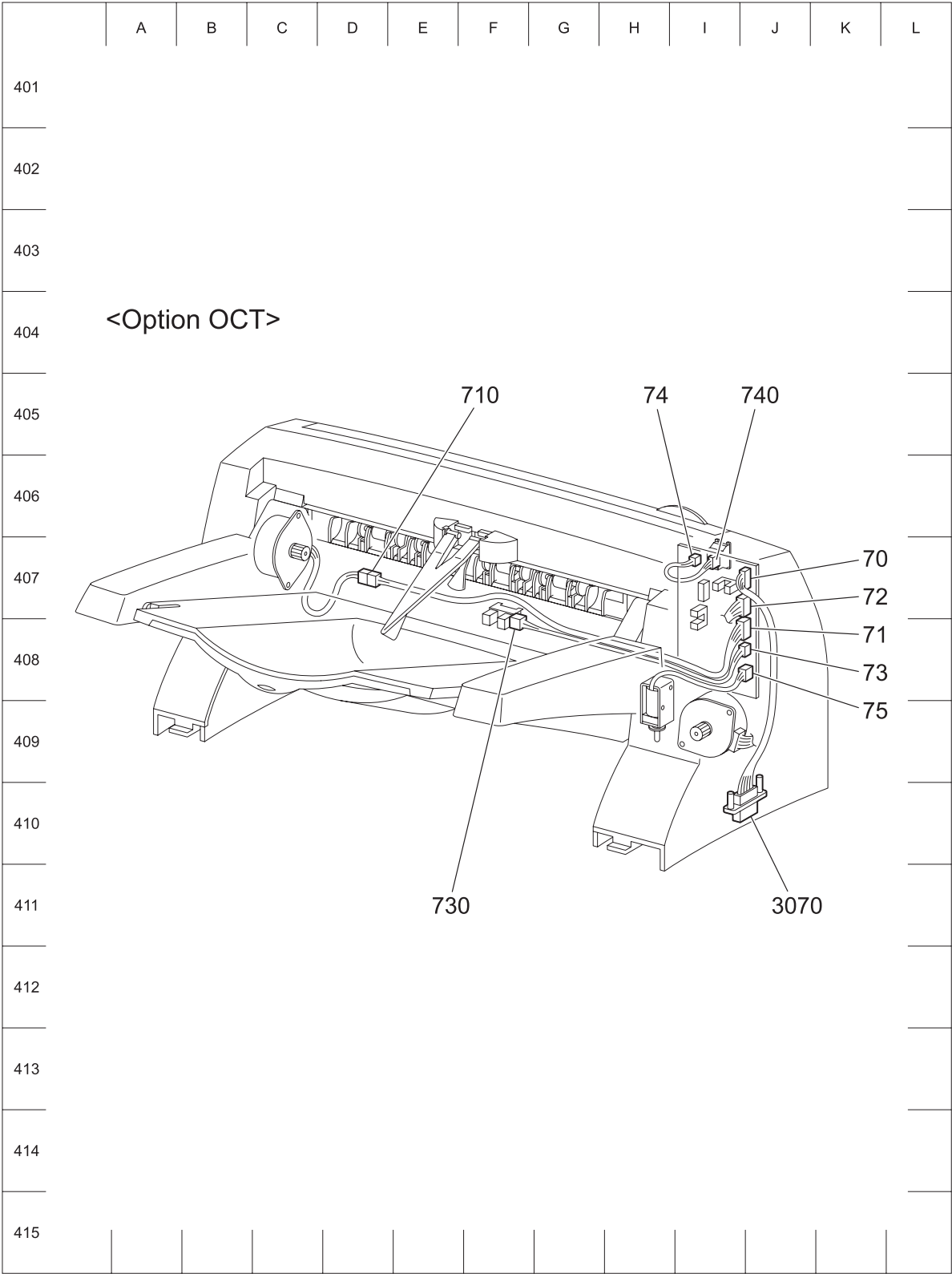

JG4801AA

550 Sheet Feeder

4. Connector [P (plug) / J (jack)]

4.1 List of P/J

P/J	Coordinates	Remarks
80	I-208	Connects HARNESS ASSY SIZE FDR2 and PWBA FEEDER 550
81	H-208	Connects HARNESS LOW PAPER and PWBA FEEDER 550
82	H-208	Connects HARNESS ASSY FDR MOT and PWBA FEEDER 550
83	I-208	Connects HARNESS ASSY FDR2 and PWBA FEEDER 550
84	I-208	Connects HARNESS ASSY FDR5 and PWBA FEEDER 550
85	H-208	Connects HARNESS ASSY CLSNR2 and PWBA FEEDER 550
801	H-206	Connects HARNESS ASSY SIZE FDR1 and HARNESS ASSY SIZE FDR2
802	C-207	Connects HARNESS ASSY SIZE FDR1 and OPT ASSY SIZE
810	J-207	Connects SENSOR LOW PAPER and HARNESS LOW PAPER
820	G-206	Connects MOTOR FEEDER and HARNESS ASSY FDR MOT
852	I-207	Connects SENSOR NO PAPER and HARNESS ASSY CLSNR1
853	G-206	Connects CLUTCH ASSY PH and HANESS ASSY CLSNR1
854	H-206	Connects CLUTCH ASSY PR-REGI and HARNESS ASSY CLSNR1
855	J-207	Connects HARNESS ASSY CLSNR1 and HARNESS ASSY CLSNR2
2083	G-208	Connects HARNESS ASSY FDR1 and HARNESS ASSY FDR2
8483	G-209	Connects HARNESS ASSY FDR5 and HARNESS ASSY FDR5

4.2 550 Sheet Feeder P/J Diagram

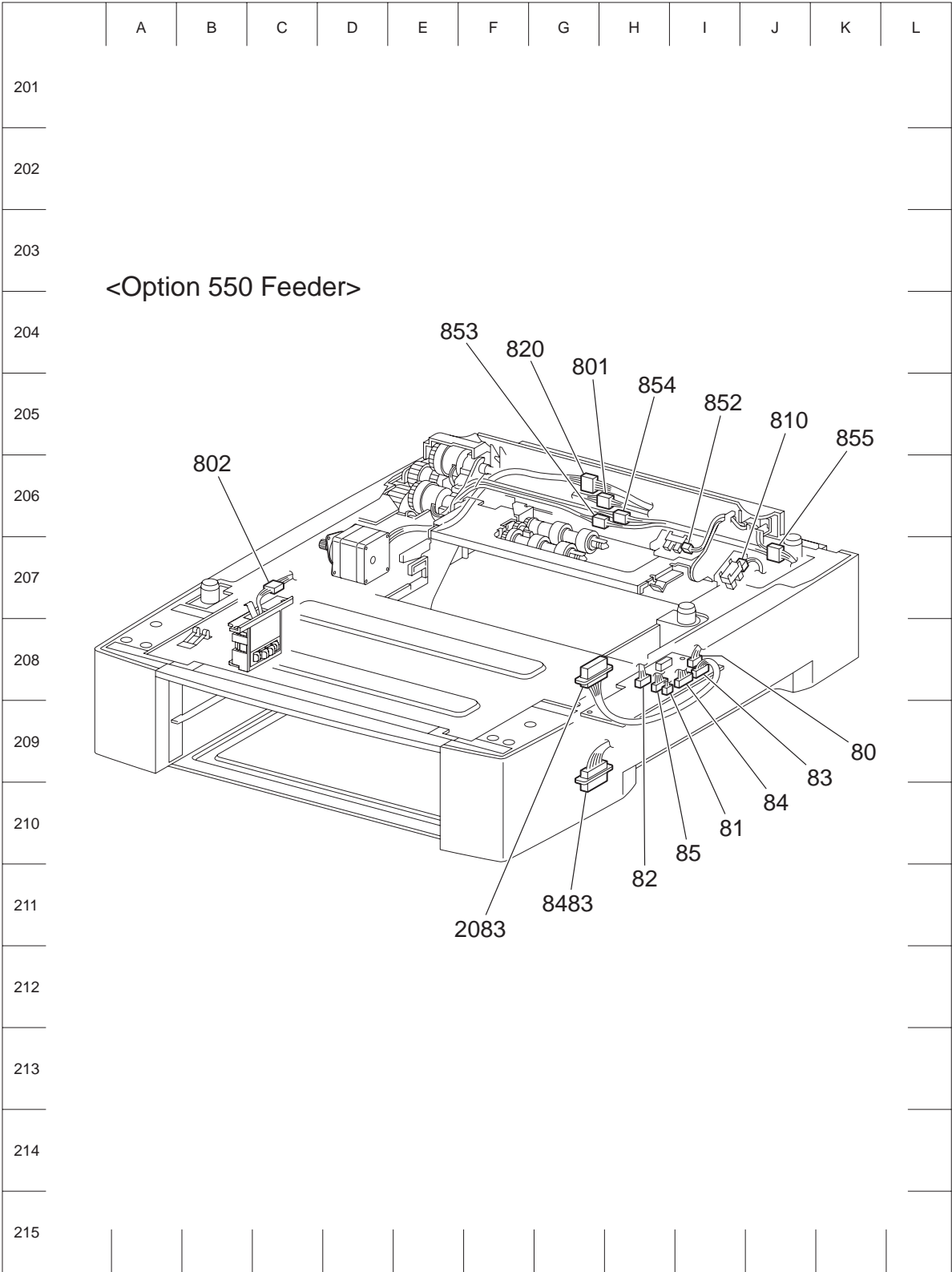

J24501AA

Chapter 3 Principles of Operation Contents

Chapter 3 Principles of Operation	3 - 1
Engine	3 - 1
1. Summary of Printing Process.....	3 - 1
2. Flow of Print Data.....	3 - 6
3. Driving Force Transmission Path	3 - 7
3.1 MAIN MOTOR.....	3 - 7
3.2 MOTOR ASSY EXIT	3 - 7
3.3 Gear Layout	3 - 8
4. Paper Transport.....	3 - 11
4.1 Paper Transport Path.....	3 - 11
4.2 Layout of Paper Transport Path.....	3 - 12
5. Actions of Main Functional Components	3 - 13
5.1 Paper Cassette	3 - 13
5.2 Paper Feeder	3 - 16
5.3 Xero	3 - 18
5.4 Fuser.....	3 - 22
5.5 500 Paper Exit & Option Face Up Tray.....	3 - 24
5.6 Drive.....	3 - 26
5.7 Electrical	3 - 27
6. Control	3 - 29
6.1 Control of Paper Size.....	3 - 29
6.1.1 Cassette Feeding (Paper Cassette).....	3 - 29
6.2 ROS Control.....	3 - 30
6.2.1 Rotation of Scanner Motor	3 - 30
6.2.2 Warm-up of ROS	3 - 30
6.2.3 ROS Reference Value	3 - 30
6.3 Fuser Control	3 - 31
6.3.1 Fuser Control	3 - 31
6.3.2 ON/OFF Control of Halogen Lamp	3 - 31
6.3.3 Warm-up of Fuser.....	3 - 31
6.3.4 Fuser Temperature in Ready State.....	3 - 31
6.3.5 Fuser Temperature when Abnormal Temperature (higher or lower) is Detected	3 - 31
7. Schematic Diagram of Safety System	3 - 32
Duplex Option.....	3 - 33
8. Driving Force Transmission Path	3 - 33
8.1 MOTOR DUPLEX	3 - 33
8.2 Gear Layout	3 - 33
9. Paper Transport.....	3 - 34
9.1 Paper Transport Path.....	3 - 34
9.2 Layout of Paper Transport Path.....	3 - 35
10. Actions of Main Functional Components	3 - 36

Chapter 3 Principles of Operation Contents

OCT Option	3 - 38
11. Driving Force Transmission Path	3 - 38
11.1 MOTOR ASSY OCT	3 - 38
11.2 Gear Layout	3 - 38
12. Paper Transport.....	3 - 39
12.1 Paper Transport Path.....	3 - 39
12.2 Layout of Paper Transport Path	3 - 40
13. Actions of Main Functional Components	3 - 41
550 Sheet Feeder Option	3 - 43
14. Driving Force Transmission Path	3 - 43
14.1 MOTOR FEEDER	3 - 43
14.2 Gear Layout	3 - 43
15. Paper Transport.....	3 - 44
15.1 Paper Transport Path.....	3 - 44
15.2 Layout of Paper Transport Path	3 - 45
16. Actions of Main Functional Components	3 - 46

Chapter 3 Principles of Operation

Engine

1. Summary of Printing Process

Electrophotography is used in the printer to print image on paper using a video signal sent from the PWBA ESS to the MCU of the HVPS/MCU. The electrophotography is composed of the following 7 steps:

- (1) Charging - Negative charges are uniformly distributed over the surface of the drum by Bias Charge Roll.
- (2) Exposure - The laser scanner scans the surface of the drum with a quite thin laser beam modulated according to the signal from the PWBA ESS (controller), to create an invisible electrostatic latent image on the drum surface.
- (3) Development - During development, toner particles are attracted to the electrostatic latent image on the drum surface. Thus, a visible toner image is created.
- (4) Transfer - The toner image is transferred from the drum surface to the paper.
- (5) Peeling - Electric charges on the paper are partially neutralized. As a result, the paper is peeled off from the drum surface.
- (6) Fixing - The toner image is permanently fixed to the paper by heat and pressure.
- (7) Cleaning - The remaining toner is removed from the drum surface.

Summary of print process:

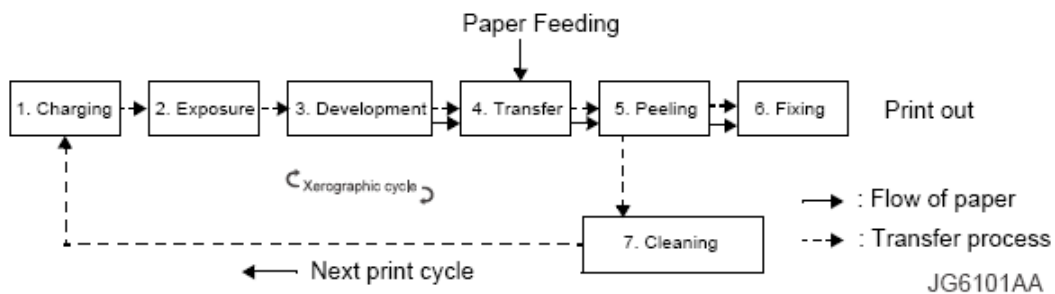

By rotating the drum, the surface undergoes various steps including charging, exposure, development, transfer, peeling, and cleaning. A toner image is created on the surface of the drum and transferred to the paper. The paper is subjected to some steps including transfer, peeling, and fixing by the paper transport mechanism. When the paper is placed in position relative to the image, the toner image is transferred to the paper from the drum surface, and then fixed.

Main components directly associated with the print process and transport of the paper are shown in the following figure.

Components associated with print process:

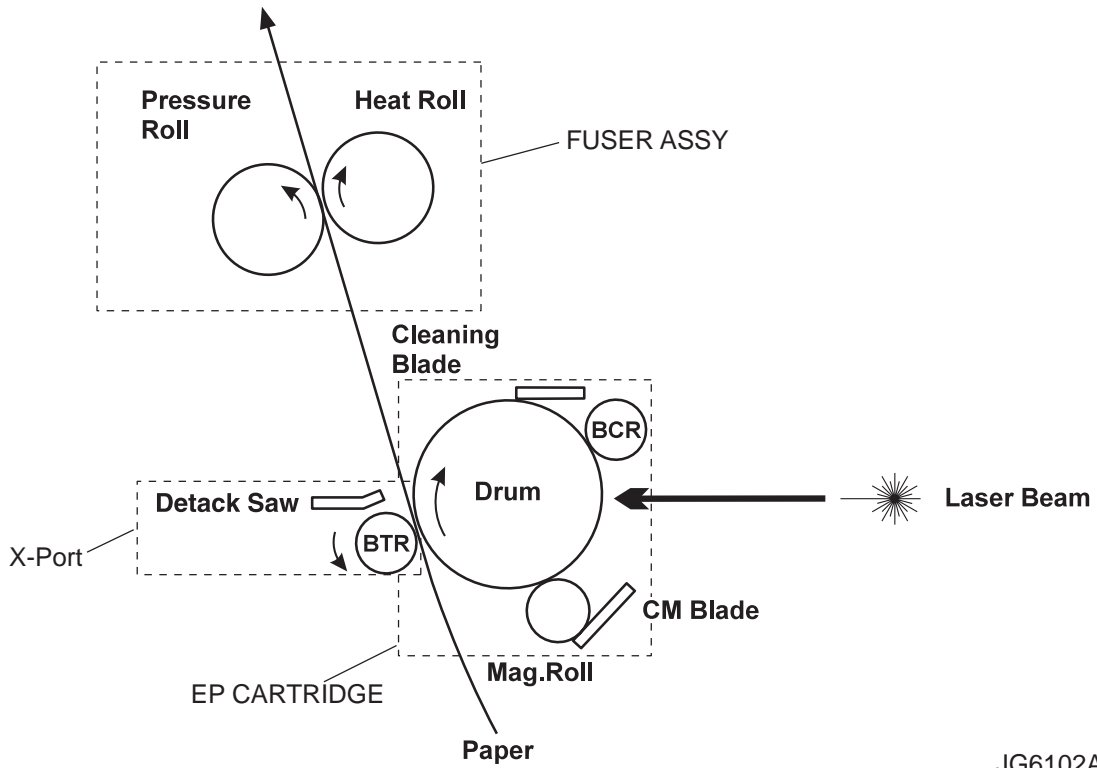

JG6102AA

Components associated with transport of paper:

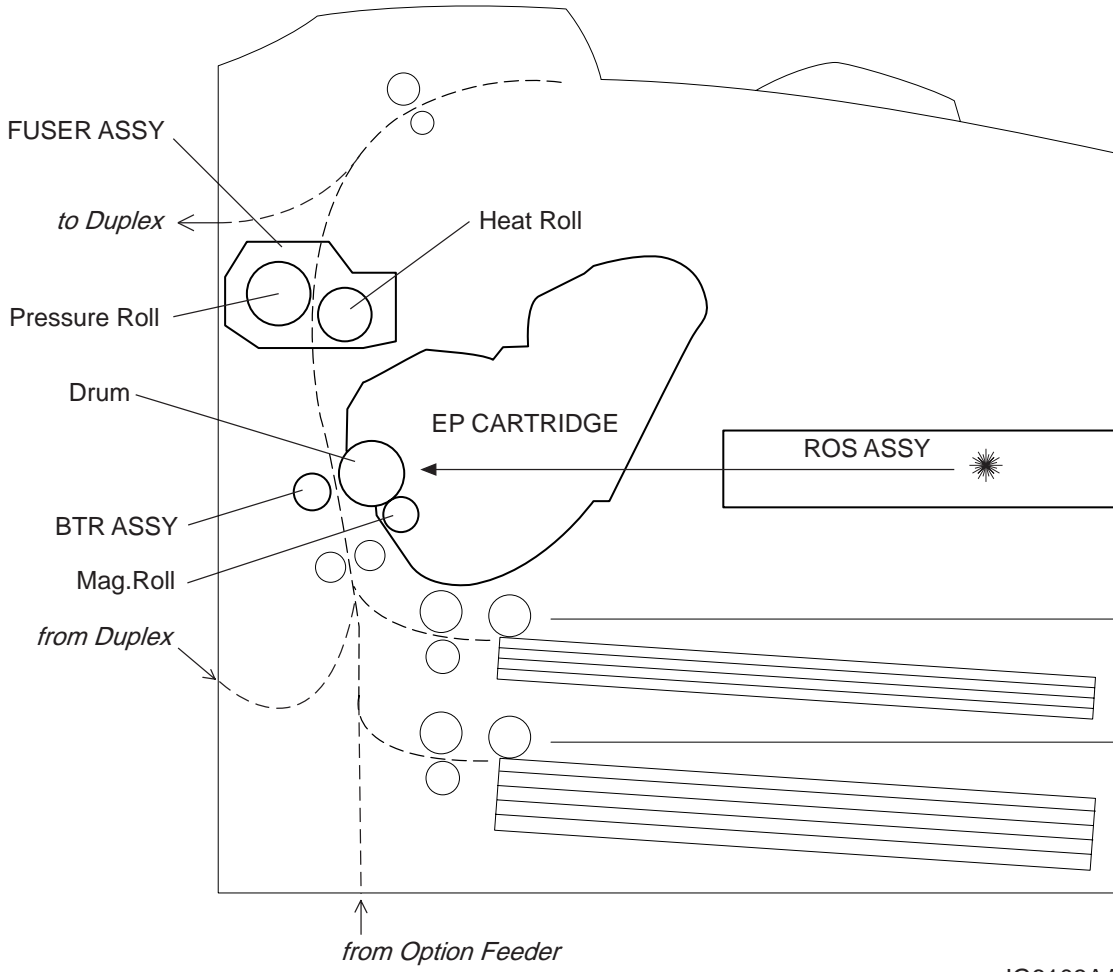

JG6103AA

In the exposure step, the surface of the drum negatively charged by the previous charging step is scanned by a thin laser beam. The light radiated from the laser diode of the ROS (Raster Output Scanner) scans the drum from one end to the other. The light passes via a rotating polygon mirror (12 facets) and also via a lens.

The radiation of the laser beam is adjusted according to a video signal from the PWBA ESS.

The laser beam shot at the drum excites electrons directed to the photoconductor. As a result, electron hole pairs are induced in the photoconductive layer. Since electrons are moved toward the body inside the drum by the electric field, the electron-hole pairs move to the surface of the photoconductive layer. Negative charges in this portion decrease, thus creating an invisible electrostatic latent image there.

Toner particles are adsorbed onto this electrostatic latent image in the next step. Thus, the image is developed. The toner particles adsorbed to the drum are attracted to positive charges supplied by the BTR, and are transferred to the paper. The drum is sent for peeling and cleaning steps.

Electrostatic latent image formed on drum:

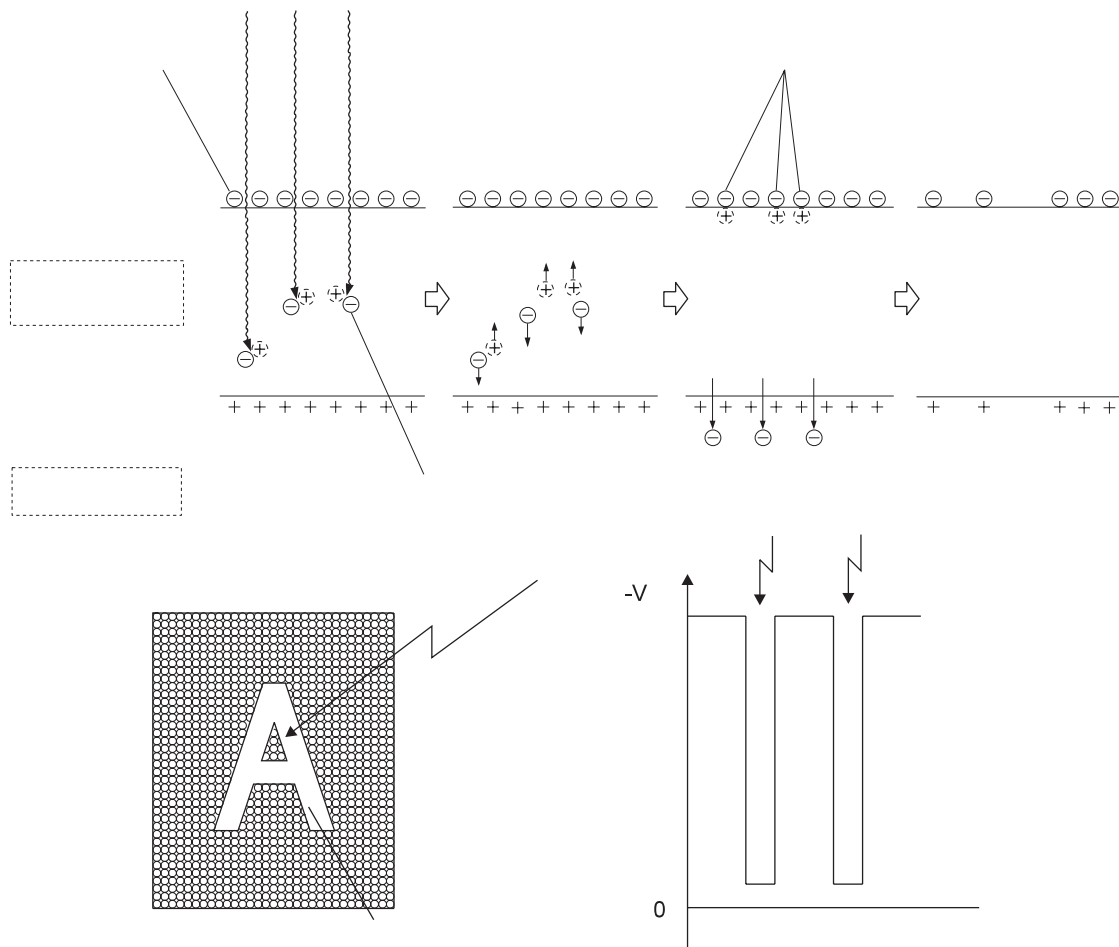

JG6104AA

In the cleaning step, the remaining toner is removed from the drum surface. The drum surface is prepared for the next cycle.

NOTE

The toner is scraped off the drum surface by a cleaning blade.

The toner scraped off in the cleaning step is collected in a recovery toner compartment partitioned from unused toner.

The transfer rate is normally more than 90%, but varies according to the image coverage range and environmental conditions such as temperature and humidity.

The used toner cannot be reused. When the printing step is started, the whole drum surface is scanned with a laser beam. If charges generated in the previous step remain on the drum surface, they are completely removed. When the continuous printing step is started and finished, a negative high voltage is applied to the BTR. If toner particles adhere to the BTR in the previous printing step, the toner particles are returned to the drum surface. In this way, the surface of the BTR is cleaned.

2. Flow of Print Data

The NIC (Network Interface Card) of the printer connected with a network receives a packet signal in a bit stream from a client or server of the network, and decomposes the packet signal received next into a data format adapted for a layer from which the data is sent to the Controller. The Controller processes the data from the NIC by the same method as for data received from the host computer via a parallel port. (These two types of data are referred to as host data.) PWBA ESS acts to buffer the rasterized bit-image host data or converts host data in PDL (Page Description Language) into rasterized bit-image data. The PWBA ESS sends each line of the rasterized bit-image data to the MCU of the HVPS/MCU whenever the laser beam makes a scan. This signal carrying image data (/VDO signal) is converted into LVDS signal by the MCU of the HVPS/ MCU, and is sent as XP.DATA+ and XP.DATA- signals to the ROS ASSY, where the signal is converted into a laser beam. The beam is emitted with a quite small diameter. The beam is turned ON and OFF according to the video signal. The laser beam is reflected off the surface of a rotating polygon mirror, so that the beam is concentrated to the surface of the drum of the EP CARTRIDGE by a series of lenses. As a result, an electrostatic latent image is created on the drum surface.

Print data (electrical signal) from the printer controller is converted into a print image through the following flow.

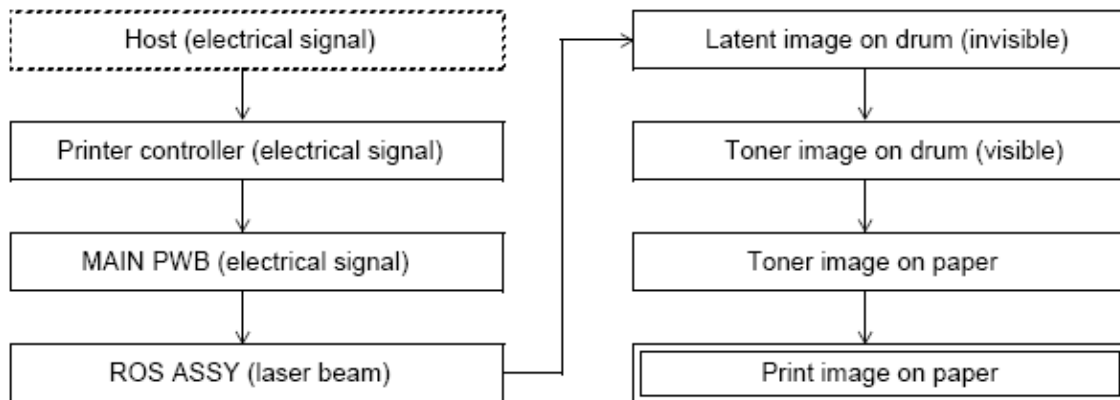

JG6105AA

3. Driving Force Transmission Path

3.1 MAIN MOTOR

The rotating force of the MAIN MOTOR is transmitted via gears in the GEAR ASSY HOUSING and via the GEAR ASSY PLATE to components that need mechanical driving force as shown in the following flow.

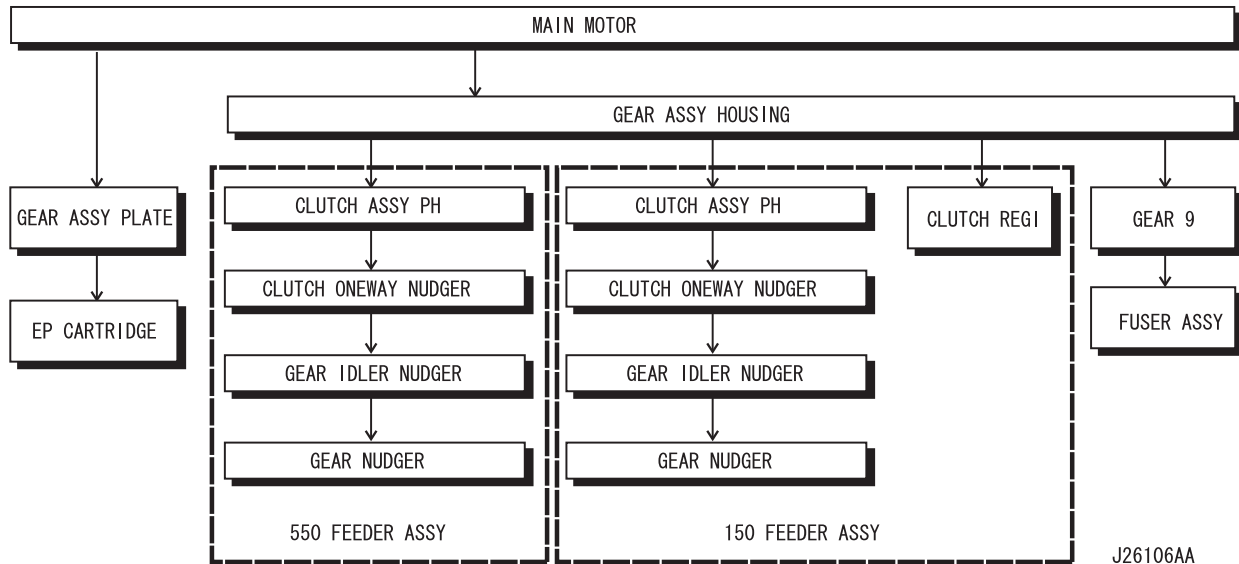

The driving force transmitted to the EP CARTRIDGE drives the Drum, and is transmitted to the BTR ASSY through the Drum Gear.

The driving force transmitted to the 550 FEEDER ASSY drives the ROLL ASSY NUDGER and ROLL ASSY FEED.

The driving force transmitted to the 150 FEEDER ASSY drives the ROLL REGI METAL and ROLL REGI RUBBER, as well as the ROLL ASSY NUDGER and ROLL ASSY FEED.

The driving force transmitted to the FUSER ASSY drives the Heat Roll.

3.2 MOTOR ASSY EXIT

The rotating force of the MOTOR ASSY EXIT is transmitted via various gears to components that need mechanical driving force as shown in the following flow.

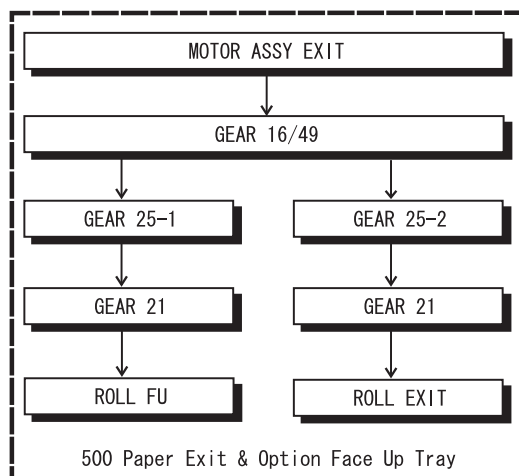

J26107AA

3.3 Gear Layout

Drive path in EP CARTRIDGE:

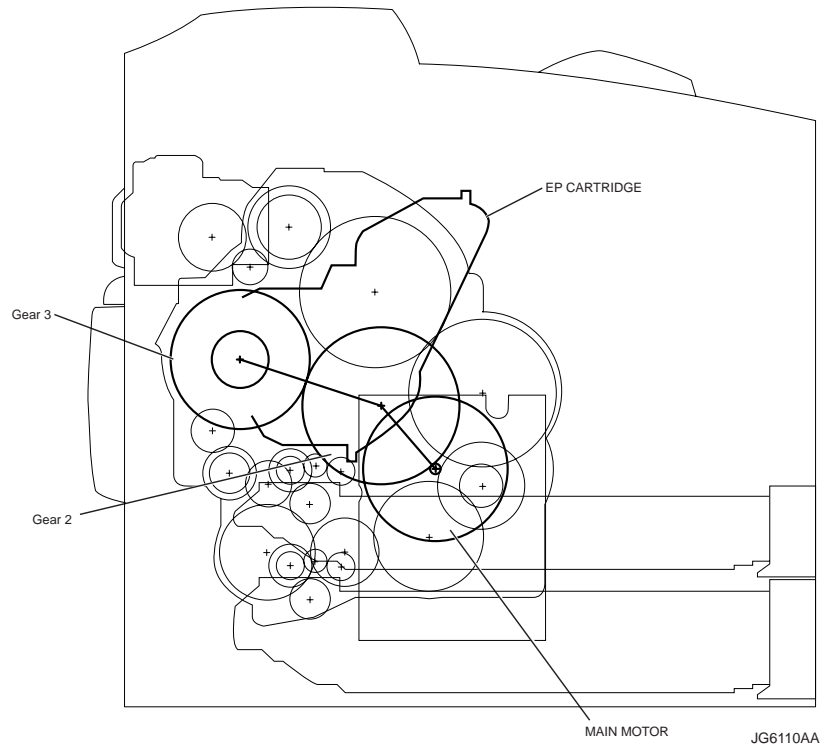

Drive path in FEEDER ASSY:

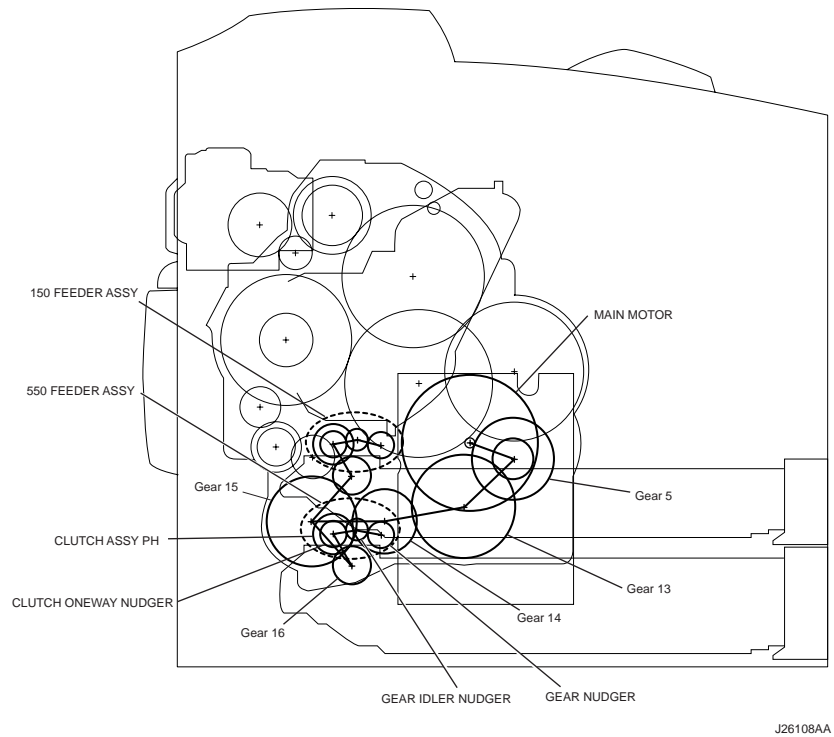

Drive path in CLUTCH REGI:

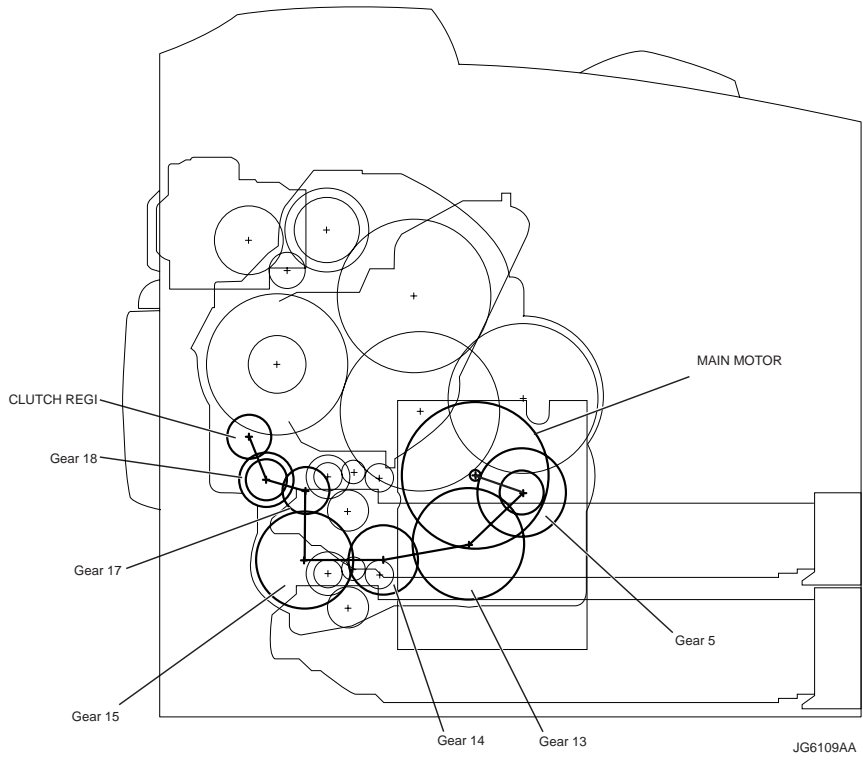

Drive path in FUSER ASSY:

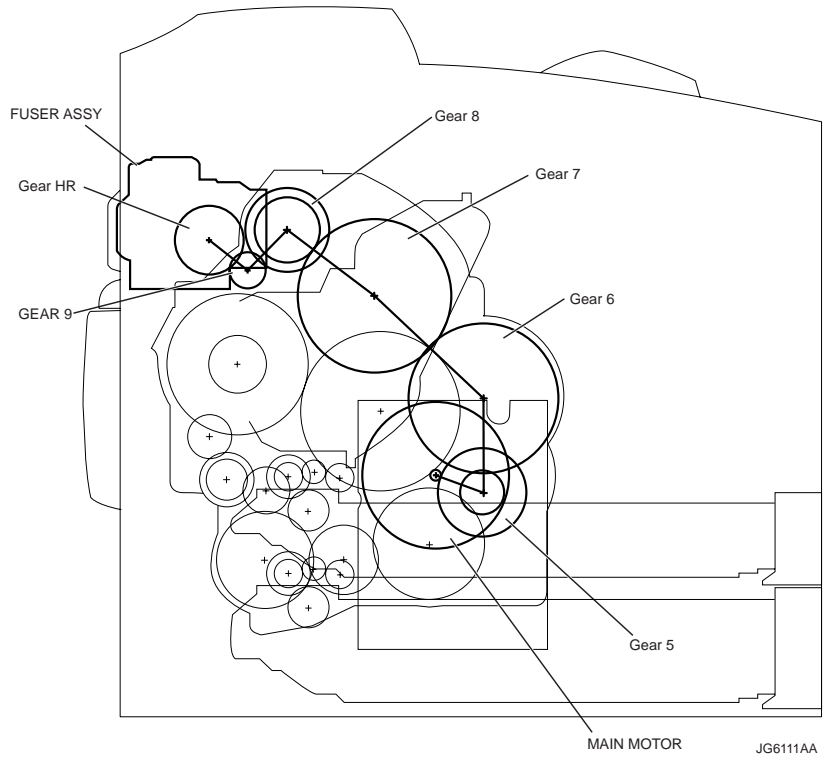

Drive path in 500 Paper Exit & Option Face Up Tray:

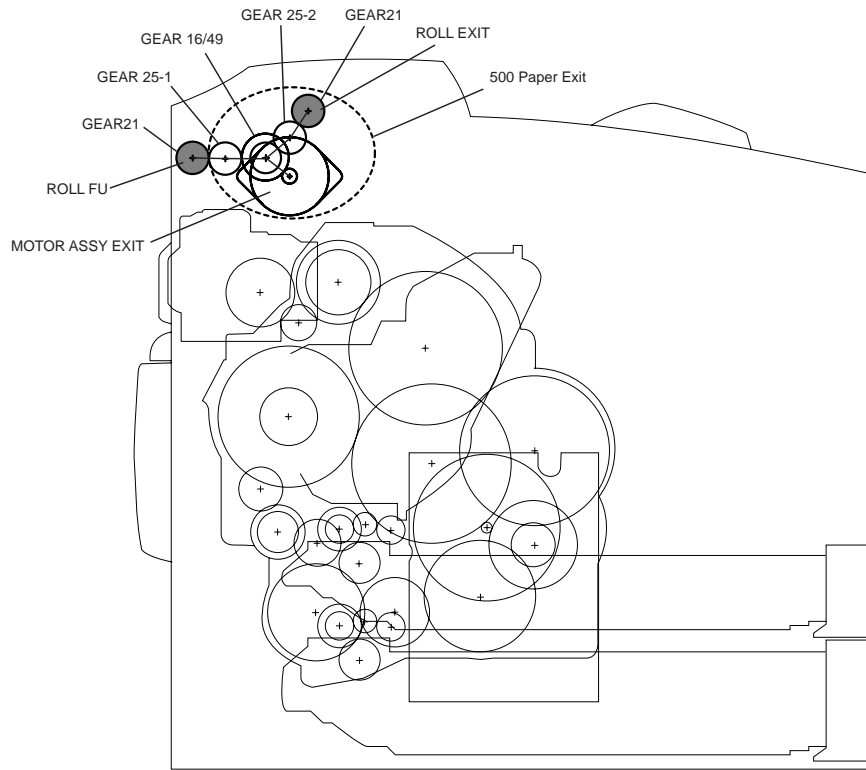

JG6112AA

4. Paper Transport

4.1 Paper Transport Path

The paper is supplied from the Tray1 and Tray 2 or the optional Tray3 and Tray 4, and is transported into the printer along the paper path shown below.

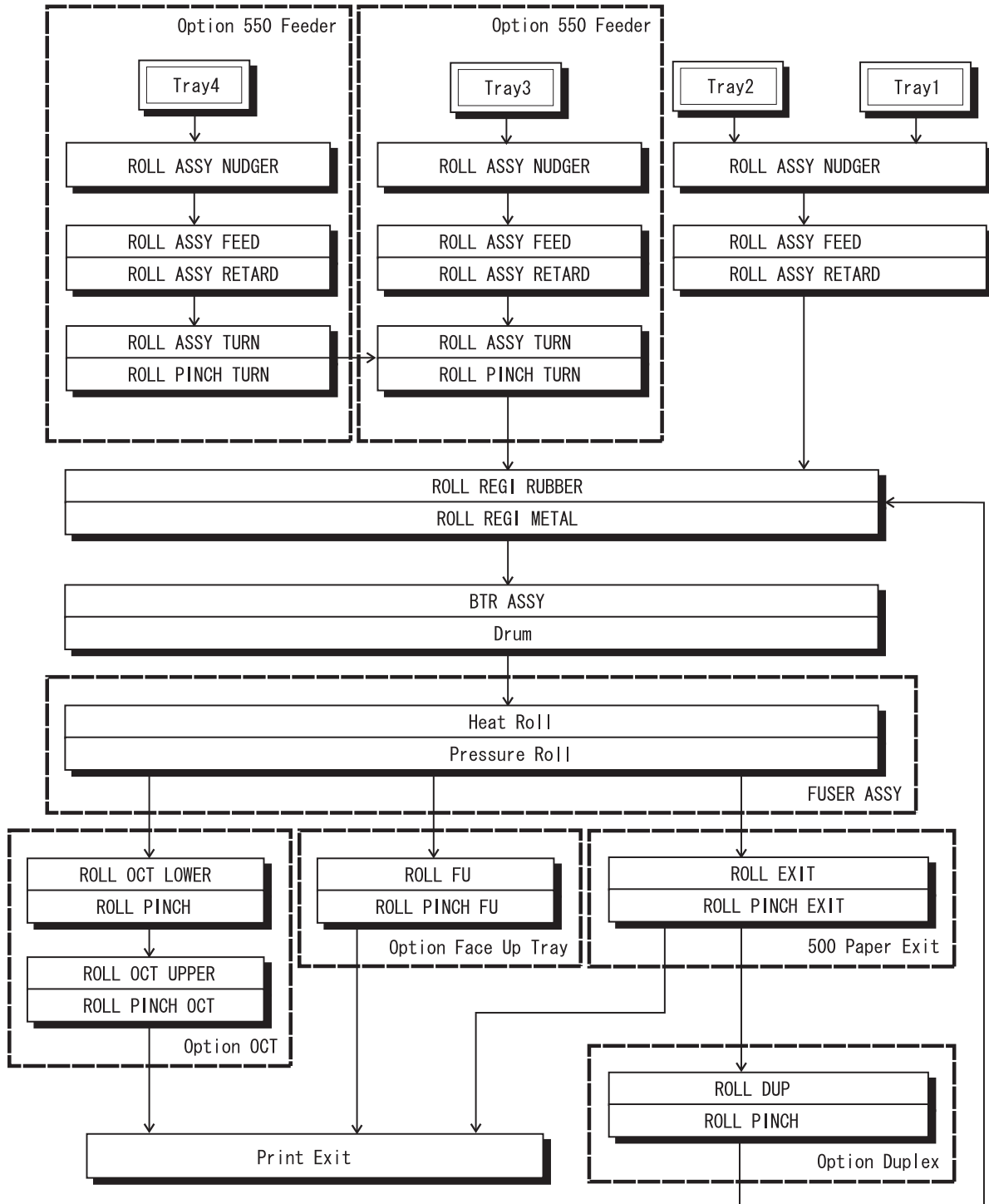

4.2 Layout of Paper Transport Path

The following is a cross section of the JIGEN printer. Main components directly associated with the paper path and transport are shown here.

Main components associated with transport of paper (when Option Duplex, Option 550 Feeder, Option OCT and 500 Paper Exit & Option Face Up Tray are installed):

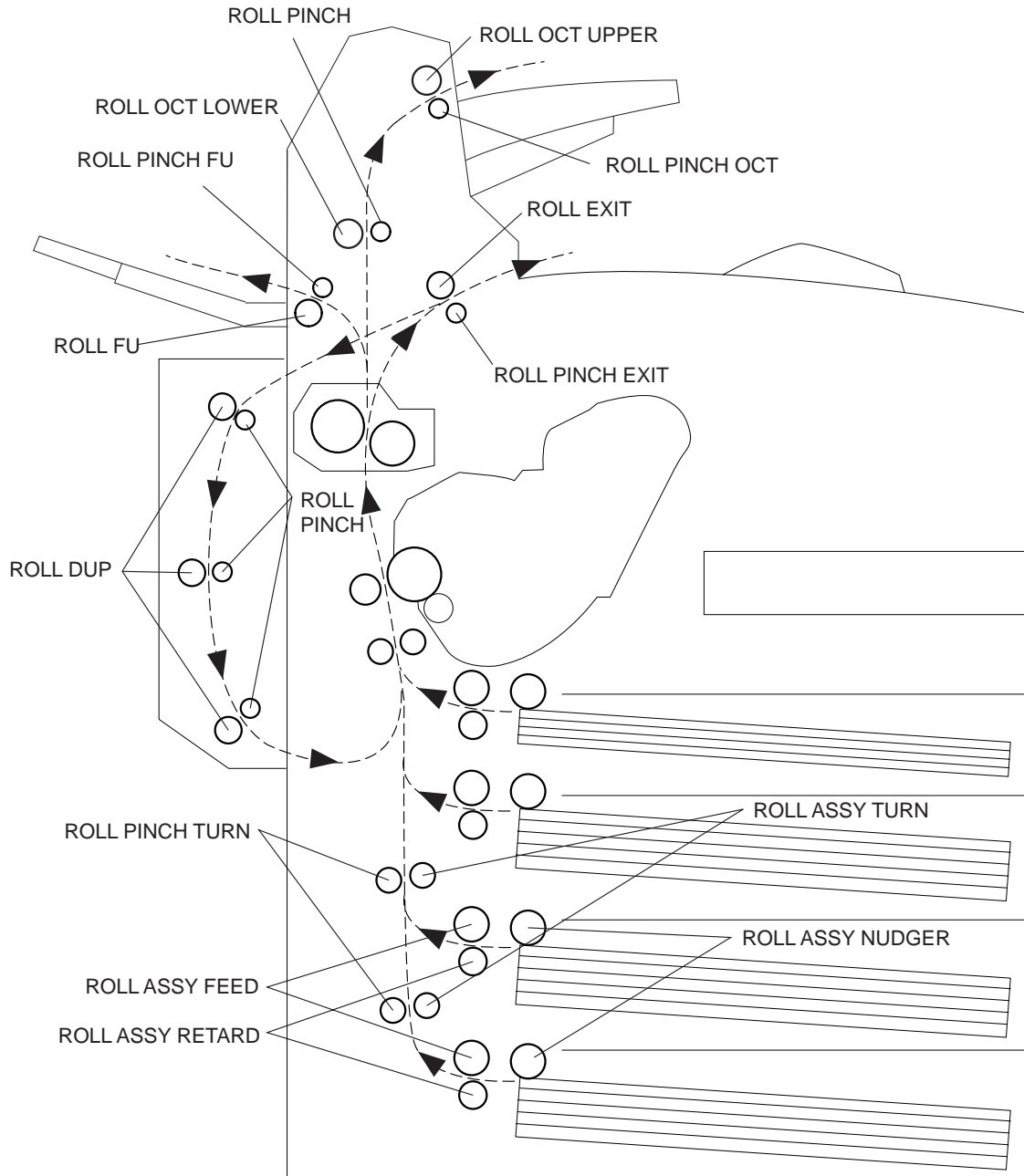

JG6115AA

5. Actions of Main Functional Components

The functions of the main components of the JIGEN printer are described in the following sections:

- 5.1 Paper Cassette
- 5.2 Paper Feeder
- 5.3 Xero
- 5.4 Fuser
- 5.5 500 Paper Exit & Option Face Up Tray
- 5.6 Drive
- 5.7 Electrical

5.1 Paper Cassette

Paper cassette models available include the 150 Paper Cassette and the 550 Paper Cassette. They are functionally equivalent, therefore only the 150 Paper Cassette is described here. Since a LOW INDICATOR does not exist on the 150 models, explanation for this indicator applies to the 550 Paper Cassette only.

If the paper is smaller than A4, adjust the GUIDE ASSY END 150 and GUIDE ASSY SD on the Paper Cassette to match the size. If the paper is larger than A4, disengage the EXTENSION that locks the HOUSING BASE 150 and HOUSING EXTENSION 150, and pull out the extension. Then adjust the GUIDE ASSY END 150 and GUIDE ASSY SD to match the size. When the extension is returned its original position, the LOCK EXTENSION locks automatically.

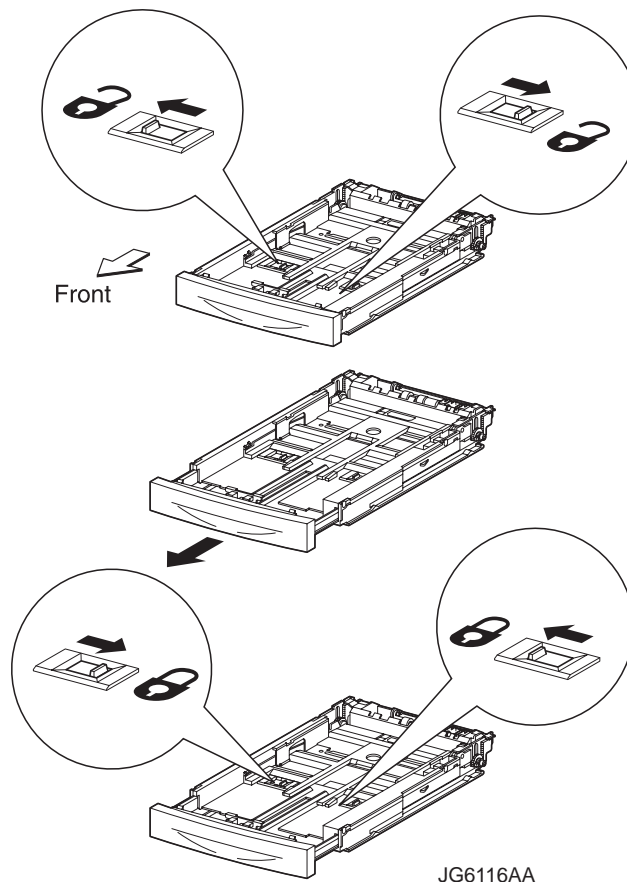

GUIDE ASSY L150 and GUIDE ASSY SD R150

The GUIDE ASSY SD R150 can be adjusted to different paper sizes by moving it to the left or right. The guides come into contact with the left and right edges of the paper and hold it in position. The GUIDE ASSY SD L150 moves simultaneously with the GUIDE ASSY SD R150.

LOCK EXTENSION

The 150 Paper Cassette is so constructed that it can cope with the length of the paper in the direction of travel by moving the position of the HOUSING EXTENSION150 forward and backward. The LOCK EXTENSION is adopted as a mechanism for holding the HOUSING EXTENSION150 in position.

GUIDE ASSY END150

This can be adjusted to different paper sizes by making a forward or backward adjustment. This makes contact with the rear end of the paper, and holds it in position in the forward and rearward directions. The paper size to which the cassette is set is transmitted to the LINK SW SIZE 1/2/3 via the GEAR SECTOR and RACK SIZE by the GUIDE ASSY END150. The three LINK SW SIZE units turns ON or OFF respectively according to the transmitted paper size. The paper size is detected by transmitting the ON/OFF information to the Size Switch in the GUIDE TRAY LEFT. The types of paper that can be automatically detected are as follows:

Type	Size (mm × mm)
Letter SEF	215.9 × 279.4
Legal 14" SEF	215.9 × 355.6
Legal 13" SEF	215.9 × 330.2
Executive SEF	184.2 × 266.7
A4 SEF	210.0 × 297.0
B5 (JIS) SEF	182.0 × 257.0
A5 SEF	148.5 × 210.0

LEVER BTM LOCK and STOPPER GEAR

These are at the rear end of the cassette (i.e. the exit path of the paper). When the cassette is inserted into the printer, the protrusions on the Feeder trigger the mechanism that depresses the LEVER BTM LOCK, slides the RACK BTM LOCK 150, and then simultaneously unlocks the GEAR PINION and GEAR PB R of the STOPPER GEAR.

PLATE ASSY BTM

The force pushing up the PLATE ASSY BTM is supplied via the SPRING BTM UP150 by unlocking the LEVER BTM LOCK and STOPPER GEAR. When the PLATE ASSY BTM is pushed up, the supplied paper and ROLL ASSY NUDGER touch each other.

LOW INDICATOR

The LOW INDICATOR is installed only on the 550 Paper Cassette. The amount of paper remaining in the cassette is indicated by the LOW IND FRONT. As the amount of paper reduces, the PLATE ASSY BTM rises and the LOW IND FRONT goes down in the GUIDE INDICATOR.

150 Paper Cassette:

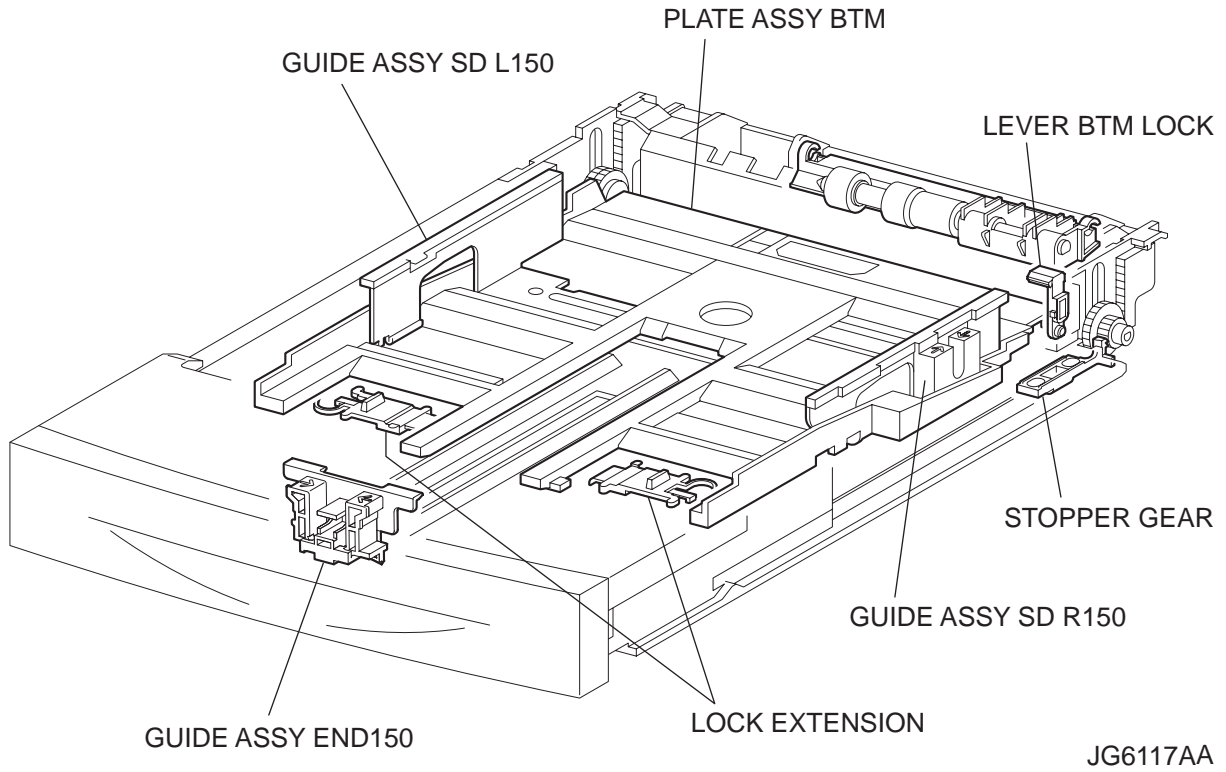

550 Paper Cassette:

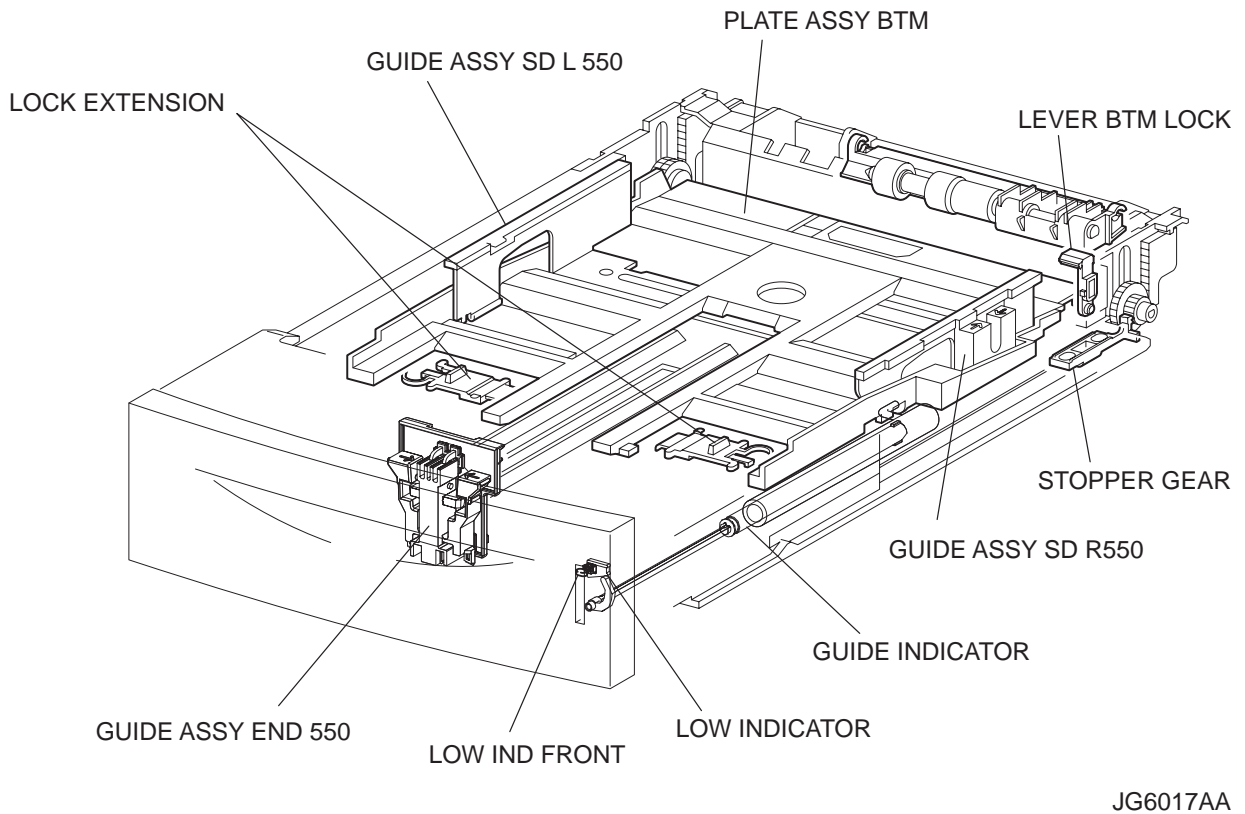

5.2 Paper Feeder

Since the Tray1 and Tray2 are functionally equivalent in terms of the Size Switch, ACTUATOR NO PAPER, and SENSOR NO PAPER, only the components of one tray are described here. Since the ACTUATOR LOW PAPER and SENSOR LOW PAPER are not installed in the Tray1, the description of these components applies to the Tray2 only.

150 FEEDER ASSY(Tray1) / 550 FEEDER ASSY(Tray2)

This is a mechanism for supplying paper from the Paper Cassette into the printer. The driving force from the MAIN MOTOR is transmitted via the CLUTCH ASSY PH to the ROLL ASSY FEED and ROLL ASSY NUDGER that are components of FEEDER ASSY. Thus, the paper is transported. When the ROLL ASSY NUDGER picks up some sheets of paper and the paper gets low, the position of the ROLL ASSY NUDGER drops accordingly. The lowered ROLL ASSY NUDGER pushes down the lock lever of the PLATE ASSY BTM, releasing it. The PLATE ASSY BTM is pushed up by a spring, and thus the paper is raised. The raised paper then raises the SUPPORT NUDGER. The SUPPORT NUDGER disengages from the lock lever of the PLATE ASSY BTM. The PLATE ASSY BTM stops moving upward.

Size Switch

A switch for setting the size of paper supplied from each Paper Cassette is mounted. A signal indicating the set size is transmitted as a voltage to the HVPS/MCU.

ACTUATOR NO PAPER

If paper runs out in the Paper Cassette, the ACTUATOR NO PAPER drops and the flag of the ACTUATOR NO PAPER that shielded the detection portion of the SENSOR NO PAPER moves off the detection portion. Thus, the light is transmitted.

SENSOR NO PAPER

The presence or absence of paper in the Paper Cassette is detected by the position of the ACTUATOR NO PAPER. This is converted into an electrical signal. If the detection portion is shielded (i.e., there is paper), /NO-PAPER 1/2 SNR ON signal is turned OFF.

SENSOR REGI

The paper transported from the Paper Cassette pushes up the ACTUATOR B. The flag of the ACTUATOR A optically exposes the detection portion of the SENSOR REGI. Thus, the passage of paper is detected.

CLUTCH REGI

This electromagnetic clutch turns ON and OFF the driving force to the ROLL REGI RUBBER and ROLL REGI METAL, to place the paper in position.

ACTUATOR LOW PAPER

When paper is low in the Paper Cassette installed in the Tray2, the arm of the ACTUATOR LOW PAPER is pushed up by the PLATE ASSY BTM. The flag of the ACTUATOR LOW PAPER that shielded the detection portion of the SENSOR LOW PAPER moves off the detection portion. Thus, the light is transmitted.

SENSOR LOW PAPER

When paper is low in the Tray2 Paper Cassette, this is detected by the position of the ACTUATOR LOW PAPER and converted into an electrical signal. When the detection portion is shielded (i.e. paper is high), /LOW PAPER SNR ON signal is turned OFF.

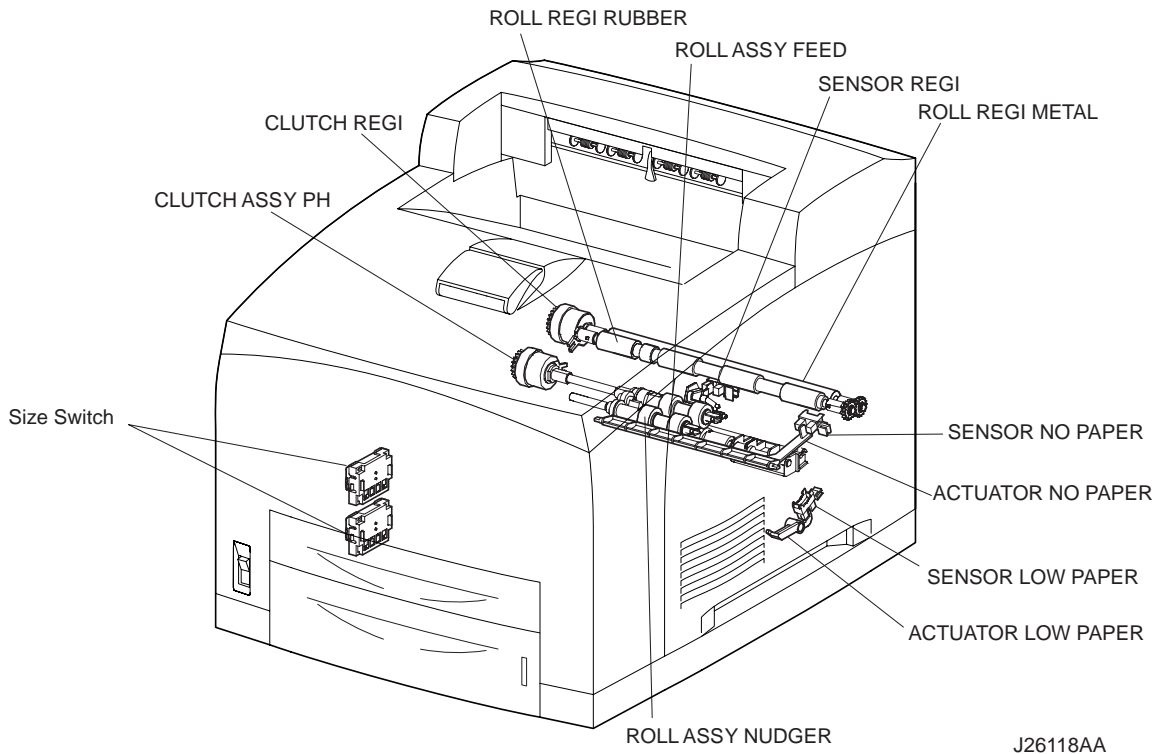

J26118AA

5.3 Xero

EP CARTRIDGE

The EP CARTRIDGE is also known as CRU (Customer Replaceable Unit), and is made up of the following five components.

-Drum

This is a cylinder of aluminum and coated with a photoconductive material. Because of this photoconductive coating layer, electric charges are retained on the surface in the dark, and electrical conduction occurs when exposed to light.

-BCR (Bias Charge Roll)

This uniformly distributes electric charges over the drum surface, and erases a charge-reduced pattern remaining from the previous cycle.

-Magnet Roll

This holds toner as a thin layer on the surface of this roll, and acts to transport the toner into the gap between the drum and Magnet Roll. The toner is supplied to the Magnet Roll by the Agitator in the Toner Compartment.

-CM Blade (Charging and Metering Blade)

This spreads the toner into a thin layer over the Magnet Roll, and applies negative charges to the toner tribo-electrically.

-Cleaning Blade

This scrapes toner remaining after the transfer step off the drum surface.

BTR ASSY

The BTR of the BTR ASSY is in contact with the drum of the EP CARTRIDGE, and is driven by the Drum Gear. When the paper moves between the BTR and Drum, the BTR applies positive charges to the rear surface of the paper. The negatively charged toner image is attracted by positive charges on the rear surface of the paper. Thus, the image is transferred from the surface of the drum to the surface of the paper.

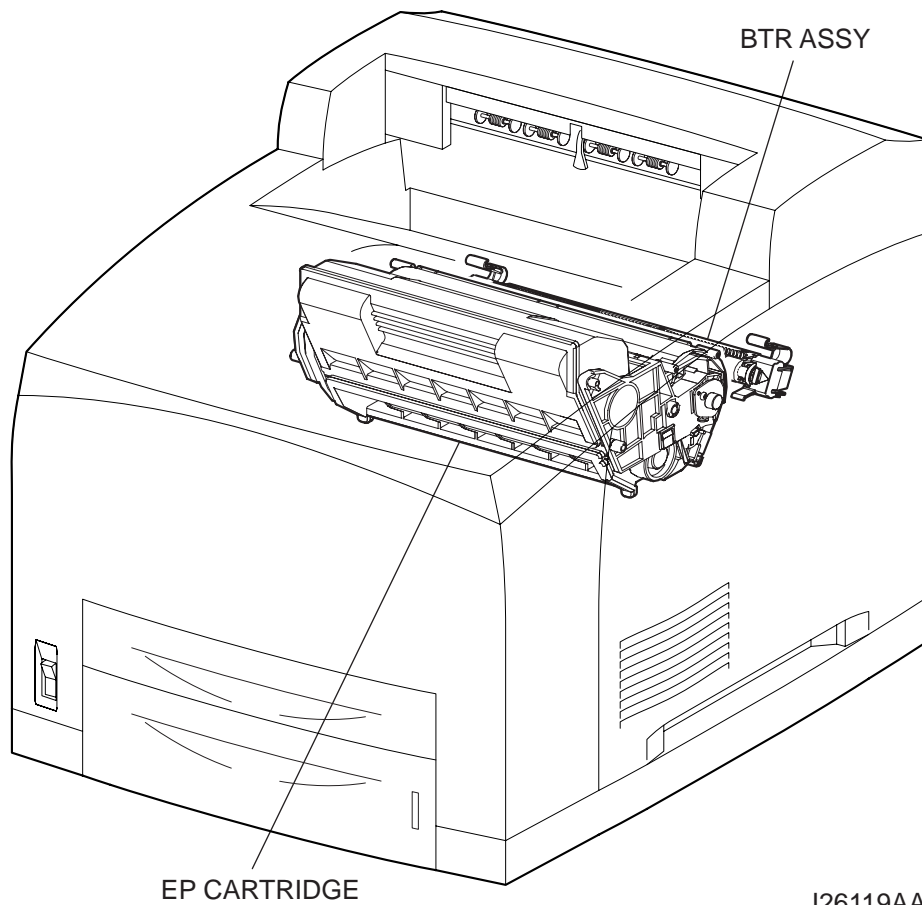

J26119AA

ROS ASSY

The ROS (Raster Output Scanner) scans the surface of the drum with a laser beam. The ROS ASSY consists of the following three components, i.e., LD (Laser Diode) Assembly, Scanner Assembly, and SOS PWB.

-LD Assembly

The LD Assembly produces a laser beam. This beam is turned ON and OFF according to a print data signal.

-Scanner Assembly

The Scanner Assembly consists of a Polygon Mirror (12 facets) and a Scanner Motor. The Polygon Mirror is mounted to the shaft of the Scanner Motor. The Scanner Motor rotates the Polygon Mirror at a specified speed. The rotating Polygon Mirror reflects the beam to the drum surface through lenses and mirrors, to scan the beam from one end to the other of the drum. One scan is made with one facet of the mirror. The Scanner Motor is driven by three phase, full-wave current linear drive. The current through the winding of each phase is switched by a Hall amplifier matrix. The signal from the phase detection terminal of the Motor is used.

-SOS PWB

When the laser beam hits the SOS Sensor of the SOS PWB, the beam is converted into an electrical signal (SOS signal), and the initial position where a scan is started on each line is detected.

When the laser beam is scanned across the drum surface from one end to the other while turning ON and OFF the beam, one line of latent image is created. If the scanning by the laser beam is repeated while rotating the drum, a two-dimensional image is created. The resolution in the scanning direction (from right to left) is determined by the rotational speed of the Scanner Motor and by the speed at which the laser is adjusted. The resolution in the process direction (from top to bottom) is determined by the rotational speed of the Scanner Motor. (If the scanning speed is increased, the next row to be scanned can be started earlier accordingly.)

Conceptual diagram of image creation by scanning

Conceptual diagram of image creation by scanning

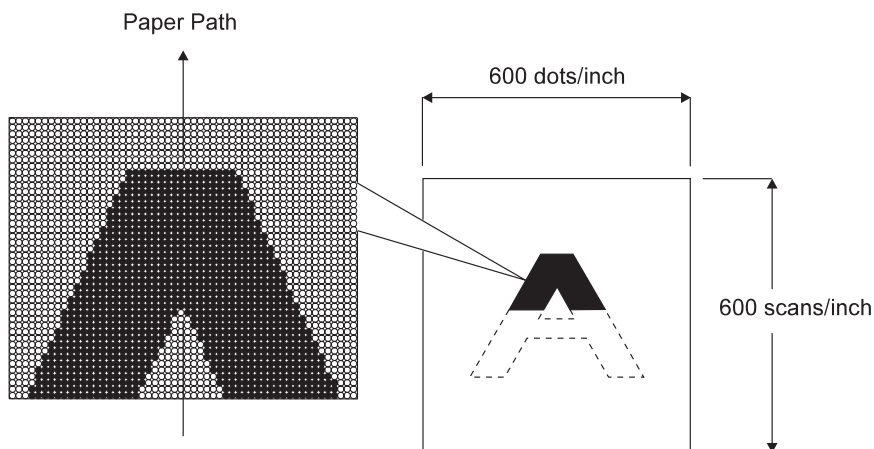

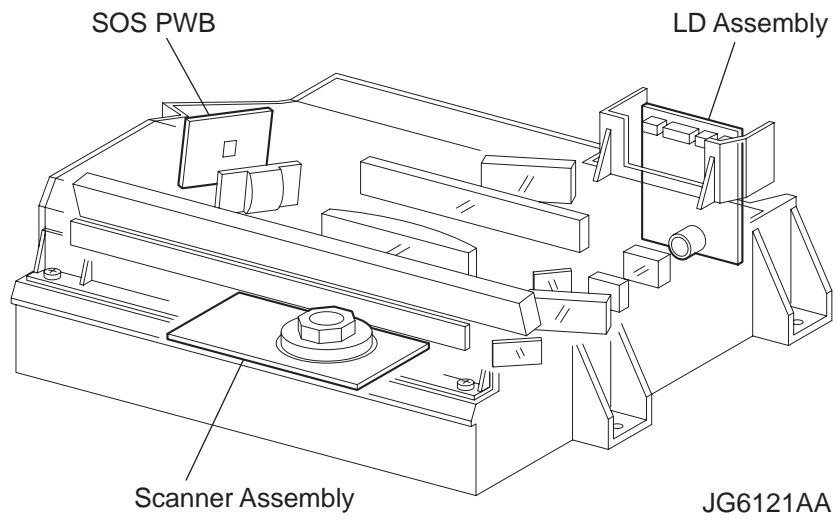

5.4 Fuser

Heat Roll

This is a hollow metal tube having a coated surface. This tube is heated by the inside Heater Rod. Heat is applied to the paper passing between this roll and the Pressure Roll. This heat fuses and fixes the toner on the paper.

Pressure Roll

This is a metal shaft coated with sponge rubber. Pressure is applied to the paper between this roll and the Heat Roll. This pressure presses the melted toner against the paper.

Heater Assembly

The Heater Assembly consists of a Heater Rod located in a Heat Roll and a harness connecting the Heater Rod to a terminal. The Heater Rod consists of heater coil inside a quartz glass and heats up the Heat Roll.

Temperature Sensor

This is a resistor (thermistor) having a known value of resistance that sensitively varies with temperature. This sensor is mounted in contact with the surface of the Heat Roll, and monitors the temperature of the surface. The power supply of the Heater Rod is turned ON and OFF using the signal from this sensor, so that the surface temperature of the Heat Roll can be maintained within a specified range. This signal is also used to provide a first stage of overheat protection.

Thermostat Sensor (STS)

Two STS are installed. The STS are connected to the Heat Roll in series. This provides a second stage of overheat protection. If the first stage does not prevent the Fuser from overheating, the Thermostat cuts off the power-supply circuit for the Heater Rod. The STS operates as follows:

- (1) If the paper is set incorrectly, the Pressure Roll may melt and adhere. As a countermeasure against this, the power-supply circuit is cut off to cool down the roll, if the detected temperature gets higher than a preset temperature.
- (2) If the temperatures increase at both sides of the Heat Roll, both ends of the paper may curl. As a countermeasure against this, the mode is switched to Short lamp lighting to control the temperature rise, if the detected temperature exceeds the preset temperature.

Heat Roll Fingers

These fingers peel off the leading edge of the paper from the Heat Roll to prevent the paper from getting wound around the Heat Roll.

Heat Roll Diode

The negative charge accumulated on the Heat Roll may deteriorate the toner image on the paper during fixing. The Heat Roll Diode discharges the charge to the frame ground.

Exit Sensor

This sensor detects the arrival of the paper at a detection point in the exit area positioned behind the Fuser. This sensor also detects the discharge of the paper from this point. When the sensor receives light (i.e., paper is present), /EXIT goes Low.

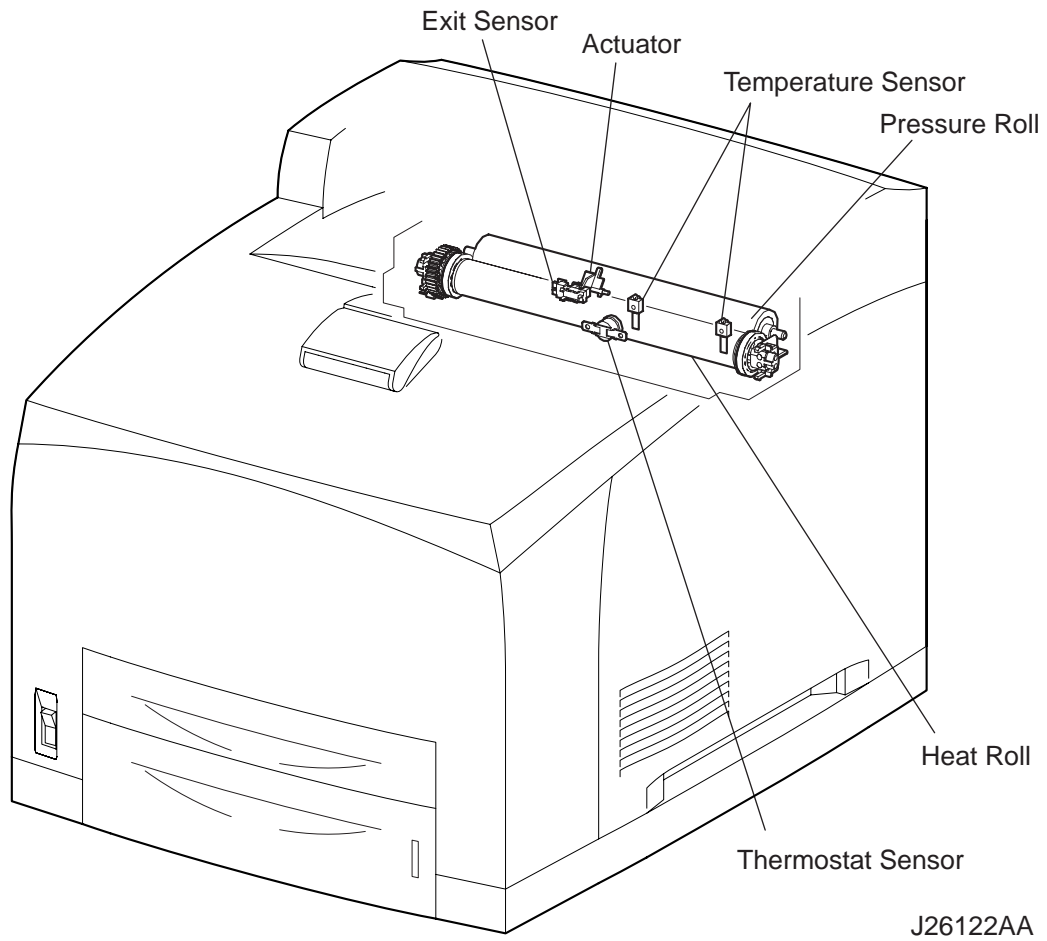

5.5 500 Paper Exit & Option Face Up Tray

500 Paper Exit is components for discharging the printed paper out of the printer. 500 Paper Exit enables Face-Up output to the Option Face Up Tray (mounted on the rear surface of the machine), and output to Option OCT as well as Face-Down output.

MOTOR ASSY EXIT

This motor drives the ROLL EXIT that conveys paper to each output tray. If the optional DUPLEX is installed, this motor has also a function of reversing and inserting paper into the Duplex.

ROLL EXIT

This roll transports the printed paper sent out from the Fuser, to the Face-Down output tray.

ROLL FU

This roll discharges the printed paper sent out from the Fuser, to the Face-Up output tray.

SENSOR FACE UP OPEN

This sensor detects that the Face-Up print has been selected. If the LEVER GATE FU is raised, a signal is detected by the Actuator attached to the interlocking GATE FU, and the Face-Up print mode is set.

SENSOR FULL STACK

This sensor detects that the 500 Exit Face-Down output tray is full, using the ACTUATOR FULL STACK.

GATE FU

This gate switches the paper transport path interlocking with the LEVER GATE FU. When the LEVER GATE FU is raised, the GATE FU blocks the normal paper output path and switches the output direction to the Face-Up output tray.

GATE OCT EXIT

This gate switches the paper transport path interlocking with the LINK GATE OCT. When the SOLENOID ASSY GATE installed in the optional OCT operates, the LINK GATE OCT pushed down by the spindle of the SOLENOID ASSY GATE blocks the normal paper output path and switches the output direction to the OCT output tray.

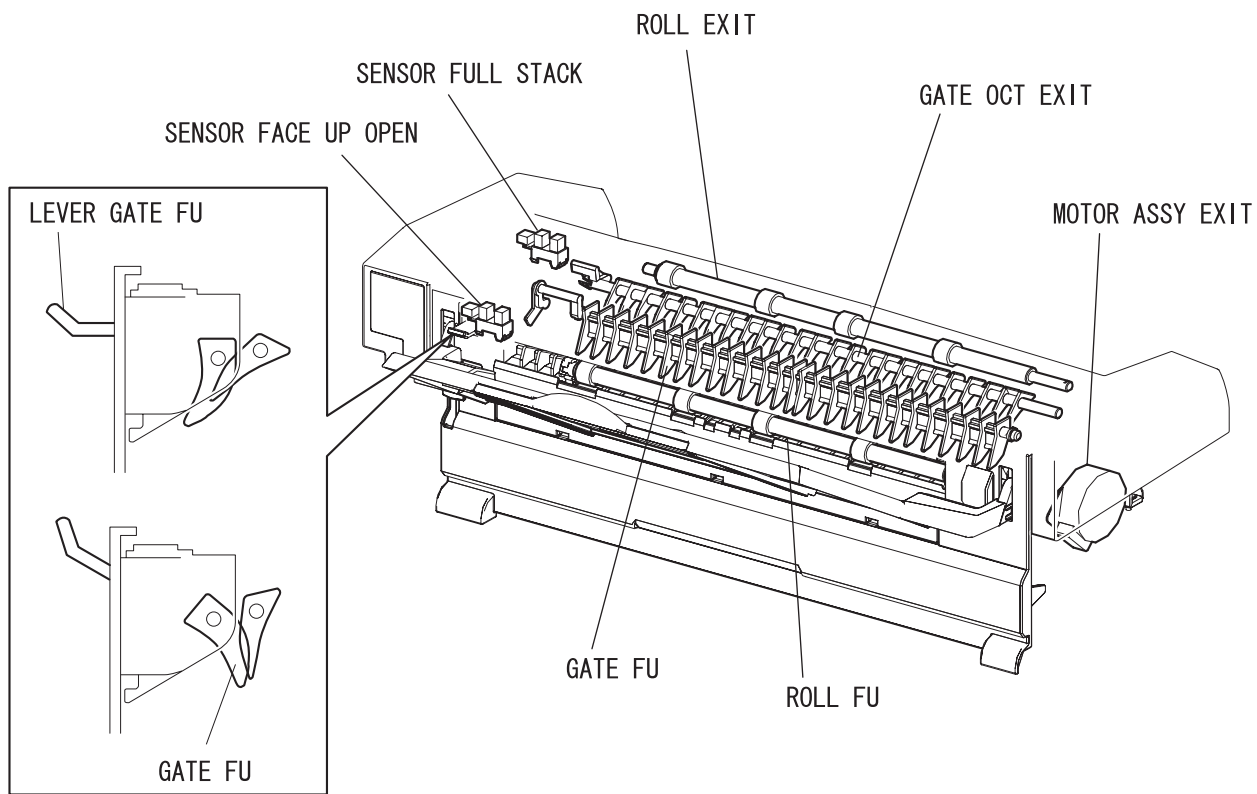

JG6123AA

5.6 Drive

GEAR ASSY HOUSING

This housing is composed of gears for transmitting power from the MAIN MOTOR that drives the printer body to various portions of the printer.

GEAR ASSY PLATE

This transmits power from the MAIN MOTOR to the EP CARTRIDGE.

LEVER LINK

This connects and disconnects the power from the MAIN MOTOR to the FUSER ASSY. When the COVER OPEN is opened, the LEVER LINK pushes up the Gear 8 in the GEAR ASSY HOUSING, and disconnects the GEAR 9. Thus, the power path to the FUSER ASSY is disconnected. As the LEVER LINK moves up and down, the Gear 4 in the GEAR ASSY PLATE moves right and left via the LINK GEAR 3, and power to the Drum of the EP CARTRIDGE is connected or disconnected.

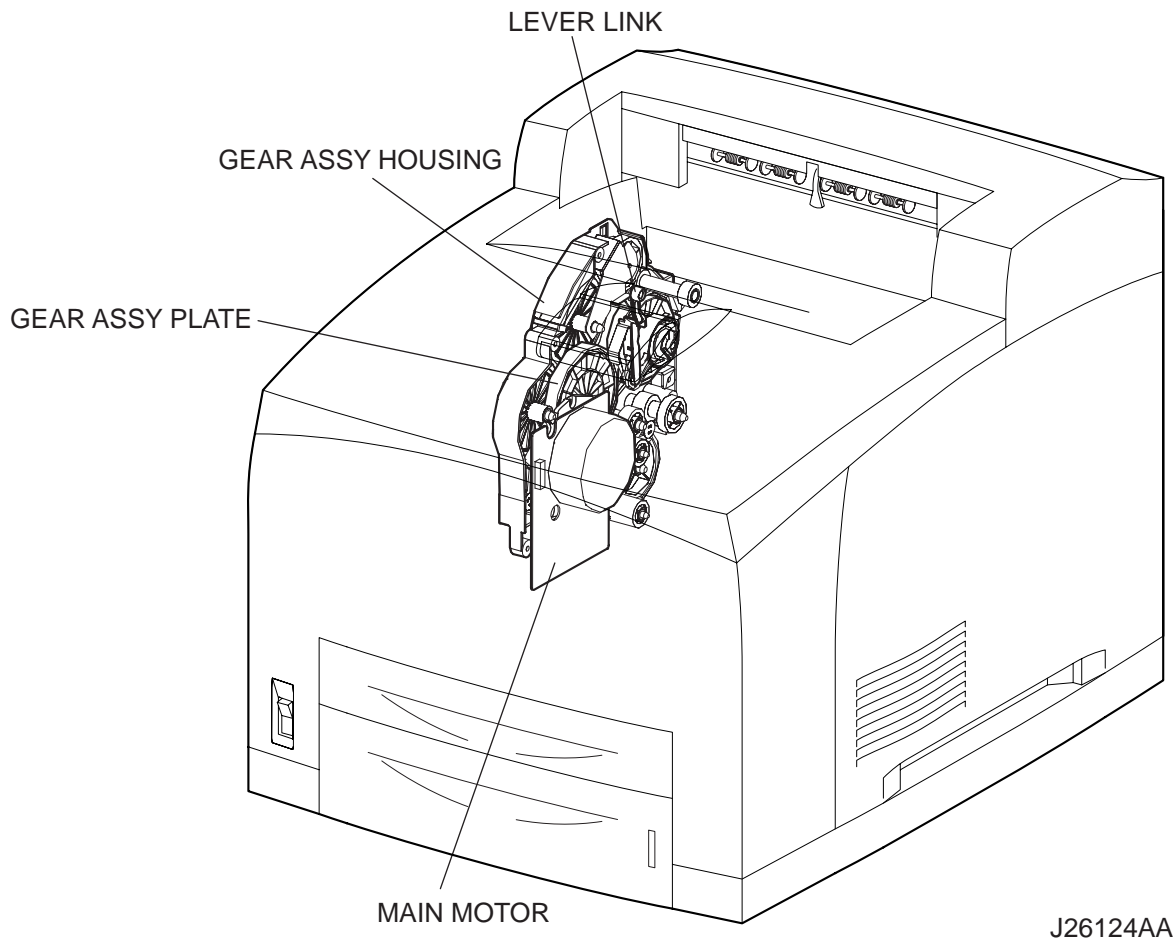

5.7 Electrical

INTERLOCK S/W 24V

This safety switch cuts off a 24 VDC power supply from the LVPS to the HVPS MCU and MAIN MOTOR when the COVER OPEN is open.

INTERLOCK S/W 5V

This safety switch cuts off a 5 VDC power supply from the LVPS to the LD Assembly of the ROS ASSY when the COVER OPEN is open.

INTERLOCK S/W REAR

This safety switch interrupts a 24 VDC power supply from the LVPS to the HVPS/MCU and MAIN MOTOR when the COVER REAR is open.

FAN MAIN

This vents air inside the printer to prevent an excessive rise in the inside temperature.

FAN SUB

This fan takes outside air into the printer to prevent an excessive rise in the inside temperature. This is mounted on the ROS ASSY in the center on the front side.

LVPS

This generates low DC voltages (5 V and 3 V for Logical Circuit, 5 V for Laser Diode, and 24 V for Motor and Clutch) from the AC power.

HVPS/MCU

The functions of the HVPS and MCU are incorporated in this substrate. The HVPS generates high AC and DC voltages and supplies them to the BCR (charging), Magnet Roll (development), BTR (transfer), and Detack Saw (peeling). The MCU controls the printing operation according to the information obtained through communications with the Print Controller and from sensors and switches.

PWBA ESS

This receives data from the Host Computer, performs printing, and controls the whole printer.

PWBA EXIT MOTOR

This controls the MOTOR ASSY EXIT according to a signal from the HVPS/MCU.

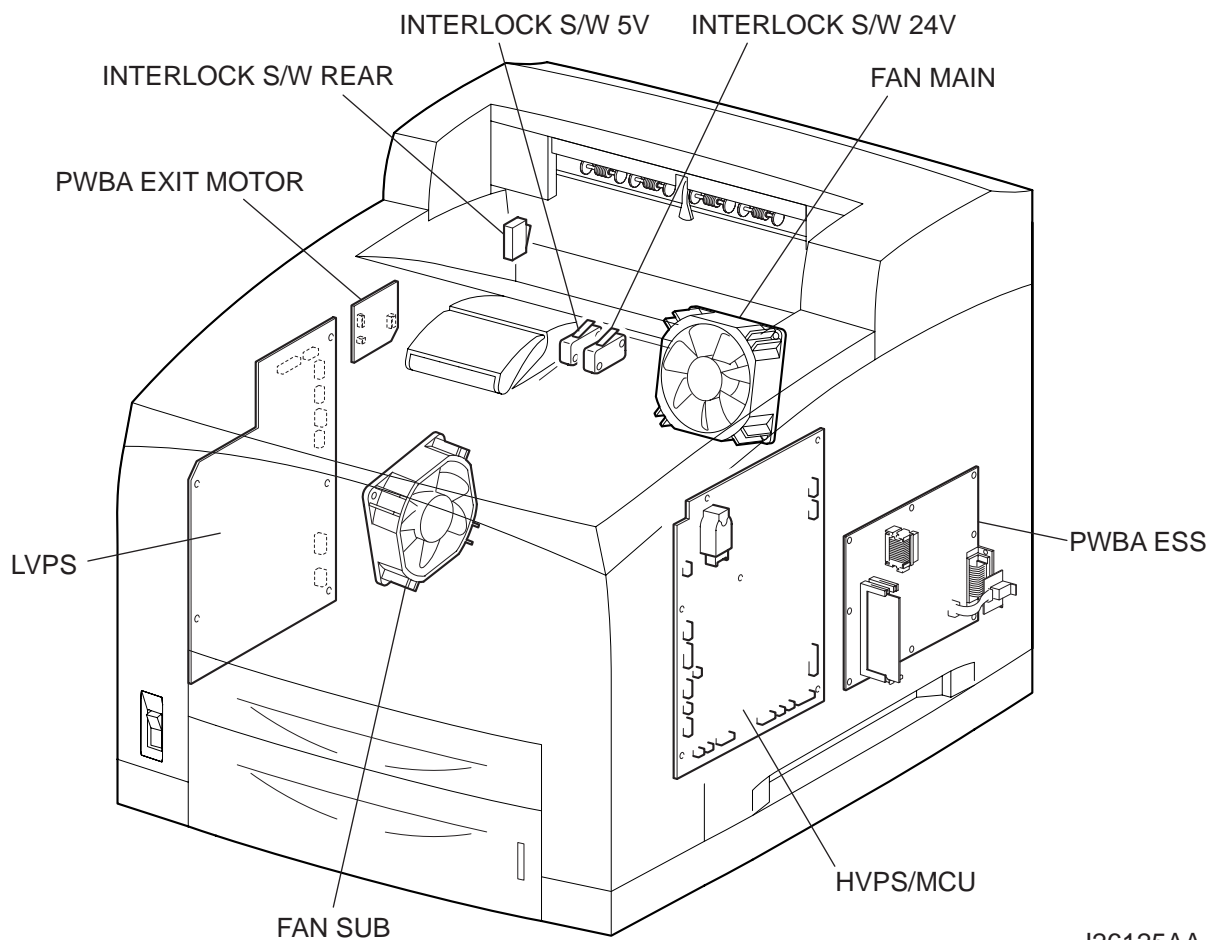

J26125AA

6. Control

6.1 Control of Paper Size

6.1.1 Cassette Feeding (Paper Cassette)

The following table gives the states (ON(1) or OFF (0)) of the switches in the Size Switch, corresponding to the paper sizes of the Paper Cassette.

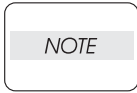

The switches in the Size Switch are denoted by "SW1", "SW2", "SW3", and "SW4", respectively, from the front side.

Paper Size	Size Switch			
	SW1	SW2	SW3	SW4
No cassette	0	0	0	0
Executive SEF	0	0	0	1
B5(JIS) SEF	0	0	1	1
A5 SEF	0	1	0	1
Legal 14"SEF	0	1	1	1
Letter SEF	1	0	0	1
A4 SEF	1	1	0	1
Legal 13"SEF	1	1	1	1

6.2 ROS Control

6.2.1 Rotation of Scanner Motor

The control (ON/OFF) of the rotation of the Scanner Motor is performed as shown below according to the mode of operation.

Mode of operation	ON/OFF of rotation of Scanner Motor
Standby state	Kept OFF.
Printing state	Turned on by receiving signal from the Controller, and turned off after 10 s since end of printing.
Power-saving state	Kept OFF.

The following table gives the resolution that differs according to the specifications of the machine, and the corresponding rotational speeds of the Scanner Motor.

Process Speed	Resolution	RPM of Scanner	CLK signal frequency
269mm/s	600dpi	31,772rpm	3,177.2Hz
	1200dpi	31,772rpm	3,177.2Hz

dpi (dot per inch)

rpm (revolutions per minute)

NOTE

Each facet of the Polygon Mirror (12 facets) is scanned with a laser beam.

6.2.2 Warm-up of ROS

The Scanner Motor rotates simultaneously with the warm-up of the ROS. The SOS signal is sampled at intervals of 100 ms. If the obtained value is shorter than the Ready reference value three consecutive times, the warm-up of the ROS is ended (The Scanner Motor is rotating at a constant speed).

6.2.3 ROS Reference Value

ROS reference value	Description
Ready reference value	SOS signal interval corresponding to less than 98% of the specified rotational speed of the Scanner Motor
Fail reference value	SOS signal interval corresponding to less than 90% of the specified rotational speed of the Scanner Motor

NOTE

If the speed of the Scanner Motor increases by more than 1%, the laser beam does not enter the SOS Sensor, and "U2" is detected in terms of Fail reference value.

6.3 Fuser Control

6.3.1 Fuser Control

The Halogen Lamp is controllably turned ON and OFF, based on the Fuser control temperature. At the start of warm-up and when the MAIN MOTOR is at rest, the standby temperature is taken as the Fuser control temperature. When the MAIN MOTOR is operating except at warm-up, the running temperature is taken as the Fuser control temperature.

6.3.2 ON/OFF Control of Halogen Lamp

The Halogen Lamp is controllably turned ON and OFF to maintain the Fuser control temperature.

6.3.3 Warm-up of Fuser

The Halogen Lamp is lit up (turned ON) simultaneously with the start of warm-up of the Fuser. When the temperature of the HEAT ROLL surface (detected temperature of THERMISTER) reaches the Fuser control temperature (standby temperature), the warm-up of the Fuser is ended. During warm-up of the Fuser, the MAIN MOTOR is in operation.

6.3.4 Fuser Temperature in Ready State

180 to 185°C in Ready (standby) state (During operation, it is higher than 185°C.)

6.3.5 Fuser Temperature when Abnormal Temperature (higher or lower) is Detected

Higher temperature: 250°C

Lower temperature: 130°C

7. Schematic Diagram of Safety System

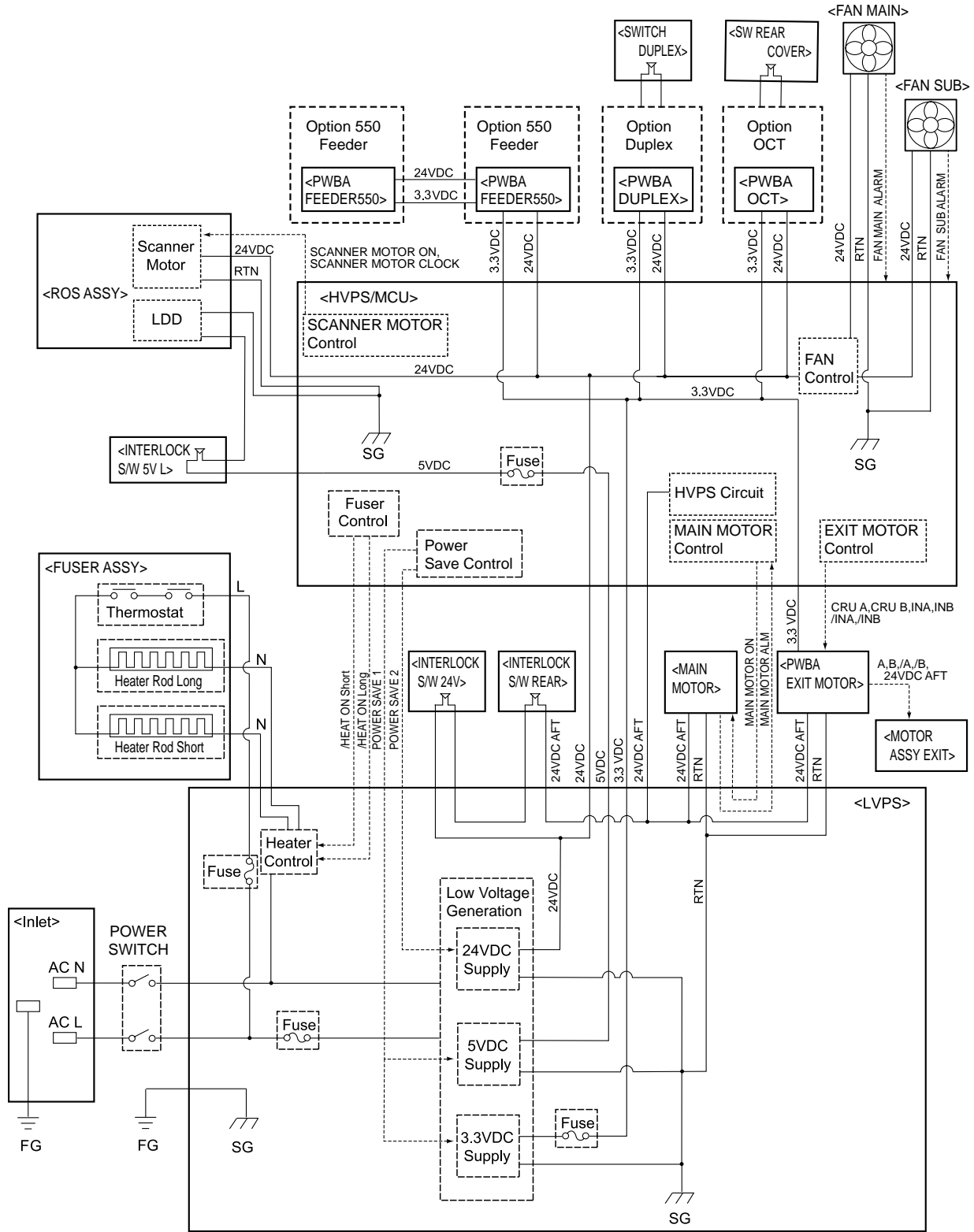

J26126AA

Duplex Option

8. Driving Force Transmission Path

8.1 MOTOR DUPLEX

The rotating force of the MOTOR DUPLEX is transmitted via various gears to components that need mechanical driving force as shown in the flow given below.

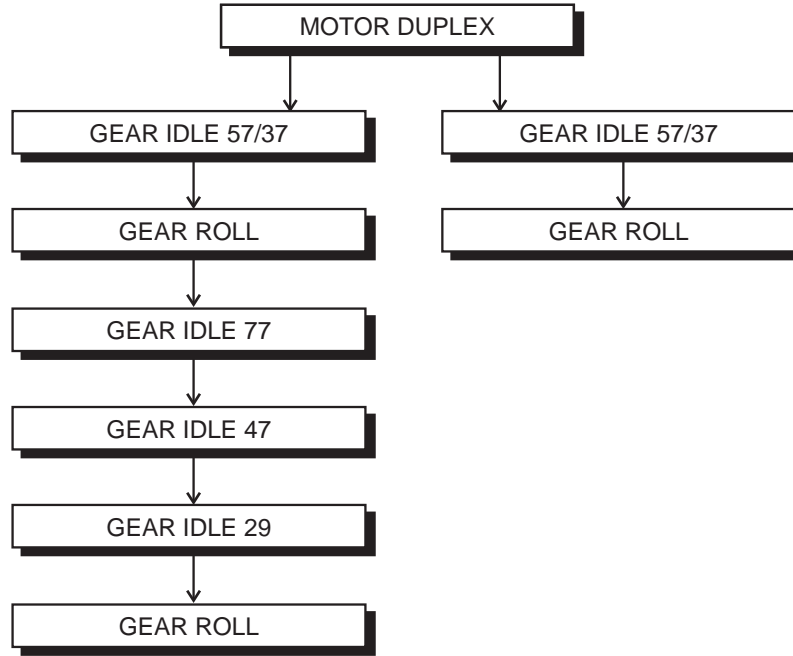

J26611AA

8.2 Gear Layout

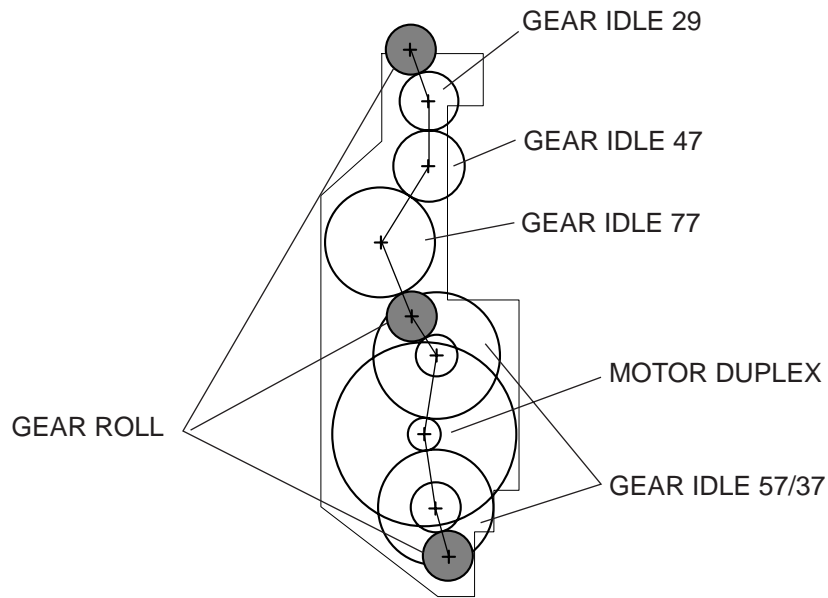

J26612AA

9. Paper Transport

9.1 Paper Transport Path

When the Option Duplex has been added, the paper is transported in the sequence given below.

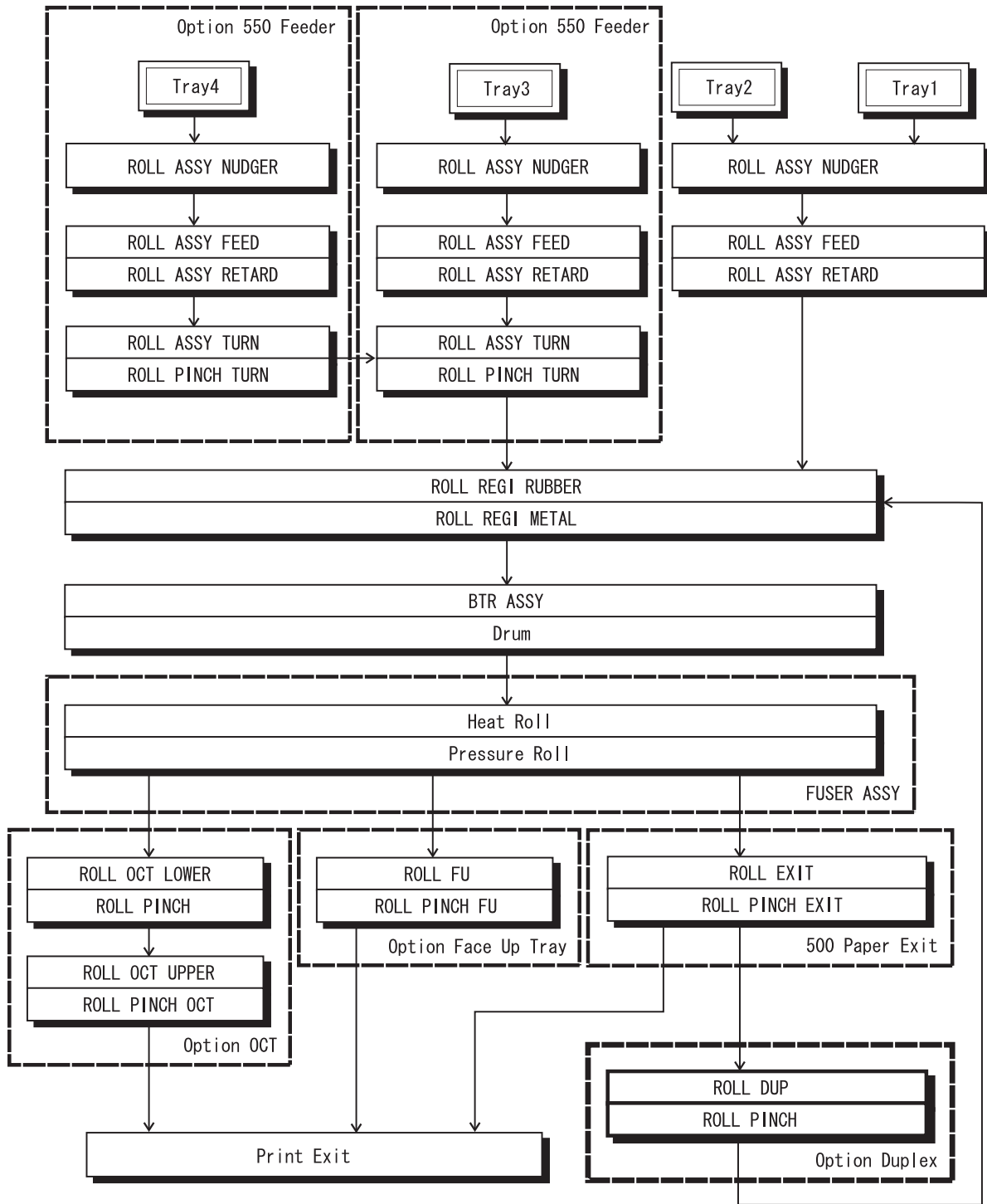

9.2 Layout of Paper Transport Path

Main components regarding the transport of the paper when the Option Duplex is installed are given below.

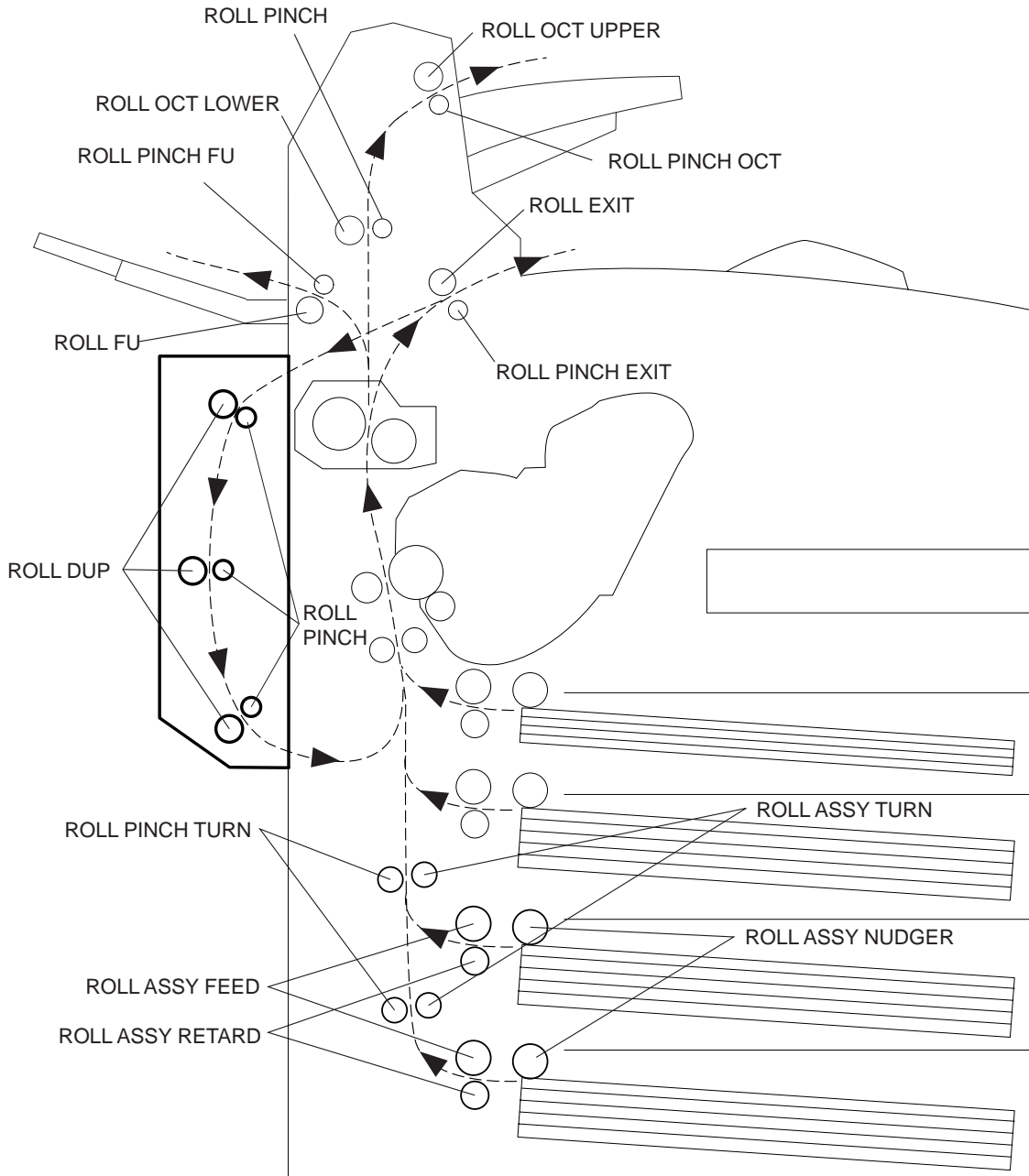

JG6614AA

10. Actions of Main Functional Components

The Option Duplex is available as an optional unit for JIGEN laser printer. Duplex printing is enabled by mounting this optional unit to the rear side of the base engine.

SWITCH DUPLEX

This switch detects that the HSG LOWER DUP and COVER HSG DUP are closed.

SENSOR DUP

This sensor detects the presence or absence of paper in the Duplex.

FAN DUPLEX

This fan vents air within the Duplex and takes in outside air, to prevent abnormal temperature rise in the Duplex

ROLL DUP

This roll feeds the paper having the printed first surface back into the printer through the Duplex, to print on the second surface.

PWBA DUPLEX

A CPU is installed in the PWBA DUPLEX. This CPU receives instructions from HVPS/MCU and from sensors and switches, and controls feeding operation in the PWBA DUPLEX. A flash ROM is used with the CPU installed in the PWBA DUPLEX, so that the firmware can be rewritten through communications.

MOTOR DUPLEX

This motor gives the driving force the three ROLL DUPs, which transport the paper into the printer.

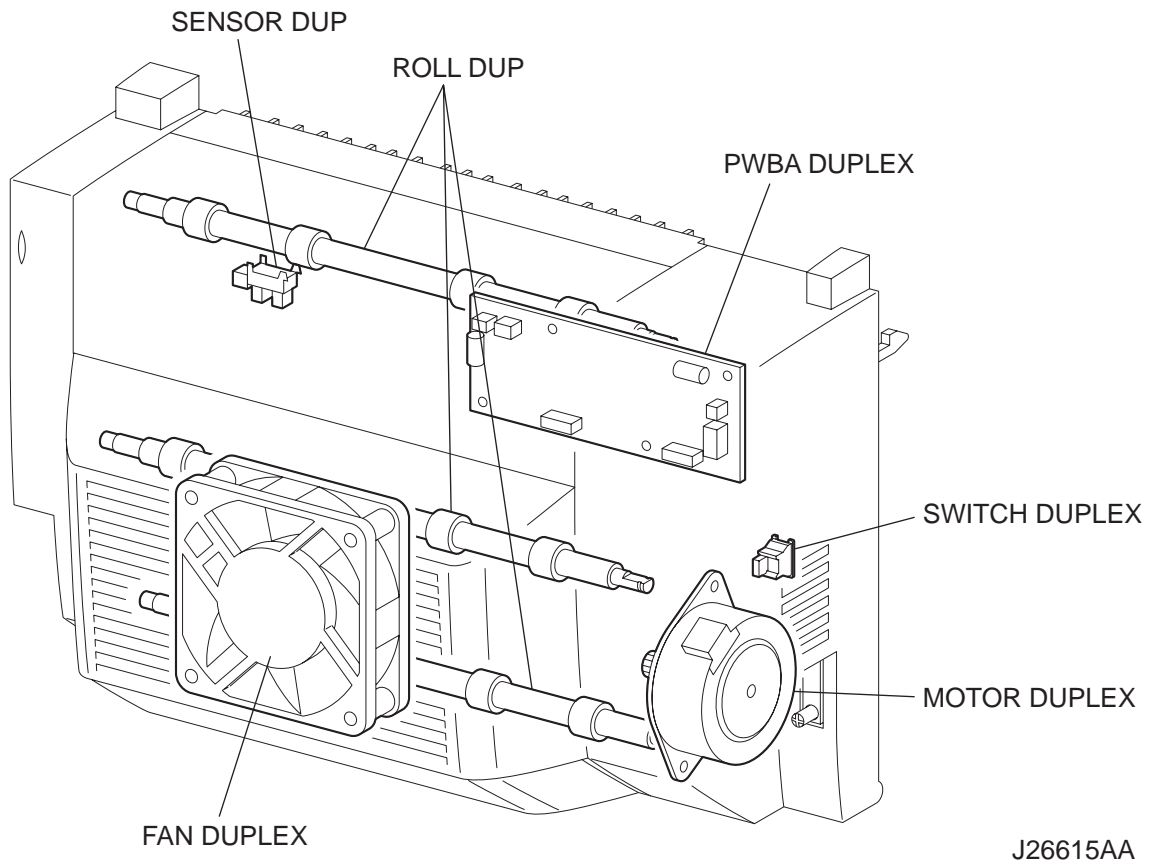

OCT Option

11. Driving Force Transmission Path

11.1 MOTOR ASSY OCT

The rotating force of the MOTOR ASSY OCT is transmitted via various gears to components that need mechanical driving force as shown in the flow given below.

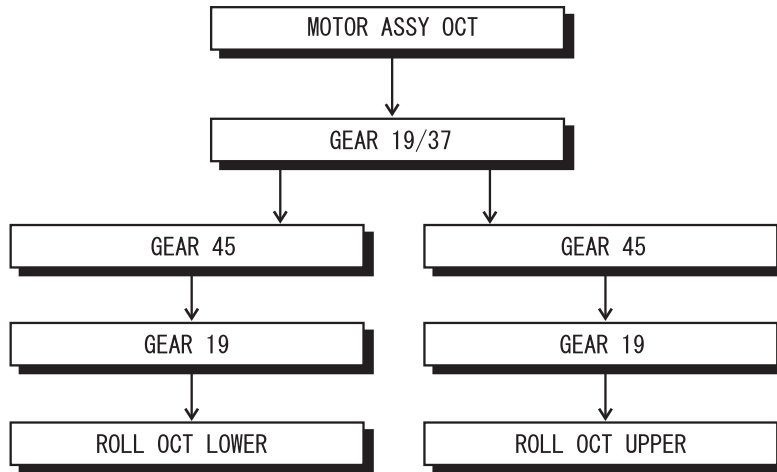

JG6811AA

11.2 Gear Layout

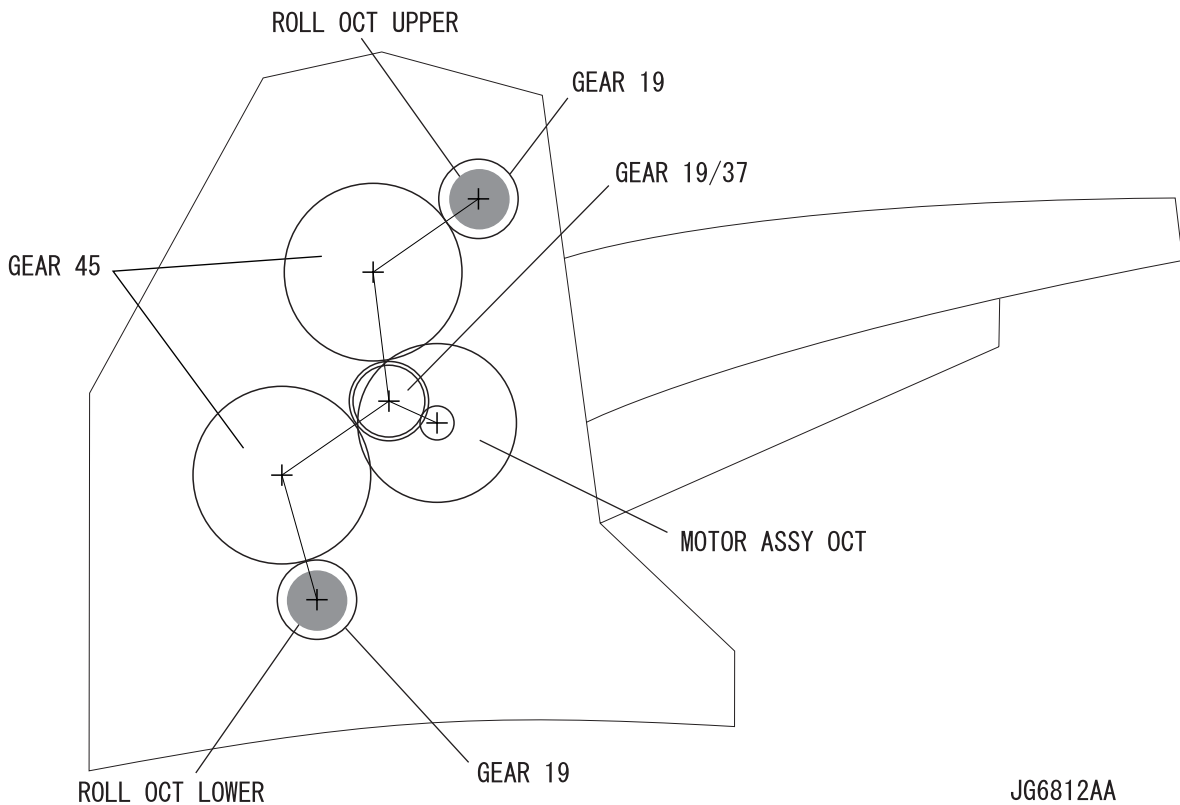

JG6812AA

12. Paper Transport

12.1 Paper Transport Path

When the Option OCT has been added, the paper is transported in the sequence given below.

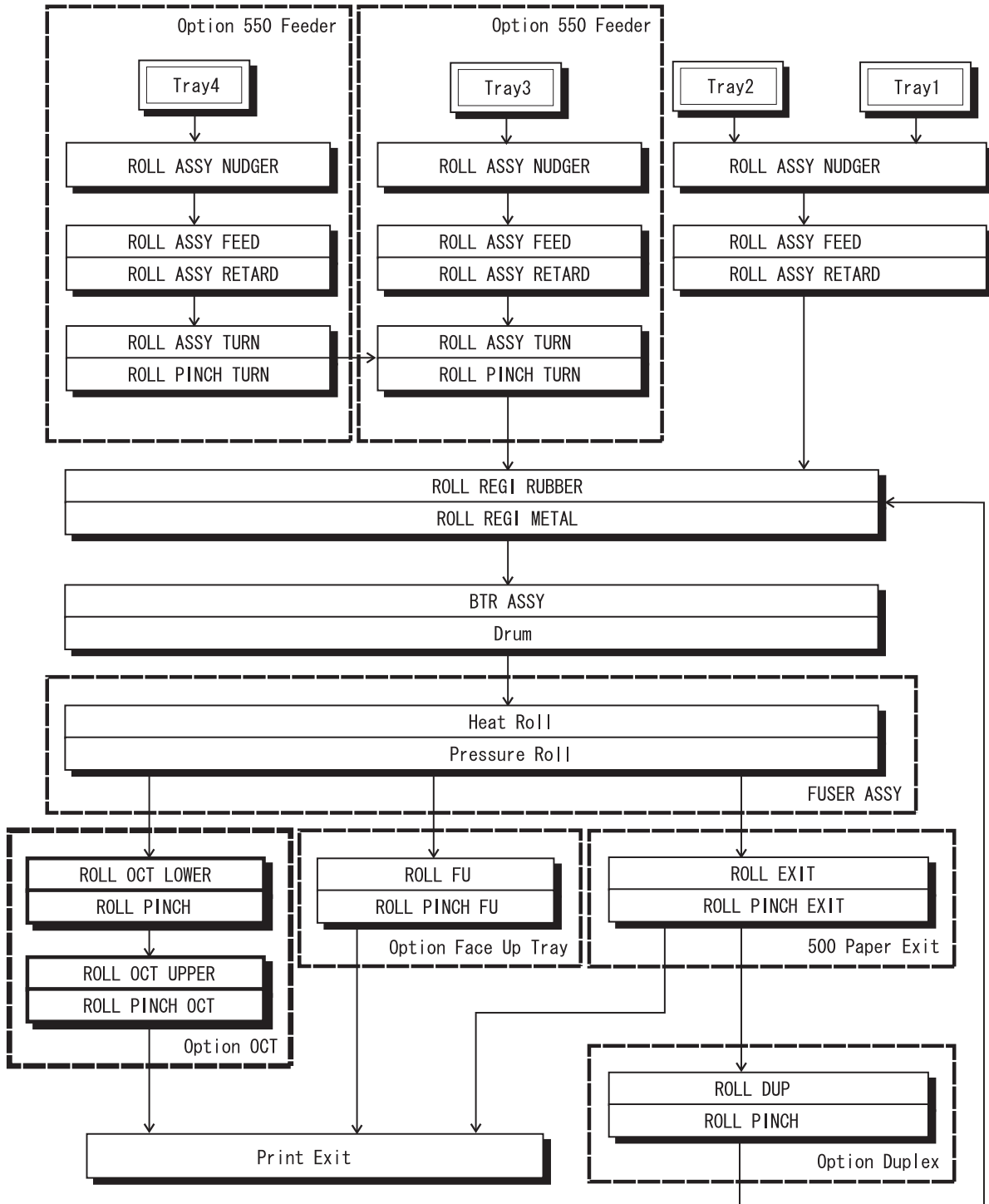

12.2 Layout of Paper Transport Path

Main components regarding the transport of the paper when the Option OCT is installed are given below.

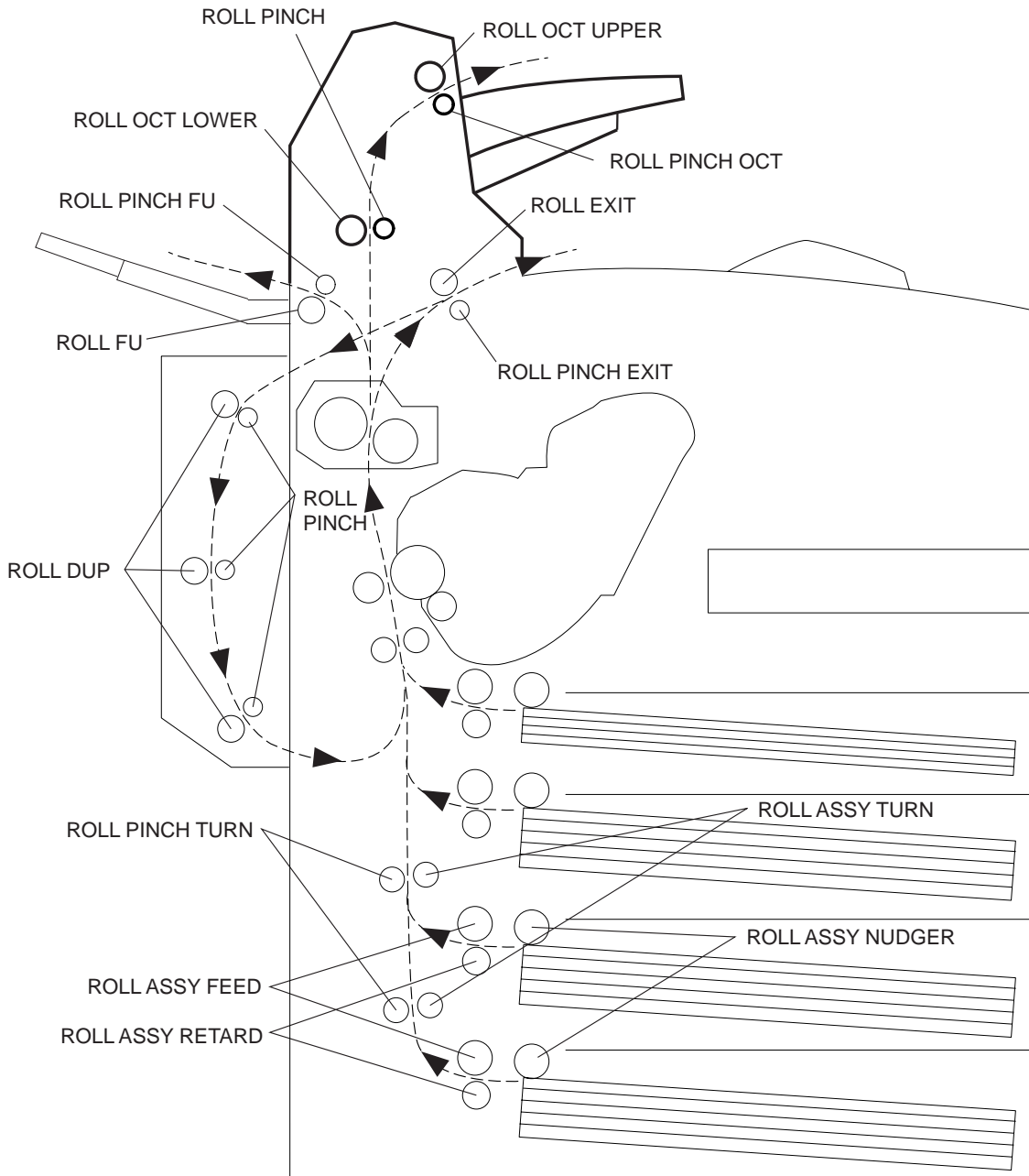

JG6814AA

13. Actions of Main Functional Components

The Option OCT is available as an optional unit for JIGEN laser printer. Offset output is enabled by mounting this optional unit to the top of the 500 Paper Exit.

MOTOR ASSY OCT

This motor gives the driving force to the ROLL OCT LOWER and ROLL OCT UPPER, which transport the printed paper to the tray of the OCT.

MOTOR ASSY OFFSET

This motor gives the driving force to the CHUTE OFFSET ASSY via the GEAR CAM.

SOLENOID ASSY GATE

This solenoid switches between the paper paths to the standard and OCT paper output trays. When the SOLENOID ASSY GATE operates, the GATE OCT EXIT is operated by the LINK GATE OCT pushed downward against the spindle of the SOLENOID ASSY GATE. Thus, the paper output direction is switched to the OCT paper output tray.

PWBA OCT

A CPU is installed in the PWBA OCT. This CPU receives instructions from HVPS/MCU and information from sensors and switches, and controls the operation for transporting the paper through the OCT.

S/W REAR COVER

This switch detects that the COVER REAR is closed.

SENSOR OCT

This sensor detects the presence or absence of paper in the OCT.

Sensor Full Stack OCT This sensor is located on the PWBA OCT, and detects that the paper output tray is full, using the ACTUATOR FULL STACK.

Sensor Offset

This sensor is located on the PWBA OCT, and detects an offset operation, using the Actuator in the CHUTE OFFSET.

ROLL OCT LOWER

This roll transports the printed paper sent out from the Fuser, to the ROLL UPPER OCT.

ROLL OCT UPPER

This roll discharges the printed paper sent out from the ROLL OCT LOWER, to the tray of the OCT.

CHUTE OFFSET ASSY

This is driven by the MOTOR ASSY OCT and GEAR CAM. During paper output, it moves right and left to perform offset operation. The standard distance between offset paper and non-offset paper is 25mm. The Offset Deal (the closest distance between a batch of offset sheets and a batch of non-offset sheets) should be more than 10mm.

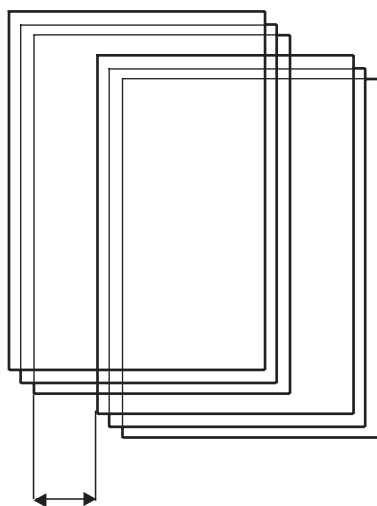

JG6805AA

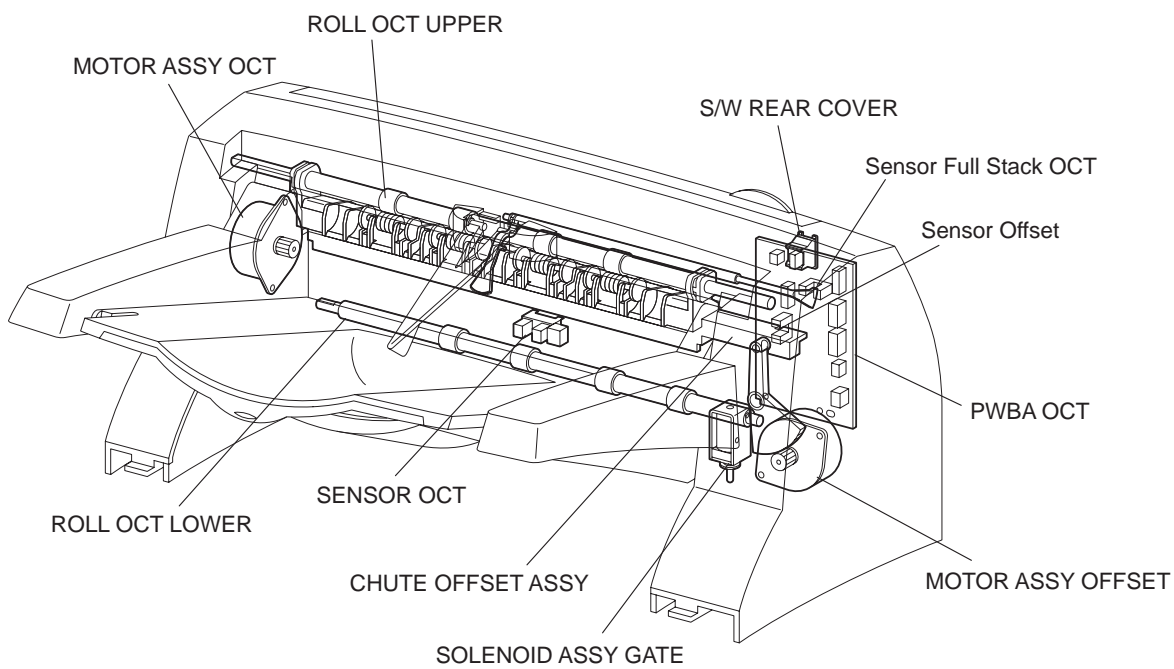

JG6815AB

550 Sheet Feeder Option

14. Driving Force Transmission Path

14.1 MOTOR FEEDER

The rotating force of the MOTOR FEEDER is transmitted via various gears to components that need mechanical driving force as shown in the flow given below.

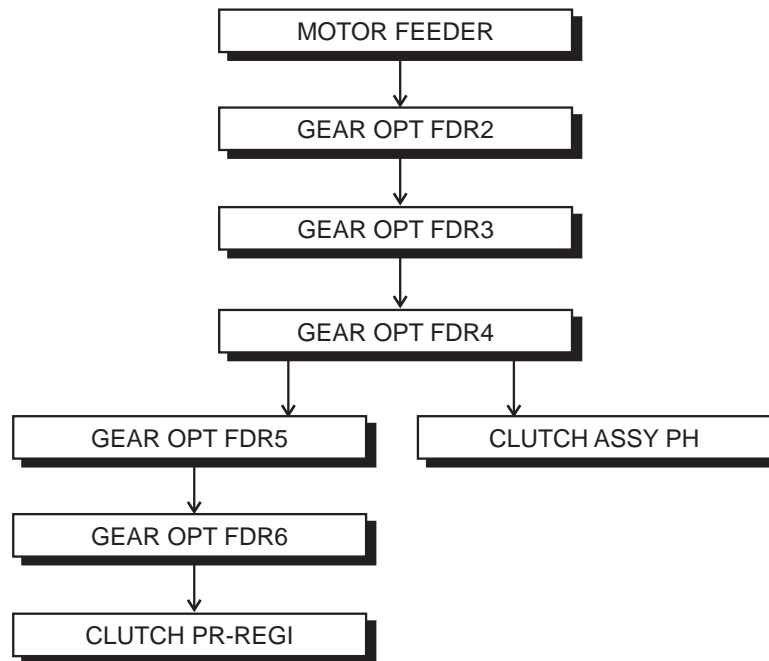

JG6511AA

14.2 Gear Layout

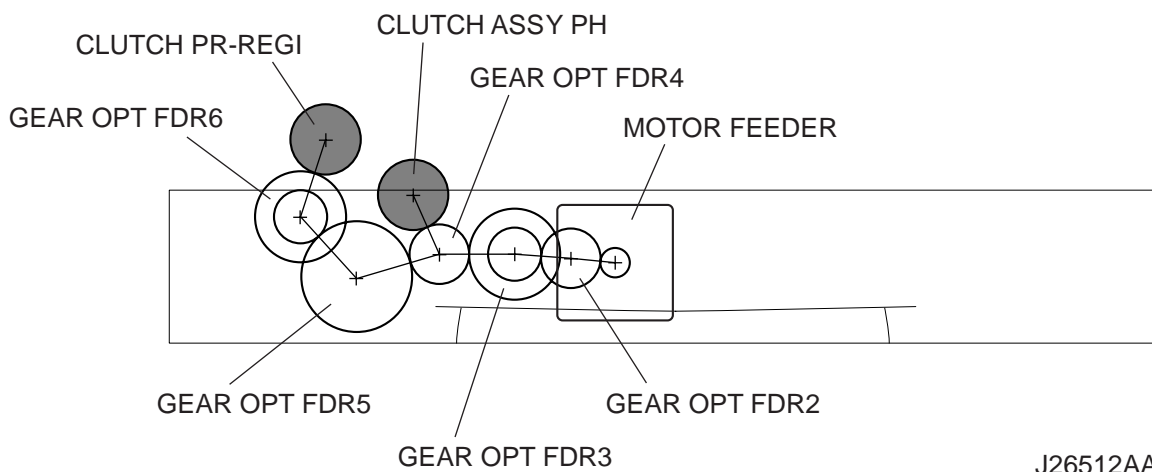

J26512AA

15. Paper Transport

15.1 Paper Transport Path

When the Option 550 Feeder has been added, the paper is transported in the sequence given below.

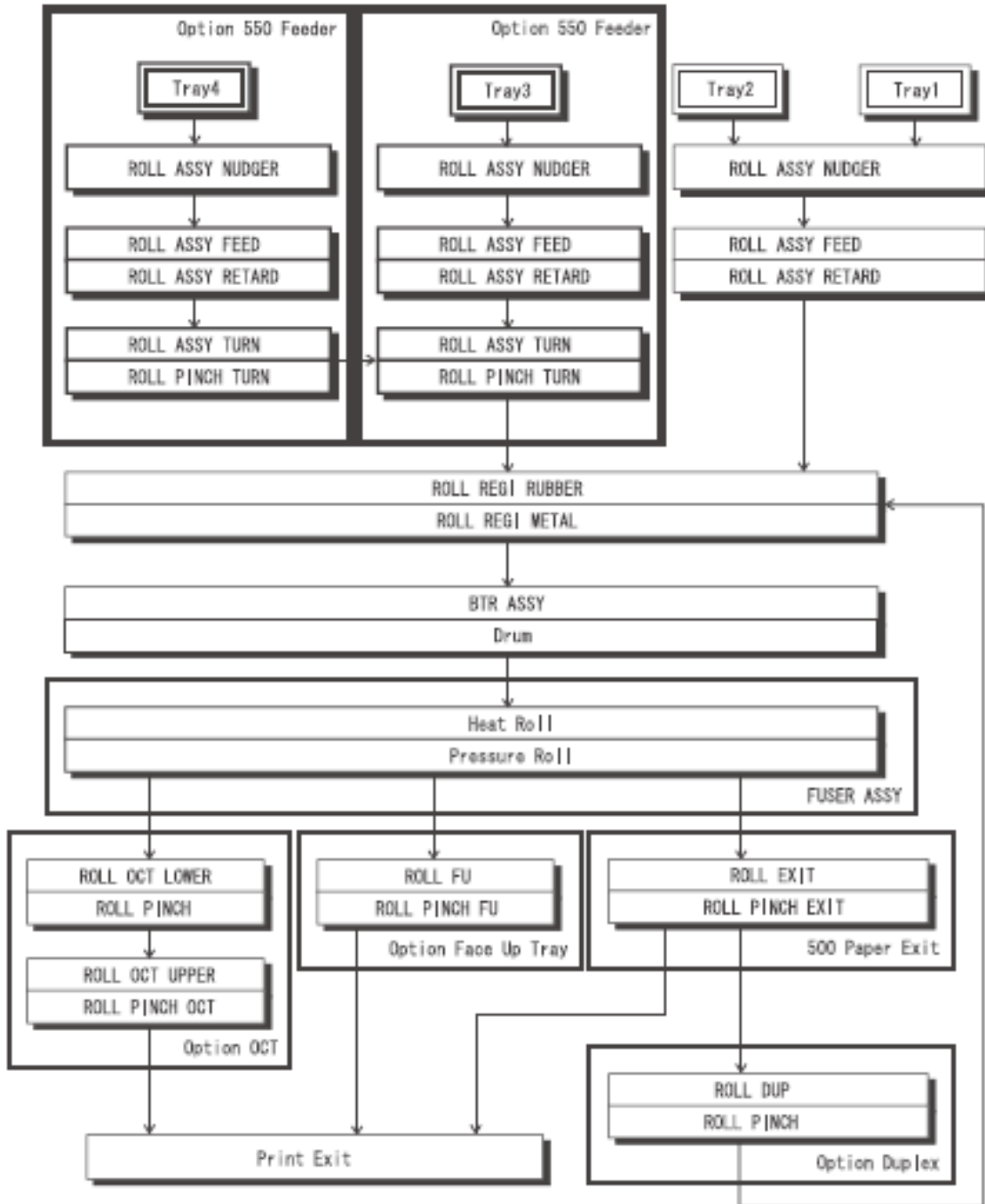

J06513AA

15.2 Layout of Paper Transport Path

Main components regarding the transport of the paper when the Option 550 Feeder is installed are given below.

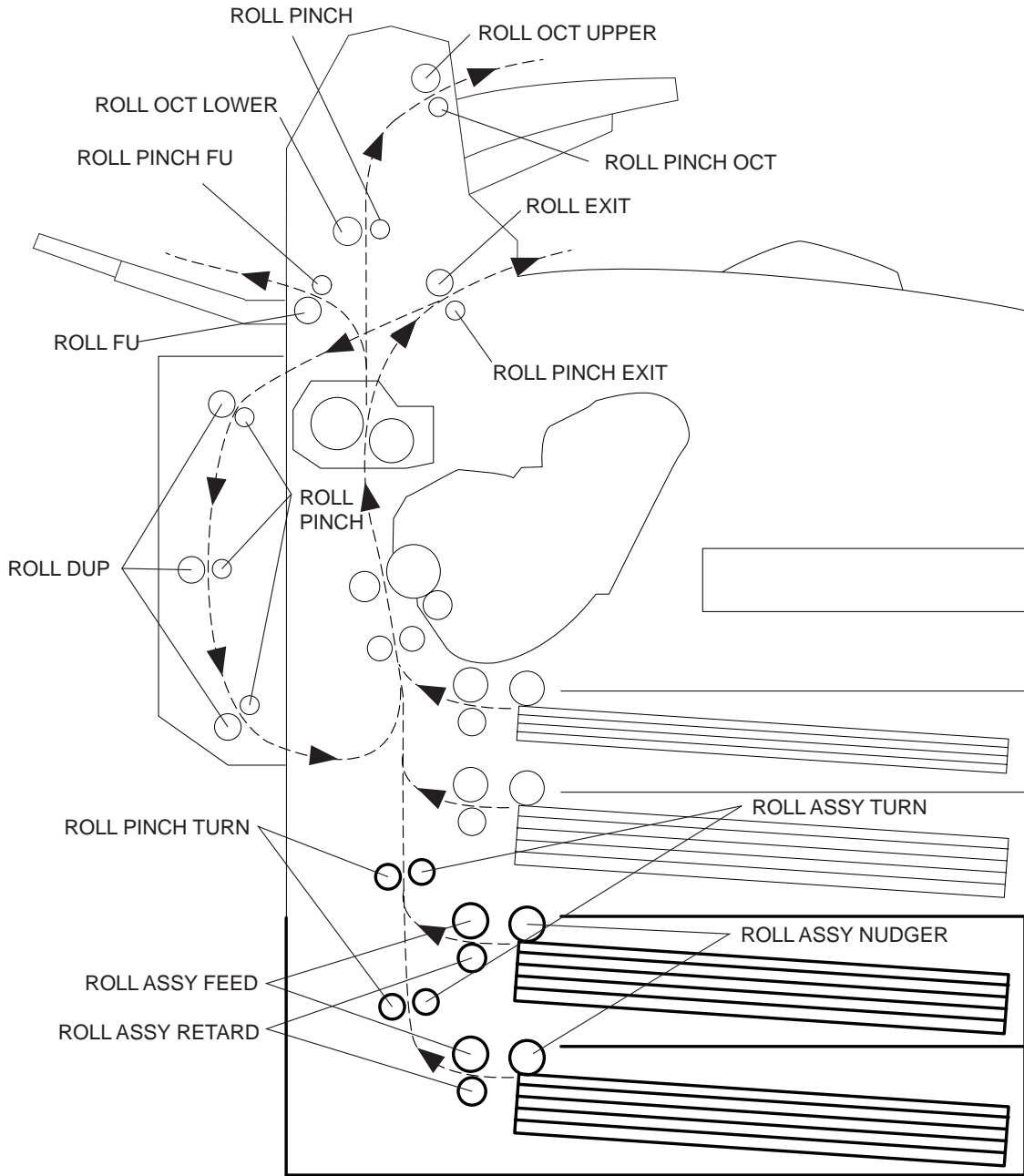

JG6514AA

16. Actions of Main Functional Components

The Option 550 Feeder is available as an optional feeder for JIGEN laser printer. The Paper Cassette installed in the optical feeder is identical in function with the standard Paper Cassette used by the base engine, and so the description of the Paper Cassette is omitted here.

OPT ASSY SIZE

A switch for setting the size of paper supplied from Paper Cassette is mounted. A signal indicating the set size is transmitted as a voltage to the MCU side of HVPS/MCU.

ACTUATOR NO PAPER

If paper runs out in the Paper Cassette, the ACTUATOR NO PAPER drops and the flag of the ACTUATOR NO PAPER that shielded the detection portion of the SENSOR NO PAPER moves off the detection portion. Thus, the light is transmitted.

SENSOR NO PAPER

The presence or absence of paper in the Paper Cassette is detected by the position of the ACTUATOR NO PAPER. This is converted into an electrical signal. If the detection portion is shielded (i.e., there is paper), /NO PAPER FEED 550 SNR ON signal is turned OFF.

ACTUATOR LOW PAPER

When paper is low in the Paper Cassette, the arm of the ACTUATOR LOW PAPER is pushed up by the PLATE ASSY BTM. The flag of the ACTUATOR LOW PAPER that shielded the detection portion of the SENSOR LOW PAPER moves off the detection portion. Thus, the light is transmitted.

SENSOR LOW PAPER

The state that paper is low in the Paper Cassette is detected by the position of the ACTUATOR LOW PAPER. This is converted into an electrical signal. If the detection portion is shielded (i.e., paper is high), /LOW PAPER FEED 550 SNR ON signal is turned OFF.

550 FEEDER OPTION

This is a mechanism for supplying paper from the Paper Cassette into the printer. The driving force from the MOTOR FEEDER is transmitted via the CLUTCH ASSY PH to the ROLL ASSY FEED and ROLL ASSY NUDGER. Thus, the paper is transported. When the ROLL ASSY NUDGER picks up some sheets of paper and the paper gets low, the position of the ROLL ASSY NUDGER drops accordingly. The lowered ROLL ASSY NUDGER pushes down the lock lever of the PLATE ASSY BTM, releasing it. The PLATE ASSY BTM is pushed up by a spring, and thus the paper is raised. The raised paper then raises the SUPPORT NUDGER. The SUPPORT NUDGER disengages from the lock lever of the PLATE ASSY BTM. The PLATE ASSY BTM stops moving upward.

ROLL ASSY TURN

This roll conveys the paper into the printer after the paper is transported by the ROLL ASSY FEED and ROLL ASSY NUDGER. The driving power from the

MOTOR FEEDER is transmitted to the ROLL ASSY via the CLUTCH PR-REGI. This conveys the paper into the printer together with ROLL PINCH TURN.

PWBA FEEDER 550

A CPU is installed in the PWBA FEEDER 550. This CPU receives instructions from HVPS/MCU and from sensors and switches, and controls feeding operation in the Option 550 Feeder. A flash ROM is used with the CPU installed in the PWBA FEEDER, so that the firmware can be rewritten through communications.

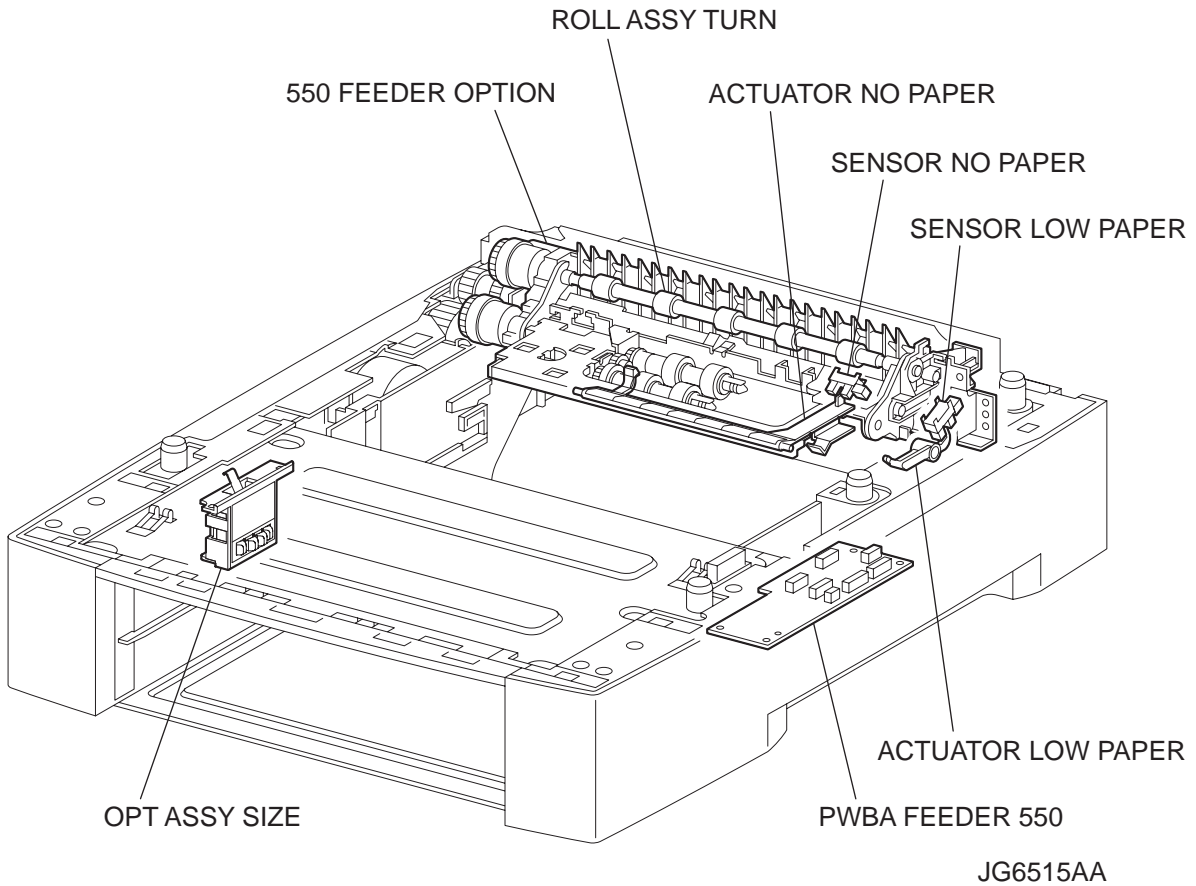

Chapter 4 Wiring Diagrams and Signal Information CONTENTS

Chapter 4 Wiring

Engine

1. Connection Wiring Diagram.....	4 - 1
1.1 Symbols in the General Connection Wiring Diagram.....	4 - 1
1.2 General Wiring Diagram	4 - 3
2. Interconnection Wiring Diagram of Parts.....	4 - 4
2.1 Instructions for the Use of the Interconnection Wiring Diagram of Parts	4 - 4
2.2 Configuration of the Interconnection Wiring Diagram of Parts.....	4 - 6
Duplex Transport Option 16	
2.1 Connection Wiring Diagram	4 - 16
2.2 Configuration of the Interconnection Wiring Diagram of Parts.....	4 - 16
OCT Option 18	
2.1 General Wiring Diagram	4 - 18
2.2 Configuration of the Interconnection Wiring Diagram of Parts.....	4 - 19
Option OCT 20	
2.1 General Wiring Diagram	4 - 21
2.2 Configuration of the Interconnection Wiring Diagram of Parts.....	4 - 22





Chapter 4 Wiring





Engine

1. Connection Wiring Diagram

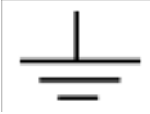
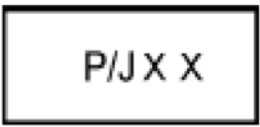
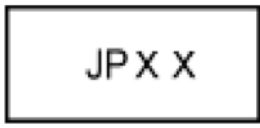
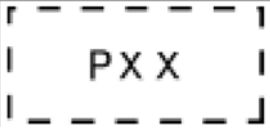
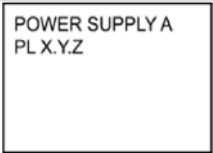
1.1 Symbols in the General Connection Wiring Diagram

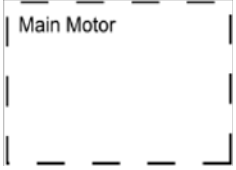
The symbols in the general connection wiring diagram are described below.

Symbols	Description
	Represents an interconnection between parts using wiring harness or wire.
	Represents an interconnection which differs according to the specifications.
	Represents an interconnection between parts using a conductive member such as a plate spring.
	Represents a connection between parts by tightening of a screw.
	Indicates a frame ground.
	Represents a connector. The connector No. is indicated inside the box.
	Represents a connection terminal with a plate spring on the printed circuit board. The connector (terminal) No. is indicated inside the box.
	Represents a connector directly connected to the printed circuit board. The connector No. is indicated inside the box.
	The box containing a part name represents a part. "PL X.Y.Z" indicates the item "Z" of the plate (PL) "X.Y" described in Chapter 5 "Parts List."

Symbols	Description
	<p>Represents a functional part within a part, and indicates the name of the functional part.</p>
	<p>Represents a section in "2. Interconnection Wiring Diagram of Parts," and indicates its section No.</p>
	<p>Represents a screw for fixing wiring harness and a conductive member such as a plate spring.</p>
	<p>Represents a conductive member such as a plate spring.</p>

1.2 General Wiring Diagram

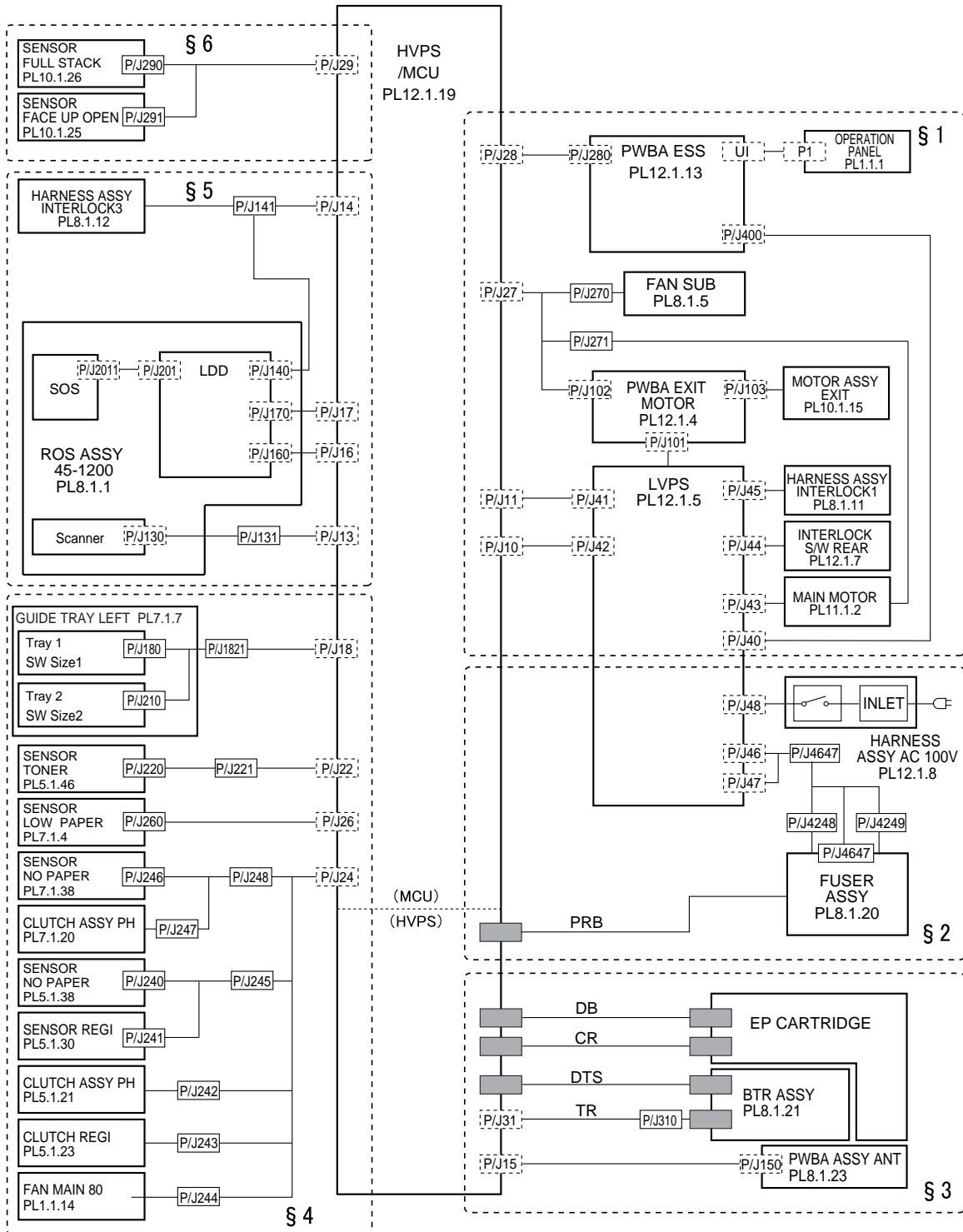









J27001AA

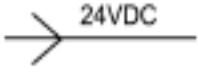

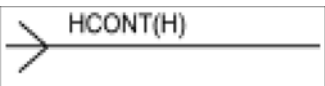

2. Interconnection Wiring Diagram of Parts

2.1 Instructions for the Use of the Interconnection Wiring Diagram of Parts

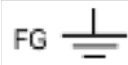
The symbols in the interconnection wiring diagram of parts are described below.

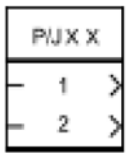
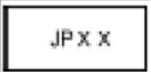
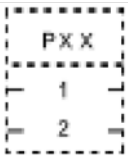
Note that the description of general symbols is omitted.

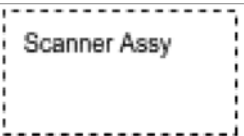
Symbols	Description
	<p>Represents an interconnection between parts using wiring harness or wire, and indicates its signal name/contents. The arrow ">" or "<" on the line represents the direction of the signal.</p>
	<p>Represents an interconnection between parts using wiring harness or wire, which differs according to the specifications, and indicates its signal name/contents. The arrow ">" or "<" on the line represents the direction of the signal.</p>
	<p>Represents a interconnection between parts using a conductive member such as a plate spring, and indicates its signal name/ contents. The arrow ">" or "<" on the line represents the direction of the signal.</p>
	<p>Represents a function and a logical value (High (H) or Low (L)) of a signal when the function is activated. The voltage indicates a value when the signal is High. The arrow indicates the direction of the signal.</p>
	<p>Represents a function and a logical value (High (H) or Low (L)) of a signal when the function is in a detectable state. The voltage indicates a value when the signal is High. The arrow indicates the direction of the signal.</p>
	<p>Represents a connection between lead wires.</p>
	<p>Represents a connection between parts by tightening of a screw.</p>
	<p>Represents a connection between "A" and "A".</p>
<p data-bbox="300 1602 386 1633">24VDC</p>	<p>The DC voltage indicates an approximate value measured when the negative side is connected to a signal ground (SG).</p>
	<p>Indicates a signal ground (SG).</p>
	<p>Indicates a frame ground (FG).</p>

Symbols	Description
<p style="text-align: center;">RTN</p>	<p>Indicates a return.</p>
	<p>Represents a connector. The connector and PIN Nos. are shown at the upper and lower parts respectively. "P,-" indicates the plug side of the connector. "J,>" indicates the jack side of the connector.</p>
	<p>Represents a connection terminal with a plate spring on the printed circuit board. The connector No. is indicated inside the box.</p>
	<p>Represents a connector directly connected to the printed circuit board. The connector No. is indicated inside the box.</p>
	<p>Represents a part. "PL X.Y.Z" indicates the item "Z" of the plate (PL) "X.Y" described in Chapter 5 "Parts List."</p>
	<p>Represents a functional part within a part, and indicates the name of the functional part.</p>
	<p>Indicates a reference item associated with the section.</p>

2.2 Configuration of the Interconnection Wiring Diagram of Parts

The interconnection wiring diagram is divided into 6 sections (1 - 6) indicating details of the interconnections of parts.

1 HARNESS ASSY INTERLOCK1, INTERLOCK S/W REAR, MAIN MOTOR 45, FAN SUB, MOTOR ASSY EXIT

- Connections of HARNESS ASSY INTERLOCK1 and INTERLOCK S/W REAR with LVPS
- Connections of MAIN MOTOR 45 with LVPS
- Connections of FAN SUB with HVPS/MCU
- Connections of MOTOR ASSY EXIT with PWBA EXIT MOTOR
- Connections of HVPS/MCU with LVPS, PWBA EXIT MOTOR and PWBA ESS

2 FUSER ASSY, POWER SWITCH

- Connections of FUSER ASSY with LVPS and GUIDE ASSY CRU R
- Connections of POWER SWITCH with LVPS

3 EP Cartridge, HOUSING ASSY BTR J2

- Connections of EP Cartridge with GUIDE ASSY CRU R
- Connections of HOUSING ASSY BTR J2 with GUIDE ASSY CRU R
- Connections of PWBA ASSY ANT with HVPS/MCU
- Connections of GUIDE ASSY CRU R with HVPS/MCU

4 150 Paper Feeder, 550 Paper Feeder, FAN MAIN 80

- Connections of GUIDE TRAY LEFT with HVPS/MCU
- Connections of SENSOR NO PAPER with HVPS/MCU
- Connections of SENSOR REGI with HVPS/MCU
- Connections of CLUTCH ASSY PH with HVPS/MCU
- Connections of CLUTCH REGI with HVPS/MCU
- Connections of SENSOR LOW PAPER with HVPS/MCU
- Connections of SENSOR NO PAPER with HVPS/MCU
- Connections of CLUTCH ASSY PH with HVPS/MCU
- Connections of FAN MAIN 80 with HVPS/MCU
- Connections of SENSOR TONER with HVPS/MCU

5 ROS ASSY 45-1200, HARNESS ASSY INTERLOCK3

- Connections of ROS ASSY 45-1200 with HVPS/MCU
- Connections of HARNESS ASSY INTERLOCK3 with HVPS/MCU

6 500 Paper Exit

- Connections of HVPS/MCU with SENSOR FACE UP OPEN
- Connections of HVPS/MCU with SENSOR FULL STACK

1 HARNESS ASSY INTERLOCK1, INTERLOCK S/W REAR, MAIN MOTOR 45, FAN SUB, MOTOR ASSY EXIT

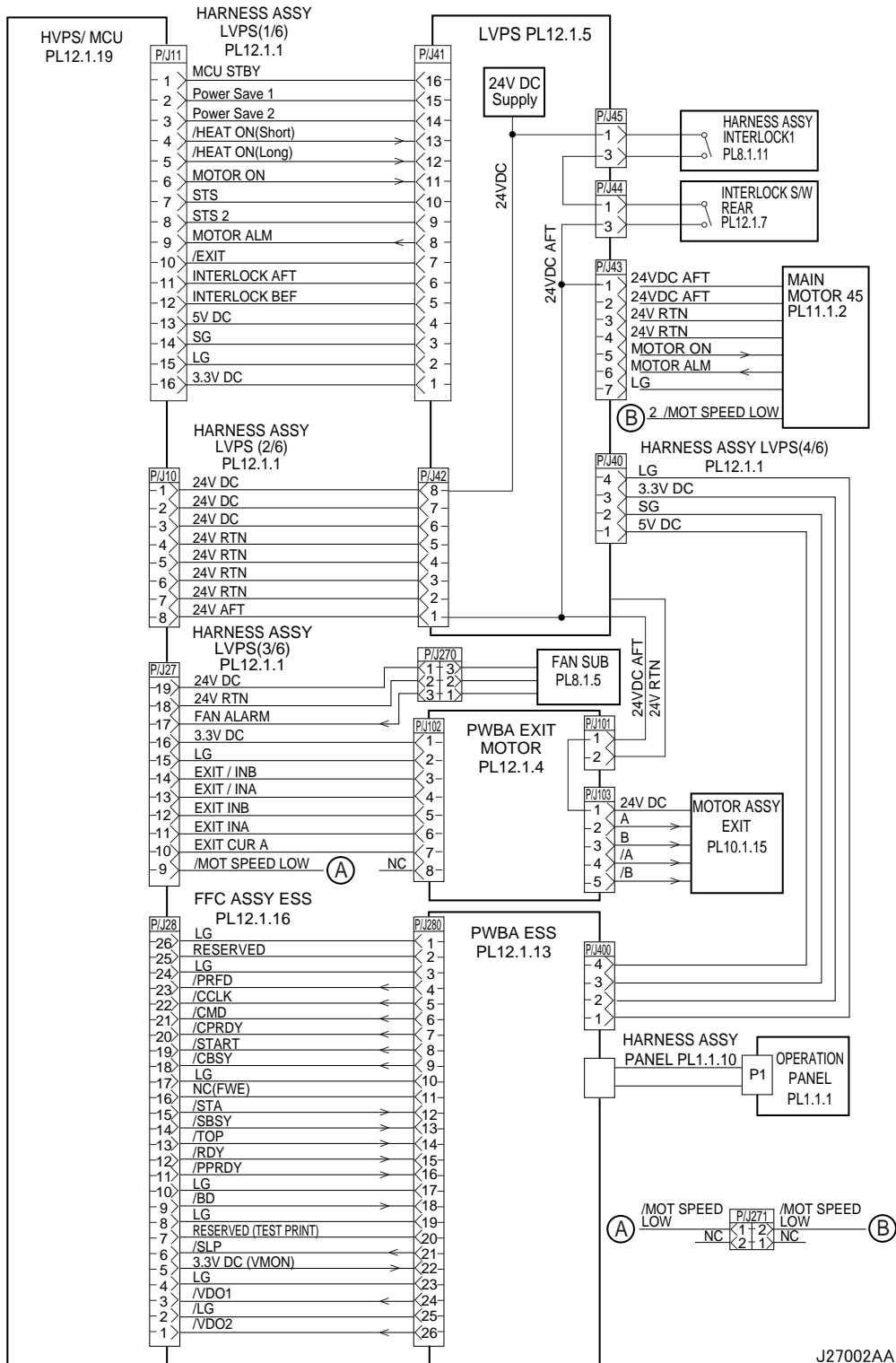

J27002AA

Signal line name	Description
/HEAT ON	AC power-supply control signal for Heater Rod. Low: ON/High: OFF
MOTOR ON	Control signal for MAIN MOTOR 45.
MOTOR ALM	Monitor signal for MAIN MOTOR 45.
INTERLOCK AFT	Signal indicating that the rear cover is open. This signal goes High when the front or rear cover is open.
INTERLOCK BEF	Signal indicating that the front cover is open. This signal goes High when the front cover is open.
FAN ALARM	FUN SUB monitor signal. If a trouble occurs, this signal goes High.
EXIT /INB	Excitation signal for EXIT MOTOR. Phase /B.
EXIT /INA	Excitation signal for EXIT MOTOR. Phase /A.
EXIT INB	Excitation signal for EXIT MOTOR. Phase B.
EXIT INA	Excitation signal for EXIT MOTOR. Phase A.
EXIT CUR A	Current-switching signal for EXIT MOTOR.
/MOT SPEED LOW	Half-speed signal for MAIN MOTOR.
A and B	Current output to each winding of EXIT MOTOR. Phases A and B.
/A and /B	Current output to each winding of EXIT MOTOR. Phases A and B.
/PRFD	Prefeed signal. This is effective only when /RDY is Low.
/CCLK	Clock signal. This is sent out simultaneously with /STA or /CMD.
/CMD	Command signal. When /CBSY is Low, it is sent out from the controller in synchronism with /CCLK.
/CPRDY	Ready signal for the controller power supply. This signal goes Low when the controller power supply is ON and, at the same time, initialization of the CPU is completed. When a trouble occurs with the CPU, the signal goes High.
/START	Print start signal. This is effective only when /RDY is Low.
/CBSY	Command busy signal. This goes Low when /CMD is sent out (except when /SBSY is Low or /PPRDY is High).
/STA	Status signal. Status is sent in synchronism with /CCLK when /SBSY is Low.
/SBSY	Status busy signal. This signal is Low when the printer is sending /STA (except when /CBSY is Low or /CPRDY is High).
/TOP	Vertical sync signal for image data. This is periodically sent out when ROS MOTOR is in operation.
/RDY	Ready signal. This signal is Low in a standby state where reception of /START is awaited.
/PPRDY	Ready signal for the printer power supply. This goes Low when the printer power supply is turned on and initialization of the CPU is completed. This signal goes High when the MCP detects an error.
/BD	Horizontal sync signal for image data. This is periodically sent out when ROS MOTOR is in operation.
/SLP	Control signal for LVPS. This goes Low in power saving mode.
/VDO1	Image data signal. This is sent out in synchronism with /TOP and /BD. This signal goes High (White) for other than effective data.
/VDO2	

2 FUSER ASSY, POWER SWITCH

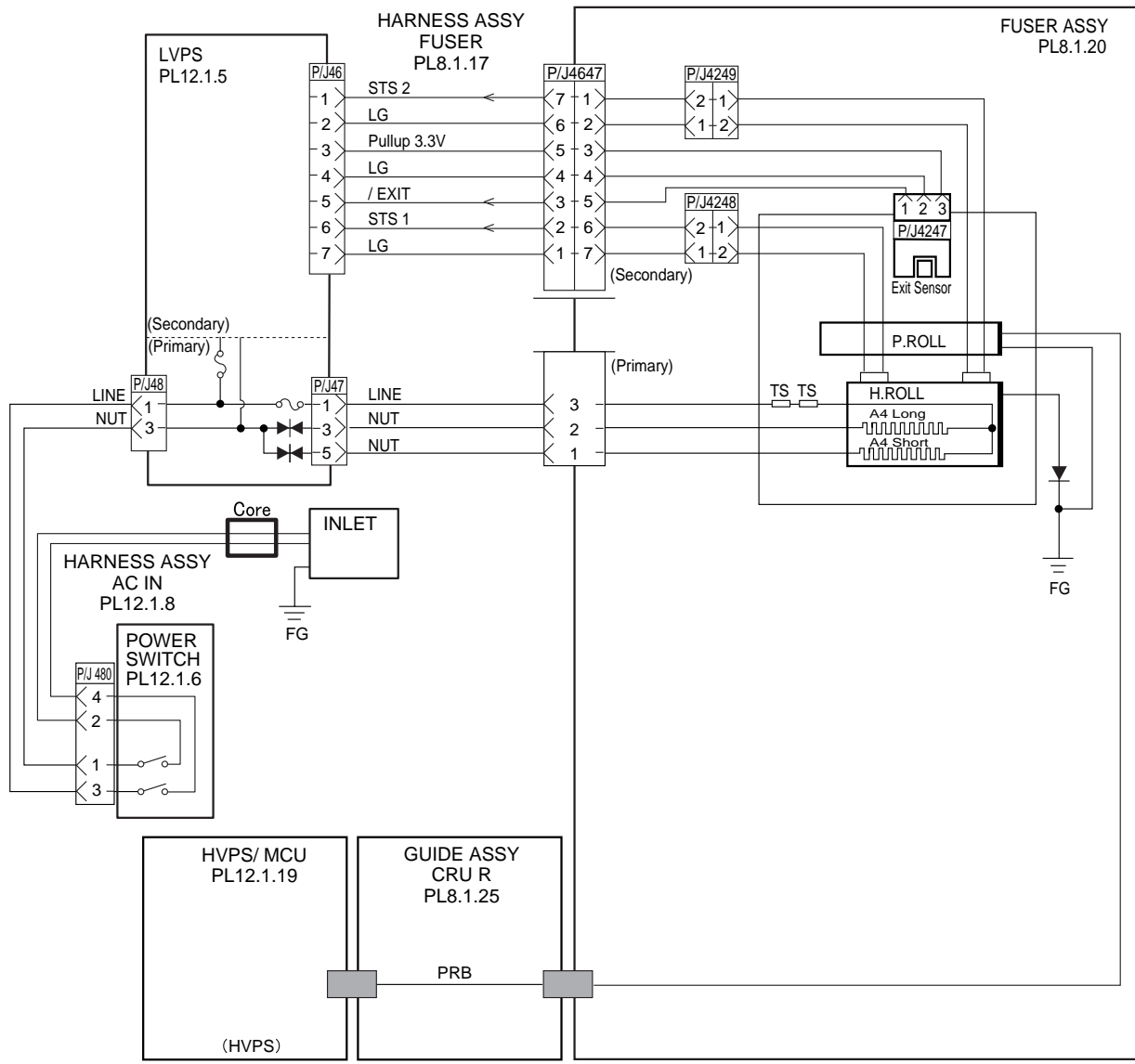

J27003AA

Signal line name	Description
/EXIT	Signal from Exit Sensor. This signal goes Low when light is received.
STS	Temperature monitor signal (analog signal) from Temperature Sensor (Thermistor). It detects the temperature on the surface of Heat Roll.
PRB	Output from HVPS which applies a high voltage to Pressure Roll.

3 EP Cartridge, HOUSING ASSY BTR J2

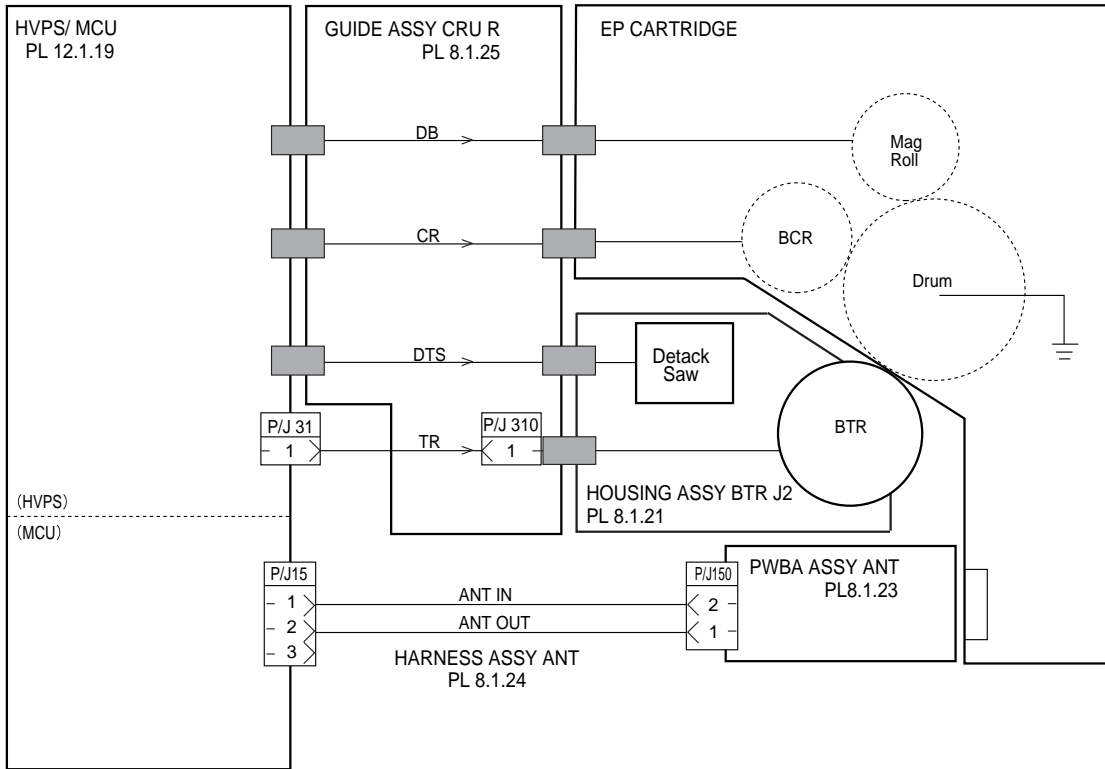

J27004AA

Signal line name	Description
DB	Output from HVPS to Mag Roll (Development bias)
CR	Output from HVPS to BCR
DTS	Output from HVPS to Detack Saw
TR	Output from HVPS to BTR

4 150 Paper Feeder, 250/550 Paper Feeder, FAN MAIN 80

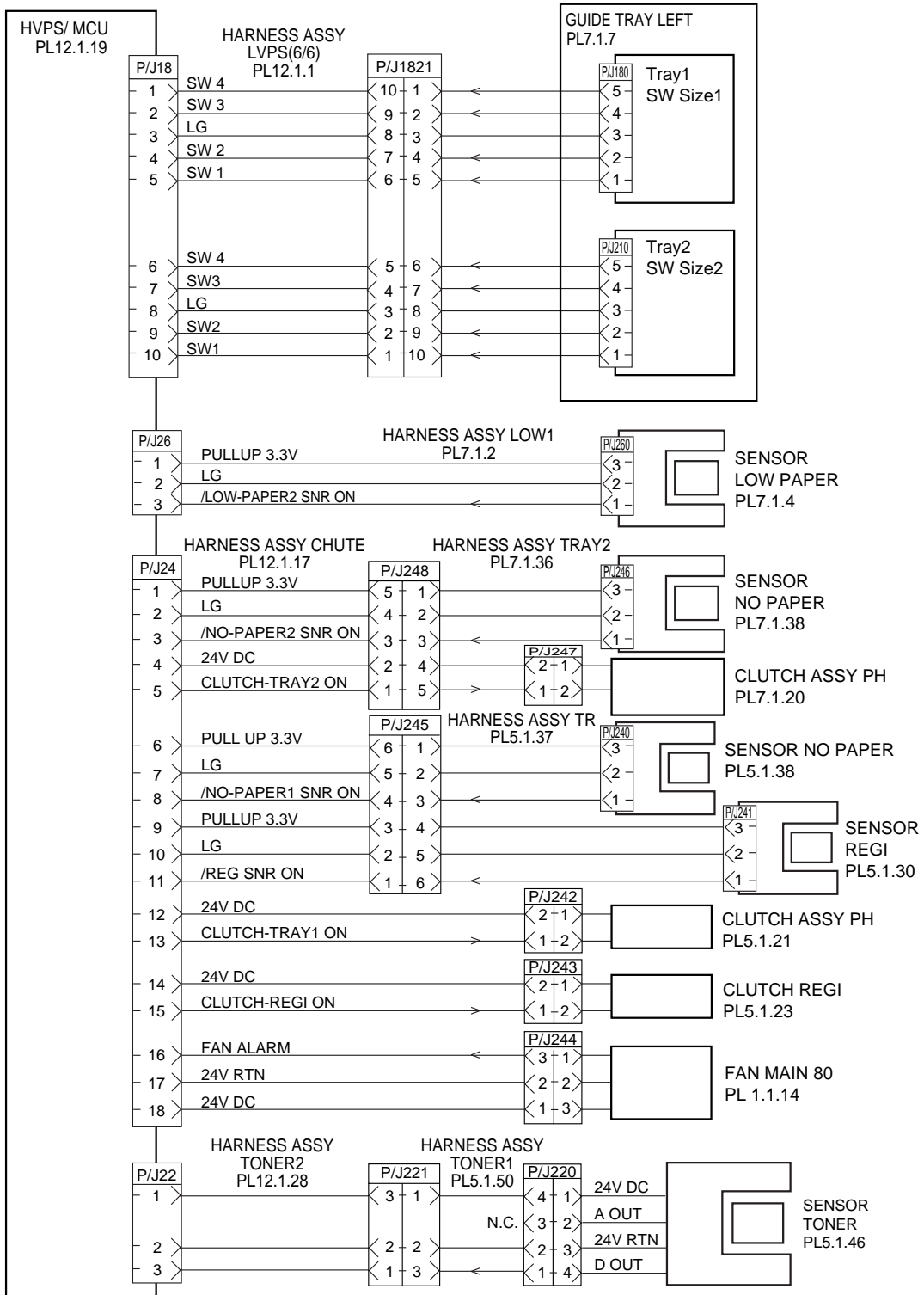

J27005AA

Signal line name	Description
/LOW-PAPER2 SNR ON	Signal from SENSOR LOW PAPER. This signal goes Low when light is received.
/NO-PAPER2 SNR ON	Signal from SENSOR NO PAPER of Tray2. This signal goes Low when light is received.
CLUTCH-TRAY2 ON	Control signal for CLUTCH ASSY PH of Tray2. Low: ON / High: OFF
/NO-PAPER1 SNR ON	Signal from SENSOR NO PAPER of Tray1. This signal goes Low when light is received.
/REG SNR ON	Signal from SENSOR REGI. This signal goes Low when light is received.
CLUTCH-TRAY1 ON	Control signal for CLUTCH ASSY PH of Tray1. Low: ON / High: OFF
CLUTCH-REGI ON	Control signal for CLUTCH REGI. Low: ON / High: OFF
FAN ALARM	Fan monitor signal. This signal goes High if there is a trouble with FAN MAIN 80.
D OUT	Signal indicating detection of toner in the EP cartridge, from SENSOR TONER.

5 ROS ASSY 45-1200, INTERLOCK S/W 5V, HARNESS ASSY INTERLOCK3

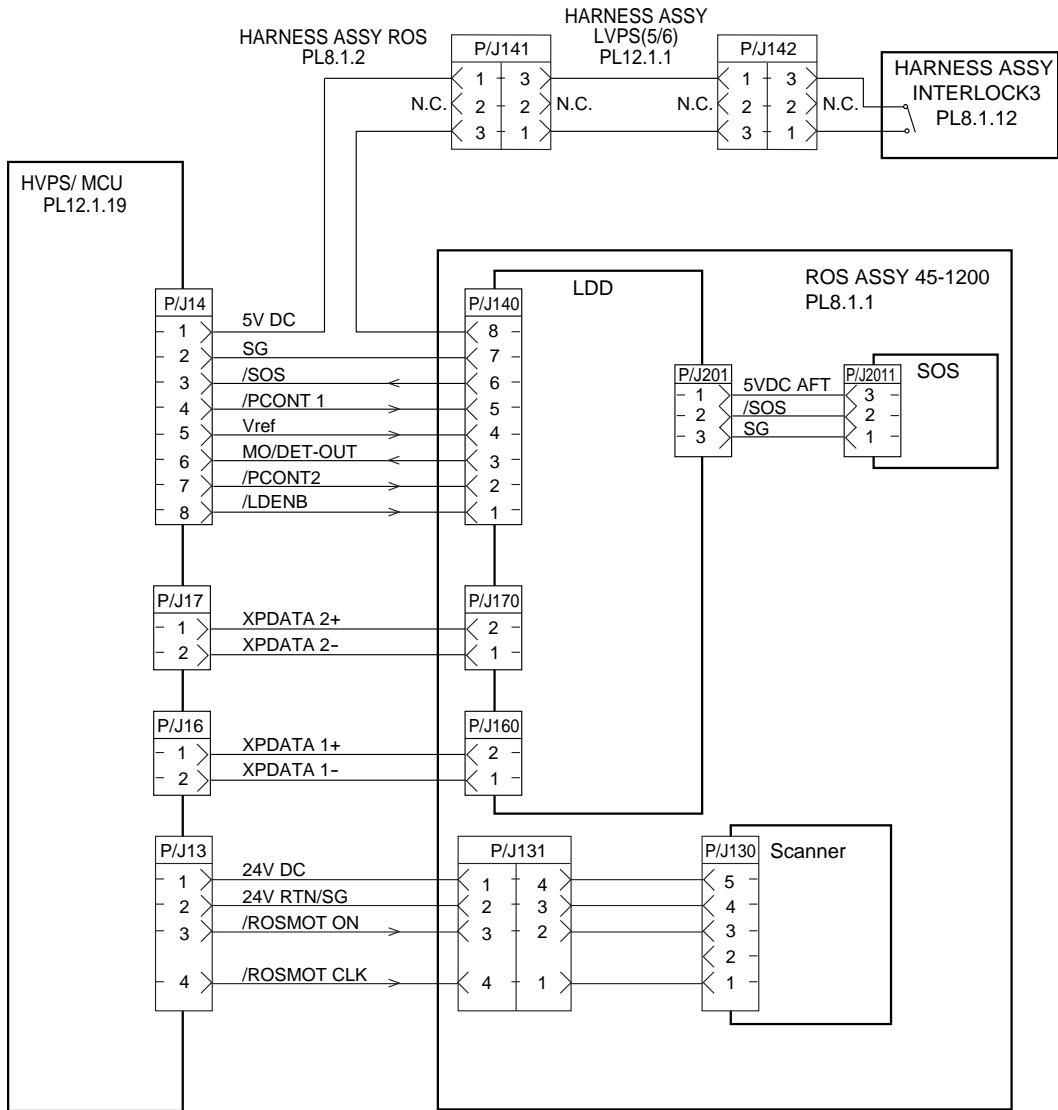

J27006AA

Signal line name	Description
/SOS	SYNC signal generated by SOS Sensor. This signal commands start of each scan.
/PCONT	Sample / Hold circuit Low: Sampled (LD is forcibly lit up); High: Held
Vref	Laser output control signal for determining or adjusting the current flowing through Laser Diode.
MO/DET-OUT	Laser output monitor signal for providing feedback of laser output beam from Laser Diode (analog signal).
/LDENB	Control signal permitting emission of Laser Diode. High: Laser Diode OFF.
XP DATA+	Print image data.
XP DATA-	
/ROSMOT ON	Sensor Motor Control signal for turning ON/OFF Scanner Motor. Low: ON / High: OFF
/ROSMOT CLK	Clock signal to ROS Motor.

6 500 Paper Exit

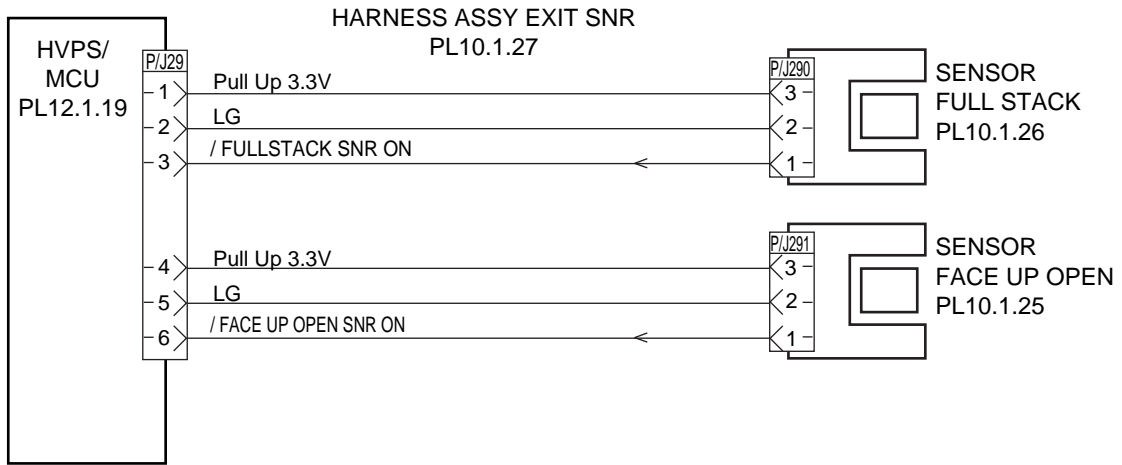

JG7007AA

Signal line name	Description
/FULLSTACK SNR ON	Signal from SENSOR FULL STACK. This signal goes Low when light is received.
/FACE UP OPEN SNR ON	Signal from SENSOR FACE UP OPEN. This signal goes Low when light is received.

Duplex Transport Option

2.1 Connection Wiring Diagram

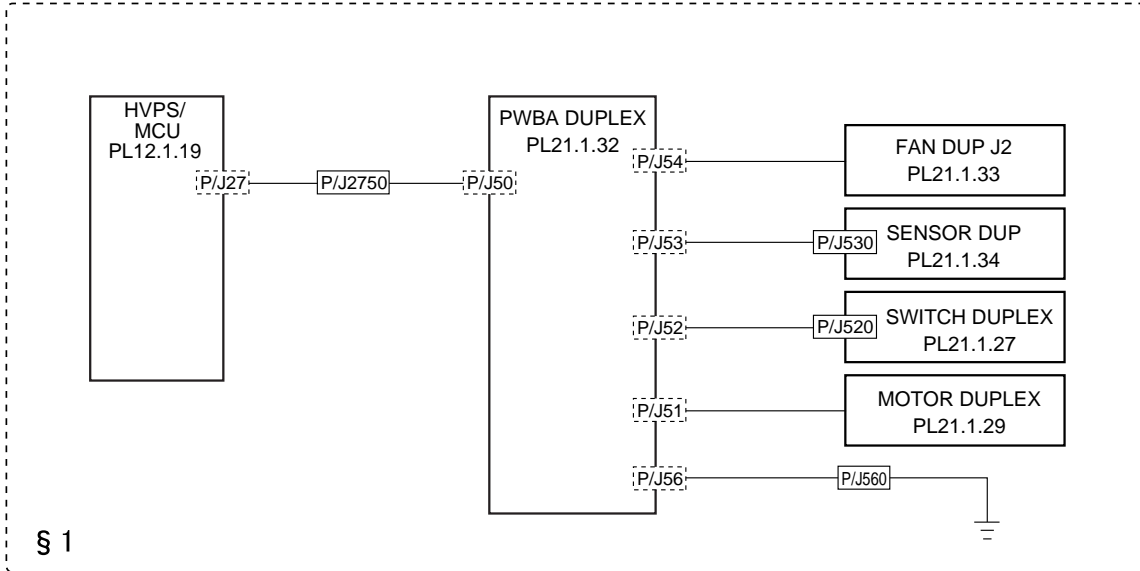

J27601AA

2.2 Configuration of the Interconnection Wiring Diagram of Parts

Option Duplex

- Connections of HVPS/MCU with PWBA DUPLEX
- Connections of PWBA DUPLEX with FAN DUP J2
- Connections of PWBA DUPLEX with SENSOR DUP
- Connections of PWBA DUPLEX with SWITCH DUPLEX
- Connections of PWBA DUPLEX with MOTOR DUPLEX

Option Duplex

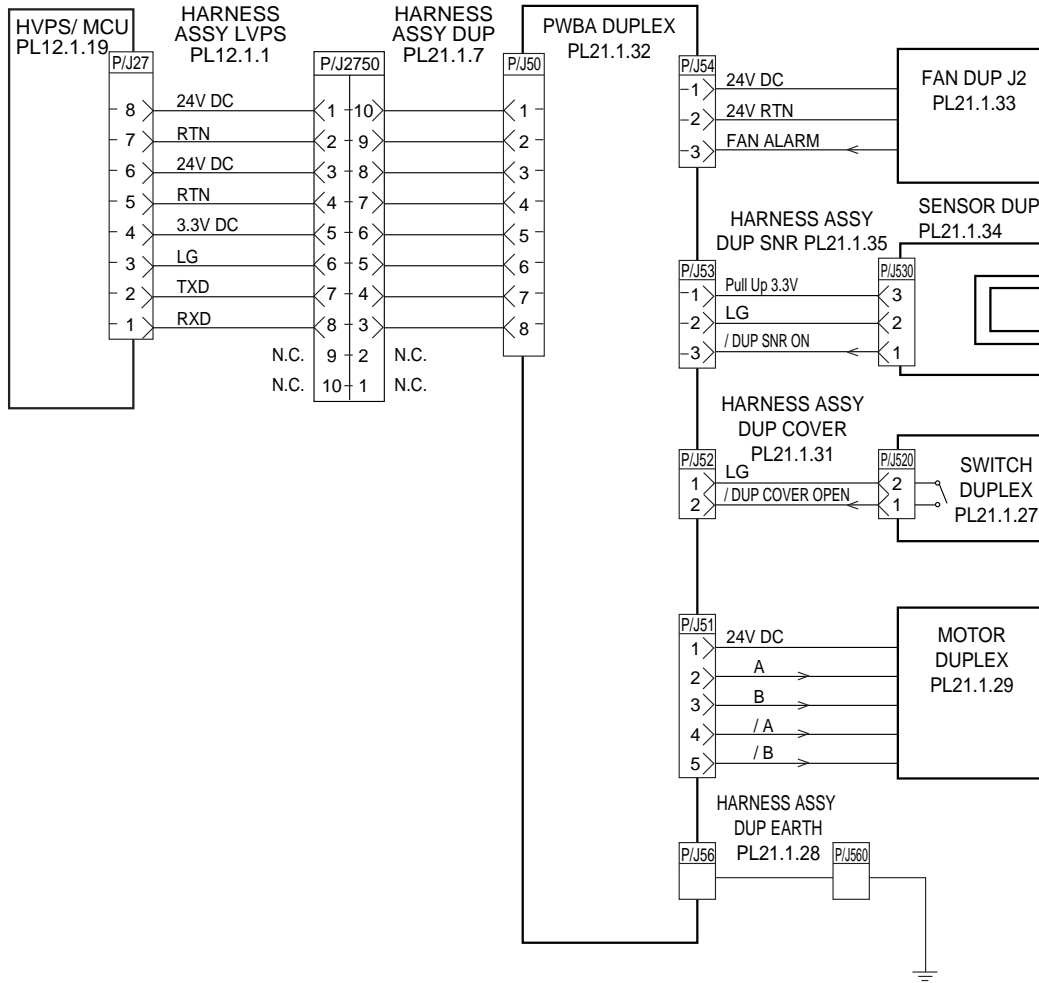

J27602AA

Signal line name	Description
FAN ALARM	Fan monitor signal. This signal goes High if there is a trouble with FAN DUP J2.
/DUP SNR ON	Signal from SENSOR DUP. This signal goes Low when light is received.
/DUP COVER OPEN	Signal from SWITCH DUPLEX. This signal goes Low when the cover of Duplex (COVER HSG DUP) is closed.
A and B	Excitation signal for MOTOR DUPLEX. Phases A and B.
/A and /B	Excitation signal for MOTOR DUPLEX. Phases /A and /B.

OCT Option

2.1 General Wiring Diagram

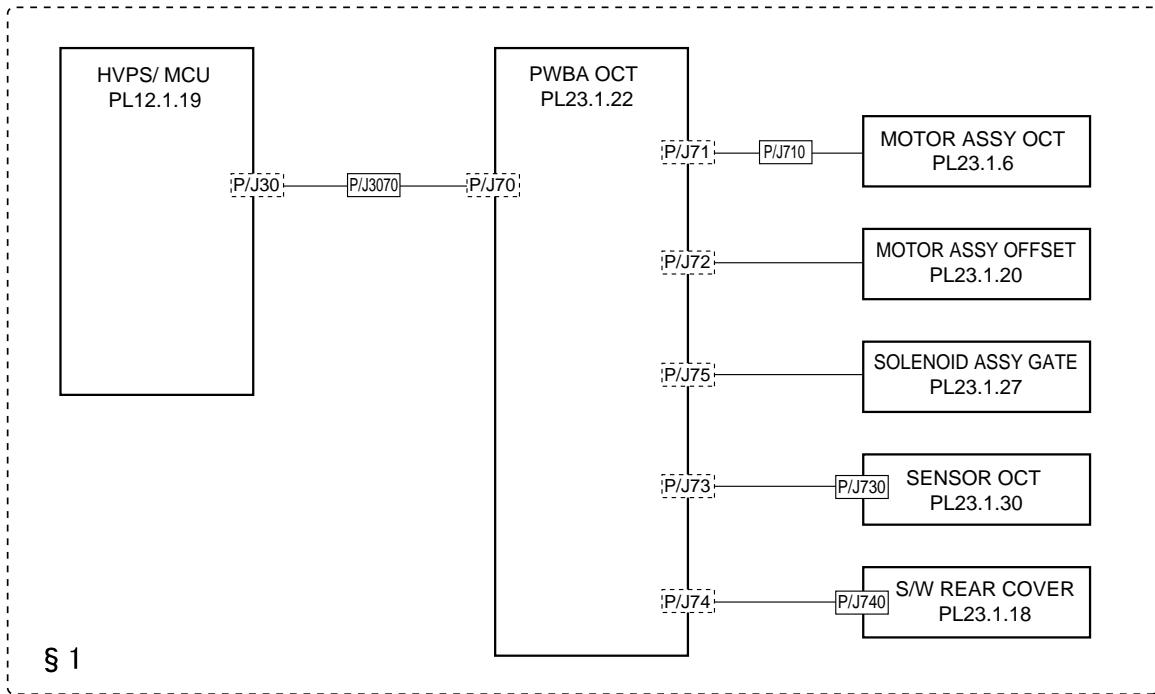

JG7801AA

2.2 Configuration of the Interconnection Wiring Diagram of Parts

Option OCT

Connections of HVPS/MCU with PWBA OCT

Connections of PWBA OCT with MOTOR ASSY OCT

Connections of PWBA OCT with MOTOR ASSY OFFSET

Connections of PWBA OCT with SOLENOID ASSY GATE

Connections of PWBA OCT with SENSOR OCT

Connections of PWBA OCT with S/W REAR COVER

Option OCT

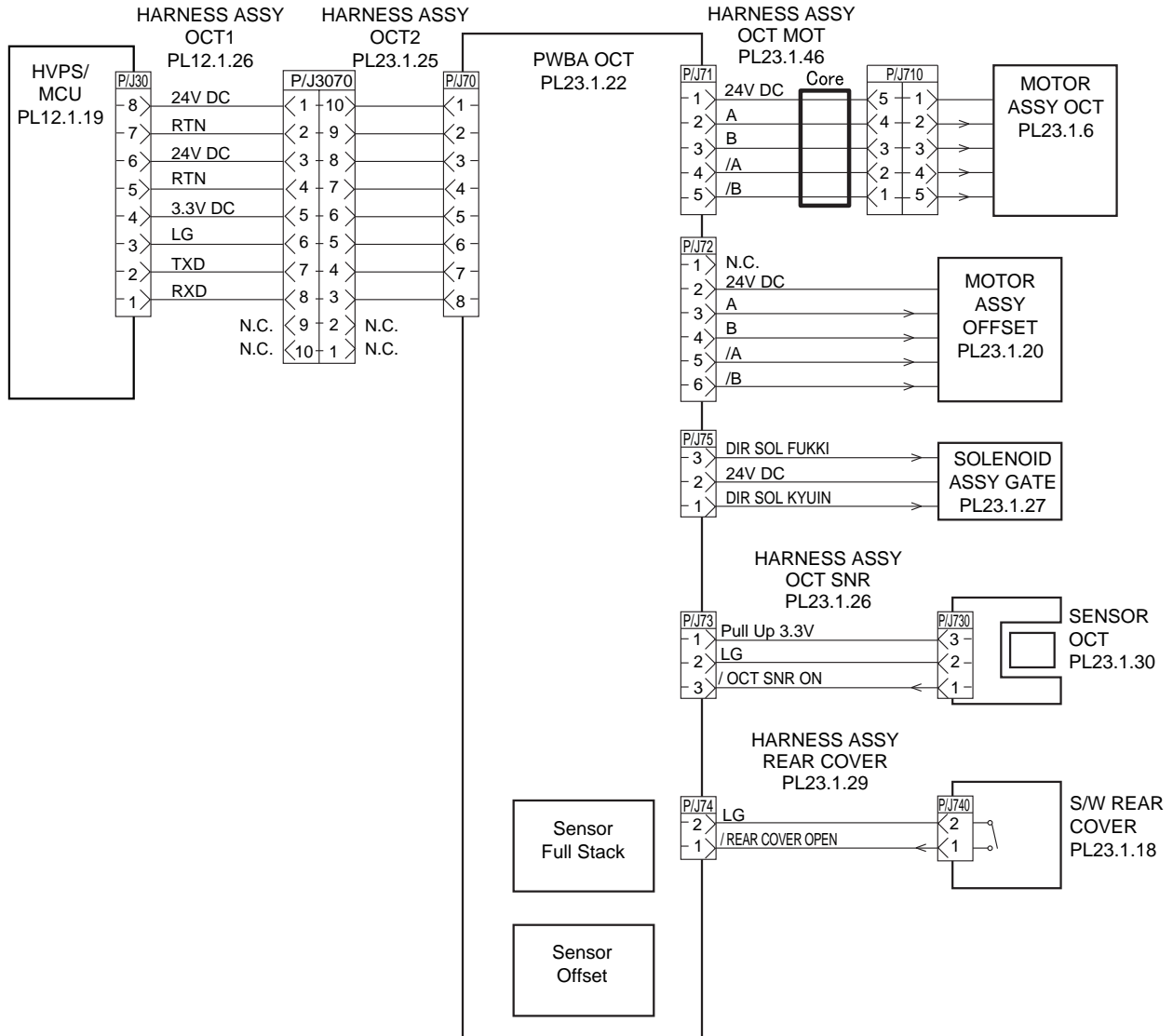

J27802AA

Signal line name	Description
A and B	Excitation signal for MOTOR ASSY OCT and MOTOR ASSY OFFSET. Phases A and B.
/A and /B	Excitation signal for MOTOR ASSY OCT and MOTOR ASSY OFFSET. Phases /A and /B.
DIR SOL FUKKI DIR SOL KYUIN	Control signal for SOLENOID ASSY GATE.
/OCT SNR ON	Signal from SENSOR DUP. This signal goes Low when light is received.
/REAR COVER OPEN	Signal from S/W REAR COVER. This signal goes Low when the rear cover of OCT (COVER REAR) is closed.

2.1 General Wiring Diagram

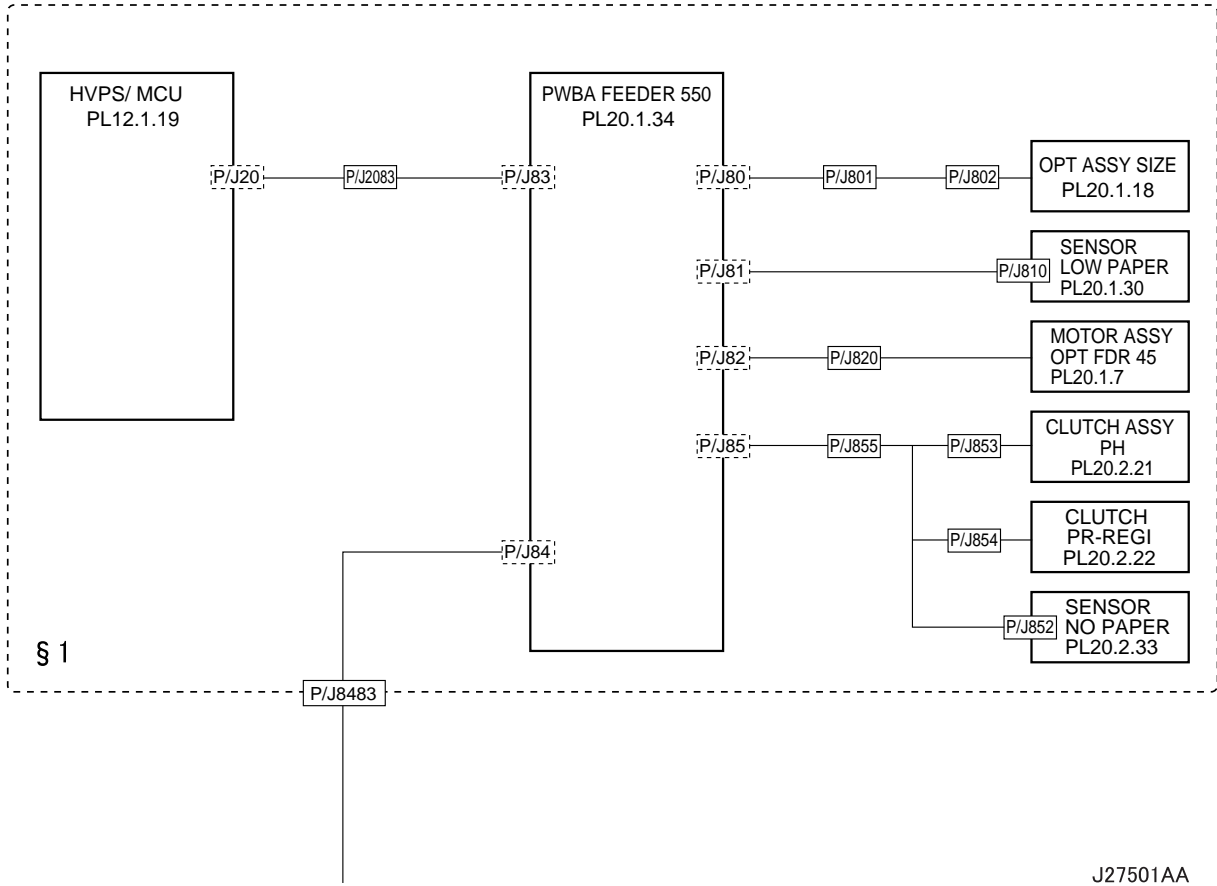

NOTE

Option 550 Paper Feeder are connectable to two sets.

2.2 Configuration of the Interconnection Wiring Diagram of Parts

Option 550 Paper Feeder

Connections of HVPS/MCU with PWBA FEEDER250

Connections of PWBA FEEDER550 with OPT ASSY SIZE

Connections of PWBA FEEDER550 with SENSOR LOW PAPER

Connections of PWBA FEEDER550 with MOTOR ASSY OPT FDR 45

Connections of PWBA FEEDER550 with CLUTCH ASSY PH

Connections of PWBA FEEDER550 with CLUTCH PR-REGI

Connections of PWBA FEEDER550 with SENSOR NO-PAPER

Option 550 Paper Feeder

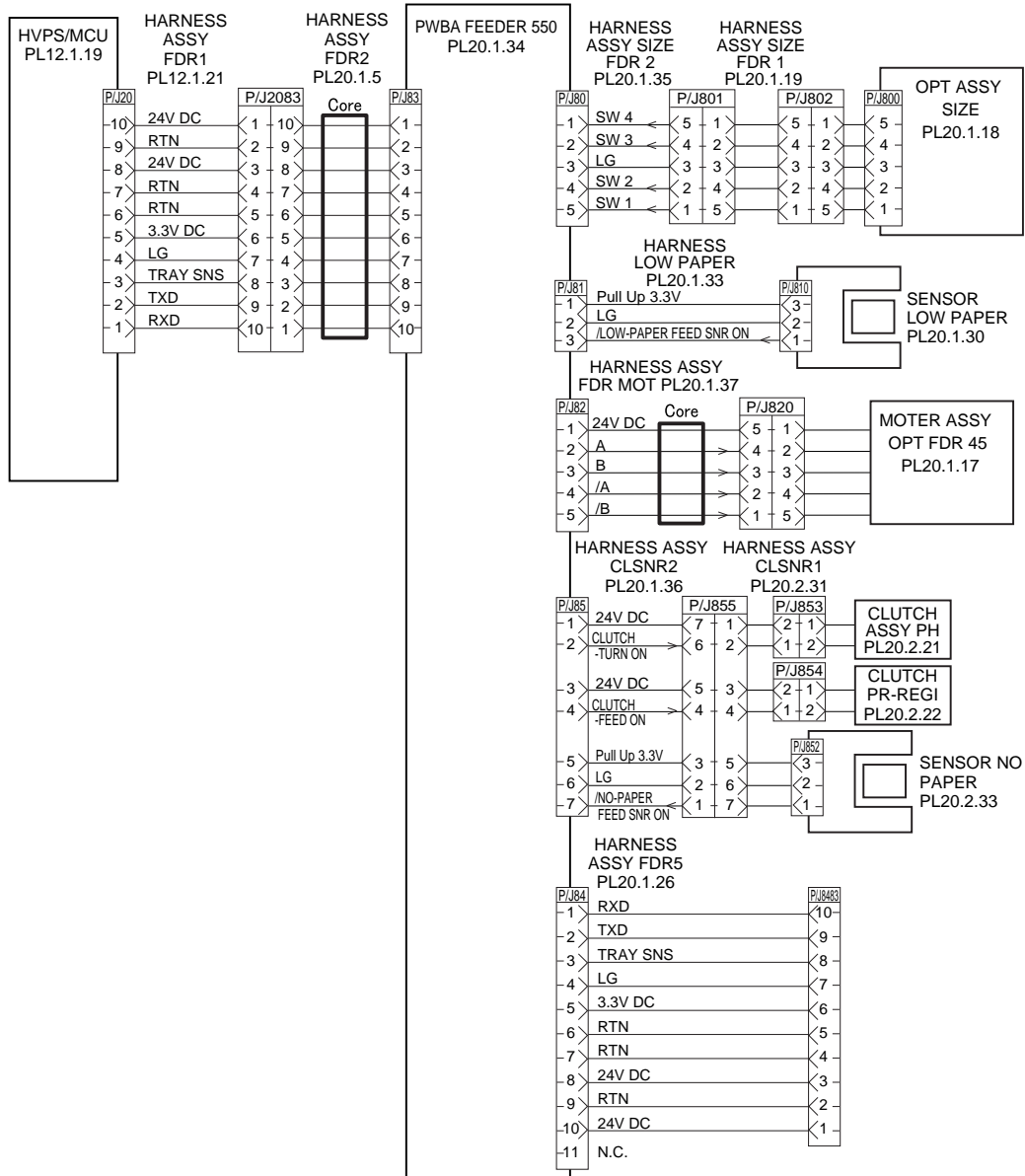

J27502AA

Signal line name	Description
TRAY SNS	Signal detecting an Option 550 Paper Feeder. ID is recognized by the number of falling edges.
/LOW-PAPER FEED SNR ON	Signal from SENSOR LOW PAPER. This signal goes Low when light is received.
A and B	Excitation signal for MOTOR ASSY OPT FDR 45. Phases A and B.
/A and /B	Excitation signal for MOTOR ASSY OPT FDR 45. Phases /A and /B.
CLUTCH-TURN ON	Control signal for CLUTCH ASSY PH. Low: ON / High: OFF
CLUTCH-FEED ON	Control signal for CLUTCH PR-REGI. Low: ON / High: OFF
/NO-PAPER FEED SNR ON	Signal from SENSOR NO PAPER. This signal goes Low when light is received.

Chapter 5 Printer Specifications Contents

Chapter 5 Printer Specifications

Engine

1. Configuration of Printer.....	5 - 1
1.1 Basic Configuration.....	5 - 1
1.2 Engine Configuration with Options.....	5 - 1
2. Electrical Properties.....	5 - 2
2.1 Power Source	5 - 2
2.1.1 For 120 VAC Printer.....	5 - 2
2.1.2 For 220/240 VAC Printer.....	5 - 2
2.2 Power Consumption.....	5 - 2
2.2.1 Maximum Power Consumption	5 - 2
2.2.2 Average Power Consumption	5 - 2
3. Mechanical Properties.....	5 - 3
3.1 Print Engine Size and Weight (REF).....	5 - 3
3.2 Media Input Tray Size and Weight (REF)	5 - 4
3.2.1 150 Tray.....	5 - 4
3.2.2 550 Tray.....	5 - 4
3.3 Media Input Tray/Deck (packaged in the same box), Size and Weight (REF).....	5 - 5
3.3.1 Media Input Tray/Deck.....	5 - 5
3.4 EP Cartridge Size and Weight (REF).....	5 - 5
3.5 Duplex Unit Size and Weight	5 - 6
3.6 500 Sheet Offset Catch Tray Size and Weight	5 - 6
3.7 Face Up Tray Size and Weight (REF)	5 - 7
3.8 Minimum Space Requirements.....	5 - 7
4. Specification	5 - 8
4.1 Base Print Engine Specification.....	5 - 8
4.1.1 Printing System.....	5 - 8
4.1.2 Exposure System.....	5 - 8
4.1.3 Transfer System.....	5 - 8
4.1.4 Fixing System	5 - 8
4.1.5 Resolution.....	5 - 8
4.1.6 Warm-up Time	5 - 8
4.1.7 First Print Output Time (FPOT).....	5 - 8
4.1.8 Continuous Print Speed.....	5 - 9
4.1.9 Printable Area	5 - 9
4.2 Media Feed Specifications.....	5 - 9
4.2.1 1st Media Input Tray (150 Sheet Universal)	5 - 9
4.2.2 2nd Media Input Tray (550 Sheet Universal)	5 - 10
4.2.3 Auxiliary Paper Deck (Option).....	5 - 11
4.2.4 Duplex Unit (Option)	5 - 12

Chapter 5 Printer Specifications Contents

4.3 Paper Output Tray	5 - 12
4.3.1 500 Sheet Face Down Output Tray	5 - 12
4.3.2 Face Up Output Tray (Option)	5 - 13
4.3.3 500 Sheet Offset Catch Tray (Option)	5 - 13
4.4 Printing Media	5 - 13
4.4.1 Baseline Paper.....	5 - 13
4.5 EP Cartridge Specification	5 - 14
4.5.1 EP Cartridge Life.....	5 - 14
5. Environmental Specifications	5 - 15
5.1 Installation and Storage Requirements.....	5 - 15
5.1.1 Print Engine Installation Requirements: Unpacked condition, an EP Cartridge installed.	5 - 15
5.2 Acoustic Noise	5 - 15
5.3 Inclination.....	5 - 15
5.4 Illumination.....	5 - 15
5.5 Dust Emission	5 - 15
5.6 Chemical Substances	5 - 15
5.7 Pollution/Safety	5 - 16
5.8 Ozone Emission.....	5 - 16
5.9 Styrene/Benzene/TVOC	5 - 16
6. Regulatory Agency Approvals	5 - 17
6.1 Safety Specifications.....	5 - 17
6.1.1 For 120V/240V Type.....	5 - 17
6.1.2 For 220V/240V Type.....	5 - 17
6.1.3 E.M.I. (Electro-Magnetic Interference) Specifications.....	5 - 17
7. Reliability Specifications	5 - 18
7.1 MPBF (Mean Prints Between Failures).....	5 - 18
7.2 MTTR (Mean Time To Repair)	5 - 18
7.3 Printer Life.....	5 - 18
7.3.1 Print Engine Life.....	5 - 18
7.3.2 Paper Deck Life	5 - 18
7.3.3 EP Cartridge Life.....	5 - 19
7.3.4 Duplex Unit Life.....	5 - 19
7.3.5 500 Sheet Offset Catch Tray	5 - 19
7.4 Average Number of Printed Sheets (Monthly)	5 - 19
7.5 Maximum Number of Printed Sheets (Monthly)	5 - 19
8. Print Quality Specifications.....	5 - 20
8.1 Print Quality Evaluation and Guaranteed Conditions.....	5 - 20
8.2 Print Alignment.....	5 - 20

Chapter 5 Printer Specifications

Engine

1. Configuration of Printer

1.1 Basic Configuration

The basic printer consists of the print engine main unit, consumables (CRU), 150 Sheet Universal and 550 Sheet Universal Trays.

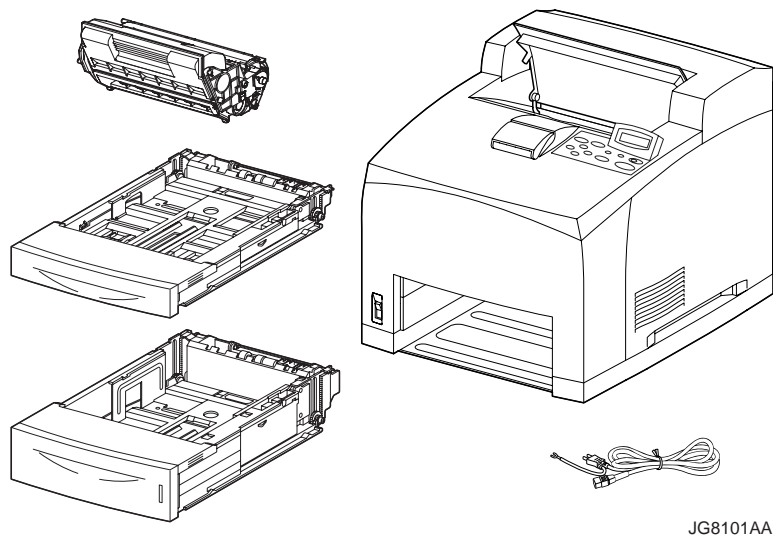

1.2 Engine Configuration with Options

Functional configuration of this printer is shown below.

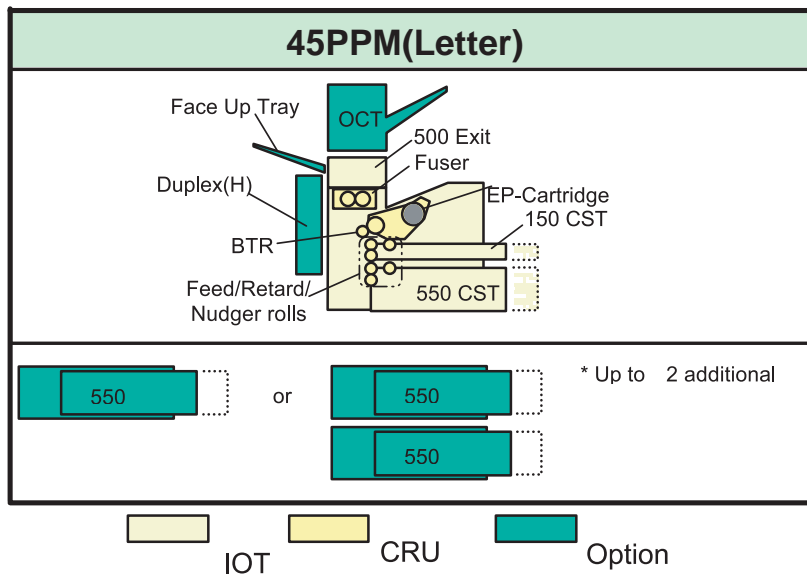

J28009AA

2. Electrical Properties

2.1 Power Source

Two types of power source as follows are available for this printer, which are selected according to the specifications.

2.1.1 For 120 VAC Printer

Voltage			Frequency		
Min	Nominal	Max	Min	Nominal	Max
98VAC	120VAC	132VAC	47Hz	50/60Hz	63Hz

2.1.2 For 220/240 VAC Printer

Voltage			Frequency		
Min	Nominal	Max	Min	Nominal	Max
198VAC	220/240VAC	264VAC	47Hz	50/60Hz	63Hz

2.2 Power Consumption

2.2.1 Maximum Power Consumption

Operation (+/- 10%)	Power Consumption	Electrical Current	Power Consumption		
			Low Power Mode 1	Low Power Mode 2	Sleep Mode *5 (Fan Stop)
			Fan Low Speed	Fan Stop *5	
110 VAC	Maximum: 1210 W	Maximum: 12.2 A	Maximum: 16.5 W	Maximum: 6.5 W	Maximum: 3.5 W
220 VAC	Maximum: 1270 W	Maximum: 5.8 A	Maximum: 17.6 W	Maximum: 9.0 W	Maximum: 5.0 W

NOTE

1. No electrical current shall be supplied to the Fuser unit in Low Power Mode.
2. No electrical current shall be supplied to the Fuser / Fan / MCU unit in Sleep Mode.
3. Power consumption is without the Controller.
4. Specified with FX method.
5. The controller consuming current at low power mode 2 and sleep mode shall not exceed 1A @ 3.3V and 0.5A @ 5V.

2.2.2 Average Power Consumption

Input Voltage	Base w/OCT and Option Feeder		
	Standby	Simplex	Duplex
120 VAC	110 W	880 W	629 W
230 VAC	89 W	728 W	633 W

3. Mechanical Properties

Dimensions shall be specified with nominal values including dimensional tolerances of +/- 5mm and +/- 0.5 kg. The dimensions shall not include any of the local projections including a lever and a handle.

3.1 Print Engine Size and Weight (REF)

Configura-tion/Condi-tion	Configuration		Width (mm)	Depth (mm)		Height (mm)	Weight (kg)
	Input Tray	Exit		To A4/Letter	To Legal 14		
Unpacked (Note 2)	550	500	421.8	465.4	524.0	404.3	21.1
Packaged (Note 3)			570.0	554.0		590.0	27.3

The size and weight shall basically apply to the engine configuration.

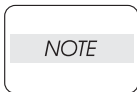

- :
1. These sizes exclude print engine's side and rear louver, a rear knob and top bump.
 2. Unpacked: Neither an EP cartridge nor a controller shall be included.
 3. Packaged: An EP cartridge shall be included.
 4. Depth size is the condition which telescope by the paper size.

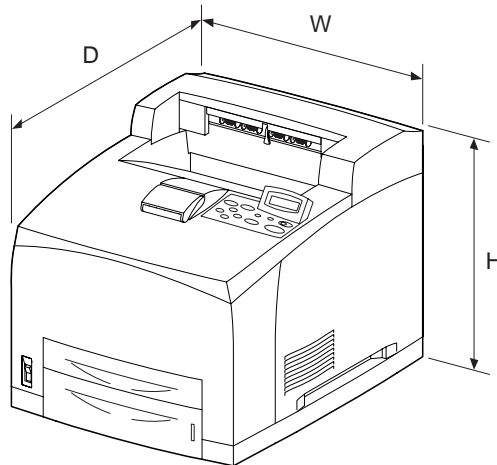

JG8102AA

3.2 Media Input Tray Size and Weight (REF)

Configuration	Condition	Width (mm)	Depth (mm)		Height (mm)	Weight (kg)
			To A4/Letter	To Legal 14		
150 Tray	Unpacked	283.7	390.6	449.2	50.4	1.60
	Packaged	487.0	375.0		157.0	2.4
550 Tray	Unpacked	283.7	394.6	453.2	85.6	2.12
	Packaged	487.0	375.0		189.0	3.0

3.2.1 150 Tray

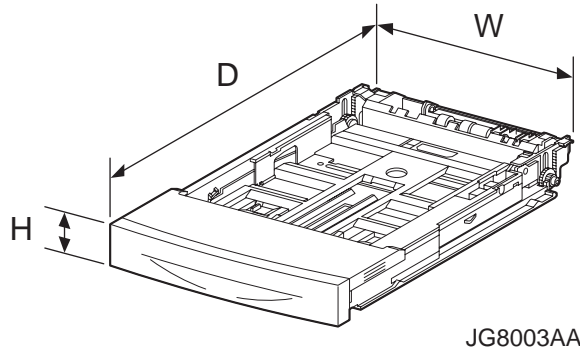

3.2.2 550 Tray

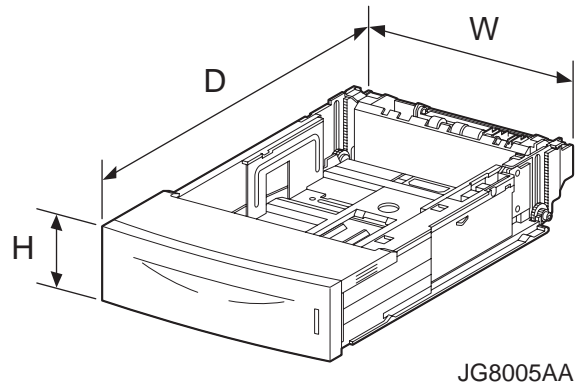

3.3 Media Input Tray/Deck (packaged in the same box), Size and Weight (REF)

Configuration	Condition	Width (mm)	Depth (mm)		Height (mm)	Weight (kg)
			To A4/Letter	To Legal 14		
550 Input Tray Feeder	Unpacked	421.8	451.6	510.2	143.0	6.3
	Packaged	551.0	541.0		252.0	8.5

3.3.1 Media Input Tray/Deck

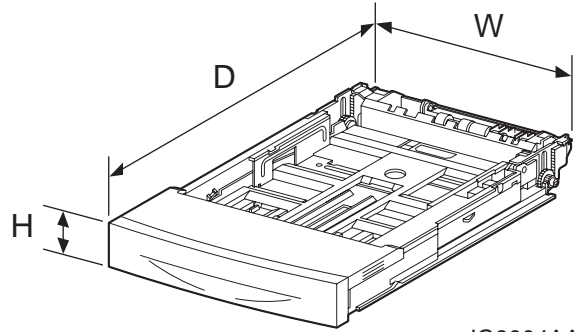

JG8004AA

3.4 EP Cartridge Size and Weight (REF)

Condition	Width (mm)	Depth (mm)	Height (mm)	Weight (kg)
Unpacked	298.5	177.4	159.0	1.96/1.70
Packaged	386.0	241.0	232.0	2.57/2.24

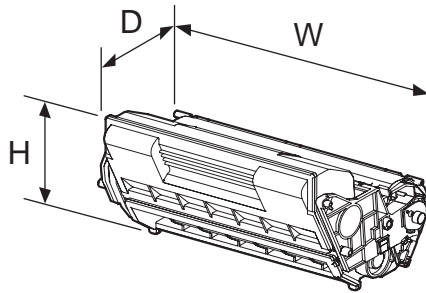

JG8006AA

3.5 Duplex Unit Size and Weight

Condition	Width (mm)	Depth (mm)	Height (mm)	Weight (kg)
Unpacked	351.7	146.2	238.0	1.9
Packaged	454.0	322.0	237.0	2.6

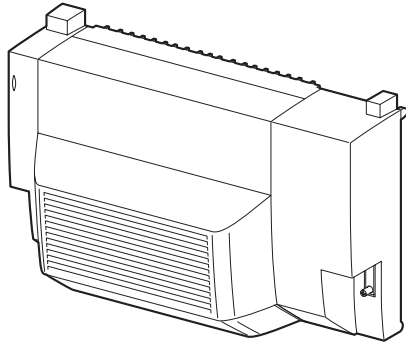

J20009AA

3.6 500 Sheet Offset Catch Tray Size and Weight

Condition	Width (mm)	Depth (mm)	Height (mm)	Weight (kg)
Unpacked	417.8	312.5	226.4	2.6
Packaged	529.0	442.0	327.0	3.9

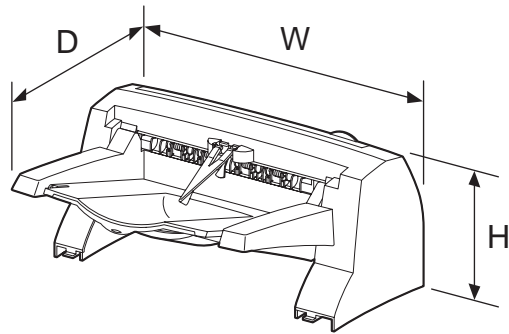

JG8801AA

3.7 Face Up Tray Size and Weight (REF)

Condition	Width (mm)	Depth (mm)	Height (mm)	Weight (kg)
Unpacked (Installation)	320.6	162.6	89.4	0.25
Unpacked (Simple)		169.6	43.0	
Packaged	360.0	200.0	95.0	0.6

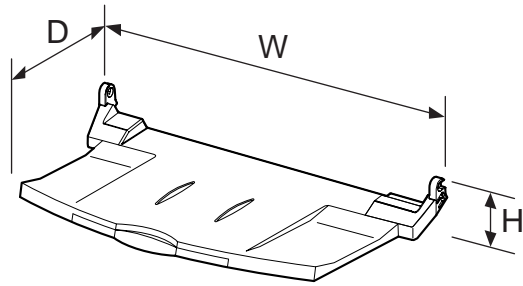

JG8711AA

3.8 Minimum Space Requirements

There must be sufficient space around the print engine for proper access, ventilation and operation.

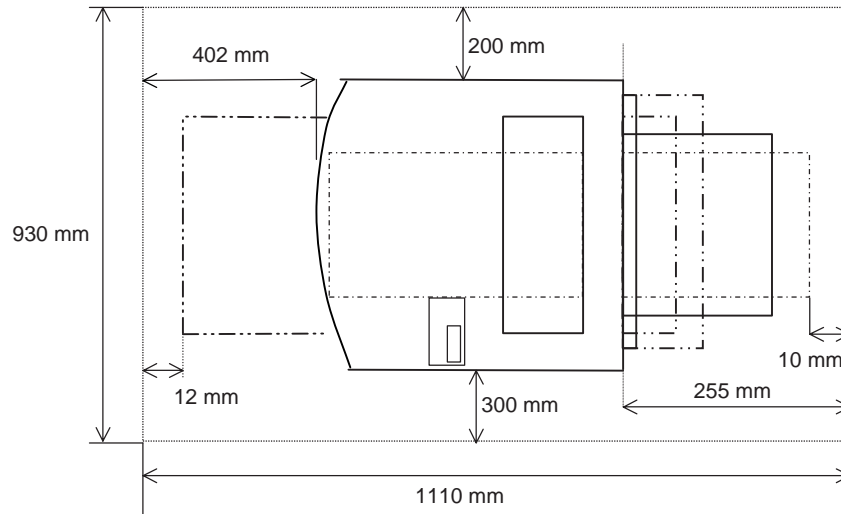

JG8103AA

4. Specification

4.1 Base Print Engine Specification

4.1.1 Printing System

Electro-photographic system (roller charging, single component magnetic toner development).

4.1.2 Exposure System

Semiconductor laser beam scanning system.

4.1.3 Transfer System

Roller transfer system.

4.1.4 Fixing System

Thermal fusing system by a heated roller.

4.1.5 Resolution

600 dpi or 1200 dpi (Dual laser beam, 600 dpi/1200 dpi switch-able at full engine speed).

4.1.6 Warm-up Time

The Print Engine shall reach a READY state within 17 sec maximum after the application of power as a nominal voltage (120V/220V).

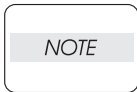

: measured at 22°C.

4.1.7 First Print Output Time (FPOT)

The First Print Output Time (FPOT) shall be defined as the time from when the printer receives a START signal in the READY state, until a single page is printed and delivered into the output tray, under the scanning condition (Fuser Ready).

The following data are theoretical values without misfeed margin (0.2 sec.).

Configuration		Paper Size	Mode	Tray 1 (t sec)	Tray 2 (t sec)	Tray 3 (t sec)	Tray 4 (t sec)
Tray 2	Exit						
550	500	Letter SEF	Simplex	7.9	7.9	7.9	8.2
			Duplex	11.1	11.1	11.1	11.3
		A4 SEF	Simplex	7.9	7.9	7.9	8.2
			Duplex	11.2	11.2	11.2	11.4

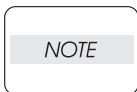

- 1. SEF: Short Edge Feed
- 2. Duplex: 1 sht.Batch Mode
- 3. FPOT from sleep mode

Configuration		Paper Size	Mode	Tray 1 (t sec)	Tray 2 (t sec)	Tray 3 (t sec)	Tray 4 (t sec)
Tray 2	Exit						
550	500	Letter SEF	Simplex	24.9	24.9	24.9	25.2
			Duplex	28.1	28.1	28.1	28.3
		A4 SEF	Simplex	24.9	24.9	24.9	25.2
			Duplex	28.2	28.2	28.2	28.4

4.1.8 Continuous Print Speed

The following data are theoretical values for Input Trays 1,2,3 and 4.

Paper Size	Simplex/ Thin Paper Mode (ppm)	Simplex OHP Mode (ppm)	* ⁴ Simplex Thick Stock Mode1/ Label Mode (ppm)	* ⁵ Simplex Thick Stock Mode2 (ppm)	Simplex Thick Stock Mode3 (1/2 Speed) (ppm)	Duplex (ipm)	* ⁴ Duplex Thick Stock Mode1 (ppm)	* ⁵ Duplex Thick Stock Mode2 (ipm)
Letter SEF	45.1	22.4 (Target)	33.0 (Target)	13.1 (Target)	22.6 (Target)	27.2	24.7 (Target)	13.1 (Target)
A4 SEF	43.0	22.4 (Target)	33.0 (Target)	13.1 (Target)	21.5 (Target)	26.4	24.4 (Target)	13.1 (Target)
Legal 14"SEF	37.2 (Target)	-	33.0 (Target)	13.1 (Target)	18.6 (Target)	24.1 (Target)	23.4 (Target)	13.1 (Target)
Legal 13"SEF	39.5 (Target)	-	33.0 (Target)	13.1 (Target)	19.8 (Target)	25.0 (Target)	23.8 (Target)	13.1 (Target)
Executive	45.1 (Target)	-	33.0 (Target)	13.1 (Target)	22.6 (Target)	27.5 (Target)	24.9 (Target)	13.1 (Target)
B5 (JIS) SEF	45.1 (Target)	-	33.0 (Target)	13.1 (Target)	22.6 (Target)	27.7 (Target)	25.1 (Target)	13.1 (Target)
Envelopes	-	-	19.7 (Target)	13.1 (Target)	18.0 (Target)	-	-	-

NOTE

Notes:

1. The controller requires 2 pages of print buffer (one-batch mode) to achieve the duplex speeds.
2. Envelopes: Specified Com#10.
3. Print speed is a theoretical feeding out speed.
4. During consecutive running thick stock Mode 1, engine will go into fuser cool down mode*⁶ after every 50 impressions.
5. During consecutive running thick stock Mode 2, engine will go into fuser cool down mode*⁶ after every 30 impressions.
6. Fuser cool down mode means: Main motor stops scanner motor is spinning and main fan is working at high speed approximately 1 min.

4.1.9 Printable Area

The print engine shall be capable of producing printed images meeting the Print Quality Spec to within 4mm of the edge of the paper. Within the 4mm border, the print engine shall be capable of legibly printing 6 point Arial font or larger on baseline paper.

For Duplex side, the lead edge guaranteed border will be 6mm.

4.2 Media Feed Specifications

4.2.1 1st Media Input Tray (150 Sheet Universal)

The 1st Media Input Tray shall support the following media:

1. Media Size

- Width: 76.2mm (3.0 inch) ~ 215.9mm (8.5 inch)
- Length: 127.0mm (5.0 inch) ~ 900mm (35.4 inch)

2. Media Weight

- Qualified paper: 64gsm(17.1lb) ~ 216gsm(80lb)

3. Media Stack Capacity

- Baseline paper: 150 sheets (Xerox 4200 20lb Letter / RX 80 A4: 3R91720 / Fuji Xerox P A4)
- Other paper: Reference Media Stack Capacity
 - Standard paper: 17.5 mm maximum
 - Envelopes River series C5: 20 sheets (Max: 17.5mm) (Note 1)
 - Envelopes Columbian com10: 15 sheets (Max: 17.5mm) (Note 1)
 - Japanese Official Postcards: 55 sheets (Max: 17.5mm) (Note 1)
 - Transparency sheets: 100 sheets (Max: 11.9mm) (Note 1)
 - Labels: 100 sheets (Max: 17.5mm) (Note 1)
 - Thicker stock: 60 sheets (Max: 17.5mm) (Note 1)

This tray shall automatically sense the following 7 paper sizes when the End Guide is properly adjusted.

No.	Type	Size (mm x mm)	Weight
1	Letter SEF	215.9 x 279.4	(See Note)
2	Legal 14" SEF	215.9 x 355.6	
3	Legal 13" SEF	215.9 x 330.2	
4	Executive SEF	184.2 x 266.7	
5	A4 SEF	210.0 x 297.0	
6	B5 (JIS) SEF	182.0 x 257.0	
7	A5 SEF	148.0 x 210.0	

NOTE

1. The curl, diagonal curl or concave of Special Media shall be within 5mm.
2. Stack Height is specified with the Label on the Tray.
3. The flap is to be placed in the side edge; otherwise the flap is to be opened at the trailing edge. For this case, the opened flap is to be free of any paste or adhesive tape.
4. "No Paper Sensor" shall be available on this media tray as standard
5. Print quality on media up to 335.6mm (14.0 inch) long is guaranteed.

4.2.2 2nd Media Input Tray (550 Sheet Universal)

1. Media Size

- Width: 98.4mm ~ 215.9mm
- Length: 148.0mm ~ 355.6mm

2. Media Weight

- Simplex Mode: 64gsm (17.1lb) ~ 216gsm (80lb)
- Duplex Mode: 64gsm (17.1lb) ~ 216gsm (80lb)

3. Media Stack Capacity

- Baseline paper: 550 sheets (Xerox 4200 20lb Letter / RX 80 A4: 3R91720 / Fuji Xerox P A4)
- Other paper: Reference Media Stack Capacity
 - Standard paper: 59.4 mm maximum
 - Envelopes River series C5: 80 sheets (Max: 49.4mm) (Note 1)
 - Envelopes Columbian com10: 80 sheets (Max: 49.4mm) (Note 1)
 - Japanese Official Postcards: 200 sheets (Max: 49.4mm) (Note 1)
 - Transparency sheets: 100 sheets (Max: 12.4mm) (Note 1)
 - Labels: 290 sheets (Max: 49.4mm) (Note 1)
 - Thicker stock: 160 sheets (Max: 49.4mm) (Note 1)

This tray shall automatically sense the following 7 paper sizes when the End Guide is properly adjusted.

No.	Type	Size (mm x mm)	Weight
1	Letter SEF	215.9 x 279.4	(See Note)
2	Legal 14" SEF	215.9 x 355.6	
3	Legal 13" SEF	215.9 x 330.2	
4	Executive SEF	184.2 x 266.7	
5	A4 SEF	210.0 x 297.0	
6	B5 (JIS) SEF	182.0 x 257.0	
7	A5 SEF	148.0 x 210.0	

NOTE

1. The curl, diagonal curl or concave of Special Media shall be within 5mm.
2. Stack Height is specified with the Label on the Tray.
3. The flap is to be placed in the side edge; otherwise the flap is to be opened at the trailing edge. For this case, the opened flap is to be free of any paste or adhesive tape.
4. "No Paper Sensor" shall be available on this media tray as standard

4.2.3 Auxiliary Paper Deck (Option)

The Auxiliary paper deck may be installed on the printer to provide a 3rd or 4th 550 sheet input source. The Low Paper Indicator and No Paper Sensor shall also be included on the Auxiliary Paper Input Tray. Capability to load paper into a lower tray while the unit is printing on paper fed from an upper tray is available from the print engine.

Maximum Paper Stack Capacity

Three (3) types of paper tray combinations shall be available as shown below:

Combination	1st Tray (standard)	2nd Tray (standard)	3rd Tray (optional)	4th Tray (optional)	Total Capacity
1	150 sheets	550 sheets			700 sheets
2	150 sheets	550 sheets	550 sheets	-	1250 sheets
	150 sheets	550 sheets	550 sheets	550 sheets	1800 sheets

4.2.4 Duplex Unit (Option)

This unit is capable of printing on both sides of the paper.

1. Media Size

- Width: 88.9mm ~ 215.9mm
- Length: 139.7mm ~ 355.6mm

No.	Type	Size (mm x mm)
1	Letter SEF	215.9 x 279.4
2	A4 SEF	210.0 x 297.0
3	Legal 13" SEF	215.9 x 330.2
4	Legal 14" SEF	215.9 x 355.6
5	B5 (JIS) SEF	182.0 x 257.0
6	B5 (ISO) SEF	176.0 x 250.0
7	Executive SEF	184.2 x 266.7
8	Statement SEF	139.7 x 215.9
9	A5 SEF	148.0 x 210.0
10	1/3 A4 SEF	99.0 x 210.0
11	A6 Postcard	105.0 x 148.0
12	Japanese Postcard	100.0 x 148.0
13	US Postcard	88.9 x 139.7

2. Media Weight

- 64gsm (17.1lb) ~ 216gsm (80lb)
- Duplex Mode: 64gsm (17.1lb) ~ 216gsm (80lb)

3. Media Stack Capacity

- Capability to duplex print from the cassette input is supported by the engine for the 13 paper sizes shown in the table above in 1 sheet batch mode.

Paper size except for the above 13 paper sizes is supported as a custom.

4.3 Paper Output Tray

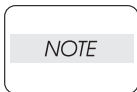

: Paper shall be flipped over if the feeding performance does not meet with face side.

4.3.1 500 Sheet Face Down Output Tray

Under normal conditions (22°C, 55-60%RH), the print engine output tray has a capacity of 500 sheets of face-down output on the top cover, assuming the following paper. This applies to newly-opened paper which has been rested in the packaged condition for more than 12 hours in the operating environment.

- A4 (SEF): 500 sheets
- 20 lb Letter: 500 sheets

4.3.2 Face Up Output Tray (Option)

Under normal conditions (22°C, 55-60%RH), the print engine output tray has a capacity of 500 sheets of face-down output on the top cover, assuming the following paper. This applies to newly-opened paper which has been rested in the packaged condition for more than 12 hours in the operating environment.

- A4 (SEF): 500 sheets
- 20 lb Letter: 500 sheets

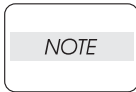

- :
- * Other Media: 10 mm maximum
 - * Supported paper size is:

Width: 88.9 mm - 215.9 mm

Length: 127.0 mm - 297.0 mm

4.3.3 500 Sheet Offset Catch Tray (Option)

Under normal conditions (22°C, 55-60%RH), this unit has a capacity of 500 sheets of face-down output, assuming the following paper. This applies to newly-opened paper which has been rested in the packaged condition for more than 12 hours in the operating environment.

- A4 (SEF): 500 sheets
- 20 lb Letter: 500 sheets

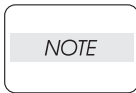

- :
- This unit has the capability to offset the output job position in the output tray
 - * Supported paper size is:

Width: 88.9 mm - 215.9 mm

Length: 139.7 mm - 355.6 mm

4.4 Printing Media

4.4.1 Baseline Paper

- A4
- 20 lb Letter

4.5 EP Cartridge Specification

The EP Cartridge contains an OPC drum, a developing roller and blade, a primary charge roller, a drum cleaner, consumable memory device and the toner. The toner color shall be black.

4.5.1 EP Cartridge Life

Three EP cartridges are available for the print engine. The 6K EP cartridge shall have an average print life of 6,000 impressions on an average of 5% image coverage on Letter size paper. The 10K EP cartridge shall have an average of 10,000 impressions under the same conditions. The 17K EP cartridge shall have an average print life of 17,000 impressions under the same conditions.

Print life shall be defined as the number of impressions, with the print quality specified in section 10, without shaking the EP cartridge.

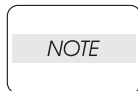

: The life of EP Cartridge packed with a print engine shall be 6,000 impressions.

5. Environmental Specifications

5.1 Installation and Storage Requirements

5.1.1 Print Engine Installation Requirements: Unpacked condition, an EP Cartridge installed.

Condition	Temperature (°C)	Humidity (% RH)	Altitude (m)	Remarks
Operating	5 - 35	15 - 85	0 - 3,500	non-condensing
Non-operating	-20 - 40	5 - 85		

5.2 Acoustic Noise

Sound power shall be determined in accordance with ISO 7779 annex C (9 Positions Method, logarithm mean value).

*Standby mode:	5.00 B
*Low power mode:	5.00 B
*Sleep mode:	Only background noise (FAN OFF)
*Printing mode:	

Configuration	Specification LWA (B)
Base Engine	6.95 B
Base Engine with options (See Note 1)	7.50 B

5.3 Inclination

Errors shall not occur when the print engine is operated within an inclination of +/- 5°.

5.4 Illumination

Errors including minor print quality errors, shall not occur below 3,000 Lux (without direct sunlight)

5.5 Dust Emission

The print engine shall not emit more than 4.0 mg/h.

Method: BAM RAL-UZ (Edition October 2003)

5.6 Chemical Substances

The print engine, including a photoreceptor and toner, shall not contain nor use for fabrication any ozone depleting chemicals or any PCB, PBDE, Trichloroethylene and Asbestos.

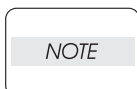

- :
1. PCB: Polychlorinated Biphenyl
 2. PBDE: Polybrominated Diphenyl Ether
 3. CFC: Chlorofluoro Carbons
 4. PBBO: Polybrominated Biphenyl Oxides
 5. PBB: Polybrominated Biphenyl

5.7 Pollution/Safety

The print engine shall meet the regulations (See Note 1). Under the normal operation, no smoke or fire shall be observed.

Mis-use by an operator or power problems shall not cause fire.

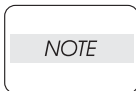

1: See section for safety regulations.

5.8 Ozone Emission

The print engine shall not emit more than 2.0 mg/h.

5.9 Styrene/Benzene/TVOC

The print engine shall meet styrene, benzene and TVOC emission levels as set forth in BAM RAL-UZ 85 (Edition October 2003)

7. Reliability Specifications

The print engine shall meet the following specifications.

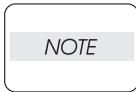

:

1. A single sheet shall be defined as two (2) impressions in the duplex mode.
2. Paper shall be flipped over if the feeding performance does not meet with face side.

7.1 MPBF (Mean Prints Between Failures)

MPBF: 300,000 impressions.

MPBF includes all input and output options. For the purpose of MPBF calculations the definition of "failure" shall be any failure where the print engine does not meet the performance specification.

This value does not include use induced errors. The following failures shall be excluded from failure count for MPBF.

1. Caused by operation or installation which does not conform to the instructions.
2. Caused by the use of media that is outside of the stated specification limits as represented by the Baseline, Standard paper and Special Media list.
3. Caused by operation outside the conditions defined in this specification.
4. Caused by use of parts which have gone beyond their stated life.
5. Recoverable failure following replacement of a toner cartridge.
6. Caused by a service engineer error or an error in their instructions.
7. Caused by premature failure (including transportation damage, mfg. defect, improper handling).
8. Caused by ESS controller and MCU firmware conflicts.

7.2 MTTR (Mean Time To Repair)

Average MTTR is expected to be within 15 minutes. 95% of the total repair jobs can be finished within 30 minutes. Failure diagnosis time shall not be included.

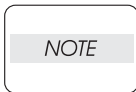

: These values are applied to an unpacked engine, not for an engine in a box. These values are for repairs performed by a trained service engineer.

7.3 Printer Life

7.3.1 Print Engine Life

The print engine life shall be 1,000,000 impressions (Letter SEF) or 5 years from the time the printer is installed (whichever comes first).

7.3.2 Paper Deck Life

The paper deck life shall conform to the print engine life (Section 7.3.1)

7.3.3 EP Cartridge Life

Three EP cartridges are available for the print engine. The 6K EP cartridge shall have an average print life of 6,000 impressions on an average of 5% image coverage on Letter size paper. The 10K EP cartridge shall have an average of 10,000 impressions under the same conditions. The 17K EP cartridge shall have an average print life of 17,000 impressions under the same conditions.

Print life shall be defined as the number of impressions, with the print quality specified in section 10, without shaking the EP cartridge.

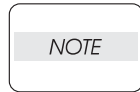

: The life of EP Cartridge packed with a print engine shall be 6,000 impressions.

7.3.4 Duplex Unit Life

500,000 duplex sheets

7.3.5 500 Sheet Offset Catch Tray

1,000,000 impressions

7.4 Average Number of Printed Sheets (Monthly)

10,000 impressions

7.5 Maximum Number of Printed Sheets (Monthly)

200,000 impressions

8. Print Quality Specifications

Specification values described below are the values within 95% in-spec rate.

8.1 Print Quality Evaluation and Guaranteed Conditions

Print quality shall include print alignment, print density, uniformity, resolution and other items.

Unless otherwise indicated, the following are the guaranteed conditions in simplex mode and in duplex mode.

1. Environmental Conditions

- a) Guaranteed print quality environment “at installation” (1-500 impressions)

Temperature: 18° C - 27° C

Humidity: 20% RH - 60% RH

- b) Guaranteed print quality environment “as used” (501 - 6,000/10,000/17,000 impressions)

Temperature: 10° C - 32° C

Humidity: 15% RH - 85% RH

2. Guaranteed Paper

- a) Skew
- b) Perpendicularity
- c) Linearity
- d) Parallelism Accuracy
- e) Lead Edge Registration
- f) Side Edge Registration
- g) Magnification

8.2 Print Alignment

Item		Specification	Evaluation Length
Skew		+/- 1.2mm maximum	190mm
Perpendicularity		+/- 0.8mm maximum	114.5mm
Linearity	V	+/- 0.5mm maximum	234mm
	H	+/- 0.5mm maximum	190mm
	D	+/- 1.2mm maximum	269mm
Parallelism Accuracy		+/- 1.2mm maximum	234mm
Registration	Lead	+/- 2.0mm maximum	-
	Side	+/- 2.5mm maximum	-
Magnification	V	100 +/- 0.5%	234mm
	H	100 +/- 0.5%	190mm

Chapter 6 Controller/ESS Options Contents

Chapter 6 ESS Options

1. ESS Options	6 - 1
1.1 ESS Configuration	6 - 1
2. Option Installation.....	6 - 2
2.1 Installing the HDD	6 - 2
2.2 Installing the CF	6 - 3
2.3 Installing the Development Flash Card	6 - 4
2.4 Installing the SIMM Card.....	6 - 5
2.5 Installing the NIC.....	6 - 7

Chapter 6 ESS Options

1. ESS Options

1.1 ESS Configuration

The ESS has several options that can be installed to enhance performance:

- a. Hard Drive (HDD)
- b. Compact Flash (CF)
- c. Single In-line Memory Module (SIMM) Card

2. Option Installation

2.1 Installing the HDD

- 1) Turn the printer power OFF and remove the power cord from the outlet.
- 2) Remove the COVER RIGHT (RRP1.2) (PL1.1.4)
- 3) Remove the SHIELD ASSY WINDOW (RRP12.8) (PL12.1.15)

NOTE

In the step that follows take care when seating the device. The pins are fragile and can be easily damaged.

- 4) Seat the HDD in the ESS PWB (See figure below)

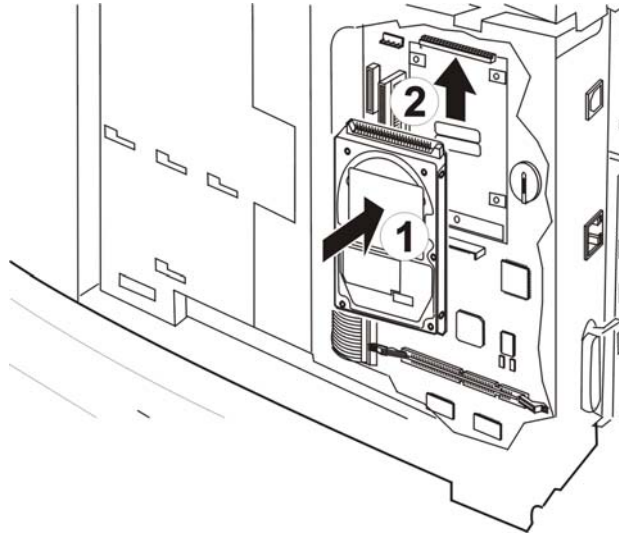

- 5) Push the latch into position to secure the HDD (See figure below)

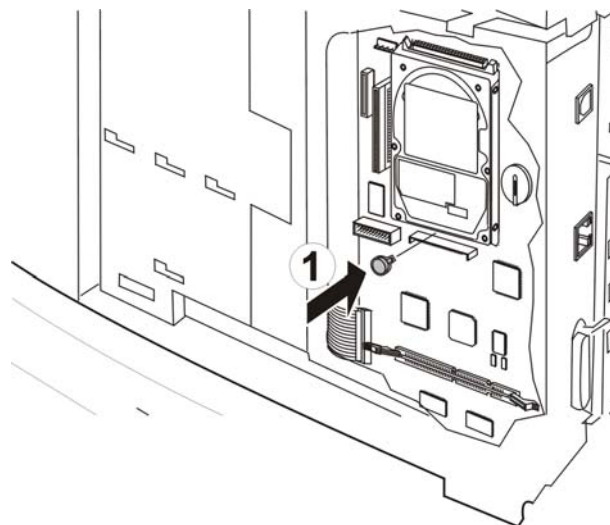

- 6) Replace the SHIELD ASSY WINDOW.
- 7) Replace the COVER RIGHT.
- 8) Plug the power cord into the AC outlet and turn the printer power ON.

2.2 Installing the CF

- 1) Turn the printer power OFF and remove the power cord from the outlet.
- 2) Remove the COVER RIGHT (RRP1.2) (PL1.1.4).
- 3) Remove the SHIELD ASSY WINDOW (RRP12.8) (PL12.1.15).
- 4) Align the CF with the socket on the ESS PWB (See figure below).

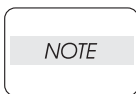
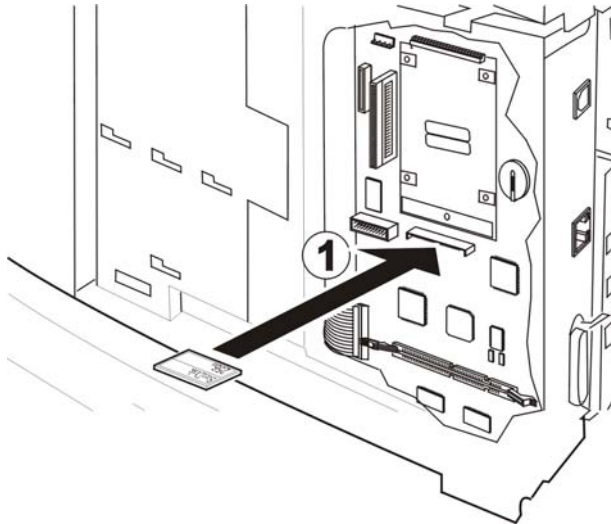

In the step that follows take care when seating the device. The pins are fragile and can be easily damaged.

- 5) Carefully seat the CF in the socket on the ESS PWB (See figure below).

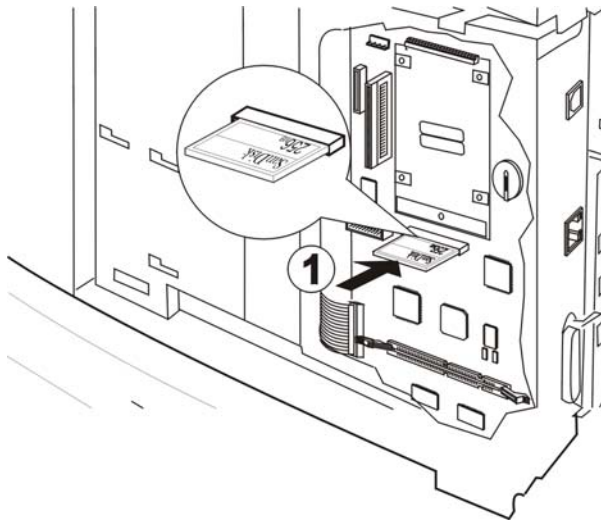

- 6) Replace the SHIELD ASSY WINDOW.
- 7) Replace the COVER RIGHT.
- 8) Plug the power cord into the AC outlet and turn the printer power ON.

2.3 Installing the SIMM Card

- 1) Turn the printer power OFF and remove the power cord from the outlet.
- 2) Remove the COVER RIGHT (RRP1.2) (PL1.1.4).
- 3) Remove the SHIELD ASSY WINDOW (RRP12.8) (PL12.1.15).
- 4) Release the latches on the SIMM Card socket (See figure below).

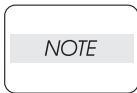
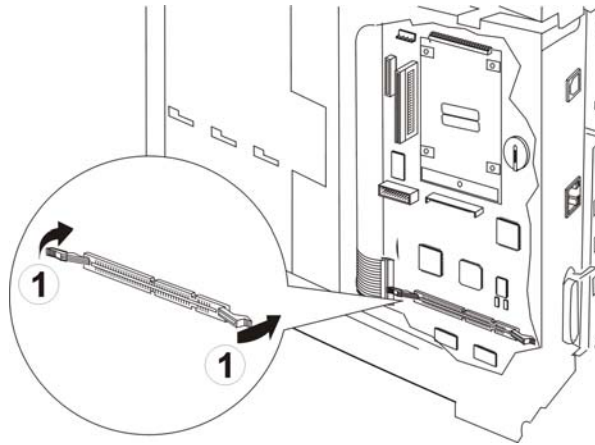

In the step that follows take care when seating the device. The pins are fragile and can be easily damaged.

- 5) Carefully align the SIMM Card with the socket on the ESS PWB (See figure below).

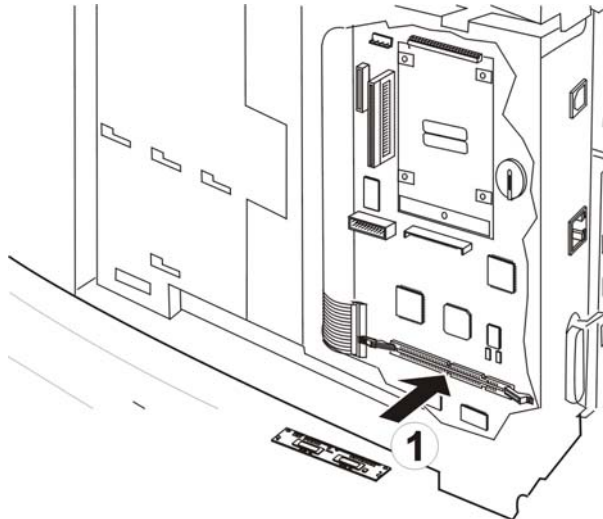

- 6) Seat the SIMM Card into the socket on the ESS.
- 7) Raise the latches on the SIMM Card socket firmly capturing the Card (See figure below).

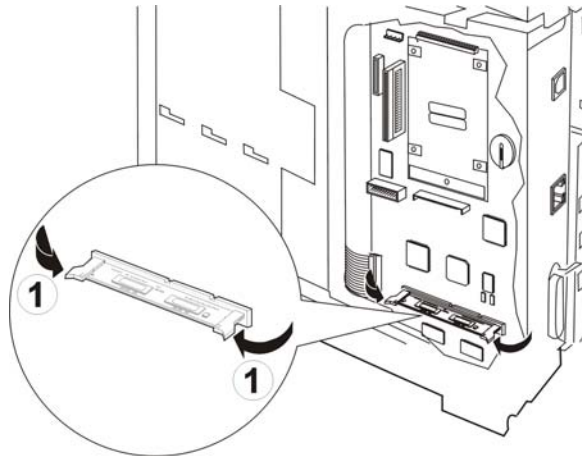

- 8) Replace the SHIELD ASSY WINDOW.
- 9) Replace the COVER RIGHT.
- 10) Plug the power cord into the AC outlet and turn the printer power ON.