

# B411/B431

# Maintenance Manual

062110A

## **Copyright © 2008 by Oki Data. All Rights Reserved**

---

Oki Data America's, Inc. ("Oki Data"), authorizes you to view, copy, and print documents published by Oki Data for noncommercial use within your organization only. In consideration of this authorization, you agree and acknowledge that any copy of these documents shall retain all copyright and proprietary rights contained herein. Each document published by Oki Data may contain additional copyright information and proprietary notification relating to that individual document.

Nothing contained herein shall be construed as conferring by estoppel, implication or otherwise any license or right under any patent or trademark of Oki Data, Oki Electric Industry Co., Ltd. ("Oki Electric"), or any third party. Except as provided above nothing contained herein shall be construed as conferring any license or right under any Oki Data copyright.

Oki Data has taken care to insure that the information which follows is complete, accurate and up-to-date. However, Oki Data assumes no responsibility for errors or omissions which may occur. All the information provided is subject to change from time to time at the sole discretion of Oki Data.

All publications may include technical inaccuracies or typographical errors. We reserve the right to make periodic changes, additions, and deletions to publications without notice.

The most up-to-date drivers and manuals are available from the web site:

<http://www.okiprintingsolutions.com>





**Document Revision History**

Rev. No.	Date	Corrected items			Person in charge
		No.	Page	Description of change	
1	2010-06-11			ISSUE	PED15 T.Kobayashi

# PREFACE

This Maintenance Manual describes the maintenance methods in the printer field for the maintenance personnel. In addition, regarding the handling and operating method of the printer, please refer to the "User's Manual".

The differences between various types of printers described in this Maintenance Manual are as follows.

	B411d	B411dh	B431d	B431dh
				
Engine speed (letter/A4)	35/33	35/33	40/38	40/38
Resolution	2400 x 600 dpi	2400 x 600 dpi	1200 x 1200 dpi	1200 x 1200 dpi
Emulation	PCL6/SIDM	PCL6/SIDM	PCL6/PS3/SIDM	PCL6/PS3/SIDM
Option	N/A	N/A	N/A	N/A
LCD display	16 character x 2	16 character x 2	16 character x 2	16 character x 2
Switch	1 (online/offline)	1 (online/offline)	6	6
LED lights	2	2	2	2
Input tray (Manual/Auto)	Single sheet manual feed	Single sheet manual feed	100 sheets Multi Purpose Tray	100 sheets Multi Purpose Tray
Input tray (1st bin)(20 lb paper)	250 sheets	250 sheets	250 sheets	250 sheets
Maximum Input capacity	781	781	880	880
Interface	USB 2.0	✓	✓	✓
	Parallel	✓	✓	✓
	Ethernet	N/A	N/A	✓
Auto Duplex	Standard	Standard	Standard	Standard
Monthly Duty Cycle	80,000 pages	80,000 pages	80,000 pages	80,000 pages
Starter Toner@ISO19752	2,000	2,000	2,000	2,000
Toner life@ISO19752	3,000/4,000	3,000/4,000	3,000/4,000/10,000	3,000/4,000/10,000
Dimensions (inch./mm)	Width 15.2"/387mm	15.2"/387mm	15.2"/387mm	15.2"/387mm
	Depth 14.3"/364mm	14.3"/364mm	14.3"/364mm	14.3"/364mm
	Height 9.6"/244.5mm	9.6"/244.5mm	9.6"/244.5mm	9.6"/244.5mm
	ODA 100v	✓	✓	✓
	ODA 200v	✓	✓	✓
	OEL	✓	✓	✓
Sales Territories	AOS 1byte	✓	✓	✓
	Korea	✓	N/A	✓
	Japan	N/A	N/A	✓
	China	N/A	N/A	✓

**Note!** • It is prohibited to reprint entire or partial of the content without prior consent.

- For the reason of printer improving and manual content revising, the content of this maintenance manual may change without any warning in the future.

# Contents

1. CONFIGURATION .....	7
1.1 System Configuration .....	7
1.2 Printer Configuration .....	8
1.3 Optional Configuration.....	10
1.4 Specification.....	11
1.5 Printing display .....	14
1.5.1 VCCI label, Serial No. label.....	14
1.5.2 Warning label .....	14
1.5.3 Warning / Caution display .....	15
2. Operational explanation .....	16
2.1 Electrophotographic process mechanism .....	16
2.2 Printing process .....	22
2.3 Toner entrance detection.....	26
3. Parts replacement.....	27
3.1 Preparation for parts replacement.....	27
3.2 Parts layout .....	29
3.3 Parts replacement method .....	31
3.3.1 LED Head.....	32
3.3.2 Roller-Transfer.....	33
3.3.3 Duplex Belt.....	34
3.3.4 Cover-Side-R.....	35
3.3.5 Cover-Side-L .....	36
3.3.6 CU-Board .....	37
3.3.7 Power Supply Unit.....	38
3.3.8 DC Motor .....	39
3.3.9 Hopping / MPT / Regist Clutch .....	40
3.3.10 HV-Board / Motor-FAN .....	41
3.3.11 Cover Assy OPE .....	42
3.3.12 Ope PCB Assy ( B431 ) .....	43
3.3.13 Cover Assy Stacker.....	44
3.3.14 Stacker Cover.....	46
3.3.15 Fuser Assy .....	47
3.3.16 MPT Assy , Manual Assy).....	48
3.3.17 Cover Assy Rear .....	49
3.3.18 Guide Eject Lower Assy .....	51
3.3.19 Eject Motor .....	52
3.3.20 Plate Side R Assy / Plate Side L Assy / Front Assy .....	53
3.3.21 Plate Side L Assy .....	54
3.3.22 Plate Side R Assy .....	55
3.3.23 Roller Regist.....	56
3.3.24 Roller Feed Assy.....	57
3.3.25 Lever In Sensor / Lever WR Sensor / /Photo Interrupter.....	58

3.3.26	Paper feeding roller (Roller-Pick-Up,Roller-Feed-NOW,Roller-Assy-MPT)	59
3.3.27	Frame-Assy-Retard , Spring-Retard	61
3.4	Lubricating points	62
<b>4.</b>	<b>ADJUSTMENT</b>	<b>79</b>
4.1	Category and function of maintenance mode	79
4.1.1	User maintenance mode (Administrator Menu)	79
4.1.2	System maintenance mode (System maintenance menu)	84
4.1.3	Self-diagnostic Mode	89
4.1.4	Energy conservation mode setting	104
4.1.5	EEPROM Initialization	105
4.2	Adjustment at part replacement	106
4.2.1	EEPROM data upload / download method	106
<b>5.</b>	<b>Periodic Maintenance</b>	<b>107</b>
5.1	Periodic Replacement Parts	107
5.2	Cleaning	107
5.3	Cleaning of LED lens array	107
5.4	Cleaning the Feed rollers and the Retard roller	108
<b>6.</b>	<b>Procedures for Repairing</b>	<b>109</b>
6.1	Troubleshooting	109
6.2	Points to be checked before modifying printing problems.	109
6.3	Points to be checked when the printing problems are modified	109
6.4	Preparation for Troubleshooting	109
6.5	Troubleshooting Flow	110
6.5.1	LCD Status Message/ Trouble Table	110
6.5.2	LCD Message Troubleshooting	118
6.5.3	Print Troubleshooting	126
<b>7.</b>	<b>Connection Diagram</b>	<b>135</b>
7.1	Connection diagram	135
7.2	Board Layout	136
7.3	Resistance value	150
<b>Appendix A Centronics Parallel Interface</b>		<b>152</b>
<b>Appendix B USB Interface</b>		<b>159</b>
<b>Appendix C Maintenance Manual for Second Tray unit</b>		<b>161</b>
1	Overview	161
1.1	Function	161
1.2	Exterior and Parts Name	161
2	Description for Operation of Second Tray unit	162
3	Part Replacement	163
3.1	Precautions on replacing parts	163
3.2	Arrangement of Parts	164
3.3	How to Replace Parts	165
3.3.1	Roller-Pick-Up, Roller-Feed-Now	166
3.3.2	Guard-Connector, Connector (9715S-08Z02-G4C)	167
3.3.3	Board-GOG	168

3.3.4	CONN Cord-AMP8P-AMP8P .....	169
3.3.5	Gear-Assy-Clatch (Hop, Regist), Motor-Pulse.....	170
3.3.6	Frame-Assy-Retard, Spring-Retard.....	172
4.	Cleaning of Paper Feed Roller and Separation Roller .....	173
5.	Procedure for Troubleshooting.....	174
5.1	Precautions for Troubleshooting .....	174
5.2	Preparation before Troubleshooting .....	174
5.3	Troubleshooting Method.....	175
5.3.1	LCD Status Message List .....	176
6.	Connection Diagram.....	178
6.1	Connection diagram .....	178
6.2	Board Arrangement.....	178
	Appendix D Network Interface.....	180

# 1. CONFIGURATION

## 1.1 System Configuration

As the diagram 1.1 shows, for the standard configuration printer is configured by controller unit and engine unit.

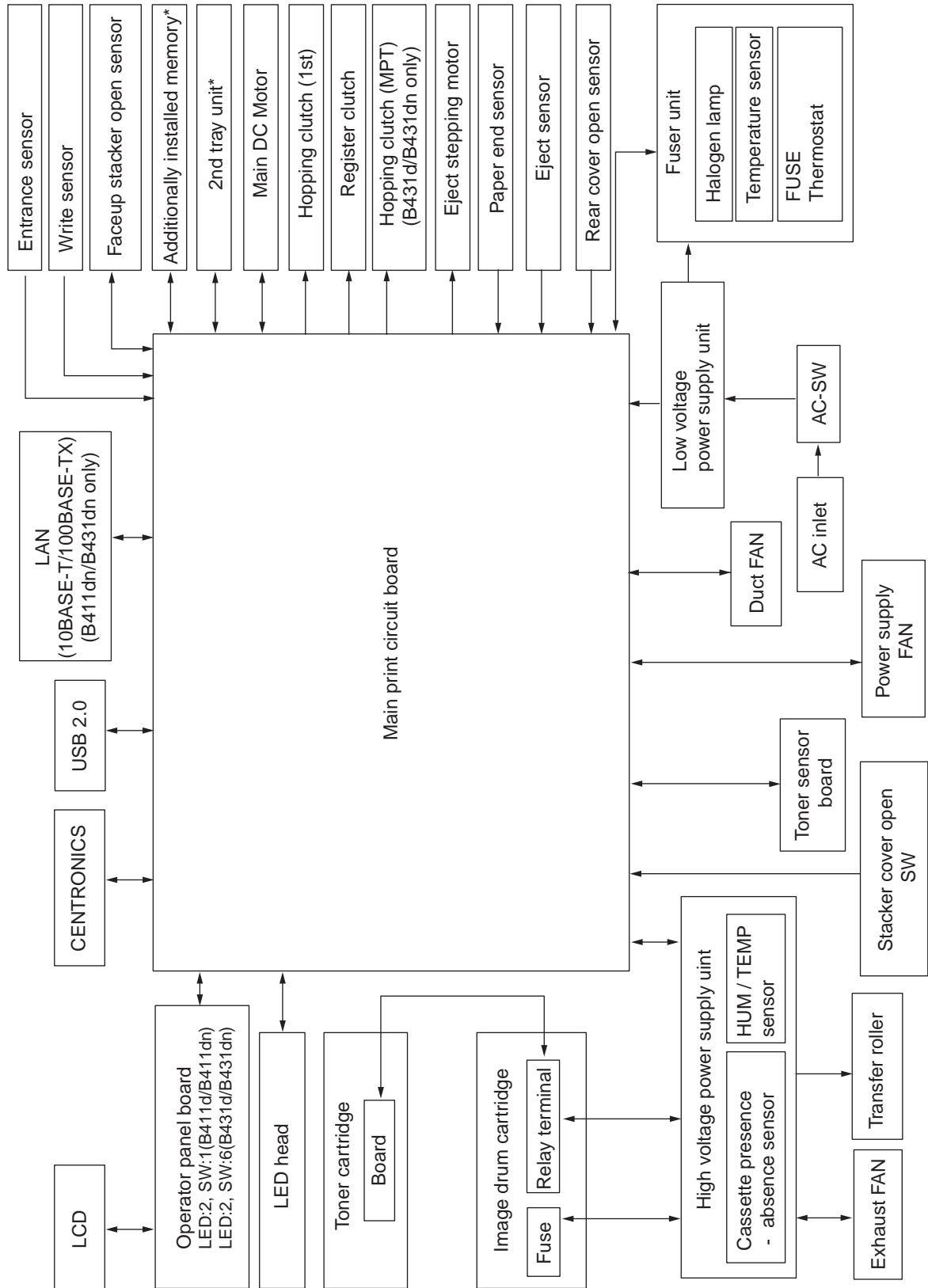

Figure1-1



## 1.2 Printer Configuration

The printer main unit includes the following hardware parts.

- Electrophotographic processing part
- Paper feeding part
- Controller
- Operational part
- Power supply unit

**Note!** • Fuser-Assy has to be replaced by Assy unit.

- It is forbidden to disassemble Fuser-Assy or reuse the disassembled Fuser-Assy.

The configuration of printer main unit is shown as diagram 1-2~1-4

B411d/B411dn

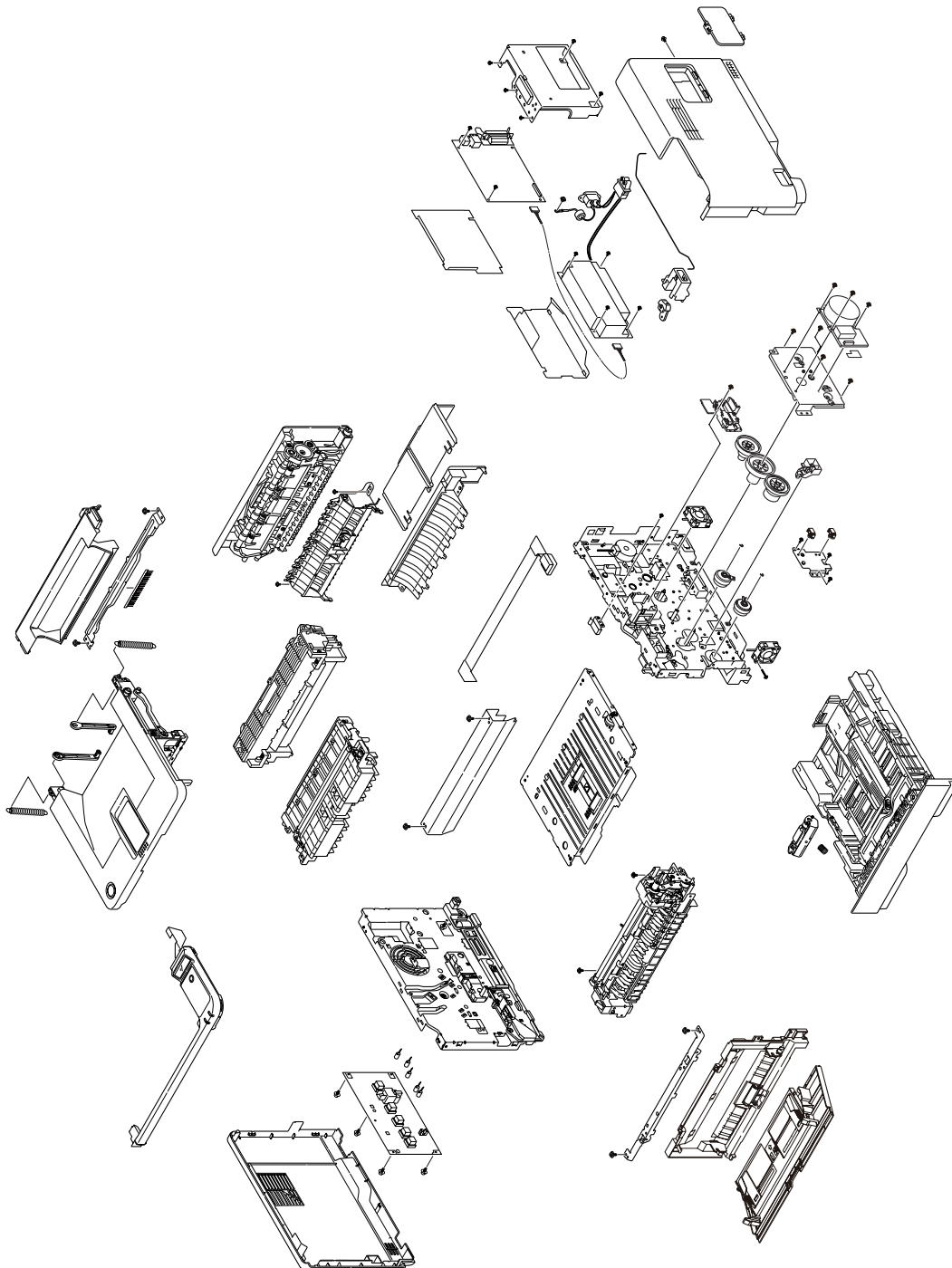

Figure1-2

B431d/B431dn

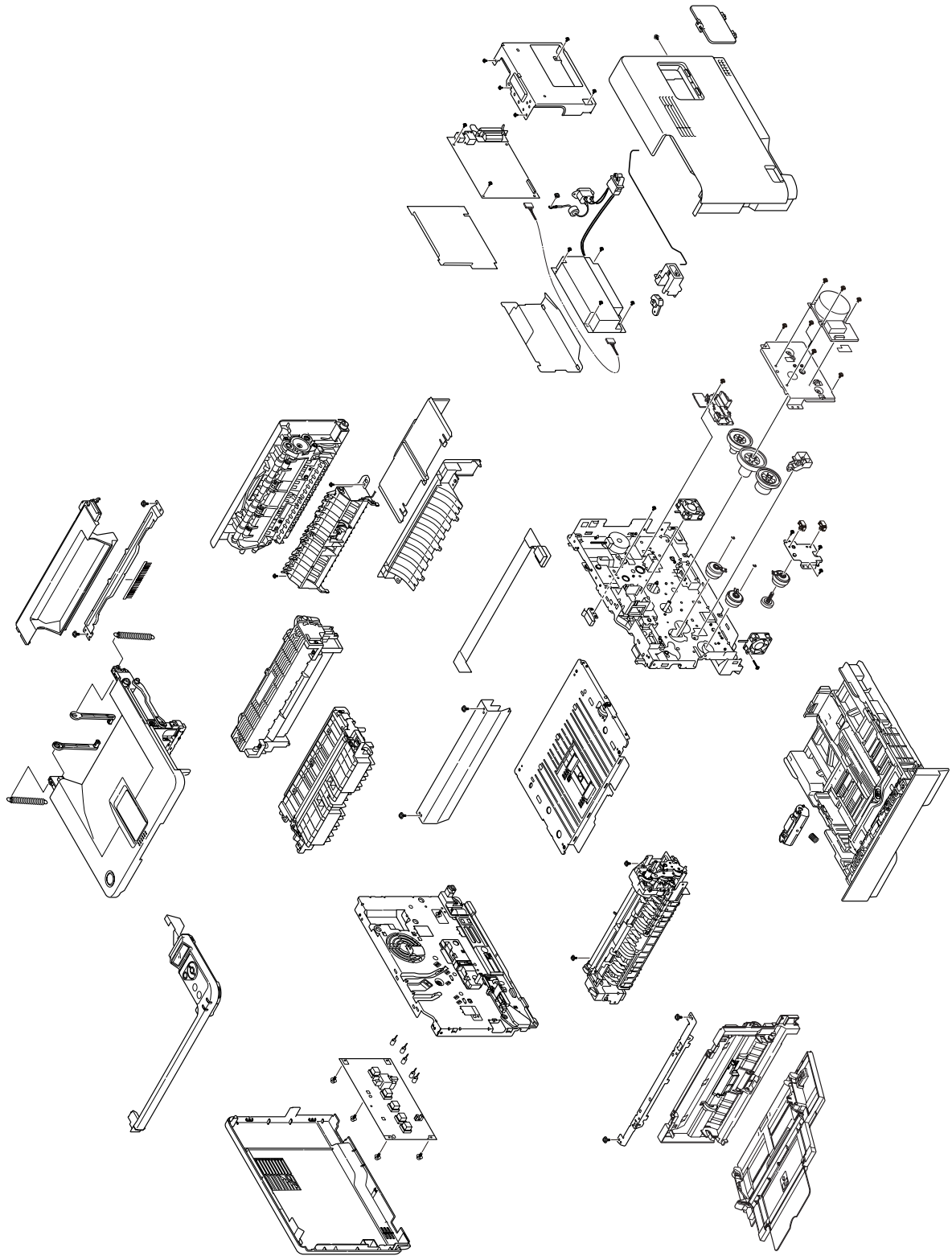
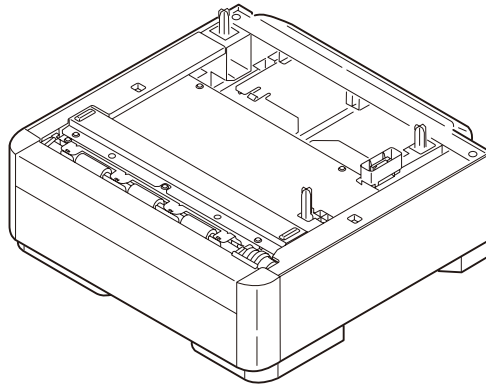

Figure1-3

### 1.3 Optional Configuration

The options attached to the printer are as follows. These options can be ordered respectively for the printer main unit.

- (1) Second tray unit



- (2) Additionally installed memory (Domestic oriented printer only use 64MB,128MB,256MB.)

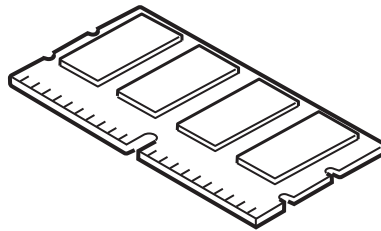

## 1.4 Specification

- (1) Type Desktop
- (2) Dimension 244.5mm (Height) x 387mm (Width) x 364 (Depth)  
:B411d/B411dn/B431d/B431dn
- (3) Weight Approx. 11.6kg (It includes the weight of the printer main unit and consumables.  
It doesn't include the weight of options and paper. )
- (4) Development method Dray type – Element developing method  
Exposure method LED Head method
- (5) Paper type, thickness, Size  
Recommended paper Normal paper.....Excellent paper A4 and Excellent white A4  
OHP Sheet.....Sumitomo 3M PP2500  
Label paper.....Kokuyo LBP-A693

Category	Size unit: mm (inch)		Thickness
Normal Paper	A4	210x297	Weight 55~140kg(64~163g/m <sup>2</sup> ) For double-side printing, weight55~105kg (64~122g/m <sup>2</sup> )  Tray 1, Width 100~215.9, Length 148~355.6 Tray 2, Width 148~215.9, Length 210~355.6 MP Tray or Manual Tray, Width 86~215.9, Length 140~1320.8
	A5	148x210	
	A6	105x148	
	B5	182x257	
	Letter	215.9x279.4(8.5x11)	
	Legal(13 inch)	215.9x330.2(8.5x13)	
	Legal(13.5 inch)	215.9x342.9(8.5x13.5)	
	Legal(14 inch)	215.9x355.6(8.5x14)	
	Statement	139.7x 215.9(5.5x8.5)	
	Executive	184.15x266.7(7.25x10.5)	
	16K 184x260mm	184x260	
	16K 195x270mm	195x270	
	16K 197x273mm	197x273	
Custom	Width86~215.9 Length 140~355.6		
Postcard	Postcard	100x148	Postcard
	Return Postcard	148x200	
Envelope	Envelope 1 (Chou #3)	120x235	The envelope should be using 85g/m <sup>2</sup> paper. The flap of the envelope Chou type should not be with fold, the flap of the envelope you should be clearly folded.
	Envelope 2 (Chou #4)	90x205	
	Envelope 3 (You #4)	105x235	
	Com-9	98.4x225.4(3.875x8.875)	The envelope should be using 24 lb. paper and the flap part of it should be clearly folded.
	Com-10	104.78x241.3(4.125x9.5)	
	DL	110x220(4.33x8.66)	
	C5	162x229(6.4x9)	
	C6	114x162(4.49x6.38)	
	Monarch	98.4x190.5(3.875x7.5)	
Custom	Width86~215.9 Length 140~355.6		
Label Paper	A4	210x297	0.1~0.15mm
	Letter	215.9x279.4(8.5x11)	
OHP Sheet	A4	210x297	0.1~0.15mm
	Letter	215.9x279.4(8.5x11)	
Partial Printing Paper	-	-	Weight 55~140kg(64~163g/m <sup>2</sup> )
Paper for Color Printing	-	-	Weight 55~140kg(64~163g/m <sup>2</sup> )

## (6) Paper feeding method / Ejecting method

○ : It is possible to use it.  
 × : It is not possible to use it.  
 △ : It is possible to use it by a part of size

Type	Thickness (Weight:Kg)	Size	Paper feeding Method				Paper ejecting method		Double-side print									
			Paper cassette		MP Tray*1	Manual	Face up*6	Face down*7	Automatic double-side print*2				Manual double-side print					
			Tray 1	Tray 2*3					Tray 1	Tray 2*3	MP Tray*1	Manual	Tray 1	Tray 2*3	MP Tray*1	Manual		
Normal paper	Weight 55~105kg	A4 B5 Letter Executive 16K 184 x 260mm 16K 195 x 270mm 16K 197 x 273mm	○	○	○	○	○	○	○	○	○	×	○	○	○	○		
		Legal(13 inch) Legal(13.5 inch) Legal(14 inch)	○	○	○	○	×	○	○	○	×	○	○	○	○			
		A5*5	○	○	○	○	○	○	×	×	×	×	○	×	○	○		
		Statement A6*5	○	×	○	○	○	○	×	×	×	×	○	×	○	○		
		Custom*4 Width 86~215.9mm Length 140~1320.8mm	△	△	○	○	△	○	×	×	×	×	△	△	△	△		
	Weight 106~140kg	A4 B5 Letter Executive Legal(13 inch) Legal(13.5 inch) Legal(14 inch) A5 Statement A6 Custom*4 Width 86~215.9mm Length 140~1320.8mm	×	×	○	○	○	×	×	×	×	×	×	×	×	×		
		Postcard*5	Refer to previous page	Postcard/ Return postcard	×	×	○	○	○	×	×	×	×	×	×	×	×	
		Envelope	Refer to previous page	Envelope1 (CHOU 3) Envelope2 (CHOU 4) Envelope3 (YOU 4) Com-9 Com-10 DL C5 C6 Monarch Custom Width 86~215.9mm Length 140~355.6mm	×	×	○	○	○	×	×	×	×	×	×	×	×	
				Lable paper	0.1~0.5mm	A4/Letter	×	×	○	○	○	×	×	×	×	×	×	×
				OHP	0.1~0.5mm	A4/Letter	×	×	○	○	○	×	×	×	×	×	×	×

\*1: Multipurpose tray can be used for B431.

\*2: Face-up paper ejecting is not available at automatic double-side printing.

\*3: Tray 2 (The second tray unit) is for option.

\*4: Tray 1 is 100 to 215.9 mm in width and 148 to 355.6 mm in length. Tray 2 is 148 to 215.9 mm in width and 210 to 355.6 mm in length. Each of the multi-purpose trays and manual feeder trays is 86 to 215.9 mm in width and 140 to 1320.8 mm in length.

\*5: If Medium Heavy, Heavy or Ultra Heavy is specified for media weight where A5, A6, Postcard, or Envelope is specified for media size, the print speed is reduced.

\*6: If printed sheets of paper get curled and cannot be ejected smoothly, change the selection for ejection to face-down.

\*7: If paper is warped (curled) significantly, change the selection for ejection to face-up.

- (7) Printing speed
- Continuous printing : Maximum 33 ppm (B411dn)  
 (A4, At copy mode, : Maximum 38 ppm (B431dn)  
 First try) For the resolution degree of 600 x 2400, if to enhance the printing quality, the printing speed changes to be decreased.
- Warm up time : Approx. 20 second (22°C, 100V)

- (8) Paper feeding method                      Automatic feeding
- (9) Paper ejecting method                    Face down (Rear ejecting) / Face up (Front ejecting)
- (10) Resolution (Max.)                        2400 × 600 dots / inch (B411dn)  
1200 × 1200 dots / inch (B431dn)
- (11) Input electricity                            AC100V ± 10V, 50/60Hz ± 1Hz(B411dn/B431dn)
- (12) Electricity consumption                 Up and running: Maximum 900W, Average 510W (25°C)(B411dn)  
550W (25°C)(B431dn)  
  
Ready and waiting: Average 70W (25°C)  
Power-saving mode: (Without option)    Approx. 6.5W or less  
(With option)                                Approx. 7.5W

(13) Temperature and Humidity

	Temperature	Humidity
Up and running	10~32°C	20~80%RH (Relative Humidity) No condensation. However, Maximum temperature of wet ball should be 25°C.
Power switch off	0~43°C	10~90%RH (Relative Temperature) No condensation. However, Maximum temperature of wet ball should be 26.8°C.
Keeping	-10~43°C	10~90%RH (Relative Humidity) No condensation. However, Maximum temperature of wet ball should be 26.8°C.

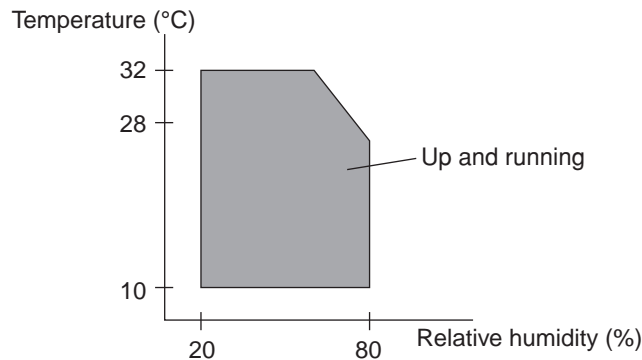

- (14) Operating noise    In Printing                      : Average below 53dBA for SLOW. (B411dn)  
(Rage A based                      : Average below 54dBA for SLOW. (B431dn)  
on JIS Z9831)    Ready and waiting : Average below 30dBA for SLOW.  
At power save                      : No sound (Background level)
- (15) Consumables    Toner cartridge                : Approx. 3,000 piece /Approx. 4,000 piece/Approx. 10,000 piece(A4 ISO/IEC 19752 Continuous printing as printing paten. But, except the 1st Toner cartridge)  
Image drum                        : Approx. 44,000 piece (Continuously single-side printing of A4)  
Cartridge                            : Approx. 30,000 piece (Single-side 3 pages/job) At Power save off.  
Approx. 1,7500 piece (Single-side 1 page/job) At Power save off.

### 1.5 Printing display

#### 1.5.1 VCCI label, Serial No. label

The VCCI label and Serial No. label have been attached on the specified part of printer as shows below.

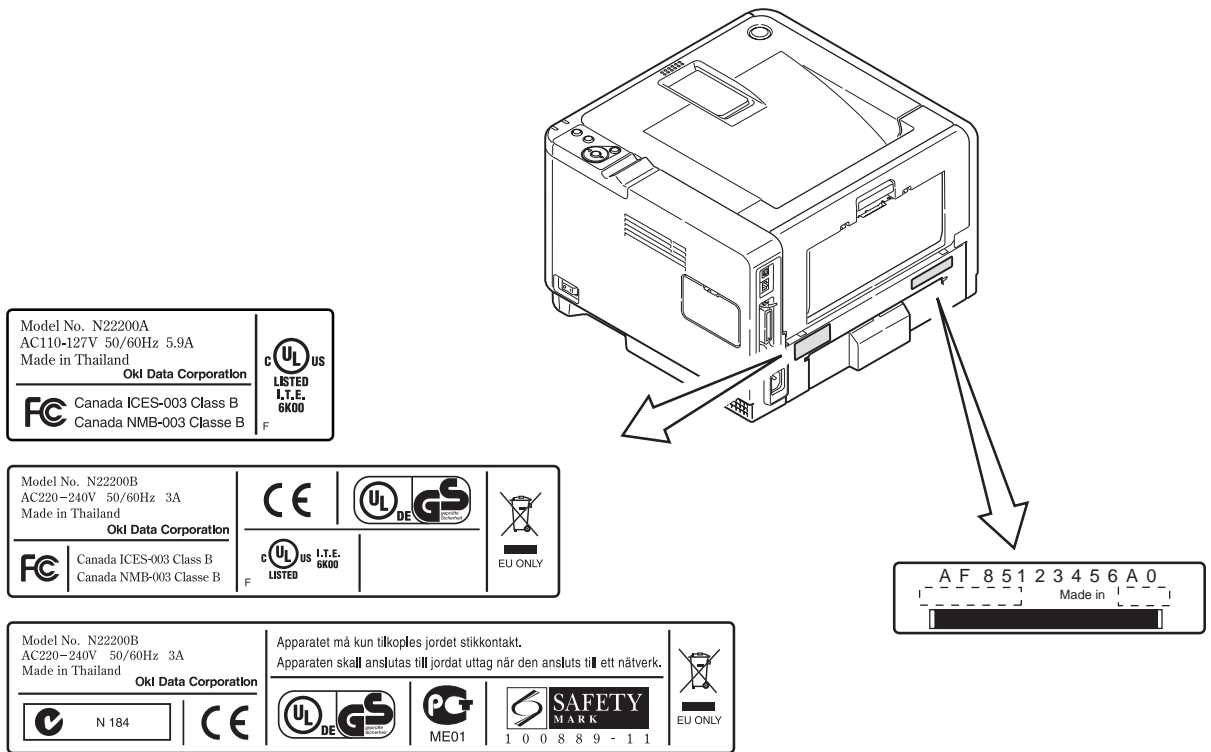

#### 1.5.2 Warning label

Warning label has been attached on the part of printer that may cause injury to the operator. Maintenance must be performed following the indication of the warning label.

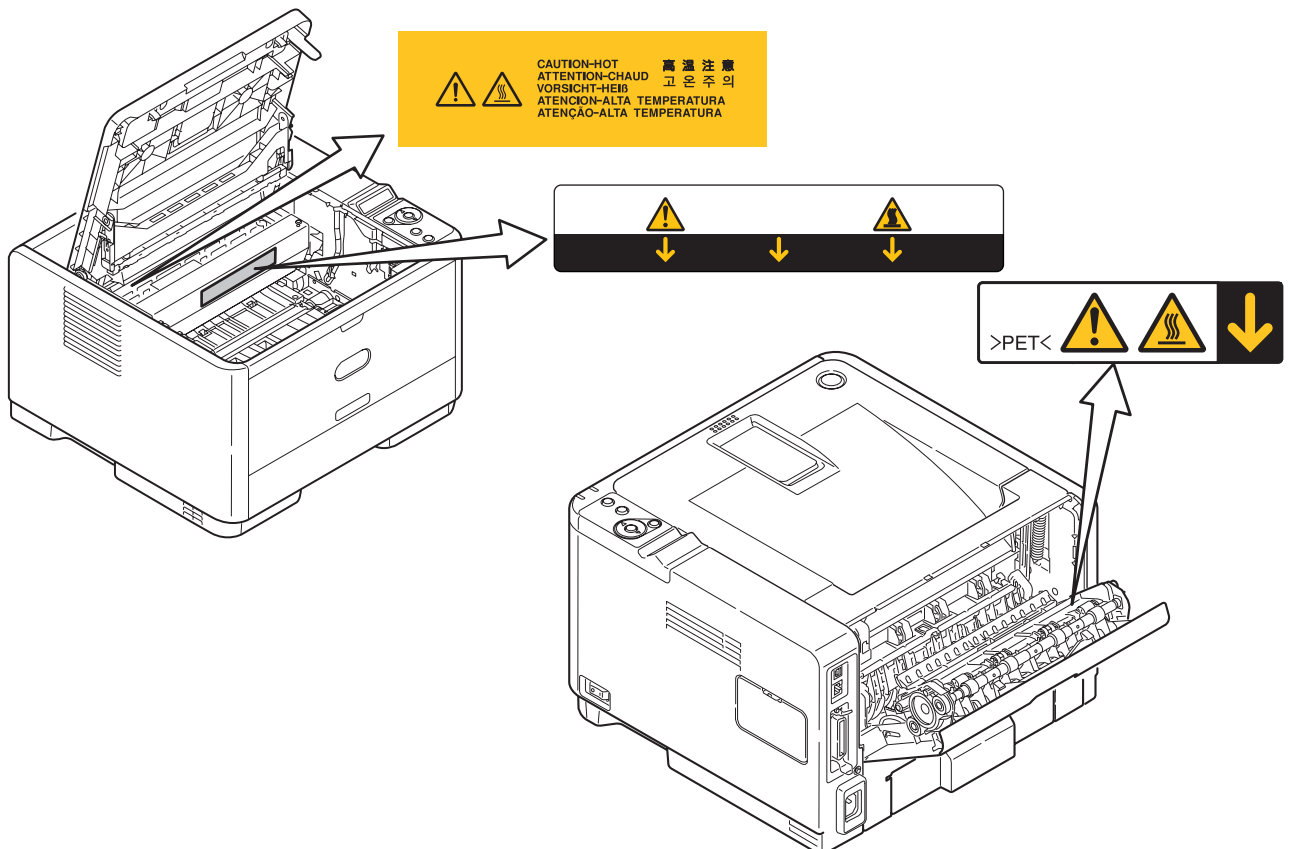

### 1.5.3 Warning / Caution display

The following warning / caution are displayed on the electrical power / sensor board.

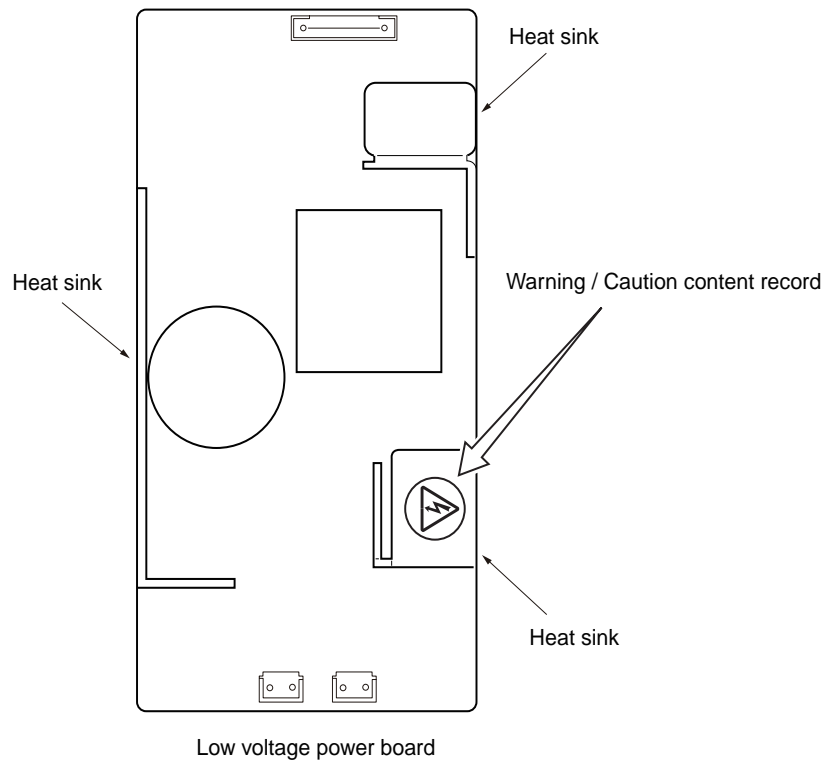
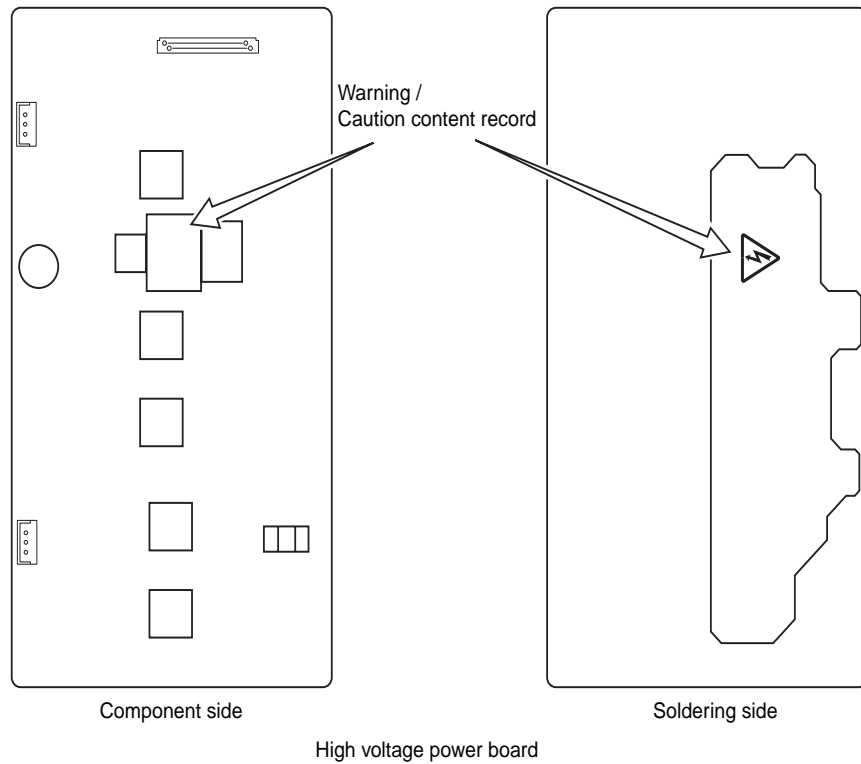

- Note!**
- There is a risk of electric shock in the middle of the heat sink and transformer. Be sure to check before touch it.
  - It may happen that the electricity has still left on the electrical circuit even after the fuse opened.



## 2. Operational explanation

### 2.1 Electrophotographic process mechanism

#### (1) Electrophotographic process

The following describes the overview of electrophotographic process.

##### 1. Charging

Equally charge the surface of image drum by implying negative voltage to the charged roller due to negative charge.

##### 2. Exposure

The light from LED Head is exposed on the negative-charged surface of image drum. The surface electrical potential of the exposed part of image drum surface becomes lower. Then forms electrostatic latent image.

##### 3. Development

Negative-charged toner is attracted to the electrostatic latent image due to electrostatic while touching the image drum. Then forms viewable image.

##### 4. Transfer

Overlap paper on the surface of OPC drum, from the backside of paper transfer toner image to the paper by applying electrical charge by transfer roller.

##### 5. Fusing

The toner image that is transferred to paper is fused on paper by heat and pressure.

##### 6. Drum cleaning

The cleaning blade scrapes off the toner that was not transferred and remains on the image drum.

##### 7. Static elimination

Residual potential on the image drum is removed.

1. Charging

Charge the image drum surface by implying voltage to the charged roller that contacts the image drum surface.

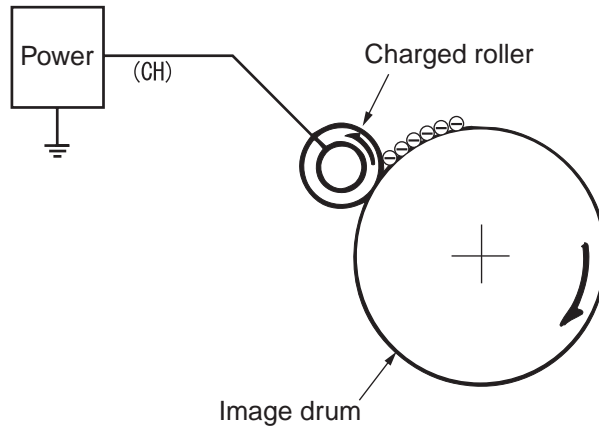

2. Exposure

The light emitting from the LED Head will be exposed to the negative charged image drum. When the surface electric potential of exposed part of the image drum goes to decrease, the electrostatic latent image complying with image signal is formed.

Image drum is coated by basic layer (UL), charge generating layer (CGL), charge transferring layer (CTL) on the basic material aluminum. The thickness of the organic light sensor (OPC) that is consisted by CTL and CGL is approximate 20µm.

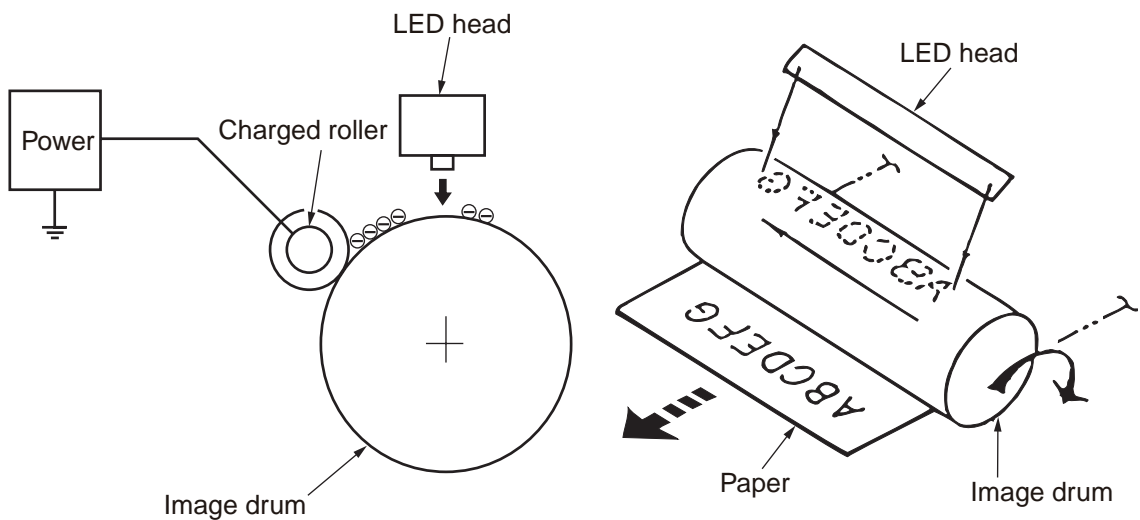

## 3. Image development

Toner is attracted to the electrostatic latent image on the image drum surface, then the electrostatic latent image changes to toner image.

- 1 As the roller on the supply spot of toner rotates while scrubbing the image-developing roller, friction electricity occurs between the image developing roller and toner; toner is attracted to the image-developing roller.

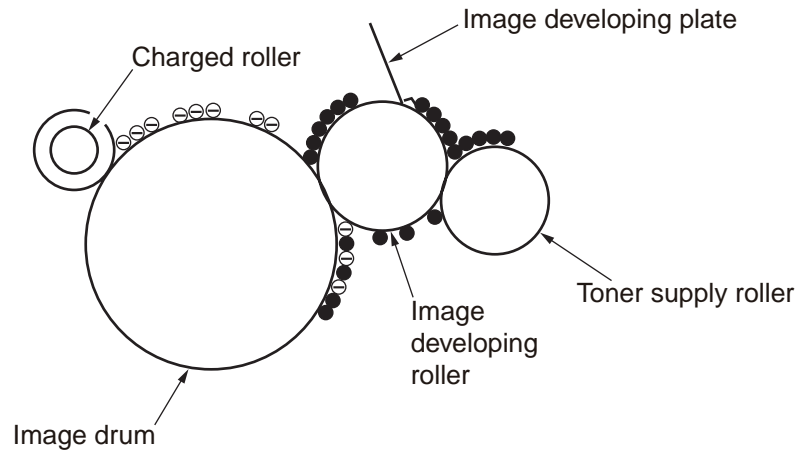

2. The toner that has been attracted to the image-developing roller is dropped down to the developing plate to make a thin toner film on the image developing roller side.
- 3 The toner is attracted by the exposed part (Low electrical potential part) of the image drum when the image drum contact the image developing roller, so as to see the electrostatic latent image.

**Note!** The necessary bypass voltage in image processing is impressed on the toner feeding roller and image developing roller as show below.

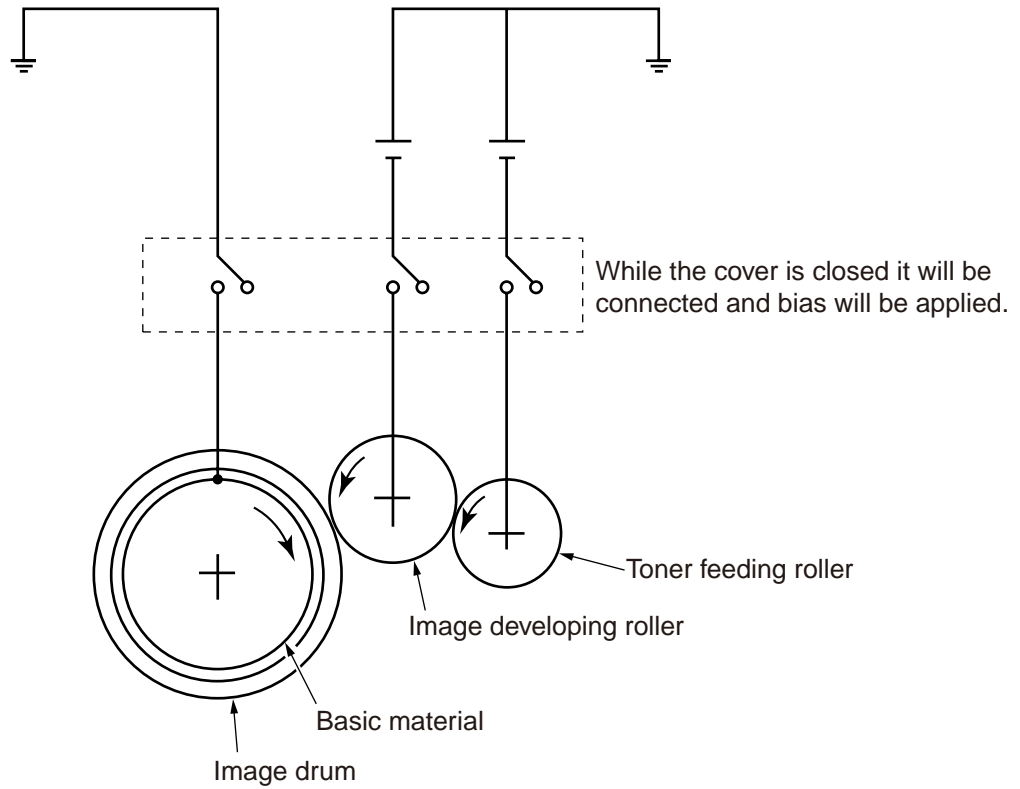

4. Transfer

The transfer roller, which is from conductive sponge material, is created to meet intimate attachment of image drum roller surface and feeding paper. The feeding paper is set up on the surface of image drum. Plus charge, which is the converse polarity with toner polarity, is applied from the backside of the paper.

As high plus voltage is applied to transfer roller from the power supply, the plus charge on the transfer roller surface is induced and transferred to the paper while the paper contact the transfer roller. The negative charged toner, which has been attracted to the image drum surface, is transferred to the surface of feeding paper by the plus charge of the backside of the paper.

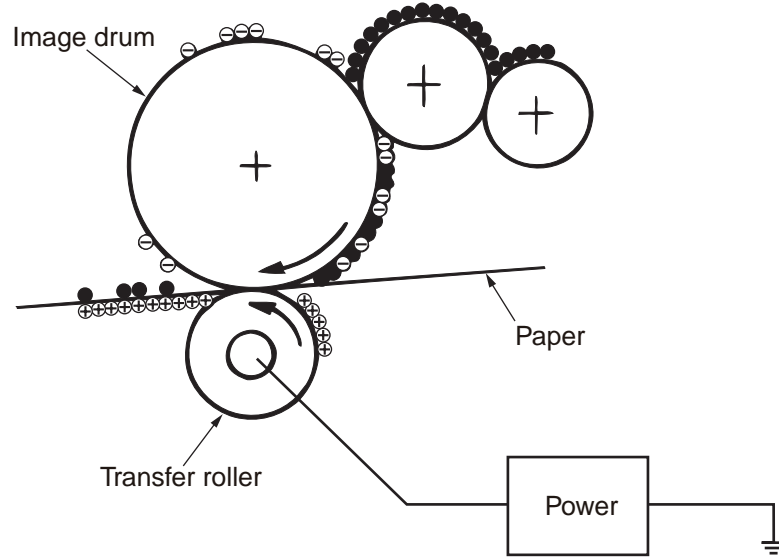

5. Fusing

After the termination of transfer the unsettled toner image is settled to paper by heat and pressure while passing between Heat roller and Back up roller. Heat roller is Teflon coated and is mounted by heater that can generate heat (Halogen lamp).

The thermistor that contacts the Heat roller adjusts the Heat roller temperature to the temperature specified by the menu complying with the paper width. For safety the thermostat shuts off the voltage supply to the Heater by opening the thermostat in the case of abnormally temperature increasing.

The back up roller is held by the pressure springs on each terminal due to the pressure applied.

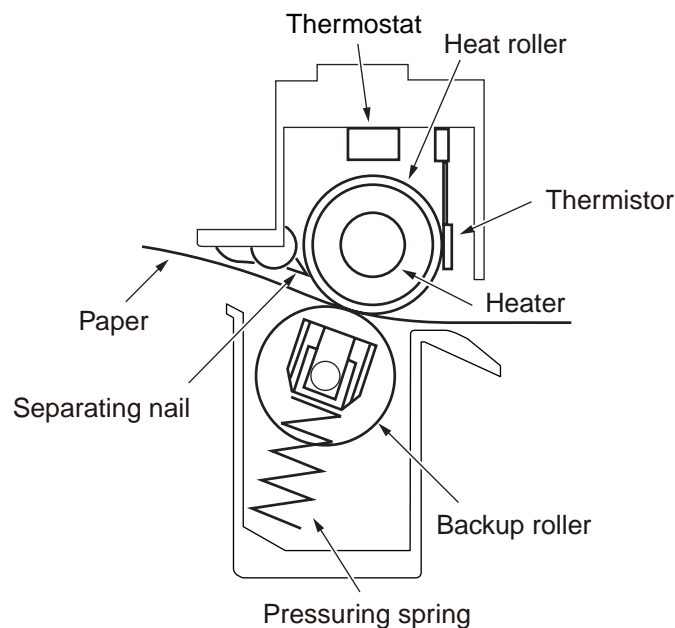

6. Drum cleaning

After completion of transfer, the toner remaining on the image drum is scraped off by the cleaning blade. As a result of this, the surface of the image drum is cleaned, and the remaining toner that has been scraped off is collected as waste toner in a waste toner area.

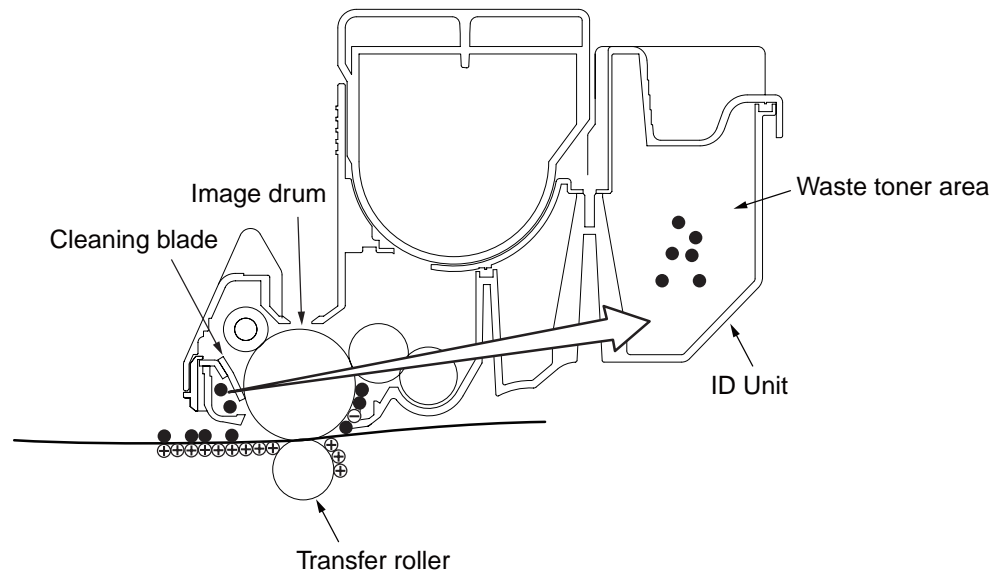

7. Static elimination

After completing transfer, the image drum is illuminated with its surface to decay static charge of its surface.

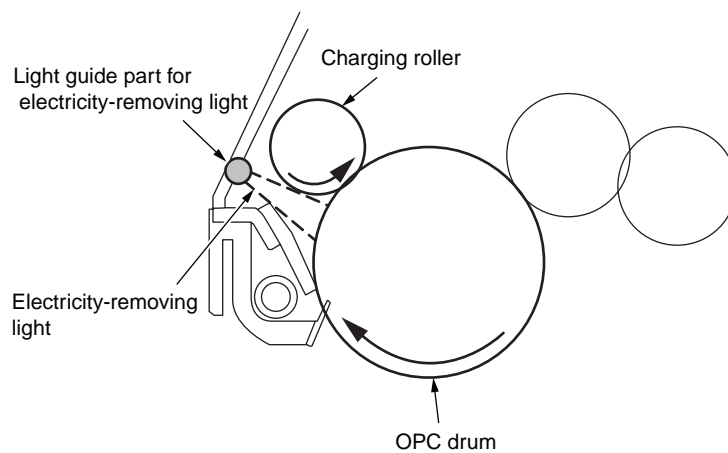

### 2.2 Printing process

The paper fed from Tray 1 and Tray 2 is conveyed by feeding roller, conveying roller, and resist roller. When feeding paper is from MPT, it is conveyed by MPT, feeding roller, and resist roller. After that the feeding paper that is conveyed by image drum and the nip part of transfer roller forms toner image on the paper through electrophotographic process. And then, the toner on the paper is fused by the heat and pressure as the fuser unit passing through. The paper that fused the toner image is ejected from the face down stacker of the ejecting roller. To eject printed pages on the face-up stacker, open the face-up stacker. (Duplex printing is not available during face-up ejection.)

The above is about the operations at simplex printing, yet the below explains the operations at duplex printing. While duplex printing, paper, which firstly passes the fuser unit after its backside is printed, is conveyed to the inside of the duplex unit, by the reverse rotation of the first and the second ejecting rollers in a certain period of time after the paper rear end passes the fuser unit. The paper is conveyed by the conveying roller of the duplex unit and then arrives the route for paper feeding from a tray. After that, the paper is handled in the same way as paper fed from a tray for simplex printing.

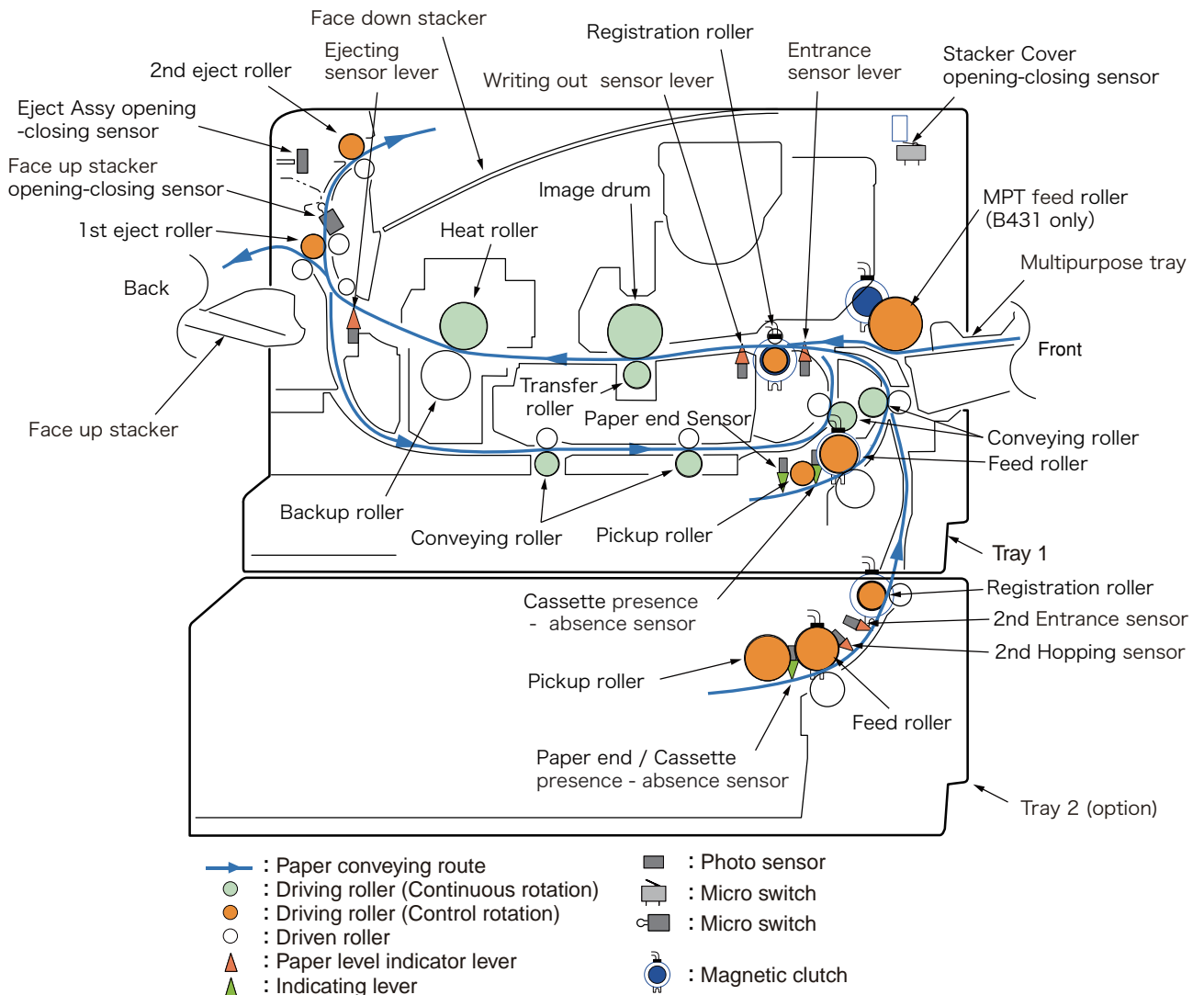

(1) Paper feeding from Tray 1

1. As DC motor rotating (Clockwise rotation), if set the paper feeding clutch as ON, as the paper feeding roller and pickup roller rotating, the paper that is inside the tray is conveyed.
2. The paper is conveyed by the conveying roller. After the entrance sensor level set to be ON, it bumps into the stopping resist roller, a certain more amount of paper is conveyed. (This corrects the paper skew.)
3. If set the resist clutch as ON, the paper is conveyed by resist roller.

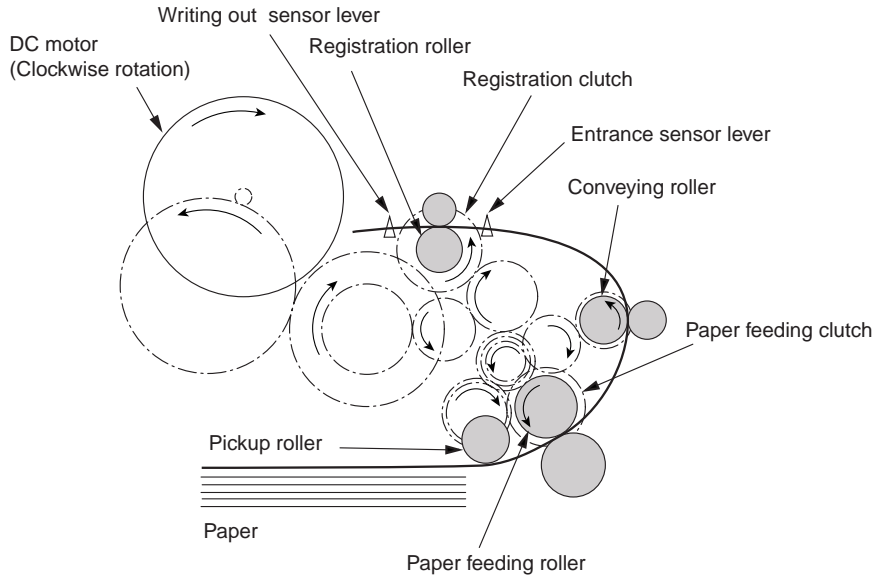

(2) Paper feeding from Multipurpose tray (MPT)(B431)

1. As DC motor rotating (Clockwise rotation), if set paper feeding clutch as ON the MPT paper feeding roller starts to rotate, the paper in the tray is conveyed.
2. After setting the entrance sensor lever as ON, the paper bumps into the stopping resist roller, a certain more amount of paper is conveyed. (This corrects the skew of paper.)
3. If set the resist clutch as ON, the paper is conveyed by resist roller.

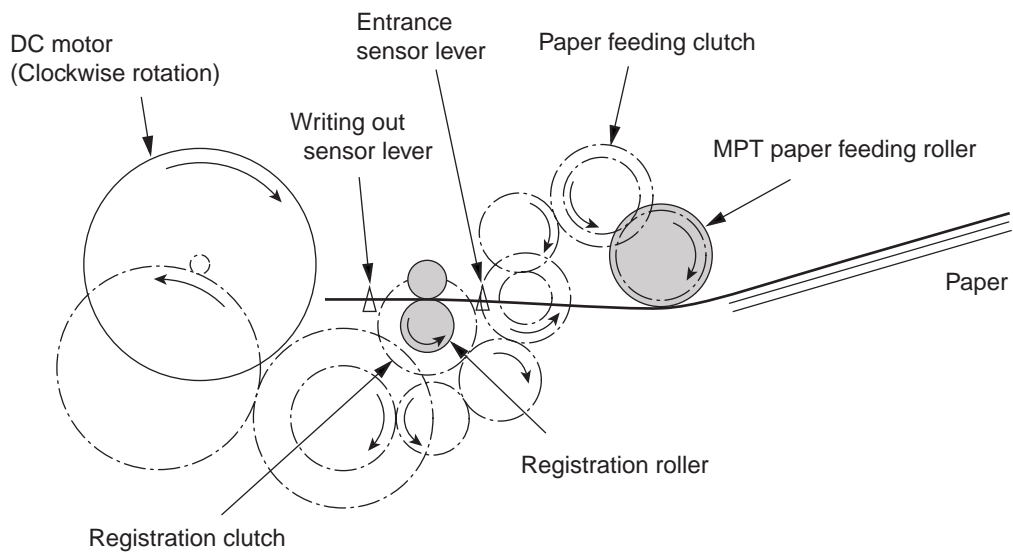



## (3) Fuser unit and paper ejecting

1. The fuser unit is driven by the DC motor. After the DC motor starts running (clockwise), the heat roller starts rotating.
2. Simultaneously the eject motor starts running (counterclockwise), and then the eject roller starts rotating and ejects paper.

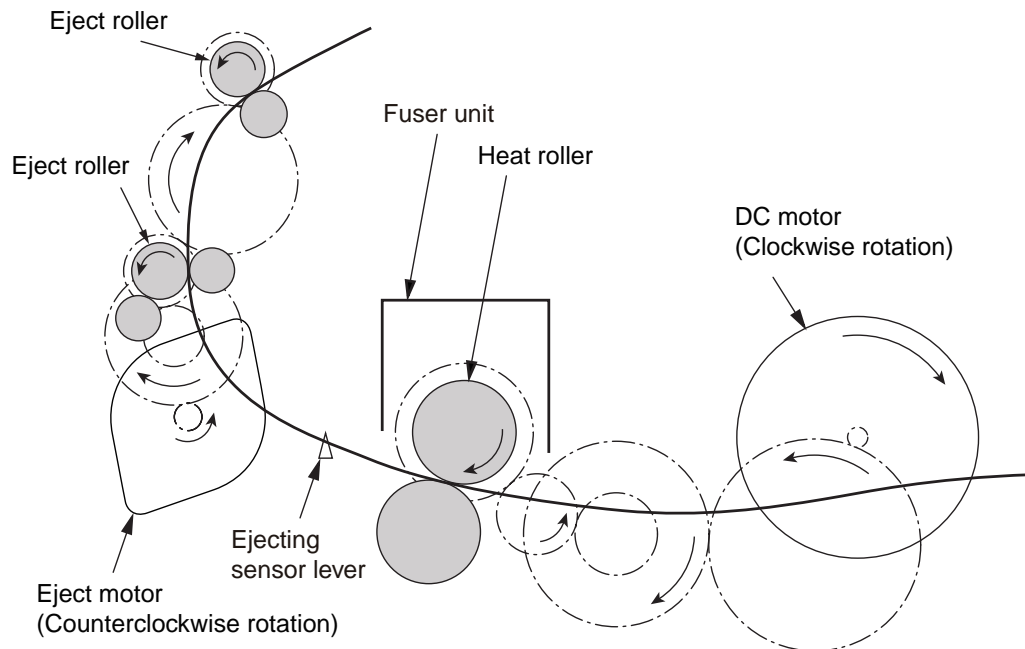

(4) Paper reversing and paper multi-feeding

1. In a certain period of time after the paper rear end passes the eject sensor lever, the eject motor runs backward (clockwise) and then the eject roller rotates in the reverse direction (clockwise).
2. By the inverse rotation of the eject roller the paper is inversely rotated and conveyed to Duplex.
3. Paper is conveyed by Duplex conveying roller.
4. After setting the entrance sensor lever as ON, paper bumps into the stopped resist roller, still a certain more amount of paper is conveyed. (This corrects the skew of paper.).
5. If set the Resist clutch as ON, paper is conveyed by Resist roller.

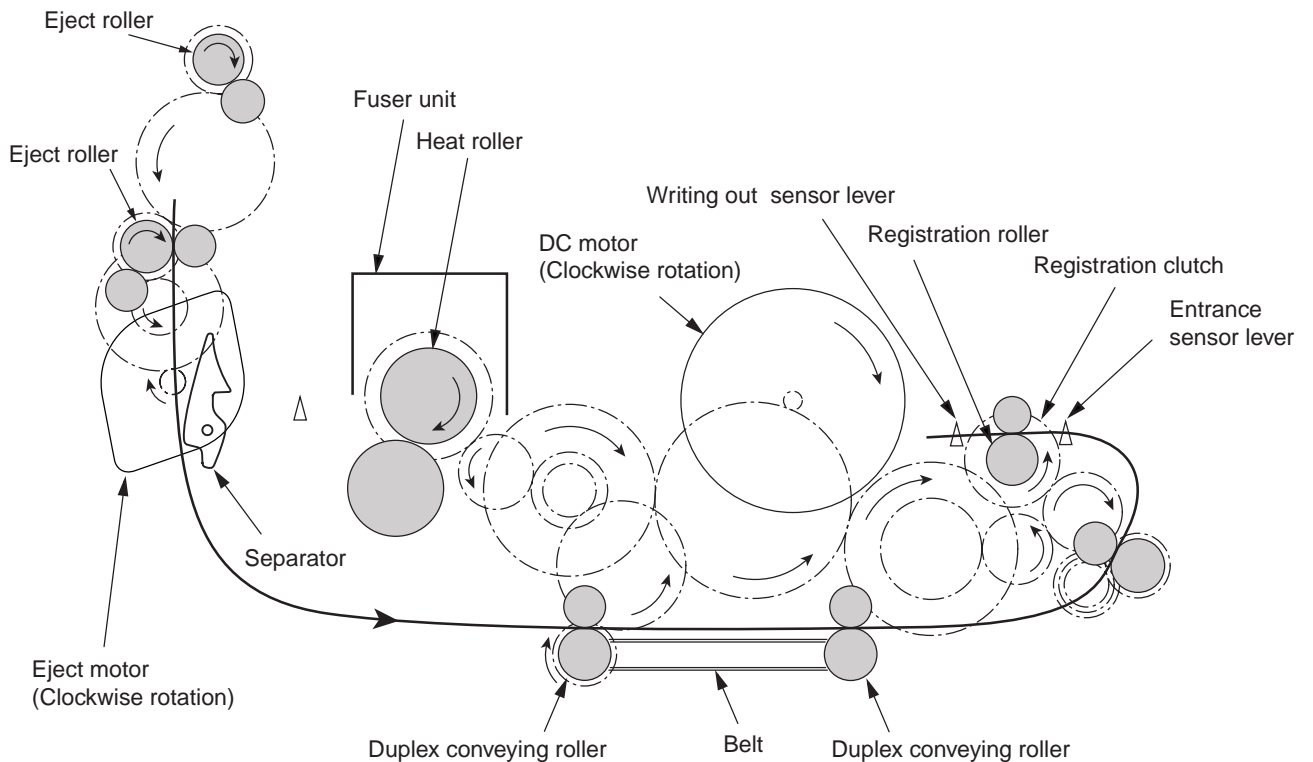
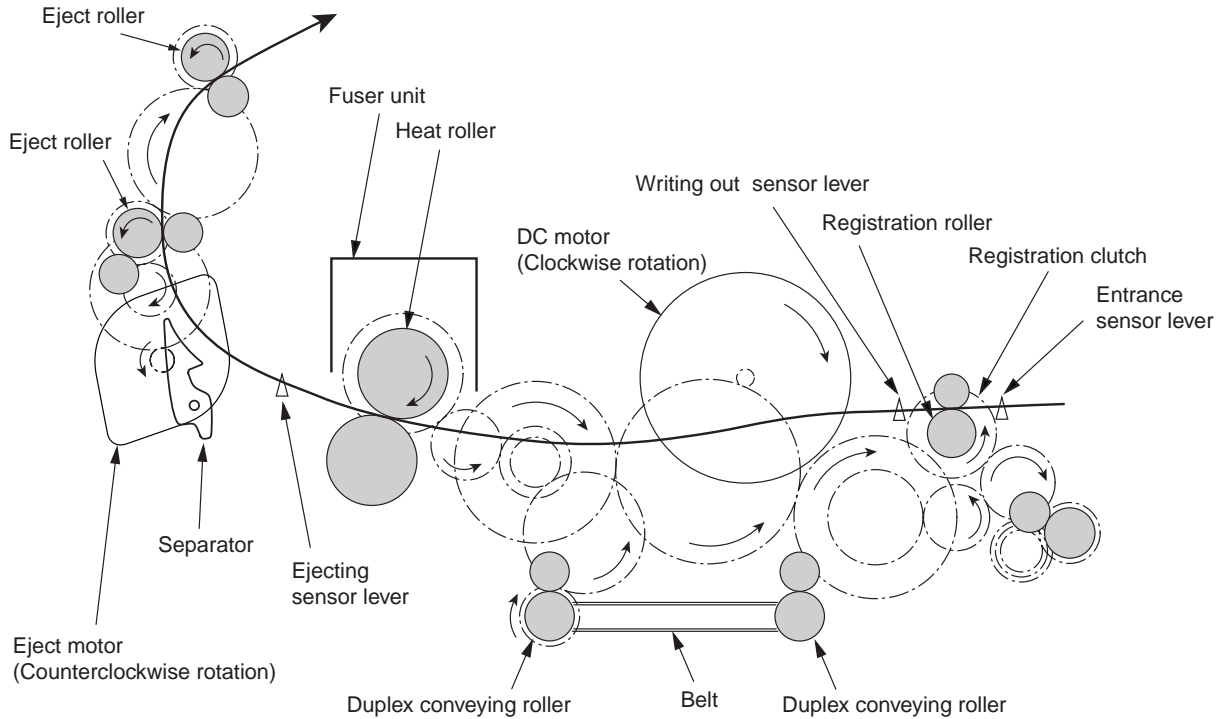

## 2.3 Toner entrance detection

### Toner sensor detection principle

Toner low is detected by the toner sensor (reflect sensor) installed in the printer. The light shield plate is installed in the ID, and its rotation is synchronized with mixing of toner. If the light shield plate or toner sensor is dirty with toner or something, or the ID unit and the toner sensor are facing each other at an improper position due to improper setting of the ID unit or any reasons, toner low cannot be detected correctly, and a toner sensor error occurs.

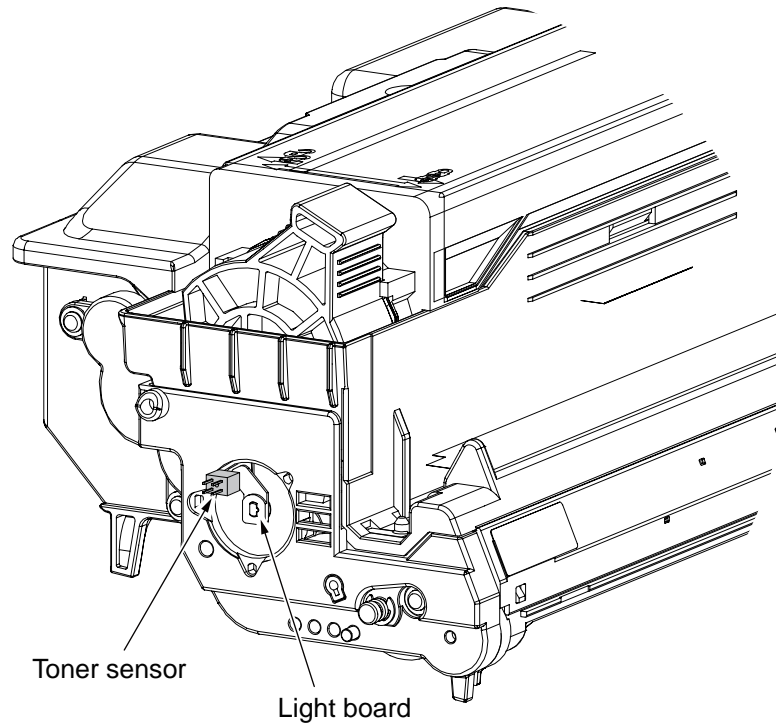

### Toner count principle

After the image data is transformed into binary data which can be printed by the printer, the data is counted as print dot number by LSI. The amount of the used toner is calculated from this count value, and the residual amount is displayed on the menu.

Toner LOW detection (residual amount display on LCD) by the toner sensor is to detect a certain amount of the reduction of the toner left in ID.

## 3. Parts replacement

This section explains the replacement procedure of part, assembly, and unit in the working place. Disassembling procedure relating to reassembling is conducted conversely.

### 3.1 Preparation for parts replacement

- (1) Be sure to unplug the AC cord and interface cable before starting to replace parts.
  - (a) Unplugging the AC cord by the following procedures.
    - i) Shut off the power switch of the printer. ("O")
    - ii) Unplug the AC insert plug of AC cord from the AC socket.
    - iii) Unplug the AC cord and interface cable from printer.

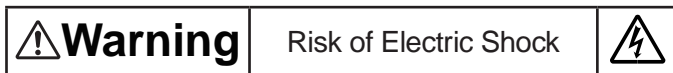

There is a risk of electric shock during replacement of the low voltage power supply.

Use insulating gloves or avoid direct contact with any conducting part of the power supply, and caution should be exercised during replacement.

The capacitor may take one minute to complete discharge after the AC cord is unplugged. Also, there is a possibility that the capacitor doesn't discharge because of a breakage of the PCB, etc., so remember the possibility of electric shock to avoid electric shock.

- (b) Reconnecting the printer by the following procedures.
  - i) Connect the AC cord and interface cable to the printer.
  - ii) Connect the AC insert plug to the AC socket.
  - iii) Turn on the power switch of the printer. ("I")

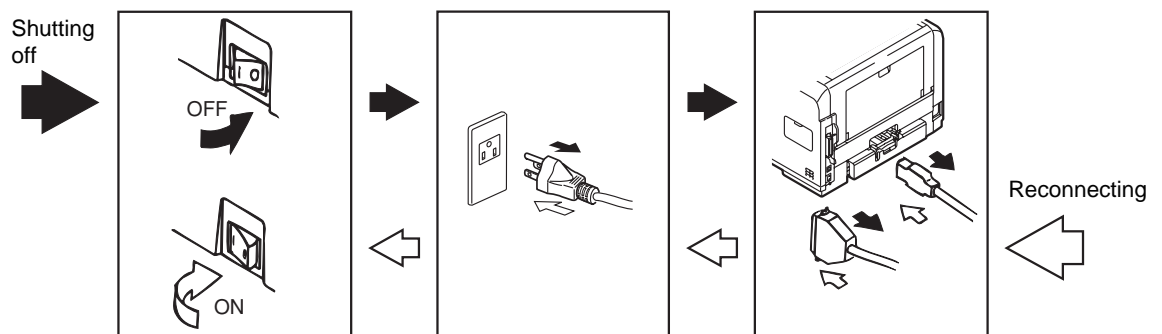







- (2) Do not disassemble the printer in the case of normal operation.
- (3) Do not disengage the part that there is not any necessary to touch. Disassembly should be the minimum.
- (4) Be sure to use the specified maintenance tools.
- (5) Be sure to temporarily install the small part such as screw, collar, and so on at its original position during disassembling because it is easy to be lost.
- (6) Do not use the gloves that is easy to occur electrostatic while dealing with IC such as micro-sensor, ROM, RAM, etc. and PCB.
- (7) Do not put the print circuit board on the equipment or on the floor directly.
- (8) Do not put the Print Circuit Board on the printer or on the floor directly.

## [Maintenance tools]

The necessary tools for replacing the print circuit board, assembly, and unit is shown as graph 3-1.

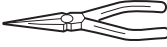
Graph 3-1 Maintenance tools

No.	Maintenance tools	Quantity	Application	Remark
1	 No.2-200⊕Magnetic driver	1	3~5mm Screw	
2	 No.3-100 Driver	1		
3	 No.5-200 Driver	1		
4	 Digital multi-meter	1		
5	 Pliers	1		
6	 Handy cleaner	1		Refer to the following Note!
7	 E ring pliers	1	For E ring removing	

**Note!** Use vacuum by the type that applying to toner. It may cause fire if use normal vacuum.

### 3.2 Parts layout

This section explains the main parts layout of the equipment.

B411d/B411dn

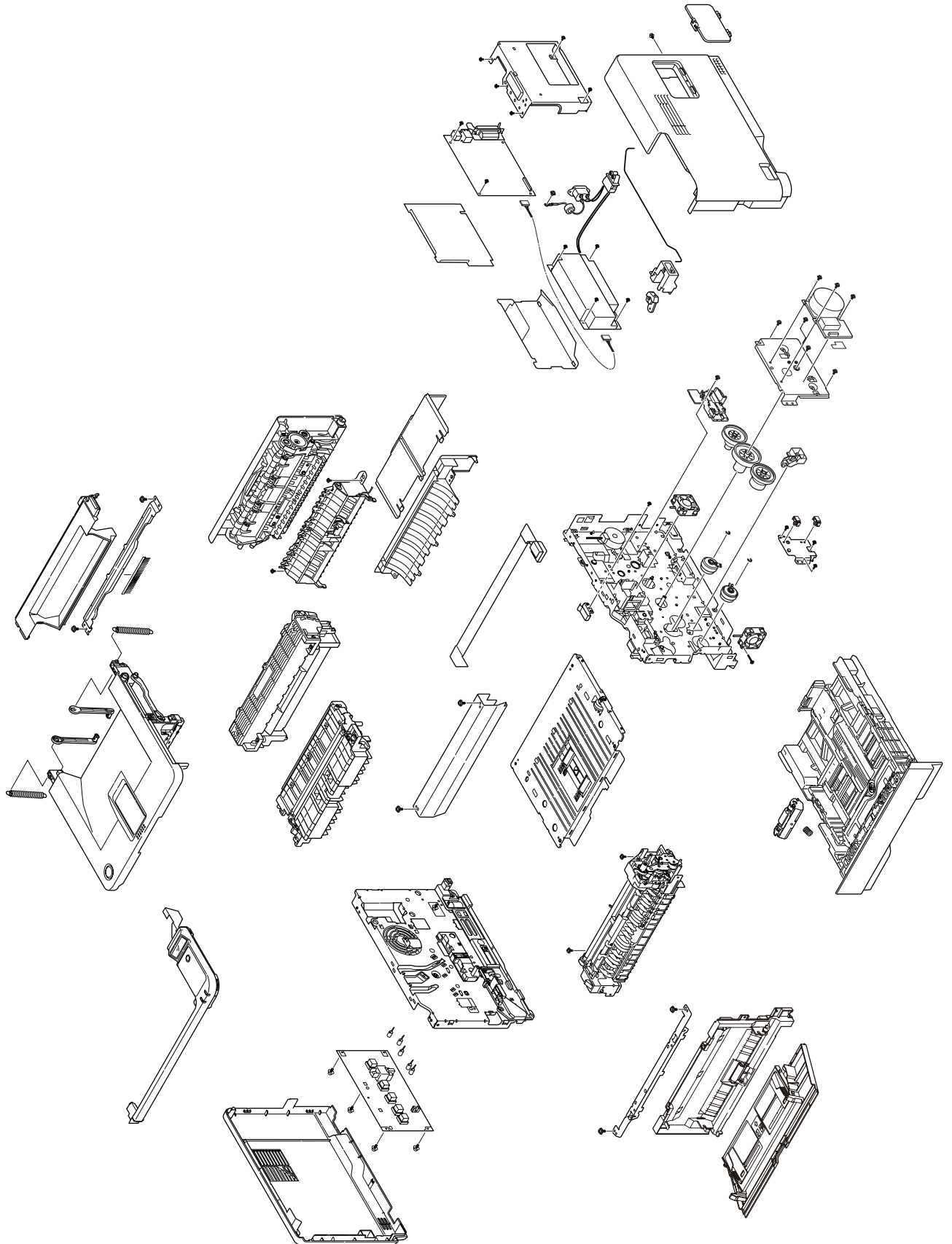

Figure 3-1

B431d/B431dn

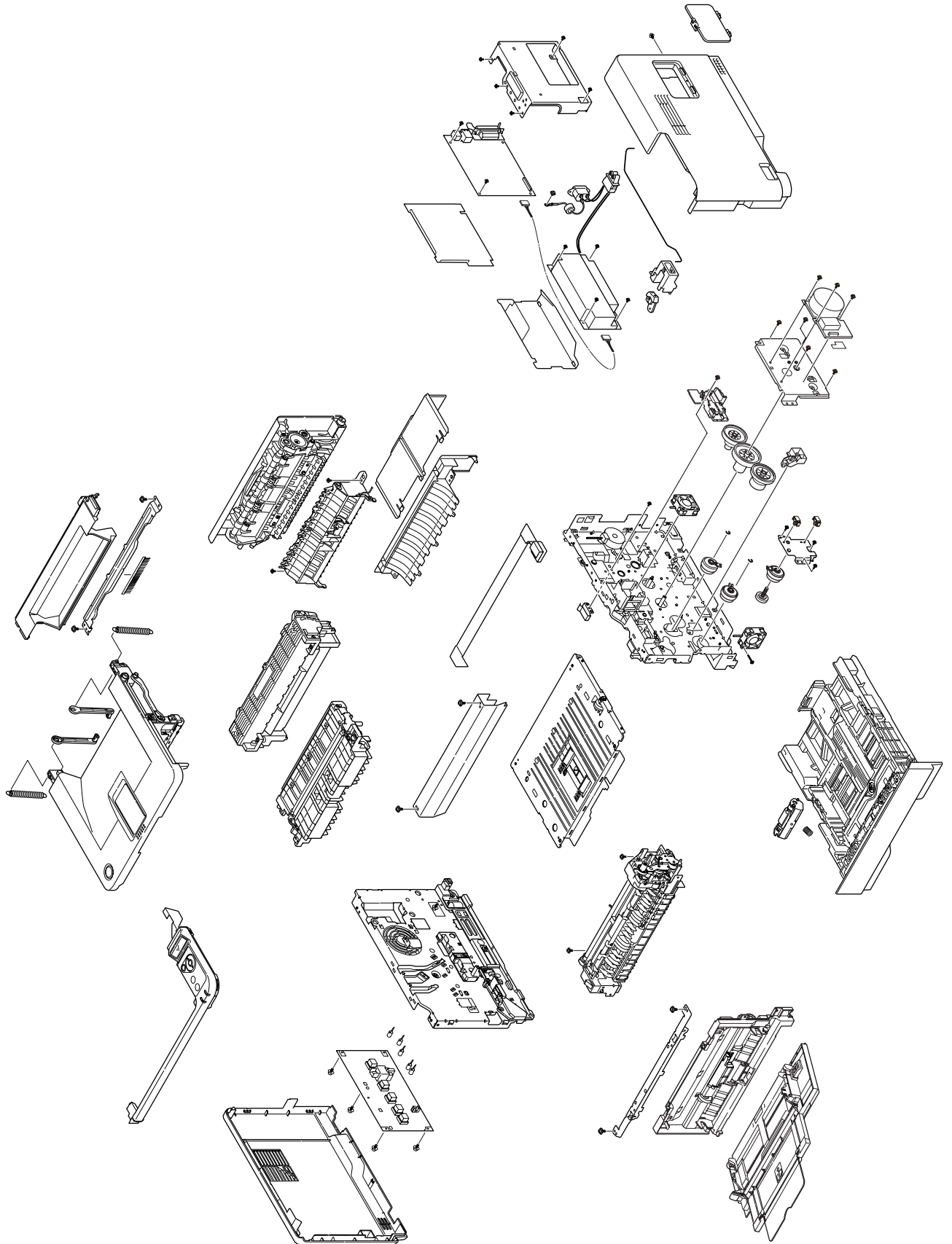

Figure 3-2

### 3.3 Parts replacement method

This section explains the replacement method of the parts and assemblies that are shown in the following disassembling diagram.

The explaining diagram of parts replacement procedure is B431dn.

Replace part after performing the following operation.

- (1) Unplug the AC power cord from the main unit inlet by the disconnected status of power switch.
- (2) Unplug the interface cable from the main unit.

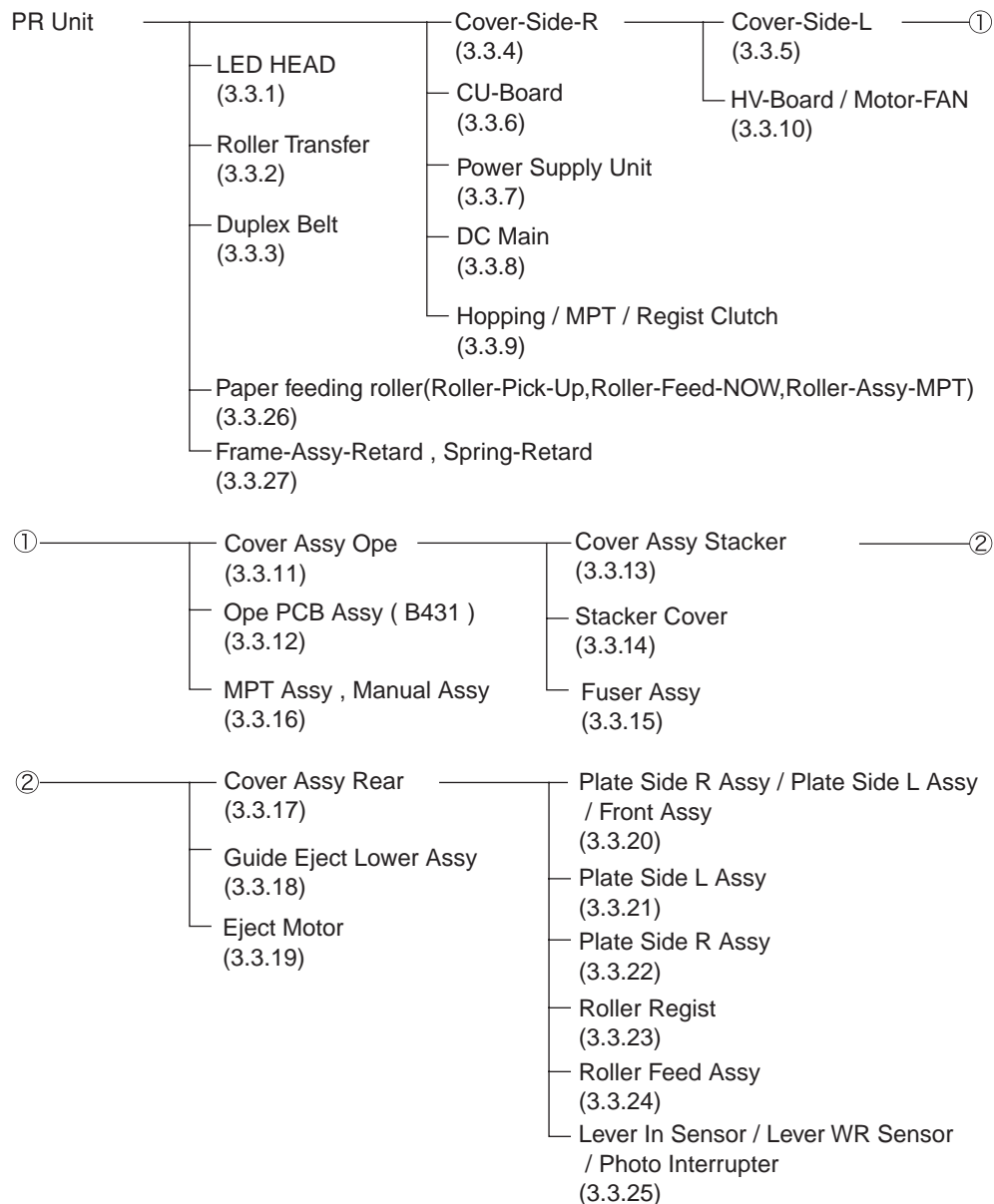



### 3.3.1 LED Head

- (1) Open the Stacker Cover.
- (2) Remove the ID UNIT.
- (3) Disengage the tab of the Holder-Head from the stacker cover by using a flat-head screwdriver or something.
- (4) Pull the Holder-Head toward you as illustrated below.
- (5) Open the Holder-Head by arrow direction and then remove the hook. remove the LED Assy ①.
- (6) Remove the FFC cable from the connector of LED Assy ①.
- (7) Installing is performed by the reverse procedure with removing.

**Note!** Beware of not to touch or press the SLA parts of LED Head directly.

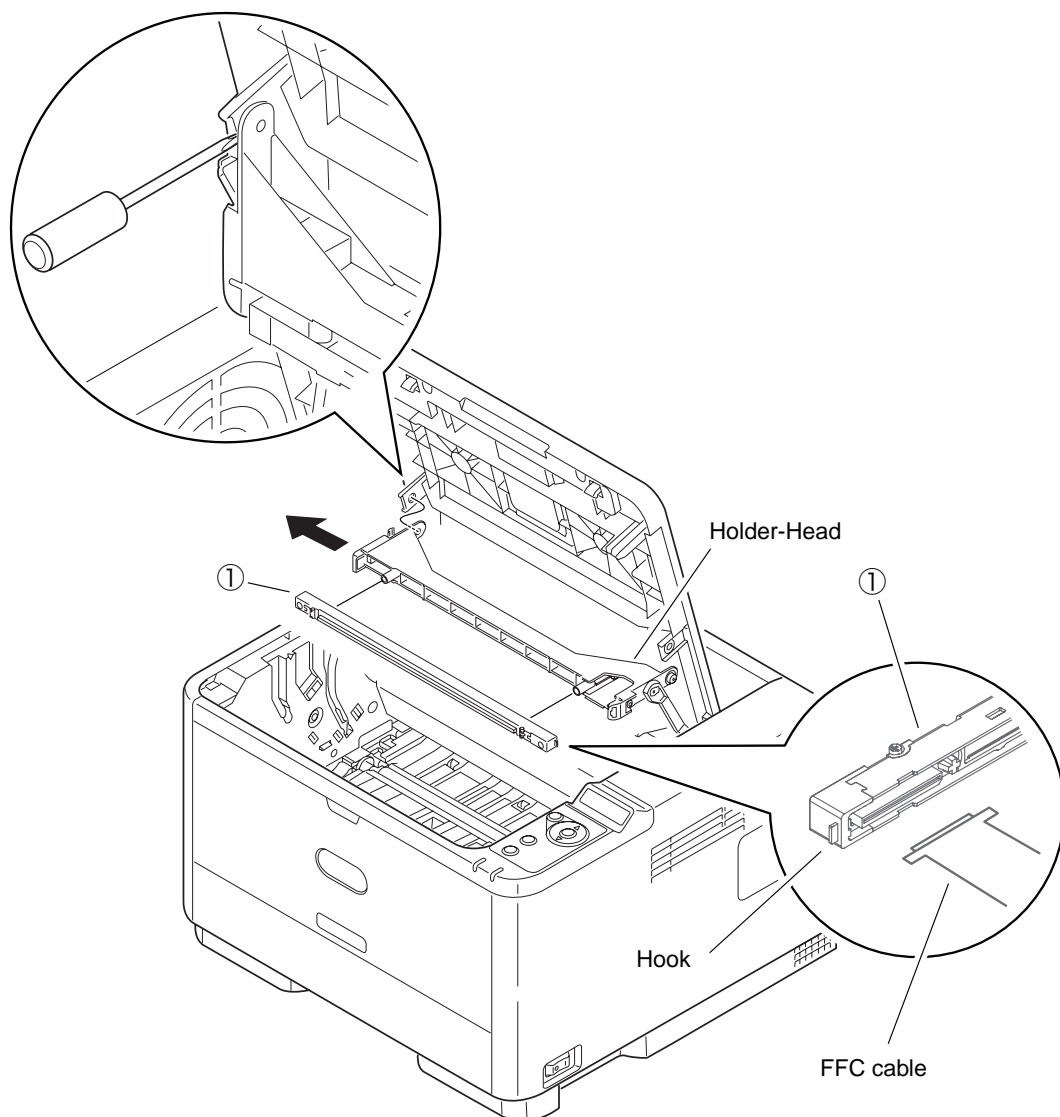

### 3.3.2 Roller-Transfer

- (1) Open the Stacker Cover.
- (2) Remove the ID UNIT.
- (3) Take the Frame-Assy-TR out of the printer.
- (4) Disengage the latches of Bearing-TR ① on both ends.
- (5) Hold the Bearing-TR ① on the both side, and then lift up the Roller-Transfer ②.  
(At this moment, Gear-TR ③ is also removed.)
- (6) Installing is performed by the inverse procedure with removing.

(Note on removing / installing)

1. While installing, pay attention to the up-and-down direction of Bearing-TR ①.
2. Operating carefully, not to touch Roller-Transfer ② surface.
3. Be careful not to fit each Bearing-TR ① to the Frame-Assy-TR with their springs inclined.

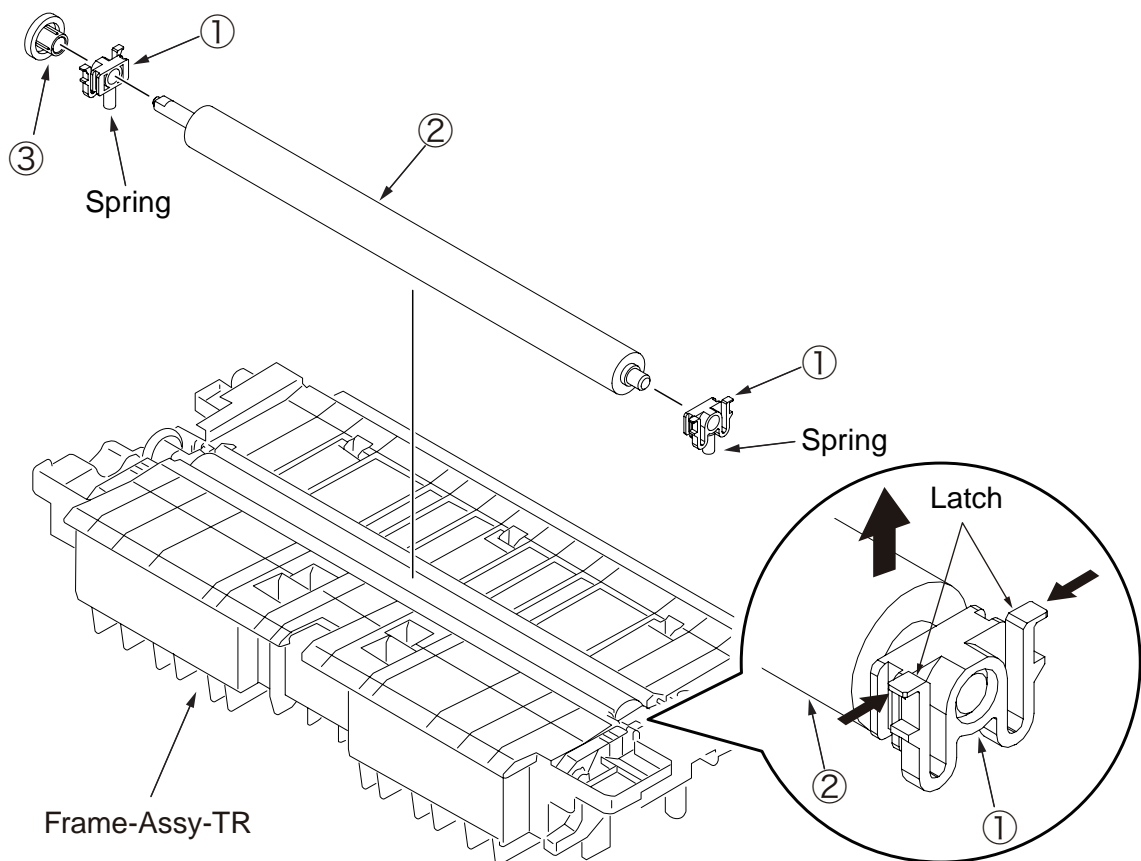

### 3.3.3 Duplex Belt

- (1) Take out the Frame-Assy-TR. (Refer to 3.3.2)
- (2) Remove the cassette and set the printer unit on its right side.
- (3) Remove the E-ring ① and slide the Shaft-Dup-Clutch in the direction of the arrow.
- (4) Remove the screw (Silver) ② and Frame-Duplex-Assy ③.
- (5) Remove the four pieces of Bearing ④, Roller-Feed-Duplex ⑤ and Duplex-Belt ⑥.
- (6) Installing is performed by the inverse procedure with removing.

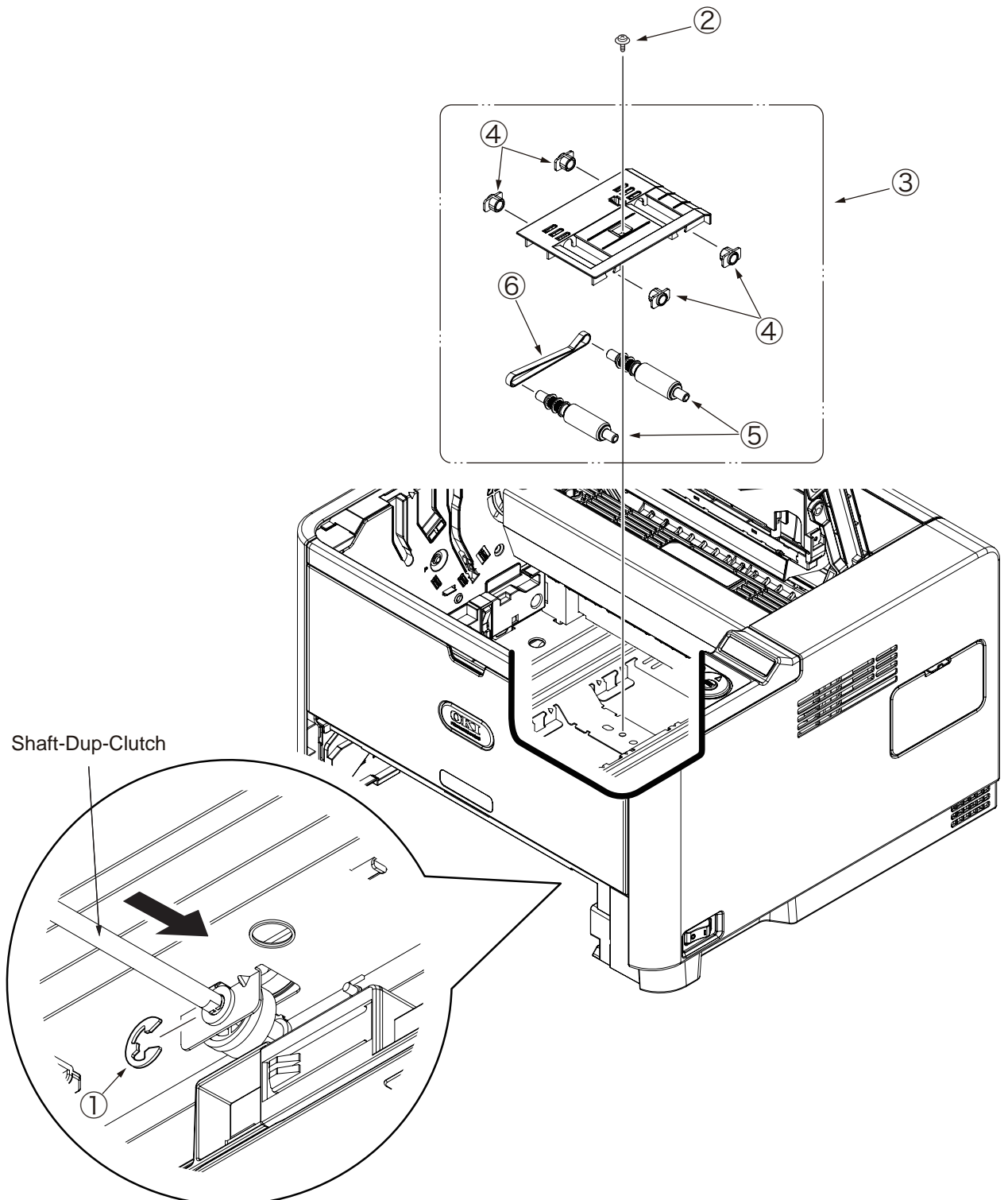

### 3.3.4 Cover-Side-R

- (1) Remove the cassette.
- (2) Open MPT, the Cover-Assy-Stacker and the Cover-Assy-Rear.
- (3) Remove the screw (Silver) ①.
- (4) Disengage the four tabs (a to d) and remove Cover-Side-R ② by opening it from the front side of the printer in the direction of the arrow.
- (5) Installing is performed by the inverse procedure with removing.

(Note on removing / installing)

1. Beware of not to touch the DC motor inattentively (Do not rotate motor).

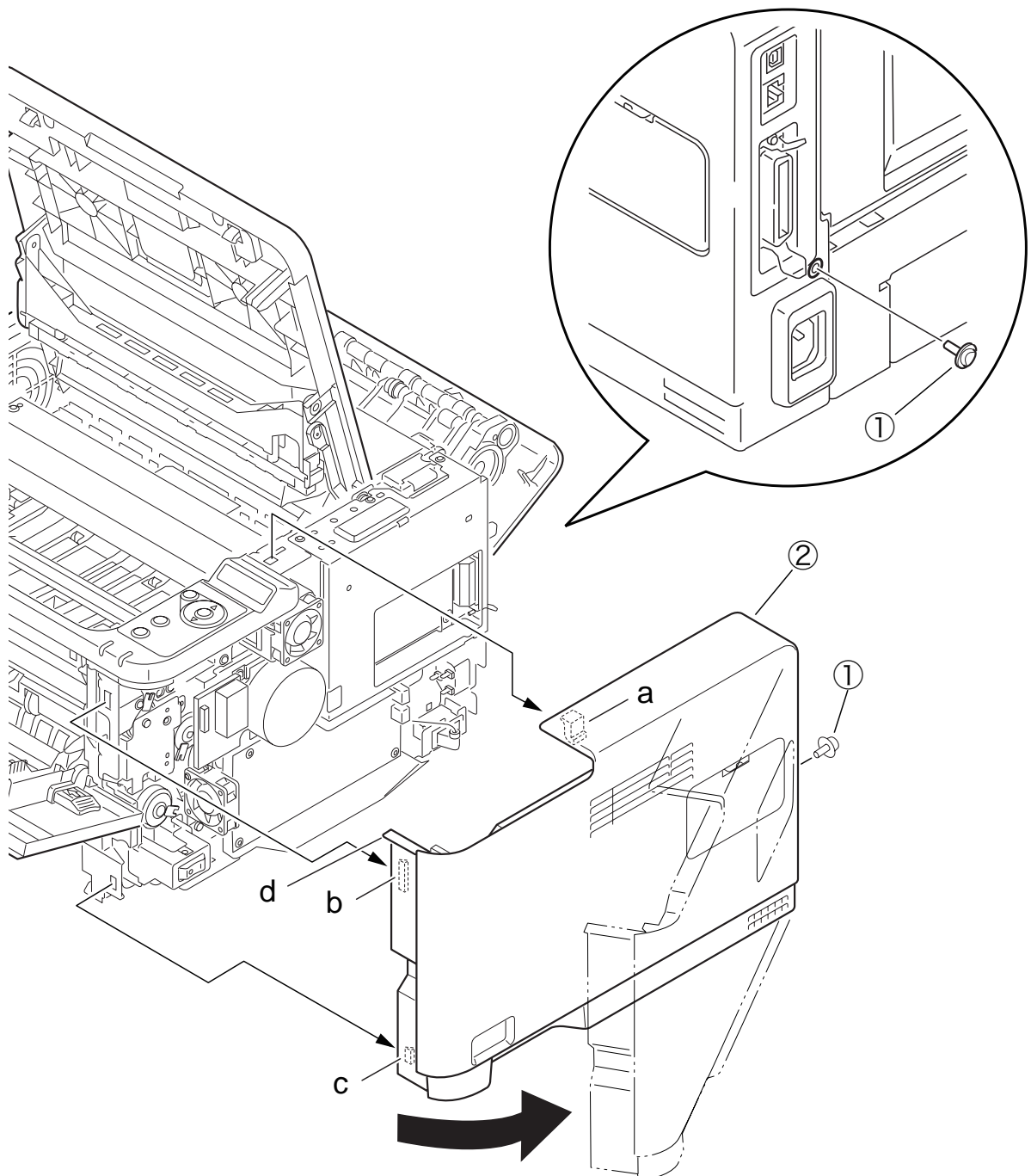

### 3.3.5 Cover-Side-L

- (1) Remove the cassette.
- (2) Open MPT, the Cover-Assy-Stacker and the Cover-Assy-Rear.
- (3) Disengage the four tabs (a to d) and remove Cover-Side-L ① by opening it from the front side of the printer in the direction of the arrow.
- (4) Installing is performed by the inverse procedure with removing.

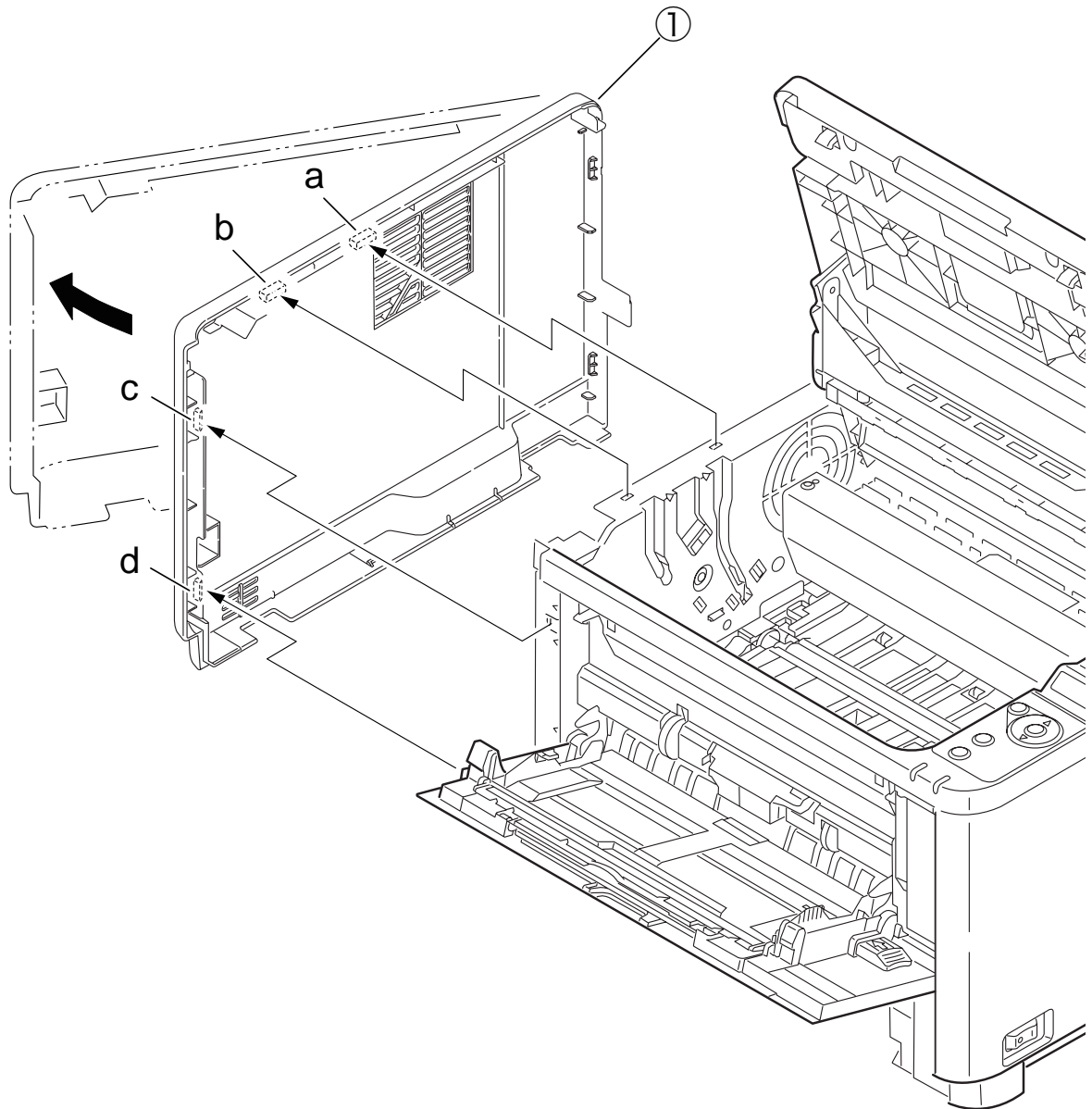

### 3.3.6 CU-Board

- (1) Remove the Cover-Side-R. (Refer to 3.3.4)
- (2) Remove the five screws (Silver) ①. Remove the Plate-Shield ②.

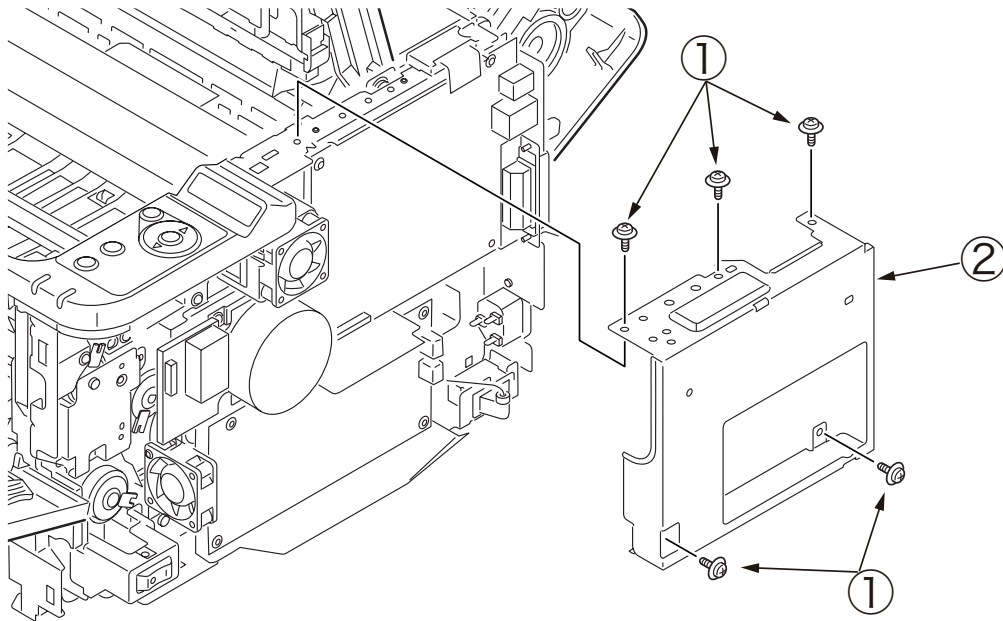

- (3) Remove the two screw (Silver : Small) ③, remove the two screw (Silver) ④.
- (4) Disconnect every cord from CU-Board ⑤ and remove the CU-Board ⑤.
- (5) Installing is performed by the inverse procedure with removing.

(Note on removing / installing)

1. Beware of not to touch the DC motor inattentively (Do not rotate motor).
2. Beware of not to tuck down the cable while installing the Plate-Shield ②.
3. See 7.2(1) for the CU-Board ⑤ connector layout.

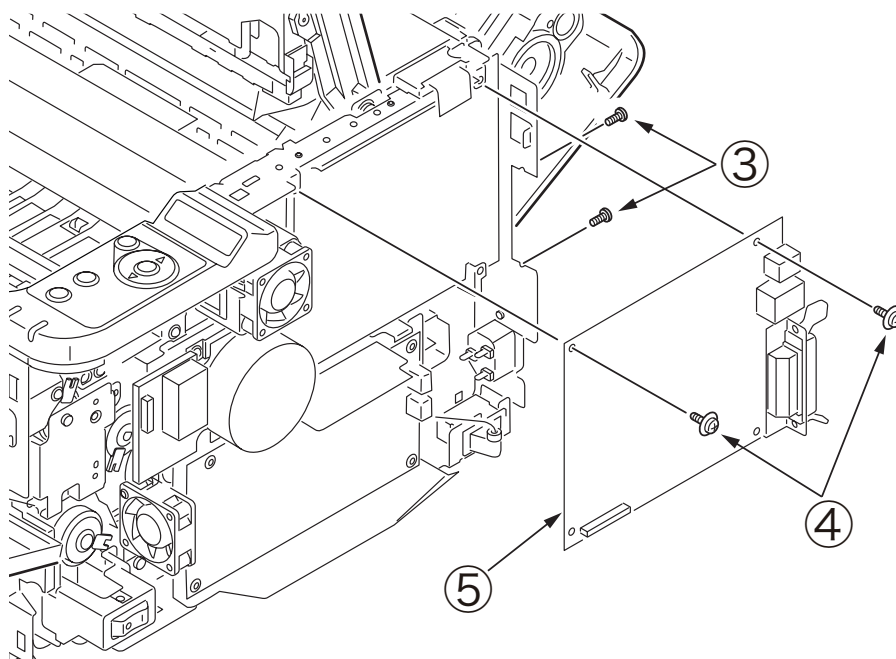

### 3.3.7 Power Supply Unit



There is a risk of electric shock during replacement of the low voltage power supply.

Use insulating gloves or avoid direct contact with any conducting part of the power supply, and caution should be exercised during replacement.

The capacitor may take one minute to complete discharge after the AC cord is unplugged. Also, there is a possibility that the capacitor doesn't discharge because of a breakage of the PCB, etc., so remember the possibility of electric shock to avoid electric shock.

- (1) Remove the Cover-Side-R. (Refer to 3.3.4)
- (2) Disconnect all of the three cables from Power Supply Unit (Board) ②.
- (3) Remove the four screws (Silver) ①. Remove the Power Supply Unit (Board) ②.
- (4) Remove the Sheet-Insulation-LV ③.
- (5) Pull out the Shaft-AC-Switch in the direction of the arrow.
- (6) Remove the two screws (Silver) ④ and the screw ⑤, disengage the two tabs (a and b), and remove Power Supply Unit (AC-Inlet) ⑥.
- (7) Installing is performed by the inverse procedure with removing.

(Note on removing / installing)

1. Beware of not to touch the DC motor inattentively (Do not rotate motor).
2. Do not apply excessive pressure to the power switch.

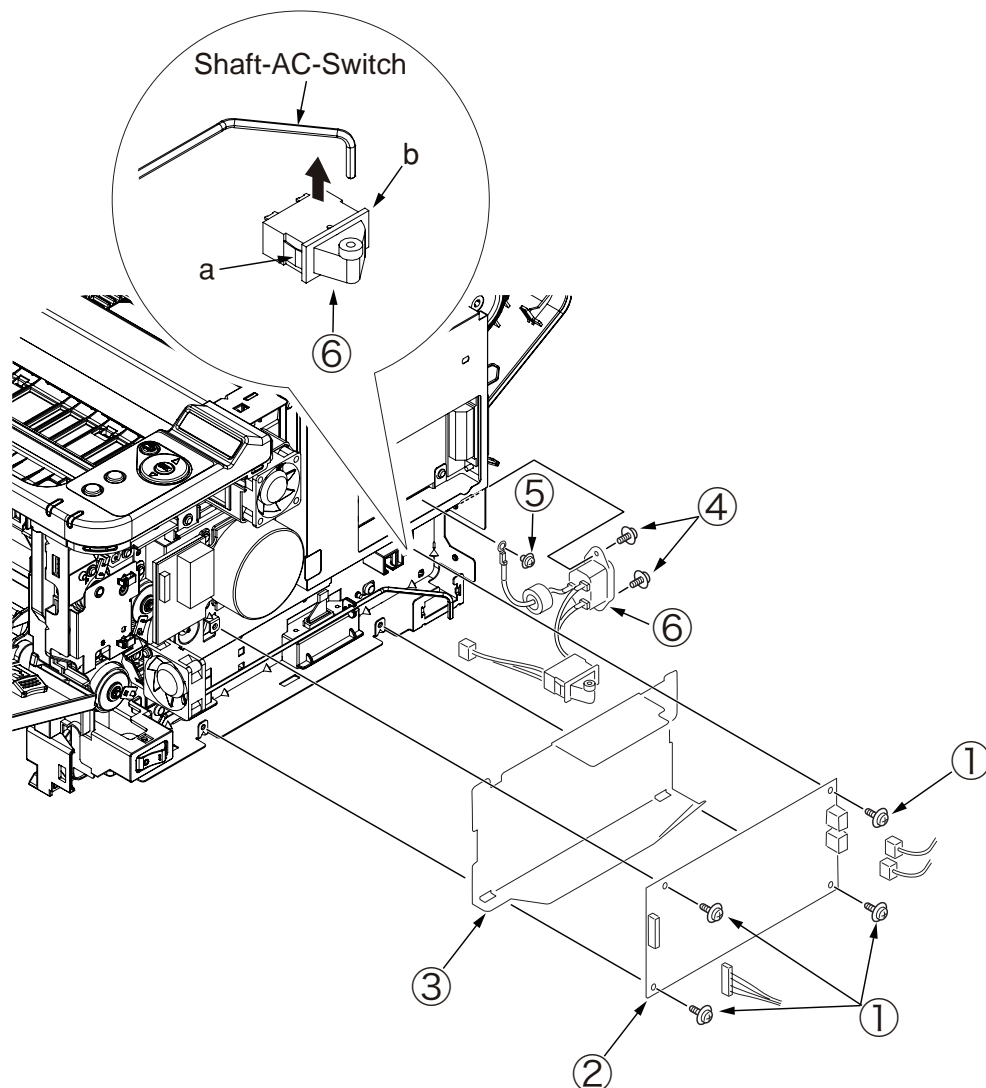

### 3.3.8 DC Motor

- (1) Remove the Cover-Side-R. (Refer to 3.3.4)
- (2) Remove the five screws (Silver) ①. Remove the Plate-Shield ②.
- (3) Remove the cable of DC Motor ③ from CU-board.
- (4) Remove the three screws (Silver) ④, remove the DC Motor ③.
- (5) Installing is performed by the inverse procedure with removing.

(Note on removing / installing)

1. Beware of not to touch the DC motor inattentively (Do not rotate motor).

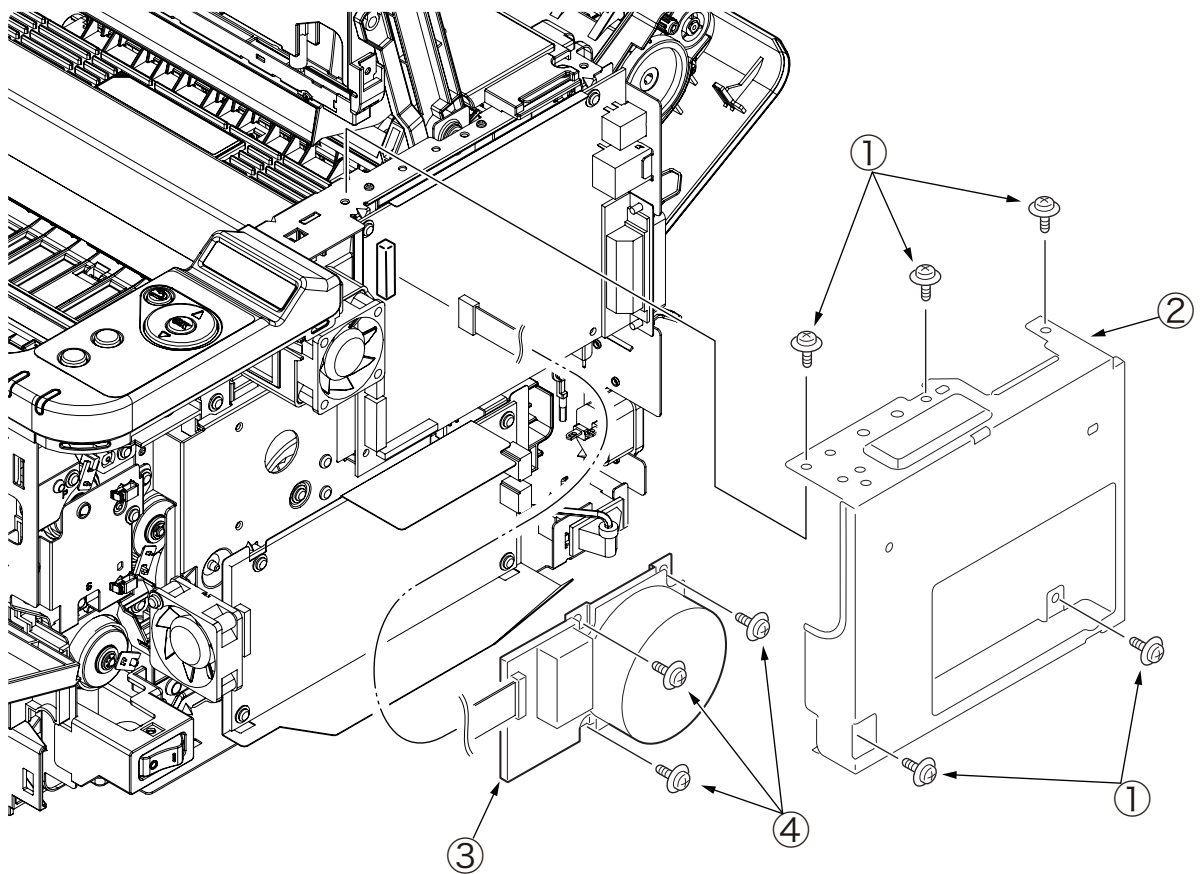



### 3.3.9 Hopping / MPT / Regist Clutch

- (1) Remove the CU-Board. (Refer to 3.3.6)
- (2) Remove the Power-Supply Unit ( Board ). (Refer to 3.3.7)
- (3) Remove the DC Motor. (Refer to 3.3.8)
- (4) Remove the Sheet-Insulation-CU ① .
- (5) Remove the two screws (Black) ② and screw (Silver) ③,remove the Plate-Clutch-MPT ④.
- (6) Remove the four screws (Silver) ⑤ ,remove the Plate-Gear ⑥.
- (7) Remove the Gear-Reduction ⑦.
- (8) Remove the screw (Silver) ⑧, Frame-AC-Switch ⑨ and Shaft-AC-Switch ⑩.
- (9) Remove the E-ring ⑪ ,remove the Regist Clutch ⑫.
- (10)Remove the E-ring ⑬ ,remove the Hopping Clutch ⑭.
- (11) Remove the MPT Clutch ⑮ and the Gear-MPT ⑯. ( only B431 )
- (12)Remove the screw (Silver : 18mm) ⑰ ,remove Motor-FAN ⑱.
- (13)Installing is performed by the inverse procedure with removing.

(Note on removing / installing)

1. Beware of not to touch the DC motor inattentively (Do not rotate motor).
2. Install Motor-FAN ⑱ with the label side seen from the rear side of the printer and with its notch fitted to the appropriate projection of Plate-Gear ⑥.
3. While removing or installing FAN ⑱, do not press impeller of the FAN as shown by the following photo. In case of the impeller unfastened by mistake, do not reuse it and install a new FAN ⑱.

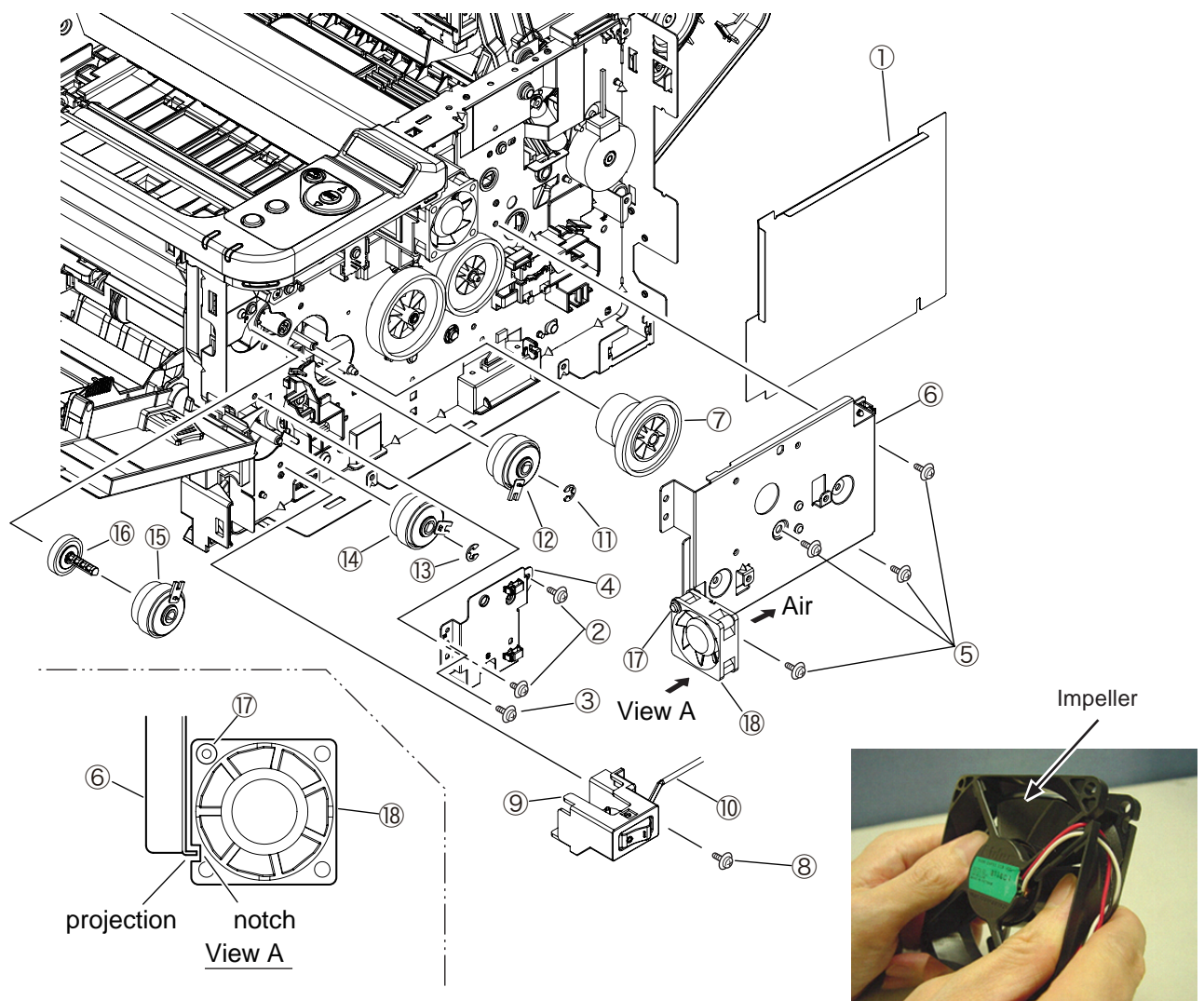

## 3.3.10 HV-Board / Motor-FAN

- (1) Remove the Cover-Side-L. (Refer to 3.3.5)
- (2) Remove the screw (Black) ① and the four screws (Silver) ②, disengage the two tabs (a and b), and remove HV-Board ③. Be careful not to lose Spring-Contact ④ that is removed with the board.
- (3) Disconnect all of the three cables from HV-Board ③.
- (4) Disengage the two tabs (c and d), and remove Motor-FAN ⑤.
- (5) Installing is performed by the inverse procedure with removing.

(Note on removing / installing)

1. Install Motor-FAN ⑤ with the label side outward and with its notch fitted to the appropriate projection of the Plate-Side-L.
2. See 7.2(2) for the HV-Board ③ connector layout.
3. While removing or installing FAN ⑤, do not press impeller of the FAN as shown by the following photo. In case of the impeller unfastened by mistake, do not reuse it and install a new FAN ⑤.

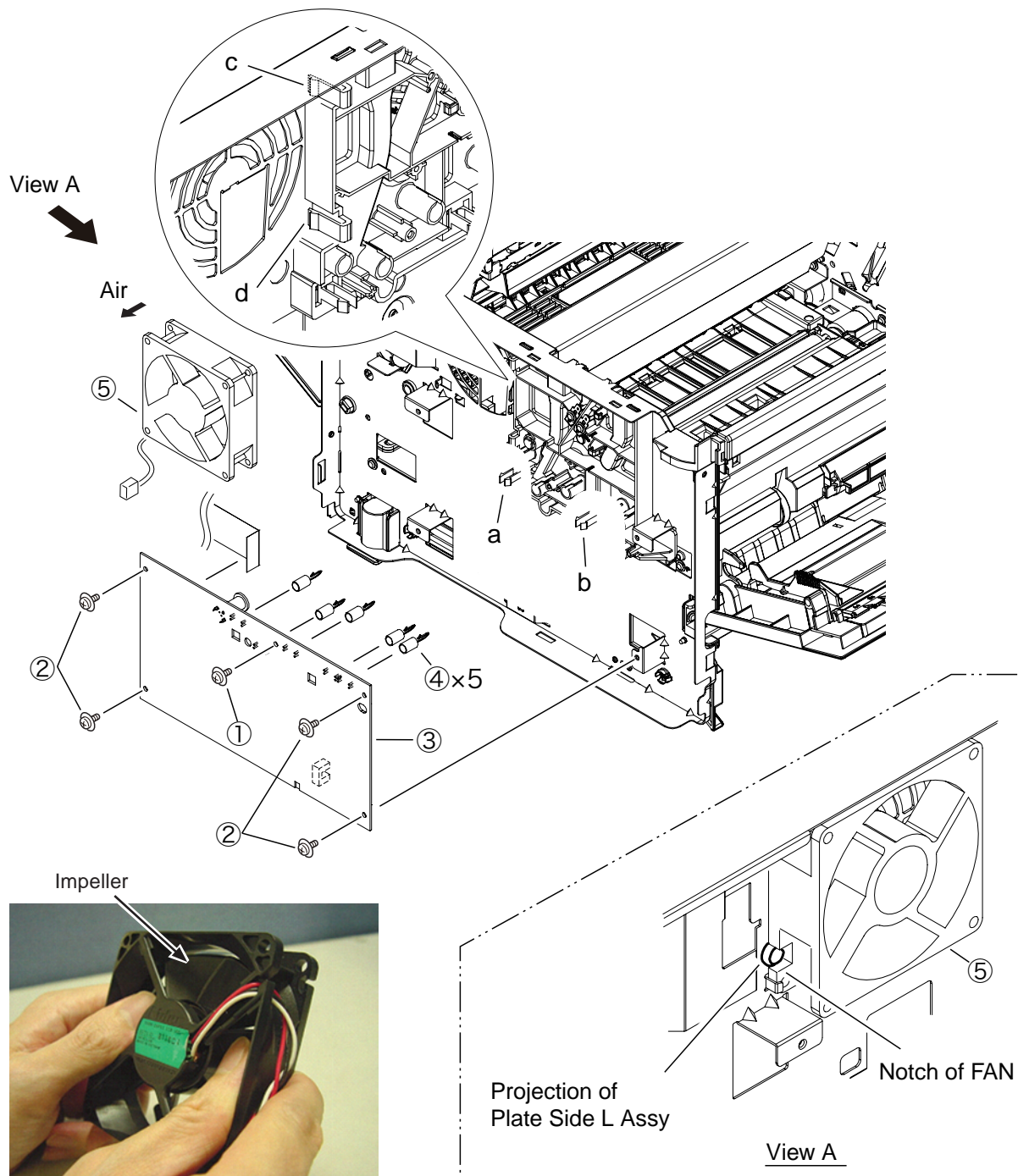

### 3.3.11 Cover Assy OPE

- (1) Remove the Cover-Side-R and Cover-Side-L. (Refer to 3.3.4 / 3.3.5)
- (2) Remove the five screws (Silver) ①. Remove the Plate-Shield ②.
- (3) Remove the FFC cable from the CU-board.
- (4) Remove the two screws (Black) ③. Remove the Cover-Assy-Ope ④.
- (5) Installing is performed by the reverse procedure with removing.

(Note on removing / installing)

1. Beware of not to touch the DC motor inattentively (Do not rotate motor).

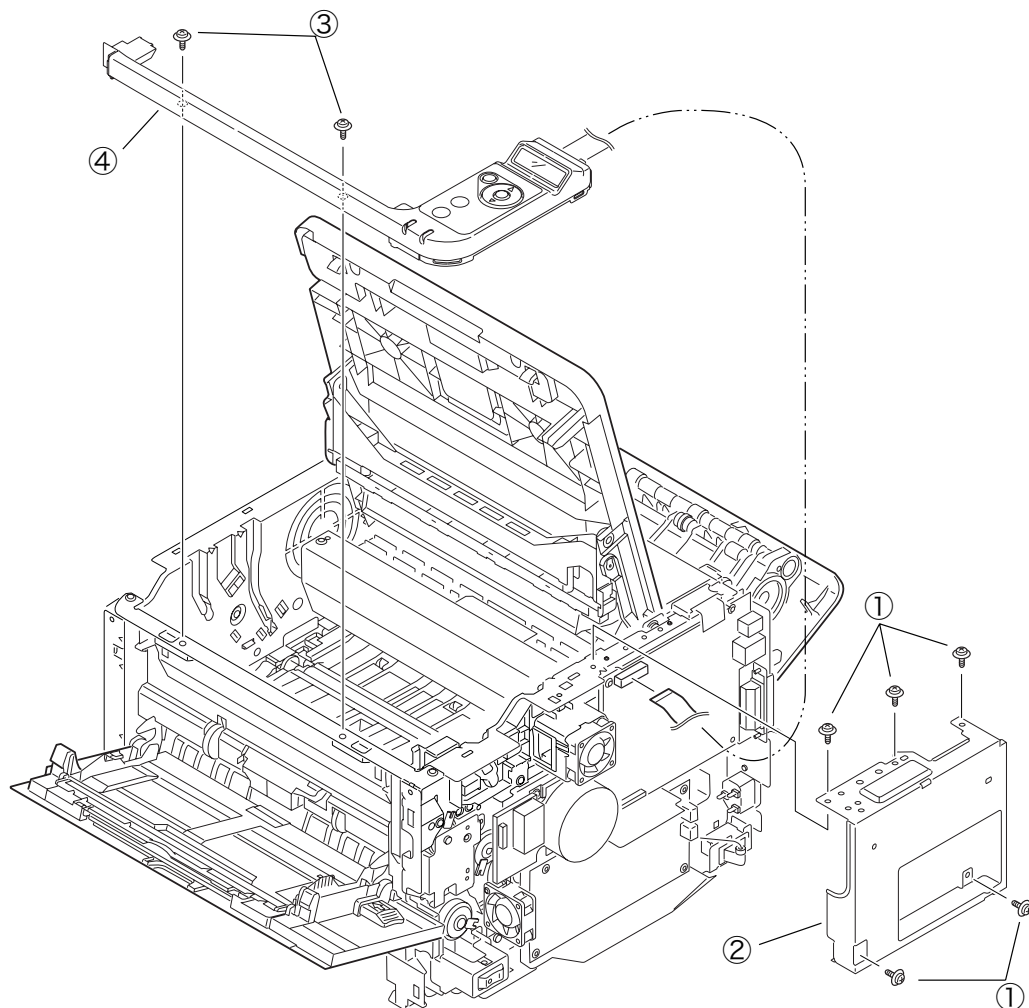

### 3.3.12 Ope PCB Assy ( B431 )

- (1) Remove the Cover Assy Ope. (Refer to 3.3.11)
- (2) Remove the two screws (Black) ①.
- (3) Remove the Ope PCB Assy ②.
- (4) Remove the FFC cable and the LCD ③.
- (5) Installing is performed by the reverse procedure with removing.

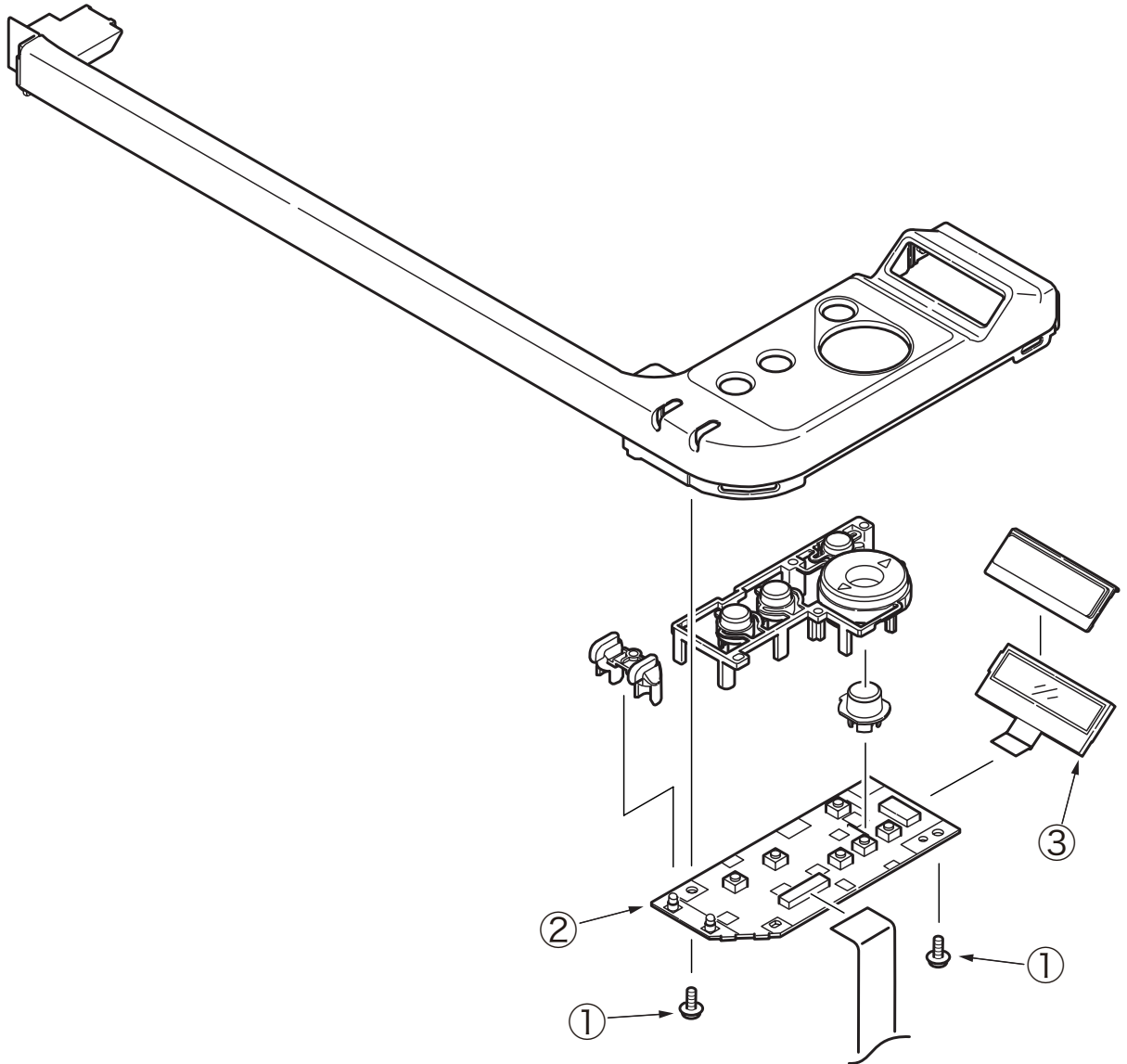

### 3.3.13 Cover Assy Stacker

- (1) Remove the Cover-Side-R and Cover-Side-L. (Refer to 3.3.4 / 3.3.5)
- (2) Remove the two screws (Silver) ①. Remove the Cover-Eject ②.  
(At this moment, Plate-Rear ③ is also removed.)
- (3) With the Cover Assy Stacker closed, detach Lever-Link-Fuser ④ (on both sides) from the Fuser Assy release lever by using a flat-head screwdriver or something.
- (4) Remove the CU-Board. (Refer to 3.3.6)
- (5) Remove the Sheet-Insulation-CU ⑤.
- (6) With the Cover Assy Stacker opened, remove Spring-Stacker ⑥ (on both sides).

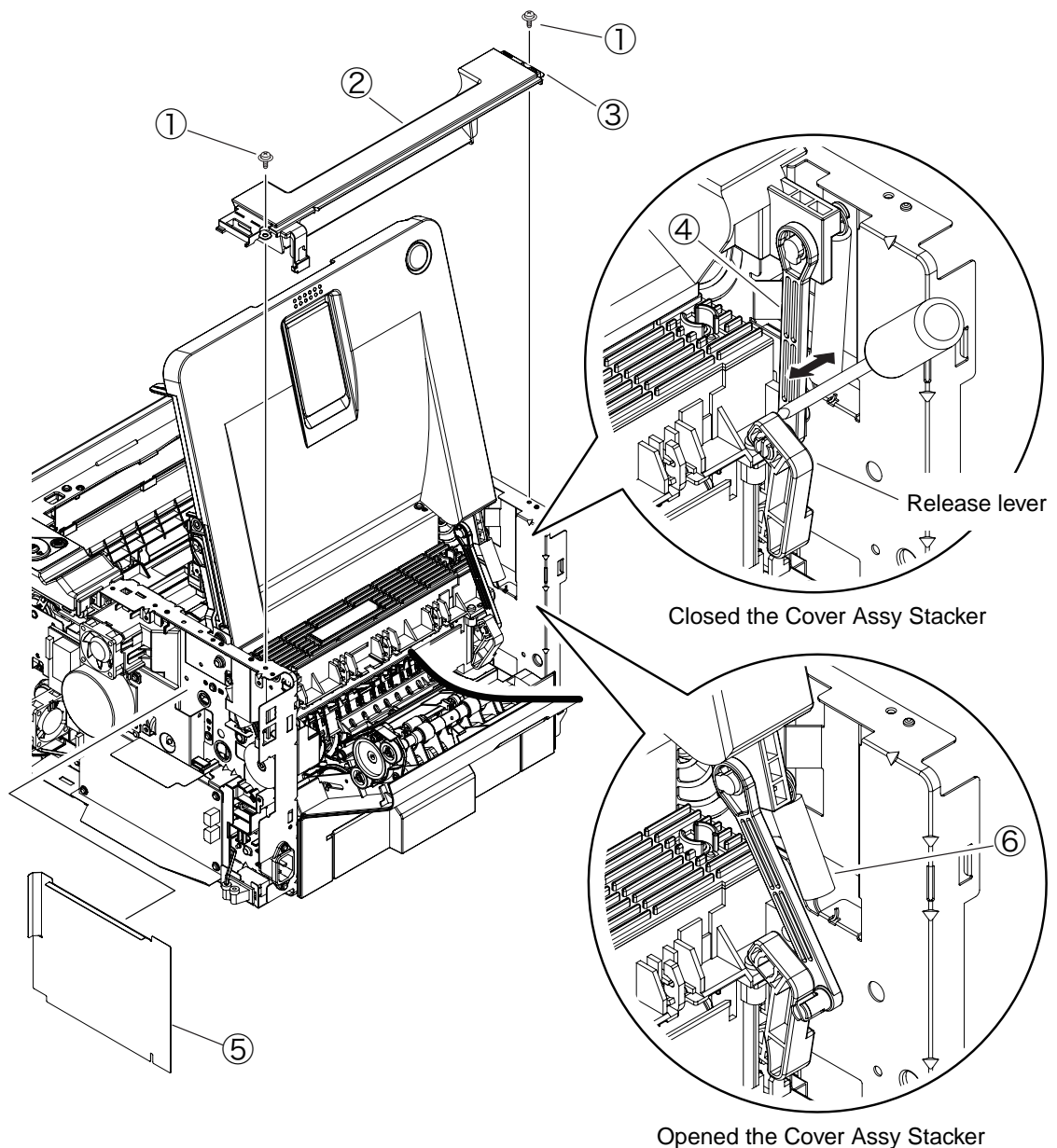

- (7) Remove the Cover Assy Stacker ⑦.  
(8) Installing is performed by the reverse procedure with removing.

(Note on removing / installing)

1. Beware of not to touch the DC motor inattentively (Do not rotate motor).

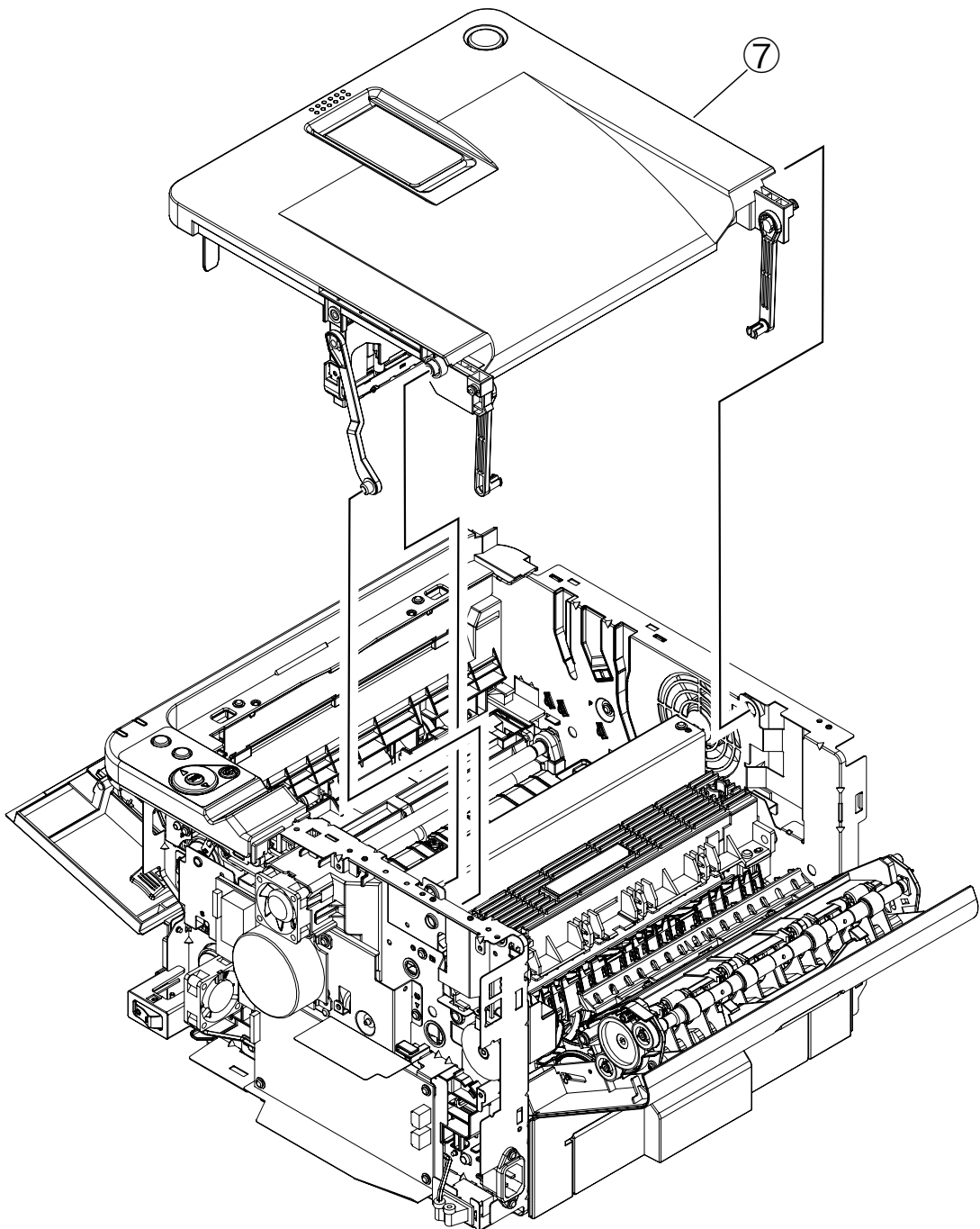

### 3.3.14 Stacker Cover

- (1) Remove the Cover Assy Stacker. (Refer to 3.3.13)
- (2) Remove the LED Head. (Refer to 3.3.1)
- (3) Remove the Lever-Link-Fuser ① (on both sides).
- (4) Remove the four screws (Black) ②, remove the Cover-Lever③.
- (5) Remove the Lever-Lock-Top ④ , Lever-Lock-Button ⑤. Remove the Spring-Lever-Top ⑥.
- (6) Installing is performed by the reverse procedure with removing.

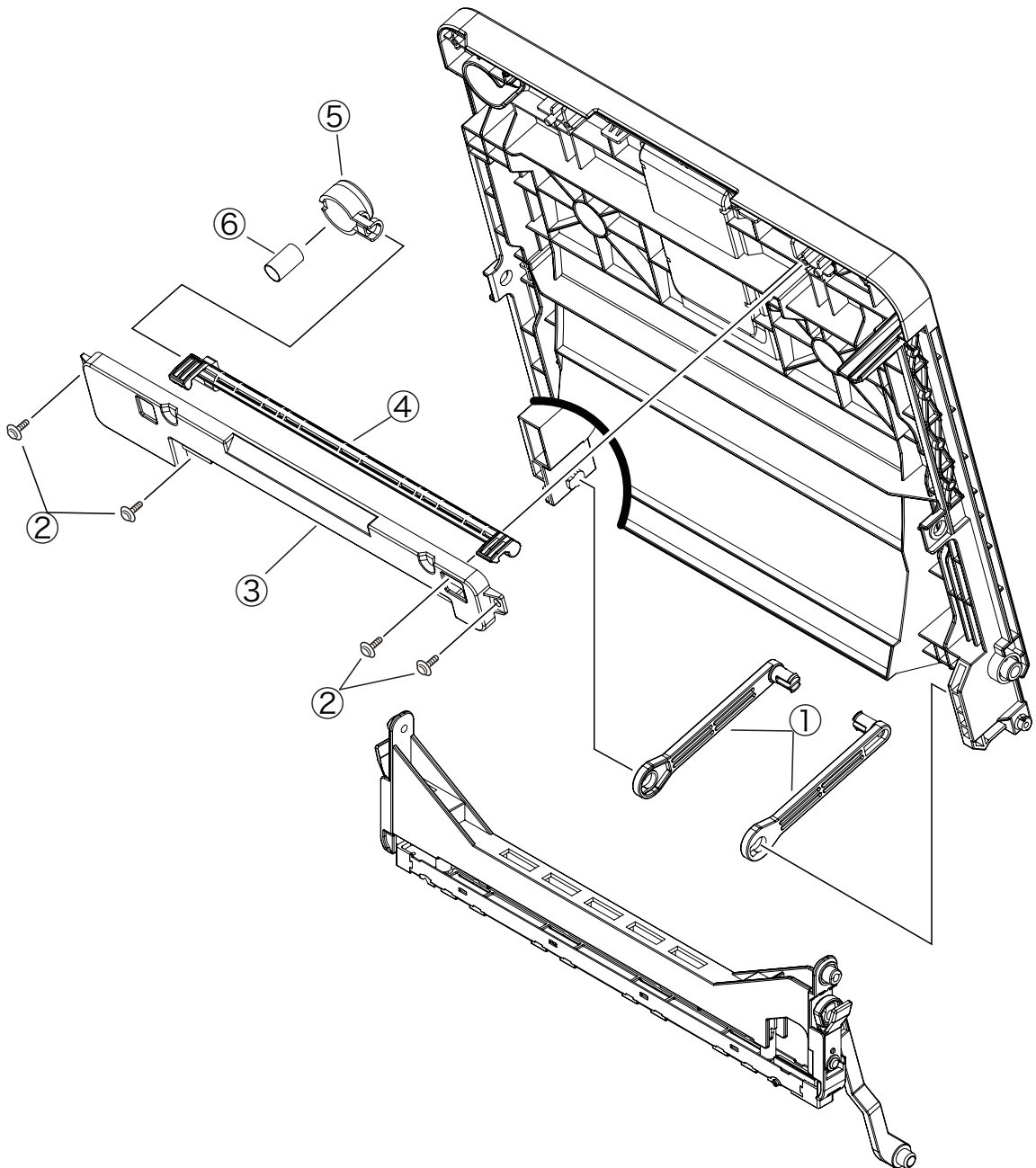

## 3.3.15 Fuser Assy

**Note!** Replace the Fuser-Assy by Assy unit.

It is forbidden for disassembling the Fuser-Assy, also, reusing the disassembled Fuser-Assy.

- (1) Take out the Frame-Assy-TR. (Refer to 3.3.2)
- (2) Remove the Cover Assy Stacker. (Refer to 3.3.13)
- (3) Remove the two screws (Silver) ①. Remove the Plate-Duct-Assy ②.
- (4) Remove the screw (Silver) ③. Remove the Plate-Stacker-Lock ④.
- (5) Remove the screw (Silver) ⑤ and screw (Black) ⑥ and lift off Fuser-Assy ⑦ after disconnecting every cable from it.
- (6) Installing is performed by the inverse procedure with removing.

**Note!** Fuser-Assy ⑦ may be really hot, beware of handling.

(Note on removing / installing)

1. Beware of not to touch the DC motor inattentively (Do not rotate the motor).
2. Install the Fuser-Assy ⑦ carefully to avoid cables from being caught.

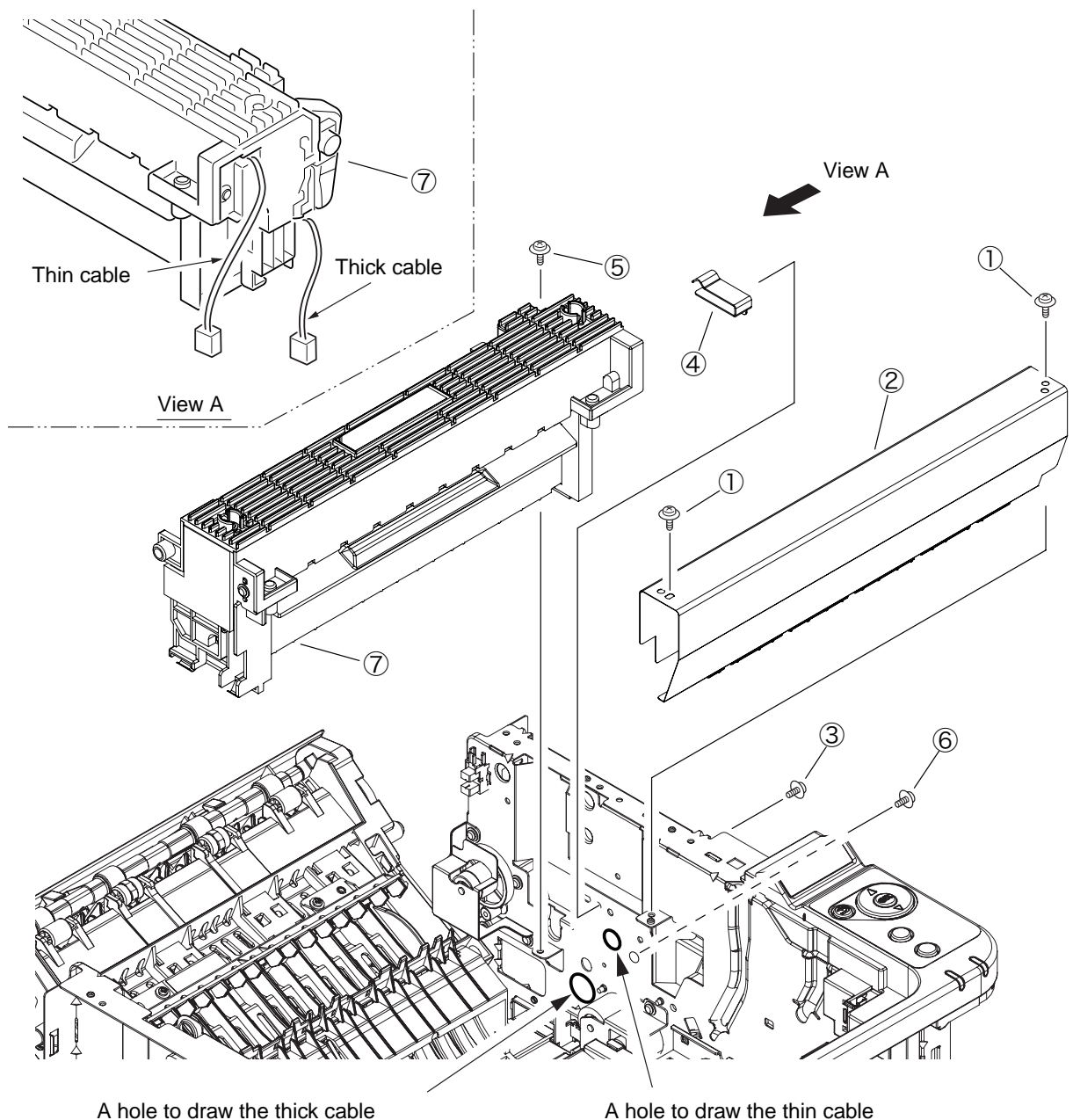



### 3.3.16 MPT Assy , Manual Assy

- (1) Remove the Cover-Side-R and Cover-Side-L. (Refer to 3.3.4 / 3.3.5)
- (2) Remove the Cover-Assy-OPE. (Refer to 3.3.11)
- (3) Remove the two screws (Silver) ①. Remove the Plate-Front ②.
- (4) Remove the two screws (Silver) ③. Remove the screw (Black) ④.
- (5) Remove MPT Assy ⑤ (of B431) or Manual Assy ⑤ (of B411).
- (6) Installing is performed by the inverse procedure with removing.

(Note on removing / installing)

1. Beware of not to touch the DC motor inattentively (Do not rotate motor).

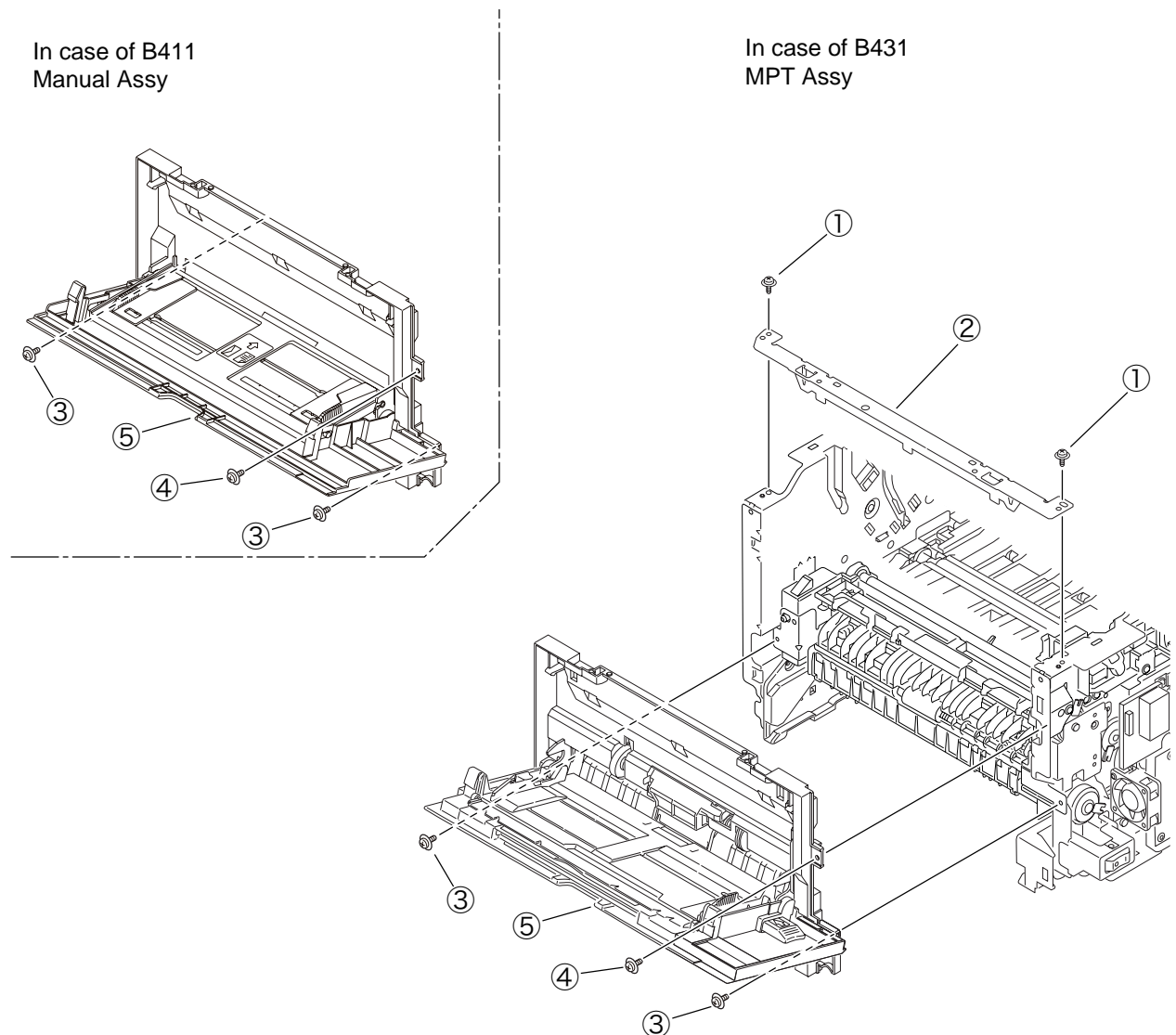

### 3.3.17 Cover Assy Rear

- (1) Remove the Cover-Side-R and Cover-Side-L. (Refer to 3.3.4 / 3.3.5)
- (2) Remove the CU-Board. (Refer to 3.3.6)
- (3) Remove the Sheet-Insulation-CU ① .
- (4) Remove the Spacer ②.
- (5) Slide Cover Assy Rear ③ and pull it out of the hole on the right of the printer.  
(Remove Cover Assy Rear ③ carefully to avoid Cable-Sensor-FU ⑮ from being caught.)

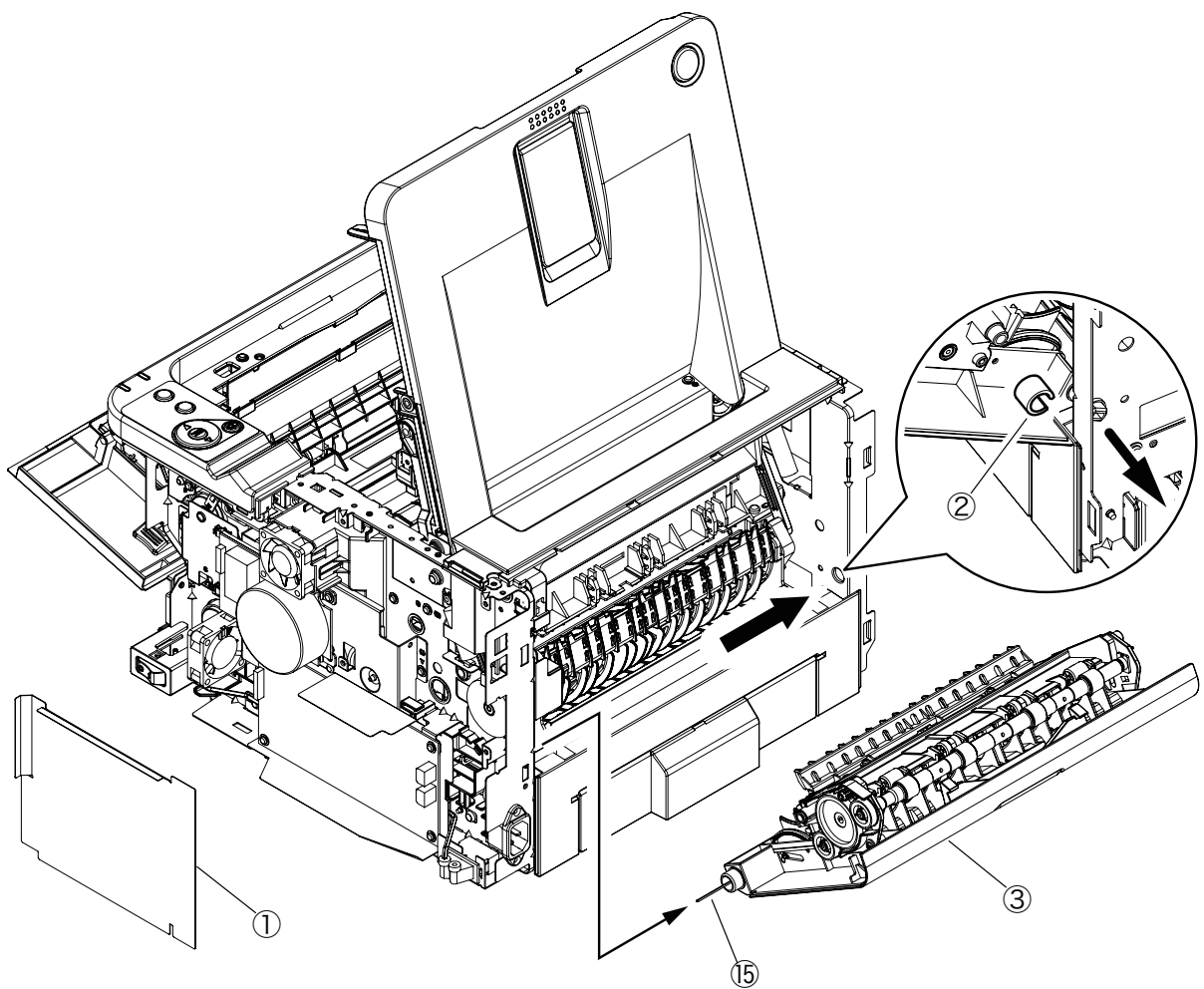

- (6) Remove the two screws (Black) ④ and separate Cover-Rear ⑤ and Guide-Eject-Upper-Assy ⑥.
- (7) Remove the Gear-Idle ⑦.
- (8) Remove the Gear-Exit ⑧ (2 places), remove the Bearing-Eject\_R ⑨ (2 places). Remove the Bearing-Feeder ⑩ (2 places).
- (9) Remove the Shaft-Assy-Eject ⑪ (2 places).
- (10) Remove the Separator-FU ⑫ . Remove the Spring-Separator\_FU ⑬.
- (11) Remove the Stacker-Sensor ⑭. Remove the Cable-Sensor-FU ⑮.
- (12) Installing is performed by the inverse procedure with removing.

(Note on removing / installing)

- 1. Beware of not to touch the DC motor inattentively (Do not rotate motor).

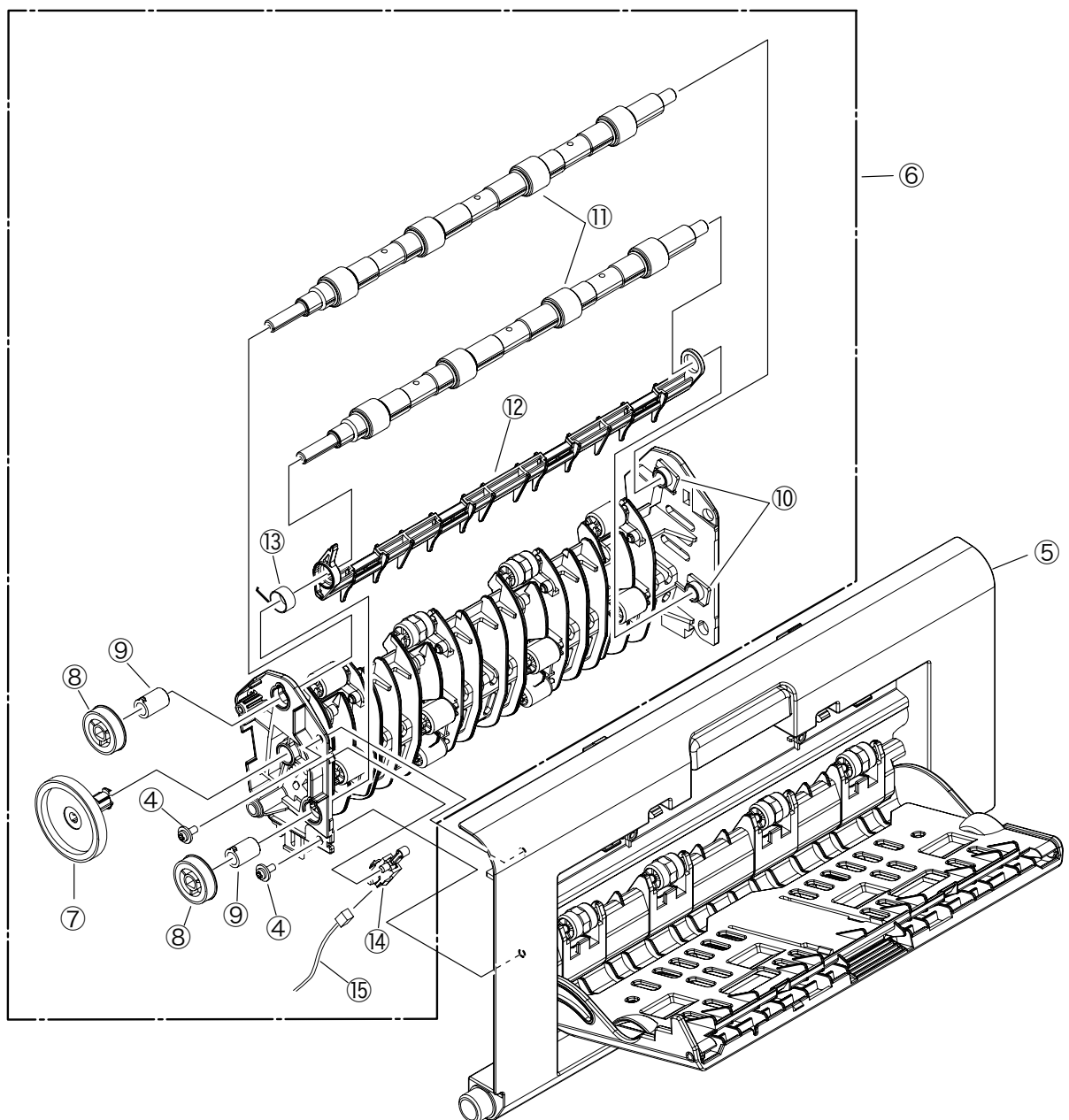

### 3.3.18 Guide Eject Lower Assy

- (1) Remove the Cover-Side-R and Cover-Side-L. (Refer to 3.3.4 / 3.3.5)
- (2) Remove the CU-Board. (Refer to 3.3.6)
- (3) Remove the Sheet-Insulation-CU ① .
- (4) Remove the two screws (Silver) ②. Remove the Cover-Eject ③.  
(At this moment, Plate-Rear ④ is also removed.)
- (5) Remove the two screws (Silver : 8mm) ⑤. Remove the Cover-Cassette-Rear Assy ⑥ and Guide-Eject-Lower-Assy ⑦.
- (6) Remove the post ⑧. Remove the Separator-SB-FD ⑨.
- (7) Remove the Lever-Exit-Sensor ⑩ and Spring-Sensor-Exit ⑪.
- (8) Installing is performed by the inverse procedure with removing.

(Note on removing / installing)

1. Beware of not to touch the DC motor inattentively (Do not rotate motor).
2. Install Cover-Cassette-Rear Assy ⑥ carefully to avoid the FFC cable from being caught.

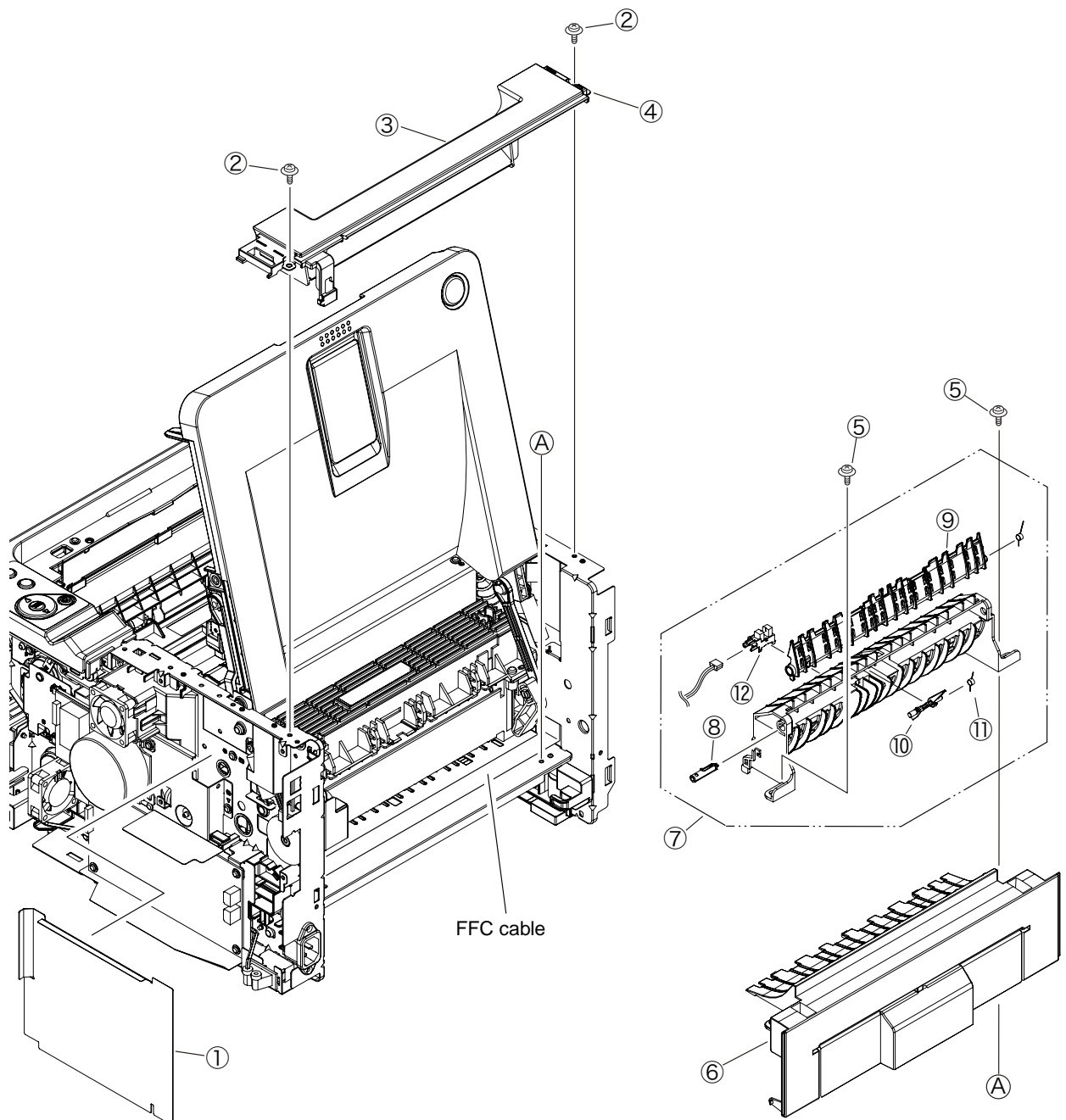

### 3.3.19 Eject Motor

- (1) Remove the Cover-Side-R and Cover-Side-L. (Refer to 3.3.4 / 3.3.5)
- (2) Remove the CU-Board. (Refer to 3.3.6)
- (3) Remove the Cover Assy Stacker. (Refer to 3.3.13)
- (4) Remove the Fuser Assy. (Refer to 3.3.15)
- (5) Remove the Cover Assy Rear. (Refer to 3.3.17)
- (6) Remove the Guide-Eject-Lower-Assy. (Refer to 3.3.18)
- (7) Remove the two screws (Silver) ①. Remove the Plate-Gear-Exit ② and Gear ③.
- (8) Remove the two screws (Silver) ④. Remove the Eject-Motor ⑤.
- (9) Installing is performed by the inverse procedure with removing.

(Note on removing / installing)

1. Beware of not to touch the DC motor inattentively (Do not rotate motor).

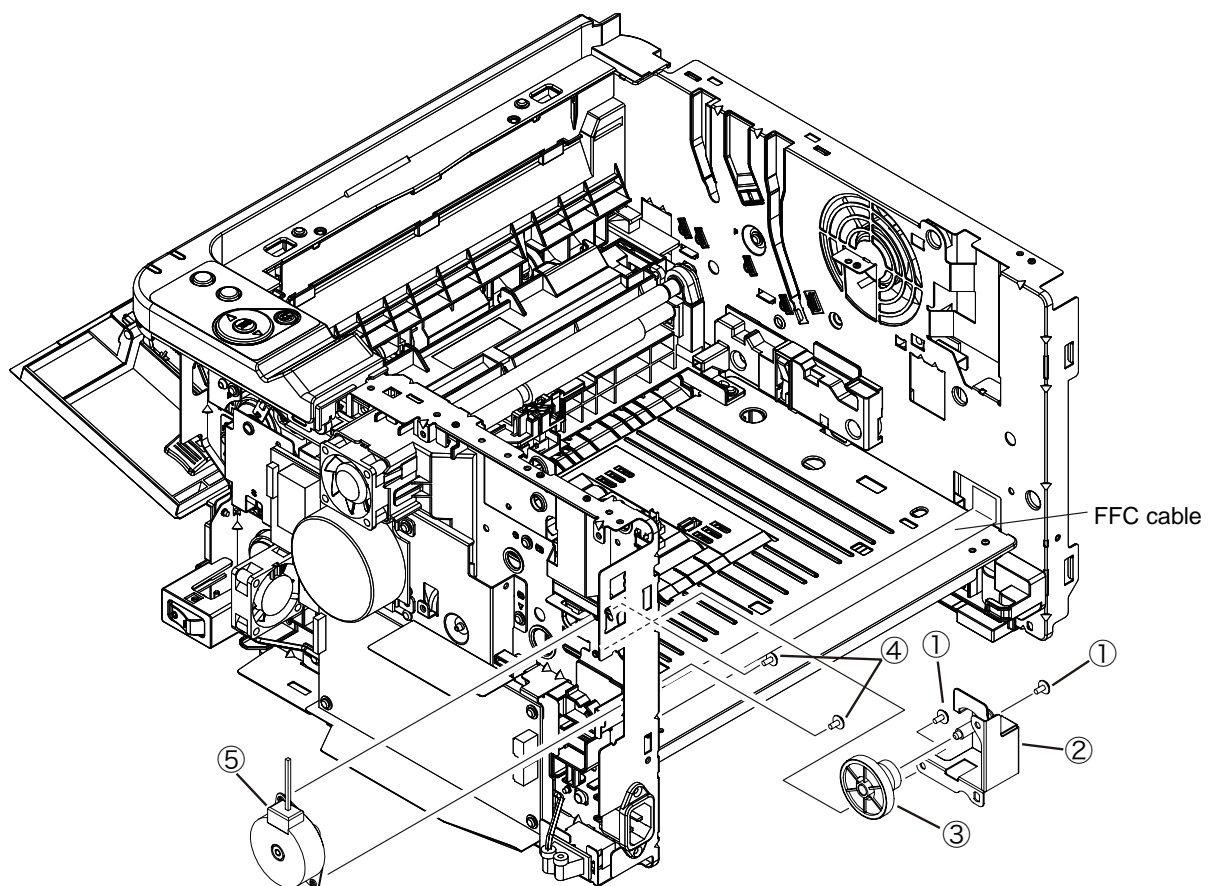

### 3.3.20 Plate Side R Assy / Plate Side L Assy / Front Assy

- (1) Remove the Cover-Side-R and Cover-Side-L. (Refer to 3.3.4 / 3.3.5)
- (2) Remove the CU-Board. (Refer to 3.3.6)
- (3) Remove the Power Supply Unit. (Refer to 3.3.7)
- (4) Remove the DC Motor. (Refer to 3.3.8)
- (5) Remove the Hoppng / MPT / Regist Clutch. (Refer to 3.3.9)
- (6) Remove the HV-Board / Motor-FAN. (Refer to 3.3.10)
- (7) Remove the Cover-Assy OPE. (Refer to 3.3.11)
- (8) Remove the Cover Assy Stacker. (Refer to 3.3.13)
- (9) Remove the Fuser Assy. (Refer to 3.3.15)
- (10) Remove the MPT Assy , Manual Assy. (Refer to 3.3.16)
- (11) Remove the Cover Assy Rear. (Refer to 3.3.17)
- (12) Remove the Guide Eject Lower Assy. (Refer to 3.3.18)
- (13) Remove the screw(Black) ① and the two screws(Silver) ② and separate the Plate Side L Assy.
- (14) Remove the screw(Silver) ③, screw(Black) ④ and the two screws(Silver) ⑤ and separate the Plate Side R Assy.
- (15) Remove the two screws (Silver) ⑥. Remove the Front Assy.
- (16) Installing is performed by the inverse procedure with removing.

(Note on removing / installing)

1. Beware of not to touch the DC motor inattentively (Do not rotate motor).

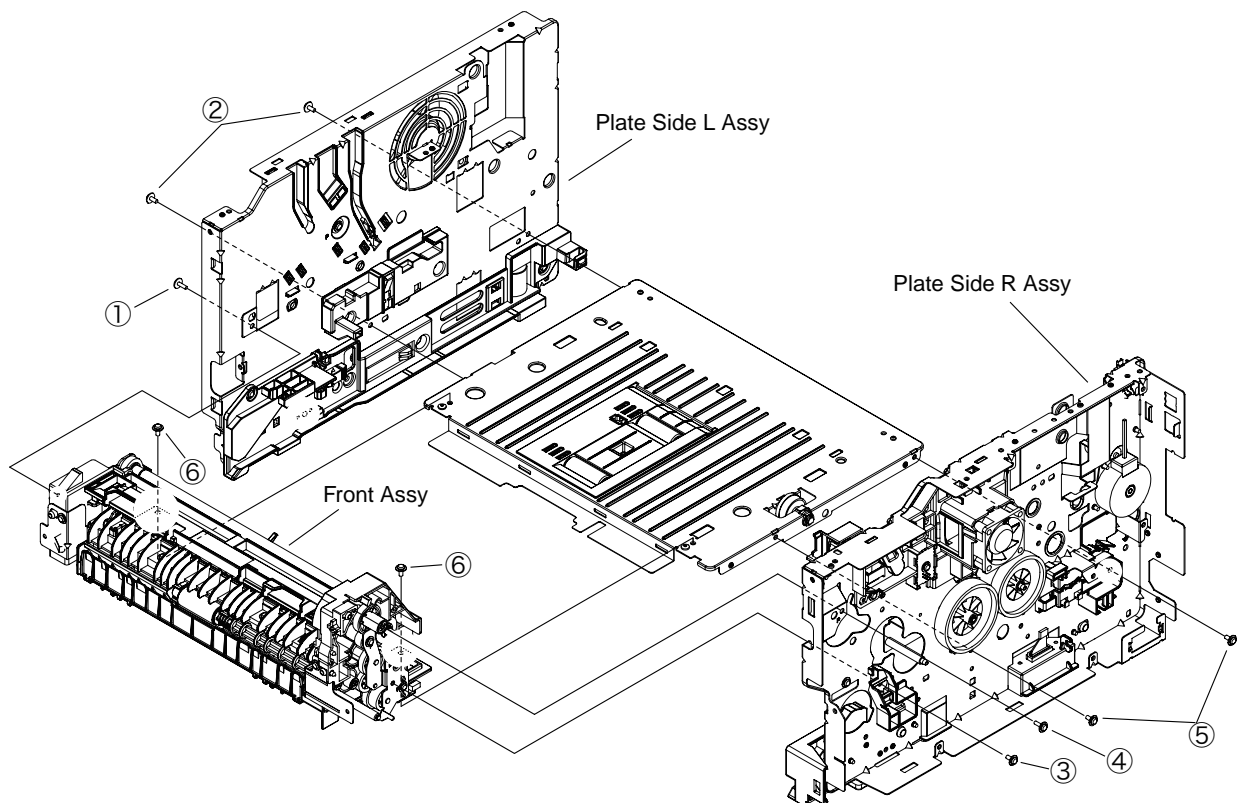

### 3.3.21 Plate Side L Assy

- (1) Separate the Plate Side L Assy. (Refer to 3.3.20)
- (2) Remove the three screws (Silver) ①. Remove the Guide-Cassette-L ② and Spring-Lock-Cassette ③.
- (3) Remove Lever-Sensor Cassette ④ and Spring-Sensor ⑤ from the Guide-Cassette-L ②.
- (4) Remove the two screws (Silver) ⑥. Remove the Frame-inner-L ⑦.
- (5) Remove the screw (Black) ⑧, disengage the two tabs (a and b), and remove Guide-ID-L ⑨.
- (6) Remove the Spring-ID-Lock-L ⑩.
- (7) Installing is performed by the inverse procedure with removing.

(Note on removing / installing)

1. Beware of not to touch the DC motor inattentively (Do not rotate motor).

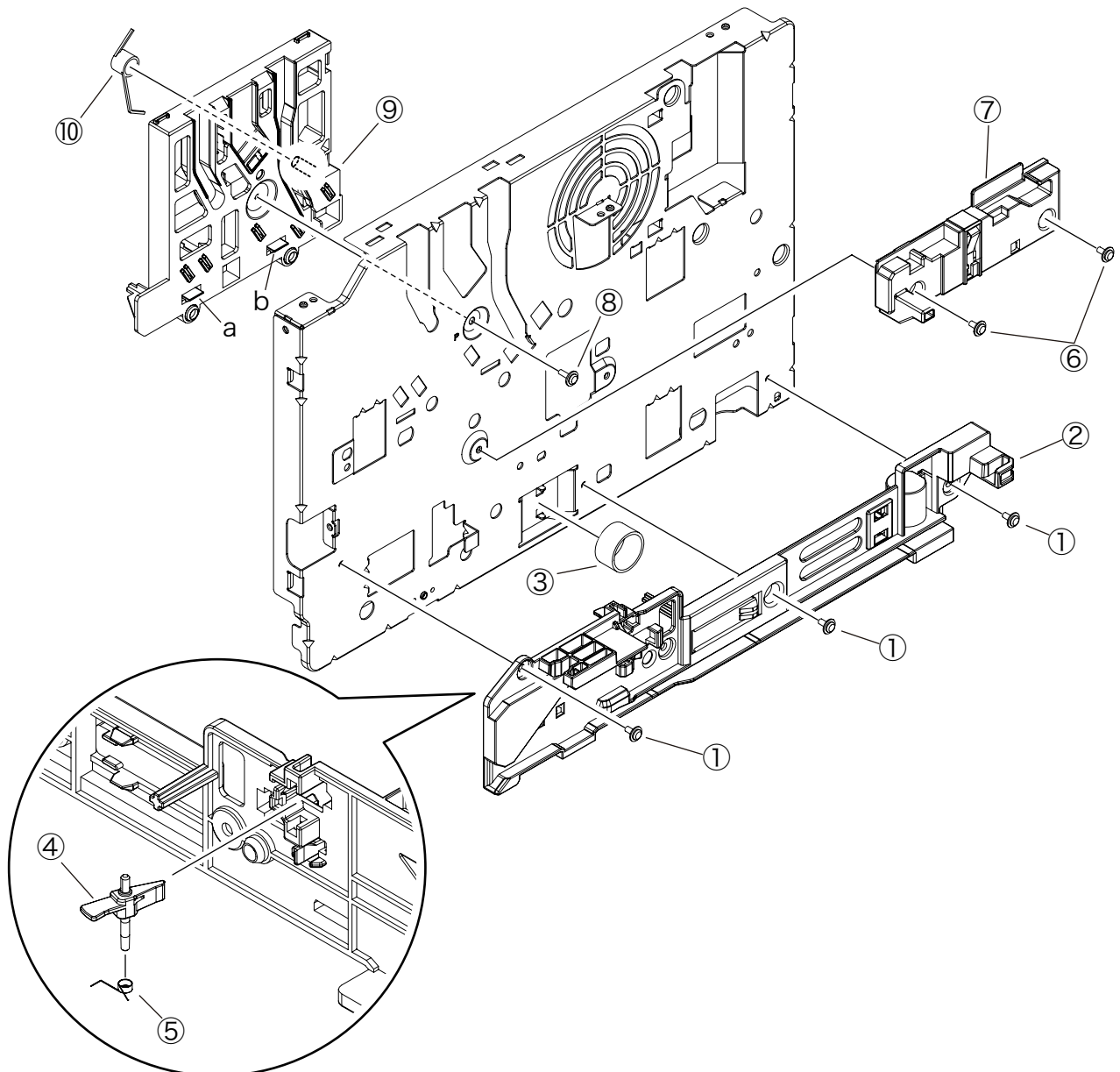

## 3.3.22 Plate Side R Assy

- (1) Separate the Plate Side R Assy. (Refer to 3.3.20)
- (2) Remove the three screws (Silver) ①. Remove the Guide-Cassette-R ②.
- (3) Remove the two screws (Black) ③. Remove the Connector ④.
- (4) Remove the four screws (Silver) ⑤. Remove the Plate-ID-Gear ⑥, Gear-Idle-Z21 ⑦, Gear-Idle-Z30-33 ⑧.
- (5) Remove the screw (Silver) ⑨. Remove the Holder-Switch ⑩ and Micro switch ⑪.
- (6) Remove the two screws (Silver) ⑫, screw (Black) ⑬. Remove the Guide-ID-R ⑭ and Motor-Fan(X40) ⑮, Board-974 ⑯, Spring-ID Lock R ⑰.
- (7) Remove the screw (Silver) ⑱. Remove the Guide-Cable ⑲.
- (8) Installing is performed by the inverse procedure with removing.

(Note on removing / installing)

1. Beware of not to touch the DC motor inattentively (Do not rotate motor).
2. Install Motor-FAN ⑮ with the label side inward and with its notch fitted to the appropriate projection of Guide-ID-R ⑭.
3. While removing or installing FAN ⑮, do not press impeller of the FAN as shown by the following photo. In case of the impeller unfastened by mistake, do not reuse it and install a new FAN ⑮.

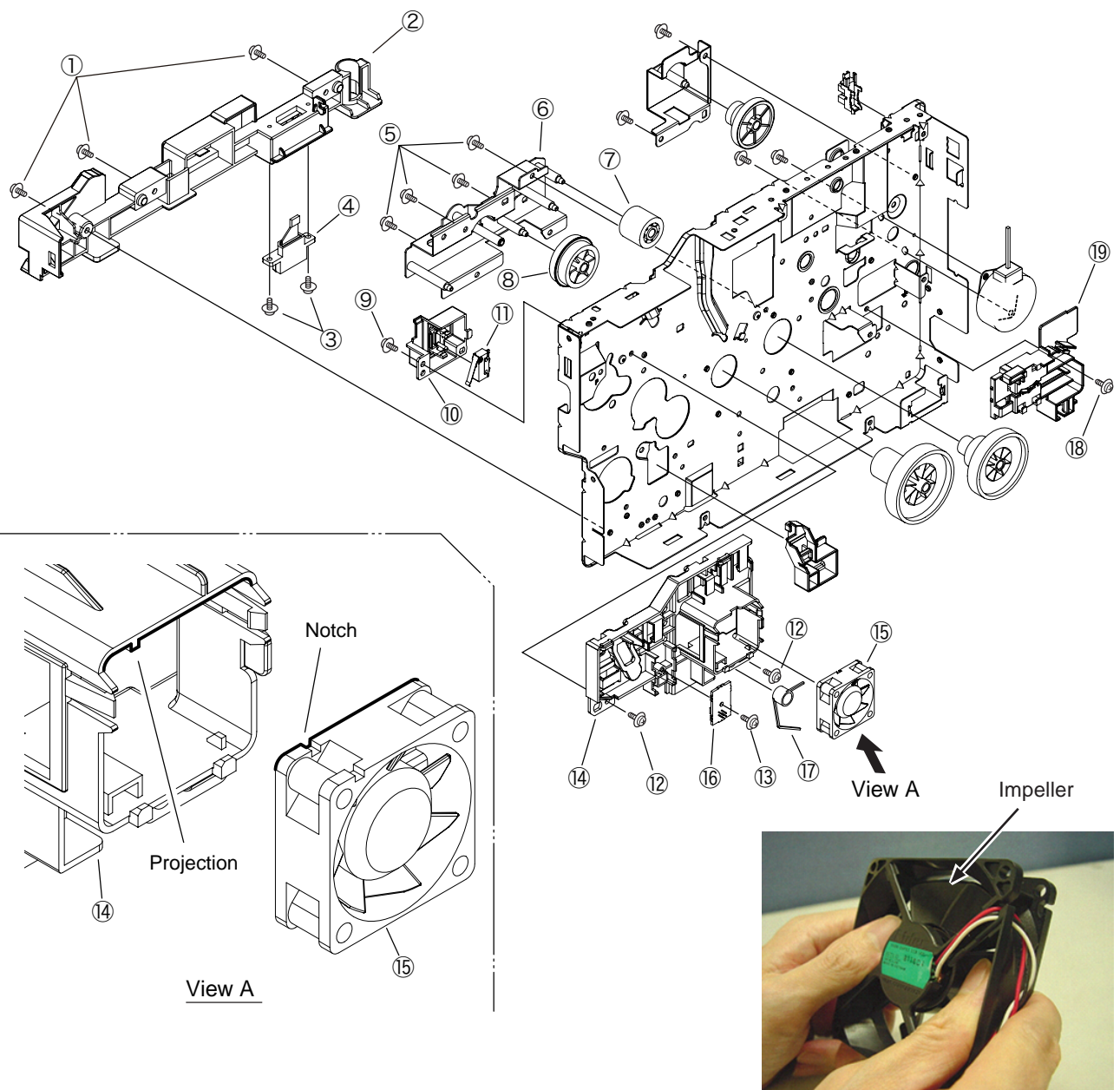



### 3.3.23 Roller Register

- (1) Separate the Front Assy. (Refer to 3.3.20)
- (2) Remove the two screws (Black) ① and Plate-Feed-B ②.  
(Be careful not to lose the gear that is removed with the plate.)
- (3) Remove the Gear-Idle-MPT ③. Remove the Gear-Reduction-MPT ④. (B431 only)
- (4) Remove the E-ring ⑤. Remove the Regist-Gear ⑥.
- (5) Remove the Gear-Pressure ⑦.
- (6) Remove the screw (Black) ⑧. Remove the Plate-Contact-REG ⑨.
- (7) Remove the two screws (Black) ⑩. Remove the Holder-Regist-L/R ⑪.
- (8) Remove the Roller-Pressure ⑫. Remove the Roller-Regist ⑬.
- (9) Installing is performed by the inverse procedure with removing.

(Note on removing / installing)

1. Beware of not to touch the DC motor inattentively (Do not rotate motor).

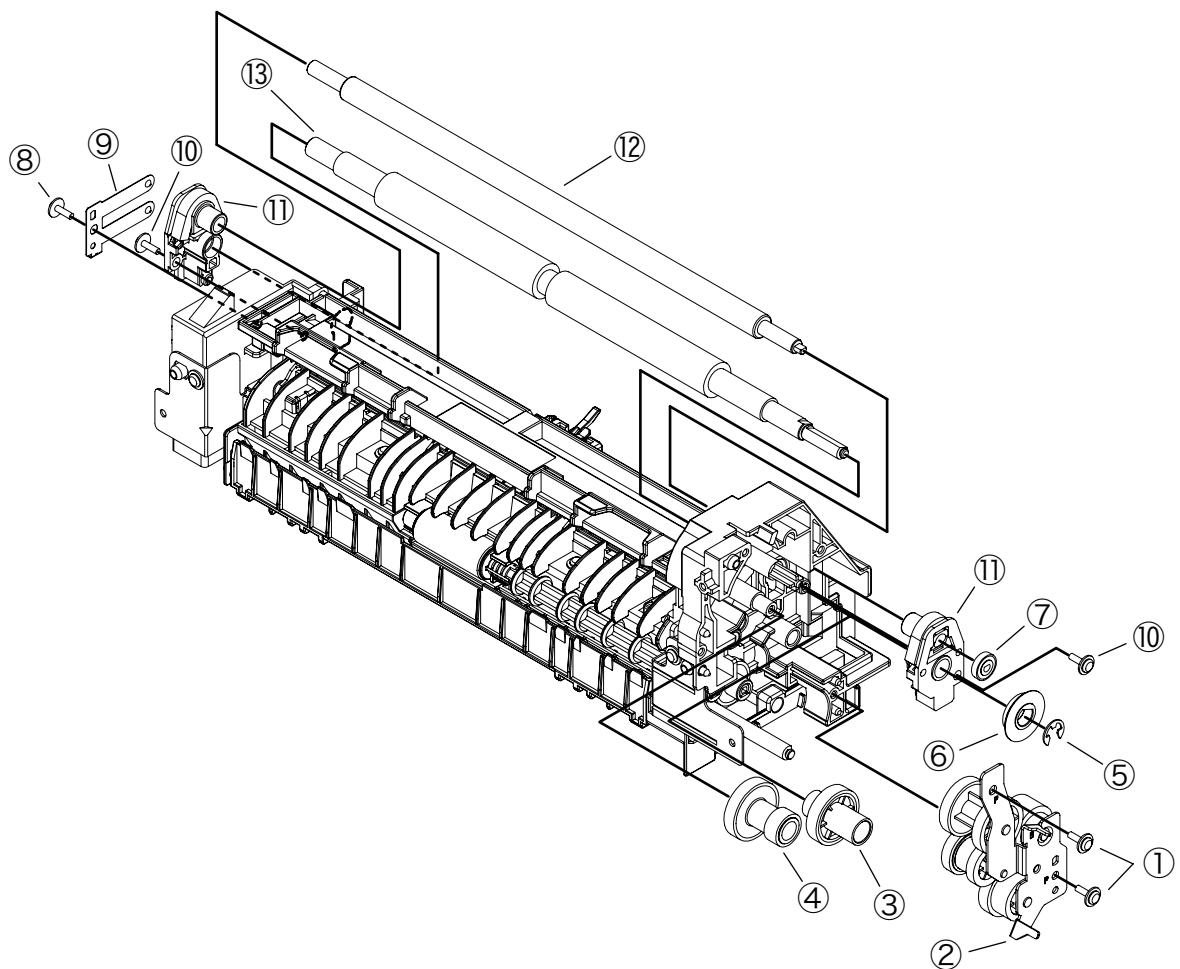

### 3.3.24 Roller Feed Assy

- (1) Separate the Front Assy. (Refer to 3.3.20)
- (2) Remove the two screws (Black) ① and Plate-Feed-B ②.  
(Be careful not to lose the gear that is removed with the plate.)
- (3) Remove the two screws (Black) ③. Separate the Regist Assy.
- (4) Remove the two screws (Silver) ④. Remove the Frame-Hopping-Upper ⑤.
- (5) Remove the two Gear-Roller-Feed ⑥. Remove the two Bush-Feed ⑦.
- (6) Remove the two Roller-Feed-Assy ⑧.
- (7) Installing is performed by the inverse procedure with removing.

(Note on removing / installing)

1. Beware of not to touch the DC motor inattentively (Do not rotate motor).

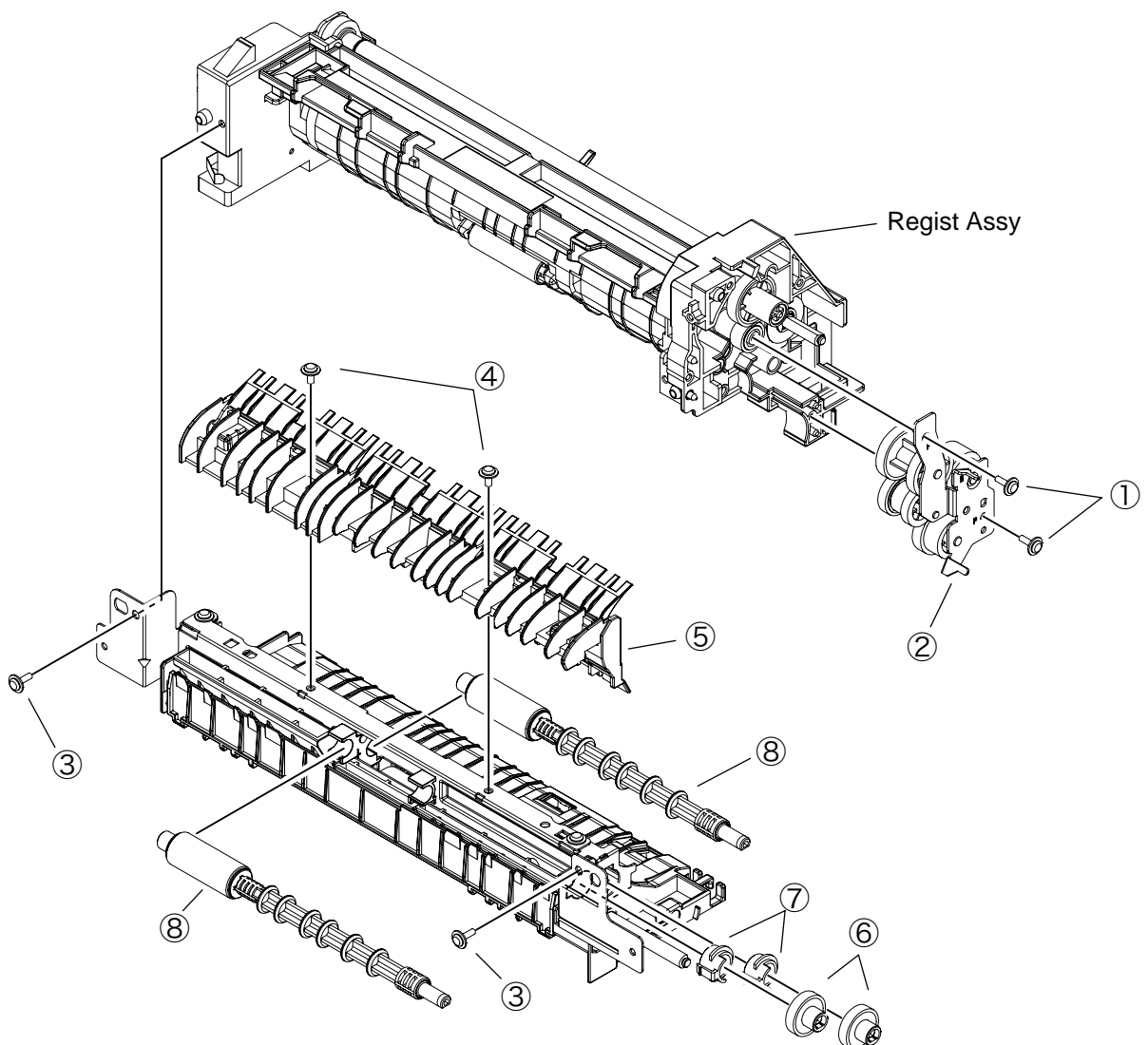

### 3.3.25 Lever In Sensor / Lever WR Sensor / /Photo Interrupter

- (1) Separate the Front Assy. (Refer to 3.3.20)
- (2) Separate the Roller-Pressure and Roller Regist. (Refer to 3.3.23)
- (3) Remove the two screws (Black) ①. Remove the Holder-Sensor ②.
- (4) Remove the Lever-In-Sensor ③. Remove the Spring-Sensor ④.
- (5) Remove the Lever-WR-Sensor ⑤. Remove the Spring-Sensor ⑥.
- (6) Remove the two Photo Interrupter ⑦.
- (7) Installing is performed by the inverse procedure with removing.

(Note on removing / installing)

1. Beware of not to touch the DC motor inattentively (Do not rotate motor).
2. Make sure that the latch B of Holder-Sensor ② has engaged the latch A of the Front

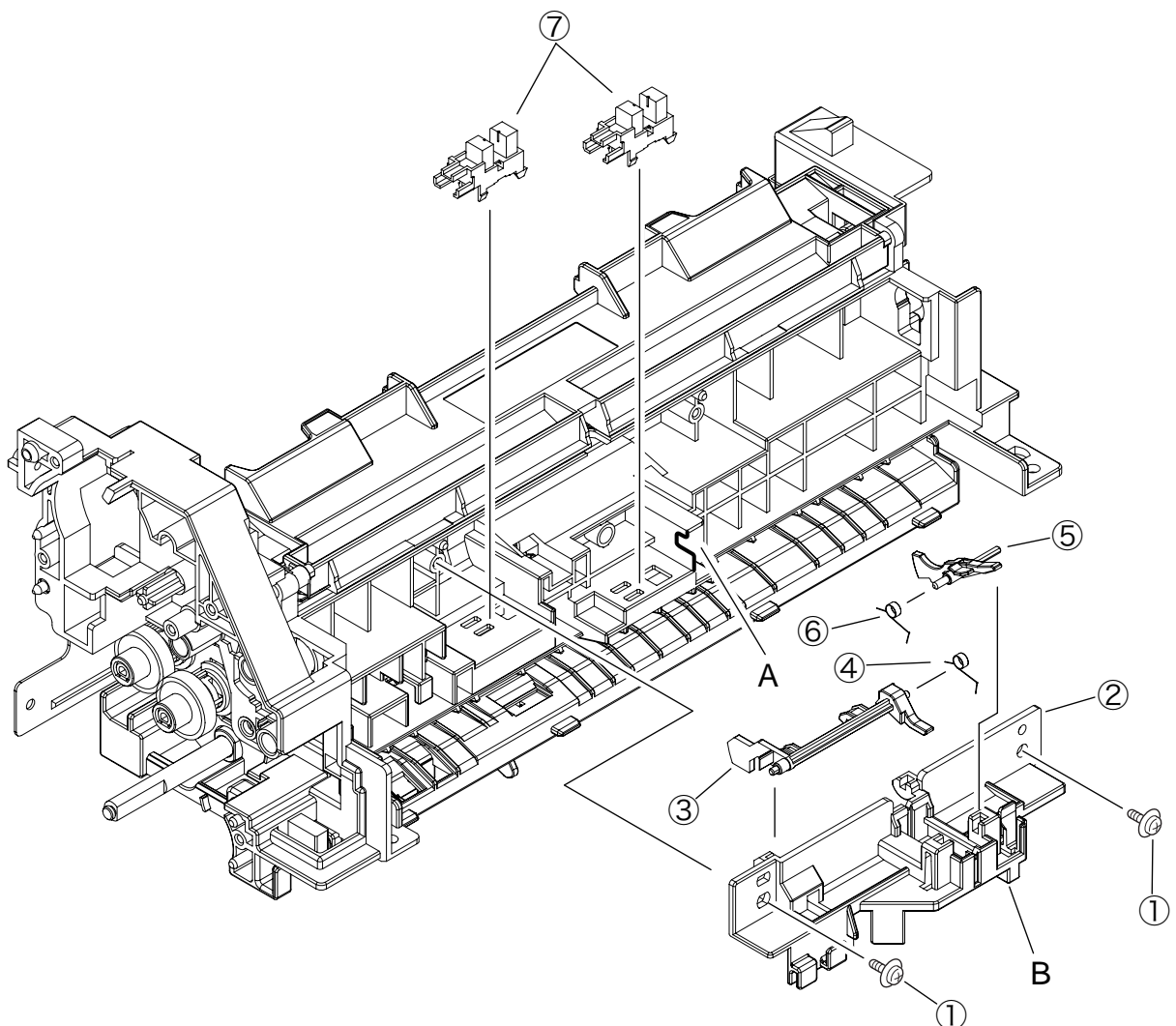

### 3.3.26 Paper feeding roller (Roller-Pick-Up, Roller-Feed-NOW, Roller-Assy-MPT)

- In the case of Tray 1

- (1) Turn off the printer and pull out the paper cassette tray.
- (2) Remove the feed roller ① as pushing its tab outward.

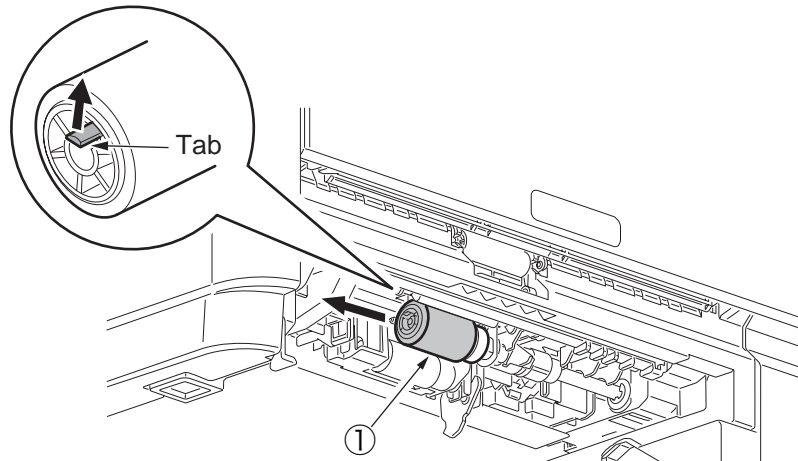

- (3) As pushing the tab downward, open the cover (black) that is on the left of the feed roller ②.
- (4) Pull out the feed roller ② downward.
- (5) Installing is performed by the inverse procedure with removing.

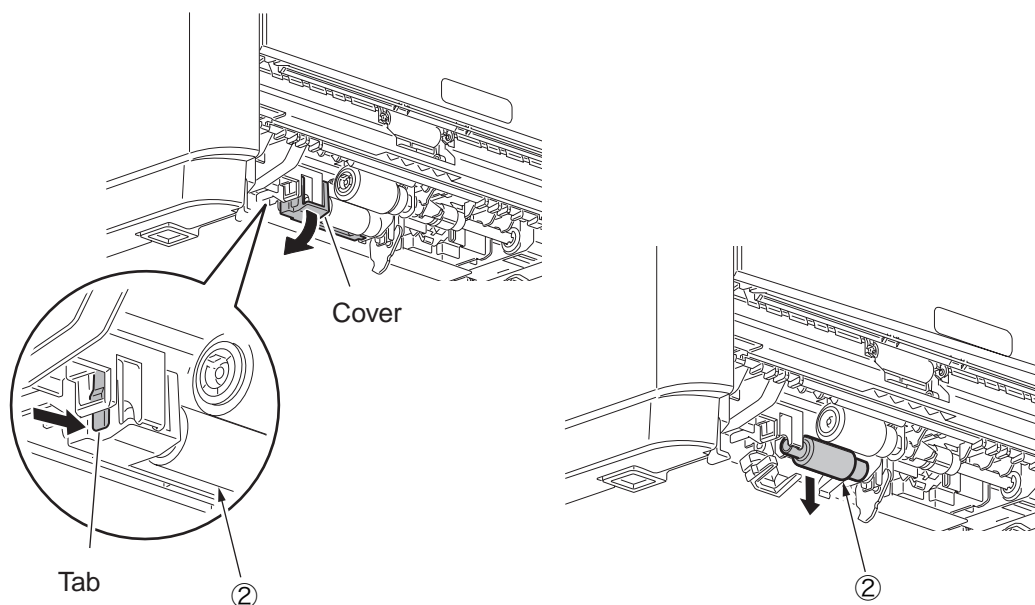

(Note on removing / installing)

1. To install the feed roller (with no gear: Roller-Feed-NOW) ①, keep pushing it until it clicks into place and is fixed to the shaft.
2. To install the feed roller (with a gear: Roller-Pick-Up) ②, keep pushing the cover until the tab of the cover clicks into place.

- In the case of Multi-purpose Tray ( B431dn)
  - (1) Turn off the printer.
  - (2) Open the multipurpose tray and the paper support.
  - (3) Open the feed roller cover by pushing its tab to the right.
  - (4) Remove the feed roller ① by rotating it toward you.
  - (5) Installing is performed by the inverse procedure with removing.

(Note on removing / installing)

1. To install the feed roller (Roller-Assy-MPT) ①, keep pushing the cover until the tab of the cover clicks into place.

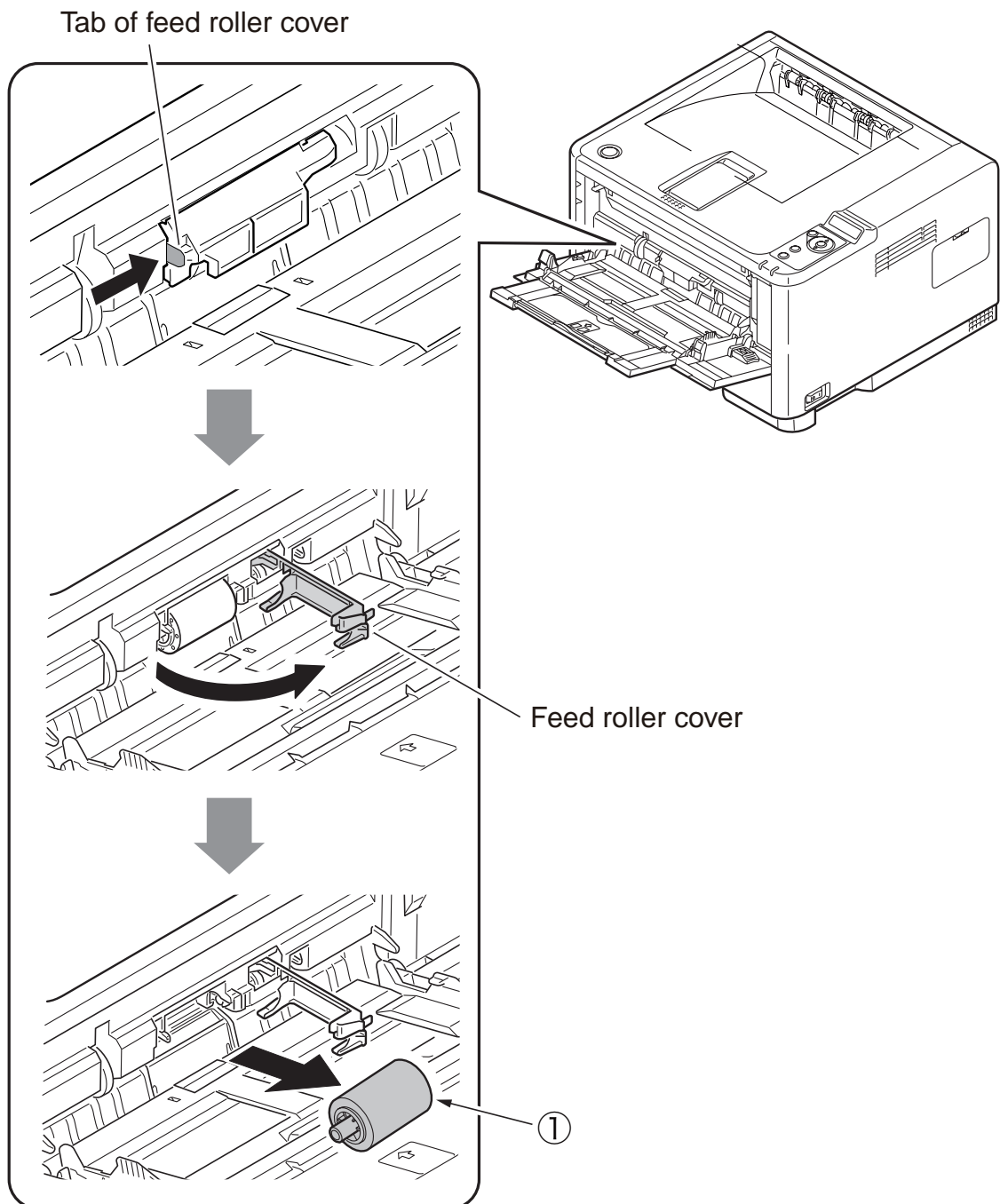

### 3.3.27 Frame-Assy-Retard , Spring-Retard

- (1) Remove the cassette.
- (2) Open the Retard-Cover by pushing two tabs in the directions of the arrows.
- (3) Remove Frame-Assy-Retard ① by pushing it in the direction of the arrow.  
(Spring-Retard ② is removed together.)
- (4) Installing is performed by the inverse procedure with removing.

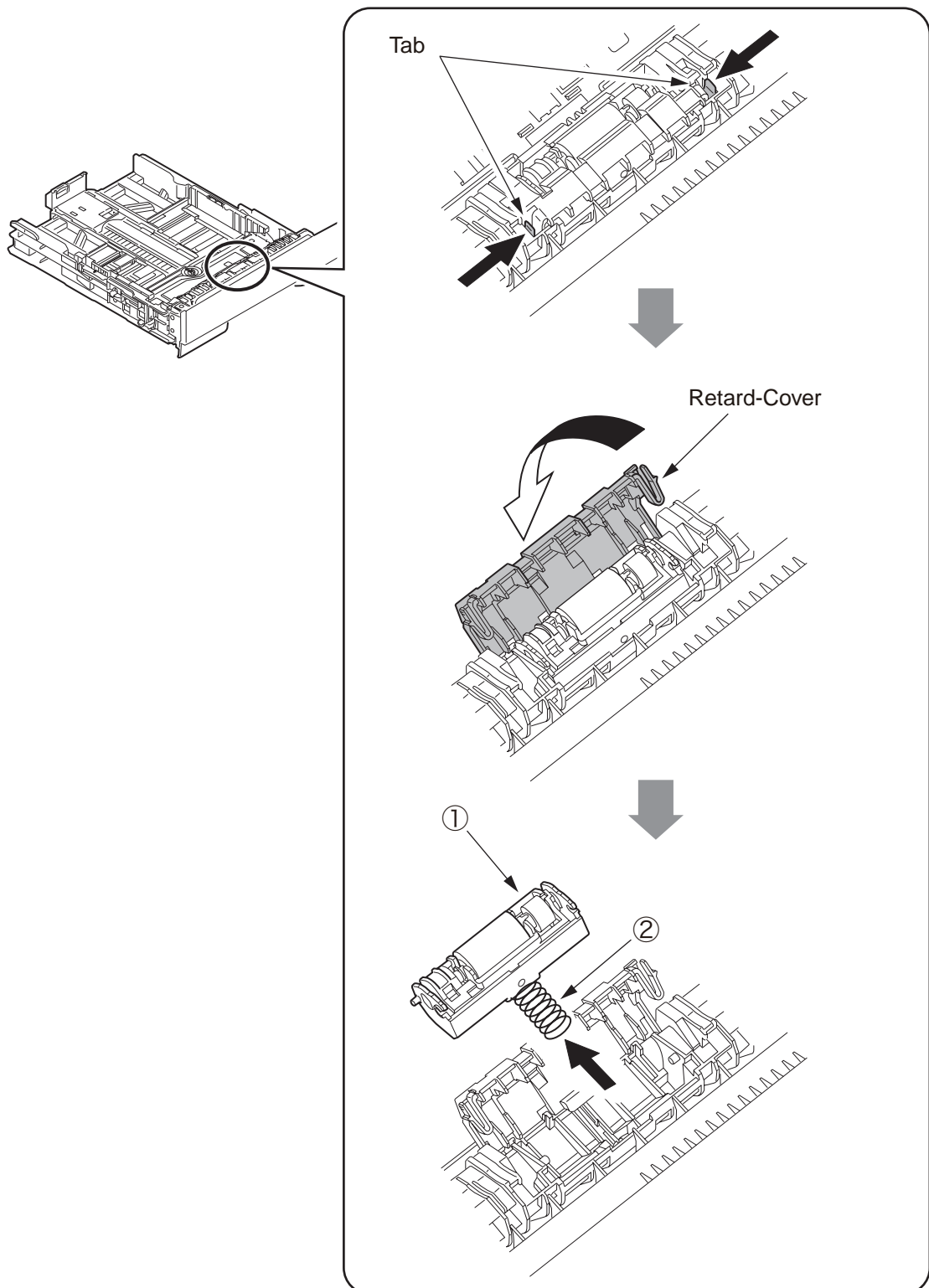

### 3.4 Lubricating points

This subsection indicates the lubricating points of the printer. Conversely, it means that any other parts than the specified lubricating points must not be lubricated.

There is no need to lubricate in the midst of a disassembling job. However, if lubricating oil has been wiped off, supply the specified oil.

#### Lubricating work

(1) Symbols and names of oils

EM-30LP : MOLYKOTE EM-30LP

Tetra : Tetra C-9310 or C-5005

(2) Boundary samples of grease

Class	S	A	B	C	D	E	F
Amount of grease(cc)	0.0005	0.003	0.005	0.01	0.03	0.05	0.1
W(mm)	1.24	2.25	2.67	3.37	4.86	5.76	7.26
Sample	•	•	•	•	•	•	•



① Plate-Assy-Side-L

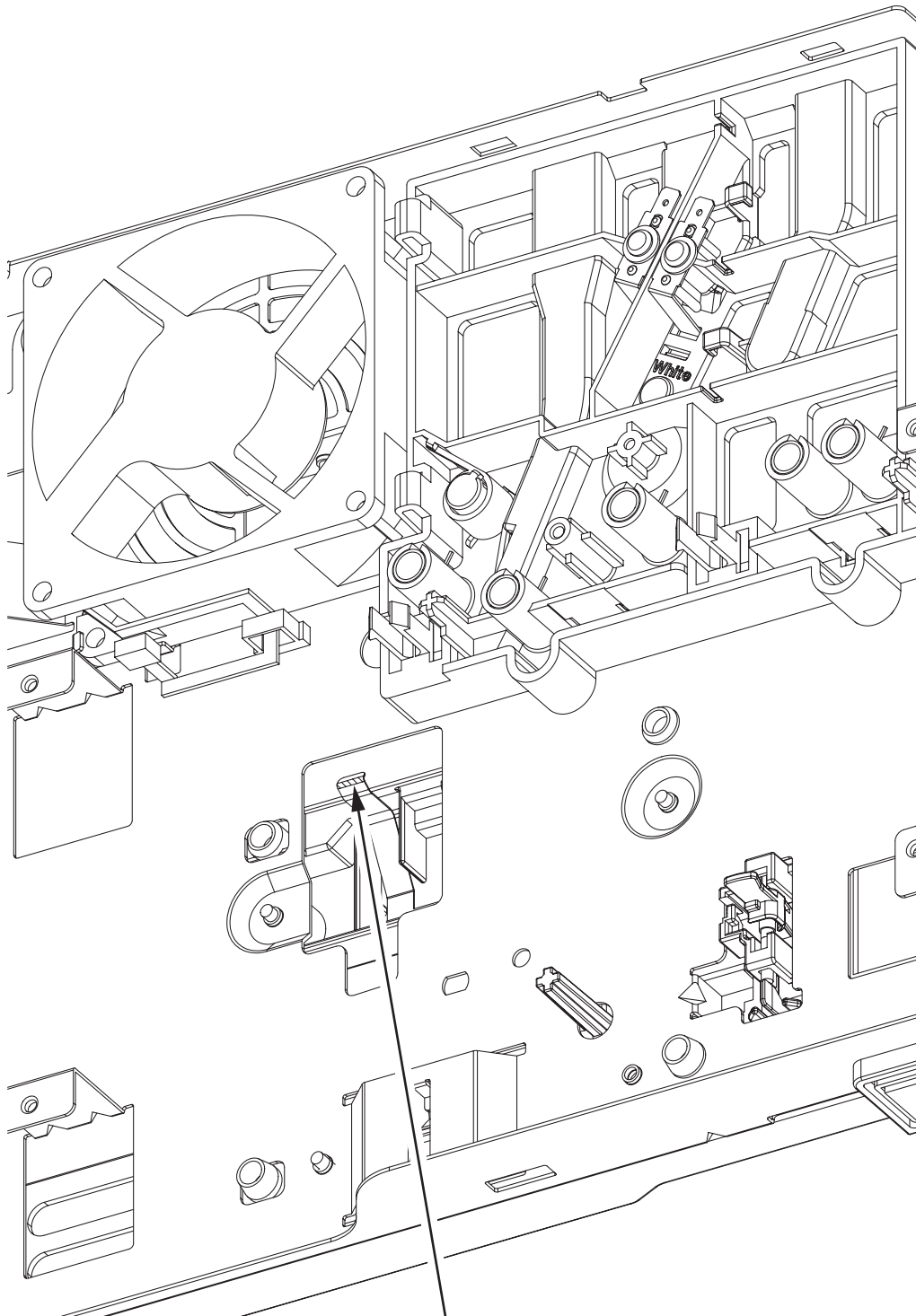

C-9310 or C-5005 Class A  
Apply a normal amount of Tetra (C-9310 or C-5005)  
to the hatched areas.( Contact surface )



②-1 Plate-Assy-Side-R

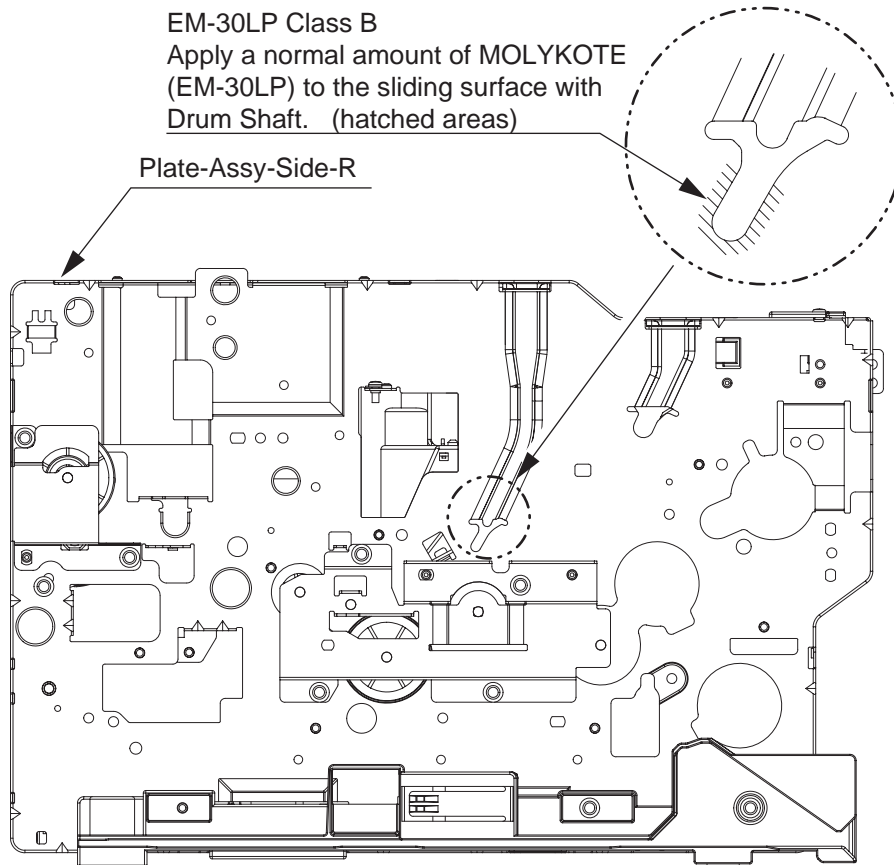

②-2 Plate-Assy-Side-R

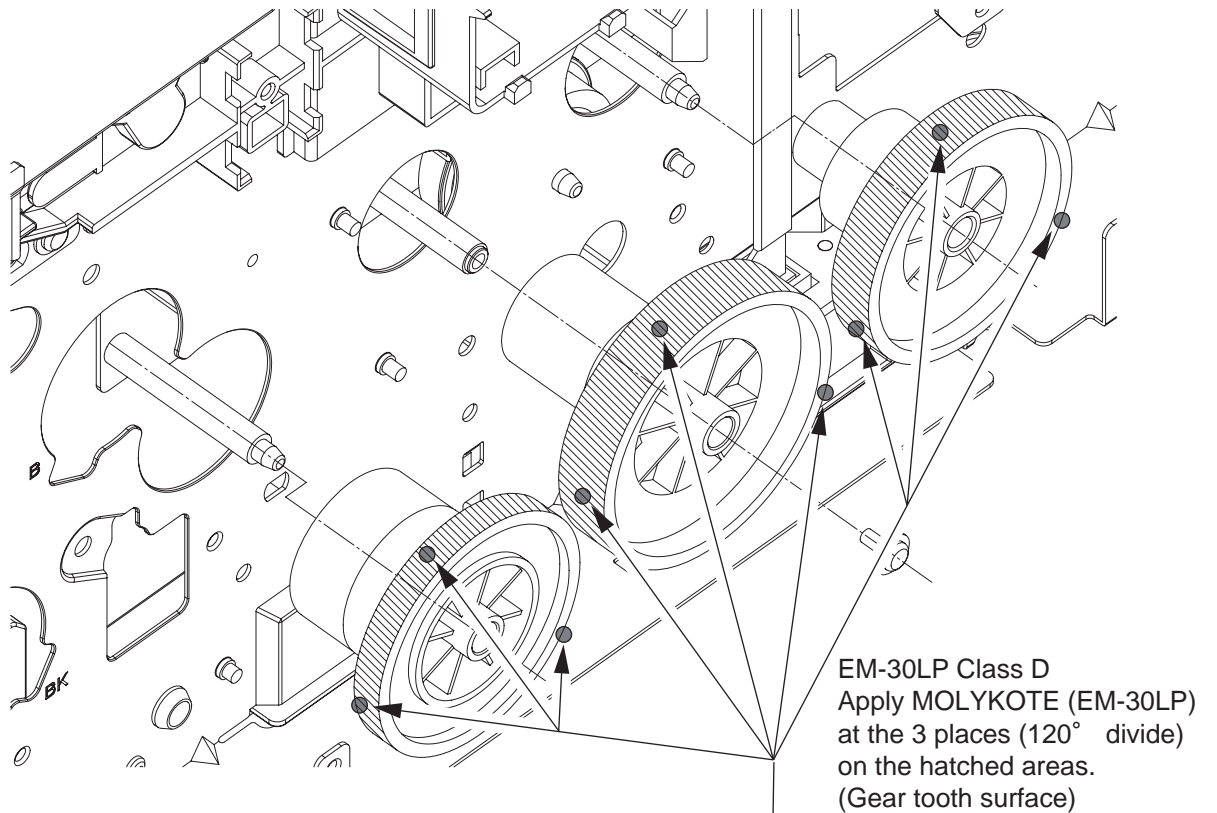

②-3 Plate-Assy-Side-R

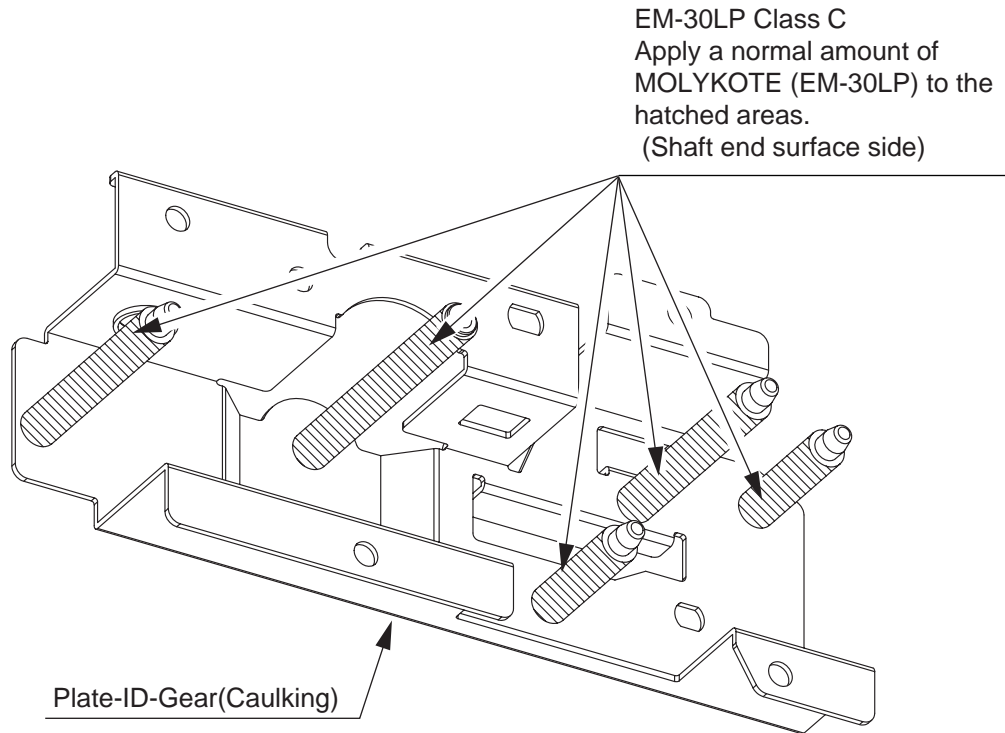

②-4 Plate-Assy-Side-R

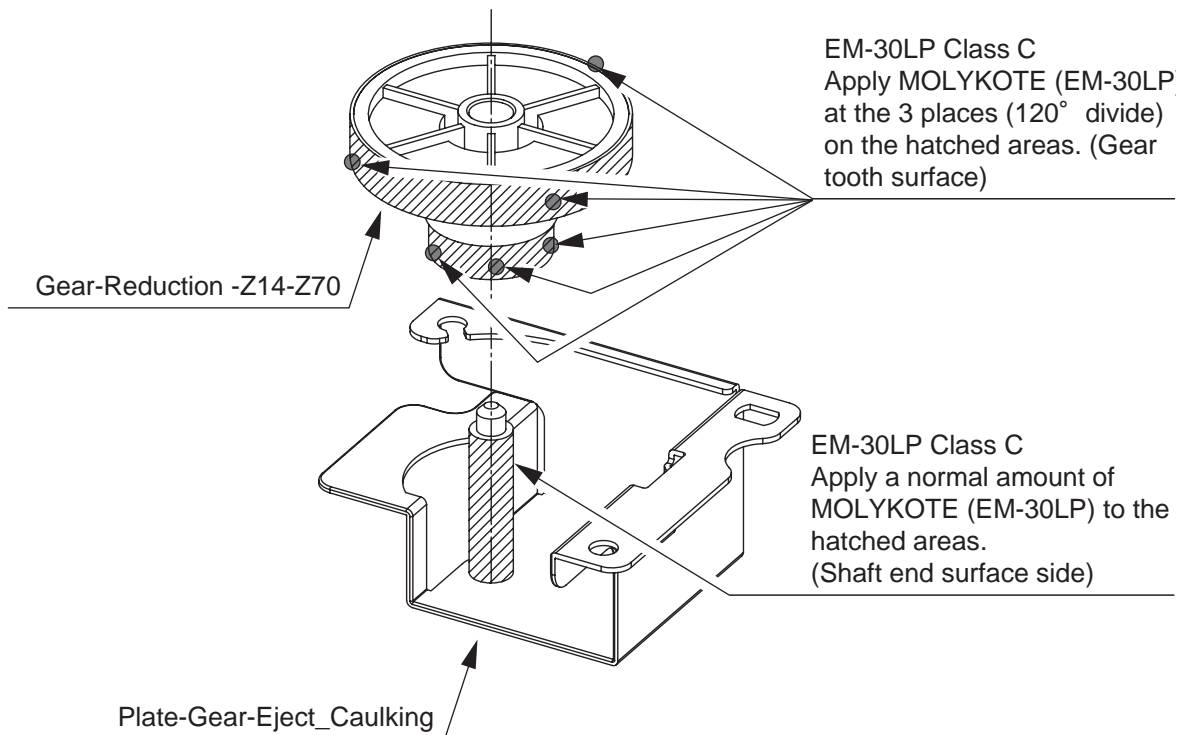

③ Frame-Assy-Hopping

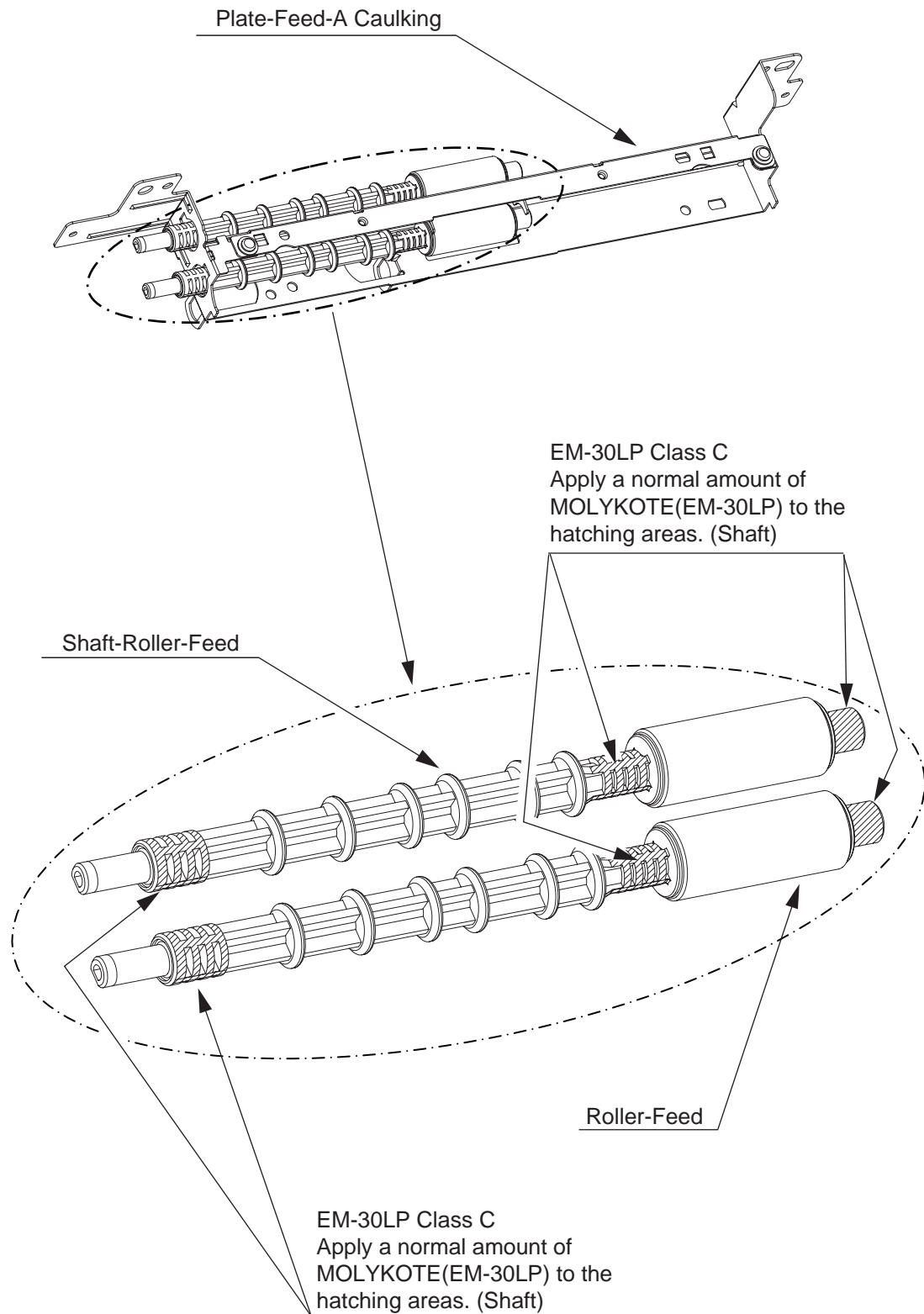

④-1 Frame Assy-Regist

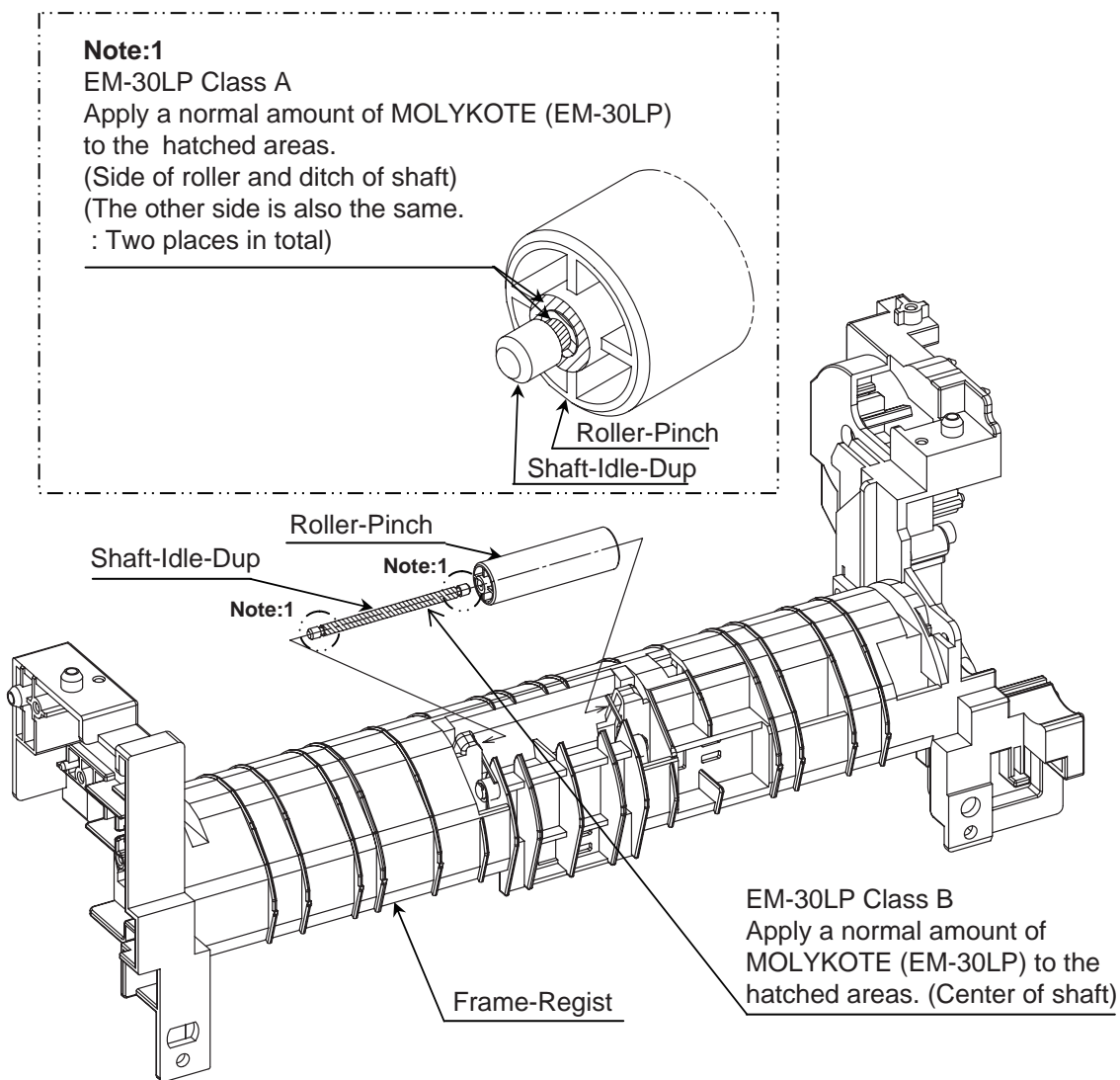

④-2 Frame Assy-Regist

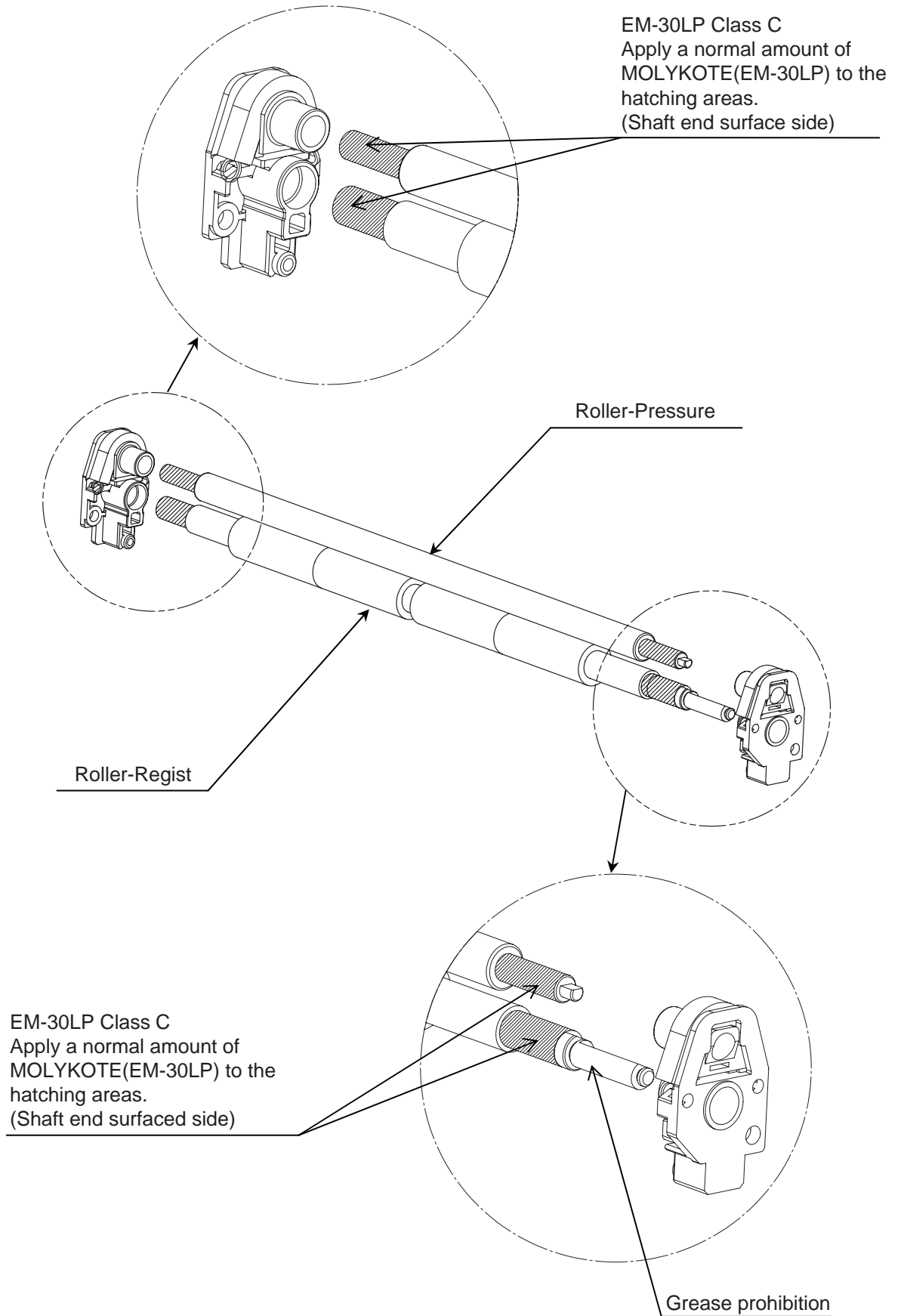

⑤-1 Front-Assy

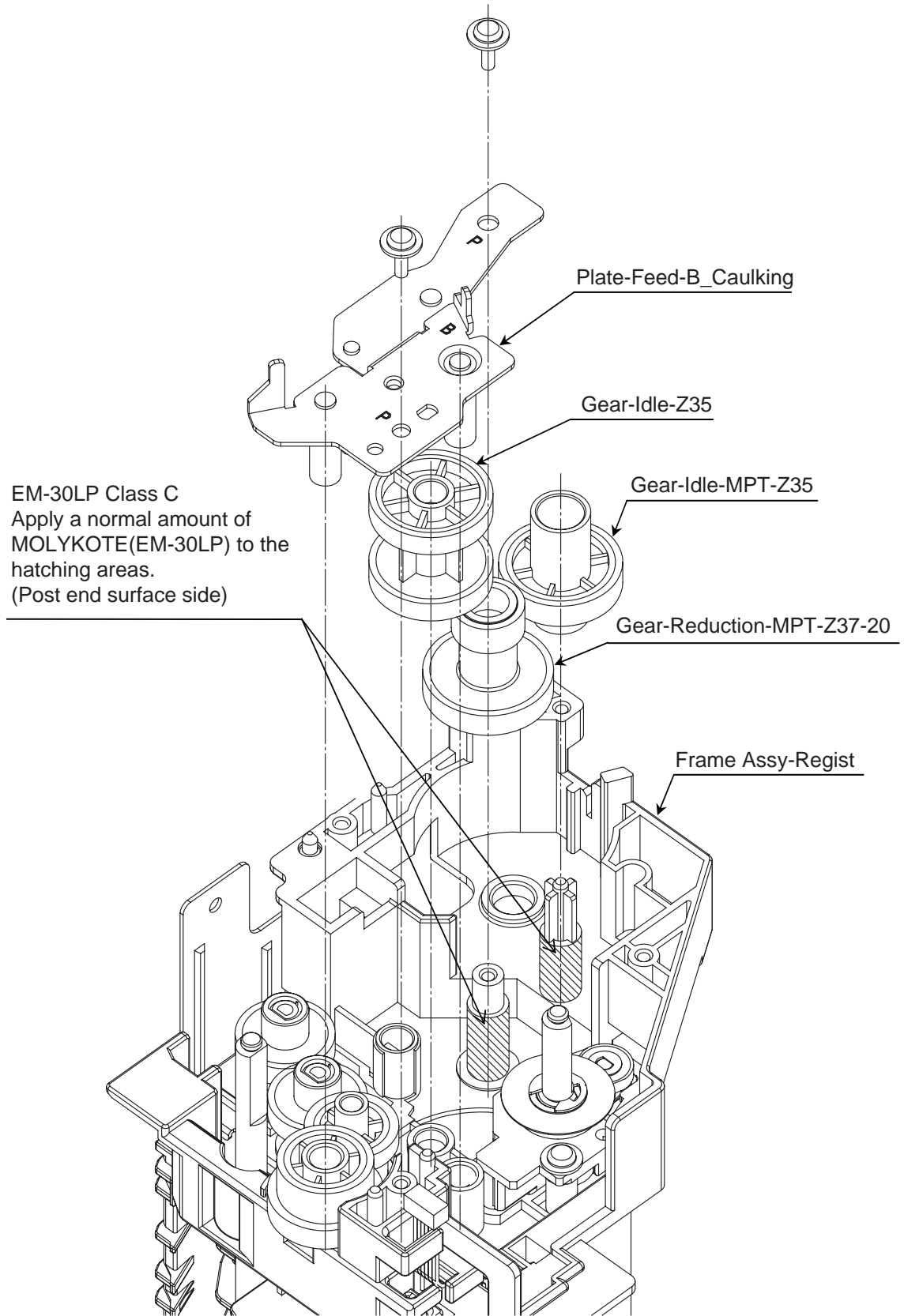

⑤-2 Front-Assy

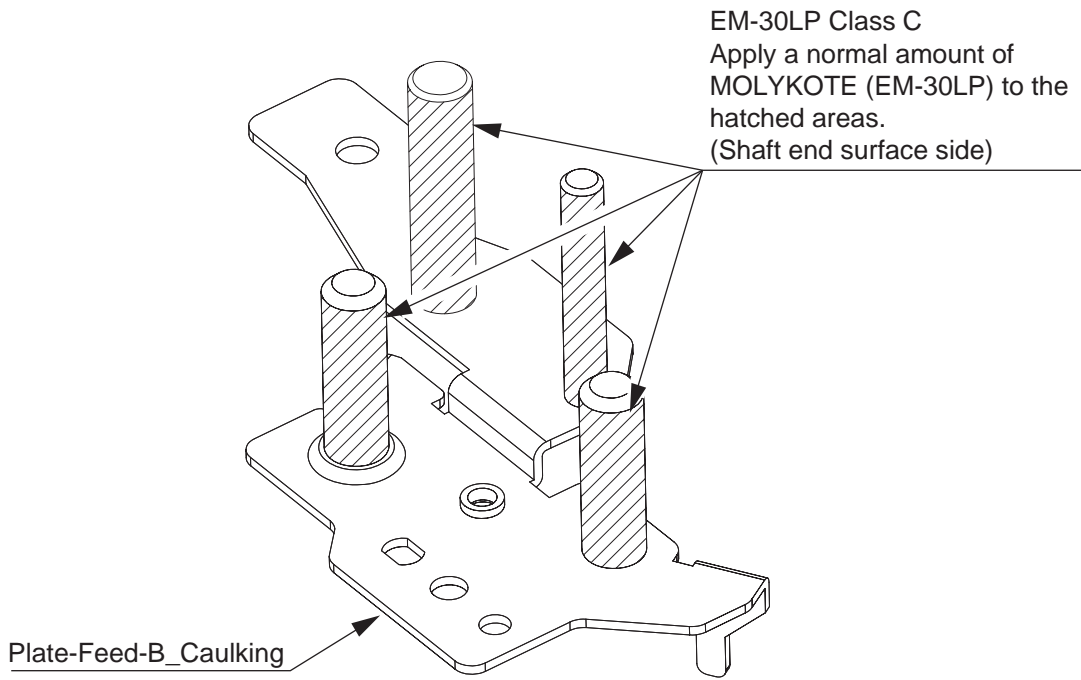

⑥ Frame-Assy-MPT / Frame-Assy-Manual

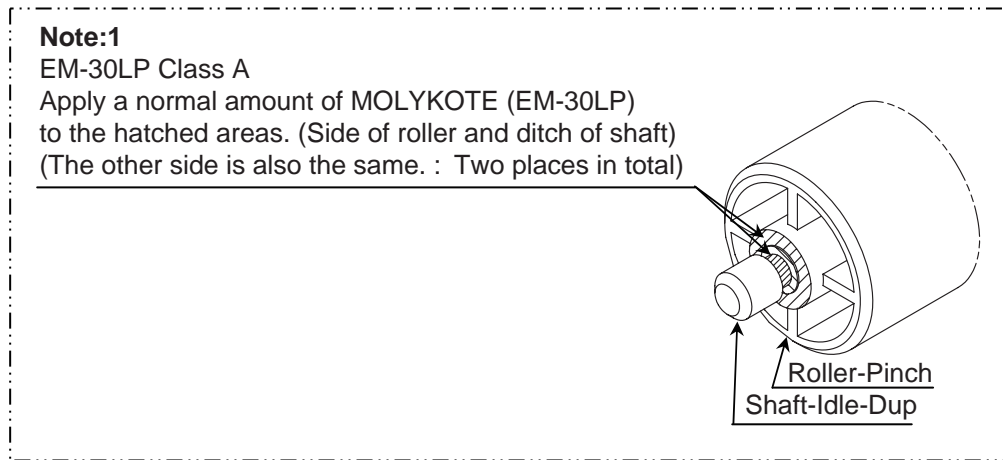

EM-30LP Class B  
Apply a normal amount of  
MOLYKOTE (EM-30LP) to the  
hatched areas.  
(Center of shaft)

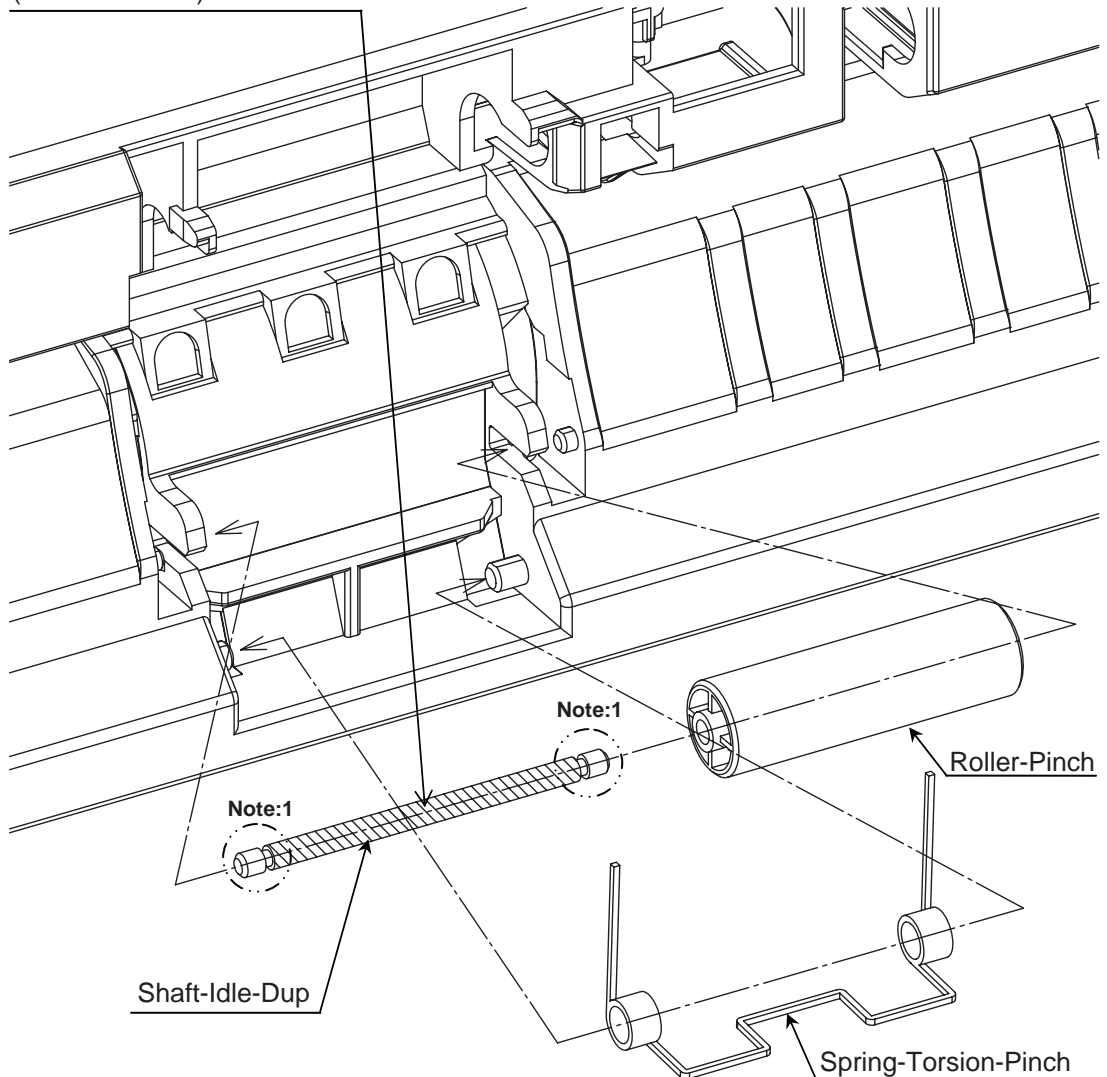



⑦-1 Guide-Assy –Eject-U

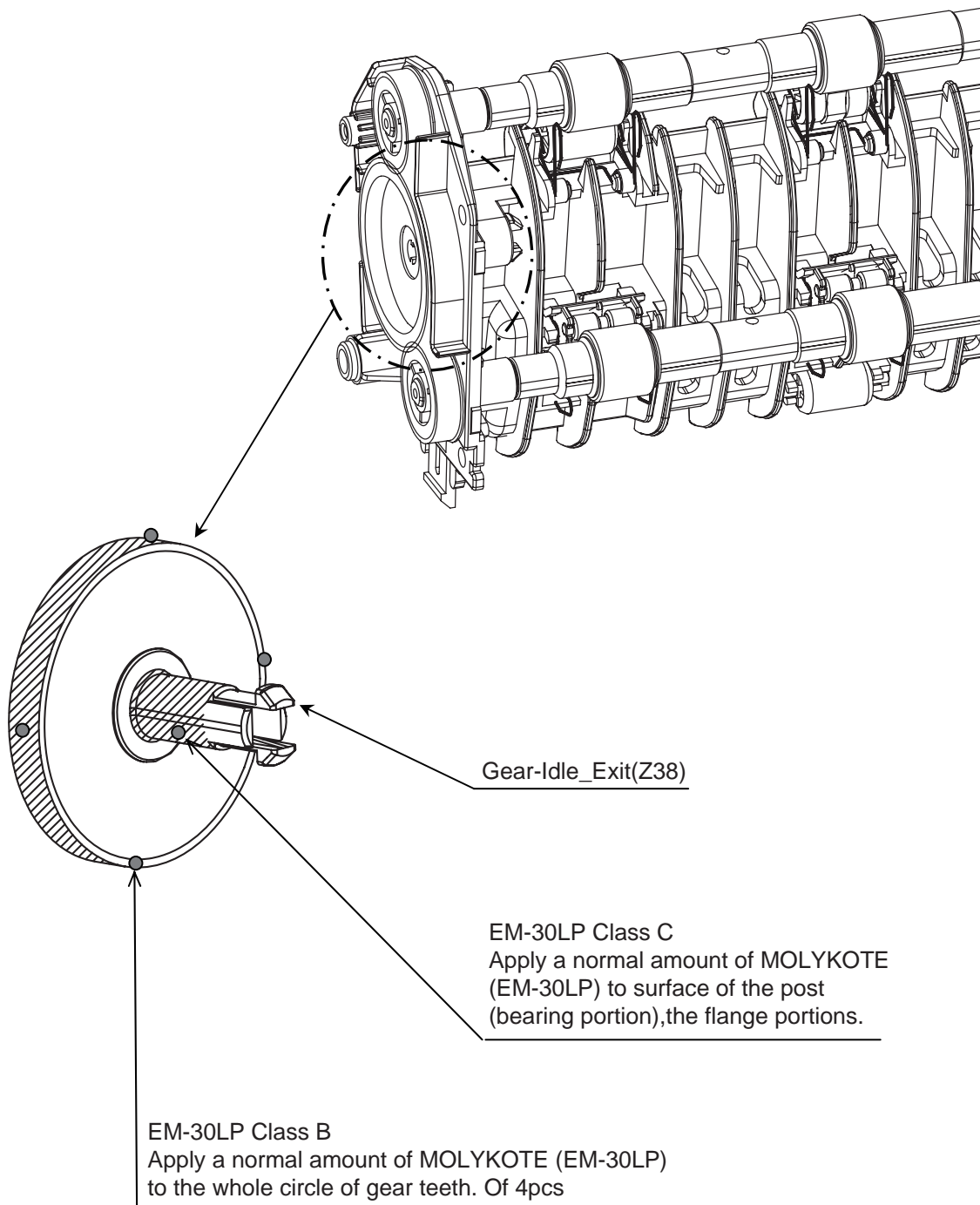

⑦-2 Guide-Assy -Eject-U

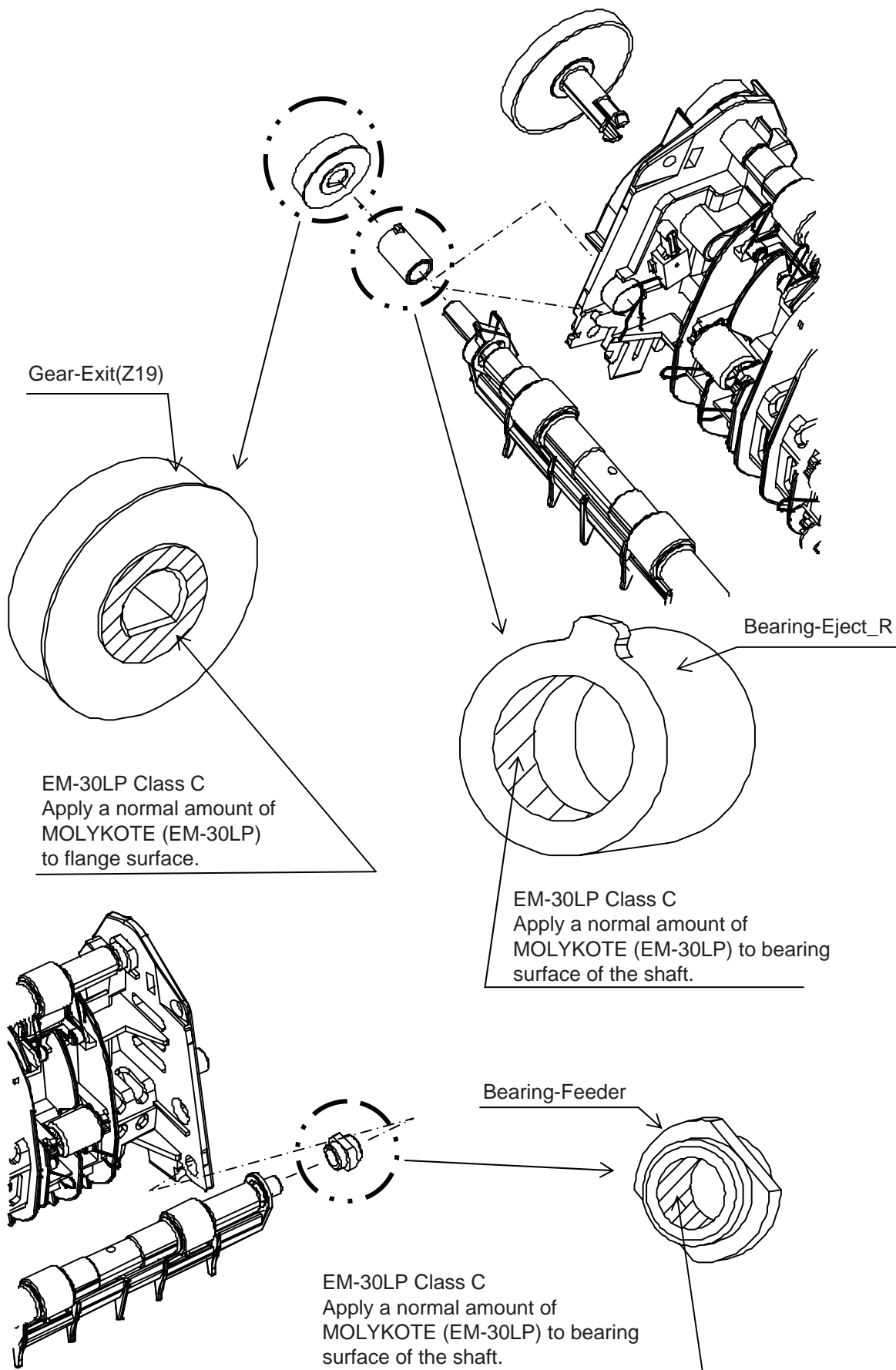

Note1) Please wipe the amount that grease began to see the sliding area off.

⑧-1 Frame-Assy-TR

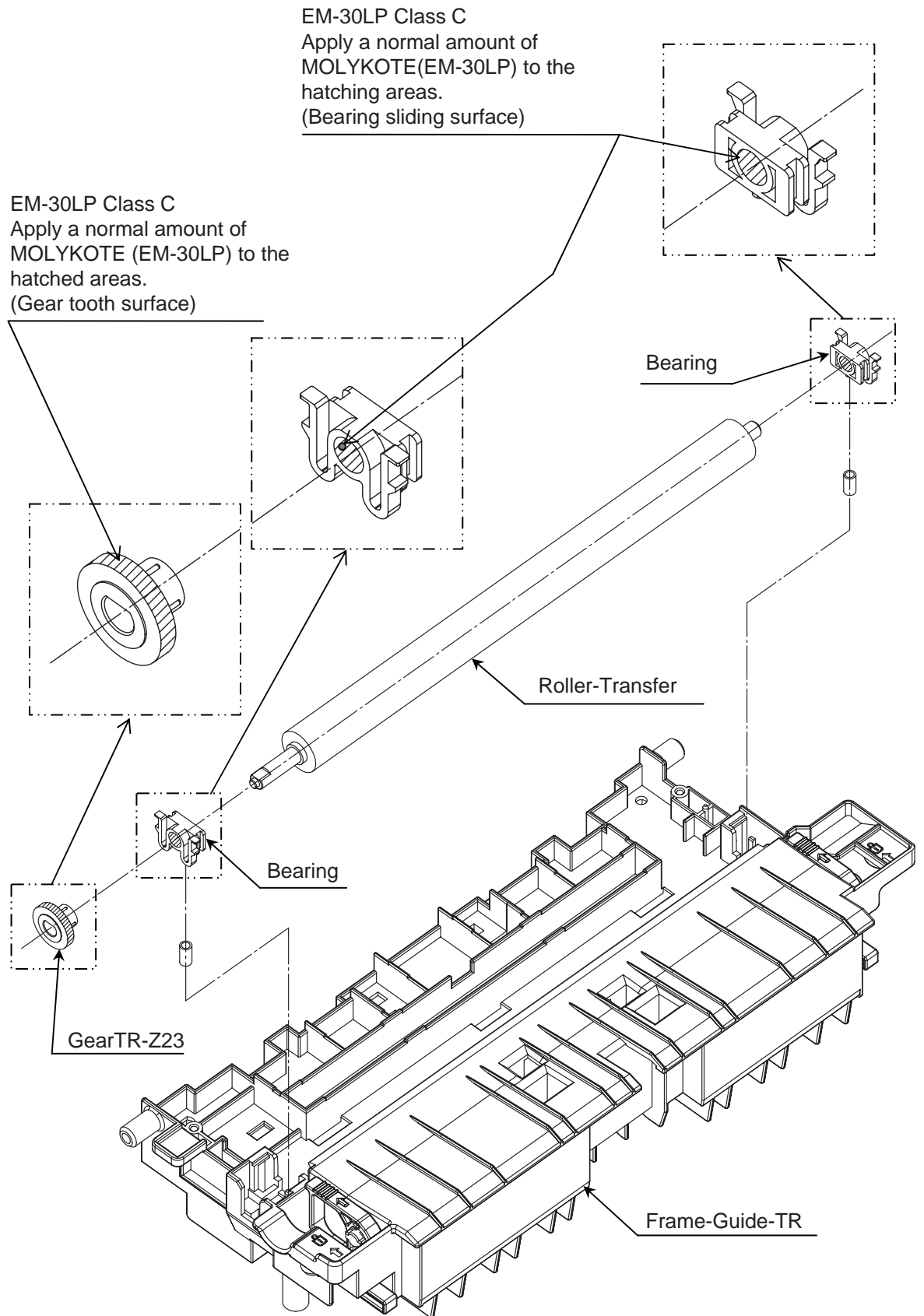

⑧-2 Frame-Assy-TR

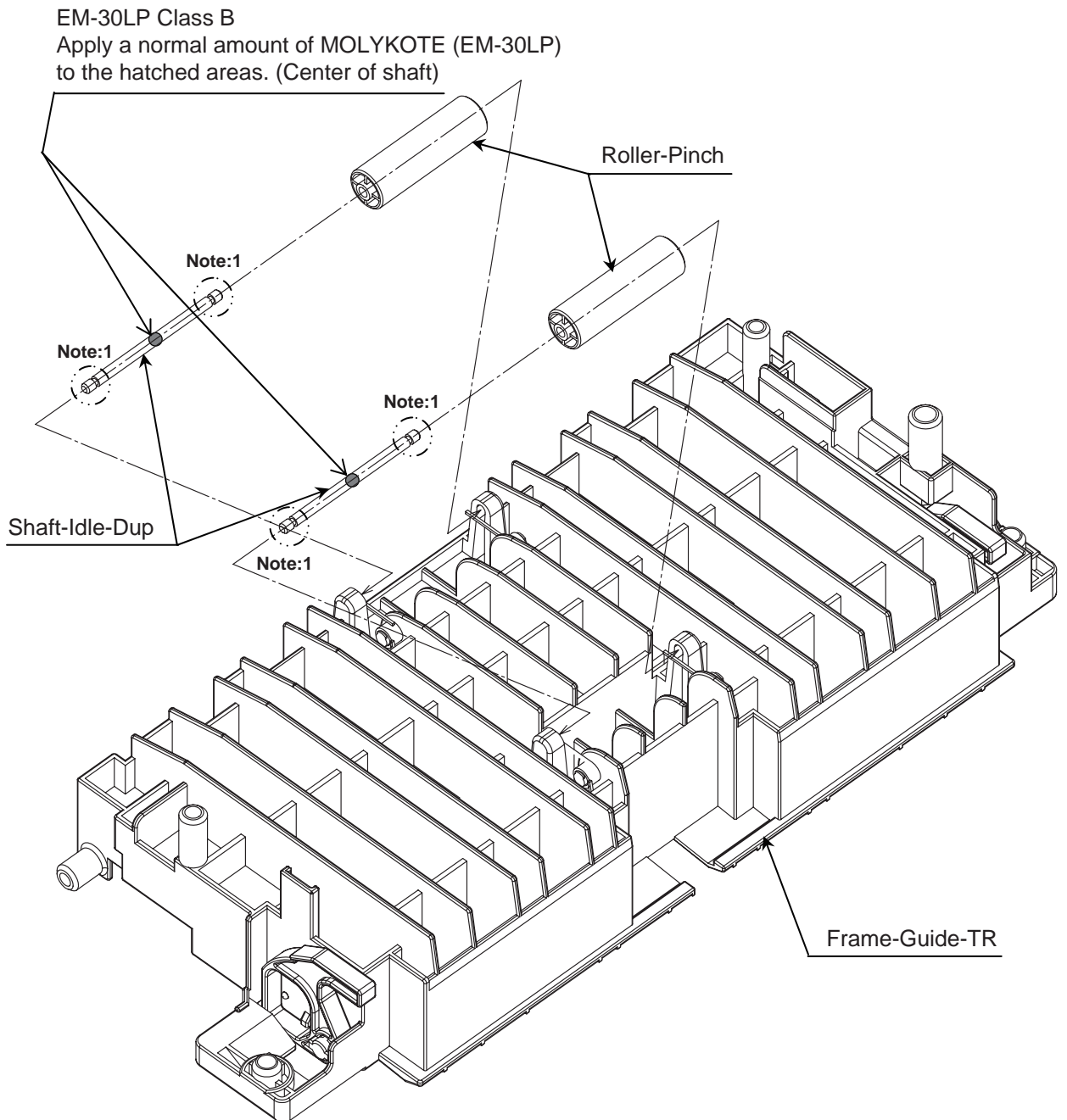
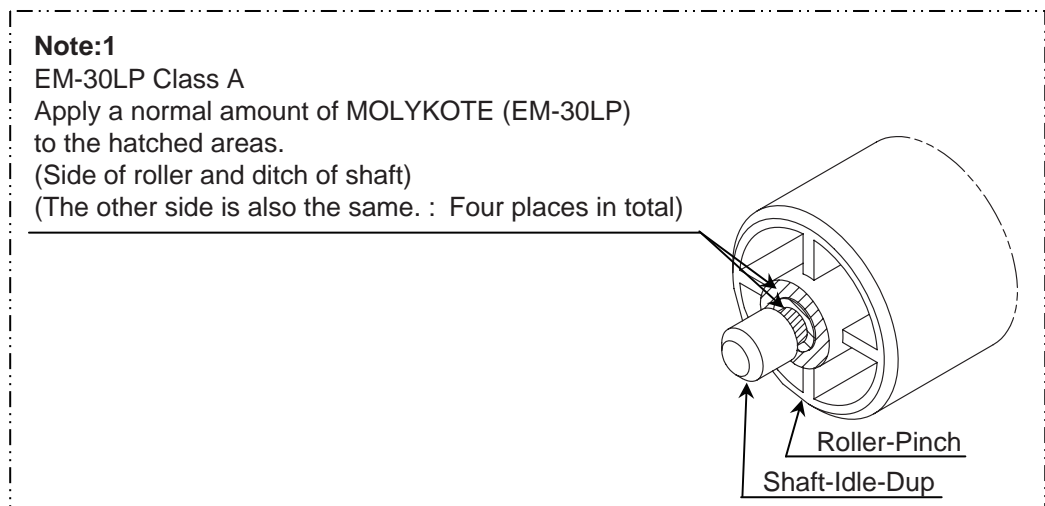

⑧-3 Frame-Assy-TR

C-9310 or C-5005 Class A  
Apply a normal amount of Tetra(C-9310 or C-5005)  
to the hatched areas. (Contact surface)

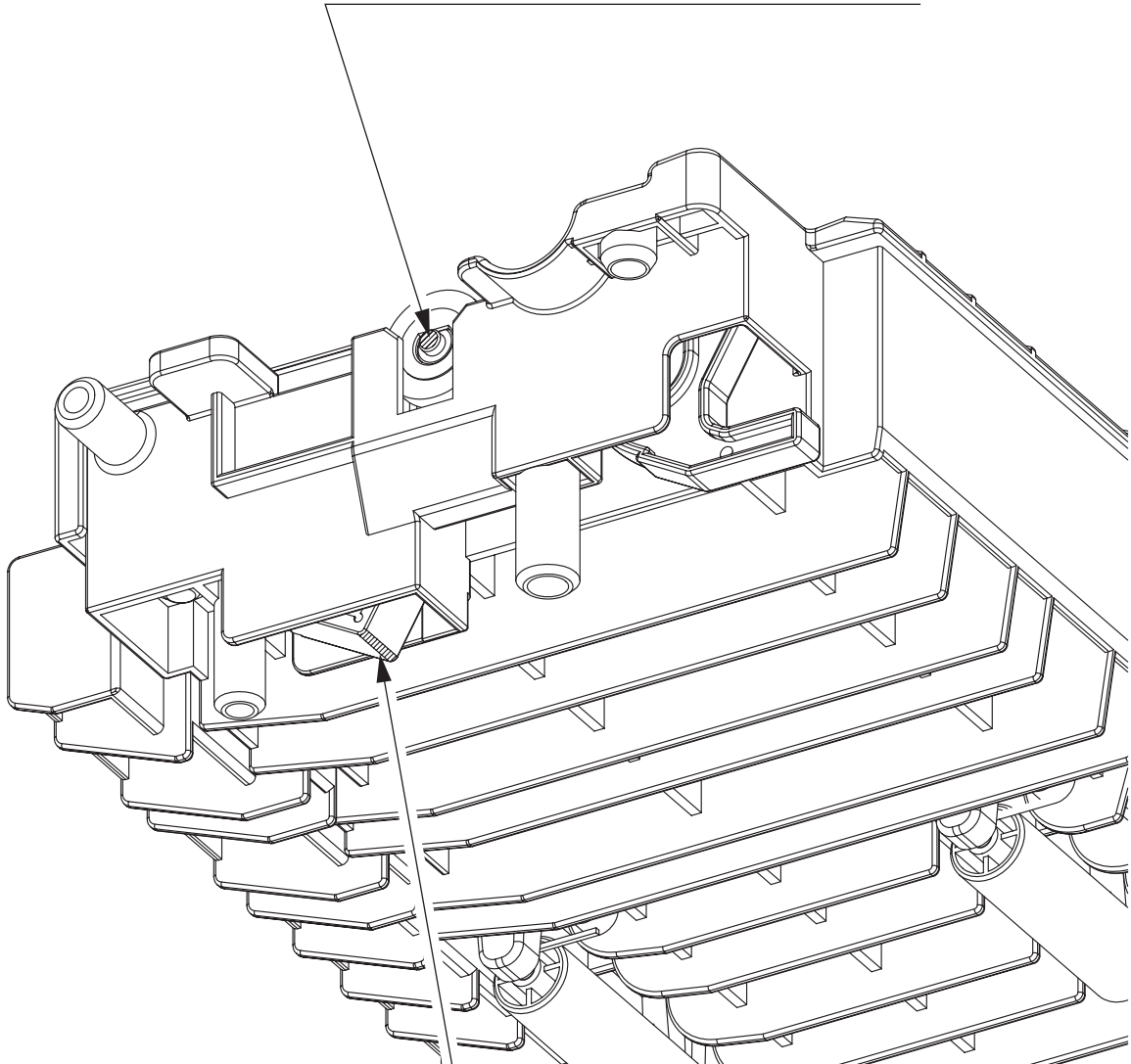

C-9310 or C-5005 Class A  
Apply a normal amount of Tetra(C-9310 or C-5005)  
to the hatched areas.(Contact surface)

⑨ Duplex-Assy

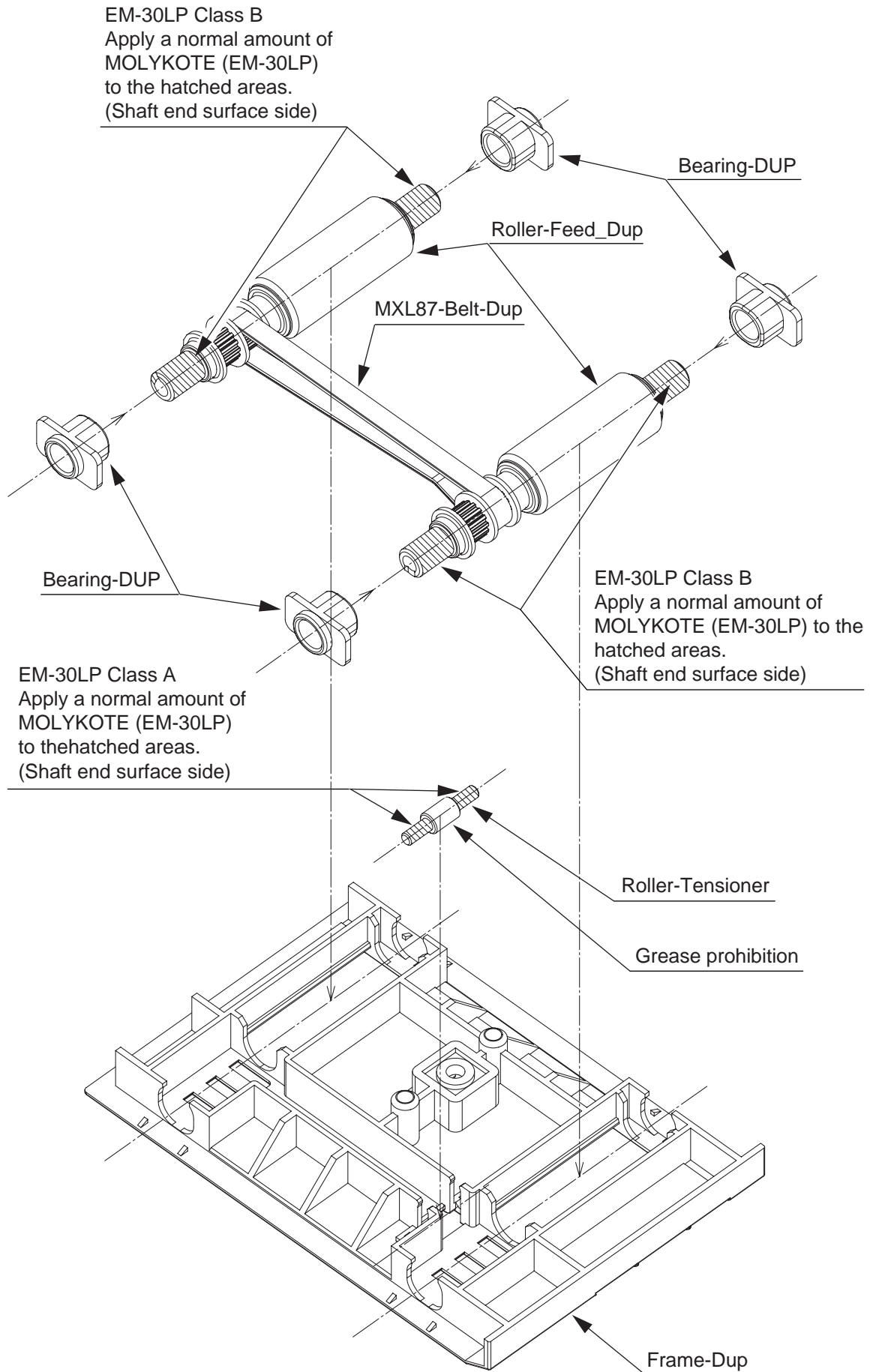

⑩ Fuser-Assy

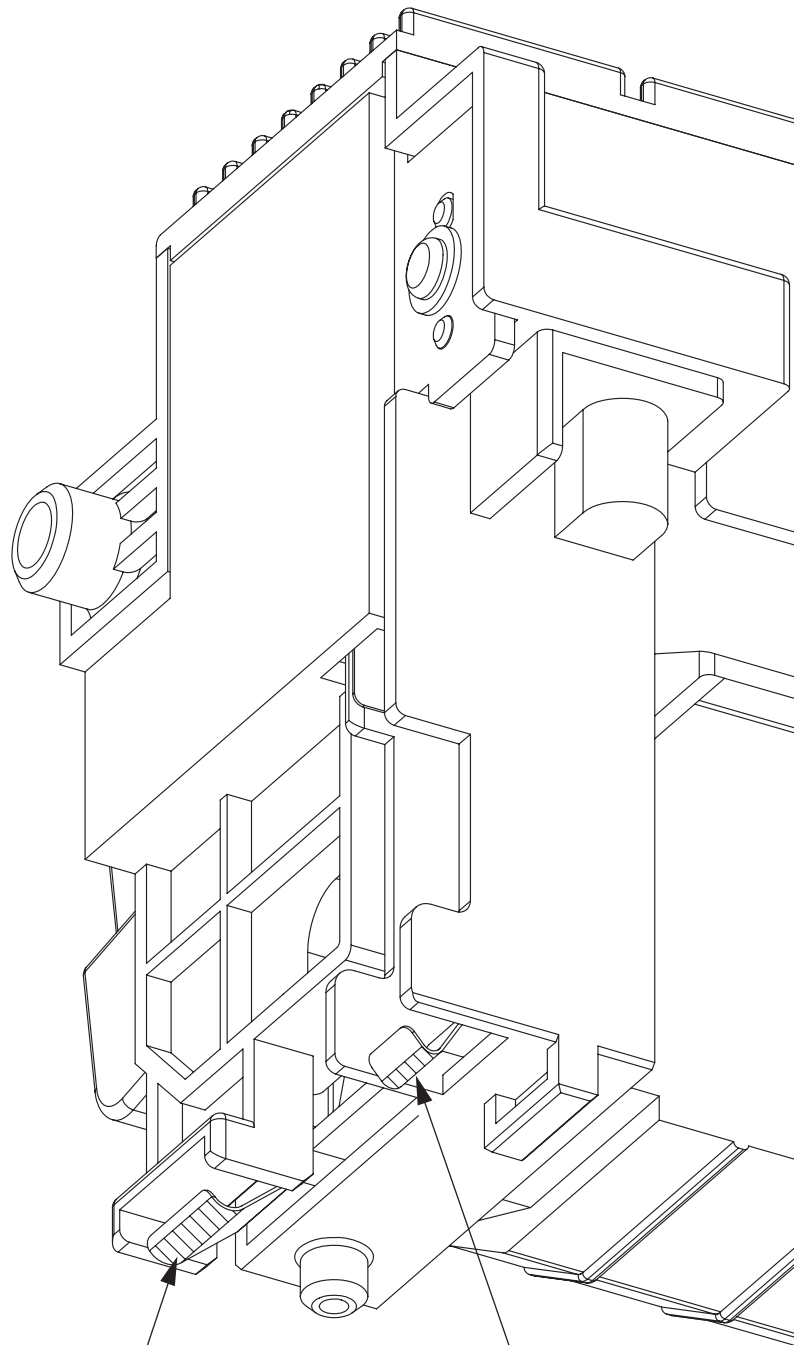

C-9310 or C-5005 Class A  
Apply a normal amount of  
Tetra(C-9310 or C-5005)  
to the hatched areas.  
(Contact surface)

## 4. ADJUSTMENT

This chapter provides explains relating to the adjustment that is necessary while replacing part. Adjustment is performed by modifying the value of parameter that is set on the EEPROM of main PCB board. Parameter can be set by key operation that is from the operator panel. There are 3 kinds of maintenance mode (menu) on this printer. While replacing part it is need to choose one of the mode.

### 4.1 Category and function of maintenance mode

- Maintenance mode can be divided into User maintenance mode that is released to user, Engine Maintenance Mode and System Maintenance Mode that are not released to user but for the only use of maintenance personnel.
- To view each category, push the button of "MENU Δ" and "MENU ▽". After the screen displays the last category, the display returns to the first category..
- If want the displayed function to be effective, push the "OK" button.
- For terminating the mode that is in category displaying, push the key of "ON LINE" and return to operation mode.

#### 4.1.1 User maintenance mode (Administrator Menu)

To open Administrator Menu, switch the power on while holding down the "OK" button.

After the category has been displayed, let go of the button "OK".

Administrator Menu has the following function.

- Note!**
- This mode is only B431.
  - Refer to "Configuration Tool" for B411.
  - (\*1) cannot be set by "Configuration Tool".

Category	Operation panel display		Default value	Function * Only English is supported for panel display
	Setting item (Upper case)	Setting item (Lower case)		
OP MENU	ALL CATEGORY	ENABLE DISABLE	*	Sets category ALL Enable/Disable of user menu. If set to invalidation, user menu wont to be display. The following setting item is not displayed if it is invalid. When doing panel lock, must invalidate this menu.
	INFORMATION MENU	ENABLE DISABLE	*	Setting validation / Invalidation of INFORMATION MENU category. If invalidate it the INFORMATION MENU category of user menu is not displayed.
	SHUTDOWN MENU	ENABLE DISABLE	*	Set Category SHUTDOWN MENU Enable/Disable. Set to Disable, Category SHUTDOWN MENU of user menu is not displayed.
	PRINT MENU	ENABLE DISABLE	*	Set Category PRINT MENU Enable/Disable. Set to Disable, Category PRINT MENU of user menu is not displayed.
	MEDIA MENU	ENABLE DISABLE	*	Set Category MEDIA MENU Enable/Disable. Set to Disable, Category MEDIA MENU of user menu is not displayed.
	SYS CONFIG MENU	ENABLE DISABLE	*	Set Category SYSTEM CONFIG MENU Enable/Disable. Set to Disable, Category SYSTEM CONFIG MENU of user menu is not displayed.
	PCL EMULATION	ENABLE DISABLE	*	Set Category PCL EMULATION MENU Enable/Disable. Set to Disable, Category PCL EMULATION MENU of user menu is not displayed.
	PPR EMULATION	ENABLE DISABLE	*	Set Category PPR EMULATION MENU Enable/Disable. Set to Disable, Category PPR EMULATION MENU of user menu is not displayed. Except Japan Oriented. [Display Condition] "SYSTEM MAINTENANCE"- "PERSONALITY"- "IBM PPR III XL" is Enable.



Category	Operation panel display		Default value	Function * Only English is supported for panel display
	Setting item (Upper case)	Setting item (Lower case)		
OP MENU	FX EMULATION	ENABLE DISABLE	*	Set Category FX EMULATION MENU Enable/Disable. Set to Disable, Category FX EMULATION MENU of user menu is not displayed. Except Japan Oriented. [Display Condition] "SYSTEM MAINTENANCE"- "PERSONALITY"- "EPSON FX" is Enable.
	ESC/P EMULATION	ENABLE DISABLE	*	Set Category ESC/P MENU Enable/Disable. Set to Disable, Category ESC/P MENU of user menu is not displayed. Only displayed as Japan domestic oriented. [Display Condition] "SYSTEM MAINTENANCE"- "PERSONALITY"- "ESC/P" is Enable.
	PARALLEL MENU	ENABLE DISABLE	*	Set Category PARALLEL MENU Enable/Disable. Set to Disable, Category PARALLEL MENU of user menu is not displayed.
	USB MENU	ENABLE DISABLE	*	Set Category USB MENU Enable/Disable. Set to Disable, Category USB MENU of user menu is not displayed.
	NETWORK MENU	ENABLE DISABLE	*	Set Category NETWORK MENU Enable/Disable. Set to Disable, Category NETWORK MENU of user menu is not displayed. [Display Condition] NIC full assembled
	MEMORY MENU	ENABLE DISABLE	*	Set Category MEMORY MENU Enable/Disable. Set to Disable, Category MEMORY MENU OF user menu is not displayed.
	SYS ADJUST MENU	ENABLE DISABLE	*	Set Category SYS ADJUST MENU Enable/Disable. Set to Disable, Category SYS ADJUST MENU of user menu is not displayed.
	MAINTENANCE MENU	ENABLE DISABLE	*	Set Category MAINTENANCE MENU Enable/Disable. Set to Disable, Category MAINTENANCE MENU of user menu is not displayed.
	USAGE MENU	ENABLE DISABLE	*	Set Category USAGE MENU Enable/Disable. Set to Disable, Category USAGE MENU of user menu is not displayed.
	MENU LOCKOUT (*1)	ENABLE DISABLE	*	Set Function MENU LOCKOUT Enable/Disable. Set to Disable, Category PASSWORD, Category CHANGE PASSWORD of user menu is not displayed. The Initial Value of PASSWORD is "aaaa".
PANEL LOCKOUT (*1)	ENABLE DISABLE	*	Set Function PANEL LOCKOUT Enable/Disable. Set to Enable, on the panel only "ONLINE" switch is Enable, it is not able to display MENU.	
CONFIG MENU	NEARLIFE LED	ENABLE DISABLE	*	Set LED ILLUMINATION CONTROL at the occurrence of NEAR LIFE WARNING of toner and drum. When it is Enable, Attention LED illuminating. When it is Disable, Attention LED non-illuminating. Once it became life warning error, the status of temporary retrieving as the cover opening or closing (LIFE WARNING) is excluded.

Category	Operation panel display		Default value	Function * Only English is supported for panel display
	Setting item (Upper case)	Setting item (Lower case)		
FILE SYS MAINTE1 (*1)	FLASH INITIALIZE	EXECUTE	-	Initialize resident FLASH. Press Enter switch then the following confirming message is displayed. ARE YOU SURE? EXECUTE OR NOT? YES / NO YES / NO If NO is chosen, it returns to the previous menu display. If YES is chosen, it reboots automatically and executes the initialization of Flash Memory. [Display condition] "ADMIN MENU"- "FILE SYS MAINTE2"- "INITIAL LOCK" is NO.
FILE SYS MAINTE2 (*1)	INITIAL LOCK	YES NO	*	Do not allow to modify setting accompanied by the initialization of Block Device (FLASH). If set this menu to YES, item "ADMIN MENU", "FILE SYS MAINTE1" is not displayed on the operation panel. [Display condition] "PRINT STATISTICS"- "USAGE REPORT" of user menu is Disable.
LANGUAGE MENU	LANG INITIALIZE	EXECUTE	-	Initialize (Delete) LED message file that is loaded on FLASH. Press Enter switch then the following message is displayed. ARE YOU SURE? YES / NO If NO is selected, return to original MENU display. If YES is selected, immediately remove the MENU and starts to delete operation after reboot. Only support Multi-language model.
PS MENU (*1)	L1 TRAY	TYPE1 TYPE2	*	As setting TYPE 1, the selecting number of level 1 operator tray is enable from 1, yet it is from 0 as setting TYPE 2, Only B431 series is displayed.
SIDM MENU	SIDM MANUAL ID#	0 ~ 2 ~ 9	*J  *E	Set Pn specified by MANUAL in CSF CONTROL COMMAND OF MANUAL-1 ID No.FX/PPR/ESCP Emu(ESC EM Pn). Default value: Japan oriented is "0", Except Japan oriented is "2".
	SIDM MANUAL 2 ID#	0 ~ 3 ~ 9	*	Set Pn specified by MANUAL in CSF CONTROL COMMAND of MANUAL-2 ID No.FX/PPR/ESCP Emu(ESC EM Pn).
	SIDM MP TRAY ID#	0 ~ 4 ~ 9	*	Set Pn specified by TRAY0 (MP Tray) in CSF CONTROL COMMAND of MP Tray ID No. FX/PPR Emu (ESC EM Pn).
	SIDM TRAY1 ID#	0 1 ~ 9	*	Set Pn specified by TRAY 1 in CSF CONTROL COMMAND of Tray 1 ID No. FX/PPR/ESCP Emu (ESC EM Pn).
	SIDM TRAY2 ID#	0 ~ 2 ~ 5 ~ 9	*J  *E	Set Pn specified by TRAY 1 in CSF CONTROL COMMAND (ESC EM Pn) of Tray 2 ID No.FX/PPR/ESCP Emu. Default Value: Japan oriented is "2", Except Japan oriented is "5". [Display condition] Tray 2 implementation

• User maintenance mode menu chart

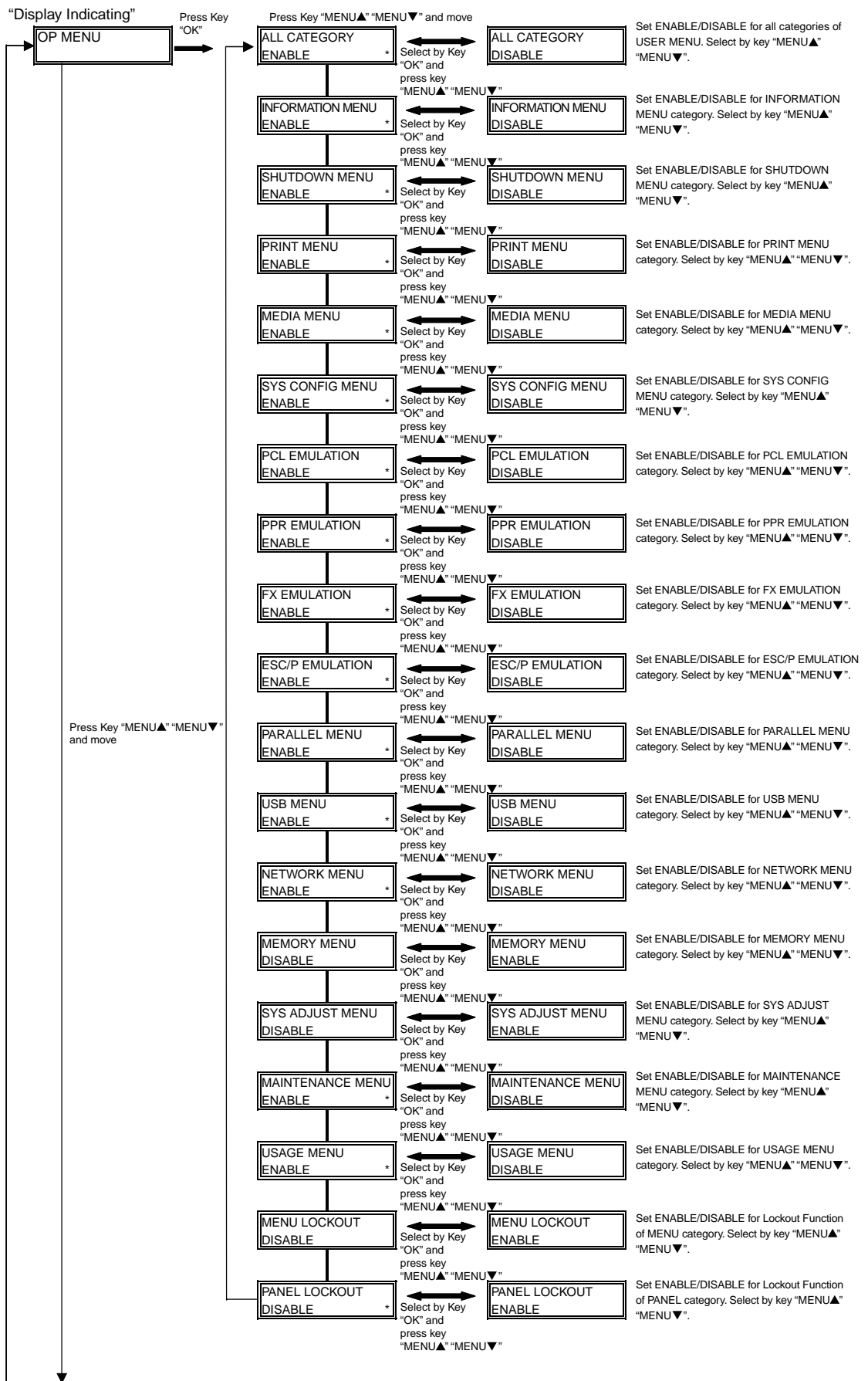

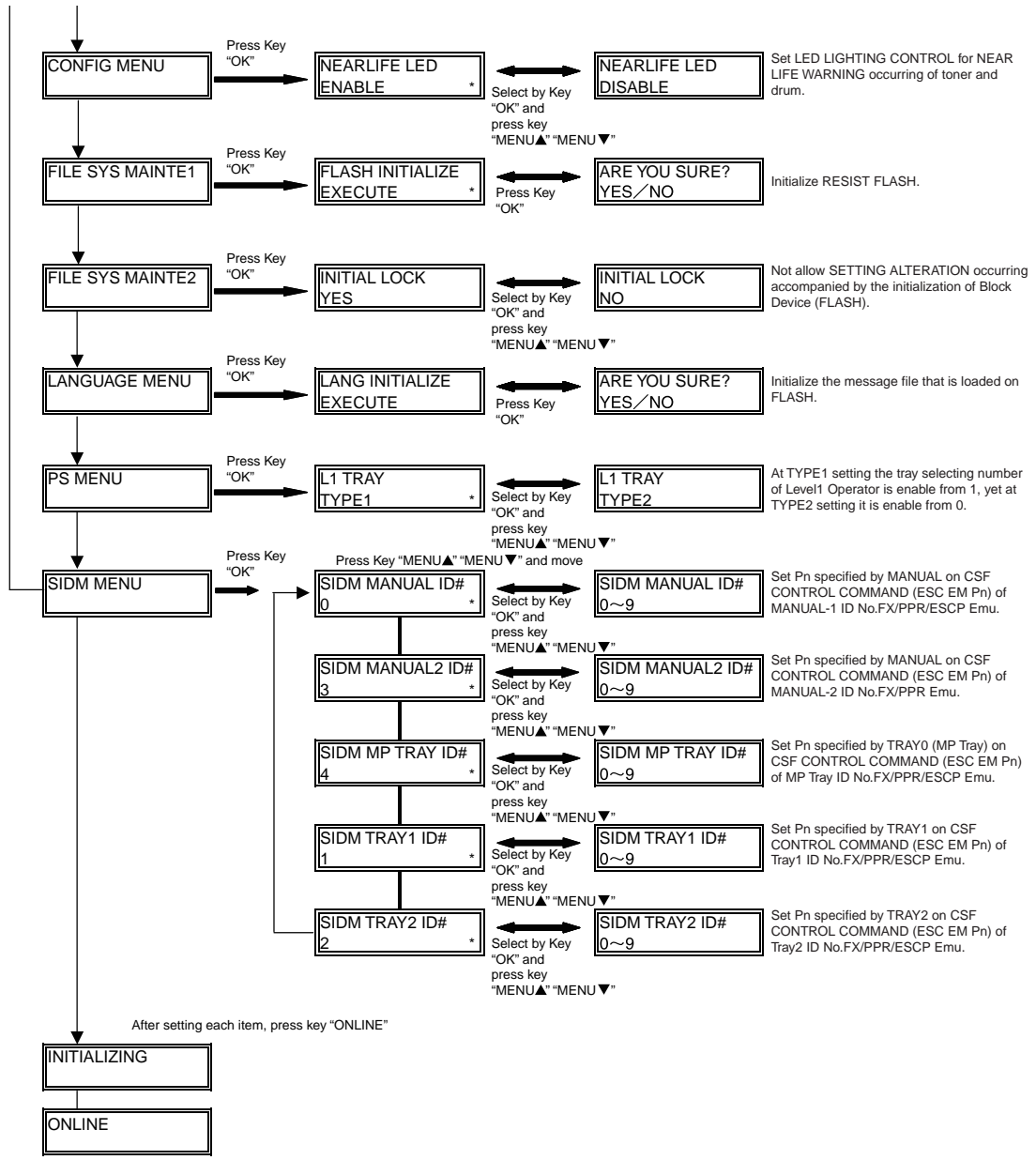

#### 4.1.2 System maintenance mode (System maintenance menu)

- Note!**
- This mode is only used by maintenance personnel; it is not released to the end user.
  - This mode is only B431.
  - Refer to "Maintenance Utility" for B411.
  - (\*1) can be set by "Maintenance Utility".

To open System Maintenance Menu, hold down the "MENU Δ" and "MENU ∇" button and turn on the power switch. After the Category has been displayed, let go of the "MENU Δ" and "MENU ∇" button.

Category	Operation panel display		Default value	Function * Only English is supported for panel display
	Setting item (Upper case)	Setting item (Lower case)		
OKIUSER (*1)	OKIUSER	ODA OEL APS JP1 JPOEM1 OEMA OEML	*	Set the destination. JPOEM1: Japan Oriented OEM OEMA: Overseas OEM for A4 default OEML: Overseas OEM for Letter default After passing the MENU, it reboots automatically. If the Japanese font exist, JP1 is default.
MAINTENANCE MENU	FLASH FORMAT	EXECUTE	-	Initialize Flash ROM. After executing it passes the MENU. The format of Flash Device that is implemented on resident (on board) starts.
	MENU RESET	EXECUTE	-	Reset the EEPROM content to the (Factory Default) setting value . After the setting alteration, it reboots automatically. ※ Part of special item is not initialized.
CONFIG MENU	CODESET	TYPE1 TYPE2	*	This MENU displays as all destination. TYPE1: Non display of Russian / Grace TYPE2: Display Russian / Grace. After passing the MENU, it reboots automatically. For destination of OEL/APS/OEMA, TYPE2 is default value. For other destinations, TYPE1 is default value.
TEST PRINT MENU	TEST PRINT MENU	ENABLE DISABLE	*	Switch between whether to display ENGINE INFORMATION that is on the INFORMATION MENU Category of USER MENU. If this item is Disable, ENGINE INFORMATION is not often displayed.
FUSE KEEP MODE	FUSE KEEP MODE	EXECUTE	-	While press ENTER Key the command is send from CU to PU and then it becomes ONLINE. Replace the consumable by the new one and check the operation as the power ON. (At this moment, the fuser of new consumable is not cut and the operation count is not added to the value of old consumable. While turn the power OFF the check mode is terminated. Till the next time of power ON it is Disable.

Category	Operation panel display		Default value	Function * Only English is supported for panel display
	Setting item (Upper case)	Setting item (Lower case)		
PERSONALITY	PCL	ENABLE DISABLE	*	<p>Change the default of Support PDL Language for each destination.</p> <p>The PDL Language that is Disable in this MWNU is not displayed on the OP MENU of EMULATE and Administrator MENU of user menu. (About "PCL XL", because it does not have specified menu, no appearance change is shown even at Disable.)</p> <p>As receiving the printing data of Disable PDL Language, it displays INVALID DATA and discards the received data.</p> <p>In the case that set the Japan Oriented "IBM PPR III XL" and "EPSON FX" as Enable, the operation is not guaranteed.</p> <p>"PS3 EMU" is only displayed at PSE implementation.</p> <p>It means Read Only While "PCL" can not be set as Disable. (Normally, it is used by Enable. Even set as Disable it still process received data.</p> <p>Default Value: For Japan Oriented equipment sets "IBM PPR" and "EPSON FX" as Disable, yet "ESC/P" as Enable. For Non Japan Oriented equipment sets "IBM PPR" and "EPSON FX" as Enable, yet "ESC/P" as Disable.</p>
	IBM PPR III XL	ENABLE DISABLE	*E *J	
	EPSON FX	ENABLE DISABLE	*E *J	
	ESC/P	ENABLE DISABLE	*J *E	
	PS3 EMULATION	ENABLE DISABLE	*	
	PCL XL	ENABLE DISABLE	*	
ROLLING ASCII	ROLLING ASCII	EXECUTE		<p>Set PRINTING Rolling ASCII as continuously printing.</p> <p>Set Rolling ASCII Paten as continuously printing.</p> <p>Press "ENTEN" switch at this menu displaying.</p> <p>After EXECUTE displayed in the lower case, press "ENTER" switch to settle the execution.</p> <p>Press "ON-LINE" switch to initialize and then continuously printing is available.</p> <p>For the termination of this mode, it is to press "ON-LINE" switch and wait for printing stopped, and then shut down power or press "CANCEL" switch.</p> <p>After this operation it can not return to any other maintenance mode.</p>
DOTSHIFT (*1)	TRAY1	-4.0MILLIMETER ~ -1.5MILLIMETER -1.0MILLIMETER -0.5MILLIMETER 0.0MILLIMETER +0.5MILLIMETER ~ +3.5MILLIMETER	*	<p>Set landscape dot Shift of Tray 1 while printing.</p> <p>In this area, even EEPROM RESET such as ROM Ver.UP is not initialized.</p>
	TRAY2	-4.0MILLIMETER ~ -1.0MILLIMETER -0.5MILLIMETER 0.0MILLIMETER +0.5MILLIMETER ~ +3.5MILLIMETER	*	<p>Set landscape dot Shift of Tray 1 while printing.</p> <p>Item is displayed even Tray 2 is not implemented.</p> <p>In this area, even EEPROM RESET such as ROM Ver.UP is not initialized.</p>

Category	Operation panel display		Default value	Function * Only English is supported for panel display
	Setting item (Upper case)	Setting item (Lower case)		
DOTSHIFT	MANUAL	-4.0MILLIMETER ~ -1.0MILLIMETER -0.5MILLIMETER 0.0MILLIMETER +0.5MILLIMETER ~ +3.5MILLIMETER	*	Set landscape DOTSHIFT of Manual Slot while printing. Item is displayed even Tray 2 is not implemented. In this area, even EEPROM RESET such as ROM Ver.UP is not initialized. Only B411 is used.
	MPT	-4.0MILLIMETER ~ -1.0MILLIMETER -0.5MILLIMETER 0.0MILLIMETER +0.5MILLIMETER ~ +3.5MILLIMETER	*	Set landscape DOTSHIFT of MPT while printing. Item is displayed even Tray 2 is not implemented. In this area, even EEPROM RESET such as ROM Ver.UP is not initialized. Only B431 is used.
ENGINE DIAG MODE			-	Included in Engine Maintenance Menu.

• System maintenance mode menu chart

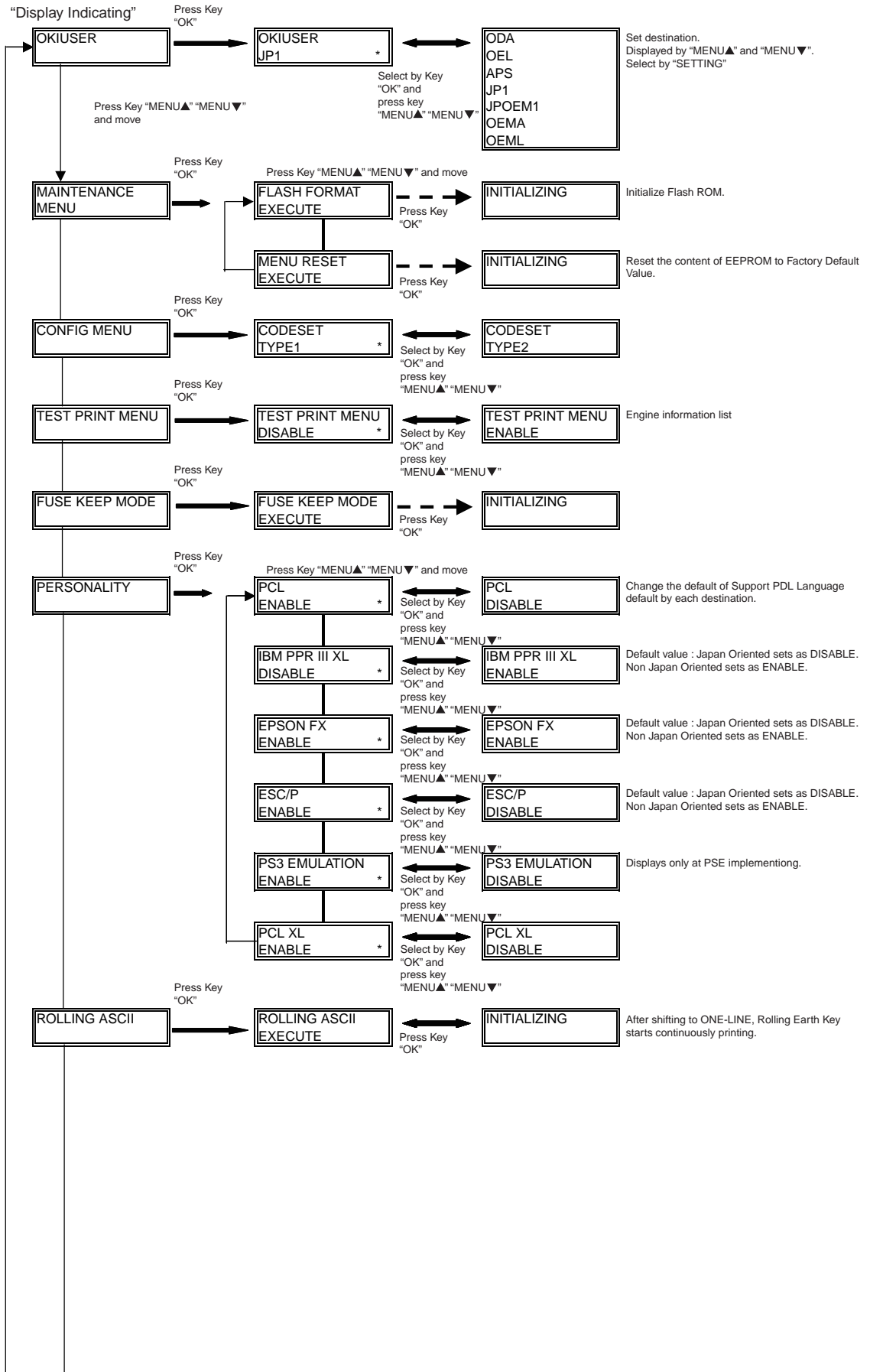



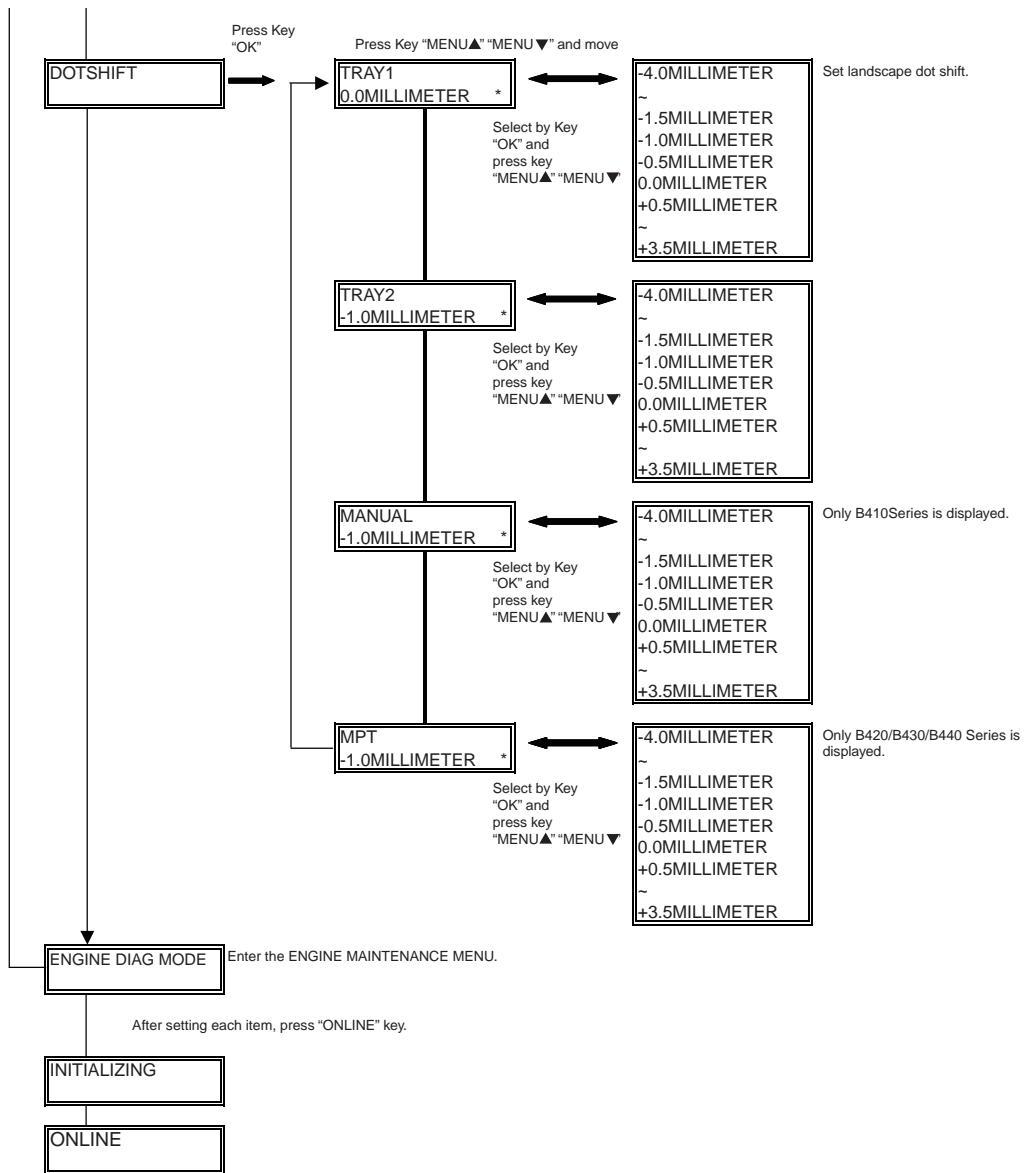

### 4.1.3 Self-diagnostic Mode

- (1) To enter Self-diagnostic mode, turn on the power switch while holding down the "MENU Δ" and "MENU ∇" buttons and then select "ENGINE DIAG MODE" .
- (2) The function of this mode is selected from Menu.
- (3) The release method of this mode is different by setting.
- (4) Self-diagnostic mode (LEVEL0 and LEVEL1) provides the followings.

#### 4.1.3.1 Operation panel

The following description on operating the self-diagnostic is premised on the operation panel layout as shown below.

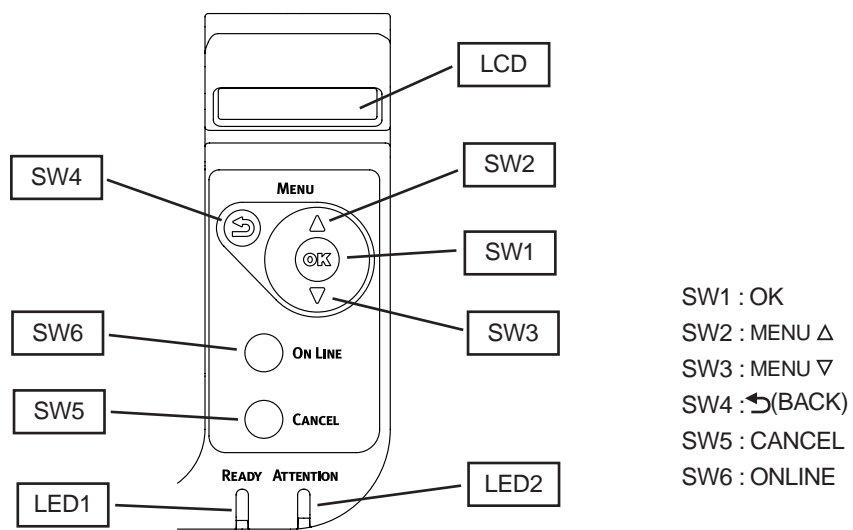

Self-diagnostic mode layout (overall)

#### (1) How to select the menu items

XXXXX  
 XXXXX

- Menu items can be selected directly.
- Menu items can be selected by pressing either [MENUΔ] or [MENU∇] key.

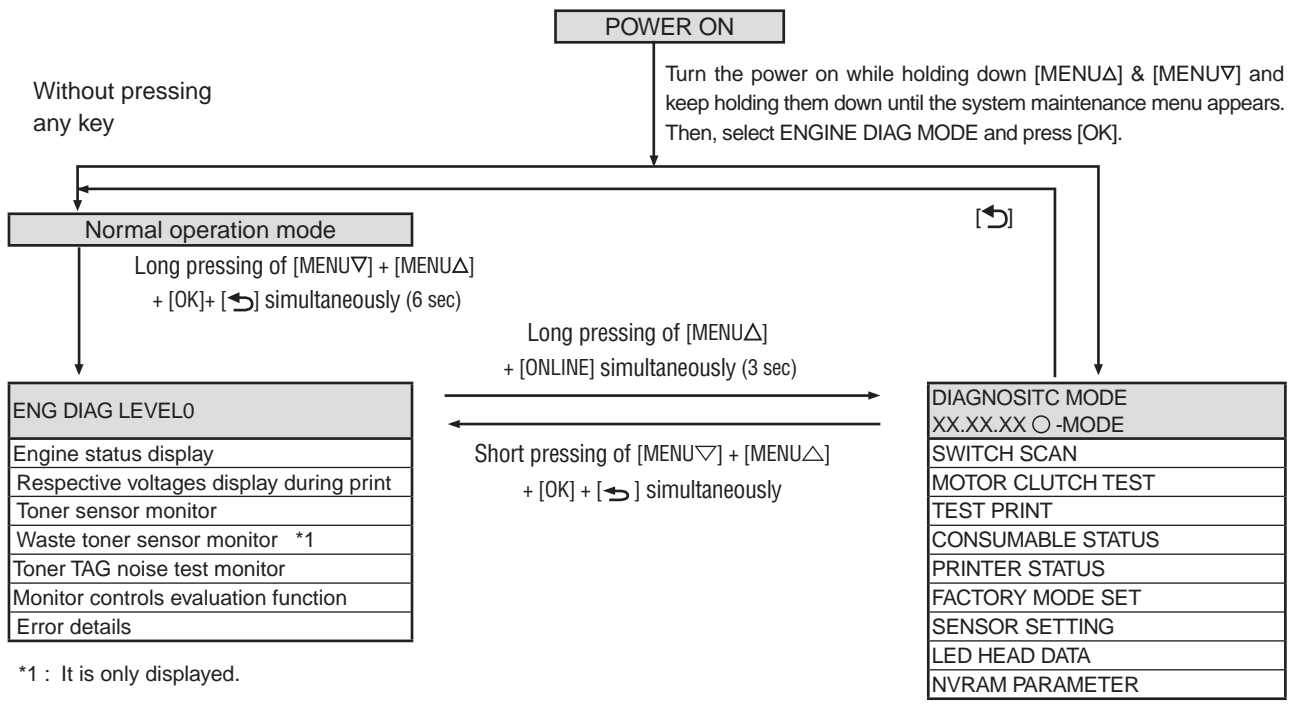

(1) How to select the menu items

LEVEL0

XXXXX  
XXXXX

Menu items can be selected by long pressing of [↵] or [ONLINE], or by short pressing of [MENUΔ] or [MENU▽].  
Menu items can be entered by pressing of [OK] or [↵], and can be selected by pressing of [MENUΔ] or [MENU▽].

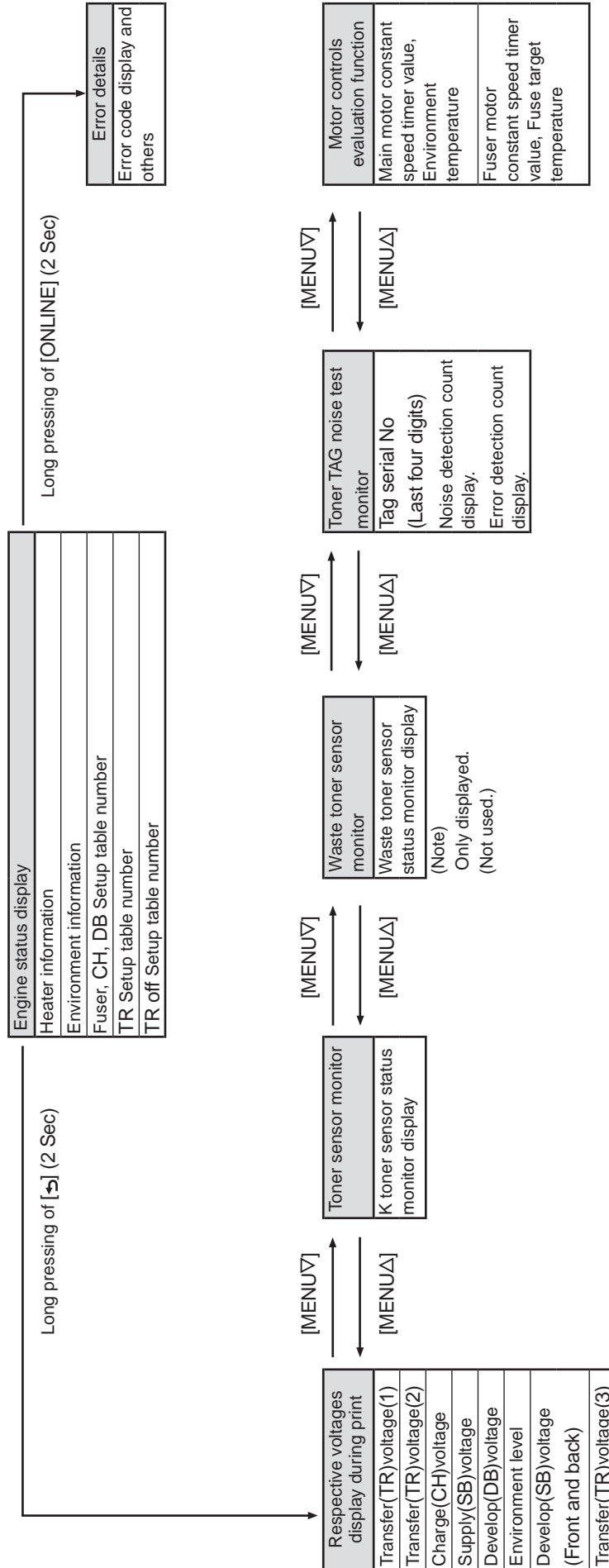



The test can be executed by pressing [OK], and can be exited by pressing [↵].

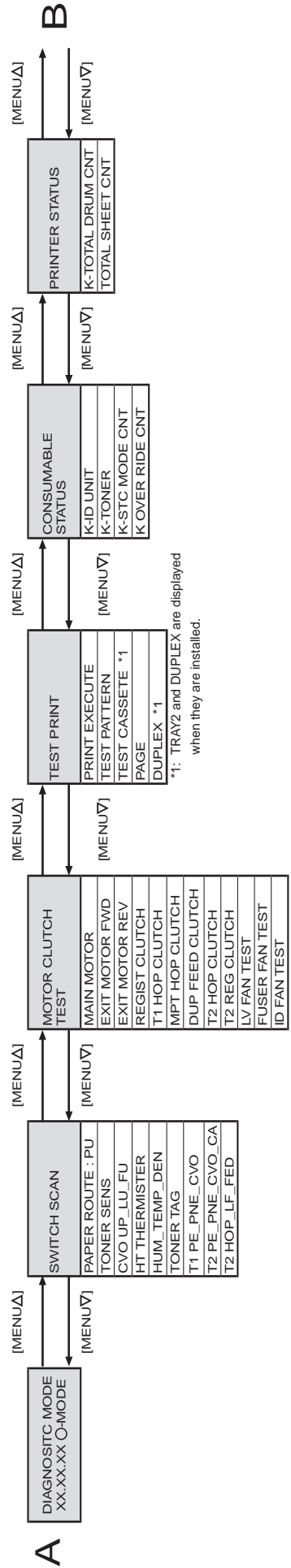

Note:  
If [OK] is pressed long (2 sec) when selecting a motor, the motor keeps running.

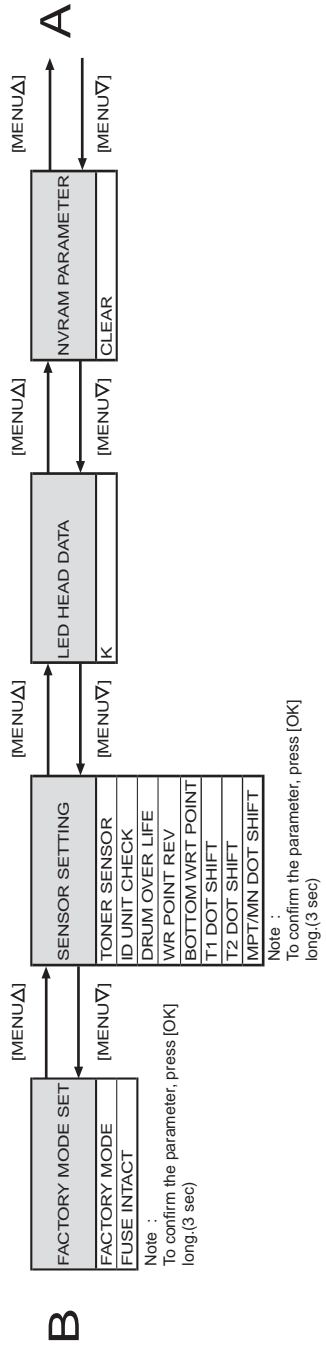

Note :  
To confirm the parameter, press [OK] long.(3 sec)

### 4.1.3.2 Ordinary self-diagnostic mode (level 1)

Menu items of the ordinary self-diagnostic mode are shown below.

	Item	Self-diagnostic menu	Adjustment contents	Maintenance utilities
1	Switch scan test	SWITCH SCAN	Entry sensor check and switch check	Refer to 2.4.1.5.1
2	Motor clutch test	MOTOR&CLTCH TEST	Motor and clutch operation test	Refer to 2.4.1.5.2
3	Test print execution	TEST PRINT	PU built-in test pattern print	It is not possible to operate it.
6	Consumable item counter display	CONSUMABLE STATUS	Consumable items consumption status display	Refer to 2.4.1.5.6
7	Consumable item accumulative counter display	PRINTER STATUS	Consumable items accumulative consumption status display	Refer to 2.4.1.5.6
8	Factory/Shipping mode selection	FACTORY MODE SET	Switching between the Factory mode and the Shipping mode	Refer to 2.4.1.5.7
9	FUSE status check		Respective FUSEs status display	Refer to 2.4.1.5.7
10	Engine parameter setting	SENSOR SETTING	Valid/Invalid setups of error detection by various sensors	Refer to 2.4.1.5.8
11	NVRAM parameter setting	NVRAM PARAMETER	Do not use this item	It is not possible to operate it.

#### 4.1.3.2.1 How to enter the self-diagnostic mode (level 1)

1. While pressing the [MENU $\Delta$ ] and [MENU $\nabla$ ] keys simultaneously, turn on the power to enter the system maintenance mode.
2. Press the [MENU $\Delta$ ] key or [MENU $\nabla$ ] key several times until the message "ENGINE DIAG MODE" is displayed. Then, press the [OK] key to display "DIAGNOSTIC MODE".

DIAGNOSTICMODE
XX.XX.XX FACTORY/SHIPPING

3. XXX.XX.XX of the message "DIAGNOSTIC MODE XX.XX.XX" that is displayed on the LCD display area indicates the PU firmware version number. The FACTORY WORKING MODE setup value is displayed in the right of the lower row. S-MODE of "SHIPPING" is displayed normally.
4. Press the [MENU $\Delta$ ] key or [MENU $\nabla$ ] key to advance to the desired step of each self-diagnostic menu. (The menu items rotate when either the [MENU $\Delta$ ] key or [MENU $\nabla$ ] key is pressed.)

#### 4.1.3.2.2 How to exit the self-diagnostic mode

1. Turn off the power once and back on 10 seconds later.

### 4.1.3.3 Switch scan test

This self-diagnostic menu is used to check the entry sensor and the switch.

1. Enter the self-diagnostic mode (level 1), press the [MENU $\Delta$ ] or [MENU $\nabla$ ] key repeatedly, and press the [OK] key when the "SWITCH SCAN" is displayed in the upper row of the display area. (Pressing the [MENU $\Delta$ ] key increments the test item and pressing the [MENU $\nabla$ ] key decrements the test item.)

SWITCH SCAN

2. Press either the [MENU $\Delta$ ] or [MENU $\nabla$ ] key until the desired menu item corresponding to the unit to be tested in Table 4-3 is displayed in the lower row of the display area. (Pressing the [MENU $\Delta$ ] key increments the test item and pressing the [MENU $\nabla$ ] key decrements the test item.)
3. Pressing the [OK] key starts the test. Name and present status of the corresponding unit are displayed.

PAPER ROTE:PU
1=H 2=L 3=H 4=L

Activate the respective units. (Figure 4-1) Status of the respective units are displayed on the corresponding areas of the LCD display. (Display changes depending on each sensor. Refer to Table 4-3 for details.)

4. Press the [CANCEL] key to return to the status of step 2.
5. Repeat steps 2 to 4 as required.
6. Press the [↵] key to exit the test. (Returns to the status of step 1.)

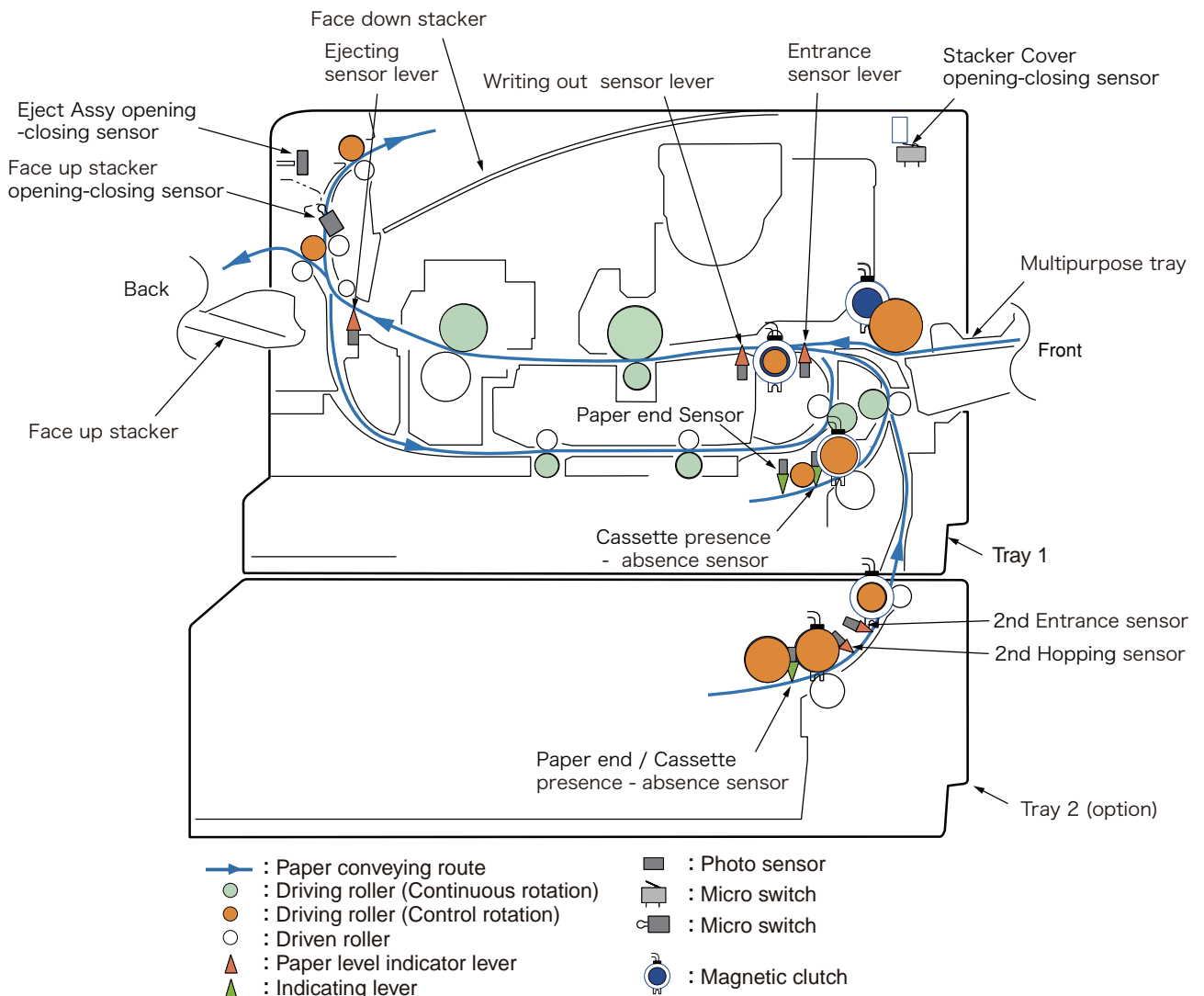

Figure 4-1 Switch and sensor location diagram

Table 4-3 SWITCH SCAN details

<Item having no function> Asterisk mark (\*) is displayed in the lower row of display area.  
 \* 1: "L" is displayed when the cover is opened.

NO	1		2		3		4	
	Display area, upper row	Details	Display area, lower row	Details	Display area, lower row	Details	Display area, lower row	Details
0	PAPER ROUTE : PU	Entrance Cassette Sns(IN1)	H:OFF L:ON	In Sns	H:OFF L:ON	Write Sns	H:OFF L:ON	Exit Sns(OUT)
2	TONER SENS	Toner-K Sns	H:ON L:OFF	Toner-Y Sns	H:ON L:OFF	Toner-M Sns	H:ON L:OFF	Toner-C Sns
3	CVO UP_LU_FU	Cover-Upper	H:Close L:Open	Cover Rear	H:Open L:Close	Cover-Face Up	H:Open L:Close	
6	HT THERMISTER	Upper-Center-Thermister	AD value: ***H	Lower-Center-Thermister	AD value: ***H	Upper-Side-Thermister	AD value: ***H	Ambient Temp - Thermister (Frame Temp)
7	HUM_TEMP_DEN	Hum Sns	AD value: ***H	Temperature-Sns	AD value: ***H	DensityK-Sns	AD value: ***H	DensityYMC-Sns
10	TONER TAG	TAG-K presence or absence	UID: ***H	TAG-Y presence or absence	UID: ***H	TAG-M presence or absence	UID: ***H	TAG-C presence or absence
17	T1 PE_PNE_CVO	1st-Paper-End Sns	Port level H,L	1st-Paper-Near-End Sns	Port level H,L	Cover-1st	H:Open L:Close	Cassette-Sns-1st
18	T1 HOP_LIFT	1st-Hopping Sns	Port level H,L	1st-Lifter Sns	Port level H,L	1st-Feed Sns	Port level H,L	
20	T2 PE_PNE_CVO_CA	2nd-Paper-End Sns	Port level H,L	2nd-Paper-Near-End Sns	Port level H,L	Cover-Open-2nd Sw	Port level H,L	Cassette-Sns-2nd
21	T2 HOP_LF_FED	2nd-Hopping Sns	Port level H,L	2nd-Lifter Sns	Port level H,L	2nd-Feed Sns(TBD)	Port level H,L	

### 4.1.3.4 Motor clutch test

This self-diagnostic menu is used to test the motor and clutch.

1. Enter the self-diagnostic mode (level 1), press the [MENUΔ] or [MENU▽] key repeatedly, and press the [OK] key when the "MOTOR & CLUTCH TEST" is displayed in the upper row of the display area. (Pressing the [MENU Δ] key increments the test item and pressing the [MENU▽] key decrements the test item.)
2. Press either the [MENUΔ] or [MENU▽] key until the desired menu item corresponding to the unit to be tested in Table 4-4 is displayed in the lower row of the display area. (Pressing the [MENUΔ] key increments the test item and pressing the [MENU▽] key decrements the test item.)

MOTOR & CLUTCH TEST
ID MOTOR

3. Pressing the [OK] key starts the test. The unit name starts flashing and the corresponding unit is activated for 10 seconds. (Refer to Figure 4-2.)

**Note!** After the corresponding unit has activated for 10 seconds, it returns to the status of step 2, and is re-activated when the corresponding switch is pressed.

- The clutch solenoid repeats turning on and off during the normal print drive.  
(If a clutch solenoid cannot be activated independently, the motor is driven at the same time.)
  - If [OK] key is pressed long (2 sec) when selecting a motor, the motor keeps running.
4. When the [CANCEL] key is pressed, the corresponding unit stops activating. (Display of the corresponding unit keeps displayed.)
  5. Repeat steps 2 to 4 as required.
  6. Pressing the [↵] key terminates the test. (Returns to the status of step 1.)

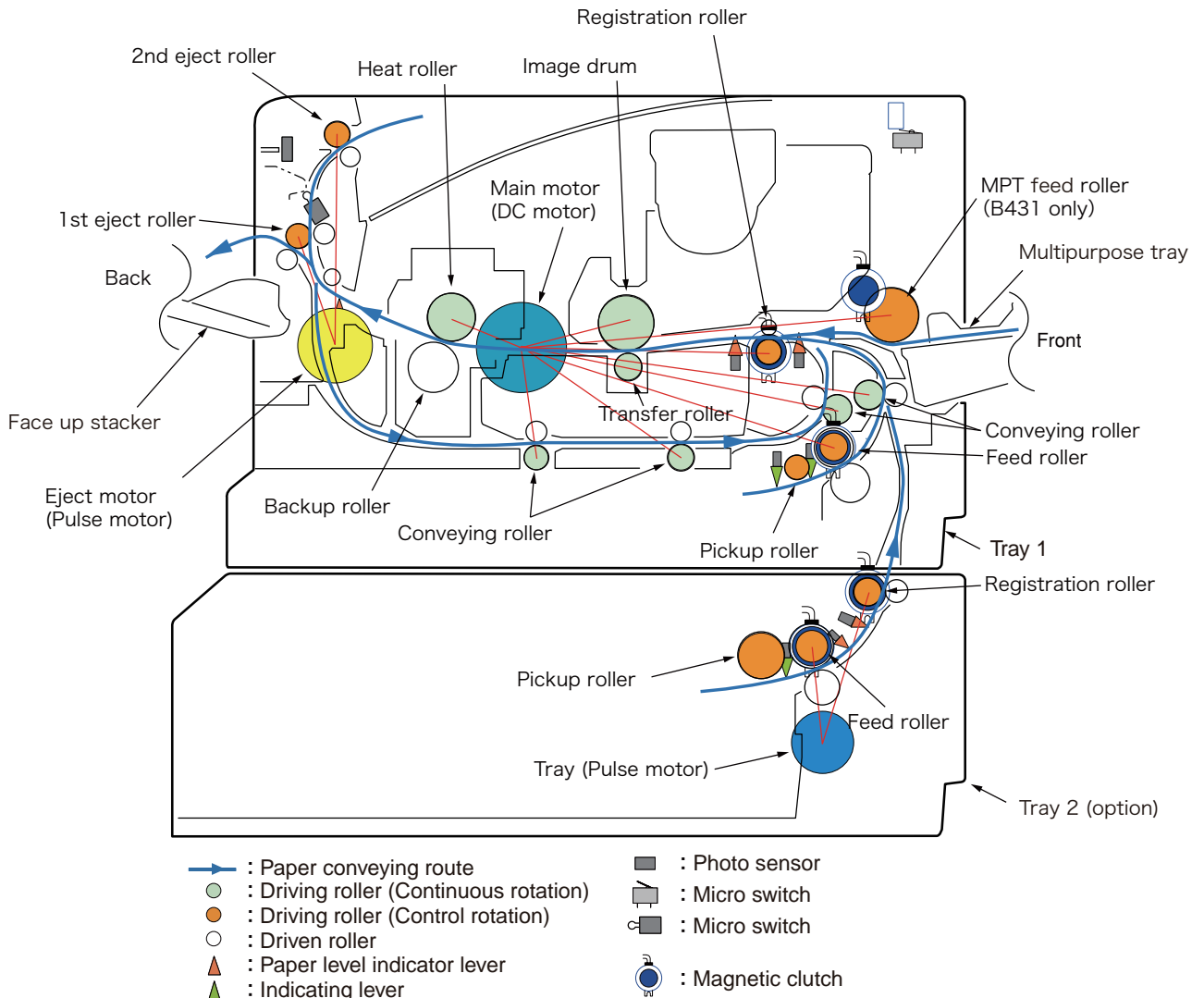

Figure 4-2



Table 4-4

Unit name display	Drive restriction condition	Remarks
MAIN MOTOR	-	-
EXIT MOTOR FWD	FaceUp Cover close	-
EXIT MOTOR REV	FaceUp Cover open	-
REGIST CLUTCH	MAIN MOTOR driving	-
T1 HOP CLUTCH	MAIN MOTOR driving	-
MPT HOP CLUTCH (*1)		-
DUP FEED CLUTCH (*2)	MAIN MOTOR driving	-
T2 HOP CLUTCH	TRAY2 MOTOR driving	OPTION
T2 REGIST CLUTCH	TRAY2 MOTOR driving	OPTION
LV FAN TEST	-	-
FUSER FAN TEST	-	-
ID FAN TEST	-	-

(\*1) B431 only.

(\*2) No duplex feed clutch is installed.

Note!

The rollers that rotate continuously (each of heat rollers, image drums, and conveying rollers) run in synchronization with the main motor.

### 4.1.3.5 Test print

This self-diagnostic menu is used to print the test pattern that is built inside PU. Other test patterns are stored in the controller.

This test print cannot be used to check the print quality.

Diagnosis for the abnormal print image should be performed in accordance with section 6.

1. Enter the self-diagnostic mode (level 1), press the [MENU $\Delta$ ] or [MENU $\nabla$ ] key repeatedly, and press the [OK] key when the "TEST PRINT" is displayed in the upper row of the display area. (Pressing the [MENU $\Delta$ ] key increments the test item and pressing the [MENU $\nabla$ ] key decrements the test item.)
2. The setting items that can be applied to the test print only is displayed in the lower row of display area. Keep pressing the [MENU $\Delta$ ], [MENU $\nabla$ ] key until the desired menu item is displayed. (Pressing the [MENU $\Delta$ ] key increments the test item and pressing the [MENU $\nabla$ ] key decrements the test item.) (If all setting items need no entry [Default setting], go to step 5.)
3. Keep pressing the [MENU $\Delta$ ], [MENU $\nabla$ ] key, and press the [OK] key at the menu item set by step 2. Then, the setting item is displayed in the upper row of display area, and the setting value is displayed in the lower row of display area.

Pressing the [MENU $\Delta$ ] key increments the setting value. Pressing the [MENU $\nabla$ ] key decrements the setting value. (The setting value that is displayed at last is applied.) Pressing the [↵] key determines the entry value, and returns to step 2. Repeat step 3 as required.

TEST PATTERN
1

Display	Setting value	Function
PRINT EXECUTE	–	Pressing the [OK] key starts print/Pressing the CANCEL key terminates print. (In units of page)
TEST PATTERN	0	0: White paper print 1~7: Refer to next page. (Pattern print) 8~15: White paper print
TEST CASSETTE	TRAY1	Selecting source of paper supply.
	TRAY2	If the TRAY 2 is not installed, TRAY2 is not displayed.
	MPT	
PAGE	0000	Setting number of the test print copies
DUPLEX	OFF	Selecting OFF for duplex (2-sided) print. Duplex (1-sided) print is performed by the stack of one sheet of paper.
	1 PAGES STACK	

- is the initial default value. The menu item that is set here is valid in this menu item only. (The setting item is not saved in EEPROM.)

**Note!** PAGE setting

Pressing the [MENU $\Delta$ ] key or the [MENU $\nabla$ ] key shifts the digit. Pressing the [ONLINE] key increments the setting value. Pressing the [MENU $\Delta$ ] key increments the setting value. If print is executed while the number of print copies remains in "0000", printing will continue infinitely.

Print setting for each color

Pressing the [MENU $\Delta$ ] key or the [MENU $\nabla$ ] key shifts the setting. Pressing the [ONLINE] key or the CANCEL, the ON/OFF switchover will be set. Pressing the [↵] key returns the panel display.

4. While the message "PRINT EXECUTE" that is set by the operation specified in step 2 is being displayed, press the [OK] key and the test print is executed with the setting value that has been set by steps 2 and 3.

Pressing the [CANCEL] key stops the test print.

If any alarm that is shown in the following details column is issued at startup of test print or while test print is in progress, the test print is interrupted. (For error details, refer to section 6.5.1 LCD Status Message/ Trouble Table. However, the comment to be displayed is different in the case of the PU test print.)

Panel display	Details
STACKER FULL	Stacker full
PAPER END SELECTED TRAY	No paper
DUPLEX UNIT IS NOT INSTALLED	DUPLEX is not installed
SELECTED TRAY IS NOT INSTALLED	Selected tray is not installed.
REMOVE PAPER OUT OF DUPLEX	DUPLEX internal error
INSTALL CASSETTE TRAY OPEN	Cassette removal

### Print pattern (It cannot be used for checking PQ.)

0 to 15..... White paper print

- During printing, the following messages are displayed.

P=***

P : Number of test print copies (unit: copies)

- Displays are switched by pressing the [MENU△] key.

T=*** U=*** [###]
H=***%

U : \*\*\* = Upper heater temperature measurement value [unit:°C]

[\*\*\*] = Print execution target temperature [unit:°C]

T : Environment temperature measurement value [unit:°C]

H : Environment humidity measurement value [unit: %]

- Displays are switched by pressing the [MENU△] key.

KTR=* . **

KTR indicate the transfer voltage setting value. (unit: KV)

- Displays are switched by pressing the [MENUΔ] key.

KR=* . **

KR : BLACK transfer roller resistance value [unit: uA]

- Displays are switched by pressing the [MENUΔ] key.

E'TMP=***UTMP=***

ETMP : Hopping motor constant speed correction parameter  
(environment temperature) [unit: DEC]

UTMP : Fuser motor constant speed correction parameter  
(fuse target temperature) [unit: DEC]

- Displays are switched by pressing the [MENUΔ] key.

DB:k**

DB : Develop voltage setting table ID number [unit: HEX]

- Displays are switched by pressing the [MENUΔ] key.

TR1:k**
TR2:k**

TR1 : Transfer voltage parameter VTR1 table ID number [unit: HEX]

TR2 : Transfer voltage parameter VTR2 table ID number [unit: HEX]

- Displays are switched by pressing the [MENUΔ] key.

TROFF: **

TROFF : Transfer OFF voltage setting table ID number [unit: HEX]

5. Repeat steps 2 to 4 as required.
6. Pressing the [CANCEL] key terminates the test. (Returns to the status of step 1.)

### 4.1.3.6 Consumable item counter display

This self-diagnostic menu is used to display the consumption status of the consumable items.

1. Enter the self-diagnostic mode (level 1), press the [MENU $\Delta$ ] or [MENU $\nabla$ ] key repeatedly, and press the [OK] key when the "CONSUMABLE STATUS" is displayed in the upper row of the display area. (Pressing the [MENU $\Delta$ ] key increments the test item and pressing the [MENU $\nabla$ ] key decrements the test item.)
2. When the [MENU $\Delta$ ], MENU- key is pressed, consumption statuses of the consumable items are displayed in order. (Pressing the [ONLINE] or [CANCEL] key is invalid.)
3. Pressing the [↵] key terminates the test. (Returns to the status of step 1.)

Display area, upper row	Display area, lower row	Format	Unit	Details
K-ID UNIT	*****IMAGES	DEC	Images	It shows the number of rotations counted after installation of a new ID UNIT on a three A4 Pages/Job basis.
K-TONER	*****%	DEC	%	It shows the amount of toner consumption.
K-STC MODE CNT	*****TIMES	DEC	Times	It shows the number of print dot counts of the toner. (It is a cumulative value counted after the first use of the printer.)
K OVER RIDE CNT	*****TIMES	DEC	Times	It shows the number of overrides of life warnings for the toner cartridge.

### 4.1.3.7 Number of print copies counter display

This self-diagnostic menu is used to display status of the number of copies of a printer.

1. Enter the self-diagnostic mode (level 1), press the [MENU $\Delta$ ] or [MENU $\nabla$ ] key repeatedly, and press the [OK] key when the "PRINTER STATUS" is displayed in the upper row of the display area. (Pressing the [MENU $\Delta$ ] key increments the test item and pressing the [MENU $\nabla$ ] key decrements the test item.)
2. When the [MENU $\Delta$ ], MENU- key is pressed, statuses of the number of print copies are displayed in order. (Pressing the [ONLINE] or [CANCEL] key is invalid.)
3. Pressing the [↵] key terminates the test. (Returns to the status of step 1.)

Display area, upper row	Display area, lower row	Format	Unit	Details
K-TOTAL DRUM CNT	*****IMAGES	DEC	Images	It shows the cumulative number of rotations.
TOTAL SHEET CNT	*****COUNTS	DEC	Prints	Total number of print copies are displayed.

### 4.1.3.8 Switching between the Factory mode and the Shipping mode

This self-diagnostic menu item is used to switch between the Factory mode and the Shipping mode.

1. Enter the self-diagnostic mode (level 1) and keep pressing the [MENU $\Delta$ ] or [MENU $\nabla$ ] key until the following message is displayed.

FACTORY MODE SET

2. When the [OK] key is pressed, the following message is displayed. Keep pressing the [MENU $\Delta$ ] or [MENU $\nabla$ ]key until the target item (refer to the following table) is displayed.

FACTORY MODE
SHIPPING MODE *

3. While the desired item to set is being displayed, press the [OK] key that enables selection of the setting values.
4. While the desired setting value is being displayed, press the [OK] key for long period (3 seconds) that registers the displayed value in EEPROM. (Returns to the status of step 2.)
5. Repeat steps 2 to 4 as required.
6. Pressing the [↵] key terminates the test. (Returns to the status of step 1.)

Display	Setting value	Function
FACTORY MODE	FACTORY MODE	Sets the Factory working mode (fuse cut invalid mode).
	SHIPPING MODE	Releases the Factory working mode to make the fuse cut function valid.
FUSE INTACT Note: ***** indicates INTACT or BLOWN.	K-ID UNIT *****	Checks the fuse status of the K-1D unit.

### 4.1.3.9 Self-diagnostic function setting

This self-diagnostic menu is used to set valid/invalid of the error detection by the various sensors.

The error detection can be made invalid or valid for locating source of abnormality. However, this menu item requires expert knowledge to set among the engine operations. Handle this menu item with utmost care.

Be sure to return the setting to the default setting upon completion of usage of this item.

1. Enter the self-diagnostic mode (level 1) and keep pressing the [MENU $\Delta$ ] or [MENU $\nabla$ ] key until the following message is displayed.

SENSOR SETTING

2. When the [OK] key is pressed, the following message is displayed. Keep pressing the [MENU $\Delta$ ] or [MENU $\nabla$ ] key until the target item (refer to the table below) is displayed.

TONER SENSOR
ENABLE *

3. When the [OK] key is pressed, the following message is displayed.  
Pressing the [MENU $\Delta$ ] key increments the setting value.  
Pressing the [MENU $\nabla$ ] key decrements the setting value.
4. While the desired setting value is being displayed, press the [OK] key for long period (3 seconds) that registers the displayed value in EEPROM. (Returns to the status of step 2.)
5. Repeat steps 2 to 4 as required.
6. Pressing the [↵] key terminates (except the status of step 4) the setting. (Returns to the status of step 1.)

Display	Setting value	Operation at the setting value	Function
TONER SENSOR	ENABLE	Detects	Valid/Invalid of toner sensor operation.
	DISABLE	Not to detect	
ID UNIT CHECK	ENABLE	Checks	Valid/Invalid of ID installation check operation.
	DISABLE	Not to check	
DRUM OVER LIFE	STOP	Not to continue	The restriction on extending the life of toner-related items five times is lifted.
	CONTINUANCE	To continue	
WR POINT REV TBL=**H $\pm$ *.***mm	00H~FFH	Correction value	The correction value is added to the existing write-down position.
BOTTOM WRT POINT TBL=**H $\pm$ *.***mm	00H~FFH	Cut value	Amount of cut at the rear end of a paper is set.
T1 DOT SHIFT **H mm	0H-FH	Correction value	The dot shift amount for TRAY1 is set.
T2 DOT SHIFT **H mm	0H-FH	Correction value	The dot shift amount for TRAY2 is set.
MPT / MN DOT SHIFT **H mm	0H-FH	Correction value	The dot shift amount for MPT/MN is set.

Hatched portion: Default is shown

#### 4.1.3.10 LED head serial number display

This self-diagnostic menu item is used to check whether the downloaded LED head data matches the serial number of the actual LED head.

1. Enter the self-diagnostic mode (level 1), press the [MENU $\Delta$ ] or [MENU $\nabla$ ] key repeatedly, and press the [OK] key when the "LED HEAD DATA" is displayed in the upper row of the display area. (Pressing the [MENU $\Delta$ ] key increments the test item and pressing the [MENU $\nabla$ ] key decrements the test item.)
2. When the [MENU $\Delta$ ] key or the [MENU $\nabla$ ] key is pressed, serial numbers of the K LED head data are displayed in order.
3. Pressing the [↵] key terminates the test. (Returns to the status of step 1.)

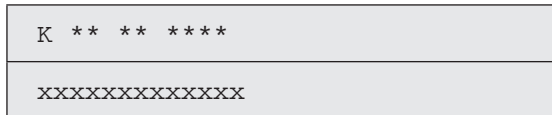

\*\* \*\* \*\*\*\*\* : Rev number  
 XXXXXXXXXXXXXXXXXXXX : serial number

#### 4.1.3.11 NVRAM parameter setting

Do not use this menu item.



#### 4.1.4 Energy conservation mode setting

This printer is equipped with two types of energy conservation mode, MODE1 as "NORMAL MODE" and MODE2 as "ECO MODE."

When energy conservation mode is set to "ECO MODE," the printer prints at a low speed at the beginning of cold start to reduce the period of time required for warming up from the normal temperature.

At factory default, it is "ECO MODE" MODE2.

##### 1. Setting method

- (1) Switch on the power of printer.
- (2) After "ON LINE" appears, open the Stacker Cover.
- (3) Press [ON LINE] switch for 5 second.

Open the Top Cover by ONLINE and NODATA status, press [ON LINE] switch for 5 second. The following setting information displays on LCD for 2 second. Then it returns to the original display automatically. The check LED blinks.

- In case of setting converted by MODE1 "NORMAL MODE" status, it changes to MODE2 "ECO MODE".

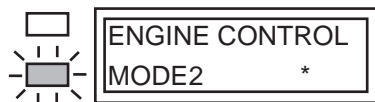

- In case of setting converted by MODE2 "ECO MODE" status, it changes to MODE1 "NORMAL MODE".

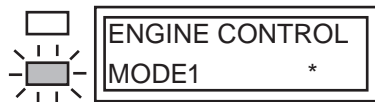

## 4.1.5 EEPROM Initialization

The treatment for EEPROM Initialization at each phenomenon is displayed as Diagram 4-1.

Diagram 4-1 EEPROM Initial Setting Range

No	Phenomenon	CU EEPROM Area						PU EEPROM Area			
		Factory Default Area	User Menu Area	OP Menu Area	Administrator Menu/ System Maintenance Menu Area (*3)	F/W Revision Area	Brands Area	Engine Maintenance Menu Area			
								Drum Counter	Page Counter	Toner Dot Counter	
1	User Maintenance Menu EEPROM RESET Operation	-	○	-	-	-	-	-	-	-	-
2	F/W Revision check error at the time of a power on.	-	○	-	○(*4)	-	○	-	-	-	-
3	CU EEPROM area mapping Revision check error at the time of a power on.	○	○	○	○(*4)	-	-	-	-	-	-
4	Brands area check error at the time of a power on. (*1)	○	○	○	○(*4)	○	○	-	-	-	-
5	Engine Maintenance Menu ENGINE RESET Operation	-	-	-	-	-	-	-	○	○(*2)	○(*5)
6	PU EEPROM area mapping check error at the time of a power on.	-	-	-	-	-	-	○(*3)	○	○	○
7	System Maintenance Menu EEPROM RESET Operation	-	○	○	○(*4)	-	-	-	-	-	-

(\*1) Destination Check is for the operation on the different product (destination) with the previously operated product (destination). It is the reset relying on the recognition regarding the destination change by PjL command and the operation at POWER ON of the new product EEPROM as an error.

(\*2) It is reset to 0 limited by Page Count less than 500 pieces. (ENGINE RESET due to PjL Command is not in this limitation.)

(\*3) About DOT SHIFT setting menu, even it is also exist in System Maintenance Menu, but because the setting value keeping area is allocated in PU EEPROM AREA, in the case of the item of System Maintenance Menu initialized, DOT SHIFT setting is not initialized. By contraries, in the case of PU EEPROM AREA initialized, DOT SHIFT setting is initialized.

(\*4) DOT SHIFT setting should not be initialized.

(\*5) Because of the support of Toner TAG, Toner Dot Counter is not reset.

## 4.2 Adjustment at part replacement

Adjustment is necessary while replacing the following part.

Replacing part	Adjustment
Main PCB board	EEPROM data upload / download

### 4.2.1 EEPROM data upload / download method

In the case of replacing the Print Board of Controller, copy the old EEPROM content to the new EEPROM of new board and then save the customer setting. To operate this, use Maintenance Utility. About the operating method of Maintenance Utility, refer to Maintenance Utility Operating Specification.

Maintenance Utility is designed for working place engineer use only. It is not released to the end user. Refer to 2.4.1.1.9 of Maintenance Utility Manual.

## 5. Periodic Maintenance

### 5.1 Periodic Replacement Parts

The following parts should be replaced at a specified cycle.

Name	Conditions	Cleaning	Remarks
• Toner Cartridge	After printing approx. 4,000 pages	• LED head	Consumables
• Image Drum Cartridge	After printing approx. 44,000 pages See 1.4 (15).		Consumables

**Note!** After using a normal cartridge, the starter toner cartridge (attached at the printer purchase) can not be used. Use the starter toner cartridge first, and then, use the normal toner after [LOW TONER] is displayed.

### 5.2 Cleaning

Remove toner powder and dust in the printer inner section. Clean the inside of and the periphery of the printer with the cloth as needed. Clean the printer inner section with the handy cleaner (maintenance tool).

**Note!** Do not touch the image drum, LED lens array, and LED head terminal.

### 5.3 Cleaning of LED lens array

If the vertical white lines, and white belt (white spot, pale printing) occur in printing as shown below, the LED lens array should be cleaned or the toner cartridge should be replaced.

**Note!** As for the LED lens array, clean it with soft tissues or soft cloth after eliminating static electricity of a maintenance tool.

White lines or White belt  
(White spot, pale printing)



Wipe the whole LED head softly with the soft tissues or cloth.

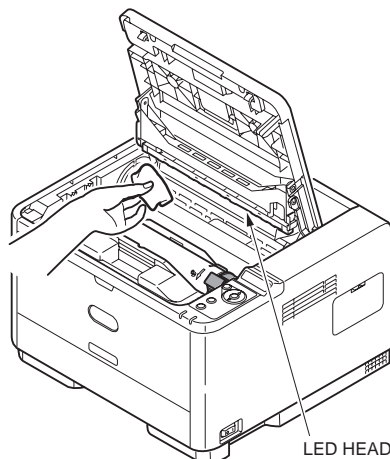

**Note!** Do not use solvents including methyl alcohol, and thinner.

## 5.4 Cleaning the Feed rollers and the Retard roller

- (1) Wipe the two feed rollers with a tightly wrung cloth soaked in water through the opening for installation of a paper cassette.

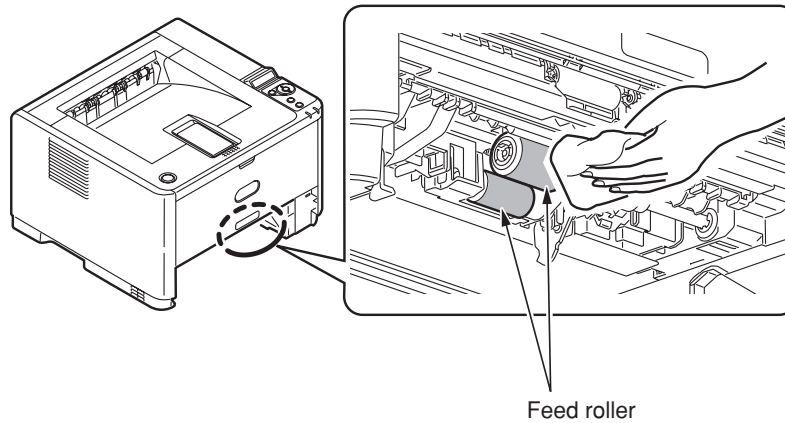

**Note!** Use water only.

- (2) Wipe the Retard roller of the paper cassette with a tightly wrung cloth soaked in water.

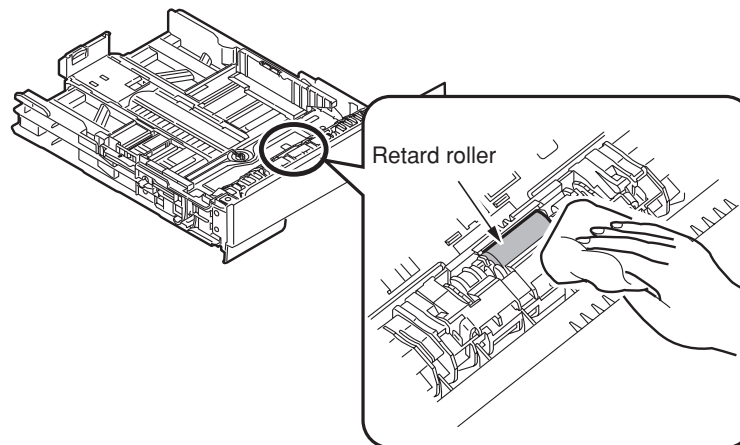

**Note!** Use water only.

## 6. Procedures for Repairing

### 6.1 Troubleshooting

- (1) Check "8. Troubleshooting" of the user's manual.
- (2) Collect the information of the status at the failure as much as possible.
- (3) Inspect the device in the status similar to the status at the failure occurrence.

### 6.2 Points to be checked before modifying printing problems.

- (1) Check that the printer is used in appropriate environment conditions.
- (2) Check that consumables (image cartridge, image drum cartridge) are proper replaced.
- (3) Check that the image drum cartridge is proper set.

### 6.3 Points to be checked when the printing problems are modified

- (1) Make sure not to touch the surface of the image drum or make extraneous materials touched on the surface.
- (2) Make sure to avoid direct sunlight.
- (3) Make sure not to touch the fuser unit since it is hot during the operation.
- (4) Make sure not to exposure the image drum to the light for more than 5 minutes at ambient temperature.

### 6.4 Preparation for Troubleshooting

- (1) Display of the operator panel

The failure status of the printer is displayed don the LCD of the operator panel. Take an appropriate action as instructed by the messages displayed on LCD.

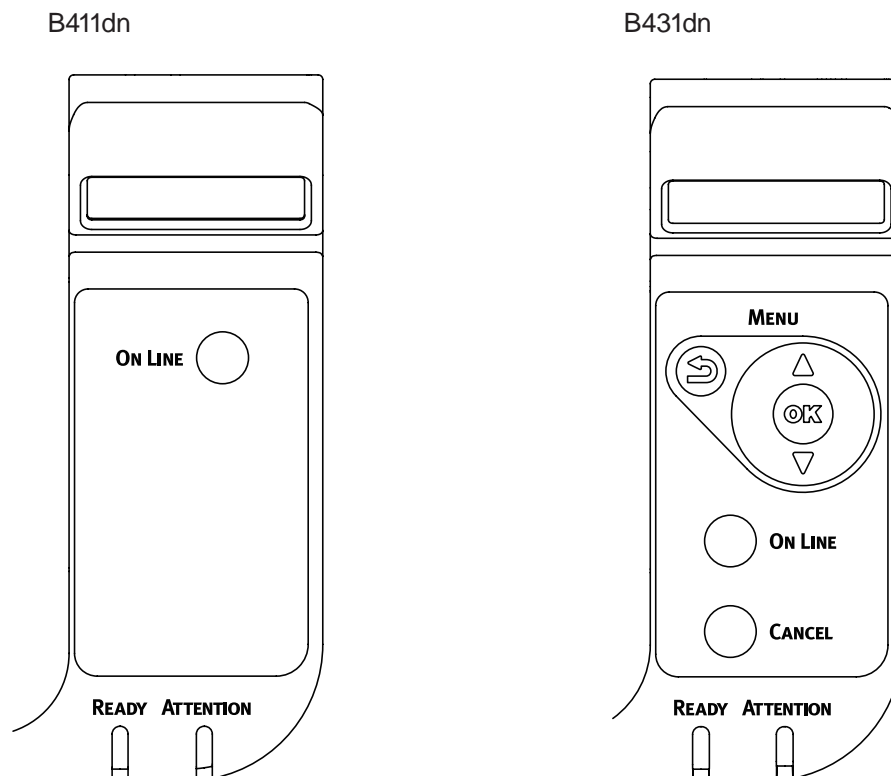

### 6.5 Troubleshooting Flow

If there are failures in the printer, troubleshooting is performed according to the following process flow.

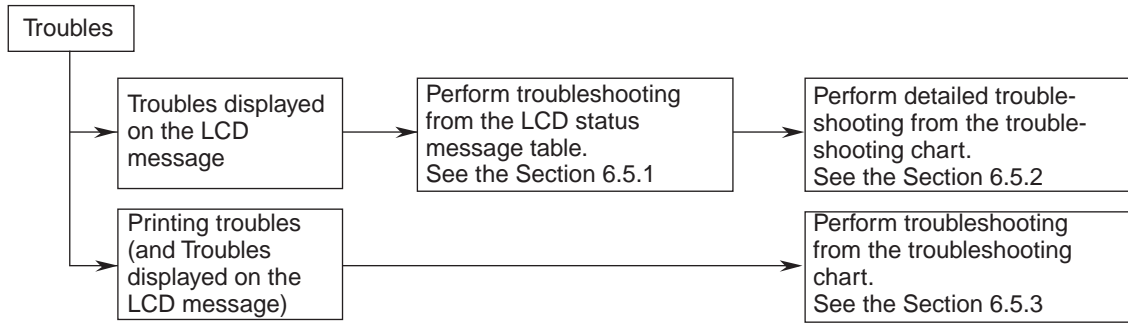

#### 6.5.1 LCD Status Message/ Trouble Table

Troubles and statuses possible to be displayed on LCD are outlined in Table 6-1.

Table 6-1 (1/8)

Status level	Error code nnn	LCD (16 digits on the upper level and 16 digits on the lower level) ("□" shows that nothing is displayed on the upper level.)	LED		Contents
			Ready	Atten	
Normal		INITIALIZING	OFF	OFF	In initializing of the printer. Since the flash memory may be damaged, the power is not turned off during the display.
Normal		MENU RESETTING	OFF	OFF	In Resetting the menu. Since the flash memory may be damaged, the power is not turned off during the display.
Normal		RAM CHECK *****	OFF	OFF	In checking RAM. Since the flash memory may be damaged, the power is not turned off during the display.
Normal		FLASH CHECK	OFF	OFF	In checking the contents of the flash memory.
Normal		FLASH FORMAT	OFF	OFF	In formatting the flash memory.
Normal		PROGRAM UPDATE MODE	OFF	OFF	The special mode where the printer updates the NIC program (control firmware). It is displayed only during the special mode for the maintenance.
Normal		WAIT A MOMENT DATA RECEIVE	OFF	Blinking	In receiving the NIC program data to be updated. It is displayed only during the special mode for the maintenance.
Normal		WAIT A MOMENT DATA RECEIVE OK	OFF	OFF	The reception of the NIC program data to be updated is completed. It is displayed only during the special mode for the maintenance.
Normal		CHECK DATA REC DATA ERROR	OFF	ON	An error occurs while the reception of the NIC program data to be updated is processing. It is displayed only during the special mode for the maintenance. %DLCODE% 1: Size error 2: Check SUM error 3: Printer model No. error 4: Module I/F version error 5: FAT Version error
Normal		WAIT A MOMENT DATA WRITING	OFF	Blinking	In writing the NIC program data to be updated. It is displayed only during the special mode for the maintenance.

Table 6-1 (2/8)

Status level	Error code nnn	LCD (16 digits on the upper level and 16 digits on the lower level) ("□" shows that nothing is displayed on the upper level.)	LED		Contents
			Ready	Atten	
Normal		POWER OFF/ON DATA WRITTEN OK	OFF	OFF	It is completed to write the NIC program data to be updated. It is displayed only during the special mode for the maintenance.
Normal		CHECK DATA DATA WRITE ERROR	OFF	OFF	An error occurs while the writing of the NIC program data to be updated is processing. It is displayed only during the special mode for the maintenance. %DLCODE% acquisition error 1: Memory alloc Error 2: Download File error 3: Device free space 4: Device insufficient space error 5: File Write error 6: CU-F/W Mismatch error
Normal		STATUS MODE	OFF	OFF	It displays that the printer has started in the normal online mode.
Normal		ONLINE	ON	OFF	ONLINE Print data can be received.
Normal		OFFLINE	OFF	OFF	OFFLINE To print, press the [online] switch to be online.
Normal		FILE ACCESSING	Not determined	Not determined	It is accessed to the flash memory by print job accounting. Since the flash memory may be damaged, the power is not turned off during the display.
Normal		DATA ARRIVE	Not determined	Not determined	In receiving data.
Normal		PROCESSING	Blinking	Not determined	In receiving data. Or Received data is being processed.
Normal		DATA	Not determined	Not determined	Received data is left. Or the device waits for the data to be sent next.
Normal		PRINTING	Not determined	Not determined	In printing.
Normal		PRINT DEMO PAGE	Not determined	Not determined	Prints the text page.
Normal		PRINT FONT	Not determined	Not determined	Prints the font list.
Normal		PRINT MENU MAP	Not determined	Not determined	In printing the menu map.
Normal		PRINT FILE LIST	Not determined	Not determined	In printing the file list.
Normal		PRINT ERROR LOG	Not determined	Not determined	In error log printing.
Normal		PRINT NETWORK CONFIG	Not determined	Not determined	In printing the network configuration.
Normal		□ COPY kkk/lll	Not determined	Not determined	When the number of copies are two or more, the number of copies currently printed is displayed. Kkk shows the number of pages currently printed, and "lll" show the total number of printed pages.
Normal		CONTINUOUS PRINT	Not determined	Not determined	In printing ROLLING ASCII.
Normal		CANCELING JOB	Blinking	Not determined	Received data is canceled.
Normal		CANCELING JOB (JAM)	Blinking	Not determined	Received data is canceled. (Operation after the recovery of the paper jam)



Table 6-1 (3/8)

Status level	Error code nnn	LCD (16 digits on the upper level and 16 digits on the lower level) ("□" shows that nothing is displayed on the upper level.)	LED		Contents
			Ready	Atten	
Normal		CANCELING JOB (USER DENIED)	Blinking	Not determined	Jobs are canceled because the jobs are sent from the user not authorized to print by the print job accounting. (1) Jobs from the user not authorized to print in the usage restriction. (2) Jobs from the user not authorized to print in color in the usage restriction. (3) Jobs from the user exceeding the set limit value.
Normal		CANCELING JOB (BUFFER FULL)	Blinking	Not determined	When the operation of print job accounting at LOG FULL is set to "CANCEL JOBS", there is not enough space to store logs and jobs are canceled.
Normal		□ ADJUSTING TEMP	Not determined	Not determined	In the warming-up operation.
Normal		□ POWER SAVE	Not determined	Not determined	In the power saving mode.
Warning		□ 509 PRINTER LIFE	Not determined	OFF	Indicates that the printer has reached the end of its life. When it has been specified to indicate a printer life warning message, this message appears when the total page count reaches 200,000.
Warning		□ TONER LOW	Not determined	ON (Blinking) (OFF)	The status where the toner is low. Replace the toner cartridge.
Warning		□ NONOEM TONER DETECTED	Not determined	ON	The appropriate toner cartridge is not installed. It is not an appropriate toner cartridge, but the operation is available.
Warning		□ TONER REGIONAL MISMATCH	Not determined	ON	The appropriate toner cartridge is not installed. Set the appropriate toner cartridge.
Warning		□ NON GENUINE TONER	Not determined	ON	Indicates the toner cartridge is not for use in the printer. Set the appropriate toner cartridge.
Warning		□ PS3 EMUL ERROR	Blinking	Not determined	The postscript error occurs during the data processing. There are mistakes in the job or the job is too complicated.
Warning		□ ORDER DRUM	Not determined	ON (OFF)	It is almost time to replace the image drum cartridge. Prepare for the replacement of the image drum and toner cartridge, and replace them.
Warning		□ TONER EMPTY	Not determined	ON	The device runs out of the toner. It is displayed when keeping using the toner after [TONER LOW] is displayed. Replace the toner cartridge. If the toner is used continuously, it may cause the failure of the image drum cartridge.
Warning		□ TONER SENSOR	Not determined	ON	The toner sensor is out of order. Turn off and on the power. Replace the image drum cartridge.
Warning		□ TONER NOT INSTALLED	Not determined	ON	The toner cartridge is not installed. Install the toner cartridge.
Warning		□ DRUM LIFE	Not determined	ON	Time to replace the image drum cartridge. Replace the image drum cartridge and toner cartridge.
Warning		□ HEAD DATA ERROR	Not determined	ON	LED head correction data has not been found or is incorrect. This warning message is not displayed in the Shipping Mode.
Warning		□ tttt EMPTY	Not determined	ON	There is no paper on tttt tray. Load paper in tttt tray.
Warning		□ FILE SYSTEM FULL	Not determined	ON	It is impossible to write in the frashmemory. Obtain a log by the print job accounting.
Warning		□ FILE IS WRITE PROTECTED	Not determined	ON	It is unwritable on Flash Memory. Try to obtain the log of Print Job Accounting.

Table 6-1 (4/8)

Status level	Error code nnn	LCD (16 digits on the upper level and 16 digits on the lower level) ("□" shows that nothing is displayed on the upper level.)	LED		Contents
			Ready	Atten	
Warning		□ INVALID ID. JOB REJECTED	Not determined	ON	It is displayed after jobs are canceled by "Canceling Jobs (User denied)" in the print job accounting. It remains displayed until the "online" switch is pressed.
Warning		□ LOG BUFFER FULL. JOB REJECTED	Not determined	ON	It is displayed after jobs are canceled by "Cancel Jobs {LOG FULL}" in the print job accounting. It remains displayed until the "online" switch is pressed.
Warning		□ FILE OPERATION FAILED %FS_ERR%	Not determined	ON	There were unauthorized accesses to the flash memory. Obtains the log by the print job accounting. %FS_ERR% 0: GENERAL ERROR 1: VOLUME NOT AVAILABLE 3: FILE NOT FOUND 4: NO FREE FILE DESCRIPTORS 5: INVALID NUMBER OF BYTES 6: FILE ALREADY EXISTS 7: ILLEGAL NAME 8: CANT DEL ROOT 9: NOT FILE 10: NOT DIRECTORY 11: NOT SAME VOLUME 12: READ ONLY 13: ROOT DIR FULL 14: DIR NOT EMPTY 15: BAD DISK 16: NO LABEL 17: INVALID PARAMETER 18: NO CONTIG SPACE 19: CANT CHANGE ROOT 20: FD OBSOLETE 21: DELETED 22: NO BLOCK DEVICE 23: BAD SEEK 24: INTERNAL ERROR 25: WRITE ONLY
Warning		□ tttt FLASH ERROR	Not determined	Not determined	A PU flash error has occurred. (An error occurred during a rewrite of a PU firmware, or writing of LED Head information and so on into a PU flash memory has failed.) tttt :PU / TRAY2
Warning		PRESS ONLINE SW INVALID DATA	Not determined	Not determined	Invalid data is received. Press the "Online" switch.
Error (Online)		LOAD mmmm IN MP TRAY AND PRESS ONLINE SWITCH	ON	OFF	There is no paper in MP tray. Load mmmm paper in the MP tray and press the "online" switch. It is displayed only for B431.
Error		MANUAL Mmmm REQUEST	ON	OFF	There is no paper in the manual tray. Load mmmm paper in the manual tray. It is displayed only for B411.
Error (Online)		tttt DUPLEX REQUEST	Not determined	Blinking	When specifying the duplex printing, load paper in a specified tray to print on the other side of the paper of which printing is completed on one side.

Table 6-1 (5/8)

Status level	Error code nnn	LCD (16 digits on the upper level and 16 digits on the lower level) ("□" shows that nothing is displayed on the upper level.)	LED		Contents
			Ready	Atten	
Error	460 461 462	LOAD mmmm/pppp AND PRESS ONLINE SWITCH nnn: tttt MEDIA MISMATCH	OFF	Blinking	The media type of paper in the tray is not matched. Load the media type displayed and press the [Online] switch. 460: Multi-purpose tray 461: Tray1 462: Tray2
Error	460 461 462	LOAD mmmm/pppp AND PRESS ONLINE SWITCH nnn: tttt SIZE MISMATCH	OFF	Blinking	The paper size in the tray is not matched. Load the paper size displayed and press the [Online] switch. 460: Multi-purpose tray 461: Tray1 462: Tray2
Error (Online)		DOWNLOAD MESSAGE PROCESSING	Not determined	Not determined	In processing of the message data to be updated.
Error (Online)		DOWNLOAD MESSAGE WRITING	Not determined	Not determined	In writing of the message data to be updated.
Error (Online)		DOWNLOAD MESSAGE SUCCESS	Not determined	Not determined	Writing of the message data to be updated succeeds.
Error (Online)		DOWNLOAD MESSAGE FAILED %CODE%	Not determined	Not determined	Writing of the message data to be updated failed. %CODE% 1: FAIL Other error. 2: DATA_ERROR Hash check error at the writing of the data, FLASH Failure. 3: OVER FLOW Download failure because the Flash capacity is full when or while writing the language file. 4: MEMORYFULL Memory ensuring failed. 5: UNSUPPORTED_DATA Downloading of the data not supported by the printer.
Error (Online)		NETWORK CONFIG WRITING	Not determined	Not determined	In storing network board configuration.
Error	581	CLOSE FACE UP STACKER nnn:DUPLX NOT AVAILABLE	OFF	Blinking	The face-up stacker is open. The face-up stacker must be closed for duplex printing.
Error (Online)		WAIT A MOMENT NETWORK INITIAL	Not determined	Not determined	In changing the network configuration.
Error		LOAD mmmm AND PRESS ONLINE SWITCH nnn:MP TRAY EMPTY	OFF	Blinking	In changing the network configuration.
Error	491 492	LOAD mmmm nnn:tttt EMPTY	OFF	Blinking	There is no paper in the tray. Load paper as the size displayed.
Error	490	INSTALL PAPER CASSETTE nnn:TRAY1 OPEN	OFF	Blinking	There is no paper in the multi-purpose tray. Load the paper size displayed, and press the online switch.
Error	440	INSTALL PAPER CASSETTE nnn:TRAY1 OPEN	OFF	Blinking	Cassette is not installed in tray1. Install the cassette.
Error	430	INSTALL PAPER CASSETTE nnn:tttt MISSING	OFF	Blinking	The cassette of the tray1 is not installed. Install the cassette.
Error	420	ADD MORE MEMORY nnn:MEMORY OVERFLOW	OFF	Blinking	The device is lacking in the memory. Press the [online] switch. The memory is added as needed.
Error	413	REPLACE TONER nnn:TONER EMPTY	OFF	Blinking	Toner is empty. It is displayed if the toner is used with [Toner Low] displayed. Replace the toner cartridge. If printing is continued, it causes the failure of the image drum cartridge.
Error	557	REPLACE TONER nnn:TONER REGIONAL MISMATCH	OFF	Blinking	The toner cartridge is not matched. Set a toner cartridge for this product.
Error	617	REPLACE TONER nnn:INCOMPATIBLE TONER	OFF	Blinking	The toner cartridge is not matched. Set a toner cartridge for this product.

Table 6-1 (6/8)

Status level	Error code nnn	LCD (16 digits on the upper level and 16 digits on the lower level) ("□" shows that nothing is displayed on the upper level.)	LED		Contents
			Ready	Atten	
Error	623	REPLACE TONER nnn:INCOMPATIBLE TONER	OFF	Blinking	The toner cartridge is not matched. Set a toner cartridge for this product.
Error	553	GENUINE TONER IS RECOMMENDED nnn:NON GENUINE TONER	OFF	Blinking	Indicates the toner cartridge is not for use in the printer. Set an appropriate toner cartridge.
Error	613	INSTALL TONER nnn:TONER MISSING	OFF	Blinking	The toner is not installed. Set the toner cartridge.
Error	543	CHECK IMAGE DRUM nnn:TONER SENSOR ERROR	OFF	Blinking	Toner sensor error. Extract and insert the image drum cartridge.
Error	400	OPEN UPPER COVER nnn:PAPER SIZE ERROR	OFF	Blinking	The paper size is not matched, or multiple pages are fed with overlapped. Open the top cover to remove a jammed sheet, and replace with the correct-size paper.
Error	390	CHECK MP TRAY(B431dn) nnn:PAPER JAM CHECK MANUAL(B411dn) nnn:PAPER JAM	OFF	Blinking	Paper jams occur while feeding from the MP tray or manual tray. Open the top cover to remove a jammed sheet.
Error	391 392	OPEN UPPER COVER nnn:PAPER JAM	OFF	Blinking	Paper jams occur while feeding from tray1 and tray2. Open the top cover to remove a jammed sheet.
Error	380	OPEN UPPER COVER nnn:PAPER JAM	OFF	Blinking	Paper jams occur while paper is fed in a paper path. Open the top cover to remove a jammed sheet.
Error	381 382 389	OPEN UPPER COVER nnn:PAPER JAM	OFF	Blinking	Paper jams occur while paper is fed in a paper path. Open the top cover to remove a jammed sheet. 381: Under the drum 382: Around the fuser unit 383: Place which can not be identified.
Error	409	OPEN UPPER COVER nnn:FACE UP STACKER ERROR	OFF	Blinking	Since the face-up stacker is operated during printing, printing is stopped, and it is regarded as an error.
Error	372	OPEN REAR COVER nnn:PAPER JAM	OFF	Blinking	Paper jams occur around the duplex unit. Open the front cover to remove a jammed paper. Paper in the rear side.
Error	347	REPLACE IMAGE DRUM nnn:DRUM LIFE	OFF	Blinking	The image drum cartridge has reached the end of its life. Replace the image drum cartridge.
Error	353 563	REPLACE IMAGE DRUM nnn:DRUM LIFE	OFF	Blinking	The image drum cartridge has reached the end of its life. Replace the image drum cartridge.
Error	547	CHECK TONER CARTRIDGE nnn:IMPROPER LOCK LEVER POSITION	OFF	Blinking	The toner is not supplied. Check that the knob of the toner cartridge is horizontal. Tap the cartridge.
Error	343	CHECK IMAGE DRUM nnn:DRUM MISSING	OFF	Blinking	The image drum cartridge is not correctly installed. Reinstall the image drum cartridge.
Error	310 587	CLOSE COVER nnn:COVER OPEN	OFF	Blinking	The top cover or the rear cover is open. Close the cover. 310: Top cover 587: Rear cover
Error		WAIT A MOMENT DATA RECEIVE	OFF	Blinking	In receiving the NIC program data to be updated.
Error		WAIT A MOMENT DATA RECEIVED OK	OFF	OFF	The reception of NIC program data to be updated is completed.

Table 6-1 (7/8)

Status level	Error code nnn	LCD (16 digits on the upper level and 16 digits on the lower level) ("□" shows that nothing is displayed on the upper level.)	LED		Contents
			Ready	Atten	
Error		CHECK DATA REC DATA ERROR <%DLCODE%>	OFF	ON	It shows that an error occurs during the processing of received NIC program data to be updated.  1: Size error 2: Check SUM error 3: Printer model No. error 4: Module I/F version error 5: FAT Version error
Error		WAIT A MOMENT DATA WRITING	OFF	Blinking	In writing the NIC program data to be updated.
Error		POWER OFF/ON DATA WRITTEN OK	OFF	OFF	It is completed to write the NIC program data to be updated.
Error		CHECK DATA DATA WRITE ERROR <%DLCODE%>	OFF	ON	An error occurs while writing the NIC program data to be updated. 1: Memory Alloc Error 2: Download File Error 3: Device Free Space Acquisition error 4: Device Inefficient Free Space error 5: File Write error 6: CU-F/W Mismatch error
Error		REBOOTING %CODE%	OFF	ON	Remove the controller unit. %CODE% 0: Remove due to other than the following causes. 1: Reboot due to the PjL command. 2: Reboot in accordance with the menu change. 3: Reboot due to the quit operator of the PostScript language. 4: Reboot from Network Utility (including Web).
Error		SHUTTING DOWN	OFF	OFF	In shutting down. It is displayed only for B431.
Error		SHUTDOWN	OFF	OFF	The shut down is completed. It is displayed only for B431.
Error		PLEASE POW OFF SHUTDOWN COMP	OFF	OFF	The shutdown is completed. Turn off the power. It is displayed only for B431.
Fatal		POWER OFF/ON nnn: ERROR	OFF	Blinking	Failures occur in the printer. The following error name is not displayed. 3 digits of the error code are entered in nnn displayed in LCD. * The lower line is only scrolled for the display.
		SERVICE CALL nnn: ERROR			
	001				Machine Check Exception
	002				DSI Exception (Data read failure)
	003				ISI Exception (Instruction read failure)
	004				Alignment Exception (Memory access error)
	005				Program Exception (Illegal instruction, trap instruction, privilege violation, and so on)
	006				Floating-point Unavailable Exception
	007				Instruction Address Breakpoint Exception (for debugging mode only)
	020				CU ROM Hash Check Error (resident or ROM slot 1)
	023				CU Font ROM Hash Check Error (resident) <Reserved>
	024				CU Font ROM Hash Check Error (ROM slot 1)
	030				CU RAM Check Error (resident)
	031				CU RAM Check Error (option slot) Reinstall the memory. The genuine memory is used as the expansion memory.
	034				RAM Configuration Error
	040				CU EEPROM Error
	041				CU Flash Memory Error

Table 6-1 (8/8)

Status level	Error code nnn	LCD (16 digits on the upper level and 16 digits on the lower level) ("□" shows that nothing is displayed on the upper level.)	LED		Contents
			Ready	Atten	
	042				Flash File System Error
	043				Flash File System Version Mismatch
	049				CU Engine Type Mismatch
	063				PCI Driver Open error <Reserved>
	070				PostScript Internal Error
	072				Engine Communication Error
	073				H/W Overrun detect
	074				F/W Overrun detect
	075				Video Interface Error
	081				Parameter Consistency Check Error
	104				Engine EEPROM Error
	106				Engine Control Error
	112				Illegal Tray2 Unit
	120				PU Board Fan Motor Error
	121				Power Supply LSI Error
	122				Power Supply Fan Motor Error
	123				Humidity Sensor
	124				Temperature Sensor
	126				Sensor Dewed Error
	127				Fuser Unit Fan Error
	128				Engine Fan Motor Error
	134				Black LED Head Missing
	153				Black Image Drum Fuse Cut Error
	163				Black Toner Sensor Error
	170				Upper Thermistor Circuit Shortened
	171				Upper Thermistor Circuit Opened
	172				Upper Heater High Temperature
	173				Upper Heater Low Temperature
					Fuser unit humidity error. Turn off the power and wait a moment. And then, turn on the power.
	182				Tray2 Unit I/F Error
					Reinstall the second tray unit of the options.
	190				System Memory Overflow
	203				EnginePageSequencer IMGACK Error
	204				EnginePageSequencer IMGSET Error
	207				EnginePageSequencer illegal Function Call
	208				EnginePageSequencer Parameter Error
	209				Media Table Download Failure
	213				EngineControl Print Sequence Error <Reserved>
	230				TONER Reader not installed
	231				TONER Reader I/F Error
	923				Black Image Drum Lock Error
	928				Fuser Motor Lock Error
	982				Excessive Optional Tray Detected
	0xF0C				System Call Exception
	0xF0D				Trace Exception
	0xFFFF				Bus Controller ROM Write Protection

### 6.5.2 LCD Message Troubleshooting

If you still have trouble even after using the LCD Status Message/ Trouble List, follow the troubleshooting flowchart displayed below to solve the trouble.

No.	Trouble	Flowchart No.
1.	The printer does not work normally after tuning on the power.	①
2.	Jam Alert <ul style="list-style-type: none"> <li>— Paper feed jam</li> <li>— Paper path jam</li> <li>— Paper ejection jam</li> </ul>	②-1 ②-2 ②-3
3.	Paper size error	③
4.	Fuser unit error	④
5.	SSIO (Synchronized serial input and output) between Printer and Option Tray (Second Tray unit) Error interface time out (No response)	⑤
6.	Fan error	⑥

① The case where the printer does not work normally after tuning on the power

- Turn off the power and then, turn on the power again.

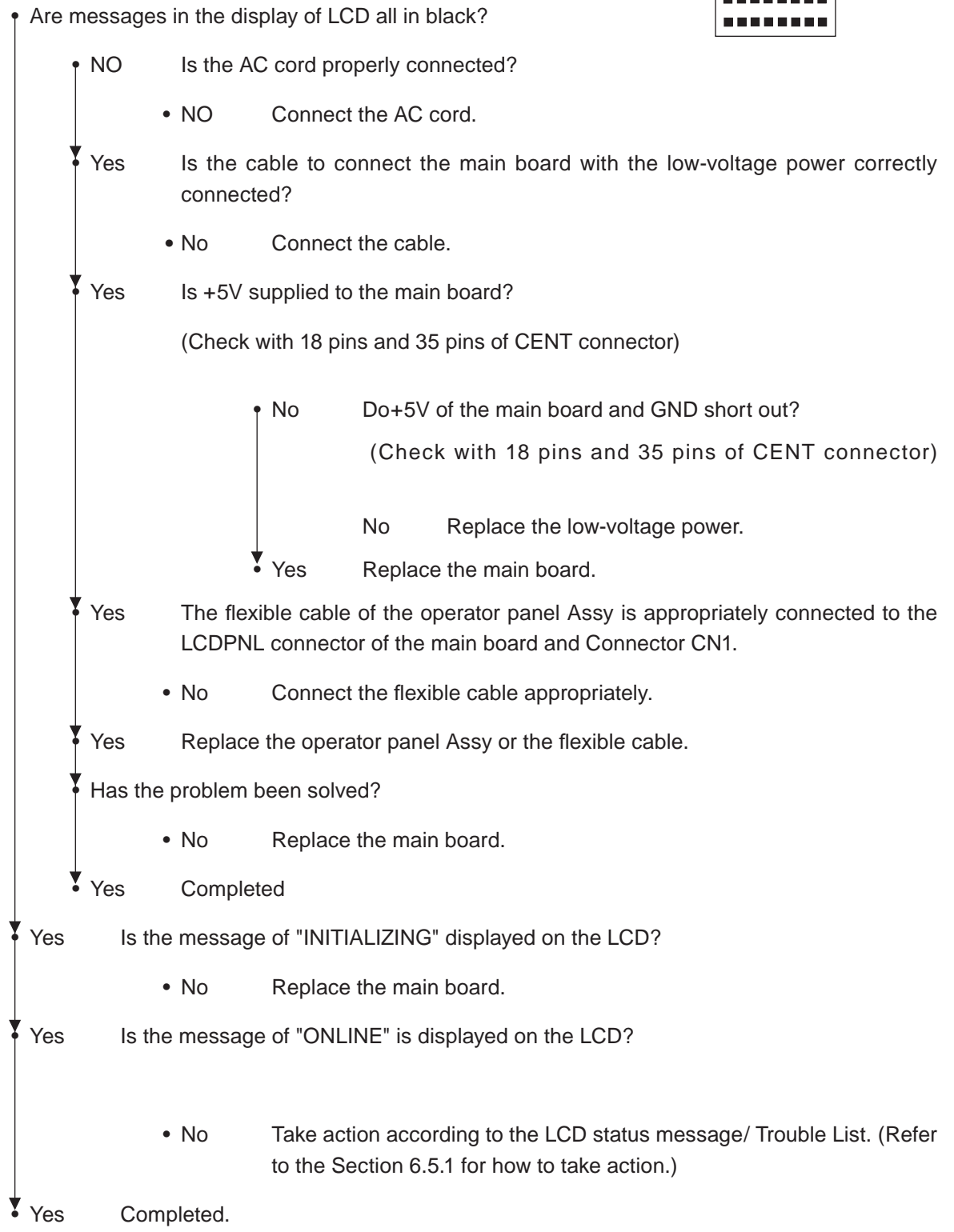
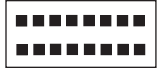



[Jam Error]

②-1 Paper feed jam

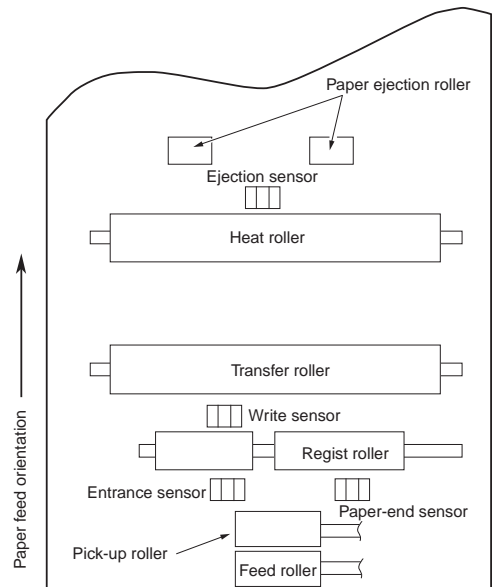
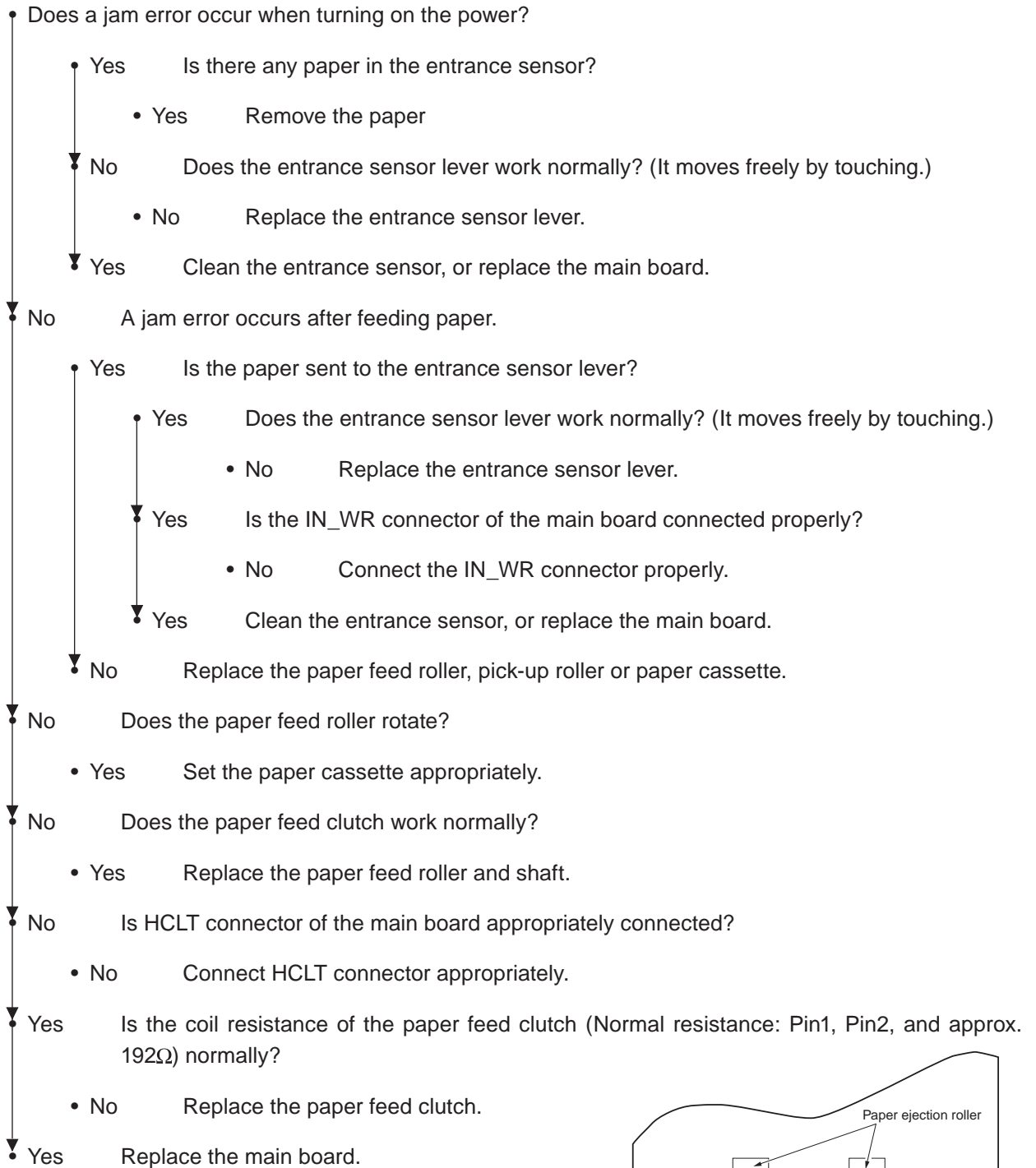

## [Jam Error]

## ②-2 Running jam

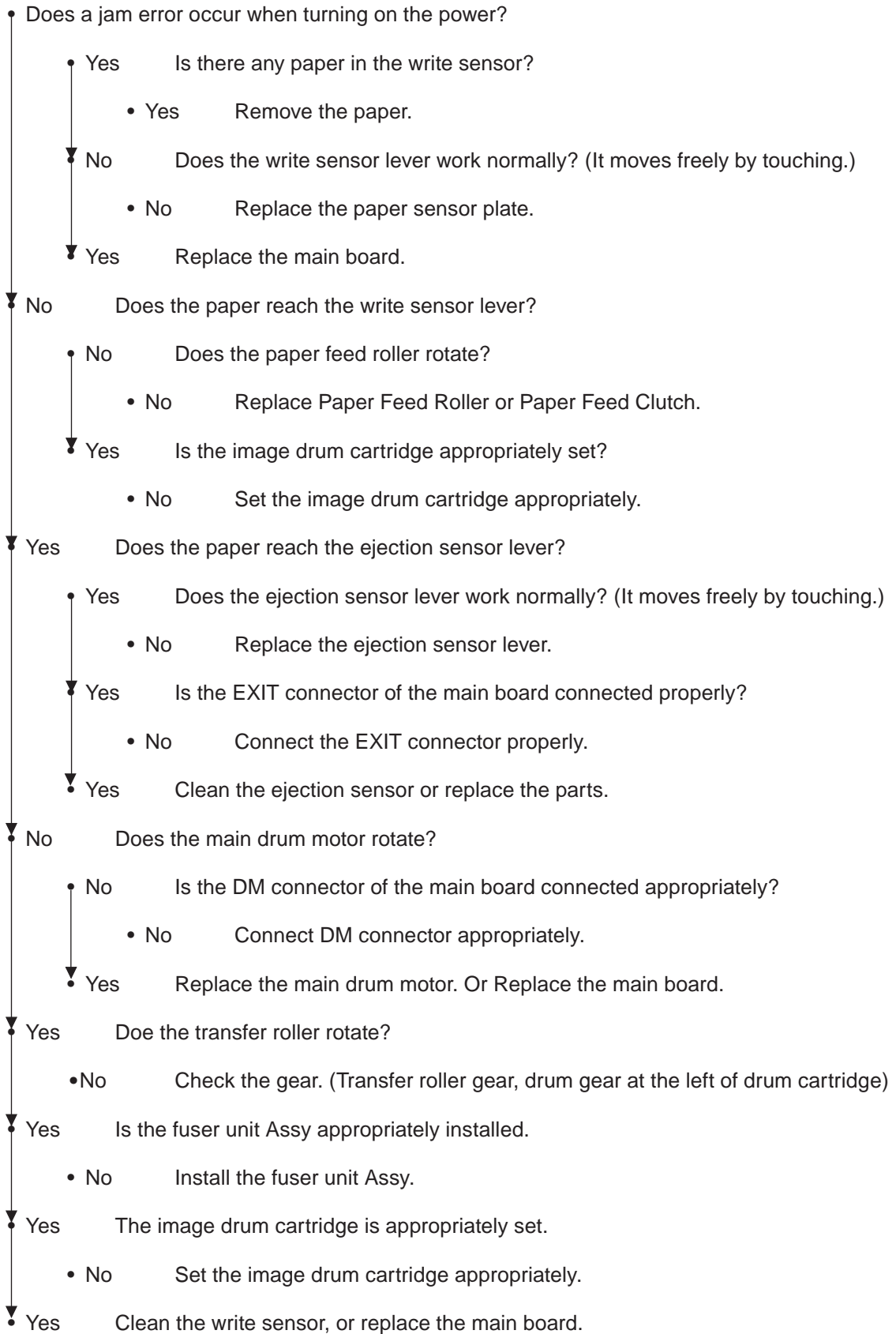

[Jam Error]

②-3 Ejection Jam

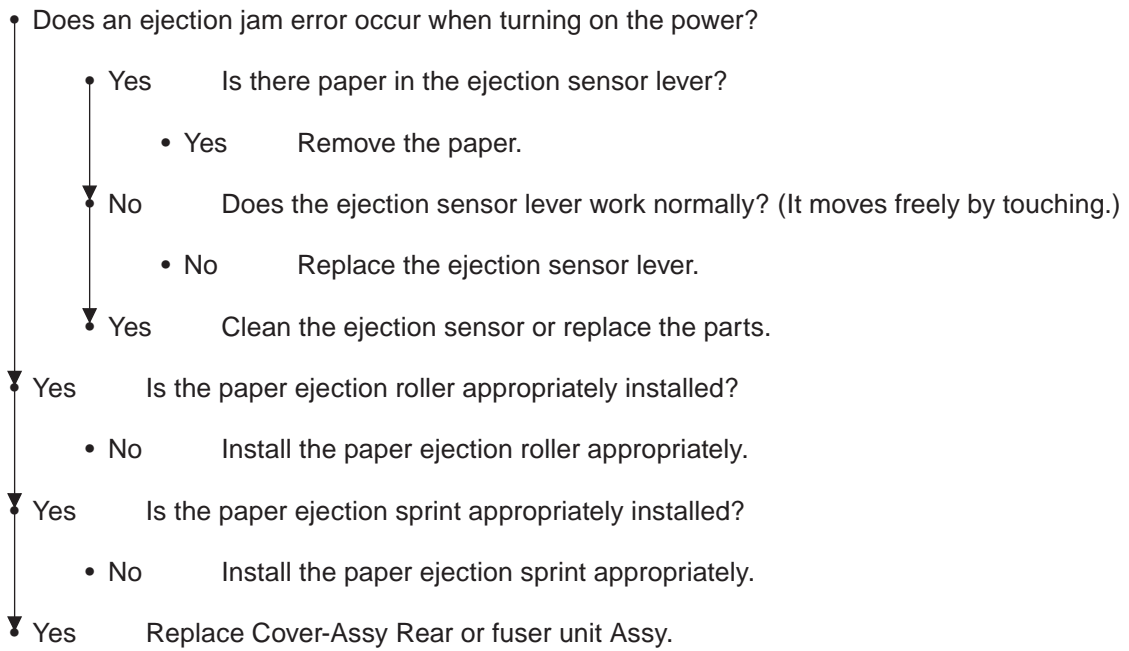

③ Paper Size Error

- Is the paper which is specified size used?
  - No Use a specified-size paper.
- ▼ Yes Does the entrance sensor lever work normally? (It moves freely by touching.)
  - No Replace the entrance sensor lever, or clean the entrance sensor.
- ▼ Yes Does the write sensor lever work appropriately? (It moves freely by touching.)
  - No Replace the write sensor lever, or clean the write sensor.
- ▼ Yes Replace the main board.

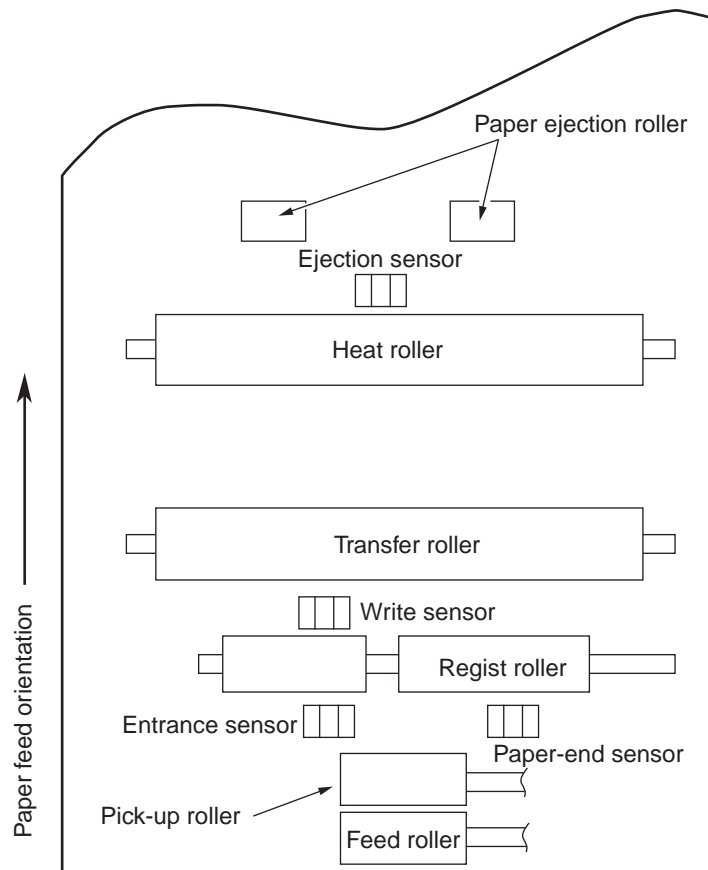

④ Fuser unit Assy (Error 170) (Error 171) (Error 172) (Error 173)

- Is the thermistor connector inserted into the THERM connector of the main board normally?
  - No      Insert the Thermistor connector correctly.
- ▼ Yes      Is the heater connector normally inserted in the CN201 connector of the low-voltage power.
  - No      Insert the heater connector appropriately.
- ▼ Yes      Is the heater ON when turning on the power?
  - No      Replace the fuser unit Assy, low-voltage power or main board.
- ▼ Yes      Replace the fuser unit Assy or the main board.

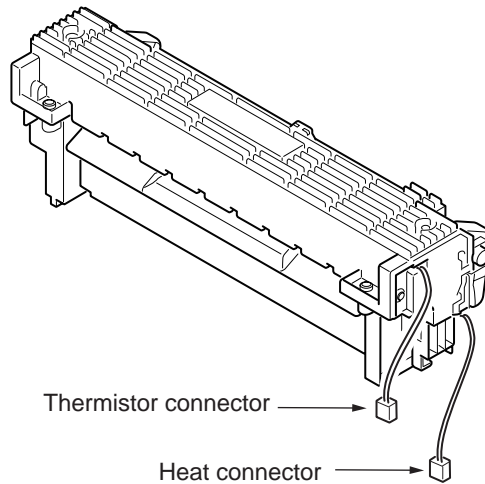

Figure 6-1

⑤ Interface Error (Error 182)

- Is the Second Tray unit used?
  - Yes      Is the printer main body appropriately set on the Second Tray unit?
    - No      Set the printer main body appropriately.
  - ▼ Yes      Replace the main board.
  - ▼ Has the trouble been solved?
    - No      Check the trouble according to the maintenance manual of the Second Tray unit of the appendix C.
  - ▼ Yes      Completed.
- ▼ No      Replace the main board.

## ⑥ Exhaust Fan Error (Error 120)

- Is the exhaust fan rotating?
  - Yes      Replace the main board.
- ▼ No      Is the fan connector of the high-voltage power supply unit connected to the board properly?
  - No      Connect the fan connector appropriately.
- ▼ Yes      Replace the exhaust fan or main board.

## ⑦ Duct Fan Error (Error 127)

- Is the duct fan rotating?
  - Yes      Replace the main board.
- ▼ No      Is the fan connector of the main board connected to the board properly?
  - No      Connect the fan connector appropriately.
- ▼ Yes      Replace the duct fan or main board.

## ⑧ Power supply unit Fan Error (Error 128)

- Is the power supply unit fan rotating?
  - Yes      Replace the main board.
- ▼ No      Is the fan connector of the main board connected to the board properly?
  - No      Connect the fan connector appropriately.
- ▼ Yes      Replace the power supply unit fan or main board.

### 6.5.3 Print Troubleshooting

The troubleshooting procedure of abnormal printing is described as follows. The typical abnormal printing is shown in the following Figure 6-2.

Trouble	Flowchart number
Pale printing or the whole printing is faded. (Fig.6-2 (A))	①
The white section is dirty. (Fig.6-2 (B))	②
White paper is outputted (Fig. 6-2 (C))	③
Vertical black belt/ Black line (Fig. 6-2 (D))	④
Periodic failure (Fig. 6-2 (E))	⑤
A part of printing is extracted	⑥
Inefficient fusing (when touching the printed sheet, printed characters or image is faded or come off.)	⑦
Vertical white belt/ White line (Fig. 6-2 (F))	⑧

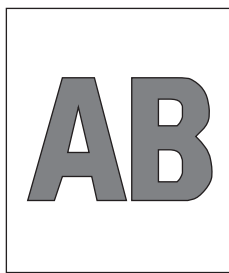

(A) Pale printing or the whole printing is faded

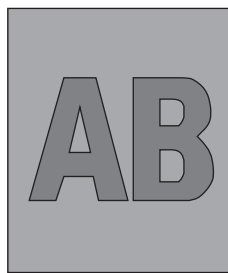

(B) The white section is dirty

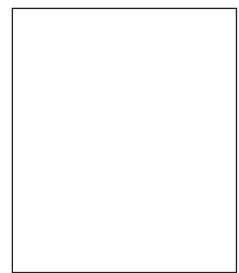

(C) White paper

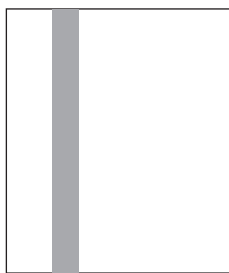

(D) Vertical black belt/ Black line

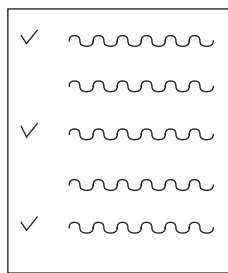

(E) Periodic failure

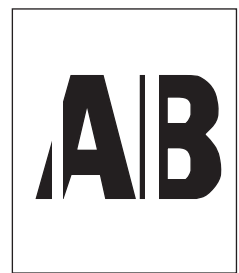

(F) Vertical white belt/ White line

Figure 6-2

① Pale printing or the whole printing is faded.

- Does the printer lack toner? (Is the message of Toner Low displayed?)
  - Yes      Supply the toner.
- ▼ No      Is specified paper used.
  - No      Use specified paper.
- ▼ Yes      Is the lens of the LED head dirty?
  - Yes      Clean the lens.
- ▼ No      Is the LED head appropriately installed?  
(Check that the HEAD connector of the main board and the PC connector of the LED head are appropriately connected.)
  - No      Install the LED head appropriately.
- ▼ Yes      Does the contact plate of the transfer roller contact the TR terminal of the high-voltage power supply unit properly? (See Figure 6-4 , Section 7.2(3))
  - No      Adjust the contact plate of the transfer roller so that it contacts the TR terminal of the high-voltage power supply unit and the transfer roller shaft well.
- ▼ Yes      Are the contact of the developing roller and toner supply roller of the image drum cartridge appropriately connected to the contact assembly? (See Figure 6-3 (A) and (C))
  - No      Adjust so that the contacts of the developing roller and toner supply roller are connected to the contact assembly.
- ▼ Yes      Replace the transfer roller.
- ▼ Has the trouble been solved?
  - Yes      Completed
- ▼ No      Replace the image drum cartridge.
- ▼ Has the trouble been solved?
  - Yes      Completed
- ▼ No      Is the surface elasticity of the back-up roller normal?
  - No      Replace the fuser Assy.
- ▼ Yes      Replace the main board or high-voltage power supply unit.

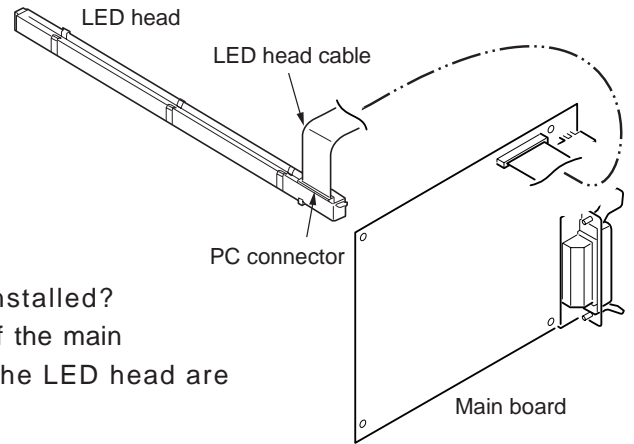



## ② The white section is dirty

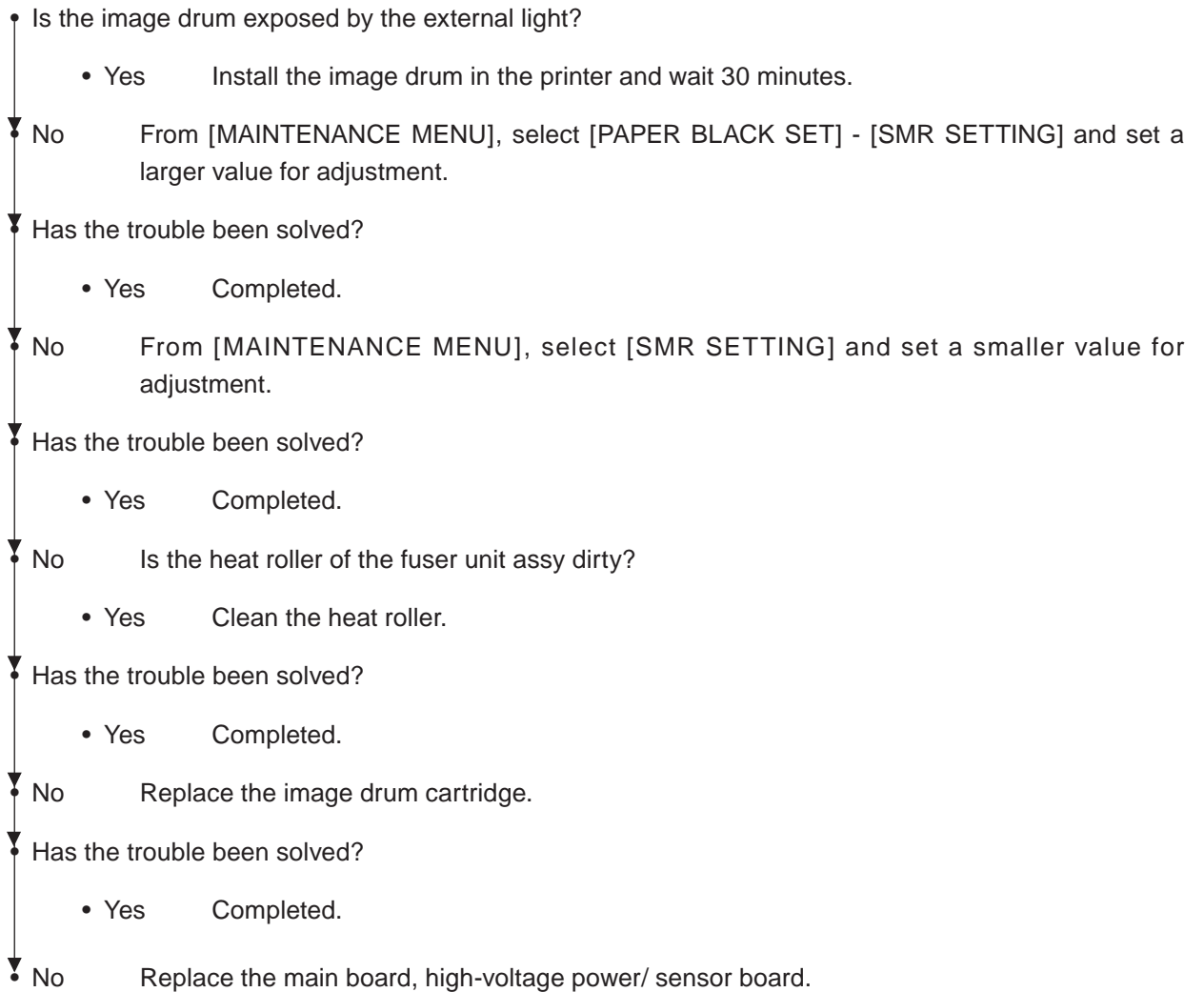

## ③ White paper is outputted

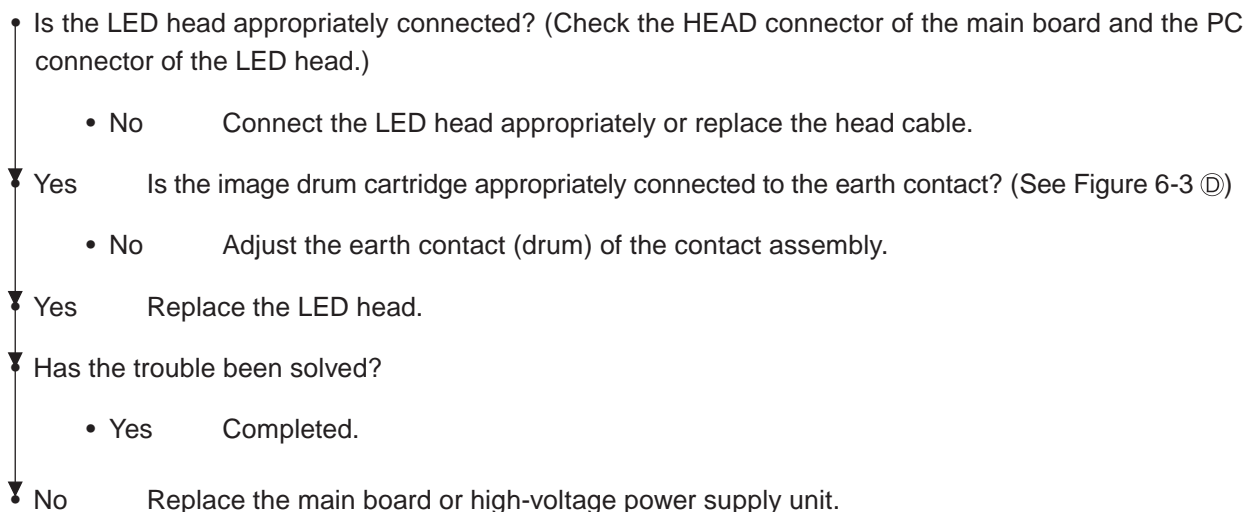

④ Vertical black belt/ Black line

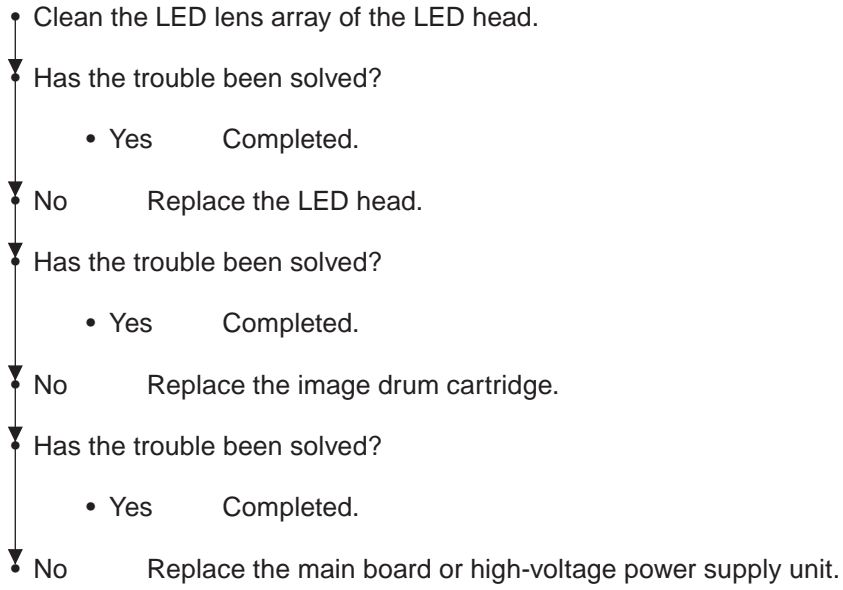

⑤ Periodic failure

	Cycle	Handling
Image Drum	94.25mm	Replace or clean the image drum cartridge.
Developing roller	39.68mm	Replace the image drum cartridge.
Toner supply roller	58.36mm	Replace the image drum cartridge.
Charging roller	37.70mm	Replace the image drum cartridge.
Transfer roller	51.52mm	Replace the transfer roller.
Heat roller	88.12mm	Replace the fuser unit Assy.
Back-up roller	89.54mm	Replace the back-up roller.

## ⑥ In case of error printing

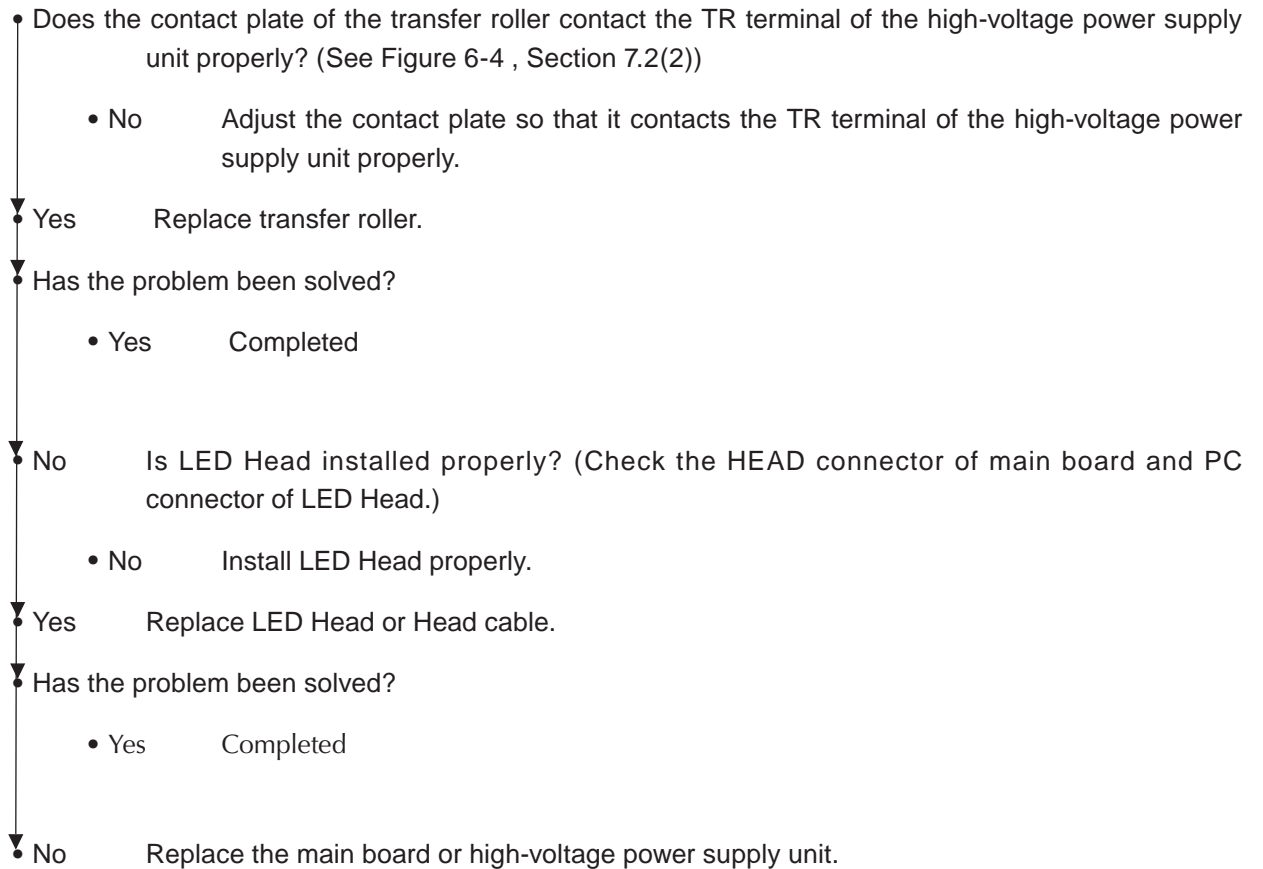

## ⑦ In case of inefficient fusing (If touch by hand the character or image that are printed on paper will be faded or unstuck.)

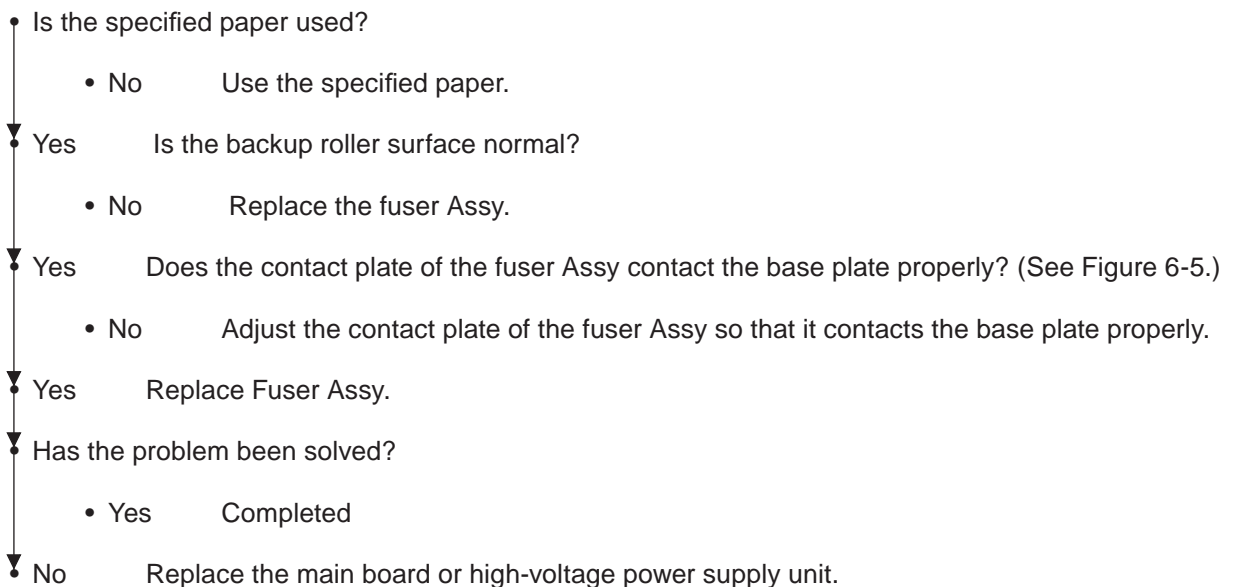

## ⑧ Vertical white belt/ White line

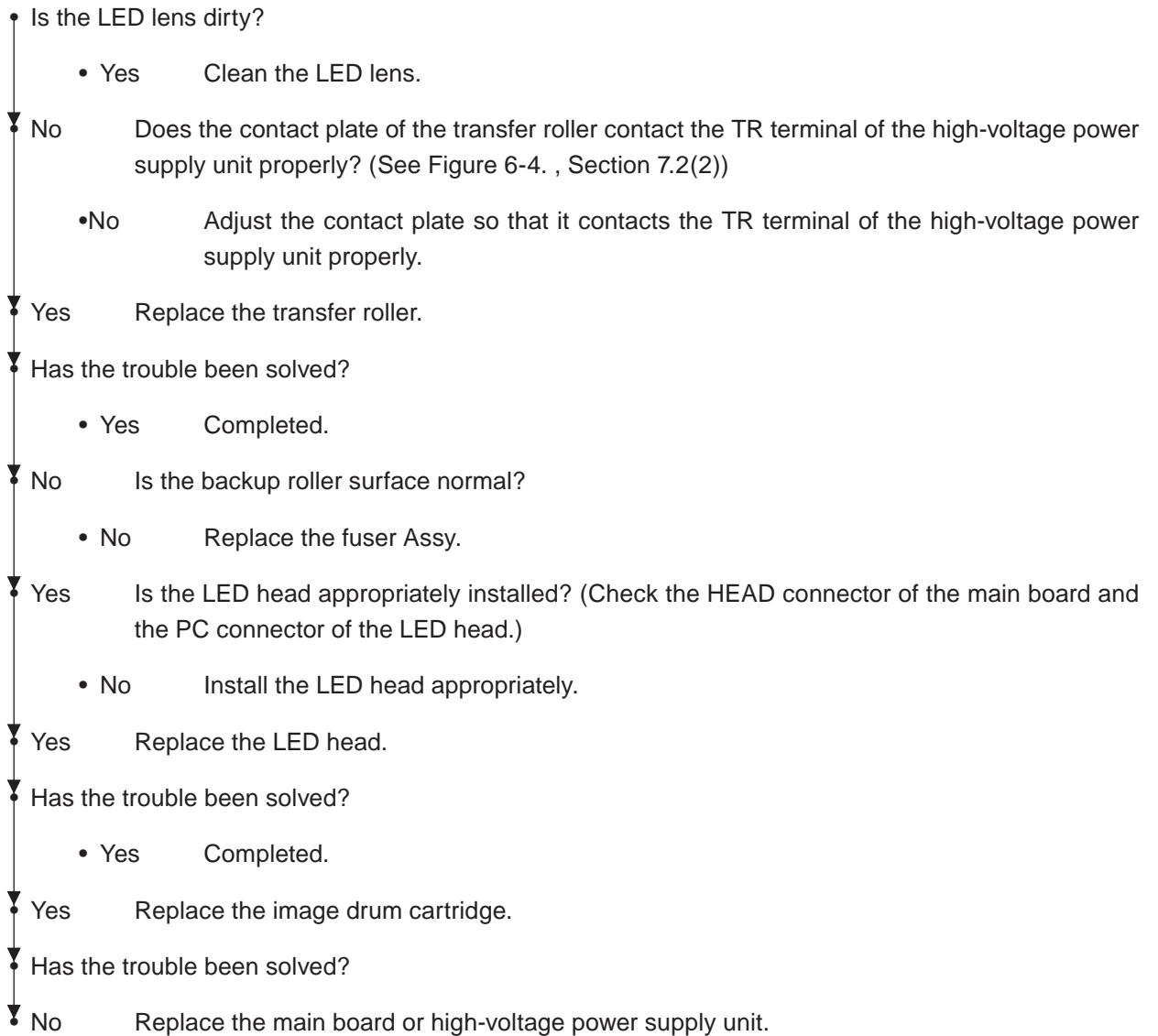

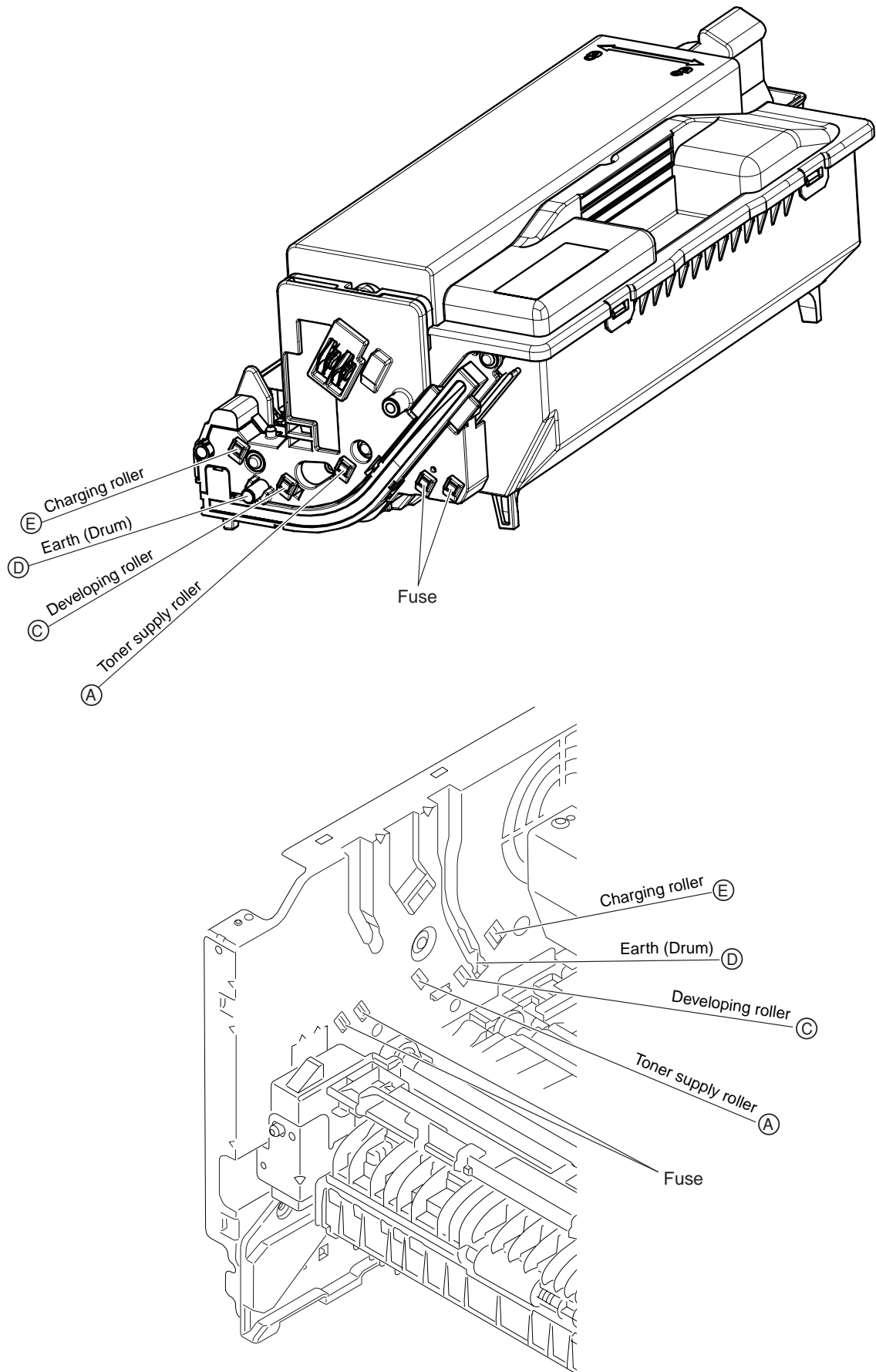

Figure 6-3

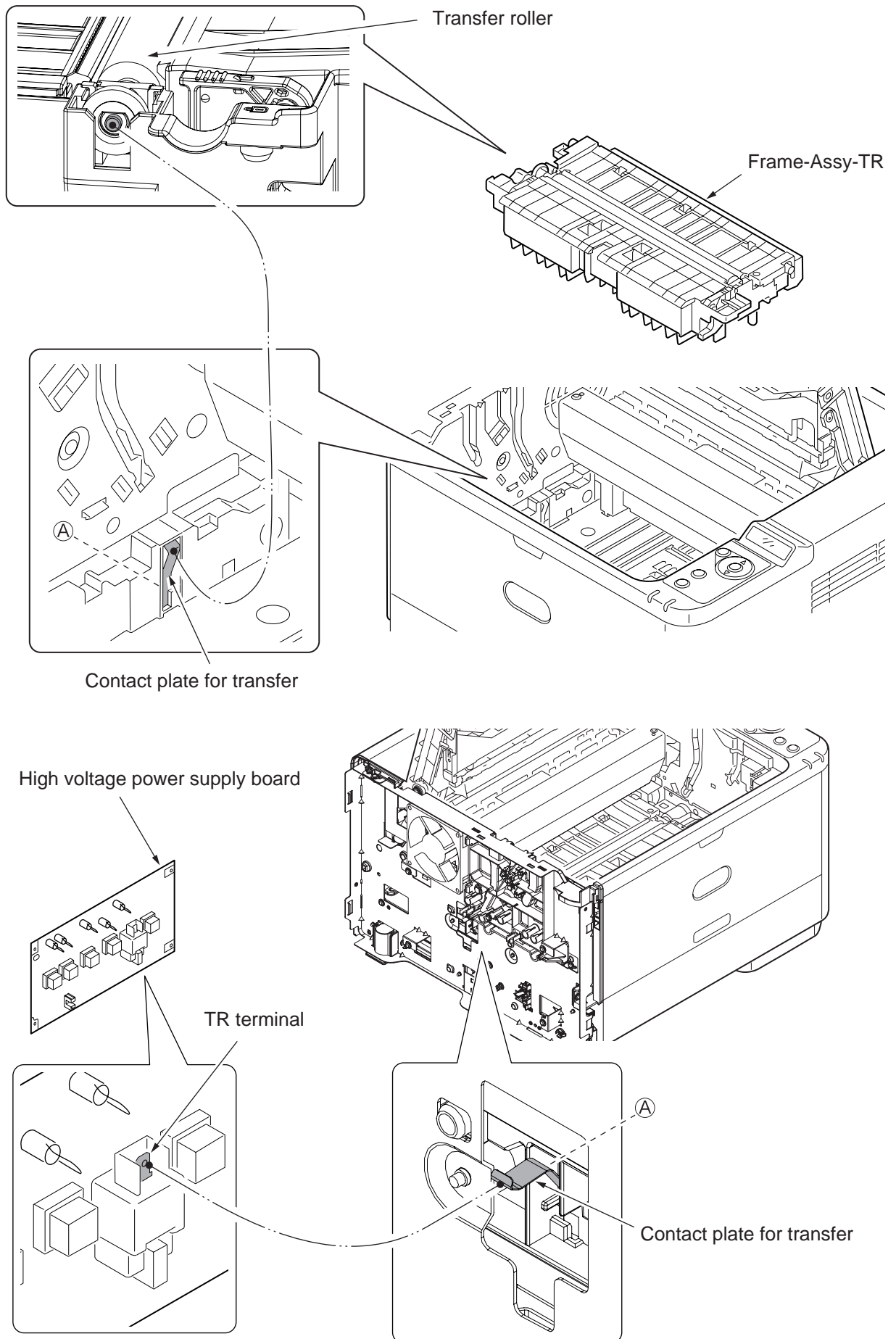

Figure 6-4

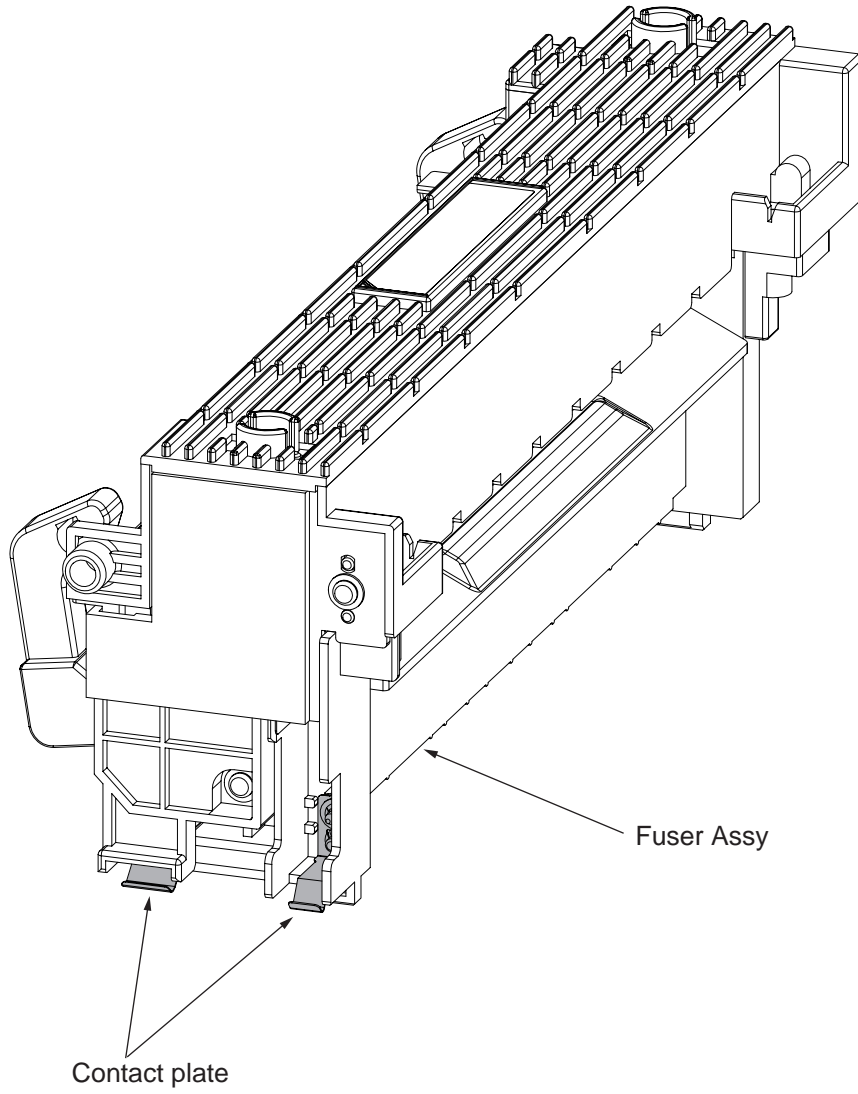
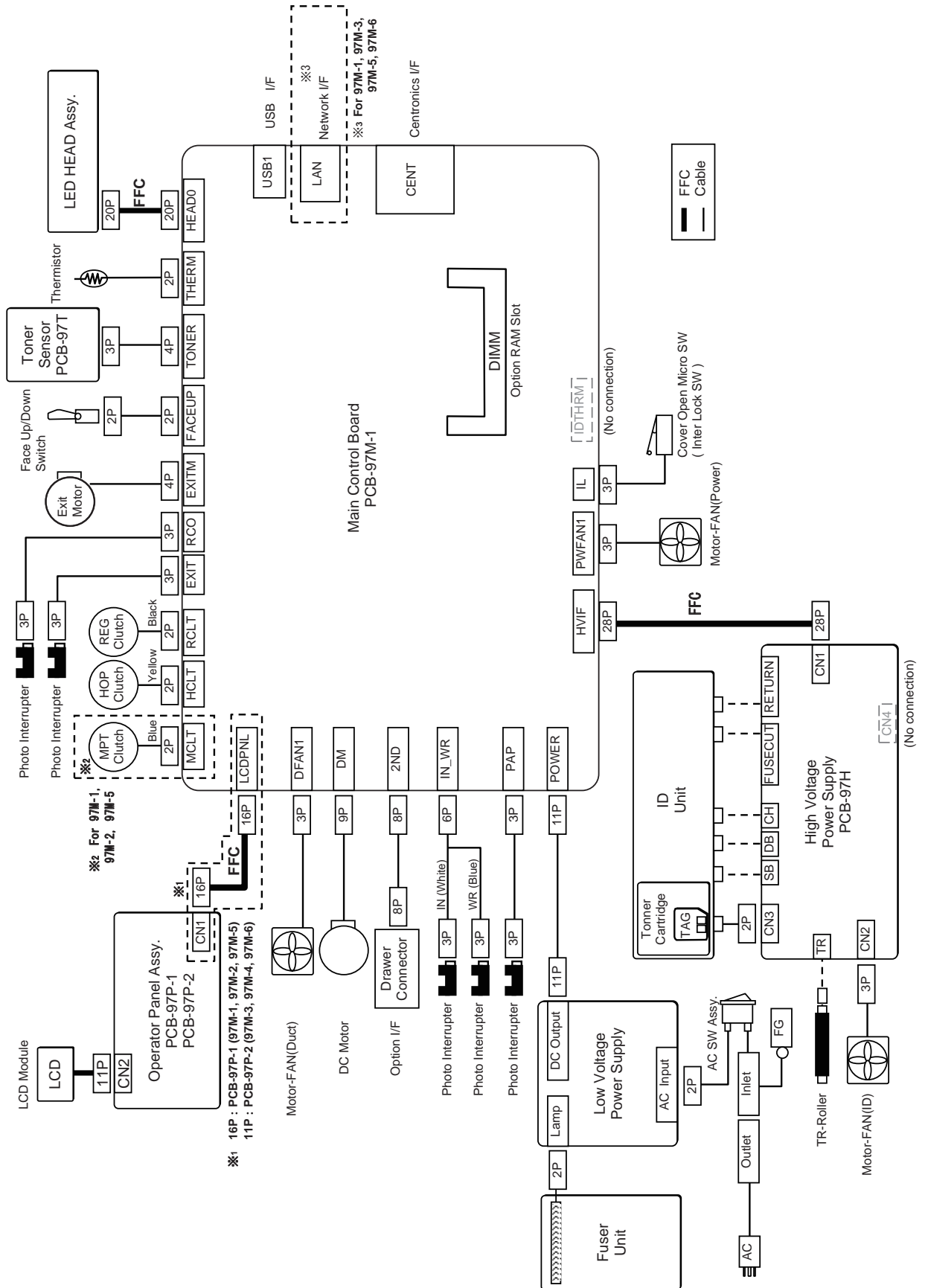

Figure 6-5

# 7. Connection Diagram

## 7.1 Connection diagram





## 7.2 Board Layout

### (1) Main control board

The front side of the printer.

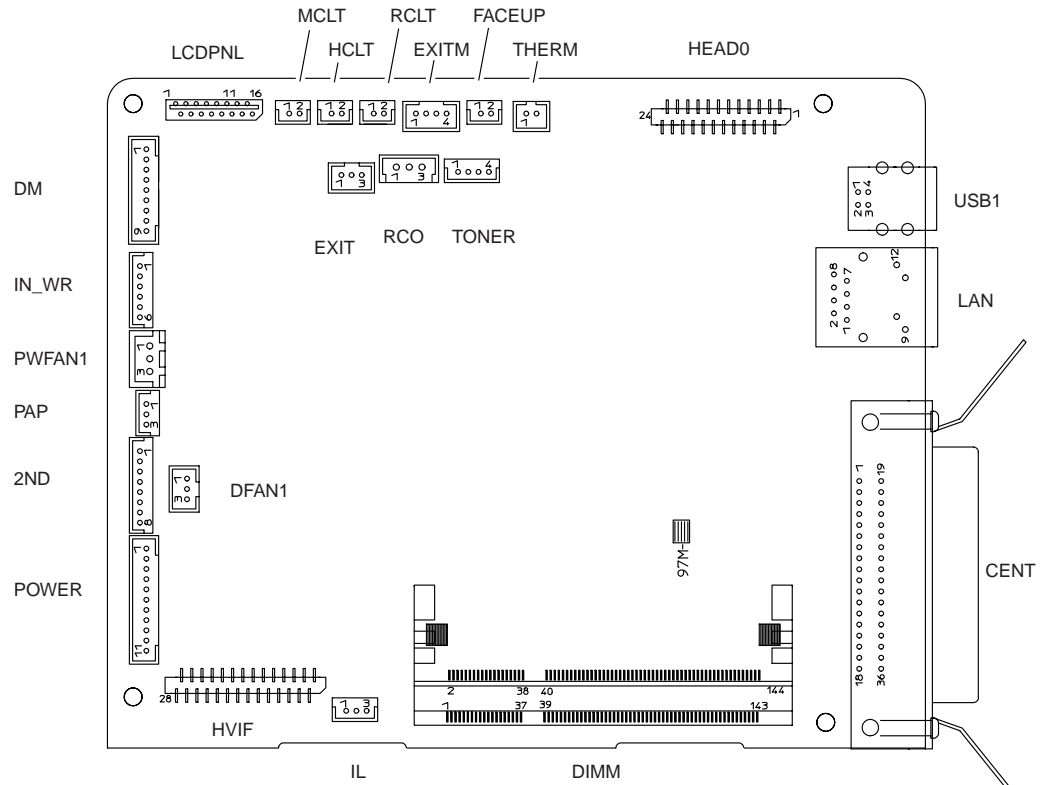

- USB1 Connector Pin Allocation  
(Connection to USB I/F)

Pin No.	I/O	Signal	Function
1	I	vbus	Power
2	I/O	D-	Serial Data
3	I/O	D+	Serial Data
4	C	GND	Logic Ground

- LAN Connector Pin Allocation  
(Connection to LAN I/F)

Pin No.	I/O	Signal	Function
1	O	TXD+	Transmission signal +
2	O	TXD-	Transmission signal -
3	I	TXCT	Transmission midpoint
4	-	NC	Not used
5	-	NC	Not used
6	I	RXCT	Reception midpoint
7	I	RXD+	Reception signal+
8	I	RXD-	Reception signal -
9	I	LLED_A	LED supply voltage
10	I	LLED_K	LED ON signal
11	I	RLED_K	LED ON signal
12	I	RLED_A	LED supply voltage

- CENT Connector Pin Allocation  
(Connection to the Centronics I/F)

1	19
2	20
3	21
4	22
5	23
6	24
7	25
8	26
9	27
10	28
11	29
12	30
13	31
14	32
15	33
16	34
17	35
18	36

Pin No.	I/O	Signal	Function
1	I	STB-N	Strobe
2	C	DATA0-P	Data bit 0
3	C	DATA1-P	Data bit 1
4	C	DATA2-P	Data bit 2
5	C	DATA3-P	Data bit 3
6	C	DATA4-P	Data bit 4
7	C	DATA5-P	Data bit 5
8	C	DATA6-P	Data bit 6
9	C	DATA7-P	Data bit 7
10	O	ACK-N	Acknowledge
11	O	BUSY-P	Busy
12	O	PE-P	Paper End
13	O	SEL-P	Select
14	I	AUTOFEED-N	Auto Feed
15	-	NC	Not connected
16	C	SG	Logic Ground
17	C	FG	Chassis Ground
18	O	HILEVEL	High Level
19	C	SG	Logic Ground
20	C	SG	Logic Ground
21	C	SG	Logic Ground
22	C	SG	Logic Ground
23	C	SG	Logic Ground
24	C	SG	Logic Ground
25	C	SG	Logic Ground
26	C	SG	Logic Ground
27	C	SG	Logic Ground
28	C	SG	Logic Ground
29	C	SG	Logic Ground
30	C	SG	Logic Ground
31	I	IPRIM-N	I Prime
32	O	FAULT-N	Fault
33	C	SG	Logic Ground
34		NC	Not connected
35	O	HILEVEL	High level
36	I	SELIN-N	Select-IN

- DIMM Connector Pin Allocation  
(Option RAM Slot)

Pin No.	I/O	Signal	Function
1		VREF	Reference Power Voltage
2	-	NC	Not used
3		VSS	Logic Ground
4	-	NC	Not used
5	-	NC	Not used
6	-	NC	Not used
7	-	NC	Not used
8	-	NC	Not used
9		VSS	Logic Ground
10	-	NC	Not used
11	-	NC	Not used
12	-	NC	Not used
13	-	NC	Not used
14	-	NC	Not used
15		VSS	Logic Ground
16	-	NC	Not used
17	-	NC	Not used
18	-	NC	Not used
19	-	NC	Not used
20	-	NC	Not used
21		VSS	Logic Ground
22		VDD	Logic Power
23	-	NC	Not used
24	-	NC	Not used
25	I/O	VSS	Logic Ground
26		A13	Address Bus13
27	-	NC	Not used
28		A11	Address Bus11
29	-	NC	Not used
30		VDD	Logic Power
31		VSS	Logic Ground
32		A6	Address Bus6
33	-	NC	Not used
34		A2	Address Bus2
35	-	NC	Not used
36		/CAS	/Column-Address Strobe
37		VSS	Logic Ground
38		VDD	Logic Power
39		VSS	Logic Ground
40	-	NC	Not used
41		DQ0	Data Bus0
42		VDD	Logic Power
43		DQ1	Data Bus1
44	-	NC	Not used
45		VSS	Logic Ground
46		VSS	Logic Ground
47		DQ2	Data Bus2
48		CK0	Clock0
49		DQS3	Data Strobe3
50		/CK0	/Clock0
51		VSS	Logic Ground
52		VSS	Logic Ground
53		/DQS0	/Data Strobe0
54	-	NC	Not used
55		DQS0	Data Strobe0

Pin No.	I/O	Signal	Function
56		VDD	Logic Power
57		VSS	Logic Ground
58		ODT0	ODTControl0
59		DM0	Data Mask0
60		CKE0	Clock Enable0
61		VSS	Logic Ground
62		/WE	/Write Enable
63		DQ4	Data Bus4
64		VDD	Logic Power
65		DQ5	Data Bus5
66	-	NC	Not used
67		VSS	Logic Ground
68		BA1	Bank Select1
69		DQ6	Data Bus6
70		A10/AP	Address Bus10/Address BusP
71		DQ7	Data Bus7
72		VDD	Logic Power
73		VSS	Logic Ground
74		A3	Address Bus3
75		DQ8	Data Bus8
76		A7	Address Bus7
77		DQ9	Data Bus9
78	-	NC	Not used
79		VSS	Logic Ground
80		VDD	Logic Power
81		DQ10	Data Bus10
82	-	NC	Not used
83		DQ11	Data Bus11
84		A8	Address Bus8
85		VSS	Logic Ground
86		A4	Address Bus4
87		/DQS1	/Data Strobe1
88		VDD	Logic Power
89		DQS1	Data Strobe1
90		A0	Address Bus0
91		VSS	Logic Ground
92		BA2	Bank Select2
93		DM1	Data Mask1
94		/S0	/S0
95		VSS	Logic Ground
96		VDD	Logic Power
97		DQ12	Data Bus12
98		/RAS	/Low Address Strobe
99		DQ13	Data Bus13
100		VSS	Logic Ground
101		VSS	Logic Ground
102		CK1	Clock1
103		DQ14	Data Bus14
104		/CK1	/Clock1
105		DQ15	Data Bus15
106		VSS	Logic Ground
107		VSS	Logic Ground
108	-	NC	Not used
109	-	NC	Not used
110		VDD	Logic Power
111	-	NC	Not used
112		BA0	Bank Select0
113		VSS	Logic Ground
114		A1	Address Bus1
115	-	NC	Not used

Pin No.	I/O	Signal	Function
116		A5	Address Bus5
117	-	NC	Not used
118		VDD	Logic Power
119		VSS	Logic Ground
120		A9	Address Bus9
121	-	NC	Not used
122		A12	Address Bus12
123	-	NC	Not used
124		VDD	Logic Power
125		VSS	Logic Ground
126	-	NC	Not used
127	-	NC	Not used
128	-	NC	Not used
129		VSS	Logic Ground
130	-	NC	Not used
131	-	NC	Not used
132		VSS	Logic Ground
133	-	NC	Not used
134		SDA	EEPROM Serial Data
135		VSS	Logic Ground
136		SA0	Logic Ground
137	-	NC	Not used
138		SA1	Logic Ground
139	-	NC	Not used
140		SA2	Logic Ground
141		VSS	Logic Ground
142		SCL	EEPROM Serial Clock
143	-	NC	Not used
144		VDDSPD	EEPROM Power

- HEAD0 Connector Pin Allocation  
(Connection the LED HEAD Assy)

Pin No.	I/O	Signal	Function
1	C	VSS	Logic Ground
2	O	CLKP	Clock
3	O	CLKN	Clock
4	C	VSS	Logic Ground
5	O	LOAD	Load
6	O	HSYNCN	Synchronizing signal
7	O	D3	Data 3
8	O	D2	Data 2
9	O	D1	Data 1
10	O	D0	Data 0
11	O	STBN	Strobe
12	O	SCK	Serial Clock
13	I	SO	Serial Data
14	O	3.3V	Logic Power
15	C	GND	LED Ground
16	O	VDD	LED Drive Power
17	C	GND	LED Ground
18	O	VDD	LED Drive Power
19	C	GND	LED Ground
20	O	VDD	LED Drive Power

- THERM Connector Pin Allocation  
(Connection to the thermistor sensor)

Pin No.	I/O	Signal	Function
1		+3.3V	Thermistor Power Voltage
2		THERM	Fusing Temperature Detection

- FACEUP Connector Pin Allocation  
(Connection to the Face Up/Down Switch)

Pin No.	I/O	Signal	Function
1		FACEUP-N	Faceup/down change
2		0V	Analog Ground

- EXITM Connector Pin Allocation  
(Connection to the Exit Motor)

Pin No.	I/O	Signal	Function
1	O	HOP1	Motor Drive Power
2	O	HOP2	Motor Drive Power
3	O	HOP3	Motor Drive Power
4	O	HOP4	Motor Drive Power

- RCLT Connector Pin Allocation  
(Connection to the Regist Clutch)

Pin No.	I/O	Signal	Function
1	O	+24V	Clutch Drive Power
2	C	REGIST	Analog Ground

- HCLT Connector Pin Allocation  
(Connection to Hopping clutch)

Pin No.	I/O	Signal	Function
1	O	+24V	Clutch Drive Power
2	C	HOPPING	Analog Ground

- MCLT Connector Pin Allocation  
(Connection to the Multi-feeder Clutch)

Pin No.	I/O	Signal	Function
1	O	+24V	Clutch Drive Power
2	C	MPT	Analog Ground

- LCDPNL Connector Pin Allocation  
(Connection to the Operator Panel)  
For B411dn only use Pin No. 1~11.

Pin No.	I/O	Signal	Function
1	O	LCD_RS	Register Selection
2	O	LCD_CSB	Register Clear
3	O	LED2	LED ON
4	O	LCD_CLK	Serial Clock
5	I	CYRI	LCD type distinction
6	O	LCD_DO	Serial Data
7	O	+3.3VLCD	Logic Circuit Power Supply
8	O	LCD_RST	LCD Reset
9	O	LED1	LED ON
10	I	SW6	Switch 6
11	C	GNDLCD	Logic Ground
12	I	SW5	Switch 5
13	I	SW4	Switch 4
14	I	SW3	Switch 3
15	I	SW2	Switch 2
16	I	SW1	Switch 1

- TONER Connector Pin Allocation  
(Connection to the Toner Sensor)

Pin No.	I/O	Signal	Function
1	O	+5V	Logic Circuit Power Supply
2	I	TONER	Toner Sensor
3	C	GND	Logic Ground
4	-	NC	Not used

- RCO Connector Pin Allocation  
(Connection to the Photo interrupter)

Pin No.	I/O	Signal	Function
1	O	+5V	Logic Circuit Power Supply
2	I	RCOPN-N	Rear Cover open
3	C	GND	Logic Ground

- EXIT Connector Pin Allocation  
(Connection to the Photo interrupter)

Pin No.	I/O	Signal	Function
1	O	+5V	Logic Circuit Power Supply
2	I	EXIT-N	Detection of the media output
3	C	GND	Logic Ground

- DM Connector Pin Allocation  
(Connection to the DC Motor)

Pin No.	I/O	Signal	Function
1	O	+24VIC	Logic Circuit Power Supply
2	O	DMON-N	Motor-ON signal
3	I	DMLOCK-P	Motor Lock detection
4	O	DMCLK-P	Motor Clock
5	O	GAIN-P	Motor Gain Chang
6	O	+24V	Motor Drive Power
7	O	+24V	Motor Drive Power
8	C	0VP	Analog Ground
9	C	GND	Logic Ground

- IN\_WR Connector Pin Allocation  
(Connection to the Photo interrupter)

Pin No.	I/O	Signal	Function
1	O	+5V	Logic Circuit Power Supply
2	I	IN	IN Sensor
3	C	GND	Logic Ground
4	O	+5V	Logic Circuit Power Supply
5	I	WR	WR Sensor
6	C	GND	Logic Ground

- PWFAN1 Connector Pin Allocation  
(Connection to the Motor-Fan(Power))

Pin No.	I/O	Signal	Function
1	O	FANPOW	FAN Drive Power
2	C	FANGND	Analog Ground
3	I	FANALM	FAN Alarm Detection



- PAP Connector Pin Allocation  
(Connection to the Photo interrupter)

Pin No.	I/O	Signal	Function
1	O	+5V	Logic Circuit Power Supply
2	I	PAPER-N	Paper end Sensor signal input
3	C	GND	Logic Ground

- 2ND Connector Pin Allocation  
(Connection to the Option tray I/F)

Pin No.	I/O	Signal	Function
1	C	0VP	Analog Ground
2	O	+24V	Motor/ Clutch Drive Power
3	C	0VL	Logic Ground
4	O	+5V	Logic Circuit Power Supply
5	I	OPTRXD	OPT data input
6	O	OPTTXD	OPT data output
7	I	OPINT-N	OPT status change
8	O	OPTFDEN-P	OPT transfer permission

- POWER Connector Pin Allocation  
(Connection to the low-voltage power supply)

Pin No.	I/O	Signal	Function
1	O	HARD_GUARD	Hard Guard
2	O	ACON1-P	Heater ON
3	I	+5V	Logic Circuit Power Supply
4	I	+5V	Logic Circuit Power Supply
5	C	0VL	Logic Ground
6	C	0VL	Logic Ground
7	O	ACZEROX	AC Zero Cross
8	C	0VP	Analog Ground
9	C	0VP	Analog Ground
10	I	+24V	Motor/ FAN/ Clutch Drive Power
11	I	+24V	Motor/ FAN/ Clutch Drive Power

- DFAN1 Connector Pin Allocation  
(Connection to the Motor-Fan(Duct))

Pin No.	I/O	Signal	Function
1	O	FANPOW	FAN Drive Power
2	C	FANGND	Analog Ground
3	I	FANALM	FAN Alarm Detection

- HVIF Connector Pin Allocation  
(Connection to High-Voltage power supply)

Pin No.	I/O	Signal	Function
1	O	+24V	High-Voltage Board Drive Power
2	C	GND	Logic Ground
3	C	GND	Logic Ground
4	I	TMP	Humidity Sensor
5	I	HUM	Humidity Sensor
6	O	HUM_PWM	Humidity Sensor PWM
7	O	FUSECUT	Fuse cut
8	O	RETURN	Fuse cut Electric Current RETURN
9	O	TAGOUT	TAG signal
10	O	PSAVE2-N	Power save 2
11	I	TRAY	1ST Cassette Sensor
12	O	DB1PWM	DB1 PWM
13	O	DB2PWM	DB2 PWM
14	O	SBPWM	SB PWM
15	I	TR_V	TR Power Voltage Detection
16	I	TR_I	TR Electric Current Detection
17	O	TR2PWM	TR2 PWM
18	O	ANSW	High-Voltage Board Analog switch change
19	O	TR1PWM	TR1 PWM
20	O	CHPWM	CH PWM
21	O	OUT_EN	High-Voltage output Enable
22	O	SCL	Serial Clock
23	I/O	SDA	Serial Data
24	O	+5V	Logic Circuit Power Supply
25	C	GND	Logic Ground
26	O	LIGHT	Electricity-removing light ON
27	I	FANALM	FAN Alarm Detection
28	O	FANPOW	FAN Drive Power

- IL Connector Pin Allocation  
(Connection to the Cover Open Micro Switch)

Pin No.	I/O	Signal	Function
1	I	+24V	High-Voltage Board Drive Power
2	-	NC	Not used
3	O	+24V	Motor/ FAN Drive Power

(2) High-Voltage Power/ Sensor Board

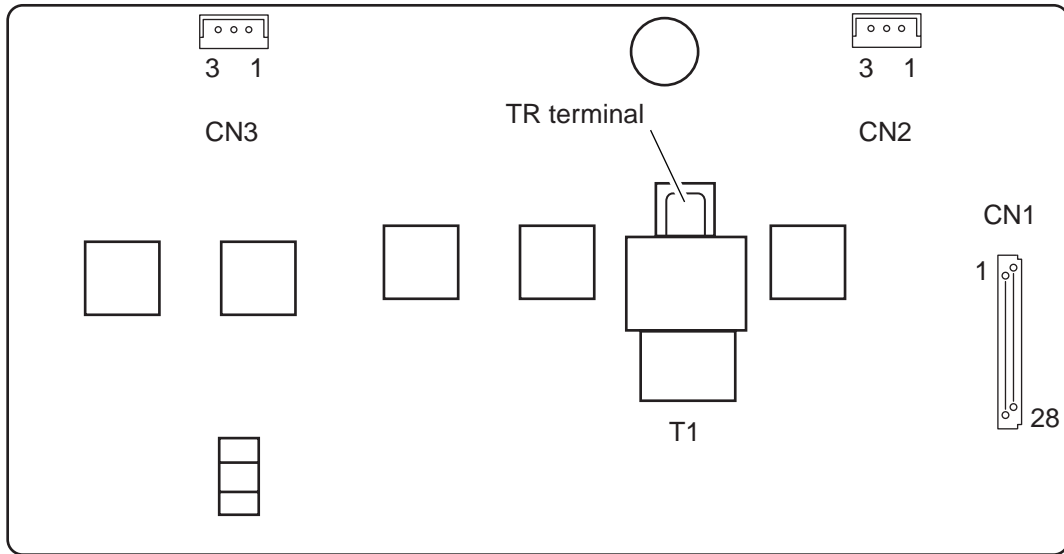

Component side

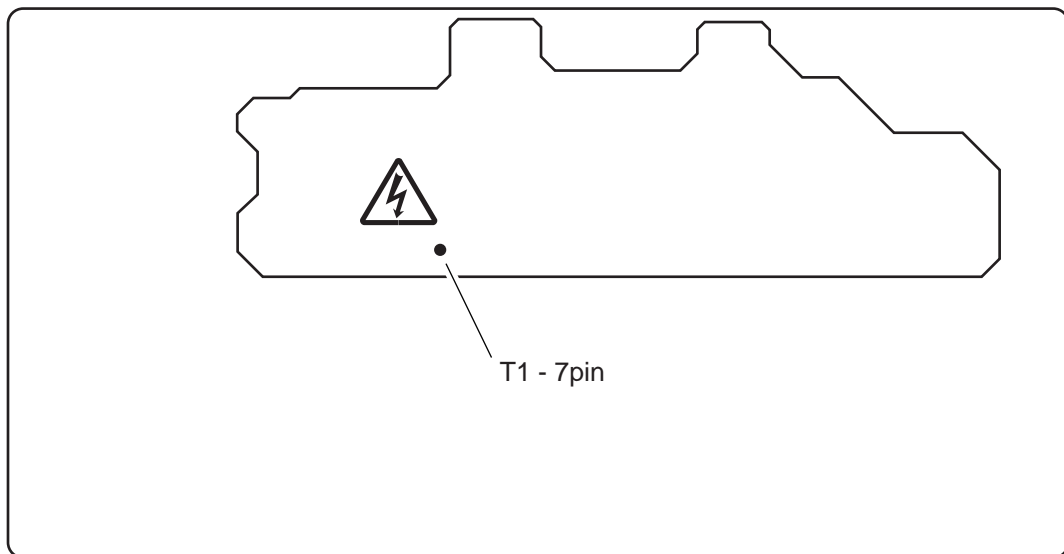

Soldering side

Checking contact between the transfer roller shaft and the TR terminal

Contact is normal if the resistance value measured between the transfer roller shaft and Pin 7 of T1 is 130 MΩ.

- CN2 Connector Pin Allocation  
(Connection to FAN(ID))

Pin No.	I/O	Signal	Function
1	O	FANPOW	FAN Drive Power
2	C	FANGND	Ground
3	I	FANALM-P	FAN Alarm Detection

- CN3 Connector Pin Allocation  
(Connection to Tag)

Pin No.	I/O	Signal	Function
1	I/O	1-WIRE	TAG signal
2	C	GND	Ground
3	C	GND	Ground

- CN1 Connector Pin Allocation  
(Connect to Main board)

Pin No.	I/O	Signal	Function
1	I	FANPOW	FAN Drive Power
2	O	FANALM-P	FAN Alarm Detection
3	I	LIGHT-P	Electricity-removing light ON
4	C	GND	Logic Ground
5	I	5V	Logic Circuit Power Supply
6	I/O	SDA	Serial Data
7	I	SCL	Serial Clock
8	I	OUT_EN-P	High-Voltage output Enable
9	I	CHPWM	CH PWM
10	I	TR1PWM	TR1 PWM
11	I	ANSW	High-Voltage Board Analog switch change
12	I	TR2PWM	TR2 PWM
13	O	TR_I	TR Electric Current Detection
14	O	TR_V	TR Power Voltage Detection
15	I	SBPWM	SB PWM
16	I	DB2PWM	DB2 PWM
17	I	DB1PWM	DB1 PWM
18	I	1STTRAY-N	1ST Cassette Sensor
19	I	TRAYON-P	Power save 2
20	I/O	TAGOUT	TAG signal
21	I	RETURN	Fuse cut Electric Current RETURN
22	I	FUSECUT	Fuse cut
23	I	HUM_PWM	Humidity Sensor PWM
24	O	HUM	Humidity Sensor
25	O	TMP	Humidity Sensor
26	C	GND	Logic Ground
27	C	GND	Logic Ground
28	I	+24V	High-Voltage Board Drive Power

(3) Low-Voltage Power

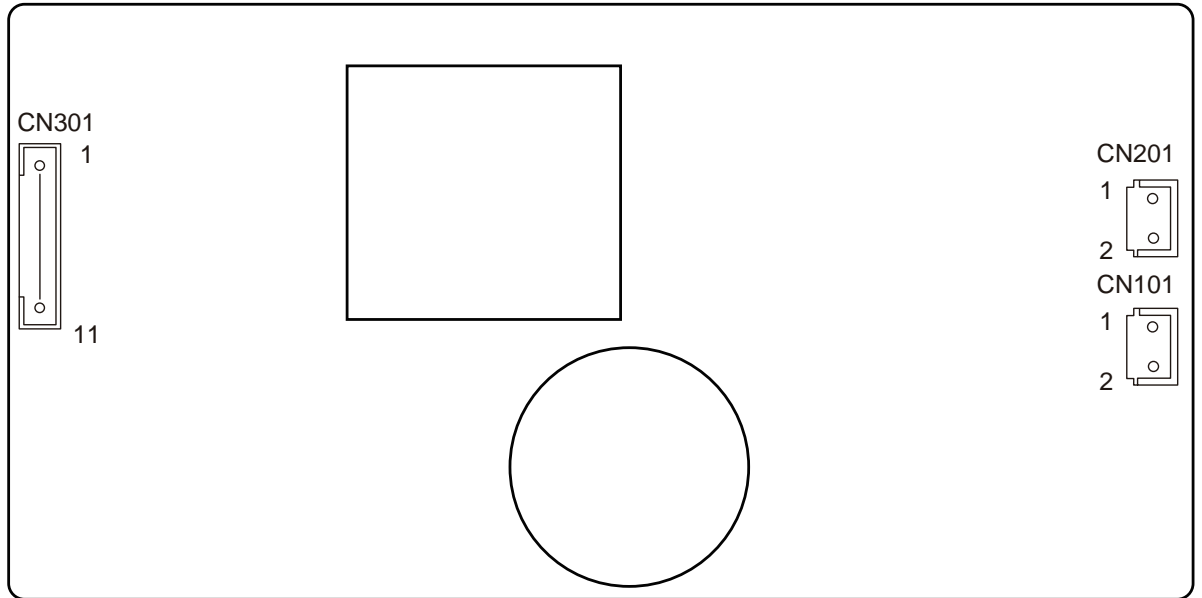

A circuit (common to 100V and 200V) for applying a load between +5V and GND to check output by using a low-voltage supply unit alone.

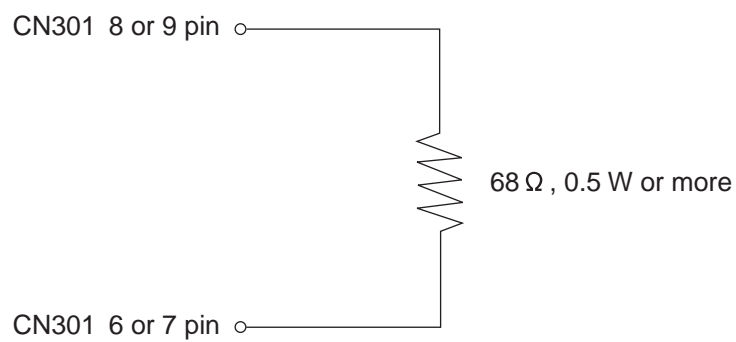

Use the above mentioned jigs to check output by using a low-voltage supply unit alone.

- CN101 Connector Pin Allocation  
(Connection to the AC SW Assy)

Pin No.	I/O	Signal	Function
1	I	AC(LIVE)	AC input
2	I	AC(NEUTRAL)	AC input

- CN2 Connector Pin Allocation  
(Connection to the Fuser Unit)

Pin No.	I/O	Signal	Function
1	O	AC(NEUTRAL)	AC output
2	O	AC(LIVE)	AC output

- CN3 Connector Pin Allocation  
(Connection to the Main Control Board)

Pin No.	I/O	Signal	Function
1	O	+24V	Motor/ FAN/ Clutch Drive Power
2	O	+24V	Motor/ FAN/ Clutch Drive Power
3	C	GND	Ground
4	C	GND	Ground
5	O	ACZEROX-P	AC Zero Cross
6	C	GND	Ground
7	C	GND	Ground
8	O	+5V	Logic Circuit Power Supply
9	O	+5V	Logic Circuit Power Supply
10	I	HEATON-N	Heater ON
11	I	HARD GUARD-N	Hard Guard

7.3 Resistance value

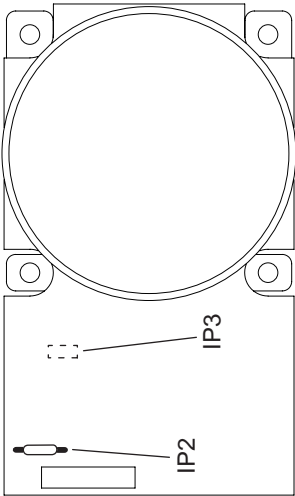
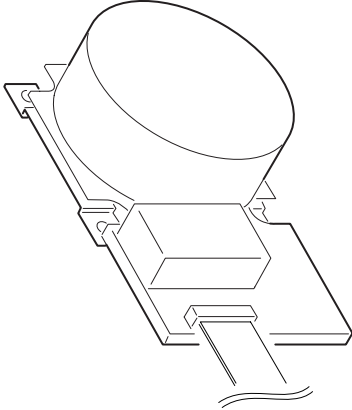
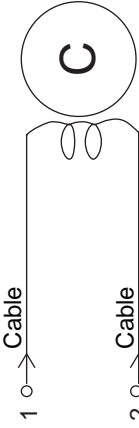
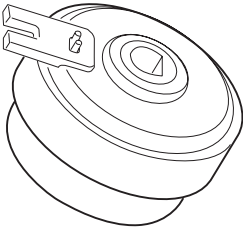
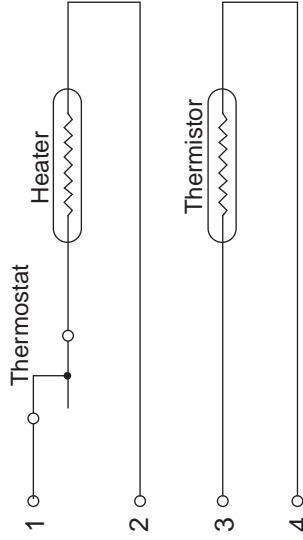
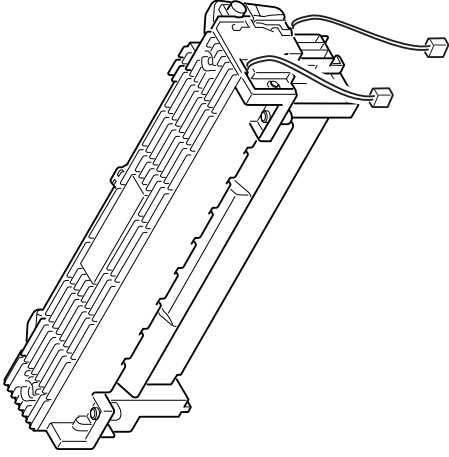
Unit	Circuit Diagram and configuration	Part Diagram	Resistance Value
DC Motor	 <p>IP2 IP3</p>		Both ends of IP2 and IP3: 1Ω or less
Clutch (Hopping) (Regist) (MP Tray)	 <p>1 Cable 2 Cable</p> <p>※Cable Color : Black (Hopping) : Blue (Regist) : Yellow (MP Tray)</p>		Between Pin1 and Pin2 : 240Ω
Fuser Unit Assy	 <p>1 2 3 4</p> <p>Thermostat Heater Thermistor</p>		Between Pin1 and 2: Several to to several tens of ohms Between pin3 and 4 :360KΩ At the ambient temperature (25°C)

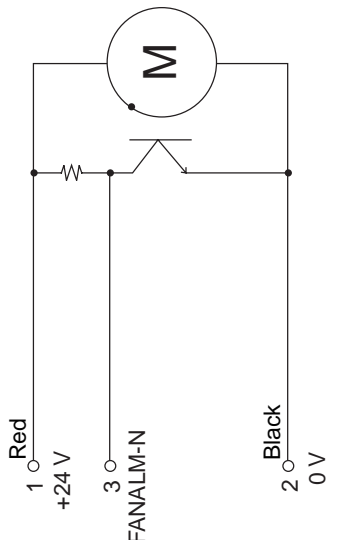
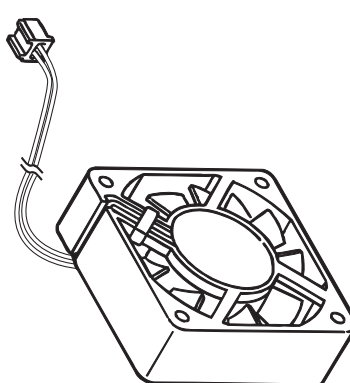
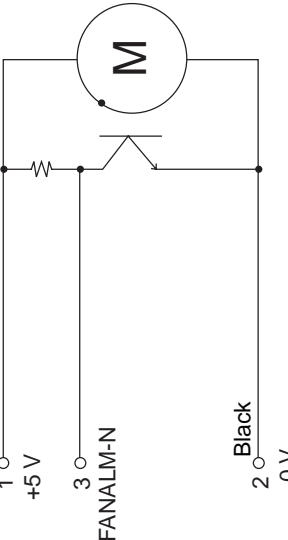
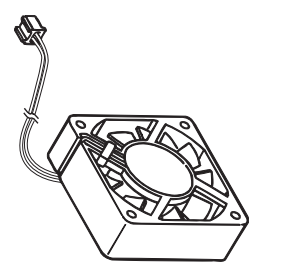
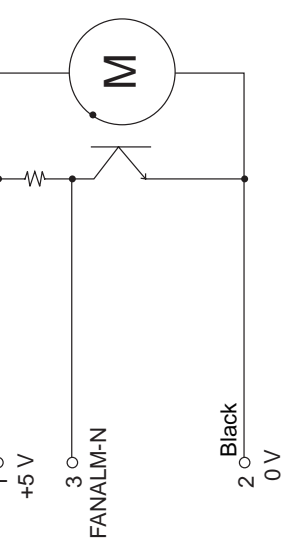
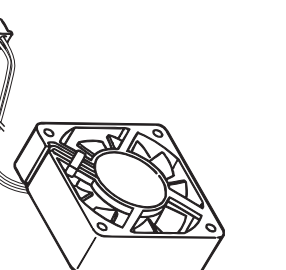
Unit	Circuit Diagram	Part Diagram	Resistance Value
<p>FAM Motor ( ID )</p>	 <p>1 Red +24 V 3 FANALM-N 2 Black 0 V</p>		
<p>FAM Motor ( Duct )</p>	 <p>1 Red +5 V 3 FANALM-N 2 Black 0 V</p>		
<p>FAM Motor ( Power )</p>	 <p>1 Red +5 V 3 FANALM-N 2 Black 0 V</p>		



## Appendix A Centronics Parallel Interface

### (1) Connector

- Printer side : 36 Pole Receptacle (Female)  
Equivalent to 57RE-40360-730B-D29A Model (DDK Ltd.)
- Cable side: 36 Pole Plug (Male)  
Equivalent to 57FE-30360-20N(D8) Model (DDK Ltd.)

### (2) Cable

Cables compatible with IEEE Std 1284-1994 under 1.8mm (or equivalent product) should be used.  
(It is recommended to use twisted pair cable with shield for noise control.)

**Note!** The cable is not included in the printer. Moreover, you can not purchase it from the Oki Data Corporation.

## (3) List of Parallel I/F Signals

Pin No	Signal Name	Direction	Function
1	nStrobe(HostClk)	TO PRINTER	Pulse to read data. The data is read at the posterior border.
2	DATA 1	TO PRINTER	8-bit parallel data The high level is "1" and the low level is "0".
3	DATA 2		
4	DATA 3		
5	DATA 4		
6	DATA 5		
7	DATA 6		
8	DATA 7		
9	DATA 8		
10	nAck(PtrClk)	FROM PRINTER	Signal to show that the data reception is completed. It is outputted at the posterior border of the busy signal.
11	Busy(PtrBusy)	FROM PRINTER	Signal to show whether the printer can receive data. The data can not be received at the high level.
12	PError(AckDataReq)	FROM PRINTER	The device becomes the high level when it out of paper in a selected feeder.
13	Select(Xflag)	FROM PRINTER	Always the high level.
14	nAutoFd(HostBusy)	TO PRINTER	It is used in the bi-directional communication.
15	Not used	-	Not connected.
16	GND	-	Signal Ground
17	FG	-	Chassis Ground
18	HILEVEL	FROM PRINTER	It is pulled up to 3.3Ω and +5V in the printer.
19~30	GND	-	Signal Ground
31	nInit(nInit)	TO PRINTER	When the low level is continued at 50μS or more, the printer is initialized. It may be enabled at 50μS or less. This signal is ignored at the factory default.
32	nFault(nDataAvail)	FROM PRINTER	It becomes the low level when the printer is in the alarm status.
33	GND	-	Signal Ground
34	Not used	-	Not Connected
35	HILEVEL	FROM PRINTER	It is pulled up to 3.3Ω and +5V in the printer.
36	nSelectIn (IEEE1284 active)	TO PRINTER	It is used in the bi-directional communication.

(Note 1) The word in parentheses is a signal name of the nibble mode.

(Note 2) Only the function of the compatible mode is described.

(Note 3) This printer supports the nibble mode of IEEE std 1284-1994 prescribed by Institute of Electrical and Electronic Engineers. When using computers or cables not compatible with this standard, unexpected operations may occur.

- Connector Pin Allocation

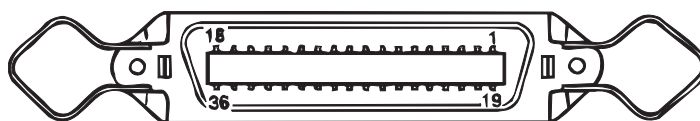

## (4) Signal Level

- LOW : 0V to +0.4V
- HIGH : +2.4V to 5.0V

(5) Specification

Item	Contents
Mode	Compatible mode, Nibble mode, and ECP mode
Data Bit Length	8 bit (Compatible mode)
Input Prime	Enable/ Disable
Receive Buffer	8K, 20K, 50k, 100k, 1M Byte
Control	The handshake control is performed in each mode. Data received from the host is store in the Receive buffer. Busy control is performed. Signal read control is performed.

(6) Time Chart

a) At the Power ON (Menu Setting: PARALLEL=ENABLE)

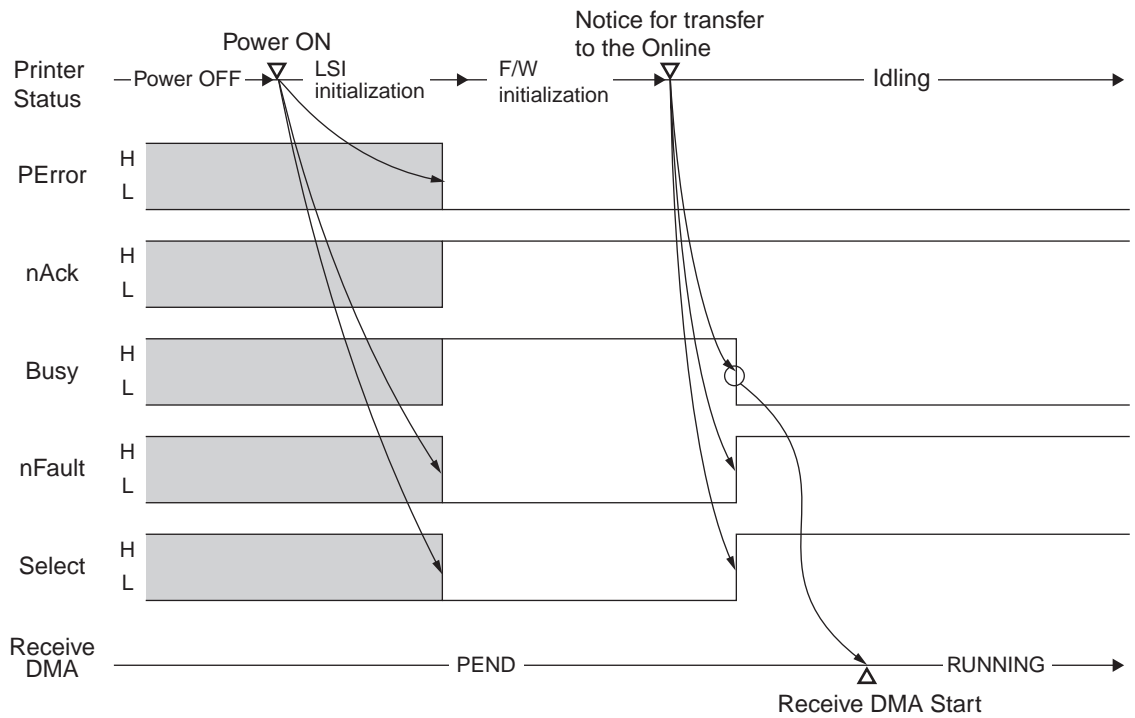

b) At the Power ON (Menu Setting : PARALLEL=ENABLE)

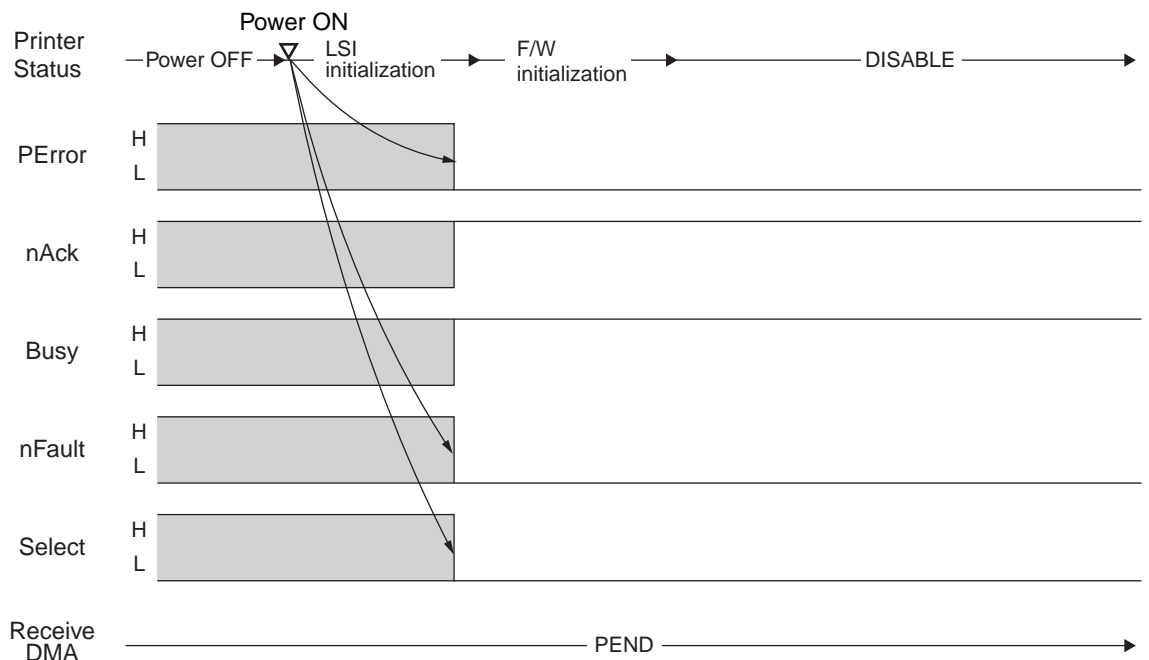

C) Data Reception (Menu Setting: Ack/ Busy Timing= Ark in Busy)

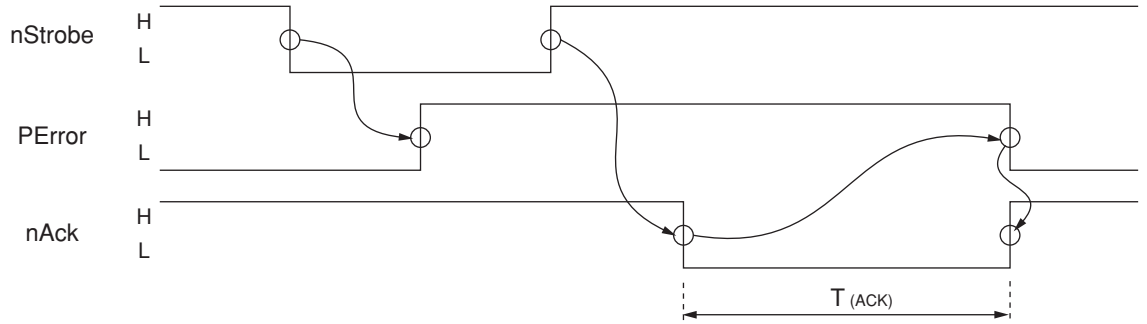

Menu Setting (Ack Width)	NARROW	MEDIUM	WIDE
T (ACK)	0.5 us	1.0 us	3.0 us

d) Data Reception (Menu Setting: Ack/ Busy Timing= Ark in Busy)

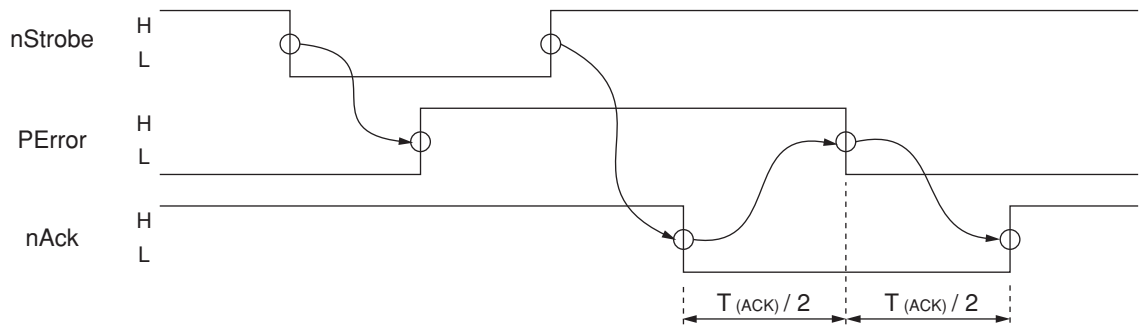

Menu Setting (Ack Width)	NARROW	MEDIUM	WIDE
T (ACK)	0.5 us	1.0 us	3.0 us

e) I-Prime (When Menu Setting is not I-PRIME=DISABLE)

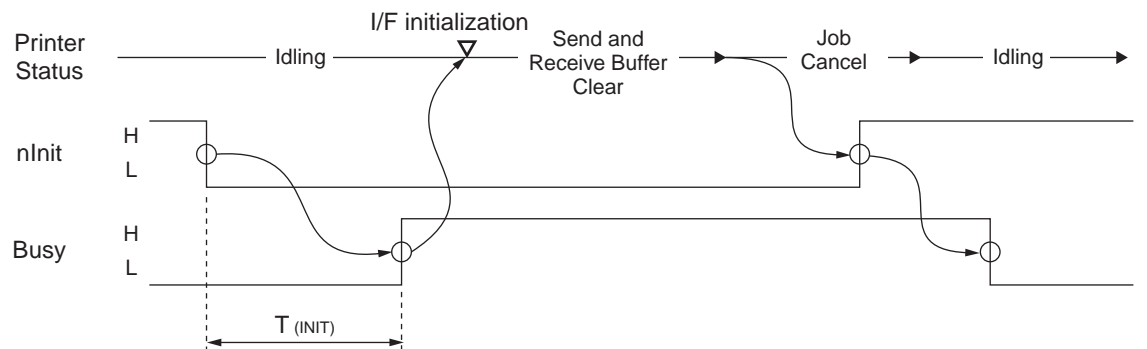

Menu Setting (I-PRIME)	3 MICRON SEC	50 MICRON SEC
T (INIT)	2.0 us	33.3 us

f) Offline

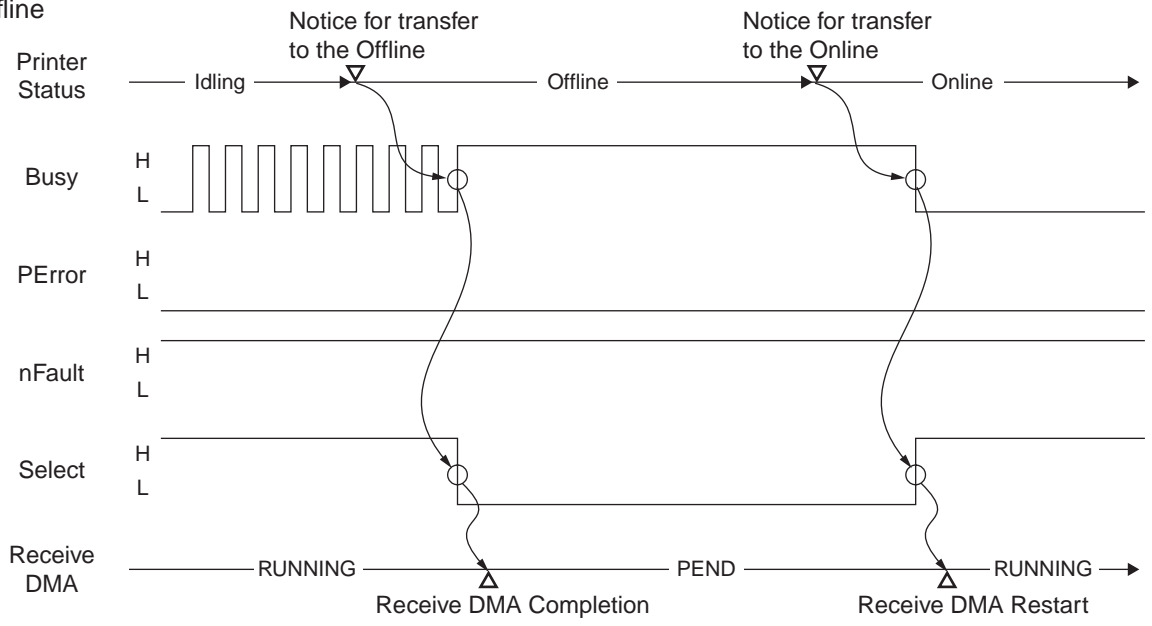

9) Paper End

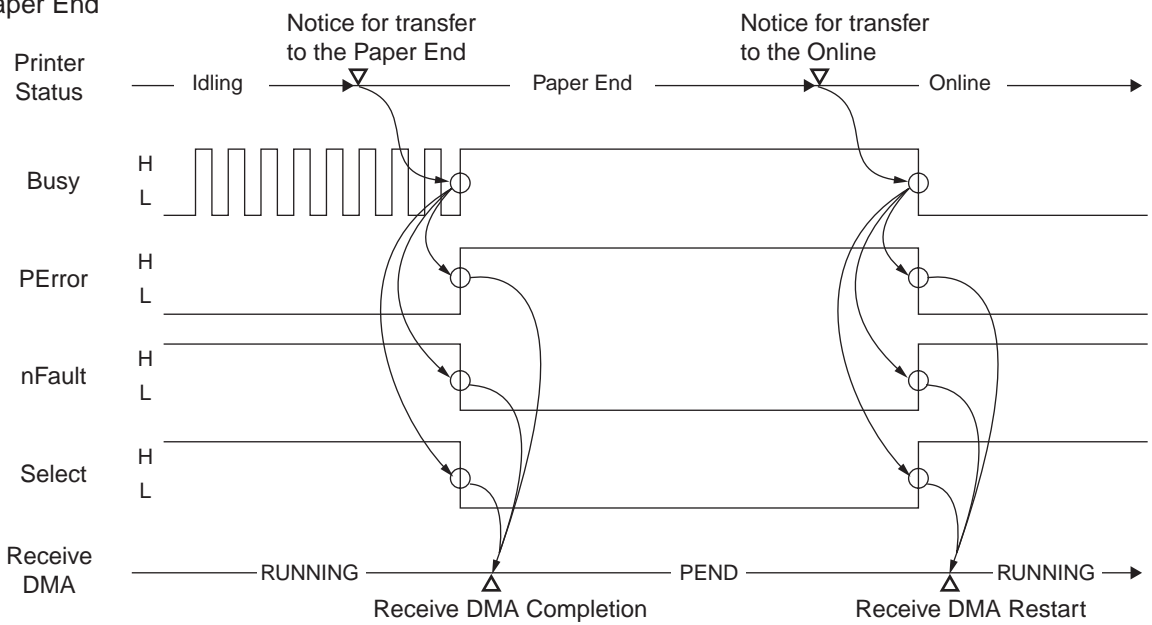

h) Warning (Other than the Paper End)

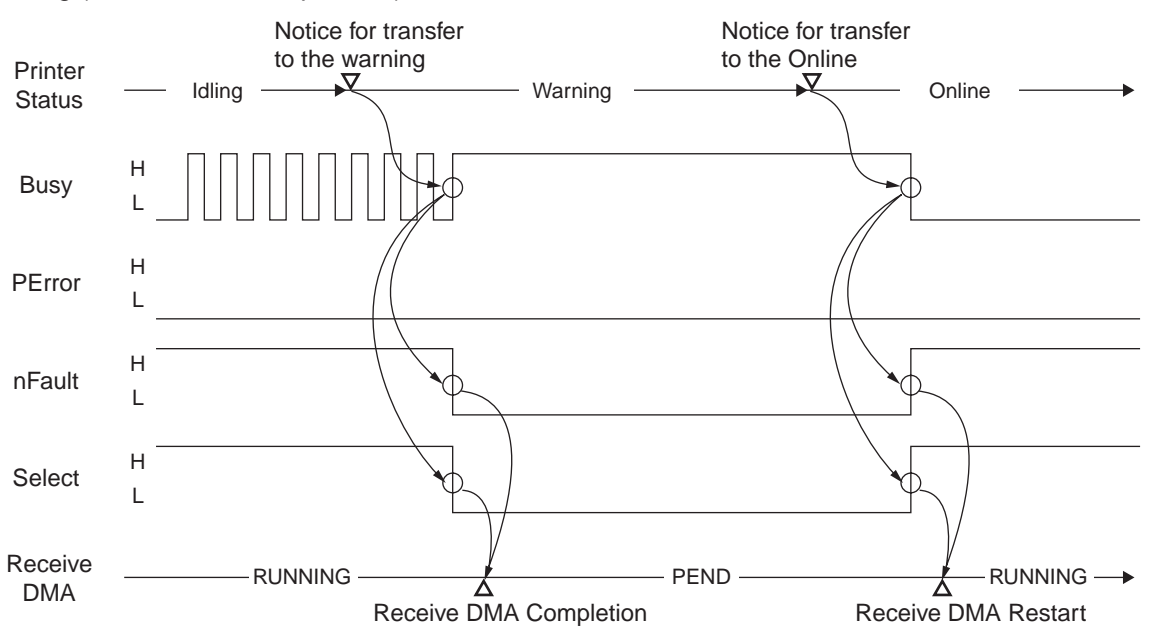

(7) Interface Parameter Setting

This is a procedure to perform on the operator panel of the printer (B420/ B430/ B440 series).  
 In the setting of B410 series, use "Printer Menu Setup Tool".

By pressin the "OK" key after selecting a display content of the operator panel with the "MENU Δ" key or "MENU ▽" key, the following setting is available.

The setting is not changed even if turning of the printer.

By pressing the "Online key", the printer exits the menu setting mode, and returns to the offline status.

Online



Press the "MENU Δ" key 9 times.



Centronics Menu

[Centronics Menu] is shown on the display.



Press the "OK" key.



Centronics  
Enable \*

Items	Enable/ Disable of Centronics I/F	
	Display	Function
Enable	Enable	Enable
Disable	Disable	Disable

Factory Default: Enable



Press the "MENU Δ" key.



Bidirectional Centronics  
Enable \*

Items	Data Transfer Direction	
	Display	Function
Enable	Bi-directional data transfer	Bi-directional data transfer
Disable	Unidirectional data transfer	Unidirectional data transfer

Factory Default: Enable



Press the "MENU Δ" key.



ECP  
Enable \*

Items	Enable/ Disable of ECP Mode	
	Display	Function
Enable	Enable	Enable
Disable	Disable	Disable

Factory Default: Enable



Press the "MENU Δ" key.



ACK Width  
Narrow \*

Items	ACK width at compatible receiving	
	Display	Function
Narrow		0.5μs
Normal		1.0μs
Wide		3.0μs

Default Setting: Narrow



Press the "MENU Δ" key.



ACK/ BUSY Timing  
ACK IN BUSY \*

Items	Output order of BUSY signal and ACK signal at compatible receiving	
	Display	Function
ACK IN BUSY		BUSY=LOW is at the posterior border of ACK pulse
ACK WHILE BUSY		BUSY=LOW is at the center of ACK pulse

Factory Default: ACK IN BUSY



Press the "MENU Δ" key.



I-PRIME  
DISABLE \*

Items	I-PRIME	
	Display	Function
Disable		I-PRIME signal is ignored.
3 microseconds		Enable at the I-PRIME signal of 3μs
50 micro seconds		Enable at the I-PRIME signal of 50μs

Factory Default : 50 Micro seconds (B410 series)  
Disable (B420/ B430/ B440 series)



Press the "MENU Δ" key.



OFFLINE RECEIVE  
DISABLE \*

Items	Enable/ Disable of Offline Receiving	
	Display	Function
Disable		Disable
Enable		Enable I/F signal does not change and still keep in signal receivable status even the alarm sounds.

Factory Default: Disable  
\*It is displayed only when PSE is installed.



Press the "Online" key.



Online

The setting is completed.

# Appendix B USB Interface

(1) Connector

- Printer side : B Receptacle (Female) (Upstream port)  
Equivalent to UBR24-4K5CO (ACON. Co., Ltd.)
- Cable side : B Plug (Male)

(2) Cable

- Cable with USB 2.0 specification under 2.0m (It is recommended to use a shielded cable.)

**Note!** The cable is not included.

(3) Interface Signal

Connector No.	Signal	Function
1	vbus	Power (+5V) (Red)
2	D-	For data transfer (White)
3	D+	For Data transfer (Green)
4	GND	Signal Ground (Black)
Shell	Shield	

(4) Connector Pin Allocation

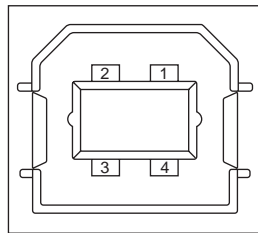

(5) Format and Type

- Full-speed transmission
- Self-power device

(6) Data Transfer Speed

- Full-speed 12Mbps

(7) Interface Circuit

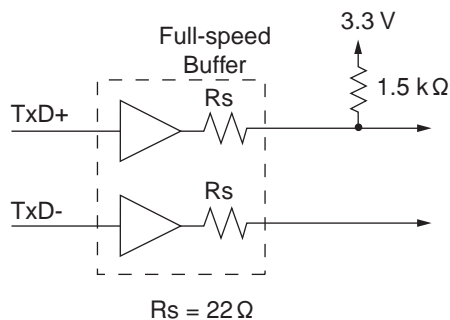



## (8) Signal Level

- Input and Output Level

Parameter	Signal	Minimum	Maximum	Unit
Input level:				
High (Driven)	VIH	2.0		V
High (Floating)	VIHZ	2.7	3.6	V
Low	VIL		0.8	V
Output level:				
Low	OL	0.0	0.3	V
High (Driven)	OH	2.8	3.6	V
Output signal crossover voltage	VCRS	1.3	2.0	V

- Signal level

Bus Status	Signal Level	
	Request	Acceptance
Difference "1"	$(D+) - (D-) > 200\text{mV}$ and $D+ > \text{VIH (Min.)}$	$(D+) - (D-) > 200\text{mV}$
Difference "0"	$(D-) - (D+) > 200\text{mV}$ and $D- > \text{VIH (Min.)}$	$(D-) - (D+) > 200\text{mV}$
Single-ended 0 (SE0)	$D+ \text{ and } D- < \text{VIL (Max.)}$	$D+ \text{ and } D- < \text{VIH (Min.)}$
Data J state: Low speed Full speed	Difference "0" Difference "1"	
Data K state: Low speed Full speed	Difference "1" Difference "0"	
Idling State Low Speed	$D- > \text{VIHZ (Min.)}$ and $D+ < \text{VIL (Max.)}$	$D- > \text{VIHZ (Min.)}$ and $D+ < \text{VIH (Min.)}$
Full Speed	$D+ > \text{VIHZ (Min.)}$ and $D- < \text{VIL (Max.)}$	$D+ > \text{VIHZ (Min.)}$ and $D- < \text{VIH (Min.)}$
Restart State	Data K State	
Start of the packet (SOP)	The data line switches from the idling to the K state	
End of the Packet (EOP)	$\uparrow$ SEO of 1 bit time, and then, J state of 1 bit time	$1 \geq \text{SEO of 1 bit time, and then, J state.}$
Not connected (Downstream port)	SEO in $\geq 2.5\mu\text{s}$	
Connected (Downstream port)	Idling in $\geq 2.5\mu\text{s}$	Idling in $\geq 2.5\mu\text{s}$
Reset	In $\geq 10\text{ms}$ , $D+ \text{ and } D- < \text{VIL (Max.)}$	In $\geq 2.5\mu\text{s}$ , $D+ \text{ and } D- < \text{VIL (Max.)}$

**Note!** The EOP width is defined by the bit time for a device type of the device receiving EOP. The bit time is an approximate value.

## Appendix C Maintenance Manual for Second Tray unit

### 1 Overview

#### 1.1 Function

The extended paper feed unit is installed under the printer. the device performs the auto paper feed by the operation of the pulse motor (hopping) to control a signal from the printer.

The main function is as follows:

- Available paper:

[Paper Type]

- Standard paper: (Ream weight 55 to 105 kg) A4, A5, B5, Custom, LETTER, Executive, LEGAL 13, LEGAL 13.5, LEGAL14, 16K

\*The custom is 148 to 215.9mm for width and 210 to 355.6 mm for length.

[Weight/ Thickness]

- Standard paper (Ream weight 55 to 105kg)

#### 1.2 Exterior and Parts Name

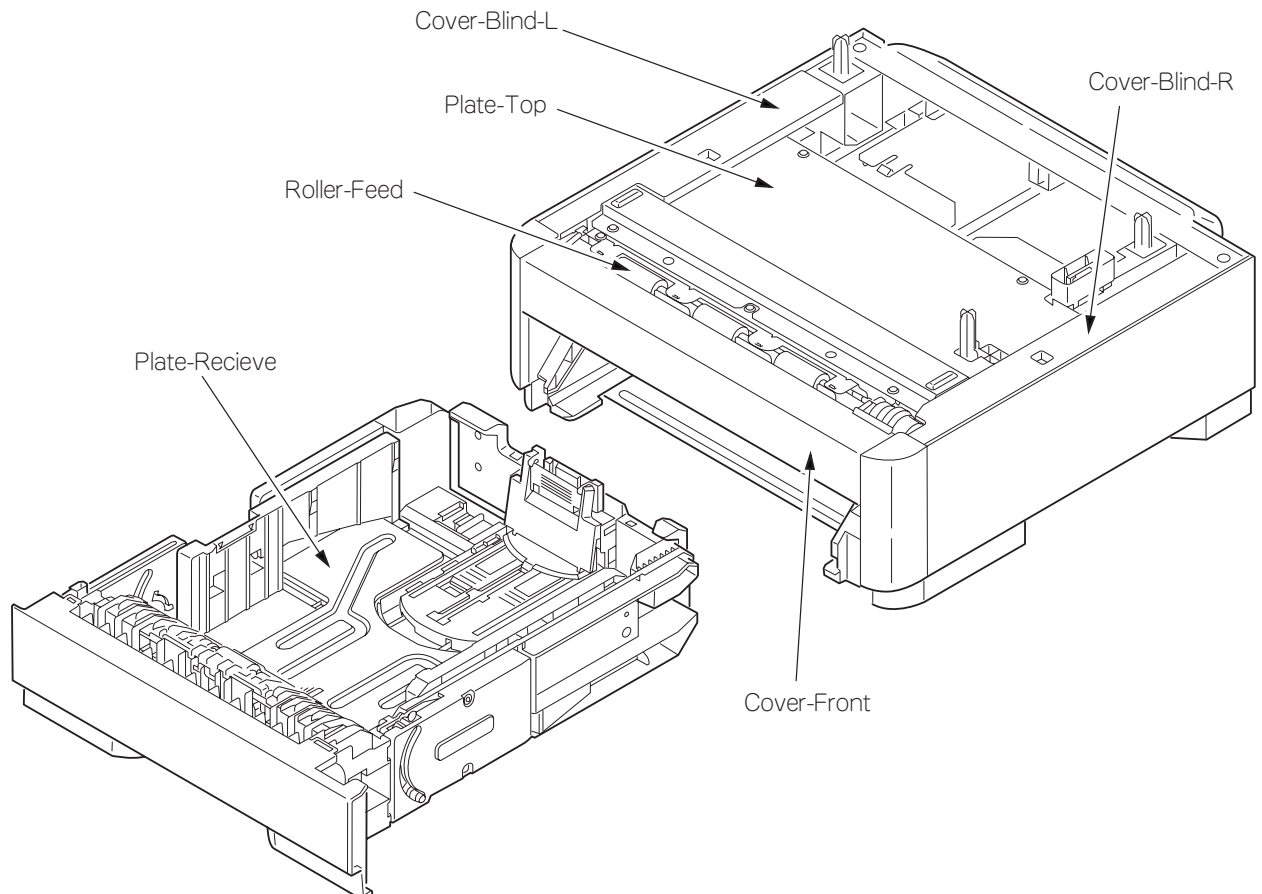

Figure.1-1 Exterior and Parts Name

## 2. Description for Operation of Second Tray unit

Second Tray unit receives a signal from the printer main body and feeds paper to the printer main body.

### Paper Feed from the Second Tray unit (Tray2)

1. When a signal is received from the printer main body, the pulse motor is rotated (Counterclockwise rotation), and by setting the paper feed clutch to ON, the paper feed roller and pick-up roller are rotated. Therefore, paper in a tray is fed.
2. After hitting the entrance sensor lever and switching the sensor to ON, the paper runs into the conveying roller (Tray 2) that is at rest, and then it is conveyed further by a certain amount. (This action corrects the paper skew.)
3. By setting the regist clutch to ON, the paper is carried by the regist roller.

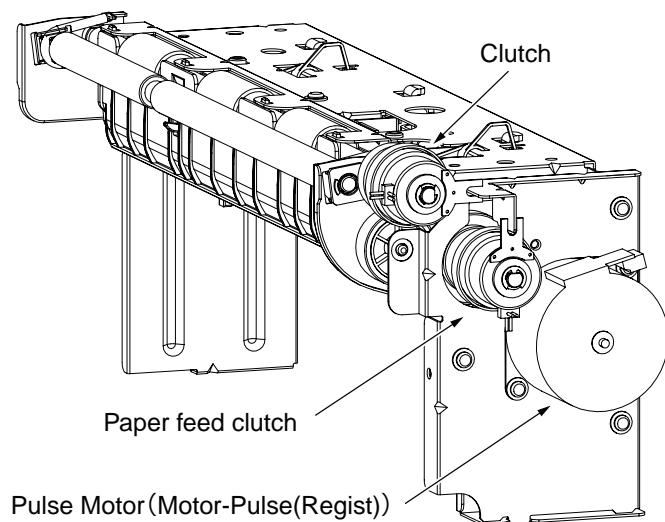
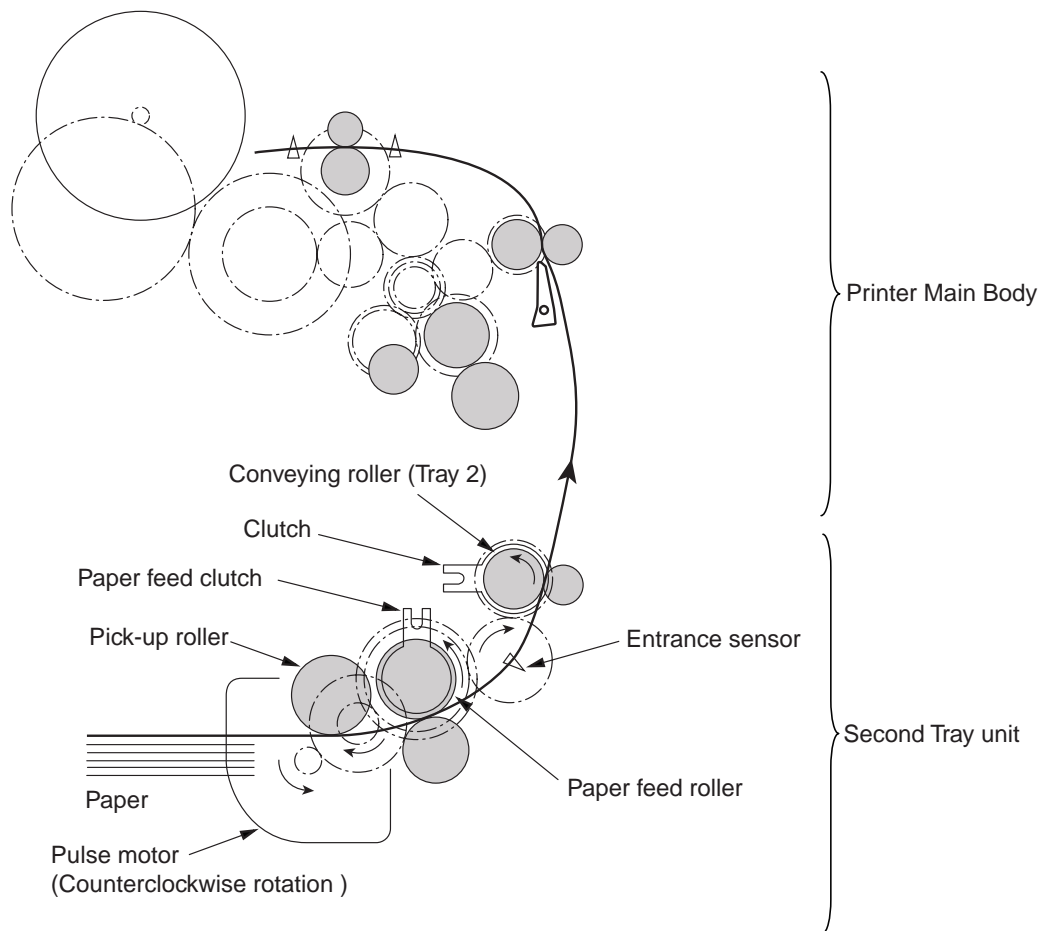

### 3. Part Replacement

This section describes how to disassemble/ assemble/ install in the field. This section describes how to disassemble, however, as for the assembly, take the opposite sequence to the disassembling procedure.





#### 3.1 Precautions on replacing parts

- (1) Make sure to turn off the printer switch and remove the printer from the device before the part replacement.
- (2) Do not disassemble the printer while it operates normally.
- (3) Do not disassemble beyond the range. (Do not remove parts other than parts shown in the part replacement procedure.)
- (4) Use specified maintenance tools.
- (5) Disassemble the parts in the specified order. Parts may be damaged if they are not disassembled in proper order.
- (6) Set small items such as screws and collars in their original position temporarily since they can be lost easily.
- (7) Do not use gloves that build up static electricity when treating a print circuit board
- (8) Do not place the print circuit board on the device or floor directly.

#### [Maintenance Tool]

The following table shows the tools for the print board/ Assy/ Unit replacement in the field.

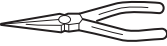
Table 3-1 Maintenance Tools

No.	Maintenance Tool	Amount	Purpose	Remarks
1	 No.2-220 ⊕ Magnetic driver	1	3-5 mm screw	
2	 No.3-200 driver	1		
3	 Digital multi-meter	1		
4	 Pliers	1		
5	 E-ring plier	1	For E ring removing	

### 3.2 Arrangement of Parts

The arrangement of main parts is as shown in the following figure.

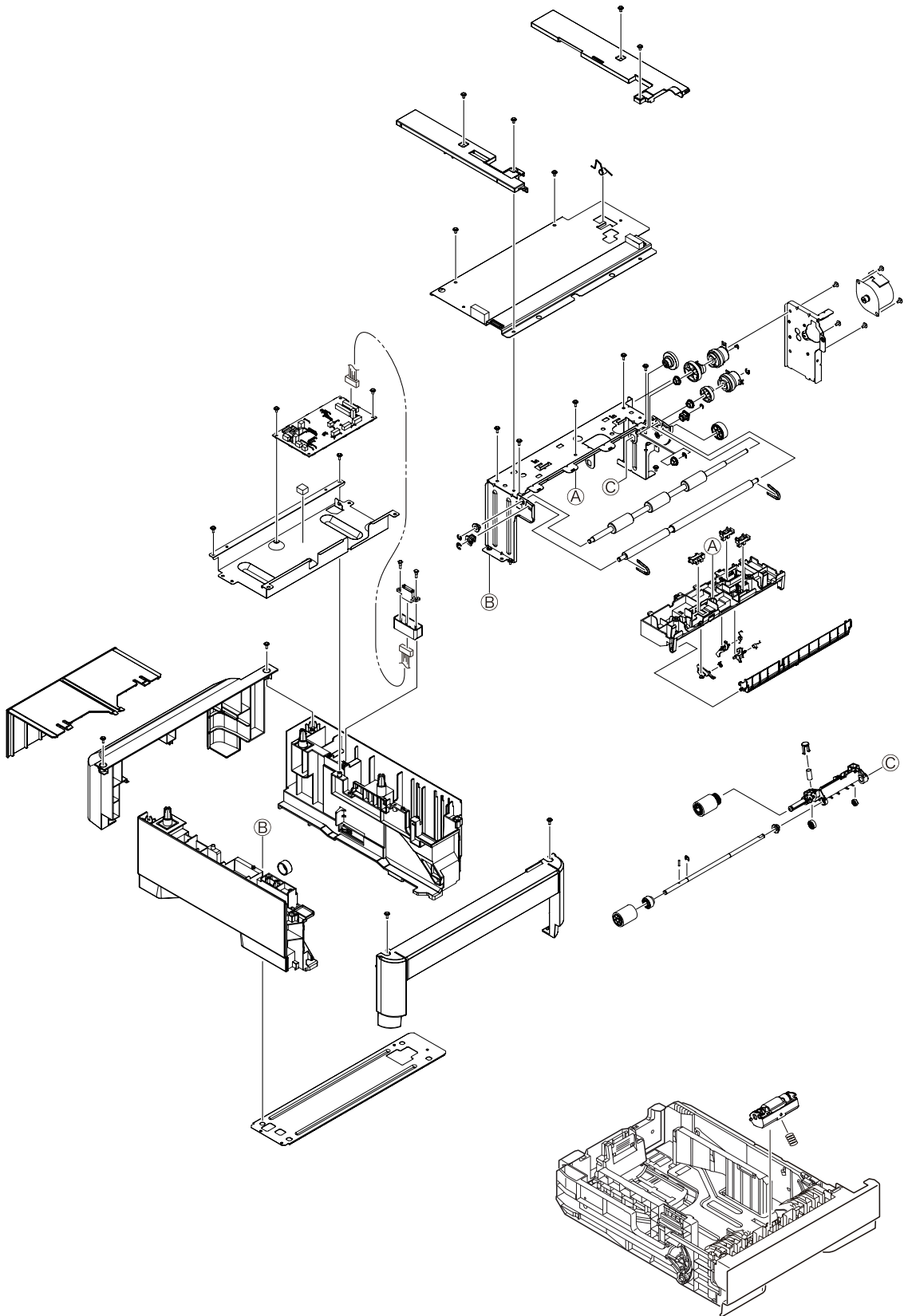
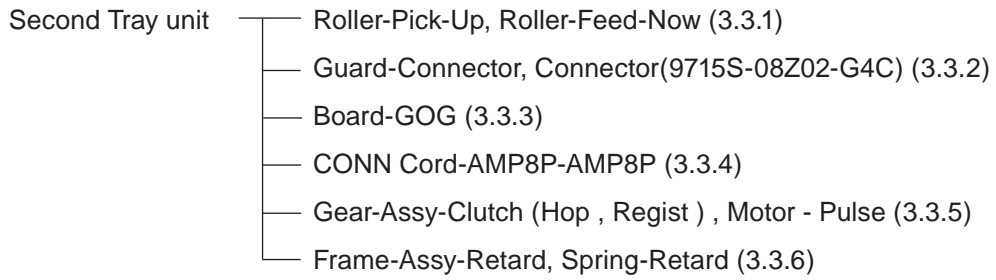

Figure 3-1

### 3.3 How to Replace Parts

This section describes how to replace parts shown in the following disassembling procedure. In the part replacement procedure, parts on which a part number is displayed in white figure in the black circle are RSPL.



### 3.3.1 Roller-Pick-Up, Roller-Feed-Now

- (1) Remove Cassette-Assy.
- (2) Push the tab in the direction of the arrow to remove Roller-Pick-Up ①.
- (3) Push the tab in the direction of the arrow to remove Roller-Feed-NOW ②.
- (4) As for reinstalling, take the opposite sequence to removal sequence.

(Precautions on reinstalling)

1. When reinstalling Roller-Pick-Up ①, push it until it clicks.
2. When installing Roller-Feed-Now ②, push it until it clicks.

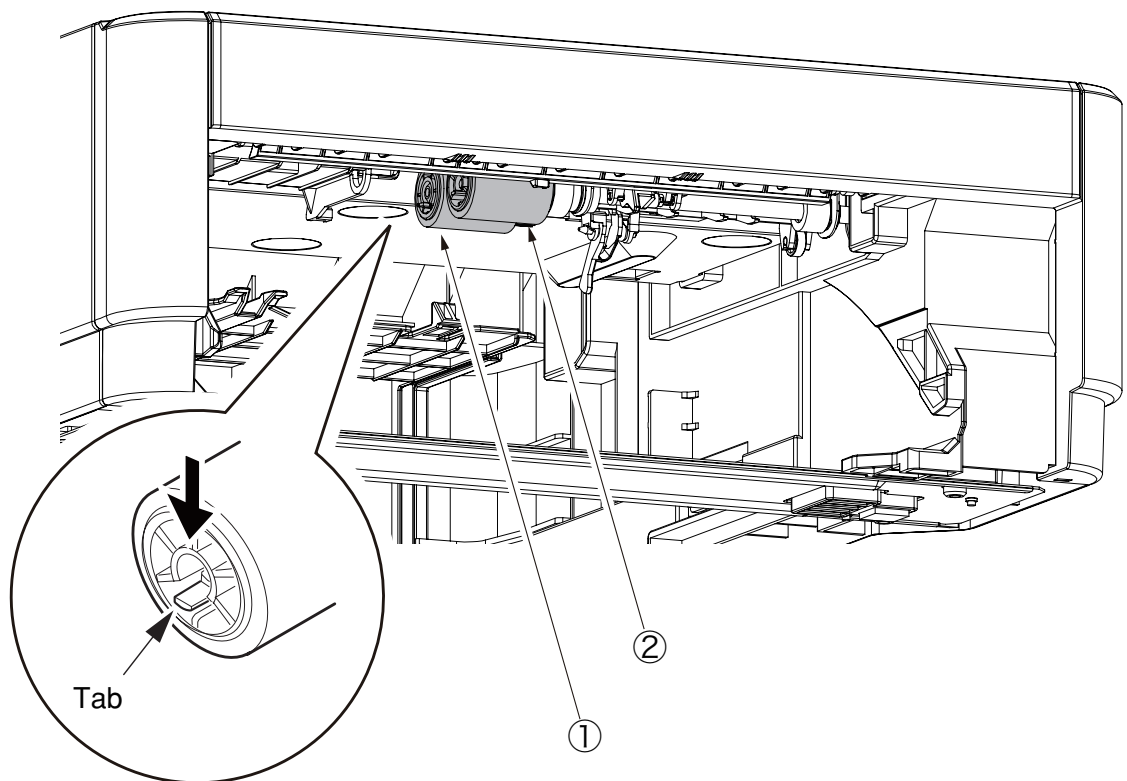

### 3.3.2 Guard-Connector, Connector (9715S-08Z02-G4C)

- (1) Remove the two screws ①. Remove the two nuts ②.
- (2) Disconnect the cable, and remove Guard-Connector ③ and Connector (9715S-08Z02-G4C) ④.
- (3) Installing is performed by the inverse procedure with removing.

(Note on removing / installing)

1. Be careful not to lose the nuts ②.

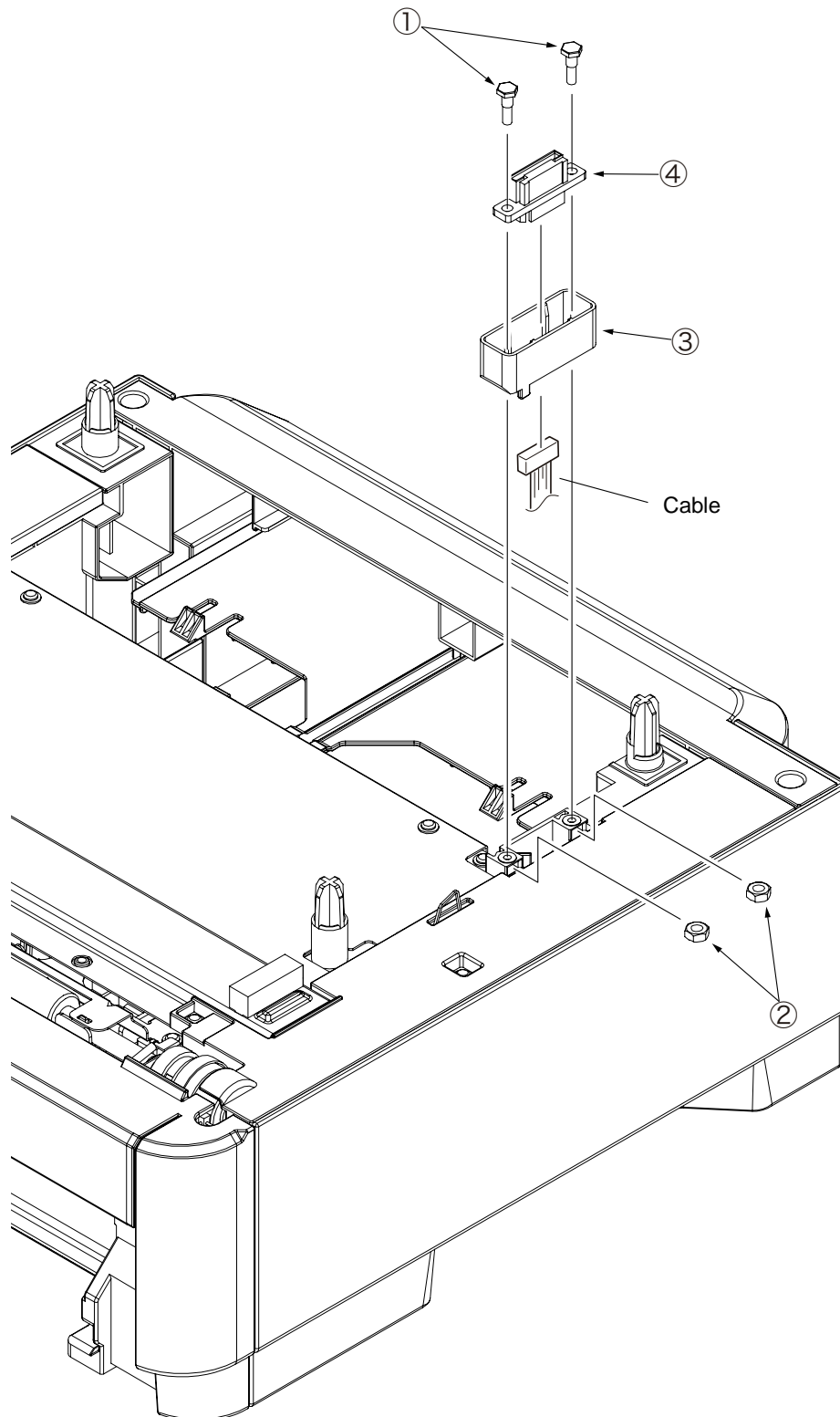



### 3.3.3 Board-GOG

- (1) Remove the two screws (Black) ①. Remove the Cover-Rear ②.
- (2) Remove the two screws (silver) ③. Remove the Cover-Blind-R ④.
- (3) Remove the two screws (silver) ⑤. Remove the Cover-Blind-L ⑥.
- (4) Remove the two screws (silver) ⑦. Remove the Plate-Top ⑧.
- (5) Disconnect the six connectors, and remove the two screws (silver) ⑨ and Board-GOG ⑩.
- (6) Installing is performed by the inverse procedure with removing.

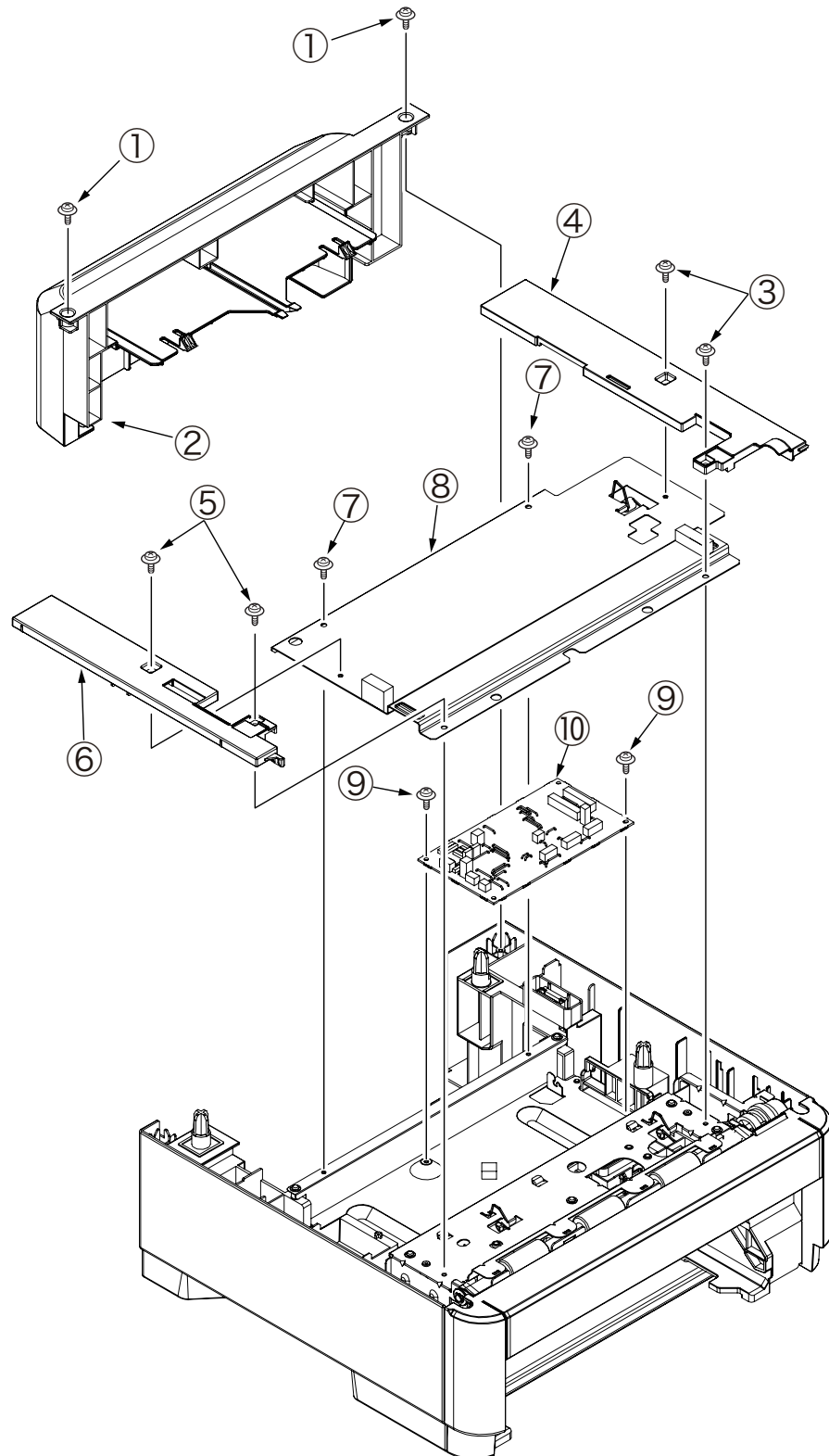

### 3.3.4 CONN Cord-AMP8P-AMP8P

- (1) Remove the Guard-Connector ①. (Refer to 3.3.2)
- (2) Remove the Cover-Rear, Cover-Blind-R/L, Plate-Top. (Refer to 3.3.3)
- (3) Remove CONN-Cord-AMP8P-AMP8P ② from Board-GOG.
- (4) Installing is performed by the inverse procedure with removing.

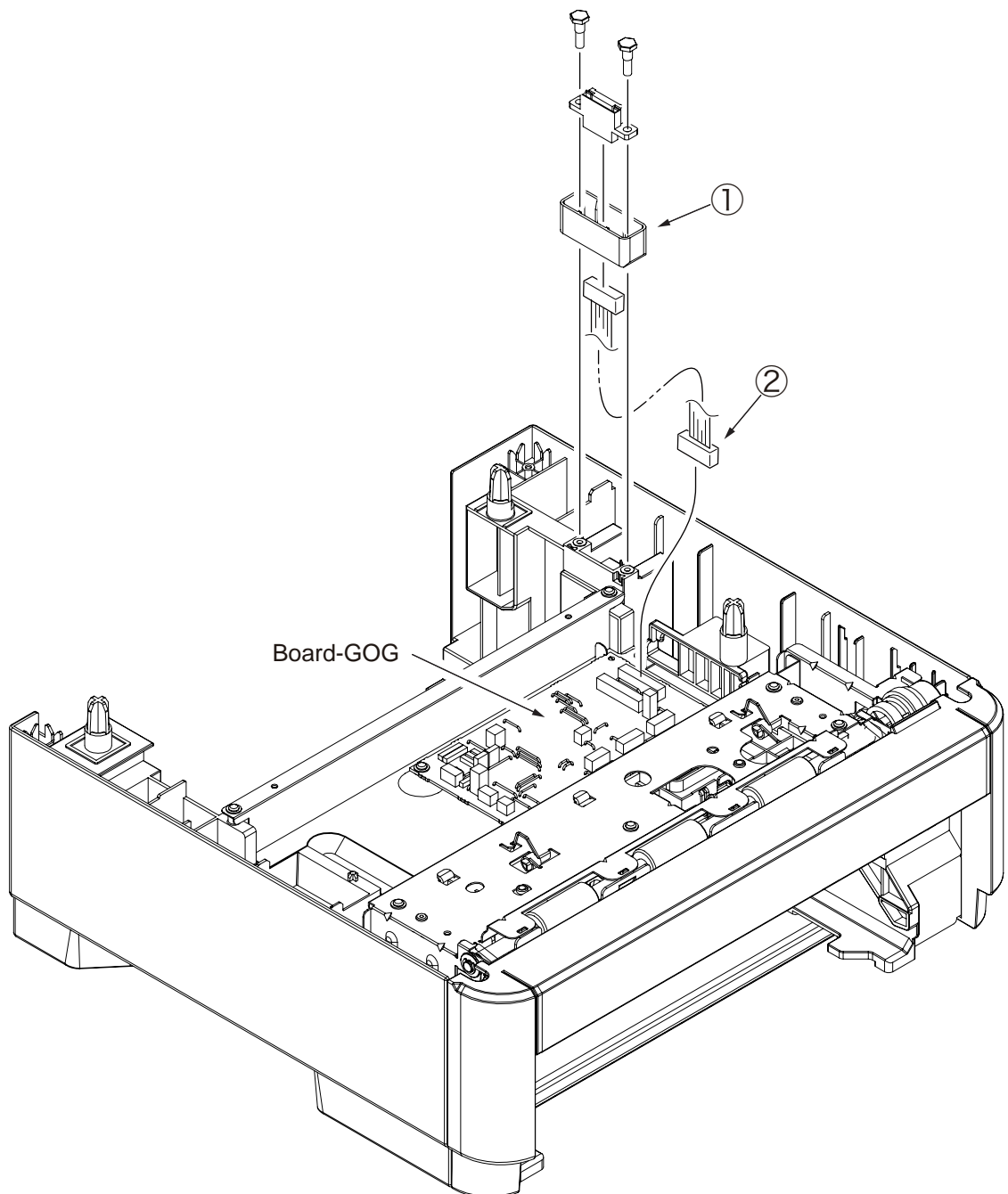

### 3.3.5 Gear-Assy-Clatch (Hop, Regist), Motor-Pulse

- (1) Remove the Cover-Rear, Cover-Blind-R/L, Plate-Top. (Refer to 3.3.3)
- (2) Remove the two screws (Black) ①, disengage the two tabs, and remove Cover-Front ②.

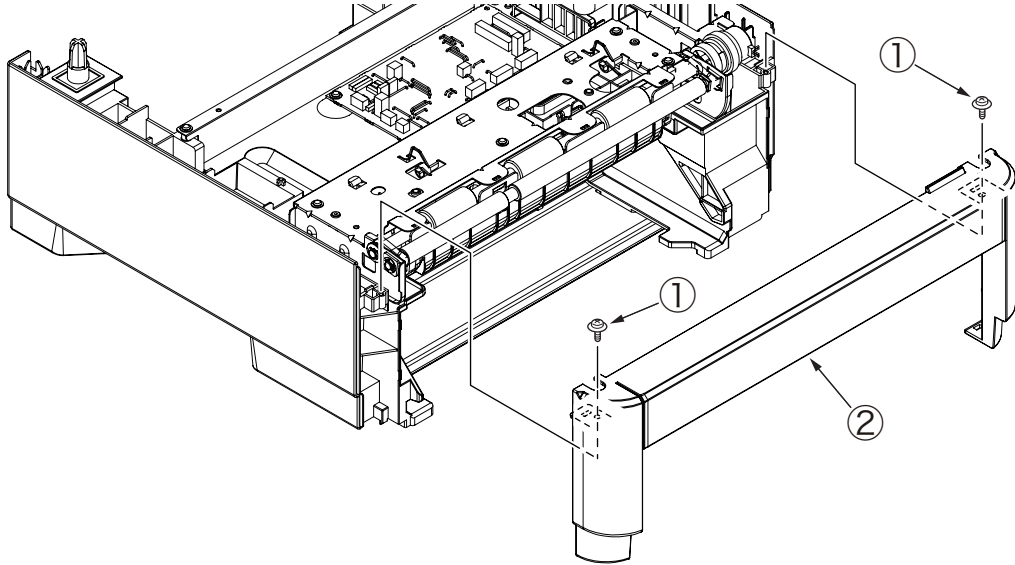

- (3) Remove the four screws (Black) ③. Remove the two screws (Silver) ④.
- (4) Disconnect the five connectors from Board-GOG, and remove Frame-Assy-Hop ⑤.

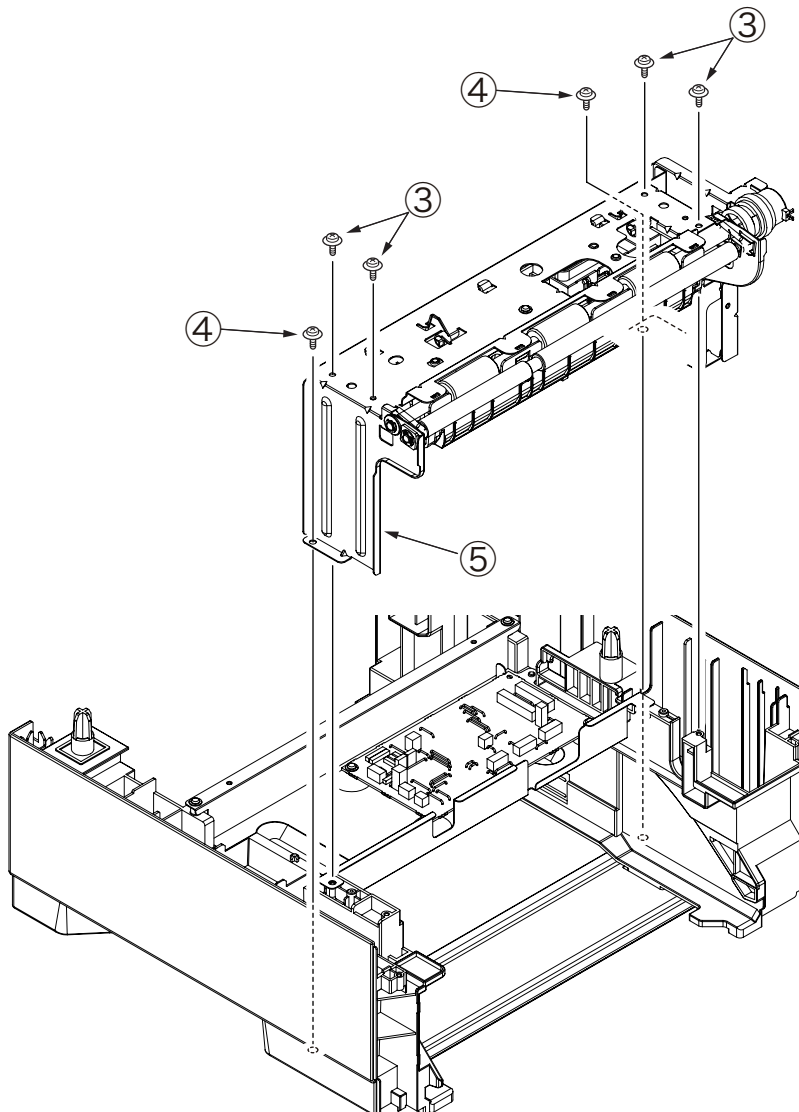

- (5) Remove the E-ring ⑥, Gear-Assy-Clutch (Hop) ⑦ and Gear-Assy-Clutch (Regist) ⑧.
- (6) Remove the two screws (Silver) ⑨. Remove the Motor-Pulse ⑩.
- (7) Installing is performed by the inverse procedure with removing.

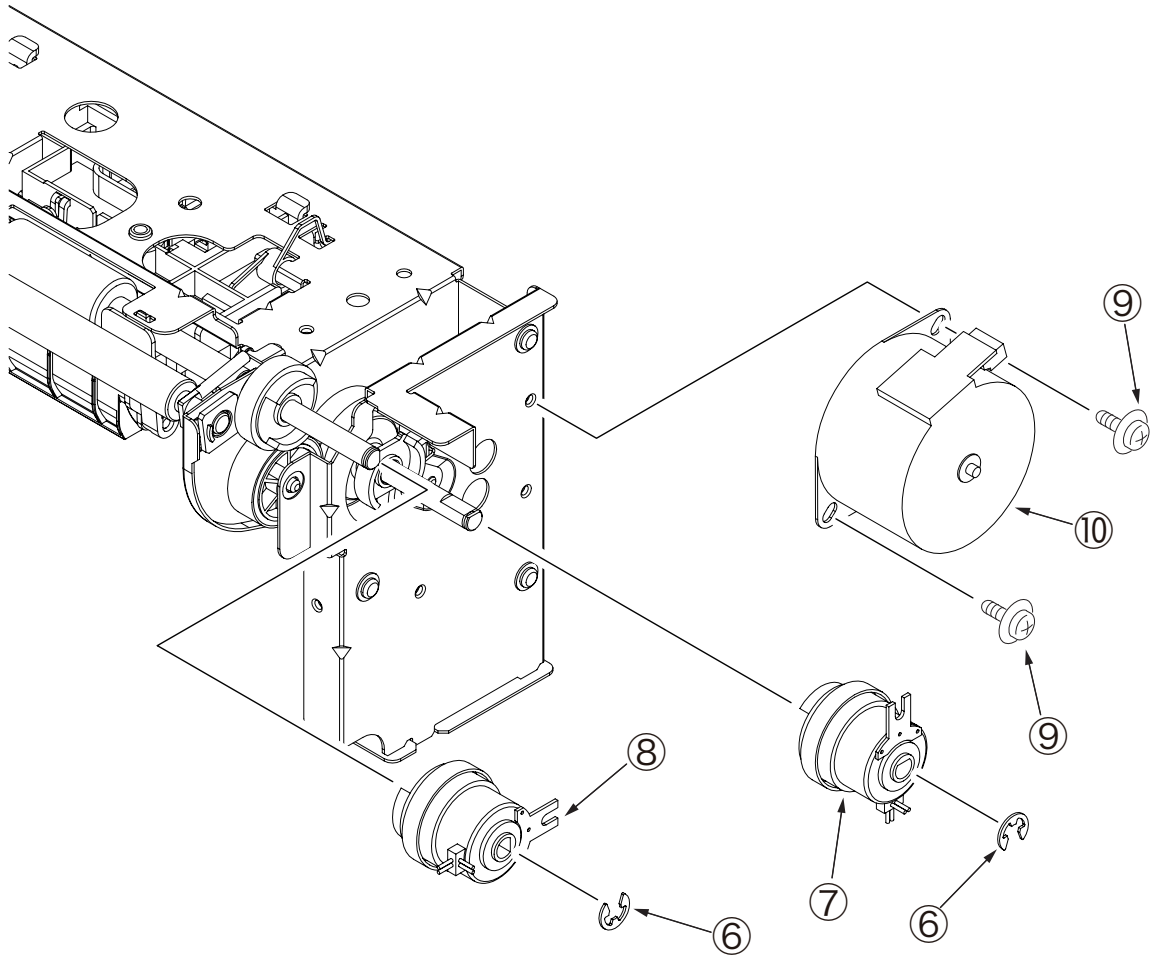

### 3.3.6 Frame-Assy-Retard, Spring-Retard

- (1) Detach Cassette-Assy.
- (2) Push two tabs in the direction of the arrow to remove Retard-Cover.
- (3) Push Frame-Assy Retard ① in the direction of the arrow. (Spring-Retard ② is also removed together.)
- (4) Installing is performed by the inverse procedure with removing.

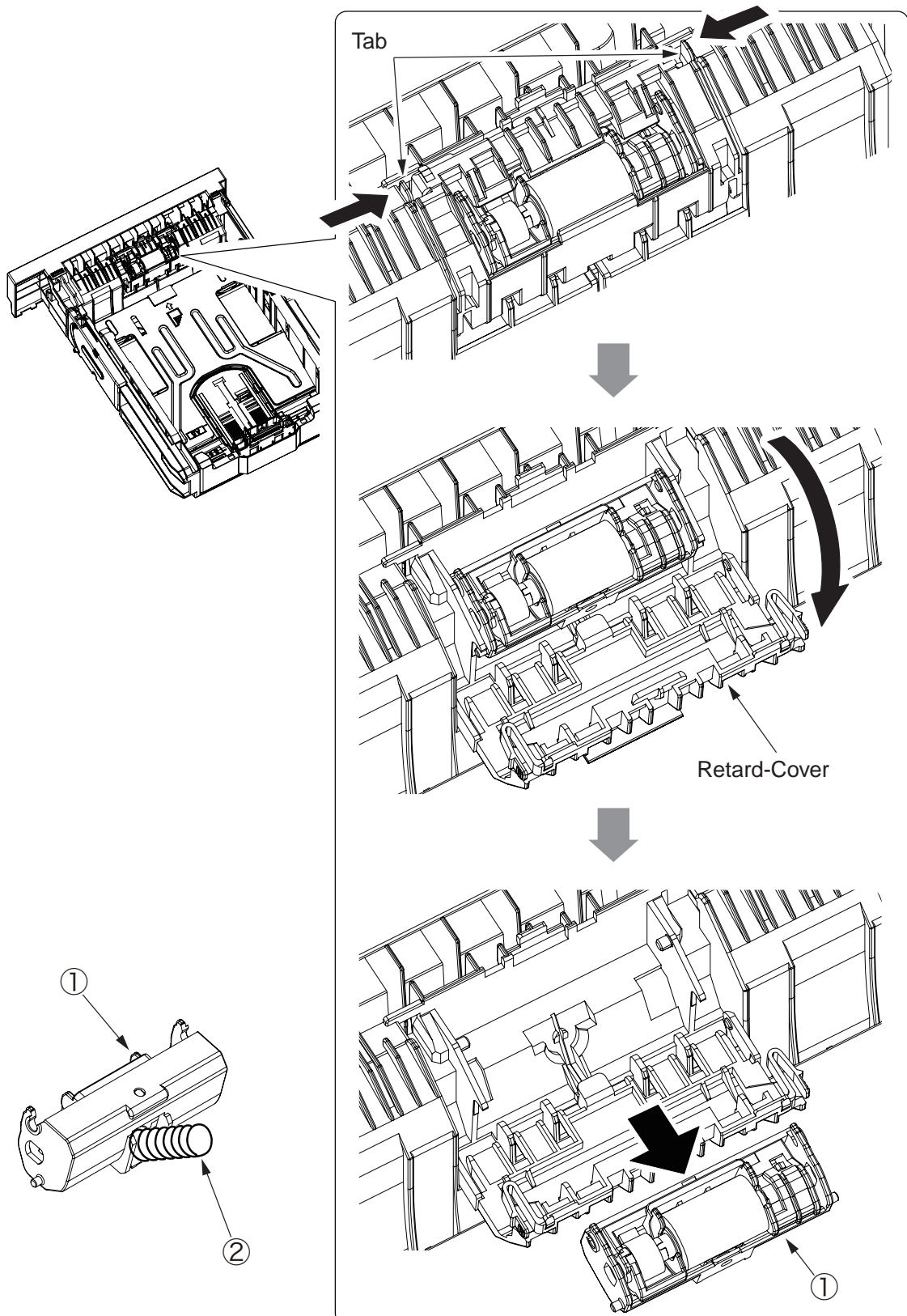

#### 4. Cleaning of Paper Feed Roller and Separation Roller

Clean the rollers when [392: Paper Jam] often occurs.

- (1) Pull the paper cassette.
- (2) Wipe the two feed rollers with a tightly wrung cloth soaked in water through the opening for installation of a paper cassette.

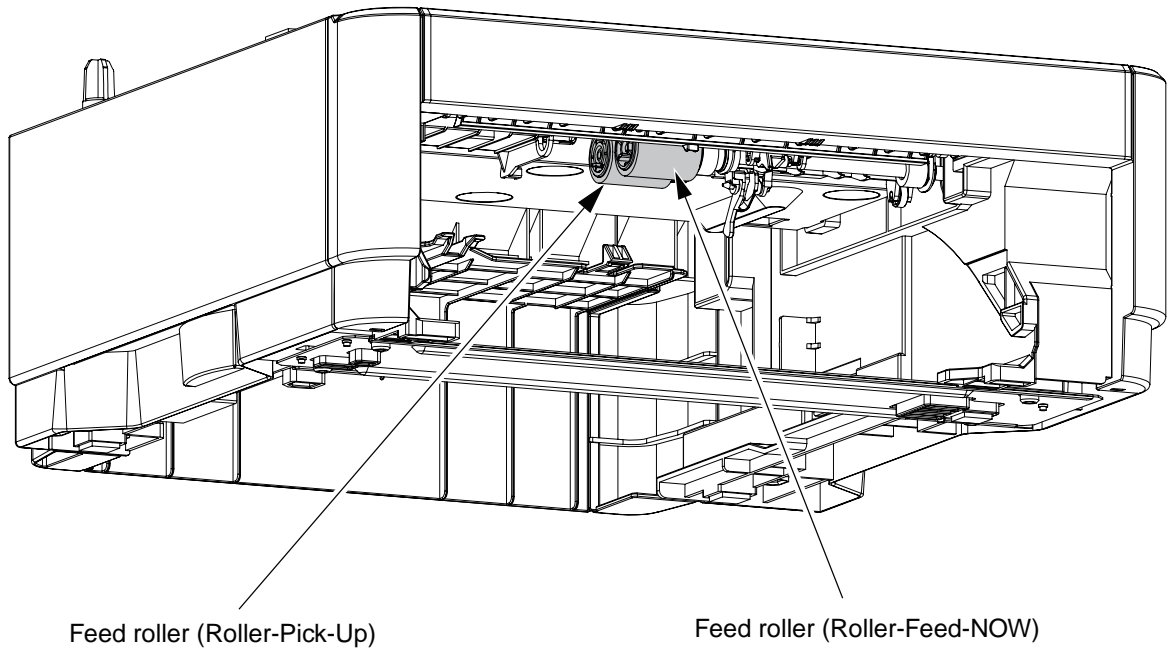

- (3) Open Retard-Cover of the paper cassette and wipe the retard roller with a tightly wrung cloth soaked in water. (Refer to 3.3.6 for how to open Retard-Cover.)

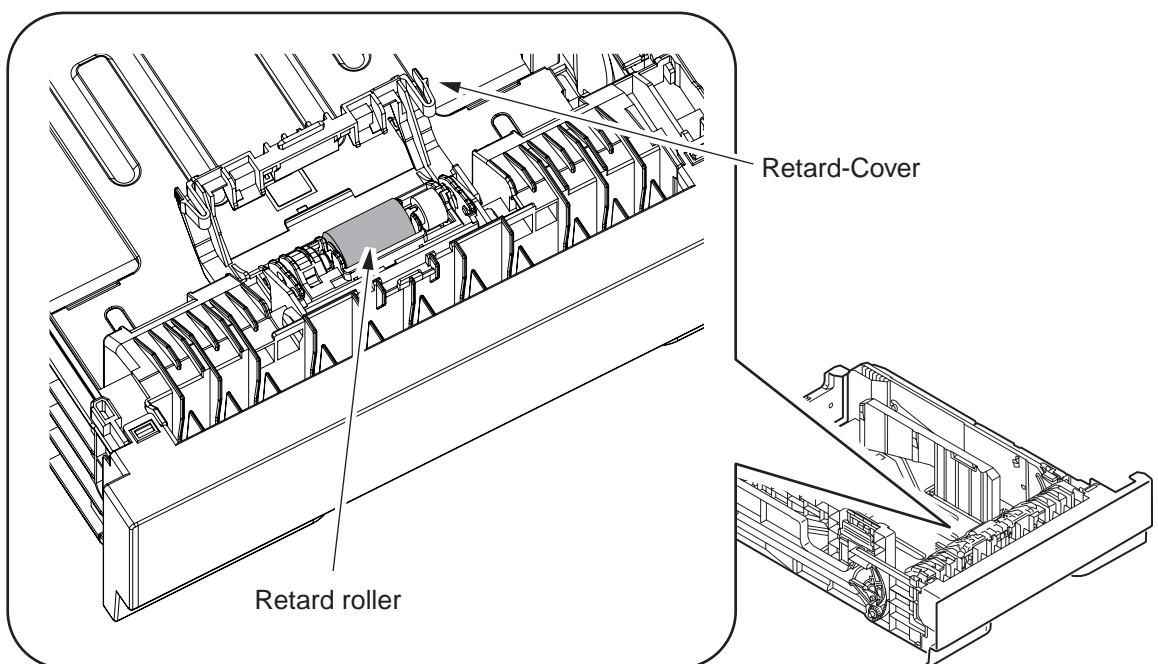

## 5. Procedure for Troubleshooting

### 5.1 Precautions for Troubleshooting

- (1) Check the basic items to be checked in the user's manual.
- (2) Obtain detail information at the failure from customers as much as possible.
- (3) Inspect the status which is close to the status at the failure.

### 5.2 Preparation before Troubleshooting

- (1) Display of Operator Panel

The failure status is displayed on the LCD (Liquid crystal display) of the operator panel. Follow the message displayed on LCD and make appropriate repairs.

B411dn

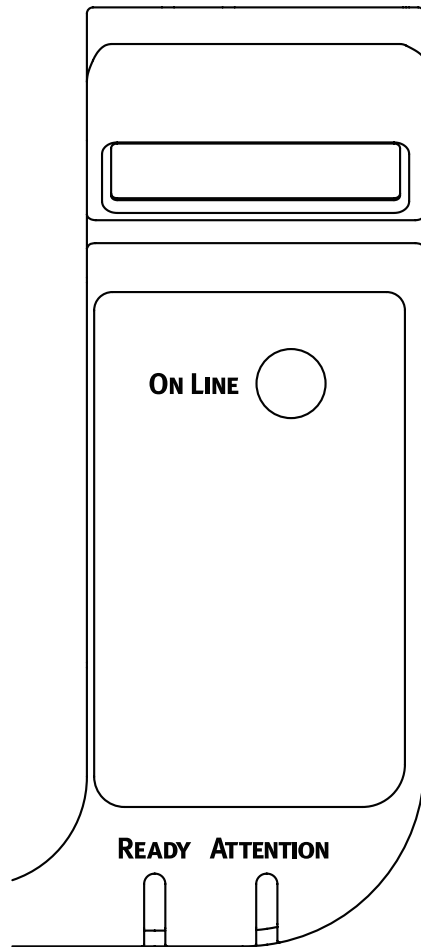

B431dn

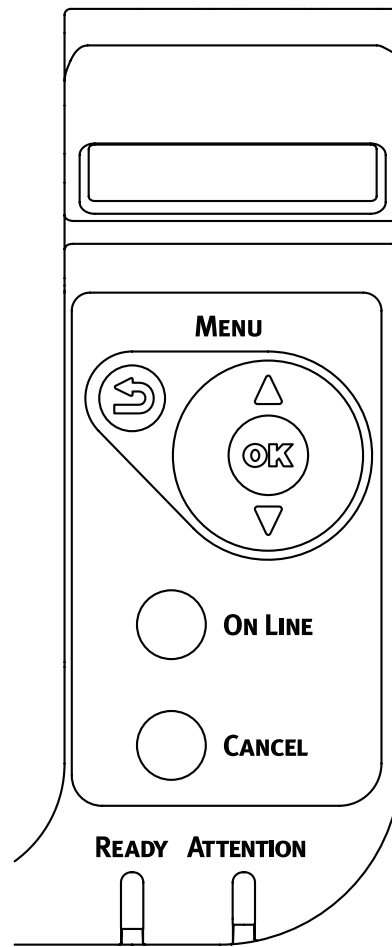

### 5.3 Troubleshooting Method

When trouble occurs in the device, search the trouble with the following steps.

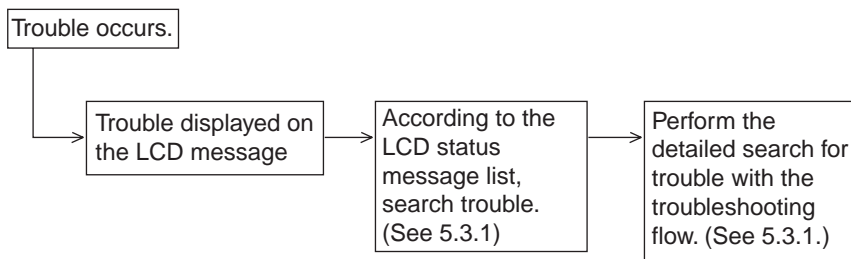



### 5.3.1 LCD Status Message List

The list of statuses and trouble displayed as the message format in LCD is outlined in Table 5-1.

Table 5-1 List of Statuses and Trouble of Second Tray unit

Category	LCD Status Message		LED		Trouble or Status	Handling
	Japanese	English	Ready	Atten		
Jam Error (Paper Feeding)	Open the top cover. 392: Paper Jam	OPEN UPPER COVER 392:PAPER JAM	OFF	Blinking	Notifies that a jam occurs during the paper feed from the Second Tray unit.	<ul style="list-style-type: none"> <li>Check paper in the Second Tray unit. Open and close the top cover to recover printing, and delete the error display.</li> <li>If it occurs frequently, take action according to the troubleshooting flow.</li> </ul>
Jam Error (Paper path)	Open the top cover. Nnn: Paper jam  *nnn: 381/382/389	OPEN UPPER COVER nnn:PAPER JAM  *nnn:381/382/389	OFF	Blinking	Notifies that a jam occurs while paper is running through the paper path.	<ul style="list-style-type: none"> <li>Check paper in the extended paper feed unit. Open and close the top cover to recover printing, and delete the error display.</li> </ul>
Jam Error (DUPLEX)	Open the rear cover. 372: Paper jam	OPEN REAR COVER 372:PAPER JAM	OFF	Blinking	Notifies that a jam occurs while printing from the duplex unit.	<ul style="list-style-type: none"> <li>Check paper in the extended paper feed unit. Open and close the top cover to recover printing, and delete the error display.</li> </ul>
Size Error	Load mmmm/pppp and press the online switch. 462: Tray2 size is wrong.	LOAD mmmm/ pppp AND PRESS ONLINE SWITCH 462:TRAY2 MEDIA MISMATCH	OFF	Blinking	Notifies that the paper size during the paper feeding from the Second Tray unit is not correct.	<ul style="list-style-type: none"> <li>Check ht epaper in the Second Tray unit. In addition, check if the paper is not overlapped. Open and close the top cover to recover printing, and delete the error display.</li> </ul>
	Open the top cover. Nnn: Paper size error.  *nnn: 380/381/382/389	OPEN UPPER COVER nnn:PAPER JAM  *nnn: 380/381/382/389	OFF	Blinking		
Media Error	Load mmmm/pppp and press the online switch. 462: Tray2 size is wrong.	LOAD mmmm/ pppp AND PRESS ONLINE SWITCH 462:TRAY2 MEDIA MISMATCH	OFF	Blinking	The media type in the Second Tray unit is different from the edition media type.	<ul style="list-style-type: none"> <li>Load paper requested to the Second Tray unit.</li> </ul>
Tray Paper Out	<input type="checkbox"/> Tray2 Paper Out	<input type="checkbox"/> TRAY2 EMPTY	OFF	Blinking	Notifies that there is no paper in the Second Tray unit.	<ul style="list-style-type: none"> <li>Load paper in the Second Tray unit.</li> </ul>
	Load mmmm. 492: Tray Paper Out	LOAD mmmm 492:TRAY2 EMPTY	ON	OFF		

- (Jam Error)

### Paper Feed Jam

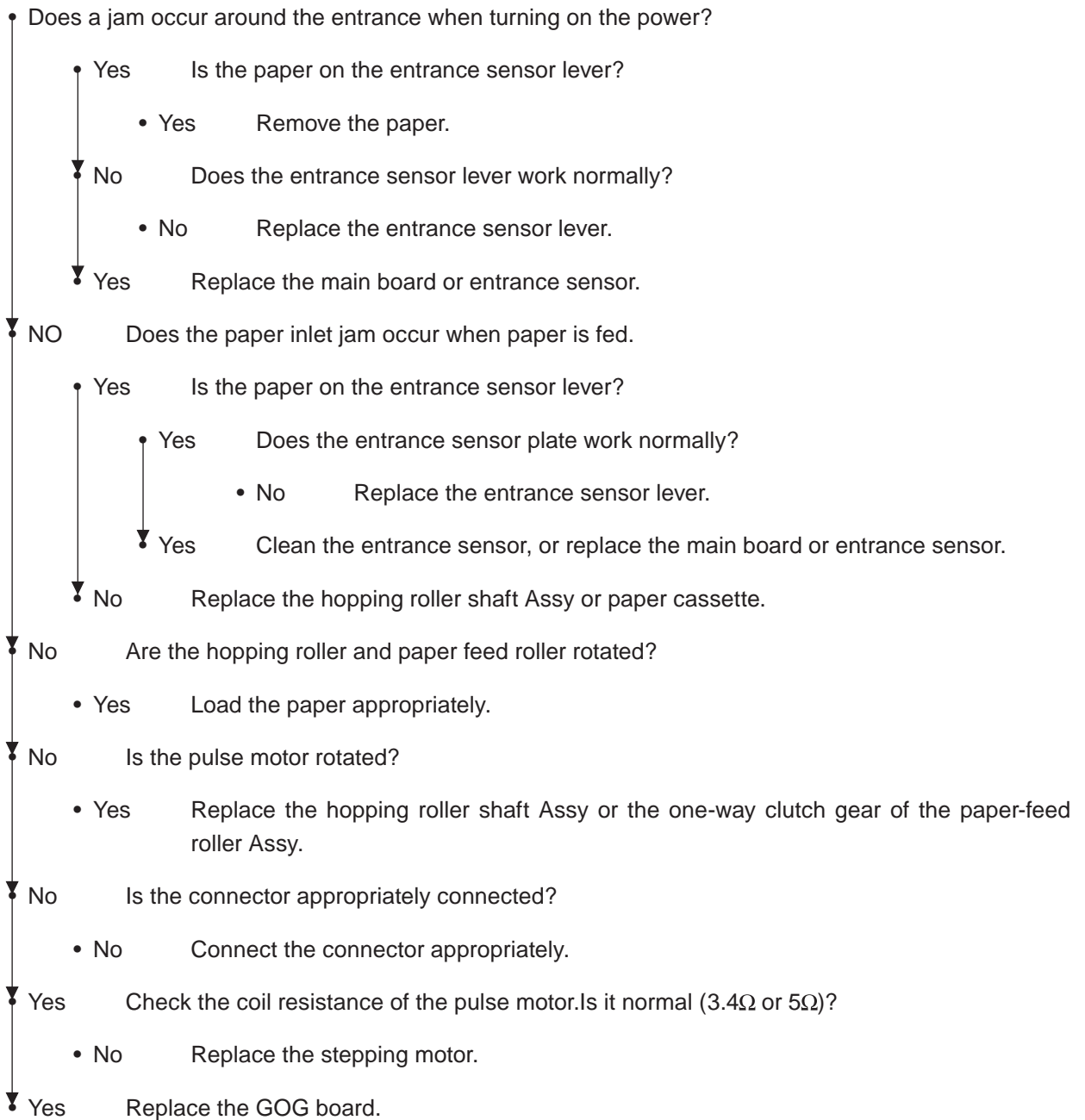

## 6. Connection Diagram

### 6.1 Connection diagram

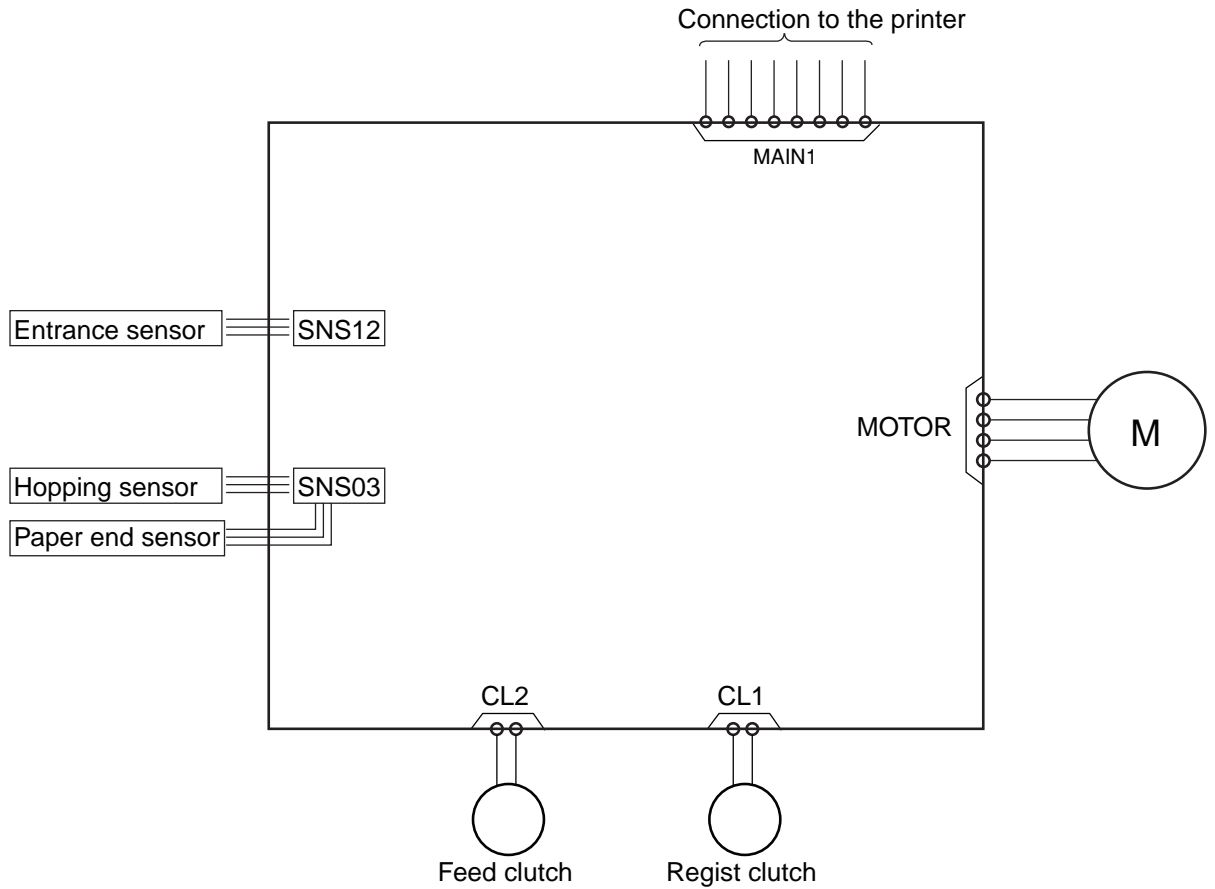

### 6.2 Board Arrangement

#### GOG board

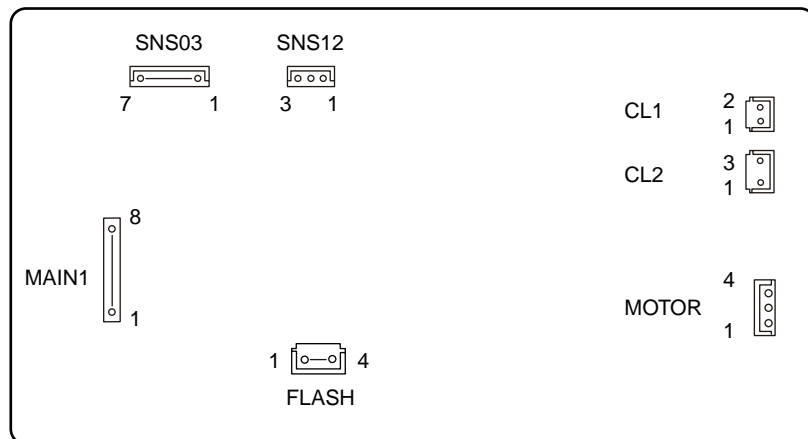

•MAIN1 Connector Pin Allocation

(Connection to the Main control board)

	PIN No.	I/O	Signal	Function
1	1	C	0VP	Analog Ground
2	2	O	24V	Motor/ Clutch Drive Power
3	3	C	0VL	Logic Ground
4	4	I	+5V	Logic Circuit Power supply
5	5	O	OPTSCK-N	OPT data output
6	6	I	OPTSD-P	OPT data input
7	7	O	OPTSDR-N	OPT status change
8	8	I	OPTPSIN-N	OPT transfer permission

•SNS03 Connector Pin Allocation

(Connection to the Hopping / Paper end sensor)

	PIN No.	I/O	Signal	Function
1	1	O	+5V	Logic Circuit Power supply
2	2	I	SNS3-N	Hopping sensor
3	3	C	0VL	Logic Ground
4	4	O	+5V	Logic Circuit Power supply
5	5	I	SNS0-N	Paper end sensor
6	6	C	0VL	Logic Ground

•SNS12 Connector Pin Allocation

(Connection to the Entrance sensor)

	PIN No.	I/O	Signal	Function
1	1	O	+5V	Logic Circuit Power supply
2	2	I	SNS1-N	Entrance sensor
3	3	C	0VL	Logic Ground

•CL1 Connector Pin Allocation

(Connection to the Regist clutch)

	PIN No.	I/O	Signal	Function
1	1	O	24V	Motor/ Clutch Drive Power
2	2	C	CLUTCH1	Analog Ground

•CL2 Connector Pin Allocation

(Connection to the Feed clutch)

	PIN No.	I/O	Signal	Function
1	1	O	POW	Motor/ Clutch Drive Power
2	2	C	CLUTCH2	Analog Ground
3	3	-	NC	Not used

•MOTOR Connector Pin Allocation

(Connection to the Pulse motor)

	PIN No.	I/O	Signal	Function
1	1	O	HOP4	Motor Drive Power
2	2	O	HOP3	Motor Drive Power
3	3	O	HOP2	Motor Drive Power
4	4	O	HOP1	Motor Drive Power

•FLASH Connector Pin Allocation

	PIN No.	I/O	Signal	Function
1	1	I/O	MODE	Serial Data
2	2	I	RESET	Reset
3	3	C	0VL	Logic Ground
4	4	O	VCC_CPU	Logic Circuit Power supply(+3.3)

## Appendix D Network Interface

### 100BASE-TX / 10BASE-T

#### (1) Network protocol

TCP/IP: (\*: B431 Only)

Network rayer	ARP, IP, ICMP, IPv6
Transport rayer	TCP, UDP
Apprication rayer	LPR, Port9100, FTP, HTTP, HTTPS*, IPP, SNMPv1/v3, TELNET, DHCP/BOOTP, DNS, DDNS, WINS, UPnP, Bonjour, SNTP, SMTP, Windows Rally (WSD Print, LLTD), SMB, CIFS

NBT/ NetBEUI:

SMB, NetBIOS, NetBIOS over TCP

NetWare:

Remote Printer mode (Max.8 print server)  
 Print Server mode (Max.8 file server, 32que)  
 Encrypted Password (Print Server mode)  
 NetWare6J/ 5J/ 4.1J (NDS, Bindery)  
 SNMP

ETHERTALK:

ELAP, AARP, DDP, AEP, NBP, ZIP, RTMP, ATP, PAP

IEEE802.1X: (B431 Only)

EAP-TLS, PEAP

#### (2) Table of Network I/F signals

Contact No.	Signal Name	Direction	Function
1	TXD+	From Printer	transfer data
2	TXD-	From Printer	transfer data
3	RXD+	To Printer	receive data
4	-	-	don't use
5	-	-	don't use
6	RXD-	To Printer	receive data
7	-	-	don't use
8	-	-	don't use

(3) Conector contact arrangement

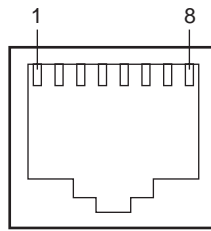

RJ45 Conector

(4) Cable

Category5 UTP RJ45

(5) IPv6 Ready Logo



(6) Setup

Each setting item can be set up by the menu and network administration tool.

Operation Panel Display		Default	Function
Items	Setting value		
TCP/IP	ENABLE DISABLE	*	Specify Enable/ Disable of TCP/IP protocol.
IP VERSION	IP v4 IP v4+v6 IP v6	*	Set an IP version. Operate with IPv4 at "IPv4". (IPv6 is disabled) Operate with both IPv4 and IPv6 at "IPv4+v6". Operate with IPv6 at "IPv6". (IPv4 is disabled)
NETBEUI	ENABLE DISABLE	*	Specify Enable/ Disable of NETBEUI protocol.
NETBIOS OVER TCP	ENABLE DISABLE	*	Specify Enable/ Disable of NETBIOS OVER TCP protocol.
NETWARE	ENABLE DISABLE	*	Specify Enable/ Disable of NetWare protocol.
ETHERTALK	ENABLE DISABLE	*	Specify Enable/ Disable of EtherTalk.
FRAME TYPE	AUTO 802.2 802.3 ETHERNET II SNAP	*	Set the frame type. [Display Conditions] • "NETWARE" is enabled.
IP ADDRESS SET	AUTO MANUAL	*	Set the setting method of an IP address. [Display Conditions] • "TCP/IP" is enabled, and "IP VERSION" is IP v4 or IPv4+v6.
IP ADDRESS	xxx.xxx.xxx.xxx	-	Set an IP address. [Display Conditions] • "TCP/IP" is enabled, and "IP VERSION" is IP v4 or IPv4+v6.

Operation Panel Display		Default	Function
Items	Setting value		
SUBNET MASK	xxx.xxx.xxx.xxx	-	Set the subnet mask. [Display Conditions] • "TCP/IP" is enabled, and "IP VERSION" is IP v4 or IPv4+v6.
GATEWAY ADDRESS	xxx.xxx.xxx.xxx	*	Set the gateway address. [Display Conditions] • "TCP/IP" is enabled, and "IP VERSION" is IP v4 or IPv4+v6.
WEB	ENABLE DISABLE	*	Specify Enable/ Disable of WEB. [Display Conditions] • "TCP/IP" is enabled.
TELNET	ENABLE DISABLE	*	Specify Enable/ Disable of TELNET. [Display Conditions] • "TCP/IP" is enabled.
FTP	ENABLE DISABLE	*	Specify Enable/ Disable of FTP. [Display Conditions] • "TCP/IP" is enabled.
SNMP	ENABLE DISABLE	*	Specify Enable/ Disable of SNMP. [Display Conditions] • "TCP/IP" or "NETWARE" is enabled.
NETWORK SCALE	NORMAL SMALL	*	Normal: usually, this setting is used. In the NORMAL, even if connected to the HUB having the spanning tree function, the device operates efficiently. However, when the computer is connected to two or three small LANs, it takes long to start a computer. At SMALL, the computer supports two or three small LANs and large LAN, however, when connected to the HUB having the spanning tree function, the device may not operate efficiently.
HUB LINK SETTING	AUTO NEGOTIATE 100BASE-TX FULL 100BASE-TX HALF 10BASE-T FULL 10BASE-T HALF	*	Set a method of link to the HUB. When setting to Auto, the connection method is automatically selected for all of the HUB, and connection is tried. When selecting other items, the connection to the HUB is tried only by the connection method.
FACTORY DEFAULTS	EXCUTE	-	Initialize the network menu.

## (7) Functions that substitute the network reset button functions

Network reset button functions available on B410/B430 can be performed by the following operation.

## (7-1) Initialization of network functions

## B431dn

Initialize network functions from the operator panel.

- ① Check that the power switch is turned on and [ONLINE] is displayed on the operator panel.
- ② Press the [MENUΔ] or [MENU∇] button several times until [NETWORK MENU] appears, and then press the [OK] button.
- ③ Press the [MENUΔ] or [MENU∇] button several times until [FACTORY DEFAULTS/EXECUTE] appears, and then press the [OK] button.

Then, the network settings are initialized.

## B411dn

- ① Turn off the printer.
- ② Connect the network cable to the printer.
- ③ Open the top cover and turn on the printer while holding down the [ONLINE] button.
- ④ After [CLOSE COVER/310:COVER OPEN] appears on the operator panel, release the button.
- ⑤ After the top cover is closed, [WAIT A MOMENT/NETWORK INITIAL] appears, and network settings are initialized.

## (7-2) Printing of Network Information

## B431dn

- ① Load A4 paper in the tray.
- ② Press the [MENUΔ] button to display [INFORMATION MENU].
- ③ Press the [OK] button to display [PRINT MENU MAP/EXECUTE].
- ④ Press the [MENUΔ] button to display [NETWORK/EXECUTE].
- ⑤ Press the [OK] button.

Then, Network Information is printed.

## B411dn

- ① Load A4 paper in the tray.
- ② Press the [ONLINE] button to put the printer into offline mode.
- ③ Hold down the [ONLINE] button for 10 seconds or more and then release it.

Then, Network Information is printed.