

6  
5  
4  
3  
2  
1

No.01

Oki Data CONFIDENTIAL

# B4100 Monochrome LED Page Printer Maintenance Manual

ODA

040623A

BOM		Use for		Certification Body	
Rev	Date	DCO No.	Contents	Design	Approval
Approval		Design		Name B4100 Maintenance Manual	
Hisao Ono		Hisao Ono			
Check					
Date				Drawing No.	
2004-04-14		Oki Data Corporation		42640901TH	
1 / 86					



# PREFACE

This Maintenance Manual describes the field maintenance methods for B4100 Monochrome LED Page Printers.

This manual is written for use by service persons. Please note that you should refer to the Printer Handbook for the handling and operating methods of the equipment.

# CONTENTS

<b>1. CONFIGURATION .....</b>	<b>6</b>
1.1 System Configuration .....	6
1.2 Printer Configuration .....	7
1.3 Specification .....	8
1.4 Safety Standards .....	10
1.4.1 Certification Label .....	10
1.4.2 Warning Label .....	10
1.4.3 Warning/Caution Marking .....	11
<b>2. PARTS REPLACEMENT .....</b>	<b>12</b>
2.1 Precautions for Parts Replacement .....	12
2.2 Parts Layout .....	14
2.3 How to Change Parts .....	17
2.3.1 Upper Cover Assy .....	18
2.3.2 LED Head .....	19
2.3.3 Operator Panel Assy .....	20
2.3.4 Lower Base Unit .....	21
2.3.5 Pulse Motor (Main/Drum) .....	22
2.3.6 Pulse Motor (Registration) .....	23
2.3.7 Face Up Stacker Assy .....	24
2.3.8 Eject Roller Assy .....	25
2.3.9 Motor Assy .....	26
2.3.10 Hopping Roller Shaft Assy .....	27
2.3.11 Stacker Cover Assy .....	28
2.3.12 Registration Roller .....	29
2.3.13 Roller Transfer Assy .....	30
2.3.14 Fusing Unit .....	31
2.3.15 Back-up Roller .....	32
2.3.16 Sensor Plate (Inlet) .....	33
2.3.17 Sensor Plate (Outlet), Sensor Wire Assy .....	34
2.3.18 Manual Feed Guide Assy .....	35
2.3.19 Sensor Plate (Paper Supply) .....	36
2.3.20 GRG-5, 7 PCB .....	37
2.3.21 Power Supply Board and High Voltage/Sensor Board .....	38
2.3.22 Cassette Guide L Assy .....	39
2.3.23 Cassette Guide R Assy .....	40
<b>3. ADJUSTMENT .....</b>	<b>41</b>
3.1 Adjustment Types and Functions .....	41
3.1.1 Status Monitor .....	41
3.1.2 Maintenance Utility .....	41
3.2 Adjustment When Replacing a Part .....	41
3.2.1 Uploading/Downloading EEPROM data .....	41
<b>4. PERIODICAL MAINTENANCE .....</b>	<b>42</b>
4.1 Periodical Replacement Parts .....	42
4.2 Cleaning .....	42
4.2.1 Cleaning of LED Lens Array .....	42
4.2.2 Cleaning Page Function .....	43



<b>5. TROUBLESHOOTING PROCEDURES .....</b>	<b>44</b>
5.1 Troubleshooting Tips .....	44
5.2 Check Points Before Correcting Image Problems .....	44
5.3 Notes When Correcting Image Problems .....	44
5.4 Preparation Before Troubleshooting .....	44
5.5 Troubleshooting .....	47
5.5.1 Status Monitor Message List .....	47
5.5.2 Status Message Troubleshooting .....	51
5.5.3 Image Troubleshooting .....	58
<b>6. WIRING DIAGRAM .....</b>	<b>67</b>
6.1 Interconnect Signal Diagram .....	67
6.2 PCB Layout and Connector Signal List .....	68
6.3 Resistance Check .....	75
<b>APPENDIX A CENTRONICS PARALLEL INTERFACE (ODA230V/OEL/AOS ONLY) ....</b>	<b>77</b>
<b>APPENDIX B UNIVERSAL SERIAL BUS (USB) .....</b>	<b>83</b>

# 1. CONFIGURATION

## 1.1 System Configuration

B4100 consists of control and engine blocks in the standard configuration, as shown in Figure 1-1.

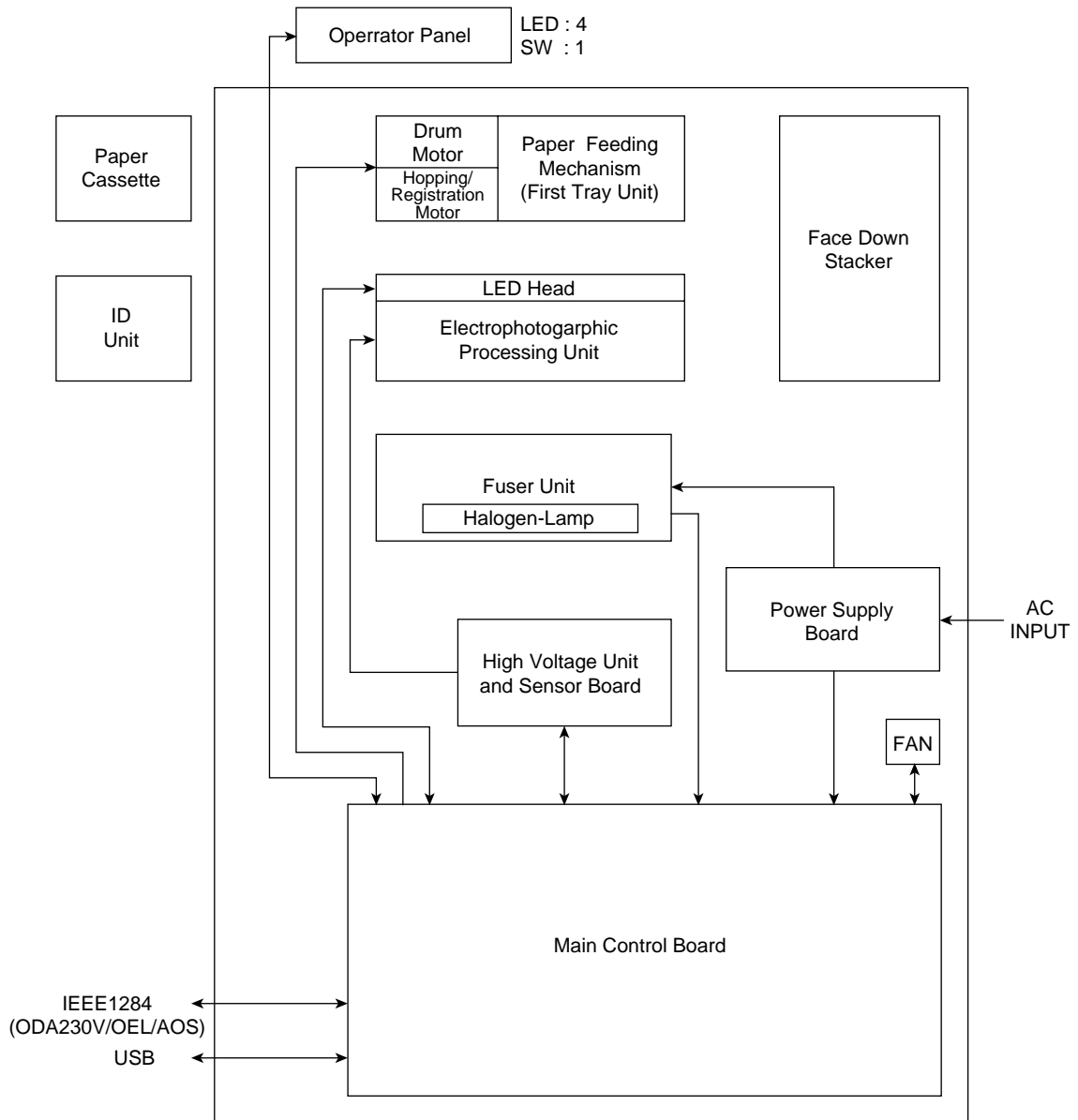

Figure 1-1

## 1.2 Printer Configuration

The printer unit consists of the following hardware components:

- Electrophotographic Processor
- Paper Feeder
- Controller
- Operator Panel
- Power Supply Unit

The printer unit configuration is shown in Figure 1-2.

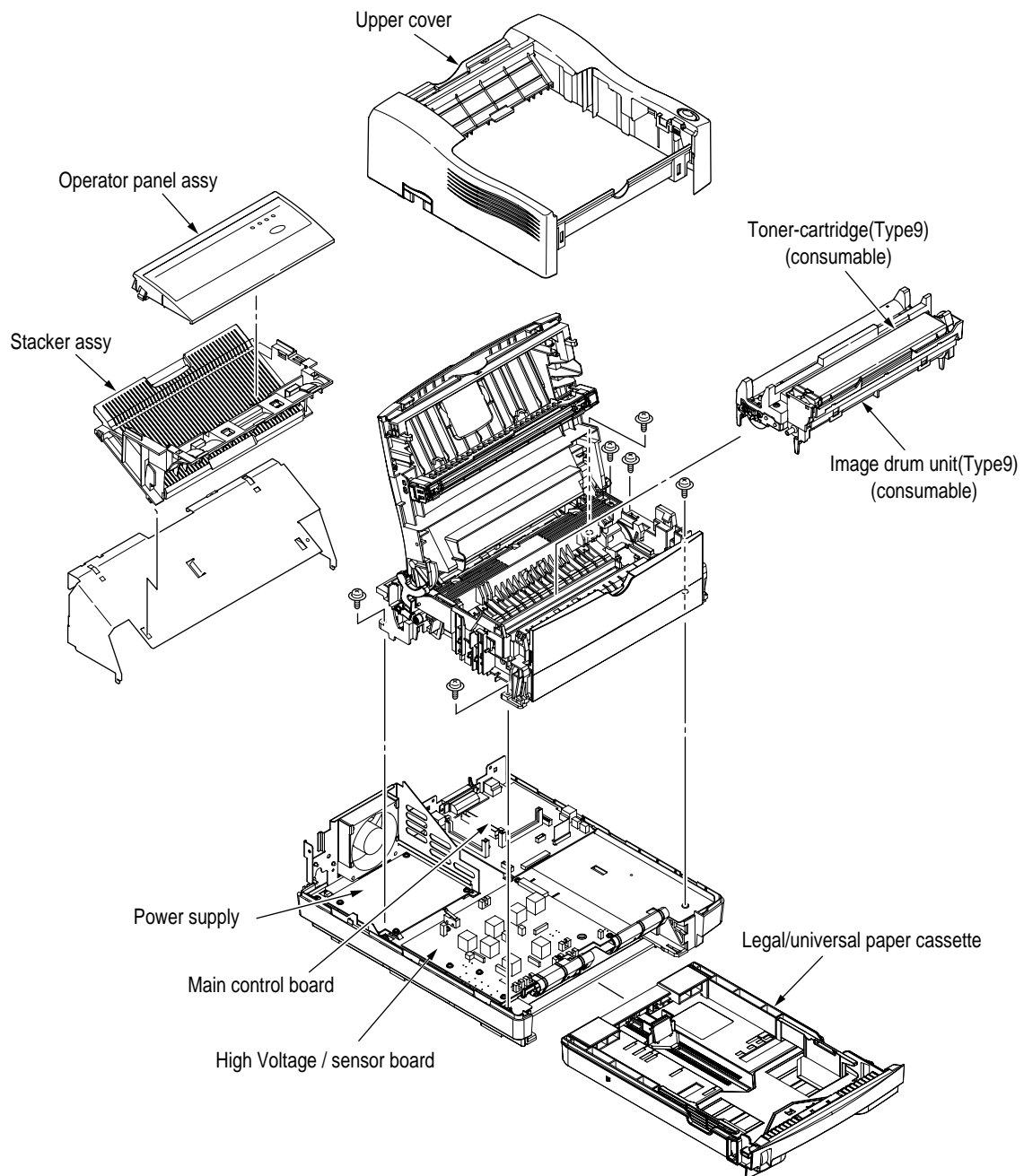

Figure 1-2

### 1.3 Specification

(1) Type	Desktop
(2) External dimensions	Height 7.9" (200 mm) Width 14.0" (355 mm) Depth 15.7" (400 mm)
(3) Weight	Approx. 9 kg
(4) Developing method Exposing method	Dry electrophotography LED stationary head
(5) Paper used	<p>&lt;Type&gt;</p> <ul style="list-style-type: none"> <li>• Standard paper <ul style="list-style-type: none"> <li>– Xerox 4200 (20 lbs)</li> </ul> </li> <li>• Application paper (manual face-up feed) <ul style="list-style-type: none"> <li>– Label</li> <li>– Envelope</li> <li>– OHP paper (transparency)</li> </ul> </li> </ul> <p>&lt;Size&gt;</p> <ul style="list-style-type: none"> <li>• Standard sizes <ul style="list-style-type: none"> <li>– Letter</li> <li>– Legal</li> <li>– Legal-13</li> <li>– Executive</li> <li>– COM-9 *</li> <li>– COM-10* [* Manual feed only]</li> <li>– Monarch*</li> <li>– DL*</li> <li>– C5*</li> <li>– A4</li> <li>– A5</li> <li>– B5 (JIS)</li> <li>– A6</li> </ul> </li> <li>• Applicable sizes <ul style="list-style-type: none"> <li>– Width : 3.5" to 8.5" (90 to 216 mm)</li> <li>– Length : 5.8" to 14" (148 to 355.6 mm)</li> </ul> </li> </ul> <p>&lt;Thickness&gt;</p> <ul style="list-style-type: none"> <li>– Automatic feed : 16 to 28 lbs (60 to 105 g/m<sup>2</sup>)</li> <li>– Manual feed : Label, OHP paper (transparency) Envelope (24 to 28 lbs)</li> </ul>
(6) Printing speed	<p>Continuous printing : 19 pages per minute with Letter size paper. 18 pages per minute with A4 size paper.</p> <p>Warm-up time : 35 seconds typical at room temperature [68°F (20°C), AC 120/230 V].</p> <p>First page print time : 6.0 seconds typical for the Letter size paper (6.2 seconds for the A4 size) after warm-up.</p>
(7) Paper feeding method	Automatic feed or manual feed
(8) Paper delivery method	Face down/face up
(9) Resolution	600 × 600 dots/inch 600 × 1200 dots/inch

(10) Power input 110~127 VAC ± 10%  
220~240 VAC ± 10%

(11) Power consumption

	120VAC	230VAC
Peak	: Approx. 700W	Approx. 700W
Typical operation	: Approx. 340W	Approx. 350W
Idle	: Approx. 66W	Approx. 68W
Power save mode	: Approx. 8W	Approx. 9W

(12) Temperature and humidity

	In operation	Power off mode	During Storage	Unit
Temperature	50-90 (10-32)	32-110 (0-43)	14-110 (-10-43)	°F (°C)
Humidity	20-80	10-90	10-90	%RH
Maximum wet bulb temperature	77 (25)	80.4 (26.8)	————	°F (°C)
Minimum difference between wet and dry bulb temperatures	35.6 (2)	35.6 (2)	————	°F (°C)

1. Storage conditions specified above apply to printers in packed condition.
2. Temperature and humidity must be in the range where no condensation occurs.

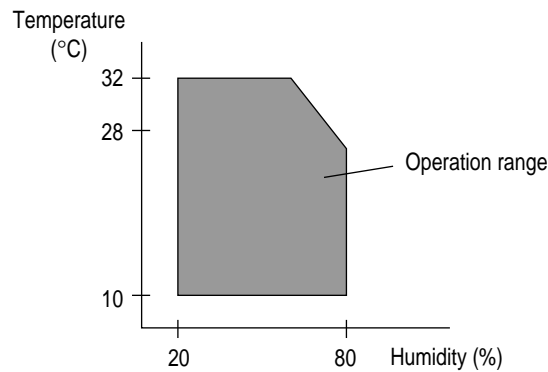

(13) Noise

During operation	: 53 dB (A) or less
Standby	: 38 dB (A) or less
Quiet mode	: Back ground level

(14) Consumables



Toner cartridge kit	2,500 (5% duty)
Image drum cartridge	25,000 (at continuous printing) 17,000 (3 page/job) without Power Save 11,000 (1 page/job) without Power Save 7,000 (1 page/job) with Power Save (Minimum)

## 1.4 Safety Standards

### 1.4.1 Certification Label



The safety certification label is affixed to the printer in the position described below.

#### ODA AC : 120V model

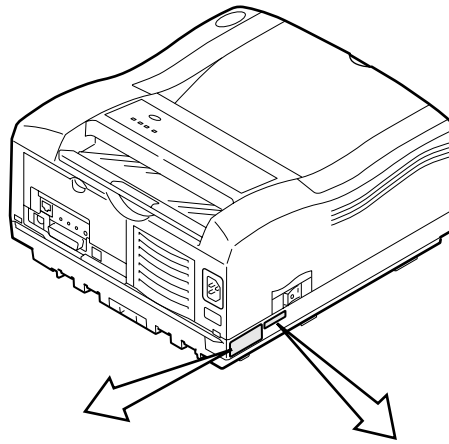
Model No. N22102A 110V~127V~ 50/60Hz 6A	
<b>Oki Data Corporation</b>  Tested To Comply With FCC Standards FOR HOME OR OFFICE USE This Class B digital apparatus complies with Canadian ICES-003. Cet appareil numérique de la classe B est conforme à la norme NMB-003 du Canada.	





#### ODA AC : 230V model

Model No. N22102B 220V~240V~ 50/60Hz 3.2A		
<b>Oki Data Corporation</b> This device complies with Part 15 of the FCC Rules. Operation is subject to the following two conditions: (1) this device may not cause harmful interference, and (2) this device must accept any interference received, including interference that may cause undesired operation.		

Serial No. _____	
Made In China	

#### OEL AC : 230V model

Model No. N22102B 220V~240V~ 50/60Hz 3.2A
<b>Oki Data Corporation</b>
 

#### AOS AC : 230V model

<b>B4100</b> Model No. N22102B 220V~240V~ 50/60Hz 3.2A	
<b>Oki Data Corporation</b> Made in China	

  

 N184
--

### 1.4.2 Warning Label

The warning labels are affixed to the sections which may cause bodily injury.

Follow the instructions on warning labels during maintenance.

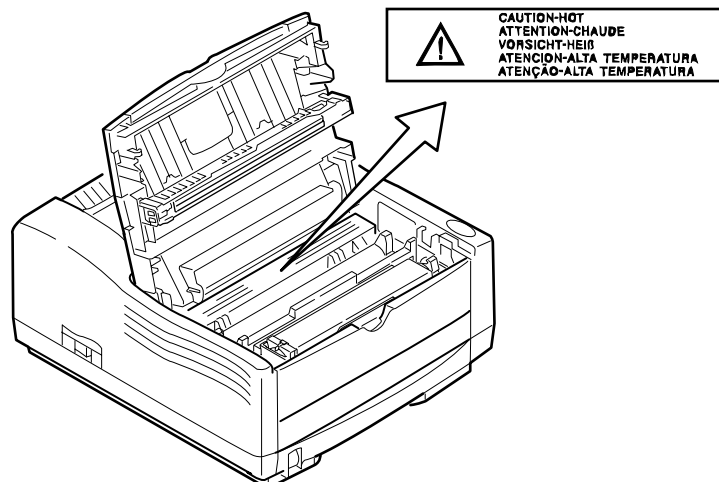

1.4.3 Warning/Caution Marking

The following warning and caution markings are made on the power supply/sensor board.

CAUTION

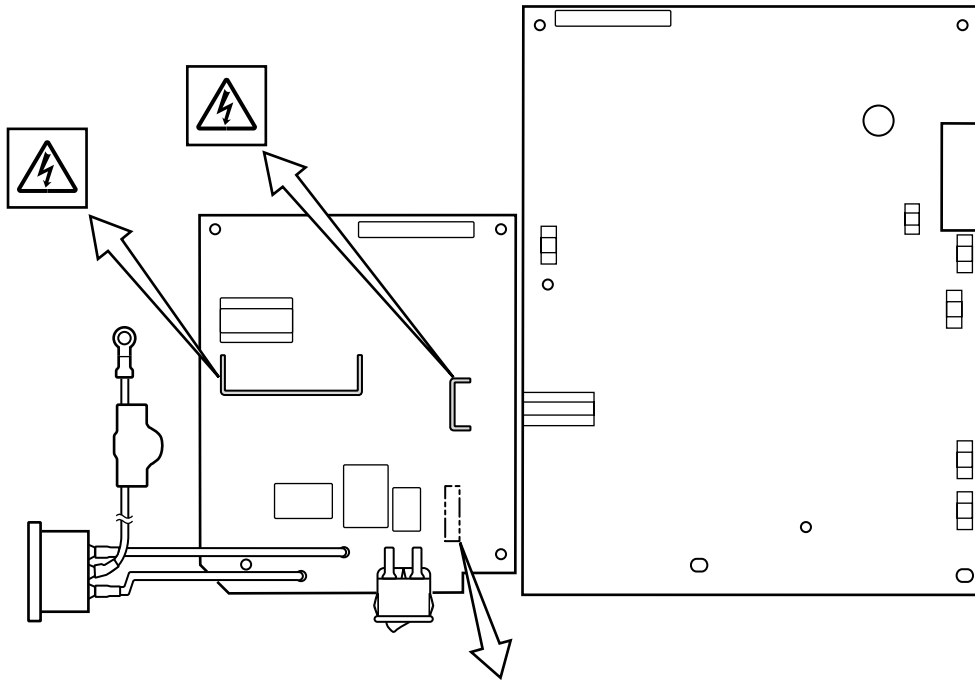

ENGLISH

Heatsink and transformer core present risk of electric shock. Test before touching.

## 2. PARTS REPLACEMENT

The section explains the procedures for replacement of parts, assemblies, and units in the field. Only the disassembly procedures are explained here. For reassembly, reverse the disassembly procedure.

### 2.1 Precautions for Parts Replacement

(1) Before starting to replace parts, remove the AC cord and interface cable.

(a) Remove the AC cord in the following sequence:

- i) Turn off ("o") the power switch of the printer
- ii) Disconnect the AC inlet plug of the AC cord from the AC receptacle.
- iii) Disconnect the AC cord and interface cable from the printer.

(b) Reconnect the printer in the following procedure.

- i) Connect the AC cord and interface cable to the printer.
- ii) Connect the AC inlet plug to the AC receptacle.
- iii) Turn on ("I") the power switch of the printer.

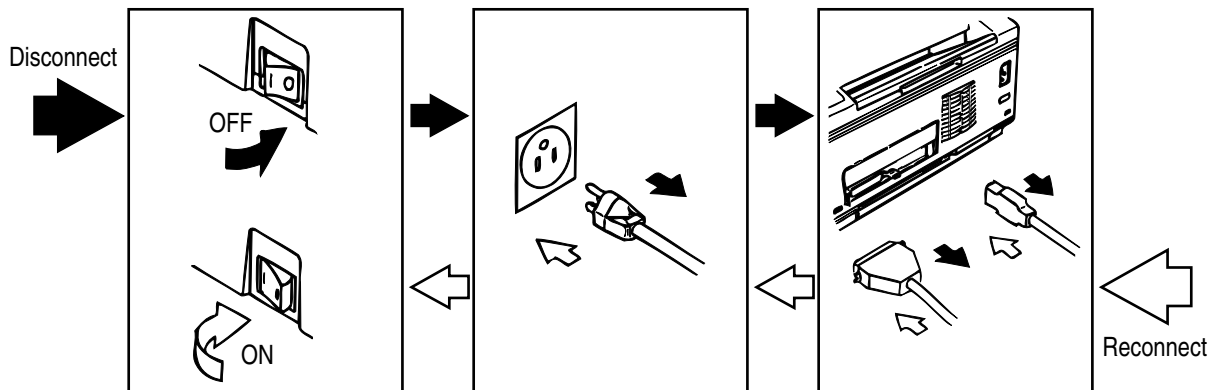

(2) Do not disassemble the printer as long as it is operating normally.

(3) Do not remove parts which do not have to be touched; try to keep the disassembly to a minimum.

(4) Use specified service tools.

(5) When disassembling, follow the laid out sequences. Parts may be damaged if these sequences are not followed.

(6) Since screws, collars and other small parts are likely to be lost, they should temporarily be attached to the original positions during disassembly.

(7) When handling IC's such as microprocessors, ROMs and RAMs, or circuit boards, do not wear gloves that are likely to generate static electricity.



(8) Do not place printed circuit boards directly on the equipment or floor.



## [Service Tools]

The tools required for field replacement of printed circuit boards, assemblies and units are listed in Table 2-1.

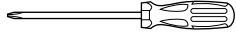
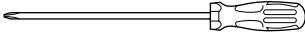
Table 2-1 Service Tools

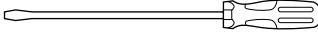
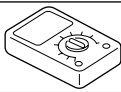
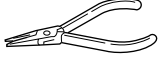
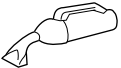
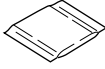
No.	Service Tools	Q' ty	Application	Remarks
1	 No. 1-100 Philips screwdriver	1	2~2.5 mm screws	
2	 No. 2-100 Philips screwdriver	1	3~5 mm screws	
3	 No. 3-100 screwdriver	1		
4	 No. 5-200 screwdriver	1		
5	 Digital multimeter	1		
6	 Pliers	1		
7	 Handy cleaner	1		
8	 LED Head cleaner	1	Cleans LED head	

## 2.2 Parts Layout

This section explains the layout of main components of the equipment.

[Lower base unit]

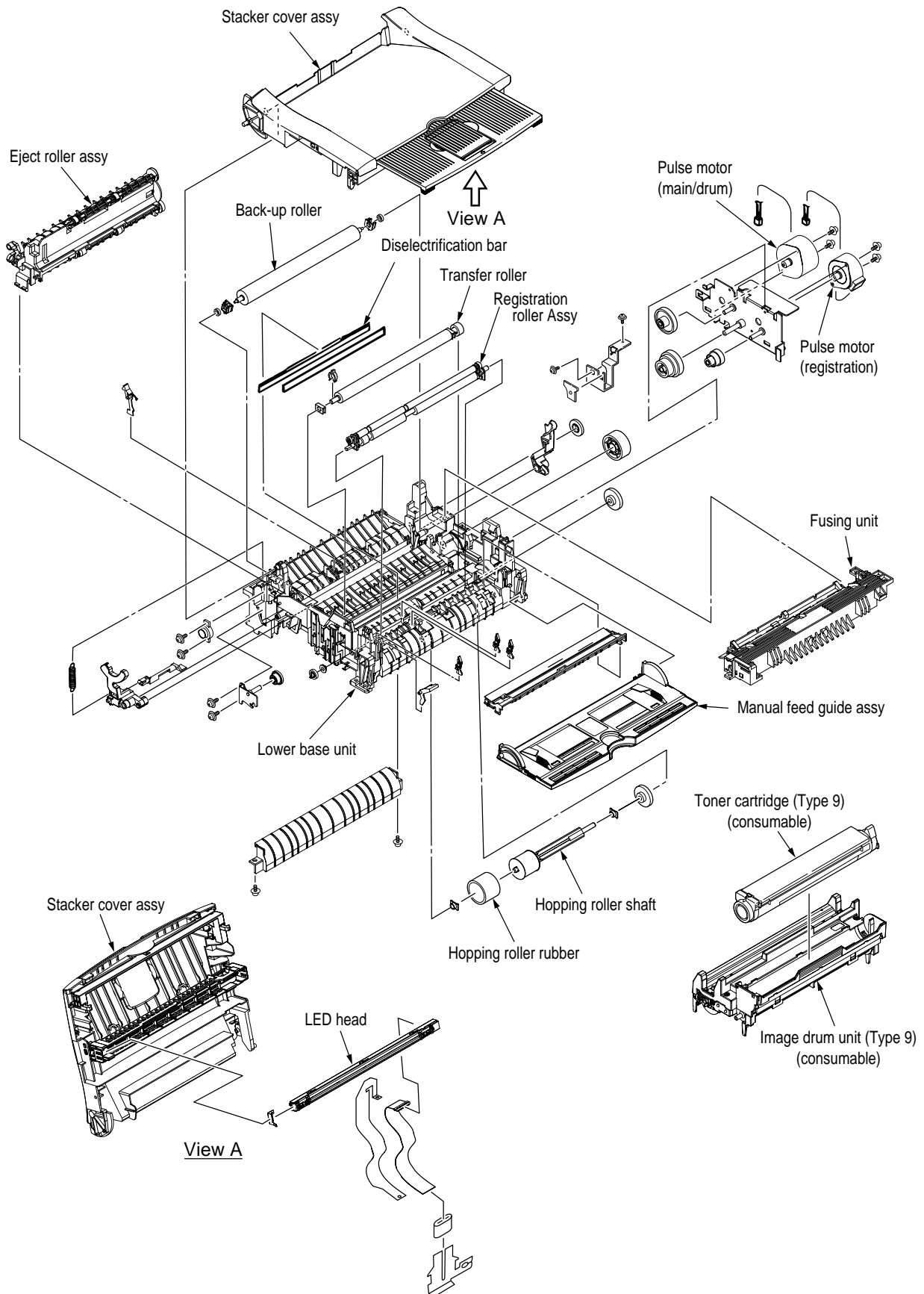

Figure 2-1

[Upper cover unit]

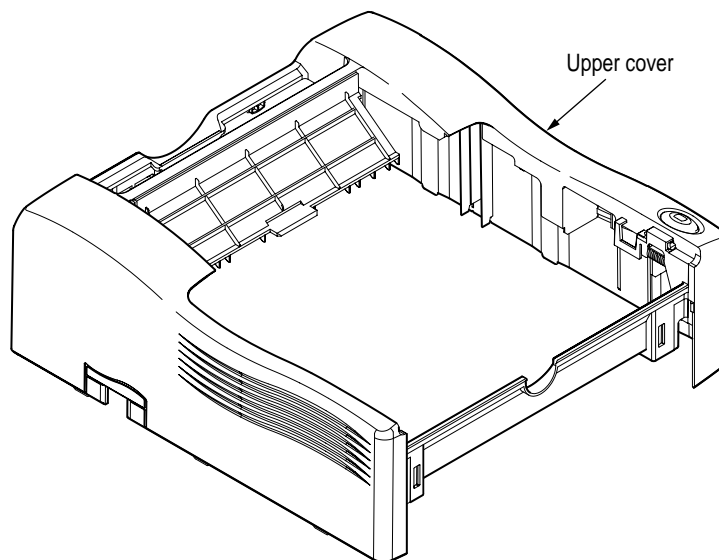

Figure 2-2

[Base unit]

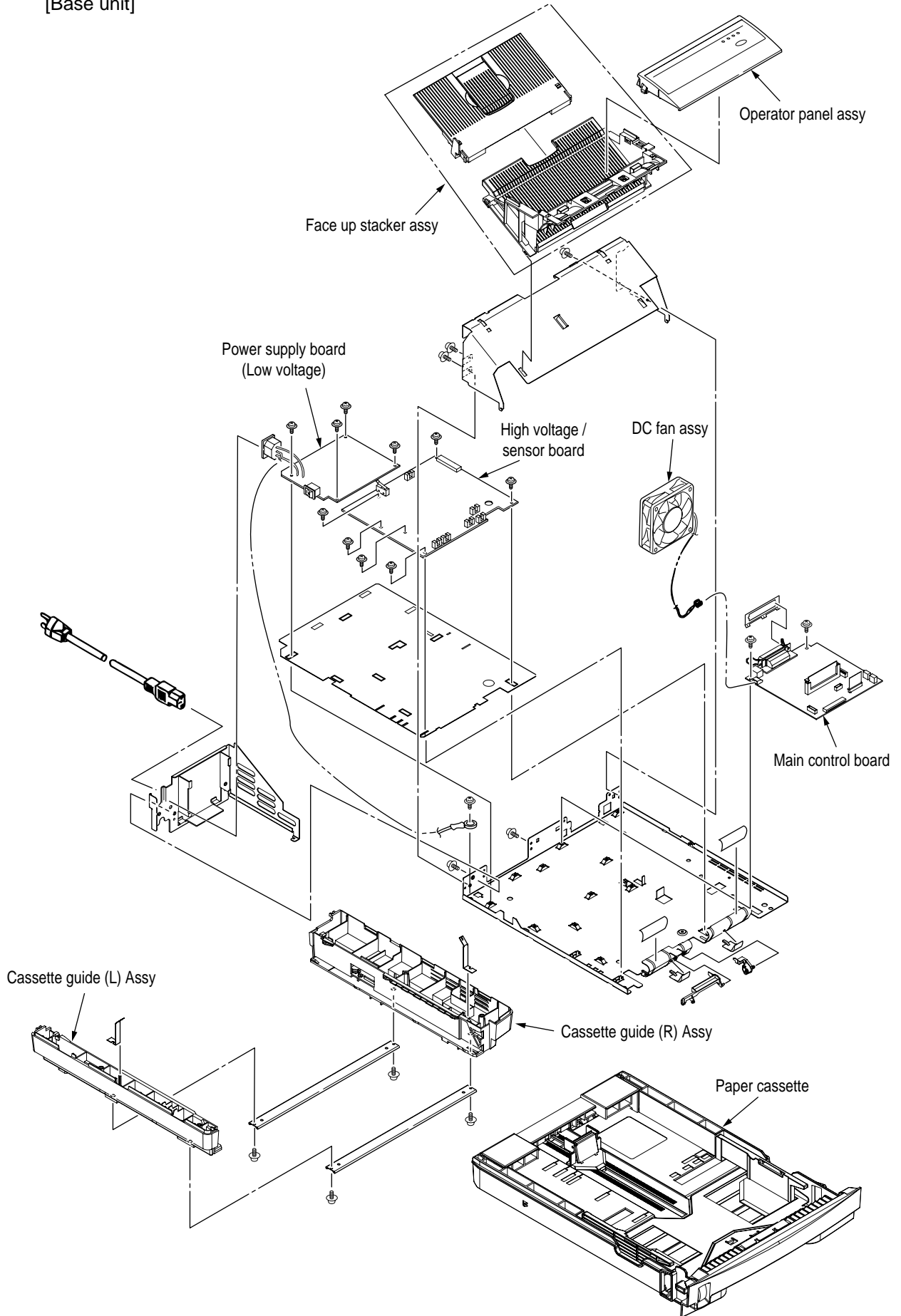
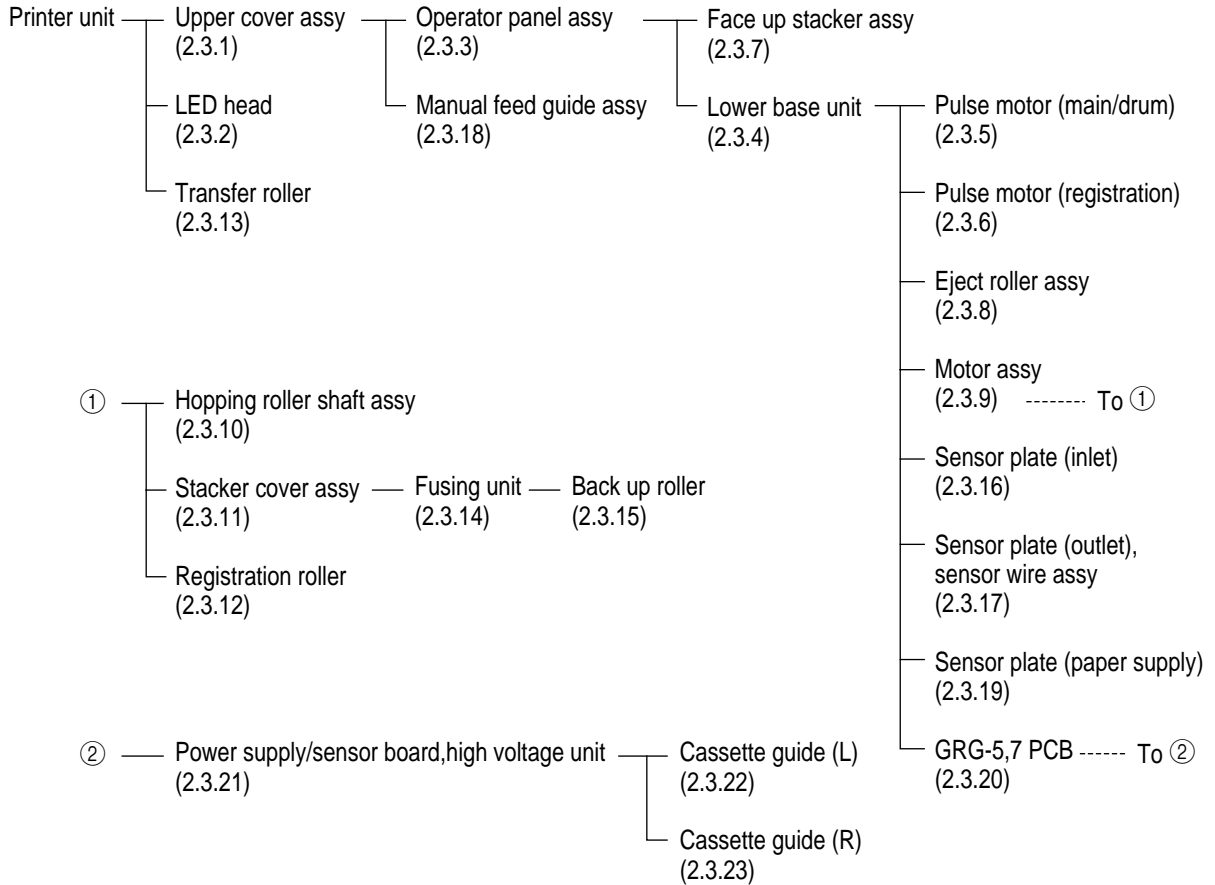

Figure 2-3

## 2.3 How to Change Parts

This section explains how to change parts and assemblies listed in the disassembly diagram below.

In the parts replacement procedure, those parts marked with the part number inside ● with white letters are RSPL parts.



### 2.3.1 Upper Cover Assy

- (1) With the power switch turned off, unplug the AC power cord from the outlet.
- (2) Disconnect the interface cable ①.
- (3) Press the button ② on right side of the Upper cover and open the stacker cover assy ③.
- (4) Take out the image drum unit ④.
- (5) Open the manual feed guide assy ⑤. Unlock the latches at two locations on the front side. Lift the front side of the upper cover ⑥ up and unlock the latches at two locations on the back side. Lift and remove the upper cover assy ⑥.

**Note :** When removing or reinstalling the upper cover, be careful not to get the motor cables tangled or caught.

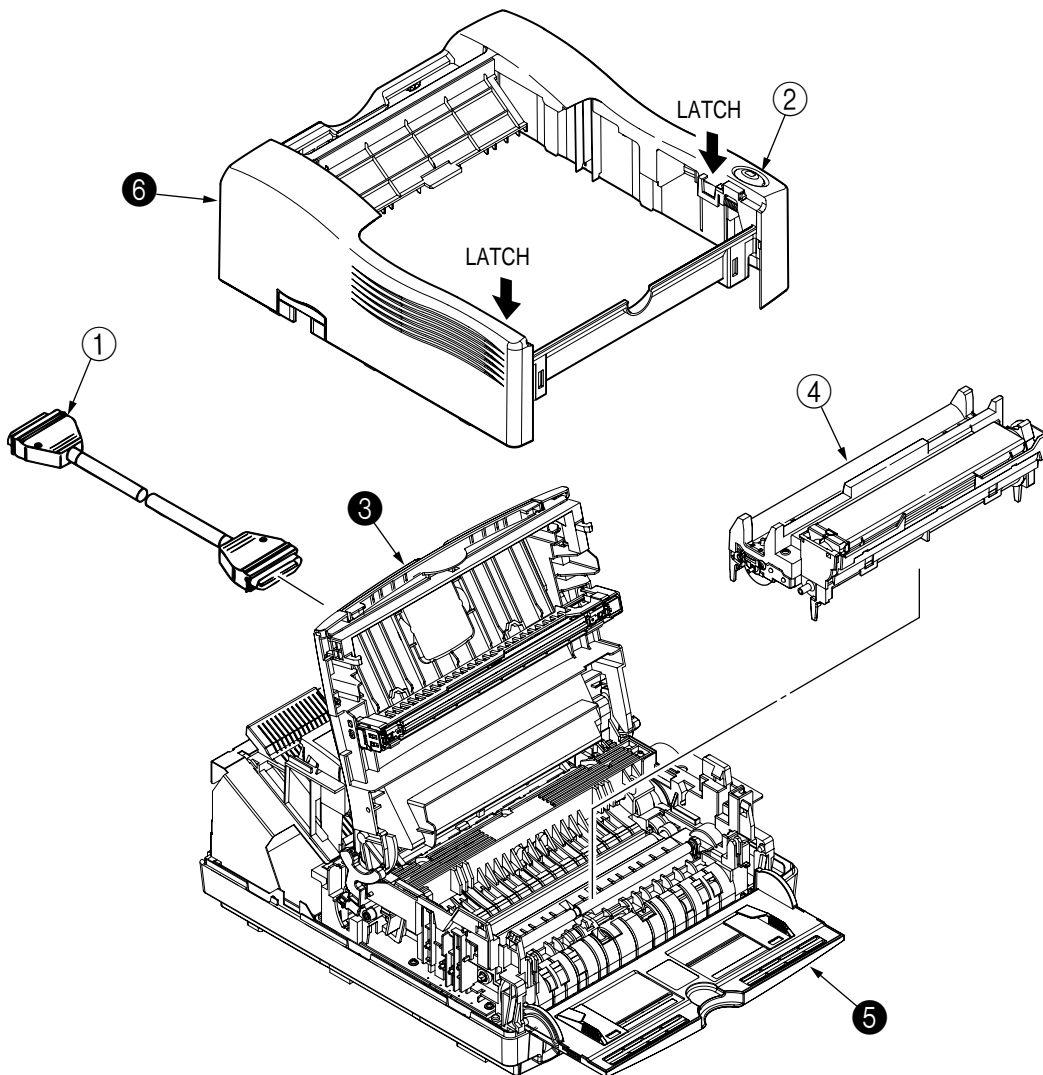

### 2.3.2 LED Head

- (1) Press the button on right side of the upper cover and open the stacker cover assy ❶.
- (2) Open the hook section on the left side of the head holder and remove the LED head ❷.
- (3) Remove the head cable ❸ from the head connector.

**Note:** Be sure not to touch directly or push on the SLA part of the LED head.

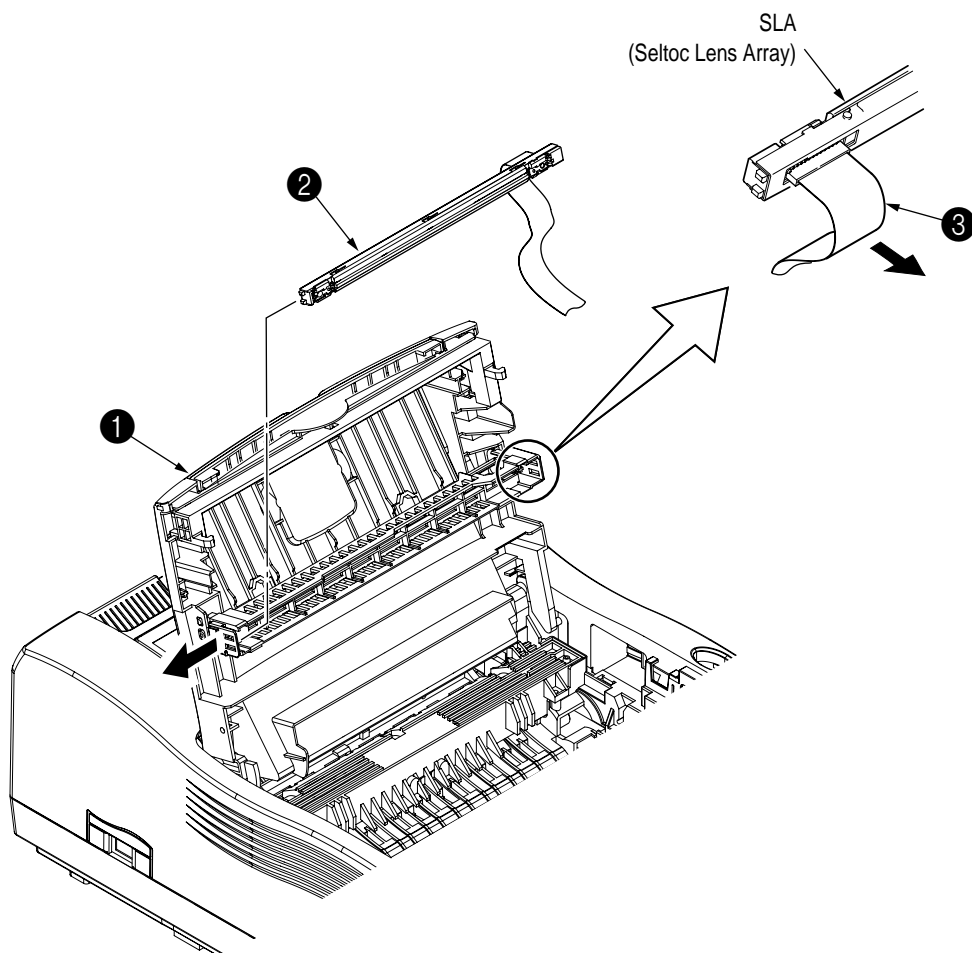

### 2.3.3 Operator Panel Assy

- (1) Unlock two latches on the upper cover from the rear side, lift the operator panel assy ❶ from the back and remove it.
- (2) Remove the Sumi card (operator panel) ❷ from the connector (CN1) ❸.

**Note :** You can remove the operator panel assy while the upper cover installed on the unit. However, it is much easier to remove the panel assy after removal of upper cover.

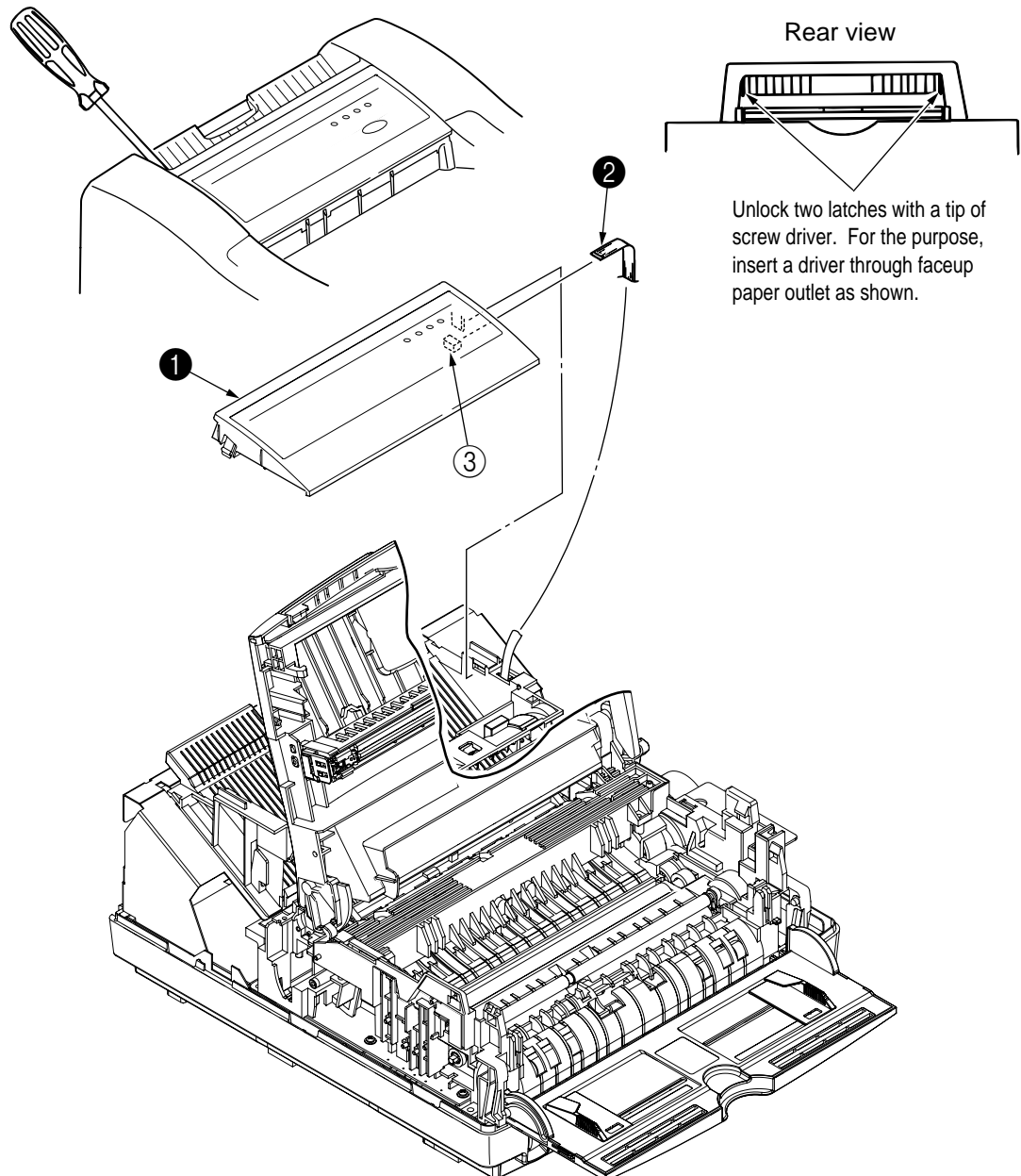



### 2.3.4 Lower Base Unit

- (1) Remove the upper cover assy (see 2.3.1).
- (2) Remove the operator panel assy (see 2.3.3).
- (3) Remove the face up stacker assy (see 2.3.7).
- (4) Remove the transfer roller assy (see 2.3.13).
- (5) Remove the connecting cables ① and ② of the pulse motors from the connectors (DM, RM) of the GRG-PCB ③.
- (6) Remove the LED head cables ④ from the connector (HEAD).
- (7) Remove the Thermistor cable ⑤ from the connector (THERM).
- (8) Remove the connecting cable ⑥ of the heater from the connector (CN2).
- (9) Open the manual feed guide assy, remove seven screws ⑦, then remove the lower base unit ⑧.

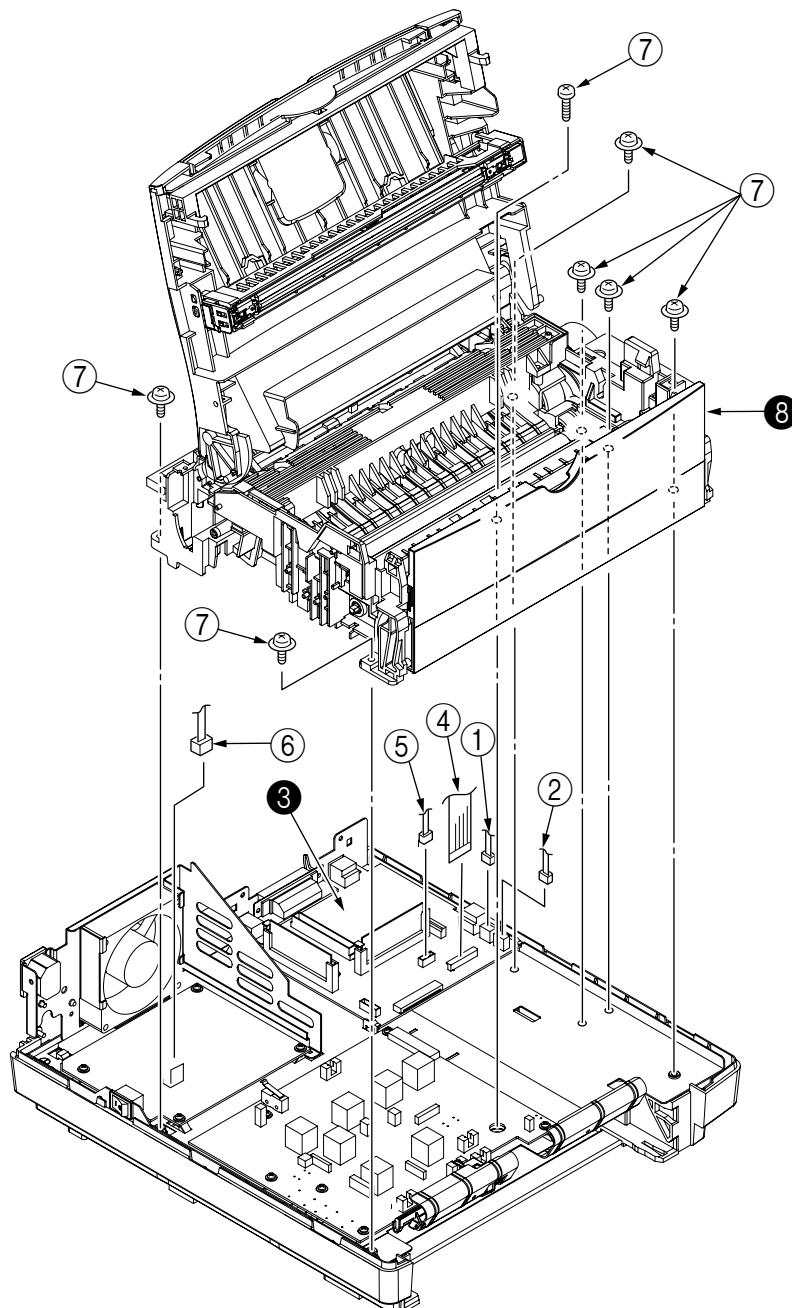

### 2.3.5 Pulse Motor (Main/Drum)

- (1) Remove the upper cover assy (see 2.3.1).
- (2) Remove the lower base unit (see 2.3.4).
- (3) Remove two screws ① and remove the pulse motor (main/drum) ② from the motor bracket ③.

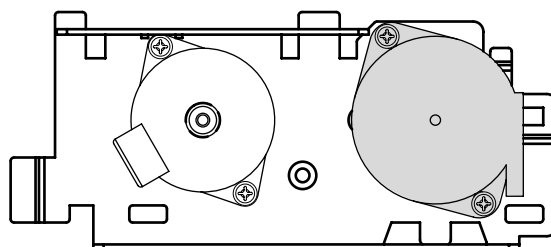

View A

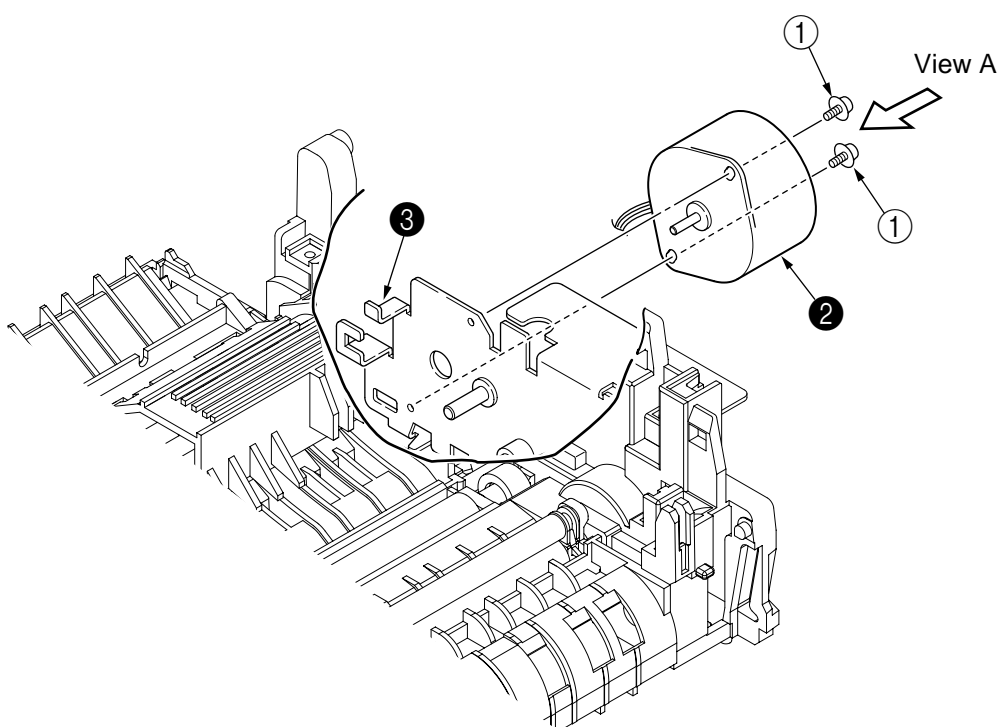

### 2.3.6 Pulse Motor (Registration)

- (1) Remove the upper cover assy (see 2.3.1).
- (2) Remove the lower base unit (see 2.3.4).
- (3) Remove two screws ① and remove the pulse motor (registration) ② from the motor bracket ③.

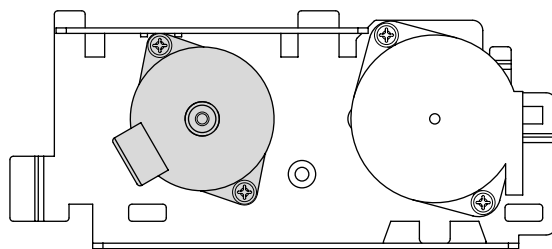

View A

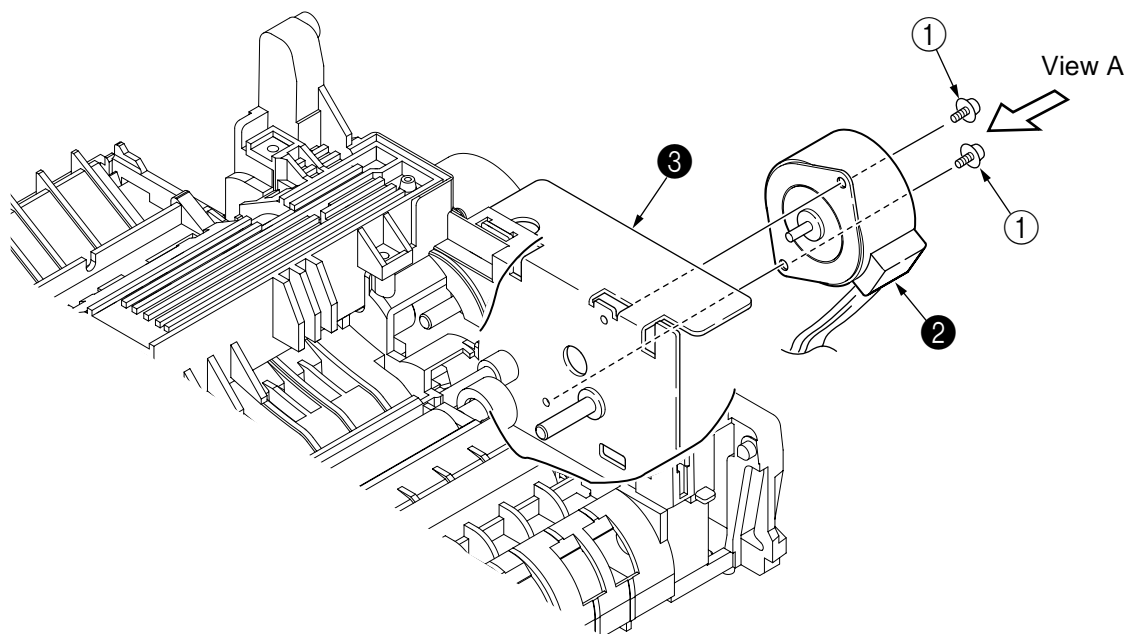

### 2.3.7 Face Up Stacker Assy

- (1) Remove the upper cover assy (see 2.3.1).
- (2) Remove the operator panel assy (see 2.3.3).
- (3) Remove the Sumi card (Operator panel cable) ① off the latch section of face up stacker ② .
- (4) Remove three screws ③ and remove both the shield plate ④ and face up stacker ② together.
- (5) Unlock the latches at two locations, and remove the face up stacker ②.

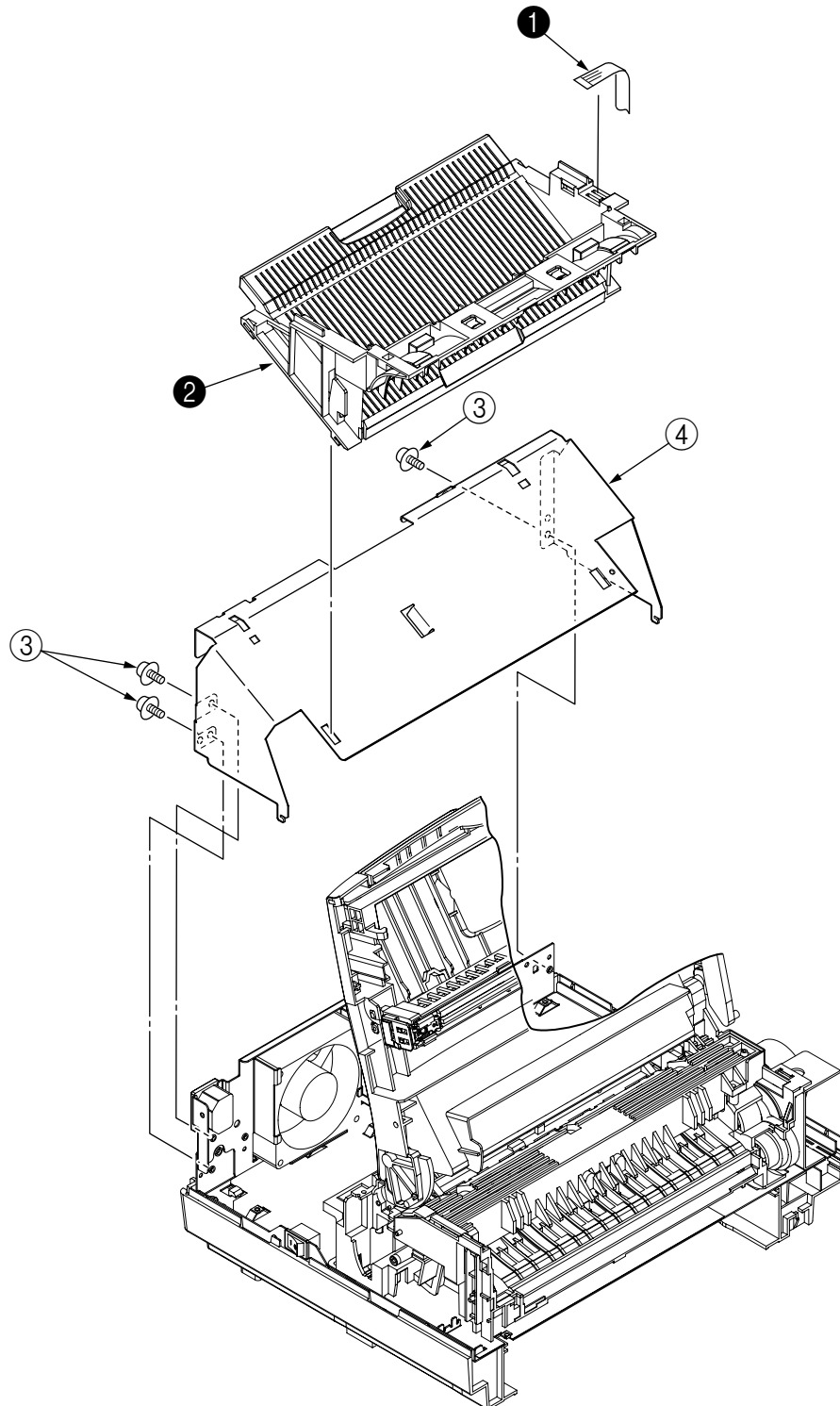

### 2.3.8 Eject Roller Assy

- (1) Remove the upper cover assy (see 2.3.1).
- (2) Remove the operator panel assy (see 2.3.3).
- (3) Remove the face up stacker assy (see 2.3.7).
- (4) Remove the stacker cover assy (see 2.3.11).
- (5) Disengage the eject roller assy ❶ from the lower base ❷ by pressing the latch section of the eject roller assy ❶ in the direction of the arrow shown below, and remove the eject roller assy ❶.

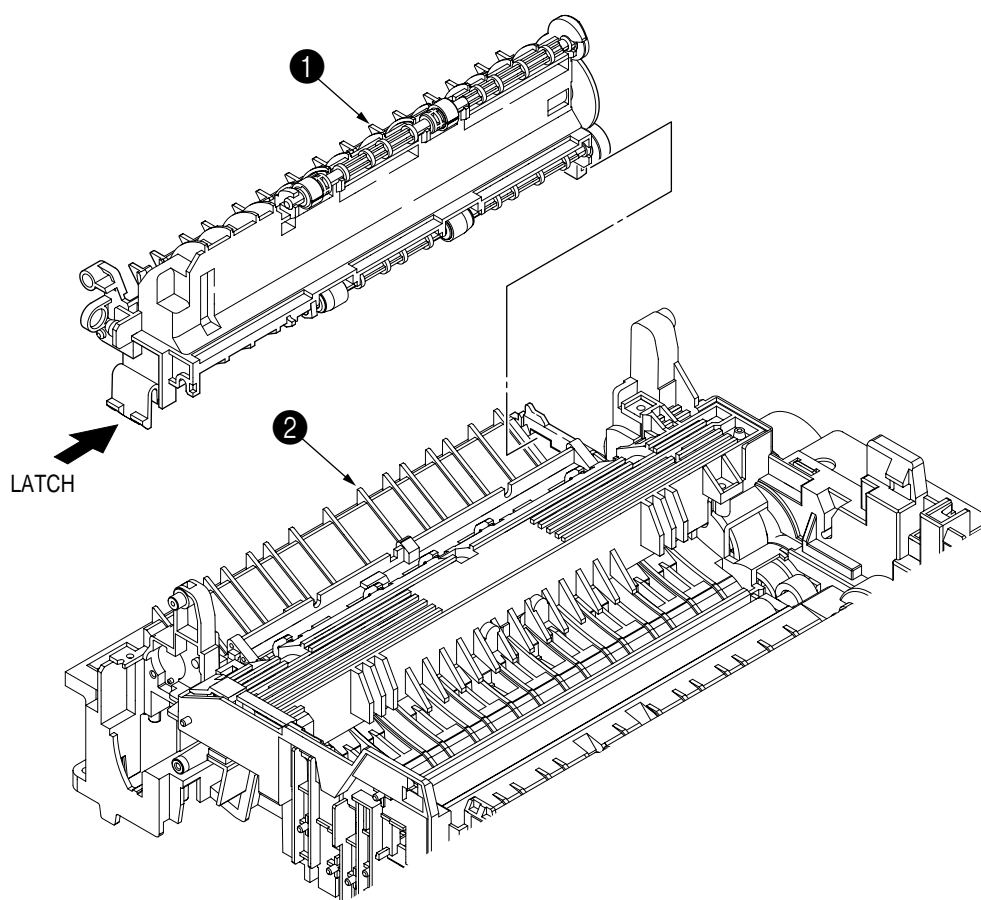

### 2.3.9 Motor Assy

- (1) Remove the upper cover assy (see 2.3.1).
- (2) Remove the operator panel assy (see 2.3.3).
- (3) Remove the face up stacker assy (see 2.3.7).
- (4) Remove the lower base unit (see 2.3.4).
- (5) Stand the lower base unit on its side as shown, and unlock two latches, then remove the motor assy ①.
- (6) Remove screw ② and remove the bracket-Motor-Sub ③ from the Motor bracket.

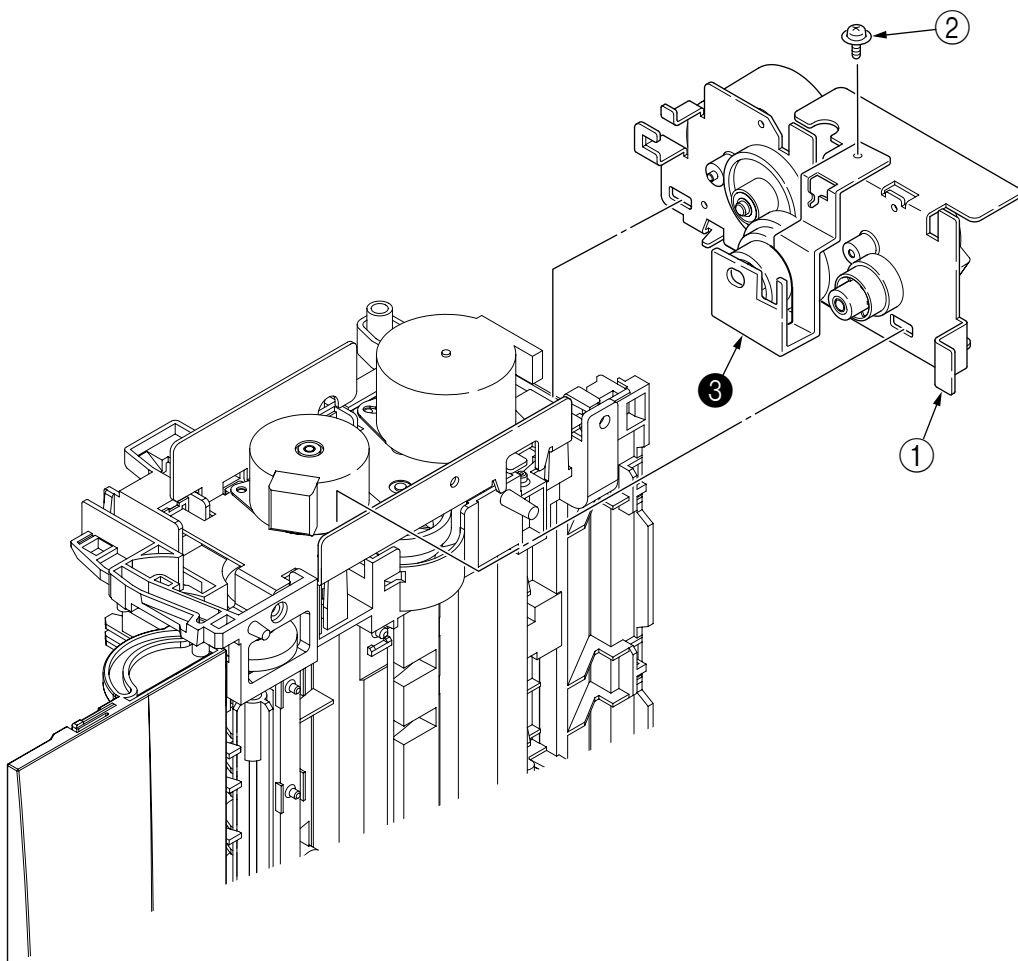

### 2.3.10 Hopping Roller Shaft Assy

- (1) Remove the upper cover (see 2.3.1).
- (2) Remove the operator panel assy (see 2.3.3).
- (3) Remove the face up stacker assy (see 2.3.7).
- (4) Remove the lower base unit (see 2.3.4).
- (5) Remove the motor assy (see 2.3.9).
- (6) With the lower base unit ❶ standing on its side, remove the one-way clutch gear ❷ and the bearing (A) ❸.
- (7) Remove the hopping roller shaft assy ❹ (the bearing (B) ❺ comes off, so be careful not to lose it).

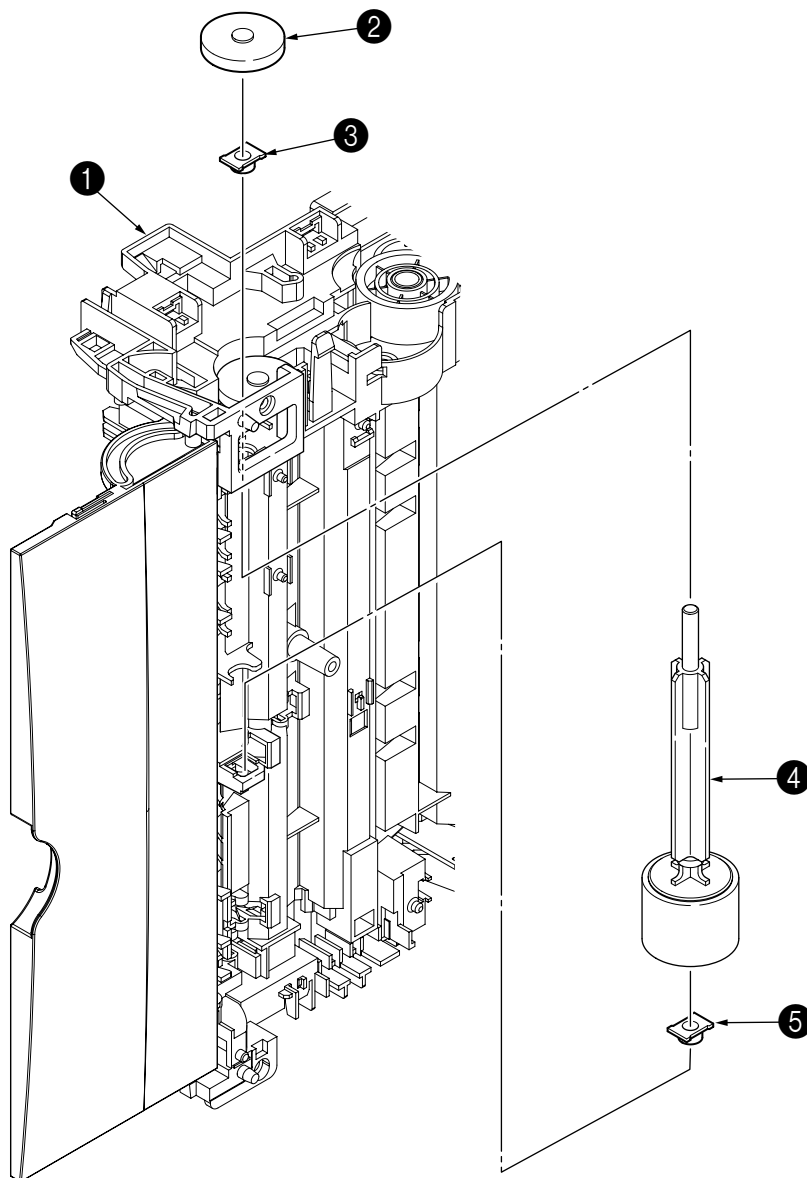

## 2.3.11 Stacker Cover Assy

- (1) Remove the upper cover assy (see 2.3.1).
- (2) Remove the operator panel assy (see 2.3.3).
- (3) Remove the face up stacker assy (see 2.3.7).
- (4) Remove the motor assy (see 2.3.9).
- (5) Remove the reset lever R ①.
- (6) Remove one screw, detach the reset spring ② from the lower base unit ③, turn the reset lever L ④ in the direction of arrow A until it stops, and remove it in the direction of arrow B.
- (7) Unlock two latches of the lower base unit ③, then remove the stacker cover assy ⑤.

**Note :** When reinstalling the reset lever L ④, fit it onto the guide of the lower base unit ③, turn it in the direction of arrow C while pressing down the shaft of back up roller, and engage the reset lever L ④.

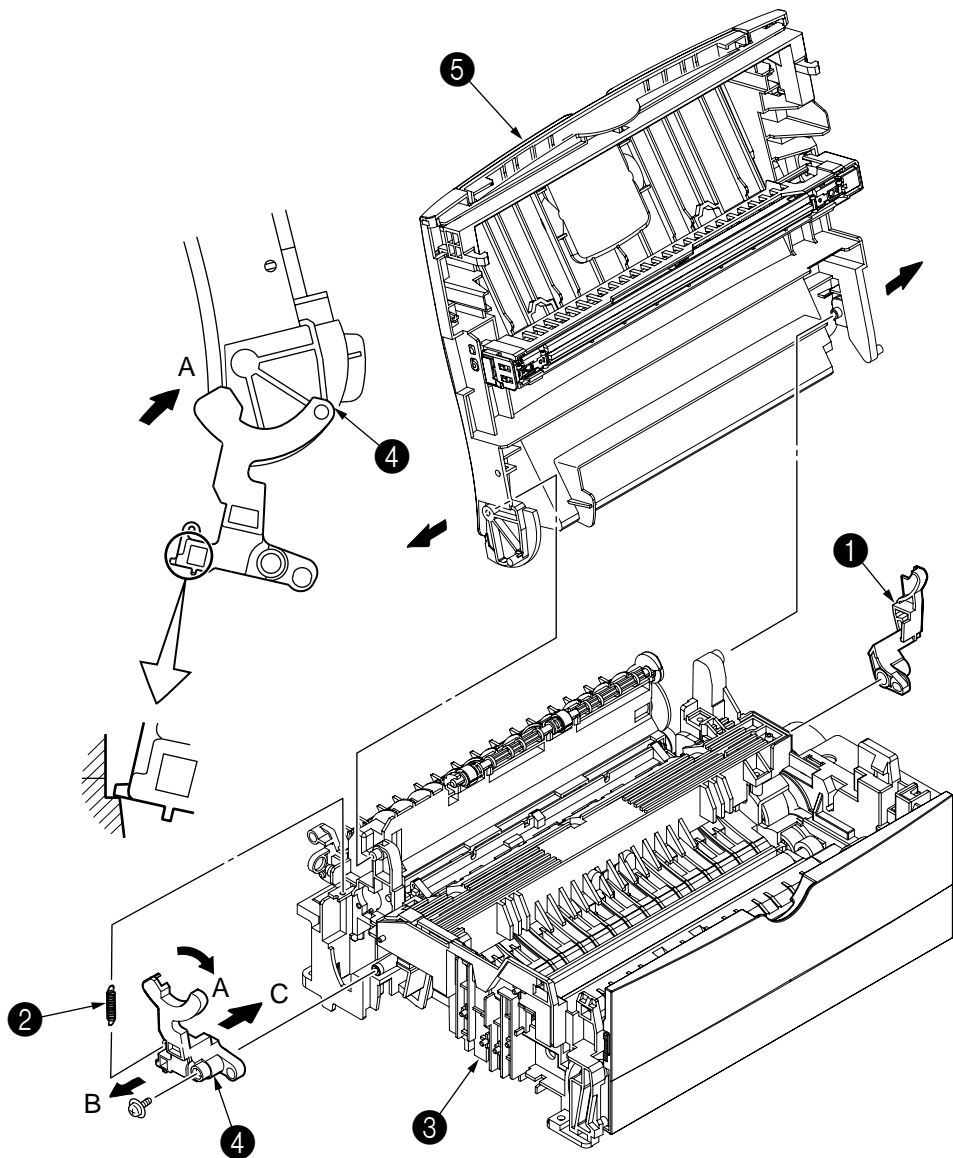



## 2.3.12 Registration Roller

- (1) Remove the upper cover (see 2.3.1).
- (2) Remove the operator panel assy (see 2.3.3).
- (3) Remove the face up stacker assy (see 2.3.7).
- (4) Remove the lower base unit (see 2.3.4).
- (5) Remove the motor assy (see 2.3.9).
- (6) Unlock the latch at the left side of the paper guide (R) ① and remove the paper guide (R) ①.
- (7) With the lower base unit standing on its side, remove the one-way clutch gear ② and the bearing ③.
- (8) Remove the Registration Gear by unloking the latch of the Gear ④.
- (9) Remove the Registration Bearing L ⑤.
- (10) Press the registration roller ⑥ in the direction of arrow A and lift up the left side of it, then remove the registration roller Assy ⑦.
- (11) Pull out the registration roller Assy ⑦ in the direction of arrow B.
- (12) Remove the pressure roller Assy gear ⑧ by unloking the latch of the gear ⑧.
- (13) Remove the bearing-Registration L ⑨ and bearing Registration R ⑩.
- (14) Remove the Spring ⑪ from the bearing ⑨, ⑩.

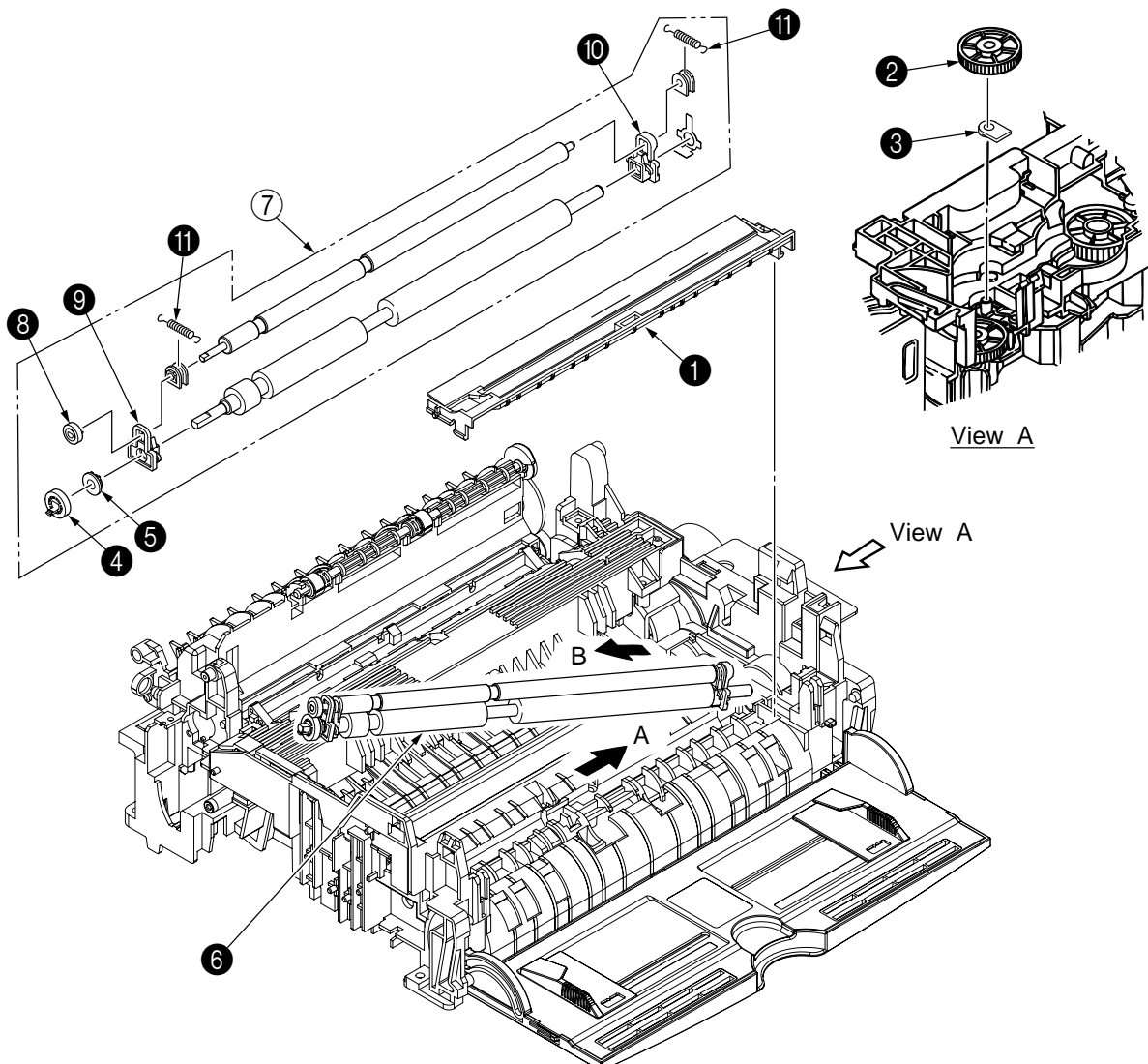

## 2.3.13 Roller Transfer Assy

- (1) With the power switch turned off, unplug the AC cord from the outlet.
- (2) Open the stacker cover.
- (4) Remove the spacer ❶.
- (4) Release the roller transfer assy ❷ by unlocking two latches of the bearing TR (never apply excessive force when unlocking the latch) and slide the roller transfer assy left to remove the gear from the bracket.
- (5) Lift the right side of the roller transfer assy ❷, and shift it to the right side, then pull it out from the main unit (at this time, the bearings ❸ of the left side and holder-TR ❹ of the right side of the roller transfer assy ❷ will also come off).

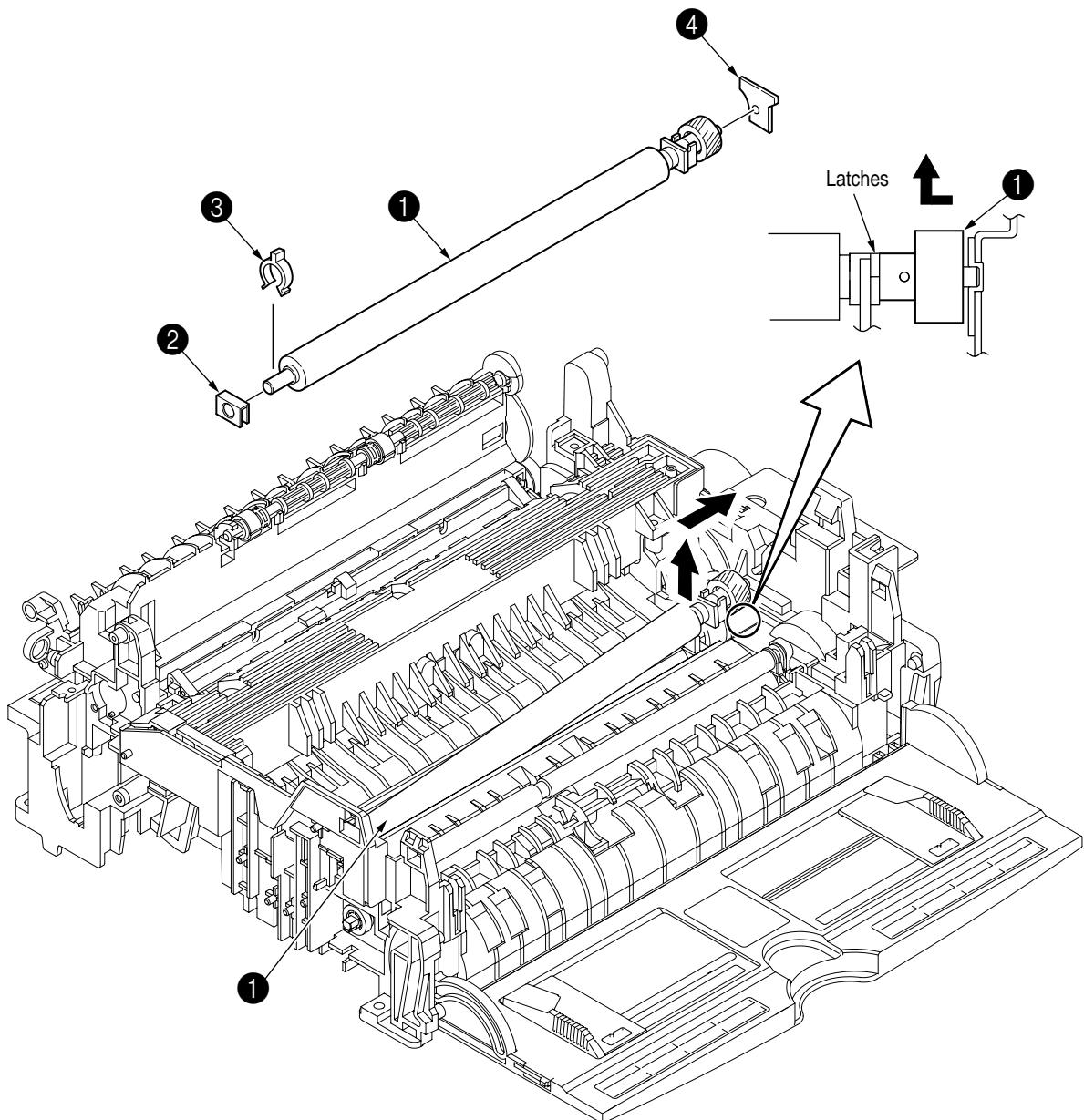

### 2.3.14 Fusing Unit

- (1) Remove the upper cover (see 2.3.1).
- (2) Remove the operator panel assy (see 2.3.3).
- (3) Remove the face up stacker assy (see 2.3.7).
- (4) Remove the lower base unit (see 2.3.4).
- (5) Remove the stacker cover assy (see 2.3.11).
- (6) Remove the connecting cable ① of the heater and connecting cable ② of the thermistor from the hooks of the lower base.
- (7) Remove four screws ③, lift and remove the fusing unit ④.

Caution: Fusing unit may be hot. Use care when handling.

- Notes :**
1. When reinstalling or removing the fusing unit, tighten or loosen the screws while holding the fusing unit assy ④ down with your hand (it is being pushed up by back up roller).
  2. When reinstalling the screws ③, be sure to direct the screws into preexisting thread and avoid damaging the threads.
  3. Do not apply excessive torque when tightening the screws ③.

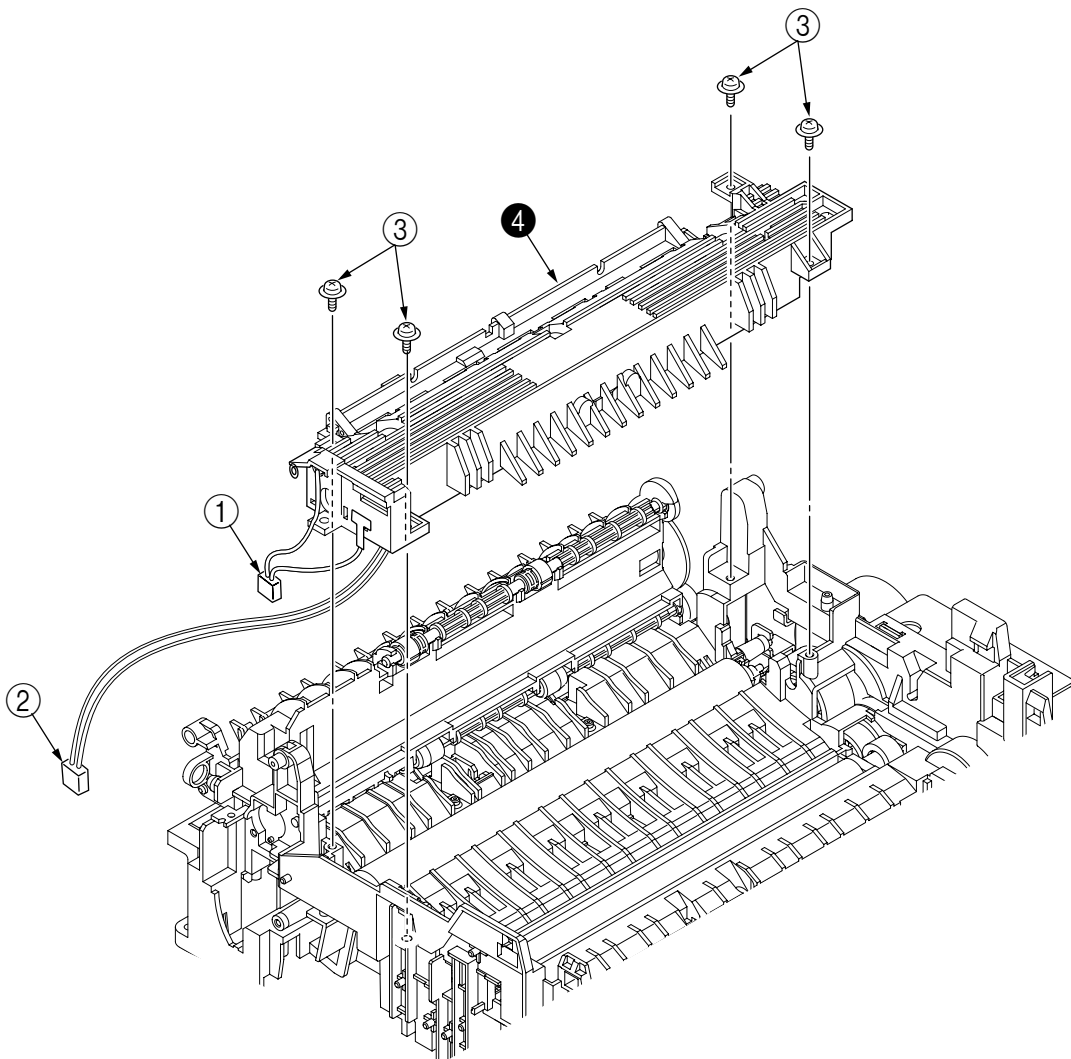

## 2.3.15 Back-up Roller

- (1) Remove the fusing unit assy (see 2.3.14).
- (2) Lift the left side of the back-up roller ①, and pull it out to the left side (at this time, two bearing Holders (back-up) ② and the bias springs (back-up) ③ and the two ball-bearings ④, washer C ⑤ will also come off).

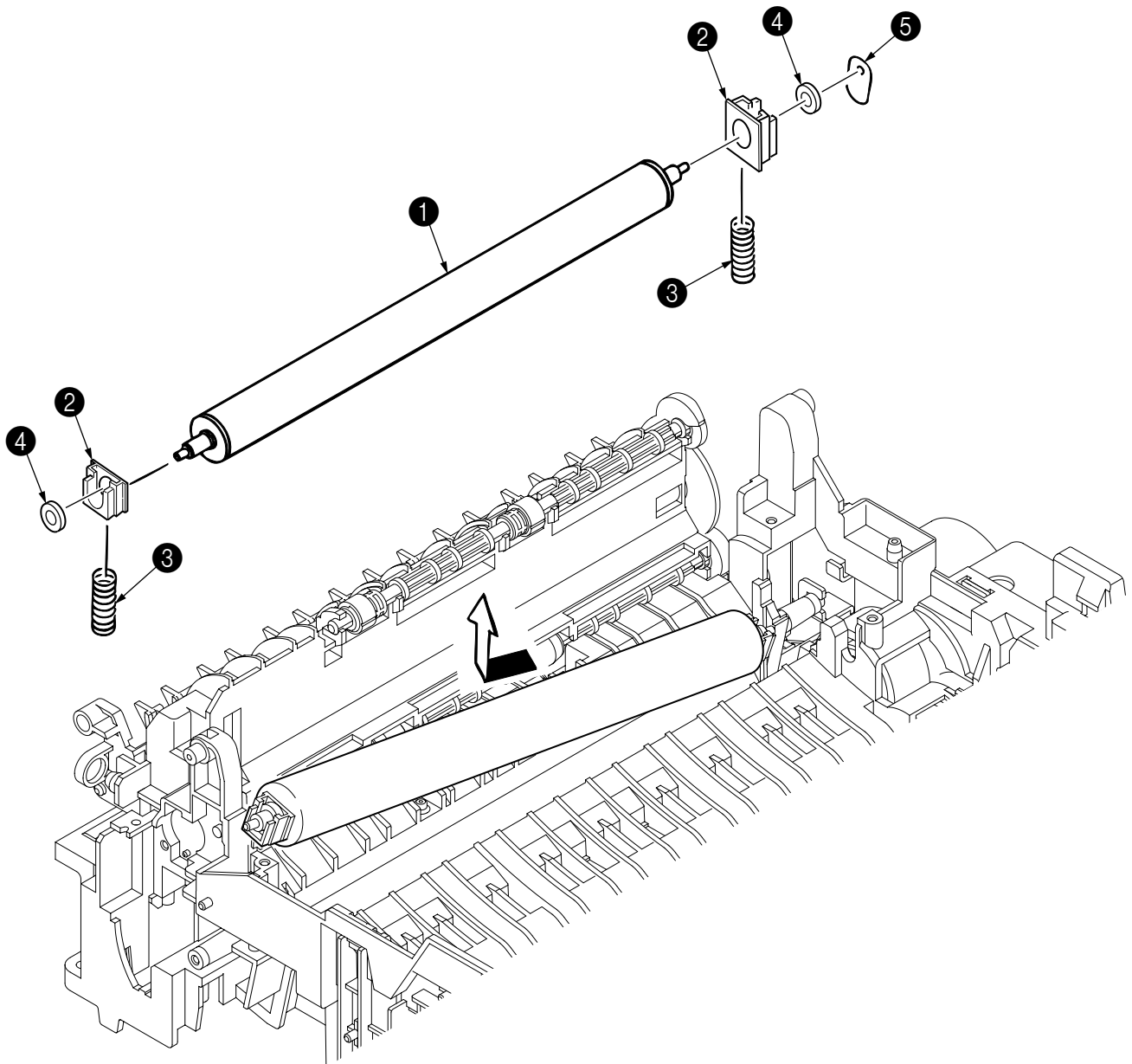

## 2.3.16 Sensor Plate (Inlet)

- (1) Remove the upper cover (see 2.3.1).
- (2) Remove the operator panel assy (see 2.3.3).
- (3) Remove the face up stacker assy (see 2.3.7).
- (4) Remove the lower base unit (see 2.3.4).
- (5) Unlock the latch at the left side of the paper guide (R) ❶ and remove the paper guide (R) ❶.
- (6) Press the clamps of three sensor plates (inlet and paper) ❷, and remove them by pressing them upward from the bottom.

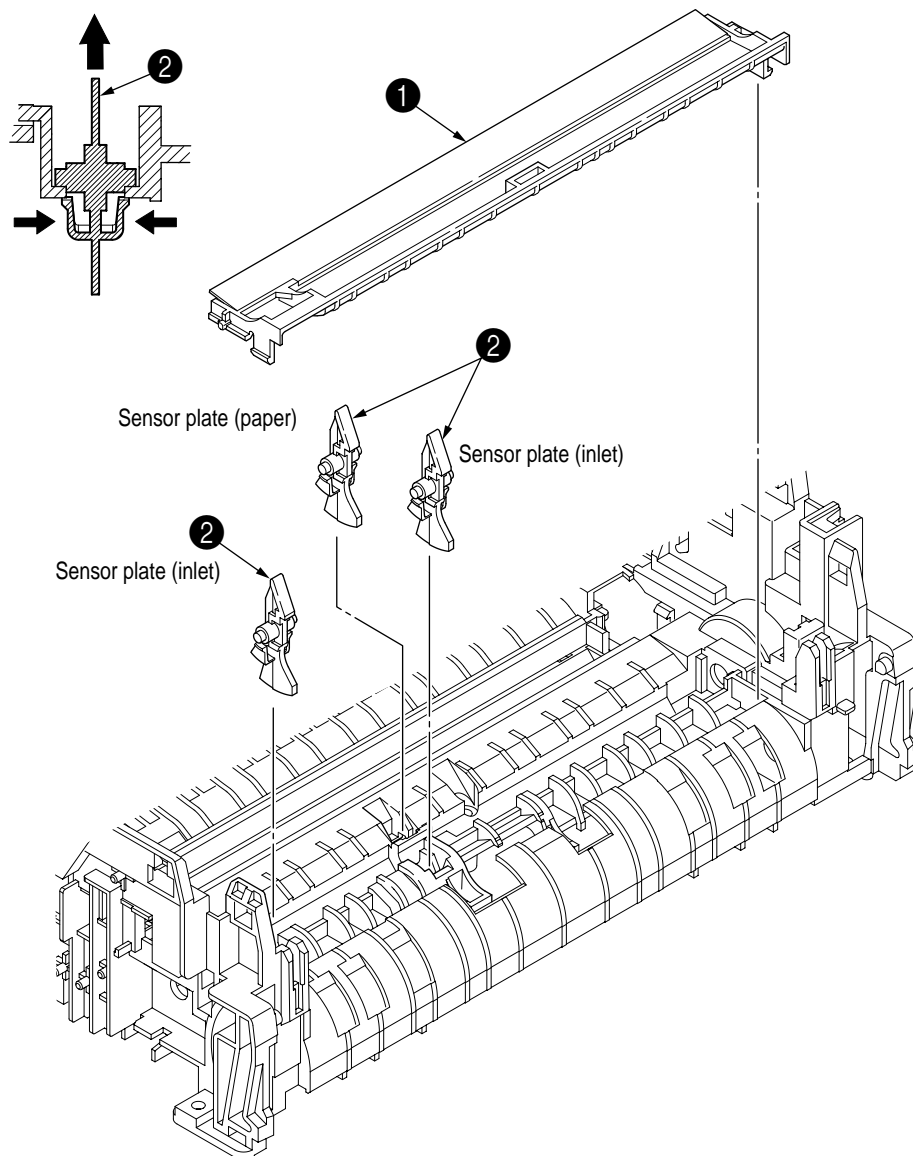

### 2.3.17 Sensor Plate (Outlet), Sensor Wire Assy

- (1) Remove the upper cover assy (see 2.3.1).
- (2) Remove the operator panel assy (see 2.3.3).
- (3) Remove the eject roller assy (see 2.3.8).
- (4) Remove the face up stacker assy (see 2.3.7).
- (5) Remove the lower base unit (see 2.3.4).
- (6) Remove the fusing unit assy (see 2.3.14).
- (7) Press the clamps of the sensor plate (outlet) ①, and remove the sensor plate by pushing it up.
- (8) Turn the clamps of the sensor wire assy ② remove the sensor wire assy from the lower base unit.

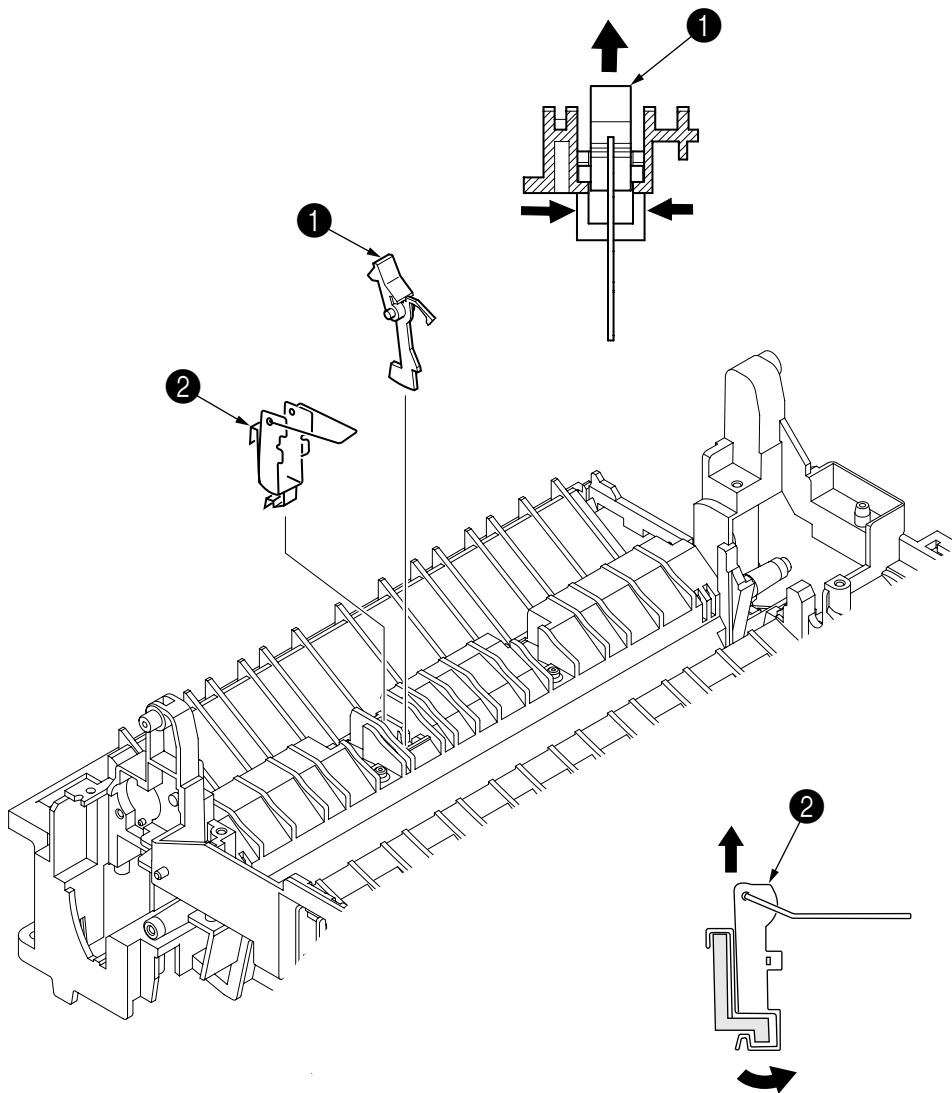

## 2.3.18 Manual Feed Guide Assy

- (1) Remove the upper cover assy (see 2.3.1).
- (2) Open the manual feed guide assy ❶, and release the engagement on both sides with the main unit by carefully bending the manual feed guide assy ❶.

**Note :** When remounting, verify the proper the engagements as shown in the diagram.

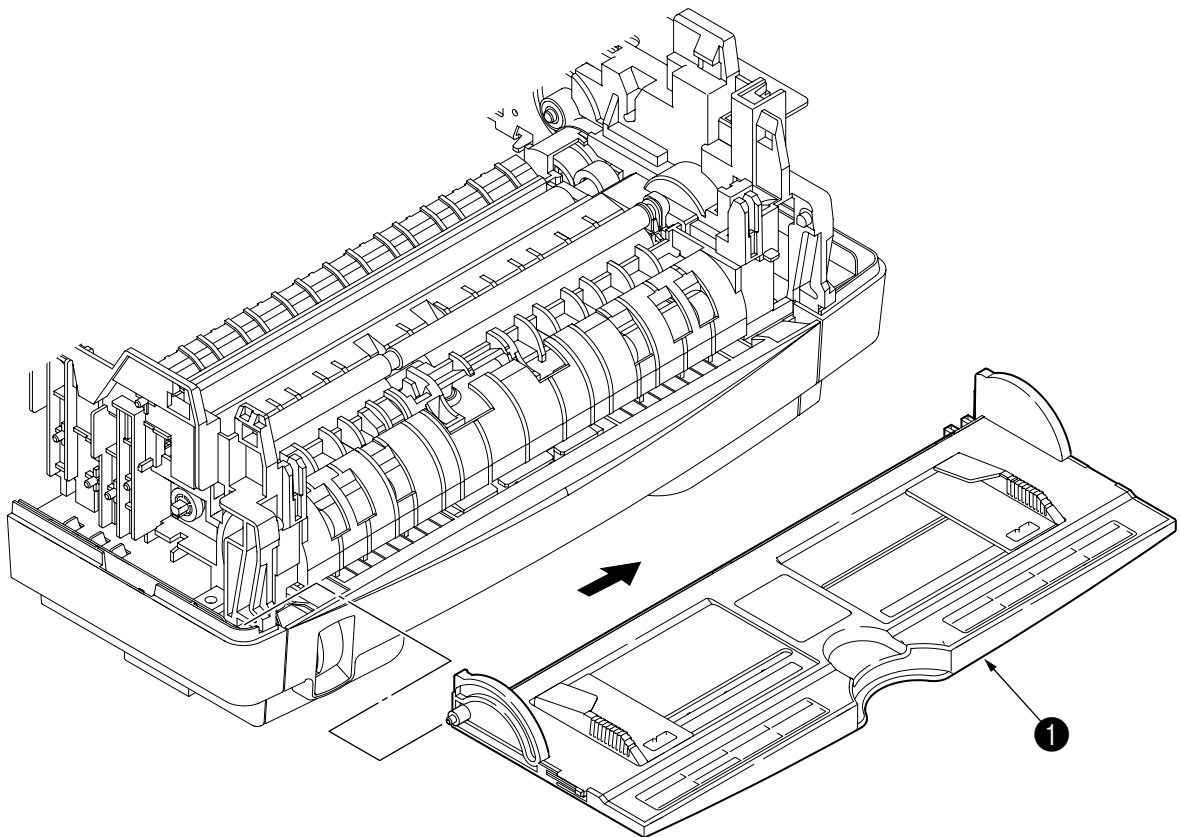
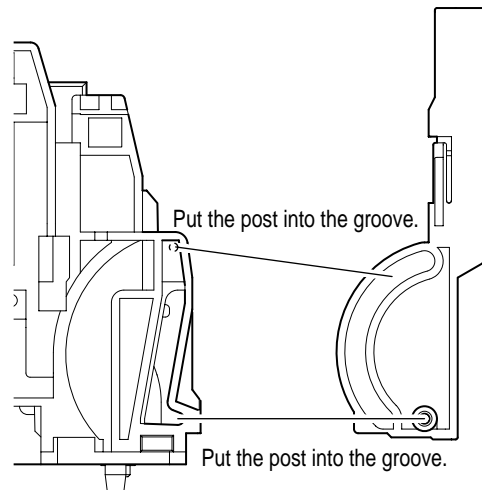

### 2.3.19 Sensor Plate (Paper Supply)

- (1) Remove the upper cover assy (see 2.3.1).
- (2) Remove the operator panel assy (see 2.3.3).
- (3) Remove the face up stacker assy (see 2.3.7).
- (4) Remove the lower base unit (see 2.3.4).
- (5) Press the clamps of the sensor plate (paper supply) ❶ to unlock the latch, and remove it from the base plate ❷.

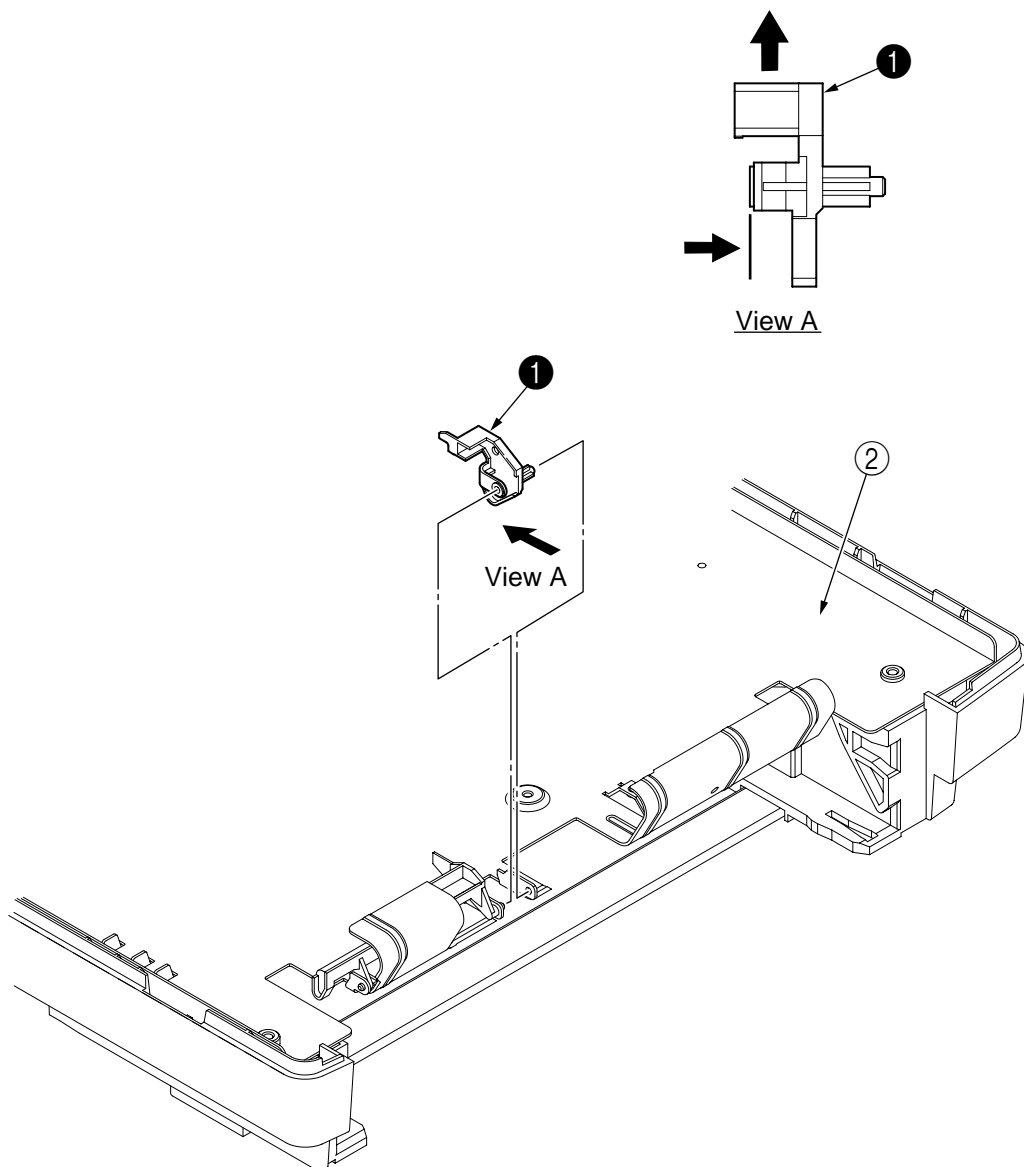



## 2.3.20 GRG-5, 7 PCB

- (1) Remove the upper cover assy (see 2.3.1).
- (2) Remove the operator panel assy (see 2.3.3).
- (3) Remove the face up stacker assy (see 2.3.7).
- (4) Remove the lower base unit (see 2.3.4).
- (5) Remove three screws ① and two screws ②.
- (6) Remove the connector FAN, and disconnect the fan motor ③.
- (7) Remove the three connectors PW\_1, PW\_2 and HVIF.
- (8) Remove the GRG-5, 7 PCB ④ and plate earth (A) ⑤.

**Note :** When reinstalling the GRG-5, 7 PCB ④ onto the base plate ⑥, insert the edge of the GRG-5, 7 PCB ④ in two slots of the base plate ⑥.

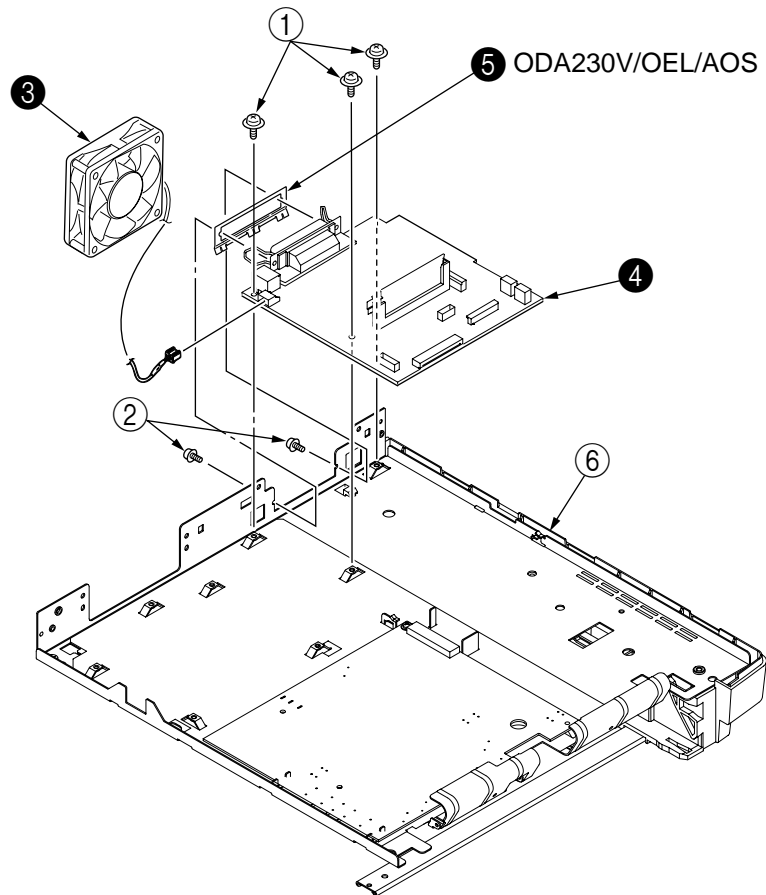

### 2.3.21 Power Supply Board and High Voltage/Sensor Board

- (1) Remove the upper cover assy (see 2.3.1).
- (2) Remove the lower base unit (see 2.3.4).
- (3) Remove two screws ① and the guide plate ②.
- (4) Remove the AC inlet ③ from the guide plate ②.
- (5) Remove the screw ④ and remove the grounding (earth) wire ⑤.
- (6) Remove the connectors CN2 from power supply board ⑥ and CN1 from high voltage/sensor board ⑦.
- (7) Remove ten screws ⑧, and remove the power supply board ⑥ and high voltage/sensor board ⑦.
- (8) Remove the Insulation plate ⑨ from the base plate ⑩.

- Notes :**
1. Be careful about the sensor (paper supply) when reinstalling the lower base.
  2. Make sure that no excessive force is applied to the power supply switch.
  3. When installing the power supply board onto the base plate, be careful not to bend the base plate (it is desirable to place a block underneath it to prevent bending).

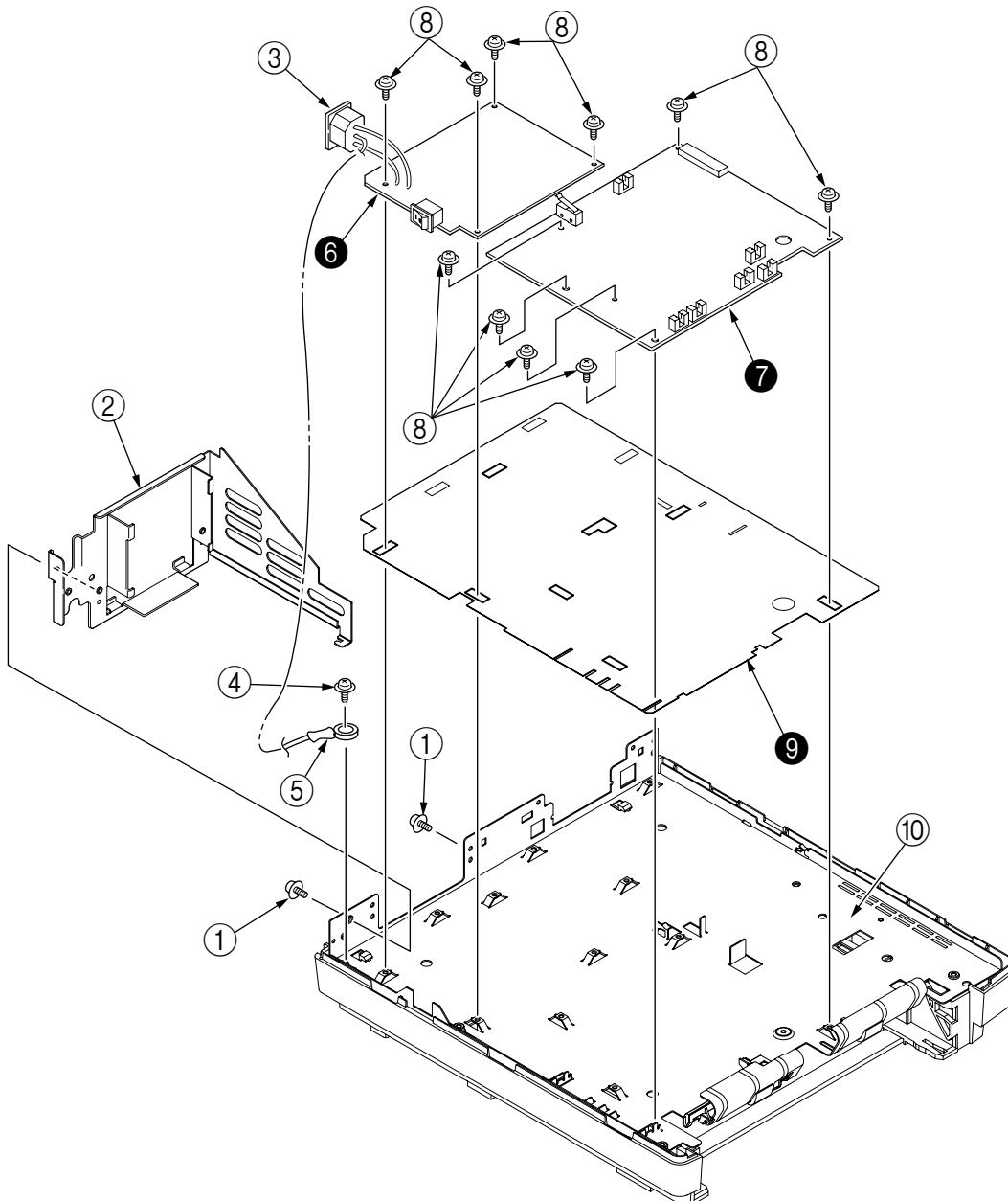

## 2.3.22 Cassette Guide L Assy

- (1) Remove the paper cassette.
- (2) Remove the upper cover assy (see 2.3.1).
- (3) Remove the lower base unit (see 2.3.4).
- (4) Remove two screws ①, and remove the beam plates ②.
- (5) Remove the cassette guide L Assy ③ by shifting it in the direction of the arrow as shown below.
- (6) Remove the earth plate ④.

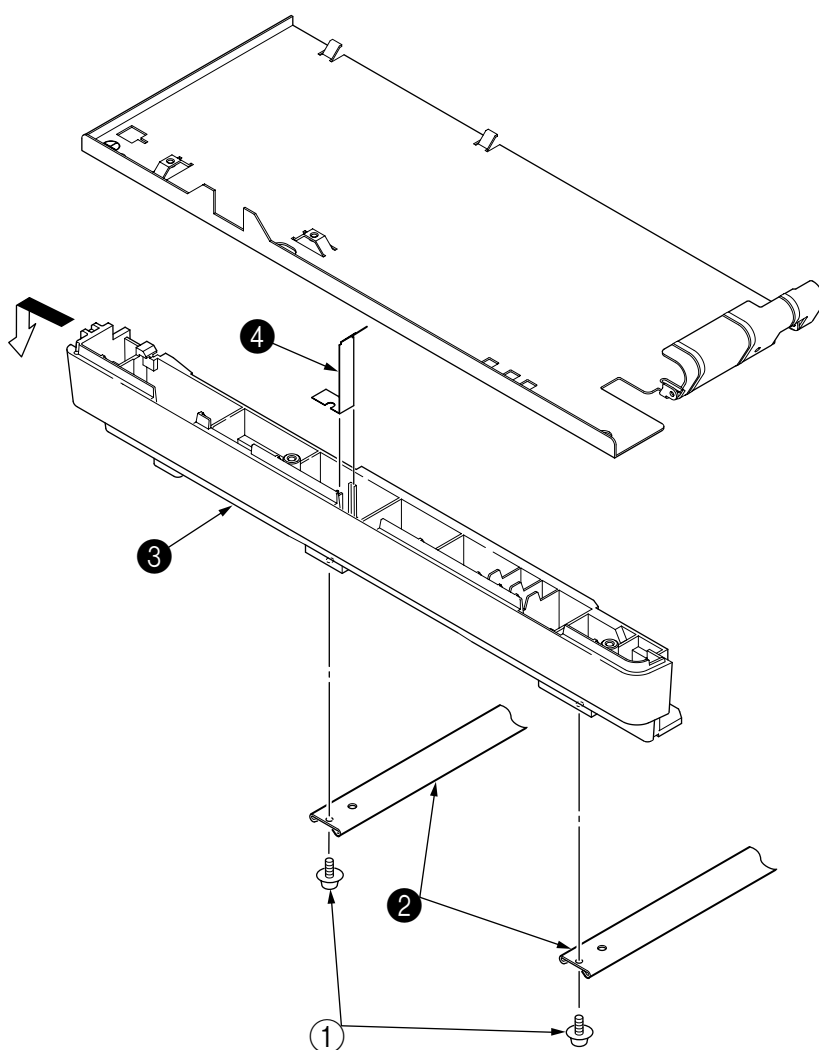

## 2.3.23 Cassette Guide R Assy

- (1) Remove the paper cassette.
- (2) Remove the upper cover assy (see 2.3.1).
- (3) Remove the lower base unit (see 2.3.4).
- (4) Remove two screws ①, and remove the beam plates ②.
- (5) Remove the cassette guide R Assy ③ by shifting it in the direction of arrow.
- (6) Remove the earth plate ④ and the cassette lock spring ⑤.

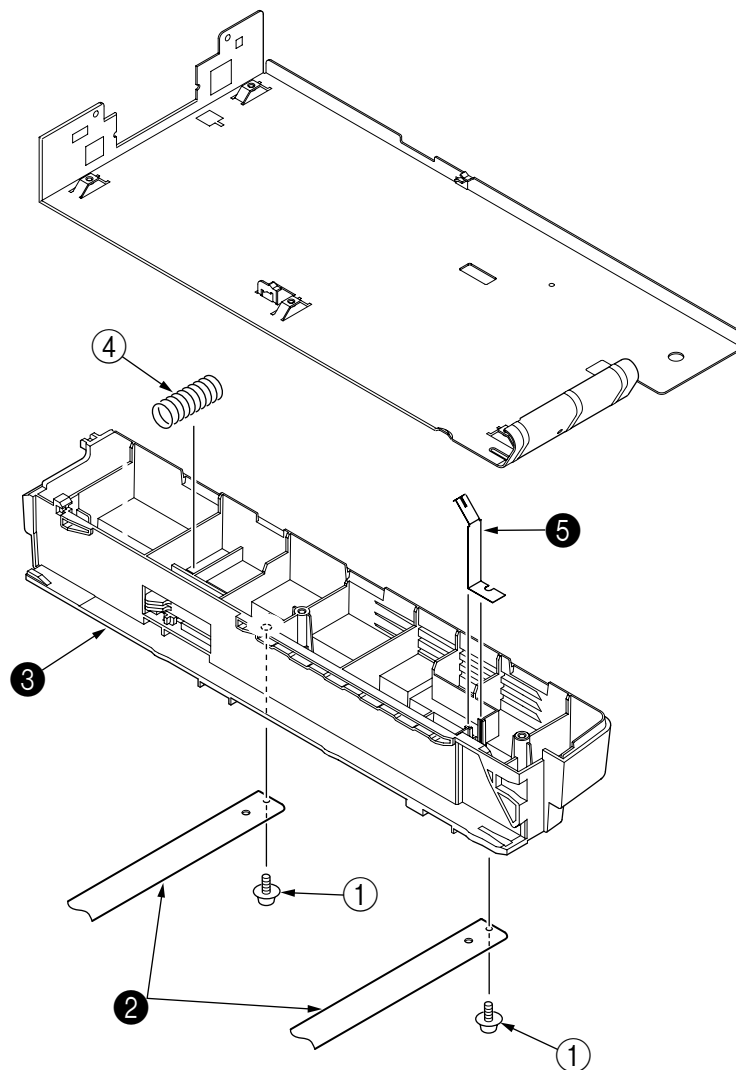

### 3. ADJUSTMENT

This chapter explains adjustment necessary when a part is replaced.

This adjustment is made by changing the parameter values set in EEPROM on the main control board. The status monitor or maintenance utility can be used to change these values.

Only servicemen and maintenance personnel can use the maintenance utility. This utility cannot be made public for printer end users.

#### 3.1 Adjustment Types and Functions

##### 3.1.1 Status Monitor

Please refer to Status Monitor.

##### 3.1.2 Maintenance Utility

A operation method of Maintenance Utility, please refer to Maintenance Utility Operating Specifications.

#### 3.2 Adjustment When Replacing a Part

Adjustment is necessary when replacing any of the following parts.

Part Replaced	Adjustment
Image Drum Cartridge	Reset the image drum counter (refer to User's manual).
Main Control Board	EEPROM data Upload / Download

##### 3.2.1 Uploading/Downloading EEPROM data

When the controller printed circuit board is replaced, the contents of the old EEPROM shall be copied to the new EEPROM on the new board to preserve customer settings. For the purpose, use the Maintenance Utility.

A operation method of Maintenance Utility, please refer to Maintenance Utility Operating Specifications.

The maintenance utility is designed to be used only by field engineer and it should not be released to the end-users.

## 4. PERIODICAL MAINTENANCE

### 4.1 Periodical Replacement Parts

The parts are to be replaced periodically as specified below:

Part name	Condition for replacement	Cleaning	Remarks
• Toner cartridge 2.5K (Type 9)	About 2,500 sheets of paper have been printed.	• LED head	Consumables
• Image drum cartridge (Type 9)	About 25,000 sheets of paper have been printed. See 1.4. (14)		Consumables

### 4.2 Cleaning

Remove any toner or dust accumulated inside the printer. Clean in and around the printer with a piece of cloth when necessary. Use the handy cleaner (service tool) to clean inside the printer.

**Note:** Do not touch the image drum, LED lens array, or LED head connector block.

#### 4.2.1 Cleaning of LED Lens Array

Clean the LED lens array or replace the toner cartridge when white lines or stripes (void, light printing) are generated vertically down the page, as shown below.

**Note:** The LED lens array must be cleaned with an LED head cleaner included in the replacement toner kit.

White lines or stripes  
(void, light printing)

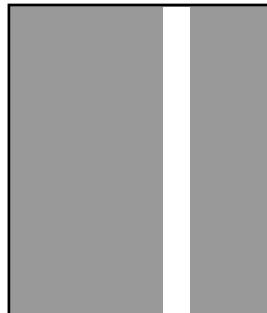

- (1) Set the LED head cleaner to the LED lens array as shown in the figure, then slide the cleaner back and forth horizontally several times to clean the head.

**Note:** Gently press the LED head cleaner onto the LED lens array.

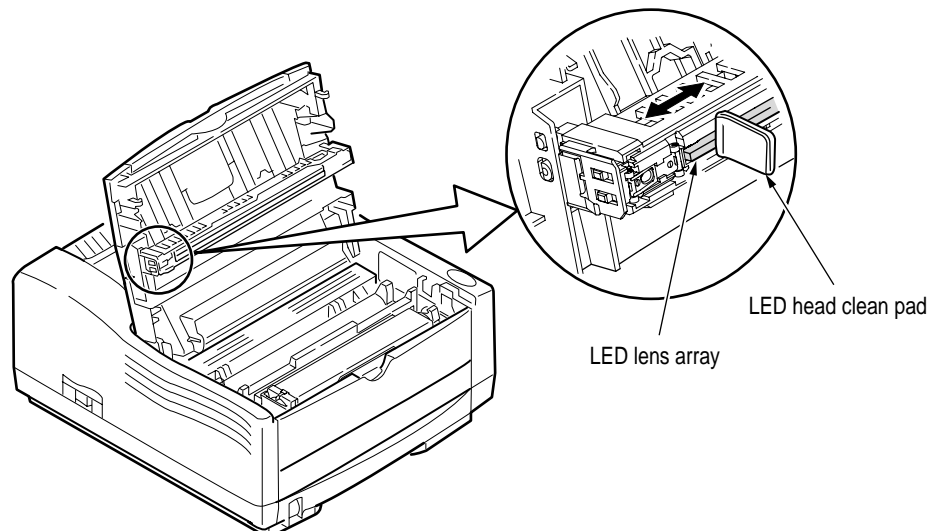

- (2) Throw the cleaner pad away.

#### 4.2.2 Cleaning Page Function

There is a charge roller cleaning function with this printer, which can be executed by the user.

- (1) Press the control switch to take the printer off line.
- (2) Open the manual feed tray and insert a sheet of A4 or 8-1/2 x 11 plain paper between the paper guides.
- (3) Press and hold down the control switch for at least five seconds.
- (4) The printer grips the paper and prints a cleaning page.
- (5) Return the printer on line by pressing the control switch.
- (6) If subsequent printing appears faded or uneven, try replacing the toner cartridge.

## 5. TROUBLESHOOTING PROCEDURES

### 5.1 Troubleshooting Tips

- (1) Check the basic check points written in the user's manual.
- (2) Gather detailed failure information as much as possible from the customer.
- (3) Check the printer under the condition close to that under which the failure occurred.

### 5.2 Check Points Before Correcting Image Problems

- (1) Is the printer running in proper ambient conditions?
- (2) Are consumables (toner and EP unit) replaced correctly?
- (3) Are sheets of paper normal?
- (4) Is the EP unit set correctly?

### 5.3 Notes When Correcting Image Problems

- (1) Do not touch the surface of the OPC drum nor place foreign matter on it.
- (2) Do not expose the OPC drum to direct sunlight.
- (3) Do not touch the fuser because it heats up during operation.
- (4) Do not expose the image drum to light for more than five minutes at room temperature.

### 5.4 Preparation Before Troubleshooting

#### (1) Message display

The failure status of printer is displayed on the status monitor of the PC.

Take proper action according to the message displayed on the status monitor.

#### (2) LED indicator

Printer is equipped with three LED. These LED indicates one of the following status:

For ODA/OEL/AOS



- ① Ready LED Indicator
- ② Manual Feed LED Indicator
- ③ Error LED Indicator





## LED Functions(1/2)

Status	○ Ready (green)	Manual Feed (amber)	Error (amber)	Remark
Online(Ready)	ON	OFF	Undefined	
Offline	OFF	OFF	Undefined	
Data Arrive	Flash 2	OFF	Undefined	
Data Processing	Flash 2	OFF	Undefined	
Data Exist	Flash 1	OFF	Undefined	
Printing	Flash 2	OFF	Undefined	
Printing (copy)	Undefined	OFF	Undefined	
Canceling Job	Flash 1	OFF	Undefined	
Canceling Job	Flash 1	OFF	Undefined	
Warming Up	Flash 1	Undefined	Undefined	
Power Saving	Undefined	OFF	OFF	
Toner Low	Undefined	Undefined	Flash 1 or Flash 2	
Toner Empty	Undefined	OFF	Flash 2	
Toner Sensor Error	Undefined	Undefined	Flash 1	
Change Drum	Undefined	Undefined	Flash 3	
Print Demo	Flash 2	Undefined	Undefined	
Print Menu Map	Flash 2	Undefined	Undefined	
Print Cleaning	Flash 2	Undefined	Undefined	
Invalid data	Undefined	OFF	Flash 2	
tttt tray paper out (BACK GROUND)	Undefined	Undefined	Flash 1	
Manual Paper Request	Undefined	Flash 2	Undefined	
tttt Tray mmmm Paper Request	OFF	OFF	Flash 2	
tttt Tray mmmm Paper Media Mismatch	OFF	OFF	Flash 2	
tttt Tray mmmm Paper Size Mismatch	OFF	OFF	Flash 2	
Toner Empty	OFF	OFF	Flash 2	
Page Buffer Overflow	OFF	OFF	Flash 2	
Paper Size Error	OFF	OFF	Flash 2	
Paper Induct Jam	OFF	OFF	Flash 2	
Paper Feed Jam	OFF	OFF	Flash 2	
Paper Exit Jam	OFF	OFF	Flash 2	
Change Drum	OFF	OFF	Flash 2	
I/D Not Installed	OFF	Undefined	Flash 2	
Cover Open	OFF	Undefined	Flash 2	
Restarting Printer	OFF	OFF	Flash 2	
Fatal Error	Flash 3	Flash 3	Flash 3	
During initializing	OFF	OFF	OFF	
Initializing EEPROM	OFF	OFF	OFF	

Flash 1: Slow blinking  
Flash 2: Blinking  
Flash 3: Fast blinking

## LED Functions(2/2)

Status	 Ready (green)	 Manual Feed (amber)	 Error (amber)	Remark
Checking RAM	OFF	OFF	OFF	
During initializing EEPROM	Flash 2 (3 times)	Flash 2 (3 times)	Flash 2 (3 times)	
Drum counter being reset	Flash 2 (2 times)	Flash 2 (2 times)	Flash 2 (2 times)	
Forced ROM start-up function Rising	Flash 2	Flash 2	Flash 2	
During initializing	ON and then OFF	ON and then OFF	ON and then OFF	

Flash 1: Slow blinking

Flash 2: Blinking

Flash 3: Fast blinking

## 5.5 Troubleshooting

If a trouble occurs in the printer, troubleshoot according to the following procedures:

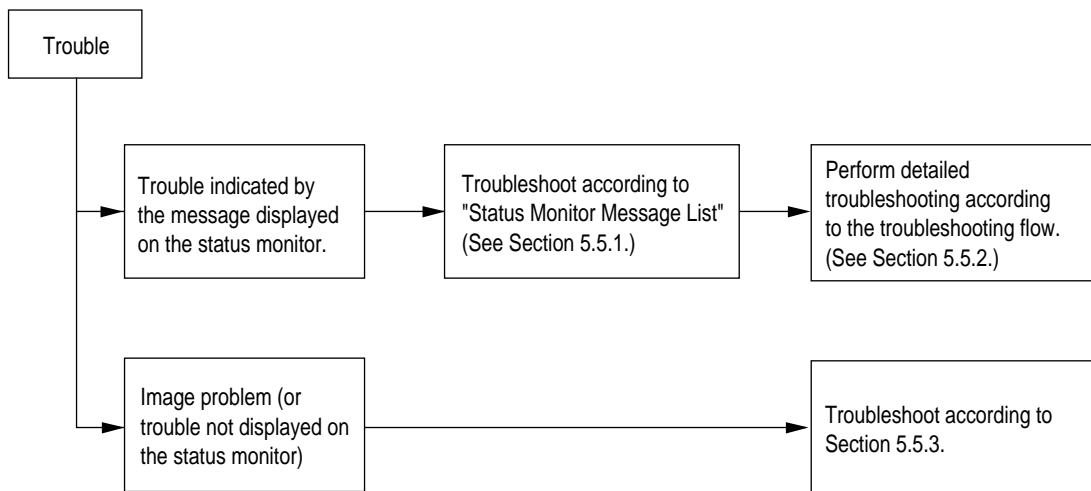

### 5.5.1 Status Monitor Message List

Table 5-1 lists the statuses and troubles to be displayed on the status monitor in the message format.

**Table 5-1**

Category	Status Message	Code	Display Content	Remedy
Normal status	Warming Up	10003	Warming-up status	Normal operation
	Online (Ready)	10001	Online (ready) status	Normal operation
	Power Save Mode	10094	Power save status	Normal operation
	Toner Low	10006	The toner amount of the toner cartridge is small.	Normal operation
	Toner Sensor	10093	The toner sensor is faulty.	Replace the toner sensor.
	Change Drum	40093	Life of I/D drum	Change the I/D Unit and reset Drum counter see Section 3.1.1 (1)
	Manual Paper In	10097	The paper is in the manual feed mode.	Normal operation
	Printing In Progress	10098	Printing in progress X=0, Non Warning X=1, Toner Low X=2, 3 Change Drum	Normal operation
	Ejection In Progress	10099	Ejection in progress X=0, Non Warning X=1, Toner Low X=2, 3 Change Drum	Normal operation
	Manual Request Executive Letter Legal 14 Legal 13 A6 A5 A4 B5 Monarch COM-10 DL C5 COM-9	411xx	Request the paper to be set in the manual feed mode.  The paper sizes are as follows: Executive, Letter, Legal 14, Legal 13, A4, A5, A6, B5, Monarch, DL, C5, COM-10, COM-9  xx: Paper size in the tray being selected	Set the requested paper in the manual feed mode.

**Table 5-1 (Cont'd)**

Category	Status Message	Code	Display Content	Remedy
Paper size error	Paper Size Error	30034	Paper of improper size was fed. 2.52" (64 mm) L 15.77" (400.56 mm)	Check the paper. Also check whether more than one sheet of paper were fed simultaneously. To release the error display, open the cover, then close it. If this error occurs frequently, see Section 5.5.2.3.
Paper jam	Paper Input Jam	40077	A paper jam occurred when sheets of paper were being supplied.	Check the paper. To release the error display, close the cover, then close it. If this error occurs frequently, see Section 5.5.2.2-1.
	Paper Feed Jam	40078	A paper jam occurred during paper feeding.	Open the cover, then remove the jammed paper. To release the error display, close the cover. If this error occurs frequently, see Section 5.5.2.2-2.
	Paper Exit Jam	40079	A paper jam occurred during paper ejection.	Open the cover, then remove the jammed paper. To release the error display, close the cover. If this error occurs frequently, see Section 5.5.2.2-3.
Cover open	ID Not Installed	40033		Installed I/D Unit
	Cover Open	40021	The upper cover is open.	To release the error display, close the cover. If this error occurs frequently, replace the power supply board.
Buffer overflow	Page Buffer Overflow	30097	The page buffer overflowed because there are a large number of print data.	To release the error display, press the reset button on the status motor of the printer driver. Install RAM or reduce the number of print data.
Device configuration error	Program ROM Check Error		An error occurred during program ROM check.	Replace program ROM or the main control board. (When replacing the main control board, also adjust EEPROM data.) (See Section 3.2.1)
	Resident RAM Check Error		An error occurred during resident RAM check.	Replace the main control board. (When replacing the main control board, also adjust EEPROM data.) (See Section 3.2.1)
	EEPROM Check Error		An error occurred during EEPROM check.	Replace the main control board. (When replacing the main control board, also adjust EEPROM data.) (See Section 3.2.1)

**Table 5-1 (Cont'd)**

Category	Status Message	Code	Display Content	Remedy
Device configuration error	Option RAM Check Error		An error occurred during option RAM check.	Check the connection of the Option RAM PC board. If the option RAM PC board is faulty, replace it.
	Fuser Error	40084	A heater timeout error occurred.	See Section 5.5.2.4.
	Thermister Open Check Error		The thermistor is open.	Replace the heater Assy.
	Thermister Short Check Error		A thermistor short occurred.	Replace the heater Assy.
	Watch Dog Timeout Error		A watchdog timeout occurred.	To release the error display, turn on the power supply again. Replace the main control board.
	Motor Timeout Error		A motor timeout occurred.	To release the error display, turn on the power supply again. Replace the main control board.

## 5.5.2 Status Message Troubleshooting

If the problems cannot be corrected by using the status message/problem list, follow the troubleshooting flowcharts given here to deal with them.

No.	Trouble	Flowchart number
1.	The printer does not work normally after the power is turned on.	①
2.	Jam alarm <ul style="list-style-type: none"> <li>— Paper input jam</li> <li>— Paper feed jam</li> <li>— Paper exit jam</li> </ul>	②-1 ②-2 ②-3
3.	Paper size error	③
4.	Fusing unit error	④
5.	Fan error	⑤

① The printer does not work normally after the power is turned on.

- Turn the power off, then back on.

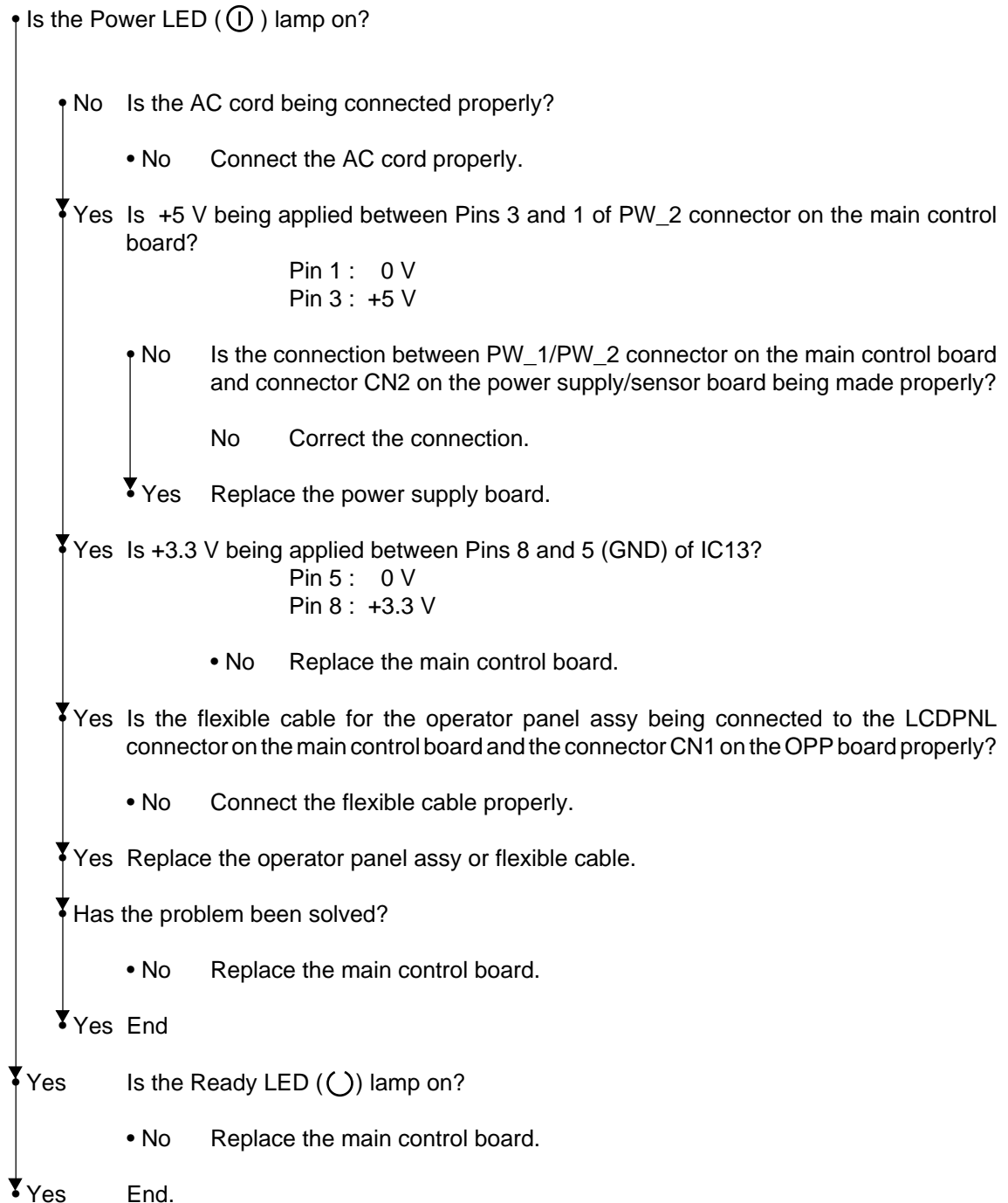



[JAM error]

## ②-1 Paper input jam (Paper Jam)

- Does the JAM error occur when the power is turned on?
  - Yes Is the paper at the inlet sensor?
    - Yes Remove the paper.
  - No Is the operation of the inlet sensor plate normal (moves freely when it is touched)?
    - No Replace the inlet sensor plate.
  - Yes Clean the inlet sensor on the high voltage/sensor board, or replace the high voltage/sensor board.
- No Does the JAM alarm occur after paper feeding?
  - Yes Is the paper fed to the inlet sensor plate?
    - Yes Is the operation of the input sensor plate normal (moves freely when it is touched)?
      - No Replace the inlet sensor plate.
    - Yes Clean the inlet sensor on the high voltage/sensor board or replace the high voltage/sensor board.
  - No Replace the hopping roller rubber or paper cassette.
- No Is the hopping roller rotating?
  - Yes Set the paper tray properly.
- No Is the registration motor rotating?
  - Yes Replace the one-way clutch gear of the hopping roller assembly.
- No Is RM connector on the main control board being connected properly?
  - No Connect RM connector properly.
- Yes Is the coil resistance (normal resistance: both between Pins 1 and 2, as well as Pins 3 and 4 are about  $7.9\Omega$ ) of the registration motor normal?
  - No Replace the registration motor.
- Yes Replace the main control board.

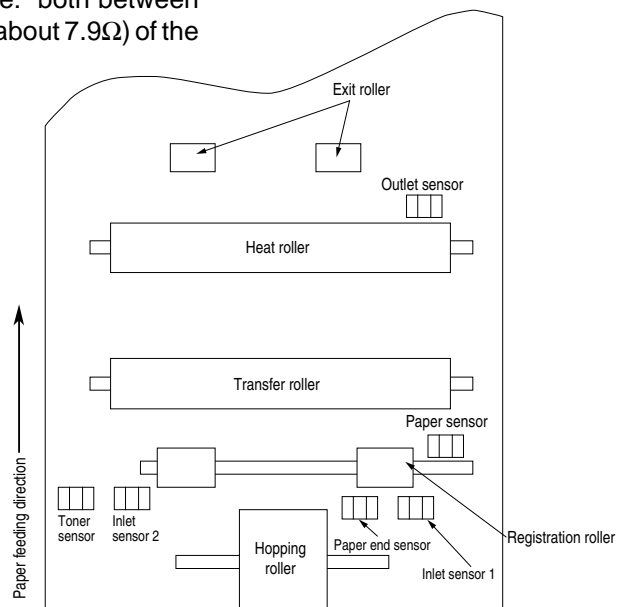

[JAM error]

## ②-2 Paper feed jam

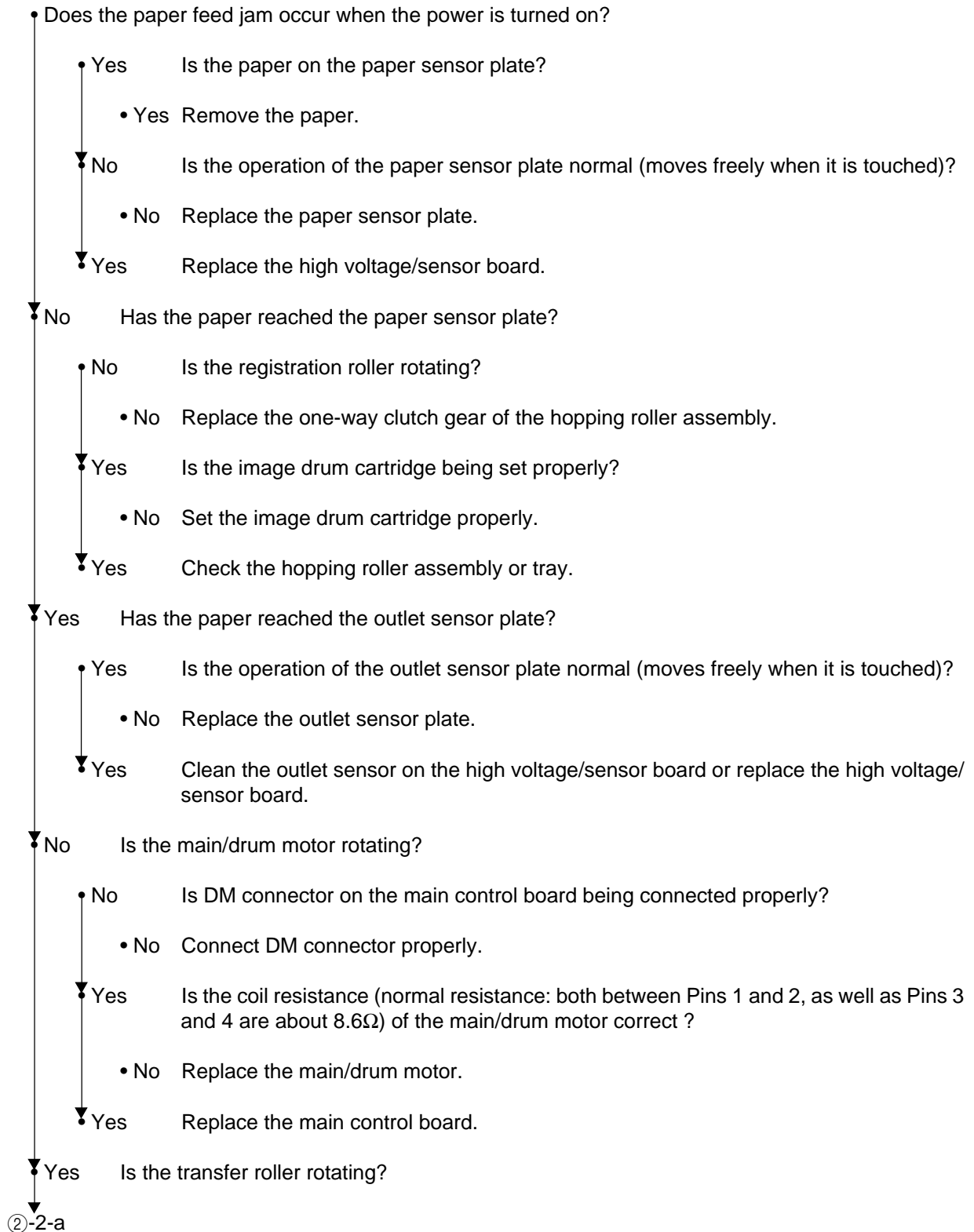

## ②-2-a

- No Check the gears (transfer roller gear, idle gear and reduction gear).
- ▼ Yes Is the fusing unit being installed properly?
  - No Install the fusing unit properly.
- ▼ Yes Is the image drum cartridge being set properly?
  - No Set the image drum cartridge properly.
- ▼ Yes Clean the paper sensor on the high voltage/sensor board or replace the high voltage/sensor board.

[JAM error]

## ②-3 Paper exit jam

- Does the paper exit jam error occur when the power is turned on?
  - Yes Is the paper on the outlet sensor plate?
    - Yes Remove the paper.
  - ▼ No In the operation of the outlet sensor plate normal (moves freely when it is touched)?
    - No Replace the outlet sensor plate.
  - ▼ Yes Clean the outlet sensor on the high voltage/sensor board or replace the high voltage/sensor board.
- ▼ No Is the face-up stacker pulled out completely from the printer or, pushed into the printer completely?
  - No Pull the face-up stacker out of the printer completely or push it into the printer completely.
- ▼ Yes Is the eject roller assembly being installed properly?
  - No Install the eject roller assembly properly.
- ▼ Yes Has the coil spring come off the eject roller assembly?
  - Yes Install the coil spring to the eject roller assembly.
- ▼ No Replace the eject roller assembly.

③ Paper size error

- Is paper of the specified size being used?
  - No Use paper of the specified size.
- Yes Are inlet sensor plates 1 and 2 operating properly (moves freely when they are touched)?
  - No Replace the inlet sensor plate or clean the inlet sensor on the high voltage/sensor board.
- Yes Does the outlet sensor plate operate properly (moves freely when it is touched)?
  - No Replace the outlet sensor plate or clean the outlet sensor on the high voltage/sensor board.
- Yes Replace the high voltage/sensor board.

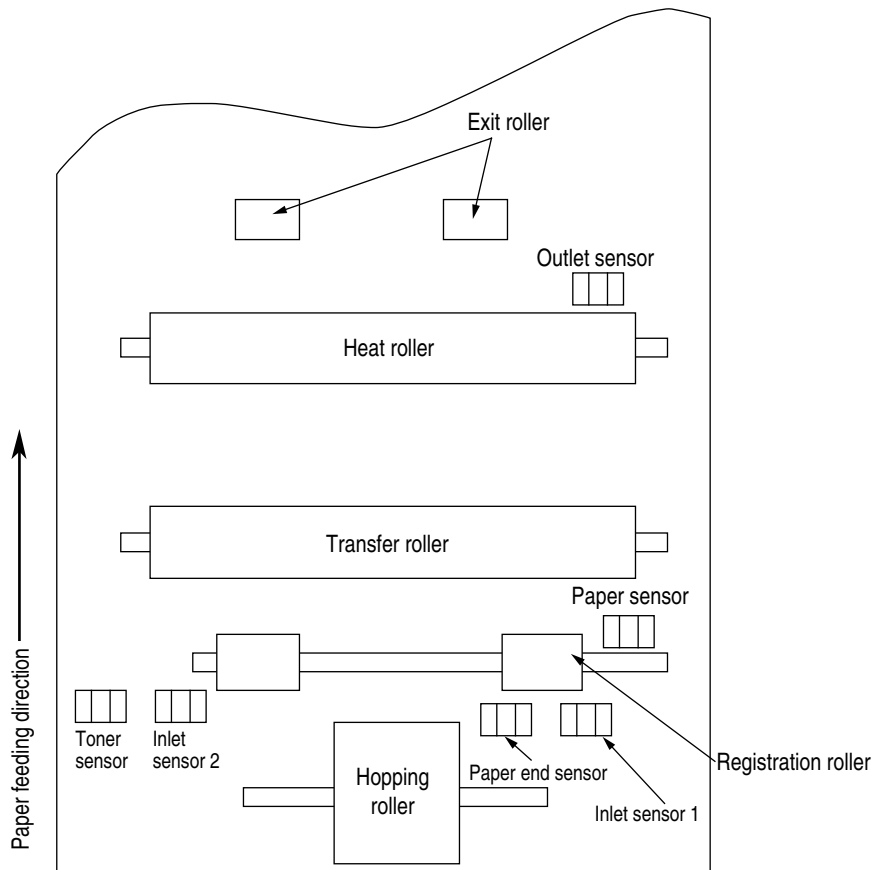

④ Fusing unit error (Status Message : Thermister Open Error  
: Thermister Short Check Error  
: Fuser Error Heater temp High  
: Fuser Error Heater temp Low)

- Turn the power off, then back on again.
- ▼ Yes Is the thermistor open or shorted? Measure the resistance between thermistor contacts (heater contacts 120V/2Ω or 240V/7Ω, and thermistor contacts 200KΩ at room temperature) (see Figure 5-2).
  - Yes Replace the fusing unit.
- ▼ No Do the thermistor connector is connected to the main control board connector?
  - No Connect the thermistor connector properly.
- ▼ Yes Is the heater of the fusing unit turned on (when the heater is turned on, light is emitted)?
  - Yes Check the thermistor connector or replace the main control board or the fusing unit.
- ▼ No Is the AC voltage being supplied to the connector for the heater of the power supply board? (see Figure 5-2)
  - No Replace the main control board or the power supply board.
- ▼ Yes Check the heater connector cord and the heater connector for poor contact .

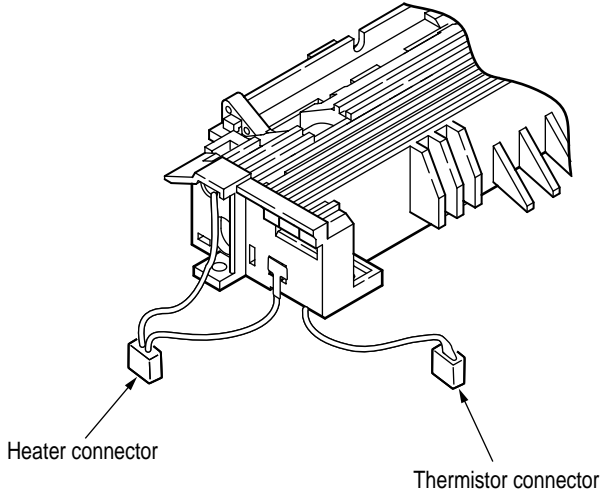

Figure 5-2

⑤ Fan error (Status Message : FAN Motor Error)

- Is the fan rotating?
  - Yes Replace the main control board.
- ▼ No Is FAN connector on the main control board being connected properly?
  - No Connect FAN connector properly.
- ▼ Yes Replace the fan or main control board.

5.5.3 Image Troubleshooting

Procedures for troubleshooting for abnormal image printouts are explained below. Figure 5-3 below shows typical abnormal images.

Problem	Flowchart number
Images are light or blurred entirely (Figure 5-3 (A))	①
Dark background density (Figure 5-3 (B))	②
Blank paper is output (Figure 5-3 (C))	③
Black vertical belts or stripes (Figure 5-3 (D))	④
Cyclical defect (Figure 5-3 (E))	⑤
Prints voids	⑥
Poor fusing (images are blurred or peels off when the printed characters and images on the paper are touched by hand)	⑦
White vertical belts or streaks (Figure 5-3 (F))	⑧

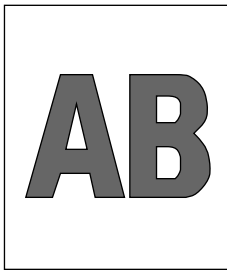

(A) Light or blurred images entirely

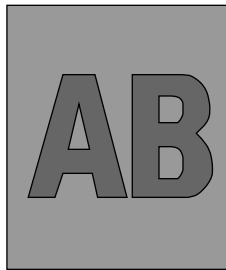

(B) Dark background density



(C) Blank paper

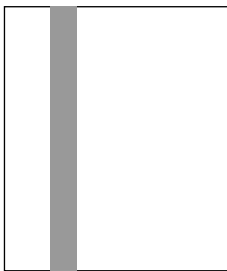

(D) Black vertical belts or stripes

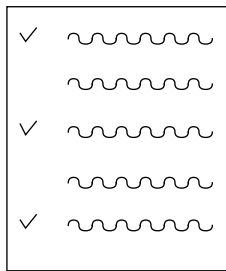

(E) Cyclical defect

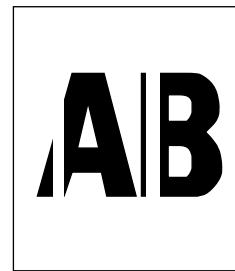

(F) White vertical belts or streaks

Figure 5-3

## ① Images are light or blurred entirely.

• Is toner low (is the TONER LOW message displayed)?

- Yes Supply toner.

▼ No Is paper of the specified grade being used?

- No Use paper of the specified grade.

▼ Yes Is the lens surface of the LED head dirty?

- Yes Clean the lens.

▼ No Is the LED head being installed properly (check the HEAD connector of the main control board and PC connector on the LED head for proper connection)?

- No Install the LED head properly.

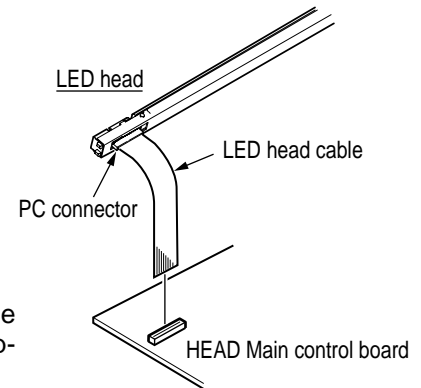

▼ Yes Is the contact plate of the transfer roller in contact with the contact assembly of the power supply/sensor board properly (see Figure 5-5)?

- No Adjust the contact plate of the transfer roller to make a proper contact with the high voltage/sensor board and shaft of the transfer roller.

▼ Yes Are the contact of the developing roller and the contact of the toner supply roller of the image drum cartridge in contact with the contact assembly properly (see Figure 5-4 (A) and (B))?

- No Adjust the contacts of the developing and toner supply roller to make a proper contact with the contact assembly.

▼ Yes Replace the transfer roller.

▼ Has the problem been solved?

- Yes End

▼ No Replace the image drum cartridge.

▼ Has the problem been solved?

- Yes End

**Note:** After replacing the image drum cartridge, reset the drum counter (see User's Manual).

▼ No Is the tension between the back-up roller (7.52kg) and the surface of back-up roller normal?

- No Replace the back-up roller or bias spring.

▼ Yes Replace the main control board or high voltage/sensor board.

## ② Dark background density

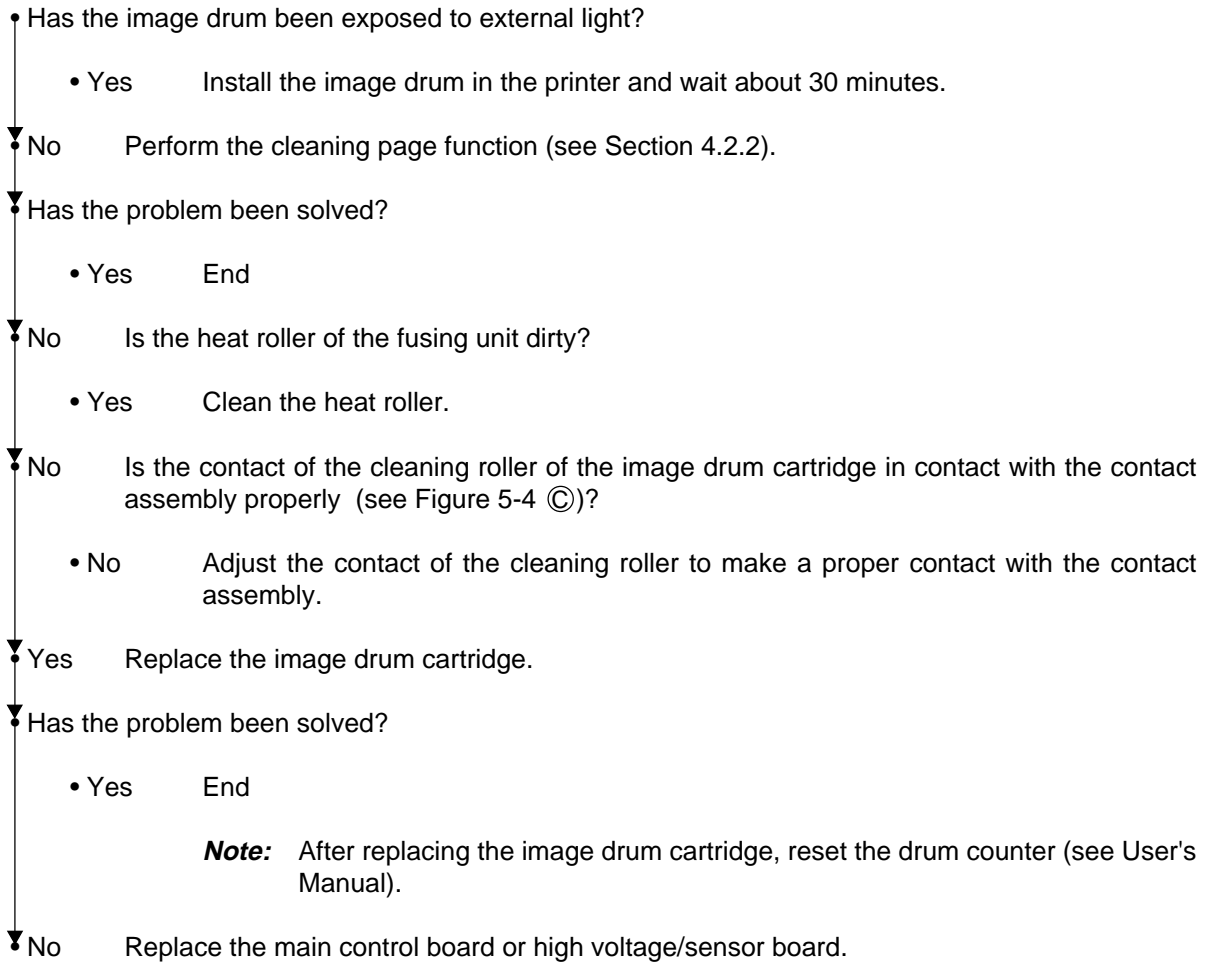

## ③ Blank paper is output.

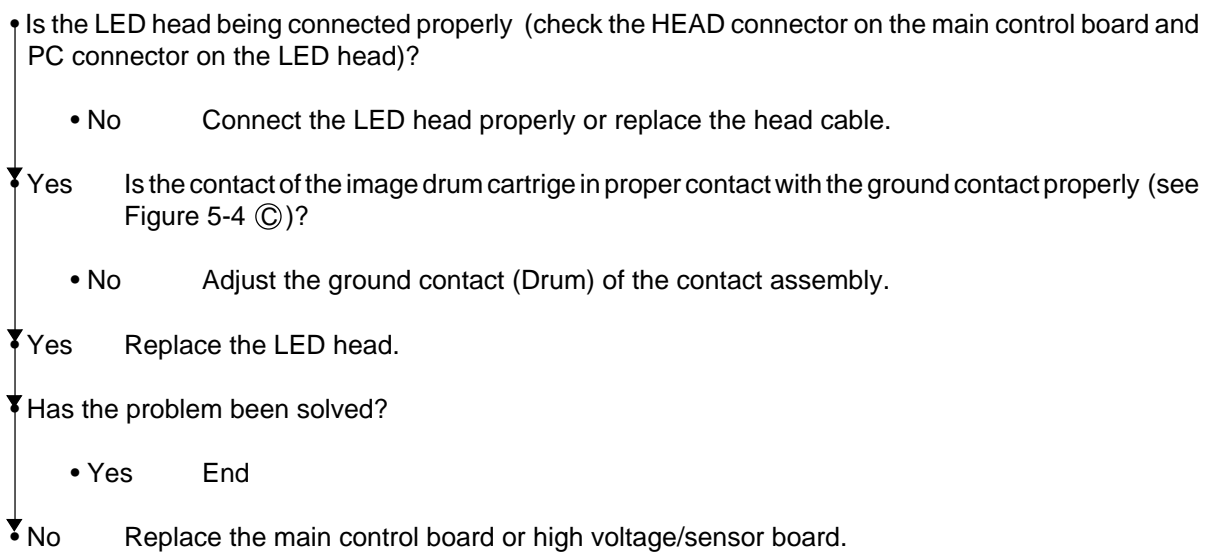



④ Black vertical belts or stripes

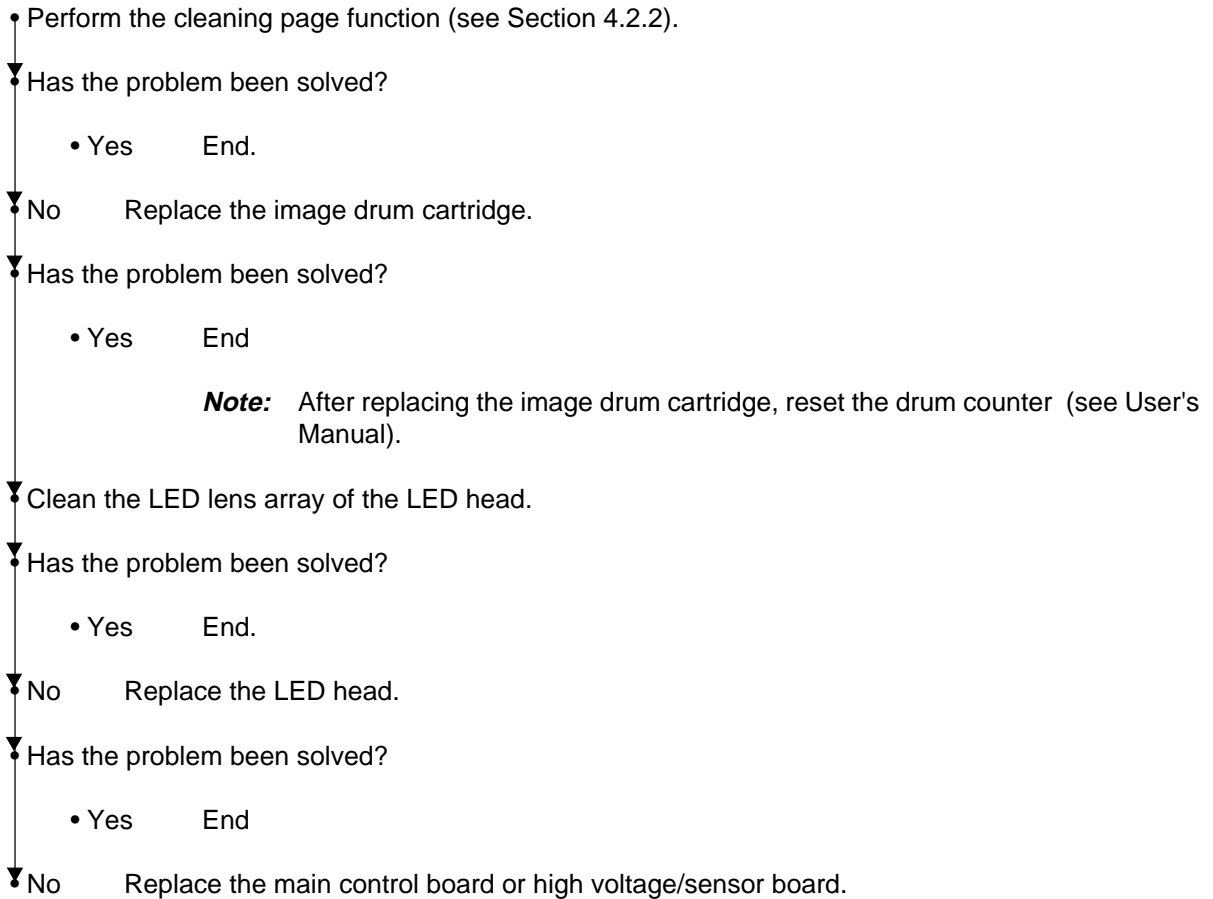

⑤ Cyclical defect

	Frequency	Remedy
Image drum	3.71" (94.2mm)	Replace or clean the image drum cartridge.
Developing roller	1.86" (47.12mm)	Replace the image drum cartridge.
Toner supply roller	2.96" (75.27mm)	Replace the image drum cartridge.
Charging roller	1.21" (30.63mm)	Replace the image drum cartridge.
Cleaning roller	0.93" (23.56mm)	Replace the image drum cartridge.
Transfer roller	1.95" (49.6mm)	Replace the transfer roller.
Heat roller	2.44" (62.0mm)	Replace the fusing unit assy.
Back-up roller	2.73" (69.4mm)	Replace the back-up roller.

**Note:** After replacing the image drum cartridge, reset the drum counter (see User's Manual).

## ⑥ Prints voids

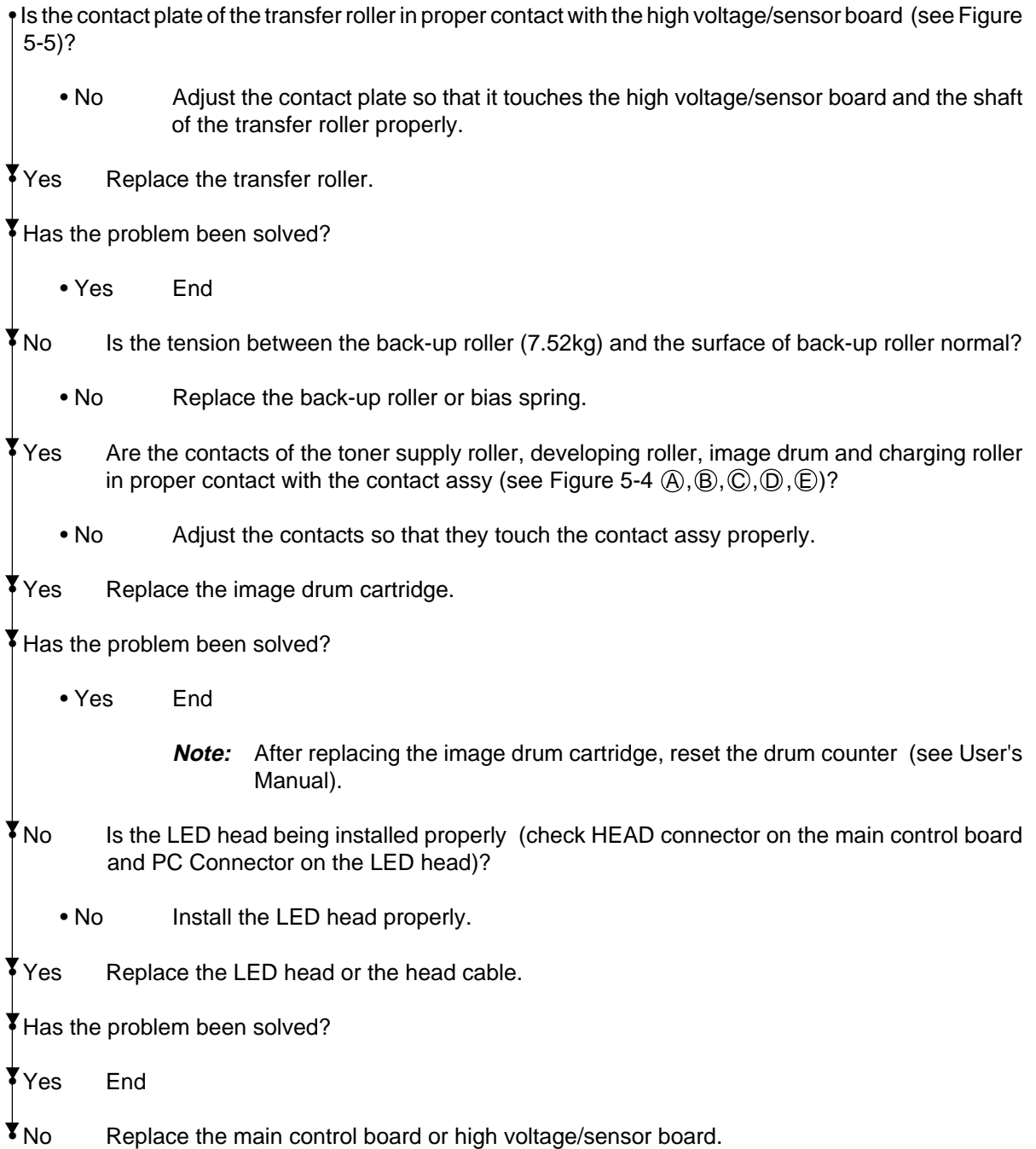

⑦ Poor fusing (images are blurred or peels off when the printed characters and images on the paper are touched by hand)

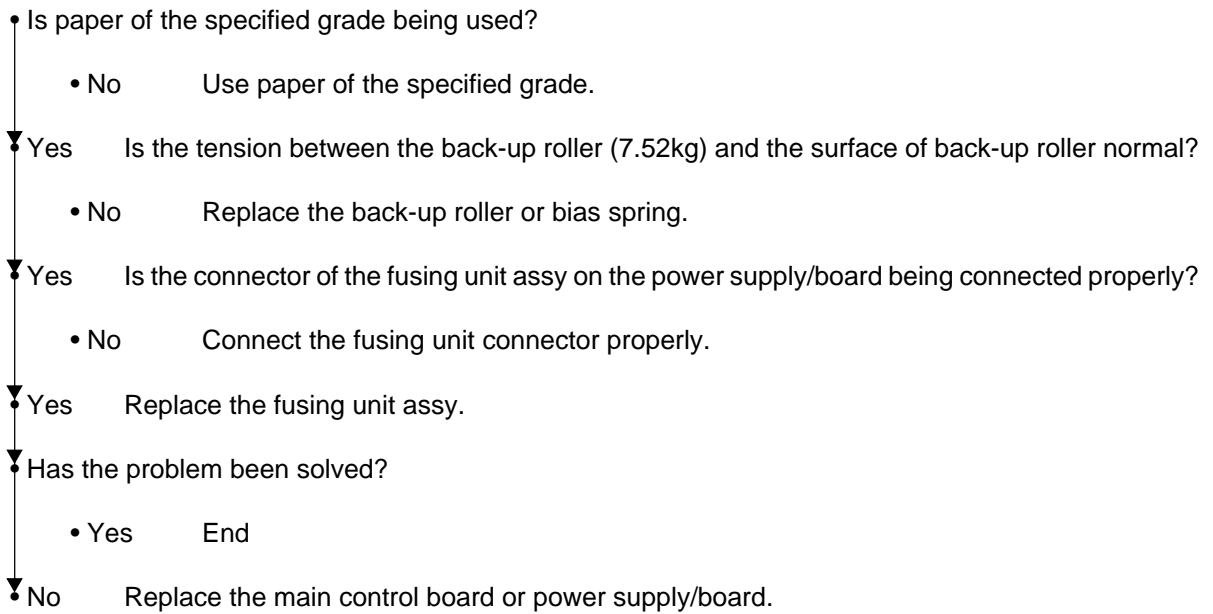

## ⑧ White vertical belts or streaks

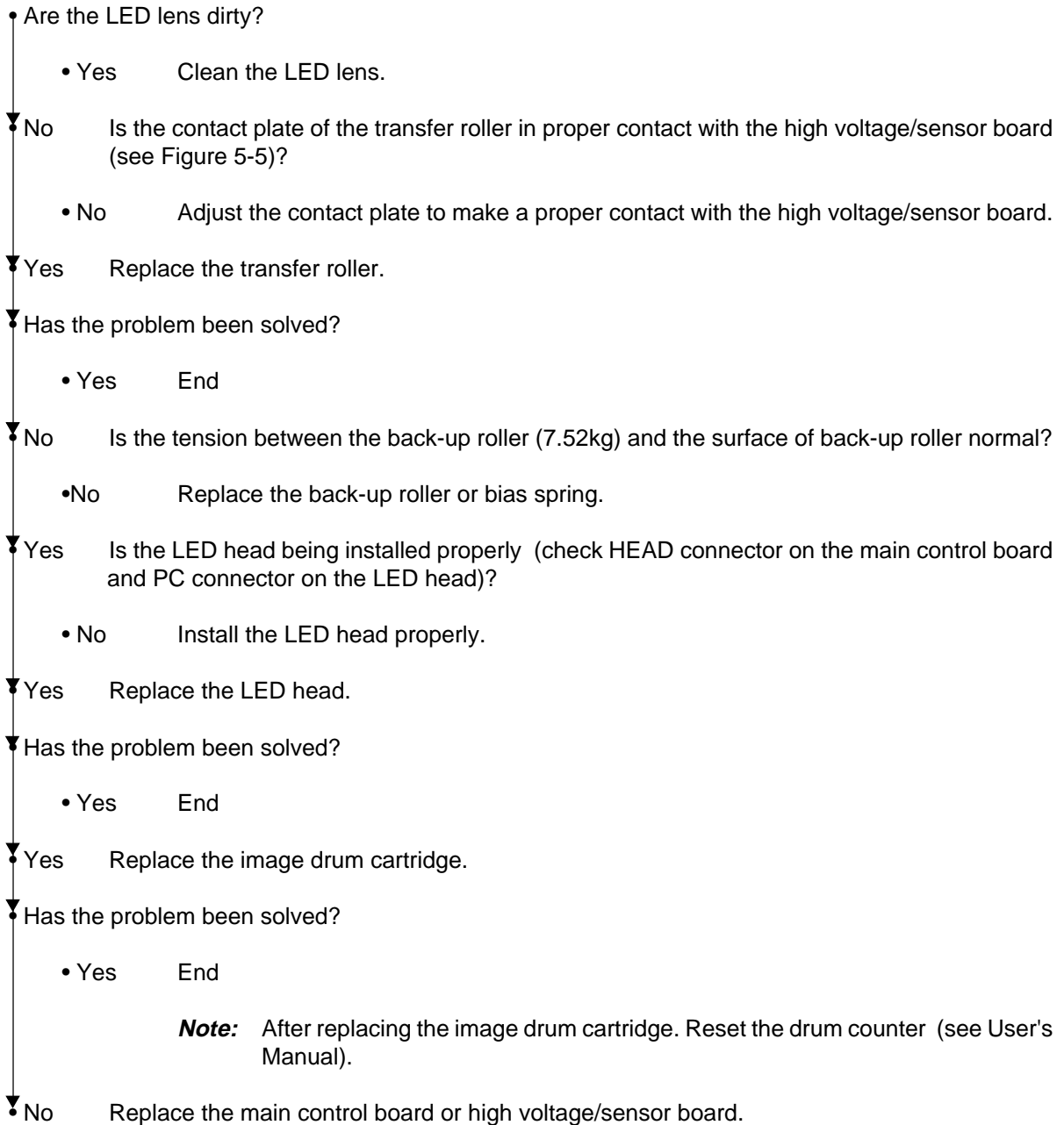

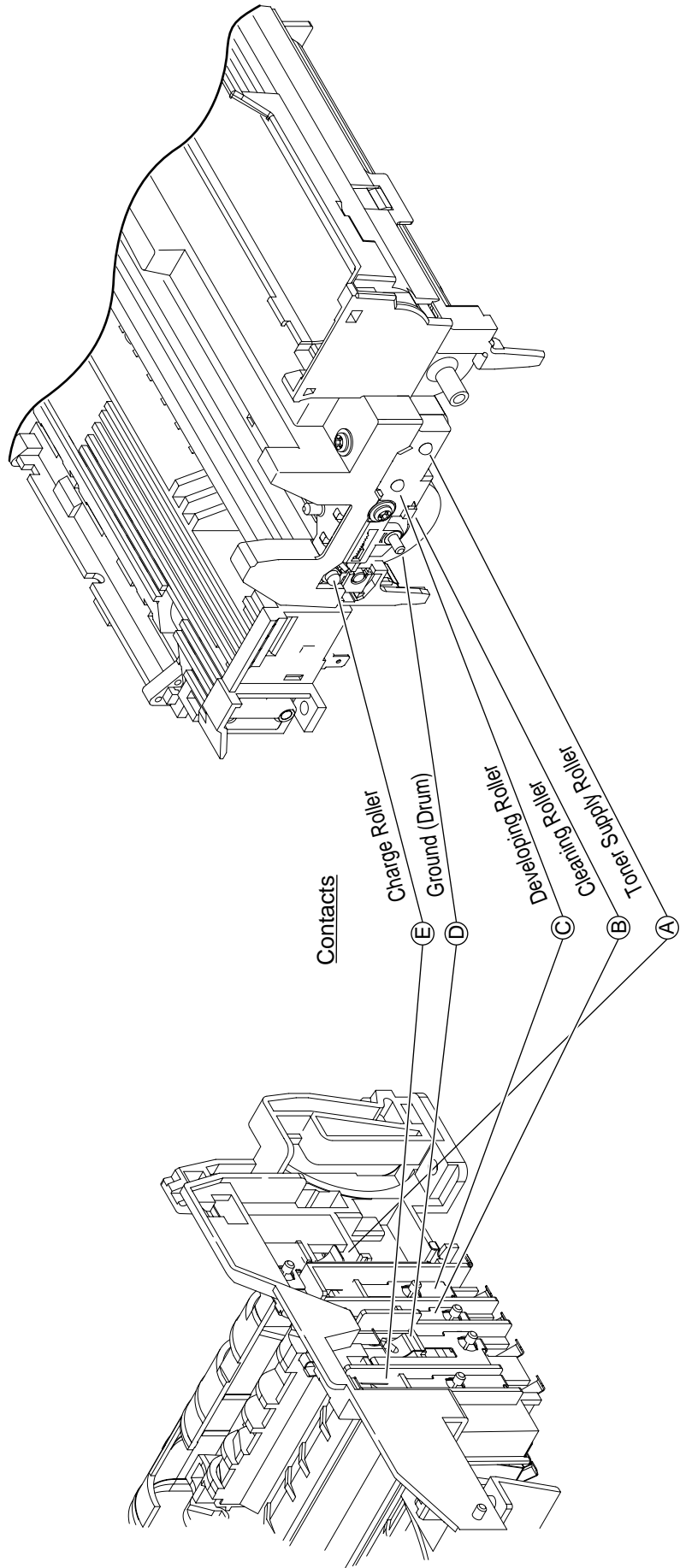

Figure 5-4

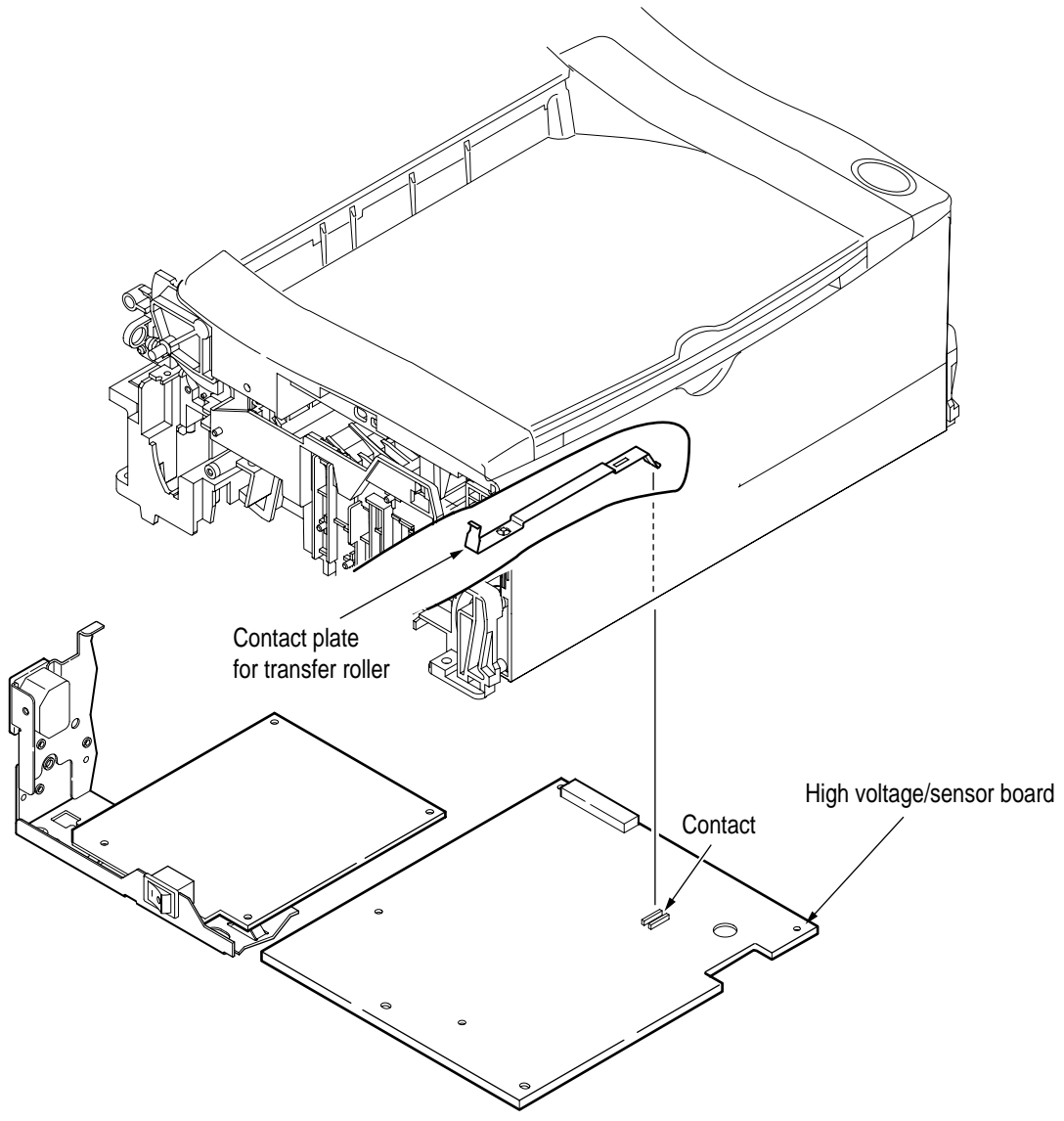
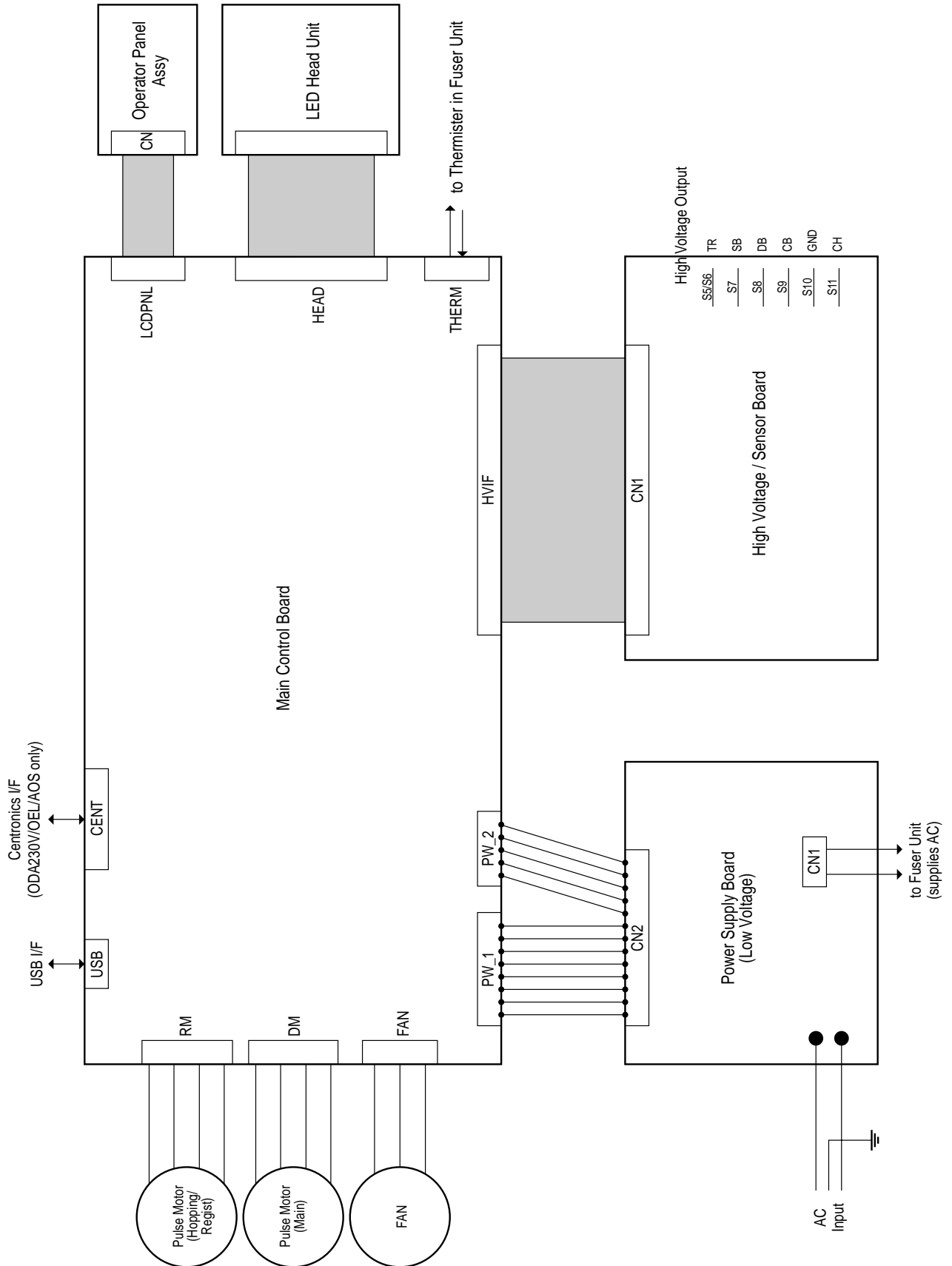

Figure 5-5

## 6. WIRING DIAGRAM

### 6.1 Interconnect Signal Diagram



## 6.2 PCB Layout and Connector Signal List

### (1) Main Control Board (GRG-5, 7 PCB)

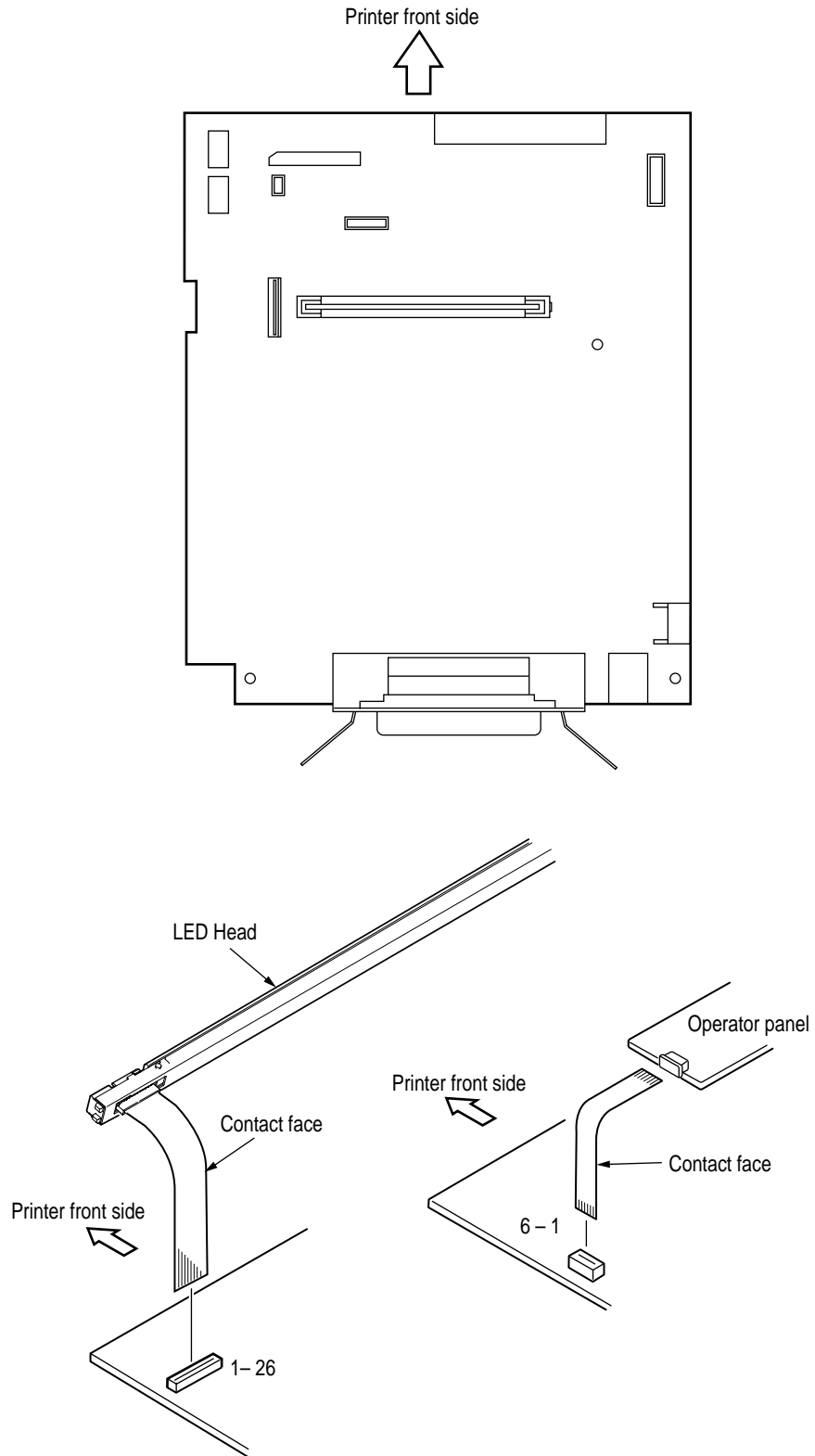



(2) Power Supply Board/High Voltage and Sensor Board

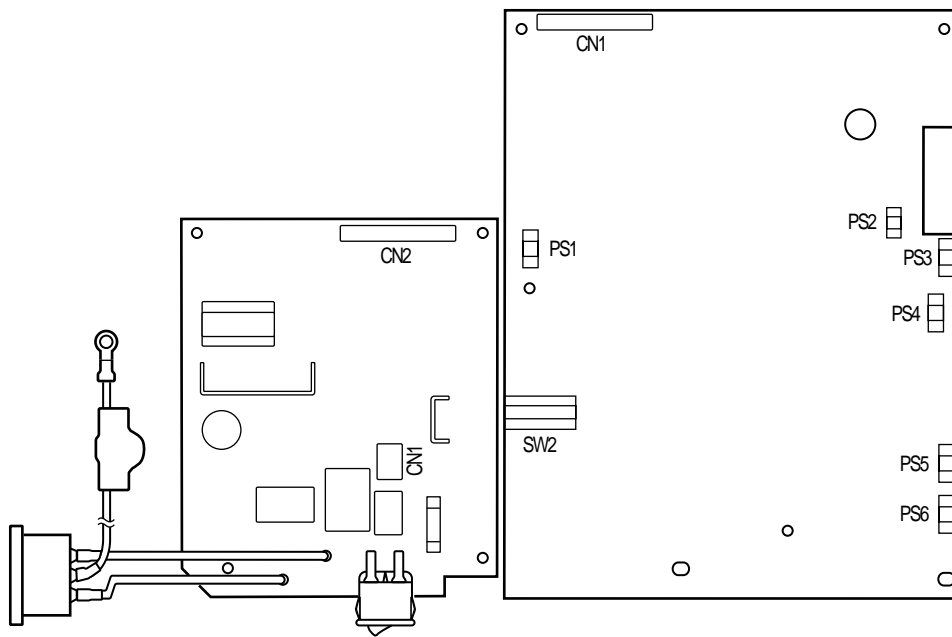

- HEAD Connector Pin Assignment  
(To LED head)

	PIN NO.	I/O*	Signal	Function
1	1	C	SG	Ground for Logic
	2	O	HDCLK-P	Clock
3	3	C	HDCLK-N	Clock
	4	C	SG	Ground for Logic
5	5	O	HDLD	Load
	6	O	HDSTB1	Hsync/CSN
7	7	O	HDDATA3	Data 3
	8	O	HDDATA2	Data 2
9	9	O	HDDATA1	Data 1
	10	O	HDDATA0	Data 0
11	11	O	HDSTB0	Strobe/SI
	12	O	HDSTB3	SCLK
13	13	O	HDSTB2	SO
	14	O	+3.3V	+3.3V for Logic
15	15	C	0VPHD	Ground for LED
	16	O	HEAD	+5V for LED
17	17	C	0VPHD	Ground for LED
	18	O	HEAD	+5V for LED
19	19	C	0VPHD	Ground for LED
	20	O	HEAD	+5V for LED
21	21	C	0VPHD	Ground for LED
	22	O	HEAD	+5V for LED
23	23	C	0VPHD	Ground for LED
	24	O	HEAD	+5V for LED

\* O: Out  
C: Common

- LCDPNL Connector Pin Assignment  
(To Operator Panel)

	PIN NO.	I/O*	Signal	Function
1	1	O	+5V	+5V
	2	O	READY	LED (READY) ON
3	3	O	PAPER	LED (PAPER) ON
	4	O	ALARM	LED (ALARM) ON
5	5	I	SW	Switch
	6	C	SG	Ground

\* I: In  
O: Out  
C: Common

- HVIF Connector Pin Assignment  
(To High Voltage Unit/Sensor Board)

		PIN NO.	I/O*	Signal	Function
1		1	I	WRSNS-N	Write Sensor
	2	2	I	IN1SNS-N	Paper Sensor 1
3		3	I	TONER-N	Toner Sensor
	4	4	I	IN2SNS-N	Paper Sensor 2
5		5	I	PAPER-N	Paper Out Sensor
	6	6	C	SG	Ground
7		7	O	SBPWN-P	SB2 Output
	8	8	O	CB2PWN-P	CB2 Output
9		9	O	DB1PWM	DB1 Output
	10	10	C	SG	Ground
11		11	O	CB1PWM	Cb1 Output
	12	12	C	SG	Ground
13		13	I	TRI_FB	TR1 Current Feedback
	14	14	I	TRV_FB	TR1 Voltage Feedback
15		15	I	DB2_V_FB	DB2 Voltage Feedback
	16	16	I	CHI	CH Current Feedback
17		17	I	CH_V_FB	CH Voltage Feedback
	18	18	I	DB_I	DB Current Feedback
19		19	I	SB_V_FB	SB2 Voltage Feedback
	20	20	C	SG	Ground
21		21	O	CHPWM-P	CH Output Control
	22	22	O	DB2PWM	DB2 Output
23		23	O	TR2PWM-P	TR2 output
	24	24	O	TR1PWM-P	TR1 Output Control
25		25	O	+5V	+5V
	26	26	O	+5V	+5V
27		27	C	SG	Ground
	28	28	C	SG	Ground
29		29	I	OUTSNS-N	Out Sensor
	30	30	I	CVOPN-N	Cover Open

\* I: In  
O: Out  
C: Common

- PW\_1 Connector Pin Assignment  
(To Power Supply Unit)

	PIN NO.	I/O*	Signal	Function
1	1	I	+38V	+38V
2	2	I	+38V	+38V
3	3	C	0VP	Analog Ground
4	4	C	0VP	Analog Ground
5	5	I	0VPHD	Ground for LED
6	6	I	0VPHD	Ground for LED
7	7	I	HEAD	+5V for LED
8	8	I	HEAD	+5V for LED

\* I: In  
O: Out  
C: Common

- PW\_2 Connector Pin Assignment  
(To Power Supply Unit)

	PIN NO.	I/O*	Signal	Function
1	1	C	SG	Ground for Logic
2	2	C	SG	Ground for Logic
3	3	I	+5V	+5V for Logic
4	4	I	+5V	+5V for Logic
5	5	O	HEATON_N	Heater On

\* I: In  
O: Out  
C: Common

- THERM Connector Pin Assignment  
(To Thermistor)

	PIN NO.	I/O*	Signal	Function
1	1	O	+5V	+5V
2	2	I	THERM	Heater

\* I: In  
O: Out

- FAN Connector Pin Assignment  
(To Fan)

	PIN NO.	I/O*	Signal	Function
1	1	O	FANPOW	Power Supply for Fan driving
2	2	C	SG	Ground
3	3	I	FANALM-P	Fan Alarm

\* I: In  
O: Out  
C: Common

- USB Connector Pin Assignment  
(USB I/F)

	PIN NO.	I/O*	Signal	Description
1	3	I	VCC	VCC
2	4	I/O	D-	D-
		I/O	D+	D+
		C	SG	Ground

\* I: In  
O: Out  
C: Common

- CENT Connector Pin Assignment  
(IEEE1284 I/F)

	Pin No.	I/O*	Signal	Function	Pin No.	I/O*	Signal	Function
1	19	I	STB-N	Strobe	19	C	SG	Logic Ground
2	20	C	DATA0-P	Data0	20	C	SG	Logic Ground
3	21	C	DATA1-P	Data1	21	C	SG	Logic Ground
4	22	C	DATA2-P	Data2	22	C	SG	Logic Ground
5	23	C	DATA3-P	Data3	23	C	SG	Logic Ground
6	24	C	DATA4-P	Data4	24	C	SG	Logic Ground
7	25	C	DATA5-P	Data5	25	C	SG	Logic Ground
8	26	C	DATA6-P	Data6	26	C	SG	Logic Ground
9	27	C	DATA7-P	Data7	27	C	SG	Logic Ground
10	28	O	ACK-N	Acknowledge	28	C	SG	Logic Ground
11	29	O	BUSY-P	Busy	29	C	SG	Logic Ground
12	30	O	PE-P	Paper End	30	C	SG	Logic Ground
13	31	O	SEL-P	Select	31	I	IPRIM-N	Iprime
14	32	I	AUTOFEED-N	Auto Feed	32	O	FAULT-N	Fault
15	33		NC	N.C.	33	C	SG	Logic Ground
16	34	C	SG	Logic Ground	34		NC	N.C.
17	35	C	FG	Frame Ground	35	O	HILEVEL	High Level
18	36	O	5VA	+5V	36	I	SELIN-N	Select In

\* O : Out  
I : In  
C : Common

- RM Connector Pin Assignment  
(To Hopping/Resistration Motor)

	PIN NO.	I/O*	Signal	Function
1	1	O	RMPH1-P	Coil 1-P
2	2	O	RMPH1-N	Coil 1-N
3	3	O	RMPH2-P	Coil 2-P
4	4	O	RMPH2-N	Coil 2-N

\* O: Out

- DM Connector Pin Assignment  
(To Main Motor)

	PIN NO.	I/O*	Signal	Function
1	1	O	DMPH1-P	Coil 1-P
2	2	O	DMPH1-N	Coil 1-N
3	3	O	DMPH2-P	Coil 2-P
4	4	O	DMPH2-N	Coil 2-N

\* O: Out

6.3 Resistance Check

Unit	Circuit Diagram	Illustration	Resistance
Registration motor			<p>Between Pins 1 and 2: 7.9Ω                      Between Pins 3 and 4: 7.9Ω</p>
Main/drum motor			<p>Between Pins 1 and 2: 8.6Ω                      Between Pins 3 and 4: 8.6Ω</p>
Fusing unit			<p>Between Pins 1 and 2: 120V 2Ω                      240V 7Ω                      Between Pins 3 and 4: 200KΩ                      (at room temperature)</p>

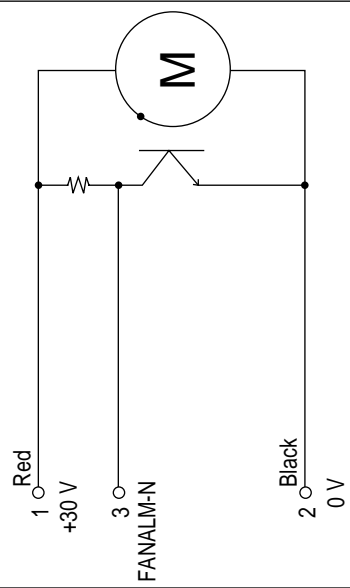
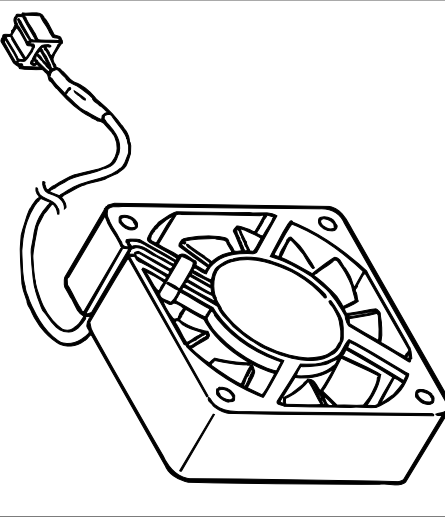
<p>Unit</p> <p>Fan</p>	<p>Circuit Diagram</p> 	<p>Illustration</p> 	<p>Resistance</p>
------------------------	--	--	-------------------



## APPENDIX A CENTRONICS PARALLEL INTERFACE

### 1) Connector

- Printer side : 36-pin receptacle  
(single port) Type 57RE-40360-730B-D29A (made by Daiichi Denshi), CN-AX05841A36AT (made by Ougat) or equivalent
- Cable side : 36-pin plug  
Type 57-30360 (made by Daiichi Denshi) or equivalent  
Plug-552274-1 (AMP), 552073-1 (AMP) or equivalent

### 2) Cable

- Cable length : 6 ft (1.8 m) max.  
(A Shielded cable composed of twisted pair wires is recommended for noise prevention.)

**Note:** Cable is not supplied with the printer, and is not available from Oki.

## 3) Table of Parallel I/F Signals

Pin No.	Signal name	Signal direction	Functions
1	$\overline{\text{DATA STROBE}}$	→ PR	Parallel data sampling strobe
2	DATA BIT - 1		
3	DATA BIT - 2		
4	DATA BIT - 3		
5	DATA BIT - 4	→ PR	PR Parallel input and output data
6	DATA BIT - 5		
7	DATA BIT - 6		
8	DATA BIT - 7		
9	DATA BIT - 8		
10	$\overline{\text{ACKNOWLEDGE}}$	← PR	Completion of data input or end of a function
11	BUSY	← PR	During print processing or alarm
12	PAPER END	← PR	End of paper
13	SELECT	← PR	Select state (ON-LINE)
14	$\overline{\text{AUTOFEED}}$	→ PR	Request to change mode
15	-		(Not used)
16	0V		Signal ground
17	CHASSIS GROUND		Chassis ground
18	+5V	← PR	50 mA max.
19 ⋮ ⋮ 30	0V		Signal ground
31	$\overline{\text{INPUT PRIME}}$	→ PR	Initializing signal
32	$\overline{\text{FAULT}}$	← PR	End of paper or during alarm
33	-		Signal ground
34	-		(Not used)
35	-		High level (3.3 kΩ)
36	$\overline{\text{SELECT IN}}$	→ PR	Request to change mode

- Connector pin arrangement

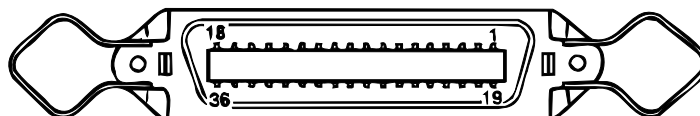

4) Signal Level

- INPUT
  - Low : 0 V to +0.4 V
  - High : +2.4 V to 5.0 V
- OUTPUT
  - Low : 0 V to +0.4 V
  - High : +2.0 V to 5.0 V

5) Specifications

Item	Description
Mode	Compatibility mode, Nibble mode, ECP mode
Data bit length	8 bits (in the compatibility mode)
Input prime	Valid/Invalid
Receive buffer	0.1M, 0.2M, 0.5M Bytes
Control	Handshaking control is performed in each mode. Data received from the host is stored in the receive buffer. Busy control is performed. Signal lead control is performed.

6) Interface circuit

a) Receiving circuit

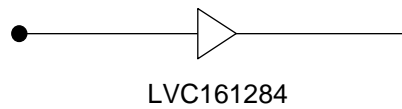

b) Sending circuit

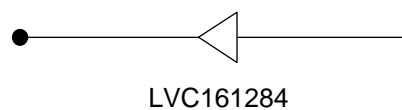

c) Other

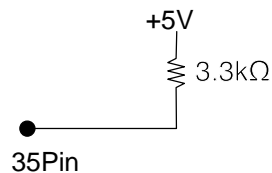

7) Timing charts

a) Power-ON (Menu Setting: PARALLEL=ENABLE)

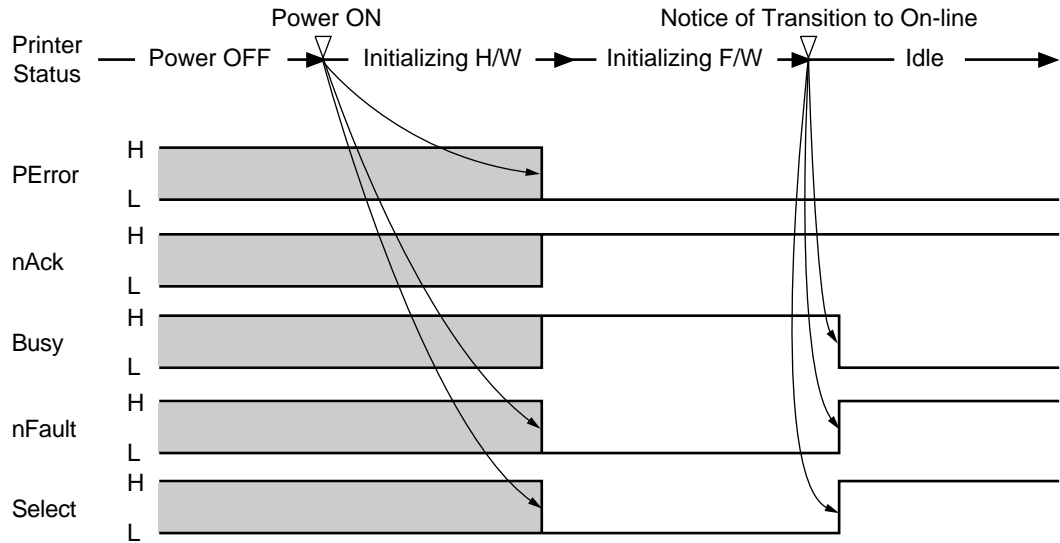

b) Power-ON (Menu Setting: PARALLEL=DISABLE)

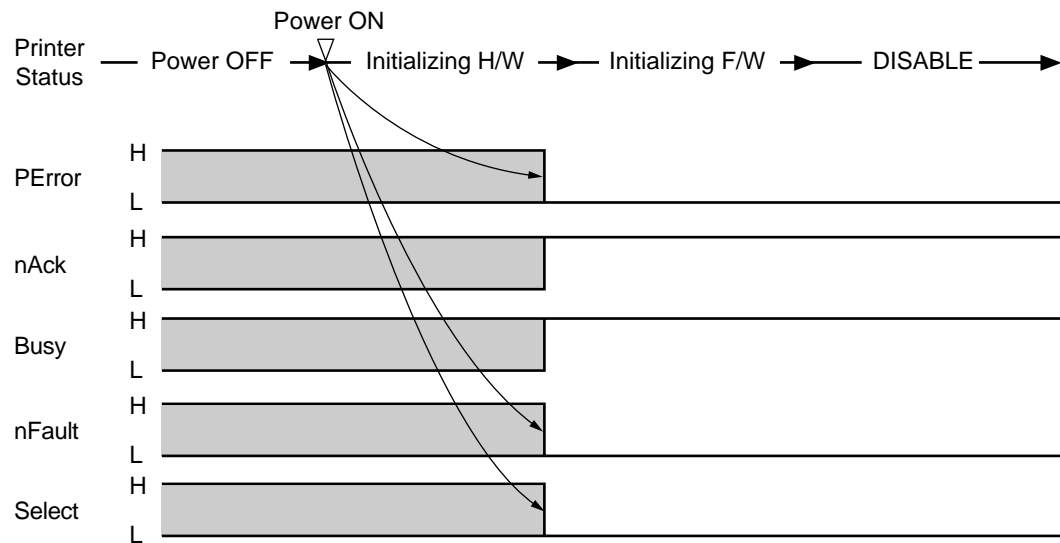

c) Data Reception (Menu Setting: Ack/Busy Timing=Ack in Busy)

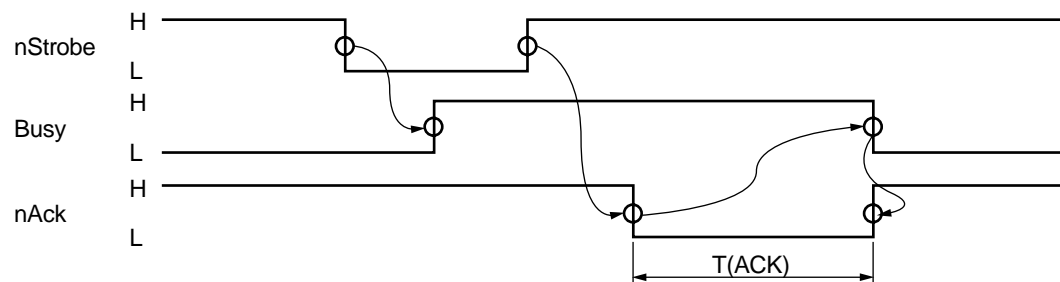

Menu Setting (Ack Width)	NARROW	MEDIUM	WIDE
T(ACK)	0.5μs	1.0μs	3.0μs

d) Data Reception (Menu Setting: Ack/Busy Timing=Ack while Busy)

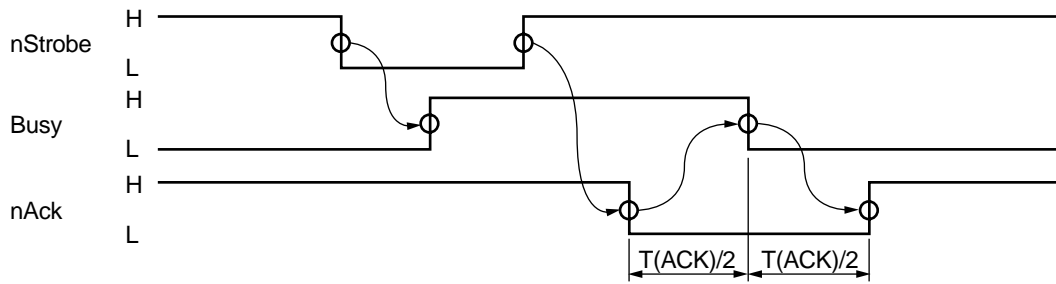

\* The T (ACK) values are the same as those shown in the section c).

e) I-Prime (Not at menu-set I-PRIME=DISABLE)

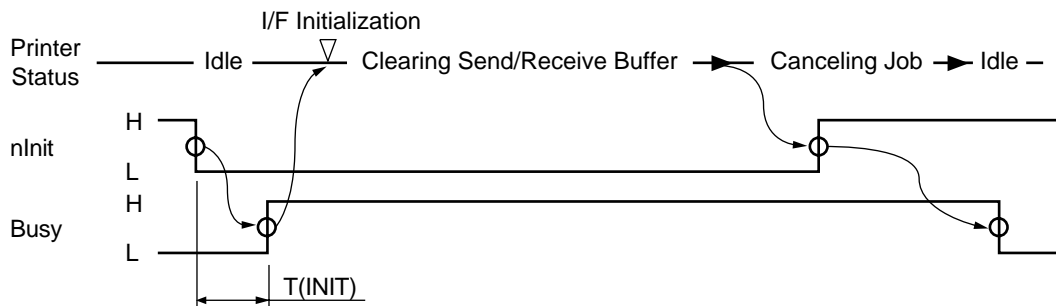

Menu Setting (I-PRIME)	3 MICRON SEC	50 MICRON SEC
T(INIT)	2.0 $\mu$ s	33.3 $\mu$ s

f) Off-line

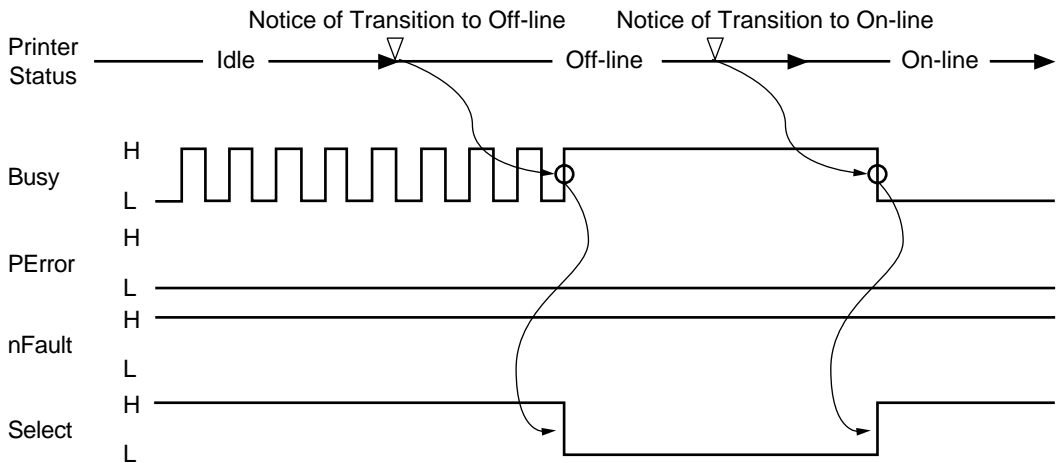

g) Paper-End

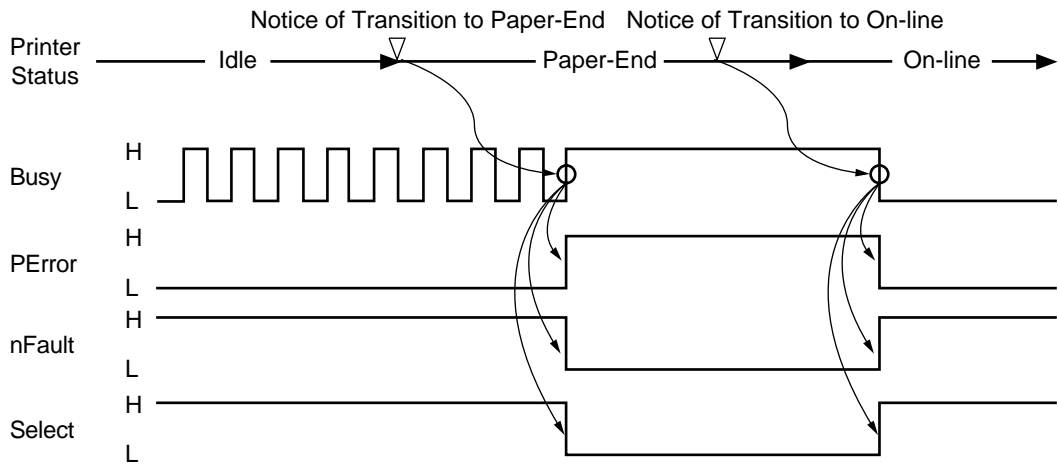

h) Warning (Paper-end state is excluded)

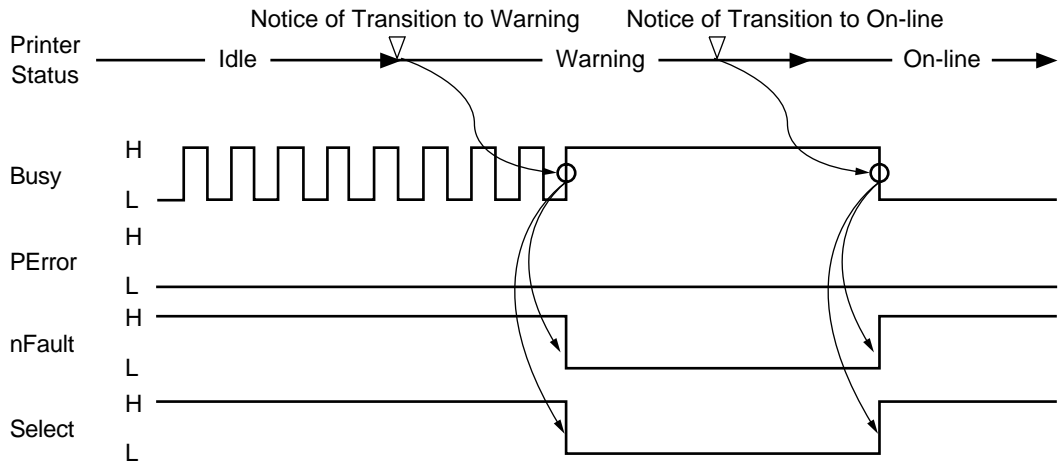

## APPENDIX B Universal Serial Bus (USB)

Universal Serial Bus Specification Revision 2.0 full speed compliance.

### 1) Connector

- Printer Side : "B" Receptacle (Upstream Input to the USB Device)
- Cable Side : Series "B" Plug

### 2) Cable

- Cable Length : Max 5m (A cable must be met USB Spec Rev 1.1 for normal operation)

**Note:** Cable is not provided.

### 3) Table of USB I / F signals

Contact Number	Signal Name
1	Vbus
2	D -
3	D +
4	GND
Shell	Shield

### 4) Connector pin arrangement

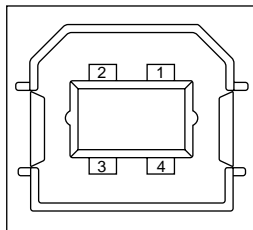

### 5) Mode & Class of Device

- Full - speed Driver
- Self - powered Device

### 6) Data Signaling Rate

- Full - speed function - 12Mb/s

### 7) Interface circuit

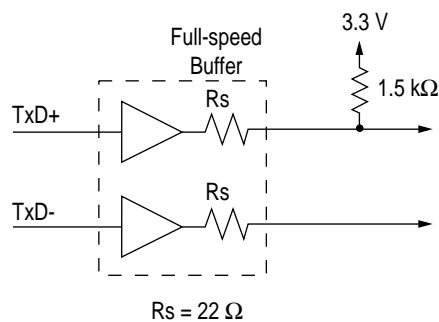

## 8) Signal Level

## • Input / Output Level

Parameter	Symbol	Min.	Max.	Units
Input Levels :				
High (driven)	V <sub>IH</sub>	2.0		V
High (floating)	V <sub>IHZ</sub>	2.7	3.6	V
Low	V <sub>IL</sub>		0.8	V
Output Levels :				
Low	OL	0.0	0.3	V
High (driven)	OH	2.8	3.6	V
Output Signal Crossover Voltage	V <sub>CRS</sub>	1.3	2.0	V

## • Signaling Levels

Bus State	Signaling Levels	
	Required	Acceptable
Differential "1"	(D+) - (D-) > 200mV and D+ > V <sub>IH</sub> (min)	(D+) - (D-) > 200mV
Differential "0"	(D-) - (D+) > 200mV and D- > V <sub>IH</sub> (min)	(D-) - (D+) > 200mV
Single-ended 0 (SE0)	D+ and D- < V <sub>IL</sub> (max)	D+ and D- < V <sub>IH</sub> (min)
Data J state:		
Low-speed	Differential "0"	
Full-speed	Differential "1"	
Data K state:		
Low-speed	Differential "1"	
Full-speed	Differential "0"	
Idle state:		
Low-speed	D- > V <sub>IHZ</sub> (min) and D+ < V <sub>IL</sub> (max)	D- > V <sub>IHZ</sub> (min) and D+ < V <sub>IH</sub> (min)
Full-speed	D+ > V <sub>IHZ</sub> (min) and D- < V <sub>IL</sub> (max)	D+ > V <sub>IHZ</sub> (min) and D- < V <sub>IH</sub> (min)
Resume state	Data K state	
Start-of-Packet (SOP)	Data lines switch from Idle to K state	
End-of-Packet (EOP)	SE0 for ≥ 1 bit time <sup>1</sup> followed by a J state for 1 bit time	SE0 for ≥ 1 bit time <sup>1</sup> followed by a J state
Disconnect (at downstream port)	SE0 for ≥ 2.5μs	
Connect (at downstream port)	Idle for ≥ 2ms	Idle for ≥ 2.5μs
Reset	D+ and D- < V <sub>IL</sub> (max) for ≥ 10ms	D+ and D- < V <sub>IL</sub> (max) for ≥ 2.5μs

**Note:** The width of EOP is defined in bit times relative to the device type receiving the EOP. The bit time is approximate.



9) Timing Chart

a) Packet Voltage Levels

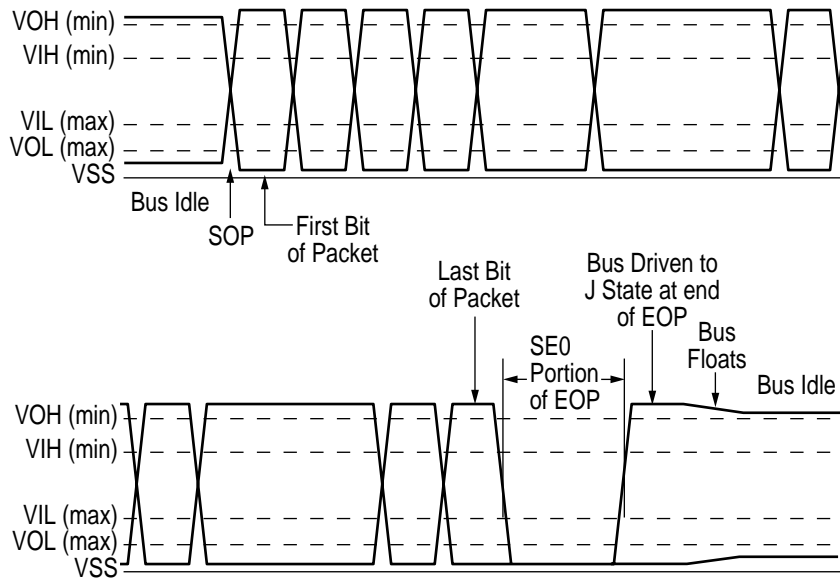

b) Disconnect Detection

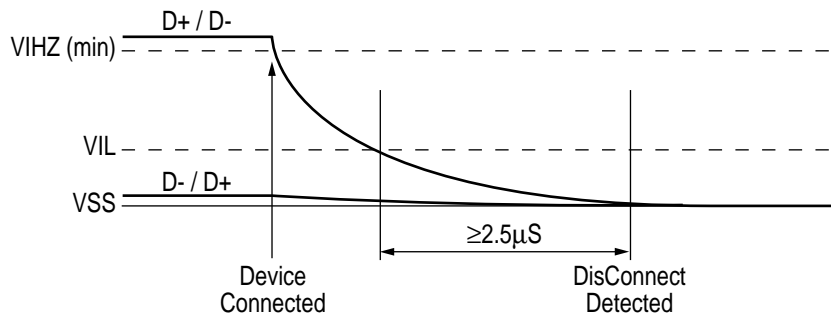

c) Full-speed Device Connect Detection

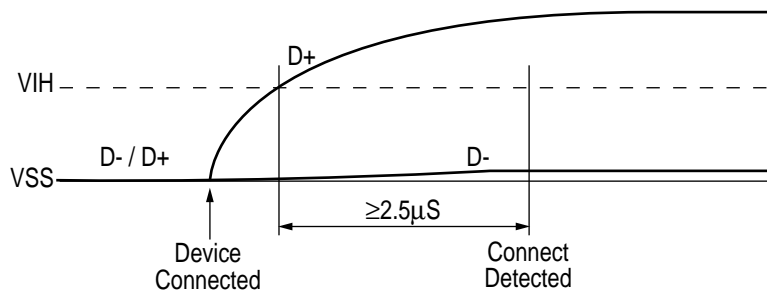

d) Differential Data Jitter

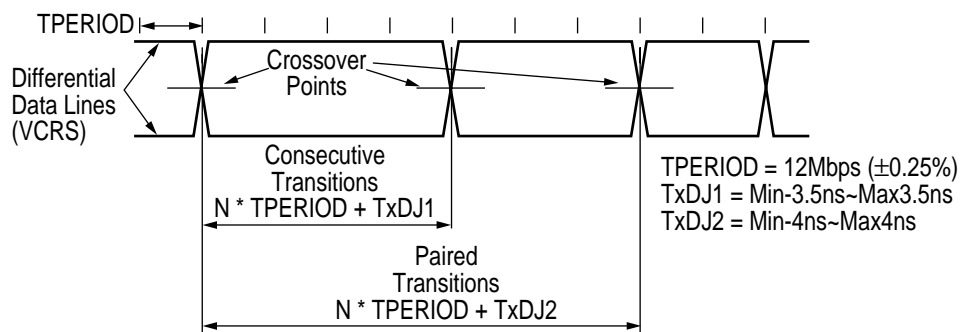

e) Differential-to-EOP Transition Skew and EOP Width

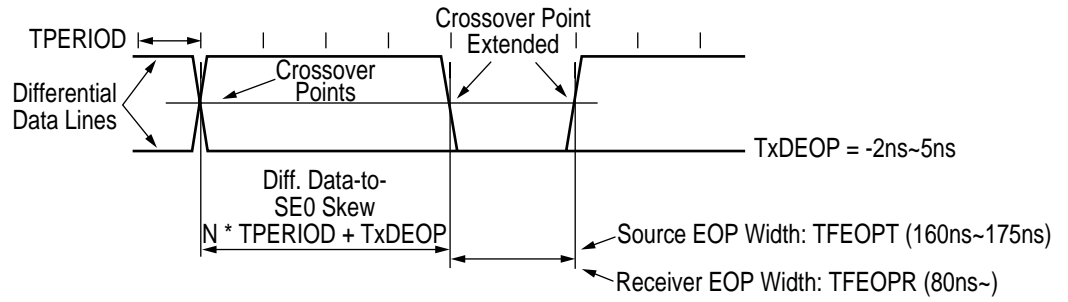

f) Receiver Jitter Tolerance

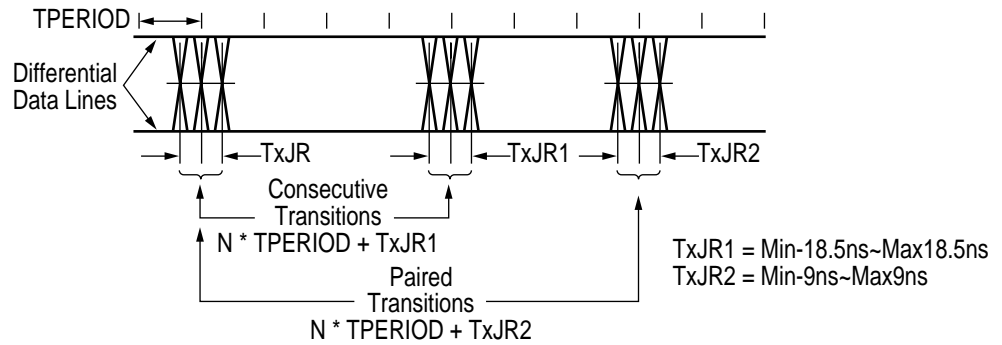

6  
5  
4  
3  
2  
1

No.01

Oki Data CONFIDENTIAL

# B4100 Monochrome LED Page Printer Disassembly for Maintenance

ODA

[Rev. 1]

BOM		Use for		Certification Body	
Rev	Date	DCO No.	Contents	Design	Approval
Approval .....Hisao-Ono.....			Design .....Hisao-Ono.....		Name <b>B4100 Disassembly for Maintenance</b>
Check .....			.....		
Date <b>2004-04-14</b>		<b>Oki Data Corporation</b>		Drawing No. <b>42640901TL</b>	
					1/3

B4100 (1/2)

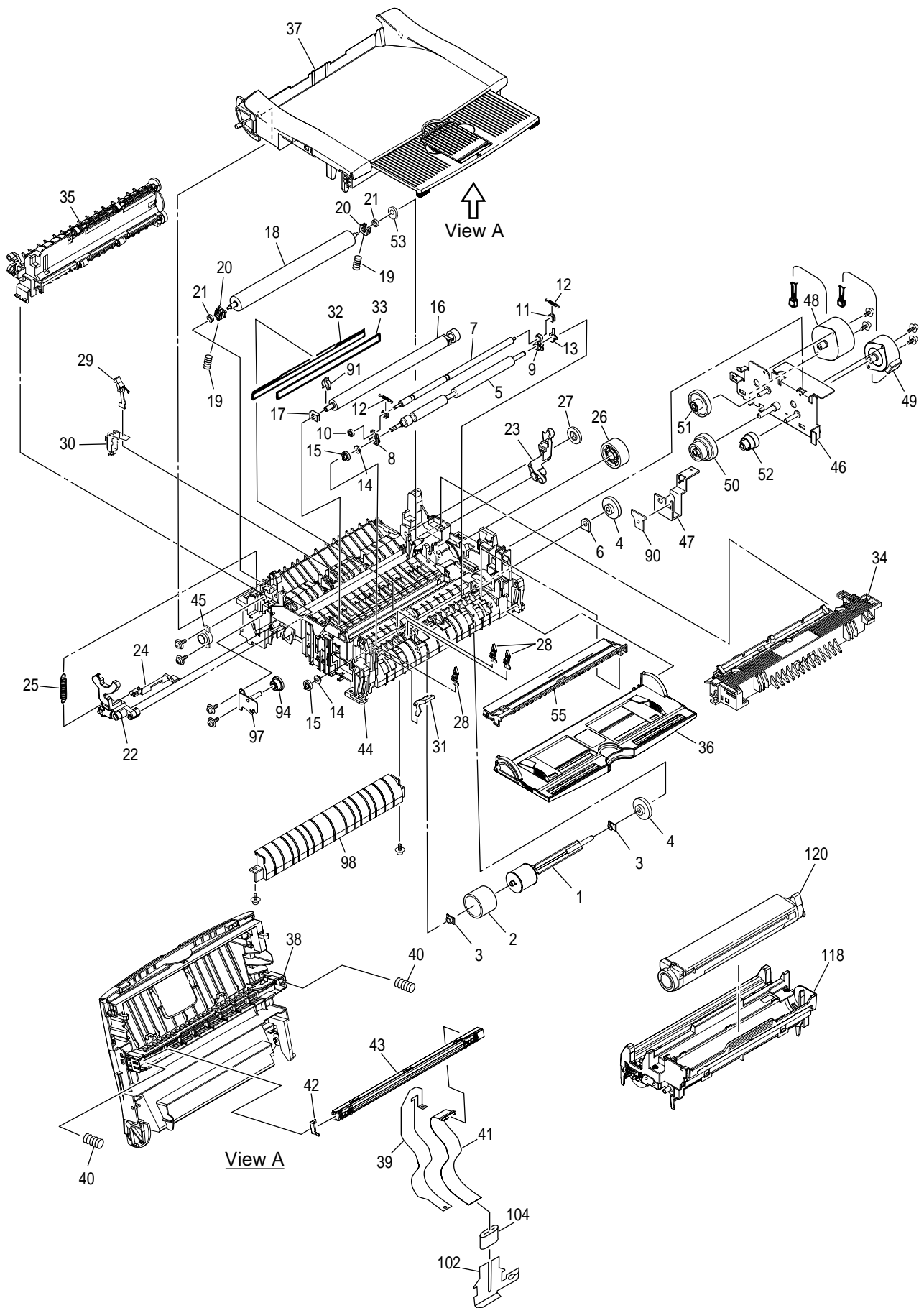

B4100 (2/2)

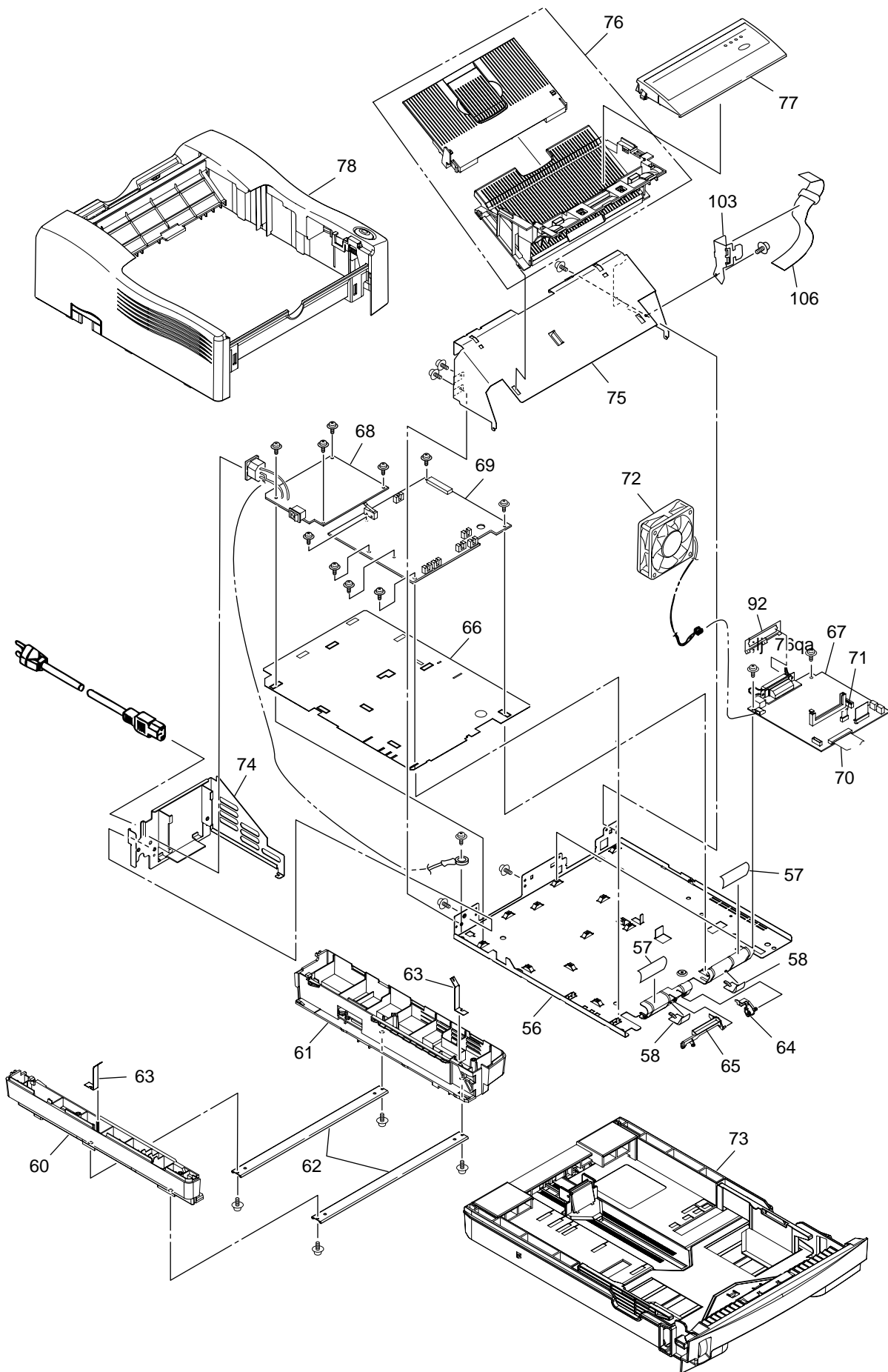

For B4100

No.	Parts No.	Name
1	51112301	Hopping Roller Shaft
2	5334201	Rubber-Hopping Roller
3	51607402	Bearing
4	51228901	One-way Clutch Gear
5	42174301	Roller-Regist
6	51607501	Bearing(Registration)
7	42174201	Roller-Pressure
8	41279501	Holder-Regist L
9	41279601	Holder-Regist R
10	42843001	Gear-Pressure
11	41279401	Bearing-Pressure
12	41281201	Spring-Tension
13	41280401	Plate-Contact PA
14	41279301	Bearing-Regist L
15	41279701	Gear-Regist
16	42208501	Roller Assy.-Transfer
17	40438001	Bearing TR
18	41301801	Roller-Back up
19	41584101	Spring Bias
20	41536201	Holder-BU
21	41584201	Bearing-Ball
22	42208601	Lever-Reset L Assy.
23	50805901	Reset Lever R
24	42551201	Arm-Switch
25	50924201	Reset Spring
26	42126101	Idle Gear
27	51229201	Idle Gear
28	51010701	Sensor Plate(Inlet)
29	40771401	Lever-Eject Sensor Assembly
30	41027701	Sensor Wire Assembly
31	42468801	Toner Sensor(Adhesion)
32		Diselectrification Bar Shaft
33		Diselectrification Film
34-a	42209201	Heat Assy
34-b	42209202	Heat Assy
35	40772501	Roller Assy.-Eject
36	42145701	Cover Assy.-Front
37	42200401	Cover Assy.-Stacker
38	42129101	Holder-Head
39	42146701	Film-FG
40	42146501	Spring-Head
41	56639709	FUJI-CARD(24P)
42	42146601	Contact-Head
43	42266801	LED Head Unit-51MXF
44	42660001	Frame Subassy.-Lower
45	42596601	Damper Oil
46	42122701	Bracket-Motor(Caulking)

For B4100

No.	Parts No.	Name
47	42352501	Bracket-Sub-M
48	42196001	Motor-Pulse(Main)
49	42196101	Motor-Pulse(Regist)
50	42121701	Gear-M3
51	42121801	Gear-M2
52	42121901	Gear-R2
53	50517201	Washer C
54		
55	42209101	Guide-Paper R(Adhesive)
56	42200501	Plate-Base Assy.
57		Polyethylene Tape
58	40828301	Guide-Paper H
59		CS-RING(CS3-SUS)
60	42209401	Cassette guide L Assy.
61	42209501	Cassette guide R Assy.
62		Beam Plate
63		FG Plate(bm)
64	51019701	Sensor Plate(Paper Supply)
65	51011501	Cassette Sensor Plate
66	42146301	Insulator
67-a	42263822	Board GRG-7
67-b	42263818	Board GRG-5
68-a	41991601	Power Supply Unit
68-b	42510301	Power Supply Unit
69	42284101	Board-HLB
70	56640903	Sumi-Card(30P)
71	42101001	Cord Assy.(13p-5P,8p)
72	42283501	Fan Motor
73	42209601	Cassette Assy.-Paper
74	42146201	Plate-Guide
75		Plate-Shield
76	42146801	Face Up Stacker Assy.
77	42200205	Frame Assy.-OP Panel
78	42147207	Cover-Upper Assy.
79		
90	42406601	Holder-Tr_R
91	42406701	Spacer-Tr_L
92		Plate-Earth(CTR)
93		Plate-Earth-ENV
94	51252001	Damper-Gear
95		
96		
97		Plate-Damper(Caulking)
98	42661401	Guide-Paper
99		
100		
101		

For B4100

No.	Parts No.	Name
102		Film-Support(Head)
103		Film-Support(OP)
104		Core
106	40997102	Cord Assy.-OP