



## *Service Manual*

**Lexmark Optra™ M410/M412**  
**4045-XXX**

- ***Table of Contents***
- ***Start Diagnostics***
- ***Safety and Notices***
- ***Trademarks***
- ***Index***

**LEXMARK™**

*Lexmark and Lexmark with diamond design are trademarks of Lexmark International, Inc., registered in the United States and/or other countries.*

**Edition: May 2000**

**The following paragraph does not apply to any country where such provisions are inconsistent with local law:** LEXMARK INTERNATIONAL, INC. PROVIDES THIS PUBLICATION "AS IS" WITHOUT WARRANTY OF ANY KIND, EITHER EXPRESS OR IMPLIED, INCLUDING, BUT NOT LIMITED TO, THE IMPLIED WARRANTIES OF MERCHANTABILITY OR FITNESS FOR A PARTICULAR PURPOSE. Some states do not allow disclaimer of express or implied warranties in certain transactions; therefore, this statement may not apply to you.

This publication could include technical inaccuracies or typographical errors. Changes are periodically made to the information herein; these changes will be incorporated in later editions. Improvements or changes in the products or the programs described may be made at any time.

A form for reader's comments is provided at the back of this publication. If the form has been removed, comments may be addressed to Lexmark International, Inc., Department D22A/032-2, 740 West New Circle Road, Lexington, Kentucky 40550, U.S.A. Lexmark may use or distribute any of the information you supply in any way it believes appropriate without incurring any obligation to you. You can purchase additional copies of publications related to this product by calling 1-800-553-9727. In other countries, contact your point of purchase.

Lexmark and Optra are trademarks of Lexmark International, Inc., registered in the United States and/or other countries.

Color Jetprinter is a trademark of Lexmark International, Inc.

Other trademarks are the property of their respective owners.

**© Copyright Lexmark International, Inc. 2000.**

**All rights reserved.**

**UNITED STATES GOVERNMENT RESTRICTED RIGHTS**

This software and documentation are provided with RESTRICTED RIGHTS. Use, duplication or disclosure by the Government is subject to restrictions as set forth in subparagraph (c)(1)(ii) of the Rights in Technical Data and Computer Software clause at DFARS 252.227-7013 and in applicable FAR provisions: Lexmark International, Inc., Lexington, KY 40550.

# Table of Contents

<b>Notices and Safety Information</b> .....	<b>vii</b>
Laser Notices .....	vii
Safety Information .....	xv
<b>General Information</b> .....	<b>1-1</b>
Options .....	1-2
Printer Specifications .....	1-3
<b>Diagnostic Information</b> .....	<b>2-1</b>
Start .....	2-1
Service Error Codes .....	2-2
User Status Messages .....	2-5
User Error Messages .....	2-9
Power-On Self Test (POST) .....	2-14
Symptom Tables .....	2-15
Charge Roll Service Check .....	2-17
Cover Open Switch/Cable Service Check .....	2-19
Dead Machine Service Check .....	2-20
Erase Lamp Service Check .....	2-22
Fan Service Check .....	2-23
Fuser Service Check .....	2-23
Input Sensor Service Check .....	2-25
Input Tray(s) Option Service Check .....	2-26
Main Drive Service Check .....	2-29
Operator Panel Service Check .....	2-30
Options Service Check .....	2-32
Paper Feed Service Check .....	2-33
Parallel Port Service Check .....	2-35
Printhead Service Check .....	2-36
Print Quality Service Check .....	2-37
Serial Port Service Check .....	2-47
Transfer Roll Service Check .....	2-48
<b>Diagnostic Aids</b> .....	<b>3-1</b>
Configuration Mode .....	3-1
Print Quality Test Pages .....	3-2
Panel Menus .....	3-2
PPDS Emulation .....	3-3
Discard Buffered Jobs .....	3-3
Download Emulation .....	3-3

Demo Mode	3-4
Restore Factory Defaults	3-4
Narrow Media	3-5
Exiting the Configuration Mode	3-5
Diagnostic Mode	3-5
Exiting the Diagnostic Mode	3-5
Print Registration	3-6
Print Tests	3-6
Hardware Tests	3-8
Input Tray Tests	3-13
Base Sensor Test	3-14
Printer Setup	3-14
Error Log	3-17
Device Tests	3-17
Hardware Test Mode	3-20
Operator Panel Test	3-21
Main Motor Test	3-22
Solenoid Test	3-22
Tray 2 Motor Test	3-23
Mirror Motor Test	3-23
Sensor Monitor Test	3-24
Cooling Fan / Fuser Control Test	3-25
Erase Lamp Test	3-26
Reset Test Mode	3-26
Engine Firmware	3-26
Printer Operation	3-27
Electrophotographic Process	3-27
Paper Feeding, Transferring and Fusing	3-27
Paper Path/Sensor Locations	3-28
Cable Locations	3-29
<b>Repair Information</b>	<b>4-1</b>
Handling ESD-Sensitive Parts	4-1
Adjustment Procedures	4-2
Printhead Assembly	4-2
Paper Alignment	4-3
Removal Procedures	4-4
Covers	4-4
Charge Roller	4-8
Controller Board	4-9
Cooling Fan	4-11
Developer Drive Assembly	4-13
Engine Board	4-14

Fuser .....	4-15
HVPS .....	4-17
Inner Deflector .....	4-18
Left Side Frame .....	4-20
LVPS .....	4-21
Main Drive Assembly .....	4-23
Multipurpose Tray .....	4-24
Paper Alignment Assembly .....	4-25
Pick Roll .....	4-27
Printhead .....	4-28
Redrive Assembly .....	4-29
Right Side Frame .....	4-30
Transfer Roller .....	4-30
<b>Connector Locations .....</b>	<b>5-1</b>
Low Voltage Power Supply .....	5-1
High Voltage Power Supply .....	5-2
Engine Board .....	5-4
Interconnect Board .....	5-10
Option Tray Board .....	5-12
<b>Parts Catalog .....</b>	<b>6-1</b>
Assembly 1: Covers .....	6-2
Assembly 2: Frame .....	6-6
Assembly 3: Printhead .....	6-8
Assembly 4: Paper Feed - Multipurpose Unit .....	6-10
Assembly 5: Paper Feed - Alignment .....	6-12
Assembly 6: Paper Feed - Output .....	6-14
Assembly 7: Main Drive .....	6-16
Assembly 8: Developer Drive .....	6-18
Assembly 9: Fuser .....	6-20
Assembly 10: Transfer .....	6-24
Assembly 11: Charging .....	6-26
Assembly 12: Electronics .....	6-28
Assembly 13: 250-Sheet Tray .....	6-34
Assembly 14: 500-Sheet Tray .....	6-36
Assembly 15: Options .....	6-40
<b>Index .....</b>	<b>I-1</b>

**4045-XXX**

# Notices and Safety Information

## Laser Notices

The following laser notice labels may be affixed to this printer as shown:

## Laser Advisory Label

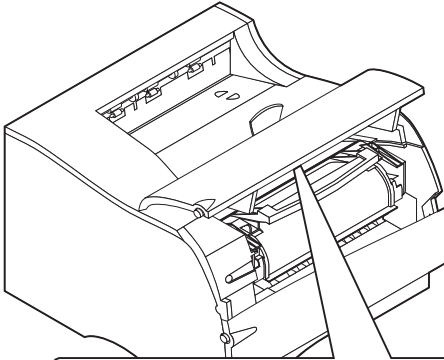

<b>CAUTION -</b>	Invisible laser radiation when open and interlock defeated. Avoid exposure to beam.
<b>ATTENTION -</b>	Radiation laser invisible si le dispositif est ouvert et non bloqué. Éviter l'exposition au rayon.
<b>VORSICHT -</b>	Unsichtbare Laserstrahlung wenn drucker offen und sperre gelöst. Nicht dem strahl aussetzen.
<b>VOORZICHTIG -</b>	Onzichtbare laserstraling wanneer deprinter open en niet vergrendeld. Vermijd blootstelling aan straal.
<b>ATTENZIONE -</b>	Radiation laser invisibile se il dispositivo è aperto e non bloccato. Evitare l'esposizione diretta.
<b>AVISO -</b>	Radiación laser invisible cuando a puerta o abierta. Evite exposición a la radiación.
<b>CUIDADO -</b>	Radiación laser invisível quando a tampa o aberta. Evite exposição aos raios.
<b>VARO!</b>	Avartaessa ja suojakalvas ohitettävissä oia alittina näkymättömsille laser säteilylle. Älä katso silmieseen.
<b>WARNING -</b>	Oyhtyig laserströling när detsnät är öppnat och spärren är utkopplad. Skåda fr strölg.
<b>ADVASEL -</b>	Usynlig laserströling när detsnät är öppet og sikkerheds bryter. Unngå eksponering for strölien.
<b>ADVARSEL -</b>	Usynlig laserströling når detsnät er åbnet og sikkerhedsbrydere er tude af funktion. Undgå udsættelse for ströling.
<b>ATENCIÓN -</b>	Radiación laser invisible si s'obre i el lanzamiento intern no és correcte. Eviteu exposar-vos-hi.
<b>注意：</b>	開閉時會有看不到的雷射輻射線外觀，請避免接觸於光線下。
<b>注意 -</b>	トップカバーを開閉するときにインターロックが解除されるので、直射光に注意してください。
<b>주의 -</b>	개방과 인력력이 상해 시 눈에 보이지 않는 레이저가 방사됩니다. 레이저 빛에 노출되지 않도록 하십시오.

---

## Class 1 Laser Statement Label

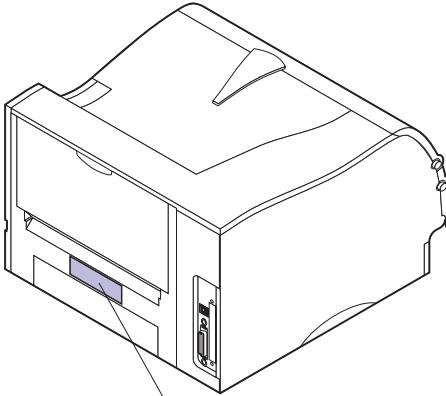

CLASS 1 LASER PRODUCT  
LASER KLASSE 1  
LOUKAN 1 LASERLAITE  
APPAREIL A LASER DE CLASSE 1  
TO IEC 825



---

## Laser Notice

The printer is certified in the U.S. to conform to the requirements of DHHS 21 CFR Subchapter J for Class I (1) laser products, and elsewhere is certified as a Class I laser product conforming to the requirements of IEC 825.

Class I laser products are not considered to be hazardous. The printer contains internally a Class IIIb (3b) laser that is nominally a 5 milliwatt gallium arsenide laser operating in the wavelength region of 770-795 nanometers. The laser system and printer are designed so there is never any human access to laser radiation above a Class I level during normal operation, user maintenance, or prescribed service condition.

---

## Laser

Der Drucker erfüllt gemäß amtlicher Bestätigung der USA die Anforderungen der Bestimmung DHHS (Department of Health and Human Services) 21 CFR Teil J für Laserprodukte der Klasse I (1). In anderen Ländern gilt der Drucker als Laserprodukt der Klasse I, der die Anforderungen der IEC (International Electrotechnical Commission) 825 gemäß amtlicher Bestätigung erfüllt.

Laserprodukte der Klasse I gelten als unschädlich. Im Inneren des Druckers befindet sich ein Laser der Klasse IIIb (3b), bei dem es sich um einen Galliumarsenlaser mit 5 Milliwatt handelt, der Wellen der Länge 770-795 Nanometer ausstrahlt. Das Lasersystem und der Drucker sind so konzipiert, daß im Normalbetrieb, bei der Wartung durch den Benutzer oder bei ordnungsgemäßer Wartung durch den Kundendienst Laserbestrahlung, die die Klasse I übersteigen würde, Menschen keinesfalls erreicht.

---

## Avis relatif à l'utilisation de laser

Pour les Etats-Unis : cette imprimante est certifiée conforme aux provisions DHHS 21 CFR alinéa J concernant les produits laser de Classe I (1). Pour les autres pays : cette imprimante répond aux normes IEC 825 relatives aux produits laser de Classe I.

Les produits laser de Classe I sont considérés comme des produits non dangereux. Cette imprimante est équipée d'un laser de Classe IIIb (3b) (arséniure de gallium d'une puissance nominale de 5 milliwatts) émettant sur des longueurs d'onde comprises entre 770 et 795 nanomètres. L'imprimante et son système laser sont conçus pour impossible, dans des conditions normales d'utilisation, d'entretien par l'utilisateur ou de révision, l'exposition à des rayonnements laser supérieurs à des rayonnements de Classe I .

---

## **Avvertenze sui prodotti laser**

Questa stampante è certificata negli Stati Uniti per essere conforme ai requisiti del DHHS 21 CFR Sottocapitolo J per i prodotti laser di classe 1 ed è certificata negli altri Paesi come prodotto laser di classe 1 conforme ai requisiti della norma CEI 825.

I prodotti laser di classe non sono considerati pericolosi. La stampante contiene al suo interno un laser di classe IIIb (3b) all'arseniuro di gallio della potenza di 5mW che opera sulla lunghezza d'onda compresa tra 770 e 795 nanometri. Il sistema laser e la stampante sono stati progettati in modo tale che le persone a contatto con la stampante, durante il normale funzionamento, le operazioni di servizio o quelle di assistenza tecnica, non ricevano radiazioni laser superiori al livello della classe 1.

---

## **Avisos sobre el láser**

Se certifica que, en los EE.UU., esta impresora cumple los requisitos para los productos láser de Clase I (1) establecidos en el subcapítulo J de la norma CFR 21 del DHHS (Departamento de Sanidad y Servicios) y, en los demás países, reúne todas las condiciones expuestas en la norma IEC 825 para productos láser de Clase I (1).

Los productos láser de Clase I no se consideran peligrosos. La impresora contiene en su interior un láser de Clase IIIb (3b) de arseniuro de galio de funcionamiento nominal a 5 milivatios en una longitud de onda de 770 a 795 nanómetros. El sistema láser y la impresora están diseñados de forma que ninguna persona pueda verse afectada por ningún tipo de radiación láser superior al nivel de

la Clase I durante su uso normal, el mantenimiento realizado por el usuario o cualquier otra situación de servicio técnico.

---

## Declaração sobre Laser

A impressora está certificada nos E.U.A. em conformidade com os requisitos da regulamentação DHHS 21 CFR Subcapítulo J para a Classe I (1) de produtos laser. Em outros locais, está certificada como um produto laser da Classe I, em conformidade com os requisitos da norma IEC 825.

Os produtos laser da Classe I não são considerados perigosos. Internamente, a impressora contém um produto laser da Classe IIIb (3b), designado laser de arseneto de potássio, de 5 milliwatts, operando numa faixa de comprimento de onda entre 770 e 795 nanómetros. O sistema e a impressora laser foram concebidos de forma a nunca existir qualquer possibilidade de acesso humano a radiação laser superior a um nível de Classe I durante a operação normal, a manutenção feita pelo utilizador ou condições de assistência prescritas.

---

## Laserinformatie

De printer voldoet aan de eisen die gesteld worden aan een laserprodukt van klasse I. Voor de Verenigde Staten zijn deze eisen vastgelegd in DHHS 21 CFR Subchapter J, voor andere landen in IEC 825.

Laserprodukten van klasse I worden niet als ongevaarlijk aangemerkt. De printer is voorzien van een laser van klasse IIIb (3b), dat wil zeggen een gallium arsenide-laser van 5 milliwatt met een golflengte van 770-795 nanometer. Het lasergedeelte en de printer zijn zo ontworpen dat bij normaal gebruik, bij onderhoud of reparatie conform de voorschriften, nooit blootstelling mogelijk is aan laserstraling boven een niveau zoals voorgeschreven is voor klasse 1.

---

## Lasermeddelelse

Printeren er godkendt som et Klasse I-laserprodukt, i overensstemmelse med kravene i IEC 825.

Klasse I-laserprodukter betragtes ikke som farlige. Printeren indeholder internt en Klasse IIIB (3b)-laser, der nominelt er en 5 milliwatt galliumarsenid laser, som arbejder på bølgelængdeområdet 770-795 nanometer. Lasersystemet og printeren er udformet således, at mennesker aldrig udsættes for en laserstråling over Klasse I-niveau ved normal drift, brugervedligeholdelse eller obligatoriske servicebetingelser.

---

## Huomautus laserlätteesta

Tämä kirjoitin on Yhdysvalloissa luokan I (1) laserlaitteiden DHHS 21 CFR Subchapter J -määrityksen mukainen ja muualla luokan I laserlaitteiden IEC 825 -määrityksen mukainen.

Luokan I laserlaitteiden ei katsota olevan vaarallisia käyttäjälle. Kirjoittimessa on sisäinen luokan IIIB (3b) 5 milliwatin galliumarsenidilaser, joka toimii aaltoalueella 770 - 795 nanometriä. Laserjärjestelmä ja kirjoitin on suunniteltu siten, että käyttäjä ei altistu luokan I määräyksiä voimakkaammalle säteilylle kirjoittimen normaalin toiminnan, käyttäjän tekemien huoltotoimien tai muiden huoltotoimien yhteydessä.

**VARO!** Avattaessa ja suojalukitus ohitettaessa olet alltiina näkymättömälle lasersäteilylle. Älä katso säteeseen.

**WARNING!** Osynlig laserstråling när denna del är öppnad och spårren är urkopplad. Betrakta ej strålen.

---

## Laser-notis

Denna skrivare är i USA certifierad att motsvara kraven i DHHS 21 CFR, underparagraf J för laserprodukter av Klass I (1). I andra länder uppfyller skrivaren kraven för laserprodukter av Klass I enligt kraven i IEC 825.

Laserprodukter i Klasse I anses ej hälsovådliga. Skrivaren har en inbyggd laser av Klasse IIIb (3b) som består av en laserenhet av gallium-arsenid på 5 milliwatt som arbetar i våglängdsområdet 770-795 nanometer. Lasersystemet och skrivaren är utformade så att det aldrig finns risk för att någon person utsätts för laserstrålning över Klasse I-nivå vid normal användning, underhåll som utförs av användaren eller annan föreskriven serviceåtgärd.

---

## Laser-melding

Skrivaren er godkjent i USA etter kravene i DHHS 21 CFR, underkapittel J, for klasse I (1) laserprodukter, og er i andre land godkjent som et Klasse I-laserprodukt i samsvar med kravene i IEC 825.

Klasse I-laserprodukter er ikke å betrakte som farlige. Skrivaren inneholder internt en klasse IIIb (3b)-laser, som består av en gallium-arsenlaserenhet som avgir stråling i bølglengdeområdet 770-795 nanometer. Lasersystemet og skrivaren er utformet slik at personer aldri utsettes for laserstråling ut over klasse I-nivå under vanlig bruk, vedlikehold som utføres av brukeren, eller foreskrevne serviceoperasjoner.

---

## Avís sobre el Làser

Segons ha estat certificat als Estats Units, aquesta impressora compleix els requisits de DHHS 21 CFR, apartat J, pels productes làser de classe I (1), i segons ha estat certificat en altres llocs, és un producte làser de classe I que compleix els requisits d'IEC 825.

Els productes làser de classe I no es consideren perillosos. Aquesta impressora conté un làser de classe IIIb (3b) d'arseniür de gal.li, nominalment de 5 mil.liwats, i funciona a la regió de longitud d'ona de 770-795 nanòmetres. El sistema làser i la impressora han sigut concebuts de manera que mai hi hagi exposició a la radiació làser per sobre d'un nivell de classe I durant una operació normal, durant les tasques de manteniment d'usuari ni durant els serveis que satisfacin les condicions prescrites.

---

## Japanese Laser Notice

レーザーに関するお知らせ

このプリンターは、米国ではDHHS 21 CFRサブチャプターJのクラスI (1)の基準を満たしたレーザー製品であることが証明されています。また米国以外ではIEC 825の基準を満たしたクラスIのレーザー製品であることが証明されています。

クラスIのレーザー製品には危険性はないと考えられています。このプリンターはクラスIII b (3 b)のレーザーを内蔵しています。このレーザーは、波長が770 ~ 795ナノメートルの範囲で、通常5ミリワットのガリウム砒化物を放射するレーザーです。このレーザーシステムとプリンターは、通常の操作、ユーザのメンテナンス、規定された修理においては、人体がクラスIのレベル以上のレーザー放射に晒されることのないよう設計されています。

---

## Chinese Laser Notice

注意：

本打印机被美国认证合乎 DHHS 21 CFR Subchapter I 对分类 I (1) 激光产品的标准，而在其他地区则被认证合乎 IEC 825 的标准。

分类 I 激光产品一般认为不具危险性，本打印机内部含有分类 IIIb (3b) 的激光，在操作过程中会产生 5 毫瓦含镓及砷的微量激光，其波长范围在 770-795 nm 之间。本激光系统及打印机的设计，在一般操作、使用者维护或规定内的维修情况下，不会使人体接触分类 I 以上等级的辐射。

---

## Korean Laser Notice

본프린터는 1등급 레이저 제품들에 대한 DHHS 21 CFR Subchapter 3의 규정을 준수하고 있음을 미국에서 인증받았으며, 그외의 나라에서도 IEC 825 규정을 준수하는 1등급 레이저 제품으로서 인증을 받았습니다.

1등급 레이저 제품들은 안전한 것으로 간주됩니다. 본 프린터는 5 밀리와트 갈륨 아르세나이드 레이저로서 770-795 나노미터의 파장대에서 활동하는 Class III (3b) 레이저를 내부에 갖고 있습니다. 본 레이저 시스템과 프린터는 정상 작동 중이나 유지 보수 중 또는 규정된 서비스 상태에서 상기의 Class I 수준의 레이저 방출에 사람이 절대 접근할 수 없도록 설계되어 있습니다.

---

## Safety Information

- This product is designed, tested and approved to meet strict global safety standards with the use of specific Lexmark components. The safety features of some parts may not always be obvious. Lexmark is not responsible for the use of other replacement parts.
- The maintenance information for this product has been prepared for use by a professional service person and is not intended to be used by others.
- There may be an increased risk of electric shock and personal injury during disassembly and servicing of this product. Professional service personnel should understand this and take necessary precautions.

---

## Consignes de Sécurité

- Ce produit a été conçu, testé et approuvé pour respecter les normes strictes de sécurité globale lors de l'utilisation de composants Lexmark spécifiques. Les caractéristiques de

sécurité de certains éléments ne sont pas toujours évidentes. Lexmark ne peut être tenu responsable de l'utilisation d'autres pièces de rechange.

- Les consignes d'entretien et de réparation de ce produit s'adressent uniquement à un personnel de maintenance qualifié.
- Le démontage et l'entretien de ce produit pouvant présenter certains risques électriques, le personnel d'entretien qualifié devra prendre toutes les précautions nécessaires.

---

## **Norme di sicurezza**

- Il prodotto è stato progettato, testato e approvato in conformità a severi standard di sicurezza e per l'utilizzo con componenti Lexmark specifici. Le caratteristiche di sicurezza di alcune parti non sempre sono di immediata comprensione. Lexmark non è responsabile per l'utilizzo di parti di ricambio di altri produttori.
- Le informazioni riguardanti la manutenzione di questo prodotto sono indirizzate soltanto al personale di assistenza autorizzato.
- Durante lo smontaggio e la manutenzione di questo prodotto, il rischio di subire scosse elettriche e danni alla persona è più elevato. Il personale di assistenza autorizzato, deve, quindi, adottare le precauzioni necessarie.

---

## **Sicherheitshinweise**

- Dieses Produkt und die zugehörigen Komponenten wurden entworfen und getestet, um beim Einsatz die weltweit gültigen Sicherheitsanforderungen zu erfüllen. Die sicherheitsrelevanten Funktionen der Bauteile und Optionen sind nicht immer offensichtlich. Sofern Teile eingesetzt werden, die nicht von Lexmark sind, wird von Lexmark keinerlei Verantwortung oder Haftung für dieses Produkt übernommen.
- Die Wartungsinformationen für dieses Produkt sind ausschließlich für die Verwendung durch einen Wartungsfachmann bestimmt.
- Während des Auseinandernehmens und der Wartung des Geräts besteht ein zusätzliches Risiko eines elektrischen Schlags und körperlicher Verletzung. Das zuständige



Fachpersonal sollte entsprechende Vorsichtsmaßnahmen treffen.

---

## **Pautas de Seguridad**

- Este producto se ha diseñado, verificado y aprobado para cumplir los más estrictos estándares de seguridad global usando los componentes específicos de Lexmark. Puede que las características de seguridad de algunas piezas no sean siempre evidentes. Lexmark no se hace responsable del uso de otras piezas de recambio.
- La información sobre el mantenimiento de este producto está dirigida exclusivamente al personal cualificado de mantenimiento.
- Existe mayor riesgo de descarga eléctrica y de daños personales durante el desmontaje y la reparación de la máquina. El personal cualificado debe ser consciente de este peligro y tomar las precauciones necesarias.

---

## **Informações de Segurança**

- Este produto foi concebido, testado e aprovado para satisfazer os padrões globais de segurança na utilização de componentes específicos da Lexmark. As funções de segurança de alguns dos componentes podem não ser sempre óbvias. A Lexmark não é responsável pela utilização de outros componentes de substituição.
- As informações de segurança relativas a este produto destinam-se a profissionais destes serviços e não devem ser utilizadas por outras pessoas.
- Risco de choques eléctricos e ferimentos graves durante a desmontagem e manutenção deste produto. Os profissionais destes serviços devem estar avisados deste facto e tomar os cuidados necessários.

---

## Informació de Seguretat

- Aquest producte està dissenyat, comprovat i aprovat per tal d'acomplir les estrictes normes de seguretat globals amb la utililització de components específics de Lexmark. Les característiques de seguretat d'algunes peces pot ser que no sempre siguin òbvies. Lexmark no es responsabilitza de l'us d'altres peces de recanvi.
- La informació pel manteniment d'aquest producte està orientada exclusivament a professionals i no està destinada a ningú que no ho sigui.
- El risc de xoc elèctric i de danys personals pot augmentar durant el procés de desmuntatge i de servei d'aquest producte. El personal professional ha d'estar-ne assabentat i prendre les mesures convenients.

---

## Chinese Safety Information

### 安全资讯

- 本产品使用特有的 Lexmark 元件，并依照严格的世界安全标准来设计、测试及验证。有些零件的安全功能可能不明显。对于其他厂牌更换零件的使用，Lexmark 概不负责。
- 本产品的维护资讯仅供专业服务人员使用，而非针对一般使用者。
- 本产品在拆卸、维修的时候，遭受电击或人员受伤的危险性会增高，专业服务人员对这点必须有所了解，并采取必要的预防措施。

---

## Korean Safety Information

### 안전 사항

- 본 제품은 특정 Lexmark 구성 요소의 사용에 있어 엄격한 세계 안전 표준에 맞도록 설계, 테스트되었으며 승인받았습니다. 일부 부품의 안전성은 항상 보장되지 않습니다. Lexmark는 다른 교체 부품의 사용에 대한 책임을 지지 않습니다.
- 본 제품에 관한 유지 보수 설명서는 전문 서비스 기술자용으로 작성된 것이므로 비 전문가가 사용할 수 없습니다.
- 본 제품을 해체하거나 정비할 경우 전기적인 충격을 받거나 상처를 입을 위험이 커집니다. 전문 서비스 기술자는 이 사실을 숙지하고 필요한 예방 조치를 취하도록 하십시오.

**4045-XXX**

---

# 1. General Information

The Lexmark Optra™ M410 and M412 laser printers are letter-quality laser page printers designed to attach to an IBM compatible Personal Computer and to most computer networks.

The M410 printer is capable of printing at speeds of 12 pages per minute. The M412 is capable of printing at speeds of 17 pages per minute. Both models print with a true 600 x 600 dpi resolution or 1200 x 1200 dpi Image Quality resolution. Each model of the base printer comes with 4MB of memory and is expandable to 132MB using both SDRAM DIMM slots. User flash memory is also available up to 16MB.

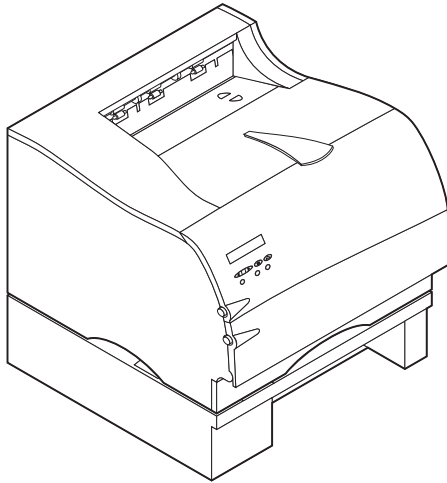

---

## Options

The following options are available. Some options are not available in every country. Contact your point of purchase for options available in your country.

500-Sheet Drawer

SDRAM Memory DIMMs: 4MB, 8MB, 16MB, 32MB and 64MB

Flash Memory DIMMs: 2MB, 4MB, 8MB and 16MB

Internal Network Options

Token Ring

Ethernet 10/100BaseTX

10Base2/T

Tri-Port Card

Hard Disk - 2.1GB

Coax/Twinax Adapter for SCS

External Network Adapter: Marknet Pro 1 and 3 series compatible

---

## Printer Specifications

Acoustics	Operating: <50 dBA Idle: <30 dBA Sleep: background noise
Sensors	Paper Present Sensing (MPF) Tray 1 inserted (only when Tray 2 option is installed) Input/Exit sensors Rear Exit sensor
Environment	Ozone free Blue Angel Energy Star
Warm-up	less than 70 seconds (from power on to Ready)
First page time	Tray 1: Less than 12 seconds from standby Tray 2: Less than 13 seconds from standby MPF: Less than 12 seconds from standby
Dimensions	Width - 405 mm (15.9") Height - 314 mm (12.4") Depth - 435 mm (17.1") Height of Tray 2 - 130 mm (5.1") Footprint - 246 square inches
Weight	14.8 Kg (32.6 lbs.) with supplies installed

---

## Maintenance Approach

The diagnostic information in this manual leads you to the correct field replaceable unit (FRU) or part. Use the service error codes, user status messages, user error messages, service checks, and diagnostic aids to determine the printer problem and repair the failure. After you complete the repair, perform tests as needed to verify the repair.

---

## Tools Required For Service

- Flat-blade screwdriver
- #1 Phillips screwdriver
- #2 Phillips screwdriver
- Needlenose pliers
- Diagonal pliers
- Spring hook
- Analog or digital multimeter
- Parallel wrap plug 1319128
- Serial wrap plug 1329048
- Twinax/serial debug cable 1381963
- Coax/serial debug cable 1381964



---

## Acronyms

CSU	Customer Setup
DIMM	Dual In-Line Memory Module
DRAM	Dynamic Random Access Memory
EDO	Enhanced Data Out
EP	Electrophotographic Process
EPROM	Erasable, Programmable Read-Only Memory
ESD	Electrostatic Discharge
FRU	Field Replaceable Unit
GB	Gigabyte
HVPS	High Voltage Power Supply
LASER	Light Amplification by Stimulated Emission of Radiation
LCD	Liquid Crystal Display
LED	Light-Emitting Diode
LVPS	Low Voltage Power Supply
MROM	Masked Read Only Memory
NVRAM	Nonvolatile Random Access Memory
OEM	Original Equipment Manufacturer
PC	Photoconductor
POR	Power-On Reset
POST	Power-On Self Test
RIP	Raster Imaging Processor
ROM	Read Only Memory
SIMM	Single In-Line Memory Module
SRAM	Static Random Access Memory
UPR	Used Parts Return
V ac	Volts alternating current
V dc	Volts direct current

**4045-XXX**

---

## 2. Diagnostic Information

---

### Start

**CAUTION:** Remove power from the printer before you connect or disconnect any cable or electronic board or assembly for personal safety and to prevent damage to the printer. Use the handholds on the side of the printer. Make sure your fingers are not under the printer when you lift or set the printer down.

Use the service error code, user status message, user error message, symptom table, service checks, and diagnostic aids in this chapter to determine the corrective action necessary to repair a malfunctioning printer.

Service error codes are indicated by a three-digit error code. If a service error code is displayed, go to the [“Service Error Codes” on page 2-2](#).

User status messages provide the user with information on the current status of the printer. Ready is displayed on the first line of the display unless Power Saver is invoked, and then Power Saver is displayed. If a user status message is displayed, go to the [“User Status Messages” on page 2-5](#).

User error messages are indicated by a two or three-digit error code that provides the user with information that explains a problem with a print cartridge, paper jam, option, port, and so on. If a user error message is displayed, go to the [“User Error Messages” on page 2-9](#).

If your machine completes the without an error, and you have a symptom, go to the [“Symptom Tables” on page 2-15](#). Locate your symptom and take the appropriate action.

If a service error code appears while you are working on the machine, go to the [“Service Error Codes” on page 2-2](#) and take the indicated action for that error.

## Service Error Codes

Service Error Codes are generally non-recoverable except in an intermittent condition when you can POR the printer to temporarily recover from the error condition.

Error Code	Action
900 RIP Software	Replace the controller board.
902 Engine Software	Indicates an unrecoverable engine software error. Replace the engine board.
920 Fuser Error	Indicates that the fuser is below temperature when printing. Go to the <a href="#">“Cold Fuser Service Check” on page 2-23.</a>
921 Fuser Error	Indicates that the fuser is below standby temperature when the printer is idle. Go to the <a href="#">“Cold Fuser Service Check” on page 2-23.</a>
922 Fuser Error	Fuser failed to reach standby temperature. Go to the <a href="#">“Cold Fuser Service Check” on page 2-23.</a>
923 Fuser Error	Fuser is too hot during printing or when printer is idle. Go to the <a href="#">“Hot Fuser Service Check” on page 2-25.</a>
924 Fuser Error	An open circuit has been detected in the Fuser Thermistor Circuit. Go to the <a href="#">“Hot Fuser Service Check” on page 2-25.</a>
931-935 Printhead Error	These errors represent a problem with the printhead. Go to the <a href="#">“Printhead Service Check” on page 2-36.</a>
931 - Printhead: no first Hsync	
932 - Printhead: Lost Hsyncs	
935 - Mirror Motor unable to reach operating speed.	
936 Transport Motor	Indicates a problem with the main drive motor. Go to the <a href="#">“Main Drive Service Check” on page 2-29.</a>

## 4045-XXX

Error Code	Action
939 Controller - Engine Communications Error	<p>The controller board and the engine board cannot communicate with one another. The controller board, engine board or interconnect board is defective. Check each board for correct installation and secure ground. If no problem is found, replace the FRUs in the following order:</p> <p>controller board</p> <p>engine board</p> <p>interconnect board</p> <p><b>Note:</b> The controller software also can cause a 939 error code. Contact your next level for software support.</p>
941 Controller Code CRC	Replace the controller board.
941 Controller Font CRC	Replace the controller board.
943 Controller Font Version	Indicates that the controller code and FONT ROM are incompatible.
944 Controller Board Failure	Replace the controller board.
945 Controller Board Failure - ASIC Failure	Replace the controller board.
946 Controller Board Failure - SRAM Failure	Replace the controller board.
947 Engine Board	Replace the engine board.
953 NVRAM Failure	Indicates the NVRAM chip on the engine board has failed. Replace the engine board.
954 NVRAM Failure	Indicates the NVRAM experienced a CRC failure. Replace the engine board.
960 RAM Memory Error	Indicates a DRAM Memory Error on the controller board. Replace the controller board.

## 4045-XXX

Error Code	Action
961 RAM in Slot 1 is Bad.	Replace the SIMM in Slot 1. If this does not fix the problem, replace the controller board.
962 RAM in Slot 2 is Bad.	Replace the SIMM in Slot 2. If this does not fix the problem, replace the controller board.
964 Emulation Error	Indicates a failure within the Download Emulation which is programmed into the code overlay SIMM. The specific error is as follows: 964 - Download Emulation CRC Failure. Checksum Failure. 965 - Download Emulation Outdated, The Download Emulation and the controller code are incompatible. Go to <a href="#">"Download Emulation" on page 3-3.</a>
965 Emulation Error	
975 - 979 Network Card	The following errors indicate a failure with the network card. 975 - Unrecognizable Network Card. Replace Network Card. 976 - Unrecoverable software error in Network Card. 978 - Bad checksum while programming Network Card. Replace Network Card. 979 - Flash parts failed while programming Network Card.

**User Status Messages**

<b>User Status Message</b>	<b>Status</b>	<b>Action</b>
Ready or Power Saver	The printer is ready to receive and process data.	Press Menu> or <Menu to take the printer out of Ready and enter all the Menus except the TESTS MENU (Busy State).
Ready/Hex	The printer is ready and HEX Trace is active, which is known as HEX Trace Ready.	Press Menu> or <Menu to take the printer out of Ready and enter the TESTS MENU (Busy State). Press Select for the values. Press Menu> until Reset Printer is on the second line of the display. Press Select to Reset the printer.
Busy	The printer is busy receiving or processing data, or printing data.  <b>Note:</b> The printer indicator light blinks while the printer is processing data.	Press Stop to take the printer out of Busy. The Not Ready message is displayed. No more data is processed, but the printer processes all paper currently in the printer paper path. Press Go to return to Ready.
Flushing Buffer	The printer is flushing corrupted print data and the current print job is being discarded.	No button actions are possible while this message is displayed.

<b>User Status Message</b>	<b>Status</b>	<b>Action</b>
Printing Menu Settings	The printer is processing or printing a list of current settings menus because Print Menu Settings is selected from the menu.	Press Stop to take the printer out of Ready. The Not Ready message is displayed. No more data is processed, but the printer processes all paper currently in the printer paper path. Press Go to return to Ready after the page prints. Press Menu> or <Menu to take the printer out of Ready and enter the TESTS MENU (Busy State). Press Select for the values. Press Menu> until Reset Printer is on the second line of the display. Press Select to reset the printer.
Printing Directory List	A directory of the flash and disk contents is processing or printing because Print Directory is selected from the menu.	Press Stop to take the printer out of Ready. The Not Ready message is displayed. No more data is processed, but the printer processes all paper currently in the paper path. Press Go to return to Ready after the page prints. Press Menu> or <Menu to take the printer out of Ready and enter the TESTS MENU (Busy Stat). Press Select for the values. Press Menu> until Reset Printer is on the second line of the display. Press Select to reset the printer.



## 4045-XXX

User Status Message	Status	Action
Restoring Factory Defaults	The printer is restoring factory defaults.	No button actions are possible while this message is displayed.
Performing Self Tests	The printer is running the normal series of start-up tests after it is powered On. When the tests are complete, the printer returns to Ready.	No button actions are possible while this message is displayed.
Not Ready (Press Go)	The printer is in the Not Ready state, which means it is not ready to receive or process data. This message displays when Menu> or <Menu is pressed during a print job.	Press Go to take the printer out of the Not Ready state. Press Menu> or <Menu to take the printer out of Ready and enter the TESTS MENU (Busy state). Press Menu> until Reset Printer is on the second line of the display. Press Select to reset the printer.
Resetting Printer	The printer is deleting any print jobs in process and restoring all settings to user defaults.	No button actions are possible while this message is displayed.
Formatting Flash (Do Not Power Off)	The flash memory is being formatted.	No button actions are possible while this message is displayed.
Program Flash (Do Not Power Off)	The flash memory is being programmed, which means fonts or macros are being written to flash memory.	Do not perform any button actions while this message is displayed.
Formatting Disk	The disk is being formatted.	No button actions are possible while this message is displayed.

User Status Message	Status	Action
Programming Disk (Do Not Power Off)	The disk is being programmed, which means fonts or macros are being written to disk.	No button actions are possible while this message is displayed.  <b>Note:</b> If information is written to flash memory and to disk at the same time, the Program Flash message is displayed.
Menus Disabled	The printer menus have been disabled. This occurs when Menu> or <Menu is pressed while the printer is Ready and Menu Lockout is active. The printer display shows this message for one second and then returns to the Ready message.	No button actions are possible while this message is displayed.
Activating Menu Changes	The printer is reset to activate a printer setting changed in the menus.	No button actions are possible while this message is displayed.

## User Error Messages

User Error Message	Explanation
200 Paper Jam Remove Cartridge	Paper is jammed at the printer Input Sensor. Open the printer's upper front door and remove the print cartridge to access the paper jam area.
201 Paper Jam Remove Cartridge	Paper is jammed between the printer's input and exit sensors. Open the printer's upper front door and remove the print cartridge to access the jam area.
202 Paper Jam Open Rear Door	Paper is jammed at the printer exit sensor. Open the printer rear door to access the jam area.
203 Paper Jam Short Paper	Paper stops behind the rear door when feeding to the top output bin. Paper or envelopes that are shorter than 6.2 inches (157.5 mm) in length must exit through the rear exit.
250 Paper Jam Check MP Feeder	Paper is jammed in the multipurpose feeder.
Insert Cartridge or Close Door	This message displays when the printer's front door is open or the print cartridge is missing. If this message cannot be cleared go to <a href="#">"Cover Open Switch/Cable Service Check"</a> on page 2-19.
34 Short Paper	The printer determines the paper length is too short to print the formatted data. This occurs when the printer does not know the actual paper size loaded in the tray. For auto-size sensing trays, this error occurs if the paper stop is in the incorrect position. Make sure the Paper Size setting is correct for the size paper that is being used.
35 Res Save Off Deficient Memory	This message displays when the printer has insufficient memory to enable Resource Save. Modification of user settings that use memory can cause this error.
37 Insufficient Collation Memory	This message is displayed when the printer memory used to store pages is too full to collate the print job.
38 Memory Full	This message is displayed when the printer memory used to store pages is full.

User Error Message	Explanation
39 Complex Page	This message is displayed when the page is too complex to print.
51 Defective Flash	This message is displayed when the printer detects a defective flash. This error may occur at power on, or during flash format and write operations. Press Go to clear the message. The flash is marked as bad and normal operation continues. Flash operations are not allowed until the problem is resolved.
52 Flash Full	This message is displayed when there is not enough free space in the flash memory to hold the resources that have been requested to be written to flash.
53 Unformatted Flash	This message is displayed when the printer detects an unformatted flash at power on. Press Go to clear the message. The flash is marked as bad and normal operation continues. Flash operations are not allowed until the flash is formatted.
54 Network Software Error	This error is displayed when the connection to the network port is lost during power on. Press Go to clear the message. The printer clears the setting, but no communication can exist with the network until the network software is reloaded.
56 Parallel Port Disabled	This error is displayed when data is sent to the printer across the parallel port, but the parallel port has been disabled. Once this message is displayed, reporting of further errors is suppressed until the menus are entered, or the printer is reset.
61 Defective Disk	This error code is displayed when the printer detects a defective disk. This error may occur at power on or during disk format and write operations. The following actions may be taken while this message is displayed: Press Go to clear the message. The disk is marked defective and normal printer operations continue. Disk operations are not allowed with a defective disk. The Format Disk menu is not shown.

User Error Message	Explanation
62 Disk Full	This error code is displayed when there is not enough free space on the disk to hold the resources that have been requested to be written to the disk. This message displays for both resource and PostScript Disk operators when the disk is full.
63 Unformatted Disk	This error code displays when the printer detects an unformatted disk at power on. Press Go to clear the message. The disk is marked as bad and normal operation continues. Disk operations are not allowed until the disk is formatted.

### User Line 2 Messages

If none of the conditions exist that are listed in the following table, line 2 is blank. If any of the messages in the table are displayed the following actions can be taken:

Press Menu> or <Menu to take the printer offline and access the Ready Menu group.

**Note:** The Menu buttons are not active if Menu Lockout is turned on.

Press Stop to take the printer offline. The Not Ready message is displayed. No more data is processed from the host computer. Press the Go button to return the printer to the Ready state.

User Message	Explanation
Tray 1 Missing	This message displays when tray 1 is missing and tray 2 is installed.

## User Line 2 Link Messages

If the printer is locked on a particular link, the link indication displays. If the printer is ready to process any link, no messages display. The link messages are listed in the following table.

User Message	Explanation
Check Configuration ID	The printer configuration ID is not set or is invalid. This condition can only be cleared when a valid configuration ID is set. Go to <a href="#">“Setting Configuration ID”</a> on page 3-15.
Parallel	This is the host interface from which the printer is currently drawing data.
Serial	
Network	
LocalTalk	
Infrared	
USB	
Fax	

## Check Device Connection Messages

The messages in the following table display when the printer loses communications with one of the following devices.

<b>User Status Message</b>	<b>Explanation</b>
Check Tray 2 Connection	<p>This message can occur in two ways. The specified device could have been removed from the printer, for instance to clear a paper jam. Otherwise, the device can still be attached to the printer, but is experiencing a communications problem, not fully connected, or having a hardware failure.</p> <p>If the device is temporarily removed or not connected properly, then reattach it. When the option is recognized, the printer automatically clears the error and continues.</p> <p>If the option is experiencing a hardware problem, turn the printer off and back on. If the error occurs again, turn the printer off, remove the option and call for service.</p>

## ***Power-On Self Test (POST)***

When you turn the printer On, it performs a Power-On Self Test. Check for correct POST functioning of the base printer by observing the following:

1. The LED comes on.
2. The operator panel displays one row of pels, and then clears.
3. The operator panel displays one and a half rows of diamonds, and then clears.
4. "Performing Self Test" appears on the display.
5. "Ready" appears on the display.
6. The fuser lamp turns on. The fuser takes longer to warm up from a cold start than a warm start.
7. The cooling fan turns on and runs full speed.
8. The main drive motor turns on.
9. The developer drive assembly drives the developer shaft in the toner cartridge.
10. The exit rollers turn.
11. The printhead mirror motor turns on.
12. The cooling fan turns on and runs slowly.
13. The main drive motor turns off.
14. The exit rollers stop turning.
15. The printhead mirror motor turns off.
16. The LED stays on solid and the operator panel displays "Ready".



## Symptom Tables

Symptom	Action
Dead Machine	Go to the <a href="#">“Dead Machine Service Check”</a> on page 2-20.
Operator Panel - One or more buttons do not work.	Go to the <a href="#">“Operator Panel Buttons Service Check”</a> on page 2-30.
Operator Panel - Display is blank. Printer sounds 5 beeps.	Go to the <a href="#">“Operator Panel Service Check”</a> on page 2-30.
Operator Panel - Display is blank. Printer does not emit 5 beeps.	Replace the operator panel assembly.
Operator Panel continuously displays all diamonds, sounds five beeps and does not complete POST.	Go to the <a href="#">“Operator Panel Service Check”</a> on page 2-30.
Paper feed problems - Base printer or Integrated 250 Paper Tray	Go to the <a href="#">“Paper Feed Service Check”</a> on page 2-33.
Paper jams at exit of Redrive Assembly.	Go to the <a href="#">“Paper Feed Service Check”</a> on page 2-33.
Print quality - Black page	Go to <a href="#">“Print Quality - All Black Page”</a> on page 2-38.
Print quality - Blank page	Go to <a href="#">“Print Quality - Blank Page”</a> on page 2-38.
Print quality - Light print	Go to <a href="#">“Print Quality - Light Print”</a> on page 2-46.
Print quality - Background	Go to <a href="#">“Print Quality - Background”</a> on page 2-42.
Print quality - Residual image	Go to <a href="#">“Print Quality - Residual Image”</a> on page 2-45.
Print quality - Skew	Go to the <a href="#">“Paper Feed Service Check”</a> on page 2-33.
Print quality - Banding	Go to <a href="#">“Print Quality - Banding”</a> on page 2-44.
Print quality - Random marks	Go to <a href="#">“Print Quality - Random Marks”</a> on page 2-39.

**4045-XXX**

<b>Symptom</b>	<b>Action</b>
Print quality - Toner on backside of printed page.	Go to <a href="#">“Print Quality - Toner on backside of printed page”</a> on page 2-47.
Print quality - Vertical black bands on edge of copy.	Go to <a href="#">“Print Quality - Black bands on outer edges of the page”</a> on page 2-44.
Paper feed problem with 500 sheet paper tray option.	Go to <a href="#">“Input Tray(s) Option Service Check”</a> on page 2-26.

---

## Service Checks

**Note:** Anytime the engine board is replaced, the Configuration ID must be reset in NVRAM on the new engine board.

Review the following information before performing any service checks.

- Paper feed Problems (especially paper jams): Go to [“Viewing the Error Log” on page 3-17](#) and check the printer error log for indications of repetitive entries that help to isolate a problem to a particular area of the printer or option.
- Paper feed Problems with error message: Use the [“User Error Messages” on page 2-9](#) to help diagnose the problem.
- Print Quality Problems: Go to [“Print Quality Test Pages” on page 3-2](#) and print a test page to help diagnose problems before changing any settings or working on the printer.
- Use the resident diagnostics test provided to help isolate a problem before taking the machine apart or removing any options.

### ***Charge Roll Service Check***

Service Tip: Close and evenly spaced repetitive marks 47.5 mm apart or spots on the page can be caused by a damaged or contaminated charge roll.

	<b>FRU</b>	<b>Action</b>
1	Charge Roll Assembly	Check the charge roll for correct installation, toner buildup, marks, cuts or other signs of contamination or damage. Replace as necessary.
2	Left Side Charge Roll Arm and Bushing	Check the left side charge roll arm and bushing for correct assembly operation. Check for damage to the arm or bearing assembly.

	FRU	Action
3	Right Side Charge Roll Arm and Bushing	<p>Check the right side charge roll arm and bushing for correct assembly operation. Check the right charge roll bushing for signs of wear or contamination. Excessive contamination could cause intermittent charging of the charge roll. If incorrect, replace the bushing. Check for continuity from the bushing to the charge roll high voltage contact on the right side frame. If incorrect, replace the right charge roller arm.</p> <p><b>Note:</b> The screw that attaches the charge roll lead to the contact must be secure.</p>

**Cover Open Switch/Cable Service Check**

	<b>FRU</b>	<b>Action</b>
1	Toner Cartridge	Check the toner cartridge to make sure it is correctly installed and that the right and left cartridge tracks are not loose or broken. Check to make sure the cover open switch activation tab on the toner cartridge is not broken and that the tab correctly activates the cover open switch spring.
2	Cover Open Switch/Cable Assembly	<p>Check the cover open switch for proper mechanical operation. If incorrect, repair as necessary. Disconnect the cover open switch cable from J4 at the engine board and measure the voltage at J4-6. It measures approximately +5 V dc. If the voltage is incorrect, replace the engine board. If the voltage is correct, check for ground at J4-8. If incorrect, replace the engine board. If the ground is correct, check the continuity between J4-6 and J4-7 on the cable. If no change in continuity occurs as the switch is activated, replace the cover open switch/cable assembly. If the continuity changes as the switch is activated, replace the engine board.</p> <p><b>Note:</b> It is easier to check the voltages on J4 with the controller board removed.</p>

## Dead Machine Service Check

**Note:** Remove any paper handling options before servicing the printer for a dead machine condition. Observe all necessary ESD precautions when removing and handling the controller board, engine board or any of the installed option cards or assemblies.

**Service Tip:** The LVPS uses a self-docking connector that mates with another connector mounted on the left side frame assembly. Some force may be required to pull the LVPS loose from the connector.

	FRU	Action
1	Line Voltage	Check the AC line voltage. If the line voltage is incorrect, inform the customer.
2	AC Line Cord	Check the line cord for any signs of damage. If correct, check the continuity of the line cord and replace if necessary.
3	+24 V dc at Tray 2 Connector	Check for +24 V dc at pin 7 of the tray 2 connector located under the printer. If +24 V dc is present at the connector, go to step 9. If +24 V dc is not present, go to step 4.
4	Controller Board	Remove the controller board. Turn on the printer. If the printer powers on in the Hardware Test Mode, replace the controller board. If the printer does not power on, go to step 5.
5	Engine Board Test Points	Check for +5 V dc at the TP5 test point and +24 V dc at the TP6 test point on the engine board. If correct, replace the engine board. If incorrect, go to step 6.
6	LVPS Fuse F1	Remove the LVPS from the printer and check fuse F1. Replace the fuse if the fuse is blown.

	FRU	Action
7	LVPS Fuse F1 - Continues to blow after LVPS installed in the printer.	<p>Replace fuse F1 if necessary. Turn the LVPS on/off switch Off and connect the AC line cord and turn the LVPS On.</p> <p><b>CAUTION:</b> Before checking fuse F1 turn the LVPS Off and disconnect the AC line cord. Check fuse F1. If the fuse is blown, replace the LVPS.</p>
8	LVPS	<p>Remove the LVPS from the machine.</p> <p><b>CAUTION:</b> Before making any measurements on the LVPS output connector, observe all necessary safety precautions before applying AC power. Measure the voltages on LVPS output connector CN1. If any voltages are incorrect, replace the LVPS.</p>
9	Engine Board	<p>Turn the printer off and disconnect all the cables from the engine board. Check for +5 V dc at TP5 test point and +24 V dc at test point TP6 on the engine board. If incorrect, replace the FRUs in the following order:</p> <p>engine board</p> <p>interconnect board</p> <p>If correct, turn the printer off and reconnect one cable at a time until you find the defective assembly.</p> <p>Service Tip: A short or low resistance load that is attached to the engine board can cause the LVPS to overcurrent and shut the +5 V dc supply down to 0 V dc.</p>

## Erase Lamp Service Check

Error code 928 may be displayed when the printer detects that the erase lamp assembly, cable or engine board is defective.

**Note:** If the erase lamp assembly is defective, both the erase lamp and lens are replaced as a kit.

Make the following checks when a 928 service error displays.

	FRU	Action
1	Cable, Front Harness	Check the connection of the front harness to connector J10 on the engine board for correct installation. If incorrect, repair as necessary. Check the front harness to erase lamp assembly for correct installation. If incorrect, repair as necessary.
2	Engine Board	Remove the controller board and toner cartridge from the machine. Perform the Erase Lamp Test in the Hardware Test Mode. The erase lamps turn on. The lamps can be observed through the front of the machine with the cover open and print cartridge removed. If the lamps do not turn on, measure the voltage on J12-1. The voltage reads approximately +24 V dc. If incorrect, replace the engine board. If correct, check the voltage at J12-2. The voltage reads between 0.6 V dc to 0.8 V dc. If incorrect, check the continuity of the erase lamp cable. If incorrect, replace the cable. If correct, replace the erase lamp assembly.



## ***Fan Service Check***

Check the cable connections at J13 on the engine board and at the main fan assembly. The main fan runs continuously when the printer is powered on unless the printer is in the Power Saver mode.

	<b>FRU</b>	<b>Action</b>
1	Fan	Manually spin the fan and check that it rotates freely. Check the cable connection to the engine board, J13 for correct installation.
2	Engine Board	Check the continuity of the cable. If incorrect, replace the cable. Perform the Cooling Fan Test in the Hardware Test Mode. Turn the cooling fan on to slow or fast. Disconnect the fan connector at J13 and measure the voltage. The voltage measures +24 V dc. If correct, replace the fan. If incorrect, replace the engine board.

## ***Fuser Service Check***

### **Cold Fuser Service Check**

Error codes 920, 921, and 922 may display for a cold fuser failure. A 920 error caused by low line voltage can sometimes be cleared by turning the machine off and then on again.

Service Tip: Set the Fuser Temperature to NORMAL before starting this service check.

	FRU	Action
1	Fuser Lamp	Remove the controller board and run the Cooling Fan Test in the Hardware Test Mode. Observe the lamp through the left side frame. If the lamp doesn't come on, unplug the printer and check the continuity between the two pins on the fuser lamp cable going to the fuser assembly. If you do not measure continuity, remove the fuser assembly and check the continuity of the lamp. If incorrect, replace the lamp. If correct, replace the contact in the fuser cover.
2	LVPS	Turn the printer off. Disconnect the fuser lamp connectors at the fuser assembly. Turn the printer on and check across the cable for line voltage. If incorrect, remove the LVPS and check both F1 and F2 fuses. Remove the LVPS from the printer. Replace any open fuses and attach the power cord. If the fuses open, replace the LVPS. If the fuses open after the lamp cables are connected to the fuser, the fuser lamp circuit is shorted. Inspect the fuser lamp contacts in the fuser cover. Replace the contacts as necessary.
3	Thermistor	Disconnect the thermistor cable from the engine board. The resistance is as follows:  HOT - 1K ohms  COLD = 150K ohms to 475K ohms

## 4045-XXX

### Hot Fuser Service Check

Error codes 923 and 924 may display for a hot fuser failure.

**CAUTION:** The fuser may be hot, use caution before removing or servicing.

	<b>FRU</b>	<b>Action</b>
1	Fuser Thermistor	Check for damage to the thermistor assembly. Check the resistance of the thermistor:  HOT - 1K ohms  COLD =150K ohms to 475K ohms  With the cable connected, check the continuity from J8-6 and J8-7 to ground. If there is continuity, replace the fuser thermistor.
2	Engine Board	Error code 924 indicates the engine board detects an open circuit in the thermistor circuit for the fuser assembly. The voltage on J8-6 on the engine board measures approximately +5 V dc. If incorrect, replace the engine board.
3	Fuser Hot Roll Backup Roll Bearings	Examine the fuser assembly for signs of overheating or damage. Check the hot roll and backup roll for signs of excessive toner, label glue, labels or other contaminants. If any are found, repair as necessary or replace the fuser assembly.

### ***Input Sensor Service Check***

Service Tip: Run the Base Sensor Test. Check the input sensor for proper operation. The display changes from open to closed as the sensor flag is manually moved in and out of the sensor.

## 4045-XXX

Service Tip: Run the Sensor Monitor Test in the Hardware Test Mode with the controller board removed.

	FRU	Action
1	Input Sensor Flag	Check the input sensor flag for damage and proper operation. If a problem is found, repair as necessary.
2	Engine Board	Check for approximately +5 V dc at J2-3 on the engine board. If incorrect, replace the engine board.
3	Input Sensor Cable	Check the continuity of the input sensor cable. If incorrect, replace the cable. If correct, replace the input sensor assembly.

### ***Input Tray(s) Option Service Check***

#### **500-Sheet Input Tray Option**

Service Tip: Try all the other input paper sources to make sure they are properly feeding paper. Run the Tray 2 Motor Test in the Hardware Test Mode to verify motor and related paper feed components are working properly. With the motor on, actuate the tray 2 solenoid from the Solenoid Test to feed paper.

**Printer does not recognize Tray 2 is installed**

	FRU	Action
1	Tray 2 Interconnect Cable	Make sure the printer is positioned correctly on top of tray 2. The tray 2 interconnect cable contacts must engage the tray 2 cable on the base printer. Replace the cable if the contacts are defective.

**Printer displays message “Insert Tray 1” when trying to print from Tray 2**

	FRU	Action
1	Tray 1 Inserted Sensor	Check the tray 2 option for correct installation with the base printer. Run the Sensor Test in the Hardware Test Mode to verify the printer detects the tray 1 present sensor. If the sensor is not detected, check the sensor for correct installation and connection at the tray 2 board. If the installation is correct, replace the sensor.

**200 Paper Jam message displays, paper is jammed before the input sensor OR Tray 2 Empty message displays when tray 2 has paper in the tray.**

	FRU	Action
1	Paper Path/Guides/Tray 2	Check the paper path for any foreign objects. Make sure tray 2 is fully installed and the lift plate raises when the tray is inserted.
2	Pick Roll	Check the pick roll for signs of wear and correct installation. Replace as necessary.
3	Solenoid	Check the solenoid for correct operation. Use the Solenoid Test to check for correct operation. Replace as necessary.

**4045-XXX**

	<b>FRU</b>	<b>Action</b>
4	Tray 2 Motor	Use the Tray 2 Motor Test to check the tray 2 motor. Replace as necessary.

## Main Drive Service Check

Service Tip: Excessive gear or main drive assembly noise is usually caused by a defective motor assembly or engine board.

Service Tip: If there are equally spaced horizontal lines across the page, go to [“Print Quality - Evenly spaced horizontal lines or marks” on page 2-41](#).

**WARNING:** Whenever the gearbox assembly is removed from the machine it must be handled very carefully. Do not allow any of the gears to come in contact with any metal or other hard surface to avoid gear damage. It is also very important not to let any dirt, paper, staples or other material come intact with the grease in the gearbox assembly.

	FRU	Action
1	Main Drive Assembly (Excessive noise or vibration)	Remove the controller board and run the Main Motor Test in the Hardware Test Mode. If the noise goes away with the toner cartridge removed, inform the customer to replace the toner cartridge. Determine if the noise is in the main drive assembly, fuser, developer drive assembly or alignment assembly. Look for any loose, worn or binding parts in all assemblies. Repair as necessary.  If a service error code 936 - Transport Motor message displays, check the voltage at J3-6 and J3-8 on the engine board. The voltages measure approximately +5 V dc when the motor is not running and go to 0 V dc when the motor is running. If incorrect, replace the engine board.
2	Main Drive Motor Cable	Check the continuity of the main drive motor cable. If incorrect, replace the cable.

	FRU	Action
3	Motor does not turn, no gear error code 936 or User message 201 Paper Jam displays.	<p>Check the voltages at J3 on the engine board with the main motor cable connected.</p> <p>J3-1 - +24 V dc                      J3-2 - +24 V dc                      J3-3 - Ground                      J3-4 - Ground                      J3-5 - +2.5 V dc                      J3-7 - +5 V dc                      J3-9 - +5 V dc</p> <p>If any voltage is incorrect, replace the FRUs in the following order:</p> <p>main drive motor assembly</p> <p>engine board</p>

**Operator Panel Service Check**

**Operator Panel Buttons Service Check**

**Note:** Before continuing with this service check do the [“Button Test” on page 3-9](#) and [“Operator Panel Test” on page 3-21](#).

	FRU	Action
1	Operator Panel Assembly	If any button fails the Button Test, replace the operator panel assembly.
2	Engine Board (No buttons work)	Check the voltage at J1-2. The voltage measures approximately +5 V dc with the controller board removed. If incorrect, replace the engine board. If correct, check the continuity of the operator panel cable. If incorrect, replace the cable. If correct, replace the operator panel assembly.



## Operator Panel Display Service Check

**SERVICE TIP:** The printer has detected a problem with the engine board, operator panel cable or operator panel assembly if POST does not complete and the printer emits 5 beeps and stops in a continuous pattern until the printer is turned off. The operator panel cable is an individual cable on some printers and a combination cable assembly with the cover switch cable on later models.

**Note:** If the operator panel is operating properly except for a PEL or a few PELS missing or broken, run the [“LCD Test” on page 3-8](#) from the hardware tests before continuing with this diagnostic service check.

	FRU	Action
1	Operator Panel Cable	Check for proper installation of the cable at the engine board (J1) and at the operator panel. Check the continuity of the operator panel cable. If incorrect, replace the cable.
2	Operator Panel Display blank, 5 beeps, LED Off	Check the voltage at J1-2 on the engine board. It measures approximately +5 V dc. If incorrect, replace the engine board. If correct, replace the operator panel assembly.
3	Operator Panel Display blank, 5 beeps, LED On	Check for ground between J1-4 and ground. If correct, replace the operator panel assembly. If incorrect, replace the engine board.
4	Operator Panel all diamonds, No Beeps	Check to make sure a DIMM is not plugged in backward. This condition causes the printer to fail POST displaying all diamonds on the operator panel with no beeps.
5	Operator Panel all diamonds, 5 Beeps	Check the voltage at Pins J1-1, J1-3 and J1-5. The voltage measures approximately +5 V dc. If incorrect, replace the FRUs in the following order:  operator panel assembly  engine board

## ***Options Service Check***

### **Flash Memory Option(s)**

Run a copy of the test page and check to see if the option you are checking is listed. The printer does not recognize the option being installed if the option is not listed. Check to make sure that the Memory DIMM is installed correctly and is not broken or damaged. If the Memory DIMM is correctly installed not broken or damaged then run the [“Flash Test” on page 3-19](#). If the test fails, replace the FLASH DIMM. If the problem continues, replace the controller board.

### **DRAM Memory Option(s)**

This service check is the same as the flash memory option service check with the following exception:

Run the [“DRAM Memory Test” on page 3-9](#) from the menu if the DRAM Memory DIMM is correctly installed and not broken or damaged. If the test fails, replace the DRAM DIMM. If the problem continues, replace the controller board.

### **Hard Disk Option**

Check to make sure the fixed disk and the fixed disk board are correctly installed. Run the [“Quick Disk Test” on page 3-17](#) from the Device Test on the Diagnostic Menu when a problem is suspected either with the hard disk system board or with the hard disk.

**Note:** The Quick Disk Test is a non-destructive test and indicates Pass or Fail. If the test fails, replace the hard disk. If a problem still exists, replace the hard disk board.

The [“Disk Test/Clean” on page 3-18](#) is used to help restore the disk if the disk contains bad data and is unusable. This test is divided into a cleaning and a verifying or testing section.

**WARNING:** This can be a very lengthy test depending on the disk size. This test leaves the hard disk unformatted. The servicer or user must reformat the disk using the Format Disk Menu operation. This is a destructive type of test. All the data on the disk is destroyed and should not be performed on a known good disk.

## Network Card Option

### Error Code 976 - Network Card

A 976 error code indicates an unrecoverable software error in the network card. Verify that the network card is correctly installed in the socket on the interconnect board and is properly grounded. If you find no problem, contact your next level of support before replacing the network card.

### Error Code 54 - Network Card

A 54 error displays when the RIP software detects that a network card is installed in slot 1 on the interconnect board but cannot establish communications with the network card.

## ***Paper Feed Service Check***

If you have a 936 Transport Motor Error go to the [“Main Motor Test” on page 3-22](#).

	<b>FRU</b>	<b>Action</b>
1	Alignment Assembly	Check to ensure the alignment assembly is correctly attached to the left side frame and the mounting screws are tight. Check the alignment assembly for any signs of worn rollers, contaminated rollers or binds. Replace the alignment assembly if any problem is found.
2	Inner Deflector	Check the inner paper deflector for correct installation. If the deflector is bowed or not fitting correctly, replace the deflector.

**Pick roll fails to feed paper.**

	<b>FRU</b>	<b>Action</b>
1	Pick Roll	Check the pick roll for signs of wear and correct installation. Replace as necessary.
2	Pick Roll Solenoid	Check the solenoid for correct operation and installation. Use the Solenoid Test in the Hardware Test Mode to check operation. Replace as necessary.

**Printer continually feeds paper.**

	<b>FRU</b>	<b>Action</b>
1	Pick Roll Solenoid	Check the solenoid for correct operation and installation. Use the Solenoid Test in the Hardware Test Mode to check operation. Replace as necessary.
2	Pick Roll Shaft Assembly	Inspect the cam surface of the pick roller shaft assembly to make sure the solenoid actuator correctly interlocks with the cam. Replace the pick roll shaft assembly if the cam is worn.

**Paper feed failures occur only near the top of the stack of paper.**

The most common cause of this problem is paper curl. Remove the paper from tray x and check for the natural curvature in the paper. Reinstall the paper in the correct manner. If the problem persists, it may be necessary to reduce the stack height. Replace the pick roll if the paper appears to be flat in the tray but there is still a problem.

**Failures occur mainly near the bottom of the stack of paper.**

Check the paper tray lift plate for proper operation. A fatigued lift plate spring can cause paper feed problems near the bottom of the stack.

## Double Feeding Paper

**Note:** If double feeding paper occurs mostly from the bottom of the stack, check for missing or damaged restraint pads in the tray.

	FRU	Action
1	Paper	Paper is usually the primary cause of a double feeding paper problem. Flex the paper before placing the paper in the tray. Edge-welded paper is the most common cause of double feeding. Loading the paper in the tray in different locations and directions and using rough paper and short grain paper also causes double feeding.

## Multipurpose Tray

### Paper fails to feed from the multipurpose tray.

The pick roll should make one complete revolution and stop with the flat side down. If the pick roll turns but does not pick paper, check the roll for signs of wear, oil or grease on the surface of the pick roll or slick spots. If you find a problem, replace the pick roll assembly. Check to ensure the media that is being fed through the multipurpose tray assembly meets recommended paper specifications.

## Parallel Port Service Check

Run the [“Parallel Wrap Test”](#) on page 3-10.

**Note:** The Parallel Wrap Test is designed to check the parallel port hardware by using a wrap plug (P/N 1319128) and invoking the Parallel Diagnostic Test. This test helps isolate the printer from the parallel cable and host. The test provides failure information on the display for approximately three seconds. If the test indicates that a problem is detected, replace the controller board.

## Printhead Service Check

The printhead assembly does not contain any service replaceable parts or components.

	Service Error Code	Explanation
1	Error Code 931 No first HYSNC Signal Error Code 932 Lost HYSNC	These errors usually indicate a failure in the HYSNC signal to the printhead. Check the continuity of the cable connected to J5 on the engine board. If incorrect, replace the defective cable. The voltage at J5-6 measures approximately +5 V dc. If incorrect, replace the engine board. If correct, replace the printhead assembly.
2	Error Code 935 Mirror Motor unable to reach operating speed	These error codes indicate a problem with the mirror motor circuit in the printhead assembly or the mirror motor cable to the engine board cable or engine board assembly. Check the continuity of the mirror motor cable connected to J8 on the engine board. If incorrect, replace the cable. The voltage at J8-5 measures approximately +24 V dc. If incorrect, replace the engine board. If correct, replace the FRUs in the following order:  printhead assembly  engine board

## ***Print Quality Service Check***

Service Tip: Before troubleshooting any print quality problems do the following:

- Install another print cartridge if available before proceeding with the service checks.
- Use Tray 1 to test for print quality of the base printer.

Select the following menu settings as indicated. Be sure and note the original settings so you can return the printer to the original customer printer setup.

- Print Resolution: Set to 300 dpi (print quality problems should be checked at different resolution settings).
- Print Darkness: Set to NORMAL.
- Toner Saver: Set to OFF.
- PQET: Set to OFF.

An incorrect printer driver for the installed software can cause problems. Incorrect characters could print and the copy may not fit the page correctly.

Measure all voltages from the connector to printer ground. All voltages measured during the print cycle are measured with the controller board removed while running the print test.

**Print Quality - All Black Page**

Service Tip: An all black page is generally caused by a problem in the high voltage system or an incorrect high voltage in the printing process resulting in toner development on the entire photoconductor drum.

	<b>FRU</b>	<b>Action</b>
1	High Voltage Contacts	Check the high voltage contacts on the right side frame to ensure they fit securely and are not pitted, contaminated or damaged. If incorrect, replace the contact.
2	Engine Board	Check the voltages on J9-1 through J9-9. If incorrect, replace the HVPS.
3	HVPS Cable/HVPS	Check the continuity of the HVPS cable. If incorrect, replace the cable assembly. If correct, replace the HVPS.

**Print Quality - Blank Page**

	<b>FRU</b>	<b>Action</b>
1	Print Cartridge	Check the print cartridge for any signs of damage, especially the PC drum contact on the cartridge.
2	Developer Drive and Coupler	Make sure the developer drive is working properly and the coupler is correctly installed between the main drive and the developer drive.



	FRU	Action
3	High Voltage Contact	<p>Check the contacts on the right side frame for damage, cartridge contact wear or contamination. If the contacts are bent or damaged, replace the contacts.</p> <p><b>Note:</b> Inspect the HVPS contacts on the board for any signs of damage or contamination.</p>
4	HVPS/HVPS Cable/ Engine Board	<p>If the voltages at J9 are incorrect, replace the engine board. If the voltages are correct, check the HVPS cable for continuity. If you measure continuity, replace the HVPS.</p>
5	Printhead Assembly	<p>Generally a 93x service error is posted if the printhead assembly fails and the printer does not give a blank copy symptom.</p> <p>The printhead used in the printer does not have a mechanical shutter as previous laser printers. The printer is interlocked through the front top cover switch.</p>

### Print Quality - Random Marks

Service Tip: The primary cause of random marks is due to loose material moving around inside the printer and attaching to the photoconductor, charge roll or transfer roll.

	Symptom	Action
1	Random Marks	<p>Check the print cartridge for any signs of loose or foreign material that might be on the photoconductor. Check the transfer roll and charge roll for any pieces of material that are stuck to the rolls.</p>

**Print Quality - Blurred or Fuzzy Print**

Blurred or fuzzy print is usually caused by a problem in the main drive gearbox assembly, alignment assembly, any feed roller or in the transfer roll bearings or transfer roll. Check the gearbox assembly for correct operation. Check the transfer roll for binds or a contaminated shaft or bearings.

Blurred print can also be caused by incorrect feeding from one of the input paper sources.

Check the high voltage contacts to ensure they are not bent, corroded or damaged. Replace as necessary.

**Print Quality - Evenly spaced horizontal lines or marks**

	<b>FRU</b>	<b>Action</b>
1	Lines spaced 2.2 mm (.08 inch) apart	This can be caused by the motor pinion gear on the main drive motor. Replace the main drive assembly.
2	Lines spaced 211.5 mm (8.33 inches) apart  Lines spaced 141 mm (5.56 inches) apart	This can be caused by a defective gear in the main drive assembly. Replace the main drive gearbox assembly.
3	Lines spaced 15.6 mm (0.61 inch) apart	Replace the FRUs in the following order:  developer drive assembly  main drive assembly
4	Lines spaced 47 mm (1.85 inch) apart	Replace the FRUs in the following order:  toner cartridge  charge roll  main drive assembly
5	Lines spaced 38.0 mm (1.50 inches) apart  Lines spaced 46.5 mm (1.83 inches) apart	This can be caused by a defective gear in the developer drive assembly. Replace the developer drive assembly.
6	Lines spaced 80.0 mm (3.14 inches) apart	Replace the hot roll.
7	Lines spaced 77 mm (3.03 inches) apart	Replace the backup roll
8	Lines spaced 52 mm (2.06 inches) apart	Replace the transfer roll.

	<b>FRU</b>	<b>Action</b>
9	Lines spaced 112.8 mm (4.45 inches) apart	Replace the FRUs in the following order:  alignment assembly  main drive assembly
10	Lines spaced 94 mm (3.7 inches) apart	Replace the FRUs in the following order:  toner cartridge  main drive assembly
11	Lines spaced 45.1 mm (1.78 inches) apart  Lines spaced 52.6 mm (2.07 inches) apart  Lines spaced 75.2 mm (2.96 inches) apart	Replace the alignment assembly.

### **Print Quality - Background**

**Service Tip:** Some background problems can be caused by rough papers or non-Lexmark toner cartridges. If the rough paper mode is on, turn it off and run the print test.

Some slick or coated papers may also cause background. Some problems occur with printers that run a large amount of graphics in a humid environment. The customer may try to improve the print quality by increasing the transfer setting.

	<b>FRU</b>	<b>Action</b>
1	Erase Lamp/Lens Assembly	Check the erase lamp lens for any signs of toner, paper dust or other types of contamination. Clean the lens with a soft dry cloth if necessary. If unable to clean the contamination off the lens, replace the lens and lamp assembly. Check the erase lamp assembly. Use the same procedure as outlined in the <a href="#">“Erase Lamp Test” on page 3-26.</a>
2	Printhead	The printhead on the Optra M410 printers cannot be cleaned. Try another printhead if all other attempts fail to correct a background problem.
3	Transfer Roll Assembly	Check the high voltage contact from the HVPS to the transfer roll. Check the transfer arm assembly right side bearing for any signs of contamination, pitting or a loose cable to the bearing. If any problems are found, replace the defective part. Check the transfer roll shaft for any signs of contamination, wear or pitting on the ends of the shaft that go into the bearings. If a problem is found, clean the ends of the shaft or replace the transfer roll assembly.
4	High Voltage Contacts	Check the high voltage contacts on the right side frame to ensure they are clean and not bent, deformed, or pitted. If incorrect, replace the contact.

## Print Quality - Banding

Service Tip: Banding is difficult to detect except on a page with a uniform gray or a large amount of graphics printed on the page.

Banding is primarily due to a variation in the speed of the paper as it feeds through the printer, especially in the development and transfer process. Inspect the alignment assembly, main drive assembly and all other paper feed components for signs of wear, dirt, binds, or damage, especially the drive gears. Banding appears as light or dark horizontal lines on a uniformly gray page.

## Print Quality - Black bands on outer edges of the page

This print quality problem appears as vertical black bands on one or both sides of the copy and can be wide, narrow, light or dark.

	FRU	Action
1	Charge Roll Linkage Springs	If the problem is just on one side of the page, check the charge roll linkage spring on that side. You can check to see if enough force is being applied to the charge roll by applying a slight downward pressure with your finger to the charge roll link arm that the spring is attached to while you run a print test sample. See if the problem changes or goes away. If this fixes or changes the problem, then check the springs and charge roll link arm assemblies for binds or defective parts. Replace as necessary.
2	Charge Roll Assembly Charge Roll Link Arm	Check the charge roll for any signs of toner buildup or other contamination on the outer edges that correspond to the bands on the page. Check the charge links and arms for proper operation, binds or incorrectly mounted counterbalance springs. Repair or replace as necessary.

	FRU	Action
3	HVPS	<p>Check the following voltages at J9-7 on the engine board:</p> <p>Printer Idle J9-7 measures 0 V dc</p> <p>Printer Printing Test Page J9-7 voltage changes from 0 V dc to +4 V dc</p> <p>If the voltage does not vary, check the continuity of line J9-7 in the front cable harness. If there is no continuity, replace the cable harness. If there is continuity, replace the HVPS. If this does not correct the problem, replace the engine board.</p> <p>Turn the printer Off and check the resistance between J9-9 and printer ground. The resistance measures approximately 0 ohms. If incorrect, make sure the engine board is mounted correctly and securely grounded. If correct, replace the engine board.</p>

### Print Quality - Residual Image

Service Tip: Install a new print cartridge if available before doing this service check. Residual image can be caused by the photoconductor, cleaning blade and other parts inside the print cartridge.

	FRU	Action
1	Erase Lamp Assembly	Check the erase lamp lens assembly for any signs of paper dust, toner buildup or any other contamination. Clean with a soft cloth or replace the lens and lamp assembly which are provided together in a kit. If the lens is clean then check the erase lamp assembly for failed erase lamps. If defective, replace the erase lamp assembly.
2	Fuser Assembly	Check the fuser assembly for signs of toner contamination. The hot roll especially might cause toner to be retained and deposited on the page.

### Print Quality - Light Print

	FRU	Action
1	Transfer Roll	Check the right end of the transfer roll shaft for signs of wear or contamination. If incorrect, replace the transfer roll.
2	Right Side Transfer Roll Arm Assembly	Check the right side transfer roll arm assembly bearing for any signs of wear or contamination. Also check to ensure the transfer cable is firmly attached to the bearing. If incorrect, reposition the bearing to make contact with the wire. Replace the bearing as necessary. Check the connection of the transfer roll assembly cable to the transformer on the HVPS board. Check the continuity of the cable from the bearing to the spade terminal on the cable. If incorrect, replace the right side transfer arm assembly. If correct, replace the HVPS.



**Print Quality - Toner on backside of printed page**

Service Tip: This is generally caused by loose toner in the machine in the paper path being carried through the printer on the backside of the paper.

	<b>FRU</b>	<b>Action</b>
1	Fuser Assembly	Toner is being carried out on the backside of the media. This problem is generally caused by a toner buildup on the fuser hotroll or backup roll. Check the fuser hotroll and backup roll for any noticeable buildup of toner. Repair as necessary.
2	Transfer Roll	Check the transfer roll for any signs of toner buildup or loose toner. Clean the area and run another copy. If the problem continues, replace the FRUs in the following order:  HVPS  engine board

**Serial Port Service Check**

Run the [“Serial Wrap Test”](#) on page 3-11.

**Note:** The Serial Wrap Test is designed to check the serial port hardware by using a wrap plug (P/N 1329048) and invoking the Serial Post Diagnostic Test. The test helps isolate the printer from the serial cable and host. The test provides failure information on the display for approximately three seconds. If the test indicates a problem, replace the controller board.

## Transfer Roll Service Check

**Service Tip:** The circumference of the transfer roll is 52 mm. Any print quality problems such as lines that are spaced 52 mm apart indicate you should check the transfer roll for damage, toner or foreign material buildup.

**CAUTION:** Make sure the printer is powered Off before making any checks on the transfer roll or associated parts for personal safety and to prevent damage to the printer.

	FRU	Action
1	Transfer Roll Assembly	Check the transfer roll for any signs of toner buildup, surface damage to the roll, oil or other contaminants on the surface of the roll. Replace the transfer roll as necessary.
2	Left Transfer Arm Assembly	Check the left transfer roll arm assembly to make sure it is fastened and locked in the down position. If the arm is not locked down, check to ensure the arm is not broken and will lock into the EP frame correctly. Check the left transfer arm assembly spring for proper operation.
3	Right Transfer Arm Assembly	Check the right transfer arm assembly to make sure it is fastened and locked in the down position. If the arm is not locked down, check to make sure the arm is not broken and will lock into the EP frame correctly. Check the right transfer arm assembly spring for proper operation. For any background problems, check to ensure the contact to the HVPS board is correct and that there is approximately 0 ohms resistance between the transfer roll shaft and the HVPS contact. If correct, go to <a href="#">"Print Quality - Background"</a> on page 2-42.

---

## 3. Diagnostic Aids

This chapter explains the tests and procedures to identify printer failures and verify repairs have corrected the problem.

To run the printer diagnostic tests described in this chapter, you must put the printer in Diagnostic Mode.

---

### Configuration Mode

Configuration Mode contains a set of menus, settings and operations which are used to configure the printer for operation. To access any of the Configuration Mode functions, you must put the printer in Configuration Mode.

To enter the Configuration Mode:

1. Turn the printer off.
2. Press and hold the Select and Return buttons.
3. Turn the printer on.
4. Release the buttons when "Performing Self Test" displays on the operator panel. The operator panel will display "CONFIG MENU" once the printer reaches Configuration Mode.
5. Press either of the Menu buttons (<>) to scroll through the "CONFIG MENU" options.
6. Press the Select button to open sub menu options.
7. Press either of the Menu buttons (<>) to scroll through the sub menu.
8. Press the Return button to go back to the previous level from a sub menu.

The CONFIG MENU items display on the operator panel in the order shown:

Prt Quality Pgs

Panel Menus

PPDS Emulation

Buffered Jobs (only displayed if buffered jobs have been stored on the disk)

## 4045-XXX

Download Emuls (only displayed if at least one downloaded emulator is installed)

Demo Mode

Factory Defaults

Narrow Media

Exit Config Menu

To exit the Configuration Mode:

1. Go to Exit Config Menu.
2. Press the Select button to exit and to save any changes.

### ***Print Quality Test Pages***

The purpose of this diagnostic function is to allow printing of the print quality test pages with the toner cartridge lockout function disabled. The print quality test consists of three pages. Page one contains a mixture of graphics and text. Pages two and three only contain graphics. The Print Quality Test pages must always be printed on letter, legal or A4 paper.

To run the Print Quality Test Pages in the Configuration Mode:

1. Select PRT Quality Pgs from the CONFIG MENU.

The following is printed on page 1.

- Margin Settings
- Contents of the Diagnostic Error Log.
- Printer configuration information:
  - printer serial number, controller code level, engine code level, operator panel code level, smart option code levels, font versions, and so on.
- Values for the Quality Menu settings used to print the pages.

### ***Panel Menus***

This function prevents users from accessing the “Ready Menu Group” and modifying default printer settings. If a user attempts to access the “Ready Menu Group” while the menus are disabled, the printer posts the message “Menus Disabled” to inform the user the menus are not accessible.

To Enable/Disable the menus:

1. Select Panel Menus from the CONFIG MENU.
2. Select Enable or Disable.
  - Enable will unlock menus.
  - Disable will lock menus.

### ***PPDS Emulation***

This function is used to activate/deactivate the PPDS emulation setting.

To change this setting:

1. Select PPDS Emulation from the CONFIG MENU.
2. Select Activate or Deactivate.
  - If Activate is selected, the printer language is set to PPDS Emulation and the PCL and PS Smartswitch settings are turned off.
  - If Deactivate is selected, the printer language is set to PCL 5 Emulation and the PCL and PS Smartswitch settings are turned on.

### ***Discard Buffered Jobs***

If the printer is power cycled after jobs have been buffered to the disk, then the printer attempts to print all buffered jobs stored on the disk. If many jobs have been buffered to the disk, then it may take the printer a long time to complete power cycle initialization since each buffered job must be processed during the initialization phase. The user can terminate the processing of buffered job during initialization by executing an operation to discard all buffered jobs.

To discard all buffered jobs:

1. Select Buffered Jobs from the CONFIG MENU.
2. Select Disable.

### ***Download Emulation***

To help resolve Download Emulation problems, the following steps are necessary to instruct the printer to POR without activating any download emulations.

## 4045-XXX

To disable the Download Emulation:

1. Select Download Emuls from the CONFIG MENU.
2. Select Disable.

The printer automatically exits the Configuration Menu Group and initializes as if the Download Emulator were not installed. Once the printer is idle, a new Emulator can be downloaded again.

**Note:** If the user power cycles the printer after selecting the Disable option, the Downloaded Emulator will be reactivated.

## ***Demo Mode***

The Demo Mode setting is used to remember whether or not demo mode is active. If the Demo Mode setting is set to On, then demo mode is entered each time the printer is powered on. If the Demo Mode setting is set to Off, then normal mode is entered each time the printer is powered on.

To Activate/Deactivate Demo Mode:

1. Select Demo Mode from the CONFIG MENU.
2. Press the Menu button to locate Activate or Deactivate.
3. Press the Select button to store your selection.

## ***Restore Factory Defaults***

This operation will restore the factory default values for most printer settings.

**WARNING:** Extreme care should be used when using this operation as it cannot be undone.

To Restore Factory Defaults:

1. Select Factory Defaults from the CONFIG MENU.
2. Select Factory Defaults=Restore All.

The actual restoration of the factory default values occurs upon exiting of the CONFIG MENU.

## ***Narrow Media***

The Narrow Media selection is used to set media width.

To change media width:

1. Select Narrow Media from the CONFIG MENU.
2. Locate your media choice using either Menu button.
3. Press the Select button to store your selection.

## ***Exiting the Configuration Mode***

Select Exit Config Menu to exit the Configuration Mode and return to the normal mode.

---

## **Diagnostic Mode**

To enter the Diagnostic Mode:

1. Turn the printer off.
2. Press and hold the Go and Return buttons.
3. Turn the printer on.
4. Release the buttons when "Performing Self Test" displays on the operator panel.

The tests display on the operator panel in the order shown:

- Print Registration
- Print Tests
- Hardware Tests
- Input Tray Tests
- Base Sensor Test
- Printer Setup
- Error Log
- Device Tests (if installed)

## ***Exiting the Diagnostic Mode***

Select Exit Diagnostics to exit the Diagnostics Mode and return to normal mode.

## ***Print Registration***

The print registration range is as follows:

Bottom Margin: -20 to +20

Top Margin: -25 to +25

Left Margin: -25 to +25

Right Margin: -10 to +10

To set Print Registration:

1. Select Registration from the Diagnostic menu.
2. The Top margin sign/value pair blinks. This indicates it is the margin value being changed.
3. To select the margin value to be changed press Select until the margin value pair you want to change is blinking.
4. To change the margin value press either Menu> or <Menu. When the value you want is displayed, press Select to save the value.
5. To exit the Registration menu, press Return.

To verify the margin values are correct you must print the "Quick Test Page" from the registration screen. Press Go to print the test page. While printing the Quick Test Page the "Quick Test Printing" message displays. Once the Quick Test Page completes printing, the Registration screen displays again.

The "Quick Test Page" should be printed on letter or A4 paper.

## ***Print Tests***

The purpose of the diagnostic Print Tests is to verify that the printer can print on media from each of the installed input options. Each of the installed options is listed in the following order in the menu:

Tray 1

Tray 2 (if installed)

Multipurpose Feeder



## 4045-XXX

For each input source selected you have the following choice:

- Single (prints the Print Test Page once)
- Continuous (continue printing the Print Test Page until Return or Stop is pressed).

The contents of the Print Test Page varies depending on the media installed in the selected input source.

To run the Print Test Page:

1. Select Print Tests from the Diagnostic menu.
2. Select the media source.
3. Select Single or Continuous.
  - If single is selected no buttons are active during printing.
  - If continuous is selected, Return or Stop can be selected to cancel the test.

Check each Test Page from each source to assist in Print Quality and Paper Feed problems.

### **Print Quality Test Pages**

The purpose of this diagnostic function is to allow printing of the print quality test pages with the toner cartridge lockout function disabled. The print quality test consists of three pages. Page one contains a mixture of graphics and text. Pages two and three only contain graphics. The Print Quality Test pages must always be printed on letter, legal or A4 paper.

To run the Print Quality Test Pages in Diagnostic Mode:

1. Enter the Diagnostic Mode.
2. Select Print Tests from the Diagnostic menu.
3. Select Print Quality Pages from the Print Tests menu.

## 4045-XXX

The following is printed on page 1:

- Margin Settings
- Contents of the Diagnostic Error Log.
- Printer configuration information:
  - printer serial number, controller code level, engine code level, operator panel code level, smart option code levels, font versions, and so on.
- Values for the Quality Menu settings used to print the pages.

### Printing Menu Settings Page

**Note:** This test page must be printed on letter, legal or A4 paper.

To print the Menu Settings Page:

1. Perform a normal POR into user mode.
2. Select the Utilities menu.
3. Select the Print menu from the Utilities menu.

### *Hardware Tests*

The following Hardware Tests can be selected from this menu:

LCD Test  
Button Test  
DRAM Memory Test  
ROM Memory Test  
Parallel Wrap  
Serial 1 Wrap (if available)

#### **LCD Test**

To run the LCD Test:

1. Select LCD Test from the Diagnostic menu.
  - The LCD test continually executes the LCD display test.
2. Press Return/Stop to cancel the test.

### Button Test

To run the Button Test:

1. Select Button Test from the Diagnostic menu.
  - With no buttons pressed, several OP (Open) appear on the display.
2. Press each button one at a time and a CL (Closed) displays in place of an OP. The proper operation of each button can be checked.
3. Press Return/Stop to cancel the test.

### DRAM Memory Test

The purpose of this test is to check the validity of DRAM, both standard and optional. The test writes patterns of data to DRAM to verify that each bit in memory can be set and read correctly.

To run the DRAM Memory Test:

1. Select DRAM Memory Test from the menu.
  - The power indicator blinks indicating the test is in progress.
2. Press Return/Stop to exit the test.

P:##### represents the number of times the memory test has passed and finished successfully. Initially 000000 displays with the maximum pass count being 999,999.

F:##### represents the of time the memory test has failed and finished with errors. Initially 00000 displays with the maximum fail count being 99,999.

Once the maximum pass count or fail count is reached, the test is stopped, the power indicator is turned on solid, and the final results display. If the test fails, the message DRAM Error, displays for approximately three seconds and the failure count increases by 1.

## **ROM Memory Test**

The ROM Memory Test is used to check the validity of the RIP code and fonts.

To run the ROM Memory Test:

1. Select ROM Memory Test from the menu. P and F represent the same numbers for DRAM.
  - The power indicator blinks indicating the test is in process. The test runs continuously.
2. Press Return/Stop to exit the test.

Each time the test finishes, the screen updates with the result. If the test passes, the Pass Count increases by 1, however if the test fails, one of the following messages displays for approximately three seconds:

ROM Checksum Error  
ROM Burst Read Error

Once the maximum pass count or fail count is reached, the test stops with the power indicator on solid. The final results display on the screen.

## **Parallel Wrap Test**

This test is used with a wrap plug to check operation of the parallel port hardware. Each parallel signal is tested.

To run the Parallel Wrap Test:

1. Disconnect the parallel interface cable and install the wrap plug (P/N 1319128).
2. Select the Parallel Wrap Test from the menu.
  - The power indicator blinks indicating the test is in progress. The test runs continuously until canceled.

## 4045-XXX

Each time the test finishes, the screen updates. If the test passes, the Pass Count increases by 1, however if the test fails, one of the following messages displays for approximately three seconds:

- Sync Busy Error
- Byte Interrupt Request Error
- Strobe Interrupt Request Error
- Init Fail Error
- Init Busy Error
- Init Rise Error
- Host Busy Error
- RAM Data FF Error
- RAM Data AA Error
- RAM Data 00 Error
- RAM Data 55 Error
- DMA Count Error
- DMA Address Error
- DMA Interrupt Error
- DMA Memory Error
- DMA Background Error
- Clear Init Rise Error
- False Init Rise Error
- Autofeed Rising Interrupt Error
- Clear Autofeed Rise Error
- False Autofeed Rise Error
- Autofeed Falling Interrupt Error
- Clear Autofeed Fall Error

Once the maximum count is reached the test stops. The power indicator goes on solid and the final results display.

Press Return/Stop to exit the test.

### **Serial Wrap Test**

This test is used to check the operation of the Serial Port Hardware using a wrap plug. Each signal is tested.

## 4045-XXX

To run the Serial Wrap Test:

1. Disconnect the serial interface cable and install the wrap plug.
2. Select the Serial 1 Wrap Test from the menu. P and F represent the same numbers for DRAM.
  - The power indicator blinks indicating the test is running.
3. This test runs continuously unless canceled by pressing Return/Stop.

Each time the test finishes, the screen updates with the result. If the test passes, the Pass Count increases by 1, however if the test fails, one of the following failure messages displays for approximately three seconds and the Fail Count increases by 1:

Receive Status Interrupt Error  
Status Error  
Receive Data Interrupt Error  
Transmit Data Interrupt Error  
Transmit Empty Error  
Threshold Error  
Receive Data Ready Error  
Break Interrupt Error  
Framing Error  
Parity Error  
Overrun Error  
Data Error  
Data 232 Error  
Data 422 Error  
FIFO Error  
DSR Error  
DSR PIO Error  
DSR Interrupt Error  
CTS Error  
CTS PIO Error  
CTS Interrupt Error

Once the maximum count is reached the test stops. The power indicator goes on solid and the final results display.

Press Return/Stop to exit the test.

## ***Input Tray Tests***

### **Feed Test**

This test lets you observe the paper path as media is feeding through the printer. A blank sheet of paper feeds through the printer as the laser turns off during this test. The only way to observe the paper path is to open the lower front door that is used to access the envelope or multipurpose feeder. The paper is placed in the output bin.

To run the Feed Test:

1. Select Feed Test from the menu.
2. Select the input source from the sources displayed on the Feed Test menu. All installed sources are listed.
3. Select either Single (feeds one sheet of media from the selected source) or Continuous (continues feeding media from the selected source until Return/Stop is pressed).
4. Press Return/Stop to exit test.

### **Sensor Test**

This test is used to determine if the input tray sensors are working correctly.

To run the Sensor Test:

1. Select the Sensor Test from the Input Tray Test menu.
  - "Input Tray/Empty=OP/Pass=OP" message displays.
  - EM = Input Tray Empty Sensor
  - IN = Input Tray Inserted Sensor
2. Once this message displays, you can manually actuate each sensor. The tray empty sensor can be actuated by hand, however a sheet of paper can be used to cover the pass through sensor. When the sensor is closed, CL displays, when the sensor is open, OP displays.
3. Press Return/Stop to exit the test.

The multipurpose tray and the envelope feeder do not have a paper low sensor. The multipurpose tray does not have a pass through sensor.

## ***Base Sensor Test***

This test is used to determine if the sensors located inside the printer are working correctly.

The following sensors can be checked:

- Upper Front Door Sensor
- Rear Exit Door Sensor

To run the Base Sensor Test:

1. Select the Base Sensor Test.
  - The operator panel displays OP for open and CL for closed.
2. Manually toggle the sensors by hand to verify that each sensor switches from open to closed.

## ***Printer Setup***

### **Setting the Page Count**

This lets you change the page count from the Diagnostic menu. This is used whenever the engine board is replaced because this board contains the printer's NVRAM Memory where the page count is stored.

To set the Page Count:

1. Select Page Count from the diagnostic menu.
  - The current page count displays.
  - The leftmost digit blinks, indicating it is the first digit to be changed.
2. Press either Menu> or <Menu until the value you want displays.
3. Press Select to move to the next digit, press Menu> or <Menu until the value you want displays. Continue with each digit until you set the page count. You can skip any digit by pressing Select.
4. Press Select to save the new page count in NVRAM.
5. Press Return/Stop to exit the Diagnostic menu.



### Viewing the Permanent Page Count

The Permanent Page Count can only be viewed and cannot be changed.

To view the Permanent Page Count:

1. Select Permanent Page Count from the menu.
2. Press Return/Stop to exit the Diagnostic menu.

### Setting Configuration ID

The configuration ID is used to communicate information about certain areas of the printer that cannot be determined using hardware sensors. The Configuration ID is originally set at the factory when the printer is manufactured, however it requires resetting whenever you replace the engine board and can be set on the operator panel. However the Configuration ID is the only diagnostic function displayed until a valid ID is entered.

To set the Configuration ID:

1. Select Configuration ID from the Printer Setup menu.
  - The current ID displays on the screen. The Configuration ID is on a label located inside the printer. The label is visible when the top front cover is open.
  - The leftmost digit blinks indicating that it is the first digit to be changed.
2. To change the value, press either Menu> or <Menu until the value you want is reached. Press Select to move to the next digit, or press Select again to skip a digit. Change each digit as required. When the last digit is changed, press Select to validate the Configuration ID. If the ID is invalid then "INVALID ID" message displays on Line 2 before the ID redisplay. You have to reenter the Configuration ID until a valid ID is verified. If the ID is valid then the ID is saved in NVRAM and the printer automatically PORs to activate the new setting.

**Note:** When the printer PORs it does so in the normal mode.

**Factory Defaults**

You can select either U.S. or non-U.S. as the factory default. The table shows the differences between the two settings.

	<b>Paper Size</b>	<b>Envelopes</b>	<b>Symbol Set</b>	<b>Lines Per Page</b>
U.S.	Letter	10 Envelope	PC-8	60
Non-U.S.	A4	DL Envelope	PC-850	64

**Serial Number**

This setting lets you change the serial number when you replace the controller board. This number should match the serial number printed on the label. The label is visible when you open the upper front cover.

**Edge To Edge**

When Edge To Edge is set to “On”, the printer’s graphics and printing engine shift all four margins (top, bottom, right and left) to the physical edges of the page. When Edge To Edge is set to “Off”, the printing area is set back to the margin settings.

**Parallel Strobe Adjust**

This setting lets you adjust the factory setting for the amount of time the strobe is sampled to determine that valid data is available on the parallel port. Increasing the value by each increment means the strobe is sampled 50ns longer. Decreasing the value by each increment means the strobe is sampled 50ns less.

## **Error Log**

### **Viewing the Error Log**

The error log is helpful by providing a history of printer errors. The error log contains the 12 most recent errors that have occurred on the printer. The most recent error displays in position 1 and the oldest error displays in position 12 (if 12 errors have occurred). If an error occurs after the log is full, the oldest error is discarded. Identical errors in consecutive positions in the log are entered. All 2xx and 9xx error messages are stored in the error log.

To view the Error Log:

1. Select Display Log from the Error Log menu.
  - The Error log displays on three screens as only four entries display at a time.
2. To move to the next screen press Menu> to move forward or <Menu to move backward.
3. Press Return/Stop to exit the Error Log.

### **Clearing the Error Log**

To clear the Error Log:

1. Select Clear Log from the Error Log menu.
2. Select "YES" to clear the Error Log or "NO" to exit the Clear Log menu.
  - If "YES" is selected, the Empty Error Log displays on the screen.
3. Press Return/Stop to exit the Clear Log menu.

## **Device Tests**

### **Quick Disk Test**

This test performs a non-destructive read/write on one block per track on the disk. The test reads one block on each track, saves the data, and proceeds to write and read four test patterns to the bytes in the block. If the block is good, the saved data is written back to the disk.

## 4045-XXX

To run the Quick Disk Test:

1. Select the Quick Disk Test from the Device Tests menu.
  - The power indicator blinks while the test is in progress.
  - “Quick Disk Test/Test Passed” message displays if the test passes and the power indicator turns on solid.
  - “Quick Disk Test/Test Failed” message displays if the test failed and the power indicator turns on solid.
  - Press Go, Return, or Stop to return to the Device Tests menu.

### Disk Test/Clean

**WARNING:** This test destroys all data on the disk and should not be attempted on a good disk. Also note that this test may run approximately 1 1/2 hours depending on the disk size.

To run the Disk Test/Clean Test:

1. Select Disk Test/Clean from the Device Tests menu.
  - “Files will be lost/Go or Stop?” message displays to warn the user that all contents on the disk will be lost.
2. To exit the test immediately and return to the Device Tests menu, press Return/Stop. To continue with the test, press Go.
  - If go is selected, “Disk Test/Clean/BAD:000000 00%” message displays. The screen updates periodically indicating the percentage of test completed and the number of bad blocks found.
3. The power indicator blinks during the test. The test can be canceled anytime during the test by pressing Return/Stop.
  - Once the test is complete, the power indicator turns on solid and a message displays.
  - “xxxx Bad Blocks/yyyyyy Usable” message displays if fewer than 2000 bad blocks are detected. xxxx indicates the number of bad blocks and yyyyyy indicates the number of usable blocks.
  - “xxxx Bad Blocks/Replace Disk” message displays if more than 2000 bad blocks are detected. The disk cannot be recovered because too many bad blocks exist on the disk.
4. Press Go or Return/Stop to return to the Device Tests menu.

## 4045-XXX

### Flash Test

This test causes the file system to write and read data on the flash to test the flash.

**WARNING:** This test destroys all data on the flash because the flash is reformatted at the end of the test.

To run the Flash Test:

1. Select Flash Test from the Device Tests menu.
  - The power indicator blinks while the test is running.
  - “Flash Test/Test Passed” message displays if the test passes and the power indicator turns on solid.
  - “Flash Test/Test Failed” message displays if the test fails and the power indicator turns on solid.

Press Go or Return/Stop to return to the Device Tests menu.

---

## Hardware Test Mode

In addition to the Hardware Tests of the Diagnostic Mode, the Hardware Test Mode lets you check various hardware components. This mode is unique as it operates only when the controller board is removed. This eliminates the controller board as the failing FRU since the controller board is not part of the test.

To enter the Hardware Test Mode:

1. Turn the printer off.
2. Disconnect all cables connected to the controller board.
3. Remove the controller board and shield assembly from the printer.
4. Turn the printer on.

The following menu items are displayed on the operator panel:

- Op Panel Test
- Main Motor
- Solenoid Test
- Tray 2 Motor
- Mirror Motor
- Sensor Monitor
- Cooling Fan (status)
- Fuser Ctrl
- Erase Lamp
- Reset Test Mode
- Engine Firmware

**Note:** The Operator Panel Test is the first menu item to appear on the operator panel when the printer is powered on in the Hardware Test Mode. You can scroll through the menu items to select the next test. However, the printer must be powered off and on to display the Operator Panel Test again once you scroll past it. You can scroll forward and backward through the other tests without powering the printer off and on.

Service Tip: If "Engine Service" appears on the operator panel once the printer is turned on, one of the operator panel buttons is stuck.

## ***Operator Panel Test***

Use the Operator Panel Test to diagnose both the operator panel display and buttons.

To run the Operator Panel Test:

1. Press GO to initiate Operator Panel Test.
2. Press the buttons in the order shown in the following table and check the results on the display. If you do not get the expected results, replace the operator panel.

<b>Button</b>	<b>Result</b>
< (Menu)	< and PUSH display on the operator panel.
> (Menu)	> and PUSH display on the operator panel.
* (Select)	* and PUSH display on the operator panel. The LED also flashes.
^ (Return)	^ and PUSH display on the operator panel. The bottom row of pels turn on.
Green (GO)	Green and PUSH display on the operator panel. The top row of pels turn on.
Red (STOP)	Red and PUSH display on the operator panel. The Operator Panel Test automatically exits back to the menu.

## **Main Motor Test**

The Main Motor Test lets you turn the main motor on. This causes all gears in the printer to turn. Remove the print cartridge before performing this test to prevent toner from spilling into the printer. The MPF and Tray 1 pick roller solenoids can be actuated from the Solenoid Test while the main motor is on during the Main Motor Test. The pick rollers make one full turn when the solenoids are activated.

To run the Main Motor Test:

1. Select Main Motor from the menu.
2. Press GO to turn the main motor on. The operator panel displays "Rotating Main Mo" while the motor is turning.
3. Press STOP to turn the main motor off.

Once the main motor is turned on, select either the Tray 1 or MPF solenoid from the Solenoid Test to cause the pick roller to turn.

## **Solenoid Test**

This test lets you actuate the three different pick roller solenoids (two within the base printer and one within the Tray 2 option).

To run the Solenoid Test:

1. Select Solenoid Test from the menu and press Select (\*).
2. Select which solenoid to test by pressing the Menu buttons (< or >).
3. Press and hold GO to activate the selected solenoid. Check that the selected solenoid is working properly. Release the button to deactivate the solenoid.
4. Press Return (^) to return to the menu.

If the selected solenoid did not function properly, check the cable connections leading to the solenoid.



## ***Tray 2 Motor Test***

This test lets you turn the Tray 2 motor on. In conjunction with the Tray 2 Motor Test, the Tray 2 pick roller solenoid can be actuated from the Solenoid Test while the Tray 2 motor is on. The Tray 2 pick roller makes one full turn when the solenoid is activated.

To run the Tray 2 Motor Test:

1. Select Tray 2 Motor from the menu.
2. Press GO to turn the main motor on. The operator panel displays "Driving T2 Motor" while the motor is turning.
3. Press STOP to turn the main motor off.

Once the Tray 2 motor is turned on, select the Tray 2 solenoid from the Solenoid Test to cause the pick roller to turn.

## ***Mirror Motor Test***

This test lets you turn on the printhead mirror motor.

To run the Mirror Motor Test:

1. Select Mirror Motor from the menu.
2. Press GO to turn the mirror motor on. The operator panel displays "Rotating Mirror" while the motor is turning.
3. Press STOP to turn the main motor off.

## Sensor Monitor Test

This test lets you monitor signals from all photo sensors and switches in the printer. While each sensor/switch is actuated, the operator panel displays a value of opened or closed.

To run the Sensor Monitor Test:

1. Select Sensor Monitor from the menu.
2. Toggle or actuate each sensor/switch. The second row of the operator panel displays the signal status. Only the first six positions of the second row are used in this test. Check the corresponding position on the operator panel with the table for the correct signal status.

Sensor/Switch	Display Position	Signal Status
MPF Paper Present Sensor	1	o = No paper is present
		1 = Paper is present
Paper Input Sensor	2	o = No paper is present.
		1 = Paper is present
Paper Exit Sensor	3	o = No paper is present.
		1 = Paper is present
Cover Open/Cartridge Present Switch	4	O = Cover is open and/or cartridge is missing.
		C = Cover is closed and cartridge is present.
Rear Door Open Sensor	5	O = Rear door is open.
		C = Rear door is closed.
Tray 2 Attached	6	o = Tray 2 is not (correctly) attached to printer.
		1 = Tray 2 is attached to printer.

## ***Cooling Fan / Fuser Control Test***

This test lets you turn on the cooling fan to slow and fast speeds. The fuser warms to standby temperature when the fan is set to slow speed and to printing temperature when the fan is set to fast speed. The fuser turns off when the fan turns off.

To run the Cooling Fan Test/Fuser Control Test:

1. Select Cooling Fan (status) from the menu. Status displays the current status of the fan (Stop, Slow, or Fast).
2. Press GO to turn the fan on to Fast. Pressing GO again alternates the fan speed from Fast to Slow. Press STOP to turn the fan off.

Once the cooling fan turns on, press the right menu > button to monitor fuser temperature rise. "Heating Print" displays on the top line of the operator panel. The number displayed on the bottom left of the operator panel is a preset thermistor value corresponding to either standby or printing fuser temperatures, depending on whether the cooling fan is set to slow or fast. The number displayed on the bottom right of the operator panel is the current thermistor value. This value increases from 0 and stabilizes somewhat near the preset thermistor value. The numbers themselves are not actual temperature measurements. However, the higher the value, the higher the thermistor temperature. The two numbers are used only in comparison with each other to assure the fuser temperature control system is working properly.

**Note:** The message "Error!! 00 10 24" displays if the thermistor is disconnected or defective. The message "Error!! 00 20 23" displays if the thermistor detects the fuser is too hot or if the thermistor circuit is shorted.

## ***Erase Lamp Test***

This test is used to activate the LEDs of the Erase Lamp. When the LEDs turn on, they are visible with the front cover open and the cartridge removed.

To run the Erase Lamp Test:

1. Select Erase Lamp from the menu.
2. Press GO to unlock the LED value indicated in the bottom left of the operator panel. The brackets around the number will turn to " ) ( " indicating the value can now be changed with the menu buttons.
3. Press the left menu button ( < ) once to turn the LEDs on and change the value to 255. Open the front cover and view the LEDs. If the LEDs are working properly, they should be on.
4. Press the right menu button ( > ) once to turn off the LEDs and change the value back to 0. Press STOP to relock the value.

## ***Reset Test Mode***

This function lets you reset any changes made during the test mode. To reset test mode, select Reset Test Mode from the menu and press GO.

## ***Engine Firmware***

The purpose of this function is to display the current level engine code. To view the code, select Engine Firmware from the menu. The engine code version level displays on the second line of the operator panel.

---

## Printer Operation

The printer makes an image by applying toner dots to paper and fusing them in place. The process is divided into two steps. The first step is the Electrophotographic Process which forms the image on the PC drum. The second step consists of Feeding, Transferring and Fusing.

---

### Electrophotographic Process

The photoconductive drum, located within the toner cartridge assembly, creates the image to be printed on a page. As the PC drum makes a full rotation, it is electrically charged, an image is exposed to the PC drum, the image is developed with toner, the toner is transferred to the paper, and the PC drum is cleaned.

---

### Paper Feeding, Transferring and Fusing

Paper feeds into the printer from three different sources: Tray 1, Multipurpose Feeder, and the optional Tray 2. When the printer receives a printing command, the main drive motor turns on. Depending upon the selected paper source, a pick roller solenoid is actuated to allow the appropriate pick roller to turn. Paper is then corner-fed via a D-roll type pick roller and travels along a paper path toward the PC drum and transfer roller. An input sensor located before the PC drum detects the leading edge of the paper. If the paper is not detected within a certain time from when it was picked, a paper jam is detected. After the paper passes through the sensor, the paper travels between the PC drum and transfer roller. Toner is drawn from the PC drum onto the paper via the electric field produced from the transfer roller. While the toner is electrostatically held to the paper, the paper travels to the fuser where the toner is permanently fused to the paper. The fuser contains a hot roll and backup roller which apply heat and pressure to the toner on the paper as it passes through the fuser. As the paper exits the fuser, a paper exit sensor detects the paper. If the exit sensor does not detect the paper within a certain time from the input sensor, a paper jam is detected. After the paper passes through the sensor, it is directed either to the main exit bin or the rear exit (if the rear door is open).

## Paper Path/Sensor Locations

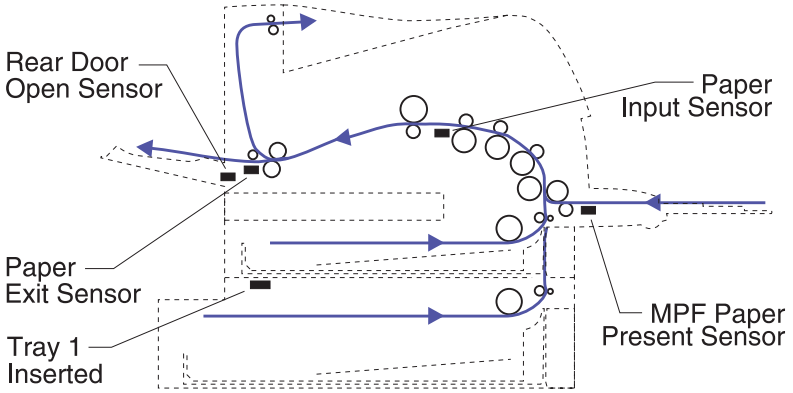

# Cable Locations

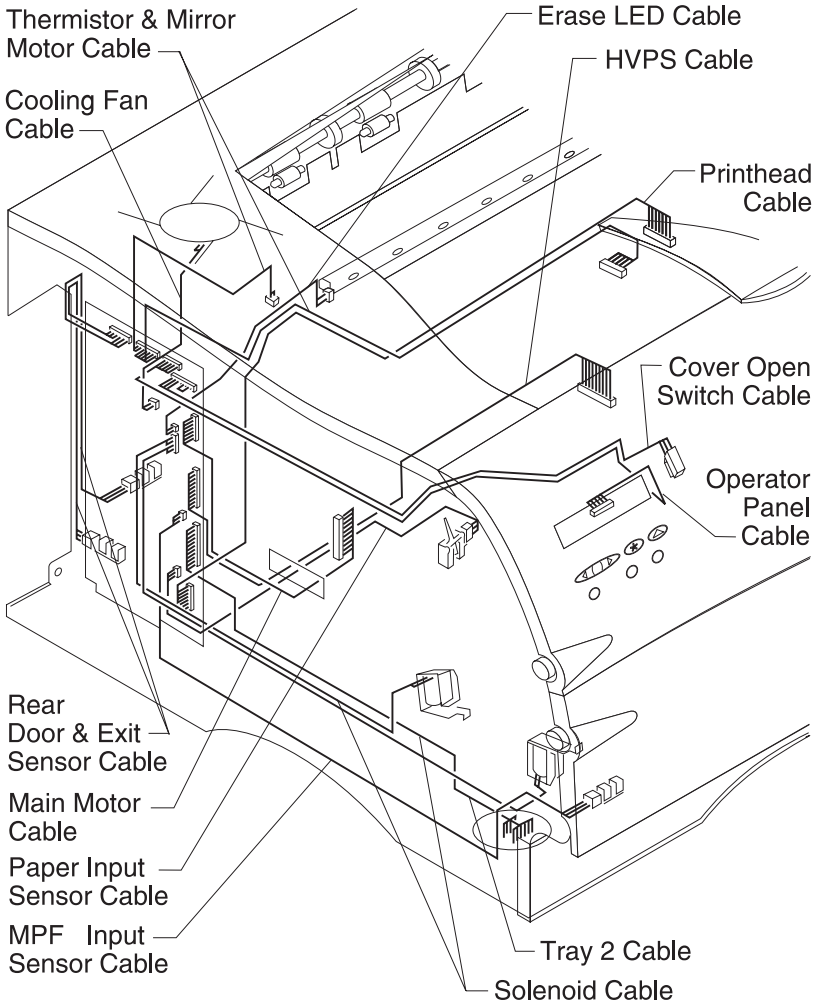

**4045-XXX**



---

## 4. Repair Information

---

### Handling ESD-Sensitive Parts

---

Many electronic products use parts that are known to be sensitive to electrostatic discharge (ESD). To prevent damage to ESD-sensitive parts, follow the instructions below in addition to all the usual precautions, such as turning off power before removing logic boards:

- Keep the ESD-sensitive part in its original shipping container (a special “ESD bag”) until you are ready to install the part into the machine.
- Make the least-possible movements with your body to prevent an increase of static electricity from clothing fibers, carpets, and furniture.
- Put the ESD wrist strap on your wrist. Connect the wrist band to the system ground point. This discharges any static electricity in your body to the machine.
- Hold the ESD-sensitive part by its edge connector shroud (cover); do not touch its pins. If you are removing a pluggable module, use the correct tool.
- Do not place the ESD-sensitive part on the machine cover or on a metal table; if you need to put down the ESD-sensitive part for any reason, first put it into its special bag.
- Machine covers and metal tables are electrical grounds. They increase the risk of damage because they make a discharge path from your body through the ESD-sensitive part. (Large metal objects can be discharge paths without being grounded.)
- Prevent ESD-sensitive parts from being accidentally touched by other personnel. Install machine covers when you are not working on the machine, and do not put unprotected ESD-sensitive parts on a table.
- If possible, keep all ESD-sensitive parts in a grounded metal cabinet (case).
- Be extra careful in working with ESD-sensitive parts when cold-weather heating is used because low humidity increases static electricity.

---

## Adjustment Procedures

### *Printhead Assembly*

This adjustment must be performed whenever the printhead is removed, replaced or the printhead mounting screws are loosened. An incorrectly adjusted printhead produces horizontally skewed images down the page.

To perform the printhead adjustment:

1. Turn the printer off.
2. Press and hold Return and Go.
3. Turn the printer On and release the buttons when "Performing Self Test" displays.
4. Select Print Test, Tray 1 and Single from the menu. The test page should only be printed on letter or A4 paper from Tray 1. The Print Test page consists of horizontal lines that can be used for skew adjustment, page count setting, printer serial number code levels and print registration settings.
5. Check the Print Test page for any sign of skew by folding the paper in half (left edge to right edge). Check the horizontal lines at the top left and top right of the test page for equal distance from the top of the page. If any adjustment is necessary, perform the following:
  - a. Remove the top cover.
  - b. Loosen the three printhead mounting screws.
  - c. Adjust the position of the printhead.
  - d. Replace the top cover.
  - e. Print a Print Test page and check for skew again.

This procedure may take two or three attempts before you get satisfactory results.

6. When you have the correct printhead adjustment, gently tighten the three printhead mounting screws being careful not to move the printhead assembly.

## ***Paper Alignment***

This adjustment must be performed whenever the paper alignment assembly is removed or replaced. An incorrectly adjusted alignment assembly produces vertically skewed images down the page.

To perform the paper alignment adjustment:

1. Print the Print Test page and check the margin registration adjustments on the test page. These adjustments should be within the range specified in [“Print Registration” on page 3-6](#).
2. Check for skew by folding the paper in half (bottom edge to top edge). The horizontal lines on the top and bottom of the page should line up. If adjustment is necessary, turn the adjustment screw (A) a few turns, print a Print Test page and check for skew again. This procedure may take two or three attempts before you get satisfactory results.

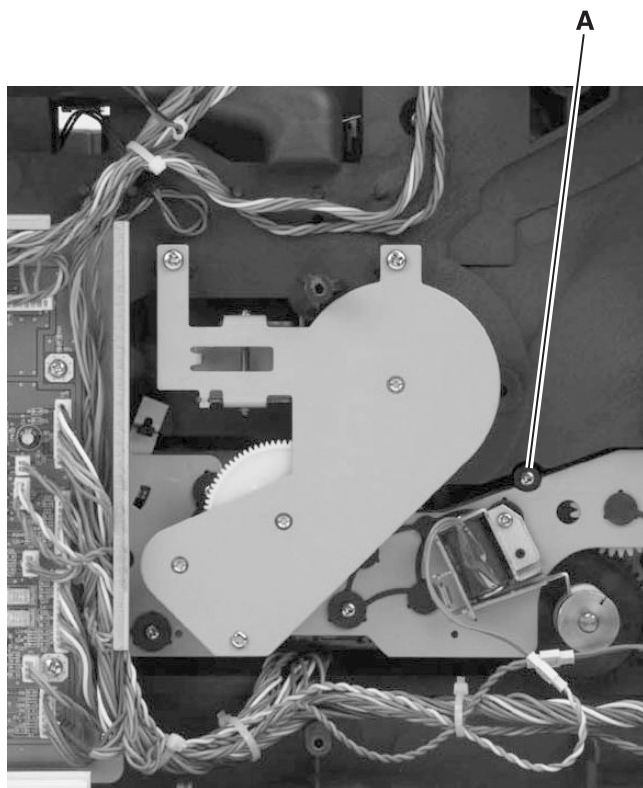

---

## Removal Procedures

**CAUTION:** Be sure to unplug the power cord whenever you are working on the printer with one of the covers removed. Also remove the print cartridge before you perform removal procedures.

### *Covers*

#### **Left Side Cover**

1. Open the upper door and multipurpose tray.
2. Press the two tabs (A) to open the left side cover.
3. Remove the left side cover from the rear hinge.

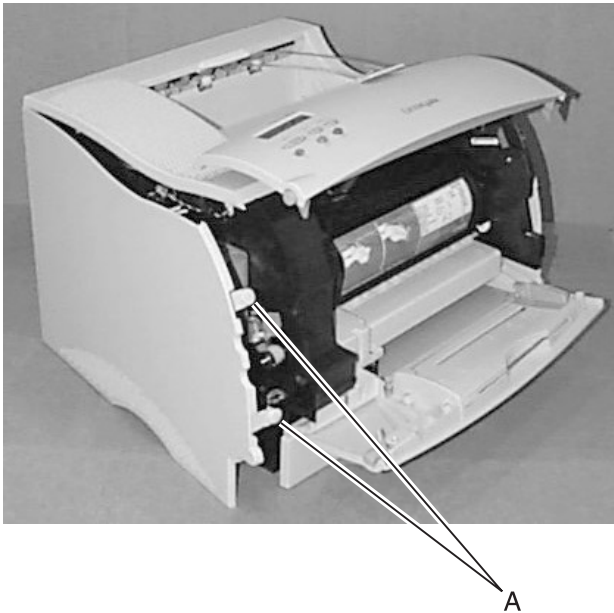

4045-XXX

## Right Side Cover

1. Open the upper door and multipurpose tray.
2. Remove the screw (A) located in the front of the right side frame mounted into the cover.



**4045-XXX**

3. Remove the screw (B) located at the top rear of the printer.
4. Lift the right side cover up and away from the printer.

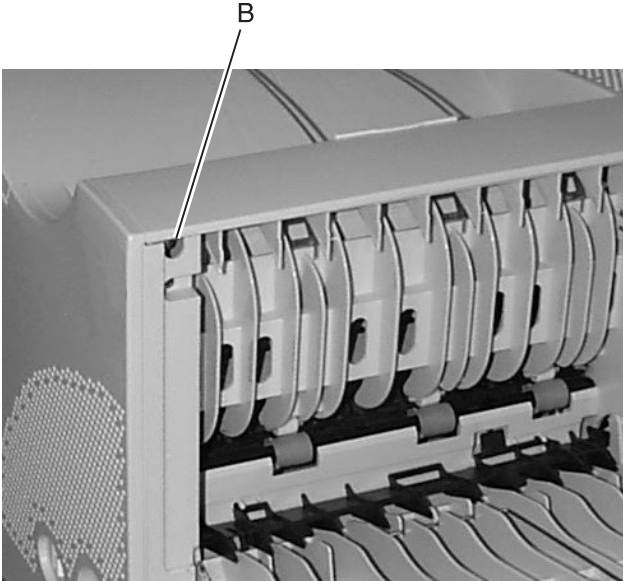

## Top Cover

1. Remove the left and right side covers.
2. Remove the two screws (A) from the right side of the top cover.



3. Remove the screw (B) from the left side of the top cover.

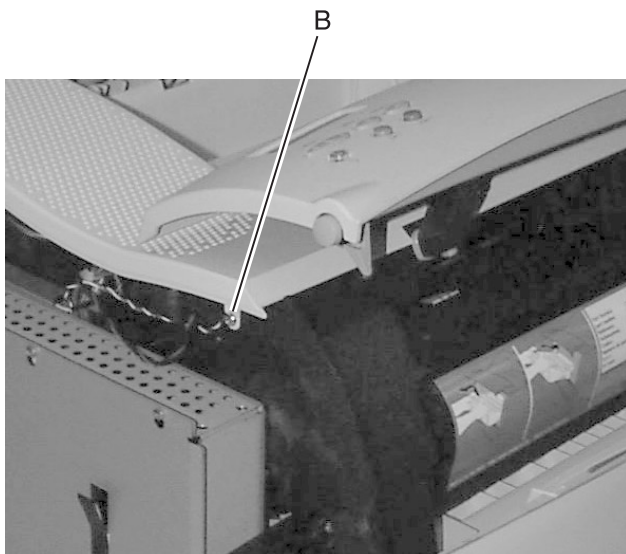

4. Remove the fuser air duct from the top cover.
5. Lift the top cover from the printer.

## ***Charge Roller***

1. Open the upper door and multpurpose tray.
2. Spread the charge roller support arms (A) apart and remove the charge roller.

**Note:** Make sure the HVPS charge wire is pinched between the bearing and right charge roller arm, ensuring good electrical contact.

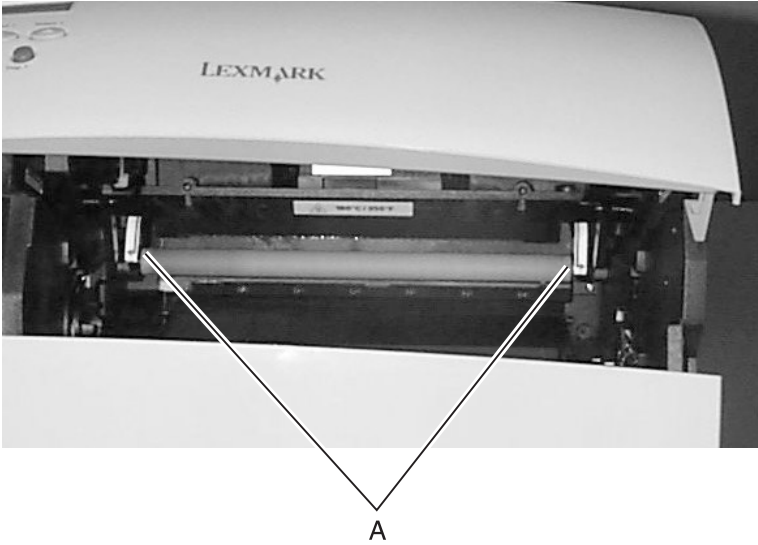



## **Controller Board**

1. Remove the left side cover.
2. Loosen the six screws (A) and remove the outer EMC shield.

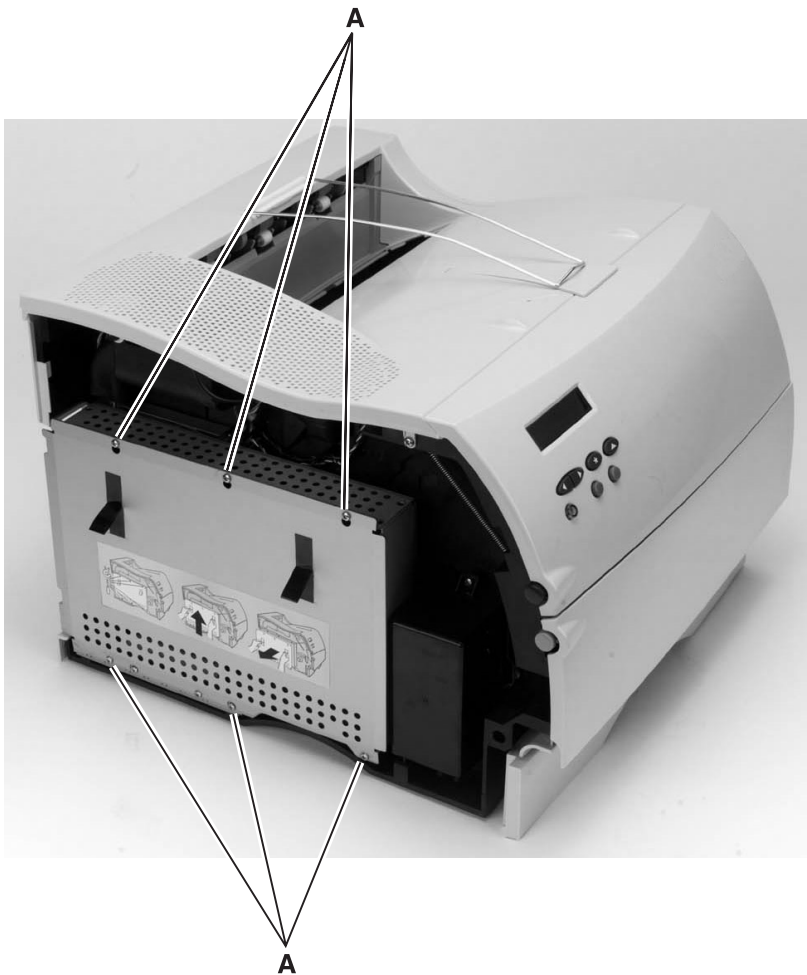

## 4045-XXX

3. Remove the four screws (B) and two screws (C) securing the inner EMC shield.
4. Lift the inner EMC shield/controller board assembly up and away from the interconnect board.
5. Remove the screws (D) from the controller board.
6. Remove the controller board from the inner EMC shield.

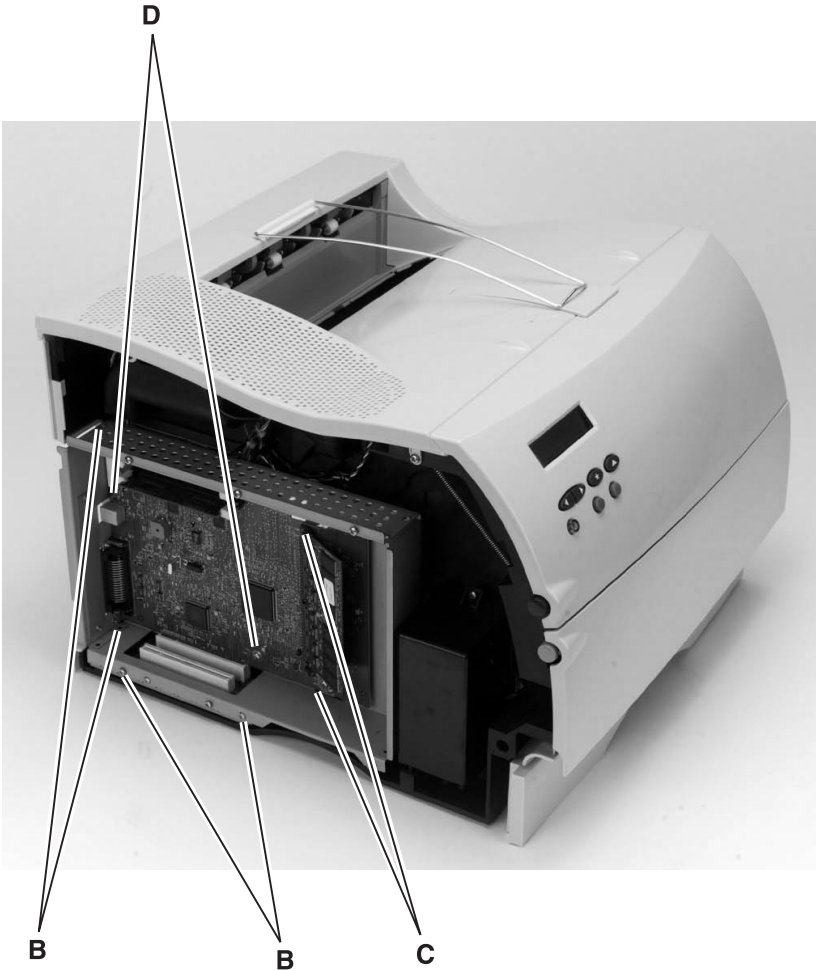

## Cooling Fan

1. Remove the top cover.
2. Remove the controller board/inner EMC shield assembly.
3. Disconnect the cooling fan from the engine board.
4. Release the two retaining tabs and push the air duct inward approximately 10 mm to provide clearance for fan removal.

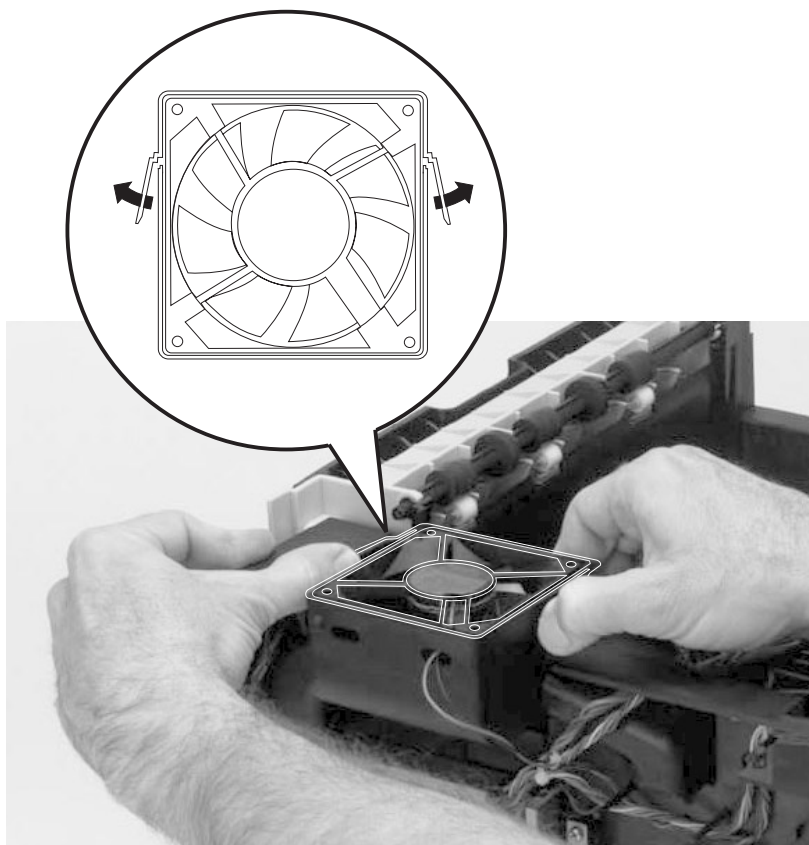

5. Remove the cooling fan.

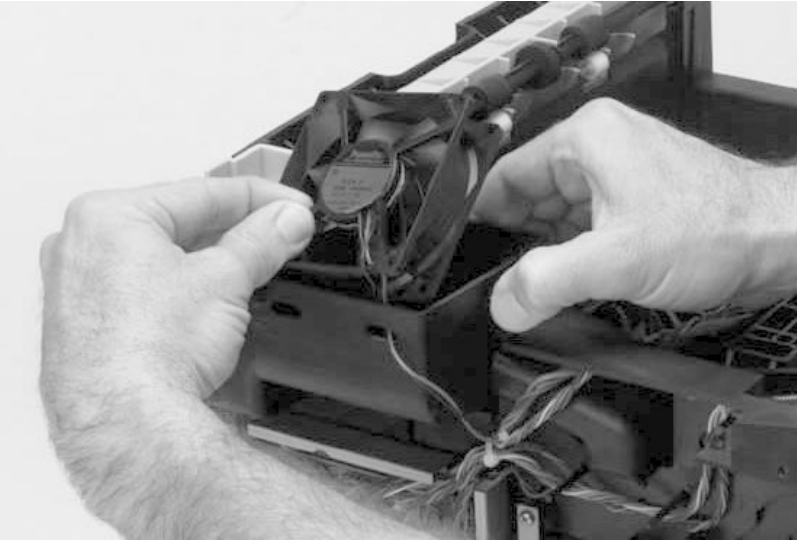

## ***Developer Drive Assembly***

1. Remove the inner EMC shield/controller board assembly.
2. Remove the two screws (A) and screw (B).
3. Remove the developer drive assembly.

**Note:** When you reinstall the developer drive assembly, be sure that the developer drive assembly engages with left charge roller arm. Be sure that the developer drive assembly wheel aligns with the hub on the main drive assembly.



## ***Engine Board***

1. Remove the inner EMC shield/controller board assembly.
2. Disconnect all connectors from the engine board.
3. Remove the four screws (A) from the engine board.
4. Lift the engine board from the interconnect board and remove the engine board.

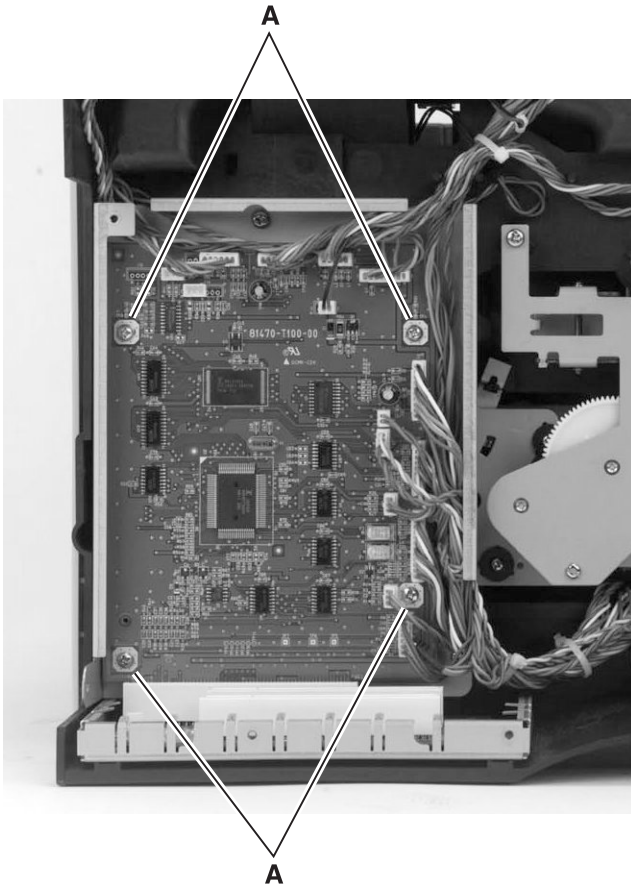

## ***Fuser***

1. Remove the right side cover.
2. Disconnect the two LVPS wires (A) from the fuser.

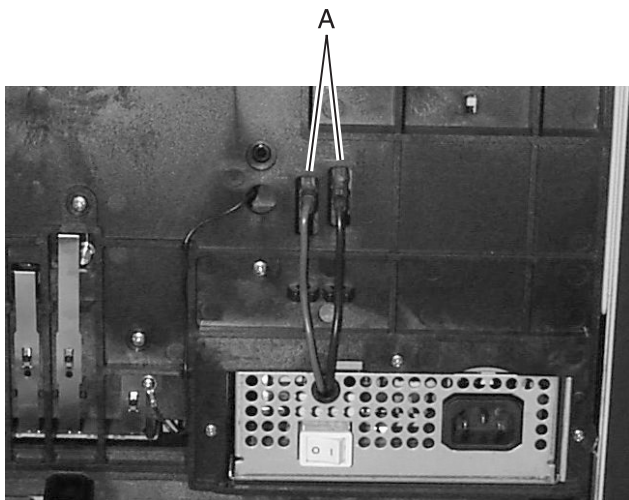

3. Remove the redrive assembly.
4. Remove the screw from the inner air duct cover and remove the cover.

5. Disconnect the thermistor from the printhead/mirror motor cable.

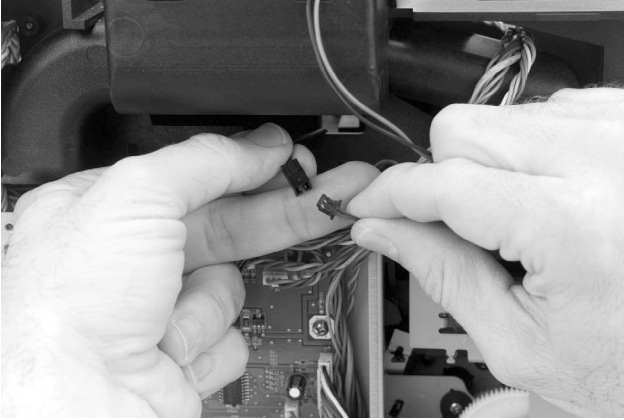

6. Remove the four fuser mounting screws (B) and slide the fuser out of the printer.

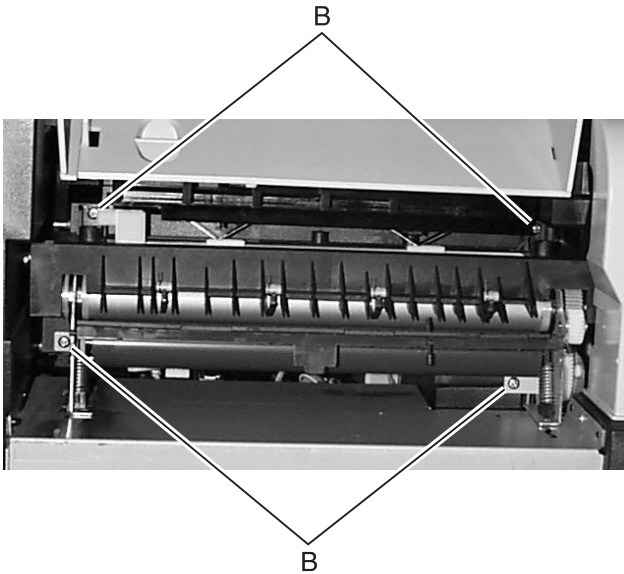



## HVPS

1. Remove the inner deflector.
2. Disconnect the HVPS transfer wire from the HVPS (A).
3. Disconnect the HVPS cable from the HVPS (B).
4. Remove the two screws (C) securing the HVPS and remove the HVPS.

**Note:** Make sure HVPS contacts (D) make good electrical contact with the HVPS.

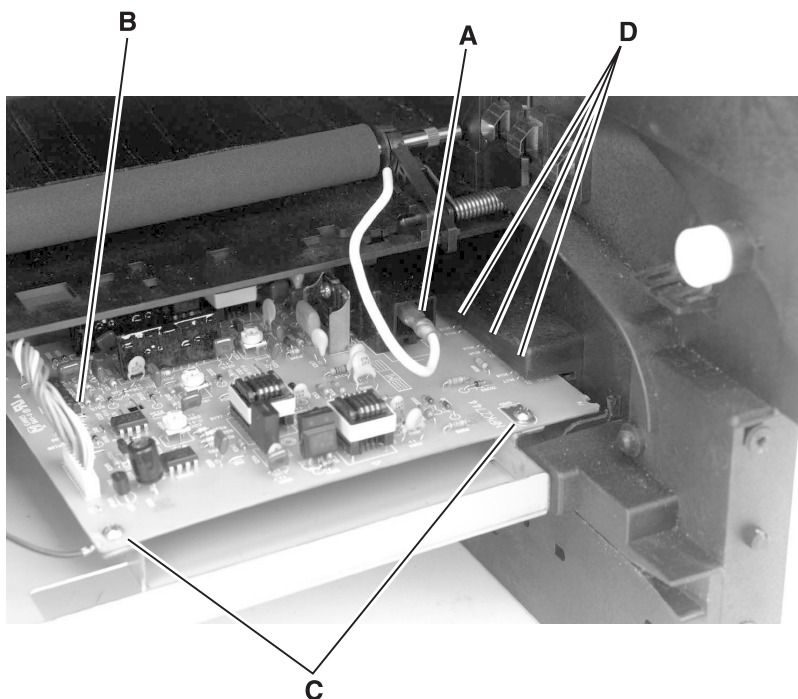

## *Inner Deflector*

1. Open the upper door and multipurpose tray.
2. Remove the screw (A) securing the upper paper deflector and remove the upper paper deflector.

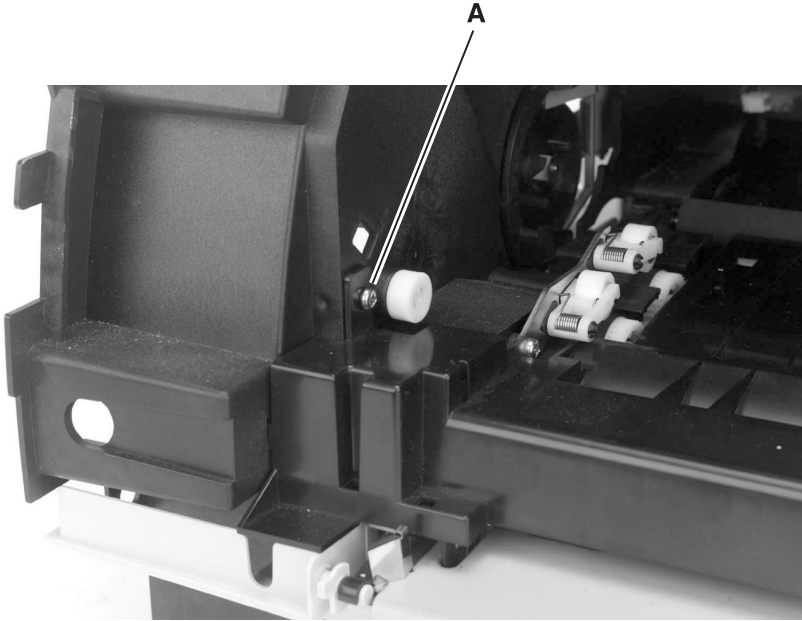

## 4045-XXX

3. Disconnect the MPF paper sensor, remove the four screws (B) securing the MPF and remove the MPF.

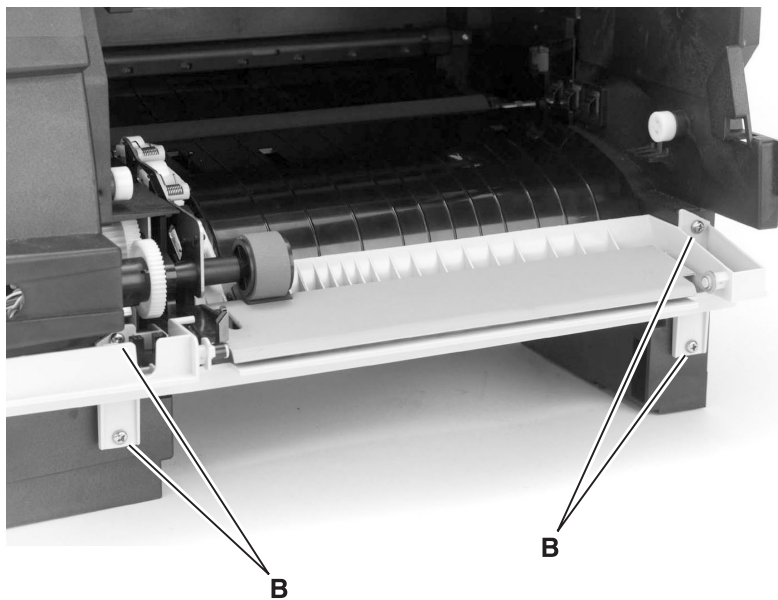

## 4045-XXX

4. Press the snap fittings (C) down to unlock the inner deflector from the printer.
5. Pull the inner deflector toward you. Be careful not to damage the input sensor lever (D).

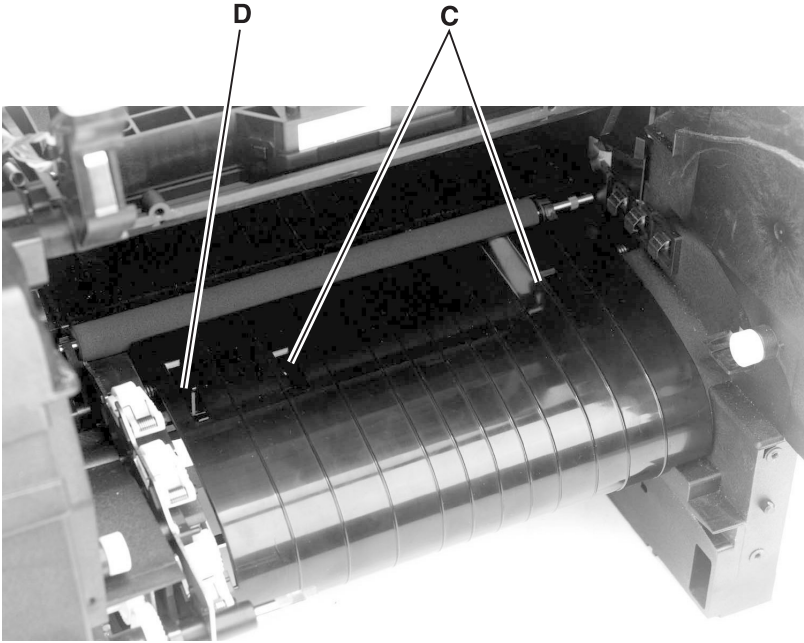

### ***Left Side Frame***

1. Remove the redrive assembly.
2. Remove the paper alignment assembly.
3. Remove the main drive assembly.
4. Remove the rear drive assembly.
5. Remove the end stop and end stop spring from the left hinge.
6. Remove the six screws from the left side frame and remove the frame.

4045-XXX

## LVPS

1. Remove the right side cover.
2. Disconnect the fuser lamp wires from the fuser.
3. Remove the screw (A) from the bottom of the printer.

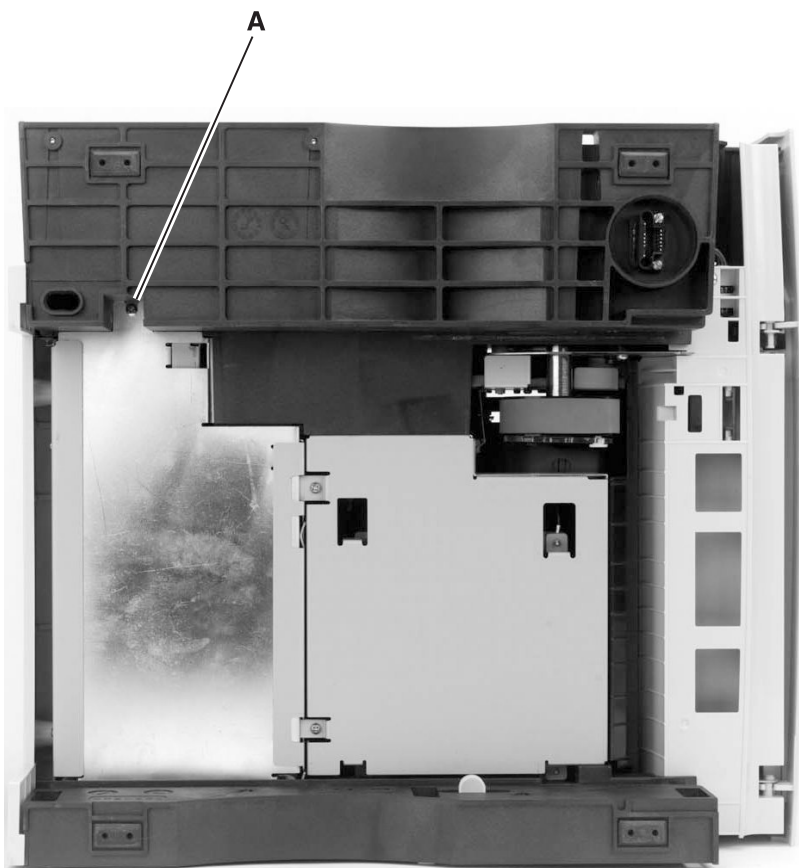

## 4045-XXX

4. Remove the screw covers and remove the two screws (B) from the rear of the printer.
5. Slide the LVPS to the right and remove the LVPS.

**Note:** When you reinstall the LVPS, connect the black fuser lamp wire to the rear contact that is labeled black and the other wire to the front contact.

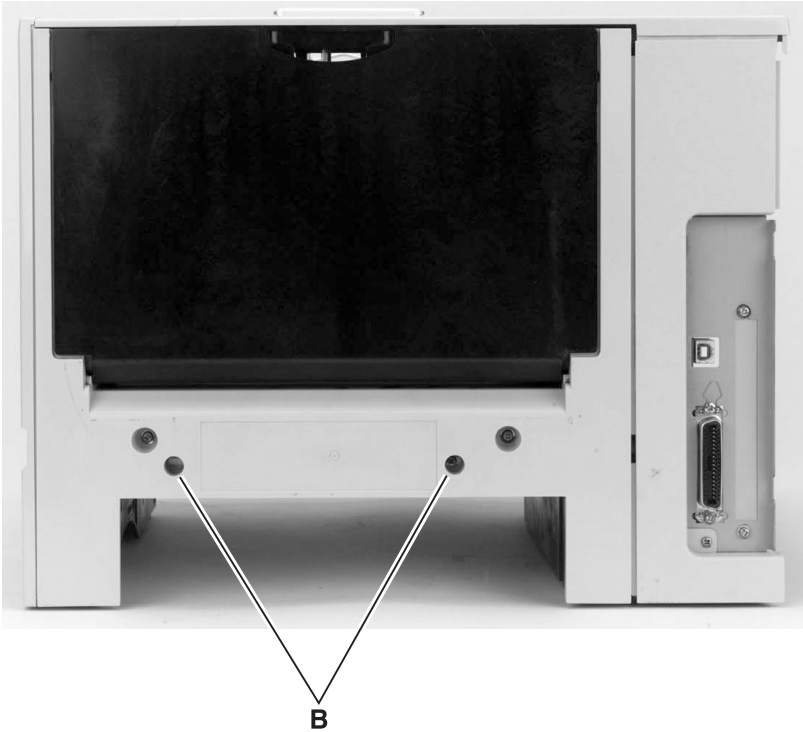

## Main Drive Assembly

1. Remove the developer drive assembly.
2. Remove the engine board and engine board shield.
3. Remove the gear cover.
4. Remove the pick roll solenoid from the main drive assembly.
5. Remove the link (A) from the rear of the main drive assembly.
6. Remove screws (B) securing the main drive assembly.
7. Remove the main drive assembly.

**Note:** Close the front door when you reconnect the link to the main drive assembly.

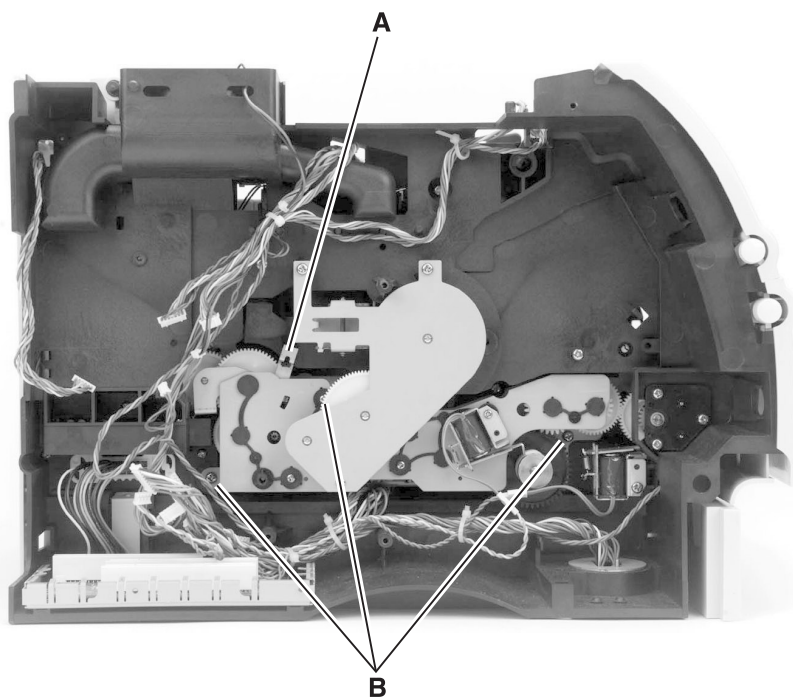

## ***Multipurpose Tray***

1. Open the multipurpose tray to a position that allows the left and right tray hinge slots (A) to align with the rectangular mounting posts (B).
2. Pull upward on each tray hinge to remove the tray from the two mounting posts. Be careful not to break the hinges.

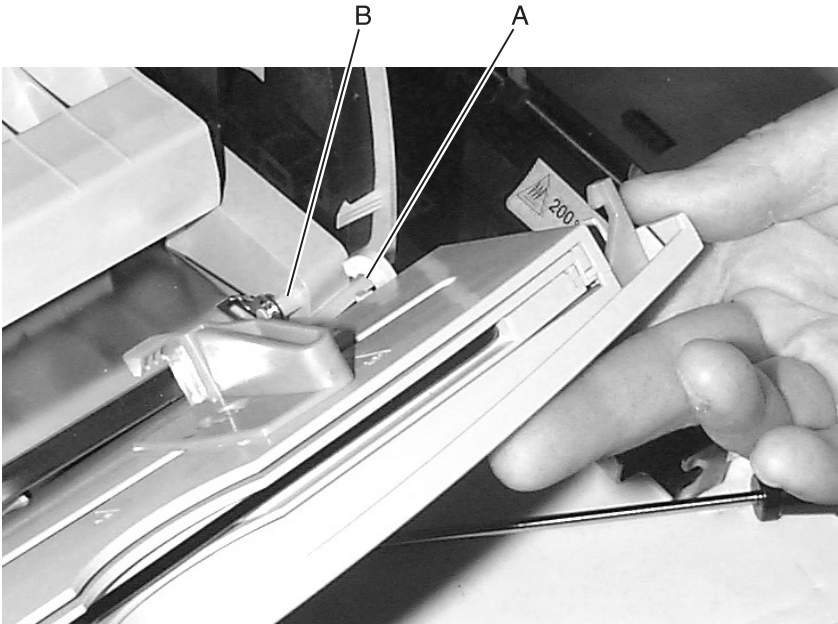



## ***Paper Alignment Assembly***

1. Remove the inner deflector.
2. Remove the pick roll.
3. Remove the paper input sensor.
4. Remove the two screws (A) from the paper alignment assembly located inside the printer.

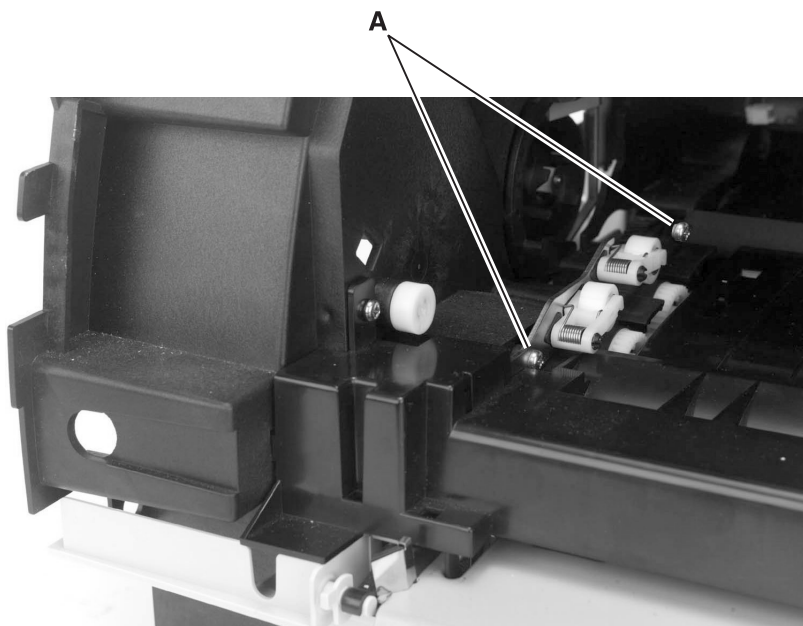

## 4045-XXX

5. Remove the left side cover.
6. Remove the paper alignment adjustment screw (B) from the left side frame.
7. Slide the paper alignment assembly to the right and remove it from the printer.

**Note:** Go to the [“Adjustment Procedures” on page 4-2](#) and perform the paper alignment adjustment whenever the paper alignment assembly is removed or the screws are loosened.

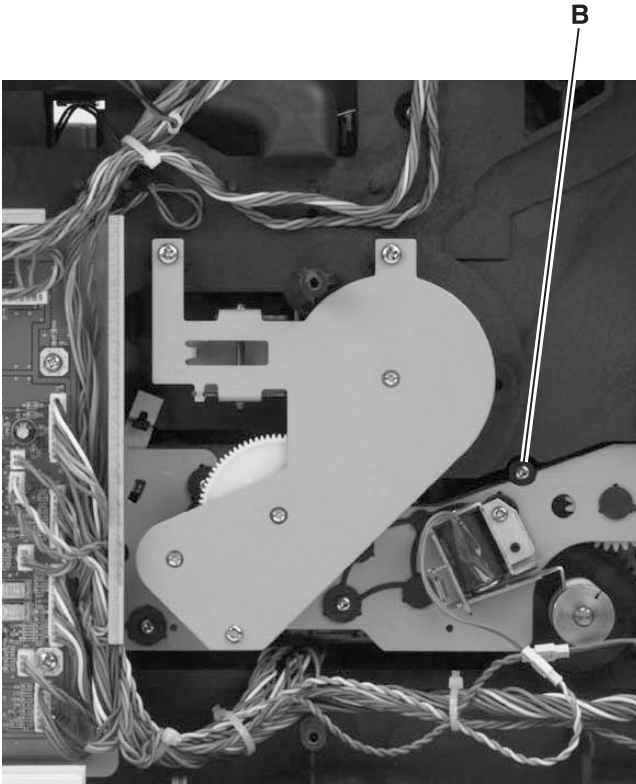

### ***Pick Roll***

1. Remove tray 1.
2. Gain access to the pick roll by positioning the printer on its right side.
3. Pull the pick roll from the pick roll shaft in the direction of the arrow (A) and remove the pick roll.

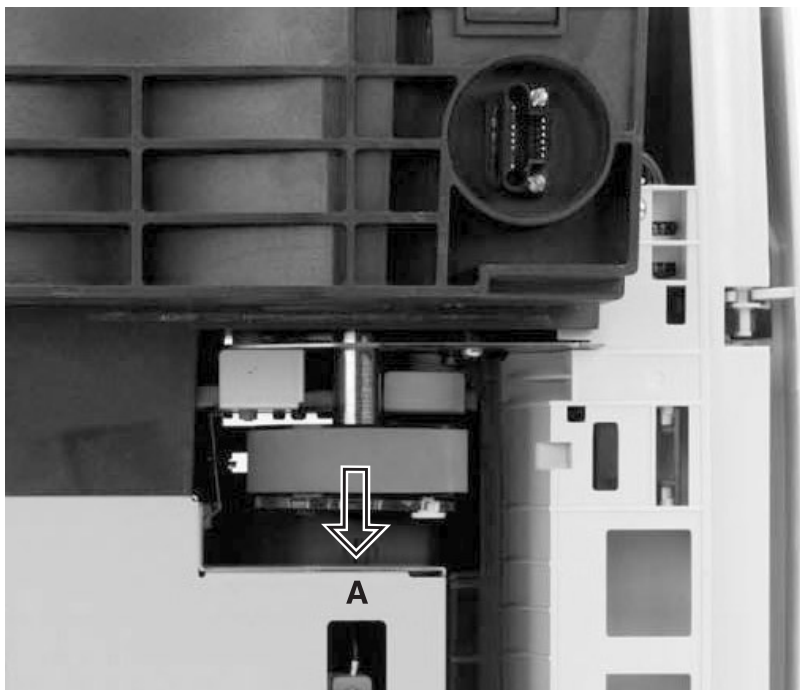

## Printhead

1. Remove the top cover.
2. Disconnect the two printhead cables from the printhead assembly.
3. Remove the three printhead mounting screws (A) and remove the printhead.

**Note:** Go to the [“Adjustment Procedures” on page 4-2](#) and perform the printhead assembly adjustment whenever the printhead is removed or the printhead mounting screws are loosened.

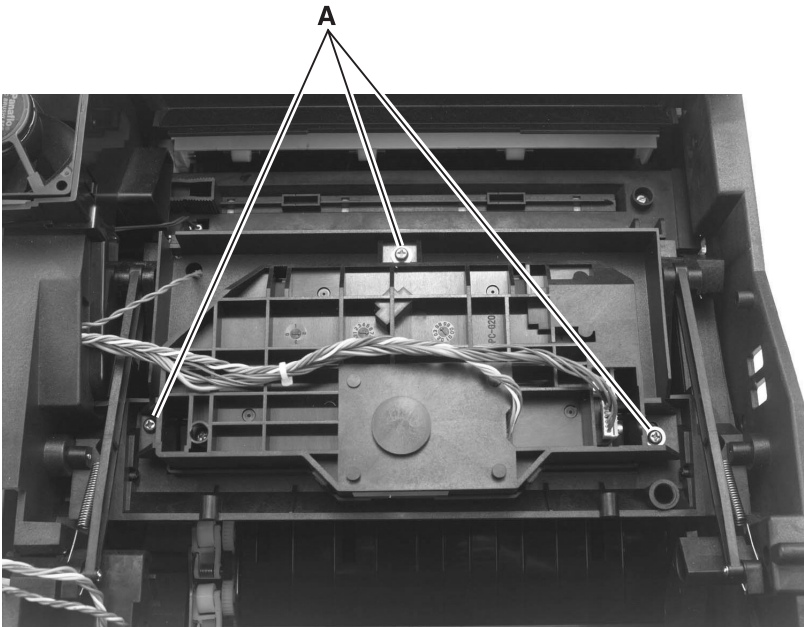

## ***Redrive Assembly***

1. Remove the top cover.
2. Remove the two lower mounting screws (A).
3. Open the rear door and remove the two upper mounting screws (B).
4. Lift the redrive assembly up and away from the rear of the printer.
5. Disconnect the cables from the exit and rear door open sensors and remove the redrive assembly.

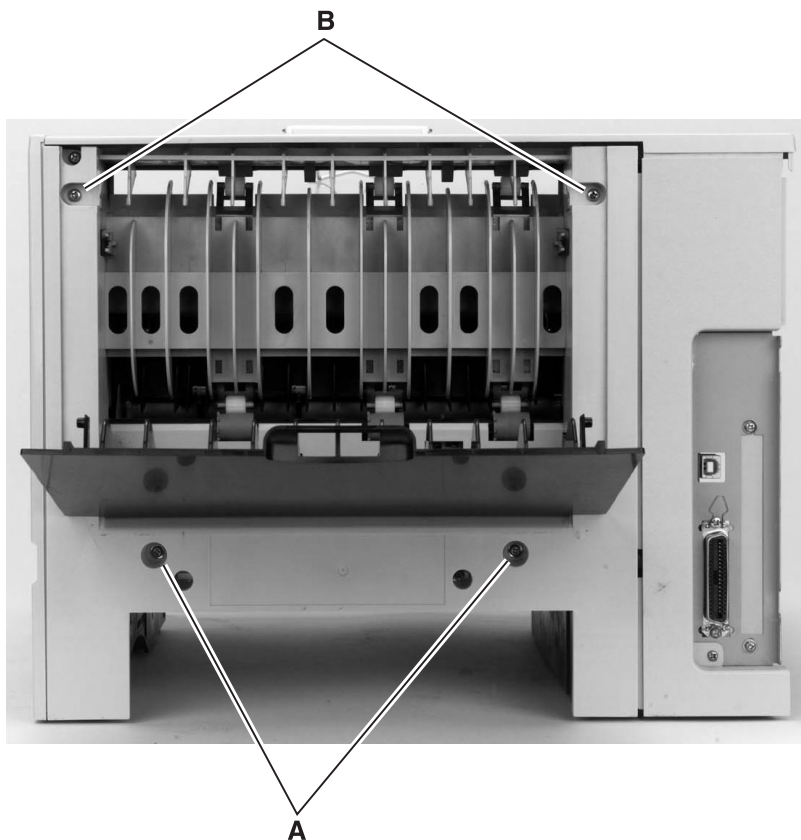

## ***Right Side Frame***

1. Remove the redrive assembly.
2. Remove the inner deflector.
3. Position the printer on its left side.
4. Remove the nine screws from the right side frame.
5. Lift and remove the right side frame from the printer.

## ***Transfer Roller***

1. Open the upper door and multipurpose tray.
2. Remove the print cartridge.
3. Unsnap the transfer roller from the left arm.
4. Slide the transfer roller to the left, removing the roller from the right bearing.

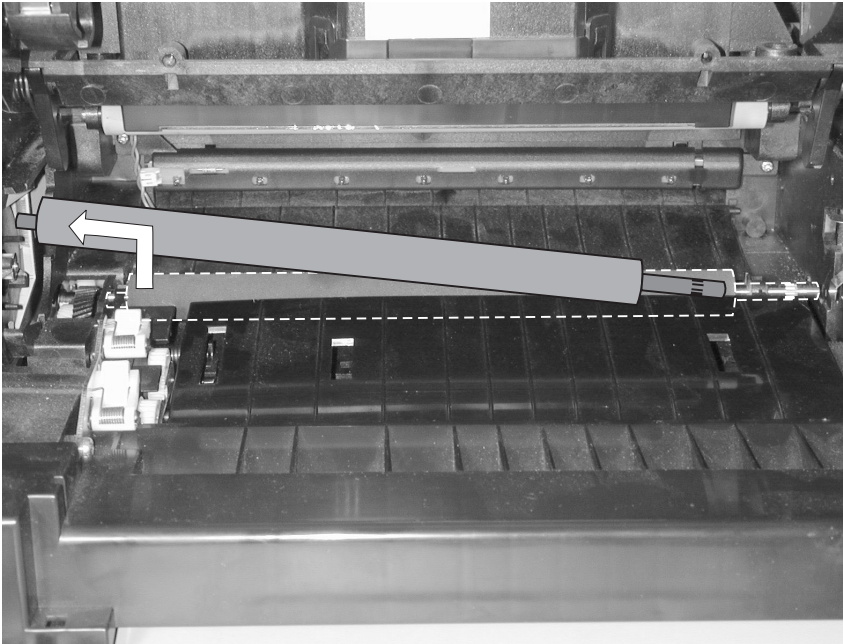

## 5. Connector Locations

### Low Voltage Power Supply

Connector	Pin No.	Signal
CN1 Interconnect Board	1	+5 V dc
	2	+5 V dc
	3	Ground
	4	+24 V dc
	5	+24 V dc
	6	Ground
	7	N/A
	8	+5 V dc
	9	Ground
	10	Ground
	11	+24 V dc
	12	Ground
	13	Ground
	14	Heat On

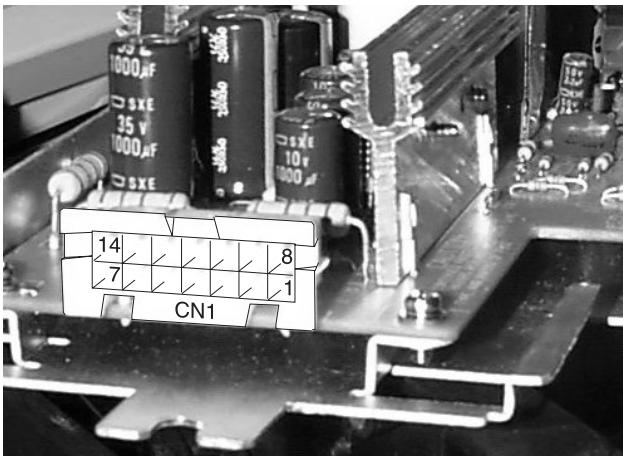

## High Voltage Power Supply

Connector	Pin No.	Signal
CN1 Engine Board	1	Transfer Servo
	2	Transfer Current PWM
	3	Transfer V-Level Enable
	4	Transfer V-Level PWM
	5	Charge Enable
	6	Developer Enable
	7	Developer PWM
	8	+24 V dc
	9	Ground



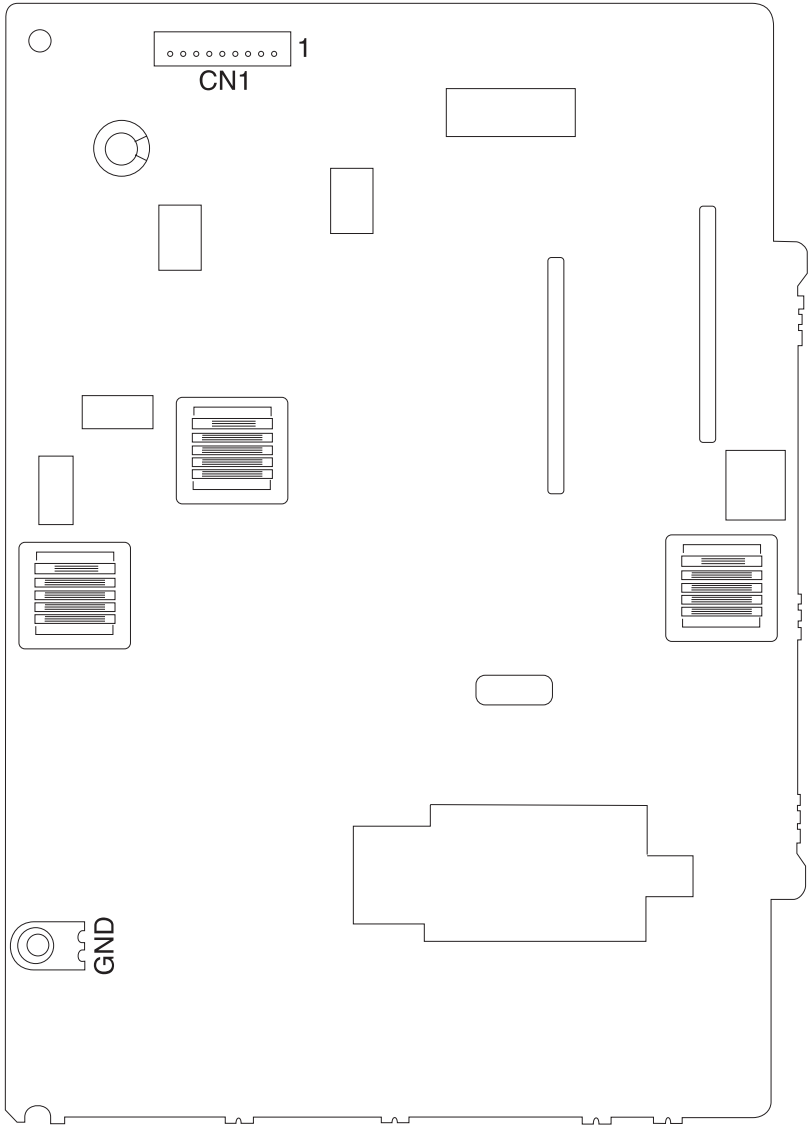

## Engine Board

Connector	Pin No.	Signal
J1 Operational	1	SDA
	2	+5 V dc
	3	SCL
	4	Ground
	5	FPIRQ-
J2 Paper Input Sensor	1	Paper Input Sensor
	2	Ground
	3	LED Drive
J3 Main Motor	1	+24 V dc CVSW
	2	+24 V dc CVSW
	3	Ground
	4	Ground
	5	MMotor Clock
	6	MMotor Enable
	7	MMotor CW+
	8	MMotor Lock
	9	+5 V dc
	10	Ground

## 4045-XXX

Connector	Pin No.	Signal
J4 Cover Open Switch	1	Not Used
	2	Not Used
	3	Not Used
	4	Not Used
	5	Not Used
	6	+5 V dc
	7	Cover Open Switch
	8	Ground
J5 Printhead	1	Adjust
	2	LD Enable
	3	Video
	4	Ground
	5	Ground
	6	+5 V dc
	7	HSYNC
J6 RS232C Interface	X	Not Used
J7 Paper Output Sensor Exit Tray O/C Sensor	1	Paper Out Sensor
	2	Ground
	3	LED Drive
	4	Exit OC Sensor
	5	Ground
	6	LED Drive

**4045-XXX**

<b>Connector</b>	<b>Pin No.</b>	<b>Signal</b>
J8 Printhead (Mirror Motor) Fuser Temp Sensor	1	PMotor Clock
	2	PMotor Lock
	3	PMotor Enable
	4	Ground
	5	+24 V dc
	6	+5 V dc
	7	HTEMP-
J9 HVPS	1	Transfer Servo
	2	Transfer Current PWM
	3	Transfer V-Level PWM
	4	Transfer V-Level PWM
	5	Charge Enable
	6	Developer Enable
	7	Developer PWM
	8	+24 V CVSW
	9	Ground

## 4045-XXX

Connector	Pin No.	Signal
J10 Option (Integrated) Paper Tray	1	Tray1 Present Sensor
	2	N/A
	3	Tray2 Paper Sensor
	4	N/A
	5	Tray2 Present Sensor
	6	N/A
	7	+24 V dc
	8	T2M1ON
	9	T2M2ON
	10	N/A
	11	Ground
	12	Ground
J11 MMF/D-Roll	1	+24 V dc
	2	MMF Solenoid
	3	+24 V dc
	4	Tray 1 Solenoid
J12 Erase Lamp	1	+24 V dc
	2	Erase Lamp PWM
J13 Fan Motor	1	+24 V dc/+12 V dc FAN
	2	Fan Enable
J14	X	Not Used
J15 Interconnect Board	N/A	N/A
J16	X	Not Used

**4045-XXX**

<b>Connector</b>	<b>Pin No.</b>	<b>Signal</b>
J17 MMF Input Sensor	1	MMF Paper Input Sensor
	2	Ground
	3	+5 V dc

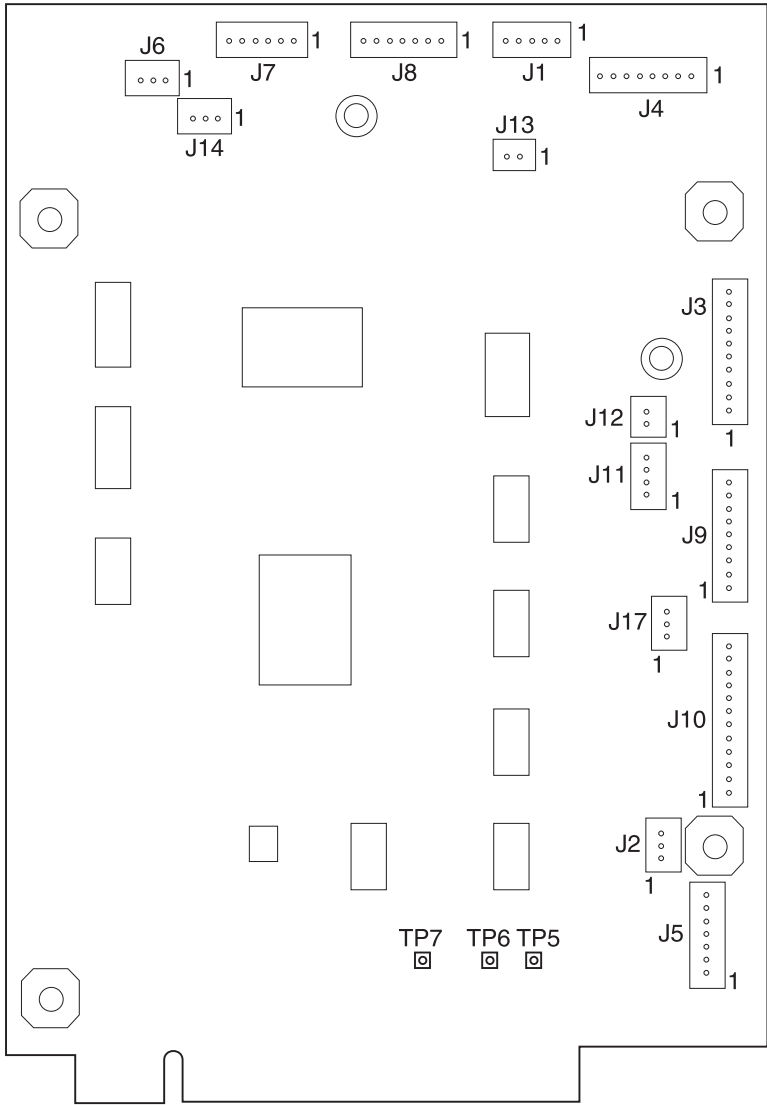

## Interconnect Board

Connector	Pin No.	Signal
J21 INA	1	N/A
J22 Controller Board	1	N/A
J23 LVPS	1	+5 V dc
	2	+5 V dc
	3	+5 V dc
	4	Ground
	5	Ground
	6	Ground
	7	+24 V dc
	8	+24 V dc
	9	+24 V dc
	10	Ground
	11	Ground
	12	Ground
	13	N.C.
	14	Heat On
J24 Engine Board	1	N/A
J25	X	Not Used



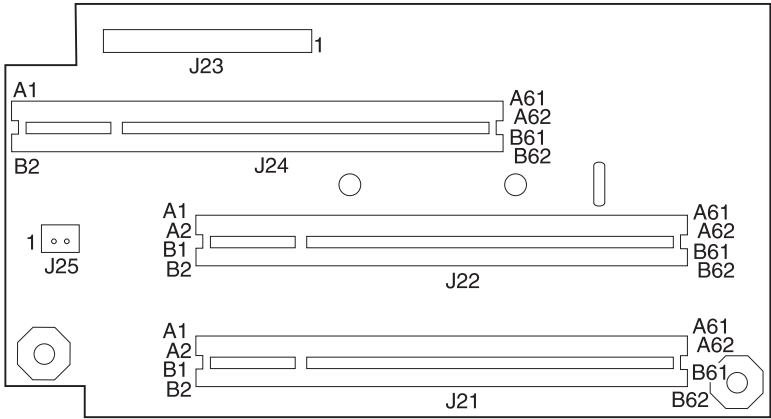

## Option Tray Board

Connector	Pin No.	Signal
J1 Option (Integrated) Paper Tray	1	Tray 1 Present Sensor
	2	N/A
	3	Tray 2 Paper Sensor
	4	N/A
	5	Tray 2 Present Sensor
	6	N/A
	7	+24 V dc CVSW
	8	T2M1ON
	9	T2M2ON
	10	N/A
	11	Ground
J2 Tray 1 Present	1	Tray 1 Present Sensor
	2	Ground
	3	LED Drive
J3	X	Not Used
J4 Tray 2 Motor	1	Motor ON
	2	Ground
J5 Tray 2 Solenoid	1	+24 V dc CVSW
	2	Solenoid ON

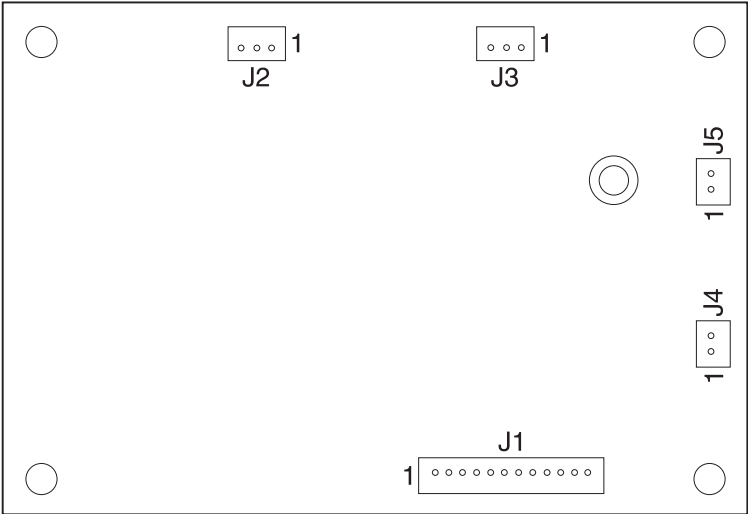

**4045-XXX**

---

## 6. Parts Catalog

---

### How To Use This Parts Catalog

---

- **SIMILAR ASSEMBLIES:** If two assemblies contain a majority of identical parts, they are shown on the same list. Common parts are shown by one index number. Parts peculiar to one or the other of the assemblies are listed separately and identified by description.
- **AR: (As Required)** in the Units column indicates that the quantity is not the same for all machines.
- **NS: (Not Shown)** in the Asm-Index column indicates that the part is procurable but is not pictured in the illustration.
- **PP: (Parts Packet)** in the parts description column indicates the part is contained in a parts packet.
- **INDENTURE:** The indenture is marked by a series of dots located before the parts description. The indenture indicates the relationship of a part to the next higher assembly. For example:

#### INDENTURE RELATIONSHIP OF PARTS

(No dot) MAIN ASSEMBLY

(One dot) o Detail parts of a main assembly

(One dot) o Subassembly of the main assembly

(Two dot) o o Detail part of a one-dot subassembly

(Two dot) o o Subassembly of a one-dot subassembly

# Assembly 1: Covers

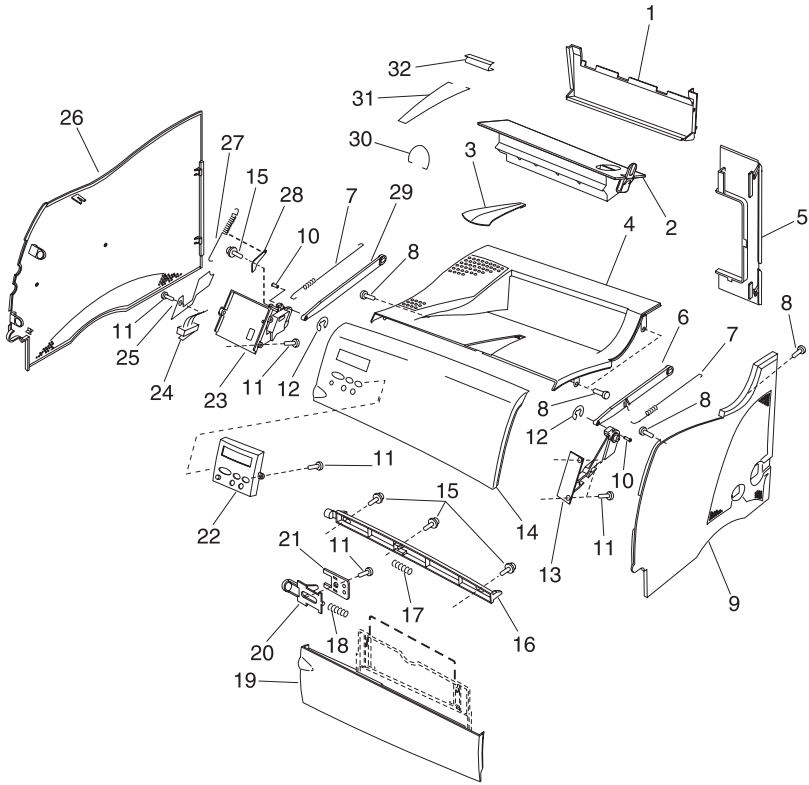

<b>Asm-Index</b>	<b>Part Number</b>	<b>Units</b>	<b>Description</b>
1-1	12G0258	1	Cover, Exit
1-2	12G0259	1	Duct, Fuser Cooling Air
1-3	12G0254	1	Support, Paper
1-3	1263566	1	Bail Assembly, Optional
1-4	12G0253	1	Cover, Top
1-5	12G0257	1	Cover, Rear
1-6	12G0428	1	Link, Right Hinge
1-7	12G0267	2	Link, Spring
1-8		6	Screw, M4x8 PP 12G0445
1-9	12G0256	1	Cover, Right Side
1-10	12G0426	2	Pin, Hinge
1-11		10	Screw, M3x8 PP 12G0445
1-12		2	Clip, PP 12G0445
1-13	12G0427	1	Hinge, Right
1-14	12G0260	1	Cover, Upper Front M410
1-14	12G3550	1	Cover, Upper Front M412
1-15		4	Screw w/washer, M3x8 PP12G0445
1-16	12G0264	1	Hook, Upper
1-17	12G0265	1	Spring, Upper Hook
1-18	12G0431	1	Spring, MPF Latch
1-19	12G0266	1	Tray, MPF Input
1-20	12G0430	1	Latch, MPF Tray
1-21	12G0429	1	Cover, MPF Latch
1-22	12G0440	1	Panel Asm, Operator, 110V
1-22	12G0441	1	Panel Asm, Operator, 220V
1-23	12G0424	1	Hinge, Left
1-24	12G1860	1	Cable Asm, Op Panel & Cover Open Switch
1-25	12G0262	1	Cover, Left Hinge
1-26	12G0255	1	Cover, Left Side
1-27	12G0269	1	Spring, End Stop

### Assembly 1: Covers (continued)

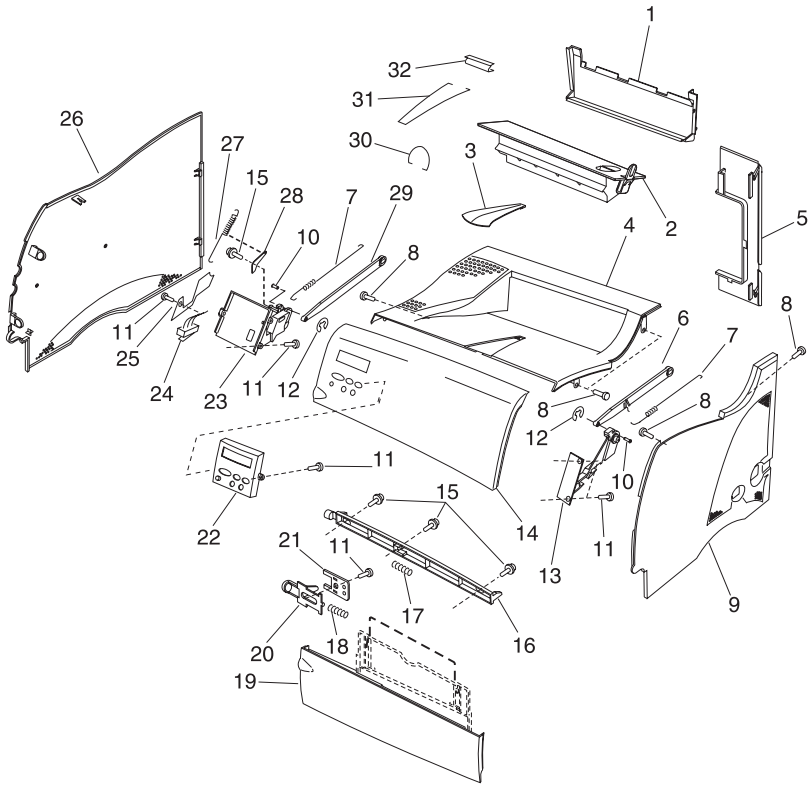



**4045-XXX**

<b>Asm-Index</b>	<b>Part Number</b>	<b>Units</b>	<b>Description</b>
1-28	12G0268	1	Stop, End
1-29	12G0425	1	Link, Left Hinge
1-30	12G0437	1	Bail, Optional Front Paper
1-31	12G0438	1	Bail, Main Rear Paper
1-32	12G0439	1	Holder, Rear Paper Bail
NS	12G3701	1	Overlay NLS pack: English, French, German, Italian, Spanish, Danish, Dutch, Norwegian, Swedish, Finnish
NS	12G3702	1	Overlay XNLS pack: Czech, Hungarian, Polish, Russian, Turkish
NS	12G3703	1	Overlay pack: French/Canadian

## Assembly 2: Frame

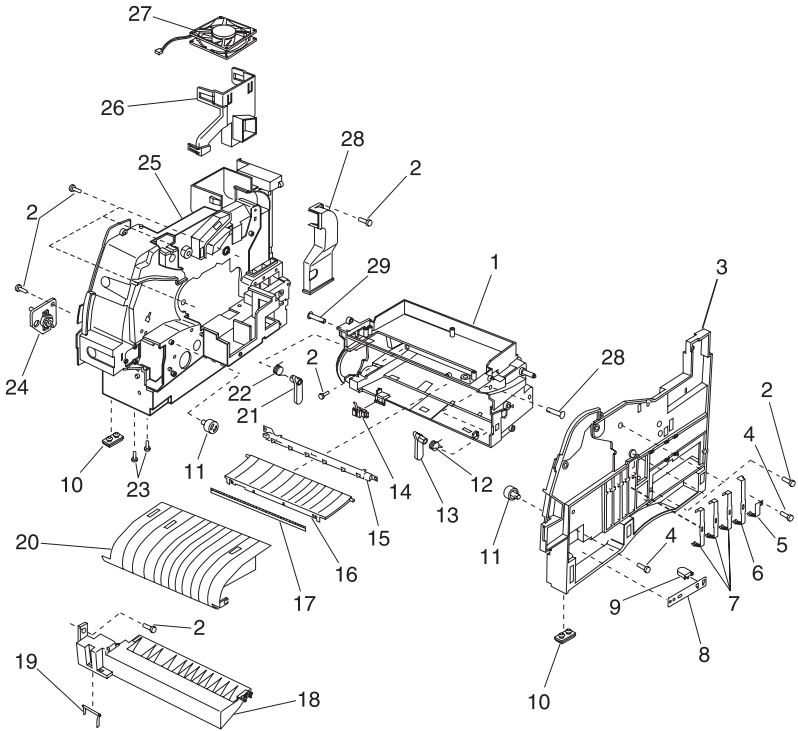

**4045-XXX**

<b>Asm-Index</b>	<b>Part Number</b>	<b>Units</b>	<b>Description</b>
2-1	12G0274	1	Frame, Base
2-2		8	Screw, M4x12 PP 12G0445
2-3	12G0288	1	Frame, Right Side
2-4		2	Screw, M3x8 PP 12G0445
2-5	12G0291	1	Contact, HVPS Charge
2-6	12G0290	1	Contact, HVPS Drum
2-7	12G0289	3	Contact, HVPS Drum
2-8	12G0293	1	Spring, Cartridge Locate
2-9	12G0292	1	Pin, Cartridge Locate
2-10	12G0250	4	Foot, Rubber
2-11	12G0423	2	Support, Cartridge
2-12	12G0277	1	Spring, IC Locate Arm, Right
2-13	12G0275	1	Arm, IC Locate, Right
2-14	12G3560	1	Sensor, Paper Input
2-15	12G0451	1	LED Asm, Erase
2-16	12G0281	1	Guide, Middle Paper
2-17	12G0282	1	Brush, Erase
2-18	12G0296	1	Guide, Paper
2-19	12G0295	1	Lever, Input Sensor
2-20	12G0280	1	Guide, Front Paper
2-21	12G0276	1	Arm, IC Locate, Left
2-22	12G0278	1	Spring, IC Locate Arm, Left
2-23		2	Screw, M4x8 PP 12G0445
2-24	12G0294	1	Plate Asm, MPF
2-25	12G0283	1	Frame, Left Side
2-26	12G0285	1	Duct, Fuser Cooling Air
2-27	12G0284	1	Cable & Fan Asm, Cooling
2-28	12G0286	1	Cover, Inner Air Duct
2-29	12G0279	2	Pin, IC Locate Arm

4045-XXX

## Assembly 3: Printhead

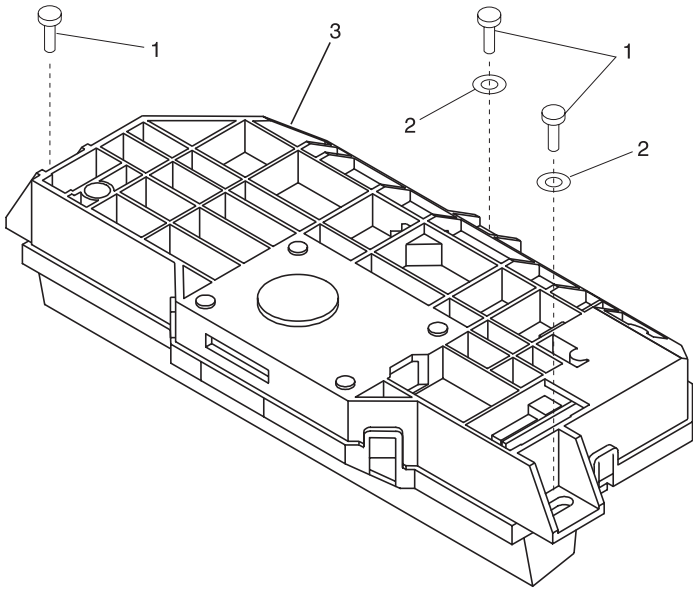

**4045-XXX**

<b>Asm-Index</b>	<b>Part Number</b>	<b>Units</b>	<b>Description</b>
3-1		3	Screw, M4x12 PP 12G0445
3-2		2	Washer, PP 12G0445
3-3	12G0298	1	Printhead, Complete M410
3-3	12G3551	1	Printhead, Complete M412

### Assembly 4: Paper Feed - Multipurpose Unit

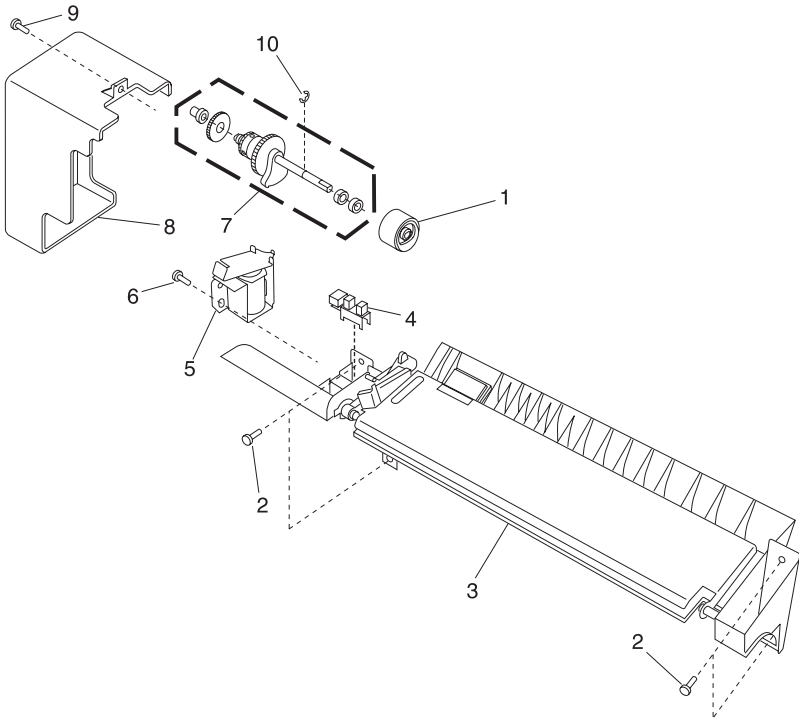

**4045-XXX**

<b>Asm-Index</b>	<b>Part Number</b>	<b>Units</b>	<b>Description</b>
4-1	12G0299	1	Roller Asm, MPF Pick
4-2		4	Screw, M4x12 PP 12G0445
4-3	12G0301	1	Feeder Asm, MPF
4-4	12G0252	1	Sensor, MPF Input
4-5	12G0251	1	Solenoid, MPF Pick Roller
4-6		1	Screw, M3x8 PP 12G0445
4-7	12G0300	1	Shaft Asm, MPF Pick Roller
4-8	12G0302	1	Cover, Gear
4-9		1	Screw, M4x8 PP 12G0445
4-10		1	Clip, PP 12G0445

## Assembly 5: Paper Feed - Alignment

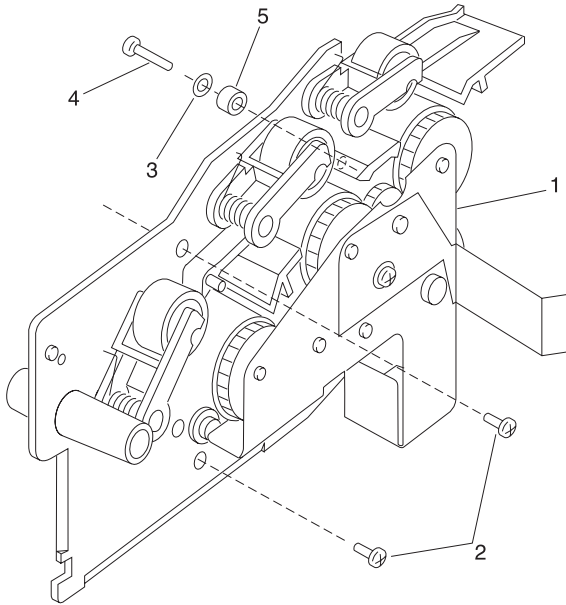



**4045-XXX**

<b>Asm-Index</b>	<b>Part Number</b>	<b>Units</b>	<b>Description</b>
5-1	12G0303	1	Aligner Asm, Paper Feed
5-2		2	Screw, M4x8 PP 12G0445
5-3		1	Spring Washer, PP 12G0445
5-4		1	Screw, Adjustment M3x16 PP 12G0445
5-5	12G0452	1	Spacer, Adjustment Screw

### Assembly 6: Paper Feed - Output

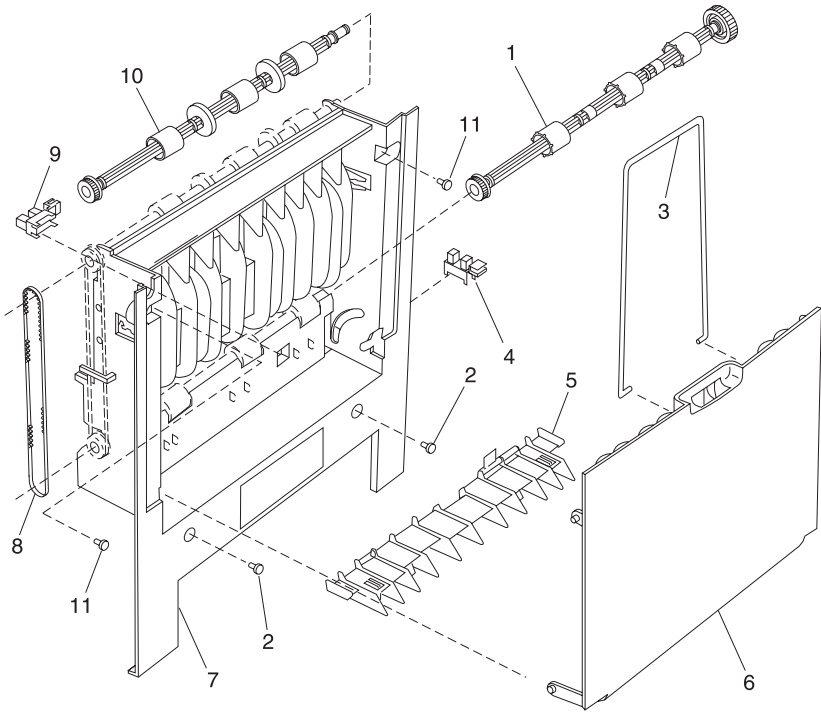

**4045-XXX**

<b>Asm-Index</b>	<b>Part Number</b>	<b>Units</b>	<b>Description</b>
6-1	12G0308	1	Roller, Lower Redrive
6-2		2	Screw, M3x6 PP 12G0445
6-3	12G0305	1	Bail, Rear Door Paper
6-4	12G0252	1	Sensor, Rear Door
6-5	12G0309	1	Deflector, Paper
6-6	12G0304	1	Door, Rear
6-7	12G0306	1	Frame, Rear Paper Exit
6-8	12G0310	1	Belt, Redrive Roller
6-9	12G0252	1	Sensor, Paper Exit
6-10	12G0307	1	Roller, Upper Redrive
6-11		2	Screw, M4x8 PP 12G0445

## Assembly 7: Main Drive

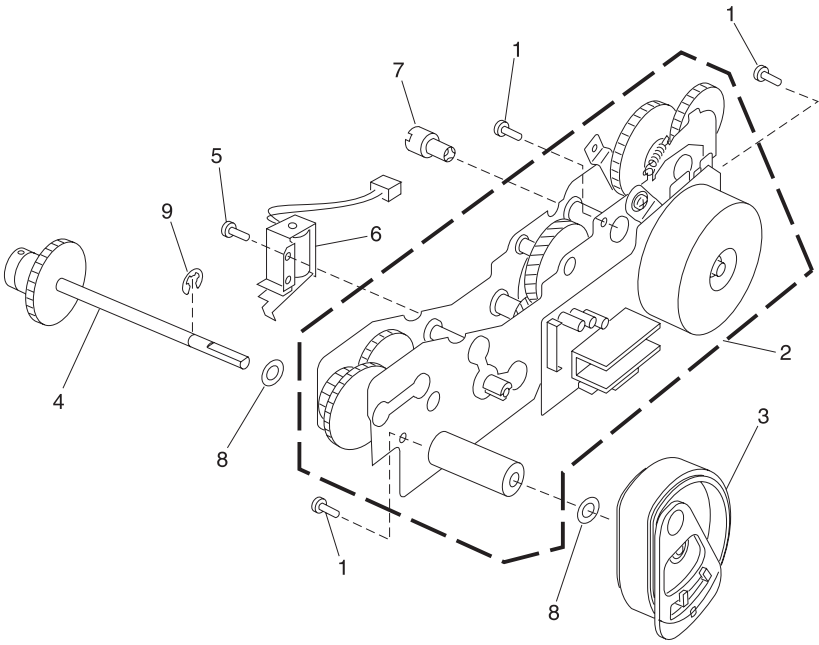

**4045-XXX**

<b>Asm-Index</b>	<b>Part Number</b>	<b>Units</b>	<b>Description</b>
7-1		3	Screw, M4x12 PP 12G0445
7-2	12G0321	1	Drive Asm, Main M410
7-2	12G3552	1	Drive Asm, Main M412
7-3	12G0323	1	Roller, Pick
7-4	12G0322	1	Shaft Asm, Pick Roller
NS	12G3673	1	Clutch Spring, Pick Roller
7-5		1	Screw, M3x8 PP 12G0445
7-6	12G0443	1	Solenoid, Main Pick Roller
7-7	12G0324	1	Coupling, Spline Drive
7-8		2	Washer, PP12G0445
7-9		1	Clip, PP12G0445

## Assembly 8: Developer Drive

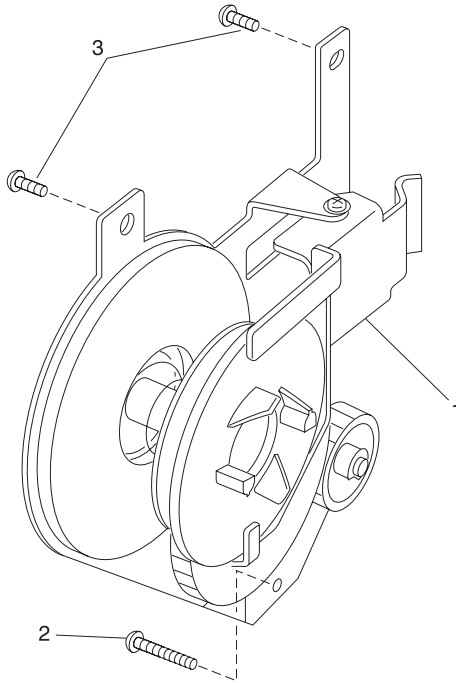

**4045-XXX**

<b>Asm-Index</b>	<b>Part Number</b>	<b>Units</b>	<b>Description</b>
8-1	12G0325	1	Drive Asm, Developer
8-2		1	Screw, M3x25 PP12G0445
8-3		2	Screw, M4x12 PP12G0445

# Assembly 9: Fuser

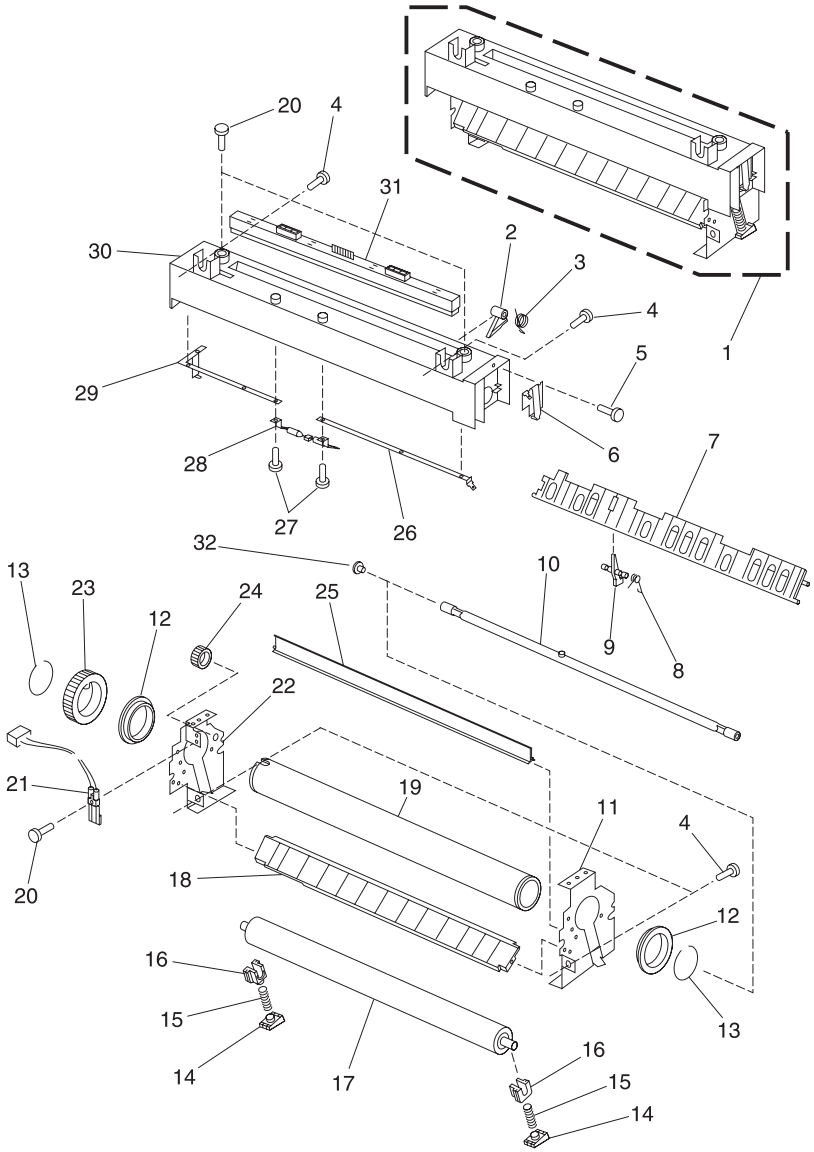



**4045-XXX**

<b>Asm-Index</b>	<b>Part Number</b>	<b>Units</b>	<b>Description</b>
9-1	12G0351	1	Fuser Asm, 115V M410
9-1	12G3554	1	Fuser Asm, 115V M412
9-1	12G0352	1	Fuser Asm, 220V M410
9-1	12G3555		Fuser Asm, 220V M412
9-2	12G0331	4	Finger, Detack
9-3	12G0344	4	Spring, Detack Finger
9-4		4	Screw, M4x12 PP 12G0445
9-5		3	Screw, M3x8SW PP 12G0445
9-6	12G0343	1	Contact, Fuser Lamp, Rear
9-7	12G0347	1	Guide, Fuser Paper Exit
9-8	12G0349	1	Spring, Exit Sensor Lever
9-9	12G0348	1	Lever, Paper Exit Sensor
9-10	12G0328	1	Lamp, 115V M410
9-10	12G0329	1	Lamp, 220V M410
9-10	12G3562	1	Lamp, 115V M412
9-10	12G3563	1	Lamp, 220V M412
9-11	12G0339	1	Frame, Right Fuser
9-12	12G0330	2	Bushing, Hot Roll
9-13	12G0334	2	Clip, Gear Retaining
9-14	12G0337	2	Stand, Bushing Spring
9-15	12G0336	2	Spring, Roller Bushing M410
9-15	12G3553	2	Spring, Roller Bushing M412

### Assembly 9: Fuser (continued)

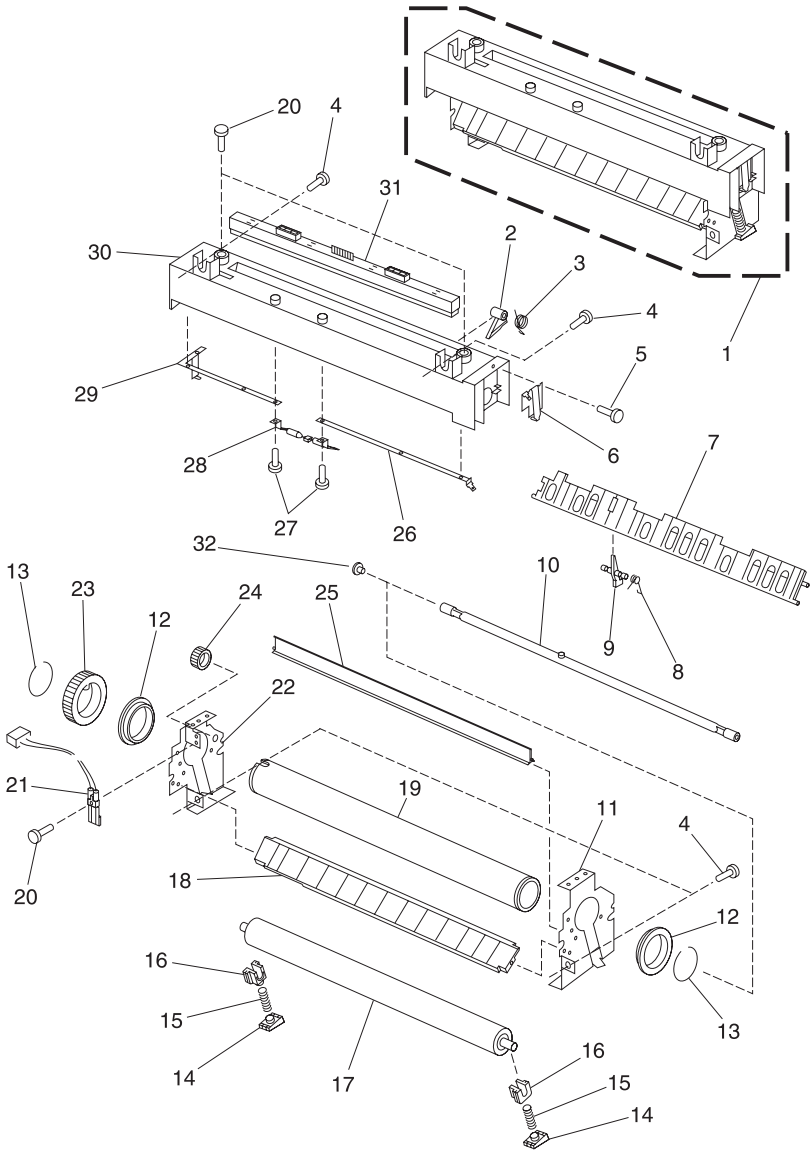

**4045-XXX**

<b>Asm-Index</b>	<b>Part Number</b>	<b>Units</b>	<b>Description</b>
9-16	12G0335	2	Bushing, Backup Roller
9-17	12G0327	1	Roller, Fuser Backup M410
9-17	12G3561	1	Roller, Fuser Backup M412
9-18	12G0350	1	Guide, Fuser Paper Entry
9-19	12G0326	1	Hot Roll, Fuser
9-20		3	Screw, M3x8 PP 12G0445
9-21	12G0353	1	Thermistor, Fuser
9-22	12G0338	1	Frame, Left Fuser
9-23	12G0332	1	Gear, Hot Roll
9-24	12G0346	1	Gear, Fuser Idler
9-25	12G0446	1	Guide, Upper Fuser Entry
9-26	12G0342	1	Contact, Fuser Lamp, Front
9-27		2	Screw, M3x5 PP 12G0445
9-28	12G0333	1	Fuse, Thermal
9-29	12G0341	1	Contact, Lamp to Fuse
9-30	12G0340	1	Cover, Fuser
9-31	12G0345	1	Wiper, Fuser
9-32	12G0453	1	Cover, Lamp

4045-XXX

## Assembly 10: Transfer

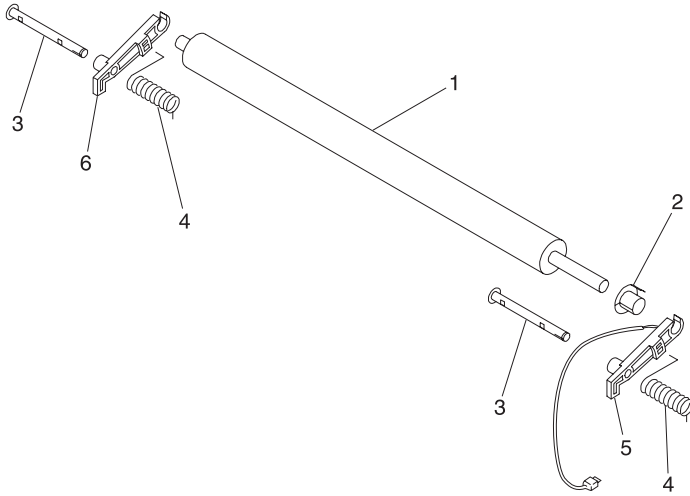

**4045-XXX**

<b>Asm-Index</b>	<b>Part Number</b>	<b>Units</b>	<b>Description</b>
10-1	12G0354	1	Roller, Transfer
10-2	12G0358	1	Bushing, Right Roller
10-3	12G0355	2	Pin, Transfer Roller
10-4	12G0359	2	Spring, Transfer Roller
10-5	12G0357	1	Arm, Right Transfer Roller
10-6	12G0356	1	Arm, Left Transfer Roller

4045-XXX

## Assembly 11: Charging

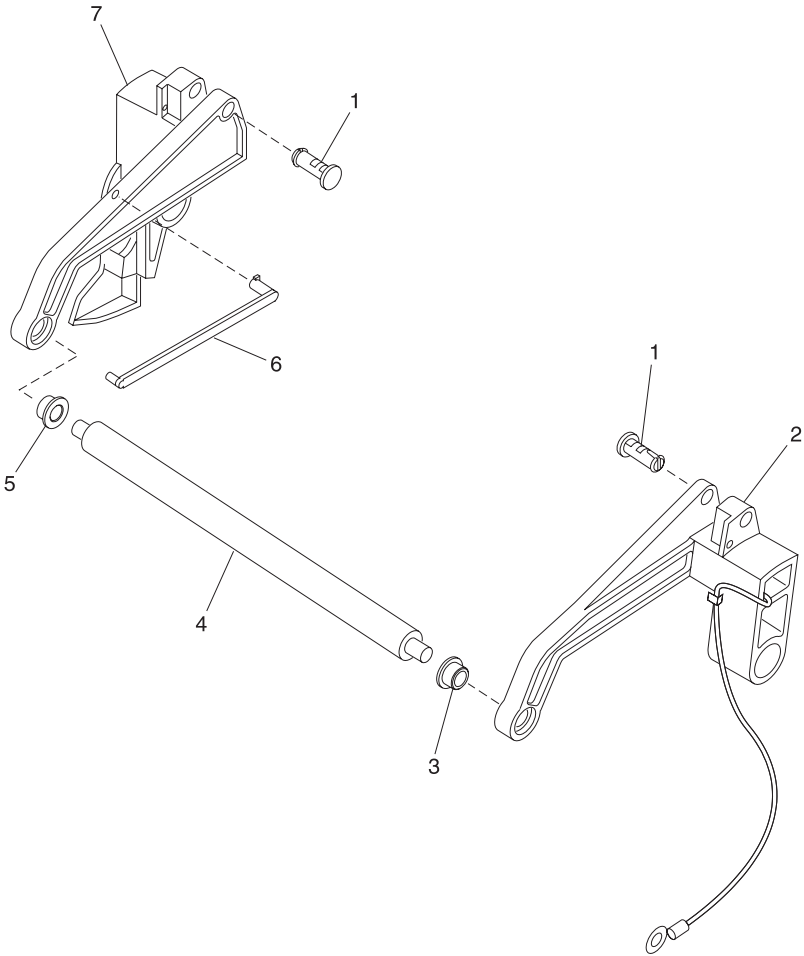

**4045-XXX**

<b>Asm-Index</b>	<b>Part Number</b>	<b>Units</b>	<b>Description</b>
11-1	12G0364	2	Pin, Charge Roller Arm
11-2	12G0362	1	Arm, Right Charge Roller
11-3	12G0358	1	Bushing, Right Roller
11-4	12G0360	1	Roller, Charge
11-5	12G0363	1	Bushing, Left Charge Roller
11-6	12G0365	1	Link, Developer Drive Engage
11-7	12G0361	1	Arm, Left Charge Roller

# Assembly 12: Electronics

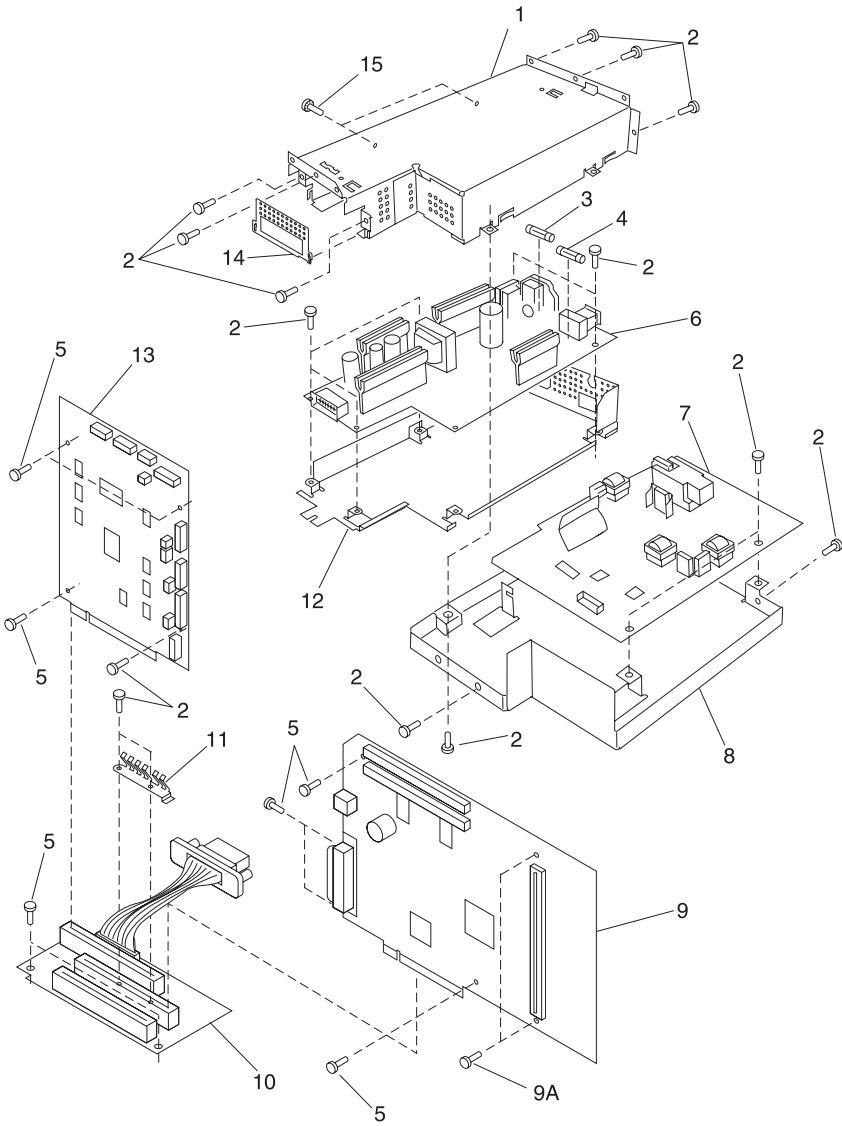



**4045-XXX**

<b>Asm-Index</b>	<b>Part Number</b>	<b>Units</b>	<b>Description</b>
12-1	12G0367	1	Frame, Upper LVPS
12-2		26	Screw, M3x6 PP 12G0445
12-3	12G0370	1	Fuse, 4A, 110V
12-3	12G0373	1	Fuse, 2A, 220V
12-4	12G0371	1	Fuse, 12A, 110V
12-4	12G0374	1	Fuse, 6.3A, 220V
12-5		12	Screw, M3x5 PP 12G0445
12-6	12G0369	1	Card Asm, LVPS 110V
12-6	12G0372	1	Card Asm, LVPS 220V
12-7	12G0376	1	Card Asm, HVPS
12-8	12G0366	1	Base Plate, HVPS
12-9	12G3567	1	Card Asm, Controller/RIP M410
12-9	12G3556	1	Card Asm, Controller/RIP M412
12-9A		2	Screw, M4x8 PP 12G0445
12-10	12G0379	1	Card Asm, Interconnect
12-11	12G0380	1	Contact, Ground
12-12	12G0375	1	Frame, Lower LVPS
12-13	12G0378	1	Card Asm, Engine M410
12-13	12G3557	1	Card Asm, Engine M412
12-14	12G0368	1	Cover, LVPS Connector
12-15		3	Screw w/Starwasher, M3x6 PP 12G0445



**4045-XXX**

<b>Asm-Index</b>	<b>Part Number</b>	<b>Units</b>	<b>Description</b>
12-16	12G0381	1	Shield, Controller Board
12-16A		2	Screw, M3x6T PP 12G0445
12-17		9	Screw, M4x8 PP 12G0445
12-17A		1	Screw, M3x25 PP 12G0445
12-18	12G0384	1	Shield, Engine Board
12-19	12G0383	1	Shield, Interface Board
12-20	12G0382	1	Cover, Controller Bd Shield
12-21	12G0385	1	Cover, Blank Bus
12-22	12G0436	1	Cover, Internal Gear

### Assembly 12: Electronics (continued)

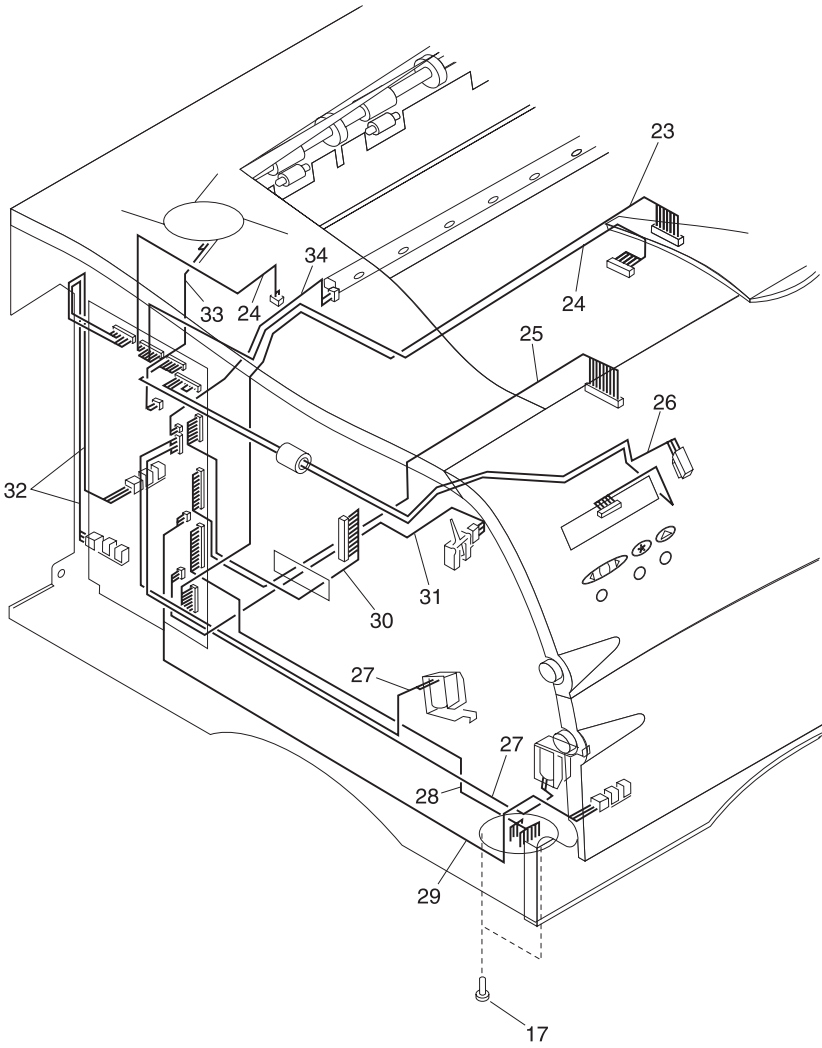

4045-XXX

Asm-Index	Part Number	Units	Description
12-23	12G0422	1	Cable, Printhead
12-24	12G0413	1	Cable, Thermistor & Mirror Motor
12-25	12G0420	1	Cable, HVPS
12-26	12G1860	1	Cable Asm, Op Panel & Cover Open Switch
12-27	12G0411	1	Cable, Solenoid
12-28	12G0421	1	Cable, Tray 2 M410
12-28	12G3559	1	Cable, Tray 2 M412
12-29	12G0417	1	Cable, MPF Paper Present Sensor
12-30	12G0419	1	Cable, Main Motor
12-31	12G0418	1	Cable, Paper Input Sensor
12-32	12G0412	1	Cable, Rear Door & Exit Sensor
12-33	12G0284	1	Cable & Fan Asm, Cooling
12-34	12G0416	1	Cable, Erase LED
NS	1342530	1	Power Cord Set, Brazil (HV)
NS	1342534	1	Power Cord Set, 8 ft. - Chile (HV)
NS	1339535	1	Power Cord Set, 8 ft. - U.S., Canada (LV), Nicaragua, Venezuela, Peru (LV), Bolivia, Colombia, Costa Rica, Ecuador, El Salvador, Guatemala, Honduras, Mexico, Panama, Brazil (LV)
NS	1342536	1	Power Cord Set, 6 ft. - Argentina (HV), Paraguay (HV), Uruguay (HV), APG (LV)
NS	1339537	1	Power Cord Set, 8 ft. - U.K., Ireland, Finland, Bahrain, Qatar, Oman, Jordan, Iraq, Kuwait, Yeman, Egypt, Sudan, Saudi Arabia
NS	1339538	1	Europe, 6 ft.
NS	1339539	1	Power Cord Set, 6 ft. - Israel
NS	1339540	1	Power Cord Set, 6 ft. - Switzerland
NS	1339541	1	Power Cord Set, 6 ft. - South Africa
NS	1339542	1	Power Cord Set, 6 ft. - Italy
NS	1339543	1	Power Cord Set, 8 ft. - Denmark

# Assembly 13: 250-Sheet Tray

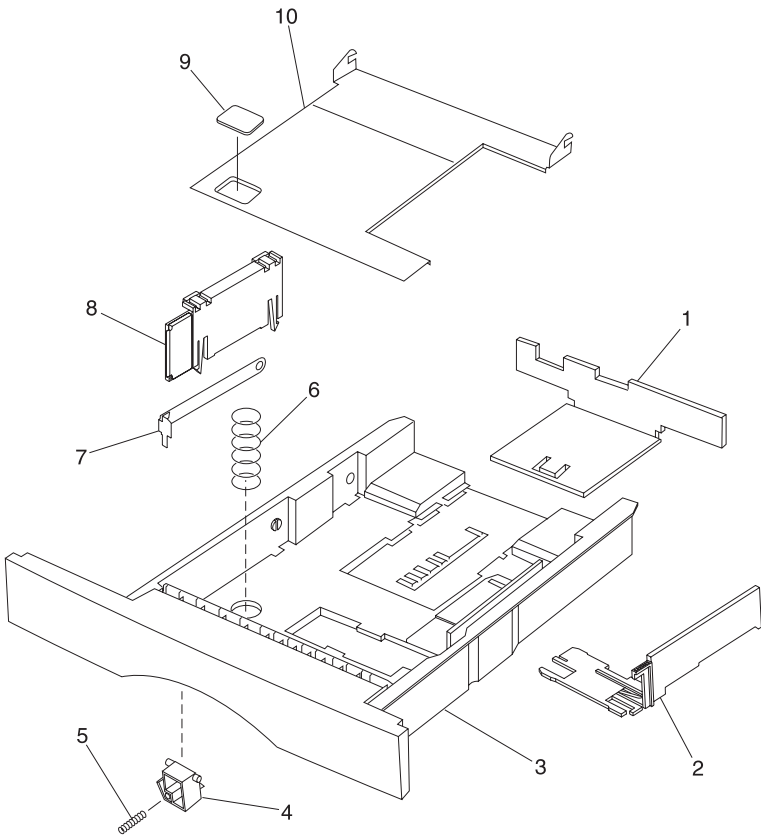

**4045-XXX**

<b>Asm-Index</b>	<b>Part Number</b>	<b>Units</b>	<b>Description</b>
13-1	12G0315	1	Guide, Rear Paper
13-2	12G0313	1	Guide, Right Paper
13-3	12G0311	1	Base, 250-Sheet Paper Tray
13-4	12G0319	1	Holder, Lift Plate
13-5	12G0320	1	Spring, Lift Plate Holder
13-6	12G0318	1	Spring, Lift Plate
13-7	12G0314	1	Buckler, Corner
13-8	12G0316	1	Cover Asm, Corner Buckler
13-9	12G0317	1	Pad, Pick Roller Friction
13-10	12G0312	1	Plate, Lift

# Assembly 14: 500-Sheet Tray

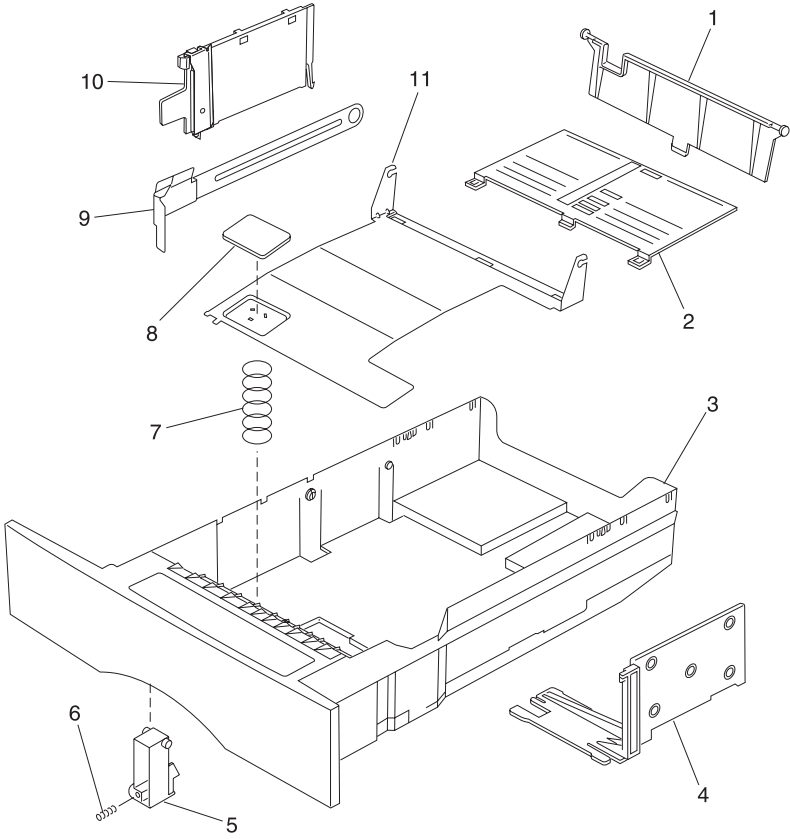



**4045-XXX**

<b>Asm-Index</b>	<b>Part Number</b>	<b>Units</b>	<b>Description</b>
14-1	12G0391	1	Guide, Rear Paper
14-2	12G0392	1	Slider, Rear Paper Guide
14-3	12G0386	1	Base, 500-Sheet Paper Tray
14-4	12G0393	1	Guide, Right Paper
14-5	12G0390	1	Holder, Lift Plate
14-6	12G0396	1	Spring, Lift Plate Holder
14-7	12G0395	1	Spring, Lift Plate
14-8	12G0394	1	Pad, Pick Roller Friction
14-9	12G0387	1	Buckler, Corner
14-10	12G0388	1	Cover Asm, Corner Buckler
14-11	12G0389	1	Plate, Lift

### Assembly 14: 500-Sheet Tray (continued)

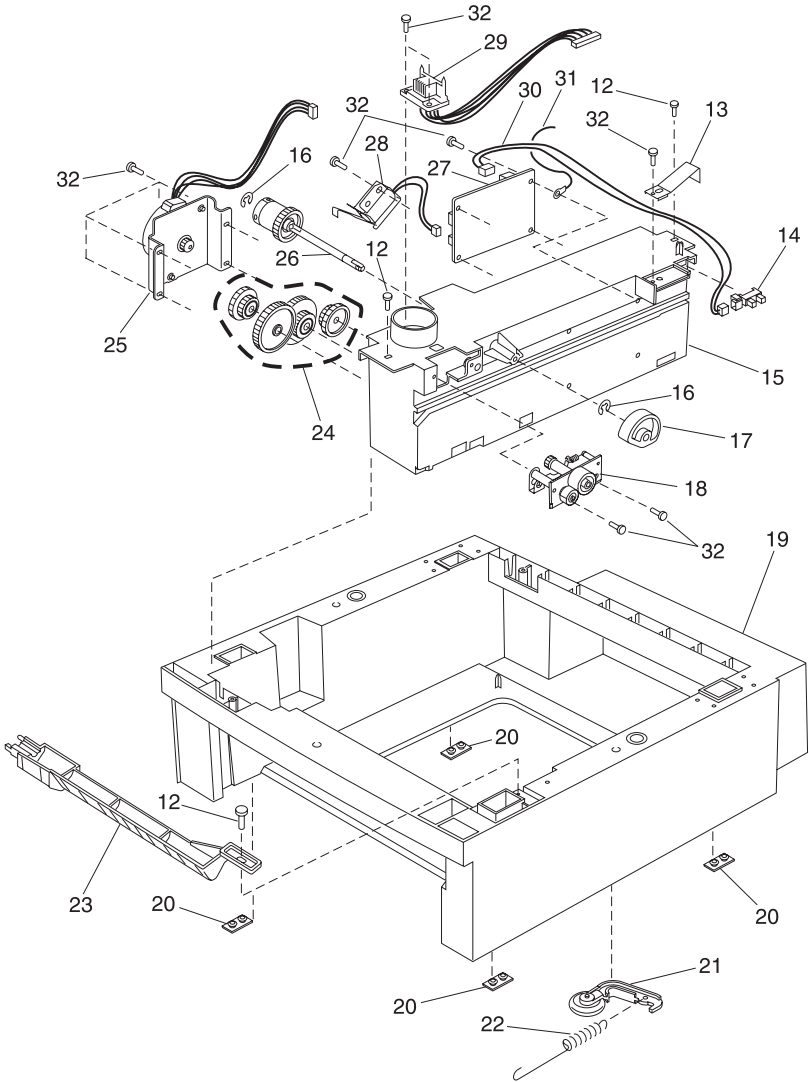

**4045-XXX**

<b>Asm-Index</b>	<b>Part Number</b>	<b>Units</b>	<b>Description</b>
14-12		3	Screw, M4x10, PP 12G0445
14-13	12G0404	1	Lever, Tray 1 Inserted
14-14	12G0252	1	Sensor, Tray 1 Inserted
14-15	12G0398	1	Frame, 500-Sheet Drive
14-16		2	Clip, PP 12G0445
14-17	12G0399	1	Roller, 500-Sheet Pick
14-18	12G0403	1	Roller Asm, Alignment
14-19	12G0397	1	Base, 500-Sheet Feeder M410
14-19	12G3564	1	Base, 500-Sheet Feeder M412
14-20	12G0250	4	Foot, Rubber
14-21	12G0402	1	Lever Asm, Tray Bias
14-22	12G0405	1	Spring, Tray Bias
14-23	12G0406	1	Guide, Paper
14-24		1	Gears, Tray 2 Idler PP 12G0448
14-25	12G0409	1	Motor Asm, Tray 2 M410
14-25	12G3565	1	Motor Asm, Tray 2 M412
14-26	12G0400	1	Shaft Asm, 500-Sheet P. Roller
14-27	12G0408	1	Card Asm, Tray 2 M410
14-27	12G3558	1	Card Asm, Tray 2 M412
14-28	12G0444	1	Solenoid, Tray 2 Pick Roller
14-29	12G0407	1	Cable, Tray 2 Interconnect
14-30	12G0449	1	Cable, Tray 1 Sensor
14-31	12G0450	1	Cable, Tray 2 Ground
14-32		14	Screw, M3x10 PP 12G0445

## Assembly 15: Options

Asm-Index	Part Number	Units	Description
15	99A1752	1	Memory, 4MB SDRAM DIMM
15	99A1753	1	Memory, 8MB SDRAM DIMM
15	99A1754	1	Memory, 16MB SDRAM DIMM
15	99A1755	1	Memory, 32MB SDRAM DIMM
15	99A1756	1	Memory, 64MB SDRAM DIMM
15	99A1757	1	Memory, 2MB Flash DIMM
15	99A1758	1	Memory, 4MB Flash DIMM
15	99A1759	1	Memory, 8MB Flash DIMM
15	99A1774	1	Memory, 16MB Flash DIMM
15	99A1683	1	Memory, 2MB Flash DIMM w/ Optra Forms
15	99A1684	1	Memory, 4MB Flash DIMM w/ Optra Forms
15	99A1685	1	Memory, 8MB Flash DIMM w/ Optra Forms
15	99A1686	1	Memory, 16MB Flash DIMM w/ Optra Forms
15	12G1695	1	Card Asm, INA, Ethernet 10/100BaseTX
15	12G1696	1	Card Asm, INA, 10Base2/T
15	12G1697	1	Card Asm, INA, Token Ring
15	99A0560	1	Card Asm, Tri-port
15	99A0516	1	Adapter, Hard Disk
15	99A0459	1	Disk Drive, 2.1+ GB
15	99A0799	1	Disk Drive, 2.1+ GB w/OptraForms
15	99A0923	1	Card Asm, Parallel/USB
15	16A0190	1	Card Asm, ENA Marknet Pro 1 10/100 Base TX
15	16A0187	1	Card Asm, ENA Marknet Pro 1 10Base 2/T
15	16A0185	1	Card Asm, ENA Marknet Pro 3 10/100 Base TX
15	16A0186	1	Card Asm, ENA Marknet Pro 3 Token Ring
15	99A0629	1	Adapter, Coax/Twinax for SCS

# Index

## A

- Acronyms 1-5
- Adjustment Procedures 4-2
  - Paper Alignment 4-3
  - Printhead Assembly 4-2

## B

- Base Sensor Test 3-14
- Button Test 3-9

## C

- Cable Locations 3-29
- Configuration Mode 3-1
- Connector Locations
  - Engine Board 5-4
  - High Voltage Power Supply 5-2
  - Interconnect Board 5-10
  - Low Voltage Power Supply 5-1
  - Option Tray Board 5-12

## D

- Demo Mode 3-4
- Device Tests 3-17
- Diagnostic Aids
  - Configuration Mode 3-1
  - Demo Mode 3-4
  - Device Tests
    - Disk Test/Clean 3-18
    - Flash Test 3-19
    - Quick Disk Test 3-17
  - Discard Buffered Jobs 3-3
  - Download Emulation 3-3
  - Error Log 3-17
    - Clearing the Error Log 3-17
    - Viewing the Error Log 3-17
  - Exiting the Configuration Mode 3-5
  - Exiting the Diagnostic Mode 3-5
  - Hardware Test Mode 3-20
    - Engine Firmware 3-26
    - Erase Lamp Test 3-26
    - Fan/Fuser Test 3-25
    - Main Motor Test 3-22

- Mirror Motor Test 3-23
- Operator Panel Test 3-21
- Reset Test Mode 3-26
- Sensor Monitor Test 3-24
- Solenoid Test 3-22
- Tray 2 Motor Test 3-23

## Hardware Tests 3-8

- Button Test 3-9
- DRAM Memory Test 3-9
- LCD Test 3-8
- Parallel Wrap Test 3-10
- ROM Memory Test 3-10
- Serial Wrap Test 3-11

## Input Tray Tests 3-13

## Panel Menus 3-2

## Paper Feed Tests

- Base Sensor Test 3-14

## PPDS Emulation 3-3

## Print Quality Test Pages 3-2

## Print Registration 3-6

## Print Tests 3-6

## Printer Setup 3-14

### Edge to Edge 3-16

### Factory Defaults 3-16

### Parallel Strobe Adjust 3-16

### Serial Number 3-16

### Setting Configuration ID 3-15

### Setting the Page Count 3-14

### Viewing the Permanent Page Count 3-15

## Restore Factory Defaults 3-4

## Diagnostic Mode 3-5

## Discard Buffered Jobs 3-3

## Disk Test/Clean 3-18

## Download Emulation 3-3

## DRAM Memory Test 3-9

## E

### Edge to Edge 3-16

### Electrophotographic Process 3-27

### Engine Board Connectors 5-4

### Engine Firmware 3-26

## 4045-XXX

- Erase Lamp Test 3-26
- Error Codes
  - Service Error Codes 2-2
  - User Error Messages 2-9
- Error Log 3-17
- ESD-sensitive Parts 4-1
- Exiting the Configuration Mode 3-5
- Exiting the Diagnostic Mode 3-5

## F

- Factory Defaults 3-16
- Fan/Fuser Test 3-25
- Flash Test 3-19

## H

- Handling ESD-sensitive Parts 4-1
- Hardware Test Mode 3-20
- How To Use This Parts Catalog 6-1
- HVPS Connectors 5-2

## I

- Input Tray Tests 3-13
- Interconnect Board Connectors 5-10

## L

- Laser Notice vii
- LCD Test 3-8
- LVPS Connectors 5-1

## M

- Main Motor Test 3-22
- Maintenance Approach 1-4
- Messages
  - Check Device Connection Messages 2-13
  - Service Error Codes 2-2
  - User Error Messages 2-9
  - User Line 2 Link Messages 2-12
  - User Line 2 Messages 2-11
  - User Status Messages 2-5
- Mirror Motor Test 3-23

## O

- Operator Panel Test 3-21
- Option Tray Board 5-12

## P

- Panel Menus 3-2
- Paper Feeding, Transferring and Fusing 3-27
- Paper Path/Sensor Locations 3-28
- Parallel Strobe Adjust 3-16
- Parallel Wrap Test 3-10
- Parts Catalog 6-1
  - Charging 6-26
  - Covers 6-2
  - Developer Drive 6-18
  - Electronics 6-28
  - Frame 6-6
  - Fuser 6-20
  - Main Drive 6-16
  - Options 6-40
  - Paper Feed - Alignment 6-12
  - Paper Feed - Multipurpose Unit 6-10
  - Paper Feed - Output 6-14
  - Printhead 6-8
  - Transfer 6-24
  - 250-Sheet Tray 6-34
  - 500-Sheet Tray 6-36
- Power-On Self Test (POST) 2-14
- PPDS Emulation 3-3
- Print Quality Test Pages 3-2
- Print Registration 3-6
- Print Tests 3-6
- Printer Operation 3-27
- Printer Setup 3-14

## Q

- Quick Disk Test 3-17

## R

- Removals
  - Charge Roller 4-8
  - Controller Board 4-9
  - Cooling Fan 4-11
  - Covers 4-4
  - Developer Drive Assembly 4-13
  - Engine Board 4-14
  - Fuser 4-15
  - HVPS 4-17

## 4045-XXX

Inner Deflector 4-18  
Left Side Frame 4-20  
LVPS 4-21  
Main Drive Assembly 4-23  
Multipurpose Tray 4-24  
Paper Alignment Assembly 4-25  
Pick Roll 4-27  
Printhead 4-28  
Redrive Assembly 4-29  
Right Side Frame 4-30  
Transfer Roller 4-30  
Reset Test Mode 3-26  
Restore Factory Defaults 3-4  
ROM Memory Test 3-10

## S

Safety Information xv  
Sensor Monitor Test 3-24  
Serial Number 3-16  
Serial Wrap Test 3-11  
Service Checks  
  Charge Roll 2-17  
  Cover Open Switch/Cable 2-19  
  Dead Machine 2-20  
  Erase Lamp 2-22  
  Fan 2-23  
  Fuser 2-23  
  Input Sensor 2-25  
  Input Tray(s) Option 2-26  
  Main Drive 2-29  
  Operator Panel 2-30  
  Options 2-32  
  Paper Feed 2-33  
  Parallel Port 2-35  
  Print Quality 2-37  
  Printhead 2-36  
  Serial Port 2-47  
  Transfer Roll 2-48  
Setting Configuration ID 3-15  
Setting the Page Count 3-14  
Solenoid Test 3-22  
Status Messages 2-5  
Symptom Tables 2-15

## T

Tray 2 Motor Test 3-23

## U

Unique Tools 1-4  
User Line 2 Link Messages 2-12  
User Line 2 Messages 2-11  
User Status Messages 2-5

## V

Viewing the Permanent Page Count  
3-15

## Part Numbers

12G0250 6-7, 6-39  
12G0251 6-11  
12G0252 6-11, 6-15, 6-39  
12G0253 6-3  
12G0254 6-3  
12G0255 6-3  
12G0256 6-3  
12G0257 6-3  
12G0258 6-3  
12G0259 6-3  
12G0260 6-3  
12G0262 6-3  
12G0264 6-3  
12G0265 6-3  
12G0266 6-3  
12G0267 6-3  
12G0268 6-5  
12G0269 6-3  
12G0274 6-7  
12G0275 6-7  
12G0276 6-7  
12G0277 6-7  
12G0278 6-7  
12G0279 6-7  
12G0280 6-7  
12G0281 6-7  
12G0282 6-7  
12G0283 6-7  
12G0284 6-7, 6-33  
12G0285 6-7  
12G0286 6-7  
12G0288 6-7  
12G0289 6-7  
12G0290 6-7

## 4045-XXX

12G0291	6-7	12G0339	6-21
12G0292	6-7	12G0340	6-23
12G0293	6-7	12G0341	6-23
12G0294	6-7	12G0342	6-23
12G0295	6-7	12G0343	6-21
12G0296	6-7	12G0344	6-21
12G0298	6-9	12G0345	6-23
12G0299	6-11	12G0346	6-23
12G0300	6-11	12G0347	6-21
12G0301	6-11	12G0348	6-21
12G0302	6-11	12G0349	6-21
12G0303	6-13	12G0350	6-23
12G0304	6-15	12G0351	6-21
12G0305	6-15	12G0352	6-21
12G0306	6-15	12G0353	6-23
12G0307	6-15	12G0354	6-25
12G0308	6-15	12G0355	6-25
12G0309	6-15	12G0356	6-25
12G0310	6-15	12G0357	6-25
12G0311	6-35	12G0358	6-25, 6-27
12G0312	6-35	12G0359	6-25
12G0313	6-35	12G0360	6-27
12G0314	6-35	12G0361	6-27
12G0315	6-35	12G0362	6-27
12G0316	6-35	12G0363	6-27
12G0317	6-35	12G0364	6-27
12G0318	6-35	12G0365	6-27
12G0319	6-35	12G0366	6-29
12G0320	6-35	12G0367	6-29
12G0321	6-17	12G0368	6-29
12G0322	6-17	12G0369	6-29
12G0323	6-17	12G0370	6-29
12G0324	6-17	12G0371	6-29
12G0325	6-19	12G0372	6-29
12G0326	6-23	12G0373	6-29
12G0327	6-23	12G0374	6-29
12G0328	6-21	12G0375	6-29
12G0329	6-21	12G0376	6-29
12G0330	6-21	12G0378	6-29
12G0331	6-21	12G0379	6-29
12G0332	6-23	12G0380	6-29
12G0333	6-23	12G0381	6-31
12G0334	6-21	12G0382	6-31
12G0335	6-23	12G0383	6-31
12G0336	6-21	12G0384	6-31
12G0337	6-21	12G0385	6-31
12G0338	6-23	12G0386	6-37



## 4045-XXX

12G0387	6-37	12G0443	6-17
12G0388	6-37	12G0444	6-39
12G0389	6-37	12G0446	6-23
12G0390	6-37	12G0449	6-39
12G0391	6-37	12G0450	6-39
12G0392	6-37	12G0451	6-7
12G0393	6-37	12G0452	6-13
12G0394	6-37	12G0453	6-23
12G0395	6-37	12G1695	6-40
12G0396	6-37	12G1696	6-40
12G0397	6-39	12G1697	6-40
12G0398	6-39	12G1860	6-3, 6-33
12G0399	6-39	12G3550	6-3
12G0400	6-39	12G3551	6-9
12G0402	6-39	12G3552	6-17
12G0403	6-39	12G3553	6-21
12G0404	6-39	12G3554	6-21
12G0405	6-39	12G3555	6-21
12G0406	6-39	12G3556	6-29
12G0407	6-39	12G3557	6-29
12G0408	6-39	12G3558	6-39
12G0409	6-39	12G3559	6-33
12G0411	6-33	12G3560	6-7
12G0412	6-33	12G3561	6-23
12G0413	6-33	12G3562	6-21
12G0416	6-33	12G3563	6-21
12G0417	6-33	12G3564	6-39
12G0418	6-33	12G3565	6-39
12G0419	6-33	12G3567	6-29
12G0420	6-33	12G3673	6-17
12G0421	6-33	12G3701	6-5
12G0422	6-33	12G3702	6-5
12G0423	6-7	12G3703	6-5
12G0424	6-3	1263566	6-3
12G0425	6-5	1339538	6-33
12G0426	6-3	1339539	6-33
12G0427	6-3	1339540	6-33
12G0428	6-3	1339541	6-33
12G0429	6-3	1339542	6-33
12G0430	6-3	1339543	6-33
12G0431	6-3	1342530	6-33
12G0436	6-31	1342534	6-33
12G0437	6-5	1342535	6-33
12G0438	6-5	1342536	6-33
12G0439	6-5	1342537	6-33
12G0440	6-3	16A0185	6-40
12G0441	6-3	16A0186	6-40

## **4045-XXX**

16A0187 6-40  
16A0190 6-40  
99A0459 6-40  
99A0516 6-40  
99A0560 6-40  
99A0629 6-40  
99A0799 6-40  
99A0923 6-40  
99A1683 6-40  
99A1684 6-40  
99A1685 6-40  
99A1686 6-40  
99A1752 6-40  
99A1753 6-40  
99A1754 6-40  
99A1755 6-40  
99A1756 6-40  
99A1757 6-40  
99A1758 6-40  
99A1759 6-40  
99A1774 6-40

# Reader Comment Form

Lexmark Optra™ M410/M412  
(4045-XXX) Service Manual  
P/N 12G3517  
May, 2000

You may use this form to communicate your comments about this publication, with the understanding that Lexmark may use or distribute whatever information you supply in any way it believes appropriate without incurring any obligation to you.

1. Did you find the book well organized?

Yes  No

2. Was the content of the book accurate and complete?

Yes  No

3. Was the book easy to use?

Yes  No

4. What can we do to improve the book?

---

---

5. What is your job title?

---

Questions or comments about supplies, service, applications, and so on slow response time considerably. Please refer those questions or comments to your authorized dealer or point of purchase.

**Note:** Please direct all requests for copies of publications to your point of purchase. Publications are not stocked at the location to which this form is addressed.