



Lexmark™

MS321, MS421, MS521, M124x, B2338, B2442, and B2546 printers

Machine Type 4600-23x, 43x, 490, 630, 690

Service Manual

- [Start diagnostics](#)
 - [Maintenance](#)
 - [Safety and notices](#)
 - [Trademarks](#)
 - [Index](#)
-

September 07, 2018

www.lexmark.com

Product information

Product name:

Lexmark B2338dn, B2338dw; Lexmark B2442dn, B2442dw; Lexmark B2546dn; Lexmark M1242; Lexmark M1246; Lexmark MS321dn; Lexmark MS421dn, MS421dw; Lexmark MS521dn printers

Machine type:

4600

Model(s):

23x, 43x, 490, 630, 690

Edition notice

September 07, 2018

The following paragraph does not apply to any country where such provisions are inconsistent with local law: LEXMARK INTERNATIONAL, INC., PROVIDES THIS PUBLICATION “AS IS” WITHOUT WARRANTY OF ANY KIND, EITHER EXPRESS OR IMPLIED, INCLUDING, BUT NOT LIMITED TO, THE IMPLIED WARRANTIES OF MERCHANTABILITY OR FITNESS FOR A PARTICULAR PURPOSE. Some states do not allow disclaimer of express or implied warranties in certain transactions; therefore, this statement may not apply to you.

This publication could include technical inaccuracies or typographical errors. Changes are periodically made to the information herein; these changes will be incorporated in later editions. Improvements or changes in the products or the programs described may be made at any time.

References in this publication to products, programs, or services do not imply that the manufacturer intends to make these available in all countries in which it operates. Any reference to a product, program, or service is not intended to state or imply that only that product, program, or service may be used. Any functionally equivalent product, program, or service that does not infringe any existing intellectual property right may be used instead. Evaluation and verification of operation in conjunction with other products, programs, or services, except those expressly designated by the manufacturer, are the user's responsibility.

Trademarks

Lexmark and the Lexmark logo are trademarks of Lexmark International, Inc., registered in the United States and/or other countries. PCL® is a registered trademark of the Hewlett-Packard Company. PCL is Hewlett-Packard Company's designation of a set of printer commands (language) and functions included in its printer products. This printer is intended to be compatible with the PCL language. This means the printer recognizes PCL commands used in various application programs, and that the printer emulates the functions corresponding to the commands.

PostScript is a registered trademark of Adobe Systems Incorporated in the United States and/or other countries.

All other trademarks are the property of their respective owners.

© 2018 Lexmark International, Inc.

All rights reserved.

P/N

Table of contents

Product information.....	2
Edition notice.....	2
Notices, conventions, and safety information.....	9
Laser notice.....	9
Conventions.....	12
Safety information.....	13
General caution statements.....	18
Change history.....	19
Change history.....	19
General information.....	21
Printer model configurations.....	21
Finding the serial number.....	22
Supported paper sizes, types, and weights.....	22
Supported paper sizes.....	22
Supported paper types.....	23
Supported paper weights.....	24
Tools required for service.....	24
Diagnostics and troubleshooting.....	27
Troubleshooting overview.....	27
Performing the initial troubleshooting check.....	27
Fixing print quality issues.....	27
Initial print quality check.....	28
Gray background or toner fog check.....	29
Blank pages check.....	31
Print is too dark check.....	37
Print is too light check.....	39
Paper curl check.....	42
Folded or wrinkled paper check.....	43
Solid black pages check.....	44
Repeating defects check.....	47
Skewed print check.....	48
Streaked vertical lines appear on prints check.....	50
Horizontal light bands check.....	51

Vertical light bands check.....	52
Vertical dark bands check.....	53
Vertical dark streaks with print missing check	55
White streaks and voided areas check	57
Fine lines are not printed correctly (specifically Chinese characters) check	60
Clipped pages or images check.....	61
Compressed images appear on prints check.....	63
Incorrect margins on prints check	64
Toner rubs off check.....	65
Toner specks appear on prints check.....	66
Paper jams.....	68
Avoiding jams	68
Identifying jam locations.....	69
Paper jam in door A	70
Paper jam in the rear door	73
Paper jam in the standard bin	74
Paper jam in the duplex unit.....	75
Paper jam in trays.....	76
Paper jam in the multipurpose feeder	76
200 paper jams.....	77
202 paper jams.....	88
230 paper jams.....	92
240-241 paper jams	95
242-244 paper jams	98
User attendance messages (0–99.99).....	104
User attendance messages.....	104
Unsupported or unresponsive toner cartridge service check	105
Unsupported or unresponsive imaging unit service check	107
Mismatched supplies error service check	108
Maintenance kit low service check.....	108
Printer hardware errors.....	109
111 errors.....	109
121 errors.....	110
126 errors.....	116
128 errors.....	118
133 errors	121
140 errors.....	122
155 errors.....	123
16y errors	125
171 errors	129
6yy errors.....	130
Procedure before starting the 9yy service checks	131
900 errors	133

Service menus..... 139

Understanding the printer control panel.....	139
Using the printer control panel.....	139
Understanding the status of the power button and indicator light.....	140
Diagnostics menu.....	141
Entering the Diagnostics menu	141
Reports	141
Advanced Print Quality Samples.....	141
Event Log.....	142
Input tray quick print.....	143
Output bin quick feed	143
Printer Setup	143
Printer diagnostics and adjustments.....	145
Additional input tray diagnostics.....	148
Config Menu.....	149
Service Engineer menu.....	151
Entering Invalid engine mode	151
Entering the Service Engineer (SE) menu	151
General SE	152
Network SE	152

Parts removal..... 153

Removal precautions.....	153
Data security notice	153
Handling ESD-sensitive parts.....	154
Controller board/control panel replacement	155
Restoring the printer configuration after replacing the controller board	155
Restoring solutions, licenses, and configuration settings	158
Updating the printer firmware	159
Backing up eSF solutions and settings	160
Disconnecting ribbon cables.....	161
Ribbon cable connectors	161
Zero Insertion Force (ZIF) connectors.....	161
Horizontal top contact connector	162
Horizontal bottom contact connector	164
Vertical mount contact connector.....	166
Horizontal sliding contact connector	168
Low Insertion Force (LIF) connector	170
Printhead assembly adjustment	171
Removal procedures.....	173
Left side removals.....	173
Left cover removal	173

Main drive gearbox removal.....	174
MPF gearbox removal.....	175
Fuser actuator removal.....	178
Reverse solenoid removal.....	179
Cartridge gearbox removal.....	180
MPF solenoid removal.....	181
Pick roller clutch removal.....	182
Right side removals.....	185
Right cover removal.....	185
Interconnect cable removal.....	187
Sensor (tray present) removal.....	188
Cooling fan removal.....	189
Controller board removal.....	191
Toner cartridge smart chip contact removal.....	192
Cartridge barrel shutter sensor kit removal.....	195
Front removals.....	198
Nameplate removal.....	198
MPF with front access cover removal.....	198
Control panel assembly removal.....	200
Control panel (2.4 inch display) flat cable removal.....	201
Control panel (2.4 inch display) cover, buttons, and board removal.....	201
Control panel display (2-line) removal.....	202
Transfer roller removal.....	203
Jam access cover removal.....	203
Sensor (front door) removal.....	204
MPF pick roller and separator pad removal.....	206
Sensor (MPF paper present) removal.....	209
Front input guide removal.....	210
Bottom removals.....	211
Power supply removal.....	211
Duplex assembly removal.....	213
Sensors (duplex and input) removal.....	215
Sensor (toner density) removal.....	216
Sensor (trailing edge) removal.....	218
Pick roller assembly removal.....	219
Rear side removals.....	224
Rear door and cover removal.....	224
Fuser removal.....	224
Redrive assembly removal.....	225
Sensor (bin full) removal.....	226
Redrive gear plate removal.....	227
Top side removals.....	228
Top cover removal.....	228
Printhead removal.....	229

Optional 250/550-sheet tray removals.....	232
Separator roller assembly removal.....	232
Component locations.....	235
Printer configurations.....	235
Attaching cables.....	235
Printer roller locations.....	237
Printer sensor locations.....	239
Controller board connectors.....	240
Maintenance.....	245
Inspection guide.....	245
Scheduled maintenance.....	245
Maintenance kits.....	245
Resetting the maintenance counter	246
Lubrication specification.....	246
Cleaning the printer.....	246
Cleaning the printhead lenses.....	247
Parts catalog.....	248
Legend.....	248
Assembly 1: Covers.....	249
Assembly 2: Control panel.....	251
Assembly 3: Electronics 1.....	253
Assembly 4: Electronics 2.....	255
Assembly 5: Electronics 3.....	257
Assembly 6: Electronics 4.....	259
Assembly 7: Paper transport 1.....	261
Assembly 8: Paper transport 2.....	263
Assembly 9: MPF and standard tray.....	265
Assembly 10: Optional trays.....	267
Assembly 11: Maintenance kits (MS521, B2546, and M1246).....	269
Assembly 12: Miscellaneous.....	271
Printer specifications.....	273
Power consumption.....	273
Product power consumption	273
Sleep Mode.....	273
Hibernate Mode.....	273

- Off mode 274
- Total energy usage 274
- Selecting a location for the printer..... 274
- Noise emission levels..... 275
- Temperature information.....276
- Options and features.....277**
 - Available internal options.....277
 - Input/output configurations and capacities.....277
- Theory of operation.....279**
 - POR sequence..... 279
 - Print cycle operation..... 279
 - Print engine layout 279
 - Print cycle 280
 - Printer operation..... 286
 - Printer sections286
 - Printer paper path287
 - Printer paper path sensors289
 - Main drive291
 - Tray drive292
- Acronyms.....293**
- Index..... 295**
- Part number index.....299**
- Part name index.....303**

Notices, conventions, and safety information

Laser notice

The printer is certified in the U.S. to conform to the requirements of DHHS 21 CFR, Chapter I, Subchapter J for Class I (1) laser products, and elsewhere is certified as a Class I laser product conforming to the requirements of IEC 60825-1: 2014.

Class I laser products are not considered to be hazardous. The printer contains a Class IIIb (3b) AlGaInP laser that is nominally 15 milliwatts operating in the wavelength region of 650–670 nanometers and enclosed in a non-serviceable printhead assembly. The laser system and printer are designed so there is never any human access to laser radiation above a Class I level during normal operation, user maintenance, or prescribed service conditions.

Avis relatif à l'utilisation du laser

Cette imprimante est certifiée conforme aux exigences de la réglementation des Etats-Unis relative aux produits laser de classe I (1) (DHHS 21 CFR, Chapitre I, Sous-chapitre J). Pour les autres pays, elle est certifiée conforme aux exigences des normes CEI 60825-1: 2014 relatives aux produits laser de classe I.

Les produits laser de Classe I ne sont pas considérés comme dangereux. L'imprimante contient un dispositif laser AlGaInP (aluminium, gallium, indium et phosphore) de classe IIIb (3b) d'une puissance nominale de 15 milliwatts fonctionnant dans la plage de longueurs d'onde allant de 650 à 670 nanomètres et scellé dans un compartiment de têtes d'impression non réparable. Le système laser ainsi que l'imprimante ont été conçus de manière à ce que personne ne soit jamais exposé à des radiations laser dépassant le niveau de classe I dans le cadre d'un fonctionnement normal, de l'entretien par l'utilisateur ou de la maintenance.

Notificació del làser

La impressora està certificada als EUA per complir els requeriments de DHHS 21 CFR, capítol I, subcapítol J per a productes de làser Classe I (1), i a la resta del món s'ha certificat com productes de làser Classe I segons els requeriments de la norma IEC 60825-1: 2014.

Els productes de làser Classe I no es consideren perillosos. La impressora conté un làser intern Classe IIIb (3b) AlGaInP que normalment és de 15 miliwatts, que funciona a la regió de longitud d'ona de 650 a 670 nanòmetres i es troba dins d'una unitat de capçals d'impressió no substituïble. El sistema làser i la impressora estan dissenyats de manera que les persones no estiguin exposades a una radiació del làser superior al nivell de Classe I durant el funcionament normal, el manteniment de l'usuari o les condicions de servei prescrites.

Aviso de láser

Esta impresora se ha certificado en EE.UU. cumpliendo con los requisitos de DHHS 21 CFR, capítulo I, subcapítulo J para los productos láser de Clase I (1) y en otros países está certificada como un producto láser de Clase I de acuerdo con los requisitos de IEC 60825-1: 2014.

Los productos láser de Clase I no se consideran peligrosos. Este producto contiene un láser interno de Clase IIIb (3b) AlGaInP que opera nominalmente a 15 milivatios en una longitud de onda de 650–670 nanómetros cerrado en un conjunto de cabezal de impresión que no se puede reparar. El sistema láser y la impresora se han diseñado para que el ser humano no acceda nunca a las radiaciones láser por encima del nivel de Clase I durante su uso normal, ni en tareas de mantenimiento o intervenciones de servicio técnico prescritas.

Aviso sobre laser

Esta impressora foi certificada nos EUA por estar em conformidade com os requisitos do DHHS 21 CFR capítulo I, subcapítulo J, para produtos a laser de Classe I (1) e, nos demais países, foi certificada como um produto a laser de Classe I em conformidade com os requisitos da IEC 60825-1: 2014.

Os produtos a laser de Classe I não são considerados prejudiciais. A impressora contém, internamente, um laser de Classe IIIb (3b) AlGaInP que funciona nominalmente a 15 miliwatts no comprimento de onda de 650-670 nanômetros, incluso em um conjunto do cabeçote de impressão sem possibilidade de manutenção. O sistema do laser e a impressora foram projetados para que jamais haja acesso humano à radiação do laser acima do nível da Classe I durante a operação normal ou a manutenção pelo usuário ou sob as condições de manutenção prescritas.

Avvertenze sui prodotti laser

La stampante è certificata negli Stati Uniti come prodotto conforme ai requisiti DHHS 21 CFR Capitolo I, Sottocapitolo J per i prodotti laser di Classe I (1), mentre in altri paesi è certificata come prodotto laser di Classe I conforme ai requisiti IEC 60825-1: 2014.

I prodotti laser di Classe I non sono considerati pericolosi. La stampante contiene internamente un laser AlGaInP di Classe IIIb (3b) con valore nominale di 15 milliwatt, funzionante nella regione della lunghezza d'onda dei 650-670 nanometri e contenuto in un gruppo testina di stampa non riparabile. Il sistema laser e la stampante sono stati progettati in modo da impedire l'esposizione a radiazioni laser superiori al livello previsto dalla Classe I durante le normali operazioni di stampa, manutenzione o assistenza.

Laserinformatie

De printer is in de Verenigde Staten gecertificeerd als een product dat voldoet aan de vereisten van DHHS 21 CFR hoofdstuk 1, paragraaf J voor laserproducten van klasse I (1). Elders is de printer gecertificeerd als een laserproduct van klasse I dat voldoet aan de vereisten van IEC 60825-1: 2014.

Laserproducten van klasse I worden geacht geen gevaar op te leveren. De printer bevat intern een laser van klasse IIIb (3b) AlGaInP met een nominaal vermogen van 15 milliwatt in een golflengtebereik van 650-670 nanometer in een niet-buikbare printkopenheid. Het lasersysteem en de printer zijn zodanig ontworpen dat gebruikers nooit blootstaan aan laserstraling die hoger is dan het toegestane niveau voor klasse I-apparaten, tijdens normaal gebruik, onderhoudswerkzaamheden door de gebruiker of voorgeschreven servicewerkzaamheden.

Lasererklæring

Printeren er certificeret i USA i henhold til kravene i DHHS 21 CFR kapitel I, underafsnit J for klasse I (1) laserprodukter og er andre steder certificeret som et klasse I-laserprodukt i henhold til kravene i IEC 60825-1: 2014.

Klasse I-laserprodukter er ikke anset som farlige. Printeren indeholder internt en Klasse IIIb (3b) AlGaAs-laser, der nominelt er en 15 milliwatt laser, som fungerer i bølglængdeområdet 650–670 nanometer og indbygget i en printhovedenhed, der ikke er servicierbar. Lasersystemet og printeren er designet på en sådan måde, at der ikke er en direkte laserstråling, der overskrider Klasse I-niveauet under normal brug, brugers vedligeholdelse eller de foreskrevne servicebetingelser.

Laser-Hinweis

Der Drucker wurde in den USA zertifiziert und entspricht den Anforderungen der Vorschriften DHHS 21 CFR Kapitel I für Laserprodukte der Klasse I (1), andernorts ist er als Laserprodukt der Klasse I zertifiziert, das den Anforderungen von IEC 60825-1: 2014 entspricht.

Laserprodukte der Klasse I werden nicht als gefährlich betrachtet. Der Drucker enthält im Inneren einen Laser der Klasse IIIb (3b) AlGaInP mit 15 Milliwatt, im Wellenlängenbereich von 650 bis 670 Nanometern arbeitet. Dieser befindet sich in einer Druckkopfeinheit, die nicht gewartet werden kann. Das Lasersystem und der Drucker sind so konstruiert, dass unter normalen Betriebsbedingungen, bei der Wartung durch den Benutzer oder bei den vorgeschriebenen Wartungsbedingungen Menschen keiner Laserstrahlung ausgesetzt sind, die die Werte für Klasse I überschreitet.

Laserilmoitus

Tämä tulostin on sertifioitu Yhdysvalloissa DHHS 21 CFR, Chapter I, Subchapter J -standardin mukaiseksi luokan I (1) -lasertuotteeksi ja muualla IEC 60825-1: 2014 -standardin mukaiseksi luokan I lasertuotteeksi.

Luokan I lasertuotteita ei pidetä haitallisina. Tulostimen sisällä on luokan IIIb (3b) AlGaInP -laser, jonka nimellisteho on 15 mW milliwatts, joka toimii 650–670 nanometrillä ja joka on suljettu tulostuspäähän, jota käyttäjä ei voi huoltaa. Laserjärjestelmä ja tulostin ovat rakenteeltaan sellaisia, että käyttäjä ei joudu alttiiksi luokkaa 1 suuremmalle säteilylle normaalin käytön, ylläpidon tai huollon aikana.

Lasermerknad

Skriveren er sertifisert i USA for samsvar med kravene i DHHS 21 CFR, kapittel I, underkapittel J for laserprodukter av klasse I (1) og er andre steder sertifisert som et laserprodukt av klasse I som samsvarer med kravene i IEC 60825-1: 2014.

Laserprodukter av klasse I anses ikke som helseskadelige. Skriveren inneholder en intern AlGaInP-laser av klasse IIIb (3b) på nominelt 15 milliwatt, som opererer i bølglengder på 650–670 nanometer, inne i en skrivhodeenhet som ikke kan vedlikeholdes. Lasersystemet og skriveren er utformet slik at mennesker ikke utsettes for laserstråling utover nivået i klasse I under normal drift, vedlikehold eller foreskrevet service.

Meddelande om laser

Skrivaren är certifierad i USA i enlighet med kraven i DHHS 21 CFR kapitel I, underkapitel J för klass I (1)-laserprodukter, och på andra platser certifierad som en klass I-laserprodukt i enlighet med kraven i IEC 60825-1: 2014.

Laserprodukter av klass I anses inte vara skadliga. Skrivaren innehåller en klass IIIb (3b) AlGaInP-laser på nominellt 15 mW som arbetar inom en våglängd på 650–670 nm och är innesluten i en icke-servicebar skrivhuvudenhet. Lasersystemet och skrivaren är utformade så att människor aldrig utsätts för laserstrålning över klass I-nivå under normala förhållanden vid användning, underhåll eller service.

レーザーについて

本機は、米国においてクラス I (1) レーザー製品に対する DHHS 21 CFR、Chapter I、Subchapter J の要件に準拠し、その他の国では IEC 60825-1: 2014 の要件に準拠するクラス I レーザー製品として認可されています。

クラス I レーザー製品は、危険性がないとみなされています。本機には、クラス IIIb (3b) AlGaInP レーザーが内蔵されています。これは、650 ~ 670 ナノメートルの波長で、定格 15 ミリワットで動作するレーザーであり、整備不可のプリントヘッドアセンブリに収容されています。レーザーシステムとプリンタは、

通常の操作、ユーザーによるメンテナンス、または所定のサービス条件の下で、ユーザーがクラス I レベルを超えるレーザー放射に絶対にさらされないように設計されています。

레이저 고지사항

프린터는 미국에서 레이저 제품용 DHHS 21 CFR Chapter I, Subchapter J의 요구 사항을 준수하며 이외 지역에서 IEC 60825-1: 2014의 요구 사항을 준수하는 클래스 I(1) 레이저 제품으로 승인되었습니다.

Class I 레이저 제품은 위험한 제품으로 간주되지 않습니다. 프린터에는 650~670 나노미터 범위의 파장 영역에서 공칭 작동하는 15밀리와트 AlGaInP 레이저인 클래스 IIIb(3b) 레이저가 내부에 포함되어 있으며 서비스 불가 프린트 헤드 어셈블리가 포함되어 있습니다. 레이저 시스템과 프린터는 정상적인 작동, 사용자 유지 관리 또는 사전 설명된 서비스 조건에는 사람에게 클래스 I 수준 이상의 레이저 방사가 노출되지 않도록 설계되었습니다.

激光注意事项

本打印机在美国认证合乎 DHHS 21 CFR Chapter I, Subchapter J 对分类 I (1) 激光产品的标准, 而在其他地区则被认证是合乎 IEC 60825-1: 2014 的分类 I 激光产品。

一般认为分类 I 激光产品不具有危险性。本打印机内部含有分类 IIIb (3b) 的磷化铝镓铟激光, 标称值为 15 毫瓦, 其工作波长范围在 650–670nm 之间, 并被封闭在不可维修的打印头配件中。本激光系统及打印机的设计, 在一般操作、使用者维护或规定内的维修情况下, 不会使人体接触分类 I 以上等级的辐射。

雷射聲明

本印表機係經過美國核可, 符合 DHHS 21 CFR, Chapter I, Subchapter J 規定的 I (1) 級雷射產品; 在美國以外的地區, 為符合 IEC 60825-1: 2014 規定的 I 級雷射產品。

根據 I 級雷射產品的規定, 這類產品不會對人體造成傷害。本印表機所採用之 IIIb (3b) 級 AlGaInP 雷射在 650 至 670 奈米 (nanometer) 波長範圍內運作時通常為 15 毫瓦特 (milliwatt), 且含括在不可修復列印頭組件中。使用者只要以正確的方法操作及維護保養, 並依照先前所述之維修方式進行修護, 此印表機與其雷射系統絕不會產生 I 級以上的放射線, 而對人體造成傷害。

Conventions

Note: A *note* identifies information that could help you.

Warning: A *warning* identifies something that could damage the product hardware or software.

CAUTION: A *caution* indicates a potentially hazardous situation that could injure you.

Different types of caution statements include:



CAUTION—POTENTIAL INJURY: Indicates a risk of injury.



CAUTION—SHOCK HAZARD: Indicates a risk of electrical shock.



CAUTION—HOT SURFACE: Indicates a risk of burn if touched.



CAUTION—TIPPING HAZARD: Indicates a crush hazard.



CAUTION—PINCH HAZARD: Indicates a risk of being caught between moving parts.

Safety information

- The safety of this product is based on testing and approvals of the original design and specific components. The manufacturer is not responsible for safety in the event of use of unauthorized replacement parts.
- The maintenance information for this product has been prepared for use by a professional service person and is not intended to be used by others.
- There may be an increased risk of electrical shock and personal injury during disassembly and servicing of this product. Professional service personnel should understand this risk and take necessary precautions.

 **CAUTION—SHOCK HAZARD:** When you see this symbol, there is a danger from hazardous voltage in the area of the product where you are working. Unplug the product before you begin, or use caution if the product must receive power in order to perform the task.

 **CAUTION—POTENTIAL INJURY:** The lithium battery in this product is not intended to be replaced. There is a danger of explosion if a lithium battery is incorrectly replaced. Do not recharge, disassemble, or incinerate a lithium battery. Discard used lithium batteries according to the manufacturer's instructions and local regulations.

Consignes de sécurité

- La sécurité de ce produit est basée sur des tests et certifications de sa conception d'origine et de ses composants spécifiques. Le fabricant décline toute responsabilité en cas d'utilisation de pièces de rechange non autorisées.
- Les informations de maintenance de ce produit sont destinées à des professionnels qualifiés et ne sont pas conçues pour être utilisées par d'autres personnes.
- Il existe un risque potentiel de choc électrique et de blessures lors du démontage et de la maintenance de ce produit. Le personnel professionnel de maintenance doit comprendre les risques et prendre les précautions nécessaires.

 **ATTENTION—RISQUE D'ELECTROCUTION :** Ce symbole indique un danger lié à des niveaux de tension dangereux dans la zone du produit à manipuler. Débranchez le produit avant de commencer, ou agissez avec prudence si le produit doit être alimenté pour effectuer l'opération.

 **ATTENTION—RISQUE DE BLESSURE :** La batterie lithium de ce produit n'est pas destinée à être remplacée. Si vous ne respectez pas les instructions de remplacement de la batterie, vous risquez de provoquer une explosion. Ne rechargez pas, ne désassemblez pas et ne brûlez pas la batterie au lithium. Mettez les batteries lithium usagées au rebut selon les instructions du fabricant et les réglementations locales.

Informació de seguretat

- La seguretat d'aquest producte es basa en les proves i les homologacions del disseny original i dels components específics. El fabricant no és responsable de la seguretat en el cas d'ús de peces de recanvi no autoritzades.
- La informació de manteniment d'aquest producte s'ha preparat per a l'ús d'un professional tècnic i no per a l'ús d'altres persones.
- És possible que el risc de descàrrega elèctrica i lesions personals augmenti durant el desmuntatge i les tasques de manteniment d'aquest producte. El professional tècnic ha de comprendre aquest risc i prendre les precaucions necessàries.

 **PRECAUCIÓ. PERILL DE DESCÀRREGA ELÈCTRICA:** Quan vegeu aquest símbol, indica que hi ha un perill de voltatge elevat en l'àrea del producte on esteu treballant. Desconnecteu el producte abans de començar o tingueu precaució si el producte ha de rebre alimentació per realitzar la tasca.

-  **PRECAUCIÓ. POSSIBLES DANYS:** La bateria de liti d'aquest producte no ha estat dissenyada perquè se substitueixi. Hi ha perill d'explosió si no es substitueix correctament la bateria de liti. No recarregueu, desmunteu o incinereu una bateria de liti. Desfeu-vos de les bateries de liti usades d'acord amb les instruccions del fabricant i les regulacions locals.

Información de seguridad

- La seguridad de este producto se basa en las pruebas y comprobaciones del diseño original y los componentes específicos. El fabricante no se hace responsable de la seguridad en caso de uso de piezas de repuesto no autorizadas.
- La información de mantenimiento de este producto se ha preparado para su uso por parte de un profesional de asistencia técnica y no está diseñada para su uso por parte de otros usuarios.
- Es posible que haya un mayor riesgo de descarga eléctrica y daños personales durante el desmontaje y el mantenimiento de este producto. El personal de asistencia profesional debe conocer este riesgo y tomar las precauciones necesarias.

 **PRECAUCIÓN: PELIGRO DE DESCARGAS ELÉCTRICAS:** Cuando vea este símbolo, existe peligro de tensiones peligrosas en el área del producto en la que está trabajando. Desconecte el producto antes de empezar o tenga cuidado si el producto debe recibir alimentación a fin de realizar la tarea.

 **PRECAUCIÓN: POSIBLES DAÑOS PERSONALES:** La batería de litio de este producto no debe reemplazarse. Existe riesgo de explosión si se sustituye incorrectamente una batería de litio. No recargue, desmonte ni incinere una batería de litio. Deseche las baterías de litio usadas según las instrucciones del fabricante y las normativas locales.

Informações sobre segurança

- A segurança deste produto é baseada em testes e aprovações do design original e de componentes específicos. O fabricante não é responsável por segurança em caso de uso não autorizado de peças de substituição.
- As informações sobre manutenção deste produto foram preparadas para utilização por um técnico profissional experiente e não se destinam ao uso por outros.
- Pode haver maior risco de choque elétrico e danos pessoais durante a desmontagem e manutenção deste produto. Os técnicos profissionais experientes devem entender esses riscos e tomar as precauções necessárias.

 **ATENÇÃO—RISCO DE CHOQUE:** Se você vir este símbolo, existe perigo de tensão elétrica na área do produto onde está trabalhando. Desligue o produto antes de começar ou tenha cuidado se o produto precisar receber energia para executar a tarefa.

 **ATENÇÃO—RISCO DE FERIMENTO:** A bateria de lítio neste produto não deve ser substituída. Existe o risco de explosão se uma bateria de lítio for substituída incorretamente. Não recarregue, desmonte nem incinere uma bateria de lítio. Descarte as baterias de lítio usadas de acordo com as instruções do fabricante e regulamentos locais.

Informazioni sulla sicurezza

- La sicurezza di questo prodotto è basata sui test e sulle approvazioni del design originale e dei componenti specifici. Il produttore non è responsabile della sicurezza in caso di utilizzo di parti di ricambio non autorizzate.
- Le informazioni di manutenzione per questo prodotto sono state predisposte per essere utilizzate da un tecnico dell'assistenza professionale e non sono state previste per l'uso da parte di altre persone.

- È possibile che vi sia un maggior rischio di scosse elettriche e lesioni personali durante lo smontaggio e la manutenzione di questo prodotto. Il personale dell'assistenza deve comprendere questo rischio e prendere le precauzioni necessarie.

 **ATTENZIONE - PERICOLO DI SCOSSE ELETTRICHE:** Questo simbolo indica la presenza di un rischio per tensioni pericolose nell'area del prodotto in cui si lavora. Scollegare l'alimentazione prima di iniziare, o prestare la massima attenzione se per effettuare l'operazione il prodotto deve ricevere l'alimentazione.

 **ATTENZIONE - PERICOLO DI LESIONI:** La batteria al litio contenuto nel prodotto non deve essere sostituita: in caso di sostituzione errata della batteria al litio, potrebbe verificarsi un'esplosione. Non ricaricare, smontare o bruciare batterie al litio. Smaltire le batterie al litio usate seguendo le istruzioni del produttore e le norme locali.

Informatie over veiligheid

- De veiligheid van dit product is gebaseerd op testen en goedkeuringen van het oorspronkelijke ontwerp en specifieke onderdelen. De fabrikant is niet verantwoordelijk voor de veiligheid bij gebruik van ongeautoriseerde vervangende onderdelen.
- De informatie over het onderhoud van dit product is opgesteld voor gebruik door een professionele onderhoudsmonteur en is niet bedoeld voor gebruik door anderen.
- Tijdens demontage en onderhoud van dit product bestaat mogelijk een hoger risico op elektrische schokken en lichamelijk letsel. Professionele onderhoudsmonteurs dienen op de hoogte te zijn van dit risico en de noodzakelijke voorzorgsmaatregelen te nemen.

 **LET OP: GEVAAR VOOR ELEKTRISCHE SCHOKKEN:** Wanneer u dit symbool ziet, bestaat er een gevaar voor gevaarlijke spanning in het gebied van het product waaraan u werkt. Haal de stekker van het product uit het stopcontact voordat u begint, of let extra goed op als het product stroom nodig heeft om een taak te kunnen uitvoeren.

 **LET OP: RISICO OP LETSEL:** De lithiumbatterij in dit product moet niet worden vervangen. Wanneer de lithiumbatterij niet juist wordt vervangen, bestaat er explosiegevaar. Probeer nooit lithiumbatterijen op te laden, open te maken of te verbranden. Gooi gebruikte lithiumbatterijen weg volgens de aanwijzingen van de fabrikant en houd hierbij de plaatselijke regelgeving in acht.

Sikkerhedsoplysninger

- Sikkerheden for dette produkt er baseret på afprøvning og godkendelser af det oprindelige design og specifikke komponenter. Producenten er ikke ansvarlig for sikkerhed i tilfælde af brug af uautoriserede dele til udskiftning.
- Vedligeholdelsesoplysninger om dette produkt er udarbejdet til brug af en kvalificeret servicetekniker og er ikke beregnet til at blive brugt af andre.
- Der kan være en forøget risiko for elektrisk stød eller personskade ved afmontering og service af dette produkt. Professionelt servicepersonale bør forstå denne risiko og tage nødvendige forholdsregler.

 **FORSIGTIG - ELEKTRISK STØD:** Når du ser dette symbol, er der risiko for elektrisk spænding i nærheden af produktet, hvor du arbejder. Tag strømskiftet ud inden du begynder, eller udvis forsigtighed, hvis produktet skal modtage strøm for at udføre opgaven.

 **FORSIGTIG - RISIKO FOR SKADE:** Litium-batteriet i dette produkt er ikke beregnet til at blive udskiftet. Der er fare for eksplosion, hvis et litium-batteri udskiftes forkert. Du må ikke genoplade, demontere eller afbrænde et litium-batteri. Brugte litium-batterier skal bortskaffes i overensstemmelse med producentens instruktioner og lokale retningslinjer.

Sicherheitshinweise

- Die Sicherheit dieses Produkts basiert auf Tests und Zulassungen des Originaldesigns und der spezifischen Komponenten. Sofern nicht autorisierte Ersatzteile eingesetzt werden, übernimmt der Hersteller keinerlei Verantwortung in Bezug auf die Sicherheit dieses Produkts.
- Die Wartungsinformationen für dieses Produkt wurden für ausgebildete Servicemitarbeiter zusammengestellt und dürfen nicht von anderen verwendet werden.
- Möglicherweise besteht bei der Demontage und Wartung dieses Produkts eine erhöhte Stromschlag- und Verletzungsgefahr. Ausgebildete Servicemitarbeiter sollten sich dieser Gefahr bewusst sein und die notwendigen Vorsichtsmaßnahmen ergreifen.

 **VORSICHT – STROMSCHLAGGEFAHR:** Wenn Sie dieses Symbol sehen, besteht eine Gefahr durch gefährliche Spannungen in dem Produktbereich, in dem Sie arbeiten. Trennen Sie das Produkt von seiner Stromverbindung, bevor Sie beginnen, oder gehen Sie vorsichtig vor, wenn das Produkt für die Durchführung der Aufgabe mit Strom versorgt werden muss.

 **VORSICHT – MÖGLICHE VERLETZUNGSGEFAHR** Die Lithiumbatterie in diesem Produkt darf nicht ausgetauscht werden. Wird eine Lithiumbatterie nicht ordnungsgemäß ausgetauscht, besteht Explosionsgefahr. Lithiumbatterien dürfen auf keinen Fall wieder aufgeladen, auseinander genommen oder verbrannt werden. Befolgen Sie zum Entsorgen verbrauchter Lithiumbatterien die Anweisungen des Herstellers und die örtlichen Bestimmungen.

Turvallisuusohjeet

- Tämän laitteen turvallisuus perustuu alkuperäisen rakenteen ja tiettyjen osien testaukseen ja hyväksymiseen. Valmistaja ei vastaa turvallisuudessa, jos laitteessa on käytetty luvattomia vaihto-osia.
- Tämän tuotteen huoltoa koskevat tiedot on tarkoitettu vain ammattitaitoisen huoltohenkilön käyttöön.
- Tämän tuotteen purkamiseen ja huoltoon voi liittyä kasvanut sähköiskun tai henkilövahingon vaara. Ammattitaitoisen huoltohenkilön on ymmärrettävä tämä vaara ja toimittava sen edellyttämällä tavalla.

 **HUOMIO – SÄHKÖISKUN VAARA:** Tämä symboli ilmaisee, että tuotteen työskentelyalueella on olemassa vaarallinen jännite. Irrota laite verkkovirrasta ennen kuin aloitat tai toimi erittäin varovasti, jos laitteessa on oltava virta työn aikana.

 **HUOMIO – TAPATURMAN MAHDOLLISUUS:** Tuotteessa olevaa litiumakkua ei ole tarkoitettu vaihdettavaksi. Litiumakun poistaminen väärin aiheuttaa räjähdysvaaran. Älä lataa, pura tai polta litiumakkua. Hävitä käytetyt litiumakut valmistajan ohjeiden ja paikallisten säädösten mukaisesti.

Sikkerhetsinformasjon

- Sikkerheten til dette produktet er basert på testing og godkjenning av originaldesignet og bestemte komponenter. Produsenten er ikke ansvarlig for sikkerheten ved bruk av uautoriserte reservedeler.
- Vedlikeholdsinformasjonen for dette produktet er tilrettelagt for bruk av profesjonelt servicepersonale, og er ikke ment for bruk av andre.
- Det kan være en økt risiko for elektrisk støt og personskade under demontering og vedlikehold av produktet. Profesjonelt servicepersonell må være innforstått med denne risikoen og ta nødvendige forholdsregler.

 **FORSIKTIG – FARE FOR STØT:** Dette symbolet betyr at det er fare for farlig spenning i det området av produktet der du arbeider. Koble fra produktet før du begynner, eller vær forsiktig hvis produktet må ha strøm for å kunne utføre oppgaven.

-  **FORSIKTIG – POTENSIELLE SKADER:** Litiumbatteriet i dette produktet er ikke beregnet for å byttes. Det er fare for eksplosjon hvis litiumbatteriet skiftes ut på feil måte. Ikke lad opp, demonter eller destruer et litiumbatteri. Kast brukte litiumbatterier i henhold til produsentens instruksjoner og lokale regelverk.

Säkerhetsinformation

- Säkerheten för denna produkt baseras på tester och godkännanden av ursprungsdesignen och av specifika komponenter. Tillverkaren har inget ansvar vid användning av oauktorerade reservdelar.
- Underhållsinformationen för produkten är avsedd att användas av utbildade servicetekniker och inte avsedd att användas av andra.
- Risken för elektriska stötar och personskador kan vara förhöjd vid isärtagning och service av produkten. Professionell servicepersonal bör vara medvetna om denna risk och vidta nödvändiga försiktighetsåtgärder.

 **VAR FÖRSIKTIG– RISK FÖR ELEKTRISK STÖT:** När du ser denna symbol är det risk att det finns farlig spänning i den del av produkten du arbetar med. Koppla från strömmen innan du börjar, eller var försiktig om produkten måste vara strömförsörjd för att uppgiften ska kunna utföras.

 **VAR FÖRSIKTIG – RISK FÖR SKADA:** Litiumbatteriet i produkten är inte utbytbart. Om ett litiumbatteri byts ut på fel sätt finns det risk att det exploderar. Du får inte ladda om, ta isär eller elda upp ett litiumbatteri. Gör dig av med använda litiumbatterier enligt tillverkarens instruktioner och lokala föreskrifter.

安全情報

- 本製品の安全性は、本来の設計、特定コンポーネントの試験、承認に基づいています。承認されていない交換部品をお客様が使用した場合、メーカーは安全性に対して責任を負いません。
- 本製品のメンテナンス情報は、専門のサービス担当者による利用を目的としており、その他の人を対象としていません。
- 本製品の分解や保守サービスを行う場合は、感電や傷害の危険性があります。専門のサービス担当者はこの危険性を理解し、十分な対策を講じる必要があります。

 **注意—感電危険:** この表記がある場合、対象製品の作業領域には、高電圧による危険性が生じています。作業を始める前に、製品から電源コードを取り外してください。また作業時に、製品に給電する必要がある場合は、十分に注意するようにしてください。

 **注意—傷害の恐れあり:** この製品に使用されているリチウム電池は、交換を前提としていません。リチウム電池の交換を誤ると破裂する危険性があります。リチウム電池の充電、解体、焼却はしないでください。使用済みのリチウム電池を廃棄する際は、製造元の指示およびお使いの地域の法律に従ってください。

안전 정보

- 이 제품의 안전은 기본 디자인 및 특정 구성품의 승인 및 테스트를 기반으로 합니다. 제조업체는 권한 없는 교체 부품 사용 시 안전에 대해 책임을 지지 않습니다.
- 이 제품의 유지관리 정보는 전문 서비스 요원을 대상으로 하며 다른 사람은 사용할 수 없습니다.
- 제품 분해 및 서비스 중에는 감전 및 상해 위험이 증가할 수 있습니다. 전문 서비스 요원은 이와 같은 위험을 이해하고 필요한 예방 조치를 취해야 합니다.

 **주의—감전 위험:** 이 기호가 표시된 경우 작업 중인 제품 주변에서 위험 전압 위험이 있습니다. 사용 전/후에 전원 코드를 뽑아 두시고 제품에서 작업을 수행하는 데 반드시 전원이 필요한 경우에는 주의하여 사용하십시오.

-  **주의—상해 위험:** 이 제품에 들어 있는 리튬 배터리는 교체할 수 없습니다. 리튬 배터리를 잘못 교체하면 폭발할 위험이 있습니다. 리튬 배터리를 충전, 분해하거나 불에 태우지 마십시오. 제조업체의 지침과 지역 규정에 따라 다 쓴 리튬 배터리를 폐기하십시오.

安全信息

- 本产品的安全性以原始设计和特定组件的测试和审批为基础。如果使用未经授权的替换部件，制造商不对安全性负责。
- 本产品的维护信息仅供专业服务人员使用，并不打算由其他人使用。
- 本产品在拆卸和维修时，遭受电击和人员受伤的危险性会增高。专业服务人员对这点必须有所了解，并采取必要的预防措施。

 **小心—电击危险:** 当您看到此符号时，在您工作的产品区域内存在危险电压的威胁。在您开始操作之前请拔掉产品电源，如果产品必须接收功率才能执行任务，请务必谨慎操作。

 **小心—可能的伤害:** 本产品中的锂电池不可更换。如果不正确更换锂电池，可能会有爆炸危险。不要再充电、拆解或焚烧锂电池。丢弃旧的锂电池时应按照制造商的指导及当地法规进行处理。





安全資訊

- 本產品安全性係以原始設計及特定元件之測試與核准為依據。如有使用未獲授權替換組件之情形者，製造商對安全性概不負責。
- 本產品之維護資訊僅供專業維修人員使用，而非預定由他人使用。
- 拆裝及維修本產品時，有可能造成電擊與人員損傷之危險。專業維修人員應瞭解前項危險並採取必要措施。

 **請當心—觸電危險:** 當您看到此符號時，表示您所在產品工作區有危險電壓。開始工作之前，請先拔掉產品電源線，若產品必須接上電源方能執行作業，用電時請務必小心。

 **請當心—潛在受傷危險性:** 本產品中的鋰電池原本並不需要予以更換。若未正確更換鋰電池，可能會有爆炸的危險。請勿將鋰電池充電、拆裝或焚燒。請遵照製造商的指示及當地法規，丟棄用過的電池。

General caution statements

-  **CAUTION—POTENTIAL INJURY:** To avoid the risk of fire or electrical shock, connect the power cord to an appropriately rated and properly grounded electrical outlet that is near the product and easily accessible.
-  **CAUTION—POTENTIAL INJURY:** To avoid the risk of fire or electrical shock, use only the power cord provided with this product or the manufacturer's authorized replacement.
-  **CAUTION—POTENTIAL INJURY:** Do not use this product with extension cords, multioutlet power strips, multioutlet extenders, or UPS devices. The power capacity of these types of accessories can be easily overloaded by a laser printer and may result in a risk of fire, property damage, or poor printer performance.
-  **CAUTION—POTENTIAL INJURY:** Only a Lexmark Inline Surge Protector that is properly connected between the printer and the power cord provided with the printer may be used with this product. The use of non-Lexmark surge protection devices may result in a risk of fire, property damage, or poor printer performance.

Change history

Change history

September 7, 2018

- 41X1186 FRU PN was changed to 41X2047 on the Control panel Parts catalog.
- 41X1189 FRU PN was changed to 41X1627 on the Control panel Parts catalog.
- Control panel cover and buttons FRU descriptions were changed to Control panel covers on the Control panel Parts catalog.

August 2, 2018

- Date security notice was updated.
- Software CD and Smart card were added to the Miscellaneous Parts catalog.

July 6, 2018

- Output device diagnostics section under Service menus was deleted.

May 4, 2018

- For the right cover removal, an image was added showing how to open the controller board access cover.
- Printhead assembly adjustment was updated to include a note referring to the Registration adjust procedure.

April 27, 2018

- Reference to *print defects guide* on the Repeating defects check was removed.
- Reference to *second transfer roller* on the Enable edge-to-edge (printing) was removed.

General information

Printer model configurations

The Lexmark™ MS521dn, MS421dw, MS421dn, MS321dn, B2546dn, B2442dw, B2338dw, M1246, and M1242 printers are network-capable, multifunction laser printers. The printers support monochrome printing and are embedded with home screen solutions and applications. All information in this service manual pertains to all models unless explicitly noted.

The printers are available in the following models:

Model	Configurations	Machine type/model
MS521dn	Network-ready monochrome laser printer with 2.4" color display and internal duplex for medium workgroups	4600-630
MS421dn	Network-ready monochrome laser printer with 2-line APA display and internal duplex printing for small workgroups	4600-430
MS421dw	Network-ready monochrome laser printer with 2-line APA display and internal duplex printing, wireless, for small workgroups	4600-438
MS321dn	Network-ready monochrome laser printer with 2-line APA display and internal duplex printing for small workgroups	4600-230
B2546dn	Network-ready monochrome laser printer with 2.4" color display and internal duplex for medium workgroups	4600-630
B2442dw	Network-ready monochrome laser printer with 2-line APA display and internal duplex printing, wireless, for small workgroups	4600-438
B2338dw	Network-ready monochrome laser printer with 2-line APA display and internal duplex printing, wireless, for small workgroups	4600-238
M1246	Network-ready monochrome laser printer with 2.4" color display and internal duplex for medium workgroups	4600-690
M1242	Network-ready monochrome laser printer with 2-line APA display and internal duplex printing for small workgroups	4600-490

Finding the serial number

Open door A, and then find the serial number at the right side of the printer.

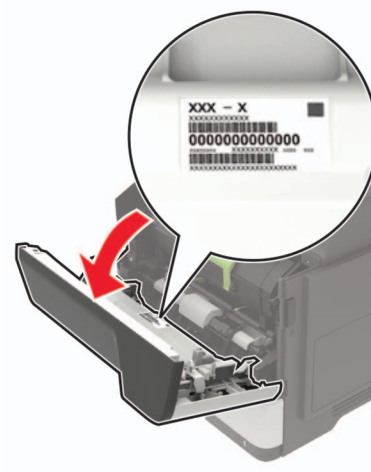

Supported paper sizes, types, and weights

The following tables provide information on standard and optional paper sources and the sizes, types, and weights of paper they support.

Note: For an unlisted paper size, select the closest *larger* listed size.

Supported paper sizes

Paper size	Tray	Multipurpose feeder	Two-sided printing
A4 210 x 297 mm (8.3 x 11.7 in.)	✓	✓	✓
A5 210 x 148 mm (5.8 x 8.3 in.)	✓	✓	X
A5 LEF* 148 x 210 mm (5.8 x 8.3 in.)	✓	✓	X
A6* 105 x 148 mm (4.1 x 5.8 in.)	✓	✓	X
JIS B5 182 x 257 mm (7.2 x 10.1 in.)	✓	✓	X
Oficio (Mexico) 216 x 340 mm (8.5 x 13.4 in.)	✓	✓	✓
Hagaki 100 x 148 mm (3.9 x 5.8 in.)	X	✓	X

* This paper size is not supported in the optional tray.

Paper size	Tray	Multipurpose feeder	Two-sided printing
Statement 140 x 216 mm (5.5 x 8.5 in.)	✓	✓	X
Executive 184 x 267 mm (7.3 x 10.5 in.)	✓	✓	X
Letter 216 x 279 mm (8.5 x 11 in.)	✓	✓	✓
Legal 216 x 356 mm (8.5 x 14 in.)	✓	✓	✓
Folio 216 x 330 mm (8.5 x 13 in.)	✓	✓	✓
Universal 76.2 x 127 mm (3 x 5 in.) to 216 x 356 mm (8.5 x 14 in.)	✓	✓	X
7 3/4 Envelope (Monarch) 98 x 191 mm (3.9 x 7.5 in.)	X	✓	X
9 Envelope 98 x 225 mm (3.9 x 8.9 in.)	X	✓	X
10 Envelope 105 x 241 mm (4.1 x 9.5 in.)	X	✓	X
DL Envelope 110 x 220 mm (4.3 x 8.7 in.)	X	✓	X
C5 Envelope 162 x 229 mm (6.4 x 9 in.)	X	✓	X
B5 Envelope 176 x 250 mm (6.9 x 9.8 in.)	X	✓	X
Other Envelope 76.2 x 127 mm (3 x 5 in.) to 216 x 356 mm (8.5 x 14 in.)	X	✓	X
* This paper size is not supported in the optional tray.			

Supported paper types

Paper type	Tray	Multipurpose feeder	Two-sided printing
Plain paper	✓	✓	✓
Card stock	X	✓	X

¹ One-sided paper labels designed for laser printers are supported for occasional use. It is recommended to print 20 or fewer pages of paper labels per month. Vinyl, pharmacy, and two-sided labels are not supported.

² Bond and Heavy Paper are supported in two-sided printing up to 90-g/m² (24-lb) paper weight.

Paper type	Tray	Multipurpose feeder	Two-sided printing
Transparency	✓	✓	X
Recycled	✓	✓	✓
Paper labels ¹	✓	✓	X
Bond ²	✓	✓	✓
Letterhead	✓	✓	✓
Preprinted	✓	✓	✓
Colored Paper	✓	✓	✓
Light Paper	✓	✓	✓
Heavy Paper ²	✓	✓	✓
Rough/Cotton	✓	✓	✓
Envelope	X	✓	X
Rough envelope	X	✓	X

¹ One-sided paper labels designed for laser printers are supported for occasional use. It is recommended to print 20 or fewer pages of paper labels per month. Vinyl, pharmacy, and two-sided labels are not supported.

² Bond and Heavy Paper are supported in two-sided printing up to 90-g/m² (24-lb) paper weight.

Supported paper weights





	Tray	Multipurpose feeder	Two-sided printing
Paper weight	60–120 g/m ² (16–32 lb)	60–216 g/m ² (16–58 lb)	60–90 g/m ² (16–24 lb)

Tools required for service

- Flat-blade screwdrivers, various sizes
- #1 Phillips screwdriver, magnetic
- #2 Phillips screwdriver, magnetic
- #2 Phillips screwdriver, magnetic short-blade
- Torx™ screwdriver (T20 head)
- Needle-nose pliers

- Diagonal side cutters
- Spring hook
- Feeler gauges
- Analog or digital multimeter
- 3-mm ball hex wrench
- Toner vacuum
- Flashlight

Diagnostics and troubleshooting

-  **CAUTION—SHOCK HAZARD:** This product uses a soft power switch. It does not physically disconnect the input AC voltage. To avoid the risk of electrical shock, always remove the power cord from the printer when removal of the input AC voltage is required.
-  **CAUTION—SHOCK HAZARD:** To avoid the risk of electrical shock and to prevent damage to the printer, remove the power cord from the electrical outlet and disconnect all connections to any external devices before you connect or disconnect any cable, electronic board, or assembly.
-  **CAUTION—HOT SURFACE:** The inside of the printer might be hot. To reduce the risk of injury from a hot component, allow the surface to cool before touching it.
-  **CAUTION—PINCH HAZARD:** To avoid the risk of a pinch injury, use caution in areas marked with this label. Pinch injuries may occur around moving parts, such as gears, doors, trays, and covers.

Troubleshooting overview

Performing the initial troubleshooting check

Before you start the troubleshooting procedures, perform the following checks:

- Use genuine Lexmark supplies and parts for the best results. Third-party supplies or parts may affect the performance, reliability, or life of the printer and its imaging components.
- With the power cord unplugged from the electrical outlet, check that the cord is free from the breakage, short circuits, disconnected wires, or incorrect connections.
- Make sure the printer is properly grounded. Check the power cord ground terminal.
- Make sure the power supply line voltage is within 10% of the rated line voltage.
- Make sure the machine is securely installed on a level surface in a well-ventilated area.
- Make sure the room temperature is between 16 and 32°C (60 and 90°F) and that the relative humidity is between 20 and 80%.
- Avoid sites generating ammonia gas, high temperature, high humidity (near water faucets, kettles, humidifiers), cold spaces, near open flames, and dusty areas.
- Avoid sites exposed to direct sunlight.
- Make sure the paper is the recommended paper for this printer.
- Make a trial print with paper from a newly opened package, and check the result.

Fixing print quality issues

- [“Initial print quality check” on page 28](#)
- [“Gray background or toner fog check” on page 29](#)

- “Blank pages check” on page 31
- “Print is too dark check” on page 37
- “Print is too light check” on page 39
- “Paper curl check” on page 42
- “Folded or wrinkled paper check” on page 43
- “Solid black pages check” on page 44
- “Repeating defects check” on page 47
- “Skewed print check” on page 48
- “Streaked vertical lines appear on prints check” on page 50
- “Horizontal light bands check” on page 51
- “Vertical light bands check” on page 52
- “Vertical dark bands check” on page 53
- “Vertical dark streaks with print missing check” on page 55
- “White streaks and voided areas check” on page 57
- “Fine lines are not printed correctly (specifically Chinese characters) check” on page 60
- “Clipped pages or images check” on page 61
- “Compressed images appear on prints check” on page 63
- “Incorrect margins on prints check” on page 64
- “Toner rubs off check” on page 65
- “Toner specks appear on prints check” on page 66

Initial print quality check

Before troubleshooting print problems, perform the following:

- Make sure that the printer is located in an area that follows the recommended operating environment and power requirement specifications.
- Check the status of supplies. Replace supplies that are low or empty.
- Load 20-lb (75-80 g/m²) plain letter or A4 paper. Make sure that the paper guides are properly set and locked. From the control panel, set the paper size and type to match the paper loaded in the tray.
- From the home screen, navigate to **Settings > Troubleshooting > Print Quality Test Pages**.
- Print and keep the menu settings page. The original menu settings page will be used to restore the custom settings if necessary.
- Make sure that the print resolution is set to 4800 CQ and the toner darkness is set to 4 on the menu settings page.
- Check the toner cartridges for damage, and replace if necessary.
- Make sure that the correct print driver is used to prevent print problems. If the wrong print driver is installed, then incorrect characters could print and the copy may not fit the page correctly.

Gray background or toner fog check

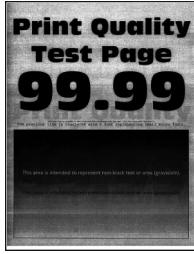

Note: Before performing this print quality check, go to the control panel home screen and navigate to **Settings > Troubleshooting > Print Quality Test Pages**, and then perform the Initial print quality check. See [“Initial print quality check” on page 28](#).

Actions	Yes	No
<p>Step 1</p> <p>a Turn off the printer, wait for 10 seconds, and then turn on the printer.</p> <p>b From the control panel:</p> <ol style="list-style-type: none"> Increase the toner darkness in the Quality menu. Note: 8 is the factory default setting. Set the paper type, texture, and weight in the Paper menu to match the paper loaded. <p>Does the problem remain?</p>	Go to step 2.	The problem is solved.
<p>Step 2</p> <p>Check if the printer is using a genuine and supported Lexmark toner cartridge.</p> <p>Note: If the printer is using a third-party cartridge, then refer the users to their cartridge supplier.</p> <p>Is the printer using a genuine and supported toner cartridge?</p>	Go to step 4.	Go to step 3.
<p>Step 3</p> <p>Install a genuine and supported toner cartridge.</p> <p>Does the problem remain?</p>	Go to step 4.	The problem is solved.

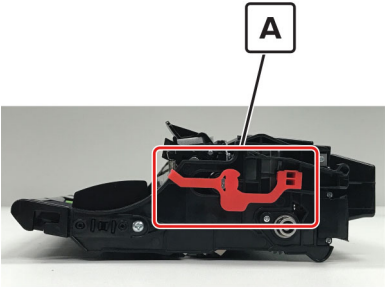
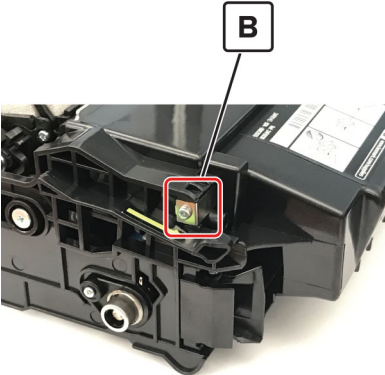
Actions	Yes	No
<p>Step 4</p> <p>a Remove any packing material left on the imaging unit, including the red separator plastic (A).</p>  <p>Note: You may need a pair of pliers to remove a piece of broken plastic inside the imaging unit.</p> <p>b Check the charge roller contact (B) on the right side of the imaging unit for damage and contamination.</p>  <p>Is the charge roller contact damaged and contaminated?</p>	<p>Go to step 5.</p>	<p>Go to step 6.</p>
<p>Step 5</p> <p>Repair or replace the charge roller contact on the imaging unit.</p> <p>Does the problem remain?</p>	<p>Go to step 6.</p>	<p>The problem is solved.</p>
<p>Step 6</p> <p>Replace the imaging unit.</p> <p>Does the problem remain?</p>	<p>Go to step 7.</p>	<p>The problem is solved.</p>
<p>Step 7</p> <p>Make sure that connection JPS1 on the controller board and the connections on the power supply are properly connected.</p> <p>Are the connections properly connected?</p>	<p>Go to step 9.</p>	<p>Go to step 8.</p>

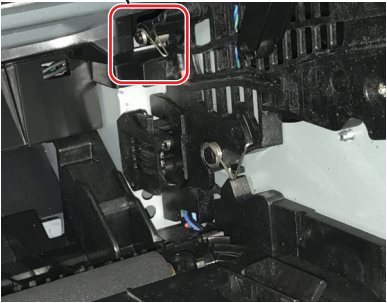
Actions	Yes	No
<p>Step 8 Reseat the connections.</p> <p>Does the problem remain?</p>	<p>Go to step 9.</p>	<p>The problem is solved.</p>
<p>Step 9</p> <p>Note: Poor electrical contact to the photoconductor is the most likely source of a full page background defect.</p> <p>a Remove any contamination from the photoconductor charge contact (C) on the right side of the frame.</p> <div data-bbox="402 573 786 953" style="text-align: center;">  </div> <p>b Perform a print test.</p> <p>Does the problem remain?</p>	<p>Go to step 10.</p>	<p>The problem is solved.</p>
<p>Step 10</p> <p>Check if the photoconductor charge contact is bent, damaged, or not in proper contact with the imaging unit.</p> <p>Is the contact free from damage and in proper contact with the imaging unit?</p>	<p>Go to step 11.</p>	<p>Contact the next level of support.</p>
<p>Step 11</p> <p>Replace the power supply. See “Power supply removal” on page 211.</p> <p>Does the problem remain?</p>	<p>Contact the next level of support.</p>	<p>The problem is solved.</p>

Blank pages check

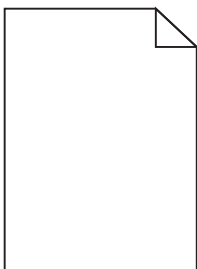

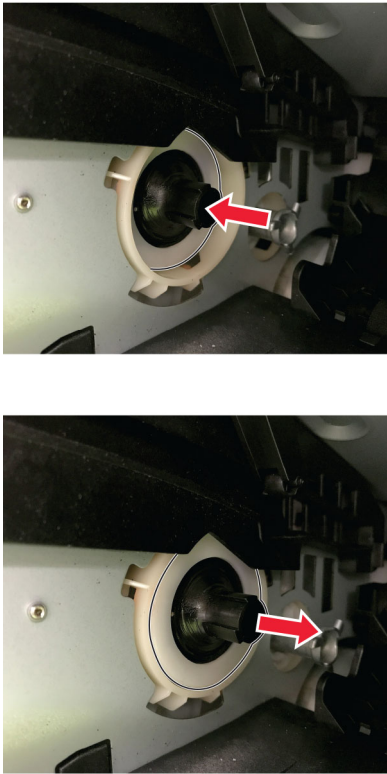

Note: Before performing this print quality check, go to the control panel home screen and navigate to **Settings > Troubleshooting > Print Quality Test Pages**, and then perform the Initial print quality check. See [“Initial print quality check” on page 28](#).

Actions	Yes	No
<p>Step 1 Check if the printer is using a genuine and supported Lexmark toner cartridge.</p> <p>Note: If the printer is using a third-party cartridge, then refer the users to their cartridge supplier.</p> <p>Is the printer using a genuine and supported toner cartridge?</p>	Go to step 3.	Go to step 2.
<p>Step 2 Install a genuine and supported toner cartridge.</p> <p>Does the problem remain?</p>	Go to step 3.	The problem is solved.
<p>Step 3</p> <ul style="list-style-type: none"> a Check and remove any packing material left on the imaging unit. b Firmly shake the imaging unit to redistribute the toner, and then reinstall it. <p>Does the problem remain?</p>	Go to step 4.	The problem is solved.
<p>Step 4 Check the imaging unit for damage and proper installation, and replace if necessary.</p> <p>Does the problem remain?</p>	Go to step 5.	The problem is solved.

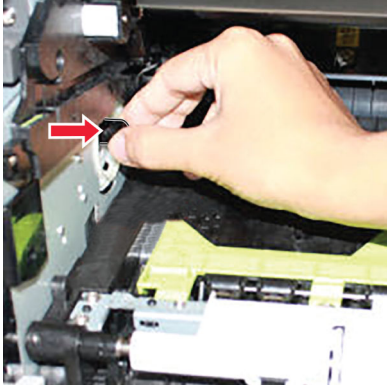
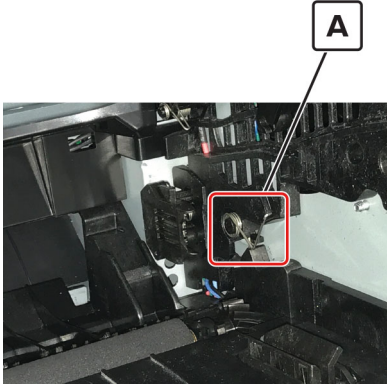
Actions	Yes	No
<p>Step 5</p> <p>Check the coupler to make sure that it is not stuck in the retracted position. While slowly closing the door, observe the coupler to see if it moves inward.</p> <p>Note: With the imaging unit removed, the coupler should retract with the door open and move inward when the front door is closed.</p>  <p>Is the coupler stuck, and not moving inward, while closing the front door?</p>	Go to step 6.	Go to step 7.

Actions	Yes	No
<p>Step 6 Reach inside the printer and manually reposition the coupler in the direction of the red arrow as shown.</p>  <p>Does the problem remain?</p>	<p>Go to step 7.</p>	<p>The problem is solved.</p>
<p>Step 7 Check if the imaging unit contact (A) is bent, damaged, or not in proper contact with the imaging unit.</p>  <p>Are the contacts free from damage, not bent and in proper contact with the imaging unit?</p>	<p>Go to step 8.</p>	<p>Contact the next level of support.</p>
<p>Step 8 Check all connections in the power supply. If necessary, replace the power supply.</p> <p>Does the problem remain?</p>	<p>Go to step 9.</p>	<p>The problem is solved.</p>
<p>Step 9 Reseat cable JPS1 on the controller board.</p> <p>Does the problem remain?</p>	<p>Go to step 10.</p>	<p>The problem is solved.</p>

Actions	Yes	No
<p>Step 10 Replace the cable.</p> <p>Does the problem remain?</p>	Go to step 11.	The problem is solved.
<p>Step 11</p> <p>a Check the transfer roller for proper installation. If necessary, remove and then reinstall the transfer roller.</p> <p>b Check the transfer roller for contamination and damage.</p> <p>Is the transfer roller free of contamination and damage?</p>	Go to step 13.	Go to step 12.
<p>Step 12 Replace the transfer roller. See “Transfer roller removal” on page 203.</p> <p>Does the problem remain?</p>	Go to step 13.	The problem is solved.
<p>Step 13 Check the transfer roller left contact spring on the transfer roller left arm for damage.</p> <p>Is the contact spring free of damage?</p>	Go to step 15.	Go to step 14.
<p>Step 14 Replace the transfer roller left arm with cable.</p> <p>Does the problem remain?</p>	Go to step 15.	The problem is solved.

Actions	Yes	No
<p>Step 15</p> <p>a Check the coupler for signs of damage. The coupler is located on the main drive motor.</p> <ul style="list-style-type: none"> • Good condition  <ul style="list-style-type: none"> • Bad condition  <p>b If the coupler is damaged, then replace the main drive motor.</p> <p>Does the problem remain?</p>	<p>Go to step 16.</p>	<p>The problem is solved.</p>
<p>Step 16</p> <p>Reseat the printhead cables on the controller board.</p> <p>Does the problem remain?</p>	<p>Go to step 17.</p>	<p>The problem is solved.</p>
<p>Step 17</p> <p>Replace the laser printhead. See “Printhead removal” on page 229.</p> <p>Does the problem remain?</p>	<p>Contact the next level of support.</p>	<p>The problem is solved.</p>

Print is too dark check

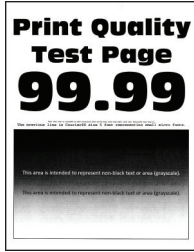

Note: Before performing this print quality check, go to the control panel home screen and navigate to **Settings > Troubleshooting > Print Quality Test Pages**, and then perform the Initial print quality check. See [“Initial print quality check” on page 28](#).

Actions	Yes	No
<p>Step 1</p> <p>Check if the printer is using a genuine and supported Lexmark toner cartridge.</p> <p>Note: If the printer is using a third-party cartridge, then refer the users to their cartridge supplier.</p> <p>Is the printer using a genuine and supported toner cartridge?</p>	Go to step 3.	Go to step 2.
<p>Step 2</p> <p>Install a genuine and supported toner cartridge.</p> <p>Does the problem remain?</p>	Go to step 3.	The problem is solved.
<p>Step 3</p> <p>a Turn off the printer, wait for 10 seconds, and then turn on the printer.</p> <p>b From the control panel, reduce the toner darkness in the Quality menu.</p> <p>Note: 8 is the factory default setting.</p> <p>Does the problem remain?</p>	Go to step 4.	The problem is solved.
<p>Step 4</p> <p>From the control panel, set the paper type, texture, and weight in the Paper menu to match the paper loaded.</p> <p>Does the problem remain?</p>	Go to step 5.	The problem is solved.
<p>Step 5</p> <p>Depending on the operating system, specify the paper type, texture, and weight from Printing Preferences or Print dialog.</p> <p>Does the problem remain?</p>	Go to step 6.	The problem is solved.

Actions	Yes	No
<p>Step 6</p> <p>a Check if the paper loaded has texture or rough finishes.</p> <p>b From the control panel, set the paper texture in the Paper menu to match the texture of the paper loaded.</p> <p>Does the problem remain?</p>	Go to step 7.	The problem is solved.
<p>Step 7</p> <p>Make sure that the paper loaded is from a fresh package.</p> <p>Note: Paper absorbs moisture due to high humidity. Store paper in its original wrapper until you use it.</p> <p>Does the problem remain?</p>	Go to step 8.	The problem is solved.
<p>Step 8</p> <p>Replace the imaging unit.</p> <p>Does the problem remain?</p>	Go to step 9.	The problem is solved.
<p>Step 9</p> <p>Check if the imaging unit contacts (A) are bent, damaged, or not in proper contact with the imaging unit.</p> <div data-bbox="380 961 764 1346" data-label="Image"> <p>The image shows the internal hardware of a device. Two specific contact points are highlighted with red rectangular boxes. Lines from a box labeled 'A' point to these two locations, indicating they are the contacts to be inspected for damage or proper contact.</p> </div> <p>Are the contacts free from damage, not bent and in proper contact with the imaging unit?</p>	Go to step 10.	Contact the next level of support.
<p>Step 10</p> <p>Check all connections on the power supply for proper connection.</p> <p>Is the power supply properly connected?</p>	Contact the next level of support.	Go to step 11.
<p>Step 11</p> <p>Replace the connections.</p> <p>Does the problem remain?</p>	Go to step 12.	The problem is solved.

Actions	Yes	No
<p>Step 12 Replace the power supply. See “Power supply removal” on page 211.</p> <p>Does the problem remain?</p>	Contact the next level of support.	The problem is solved.

Print is too light check

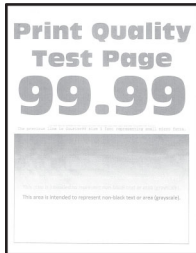

Note: Before performing this print quality check, go to the control panel home screen and navigate to **Settings > Troubleshooting > Print Quality Test Pages**, and then perform the Initial print quality check. See [“Initial print quality check” on page 28](#).

Actions	Yes	No
<p>Step 1 Check if the printer is using a genuine and supported Lexmark toner cartridge.</p> <p>Note: If the printer is using a third-party cartridge, then refer the users to their cartridge supplier.</p> <p>Is the printer using a genuine and supported toner cartridge?</p>	Go to step 3.	Go to step 2.
<p>Step 2 Install a genuine and supported toner cartridge.</p> <p>Does the problem remain?</p>	Go to step 3.	The problem is solved.
<p>Step 3</p> <p>a Turn off the printer, wait for 10 seconds, and then turn on the printer.</p> <p>b From the control panel:</p> <ol style="list-style-type: none"> Increase the toner darkness in the Quality menu. Note: 8 is the factory default setting. Set the paper type, texture, and weight in the Paper menu to match the paper loaded. <p>Does the problem remain?</p>	Go to step 4.	The problem is solved.

Actions	Yes	No
<p>Step 4</p> <p>a Remove the toner cartridge and imaging unit.</p> <p>b Push either side of the transfer roller , located below the imaging unit, to check if it depresses and bounces back into place.</p> <p>c If the transfer roller does not depress and bounce back into place, then reinstall it by pulling up the blue gear and pulling it out from the right side to the left.</p> <p>d Firmly shake the imaging unit to redistribute the toner, and then reinstall it.</p> <p>e Reinstall the toner cartridge.</p> <p>f Turn off the printer, wait for 10 seconds, and then turn on the printer.</p> <p>Does the problem remain?</p>	Go to step 5.	The problem is solved.
<p>Step 5</p> <p>Check the shutter on the imaging unit for signs of damage.</p> <p>Note: The shutter opens to receive toner from the toner cartridge.</p> <p>Is the shutter on the imaging unit working properly?</p>	Go to step 6.	Go to step 7.
<p>Step 6</p> <p>a Check the status of the imaging unit.</p> <p> 1 From the home screen, select Status/supplies.</p> <p> 2 Select View Supplies.</p> <p>b Check the condition of the imaging unit.</p> <p>Is the imaging unit near end of life and/or showing signs toner leakage?</p>	Go to step 7.	Go to step 8.
<p>Step 7</p> <p>Replace the imaging unit.</p> <p>Does the problem remain?</p>	Go to step 8.	The problem is solved.
<p>Step 8</p> <p>Replace the transfer roller. See “Transfer roller removal” on page 203.</p> <p>Does the problem remain?</p>	Go to step 9.	The problem is solved.

Actions	Yes	No
<p>Step 9 Clean the printhead lens. See “Cleaning the printhead lenses” on page 247.</p> <p>Note: This is applicable only to models installed with a galvo LSU. To determine whether the LSU is galvo, check the serial number of the printer. The sixth digit character assigned should be in the 0–9 or B–N range (Example: 4514 20HH 007CR).</p> <p>Does the problem remain?</p>	Go to step 10.	The problem is solved.
<p>Step 10 Replace the power supply. See “Power supply removal” on page 211.</p> <p>Does the problem remain?</p>	Go to step 11.	The problem is solved.
<p>Step 11 Check the cartridge gearbox for damage.</p> <p>Is the cartridge gearbox free from damage?</p>	Go to step 13.	Go to step 12.
<p>Step 12 Replace the cartridge gearbox. See “Cartridge gearbox removal” on page 180.</p> <p>Does the problem remain?</p>	Go to step 13.	The problem is solved.
<p>Step 13 Check connection JCART1 on the controller board and the connection on the cartridge gearbox.</p> <p>Are the connections properly connected?</p>	Go to step 15.	Go to step 14.
<p>Step 14 Replace the connections.</p> <p>Does the problem remain?</p>	Go to step 15.	The problem is solved.
<p>Step 15 Replace the cartridge gearbox. See “Cartridge gearbox removal” on page 180.</p> <p>Does the problem remain?</p>	Go to step 16.	The problem is solved.
<p>Step 16 Replace the controller board. See “Controller board removal” on page 191.</p> <p>Does the problem remain?</p>	Contact the next level of support.	The problem is solved.

Paper curl check



Note: Before performing this print quality check, go to the control panel home screen and navigate to **Settings > Troubleshooting > Print Quality Test Pages**, and then perform the Initial print quality check. See [“Initial print quality check” on page 28](#).

Actions	Yes	No
<p>Step 1 Check if the printer is using a genuine and supported Lexmark toner cartridge.</p> <p>Note: If the printer is using a third-party cartridge, then refer the users to their cartridge supplier.</p> <p>Is the printer using a genuine and supported toner cartridge?</p>	Go to step 3.	Go to step 2.
<p>Step 2 Install a genuine and supported toner cartridge.</p> <p>Does the problem remain?</p>	Go to step 3.	The problem is solved.
<p>Step 3 Adjust the guides in the tray to the correct position for the paper loaded.</p> <p>Does the problem remain?</p>	Go to step 4.	The problem is solved.
<p>Step 4 From the control panel, set the paper size, type, and weight in the Paper menu to match the paper loaded.</p> <p>Does the problem remain?</p>	Go to step 5.	The problem is solved.
<p>Step 5 Depending on the operating system, specify the paper size from Printing Preferences or Print dialog.</p> <p>Does the problem remain?</p>	Go to step 6.	The problem is solved.
<p>Step 6 Remove paper from the tray, and then turn it over.</p> <p>Does the problem remain?</p>	Go to step 7.	The problem is solved.

Actions	Yes	No
<p>Step 7 Make sure that the paper loaded is from a fresh package. Note: Paper absorbs moisture due to high humidity. Store paper in its original wrapper until you use it.</p> <p>Does the problem remain?</p>	Go to step 8.	The problem is solved.
<p>Step 8 Make sure that the printer supports the paper loaded.</p> <p>Is the paper supported?</p>	Contact the next level of support.	Go to step 9.
<p>Step 9 Load a supported paper.</p> <p>Does the problem remain?</p>	Contact the next level of support.	The problem is solved.

Folded or wrinkled paper check



Note: Before performing this print quality check, go to the control panel home screen and navigate to **Settings > Troubleshooting > Print Quality Test Pages**, and then perform the Initial print quality check. See [“Initial print quality check” on page 28](#).

Actions	Yes	No
<p>Step 1</p> <p>a Check if the printer is using a non-Lexmark toner cartridge. Note: If the printer is using a third-party cartridge, then do not replace the imaging unit. Refer the users to their cartridge supplier.</p> <p>b Make sure that the toner cartridge is compatible with the imaging unit.</p> <p>Does the problem remain?</p>	Go to step 2.	The problem is solved.

Actions	Yes	No
<p>Step 2</p> <p>a Check if the paper loaded is from a fresh package.</p> <p>Note: The amount of moisture in paper affects both print quality and printer ability to feed paper correctly.</p> <p>b Make sure that the printer supports the paper loaded. For a complete list of supported paper, see the printer <i>User's Guide</i>.</p> <p>Does the problem remain?</p>	Go to step 3.	The problem is solved.
<p>Step 3</p> <p>Make sure that the fuser entry guide is free of waste toner and dust.</p> <p>Warning—Potential Damage: Clean the fuser entry guide with a toner vacuum and cloth. Do not use compressed air.</p> <p>Does the problem remain?</p>	Go to step 4.	The problem is solved.
<p>Step 4</p> <p>If the fuser has reached end of life, then replace the maintenance kit.</p> <p>Does the problem remain?</p>	Contact the next level of support.	The problem is solved.

Solid black pages check

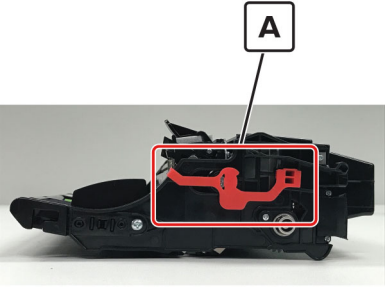
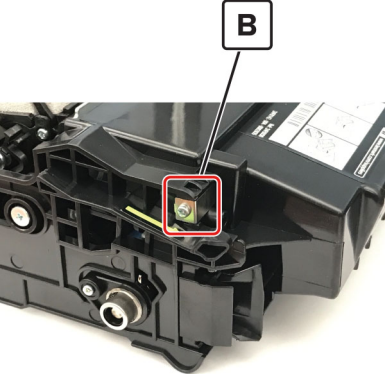

Note: Before performing this print quality check, go to the control panel home screen and navigate to **Settings > Troubleshooting > Print Quality Test Pages**, and then perform the Initial print quality check. See [“Initial print quality check” on page 28](#).

Actions	Yes	No
<p>Step 1 Check if the printer is using a genuine and supported Lexmark toner cartridge.</p> <p>Note: If the printer is using a third-party cartridge, then refer the users to their cartridge supplier.</p> <p>Is the printer using a genuine and supported toner cartridge?</p>	Go to step 3.	Go to step 2.
<p>Step 2 Install a genuine and supported toner cartridge.</p> <p>Does the problem remain?</p>	Go to step 3.	The problem is solved.
<p>Step 3</p> <p>a Remove any packing material left on the imaging unit, including the red separator plastic (A).</p>  <p>Note: You may need a pair of pliers to remove a piece of broken plastic inside the imaging unit.</p> <p>b Check the charge roller contact (B) on the right side of the imaging unit for damage and contamination.</p>  <p>Is the charge roller contact damaged and contaminated?</p>	Go to step 4.	Go to step 5.
<p>Step 4 Repair or replace the charge roller contact on the imaging unit.</p> <p>Does the problem remain?</p>	Go to step 5.	The problem is solved.

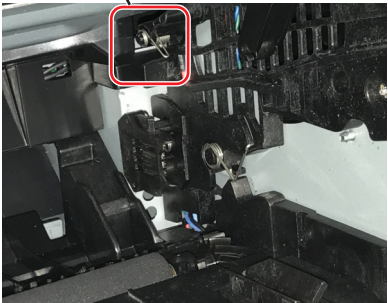
Actions	Yes	No
<p>Step 5 Replace the imaging unit.</p> <p>Does the problem remain?</p>	Go to step 6.	The problem is solved.
<p>Step 6 Check if the imaging unit contact (C) is contaminated, broken, or bent out of proper position.</p> <div data-bbox="381 499 766 877" style="text-align: center;">  </div> <p>Is the contact contaminated, broken, or bent out of proper position?</p>	Go to step 7.	Go to step 8.
<p>Step 7 Clean or repair the imaging unit contacts.</p> <p>Does the problem remain?</p>	Contact the next level of support.	The problem is solved.
<p>Step 8 Check the high voltage metal contacts on the imaging unit for damage. If necessary, replace the imaging unit.</p> <p>Does the problem remain?</p>	Go to step 9.	The problem is solved.
<p>Step 9 Check cable JPS1 from the controller board to the power supply for proper connection.</p> <p>Is the cable properly connected?</p>	Go to step 11.	Go to step 10.
<p>Step 10 Reseat the cable.</p> <p>Does the problem remain?</p>	Go to step 11.	The problem is solved.
<p>Step 11 Replace the cable.</p> <p>Does the problem remain?</p>	Contact the next level of support.	The problem is solved.

Repeating defects check

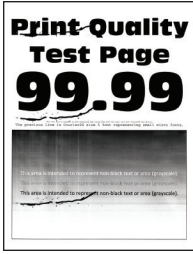

Note: Before performing this print quality check, go to the control panel home screen and navigate to **Settings > Troubleshooting > Print Quality Test Pages**, and then perform the Initial print quality check. See [“Initial print quality check” on page 28.](#)

Actions	Yes	No
<p>Step 1</p> <p>Using the Print Quality Test Pages, check if the distance between the repeating defects is equal to any of the following:</p> <ul style="list-style-type: none"> • 97 mm (3.82 in.) • 47 mm (1.85 in.) • 38 mm (1.5 in.) <p>Does the distance between the repeating defects match any of the measurements?</p>	Go to step 2.	Go to step 3.
<p>Step 2</p> <p>Replace the imaging unit.</p> <p>Does the problem remain?</p>	Go to step 3.	The problem is solved.
<p>Step 3</p> <p>Check if the distance between repeating defects is equal to 3.15 inches (85 mm).</p> <p>Does the distance between repeating defects equal to 3.15 inches (85 mm)?</p>	Go to step 4.	Contact the next level of support.
<p>Step 4</p> <p>Replace the fuser. See “Fuser removal” on page 224.</p> <p>Does the problem remain?</p>	Go to step 5.	The problem is solved.
<p>Step 5</p> <p>Replace the transfer roller. See “Transfer roller removal” on page 203.</p> <p>Does the problem remain?</p>	Contact the next level of support.	The problem is solved.

Skewed print check

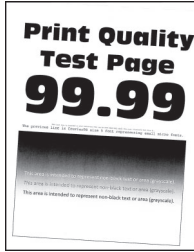

Note: Before performing this print quality check, go to the control panel home screen and navigate to **Settings > Troubleshooting > Print Quality Test Pages**, and then perform the Initial print quality check. See [“Initial print quality check” on page 28](#).

Actions	Yes	No
<p>Step 1 Check the guides in the tray where the skewed prints are sourced from. Note: If paper is sourced from the MPF, then proceed to step 9. Does the position of the guides match the paper loaded?</p>	Go to step 3.	Go to step 2.
<p>Step 2 Adjust the guides to match the paper loaded. Does the problem remain?</p>	Go to step 3.	The problem is solved.
<p>Step 3 Check if the printer supports the paper loaded. Note: For a complete list of supported paper, see the printer <i>User's Guide</i>. Is the paper supported?</p>	Go to step 5.	Go to step 4.
<p>Step 4 Remove the paper, and then load a supported one. Does the problem remain?</p>	Go to step 5.	The problem is solved.
<p>Step 5 Check the tray pick roller for excess wear and contamination. Is the pick roller free from excess wear and contamination?</p>	Go to step 7.	Go to step 6.
<p>Step 6 Replace the pick roller. See “Pick roller assembly removal” on page 219. Does the problem remain?</p>	Go to step 7.	The problem is solved.

Actions	Yes	No
<p>Step 7 Perform a print test. From the Diagnostics menu, select PRINT TESTS > Tray [x]. Note: [x] refers to the tray where the skewed prints are sourced from.</p> <p>Does the problem remain?</p>	Go to step 8.	The problem is solved.
<p>Step 8 Adjust the margins. From the Diagnostic menu, select REGISTRATION.</p> <p>Does the problem remain?</p>	Go to step 15.	The problem is solved.
<p>Step 9 Check the guides in the MPF tray.</p> <p>Does the position of the guides match the paper loaded?</p>	Go to step 11.	Go to step 10.
<p>Step 10 Adjust the guides to match the paper loaded.</p> <p>Does the problem remain?</p>	Go to step 11.	The problem is solved.
<p>Step 11 Check if the printer supports the paper loaded. Note: For a complete list of supported paper, see the printer <i>User's Guide</i>.</p> <p>Is the paper supported?</p>	Go to step 13.	Go to step 12.
<p>Step 12 Remove the paper, and then load a supported one.</p> <p>Does the problem remain?</p>	Go to step 13.	The problem is solved.
<p>Step 13 Check the MPF pick roller for excess wear and contamination.</p> <p>Is the MPF pick roller free from excess wear and contamination?</p>	Go to step 15.	Go to step 14.
<p>Step 14 Replace the MPF pick roller. See “MPF pick roller and separator pad removal” on page 206.</p> <p>Does the problem remain?</p>	Go to step 15.	The problem is solved.

Actions	Yes	No
<p>Step 15 Perform the paper skew adjustment. See “Printhead assembly adjustment” on page 171.</p> <p>Does the problem remain?</p>	Contact the next level of support.	The problem is solved.

Streaked vertical lines appear on prints check



Note: Before performing this print quality check, go to the control panel home screen and navigate to **Settings > Troubleshooting > Print Quality Test Pages**, and then perform the Initial print quality check. See [“Initial print quality check” on page 28](#).

Actions	Yes	No
<p>Step 1 Check if the printer is using a genuine and supported Lexmark toner cartridge.</p> <p>Note: If the printer is using a third-party cartridge, then refer the users to their cartridge supplier.</p> <p>Is the printer using a genuine and supported toner cartridge?</p>	Go to step 3.	Go to step 2.
<p>Step 2 Install a genuine and supported toner cartridge.</p> <p>Does the problem remain?</p>	Go to step 3.	The problem is solved.
<p>Step 3 Remove, and then reinstall the imaging unit.</p> <p>Does the problem remain?</p>	Go to step 4.	The problem is solved.
<p>Step 4 Replace the imaging unit.</p> <p>Does the problem remain?</p>	Go to step 5.	The problem is solved.

Actions	Yes	No
<p>Step 5 Remove the fuser, and check for damage or debris on the rollers and belts.</p> <p>Are the rollers and belts free of damage or debris?</p>	Contact the next level of support.	Go to step 6.
<p>Step 6 Replace the fuser.</p> <p>Does the problem remain?</p>	Contact the next level of support.	The problem is solved.

Horizontal light bands check



Note: Before performing this print quality check, go to the control panel home screen and navigate to **Settings > Troubleshooting > Print Quality Test Pages**, and then perform the Initial print quality check. See [“Initial print quality check” on page 28](#).

Actions	Yes	No
<p>Step 1 Check if the printer is using a genuine and supported Lexmark toner cartridge.</p> <p>Note: If the printer is using a third-party cartridge, then refer the users to their cartridge supplier.</p> <p>Is the printer using a genuine and supported toner cartridge?</p>	Go to step 3.	Go to step 2.
<p>Step 2 Install a genuine and supported toner cartridge.</p> <p>Does the problem remain?</p>	Go to step 3.	The problem is solved.
<p>Step 3 Turn off the printer, wait for 10 seconds, and then turn on the printer.</p> <p>Does the problem remain?</p>	Go to step 4.	The problem is solved.

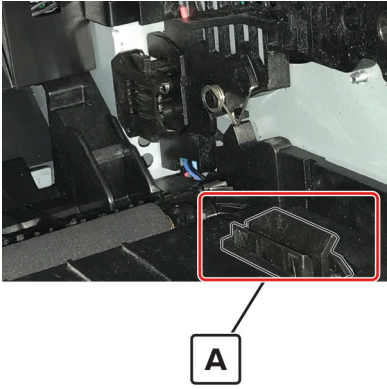
Actions	Yes	No
<p>Step 4 Check the imaging unit contact block (A), including the white and red wires, for damage or improper installation.</p>  <p>Is the imaging unit contact block free of damage and properly installed?</p>	<p>Go to step 5.</p>	<p>Contact the next level of support.</p>
<p>Step 5 Replace the power supply. See “Power supply removal” on page 211.</p> <p>Does the problem remain?</p>	<p>Contact the next level of support.</p>	<p>The problem is solved.</p>

Vertical light bands check



Note: Before performing this print quality check, go to the control panel home screen and navigate to **Settings > Troubleshooting > Print Quality Test Pages**, and then perform the Initial print quality check. See [“Initial print quality check” on page 28](#).

Actions	Yes	No
<p>Step 1</p> <p>Check if the printer is using a genuine and supported Lexmark toner cartridge.</p> <p>Note: If the printer is using a third-party cartridge, refer the users to their cartridge supplier.</p> <p>Is the printer using a genuine and supported toner cartridge?</p>	Go to step 3.	Go to step 2.
<p>Step 2</p> <p>Install a genuine and supported toner cartridge.</p> <p>Does the problem remain?</p>	Go to step 3.	The problem is solved.
<p>Step 3</p> <p>Clean the printhead lens. See “Cleaning the printhead lenses” on page 247.</p> <p>Note: This is applicable only to models installed with a galvo LSU. To determine whether the LSU is galvo, check the serial number of the printer. The sixth digit character assigned should be in the 0–9 or B–N range (Example: 4514 20HH 007CR).</p> <p>Does the problem remain?</p>	Go to step 4.	The problem is solved.
<p>Step 4</p> <p>Replace the printhead. See “Printhead removal” on page 229.</p> <p>Does the problem remain?</p>	Go to step 5.	The problem is solved.
<p>Step 5</p> <p>Replace the imaging unit.</p> <p>Does the problem remain?</p>	Contact the next level of support.	The problem is solved.

Vertical dark bands check

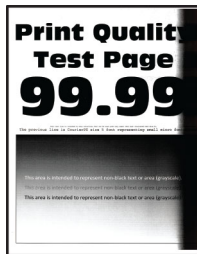

Note: Before performing this print quality check, go to the control panel home screen and navigate to **Settings > Troubleshooting > Print Quality Test Pages**, and then perform the Initial print quality check. See [“Initial print quality check” on page 28](#).

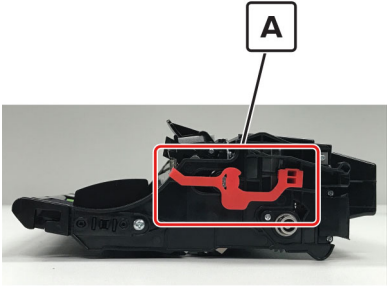
Actions	Yes	No
<p>Step 1 Check if the printer is using a genuine and supported Lexmark toner cartridge.</p> <p>Note: If the printer is using a third-party cartridge, then refer the users to their cartridge supplier.</p> <p>Is the printer using a genuine and supported toner cartridge?</p>	Go to step 3.	Go to step 2.
<p>Step 2 Install a genuine and supported toner cartridge.</p> <p>Does the problem remain?</p>	Go to step 3.	The problem is solved.
<p>Step 3 Remove, and then reinstall the toner cartridge and imaging unit.</p> <p>Does the problem remain?</p>	Go to step 4.	The problem is solved.
<p>Step 4 If a bright light enters the right side of the printer, then move the printer to avoid the bright light.</p> <p>Note: In cases where the printer cannot be moved or relocated, add a cover to the fan inlet vent to block the light from entering the printer, or contact the next level of support.</p> <p>Does the problem remain?</p>	Go to step 5.	The problem is solved.
<p>Step 5 If a separator plastic (A) is stuck inside the imaging unit or if there are other obstructions between the charge roller and photoconductor drum, then remove them.</p> <div data-bbox="380 1266 764 1549" style="text-align: center;">  </div> <p>Does the problem remain?</p>	Contact the next level of support.	The problem is solved.

Vertical dark streaks with print missing check

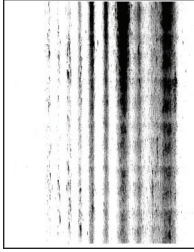

Note: Before performing this print quality check, go to the control panel home screen and navigate to **Settings > Troubleshooting > Print Quality Test Pages**, and then perform the Initial print quality check. See [“Initial print quality check” on page 28](#).

Actions	Yes	No
<p>Step 1 Check if the printer is using a genuine and supported Lexmark toner cartridge.</p> <p>Note: If the printer is using a third-party cartridge, then refer the users to their cartridge supplier.</p> <p>Is the printer using a genuine and supported toner cartridge?</p>	Go to step 3.	Go to step 2.
<p>Step 2 Install a genuine and supported toner cartridge.</p> <p>Does the problem remain?</p>	Go to step 3.	The problem is solved.

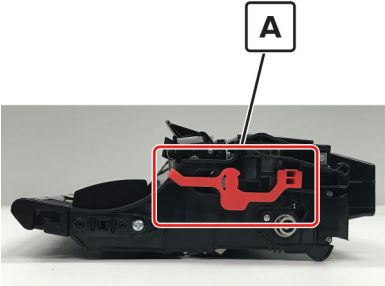
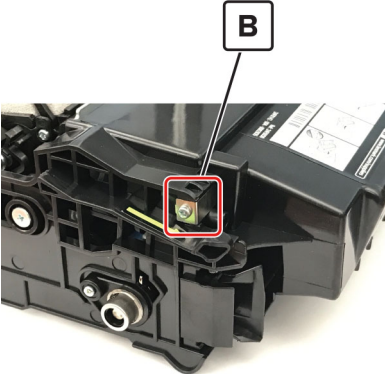
Actions	Yes	No
<p>Step 3</p> <p>a Remove any packing material left on the imaging unit, including the red separator plastic (A).</p>  <p>Note: You may need a pair of pliers to remove a piece of broken plastic inside the imaging unit.</p> <p>b Check the charge roller contact (B) on the right side of the imaging unit for damage and proper installation.</p>  <p>Is the charge roller contact damaged and contaminated?</p>	<p>Go to step 4.</p>	<p>Go to step 5.</p>
<p>Step 4</p> <p>Repair or replace the charge roller contact on the imaging unit.</p> <p>Does the problem remain?</p>	<p>Go to step 5.</p>	<p>The problem is solved.</p>
<p>Step 5</p> <p>Replace the imaging unit.</p> <p>Does the problem remain?</p>	<p>Go to step 6.</p>	<p>The problem is solved.</p>

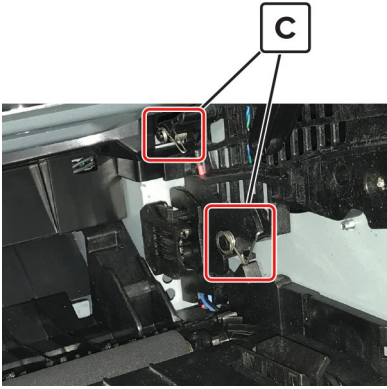
Actions	Yes	No
<p>Step 6 Check if the imaging unit contacts (C) are contaminated or bent out of proper position.</p>  <p>Are the contacts contaminated and bent out of proper position?</p>	Go to step 7.	Go to step 8.
<p>Step 7 Clean or repair the imaging unit contacts.</p> <p>Does the problem remain?</p>	Go to step 8.	The problem is solved.
<p>Step 8 Check connection JPS1 on the controller board and the connections on the power supply.</p> <p>Are the connections properly connected?</p>	Go to step 10.	Go to step 9.
<p>Step 9 Reconnect the cables.</p> <p>Does the problem remain?</p>	Go to step 10.	The problem is solved.
<p>Step 10 Replace the power supply. See “Power supply removal” on page 211.</p> <p>Does the problem remain?</p>	Contact the next level of support.	The problem is solved.

White streaks and voided areas check



Note: Before performing this print quality check, go to the control panel home screen and navigate to **Settings > Troubleshooting > Print Quality Test Pages**, and then perform the Initial print quality check. See [“Initial print quality check” on page 28](#).

Actions	Yes	No
<p>Step 1 Check if the printer is using a genuine and supported Lexmark toner cartridge.</p> <p>Note: If the printer is using a third-party cartridge, do not replace the imaging unit. Refer the users to their cartridge supplier.</p> <p>Is the printer using a genuine and supported toner cartridge?</p>	Go to step 3.	Go to step 2.
<p>Step 2 Install a genuine and supported toner cartridge.</p> <p>Does the problem remain?</p>	Go to step 3.	The problem is solved.
<p>Step 3 Set the paper type and weight settings in the Paper menu to match the paper loaded.</p> <p>Note: Make sure that the printer supports the paper loaded. For a complete list of supported paper, see the printer <i>User's Guide</i>.</p> <p>Does the problem remain?</p>	Go to step 4.	The problem is solved.
<p>Step 4</p> <p>a Update the firmware to the latest version available.</p> <p>b Enter the Diagnostics menu, and then change the EngSetting 14 value to 48.</p> <p>Note: You can also change the setting through a bundle file or NPA command.</p> <p>c Set Quiet mode to Off.</p> <p>d Review the Event Log Summary sheets and check if either error code 31.46 or 31.66 events occurred for the imaging unit. If they did, check if they are occurring with the current toner cartridge.</p> <p>Does the problem remain?</p>	Go to step 5.	The problem is solved.

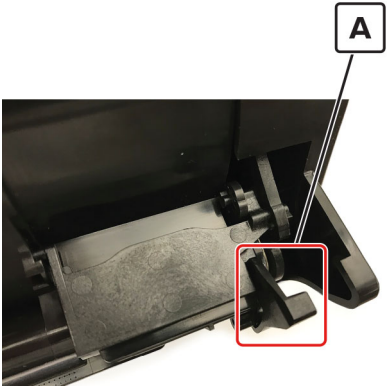
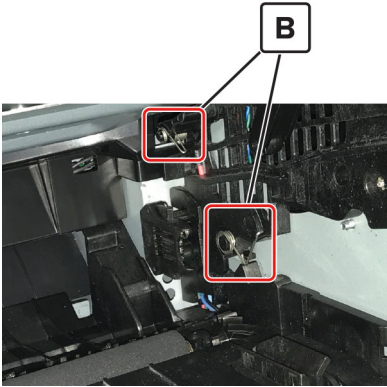
Actions	Yes	No
<p>Step 5 Check the shutter tab (A) on the toner cartridge for signs of damage.</p>  <p>Is the shutter tab damaged?</p>	<p>Go to step 6.</p>	<p>Go to step 7.</p>
<p>Step 6 Replace the imaging unit and the toner cartridge.</p> <p>Does the problem remain?</p>	<p>Go to step 7.</p>	<p>The problem is solved.</p>
<p>Step 7 Clean the printhead lens. See “Cleaning the printhead lenses” on page 247.</p> <p>Note: This is applicable only to models installed with a galvo LSU. To determine whether the LSU is galvo, check the serial number of the printer. The sixth digit character assigned should be in the 0–9 or B–N range (Example: 4514 20HH 007CR).</p> <p>Does the problem remain?</p>	<p>Go to step 8.</p>	<p>The problem is solved.</p>
<p>Step 8 Check if the imaging unit contacts (B) are contaminated or bent out of proper position.</p>  <p>Are the contacts contaminated or bent out of proper position?</p>	<p>Go to step 9.</p>	<p>Go to step 10.</p>

Actions	Yes	No
<p>Step 9 Clean or repair the imaging unit contacts.</p> <p>Does the problem remain?</p>	Contact the next level of support.	The problem is solved.
<p>Step 10 Check connection JPS1 on the controller board and all the connections on the power supply.</p> <p>Are the connections properly connected?</p>	Go to step 12.	Go to step 11.
<p>Step 11 Replace the connections.</p> <p>Does the problem remain?</p>	Go to step 12.	The problem is solved.
<p>Step 12 Replace the power supply. See “Power supply removal” on page 211.</p> <p>Does the problem remain?</p>	Go to step 13.	The problem is solved.
<p>Step 13 Replace the printhead. See “Printhead removal” on page 229.</p> <p>Does the problem remain?</p>	Contact the next level of support.	The problem is solved.

Fine lines are not printed correctly (specifically Chinese characters) check

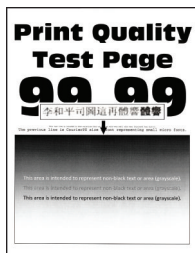

Note: Before performing this print quality check, go to the control panel home screen and navigate to **Settings > Troubleshooting > Print Quality Test Pages**, and then perform the Initial print quality check. See [“Initial print quality check” on page 28.](#)

Actions	Yes	No
<p>Step 1 Check if the printer is using a genuine and supported Lexmark toner cartridge.</p> <p>Note: If the printer is using a third-party cartridge, then refer the users to their cartridge supplier.</p> <p>Is the printer using a genuine and supported toner cartridge?</p>	Go to step 3.	Go to step 2.
<p>Step 2 Install a genuine and supported toner cartridge.</p> <p>Does the problem remain?</p>	Go to step 3.	The problem is solved.
<p>Step 3 From the control panel, adjust the Toner Darkness setting to 7.</p> <p>a From the Settings menu, navigate to: Print Settings > Quality menu > Pixel Boost > Fonts > Submit</p> <p>b From the Quality menu, select Toner Darkness, and then adjust the setting to 7.</p> <p>c Submit the changes.</p> <p>Note: Adjusting the Toner Darkness setting to 7 results in a slightly lighter print. You may leave the Toner Darkness value at 8 in order to maintain the darkness that you have grown accustomed to, but this will result in reduced toner yield.</p> <p>Does the problem remain?</p>	Contact the next level of support.	The problem is solved.

Clipped pages or images check

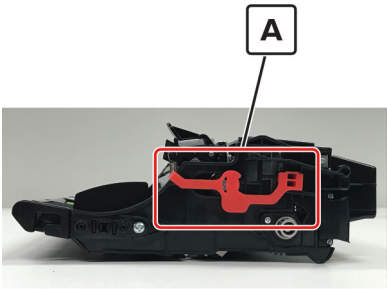

Note: Before performing this print quality check, go to the control panel home screen and navigate to **Settings > Troubleshooting > Print Quality Test Pages**, and then perform the Initial print quality check. See [“Initial print quality check” on page 28](#).

Actions	Yes	No
<p>Step 1 Check if the printer is using a genuine and supported Lexmark toner cartridge.</p> <p>Note: If the printer is using a third-party cartridge, then refer the users to their cartridge supplier.</p> <p>Is the printer using a genuine and supported toner cartridge?</p>	Go to step 3.	Go to step 2.
<p>Step 2 Install a genuine and supported toner cartridge.</p> <p>Does the problem remain?</p>	Go to step 3.	The problem is solved.
<p>Step 3 Remove, and then reinstall the imaging unit.</p> <p>Does the problem remain?</p>	Go to step 4.	The problem is solved.
<p>Step 4 Check if a separator plastic (A), or a piece of it, is stuck inside the imaging unit or if there are any other obstructions between the charge roller and photoconductor drum.</p> <div data-bbox="380 963 764 1249" style="text-align: center;">  </div> <p>Is the imaging unit free from any separator plastic fragments or other obstructions?</p>	Go to step 6.	Go to step 5.
<p>Step 5 Using a pair of pliers, remove the separator plastic fragments and other obstructions.</p> <p>Does the problem remain?</p>	Go to step 6.	The problem is solved.
<p>Step 6 Replace the imaging unit.</p> <p>Does the problem remain?</p>	Go to step 7.	The problem is solved.

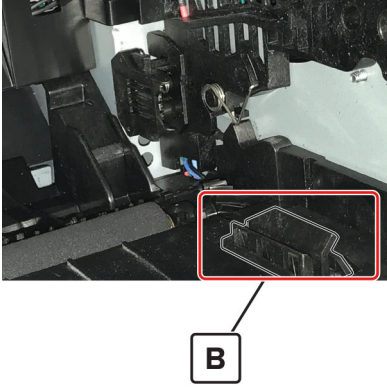
Actions	Yes	No
<p>Step 7 Check the imaging unit contact block (B) for damage or improper installation.</p>  <p>Is the imaging unit contact block damaged or improperly installed?</p>	<p>Go to step 8.</p>	<p>Contact the next level of support.</p>
<p>Step 8 Reinstall or replace the imaging unit contact block.</p> <p>Does the problem remain?</p>	<p>Contact the next level of support.</p>	<p>The problem is solved.</p>

Compressed images appear on prints check

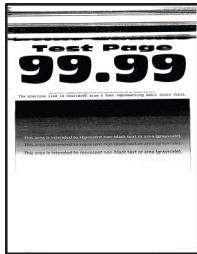

Note: Before performing this print quality check, go to the control panel home screen and navigate to **Settings > Troubleshooting > Print Quality Test Pages**, and then perform the Initial print quality check. See [“Initial print quality check” on page 28](#).

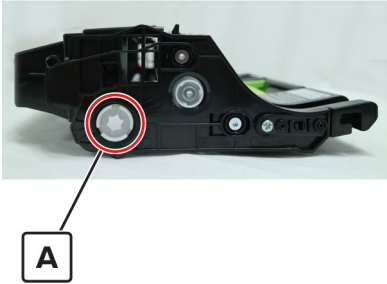
Actions	Yes	No
<p>Step 1 Remove the imaging unit, and then inspect the white photoconductor coupler (A). The coupler should be firmly connected to the imaging unit and should not freely rotate.</p>  <p>Does the coupler move freely or appear damaged?</p>	<p>Go to step 2.</p>	<p>Go to step 3.</p>
<p>Step 2 Replace the imaging unit.</p> <p>Does the problem remain?</p>	<p>Go to step 3.</p>	<p>The problem is solved.</p>
<p>Step 3 Replace the main drive gearbox. See “Main drive gearbox removal” on page 174.</p> <p>Does the problem remain?</p>	<p>Contact the next level of support.</p>	<p>The problem is solved.</p>

Incorrect margins on prints check



Note: Before performing this print quality check, go to the control panel home screen and navigate to **Settings > Troubleshooting > Print Quality Test Pages**, and then perform the Initial print quality check. See [“Initial print quality check” on page 28](#).

Actions	Yes	No
<p>Step 1 Adjust the guides in the tray according to the size of the paper loaded.</p> <p>Does the problem remain?</p>	Go to step 2.	The problem is solved.
<p>Step 2 Do one of the following:</p> <ul style="list-style-type: none"> From the printer control panel, set the paper size in the Paper menu to match the paper loaded in the tray. Change the paper loaded in the tray to match the paper size specified in the tray settings. <p>Does the problem remain?</p>	Go to step 3.	The problem is solved.
<p>Step 3 Depending on your operating system, specify the paper size from Printing Preferences or from the Print dialog.</p> <p>Does the problem remain?</p>	Go to step 4 or contact the next level of support.	The problem is solved.
<p>Step 4</p> <ol style="list-style-type: none"> Enter the Diagnostics menu, and then select Registration. Adjust the margins as necessary. <p>Does the problem remain?</p>	Contact the next level of support.	The problem is solved.

Toner rubs off check



Note: Before performing this print quality check, go to the control panel home screen and navigate to **Settings > Troubleshooting > Print Quality Test Pages**, and then perform the Initial print quality check. See [“Initial print quality check” on page 28](#).

Actions	Yes	No
<p>Step 1 Check if the printer is using a genuine and supported Lexmark toner cartridge.</p> <p>Note: If the printer is using a third-party cartridge, then refer the users to their cartridge supplier.</p> <p>Is the printer using a genuine and supported toner cartridge?</p>	Go to step 3.	Go to step 2.
<p>Step 2 Install a genuine and supported toner cartridge.</p> <p>Does the problem remain?</p>	Go to step 3.	The problem is solved.
<p>Step 3 From the control panel, set the paper type, texture, and weight in the Paper menu to match the paper loaded.</p> <p>Does the problem remain?</p>	Go to step 4.	The problem is solved.
<p>Step 4 Remove, and then reinstall the fuser.</p> <p>Does the problem remain?</p>	Go to step 5.	The problem is solved.
<p>Step 5 Replace the fuser. See “Fuser removal” on page 224.</p> <p>Does the problem remain?</p>	Go to step 6.	The problem is solved.
<p>Step 6 Reseat the connections on the power supply.</p> <p>Does the problem remain?</p>	Go to step 7.	The problem is solved.
<p>Step 7 Replace the power supply. See “Power supply removal” on page 211.</p> <p>Does the problem remain?</p>	Contact the next level of support.	The problem is solved.

Toner specks appear on prints check



Note: Before performing this print quality check, go to the control panel home screen and navigate to **Settings > Troubleshooting > Print Quality Test Pages**, and then perform the Initial print quality check. See [“Initial print quality check” on page 28](#).

Actions	Yes	No
<p>Step 1 Check if the printer is using a genuine and supported Lexmark toner cartridge.</p> <p>Note: If the printer is using a third-party cartridge, then refer the users to their cartridge supplier.</p> <p>Is the printer using a genuine and supported toner cartridge?</p>	Go to step 3.	Go to step 2.
<p>Step 2 Install a genuine and supported toner cartridge.</p> <p>Does the problem remain?</p>	Go to step 3.	The problem is solved.
<p>Step 3</p> <p>a Check the status of the imaging unit.</p> <ol style="list-style-type: none"> 1 From the home screen, select Status/supplies. 2 Select View Supplies. <p>b Check the condition of the imaging unit.</p> <p>Is the imaging unit near end of life and/or showing signs of toner leakage?</p>	Go to step 4.	Go to step 5.
<p>Step 4 Replace the imaging unit.</p> <p>Does the problem remain?</p>	Go to step 5.	The problem is solved.
<p>Step 5 Check if toner specks appear only on the edges or back side of the pages.</p> <p>Do toner specks appear only on the edges or back side of the pages?</p>	Go to step 6.	Go to step 7.
<p>Step 6 Replace the transfer roller. See “Transfer roller removal” on page 203.</p> <p>Does the problem remain?</p>	Go to step 7.	The problem is solved.
<p>Step 7 Check the printer for stray toner contamination.</p> <p>Is the printer contaminated with stray toner?</p>	Go to step 8.	Contact the next level of support.

Actions	Yes	No
<p>Step 8</p> <p>Using an approved toner vacuum cleaner, completely clean the printer, toner cartridge, and imaging unit of toner contamination.</p> <p>Does the problem remain?</p>	<p>Contact the next level of support.</p>	<p>The problem is solved.</p>

Paper jams

Avoiding jams

Load paper properly

- Make sure that the paper lies flat in the tray.
- Do not remove a tray while the printer is printing.
- Do not load a tray while the printer is printing. Load it before printing, or wait for a prompt to load it.
- Do not load too much paper. Make sure that the stack height is below the maximum paper fill indicator.
- Do not slide paper into the tray. Load paper as shown in the illustration.

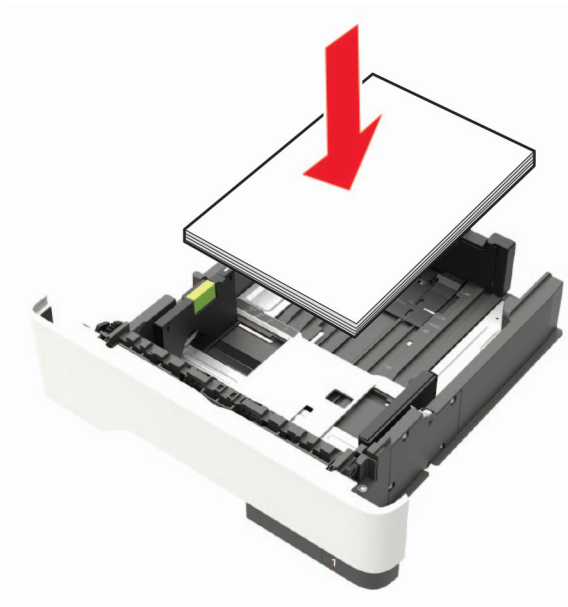

- Make sure that the paper guides are properly positioned.
- Push the tray firmly into the printer after loading paper.

Use recommended paper

- Use only recommended paper or specialty media.
- Do not load wrinkled, creased, damp, bent, or curled paper.

- Flex, fan, and straighten paper before loading it.

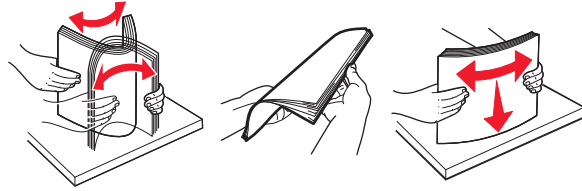

- Do not use paper that has been cut or trimmed by hand.
- Do not mix paper sizes, weights, or types in the same tray.
- Make sure that the paper size and type are set correctly on the Embedded Web Server or the computer.

Note: Depending on your operating system, access the Paper menu using Local Printer Settings Utility or Printer Settings.

- Store paper according to manufacturer recommendations.

Identifying jam locations

Notes:

- When Jam Assist is set to On, the printer automatically flushes blank pages or partially printed pages after a jammed page has been cleared. Check your printed output for blank pages.
- When Jam Recovery is set to On or Auto, the printer reprints jammed pages.

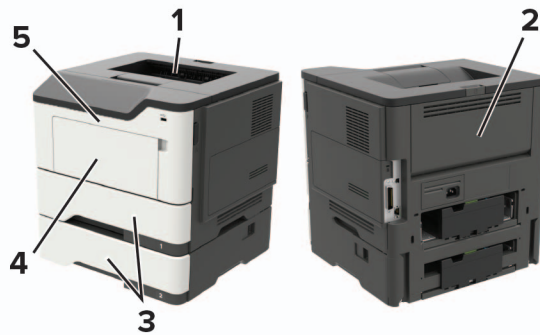

	Jam location
1	Standard bin
2	Rear door
3	Tray [x]
4	Multipurpose feeder
5	Door A

Paper jam in door A

1 Remove the tray.

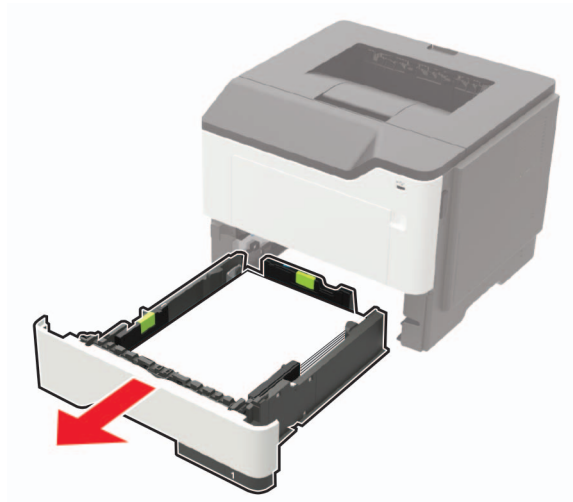

2 Open door A.

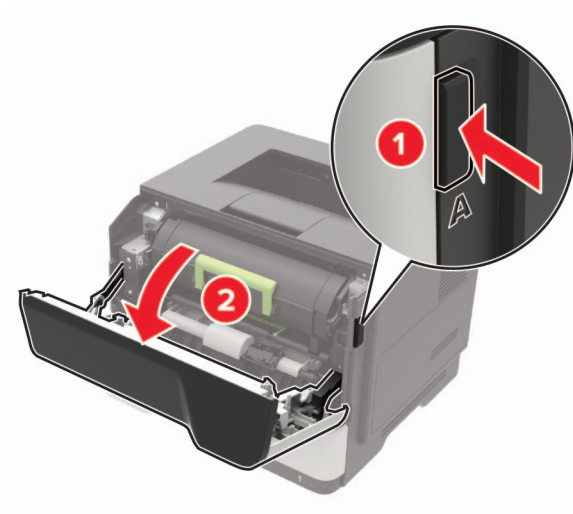

3 Remove the toner cartridge.

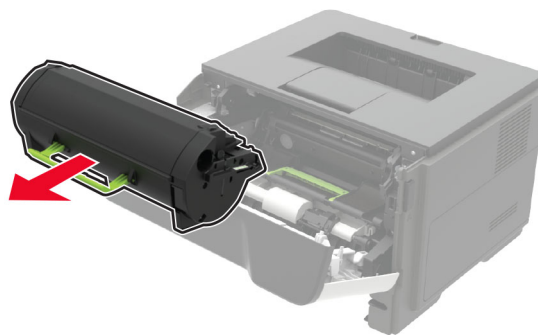

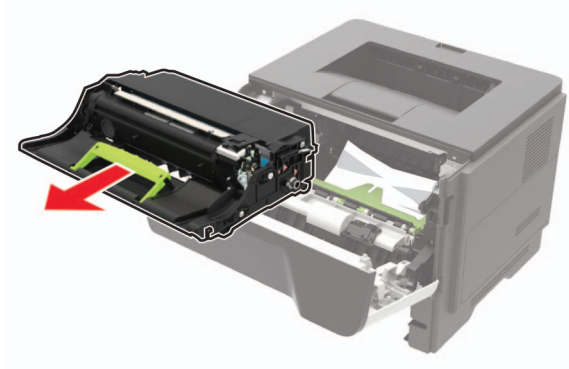
4 Remove the imaging unit.

Warning—Potential Damage: Do not expose the imaging unit to direct light for more than 10 minutes. Extended exposure to light may cause print quality problems.

Warning—Potential Damage: Do not touch the photoconductor drum. Doing so may affect the quality of future print jobs.

**5** Remove the jammed paper.

CAUTION—HOT SURFACE: The inside of the printer might be hot. To reduce the risk of injury from a hot component, allow the surface to cool before touching it.

Note: Make sure that all paper fragments are removed.

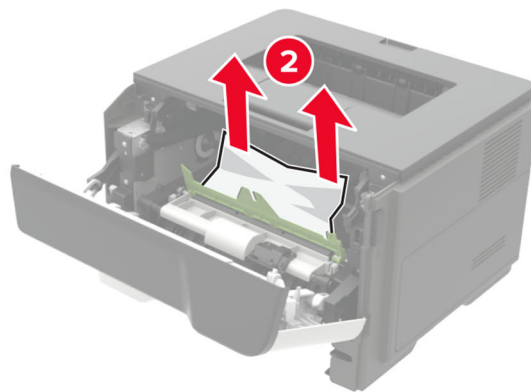
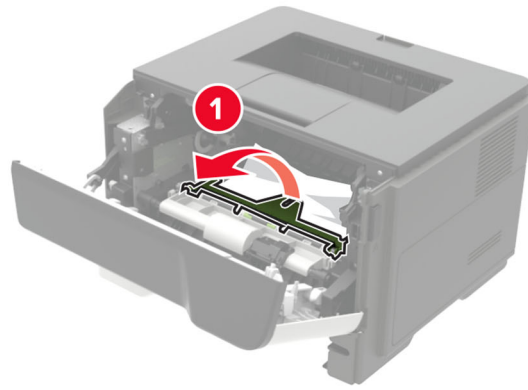

6 Insert the imaging unit.

Note: Use the arrows inside the printer as guides.

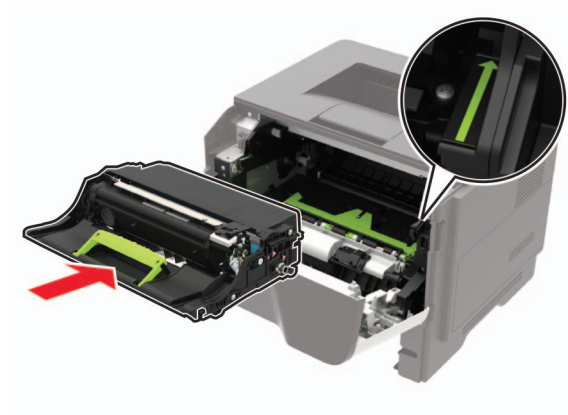

7 Insert the toner cartridge.

Note: Use the arrows inside the printer as guides.

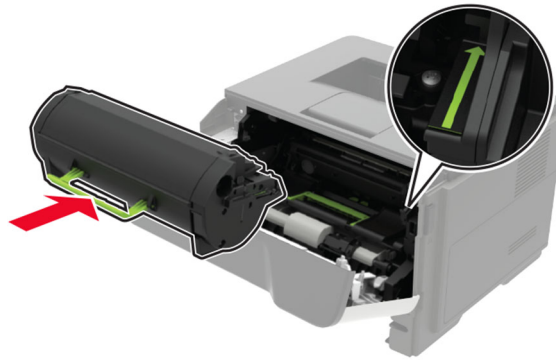

- 8 Close door A.
- 9 Insert the tray.

Paper jam in the rear door

- 1 Open the rear door.

 **CAUTION—HOT SURFACE:** The inside of the printer might be hot. To reduce the risk of injury from a hot component, allow the surface to cool before touching it.

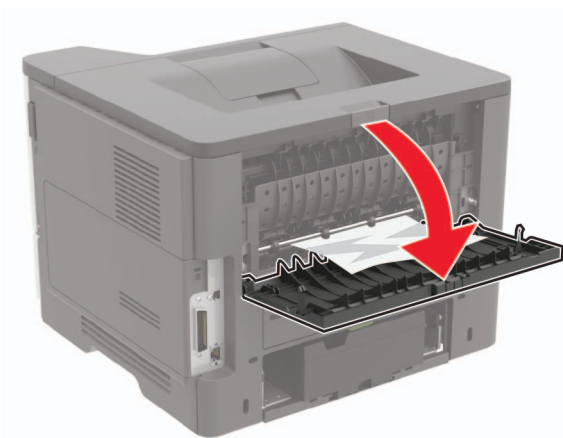

- 2 Remove the jammed paper.

Note: Make sure that all paper fragments are removed.

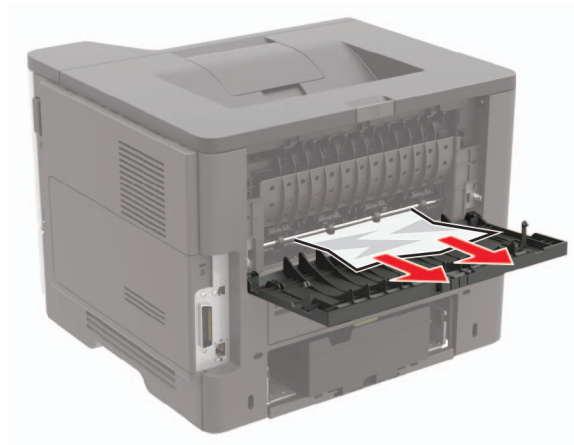

3 Close the rear door.

Paper jam in the standard bin

Remove the jammed paper.

Note: Make sure that all paper fragments are removed.

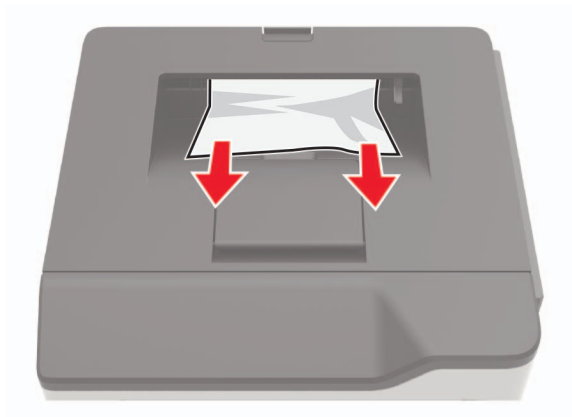

Paper jam in the duplex unit

- 1 Remove the tray.

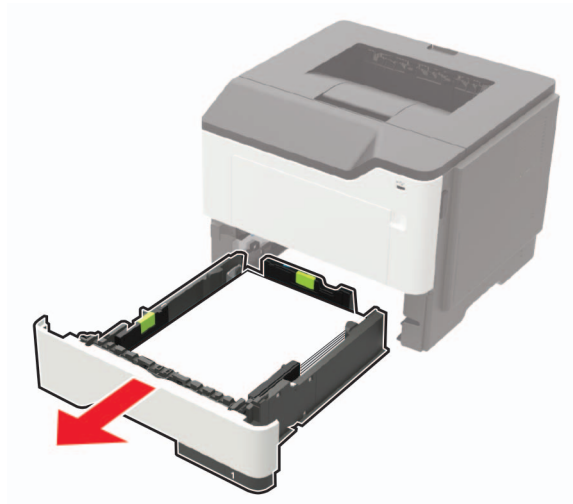

- 2 Remove the jammed paper.

Note: Make sure that all paper fragments are removed.

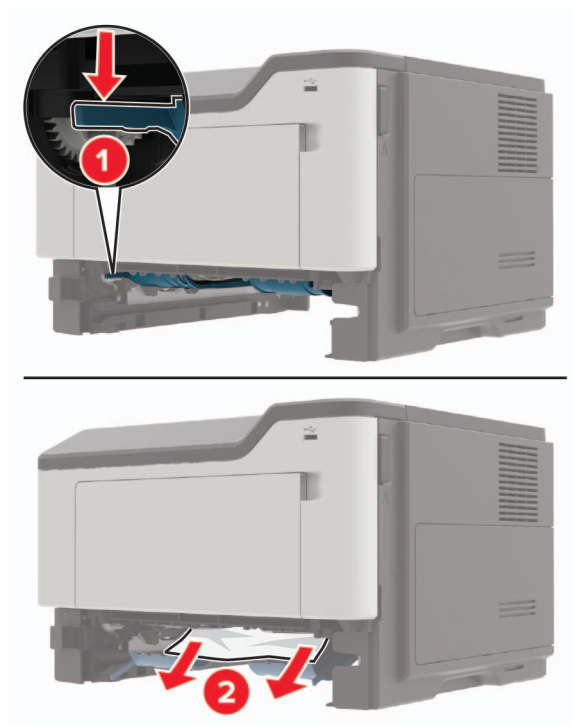

- 3 Insert the tray.

Paper jam in trays

- 1 Remove the tray.

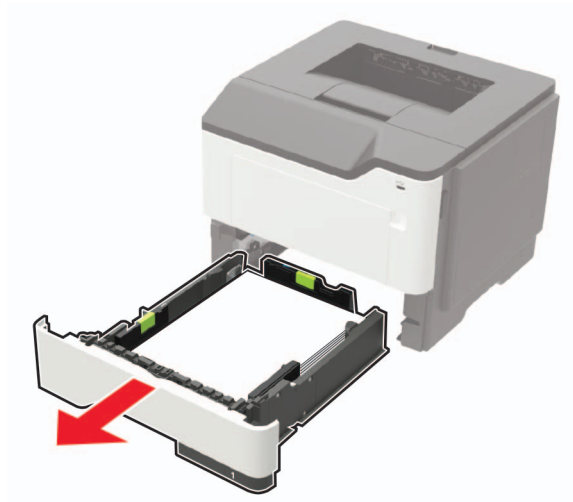

- 2 Remove the jammed paper.

Note: Make sure that all paper fragments are removed.

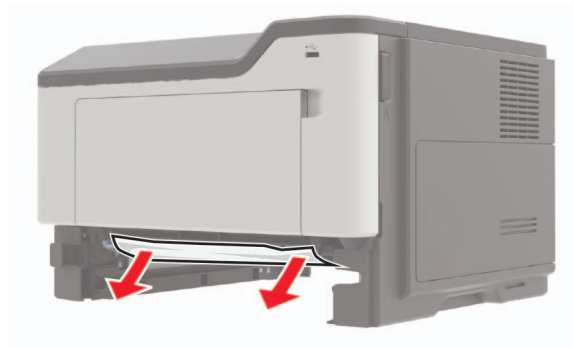

- 3 Insert the tray.

Paper jam in the multipurpose feeder

- 1 Remove paper from the multipurpose feeder.
- 2 Remove the jammed paper.

Note: Make sure that all paper fragments are removed.



3 Flex, fan, and align the paper edges before loading.

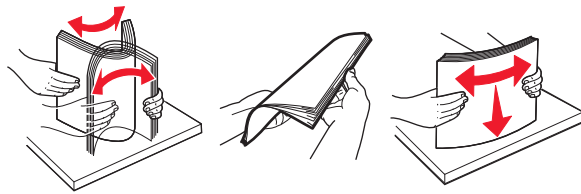

4 Reload paper, and then adjust the paper guide.



200 paper jams

200 paper jam messages

Error code	Description	Action
200.02	Paper fed from the MPF was detected earlier than expected at the sensor (input).	See “MPF to sensor (input) jam at leading edge service check” on page 79.
200.03	Paper fed from the MPF was detected later than expected or was never detected at the sensor (input).	
200.04	Paper fed from the MPF cleared the sensor (input) earlier than expected.	See “MPF to sensor (input) jam at trailing edge service check” on page 81.
200.05	Paper fed from the MPF never cleared the sensor (input).	

Error code	Description	Action
200.13	Paper fed from tray 1 was detected later than expected or was never detected at the sensor (input).	See “Tray 1 to sensor (input) jam at leading edge service check” on page 82.
200.14	Paper fed from tray 1 cleared the sensor (input) earlier than expected.	See “Tray 1 to sensor (input) jam at trailing edge service check” on page 83.
200.15	Paper fed from tray 1 never cleared the sensor (input).	
200.22	Paper fed from tray 2 was detected earlier than expected at the sensor (input).	See “Optional tray to sensor (input) jam at leading edge service check” on page 85.
200.23	Paper fed from tray 2 was detected later than expected or was never detected at the sensor (input).	
200.24	Paper fed from tray 2 cleared the sensor (input) earlier than expected.	See “Optional tray to sensor (input) jam at trailing edge service check” on page 86.
200.25	Paper fed from tray 2 never cleared the sensor (input).	
200.32	Paper fed from tray 3 was detected earlier than expected at the sensor (input).	See “Optional tray to sensor (input) jam at leading edge service check” on page 85.
200.33	Paper fed from tray 3 was detected later than expected or was never detected at the sensor (input).	
200.34	Paper fed from tray 3 cleared the sensor (input) earlier than expected.	See “Optional tray to sensor (input) jam at trailing edge service check” on page 86.
200.35	Paper fed from tray 3 never cleared the sensor (input).	
200.42	Paper fed from tray 4 was detected earlier than expected at the sensor (input).	See “Optional tray to sensor (input) jam at leading edge service check” on page 85.
200.43	Paper fed from tray 4 was detected later than expected or was never detected at the sensor (input).	
200.44	Paper fed from tray 4 cleared the sensor (input) earlier than expected.	See “Optional tray to sensor (input) jam at trailing edge service check” on page 86.
200.45	Paper fed from tray 4 never cleared the sensor (input).	
200.91	Paper remains detected at the sensor (input) after the printer is turned on.	See “Sensor (input) static jam service check” on page 88.

MPF to sensor (input) jam at leading edge service check

Action	Yes	No
<p>Step 1 Make sure that the paper is loaded properly. Use the recommended paper. See “Avoiding jams” on page 68.</p> <p>Does the problem remain?</p>	Go to step 2.	The problem is solved.
<p>Step 2 a Enter the Diagnostics menu, and then navigate to: Input tray quick print > Tray 1 > Single b Check if the same error occurs.</p> <p>Does the same problem remain?</p>	Go to step 10.	Go to step 3.
<p>Step 3 Check the MPF pick roller and separator pad for wear and damage.</p> <p>Are the MPF roller and separator pad free of wear and damage?</p>	Go to step 5.	Go to step 4.
<p>Step 4 Replace the MPF pick roller and separator pad. See “MPF pick roller and separator pad removal” on page 206.</p> <p>Does the problem remain?</p>	Go to step 5.	The problem is solved.
<p>Step 5 Check the MPF gearbox for wear and damage.</p> <p>Is the MPF gearbox free of wear and damage?</p>	Go to step 7.	Go to step 6.
<p>Step 6 Replace the MPF gearbox. See “MPF gearbox removal” on page 175.</p> <p>Does the problem remain?</p>	Go to step 7.	The problem is solved.
<p>Step 7 a Enter the Diagnostics menu, and then navigate to: Printer diagnostics and adjustments > Motor tests b Select the solenoid (MPF pick), and then touch Start.</p> <p>Does the solenoid run?</p>	Go to step 10.	Go to step 8.
<p>Step 8 Check the solenoid for wear and damage.</p> <p>Is the solenoid free of wear and damage?</p>	Go to step 10.	Go to step 9.

Action	Yes	No
<p>Step 9 Replace the MPF solenoid. See “MPF solenoid removal” on page 181.</p> <p>Does the problem remain?</p>	Go to step 10.	The problem is solved.
<p>Step 10 a Enter the Diagnostics menu, and then navigate to: Printer diagnostics and adjustments > Sensor tests b Find the sensor (Input).</p> <p>Does the sensor status change while toggling the sensor?</p>	Go to step 13.	Go to step 11.
<p>Step 11 a Reseat the sensor cable from the controller board. b Check the sensor and its actuator for improper installation and damage.</p> <p>Is the sensor properly installed and free of damage?</p>	Go to step 13.	Go to step 12.
<p>Step 12 Replace the sensor. See “Sensors (duplex and input) removal” on page 215.</p> <p>Does the problem remain?</p>	Go to step 13.	The problem is solved.
<p>Step 13 a Check the jam access cover for obstructions along the paper path. b Check if the jam access cover components are functional and free of damage.</p> <p>Are the jam access cover and its components functional and free of damage?</p>	Contact the next level of support.	The problem is solved.
<p>Step 14 Replace the jam access cover. See “Jam access cover removal” on page 203.</p> <p>Does the problem remain?</p>	Contact the next level of support.	The problem is solved.

MPF to sensor (input) jam at trailing edge service check

Action	Yes	No
<p>Step 1 Make sure that the paper is loaded properly. Use the recommended paper. See “Avoiding jams” on page 68.</p> <p>Does the problem remain?</p>	Go to step 2.	The problem is solved.
<p>Step 2 a Enter the Diagnostics menu, and then navigate to: Input tray quick print > Tray 1 > Single b Check if the same error occurs.</p> <p>Does the same problem remain?</p>	Go to step 8.	Go to step 3.
<p>Step 3 Check the MPF gearbox for wear and damage.</p> <p>Is the MPF gearbox free of wear and damage?</p>	Go to step 5.	Go to step 4.
<p>Step 4 Replace the MPF gearbox. See “MPF gearbox removal” on page 175.</p> <p>Does the problem remain?</p>	Go to step 5.	The problem is solved.
<p>Step 5 a Enter the Diagnostics menu, and then navigate to: Printer diagnostics and adjustments > Motor tests b Select the solenoid (MPF pick), and then touch Start.</p> <p>Does the solenoid run?</p>	Go to step 8.	Go to step 6.
<p>Step 6 Check the solenoid for wear and damage.</p> <p>Is the solenoid free of wear and damage?</p>	Go to step 8.	Go to step 7.
<p>Step 7 Replace the MPF solenoid. See “MPF solenoid removal” on page 181.</p> <p>Does the problem remain?</p>	Go to step 8.	The problem is solved.
<p>Step 8 Check the transfer roller and its spring for improper installation and damage.</p> <p>Is the transfer roller properly installed and free of damage?</p>	Go to step 10.	Go to step 9.

Action	Yes	No
<p>Step 9 Reinstall or replace the transfer roller. See “Transfer roller removal” on page 203.</p> <p>Does the problem remain?</p>	Go to step 10.	Go to step 11.
<p>Step 10 Check if the fuser cam is functional and free of damage.</p> <p>Is the fuser cam functional and free of damage?</p>	Contact the next level of support.	Go to step 11.
<p>Step 11 Replace the fuser cam. See “Fuser actuator removal” on page 178.</p> <p>Does the problem remain?</p>	Contact the next level of support.	The problem is solved.

Tray 1 to sensor (input) jam at leading edge service check

Action	Yes	No
<p>Step 1 Make sure that the paper is loaded properly. Use the recommended paper. See “Avoiding jams” on page 68.</p> <p>Does the problem remain?</p>	Go to step 2.	The problem is solved.
<p>Step 2 a Enter the Diagnostics menu, and then navigate to: Input tray quick print > MPF Tray > Single b Check if the same error occurs.</p> <p>Does the same problem remain?</p>	Go to step 7.	Go to step 3.
<p>Step 3 Check the tray 1 pick roller for wear and damage.</p> <p>Is the pick roller free of wear and damage?</p>	Go to step 5.	Go to step 4.
<p>Step 4 Replace the pick roller. See “Pick roller assembly removal” on page 219.</p> <p>Does the problem remain?</p>	Go to step 5.	The problem is solved.
<p>Step 5 Check the tray 1 separator pad for wear and damage.</p> <p>Is the separator pad free of wear and damage?</p>	Go to step 7.	Go to step 6.

Action	Yes	No
<p>Step 6 Replace tray 1.</p> <p>Does the problem remain?</p>	Go to step 7.	The problem is solved.
<p>Step 7 Reseat the pick roller clutch cable, and then check if the pick roller clutch is functional and free of damage.</p> <p>Is the pick roller clutch functional and free of damage?</p>	Go to step 9.	Go to step 8.
<p>Step 8 a Reseat the pick roller clutch cable. b Check if the pick roller clutch is functional and free of damage.</p> <p>Is the pick roller clutch functional and free of damage?</p>	Contact the next level of support.	Go to step 9.
<p>Step 9 Replace the pick roller clutch. See “Pick roller clutch removal” on page 182.</p> <p>Does the problem remain?</p>	Contact the next level of support.	The problem is solved.

Tray 1 to sensor (input) jam at trailing edge service check

Action	Yes	No
<p>Step 1 Make sure that the paper is loaded properly. Use the recommended paper. See “Avoiding jams” on page 68.</p> <p>Does the problem remain?</p>	Go to step 2.	The problem is solved.
<p>Step 2 a Enter the Diagnostics menu, and then navigate to: Input tray quick print > MPF tray > Single b Check if the same error occurs.</p> <p>Does the same problem remain?</p>	Go to step 5.	Go to step 3.
<p>Step 3 Check the tray 1 separator pad for wear and damage.</p> <p>Is the separator pad free of wear and damage?</p>	Go to step 5.	Go to step 4.
<p>Step 4 Replace tray 1.</p> <p>Does the problem remain?</p>	Go to step 5.	The problem is solved.

Action	Yes	No
<p>Step 5 Check the transfer roller and its spring for improper installation and damage.</p> <p>Is the transfer roller properly installed and free of damage?</p>	Go to step 7.	Go to step 6.
<p>Step 6 Reinstall or replace the transfer roller. See “Transfer roller removal” on page 203.</p> <p>Does the problem remain?</p>	Go to step 7.	The problem is solved.
<p>Step 7 Check if the fuser cam is functional and free of damage.</p> <p>Is the fuser cam functional and free of damage?</p>	Go to step 9.	Go to step 8.
<p>Step 8 Replace the fuser cam. See “Fuser actuator removal” on page 178.</p> <p>Does the problem remain?</p>	Go to step 9.	The problem is solved.
<p>Step 9 a Enter the Diagnostics menu, and then navigate to: Printer diagnostics and adjustments > Sensor tests b Find the sensor (Input).</p> <p>Does the sensor status change while toggling the sensor?</p>	Contact the next level of support.	Go to step 10.
<p>Step 10 a Reseat the sensor cable from the controller board. b Check the sensor and its actuator for improper installation and damage.</p> <p>Is the sensor properly installed and free of damage?</p>	Contact the next level of support.	Go to step 11.
<p>Step 11 Replace the sensor. See “Sensors (duplex and input) removal” on page 215.</p> <p>Does the problem remain?</p>	Contact the next level of support.	The problem is solved.

Optional tray to sensor (input) jam at leading edge service check

Action	Yes	No
<p>Step 1 Make sure that the paper is loaded properly. Use the recommended paper. See “Avoiding jams” on page 68.</p> <p>Does the problem remain?</p>	Go to step 2.	The problem is solved.
<p>Step 2 a Enter the Diagnostics menu, and then navigate to: Input tray quick print > MPF Tray > Single b Check if the same error occurs.</p> <p>Does the same problem remain?</p>	Go to step 7.	Go to step 3.
<p>Step 3 Check the optional tray pick roller for wear and damage.</p> <p>Is the pick roller free of wear and damage?</p>	Go to step 5.	Go to step 4.
<p>Step 4 Replace the pick roller.</p> <p>Does the problem remain?</p>	Go to step 5.	The problem is solved.
<p>Step 5 Check the optional tray separator roller assembly for wear and damage.</p> <p>Is the separator roller assembly free of wear and damage?</p>	Go to step 7.	Go to step 6.
<p>Step 6 Replace the separator roller assembly. See “Separator roller assembly removal” on page 232.</p> <p>Does the problem remain?</p>	Go to step 7.	The problem is solved.
<p>Step 7 a Remove the tray insert from the affected optional tray. b Check if the lift plate moves properly. c Check the lift plate gears for damage.</p> <p>Is the tray insert functional and free of damage?</p>	Go to step 9.	Go to step 8.
<p>Step 8 Replace the tray insert.</p> <p>Does the problem remain?</p>	Go to step 9.	The problem is solved.

Action	Yes	No
<p>Step 9</p> <p>a Reseat the optional tray motor (pick/lift) cable.</p> <p>b Check if the motor is functional and free of damage.</p> <p>Is the motor (pick/lift) functional and free of damage?</p>	Contact the next level of support.	Go to step 10.
<p>Step 10</p> <p>Replace the optional tray.</p> <p>Does the problem remain?</p>	Contact the next level of support.	The problem is solved.

Optional tray to sensor (input) jam at trailing edge service check

Action	Yes	No
<p>Step 1</p> <p>Make sure that the paper is loaded properly. Use the recommended paper. See “Avoiding jams” on page 68.</p> <p>Does the problem remain?</p>	Go to step 2.	The problem is solved.
<p>Step 2</p> <p>a Enter the Diagnostics menu, and then navigate to: Input tray quick print > MPF tray > Single</p> <p>b Check if the same error occurs.</p> <p>Does the same problem remain?</p>	Go to step 5.	Go to step 3.
<p>Step 3</p> <p>Check the optional tray separator roller assembly for wear and damage.</p> <p>Is the separator roller assembly free of wear and damage?</p>	Go to step 5.	Go to step 4.
<p>Step 4</p> <p>Replace the separator roller assembly. See “Separator roller assembly removal” on page 232.</p> <p>Does the problem remain?</p>	Go to step 5.	The problem is solved.
<p>Step 5</p> <p>Check the transfer roller and its spring for improper installation and damage.</p> <p>Is the transfer roller properly installed and free of damage?</p>	Go to step 7.	Go to step 6.

Action	Yes	No
<p>Step 6 Reinstall or replace the transfer roller. See “Transfer roller removal” on page 203.</p> <p>Does the problem remain?</p>	Go to step 7.	The problem is solved.
<p>Step 7 Check if the fuser cam is functional and free of damage.</p> <p>Is the fuser cam functional and free of damage?</p>	Go to step 9.	Go to step 8.
<p>Step 8 Replace the fuser cam. See “Fuser actuator removal” on page 178.</p> <p>Does the problem remain?</p>	Go to step 9.	The problem is solved.
<p>Step 9</p> <p>a Enter the Diagnostics menu, and then navigate to: Printer diagnostics and adjustments > Sensor tests</p> <p>b Find the sensor (Input).</p> <p>Does the sensor status change while toggling the sensor?</p>	Contact the next level of support.	Go to step 10.
<p>Step 10</p> <p>a Reseat the sensor cable from the controller board.</p> <p>b Check the sensor and its actuator for improper installation and damage.</p> <p>Is the sensor properly installed and free of damage?</p>	Contact the next level of support.	Go to step 11.
<p>Step 11 Replace the sensor. See “Sensors (duplex and input) removal” on page 215.</p> <p>Does the problem remain?</p>	Contact the next level of support.	The problem is solved.

Sensor (input) static jam service check

Action	Yes	No
<p>Step 1 Make sure that the paper is loaded properly. Use the recommended paper. See “Avoiding jams” on page 68.</p> <p>Does the problem remain?</p>	Go to step 2.	The problem is solved.
<p>Step 2 a Enter the Diagnostics menu, and then navigate to: Printer diagnostics and adjustments > Sensor tests b Find the sensor (Input).</p> <p>Does the sensor status change while toggling the sensor?</p>	Contact the next level of support.	Go to step 3.
<p>Step 3 a Reseat the sensor cable from the controller board. b Check the sensor and its actuator for improper installation and damage.</p> <p>Is the sensor properly installed and free of damage?</p>	Contact the next level of support.	Go to step 4.
<p>Step 4 Replace the sensor. See “Sensors (duplex and input) removal” on page 215.</p> <p>Does the problem remain?</p>	Contact the next level of support.	The problem is solved.

202 paper jams

202 paper jam messages

Error code	Description	Action
202.03	Paper fed from the MPF never reached the sensor (fuser exit).	See “Sensor (fuser exit) jam at leading edge service check” on page 89 .
202.05	Paper fed from the MPF never cleared the sensor (fuser exit).	See “Sensor (fuser exit) jam at trailing edge service check” on page 90 .
202.13	Paper fed from tray 1 never reached the sensor (fuser exit).	See “Sensor (fuser exit) jam at leading edge service check” on page 89 .
202.15	Paper fed from tray 1 never cleared the sensor (fuser exit).	See “Sensor (fuser exit) jam at trailing edge service check” on page 90 .
202.23	Paper fed from tray 2 never reached the sensor (fuser exit).	See “Sensor (fuser exit) jam at leading edge service check” on page 89 .
202.25	Paper fed from tray 2 never cleared the sensor (fuser exit).	See “Sensor (fuser exit) jam at trailing edge service check” on page 90 .

Error code	Description	Action
202.33	Paper fed from tray 3 never reached the sensor (fuser exit).	See “Sensor (fuser exit) jam at leading edge service check” on page 89.
202.35	Paper fed from tray 3 never cleared the sensor (fuser exit).	See “Sensor (fuser exit) jam at trailing edge service check” on page 90.
202.43	Paper fed from tray 4 never reached the sensor (fuser exit).	See “Sensor (fuser exit) jam at leading edge service check” on page 89.
202.45	Paper fed from tray 4 never cleared the sensor (fuser exit).	See “Sensor (fuser exit) jam at trailing edge service check” on page 90.
202.91	Paper remains detected at the sensor (fuser exit) after the printer is turned on.	See “Sensor (fuser exit) static jam service check” on page 91.
202.93	The sensor (fuser exit) detected a jam during or after a flush action.	

Sensor (fuser exit) jam at leading edge service check

Action	Yes	No
<p>Step 1</p> <p>Make sure that the paper is loaded properly. Use the recommended paper. See “Avoiding jams” on page 68.</p> <p>Does the problem remain?</p>	Go to step 2.	The problem is solved.
<p>Step 2</p> <p>a Enter the Diagnostics menu, and then navigate to: Input tray quick print ></p> <p>b Do feed tests from different trays. Check if the same error occurs.</p> <p>Does the same problem remain?</p>	Go to step 3.	Go to step 7.
<p>Step 3</p> <p>Check if the fuser cam is functional and free of damage.</p> <p>Is the fuser cam functional and free of damage?</p>	Go to step 5.	Go to step 4.
<p>Step 4</p> <p>Replace the fuser cam. See “Fuser actuator removal” on page 178.</p> <p>Does the problem remain?</p>	Go to step 5.	The problem is solved.
<p>Step 5</p> <p>a Reseat the fuser cables from the controller board.</p> <p>b Reseat the fuser cable from the LVPS.</p> <p>c Reseat the fuser cable from the extension cable.</p> <p>Does the problem remain?</p>	Go to step 6.	The problem is solved.

Action	Yes	No
<p>Step 6 Check the fuser for problems. See “Fuser error service check” on page 112.</p> <p>Does the problem remain?</p>	Go to step 7.	The problem is solved.
<p>Step 7 Do the service checks related to the affected source tray.</p> <p>Does the problem remain?</p>	Contact the next level of support.	The problem is solved.

Sensor (fuser exit) jam at trailing edge service check

Action	Yes	No
<p>Step 1 Make sure that the paper is loaded properly. Use the recommended paper. See “Avoiding jams” on page 68.</p> <p>Does the problem remain?</p>	Go to step 2.	The problem is solved.
<p>Step 2 a Remove all obstructions along the rear door paper path. b Check the rear door and its components for damage.</p> <p>Are the rear door and its components free of damage?</p>	Go to step 4.	Go to step 3.
<p>Step 3 Replace the rear door and cover or rear access door. See “Rear door and cover removal” on page 224.</p> <p>Does the problem remain?</p>	Go to step 4.	The problem is solved.
<p>Step 4 Check the redrive assembly and its components for wear and damage.</p> <p>Are the redrive assembly and its components free of wear and damage?</p>	Contact the next level of support.	Go to step 5.
<p>Step 5 Replace the redrive assembly. See “Redrive assembly removal” on page 225.</p> <p>Does the problem remain?</p>	Contact the next level of support.	The problem is solved.

Sensor (fuser exit) static jam service check

Action	Yes	No
<p>Step 1 Make sure that the paper is loaded properly. Use the recommended paper. See “Avoiding jams” on page 68.</p> <p>Does the problem remain?</p>	Go to step 2.	The problem is solved.
<p>Step 2 a Reseat the fuser cables from the controller board. b Reseat the fuser cable from the LVPS. c Reseat the fuser cable from the extension cable.</p> <p>Does the problem remain?</p>	Go to step 3.	The problem is solved.
<p>Step 3 Check if the fuser cam is functional and free of damage.</p> <p>Is the fuser cam functional and free of damage?</p>	Go to step 5.	Go to step 4.
<p>Step 4 Replace the fuser cam. See “Fuser actuator removal” on page 178.</p> <p>Does the problem remain?</p>	Go to step 5.	The problem is solved.
<p>Step 5 a Enter the Diagnostics menu, and then navigate to: Printer diagnostics and adjustments > Sensor tests b Find the sensor (Fuser exit).</p> <p>Does the sensor status change while toggling the sensor?</p>	Go to step 7.	Go to step 6.
<p>Step 6 Replace the fuser. See “Fuser removal” on page 224.</p> <p>Does the problem remain?</p>	Contact the next level of support.	The problem is solved.
<p>Step 7 Check the fuser for problems. See “Fuser error service check” on page 112.</p> <p>Does the problem remain?</p>	Contact the next level of support.	The problem is solved.

230 paper jams

230 paper jam messages

Error code	Description	Action
230.03	Paper fed from the MPF never reached the sensor (duplex).	See “Sensor (duplex) jam at leading edge service check” on page 92.
230.05	Paper fed from the MPF never cleared the sensor (duplex).	See “Sensor (duplex) jam at trailing edge service check” on page 94.
230.13	Paper fed from tray 1 never reached the sensor (duplex).	See “Sensor (duplex) jam at leading edge service check” on page 92.
230.15	Paper fed from tray 1 never cleared the sensor (duplex).	See “Sensor (duplex) jam at trailing edge service check” on page 94.
230.23	Paper fed from tray 2 never reached the sensor (duplex).	See “Sensor (duplex) jam at leading edge service check” on page 92.
230.25	Paper fed from tray 2 never cleared the sensor (duplex).	See “Sensor (duplex) jam at trailing edge service check” on page 94.
230.33	Paper fed from tray 3 never reached the sensor (duplex).	See “Sensor (duplex) jam at leading edge service check” on page 92.
230.35	Paper fed from tray 3 never cleared the sensor (duplex).	See “Sensor (duplex) jam at trailing edge service check” on page 94.
230.43	Paper fed from tray 4 never reached the sensor (duplex).	See “Sensor (duplex) jam at leading edge service check” on page 92.
230.45	Paper fed from tray 4 never cleared the sensor (duplex).	See “Sensor (duplex) jam at trailing edge service check” on page 94.
230.91	Paper remains detected at the sensor (duplex) after the printer is turned on.	See “Sensor (duplex) static jam service check” on page 95.

Sensor (duplex) jam at leading edge service check

Action	Yes	No
<p>Step 1</p> <p>Make sure that the paper is loaded properly. Use the recommended paper. See “Avoiding jams” on page 68.</p> <p>Does the problem remain?</p>	Go to step 2.	The problem is solved.
<p>Step 2</p> <p>a Enter the Diagnostics menu, and then navigate to: Input tray quick print ></p> <p>b Do feed tests from different trays. Check if the same error occurs.</p> <p>Does the same problem remain?</p>	Go to step 3.	Perform the appropriate service check for the specific error.

Action	Yes	No
<p>Step 3</p> <p>a Enter the Diagnostics menu, and then navigate to: Printer diagnostics and adjustments > Motor tests</p> <p>b Select the solenoid (Redrive Solenoid), and then touch Start.</p> <p>Does the solenoid run?</p>	Go to step 6.	Go to step 4.
<p>Step 4</p> <p>Check the solenoid for wear and damage.</p> <p>Is the solenoid free of wear and damage?</p>	Go to step 6.	Go to step 5.
<p>Step 5</p> <p>Replace the reverse solenoid. See “Reverse solenoid removal” on page 179.</p> <p>Does the problem remain?</p>	Go to step 6.	The problem is solved.
<p>Step 6</p> <p>a Enter the Diagnostics menu, and then navigate to: Printer diagnostics and adjustments > Sensor tests</p> <p>b Find the sensor (Duplex path 1).</p> <p>Does the sensor status change while toggling the sensor?</p>	Go to step 9.	Go to step 7.
<p>Step 7</p> <p>a Reseat the sensor cable from the controller board.</p> <p>b Check the sensor and its actuator for improper installation and damage.</p> <p>Is the sensor properly installed and free of damage?</p>	Go to step 9.	Go to step 8.
<p>Step 8</p> <p>Replace the sensor. See “Sensors (duplex and input) removal” on page 215.</p> <p>Does the problem remain?</p>	Go to step 9.	The problem is solved.
<p>Step 9</p> <p>a Remove tray 1 to access the parts under the printer.</p> <p>b Check the duplex assembly and its gears, belt, and gear links for wear and damage.</p> <p>Are the duplex assembly and its components free of wear and damage?</p>	Contact the next level of support.	Go to step 10.

Action	Yes	No
<p>Step 10 Replace the duplex assembly. See “Duplex assembly removal” on page 213.</p> <p>Does the problem remain?</p>	Contact the next level of support.	The problem is solved.

Sensor (duplex) jam at trailing edge service check

Action	Yes	No
<p>Step 1 Make sure that the paper is loaded properly. Use the recommended paper. See “Avoiding jams” on page 68.</p> <p>Does the problem remain?</p>	Go to step 2.	The problem is solved.
<p>Step 2 a Enter the Diagnostics menu, and then navigate to: Printer diagnostics and adjustments > Sensor tests b Find the sensor (Duplex path 1).</p> <p>Does the sensor status change while toggling the sensor?</p>	Go to step 5.	Go to step 3.
<p>Step 3 a Reseat the sensor cable from the controller board. b Check the sensor and its actuator for improper installation and damage.</p> <p>Is the sensor properly installed and free of damage?</p>	Go to step 5.	Go to step 4.
<p>Step 4 Replace the sensor. See “Sensors (duplex and input) removal” on page 215.</p> <p>Does the problem remain?</p>	Go to step 5.	The problem is solved.
<p>Step 5 a Remove tray 1 to access the parts under the printer. b Check the duplex assembly and its gears, belt, and gear links for wear and damage.</p> <p>Are the duplex assembly and its components free of wear and damage?</p>	Contact the next level of support.	Go to step 6.
<p>Step 6 Replace the duplex assembly. See “Duplex assembly removal” on page 213.</p> <p>Does the problem remain?</p>	Contact the next level of support.	The problem is solved.

Sensor (duplex) static jam service check

Action	Yes	No
<p>Step 1 Make sure that the paper is loaded properly. Use the recommended paper. See “Avoiding jams” on page 68.</p> <p>Does the problem remain?</p>	Go to step 2.	The problem is solved.
<p>Step 2 a Enter the Diagnostics menu, and then navigate to: Printer diagnostics and adjustments > Sensor tests b Find the sensor (Duplex path 1).</p> <p>Does the sensor status change while toggling the sensor?</p>	Contact the next level of support.	Go to step 3.
<p>Step 3 a Reseat the sensor cable from the controller board. b Check the sensor and its actuator for improper installation and damage.</p> <p>Is the sensor properly installed and free of damage?</p>	Contact the next level of support.	Go to step 4.
<p>Step 4 Replace the sensor. See “Sensors (duplex and input) removal” on page 215.</p> <p>Does the problem remain?</p>	Contact the next level of support.	The problem is solved.

240-241 paper jams

240-241 paper jam messages

Error code	Description	Action
240.06	Paper fed from the MPF was picked but it never reached the sensor (input).	See “MPF pick failure service check” on page 96 .
240.91	Paper remains detected at the sensor (MPF paper present) after the printer is turned on.	See “Sensor (MPF paper present) static jam service check” on page 98 .
241.16	Paper fed from tray 1 was picked but it never reached the sensor (input).	See “Tray 1 to sensor (input) jam at trailing edge service check” on page 83 .

MPF pick failure service check

Action	Yes	No
<p>Step 1 Make sure that the paper is loaded properly. Use the recommended paper. See “Avoiding jams” on page 68.</p> <p>Does the problem remain?</p>	Go to step 2.	The problem is solved.
<p>Step 2 a Enter the Diagnostics menu, and then navigate to: Input tray quick print > Tray 1 > Single b Check if the same error occurs.</p> <p>Does the same problem remain?</p>	Go to step 3.	Perform the appropriate service check for the specific error.
<p>Step 3 a Check the jam access cover for obstructions along the paper path. Check if the cover interferes with the MPF pick roller movement. b Check if the jam access cover components are functional and free of damage.</p> <p>Are the jam access cover and its components functional and free of obstructions and damage?</p>	Go to step 5.	Go to step 4.
<p>Step 4 Reinstall or replace the jam access cover. See “Jam access cover removal” on page 203.</p> <p>Does the problem remain?</p>	Go to step 5.	The problem is solved.
<p>Step 5 Check the MPF pick roller and separator pad for wear and damage.</p> <p>Are the MPF roller and separator pad free of wear and damage?</p>	Go to step 7.	Go to step 6.
<p>Step 6 Replace the MPF pick roller and separator pad. See “MPF pick roller and separator pad removal” on page 206.</p> <p>Does the problem remain?</p>	Go to step 7.	The problem is solved.
<p>Step 7 a Enter the Diagnostics menu, and then navigate to: Printer diagnostics and adjustments > Sensor tests b Find the sensor (MPF media present).</p> <p>Does the sensor status change while toggling the sensor?</p>	Go to step 10.	Go to step 8.

Action	Yes	No
<p>Step 8</p> <p>a Reseat the sensor cable from the controller board.</p> <p>b Check the sensor and its actuator for improper installation and damage.</p> <p>Is the sensor properly installed and free of damage?</p>	Go to step 10.	Go to step 9.
<p>Step 9</p> <p>Replace the sensor (MPF paper present). See “Sensor (MPF paper present) removal” on page 209.</p> <p>Does the problem remain?</p>	Go to step 10.	The problem is solved.
<p>Step 10</p> <p>a Enter the Diagnostics menu, and then navigate to: Printer diagnostics and adjustments > Motor tests</p> <p>b Select the solenoid (MPF pick), and then touch Start.</p> <p>Does the solenoid run?</p>	Go to step 13.	Go to step 12.
<p>Step 11</p> <p>Check the solenoid for wear and damage.</p> <p>Is the solenoid free of wear and damage?</p>	Go to step 13.	Go to step 12.
<p>Step 12</p> <p>Replace the MPF solenoid. See “MPF solenoid removal” on page 181.</p> <p>Does the problem remain?</p>	Go to step 13.	The problem is solved.
<p>Step 13</p> <p>Check the MPF gearbox for wear and damage.</p> <p>Is the MPF gearbox free of wear and damage?</p>	Contact the next level of support.	Go to step 14.
<p>Step 14</p> <p>Replace the MPF gearbox. See “MPF gearbox removal” on page 175.</p> <p>Does the problem remain?</p>	Contact the next level of support.	The problem is solved.

Sensor (MPF paper present) static jam service check

Action	Yes	No
<p>Step 1</p> <p>Make sure that the paper is loaded properly. Use the recommended paper. See “Avoiding jams” on page 68.</p> <p>Does the problem remain?</p>	Go to step 2.	The problem is solved.
<p>Step 2</p> <p>a Enter the Diagnostics menu, and then navigate to: Printer diagnostics and adjustments > Sensor tests</p> <p>b Find the sensor (MPF media present).</p> <p>Does the sensor status change while toggling the sensor?</p>	Contact the next level of support.	Go to step 3.
<p>Step 3</p> <p>a Reseat the sensor cable from the controller board.</p> <p>b Check the sensor and its actuator for improper installation and damage.</p> <p>Is the sensor properly installed and free of damage?</p>	Contact the next level of support.	Go to step 4.
<p>Step 4</p> <p>Replace the sensor (MPF paper present). See “Sensor (MPF paper present) removal” on page 209.</p> <p>Does the problem remain?</p>	Contact the next level of support.	The problem is solved.

242-244 paper jams

242 paper jam messages

Error code	Description	Action
242.26	Paper fed from tray 2 was picked but it never reached the sensor (input).	See “Optional tray sensor (tray x pass-through) jam at leading edge service check” on page 101 .
242.31	Paper remains detected at the sensor (tray 2 pass-through) although the printer is idle. Tray 3 is the paper source.	See “Optional tray sensor (tray x pass-through) static jam service check” on page 101 .
242.33	Paper fed from tray 3 never reached the sensor (tray 2 pass-through).	See “Optional tray sensor (tray x pass-through) jam at leading edge service check” on page 101 .
242.35	Paper fed from tray 3 cleared the sensor (tray 2 pass-through) later than expected.	See “Optional tray sensor (tray x pass-through) jam at trailing edge service check” on page 102 .
242.37	Paper fed from tray 3 never cleared the sensor (tray 2 pass-through).	

Error code	Description	Action
242.41	Paper remains detected at the sensor (tray 2 pass-through) although the printer is idle. Tray 4 is the paper source.	See “Optional tray sensor (tray x pass-through) static jam service check” on page 101.
242.43	Paper fed from tray 4 never reached the sensor (tray 2 pass-through).	See “Optional tray sensor (tray x pass-through) jam at leading edge service check” on page 101.
242.45	Paper fed from tray 4 cleared the sensor (tray 2 pass-through) later than expected.	See “Optional tray sensor (tray x pass-through) jam at trailing edge service check” on page 102.
242.47	Paper fed from tray 4 never cleared the sensor (tray 2 pass-through).	
242.82	The motor (tray 2 pick) has stalled.	See “Optional tray pick failure service check” on page 103.
242.83	The motor (tray 2 pick) has stalled.	
242.84	The motor (tray 2 pick) has stalled.	
242.91	Paper remains detected at the sensor (tray 2 pass-through) after the printer is turned on.	See “Optional tray sensor (tray x pass-through) static jam service check” on page 101.
242.93	Paper never reached the sensor (tray 2 pass-through). Paper source is undetermined.	See “Optional tray sensor (tray x pass-through) jam at leading edge service check” on page 101.
242.95	Paper cleared the sensor (tray 2 pass-through) later than expected. Paper source is undetermined.	See “Optional tray sensor (tray x pass-through) jam at trailing edge service check” on page 102.
242.96	Paper was picked but it never reached the sensor (input). Paper source is undetermined.	See “Optional tray sensor (tray x pass-through) jam at leading edge service check” on page 101.
242.97	Paper never cleared the sensor (tray 2 pass-through). Paper source is undetermined.	See “Optional tray sensor (tray x pass-through) jam at trailing edge service check” on page 102.

243 paper jam messages

Error code	Description	Action
243.36	Paper fed from tray 3 was picked but it never reached the sensor (tray 2 pass-through).	See “Optional tray sensor (tray x pass-through) jam at leading edge service check” on page 101.
243.41	Paper remains detected at the sensor (tray 3 pass-through) although the printer is idle. Tray 4 is the paper source.	See “Optional tray sensor (tray x pass-through) static jam service check” on page 101.
243.43	Paper fed from tray 4 never reached the sensor (tray 3 pass-through).	See “Optional tray sensor (tray x pass-through) jam at leading edge service check” on page 101.

Error code	Description	Action
243.45	Paper fed from tray 4 cleared the sensor (tray 3 pass-through) later than expected.	See “Optional tray sensor (tray x pass-through) jam at trailing edge service check” on page 102.
243.47	Paper fed from tray 4 never cleared the sensor (tray 3 pass-through).	
243.82	The motor (tray 3 pick) has stalled.	See “Optional tray pick failure service check” on page 103.
243.83	The motor (tray 3 pick) has stalled.	
243.84	The motor (tray 3 pick) has stalled.	
243.91	Paper remains detected at the sensor (tray 3 pass-through) after the printer is turned on.	See “Optional tray sensor (tray x pass-through) static jam service check” on page 101.
243.92	Paper was detected earlier than expected at the sensor (tray 3 pass-through). Paper source is undetermined.	See “Optional tray sensor (tray x pass-through) jam at leading edge service check” on page 101.
243.93	Paper never reached the sensor (tray 2 pass-through). Paper source is undetermined.	
243.95	Paper cleared the sensor (tray 3 pass-through) later than expected. Paper source is undetermined.	See “Optional tray sensor (tray x pass-through) jam at trailing edge service check” on page 102.
243.96	Paper was picked but it never reached the sensor (tray 3 pass-through). Paper source is undetermined.	See “Optional tray sensor (tray x pass-through) jam at leading edge service check” on page 101.
243.97	Paper never cleared the sensor (tray 3 pass-through). Paper source is undetermined.	See “Optional tray sensor (tray x pass-through) jam at trailing edge service check” on page 102.

244 paper jam messages

Error code	Description	Action
244.46	Paper fed from tray 4 was picked but it never reached the sensor (tray 3 pass-through).	See “Optional tray sensor (tray x pass-through) jam at leading edge service check” on page 101.
244.82	The motor (tray 4 pick) has stalled.	See “Optional tray pick failure service check” on page 103.
244.83	The motor (tray 4 pick) has stalled.	
244.84	The motor (tray 4 pick) has stalled.	
244.91	Paper remains detected at the sensor (tray 4 pass-through) after the printer is turned on.	See “Optional tray sensor (tray x pass-through) static jam service check” on page 101.

Optional tray sensor (tray x pass-through) static jam service check

Action	Yes	No
<p>Step 1</p> <p>Make sure that the paper is loaded properly. Use the recommended paper. See “Avoiding jams” on page 68.</p> <p>Does the problem remain?</p>	Go to step 2.	The problem is solved.
<p>Step 2</p> <p>a Enter the Diagnostics menu, and then navigate to: Additional input tray diagnostics > Option Sensor tests</p> <p>b Find the sensor (Pass-through (tray x)) of the affected optional tray.</p> <p>Does the sensor status change while toggling the sensor?</p>	Contact the next level of support.	Go to step 3.
<p>Step 3</p> <p>a Reseat the sensor cable from the optional tray controller board.</p> <p>b Check the sensor and its actuator for improper installation and damage.</p> <p>Is the sensor properly installed and free of damage?</p>	Contact the next level of support.	Go to step 4.
<p>Step 4</p> <p>Replace the affected optional tray.</p> <p>Does the problem remain?</p>	Contact the next level of support.	The problem is solved.

Optional tray sensor (tray x pass-through) jam at leading edge service check

Action	Yes	No
<p>Step 1</p> <p>Make sure that the paper is loaded properly. Use the recommended paper. See “Avoiding jams” on page 68.</p> <p>Does the problem remain?</p>	Go to step 2.	The problem is solved.
<p>Step 2</p> <p>a Enter the Diagnostics menu, and then navigate to: Input tray quick print ></p> <p>b Do feed tests from tray 3 and tray 4. Check if the same error occurs.</p> <p>Does the same problem remain?</p>	Go to step 3.	Perform the appropriate service check for the specific error.

Action	Yes	No
<p>Step 3</p> <p>a Identify the separator rollers and pass-through rollers involved in the paper path.</p> <p>b Check these separator rollers and pass-through rollers for improper installation, wear, and damage.</p> <p>Are the rollers properly installed and free of wear and damage?</p>	Go to step 5.	Go to step 4.
<p>Step 4</p> <p>Reinstall or replace the affected separator roller assembly or tray insert.</p> <p>Does the problem remain?</p>	Go to step 5.	The problem is solved.
<p>Step 5</p> <p>a Enter the Diagnostics menu, and then navigate to: Additional input tray diagnostics > Option Sensor tests</p> <p>b Find the sensor (Pass-through (tray x)) of the affected optional tray.</p> <p>Does the sensor status change while toggling the sensor?</p>	Contact the next level of support.	Go to step 6.
<p>Step 6</p> <p>a Reseat the sensor cable from the optional tray controller board.</p> <p>b Check the sensor and its actuator for improper installation and damage.</p> <p>Is the sensor properly installed and free of damage?</p>	Contact the next level of support.	Go to step 7.
<p>Step 7</p> <p>Replace the affected optional tray.</p> <p>Does the problem remain?</p>	Contact the next level of support.	The problem is solved.

Optional tray sensor (tray x pass-through) jam at trailing edge service check

Action	Yes	No
<p>Step 1</p> <p>Make sure that the paper is loaded properly. Use the recommended paper. See “Avoiding jams” on page 68.</p> <p>Does the problem remain?</p>	Go to step 2.	The problem is solved.
<p>Step 2</p> <p>Check if the paper size matches the size set on the source tray guides.</p> <p>Does the paper size match the size set on the tray?</p>	Go to step 4.	Go to step 3.

Action	Yes	No
<p>Step 3 Change the paper size or adjust the size setting in the tray.</p> <p>Does the problem remain?</p>	Go to step 4.	The problem is solved.
<p>Step 4</p> <p>a Identify the separator rollers and pass-through rollers involved in the paper path.</p> <p>b Check these separator rollers and pass-through rollers for improper installation, wear, and damage.</p> <p>Are the rollers properly installed and free of wear and damage?</p>	Contact the next level of support.	Go to step 5.
<p>Step 5 Reinstall or replace the affected separator roller assembly or tray insert.</p> <p>Does the problem remain?</p>	Contact the next level of support.	The problem is solved.

Optional tray pick failure service check

Action	Yes	No
<p>Step 1 Make sure that the paper is loaded properly. Use the recommended paper. See “Avoiding jams” on page 68.</p> <p>Does the problem remain?</p>	Go to step 2.	The problem is solved.
<p>Step 2 Restart the printer.</p> <p>Does the problem remain?</p>	Go to step 3.	The problem is solved.
<p>Step 3</p> <p>a Reseat the source tray pick motor cable from the optional tray controller board.</p> <p>b Check if the motor (pick) of the source tray is functional and free of damage.</p> <p>Is the motor functional and free of damage?</p>	Go to step 4.	Go to step 7.
<p>Step 4 Check the source tray pick motor gears for damage.</p> <p>Are the gears free of damage?</p>	Go to step 6.	Go to step 5.

Action	Yes	No
<p>Step 5 Check the tray insert and its lift plate gears for wear and damage.</p> <p>Are the tray insert and its gears free of wear and damage?</p>	Contact the next level of support.	Go to step 6.
<p>Step 6 Replace the affected tray insert.</p> <p>Does the problem remain?</p>	Go to step 7.	The problem is solved.
<p>Step 7 Replace the optional tray.</p> <p>Does the problem remain?</p>	Contact the next level of support.	The problem is solved.

User attendance messages (0–99.99)

User attendance messages

Error code	Description	Action
31.40	The toner cartridge is missing or unresponsive.	See “Unsupported or unresponsive toner cartridge service check” on page 105.
31.60	The imaging unit is missing or unresponsive.	See “Unsupported or unresponsive imaging unit service check” on page 107.
32.40	The toner cartridge is unsupported.	See “Unsupported or unresponsive toner cartridge service check” on page 105.
32.60	The imaging unit is unsupported.	See “Unsupported or unresponsive imaging unit service check” on page 107.
41.40	The imaging unit and toner cartridge are mismatched or incompatible.	See “Mismatched supplies error service check” on page 108.
42.xx	The toner cartridge is incompatible due to printer region mismatch.	
43.40	A toner cartridge shutter error was detected.	
44.40	The toner cartridge and printer are mismatched.	
44.60	The imaging unit and printer are mismatched.	

Error code	Description	Action
80.0x	The remaining life of the fuser is nearly low.	See “Maintenance kit low service check” on page 108.
80.1x	The remaining life of the fuser is low.	
80.2x	The remaining life of the fuser is very low.	
80.3x	The fuser life has ended.	
80.4x	The fuser life has ended. The printer forces a hard stop on the fuser.	
84.0x	The remaining life of the imaging unit is nearly low.	
84.1x	The remaining life of the imaging unit is low.	
84.2x	The remaining life of the imaging unit is very low.	
84.3x	The imaging unit life has ended.	
84.4x	The imaging unit life has ended. The printer forces a hard stop on the imaging unit.	
88.0x	The remaining life of the toner cartridge is nearly low.	
88.1x	The remaining life of the toner cartridge is low.	
88.2x	The remaining life of the toner cartridge is very low.	
88.3x	The toner cartridge life has ended.	
88.4x	The toner cartridge life has ended. The printer forces a hard stop on the toner cartridge.	

Unsupported or unresponsive toner cartridge service check

Action	Yes	No
<p>Step 1</p> <p>Check whether the toner cartridge installed is genuine.</p> <p>Is the cartridge a genuine and supported Lexmark unit?</p>	Go to step 3.	Go to step 2.
<p>Step 2</p> <p>Install a genuine and supported Lexmark toner cartridge.</p> <p>Does the problem remain?</p>	Go to step 3.	The problem is solved.
<p>Step 3</p> <p>a Check the toner cartridge contacts for contamination.</p> <p>b Check the toner cartridge for leaks and damage.</p> <p>Are the toner cartridge and its contacts free of contamination and damage?</p>	Go to step 5.	Go to step 4.

Action	Yes	No
<p>Step 4 Clean or replace the toner cartridge.</p> <p>Does the problem remain?</p>	Go to step 5.	The problem is solved.
<p>Step 5 a Check the toner cartridge smart chip contacts for contamination. b Check if the contacts are bent or damaged.</p> <p>Are the contacts free of contamination and damage?</p>	Go to step 7.	Go to step 6.
<p>Step 6 Clean, repair, or replace the smart chip contact. See “Toner cartridge smart chip contact removal” on page 192.</p> <p>Does the problem remain?</p>	Go to step 7.	The problem is solved.
<p>Step 7 Reseat the smart chip contact cable on the controller board.</p> <p>Does the problem remain?</p>	Go to step 8.	The problem is solved.
<p>Step 8 Check the sensor (cartridge barrel) and its actuator for damage and misalignment.</p> <p>Are the sensor and its actuator properly installed and free of damage?</p>	Go to step 10.	Go to step 9.
<p>Step 9 Replace the sensor. See “Cartridge barrel shutter sensor kit removal” on page 195.</p> <p>Does the problem remain?</p>	Go to step 10.	The problem is solved.
<p>Step 10 Reseat sensor cable from the controller board.</p> <p>Does the problem remain?</p>	Contact the next level of support.	The problem is solved.

Unsupported or unresponsive imaging unit service check

Action	Yes	No
<p>Step 1 Check whether the imaging unit installed is genuine.</p> <p>Is the imaging unit a genuine and supported Lexmark unit?</p>	Go to step 3.	Go to step 2.
<p>Step 2 Install a genuine and supported Lexmark imaging unit.</p> <p>Does the problem remain?</p>	Go to step 3.	The problem is solved.
<p>Step 3 a Check the imaging unit contacts for contamination. b Check the imaging unit for leaks and damage.</p> <p>Are the imaging unit and its contacts free of contamination and damage?</p>	Go to step 5.	Go to step 4.
<p>Step 4 Clean or replace the imaging unit.</p> <p>Does the problem remain?</p>	Go to step 5.	The problem is solved.
<p>Step 5 a Check the imaging unit smart chip contacts for contamination. b Check if the contacts are bent or damaged.</p> <p>Are the contacts free of contamination and damage?</p>	Go to step 7.	Go to step 6.
<p>Step 6 Clean or repair the smart chip contact.</p> <p>Does the problem remain?</p>	Go to step 7.	The problem is solved.
<p>Step 7 Reseat the smart chip contact cable on the controller board.</p> <p>Does the problem remain?</p>	Contact the next level of support.	The problem is solved.

Mismatched supplies error service check

Action	Yes	No
<p>Step 1 Check whether the supplies installed are genuine.</p> <p>Are the supplies genuine and supported Lexmark units?</p>	Go to step 3.	Go to step 2.
<p>Step 2 Install genuine and supported Lexmark units.</p> <p>Does the problem remain?</p>	Go to step 3.	The problem is solved.
<p>Step 3 Check the following:</p> <ul style="list-style-type: none"> • Check if the supplies have matching types. Do not install ICR supplies together with non-MICR supplies. • Check if the supply is supported by the region. • Check if the supply is supported by the specific printer model. <p>Is the affected supply the correct or matching unit?</p>	Contact the next level of support.	Go to step 4.
<p>Step 4 Replace the affected supply with the correct unit.</p> <p>Does the problem remain?</p>	Contact the next level of support.	The problem is solved.

Maintenance kit low service check

Action	Yes	No
<p>Step 1 Print a test page using paper from a newly opened package, and then check the result.</p> <p>Are there print quality defects on the test page?</p>	Go to step 2.	Go to step 3.
<p>Step 2 Identify, and then resolve the print quality defect. See “Fixing print quality issues” on page 27.</p> <p>Note: If a supply was replaced, then make sure that the maintenance kit count is reset.</p> <p>Does the problem remain?</p>	Go to step 3.	The problem is solved.
<p>Step 3 Check if the printer has feed problems by doing a feed test.</p> <p>Does the printer have a problem feeding during the test?</p>	Go to step 4.	Go to step 5.

Action	Yes	No
<p>Step 4 Resolve the feed problem.</p> <p>Note: If a transfer roller was replaced, then make sure that the maintenance kit count is reset.</p> <p>Does the problem remain?</p>	Go to step 5.	The problem is solved.
<p>Step 5 Replace the affected maintenance kit with a new supply unit.</p> <p>Does the problem remain?</p>	Contact the next level of support.	The problem is solved.

Printer hardware errors

111 errors

111 error messages

Error code	Description	Action
111.20	Printhead error (mirror motor lock) was detected before the motor was turned on.	See “Printhead error service check” on page 110.
111.21	No printhead power (+5V) when the laser servo started.	
111.30	The printhead failed during power on tests.	
111.31	Printhead error (no first HSYNC) was detected.	
111.32	Printhead error (lost first HSYNC) was detected.	
111.33	Printhead error (lost first HSYNC) was detected during servo.	
111.34	Printhead error (mirror motor lost lock) was detected.	
111.35	Printhead error (mirror motor no first lock) was detected.	
111.36	Printhead error (mirror motor never stabilized) was detected.	
111.41	Printhead NVRAM read failure occurred.	

Printhead error service check

Action	Yes	No
<p>Step 1</p> <p>a Remove the top cover. See “Top cover removal” on page 228.</p> <p>b Remove the right cover. See “Right cover removal” on page 185.</p> <p>c Reseat the printhead cable from the printhead and the controller board.</p> <p>Does the problem remain?</p>	Go to step 2.	The problem is solved.
<p>Step 2</p> <p>Check the printhead and its cables for damage and improper installation.</p> <p>Is the printhead free of damage and properly installed?</p>	Contact the next level of support.	Go to step 3.
<p>Step 3</p> <p>Reinstall or replace the printhead. See “Printhead removal” on page 229.</p> <p>Installation note: Perform all the mechanical and electronic adjustments to the printhead after replacing it. See “Printhead assembly adjustment” on page 171.</p> <p>Does the problem remain?</p>	Contact the next level of support.	The problem is solved.

121 errors

121 error messages

Error code	Description	Action
121.00	Fuser did not reach the required temperature.	See “Fuser low temperature error service check” on page 114.
121.01	During an attempt to heat up, the fuser was not detected.	See “Fuser error service check” on page 112.
121.02	Fuser went over the required temperature (during EWC/line voltage detection).	See “Fuser high temperature error service check” on page 113.
121.03	Fuser hardware and driver are mismatched.	See “Fuser error service check” on page 112.
121.04	During an attempt to heat up, the fuser relay was open and the microcontroller was not reporting an error.	
121.05	During an attempt to heat up, the fuser relay was open and the microcontroller was reporting an error.	

Error code	Description	Action
121.09	Fuser did not reach the required temperature for motors. Note: Error is not applicable to standby mode.	See “Fuser low temperature error service check” on page 114.
121.10	Fuser did not reach the required temperature (during start of EWC/line voltage detection).	
121.11	Fuser reached the required temperature (during final EWC/line voltage detection) too late.	
121.12	Fuser did not reach the required temperature (during final EWC/line voltage detection).	
121.13	Fuser reached the required temperature (during final EWC/line voltage detection) too fast.	See “Fuser high temperature error service check” on page 113.
121.19	Fuser high power trace reached the required temperature (during final EWC/line voltage detection) too fast.	
121.20	Fuser high power trace heating rate went over the limit.	
121.21	Fuser low power trace heating rate (from 165°C to 180°C) went over the limit.	
121.22	Open fuser relay was detected.	
121.28	Fuser did not reach the required temperature (during EP warm-up).	See “Fuser low temperature error service check” on page 114.
121.32	Fuser did not reach the required temperature (on 100% power).	
121.33	Fuser did not reach the required temperature (while page is in the fuser).	
121.34	Fuser did not reach the required temperature (during steady state control).	
121.36	Open fuser relay was detected with very cold or unknown ambient temperature.	
121.41	Fuser mechanism failed to detect the expected cam sensor transition.	
121.50	Fuser went over the required temperature (during global overtemp check).	See “Fuser high temperature error service check” on page 113.
121.52	Main thermistor temperature is out of range.	
121.53	Main thermistor temperature change rate is out of range.	
121.71	Open fuser main heater thermistor was detected.	See “Fuser error service check” on page 112.

Fuser error service check

Action	Yes	No
<p>Step 1</p> <p>a Turn off the printer, and then unplug the power cord.</p> <p>b Remove the rear door and cover. See “Rear door and cover removal” on page 224.</p> <p>c Reseat the fuser cable from the power supply and the controller board.</p> <p>Does the problem remain?</p>	Go to step 2.	The problem is solved.
<p>Step 2</p> <p>Disconnect the fuser cable from the power supply, and then measure its resistance.</p> <p>Check if the resistance is close to the following values:</p> <ul style="list-style-type: none"> • 220V fuser—43 ohms • 110V fuser—10 ohms • 100V fuser—8 ohms <p>Does the fuser have a normal resistance value?</p>	Go to step 3.	Go to step 5.
<p>Step 3</p> <p>a Remove the fuser. See “Fuser removal” on page 224.</p> <p>b Check the fuser gears for wear and damage. Rotate the gears, and then check if they move properly.</p> <p>c Check the fuser cables and connectors for damage.</p> <p>d Check the fuser belts for wear and damage.</p> <p>Is the fuser free of wear and damage?</p>	Go to step 4.	Go to step 5.
<p>Step 4</p> <p>Reinstall the fuser.</p> <p>Does the problem remain?</p>	Go to step 5.	The problem is solved.
<p>Step 5</p> <p>Replace the fuser. See “Fuser removal” on page 224.</p> <p>Does the problem remain?</p>	Contact the next level of support.	The problem is solved.

Fuser high temperature error service check



Action	Yes	No
<p>Step 1</p> <p>a Remove the right cover. See “Right cover removal” on page 185.</p> <p>b Reseat the cooling fan cable on the controller board.</p> <p>c Check the cooling fan for damage.</p> <p>Is the fan free of damage?</p>	Go to step 3.	Go to step 2.
<p>Step 2</p> <p>Replace the fan. See “Cooling fan removal” on page 189.</p> <p>Does the problem remain?</p>	Go to step 3.	The problem is solved.
<p>Step 3</p> <p>a Remove the rear door and cover. See “Rear door and cover removal” on page 224.</p> <p>b Reseat all the cables from the controller board.</p> <p>c Reseat all the cables from the power supply.</p> <p>Does the problem remain?</p>	Go to step 4.	The problem is solved.
<p>Step 4</p> <p>a Turn off the printer, and then remove the power cord.</p> <p>b Check if the resistance (between terminals A and D) of the power supply socket is close to 30 ohms.</p> <p>Does the socket have a normal resistance value?</p>	Go to step 5.	Go to step 7.
<p>Step 5</p> <p>a Disconnect the fuser cable from the power supply, plug the power cord, and then turn on the printer.</p> <p>b Check if the voltage output of the fuser cable socket on the power supply is normal (100V, 110V, or 220V).</p> <p> CAUTION—SHOCK HAZARD: To avoid the risk of electrical shock, do not touch the exposed wires and circuits.</p> <p>Does the power supply provide the fuser with the normal voltage value?</p>	Go to step 6.	Go to step 7.

Action	Yes	No
<p>Step 6</p> <p>a Turn off the printer, and then unplug the power cord.</p> <p>b Remove the power supply. See “Power supply removal” on page 211.</p> <p>c Check the power supply, including its fuse and capacitors, for damage.</p> <p> CAUTION—SHOCK HAZARD: To avoid the risk of electrical shock, do not touch the exposed wires and circuits.</p> <p>Is the power supply free of damage?</p>	Go to step 8.	Go to step 7.
<p>Step 7</p> <p>Replace the power supply. See “Power supply removal” on page 211.</p> <p>Does the problem remain?</p>	Go to step 8.	The problem is solved.
<p>Step 8</p> <p>Check the fuser for problems. See “Fuser error service check” on page 112.</p> <p>Does the problem remain?</p>	Contact the next level of support.	The problem is solved.

Fuser low temperature error service check

Note: Make sure that the voltage output of the electrical outlet matches the voltage rating of the printer.

Action	Yes	No
<p>Step 1</p> <p>a Remove the right cover. See “Right cover removal” on page 185.</p> <p>b Remove the rear door and cover. See “Rear door and cover removal” on page 224.</p> <p>c Reseat all the cables from the controller board.</p> <p>d Reseat all the cables from the power supply.</p> <p>Does the problem remain?</p>	Go to step 2.	The problem is solved.
<p>Step 2</p> <p>a Turn off the printer, and then remove the power cord.</p> <p>b Check if the resistance (between terminals A and D) of the power supply socket is close to 30 ohms.</p> <p>Does the socket have a normal resistance value?</p>	Go to step 3.	Go to step 5.

Action	Yes	No
<p>Step 3</p> <p>a Disconnect the fuser cable from the power supply, and then turn on the printer.</p> <p>b Check if the voltage output of the fuser cable socket on the power supply is normal (100V, 110V, or 220V).</p> <p> CAUTION—SHOCK HAZARD: To avoid the risk of electrical shock, do not touch the exposed wires and circuits.</p> <p>Does the power supply provide the fuser with the normal voltage value?</p>	Go to step 4.	Go to step 5.
<p>Step 4</p> <p>a Turn off the printer, and then unplug the power cord.</p> <p>b Remove the power supply. See “Power supply removal” on page 211.</p> <p>c Check the power supply, including its fuse and capacitors, for damage.</p> <p> CAUTION—SHOCK HAZARD: To avoid the risk of electrical shock, do not touch the exposed wires and circuits.</p> <p>Is the power supply free of damage?</p>	Go to step 6.	Go to step 5.
<p>Step 5</p> <p>Replace the power supply. See “Power supply removal” on page 211.</p> <p>Does the problem remain?</p>	Go to step 6.	The problem is solved.
<p>Step 6</p> <p>Check the fuser for problems. See “Fuser error service check” on page 112.</p> <p>Does the problem remain?</p>	Contact the next level of support.	The problem is solved.

126 errors



126 error messages

Error code	Description	Action
126.05	The LVPS power dropped but the printer was not in sleep mode.	See “LVPS service check” on page 116.
126.06	LVPS 25V line error was detected.	
126.07	LVPS 5V rail was down during power-on.	
126.10	No line frequency was detected.	
126.11	Line frequency has gone outside the operating range.	
126.12	LVPS mismatch was detected.	See “LVPS mismatch service check” on page 117.
126.13	LVPS mismatch was detected.	

LVPS service check

Note: Make sure that the voltage output of the electrical outlet matches the voltage rating of the printer.

Action	Yes	No
<p>Step 1</p> <p>a Turn off the printer, and then unplug the power cord.</p> <p>b Remove the rear door and cover. See “Rear door and cover removal” on page 224.</p> <p>c Remove the right cover. See “Right cover removal” on page 185.</p> <p>d Reseat all the cables from the controller board.</p> <p>e Reseat all the cables from the power supply.</p> <p> CAUTION—SHOCK HAZARD: To avoid the risk of electrical shock, do not touch the exposed wires and circuits.</p> <p>Does the problem remain?</p>	Go to step 2.	The problem is solved.
<p>Step 2</p> <p>a Turn off the printer, and then remove the power cord.</p> <p>b Check if the resistance (between terminals A and D) of the power supply socket is close to 30 ohms.</p> <p>Does the socket have a normal resistance value?</p>	Go to step 3.	Go to step 5.

Action	Yes	No
<p>Step 3</p> <p>a Disconnect the fuser cable from the power supply, and then turn on the printer.</p> <p>b Check if the voltage output of the fuser cable socket on the power supply is normal (100V, 110V, or 220V).</p> <p> CAUTION—SHOCK HAZARD: To avoid the risk of electrical shock, do not touch the exposed wires and circuits.</p> <p>Does the power supply provide the fuser with the normal voltage value?</p>	Go to step 4.	Go to step 5.
<p>Step 4</p> <p>a Turn off the printer, and then remove the power cord.</p> <p>b Remove the power supply. See “Power supply removal” on page 211.</p> <p>c Check the power supply, including its fuse and capacitors, for damage.</p> <p> CAUTION—SHOCK HAZARD: Do not touch the exposed wires and circuits.</p> <p>Is the power supply free of damage?</p>	Contact the next level of support.	Go to step 5.
<p>Step 5</p> <p>Replace the power supply. See “Power supply removal” on page 211.</p> <p>Does the problem remain?</p>	Contact the next level of support.	The problem is solved.

LVPS mismatch service check

Note: Make sure that the voltage output of the electrical outlet matches the voltage rating of the printer.

Action	Yes	No
<p>Step 1</p> <p>a Turn off the printer, and then unplug the power cord.</p> <p>b Remove the rear door and cover. See “Rear door and cover removal” on page 224.</p> <p>c Remove the right cover. See “Right cover removal” on page 185.</p> <p>d Reseat all the cables from the controller board.</p> <p>e Reseat all the cables from the power supply.</p> <p> CAUTION—SHOCK HAZARD: To avoid the risk of electrical shock, do not touch the exposed wires and circuits.</p> <p>Does the problem remain?</p>	Go to step 2.	The problem is solved.

Action	Yes	No
<p>Step 2</p> <p>a Check the power rating label of the printer.</p> <p>b Check the LVPS part number. Check if the power rating of this specific LVPS matches with the printer power rating.</p> <p>Do the printer and LVPS have matching power ratings?</p>	Contact the next level of support.	Go to step 3.
<p>Step 3</p> <p>Replace the power supply. See “Power supply removal” on page 211.</p> <p>Does the problem remain?</p>	Contact the next level of support.	The problem is solved.

128 errors

128 error messages

Error code	Description	Action
128.01	TDS baseline is too low.	See “Toner density error service check” on page 119 .
128.02	TDS baseline is too high.	
128.03	TDS baseline range is excessive.	
128.16	TDS calibration is at maximum.	
128.17	TDS calibration is too low.	
128.18	TDS calibration is too close to baseline.	
128.32	Photoconductor drum measurement is too high.	See “Photoconductor measurement error service check” on page 120 .
128.33	Photoconductor drum measurement is too different from calibration.	
128.34	Photoconductor drum measurement is too close to baseline.	
128.35	Photoconductor drum measurement data is not enough.	

Toner density error service check

Action	Yes	No
<p>Step 1 Reseat the toner density sensor cable.</p> <p>Does the problem remain?</p>	Go to step 2.	The problem is solved.
<p>Step 2 a Remove the toner cartridge and imaging unit. b Clean and check both units for toner leaks.</p> <p>Are the toner cartridge and imaging unit free of leaks?</p>	Go to step 3.	Replace the affected toner cartridge and imaging unit, and then go to step 3.
<p>Step 3 a Remove the transfer roller to access the area underneath it. See “Transfer roller removal” on page 203. b Clear the area of dust and toner contamination. c Remove tray 1, and then manually actuate the toner density sensor wiper by moving the pick roller up and down.</p> <p>Does the problem remain?</p>	Go to step 4.	The problem is solved.
<p>Step 4 a Remove the sensor (toner density). See “Sensor (toner density) removal” on page 216. b Check the sensor and its wiper bracket for damage.</p> <p>Are the sensor and its wiper bracket free of damage?</p>	Go to step 5.	Go to step 6.
<p>Step 5 a Clean, and then reinstall the sensor and its wiper bracket. Add lubrication to the wiper bracket if necessary. See “Sensor (toner density) removal” on page 216. b Check the pick roller cam for damage. Note: The rotation of the pick roller cam triggers the movement of the wiper bracket.</p> <p>Is the pick roller cam free of damage?</p>	Go to step 6.	Go to step 7.
<p>Step 6 Replace the sensor (toner density). See “Sensor (toner density) removal” on page 216.</p> <p>Does the problem remain?</p>	Go to step 7.	The problem is solved.
<p>Step 7 Replace the pick roller cam. See “Pick roller assembly removal” on page 219.</p> <p>Does the problem remain?</p>	Contact the next level of support.	The problem is solved.

Photoconductor measurement error service check

Action	Yes	No
<p>Step 1</p> <p>a Check the imaging unit contacts for contamination. b Check the imaging unit for leaks and damage.</p> <p>Are the imaging unit and its contacts free of contamination and damage?</p>	Go to step 3.	Go to step 2.
<p>Step 2</p> <p>Clean or replace the imaging unit.</p> <p>Does the problem remain?</p>	Go to step 3.	The problem is solved.
<p>Step 3</p> <p>a Check the imaging unit smart chip contacts for contamination. b Check if the contacts are bent or damaged.</p> <p>Are the contacts free of contamination and damage?</p>	Go to step 5.	Go to step 4.
<p>Step 4</p> <p>Clean or repair the smart chip contact.</p> <p>Does the problem remain?</p>	Go to step 5.	The problem is solved.
<p>Step 5</p> <p>a Remove the right cover. See “Right cover removal” on page 185. b Reseat the smart chip contact cable on the controller board.</p> <p>Does the problem remain?</p>	Go to step 6.	The problem is solved.
<p>Step 6</p> <p>Check whether the imaging unit installed is genuine.</p> <p>Is the imaging unit a genuine and supported Lexmark unit?</p>	Go to step 8.	Go to step 7.
<p>Step 7</p> <p>Install a genuine and supported Lexmark imaging unit.</p> <p>Does the problem remain?</p>	Go to step 8.	The problem is solved.
<p>Step 8</p> <p>a Check the imaging unit contacts for contamination. b Check the toner delivery mechanism for damage. c Check the photoconductor drum for scratches and damage.</p> <p>Are the imaging unit and its contacts free of contamination and damage?</p>	Contact the next level of support.	Go to step 9.

Action	Yes	No
Step 9 Clean or replace the imaging unit. Does the problem remain?	Contact the next level of support.	The problem is solved.

133 errors

133 error messages

Error code	Description	Action
133.04	CTLS timeout was detected at the imaging unit.	See “Imaging unit CTLS error service check” on page 121.
133.05	CTLS reading at the imaging unit is above the maximum expected value.	
133.06	CTLS reading at the imaging unit is below the minimum expected value.	
133.08	Excessive CTLS noise was detected at the imaging unit.	

Imaging unit CTLS error service check

Action	Yes	No
Step 1 a Check the imaging unit CTLS contacts for contamination. b Check if the contacts are bent or damaged. Are the contacts free of contamination and damage?	Go to step 3.	Go to step 2.
Step 2 Clean or repair the smart chip contact. Does the problem remain?	Go to step 3.	The problem is solved.
Step 3 a Remove the right cover. See “Right cover removal” on page 185. b Reseat the CTLS contact cable on the controller board. Does the problem remain?	Go to step 4.	The problem is solved.
Step 4 Check the imaging unit for problems. See “Unsupported or unresponsive imaging unit service check” on page 107. Does the problem remain?	Contact the next level of support.	The problem is solved.

140 errors

140 error messages

Error code	Description	Action
140.81	Motor (main) does not turn off.	See “Main drive failure service check” on page 122.
140.82	Motor (main) speed did not ramp up to the required level.	
140.83	Motor (main) stalled.	
140.84	Motor (main) ran too slow.	
140.85	Motor (main) ran too fast.	
140.86	Motor (main) did not run at the correct timing.	

Main drive failure service check

Action	Yes	No
<p>Step 1</p> <p>a Remove the left cover. See “Left cover removal” on page 173.</p> <p>b Remove the right cover. See “Right cover removal” on page 185.</p> <p>c Reseat the cable from the main drive gearbox and the controller board.</p> <p>Does the problem remain?</p>	Go to step 2.	The problem is solved.
<p>Step 2</p> <p>a Enter the Diagnostics menu, and then navigate to: Printer diagnostics and adjustments > Motor tests > Transport</p> <p>b Touch Start.</p> <p>Does the motor run?</p>	Contact the next level of support.	Go to step 3.
<p>Step 3</p> <p>Check the motor and its gears for misalignment, wear, and damage.</p> <p>Is the main drive gearbox properly installed and free of wear and damage?</p>	Contact the next level of support.	Go to step 4.
<p>Step 4</p> <p>Reinstall or replace the main drive gearbox. See “Main drive gearbox removal” on page 174.</p> <p>Does the problem remain?</p>	Contact the next level of support.	The problem is solved.

155 errors

155 error messages

Error code	Description	Action
155.80	Motor (cartridge) does not turn on.	See “Cartridge drive failure service check” on page 123.
155.81	Motor (cartridge) does not turn off.	
155.82	Motor (cartridge) speed did not ramp up to the required level.	
155.83	Motor (cartridge) has stalled.	
155.84	Motor (cartridge) ran too slow.	
155.85	Motor (cartridge) ran too fast.	
155.86	Motor (cartridge) did not run at the correct timing.	

Cartridge drive failure service check

Action	Yes	No
<p>Step 1</p> <p>a Open, and then close the front door to check if the door plunger properly presses the cartridge button.</p> <p>b Check the door and the plunger for damage.</p> <p>Is the plunger functional and free of damage?</p>	Go to step 3.	The problem is solved.
<p>Step 2</p> <p>Replace the MPF with front access cover.</p> <p>Does the problem remain?</p>	Go to step 3.	The problem is solved.
<p>Step 3</p> <p>a Check if the cartridge button is stuck.</p> <p>b Check the cartridge gear for contamination and damage.</p> <p>Is the cartridge functional, clean, and free of damage?</p>	Go to step 5.	Go to step 4.
<p>Step 4</p> <p>Clean or replace the cartridge.</p> <p>Does the problem remain?</p>	Go to step 5.	The problem is solved.

Action	Yes	No
<p>Step 5</p> <p>a Remove the left cover. See “Left cover removal” on page 173.</p> <p>b Remove the right cover. See “Right cover removal” on page 185.</p> <p>c Reseat the cable from the motor (cartridge) and the controller board.</p> <p>Does the problem remain?</p>	Go to step 6.	The problem is solved.
<p>Step 6</p> <p>a Enter the Diagnostics menu, and then navigate to: Printer diagnostics and adjustments > Motor tests > K toner add</p> <p>b Touch Start.</p> <p>Does the motor run?</p>	Contact the next level of support.	Go to step 7.
<p>Step 7</p> <p>Check the motor (cartridge) and its gears for misalignment, wear, and damage.</p> <p>Is the cartridge gearbox properly installed and free of wear and damage?</p>	Contact the next level of support.	Go to step 8.
<p>Step 8</p> <p>Reinstall or replace the cartridge gearbox. See “Cartridge gearbox removal” on page 180.</p> <p>Does the problem remain?</p>	Contact the next level of support.	The problem is solved.

16y errors

162-164 error messages

Error code	Description	Action
162.80	The motor (tray 2 pick) does not turn on.	See “Optional tray pick drive failure service check” on page 127.
162.81	The motor (tray 2 pick) does not turn off.	
162.82	The motor (tray 2 pick) speed did not ramp up to the required level.	
162.83	The motor (tray 2 pick) stalled.	
162.84	The motor (tray 2 pick) ran too slow.	
162.85	The motor (tray 2 pick) ran too fast.	
162.86	The motor (tray 2 pick) did not run at the correct timing.	
163.80	The motor (tray 3 pick) does not turn on.	
163.81	The motor (tray 3 pick) does not turn off.	
163.82	The motor (tray 3 pick) speed did not ramp up to the required level.	
163.83	The motor (tray 3 pick) stalled.	
163.84	The motor (tray 3 pick) ran too slow.	
163.85	The motor (tray 3 pick) ran too fast.	
163.86	The motor (tray 3 pick) did not run at the correct timing.	
164.80	The motor (tray 4 pick) does not turn on.	
164.81	The motor (tray 4 pick) does not turn off.	
164.82	The motor (tray 4 pick) speed did not ramp up to the required level.	
164.83	The motor (tray 4 pick) stalled.	
164.84	The motor (tray 4 pick) ran too slow.	
164.85	The motor (tray 4 pick) ran too fast.	
164.86	The motor (tray 4 pick) did not run at the correct timing.	

166-168 error messages

Error code	Description	Action
166.80	The motor (tray 2 transport) does not turn on.	See “Optional tray pass-through drive failure service check” on page 128.
166.81	The motor (tray 2 transport) does not turn off.	
166.82	The motor (tray 2 transport) speed did not ramp up to the required level.	
166.83	The motor (tray 2 transport) stalled.	
166.84	The motor (tray 2 transport) ran too slow.	
166.85	The motor (tray 2 transport) ran too fast.	
166.86	The motor (tray 2 transport) did not run at the correct timing.	
167.80	The motor (tray 3 transport) does not turn on.	
167.81	The motor (tray 3 transport) does not turn off.	
167.82	The motor (tray 3 transport) speed did not ramp up to the required level.	
167.83	The motor (tray 3 transport) stalled.	
167.84	The motor (tray 3 transport) ran too slow.	
167.85	The motor (tray 3 transport) ran too fast.	
167.86	The motor (tray 3 transport) did not run at the correct timing.	
168.80	The motor (tray 4 transport) does not turn on.	
168.81	The motor (tray 4 transport) does not turn off.	
168.82	The motor (tray 4 transport) speed did not ramp up to the required level.	
168.83	The motor (tray 4 transport) stalled.	
168.84	The motor (tray 4 transport) ran too slow.	
168.85	The motor (tray 4 transport) ran too fast.	
168.86	The motor (tray 4 transport) did not run at the correct timing.	

Optional tray pick drive failure service check

Action	Yes	No
<p>Step 1 Check if the optional tray motor (pick) runs.</p> <p>Does the motor run?</p>	Go to step 3.	Go to step 2.
<p>Step 2 Reseat the motor cable, and then reseat the cable on the optional tray controller board.</p> <p>Does the problem remain?</p>	Go to step 3.	The problem is solved.
<p>Step 3 a Remove the optional tray. b Under the printer, check the interconnect cable for damage.</p> <p>Is the cable free of damage?</p>	Go to step 5.	Go to step 4.
<p>Step 4 Replace the interconnect cable. See “Interconnect cable removal” on page 187.</p> <p>Does the problem remain?</p>	Go to step 5.	The problem is solved.
<p>Step 5 Reinstall or replace the optional tray. Note: Make sure that the interconnect cable properly fits with the socket on the optional tray.</p> <p>Does the problem remain?</p>	Go to step 6.	The problem is solved.
<p>Step 6 a Remove the tray insert from the affected optional tray. b Check if the lift plate moves properly. c Check the lift plate gears for damage.</p> <p>Is the tray insert functional and free of damage?</p>	Contact the next level of support.	Go to step 7.
<p>Step 7 Replace the tray insert.</p> <p>Does the problem remain?</p>	Contact the next level of support.	The problem is solved.

Optional tray pass-through drive failure service check

Action	Yes	No
<p>Step 1</p> <p>a Enter the Diagnostics menu, and then navigate to: Printer diagnostics and adjustments > Motor tests > Pass-through (tray [x])</p> <p>b Touch Start.</p> <p>Does the motor run?</p>	Go to step 3.	Go to step 2.
<p>Step 2</p> <p>Reseat the motor cable, and then reseat the cable on the optional tray controller board.</p> <p>Does the problem remain?</p>	Go to step 3.	The problem is solved.
<p>Step 3</p> <p>a Remove the optional tray.</p> <p>b Under the printer, check the interconnect cable for damage.</p> <p>Is the cable free of damage?</p>	Go to step 5.	Go to step 4.
<p>Step 4</p> <p>Replace the interconnect cable. See “Interconnect cable removal” on page 187.</p> <p>Does the problem remain?</p>	Go to step 5.	The problem is solved.
<p>Step 5</p> <p>Reinstall or replace the optional tray.</p> <p>Note: Make sure that the interconnect cable properly fits with the socket on the optional tray.</p> <p>Does the problem remain?</p>	Go to step 6.	The problem is solved.
<p>Step 6</p> <p>Remove the tray insert from the source tray, and then check it for damage.</p> <p>Is the tray insert from the source tray free of damage?</p>	Contact the next level of support.	Go to step 7.
<p>Step 7</p> <p>Replace the tray insert.</p> <p>Does the problem remain?</p>	Contact the next level of support.	The problem is solved.

171 errors

171 error messages

Error code	Description	Action
171.82	Cooling fan error.	See “Cooling fan failure service check” on page 129.
171.83	Cooling fan error.	
171.84	Cooling fan error.	
171.85	Cooling fan error.	

Cooling fan failure service check

Action	Yes	No
<p>Step 1</p> <p>a Enter the Diagnostics menu, and then navigate to: Printer diagnostics and adjustments > Motor tests > Fan (main)</p> <p>b Touch Start.</p> <p>Does the fan spin?</p>	Contact the next level of support.	Go to step 2.
<p>Step 2</p> <p>a Remove the right cover. See “Right cover removal” on page 185.</p> <p>b Reseat the fan cable from the controller board.</p> <p>Does the problem remain?</p>	Go to step 3.	The problem is solved.
<p>Step 3</p> <p>Replace the fan. See “Cooling fan removal” on page 189.</p> <p>Does the problem remain?</p>	Contact the next level of support.	The problem is solved.

6yy errors

600-611 error messages

Error code	Description	Action
600.01	Toner tally from the RIP was not received.	See “Engine error service check” on page 130.
600.02	Video did not start.	
600.04	Duplex page was not picked.	
600.05	Invalid PH NVRAM Type error was detected.	
600.06	Paperport driver is unresponsive.	
600.07	Page is at image point before EP is ready.	
600.09	EP update error was detected.	
600.10	EP late run-in error was detected.	
600.95	RIP intentionally declared a jam error, usually to prevent a kiosk user from printing free pages.	
602.19	Tray 1 was unable to be ready for picking.	
602.29	Tray 2 was unable to be ready for picking.	
602.39	Tray 3 was unable to be ready for picking.	
602.49	Tray 4 was unable to be ready for picking.	
611.02	An Input ISR error occurred and the printhead was not ready.	
611.32	Lost Hsync errors were detected. Laser safety interlock system may be the cause.	
611.34	A mirror motor lock error was detected.	

Engine error service check

Action	Yes	No
<p>Step 1</p> <p>Restart the printer.</p> <p>Does the problem remain?</p>	Go to step 2.	The problem is solved.
<p>Step 2</p> <p>a Remove the right cover. See “Right cover removal” on page 185.</p> <p>b Reseat all the cables on the controller board.</p> <p>c Check the controller board contacts and pins for damage.</p> <p>Is the controller board free of damage?</p>	Contact the next level of support.	Go to step 3.

Action	Yes	No
<p>Step 3 Replace the controller board. See “Controller board removal” on page 191.</p> <p>Does the problem remain?</p>	Contact the next level of support.	The problem is solved.

Printhead communication error service check

Action	Yes	No
<p>Step 1 Restart the printer.</p> <p>Does the problem remain?</p>	Go to step 2.	The problem is solved.
<p>Step 2</p> <p>a Remove the top cover. See “Top cover removal” on page 228.</p> <p>b Remove the right cover. See “Right cover removal” on page 185.</p> <p>c Reseat the printhead cable from the printhead and the controller board.</p> <p>Does the problem remain?</p>	Go to step 3.	The problem is solved.
<p>Step 3 Update the firmware to the latest version.</p> <p>Does the problem remain?</p>	Go to step 4.	The problem is solved.
<p>Step 4 Check the printhead and its cables for damage and improper installation.</p> <p>Is the printhead free of damage and properly installed?</p>	Contact the next level of support.	Go to step 5.
<p>Step 5 Reinstall or replace the printhead. See “Printhead removal” on page 229.</p> <p>Installation note: Perform all the mechanical and electronic adjustments to the printhead after replacing it. See “Printhead assembly adjustment” on page 171.</p> <p>Does the problem remain?</p>	Contact the next level of support.	The problem is solved.

Procedure before starting the 9yy service checks

Retrieve certain information that helps your next level of support in diagnosing the problem before replacing the controller board.

Warning—Potential Damage: Do not replace the controller board unless instructed by your next level of support.

- 1 Collect the history information and firmware logs (Fwdebug and logs.tar.gz) from the SE menu.
- 2 Collect the settings from the Menu Settings Page.
- 3 Collect information from the user.

Note: Not all of the items are retrievable from the printer that you are working on.

A. Collecting the history information from the SE menu

Note: Make sure that your printer is connected to a network or to a print server.

- 1 Open a web browser, type **http://printer_IP_address/se**, and then press **Enter**.

Notes:

- **printer_IP_address** is the TCP/IP address of the printer.
- **se** is required to access the printer diagnostic information.

- 2 Click **History Information**, copy all information, and then save it as a text file.
- 3 E-mail the text file to your next level of support.

B. Collecting the firmware logs (Fwdebug and logs.tar.gz) from the SE menu

Notes:

- Make sure that your printer is connected to a network or to a print server.
- Some printers are designed to restart automatically after a 9yy error. On these printers, you can retrieve the secondary crash code information using the SE menu.

- 1 Open a web browser, type **http://printer_IP_address/se**, and then press **Enter**.
- 2 Click **Logs Gzip Compressed**.

Note: A logs.tar.gz file is saved to the Downloads folder. The file may take several minutes to save. You may rename the file if a logs.tar.gz already exists in the Downloads folder.

- 3 E-mail the logs to your next level of support.

Note: To download the FWdebug log to a flash drive, see [“General SE” on page 152](#).

C. Collecting the settings from the Menu Settings Page

Note: The Menu Settings Page is different for each printer. For more information, see the *User's Guide*. Your next level of support will tell you which page they want to see.

Copying the Menu Settings Page from the Embedded Web Server (EWS)

Note: Make sure that your printer is connected to a network or to a print server.

- 1 Open a web browser, type **http://printer_IP_address**, and then press **Enter**.
- 2 Click Settings, and then select one of the settings pages from the links shown on the page.

- 3 Copy all the information, and then save it as a text file.
- 4 E-mail the text file to your next level of support.

Printing the Menu Settings Page

- 1 From the home screen, navigate to:
Reports > Menu Settings Page
- 2 Print the Menu Settings Page, and then use Scan to E-mail to send it to your next level of support.

D. Collecting information from the user

Ask the user for information about the following:

- Print job being run
- Operating system being used
- Print driver being used
- Other information on what was happening when the 9yy error occurred

900 errors

900 error messages

Error code	Description	Action
900.xx	RIP firmware errors	Go to “System software error service check” on page 133.

System software error service check

There are different types of 900.xx errors that can occur. There may be a communication problem (bad cable, network connection, and so on) software issue, or a hardware problem with the controller board, or ISP (internal solutions port). The communication and software aspects should be checked first. Determine if the problem is constant or intermittent. Use the troubleshooting procedure below to isolate the issue. Take any notes as instructed. You will need that information in the event you need to contact your next level of support.

Before troubleshooting:

- 1 Perform the [“Procedure before starting the 9yy service checks” on page 131.](#)
- 2 Determine the operating system used when the error occurred. If possible determine whether a PostScript or PCL file was sent to the device when the error occurred. Ask the customer which Lexmark Solutions applications are installed on the device.

Action	Yes	No
<p>Step 1 POR the printer.</p> <p>Does the error remain?</p>	Go to step 2.	The problem is solved.
<p>Step 2</p> <p>a Write down the exact 900.xx error code displayed on the device.</p> <p>b Turn off the printer.</p> <p>c Clear the print queues.</p> <p>d Disconnect all communication cables, and remove all memory options.</p> <p>e Remove any installed ISP.</p> <p>f POR the printer into the Diagnostics menu.</p> <p>Does the error remain during startup?</p>	Go to step 3.	Go to step 6.
<p>Step 3</p> <p>Check all the cables connected to the controller board for proper connectivity.</p> <p>Are the cables properly connected?</p>	Go to step 5.	Go to step 4.
<p>Step 4</p> <p>a Properly connect the cables to the controller board.</p> <p>b POR the printer into the Diagnostics menu.</p> <p>Does the error remain during startup?</p>	Go to step 5.	Go to step 6.
<p>Step 5</p> <p>a Replace the controller board.</p> <p>b POR the printer.</p> <p>Does the error remain during startup?</p> <p>Note: If an error different from the original 900.xx is displayed, consult the service check for that error.</p>	Go to step 31.	The problem is solved.
<p>Step 6</p> <p>Print the following:</p> <ul style="list-style-type: none"> • Error log • Menu settings page • Network settings page <p>Does the error remain while these pages were printing?</p>	Go to step 31.	Go to step 7.

Action	Yes	No
<p>Step 7</p> <p>Note: Before performing this step, write down the following information about the file being sent to the printer:</p> <ul style="list-style-type: none"> • Application used • Operating system • Driver type • File type (PCL, PostScript, XPS, etc.) <p>a Reattach the communications cable.</p> <p>b POR the printer.</p> <p>c Send the printer a print job.</p> <p>Does the error remain?</p>	Go to step 8.	Go to step 10.
<p>Step 8</p> <p>a POR the printer.</p> <p>b Send a different print job to the printer.</p> <p>Does the error remain?</p>	Go to step 9.	Go to step 10.
<p>Step 9</p> <p>a Upgrade the firmware.</p> <p>Note: Contact your next level of support for the correct firmware level to use.</p> <p>b POR the printer.</p> <p>c Send the printer a print job.</p> <p>Does the error remain?</p>	Go to step 31.	Go to step 10.
<p>Step 10</p> <p>Is the device an MFP?</p>	Go to step 11.	Go to step 13.
<p>Step 11</p> <p>Run a copy job.</p> <p>Does the error remain?</p>	Go to step 31.	Go to step 12.
<p>Step 12</p> <p>Run a scan to PC job.</p> <p>Does the error remain?</p>	Go to step 31.	Go to step 13.
<p>Step 13</p> <p>Is there optional memory installed?</p>	Go to step 14.	Go to step 16.
<p>Step 14</p> <p>a Reinstall the memory.</p> <p>b Send a print job to the printer.</p> <p>Does the error remain?</p>	Go to step 15.	Go to step 16.

Action	Yes	No
<p>Step 15</p> <p>a Install a Lexmark recommended memory option.</p> <p>b Send a print job to the printer.</p> <p>Does the error remain?</p>	Go to step 31.	The problem is solved.
<p>Step 16</p> <p>Is there a modem installed?</p>	Go to step 17.	Go to step 21.
<p>Step 17</p> <p>a Reinstall the modem.</p> <p>b POR the printer.</p> <p>Does the error remain?</p>	Go to step 18.	Go to step 20.
<p>Step 18</p> <p>a Upgrade the firmware if it was not upgraded in a previous step.</p> <p>Note: Contact your next level of support for the correct firmware level to use.</p> <p>b POR the printer.</p> <p>c Send the printer a print job.</p> <p>Does the error remain?</p>	Go to step 19.	The problem is solved.
<p>Step 19</p> <p>a Replace the modem.</p> <p>b POR the printer.</p> <p>Does the error remain?</p>	Go to step 31.	The problem is solved.
<p>Step 20</p> <p>Run a fax job.</p> <p>Does the error remain?</p>	Go to step 31.	Go to step 21.
<p>Step 21</p> <p>Is there an ISP option installed?</p>	Go to step 22.	The problem is solved.
<p>Step 22</p> <p>a Reinstall the first ISP option.</p> <p>b POR the printer.</p> <p>Does the error remain?</p>	Go to step 24.	Go to step 23.
<p>Step 23</p> <p>Run a job to test the option.</p> <p>Does the error remain?</p>	Go to step 24.	Go to step 26.

Action	Yes	No
<p>Step 24</p> <p>a Upgrade the firmware if it was not upgraded in a previous step. Note: Contact your next level of support for the correct firmware level to use.</p> <p>b POR the printer.</p> <p>c Send the printer a print job.</p> <p>Does the error remain?</p>	Go to step 25.	The problem is solved.
<p>Step 25</p> <p>a Replace the faulty ISP option.</p> <p>b POR the printer.</p> <p>Does the error remain?</p>	Go to step 31.	Go to step 26.
<p>Step 26</p> <p>Are there any more ISP options to install?</p>	Go to step 27.	The problem is solved.
<p>Step 27</p> <p>a Install the next ISP option.</p> <p>b POR the printer.</p> <p>Does the error remain?</p>	Go to step 29.	Go to step 28.
<p>Step 28</p> <p>Run a job to test the option.</p> <p>Does the error remain?</p>	Go to step 29.	Go to step 26.
<p>Step 29</p> <p>a Upgrade the firmware if it was not upgraded in a previous step. Note: Contact your next level of support for the correct firmware level to use.</p> <p>b POR the printer.</p> <p>c Send the printer a print job.</p> <p>Does the error remain?</p>	Go to step 30.	Go to step 26.
<p>Step 30</p> <p>a Replace the faulty ISP option.</p> <p>b POR the printer.</p> <p>Does the error remain?</p>	Go to step 31.	Go to step 26.

Action	Yes	No
<p>Step 31</p> <p>Contact your next level of support. You will need the following information:</p> <ul style="list-style-type: none">• Exact 900.xx error digits and complete error message• Printed menu settings page• Printed network settings page• Device error log• A sample print file if the error appears to be isolated to a single file• File/Application used if the error is related to specific print file• Device operating system• Driver used (PCL/PS)• Frequency of the occurrence of the error		

Service menus

Understanding the printer control panel

Using the printer control panel

MS521, B2546, and M1246

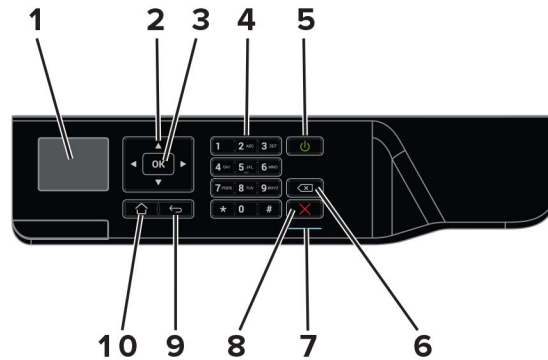

	Use the	To
1	Display	View printing options, printer status, and error messages.
2	Arrow buttons	Scroll through menus or move between screens and menu options.
3	Select button	<ul style="list-style-type: none"> Select menu options. Save the setting.
4	Numeric keypad	Enter numbers or symbols in an input field.
5	Power button	Turn on or turn off the printer. Note: To turn off the printer, press and hold the power button for five seconds.
6	Backspace button	Move the cursor backward and delete a character in an input field.
7	Indicator light	Check the printer status.
8	Stop or Cancel button	Stop the current printer task.
9	Back button	Return to the previous screen.
10	Home button	Go to the home screen.

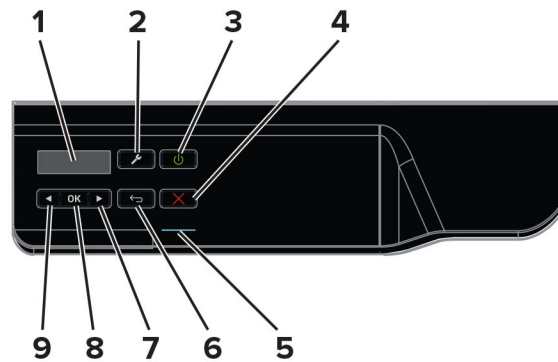
MS321, MS421, B2338, B2442, and M1242

	Use the	To
1	Display	View printing options, printer status, and error messages.
2	Menus button	Open the menus.
3	Power button	Turn on or turn off the printer. Note: To turn off the printer, press and hold the power button for five seconds.
4	Stop or Cancel button	Stop the current printer task.
5	Indicator light	Check the printer status.
6	Back button	Return to the previous screen.
7	Right arrow button	<ul style="list-style-type: none"> • Scroll through menus or move between screens and menu options. • Increase the numeric value of a setting being displayed.
8	Select button	<ul style="list-style-type: none"> • Select menu options. • Display available values or settings for a menu. An asterisk (*) indicates the current default setting. • Save settings.
9	Left arrow button	<ul style="list-style-type: none"> • Scroll through menus or move between screens and menu options. • Decrease the numeric value of a setting being displayed.

Understanding the status of the power button and indicator light

Indicator light	Printer status
Off	The printer is off or in Hibernate mode.
Blue	The printer is ready or processing data.
Red	The printer requires user intervention.

Power button light	Printer status
Off	The printer is off, ready, or processing data.
Solid amber	The printer is in sleep mode.
Blinking amber	The printer is in hibernate mode.

Diagnostics menu

Entering the Diagnostics menu

The Diagnostics menu contains tests that are used to help isolate issues with the printer. To access some of these tests, avoid POST tests that run at POR. Some POST tests can generate errors that prevent a diagnostic test from running.

To access the Diagnostics menu from the home screen:

- For 2-line control panel printers, press the left arrow button twice, press , and then press the right arrow button.
- For 2.4- and 4.3-inch control panel printers, press **** 3 6**.

Reports

Device Settings

This report lists all the current printer settings.

Enter the Diagnostics menu, and then navigate to:

Reports > Device > Device Settings

For non-touch-screen printer models, press  to navigate through the settings.

Installed Licenses

This setting lists all the installed licenses and their feature data.

Enter the Diagnostics menu, and then navigate to:

Reports > Licenses > Installed Licenses

For non-touch-screen printer models, press  to navigate through the settings.

Advanced Print Quality Samples

This setting prints a list of the printer settings and sample pages to check print quality.

Enter the Diagnostics menu, and then navigate to:

Advanced Print Quality Samples

For non-touch-screen printer models, press  to navigate through the settings.

Event Log

Display Log

This setting displays the panel text that appears when the event occurs.

Enter the Diagnostics menu, and then navigate to:

Event Log > Display Log

For non-touch-screen printer models, press  to navigate through the settings.

Print Log

This setting lists an extended version of the various printer events.

1 Enter the Diagnostics menu, and then navigate to:

Event Log > Print Log

For non-touch-screen printer models, press  to navigate through the settings.

2 Press  or touch **Start**.

Note: The events that appear in the report vary depending on the operational history of the printer.

Print Log Summary

This setting lists a brief summary of the various printer events.

1 Enter the Diagnostics menu, and then navigate to:

Event Log > Print Log Summary

For non-touch-screen printer models, press  to navigate through the settings.

2 Touch **Start**.

Note: The events that appear in the report vary depending on the operational history of the printer.

Mark Log

This setting allows you to create a service, maintenance, or custom log entry. Each log entry is added in the printer event log.

1 Enter the Diagnostics menu, and then navigate to:

Event Log > Mark Log

For non-touch-screen printer models, press  to navigate through the settings.

2 Select a log that you want to create, and then touch **Start**.

Input tray quick print

This setting lets you print a single or continuous Quick Test page in either duplex or simplex mode.

For non-touch-screen printer models, press  to navigate through the settings.

- 1 Enter the Diagnostics menu, and then touch **Input tray quick print**.
- 2 Select where you want to print the pages from.
- 3 Select whether to print a single or continuous test page, and then touch **Start**.

Output bin quick feed

This setting allows you to send a single or continuous test page to a bin.

For non-touch-screen printer models, press  to navigate through the settings.

- 1 Enter the Diagnostics menu, and then touch **Output bin quick feed**.
- 2 Select where you want to send the test page.
- 3 Select whether to send a single or continuous test page, and then touch **Start**.

Printer Setup

Printed page count (mono)

This setting displays the amount of pages printed in mono.

For non-touch-screen printer models, press  to navigate through the settings.

- 1 Enter the Diagnostics menu, and then touch **Printer Setup**.
- 2 View the printed page count for mono.

Printed page count (color)

This setting displays the amount of pages printed in color.

For non-touch-screen printer models, press  to navigate through the settings.

- 1 Enter the Diagnostics menu, and then touch **Printer Setup**.
- 2 View the printed page count for color.

Permanent page count

This setting displays the total number of pages printed in mono and color. After all the print tests are completed, this value resets to zero.

For non-touch-screen printer models, press  to navigate through the settings.

- 1 Enter the Diagnostics menu, and then touch **Printer Setup**.
- 2 View the permanent page count.

Enable edge-to-edge (printing)

This setting shifts all four margins to the physical edges of the page.

- 1 Enter the Diagnostics menu, and then navigate to:
Printer Setup > Enable edge-to-edge (printing)

For non-touch-screen printer models, press  to navigate through the settings.

- 2 Select a setting to adjust.

Note: This feature does not work in PPDS emulation.

Enable edge-to-edge (copy)

This setting determines whether the printer accepts the ADF or flatbed edge erase value when performing an ADF or flatbed copy.

- 1 Enter the Diagnostics menu, and then navigate to:
Printer Setup > Enable edge-to-edge (copy)

For non-touch-screen printer models, press  to navigate through the settings.

- 2 Select a setting to adjust.

Processor ID

This setting indicates the ID of the processor on the controller board.

For non-touch-screen printer models, press  to navigate through the settings.

- 1 Enter the Diagnostics menu, and then touch **Printer Setup**.
- 2 View the processor ID.

Serial number

This setting displays a read-only value of the serial number.

For non-touch-screen printer models, press  to navigate through the settings.

- 1 Enter the Diagnostics menu, and then touch **Printer Setup**.
- 2 View the serial number.

Model name

This setting displays the model name of the printer.

For non-touch-screen printer models, press  to navigate through the settings.

- 1 Enter the Diagnostics menu, and then touch **Printer Setup**.
- 2 View the model name.

Engine setting [x]

Warning—Potential Damage: Do not change this setting without specific instructions from the next level of support.

This setting allows you to select a printer engine setting. Possible values are 0–255. 0 is the default.

For non-touch-screen printer models, press  to navigate through the settings.

- 1 Enter the Diagnostics menu, and then navigate to:
Printer Setup > Engine setting [x]
- 2 Select a setting, enter a value, and then touch **OK**.

EP setup

Warning—Potential Damage: Do not change this setting without specific instructions from the next level of support.

This setting allows you to adjust the EP setup of the printer.

For non-touch-screen printer models, press  to navigate through the settings.

- 1 Enter the Diagnostics menu, and then navigate to:
Printer Setup > EP setup
- 2 Select a setting.

Printer diagnostics and adjustments

Sensor tests

For non-touch-screen printer models, press  to navigate through the settings.

- 1 Enter the Diagnostics menu, and then touch **Printer diagnostics & adjustments**.
- 2 From the Sensor tests section, touch **Start**.
A dialog listing the sensor tests appears.
- 3 Find, and then manually toggle the sensor.

Notes:

- The sensor status on the screen toggles between **1** and **0** when the sensor is properly working.

- If a sensor test fails, the test failure may not indicate a failed sensor. Further troubleshooting may be required. Check the boards and cables for possible issues.
- For the fuser exit sensor actuator, toggle it toward the rear door.

List of sensor tests

Test
MPF media present
Pick roller index (tray 1)
Media out (tray 1)
Input
Narrow media
Fuser exit
Duplex path 1
Output bin full
Door interlock
Trailing edge

Motor tests

For non-touch-screen printer models, press  to navigate through the settings.

1 Enter the Diagnostics menu, and then navigate to:

Printer diagnostics & adjustments > Motor tests

2 Select a motor, and then touch **Start**.

Notes:

- If the motor is activated, then it is properly working.
- Some motors require automatic deactivation to avoid secondary issues such as possible damage and contamination.
- Some tests require a special action to activate a motor such as removing a major component.
- If the motor fails, the test failure may not indicate a failed motor. Further troubleshooting may be required. Check the boards and cables for possible issues.
- To stop a running motor in non-touch-screen printer models, press .

List of motor tests

Test
MPF pick
Pick (tray 1) picking
Pick (tray 1) lifting
Duplex solenoid

Test
Redrive solenoid
K toner add
Transport
Fan (main)

Memory tests

For non-touch-screen printer models, press  to navigate through the settings.

- 1 Enter the Diagnostics menu, and then navigate to:
Printer diagnostics & adjustments > Memory tests
- 2 Select a test, and then press  or touch **Start**.

Registration adjust

This setting lets you adjust the skew, margins, or perform a Quick Test.

For non-touch-screen printer models, press  to navigate through the settings.

- 1 Enter the Diagnostics menu, and then navigate to:
Printer diagnostics & adjustments > Registration adjust
- 2 Select a setting to adjust.

Add-on cards tests

This setting allows you to test the add-on cards installed on the printer.

For non-touch-screen printer models, press  to navigate through the settings.

- 1 Enter the Diagnostics menu, and then navigate to:
Printer diagnostics & adjustments > Add-on cards tests
- 2 Select a card.

Margin Offset

This setting allows you to adjust the margin offset and to print or reset the default settings.

For non-touch-screen printer models, press  to navigate through the settings.

- 1 Enter the Diagnostics menu, and then navigate to:
Printer diagnostics & adjustments > Margin Offset
- 2 Select a setting.

Universal Override

This setting allows the user to feed custom media sizes to a Custom Media Tray.

For non-touch-screen printer models, press  to navigate through the settings.

- 1 Enter the Diagnostics menu, and then navigate to:
Printer diagnostics & adjustments > Universal Override
- 2 Select a setting to adjust.

Additional input tray diagnostics

Sensor tests

For non-touch-screen printer models, press  to navigate through the settings.

- 1 Enter the Diagnostics menu, and then touch **Additional input tray diagnostics**.
- 2 From the Sensor tests section, touch **Start**.
A dialog listing the sensor tests appears.
- 3 Find, and then manually toggle the sensor.

Notes:

- The sensor status on the screen toggles between **1** and **0** when the sensor is properly working.
- If a sensor test fails, the test failure may not indicate a failed sensor. Further troubleshooting may be required. Check the boards and cables for possible issues.

List of sensor tests

Test	Procedure to perform before the test
Pick roller index (tray [x])	Remove tray [x].
Media low (tray [x])	
Pass-through (tray [x])	
Media size (tray [x]) switch [x]	

Motor tests

For non-touch-screen printer models, press  to navigate through the settings.

- 1 Enter the Diagnostics menu, and then navigate to:
Additional input tray diagnostics > Motor tests
- 2 Select a motor, and then press  or touch **Start**.

Notes:

- If the motor is activated, then it is properly working.

- Some motors require automatic deactivation in order to avoid secondary issues such as possible damage and contamination.
- Some tests require a special action to activate a motor such as removing a major component.
- If the motor fails, the test failure may not indicate a failed motor. Further troubleshooting may be required. Check the boards and cables for possible issues.

Config Menu

Menu item	Description
USB Configuration USB PnP 1* 2	Change the USB driver mode of the printer to improve its compatibility with a personal computer.
USB Configuration USB Speed Full Auto*	Set the USB port to run at full speed and disable its high-speed capabilities.
Tray Configuration Tray Linking Automatic* Off	Set the printer to link the trays that have the same paper type and paper size settings.
Tray Configuration Show Tray Insert Message Off Only for unknown sizes* Always	Show the Tray Insert message.
Tray Configuration A5 Loading Short Edge* Long Edge	Specify the page orientation when loading A5-size paper.
Tray Configuration Paper Prompts Auto* Multipurpose Feeder Manual Paper Envelope Prompts Auto* Multipurpose Feeder Manual Envelope	Set the paper source that the user fills when a prompt to load paper or envelope appears. Note: For Multipurpose Feeder to appear, set Configure MP to Cassette from the Paper menu.
Note: An asterisk (*) next to a value indicates the factory default setting.	

Menu item	Description
Tray Configuration Action for Prompts Prompt user* Continue Use current	Set the printer to resolve paper- or envelope-related change prompts.
Reports Menu Settings Page Event Log Event Log Summary HealthCheck Statistics	Print reports about printer menu settings, printer events, and event logs.
Supply Usage And Counters Clear Supply Usage History Reset Maintenance Counter	Reset the supply page counter or view the total printed pages.
Printer Emulations PPDS Emulation Off* On	Set the printer to recognize and use the PPDS data stream.
Print Configuration Font Sharpening 0–150 (24*)	Set a text point-size value below which the high-frequency screens are used when printing font data. For example, if the value is 24, then all fonts sized 24 points or less use the high-frequency screens.
Print Configuration Print Density 1–5 (3*)	Adjust the toner density when printing or copying documents.
Device Operations Quiet Mode Off* On	Set the amount of noise that the printer produces. Note: Enabling this setting slows the printer performance.
Device Operations Panel Menus Off On*	Enable access to the control panel menus.
Device Operations Safe Mode Off* On	Set the printer to operate in a special mode, in which it attempts to continue offering as much functionality as possible, despite known issues. For example, when set to On, and the duplex motor is nonfunctional, the printer performs one-sided printing of the documents even if the job is two-sided printing.
Device Operations Clear Custom Status Off On*	Erase user-defined strings for the Default or Alternate custom messages.
Note: An asterisk (*) next to a value indicates the factory default setting.	

Menu item	Description
Device Operations Clear all remotely-installed messages	Erase messages that were remotely installed.
Device Operations Automatically Display Error Screens On* Off	Show existing error messages on the display after the printer remains inactive on the home screen for a length of time equal to the Screen Timeout setting.
Device Operations Custom Supply Levels Off* On	Let <i>printservice</i> read and edit values from the Embedded Web Server.
Note: An asterisk (*) next to a value indicates the factory default setting.	

Service Engineer menu

Entering Invalid engine mode

This mode allows the printer to load the correct firmware code.

- 1 Turn off the printer.
- 2 Press and hold **3**, **4**, and **6** while turning on the printer.
- 3 Release the buttons after 10 seconds.

For 2-line display printer models, do the following:

- 1 Turn off the printer.
- 2 Press and hold ◀ and .
- 3 Turn on the printer.
- 4 Release the buttons when a line of dots appears.

Entering the Service Engineer (SE) menu

To access the Service Engineer (SE) menu:

- 1 Turn on the printer.
- 2 When the home screen appears, press * * **411** on the control panel.

For 2-line display printer models, do the following:

- 1 Turn on the printer.
- 2 Press ▶▶  ◀.

General SE

This setting allows you to save a log file to a USB drive.

Enter the Service Engineer (SE) menu, and then navigate to:

General SE > Capture Logs to USB Drive

For non-touch-screen printer models, press  to navigate through the settings.

Network SE

Enter the Service Engineer (SE) menu, and then touch **Network SE**.





For non-touch-screen printer models, press  to navigate through the settings.

Note: Use these settings as directed by the next level of support.

Top level menu	Intermediate menu
Print SE Menus	Print SE Menus
History	<ul style="list-style-type: none"> • Print History • Mark History
MAC	<ul style="list-style-type: none"> • Set Card Speed • LAA • Keep Alive
NPAP	Print Alerts
TCP/IP	<ul style="list-style-type: none"> • netstat • arp • Allow SNMP Set • MTU • Meditech Mode • RAW LPR Mode
Wireless	Enable Wi-Fi Direct Sigma Control Agent
Ping Test	<ul style="list-style-type: none"> • Ping • Ping6
Other Actions	<ul style="list-style-type: none"> • ifconfig • IPtables [Firewall Dump] • IP6tables [Firewall Dump] • IPsec Dump

Parts removal

Removal precautions

-  **CAUTION—SHOCK HAZARD:** This product uses a soft power switch. It does not physically disconnect the input AC voltage. To avoid the risk of electrical shock, always remove the power cord from the printer when removal of the input AC voltage is required.
-  **CAUTION—SHOCK HAZARD:** To avoid the risk of electrical shock and to prevent damage to the printer, remove the power cord from the electrical outlet and disconnect all connections to any external devices before you connect or disconnect any cable, electronic board, or assembly.
-  **CAUTION—HOT SURFACE:** The inside of the printer might be hot. To reduce the risk of injury from a hot component, allow the surface to cool before touching it.
-  **CAUTION—PINCH HAZARD:** To avoid the risk of a pinch injury, use caution in areas marked with this label. Pinch injuries may occur around moving parts, such as gears, doors, trays, and covers.

Data security notice

Identifying printer memory

- **Volatile memory**—The printer uses standard random access memory (RAM) to buffer user data temporarily during simple print and copy jobs.
- **Nonvolatile memory**—The printer may use two forms of nonvolatile memory: EEPROM and NAND (flash memory). Both types are used to store the operating system, printer settings, network information, scanner and bookmark settings, and embedded solutions.
- **Hard disk memory**—Some printers have a hard disk drive installed. The hard disk is designed for printer-specific functionality and cannot be used for long-term storage of data that is not print-related. The hard disk does not let users extract information, create folders, create disk or network file shares, or transfer FTP information directly from a client device. The hard disk can retain buffered user data from complex print jobs, form data, and font data.

The following parts can store memory:

- Printer control panel
- User interface controller card (UICC)
- Controller board
- Optional hard disks

Note: The printer control panel and controller board contain NVRAM.

Erasing printer memory

To erase volatile memory, turn off the printer.

To erase nonvolatile memory, do the following:

- 1 From the home screen, navigate to **Settings > Device > Maintenance > Out of Service Erase > Sanitize all information on nonvolatile memory**.
- 2 Select **Sanitize all information on nonvolatile memory**, and then select **ERASE**.

3 Follow the instructions on the screen.

To erase hard disk memory, do the following:

- 1** From the home screen, navigate to **Settings > Device > Maintenance > Out of Service Erase > Sanitize all information on hard disk**.
- 2** Select **Sanitize all information on hard disk**, and then select **ERASE**.
- 3** Follow the instructions on the screen.

Note: This process can take from several minutes to more than an hour, making the printer unavailable for other tasks.

If a hard disk is replaced, then do the following:

- 1** Remove the hard disk, and then return it to the customer.
- 2** Request the customer to sign the *Customer Retention* form.

Note: You can get printed copies of the form from your Lexmark partner manager.
- 3** Take a photo of the signed form, and then upload it to the Service Request debrief tool.
- 4** Fax or e-mail the signed form to the number or e-mail address shown at the bottom of the form.

Handling ESD-sensitive parts

Many electronic products use parts that are known to be sensitive to electrostatic discharge (ESD). To prevent damage to ESD-sensitive parts, do the following:

- Turn off the printer before removing logic boards.
- Keep the parts in their original packing material until you are ready to install them into the printer.
- Make the least-possible movements with your body to prevent an increase of static electricity from clothing fibers, carpets, and furniture.
- Put the ESD wrist strap on your wrist. Connect the wrist band to the system ground point. This action discharges any static electricity in your body to the printer.
- Hold the parts by their edge connector shroud. Do not touch its pins. If you are removing a pluggable module, then use the correct tool.
- If possible, keep all parts in a grounded metal cabinet.
- Do not place the parts on the printer cover or on a metal table. If you need to put down the parts, then put them into their packing material.
- Prevent parts from being accidentally touched by other personnel. Cover the printer when you are not working on it.
- Be careful while working with the parts when cold-weather heating is used. Low humidity increases static electricity.

Controller board/control panel replacement

Note: Perform this procedure only if both the controller board and the control panel fail.



CAUTION—POTENTIAL INJURY: The lithium battery in this product is not intended to be replaced. There is a danger of explosion if a lithium battery is incorrectly replaced. Do not recharge, disassemble, or incinerate a lithium battery. Discard used lithium batteries according to the manufacturer's instructions and local regulations.

Warning—Potential Damage: When replacing both the controller board and control panel, replace the parts in the following order to avoid damaging the printer.

- 1 Replace the controller board first, and then start the printer into diagnostics mode.
 - Note:** Do not replace the control panel and controller board at the same time.
- 2 Turn off the printer, replace the control panel, and then start the printer into Diagnostics mode. Allow the printer to go through a complete start-up cycle.
- 3 If the problem persists, then leave the new control panel and reinstall the old controller board.
- 4 Restart the printer and allow it to go through a complete start-up cycle.
- 5 After the start-up, turn off the printer, and then install the new controller board.
- 6 Restart the printer and allow it to go through a complete start-up cycle.

If the procedure is successful, then there is no need to adjust any settings.

If the procedure fails, then contact technical support for assistance.

Restoring the printer configuration after replacing the controller board

Restore the printer to its correct configuration to complete the replacement service. Use the Service Restore Tool to download the software bundle, and then flash the printer settings and embedded solutions.

Note: The software bundle contains the latest version of the firmware, applications, and software licenses from the Lexmark Virtual Solutions Center (VSC). The printer firmware may be at a different level from what was used before replacing the controller board.

Using the Service Restore Tool

- 1 Go to <https://cdp.lexmark.com/service-restore-tool/> to access the tool.
- 2 Log in using your Lexmark or partner login.
 - If your login fails, then contact your next level of support.

- 3 Enter the printer serial number, and then submit the information.

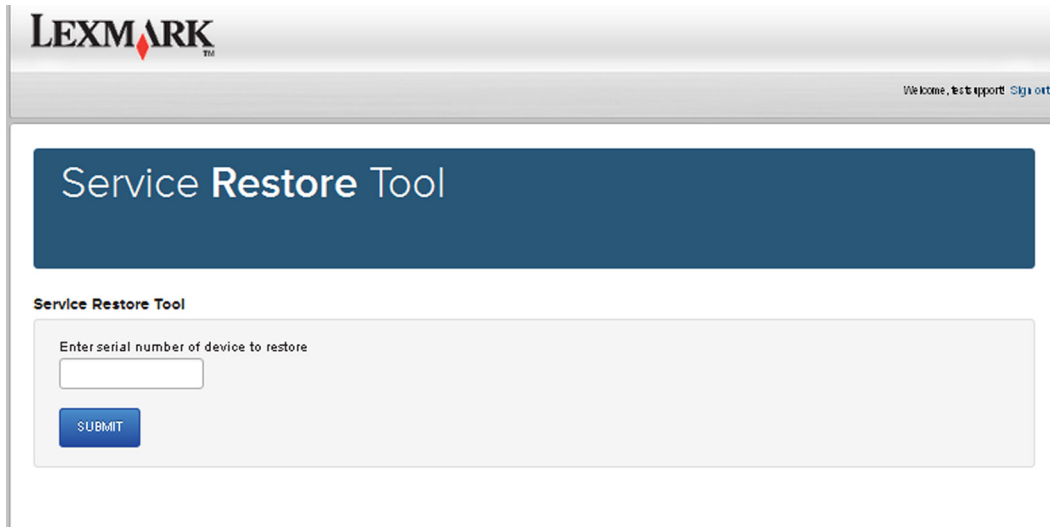

The screenshot shows the Lexmark Service Restore Tool interface. At the top left is the Lexmark logo. At the top right, there is a navigation bar with the text "Welcome, [test support](#) [Sign out](#)". Below this is a large blue header with the text "Service Restore Tool". Underneath the header, the text "Service Restore Tool" is repeated. A form area contains the instruction "Enter serial number of device to restore" above a text input field. Below the input field is a blue "SUBMIT" button.

Note: Make sure that the serial number that appears on the verification screen is correct.

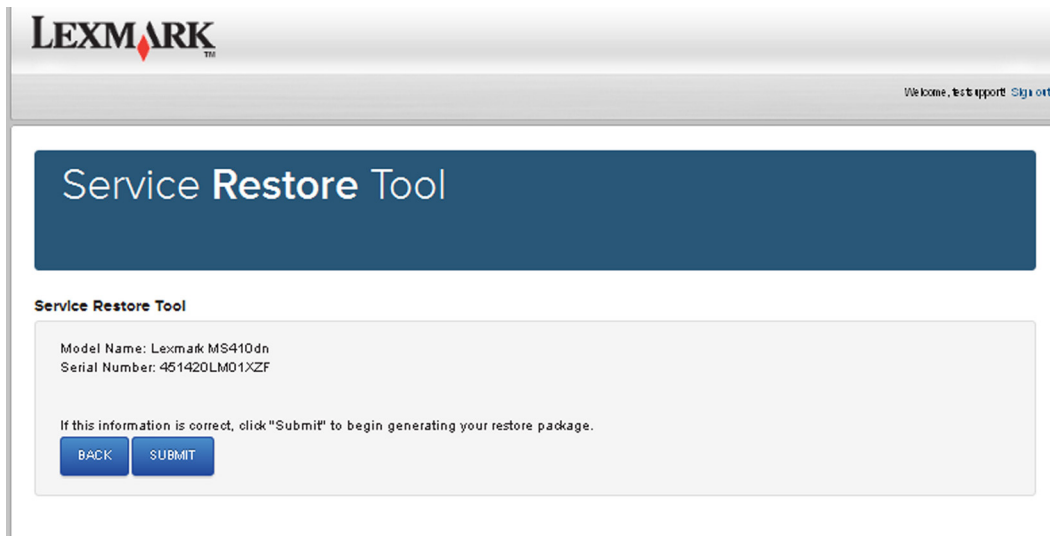

The screenshot shows the Lexmark Service Restore Tool interface at the verification stage. At the top left is the Lexmark logo. At the top right, there is a navigation bar with the text "Welcome, [test support](#) [Sign out](#)". Below this is a large blue header with the text "Service Restore Tool". Underneath the header, the text "Service Restore Tool" is repeated. A form area displays the following information: "Model Name: Lexmark MS410dn" and "Serial Number: 451420LM01XZF". Below this information is the instruction "If this information is correct, click 'Submit' to begin generating your restore package." At the bottom of the form area are two blue buttons: "BACK" and "SUBMIT".

- 4 Save the zip file.

Note: Make sure that the serial number in the zip file matches the serial number of the printer being restored.

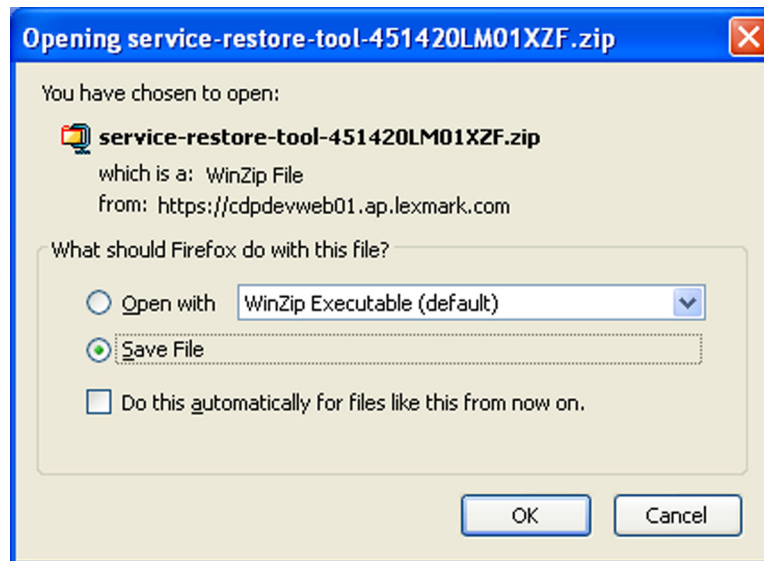

5 Extract the contents of the zip file, open the *Readme* file, and then follow the instructions in the file.

Notes:

- Perform the install instructions on the *Readme* file in the exact order shown. Only restart the printer when instructed to in the file.
- For more information on how to flash the downloaded files, see [“Updating the printer firmware” on page 159](#).
- To load the zip files that are extracted from the Service Restore Tool, see [“Restoring solutions, licenses, and configuration settings” on page 158](#).

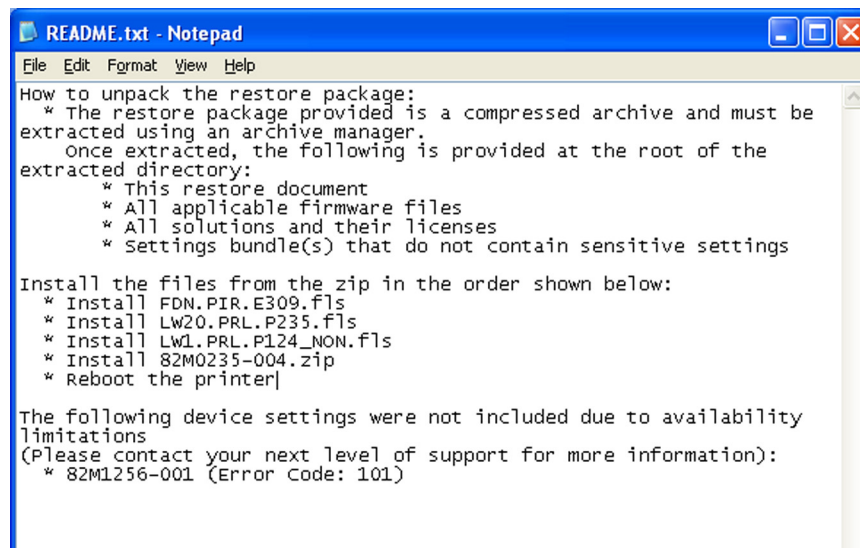

6 After performing the installation instructions in the *Readme* file, confirm from the customer if all the eSF apps have been installed.

Notes:

- If you are unable to access the administrative menus to verify that the printer is restored, then ask the customer for access rights.
- If a 10.00 error appears after you restart the printer, then contact the next level of support.

Restoring solutions, licenses, and configuration settings

To load the zip files that are extracted from the Service Restore Tool, do the following:

- 1 Open a web browser, and then type the printer IP address.

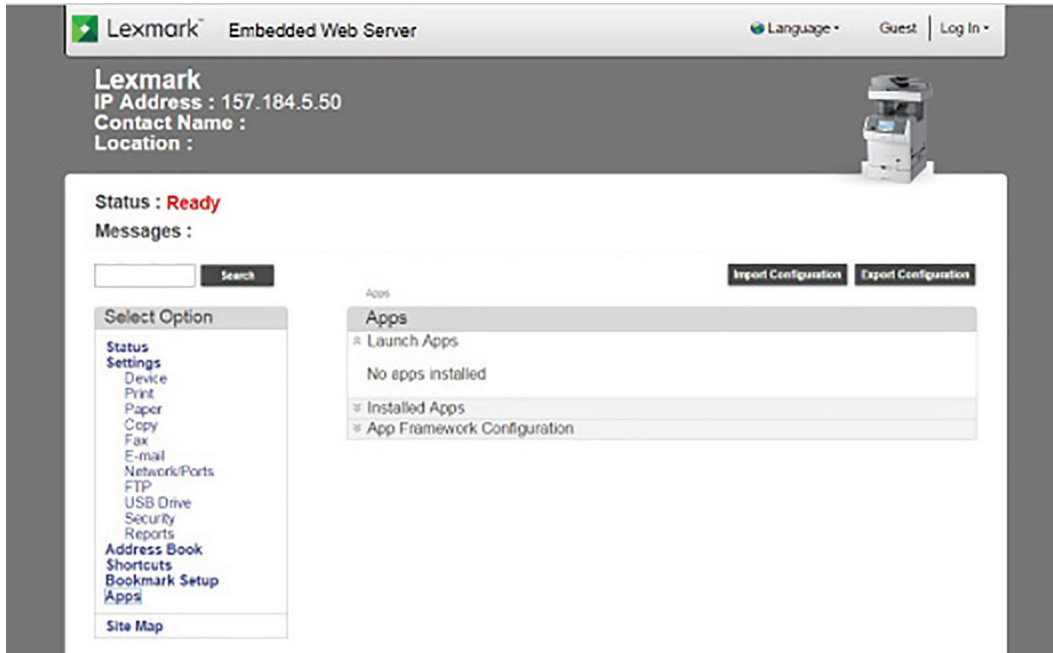

- 2 Click **Import Configuration**, and then click **Browse**.

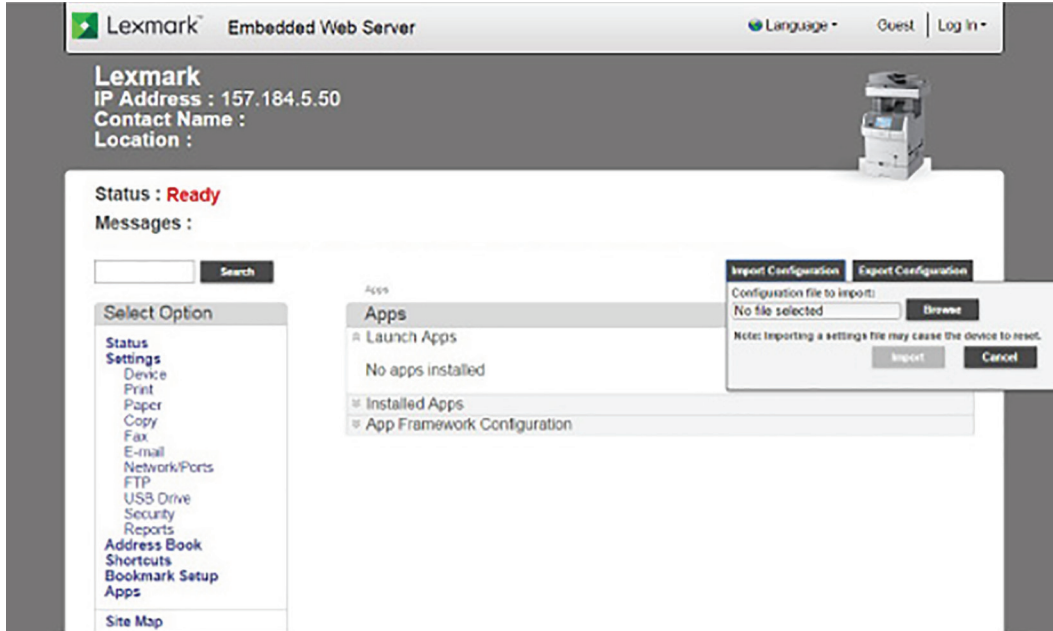

- 3 Navigate to the folder where the zip files are extracted from the Service Restore Tool.

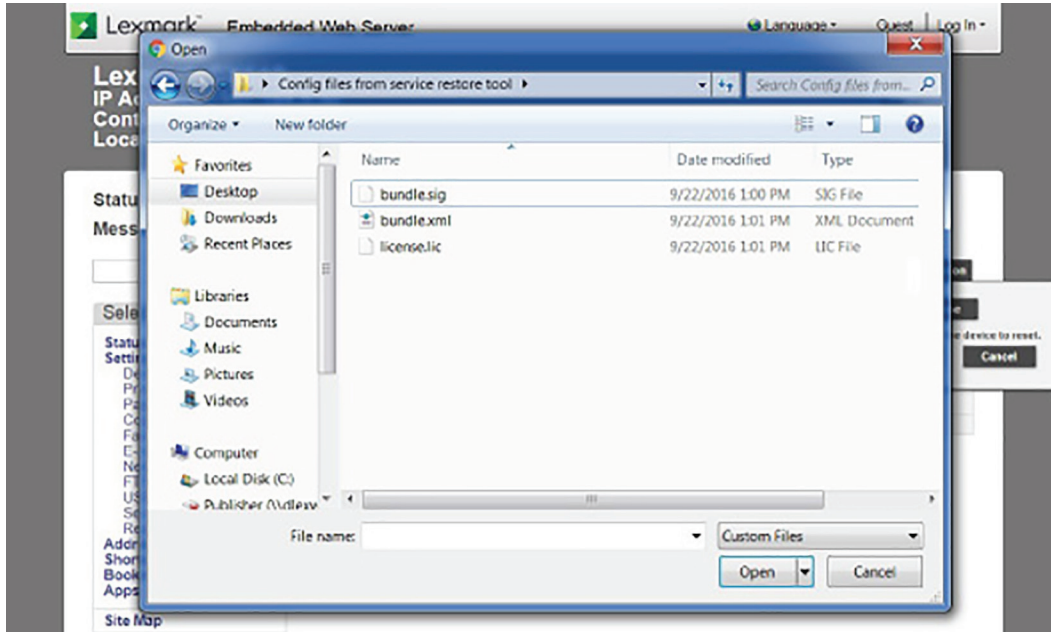

- 4 Select the file to import, and then click **Import**.
- 5 Repeat step 2 through to step 4 for the other files that are included in the extracted zip file.

Updating the printer firmware

Warning—Potential Damage: Before updating the printer firmware, ask the next level of support for the correct code. Using an incorrect code level may damage the printer.

The printer must be in ready state in order to update the firmware.

Using a flash drive

This option is available only in printer models with front USB port.

Make sure to enable the Enable Drive and Update Code settings. You can find the settings in the Flash drive menu under the Settings menu.

- 1 Insert the flash drive into the USB port.
- 2 From the home screen, navigate to **USB Menu: Print from USB > Accept** or **OK**.
- 3 Select the file that you need to flash.

Note: Do not turn off the printer while the update is going on.

Using a network computer

Using the File Transfer Protocol (FTP)

Make sure that the printer is in ready state before flashing the printer.

- 1 Turn on the printer.
- 2 Obtain the IP address:
 - From the home screen
 - From the TCP/IP section of the Network/Ports menu
- 3 From the command prompt of a network computer, open an FTP session to the printer IP address.
- 4 Use a PUT command to place the firmware file on the printer.
The printer performs a POR sequence and terminates the FTP session.
- 5 Repeat steps 2 through 4 for the other files.

Using the Embedded Web Server

Make sure that the printer is in ready state before flashing the printer.

- 1 Open a Web browser, and then type the printer IP address.
- 2 From the home page, navigate to **Configuration > Update Firmware**.
- 3 Select the file to use.
The printer performs a POR sequence and terminates the FTP session.
- 4 Repeat steps 2 through 4 for the other files.

Backing up eSF solutions and settings

Note: Export the eSF solutions and settings from the printer before replacing the controller board.

Exporting eSF solutions and settings file

- 1 Reset the printer into Invalid engine mode. See [“Entering Invalid engine mode” on page 151](#).
- 2 Open a Web browser, and then type the printer IP address.
Note: If the Web page cannot be accessed or an error occurs when starting the printer into Invalid engine mode, then data backup is not an option. Inform the customer that the data cannot be saved.
- 3 Navigate to **Settings > Solutions > Embedded Solutions**.
- 4 From the Embedded Solutions page, select the applications that you want to export.
- 5 Click **Export**.
Note: The size limit of the export file is 128 KB.

Importing eSF solutions and settings file

After replacing the controller board, import back to the printer the eSF solutions and settings that were exported.

1 Reset the printer into Invalid engine mode. See [“Entering Invalid engine mode” on page 151](#).

2 Open a Web browser, and then type the printer IP address.

Note: If the Web page cannot be accessed or an error occurs when starting the printer into Invalid engine mode, then data backup is not an option. Inform the customer that the data cannot be saved.

3 Navigate to **Settings > Solutions > Embedded Solutions**.

4 From the Embedded Solutions page, select the applications that you want to import.

5 Click **Import**.

Disconnecting ribbon cables

Warning—Potential Damage: The ribbon cable and its socket may get damaged if it is not properly disconnected. When disconnecting the cable, hold its connector and press its tab before unplugging it.

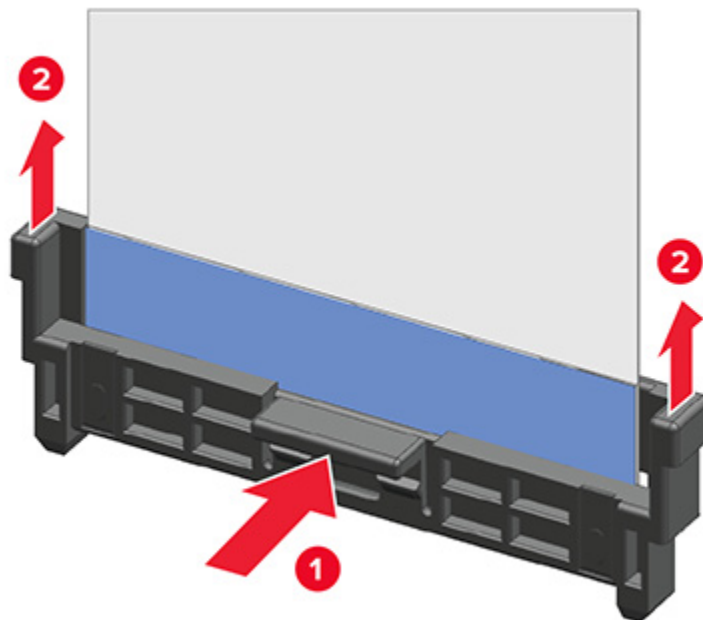

Ribbon cable connectors

Zero Insertion Force (ZIF) connectors

These connectors are used on the boards and cards that are installed in the printer.

To avoid damaging the connectors and their cables, observe the following:

- Do not insert the cables where the contacts are facing the locking actuator.
- Do not insert the cables diagonally into the ZIF socket.
- Avoid using a fingernail or sharp object to open the locking actuator.
- Avoid pressing against the cables when opening the locking actuator.

These are the types of the ZIF connectors that are used in this printer:

- Horizontal top contact connector
- Horizontal bottom contact connector
- Vertical mount contact connector
- Horizontal sliding connector

Horizontal top contact connector

This connector uses a back flip locking actuator to lock the ribbon cable into the ZIF connector.

Warning—Potential Damage: When opening or closing this type of actuator, lift or close the two tabs located on each end of the actuator. The two tabs should be moved simultaneously. Do not close the actuator from the center.

Removing the cable

- 1 Unlock the actuator.

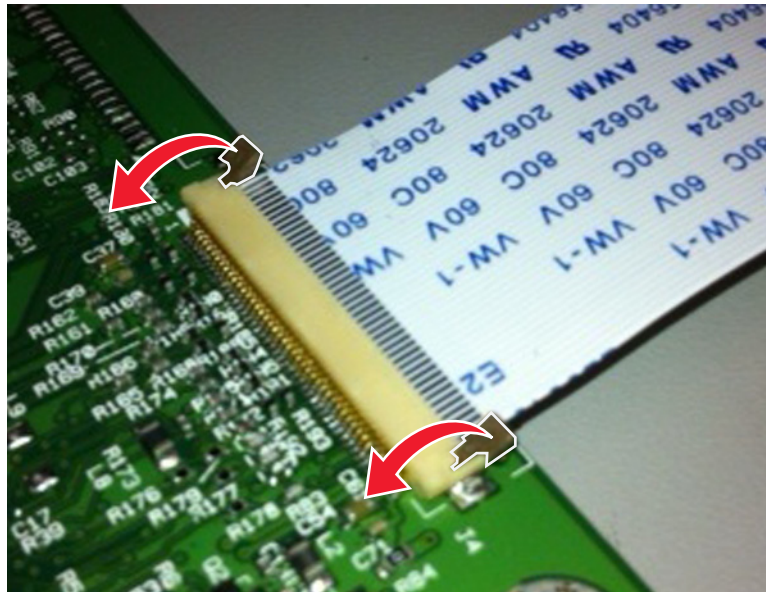

- 2 Remove the cable.

Inserting the cable

Make sure that the actuator is unlocked before installing the cable. The tabs are vertical when the actuator is locked.

- 1 Insert the cable on top of the actuator with the contacts facing up.

Note: Make sure that the cable is installed squarely into the connector to avoid intermittent failures.

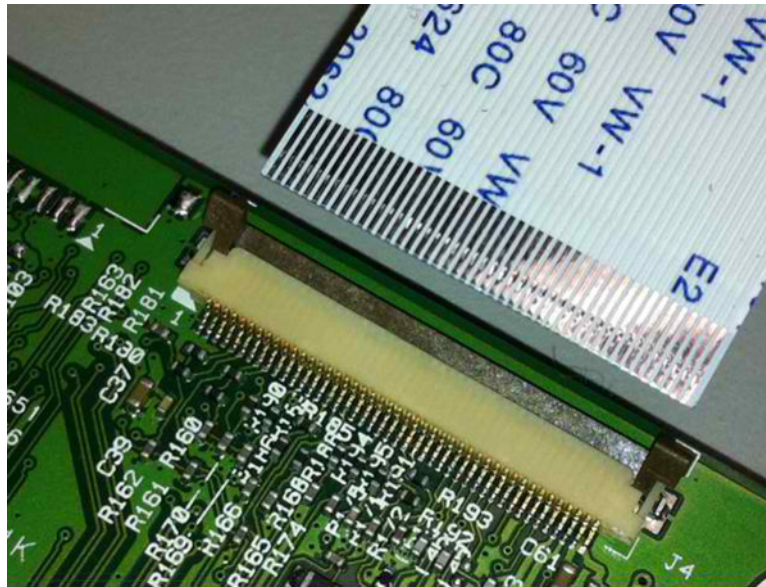

2 Rotate the locking actuator to the locked position.

Notes:

- Do not move the cable while locking the actuator.
- If the cable moves, open the actuator, reposition the cable, and then close the actuator.

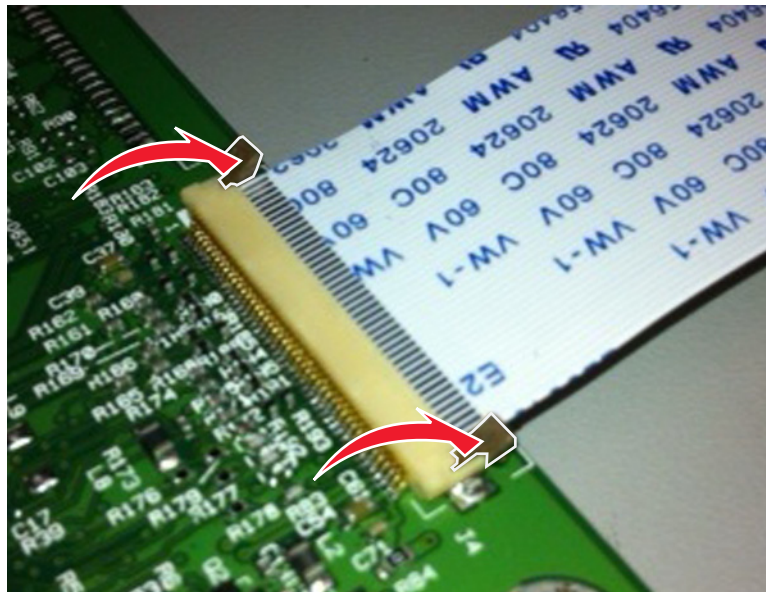

Horizontal bottom contact connector

This connector uses a flip locking actuator to lock the ribbon cable into the ZIF connector.

Warning—Potential Damage: When opening or closing this type of actuator, gently lift the center of the actuator using your finger. Do not use a fingernail or screwdriver to open the actuator to avoid damaging the ribbon cable. Do not close the actuator from its ends.

Removing the cable

- 1 Unlock the actuator.

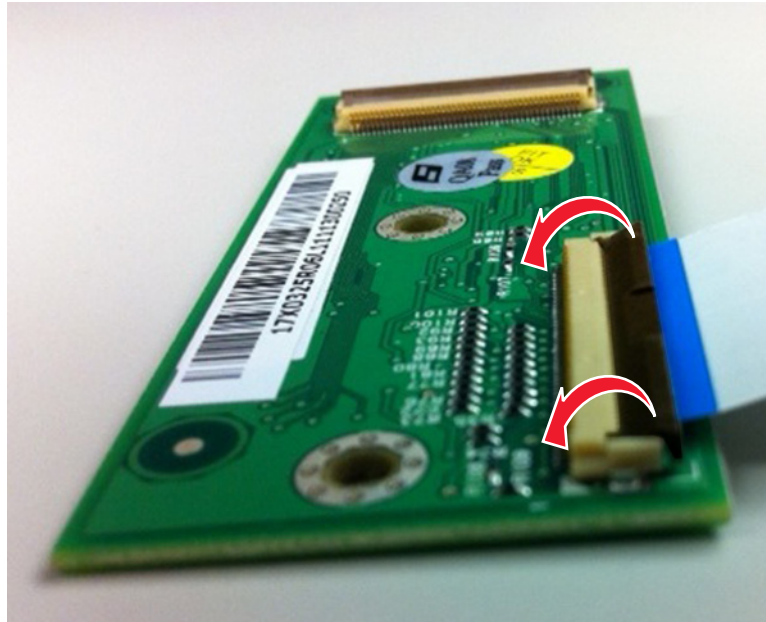

- 2 Remove the cable.

- 3 Rotate the locking actuator to the locked position.

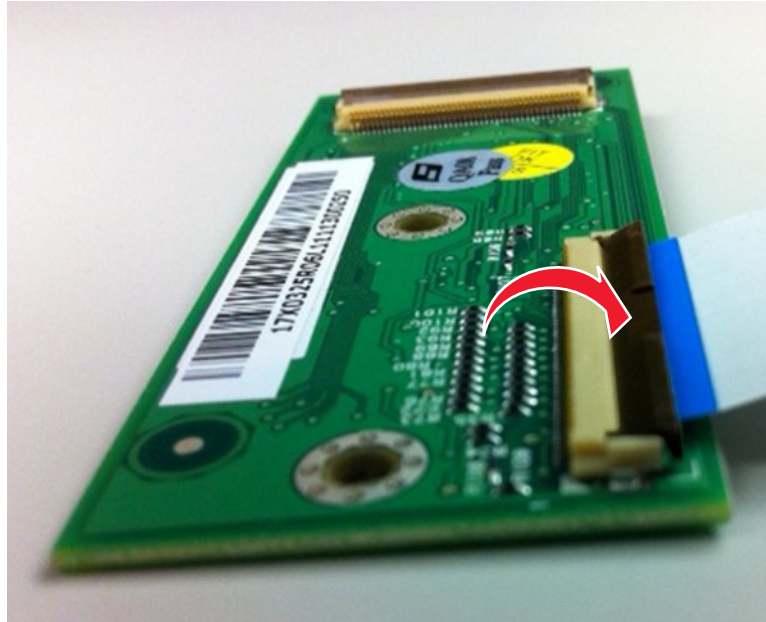

Vertical mount contact connector

This connector uses a back flip locking actuator to lock the ribbon cable into the ZIF connector.

Warning—Potential Damage: When opening or closing this type of actuator, gently lift the center of the actuator using your finger. Do not use a fingernail or screwdriver to open the actuator to avoid damaging the ribbon cable. Do not close the actuator from its ends.

Removing the cable

- 1 Rotate the locking actuator from the center of the actuator to the unlocked position.

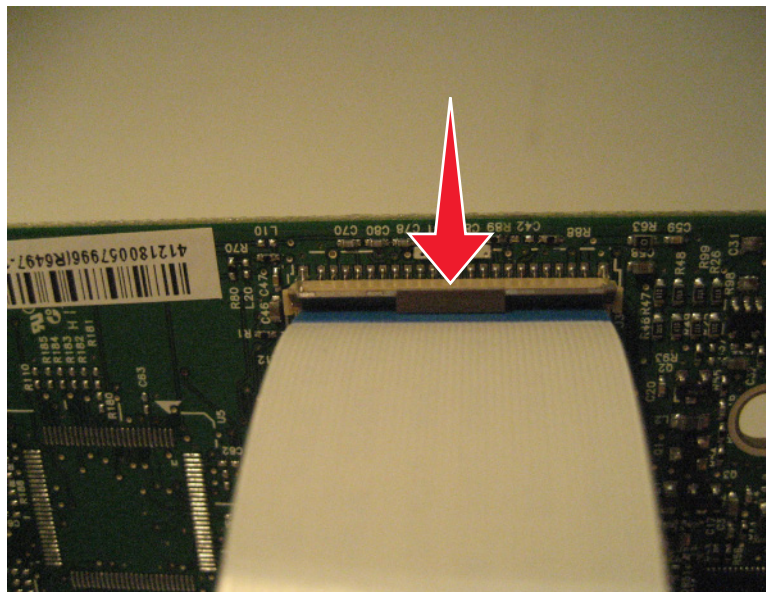

- 2 Remove the cable.

Inserting the cable

- 1 Make sure that the locking actuator is in the open position.



- 2 Insert the cable on top of the actuator with the contacts facing away from the locking actuator.

Note: Make sure that the cable is installed squarely into the connector to avoid intermittent failures.



- 3 Rotate the locking actuator to the locked position.

Notes:

- Do not move the cable while locking the actuator.
- If the cable moves, open the actuator, reposition the cable, and then close the actuator.

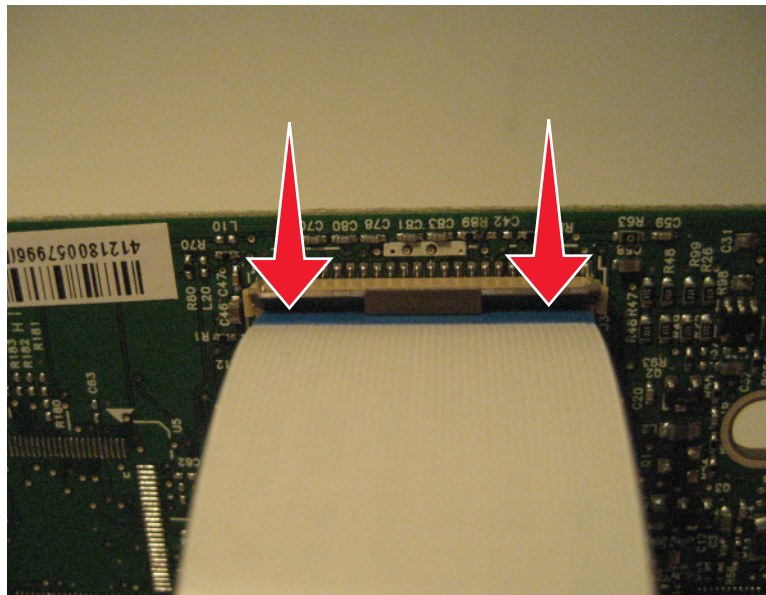

Horizontal sliding contact connector

This connector uses a slide locking actuator to lock the ribbon cable into the ZIF connector.

Warning—Potential Damage: When opening or closing this type of actuator, gently push or pull the two tabs located on each end of the actuator. Do not close the actuator from the center of the actuator. Do not use a screwdriver to open or close the actuator to avoid damage to the cable or connector.

Removing the cable

- 1 Slide the tabs away from the connector.

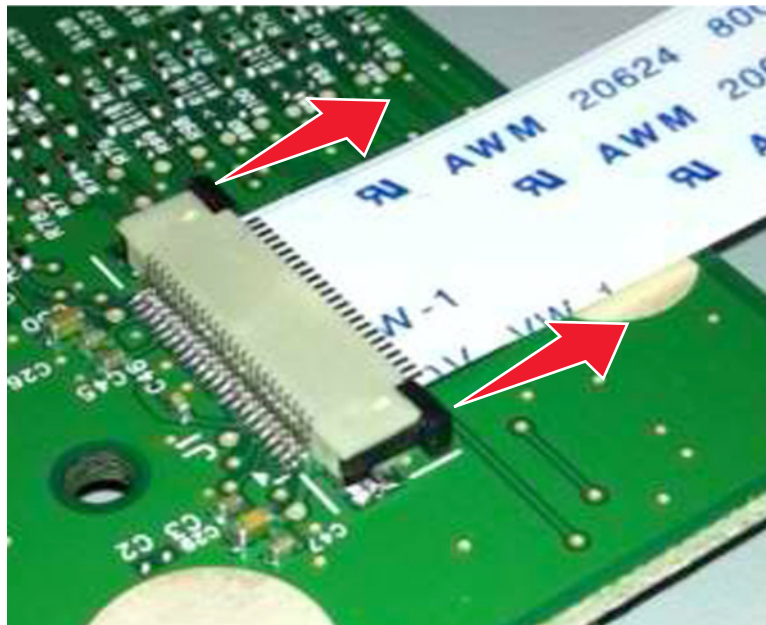

- 2 Remove the cable.

Inserting the cable

- 1 Make sure that the locking actuator is in the open position. If you are opening the connector, then pull back the end tabs using equal force to avoid breaking the connector.

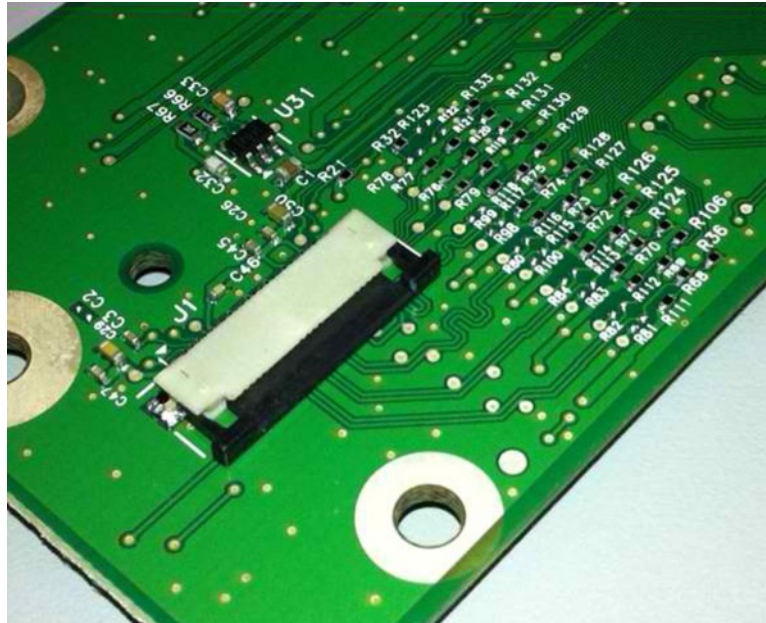

- 2 Insert the cable on top of the actuator with the contacts facing away from the locking actuator.



- 3 Slide the locking actuator toward the connector to lock the cable.

Notes:

- Do not move the cable while locking the actuator.
- If the cable moves, open the actuator, reposition the cable, and then close the actuator.

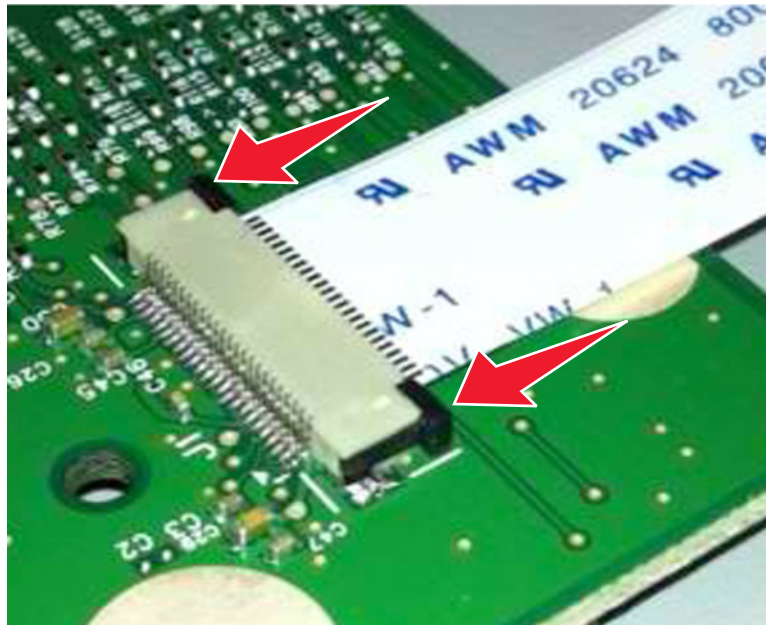

Low Insertion Force (LIF) connector

Warning—Potential Damage: When installing a cable into an LIF connector, avoid bending the edges of the cables and damaging the contacts on the cables.

Inserting the cable

- 1 Make sure that the contacts of the controller board and connectors are on the same side.

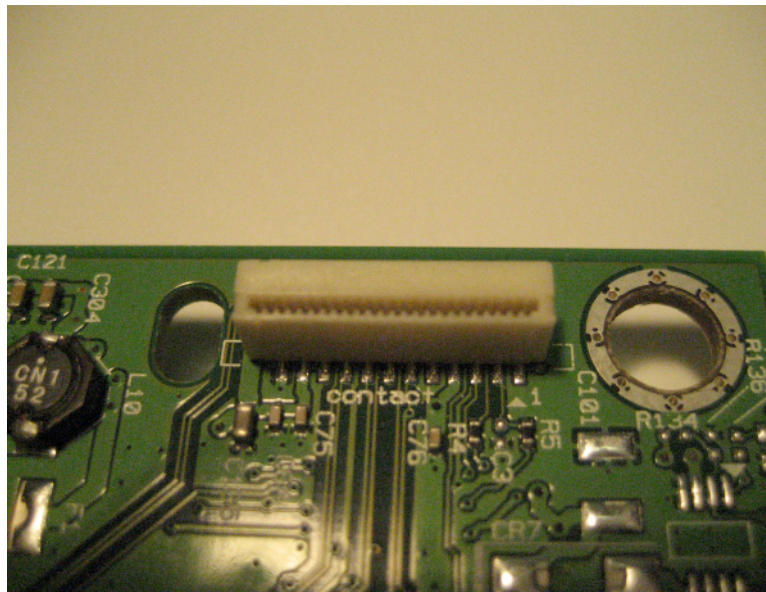

- 2 Insert the cable.

Note: Make sure that the cable is installed straight into the connector to avoid intermittent failures.

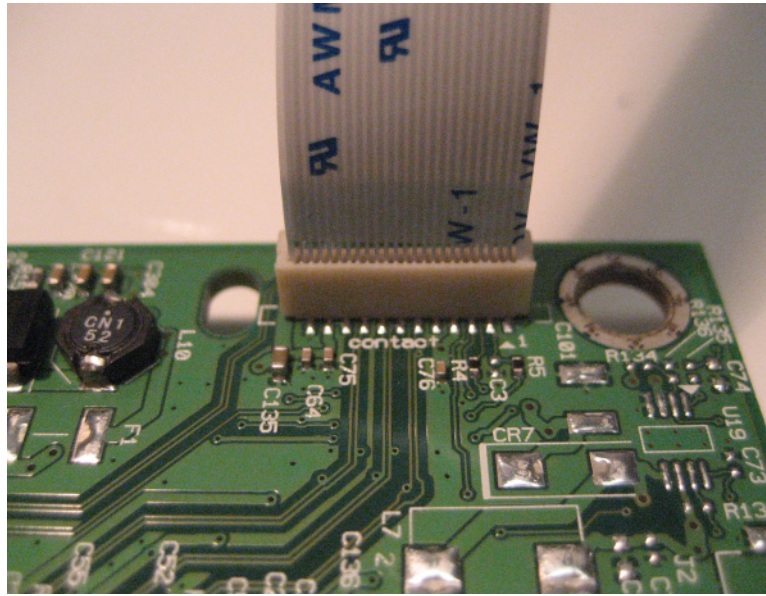

Printhead assembly adjustment

A printhead needs to be correctly positioned after it has been removed. Use a sharp pencil or a small, flat-blade screwdriver to mark the location of the old printhead on the printer frame. Align the new printhead relative to the location of the old printhead.

Note: Skew is caused by a sheet being fed through the printer while misaligned. The entire image is rotated relative to the sheet edges. However, a mechanically misaligned printhead causes the horizontal lines to appear skewed, while the vertical lines remain parallel to the vertical edges. There are no adjustments for skew. Check the pick tires for wear, the paper path for obstructions, the fuser for proper setting, and the tray paper guides for fit to the media.

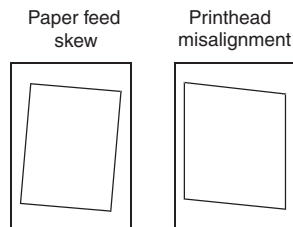

To adjust the printhead:

- 1 POR into the Diagnostics menu, and print a Quick test page:
Diagnostics Menu > Print Tests > Tray 1 > Single
- 2 Fold the printed test page on the left side so that a few millimeters of grid lines wrap around the outside of the fold.

- 3 Fold a second vertical fold near the center so that the left side top edge aligns with the right side top edge.

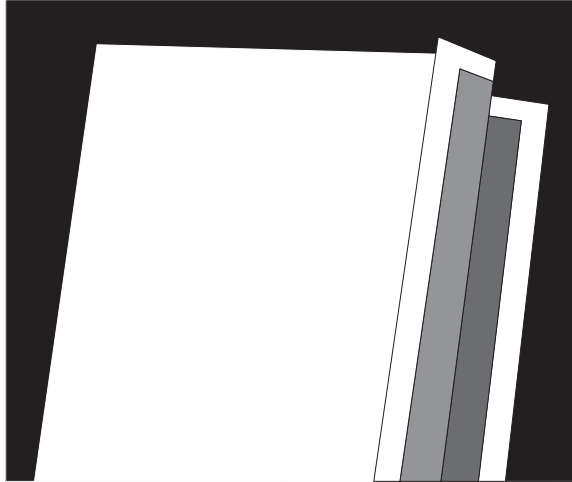

- 4 If the grid lines of the right flap align below the corresponding lines on the left flap, then adjust the printhead clockwise relative to the printer, and recheck. If the grid lines of the left flap align below the corresponding lines of the right side, then adjust the printhead counterclockwise.

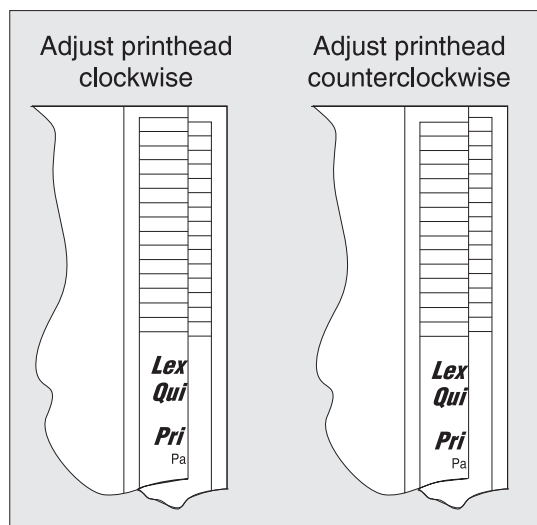

- 5 Print another Quick test page, and check if adjustments are still needed.
- 6 After obtaining a properly adjusted image on the paper, tighten all the screws.

Note: If necessary, print a Quick test page again and perform the Registration adjust procedure to correct the skew and misalignments. See [“Registration adjust” on page 147](#).

Removal procedures

Keep the following tips in mind as you replace parts:

- Some removal procedures require removing cable ties. You must replace cable ties during reassembly to avoid pinching wires, obstructing the paper path, or restricting mechanical movement.
- Remove the toner cartridges, imaging kit, and trays before removing other printer parts. The imaging kit must be carefully set on a clean, smooth, and flat surface. It should also be protected from light while out of the device.
- Disconnect all external cables from the printer to prevent possible damage during service.
- Unless otherwise stated, reinstall the parts in reverse order of removal.
- When reinstalling a part held with several screws, start all screws before the final tightening.
- For printers that have a soft power switch, make sure to unplug the power cord after powering off.

Left side removals

Left cover removal

- 1 Open the front door.
- 2 Position the printer on its right side.
- 3 Remove the screw (A).
- 4 Release the latches (B).

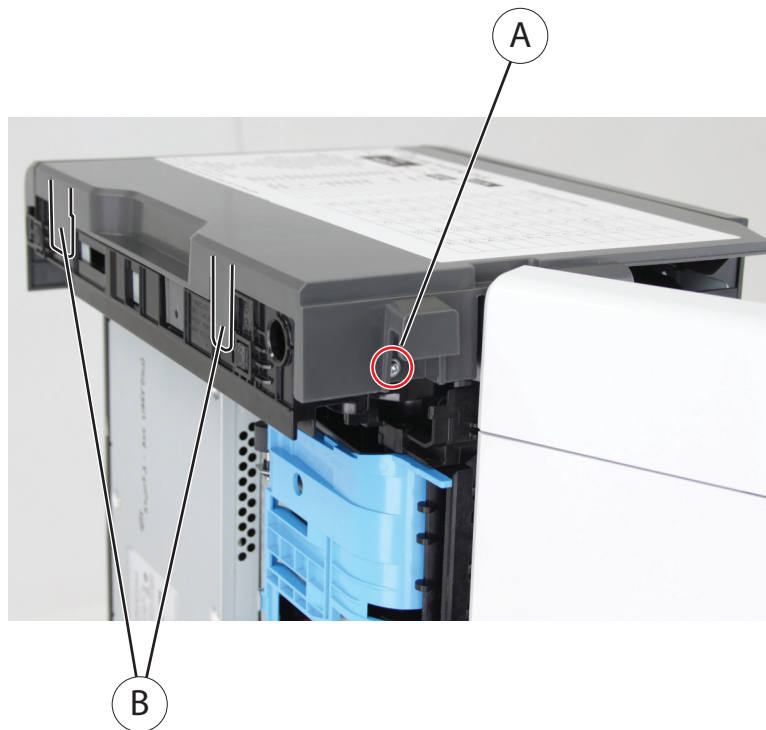

- 5 Remove the left cover.

Note: The front cover hinders the removal.

Main drive gearbox removal

- 1 Remove the left cover. See [“Left cover removal” on page 173](#).
- 2 Release the latch (A), and then detach the link.

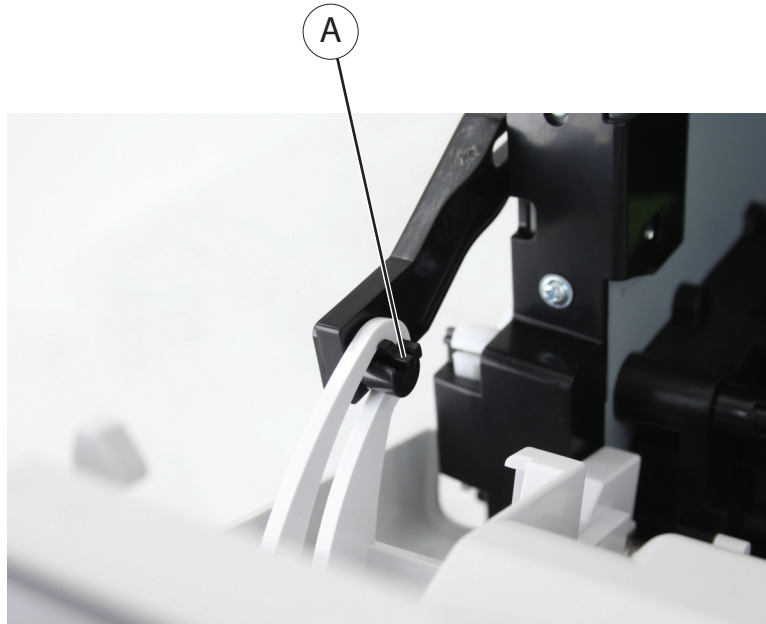

- 3 Remove the four screws (B).

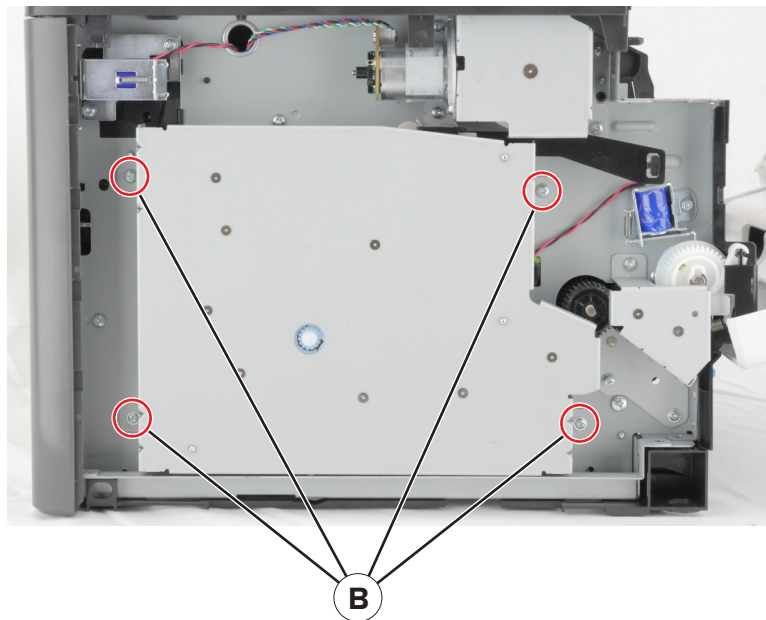

- 4 Disconnect the cable from the main drive gearbox.
- 5 Remove the gearbox.

Warning—Potential Damage: Do not lose the fuser gear (C) and spring (D).

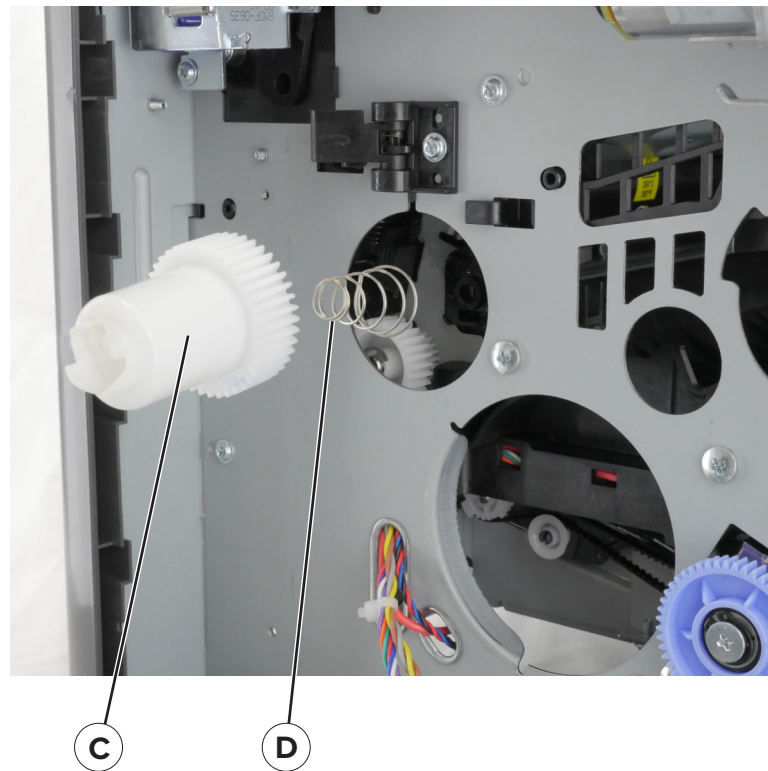

MPF gearbox removal

- 1 Remove the front door. See [“MPF with front access cover removal” on page 198.](#)
- 2 Remove the left cover. See [“Left cover removal” on page 173.](#)
- 3 Remove the main drive gearbox. See [“Main drive gearbox removal” on page 174.](#)
- 4 Disconnect the spring (A).

5 Remove the three screws (B).

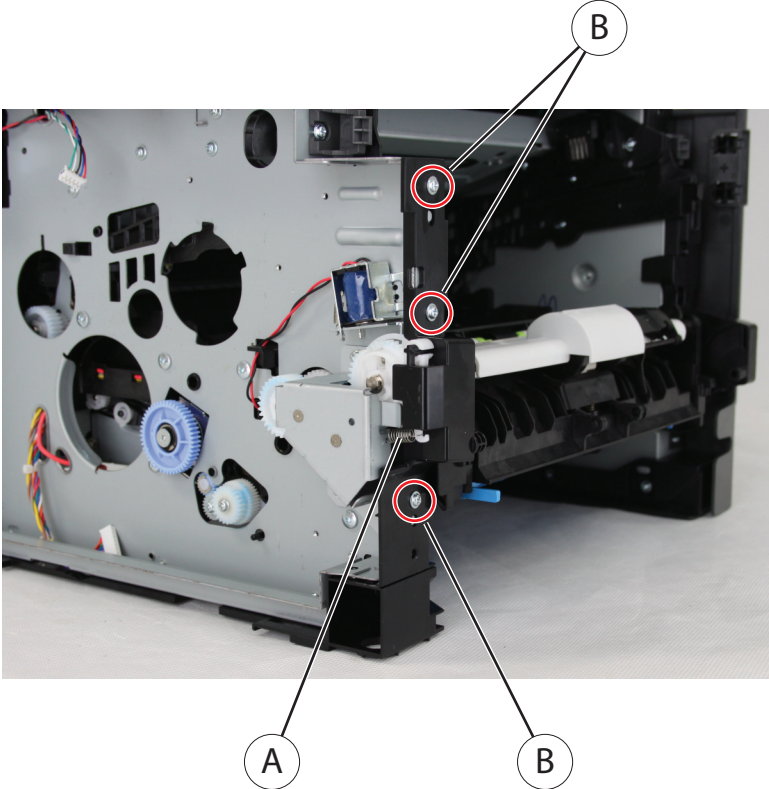

6 Remove the three screws (C).

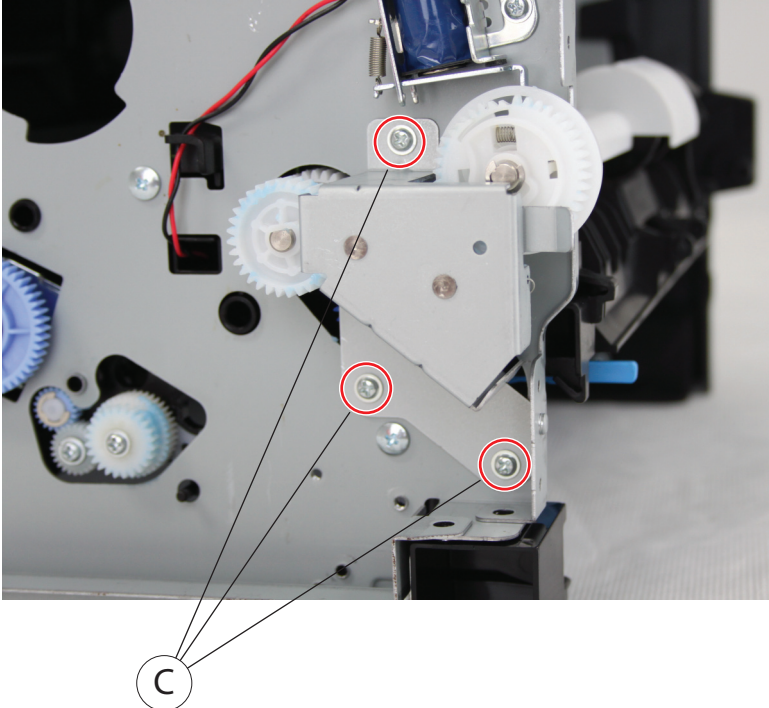

7 Remove the E-clip (D), and then remove the gear.

Note: The solenoid hinders the removal.

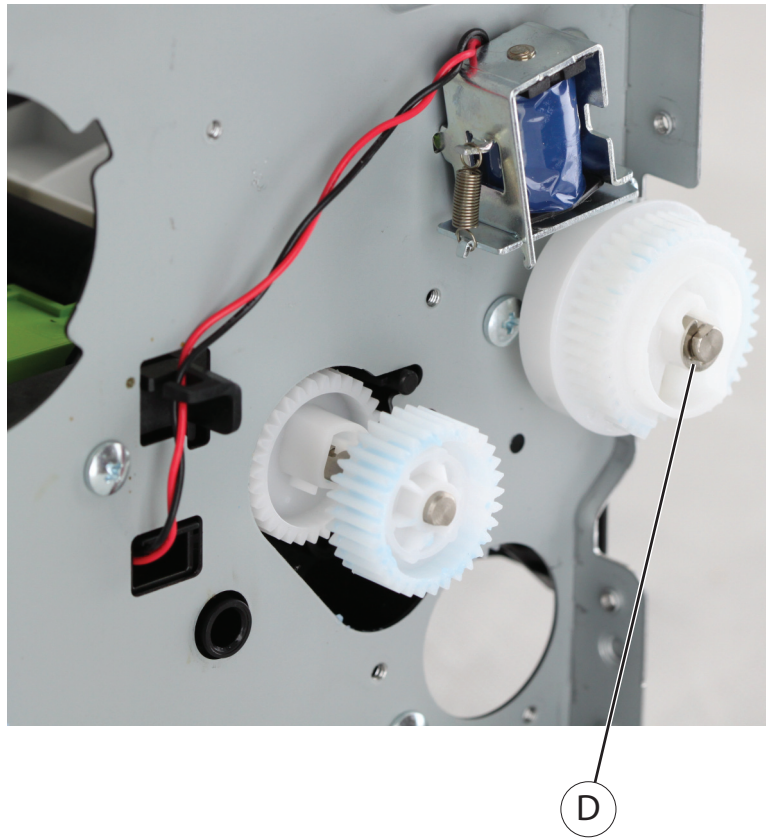

8 Release the two latches (E), and then remove the gears (F).

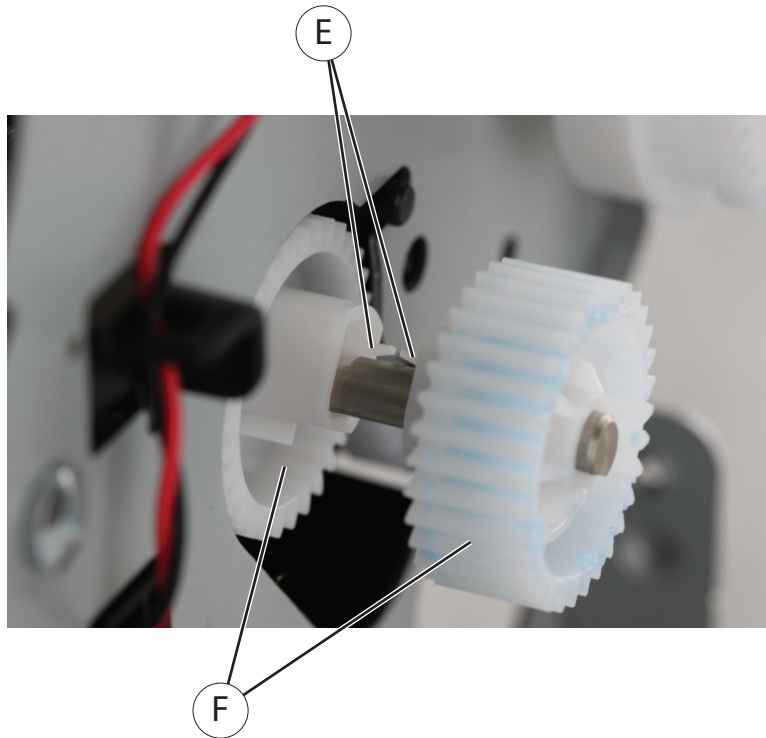

Fuser actuator removal

- 1 Remove the left cover. See [“Left cover removal” on page 173](#).
- 2 Release the latch (A), and then detach the link.

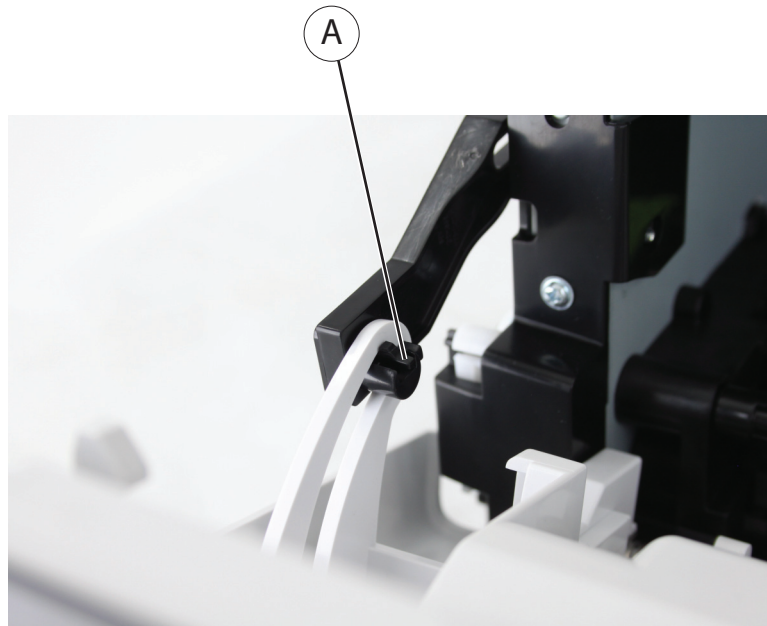

- 3 Remove the four screws (B).

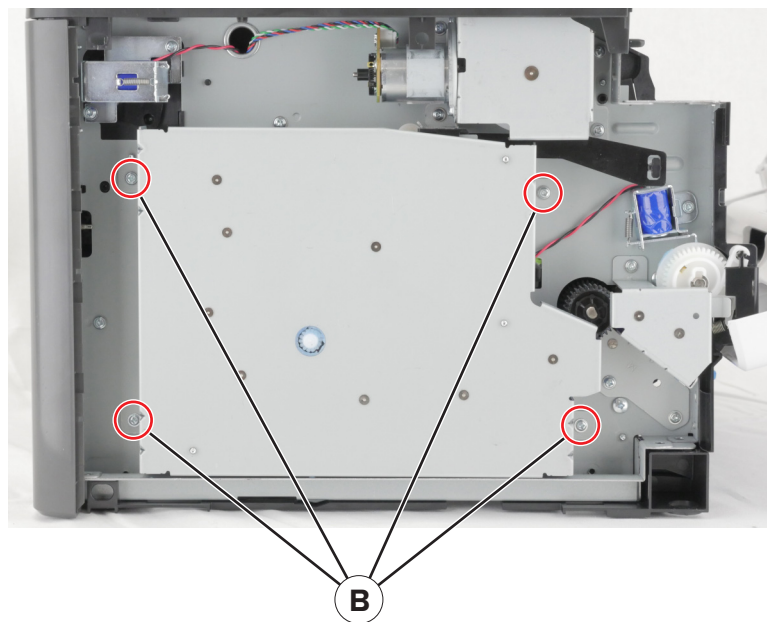

- 4 Remove the screw (C).

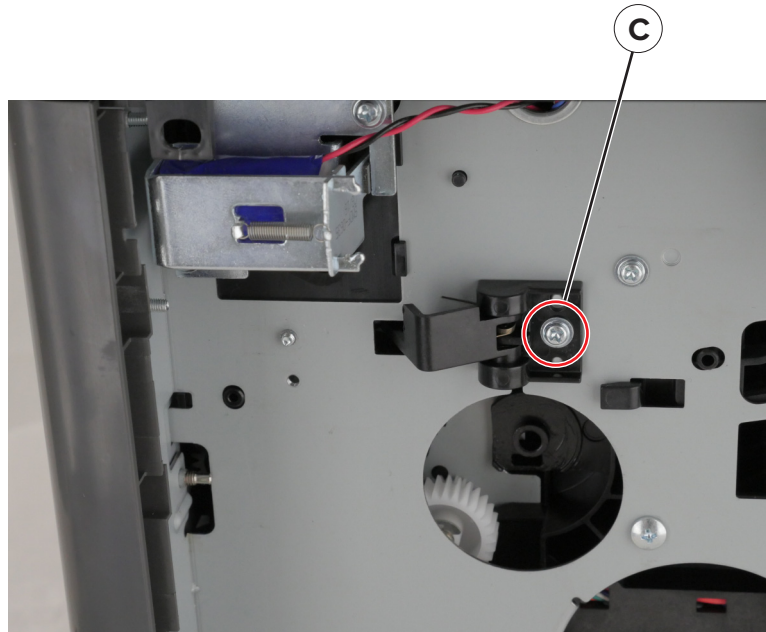

- 5 Remove the fuser actuator.

Installation note: To test if the actuator is properly installed, push, and then release the actuator (A). The actuator should bounce back.

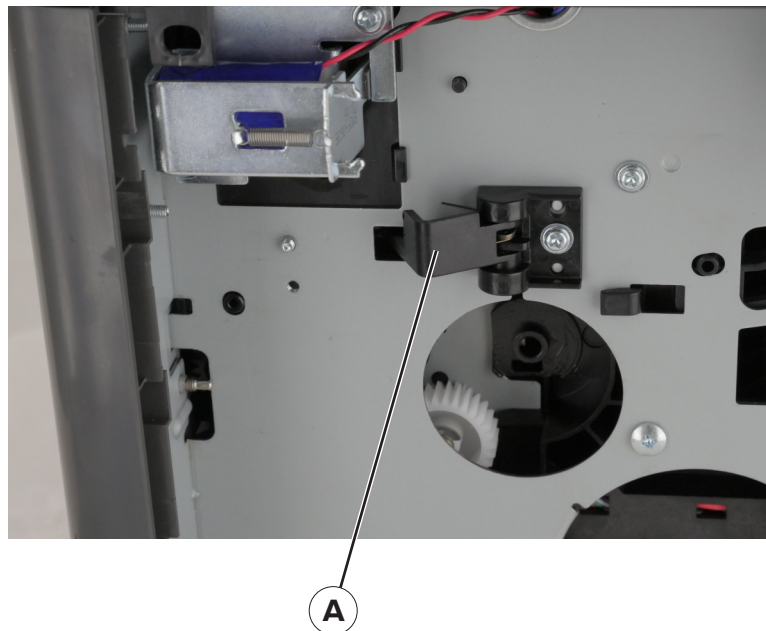

Reverse solenoid removal

- 1 Remove the right cover. See [“Right cover removal” on page 185.](#)
- 2 Remove the left cover. See [“Left cover removal” on page 173.](#)
- 3 Remove the rear cover. See [“Rear door and cover removal” on page 224.](#)

- 4 Remove the top cover. See [“Top cover removal” on page 228](#).
- 5 Disconnect the cable JDUPSOL1 from the controller board.
- 6 Remove the two screws (A).

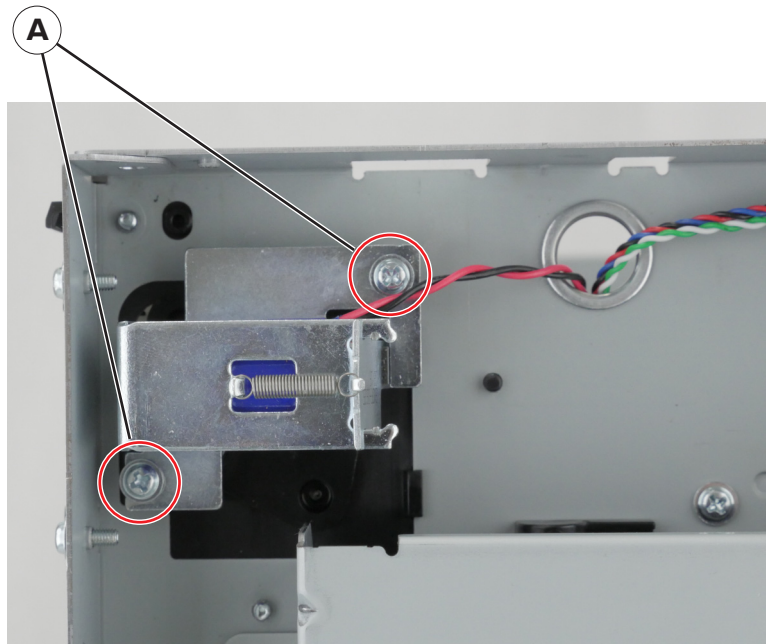

- 7 Remove the solenoid.

Cartridge gearbox removal

- 1 Remove the left cover. See [“Left cover removal” on page 173](#).
- 2 Remove the four screws (A).

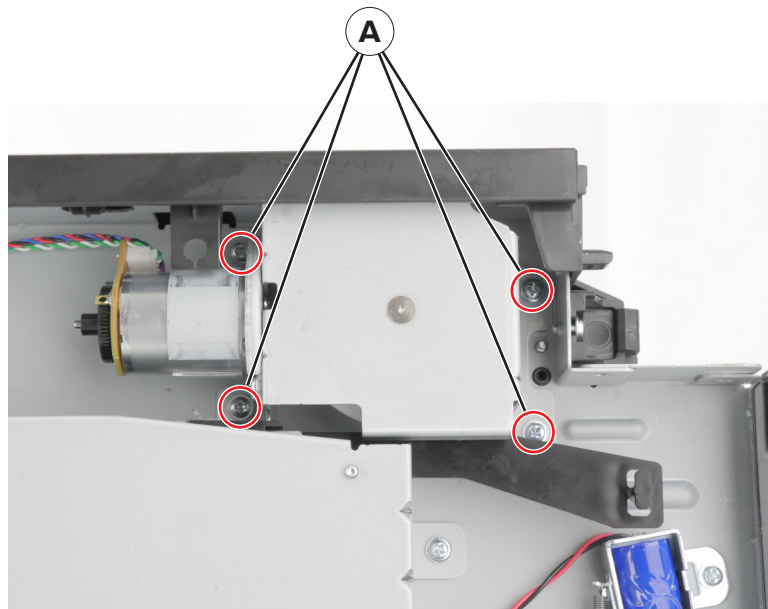

- 3 Remove the screw (B).

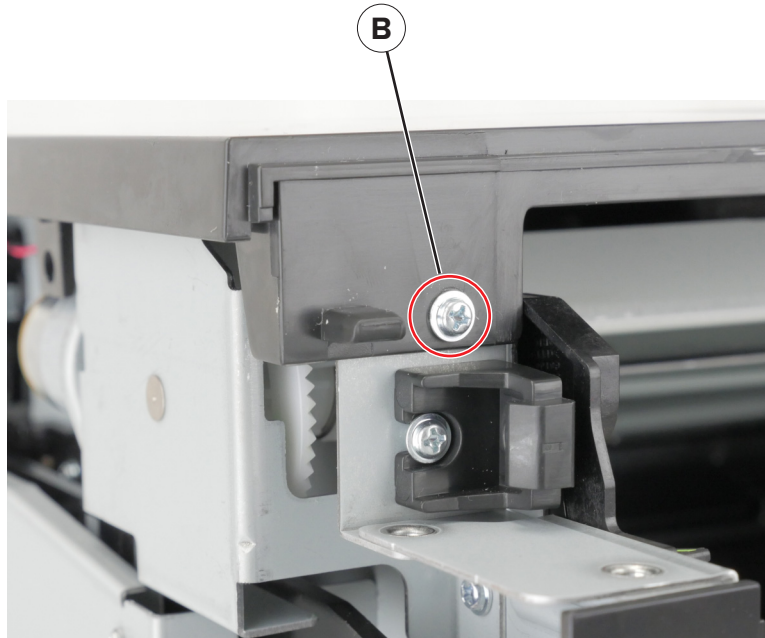

- 4 Lift the top cover enough to remove the cartridge gearbox.
 5 While lifting the cover, disconnect the cable from the gearbox, and then remove the gearbox.

MPF solenoid removal

- 1 Remove the left cover. See [“Left cover removal” on page 173](#).
 2 Remove the screw (A).

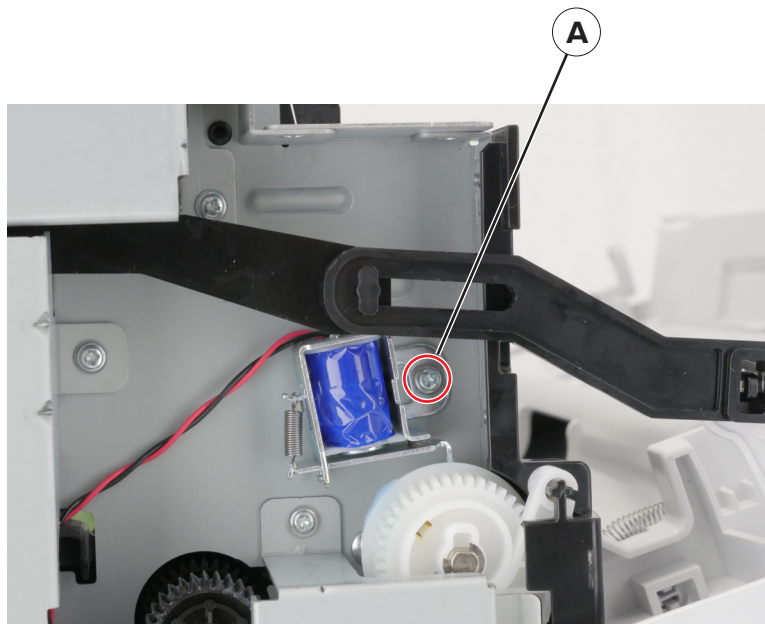

- 3 Cut the cable, and then remove the solenoid.

- 4 Remove the rear cover. See [“Rear door and cover removal” on page 224](#).
- 5 Remove the power supply. See [“Power supply removal” on page 211](#).
- 6 Remove the duplex assembly. See [“Duplex assembly removal” on page 213](#).
- 7 Release the cut cable.
Note: Pay attention to the cable route.
- 8 Open the controller board access cover, and then disconnect the cable.

Pick roller clutch removal

- 1 Remove the left cover. See [“Left cover removal” on page 173](#).
- 2 Remove the main drive gearbox. See [“Main drive gearbox removal” on page 174](#).
- 3 Remove the rear cover. See [“Rear door and cover removal” on page 224](#).
- 4 Remove the power supply. See [“Power supply removal” on page 211](#).
- 5 Remove the duplex assembly. See [“Duplex assembly removal” on page 213](#).
- 6 Using needle-nose pliers, block the roller (A) to prevent the shaft from rotating.

7 While blocking the roller, remove the screw (B).

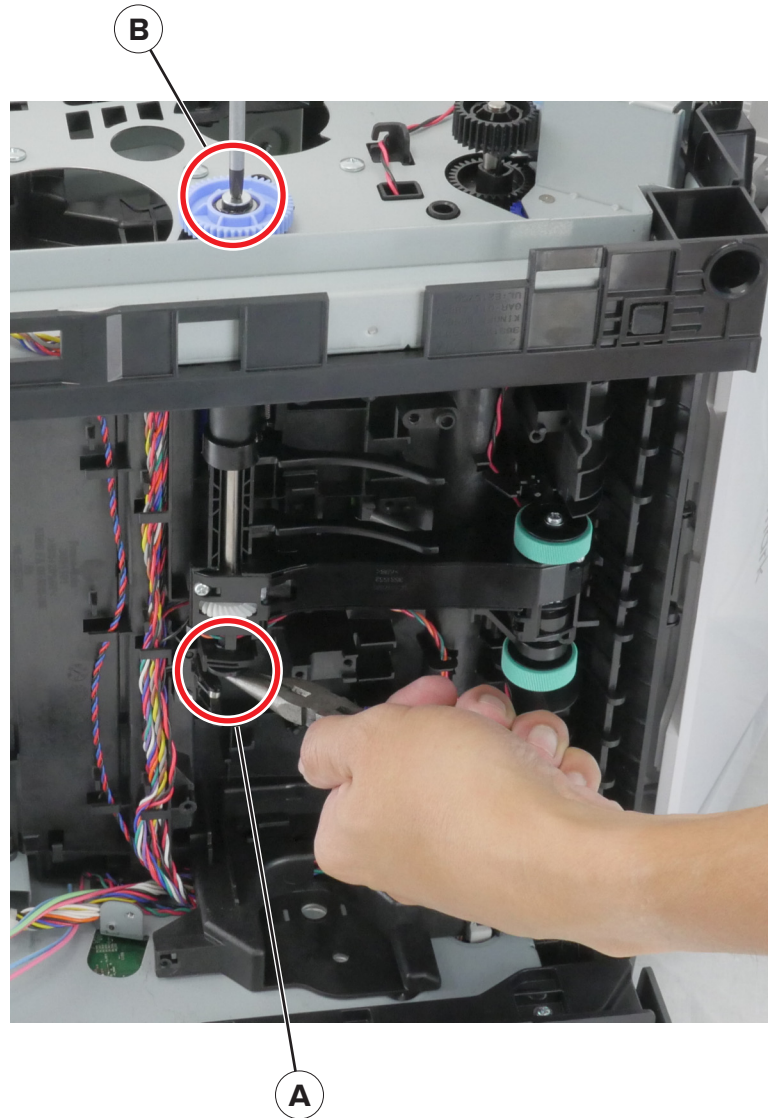

8 Pull out the pick roller assembly clutch, and then cut the cable to remove it.

Installation note: Route the cables as shown.

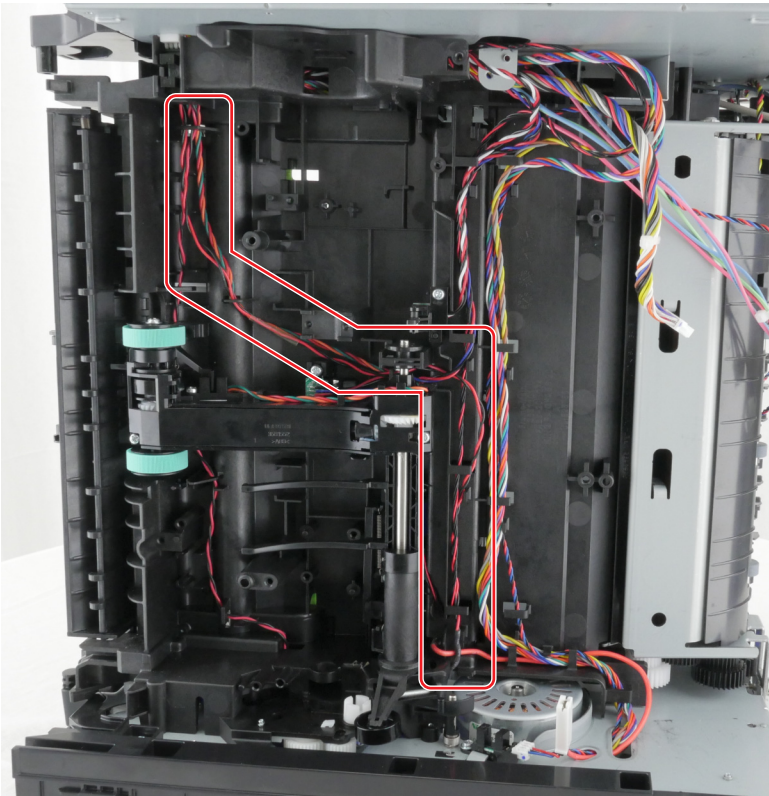

Parts removal

Right side removals

Right cover removal

- 1 Open the front door.
- 2 Using a flat-head screwdriver, open the controller board access cover.

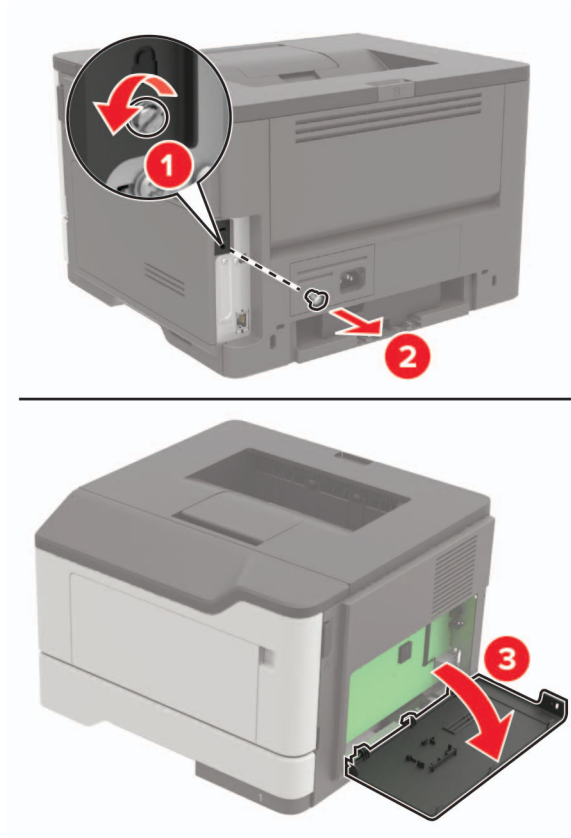

- 3 Position the printer on its left side, and then remove the screw (A).

4 Remove the two screws (B) using a #1 Phillips screwdriver.

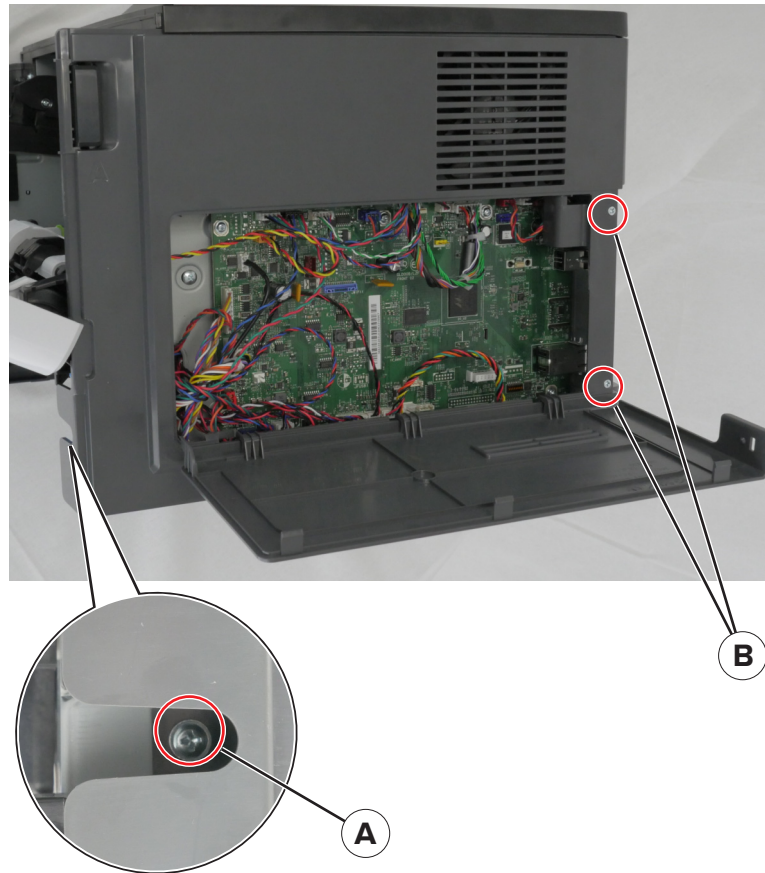

5 Release the two latches (C).

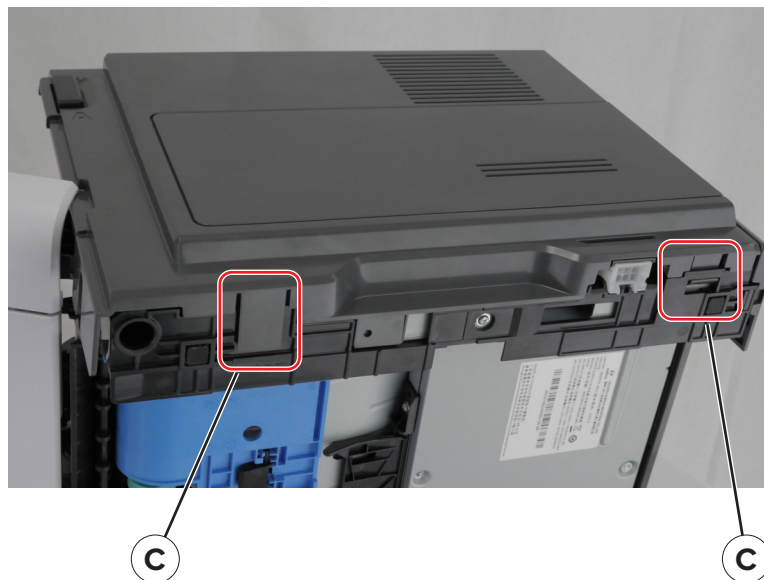

6 Remove the right cover.

Note: The front cover hinders the removal.

Interconnect cable removal

- 1 Remove the right cover. See [“Right cover removal” on page 185](#).
- 2 Position the printer on its rear side.
- 3 Disconnect the cable JOPT1 from the controller board.
- 4 Remove the three screws (A).
- 5 Detach the right foot (B).

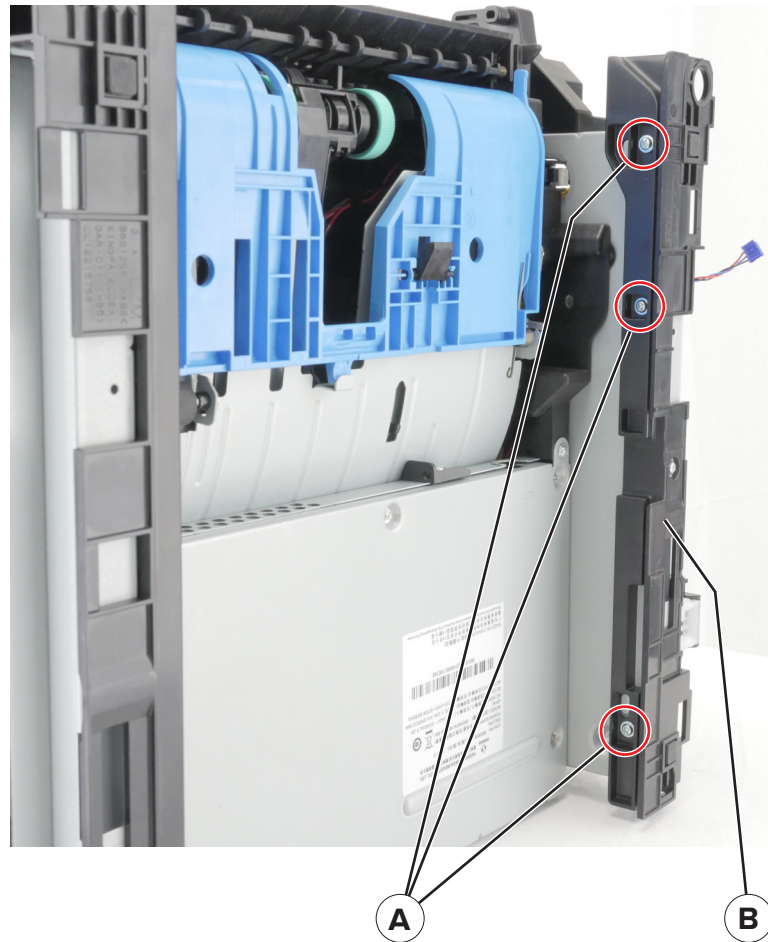

- 6 Release the two latches (C).

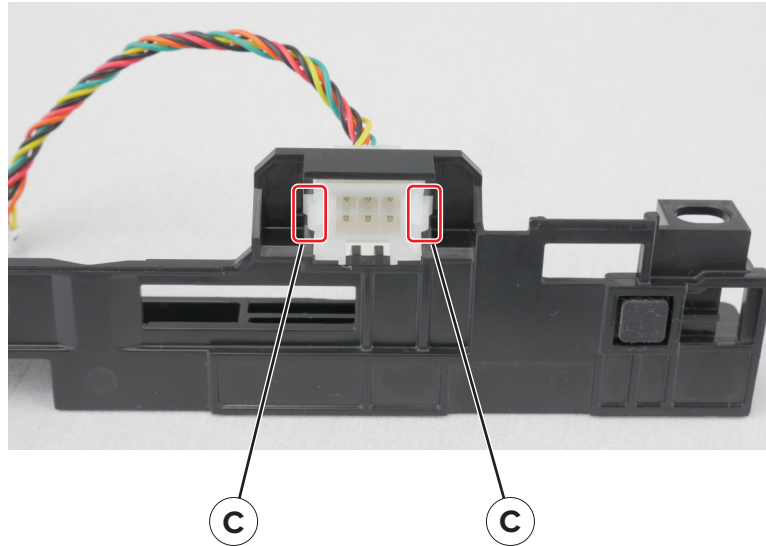

- 7 Remove the cable.

Sensor (tray present) removal

- 1 Remove the right cover. See [“Right cover removal” on page 185.](#)
- 2 Disconnect the cable (A).

3 Release the three latches (B), and then pry to remove the sensor.

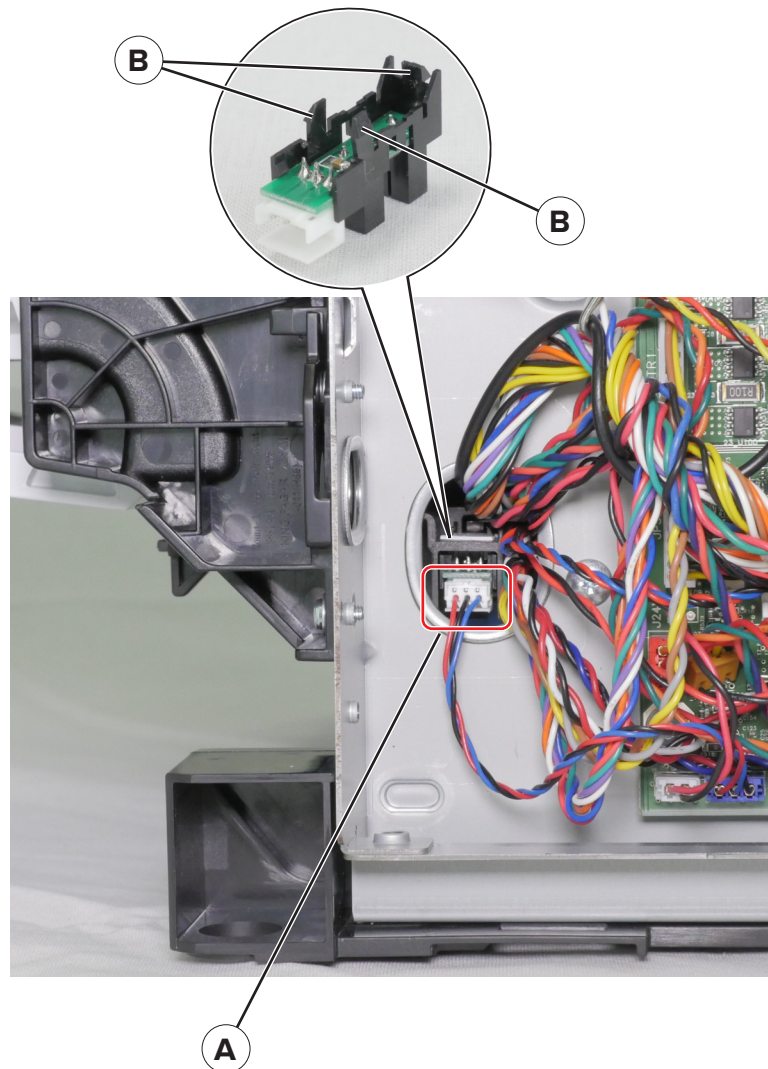

Cooling fan removal

- 1** Remove the right cover. See [“Right cover removal” on page 185](#).
- 2** Disconnect the cable JFAN1 from the controller board.

3 Remove the three screws (A), and then remove the fan duct.

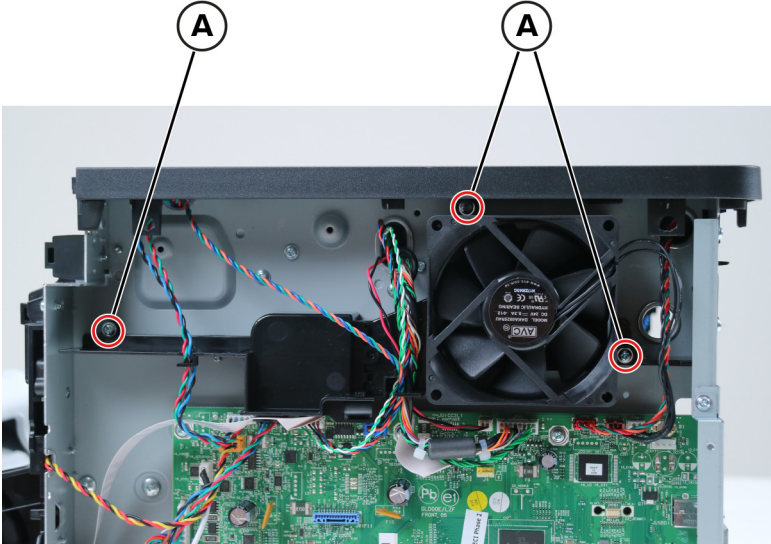

4 Remove the screw (B), and then remove the fan bracket.

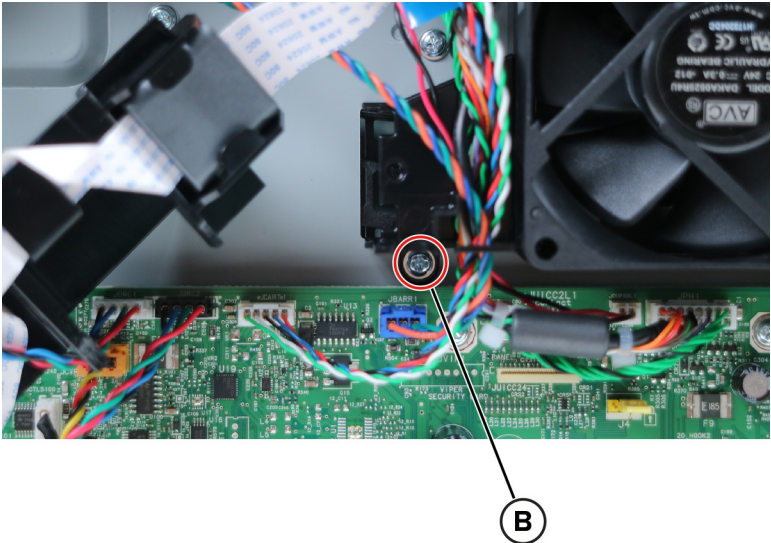

- 5 Remove the two screws (C), and then remove the fan.

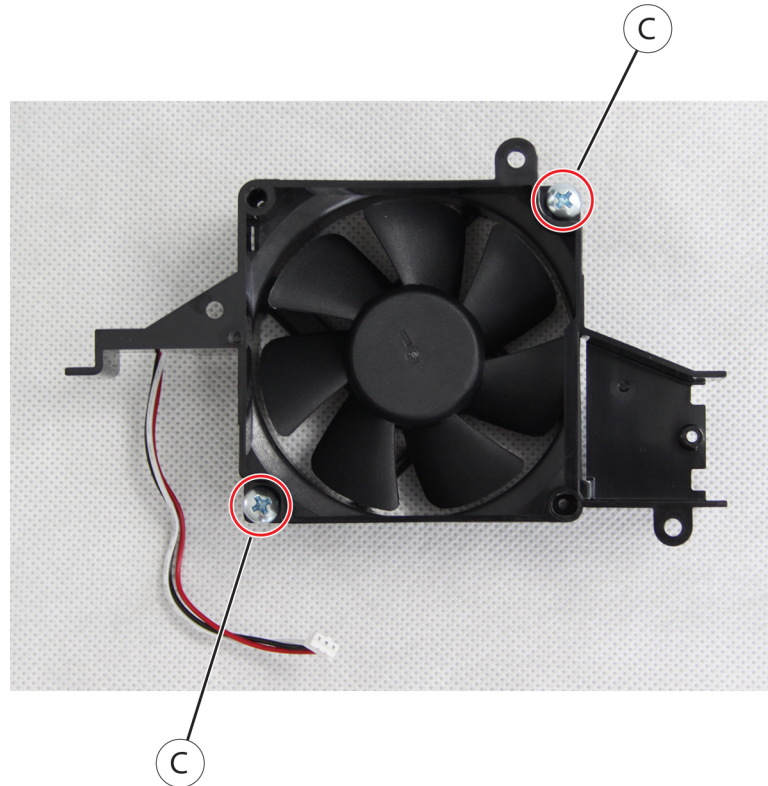

Controller board removal

- 1 Remove the right cover. See [“Right cover removal” on page 185](#).
- 2 Disconnect all the cables.

- 3 Remove the ground screw (A) and the four screws (B).

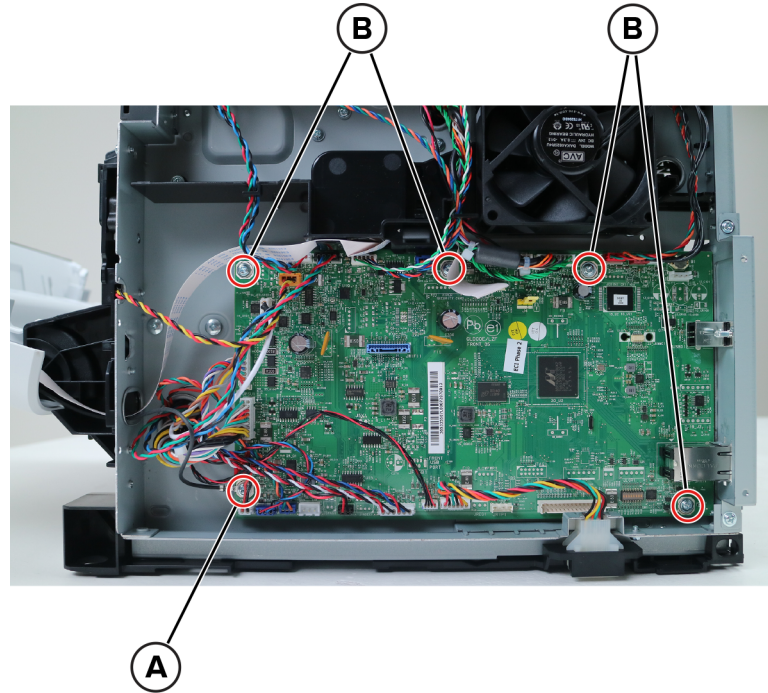

- 4 Remove the screw (C).

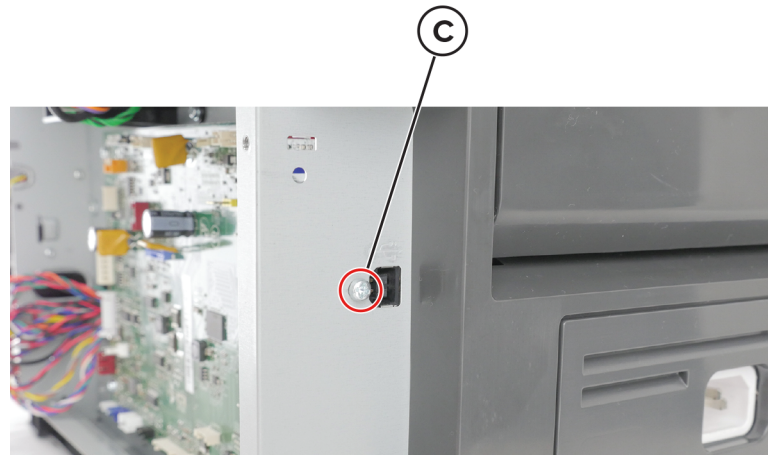

- 5 Remove the controller board.

Installation note: Restore the printer configuration after replacing the controller board. See [“Restoring the printer configuration after replacing the controller board” on page 155](#).

Toner cartridge smart chip contact removal

- 1 Remove the top cover. See [“Top cover removal” on page 228](#).
- 2 Remove the right cover. See [“Right cover removal” on page 185](#).
- 3 Disconnect the cable JBARR1 from the controller board.

- 4 Remove the screw (A).

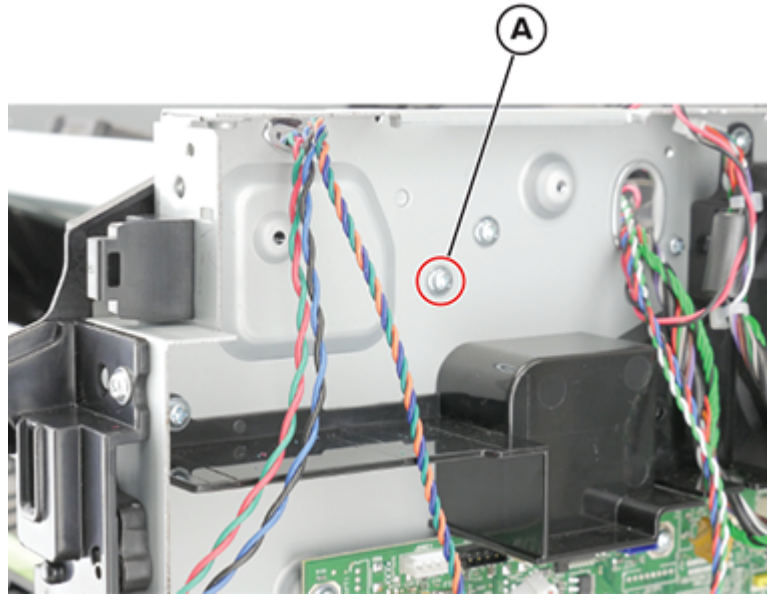

- 5 Remove the two screws (B), and then lower the right cartridge guide.

- 6 Slightly pull the right cartridge guide to detach it.

Note: The laser scanning unit frame (C) hinders the detachment.

Warning—Potential Damage: To avoid damaging the right cartridge guide, do not cut or disconnect the cable at the rear of the cartridge guide. Leave the cartridge guide dangling.

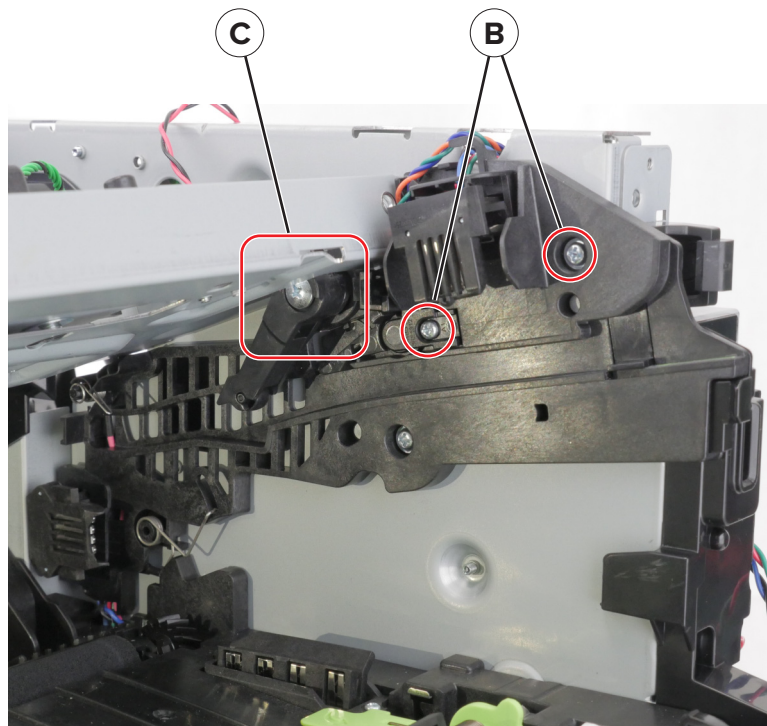

7 Release the four latches (E).

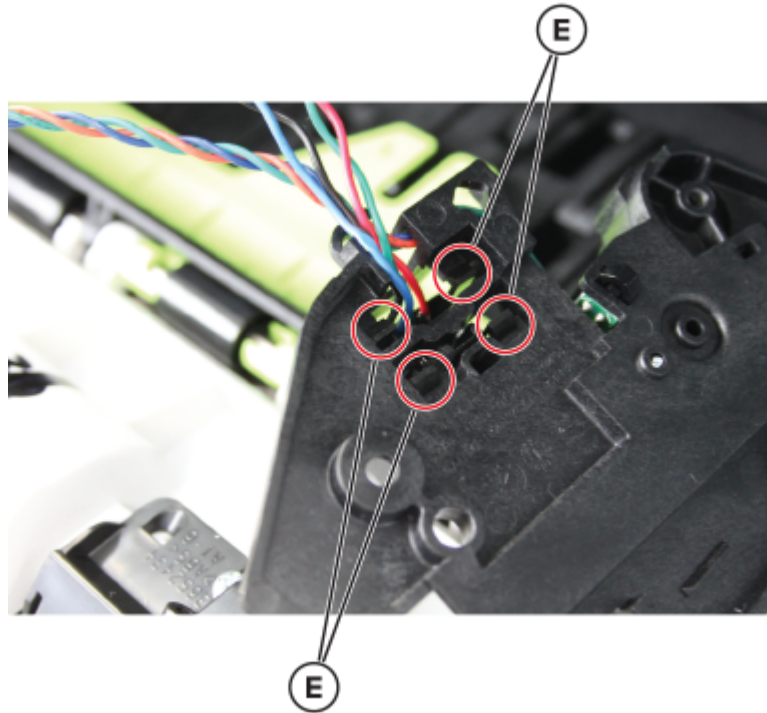

8 Remove the toner cartridge smart chip contact.

Note: Pay attention to the original position of the spring (F), actuator (G), and lock (H).

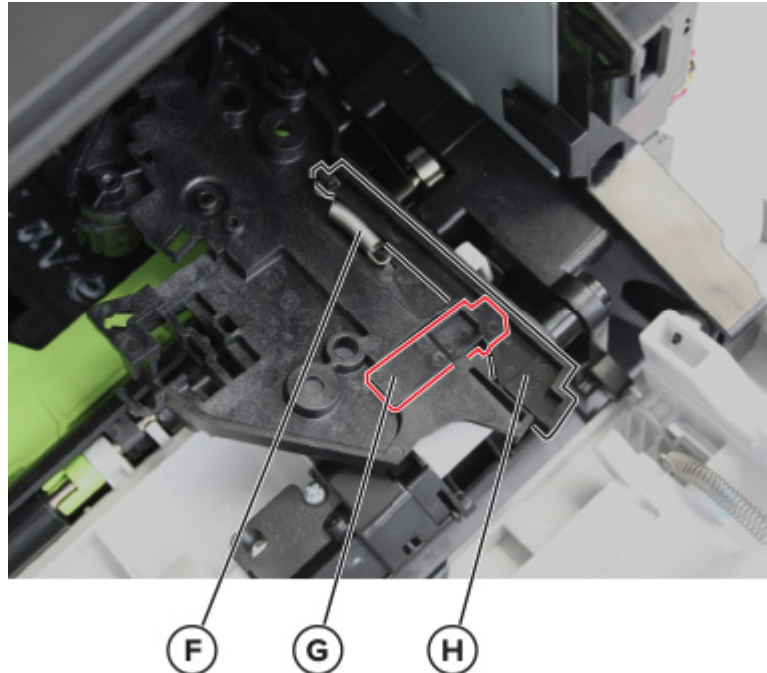

Installation notes:

- To test if the spring and actuator are properly installed, press the actuator (A). The lock (B) should move up.

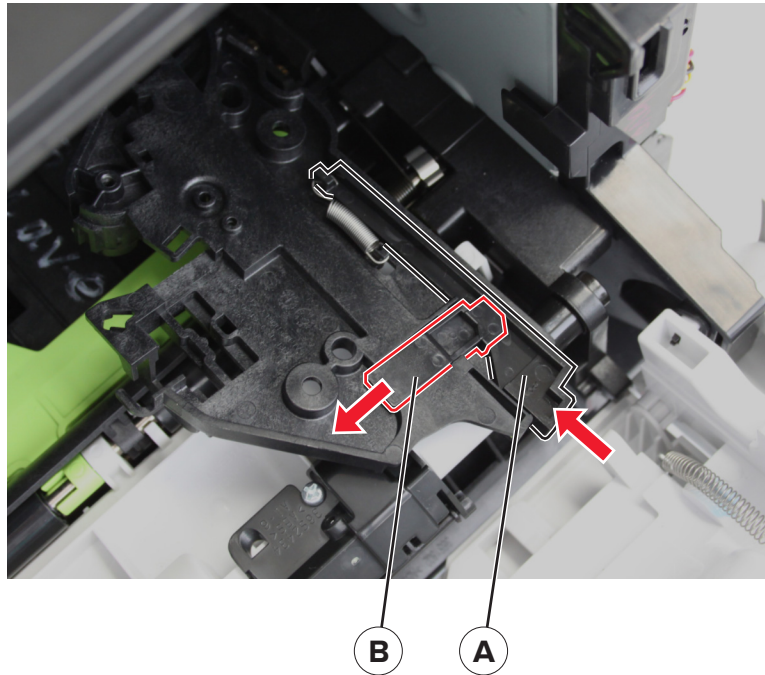

- Make sure that the tab (C) at the back of the cartridge guide is properly installed as shown.

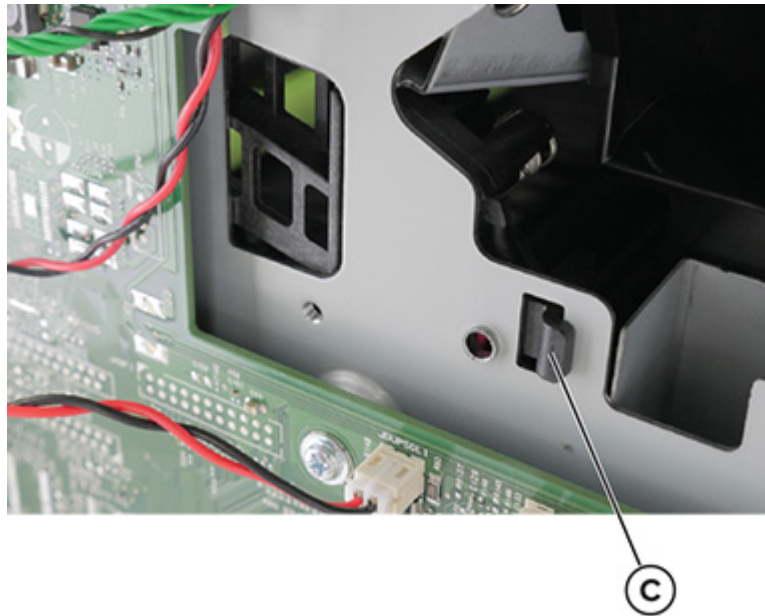
**Cartridge barrel shutter sensor kit removal**

- 1 Remove the top cover. See [“Top cover removal” on page 228](#).
- 2 Remove the right cover. See [“Right cover removal” on page 185](#).
- 3 Disconnect the cable JCVR1 from the controller board.

- 4 Remove the screw (A), and then remove the bracket, actuator, spring, and sensor.

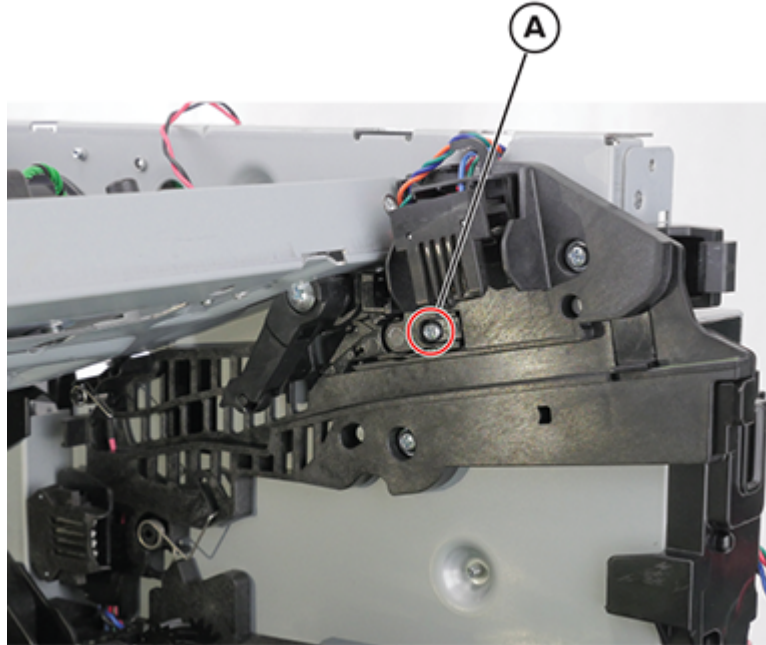

Installation notes:

- a Install the sensor (cartridge barrel shutter) actuator (A) as shown.

Note: Make sure that the spring (B) is behind the boss (C).

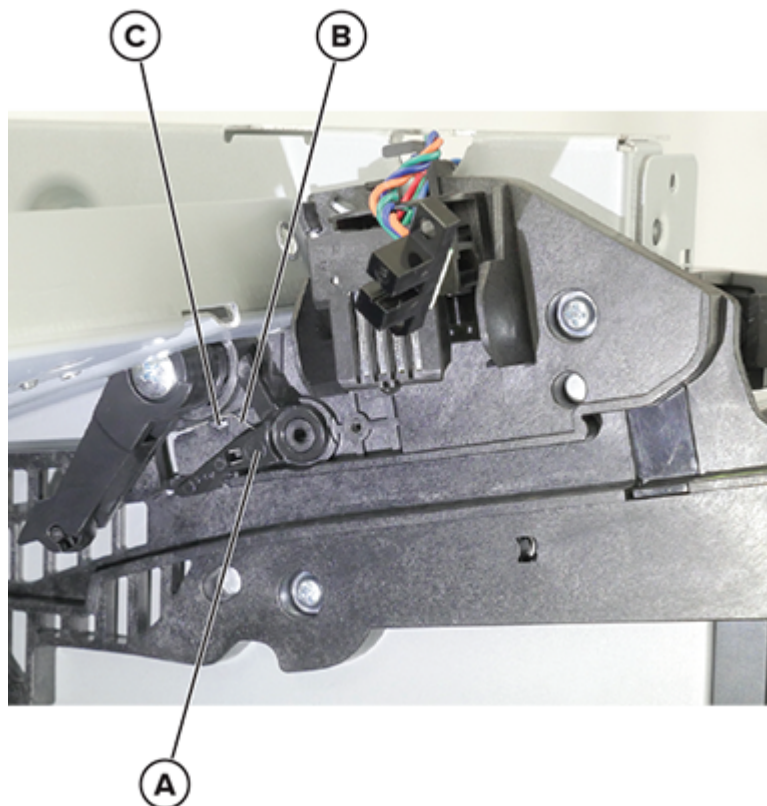

b Install the bracket (D) to the sensor (E) as shown.

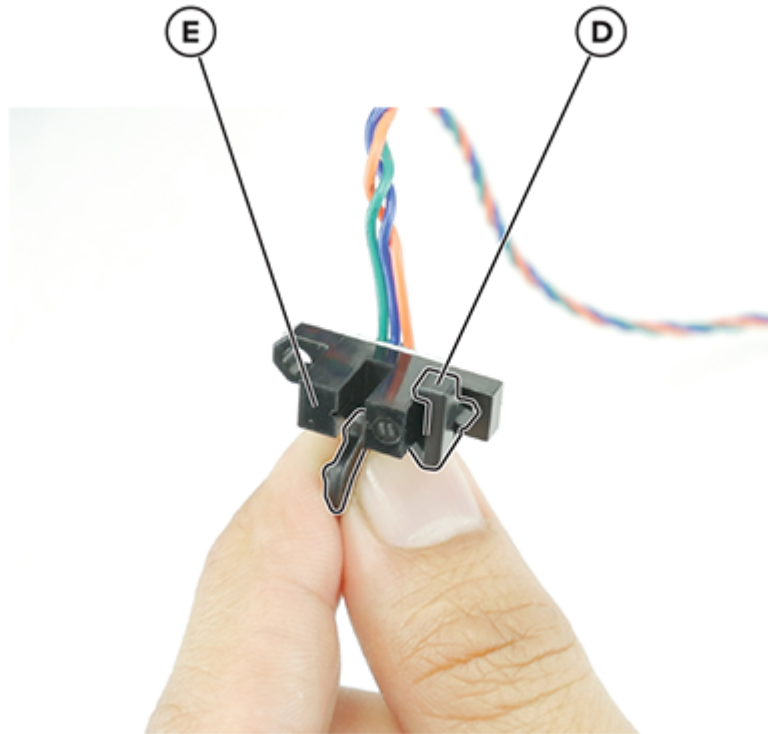

c Install the sensor and bracket as shown.

Note: Make sure that sensor is aligned with the actuator.

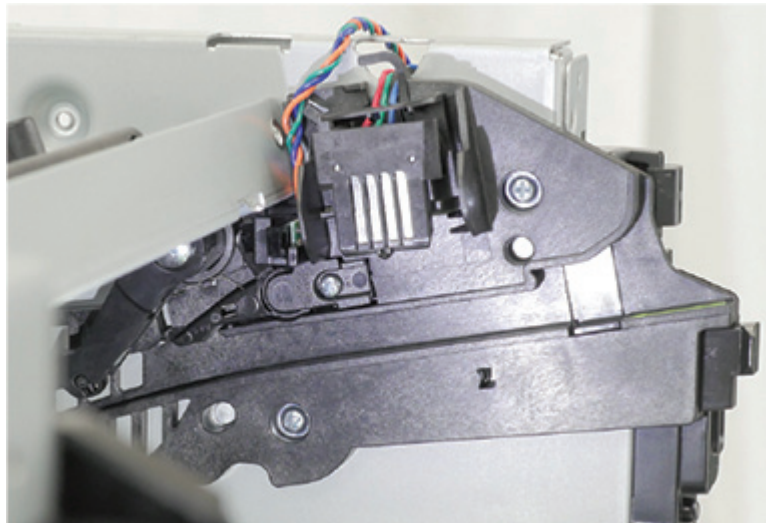

Front removals

Nameplate removal

- 1 Open the front door.
- 2 Push the latch to the left, and then remove the screw (A).
- 3 Remove the four screws (B).
- 4 Remove the nameplate.

Note: The MPF hinders the removal.

Warning—Potential Damage: Avoid damaging the cable (C) when removing the nameplate.

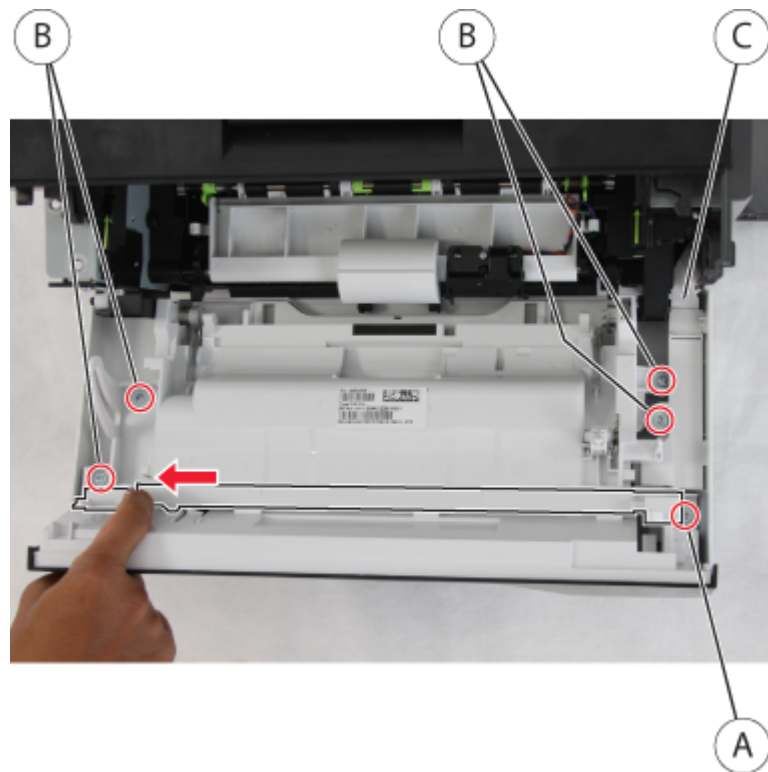

MPF with front access cover removal

- 1 Remove the right cover. See [“Right cover removal” on page 185.](#)
- 2 Remove the nameplate. See [“Nameplate removal” on page 198.](#)

3 Release the latch (A), and then detach the link.

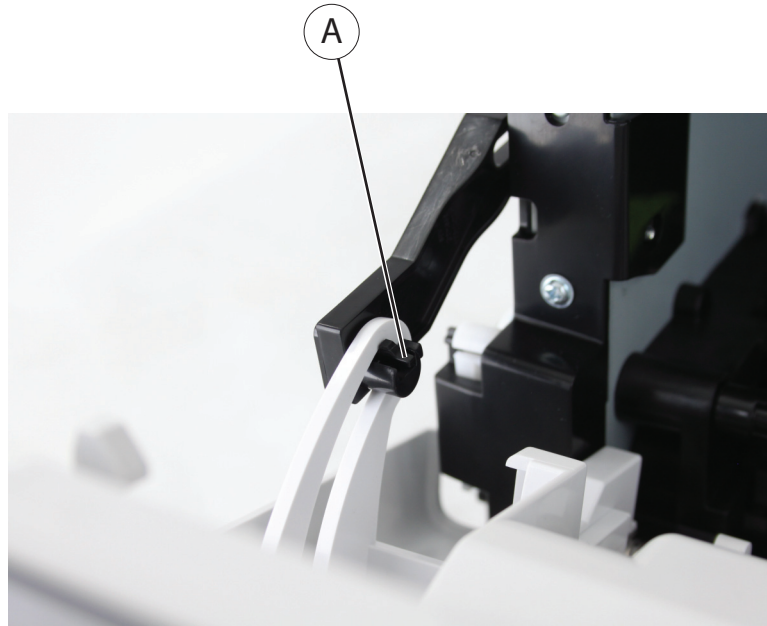

4 Disconnect the cable (B) on the controller board, and then remove the ground screw (C).

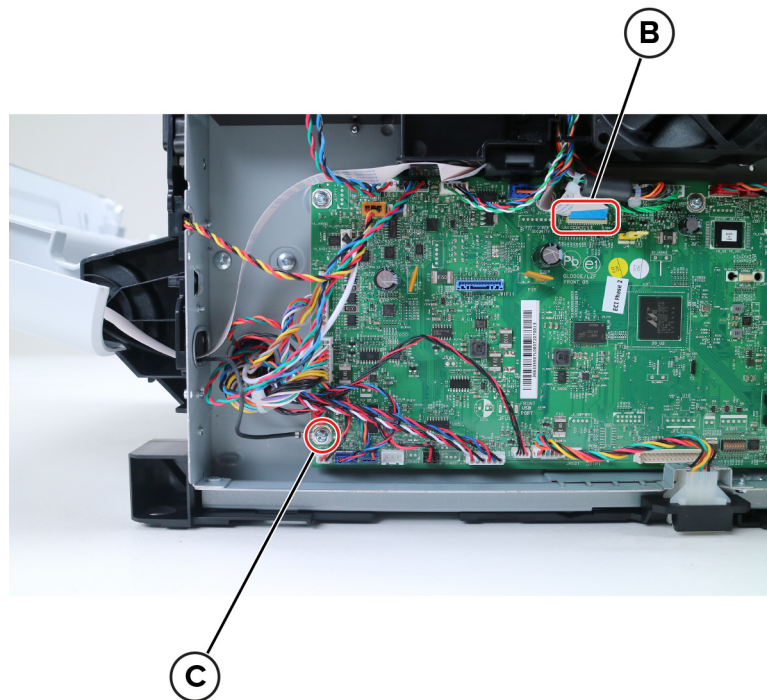

- 5 Push the MPF with front access cover to the right, and then remove it.

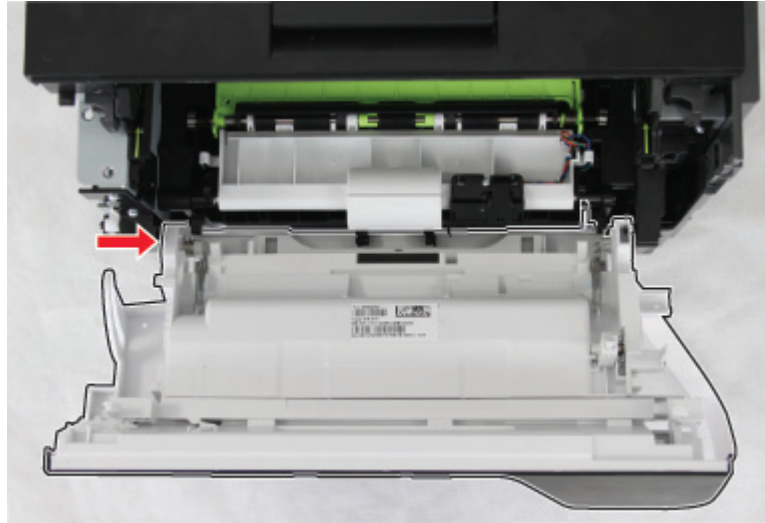

Control panel assembly removal

- 1 Remove the nameplate. See [“Nameplate removal” on page 198](#).
- 2 Open the controller board access cover, and then disconnect the control panel cable.
- 3 Remove the three screws (A) and the bezel (B).

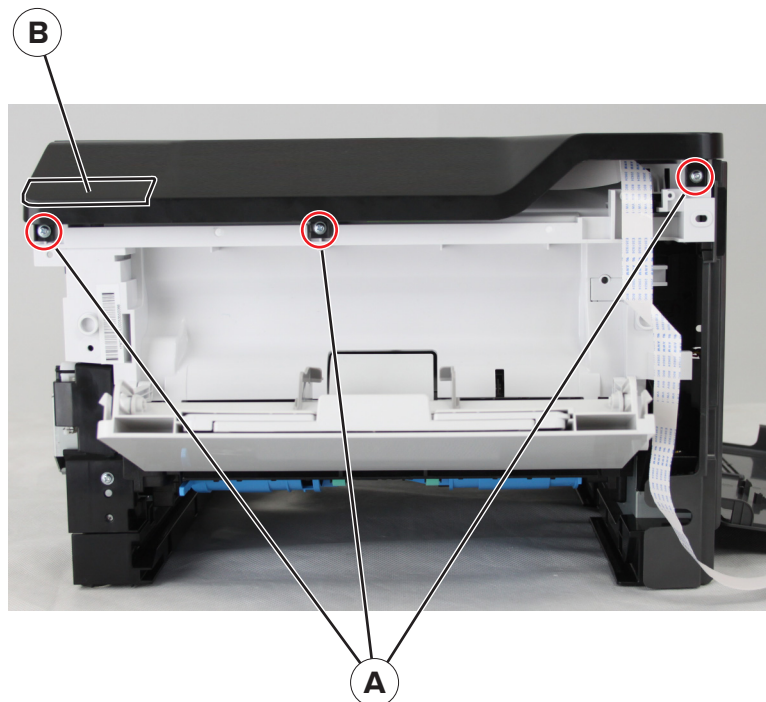

- 4 Remove the control panel assembly.

Control panel (2.4 inch display) flat cable removal

- 1 Remove the control panel assembly. See [“Control panel assembly removal” on page 200](#).
- 2 Disconnect the cable (A).

Warning—Potential Damage: The ribbon cable and its socket may get damaged if it is not properly disconnected. When disconnecting the cable, hold its connector and press its tab before unplugging it.

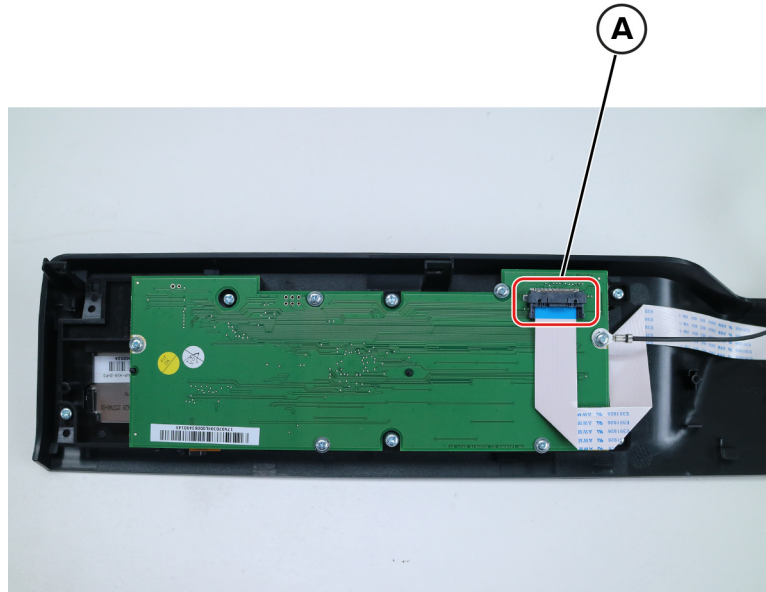

Control panel (2.4 inch display) cover, buttons, and board removal

- 1 Remove the control panel assembly. See [“Control panel assembly removal” on page 200](#).
- 2 Disconnect the cable (A), and then remove the 12 screws (B).

Warning—Potential Damage: The ribbon cable and its socket may get damaged if it is not properly disconnected. When disconnecting the cable, hold its connector and press its tab before unplugging it.

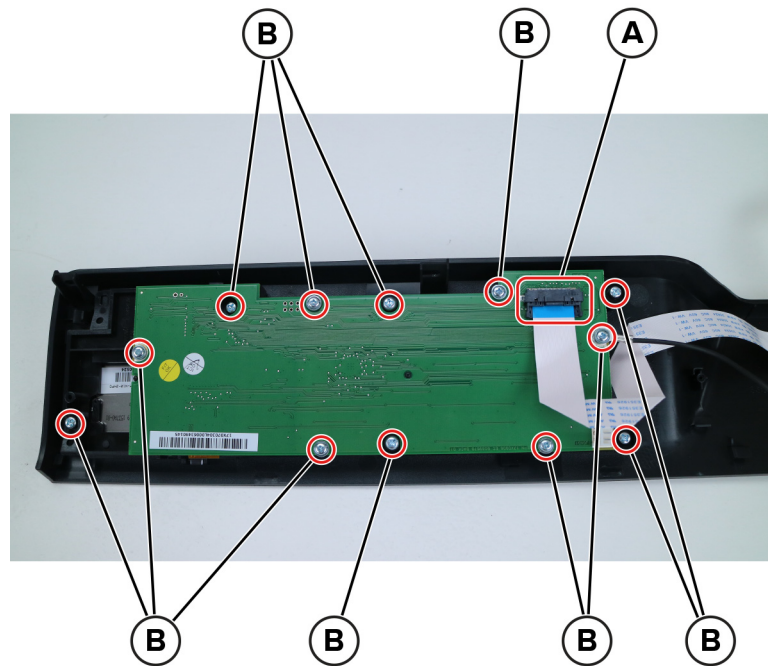

3 Remove the cover, buttons, and board.

Control panel display (2-line) removal

Note: Use a #1 Phillips screwdriver to remove all the screws.

- 1** Remove the control panel assembly. See [“Control panel assembly removal” on page 200](#).
- 2** Remove the four screws (A).
- 3** Disconnect the cable (B), and then remove the display.

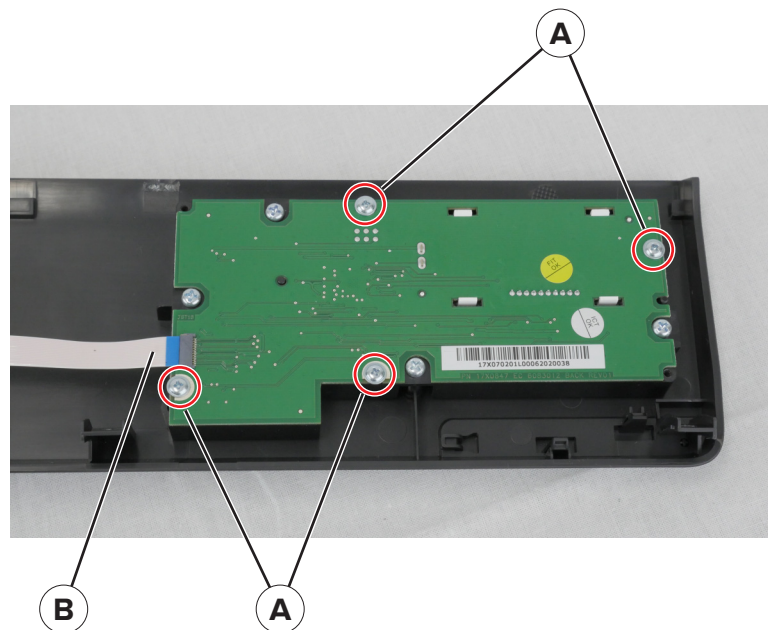

Parts removal

Transfer roller removal

1 Open the front door.

 **CAUTION—HOT SURFACE:** The inside of the printer might be hot. To reduce the risk of injury from a hot component, allow the surface to cool before touching it.

2 Release the two latches (A) on each end of the transfer roller.

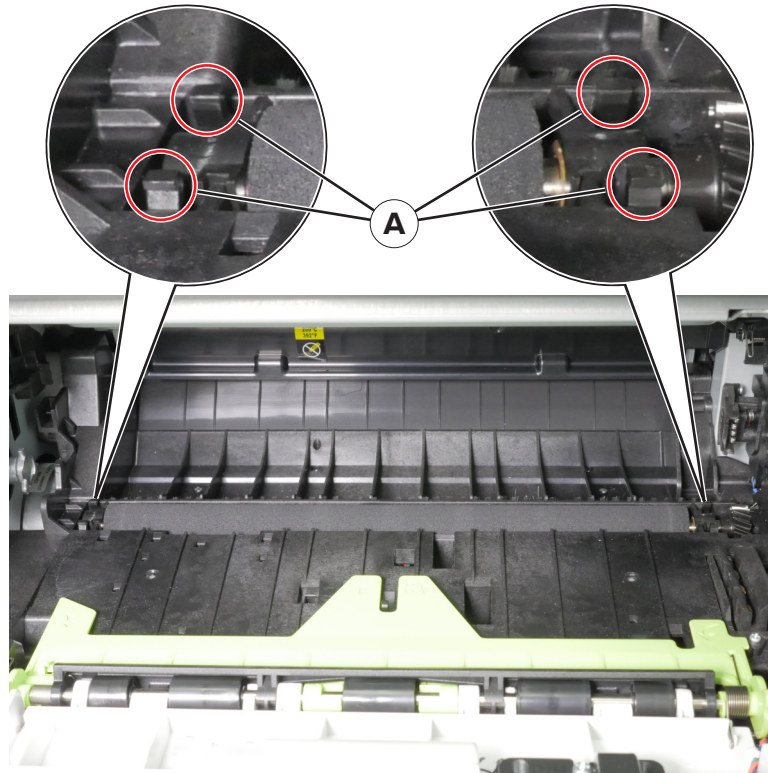

3 Remove the roller.

Jam access cover removal

1 Open the front door.

2 Remove the screw (A), and then release the cable from the jam access cover.

3 Push down, and then pull the two ends (B) of the springs to remove them.

4 Repeat step 3 for the other side.

5 Release the two latches (C).

6 Remove the clip (D).

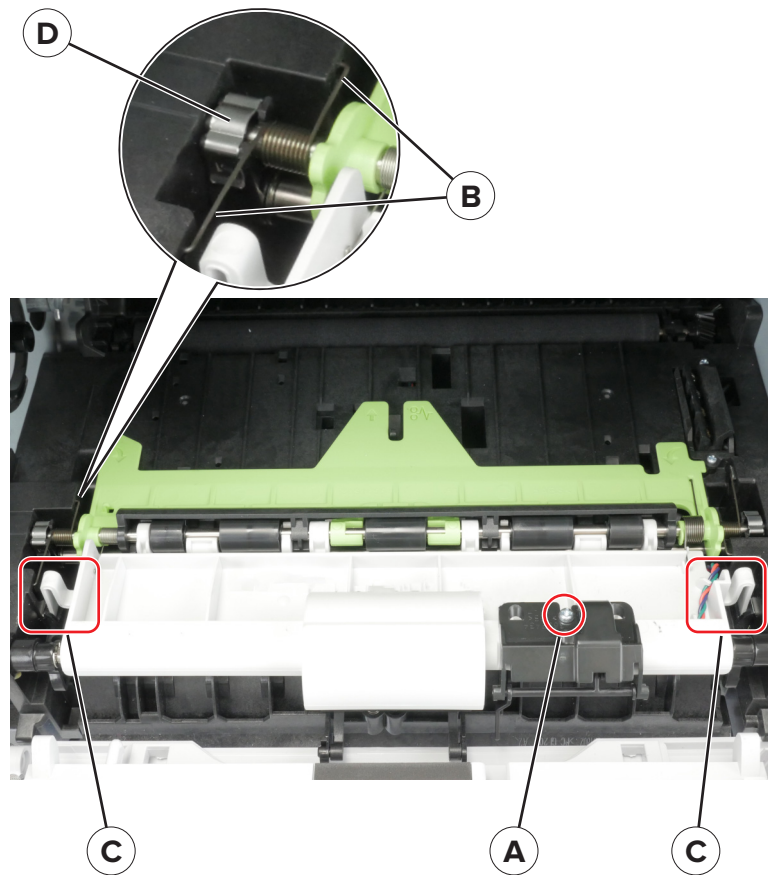

7 Remove the cover.

Sensor (front door) removal

- 1** Remove the nameplate. See [“Nameplate removal” on page 198](#).
- 2** Remove the right cover. See [“Right cover removal” on page 185](#).
- 3** Disconnect the JCVR1 and control panel cables from the controller board.

4 Remove the four screws (A).

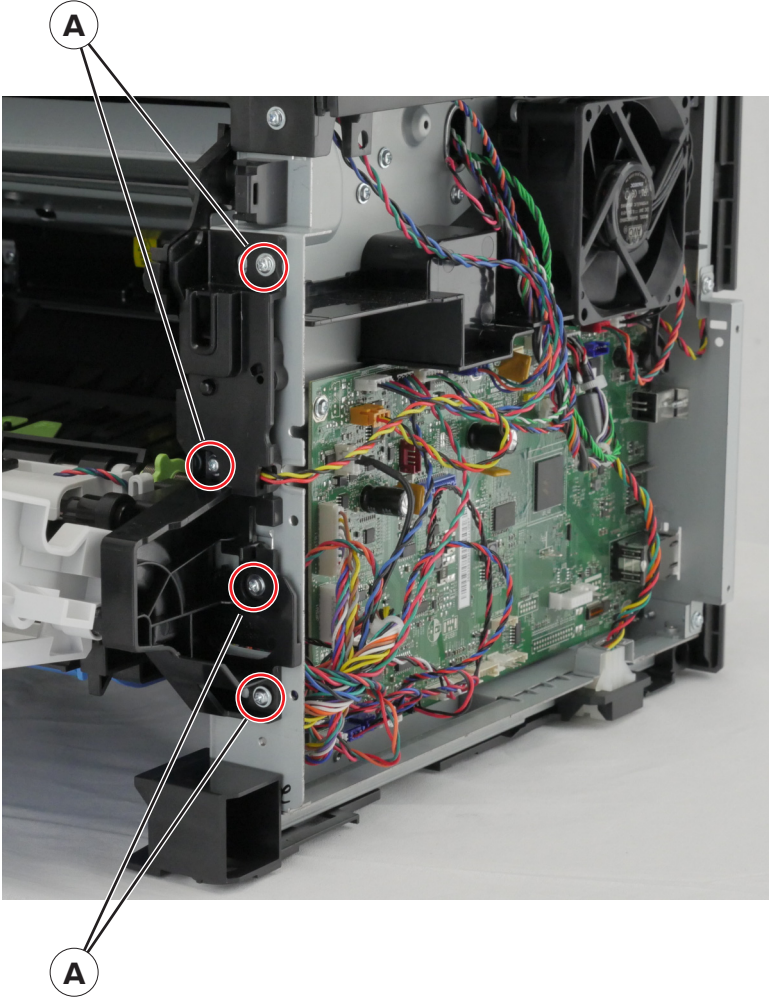

- 5 Using a #1 Phillips screwdriver, remove the screw (B).

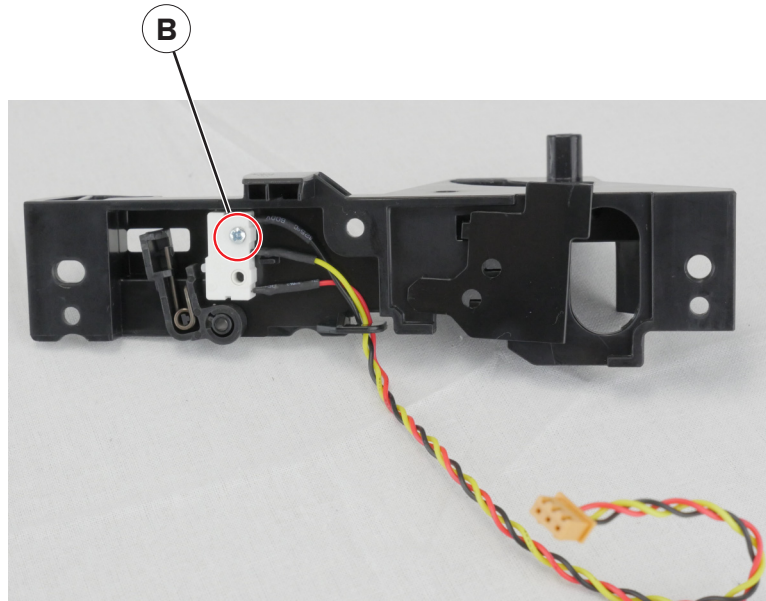

- 6 Remove the sensor.

MPF pick roller and separator pad removal

- 1 Open the front door.
- 2 Press the latches (A), and then open the cover.

Warning—Potential Damage: Avoid damaging the MPF sensor flag (B) when removing the cover.

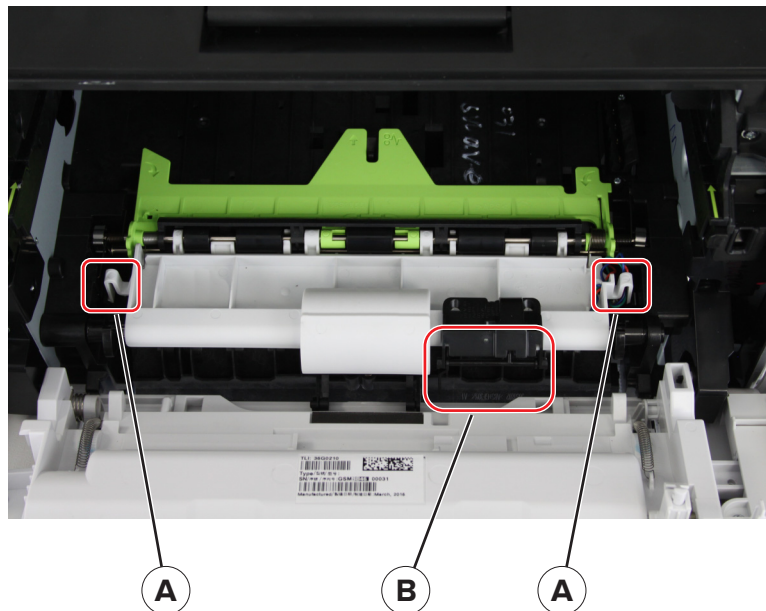

- 3 Using a #1 Phillips screwdriver, remove the two screws (C).

4 Hold the end of the shaft (D), and then pull out the roller to remove it.

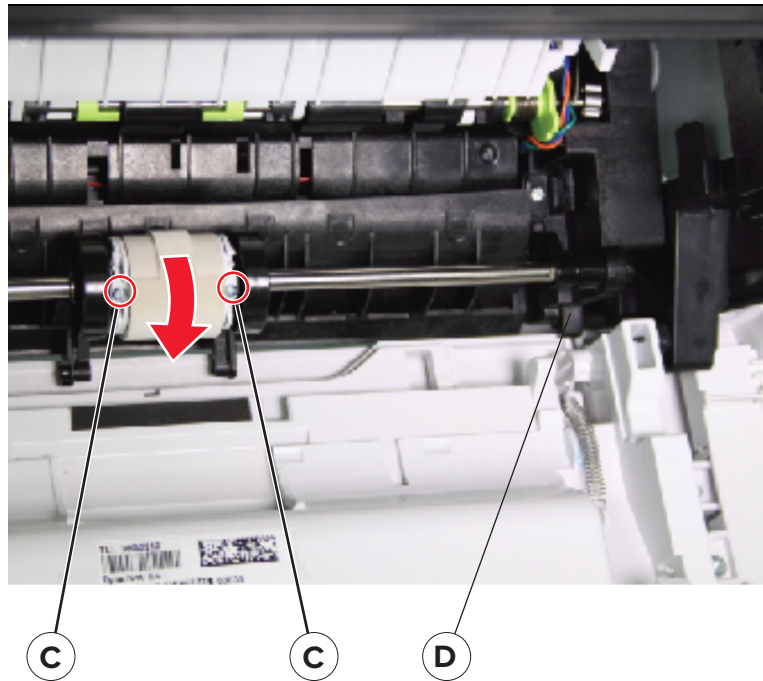

5 Remove the two E-clips (A).

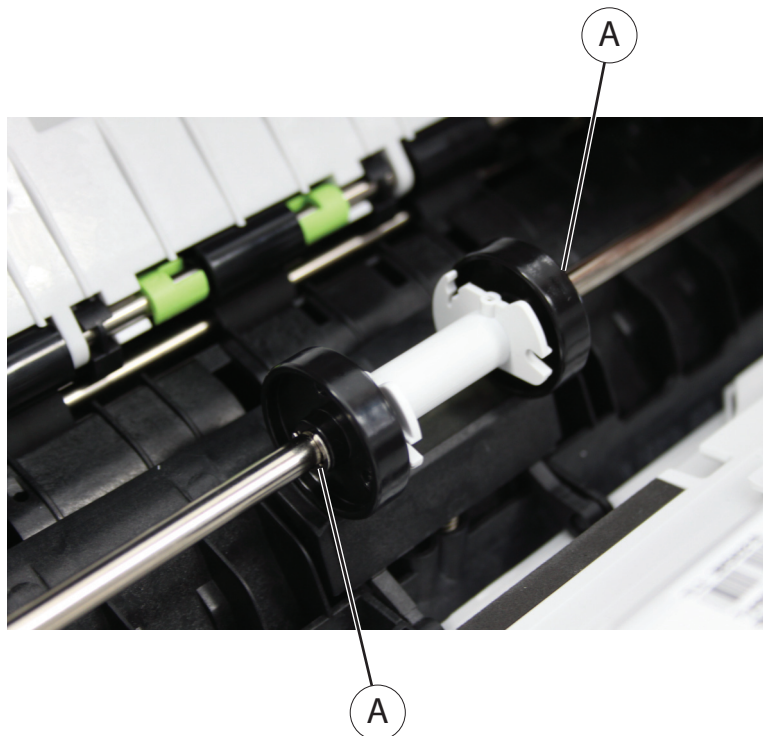

6 Move the roller (B) to the left, and then remove the pin (C).

7 Move the hub (D) and roller (E) to the right.

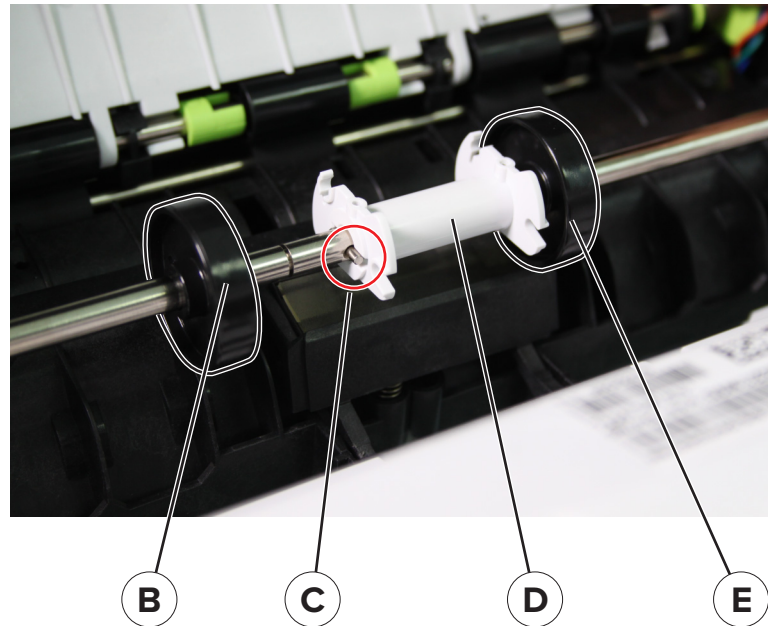

8 Push the separator pad (F) to the right.

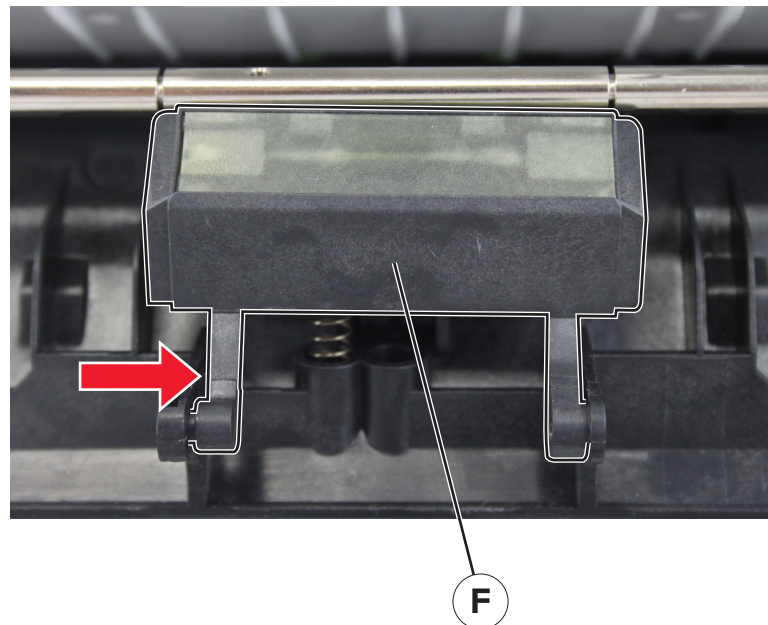

9 Push down the pad to remove it.

Warning—Potential Damage: Do not lose the spring (G).

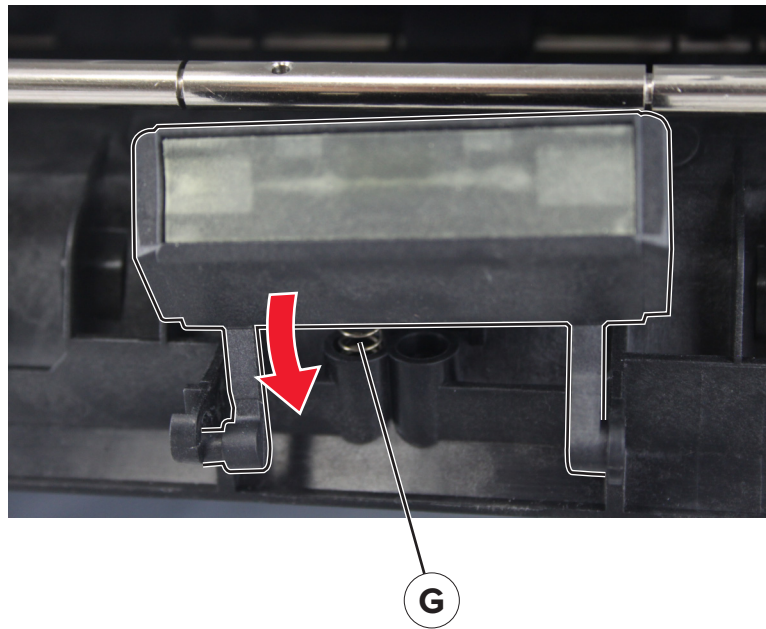

Sensor (MPF paper present) removal

- 1 Open the front door.
- 2 Remove the screw (A).

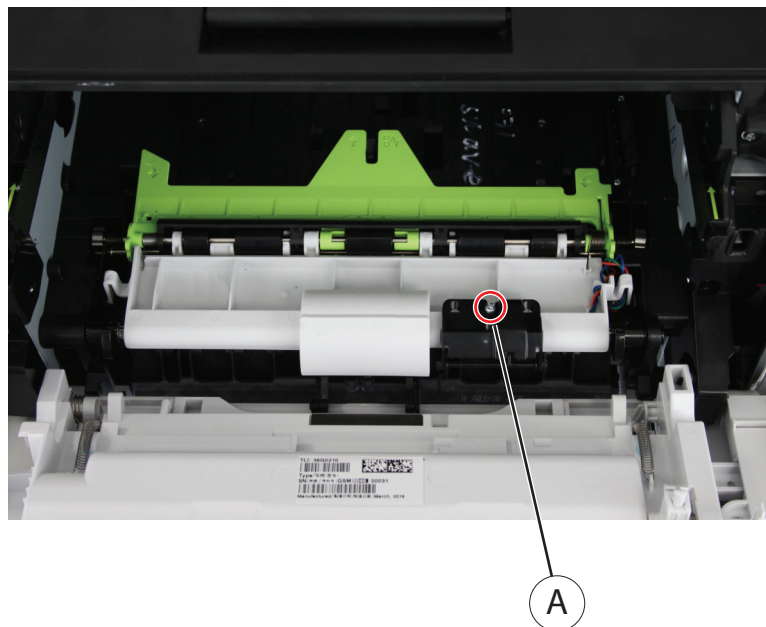

- 3 Open the controller board access cover, disconnect the cable JMPFPP1, and then release the cable.
- 4 Remove the sensor.

Installation note: Pay attention to the position of the MPF sensor flag when installing the sensor.

Front input guide removal

- 1 Remove the MPF with front access cover. See [“MPF with front access cover removal” on page 198](#).
- 2 Remove the MPF pick roller and separator pad. See [“MPF pick roller and separator pad removal” on page 206](#).
- 3 Remove the two screws (A).

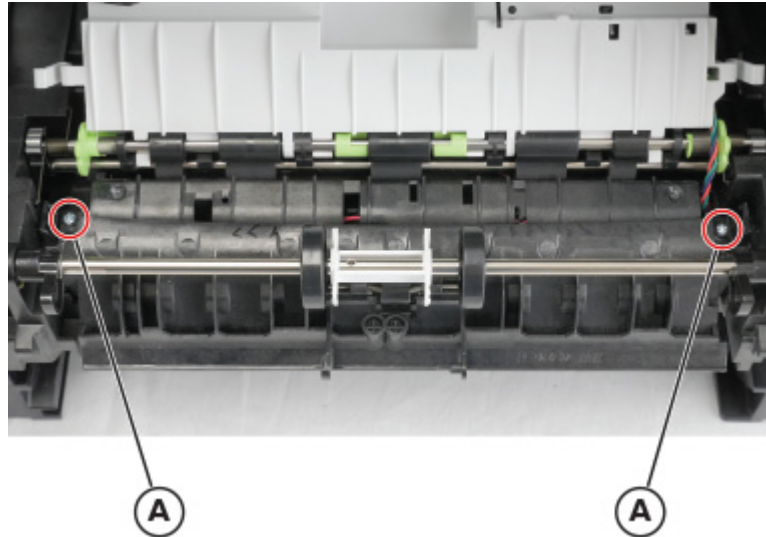

- 4 Remove the input guide.

Bottom removals

Power supply removal

⚠ CAUTION—POTENTIAL INJURY: This product uses a soft power switch. It does not physically disconnect the input AC voltage. To avoid the risk of electrical shock, always remove the power cord from the printer when removal of the input AC voltage is required.

⚠ CAUTION—SHOCK HAZARD: The low-voltage power supply (LVPS) may have residual voltage present. To avoid the risk of electrical shock, do not touch its circuit components. Only handle it by its metal housing.

- 1 Remove the rear cover. See [“Rear door and cover removal” on page 224](#).
- 2 Disconnect the cable (A), and then remove the screws (B).

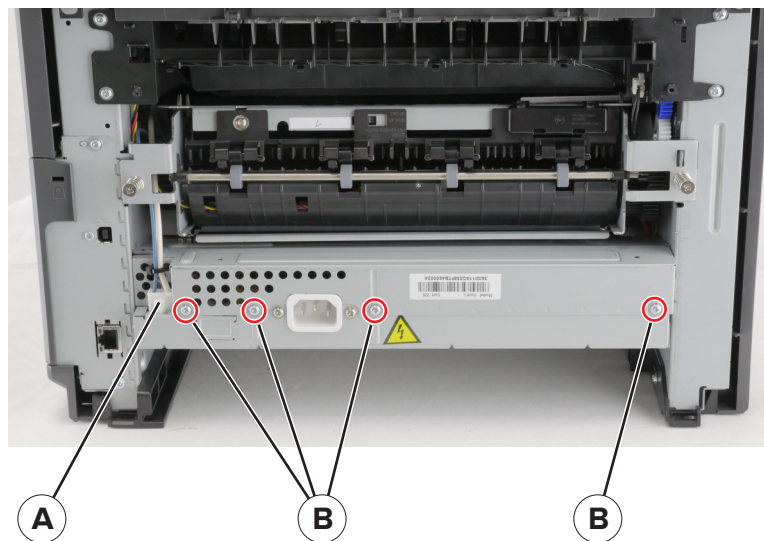

3 Disconnect the cable (C) under the printer, and then remove the two screws (D).

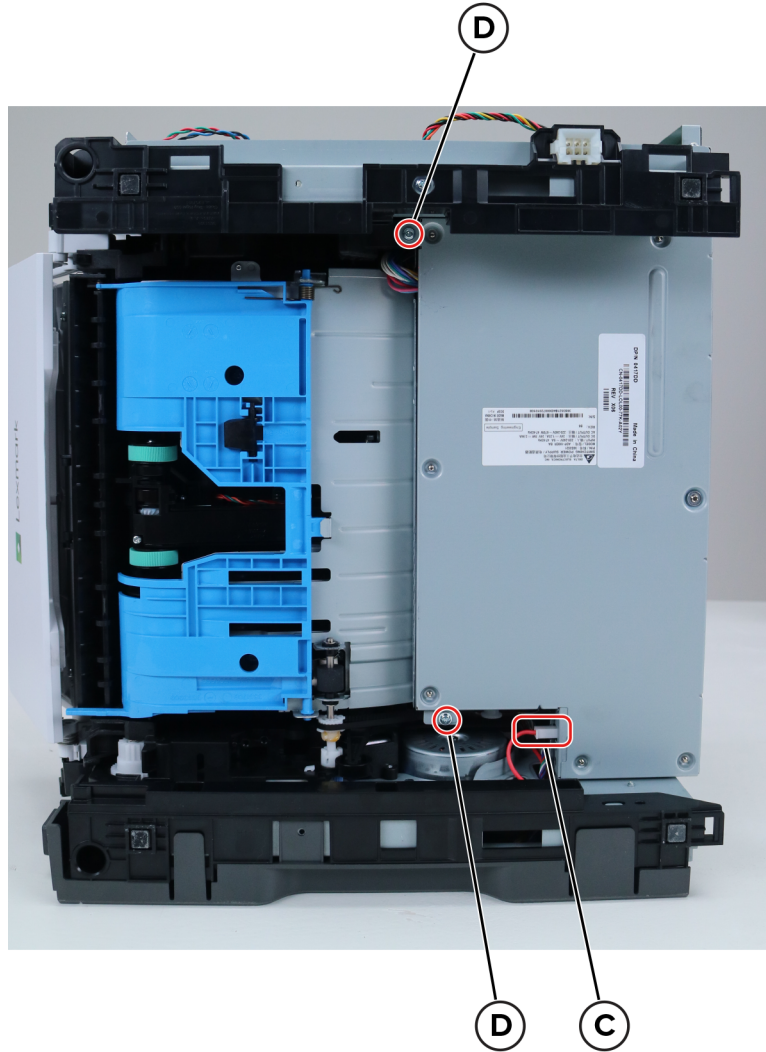

4 Disconnect the three cables (E).

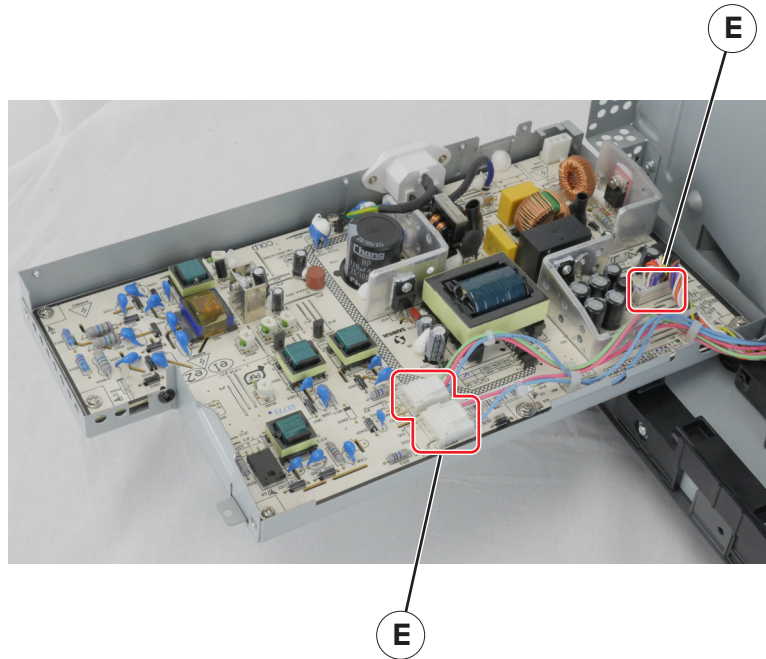

5 Remove the power supply.

Duplex assembly removal

- 1 Remove the rear cover. See [“Rear door and cover removal” on page 224.](#)
- 2 Remove the power supply. See [“Power supply removal” on page 211.](#)
- 3 Position the printer on its right side.

- 4 Remove the two screws (A) and the screw (B) on the left side of the printer.



- 5 Remove the power supply shield.
6 Remove the four screws (C).
7 Remove the duplex.

Note: Make sure that the duplex link (D) stays attached to the duplex assembly.

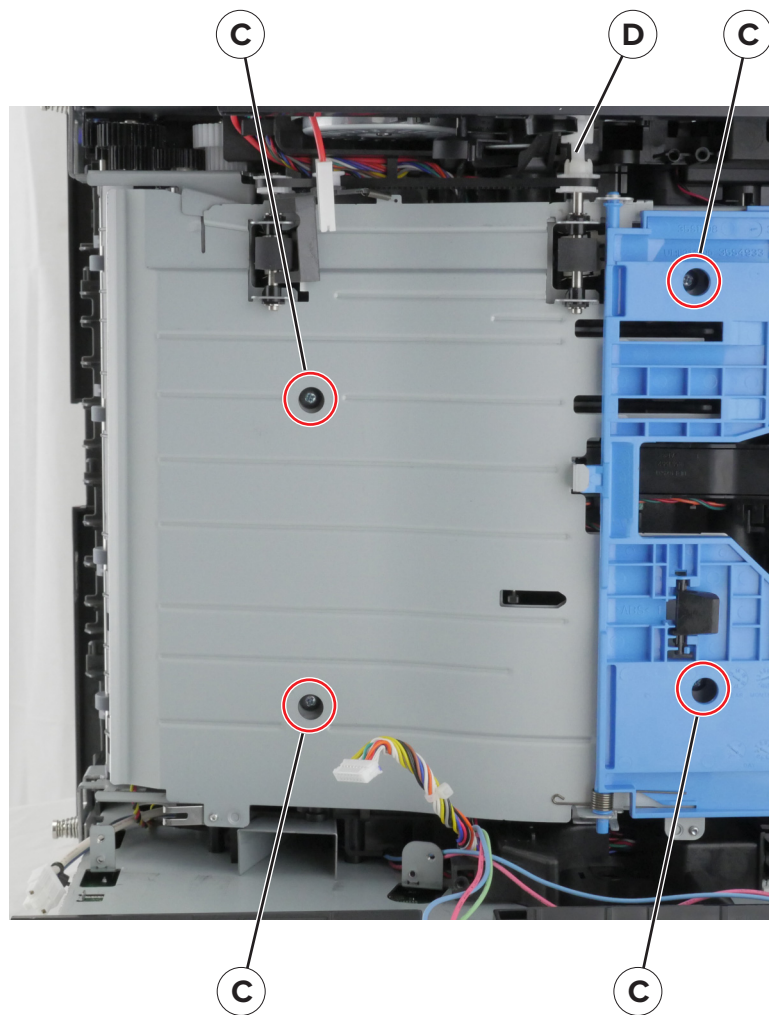

Sensors (duplex and input) removal

- 1 Remove the rear cover. See [“Rear door and cover removal” on page 224.](#)
- 2 Remove the power supply. See [“Power supply removal” on page 211.](#)
- 3 Remove the duplex. See [“Duplex assembly removal” on page 213.](#)

4 Remove the two screws (A), cut the cable near the frame, and then remove the sensors.

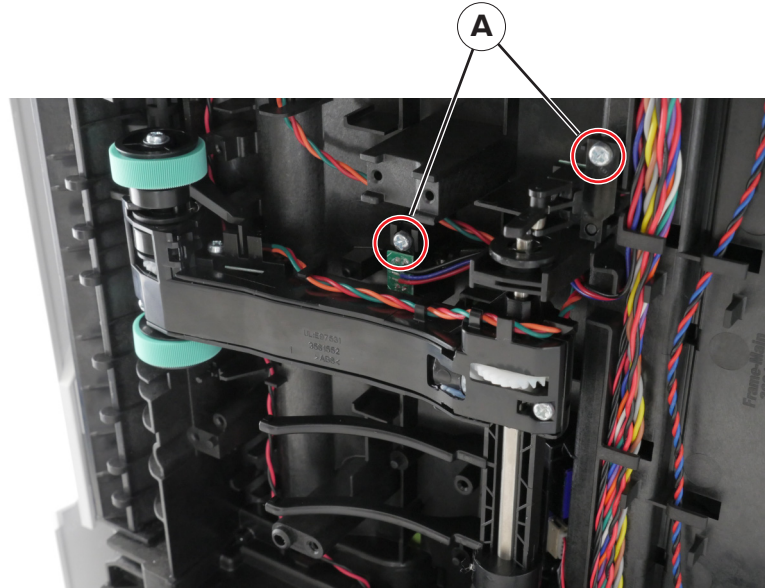

5 Open the controller board access cover, and then disconnect the cable JDUPPI1.

6 Remove the cables.

Installation note: Route the sensor (input) cable (A) and sensor (duplex) cable (B) as shown.

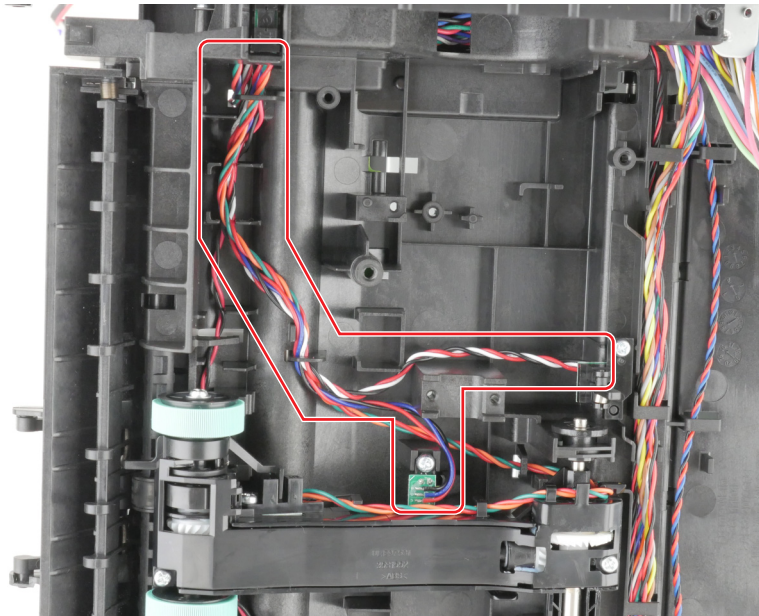

Sensor (toner density) removal

- 1 Remove the rear cover. See [“Rear door and cover removal” on page 224.](#)
- 2 Remove the power supply. See [“Power supply removal” on page 211.](#)
- 3 Remove the duplex. See [“Duplex assembly removal” on page 213.](#)

- 4 Position the printer on its left side.
- 5 Remove the spring (A) and the two screws (B).

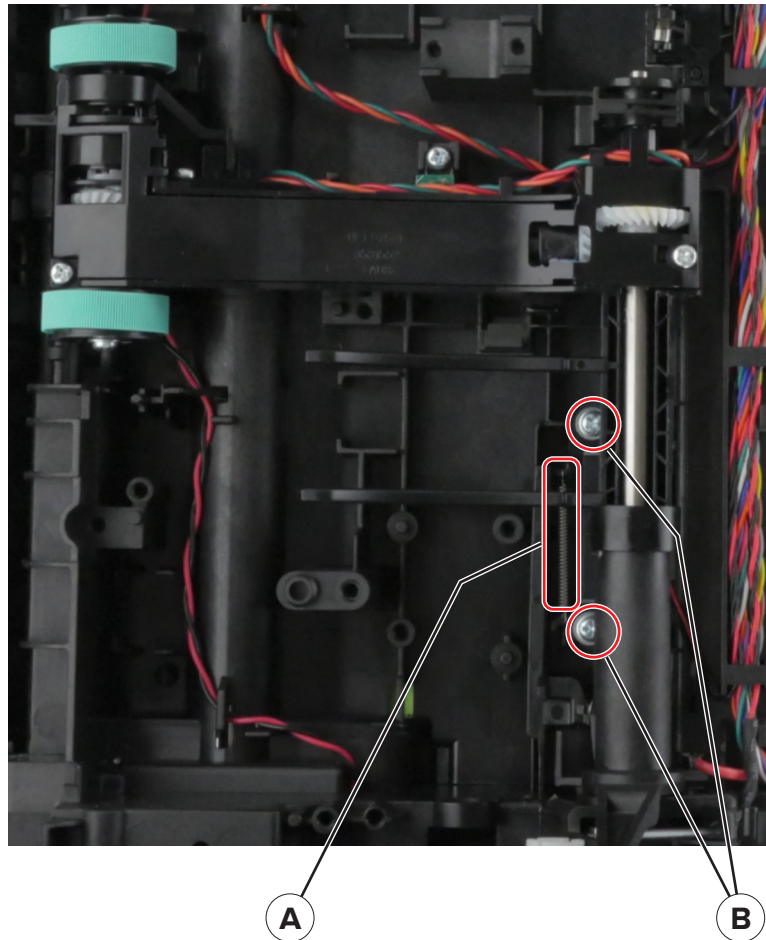

- 6 Disconnect the cable, and then remove the sensor.

Installation notes:

- a Apply RheoGel 793 to the top and bottom of the shutter blade extension.

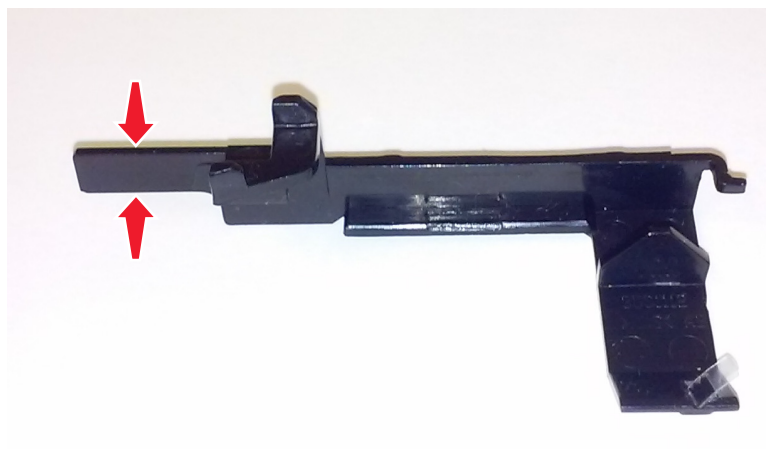

- b Apply RheoGel 793 to the point of contact between the bracket (A) and cam.

- c Apply RheoGel 793 to the point of contact to the lower edge (B), where the wiper bracket glides.

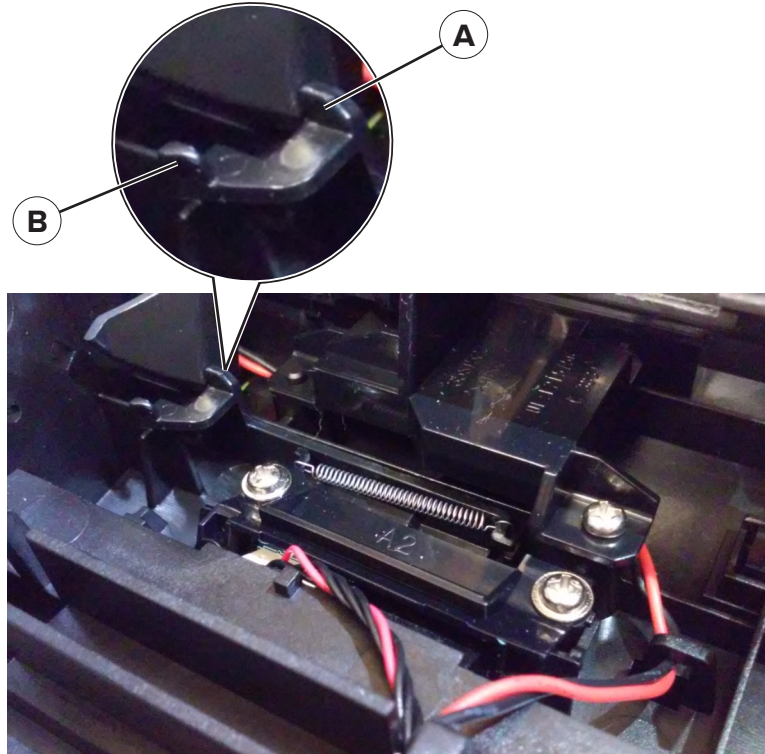

Sensor (trailing edge) removal

- 1 Remove the left cover. See [“Left cover removal” on page 173.](#)
- 2 Remove the rear cover. See [“Rear door and cover removal” on page 224.](#)
- 3 Remove the power supply. See [“Power supply removal” on page 211.](#)
- 4 Remove the duplex assembly. See [“Duplex assembly removal” on page 213.](#)
- 5 Position the printer on its left side.
- 6 Open the controller board access cover.
- 7 Disconnect the cable JACM1, and then release the cable.

- 8 Remove the screw (A) and the sensor.

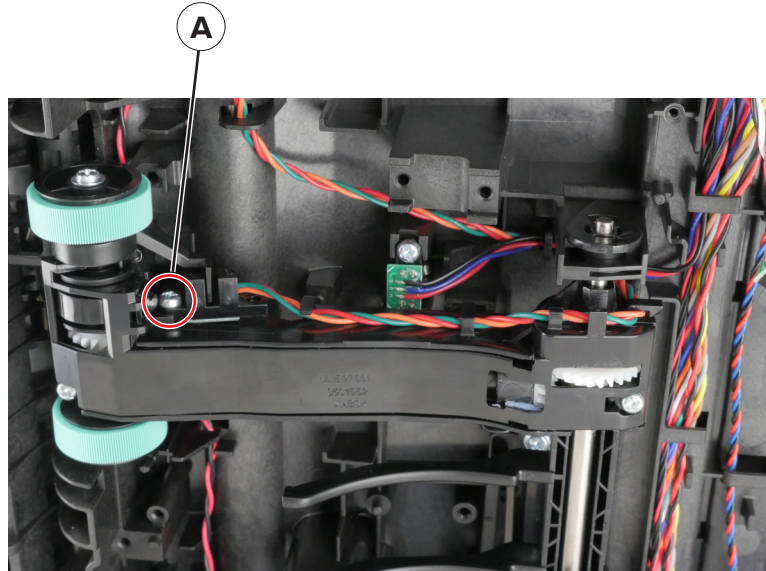

- 9 Remove the cable JACM1.

Pick roller assembly removal

- 1 Remove the left cover. See [“Left cover removal” on page 173.](#)
- 2 Remove the main drive gearbox. See [“Main drive gearbox removal” on page 174.](#)
- 3 Remove the rear cover. See [“Rear door and cover removal” on page 224.](#)
- 4 Remove the power supply. See [“Power supply removal” on page 211.](#)
- 5 Remove the duplex. See [“Duplex assembly removal” on page 213.](#)
- 6 Position the printer on its right side.
- 7 Using needle-nose pliers, block the roller (A) to prevent it from rotating.

8 While blocking the roller, remove the screw (B).

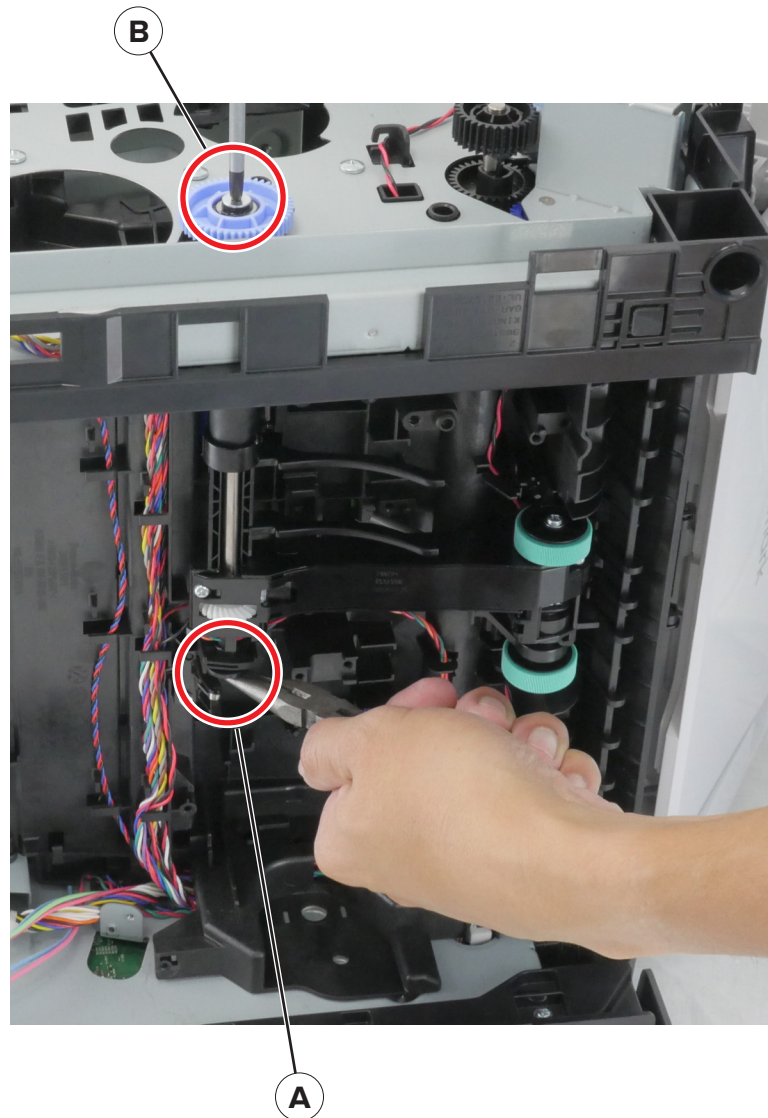

9 Release the pick roller clutch cable.

10 Pull out the clutch, and then leave it hanging.

11 Pry, rotate, and then remove the bushing (C).

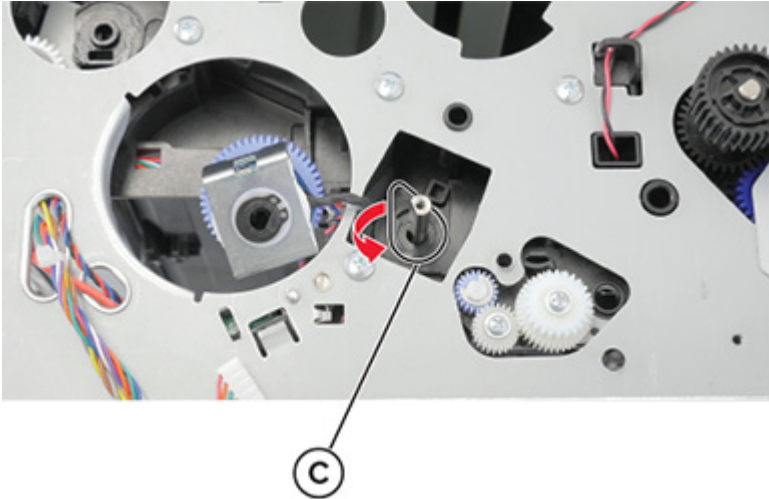

12 Remove the two screws (D), and then detach the sensors.

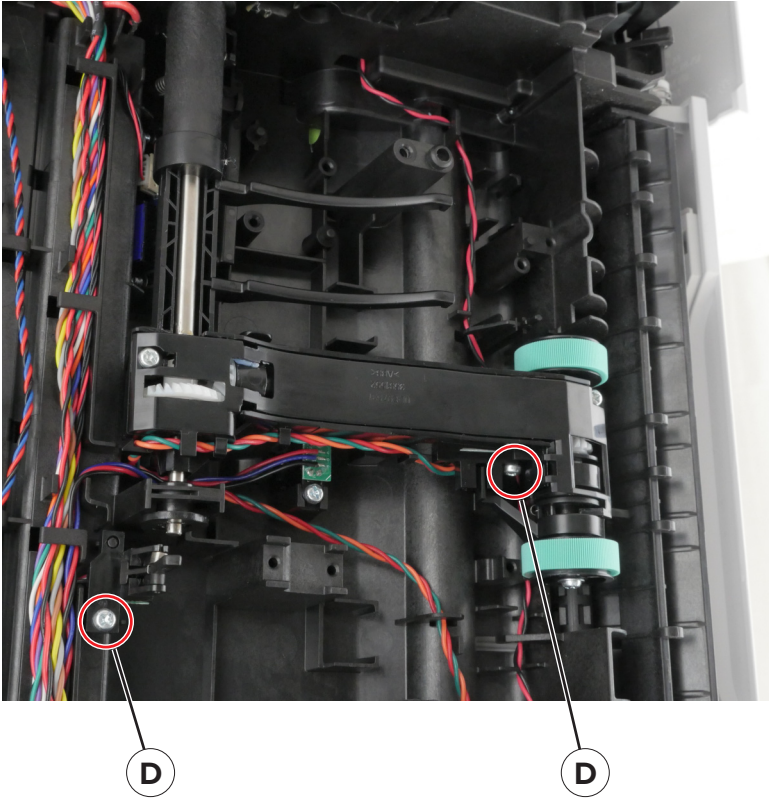

13 Disconnect the two springs (E).

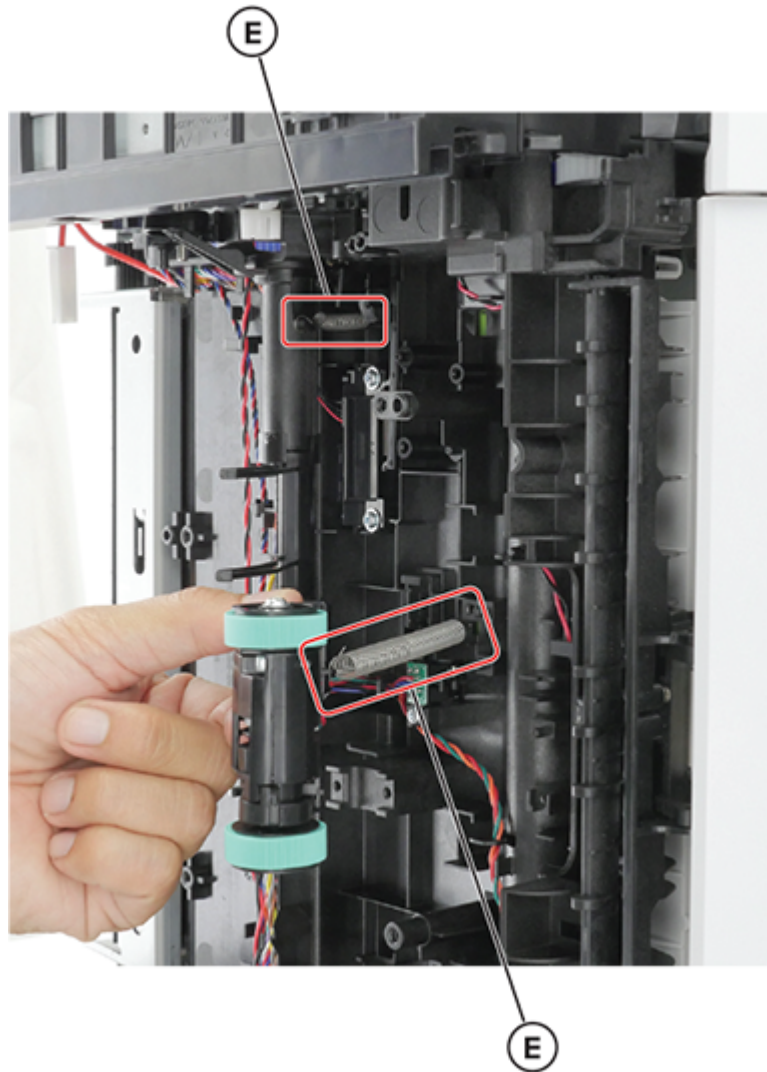

14 Pry, rotate, and then remove the bushing (F).

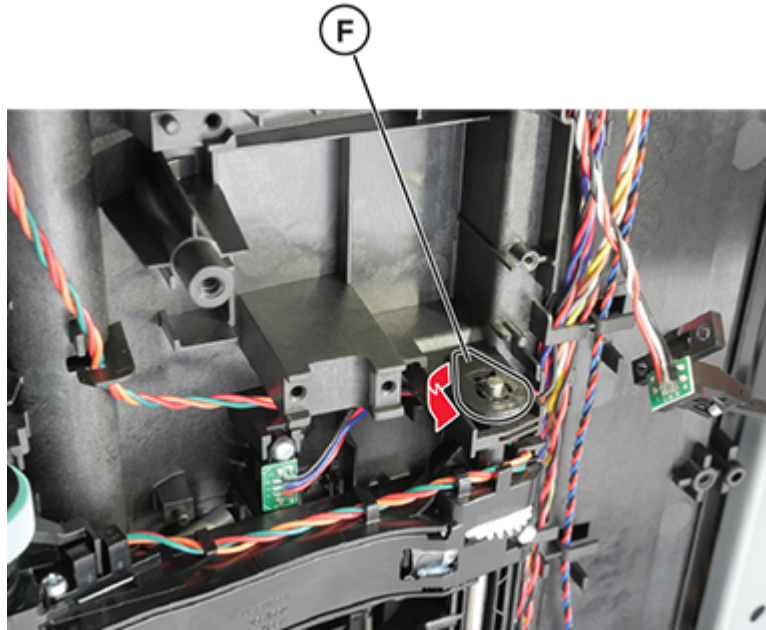

15 Pull out the shaft, and then remove the pick roller assembly.

Rear side removals

Rear door and cover removal

- 1 Open the rear door.

 **CAUTION—HOT SURFACE:** The inside of the printer might be hot. To reduce the risk of injury from a hot component, allow the surface to cool before touching it.

- 2 Remove the two screws (A).

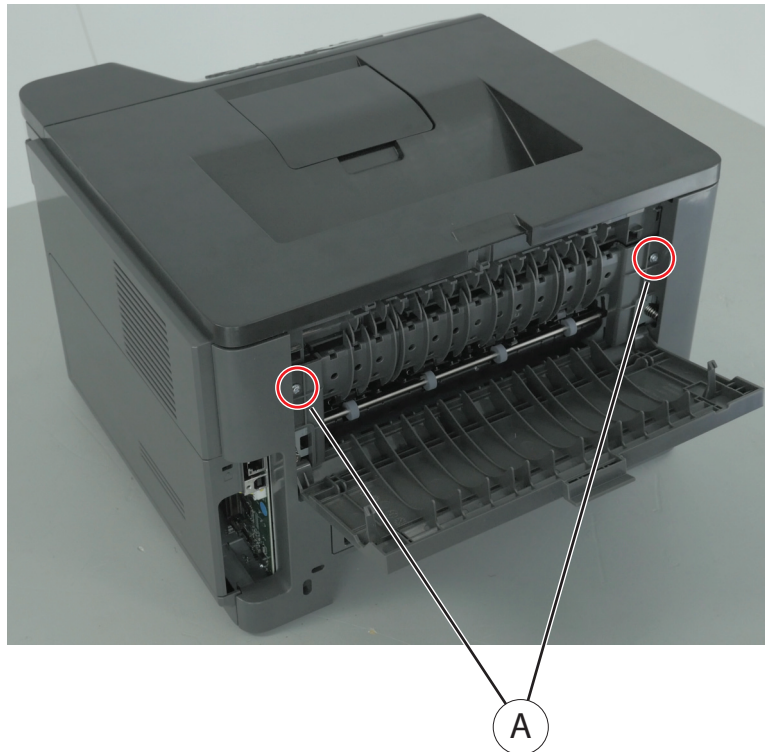

- 3 Remove the rear door and cover.

Fuser removal

- 1 Remove the rear cover. See [“Rear door and cover removal” on page 224](#).

 **CAUTION—HOT SURFACE:** The inside of the printer might be hot. To reduce the risk of injury from a hot component, allow the surface to cool before touching it.

- 2 Remove the right cover. See [“Right cover removal” on page 185](#).
- 3 Disconnect the cable JEXIT1.

4 Disconnect the two cables (A), and then remove the two screws (B).

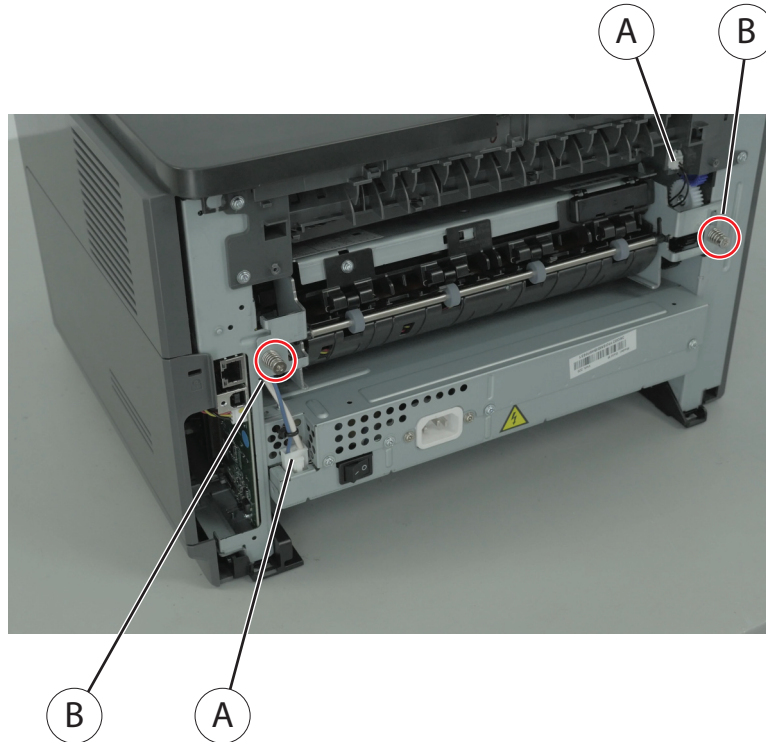

5 Remove the fuser.

Installation note: Open the front door before installing the fuser. To check if the fuser is properly installed, open and close the front door and check if the fuser shutter moves to the left and right.

Redrive assembly removal

- 1 Remove the right cover. See [“Right cover removal” on page 185.](#)
- 2 Remove the left cover. See [“Left cover removal” on page 173.](#)
- 3 Remove the rear cover. See [“Rear door and cover removal” on page 224.](#)
- 4 Remove the top cover. See [“Top cover removal” on page 228.](#)
- 5 Disconnect the cables JNRW1 and JFUTHM1 from the controller board.

- 6 Remove the four screws (A) and the cable (B).

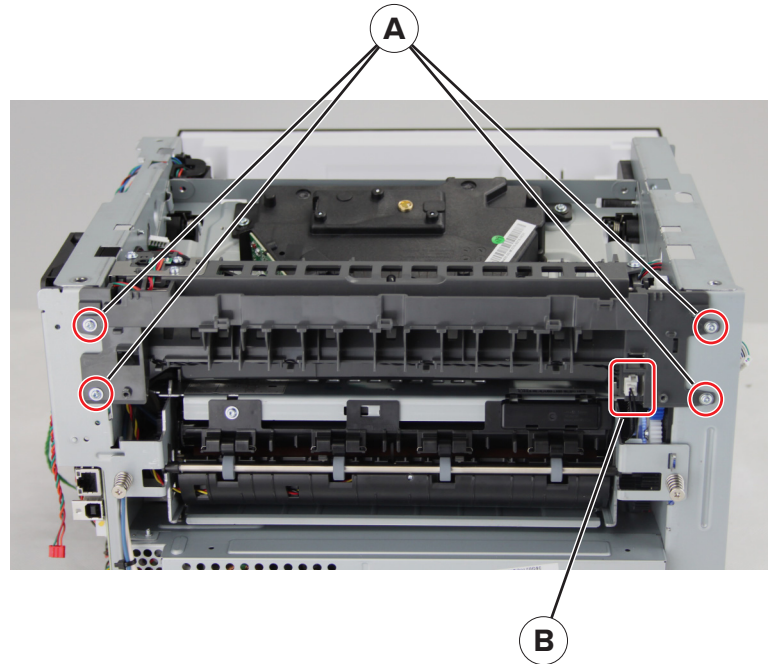

- 7 Remove the redrive assembly.

Sensor (bin full) removal

- 1 Remove the right cover. See [“Right cover removal” on page 185](#).
- 2 Remove the left cover. See [“Left cover removal” on page 173](#).
- 3 Remove the rear cover. See [“Rear door and cover removal” on page 224](#).
- 4 Remove the top cover. See [“Top cover removal” on page 228](#).
- 5 Remove the redrive assembly. See [“Redrive assembly removal” on page 225](#).
- 6 Remove the two screws (A), and then remove the plate.

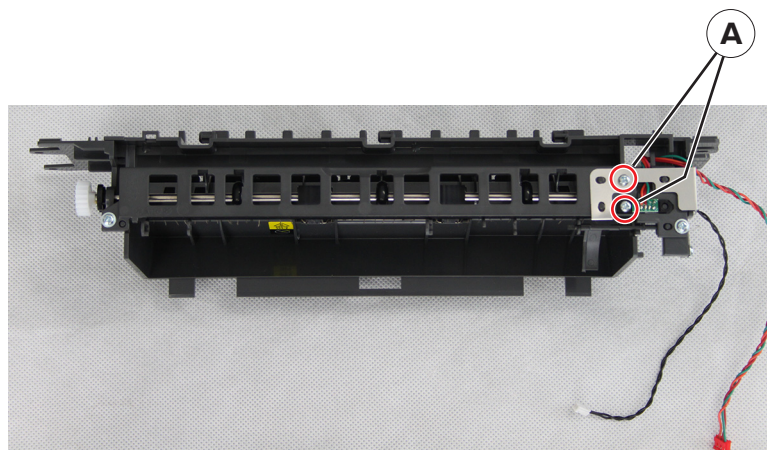

- 7 Remove the sensor.

Redrive gear plate removal

- 1 Remove the top cover. See [“Top cover removal” on page 228.](#)
- 2 Remove the left cover. See [“Left cover removal” on page 173.](#)
- 3 Remove the redrive assembly. See [“Redrive assembly removal” on page 225.](#)
- 4 Remove the two screws (A), and then detach the reverse solenoid.

Note: Do not disconnect the reverse solenoid cable from the controller board.

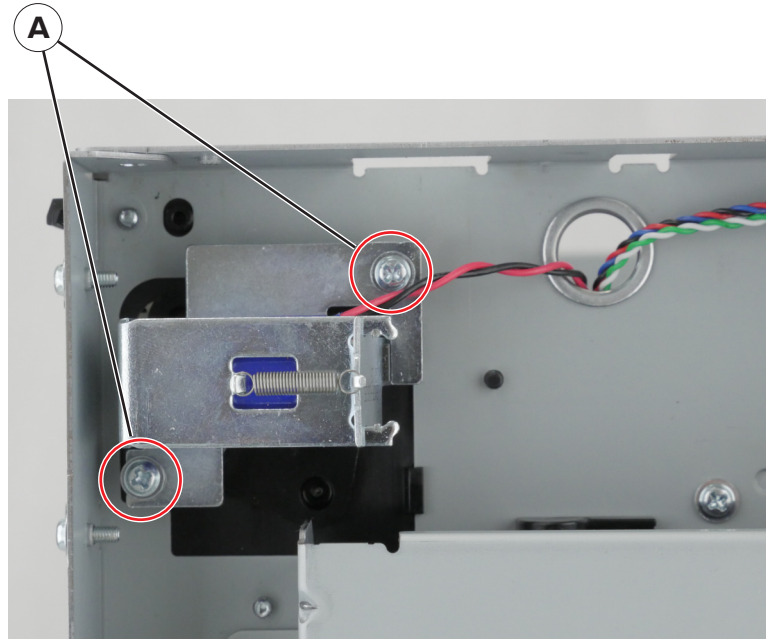

5 Remove the two screws (B).

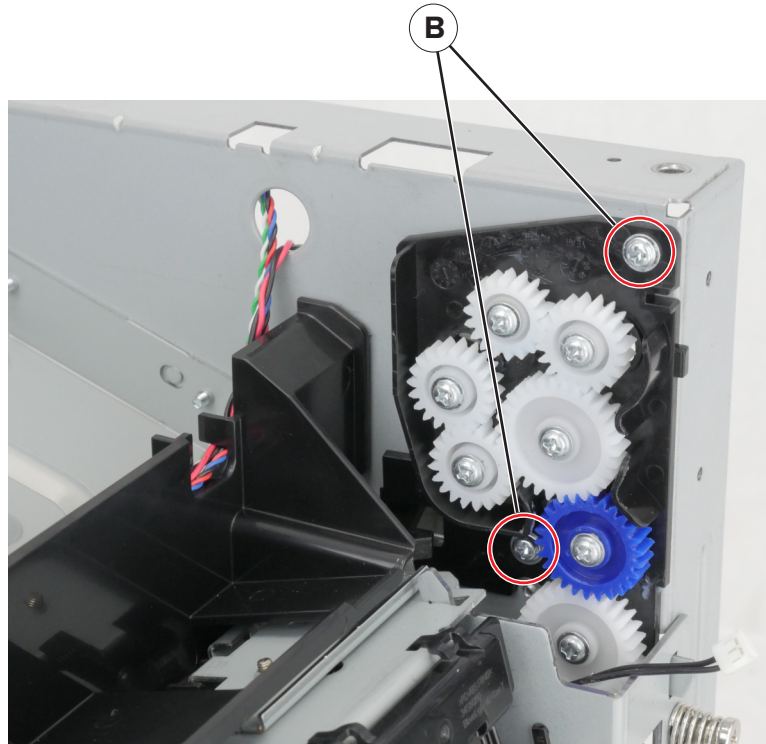

6 Remove the redrive gear plate.

Top side removals

Top cover removal

- 1 Remove the right cover. See [“Right cover removal” on page 185.](#)
- 2 Remove the left cover. See [“Left cover removal” on page 173.](#)
- 3 Remove the rear cover. See [“Rear door and cover removal” on page 224.](#)
- 4 Open the front door.

5 Remove the two screws (A).

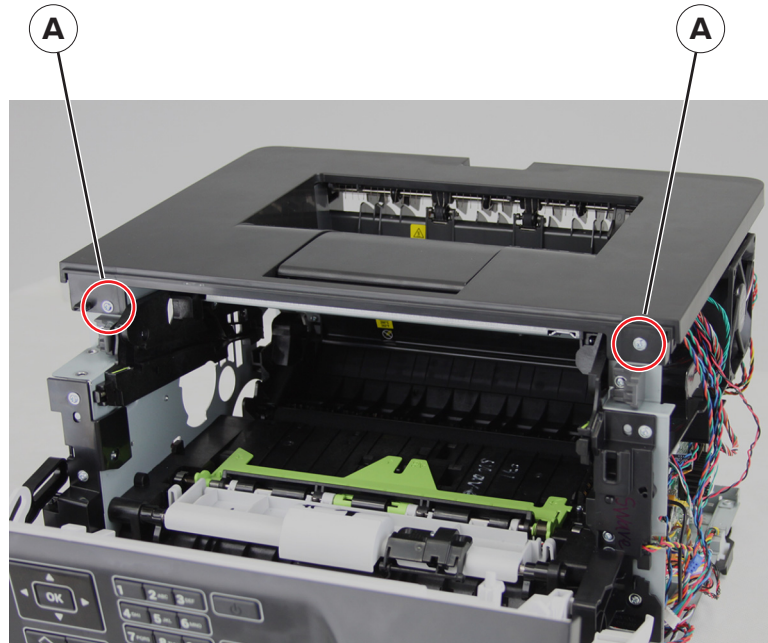

6 Pull, and then lift the top cover to remove it.

Printhead removal

- 1 Remove the right cover. See [“Right cover removal” on page 185.](#)
- 2 Remove the left cover. See [“Left cover removal” on page 173.](#)
- 3 Remove the rear cover. See [“Rear door and cover removal” on page 224.](#)
- 4 Remove the top cover. See [“Top cover removal” on page 228.](#)

- 5 Using a small, flat-blade screwdriver or a sharp pencil, mark the location of the printhead on the printer frame.

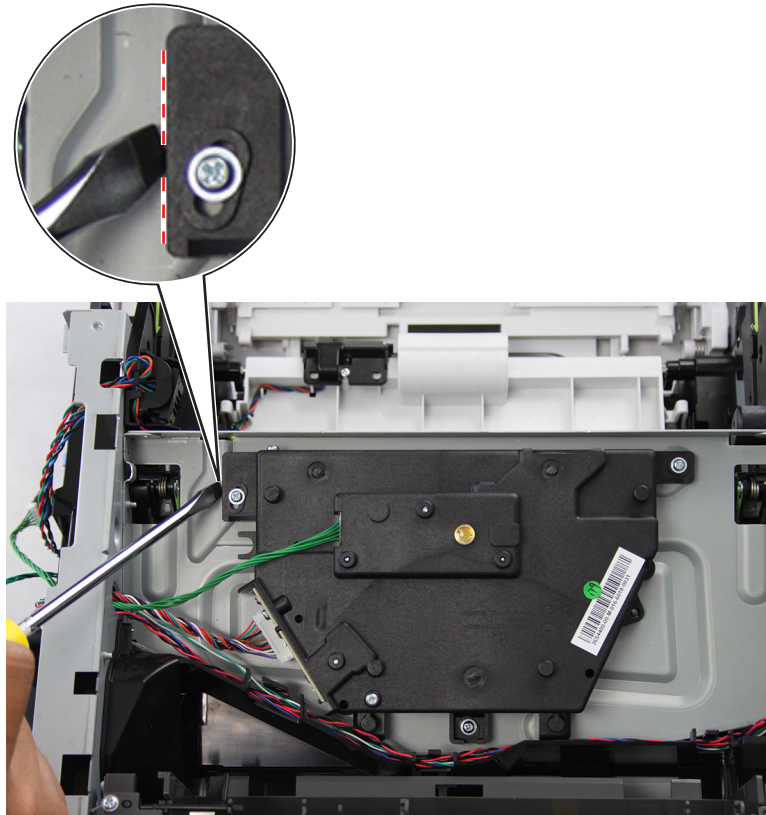

- 6 Disconnect the printhead cable from the controller board.

7 Remove the three screws (A).

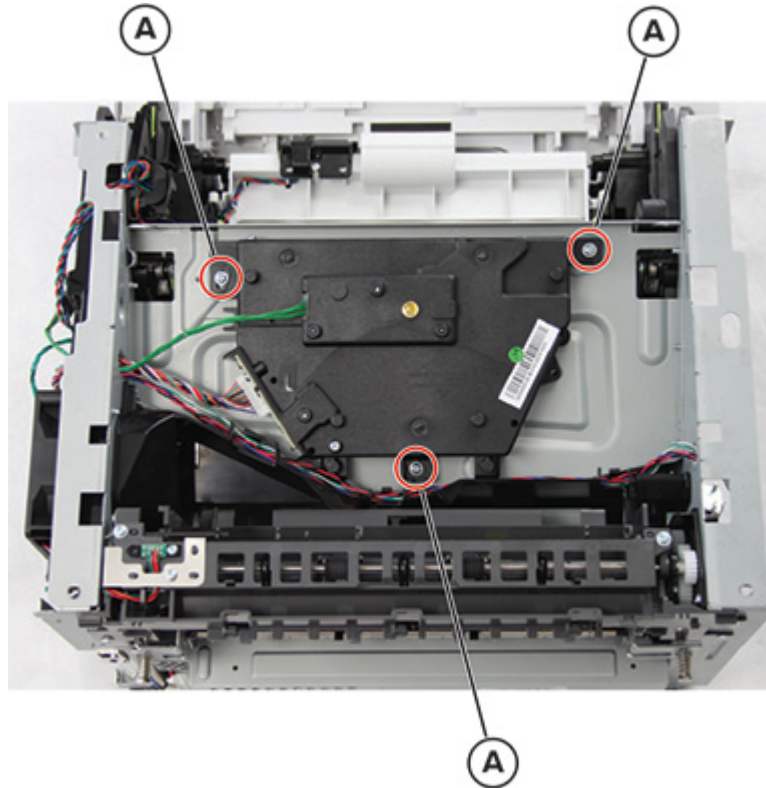

8 Remove the printhead.

Installation note: Perform all the mechanical and electronic adjustments to the printhead after replacing it. See [“Printhead assembly adjustment” on page 171](#).

Optional 250/550-sheet tray removals

Separator roller assembly removal

- 1 Remove the tray insert.
- 2 Under the tray, remove the screw (A).

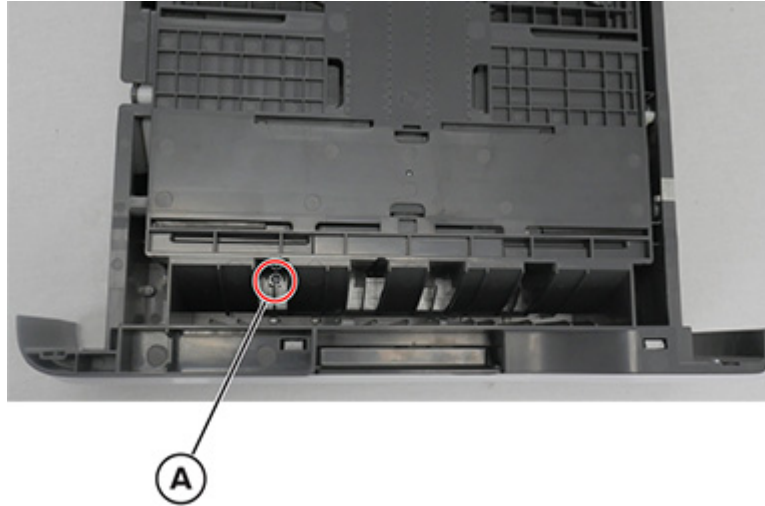

3 Remove the screw (B) on the left side. Do the same for the screw (C) on the opposite side.

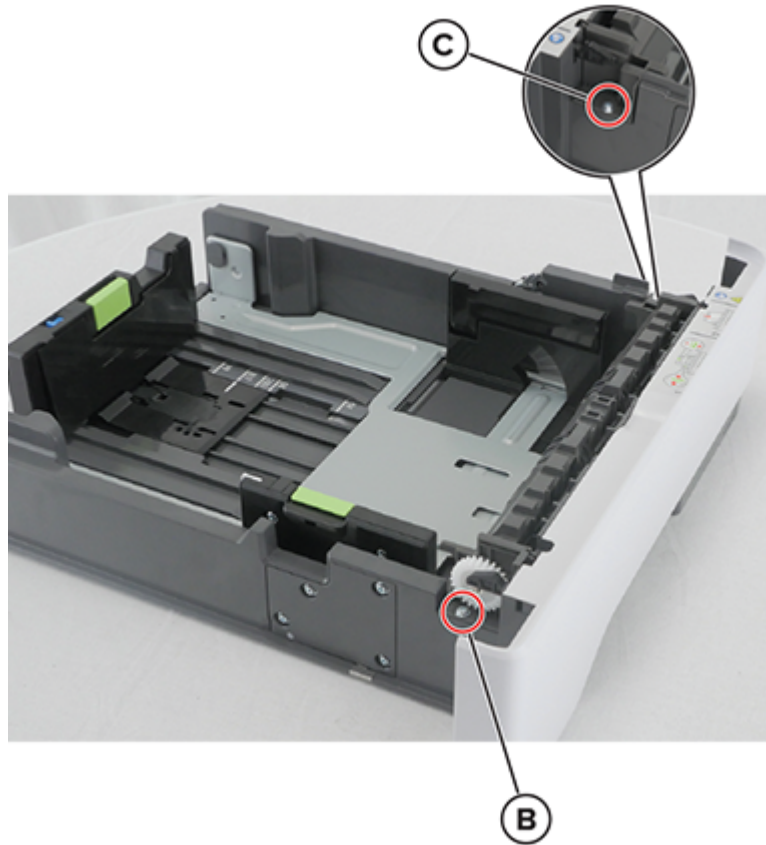

4 Remove the roller assembly.

Component locations

Printer configurations

CAUTION—TIPPING HAZARD: Installing one or more options on your printer or MFP may require a caster base, furniture, or other feature to prevent instability causing possible injury. For more information on supported configurations, see www.lexmark.com/multifunctionprinters.

CAUTION—TIPPING HAZARD: To reduce the risk of equipment instability, load each tray separately. Keep all other trays closed until needed.

You can configure your printer by adding optional 250- or 550-sheet trays.



1	Control panel
2	Standard bin
3	Controller board access cover
4	Standard 250-sheet tray
5	Optional 250- or 550-sheet tray
6	Multipurpose feeder
7	Door A

Attaching cables

CAUTION—SHOCK HAZARD: To avoid the risk of electrical shock, do not set up this product or make any electrical or cabling connections, such as the power cord, fax feature, or telephone, during a lightning storm.

⚠ CAUTION—POTENTIAL INJURY: To avoid the risk of fire or electrical shock, connect the power cord to an appropriately rated and properly grounded electrical outlet that is near the product and easily accessible.

⚠ CAUTION—POTENTIAL INJURY: To avoid the risk of fire or electrical shock, use only the power cord provided with this product or the manufacturer's authorized replacement.

Warning—Potential Damage: To avoid loss of data or printer malfunction, do not touch the USB cable, any wireless network adapter, or the printer in the areas shown while actively printing.

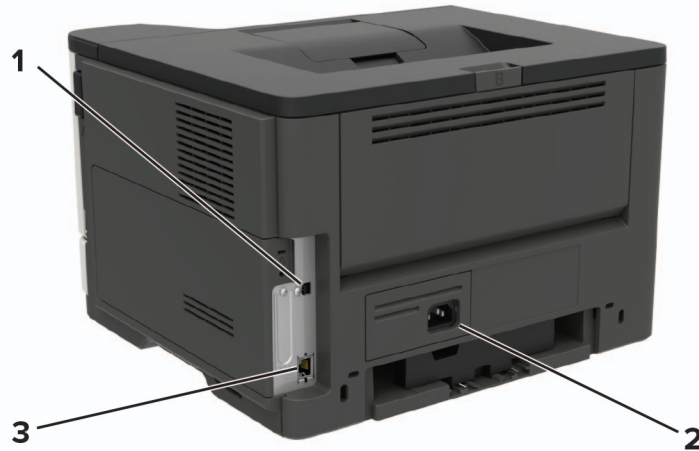

	Use the	To
1	USB printer port	Connect the printer to a computer.
2	Power cord socket	Connect the printer to an electrical outlet.
3	Ethernet port	Connect the printer to a network.

Printer roller locations

Standard path rollers

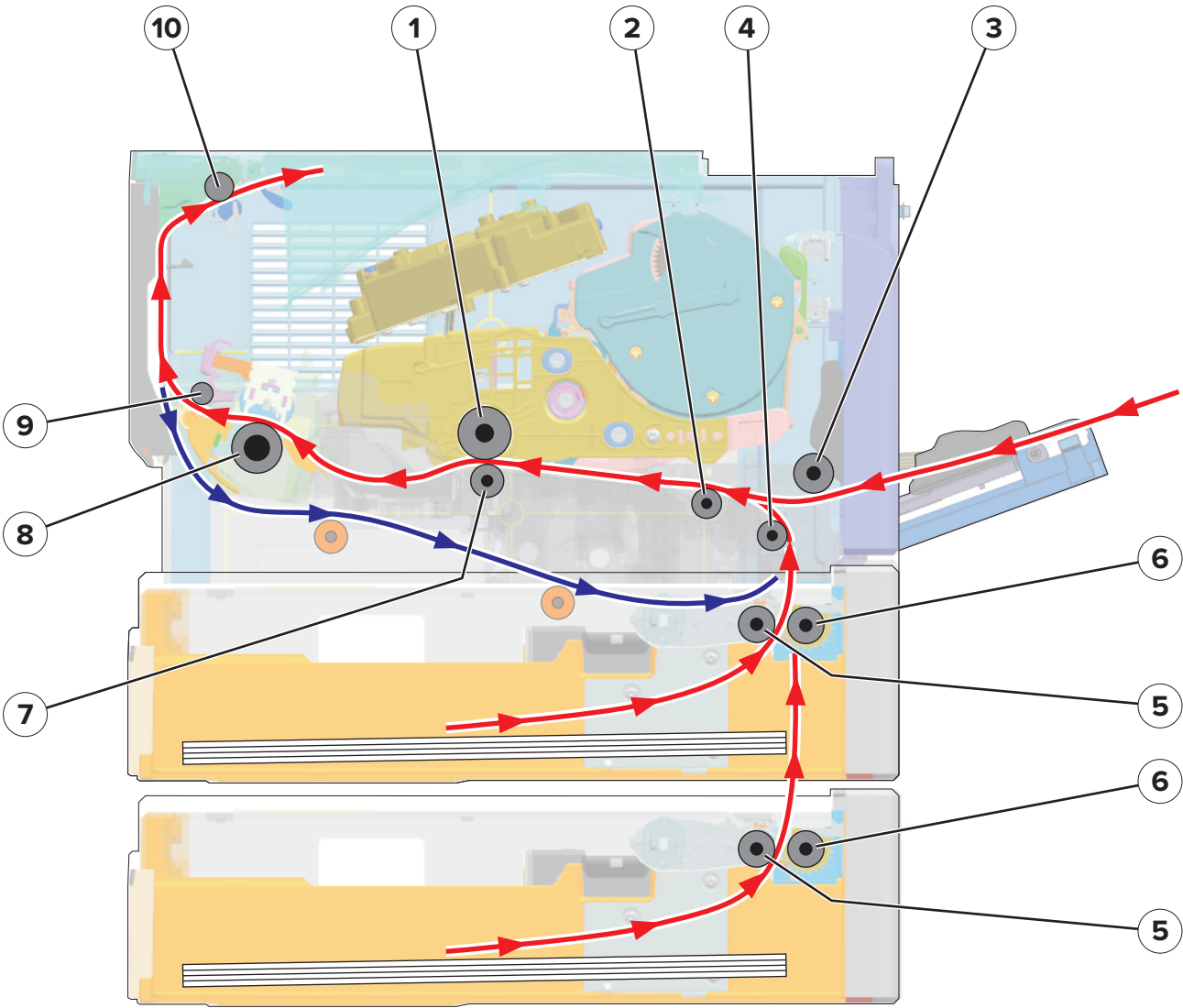

1	Photoconductor drum
2	First input roller
3	MPF pick roller
4	Second input roller
5	Pick roller
6	Separator roller
7	Transfer roller
8	Fuser roller
9	Fuser exit roller

10	Paper exit roller
----	-------------------

Duplex path rollers

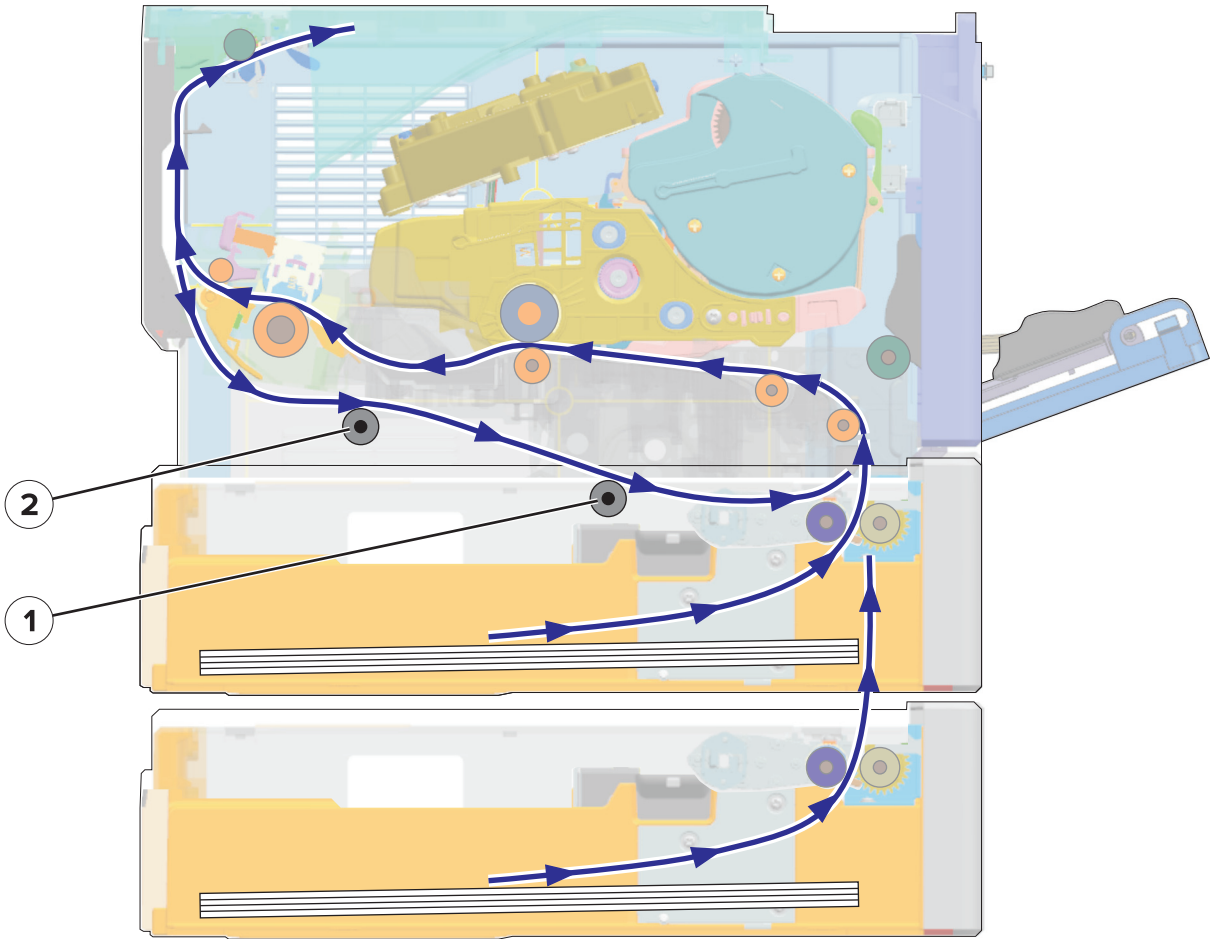

1	Duplex rear roller
2	Duplex front roller

Printer sensor locations

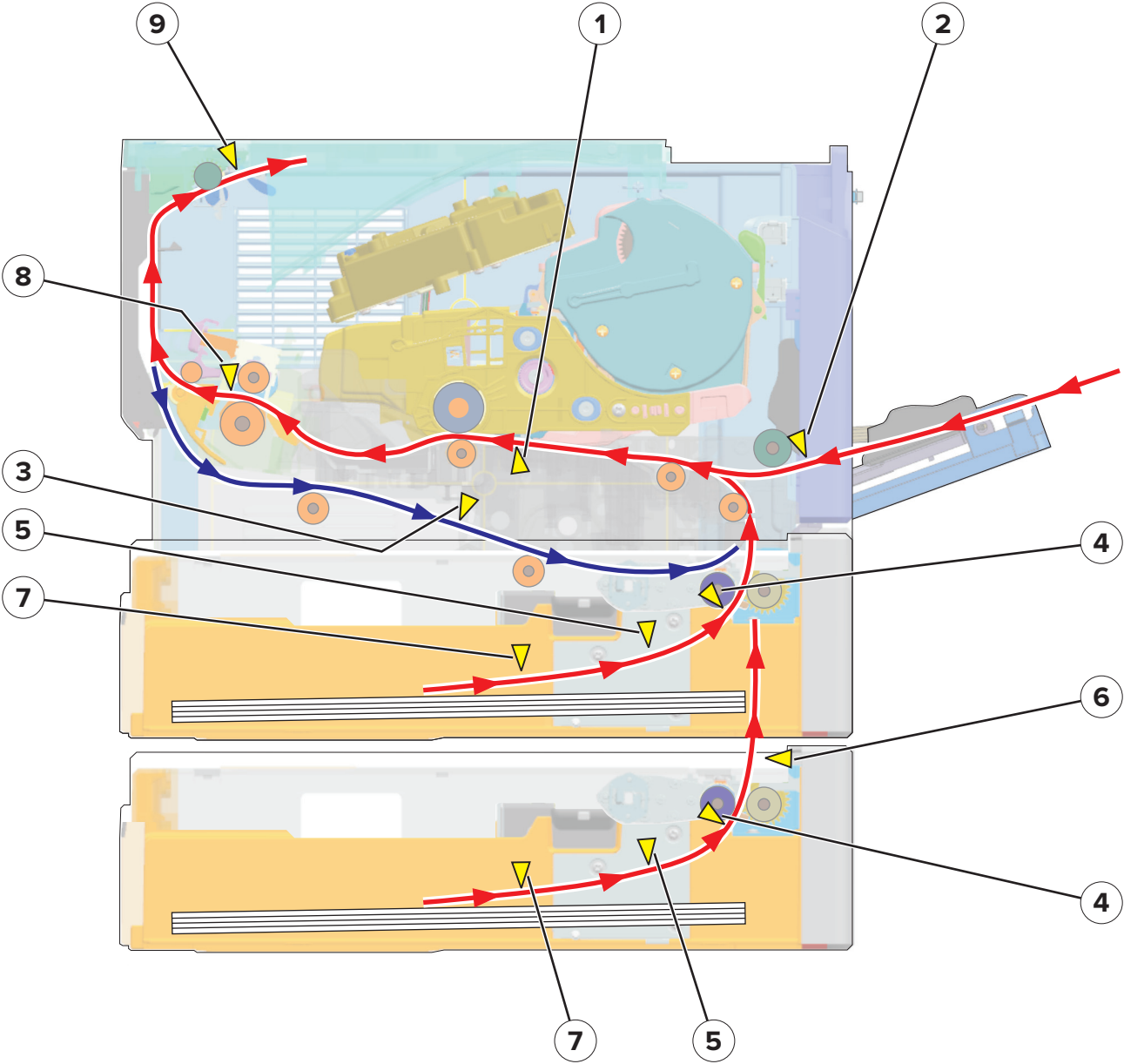

#	Sensor
1	Sensor (input)
2	Sensor (MPF paper present)
3	Sensor (duplex)
4	Sensor (index)
5	Sensor (trailing edge)
6	Sensor (pass-through)
7	Sensor (media present)

Component locations

#	Sensor
8	Sensor (fuser exit)
9	Sensor (narrow media/bin full)

Controller board connectors

Connector	Connects to	Pin no.	Signal
JDRC1	Cartridge smart chip contact	1	+3.3V
		2	DAT_SC_CN1
		3	CLK_SC_CN1
		4	Ground
JDRC2	Imaging unit smart chip contact	1	3.3V
		2	I2C_DAT_SC_CN2
		3	I2C_CLK_SC_CN2
		4	Ground
JCART1	Motor (toner cartridge)	1	V_5CART_1 +5V
		2	S_CART_ENC_CN
		3	Ground
JBARR1	Sensor (cartridge barrel)	1	V_5V_BARR +5V
		2	S_TONER_LOW
		3	Ground
JUICC24	2.4-inch control panel FFC	N/A	N/A
JUICC2L1	2-line control panel FFC	N/A	N/A
JDUPSOL1	Reverse solenoid	1	24V
		2	V_DUPSOL_CN_N

Connector	Connects to	Pin no.	Signal
JPH1	Printhead	1	LDEN_C
		2	BOOST_CN
		3	VDO_ADJ_C
		4	Ground
		5	LPOWER_C
		6	SHADE_CN
		7	Ground
		8	VIDEO -
		9	VIDEO +
		10	no connection
		11	HSYNC_CN
		12	PH_+5V
JNRW1	Sensor (narrow media)	1	V_3.3V_TRAY1_P
		2	JNRW1
		3	Ground
JTHM1	Belt fuser	1	A_FUSER_TH_C +2V_ADC
		2	Ground
JFAN1	Cooling fan	1	V_MAIN_FAN24V
		2	Ground
		3	MAIN_FAN_ENC_R
JEXIT1	Sensor (exit)	1	V_5V_PAPER_OUT
		2	S_PAPER_OUT_C
		3	Ground
JUSBD1	USB connector with flange	1	V_USBD_5V
		2	USB_DEV_N
		3	USB_DEV_N
		4	USB_DEV_GND
JRIP1	Debug port	1	Ground
		2	RXDO_RIP_CN
		3	TXDO_RIP_CN
		4	JRIP_100_+5V

Connector	Connects to	Pin no.	Signal
JOPT1	Resettable fuse	1	24V_F_OPT
		2	S_OPT_TXR
		3	S_INPUT_FDT
		4	S_OPT_RXR
		5	Ground
		6	5V_PHD
JTDS1	Sensor (toner density)	1	S_TDS_LED_PWM
		2	S_A_TDS_C
		3	no connection
		4	V_TDS+5V_C
JDUPPI1	Sensor (duplex and input)	1	V_5V_DUPLEX
		2	S_DUPLEX_C
		3	no connection
		4	V_5V_DUPLEX
		5	S_PAPER_IN_C
		6	Ground
JFEED1	Feed solenoid	1	V_FDSOL +24V_MSF
		2	V_FDSOL
JP_PRE1	Sensor (paper present)	1	V_5V_PAPER_P
		2	S_PAPER_P_C
		3	Ground
JMPFPP1	Sensor (MPF)	1	V_3.3V_MPF_PP
		2	S_MPF_SNS_R
		3	Ground
JTPRES1	Sensor (tray present)	1	V_3.3V_TRAY1_P
		2	S_TRAY1PP_C
		3	Ground
JMPFSOL1	MPF solenoid	1	V_MPFSOL +24V_MSF
		2	V_MPFSOL-

Connector	Connects to	Pin no.	Signal
JPSU1	Power supply	1	NC_JPSU1
		2	PSU_DET_CN
		3	CHARGE_C
		4	SERVO_OUT_C
		5	DEV_C
		6	TXENABLE_C
		7	TX_C
		8	FUSER_RELAY
		9	TAR_C
		10	FUSER_ON_C
		11	ZEROX_C
		12	SHUTOFF_24V
		13	24V_CONT
		14	Ground
		15	24V
		16	Ground
		17	24V
		18	Ground
JMTR1	Motor (main)	1	MAIN_HALL_U_CN
		2	MAIN_HALL_V_CN
		3	MAIN_HALL_W_CN
		4	MAIN_FG_CN
		5	Ground
		6	5V_ENG
		7	V_MAINC1_U
		8	V_MAINC1_V
		9	V_MAINC1_W

Connector	Connects to	Pin no.	Signal
JWIFI1	Wireless network	1	Ground
		2	NC_USB_DP
		3	NC_USB_DM
		4	Ground
		5	USB_WIFI_P_CN
		6	USB_WIFI_N_CN
		7	Ground
		8	no connection
		9	ISP_RESET-
		10	5V
		11	SDA_ISP
		12	5V
		13	SCL_ISP
		14	5V_WIFI
		M1	Ground
M2	Ground		
JRESET1	not used	--	not used
JCVR1	Cover open	1	V_5V_INDEX
		2	S_INDEX_C
		3	Ground

Maintenance

Inspection guide

The purpose of this inspection guide is to aid you in identifying the intervals, based on page count, at which parts must be inspected (for visible physical damage), cleaned, or replaced.

If any unsafe conditions exist, find out how serious the hazard could be and if you can continue before you correct the hazard.

As you service the machine, check for the following:

- Damaged, missing, or altered parts, especially in the area of the On/Off switch and the power supply
- Damaged, missing, or altered covers, especially in the area of the top cover and the power supply cover
- Possible safety exposure from any non-Lexmark attachments

Use the following table to determine when specified parts should be inspected:

PART	EVERY SERVICE CALL	EVERY 200K
Fuser	Inspect	Replace
MPF pick roller and separator pad	Inspect	Replace
Pick tires	Inspect	Replace
Transfer roller	Inspect	Replace

Scheduled maintenance

The control panel displays an 80.xy error when it reaches 200K page counts. It is necessary to install the appropriate maintenance kit to maintain the print quality and reliability of the printer. Reset the maintenance counter after replacing the maintenance kit.

Maintenance kits

Note: This kit is applicable only to MS521, B2546, and M1246 printers.

Part number and kit	Contents
41X1230—Maintenance Kit (100 V)	<ul style="list-style-type: none"> • 41X1180—Fuser (100 V) • 41X1197—MPF pick roller and separator pad • 41X0918—Pick tires • 40X8393—Transfer roller
41X1228—Maintenance Kit (110 V)	<ul style="list-style-type: none"> • 41X1178—Fuser (110 V) • 41X1197—MPF pick roller and separator pad • 41X0918—Pick tires • 40X8393—Transfer roller

Part number and kit	Contents
41X1229—Maintenance Kit (220 V)	<ul style="list-style-type: none"> • 41X1179—Fuser (220 V) • 41X1197—MPF pick roller and separator pad • 41X0918—Pick tires • 40X8393—Transfer roller

When performing the 200K scheduled maintenance procedure, the following areas should be cleaned of media dust and toner contamination:

- Media trays
- Imaging unit area
- Transfer roller area
- Duplex area
- Standard bin

Resetting the maintenance counter

Always reset the maintenance counter after installing the maintenance kit.

To reset the maintenance counter:

- 1 POR into the Configuration menu, and navigate to **Reset Maintenance Counter**.
- 2 Depending on the printer model, press **OK** or touch  to reset the counter, or press **X** to exit without resetting the counter.

Once initiated, the operation cannot be canceled.

Lubrication specification

Lubricate only when the parts are replaced or if necessary, not on a scheduled basis. The use of lubricants other than those specified in this service manual may cause premature failure. Some unauthorized lubricants may chemically attack polycarbonate parts. Use Grease P/N 99A0394 Nyogel 744.

Cleaning the printer

 **CAUTION—SHOCK HAZARD:** To avoid the risk of electrical shock when cleaning the exterior of the printer, unplug the power cord from the electrical outlet and disconnect all cables from the printer before proceeding.

Notes:

- Perform this task after every few months.
 - Damage to the printer caused by improper handling is not covered by the printer warranty.
- 1 Turn off the printer, and then unplug the power cord from the electrical outlet.
 - 2 Remove paper from the standard bin and multipurpose feeder.
 - 3 Remove any dust, lint, and pieces of paper around the printer using a soft brush or vacuum.

4 Wipe the outside of the printer with a damp, soft, lint-free cloth.

Notes:

- Do not use household cleaners or detergents, as they may damage the finish of the printer.
- Make sure that all areas of the printer are dry after cleaning.

5 Connect the power cord to the electrical outlet, and then turn on the printer.

 **CAUTION—POTENTIAL INJURY:** To avoid the risk of fire or electrical shock, connect the power cord to an appropriately rated and properly grounded electrical outlet that is near the product and easily accessible.

Cleaning the printhead lenses

1 Open the front door.

2 Remove the toner cartridge and imaging unit.

3 From the printhead access opening (A) in the top of the frame at the front of the printer, find the printhead lens.

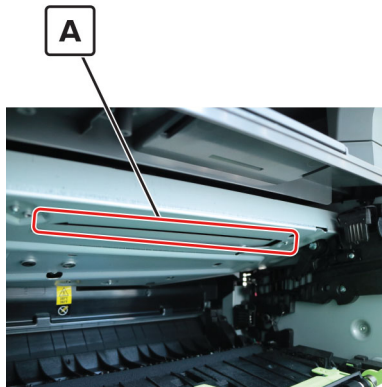

4 Insert a soft, lint-free cloth in the opening, and gently move the cloth back and forth along the surface of the lens to clean it.

5 Repeat step 4.

6 Reinstall the imaging unit and toner cartridge.

7 Close the front door.

Parts catalog

Legend

The following column headings are used in the parts catalog:

- **Asm-index**—Identifies the item in the illustration.
- **Part number**—Identifies the unique number that correlates with the part.
- **Units/mach**—Refers to the number of units actually used in the base machine or product.
- **Units/FRU**—Refers to the number of units in a particular FRU.
- **Description**—A brief description of the part.

The following abbreviations are used in the parts catalog:

- **NS** (not shown) in the Asm-index column indicates that the part is procurable but is not pictured in the illustration.
- **PP** (parts packet) in the Description column indicates that the part is contained in a parts packet.

Assembly 1: Covers

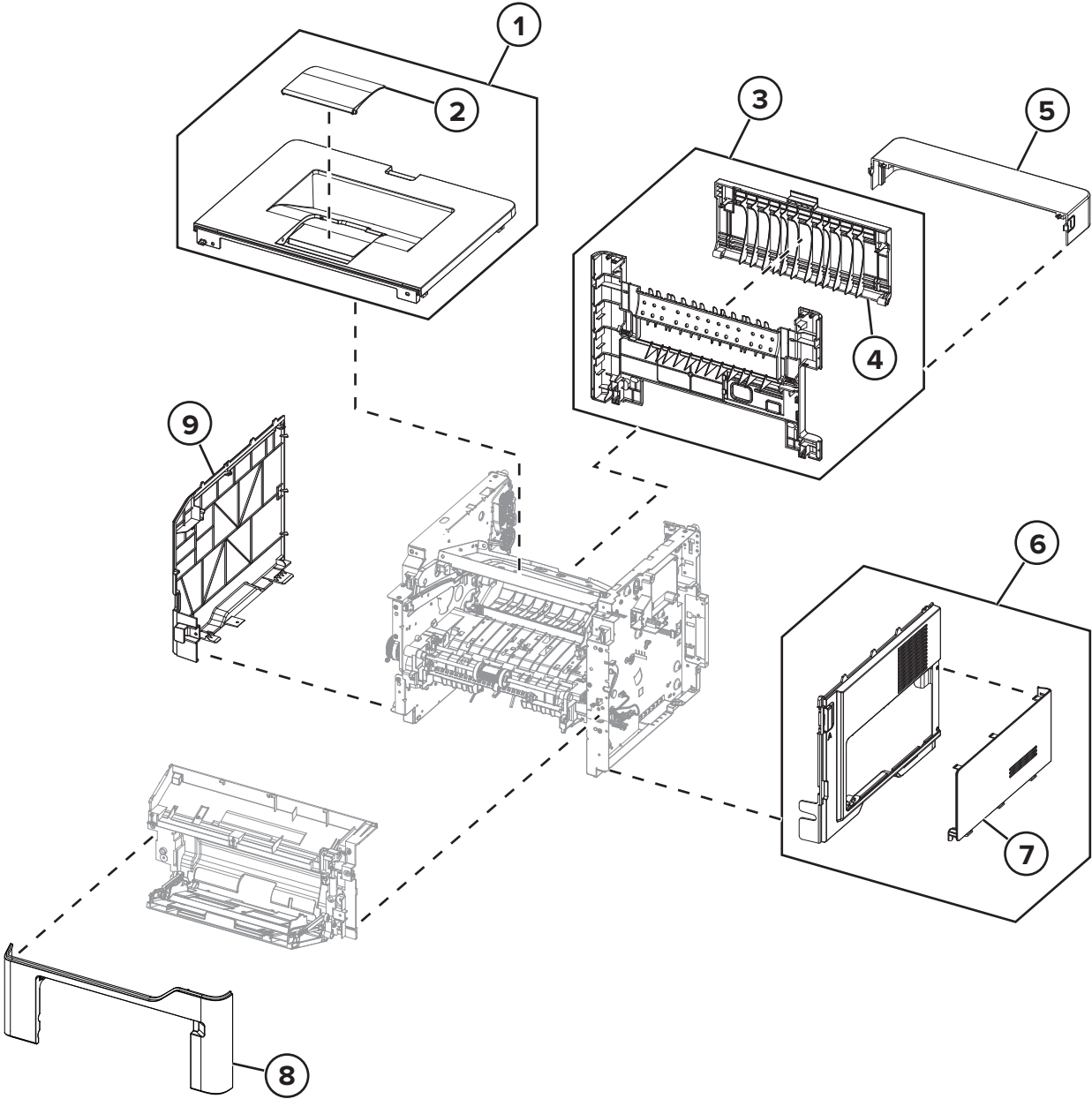

Assembly 1: Covers

Asm-index	P/N	Units/mach	Units/FRU	Description	Removal procedure
1	41X1171	1	1	Top cover	“Top cover removal” on page 228
2	41X2262	1	1	Output extender	--
3	41X1169	1	1	Rear door and cover	“Rear door and cover removal” on page 224
4	41X2263	1	1	Rear access door	--
5	40X8520	1	1	Dust cover	--
6	41X1165	1	1	Right cover	“Right cover removal” on page 185
7	41X1233	1	1	Right access cover	--
8	41X1163	1	1	Nameplate	“Nameplate removal” on page 198
9	41X1167	1	1	Left cover	--

Assembly 2: Control panel

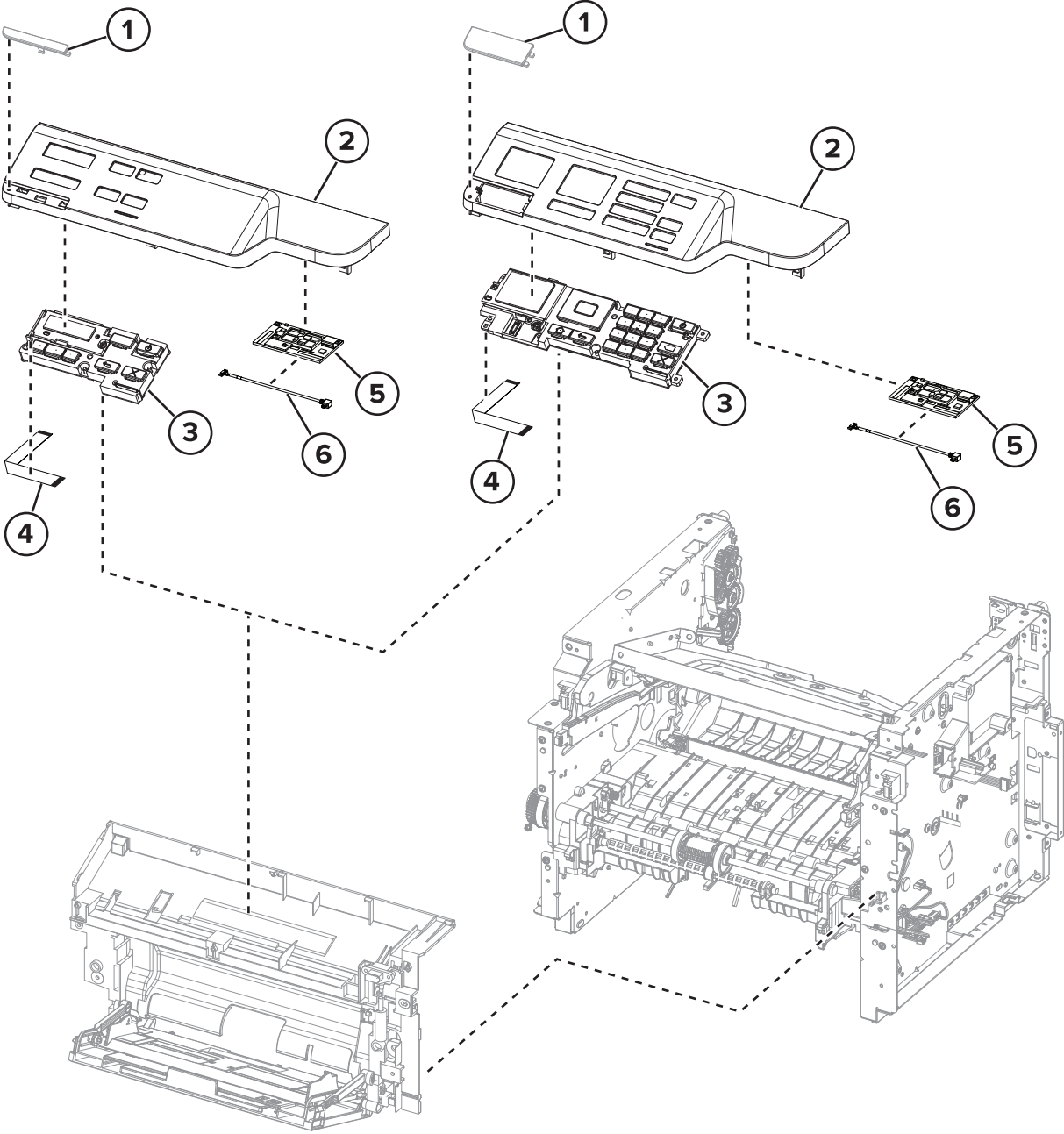

Assembly 2: Control panel

Asm-index	P/N	Units/mach	Units/FRU	Description	Removal procedure
1	41X1155	1	1	Bezel (MS321)	--
1	41X1156	1	1	Bezel (MS421)	--
1	41X1157	1	1	Bezel (MS521)	--
2	41X2264	1	1	Control panel covers (MS321, MS421)	--
2	41X2265	1	1	Control panel covers (MS521)	“Control panel (2.4 inch display) cover, buttons, and board removal” on page 201
3	41X2047	1	1	Control panel display assembly (MS321, MS421)	--
3	41X1627	1	1	Control panel display assembly (MS521)	--
4	41X2267	1	1	Flat cable, 2.4-inch display (MS521)	“Control panel (2.4 inch display) flat cable removal” on page 201
4	41X2266	1	1	Flat cable, 2-line display (MS321, MS421)	--
5	41X1873	1	1	Wireless module	--
6	41X2270	1	1	Wireless module cable	--

Assembly 3: Electronics 1

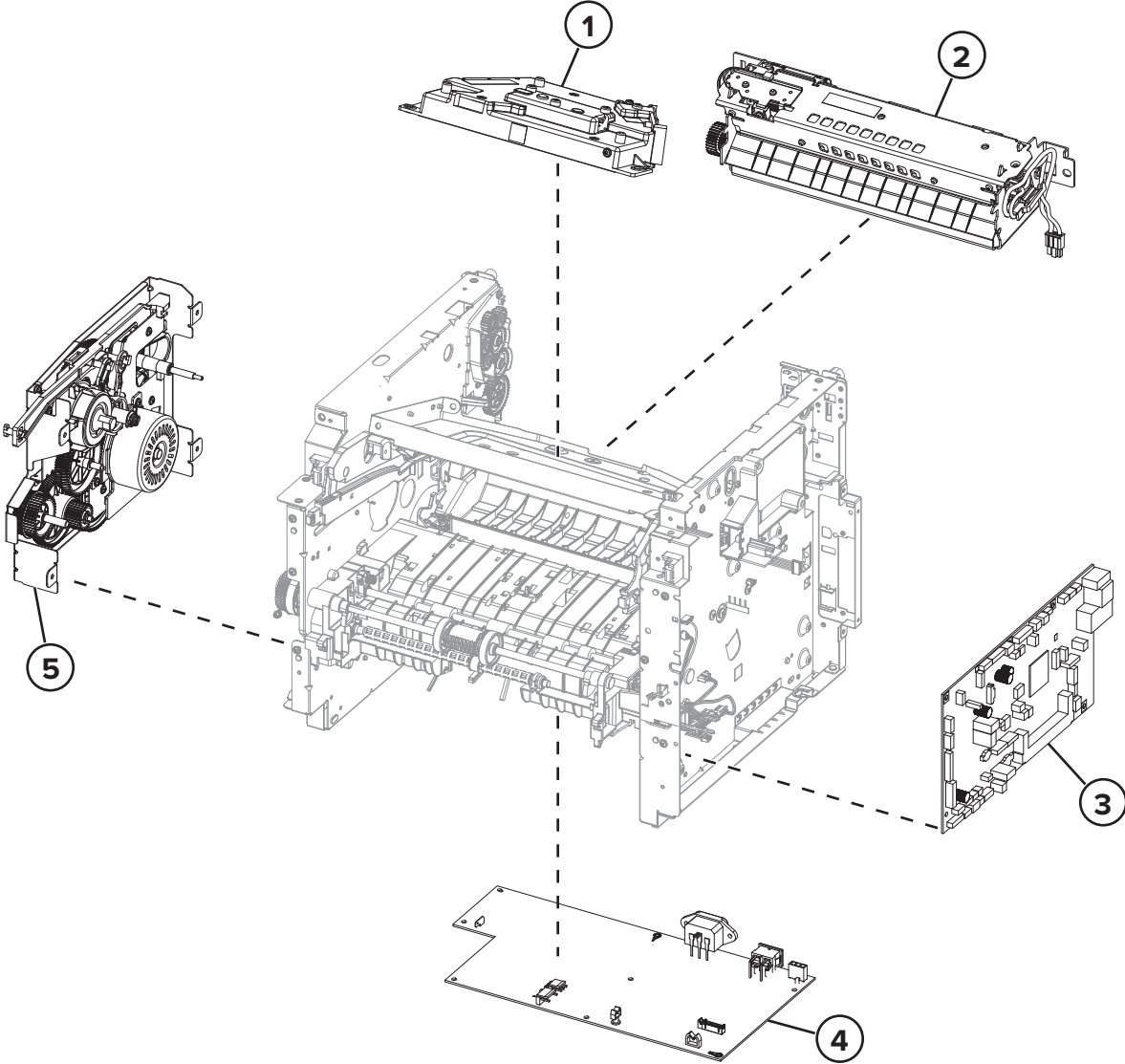

Assembly 3: Electronics 1

Asm-index	P/N	Units/mach	Units/FRU	Description	Removal procedure
1	41X1185	1	1	Printhead	“Printhead removal” on page 229
2	41X1178	1	1	Fuser, 110V	“Fuser removal” on page 224
2	41X1179	1	1	Fuser, 220V	“Fuser removal” on page 224
2	41X1180	1	1	Fuser, 100V	“Fuser removal” on page 224
3	41X1191	1	1	Controller board (MS321, MS421)	“Controller board removal” on page 191
3	41X1193	1	1	Controller board (MS521)	“Controller board removal” on page 191
4	41X1201	1	1	Power supply, 100V/110V	“Power supply removal” on page 211
4	41X1202	1	1	Power supply, 220V	“Power supply removal” on page 211
5	41X1224	1	1	Main drive gearbox	“Main drive gearbox removal” on page 174

Assembly 4: Electronics 2

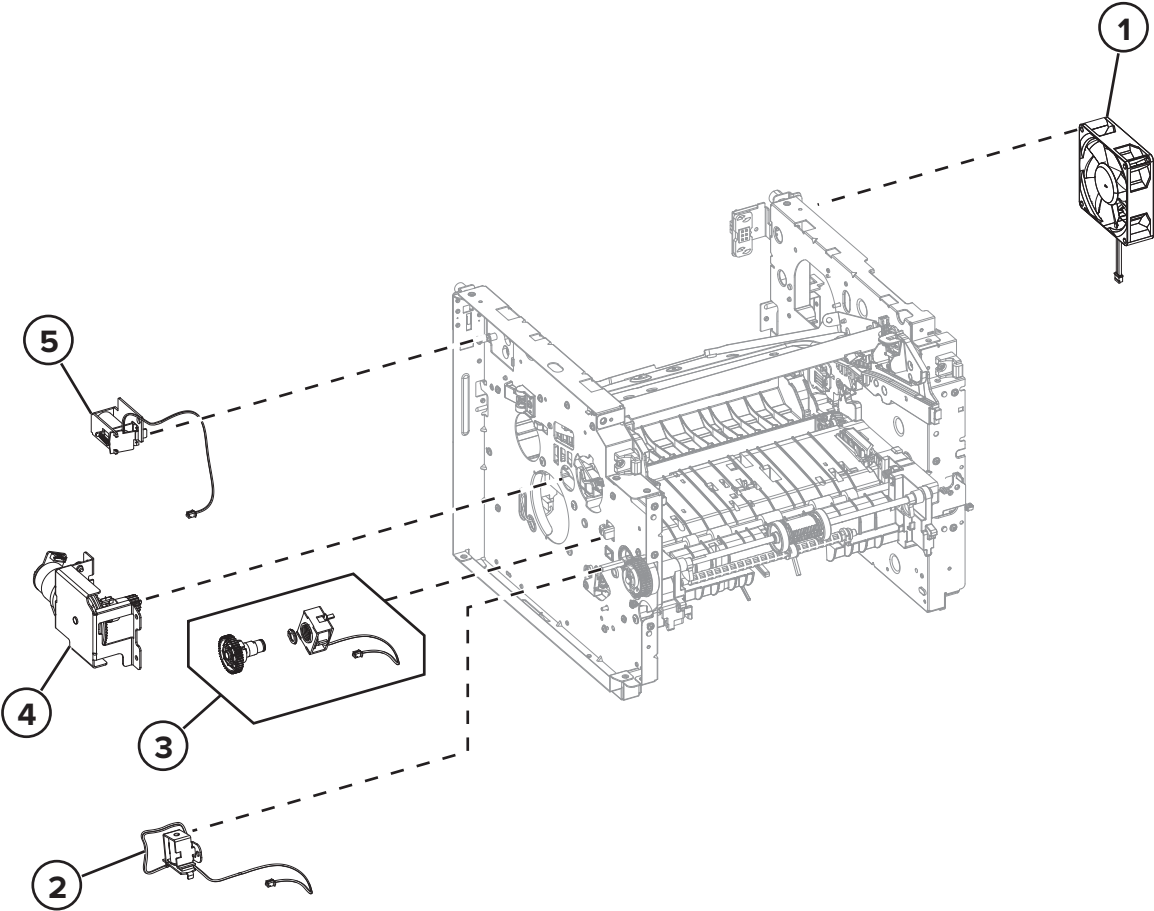

Assembly 4: Electronics 2

Asm-index	P/N	Units/mach	Units/FRU	Description	Removal procedure
1	41X2259	1	1	Cooling fan	“Cooling fan removal” on page 189
2	41X1213	1	1	MPF solenoid	“MPF solenoid removal” on page 181
3	41X2391	1	1	Pick roller clutch	“Pick roller clutch removal” on page 182
4	41X1237	1	1	Motor (cartridge)	“Cartridge gearbox removal” on page 180
5	41X1214	1	1	Reverse solenoid	“Reverse solenoid removal” on page 179

Assembly 5: Electronics 3

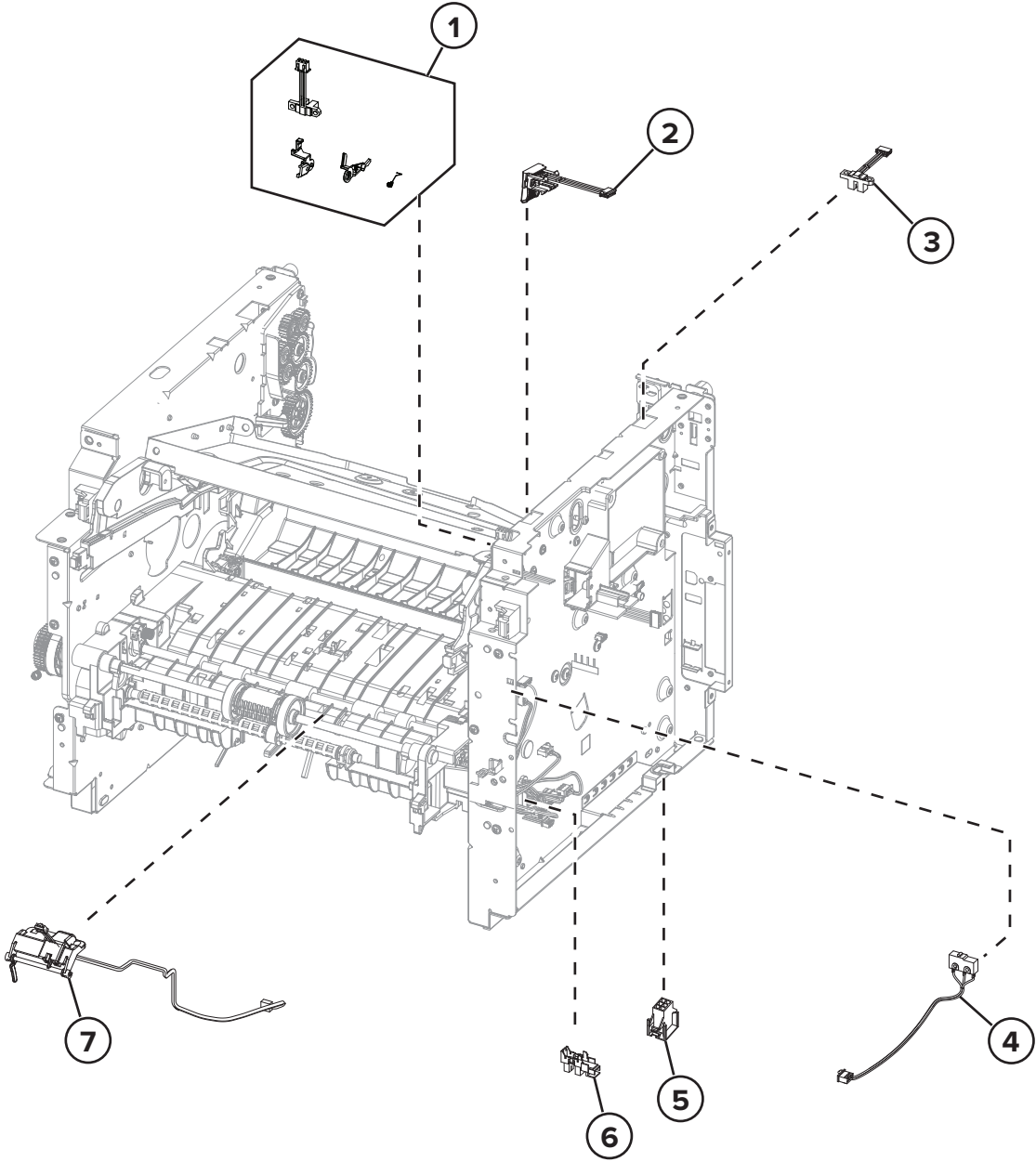

Assembly 5: Electronics 3

Asm-index	P/N	Units/mach	Units/FRU	Description	Removal procedure
1	41X1988	1	1	Cartridge barrel sensor kit	“Cartridge barrel shutter sensor kit removal” on page 195
2	41X1162	1	1	Toner cartridge smart chip contact	“Toner cartridge smart chip contact removal” on page 192
3	41X1211	1	1	Sensor (bin full)	“Sensor (bin full) removal” on page 226
4	41X1209	1	1	Sensor (front door)	“Sensor (front door) removal” on page 204
5	41X1236	1	1	Interconnect cable	“Interconnect cable removal” on page 187
6	41X1238	1	1	Sensor (tray present)	“Sensor (tray present) removal” on page 188
7	41X1210	1	1	Sensor (MPF paper present)	“Sensor (MPF paper present) removal” on page 209

Assembly 6: Electronics 4

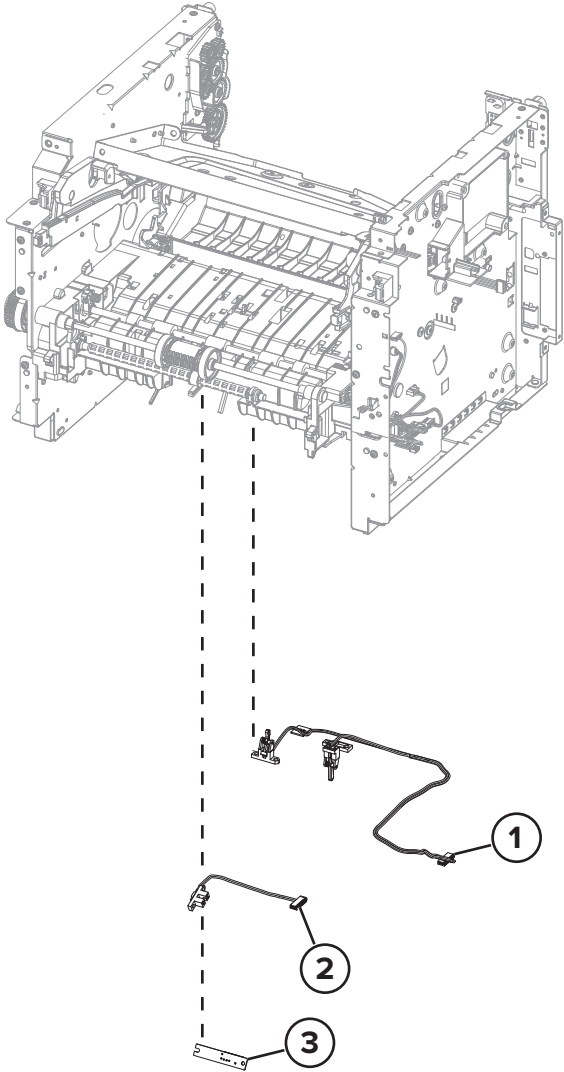

Assembly 6: Electronics 4

Asm-index	P/N	Units/mach	Units/FRU	Description	Removal procedure
1	41X1206	1	1	Sensor (duplex and input)	“Sensors (duplex and input) removal” on page 215
2	41X1240	1	1	Sensor (trailing edge)	“Sensor (trailing edge) removal” on page 218
3	40X8046	1	1	Sensor (toner density)	“Sensor (toner density) removal” on page 216

Assembly 7: Paper transport 1

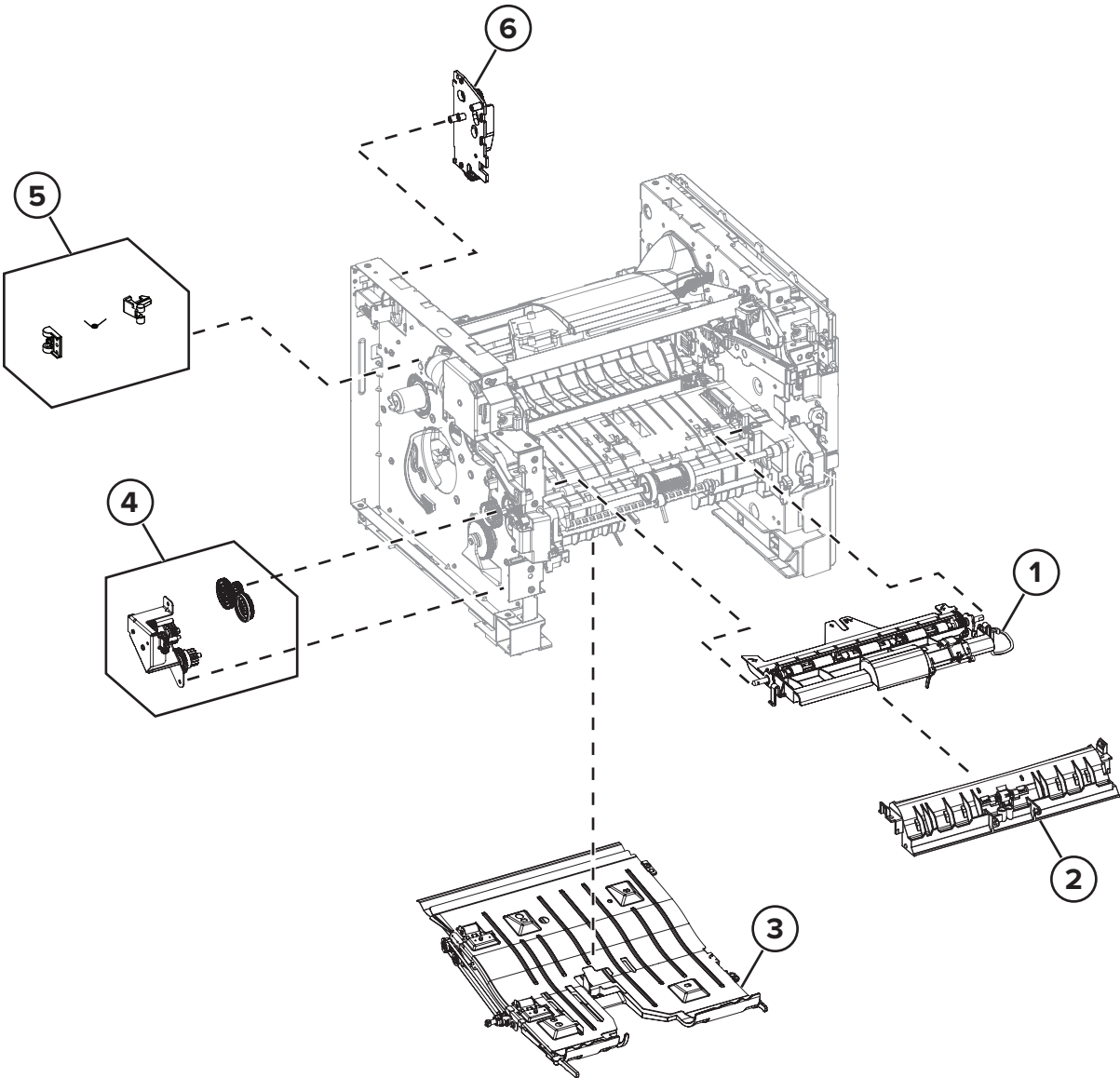

Assembly 7: Paper transport 1

Asm-index	P/N	Units/mach	Units/FRU	Description	Removal procedure
1	41X1183	1	1	Jam access cover	“Jam access cover removal” on page 203
2	41X1184	1	1	Front input guide	“Front input guide removal” on page 210
3	41X1176	1	1	Duplex assembly	“Duplex assembly removal” on page 213
4	41X1182	1	1	MPF gearbox (MS521)	“MPF gearbox removal” on page 175
4	41X2271	1	1	MPF gearbox (MS321, MS421)	“MPF gearbox removal” on page 175
5	41X2255	1	1	Fuser cam	“Fuser actuator removal” on page 178
6	41X2268	1	1	Redrive gear plate	“Redrive gear plate removal” on page 227

Assembly 8: Paper transport 2

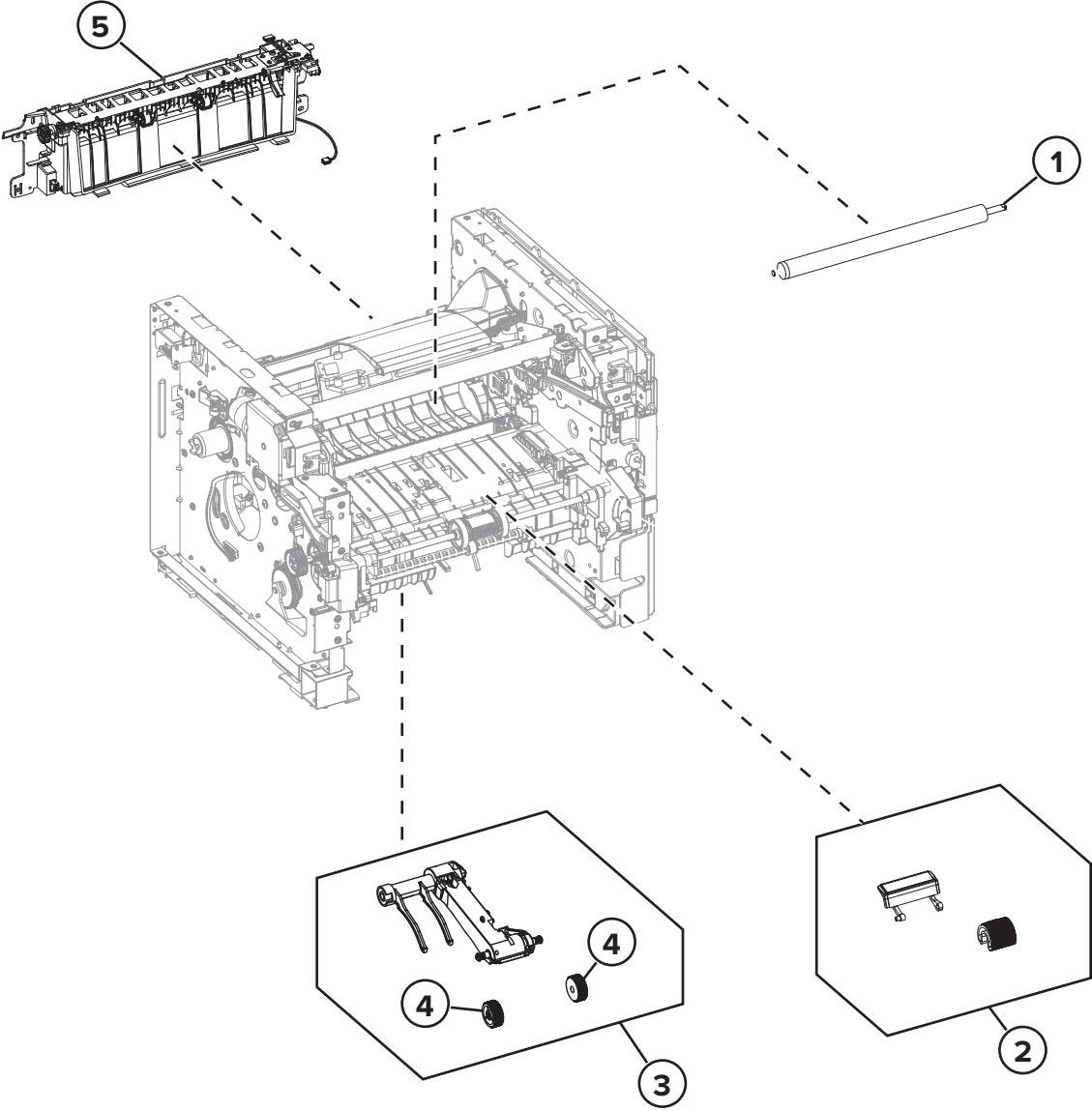

Assembly 8: Paper transport 2

Asm-index	P/N	Units/mach	Units/FRU	Description	Removal procedure
1	40X8393	1	1	Transfer roller	“Transfer roller removal” on page 203
2	41X1197	1	1	MPF pick roller and separator pad	“MPF pick roller and separator pad removal” on page 206
3	41X1223	1	1	Pick roller assembly	“Pick roller assembly removal” on page 219
4	41X0918	2	2	Pick tire	--
5	41X1203	1	1	Redrive assembly	“Redrive assembly removal” on page 225

Assembly 9: MPF and standard tray

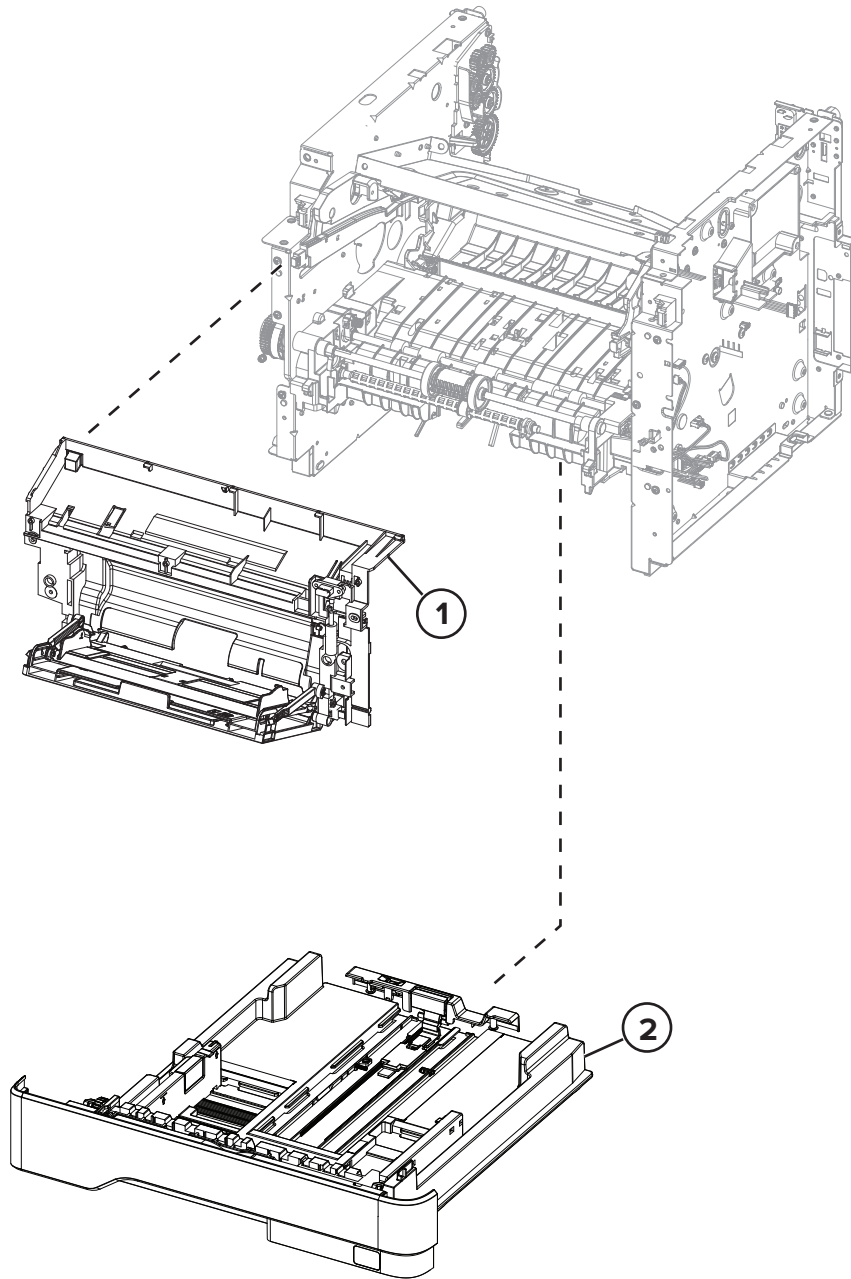

Assembly 9: MPF and standard tray

Asm-index	P/N	Units/mach	Units/FRU	Description	Removal procedure
1	41X1218	1	1	MPF with front access cover	“MPF with front access cover removal” on page 198
2	41X2125	1	1	Standard 250-sheet tray insert (MS321, MS421)	--
2	41X1220	1	1	Standard 250-sheet tray insert (MS521)	--

Assembly 10: Optional trays

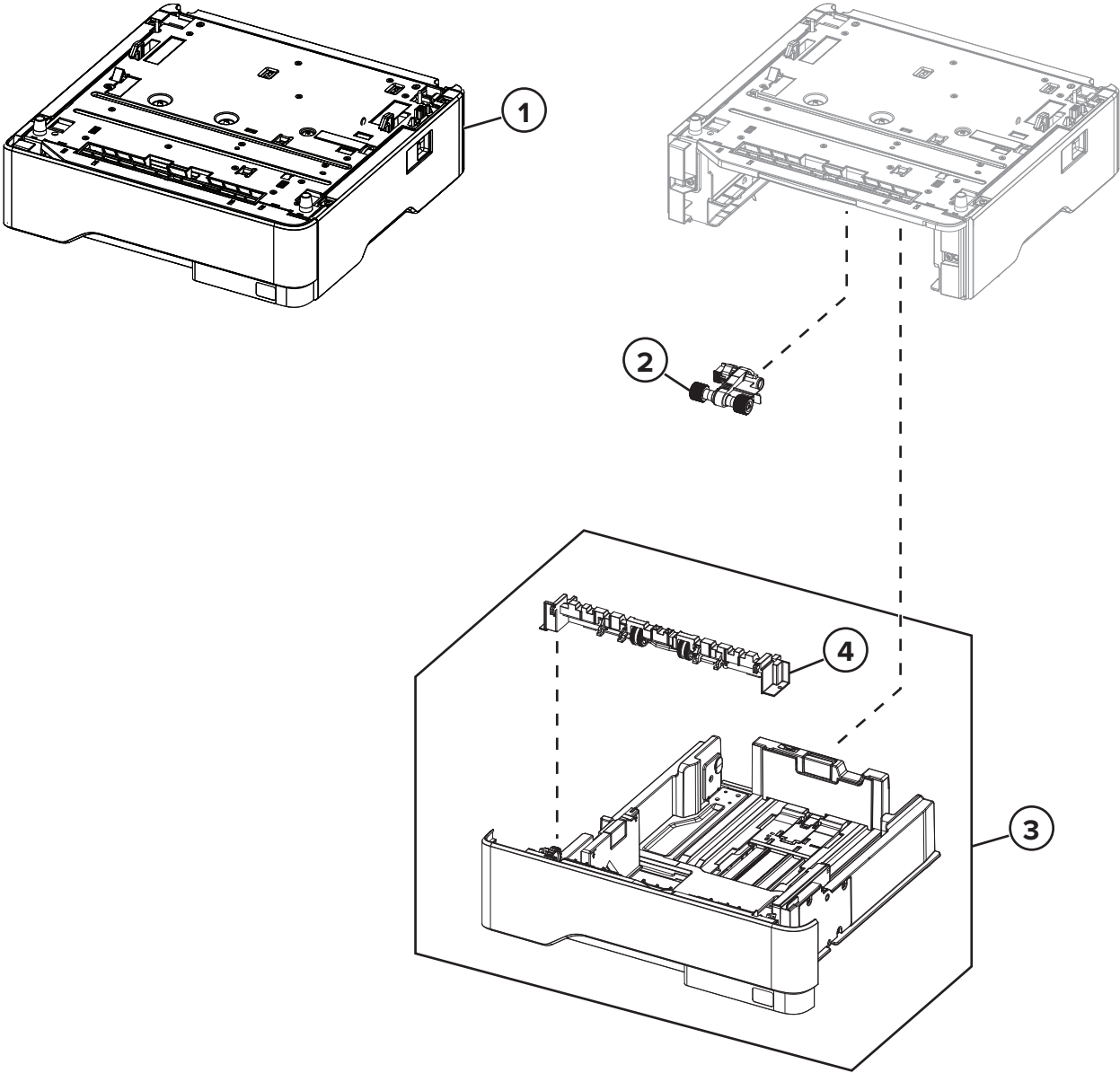

Assembly 10: Optional trays

Asm-index	P/N	Units/opt	Units/FRU	Description	Removal procedure
1	41X1216	1	1	Optional 550-sheet tray	--
1	41X1217	1	1	Optional 250-sheet tray	--
2	41X1239	1	1	Pick roller	--
3	41X1222	1	1	550-sheet tray insert (optional tray)	--
3	41X1221	1	1	250-sheet tray insert (optional tray)	--
4	41X1212	1	1	Separator roller assembly	“Separator roller assembly removal” on page 232

Assembly 11: Maintenance kits (MS521, B2546, and M1246)

Asm-index	P/N	Units/mach	Units/FRU	Description	Removal procedure
NS	41X1230	1	1	Maintenance Kit (100 V) <ul style="list-style-type: none"> • Fuser (100 V) • MPF pick roller and separator pad • Pick tires • Transfer roller 	N/A
NS	41X1228	1	1	Maintenance Kit (110 V) <ul style="list-style-type: none"> • Fuser (110 V) • MPF pick roller and separator pad • Pick tires • Transfer roller 	N/A
NS	41X1229	1	1	Maintenance Kit (220 V) <ul style="list-style-type: none"> • Fuser (220 V) • MPF pick roller and separator pad • Pick tires • Transfer roller 	N/A

Assembly 12: Miscellaneous

Asm-index	P/N	Units/mach	Units/FRU	Description	Removal procedure
NS	41X1010	1	1	User Flash Memory, 256MB	--
NS	41X1002	1	1	Forms and Bar Code card (MS521)	--
NS	41X1004	1	1	IPDS card (MS521)	--
NS	41X1006	1	1	PRESCRIBE card (MS521)	--
NS	41X1014	1	1	Font card, Traditional Chinese	--
NS	41X1013	1	1	Font card, Simplified Chinese	--
NS	41X1015	1	1	Font card, Korean	--
NS	41X1016	1	1	Font card, Japanese	--
NS	41X1372	1	1	Marknet N8370, Rear WiFi (MS521)	--
NS	41X2051	1	1	Parallel card, thin (MS521)	--
NS	41X2055	1	1	Smart card	--
NS	40X1368	1	1	USB 2.0 cable (2 meters)	--
NS	3086579	1	1	Software CD Note: The part number is for internal use only and is not orderable.	--

Printer specifications

Power consumption

Product power consumption

The following table documents the power consumption characteristics of the product.

Note: Some modes may not apply to your product.

Mode	Description	Power consumption (Watts)
Printing	The product is generating hard-copy output from electronic inputs.	620 (MS521, M1246, B2546), 570 (MS421, M1242, B2442), 520 (MS321, B2338)
Copy	The product is generating hard-copy output from hard-copy original documents.	N/A
Scan	The product is scanning hard-copy documents.	N/A
Ready	The product is waiting for a print job.	8 (MS521, M1246, B2546), 7.5 (MS421, M1242, B2442), 7 (MS321, B2338)
Sleep Mode	The product is in a high-level energy-saving mode.	2 (MS521, M1246, B2546), 1.9 (MS421, M1242, B2442), 1.8 (MS321, B2338)
Hibernate	The product is in a low-level energy-saving mode.	0.1
Off	The product is plugged into an electrical outlet, but the power switch is turned off.	0.1

The power consumption levels listed in the previous table represent time-averaged measurements. Instantaneous power draws may be substantially higher than the average.

Values are subject to change. See www.lexmark.com for current values.

Sleep Mode

This product is designed with an energy-saving mode called *Sleep Mode*. The Sleep Mode saves energy by lowering power consumption during extended periods of inactivity. The Sleep Mode is automatically engaged after this product is not used for a specified period of time, called the *Sleep Mode Timeout*.

Factory default Sleep Mode Timeout for this product (in minutes):	15
---	----

By using the configuration menus, the Sleep Mode Timeout can be modified between 1 minute and 120 minutes. Setting the Sleep Mode Timeout to a low value reduces energy consumption, but may increase the response time of the product. Setting the Sleep Mode Timeout to a high value maintains a fast response, but uses more energy.

Hibernate Mode

This product is designed with an ultra-low power operating mode called *Hibernate mode*. When operating in Hibernate Mode, all other systems and devices are powered down safely.

The Hibernate mode can be entered in any of the following methods:

- Using the Hibernate Timeout
- Using the Schedule Power modes

Factory default Hibernate Timeout for this product in all countries or regions	3 days
--	--------

The amount of time the printer waits after a job is printed before it enters Hibernate mode can be modified between one hour and one month.

Off mode

If this product has an off mode which still consumes a small amount of power, then to completely stop product power consumption, disconnect the power supply cord from the electrical outlet.

Total energy usage

It is sometimes helpful to calculate the total product energy usage. Since power consumption claims are provided in power units of Watts, the power consumption should be multiplied by the time the product spends in each mode in order to calculate energy usage. The total product energy usage is the sum of each mode's energy usage.

Selecting a location for the printer

- Leave enough room to open trays, covers, and doors and to install hardware options.
- Set up the printer near an electrical outlet.



CAUTION—POTENTIAL INJURY: To avoid the risk of fire or electrical shock, connect the power cord to an appropriately rated and properly grounded electrical outlet that is near the product and easily accessible.



CAUTION—SHOCK HAZARD: To avoid the risk of electrical shock, do not place or use this product near water or wet locations.

- Make sure that airflow in the room meets the latest revision of the ASHRAE 62 standard or the CEN Technical Committee 156 standard.
- Provide a flat, sturdy, and stable surface.
- Keep the printer:
 - Clean, dry, and free of dust
 - Away from stray staples and paper clips
 - Away from the direct airflow of air conditioners, heaters, or ventilators
 - Free from direct sunlight and humidity extremes
- Observe the recommended temperatures and avoid fluctuations.

Ambient temperature	10 to 32°C (50 to 90°F)
Storage temperature	0 to 40°C (32 to 104°F)

- Allow the following recommended amount of space around the printer for proper ventilation:

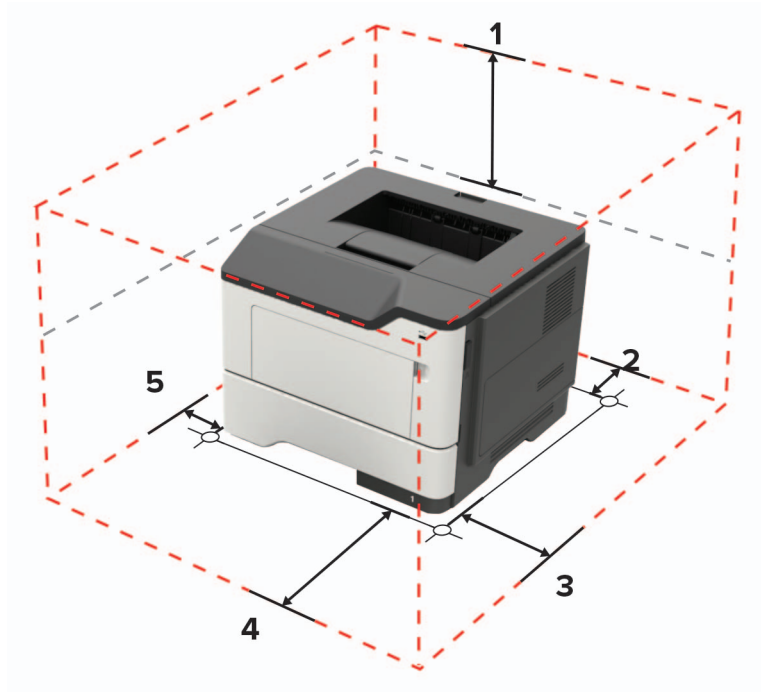

1	Top	305 mm (12 in.)
2	Rear	100 mm (3.94 in.)
3	Right side	110 mm (4.33 in.)
4	Front	305 mm (12 in.)
5	Left side	65 mm (2.56 in.)

Noise emission levels

The following measurements were made in accordance with ISO 7779 and reported in conformance with ISO 9296.

Note: Some modes may not apply to your product.

1-meter average sound pressure, dBA	
Printing	55 (MS521, M1246, B2546), 54 (MS421, M1242, B2442, MS321, B2338)
Scanning	N/A
Copying	N/A
Ready	15 (MS521, M1246, B2546), 0 (MS421, M1242, B2442, MS321, B2338)

Values are subject to change. See www.lexmark.com for current values.

Temperature information

Ambient operating temperature	10 to 32°C (50 to 90°F)
Shipping temperature	-20 to 40°C (-4 to 104°F)
Storage temperature and relative humidity	0 to 40°C (32 to 104°F) 8 to 80% RH

Options and features

Available internal options

- 256MB user flash memory
- Firmware Cards (DLEs)

Note: These options are not supported by the MS321 and B2338 models.

- Forms and Bar Code Card
- IPDS card
- PRESCRIBE Card
- DBCS Font Cards
 - Traditional Chinese Font Card
 - Simplified Chinese Font Card
 - Korean Font Card
 - Japanese Font Card
- Internal Print Server
 - Marknet N8370 (MS521, B2546, and M1246)
- Local Interface Card
 - Thin Parallel (MS521, B2546, and M1246)

Input/output configurations and capacities

Input sources

Printer model	Number of standard trays	Maximum number of optional trays*	Maximum number of trays
MS321, B2338	2	1	3
MS421, B2442, and M1242	2	1	3
MS521, B2546, and M1246	2	3	5

* The printer can support a maximum of three optional trays in one configuration.

Input capacities

Printer model	Standard tray	Multipurpose feeder	Total standard capacity	Maximum optional capacity	Maximum input capacity
MS321, B2338	250	100	300	550	900
MS421, B2442, and M1242	250	100	300	550	900

Paper capacity means 20-lb xerographic paper at ambient environment per sheet.

Printer model	Standard tray	Multipurpose feeder	Total standard capacity	Maximum optional capacity	Maximum input capacity
MS521, B2546, and M1246	250	100	300	1650	2000
Paper capacity means 20-lb xerographic paper at ambient environment per sheet.					

Output destinations

Printer model	Number of standard destinations
MS321, B2338	1
MS421, B2442, and M1242	1
MS521, B2546, and M1246	1

Output capacities

Printer model	Standard output capacity	Maximum output capacity
MS321, B2338	150	150
MS421, B2442, and M1242	150	150
MS521, B2546, and M1246	150	150
Paper capacity means 20-lb xerographic paper at ambient environment per sheet.		

Theory of operation

POR sequence

As the printer turns on, the engine code goes through a series of tests to verify hardware integrity. If a hardware failure is detected, then it is reported to the printer. If the POR sequence cannot be completed successfully, then the printer may post an error message. The message states that service may be needed.

Print cycle operation

Print engine layout



1	Printhead
2	Toner cartridge
3	Imaging unit
4	Transfer roller
5	Fuser

Print cycle

Flowchart

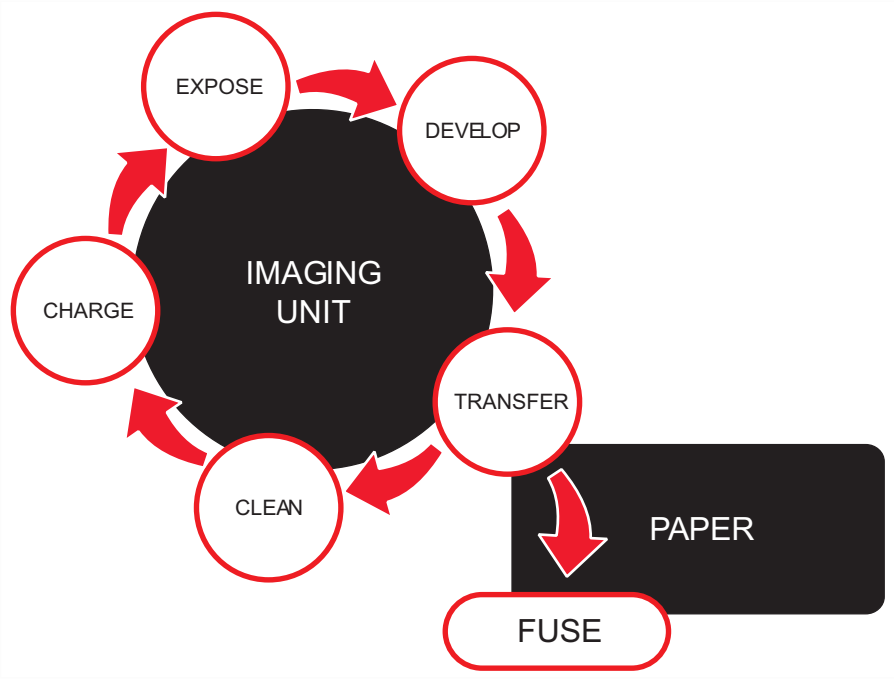

Charge

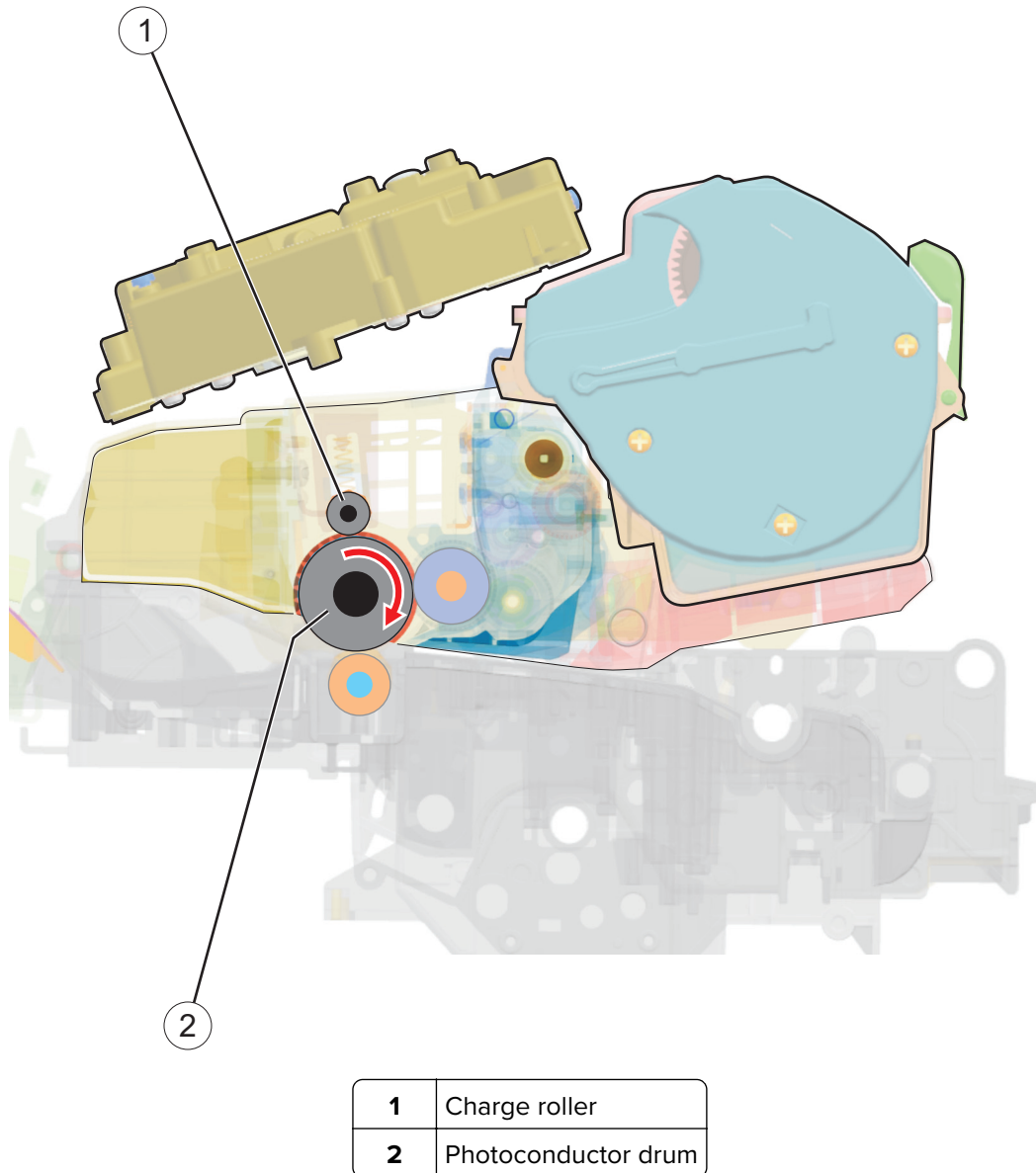

A uniform negative electrical charge is applied by the charge roller to the surface of the photoconductor drum. The photoconductive properties of the surface material allow it to hold the charge as long as it is not exposed to light.

Expose

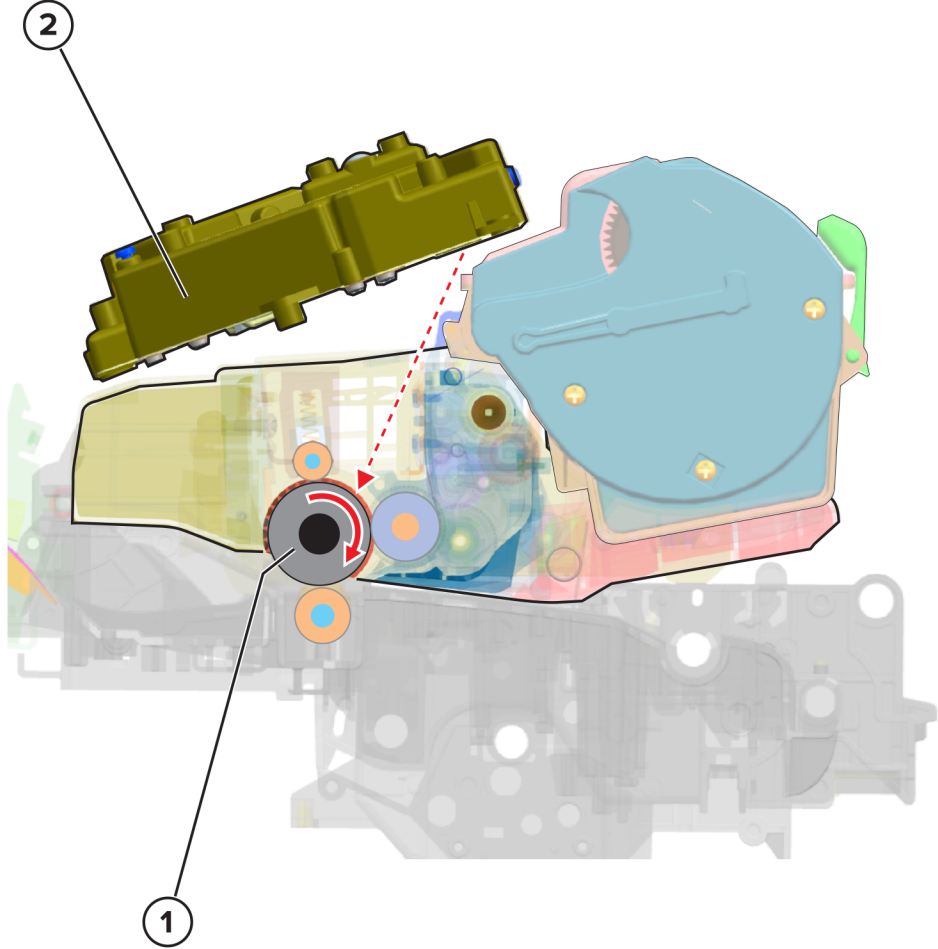

1	Photoconductor drum
2	Printhead

The printhead emits the light that contacts the surface of the photoconductor drum. The light turns on or off coinciding with the digital latent image. The light causes areas of the photoconductor drum surface to lose charge, resulting in a relative opposite polarity.

Develop

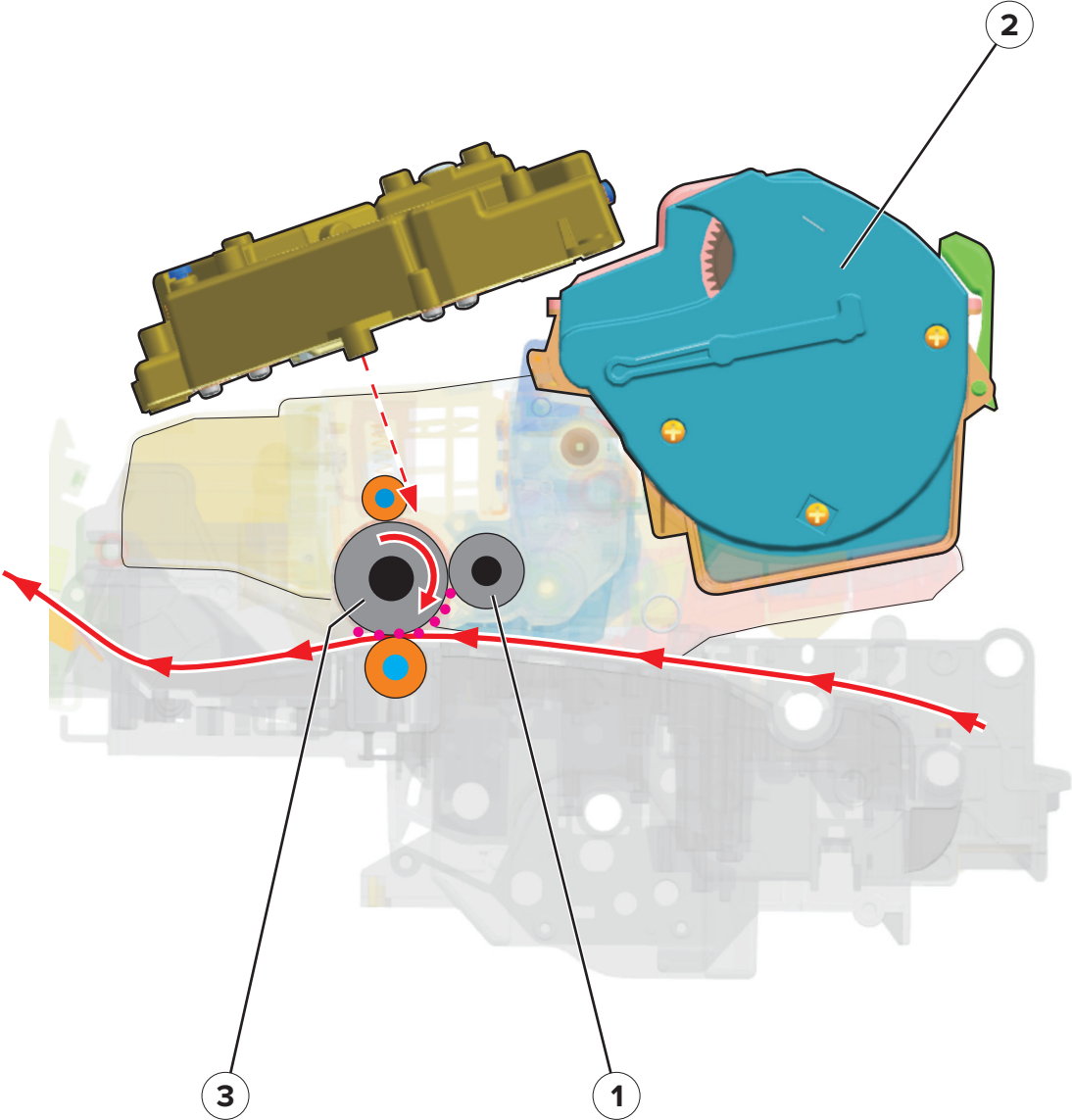

1	Developer roller
2	Toner cartridge
3	Photoconductor drum

The developer unit applies the toner from the toner cartridge to the photoconductor drum. The difference in charge causes the toner particles to attract to the photoconductor drum areas which are exposed to light.

Transfer

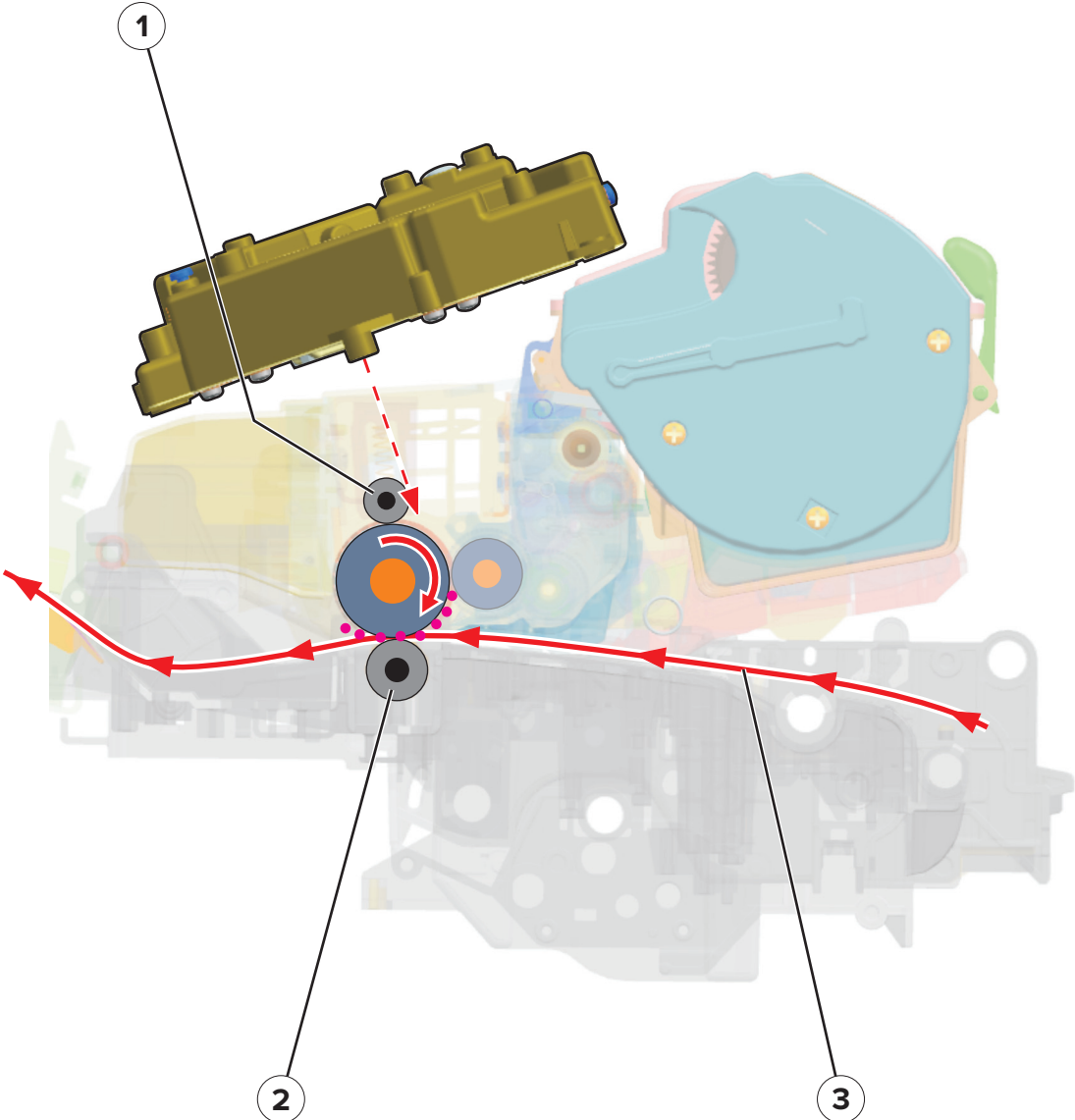

1	Charge roller
2	Transfer roller
3	Paper

The transfer roller applies a positive charge to the paper, which is pressed between the transfer roller and the photoconductor drum. Due to relative opposite polarities between the paper, from the transfer roller, and the photoconductor drum, from the charge roller, the charge attracts the toner onto the paper.

Clean

The cleaning blade removes the toner residue from the photoconductor drum. The cycle (charge, expose, develop, transfer, and clean) repeats until the whole image is transferred to the paper.

Fuse

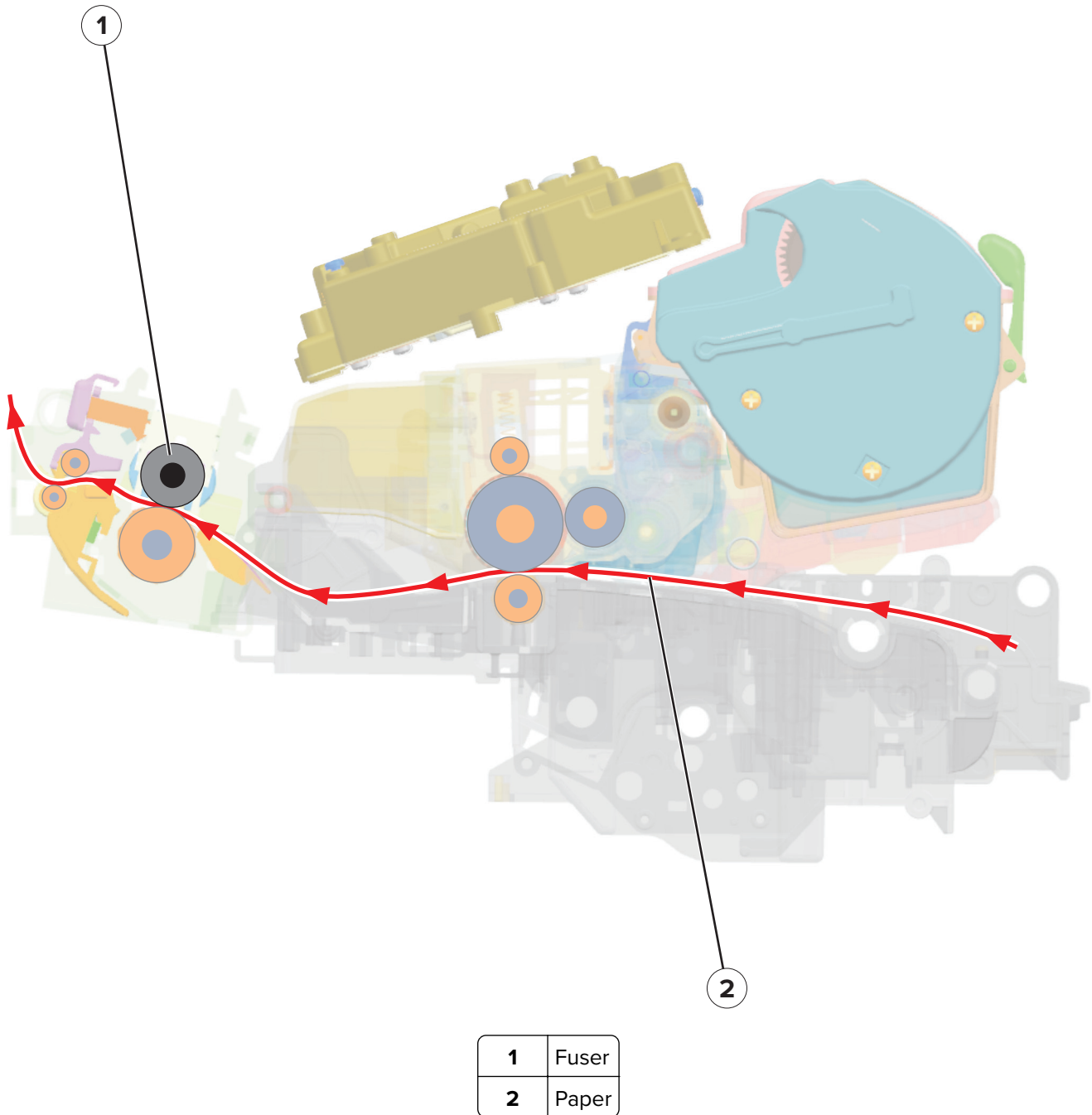

Even if the toner image is already on the paper, the toner particles are not yet permanently bonded to the surface. For the final part of printing, the paper is transported to the fuser where heat and pressure are applied to it. As a result, the toner particles melt and permanently fuse with the paper, completing the print process. The print cycle repeats for the succeeding pages.

Printer operation

Printer sections

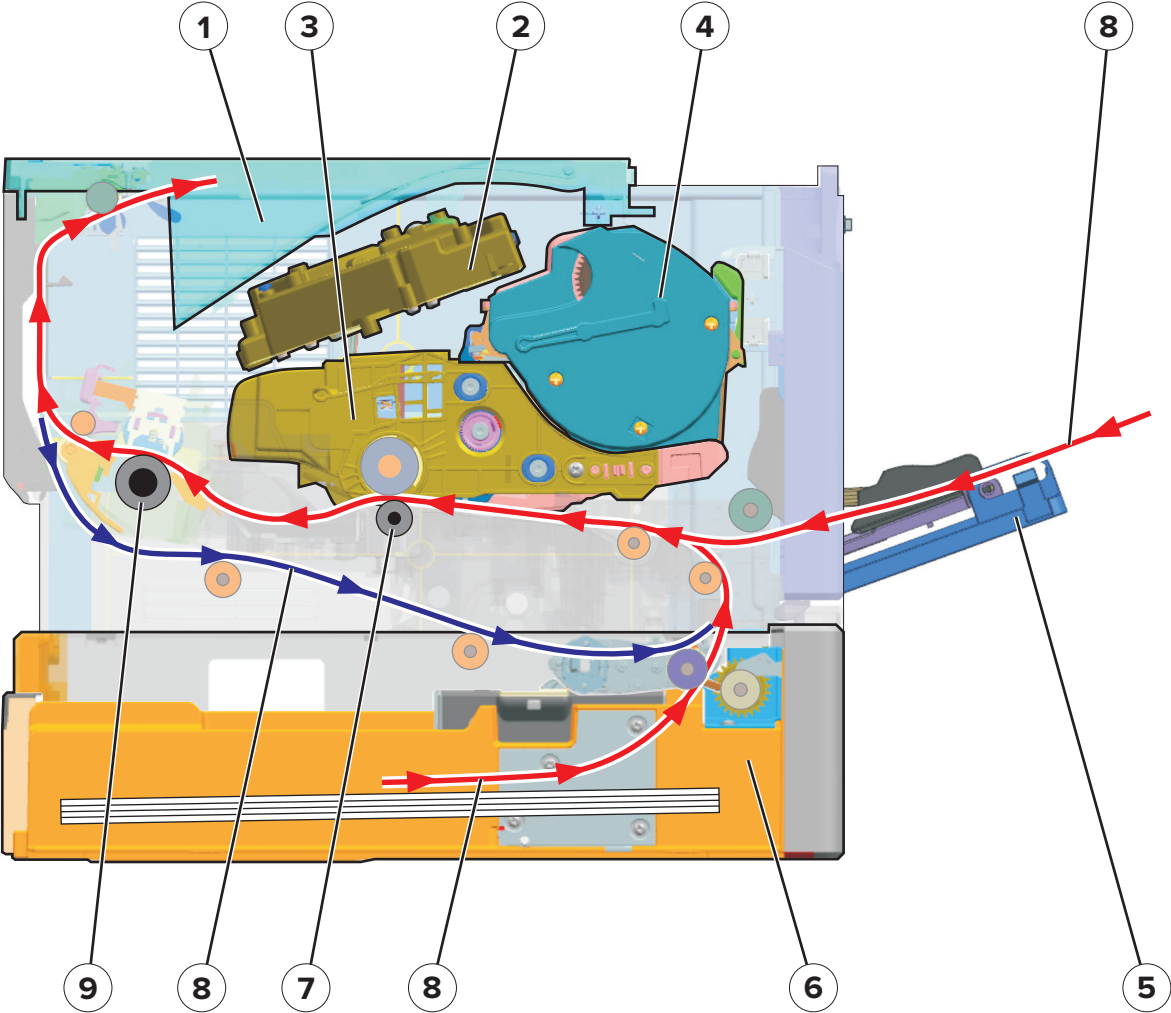

1	Bin
2	Printhead
3	Imaging unit
4	Toner cartridge
5	MPF
6	Tray
7	Transfer roller
8	Paper paths
9	Fuser

Printer paper path

One-sided print job

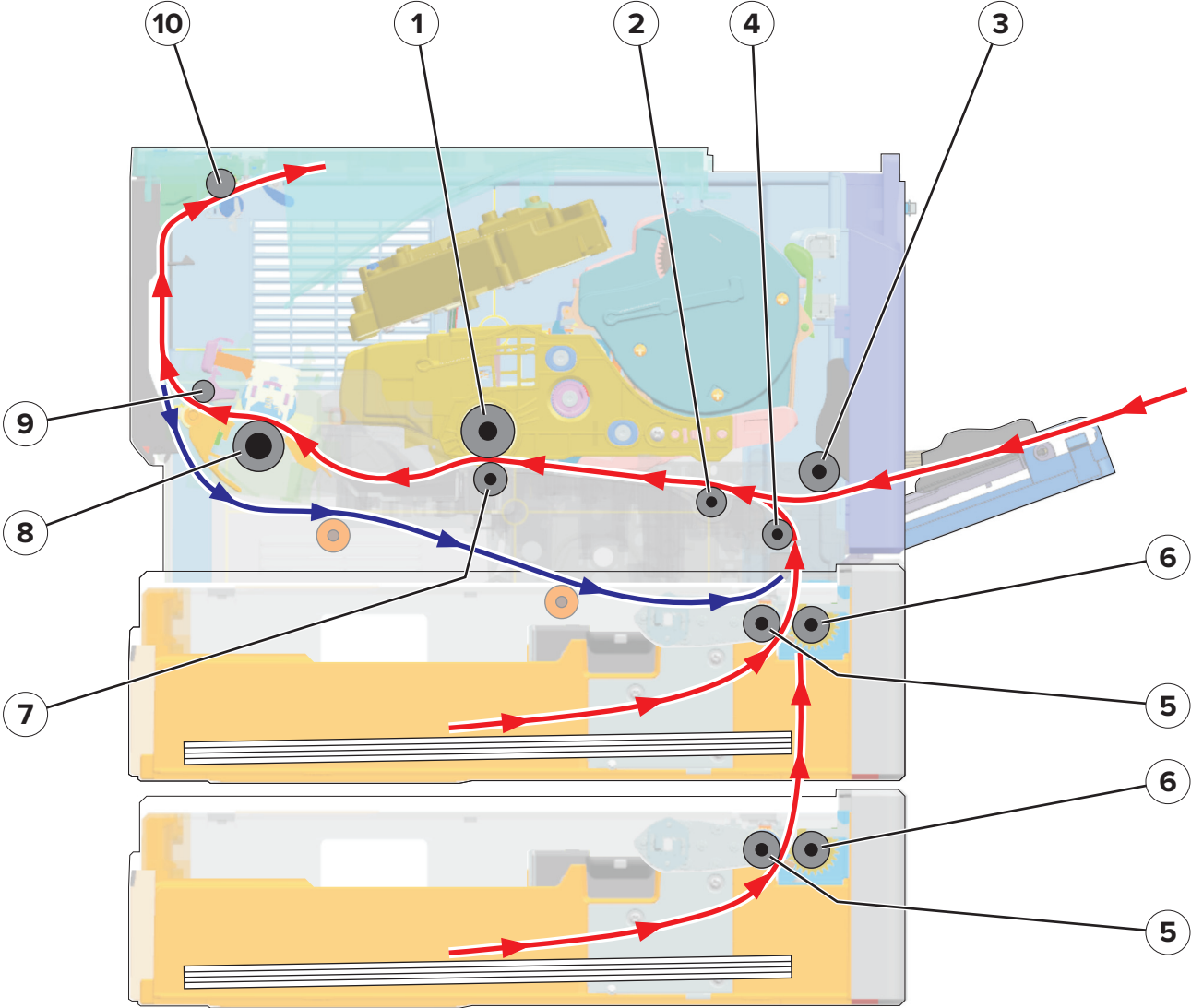

1	Photoconductor drum
2	First input roller
3	MPF pick roller
4	Second input roller
5	Pick roller
6	Separator roller
7	Transfer roller
8	Fuser
9	Fuser exit roller

10	Paper exit roller
-----------	-------------------

The pick roller picks and feeds the paper to the separator roller. The separator roller feeds the paper to the second input roller, which feeds it to the first input roller. For MPF print jobs, the MPF pick roller picks and feeds the paper to the first input roller.

The deskew shutter along the first input roller corrects the skew on the paper.

The first input roller feeds the paper to the transfer roller. At the transfer roller, the photoconductor drum transfers the developed image to the paper to create the printed image.

As the paper passes the fuser, heat and pressure are applied to permanently bond the toner to the paper.

After printing, the printer ejects the paper by the exit roller.

Two-sided print job

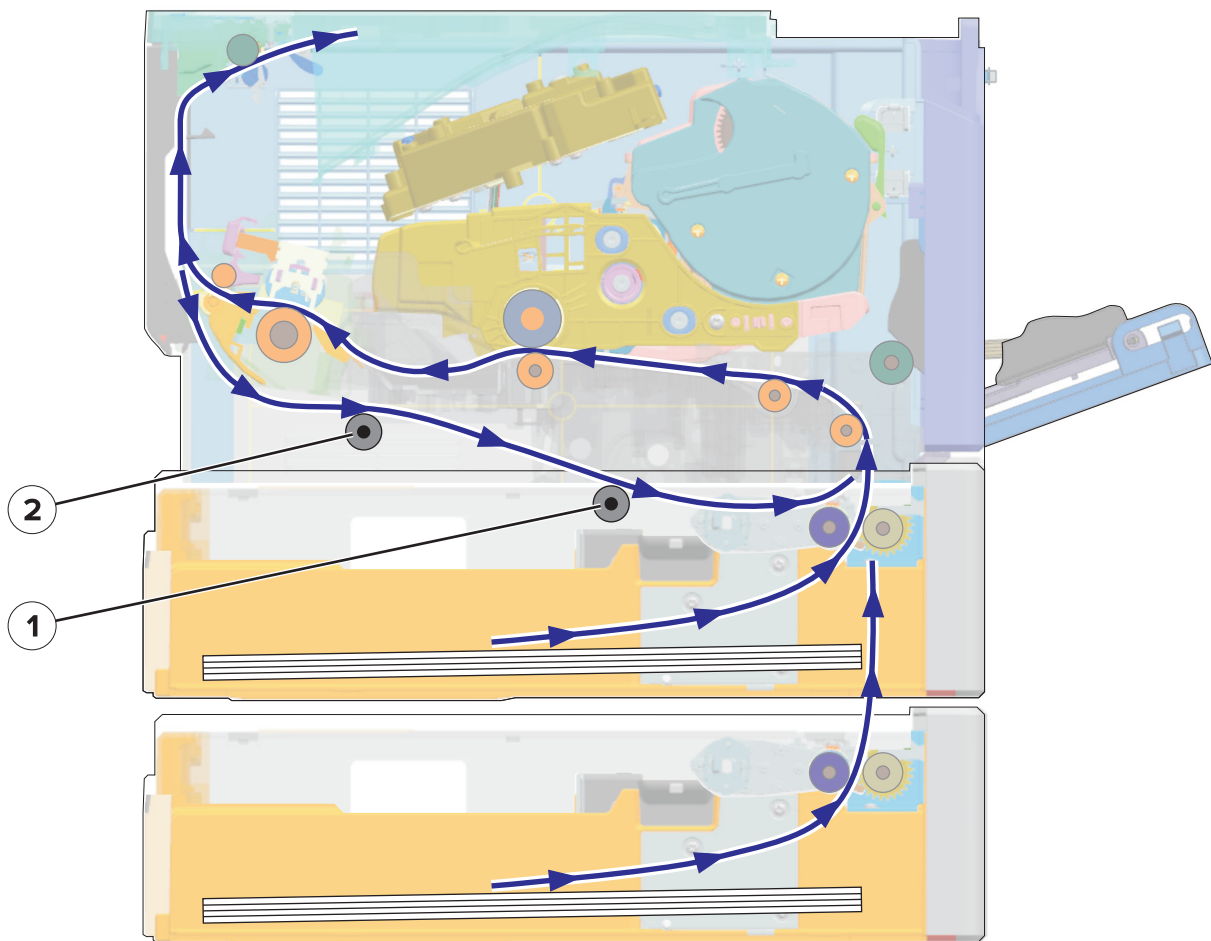

1	Duplex rear roller
2	Duplex front roller

After the first side is printed, the paper is diverted to the top of the paper exit roller. The duplex path opens, and then the paper reverses direction to get its opposite page printed.

The paper travels along the duplex path until it reenters the second input roller. From there, the paper continues its path until the print job is done.

Printer paper path sensors

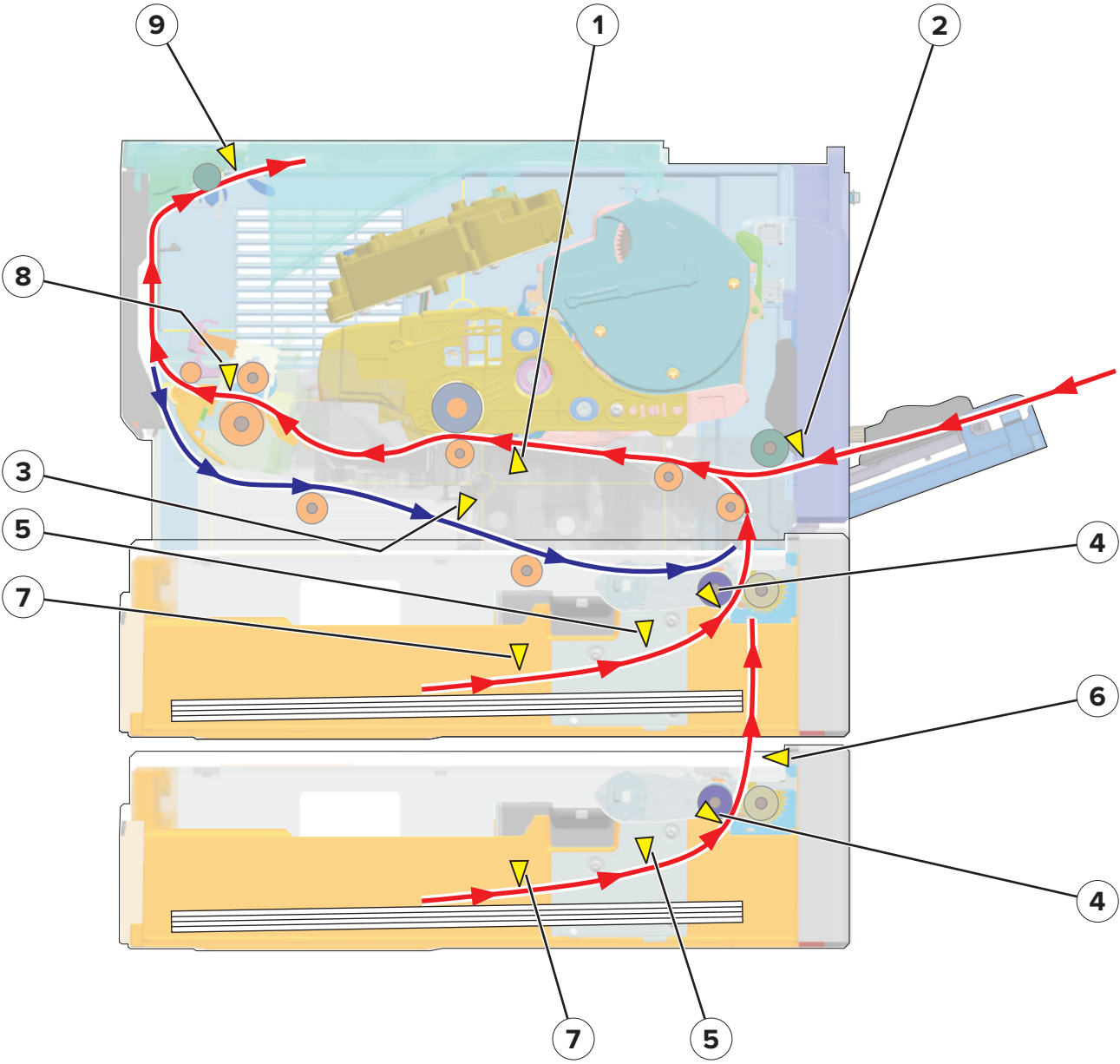

#	Sensor	Function
1	Sensor (input)	Detects the paper traveling between the first input roller and the transfer roller
2	Sensor (MPF paper present)	Detects if paper is in the MPF tray
3	Sensor (duplex)	Detects the paper traveling along the duplex path

#	Sensor	Function
4	Sensor (index)	<p>Detects if the pick roller is at the correct height to pick paper from the tray</p> <p>Note: The sensor in the standard tray is supported only in some printer models.</p>
5	Sensor (trailing edge)	Detects the trailing edge of the paper fed from the tray
6	Sensor (pass-through)	Detects paper fed from tray 2
7	Sensor (media present)	<p>Detects if paper is in the tray</p> <p>Note: The sensor in the standard tray is supported only in some printer models.</p>
8	Sensor (fuser exit)	Detects the paper exiting the fuser
9	Sensor (narrow media/bin full)	Detects if the paper is narrow and the bin is full

Main drive

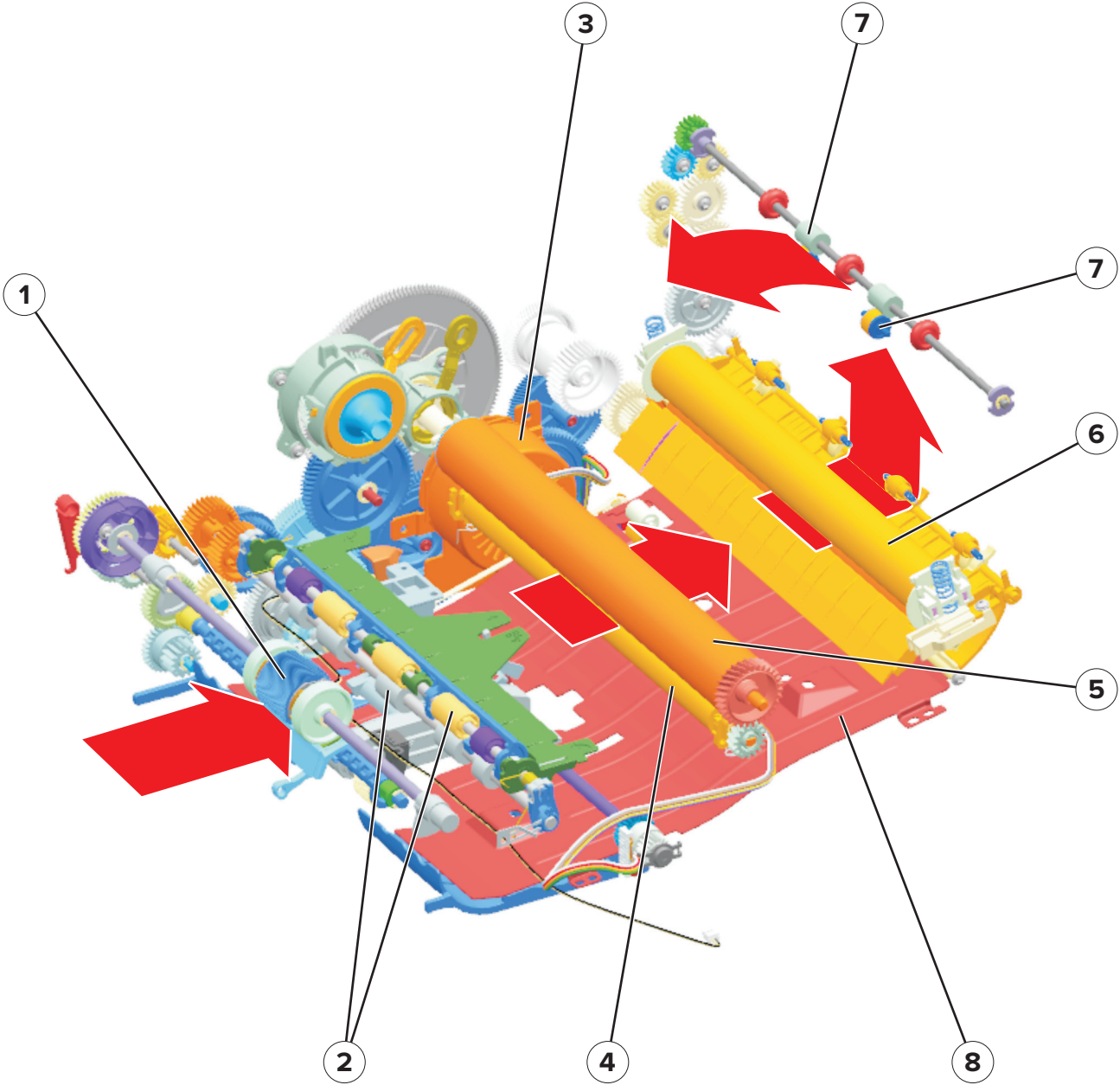

1	MPF
2	Paper input
3	Main drive gearbox motor
4	Transfer roller
5	Photoconductor
6	Fuser
7	Paper exit
8	Duplex

The gearbox provides mechanical power to the printer. Its motor transfer power through a number of gears to the following parts: MPF, paper input, transfer roll, photoconductor drum, fuser, paper exit, and duplex.

Tray drive

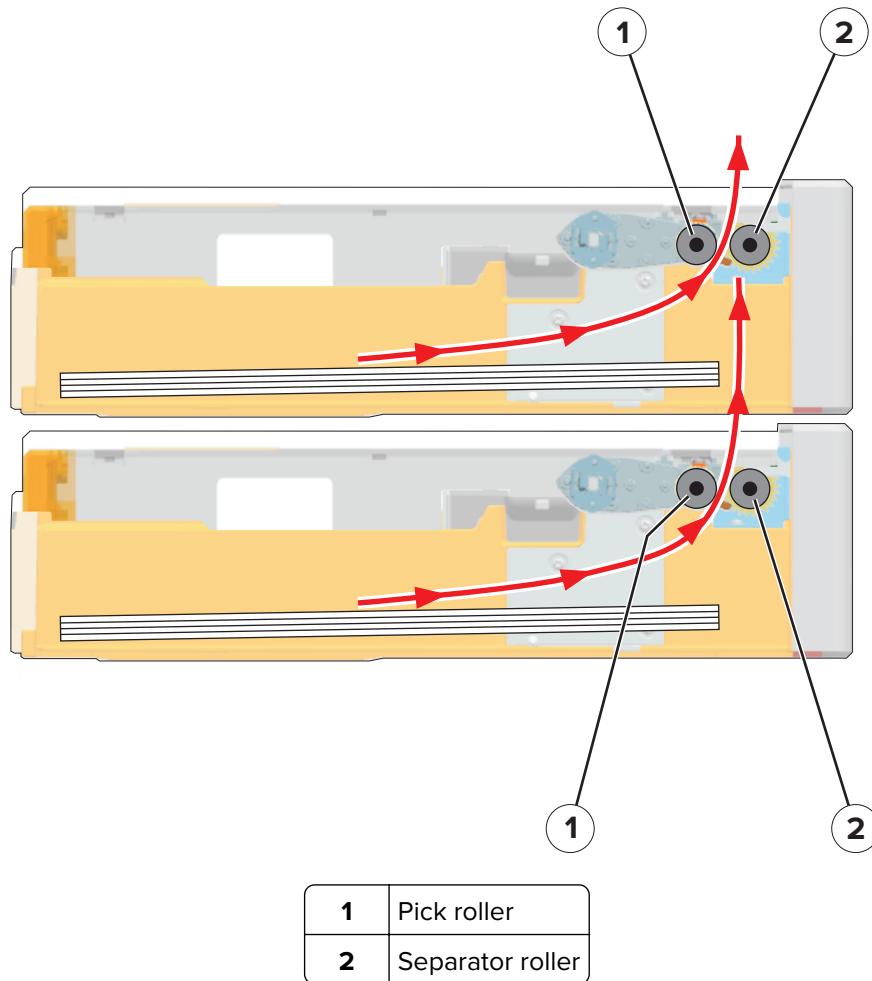

To prepare for feeding, the lift plate raises to push the paper against the pick roller. The lift plate stops pushing at the point where the pick roller is at the proper height for picking. After the pick roller is in position, it feeds the topmost paper to the separator roller. The separator roller rotates in a direction opposite to the pick roller to ensure that only one sheet is fed at a time.

The motor (pick/lift) controls the pick roller and lift plate.

The lift plate in the standard tray is supported only in some printer models.

Acronyms

Acronyms

ASIC	Application-Specific Integrated Circuit
BLDC	Brushless DC Motor
BOR	Black Only Retract
C	Cyan
CCD	Charge Coupled Device
CCP	Carbonless Copy Paper
CRC	Cyclic Redundancy Check
CSU	Customer Setup
CTLS	Capacitance Toner Level Sensing
DIMM	Dual Inline Memory Module
DRAM	Dynamic Random Access Memory
EDO	Enhanced Data Out
EP	Electrophotographic Process
EPROM	Erasable Programmable Read-Only Memory
ESD	Electrostatic Discharge
FRU	Field Replaceable Unit
GB	Gigabyte
HCF	High-Capacity Feeder
HCIT	High-Capacity Input Tray
HCOF	High-Capacity Output Finisher
HVPS	High Voltage Power Supply
ITU	Image Transfer Unit
K	Black
LCD	Liquid Crystal Display
LDAP	Lightweight Directory Access Protocol
LED	Light-Emitting Diode
LVPS	Low Voltage Power Supply
M	Magenta
MB	Megabyte
MFP	Multi-Function Printer
MPF	Multipurpose Feeder
MROM	Masked Read Only Memory

MS	Microswitch
NVM	Nonvolatile Memory
NVRAM	Nonvolatile Random Access Memory
OEM	Original Equipment Manufacturer
OPT	Optical Sensor
PC	Photoconductor
pel, pixel	Picture element
POR	Power-On Reset
POST	Power-On Self Test
PSD	Position Sensing Device
PWM	Pulse Width Modulation
RIP	Raster Imaging Processor
ROM	Read Only Memory
SDRAM	Synchronous Dual Random Access Memory
SIMM	Single Inline Memory Module
SRAM	Static Random Access Memory
TPS	Toner Patch Sensing
UPR	Used Parts Return
V ac	Volts alternating current
V dc	Volts direct current
VTB	Vacuum Transport Belt
Y	Yellow

Index

A

acronyms 293
 additional input tray diagnostics
 motor tests 148
 sensor tests 148
 advanced print quality samples 141
 attaching cables 235
 available internal options 277
 avoiding paper jams 68

B

blank pages 31

C

change history 19
 charge 281
 clean 284
 cleaning
 exterior of the printer 246
 interior of the printer 246
 printhead lenses 247
 cleaning the printer 246
 clearing jam
 in door A 70
 clipped pages or images 61
 compressed images appear on prints 63
 configurations
 printer models 21
 connectors
 controller board 240
 control panel
 controller board, removing with 155
 using 139
 controller board
 control panel, removing with 155
 controller board, restoring configuration 155

D

data security notice 153
 develop 283
 diagnostics menu
 accessing 141

E

electrostatic-sensitive parts 154
 embedded solutions 160
 emission notices 275

error codes
 0-99.99 104
 111 error messages 109
 121 error messages 110
 126 error messages 116
 128 error messages 118
 133 error messages 121
 140 error messages 122
 155 error messages 123
 162-164 error messages 125
 166-168 error messages 126
 171 error messages 129
 200 paper jam messages 77
 202 paper jam messages 88
 230 paper jam messages 92
 240-241 paper jam messages 95
 242 paper jam messages 98
 243 paper jam messages 99
 244 paper jam messages 100
 600-611 error messages 130
 900 error messages 133
 ESD-sensitive parts 154
 eSF solutions 160
 Ethernet port 235
 event log
 display log 142
 mark log 142
 print log 142
 print log summary 142
 expose 282

F

finding
 serial number 22
 fine lines are not printed correctly 60
 folded or wrinkled paper 43
 fuse 285

H

horizontal bottom contact connector 164
 horizontal light bands 51
 horizontal sliding contact connector 168
 horizontal top contact connector 162

I

identifying jam locations 69
 incorrect margins on prints 64

- indicator light
 - printer status 140
- input capacities 277
- input configurations 277
- inspection guide 245
- invalid code, fixing 151
- invalid engine mode
 - accessing 151
- J**
- jams
 - avoiding 68
- jams, clearing
 - in the duplex unit 75
 - in the multipurpose feeder 76
 - in the standard bin 74
 - trays 76
- L**
- locating paper jams 69
- locations
 - duplex path rollers 237
 - duplex path sensors 239
 - standard path rollers 237
 - standard path sensors 239
- low insertion force (LIF) connector 170
- lubrication
 - guidelines 246
- M**
- maintenance counter 246
- maintenance kit
 - resetting the counter 246
- maintenance kits 245
- menu
 - Config Menu 149
- moving the printer 274
- N**
- noise emission levels 275
- notices 273, 274, 275, 276
- O**
- output capacities 277
- output configurations 277
- P**
- paper curl 42
- paper jam in door A 70
- paper jam in the duplex unit 75
- paper jam in the multipurpose feeder 76
- paper jam in the rear door 73
- paper jam in trays 76
- paper jam, clearing
 - in the duplex unit 75
 - in the multipurpose feeder 76
 - in the rear door 73
 - trays 76
- paper jams
 - avoiding 68
- paper jams, clearing
 - in the standard bin 74
- paper path, duplex 287
- paper path, simplex 287
- parts catalog legend 248
- power button light
 - printer status 140
- power cord socket 235
- print cycle 280
 - charge 281
 - clean 284
 - develop 283
 - expose 282
 - flowchart 280
 - fuse 285
 - transfer 284
- print engine layout 279
- print is too dark 37
- print is too light 39
- print quality
 - initial check 28
- print quality troubleshooting
 - blank pages 31
 - clipped pages or images 61
 - compressed images appear on prints 63
 - fine lines are not printed correctly 60
 - folded or wrinkled paper 43
 - gray background on prints 29
 - horizontal light bands 51
 - incorrect margins on prints 64
 - paper curl 42
 - print is too dark 37
 - print is too light 39
 - repeating defects 47
 - skewed print 48
 - solid black pages 44
 - streaked vertical lines appear on prints 50
 - toner rubs off 65
 - toner specks appear on prints 66
 - vertical dark bands 53
 - vertical dark streaks with print missing 55
 - vertical light bands 52

- white streaks and voided areas 57
- printer
 - minimum clearances 274
 - selecting a location 274
- printer configurations 235
- printer diagnostics
 - input tray quick print 143
 - output bin quick feed 143
- printer diagnostics & adjustments
 - memory tests 147
 - motor tests 146
 - sensor tests 145
 - universal override 148
- printer diagnostics and adjustments
 - add-on cards tests 147
 - margin offset 147
 - registration adjust 147
- printer model
 - configurations 21
- printer ports 235
- printer sections 286
- printer setup
 - enable edge-to-edge (copy) 144
 - enable edge-to-edge (printing) 144
 - engine setting [x] 145
 - EP setup 145
 - model name 145
 - permanent page count 143
 - printed page count (color) 143
 - printed page count (mono) 143
 - process ID 144
 - serial number 144
- printhead lenses
 - cleaning 247

R

- removal
 - redrive assembly 225
 - redrive gear plate 227
 - separator roller assembly 232
- removal procedures
 - tips 173
- removals
 - cartridge gearbox 180
 - control panel assembly 200
 - control panel board 201
 - control panel buttons 201
 - control panel cover 201
 - control panel display 202
 - control panel flat cable 201
 - controller board 191
 - cooling fan 189

- duplex assembly 213
- duplex sensor 215
- front input guide 210
- fuser 224
 - fuser actuator 178
- input sensor 215
- interconnect cable 187
- jam access 203
- left cover 173
- main drive gearbox 174
- MPF gearbox 175
- MPF pick roller and separator pad 206
- MPF solenoid 181
- MPF with front access cover 198
- nameplate 198
- pick roller assembly 219
- pick roller clutch 182
- power supply 211
- printhead 229
- rear door and cover 224
- reverse solenoid 179
- right cover 185
- sensor (bin full) 226
- sensor (cartridge barrel shutter) 195
- sensor (front door) 204
- sensor (MPF paper present) 209
- sensor (toner density) 216
- sensor (trailing edge) 218
- sensor (tray present) 188
- toner cartridge smart chip contact 192
- top cover 228
- transfer roller 203
- removing paper jam
 - in door A 70
- reports
 - device settings 141
 - installed licenses 141
- restoring
 - configuration file 158
 - license file 158
- ribbon cables 161
- roller locations 237

S

- scheduled maintenance 245
- selecting a location for the printer 274
- sensor locations 239
- sensors, paper path 289
- service engineer (SE) menu
 - accessing 151
 - general SE 152
 - network SE 152

- solid black pages 44
- streaked vertical lines appear on prints 50
- supported paper sizes 22
- supported paper types 23
- supported paper weights 24

T

- theory
 - duplex paper path 287
 - main drive 291
 - paper path sensors 289
 - simplex paper path 287
 - tray drive 292
- theory of operation
 - POR sequence 279
- toner rubs off 65
- toner specks appear on prints 66
- tools, required 24
- transfer 284
- tray
 - drive 292
- troubleshooting
 - initial check 27
- troubleshooting, print quality
 - blank pages 31
 - clipped pages or images 61
 - compressed images appear on prints 63
 - fine lines are not printed correctly 60
 - folded or wrinkled paper 43
 - gray background on prints 29
 - horizontal light bands 51
 - incorrect margins on prints 64
 - paper curl 42
 - print is too dark 37
 - print is too light 39
 - repeating defects 47
 - skewed print 48
 - solid black pages 44
 - streaked vertical lines appear on prints 50
 - toner rubs off 65
 - toner specks appear on prints 66
 - vertical dark bands 53
 - vertical dark streaks with print missing 55
 - vertical light bands 52
 - white streaks and voided areas 57

U

- understanding the status of the power button and indicator light 140
- updating the printer firmware
 - using a flash drive 159

- using a network computer 159
- USB printer port 235

V

- vertical dark bands 53
- vertical dark streaks with print missing 55
- vertical mount contact connector 166

W

- white streaks and voided areas 57

Z

- zero insertion force (ZIF) connectors 161

Part number index

P/N	Part name	Page
3086579	Software CD.....	271
40X1368	USB 2.0 cable (2 meters).....	271
40X8046	Sensor (toner density).....	260
40X8393	Transfer roller.....	264
40X8520	Dust cover.....	250
41X0918	Pick tire.....	264
41X1002	Forms and Bar Code card (MS521).....	271
41X1004	IPDS card (MS521).....	271
41X1006	PRESCRIBE card (MS521).....	271
41X1010	User Flash Memory, 256MB.....	271
41X1013	Font card, Simplified Chinese.....	271
41X1014	Font card, Traditional Chinese.....	271
41X1015	Font card, Korean.....	271
41X1016	Font card, Japanese.....	271
41X1155	Bezel (MS321).....	252
41X1156	Bezel (MS421).....	252
41X1157	Bezel (MS521).....	252
41X1162	Toner cartridge smart chip contact.....	258
41X1163	Nameplate.....	250
41X1165	Right cover.....	250
41X1167	Left cover.....	250
41X1169	Rear door and cover.....	250
41X1171	Top cover.....	250
41X1176	Duplex assembly.....	262
41X1178	Fuser, 110V.....	254
41X1179	Fuser, 220V.....	254
41X1180	Fuser, 100V.....	254
41X1182	MPF gearbox (MS521).....	262
41X1183	Jam access cover.....	262
41X1184	Front input guide.....	262
41X1185	Printhead.....	254
41X1191	Controller board (MS321, MS421).....	254

P/N	Part name	Page
41X1193	Controller board (MS521).....	254
41X1197	MPF pick roller and separator pad.....	264
41X1201	Power supply, 100V/110V.....	254
41X1202	Power supply, 220V.....	254
41X1203	Redrive assembly.....	264
41X1206	Sensor (duplex and input).....	260
41X1209	Sensor (front door).....	258
41X1210	Sensor (MPF paper present).....	258
41X1211	Sensor (bin full).....	258
41X1212	Separator roller assembly.....	268
41X1213	MPF solenoid.....	256
41X1214	Reverse solenoid.....	256
41X1216	Optional 550-sheet tray.....	268
41X1217	Optional 250-sheet tray.....	268
41X1218	MPF with front access cover.....	266
41X1220	Standard 250-sheet tray insert (MS521).....	266
41X1221	250-sheet tray insert (optional tray).....	268
41X1222	550-sheet tray insert (optional tray).....	268
41X1223	Pick roller assembly.....	264
41X1224	Main drive gearbox.....	254
41X1228	Maintenance Kit (110 V).....	269
41X1229	Maintenance Kit (220 V).....	269
41X1230	Maintenance Kit (100 V).....	269
41X1233	Right access cover.....	250
41X1236	Interconnect cable.....	258
41X1237	Motor (cartridge).....	256
41X1238	Sensor (tray present).....	258
41X1239	Pick roller.....	268
41X1240	Sensor (trailing edge).....	260
41X1372	Marknet N8370, Rear WiFi (MS521).....	271
41X1627	Control panel display assembly (MS521).....	252
41X1873	Wireless module.....	252
41X1988	Cartridge barrel sensor kit.....	258
41X2047	Control panel display assembly (MS321, MS421).....	252

P/N	Part name	Page
41X2051	Parallel card, thin (MS521).....	271
41X2055	Smart card.....	271
41X2125	Standard 250-sheet tray insert (MS321, MS421).....	266
41X2255	Fuser cam.....	262
41X2259	Cooling fan.....	256
41X2262	Output extender.....	250
41X2263	Rear access door.....	250
41X2264	Control panel covers (MS321, MS421).....	252
41X2265	Control panel covers (MS521).....	252
41X2266	Flat cable, 2-line display (MS321, MS421).....	252
41X2267	Flat cable, 2.4-inch display (MS521).....	252
41X2268	Redrive gear plate.....	262
41X2270	Wireless module cable.....	252
41X2271	MPF gearbox (MS321, MS421).....	262
41X2391	Pick roller clutch.....	256

Part name index

P/N	Part name	Page
41X1221	250-sheet tray insert (optional tray).....	268
41X1222	550-sheet tray insert (optional tray).....	268
41X1155	Bezel (MS321).....	252
41X1156	Bezel (MS421).....	252
41X1157	Bezel (MS521).....	252
41X1988	Cartridge barrel sensor kit.....	258
41X2264	Control panel covers (MS321, MS421).....	252
41X2265	Control panel covers (MS521).....	252
41X2047	Control panel display assembly (MS321, MS421).....	252
41X1627	Control panel display assembly (MS521).....	252
41X1191	Controller board (MS321, MS421).....	254
41X1193	Controller board (MS521).....	254
41X2259	Cooling fan.....	256
41X1176	Duplex assembly.....	262
40X8520	Dust cover.....	250
41X2266	Flat cable, 2-line display (MS321, MS421).....	252
41X2267	Flat cable, 2.4-inch display (MS521).....	252
41X1016	Font card, Japanese.....	271
41X1015	Font card, Korean.....	271
41X1013	Font card, Simplified Chinese.....	271
41X1014	Font card, Traditional Chinese.....	271
41X1002	Forms and Bar Code card (MS521).....	271
41X1184	Front input guide.....	262
41X2255	Fuser cam.....	262
41X1180	Fuser, 100V.....	254
41X1178	Fuser, 110V.....	254
41X1179	Fuser, 220V.....	254
41X1236	Interconnect cable.....	258
41X1004	IPDS card (MS521).....	271
41X1183	Jam access cover.....	262
41X1167	Left cover.....	250
41X1224	Main drive gearbox.....	254

P/N	Part name	Page
41X1230	Maintenance Kit (100 V).....	269
41X1228	Maintenance Kit (110 V).....	269
41X1229	Maintenance Kit (220 V).....	269
41X1372	Marknet N8370, Rear WiFi (MS521).....	271
41X1237	Motor (cartridge).....	256
41X2271	MPF gearbox (MS321, MS421).....	262
41X1182	MPF gearbox (MS521).....	262
41X1197	MPF pick roller and separator pad.....	264
41X1213	MPF solenoid.....	256
41X1218	MPF with front access cover.....	266
41X1163	Nameplate.....	250
41X1217	Optional 250-sheet tray.....	268
41X1216	Optional 550-sheet tray.....	268
41X2262	Output extender.....	250
41X2051	Parallel card, thin (MS521).....	271
41X1239	Pick roller.....	268
41X1223	Pick roller assembly.....	264
41X2391	Pick roller clutch.....	256
41X0918	Pick tire.....	264
41X1201	Power supply, 100V/110V.....	254
41X1202	Power supply, 220V.....	254
41X1006	PRESCRIBE card (MS521).....	271
41X1185	Printhead.....	254
41X2263	Rear access door.....	250
41X1169	Rear door and cover.....	250
41X1203	Redrive assembly.....	264
41X2268	Redrive gear plate.....	262
41X1214	Reverse solenoid.....	256
41X1233	Right access cover.....	250
41X1165	Right cover.....	250
41X1211	Sensor (bin full).....	258
41X1206	Sensor (duplex and input).....	260
41X1209	Sensor (front door).....	258
41X1210	Sensor (MPF paper present).....	258

P/N	Part name	Page
40X8046	Sensor (toner density).....	260
41X1240	Sensor (trailing edge).....	260
41X1238	Sensor (tray present).....	258
41X1212	Separator roller assembly.....	268
41X2055	Smart card.....	271
3086579	Software CD.....	271
41X2125	Standard 250-sheet tray insert (MS321, MS421).....	266
41X1220	Standard 250-sheet tray insert (MS521).....	266
41X1162	Toner cartridge smart chip contact.....	258
41X1171	Top cover.....	250
40X8393	Transfer roller.....	264
40X1368	USB 2.0 cable (2 meters).....	271
41X1010	User Flash Memory, 256MB.....	271
41X1873	Wireless module.....	252
41X2270	Wireless module cable.....	252

MS321, B2338, MS421, B2442,
M1242, MS521, B2546, M1246
WIRING DIAGRAM

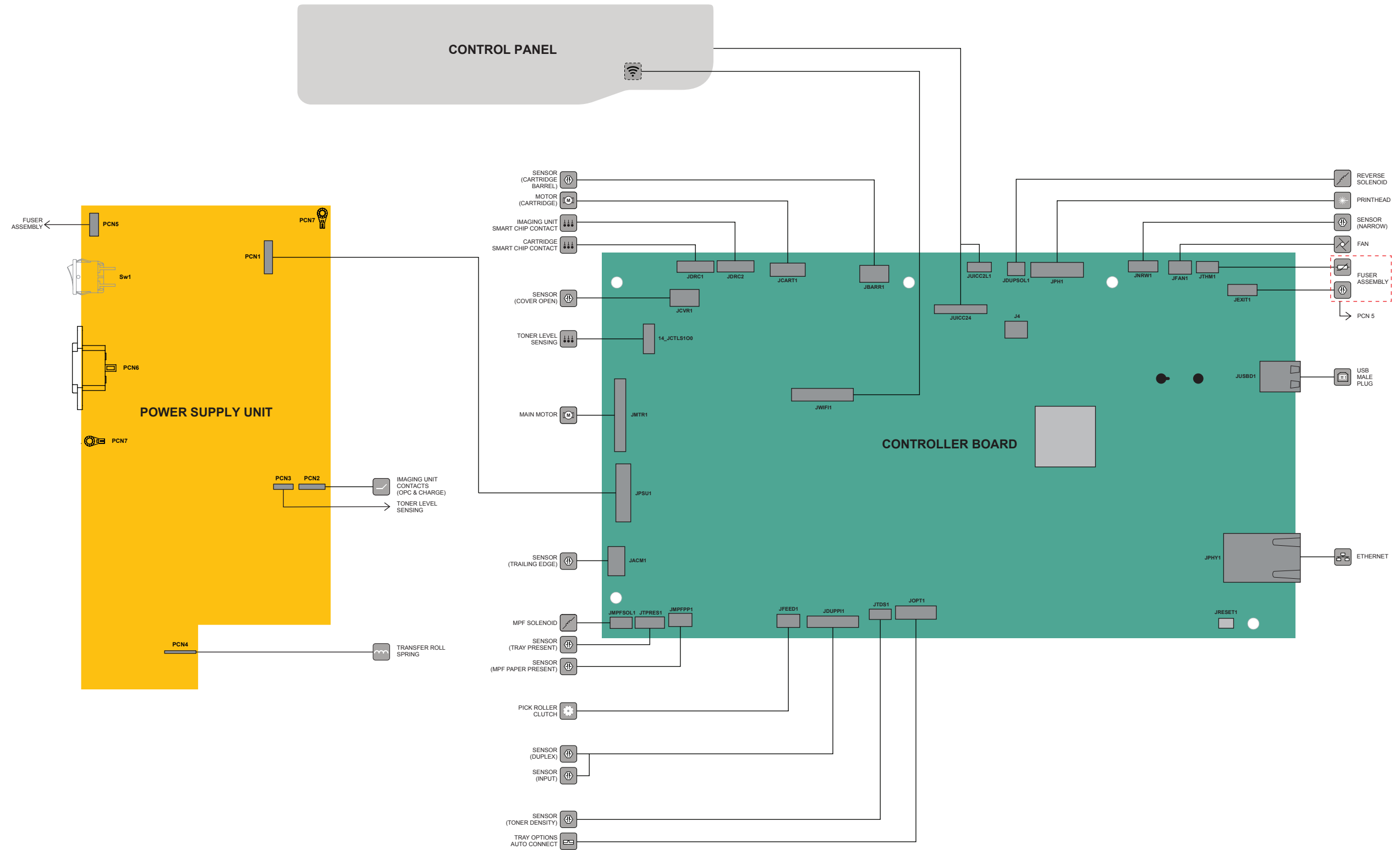

NOTES:

- WiFi hardware in the control panel is only available on **dw** models.
- For MS321 and B2338, the control panel connects only to **JUICC2L1**.
- For MS421, B2442, M1242, MS521, B2546, and M1246, the control panel connects only to **JUICC24**.