



TASKalfa

550c

650c

750c

PARTS LIST

Published in July 2009
5JNPL061
845JN111
Rev.1

NOTES

1. Indicate parts number and parts description together with the machine model name when placing an order.

e.g.	Parts Number	Parts Name	Machine Model	Quantity
	5JN712W0	COVER-FRT-EPU-434T	TASKalfa 650c	1

2. Symbols in the "Parts Number" column.

- Parts with "☉" indicate regular maintenance parts.

CONTENTS

FIG. 1	COVER-1-ASM	2	FIG. 51	OPTICAL-DRIVE-ASM.....	102
FIG. 2	COVER-2-ASM	4	FIG. 52	CRG-1-ASM.....	104
FIG. 3	CONTROL-PANEL-ASM	6	FIG. 53	CRG-2-ASM.....	106
FIG. 4	ARM-ASM	8	FIG. 54	OPTICAL-ELECTRIC-ASM.....	108
FIG. 5	LOWER-FRAME-ASM	10	FIG. 55	DRIVE-DEV-ASM.....	110
FIG. 6	UPPER-FRAME-ASM	12	FIG. 56	DRIVE-DRUM-ASM	112
FIG. 7	FEED-COVER-ASM.....	14	FIG. 57	TONER-ASM.....	114
FIG. 8	FEED-DRIVE-1-ASM	16	FIG. 58	EPU-COVER-ASM.....	116
FIG. 9	FEED-DRIVE-2-ASM	18	FIG. 59	EPU-TRAY-1-ASM	118
FIG. 10	FEED-RGST-ASM.....	20	FIG. 60	EPU-TRAY-2-ASM	120
FIG. 11	FEED-ASM.....	22	FIG. 61	EPU-TRAY-3-ASM	122
FIG. 12	TANDEM-LCF-DRIVE-ASM	24	FIG. 62	DEVELOPER-ASM	124
FIG. 13	TANDEM-LCF-1-ASM	26	FIG. 63	CLEANER-ASM	126
FIG. 14	TANDEM-LCF-2-ASM	28	FIG. 64	CHARGER-ASM	128
FIG. 15	MANUAL-FEED-DRIVE-1-ASM	30	FIG. 65	EPU-TONNER-AUGER-ASM	130
FIG. 16	MANUAL-FEED-DRIVE-2-ASM	32	FIG. 66	DRAWER-DRIVE-ASM	132
FIG. 17	MANUAL-TRAY-ASM	34	FIG. 67	DRAWER-ASM	134
FIG. 18	ADU-DRIVE-ASM.....	36	FIG. 68	SYS-ASM.....	136
FIG. 19	ADU-COVER-ASM.....	38	FIG. 69	LGC-ASM.....	138
FIG. 20	ADU-MID-ASM	40	FIG. 70	ELECTRIC-ASM	140
FIG. 21	ADU-GUIDE-1-ASM	42	FIG. 71	PS-HVT-ASM	142
FIG. 22	ADU-GUIDE-2-ASM	44	FIG. 72	RADF-FEED-1-ASM	144
FIG. 23	BRIDGE-1-ASM	46	FIG. 73	RADF-FEED-2-ASM1	146
FIG. 24	BRIDGE-2-ASM	48	FIG. 74	RADF-FEED-3-ASM	148
FIG. 25	BRIDGE-3-ASM	50	FIG. 75	RADF-FEED-4-ASM	150
FIG. 26	BRIDGE-4-ASM	52	FIG. 76	RADF-FEED-5-ASM	152
FIG. 27	TRANSFER-ROLLER-TONNER- AUGER-ASM.....	54	FIG. 77	RADF-FEED-6-ASM	154
FIG. 28	TRANSFER-ROLLER-DRIVE-ASM	56	FIG. 78	RADF-FEED-DRIVE-ASM	156
FIG. 29	TRANSFER-ROLLER-ASM	58	FIG. 79	RADF-HINGE-ASM.....	158
FIG. 30	TRANSFER-BELT-1	60	FIG. 80	RADF-REAR-FRAME-ASM	160
FIG. 31	TRANSFER-BELT-2	62	FIG. 81	RADF-COVER-ASM	162
FIG. 32	TRANSFER-BELT-3	64	FIG. 82	RADF-GUIDE-OPEN-ASM	164
FIG. 33	TRANSFER-BELT-4	66	FIG. 83	RADF-PLATEN-ASM	166
FIG. 34	TRANSFER-BELT-CLEANER	68	FIG. 84	RADF-TRAY-ASM	168
FIG. 35	EXIT-1-ASM	70	FIG. 85	HARNESS-SYS_SLG	170
FIG. 36	EXIT-2-ASM	72	FIG. 86	HARNESS-LGC-1	172
FIG. 37	EXIT-3-ASM	74	FIG. 87	HARNESS-LGC-2	174
FIG. 38	FUSER-AROUND-ASM	76	FIG. 88	HARNESS-LGC-3.....	176
FIG. 39	FUSER-DRIVE-ASM.....	78	FIG. 89	HARNESS-PFC-2	178
FIG. 40	FUSER-COV-FRAME-ASM.....	80	FIG. 90	HARNESS-PFC-2	180
FIG. 41	FUSER-GUIDE-ASM.....	82	FIG. 91	HARNESS-DRV_ADU	182
FIG. 42	FUSER-PR-ASM.....	84	FIG. 92	HARNESS-DLG	184
FIG. 43	FUSER-HR-ASM.....	86	FIG. 93	HARNESS-EPU	186
FIG. 44	FRONT-FRAME-ASM	88	FIG. 94	HARNESS-PS-HVT	188
FIG. 45	REAR-FRAME-1-ASM	90	FIG. 95	JIGS & GREASE.....	190
FIG. 46	REAR-FRAME-2-ASM	92	FIG. 96	DOWNLOAD JIGS.....	192
FIG. 47	REAR-FRAME-3-ASM	94	FIG. 97	SUPPLIES	194
FIG. 48	LSU-ASM	96	FIG. 98	REPLACE UNIT	196
FIG. 49	DUCT-ASM.....	98	FIG. 99	PM-KIT	198
FIG. 50	OPTICAL-FRAME-ASM	100	FIG. 100	SERVICE.	200

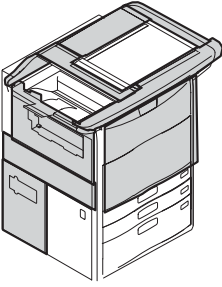
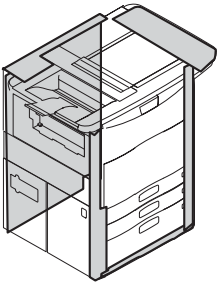
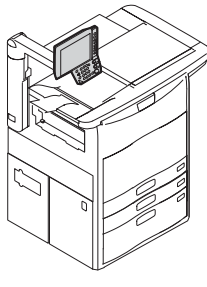
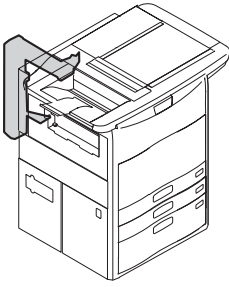
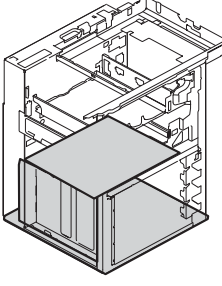
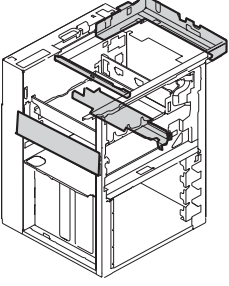
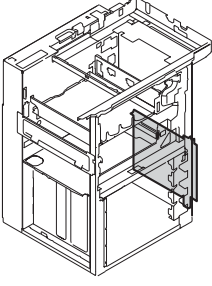
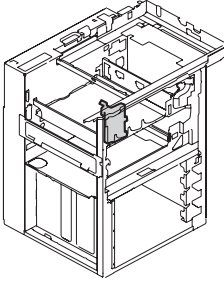
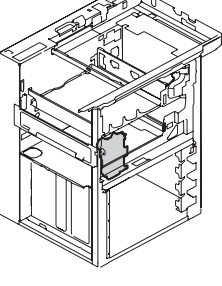
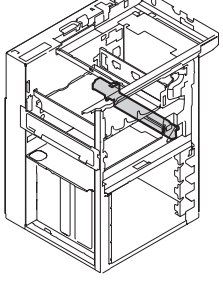
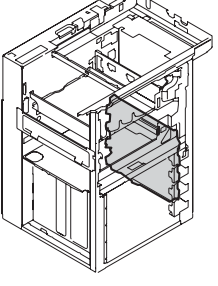
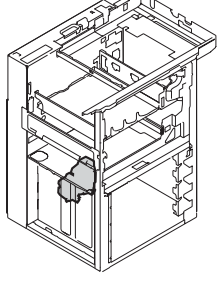
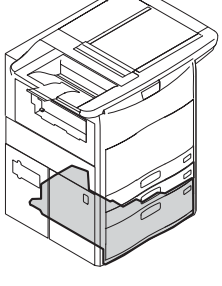
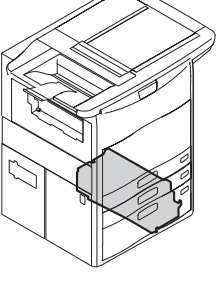
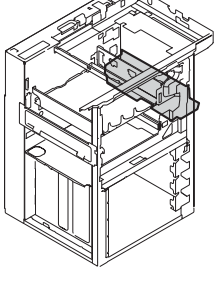
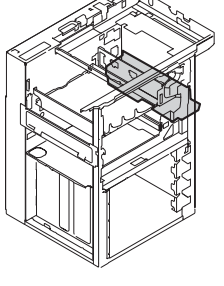
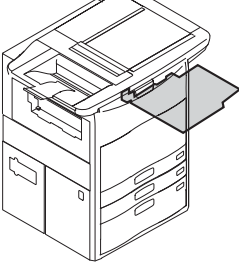
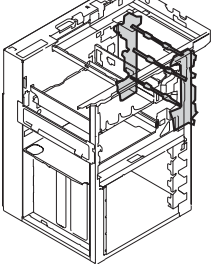
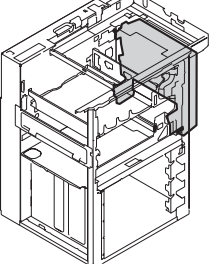
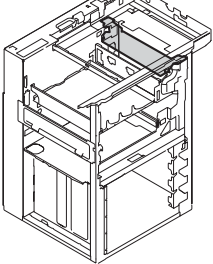
<p>1. COVER-1-ASM</p> 	<p>2. COVER-2-ASM</p> 	<p>3. CONTROL-PANEL-ASM</p> 	<p>4. ARM-ASM</p> 
<p>5. LOWER-FRAME-ASM</p> 	<p>6. UPPER-FRAME-ASM</p> 	<p>7. FEED-COVER-ASM</p> 	<p>8. FEED-DRIVE-1-ASM</p> 
<p>9. FEED-DRIVE-2-ASM</p> 	<p>10. FEED-RGST-ASM</p> 	<p>11. FEED-ASM</p> 	<p>12. TANDEM-LCF-DRIVE-ASM</p> 
<p>13. TANDEM-LCF-1-ASM</p> 	<p>14. TANDEM-LCF-2-ASM</p> 	<p>15. MANUAL-FEED-DRIVE-1-ASM</p> 	<p>16. MANUAL-FEED-DRIVE-2-ASM</p> 
<p>17. MANUAL-TRAY-ASM</p> 	<p>18. ADU-DRIVE-ASM</p> 	<p>19. ADU-COVER-ASM</p> 	<p>20. ADU-MID-ASM</p> 

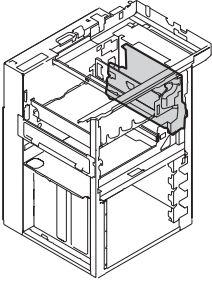
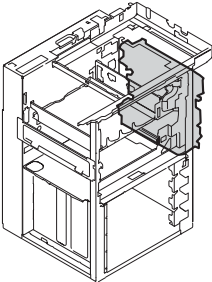
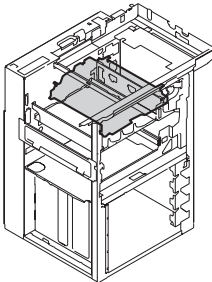
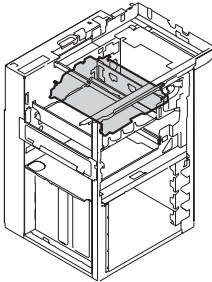
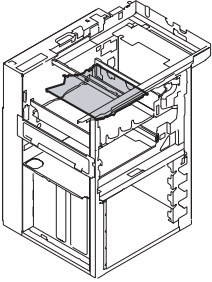
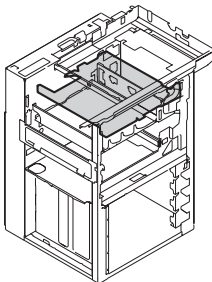
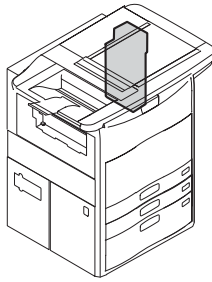
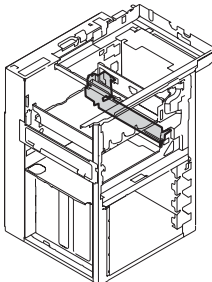
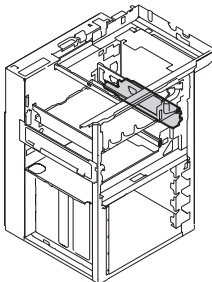
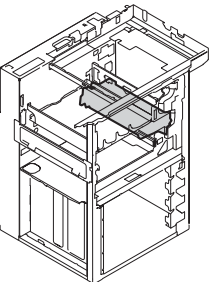
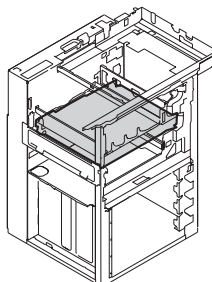
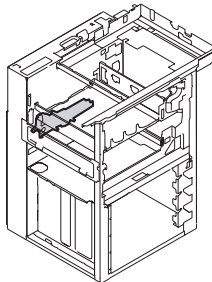
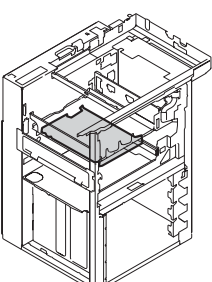
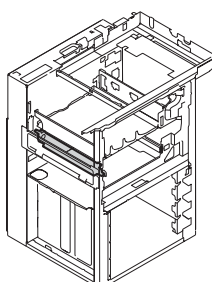
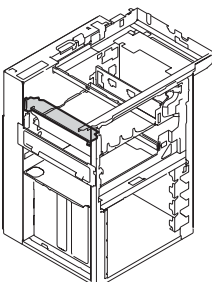
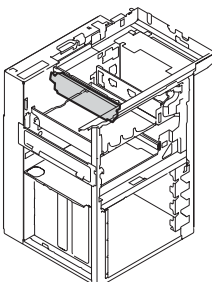
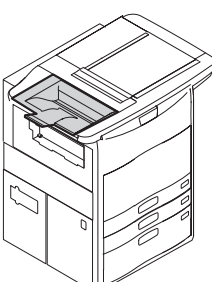
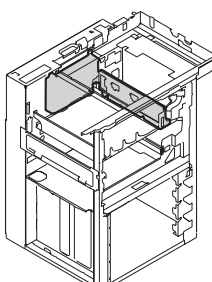
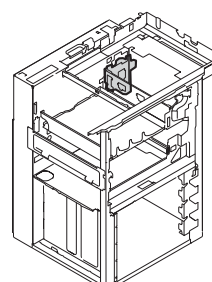
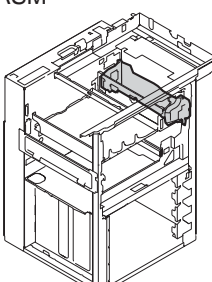
<p>21.ADU-GUIDE-1-ASM</p> 	<p>22.ADU-GUIDE-2-ASM</p> 	<p>23.BRIDGE-1-ASM</p> 	<p>24.BRIDGE-2-ASM</p> 
<p>25.BRIDGE-3-ASM</p> 	<p>26.BRIDGE-4-ASM</p> 	<p>27.TRANSFER-ROLLER-TONNER-AUGER-ASM</p> 	<p>28.TRANSFER-ROLLER-DRIVE-ASM</p> 
<p>29.TRANSFER-ROLLER-ASM</p> 	<p>30.TRANSFER-BELT-1</p> 	<p>31.TRANSFER-BELT-2</p> 	<p>32.TRANSFER-BELT-3</p> 
<p>33.TRANSFER-BELT-4</p> 	<p>34.TRANSFER-BELT-CLEANER</p> 	<p>35.EXIT-1-ASM</p> 	<p>36.EXIT-2-ASM</p> 
<p>37.EXIT-3-ASM</p> 	<p>38.FUSER-AROUND-ASM</p> 	<p>39.FUSER-DRIVE-ASM</p> 	<p>40.FUSER-COV-FRAME-ASM</p> 

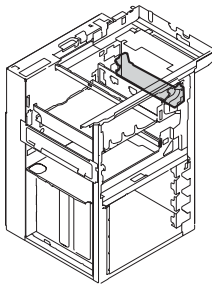
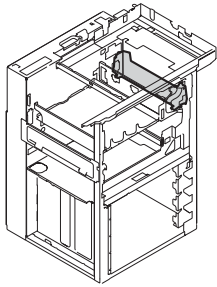
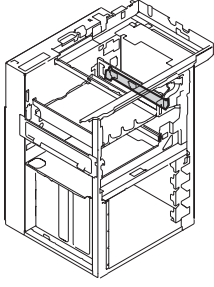
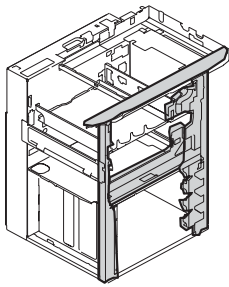
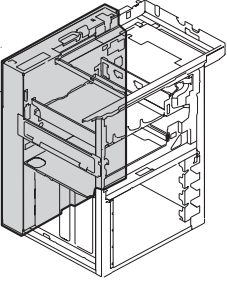
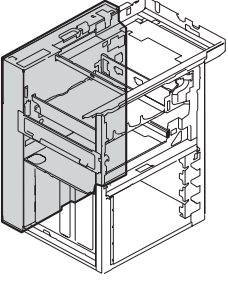
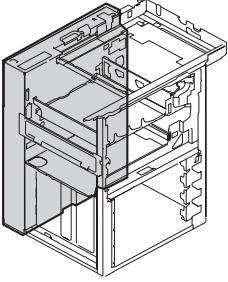
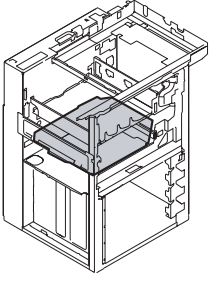
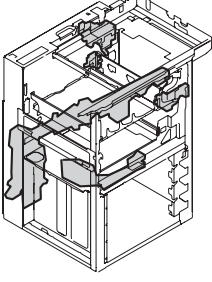
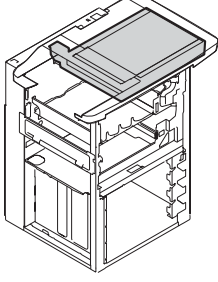
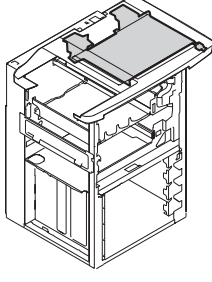
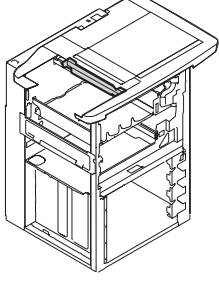
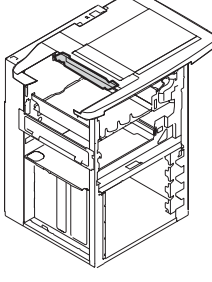
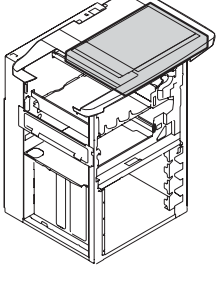
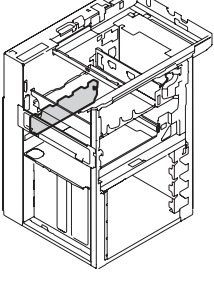
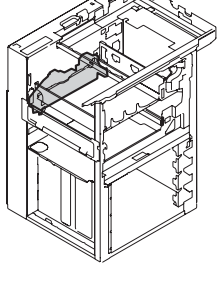
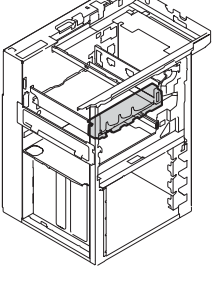
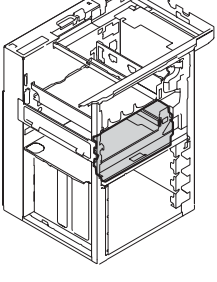
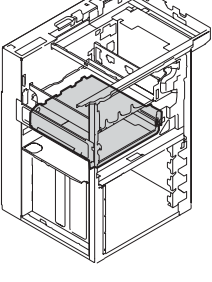
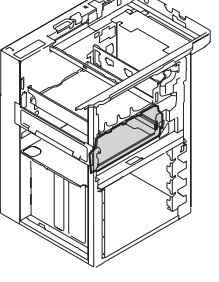
<p>41.FUSER-GUIDE-ASM</p> 	<p>42.FUSER-PR-ASM</p> 	<p>43.FUSER-HR-ASM</p> 	<p>44. FRONT-FRAME-ASM</p> 
<p>45. REAR-FRAME-1-ASM</p> 	<p>46. REAR-FRAME-2-ASM</p> 	<p>47. REAR-FRAME-3-ASM</p> 	<p>48.LSU-ASM</p> 
<p>49.DUCT-ASM</p> 	<p>50. OPTICAL-FRAME-ASM</p> 	<p>51. OPTICAL-DRIVE-ASM</p> 	<p>52. CRG-1-ASM</p> 
<p>53.CRG-2-ASM</p> 	<p>54.OPTICAL-ELECTRIC-ASM</p> 	<p>55.DRIVE-DEV-ASM</p> 	<p>56.DRIVE-DRUM-ASM</p> 
<p>57.TONER-ASM</p> 	<p>58.EPU-COVER-ASM</p> 	<p>59.EPU-TRAY-1-ASM</p> 	<p>60.EPU-TRAY-2-ASM</p> 

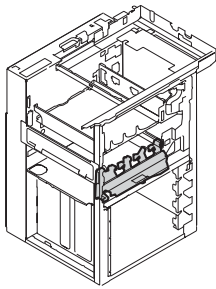
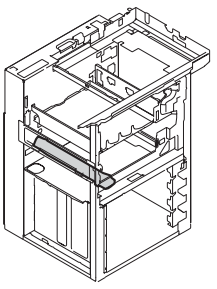
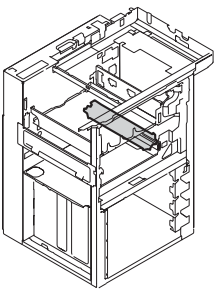
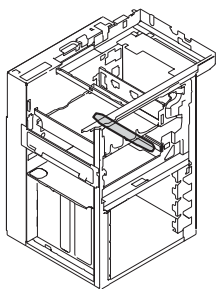
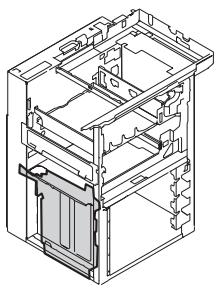
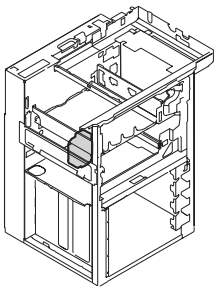
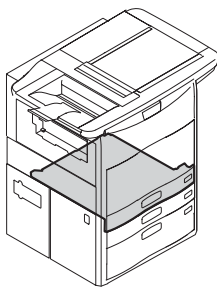
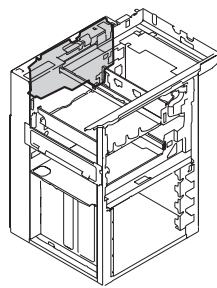
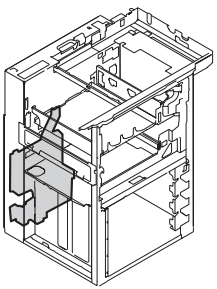
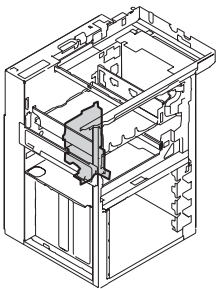
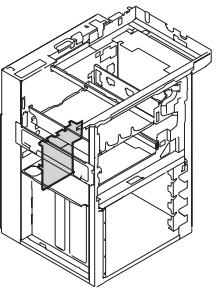
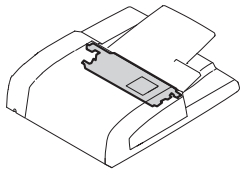
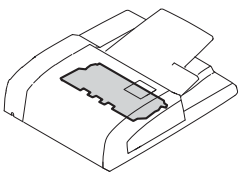
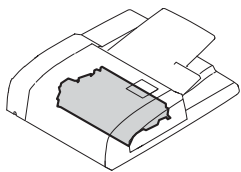
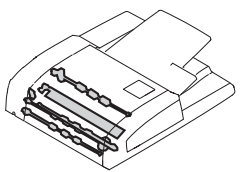
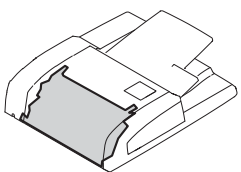
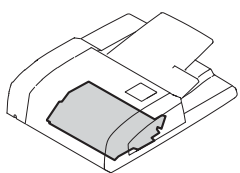
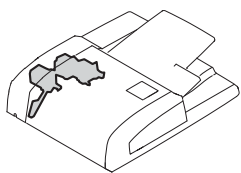
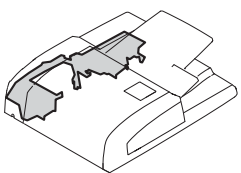
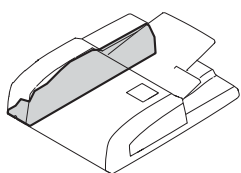
<p>61.EPU-TRAY-3-ASM</p> 	<p>62.DEVELOPER-ASM</p> 	<p>63.CLEANER-ASM</p> 	<p>64.CHARGER-ASM</p> 
<p>65.EPU-TONER-AUGER-ASM</p> 	<p>66.DRAWER-DRIVE-ASM</p> 	<p>67.DRAWER-ASM</p> 	<p>68.SYS-ASM</p> 
<p>69.LGC-ASM</p> 	<p>70.ELECTRIC-ASM</p> 	<p>71.PS-HVT-ASM</p> 	<p>72.RADF-FEED-1-ASM</p> 
<p>73.RADF-FEED-2-ASM</p> 	<p>74.RADF-FEED-3-ASM</p> 	<p>75.RADF-FEED-4-ASM</p> 	<p>76.RADF-FEED-5-ASM</p> 
<p>77.RADF-FEED-6-ASM</p> 	<p>78.RADF-FEED-DRIVE-ASM</p> 	<p>79.RADF-HINGE-ASM</p> 	<p>80.RADF-REAR-FRAME-ASM</p> 

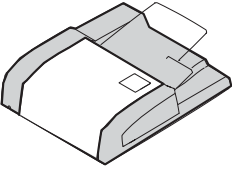
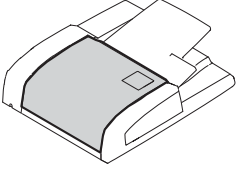
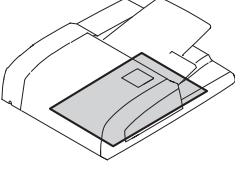
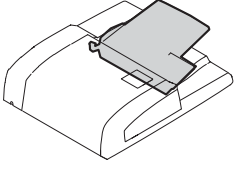
81.RADF-COVER-ASM	82.RADF-GUIDE-OPEN-ASM	83.RADF-PLATEN-ASM	84.RADF-TRAY-ASM
			

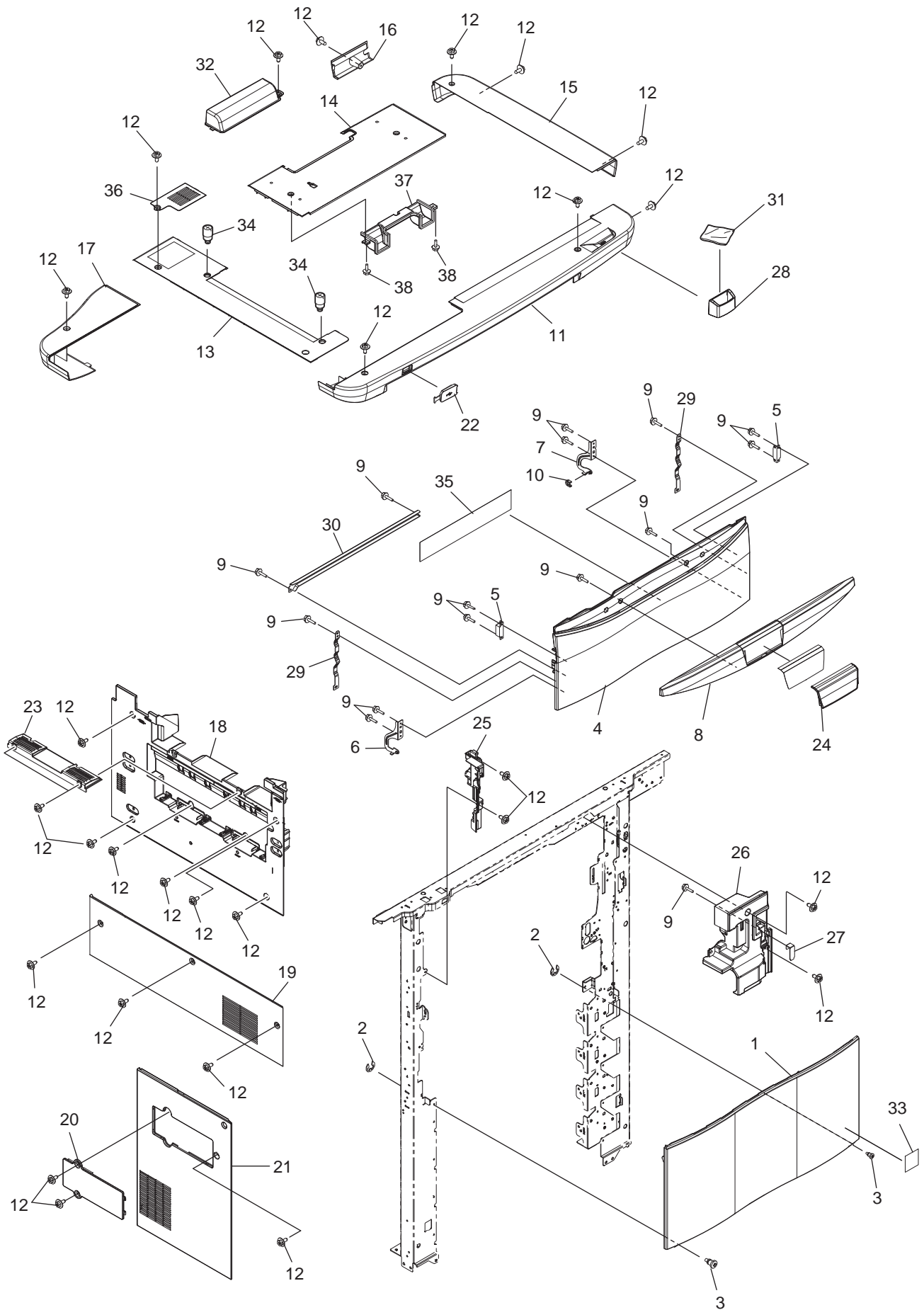

	Ref. No.	Part.No.	Alternative.	Description	Quantity	
					120	230
⊙	1	305JN712W0	5JN712W0	:COVER-FRT-EPU-434T	1	1
	2	305JN72LV0	5JN72LV0	RETAIN NG RING:RR/E-4-SS	2	2
	3	305JN707M0	5JN707M0	SCREW-CLNR-DEV	2	2
⊙	4	305JN712X0	5JN712X0	COVER-FRT-TNR-434T	1	1
	5	305JN72KQ0	5JN72KQ0	MAGNET CATCH:CA-0168C	2	2
	6	305JN71310	5JN71310	H NGE ASSY:ASYS-HNG-L	1	1
	7	305JN71300	5JN71300	H NGE ASSY:ASYS-HNG-R	1	1
⊙	8	305JN712T0	5JN712T0	PLATE-EMBLEM	1	1
	9	305JN72NF0	5JN72NF0	SCREW:S/TPP/FHEXM-3X10-NI	15	15
	10	305JN701E0	5JN701E0	STOP-R NG-6-5	1	1
⊙	11	305JN71360	5JN71360	COVER-TBL-FRT-434T	1	1
	12	305JN72NT0	5JN72NT0	SCREW:S/TPS/FHEXM/R-4X8-ZU3	27	27
⊙	13	305JN725P0	5JN725P0	COVER-TP-LFT-CNT-434T	1	1
⊙	14	305JN725Q0	5JN725Q0	COVER-TP-RER-434T	1	1
⊙	15	305JN725N0	5JN725N0	COVER-TP-RGT-434T	1	1
⊙	16	305JN725R0	5JN725R0	COVER-TP-RER-U-434T	1	1
⊙	17	305JN71370	5JN71370	COVER-TBL-FAX-434T	1	1
⊙	18	305JN713B0	5JN713B0	COVER-LFT-EXIT-430T	1	1
⊙	19	305JN71340	5JN71340	COVER-LFT-LSU-430T	1	1
	20	305JN713S0	5JN713S0	COVER ASSY:ASYS-COVER-FLT-F43X	1	1
⊙	21	305JN71330	5JN71330	COVER-DUCT-430T	1	1
	22	305JN71410	5JN71410	CAP-434	1	1
⊙	23	305JN71400	5JN71400	COVER-LFT-EX-UPR-430T	1	1
⊙	24	305JN712R0	5JN712R0	COVER-EMBLEM	1	1
	25	305JN713Q0	5JN713Q0	COVER_INNER_L-430T	1	1
	26	305JN713W0	5JN713W0	COVER_INNER_R	1	1
	27	305JN713R0	5JN713R0	PLATE PLT_MAG_CV_IN_R	1	1
	28	305JN70W80	5JN70W80	HOLDER ASSY:ASYS-CLOTH-SCN	1	1
	29	305JN71320	5JN71320	BAND-CV-FRT-TNR	2	2
	30	305JN713U0	5JN713U0	PLATE PLT_BR DGE_CV_FRT_TNR	1	1
	31	305JN70W70	5JN70W70	CLEANING CLOTH :CLOTH-SCN	1	1
⊙	32	305JN713Z0	5JN713Z0	COVER-TP-REAR-434R	1	1
	33	305JN70Z00	5JN70Z00	LABEL LBL-ENERGY-T-PS-N	1	1
	34	305JN72690	5JN72690	SCREW-DF-EMI	2	2
	35	305JN72PS0	5JN72PS0	SHEET-INST-TONER-430	1	1
	36	305JN726C0	5JN726C0	COVER ASSY:ASYS-COVER-TP-LFT-SUB-434	1	1
	37	305JN71140	5JN71140	COVER ASSY:ASYS-DUCT-TP-REAR-L	1	1
	38	305JN72NE0	5JN72NE0	SCREW:S/TPP/FHEXM-3X8-NI	2	2

• Parts with "⊙" indicate regular maintenance parts.

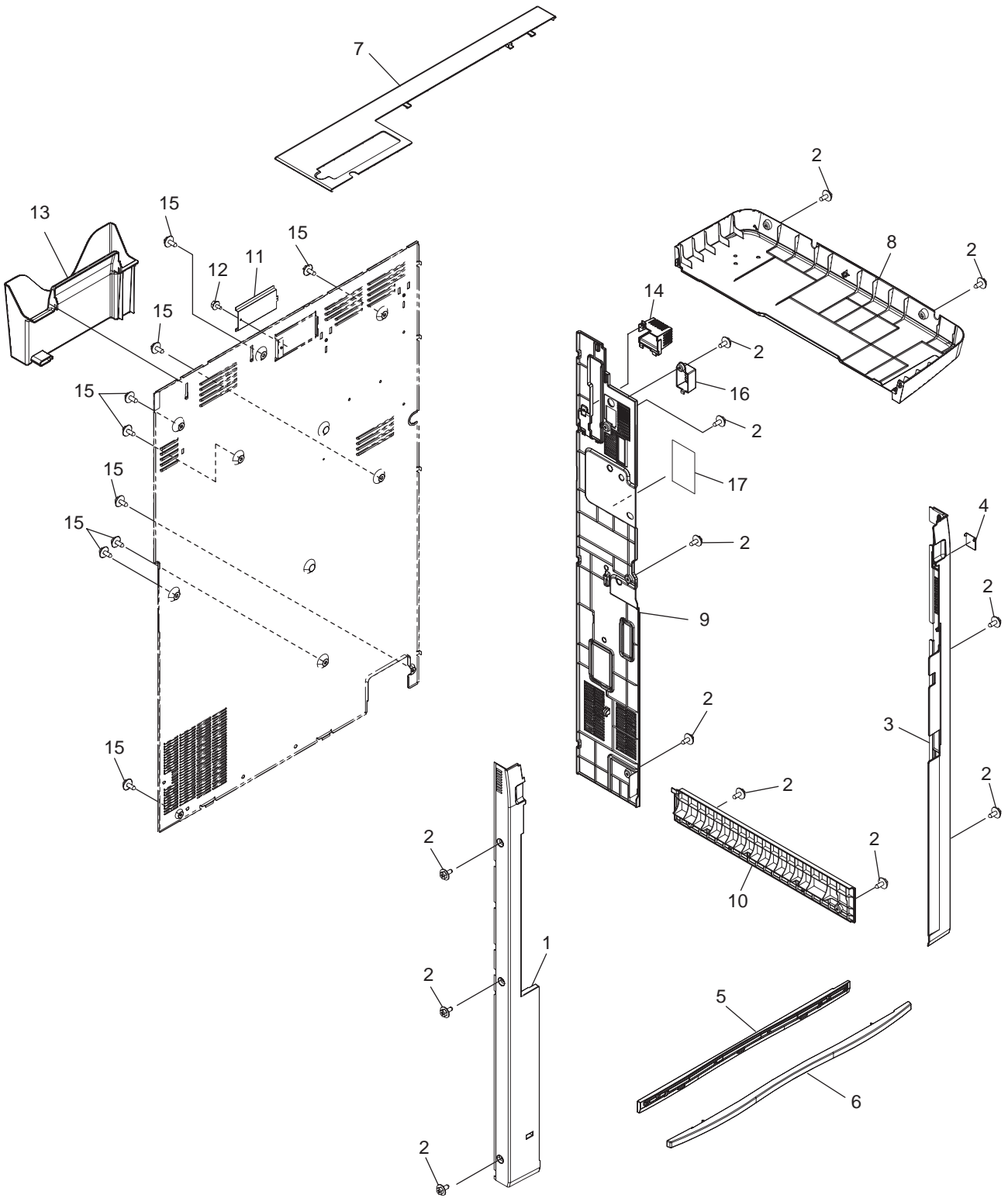

	Ref. No.	Part.No.	Alternative.	Description	Quantity	
					120	230
⊙	1	305JN712U0	5JN712U0	COVER-FRT-CNR-L-434T	1	1
	2	305JN72NT0	5JN72NT0	SCREW:S/TPS/FHEXM/R-4X8-ZU3	13	13
⊙	3	305JN712V0	5JN712V0	COVER-FRT-CNR-R-434T	1	1
	4	305JN71390	5JN71390	COVER-LID-SW	1	1
⊙	5	305JN712Z0	5JN712Z0	COVER-FRT-SK RT-434	1	1
	6	305JN71310	5JN71310	H NGE ASSY:ASYS-HNG-L	1	1
⊙	7	305JN71380	5JN71380	COVER-TBL-BCK-430T	1	1
	8	305JN713V0	5JN713V0	COVER ASSY:ASYS-COVER-TBL-UDR	1	1
⊙	9	305JN713C0	5JN713C0	COVER-RGT-RER-430T	1	1
⊙	10	305JN712Y0	5JN712Y0	COVER-LCF-RAIL-430T	1	1
	11	305JN713M0	5JN713M0	COVER-RER-SUB-EFI	1	1
	12	305JN72NR0	5JN72NR0	SCREW:S/TPS/FHEXM/R-3X6-ZU3	1	1
⊙	13	305JN70UX0	5JN70UX0	COVER:POCKET-MANUAL-T	1	1
⊙	14	305JN713D0	5JN713D0	COVER-CABLE-RGT-RER-430G	1	1
	15	305JN72NB0	5JN72NB0	SCREW:S/FHEXM-M4X8-NI	9	9
	16	305JN713Y0	5JN713Y0	COVER-FILTER-FUS	1	1
	17	305JN724R0	5JN724R0	LABEL LBL- NST-FUS-HND	1	1

• Parts with "⊙" indicate regular maintenance parts.

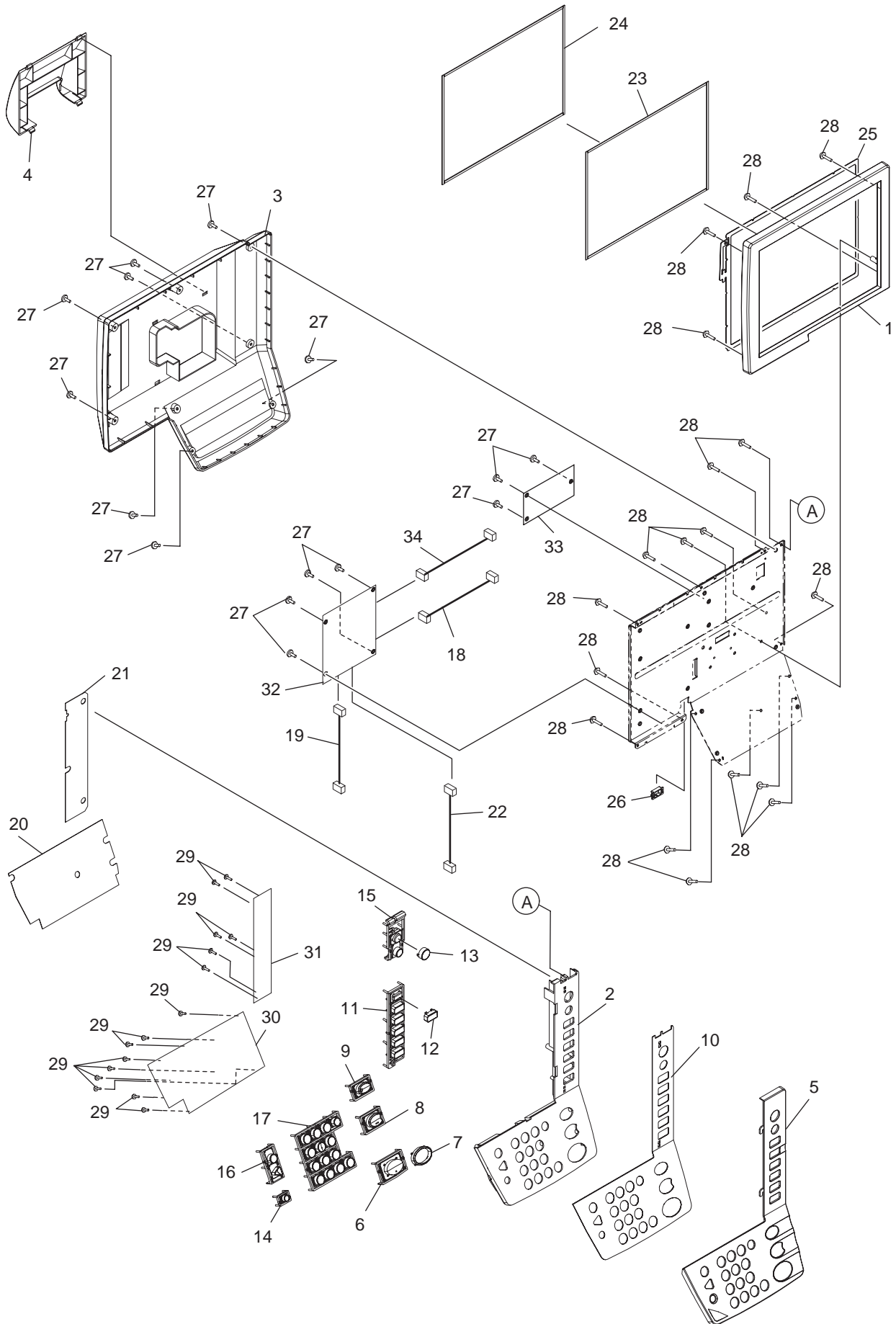

	Ref. No.	Part.No.	Alternative.	Description	Quantity	
					120	230
	1	305JN711T0	5JN711T0	COVER-CONPANE-434U1	1	1
	2	305JN711U0	5JN711U0	COVER-CONPANE-434U2	1	1
	3	305JN711V0	5JN711V0	COVER-CONPANE-434BK	1	1
	4	305JN71250	5JN71250	COVER-CONPANE-434HG	1	1
	5	305JN711W0	5JN711W0	COVER-CONPANE-SHEET	1	1
	6	305JN712J0	5JN712J0	KEY-START-434	1	1
	7	305JN711X0	5JN711X0	KEY-START-RING	1	1
	8	305JN712H0	5JN712H0	KEY-STOP-434	1	1
	9	305JN712G0	5JN712G0	KEY-RESET-434U	1	1
	10	305JN712P0	5JN712P0	SHEET-PANEL-434U	1	1
	11	305JN712E0	5JN712E0	KEY-FUNCTION-434	1	1
	12	305JN711Y0	5JN711Y0	KEY-434MN	1	1
	13	305JN712D0	5JN712D0	KEY-POWER-434	1	1
	14	305JN711Z0	5JN711Z0	KEY-434CN	1	1
	15	305JN712M0	5JN712M0	KEY-ENERGY-SAVE-434	1	1
	16	305JN712L0	5JN712L0	KEY-JUMP-434	1	1
	17	305JN712K0	5JN712K0	KEY-TEN-434	1	1
	18	305JN729W0	5JN729W0	WIRE HARNESS HRNS-DSP-LCD-430	1	1
	19	305JN72A70	5JN72A70	WIRE HARNESS:HRNS-DSP-KEY1-430	1	1
	20	305JN71200	5JN71200	SHEET:SH LD-SHEET-A	1	1
	21	305JN71210	5JN71210	SHEET:SH LD-SHEET-B	1	1
	22	305JN72A80	5JN72A80	WIRE HARNESS:HRNS-DSP-KEY2-430	1	1
⊙	23	305JN71240	5JN71240	PANEL ASSY:ASYS-PNL-TOUCH-430	1	1
⊙	24	305JN71220	5JN71220	DISPLAY ASSY:ASYS-DSP-LCD-430	1	1
	25	305JN71230	5JN71230	SHEET:MYLAR-SHIELD-LCD	1	1
	26	305JN72K10	5JN72K10	BAND:ESC-0912	1	1
	27	305JN72LF0	5JN72LF0	SCREW:S/BID-M3X6-NI	15	15
	28	305JN72N00	5JN72N00	SCREW:S/TPP/BRZ-3X10-NI	18	18
	29	305JN72MZ0	5JN72MZ0	SCREW:S/TPB/BID-2X6-NI	15	15
⊙	30	305JN72AA0	5JN72AA0	PWB ASSY:PWA-F-KEY1-430	1	1
⊙	31	305JN72AB0	5JN72AB0	PWB ASSY:PWA-F-KEY2-430	1	1
⊙	32	305JN72A90	5JN72A90	PWB ASSY:PWA-F-DSP-430	1	1
	33	305JN72AM0	5JN72AM0	INVERTER:INV-DSP-430	1	1
	34	305JN72A60	5JN72A60	WIRE HARNESS:HRNS-INV-DSP-430	1	1

• Parts with "⊙" indicate regular maintenance parts.

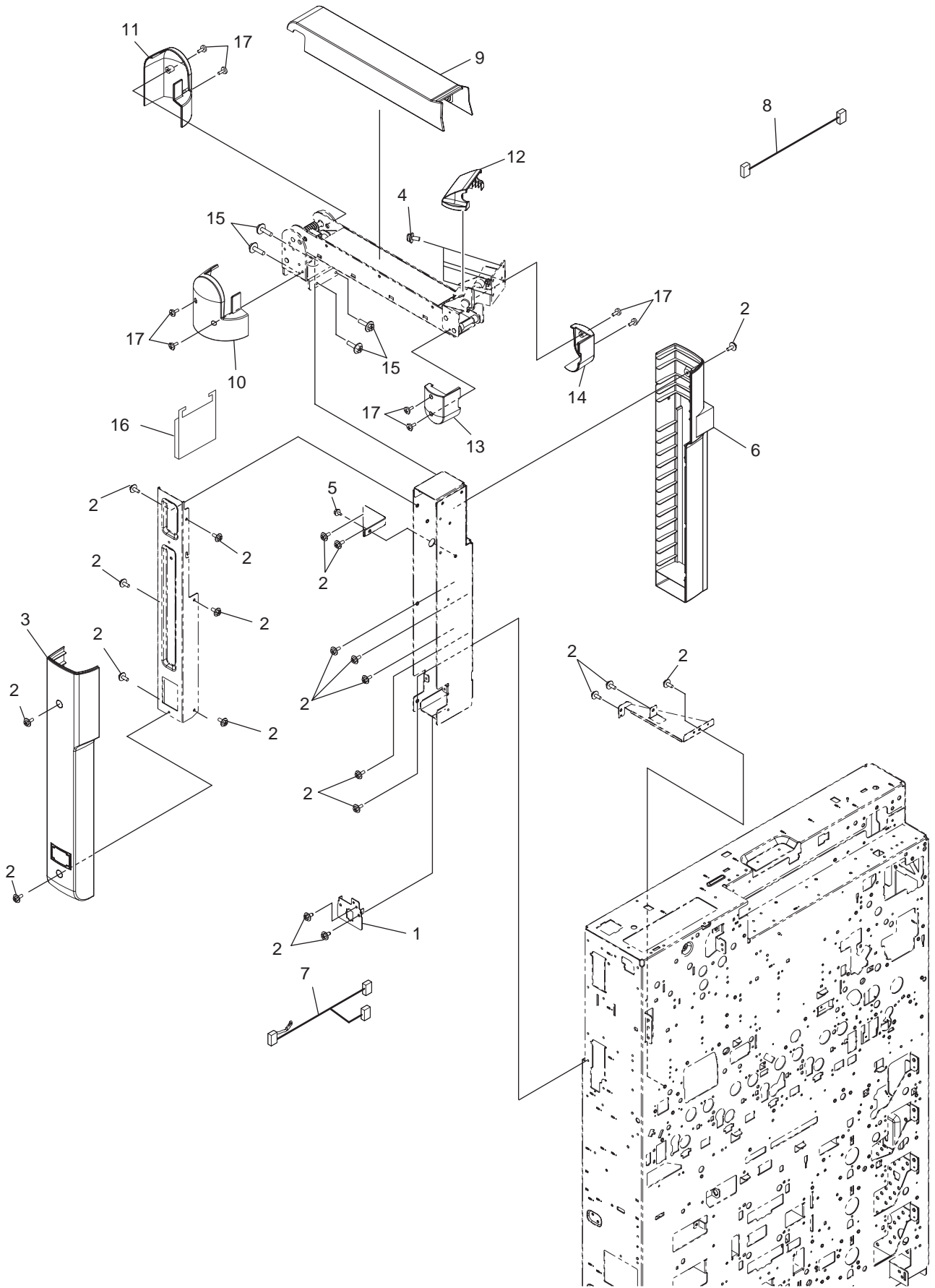

	Ref. No.	Part.No.	Alternative.	Description	Quantity	
					120	230
	1	305JN70ZP0	5JN70ZP0	BRACKET:BRKT-FIN-CBL-CONP	1	1
	2	305JN72NT0	5JN72NT0	SCREW:S/TPS/FHEXM/R-4X8-ZU3	21	21
⊙	3	305JN713L0	5JN713L0	COVER-OPE-LFT	1	1
	4	305JN72N80	5JN72N80	SCREW:S/PAN/SWWP-M4X8-ZU3	4	4
	5	305JN72NR0	5JN72NR0	SCREW:S/TPS/FHEXM/R-3X6-ZU3	1	1
⊙	6	305JN713K0	5JN713K0	COVER-OPE-RGT	1	1
	7	305JN727U0	5JN727U0	WIRE HARNESS:HRNS-FIN-430	1	1
	8	305JN729V0	5JN729V0	WIRE HARNESS HRNS-SYS-OPE-430	1	1
	9	305JN71260	5JN71260	COVER-ARM-MAIN	1	1
	10	305JN71270	5JN71270	COVER-ARM-LWR-L	1	1
	11	305JN71280	5JN71280	COVER-ARM-LWR-R	1	1
	12	305JN712B0	5JN712B0	COVER-ARM-UPR-C2	1	1
	13	305JN712A0	5JN712A0	COVER-ARM-UPR-L	1	1
	14	305JN71290	5JN71290	COVER-ARM-UPR-R	1	1
	15	305JN72NC0	5JN72NC0	SCREW:S/FHEXM-M4X12-NI	4	4
	16	305JN712C0	5JN712C0	COVER-ARM-SHUTTER	1	1
	17	305JN72LF0	5JN72LF0	SCREW:S/BID-M3X6-NI	8	8

• Parts with "⊙" indicate regular maintenance parts.

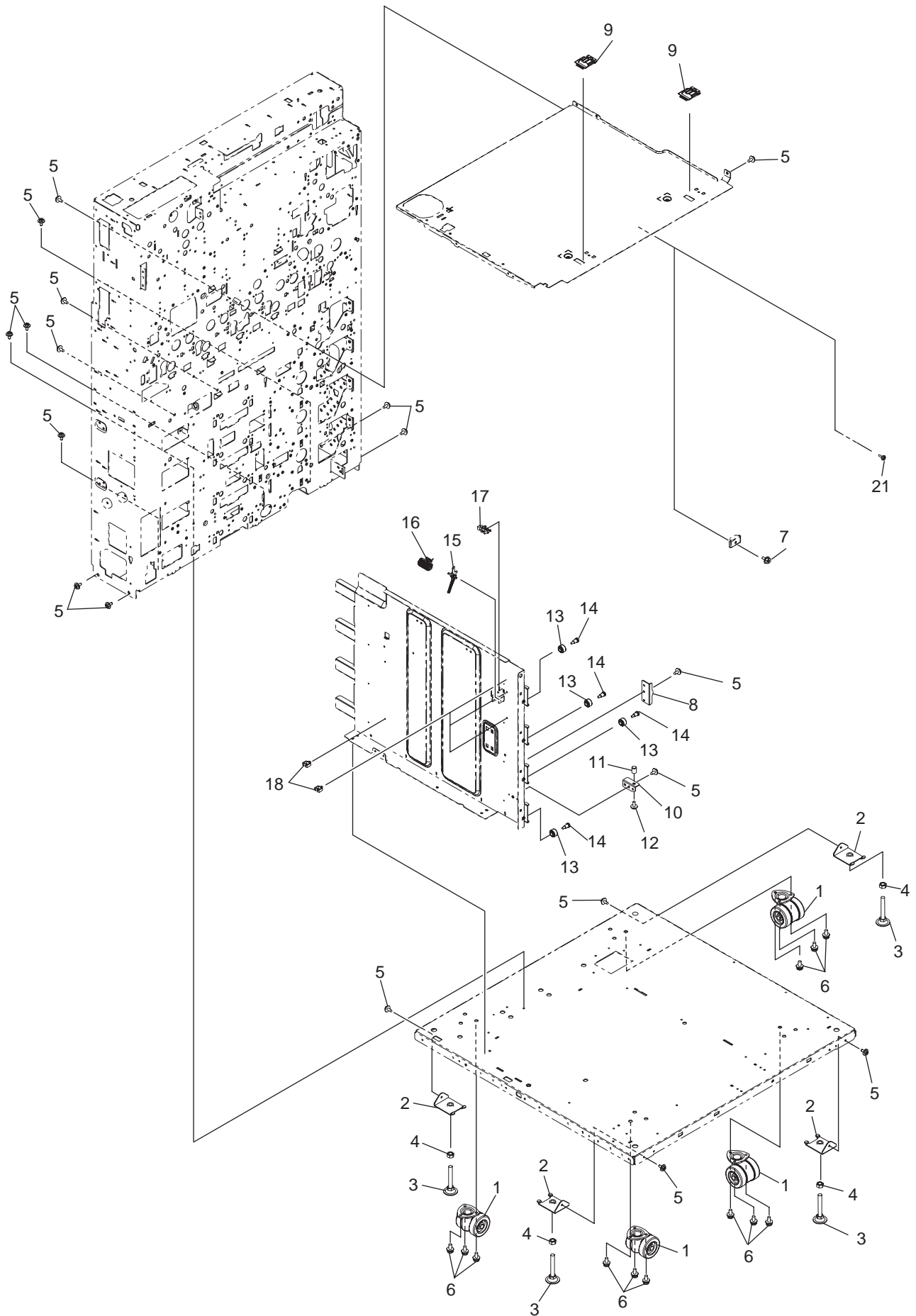

	Ref. No.	Part.No.	Alternative.	Description	Quantity	
					120	230
	1	305JN70Z40	5JN70Z40	CASTER:BWP-50N-CUSTOM	4	4
	2	305JN70V50	5JN70V50	BRACKET ASSY:ASYS-BRKT-ADJ-390	4	4
	3	305JN70V60	5JN70V60	LEVEL BOLT FOOT-H-AD-502-ZU3-39X	4	4
	4	305JN72LR0	5JN72LR0	NUT:N/HEX/1-M8-SS	4	4
	5	305JN72NT0	5JN72NT0	SCREW:S/TPS/FHEXM/R-4X8-ZU3	28	28
	6	305JN72NU0	5JN72NU0	SCREW:S/PAN/SWWP-M5X10-NI	12	12
	7	305JN72N90	5JN72N90	SCREW:S/FHEXM-M3X6-NI	1	1
	8	305JN71U30	5JN71U30	BRACKET:BRKT-STOP-TNDM-FRSD	1	1
	9	305JN72510	5JN72510	GUIDE-LSU-430	2	2
	10	305JN71TA0	5JN71TA0	PLATE:PLT-LATCH-L	1	1
	11	305JN71T90	5JN71T90	PIN:STUD-LATCH-1	1	1
	12	305JN72NB0	5JN72NB0	SCREW:S/FHEXM-M4X8-NI	1	1
	13	305JN71R40	5JN71R40	ROLLER:ROLL-LEFT-F-CST-F43X	3	3
	14	305JN71R50	5JN71R50	SCREW:ROLL-CST-F43X	3	3
	15	305JN718U0	5JN718U0	ACTUATOR:ACTR-SNSR-WTNR-BOX	1	1
	16	305JN719G0	5JN719G0	SPRING:SPG-T-ACT-WTNR-BOX	1	1
⊙	17	305JN72H20	5JN72H20	SENSOR LG248BL1	1	1
	18	305JN72K20	5JN72K20	CLAMP MSB-1207	4	4
	19	305JN70WP0	5JN70WP0	SCREW-FUS-3X8-S	1	1

• Parts with "⊙" indicate regular maintenance parts.

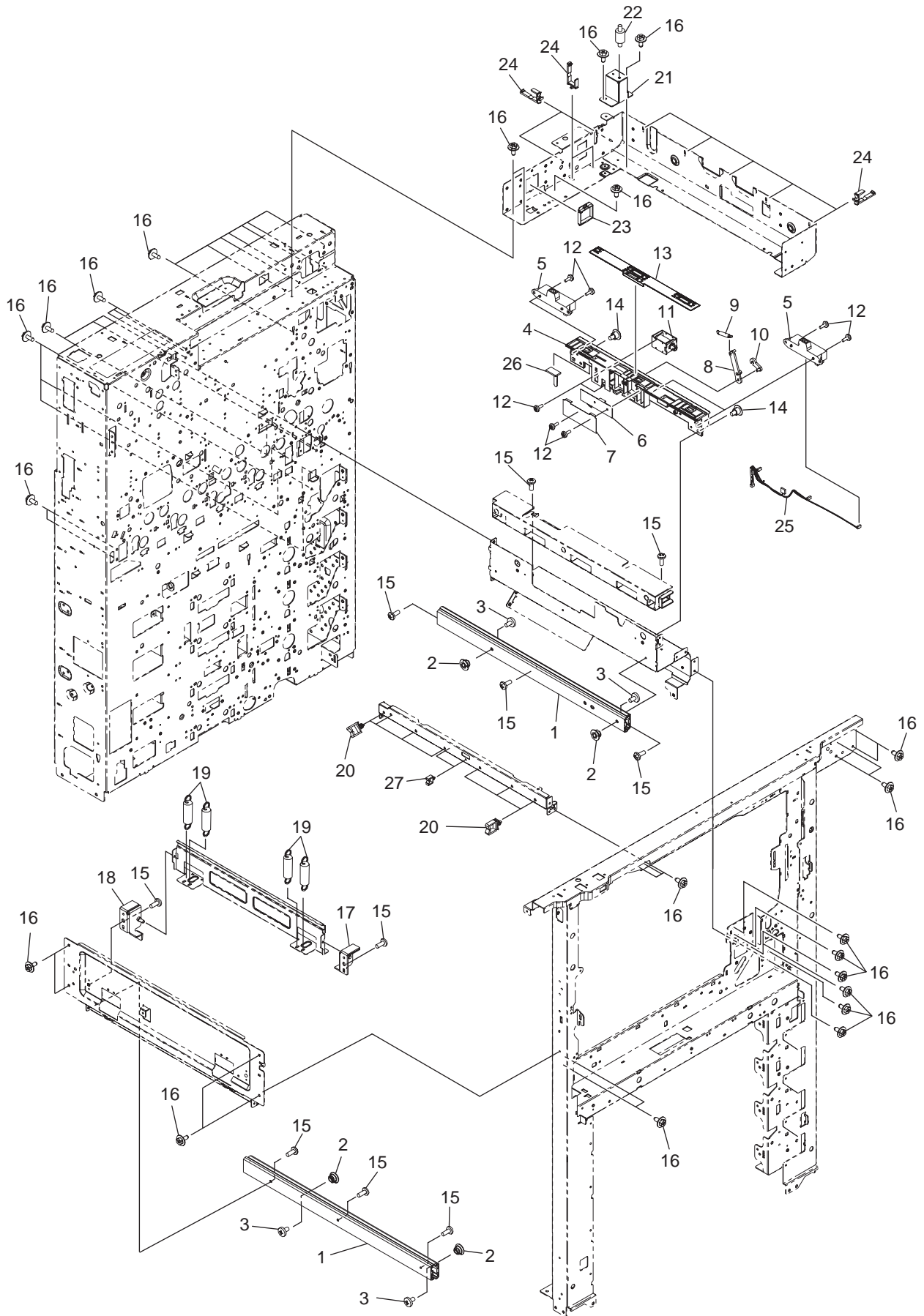

	Ref. No.	Part.No.	Alternative.	Description	Quantity	
					120	230
	1	305JN70VY0	5JN70VY0	RA L-TRU-390	2	2
	2	305JN716X0	5JN716X0	PIN:STUD-RAIL	4	4
	3	305JN72MA0	5JN72MA0	SCREW:S/BID-M4X6-NC	4	4
	4	305JN71AW0	5JN71AW0	HOLDER:HLDR-IMG-POS-SNS	1	1
⊙	5	305JN70X10	5JN70X10	SENSOR:SNSR-POS-380	3	3
⊙	6	305JN70X70	5JN70X70	SENSOR:SNSR-CTD-380	1	1
	7	305JN71AT0	5JN71AT0	SHEET:MYLAR- MG-SNS	1	1
	8	305JN71AV0	5JN71AV0	ARM:LINK-IMG-POS-SNS-2	1	1
	9	305JN70WE0	5JN70WE0	SPRING:SPG-E-4R5XR3X20R8	1	1
	10	305JN71AU0	5JN71AU0	ARM:LINK- MG-POS-SNS-1	1	1
⊙	11	305JN70WF0	5JN70WF0	SOLENOID:SND-TDS-10A-380	1	1
	12	305JN72NJ0	5JN72NJ0	SCREW:S/PAN-M3X6-ZU3	10	10
	13	305JN71AS0	5JN71AS0	SHUTTER:SHUT-IMG-POS-SNS	1	1
	14	305JN706X0	5JN706X0	SCREW-LOCK-ARM	2	2
	15	305JN72MX0	5JN72MX0	SCREW:S/TPS/BID-4X8-ZU3	10	10
	16	305JN72NT0	5JN72NT0	SCREW:S/TPS/FHEXM/R-4X8-ZU3	42	42
	17	305JN71DA0	5JN71DA0	BRACKET ASSY:ASYS-BRKT-TNS-CLN-F	1	1
	18	305JN71DB0	5JN71DB0	BRACKET ASSY:ASYS-BRKT-TNS-CLN-R	1	1
	19	305JN71B50	5JN71B50	SPRING:SPG-CLN-TBU-TNS	4	4
	20	305JN72JF0	5JN72JF0	CLAMP:WS-2U	7	7
	21	305JN725W0	5JN725W0	BRACKET:BRKT-DMP-RER-RGT	1	1
	22	305JN725X0	5JN725X0	INSULATOR-430	1	1
	23	305JN70150	5JN70150	BAND:BD/W-TWS-3027	1	1
	24	305JN72J20	5JN72J20	CLAMP RLWS3TV0	9	9
	25	305JN728U0	5JN728U0	WIRE HARNESS:HRNS-CTD-430	1	1
	26	305JN72J70	5JN72J70	CLAMP K-103G	1	1
	27	305JN72K20	5JN72K20	CLAMP MSB-1207	2	2

• Parts with "⊙" indicate regular maintenance parts.

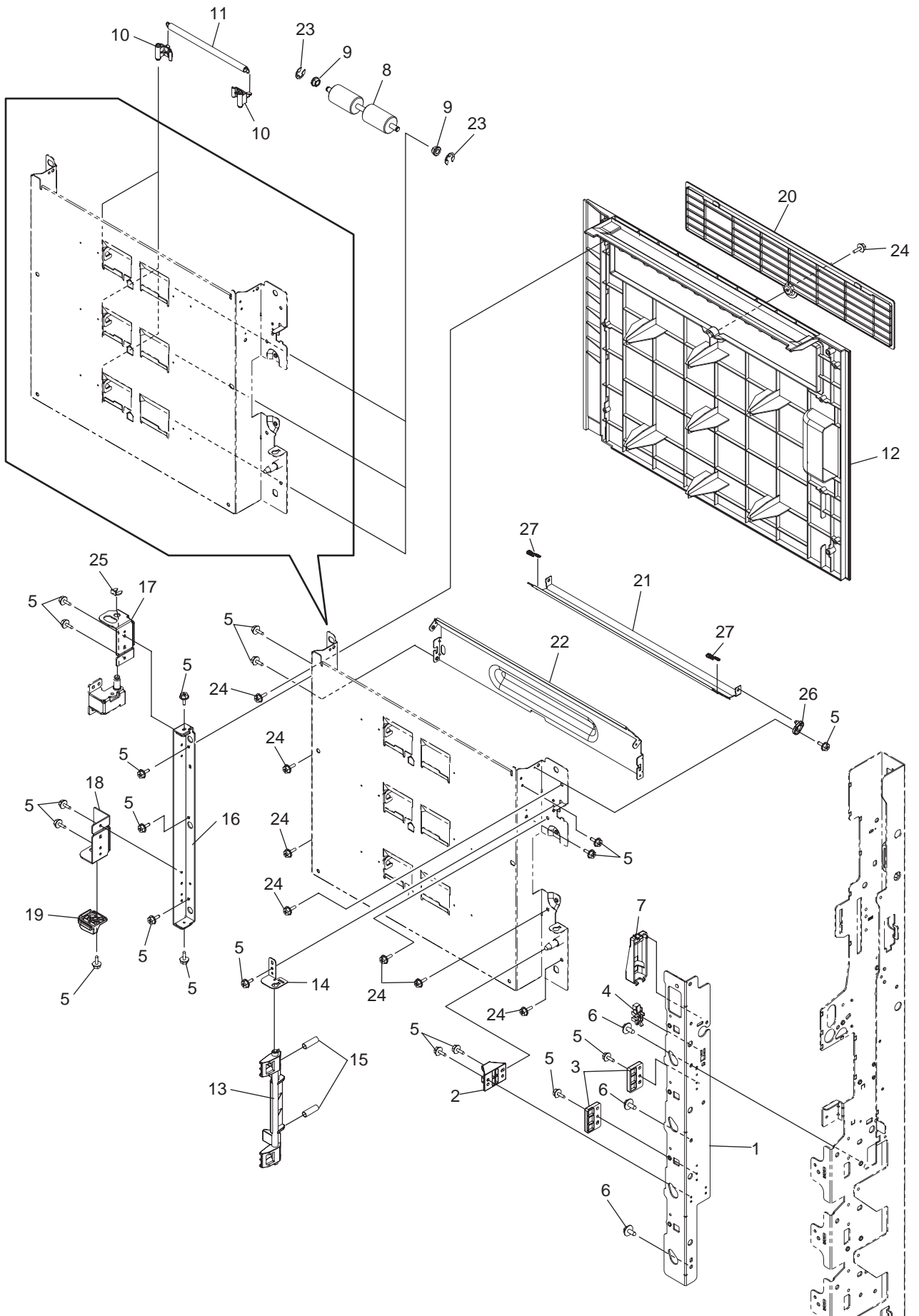

	Ref. No.	Part.No.	Alternative.	Description	Quantity	
					120	230
	1	305JN71J20	5JN71J20	BRACKET:BRKT-POS-FS-UNIT-F	1	1
	2	305JN71J60	5JN71J60	GUIDE-STUD-POS-F43X	1	1
	3	305JN71J50	5JN71J50	HOOK-COVER-LOCK-F43X	2	2
⊙	4	305JN72H20	5JN72H20	SENSOR LG248BL1	1	1
	5	305JN72NS0	5JN72NS0	SCREW:S/TPS/FHEXM/R-3X8-ZU3	21	21
	6	305JN72NT0	5JN72NT0	SCREW:S/TPS/FHEXM/R-4X8-ZU3	3	3
	7	305JN71J70	5JN71J70	COVER-OPEN-SENS	1	1
⊙	8	305JN70UZ0	5JN70UZ0	ROLLER-IDLE-390	3	3
	9	305JN701B0	5JN701B0	BUSH-6-GCB	6	6
	10	305JN71JF0	5JN71JF0	LEVER LVR-IDLE-F43X	6	6
	11	305JN71JD0	5JN71JD0	SPRING:SPG-E-COVER-IDLE-F43X	3	3
⊙	12	305JN71J30	5JN71J30	COVER-FEED-LOW-F430-T	1	1
⊙	13	305JN70UV0	5JN70UV0	HANDLE:HNDL-HOOK-EXIT	1	1
	14	305JN71JK0	5JN71JK0	BRACKET:BRKT-LATCH-FIXATION	1	1
	15	305JN71JE0	5JN71JE0	SPRING:SPG-C-7R2XR7X22R1	2	2
	16	305JN71JJ0	5JN71JJ0	BRACKET:BRKT-STAY-H NGE	1	1
	17	305JN71JL0	5JN71JL0	BRACKET:BRKT-COVER-HINGE-U-U-F43X	1	1
	18	305JN71JN0	5JN71JN0	BRACKET:BRKT-COVER-HINGE-U-L-F43X	1	1
	19	305JN71JM0	5JN71JM0	GUIDE-SLOPE-U	1	1
⊙	20	305JN71JH0	5JN71JH0	COVER-FEED-LOW-SUB-F430-T	1	1
	21	305JN71MF0	5JN71MF0	GUIDE-OLCF-UPPER	1	1
	22	305JN71JG0	5JN71JG0	GUIDE-OLCF-LOW	1	1
	23	305JN72LW0	5JN72LW0	RETAIN NG RING:RR/E-5-SS	6	6
	24	305JN72NE0	5JN72NE0	SCREW:S/TPP/FHEXM-3X8-NI	8	8
	25	305JN701W0	5JN701W0	STOP-R NG-6-1.5	1	1
	26	305JN70V20	5JN70V20	HOLDER:HLDR-GU DE-FS	1	1
	27	305JN71ME0	5JN71ME0	GUIDE-LIFT-OLCF-UPPER	2	2

• Parts with "⊙" indicate regular maintenance parts.

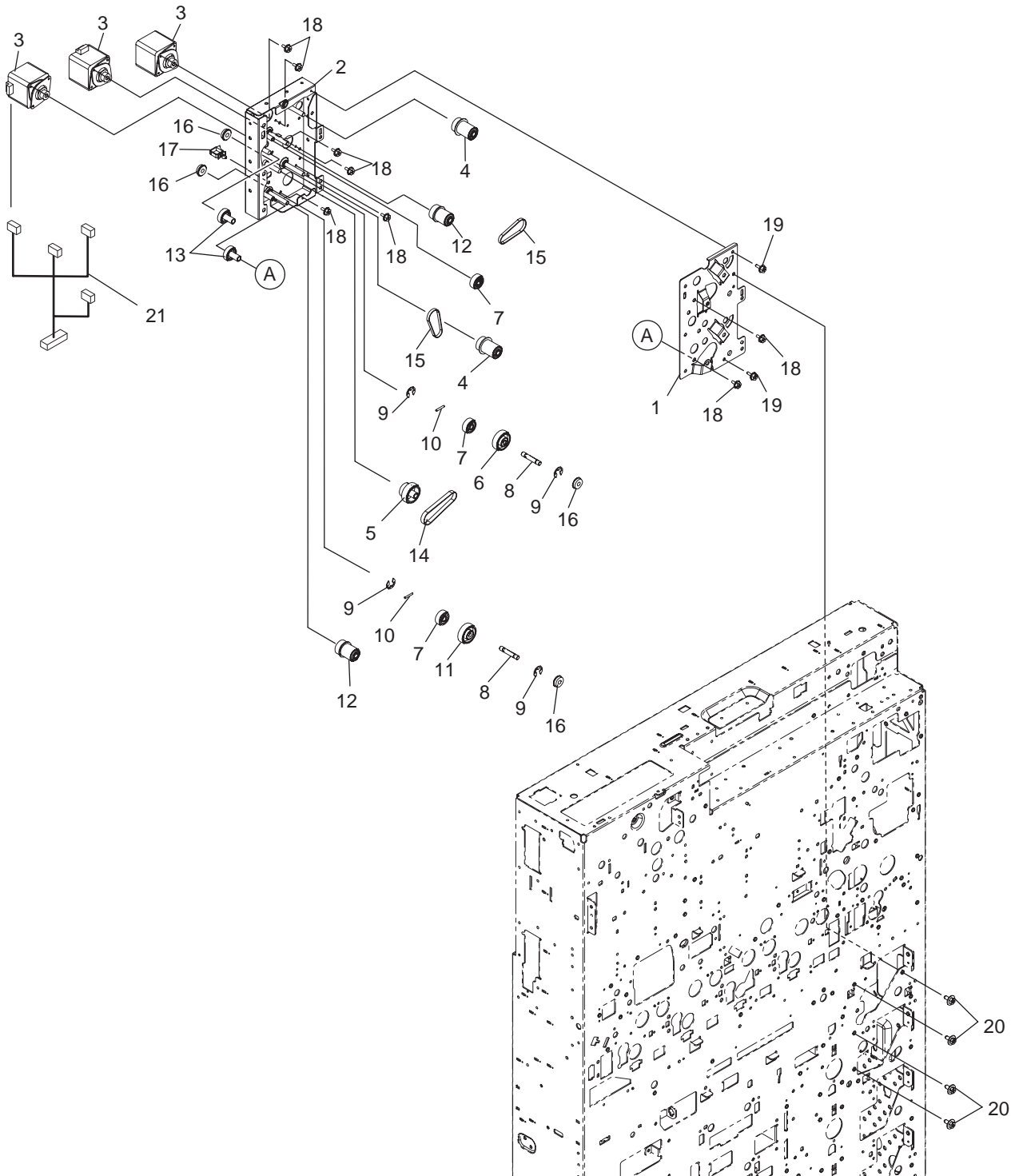

	Ref. No.	Part.No.	Alternative.	Description	Quantity	
					120	230
	1	305JN71JZ0	5JN71JZ0	BRACKET:BRKT-DRV-FEED-FRT-430	1	1
	2	305JN71JY0	5JN71JY0	BRACKET ASSY:ASYS-BRKT-DRV-FEED-RER	1	1
⊙	3	305JN72BF0	5JN72BF0	MOTOR:MOTRS-TR-430	3	3
	4	305JN71JX0	5JN71JX0	GEAR ASSY:ASYS-BE-G10S017_PS2M32-6	2	2
	5	305JN71JW0	5JN71JW0	GEAR ASSY:ASYS-BE-G10S027_PS2M32-6	1	1
⊙	6	305JN71JR0	5JN71JR0	GEAR-10S027-06-RB	1	1
⊙	7	305JN71JT0	5JN71JT0	GEAR-10S019-06	3	3
	8	305JN71JS0	5JN71JS0	PIN:STUD-DRV-FEED-4	2	2
	9	305JN72LW0	5JN72LW0	RETAIN NG RING:RR/E-5-SS	4	4
	10	305JN72MC0	5JN72MC0	PIN:P/PRL/AH7-2X12-SS	2	2
⊙	11	305JN71JU0	5JN71JU0	GEAR-10S027-06-LW	1	1
⊙	12	305JN71JQ0	5JN71JQ0	GEAR-10S019_10S017	2	2
⊙	13	305JN71KF0	5JN71KF0	GEAR-10S019-06-B	2	2
	14	305JN71NK0	5JN71NK0	TIMING BELT:BLT-SY-S2M-148-6	1	1
	15	305JN71P60	5JN71P60	TIMING BELT:BLT-SY-S2M-118-5	2	2
	16	305JN72KH0	5JN72KH0	BEARING:RNR-1560ZZRP0P24LY121	4	4
	17	305JN72JZ0	5JN72JZ0	CLAMP LWS-1211Z	1	1
	18	305JN72N90	5JN72N90	SCREW:S/FHEXM-M3X6-NI	8	8
	19	305JN72NS0	5JN72NS0	SCREW:S/TPS/FHEXM/R-3X8-ZU3	2	2
	20	305JN72NT0	5JN72NT0	SCREW:S/TPS/FHEXM/R-4X8-ZU3	4	4
	21	305JN72850	5JN72850	WIRE HARNESS:HRNS-PFC-STMT-430	1	1

• Parts with "⊙" indicate regular maintenance parts.

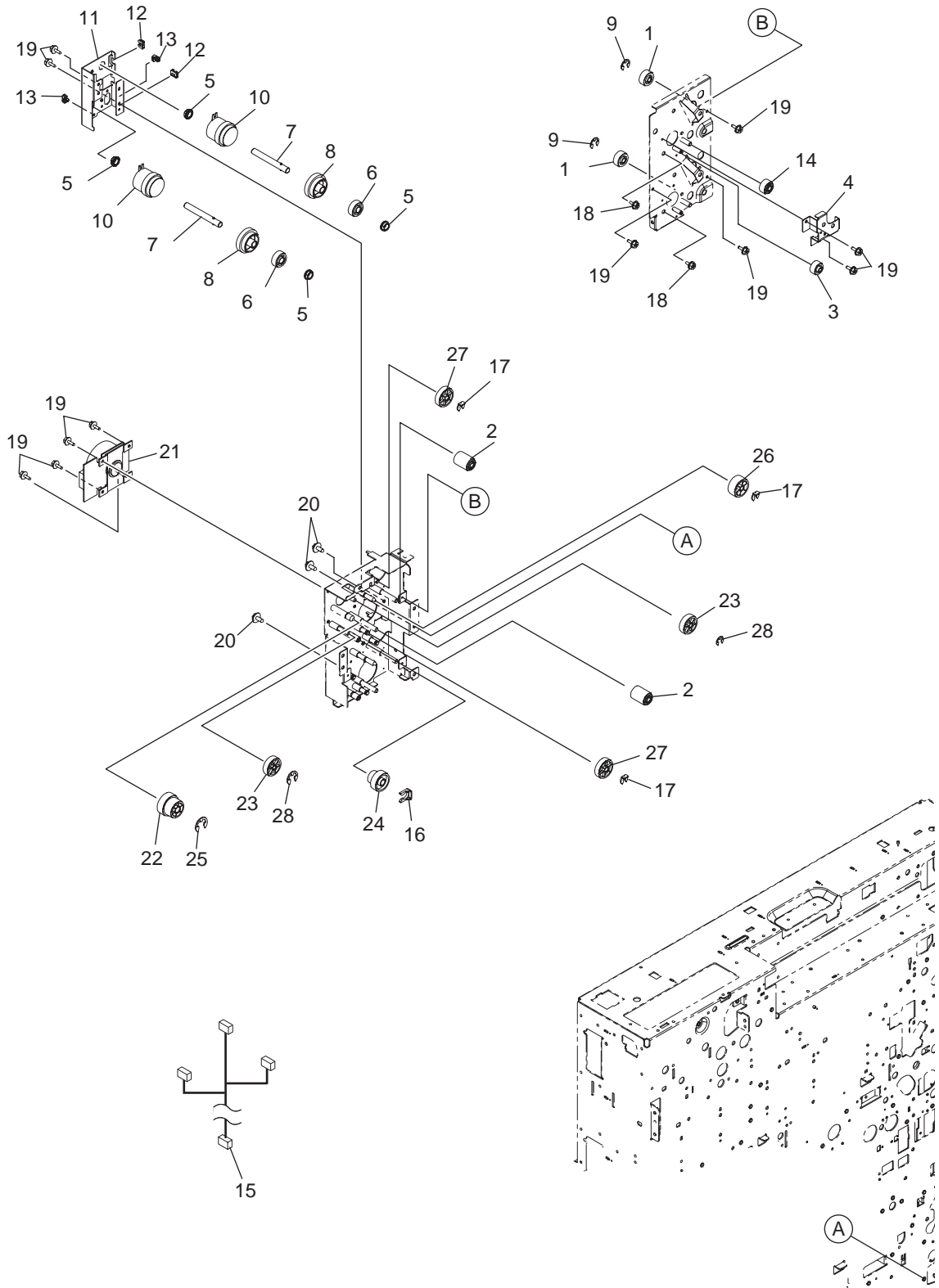

	Ref. No.	Part.No.	Alternative.	Description	Quantity	
					120	230
⊙	1	305JN71M10	5JN71M10	GEAR-10S19-06	2	2
⊙	2	305JN71LS0	5JN71LS0	GEAR-10S17-06-262	2	2
⊙	3	305JN71LW0	5JN71LW0	GEAR-10S16-05	1	1
	4	305JN71LT0	5JN71LT0	PLATE-GEAR	1	1
	5	305JN70YS0	5JN70YS0	BUSH-8X12X5R5F-NU4	4	4
⊙	6	305JN71M20	5JN71M20	GEAR-10S20-08	2	2
	7	305JN71M50	5JN71M50	SHAFT ASSY:ASYS-SHAFT-DRV	2	2
⊙	8	305JN70WM0	5JN70WM0	GEAR-05S56-08	2	2
	9	305JN72LV0	5JN72LV0	RETAIN NG RING:RR/E-5-SS	2	2
⊙	10	305JN705M0	5JN705M0	CLUTCH:CLUCH-G28-08D	2	2
	11	305JN71LU0	5JN71LU0	BRACKET:BRKT-CL	1	1
	12	305JN72J60	5JN72J60	BAND:ES-0505	2	2
	13	305JN72KG0	5JN72KG0	CLAMP LBWS-0206S-V0	2	2
⊙	14	305JN71LV0	5JN71LV0	GEAR-10S17-06-139	1	1
	15	305JN72AD0	5JN72AD0	WIRE HARNESS:HRNS-PFC-FDTM-430	1	1
	16	305JN701N0	5JN701N0	STOP RING	1	1
	17	305JN701W0	5JN701W0	STOP-R NG-6-1.5	3	3
	18	305JN72N90	5JN72N90	SCREW:S/FHEXM-M3X6-NI	2	2
	19	305JN72NS0	5JN72NS0	SCREW:S/TPS/FHEXM/R-3X8-ZU3	11	11
	20	305JN72NT0	5JN72NT0	SCREW:S/TPS/FHEXM/R-4X8-ZU3	4	4
⊙	21	305JN729Y0	5JN729Y0	MOTOR:MOTRD-FEED-430	1	1
⊙	22	305JN71M00	5JN71M00	GEAR-05H57_05S50-08	1	1
⊙	23	305JN71LZ0	5JN71LZ0	GEAR-05S53-05	2	2
⊙	24	305JN71LX0	5JN71LX0	GEAR-05S54_S3M20-08	1	1
	25	305JN72LY0	5JN72LY0	RETAIN NG RING:RR/E-7-SS	1	1
⊙	26	305JN71LY0	5JN71LY0	GEAR-05S54-06	1	1
⊙	27	305JN71J10	5JN71J10	GEAR-05S55-06	2	2
	28	305JN72LV0	5JN72LV0	RETAIN NG RING:RR/E-4-SS	2	2

• Parts with "⊙" indicate regular maintenance parts.

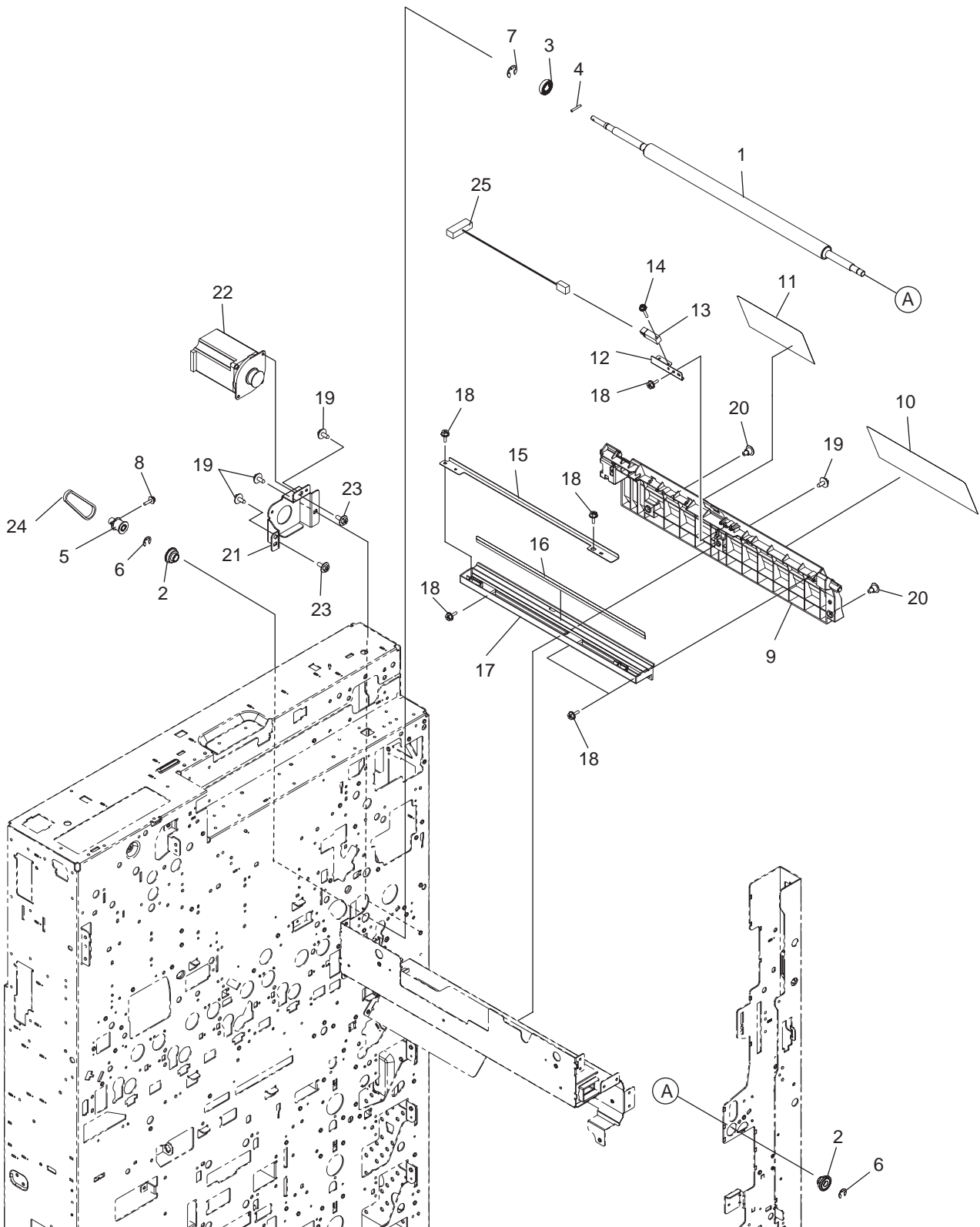

	Ref. No.	Part.No.	Alternative.	Description	Quantity	
					120	230
⊙	1	305JN71K40	5JN71K40	ROLLER-RGST-L-430	1	1
	2	305JN71KE0	5JN71KE0	BUSH:ASYS-BUSH-RGST	2	2
⊙	3	305JN71K10	5JN71K10	GEAR-RGST	1	1
	4	305JN72M70	5JN72M70	PIN:P/PRL/AH7-2X14-SS	1	1
	5	305JN70UY0	5JN70UY0	PULLEY PULLY-3GT16-06-390	1	1
	6	305JN72LY0	5JN72LY0	RETAIN NG RING:RR/E-7-SS	2	2
	7	305JN72LZ0	5JN72LZ0	RETAIN NG RING:RR/E-9-SS	1	1
	8	305JN72LB0	5JN72LB0	SCREW:S/PAN/SWWP-M3X10-NI	1	1
	9	305JN71LP0	5JN71LP0	GUIDE-RGST-L-430	1	1
	10	305JN71EC0	5JN71EC0	SHEET-GUIDE-RGST-L-FRT6	1	1
	11	305JN71LQ0	5JN71LQ0	SHEET-GUIDE-RGST-L-RER	1	1
	12	305JN71LR0	5JN71LR0	BRACKET:BRKT-SNSR-RGST	1	1
⊙	13	305JN72H60	5JN72H60	SENSOR PS119ED1	1	1
	14	305JN72N70	5JN72N70	SCREW:S/PAN/SWWP-M3X14-NI	1	1
	15	305JN71M70	5JN71M70	BRACKET:BRKT-SHEET-CLEAN	1	1
	16	305JN71MA0	5JN71MA0	SHEET:MYLAR-GUIDE-RGST-L-430	1	1
	17	305JN71M60	5JN71M60	HOLDER-PAPER-POWDER-L	1	1
	18	305JN72NE0	5JN72NE0	SCREW:S/TPP/FHEXM-3X8-NI	6	6
	19	305JN72NT0	5JN72NT0	SCREW:S/TPS/FHEXM/R-4X8-ZU3	4	4
	20	305JN706X0	5JN706X0	SCREW-LOCK-ARM	2	2
⊙	21	305JN71K50	5JN71K50	BRACKET:BRKT-MOT-RGST-430	1	1
	22	305JN70W30	5JN70W30	MOTOR:MOTRS-RGT-390	1	1
	23	305JN72NB0	5JN72NB0	SCREW:S/FHEXM-M4X8-NI	2	2
	24	305JN70130	5JN70130	TIMING BELT:BLT/T-174-3GT-4	1	1
	25	305JN729A0	5JN729A0	WIRE HARNESS:HRNS-RGTSN-430	1	1

• Parts with "⊙" indicate regular maintenance parts.

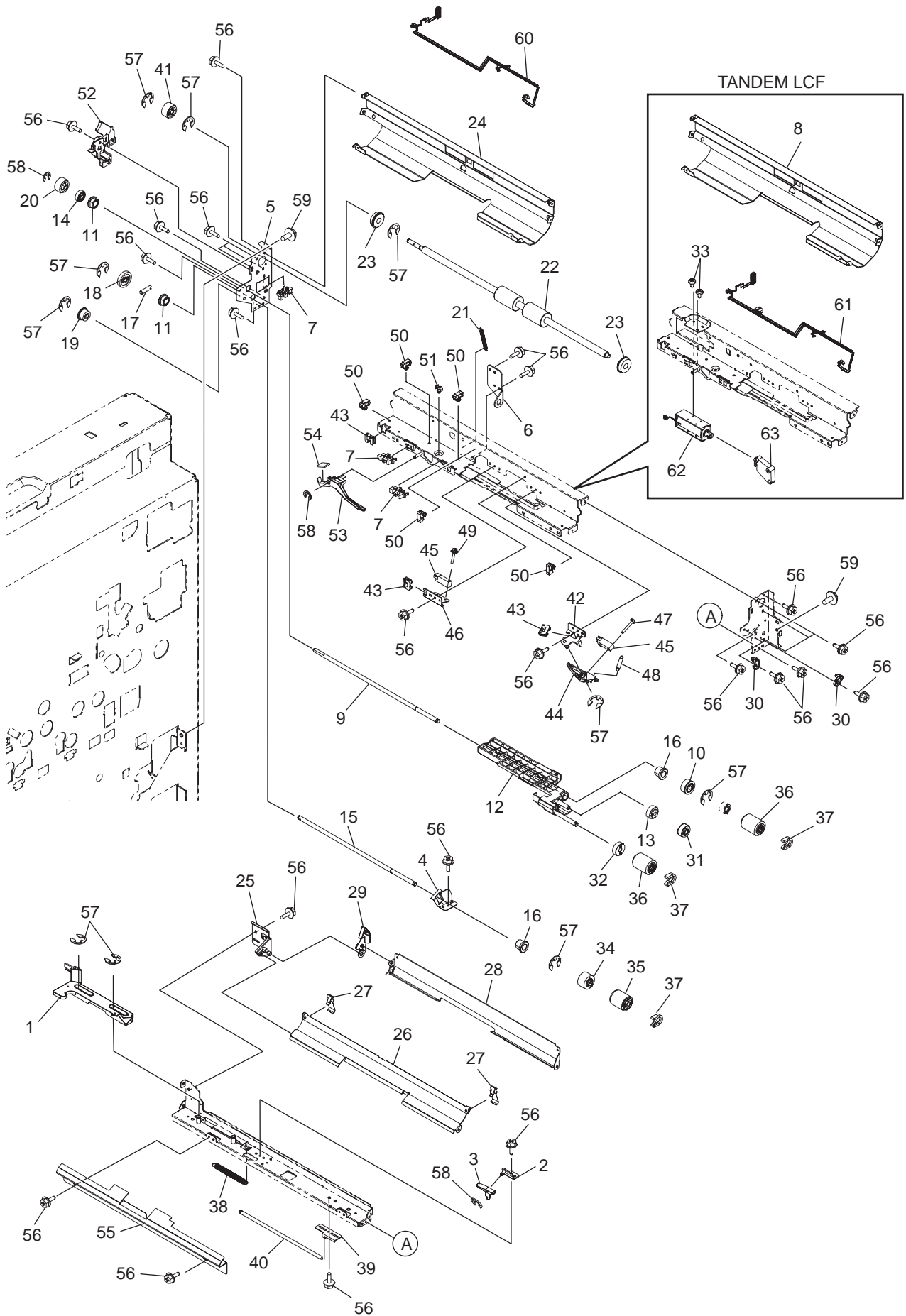

	Ref. No.	Part.No.	Alternative.	Description	Quantity	
					120	230
	1	305JN71KY0	5JN71KY0	LEVER-FEED-UNIT	1	1
	2	305JN71L10	5JN71L10	BRACKET ASSY:ASYS-BRKT-LEVER-SPT	1	1
	3	305JN71L20	5JN71L20	LEVER-SPT-ROL-430	1	1
	4	305JN71L30	5JN71L30	BRACKET:BRKT-SUP-ROL-SPT	1	1
	5	305JN71L90	5JN71L90	FRAME ASSY:ASYS-FRM-FS-R-430	1	1
	6	305JN71L40	5JN71L40	BRACKET:BRKT-SUP-ROL-FEED	1	1
⊙	7	305JN72H20	5JN72H20	SENSOR LG248BL1	3	3
	8	305JN71LD0	5JN71LD0	GUIDE-FS-UT-430	1	1
⊙	9	305JN71LA0	5JN71LA0	SHAFT-ROL-FEED-430	1	1
	10	305JN71L80	5JN71L80	GEAR-08S24-6L	1	1
	11	305JN701B0	5JN701B0	BUSH-6-GCB	2	2
	12	305JN71L60	5JN71L60	ARM ASSY:ASYS-ARM-PICK-430	1	1
⊙	13	305JN71MD0	5JN71MD0	GEAR-08S23-6	1	1
⊙	14	305JN71LC0	5JN71LC0	GEAR-08S20-6	1	1
	15	305JN71L70	5JN71L70	SHAFT ASSY:ASYS-SHAFT-ROL-SPT-430	1	1
	16	305JN702G0	5JN702G0	BUSH-F6-GCB	2	2
	17	305JN72M10	5JN72M10	PIN P/PRL/AH7-2X8-SS	1	1
⊙	18	305JN701C0	5JN701C0	GEAR-08-30	1	1
⊙	19	305JN70V40	5JN70V40	GEAR ASSY:K-GEAR-08S022-LW-390	1	1
	20	305JN71L00	5JN71L00	GEAR-10S20-6	1	1
	21	305JN702C0	5JN702C0	SPRING:SPE-P/U-110	1	1
⊙	22	305JN71LE0	5JN71LE0	ROLLER-FS-TR-430	1	1
	23	305JN72KH0	5JN72KH0	BEARING:RNR-1560ZZRP0P24LY121	2	2
	24	305JN71M40	5JN71M40	GUIDE-FS-U-430	1	1
	25	305JN71LL0	5JN71LL0	BRACKET ASSY:ASYS-BRKT-GUIDE-FEED	1	1
	26	305JN71LG0	5JN71LG0	GUIDE-FS-OPEN-UP	1	1
	27	305JN702F0	5JN702F0	SPRING:SPL-F/S-TR	2	2
	28	305JN71LF0	5JN71LF0	GUIDE-FS-OPEN-LOW	1	1
	29	305JN71LM0	5JN71LM0	HOLDER-FS-TR-430	1	1
⊙	30	305JN70V20	5JN70V20	HOLDER:HLDR-GU DE-FS	2	2
⊙	31	305JN71MB0	5JN71MB0	GEAR-08S23-6-CUP	1	1
⊙	32	305JN71MC0	5JN71MC0	GEAR-08S24-6-CUP	1	1
	33	305JN72N30	5JN72N30	SCREW:S/PAN-M3X4-NI	2	2
	34	305JN71MK0	5JN71MK0	TORQUE LIMITER:TL-SEP-ROL-Y-N	1	1
⊙	35	305JN702H0	5JN702H0	ROLLER ASSY:ASYS-ROL-SPT	1	1
⊙	36	305JN702J0	5JN702J0	ROLLER ASSY:ASYS-ROL-FEED	2	2
	37	305JN701E0	5JN701E0	STOP-R NG-6-5	3	3
	38	305JN702E0	5JN702E0	SPRING:SPE090-090-0531	1	1
	39	305JN71LN0	5JN71LN0	BRACKET:BRKT-HOLD-SPE-430	1	1
⊙	40	305JN71MG0	5JN71MG0	SPRING:SPG-E-7XR6X82-ROL-SPT	1	1
	41	305JN71LB0	5JN71LB0	GEAR-10S20-6L	1	1
	42	305JN71LJ0	5JN71LJ0	BRACKET ASSY:ASYS-BRKT-SNSR-SPT	1	1
	43	305JN72J60	5JN72J60	BAND:ES-0505	3	3
⊙	44	305JN71LH0	5JN71LH0	LEVER-FS-SNSR-SPT	1	1
	45	305JN72H70	5JN72H70	SENSOR PS124TD1-B	2	2
	46	305JN71LK0	5JN71LK0	BRACKET:BRKT-SNSR-TR	1	1
	47	305JN72N50	5JN72N50	SCREW:S/TPP/PAN-3X16-NI	1	1
	48	305JN71MJ0	5JN71MJ0	SPRING:SPG-E-LEV-SNSR-SPT	1	1
	49	305JN72N70	5JN72N70	SCREW:S/PAN/SWWP-M3X14-NI	1	1
	50	305JN72KG0	5JN72KG0	CLAMP LBWS-0206S-V0	5	5
	51	305JN72JX0	5JN72JX0	CLAMP UAMS-02WH-2	1	1
	52	305JN71KZ0	5JN71KZ0	COVER-FEED-UNIT-RER	1	1
	53	305JN71M30	5JN71M30	ACTUATOR:ACT-SW-EMPTY-430	1	1
	54	305JN702D0	5JN702D0	SHEET-DUMP-EMP	1	1
	55	305JN71L50	5JN71L50	GUIDE ASSY:ASYS-GUIDE-FEED-ENT-430	1	1
	56	305JN72NS0	5JN72NS0	SCREW:S/TPS/FHEXM/R-3X8-ZU3	26	26
	57	305JN72LW0	5JN72LW0	RETAIN NG RING:RR/E-5-SS	10	10
	58	305JN72LU0	5JN72LU0	RETAINING RING:RR/E-3-SS	3	3
	59	305JN72NT0	5JN72NT0	SCREW:S/TPS/FHEXM/R-4X8-ZU3	2	2
	60	305JN728R0	5JN728R0	WIRE HARNESS:HRNS-CSTMJ-430	1	1
⊙	61	305JN728T0	5JN728T0	WIRE HARNESS:HRNS-TLCFMJ-430	1	1
	62	305JN705N0	5JN705N0	SOLENOID:SOL-PICK-340	1	1
	63	305JN702B0	5JN702B0	LEVER-P/U-SND	1	1

• Parts with "⊙" indicate regular maintenance parts.

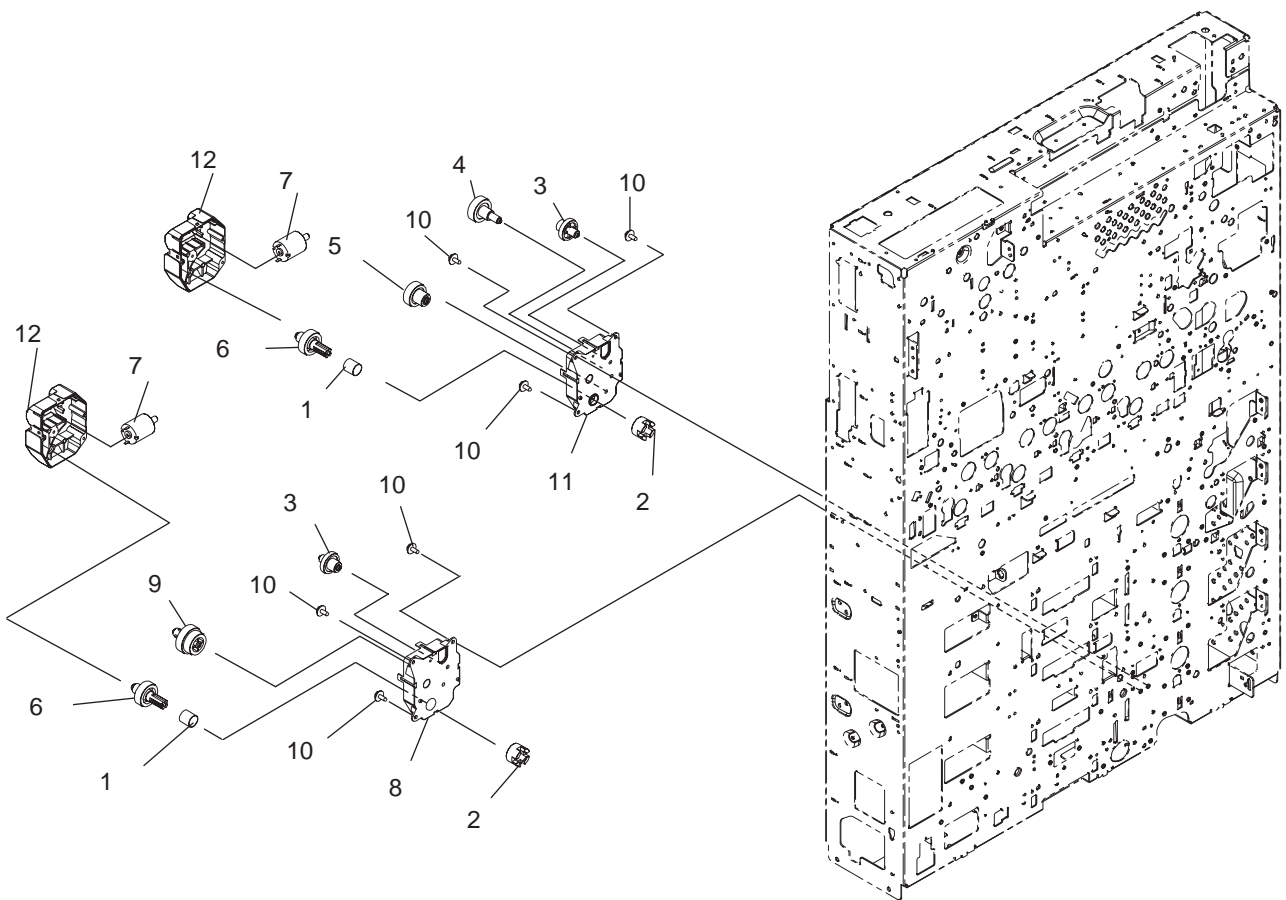

	Ref. No.	Part.No.	Alternative.	Description	Quantity	
					120	230
	1	305JN71TB0	5JN71TB0	SPRING:SPG-DRV-TANDEM-CUP	2	2
	2	305JN71SB0	5JN71SB0	COUPL NG:CUP-DRV-TANDEM	2	2
⊙	3	305JN71RW0	5JN71RW0	GEAR-08S-34-08S-17	2	2
⊙	4	305JN71S80	5JN71S80	GEAR-08S-39-08S-16-L	1	1
⊙	5	305JN71SC0	5JN71SC0	GEAR-08S-37-08S-20	1	1
⊙	6	305JN71S90	5JN71S90	GEAR-08S-38	2	2
⊙	7	305JN71TU0	5JN71TU0	MOTOR ASSY :ASYS-MOTR_D-TLCF-430	2	2
	8	305JN71S60	5JN71S60	COVER:BOX-DRV-TANDEM-F-2	1	1
⊙	9	305JN71SA0	5JN71SA0	GEAR-08S-44-08S-36	1	1
	10	305JN72NT0	5JN72NT0	SCREW:S/TPS/FHEXM/R-4X8-ZU3	6	6
	11	305JN71S50	5JN71S50	COVER:BOX-DRV-TANDEM-F	1	1
	12	305JN71S70	5JN71S70	COVER:BOX-DRV-TANDEM-R	2	2

• Parts with "⊙" indicate regular maintenance parts.

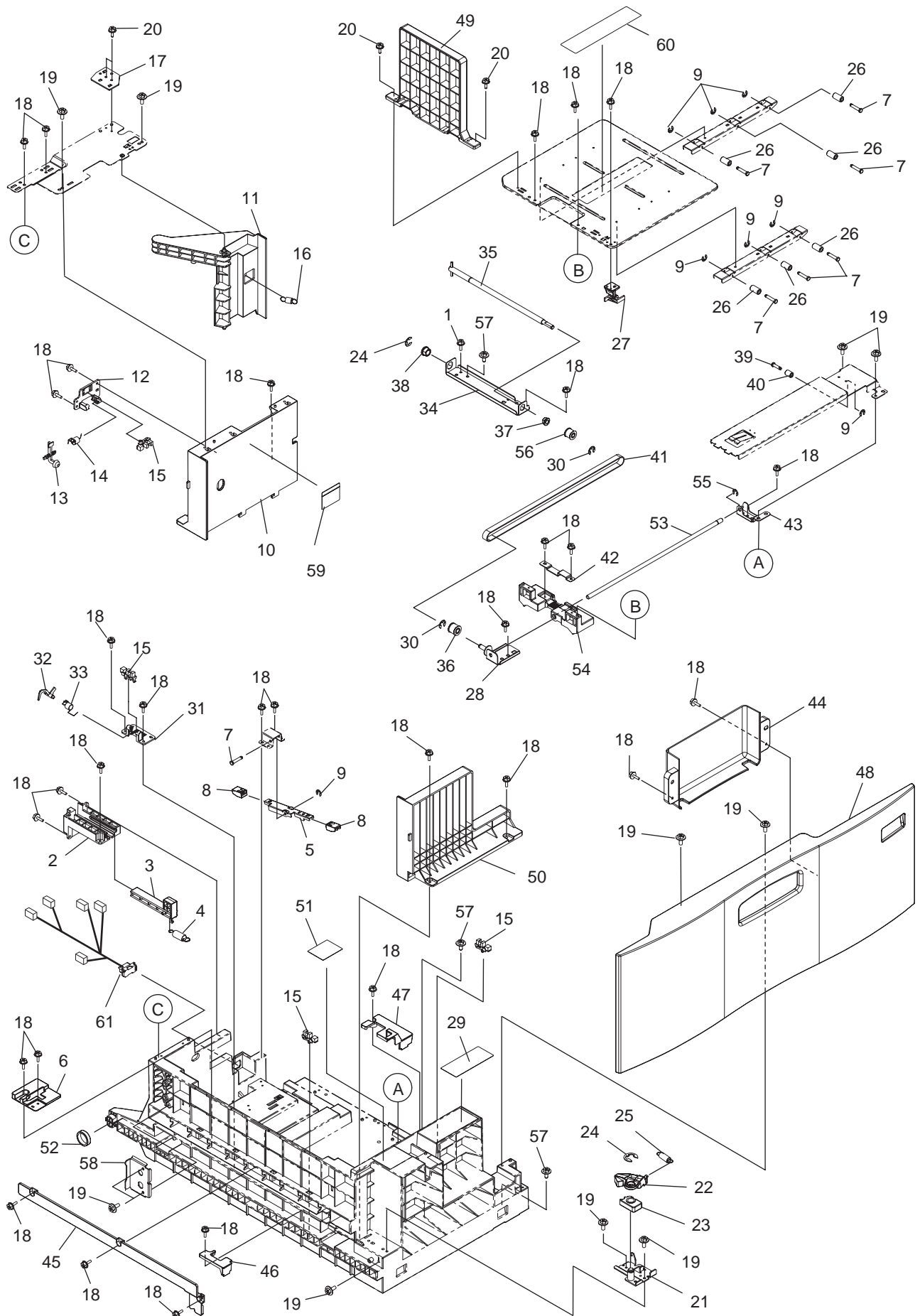

	Ref. No.	Part.No.	Alternative.	Description	Quantity	
					120	230
	1	305JN72P30	5JN72P30	SCREW:S/TPD3/FHEXM-4X10-ZU3	1	1
	2	305JN71SM0	5JN71SM0	STOPPER:STOP-HOLD	1	1
	3	305JN71SL0	5JN71SL0	ARM:LINK-STOP-SHAFT	1	1
	4	305JN71SE0	5JN71SE0	SPRING:SPG-PISTON-TANDEM	1	1
	5	305JN71T30	5JN71T30	BRACKET:BRKT-STP-TRAY2	1	1
	6	305JN71TY0	5JN71TY0	COVER-ENPTY-SNS	1	1
	7	305JN71TC0	5JN71TC0	SHAFT:SFT-ROLL	7	7
	8	305JN71T20	5JN71T20	COVER:COV-CST-COUP-TNDM	2	2
	9	305JN72LU0	5JN72LU0	RETAINING RING:RR/E-3-SS	8	8
	10	305JN71T40	5JN71T40	GUIDE-SIDE-TRAY2-R	1	1
	11	305JN71T10	5JN71T10	STOPPER-TRAY2-R-2	1	1
	12	305JN71T00	5JN71T00	BASE-SNS-2	1	1
	13	305JN71SZ0	5JN71SZ0	ACTUATOR:SENSOR-ACTR-3	1	1
	14	305JN71TF0	5JN71TF0	SPRING-ACT-EMPTY2	1	1
⊙	15	305JN72H20	5JN72H20	SENSOR LG248BL1	4	4
	16	305JN71SD0	5JN71SD0	SPRING:SPG-SHUT-TANDEM-2	1	1
	17	305JN71TW0	5JN71TW0	PLATE:PLT-ATC-A	1	1
	18	305JN72NE0	5JN72NE0	SCREW:S/TPP/FHEXM-3X8-NI	31	31
	19	305JN72NG0	5JN72NG0	SCREW:S/TPP/FHEXM-4X8-NI	11	11
	20	305JN72NS0	5JN72NS0	SCREW:S/TPS/FHEXM/R-3X8-ZU3	4	4
	21	305JN71TJ0	5JN71TJ0	PLATE ASSY:ASYS-PLT-LATCH-2	1	1
	22	305JN71TK0	5JN71TK0	BLOCK-LATCH-LINK	1	1
	23	305JN71TH0	5JN71TH0	BLOCK-LATCH-HOLD	1	1
	24	305JN72LY0	5JN72LY0	RETAIN NG RING:RR/E-7-SS	2	2
	25	305JN71RH0	5JN71RH0	SPACER:SPE087-090-0269	1	1
	26	305JN71SH0	5JN71SH0	ROLLER:ROLL-TRAY	6	6
	27	305JN71TD0	5JN71TD0	ACTUATOR:ACTR-MOVE-SNSR	1	1
	28	305JN71SJ0	5JN71SJ0	PULLEY ASSY:ASYS-PLY-HOLD	1	1
	29	305JN71U10	5JN71U10	LABEL LBL-P-SET-430-TLCF	1	1
	30	305JN72LV0	5JN72LV0	RETAIN NG RING:RR/E-4-SS	2	2
	31	305JN71SG0	5JN71SG0	BASE-SNS-EMPTY	1	1
	32	305JN71SF0	5JN71SF0	ACTUATOR:ACT-SENS-EMPTY-TDM	1	1
	33	305JN71U90	5JN71U90	SPRING:SPG-ACT-EMPTY	1	1
	34	305JN71S30	5JN71S30	BRACKET:BRKT-PLY-HOLD	1	1
	35	305JN71TL0	5JN71TL0	TRAY ASSY:ASYS-TRAY2-DRIVE	1	1
	36	305JN707Y0	5JN707Y0	PULLEY:PLY-DRIVE-2	1	1
	37	305JN701B0	5JN701B0	BUSH-6-GCB	1	1
	38	305JN72GK0	5JN72GK0	BUSH-8X12X8F-NU4	1	1
	39	305JN71TR0	5JN71TR0	SHAFT:SFT-BELT-ADL	1	1
	40	305JN71TQ0	5JN71TQ0	ROLLER:RLR-BELT-ADL	1	1
	41	305JN71TV0	5JN71TV0	TIMING BELT:BELT-3GT-600-9-B50N17	1	1
	42	305JN71TT0	5JN71TT0	BRACKET:BRKT-BELT-HOLD	1	1
	43	305JN71S20	5JN71S20	BRACKET:BRKT-HOLD-ST	1	1
⊙	44	305JN712S0	5JN712S0	COVER-HNDL-CST-434	1	1
	45	305JN71TX0	5JN71TX0	COVER-S DE-HRNS	1	1
	46	305JN71TE0	5JN71TE0	COVER-SNSR-H	1	1
	47	305JN71T70	5JN71T70	COVER-SNSR-R	1	1
	48	305JN71350	5JN71350	COVER-TANDEM-LCF-434	1	1
	49	305JN71RZ0	5JN71RZ0	GUIDE-END	1	1
	50	305JN71SY0	5JN71SY0	GUIDE-SIDE-TRAY2-F	1	1
	51	305JN71U20	5JN71U20	LABEL LBL-CST2-SET-430-TLCF	1	1
	52	305JN71R70	5JN71R70	ROLLER-LEFT-R-BP	1	1
	53	305JN71TG0	5JN71TG0	SHAFT:SFT-GU DE	1	1
	54	305JN71SK0	5JN71SK0	TRAY-BASE	1	1
	55	305JN72LW0	5JN72LW0	RETAIN NG RING:RR/E-5-SS	1	1
	56	305JN707X0	5JN707X0	PULLEY:PLY-DRIVE-1	1	1
	57	305JN72NT0	5JN72NT0	SCREW:S/TPS/FHEXM/R-4X8-ZU3	3	3
	58	305JN71U40	5JN71U40	BRACKET:BRKT-STOP-TNDM-CST2	1	1
	59	305JN707Z0	5JN707Z0	LABEL LBL-P-LIMIT	1	1
	60	305JN71UA0	5JN71UA0	LABEL LBL-P-SET-TRY-L2	1	1
	61	305JN72840	5JN72840	WIRE HARNESS:HRNS-TLCF2-430	1	1

• Parts with "⊙" indicate regular maintenance parts.

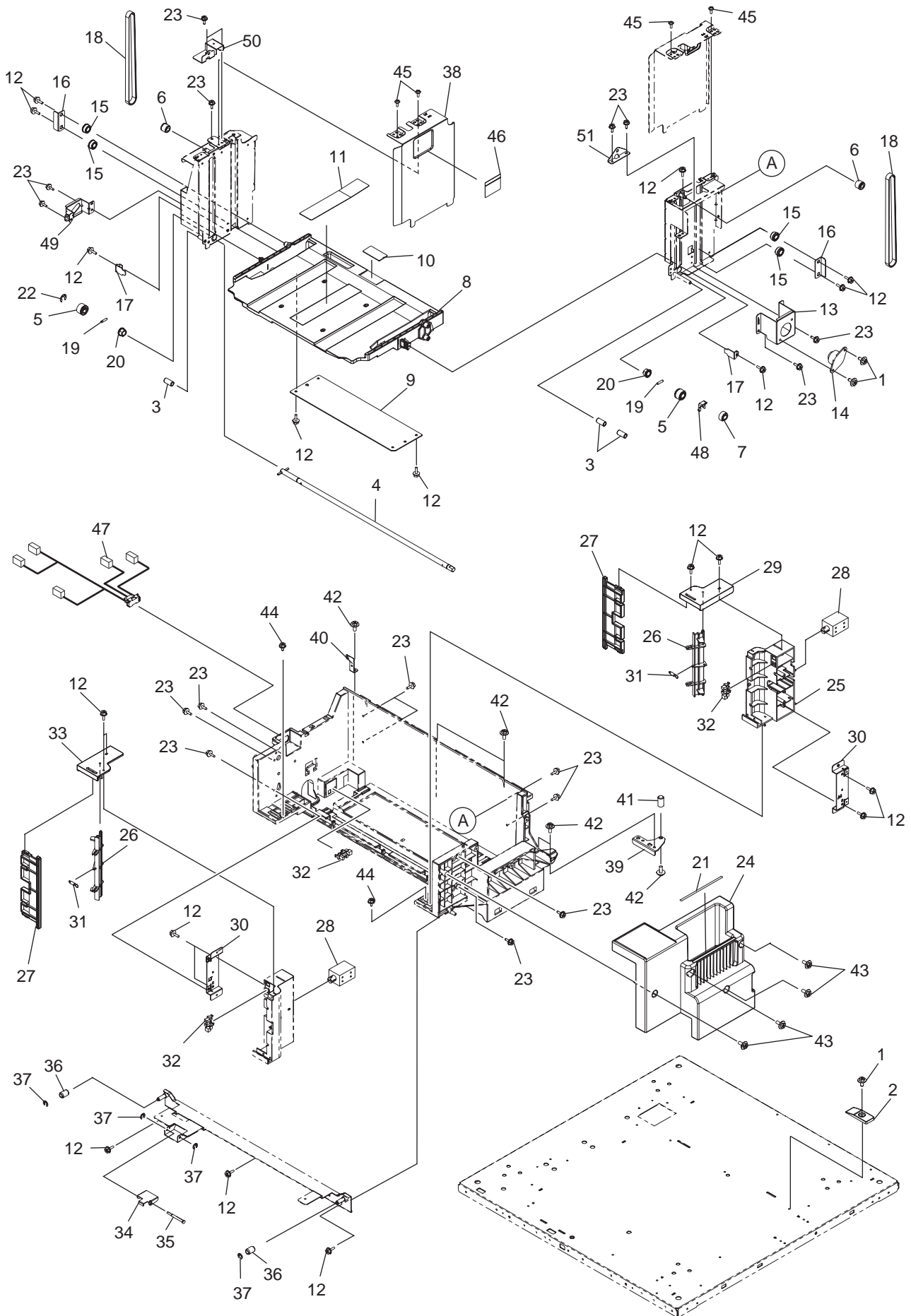

	Ref. No.	Part.No.	Alternative.	Description	Quantity	
					120	230
	1	305JN72NT0	5JN72NT0	SCREW:S/TPS/FHEXM/R-4X8-ZU3	3	3
	2	305JN71SP0	5JN71SP0	BASE:STP-BASE-TANDEM	1	1
	3	305JN71U80	5JN71U80	ROLLER:RLR-BELT- DLER-2	3	3
	4	305JN71T60	5JN71T60	SHAFT ASSY:ASYS-SFT-TRAY-BP-TDM	1	1
	5	305JN71RV0	5JN71RV0	PULLEY:PULLY-BP-TDM2-Z18	2	2
	6	305JN71RU0	5JN71RU0	PULLEY:PULLY-BP-TDM1-Z14	2	2
	7	305JN71RX0	5JN71RX0	GEAR-DUMP-Z14	1	1
	8	305JN71S40	5JN71S40	TRAY1-T-LCF	1	1
	9	305JN707W0	5JN707W0	PLATE:PLT-BALANCER	1	1
	10	305JN702S0	5JN702S0	PAD-TRAY	1	1
	11	305JN70800	5JN70800	LABEL LBL-P-SET-TRY-R	1	1
	12	305JN72NE0	5JN72NE0	SCREW:S/TPP/FHEXM-3X8-NI	20	20
	13	305JN71SQ0	5JN71SQ0	BRACKET:BRKT-DAMP-BP	1	1
	14	305JN70UW0	5JN70UW0	ROTARY DAMPER:OIL-DAMPER-390	1	1
	15	305JN71RY0	5JN71RY0	ROLLER-BP-TDM	4	4
	16	305JN71S00	5JN71S00	BRACKET:BRKT-GU DE-BP	2	2
	17	305JN71SR0	5JN71SR0	BRACKET:BRKT-LU-BELT-BP	2	2
	18	305JN71TZ0	5JN71TZ0	TIMING BELT:BELT-3GT-402-8-B50N17	2	2
	19	305JN72MF0	5JN72MF0	PIN:P/PRL/AH7-3X12-SS	2	2
	20	305JN72GK0	5JN72GK0	BUSH-8X12X8F-NU4	2	2
	21	305JN71U00	5JN71U00	LABEL LBL-COV-R-TLCF	1	1
	22	305JN72LY0	5JN72LY0	RETAIN NG RING:RR/E-7-SS	1	1
	23	305JN72NS0	5JN72NS0	SCREW:S/TPS/FHEXM/R-3X8-ZU3	18	18
	24	305JN71T50	5JN71T50	COVER ASSY:ASYB-INN-COV-TLCF430	1	1
	25	305JN71ST0	5JN71ST0	HOLDER:HLDR-SHUT-F	1	1
	26	305JN71SU0	5JN71SU0	JOINT-SHUT-TANDEM	2	2
	27	305JN71SV0	5JN71SV0	PLATE:PLT-SHUTTER-TANDEM	2	2
⊙	28	305JN705P0	5JN705P0	SOLENOID:SOL-END-340	2	2
	29	305JN71SN0	5JN71SN0	PLATE-SHUT-F	1	1
	30	305JN71SS0	5JN71SS0	BRACKET:BRKT-HOLD-SHUT	2	2
	31	305JN71TM0	5JN71TM0	SPRING:SPG-SHUT-TANDEM	2	2
⊙	32	305JN72H20	5JN72H20	SENSOR LG248BL1	3	3
	33	305JN71SW0	5JN71SW0	PLATE-SHUT-R	1	1
	34	305JN71UB0	5JN71UB0	BRACKET:BRKT-STP-TANDEM	1	1
	35	305JN71TN0	5JN71TN0	SHAFT:SFT-STP-TANDEM	1	1
	36	305JN71SX0	5JN71SX0	ROLLER:RLR-RAIL-CENTER	2	2
	37	305JN72LU0	5JN72LU0	RETAINING RING:RR/E-3-SS	4	4
	38	305JN71TP0	5JN71TP0	TRAY:FENCE-TRAY1-R	1	1
	39	305JN71R80	5JN71R80	PLATE-LATCH	1	1
	40	305JN71TS0	5JN71TS0	PLATE:PLT-SPG-SE-R	1	1
	41	305JN702M0	5JN702M0	PIN:STUD-CST-POS	1	1
	42	305JN72NB0	5JN72NB0	SCREW:S/FHEXM-M4X8-NI	6	6
	43	305JN72NG0	5JN72NG0	SCREW:S/TPP/FHEXM-4X8-NI	4	4
	44	305JN72NR0	5JN72NR0	SCREW:S/TPS/FHEXM/R-3X6-ZU3	2	2
	45	305JN72MV0	5JN72MV0	SCREW:S/TPS/BID-3X6-ZU3	4	4
	46	305JN707Z0	5JN707Z0	LABEL LBL-P-LIMIT	1	1
	47	305JN72830	5JN72830	WIRE HARNESS:HRNS-TLCF1-430	1	1
	48	305JN701N0	5JN701N0	STOP RING	1	1
	49	305JN71U50	5JN71U50	BRACKET:BRKT-HOLD-IDLER-R	1	1
	50	305JN71U60	5JN71U60	BRACKET:BRKT-SUPPORT-R	1	1
	51	305JN71U70	5JN71U70	BRACKET:BRKT-SUPPORT-F	1	1

• Parts with "⊙" indicate regular maintenance parts.

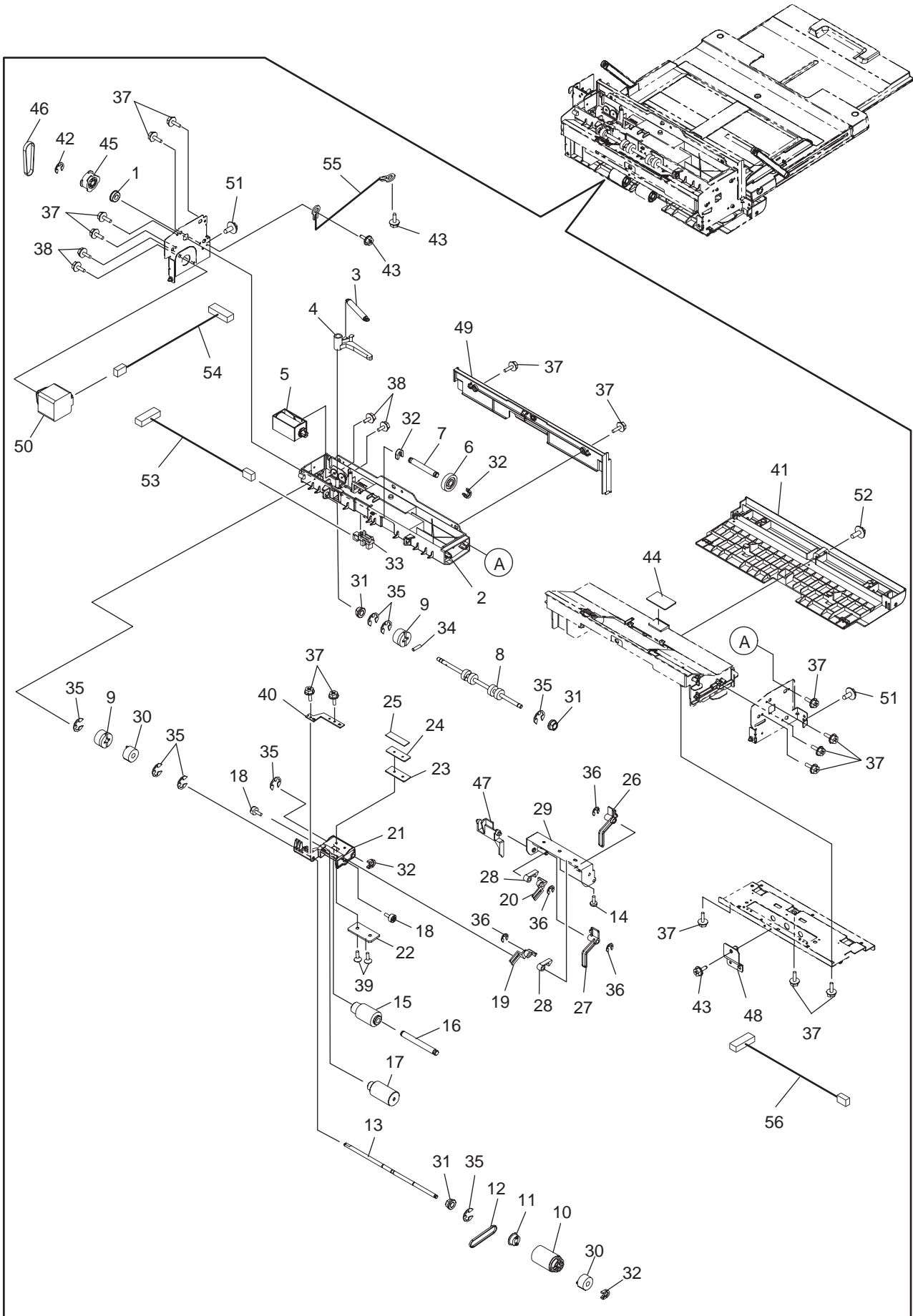

	Ref. No.	Part.No.	Alternative.	Description	Quantity	
					120	230
	1	305JN72JQ0	5JN72JQ0	BEARING-LF-1260ZZ	1	1
	2	305JN71P10	5JN71P10	GUIDE ASSY:ASYS-GUIDE-BYP-U	1	1
	3	305JN705V0	5JN705V0	SPRING:SPG-E-6R5XR7X28R5L	1	1
	4	305JN705T0	5JN705T0	LEVER-PICK	1	1
⊙	5	305JN705Q0	5JN705Q0	SOLENOID:SOL-SFB-340	1	1
⊙	6	305JN701V0	5JN701V0	GEAR-06S-032-06	1	1
	7	305JN70XN0	5JN70XN0	PIN:STUD-G032-BYPS	1	1
⊙	8	305JN70XK0	5JN70XK0	ROLLER-TR-BYPASS-18.5	1	1
⊙	9	305JN705W0	5JN705W0	GEAR-06S-027-06	2	2
⊙	10	305JN70240	5JN70240	ROLLER ASSY:K-RLR-FEED-SFB	1	1
	11	305JN700S0	5JN700S0	PULLEY PLY/T-2GT020-06	1	1
	12	305JN70630	5JN70630	TIMING BELT:BLT-SY-138-2GT-2.8	1	1
	13	305JN71N80	5JN71N80	SHAFT:SFT-ROLL-FEED-BYP	1	1
	14	305JN72LK0	5JN72LK0	SCREW:S/TPP/PAN-3X6-NI	1	1
⊙	15	305JN70250	5JN70250	ROLLER ASSY:K-ROLL-PICK-BYP	1	1
	16	305JN70XL0	5JN70XL0	SHAFT:SFT-ROL-PIC-BYP-350	1	1
	17	305JN70XH0	5JN70XH0	WEIGHT-PICK-BYP-T	1	1
	18	305JN70XG0	5JN70XG0	SCREW-WEIGHT-3*6	2	2
	19	305JN700N0	5JN700N0	LEVER-STOPPER-F	1	1
	20	305JN700P0	5JN700P0	LEVER-STOPPER-R	1	1
	21	305JN705R0	5JN705R0	ARM-PICK-350	1	1
	22	305JN70600	5JN70600	WEIGHT-PICK-BYP-LOW	1	1
	23	305JN70610	5JN70610	WEIGHT-PICK-BYP-MID	1	1
	24	305JN70620	5JN70620	WEIGHT-PICK-BYP-UP	1	1
	25	305JN705S0	5JN705S0	PAD:CUSHION-PAD	1	1
	26	305JN705Y0	5JN705Y0	LEVER:STPR-BYP-F-350	1	1
	27	305JN705Z0	5JN705Z0	LEVER:STPR-BYP-R-350	1	1
	28	305JN700Q0	5JN700Q0	ARM-STOPPER	2	2
⊙	29	305JN72GM0	5JN72GM0	BRACKET ASSY:ASYS-BRKT-STOPPER	1	1
	30	305JN70V90	5JN70V90	CLUTCH-6-LB-390	2	2
	31	305JN701B0	5JN701B0	BUSH-6-GCB	3	3
	32	305JN701E0	5JN701E0	STOP-R NG-6-5	4	4
⊙	33	305JN72H20	5JN72H20	SENSOR LG248BL1	1	1
	34	305JN72M10	5JN72M10	PIN P/PRL/AH7-2X8-SS	1	1
	35	305JN72LW0	5JN72LW0	RETAIN NG RING:RR/E-5-SS	8	8
	36	305JN72LU0	5JN72LU0	RETAINING RING:RR/E-3-SS	4	4
	37	305JN72NE0	5JN72NE0	SCREW:S/TPP/FHEXM-3X8-NI	15	15
	38	305JN72N90	5JN72N90	SCREW:S/FHEXM-M3X6-NI	4	4
	39	305JN72ML0	5JN72ML0	SCREW:S/CTS-M3X8-NI	2	2
⊙	40	305JN705X0	5JN705X0	PLATE-ARM-PICK	1	1
	41	305JN71NM0	5JN71NM0	COVER-SFB-L-43XG	1	1
	42	305JN72LV0	5JN72LV0	RETAIN NG RING:RR/E-4-SS	1	1
	43	305JN72NR0	5JN72NR0	SCREW:S/TPS/FHEXM/R-3X6-ZU3	3	3
	44	305JN70090	5JN70090	PAD-BRAKE	1	1
	45	305JN71PL0	5JN71PL0	PULLEY PULLY-S2M30-6D	1	1
⊙	46	305JN71NK0	5JN71NK0	TIMING BELT:BLT-SY-S2M-148-6	1	1
	47	305JN705U0	5JN705U0	ACTUATOR:ACTR-EMP-SW-BYP	1	1
⊙	48	305JN71NC0	5JN71NC0	BRACKET ASSY:ASYS-BRKT-SFB-EXIT-43X	1	1
⊙	49	305JN71NA0	5JN71NA0	COVER-SFB-43XG	1	1
⊙	50	305JN72BF0	5JN72BF0	MOTOR:MOTRS-TR-430	1	1
	51	305JN72NT0	5JN72NT0	SCREW:S/TPS/FHEXM/R-4X8-ZU3	2	2
	52	305JN72NG0	5JN72NG0	SCREW:S/TPP/FHEXM-4X8-NI	1	1
	53	305JN727L0	5JN727L0	WIRE HARNESS:HRNS-SFBSW-430	1	1
	54	305JN727Q0	5JN727Q0	WIRE HARNESS:HRNS-SFBM-430	1	1
	55	305JN727P0	5JN727P0	WIRE HARNESS:HRNS-SFBFG-430	1	1
	56	305JN727M0	5JN727M0	WIRE HARNESS:HRNS-SFBFED-430	1	1

• Parts with "⊙" indicate regular maintenance parts.

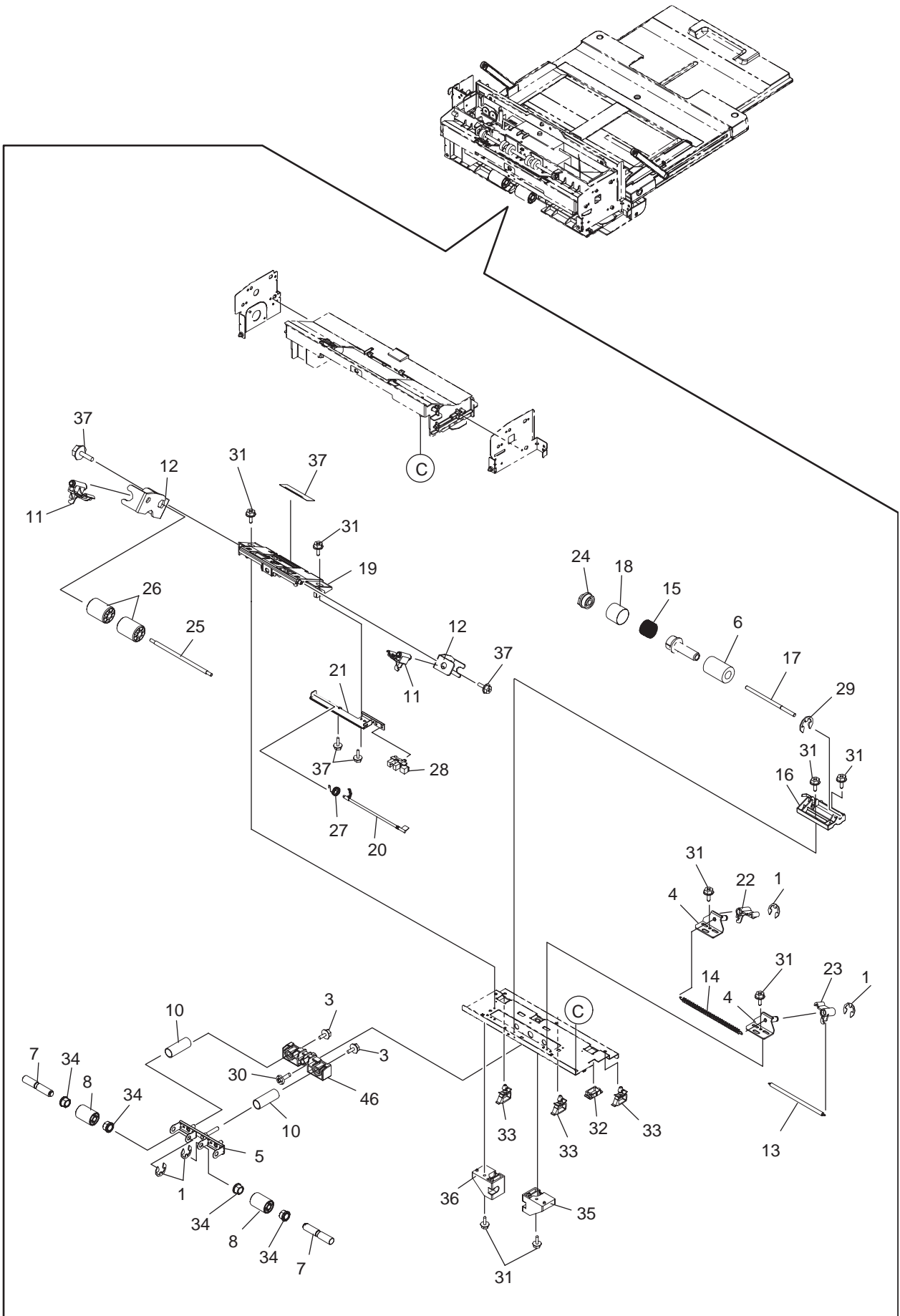

	Ref. No.	Part.No.	Alternative.	Description	Quantity	
					120	230
⊙	1	305JN72LW0	5JN72LW0	RETAIN NG RING:RR/E-5-SS	4	4
	2	305JN72NE0	5JN72NE0	SCREW:S/TPP/FHEXM-3X8-NI	4	4
	3	305JN72N90	5JN72N90	SCREW:S/FHEXM-M3X6-NI	2	2
	4	305JN70640	5JN70640	BRACKET ASSY:ASYS-BRKT-LVR-SPT	2	2
	5	305JN71N10	5JN71N10	BRACKET ASSY:ASYS-BRKT-GUIDE-SPG1	1	1
	6	305JN70690	5JN70690	ROLLER ASSY:ASYS-ROLL-SPT-L30	1	1
	7	305JN71MZ0	5JN71MZ0	SHAFT-IDLE-TR1	2	2
	8	305JN71N00	5JN71N00	ROLLER:ROLL-IDLE-TR1-BP	2	2
	9	305JN71NF0	5JN71NF0	GUIDE-HOLD- DLE-TR1	1	1
	10	305JN71N20	5JN71N20	SPRING:SPG-C-1600BP	2	2
	11	305JN71JF0	5JN71JF0	LEVER LVR-IDLE-F43X	2	2
	12	305JN71N50	5JN71N50	BRACKET:BRKT-FRAME-AD	2	2
	13	305JN71NY0	5JN71NY0	SPRING:SPG-E-6XR6X92R4-SPT	1	1
	14	305JN707U0	5JN707U0	SPRING:SPG-E-6R7XR7X79R55	1	1
	15	305JN70680	5JN70680	SPRING:SPR-1.0-15 65-13L	1	1
	16	305JN70660	5JN70660	HOLDER-ROL-SPT-BYP	1	1
	17	305JN70XM0	5JN70XM0	SHAFT-ROL-SPT	1	1
	18	305JN70650	5JN70650	COVER-SPE-ARBOR-17	1	1
	19	305JN71N60	5JN71N60	CASE-BYPASS-RLR	1	1
	20	305JN70XJ0	5JN70XJ0	SHAFT:ACTUATOR-BYP	1	1
	21	305JN71N90	5JN71N90	BRACKET:BRKT-ACT-BYP-43X	1	1
	22	305JN706B0	5JN706B0	LEVER-SPT-R	1	1
	23	305JN706A0	5JN706A0	LEVER-SPT-F	1	1
	24	305JN70670	5JN70670	BUSH:ARBOR-SPT-BYP	1	1
	25	305JN71NW0	5JN71NW0	SHAFT:SFT-BYPASS-TR-L2	1	1
	26	305JN71N70	5JN71N70	ROLLER:IDLER-TR1	2	2
	27	305JN706C0	5JN706C0	SPRING:SPG-T-SNSR-LOW-T	1	1
	28	305JN72H20	5JN72H20	SENSOR LG248BL1	1	1
	29	305JN72LV0	5JN72LV0	RETAIN NG RING:RR/E-4-SS	1	1
	30	305JN72MW0	5JN72MW0	SCREW:S/TPS/BID-3X8-ZU3	1	1
	31	305JN72NR0	5JN72NR0	SCREW:S/TPS/FHEXM/R-3X6-ZU3	8	8
	32	305JN72K10	5JN72K10	BAND:ESC-0912	1	1
	33	305JN72JP0	5JN72JP0	CLAMP LWS-0711Z	3	3
	34	305JN72GK0	5JN72GK0	BUSH-8X12X8F-NU4	4	4
	35	305JN71NU0	5JN71NU0	HOLDER-SHAFT-F	1	1
	36	305JN71NV0	5JN71NV0	HOLDER-SHAFT-R	1	1
	37	305JN71NX0	5JN71NX0	SHEET:MYLAR-BYP-FEED	1	1

• Parts with "⊙" indicate regular maintenance parts.

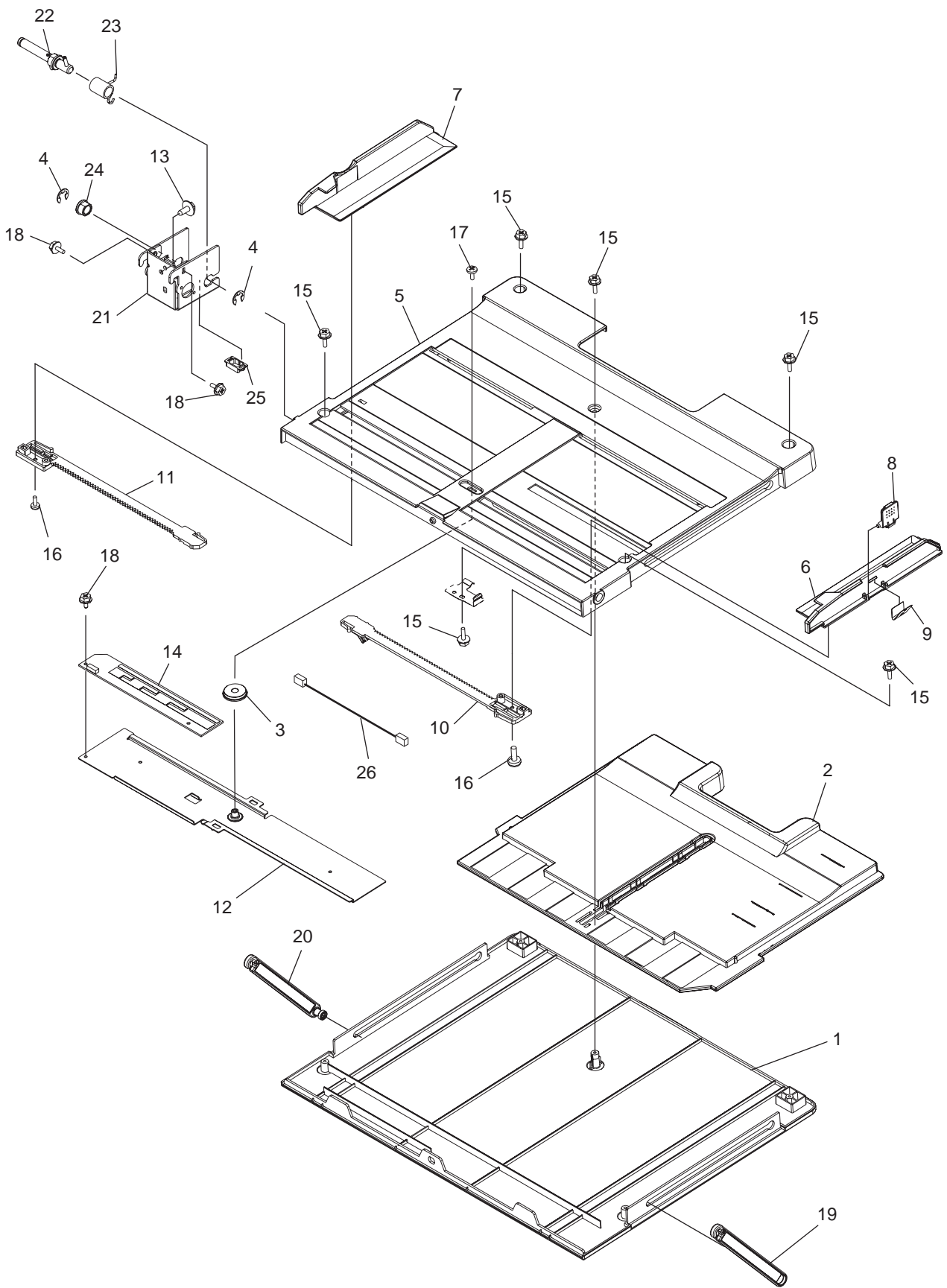

	Ref. No.	Part.No.	Alternative.	Description	Quantity	
					120	230
⊙	1	305JN71NH0	5JN71NH0	TRAY-BYPASS-L	1	1
⊙	2	305JN71NR0	5JN71NR0	TRAY-BYP-M-430	1	1
	3	305JN701A0	5JN701A0	GEAR:P NION-18-395	1	1
	4	305JN72LY0	5JN72LY0	RETAIN NG RING:RR/E-7-SS	2	2
⊙	5	305JN71NJ0	5JN71NJ0	TRAY-BYPASS-UP	1	1
⊙	6	305JN71NG0	5JN71NG0	GUIDE-TRAY-FRT-43X	1	1
⊙	7	305JN70W90	5JN70W90	GUIDE-TRAY-RER-43X	1	1
⊙	8	305JN706D0	5JN706D0	LEVER-GUIDE-F-43X	1	1
	9	305JN706E0	5JN706E0	SPRING:SPG-GU DE-F	1	1
	10	305JN70WC0	5JN70WC0	RACK ASSY:ASYS-RACK-BYPASS-380	1	1
	11	305JN70WA0	5JN70WA0	RACK-BYPASS-380	1	1
	12	305JN70WB0	5JN70WB0	PLATE ASSY:ASYS-PLATE-PINION-380	1	1
	13	305JN72NT0	5JN72NT0	SCREW:S/TPS/FHEXM/R-4X8-ZU3	1	1
⊙	14	305JN70X80	5JN70X80	PWB ASSY:PWA-F-SFB-380	1	1
	15	305JN72NE0	5JN72NE0	SCREW:S/TPP/FHEXM-3X8-NI	6	6
	16	305JN72LK0	5JN72LK0	SCREW:S/TPP/PAN-3X6-NI	2	2
	17	305JN72LF0	5JN72LF0	SCREW:S/BID-M3X6-NI	1	1
	18	305JN72NR0	5JN72NR0	SCREW:S/TPS/FHEXM/R-3X6-ZU3	3	3
	19	305JN71NN0	5JN71NN0	ARM-TRAY-SFB-F	1	1
	20	305JN71NP0	5JN71NP0	ARM-TRAY-SFB-R	1	1
	21	305JN71N40	5JN71N40	BRACKET:BRKT-TRAY-BYP-R	1	1
	22	305JN71NL0	5JN71NL0	SHAFT ASSY:ASYS-SFT-TRAY-BYP-43X	1	1
	23	305JN71NB0	5JN71NB0	SPACER:SPA-TRAY-SFB-43X	1	1
	24	305JN70070	5JN70070	BUSH-8	1	1
	25	305JN72K10	5JN72K10	BAND:ESC-0912	1	1
	26	305JN727H0	5JN727H0	WIRE HARNESS:HRNS-SFBSIZE-430	1	1

• Parts with "⊙" indicate regular maintenance parts.

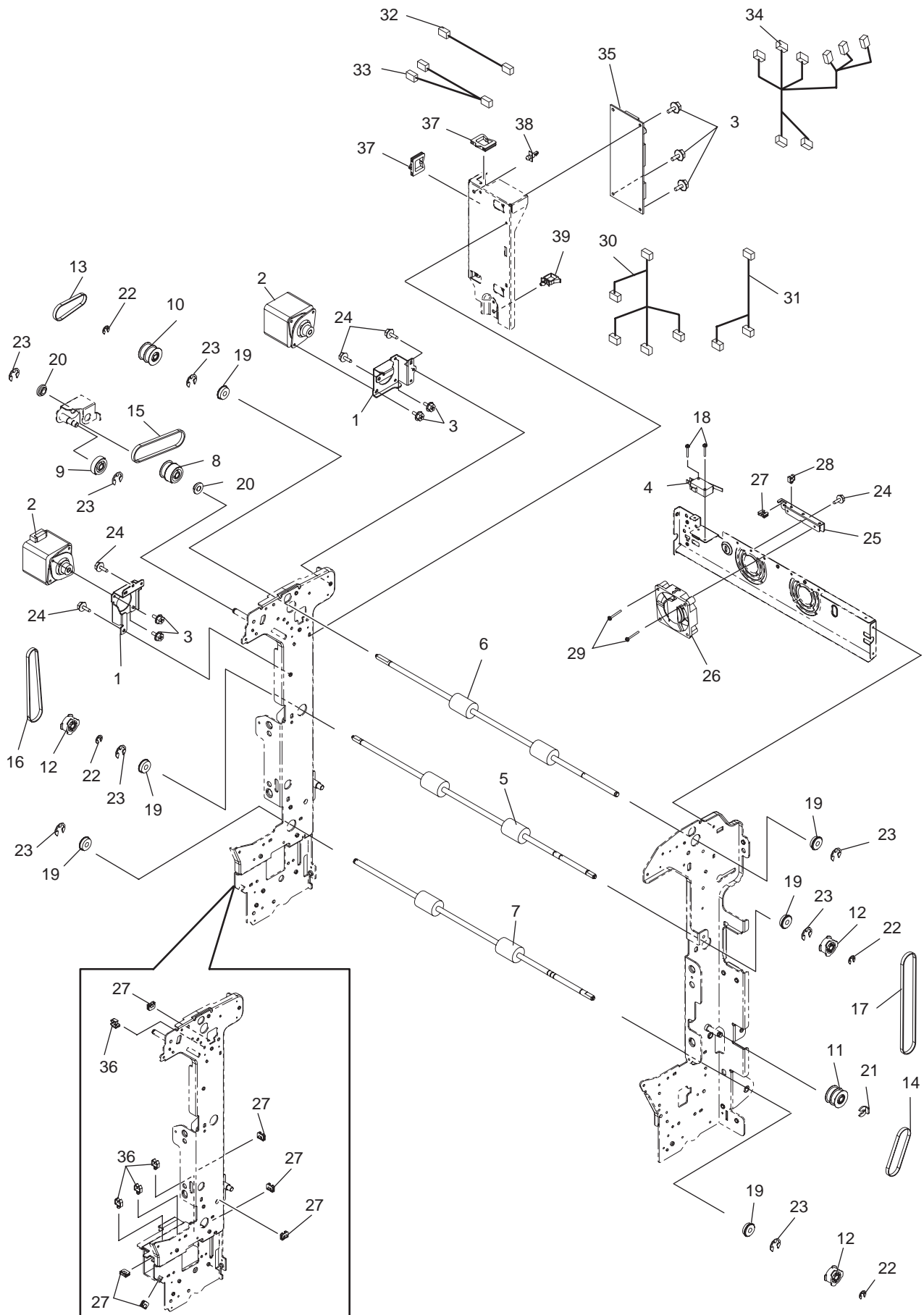

	Ref. No.	Part.No.	Alternative.	Description	Quantity	
					120	230
	1	305JN71PP0	5JN71PP0	BRACKET:BRKT-MOTOR-ADU	2	2
	2	305JN72750	5JN72750	MOTOR:MOTRS-MT-430	2	2
	3	305JN72N90	5JN72N90	SCREW:S/FHEXM-M3X6-NI	7	7
⊙	4	305JN72HU0	5JN72HU0	SWITCH:V-152-1C25	1	1
⊙	5	305JN71PA0	5JN71PA0	ROLLER:RLR-ADU-MID-430	1	1
⊙	6	305JN71P20	5JN71P20	ROLLER:RLR-ADU-UP-430	1	1
⊙	7	305JN71P90	5JN71P90	ROLLER:RLR-ADU-LOW-430	1	1
⊙	8	305JN71P70	5JN71P70	GEAR-10S20_PS2M30-6	1	1
⊙	9	305JN71P40	5JN71P40	GEAR-10S20-6	1	1
	10	305JN71P80	5JN71P80	PULLEY PULLY-S2M30-6D-DBL	1	1
	11	305JN71PD0	5JN71PD0	PULLEY PULLY-S2M30-6-DBL	1	1
	12	305JN71PL0	5JN71PL0	PULLEY PULLY-S2M30-6D	3	3
	13	305JN71P60	5JN71P60	TIMING BELT:BLT.SY-S2M-118-5	1	1
	14	305JN71PE0	5JN71PE0	TIMING BELT:BLT.SY-S2M-142-4	1	1
	15	305JN71PF0	5JN71PF0	TIMING BELT:BLT.SY-S2M-186-4	1	1
	16	305JN71PM0	5JN71PM0	TIMING BELT:BLT.SY-S2M-224-4	1	1
	17	305JN71P30	5JN71P30	TIMING BELT:BLT.SY-S2M-300-4	1	1
	18	305JN72MQ0	5JN72MQ0	SCREW:S/TPS/PAN-3X16-ZU3	2	2
	19	305JN72KH0	5JN72KH0	BEARING:RNR-1560ZZRP0P24LY121	6	6
	20	305JN706J0	5JN706J0	GUIDE:BUSH-6X10X4F-POM	2	2
	21	305JN701W0	5JN701W0	STOP-R NG-6-1.5	1	1
	22	305JN72LU0	5JN72LU0	RETAINING RING:RR/E-3-SS	4	4
	23	305JN72LW0	5JN72LW0	RETAIN NG RING:RR/E-5-SS	8	8
	24	305JN72NS0	5JN72NS0	SCREW:S/TPS/FHEXM/R-3X8-ZU3	5	5
	25	305JN71QH0	5JN71QH0	BRACKET:BRKT-FAN-ADU	1	1
⊙	26	305JN70VZ0	5JN70VZ0	FAN MOTOR:FAND-6015-390	1	1
	27	305JN72J60	5JN72J60	BAND:ES-0505	7	7
	28	305JN72K20	5JN72K20	CLAMP MSB-1207	1	1
	29	305JN72MR0	5JN72MR0	SCREW:S/TPS/PAN-3X20-ZU3	2	2
	30	305JN727F0	5JN727F0	WIRE HARNESS HRNS-ADU-SFB-430	1	1
	31	305JN727G0	5JN727G0	WIRE HARNESS:HRNS-SFB-430	1	1
	32	305JN72B80	5JN72B80	WIRE HARNESS:HRNS-ADU-TNR-430	1	1
	33	305JN72960	5JN72960	WIRE HARNESS:HRNS-ADUM-430	1	1
	34	305JN72BC0	5JN72BC0	WIRE HARNESS HRNS-ADU-SNR1-430	1	1
⊙	35	305JN72B70	5JN72B70	PWB ASSY:PWA-F-ADU-430	1	1
	36	305JN72J00	5JN72J00	CLAMP UAMS-07-0	4	4
	37	305JN72J50	5JN72J50	BAND:EDS-1717U	2	2
	38	305JN72JG0	5JN72JG0	LOCKING SUPPORT:SPLSN-4U	1	1
	39	305JN72JZ0	5JN72JZ0	CLAMP LWS-1211Z	1	1

• Parts with "⊙" indicate regular maintenance parts.

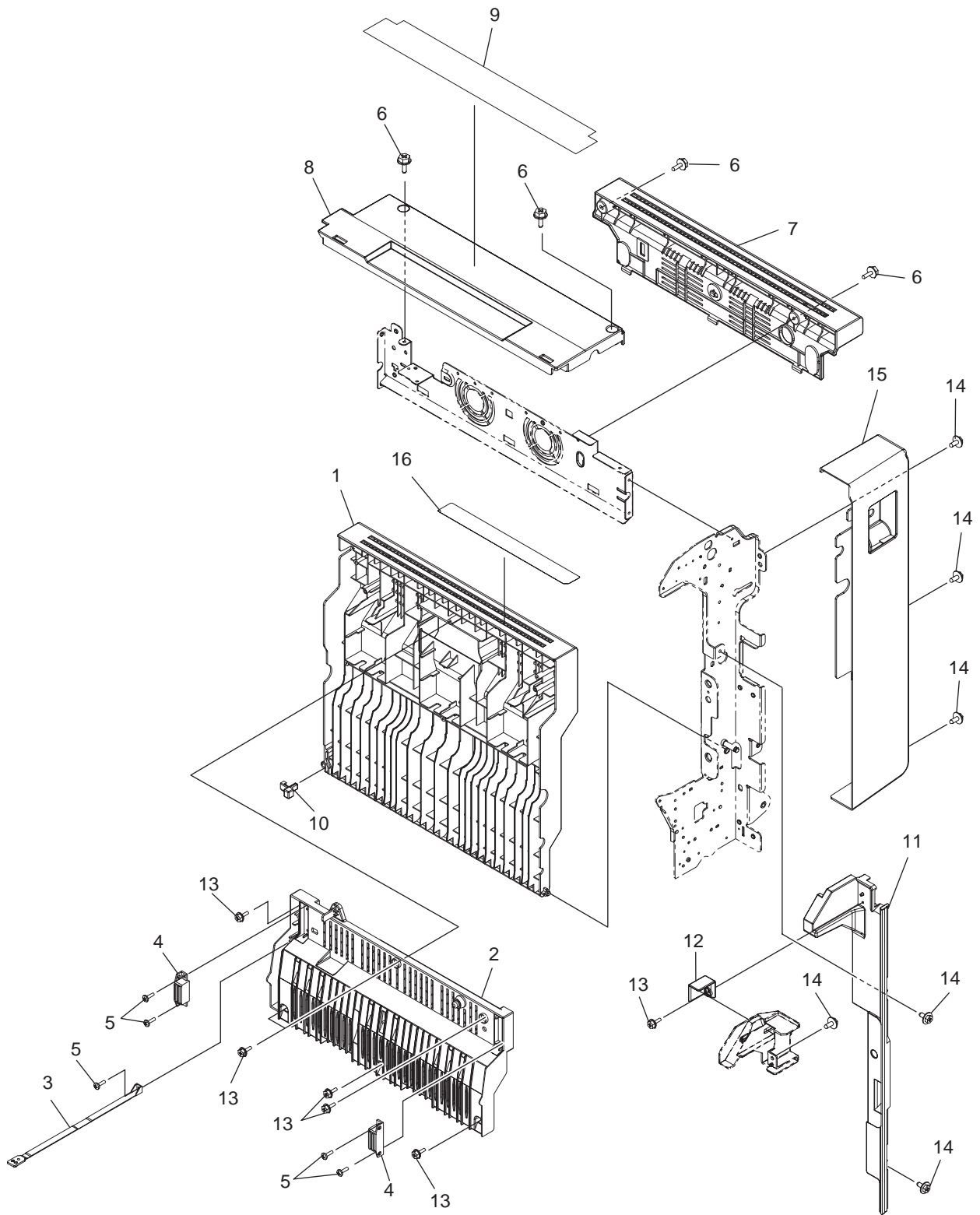

	Ref. No.	Part.No.	Alternative.	Description	Quantity	
					120	230
	1	305JN71QQ0	5JN71QQ0	COVER-ADU-RIGHT-430-T	1	1
	2	305JN71PNO	5JN71PNO	GUIDE-ADU-RIGHT-UP	1	1
	3	305JN71QK0	5JN71QK0	STOPPER-STRING-430	1	1
	4	305JN72KDO	5JN72KDO	MAGNET CATCH-CA-0131B	2	2
	5	305JN72MK0	5JN72MK0	SCREW:S/TPP/BID-3X8-NI	5	5
	6	305JN72NS0	5JN72NS0	SCREW:S/TPS/FHEXM/R-3X8-ZU3	4	4
⊙	7	305JN71QP0	5JN71QP0	COVER-ADU-U-SUB-430-T	1	1
⊙	8	305JN71QD0	5JN71QD0	COVER-ADU-UP-430	1	1
	9	305JN72DE0	5JN72DE0	LABEL LBL-ADU-UPPER	1	1
	10	305JN701T0	5JN701T0	STOPPER-COV-FED	1	1
	11	305JN71QC0	5JN71QC0	COVER-ADU-FRT-SUB-UP	1	1
	12	305JN71QE0	5JN71QE0	PLATE:PUSHER-COVER-ADU-SW	1	1
	13	305JN72NE0	5JN72NE0	SCREW:S/TPP/FHEXM-3X8-NI	7	7
	14	305JN72NT0	5JN72NT0	SCREW:S/TPS/FHEXM/R-4X8-ZU3	6	6
⊙	15	305JN71Q90	5JN71Q90	COVER-ADU-FRT-430G	1	1
	16	305JN71QS0	5JN71QS0	LABEL LBL-ADU-OPEN	1	1

• Parts with "⊙" indicate regular maintenance parts.

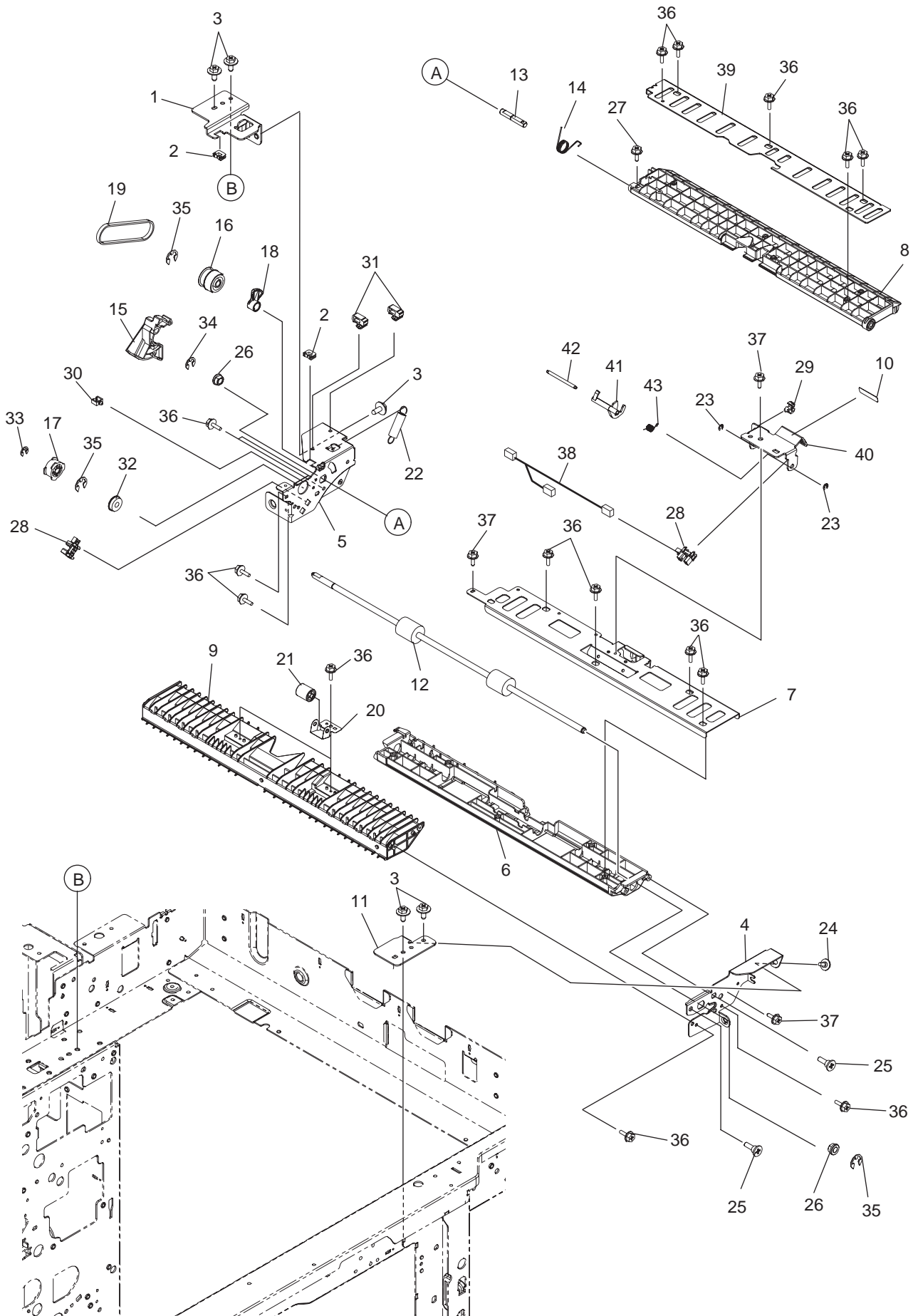

	Ref. No.	Part.No.	Alternative.	Description	Quantity	
					120	230
	1	305JN71Q70	5JN71Q70	BRACKET:BRKT-HOLD-MID-R	1	1
	2	305JN72J60	5JN72J60	BAND:ES-0505	2	2
	3	305JN72NT0	5JN72NT0	SCREW:S/TPS/FHEXM/R-4X8-ZU3	5	5
	4	305JN71QN0	5JN71QN0	FRAME ASSY:ASYS-FRM-M D-GID-F	1	1
	5	305JN71PY0	5JN71PY0	FRAME ASSY:ASYS-FRM-M D-GID-R	1	1
	6	305JN71PV0	5JN71PV0	GUIDE-MID-JCT-U	1	1
	7	305JN71Q60	5JN71Q60	STAY-GUIDE-MID-JCT	1	1
	8	305JN71PZ0	5JN71PZ0	GUIDE-SEPT-JCT	1	1
	9	305JN71PW0	5JN71PW0	GUIDE-EXIT-M	1	1
	10	305JN72400	5JN72400	SHEET-SNSR-TLP1255	1	1
	11	305JN71Q10	5JN71Q10	BRACKET:BRKT-HOLD-MID-F	1	1
⊙	12	305JN71PT0	5JN71PT0	ROLLER:RLR-ADU-LFT-UP-430	1	1
	13	305JN71PX0	5JN71PX0	SHAFT-SEPT-GUIDE-R	1	1
	14	305JN71Q00	5JN71Q00	SPRING:SPG-GU DE-JCT	1	1
⊙	15	305JN71Q50	5JN71Q50	ARM:CRANK-MOV-GUIDE	1	1
	16	305JN71P70	5JN71P70	GEAR-10S20_PS2M30-6	1	1
	17	305JN71PL0	5JN71PL0	PULLEY PULLY-S2M30-6D	1	1
	18	305JN71PU0	5JN71PU0	CAM:CARR-GEAR-M D	1	1
	19	305JN71PF0	5JN71PF0	TIMING BELT:BLT.SY-S2M-186-4	1	1
	20	305JN71Q40	5JN71Q40	SPRING:SPL-PINCH-ADU-MID	2	2
⊙	21	305JN72GH0	5JN72GH0	ROLLER:RLR-P NCH-14-4	2	2
	22	305JN71QF0	5JN71QF0	SPRING:SPG-E-9R1XR7X26R08	1	1
	23	305JN72LT0	5JN72LT0	RETAIN NG RING:RR/E-2-SS	2	2
	24	305JN70XQ0	5JN70XQ0	SCREW-M3-4-1.4	1	1
	25	305JN71QJ0	5JN71QJ0	SCREW-M3X8-3.2-P	2	2
	26	305JN701B0	5JN701B0	BUSH-6-GCB	2	2
	27	305JN72N90	5JN72N90	SCREW:S/FHEXM-M3X6-NI	1	1
⊙	28	305JN72GY0	5JN72GY0	SENSOR:TLP1255(C8)	2	2
	29	305JN72JX0	5JN72JX0	CLAMP UAMS-02WH-2	1	1
	30	305JN72K20	5JN72K20	CLAMP MSB-1207	1	1
	31	305JN72KG0	5JN72KG0	CLAMP LBWS-0206S-V0	2	2
	32	305JN72KH0	5JN72KH0	BEARING:RNR-1560ZZRP0P24LY121	1	1
	33	305JN72LU0	5JN72LU0	RETAINING RING:RR/E-3-SS	1	1
	34	305JN72LV0	5JN72LV0	RETAIN NG RING:RR/E-4-SS	1	1
	35	305JN72LW0	5JN72LW0	RETAIN NG RING:RR/E-5-SS	3	3
	36	305JN72NE0	5JN72NE0	SCREW:S/TPP/FHEXM-3X8-NI	17	17
	37	305JN72MV0	5JN72MV0	SCREW:S/TPS/BID-3X6-ZU3	2	2
	38	305JN72C30	5JN72C30	WIRE HARNESS:HRNS-MIDSN-430	1	1
	39	305JN71QM0	5JN71QM0	BRACKET:BRKT-SUPPORT-JCT-GUIDE	1	1
	40	305JN71QU0	5JN71QU0	BRACKET:BRKT-SNSR-ADU-MID	1	1
	41	305JN71QT0	5JN71QT0	ACTUATOR:ACTR-SNSR-ADU-MID	1	1
	42	305JN71QW0	5JN71QW0	PIN-SNSR-ADU-M D	1	1
	43	305JN71QV0	5JN71QV0	SPRING:SPG-SNSR-ADU-MID	1	1

• Parts with "⊙" indicate regular maintenance parts.

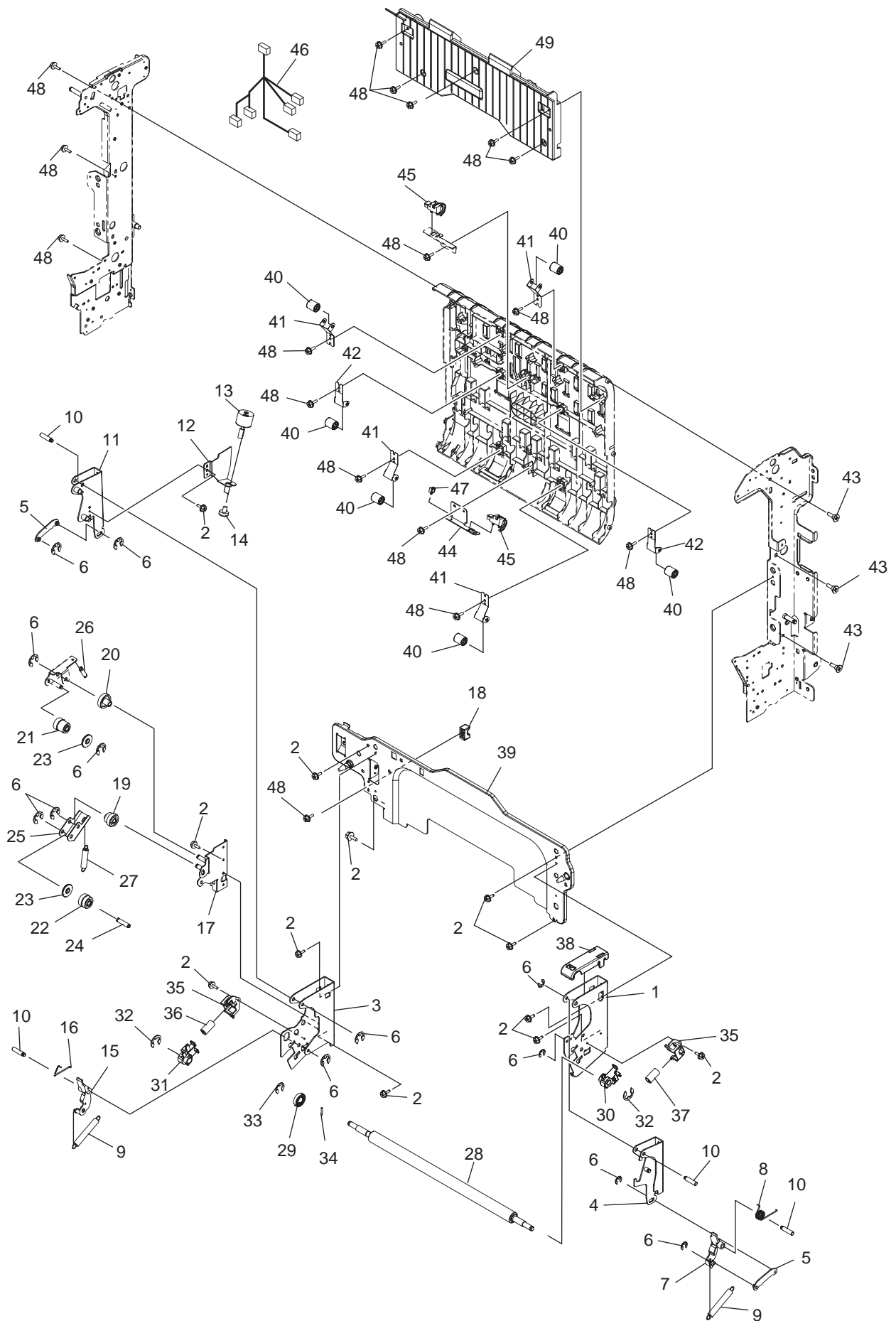

	Ref. No.	Part.No.	Alternative.	Description	Quantity	
					120	230
	1	305JN71G50	5JN71G50	FRAME ASSY:ASYS-FRAME-TRU-F	1	1
	2	305JN72NS0	5JN72NS0	SCREW:S/TPS/FHEXM/R-3X8-ZU3	12	12
	3	305JN71G60	5JN71G60	FRAME ASSY:ASYS-FRAME-TRU-R	1	1
	4	305JN71G70	5JN71G70	ARM ASSY:ASYS-ARM-TRU-F	1	1
	5	305JN71GA0	5JN71GA0	LINK ASSY:ASYS-LINK-ARM-TRU	2	2
	6	305JN72LV0	5JN72LV0	RETAIN NG RING:RR/E-4-SS	12	12
	7	305JN71GB0	5JN71GB0	ARM:LINK-ARM-TRU-A-F	1	1
	8	305JN71HP0	5JN71HP0	SPRING:SPG-T-RELEASE-TRU-F	1	1
	9	305JN71HF0	5JN71HF0	SPRING:SPG-E-TRU-ROL-430	2	2
	10	305JN71GS0	5JN71GS0	PIN:STUD-PIVOT-TRU-430	4	4
	11	305JN71G80	5JN71G80	ARM ASSY:ASYS-ARM-TRU-R	1	1
	12	305JN71F90	5JN71F90	BRACKET:BRKT-DRV-AUG-TR2	1	1
⊙	13	305JN72A20	5JN72A20	MOTOR:MOTRD-TR2-UTNR-430	1	1
	14	305JN72NK0	5JN72NK0	SCREW:S/PAN-M2.6X2.5-NI	2	2
	15	305JN71GC0	5JN71GC0	ARM:LINK-ARM-TRU-A-R	1	1
	16	305JN71H70	5JN71H70	SPRING:SPG-T-RELEASE-TRU-R	1	1
	17	305JN71G20	5JN71G20	BRACKET ASSY:ASYS-BRKT-DRV-TR2	1	1
	18	305JN71HG0	5JN71HG0	HOLDER-SFT-LOCK-ADU-L	1	1
⊙	19	305JN71FW0	5JN71FW0	GEAR-6H31_6H24-6-TR2	1	1
⊙	20	305JN71FX0	5JN71FX0	GEAR-6H35-6-TR2	1	1
⊙	21	305JN71FV0	5JN71FV0	GEAR-6S27_6H28-6-TR2	1	1
⊙	22	305JN71FU0	5JN71FU0	GEAR-6H28_8S23-6-TR2	1	1
	23	305JN71FZ0	5JN71FZ0	COLLAR-TR2-DRV	2	2
	24	305JN71GN0	5JN71GN0	SHAFT-PLT-TR2	1	1
	25	305JN71G30	5JN71G30	BRACKET:BRKT-UNIT-GEAR	1	1
	26	305JN71H10	5JN71H10	SPRING:SPG-E-6XR4X19R2-TR2	1	1
	27	305JN71H20	5JN71H20	SPRING:SPG-E-8R5XR9X31R4-TRU	1	1
⊙	28	305JN71K60	5JN71K60	ROLLER-RGST-R-430	1	1
⊙	29	305JN71K10	5JN71K10	GEAR-RGST	1	1
	30	305JN71M80	5JN71M80	BUSH ASSY:ASYB-BUSH-ROL-RGST-F	1	1
	31	305JN71M90	5JN71M90	BUSH ASSY:ASYB-BUSH-ROL-RGST-R	1	1
	32	305JN72LY0	5JN72LY0	RETAIN NG RING:RR/E-7-SS	2	2
	33	305JN72LZ0	5JN72LZ0	RETAIN NG RING:RR/E-9-SS	1	1
	34	305JN72M70	5JN72M70	PIN:P/PRL/AH7-2X14-SS	1	1
	35	305JN70WK0	5JN70WK0	HOLDER-RGST-SPE	2	2
	36	305JN71J40	5JN71J40	SPRING:SPG-C-11X1X53R1	1	1
	37	305JN71JP0	5JN71JP0	SPRING:SPG-C-11R1X1X48R5	1	1
	38	305JN71GH0	5JN71GH0	COVER:COV-FRAME-TRU-F	1	1
	39	305JN71FA0	5JN71FA0	FRAME ASSY:ASYS-FRAME-TRU-430	1	1
⊙	40	305JN72GH0	5JN72GH0	ROLLER:RLR-P NCH-14-4	6	6
	41	305JN71PQ0	5JN71PQ0	SPRING:SPL-PINCH-ADU-SIDE	4	4
	42	305JN72EW0	5JN72EW0	SPRING:SPL-IDLE-BR	2	2
	43	305JN71QJ0	5JN71QJ0	SCREW-M3X8-3.2-P	3	3
	44	305JN71PR0	5JN71PR0	BRACKET:BRKT-SNSR-ADU-LOW	1	1
⊙	45	305JN70W40	5JN70W40	SENSOR:SNSR-FED-390	2	2
	46	305JN72970	5JN72970	WIRE HARNESS HRNS-ADU-SNR2-430	1	1
	47	305JN72K20	5JN72K20	CLAMP MSB-1207	1	1
	48	305JN72NE0	5JN72NE0	SCREW:S/TPP/FHEXM-3X8-NI	17	17
	49	305JN71QL0	5JN71QL0	COVER-HRNS-ADU-430	1	1
	50	305JN71QJ0	5JN71QJ0	SCREW-M3X8-3.2-P	3	3

• Parts with "⊙" indicate regular maintenance parts.

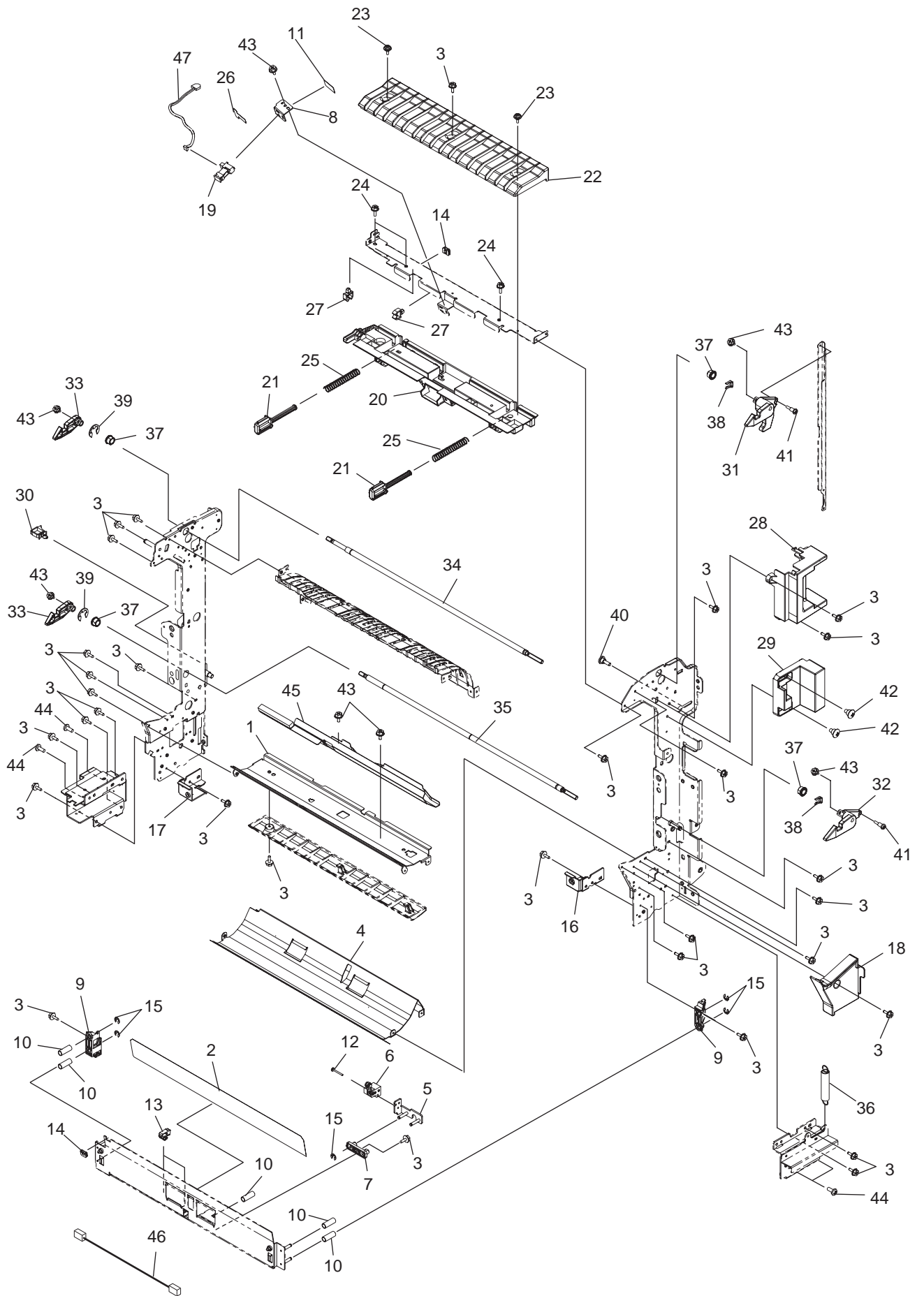

	Ref. No.	Part.No.	Alternative.	Description	Quantity	
					120	230
	1	305JN71P50	5JN71P50	GUIDE ASSY:ASYS-GUIDE-RGST-R-430	1	1
	2	305JN71NQ0	5JN71NQ0	SHEET:MYLAR-GUIDE-TRANS	1	1
	3	305JN72NS0	5JN72NS0	SCREW:S/TPS/FHEXM/R-3X8-ZU3	31	31
	4	305JN71PS0	5JN71PS0	GUIDE ASSY:ASYS-GUIDE-ADU-LOW	1	1
	5	305JN71P00	5JN71P00	BRACKET ASSY:ASYS-BRKT-MR-SENS	1	1
⊙	6	305JN72DB0	5JN72DB0	SENSOR:SNSR-MR-430	1	1
	7	305JN71N30	5JN71N30	GUIDE-ADJUST-SENS	1	1
	8	305JN72410	5JN72410	BRACKET:BRKT-ADU-RTN-SNSR-SUB	1	1
	9	305JN71NZ0	5JN71NZ0	BUSH-HLD-G-TR1-3	2	2
	10	305JN71NT0	5JN71NT0	SPRING:SPG-GU DE-ADJ-TR1	5	5
	11	305JN723Z0	5JN723Z0	SHEET-SNSR-GP2Y	1	1
	12	305JN72P00	5JN72P00	SCREW:S/BID-M3X20-ZU3	1	1
	13	305JN72KG0	5JN72KG0	CLAMP LBWS-0206S-V0	2	2
	14	305JN72J60	5JN72J60	BAND:ES-0505	2	2
	15	305JN72LU0	5JN72LU0	RETAINING RING:RR/E-3-SS	5	5
	16	305JN71ND0	5JN71ND0	BRACKET:BRKT-ADU-L-F	1	1
	17	305JN71NE0	5JN71NE0	BRACKET:BRKT-ADU-L-R	1	1
	18	305JN71QA0	5JN71QA0	COVER-ADU-FRT-SUB-LOW	1	1
⊙	19	305JN72H80	5JN72H80	SENSOR:GP2Y5D91S00F	1	1
	20	305JN723L0	5JN723L0	COVER:COV-ADU-RTN-L	1	1
	21	305JN72340	5JN72340	LOD:PUSH-COV-SNSR-FUS	2	2
	22	305JN722L0	5JN722L0	GUIDE-ADU-RTN	1	1
	23	305JN70340	5JN70340	SCREW-BKT-DEV	2	2
	24	305JN72NE0	5JN72NE0	SCREW:S/TPP/FHEXM-3X8-NI	3	3
	25	305JN72380	5JN72380	SPRING:SPG-C-GUIDE-RTN	2	2
	26	305JN72420	5JN72420	SHEET-ADU-RTN-SNSR	1	1
	27	305JN72JD0	5JN72JD0	CLAMP UAMS-05L-0-46	2	2
⊙	28	305JN71QB0	5JN71QB0	COVER-LEV-OPEN-ADU	1	1
⊙	29	305JN71QG0	5JN71QG0	LEVER-OPEN-ADU-430	1	1
	30	305JN72JZ0	5JN72JZ0	CLAMP LWS-1211Z	1	1
	31	305JN71PC0	5JN71PC0	LEVER-LOCK-ADU-FU	1	1
	32	305JN71PJ0	5JN71PJ0	LEVER-LOCK-ADU-FL	1	1
	33	305JN71PB0	5JN71PB0	LEVER-LOCK-ADU-RU	2	2
	34	305JN71PG0	5JN71PG0	SHAFT-LOCK-LEV-ADU-UP	1	1
	35	305JN71Q80	5JN71Q80	SHAFT-LOCK-LEV-ADU-LOW	1	1
	36	305JN71QR0	5JN71QR0	SPRING:SPG-E-15X1R4X44R7	1	1
	37	305JN72GK0	5JN72GK0	BUSH-8X12X8F-NU4	4	4
	38	305JN701N0	5JN701N0	STOP RING	2	2
	39	305JN72LY0	5JN72LY0	RETAIN NG RING:RR/E-7-SS	2	2
	40	305JN71QJ0	5JN71QJ0	SCREW-M3X8-3.2-P	1	1
	41	305JN70310	5JN70310	SCREW-CON-DEV-V	2	2
	42	305JN706X0	5JN706X0	SCREW-LOCK-ARM	2	2
	43	305JN72N90	5JN72N90	SCREW:S/FHEXM-M3X6-NI	7	7
	44	305JN72MX0	5JN72MX0	SCREW:S/TPS/BID-4X8-ZU3	4	4
	45	305JN71HH0	5JN71HH0	BRACKET ASSY:ASYS-BRKT-BRUSH	1	1
	46	305JN727J0	5JN727J0	WIRE HARNESS:HRNS-MEDIA-430	1	1
	47	305JN729P0	5JN729P0	WIRE HARNESS:HRNS-FEXSN-430	1	1

• Parts with "⊙" indicate regular maintenance parts.

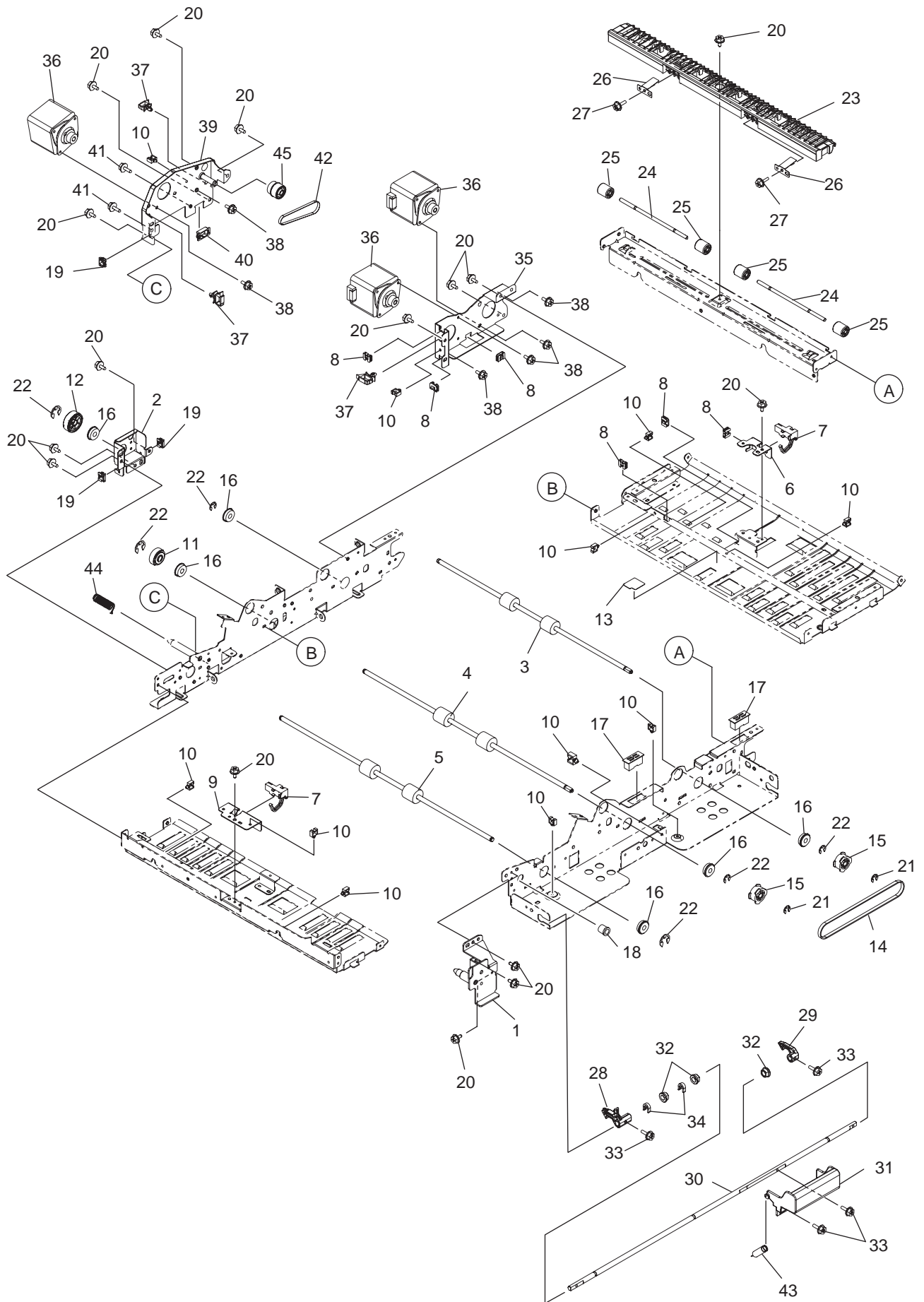

	Ref. No.	Part.No.	Alternative.	Description	Quantity	
					120	230
	1	305JN72FB0	5JN72FB0	BRACKET ASSY:ASYS-BKT-P N-F	1	1
	2	305JN72FD0	5JN72FD0	PLATE-EX-DRV	1	1
⊙	3	305JN72GB0	5JN72GB0	ROLLER:RLR-BR-L1	1	1
⊙	4	305JN72GC0	5JN72GC0	ROLLER:RLR-BR-L2	1	1
⊙	5	305JN72GD0	5JN72GD0	ROLLER:RLR-BR-L3	1	1
	6	305JN72ET0	5JN72ET0	BRACKET:BRKT-SENS-M	1	1
⊙	7	305JN70W00	5JN70W00	SWITCH:SNSR-FED-RVS-390	2	2
	8	305JN72J60	5JN72J60	BAND:ES-0505	6	6
	9	305JN72ES0	5JN72ES0	BRACKET:BRKT-BR-ML-SW	1	1
	10	305JN72K20	5JN72K20	CLAMP MSB-1207	11	11
⊙	11	305JN72F50	5JN72F50	GEAR-10S19-06C	1	1
⊙	12	305JN72F60	5JN72F60	GEAR-10S23-06C	1	1
	13	305JN72FX0	5JN72FX0	SHEET:MYLAR-BL	1	1
	14	305JN71P30	5JN71P30	TIMING BELT:BLT.SY-S2M-300-4	1	1
	15	305JN71PL0	5JN71PL0	PULLEY PULLY-S2M30-6D	2	2
	16	305JN72KH0	5JN72KH0	BEARING:RNR-1560ZZRP0P24LY121	6	6
	17	305JN72G30	5JN72G30	MAGNET CATCH MG-CATCH-255	2	2
	18	305JN72HY0	5JN72HY0	CLAMP:OCB-500	1	1
	19	305JN72JN0	5JN72JN0	BAND:EDS-0607M	3	3
	20	305JN72NR0	5JN72NR0	SCREW:S/TPS/FHEXM/R-3X6-ZU3	16	16
	21	305JN72LU0	5JN72LU0	RETAINING RING:RR/E-3-SS	2	2
	22	305JN72LW0	5JN72LW0	RETAIN NG RING:RR/E-5-SS	6	6
	23	305JN72G00	5JN72G00	HOLDER:HLDL-BR-ENT-L	1	1
	24	305JN72FM0	5JN72FM0	SHAFT-BR-ENT-L	2	2
	25	305JN70WJ0	5JN70WJ0	ROLLER :ROLL-EXIT-L-380	4	4
	26	305JN72FN0	5JN72FN0	SPRING:SPL-BR-ENT-L	2	2
	27	305JN72NE0	5JN72NE0	SCREW:S/TPP/FHEXM-3X8-NI	2	2
	28	305JN72EK0	5JN72EK0	LEVER-BR-L	1	1
	29	305JN72EL0	5JN72EL0	LEVER-BR-R	1	1
	30	305JN72EM0	5JN72EM0	SHAFT-HANDLE-BR	1	1
	31	305JN72FR0	5JN72FR0	LEVER LEV-HAND	1	1
	32	305JN701S0	5JN701S0	BUSH-6-POM	3	3
	33	305JN72NA0	5JN72NA0	SCREW:S/FHEXM-M3X8-NI	4	4
	34	305JN701E0	5JN701E0	STOP-R NG-6-5	2	2
	35	305JN72FA0	5JN72FA0	BRACKET:BKT-DRV-BR	1	1
⊙	36	305JN72750	5JN72750	MOTOR:MOTRS-MT-430	3	3
	37	305JN72JP0	5JN72JP0	CLAMP LWS-0711Z	3	3
	38	305JN72N90	5JN72N90	SCREW:S/FHEXM-M3X6-NI	6	6
	39	305JN72FS0	5JN72FS0	BRACKET ASSY:ASYS-BKT-MOT-E	1	1
	40	305JN72K10	5JN72K10	BAND:ESC-0912	1	1
	41	305JN72NS0	5JN72NS0	SCREW:S/TPS/FHEXM/R-3X8-ZU3	2	2
	42	305JN72F30	5JN72F30	TIMING BELT:BLT.SY-S2M-178-4	1	1
	43	305JN72G10	5JN72G10	SPRING:SPG-E-7R5XR7X25R3	1	1
	44	305JN72G20	5JN72G20	SPRING:SPG-C-10R6X1X31R8L	1	1
	45	305JN72F10	5JN72F10	GEAR ASSY:ASYS-G10S19-S2M30	1	1

• Parts with "⊙" indicate regular maintenance parts.

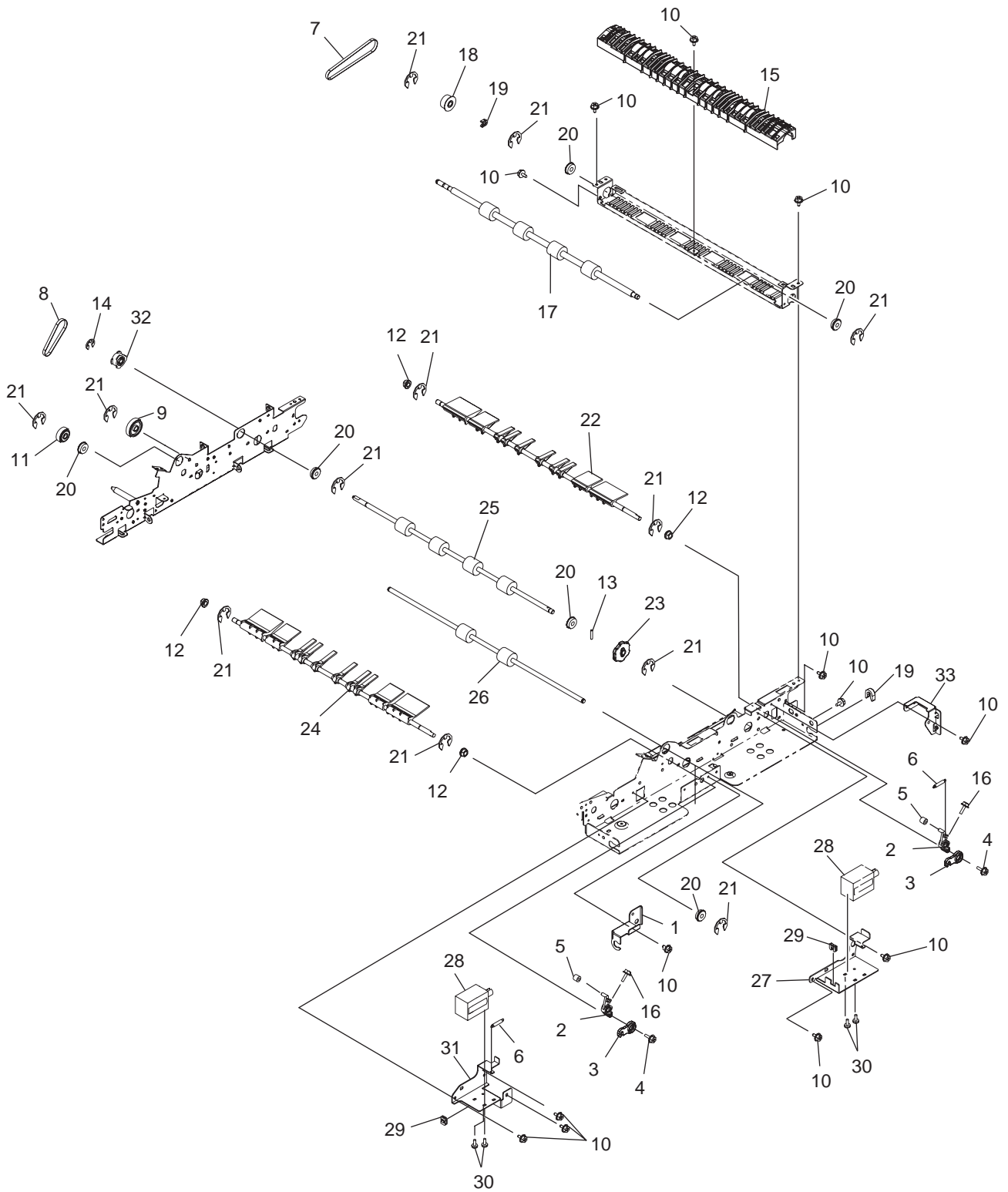

	Ref. No.	Part.No.	Alternative.	Description	Quantity	
					120	230
	1	305JN72EJ0	5JN72EJ0	BRACKET:BRKT-LEVER-BR	1	1
	2	305JN72FQ0	5JN72FQ0	ARM-GATE-BR	2	2
	3	305JN72GA0	5JN72GA0	ARM:LINK-BR-SOL-430	2	2
	4	305JN72NE0	5JN72NE0	SCREW:S/TPP/FHEXM-3X8-NI	2	2
	5	305JN70V10	5JN70V10	CUSHION:CUSH-ARM-GATE-390	2	2
	6	305JN702X0	5JN702X0	SPRING:SPE-050-030-119	2	2
	7	305JN72F40	5JN72F40	TIMING BELT:BLT.SY-S2M-212-4	1	1
	8	305JN72F20	5JN72F20	TIMING BELT:BLT.SY-S2M-130-4	1	1
⊙	9	305JN72F70	5JN72F70	GEAR-10S25-06	1	1
⊙	10	305JN72NR0	5JN72NR0	SCREW:S/TPS/FHEXM/R-3X6-ZU3	21	21
	11	305JN72F50	5JN72F50	GEAR-10S19-06C	1	1
	12	305JN701B0	5JN701B0	BUSH-6-GCB	4	4
	13	305JN72M20	5JN72M20	PIN:P/PRL/AH7-2X10-SS	1	1
	14	305JN72LU0	5JN72LU0	RETAINING RING:RR/E-3-SS	1	1
	15	305JN72FZ0	5JN72FZ0	GUIDE-BR-ENT-U	1	1
	16	305JN72NA0	5JN72NA0	SCREW:S/FHEXM-M3X8-NI	2	2
⊙	17	305JN72GF0	5JN72GF0	ROLLER:RLR-BR-ENT	1	1
⊙	18	305JN72F90	5JN72F90	PULLEY:PLY-S2M-30C	1	1
	19	305JN701E0	5JN701E0	STOP-R NG-6-5	2	2
	20	305JN72KH0	5JN72KH0	BEARING:RNR-1560ZZRP0P24LY121	6	6
	21	305JN72LW0	5JN72LW0	RETAIN NG RING:RR/E-5-SS	12	12
	22	305JN72EP0	5JN72EP0	GUIDE:GATE-BR-1	1	1
	23	305JN72F80	5JN72F80	KNOB-BR DGE	1	1
	24	305JN72ER0	5JN72ER0	GUIDE:GATE-BR-2	1	1
⊙	25	305JN72GE0	5JN72GE0	ROLLER:RLR-BR-REV	1	1
⊙	26	305JN72GG0	5JN72GG0	ROLLER:RLR-BR-EXU	1	1
	27	305JN72EN0	5JN72EN0	BRACKET:BRKT-SOL-1	1	1
⊙	28	305JN70W20	5JN70W20	SOLENOID:SOL-GATE-390	2	2
	29	305JN72J60	5JN72J60	BAND:ES-0505	2	2
	30	305JN72L80	5JN72L80	SCREW:S/PAN-M3X6-NI	4	4
	31	305JN72EQ0	5JN72EQ0	BRACKET:BRKT-SOL-2	1	1
	32	305JN71PL0	5JN71PL0	PULLEY PULLY-S2M30-6D	1	1
	33	305JN72FC0	5JN72FC0	BRACKET:BRKT-F-R	1	1

• Parts with "⊙" indicate regular maintenance parts.

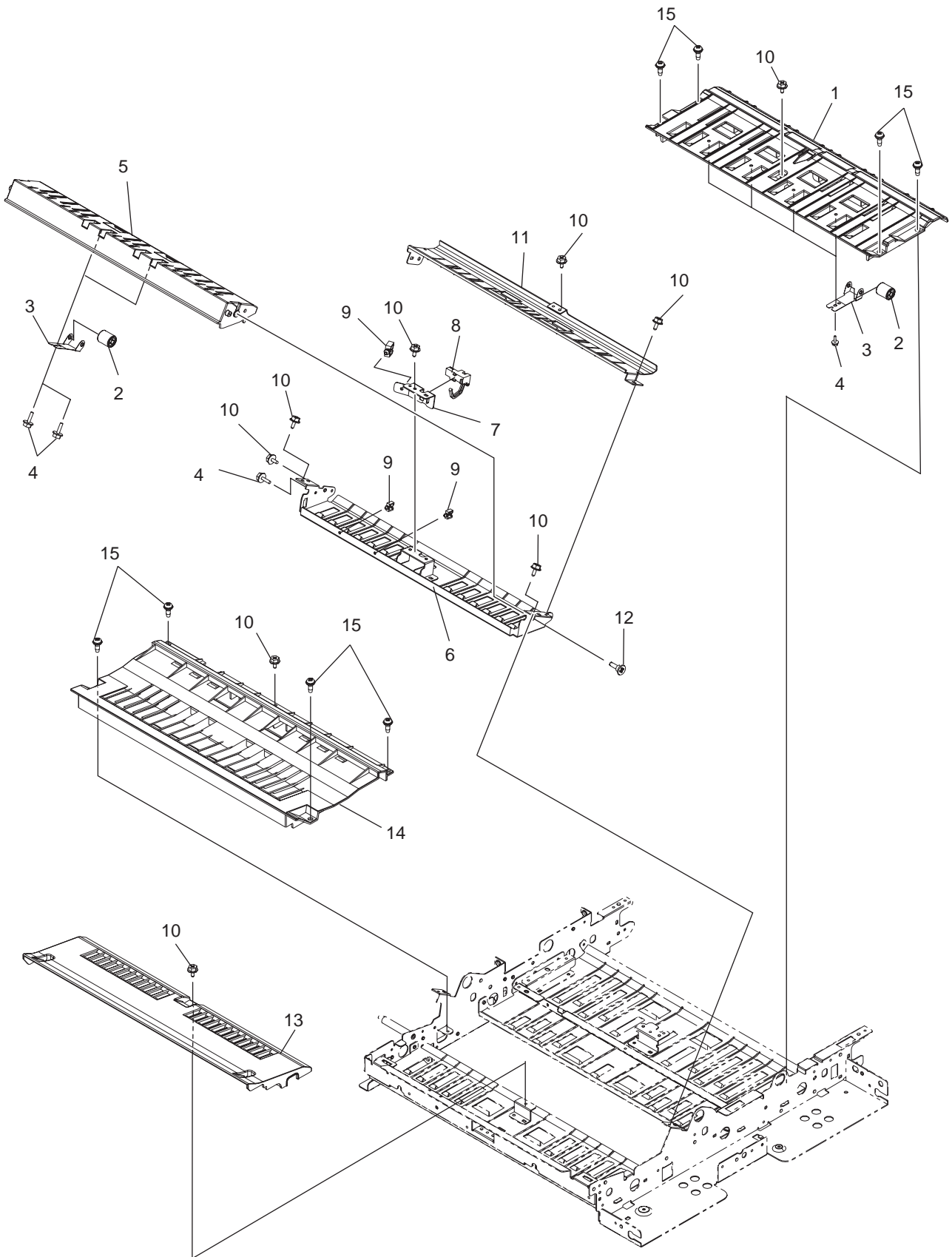

	Ref. No.	Part.No.	Alternative.	Description	Quantity	
					120	230
⊙	1	305JN72EV0	5JN72EV0	GUIDE-M-BR-R	1	1
	2	305JN72GH0	5JN72GH0	ROLLER:RLR-P NCH-14-4	2	2
	3	305JN72EW0	5JN72EW0	SPRING:SPL-IDLE-BR	2	2
	4	305JN72NE0	5JN72NE0	SCREW:S/TPP/FHEXM-3X8-NI	7	7
	5	305JN72F00	5JN72F00	GUIDE-M-EX	1	1
	6	305JN72EX0	5JN72EX0	PLATE ASSY:ASYS-PLT-GUIDE-EX	1	1
	7	305JN72EY0	5JN72EY0	BRACKET:BRKT-SENS-BR-EX	1	1
⊙	8	305JN70W00	5JN70W00	SWITCH:SNSR-FED-RVS-390	1	1
	9	305JN72K20	5JN72K20	CLAMP MSB-1207	3	3
	10	305JN72NR0	5JN72NR0	SCREW:S/TPS/FHEXM/R-3X6-ZU3	9	9
	11	305JN72EZ0	5JN72EZ0	GUIDE-EXIT-U	1	1
	12	305JN71QJ0	5JN71QJ0	SCREW-M3X8-3.2-P	1	1
	13	305JN72EU0	5JN72EU0	GUIDE-M-BR-L	1	1
	14	305JN72G40	5JN72G40	GUIDE ASSY:ASYS-GUIDE-M-BR-C	1	1
	15	305JN706T0	5JN706T0	SCREW-M3-FUS-C	8	8

• Parts with "⊙" indicate regular maintenance parts.

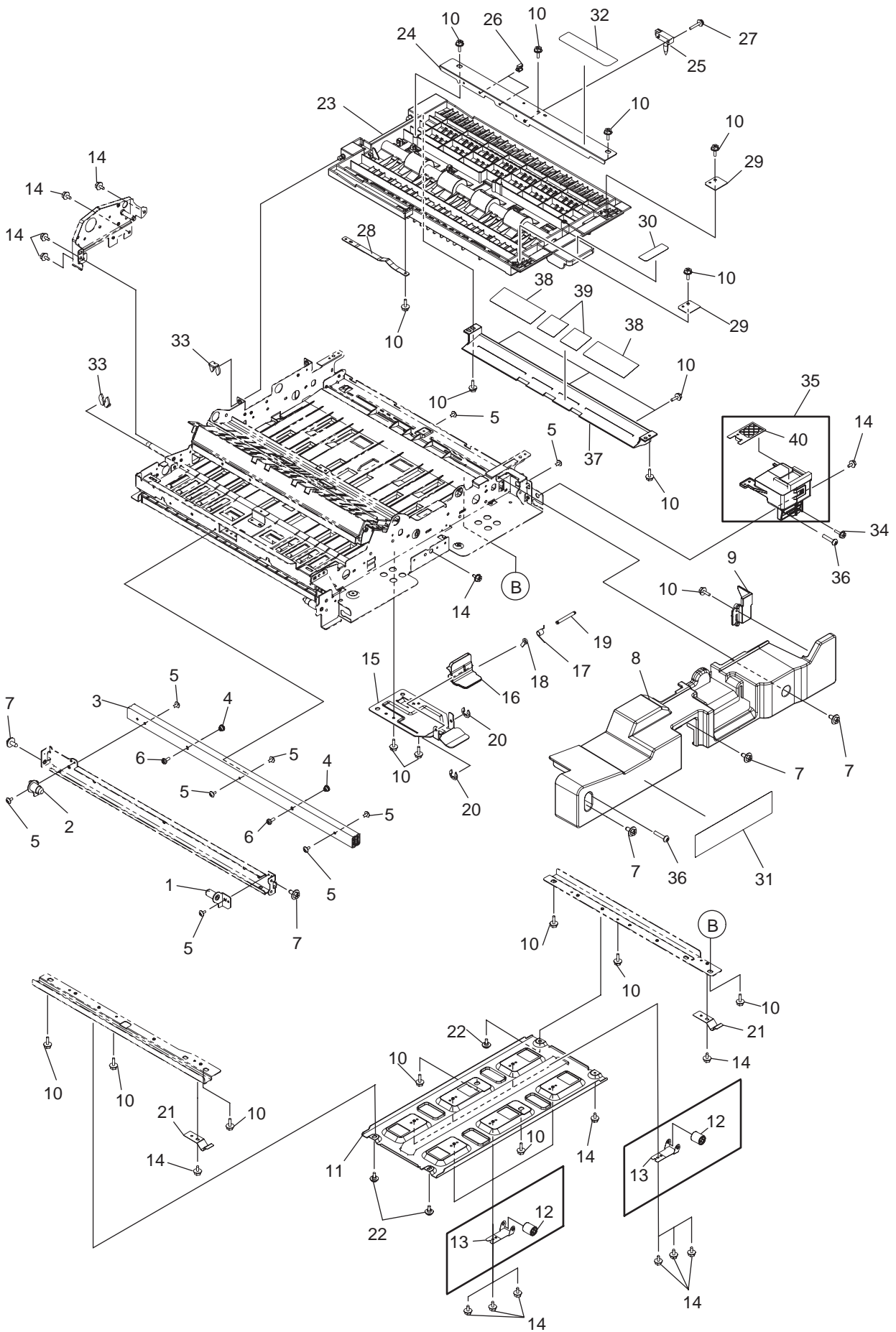

	Ref. No.	Part.No.	Alternative.	Description	Quantity	
					120	230
	1	305JN72ED0	5JN72ED0	BRACKET ASSY:ASYS-BRKT-COV-UTRAY-F	1	1
	2	305JN72EE0	5JN72EE0	BRACKET ASSY:ASYS-BRKT-COV-UTRAY-R	1	1
	3	305JN72EF0	5JN72EF0	RA L-BRIDGE-43X	1	1
	4	305JN72EG0	5JN72EG0	PIN:STUD-RAIL	2	2
	5	305JN70330	5JN70330	SCREW:SCR-M3X6BISR-NI	9	9
	6	305JN72L80	5JN72L80	SCREW:S/PAN-M3X6-NI	2	2
	7	305JN72NT0	5JN72NT0	SCREW:S/TPS/FHEXM/R-4X8-ZU3	5	5
	8	305JN72FT0	5JN72FT0	COVER-IN-BR-430T	1	1
	9	305JN72FU0	5JN72FU0	PLATE:PUSHER-SW-R	1	1
	10	305JN72NE0	5JN72NE0	SCREW:S/TPP/FHEXM-3X8-NI	22	22
⊙	11	305JN72FV0	5JN72FV0	BRACKET:BRKT-GID-RF-BR-V	1	1
	12	305JN72GH0	5JN72GH0	ROLLER:RLR-P NCH-14-4	2	2
	13	305JN72EW0	5JN72EW0	SPRING:SPL-IDLE-BR	2	2
	14	305JN72NR0	5JN72NR0	SCREW:S/TPS/FHEXM/R-3X6-ZU3	18	18
	15	305JN72FF0	5JN72FF0	PLATE-F-GUIDE-L	1	1
	16	305JN72FE0	5JN72FE0	LEVER-LOCK	1	1
	17	305JN72FG0	5JN72FG0	SPACER:SPA-LOCK-080	1	1
	18	305JN72FH0	5JN72FH0	WIRE-GUIDE-L	1	1
	19	305JN70VX0	5JN70VX0	SHAFT-LEVER-390	1	1
	20	305JN72LU0	5JN72LU0	RETAINING RING:RR/E-3-SS	2	2
	21	305JN72G90	5JN72G90	SPRING:ASYS-SPL-GUIDE-LOW	2	2
	22	305JN70XQ0	5JN70XQ0	SCREW-M3-4-1.4	3	3
	23	305JN72FK0	5JN72FK0	GUIDE-U-BR	1	1
⊙	24	305JN72FJ0	5JN72FJ0	BRACKET:BRKT-SENS-BR-U-R	1	1
	25	305JN72H60	5JN72H60	SENSOR PS119ED1	1	1
	26	305JN72K20	5JN72K20	CLAMP MSB-1207	2	2
	27	305JN72N70	5JN72N70	SCREW:S/PAN/SWWP-M3X14-NI	1	1
	28	305JN72FW0	5JN72FW0	STOPPER-GUIDE-U	1	1
	29	305JN72FL0	5JN72FL0	PLATE-MG-CATCH	2	2
	30	305JN72FY0	5JN72FY0	LABEL LBL-O-GUIDE-U-BR	1	1
	31	305JN72G50	5JN72G50	LABEL LBL-O-BRIDGE	1	1
	32	305JN70VW0	5JN70VW0	LABEL LBL-W-HOT-STAY-390	1	1
	33	305JN701W0	5JN701W0	STOP-R NG-6-1.5	2	2
	34	305JN72P70	5JN72P70	SCREW:S/TPD3/FHEXM-3X10-ZU3	1	1
	35	305JN72G70	5JN72G70	DUCT ASSY:ASYS-DUCT-FAN-BR-FRT	1	1
	36	305JN72MT0	5JN72MT0	SCREW:S/TPS/PAN-4X16-ZU3	2	2
⊙	37	305JN72FP0	5JN72FP0	GUIDE-BR-ENT2	1	1
	38	305JN702W0	5JN702W0	FILM:MYLAR-GUIDE-M95	2	2
	39	305JN702V0	5JN702V0	FILM:MYLAR-GUIDE-M39	2	2
	40	305JN72G80	5JN72G80	PLATE:GUARD-DUCT-BR-T06W1	1	1

• Parts with "⊙" indicate regular maintenance parts.

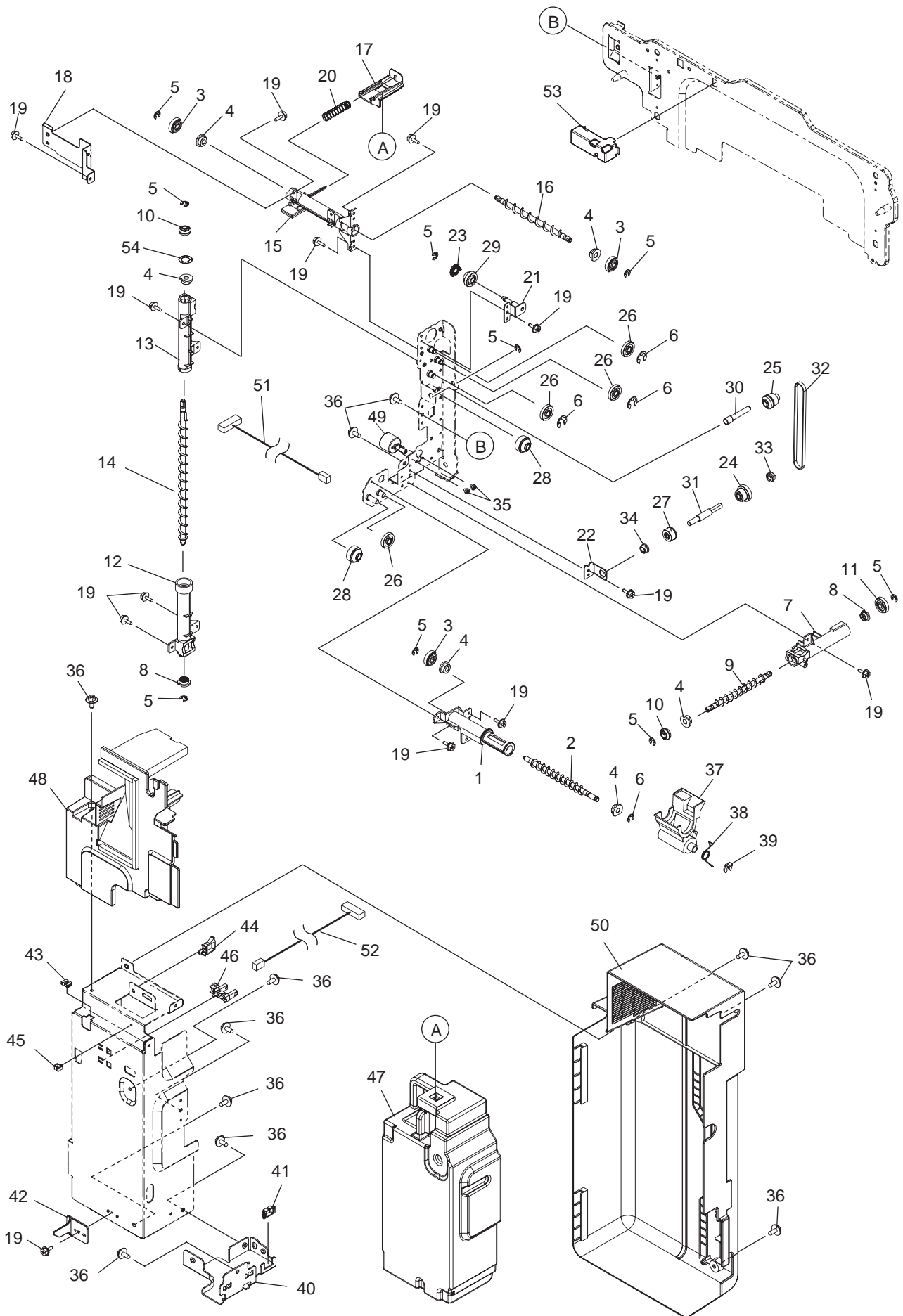

	Ref. No.	Part.No.	Alternative.	Description	Quantity	
					120	230
	1	305JN71GW0	5JN71GW0	TUBE ASSY:ASYS-TUBE-TNR-UNIT	1	1
	2	305JN71G00	5JN71G00	SPIRAL:AUG-CLN-TRU-B	1	1
	3	305JN70760	5JN70760	GEAR-08S23-6-D	3	3
	4	305JN701Z0	5JN701Z0	BUSH-0612*06F-M	6	6
	5	305JN72LU0	5JN72LU0	RETAINING RING:RR/E-3-SS	9	9
	6	305JN72LW0	5JN72LW0	RETAIN NG RING:RR/E-5-SS	4	4
	7	305JN71GX0	5JN71GX0	TUBE ASSY:ASYS-TUBE-TNR-1	1	1
	8	305JN71FT0	5JN71FT0	BUSH:ASYS-BUSH-6X12X6F-M	2	2
	9	305JN71FM0	5JN71FM0	SPIRAL:AUG-TRU-1	1	1
⊙	10	305JN70770	5JN70770	GEAR-08B20-6	2	2
⊙	11	305JN71FD0	5JN71FD0	GEAR-8S24-6-D	1	1
	12	305JN71HZ0	5JN71HZ0	TUBE ASSY:ASYS-TUBE-TNR-2	1	1
	13	305JN71GZ0	5JN71GZ0	TUBE ASSY:ASYS-TUBE-TNR-4	1	1
	14	305JN71HX0	5JN71HX0	COVER ASSY:ASYS-AUG-TRU-2	1	1
	15	305JN71GY0	5JN71GY0	TUBE ASSY:ASYS-TUBE-TNR-3	1	1
	16	305JN71HY0	5JN71HY0	SPIRAL:AUG-TRU-3	1	1
	17	305JN71GD0	5JN71GD0	SHUTTER:SHUT-TR2-TONER	1	1
	18	305JN71FS0	5JN71FS0	PLATE-WASTE-TR2	1	1
	19	305JN72NS0	5JN72NS0	SCREW:S/TPS/FHEXM/R-3X8-ZU3	13	13
	20	305JN71H30	5JN71H30	SPRING:SPG-C-10XR6X40-TRU	1	1
	21	305JN71FL0	5JN71FL0	BRACKET ASSY:ASYS-BRKT-AUG-DRV-TR2	1	1
	22	305JN71FP0	5JN71FP0	BRACKET:BRKT-W-TONER-DRV	1	1
⊙	23	305JN70780	5JN70780	GEAR-08B20-6	1	1
⊙	24	305JN71FE0	5JN71FE0	GEAR-8S24-PULLY-S2M25	1	1
⊙	25	305JN71FN0	5JN71FN0	GEAR-8B20-PULLY-S2M25	1	1
⊙	26	305JN71FB0	5JN71FB0	GEAR-8S24-TR2- DLE	4	4
⊙	27	305JN71FC0	5JN71FC0	GEAR-5H30-TR2-CLT	1	1
⊙	28	305JN71FQ0	5JN71FQ0	GEAR-8B20-8S23-6	2	2
⊙	29	305JN71FR0	5JN71FR0	GEAR-8S23-TR2-TNR	1	1
	30	305JN71GR0	5JN71GR0	SHAFT-TR2-AUG-BELT	1	1
	31	305JN71GQ0	5JN71GQ0	SHAFT-TR2-AUG-DRV	1	1
	32	305JN71H00	5JN71H00	TIMING BELT:BELT-40S2M-280-TRU	1	1
	33	305JN701S0	5JN701S0	BUSH-6-POM	1	1
	34	305JN701B0	5JN701B0	BUSH-6-GCB	1	1
	35	305JN72NK0	5JN72NK0	SCREW:S/PAN-M2.6X2.5-NI	2	2
	36	305JN72NT0	5JN72NT0	SCREW:S/TPS/FHEXM/R-4X8-ZU3	11	11
	37	305JN71HB0	5JN71HB0	DUCT ASSY:ASYS-DUCT-CLN-TR2	1	1
	38	305JN71HS0	5JN71HS0	SPRING:SPG-T-DUCT-CLN-TRU	1	1
	39	305JN701W0	5JN701W0	STOP-R NG-6-1.5	1	1
	40	305JN71HU0	5JN71HU0	BRACKET:BRKT-TR2-T_BOX	1	1
	41	305JN72K10	5JN72K10	BAND:ESC-0912	1	1
	42	305JN70ZJ0	5JN70ZJ0	LEVER LVR-FUS-INTER	1	1
	43	305JN72J60	5JN72J60	BAND:ES-0505	1	1
	44	305JN72JZ0	5JN72JZ0	CLAMP LWS-1211Z	1	1
	45	305JN72K20	5JN72K20	CLAMP MSB-1207	1	1
⊙	46	305JN72H10	5JN72H10	SENSOR LG285L2-R	1	1
⊙	47	305JN71H40	5JN71H40	TONER BOX:ASYS-BOX-TNR-TRU	1	1
	48	305JN71H50	5JN71H50	COVER ASSY:ASYS-COV-IN-R-430	1	1
⊙	49	305JN72A10	5JN72A10	MOTOR:MOTRD-SUBH-430	1	1
⊙	50	305JN71GT0	5JN71GT0	COVER-ADU-RER-430T	1	1
	51	305JN727K0	5JN727K0	WIRE HARNESS:HRNS-TR2M-430	1	1
	52	305JN729Q0	5JN729Q0	WIRE HARNESS:HRNS-TNRSN-430	1	1
	53	305JN71GV0	5JN71GV0	COVER:COV-HRNS-SNSR-TR2	1	1
	54	305JN702Y0	5JN702Y0	WASHER:WAS-06-95-Z13-P	1	1

• Parts with "⊙" indicate regular maintenance parts.

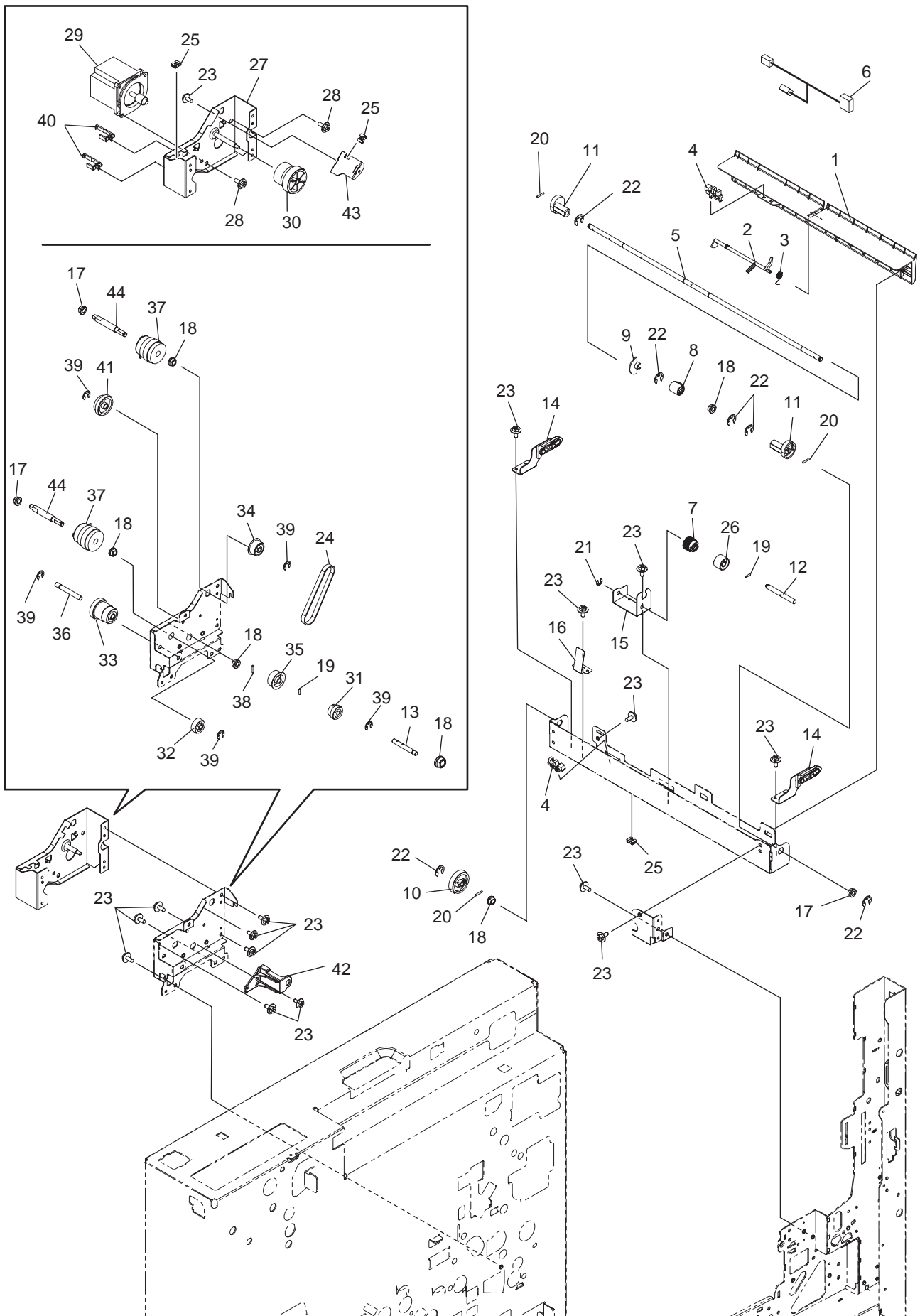

	Ref. No.	Part.No.	Alternative.	Description	Quantity	
					120	230
	1	305JN71F30	5JN71F30	GUIDE-MID-L-430	1	1
	2	305JN71GG0	5JN71GG0	ACTUATOR:ACTR-GUIDE-MID-L-430	1	1
	3	305JN70WLO	5JN70WLO	SPRING:SPG-ACT-380	1	1
⊙	4	305JN72H20	5JN72H20	SENSOR LG248BL1	2	2
	5	305JN71GU0	5JN71GU0	SHAFT ASSY:ASYS-SHAFT-CAM-TR2	1	1
	6	305JN728W0	5JN728W0	WIRE HARNESS:HRNS-TR2-PS-430	1	1
⊙	7	305JN70WY0	5JN70WY0	GEAR-08S21-TRU-S	1	1
⊙	8	305JN70XT0	5JN70XT0	GEAR-08S21-TR2-S2	1	1
	9	305JN70WZ0	5JN70WZ0	ACTUATOR:ACTR-CAM-TRU	1	1
⊙	10	305JN71F40	5JN71F40	GEAR-10S31-6-CAM	1	1
	11	305JN70WX0	5JN70WX0	CAM-TRU	2	2
	12	305JN71GP0	5JN71GP0	SHAFT-TL-TRU	1	1
	13	305JN71HR0	5JN71HR0	SHAFT-DRV-TRU-TL	1	1
	14	305JN71HT0	5JN71HT0	BRACKET ASSY:ASYS-BRKT-PUSHER	2	2
	15	305JN71EW0	5JN71EW0	BRACKET:BRKT-TL-TR2	1	1
	16	305JN71EX0	5JN71EX0	SPRING:SPG-F-DETENT	1	1
	17	305JN701S0	5JN701S0	BUSH-6-POM	4	4
	18	305JN701B0	5JN701B0	BUSH-6-GCB	5	5
	19	305JN72M10	5JN72M10	PIN P/PRL/AH7-2X8-SS	2	2
	20	305JN72M30	5JN72M30	PIN:P/PRL/BH7-2X14-SS	3	3
	21	305JN72LU0	5JN72LU0	RETAINING RING:RR/E-3-SS	1	1
	22	305JN72LW0	5JN72LW0	RETAIN NG RING:RR/E-5-SS	6	6
	23	305JN72NT0	5JN72NT0	SCREW:S/TPS/FHEXM/R-4X8-ZU3	16	16
	24	305JN71HD0	5JN71HD0	TIMING BELT:BELT-40S2M-200-TRU	1	1
	25	305JN72J60	5JN72J60	BAND:ES-0505	3	3
	26	305JN72KP0	5JN72KP0	CLUTCH:OTLV6-500B	1	1
	27	305JN71FK0	5JN71FK0	PLATE ASSY:ASYS-PLT-MTR-DRV	1	1
	28	305JN72NB0	5JN72NB0	SCREW:S/FHEXM-M4X8-NI	2	2
⊙	29	305JN71HK0	5JN71HK0	MOTOR-DRV-TRU	1	1
⊙	30	305JN71HL0	5JN71HL0	GEAR-4H76_10S39	1	1
⊙	31	305JN71GE0	5JN71GE0	GEAR-8S23-6-TR2-CLT	1	1
⊙	32	305JN71FG0	5JN71FG0	GEAR-8S23-6-CAM	1	1
⊙	33	305JN71FF0	5JN71FF0	GEAR-8S35_10S21-6-CAM	1	1
⊙	34	305JN71FJ0	5JN71FJ0	PULLEY:PULLY-S2M32-6-TR2	1	1
⊙	35	305JN71HE0	5JN71HE0	PULLEY PULLY-S2M36-TL-C	1	1
	36	305JN71HW0	5JN71HW0	SHAFT-DRV-CAM-TR2	1	1
⊙	37	305JN70XP0	5JN70XP0	CLUTCH-G28-08D-30A	2	2
	38	305JN72MC0	5JN72MC0	PIN:P/PRL/AH7-2X12-SS	1	1
	39	305JN72LV0	5JN72LV0	RETAIN NG RING:RR/E-4-SS	5	5
	40	305JN72J20	5JN72J20	CLAMP RLWS3TV0	2	2
⊙	41	305JN71FH0	5JN71FH0	GEAR-10S22_10S28	1	1
	42	305JN71HQ0	5JN71HQ0	SUPPORT PLATE:SUP-DRV-TRU	1	1
	43	305JN71HM0	5JN71HM0	BRACKET:BRKT-DRV-TRU	1	1
	44	305JN71GM0	5JN71GM0	SHAFT-DRV-TR2-CLT	2	2

• Parts with "⊙" indicate regular maintenance parts.

	Ref. No.	Part.No.	Alternative.	Description	Quantity	
					120	230
	1	305JN71H80	5JN71H80	CASE ASSY:ASYS-CASE-ROL-TR2-CLN	1	1
	2	305JN71HC0	5JN71HC0	CASE ASSY:ASYS-CASE-WASTE-TNR-TR2	1	1
	3	305JN71G10	5JN71G10	SPIRAL:AUG-CLN-TRU-A	1	1
	4	305JN71ES0	5JN71ES0	SHUTTER:SHUT-CLN-TR2	1	1
	5	305JN701Z0	5JN701Z0	BUSH-0612*06F-M	2	2
	6	305JN72LW0	5JN72LW0	RETAIN NG RING:RR/E-5-SS	2	2
⊙	7	305JN71ET0	5JN71ET0	GEAR-8H20-AUG-TR2	1	1
	8	305JN71HA0	5JN71HA0	SPRING:SPG-E-SHUT-NOZZLE-TRU	1	1
⊙	9	305JN72E50	5JN72E50	BAR LUBRICANT :LB-TR2-F43X	1	1
	10	305JN71F80	5JN71F80	PLATE:PLT-EARTH-TR2-430	1	1
	11	305JN71G90	5JN71G90	GUIDE-TRU-430	1	1
	12	305JN71GJ0	5JN71GJ0	HOLDER ASSY:ASYS-HOLDER-BLADE-TRU	1	1
	13	305JN71GL0	5JN71GL0	HOLDER:HLDR-SNSR-GUIDE-TR2	1	1
	14	305JN71F00	5JN71F00	BUSH-TRU-CASE	1	1
	15	305JN701W0	5JN701W0	STOP-R NG-6-1.5	1	1
	16	305JN71GF0	5JN71GF0	GUIDE-MID-R-430	1	1
	17	305JN71F10	5JN71F10	HOLDER:HLDR-GU DE-MID-R-FRT	1	1
	18	305JN71F20	5JN71F20	HOLDER:HLDR-GU DE-MID-R-RER	1	1
	19	305JN707S0	5JN707S0	SCREW:S/TPP/BID-3*8-NI	7	7
	20	305JN72NS0	5JN72NS0	SCREW:S/TPS/FHEXM/R-3X8-ZU3	1	1
	21	305JN707G0	5JN707G0	SCREW:S/HEX-M4X8-ZC3	1	1
	22	305JN71EY0	5JN71EY0	BUSH:ASYS-BUSH-TR2-ROL-F	1	1
	23	305JN71ER0	5JN71ER0	BUSH:ASYS-BUSH-TR2-ROL-R	1	1
⊙	24	305JN72E60	5JN72E60	BLADE BL-TR2-F43X	1	1
	25	305JN71EZ0	5JN71EZ0	BUSH-CASE-BRUSH-TR2	1	1
	26	305JN72KN0	5JN72KN0	BEARING:DDL-1680HHRP0P25LY349	2	2
	27	305JN71H60	5JN71H60	FILM-LUBRICANT	1	1
⊙	28	305JN71EU0	5JN71EU0	GEAR-4S51-TR2ROL	1	1
⊙	29	305JN71FY0	5JN71FY0	GEAR-6S32-TR2_ROL	1	1
	30	305JN71F50	5JN71F50	PLATE:PLT-AUG-UNIT-TR2	1	1
⊙	31	305JN72E70	5JN72E70	ROLLER:CR-TR2-F43X	1	1
	32	305JN72LA0	5JN72LA0	SCREW:S/PAN/SWWP-M3X8-NI	3	3
	33	305JN71G40	5JN71G40	SHEET-RECOVERY-TR2	1	1
	34	305JN71GK0	5JN71GK0	SH ELD:SHLD-BLADE-TR2-SIDE-R	1	1
	35	305JN71HJ0	5JN71HJ0	SPRING:SPG-F-EARTH-TRU-ROL	1	1
	36	305JN71HN0	5JN71HN0	SPRING:SPG-F-EARTH-TRU-ROL-B	1	1
	37	305JN701G0	5JN701G0	STOPPER:STOP-RING-6-4	2	2
	38	305JN71H90	5JN71H90	SPRING:SPG-E-BLADE-TR2	2	2
	39	305JN71F60	5JN71F60	PLATE ASSY:ASYS-PLT-SUP-TRU	1	1

• Parts with "⊙" indicate regular maintenance parts.

	Ref. No.	Part.No.	Alternative.	Description	Quantity	
					120	230
	1	305JN71CJ0	5JN71CJ0	PLATE:SEAT-TBU-TR2-CLN	1	1
	2	305JN71EM0	5JN71EM0	PIN:STUD-TBU-R-M4	1	1
	3	305JN71C00	5JN71C00	COLLAR-STAND-TBU	1	1
	4	305JN71BK0	5JN71BK0	HOLDER:HLDR-BRG-R	1	1
	5	305JN71CC0	5JN71CC0	SPRING:SPG-F-HLDR-BRG-R	1	1
	6	305JN71DR0	5JN71DR0	BRACKET ASSY:ASYS-BRKT-PLY-FW	1	1
	7	305JN71BL0	5JN71BL0	HOLDER:HLDR-BRG-R-3	1	1
	8	305JN71DW0	5JN71DW0	SPRING:SPG-E-FLY-TBU	2	2
	9	305JN71DX0	5JN71DX0	PLATE-BASE-FW	1	1
	10	305JN71DY0	5JN71DY0	PLATE-FW-120	1	1
⊙	11	305JN70170	5JN70170	HOLDER:HLDR-TR-ROLL	2	2
	12	305JN71C80	5JN71C80	SPRING:SPG-C-TR1-TBU	1	1
	13	305JN72NE0	5JN72NE0	SCREW:S/TPP/FHEXM-3X8-NI	9	9
	14	305JN71A60	5JN71A60	HOLDER-LOCK-LEVER	1	1
	15	305JN71AQ0	5JN71AQ0	PIN ASSY:ASYS-PIN-STOP	1	1
	16	305JN71A80	5JN71A80	ARM:LINK-STOP-TBU	1	1
	17	305JN72MJ0	5JN72MJ0	SCREW:S/PAN/SWWP-M4X10-NI	1	1
	18	305JN72NS0	5JN72NS0	SCREW:S/TPS/FHEXM/R-3X8-ZU3	27	27
	19	305JN71BF0	5JN71BF0	FRAME ASSY:ASYS-FRAME-F-TBU	1	1
	20	305JN71CQ0	5JN71CQ0	COVER-FR-BT-TBU	1	1
	21	305JN71DZ0	5JN71DZ0	TIMING BELT:BLT_SY-S2M-240-5	1	1
	22	305JN71BX0	5JN71BX0	SHAFT-LEVER-TBU-F43X	1	1
	23	305JN70070	5JN70070	BUSH-8	2	2
	24	305JN71AP0	5JN71AP0	BRACKET ASSY:ASYS-BRKT-LINK-H-F43X	1	1
	25	305JN71D40	5JN71D40	LEVER-TBU-F43X	1	1
	26	305JN71C90	5JN71C90	BRACKET:BRKT-L NK-F-F43X	1	1
	27	305JN71A70	5JN71A70	PLATE-LINK-H-F43X	1	1
⊙	28	305JN71BD0	5JN71BD0	SPRING:SPG-E-PLATE-TBU-FIX	1	1
⊙	29	305JN71EL0	5JN71EL0	ROLLER:RLR-RIG D-SLD	1	1
⊙	30	305JN71DS0	5JN71DS0	PULLEY ASSY:ASYS-PLY-FW-30	1	1
	31	305JN72KT0	5JN72KT0	BEARING:DDLF-1260ZZRPOP25LY349	2	2
	32	305JN71CL0	5JN71CL0	BRUSH-TBU-F43X	1	1
	33	305JN71AR0	5JN71AR0	ARM:LINK-TBU-LOCK	1	1
⊙	34	305JN71EJ0	5JN71EJ0	ROLLER ASSY:ASYS-RLR-TR2-TBU	1	1
	35	305JN72LA0	5JN72LA0	SCREW:S/PAN/SWWP-M3X8-NI	6	6
	36	305JN71E70	5JN71E70	COLLAR:COL-RIGID-TBU	1	1
	37	305JN71920	5JN71920	HOLDER:HLDR-BRG-TOP-F	1	1
	38	305JN71BJ0	5JN71BJ0	HOLDER:HLDR-BRG-F	1	1
	39	305JN71CR0	5JN71CR0	COVER-FR-UP-TBU	1	1
	40	305JN71CA0	5JN71CA0	LEVER LVR-TBU-F43X	1	1
	41	305JN71DF0	5JN71DF0	LIFT ASSY:ASYB-LIFT-R-TBU	1	1
	42	305JN71EH0	5JN71EH0	PLATE ASSY:ASYB-PLATE-TBU-UD	1	1
	43	305JN71D20	5JN71D20	CAM-TBU-UD	1	1
	44	305JN71CK0	5JN71CK0	LEVER-SF-TBU-UD	1	1
	45	305JN71CH0	5JN71CH0	SPRING:SPG-C-TBU-LIFT	1	1
	46	305JN71CG0	5JN71CG0	SCREW-BRKT-TBU-UD	1	1
	47	305JN71DQ0	5JN71DQ0	BRACKET ASSY:ASYS-BRKT-FW	1	1
	48	305JN72N90	5JN72N90	SCREW:S/FHEXM-M3X6-NI	4	4
	49	305JN72LV0	5JN72LV0	RETAIN NG RING:RR/E-4-SS	8	8
	50	305JN70110	5JN70110	SCREW-DRM-GAP	2	2
⊙	51	305JN71DD0	5JN71DD0	CLEANER ROLLER ASSY:ASYB-CLN-RLR-TBU	1	1
	52	305JN72J60	5JN72J60	BAND:ES-0505	1	1
	53	305JN72JU0	5JN72JU0	CLAMP UAMS-05-0	4	4
	54	305JN72LY0	5JN72LY0	RETAIN NG RING:RR/E-7-SS	3	3
⊙	55	305JN71BB0	5JN71BB0	ROLLER:RLR-SNS-TBU-F43X	2	2
	56	305JN71AF0	5JN71AF0	COLLAR:COLAR-RLR-LIFT	4	4
	57	305JN701B0	5JN701B0	BUSH-6-GCB	4	4
⊙	58	305JN71A90	5JN71A90	ROLLER:RLR-TR1-TBU-F43X	1	1
	59	305JN71AA0	5JN71AA0	CASE-TERM-TR1-F	1	1
	60	305JN71AB0	5JN71AB0	COVER-TERM-TR1-F	1	1
⊙	61	305JN71DT0	5JN71DT0	PULLEY ASSY:ASYS-PLY-S2M50_S2M20	1	1
	62	305JN71DM0	5JN71DM0	PLATE-LINK-TBU-LOCK	1	1
	63	305JN71DN0	5JN71DN0	BRACKET:BRKT-LEVER-STOPPER	1	1
	64	305JN718G0	5JN718G0	FLANG-DRV-WTNR	1	1
	65	305JN71DU0	5JN71DU0	FLANGE-PLY-FW-30	1	1
	66	305JN71DV0	5JN71DV0	TIMING BELT:BLT_SY-S2M-284-5	1	1

• Parts with "⊙" indicate regular maintenance parts.

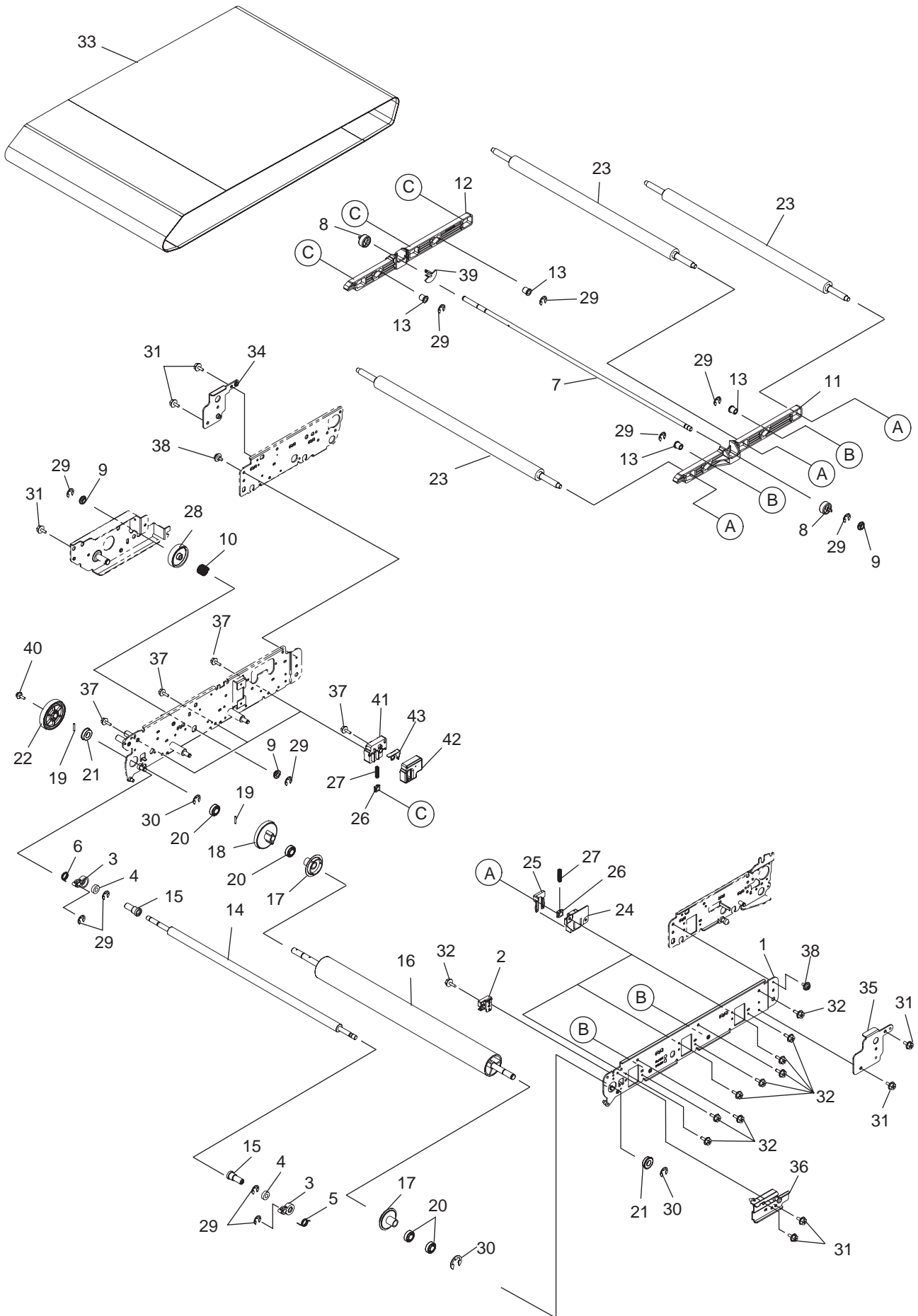

	Ref. No.	Part.No.	Alternative.	Description	Quantity	
					120	230
	1	305JN71BG0	5JN71BG0	FRAME ASSY:ASYS-FRM-TBU-F-LFT	1	1
	2	305JN71B60	5JN71B60	HOLDER:HLDR-CLN-TBU-F	1	1
	3	305JN70WU0	5JN70WU0	HOLDER:HLDR-BRG-TNS	2	2
	4	305JN72K80	5JN72K80	BEARING:DDL-1260ZZHP0P25LY13	2	2
	5	305JN70WV0	5JN70WV0	SPRING:SPG-T-LIFT-TNS-F	1	1
	6	305JN70WW0	5JN70WW0	SPRING:SPG-T-LIFT-TNS-R	1	1
	7	305JN71BC0	5JN71BC0	SHAFT-LIFT-TBU-F43X	1	1
	8	305JN71A50	5JN71A50	CAM-LINK-TBU-F43X	2	2
	9	305JN700T0	5JN700T0	BUSH-6-3.7	3	3
	10	305JN71CB0	5JN71CB0	SPRING:SPG-C-TR-TBU	1	1
	11	305JN71B90	5JN71B90	ARM:LINK-F-F43X	1	1
	12	305JN71BA0	5JN71BA0	ARM:LINK-R-F43X	1	1
	13	305JN71A40	5JN71A40	BUSH-LINK-TBU	4	4
⊙	14	305JN71EK0	5JN71EK0	ROLLER:RLR-LIFT-TBU-F43X	1	1
⊙	15	305JN71AF0	5JN71AF0	COLLAR:COLAR-RLR-LIFT	2	2
⊙	16	305JN71DP0	5JN71DP0	ROLLER:RLR-DRV-TBU-F43X-EPDM	1	1
	17	305JN71BZ0	5JN71BZ0	GUIDE-RIB-DRV	2	2
⊙	18	305JN71AC0	5JN71AC0	GEAR-CLN-TBU	1	1
	19	305JN72MC0	5JN72MC0	PIN:P/PRL/AH7-2X12-SS	2	2
	20	305JN71AG0	5JN71AG0	COLLAR:COL-CLN-TBU-POS	4	4
	21	305JN72KF0	5JN72KF0	BEARING:LNR-1680HHRPOP25LY349	2	2
⊙	22	305JN71A10	5JN71A10	GEAR-5H81-8-TBU	1	1
⊙	23	305JN71A90	5JN71A90	ROLLER:RLR-TR1-TBU-F43X	3	3
	24	305JN71AA0	5JN71AA0	CASE-TERM-TR1-F	1	1
	25	305JN71AB0	5JN71AB0	COVER-TERM-TR1-F	1	1
⊙	26	305JN70170	5JN70170	HOLDER:HLDR-TR-ROLL	2	2
	27	305JN71C80	5JN71C80	SPRING:SPG-C-TR1-TBU	2	2
⊙	28	305JN71BW0	5JN71BW0	GEAR-5H64-6	1	1
	29	305JN72LV0	5JN72LV0	RETAIN NG RING:RR/E-4-SS	11	11
	30	305JN72LY0	5JN72LY0	RETAIN NG RING:RR/E-7-SS	3	3
	31	305JN72N90	5JN72N90	SCREW:S/FHEXM-M3X6-NI	7	7
	32	305JN72NS0	5JN72NS0	SCREW:S/TPS/FHEXM/R-3X8-ZU3	12	12
⊙	33	305JN71DE0	5JN71DE0	FLAT BELT:BELT-TBU-G-F43X	1	1
	34	305JN71B80	5JN71B80	FRAME-TBU-HING-R	1	1
	35	305JN71BR0	5JN71BR0	FRAME-TBU-HING-F	1	1
	36	305JN71BE0	5JN71BE0	BRACKET ASSY:ASYS-BRKT-TBU-F-LEFT	1	1
	37	305JN72NE0	5JN72NE0	SCREW:S/TPP/FHEXM-3X8-NI	6	6
	38	305JN70300	5JN70300	SCREW-ACTR-TRU	2	2
	39	305JN71A00	5JN71A00	ACTUATOR:ACTR-LIFT-TBU-F43X	1	1
	40	305JN72LA0	5JN72LA0	SCREW:S/PAN/SWWP-M3X8-NI	1	1
	41	305JN71CF0	5JN71CF0	CASE-TERM-TR1-R	1	1
	42	305JN71BY0	5JN71BY0	COVER-TERM-TR1-R	1	1
	43	305JN71BM0	5JN71BM0	PLATE-TR1	1	1

• Parts with "⊙" indicate regular maintenance parts.

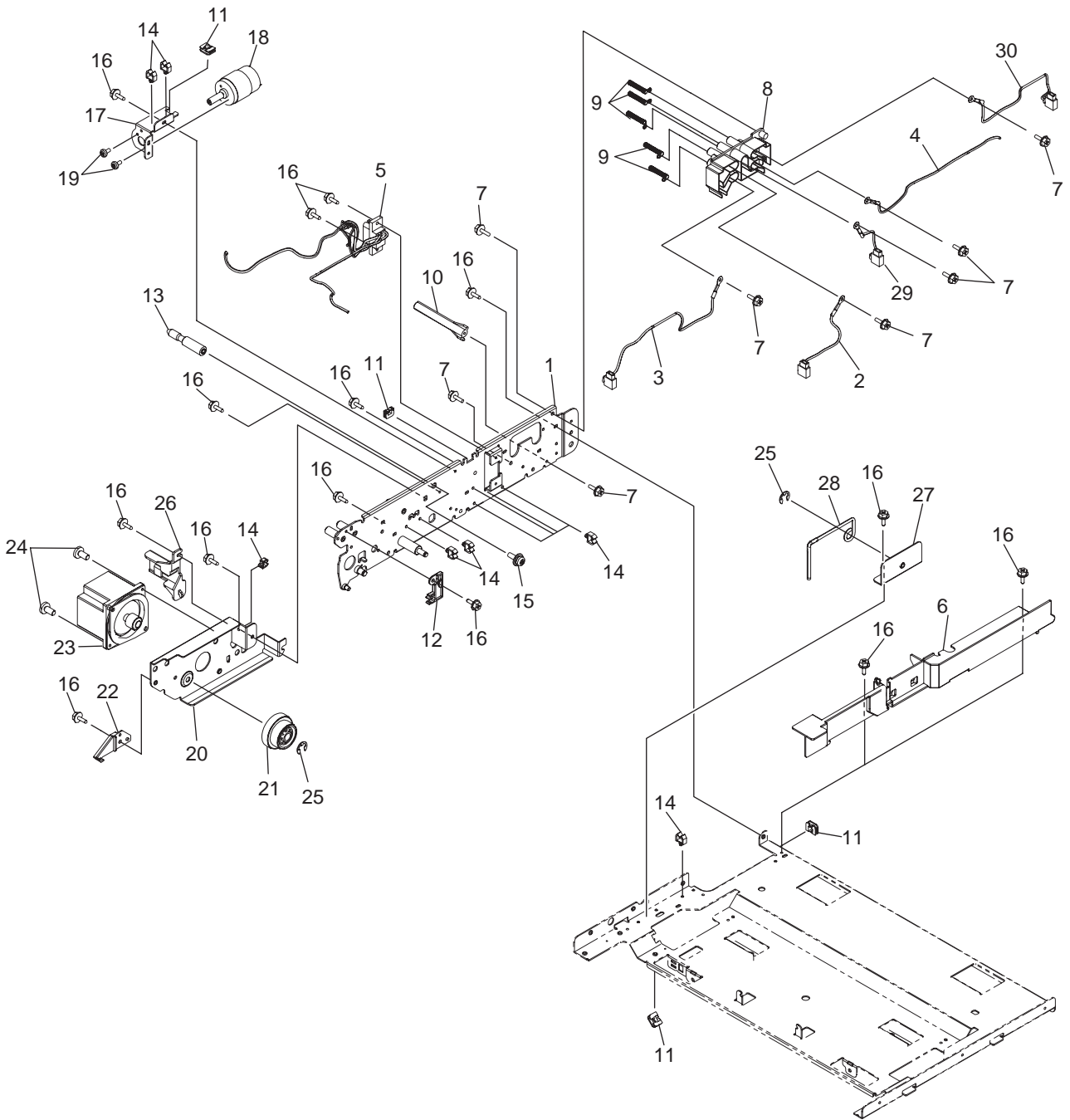

	Ref. No.	Part.No.	Alternative.	Description	Quantity	
					120	230
	1	305JN71BH0	5JN71BH0	FRAME ASSY:ASYS-FRM-TBU-R-LFT	1	1
	2	305JN72AJ0	5JN72AJ0	WIRE HARNESS:HRNS-TBUHV-M-430	1	1
	3	305JN72AK0	5JN72AK0	WIRE HARNESS:HRNS-TBUHV-Y-430	1	1
	4	305JN72AL0	5JN72AL0	WIRE HARNESS:HRNS-TBUHV-TR2-430	1	1
	5	305JN72D10	5JN72D10	WIRE HARNESS:HRNS-TBU-430	1	1
	6	305JN71EQ0	5JN71EQ0	COVER-RL-UP-TBU	1	1
	7	305JN72NE0	5JN72NE0	SCREW:S/TPP/FHEXM-3X8-NI	8	8
	8	305JN71AD0	5JN71AD0	TERMINAL PLATE:TERM-KCMY-TRU	1	1
	9	305JN71BS0	5JN71BS0	SPRING:SPG-TERM-HVT-P N	5	5
	10	305JN71C00	5JN71C00	COLLAR-STAND-TBU	1	1
	11	305JN72J60	5JN72J60	BAND:ES-0505	4	4
	12	305JN71B70	5JN71B70	HOLDER:HLDR-CLN-TBU-R	1	1
	13	305JN71EM0	5JN71EM0	PIN:STUD-TBU-R-M4	1	1
	14	305JN72JU0	5JN72JU0	CLAMP UAMS-05-0	10	10
	15	305JN72MJ0	5JN72MJ0	SCREW:S/PAN/SWWP-M4X10-NI	1	1
	16	305JN72NS0	5JN72NS0	SCREW:S/TPS/FHEXM/R-3X8-ZU3	14	14
	17	305JN71A30	5JN71A30	BRACKET:BRKT-MOT-LIFT-F43X	1	1
⊙	18	305JN71DK0	5JN71DK0	MOTOR ASSY :ASYS-TBUSETM-430	1	1
	19	305JN72MH0	5JN72MH0	SCREW:S/PAN-M2.6X4-NC	2	2
	20	305JN71CT0	5JN71CT0	BRACKET ASSY:ASYS-BRKT-DRV-TBU	1	1
⊙	21	305JN71A20	5JN71A20	GEAR-4H86_5H53-8-TBU	1	1
	22	305JN71AN0	5JN71AN0	HOLDER:HLDR-CLN-TBU-F43X	1	1
⊙	23	305JN72A30	5JN72A30	MOTOR:MOTRS-TBU-430	1	1
	24	305JN72LG0	5JN72LG0	SCREW:S/BID-M4X8-NI	2	2
	25	305JN72LY0	5JN72LY0	RETAIN NG RING:RR/E-7-SS	2	2
	26	305JN71D30	5JN71D30	CASE-HRNS-TBU	1	1
	27	305JN71EP0	5JN71EP0	PLATE ASSY:ASYS-PLATE-LVR-TBU	1	1
	28	305JN71DL0	5JN71DL0	LEVER LVR-LEFT-TBU	1	1
	29	305JN72AH0	5JN72AH0	WIRE HARNESS:HRNS-TBUHV-C-430	1	1
	30	305JN72AG0	5JN72AG0	WIRE HARNESS:HRNS-TBUHV-K-430	1	1

• Parts with "⊙" indicate regular maintenance parts.

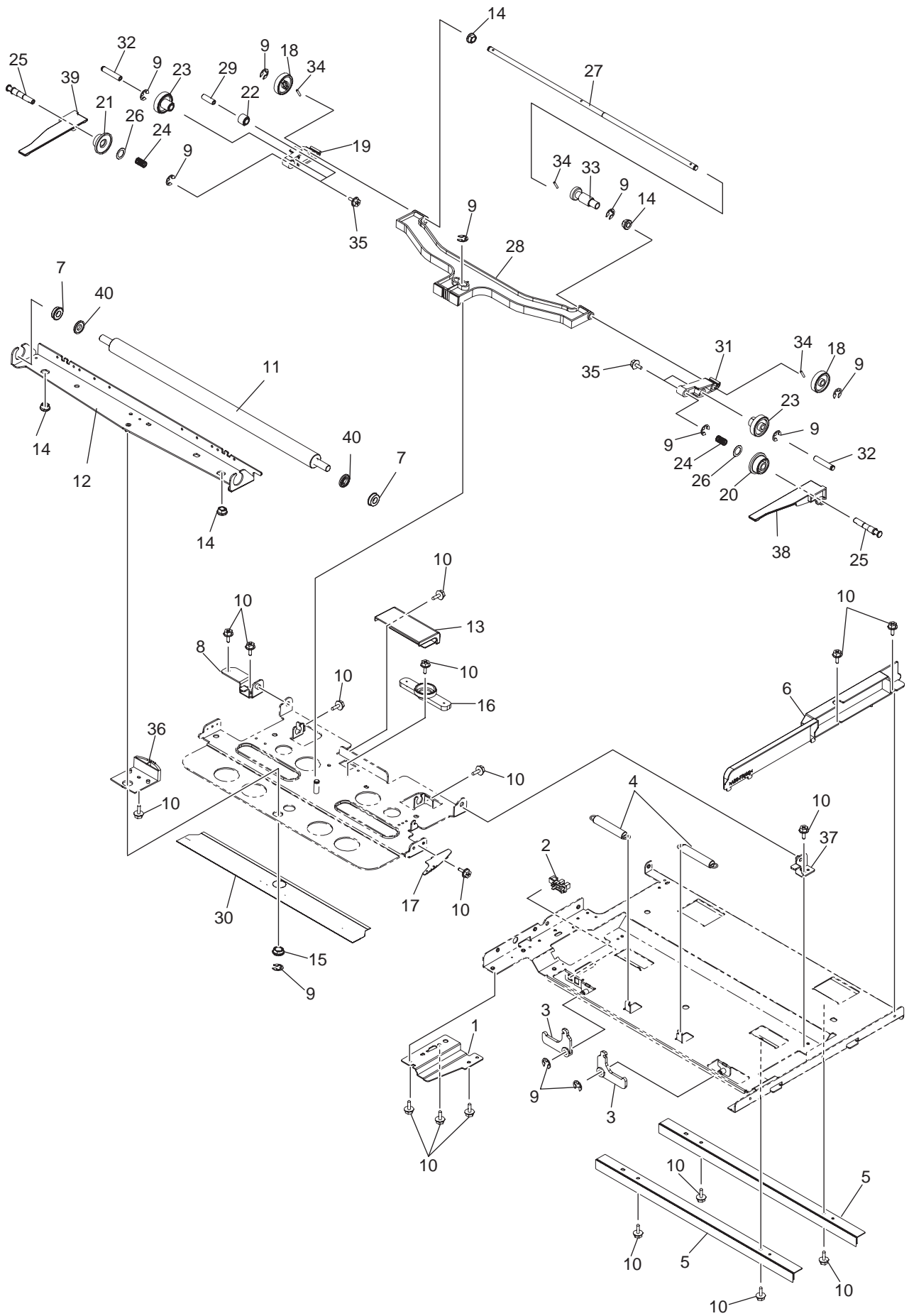

	Ref. No.	Part.No.	Alternative.	Description	Quantity	
					120	230
⊙	1	305JN71EN0	5JN71EN0	PLATE-STAY-YMC	1	1
	2	305JN72H20	5JN72H20	SENSOR LG248BL1	1	1
⊙	3	305JN71AE0	5JN71AE0	ARM-TENSION	2	2
	4	305JN71E60	5JN71E60	SPRING:SPG-E-STRNG-TBU-41N	2	2
⊙	5	305JN71CL0	5JN71CL0	BRUSH-TBU-F43X	2	2
	6	305JN71CS0	5JN71CS0	COVER-FL-UP-TBU	1	1
⊙	7	305JN72KF0	5JN72KF0	BEARING:LNR-1680HHRPOP25LY349	2	2
	8	305JN71D10	5JN71D10	BRACKET ASSY:ASYS-BRKT-HINGE-R	1	1
⊙	9	305JN72LV0	5JN72LV0	RETAIN NG RING:RR/E-4-SS	11	11
	10	305JN72NS0	5JN72NS0	SCREW:S/TPS/FHEXM/R-3X8-ZU3	18	18
⊙	11	305JN71E40	5JN71E40	ROLLER:RLR-STRNG-AL	1	1
	12	305JN71D00	5JN71D00	BRACKET ASSY:ASYS-BRKT-ROL-STRNG	1	1
⊙	13	305JN71EA0	5JN71EA0	COVER-WORM-STRNG	1	1
	14	305JN701S0	5JN701S0	BUSH-6-POM	4	4
⊙	15	305JN70YS0	5JN70YS0	BUSH-8X12X5R5F-NU4	1	1
	16	305JN71CY0	5JN71CY0	GEAR-05H50-WORM	1	1
⊙	17	305JN71C30	5JN71C30	BRACKET:BRKT-SCALE	1	1
	18	305JN71BV0	5JN71BV0	GEAR-DRIVE-SHAFT	2	2
⊙	19	305JN71C20	5JN71C20	ARM-R	1	1
	20	305JN71CP0	5JN71CP0	GEAR-ROL-GUIDE-F	1	1
⊙	21	305JN71CE0	5JN71CE0	GEAR-ROL-GUIDE-R	1	1
	22	305JN71C40	5JN71C40	GEAR-RVRS	1	1
⊙	23	305JN71BU0	5JN71BU0	GEAR-IDLE-GUIDE	2	2
	24	305JN71DG0	5JN71DG0	SPRING:SPG-GEAR-STRNG-3N	2	2
⊙	25	305JN71CM0	5JN71CM0	PIN:STUD-GEAR-GU DE	2	2
	26	305JN707Q0	5JN707Q0	WASHER-6R2X9R5XR25-PL	2	2
⊙	27	305JN71EG0	5JN71EG0	SHAFT:SFT-DRV-STEERING	1	1
	28	305JN71CZ0	5JN71CZ0	SL DER-STRNG	1	1
⊙	29	305JN71C60	5JN71C60	PIN:STUD-IDLE-ARM	1	1
	30	305JN71EF0	5JN71EF0	FELT-CLN-DRVRLR-TBU	1	1
⊙	31	305JN71C10	5JN71C10	ARM-F	1	1
	32	305JN71C70	5JN71C70	PIN:STUD-ROL-GUIDE	2	2
⊙	33	305JN71BT0	5JN71BT0	WORM-STEER NG	1	1
	34	305JN72MC0	5JN72MC0	PIN:P/PRL/AH7-2X12-SS	3	3
⊙	35	305JN72N90	5JN72N90	SCREW:S/FHEXM-M3X6-NI	5	5
	36	305JN71CX0	5JN71CX0	GEAR-10S80-STERING	1	1
⊙	37	305JN71CD0	5JN71CD0	BRACKET ASSY:ASYS-BRKT-HINGE-F	1	1
	38	305JN71CN0	5JN71CN0	HOLDER:HLDR-BELT-F	1	1
⊙	39	305JN71C50	5JN71C50	HOLDER:HLDR-BELT-R	1	1
	40	305JN71E50	5JN71E50	COLLAR-18	2	2

• Parts with "⊙" indicate regular maintenance parts.

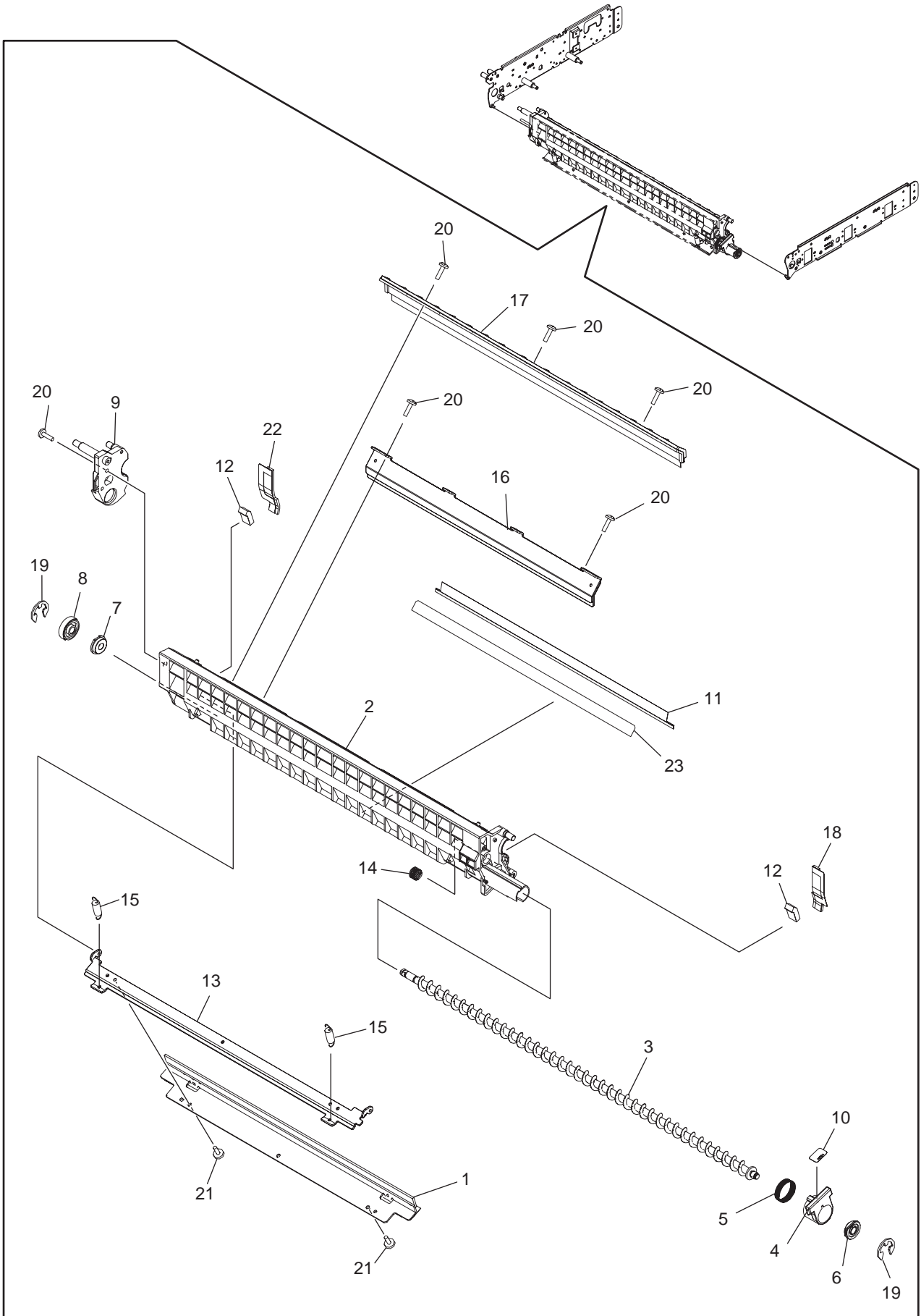

	Ref. No.	Part.No.	Alternative.	Description	Quantity	
					120	230
⊙	1	305JN72E80	5JN72E80	TRANSFER BELT CLEANING BLADE:BL-TBU-F43X	1	1
	2	305JN71AZ0	5JN71AZ0	FRAME ASSY:ASYS-FRM-CLN-TBU	1	1
	3	305JN71CW0	5JN71CW0	SPIRAL:AUG-CLN-TBU-M	1	1
	4	305JN71B20	5JN71B20	SHUTTER:SHUT-AUG-CLN-TBU	1	1
	5	305JN71B40	5JN71B40	SPRING:SPG-CLN-TBU-SHUT	1	1
	6	305JN71CU0	5JN71CU0	BUSH-06X18X4R4F-M-F	1	1
	7	305JN71CV0	5JN71CV0	BUSH-06X18X4R4F-M-R	1	1
⊙	8	305JN71B00	5JN71B00	GEAR-AUGER-CLN-TBU	1	1
	9	305JN71AY0	5JN71AY0	FRAME ASSY:ASYS-FRM-CLN-TBU-R	1	1
	10	305JN71E10	5JN71E10	LABEL LBL-SHUT-CLN-TBU	1	1
	11	305JN71B10	5JN71B10	SHEET-AUGER-CLN-TBU	1	1
	12	305JN71B30	5JN71B30	SEAL-CLN-TBU-S DE	2	2
	13	305JN71ED0	5JN71ED0	HOLDER:HLDR-BLADE-CLN-TBU	1	1
	14	305JN71E80	5JN71E80	SPRING:SPG-B-LOCK-CLN-TBU	1	1
	15	305JN71EE0	5JN71EE0	SPRING:SPG-BLADE-CLN-TBU	2	2
	16	305JN71EB0	5JN71EB0	PLATE ASSY:ASYS-PLT-WEIGHT	1	1
	17	305JN71AX0	5JN71AX0	BRACKET ASSY:ASYS-REC-CLN-TBU	1	1
⊙	18	305JN71DH0	5JN71DH0	SEAL-CLN-TBU-F	1	1
	19	305JN72LV0	5JN72LV0	RETAIN NG RING:RR/E-4-SS	2	2
	20	305JN707S0	5JN707S0	SCREW:S/TPP/BID-3*8-NI	6	6
⊙	21	305JN72LE0	5JN72LE0	SCREW:S/BID-M3X4-NI	2	2
	22	305JN71DJ0	5JN71DJ0	SEAL-CLN-TBU-R	1	1
	23	305JN71E00	5JN71E00	SHEET:MYLAR-AUG-CLN-TBU	1	1

• Parts with "⊙" indicate regular maintenance parts.

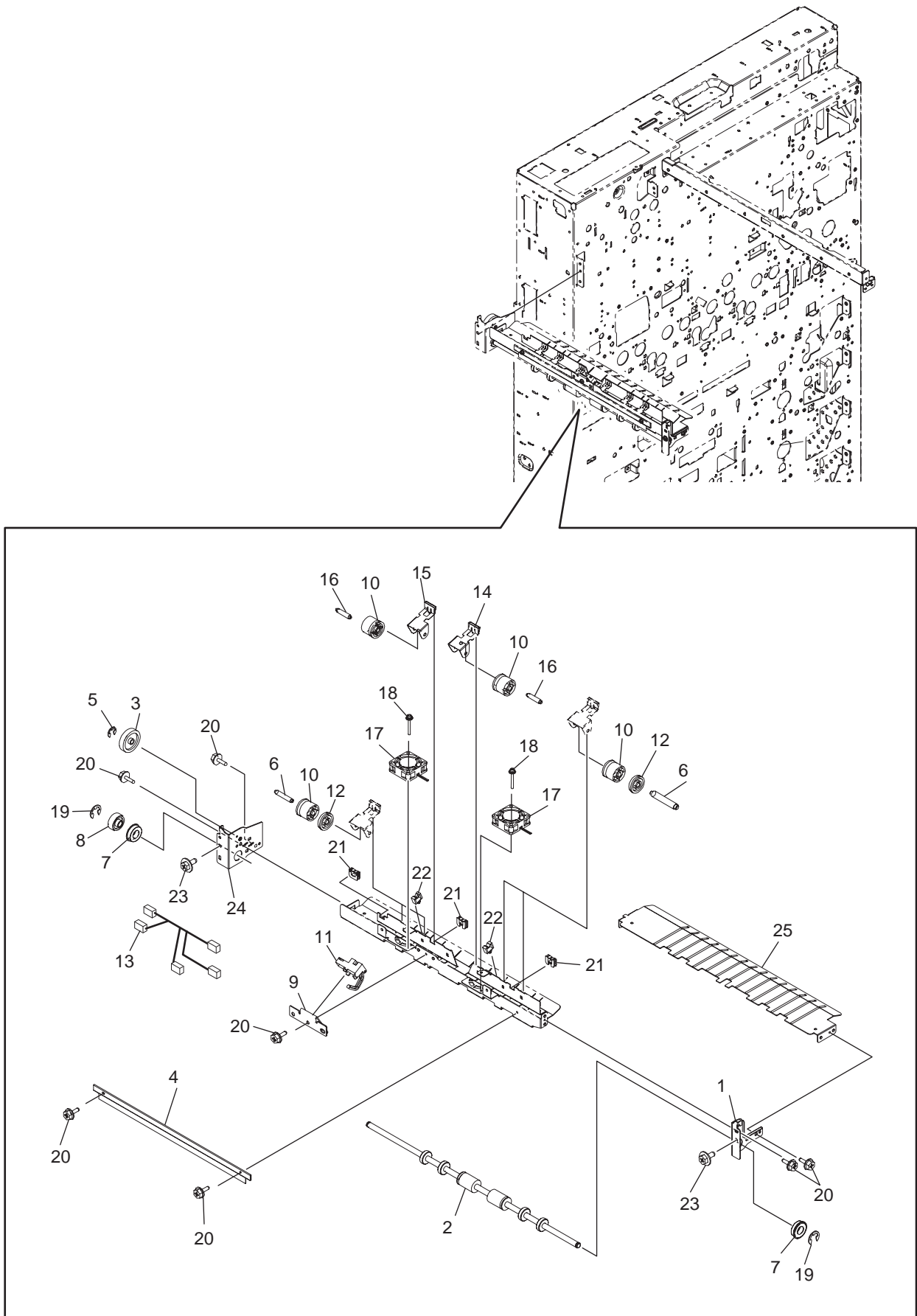

	Ref. No.	Part.No.	Alternative.	Description	Quantity	
					120	230
	1	305JN71K90	5JN71K90	FRAME-ROL-EX-L-F	1	1
⊙	2	305JN71KD0	5JN71KD0	ROLLER-EXIT-L	1	1
⊙	3	305JN701U0	5JN701U0	GEAR-10S033-06	1	1
	4	305JN71MY0	5JN71MY0	BRUSH-SUS-E-43X	1	1
	5	305JN72LW0	5JN72LW0	RETAIN NG RING:RR/E-5-SS	1	1
	6	305JN71MQ0	5JN71MQ0	PIN-ROL-EXT	4	4
	7	305JN72KB0	5JN72KB0	BEARING:LNR-1680HHRP0P15LY13	2	2
⊙	8	305JN71KM0	5JN71KM0	GEAR-10S23-8-OWL	1	1
	9	305JN71ML0	5JN71ML0	BRACKET:BRKT-EXIT-SW	1	1
⊙	10	305JN71MR0	5JN71MR0	ROLLER:ROL-EXIT	6	6
⊙	11	305JN70W00	5JN70W00	SWITCH:SNSR-FED-RVS-390	1	1
⊙	12	305JN71MS0	5JN71MS0	ROLLER:ROL-EXIT-SUB	4	4
	13	305JN72CP0	5JN72CP0	WIRE HARNESS:HRNS-EXTSN-430	1	1
	14	305JN71MT0	5JN71MT0	SPRING:SPL-EXIT-LC1	1	1
	15	305JN71MU0	5JN71MU0	SPRING:SPL-EXIT-LC2	1	1
	16	305JN71MP0	5JN71MP0	PIN-ROL-EXT-LC	2	2
⊙	17	305JN72CR0	5JN72CR0	FAN MOTOR:FAN-4015-430	2	2
	18	305JN72LC0	5JN72LC0	SCREW:S/PAN/SWWP-M3X20-NI	4	4
	19	305JN72LY0	5JN72LY0	RETAIN NG RING:RR/E-7-SS	2	2
	20	305JN72NS0	5JN72NS0	SCREW:S/TPS/FHEXM/R-3X8-ZU3	7	7
	21	305JN72J60	5JN72J60	BAND:ES-0505	3	3
	22	305JN72K20	5JN72K20	CLAMP MSB-1207	2	2
	23	305JN72NT0	5JN72NT0	SCREW:S/TPS/FHEXM/R-4X8-ZU3	2	2
	24	305JN71K80	5JN71K80	FRAME ASSY:ASYS-FRAME-ROL-EX-L-R	1	1
	25	305JN71KT0	5JN71KT0	GUIDE-EXIT-LOW-L	1	1

• Parts with "⊙" indicate regular maintenance parts.

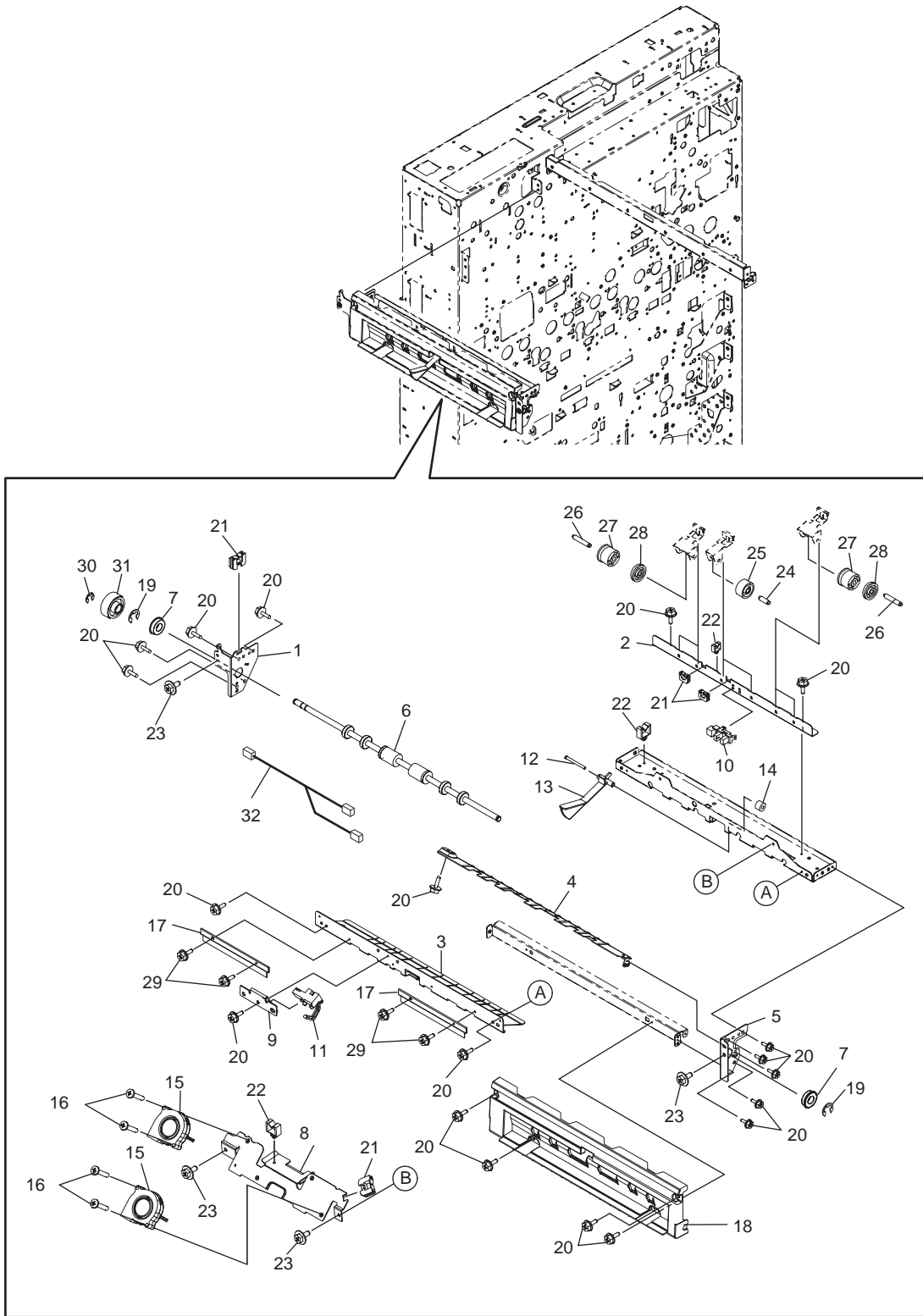

	Ref. No.	Part.No.	Alternative.	Description	Quantity	
					120	230
	1	305JN71JV0	5JN71JV0	FRAME-ROL-EX-U-R	1	1
	2	305JN71KU0	5JN71KU0	BRACKET:BRKT-EXIT-IDLE	1	1
	3	305JN71KV0	5JN71KV0	GUIDE-EXIT-UP-U	1	1
	4	305JN71KW0	5JN71KW0	GUIDE-EXIT-UP-L	1	1
	5	305JN71K00	5JN71K00	FRAME-ROL-EX-U-F	1	1
⊙	6	305JN71KC0	5JN71KC0	ROLLER-EXIT-U	1	1
	7	305JN72KB0	5JN72KB0	BEARING:LNR-1680HHRP0P15LY13	2	2
	8	305JN711A0	5JN711A0	BRACKET ASSY:ASYS-BRKT-FAN-EX-TRAY-U	1	1
	9	305JN71ML0	5JN71ML0	BRACKET:BRKT-EXIT-SW	1	1
⊙	10	305JN72H20	5JN72H20	SENSOR LG248BL1	1	1
⊙	11	305JN70W00	5JN70W00	SWITCH:SNSR-FED-RVS-390	1	1
	12	305JN70UU0	5JN70UU0	PIN-ACTR	1	1
	13	305JN71K70	5JN71K70	ACTUATOR:ACT-FULL-EXIT-UP	1	1
	14	305JN70V00	5JN70V00	CUSHION:CUSH-ACTR-STOP-390	1	1
⊙	15	305JN72CN0	5JN72CN0	FAN MOTOR:FAN-P5015-430	2	2
	16	305JN72LH0	5JN72LH0	SCREW:S/BID-M4X20-NI	4	4
	17	305JN71KG0	5JN71KG0	BRUSH-SUS-EXIT	2	2
	18	305JN71MX0	5JN71MX0	COVER-EXIT-434U	1	1
	19	305JN72LY0	5JN72LY0	RETAIN NG RING:RR/E-7-SS	2	2
	20	305JN72NS0	5JN72NS0	SCREW:S/TPS/FHEXM/R-3X8-ZU3	19	19
	21	305JN72J60	5JN72J60	BAND:ES-0505	4	4
	22	305JN72K20	5JN72K20	CLAMP MSB-1207	3	3
	23	305JN72NT0	5JN72NT0	SCREW:S/TPS/FHEXM/R-4X8-ZU3	4	4
	24	305JN701H0	5JN701H0	PIN	2	2
⊙	25	305JN71MN0	5JN71MN0	ROLLER:ROL-EXIT-C	2	2
	26	305JN71MQ0	5JN71MQ0	PIN-ROL-EXT	4	4
⊙	27	305JN71MR0	5JN71MR0	ROLLER:ROL-EXIT	4	4
⊙	28	305JN71MS0	5JN71MS0	ROLLER:ROL-EXIT-SUB	4	4
	29	305JN70330	5JN70330	SCREW:SCR-M3X6BISR-NI	4	4
	30	305JN72LW0	5JN72LW0	RETAIN NG RING:RR/E-5-SS	1	1
⊙	31	305JN71MM0	5JN71MM0	GEAR-10S23-8-D	1	1
	32	305JN727X0	5JN727X0	WIRE HARNESS:HRNS-UEXTSN-430	1	1

• Parts with "⊙" indicate regular maintenance parts.

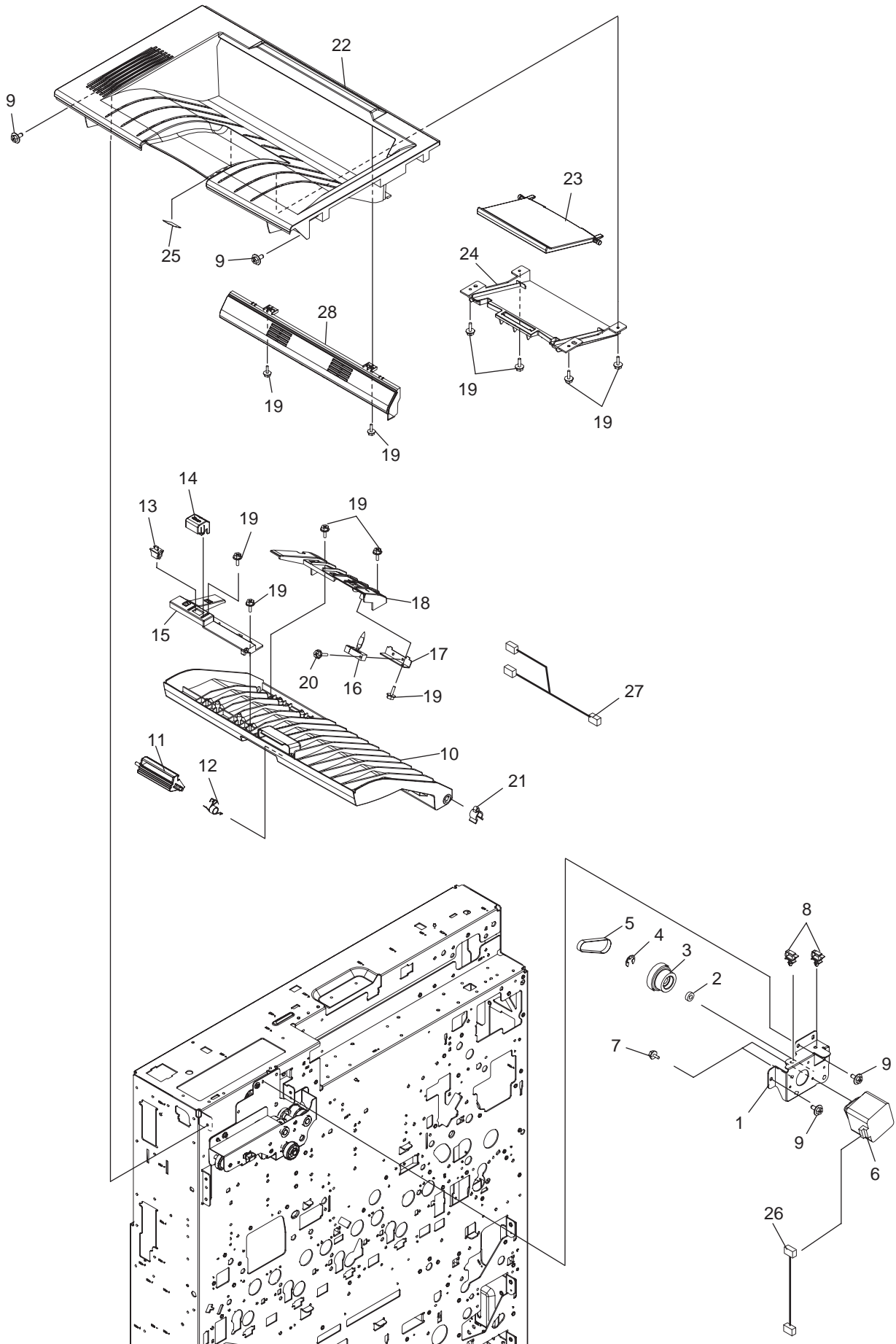

	Ref. No.	Part.No.	Alternative.	Description	Quantity	
					120	230
	1	305JN71KA0	5JN71KA0	BRACKET ASSY:ASYS-BRKT-MOT-EXIT	1	1
	2	305JN72K80	5JN72K80	BEARING:DDL-1260ZZHP0P25LY13	1	1
⊙	3	305JN71KS0	5JN71KS0	GEAR-10S23_PS2M30-6	1	1
	4	305JN72LW0	5JN72LW0	RETAIN NG RING:RR/E-5-SS	1	1
	5	305JN71KL0	5JN71KL0	TIMING BELT:BLT_SY-S2M-140-6	1	1
⊙	6	305JN72750	5JN72750	MOTOR:MOTRS-MT-430	1	1
	7	305JN72N90	5JN72N90	SCREW:S/FHEXM-M3X6-NI	2	2
	8	305JN72JP0	5JN72JP0	CLAMP LWS-0711Z	2	2
	9	305JN72NT0	5JN72NT0	SCREW:S/TPS/FHEXM/R-4X8-ZU3	4	4
⊙	10	305JN713F0	5JN713F0	TRAY-LEFT-LOW-434	1	1
⊙	11	305JN713E0	5JN713E0	LEVER-COV-TRAY-434LF	1	1
	12	305JN713P0	5JN713P0	SPRING:SPG-COV-OPEN-08	1	1
⊙	13	305JN72HG0	5JN72HG0	SWITCH:CS1A-B2CA	1	1
	14	305JN71450	5JN71450	COVER-SW-OPEN-COV-RVS	1	1
	15	305JN71460	5JN71460	HOLDER-SW-COV-RVS	1	1
⊙	16	305JN72H60	5JN72H60	SENSOR PS119ED1	1	1
	17	305JN713N0	5JN713N0	BRACKET:BRKT-SW-PS119ED1	1	1
	18	305JN713J0	5JN713J0	COVER-SNSR-TRAY	1	1
	19	305JN72NE0	5JN72NE0	SCREW:S/TPP/FHEXM-3X8-NI	11	11
	20	305JN72N70	5JN72N70	SCREW:S/PAN/SWWP-M3X14-NI	1	1
	21	305JN713T0	5JN713T0	CLIP-TRAY-LOW	1	1
	22	305JN71440	5JN71440	TRAY ASSY:ASYS-TRAY-LEFT-434E	1	1
⊙	23	305JN713G0	5JN713G0	TRAY-SUB-434LF	1	1
	24	305JN713H0	5JN713H0	HOLDER-TRAY-LEFT	1	1
	25	305JN72FX0	5JN72FX0	SHEET:MYLAR-BL	1	1
	26	305JN72810	5JN72810	WIRE HARNESS:HRNS-DRV-RT2M-430	1	1
	27	305JN72990	5JN72990	WIRE HARNESS HRNS-EXTCV-430	1	1
⊙	28	305JN71430	5JN71430	COVER-TRAY-FAN-434T	1	1

• Parts with "⊙" indicate regular maintenance parts.

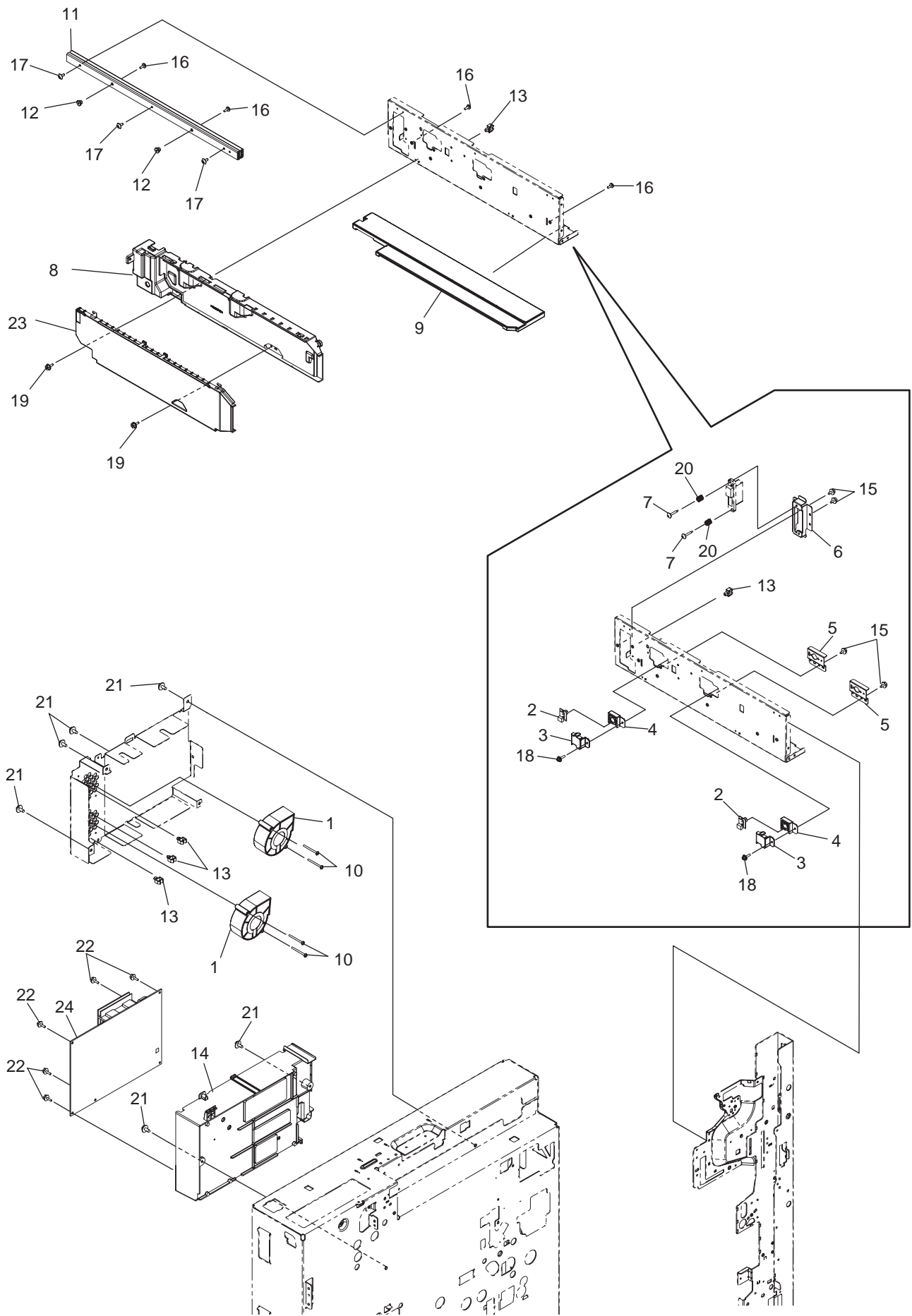

	Ref. No.	Part.No.	Alternative.	Description	Quantity	
					120	230
⊙	1	305JN71130	5JN71130	FAN MOTOR:ASYS-FAN-DUCT-FR-L	2	2
⊙	2	305JN70X00	5JN70X00	SENSOR:SNR-THRMO-380	2	2
	3	305JN721E0	5JN721E0	BASE-SNSR-THRMP LE	2	2
	4	305JN721F0	5JN721F0	HOLDER:HLDR-SNSR-THRMPLE	2	2
	5	305JN721Q0	5JN721Q0	BRACKET:BRKT-SNSR-TMP	2	2
	6	305JN721R0	5JN721R0	BRACKET:BRKT-DRAWER-FUS	1	1
	7	305JN70100	5JN70100	SCREW-D4-18-M3	2	2
	8	305JN710X0	5JN710X0	COVER ASSY:ASYS-DUCT-STAY-FUS-U	1	1
	9	305JN710Y0	5JN710Y0	DUCT ASSY:ASYS-DUCT-STAY-FUS-LOW	1	1
	10	305JN72NV0	5JN72NV0	SCREW:S/PAN/SWWP-M3X35-NI	4	4
	11	305JN72EF0	5JN72EF0	RA L-BRIDGE-43X	1	1
	12	305JN72EG0	5JN72EG0	PIN:STUD-RAIL	2	2
	13	305JN72JD0	5JN72JD0	CLAMP UAMS-05L-0-46	5	5
	14	305JN721P0	5JN721P0	CASE-PS- H-F43X	1	1
	15	305JN72NR0	5JN72NR0	SCREW:S/TPS/FHEXM/R-3X6-ZU3	4	4
	16	305JN72L80	5JN72L80	SCREW:S/PAN-M3X6-NI	4	4
	17	305JN70330	5JN70330	SCREW:SCR-M3X6BISR-NI	3	3
	18	305JN72LB0	5JN72LB0	SCREW:S/PAN/SWWP-M3X10-NI	2	2
	19	305JN72NS0	5JN72NS0	SCREW:S/TPS/FHEXM/R-3X8-ZU3	2	2
	20	305JN721S0	5JN721S0	SPRING:SPG-DRAWER-FUSER	2	2
	21	305JN72NT0	5JN72NT0	SCREW:S/TPS/FHEXM/R-4X8-ZU3	7	7
	22	305JN72NE0	5JN72NE0	SCREW:S/TPP/FHEXM-3X8-NI	5	5
	23	305JN710U0	5JN710U0	DUCT-STAY-FUS-L	1	1
⊙	24	305JN72B60	5JN72B60	PWB ASSY:PWA-F-IH-430E		1
⊙	24	305JN72B50	5JN72B50	PWB ASSY:PWA-F-IH-430U	1	

• Parts with "⊙" indicate regular maintenance parts.

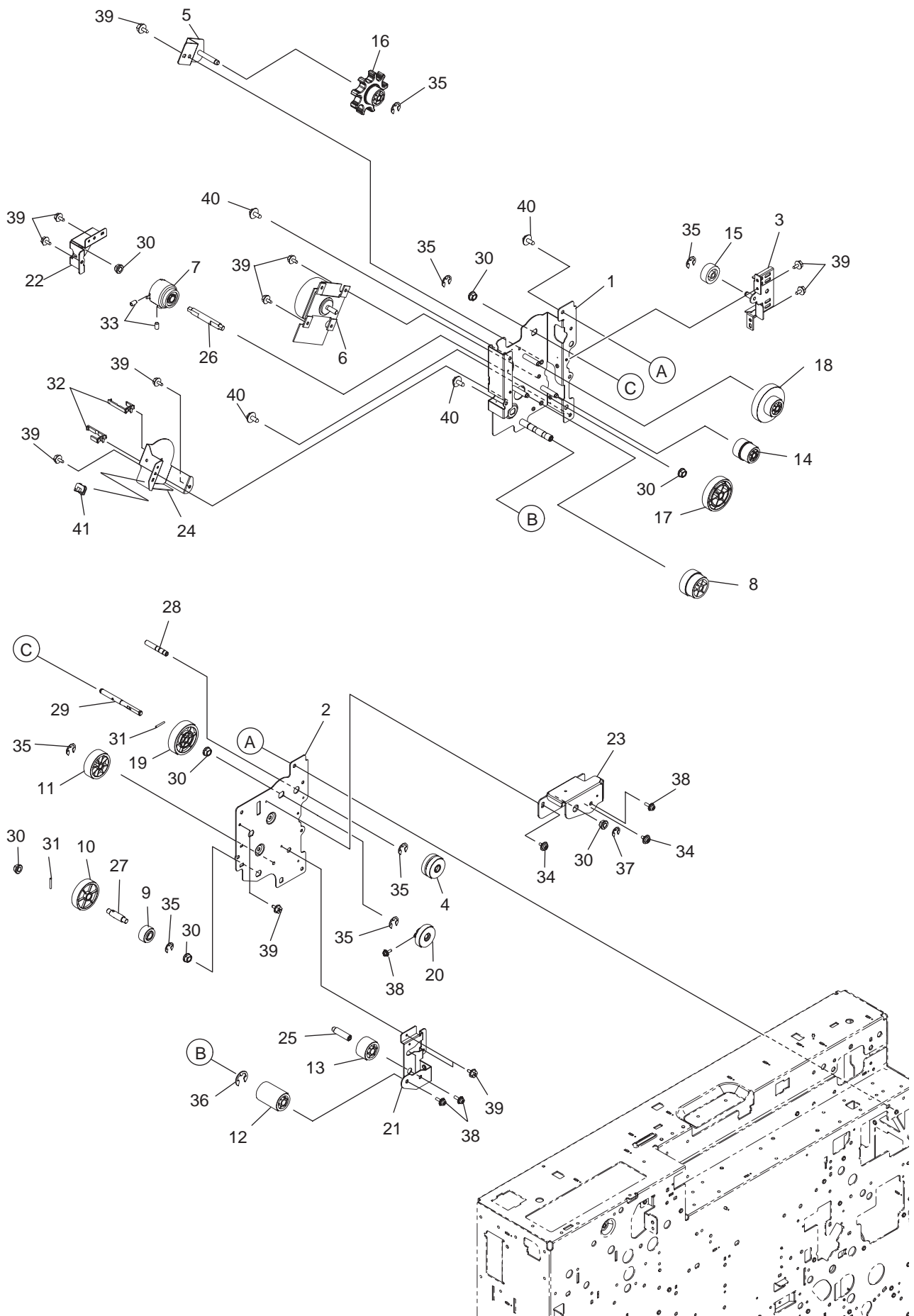

	Ref. No.	Part.No.	Alternative.	Description	Quantity	
					120	230
	1	305JN722G0	5JN722G0	PLATE ASSY:ASYS-PLT-FUS-MOT	1	1
	2	305JN722F0	5JN722F0	PLATE ASSY:ASYS-PLT-DRV	1	1
	3	305JN722Y0	5JN722Y0	BRACKET ASSY:ASYS-BRKT-IDL-HND	1	1
	4	305JN72350	5JN72350	GEAR ASSY:ASYS-GEAR-10S28	1	1
	5	305JN722K0	5JN722K0	BRACKET ASSY:ASYS-BRKT-FUS-HND	1	1
⊙	6	305JN729Y0	5JN729Y0	MOTOR:MOTRD-FEED-430	1	1
⊙	7	305JN72360	5JN72360	CLUTCH:CLUCH-33C-8-CCW-FUS	1	1
⊙	8	305JN72150	5JN72150	GEAR-5H62-5H56	1	1
⊙	9	305JN724W0	5JN724W0	GEAR-8H23-OWC-N	1	1
⊙	10	305JN722W0	5JN722W0	GEAR-5H75-8	1	1
⊙	11	305JN72160	5JN72160	GEAR-8H42-6	1	1
⊙	12	305JN72170	5JN72170	GEAR-8H29-6	1	1
⊙	13	305JN72180	5JN72180	GEAR-8H30-8	1	1
⊙	14	305JN722X0	5JN722X0	GEAR-10S23_08H26-6	1	1
⊙	15	305JN701R0	5JN701R0	GEAR-10S023-06	1	1
⊙	16	305JN70WN0	5JN70WN0	GEAR-FUS-HAND	1	1
⊙	17	305JN722T0	5JN722T0	GEAR-5H85-8	1	1
⊙	18	305JN722S0	5JN722S0	GEAR-6H79_10S24-6	1	1
⊙	19	305JN722V0	5JN722V0	GEAR-10S43-6	1	1
⊙	20	305JN722U0	5JN722U0	GEAR-10S29-SEP	1	1
	21	305JN721K0	5JN721K0	BRACKET:BRKT-HLD-DRV	1	1
	22	305JN722E0	5JN722E0	CASE-CLUTCH-DRV-BP	1	1
	23	305JN722J0	5JN722J0	CASE-GEAR-FUS-BP	1	1
	24	305JN72300	5JN72300	PLATE:PLT-GUARD-MOT-FU	1	1
	25	305JN722B0	5JN722B0	SHAFT-HLD-BKT	1	1
	26	305JN722H0	5JN722H0	SHAFT-DRV-FUS-CLUCH	1	1
	27	305JN724H0	5JN724H0	SHAFT-DRV-FUS-OWC	1	1
	28	305JN722C0	5JN722C0	PIN:STUD-GEAR-BP	1	1
	29	305JN722D0	5JN722D0	SHAFT:SFT-GEAR-BP	1	1
	30	305JN72GU0	5JN72GU0	BUSH-6-NU4	7	7
	31	305JN72ME0	5JN72ME0	PIN:P/PR/L/AH7-2X16-SS	2	2
	32	305JN72J20	5JN72J20	CLAMP RLWS3TV0	2	2
	33	305JN72LP0	5JN72LP0	SCREW:S/SET/K-M3X4-B	2	2
	34	305JN70300	5JN70300	SCREW-ACTR-TRU	2	2
	35	305JN72LW0	5JN72LW0	RETAIN NG RING:RR/E-5-SS	7	7
	36	305JN72LY0	5JN72LY0	RETAIN NG RING:RR/E-7-SS	1	1
	37	305JN72LV0	5JN72LV0	RETAIN NG RING:RR/E-4-SS	1	1
	38	305JN72LA0	5JN72LA0	SCREW:S/PAN/SWWP-M3X8-NI	4	4
	39	305JN72NR0	5JN72NR0	SCREW:S/TPS/FHEXM/R-3X6-ZU3	12	12
	40	305JN72NT0	5JN72NT0	SCREW:S/TPS/FHEXM/R-4X8-ZU3	4	4
	41	305JN72J60	5JN72J60	BAND:ES-0505	1	1

• Parts with "⊙" indicate regular maintenance parts.

	Ref. No.	Part.No.	Alternative.	Description	Quantity	
					120	230
	1	305JN721H0	5JN721H0	HOLDER:HLDR-GU DE-R	4	4
	2	305JN724K0	5JN724K0	ROLLER:ROLL-FUS-GUIDE	8	8
	3	305JN72LE0	5JN72LE0	SCREW:S/BID-M3X4-NI	4	4
	4	305JN723K0	5JN723K0	PLATE:PLT-GUIDE-L	1	1
	5	305JN70340	5JN70340	SCREW-BKT-DEV	3	3
	6	305JN72N90	5JN72N90	SCREW:S/FHEXM-M3X6-NI	19	19
	7	305JN72320	5JN72320	COVER-HAND-FUS-C	1	1
	8	305JN723P0	5JN723P0	COVER:COV-HANDLE-FUS	1	1
	9	305JN723U0	5JN723U0	COVER:COV-FUS-SIDE-F	1	1
	10	305JN723V0	5JN723V0	COVER:COV-FUS-SIDE-R	1	1
	11	305JN70WP0	5JN70WP0	SCREW-FUS-3X8-S	14	14
	12	305JN723N0	5JN723N0	BRACKET:BRKT-SLIDE-EXT-F	1	1
	13	305JN723D0	5JN723D0	BRACKET:BRKT-SLIDE-EXT-R	1	1
	14	305JN723B0	5JN723B0	BRACKET:BRKT-SLIDE-BASE	2	2
	15	305JN723E0	5JN723E0	COVER-PR-FUSER	1	1
	16	305JN723C0	5JN723C0	BRACKET:BRKT-HND-FUS	2	2
	17	305JN700B0	5JN700B0	SCREW-FUSER-M4	1	1
	18	305JN724G0	5JN724G0	LABEL LBL-HOT-JAM-FUS	1	1
	19	305JN72270	5JN72270	BRACKET:BRKT-FUSER-F	1	1
	20	305JN721C0	5JN721C0	GUIDE-FUS-U	1	1
	21	305JN72LB0	5JN72LB0	SCREW:S/PAN/SWWP-M3X10-NI	2	2
	22	305JN723H0	5JN723H0	BRACKET:BRKT-TMS-BLT	1	1
⊙	23	305JN729T0	5JN729T0	THERMISTOR:THMS-HTR-430	1	1
	24	305JN707N0	5JN707N0	SCREW-FUS-REP	2	2
	25	305JN723J0	5JN723J0	HOLDER:HLD-SCREW-FUS	2	2
	26	305JN723F0	5JN723F0	HOLDER:HLDR-FUS-SNSR	1	1
	27	305JN723M0	5JN723M0	BRACKET:BRKT-SNSR-RT	1	1
	28	305JN723Z0	5JN723Z0	SHEET-SNSR-GP2Y	1	1
⊙	29	305JN72400	5JN72400	SHEET-SNSR-TLP1255	1	1
	30	305JN72H80	5JN72H80	SENSOR:GP2Y5D91S00F	1	1
	31	305JN723R0	5JN723R0	SHEET-FUS-HND-F	1	1
	32	305JN72440	5JN72440	FRAME-FUS-SPR-F	1	1
	33	305JN72450	5JN72450	FRAME-FUS-SPR-R	1	1
	34	305JN72420	5JN72420	SHEET-ADU-RTN-SNSR	1	1
	35	305JN724A0	5JN724A0	BRACKET ASSY:ASYS-BRKT-FUS-R	1	1
⊙	36	305JN72GY0	5JN72GY0	SENSOR:TLP1255(C8)	1	1
	37	305JN72JD0	5JN72JD0	CLAMP UAMS-05L-0-46	2	2
	38	305JN72LW0	5JN72LW0	RETAIN NG RING:RR/E-5-SS	2	2

• Parts with "⊙" indicate regular maintenance parts.

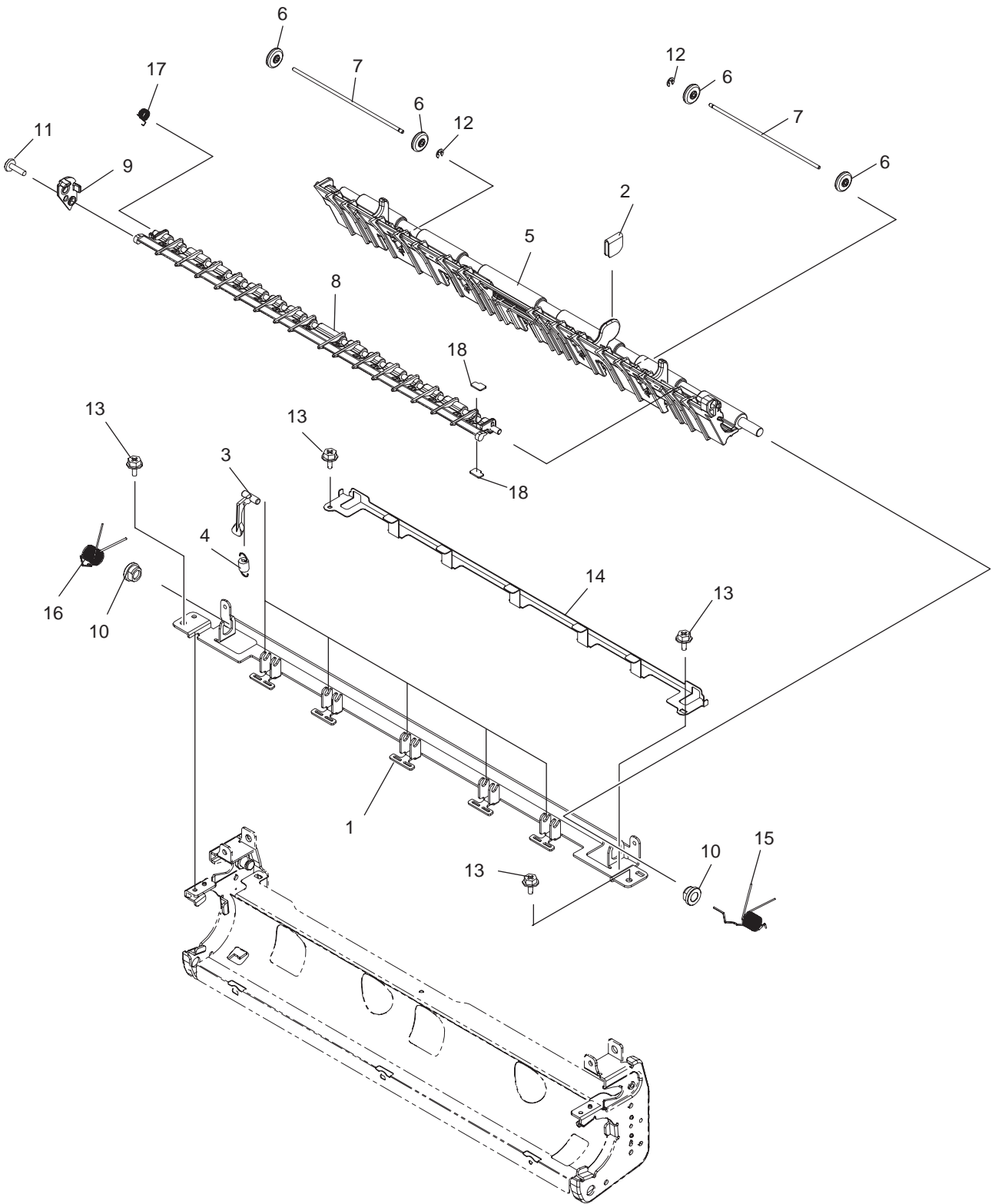

	Ref. No.	Part.No.	Alternative.	Description	Quantity	
					120	230
	1	305JN72330	5JN72330	BRACKET:BRKT-SCRIP-PR	1	1
	2	305JN723Q0	5JN723Q0	SHEET-FUS-OPEN	1	1
⊙	3	305JN706S0	5JN706S0	SCRAPR-FUS-350	5	5
	4	305JN70WQ0	5JN70WQ0	SPRING:SPG-E-SCRIP-F380	5	5
⊙	5	305JN722Q0	5JN722Q0	GUIDE ASSY:ASYS-GUIDE-EXIT-OPEN-SNSR	1	1
	6	305JN722N0	5JN722N0	ROLLER:ROLL-FUS-GUIDE	4	4
	7	305JN722P0	5JN722P0	SHAFT-GU DE-OPEN	2	2
⊙	8	305JN722R0	5JN722R0	GUIDE ASSY:ASYS-GUIDE-ADU-RTN-G	1	1
	9	305JN723Y0	5JN723Y0	COVER:COV-GUIDE-OPEN	1	1
	10	305JN702A0	5JN702A0	BUSH-0612-D6F-M	2	2
	11	305JN72MK0	5JN72MK0	SCREW:S/TPP/BID-3X8-NI	1	1
	12	305JN72M00	5JN72M00	RETAIN NG RING:RR/E-1 5-SS	2	2
	13	305JN72N90	5JN72N90	SCREW:S/FHEXM-M3X6-NI	4	4
	14	305JN723A0	5JN723A0	BRACKET ASSY:ASYS-BRKT-SCRIP-COV	1	1
	15	305JN724L0	5JN724L0	SPRING:SPG-T-GUIDE-OP-F	1	1
	16	305JN724M0	5JN724M0	SPRING:SPG-T-GUIDE-OP-R	1	1
	17	305JN724N0	5JN724N0	SPRING:SPG-T-GUIDE-OPEN	1	1
	18	305JN723S0	5JN723S0	SHEET-FUS-RTN-G	2	2

• Parts with "⊙" indicate regular maintenance parts.

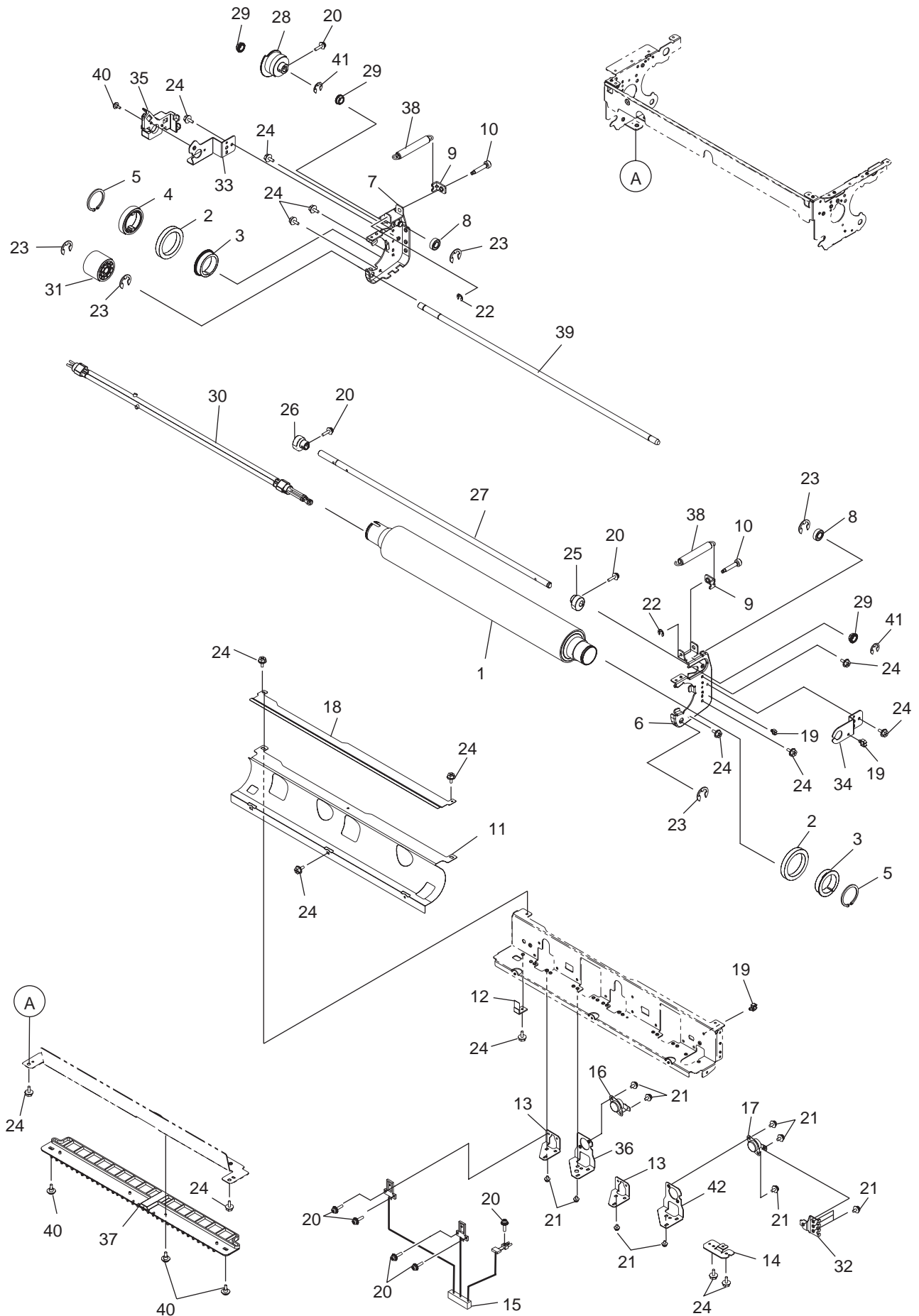

	Ref. No.	Part.No.	Alternative.	Description	Quantity	
					120	230
⊙	1	305JN72E90	5JN72E90	ROLLER:HR-L-F43X	1	1
	2	305JN72KY0	5JN72KY0	BEARING:6807ZL1S1C4KZ	2	2
	3	305JN72190	5JN72190	COLLAR-PR	2	2
⊙	4	305JN72140	5JN72140	GEAR-PRS	1	1
	5	305JN724Q0	5JN724Q0	CLIP:CRR-PR-27	2	2
	6	305JN72240	5JN72240	ARM ASSY:ASYS-ARM-PR-BP-F	1	1
	7	305JN72250	5JN72250	ARM ASSY:ASYS-ARM-PR-BP-R	1	1
	8	305JN72JV0	5JN72JV0	BEARING:DDL-1680HH	2	2
	9	305JN72220	5JN72220	BRACKET:BRKT-TENSION-FUSER	2	2
	10	305JN72210	5JN72210	SCREW-PR-SPG-F43X	2	2
	11	305JN722A0	5JN722A0	CASE-PR-FUSER	1	1
	12	305JN70V80	5JN70V80	BRUSH-FUSER	1	1
	13	305JN72470	5JN72470	BRACKET:BRKT-THRMS-PR	2	2
	14	305JN721B0	5JN721B0	BRACKET:BRKT-THRMS-E-PR	1	1
⊙	15	305JN72CZ0	5JN72CZ0	THERMISTOR:THMS-PRS-430	1	1
⊙	16	305JN72CA0	5JN72CA0	THERMOSTAT:THRMST-HTR2-430	1	1
⊙	17	305JN729U0	5JN729U0	THERMOSTAT:THRMST-HTR1-430	1	1
	18	305JN723T0	5JN723T0	PLATE:PLT-PR-FUS	1	1
	19	305JN72JD0	5JN72JD0	CLAMP UAMS-05L-0-46	3	3
	20	305JN72LB0	5JN72LB0	SCREW:S/PAN/SWWP-M3X10-NI	8	8
	21	305JN72L70	5JN72L70	SCREW:S/PAN/SWWP-M3X5-NI	12	12
	22	305JN72LU0	5JN72LU0	RETAINING RING:RR/E-3-SS	2	2
	23	305JN72LY0	5JN72LY0	RETAIN NG RING:RR/E-7-SS	4	4
	24	305JN72N90	5JN72N90	SCREW:S/FHEXM-M3X6-NI	16	16
	25	305JN72310	5JN72310	CAM-FUS-BP-F	1	1
	26	305JN72370	5JN72370	CAM-FUS-BP-R	1	1
	27	305JN72280	5JN72280	SHAFT-CAM	1	1
⊙	28	305JN722Z0	5JN722Z0	GEAR-10S30-8-CAM	1	1
	29	305JN70YS0	5JN70YS0	BUSH-8X12X5R5F-NU4	3	3
⊙	30	305JN72230	5JN72230	LAMP-PR-TRP-BP-NAD	1	
⊙	30	305JN72480	5JN72480	LAMP-PR-TRP-BP-MJD		1
⊙	30	305JN722M0	5JN722M0	LAMP-PR-TRP-BP-JPD		
⊙	31	305JN72130	5JN72130	GEAR-8H39-FUS	1	1
	32	305JN721L0	5JN721L0	BRACKET:BRKT-THRM-LAMP-BP	1	1
	33	305JN721A0	5JN721A0	BRACKET:BRKT-HLD-LAMP	1	1
	34	305JN721D0	5JN721D0	BRACKET:BRKT-HLD-LAMP-F	1	1
	35	305JN724S0	5JN724S0	HOLDER:HLDL-HRNS-LAMP	1	1
	36	305JN724C0	5JN724C0	BRACKET:BRKT-THMST-PR-C	1	1
	37	305JN724P0	5JN724P0	GUIDE-ENT-PR	1	1
	38	305JN72290	5JN72290	SPRING:SPG-PS-FUS-N	2	2
	39	305JN72260	5JN72260	SHAFT-ARM	1	1
	40	305JN70340	5JN70340	SCREW-BKT-DEV	4	4
	41	305JN72LW0	5JN72LW0	RETAIN NG RING:RR/E-5-SS	2	2
	42	305JN72460	5JN72460	BRACKET:BRKT-THMST-PR	1	1

• Parts with "⊙" indicate regular maintenance parts.

	Ref. No.	Part.No.	Alternative.	Description	Quantity	
					120	230
⊙	1	305JN72AX0	5JN72AX0	THERMOSTAT:THRMST-FMR-430	2	2
	2	305JN72N90	5JN72N90	SCREW:S/FHEXM-M3X6-NI	8	8
	3	305JN72L70	5JN72L70	SCREW:S/PAN/SWWP-M3X5-NI	7	7
	4	305JN706R0	5JN706R0	SCREW-M3-FUS	4	4
⊙	5	305JN721T0	5JN721T0	ROLLER-BELT-ST	1	1
	6	305JN723G0	5JN723G0	ROTOR-SR	1	1
	7	305JN72200	5JN72200	BRACKET ASSY:ASYS-BRKT-PLT	1	1
	8	305JN70WR0	5JN70WR0	SPRING:SPG-C-SEP-ADJ	2	2
	9	305JN72LW0	5JN72LW0	RETAIN NG RING:RR/E-5-SS	2	2
	10	305JN723W0	5JN723W0	BRACKET:BRKT-ADJ-SC-F	1	1
	11	305JN723X0	5JN723X0	BRACKET:BRKT-ADJ-SC-R	1	1
	12	305JN72NS0	5JN72NS0	SCREW:S/TPS/FHEXM/R-3X8-ZU3	2	2
⊙	13	305JN72DP0	5JN72DP0	HEATER COIL UNIT:IH-CO L-UNIT-100	1	
⊙	13	305JN72DQ0	5JN72DQ0	HEATER COIL UNIT:IH-CO L-UNIT-200		1
	14	305JN70340	5JN70340	SCREW-BKT-DEV	2	2
	15	305JN72390	5JN72390	BRACKET:BRKT-THRM	2	2
⊙	16	305JN72EA0	5JN72EA0	FLAT BELT:BT-FU-F43X	1	1
⊙	17	305JN72EB0	5JN72EB0	ROLLER:FR-U-F43X	1	1
⊙	18	305JN721U0	5JN721U0	COLLAR-BLT-MCR	2	2
	19	305JN72430	5JN72430	SHEET-FUS-FRM	1	1
	20	305JN724B0	5JN724B0	SPRING:SPG-E-FUS-SEP	2	2
	21	305JN72K90	5JN72K90	BEARING:6800ZZS1C4KZ	2	2
	22	305JN72LZ0	5JN72LZ0	RETAIN NG RING:RR/E-9-SS	2	2
	23	305JN72LY0	5JN72LY0	RETAIN NG RING:RR/E-7-SS	4	4
	24	305JN72LB0	5JN72LB0	SCREW:S/PAN/SWWP-M3X10-NI	4	4
	25	305JN72JD0	5JN72JD0	CLAMP UAMS-05L-0-46	11	11
	26	305JN72KX0	5JN72KX0	BEARING:6902ZZNRS1C4KZ	2	2
	27	305JN721X0	5JN721X0	BUSH-FUS-MR	2	2
	28	305JN70WS0	5JN70WS0	WASHER-FUSER	2	2
⊙	29	305JN721G0	5JN721G0	GEAR-8H40-FMR	1	1
	30	305JN724J0	5JN724J0	WASHER:WSHR-FUS-ST	2	2
⊙	31	305JN72120	5JN72120	GEAR-8H35_8H30-FMR	1	1
	32	305JN721V0	5JN721V0	PIN:STUD-GEAR-FR	1	1
	33	305JN724V0	5JN724V0	BRACKET:BRKT-FUS-SPR-F	1	1
	34	305JN724U0	5JN724U0	BRACKET:BRKT-FUS-SPR-R	1	1
	35	305JN724T0	5JN724T0	HOLDER ASSY:ASYS-HLD-THRM	2	2
	36	305JN72490	5JN72490	SPRING:SPG-E-SR-FUS-M	2	2
	37	305JN721W0	5JN721W0	BRACKET:BRKT-HRNS-DRW	1	1
	38	305JN721Z0	5JN721Z0	COVER-HRNS-FUS	1	1
	39	305JN721Y0	5JN721Y0	STAY-FUS-THRM	1	1

• Parts with "⊙" indicate regular maintenance parts.

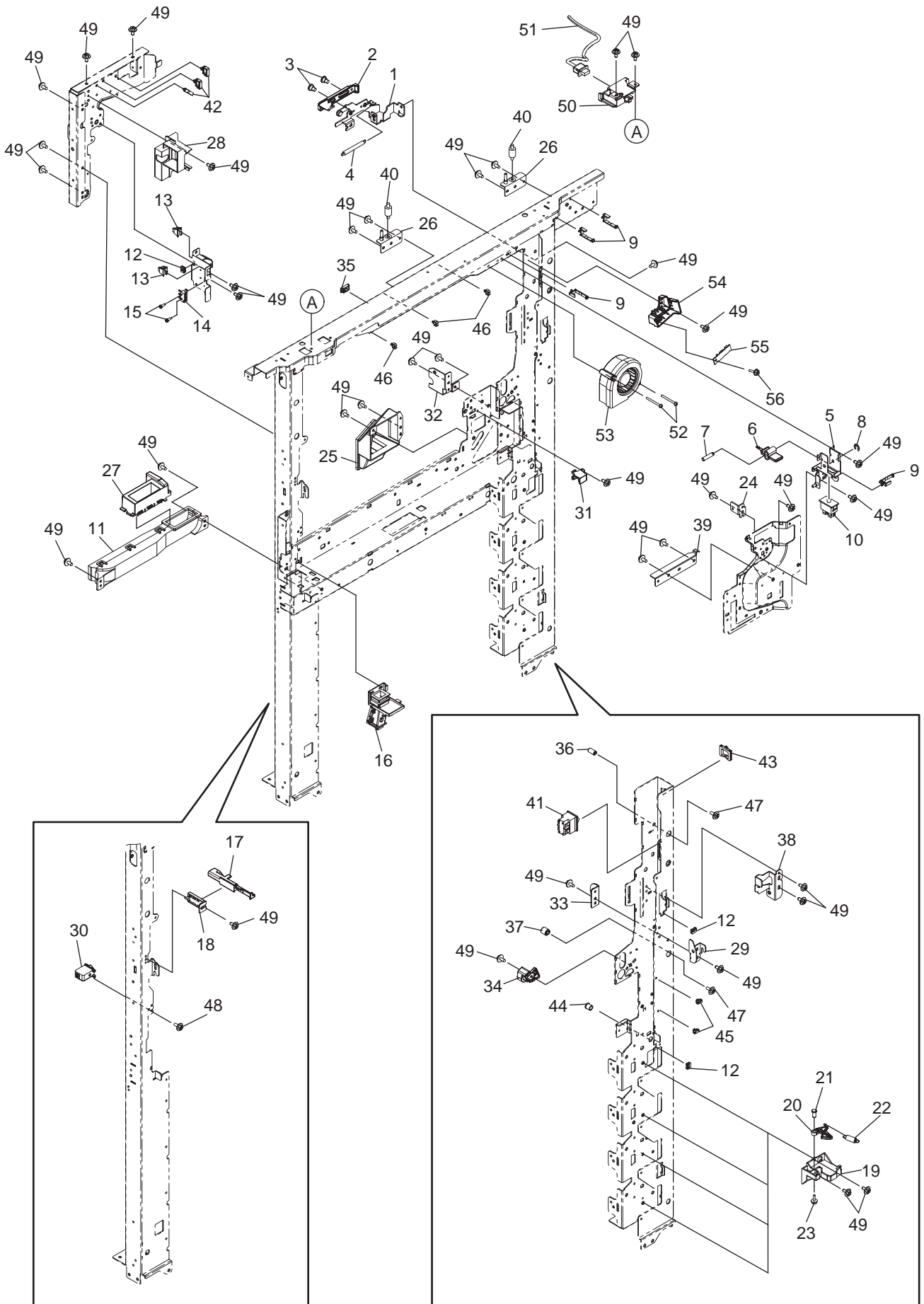

	Ref. No.	Part.No.	Alternative.	Description	Quantity	
					120	230
	1	305JN70ZS0	5JN70ZS0	BRACKET ASSY:ASYS-BKT-LVR-DOOR	1	1
	2	305JN70ZH0	5JN70ZH0	LEVER LVR-DOOR-SW	1	1
	3	305JN70280	5JN70280	SCREW-RAIL-TRU	2	2
	4	305JN70ZL0	5JN70ZL0	SPRING:SPG-E-6R5XR5X28R	1	1
	5	305JN70ZK0	5JN70ZK0	BRACKET ASSY:ASYS-BKT-DOOR-SW	1	1
	6	305JN70ZG0	5JN70ZG0	GUIDE-SW-DOOR-430	1	1
	7	305JN701P0	5JN701P0	PIN:STUD-DOOR-SW	1	1
	8	305JN72LV0	5JN72LV0	RETAIN NG RING:RR/E-4-SS	1	1
	9	305JN72J20	5JN72J20	CLAMP RLWS3TV0	4	4
⊙	10	305JN72HM0	5JN72HM0	SWITCH:FA1L-AA22	1	1
	11	305JN710G0	5JN710G0	DUCT ASSY:ASYS-DUCT-EPU-FRT	1	1
	12	305JN72J60	5JN72J60	BAND:ES-0505	3	3
⊙	13	305JN72HG0	5JN72HG0	SWITCH:CS1A-B2CA	2	2
⊙	14	305JN72HL0	5JN72HL0	SWITCH:DE2L-BALG	1	1
	15	305JN70200	5JN70200	SCREW 20°D23	2	2
	16	305JN719A0	5JN719A0	DUCT ASSY:ASYB-DUCT-WTNR-VT	1	1
	17	305JN71E90	5JN71E90	L FT PLATE:LIFT-TBU-LEFT	1	1
	18	305JN71BP0	5JN71BP0	BRACKET:ANG-TBU-LEFT	1	1
	19	305JN702N0	5JN702N0	HOLDER-LOCK-CST	4	4
	20	305JN702P0	5JN702P0	HOOK-LOCK-CST	4	4
	21	305JN702Q0	5JN702Q0	PIN:STUD-LOCK-CST	4	4
	22	305JN71RS0	5JN71RS0	SPACER:SPE096-100-0282	4	4
	23	305JN72NA0	5JN72NA0	SCREW:S/FHEXM-M3X8-NI	4	4
	24	305JN71Q20	5JN71Q20	BRACKET ASSY:ASYS-BRKT-POS-MID-F	1	1
	25	305JN72520	5JN72520	DUCT ASSY:ASYS-DUCT-LSU- N	1	1
	26	305JN72660	5JN72660	BRACKET ASSY:ASYS-BRKT-DMP-FRT	2	2
	27	305JN71030	5JN71030	DUCT-EPU-F-EXT-S	1	1
	28	305JN71040	5JN71040	DUCT-BRG-LEFT-IN	1	1
	29	305JN713A0	5JN713A0	SUPPORT PLATE:SUPPORT-PLT-HNG-CV-R	1	1
	30	305JN71720	5JN71720	STOPPER:STOP-EPU-LFT	1	1
	31	305JN71730	5JN71730	STOPPER:STOP-EPU-RGT	1	1
	32	305JN71HV0	5JN71HV0	BRACKET:BRKT-CAM-TR2-F	1	1
	33	305JN71F70	5JN71F70	PLATE:PLT-POS-HOLE-TRU	1	1
	34	305JN71K20	5JN71K20	HOLDER:HLDR-GID-RGST-F-430	1	1
	35	305JN72K10	5JN72K10	BAND:ESC-0912	1	1
	36	305JN71PH0	5JN71PH0	PIN:STUD-LOCK-ADU	1	1
	37	305JN71PK0	5JN71PK0	PIN:STUD-LOCK-ADU-FL	1	1
	38	305JN721J0	5JN721J0	BRACKET:BRKT-FUS-F	1	1
	39	305JN721M0	5JN721M0	BRACKET:BRKT-SLIDE-F	1	1
⊙	40	305JN725X0	5JN725X0	INSULATOR-430	2	2
	41	305JN72HN0	5JN72HN0	SWITCH:AJ8W200WWF	1	1
	42	305JN72HZ0	5JN72HZ0	CLAMP PLWS-1-46B	3	3
	43	305JN72J50	5JN72J50	BAND:EDS-1717U	1	1
	44	305JN72JL0	5JN72JL0	BAND:OCB-375	1	1
	45	305JN72KG0	5JN72KG0	CLAMP LBWS-0206S-V0	2	2
	46	305JN72JD0	5JN72JD0	CLAMP UAMS-05L-0-46	3	3
	47	305JN72NB0	5JN72NB0	SCREW:S/FHEXM-M4X8-NI	2	2
	48	305JN72NG0	5JN72NG0	SCREW:S/TPP/FHEXM-4X8-NI	1	1
	49	305JN72NT0	5JN72NT0	SCREW:S/TPS/FHEXM/R-4X8-ZU3	42	42
	50	305JN70ZM0	5JN70ZM0	HOLDER-USB-430	1	1
	51	305JN726U0	5JN726U0	CABLE-USB-430	1	1
	52	305JN72N60	5JN72N60	SCREW:S/TPS/PAN-4X35-ZU3	2	2
⊙	53	305JN71160	5JN71160	DUCT ASSY:ASYS-DUCT-BRDG-F	1	1
	54	305JN713X0	5JN713X0	COVER_LED_FUS	1	1
⊙	55	305JN72BB0	5JN72BB0	PWB ASSY:PWA-F-LED-430	1	1
	56	305JN72NF0	5JN72NF0	SCREW:S/TPP/FHEXM-3X10-NI	1	1

• Parts with "⊙" indicate regular maintenance parts.

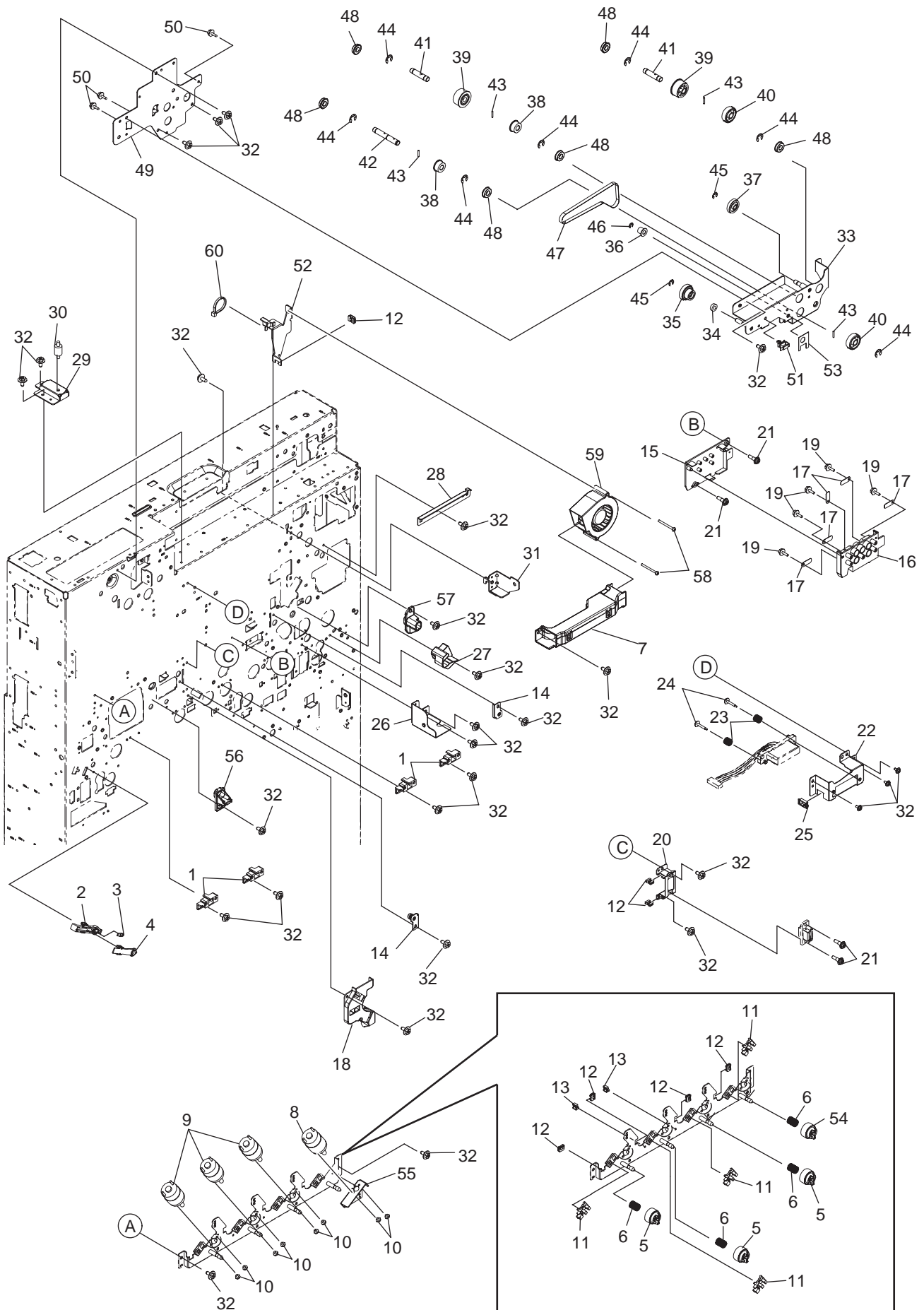

	Ref. No.	Part.No.	Alternative.	Description	Quantity	
					120	230
	1	305JN714U0	5JN714U0	BRACKET:BRKT-DRAWER-CNTR-CLNR	4	4
	2	305JN715B0	5JN715B0	TERMINAL PLATE:TERM-HVT-EPU-Y	1	1
	3	305JN714W0	5JN714W0	PLATE-TERM-HVT-EPU-187-S	1	1
	4	305JN715C0	5JN715C0	COVER-TERM-HVT-EPU-Y	1	1
⊙	5	305JN717Z0	5JN717Z0	GEAR-5H46-6-COUPPL	3	3
	6	305JN719N0	5JN719N0	SPRING:SPG-C-GEAR-DRV-TNR-430	4	4
	7	305JN71120	5JN71120	DUCT ASSY:ASYB-DUCT-BRDG-R	1	1
⊙	8	305JN71950	5JN71950	MOTOR ASSY :ASYS-MOTRD-KTNR-430	1	1
⊙	9	305JN71960	5JN71960	MOTOR ASSY :ASYS-MOTRD-CTNR-430	3	3
	10	305JN72P10	5JN72P10	SCREW:S/BID-M2.6X3-NI	8	8
⊙	11	305JN72HB0	5JN72HB0	SENSOR:LG283L1	4	4
	12	305JN72J60	5JN72J60	BAND:ES-0505	7	7
	13	305JN72K20	5JN72K20	CLAMP MSB-1207	2	2
	14	305JN71BN0	5JN71BN0	BRACKET ASSY:ASYS-BRKT-TBU-FIX	2	2
	15	305JN71AK0	5JN71AK0	COVER-TERM-KCMY	1	1
	16	305JN71AL0	5JN71AL0	CASE-TERM-KCMY	1	1
	17	305JN71AM0	5JN71AM0	PLATE-TERM-TBU	5	5
	18	305JN71AJ0	5JN71AJ0	COVER:COV-HRNS-TERM-TBU	1	1
	19	305JN72NE0	5JN72NE0	SCREW:S/TPP/FHEXM-3X8-NI	5	5
	20	305JN71AH0	5JN71AH0	BRACKET:BRKT-TERM-AMP-DRW	1	1
	21	305JN70350	5JN70350	SCREW-SOCKET	4	4
	22	305JN72EH0	5JN72EH0	BRACKET:BRKT-CON	1	1
	23	305JN70360	5JN70360	SPRING:SPC074-070-0145	2	2
	24	305JN70100	5JN70100	SCREW-D4-18-M3	2	2
	25	305JN72K10	5JN72K10	BAND:ESC-0912	1	1
	26	305JN71EV0	5JN71EV0	BRACKET:BRKT-CAM-TR2-R	1	1
	27	305JN71K30	5JN71K30	HOLDER:HLDR-GID-RGST-R-430	1	1
	28	305JN721N0	5JN721N0	BRACKET:BRKT-SLIDE-R	1	1
	29	305JN725V0	5JN725V0	BRACKET:BRKT-DMP-RER-LFT-430	1	1
	30	305JN725X0	5JN725X0	INSULATOR-430	1	1
	31	305JN71MH0	5JN71MH0	BRACKET ASSY:ASYS-BRKT-POS-M D-R-FAN	1	1
	32	305JN72NT0	5JN72NT0	SCREW:S/TPS/FHEXM/R-4X8-ZU3	27	27
	33	305JN71KB0	5JN71KB0	FRAME ASSY:ASYS-FRAME-DRIVE-EXIT-F	1	1
	34	305JN72K80	5JN72K80	BEARING:DDL-1260ZZHP0P25LY13	1	1
	35	305JN71KQ0	5JN71KQ0	GEAR-10S25_PS2M28-6	1	1
	36	305JN71KR0	5JN71KR0	GEAR: DLER-DRIVE-EXIT	1	1
	37	305JN707R0	5JN707R0	GEAR-10S022-06-DRV	1	1
	38	305JN702R0	5JN702R0	PULLEY:PLY/T-S2M-28-08	2	2
	39	305JN71KP0	5JN71KP0	GEAR-10S25-8-OWR	2	2
	40	305JN71KN0	5JN71KN0	GEAR-10S25-8-DRV	2	2
	41	305JN71KH0	5JN71KH0	SHAFT-DRIVE-EXIT-1	2	2
	42	305JN71KJ0	5JN71KJ0	SHAFT-DRIVE-EXIT-2	1	1
	43	305JN72MC0	5JN72MC0	PIN:P/PRL/AH7-2X12-SS	4	4
	44	305JN72LY0	5JN72LY0	RETAIN NG RING:RR/E-7-SS	7	7
	45	305JN72LW0	5JN72LW0	RETAIN NG RING:RR/E-5-SS	2	2
	46	305JN72LV0	5JN72LV0	RETAIN NG RING:RR/E-4-SS	1	1
	47	305JN71KK0	5JN71KK0	TIMING BELT:BLT_SY-S2M-316-6	1	1
	48	305JN72KB0	5JN72KB0	BEARING:LNR-1680HHRP0P15LY13	6	6
	49	305JN71KX0	5JN71KX0	FRAME-DRIVE-EXIT-R	1	1
	50	305JN72NS0	5JN72NS0	SCREW:S/TPS/FHEXM/R-3X8-ZU3	4	4
	51	305JN72JP0	5JN72JP0	CLAMP LWS-0711Z	1	1
	52	305JN71MV0	5JN71MV0	BRACKET:BRKT-REAR-FAN-7525	1	1
⊙	53	305JN71MW0	5JN71MW0	SHEET:MYLAR-DRIVE-EXIT	1	1
	54	305JN719X0	5JN719X0	GEAR-5H46-6-COUPPL-K	1	1
	55	305JN719W0	5JN719W0	FRAME-TNR-MOTR-RER	1	1
	56	305JN71E20	5JN71E20	HOLDER:HLDR-TBU-RL	1	1
	57	305JN71E30	5JN71E30	HOLDER:HLDR-TBU-RR	1	1
	58	305JN72N60	5JN72N60	SCREW:S/TPS/PAN-4X35-ZU3	2	2
⊙	59	305JN72CB0	5JN72CB0	FAN MOTOR:FAN-P7530-430M	1	1
	60	305JN72HX0	5JN72HX0	CLAMP:T18S	1	1

• Parts with "⊙" indicate regular maintenance parts.

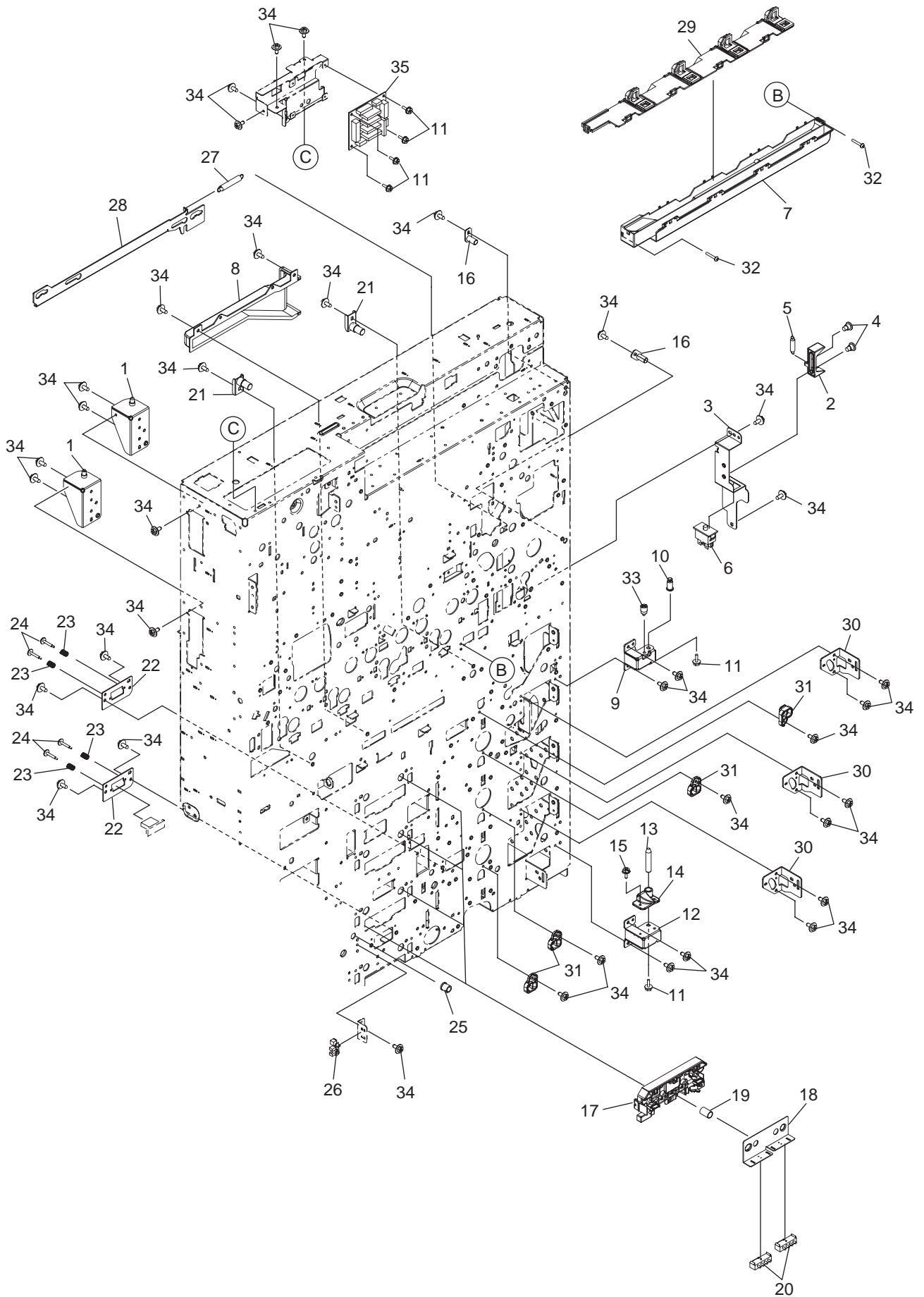

	Ref. No.	Part.No.	Alternative.	Description	Quantity	
					120	230
	1	305JN70ZA0	5JN70ZA0	BRACKET ASSY:ASYS-BRKT-HINGE	2	2
	2	305JN70ZE0	5JN70ZE0	SL DER:SLIDE-FUS-INTER	1	1
	3	305JN70ZF0	5JN70ZF0	BRACKET:BRKT-FUS-SW-INTER	1	1
	4	305JN70280	5JN70280	SCREW-RAIL-TRU	2	2
⊙	5	305JN70WD0	5JN70WD0	SPRING:SPG-E-6R5XR45X31R9	1	1
	6	305JN72HM0	5JN72HM0	SWITCH:FA1L-AA22	1	1
	7	305JN70ZW0	5JN70ZW0	DUCT-OZ-TONER-L	1	1
	8	305JN710H0	5JN710H0	DUCT ASSY:ASYS-DUCT-LSU-RER	1	1
	9	305JN71J90	5JN71J90	BRACKET:BRKT-COV-HINGE-FRM-R-U	1	1
	10	305JN71J80	5JN71J80	PIN:STUD-COV-HINGE-FRM-R-U	1	1
	11	305JN72NA0	5JN72NA0	SCREW:S/FHEXM-M3X8-NI	6	6
	12	305JN71JC0	5JN71JC0	BRACKET:BRKT-COV-HINGE-FRM-R-L	1	1
	13	305JN71JA0	5JN71JA0	PIN:STUD-COV-HINGE-FRM-R-L	1	1
	14	305JN71JB0	5JN71JB0	GUIDE-SLOPE-L	1	1
	15	305JN72NS0	5JN72NS0	SCREW:S/TPS/FHEXM/R-3X8-ZU3	1	1
	16	305JN71Q30	5JN71Q30	BRACKET ASSY:ASYS-BRKT-POS-ADU	2	2
	17	305JN71RG0	5JN71RG0	HOLDER-SENSOR-CST-F43X	4	4
	18	305JN71RD0	5JN71RD0	BRACKET:BRKT-SENSOR-CST-F43X	4	4
⊙	19	305JN71RL0	5JN71RL0	SPRING:SPG-C-8R9XR9X11R6	4	4
	20	305JN72HP0	5JN72HP0	SWITCH:HS12-0001	8	8
	21	305JN72500	5JN72500	BRACKET ASSY:ASYS-BRKT-LSU-STUD	2	2
	22	305JN71S10	5JN71S10	BRACKET:BRKT-DRW-TANDEM	2	2
	23	305JN71T80	5JN71T80	SPRING:SPG-DRAWER-TANDEM	4	4
	24	305JN70100	5JN70100	SCREW-D4-18-M3	4	4
⊙	25	305JN72JL0	5JN72JL0	BAND:OCB-375	1	1
	26	305JN72H20	5JN72H20	SENSOR LG248BL1	1	1
	27	305JN71BD0	5JN71BD0	SPRING:SPG-E-PLATE-TBU-FIX	1	1
	28	305JN71BQ0	5JN71BQ0	PLATE-TBU-FIX	1	1
	29	305JN710J0	5JN710J0	DUCT ASSY:ASYS-DUCT-OZ-TNR-UPR	1	1
	30	305JN71R10	5JN71R10	BRACKET:BRKT-HOLD-RAIL	3	3
	31	305JN71RK0	5JN71RK0	HOLDER-CST-POS	4	4
	32	305JN72MU0	5JN72MU0	SCREW:S/TPS/PAN-4X20-ZU3	2	2
	33	305JN70750	5JN70750	SCREW-SCAN-LFT	1	1
⊙	34	305JN72NT0	5JN72NT0	SCREW:S/TPS/FHEXM/R-4X8-ZU3	37	37
	35	305JN72B30	5JN72B30	PWB ASSY:PWA-F-DRV-430	1	1

• Parts with "⊙" indicate regular maintenance parts.

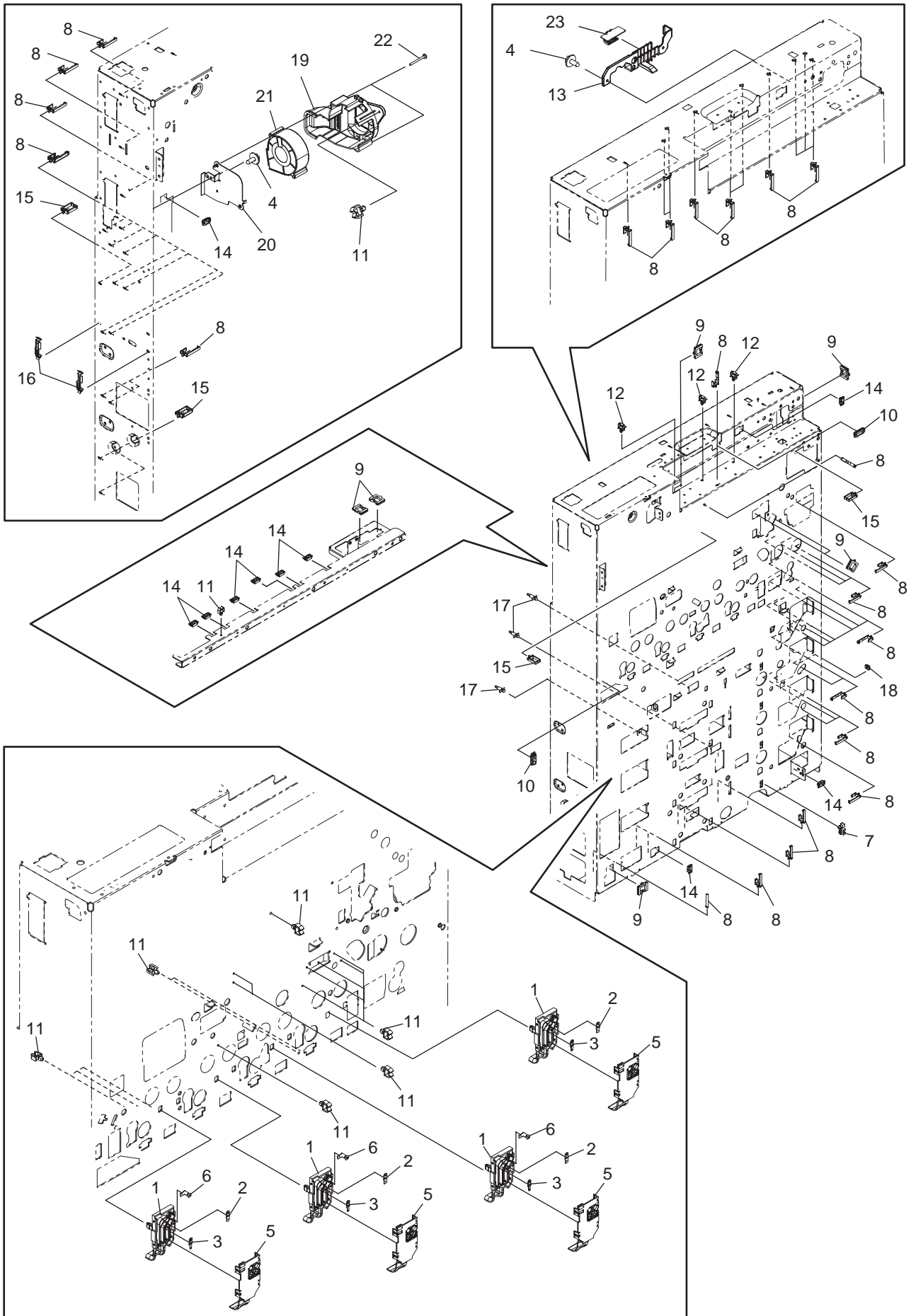

	Ref. No.	Part.No.	Alternative.	Description	Quantity	
					120	230
	1	305JN714X0	5JN714X0	TERMINAL PLATE:TERM-HVT-EPU	4	4
	2	305JN714W0	5JN714W0	PLATE-TERM-HVT-EPU-187-S	4	4
	3	305JN717D0	5JN717D0	PLATE-TERM-HVT-EPU-110-S	4	4
	4	305JN72NT0	5JN72NT0	SCREW:S/TPS/FHEXM/R-4X8-ZU3	2	2
	5	305JN714V0	5JN714V0	COVER:COV-TERM-HVT-EPU	4	4
	6	305JN714Y0	5JN714Y0	PLATE-TERM-HVT-EPU-187-D	3	3
⊙	7	305JN72H20	5JN72H20	SENSOR LG248BL1	2	2
	8	305JN72J20	5JN72J20	CLAMP RLWS3TV0	48	48
	9	305JN72J50	5JN72J50	BAND:EDS-1717U	7	7
	10	305JN72J90	5JN72J90	CLAMP:TSB-1909N	3	3
	11	305JN72JD0	5JN72JD0	CLAMP UAMS-05L-0-46	8	8
	12	305JN72JP0	5JN72JP0	CLAMP LWS-0711Z	3	3
	13	305JN71100	5JN71100	GUIDE-HRNS-AC	1	1
	14	305JN72K10	5JN72K10	BAND:ESC-0912	10	10
	15	305JN72K30	5JN72K30	CLAMP RWS-3T V0	5	5
	16	305JN72KE0	5JN72KE0	WIRE CLAMP RFC-33V0	2	2
	17	305JN72JJ0	5JN72JJ0	LOCKING SUPPORT:SPLSN-8U	3	3
	18	305JN72J60	5JN72J60	BAND:ES-0505	1	1
	19	305JN710W0	5JN710W0	COVER ASSY:DUCT-STAY-TNR-LOW	1	1
	20	305JN710Z0	5JN710Z0	PLATE-DUCT-TNR	1	1
⊙	21	305JN72CB0	5JN72CB0	FAN MOTOR:FAN-P7530-430M	1	1
	22	305JN72LJ0	5JN72LJ0	SCREW:S/BID-M4X35-NI	2	2
	23	305JN71180	5JN71180	HOLDER:HLDR-HRNS-AC	1	1

• Parts with "⊙" indicate regular maintenance parts.

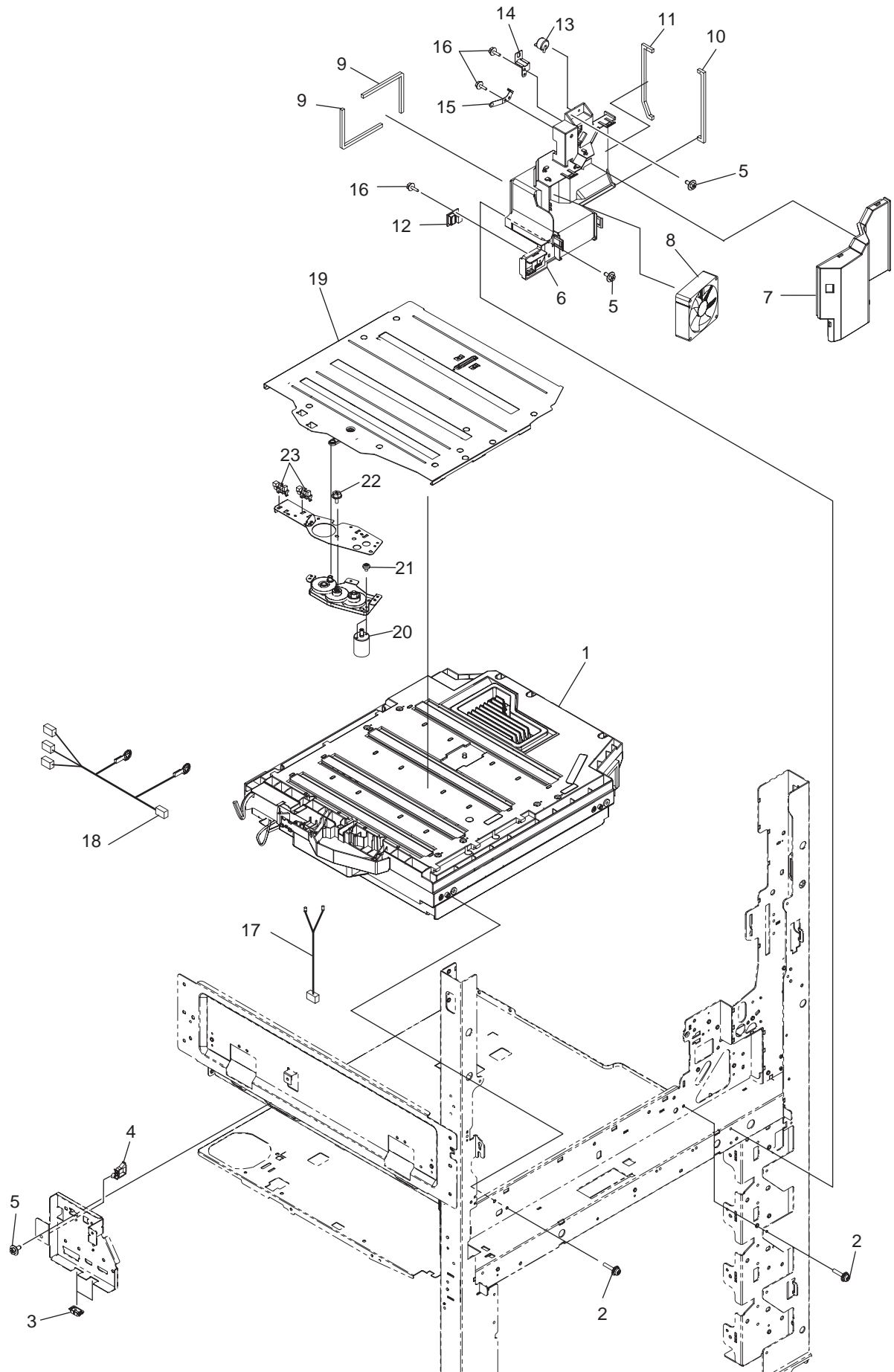

	Ref. No.	Part.No.	Alternative.	Description	Quantity	
					120	230
⊙	1	305JN72DK0	5JN72DK0	LSU-UNIT-F430	1	1
	2	305JN72LD0	5JN72LD0	SCREW:S/PAN/SWWP-M4X16-N1	2	2
	3	305JN72K10	5JN72K10	BAND:ESC-0912	2	2
	4	305JN72JZ0	5JN72JZ0	CLAMP LWS-1211Z	1	1
	5	305JN72NT0	5JN72NT0	SCREW:S/TPS/FHEXM/R-4X8-ZU3	3	3
	6	305JN724Y0	5JN724Y0	DUCT-LSU-430-IN	1	1
	7	305JN724X0	5JN724X0	DUCT-LSU-430-OUT	1	1
⊙	8	305JN706P0	5JN706P0	FAN-D-8025-350NH	1	1
	9	305JN72550	5JN72550	SEAL-LSU-DUCT- NR	2	2
	10	305JN72530	5JN72530	SEAL-LSU-DUCT-RGT1	1	1
	11	305JN72540	5JN72540	SEAL-LSU-DUCT-RGT2	1	1
	12	305JN72HF0	5JN72HF0	THERMISTOR:CHS-CSC-20	1	1
	13	305JN706Y0	5JN706Y0	VARISTOR ASSY:ASYS-ERZV10D821-350	1	1
	14	305JN706V0	5JN706V0	SPRING:SPG-F-RGST-R	1	1
	15	305JN706W0	5JN706W0	SPRING:SPG-F-RGST-L	1	1
	16	305JN72NE0	5JN72NE0	SCREW:S/TPP/FHEXM-3X8-NI	3	3
	17	305JN72760	5JN72760	WIRE HARNESS:HRNS-MT-430	1	1
⊙	18	305JN727D0	5JN727D0	WIRE HARNESS:HRNS-SHT-430	1	1
	19	305JN72DR0	5JN72DR0	SHUTTER-UNIT-430	1	1
	20	305JN724Z0	5JN724Z0	MOTOR:ASYS-MOTR-D-STR-430	1	1
⊙	21	305JN72N20	5JN72N20	SCREW:S/PAN-M3X3-NI	2	2
	22	305JN72N90	5JN72N90	SCREW:S/FHEXM-M3X6-NI	1	1
⊙	23	305JN72H20	5JN72H20	SENSOR LG248BL1	2	2

• Parts with "⊙" indicate regular maintenance parts.

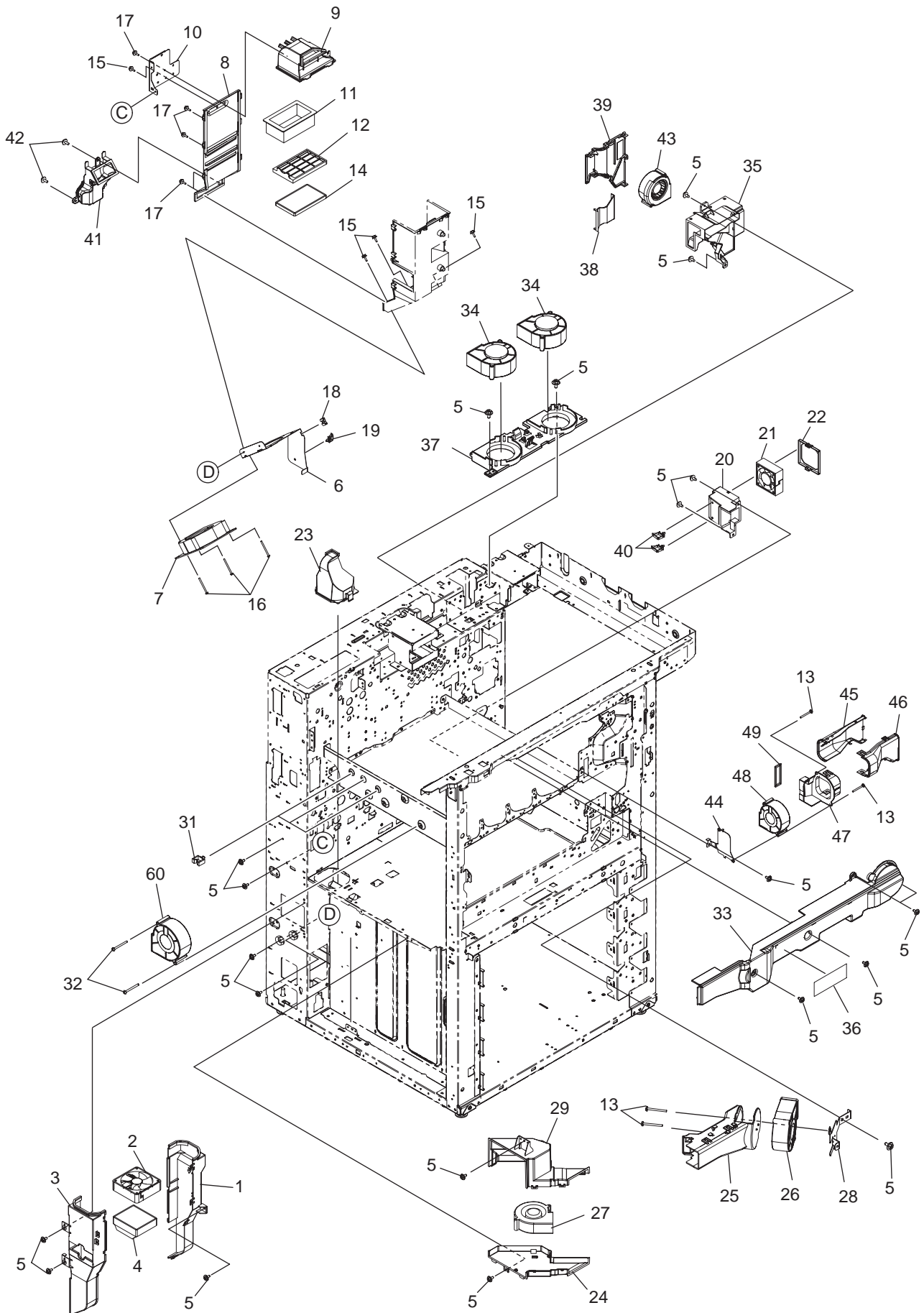

	Ref. No.	Part.No.	Alternative.	Description	Quantity	
					120	230
	1	305JN710B0	5JN710B0	DUCT ASSY:ASYS-DUCT-OZ-LWR-RGT	1	1
⊙	2	305JN71090	5JN71090	FAN MOTOR:ASYS-FAN-8025	1	1
	3	305JN710C0	5JN710C0	DUCT ASSY:ASYS-DUCT-OZ-LWR-LFT	1	1
⊙	4	305JN710K0	5JN710K0	OZONE FILTER:FLTR-OZ-430_TR	1	1
	5	305JN72NT0	5JN72NT0	SCREW:S/TPS/FHEXM/R-4X8-ZU3	21	21
	6	305JN70ZY0	5JN70ZY0	BRACKET:BRKT-CASE-FIL-TNR	1	1
⊙	7	305JN729X0	5JN729X0	FAN MOTOR:FAN-P12032-430	1	1
	8	305JN710D0	5JN710D0	COVER ASSY:ASYS-COVER-FLTR-TNR	1	1
	9	305JN710F0	5JN710F0	DUCT ASSY:ASYS-DUCT-TNR-UPR	1	1
	10	305JN70ZX0	5JN70ZX0	BRACKET:BRKT-CASE-FIL-SUB	1	1
⊙	11	305JN71080	5JN71080	AIR FILTER:FLTR-TONER-430_N	1	1
	12	305JN710M0	5JN710M0	HOLDER:HLDR-FLTR-OZ-TNR	1	1
	13	305JN72LJ0	5JN72LJ0	SCREW:S/BID-M4X35-NI	4	4
⊙	14	305JN710L0	5JN710L0	OZONE FILTER:FLTR-OZ-TNR-430_TR	1	1
	15	305JN72NS0	5JN72NS0	SCREW:S/TPS/FHEXM/R-3X8-ZU3	4	4
	16	305JN72NX0	5JN72NX0	SCREW:S/TPS/PAN-4X40-ZU3	3	3
	17	305JN72NE0	5JN72NE0	SCREW:S/TPP/FHEXM-3X8-NI	5	5
	18	305JN72J60	5JN72J60	BAND:ES-0505	1	1
	19	305JN72JP0	5JN72JP0	CLAMP LWS-0711Z	1	1
	20	305JN70ZZ0	5JN70ZZ0	DUCT-LSU-R-FAN	1	1
⊙	21	305JN710A0	5JN710A0	FAN MOTOR:ASYS-FAN-6025	1	1
	22	305JN71000	5JN71000	DUCT-LSU-R-COV	1	1
	23	305JN710E0	5JN710E0	DUCT ASSY:ASYS-DUCT-OZ-UPR	1	1
	24	305JN71020	5JN71020	DUCT-EPU-F-ENT-L	1	1
	25	305JN71170	5JN71170	DUCT ASSY:ASYB-DUCT-FRONT-LS	1	1
⊙	26	305JN71130	5JN71130	FAN MOTOR:ASYS-FAN-DUCT-FR-L	1	1
⊙	27	305JN70W10	5JN70W10	FAN MOTOR:FAND-DEV-390	1	1
	28	305JN710V0	5JN710V0	PLATE:PLT-DUCT-BRDG-FAN	1	1
	29	305JN71010	5JN71010	DUCT-EPU-F-ENT-U	1	1
⊙	30	305JN72CQ0	5JN72CQ0	FAN MOTOR:FAN-P7525-430	1	1
	31	305JN72K20	5JN72K20	CLAMP MSB-1207	3	3
	32	305JN72N40	5JN72N40	SCREW:S/TPS/PAN-4X32-ZU3	2	2
	33	305JN71190	5JN71190	DUCT ASSY:ASYS-DUCT-BRIDGE-F	1	1
⊙	34	305JN71150	5JN71150	FAN MOTOR:ASYS-FAN-TP-REAR	2	2
	35	305JN71050	5JN71050	DUCT-FUS-R-FAN	1	1
	36	305JN72G60	5JN72G60	LABEL LBL-HOT-BR-430	1	1
	37	305JN71110	5JN71110	HOLDER:HLDR-FAN-TP-REAR	1	1
	38	305JN71070	5JN71070	DUCT-FUS-R-IN	1	1
	39	305JN71060	5JN71060	DUCT-FUS-R-COV	1	1
	40	305JN72K00	5JN72K00	CLAMP LWS-1316Z	2	2
	41	305JN710T0	5JN710T0	COVER ASSY:ASYS-DUCT-TNR-OUT	1	1
	42	305JN72NB0	5JN72NB0	SCREW:S/FHEXM-M4X8-NI	2	2
⊙	43	305JN71160	5JN71160	DUCT ASSY:ASYS-DUCT-BRDG-F	1	1
	44	305JN710R0	5JN710R0	PLATE-DUCT-FRT-TNR	1	1
	45	305JN710N0	5JN710N0	DUCT-FRT-TNR-BASE	1	1
	46	305JN710P0	5JN710P0	DUCT-FRT-TNR-COUPLE	1	1
	47	305JN710Q0	5JN710Q0	DUCT-FRT-TNR-FAN-HLD	1	1
⊙	48	305JN71130	5JN71130	FAN MOTOR:ASYS-FAN-DUCT-FR-L	1	1
	49	305JN710S0	5JN710S0	SEAL-DUCT-FRT-TNR	1	1

• Parts with "⊙" indicate regular maintenance parts.

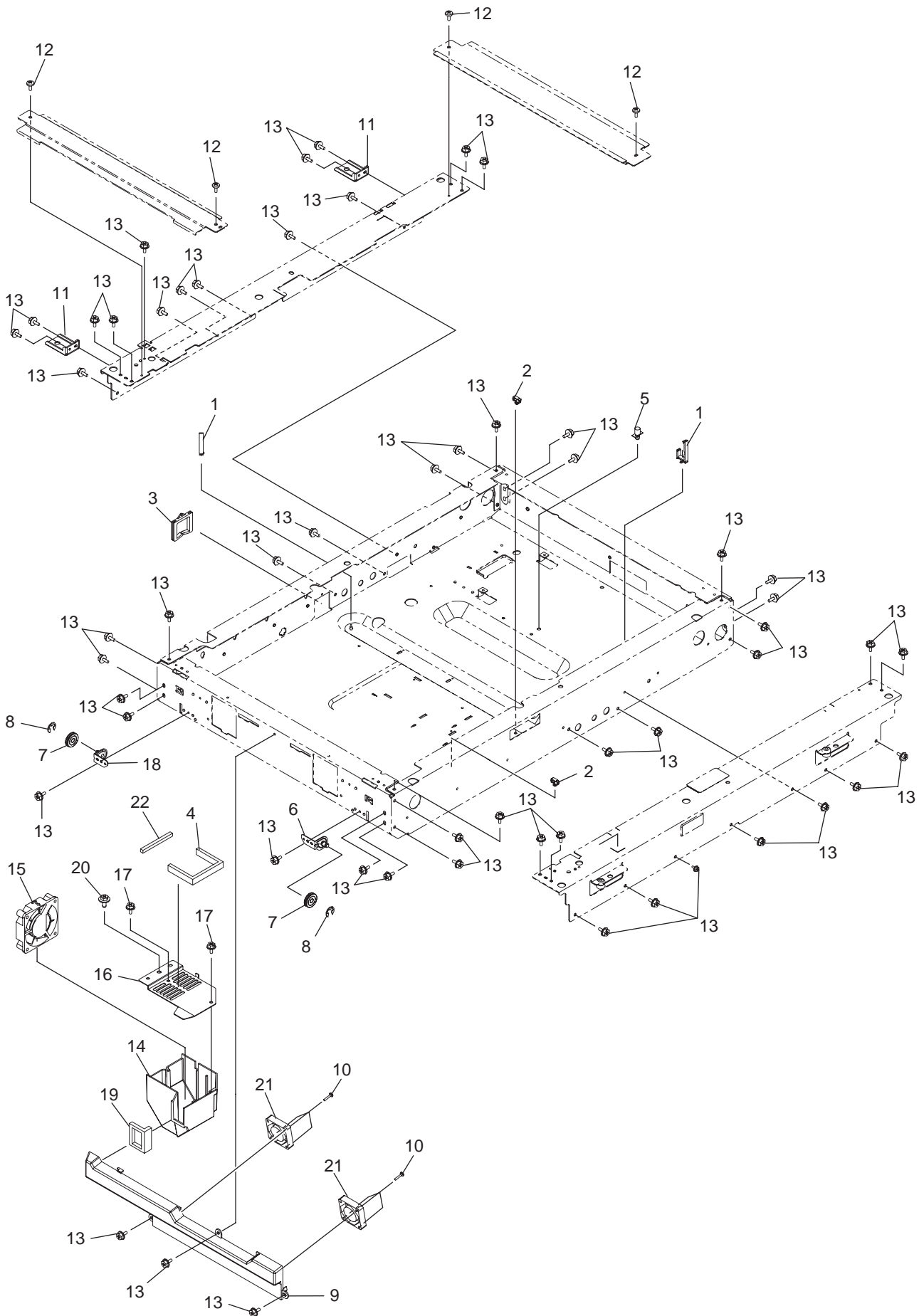

	Ref. No.	Part.No.	Alternative.	Description	Quantity	
					120	230
	1	305JN72J20	5JN72J20	CLAMP RLWS3TV0	2	2
	2	305JN72KGO	5JN72KGO	CLAMP LBWS-0206S-V0	2	2
	3	305JN72J10	5JN72J10	BAND:EDS-2323U	1	1
	4	305JN726B0	5JN726B0	CUSHION:CUSH-DUCT-SCAN-RER	1	1
	5	305JN72JE0	5JN72JE0	LOCKING SUPPORT:SPSN-6U	1	1
	6	305JN726H0	5JN726H0	PULLEY ASSY:ASYS-PLY-BRKT-FRAME-F	1	1
⊙	7	305JN726F0	5JN726F0	PULLEY:PLY-BRG-430	2	2
	8	305JN72LW0	5JN72LW0	RETAIN NG RING:RR/E-5-SS	2	2
	9	305JN726J0	5JN726J0	DUCT-FAN-SCAN-LFT-430	1	1
	10	305JN72MNO	5JN72MNO	SCREW:S/TPP/PAN-3X12-NI	4	4
	11	305JN725U0	5JN725U0	BRACKET:BRKT-DMP-SCN-RER	2	2
	12	305JN72LF0	5JN72LF0	SCREW:S/BID-M3X6-NI	4	4
	13	305JN72N90	5JN72N90	SCREW:S/FHEXM-M3X6-NI	55	55
	14	305JN72600	5JN72600	DUCT-SCAN-RER-L-430	1	1
⊙	15	305JN70W60	5JN70W60	FAN MOTOR:FAND-6015-39X	1	1
	16	305JN725Z0	5JN725Z0	COVER-DUCT-SCAN	1	1
	17	305JN72NY0	5JN72NY0	SCREW:S/TPP/BRZ-3X6-ZU3	2	2
	18	305JN726G0	5JN726G0	PULLEY ASSY:ASYS-PLY-BRKT-FRAME-R	1	1
	19	305JN725Y0	5JN725Y0	CUSHION:CUSH-DUCT-SCAN-430	1	1
	20	305JN72NT0	5JN72NT0	SCREW:S/TPS/FHEXM/R-4X8-ZU3	1	1
⊙	21	305JN72GS0	5JN72GS0	FAN MOTOR:FAND-4010-1604KL-450	2	2
	22	305JN726A0	5JN726A0	CUSHION:CUSH-DUCT-5-5-60	1	1

• Parts with "⊙" indicate regular maintenance parts.

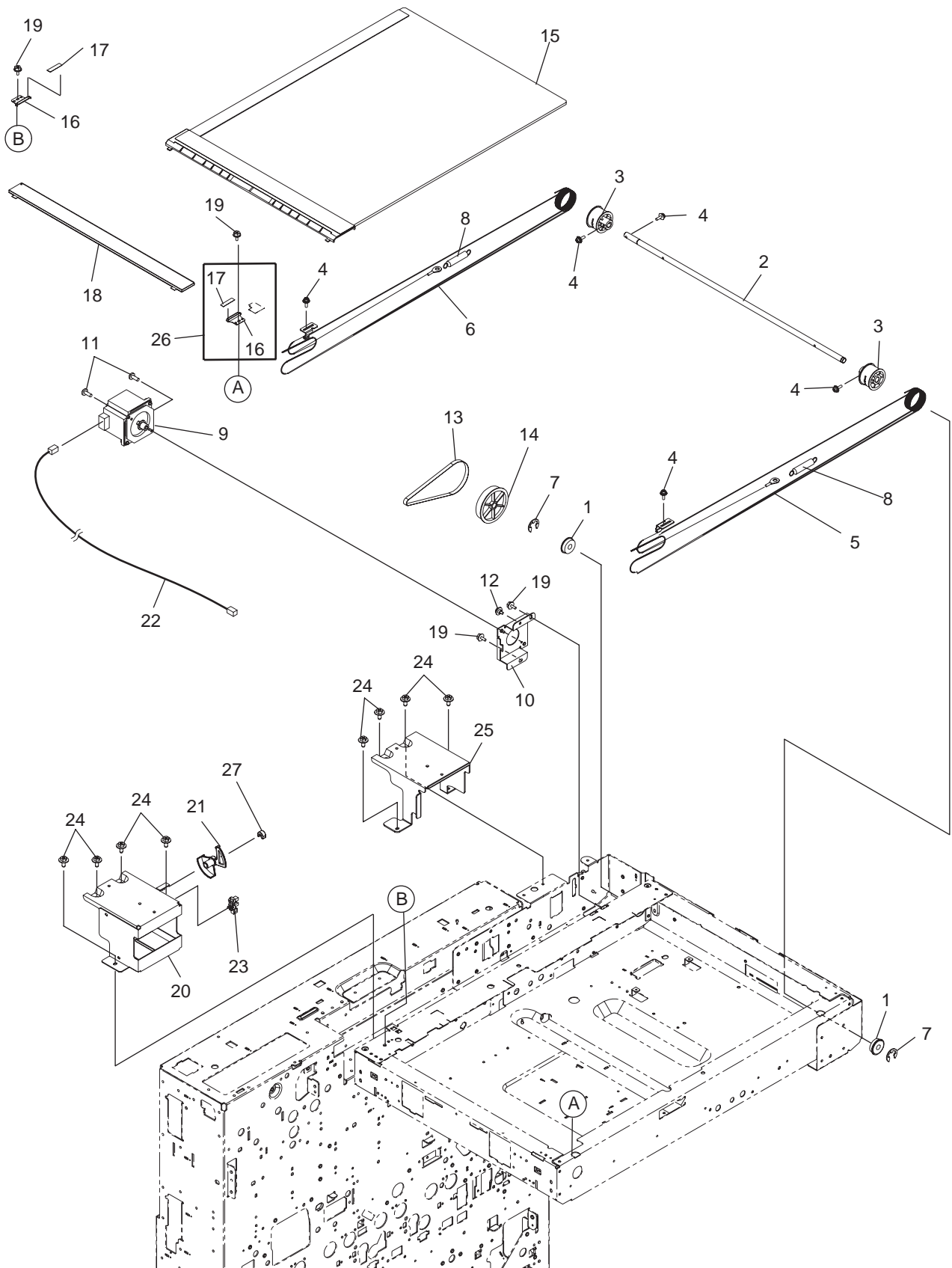

	Ref. No.	Part.No.	Alternative.	Description	Quantity	
					120	230
	1	305JN72K70	5JN72K70	BEARING:608ZZNRA2	2	2
	2	305JN725S0	5JN725S0	SHAFT-DRV-SCAN-430	1	1
⊙	3	305JN725G0	5JN725G0	PULLEY:PLY-WIRE-SCAN-430	2	2
	4	305JN72LA0	5JN72LA0	SCREW:S/PAN/SWVWP-M3X8-NI	5	5
	5	305JN725H0	5JN725H0	WIRE ASSY:ASYS-WIR_RP-SCAN-FRT-430	1	1
	6	305JN725J0	5JN725J0	WIRE ASSY:ASYS-WIR_RP-SCAN-RER-430	1	1
	7	305JN72LY0	5JN72LY0	RETAIN NG RING:RR/E-7-SS	2	2
	8	305JN72610	5JN72610	SPACER:SPE-W RE-TNS-430	2	2
⊙	9	305JN726V0	5JN726V0	MOTOR:MOTR_S-SCN-430	1	1
	10	305JN725F0	5JN725F0	BRACKET:BRKT-MOT-SCAN-430	1	1
	11	305JN72LG0	5JN72LG0	SCREW:S/BID-M4X8-NI	2	2
	12	305JN70300	5JN70300	SCREW-ACTR-TRU	1	1
	13	305JN725T0	5JN725T0	TIMING BELT:BLT-SY300-S2M-6	1	1
⊙	14	305JN72580	5JN72580	PULLEY-84S2M	1	1
⊙	15	305JN72620	5JN72620	CONTACT GLASS ASSY:ASYS-GLASS-434L	1	
⊙	15	305JN72630	5JN72630	CONTACT GLASS ASSY:ASYS-GLASS-434A		1
	16	305JN70730	5JN70730	SPRING:SPL-GLASS-ADF	2	2
	17	305JN70740	5JN70740	FILM:MYLAR-SPL-GLASS-ADF	2	2
⊙	18	305JN72640	5JN72640	CONTACT GLASS ASSY:ASYS-GLASS-ADF-430	1	1
	19	305JN72NWX	5JN72NWX	NUT:N/HEX/1-M5-NI	4	4
	20	305JN726E0	5JN726E0	BRACKET ASSY:ASYS-BRKT-DF-LFT-430	1	1
	21	305JN725L0	5JN725L0	LEVER LVR-OPEN-SNS-430	1	1
	22	305JN726P0	5JN726P0	WIRE HARNESS:HRNS-SCN-MOT-430	1	1
⊙	23	305JN72H20	5JN72H20	SENSOR LG248BL1	1	1
	24	305JN72NT0	5JN72NT0	SCREW:S/TPS/FHEXMR-4X8-ZU3	8	8
	25	305JN725K0	5JN725K0	BRACKET:BRKT-DF-RGT-430	1	1
	26	305JN726D0	5JN726D0	PLATE ASSY:ASYS-SPL-GLASS-ADF-430	1	1
	27	305JN700M0	5JN700M0	STOP-R NG-4	1	1

• Parts with "⊙" indicate regular maintenance parts.

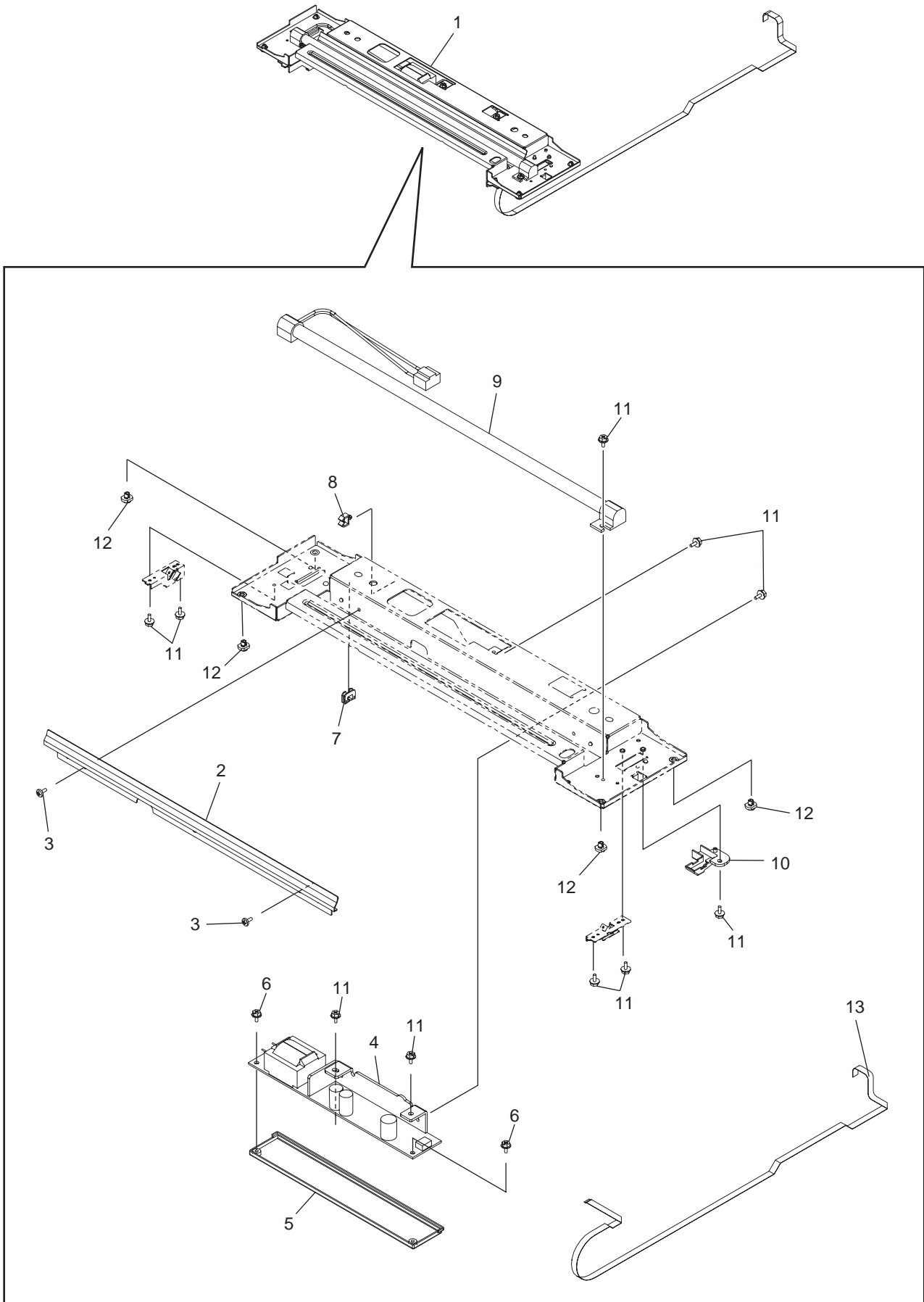

	Ref. No.	Part.No.	Alternative.	Description	Quantity	
					120	230
⊙	1	305JN72DM0	5JN72DM0	SCAN LAMP CARRIAGE ASSY:CARRIGE-1-F430S	1	1
	2	305JN72590	5JN72590	BRACKET:REF-LAMP-430	1	1
⊙	3	305JN72LF0	5JN72LF0	SCREW:S/BID-M3X6-NI	2	2
	4	305JN72710	5JN72710	INVERTER:INV-EXPO-430	1	1
⊙	5	305JN706Z0	5JN706Z0	COVER-INV	1	1
	6	305JN72NY0	5JN72NY0	SCREW:S/TPP/BRZ-3X6-ZU3	2	2
⊙	7	305JN72J60	5JN72J60	BAND:ES-0505	1	1
	8	305JN72J40	5JN72J40	CLAMP UAMS-05-2	1	1
⊙	9	305JN72700	5JN72700	LAMP-EXPO-430	1	1
	10	305JN72670	5JN72670	GUIDE-HRNS-CRG1-430	1	1
⊙	11	305JN72N90	5JN72N90	SCREW:S/FHEXM-M3X6-NI	10	10
	12	305JN70XS0	5JN70XS0	LEVEL BOLT FOOT-CRG-410	4	4
⊙	13	305JN726L0	5JN726L0	WIRE HARNESS HRNS-SCN-INV-430	1	1

• Parts with "⊙" indicate regular maintenance parts.

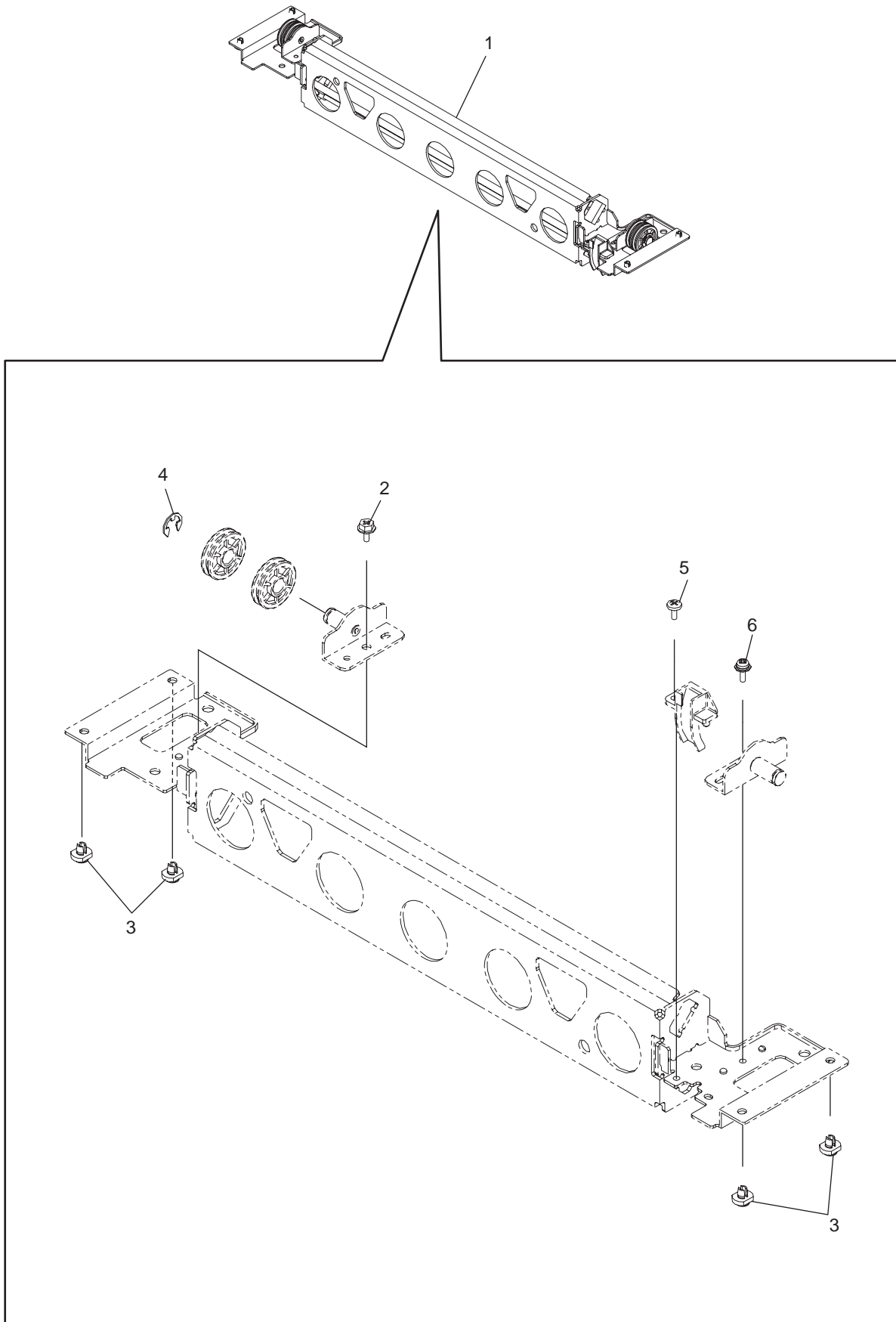

	Ref. No.	Part.No.	Alternative.	Description	Quantity	
					120	230
⊙	1	305JN72DN0	5JN72DN0	SCAN CARRIAGE FARAM ASSY:CARRIGE-2-F430S	1	1
	2	305JN72N90	5JN72N90	SCREW:S/HEXM-M3X6-NI	1	1
	3	305JN70XS0	5JN70XS0	LEVEL BOLT FOOT-CRG-410	4	4
	4	305JN72LW0	5JN72LW0	RETAIN NG RING:RR/E-5-SS	1	1
	5	305JN72LF0	5JN72LF0	SCREW:S/BID-M3X6-NI	1	1
	6	305JN72LA0	5JN72LA0	SCREW:S/PAN/SWWP-M3X8-NI	1	1

• Parts with "⊙" indicate regular maintenance parts.

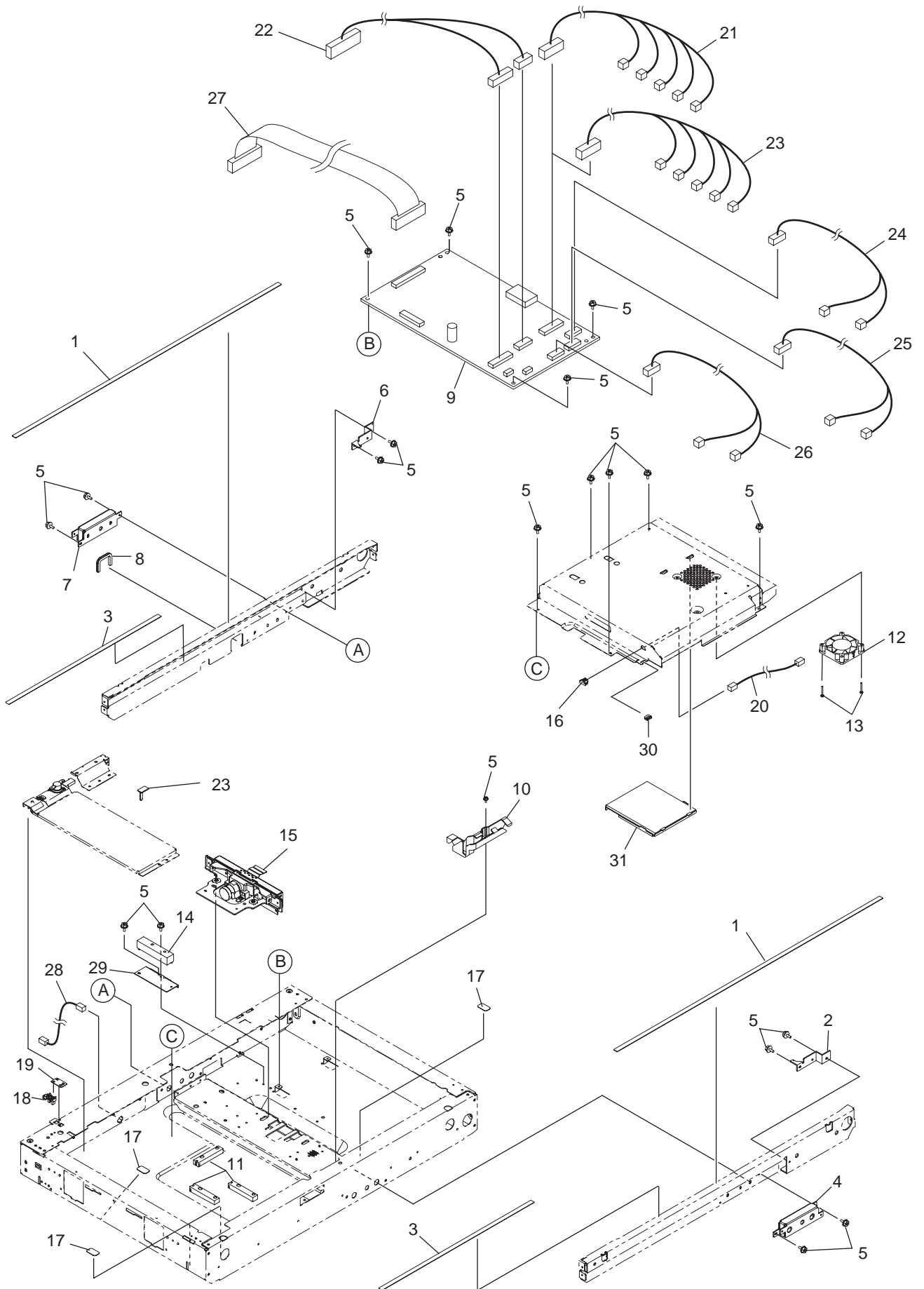

	Ref. No.	Part.No.	Alternative.	Description	Quantity	
					120	230
	1	305JN72560	5JN72560	SHEET-CRG1-430	2	2
	2	305JN725E0	5JN725E0	BRACKET:BRKT-RAIL-FRT-430	1	1
	3	305JN72570	5JN72570	SHEET-CRG2-430	2	2
	4	305JN725B0	5JN725B0	SPACER-RAIL-F-430	1	1
	5	305JN72N90	5JN72N90	SCREW:S/HEXM-M3X6-NI	19	19
	6	305JN725D0	5JN725D0	BRACKET:BRKT-RAIL-RER-430	1	1
	7	305JN725C0	5JN725C0	SPACER-RAIL-R-430	1	1
	8	305JN72680	5JN72680	BUSH-KG-016L-63	1	1
⊙	9	305JN72DC0	5JN72DC0	PWB ASSY:ASY-SLG-430S	1	1
	10	305JN725M0	5JN725M0	GUIDE-HRNS-430	1	1
⊙	11	305JN72720	5JN72720	SENSOR:SNSR-PS-182EL1	3	
⊙	11	305JN72720	5JN72720	SENSOR:SNSR-PS-182EL1		4
⊙	12	305JN70W60	5JN70W60	FAN MOTOR:FAND-6015-39X	1	1
	13	305JN72MR0	5JN72MR0	SCREW:S/TPS/PAN-3X20-ZU3	2	2
⊙	14	305JN70W50	5JN70W50	SENSOR ASSY:SNSR-PS-TY1CH56	1	1
⊙	15	305JN72DL0	5JN72DL0	LENS-UNIT-F430	1	1
	16	305JN72HQ0	5JN72HQ0	CONNECTOR:BU02P-TR-P-H (LF)(SN)	1	1
⊙	17	305JN70700	5JN70700	FILM:MYLAR-HRNS- NV	3	3
⊙	18	305JN72H20	5JN72H20	SENSOR LG248BL1	1	1
	19	305JN706K0	5JN706K0	COVER-SNSR-LIFT	1	1
	20	305JN72740	5JN72740	WIRE HARNESS:HRNS-SCN-FANRLY-430	1	1
	21	305JN70720	5JN70720	SCREW:S/PAN/SWWP-M3X8-ZC3	4	4
	22	305JN726N0	5JN726N0	WIRE HARNESS:HRNS-SCN-PS-430	1	1
	23	305JN72CL0	5JN72CL0	WIRE HARNESS:HRNS-SCN-APSL-430	1	
	24	305JN726M0	5JN726M0	WIRE HARNESS HRNS-SCN-SNSR-430	1	1
	25	305JN72BQ0	5JN72BQ0	WIRE HARNESS:HRNS-SCN-LMPFAN-430	1	1
	26	305JN72AW0	5JN72AW0	WIRE HARNESS:HRNS-SCN-SLGFAN-430	1	1
	27	305JN726K0	5JN726K0	WIRE HARNESS HRNS-SCN-SYS-430	1	1
	28	305JN72CC0	5JN72CC0	WIRE HARNESS HRNS-D_H-SCN2-430	1	1
	29	305JN725A0	5JN725A0	BRACKET:BRKT-APS-430	1	
	30	305JN72J60	5JN72J60	BAND:ES-0505	1	1

• Parts with "⊙" indicate regular maintenance parts.

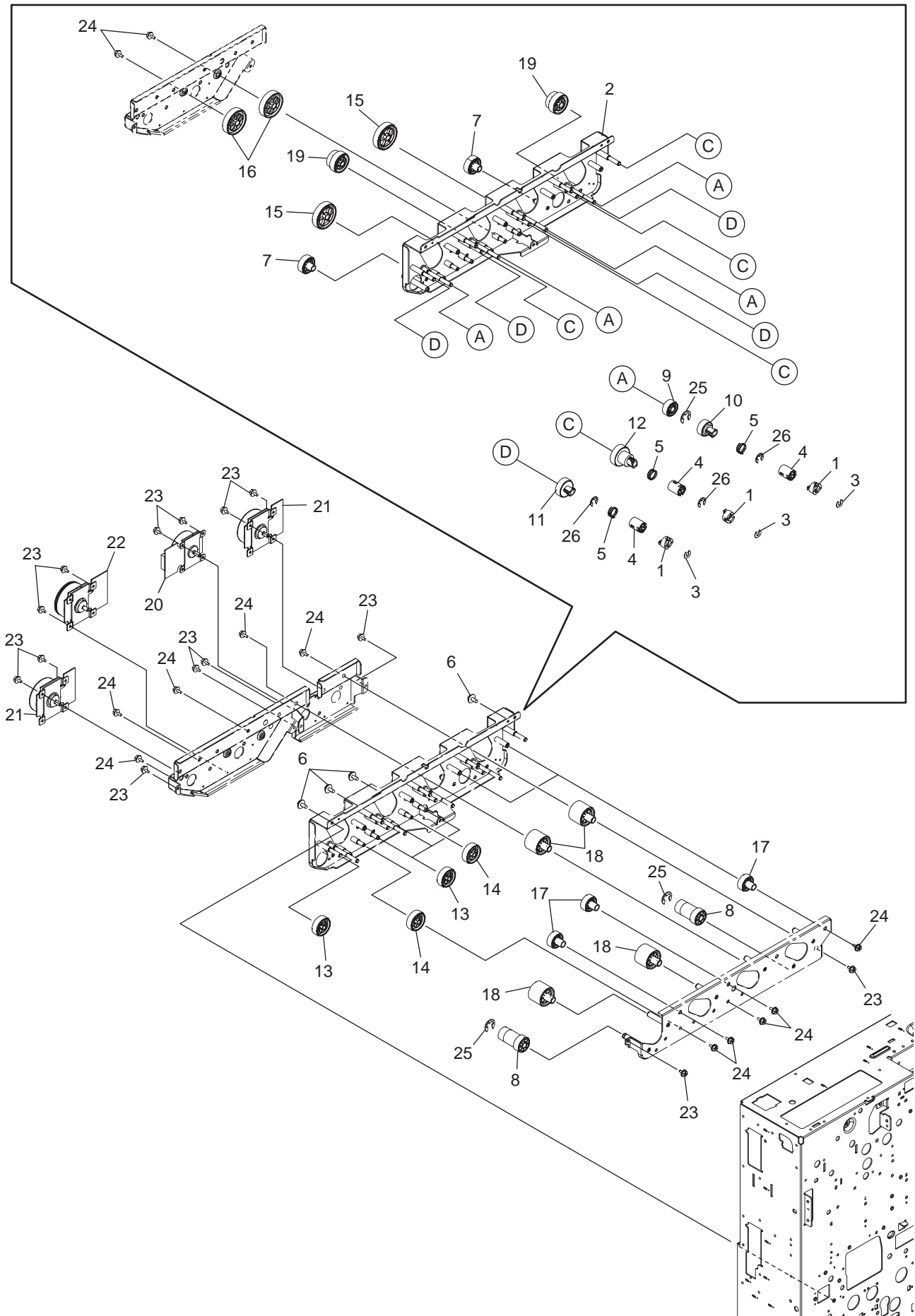

	Ref. No.	Part.No.	Alternative.	Description	Quantity	
					120	230
	1	305JN71D90	5JN71D90	COUPL NG:CPL-DEV-DRV-F	12	12
	2	305JN711C0	5JN711C0	FRAME ASSY:ASYS-FRAME-DEV-DRV	1	1
	3	305JN719K0	5JN719K0	RETAIN NG RING:RRG-4-P	12	12
	4	305JN71D80	5JN71D80	COUPL NG:CPL-DEV-DRV-R	12	12
	5	305JN711S0	5JN711S0	SPRING:SPG-C-DEV-DRIVE	12	12
	6	305JN72NT0	5JN72NT0	SCREW:S/TPS/FHEXM/R-4X8-ZU3	4	4
⊙	7	305JN711N0	5JN711N0	GEAR-5H52-8-DEV-IDLE	2	2
⊙	8	305JN711G0	5JN711G0	GEAR-5H39_5H47-8-DEV	2	2
⊙	9	305JN711H0	5JN711H0	GEAR-5H45-8-DEV	4	4
⊙	10	305JN71D60	5JN71D60	GEAR-5H45-8-CUP-DEV	4	4
⊙	11	305JN71D50	5JN71D50	GEAR-5H54-8-CUP-DEV-A	4	4
⊙	12	305JN71D70	5JN71D70	GEAR-5H61-8-CUP-DEV	4	4
⊙	13	305JN711J0	5JN711J0	GEAR-5H57-DEV	4	4
⊙	14	305JN711E0	5JN711E0	GEAR-5H58-DEV	2	2
⊙	15	305JN711K0	5JN711K0	GEAR-5H80-8-DEV	2	2
⊙	16	305JN711L0	5JN711L0	GEAR-5H79-8-DEV	2	2
⊙	17	305JN711D0	5JN711D0	GEAR-5H47-08-IDLE	4	4
⊙	18	305JN711F0	5JN711F0	GEAR-5H59-8-DEV-IDLE	4	4
⊙	19	305JN711M0	5JN711M0	GEAR-5H50_5H61-8-DEV	2	2
⊙	20	305JN72A00	5JN72A00	MOTOR:MOTRD-KMIX-430	1	1
⊙	21	305JN729Z0	5JN729Z0	MOTOR:MOTRD-DEV-430	2	2
⊙	22	305JN72BT0	5JN72BT0	MOTOR:MOTRD-CDEV-430	1	1
	23	305JN72NR0	5JN72NR0	SCREW:S/TPS/FHEXM/R-3X6-ZU3	14	14
	24	305JN72N90	5JN72N90	SCREW:S/FHEXM-M3X6-NI	13	13
	25	305JN72LY0	5JN72LY0	RETAIN NG RING:RR/E-7-SS	6	6
	26	305JN72LW0	5JN72LW0	RETAIN NG RING:RR/E-5-SS	12	12

• Parts with "⊙" indicate regular maintenance parts.

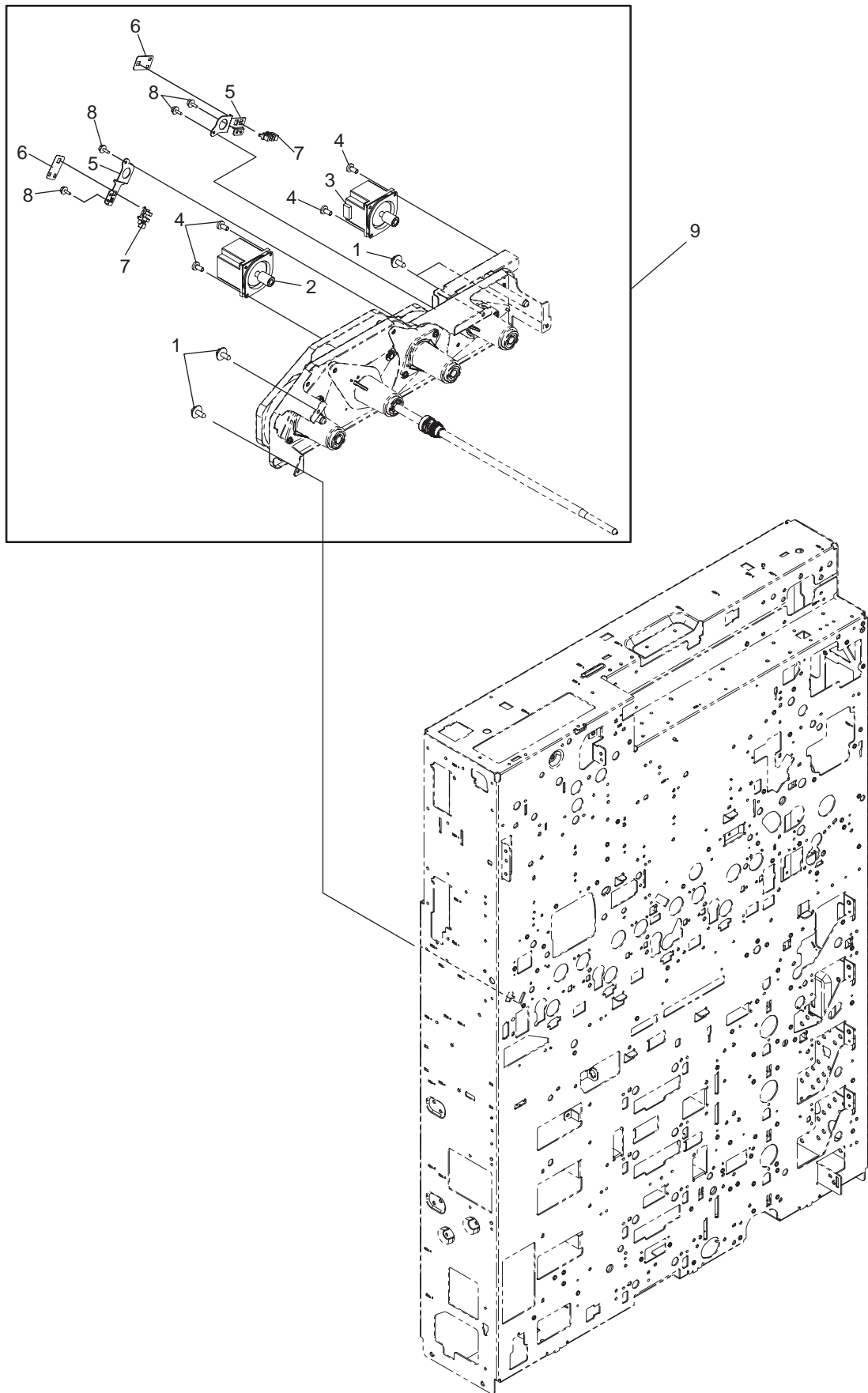

	Ref. No.	Part.No.	Alternative.	Description	Quantity	
					120	230
⊙	1	305JN72NT0	5JN72NT0	SCREW:S/TPS/FHEXM/R-4X8-ZU3	4	4
	2	305JN72A40	5JN72A40	MOTOR:MOTRS-CDRUM	1	1
⊙	3	305JN72A50	5JN72A50	MOTOR:MOTRS-KDRUM	1	1
	4	305JN711R0	5JN711R0	SCREW:S/BID-M4X8-ZC3-RED	4	4
	5	305JN711B0	5JN711B0	BRACKET:BRKT-SNS-DRUM-GEAR	2	2
	6	305JN711Q0	5JN711Q0	COVER-SNSR-LG248	2	2
⊙	7	305JN72H20	5JN72H20	SENSOR LG248BL1	2	2
	8	305JN72NA0	5JN72NA0	SCREW:S/FHEXM-M3X8-NI	4	4

• Parts with "⊙" indicate regular maintenance parts.

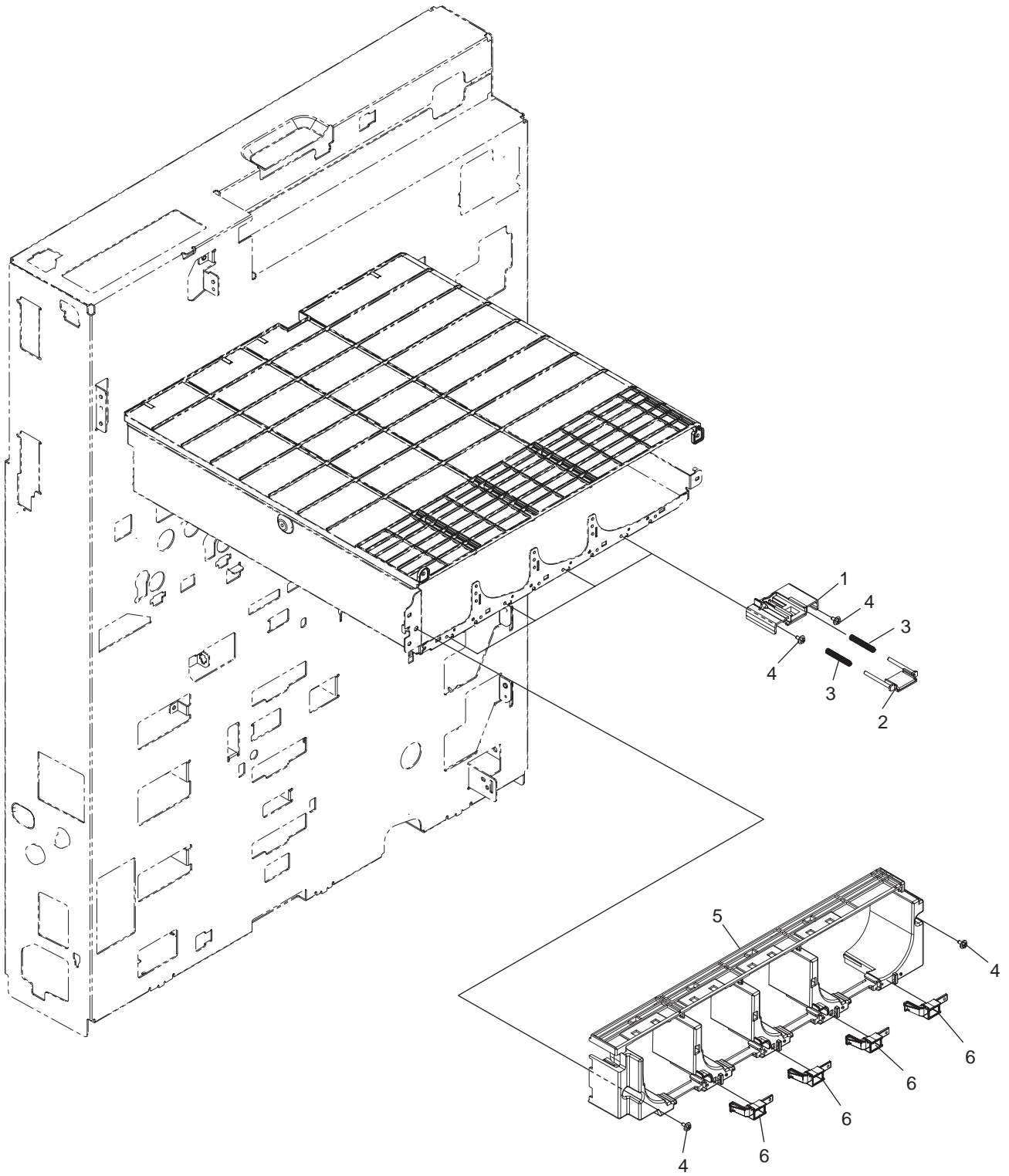

	Ref. No.	Part.No.	Alternative.	Description	Quantity	
					120	230
	1	305JN718J0	5JN718J0	DUCT-TONER	1	1
	2	305JN71930	5JN71930	SHUTTER ASSY:ASYS-SHUT-TONER-H	1	1
	3	305JN71940	5JN71940	SPRING:SPG-DUCT-TONER-H	2	2
	4	305JN72NT0	5JN72NT0	SCREW:S/TPS/FHEXM/R-4X8-ZU3	10	10
	5	305JN718Z0	5JN718Z0	COVER:COV-GUIDE-TC-430	1	1
	6	305JN718N0	5JN718N0	HOOK-COV-GUIDE-TC	4	4

• Parts with "⊙" indicate regular maintenance parts.

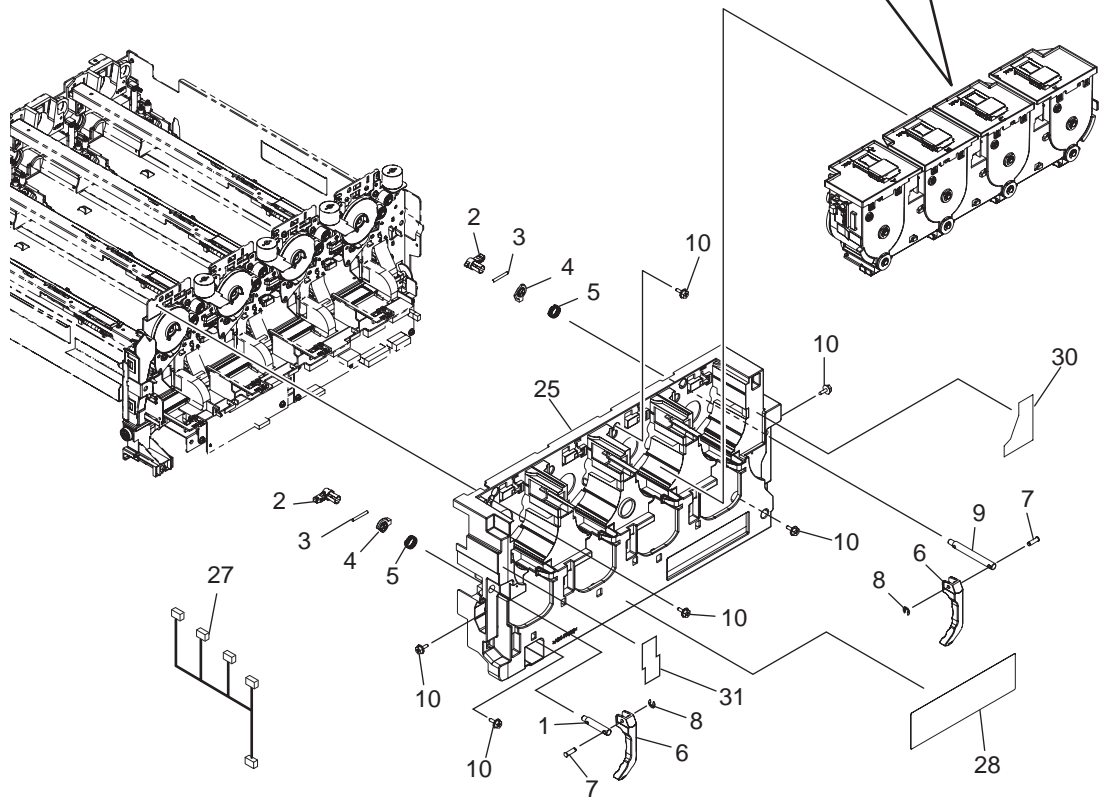
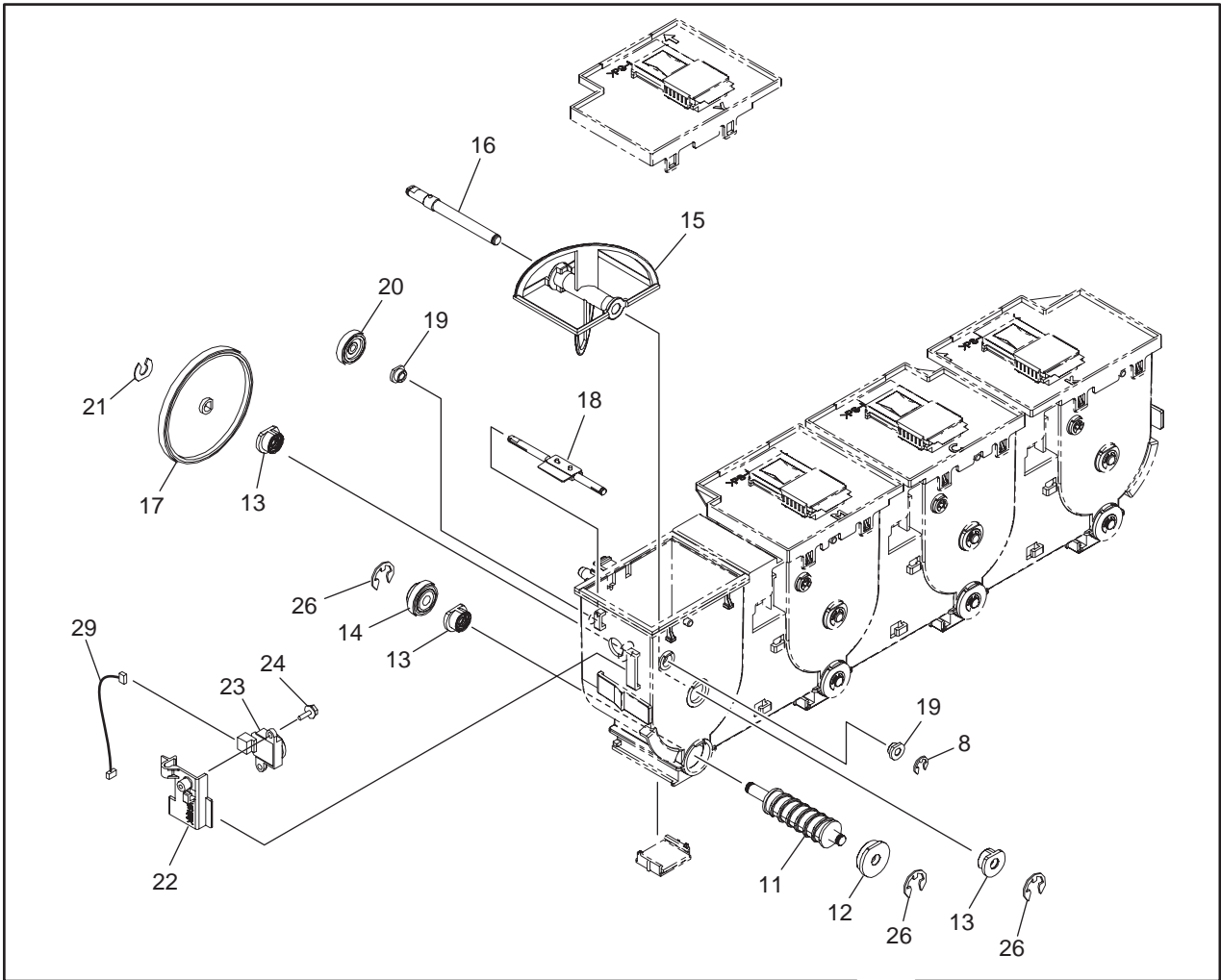

	Ref. No.	Part.No.	Alternative.	Description	Quantity	
					120	230
	1	305JN716V0	5JN716V0	SHAFT-LOCK-TRAY-EPU-LFT	1	1
	2	305JN714P0	5JN714P0	LOCK PIN:LOCK-TRAY-EPU	2	2
	3	305JN72NN0	5JN72NN0	PIN:P/PRL/AH7-3X25-SS	2	2
	4	305JN714Q0	5JN714Q0	STOPPER:STOP-LOCK-TRAY-EPU	2	2
	5	305JN716T0	5JN716T0	SPRING:SPG-LOCK-TRAY-EPU	2	2
	6	305JN71700	5JN71700	LEVER-TRAY-EPU	2	2
	7	305JN71710	5JN71710	SHAFT-LVR-EPU-TRAY	2	2
	8	305JN72LU0	5JN72LU0	RETAINING RING:RR/E-3-SS	3	3
	9	305JN716U0	5JN716U0	SHAFT-LOCK-TRAY-EPU-RGT	1	1
	10	305JN72NS0	5JN72NS0	SCREW:S/TPS/FHEXM/R-3X8-ZU3	6	6
	11	305JN71810	5JN71810	SPIRAL:AUGER-SUB-HOPPER	1	1
	12	305JN718K0	5JN718K0	BUSH:ASYB-BUSH-6X18X6F-M	1	1
	13	305JN70160	5JN70160	BRUSH ASSY:K-BUSH-MIXER-R	3	3
⊙	14	305JN717W0	5JN717W0	GEAR-8S23-6-ONEWAY	1	1
	15	305JN71800	5JN71800	PADDLE-SUB-HOPPER	1	1
⊙	16	305JN71980	5JN71980	SHAFT ASSY:ASYB-SHAFT-PADDLE-SH	1	1
⊙	17	305JN718M0	5JN718M0	GEAR-08S84-6-SUB-H	1	1
	18	305JN71970	5JN71970	PADDLE ASSY:ASYB-PDL-SENS-BP	1	1
⊙	19	305JN70290	5JN70290	BUSH-0410-05F-M	2	2
⊙	20	305JN717Y0	5JN717Y0	GEAR-8S22-4	1	1
	21	305JN719K0	5JN719K0	RETAIN NG RING:RRG-4-P	1	1
	22	305JN715P0	5JN715P0	HOLDER:HLDR-SNSR-TONER	1	1
⊙	23	305JN72GZ0	5JN72GZ0	SENSOR:TSP15D10C-01	1	1
	24	305JN72NE0	5JN72NE0	SCREW:S/TPP/FHEXM-3X8-NI	1	1
	25	305JN715R0	5JN715R0	COVER-EPU	1	1
	26	305JN72LW0	5JN72LW0	RETAIN NG RING:RR/E-5-SS	3	3
	27	305JN729M0	5JN729M0	WIRE HARNESS:HRNS-EPU-HPTN-430	1	1
	28	305JN72DF0	5JN72DF0	LABEL LBL-EPU_TBU- NST	1	1
	29	305JN72940	5JN72940	WIRE HARNESS:HRNS-Y-HPTN-430 (Y)	1	1
	29	305JN72950	5JN72950	WIRE HARNESS HRNS-MCK-HPTN-430 (M,C,K)	3	3
	30	305JN72DG0	5JN72DG0	LABEL LBL-EPU-LEVER-R	1	1
	31	305JN72DH0	5JN72DH0	LABEL LBL-EPU-LEVER-L	1	1

• Parts with "⊙" indicate regular maintenance parts.

	Ref. No.	Part.No.	Alternative.	Description	Quantity	
					120	230
	1	305JN72JT0	5JN72JT0	CLAMP UAMS-02WL-0	12	12
	2	305JN716C0	5JN716C0	BRACKET ASSY:ASYB-BRKT-FAN-OZN-MCK	1	1
	3	305JN716D0	5JN716D0	BRACKET ASSY:ASYB-BRKT-FAN-OZN-Y	1	1
⊙	4	305JN72H20	5JN72H20	SENSOR LG248BL1	4	4
	5	305JN716B0	5JN716B0	GUIDE ASSY:ASYS-GUIDE-CLNR-D-RER	1	1
	6	305JN72900	5JN72900	WIRE HARNESS:HRNS-CLNMT-430	1	1
⊙	7	305JN706M0	5JN706M0	SOLENOID:SOL_IQ	2	2
	8	305JN72NS0	5JN72NS0	SCREW:S/TPS/FHEXM/R-3X8-ZU3	9	9
	9	305JN716A0	5JN716A0	TERMINAL ASSY:ASYB-TERM-HVT-CH	4	4
	10	305JN714R0	5JN714R0	BRACKET:BRKT-DRIVE-CLNR-CHGR-2	1	1
⊙	11	305JN72GR0	5JN72GR0	MOTOR:ASYS-MOTR-SW-DRIVE-DRUM	1	1
⊙	12	305JN715D0	5JN715D0	GEAR-IDLER-DRIVE-CLNR-CHG	1	1
⊙	13	305JN716Z0	5JN716Z0	GEAR-IDLER-DRIVE-CLNR-C-2	1	1
⊙	14	305JN715N0	5JN715N0	GEAR-DRIVE-CLNR-CHGR	1	1
	15	305JN715M0	5JN715M0	DUCT-OZONE-CLNR-CHGR	1	1
	16	305JN715L0	5JN715L0	COVER:COV-DUCT-OZONE-CLNR-CHGR	1	1
	17	305JN717J0	5JN717J0	PLATE-CONDUCT-SNSR-V0	2	2
	18	305JN716Y0	5JN716Y0	TERMINAL ASSY:ASYB-TERM-HVT-CH-Y	1	1
	19	305JN715V0	5JN715V0	HOLDER:HLDR-SNSR-V0	2	2
	20	305JN715X0	5JN715X0	ARM:LINK-SOL-SNSR-V0	2	2
	21	305JN715Y0	5JN715Y0	LEVER-SHUT-SNSR-V0	2	2
⊙	22	305JN72CE0	5JN72CE0	SENSOR:SNSR-V0-PRO-430	2	2
	23	305JN715U0	5JN715U0	BRACKET:BRKT-SNSR-V0	2	2
	24	305JN715W0	5JN715W0	SHUTTER:SHUT-SNSR-V0	2	2
	25	305JN715T0	5JN715T0	ARM:LINK-SHUT-SNSR-V0	2	2
	26	305JN717H0	5JN717H0	SPRING:SPG-E-SHUT-SNSR-V0	2	2
	27	305JN70X30	5JN70X30	THERMISTOR:THMS-DRM-380	1	1
	28	305JN707S0	5JN707S0	SCREW:S/TPP/BID-3*8-NI	2	2
	29	305JN71750	5JN71750	HOLDER:HLDR-PWA-V0-PRO	2	2

• Parts with "⊙" indicate regular maintenance parts.

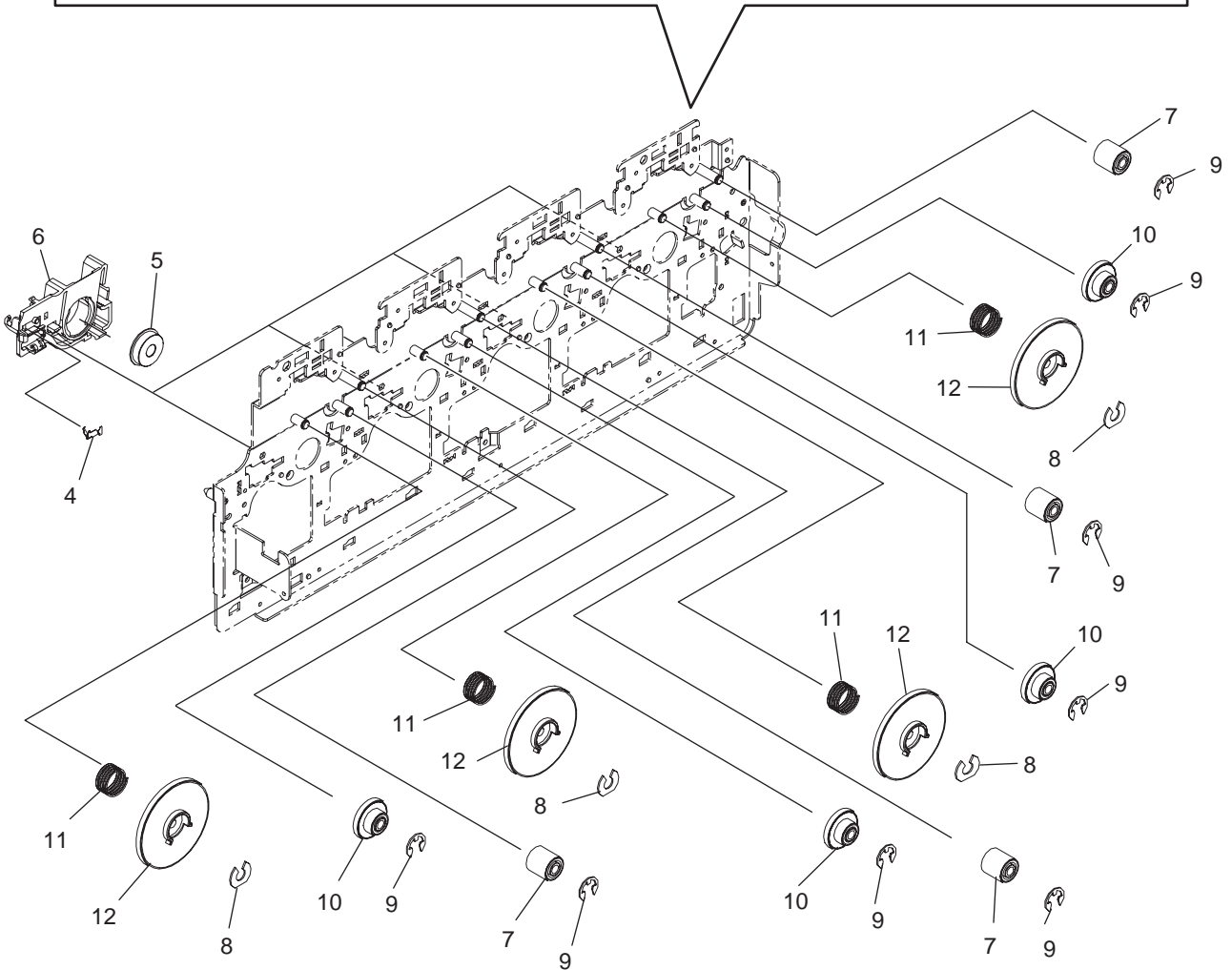
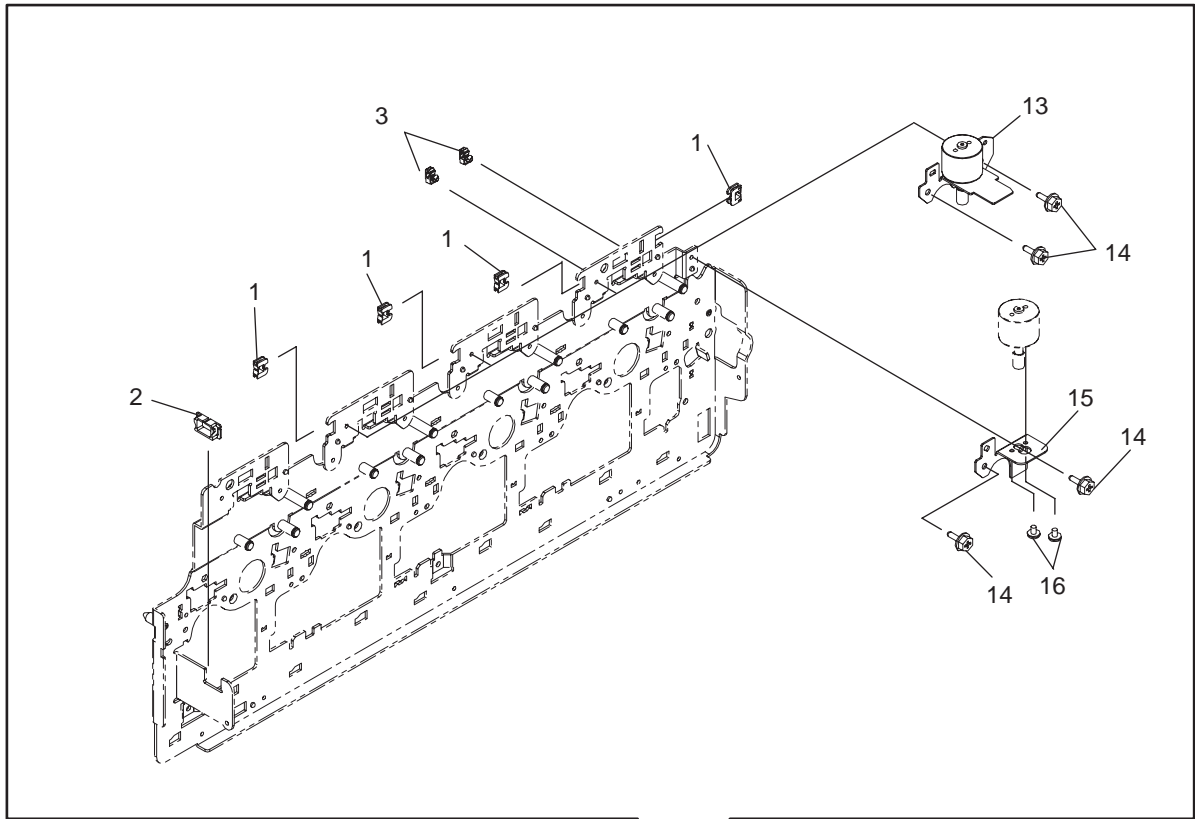

	Ref. No.	Part.No.	Alternative.	Description	Quantity	
					120	230
	1	305JN72J60	5JN72J60	BAND:ES-0505	4	4
	2	305JN72K10	5JN72K10	BAND:ESC-0912	1	1
	3	305JN72KG0	5JN72KG0	CLAMP LBWS-0206S-V0	2	2
	4	305JN717K0	5JN717K0	SPRING:SPG-F-GND-STAY-V0	4	4
	5	305JN72KA0	5JN72KA0	BEARING:608ZZNR2KS	4	4
	6	305JN714S0	5JN714S0	GUIDE-CLNR-DRUM-FRT	4	4
⊙	7	305JN719P0	5JN719P0	GEAR-5S28-6	4	4
	8	305JN719K0	5JN719K0	RETAIN NG RING:RRG-4-P	1	1
	9	305JN72LW0	5JN72LW0	RETAIN NG RING:RR/E-5-SS	8	8
⊙	10	305JN717X0	5JN717X0	GEAR-5H52_6S25-6	4	4
	11	305JN719J0	5JN719J0	SPRING:SPG-GEAR-DRV-SB	4	4
⊙	12	305JN718L0	5JN718L0	GEAR-06S100-6-SUB-H-D	4	4
⊙	13	305JN719H0	5JN719H0	MOTOR ASSY :ASYB-MOTOR-SUB-HOPPER-A	3	3
	14	305JN72NS0	5JN72NS0	SCREW:S/TPS/FHEXM/R-3X8-ZU3	8	8
	15	305JN715Q0	5JN715Q0	BRACKET:BRKT-MOTRD-SUB-HOPPER-B	1	1
	16	305JN72P10	5JN72P10	SCREW:S/BID-M2.6X3-NI	2	2

• Parts with "⊙" indicate regular maintenance parts.

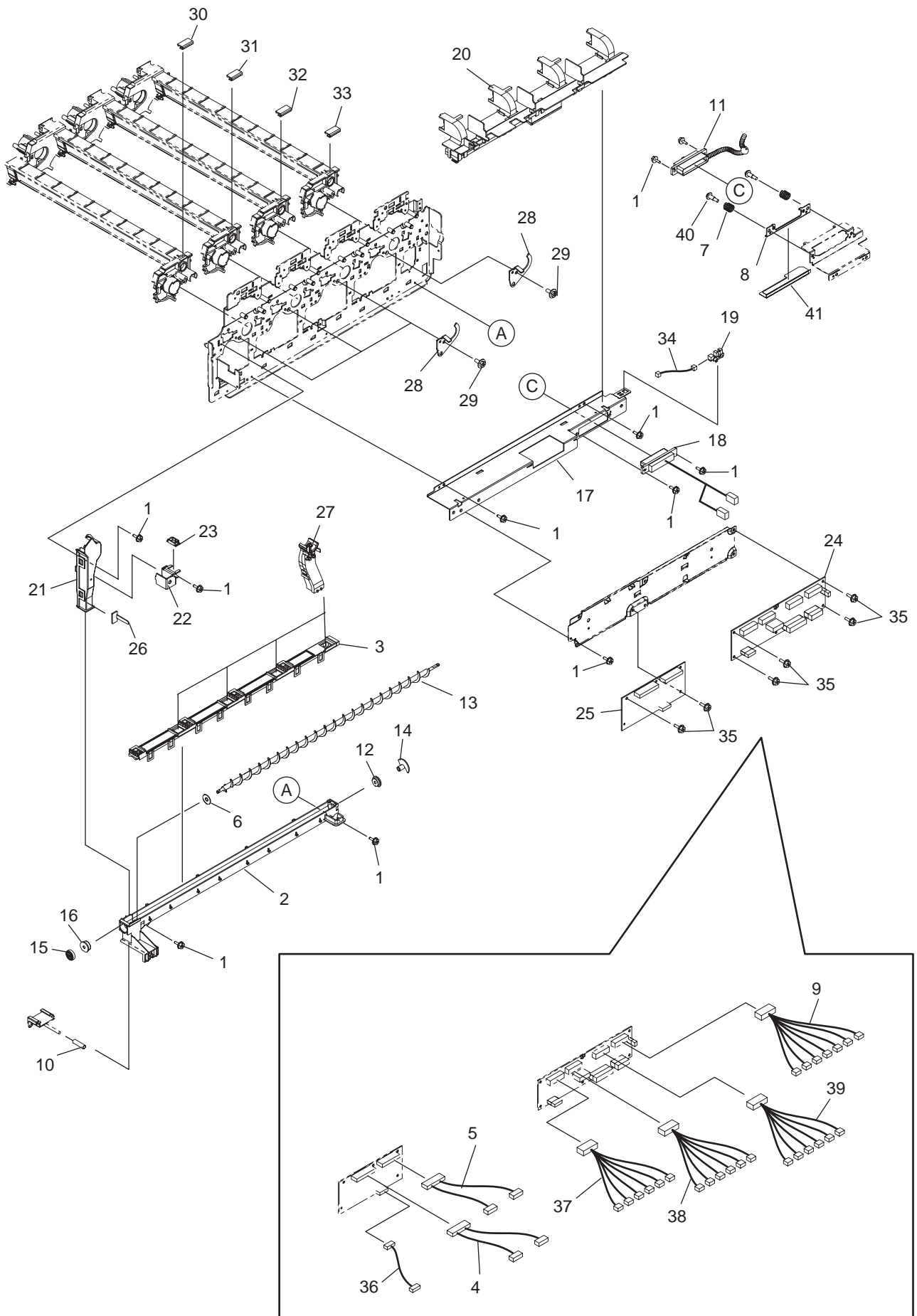

	Ref. No.	Part.No.	Alternative.	Description	Quantity	
					120	230
	1	305JN72NS0	5JN72NS0	SCREW:S/TPS/FHEXM/R-3X8-ZU3	10	10
	2	305JN718R0	5JN718R0	CASE-DUCT-WTNR-FRT	1	1
	3	305JN719U0	5JN719U0	DUCT ASSY:ASYS-DUCT-WTNR-FRT	1	1
	4	305JN729K0	5JN729K0	WIRE HARNESS:HRNS-V01-430	1	1
	5	305JN729L0	5JN729L0	WIRE HARNESS:HRNS-V02-430	1	1
	6	305JN719T0	5JN719T0	WASHER-4X12X05-P	1	1
	7	305JN717U0	5JN717U0	SPRING:SPG-DRW-EPU-MAIN	2	2
	8	305JN717T0	5JN717T0	PLATE-DRW-EPU-MAIN	1	1
	9	305JN72880	5JN72880	WIRE HARNESS:HRNS-KPU-430	1	1
	10	305JN719F0	5JN719F0	SPRING:SPG-WASTE-SHUT-EPU	1	1
	11	305JN72BS0	5JN72BS0	WIRE HARNESS:ASY-HRNS-LGC-EPU-430	1	1
	12	305JN70XR0	5JN70XR0	BUSH-4-CLN-TBU-F	1	1
	13	305JN71890	5JN71890	SPIRAL:AUGER-WASTE-TNR	1	1
	14	305JN71820	5JN71820	SH ELD-PLT-WTNR-AUG	1	1
⊙	15	305JN718C0	5JN718C0	GEAR-8S18-6-AUG-FRT	1	1
	16	305JN71910	5JN71910	BUSH:ASYS-BUSH-4-WTNR	1	1
	17	305JN715S0	5JN715S0	BRACKET:BRKT-CNTR-EPU-TRAY	1	1
⊙	18	305JN727Z0	5JN727Z0	WIRE HARNESS:ASY-HRNS-EPU-430	1	1
	19	305JN72H20	5JN72H20	SENSOR LG248BL1	1	1
	20	305JN71690	5JN71690	DUCT ASSY:ASYB-DUCT-DEV-EPU_TRAY	1	1
	21	305JN71DC0	5JN71DC0	DUCT ASSY:ASYB-DUCT-CLN-TBU	1	1
	22	305JN714T0	5JN714T0	BRACKET:BRKT-LOCK-TRAY-EPU-LFT	1	1
⊙	23	305JN72K10	5JN72K10	BAND:ESC-0912	1	1
	24	305JN72AC0	5JN72AC0	PWB ASSY:PWA-F-EPU-430	1	1
	25	305JN72CD0	5JN72CD0	SENSOR:SNSR-V0-CNT-430	1	1
	26	305JN72J70	5JN72J70	CLAMP K-103G	1	1
	27	305JN717R0	5JN717R0	DUCT ASSY:ASYB-DUCT-W_TNR-CLNR-DRUM	4	4
	28	305JN71590	5JN71590	RETAINER:RTNR-DEV-FRT	4	4
	29	305JN72NB0	5JN72NB0	SCREW:S/FHEXM-M4X8-NI	4	4
	30	305JN714M0	5JN714M0	COLLAR:PIECE-COLOR-Y	1	1
	31	305JN714L0	5JN714L0	COLLAR:PIECE-COLOR-M	1	1
	32	305JN714K0	5JN714K0	COLLAR:PIECE-COLOR-C	1	1
	33	305JN714J0	5JN714J0	COLLAR:PIECE-COLOR-K	1	1
	34	305JN728S0	5JN728S0	WIRE HARNESS:HRNS-EPOGS-430	1	1
	35	305JN72NA0	5JN72NA0	SCREW:S/FHEXM-M3X8-NI	6	6
	36	305JN72910	5JN72910	WIRE HARNESS:HRNS-V0T-430	1	1
	37	305JN72B20	5JN72B20	WIRE HARNESS:HRNS-YPU-430	1	1
	38	305JN72860	5JN72860	WIRE HARNESS:HRNS-MPU-430	1	1
	39	305JN72870	5JN72870	WIRE HARNESS:HRNS-CPU-430	1	1
	40	305JN70V70	5JN70V70	SCREW-M3-D4-7-ZU3	2	2

• Parts with "⊙" indicate regular maintenance parts.

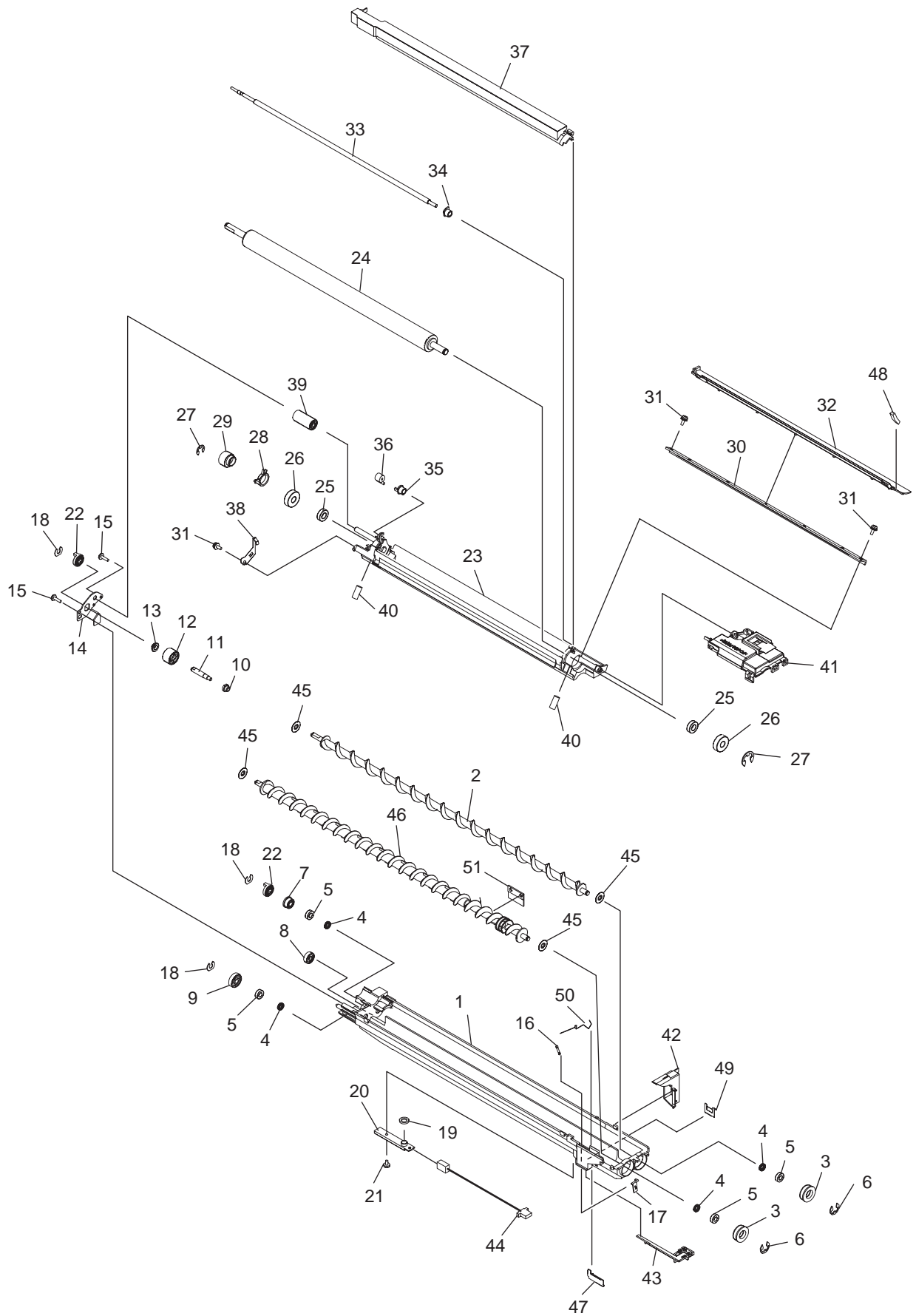

	Ref. No.	Part.No.	Alternative.	Description	Quantity	
					120	230
	1	305JN715J0	5JN715J0	CASE ASSY:ASYS-CASE-DEV	1	1
	2	305JN717B0	5JN717B0	MIXER ASSY:MIXER-RGT-430	1	1
	3	305JN71500	5JN71500	BUSH-DEV-FRT-430	2	2
	4	305JN700L0	5JN700L0	SEAL-VC6-10-2.5	4	4
	5	305JN72L00	5JN72L00	BEARING:L12602RSSH44M	4	4
	6	305JN72LW0	5JN72LW0	RETAIN NG RING:RR/E-5-SS	2	2
⊙	7	305JN71520	5JN71520	GEAR-04H30-6-MIX	1	1
	8	305JN715G0	5JN715G0	GEAR ASSY:ASYS-GEAR-MIX-430	1	1
⊙	9	305JN71530	5JN71530	GEAR-04H43-6-MIX	1	1
	10	305JN706N0	5JN706N0	GUIDE:BUSH-4X7X6F-POM	1	1
	11	305JN716G0	5JN716G0	SHAFT-IDL-DEV	1	1
⊙	12	305JN71540	5JN71540	GEAR-04H43-6-MG	1	1
	13	305JN701X0	5JN701X0	BUSH-6-3.7-GCB	1	1
	14	305JN71580	5JN71580	BRACKET:BRKT-GEAR-DEV	1	1
	15	305JN707S0	5JN707S0	SCREW:S/TPP/BID-3*8-NI	2	2
	16	305JN716J0	5JN716J0	SPRING:SPG-SHUT-DEV	1	1
	17	305JN71570	5JN71570	SHUTTER:SHUT-DEV	1	1
	18	305JN719K0	5JN719K0	RETAIN NG RING:RRG-4-P	3	3
	19	305JN706L0	5JN706L0	SEAL-ATC-BLK	1	1
⊙	20	305JN70X20	5JN70X20	SENSOR:SNSR-ATC-380	1	1
	21	305JN72N30	5JN72N30	SCREW:S/PAN-M3X4-NI	1	1
	22	305JN711P0	5JN711P0	COUPL NG:COUPL-DRV-DEV	2	2
⊙	23	305JN71660	5JN71660	HOLDER ASSY:ASYS-HLDR-MG-SEAL	1	1
	24	305JN71610	5JN71610	ROLLER:RLR-MAGT-430	1	1
	25	305JN72L10	5JN72L10	BEARING:6882RSSH44M	2	2
	26	305JN72KZ0	5JN72KZ0	BEARING:608ZM2SH44M	2	2
	27	305JN72LY0	5JN72LY0	RETAIN NG RING:RR/E-7-SS	2	2
	28	305JN71550	5JN71550	ARM:LINK-MG-RE	1	1
⊙	29	305JN71510	5JN71510	GEAR-04H43-8-MG	1	1
	30	305JN714Z0	5JN714Z0	DOCTOR ASSY:ASYS-DOCTR-430	1	1
	31	305JN72L90	5JN72L90	SCREW:S/PAN/SWWS-M3X6-NI	3	3
	32	305JN71680	5JN71680	SH ELD ASSY:ASYS-SHILD-DOC	1	1
⊙	33	305JN716F0	5JN716F0	ROLLER-RE-430	1	1
	34	305JN71790	5JN71790	BUSH-RE-FRT	1	1
	35	305JN707T0	5JN707T0	BUSH-RE-ROL-R	1	1
⊙	36	305JN71600	5JN71600	CLUTCH:CLUCH-RE-430	1	1
	37	305JN71670	5JN71670	COVER ASSY:ASYS-COV-MG	1	1
	38	305JN71560	5JN71560	ADJUSTER PLATE:ADJSTR-MAGT	1	1
	39	305JN715H0	5JN715H0	GEAR ASSY:ASYS-GEAR-MG-430	1	1
	40	305JN716E0	5JN716E0	SPRING:SPG-MG-DRM	2	2
	41	305JN71650	5JN71650	COVER ASSY:ASYS-COVER-DEV	1	1
	42	305JN715A0	5JN715A0	DUCT-DOC-FRT	1	1
	43	305JN715Z0	5JN715Z0	ACTUATOR:CNTR-ATC-430	1	1
	44	305JN728Z0	5JN728Z0	WIRE HARNESS:HRNS-ATC-430	1	1
	45	305JN70WHO	5JN70WHO	SEAL-MIXER-380	4	4
	46	305JN717C0	5JN717C0	MIXER ASSY:MIXER-LFT-430	1	1
	47	305JN717M0	5JN717M0	FLANGE ASSY:ASYS-FLANG-SHUT-DEV	1	1
	48	305JN717A0	5JN717A0	SEAL-MG-S DE-FRT	1	1
	49	305JN717V0	5JN717V0	SHEET-ADJUST-SR	1	1
	50	305JN717G0	5JN717G0	SCRAPER:SCRAPR-SR	1	1
	51	305JN716H0	5JN716H0	BLADE-PADDLE-430	1	1

• Parts with "⊙" indicate regular maintenance parts.

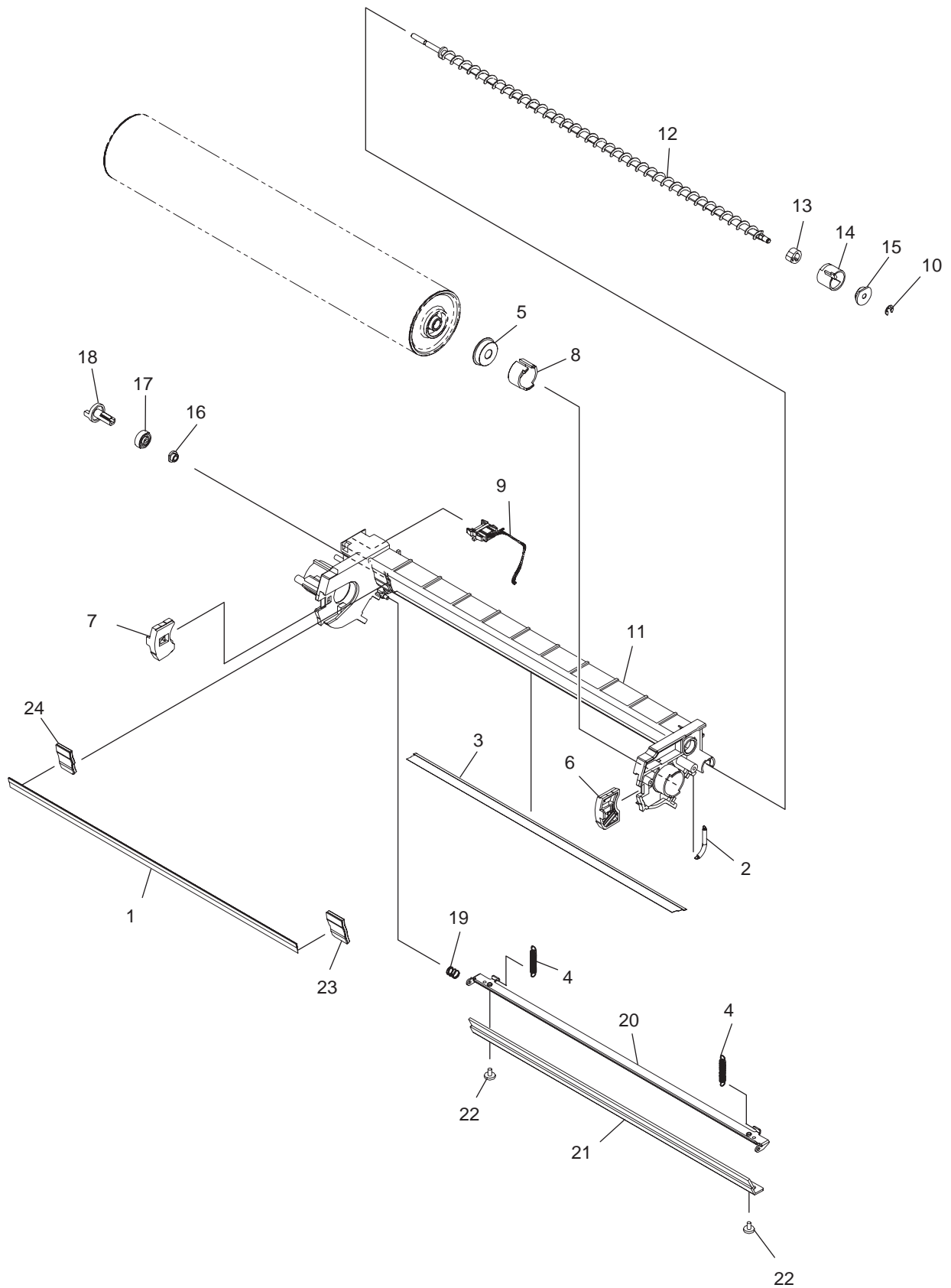

	Ref. No.	Part.No.	Alternative.	Description	Quantity	
					120	230
⊙	1	305JN716L0	5JN716L0	BLADE-REC-DRUM-430	1	1
	2	305JN716R0	5JN716R0	SPRING:SPG-E-SHUT-NOZZLE	1	1
	3	305JN717F0	5JN717F0	SHEET-BLADE-DRUM-BCK	1	1
	4	305JN716N0	5JN716N0	SPRING:SPG-E-BLADE-CLNR-DRUM	2	2
	5	305JN72KA0	5JN72KA0	BEARING:608ZZNR2KS	1	1
	6	305JN717P0	5JN717P0	GUIDE:RTNR-DR-SL-FRT	1	1
	7	305JN717N0	5JN717N0	GUIDE:RTNR-DR-SL-RER	1	1
	8	305JN71760	5JN71760	COLLAR:COLAR-CLNR-DRUM-FRT	1	1
	9	305JN727Y0	5JN727Y0	WIRE HARNESS:HRNS-EPERS-430	1	1
	10	305JN72LU0	5JN72LU0	RETAINING RING:RR/E-3-SS	1	1
	11	305JN717S0	5JN717S0	CASE ASSY:ASYS-CASE-CLNR-DRUM-430	1	1
	12	305JN714F0	5JN714F0	SPIRAL:AUGER-CLNR-DRUM-430	1	1
	13	305JN717L0	5JN717L0	CAM-NOZZLE-CLNR	1	1
	14	305JN717Q0	5JN717Q0	SHUTTER:SHUT-AUGER-CLNR-DRUM	1	1
	15	305JN70XR0	5JN70XR0	BUSH-4-CLN-TBU-F	1	1
	16	305JN70290	5JN70290	BUSH-0410-05F-M	1	1
⊙	17	305JN715F0	5JN715F0	GEAR-CLNR-DRUM-AUGER	1	1
	18	305JN714G0	5JN714G0	COUPL NG:COUPL-AUGER-CLNR-DRUM	1	1
	19	305JN716S0	5JN716S0	SPRING:SPG-C-BIAS-BLADE-DRUM	1	1
	20	305JN714H0	5JN714H0	HOLDER:HLDR-BLADE-CLNR-DRUM	1	1
⊙	21	305JN72EC0	5JN72EC0	BLADE BL-D-F43X	1	1
	22	305JN72LE0	5JN72LE0	SCREW:S/BID-M3X4-NI	2	2
⊙	23	305JN716P0	5JN716P0	SEAL-BLADE-SIDE-FRT	1	1
⊙	24	305JN716Q0	5JN716Q0	SEAL-BLADE-SIDE-RER	1	1

• Parts with "⊙" indicate regular maintenance parts.

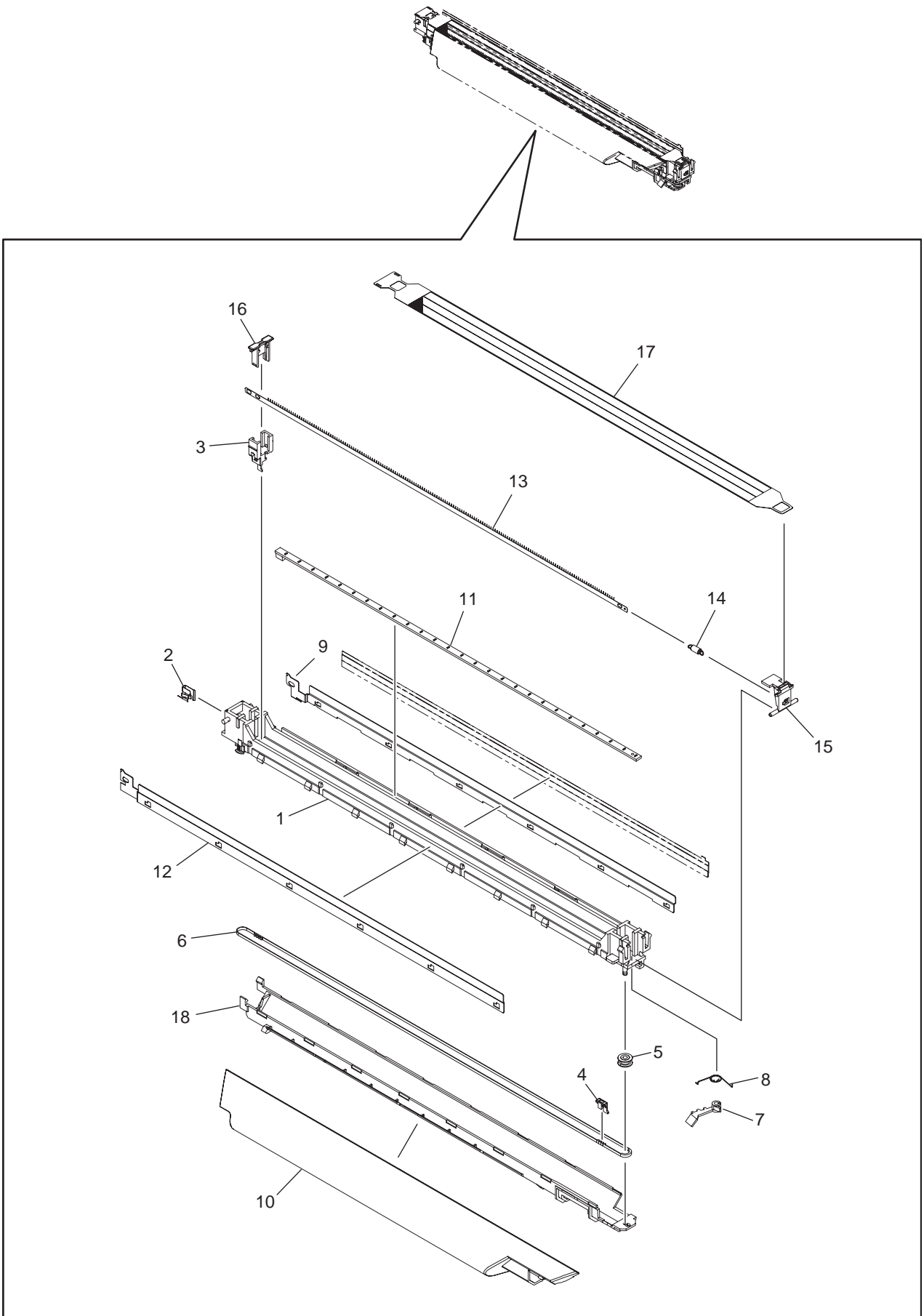

	Ref. No.	Part.No.	Alternative.	Description	Quantity	
					120	230
	1	305JN71740	5JN71740	CASE ASSY:ASYS-CASE-CHARGR-MAIN-430	1	1
	2	305JN714N0	5JN714N0	SPRING:SPG-F-BIAS-MAIN-CHGR	1	1
	3	305JN714A0	5JN714A0	BRACKET:BRKT-HLDR-CLNR-CH	1	1
⊙	4	305JN715E0	5JN715E0	SL DER:SLIDE-PSN-CLNR-CHGR	1	1
	5	305JN72PQ0	5JN72PQ0	PULLEY-3-6-10	1	1
	6	305JN716W0	5JN716W0	TIMING BELT:BLT_SY-2GT-760-2	1	1
	7	305JN714B0	5JN714B0	LEVER-PSN-CLNR-CHGR	1	1
	8	305JN717E0	5JN717E0	SPRING:SPG-T-ACTR-CHARGR-430	1	1
	9	305JN714D0	5JN714D0	PLATE-CHARGR-MAIN-RGT	1	1
	10	305JN71620	5JN71620	DUCT-CHARGR-OZN-RER	1	1
⊙	11	305JN72BE0	5JN72BE0	LAMP-ERASE-430	1	1
	12	305JN714E0	5JN714E0	PLATE-CHARGR-MAIN-LFT	1	1
⊙	13	305JN71770	5JN71770	PIN_ARRAY-CHARGR-MAIN-430	1	1
	14	305JN716K0	5JN716K0	SPRING:SPG-E-GRID	1	1
	15	305JN714C0	5JN714C0	LEVER-CHARGR-MAIN	1	1
⊙	16	305JN71640	5JN71640	CLEANING PAD ASSY:ASYS-HLDR-CLNR-CH	1	1
⊙	17	305JN71630	5JN71630	GRID-CHARGR-MAIN-430	1	1
	18	305JN715K0	5JN715K0	DUCT-CHARGR-MAIN	1	1

• Parts with "⊙" indicate regular maintenance parts.

	Ref. No.	Part.No.	Alternative.	Description	Quantity	
					120	230
	1	305JN71900	5JN71900	BRACKET ASSY:ASYS-BRKT-DRV-WTNR-F	1	1
	2	305JN718G0	5JN718G0	FLANG-DRV-WTNR	3	3
⊙	3	305JN718D0	5JN718D0	GEAR-8S18_S2M20-6-DRV-FRT	1	1
	4	305JN72LW0	5JN72LW0	RETAIN NG RING:RR/E-5-SS	2	2
⊙	5	305JN718S0	5JN718S0	GEAR-8S21-PSM20-6	1	1
	6	305JN719B0	5JN719B0	TIMING BELT:BLT-SY-S2M-250-4	1	1
	7	305JN718V0	5JN718V0	FLANGE:FLNG-FRT-DRV	1	1
⊙	8	305JN718E0	5JN718E0	GEAR-8S24_8S18-5	1	1
	9	305JN719C0	5JN719C0	SHAFT-DRV-WTNR-F-GEAR	1	1
	10	305JN716M0	5JN716M0	RETAINING RING:RRG-3-P	6	6
	11	305JN72NS0	5JN72NS0	SCREW:S/TPS/FHEXM/R-3X8-ZU3	9	9
⊙	12	305JN718F0	5JN718F0	GEAR-8S28-4-AUGER	1	1
	13	305JN718Q0	5JN718Q0	CASE-DUCT-WTNR-DPTH	1	1
⊙	14	305JN718T0	5JN718T0	HOOK-COV-WTNR	1	1
	15	305JN718P0	5JN718P0	COVER:COV-DUCT-WTNR-DPTH	1	1
	16	305JN707S0	5JN707S0	SCREW:S/TPP/BID-3*8-NI	3	3
	17	305JN71910	5JN71910	BUSH:ASYS-BUSH-4-WTNR	4	4
	18	305JN718X0	5JN718X0	SPIRAL:AUGER-WTNR-UPR	1	1
⊙	19	305JN71850	5JN71850	PULLEY:PULLY-S2M20-4-U	1	1
	20	305JN71860	5JN71860	COLLAR:COLAR-AUG-WTNR-SIDE	1	1
	21	305JN706N0	5JN706N0	GUIDE:BUSH-4X7X6F-POM	1	1
	22	305JN71830	5JN71830	DUCT-WTNR-TURN	1	1
	23	305JN719V0	5JN719V0	SPRING:SPG-HOOK-COV-WTNR	1	1
	24	305JN718B0	5JN718B0	SPIRAL:AUGER-DUCT-TURN	1	1
	25	305JN71870	5JN71870	COUPL NG:COUPL-DRV-WTNR-1	1	1
	26	305JN719D0	5JN719D0	SPRING:SPG-C-DUCT-FINAL	1	1
	27	305JN71840	5JN71840	SHUTTER:SHUT-DUCT-TURN	1	1
	28	305JN718A0	5JN718A0	PLATE-HINGE-WTNR-BTM	1	1
	29	305JN71880	5JN71880	STAY-H NGE-WTNR-TOP	1	1
⊙	30	305JN71990	5JN71990	TIMING BELT:BLT_SY-S2M-148-6	1	1
⊙	31	305JN719Q0	5JN719Q0	GEAR-5S25-P2GT60-6-IDLE	1	1
⊙	32	305JN71920	5JN71920	GEAR-5S86-6-WTNR-DRV	1	1
	33	305JN719L0	5JN719L0	SHAFT ASSY:ASYS-SHAFT-WTNR-DRV	1	1
	34	305JN719S0	5JN719S0	BUSH-6-POM-B	2	2
⊙	35	305JN718H0	5JN718H0	PULLEY:PULLY-S2M20-6_CPL-WTNR2	1	1
⊙	36	305JN719R0	5JN719R0	TIMING BELT:BLT-SY-138-2GT-4	1	1
	37	305JN72BW0	5JN72BW0	MOTOR:MOTRD-UTNR-430	1	1
	38	305JN72LE0	5JN72LE0	SCREW:S/BID-M3X4-NI	2	2
	39	305JN72J60	5JN72J60	BAND:ES-0505	1	1
	40	305JN72K20	5JN72K20	CLAMP MSB-1207	1	1
	41	305JN72NT0	5JN72NT0	SCREW:S/TPS/FHEXM/R-4X8-ZU3	10	10
	42	305JN72LY0	5JN72LY0	RETAIN NG RING:RR/E-7-SS	1	1
	43	305JN718W0	5JN718W0	COVER:OPENR-COV-WTNR	1	1
	44	305JN719E0	5JN719E0	SPRING:SPG-C-OPENR-WTNR	1	1
⊙	45	305JN72H10	5JN72H10	SENSOR LG285L2-R	2	2
⊙	46	305JN718Y0	5JN718Y0	GUIDE-BOX-WTNR	1	1
	47	305JN719Y0	5JN719Y0	COVER-BOX-WTNR-430T	1	1

• Parts with "⊙" indicate regular maintenance parts.

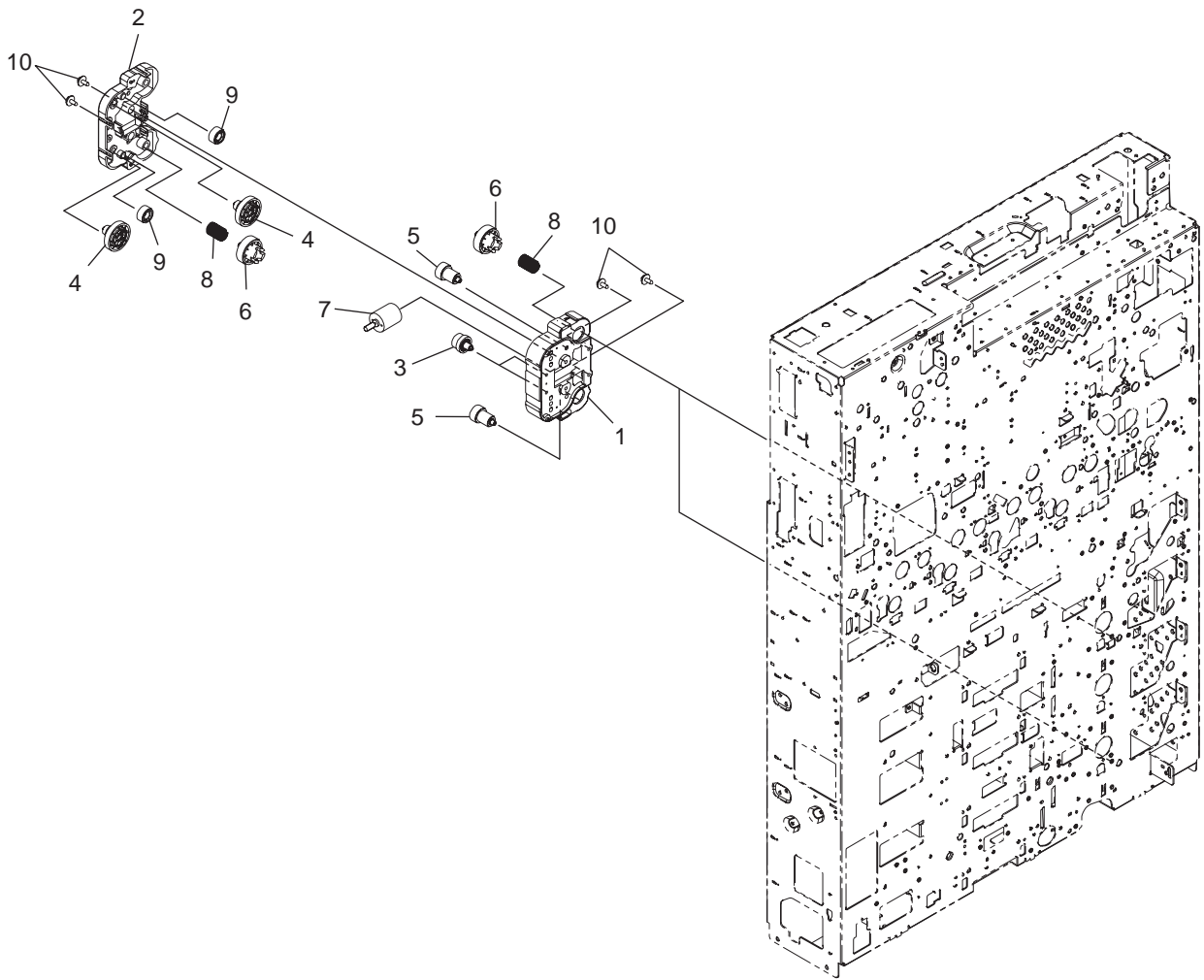

	Ref. No.	Part.No.	Alternative.	Description	Quantity	
					120	230
	1	305JN71RE0	5JN71RE0	CASE-DRV-TRY-LOW-430	1	1
	2	305JN71RF0	5JN71RF0	CASE-DRV-TRY-UP-430	1	1
⊙	3	305JN702L0	5JN702L0	GEAR:G05H-45/G05S-15	2	2
⊙	4	305JN702K0	5JN702K0	GEAR:G06S-13/G05S-80	2	2
⊙	5	305JN71R20	5JN71R20	GEAR-8S26_8S18-6	2	2
⊙	6	305JN71R60	5JN71R60	GEAR-8S45-8_CPG	2	2
⊙	7	305JN707K0	5JN707K0	MOTOR:MOTR D-TRAY-CST	1	1
	8	305JN700R0	5JN700R0	SPRING:SPC172-100-3400	2	2
⊙	9	305JN71R30	5JN71R30	GEAR-8S25-10	2	2
	10	305JN72NT0	5JN72NT0	SCREW:S/TPS/FHEXMR-4X8-ZU3	4	4

• Parts with "⊙" indicate regular maintenance parts.

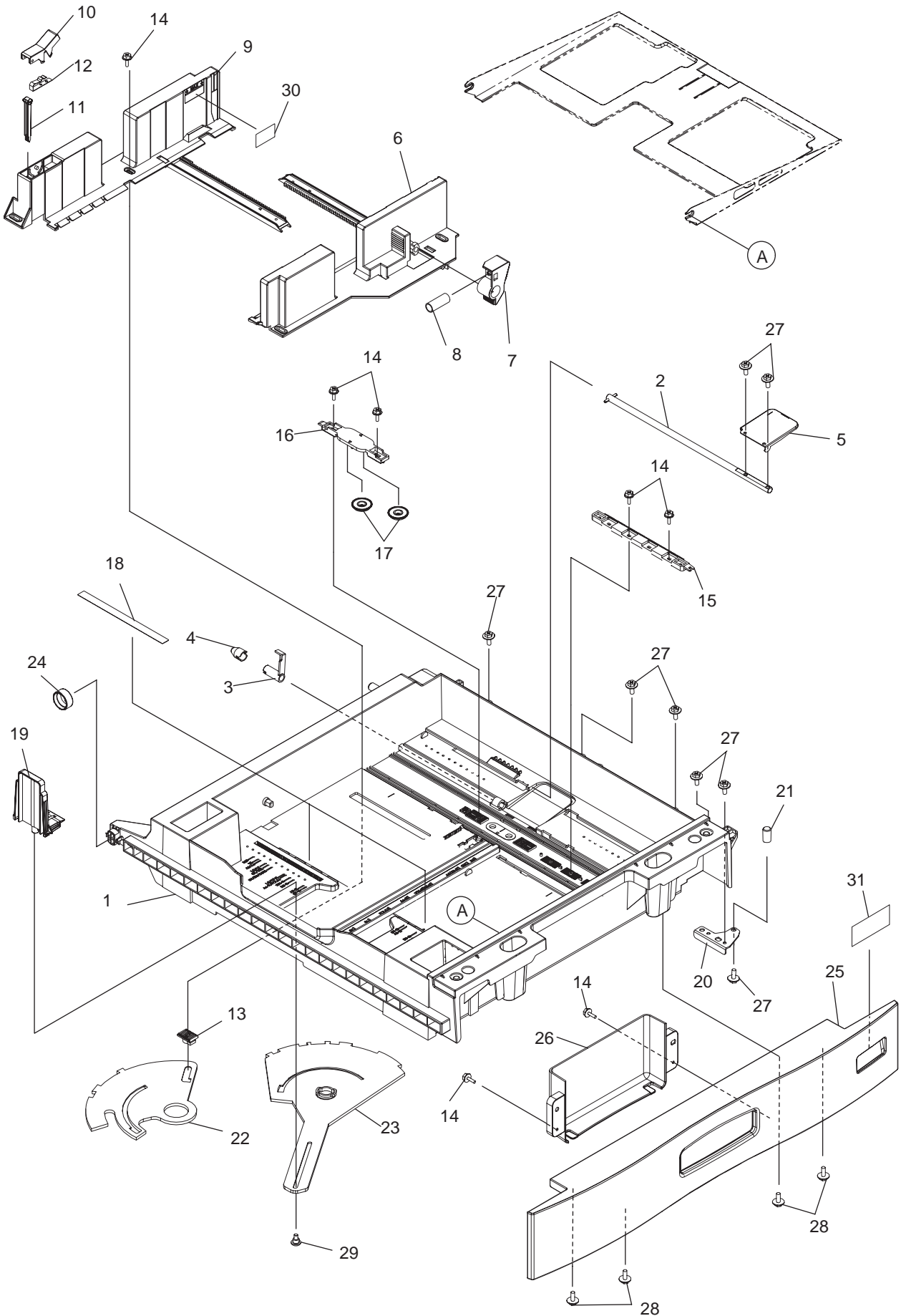

	Ref. No.	Part.No.	Alternative.	Description	Quantity	
					120	230
	1	305JN71J00	5JN71J00	CASSETTE-F43X	1	1
	2	305JN71R00	5JN71R00	SHAFT ASSY:ASYS-SFT-ELV-CST-F43X	1	1
	3	305JN71R00	5JN71R00	LEVER-SENSOR-F43X	1	1
	4	305JN705J0	5JN705J0	CAP-LEVER-SENS	1	1
	5	305JN71R00	5JN71R00	LEVER ASSY:ASYS-LEVER-ELV-CST-F43X	1	1
	6	305JN71R90	5JN71R90	CURSOR ASSY:ASYS-WALL-SIDE-F-CST-F43X	1	1
	7	305JN71R00	5JN71R00	LEVER LVR-ADJUST-WALL	1	1
	8	305JN707H0	5JN707H0	SPRING:SPC-LVR-WALL-F	1	1
	9	305JN71R00	5JN71R00	CURSOR ASSY:ASYS-WALL-SIDE-R-CST-F43X	1	1
	10	305JN706F0	5JN706F0	LEVER-LOCK-WALL-RER	1	1
	11	305JN71R00	5JN71R00	LEVER LOCK:LOCK-WALL-R	1	1
	12	305JN701M0	5JN701M0	SPRING:SPL-LOCK-WALL-R	1	1
	13	305JN71R00	5JN71R00	GUIDE-FOOT	1	1
	14	305JN72NE0	5JN72NE0	SCREW:S/TPP/FHEXM-3X8-NI	7	7
	15	305JN71Q00	5JN71Q00	HOLDER:WALL-STOP	1	1
	16	305JN71Q00	5JN71Q00	HOLDER:HOLD-CASSET-P NION	1	1
	17	305JN70Y00	5JN70Y00	GEAR-10S18-8-TRAY	2	2
	18	305JN71R00	5JN71R00	SHEET:MYLAR-CST-SIDE-WALL	2	2
	19	305JN71Q00	5JN71Q00	CURSOR:WALL-END-CST-F43X	1	1
	20	305JN71R00	5JN71R00	PLATE-LATCH	1	1
	21	305JN702M0	5JN702M0	PIN:STUD-CST-POS	1	1
	22	305JN71R00	5JN71R00	PLATE:PUSHER-S DE-CST-F43X	1	1
	23	305JN71R00	5JN71R00	PLATE:PUSHER-END-CST-F43X	1	1
	24	305JN71R00	5JN71R00	ROLLER-LEFT-R-BP	1	1
⊙	25	305JN712Q0	5JN712Q0	COVER-CST-434	1	1
⊙	26	305JN712S0	5JN712S0	COVER-HNDL-CST-434	1	1
	27	305JN72NB0	5JN72NB0	SCREW:S/FHEXM-M4X8-NI	8	8
	28	305JN72NG0	5JN72NG0	SCREW:S/TPP/FHEXM-4X8-NI	4	4
	29	305JN71Q00	5JN71Q00	SCREW-M3X8-3.2-P	1	1
	30	305JN71RR0	5JN71RR0	LABEL LBL-MAX-CST-F43X	1	1
	31	305JN72GN0	5JN72GN0	SHEET:SIZE-CST-450-A4		1
	31	305JN72GP0	5JN72GP0	SHEET:SIZE-CST-450-LT	1	

• Parts with "⊙" indicate regular maintenance parts.

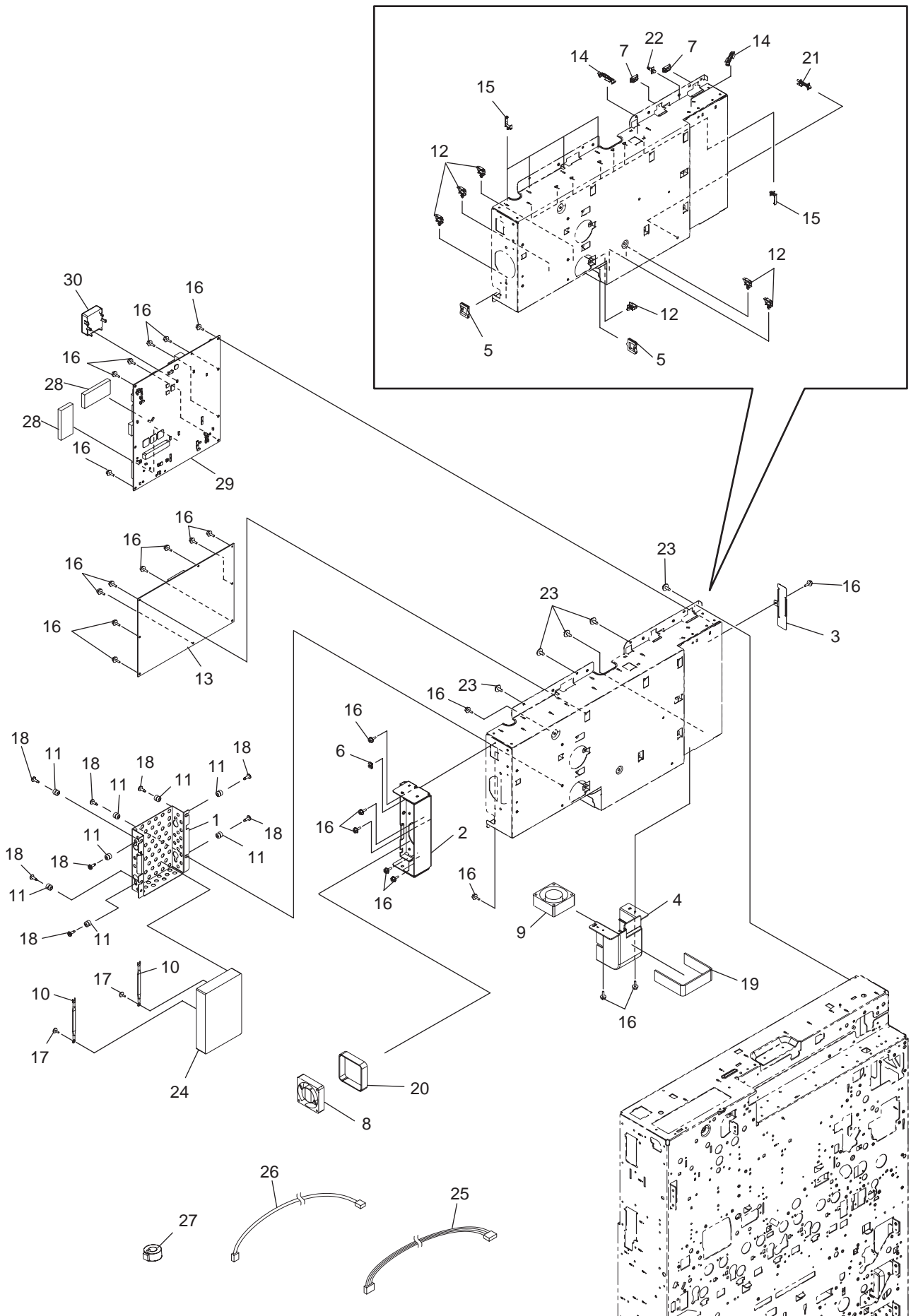

	Ref. No.	Part.No.	Alternative.	Description	Quantity	
					120	230
	1	305JN70ZB0	5JN70ZB0	BRACKET:BRKT-HDD-430	1	1
	2	305JN70Z60	5JN70Z60	BRACKET:BRKT-HINGE-CASE	1	1
	3	305JN70ZD0	5JN70ZD0	COVER-SYS-DWN	1	1
	4	305JN70ZC0	5JN70ZC0	DUCT-SYS-430	1	1
	5	305JN72J50	5JN72J50	BAND:EDS-1717U	2	2
	6	305JN72J60	5JN72J60	BAND:ES-0505	1	1
	7	305JN72K10	5JN72K10	BAND:ESC-0912	2	2
⊙	8	305JN72BV0	5JN72BV0	FAN MOTOR:FAN_D-HDD-6015-430	1	1
⊙	9	305JN726W0	5JN726W0	FAN MOTOR:FAN_D-SYS-6025-430	1	1
	10	305JN72HJ0	5JN72HJ0	WIRE HARNESS:GST-100-RFM4	2	2
	11	305JN72K60	5JN72K60	BUSH:HED-1111-ALS20ABK	8	8
	12	305JN72JP0	5JN72JP0	CLAMP LWS-0711Z	6	6
⊙	13	305JN729S0	5JN729S0	PWB ASSY:PWA-F-IMG-430	1	1
	14	305JN72KE0	5JN72KE0	WIRE CLAMP RFC-33V0	2	2
	15	305JN72JK0	5JN72JK0	CLAMP RLWS-1TV0	11	11
	16	305JN72NA0	5JN72NA0	SCREW:S/FHEXM-M3X8-NI	24	24
	17	305JN70YZ0	5JN70YZ0	SCREW-#6-32X1/4	2	2
	18	305JN707J0	5JN707J0	SCREW-HDD-CASE	8	8
	19	305JN70YU0	5JN70YU0	SEAL-FAN-280	1	1
	20	305JN706H0	5JN706H0	SEAL-FAN-T2	1	1
	21	305JN72KV0	5JN72KV0	ROCKING SUPPORT:SHCBS-14	1	1
	22	305JN72JG0	5JN72JG0	LOCKING SUPPORT:SPLSN-4U	1	1
⊙	23	305JN72NT0	5JN72NT0	SCREW:S/TPS/FHEXM/R-4X8-ZU3	5	5
	24	305JN72L50	5JN72L50	HARD DISK DRIVE:WD800JD-22LSA1	1	1
	25	305JN726T0	5JN726T0	WIRE HARNESS:HRNS-SATA-POW-430	1	1
	26	305JN726S0	5JN726S0	WIRE HARNESS:HRNS-SATA-SIG-430	1	1
	27	305JN72HD0	5JN72HD0	FERRITE CORE:TFC-25-15-12A	1	1
⊙	28	305JN72HA0	5JN72HA0	IC:HYMP112S64CP6-Y5	2	2
⊙	29	305JN72DD0	5JN72DD0	PWB ASSY:ASYB-PWA-SYS-430S	1	1
⊙	30	305JN72CT0	5JN72CT0	PWB ASSY:ASYB-SRAM-430S	1	1
⊙	30	305JN94040	5JN94040	PARTS PWB ASYB-SRAM-430S SP		1

• Parts with "⊙" indicate regular maintenance parts.

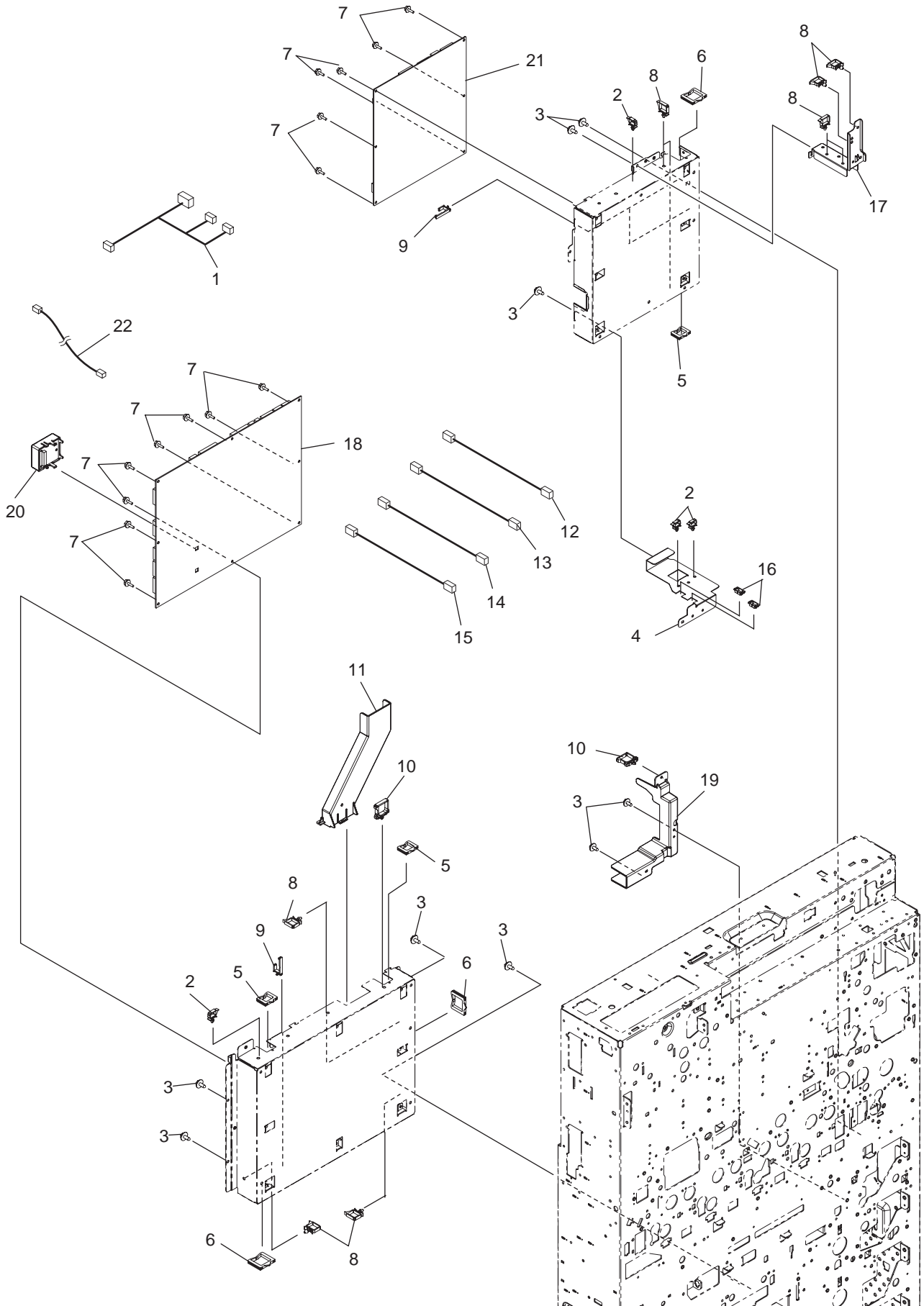

	Ref. No.	Part.No.	Alternative.	Description	Quantity	
					120	230
	1	305JN72BG0	5JN72BG0	WIRE HARNESS:HRNS-LGC-IH-430	1	1
	2	305JN72JP0	5JN72JP0	CLAMP LWS-0711Z	4	4
	3	305JN72NT0	5JN72NT0	SCREW:S/TPS/FHEXM/R-4X8-ZU3	9	9
	4	305JN70ZQ0	5JN70ZQ0	BRACKET:BRKT-HOLD-PFC	1	1
	5	305JN72J50	5JN72J50	BAND:EDS-1717U	3	3
	6	305JN72J10	5JN72J10	BAND:EDS-2323U	3	3
	7	305JN72NA0	5JN72NA0	SCREW:S/FHEXM-M3X8-NI	14	14
	8	305JN72K00	5JN72K00	CLAMP LWS-1316Z	7	7
	9	305JN72J20	5JN72J20	CLAMP RLWS3TV0	3	3
	10	305JN72KR0	5JN72KR0	CLAMP RLWC-6SV0	2	2
	11	305JN70Z90	5JN70Z90	GUIDE-HRNS-LGC	1	1
	12	305JN727E0	5JN727E0	WIRE HARNESS:HRNS-LGC-POL-430	1	1
	13	305JN727C0	5JN727C0	WIRE HARNESS:HRNS-LGC-SHT-430	1	1
	14	305JN72AE0	5JN72AE0	WIRE HARNESS:HRNS-LGC-EPUFAN-430	1	1
	15	305JN727N0	5JN727N0	WIRE HARNESS:HRNS-LGC-SNS-430	1	1
	16	305JN72K10	5JN72K10	BAND:ESC-0912	2	2
	17	305JN70ZNO	5JN70ZNO	BRACKET:BRKT-HRNS-TRU	1	1
⊙	18	305JN72CH0	5JN72CH0	PWB ASSY:ASYB-LGC-430S (550c)	1	1
⊙	18	305JN72CJ0	5JN72CJ0	PWB ASSY:ASYB-LGC-431S (650c)	1	1
⊙	18	305JN72CK0	5JN72CK0	PWB ASSY:ASYB-LGC-432S (750c)	1	1
	19	305JN70Z70	5JN70Z70	GUIDE-HRNS-REAR	1	1
⊙	20	305JN72D30	5JN72D30	PWB ASSY:ASYB-SRAM-T430-MUS (550c)	1	
⊙	20	305JN94010	5JN94010	PWB ASSY:ASYB-SRAM-T430-MES (550c)		1
⊙	20	305JN72D50	5JN72D50	PWB ASSY:ASYB-SRAM-T431-MUS (650c)	1	
⊙	20	305JN94020	5JN94020	PWB ASSY:ASYB-SRAM-T431-MES (650c)		1
⊙	20	305JN72D80	5JN72D80	PWB ASSY:ASYB-SRAM-T432-MUS (750c)	1	
⊙	20	305JN94030	5JN94030	PWB ASSY:ASYB-SRAM-T432-MES (750c)		1
⊙	21	305JN72CM0	5JN72CM0	PWB ASSY:ASYB-PFC-430S	1	1
	22	305JN727V0	5JN727V0	WIRE HARNESS:HRNS-LGC-PFCP-430	1	1

• Parts with "⊙" indicate regular maintenance parts.

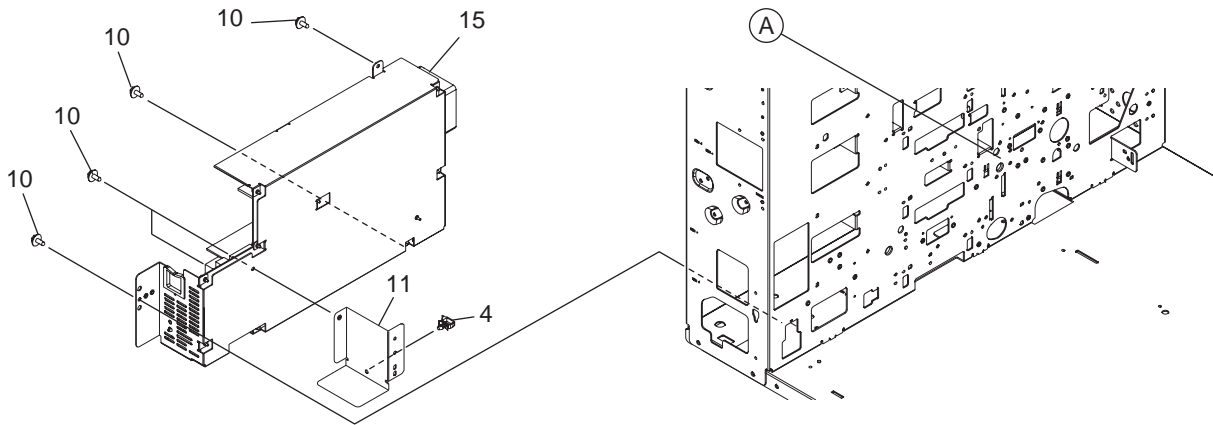

INLET-U(120V)

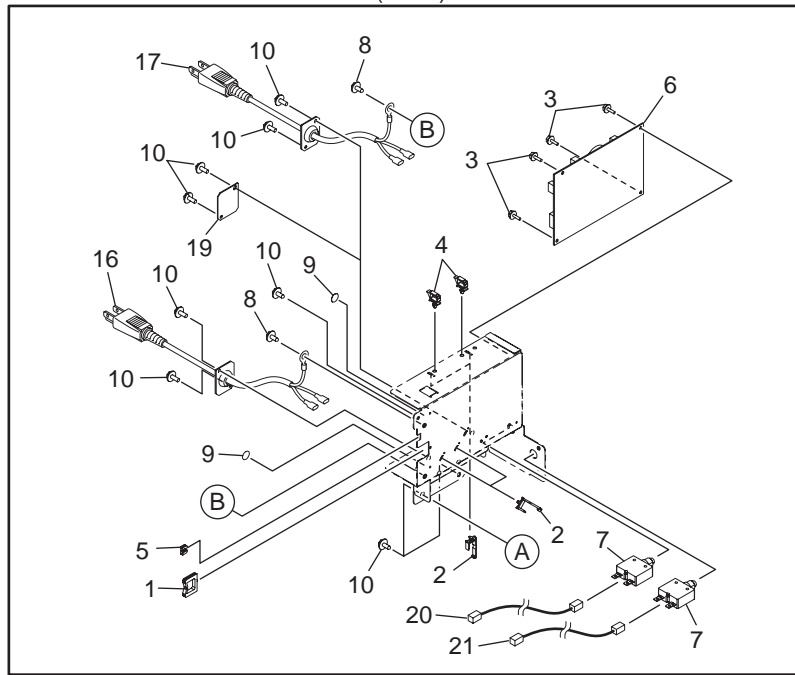

INLET-E/J(100V/220-240V)

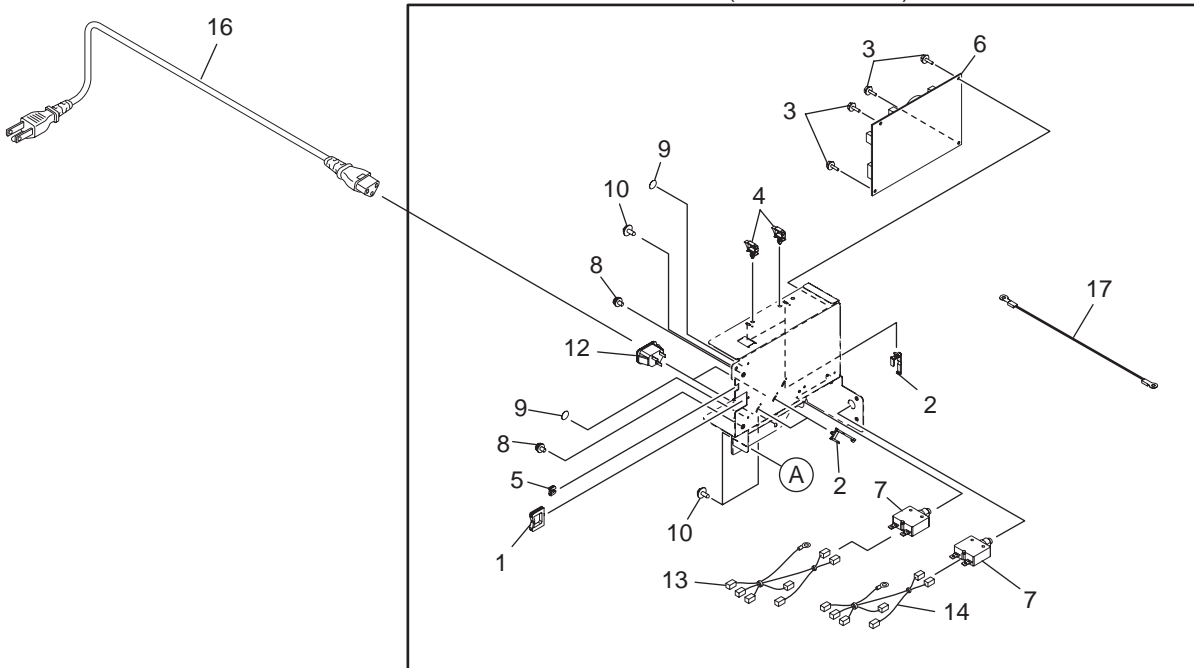

	Ref. No.	Part.No.	Alternative.	Description	Quantity	
					120	230
	1	305JN72J50	5JN72J50	BAND:EDS-1717U	2	2
	2	305JN72J20	5JN72J20	CLAMP RLWS3TV0	5	5
	3	305JN72NA0	5JN72NA0	SCREW:S/FHEXM-M3X8-NI	8	8
	4	305JN72JP0	5JN72JP0	CLAMP LWS-0711Z	4	4
	5	305JN72J60	5JN72J60	BAND:ES-0505	2	2
⊙	6	305JN72BL0	5JN72BL0	PWB ASSY:PWA-F-FIL-430-55U (55cpm)	1	
⊙	6	305JN72BM0	5JN72BM0	PWB ASSY:PWA-F-FIL-430-E		1
⊙	6	305JN72BN0	5JN72BN0	PWB ASSY:PWA-F-FIL-430-JU (65,75cpm)	1	
⊙	7	305JN72HS0	5JN72HS0	BREAKER:PE7410-1381-091H		2
⊙	7	305JN72HT0	5JN72HT0	BREAKER:PE7415-1381-091H (65,75cpm)	2	
⊙	7	305JN72HV0	5JN72HV0	BREAKER:PE7420-1381-091H (55cpm)	1	
	8	305JN72MY0	5JN72MY0	SCREW:S/PAN/SWWS-M4X6-NI	1	
	8	305JN72MY0	5JN72MY0	SCREW:S/PAN/SWWS-M4X6-NI	2	2
	9	305JN707V0	5JN707V0	LABEL MARK-EARTH-VDE-371 (55cpm)	2	
	9	305JN707V0	5JN707V0	LABEL MARK-EARTH-VDE-371	1	1
	10	305JN72NT0	5JN72NT0	SCREW:S/TPS/FHEXM/R-4X8-ZU3	10	10
	11	305JN70Z80	5JN70Z80	BRACKET:BRKT-HOLD-LVPS	1	1
	12	305JN72HK0	5JN72HK0	CONNECTOR:NC-179-F6.35 (750c)		2
	12	305JN72PV0	5JN72PV0	TERM NAL:AC-P10CF34 (550c,650c)		2
	13	305JN72770	5JN72770	WIRE HARNESS:HRNS-INLT1-F L-430		1
	14	305JN72780	5JN72780	WIRE HARNESS:HRNS-INLT2-F L-430		1
⊙	15	305JN72BX0	5JN72BX0	PWB:ASYB-PSU-F430-U	1	
⊙	15	305JN72BY0	5JN72BY0	PWB:ASYB-PSU-F430-E		1
	16	305JN70Z10	5JN70Z10	CABLE-P-INLET-EUR		2
	16	305JN72C40	5JN72C40	CABLE:ASYS-P-CABLE-UC-430 (550c)	1	
	17	305JN72C50	5JN72C50	CABLE:ASYS-P-CABLE-UC-430-B (650c,750c)	1	
	18	305JN72PW0	5JN72PW0	POWER-CORD:ASYS-P-CABLE-UC-430-B2 (650c,750c)	1	
	19	305JN70ZR0	5JN70ZR0	BRACKET:BRKT-BLIND-IH (550c)	1	
	20	305JN727B0	5JN727B0	WIRE HARNESS:HRNS-INLT1-F L-430-U	1	
	21	305JN726X0	5JN726X0	WIRE:HRNS-INLT2-F L-430-U (650c,750c)	1	

• Parts with "⊙" indicate regular maintenance parts.

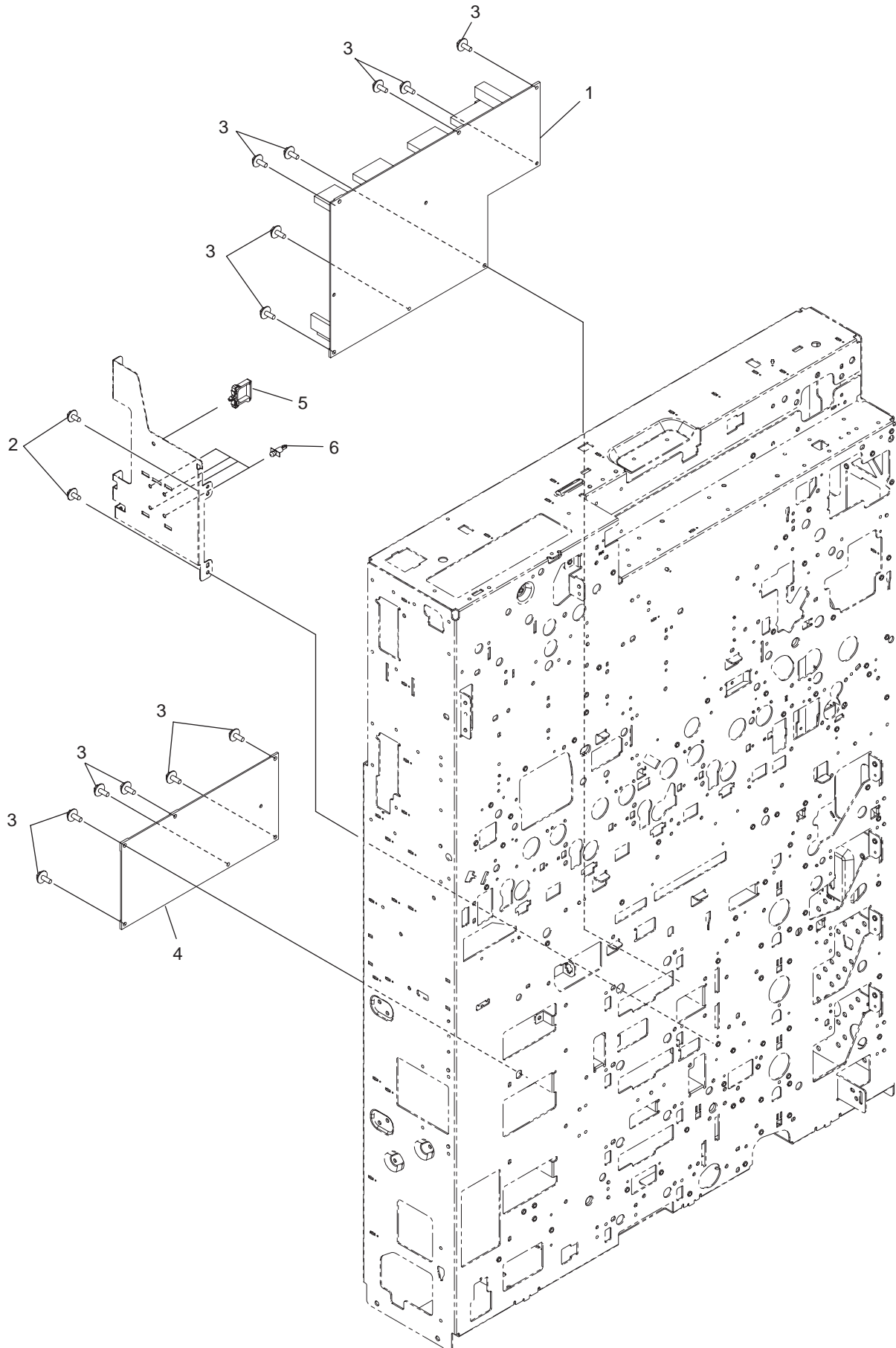

	Ref. No.	Part.No.	Alternative.	Description	Quantity	
					120	230
⊙	1	305JN72CV0	5JN72CV0	PWB:PS-HVT1-430	1	1
	2	305JN72NT0	5JN72NT0	SCREW:S/TPS/FHEXM/R-4X8-ZU3	2	2
	3	305JN72NB0	5JN72NB0	SCREW:S/FHEXM-M4X8-NI	13	13
⊙	4	305JN72AN0	5JN72AN0	PWB:PS-HVT2-430	1	1
	5	305JN72KR0	5JN72KR0	CLAMP RLWC-6SV0	1	1
	6	305JN72JH0	5JN72JH0	LOCKING SUPPORT:SPLSN-6U	4	4

• Parts with "⊙" indicate regular maintenance parts.

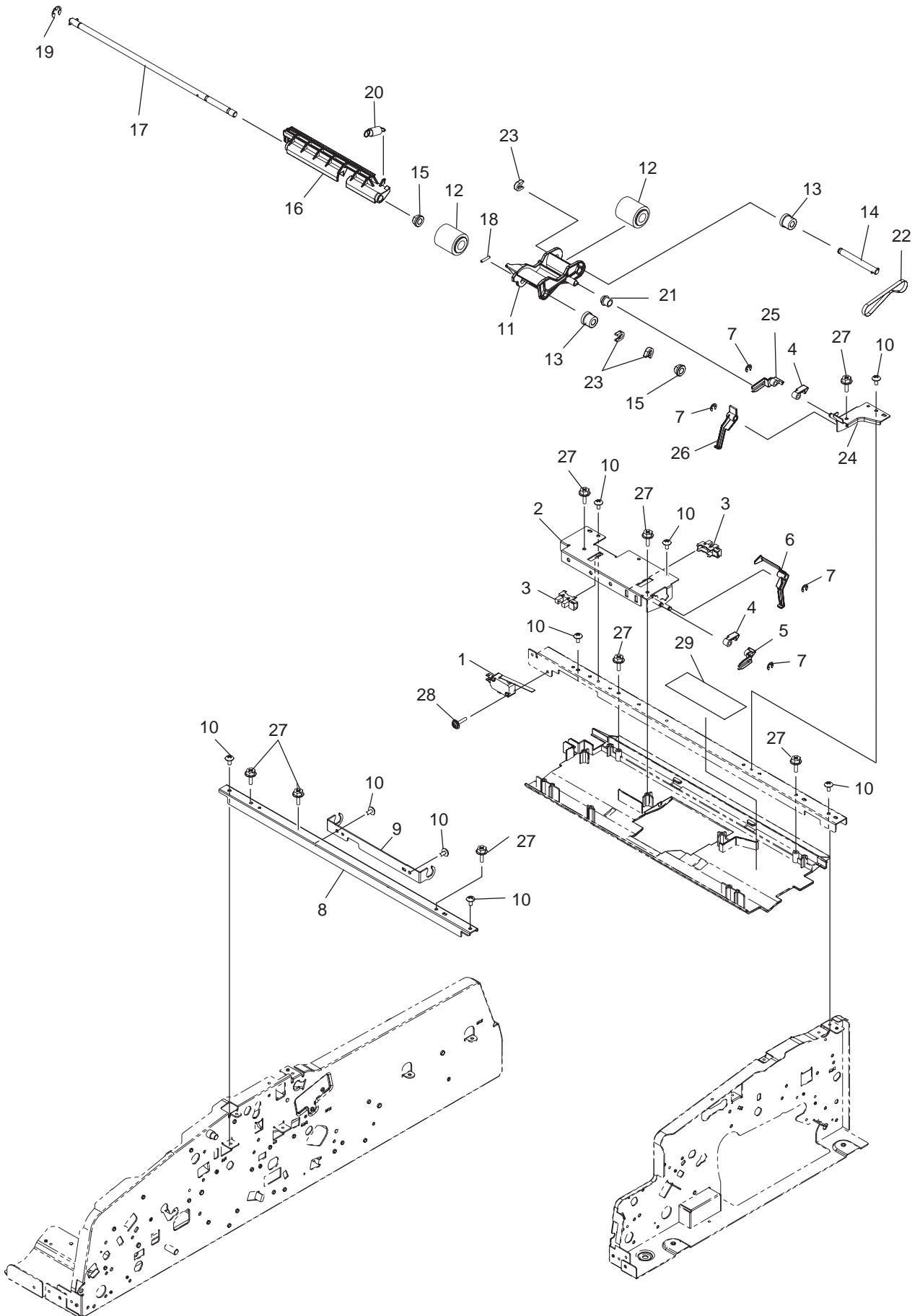

	Ref. No.	Part.No.	Alternative.	Description	Quantity	
					120	230
⊙	1	305JN72HW0	5JN72HW0	SWITCH:AM51613C731Y1N	1	1
	2	305JN71Y70	5JN71Y70	BRACKET ASSY:ASYS-BRKT-STOP-R-TQ	1	1
⊙	3	305JN72H90	5JN72H90	SENSOR:GP1A173LCS2F	2	2
⊙	4	305JN70YH0	5JN70YH0	ARM-STOPPER	2	2
	5	305JN71X20	5JN71X20	LEVER LVR-STOPPER-R-TQ	1	1
	6	305JN71WS0	5JN71WS0	STOPPER:STPR-PICK-R-TQ	1	1
	7	305JN72LU0	5JN72LU0	RETAINING RING:RR/E-3-SS	4	4
	8	305JN71XV0	5JN71XV0	STAY-FED-U-L-TQ	1	1
	9	305JN70YA0	5JN70YA0	BRACKET:BRKT-FEED-UP	1	1
	10	305JN70330	5JN70330	SCREW:SCR-M3X6BISR-NI	9	9
	11	305JN70YD0	5JN70YD0	HOLDER ASSY:ASYS-HLDR-PICK	1	1
⊙	12	305JN70YC0	5JN70YC0	ROLLER ASSY:ASYS-ROL-FEED	2	2
⊙	13	305JN70YF0	5JN70YF0	PULLEY PULLY-1R5GT26-6	2	2
	14	305JN71YS0	5JN71YS0	SHAFT ASSY:ASYS-SFT-PICUP-TQ	1	1
	15	305JN70XY0	5JN70XY0	BUSH-6X10X6F-SBK	2	2
	16	305JN71WY0	5JN71WY0	LEVER LVR-PICK-JOINT-TQ	1	1
	17	305JN71YT0	5JN71YT0	SHAFT ASSY:ASYS-SFT-FEED-TQ	1	1
	18	305JN70E90	5JN70E90	PIN-2X10	1	1
	19	305JN72LW0	5JN72LW0	RETAIN NG RING:RR/E-5-SS	1	1
	20	305JN72110	5JN72110	SPRING:SPG-E-PICKUP	1	1
	21	305JN70YE0	5JN70YE0	ROLLER:ROL-TNSN-PICK	1	1
	22	305JN70YG0	5JN70YG0	TIMING BELT:BELT-141-1R5GT-4	1	1
	23	305JN70XZ0	5JN70XZ0	STOP-R NG-6-5-POM	3	3
	24	305JN71Y50	5JN71Y50	BRACKET ASSY:ASYS-BRKT-STOP-F-TQ	1	1
	25	305JN71X10	5JN71X10	LEVER LVR-STOPPER-F-TQ	1	1
	26	305JN71WR0	5JN71WR0	STOPPER:STPR-PICK-F-TQ	1	1
	27	305JN72MK0	5JN72MK0	SCREW:S/TPP/BID-3X8-NI	8	8
	28	305JN72MG0	5JN72MG0	SCREW:S/TPS/FPAN-3X14-NC	1	1
	29	305JN720C0	5JN720C0	LABEL- NST-TQ	1	1

• Parts with "⊙" indicate regular maintenance parts.

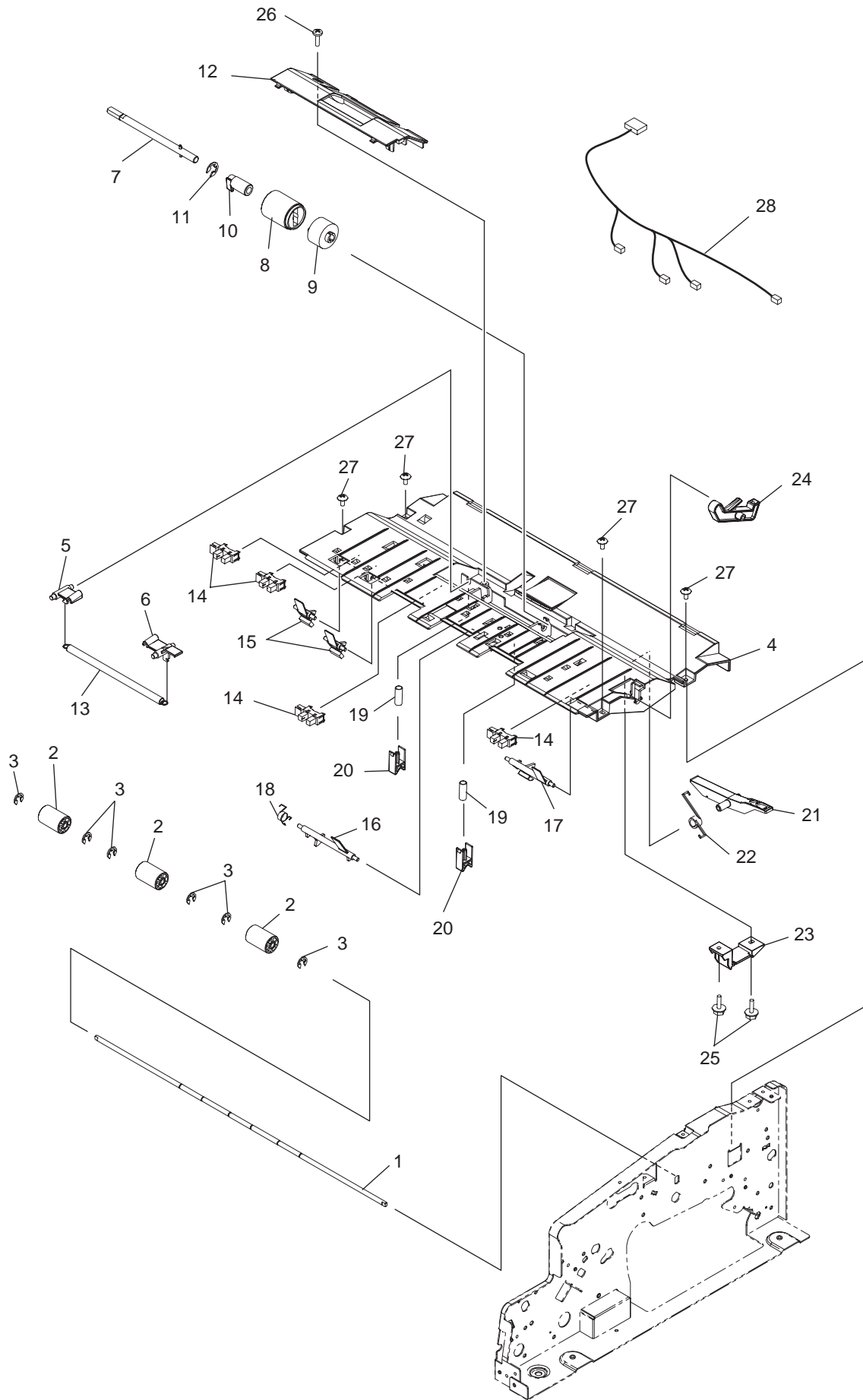

	Ref. No.	Part.No.	Alternative.	Description	Quantity	
					120	230
⊙	1	305JN71ZN0	5JN71ZN0	SHAFT:SFT-IDL-SWB-D4	1	1
	2	305JN71WL0	5JN71WL0	ROLLER:ROL-IDL-D16-D4-POM	3	3
	3	305JN72LU0	5JN72LU0	RETAINING RING:RR/E-3-SS	6	6
	4	305JN71ZP0	5JN71ZP0	GUIDE ASSY:ASYS-GUIDE-FEED-U-L-TQ	1	1
	5	305JN71XF0	5JN71XF0	LEVER LVR-SPT-R-TQ	1	1
	6	305JN71XD0	5JN71XD0	LEVER LVR-SPT-F-TQ	1	1
	7	305JN71YQ0	5JN71YQ0	SHAFT ASSY:ASYS-SFT-SEP-TQ	1	1
	8	305JN70YB0	5JN70YB0	ROLLER ASSY:ASYS-ROL-RET	1	1
	9	305JN71MK0	5JN71MK0	TORQUE LIMITER:TL-SEP-ROL-Y-N	1	1
	10	305JN71YU0	5JN71YU0	HOLDER:HLDR-ROLL-SPT-TQ	1	1
	11	305JN72LV0	5JN72LV0	RETAIN NG RING:RR/E-4-SS	1	1
	12	305JN71ZQ0	5JN71ZQ0	COVER ASSY:ASYS-COV-SPT-TQ	1	1
	13	305JN71ZR0	5JN71ZR0	SPRING:SPG-ROL-SPT-TQ	1	1
	14	305JN72H90	5JN72H90	SENSOR:GP1A173LCS2F	4	4
	15	305JN70Y80	5JN70Y80	LEVER-SENS-WIDTH	2	2
	16	305JN71X90	5JN71X90	LEVER-SENS-LENG-TQ	1	1
	17	305JN71YV0	5JN71YV0	LEVER-SENS-WIDE-A3LT	1	1
	18	305JN70Y90	5JN70Y90	SPRING:SPG-T-LVR-ALNG	1	1
	19	305JN71ZS0	5JN71ZS0	SPRING:SPR-LEV-SWB	2	2
	20	305JN71WV0	5JN71WV0	LEVER LEV-SW-B	2	2
	21	305JN71XA0	5JN71XA0	LEVER-SPT-CAM-TQ	1	1
	22	305JN71ZT0	5JN71ZT0	SPRING:SPR-LEV-SPT-CAM	1	1
	23	305JN71YX0	5JN71YX0	HOLDER:HLDR-LVR-SPT-CAM	1	1
	24	305JN71XB0	5JN71XB0	LEVER-SPT-CAM-2-TQ	1	1
	25	305JN72NE0	5JN72NE0	SCREW:S/TPP/FHEXM-3X8-NI	2	2
	26	305JN72MK0	5JN72MK0	SCREW:S/TPP/BID-3X8-NI	1	1
	27	305JN70330	5JN70330	SCREW:SCR-M3X6BISR-NI	4	4
	28	305JN71VM0	5JN71VM0	WIRE HARNESS HRNS-RADF-LENTH-430	1	1

• Parts with "⊙" indicate regular maintenance parts.

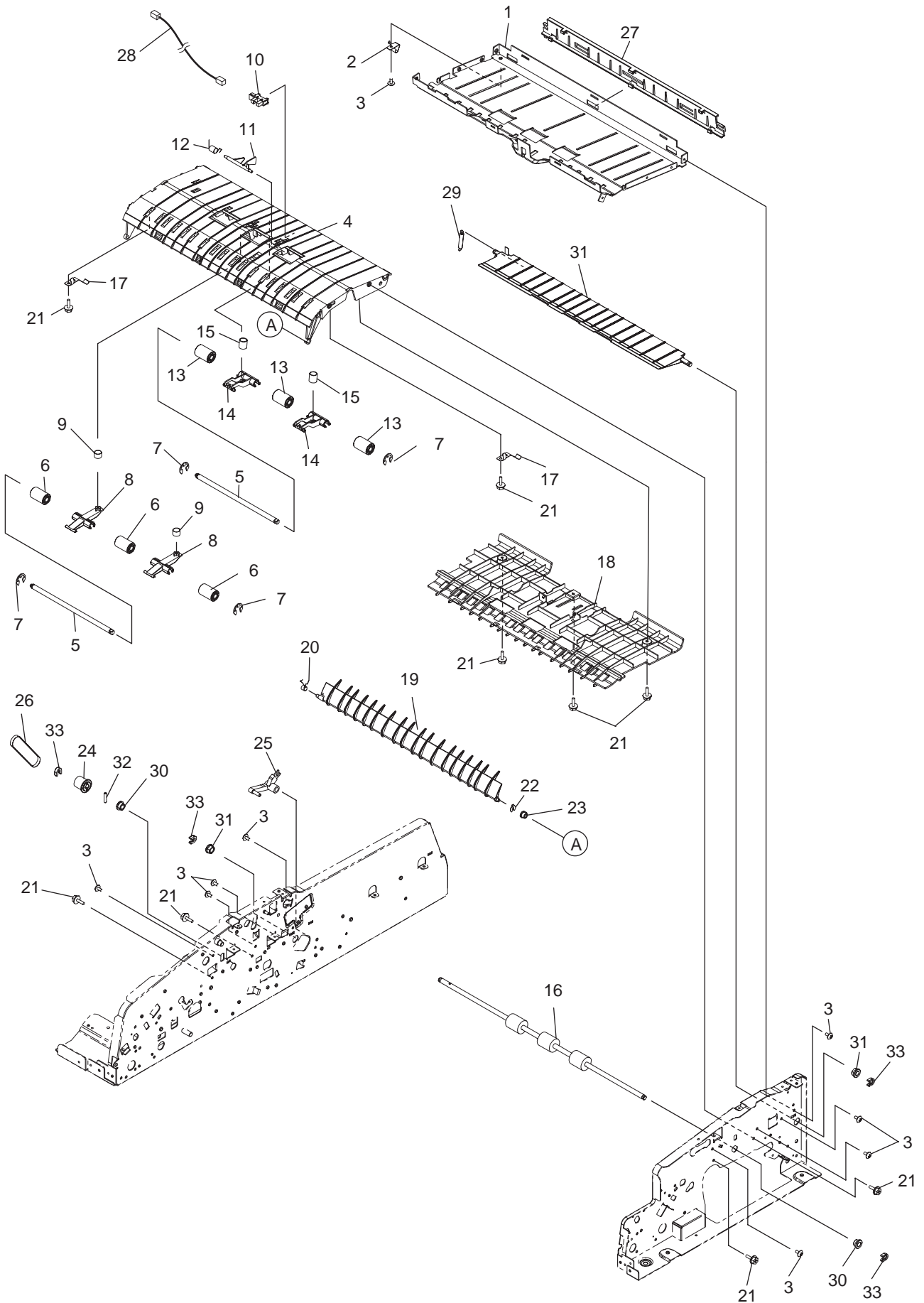

	Ref. No.	Part.No.	Alternative.	Description	Quantity	
					120	230
	1	305JN71XX0	5JN71XX0	GUIDE-SB-U-TQ	1	1
	2	305JN71YB0	5JN71YB0	SPRING:SPR-ERTH-SB	1	1
	3	305JN70330	5JN70330	SCREW:SCR-M3X6BISR-NI	9	9
	4	305JN71W20	5JN71W20	GUIDE-SB-IN	1	1
	5	305JN71Z00	5JN71Z00	SHAFT:SFT-EXIT-SB-D6	2	2
⊙	6	305JN71WP0	5JN71WP0	ROLLER:ROL-IDL-D15-D6-POM	3	3
	7	305JN72LW0	5JN72LW0	RETAIN NG RING:RR/E-5-SS	4	4
	8	305JN71X60	5JN71X60	LEVER LEV-DELTA	2	2
	9	305JN71Z10	5JN71Z10	SPRING:SPR-SB-IN	2	2
⊙	10	305JN72GX0	5JN72GX0	LED:GP1A73ARJ00F	1	1
	11	305JN71XR0	5JN71XR0	LEVER-OUT-SENS	1	1
	12	305JN71Z30	5JN71Z30	SPRING:SPR-SENS-OUT	1	1
⊙	13	305JN71WK0	5JN71WK0	ROLLER:ROL-IDL-D16-POM	3	3
	14	305JN71X70	5JN71X70	LEVER LEV-EXIT	2	2
	15	305JN71Z20	5JN71Z20	SPRING:SPR-SB-OUT	2	2
⊙	16	305JN71YJ0	5JN71YJ0	ROLLER:ROL-TRANS-RVS	1	1
	17	305JN71YA0	5JN71YA0	SPRING:SPL-GUIDE-CUSION	2	2
	18	305JN71WW0	5JN71WW0	GUIDE-SB-IN-D	1	1
	19	305JN720Q0	5JN720Q0	GUIDE:GATE-EXIT-SFT	1	1
	20	305JN71Z40	5JN71Z40	SPRING:SPR-GATE-EXIT	1	1
	21	305JN72NE0	5JN72NE0	SCREW:S/TPP/FHEXM-3X8-NI	9	9
	22	305JN720N0	5JN720N0	STOPPER:STOP-RING-3	1	1
	23	305JN70060	5JN70060	BUSH-4-7	1	1
⊙	24	305JN71WQ0	5JN71WQ0	PULLEY:PULLY-MAIN-ALNG	1	1
	25	305JN71XG0	5JN71XG0	LEVER LVR-FLAP-EXIT-TQ	1	1
	26	305JN72010	5JN72010	TIMING BELT:BLT-TRANS-RVS	1	1
	27	305JN71YC0	5JN71YC0	STAY-ORG-SUB	1	1
	28	305JN71VP0	5JN71VP0	WIRE HARNESS:HRNS-RADF-EXIT-430	1	1
	29	305JN71Z50	5JN71Z50	SPRING:SPG-FLAP-EXIT-TQ	1	1
	30	305JN70XY0	5JN70XY0	BUSH-6X10X6F-SBK	2	2
	31	305JN71ZC0	5JN71ZC0	GUIDE FLAP ASSY:ASYS-FLAP-EXIT-TQ	1	1
	32	305JN70E90	5JN70E90	PIN-2X10	1	1
	33	305JN70XZ0	5JN70XZ0	STOP-R NG-6-5-POM	4	4

• Parts with "⊙" indicate regular maintenance parts.

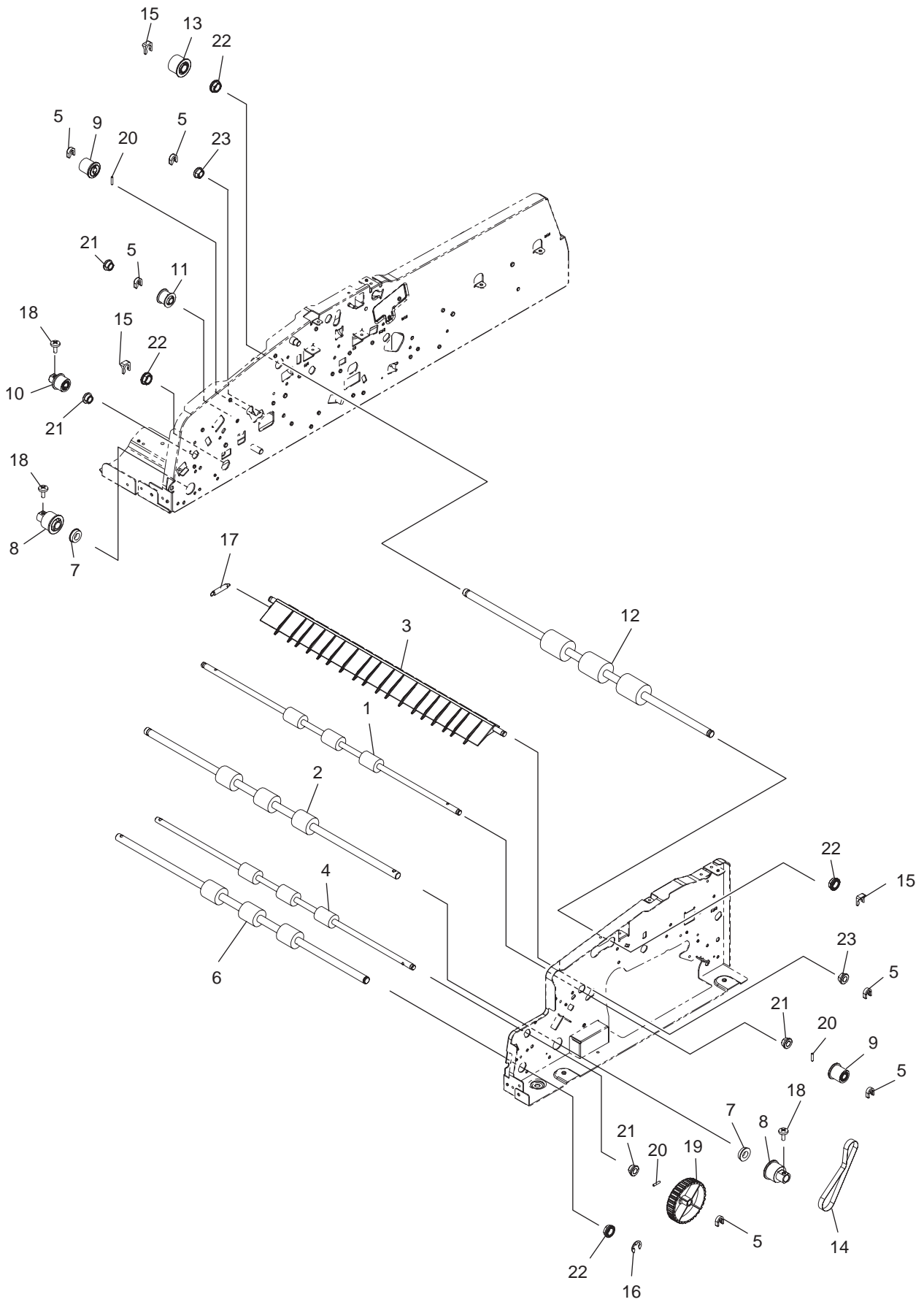

	Ref. No.	Part.No.	Alternative.	Description	Quantity	
					120	230
⊙	1	305JN71YG0	5JN71YG0	ROLLER:ROL-RVS-ALNG	1	1
⊙	2	305JN71YH0	5JN71YH0	ROLLER:ROL-READ-OUT	1	1
	3	305JN71XH0	5JN71XH0	GUIDE FLAP:FLAP-RD	1	1
⊙	4	305JN720V0	5JN720V0	ROLLER:ROL-TRANS-8	1	1
	5	305JN70XZ0	5JN70XZ0	STOP-R NG-6-5-POM	6	6
⊙	6	305JN71YM0	5JN71YM0	ROLLER:ROL-READ-IN	1	1
	7	305JN72JR0	5JN72JR0	BEARING:LF-1480ZZ	2	2
⊙	8	305JN71WU0	5JN71WU0	PULLEY:PULLY-READ	2	2
⊙	9	305JN71WQ0	5JN71WQ0	PULLEY:PULLY-MAIN-ALNG	2	2
⊙	10	305JN71WM0	5JN71WM0	PULLEY PULLY-RVS-ALNG	1	1
⊙	11	305JN70Y60	5JN70Y60	ROLLER:ROL-TNSN-FEED	1	1
⊙	12	305JN71YN0	5JN71YN0	ROLLER:ROL-ALNG-MAIN	1	1
⊙	13	305JN71WJ0	5JN71WJ0	PULLEY:PULLY-CLUCH-MA N-ALNG	1	1
	14	305JN71ZZ0	5JN71ZZ0	TIMING BELT:BLT-RD-FRONT	1	1
	15	305JN701N0	5JN701N0	STOP RING	3	3
	16	305JN72LY0	5JN72LY0	RETAIN NG RING:RR/E-7-SS	1	1
	17	305JN720D0	5JN720D0	SPRING:SPG-FLAP-READ-TQ	1	1
	18	305JN72M90	5JN72M90	SCREW:SBID-M3X6-NC	3	3
	19	305JN71WZ0	5JN71WZ0	DIAL-JAM-TQ	1	1
	20	305JN70E90	5JN70E90	PIN-2X10	3	3
	20	305JN70330	5JN70330	SCREW:SCR-M3X6BISR-NI	6	6
	21	305JN70XY0	5JN70XY0	BUSH-6X10X6F-SBK	4	4
	22	305JN70YS0	5JN70YS0	BUSH-8X12X5R5F-NU4	4	4
	23	305JN701S0	5JN701S0	BUSH-6-POM	2	2

• Parts with "⊙" indicate regular maintenance parts.

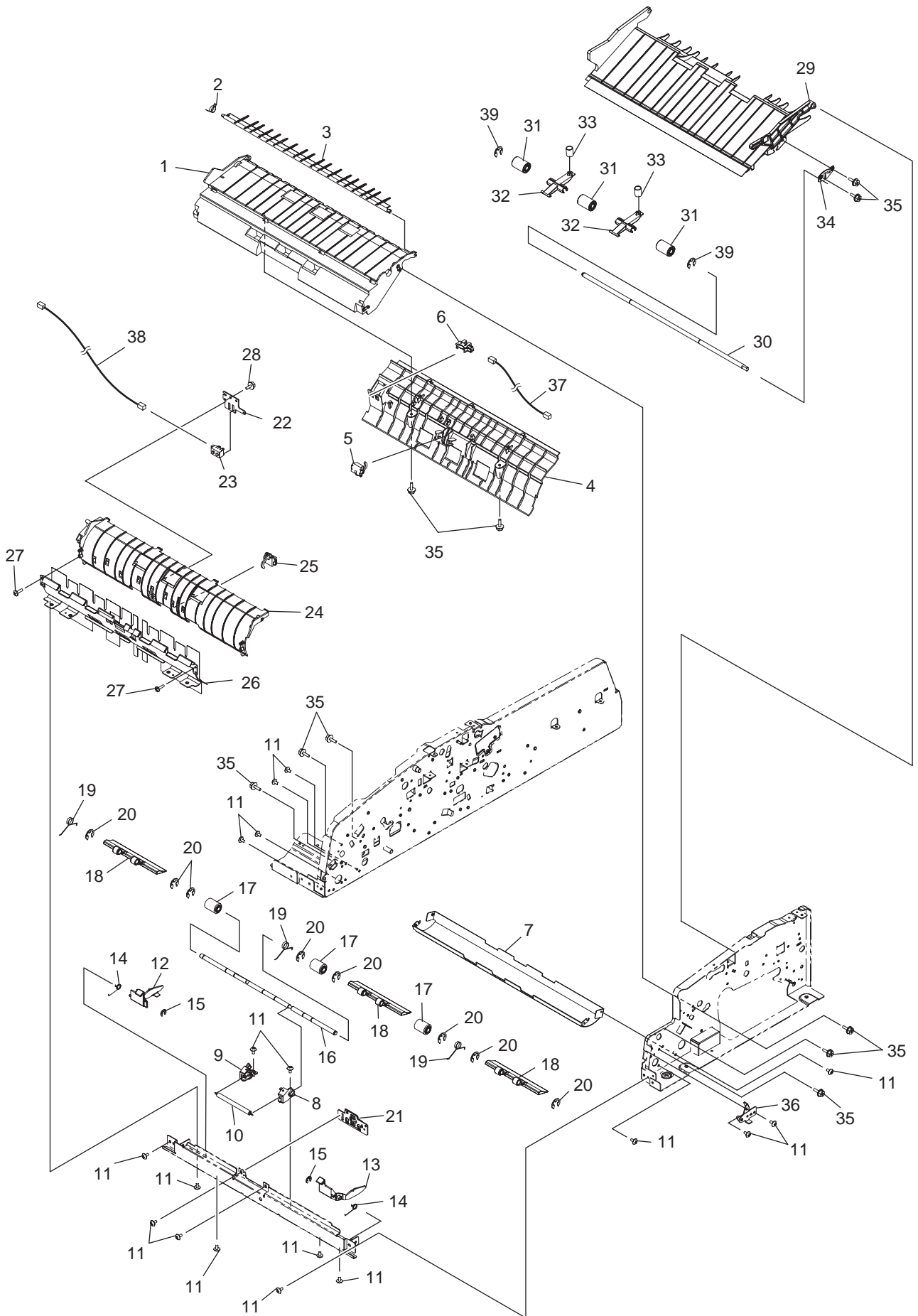

	Ref. No.	Part.No.	Alternative.	Description	Quantity	
					120	230
	1	305JN71WB0	5JN71WB0	GUIDE-RVS-ALNG	1	1
	2	305JN70Y30	5JN70Y30	SPRING:SPG-T-FLP-SB	1	1
	3	305JN71WA0	5JN71WA0	GUIDE:GATE-SB	1	1
	4	305JN720W0	5JN720W0	GUIDE ASSY:ASYS-GUIDE-READ-OUT	1	1
⊙	5	305JN71VY0	5JN71VY0	SENSOR:SNSR-RADF-EXIT-430	1	1
⊙	6	305JN72GX0	5JN72GX0	LED:GP1A73ARJ00F	1	1
	7	305JN71WE0	5JN71WE0	GUIDE-PLTN	1	1
	8	305JN71ZF0	5JN71ZF0	LEVER ASSY:ASYB-READ-IN-LEV-STAY-F	1	1
	9	305JN71ZG0	5JN71ZG0	LEVER ASSY:ASYB-READ-IN-LEV-STAY-R	1	1
	10	305JN71ZH0	5JN71ZH0	SPRING:SPR-LEV-READ-IN	1	1
	11	305JN70330	5JN70330	SCREW:SCR-M3X6BISR-NI	18	18
	12	305JN71XC0	5JN71XC0	GUIDE:STPR-GID-PLTN-R	1	1
	13	305JN71XE0	5JN71XE0	GUIDE:STPR-GID-PLTN-F	1	1
	14	305JN71ZJ0	5JN71ZJ0	SPRING:SPR-STPR-G D-PLTN	2	2
	15	305JN72LU0	5JN72LU0	RETAINING RING:RR/E-3-SS	2	2
	16	305JN71ZK0	5JN71ZK0	SHAFT:SFT-IDL-RD-IN-L	1	1
	17	305JN71YD0	5JN71YD0	ROLLER ASSY:ASYS-ROL-RD-IN-IDL	3	3
	18	305JN71WX0	5JN71WX0	GUIDE-RD-IN-GLASS	3	3
	19	305JN71ZL0	5JN71ZL0	SPRING:SPR-READ-IN-GUIDE	3	3
	20	305JN72LV0	5JN72LV0	RETAIN NG RING:RR/E-4-SS	8	8
	21	305JN71ZM0	5JN71ZM0	BRACKET ASSY:ASYB-BRKT-PRISM	1	1
	22	305JN71YF0	5JN71YF0	PLATE:PLT-SENSOR-RI	1	1
⊙	23	305JN72H30	5JN72H30	SENSOR EON-5041-701	1	1
	24	305JN71X50	5JN71X50	GUIDE-READ-IN	1	1
⊙	25	305JN71VX0	5JN71VX0	SENSOR:SNSR-RADF-MID-430	1	1
	26	305JN720K0	5JN720K0	GUIDE ASSY:ASYS-GUIDE-READ-IN-PLT	1	1
	27	305JN72MK0	5JN72MK0	SCREW:S/TPP/BID-3X8-NI	2	2
	28	305JN72NY0	5JN72NY0	SCREW:S/TPP/BRZ-3X6-ZU3	1	1
	29	305JN71ZW0	5JN71ZW0	GUIDE ASSY:ASYS-GUIDE-SB	1	1
	30	305JN71ZX0	5JN71ZX0	SHAFT:SFT-ROL-RVS-ALNG	1	1
⊙	31	305JN71WK0	5JN71WK0	ROLLER:ROL-IDL-D16-POM	3	3
	32	305JN71X60	5JN71X60	LEVER LEV-DELTA	2	2
	33	305JN71ZY0	5JN71ZY0	SPRING:SPR-DELTA	2	2
	34	305JN71Y10	5JN71Y10	BRACKET:BRKT-DELTA-SET	1	1
	35	305JN72NE0	5JN72NE0	SCREW:S/TPP/FHEXM-3X8-NI	10	10
	36	305JN71Y60	5JN71Y60	BRACKET ASSY:ASYS-BRKT-COV-JAM-F	1	1
	37	305JN71VS0	5JN71VS0	WIRE HARNESS HRNS-RADF-JCOVL-430	1	1
	38	305JN71VR0	5JN71VR0	WIRE HARNESS:HRNS-RADF-READI-430	1	1
	39	305JN72LW0	5JN72LW0	RETAIN NG RING:RR/E-5-SS	2	2

• Parts with "⊙" indicate regular maintenance parts.

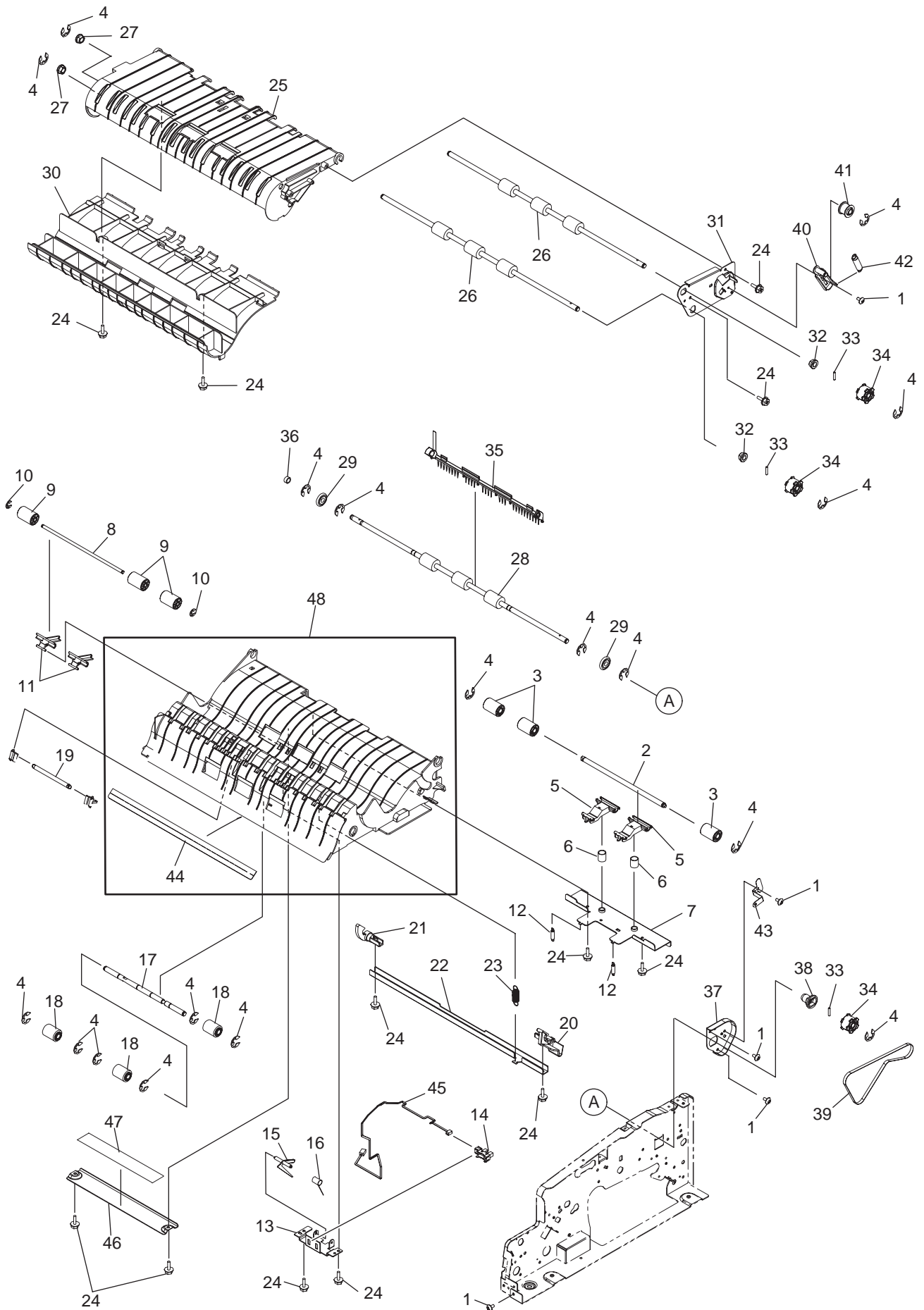

	Ref. No.	Part.No.	Alternative.	Description	Quantity	
					120	230
	1	305JN70330	5JN70330	SCREW:SCR-M3X6BISR-NI	6	6
	2	305JN71Z00	5JN71Z00	SHAFT:SFT-EXIT-SB-D6	1	1
⊙	3	305JN71WK0	5JN71WK0	ROLLER:ROL-IDL-D16-POM	3	3
	4	305JN72LW0	5JN72LW0	RETAIN NG RING:RR/E-5-SS	18	18
	5	305JN71X70	5JN71X70	LEVER LEV-EXIT	2	2
	6	305JN71Z20	5JN71Z20	SPRING:SPR-SB-OUT	2	2
	7	305JN71XS0	5JN71XS0	BRACKET:BRKT-LEV-EXIT	1	1
	8	305JN71Z60	5JN71Z60	SHAFT:SFT-EXIT-D4	1	1
⊙	9	305JN71WL0	5JN71WL0	ROLLER:ROL-IDL-D16-D4-POM	3	3
	10	305JN72LU0	5JN72LU0	RETAINING RING:RR/E-3-SS	2	2
	11	305JN71WT0	5JN71WT0	LEVER LEV-EXIT-R	2	2
	12	305JN71Z70	5JN71Z70	SPRING:SPR-LEV-EXIT	2	2
	13	305JN71XU0	5JN71XU0	BRACKET:BRKT-BACK-EXIT-SNS	1	1
⊙	14	305JN72H90	5JN72H90	SENSOR:GP1A173LCS2F	1	1
	15	305JN71X00	5JN71X00	ACTUATOR:ACTR-BACK-EXIT	1	1
	16	305JN71Z80	5JN71Z80	SPRING:SPR-BACK-SNS	1	1
	17	305JN71YP0	5JN71YP0	SHAFT:SFT-IDL-RD-OUT	1	1
	18	305JN71YD0	5JN71YD0	ROLLER ASSY:ASYS-ROL-RD-IN-IDL	3	3
	19	305JN71ZH0	5JN71ZH0	SPRING:SPR-LEV-READ-IN	1	1
	20	305JN71X30	5JN71X30	LEVER-GUIDE-LOCK-F	1	1
	21	305JN71X40	5JN71X40	LEVER-GUIDE-LOCK-R	1	1
	22	305JN71XP0	5JN71XP0	BRACKET:BRKT-GU DE-OPEN	1	1
	23	305JN71Z90	5JN71Z90	SPRING:SPR-GUIDE-EXIT-OPEN	1	1
	24	305JN72NE0	5JN72NE0	SCREW:S/TPP/FHEXM-3X8-NI	2	2
⊙	25	305JN71W80	5JN71W80	GUIDE-EXIT- N	1	1
	26	305JN71YK0	5JN71YK0	ROLLER:ROL-EXIT-SB	2	2
	27	305JN701S0	5JN701S0	BUSH-6-POM	2	2
⊙	28	305JN71YL0	5JN71YL0	ROLLER:ROL-EXIT	1	1
	29	305JN720H0	5JN720H0	ROLLER:ROL-COL-TQ	2	2
	30	305JN71W90	5JN71W90	GUIDE-EXIT- N-L	1	1
	31	305JN71XN0	5JN71XN0	PLATE-DRV-EXIT-F	1	1
	32	305JN70XY0	5JN70XY0	BUSH-6X10X6F-SBK	2	2
	33	305JN70E90	5JN70E90	PIN-2X10	3	3
⊙	34	305JN71WN0	5JN71WN0	PULLEY:PULLY-EXIT	3	3
	35	305JN720G0	5JN720G0	SHUTTER ASSY:ASYS-SHUT-EXIT-TQ	1	1
	36	305JN72GL0	5JN72GL0	BUSH-GCB-6-4-NU4	1	1
	37	305JN71XY0	5JN71XY0	PLATE:PLT-GUIDE-EXIT	1	1
	38	305JN71WF0	5JN71WF0	BUSH-GUIDE-EXIT-F	1	1
	39	305JN71ZA0	5JN71ZA0	TIMING BELT:BLT-EXIT-F	1	1
	40	305JN70Y70	5JN70Y70	PLATE ASSY:ASYS-PLT-TNSN	1	1
⊙	41	305JN70Y60	5JN70Y60	ROLLER:ROL-TNSN-FEED	1	1
	42	305JN71ZB0	5JN71ZB0	SPRING:SPR-TNSN-READ-10N	1	1
	43	305JN720F0	5JN720F0	SPRING:SPR-ERTH-FR	1	1
	44	305JN71Y30	5JN71Y30	SHEET:MYLAR-GUIDE-EXIT	1	1
	45	305JN71VQ0	5JN71VQ0	WIRE HARNESS:HRNS-RADF-EXITR-430	1	1
	46	305JN71XT0	5JN71XT0	BRACKET:BRKT-GU DE-PUSH	1	1
	47	305JN720B0	5JN720B0	LABEL LBL-PUSH-TQ	1	1
	48	305JN71Y20	5JN71Y20	GUIDE ASSY:ASYS-GUIDE-EXIT	1	1

• Parts with "⊙" indicate regular maintenance parts.

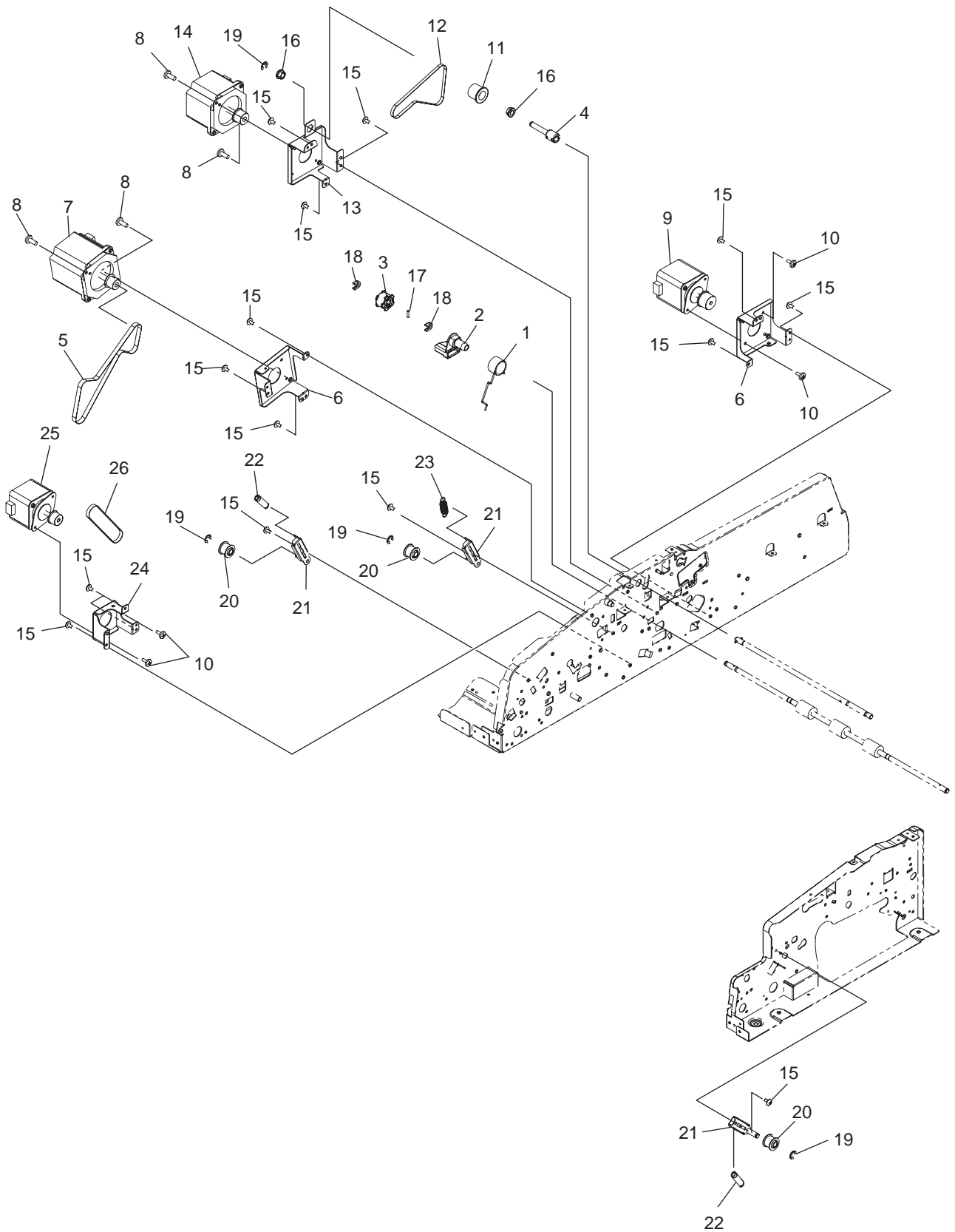

	Ref. No.	Part.No.	Alternative.	Description	Quantity	
					120	230
	1	305JN720X0	5JN720X0	SPRING:SPR-CUSHION-GUIDE-EXIT	1	1
	2	305JN71WG0	5JN71WG0	BUSH-GUIDE-EXIT-R	1	1
⊙	3	305JN71WN0	5JN71WN0	PULLEY:PULLY-EXIT	1	1
	4	305JN71YR0	5JN71YR0	COUPL NG ASSY:ASYS-CPG-FED-TQ	1	1
	5	305JN72000	5JN72000	TIMING BELT:BLT-RD-MOT-REAR	1	1
	6	305JN71XK0	5JN71XK0	BRACKET:BRKT-MOT-EXIT	2	2
⊙	7	305JN71VU0	5JN71VU0	MOTOR:MOTR_S-RADF-READ-430	1	1
	8	305JN72MB0	5JN72MB0	SCREW:S/TPS/BID-4X8-NC	4	4
⊙	9	305JN71VW0	5JN71VW0	MOTOR:MOTR_S-RADF-EXIT-430	1	1
	10	305JN72M90	5JN72M90	SCREW:S/BID-M3X6-NC	4	4
⊙	11	305JN71WC0	5JN71WC0	PULLEY:PULLY-CLUCH-FEED	1	1
	12	305JN72020	5JN72020	TIMING BELT:BLT-FEED	1	1
	13	305JN71XM0	5JN71XM0	BRACKET:BRKT-MOT-FEED	1	1
⊙	14	305JN71VT0	5JN71VT0	MOTOR:MOTR_S-RADF-FEED-430	1	1
	15	305JN70330	5JN70330	SCREW:SCR-M3X6BISR-NI	15	15
	16	305JN70XY0	5JN70XY0	BUSH-6X10X6F-SBK	2	2
	17	305JN70E90	5JN70E90	PIN-2X10	1	1
	18	305JN70XZ0	5JN70XZ0	STOP-R NG-6-5-POM	2	2
	19	305JN72LW0	5JN72LW0	RETAIN NG RING:RR/E-5-SS	4	4
⊙	20	305JN70Y60	5JN70Y60	ROLLER:ROL-TNSN-FEED	3	3
	21	305JN70Y70	5JN70Y70	PLATE ASSY:ASYS-PLT-TNSN	3	3
	22	305JN71ZB0	5JN71ZB0	SPRING:SPR-TNSN-READ-10N	2	2
	23	305JN72030	5JN72030	SPRING:SPR-TNSN-FEED-4N	1	1
	24	305JN71XL0	5JN71XL0	BRACKET:BRKT-MOT-SB	1	1
⊙	25	305JN71VV0	5JN71VV0	MOTOR:MOTR_S-RADF-SB-430	1	1
	26	305JN72010	5JN72010	TIMING BELT:BLT-TRANS-RVS	1	1

• Parts with "⊙" indicate regular maintenance parts.

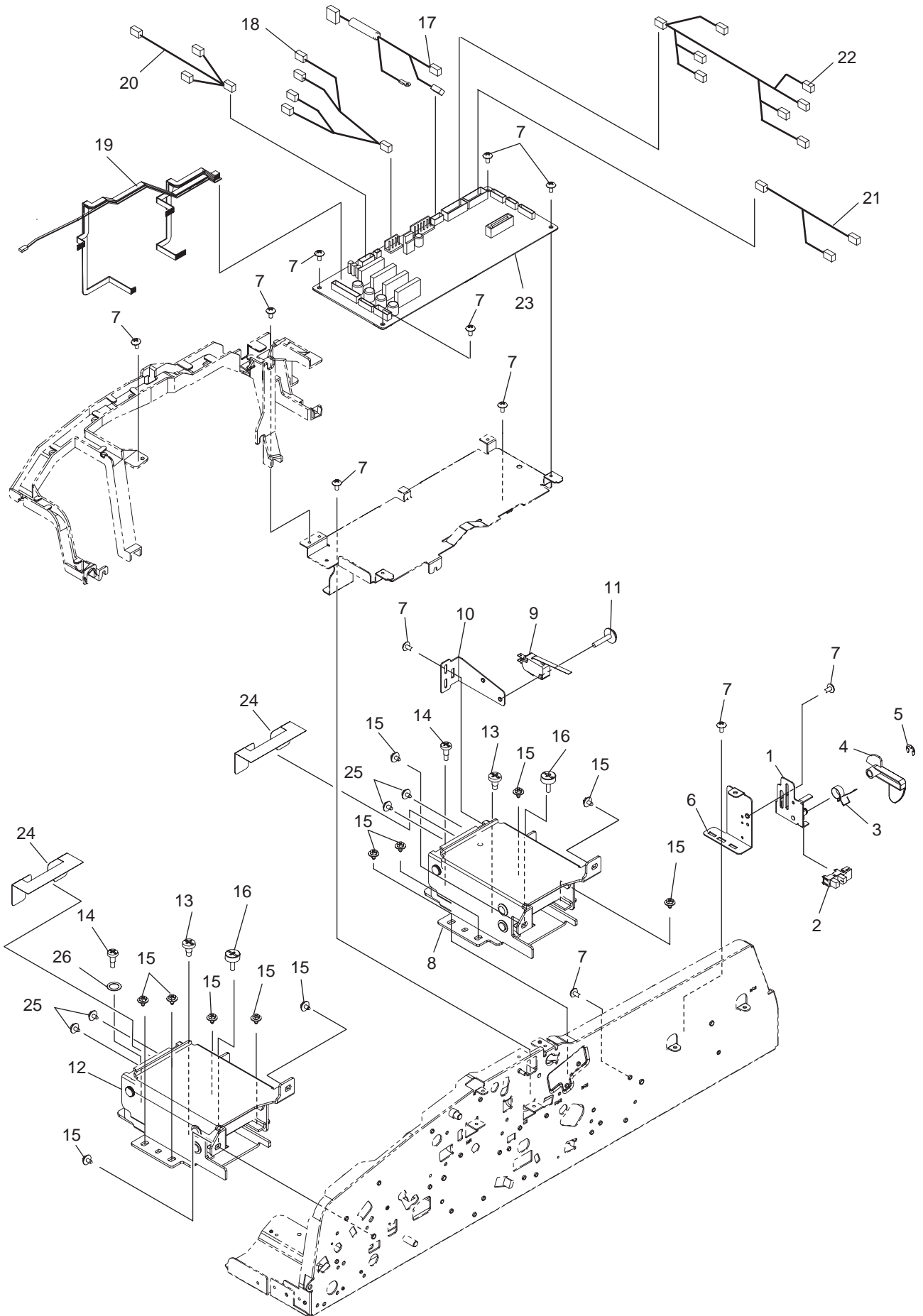

	Ref. No.	Part.No.	Alternative.	Description	Quantity	
					120	230
⊙	1	305JN70YW0	5JN70YW0	PLATE ASSY:ASYS-PLT-OPEN-N	1	1
	2	305JN72H90	5JN72H90	SENSOR:GP1A173LCS2F	1	1
	3	305JN70YM0	5JN70YM0	SPRING:SPG-T-OPEN-SW	1	1
	4	305JN70YL0	5JN70YL0	LEVER LVR-OPEN-SW	1	1
	5	305JN72LW0	5JN72LW0	RETAIN NG RING:RR/E-5-SS	1	1
	6	305JN70YN0	5JN70YN0	PLATE:PLT-INTRLOK	1	1
	7	305JN70330	5JN70330	SCREW:SCR-M3X6BISR-NI	12	12
	8	305JN72040	5JN72040	H NGE-R-TQ	1	1
⊙	9	305JN72HW0	5JN72HW0	SWITCH:AM51613C731Y1N	1	1
	10	305JN71YY0	5JN71YY0	BRACKET:BRKT-I-LOCK-SW-TQ	1	1
	11	305JN72MG0	5JN72MG0	SCREW:S/TPS/FPAN-3X14-NC	1	1
	12	305JN71YZ0	5JN71YZ0	H NGE-L-TQ	1	1
	13	305JN720E0	5JN720E0	SCREW:SCR-HINGE-TQ	2	2
	14	305JN70YP0	5JN70YP0	SCREW:SCR-HINGE-B	2	2
	15	305JN72NQ0	5JN72NQ0	SCREW:S/TPS/FHEX/R-4X6-ZU3	12	12
	16	305JN70YQ0	5JN70YQ0	SCREW:SCR-HINGE-C	2	2
	17	305JN71VF0	5JN71VF0	WIRE HARNESS:HRNS-RADF-SCIF-430	1	1
	18	305JN71W10	5JN71W10	WIRE HARNESS:HRNS-RADF-INTLK-430	1	1
⊙	19	305JN71VG0	5JN71VG0	WIRE HARNESS:HRNS-RADF-MOT-430	1	1
	20	305JN71VH0	5JN71VH0	WIRE HARNESS HRNS-RADF-SOL-430	1	1
	21	305JN71VK0	5JN71VK0	WIRE HARNESS HRNS-RADF-FEED-430	1	1
	22	305JN71VN0	5JN71VN0	WIRE HARNESS:HRNS-RADF-READ-430	1	1
	23	305JN71W00	5JN71W00	PWB ASSY:ASY-DLG-430S	1	1
	24	305JN72100	5JN72100	SHEET:MYLAR-HINGE	2	2
	25	305JN72MD0	5JN72MD0	SCREW:S/PAN-M4X6-NC	4	4
	26	305JN72LS0	5JN72LS0	WASHER:W/PL/PJO-6-SS	1	1

• Parts with "⊙" indicate regular maintenance parts.

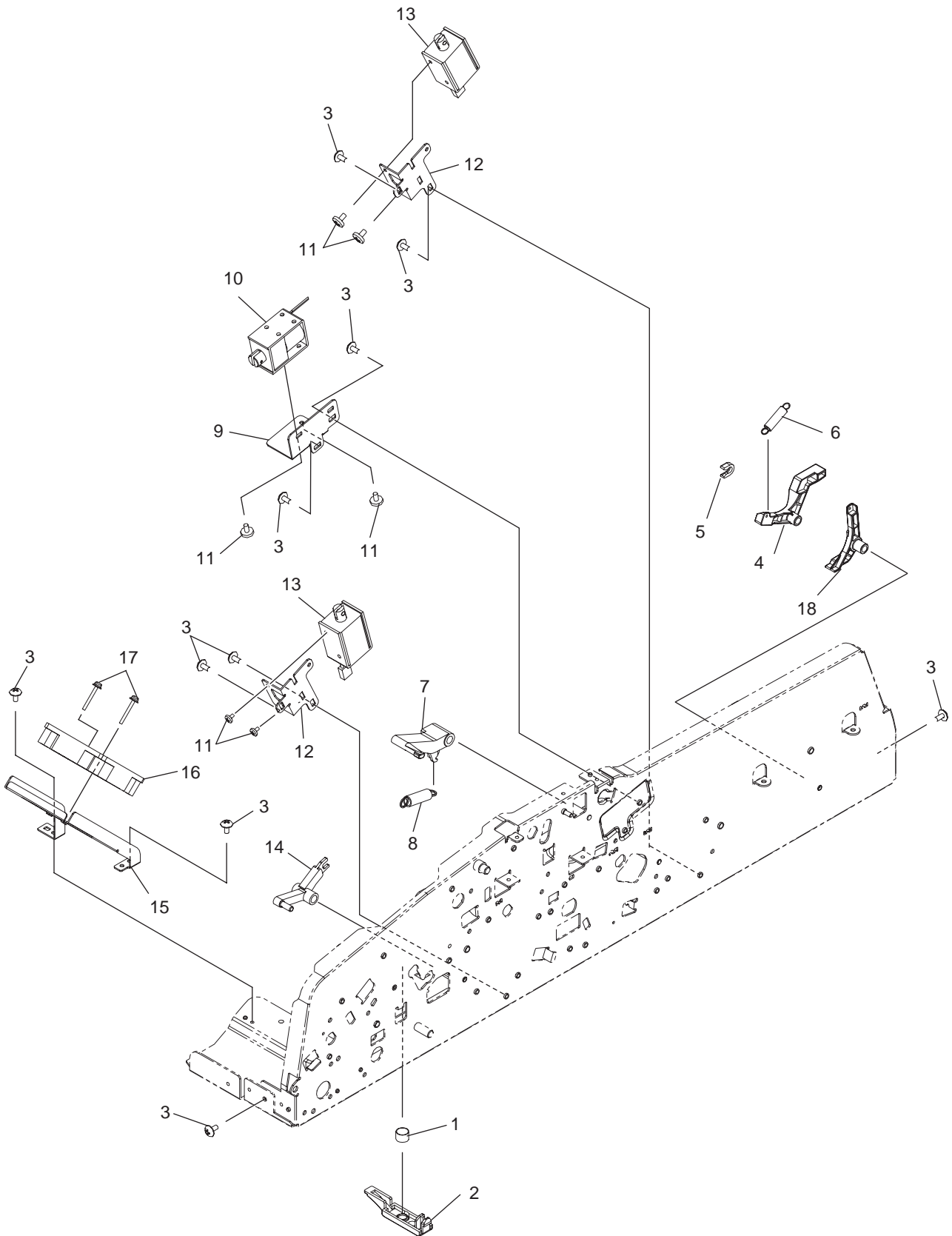

	Ref. No.	Part.No.	Alternative.	Description	Quantity	
					120	230
	1	305JN70Y00	5JN70Y00	SPRING:SPG-C-CAP-APS-R	1	1
	2	305JN70Y10	5JN70Y10	CAP-APS-R	1	1
	3	305JN70330	5JN70330	SCREW:SCR-M3X6BISR-NI	10	10
	4	305JN720T0	5JN720T0	LEVER LEV-I-LOCK-SW-OUT-TQ	1	1
	5	305JN70XZ0	5JN70XZ0	STOP-R NG-6-5-POM	1	1
	6	305JN720U0	5JN720U0	SPRING:SPR-I-LOCK-SW	1	1
	7	305JN71X80	5JN71X80	LEVER-PICK-SOL	1	1
	8	305JN720M0	5JN720M0	SPRING:SPG-E-PICK-SOL	1	1
	9	305JN71Y80	5JN71Y80	BRACKET:BRKT-SOL-PICKUP	1	1
⊙	10	305JN70XU0	5JN70XU0	SOLENOID:SOL-RUBY-PICKUP-623	1	1
	11	305JN72LE0	5JN72LE0	SCREW:S/BID-M3X4-NI	6	6
	12	305JN720R0	5JN720R0	BRACKET:BRKT-SOL-FLAP-TQ	2	2
⊙	13	305JN71VZ0	5JN71VZ0	SOLENOID:SOL-RADF-GATE-430	2	2
	14	305JN71XJ0	5JN71XJ0	LEVER LVR-FLAP-RD-TQ	1	1
	15	305JN71XW0	5JN71XW0	BRACKET:BRKT-FAN-TQ	1	1
⊙	16	305JN70VZ0	5JN70VZ0	FAN MOTOR:FAND-6015-390	1	1
	17	305JN72LC0	5JN72LC0	SCREW:S/PAN/SWWP-M3X20-NI	2	2
	18	305JN720S0	5JN720S0	LEVER LEV-I-LOCK-SW-IN-TQ	1	1

• Parts with "⊙" indicate regular maintenance parts.

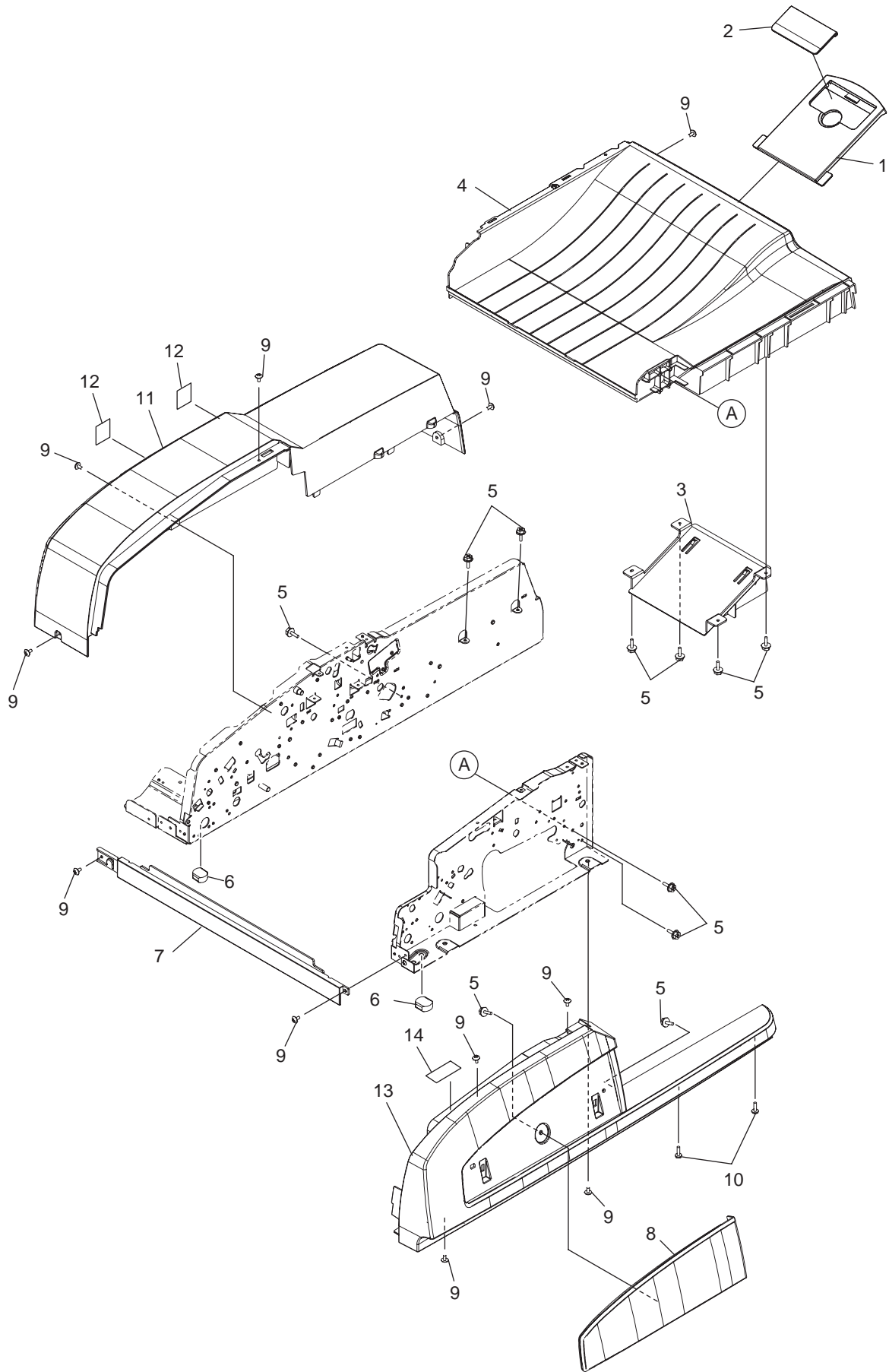

	Ref. No.	Part.No.	Alternative.	Description	Quantity	
					120	230
⊙	1	305JN70Y40	5JN70Y40	TRAY-SUB-EXT-OUT	1	1
⊙	2	305JN70Y50	5JN70Y50	TRAY-SUB-EXT-IN	1	1
	3	305JN71YE0	5JN71YE0	HOLDER:HLDR-TRAY-SUB-TQ	1	1
⊙	4	305JN71W30	5JN71W30	TRAY-EXIT-TQ	1	1
	5	305JN72NE0	5JN72NE0	SCREW:S/TPP/FHEXM-3X8-NI	11	11
	6	305JN72GQ0	5JN72GQ0	GASKET-5-12-4	2	2
⊙	7	305JN71XQ0	5JN71XQ0	COVER:COV-LEFT-TQ	1	1
⊙	8	305JN71W60	5JN71W60	COVER:COV-POCKET-TQ	1	1
	9	305JN70330	5JN70330	SCREW:SCR-M3X6BISR-NI	11	11
	10	305JN72MK0	5JN72MK0	SCREW:S/TPP/BID-3X8-NI	2	2
⊙	11	305JN71W40	5JN71W40	COVER:COV-REAR-TQ	1	1
⊙	12	305JN70Y20	5JN70Y20	LABEL LBL.W-COV-PS	2	2
⊙	13	305JN720Y0	5JN720Y0	COVER:COV-FRONT-TQ	1	1
⊙	14	305JN70XW0	5JN70XW0	LABEL-JAM-1-623	1	1

• Parts with "⊙" indicate regular maintenance parts.

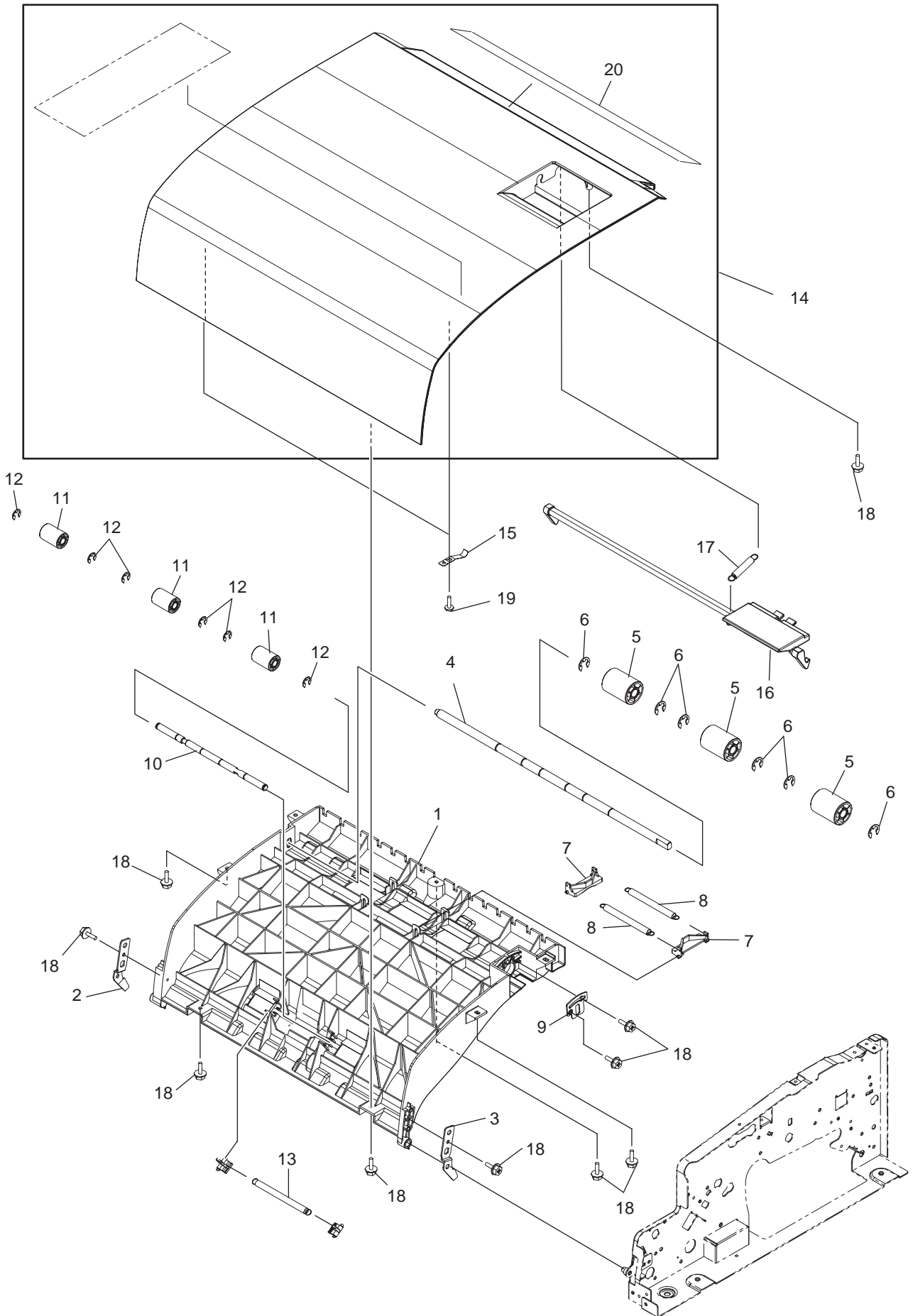

	Ref. No.	Part.No.	Alternative.	Description	Quantity	
					120	230
	1	305JN720J0	5JN720J0	GUIDE ASSY:ASYS-GUIDE-COV-OP	1	1
	2	305JN71Y40	5JN71Y40	BRACKET ASSY:ASYS-BRKT-COV-OP	1	1
	3	305JN71Y00	5JN71Y00	BRACKET:BRKT-COV-OP-F	1	1
	4	305JN72050	5JN72050	SHAFT:SFT-IDL-RD-IN-D8	1	1
⊙	5	305JN71Y90	5JN71Y90	ROLLER:ROL-IDL-ALNG	3	3
	6	305JN72LY0	5JN72LY0	RETAIN NG RING:RR/E-7-SS	6	6
	7	305JN71W00	5JN71W00	LEVER LEV-IDL-ALNG	2	2
	8	305JN72060	5JN72060	SPRING:SPR-LEV-COV-IDL	2	2
	9	305JN71XZ0	5JN71XZ0	BRACKET:BRKT-COV-OP-IDL-SET	1	1
	10	305JN72070	5JN72070	SHAFT:SFT-IDL-D6	1	1
⊙	11	305JN71WK0	5JN71WK0	ROLLER:ROL-IDL-D16-POM	3	3
	12	305JN72LW0	5JN72LW0	RETAIN NG RING:RR/E-5-SS	6	6
	13	305JN72080	5JN72080	SPRING:SPR-LEV-READ-IN-U	1	1
⊙	14	305JN72090	5JN72090	COVER ASSY:ASYS-COV-OP-KM	1	1
	15	305JN70YJ0	5JN70YJ0	SPRING:SPG-F-GID-SB-PUSH	2	2
⊙	16	305JN71WH0	5JN71WH0	LEVER LVR-COV-OPEN-TQ	1	1
	17	305JN720A0	5JN720A0	SPRING:SPG-COV-JAM	1	1
	18	305JN72NE0	5JN72NE0	SCREW:S/TPP/FHEXM-3X8-NI	10	10
	19	305JN72MK0	5JN72MK0	SCREW:S/TPP/BID-3X8-NI	2	2
	20	305JN720Z0	5JN720Z0	LABEL LBL-SIZE-KM	1	1

• Parts with "⊙" indicate regular maintenance parts.

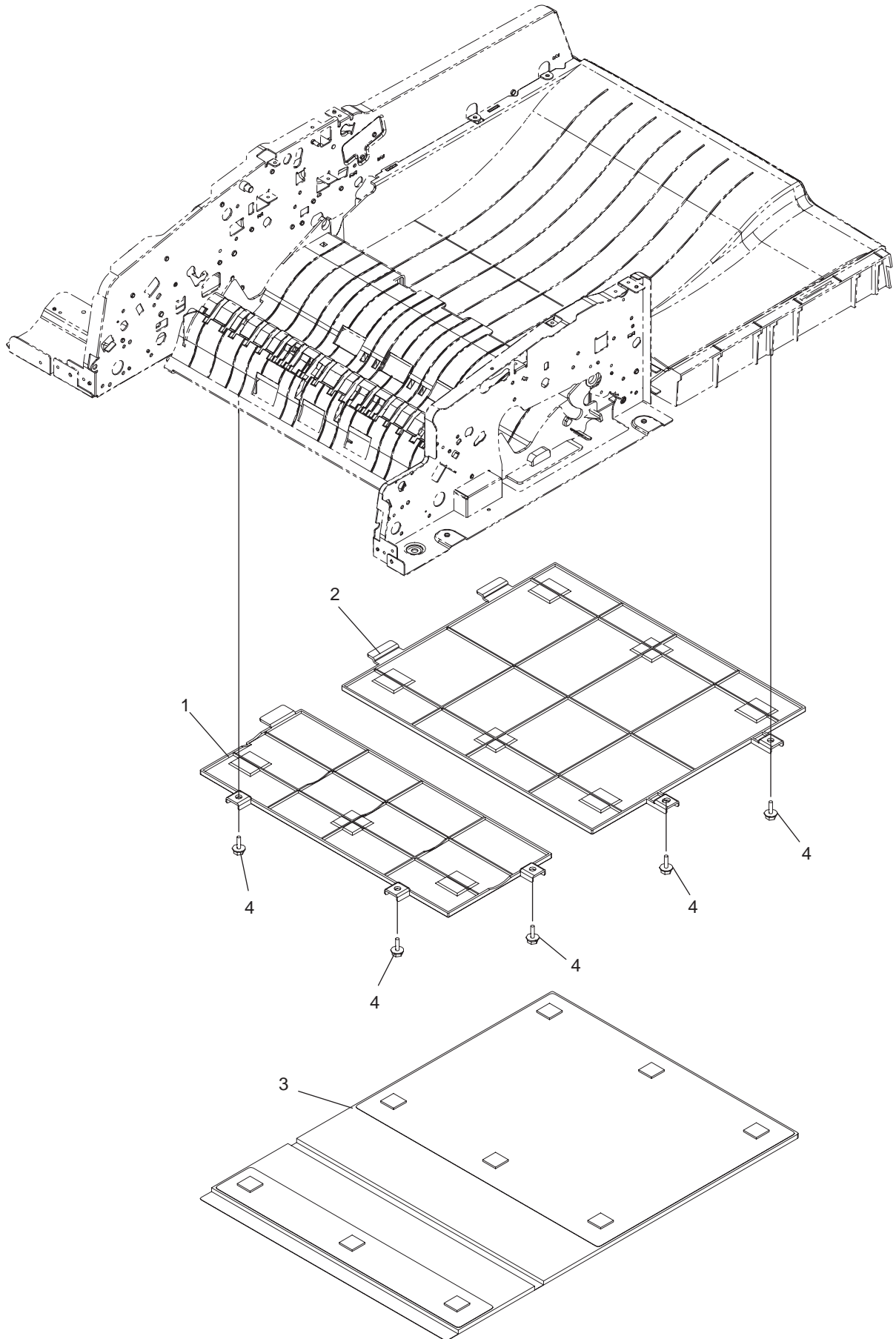

	Ref. No.	Part.No.	Alternative.	Description	Quantity	
					120	230
⊙	1	305JN71ZD0	5JN71ZD0	BASE ASSY:ASYS-BASE-PLTN-L	1	1
	2	305JN71ZE0	5JN71ZE0	BASE ASSY:ASYS-BASE-PLTN-R	1	1
	3	305JN71YW0	5JN71YW0	SHEET ASSY:ASYS-SHEET-PLTN-TQ	1	1
	4	305JN72NE0	5JN72NE0	SCREW:S/TPP/FHEXM-3X8-NI	5	5

• Parts with "⊙" indicate regular maintenance parts.

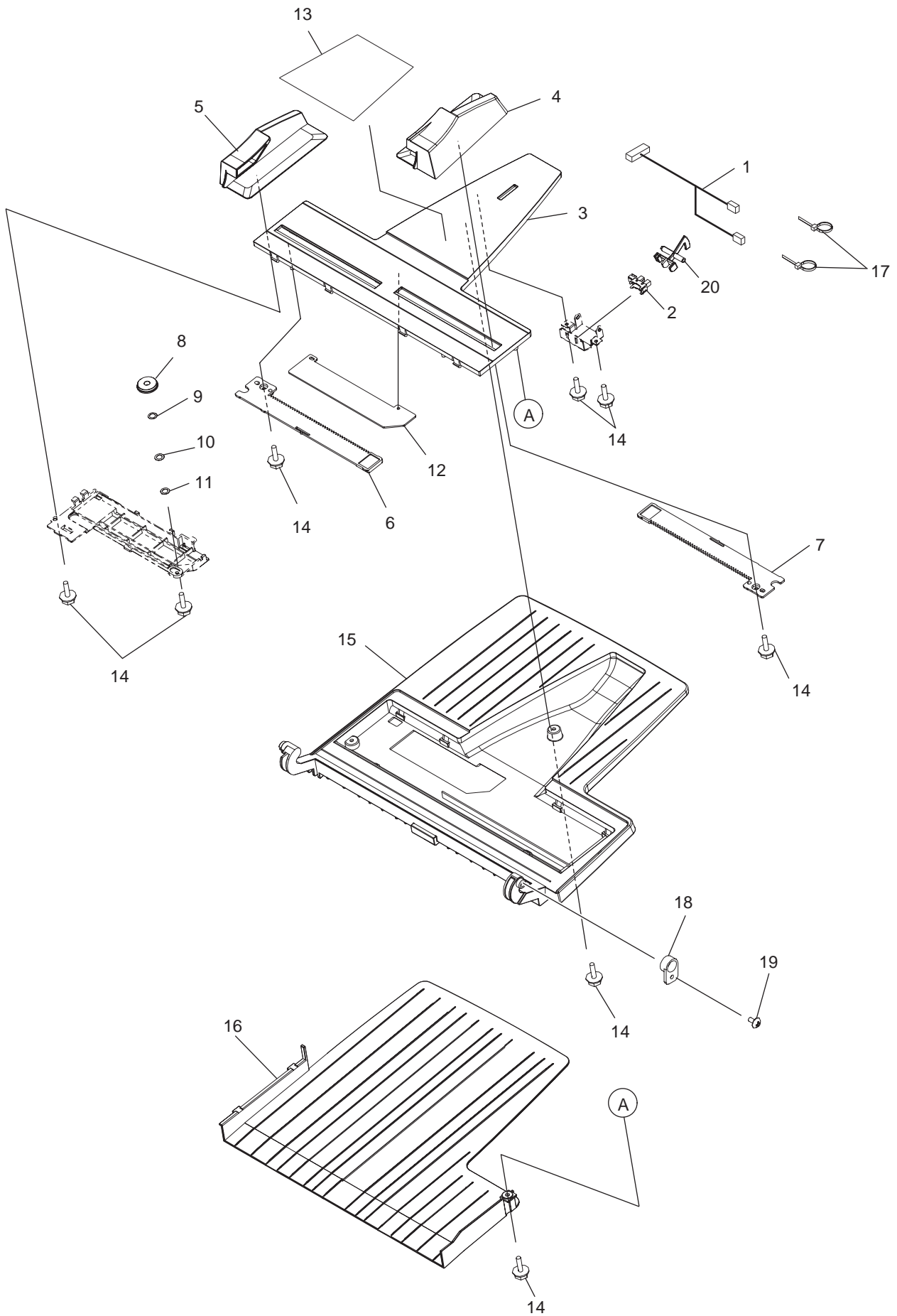

	Ref. No.	Part.No.	Alternative.	Description	Quantity	
					120	230
	1	305JN71VJ0	5JN71VJ0	WIRE HARNESS:HRNS-RADF-TRAY-430	1	1
⊙	2	305JN72H90	5JN72H90	SENSOR:GP1A173LCS2F	1	1
⊙	3	305JN720P0	5JN720P0	TRAY-INNER-KM	1	1
⊙	4	305JN71ZU0	5JN71ZU0	GUIDE ASSY:ASYS-G D-TRY-F-KM	1	1
⊙	5	305JN71ZV0	5JN71ZV0	GUIDE ASSY:ASYS-G D-TRY-R-KM	1	1
	6	305JN70YY0	5JN70YY0	RACK-TRAY-PC	1	1
	7	305JN70YX0	5JN70YX0	RACK:ASYS-RACK-TRY-PC	1	1
	8	305JN701A0	5JN701A0	GEAR:P NION-18-395	1	1
	9	305JN707P0	5JN707P0	WASHER-6R2X9R5XR13-PL	1	1
	10	305JN700A0	5JN700A0	WASHER-W-6-10	1	1
	11	305JN72K50	5JN72K50	WASHER:STW-FT60 T0.25	1	1
⊙	12	305JN70XV0	5JN70XV0	PWB ASSY:PWA-F-TRAY-623	1	1
⊙	13	305JN720L0	5JN720L0	LABEL-CAUTION-KM	1	1
	14	305JN72NE0	5JN72NE0	SCREW:S/TPP/FHEXM-3X8-NI	8	8
⊙	15	305JN71W50	5JN71W50	TRAY-ORG-TQ	1	1
⊙	16	305JN71W70	5JN71W70	TRAY-MID-TQ	1	1
	17	305JN72KW0	5JN72KW0	CLAMP:YJ-100	2	2
	18	305JN70YK0	5JN70YK0	HOLDER:HLD-TRAY-F	1	1
	19	305JN70330	5JN70330	SCREW:SCR-M3X6BISR-NI	1	1
	20	305JN72PR0	5JN72PR0	ACT-SENSOR-TRAY-KM	1	1

• Parts with "⊙" indicate regular maintenance parts.

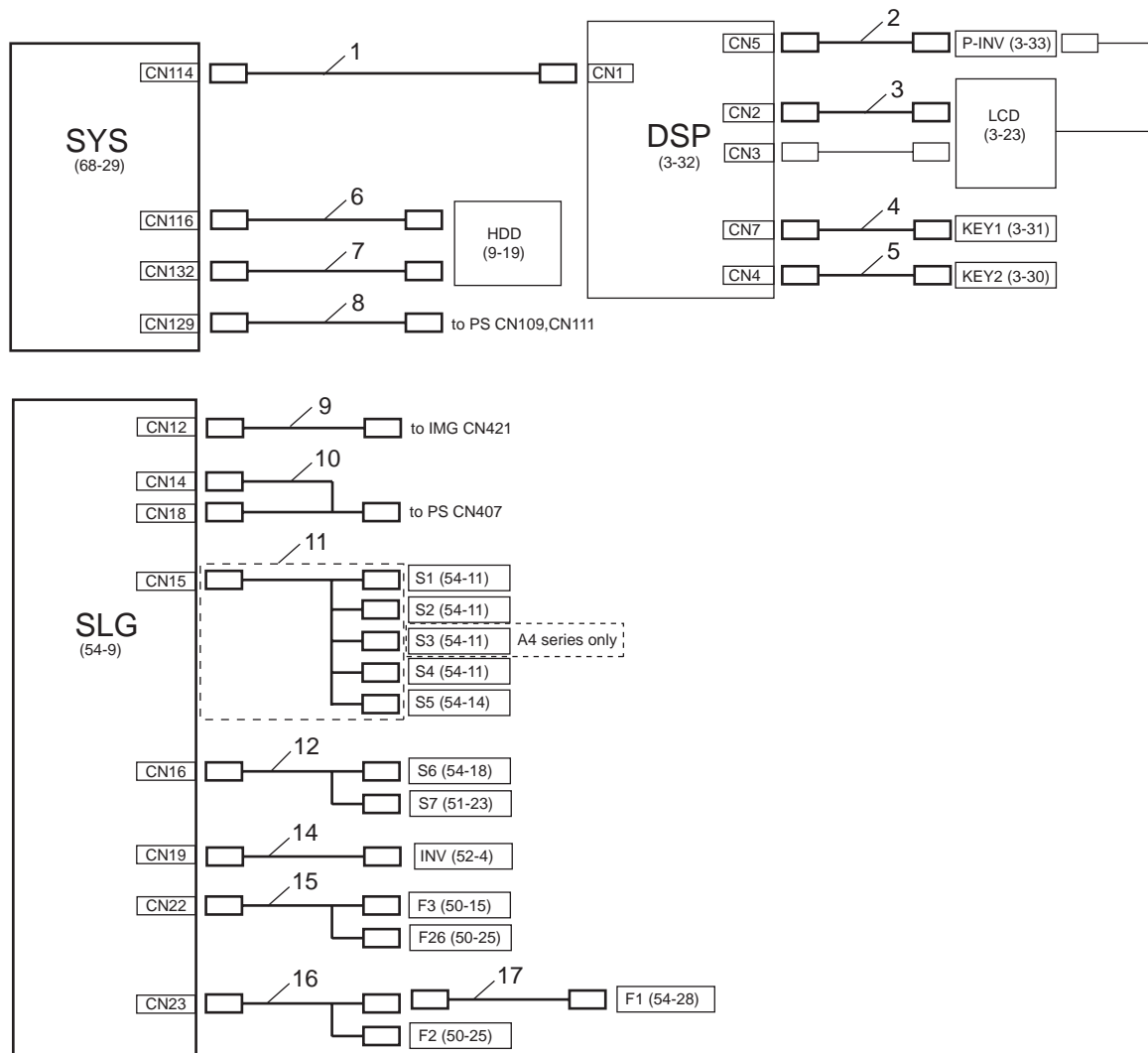

	Ref. No.	Part.No.	Alternative.	Description	Quantity	
					120	230
	1	305JN729V0	5JN729V0	WIRE HARNESS HRNS-SYS-OPE-430	1	1
	2	305JN72A60	5JN72A60	WIRE HARNESS:HRNS-INV-DSP-430	1	1
	3	305JN729W0	5JN729W0	WIRE HARNESS HRNS-DSP-LCD-430	1	1
	4	305JN72A70	5JN72A70	WIRE HARNESS:HRNS-DSP-KEY1-430	1	1
	5	305JN72A80	5JN72A80	WIRE HARNESS:HRNS-DSP-KEY2-430	1	1
	6	305JN726S0	5JN726S0	WIRE HARNESS:HRNS-SATA-SIG-430	1	1
	7	305JN726T0	5JN726T0	WIRE HARNESS:HRNS-SATA-POW-430	1	1
	8	305JN72B10	5JN72B10	WIRE HARNESS:HRNS-LVPS-SYS-430	1	1
	9	305JN726K0	5JN726K0	WIRE HARNESS HRNS-SCN-SYS-430	1	1
	10	305JN726N0	5JN726N0	WIRE HARNESS:HRNS-SCN-PS-430	1	1
	11	305JN726Q0	5JN726Q0	WIRE HARNESS HRNS-SCN-APSA-430		1
	11	305JN72CL0	5JN72CL0	WIRE HARNESS:HRNS-SCN-APSL-430	1	
	12	305JN726M0	5JN726M0	WIRE HARNESS HRNS-SCN-SNSR-430	1	1
	13	305JN726P0	5JN726P0	WIRE HARNESS:HRNS-SCN-MOT-430	1	1
⊙	14	305JN726L0	5JN726L0	WIRE HARNESS HRNS-SCN-INV-430	1	1
	15	305JN72BQ0	5JN72BQ0	WIRE HARNESS:HRNS-SCN-LMPFAN-430	1	1
	16	305JN72AW0	5JN72AW0	WIRE HARNESS:HRNS-SCN-SLGFAN-430	1	1
	17	305JN72740	5JN72740	WIRE HARNESS:HRNS-SCN-FANRLY-430	1	1

• Parts with "⊙" indicate regular maintenance parts.

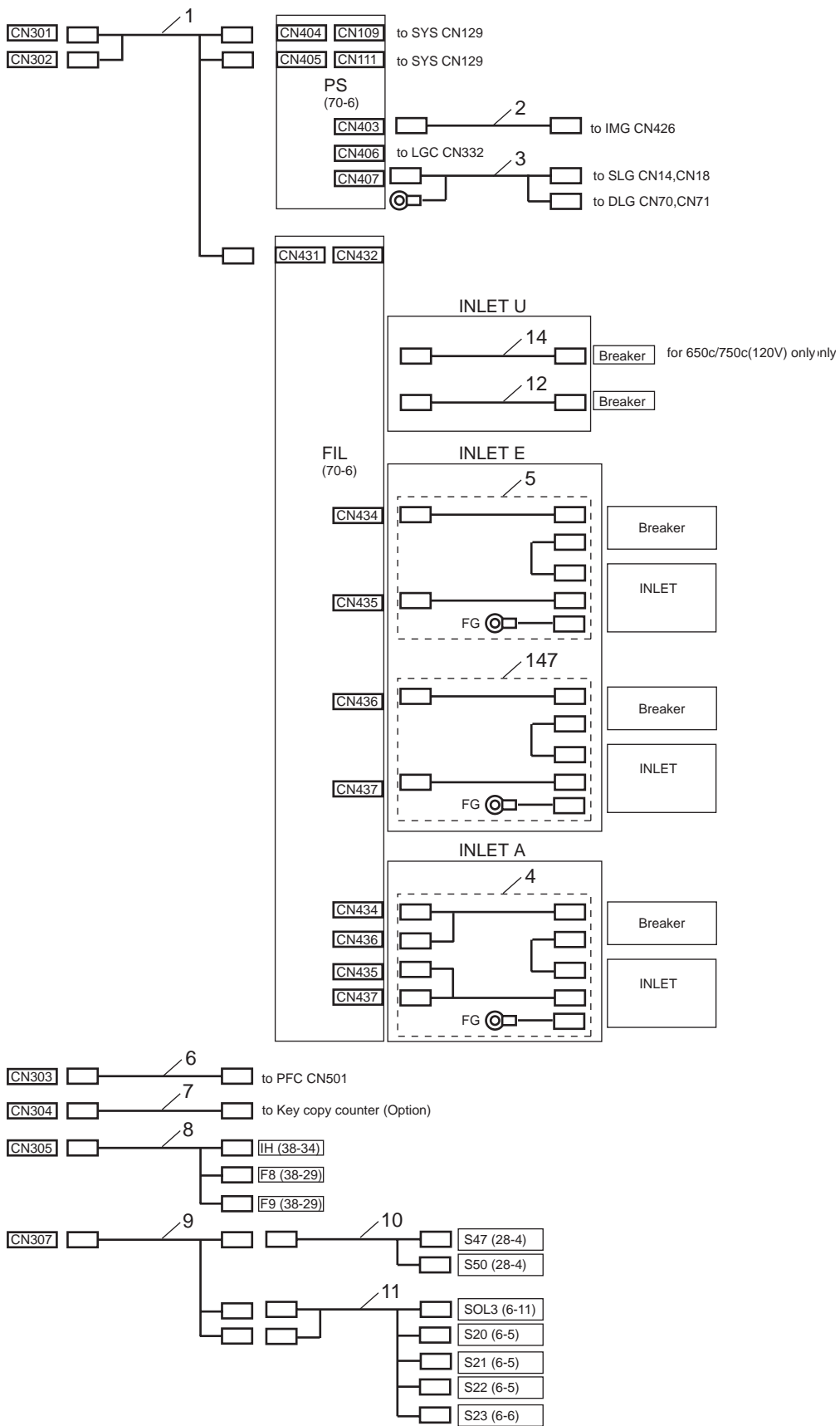

	Ref. No.	Part.No.	Alternative.	Description	Quantity	
					120	230
	1	305JN727R0	5JN727R0	WIRE HARNESS:HRNS-LVPS-LGC-430	1	1
	2	305JN727S0	5JN727S0	WIRE HARNESS HRNS-LVPS-IMG-430	1	1
	3	305JN727T0	5JN727T0	WIRE HARNESS:HRNS-LVPS-SCN-430	1	1
	4	305JN72BH0	5JN72BH0	WIRE HARNESS:HRNS-INLT-FIL-430-A	1	1
	5	305JN72770	5JN72770	WIRE HARNESS:HRNS-INLT1-F L-430	1	1
	6	305JN727V0	5JN727V0	WIRE HARNESS:HRNS-LGC-PFCP-430	1	1
	7	305JN72930	5JN72930	WIRE HARNESS:HRNS-LGC-TSK-430	1	1
	8	305JN72BG0	5JN72BG0	WIRE HARNESS:HRNS-LGC-IH-430	1	1
	9	305JN728X0	5JN728X0	WIRE HARNESS:HRNS-LGC-CTD-430	1	1
	10	305JN728W0	5JN728W0	WIRE HARNESS:HRNS-TR2-PS-430	1	1
	11	305JN728U0	5JN728U0	WIRE HARNESS:HRNS-CTD-430	1	1
	12	305JN727B0	5JN727B0	WIRE HARNESS:HRNS-INLT1-F L-430-U	1	1
	13	305JN72780	5JN72780	WIRE HARNESS:HRNS-INLT2-F L-430	1	1
	14	305JN726X0	5JN726X0	WIRE HARNESS:HRNS-INLT2-F L-430-U (65,75cpm)	1	

• Parts with "⊙" indicate regular maintenance parts.

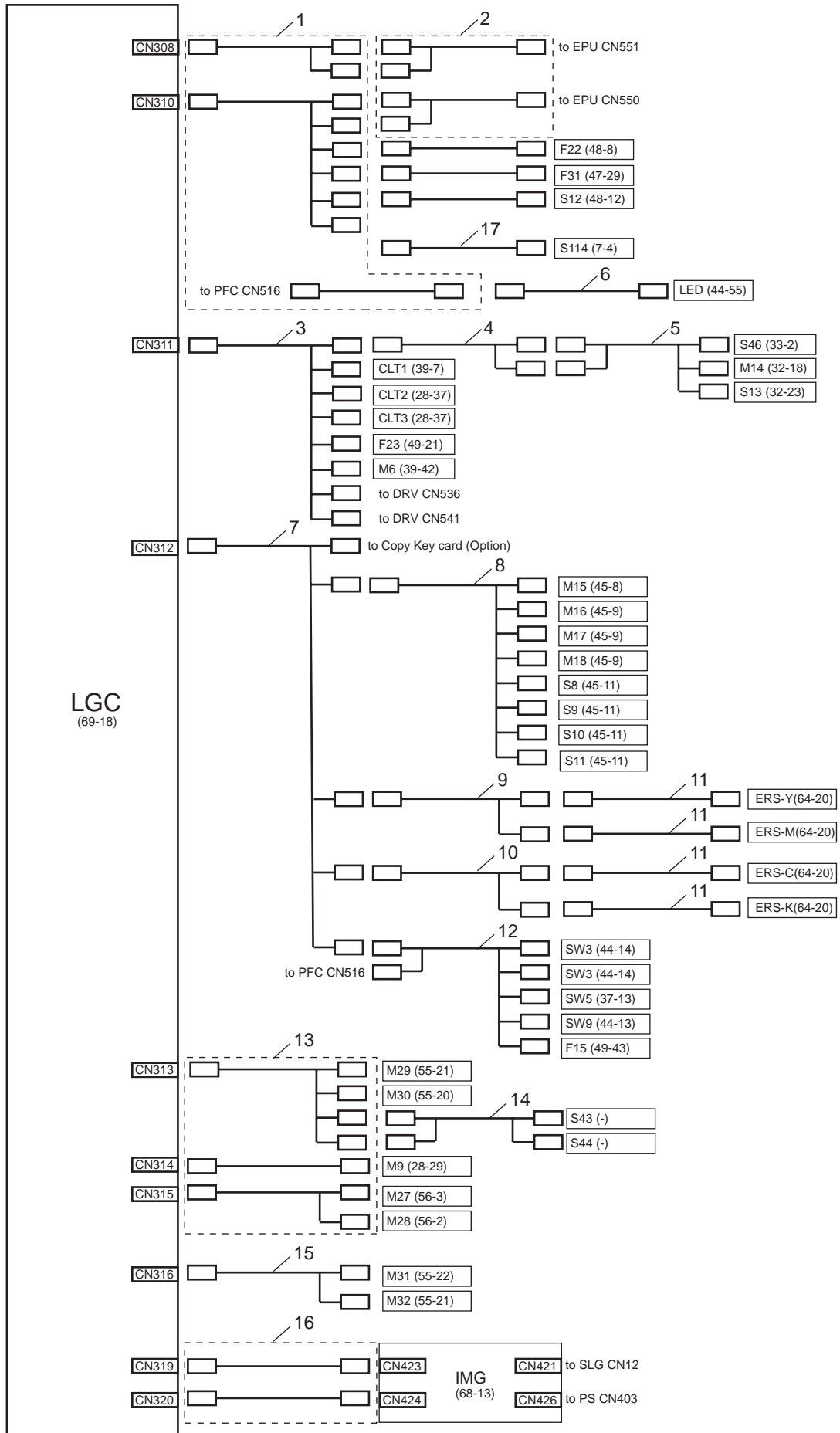

	Ref. No.	Part.No.	Alternative.	Description	Quantity	
					120	230
	1	305JN72BS0	5JN72BS0	WIRE HARNESS:ASY-HRNS-LGC-EPU-430	1	1
	2	305JN727Z0	5JN727Z0	WIRE HARNESS:ASY-HRNS-EPU-430	1	1
	3	305JN729H0	5JN729H0	WIRE HARNESS:HRNS-LGC-TBU-430	1	1
	4	305JN727W0	5JN727W0	WIRE HARNESS:HRNS-TBU1-430	1	1
	5	305JN72D10	5JN72D10	WIRE HARNESS:HRNS-TBU-430	1	1
	6	305JN72B90	5JN72B90	WIRE HARNESS:HRNS-LED-430	1	1
	7	305JN72B00	5JN72B00	WIRE HARNESS:HRNS-LGC-TNRD-430	1	1
	8	305JN729N0	5JN729N0	WIRE HARNESS HRNS-TNRD-430	1	1
	9	305JN72AZ0	5JN72AZ0	WIRE HARNESS HRNS-ERSCK-430	1	1
	10	305JN729J0	5JN729J0	WIRE HARNESS:HRNS-ERSYM-430	1	1
	11	305JN727Y0	5JN727Y0	WIRE HARNESS:HRNS-EPERS-430	1	1
	12	305JN72BA0	5JN72BA0	WIRE HARNESS:HRNS-FRTSW-430	1	1
	13	305JN72BU0	5JN72BU0	WIRE HARNESS:ASY-HRNS-LGC-DVTR2-430	1	1
	14	305JN72BP0	5JN72BP0	WIRE HARNESS:ASY-HRNS-LGC-DRM-430	1	1
	15	305JN728F0	5JN728F0	WIRE HARNESS:HRNS-LGC-CDRV-430	1	1
	16	305JN728V0	5JN728V0	WIRE HARNESS:HRNS-LGC-IMG-430	1	1
	17	305JN729F0	5JN729F0	WIRE HARNESS:HRNS-SIDE-430	1	1

• Parts with "⊙" indicate regular maintenance parts.

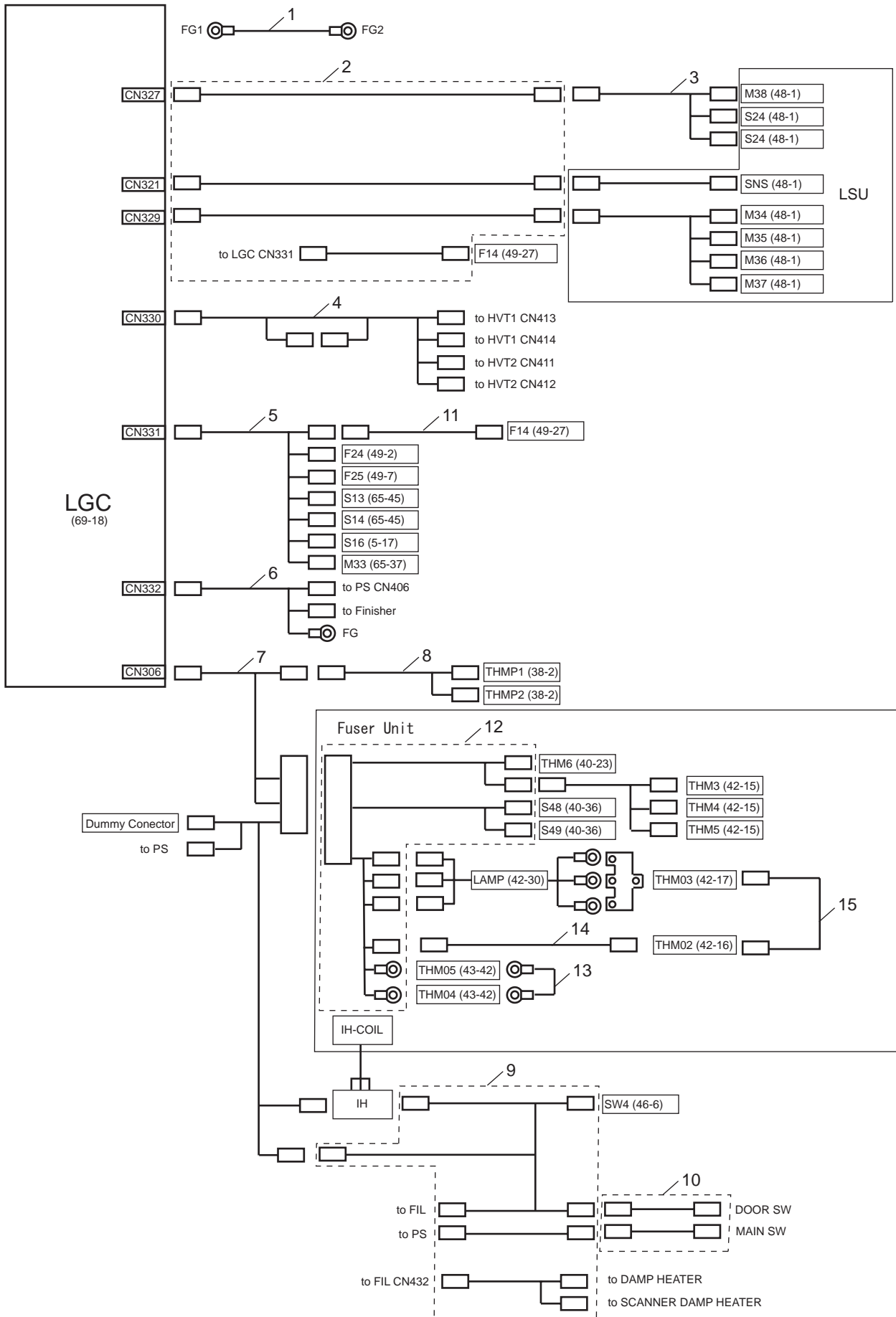

	Ref. No.	Part.No.	Alternative.	Description	Quantity	
					120	230
	1	305JN727P0	5JN727P0	WIRE HARNESS:HRNS-SFBFG-430	1	1
	2	305JN728N0	5JN728N0	WIRE HARNESS:ASYB-HRNS-LGC-LSU-430	1	1
	3	305JN727D0	5JN727D0	WIRE HARNESS:HRNS-SHT-430	1	1
	4	305JN728E0	5JN728E0	WIRE HARNESS:HRNS-LGC-HVT-430	1	1
	5	305JN72920	5JN72920	WIRE HARNESS:HRNS-LGC-USTN-430 (55cpm)	1	1
	5	305JN72AU0	5JN72AU0	WIRE HARNESS:HRNS-LGC-USTN-431 (65cpm)	1	1
	5	305JN72AV0	5JN72AV0	WIRE HARNESS:HRNS-LGC-USTN-432 (75cpm)	1	1
	6	305JN727U0	5JN727U0	WIRE HARNESS:HRNS-FIN-430	1	1
	7	305JN729G0	5JN729G0	WIRE HARNESS:HRNS-LGC-FUS-430	1	1
	8	305JN728Y0	5JN728Y0	WIRE HARNESS:HRNS-THMP-430	1	1
	9	305JN72790	5JN72790	WIRE HARNESS:HRNS-MAIN1-430	1	1
	10	305JN727A0	5JN727A0	WIRE HARNESS:HRNS-MAIN2-430	1	1
	11	305JN71VQ0	5JN71VQ0	WIRE HARNESS:HRNS-RADF-EXITR-430	1	1
	12	305JN72BJ0	5JN72BJ0	WIRE HARNESS:HRNS-FUS-430	1	1
	12	305JN72BK0	5JN72BK0	WIRE HARNESS:HRNS-FUS-MJD-430		1
	13	305JN728B0	5JN728B0	WIRE HARNESS:HRNS-HR-TMOS-430	1	1
	14	305JN728C0	5JN728C0	WIRE HARNESS:HRNS-PR-TMOS1-430	1	1
	15	305JN728D0	5JN728D0	WIRE HARNESS:HRNS-PR-TMOS2-430	1	1

• Parts with "⊙" indicate regular maintenance parts.

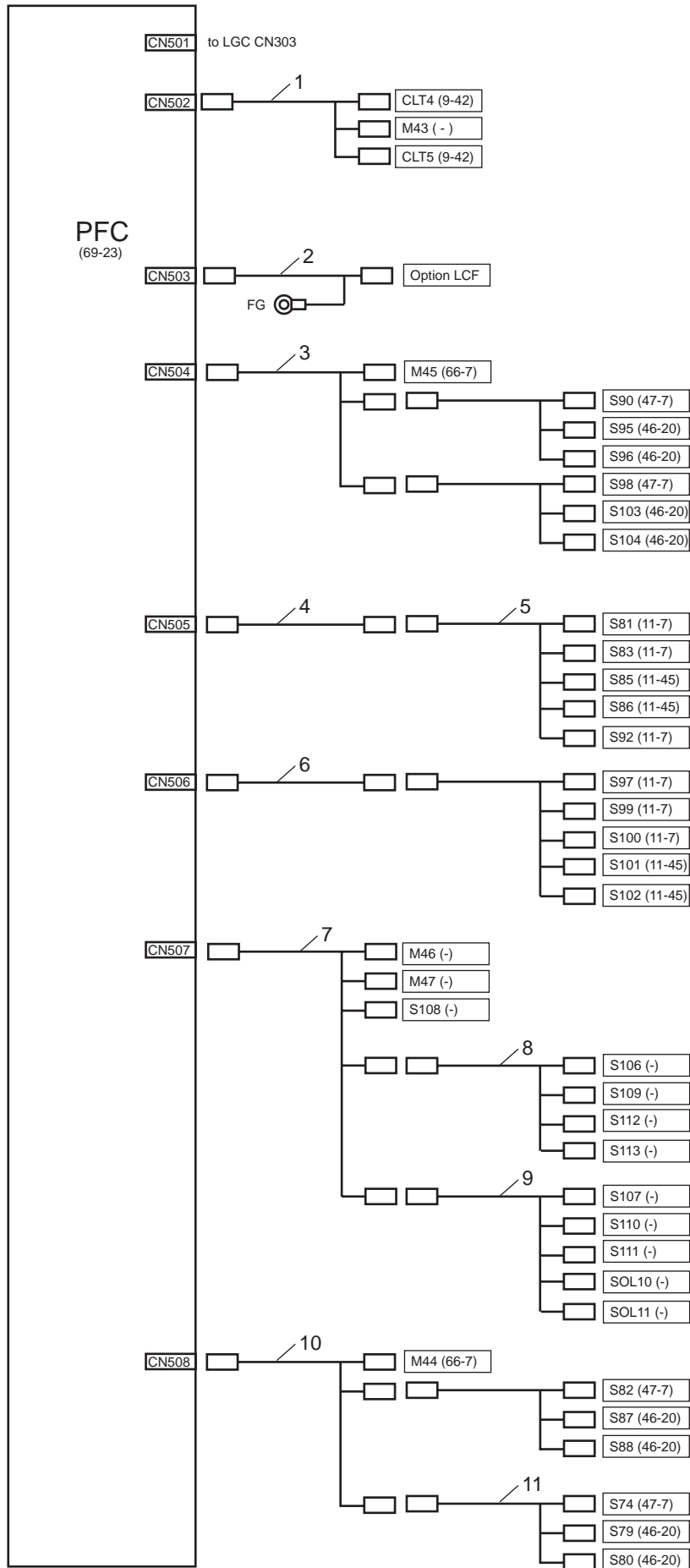

	Ref. No.	Part.No.	Alternative.	Description	Quantity	
					120	230
	1	305JN72AD0	5JN72AD0	WIRE HARNESS:HRNS-PFC-FDTM-430	1	1
	2	305JN728G0	5JN728G0	WIRE HARNESS:HRNS-PFC-OLCF-430	1	1
	3	305JN729D0	5JN729D0	WIRE HARNESS:HRNS-PFC-SIZE34-430	1	1
	4	305JN728P0	5JN728P0	WIRE HARNESS:HRNS-PFC-CST3-430	1	1
	5	305JN728T0	5JN728T0	WIRE HARNESS:HRNS-TLCFMJ-430	1	1
	6	305JN728Q0	5JN728Q0	WIRE HARNESS:HRNS-PFC-CST4-430	1	1
	7	305JN72820	5JN72820	WIRE HARNESS:HRNS-PFC-TLCF-430	1	1
	8	305JN72840	5JN72840	WIRE HARNESS:HRNS-TLCF2-430	1	1
	9	305JN72830	5JN72830	WIRE HARNESS:HRNS-TLCF1-430	1	1
	10	305JN729C0	5JN729C0	WIRE HARNESS:HRNS-PFC-SIZE12-430	1	1
	11	305JN729E0	5JN729E0	WIRE HARNESS:HRNS-PSIZE-430	1	1

• Parts with "⊙" indicate regular maintenance parts.

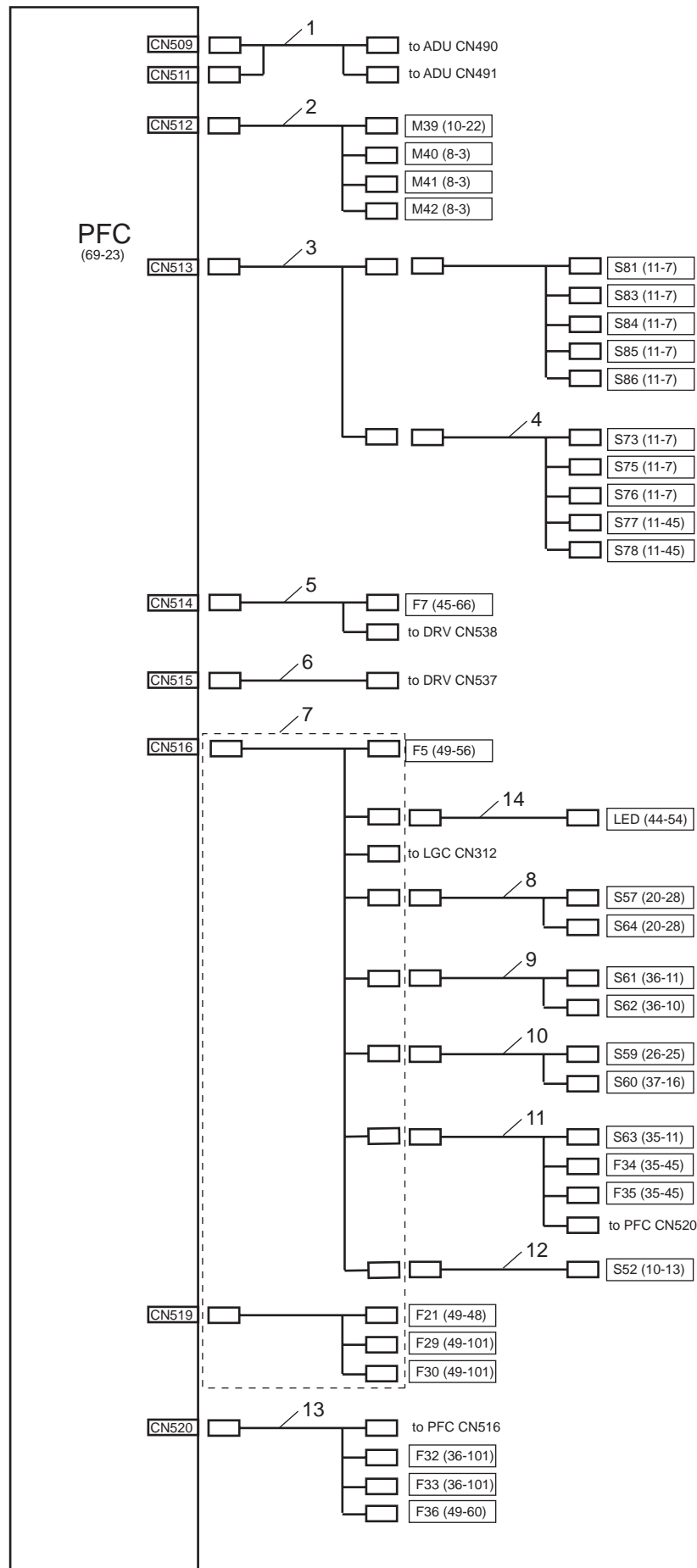

	Ref. No.	Part.No.	Alternative.	Description	Quantity	
					120	230
	1	305JN728M0	5JN728M0	WIRE HARNESS:HRNS-PFC-ADU-430	1	1
	2	305JN72850	5JN72850	WIRE HARNESS:HRNS-PFC-STMT-430	1	1
	3	305JN728A0	5JN728A0	WIRE HARNESS:HRNS-PFC-CST12-430	1	1
	4	305JN728R0	5JN728R0	WIRE HARNESS:HRNS-CSTMJ-430	1	1
	5	305JN72BR0	5JN72BR0	WIRE HARNESS:HRNS-PFC-DRV/PW-430	1	1
	6	305JN72800	5JN72800	WIRE HARNESS:HRNS-PFC-DRV-430	1	1
	7	305JN72CU0	5JN72CU0	WIRE HARNESS:ASY-HRNS-PFC-SNR-430	1	1
	8	305JN72C30	5JN72C30	WIRE HARNESS:HRNS-MIDSN-430	1	1
	9	305JN727X0	5JN727X0	WIRE HARNESS:HRNS-UEXTSN-430	1	1
	10	305JN72990	5JN72990	WIRE HARNESS:HRNS-EXTCV-430	1	1
	11	305JN72CP0	5JN72CP0	WIRE HARNESS:HRNS-EXTSN-430	1	1
	12	305JN729A0	5JN729A0	WIRE HARNESS:HRNS-RGTSN-430	1	1
	13	305JN72CG0	5JN72CG0	WIRE HARNESS:HRNS-PFC-FAN1-430	1	1
	14	305JN71VR0	5JN71VR0	WIRE HARNESS:HRNS-RADF-READI-430	1	1

• Parts with "⊙" indicate regular maintenance parts.

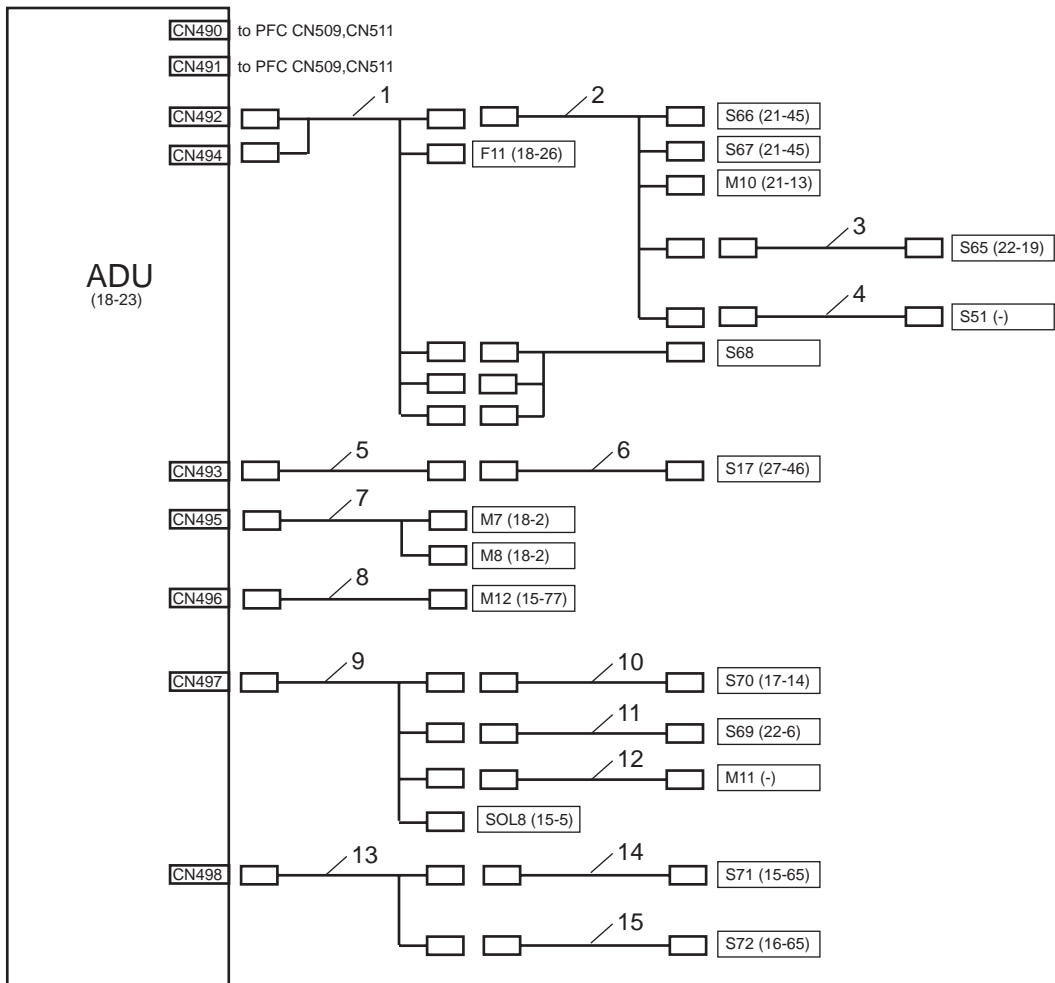
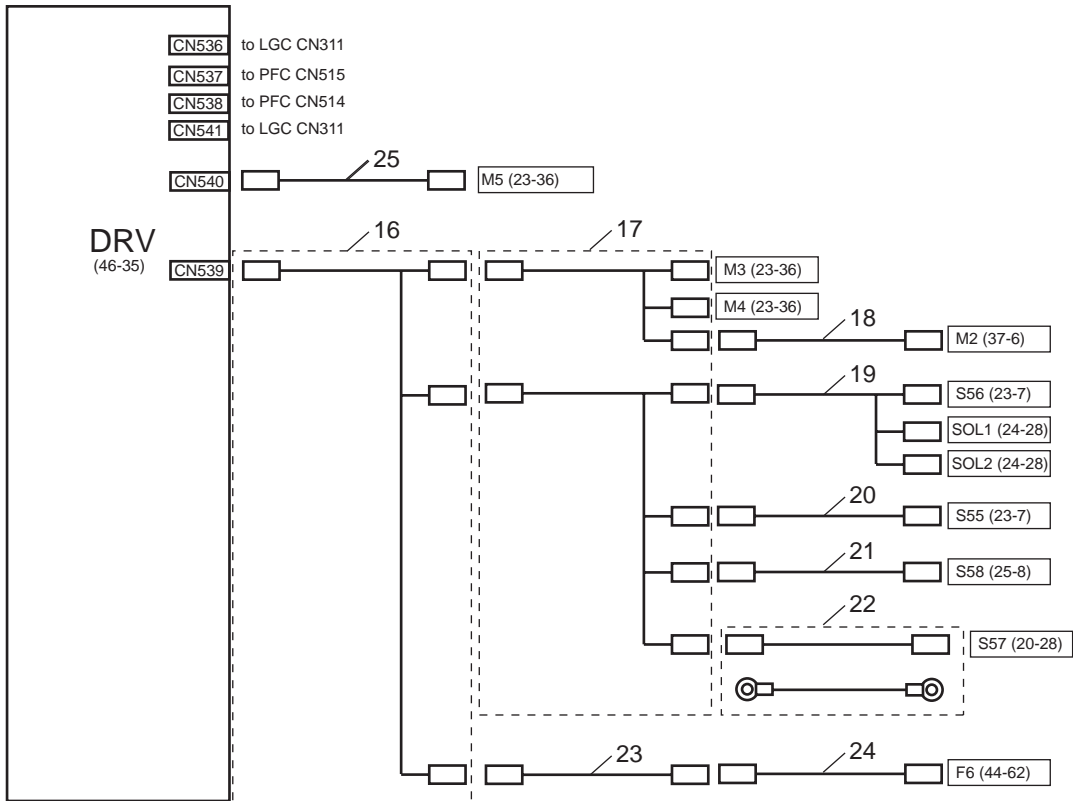

	Ref. No.	Part.No.	Alternative.	Description	Quantity	
					120	230
	1	305JN72BC0	5JN72BC0	WIRE HARNESS HRNS-ADU-SNR1-430	1	1
	2	305JN72970	5JN72970	WIRE HARNESS HRNS-ADU-SNR2-430	1	1
	3	305JN729P0	5JN729P0	WIRE HARNESS:HRNS-FEXSN-430	1	1
	4	305JN72980	5JN72980	WIRE HARNESS:HRNS-TR2SN-430	1	1
	5	305JN72B80	5JN72B80	WIRE HARNESS:HRNS-ADU-TNR-430	1	1
	6	305JN729Q0	5JN729Q0	WIRE HARNESS:HRNS-TNRSN-430	1	1
	7	305JN72960	5JN72960	WIRE HARNESS:HRNS-ADUM-430	1	1
	8	305JN727Q0	5JN727Q0	WIRE HARNESS:HRNS-SFBM-430	1	1
	9	305JN727F0	5JN727F0	WIRE HARNESS HRNS-ADU-SFB-430	1	1
	10	305JN727H0	5JN727H0	WIRE HARNESS:HRNS-SFBSIZE-430	1	1
	11	305JN727J0	5JN727J0	WIRE HARNESS:HRNS-MEDIA-430	1	1
	12	305JN727K0	5JN727K0	WIRE HARNESS:HRNS-TR2M-430	1	1
	13	305JN727G0	5JN727G0	WIRE HARNESS:HRNS-SFB-430	1	1
	14	305JN727L0	5JN727L0	WIRE HARNESS:HRNS-SFBSW-430	1	1
	15	305JN727M0	5JN727M0	WIRE HARNESS:HRNS-SFBFED-430	1	1
	16	305JN72C00	5JN72C00	WIRE HARNESS:HRNS-RLY-430	1	1
	17	305JN72890	5JN72890	WIRE HARNESS:HRNS-RLY1-430	1	1
	18	305JN728L0	5JN728L0	WIRE HARNESS:HRNS-RLY1-EXM-430	1	1
	19	305JN728H0	5JN728H0	WIRE HARNESS:HRNS-RLY1-SOL-430	1	1
	20	305JN728K0	5JN728K0	WIRE HARNESS:HRNS-RLY1-FED1-430	1	1
	21	305JN728J0	5JN728J0	WIRE HARNESS:HRNS-RLY1-RVS2-430	1	1
	22	305JN72BD0	5JN72BD0	WIRE HARNESS:HRNS-RLY1-RVS1-430	1	1
	23	305JN72C10	5JN72C10	WIRE HARNESS:HRNS-DRV-FAN-430	1	1
	24	305JN72C20	5JN72C20	WIRE HARNESS:HRNS-RLYFN-430	1	1
	25	305JN72810	5JN72810	WIRE HARNESS:HRNS-DRV-RT2M-430	1	1

• Parts with "⊙" indicate regular maintenance parts.

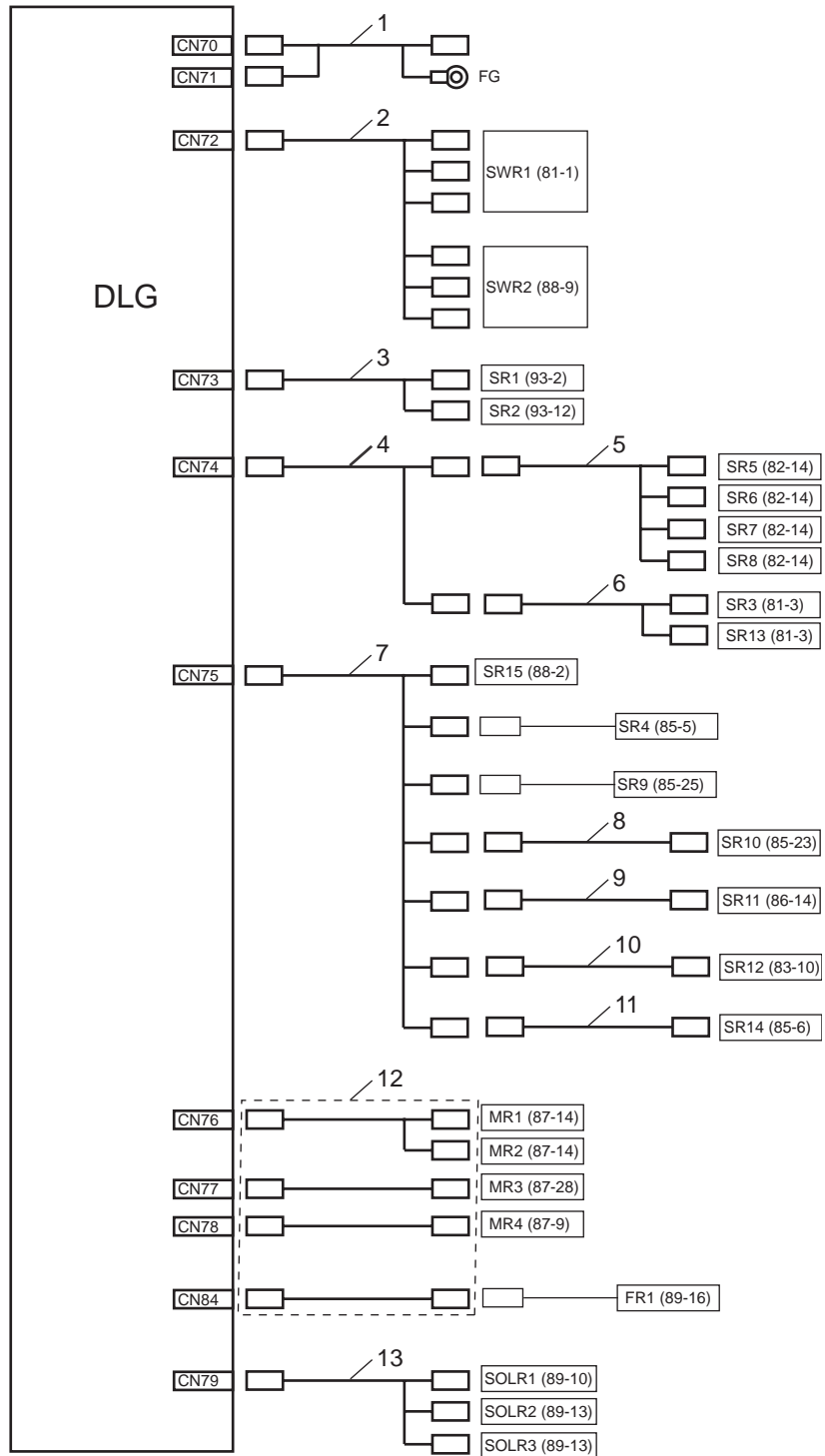

	Ref. No.	Part.No.	Alternative.	Description	Quantity	
					120	230
	1	305JN71VF0	5JN71VF0	WIRE HARNESS:HRNS-RADF-SCIF-430	1	1
	2	305JN71W10	5JN71W10	WIRE HARNESS:HRNS-RADF-INTLK-430	1	1
	3	305JN71VJ0	5JN71VJ0	WIRE HARNESS:HRNS-RADF-TRAY-430	1	1
	4	305JN71VK0	5JN71VK0	WIRE HARNESS HRNS-RADF-FEED-430	1	1
	5	305JN71VM0	5JN71VM0	WIRE HARNESS HRNS-RADF-LENTH-430	1	1
	6	305JN71VL0	5JN71VL0	WIRE HARNESS:HRNS-RADF-JCOVU-430	1	1
	7	305JN71VN0	5JN71VN0	WIRE HARNESS:HRNS-RADF-READ-430	1	1
	8	305JN71VR0	5JN71VR0	WIRE HARNESS:HRNS-RADF-READI-430	1	1
	9	305JN71VQ0	5JN71VQ0	WIRE HARNESS:HRNS-RADF-EXITR-430	1	1
	10	305JN71VP0	5JN71VP0	WIRE HARNESS:HRNS-RADF-EXIT-430	1	1
	11	305JN71VS0	5JN71VS0	WIRE HARNESS HRNS-RADF-JCOVL-430	1	1
	12	305JN71VG0	5JN71VG0	WIRE HARNESS:HRNS-RADF-MOT-430	1	1
	13	305JN71VH0	5JN71VH0	WIRE HARNESS HRNS-RADF-SOL-430	1	1

• Parts with "⊙" indicate regular maintenance parts.

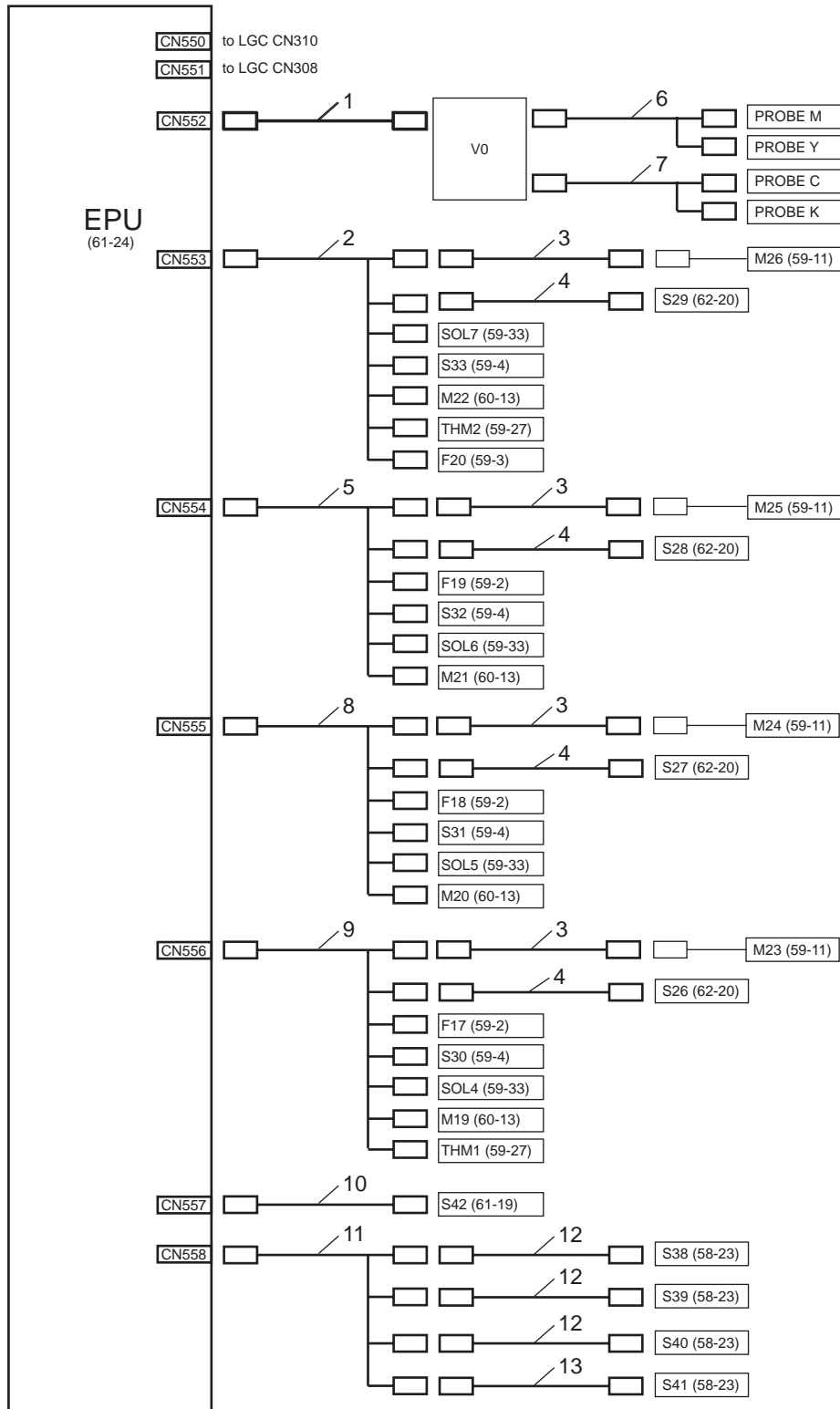

	Ref. No.	Part.No.	Alternative.	Description	Quantity	
					120	230
	1	305JN72910	5JN72910	WIRE HARNESS:HRNS-V0T-430	1	1
	2	305JN72B20	5JN72B20	WIRE HARNESS:HRNS-YPU-430	1	1
	3	305JN72900	5JN72900	WIRE HARNESS:HRNS-CLNMT-430	1	1
	4	305JN728Z0	5JN728Z0	WIRE HARNESS:HRNS-ATC-430	1	1
	5	305JN72860	5JN72860	WIRE HARNESS:HRNS-MPU-430	1	1
	6	305JN729K0	5JN729K0	WIRE HARNESS:HRNS-V01-430	1	1
	7	305JN729L0	5JN729L0	WIRE HARNESS:HRNS-V02-430	1	1
	8	305JN72870	5JN72870	WIRE HARNESS:HRNS-CPU-430	1	1
	9	305JN72880	5JN72880	WIRE HARNESS:HRNS-KPU-430	1	1
	10	305JN728S0	5JN728S0	WIRE HARNESS:HRNS-EPOGS-430	1	1
	11	305JN729M0	5JN729M0	WIRE HARNESS:HRNS-EPU-HPTN-430	1	1
	12	305JN72950	5JN72950	WIRE HARNESS HRNS-MCK-HPTN-430	1	1
	13	305JN72940	5JN72940	WIRE HARNESS:HRNS-YHPTN-430	1	1

• Parts with "⊙" indicate regular maintenance parts.

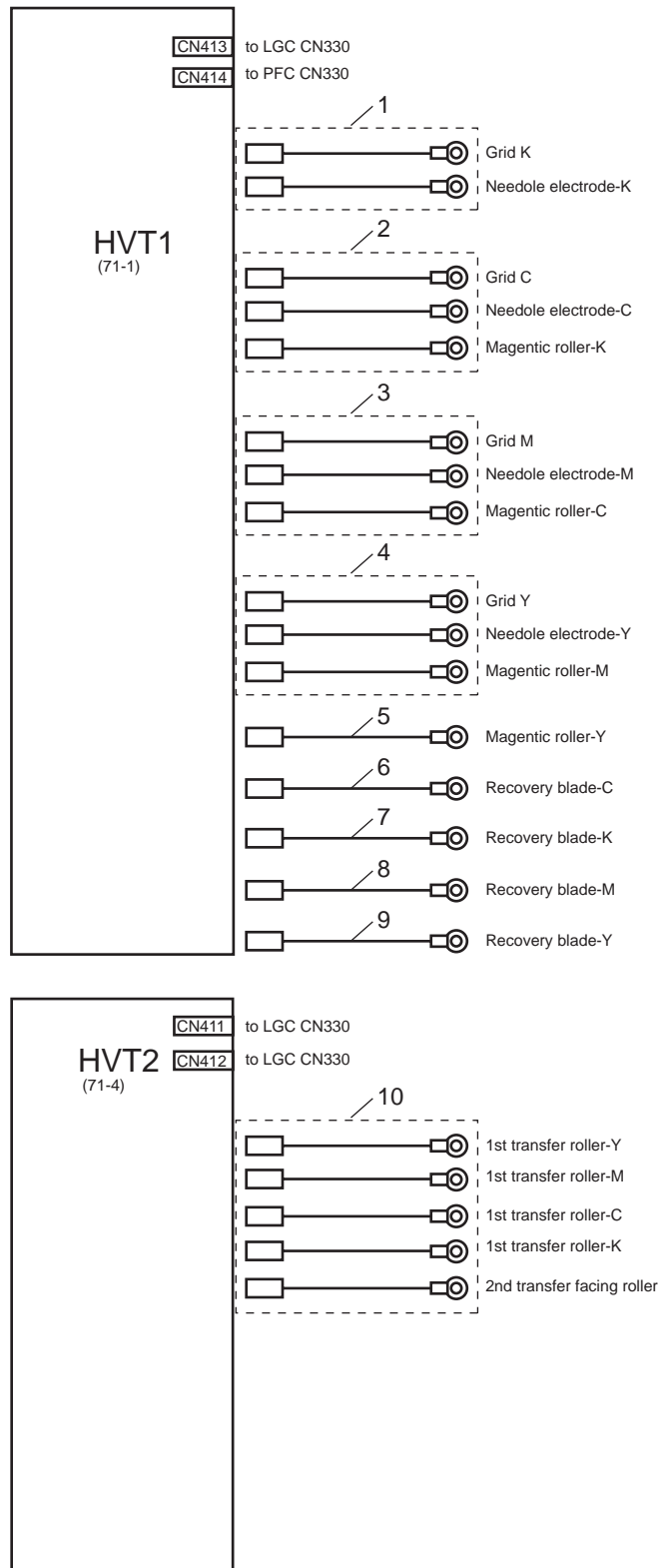

	Ref. No.	Part.No.	Alternative.	Description	Quantity	
					120	230
	1	305JN72C60	5JN72C60	WIRE HARNESS:HRNS-HVPS-KPU-430	1	1
	2	305JN72C70	5JN72C70	WIRE HARNESS:HRNS-HVPS-CPU-430	1	1
	3	305JN72C80	5JN72C80	WIRE HARNESS:HRNS-HVPS-MPU-430	1	1
	4	305JN72C90	5JN72C90	WIRE HARNESS:HRNS-HVPS-YPU-430	1	1
	5	305JN72AF0	5JN72AF0	WIRE HARNESS:HRNS-HVPS-YPUDEV-430	1	1
	6	305JN72AH0	5JN72AH0	WIRE HARNESS:HRNS-TBUHV-C-430	1	1
	7	305JN72AG0	5JN72AG0	WIRE HARNESS:HRNS-TBUHV-K-430	1	1
	8	305JN72AJ0	5JN72AJ0	WIRE HARNESS:HRNS-TBUHV-M-430	1	1
	9	305JN72AK0	5JN72AK0	WIRE HARNESS:HRNS-TBUHV-Y-430	1	1
	10	305JN72CF0	5JN72CF0	WIRE HARNESS:HRNS-HVPS-TR-430	1	1

• Parts with "⊙" indicate regular maintenance parts.

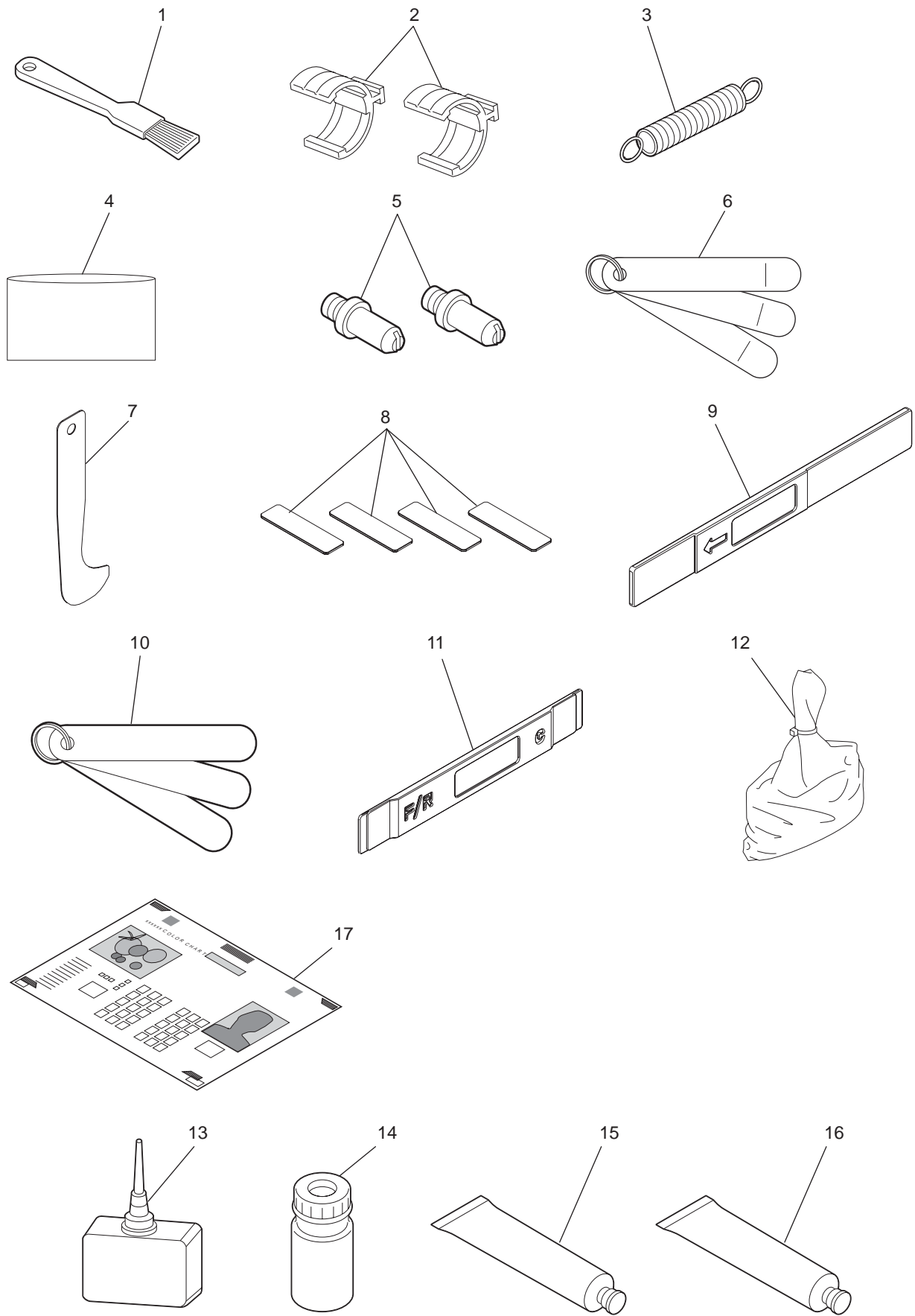

	Ref. No.	Part.No.	Alternative.	Description	Quantity	
					120	230
⊙	1	305JN701D0	5JN701D0	BRUSH-33	1	1
⊙	2	305JN70270	5JN70270	HOLDER-WIRE-SCAN	2	2
⊙	3	305JN701Y0	5JN701Y0	SPRING:SPE-MOT-TNS	1	1
⊙	4	305JN701J0	5JN701J0	BAG-DRUM	1	1
⊙	5	305JN70YR0	5JN70YR0	SHAFT:SFT-PA-PIN-R	1	1
⊙	6	305JN70180	5JN70180	TOOL ASSY:ASM-JIG-DOC-310	1	1
⊙	7	305JN71780	5JN71780	TOOL:JIG-CLNR-DOCTOR	1	1
⊙	8	305JN719M0	5JN719M0	TOOL:PLATE-TONER-SEAL	1	1
⊙	9	305JN724D0	5JN724D0	TOOL:JIG-FU-THRMST-BP	1	1
⊙	10	305JN724F0	5JN724F0	TOOL:ASYB-JIG-THRMIS-BP	1	1
⊙	11	305JN724E0	5JN724E0	TOOL:JIG-FU-SEP-BP	1	1
⊙	12	305JN70190	5JN70190	POWDER FOR CLEANER P-POWDER-PPT001	1	1
⊙	13	305JN701L0	5JN701L0	OIL-LAUNA40-100	1	1
	14	305JN70260	5JN70260	GREASE-HP300-S	1	1
	15	305JN72PF0	5JN72PF0	GREASE:ASM-PG-ALV2	1	1
	16	305JN72PE0	5JN72PE0	GREASE:MOLYKOTE_EM-30L_100G	1	1
	17	305JN72PJ0	5JN72PJ0	SHEET:CHART-COLOR-A4		1
	17	305JN72PH0	5JN72PH0	SHEET:CHART-COLOR-LT	1	

• Parts with "⊙" indicate regular maintenance parts.

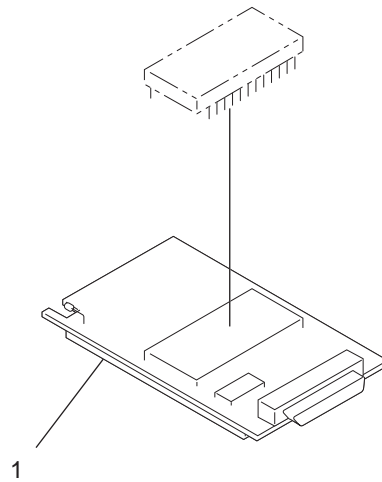

	Ref. No.	Part.No.	Alternative.	Description	Quantity	
					120	230
⊙	1	305JN70220	5JN70220	PWB ASSY:K-PWA-DLM-320	1	1

• Parts with "⊙" indicate regular maintenance parts.

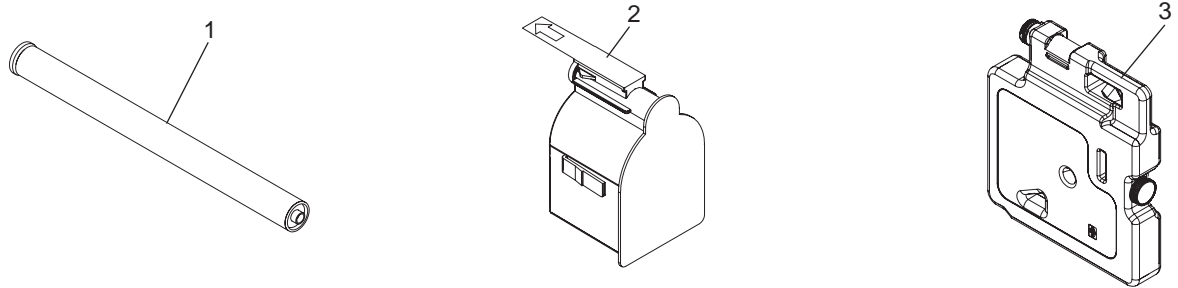

	Ref. No.	Part.No.	Alternative.	Description	Quantity	
					120	230
⊙	1	305JN70010	5JN70010	DK-800	1	1
	2	305JN70020	5JN70020	D-87Y	1	1
	2	305JN70030	5JN70030	D-87M	1	1
	2	305JN70040	5JN70040	D-87C	1	1
	2	305JN70050	5JN70050	D-87K	1	1
	2	305JN70050	5JN70050	D-87K	1	1
⊙	3	305JN72P90	5JN72P90	WT-800:TONER BAG	1	1

• Parts with "⊙" indicate regular maintenance parts.

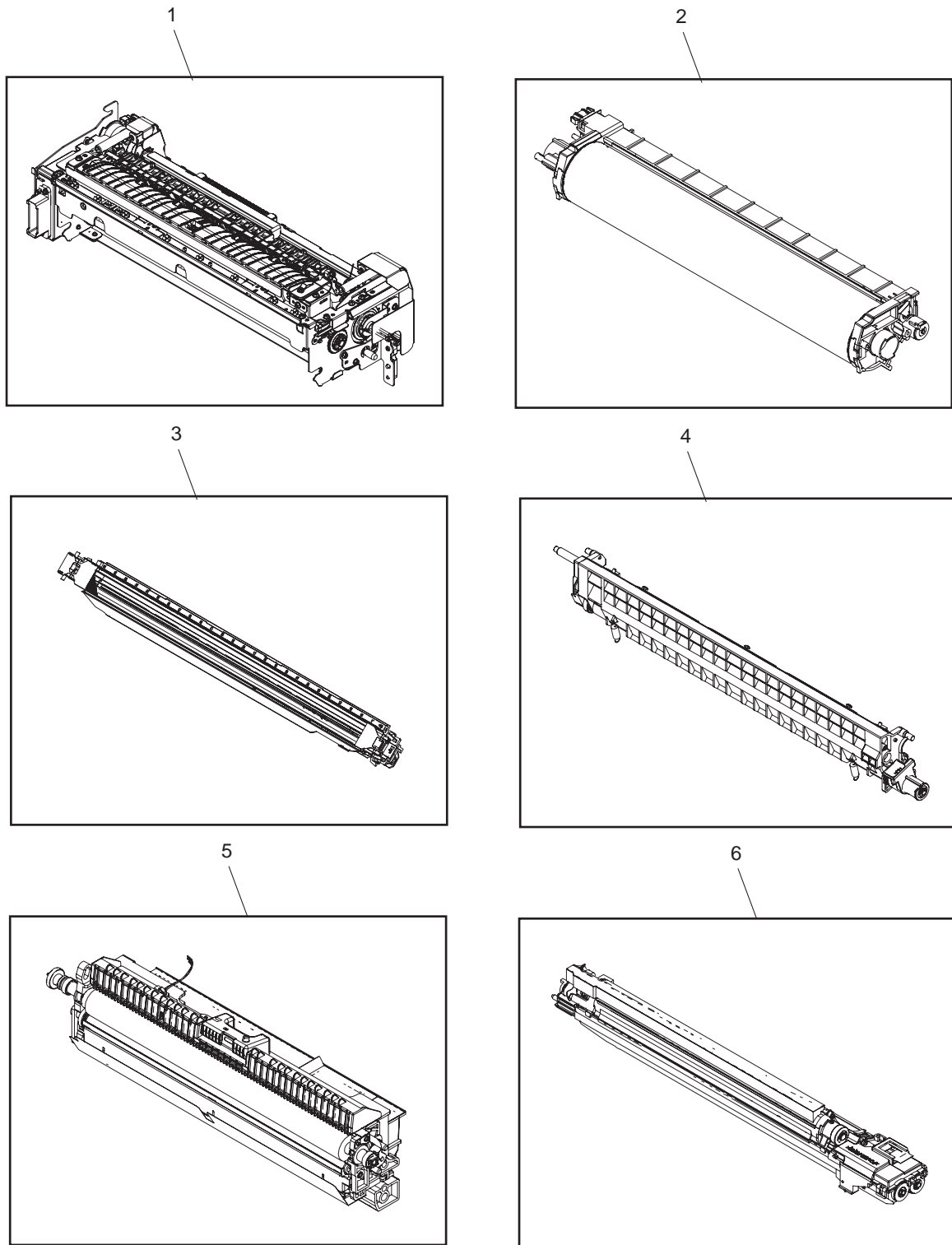

	Ref. No.	Part.No.	Alternative.	Description	Quantity	
					120	230
⊙	1	305JN72DS0	5JN72DS0	FUSER ASSY:FUSER-F43X-115	1	
⊙	1	305JN72DT0	5JN72DT0	FUSER ASSY:FUSER-F43X-220M		1
⊙	2	305JN72DV0	5JN72DV0	CLEANER DRUM ASSY:CLN-DRUM-F43X	1	1
⊙	3	305JN72DW0	5JN72DW0	TRANSFER CHARGER ASSY:TR-CH-F43X	1	1
⊙	4	305JN72DX0	5JN72DX0	TRANSFER BELT ASSY:TR-BLT-CLN-F43X	1	1
⊙	5	305JN72DY0	5JN72DY0	TRANSFER BELT ASSY:TR2-UNIT-F43X	1	1
⊙	6	305JN72DZ0	5JN72DZ0	DEVELOPER ASSY:DEVE-UNIT-F43X	1	1

• Parts with "⊙" indicate regular maintenance parts.

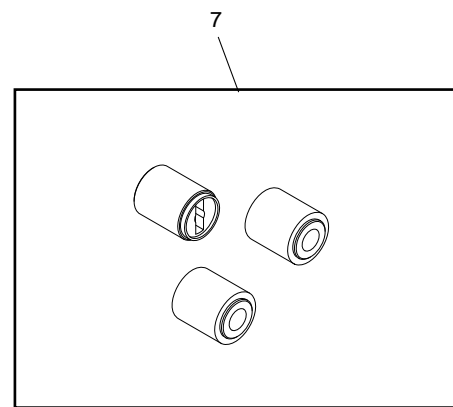
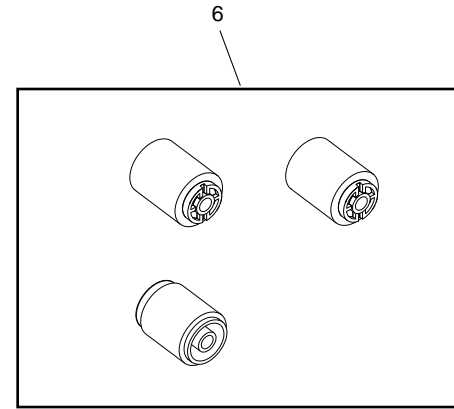
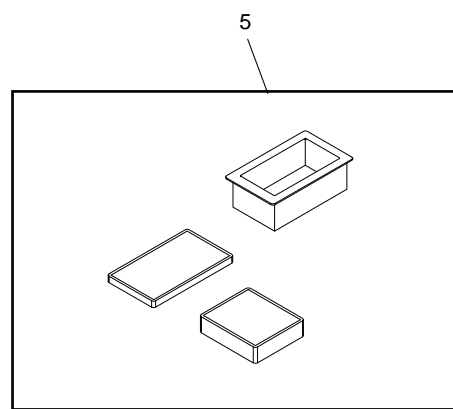
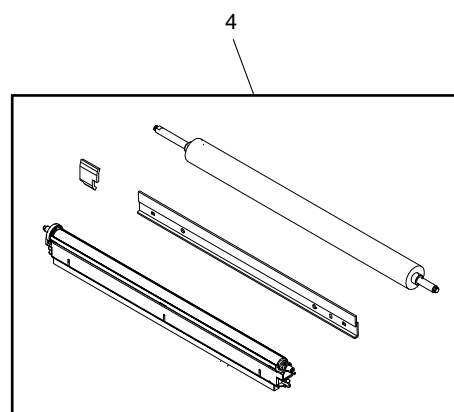
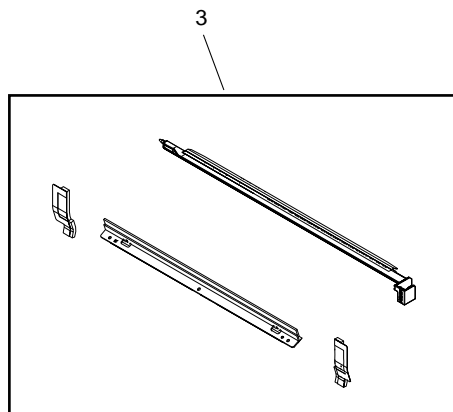
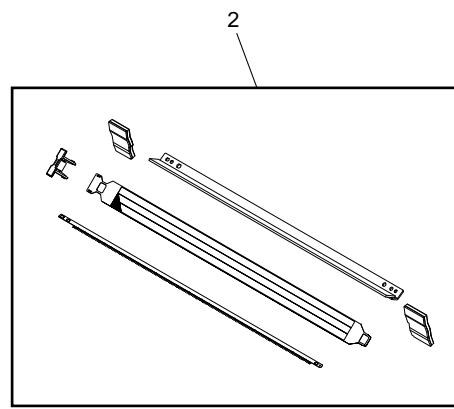
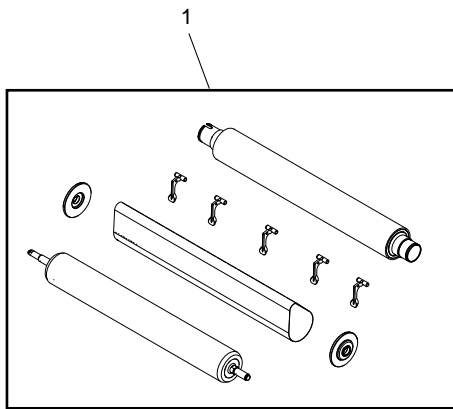

	Ref. No.	Part.No.	Alternative.	Description	Quantity	
					120	230
⊙	1	305JN72E00	5JN72E00	PM-800 FUSER SEC_FR-KIT-F43X	1	1
⊙	2	305JN72E10	5JN72E10	PM-800 CLEAN NG SEC_EPU-KIT-F43X	1	1
⊙	3	305JN72E20	5JN72E20	PM-800 PR MARY TRANSFER SEC_TBU-KIT-F43X	1	1
⊙	4	305JN72E30	5JN72E30	PM-800 2ND TRANSFER SEC_TR2-KIT-F43X	1	1
⊙	5	305JN72E40	5JN72E40	PM-800 OZONE F LTER_FLTR-KIT-F43X	1	1
⊙	6	305JN702Z0	5JN702Z0	PM-800 FEED SEC_ROL-KIT-81CST	1	1
⊙	7	305JN70XX0	5JN70XX0	PM-800 DP FEED SEC_DF-KIT-3018	1	1

• Parts with "⊙" indicate regular maintenance parts.

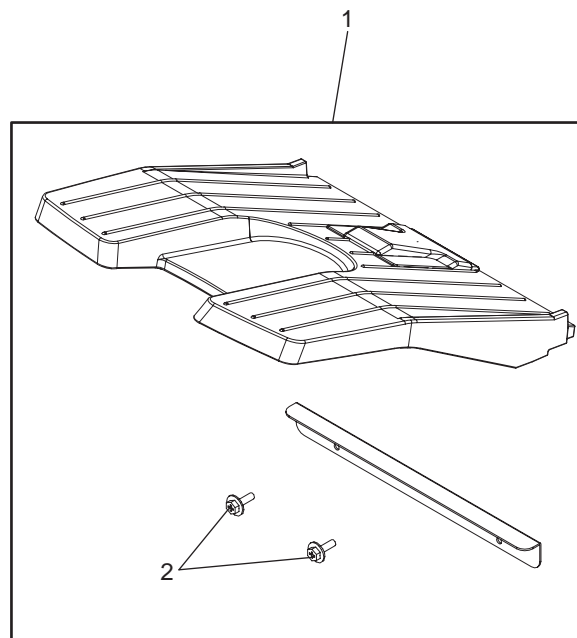

	Ref. No.	Part.No.	Alternative.	Description	Quantity	
					120	230
⊙	1	305JN71420	5JN71420	EXIT TRAY KIT:SET-TRAY-EXIT-F430	1	1
	2	305JN72P30	5JN72P30	SCREW:S/TPD3/FHEXM-4X10-ZU3	2	2

• Parts with "⊙" indicate regular maintenance parts.