



---

**TASKalfa 3501i**  
**TASKalfa 4501i**  
**TASKalfa 5501i**

**SERVICE  
MANUAL**

Published in May 2014  
Rev. 8

## **CAUTION**

RISK OF EXPLOSION IF BATTERY IS REPLACED BY AN INCORRECT TYPE. DISPOSE OF USED BATTERIES ACCORDING TO THE INSTRUCTIONS.

It may be illegal to dispose of this battery into the municipal waste stream. Check with your local solid waste officials for details in your area for proper disposal.

## **ATTENTION**

IL Y A UN RISQUE D'EXPLOSION SI LA BATTERIE EST REMPLACÉE PAR UN MODÈLE DE TYPE INCORRECT. METTRE AU REBUT LES BATTERIES UTILISÉES SELON LES INSTRUCTIONS DONNÉES.

Il peut être illégal de jeter les batteries dans des eaux d'égout municipales. Vérifiez avec les fonctionnaires municipaux de votre région pour les détails concernant des déchets solides et une mise au rebut appropriée.

### **Notation of products in the manual**

For the purpose of this service manual, products are identified by print speed at A4 and black and white modes.

TASKalfa 3501i: 35 ppm model

TASKalfa 4501i: 45 ppm model

TASKalfa 5501i: 55 ppm model



## Revision history

Revision	Date	Replaced pages	Remarks
1	May 15, 2013	Contents,1-1-5,1-2-2,1-2-21,1-2-38,1-2-47,1-2-83,1-3-15,1-3-23,1-3-74,1-3-94 to 1-3-99,1-4-5,1-4-26,1-4-65,1-4-75,1-4-76,1-4-79,1-4-86,1-4-87,1-4-90,1-4-132,1-4-136,1-5-14,1-5-39,1-5-64,1-5-65,1-5-82 to 1-5-84,2-1-5 to 2-1-7,2-2-4,2-2-5,2-2-10,2-2-11,2-3-28 to 2-3-30,2-3-57,2-4-4 to 2-4-6,2-4-13,2-4-21 to 2-4-24,2-4-26,2-4-27,2-4-31	-
2	August 2, 2013	1-1-2,1-1-3,1-2-2,1-2-4,1-2-5,1-2-7,1-2-17 to 1-2-19,1-4-23,1-5-21,2-4-5	-
3	October 9, 2013	Contents,1-1-8,1-2-6,1-2-29,1-2-30,1-2-38,1-2-67,1-2-93,1-2-103,1-3-2,1-3-5,1-3-8,1-3-15,1-3-16,1-3-19,1-3-23,1-3-24,1-3-27,1-3-41,1-3-42,1-3-47,1-3-49,1-3-53,1-3-55,1-3-90,1-3-101,1-3-108,1-3-109,1-3-113,1-3-136,1-3-142,1-3-143,1-3-145,1-3-172,1-3-173,1-3-183,1-3-188,1-3-190,1-4-61,1-4-92,1-4-93,1-4-121,1-4-125,1-5-10,1-5-19,1-5-30,1-5-54,1-5-63,1-5-64,1-5-69,1-5-98,1-5-100,1-6-2,2-2-6,2-2-7,2-3-10,2-3-27,2-3-43,2-4-1 to 2-4-15,2-4-17 to 2-4-19,2-4-23,2-4-25	-
4	January 8, 2014	Contents,1-1-2,1-1-4,1-1-15,1-2-5,1-2-93,1-2-113 to 1-2-121,1-3-8,1-3-112,1-3-148 to 1-3-156,1-3-160 to 1-3-168,1-3-196,1-4-48,1-4-60,1-4-139 to 1-4-143,1-4-231,1-5-47,1-5-50 to 1-5-52,2-4-4,2-4-5 to 2-4-7,2-4-11 to 2-4-14,2-4-22 to 2-4-35	-
5	March 20,2014	Contents,1-1-15,1-2-19,1-3-5,1-3-8,1-3-82,1-3-89,1-3-90,1-3-127,1-3-128,1-3-149,1-3-159,1-3-171,1-3-187,1-4-140 to 1-4-143,1-5-65,1-5-71 to 1-5-75,1-5-90,1-5-99,1-5-105,1-6-1,1-6-2,2-4-4,2-4-10,2-4-11,2-4-15	-
6	May 15,2014	1-2-17,1-3-82,1-3-195,1-4-210,1-5-63,1-6-1,1-6-2, INSTALLATION GUIDE	-
7	April 28,2015	1-2-69, 1-3-18,1-3-22, 1-3-78, 1-4-137, 1-4-232 to 1-4-238, 1-5-34 to 1-5-36, 1-5-46, 2-3-64,	-

Revision	Date	Pages	Revised contents
8	11 July 2016	1-2-67, 1-2-68	Correction: Position of the wire saddles

This page is intentionally left blank.



---

# Safety precautions

---

This booklet provides safety warnings and precautions for our service personnel to ensure the safety of their customers, their machines as well as themselves during maintenance activities. Service personnel are advised to read this booklet carefully to familiarize themselves with the warnings and precautions described here before engaging in maintenance activities.

## Safety warnings and precautions

Various symbols are used to protect our service personnel and customers from physical danger and to prevent damage to their property. These symbols are described below:

**⚠ DANGER:** High risk of serious bodily injury or death may result from insufficient attention to or incorrect compliance with warning messages using this symbol.

**⚠ WARNING:** Serious bodily injury or death may result from insufficient attention to or incorrect compliance with warning messages using this symbol.

**⚠ CAUTION:** Bodily injury or damage to property may result from insufficient attention to or incorrect compliance with warning messages using this symbol.

### Symbols

The triangle ( $\triangle$ ) symbol indicates a warning including danger and caution. The specific point of attention is shown inside the symbol.



General warning.



Warning of risk of electric shock.



Warning of high temperature.

⊘ indicates a prohibited action. The specific prohibition is shown inside the symbol.



General prohibited action.



Disassembly prohibited.

● indicates that action is required. The specific action required is shown inside the symbol.



General action required.





Remove the power plug from the wall outlet.











Always ground the copier.

# 1. Installation Precautions

## WARNING











- Do not use a power supply with a voltage other than that specified. Avoid multiple connections to one outlet: they may cause fire or electric shock. When using an extension cable, always check that it is adequate for the rated current. .... 
- Connect the ground wire to a suitable grounding point. Not grounding the copier may cause fire or electric shock. Connecting the earth wire to an object not approved for the purpose may cause explosion or electric shock. Never connect the ground cable to any of the following: gas pipes, lightning rods, ground cables for telephone lines and water pipes or faucets not approved by the proper authorities. .... 

## CAUTION:





- Do not place the copier on an infirm or angled surface: the copier may tip over, causing injury. .... 
- Do not install the copier in a humid or dusty place. This may cause fire or electric shock. .... 
- Do not install the copier near a radiator, heater, other heat source or near flammable material. This may cause fire. .... 
- Allow sufficient space around the copier to allow the ventilation grills to keep the machine as cool as possible. Insufficient ventilation may cause heat buildup and poor copying performance. .... 
- Always handle the machine by the correct locations when moving it. .... 
- Always use anti-toppling and locking devices on copiers so equipped. Failure to do this may cause the copier to move unexpectedly or topple, leading to injury. .... 
- Avoid inhaling toner or developer excessively. Protect the eyes. If toner or developer is accidentally ingested, drink a lot of water to dilute it in the stomach and obtain medical attention immediately. If it gets into the eyes, rinse immediately with copious amounts of water and obtain medical attention. .... 
- Advise customers that they must always follow the safety warnings and precautions in the copier's instruction handbook. .... 












## 2. Precautions for Maintenance

### WARNING

- Always remove the power plug from the wall outlet before starting machine disassembly. .... 
- Always follow the procedures for maintenance described in the service manual and other related brochures. .... 
- Under no circumstances attempt to bypass or disable safety features including safety mechanisms and protective circuits. .... 
- Always use parts having the correct specifications. .... 
- Always use the thermostat or thermal fuse specified in the service manual or other related brochure when replacing them. Using a piece of wire, for example, could lead to fire or other serious accident. .... 
- When the service manual or other serious brochure specifies a distance or gap for installation of a part, always use the correct scale and measure carefully. .... 
- Always check that the copier is correctly connected to an outlet with a ground connection. .... 
- Check that the power cable covering is free of damage. Check that the power plug is dust-free. If it is dirty, clean it to remove the risk of fire or electric shock. .... 
- Never attempt to disassemble the optical unit in machines using lasers. Leaking laser light may damage eyesight. .... 
- Handle the charger sections with care. They are charged to high potentials and may cause electric shock if handled improperly. .... 



### CAUTION

- Wear safe clothing. If wearing loose clothing or accessories such as ties, make sure they are safely secured so they will not be caught in rotating sections. .... 
- Use utmost caution when working on a powered machine. Keep away from chains and belts. .... 
- Handle the fixing section with care to avoid burns as it can be extremely hot. .... 
- Check that the fixing unit thermistor, heat and press rollers are clean. Dirt on them can cause abnormally high temperatures. .... 

- Do not remove the ozone filter, if any, from the copier except for routine replacement. .... 
- Do not pull on the AC power cord or connector wires on high-voltage components when removing them; always hold the plug itself. .... 
- Do not route the power cable where it may be stood on or trapped. If necessary, protect it with a cable cover or other appropriate item. .... 
- Treat the ends of the wire carefully when installing a new charger wire to avoid electric leaks. .... 
- Remove toner completely from electronic components. .... 
- Run wire harnesses carefully so that wires will not be trapped or damaged. .... 
- After maintenance, always check that all the parts, screws, connectors and wires that were removed, have been refitted correctly. Special attention should be paid to any forgotten connector, trapped wire and missing screws. .... 
- Check that all the caution labels that should be present on the machine according to the instruction handbook are clean and not peeling. Replace with new ones if necessary. .... 
- Handle greases and solvents with care by following the instructions below: ..... 
  - Use only a small amount of solvent at a time, being careful not to spill. Wipe spills off completely.
  - Ventilate the room well while using grease or solvents.
  - Allow applied solvents to evaporate completely before refitting the covers or turning the power switch on.
  - Always wash hands afterwards.
- Never dispose of toner or toner bottles in fire. Toner may cause sparks when exposed directly to fire in a furnace, etc. .... 
- Should smoke be seen coming from the copier, remove the power plug from the wall outlet immediately. .... 

### 3. Miscellaneous

#### WARNING

- Never attempt to heat the drum or expose it to any organic solvents such as alcohol, other than the specified refiner; it may generate toxic gas. .... 
- Keep the machine away from flammable liquids, gases, and aerosols. A fire or an electric shock might occur. .... 

This page is intentionally left blank.



# CONTENTS

## 1-1 Specifications

1-1-1 Specifications .....	1-1-1
1-1-2 Parts names .....	1-1-12
(1) Machine .....	1-1-12
(2) Option .....	1-1-14
(3) Operation panel .....	1-1-16
1-1-3 Machine cross section .....	1-1-17

## 1-2 Installation

1-2-1 Installation environment .....	1-2-1
1-2-2 Unpacking and installation .....	1-2-2
(1) Installation procedure .....	1-2-2
(2) Setting initial copy modes .....	1-2-20
1-2-3 Installing the key counter (option) .....	1-2-21
(1) Installing directly on the device .....	1-2-21
(2) Mounting on the document table .....	1-2-29
1-2-4 Installing the key card MK-2 (option for Japan only) .....	1-2-38
1-2-5 Installing the KMAS (option for japan only) .....	1-2-51
1-2-6 Installing the coin vender (option for japan only) .....	1-2-60
1-2-7 Installing the cassette heater (option) .....	1-2-65
1-2-8 Installing the gigabit ethernet board (option) .....	1-2-70
1-2-9 Installing the Wire-less interface kit (option) .....	1-2-72
1-2-10 Installing the IC card reader holder (option) .....	1-2-74
1-2-11 Installing the keyboard holder (option) .....	1-2-85
1-2-12 Installing the Printed Document Guard Kit (option) .....	1-2-93
1-2-13 Installing the handset (option for Japan only) .....	1-2-96
(1) Installing directly on the device .....	1-2-96
(2) Mounting on the document table .....	1-2-103
1-2-14 Optional Applications .....	1-2-113
(1) Data Security Kit .....	1-2-114
(2) Internet FAX Kit .....	1-2-115
(3) Card Authentication Kit .....	1-2-119
(4) ThinPrint Option .....	1-2-120
(5) Emulation Upgrade Kit .....	1-2-121

## 1-3 Maintenance Mode

1-3-1 Maintenance mode .....	1-3-1
(1) Executing a maintenance item .....	1-3-1
(2) Maintenance modes item list .....	1-3-2
(3) Contents of the maintenance mode items .....	1-3-10

## 1-4 Troubleshooting

1-4-1 Paper misfeed detection .....	1-4-1
(1) Paper misfeed indication .....	1-4-1
(2) Paper misfeed detection condition .....	1-4-3
1-4-2 Troubleshooting .....	1-4-26
(1) First check items .....	1-4-26
(2) Items and corrective actions relating to the device that will cause paper jam .....	1-4-30

(3) Paper jam at feeding from cassette 1 Electrical parts that could cause paper jam during paper travelling at the primary feeding (to regist roller).....	1-4-40
(4) Paper jam at feeding from cassette 2 Electrical parts that could cause paper jam during paper travelling at the primary feeding ( to regist roller).....	1-4-42
(5) Paper jam during manual feeding Electrical parts that could cause paper jam during paper travelling at the primary feeding ( to regist roller).....	1-4-44
(6) Paper jam at the duplex re-feeding part Electrical parts that could cause paper jam during paper travelling at the primary feeding ( to regist roller).....	1-4-47
(7) Electrical parts that could cause paper jam at the transfer part .....	1-4-48
(8) Electrical parts that could cause paper jam at the fuser and eject parts .....	1-4-49
(9) Electrical parts that could cause paper jam at the duplex part.....	1-4-51
(10) Electrical parts that could cause paper jam at the BR (bridge) part .....	1-4-53
(11) Electrical parts that could cause paper jam at the DF paper entry, feedshift and subtray left eject part.....	1-4-55
(12) Electrical parts that could cause paper jam at the DF process part .....	1-4-57
(13) Electrical parts that could cause paper jam at the DF eject tray part .....	1-4-58
(14) Electrical parts that could cause paper jam at the CF conveying part.....	1-4-59
1-4-3 Self-diagnostic function .....	1-4-60
(1) Self-diagnostic function .....	1-4-60
(2) Self diagnostic codes.....	1-4-61
(3) System Error (Fxxx) Outline .....	1-4-139
1-4-4 Image formation problems .....	1-4-144
1-4-5 Poor image (due to DP and scanner reading) .....	1-4-146
(1) No image appears (entirely white).....	1-4-147
(2) No image appears (entirely black).....	1-4-150
(3) Image is too light. ....	1-4-152
(4) The background is colored. ....	1-4-156
(5) White streaks are printed vertically.....	1-4-159
(6) Black streaks appear longitudinally. ....	1-4-162
(7) Streaks are printed horizontally. ....	1-4-166
(8) One side of the print image is darker or brighter than the other. ....	1-4-169
(9) Black dots appear on the image. ....	1-4-172
(10) Image is blurred. ....	1-4-174
(11) The leading edge of the image is consistently misaligned with the original. ....	1-4-177
(12) Part of image is missing. ....	1-4-179
(13) Image is out of focus. ....	1-4-182
(14) Image center does not align with the original center. ....	1-4-184
(15) Moires.....	1-4-185
(16) Skewed image .....	1-4-187
(17) Abnormal image .....	1-4-190
1-4-6 Poor image (Image rendering problems: printer engine .....	1-4-193
(1) No image appears (entirely white).....	1-4-195
(2) No image appears (entirely black).....	1-4-196
(3) Image is too light. ....	1-4-196
(4) The background is colored. ....	1-4-199
(5) White streaks are printed vertically.....	1-4-201
(6) Black streaks appear longitudinally. ....	1-4-202
(7) Black or white streaks appear horizontally. ....	1-4-203
(8) Uneven density longitudinally. ....	1-4-204

(9) Uneven density horizontally.....	1-4-205
(10) Black dots appear on the image.....	1-4-206
(11) Offset occurs.....	1-4-207
(12) Image is partly missing.....	1-4-208
(13) Image is out of focus.....	1-4-208
(14) Poor grayscale reproducibility.....	1-4-209
(15) Unevenly repeating horizontal streaks in the printed objects. Spots in the printed objects.....	1-4-210
(16) Image is blurred (Shifted transferring).....	1-4-211
(17) The leading edge of the image is consistently misaligned with the original.....	1-4-212
(18) The leading edge of the image is sporadically misaligned with the original.....	1-4-213
(19) Paper is wrinkled.....	1-4-213
(20) Fusing is loose.....	1-4-215
(21) Image center does not align with the original center.....	1-4-216
(22) Dirty paper edges with toner.....	1-4-216
(23) Dirty reverse side of paper.....	1-4-217
1-4-7 Electric problems.....	1-4-218
1-4-8 Mechanical problems.....	1-4-226
1-4-9 Send error code.....	1-4-228
(1) Scan to SMB error codes.....	1-4-228
(2) Scan to FTP error codes.....	1-4-229
(3) Scan to E-mail error codes.....	1-4-230
1-4-10 Error codes.....	1-4-232
(1) Error code.....	1-4-232
(2) Table of general classification.....	1-4-233
(2-1) U004XX error code table: Interrupted phase B.....	1-4-235
(2-2) U006XX error code table: Problems with the unit.....	1-4-235
(2-3) U008XX error code table: Page transmission error.....	1-4-235
(2-4) U009XX error code table: Page reception error.....	1-4-235
(2-5) U010XX error code table: G3 transmission.....	1-4-236
(2-6) U011XX error code table: G3 reception.....	1-4-237
(2-7) U017XX error code table: V.34 transmission.....	1-4-238
(2-8) U018XX error code table: V.34 reception.....	1-4-238

## 1-5 Assembly and disassembly

1-5-1 Precautions for assembly and disassembly.....	1-5-1
(1) Precautions.....	1-5-1
(2) Drum.....	1-5-1
(3) Toner.....	1-5-1
(4) How to tell a genuine Kyocera toner container.....	1-5-2
1-5-2 Outer covers.....	1-5-3
(1) Detaching and refitting the rear upper cover.....	1-5-3
(2) Detaching and refitting the rear lower cover.....	1-5-3
(3) Detaching and refitting the left upper cover.....	1-5-4
(4) Detaching and refitting the right lower cover.....	1-5-5
(5) Detaching and refitting the right lower rear cover.....	1-5-5
(6) Detaching and refitting the right lower front cover.....	1-5-6
(7) Detaching and refitting the ISU right cover and right upper cover.....	1-5-7
(8) Detaching and refitting the right middle rear cover.....	1-5-8
(9) Detaching and refitting the MP tray paper feed unit.....	1-5-8
(10) Detaching and refitting the paper conveying unit.....	1-5-10
(11) Detaching and refitting the ISU front cover and ISU right cover.....	1-5-10
(12) Detaching and refitting the ISU rear cover.....	1-5-11

1-5-3 Paper feed section.....	1-5-12
(1) Detaching and refitting the primary paper feed unit.....	1-5-12
(2) Detaching and refitting the forwarding pulley, paper feed pulley and separation pulley. [35 ppm model].....	1-5-16
(3) Detaching and refitting the forwarding pulley, paper feed pulley and separation pulley. [45 ppm model / 55 ppm model].....	1-5-19
(4) Detaching and refitting the MP tray paper feed unit.....	1-5-22
(5) Detaching and refitting the MP forwarding pulley, MP paper feed pulley and MP separation pulley.....	1-5-25
1-5-4 Optical section.....	1-5-30
(1) Detaching and refitting the exposure lamp.....	1-5-30
(2) Detaching and refitting the scanner wires.....	1-5-33
(3) Detaching and refitting the ISU.....	1-5-37
(4) Detaching and refitting the LSU.....	1-5-42
1-5-5 Image formation section.....	1-5-44
(1) Detaching and refitting the inner unit.....	1-5-44
(2) Detaching and refitting the developer unit.....	1-5-46
(3) Detaching and refitting the drum unit.....	1-5-47
(4) Detaching and refitting the charger roller unit.....	1-5-49
(5) Removal and cleaning of the drum cover.....	1-5-50
1-5-6 Transfer section.....	1-5-53
(1) Detaching and refitting the paper conveying unit.....	1-5-53
(2) Detaching and refitting the transfer belt unit.....	1-5-55
1-5-7 Fuser section.....	1-5-57
(1) Detaching and refitting the fuser unit.....	1-5-57
1-5-8 PWBs.....	1-5-59
(1) Detaching and refitting the main PWB.....	1-5-59
(2) Remarks on main PWB replacement.....	1-5-64
(3) Detaching and refitting the engine PWB.....	1-5-67
(4) Remarks on engine PWB replacement.....	1-5-69
(5) Error symptom at an erroneous insertion of the engine PWB FFC.....	1-5-70
(6) Detaching and refitting the power source PWB.....	1-5-71
(7) Detaching and refitting the power source assembly.....	1-5-72
(8) Detaching and refitting the high voltage PWB.....	1-5-76
(9) Detaching and refitting the operation PWB.....	1-5-77
(10) Detaching and refitting the fuser heater PWB.....	1-5-83
1-5-9 Drive section.....	1-5-88
(1) Detaching and refitting the drum drive unit.....	1-5-88
(2) Detaching and refitting the developer drive unit.....	1-5-90
(3) Detaching and refitting the fuser drive unit and feed drive unit.....	1-5-91
(4) Detaching and refitting the lift motor 1 and 2.....	1-5-97
1-5-10 Others.....	1-5-98
(1) Detaching the eject filter.....	1-5-98
(2) Detaching and refitting the toner filter.....	1-5-99
(3) Detaching and refitting the left filter.....	1-5-100
(4) Detaching and refitting the LSU filter and belt filter.....	1-5-101
(5) Detaching and refitting the drum filter and developer filter.....	1-5-102
(6) Detaching and refitting the toner disposal box.....	1-5-103
(7) Detaching and refitting the hard disk unit.....	1-5-104
(8) Detaching and refitting the eject unit.....	1-5-106
(9) Direction of installing the principal fan motors.....	1-5-107
(10) Skewed paper feeding check/adjustment.....	1-5-108

1-6 Upgrading the firmware	
1-6-1 Upgrading the firmware .....	1-6-1
<b>2-1 Mechanical Construction</b>	
2-1-1 Paper feed/conveying section .....	2-1-1
(1) Cassette paper feed section .....	2-1-1
(2) MP tray paper feed section .....	2-1-3
(3) Paper conveying section .....	2-1-5
2-1-2 Drum section .....	2-1-8
2-1-3 Developer section .....	2-1-10
2-1-4 Optical section .....	2-1-12
(1) Image scanner section .....	2-1-12
(2) Laser scanner section .....	2-1-14
2-1-5 Transfer/Separation section .....	2-1-17
(1) Transfer belt unit section .....	2-1-17
2-1-6 Fuser section .....	2-1-19
2-1-7 Eject/Feedshift section .....	2-1-21
2-1-8 Duplex conveying section .....	2-1-23
<b>2-2 Electrical Parts Layout</b>	
2-2-1 Electrical parts layout .....	2-2-1
(1) PWBs .....	2-2-1
(2) Switches and sensors .....	2-2-4
(3) Motors .....	2-2-6
(4) Fan motors .....	2-2-8
(5) Others .....	2-2-10
<b>2-3 Operation of the PWBs</b>	
2-3-1 Main PWB .....	2-3-1
2-3-2 Engine PWB .....	2-3-10
2-3-3 Power source PWB .....	2-3-28
2-3-4 ISC PWB .....	2-3-32
2-3-5 Operation PWB 1 .....	2-3-37
2-3-6 Front PWB .....	2-3-43
2-3-7 Feed PWB 1 .....	2-3-49
2-3-8 Feed PWB 2 .....	2-3-59
2-3-9 Relay PWB .....	2-3-65
2-3-10 LSU relay PWB .....	2-3-71
<b>2-4 Appendixes</b>	
2-4-1 Appendixes .....	2-4-1
(1) List of maintenance parts .....	2-4-1
(2) Maintenance kits .....	2-4-3
(3) Periodic maintenance procedures .....	2-4-4
(4) Image adjustment after replacing the maintenance kit .....	2-4-9
(5) Inner Cleaning .....	2-4-10
(6) Repetitive defects gauge .....	2-4-15
(7) Firmware environment commands .....	2-4-16
(8) Timing chart .....	2-4-22
(9) Chart of image adjustment procedures .....	2-4-37
(10) Wiring diagram .....	2-4-39

## INSTALLATION GUIDE

DOCUMENT PROCESSOR  
PAPER FEEDER  
LARGE CAPACITY FEEDER  
SIDE DECK  
1000-SHEETS FINISHER  
4000-SHEETS FINISHER  
FINISHER ATTACHMENT KIT  
CENTER-FOLDING UNIT  
MAILBOX  
PUNCH UNIT  
INNER JOB SEPARATOR  
100-SHEETS INNER JOB SEPARATOR  
RIGHT JOB SEPARATOR  
BANNER GUIDE  
FAX System  
DOCUMENT TABLE

## 1-1-1 Specifications

### Common functions

Item	Specifications			
	35 ppm	45 ppm	55 ppm	
Type	Desktop			
Printing method	Electrophotography by semiconductor laser			
Paper weight	Cassette	60 to 220 g/m <sup>2</sup>		
	MP tray	60 to 300 g/m <sup>2</sup>		
Paper type	Cassette 1, 2	Plain, Rough, Vellum, Recycled, Preprinted, Bond, Color (Colour), Prepunched, Letterhead, Thick, High Quality, Custom 1 to 8 (Duplex: Same as simplex)		
	MP tray	Plain, Transparency (OHP film), Rough, Vellum, Labels, Recycled, Preprinted, Bond, Cardstock, Color (Colour), Prepunched, Letterhead, Thick, Coated, Envelope, High Quality, Index Tab Dividers, Custom 1 to 8		
Paper size	Cassette 1, 2	A3, B4, A4, A4-R, B5, B5-R, A5-R, Ledger, Legal, Oficio II, 12 × 18", Letter-R, Letter, Statement-R, Folio, 8K, 16K, 16K-R, 216 × 340 mm, Size Entry (Metric: X; 182 to 457 mm (in 1 mm increments), Y; 140 to 304 mm (in 1 mm increments), Inch: X; 7.17 to 18.00" (in 0.01" increments), Y; 5.51 to 12.00" (in 0.01" increments))		
	MP tray	A3, B4, A4, A4R, B5, ISO B5, B5R, A5R, B6R, A6R, Return postcard, Postcards, Envelope DL, Envelope C5, Envelope C4, Envelope #10 (Commercial #10), Envelope #9 (Commercial #9), Envelope #6 (Commercial #6 3/4), Envelope Monarch, Youkei 2, Youkei 4, Ledger, Legal, Letter, LetterR, Executive, StatementR, Oficio II, 12 × 18", Folio, 216 × 340mm, 8K, 16K, 16KR, Custom (98 × 148 mm to 304.8 × 1,220 mm)		
Warm-up time (22 °C/71.6 °F, 60% RH)	Power on	23 s or less	23 s or less	23 s or less
	Low Power	10 s or less	10 s or less	10 s or less
	Sleep	16 s or less	16 s or less	16 s or less
Paper capacity	Cassette	550 sheets (64 g/m <sup>2</sup> ) 500 sheets (80 g/m <sup>2</sup> )		
	MP tray	A4/Letter or less 165 sheets (64 g/m <sup>2</sup> ) 150 sheets (80 g/m <sup>2</sup> ) More than A4/Letter 55 sheets (64 g/m <sup>2</sup> ) 50 sheets (80 g/m <sup>2</sup> )		
Output tray capacity	Inner tray	250 sheets (80 g/m <sup>2</sup> ) * : 180 sheets (with 100-sheets inner job separator)		
	with inner job separator	30 sheets (80 g/m <sup>2</sup> )		
	with 100-sheets inner job separator	100 sheets (80 g/m <sup>2</sup> )		
	with right job separator	70 sheets (80 g/m <sup>2</sup> )		

Item	Specifications		
	35 ppm	45 ppm	55 ppm
<b>Light source</b>	LED		
<b>Scanning system</b>	Flat bed scanning by CCD image sensor		
<b>Photoconductor</b>	a-Si (drum diameter 40 mm)		
<b>Image write system</b>	Semiconductor laser		
<b>Charging system</b>	Charger roller		
<b>Developing system</b>	Touch down developing system Developer: 2-component Toner replenishing: Automatic from the toner container and toner hopper		
<b>Transfer system</b>	Transfer belt and roller		
<b>Separation system</b>	Small diameter separation		
<b>Cleaning system</b>	Counter blade, Cleaning roller		
<b>Charge erasing system</b>	Exposure by cleaning lamp (LED)		
<b>Fusing system</b>	Heat roller fusing Heat source: Halogen heaters Abnormally high temperature protection devices: thermostat		
<b>CPU</b>	Dual Core (Freescale QorIQ P1022) 800MHz		
<b>Memory</b>	2GB		
<b>Hard Disk</b>	160 GB or more (standard)		
<b>Interface</b>	<b>Standard</b>	USB Interface connector: 1 (Hi-Speed USB) USB port: 4 (Hi-Speed USB) Network interface: 1 (10 BASE-T/100 BASE-TX/1000 BASE-T)	
	<b>Option</b>	Fax slot: 2 Network interface: 1 (10 BASE-T/100 BASE-TX/1000 BASE-T)	
<b>Resolution</b>	600 × 600 dpi		
<b>Operating environment</b>	<b>Temperature</b>	10 to 32.5 °C/50 to 90.5 °F	
	<b>Humidity</b>	15 to 80% RH	
	<b>Altitude</b>	2,500 m/8,202 ft or less	
	<b>Brightness</b>	1,500 lux or less	
<b>Dimensions (W × D × H)</b>	<b>machine only</b>	25 1/2 × 30 3/16 × 29 13/32" 648 × 767 × 747 mm	
	<b>with paper feeder</b>	25 1/2 × 30 3/16 × 41 7/16" 648 × 767 × 1053 mm	
<b>Space required (W × D)</b>	36 13/32 × 30 3/16" (using MP tray) 925 × 767 mm (using MP tray)		
<b>Weight</b>	189.6 lb / 86 kg (with toner container)		
<b>Power source</b>	120 V AC, 60 Hz, more than 12.0 A 220 - 240 V AC, 50/60 Hz, more than 7.2 A		



Item	Specifications		
	35 ppm	45 ppm	55 ppm
<b>Options</b>	Document processor, Original cover, Paper feeder, Large capacity feeder, Side deck, 1000-sheet finisher, 4000-sheet finisher, Center-folding unit, Mailbox, Punch unit, Inner job separator, 100-sheets inner job separator, Right job separator, Key counter, Fax kit, Expansion memory for Fax, Internet fax kit (A), Data security kit, Printed document guard kit, Emulation option kit, Gigabit ethernet board, Wireless interface board, Document table, IC card reader holder, Keyboard holder, Scan Extension Kit (A) and Banner Tray		

### Copy functions

Item	Specifications		
	35 ppm	45 ppm	55 ppm
<b>Copying speed</b>	A4 : 35 ppm Letter : 35 ppm A4R : 24 ppm LetterR : 24 ppm A3 : 17 ppm Ledger : 24 ppm B4 : 21 ppm Legal : 21 ppm B5 : 35 ppm B5-R : 24 ppm A5-R : 17 ppm	A4 : 45 ppm Letter : 45 ppm A4R : 31 ppm LetterR : 31 ppm A3 : 22 ppm Ledger : 22 ppm B4 : 27 ppm Legal : 27 ppm B5 : 45 ppm B5-R : 31 ppm A5-R : 22 ppm	A4 : 55 ppm Letter : 55 ppm A4R : 38 ppm LetterR : 38 ppm A3 : 27 ppm Ledger : 27 ppm B4 : 33 ppm Legal : 33 ppm B5 : 55 ppm B5-R : 38 ppm A5-R : 27 ppm
<b>First copy time (A4, feed from cassette)</b>	4.5 s or less	3.6 s or less	3.1 s or less
<b>Zoom level</b>	Manual mode : 25 to 400%, 1% increments Auto mode : Preset Zoom		
<b>Continuous copying</b>	1 to 999 sheets		
<b>Resolution</b>	600 × 600 dpi		
<b>Originals</b>	Sheet, Book, 3-dimensional objects (maximum original size: A3/Ledger)		
<b>Original feed system</b>	Fixed		

## Printer functions

Item	Specifications		
	35 ppm	45 ppm	55 ppm
<b>Printing speed</b>	A4 : 35 ppm Letter : 35 ppm A3 : 17 ppm Ledger : 17 ppm	A4 : 45 ppm Letter : 45 ppm A3 : 22 ppm Ledger : 22 ppm	A4 : 55 ppm Letter : 55 ppm A3 : 27 ppm Ledger : 27 ppm
<b>First print time* (A4, feed from cassette)</b>	6.0 s or less	5.3 s or less	4.9 s or less
<b>Resolution</b>	600 x 600 dpi		
<b>Operating system</b>	Windows XP, Windows Server 2003, Windows Vista, Windows 7, Windows 8, Windows Server 2008, Apple Macintosh OS 10.x		
<b>Interface</b>	USB interface connector: 1 (USB Hi-speed) Network interface: 1 (10BASE-T/100BASE-TX/1000BASE-T) Option interface (option): 1 * : Gigabit ethernet board, Wireless interface board		
<b>Page description language</b>	PRESCRIBE		
<b>Emulation</b>	PCL6 (PCL5e, PCL-XL), KPDL3 (PostScript3 compatible)		

\* : Excluding time for system stabilization immediately after turning on the main power.

## Scanner functions

Item	Specifications	
<b>System requirements</b>	CPU: Celeron 266 MHz or higher RAM: 300 MB or more	
<b>Resolution</b>	600 dpi, 400 dpi, 300 dpi, 200 dpi, 200 x100 dpi, 200 x 400 dpi	
<b>File format</b>	PDF (high compressive, encrypted, PDF/A), TIFF, JPEG, XPS	
<b>Scanning speed (A4 landscape, 300 dpi, Image quality: Text/Photo original)*1</b>	<b>Simplex</b>	B/W : 80 images/min Color: 50 images/min
	<b>Duplex</b>	B/W : 160 images/min Color: 80 images/min
<b>Interface</b>	Ethernet (10 BASE-T/100 BASE-TX/1000 BASE-T)	
<b>Network protocol</b>	TCP/IP	
<b>Transmission system</b>	SMB, SMTP, FTP, FTP over SSL, USB, TWAIN*2, WIA*3, WSD	

\*1 When using the dual scan document processor (except TWAIN and WIA scanning)

\*2 Available operating system: Windows XP, Windows Server 2003, Windows Vista, Windows Server 2008, Windows 7

\*3 Available operating system: Windows Vista, Windows 7, Windows Server 2008, Windows Server 2008 R2, Windows 7

**Document Processor (Option)**

Item	Specifications			
	Document Processor		Document Processor (Dual scan DP)	
<b>Original Feed Method</b>	Automatic feed			
<b>Supported Original Types</b>	Sheet originals			
<b>Paper Size</b>	<b>Maximum</b>	Ledger/A3		
	<b>Minimum</b>	Statement-R/A5-R	Statement-R/A6-R	
<b>Paper Weight</b>	<b>1-sided</b>	45 to 160 g/m <sup>2</sup>	35 to 220 g/m <sup>2</sup>	35 to 220 g/m <sup>2</sup> (B6R or less)
	<b>2-sided</b>	50 to 120 g/m <sup>2</sup>	50 to 220 g/m <sup>2</sup>	
<b>Loading Capacity</b>	100 sheets (50 to 80 g/m <sup>2</sup> ) maximum When originals have different widths: 30 sheets (50 to 80 g/m <sup>2</sup> ) maximum		175 sheets (50 to 80 g/m <sup>2</sup> ) maximum When originals have different widths: 30 sheets (50 to 80 g/m <sup>2</sup> ) maximum	
<b>Dimensions (W × D × H)</b>	22 23/32 × 21 13/64 × 7 5/64" 577 × 534 × 180 mm		23 5/8 × 20 13/64 × 6 45/64" 600 × 513 × 170 mm	
<b>Weight</b>	32 lbs. or Less /14.5 kg or less			

**Paper Feeder (500-sheet x 2) (Option)**

Item	Specifications	
	<b>Paper Supply Method</b>	Feed & reverse roller method (No. Sheets: 500, 80 g/m <sup>2</sup> , 2 cassettes/No. Sheets: 550, 64 g/m <sup>2</sup> , 2 cassettes)
<b>Paper Size</b>	A3, B4, A4, A4-R, B5, B5-R, A5-R, Ledger, Legal, Oficio II, 12 × 18", Letter, Letter-R, Statement-R, Folio, 8K, 16K, 16K-R, 216 × 340 mm	
<b>Supported Paper</b>	<b>Paper weight</b>	60 to 256 g/m <sup>2</sup>
	<b>Media types</b>	Plain, Recycled, Thick
<b>Dimensions (W × D × H)</b>	23 35/64 × 27 35/64 × 12 13/32" 598 × 699.6 × 315 mm	
<b>Weight</b>	Approx. 66.1 lbs. / Approx. 30 kg	

**Large Capacity Feeder (1,500-sheet x 2) (Option)**

Item		Specifications
<b>Paper Supply Method</b>		Feed & reverse roller method (No. Sheets: 3,000 (80 g/m <sup>2</sup> )/No. Sheets: 3,500 (64 g/m <sup>2</sup> ))
<b>Paper Size</b>		A4, B5, Letter
<b>Supported Paper</b>	<b>Paper weight</b>	60 to 256 g/m <sup>2</sup>
	<b>Media types</b>	Plain, Recycled, Thick
<b>Dimensions (W x D x H)</b>		23 35/64 x 27 52/64 x 12 26/64" 598 x 706.6 x 315 mm
<b>Weight</b>		Approx. 63.93 lbs / Approx. 29 kg

**Side Feeder (3,000-sheet) (Option)**

Item		Specifications
<b>Paper Supply Method</b>		Feed & reverse roller method (No. Sheets: 3,000, 80 g/m <sup>2</sup> /No. Sheets: 3,500 64 g/m <sup>2</sup> )
<b>Paper Size</b>		A4, B5, Letter
<b>Supported Paper</b>	<b>Paper weight</b>	60 to 300 g/m <sup>2</sup>
	<b>Media types</b>	Plain, Recycled, Thick
<b>Dimensions (W x D x H)</b>		12 41/64 x 24 13/32 x 19 27/32" 321 x 620 x 504 mm
<b>Weight</b>		Approx. 55.1 lbs. / Approx. 25 kg

**1,000-sheet Finisher (Option)**

<b>Item</b>		<b>Specifications</b>	
<b>Type</b>		Floor model	
<b>Number of trays</b>		Two trays	
<b>Paper weight</b>		45 to 300 g/m <sup>2</sup>	
<b>Tray capacity</b>	<b>Main Try (Try A) When not stapling</b>	A3, B4, Ledger, Legal, Oficio II, Folio, 8K, 16K-R, 216 x 340 mm, Statement-R, Executive, Foolscap, A3 Wide (310 x433 mm), Ledger Wide (310 x440 mm), 12 x 18": 500 sheets A4, A4R, B5, A5R, B5R, B6R, Letter, LetterR, 16K, Custom (98 x 148 mm to 297 x 432 mm): 1,000 sheets	
	<b>Sub Try left (Try B)</b>	A3, B4, A4, A4R, B5, B5 (ISO), B5R, A5R, A6, B6R, Letter, Letter R, Ledger, Legal, Oficio II, 12 x 18", Statement R, Folio, 8K, 16K, 16K-R, 216 x 340 mm, Oufuku hagaki, Cardstock, Envelope DL, Envelope C5, Envelope C4, Envelope #10 (Commercial #10), Envelope #9 (Commercial #9), Envelope #6 (Commercial #6 3/4), Envelope Monarch, Youkei 2, Youkei 4, Statement-R, Executive, Foolscap, A3 Wide (310 x433 mm), Ledger Wide (310 x440 mm), 13 x 19", Custom (98 x 148mm to 297 x 432mm): 100 sheets	
<b>Supported Paper Weight</b>		Stapling: 90 g/m <sup>2</sup> or less	
<b>Stapling</b>	<b>Number of Sheets</b>	A3, B4, B5R, Ledger, Legal, Oficio II, 12 x 18", 216 x 340 mm, Folio, 8K, 16K-R	30 sheets (52 to 90 g/m <sup>2</sup> ) 20 sheets (91 to 105 g/m <sup>2</sup> ) 2 cover sheet only (106 g/m <sup>2</sup> to 256 g/m <sup>2</sup> )
		A4, A4R, B5, Letter, Letter R, 16K	50 sheets (52 to 90 g/m <sup>2</sup> ) 40 sheets (91 to 105 g/m <sup>2</sup> ) 2 cover sheet only (106 g/m <sup>2</sup> to 256 g/m <sup>2</sup> )
	<b>Media types</b>	Plain, Recycled, Prepunched, Preprinted, Bond, Letterhead, Color (Colour), Vellum, Thick, High Quality, Rough, Transparency (OHP film), Labels, Envelope, Cardstock, Coated, Custom 1 to 8	
<b>Power source</b>		Electrically connected to the machine	
<b>Dimensions (W x D x H)</b>		26 7/32 x 24 11 x 32 x 42 5/8" 666 x 618.5 x 1,083 mm	
<b>Weight</b>		Approx. 66.1 lb / Approx. 30 kg or less	

**4,000-sheet Finisher (Option)**

Item		Specifications
Type		Floor model
Number of trays		Three tray
Tray capacity	Main Try (Try A) When not stapling	A3, B4, B5R, Ledger, Legal, 8K: 1500 sheets A4, A4R, B5, Letter, LetterR, 16K, 16KR, Folio: 4000 sheets * A5R, B6R, Statement R: 500 sheets
	Sub Try left (Try B)	A4, A4R, B5, B5R, A5, A5R, Folio, Ledger, Legal, 12 × 18", A3, B4, 8K, Letter, Letter R, Statement-R, 16K, 16KR: 200 sheets
	Sub Try right (Try C)	A4, B5, B5 (ISO), B5R, B6, A5, A5R, A6, A6R, Letter, Statement R, 16K, Cardstock, Oufuku hagaki: 100 sheets
Stapling	Maximum Number	A3, B4, B5R, Ledger, Legal, Oficio II, 12 × 18", 216 × 340 mm, Folio, 8K, 16KR 30 sheets (52 to 90 g/m <sup>2</sup> ) 20 sheets (91 to 105 g/m <sup>2</sup> ) 2 cover sheet only (106 g/m <sup>2</sup> to 256 g/m <sup>2</sup> )
		A4, A4R, B5, Letter, Letter R, 16K 65 sheets (52 to 90 g/m <sup>2</sup> ) 55 sheets (91 to 105 g/m <sup>2</sup> ) 2 cover sheet only (106 g/m <sup>2</sup> to 256 g/m <sup>2</sup> )
Media types		Plain, Recycled, Prepunched, Preprinted, Bond, Letterhead, Color (Colour), Vellum, Thick, High Quality, Rough, Transparency (OHP film), Labels, Envelope, Cardstock, Coated, Custom 1 to 8
Power source		Electrically connected to the machine
Dimensions (W × D × H)		607.2 × 668.5 × 1061.3 mm 23 29/32 × 26 5/16 × 41 25/32"
Weight		Approx. 88.2 lb / Approx. 40 kg or less

\* : \* when the center-folding unit installed, 3000 sheets.

**Punch unit (option)**

Item		Specifications
Paper size	2 Holes	A3, B4, A4, A4R, B5, Folio, Legal, Letter, Letter R, 12 × 18", Statement R, 12 × 18", A5R, B5R, 8K, 16K, 16K-R
	3 Holes, 4 Holes	A3, B4, A4, Letter, Ledger, 12 × 18", 8K, 16K
Paper weight		45 to 300 g/m <sup>2</sup>
Media types	4,000-sheet Finisher	Plain, Transparency, Preprinted, Bond, Recycled, Rough, Letterhead, Color (Colour), Prepunched, Thick, Coated, High Quality, Custom
	1,000-sheet Finisher	Plain, Transparency, Preprinted, Bond, Recycled, Rough, Letterhead, Color (Colour), Prepunched, Thick, Coated, High Quality, Custom

**Mail box (option)**

Item	Specifications
Number of trays	7 trays
Paper size (80 g/m <sup>2</sup> )	A3, B4, Ledger, Legal: 50 sheets A4, A4R, B5, B5R, A5R, Letter, Letter R, 216 x 340 mm, Executive, Executive-R, Folio, Foolscap, 8K, 16K, 16K-R, Statement R, Oficio II: 100 sheets
Dimensions (W x D x H)	20 1/16" x 15 3/4" x 18 1/2" 510 x 400 x 470 mm
Weight	Approx. 22 lbs / 10 kg

**Center-folding unit (option)**

Item		Specifications
Sizes	Bi-Fold	A3, B4, A4R, Ledger, Legal, Letter R, Oficio II, 8K
	Saddle Stitch	A3, B4, A4R, Ledger, Legal, Letter R, Oficio II, 8K
	Tri-Fold	A4R, Letter R
Number of sheets	Bi-Fold	5 sheets (60 to 90 g/m <sup>2</sup> ) 3 sheets (91 to 120 g/m <sup>2</sup> ) 1 sheet (121 to 256 g/m <sup>2</sup> )
	Saddle Stitch	16 sheets (60 to 90 g/m <sup>2</sup> ) 13 sheets (91 to 105 g/m <sup>2</sup> ) 1 cover sheet only (106 to 256 g/m <sup>2</sup> )
	Tri-Fold	5 sheets (60 to 90 g/m <sup>2</sup> ) 3 sheets (91 to 120 g/m <sup>2</sup> )
Maximum number for storage (80 g/m <sup>2</sup> )	Bi-Fold	5 sheets or less per set: 30 sets or more 6 to 10 sheets per set: 20 sets or more 11 to 16 sheets per set: 10 sets or more.
	Saddle Stitch	5 sheets or less per set: 30 sets or more 6 to 10 sheets per set: 20 sets or more 11 to 16 sheets per set: 10 sets or more.
	Tri-Fold	1 sheet per set: 30 sets or more 2 to 5 sheets per set: 5 sets or more.
Media types	Bi-Fold	Plain, Recycled, Thick, Coated
	Saddle Stitch	Plain, Recycled, Thick, Coated
	Tri-Fold	Plain, Recycled, Thick

**Inner Job Separator (Option)**

Item		Specifications
<b>Number of trays</b>		1 tray
<b>Maximum Sheets</b>		30 sheets ( 80 g/m <sup>2</sup> )
<b>Paper Size</b>		A3, B4, A4, A4-R, B5, B5-R, A5-R, Folio, Ledger, Legal, Letter, Letter-R, Executive, Executive-R, Foolscap, Oficio II, Statement-R, 8K, 16K, 16K-R, 216 x 340 mm
<b>Supported Paper</b>	<b>Paper weight</b>	60 to 256 g/m <sup>2</sup>
	<b>Media types</b>	Plain, Transparency, Preprinted, Bond, Recycled,Rough, Letterhead, Color (Colour), Prepunched,Thick, Coated, High Quality, Custom 1 to 8
<b>Dimensions (W x D x H)</b>		17 7/16 x 15 7/16 x 4 1/64" 443 x 392 x 102 mm
<b>Weight</b>		Approx. 1.76 lbs. / Approx. 0.8 kg

**100-sheets Inner Job Separator (Option)**

Item		Specifications
<b>Number of trays</b>		1 tray
<b>Maximum Sheets</b>		100 sheets ( 80 g/m <sup>2</sup> )
<b>Paper Size</b>		A3, B4, A4, A4-R, B5, B5-R, A5-R, Folio, Ledger, Legal, Letter, Letter-R, Executive, Executive-R, Foolscap, Oficio II, Statement-R, 8K, 16K, 16K-R, 216 x 340 mm
<b>Supported Paper</b>	<b>Paper weight</b>	60 to 256 g/m <sup>2</sup>
	<b>Media types</b>	Plain, Transparency, Preprinted, Bond, Recycled,Rough, Letterhead, Color (Colour), Prepunched,Thick, Coated, High Quality, Custom 1 to 8
<b>Dimensions (W x D x H)</b>		18 1/2 x 17 43/64 x 4 1/64" 470 x 449 x 102 mm
<b>Weight</b>		Approx. 4.63 lbs. / Approx. 2.1 kg



**Right Job Separator (Option)**

Item		Specifications
<b>Number of trays</b>		1 tray
<b>Maximum Sheets</b>		A4, A4-R, B5, Letter, Letter-R, B5-R, A5-R, Executive, Executive-R, Statement-R, 16K, 16K-R,: 70 sheets (80 g/m <sup>2</sup> ) A3, B4, Folio, Ledger, Legal, Foolscap, Oficio II, 16K, 8K, 216 x 340mm : 30 sheets (80 g/m <sup>2</sup> )
<b>Paper Size</b>		A3, B4, A4, A4-R, B5, B5-R, A5-R, Folio, Ledger, Legal, Letter, Letter-R, Executive, Executive-R, Foolscap, Oficio II, Statement-R, 8K, 16K, 16K-R, 216 x 340 mm
<b>Supported Paper</b>	<b>Paper weight</b>	60 to 256 g/m <sup>2</sup>
	<b>Media types</b>	Plain, Transparency, Preprinted, Bond, Recycled, Rough, Letterhead, Color (Colour), Prepunched, Thick, Coated, High Quality, Custom 1 to 8
<b>Dimensions (W x D x H)</b>		14 27/32 x 17 13/32 x 5 29/32" 377 x 442 x 150 mm
<b>Weight</b>		Approx. 5.1 lbs. / Approx. 2.3 kg

**Banner Tray (Option)**

Item		Specifications
<b>Max. number of sheets</b>		10 sheets (Multi Purpose tray)
<b>Paper length</b>		210 (8.26") to 304.8 (12") mm
<b>Paper weight</b>		Max. 1220 (48 1/64") mm
<b>Paper Type</b>	<b>Paper weight</b>	136 to 163 g/m <sup>2</sup>
	<b>Media types</b>	Heavy 2
<b>Dimensions (W x D x H)</b>		9 27/32 x 14 23/32 x 5 63/64" 250 x 374 x 152 mm
<b>Weight</b>		Approx. 0.78 lbs. / Approx. 0.352 kg

NOTE: These specifications are subject to change without notice.

## 1-1-2 Parts names

### (1) Machine

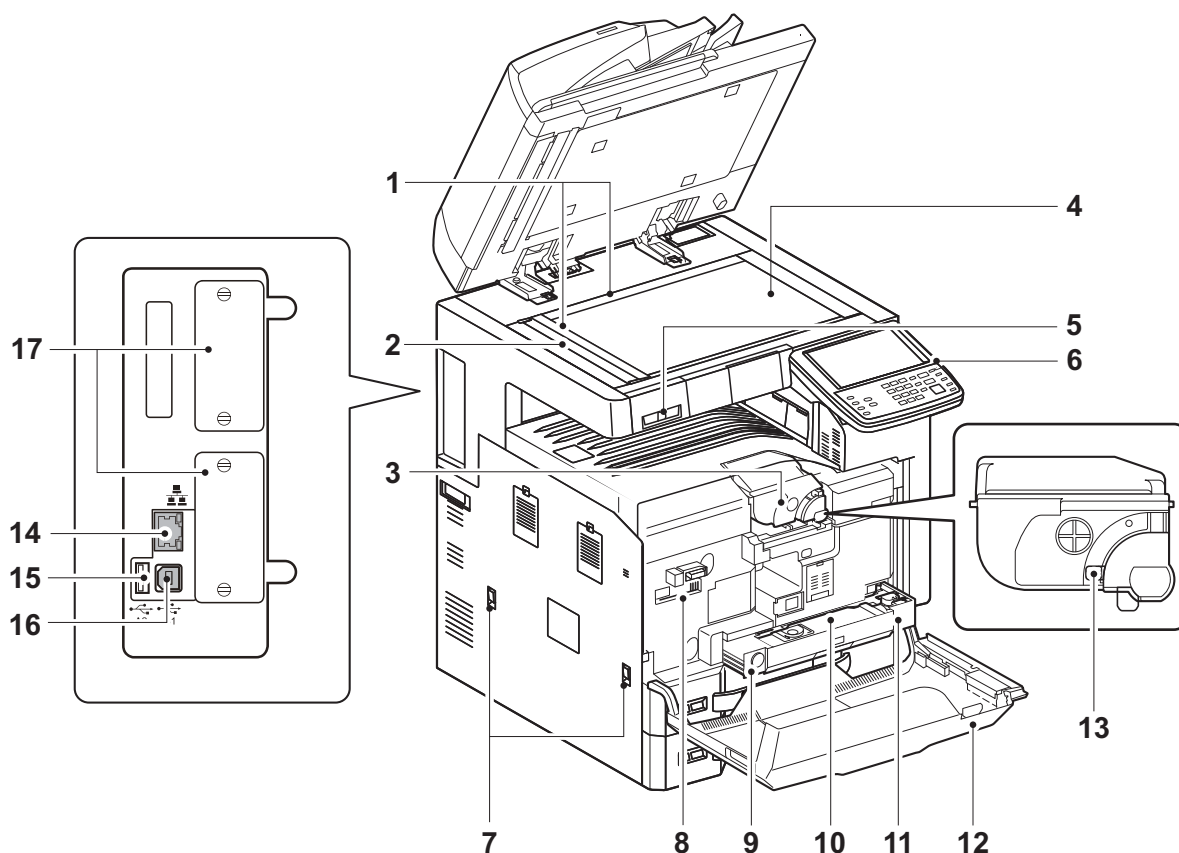


Figure 1-1-1

- |                                  |                                   |
|----------------------------------|-----------------------------------|
| 1. Original size indicator plate | 10. Waste toner box               |
| 2. Slit glass                    | 11. Waste toner tray              |
| 3. Toner container               | 12. Front cover                   |
| 4. Platen (Contact glass)        | 13. Toner container release lever |
| 5. Clip holder                   | 14. Network interface connector   |
| 6. Operation panel               | 15. USB port (A2)                 |
| 7. Handles                       | 16. USB interface connector (B1)  |
| 8. Cleaning Brush                | 17. Option interface              |
| 9. Release button                |                                   |

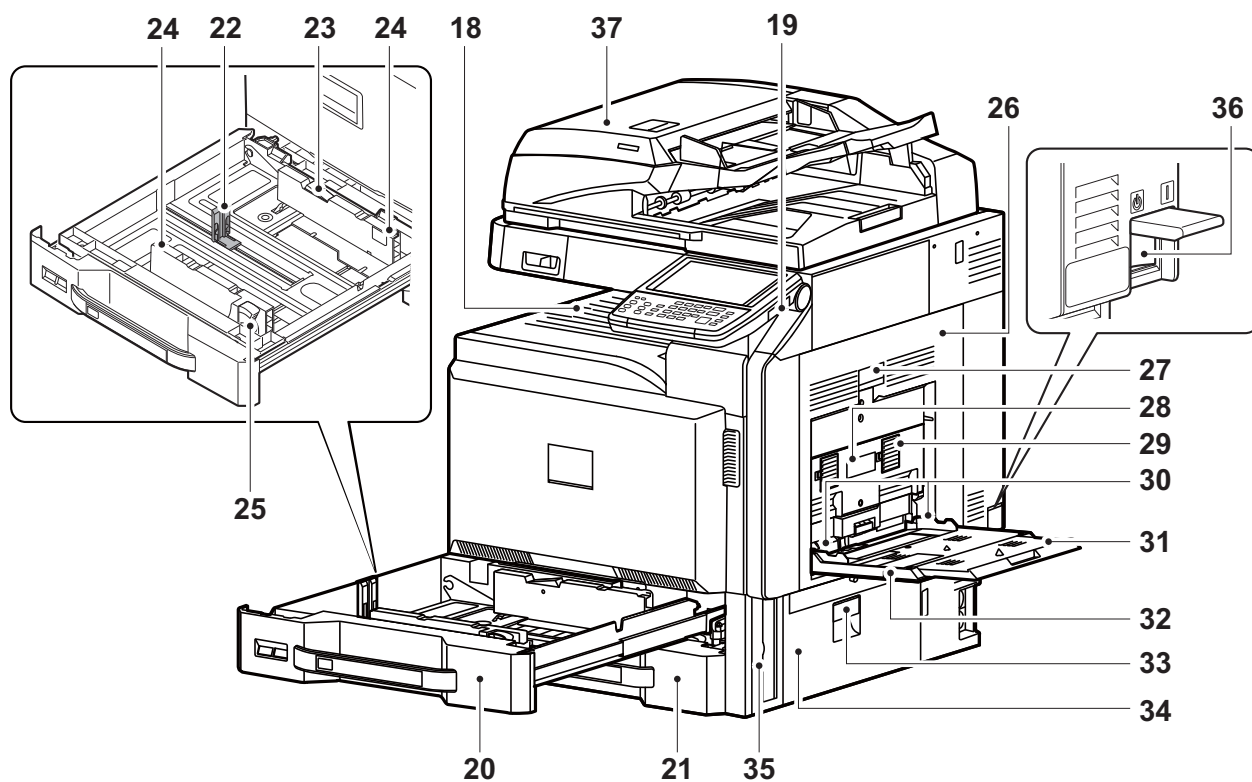
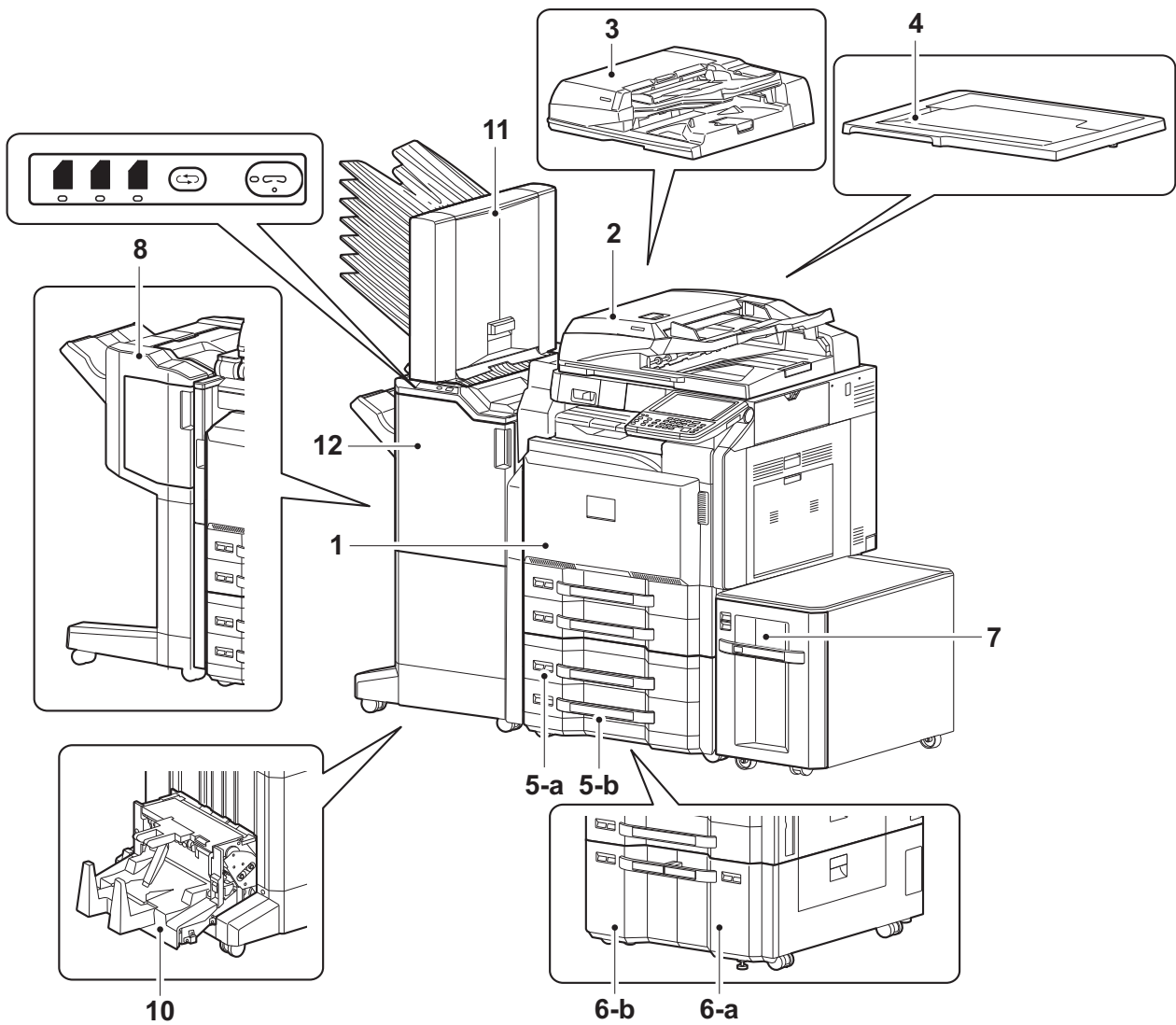


Figure 1-1-2

- |                                 |                                 |
|---------------------------------|---------------------------------|
| 18. Inner tray                  | 28. Duplex cover lever          |
| 19. Document processor (option) | 29. Duplex cover                |
| 20. USB port                    | 30. MP paper width guide        |
| 21. Cassettes                   | 31. MP support Tray             |
| 22. Paper length guide          | 32. MP (Multi-Purpose) tray     |
| 23. Guide lock lever            | 33. Paper conveying cover lever |
| 24. Paper width guide           | 34. Paper conveying cover       |
| 25. Paper width adjusting tab   | 35. Handle                      |
| 26. Paper conveying unit        | 36. Main power switch           |
| 27. Paper conveying unit lever  | 37. Document processor (option) |

**(2) Option****Figure 1-1-3**

- |                                      |                         |
|--------------------------------------|-------------------------|
| 1. Machine                           | 7. Side deck            |
| 2. Document processor (dual scan DP) | Cassette 5              |
| 3. Document processor (reversed DP)  | 8. 1000-sheet finisher  |
| 4. Original cover                    | 9. 4000-sheet finisher  |
| 5. Paper feeder                      | 10. Center-folding unit |
| a: Cassette 3                        | 11. Mailbox             |
| b: Cassette 4                        |                         |
| 6. Large capacity feeder             |                         |
| a: Cassette 3                        |                         |
| b: Cassette 4                        |                         |

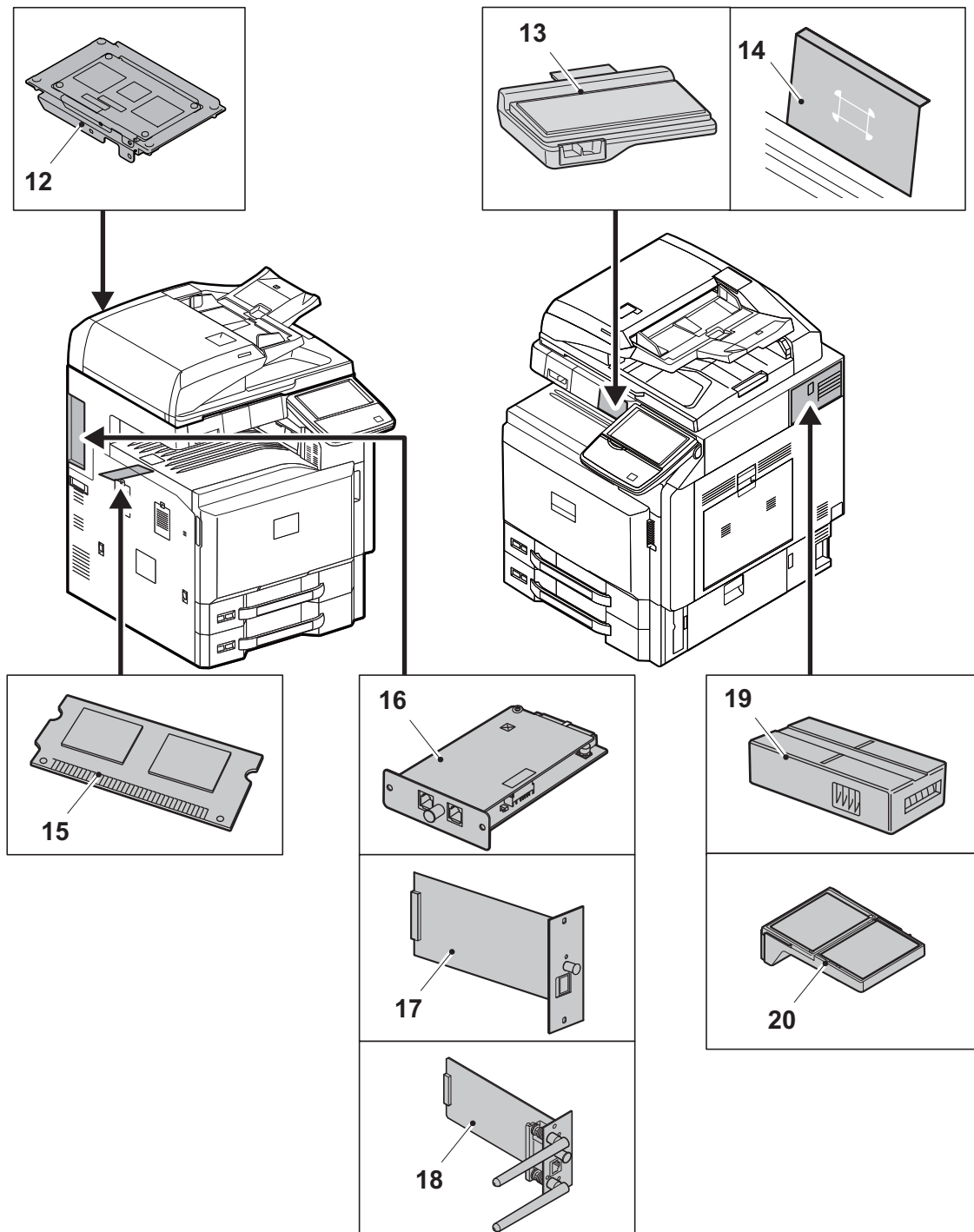


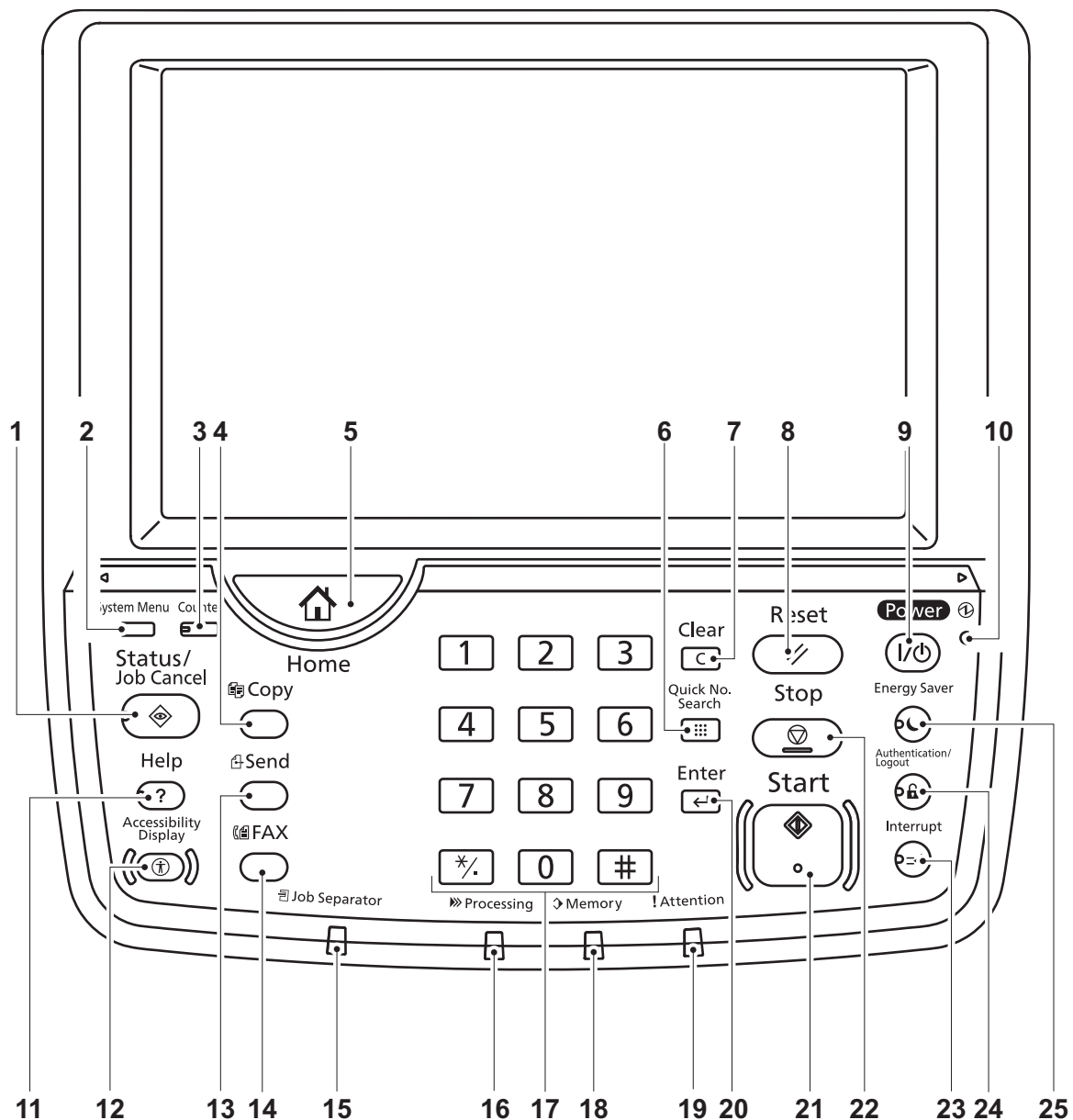
Figure 1-1-4

- 12. Printed document guard kit
- 13. Keyboard holder
- 14. IC card reader holder
- 15. Expansion memory for Fax
- 16. Fax kit
- 17. Gigabit ethernet board
- 18. Wire-less interface kit

- 19. Key counter
- 20. Document table

**Software option**

- 1. Data Security Kit
- 2. Internet FAX Kit
- 3. Card Authentication Kit
- 4. ThinPrint Option
- 5. Emulation Upgrade Kit
- 6. Scan extension kit

**(3) Operation panel****Figure 1-1-5**

- |                          |                               |                               |
|--------------------------|-------------------------------|-------------------------------|
| 1. Status/Job cancel key | 10. Main power indicator      | 19. Attention indicator       |
| 2. System menu key       | 11. Help key                  | 20. Enter key                 |
| 3. Counter key           | 12. Accessibility display key | 21. Start key                 |
| 4. Copy key              | 13. Send key                  | 22. Stop key                  |
| 5. Home key              | 14. FAX key                   | 23. Interrupt key             |
| 6. Quick no. search key  | 15. Jobseparator indicator    | 24. Authentication/Logout key |
| 7. Clear key             | 16. Processing indicator      | 25. Energy saver key          |
| 8. Reset key             | 17. Numeric keys              |                               |
| 9. Power key             | 18. Memory indicator          |                               |

### 1-1-3 Machine cross section

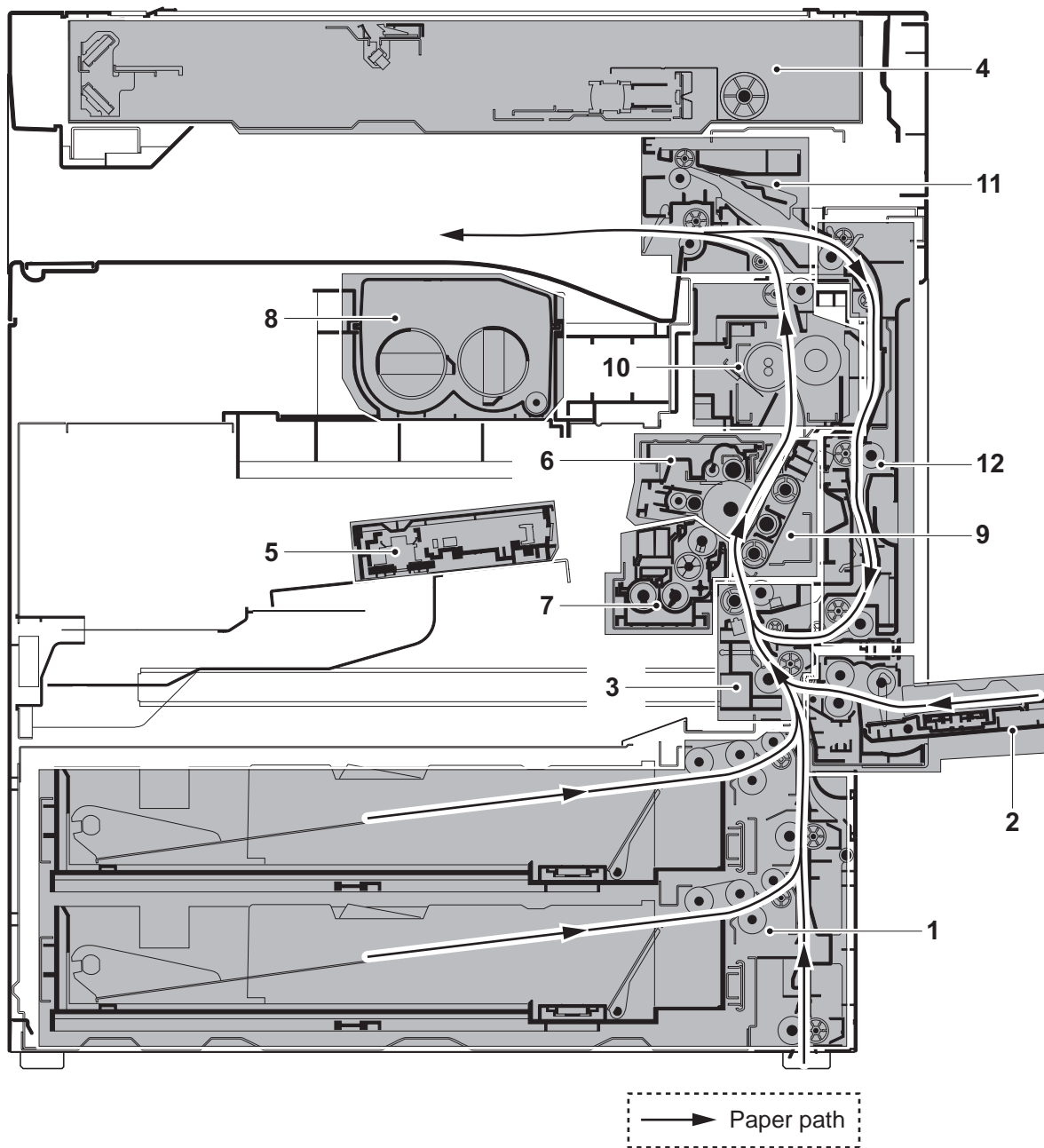


Figure 1-1-6

- |                                |                                 |
|--------------------------------|---------------------------------|
| 1. Cassette paper feed section | 7. Developer unit               |
| 2. MP tray paper feed section  | 8. Toner container section      |
| 3. Paper conveying section     | 9. Transfer/Separation sections |
| 4. Optical section             | 10. Fuser section               |
| 5. Laser scanner unit          | 11. Eject/Feed shift sections   |
| 6. Drum unit                   | 12. Duplex section              |

This page is intentionally left blank.



## 1-2-1 Installation environment

1. Temperature: 10 to 32.5°C/50 to 90.5°F  
(But humidity should be 70% or less when temperature is 90.5 °F (32.5 °C).)
2. Humidity: 15 to 80% RH  
(But temperature should be 86 °F (30 °C) or less when humidity is 80%.)  
\*: Use coated paper at a temperature of 80.6 °F (27°C) or less and a humidity of 60% or less.  
Adverse environmental conditions may affect the image quality. It is recommended to use the machine at a temperature: around 60.8 to 80.6 °F or less (16 to 27 °C), humidity: around 36 to 65%. In addition, Avoid the following locations when selecting a site for the machine.  
The machine automatically detects and displays the following message when the environmental temperature is too high or too low.  
\*: Message: "Warning for high temperature. Adjust the room temperature." or "Warning for low temperature. Adjust the room temperature."  
To use the machine under optimum conditions, adjust the temperature and the humidity of your room if the message is displayed.
3. Power supply: 120 V AC, 12.0 A                      220 - 240 V AC, 7.2 A
4. Power source frequency: 50 Hz ± 2%/60 Hz ± 2%
5. Installation location  
Avoid direct sunlight or bright lighting. Ensure that the photoconductor will not be exposed to direct sunlight or other strong light when removing paper jams.  
Avoid locations subject to high temperature and high humidity or low temperature and low humidity; an abrupt change in the environmental temperature; and cool or hot, direct air.  
Avoid places subject to dust and vibrations.  
Choose a surface capable of supporting the weight of the machine.  
Place the machine on a level surface (maximum allowance inclination: 1°).  
Avoid air-borne substances that may adversely affect the machine or degrade the photoconductor, such as mercury, acidic or alkaline vapors, inorganic gasses, NOx, SOx gases and chlorine-based organic solvents.  
Select a well-ventilated location  
\*: .If the floor is delicate against casters, when this machine is moved after installation, the floor material may be damaged.  
\*: During copying, some ozone is released, but the amount does not cause any ill effect to one's health. If, however, the machine is used over a long period of time in a poorly ventilated room or when making an extremely large number of copies, the smell may become unpleasant.  
To maintain the appropriate environment for copy work, it is suggested that the room be properly ventilated.
6. Allow sufficient access for proper operation and maintenance of the machine.  
Machine front: 100 cm/39 3/8" Machine rear: 10 cm/ 3 15/16"  
Machine right: 35 cm/13 3/4" Machine left: 30 cm/11 13/16" Machine top: 40 cm/15 3/4"

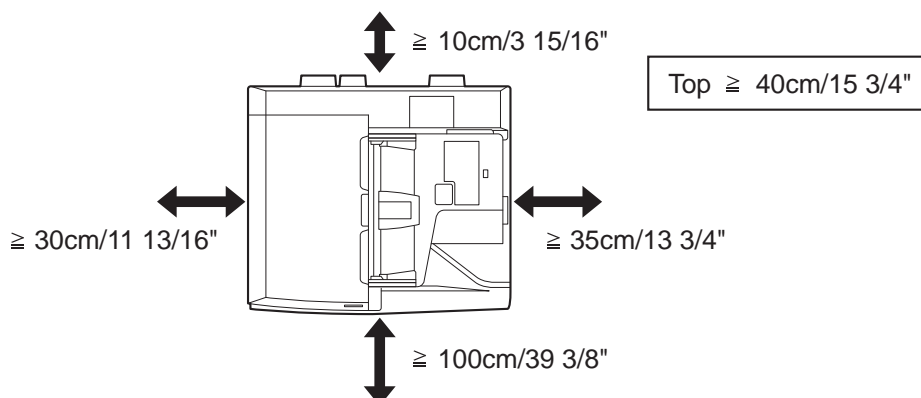
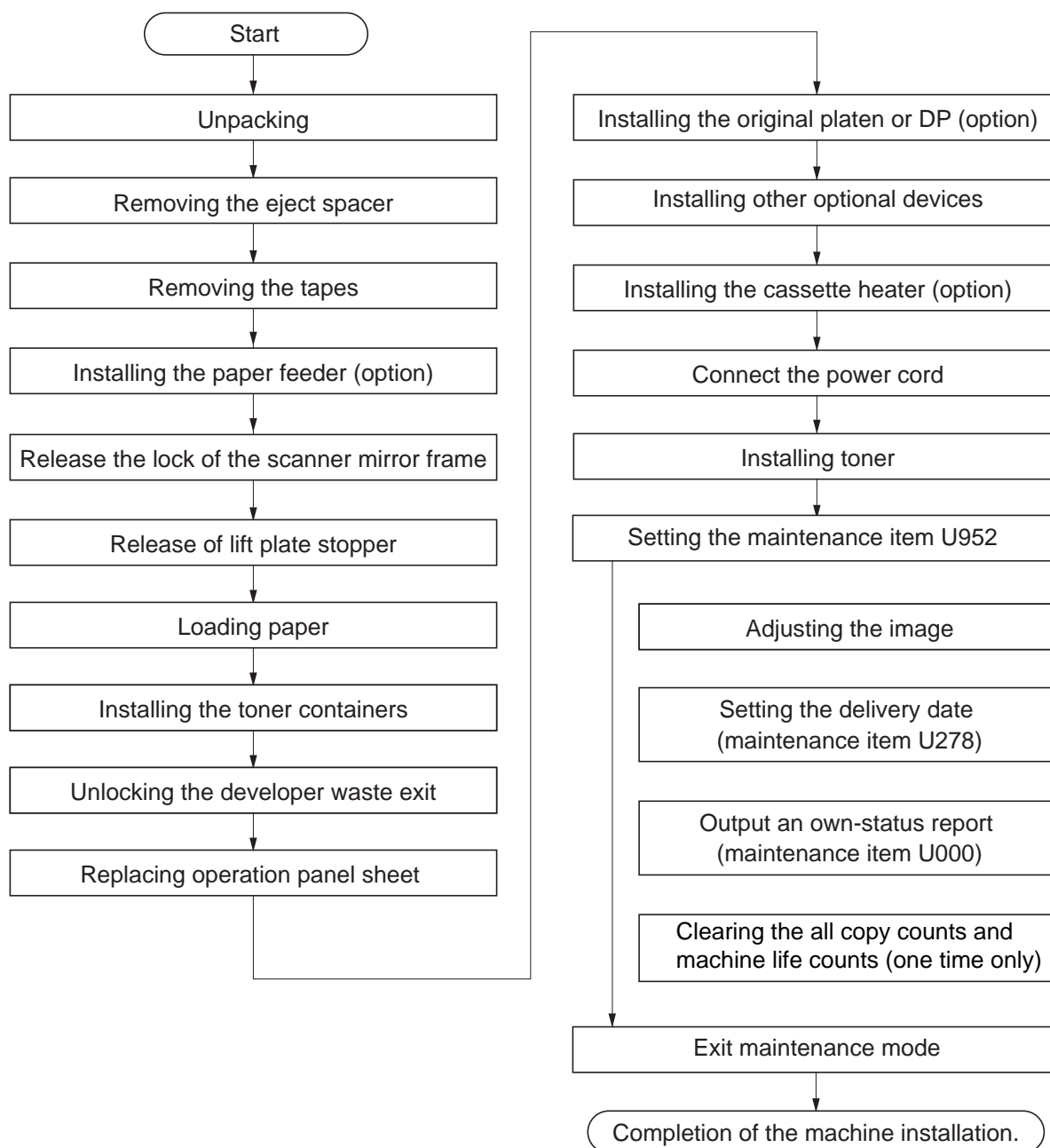


Figure 1-2-1

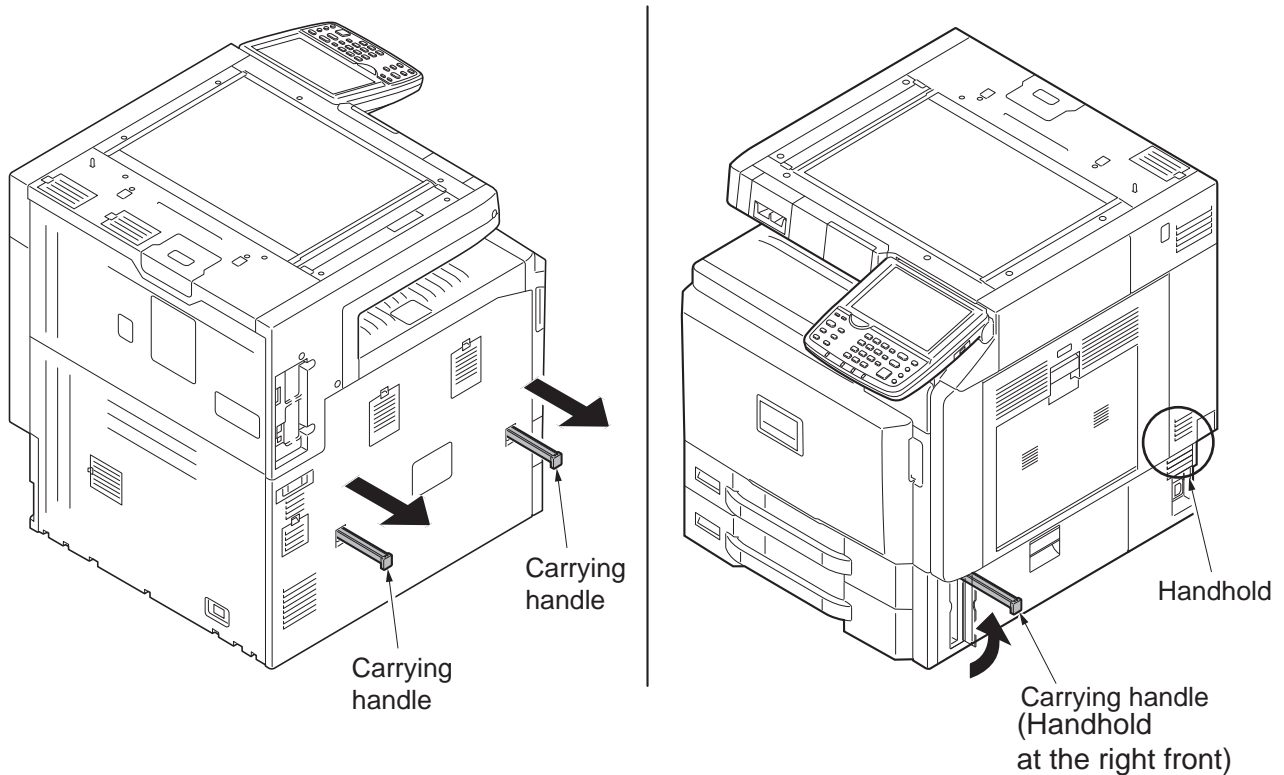
## 1-2-2 Unpacking and installation

### (1) Installation procedure



**Moving the machine**

When moving the machine, pull out three carrying handles, and move with carrying handles and the handhold.



**Figure 1-2-2**

\*: Use the handhold at the right front only for lifting the machine. Use the handhold on the right side only for carrying the machine by lifting it up. (Do not incline the machine for more than 30 degrees.)

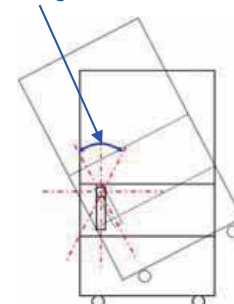
\*: Do not use the handhold at the right front to pull the machine around. Do not use the right-side handhold to move the machine horizontally on the floor. (To prevent deformation due to horizontal stress)

<Allowable angle of the right front handhold positions>

The handhold at the right front side must be lifted only upward at an angle of 30 degrees back and forth.

Do not use the handhold to incline or move the machine sideways.

Allowable range (±30degree front and backwards)



Position of the handhold seen from the right side of the machine

**Figure 1-2-3**

Unpacking

230V model

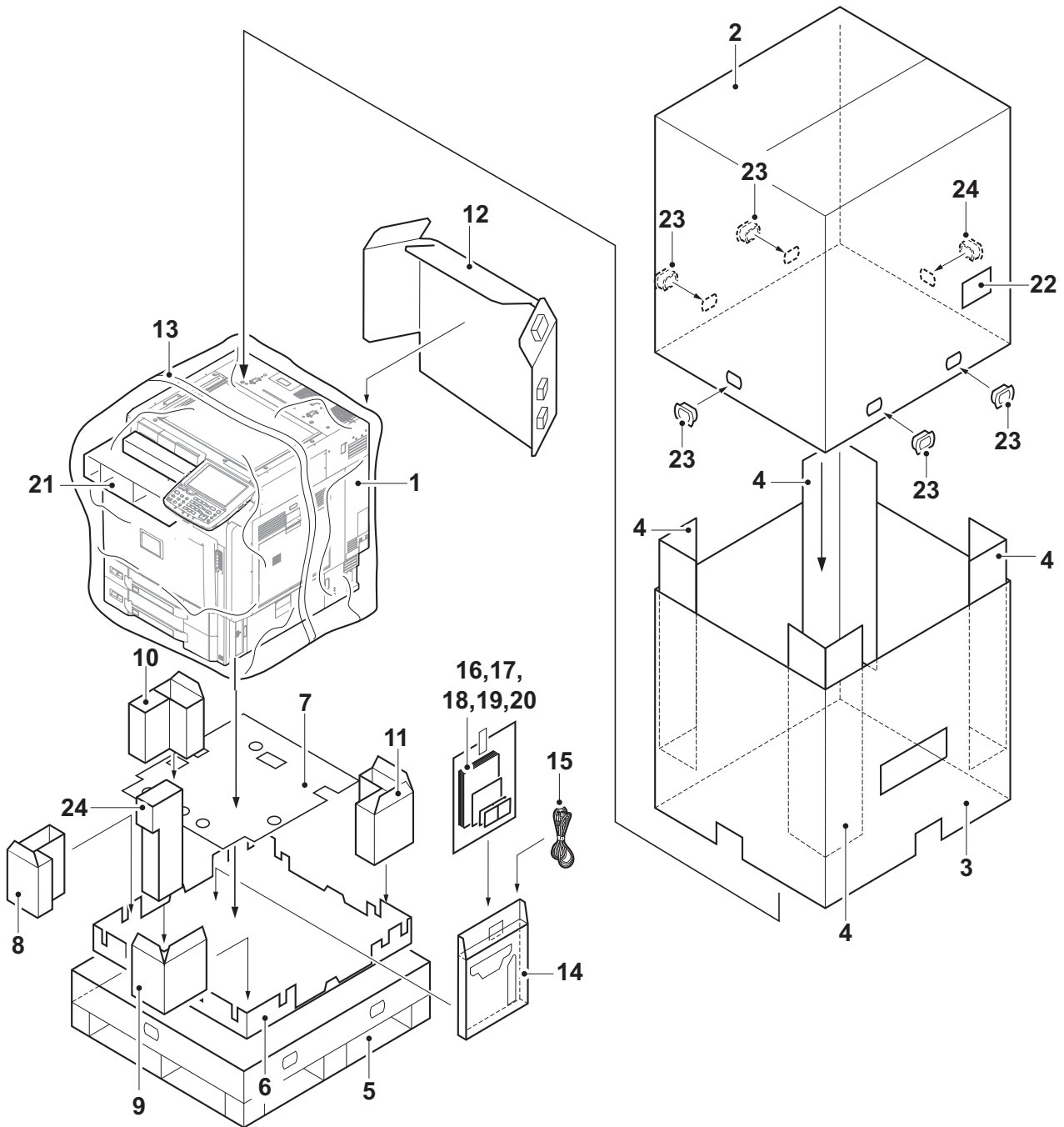


Figure 1-2-4

- |                          |                           |                            |
|--------------------------|---------------------------|----------------------------|
| 1. Machine               | 9. Bottom front right pad | 17. Paper size plates      |
| 2. Outer case            | 10. Bottom rear left pad  | 18. Paper media plates     |
| 3. Inner case            | 11. Bottom rear right pad | 19. Operation panel sheets |
| 4. Side stays            | 12. TopRear pad           | 20. Operation guide etc.   |
| 5. Skid                  | 13. Machine cover         | 21. Eject spacer           |
| 6. Bottom pad            | 14. Document tray         | 22. Barcode label          |
| 7. Bottom sheet          | 15. Power cord            | 23. Hinge joints           |
| 8. Bottom front left pad | 16. Plastic bag           | 24. Side pad               |

120V model

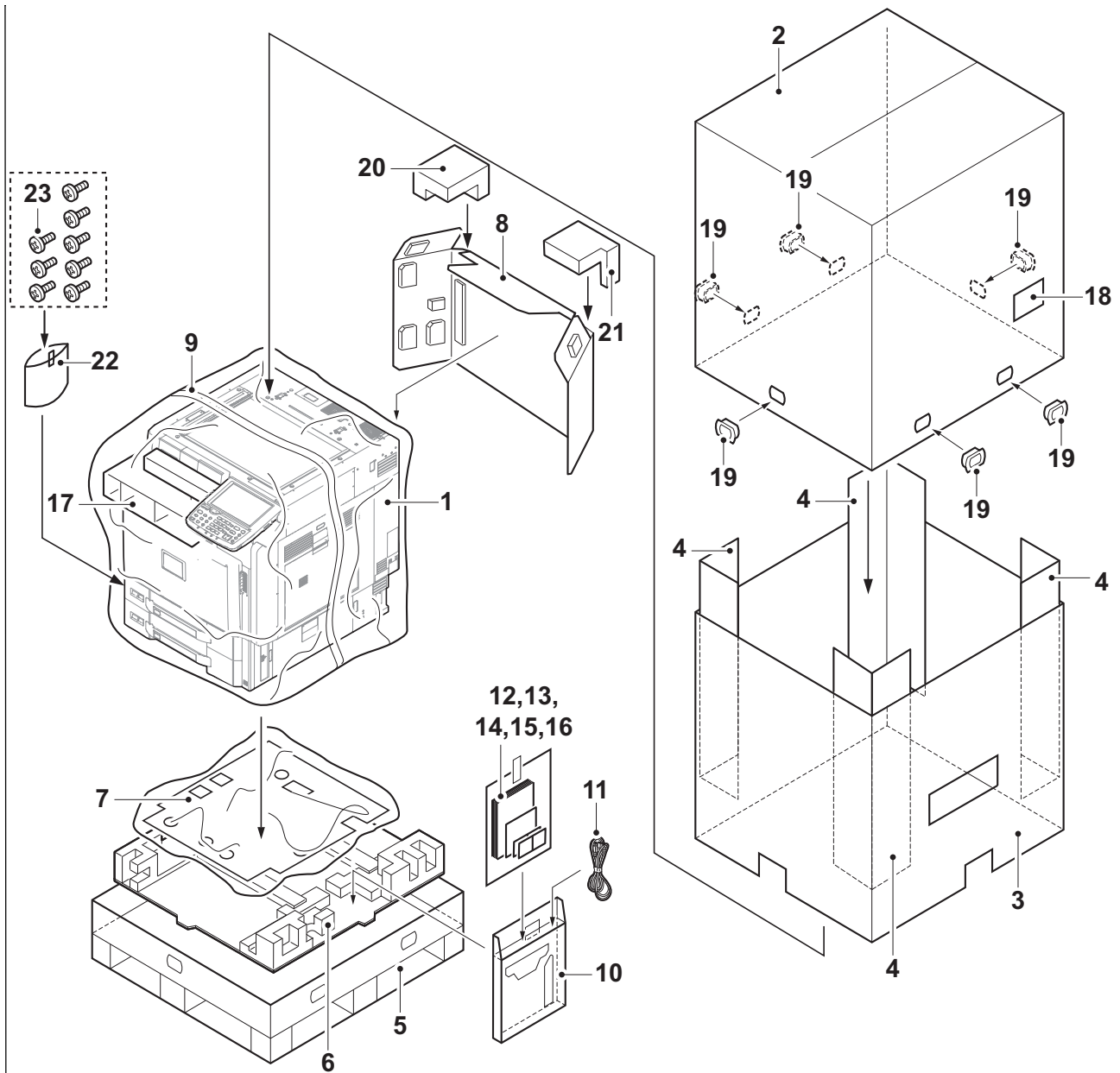


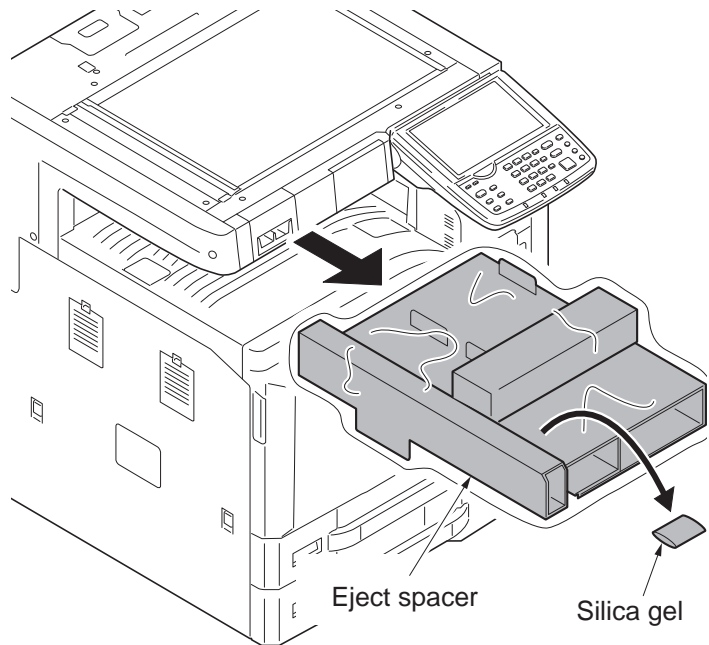
Figure 1-2-5

- |                 |                            |                   |
|-----------------|----------------------------|-------------------|
| 1. Machine      | 9. Machine cover           | 17. Eject spacer  |
| 2. Outer case   | 10. Document tray          | 18. Barcode label |
| 3. Inner case   | 11. Power cord             | 19. Hinge joints  |
| 4. Side stays   | 12. Plastic bag            | 20. Top left pad  |
| 5. Skid         | 13. Paper size plates      | 21. Top right pad |
| 6. Bottom pad   | 14. Paper media plates     | 22. Plastic bag   |
| 7. Bottom sheet | 15. Operation panel sheets | 23. M3 x 8 screws |
| 8. Top pad      | 16. Operation guide etc.   |                   |

Place the machine on a level surface.

### Removing the eject spacer

1. Remove the eject spacer and silica gel from the eject section.

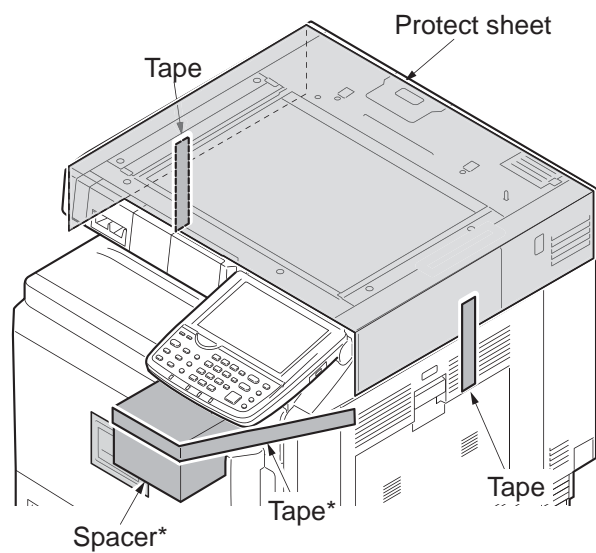


**Figure 1-2-6**

### Removing the tapes

1. Remove two tapes and then remove three protect sheets.

\*: If the spacer is attached:  
Remove the tape and then remove the spacer.



**Figure 1-2-7**

2. Remove the tape and then remove the ISU lock leaflet.
3. Remove two tapes and then remove A2 paper.
4. Remove four tapes and then remove three protect sheets.
5. Remove three tapes and then remove three protect cover.

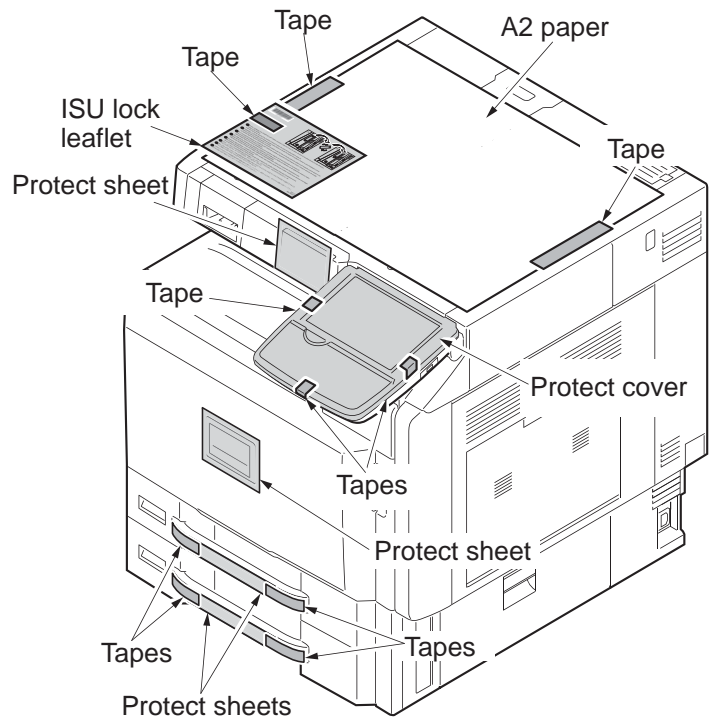


Figure 1-2-8

6. Remove seven tapes.

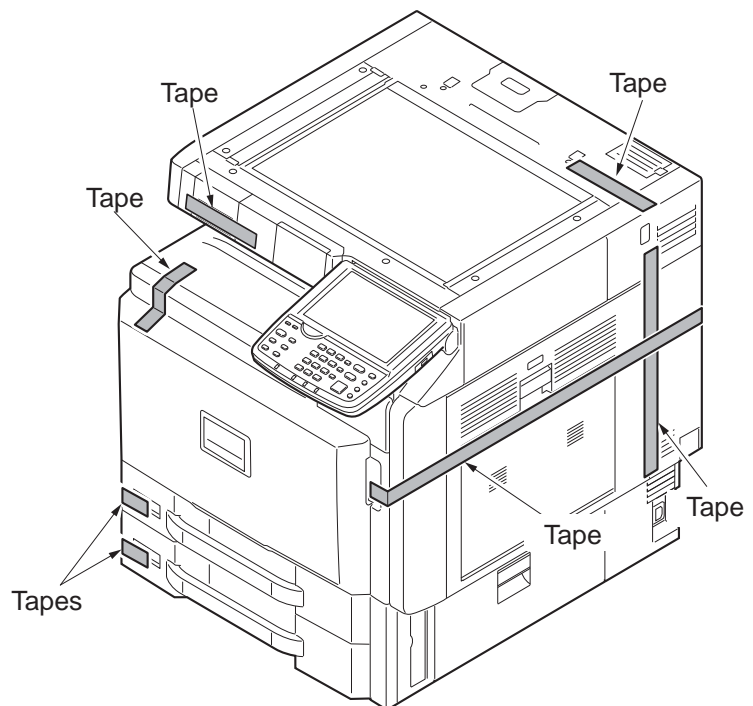


Figure 1-2-9

- 7. Pull the cassette 2 forward.
- 8. Remove two tapes.

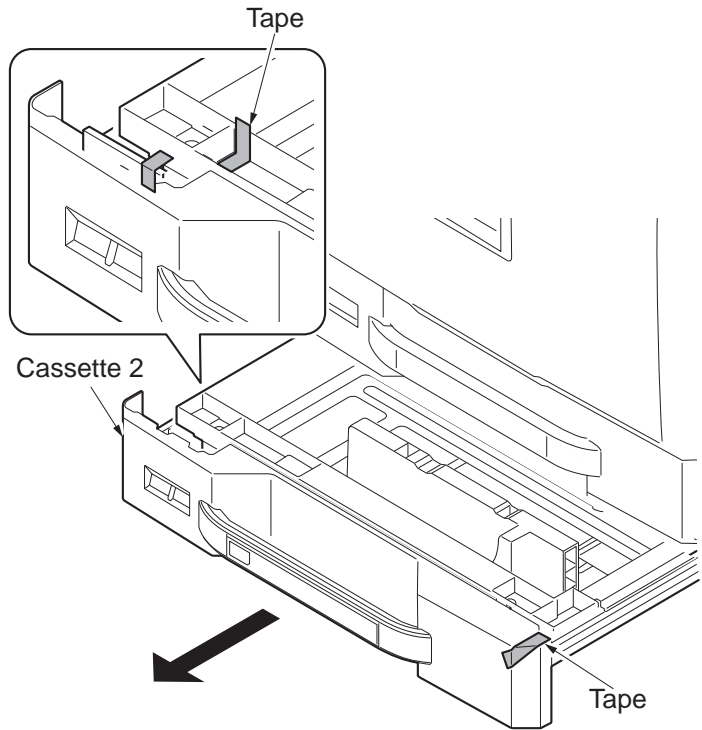


Figure 1-2-10

- 9. Pull the cassette 1 forward.
- 10. Remove two tapes.

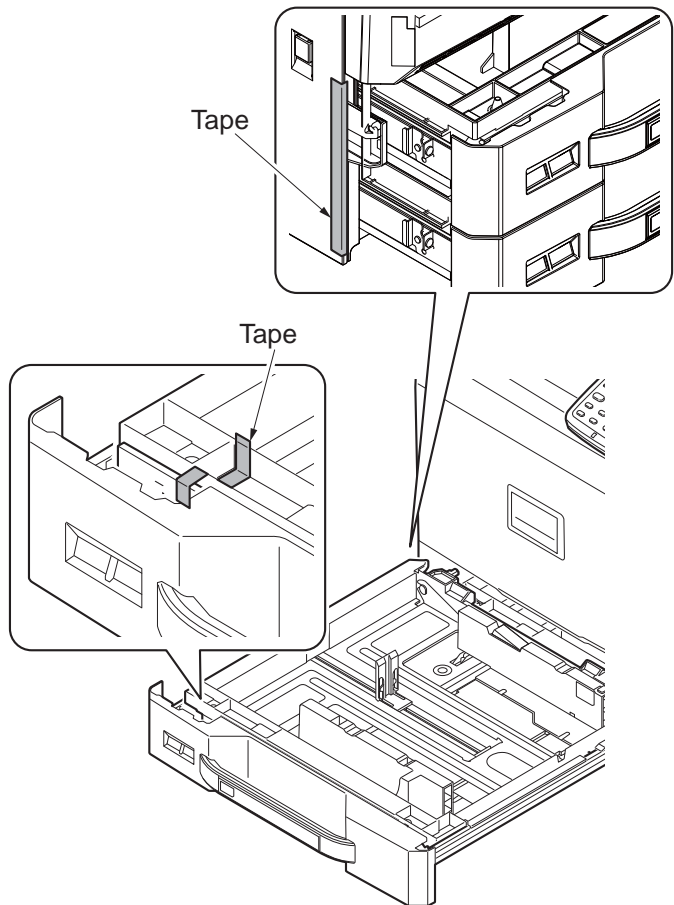


Figure 1-2-11

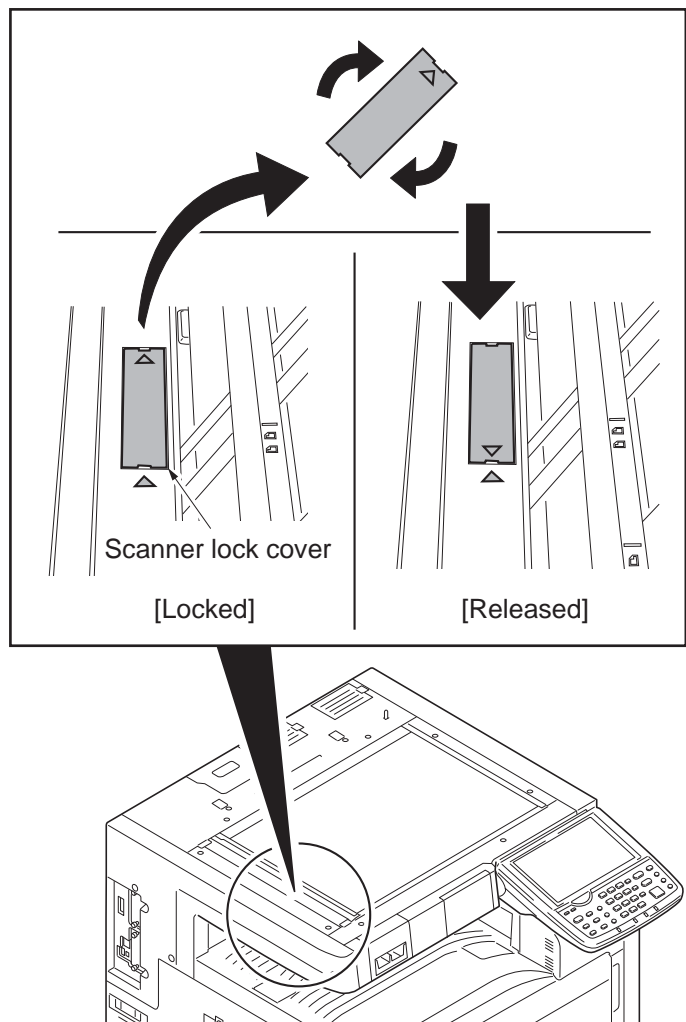


### Installing the paper feeder (option)

1. Install the optional paper feeder or large capacity feeder as necessary.
2. Verify levelness at the four corners of the contact glass using a level gauge, and adjust the level bolts at the bottom of the machine to optimize levelness.

### Release the lock of the scanner mirror frame

1. Remove the scanner lock cover.
  2. Mount the scanner lock cover in the reverse manner to restore in the original location.
- \*: Unless unlocking is performed, C3100 is caused.

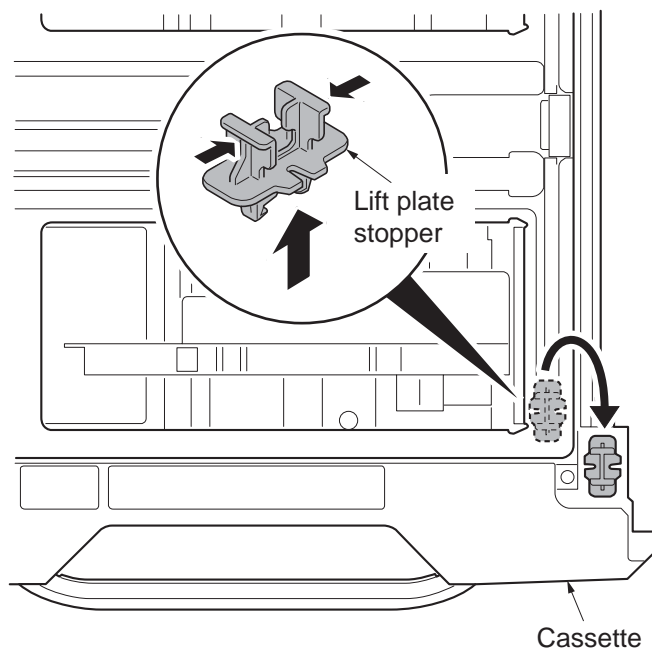


**Figure 1-2-12**

### Release of lift plate stopper

1. Pull cassette 1 and 2 out. Remove the lift plate stopper from each cassette and attach it to the storage location.

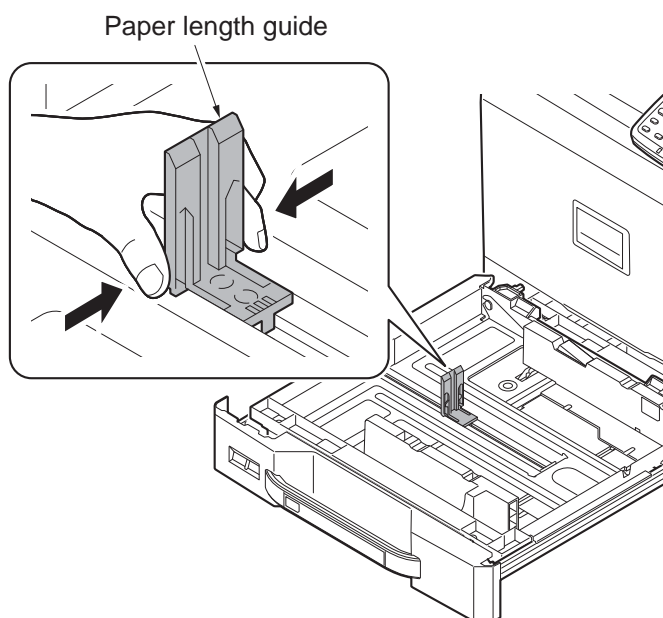
\*: When moving the machine, attach the lift plate in original position.



**Figure 1-2-13**

### Loading paper

1. Squeeze the ends of the bottom of the paper length guide and move the guide to fit the length of the paper.



**Figure 1-2-14**

2. Press the guide lock lever to release the lock.
3. Grasp the paper width adjusting tab and move the paper width guides to fit the paper.

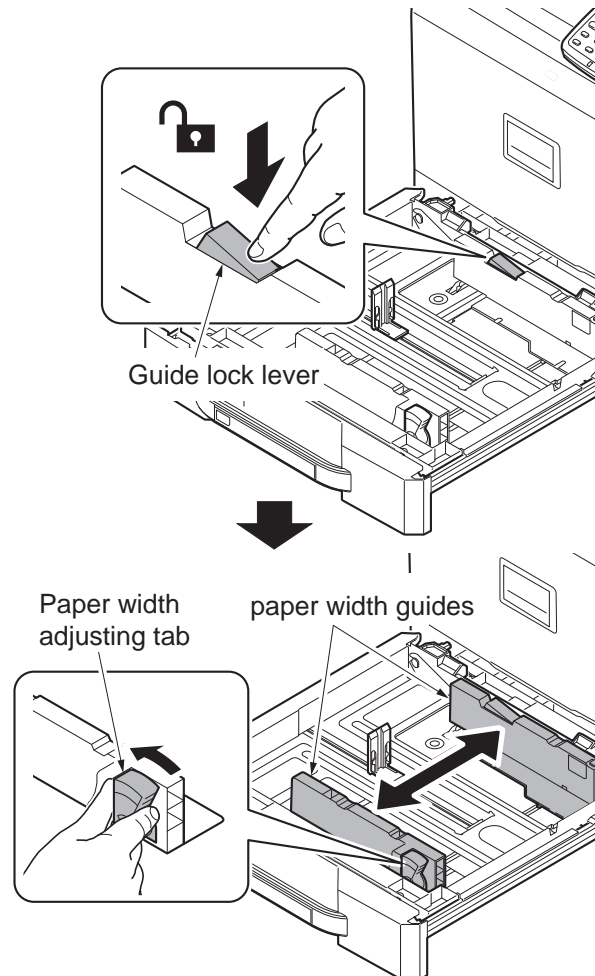


Figure 1-2-15

4. Align the paper flush against the right side of the cassette.
- \*: Before loading the paper, be sure that it is not curled or folded.
  - \*: Ensure that the loaded paper does not exceed the level indicated.
  - \*: Make sure that the paper length guide and the paper width guides are correctly abut with the paper. Be sure to remove spaces between the guides and the paper.

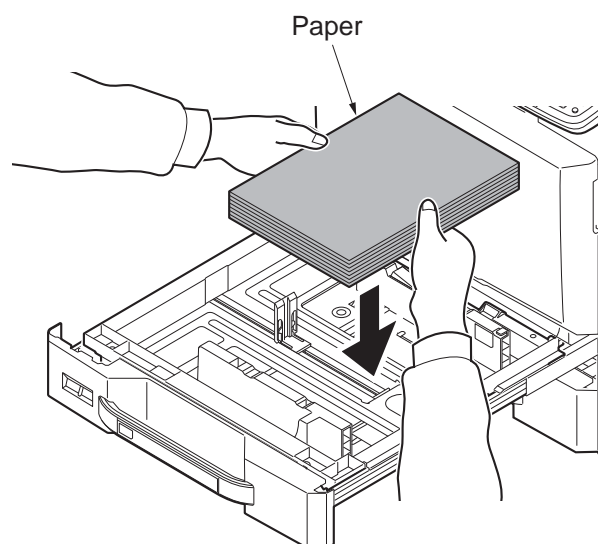


Figure 1-2-16

5. Press the guide lock lever to lock.

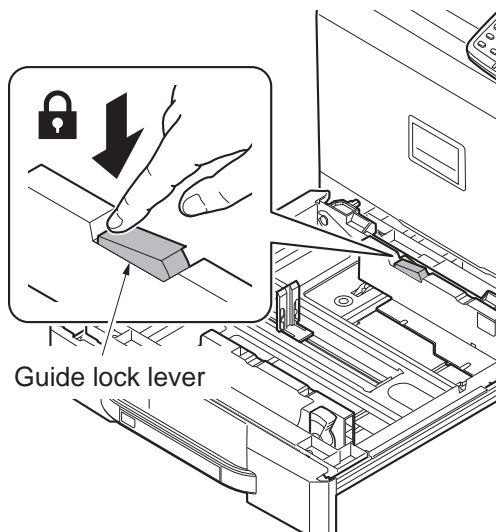


Figure 1-2-17

- 6. Insert the paper size plate and the paper media plate.
- 7. Gently push the cassette back in.

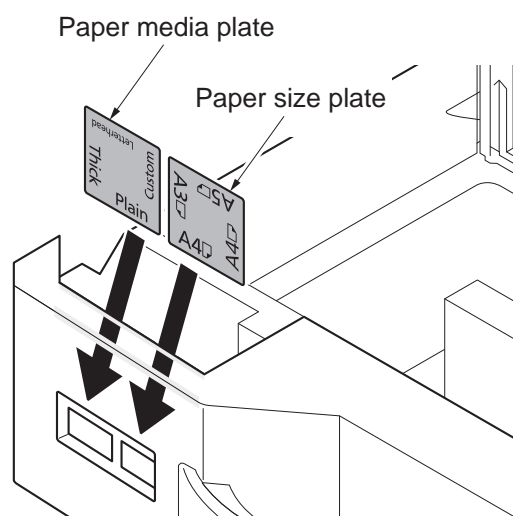
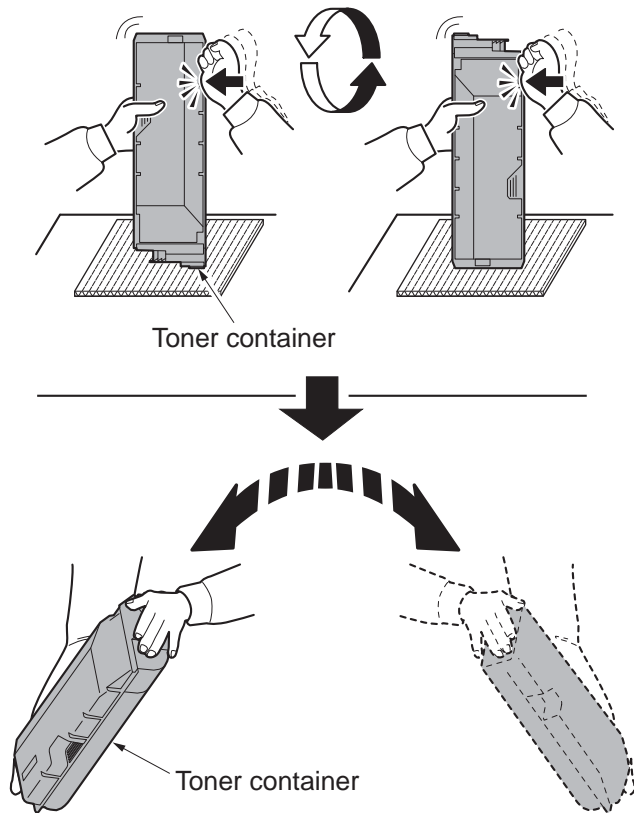


Figure 1-2-18

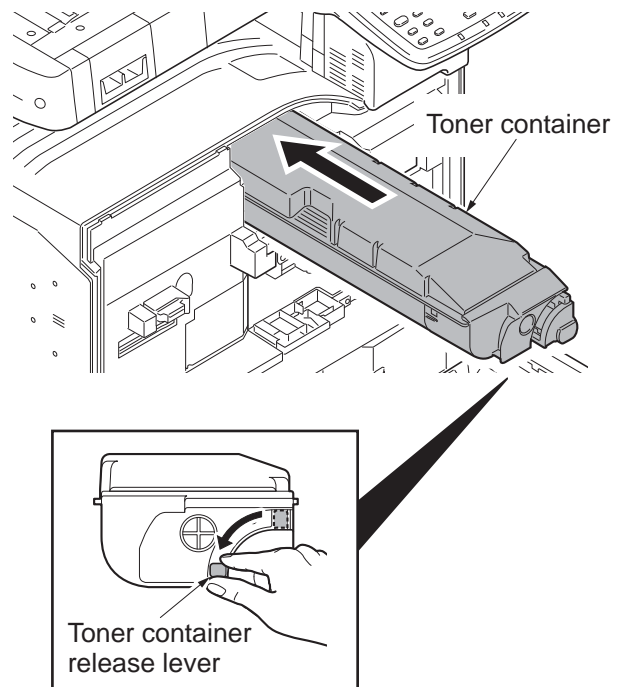
### Installing the toner containers

1. Open the front cover.
2. Hold the toner container vertically and hit the upper part about 5 times. Invert the toner container so that the other end is up, and hit in the same way.
3. Shake the toner container in a wide vertical curve like motion about 5 times.



**Figure 1-2-19**

4. Install the toner container.
5. Turn down the toner container release lever to lock the toner container.



**Figure 1-2-20**

## Unlocking the developer waste exit

### Caution

To ease setup, the device was shipped with the developer unit already replenished with developer. Therefore, to prevent developer from spilling during shipping, a developer shutter is equipped with the developer unit.

To disengage the shutter, use the following procedure: Note that if the shutter is not completely disengaged and retained in place, the developer in the developer unit may clog at the outlet causing a damage to the developer unit.

1. Remove the tape and then remove the set up leaflet.
- \*: The setup leaflet must be affixed in position before dispatching the machine.
2. Press the fixing pin and rotate.
- \*: Fully insert the fixing pin with keeping the protrusions vertical and rotate it by 90 degrees clockwise. Make sure that the protrusions are then horizontal.

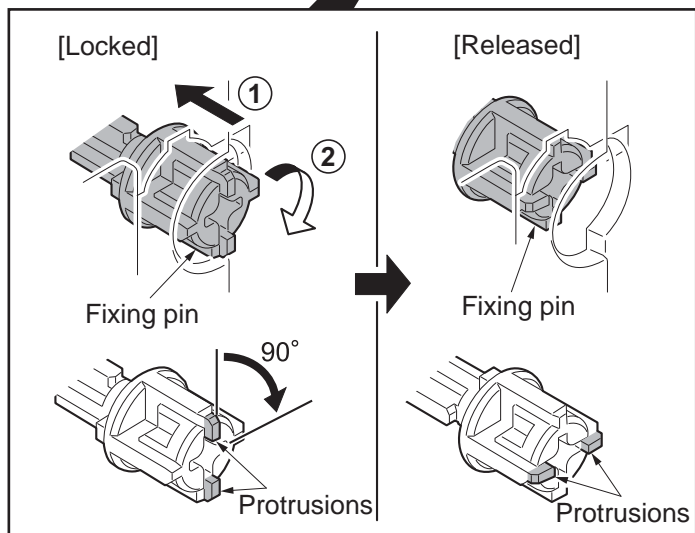
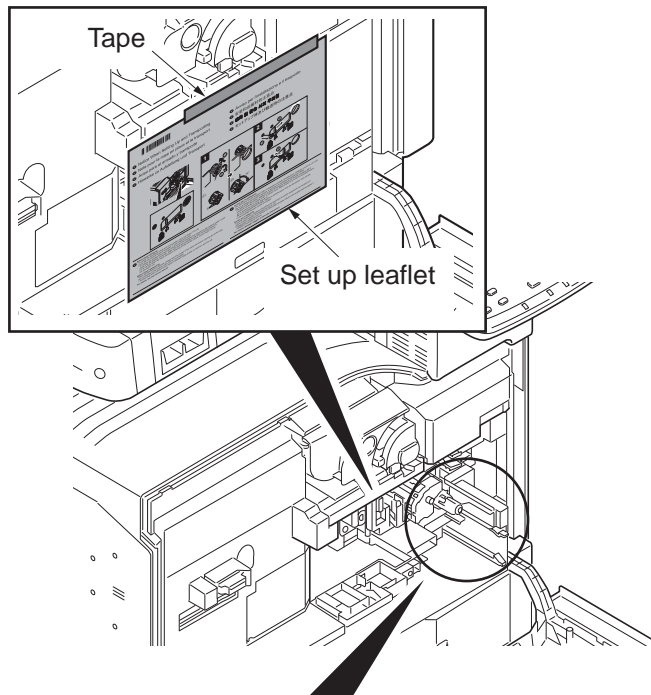


Figure 1-2-21

3. Remove a screw and slide the lever right wards.
  4. Fix the lever using the screw previously removed at the right screw hole and unlock the developer waste exit.
- \*: When the device is shipped again or removed, use the reverse procedure to lock in the developer waste exit. Failure to observe this caution could result in deteriorated print quality and/or C call (C7460).

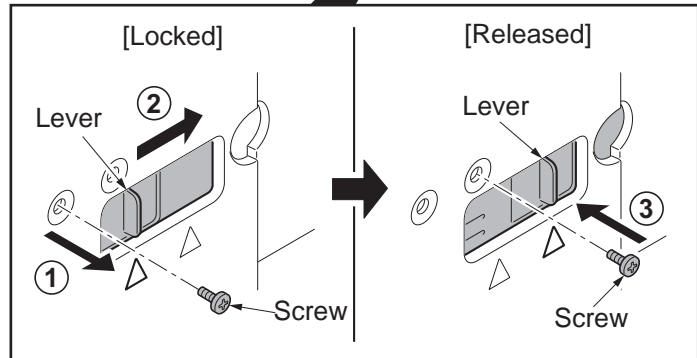
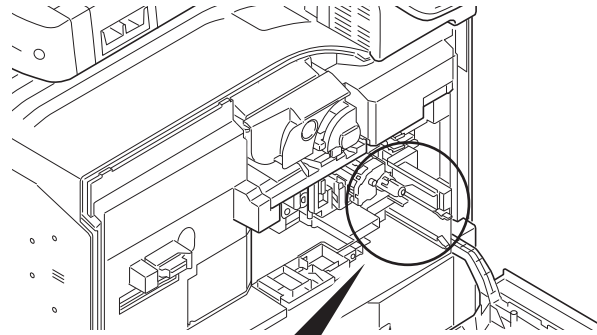


Figure 1-2-22

#### Replacing operation panel sheet

1. Insert a flat-head screwdriver and slide the operation panel covers A and B to remove them.

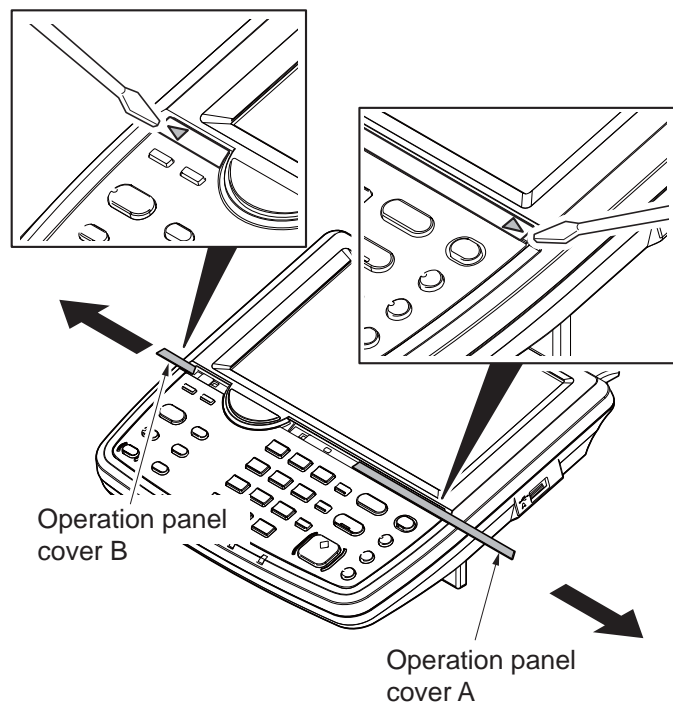
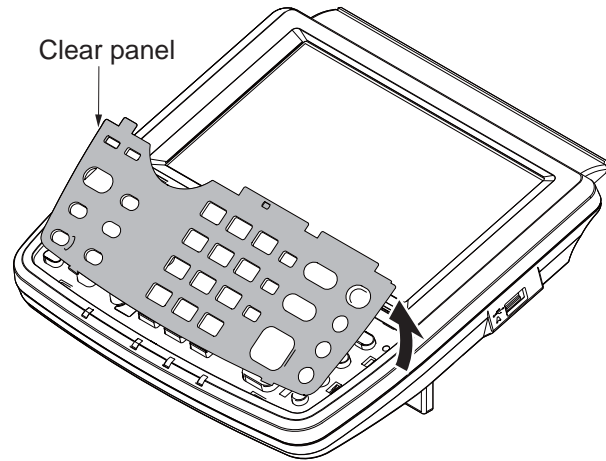


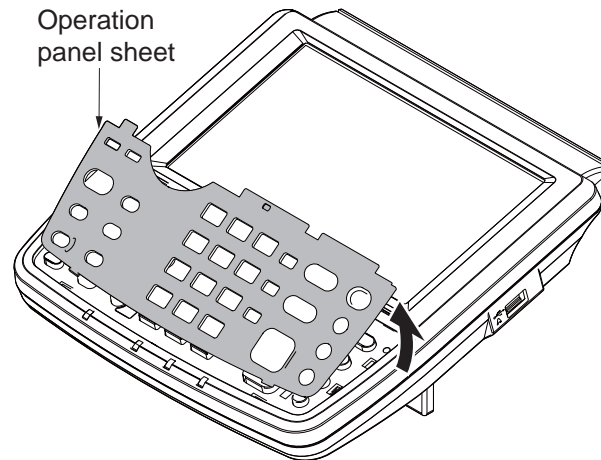
Figure 1-2-23

2. Remove the clear panel.



**Figure 1-2-24**

3. Remove the operation panel sheet.
4. Replace the operation panel sheet of the corresponding language.
5. Refit the clear panel.
6. Refit the operation panel covers A and B.



**Figure 1-2-25**

Installing the original platen or DP (option)

1. Install optional original platen or DP.

Installing other optional devices

1. Install the optional devices (job separator, document finisher and/or fax kit etc.) as necessary.



#### Installing the cassette heater (option)

1. Install the optional cassette heater as necessary (see page 1-2-65).

#### Connect the power cord

1. Connect the power cord to the power cord connector on rear lower of the machine.
2. Connect the power plug to the wall outlet.

#### Installing toner

1. Turn the main power switch on. Toner installation is started.
2. The drive chain is disengaged when toner installation is completed.  
Run maintenance mode U132 if [Add Toner] remains displayed even after the drive chain is disengaged (see page **1-3-77**).
3. Setup setting at high altitude place.  
When setup is done at high altitude place, execute as follows (such as in Mexico City).  
**35 ppm model/ 45 ppm model**  
U140 - AC Calb - High Altitude  
- 1000/ 2000/ 3000/ 4000m  
**55 ppm model**  
U140 - AC Calb - Calibration  
Result : developing leak image occur (see page **1-4-210**).  
U140 - AC Calib -> Lowering the numerical value of Magnification

#### Setting the maintenance item U952 (see page **1-3-193**)

1. Enter the maintenance mode by entering 10871087 using the numeric keys.
2. Enter 952 using the numeric keys and press the start key.
3. Select [Execute].
4. Select [SETUP].
5. Press the start key.

\*: Running the simulation allows execution histories to be logged.

#### Exit maintenance mode

1. Enter 001 using the numeric keys and press the start key.  
The machine exits the maintenance mode.

#### Completion of the machine installation

\*: The maintenance mode U952 [SETUP] includes the following:  
If U952 is not used, follow the procedure below.

### Adjusting the image

#### 1. Performing calibration

U464 Setting the ID correction operation - performing calibration

#### \*: See the operation guide

Press the System menu key.

Press [Adjustment/Maintenance] and then [Next] of [Calibration].

Press [Execute] to perform calibration. When completed, press [OK].

#### 2. Adjusting the halftone automatically

U410 (see page 1-3-147)

Load the cassette with multiple sheets of A4 or Letter paper.

Enter the maintenance mode by entering 10871087 using the numeric keys.

Enter 410 using the numeric keys and press the start key.

Press [Normal Mode] and then press the start key. A test patterns 1 and 2 are outputted.

Place the output test pattern 1 as the original.

Place approximately 20 sheets of white paper on the test pattern 1 and set them.

Press the start key. Adjustment is made.

Place the output test pattern 2 as the original.

Place approximately 20 sheets of white paper on the test pattern 2 and set them.

Press the start key. Adjustment is made.

[Finish] is displayed in [Phase] when normally completed.

Press the stop key twice to exit.

#### 3. Make test copies

Place an original and make test copies.

If paper is fed skewed, perform the adjustment of skewed paper in the cassette. (see page **1-5-104**)

### Setting the delivery date (maintenance item U278)

1. Enter 278 using the numeric keys and press the start key.
2. Select [Today].
3. Press the start key. The delivery date is set.
4. Press the stop key to exit.

### Output an own-status report (maintenance item U000)

1. Enter 000 using the numeric keys and press the start key.
2. Select [All] and press the start key. A status report is output.

3. Press the stop key to exit.

Clearing the all copy counts and machine life counts (one time only)
--

1. Enter 927 using the numeric keys and press the start key.
2. Select [Execute].
3. Press the start key. All copy counts and machine life counts are cleared.

\*: After completing the settings, back up the data with the U917 maintenance mode.  
This enables data restoration when replacing the main PWB or hard disk drive.

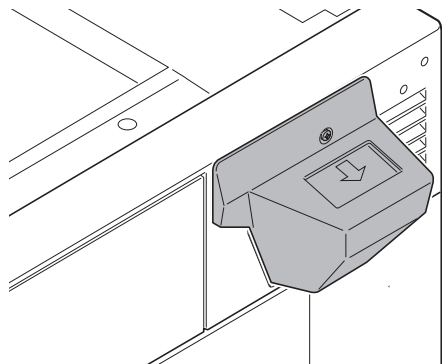
**(2) Setting initial copy modes**

Factory settings are as follows:

<b>Maintenance item No.</b>	<b>Contents</b>	<b>Factory setting</b>
U253	Switching between double and single counts	DBL(A3/Ledger)
U260	Selecting the timing for copy counting	Eject
U285	Setting service status page	On
U323	Setting abnormal temperature and humidity warning	On
U325	Setting the paper interval	Off/1
U326	Setting the black line cleaning indication	On/8
U327	Setting the cassette heater control	Off
U343	Switching between duplex/simplex copy mode	Off

## 1-2-3 Installing the key counter (option)

### (1) Installing directly on the device



Key counter installation requires the following parts:

Parts	Quantity	Part.No.
Key counter	1	3025418011
Key counter set	1	302A369709
Key counter wire	1	302K946AJ0
M4 nut	2	3CY06030

\*: 120V model is unnecessary.(default setting)

### Supplied parts of key counter set (302A369709):

Parts	Quantity	Part.No.
Key counter socket assembly	1	3029236241
Key counter cover retainer	1	302GR03010
Key counter retainer	1	302GR03020
Key counter cover	1	3066060011
Key counter mount	1	3066060041
Edging	2*	7YZM210006++H01
Band	1*	M21AH010
M3 x 8 tap-tight P screw	1*	5MBTPB3008PW++R
M4 x 10 tap-tight P screw	2*	5MBTPB4010PW++R
M4 x 10 tap-tight S screw	2*	5MBTPB4010TW++R
M3 x 6 bronze flat-head screw	2	7BB003306H
M4 x 20 tap-tight S screw	2	7BB100420H
M3 nut	1	7BC1003055++H01
M3 x 8 bronze binding screw	1*	B1B03080
M4 x 30 tap-tight S screw	1*	B1B54300
M4 x 6 chrome TP screw	5	B4A04060
M4 x 10 chrome TP screw	2*	B4A04100

\*:Not used in this model.

### Procedure

1. Press the power key on the operation panel to off. Make sure that the power indicator and the memory indicator are off before turning off the main power switch. And then unplug the power cable from the wall outlet.
2. Fit the key counter socket assembly to the key counter retainer using two M3 x 6 screws and nut.
3. Fit the key counter mount to the key counter cover using two M4 x 6 screws.
4. Fit the key counter retainer to the key counter mount using two M4 x 6 screws.

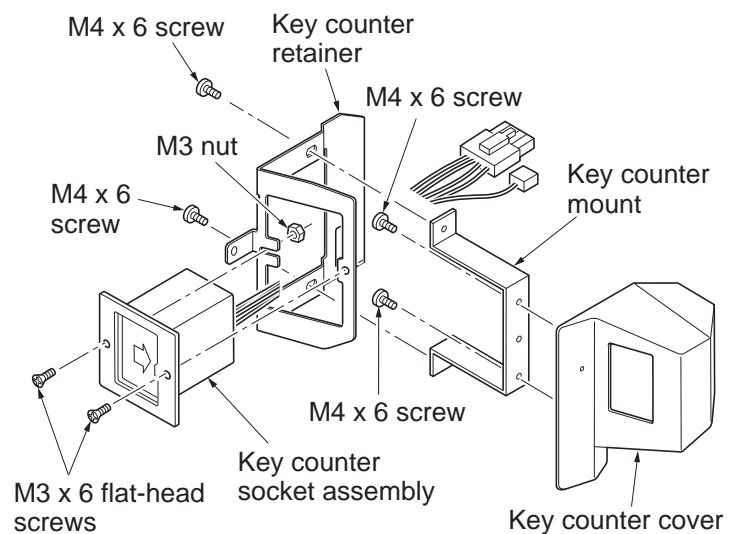


Figure 1-2-26

- \*: For the 120V model, proceed to step 26.
- 5. Pull the paper conveying unit out.
- 6. Remove two screws and then remove the ISU right cover.
- 7. Remove the screw and five hooks and then remove the right upper cover.
- \*: Unlatch the stoppers with the rear bottom one first.

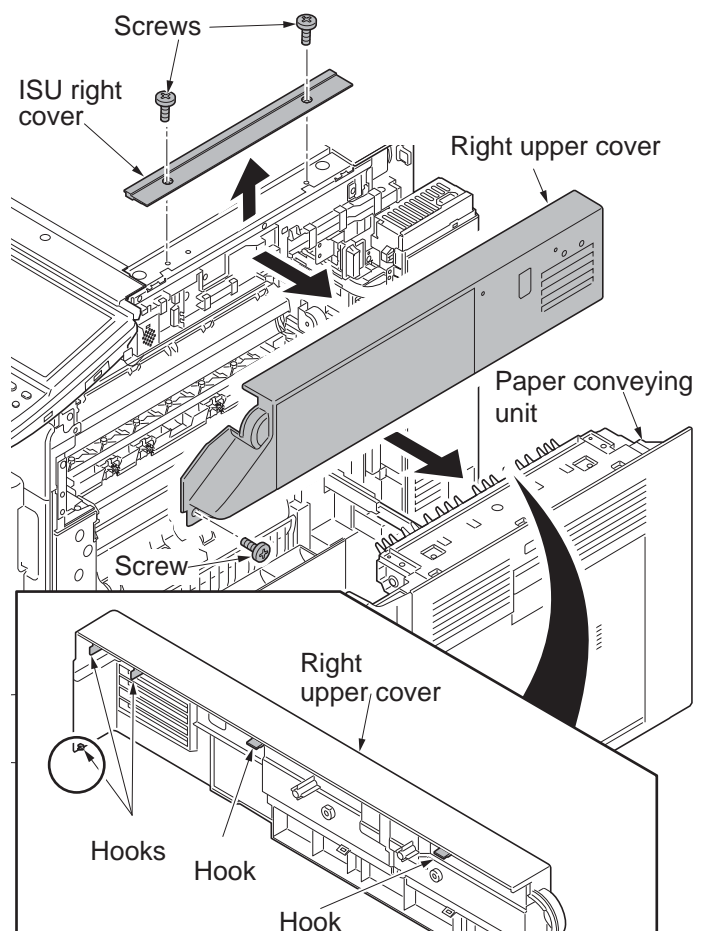
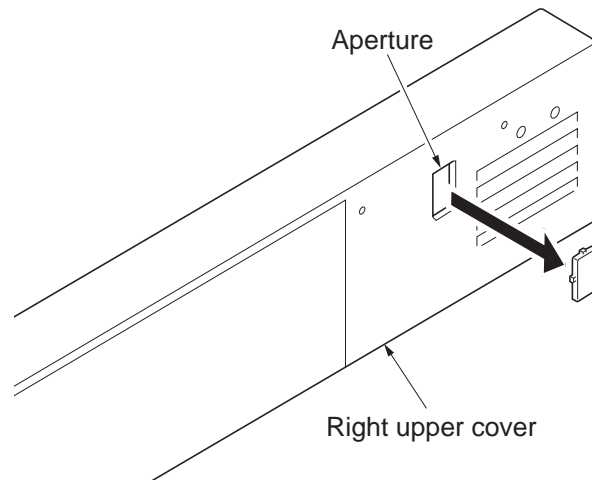
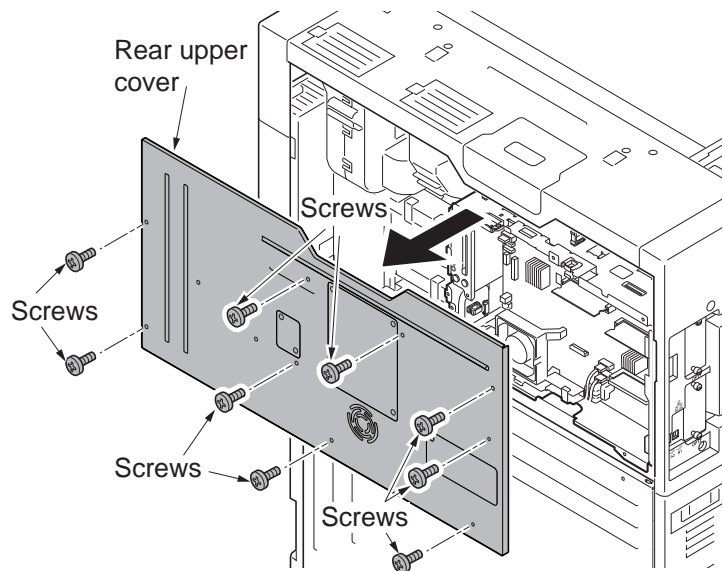


Figure 1-2-27

- Cut out the aperture plate on the right upper cover using nippers.

**Figure 1-2-28**

- Remove nine screws and then remove the rear upper cover.

**Figure 1-2-29**

10. Release seven wire saddles on the controller box.
11. Remove the wire holder.

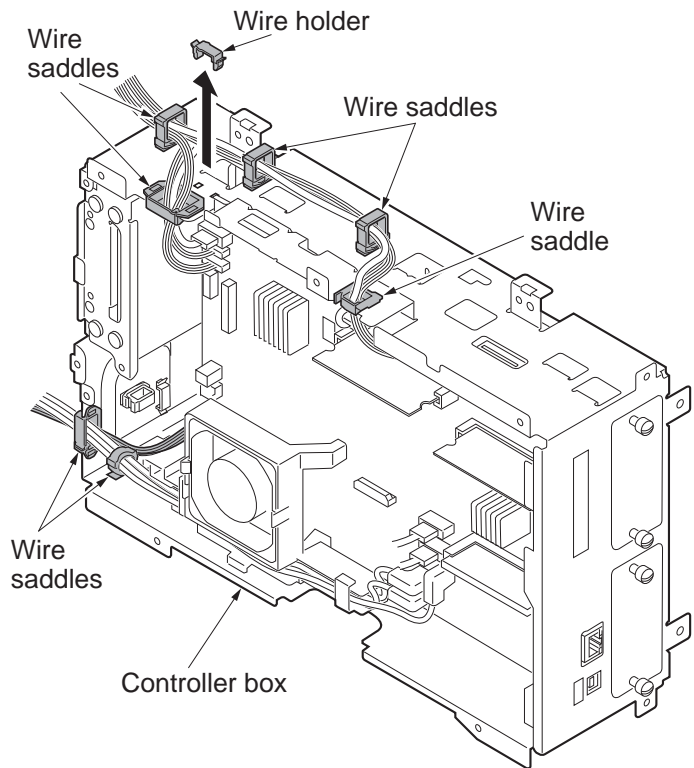
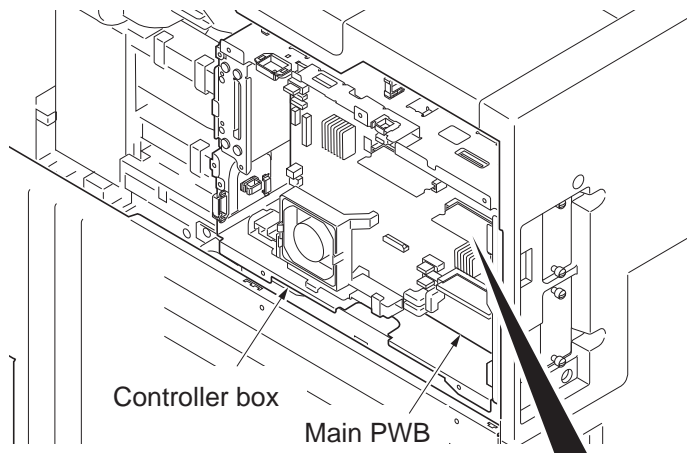
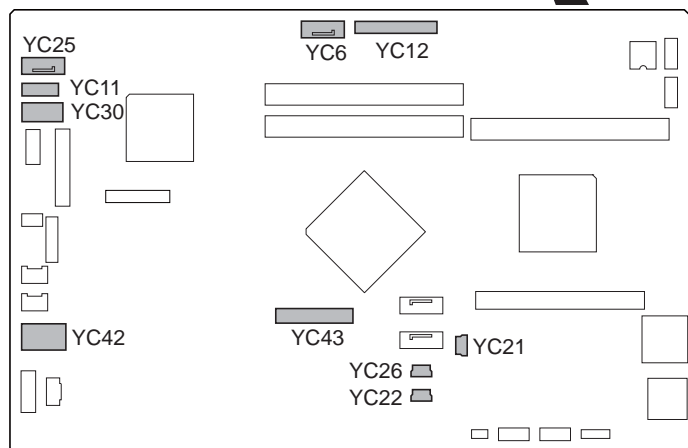


Figure 1-2-30

12. Remove the following connectors that connected to the main PWB from the outside of the control box.
- YC25
  - YC11
  - YC30
  - YC42
  - YC43 (The connector type FFC)
  - YC21 (WH)
  - YC22 (WH)
  - YC26 (BK)
  - YC6
  - YC12



\*: Before removing the connector type FFC YC43, unlock the lock by pressing the lock levers at both ends.

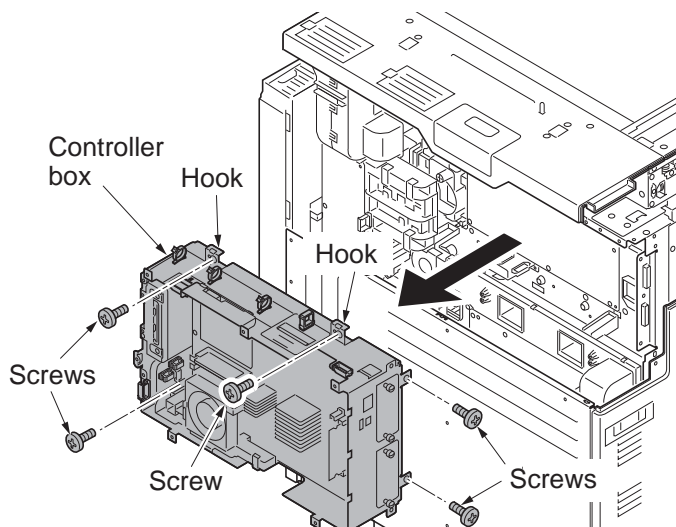


Main PWB

Figure 1-2-31

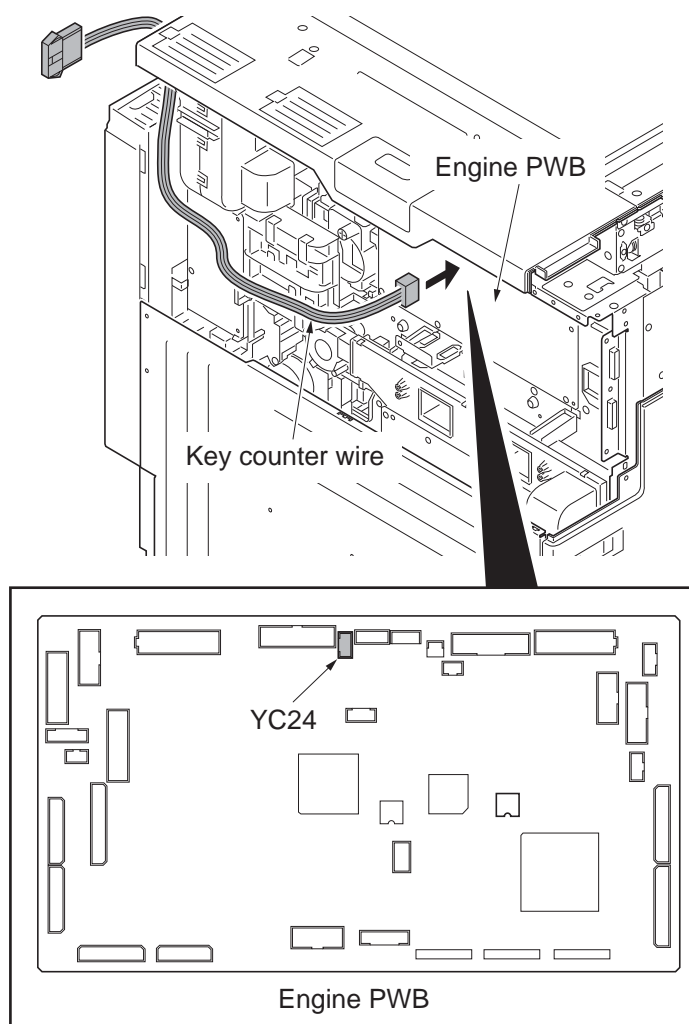


13. Remove five screws.
14. Unhook two hooks and then remove the controller box.



**Figure 1-2-32**

15. Connect the connector of the key counter wire to the connector YC24 on the engine PWB.



**Figure 1-2-33**

16. Remove two wire holders.
17. Route the key counter wire through the wire guide and fix it at the wire holders.

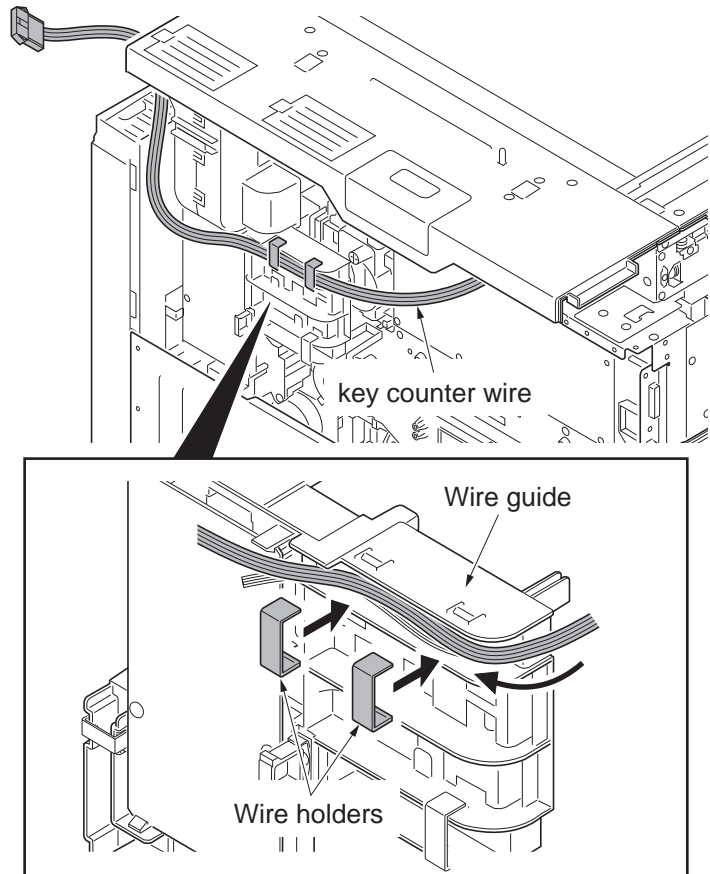


Figure 1-2-34

18. Release three wire saddles.
19. Remove the wire holder.
20. Route the key counter wire through the three wire saddles and wire guide and fix it at the wire holder.
21. Refit the controller box.
22. Refit the left upper cover and the rear upper cover.

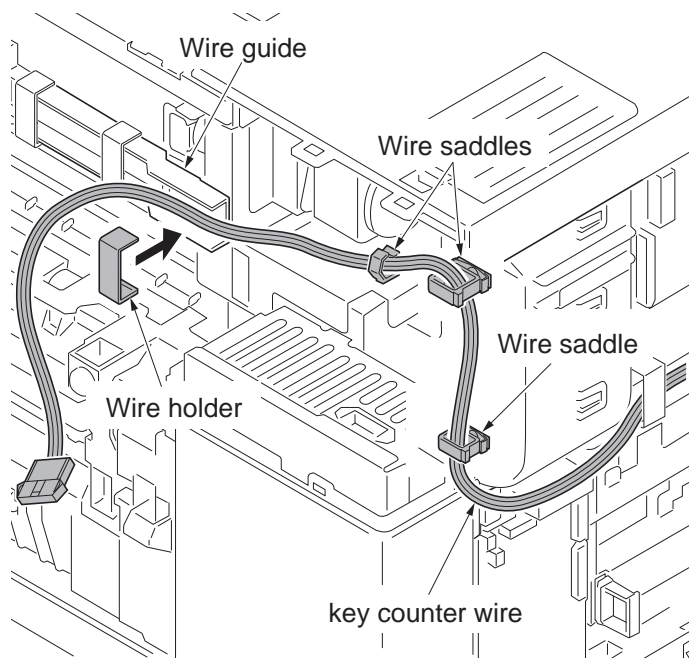
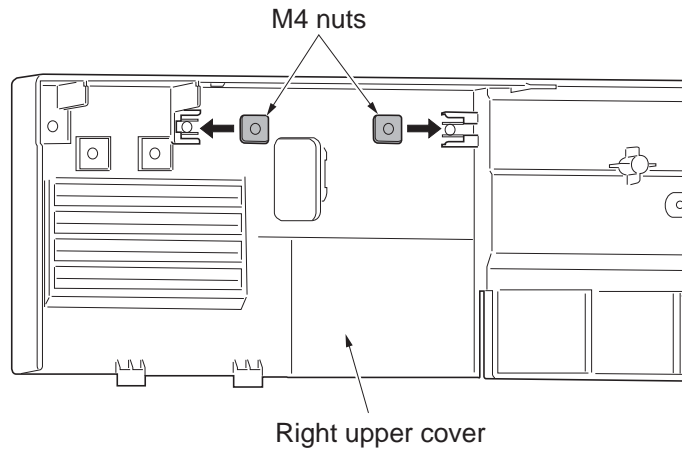


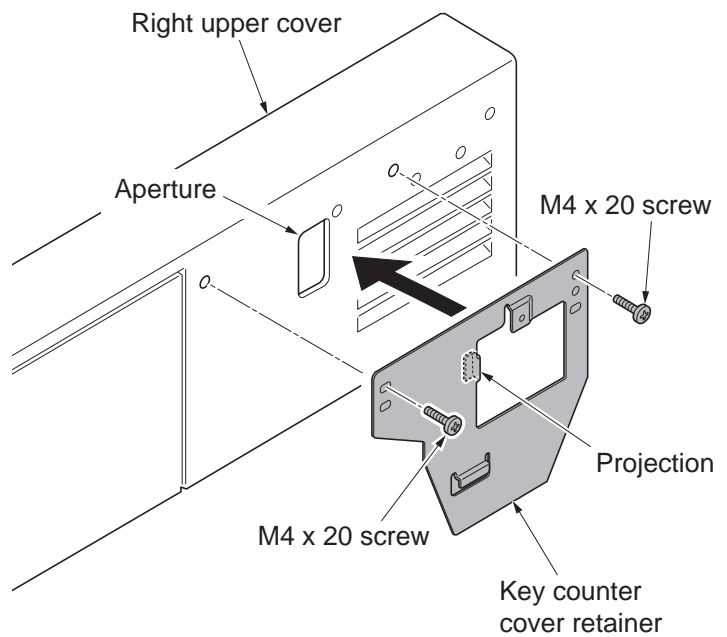
Figure 1-2-35

23. Mount two M4 nuts at the back of the right upper cover.



**Figure 1-2-36**

24. Insert the projection of the key counter cover retainer in the aperture of the right upper cover.  
25. Fit the key counter cover retainer using the two M4 x 20 screws.



**Figure 1-2-37**

26. Pass the connector of the key counter wire through the aperture in the right upper cover.
27. Refit the right upper cover.
28. Refit the ISU right cover.
29. Close the paper conveying unit.

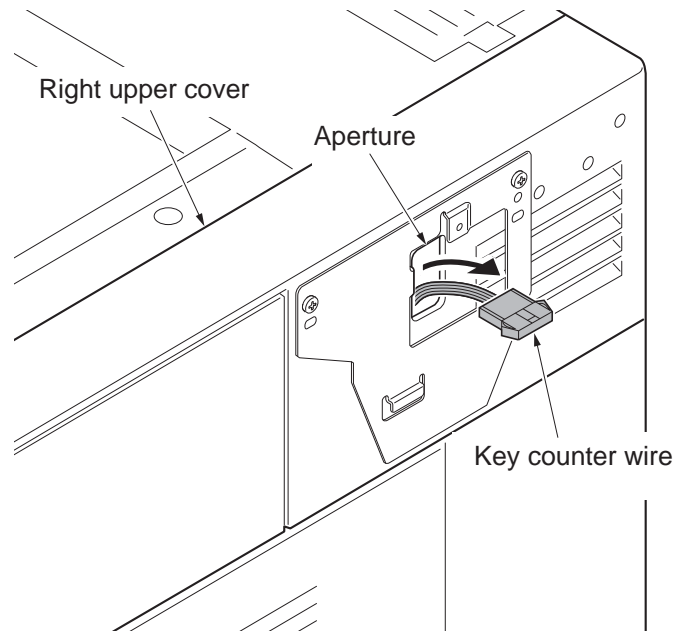


Figure 1-2-38

30. Connect the key counter signal cable to the key counter wire.
31. Fit the key counter cover to the machine using the M4 x 6 screw.

32. Insert the key counter into the key counter socket assembly.
33. Turn the main power switch on and enter the maintenance mode.
34. Run maintenance item U204 and select [Key-Counter] (see page 1-3-101).
35. Exit the maintenance mode.
36. Check that the message requesting the key counter to be inserted is displayed on the touch panel when the key counter is pulled out.
37. Check that the counter counts up as copies are made.

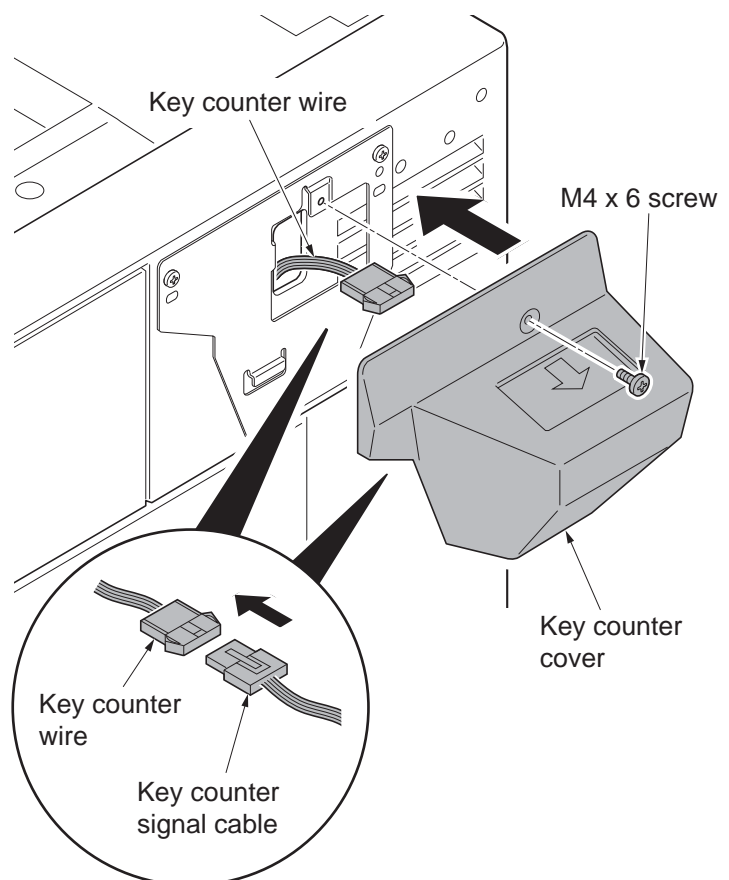
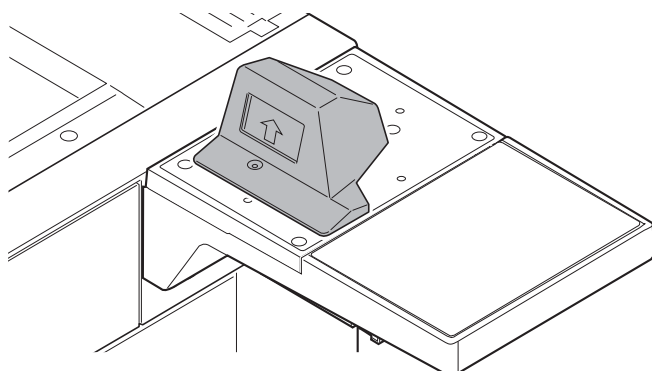


Figure 1-2-39

**(2) Mounting on the document table**

Key counter installation requires the following parts:

Parts	Quantity	Part.No.
Key counter	1	3025418011
Key counter set	1	302A369709
Key counter wire	1	302K946AJ0
Document table	1	1902LC0UN2 (option)

Supplied parts of key counter set (302A369709):

Parts	Quantity	Part.No.
Key counter socket assembly	1	3029236241
Key counter cover retainer	1	302GR03010
Key counter retainer	1	302GR03020
Key counter cover	1	3066060011
Key counter mount	1	3066060041
Edging	2*	7YZM210006++H01
Band	1*	M21AH010
M3 x 8 tap-tight P screw	1*	5MBTPB3008PW++R
M4 x 10 tap-tight P screw	2*	5MBTPB4010PW++R
M4 x 10 tap-tight S screw	2*	5MBTPB4010TW++R
M3 x 6 bronze flat-head screw	2	7BB003306H
M4 x 20 tap-tight S screw	2	7BB100420H
M3 nut	1	7BC1003055++H01
M3 x 8 bronze binding screw	1*	B1B03080
M4 x 30 tap-tight S screw	1*	B1B54300
M4 x 6 chrome TP screw	5	B4A04060
M4 x 10 chrome TP screw	2*	B4A04100

\*:Not used in this model.

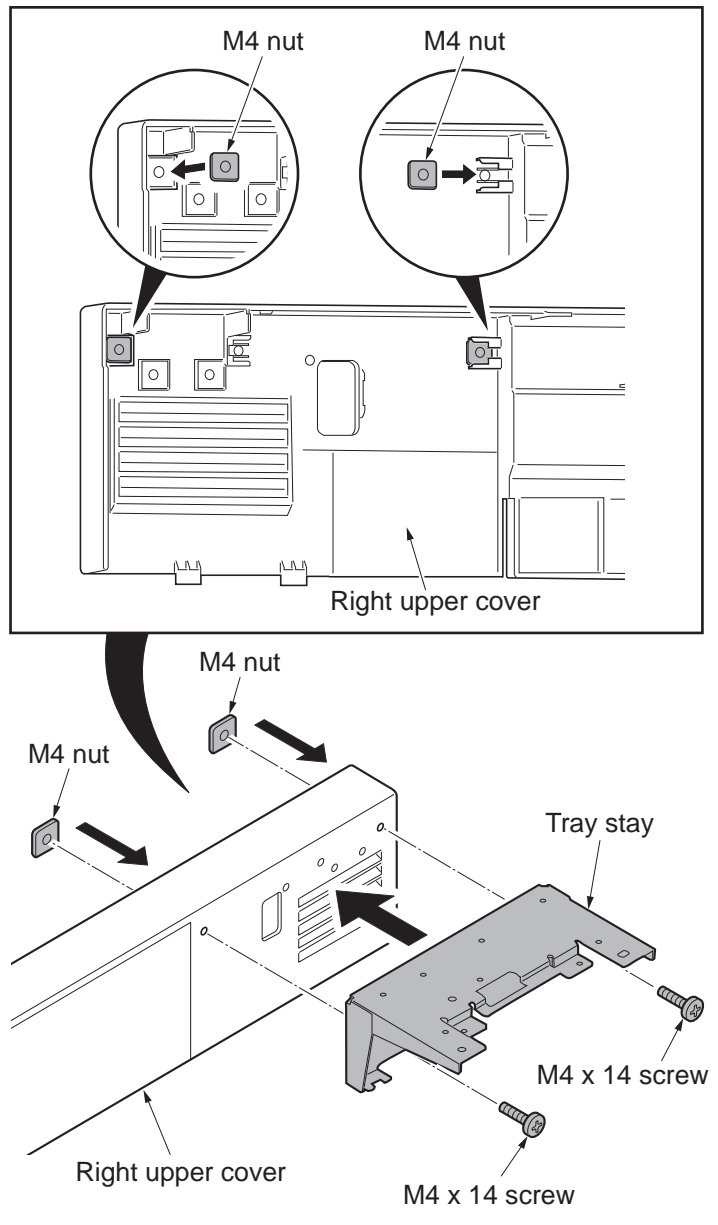
**Supplied parts of document tablet (1902LC0UN2):**

<b>Parts</b>	<b>Quantity</b>	<b>Part.No.</b>
Tray stay	1	-
Tray mount	1	-
Tray cover	1	302LC04601
Tray lower cover	1	302LC04710
Tray retainer	1	-
Sheet	2*	302LC04660
Pin	2	303NS24410
M4 nut	2	3CY06030
M4 x 8 screw	7	7BB180408H
M4 x 14 screw	2	7BB607414H

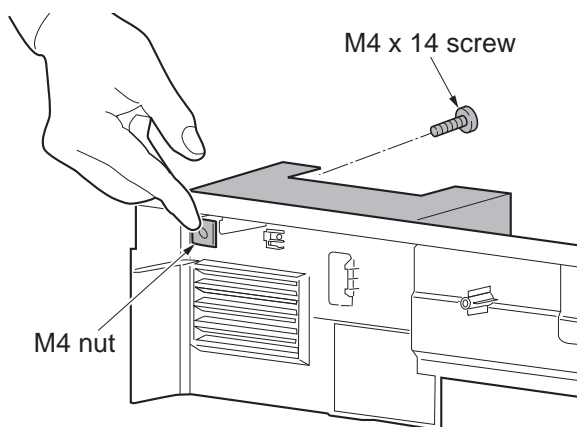
\*: Sheet x1 is not used.

**Procedure**

1. Perform steps 1 through 25 as explained in (1) Installing directly on the device.
2. Mount two M4 nuts at the back of the right upper cover.
3. Fit the tray stay to the right upper cover using two M4 x 14 screws.



\*: Secure the screws making sure that the nuts do not fall.



**Figure 1-2-40**

4. Fit the tray retainer to the machine using the M4 x 8 screw.
- \*: The procedure described above is not required if an optional right job separator has been installed.

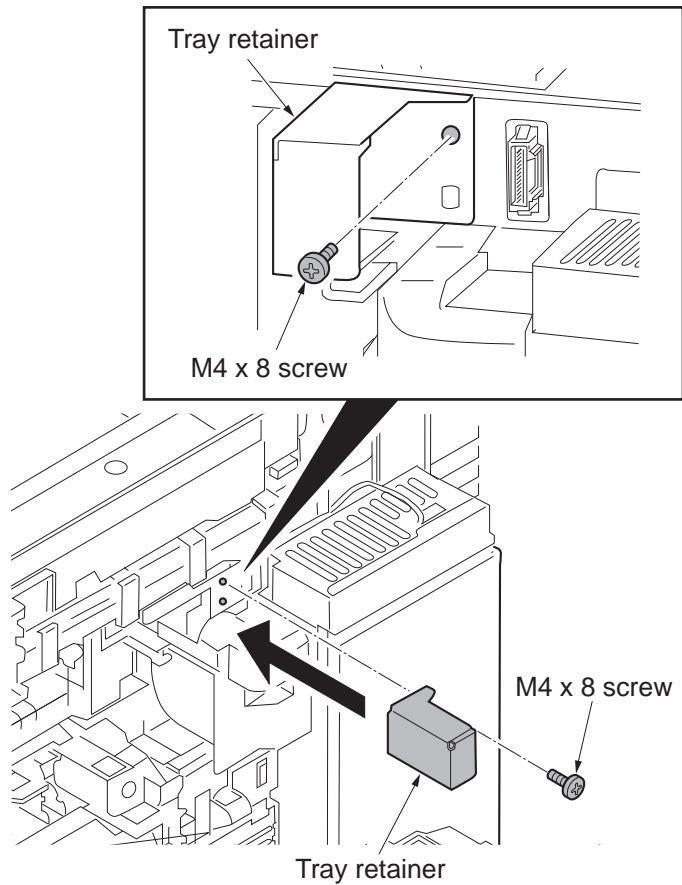


Figure 1-2-41

5. Pass the connector of the key counter wire through the aperture in the right upper cover.
6. Refit the right upper cover.
7. Refit the ISU right cover.
8. Close the paper conveying unit.

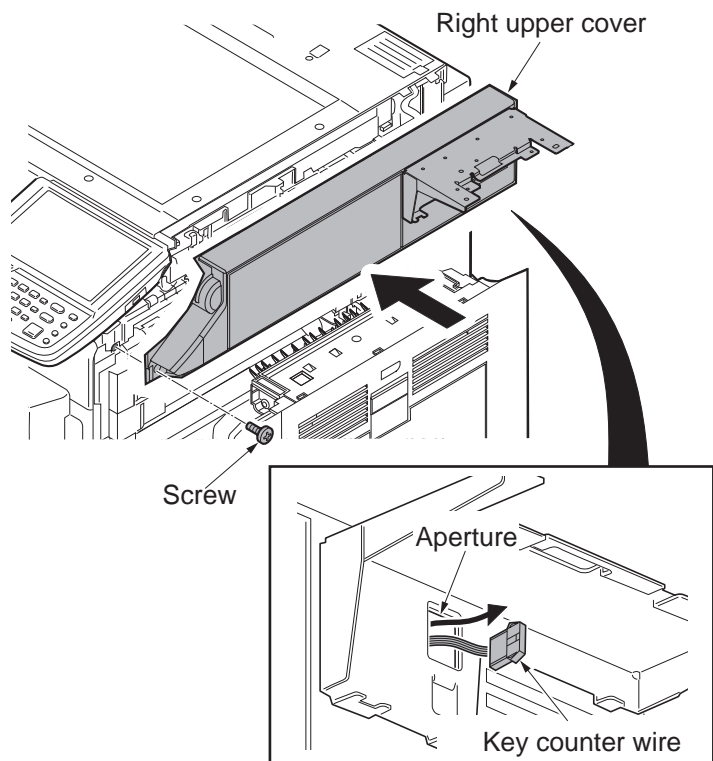


Figure 1-2-42



9. Snap in the tray mount to the tray stay and fix using two M4 x 8 screws.

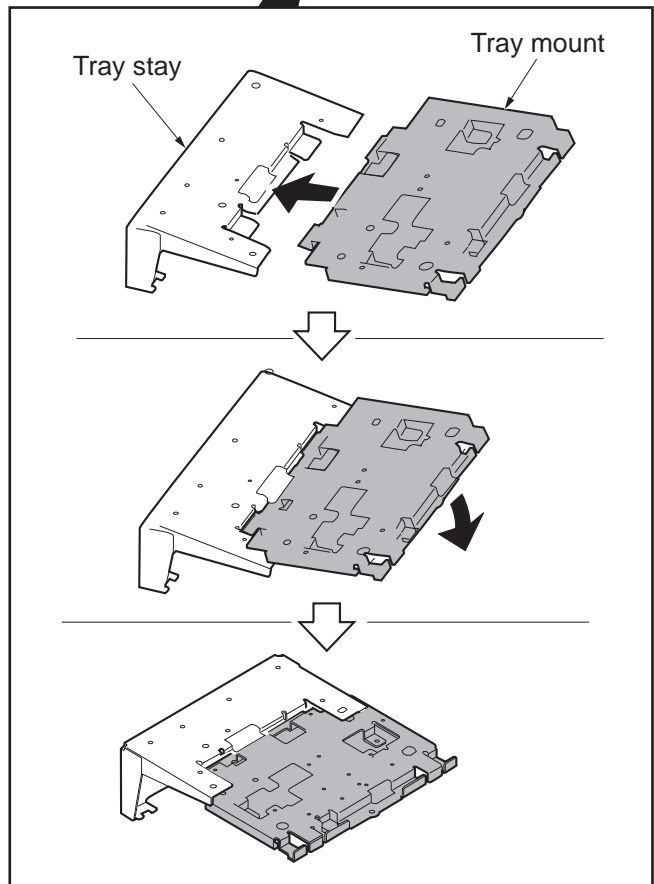
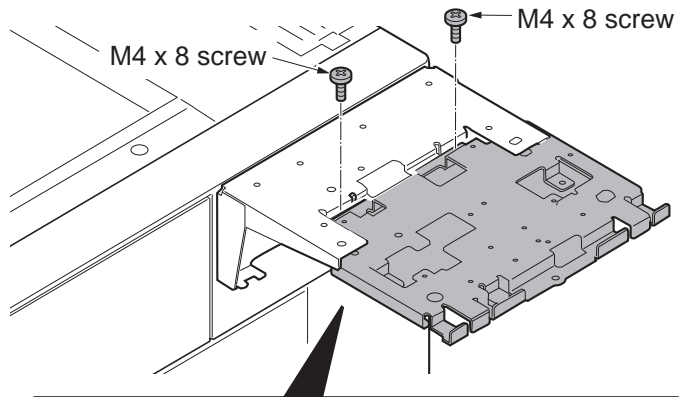
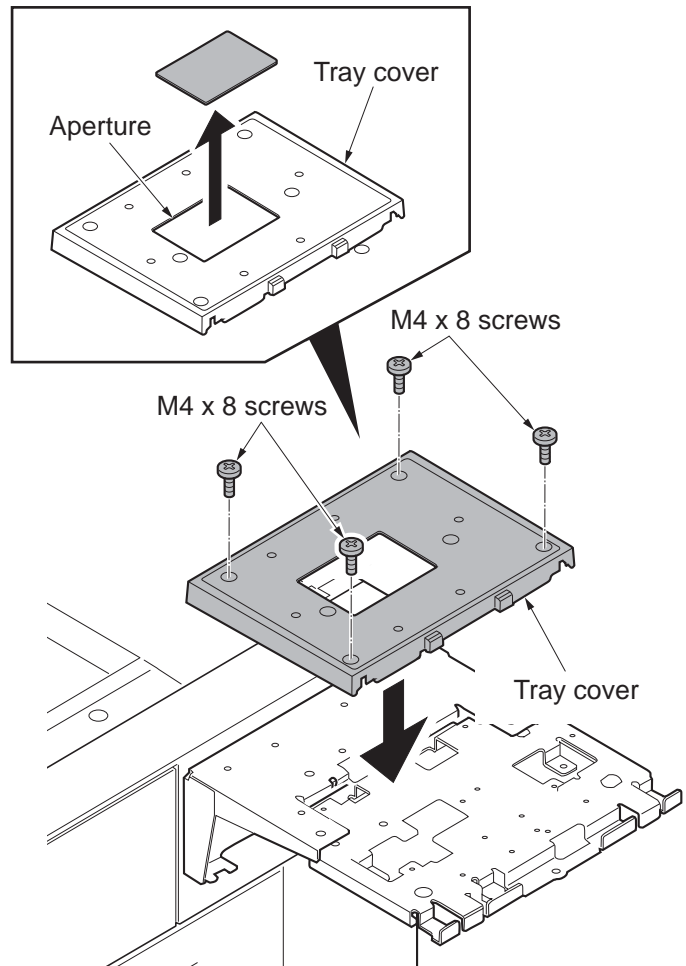
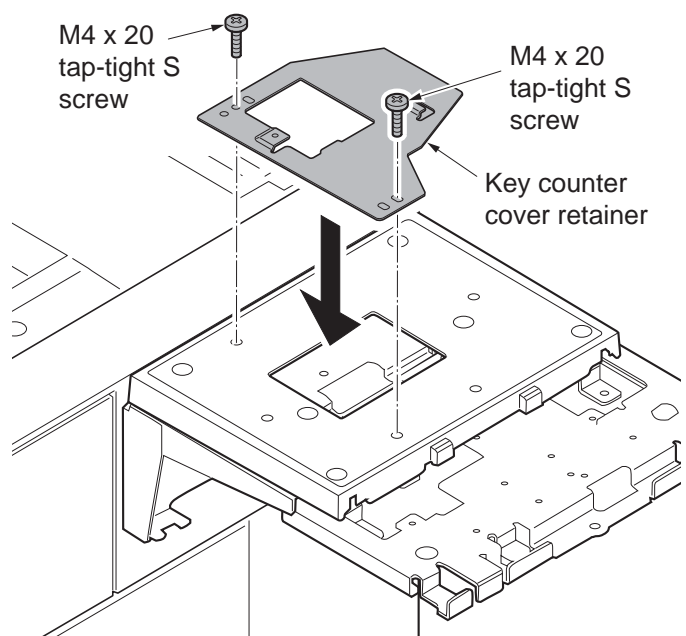


Figure 1-2-43

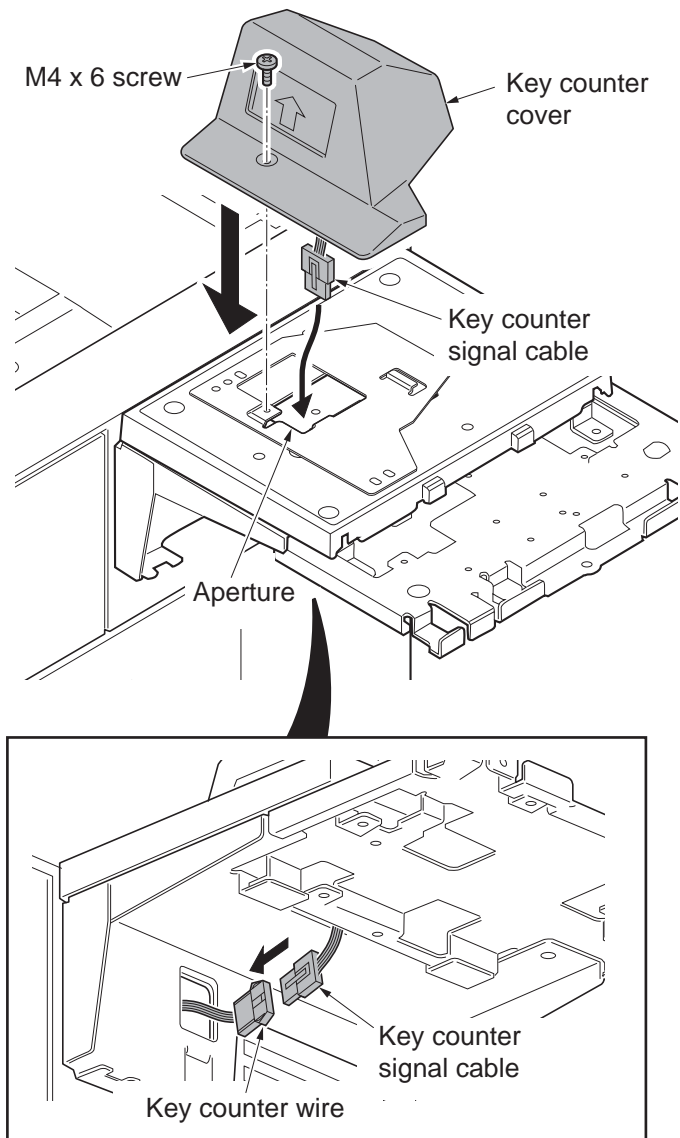
10. Cut out the aperture plate on the tray cover using nippers.
11. Fit the tray cover to the tray stay using four M4 x 8 screws.

**Figure 1-2-44**

12. Fit the key counter cover retainer using two M4 x 20 tap-tight S screws.

**Figure 1-2-45**

13. Pass the key counter signal cable through the aperture in the document table.
14. Fit the key counter cover to the document table using the M4 x 6 screw.
15. Connect the key counter signal cable to the key counter wire.

**Figure 1-2-46**

16. Fit the tray lower cover.

\*: Install the key counter signal cable and key counter wire so that they are held behind the tray lower cover.

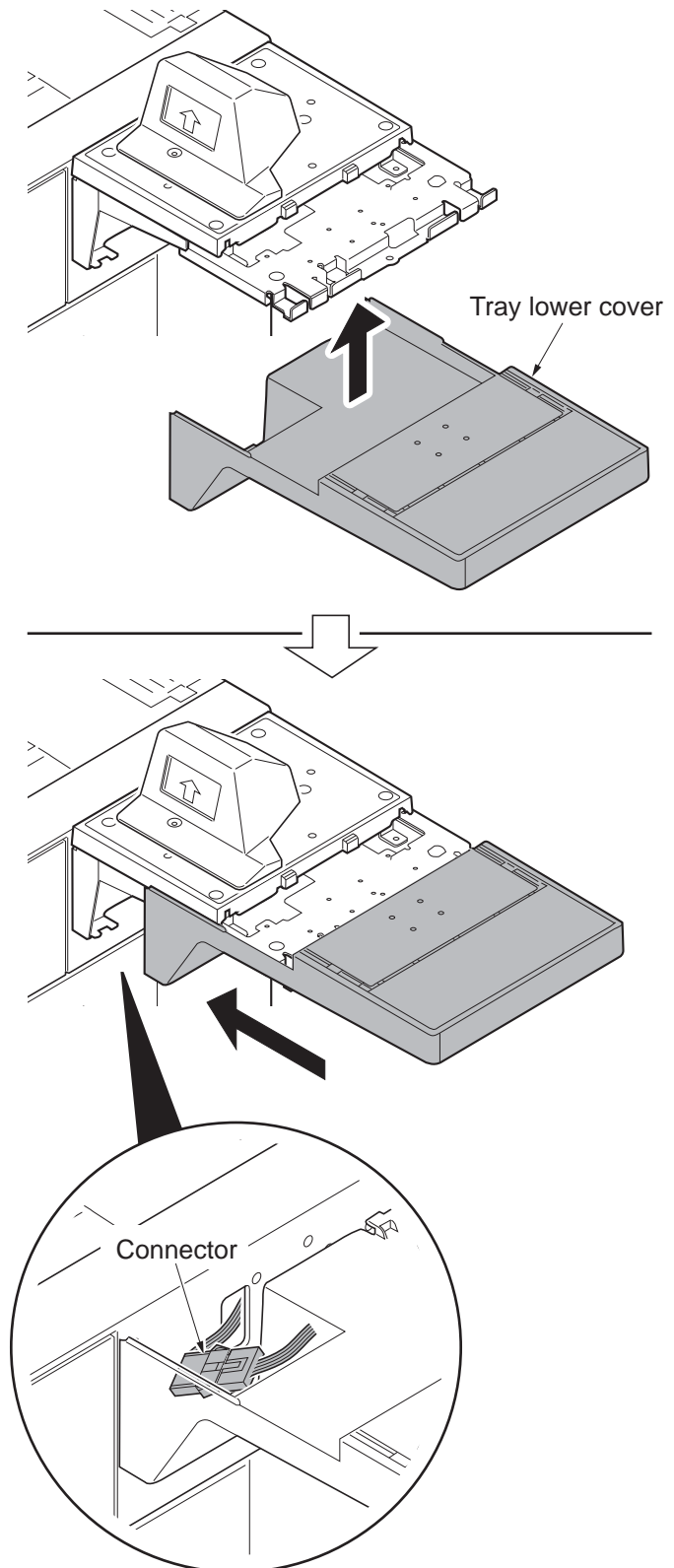
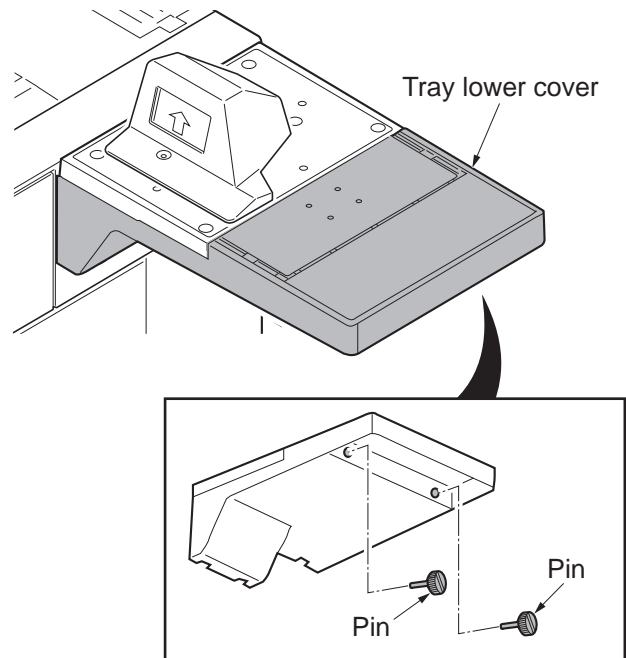


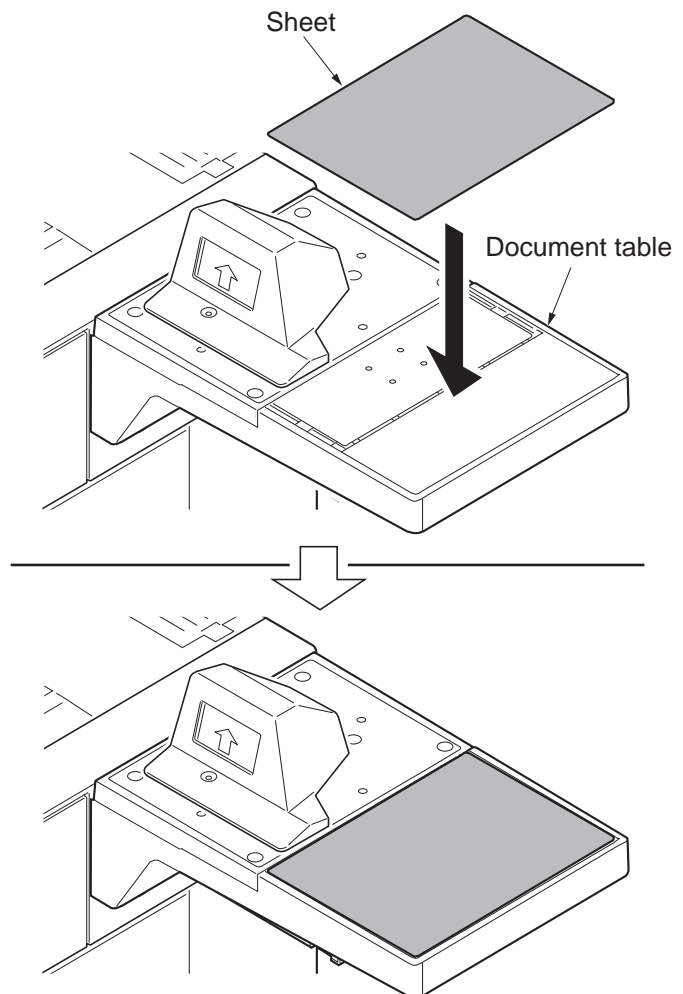
Figure 1-2-47

17. Secure the tray lower cover with two pins.



**Figure 1-2-48**

18. Adhere the sheet onto right side of the document table.
19. Insert the key counter into the key counter socket assembly.
20. Turn the main power switch on and enter the maintenance mode.
21. Run maintenance item U204 and select [Key-Counter] (see page 1-3-101).
22. Exit the maintenance mode.
23. Check that the message requesting the key counter to be inserted is displayed on the touch panel when the key counter is pulled out.
24. Check that the counter counts up as copies are made.



**Figure 1-2-49**

## 1-2-4 Installing the key card MK-2 (option for Japan only)

Key card installation requires the following parts:

Parts	Quantity	Part.No.
Key card MK-2	1	8J272002 (option)
MK-2 mount	1	Supplied with MK-2
M4 x 16 screw	2*	
Document table	1	1902LC0UN2 (option)
M4 x 20 tap-tight S screw	2	7BB100420H

Supplied parts of document tablet (1902LC0UN2):

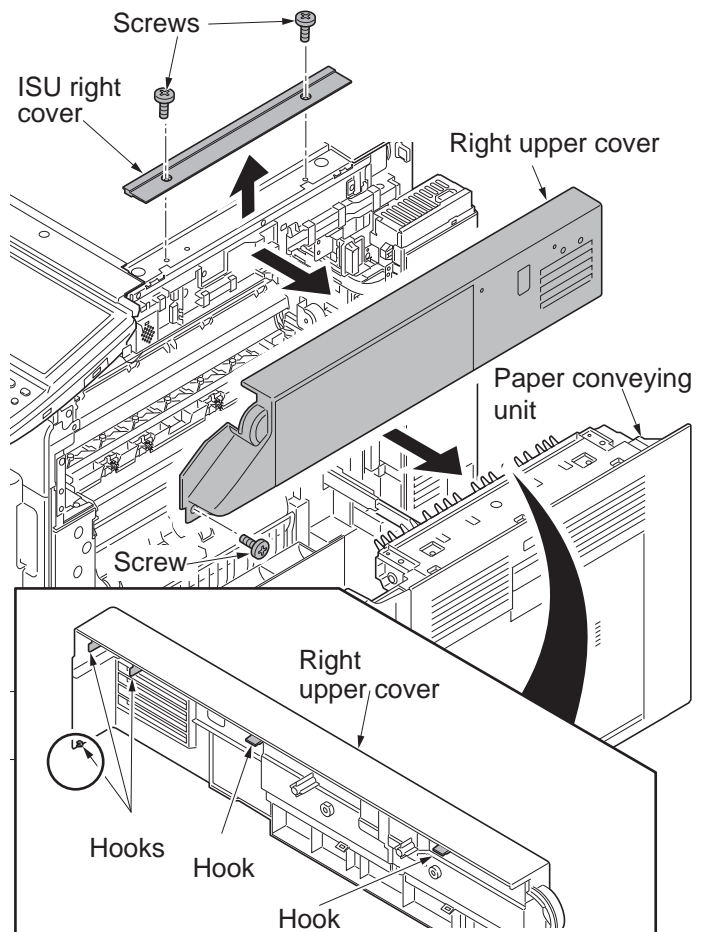
Parts	Quantity	Part.No.
Tray stay	1	-
Tray mount	1	-
Tray cover	1	302LC04601
Tray lower cover	1	302LC04710
Tray retainer	1*1	-
Sheet	2*2	302LC04660
Pin	2	303NS24410
M4 nut	2	3CY06030
M4 x 8 screw	7	7BB180408H
M4 x 14 screw	2	7BB607414H

\*1: Not used in this model.

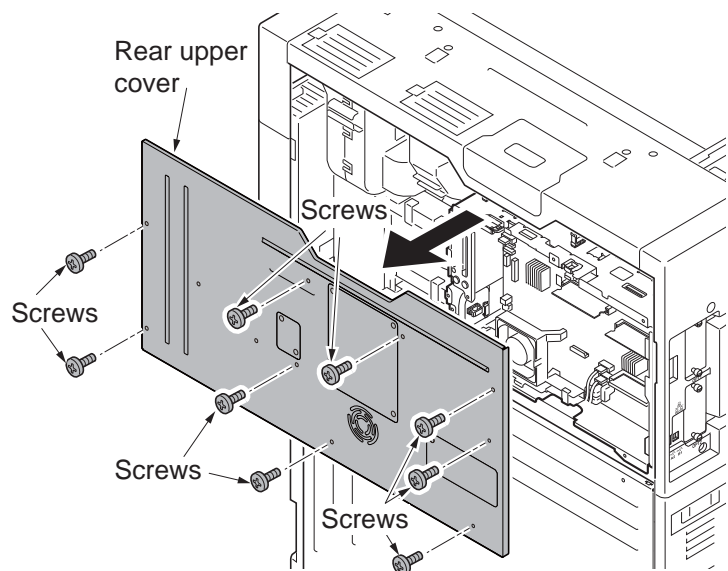
\*2: Sheet x1 is not used.

**Procedure**

1. Press the power key on the operation panel to off. Make sure that the power indicator and the memory indicator are off before turning off the main power switch. And then unplug the power cable from the wall outlet.
  2. Pull the paper conveying unit out.
  3. Remove two screws and then remove the ISU right cover.
  4. Remove the screw and five hooks and then remove the right upper cover.
- \*: Unlatch the stoppers with the rear bottom one first.

**Figure 1-2-50**

5. Remove nine screws and then remove the rear upper cover.

**Figure 1-2-51**

6. Release seven wire saddles on the controller box.
7. Remove the wire holder.

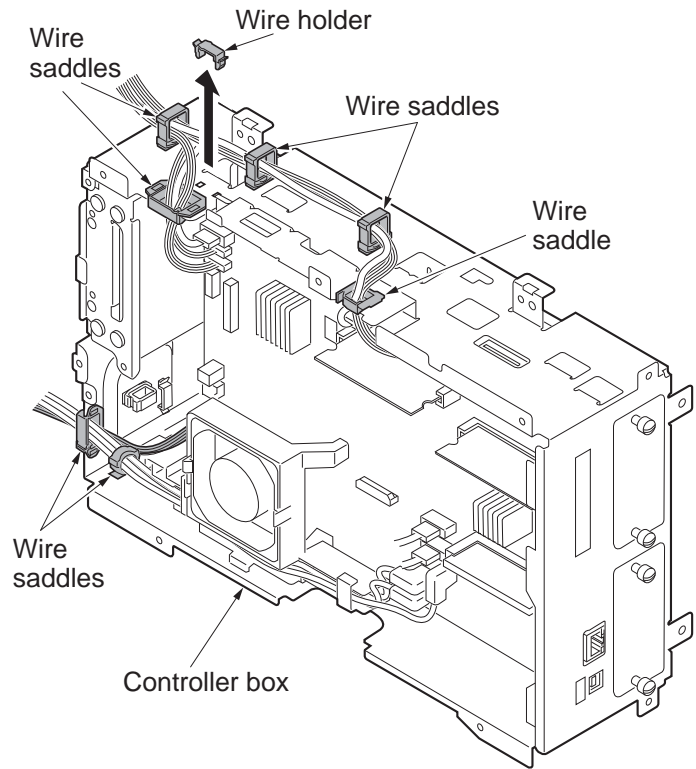
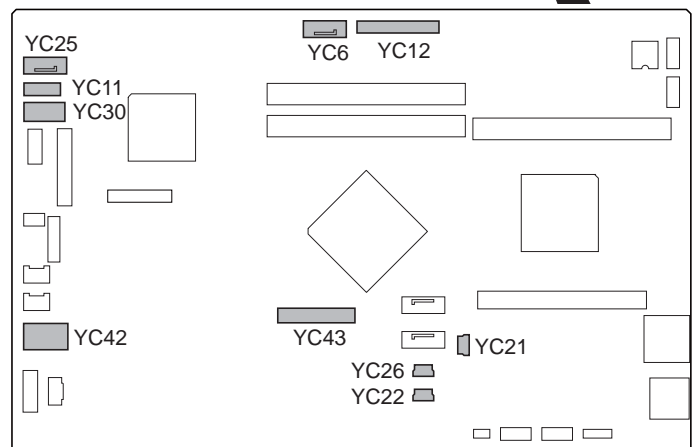
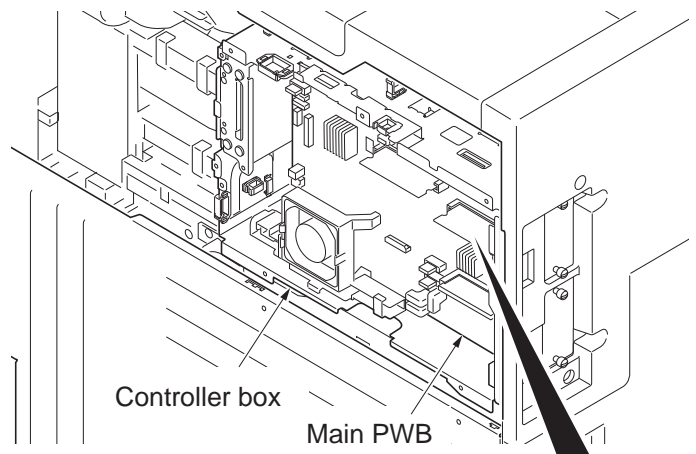


Figure 1-2-52

8. Remove the following connectors that connected to the main PWB from the outside of the control box.

- YC25
- YC11
- YC30
- YC42
- YC43 (The connector type FFC)
- YC21 (WH)
- YC22 (WH)
- YC26 (BK)
- YC6
- YC12

\*: Before removing the connector type FFC YC43, unlock the lock by pressing the lock levers at both ends.

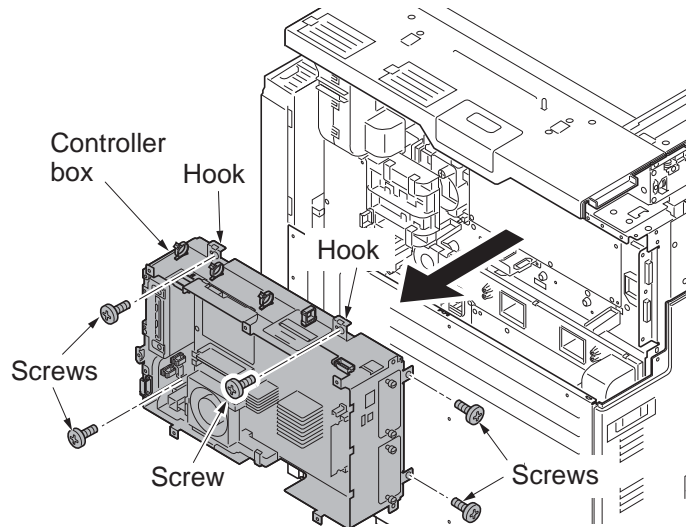


Main PWB

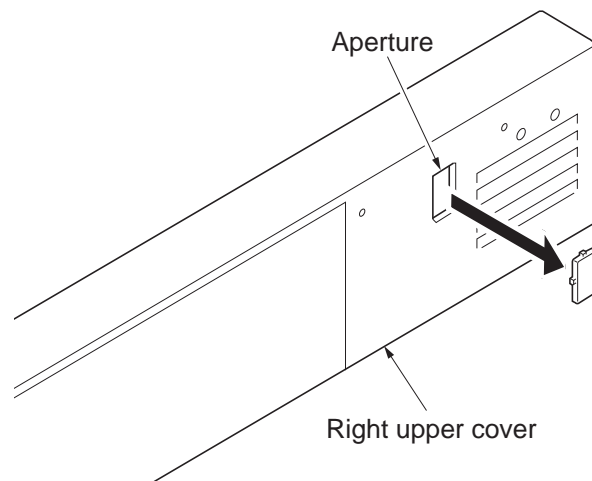
Figure 1-2-53



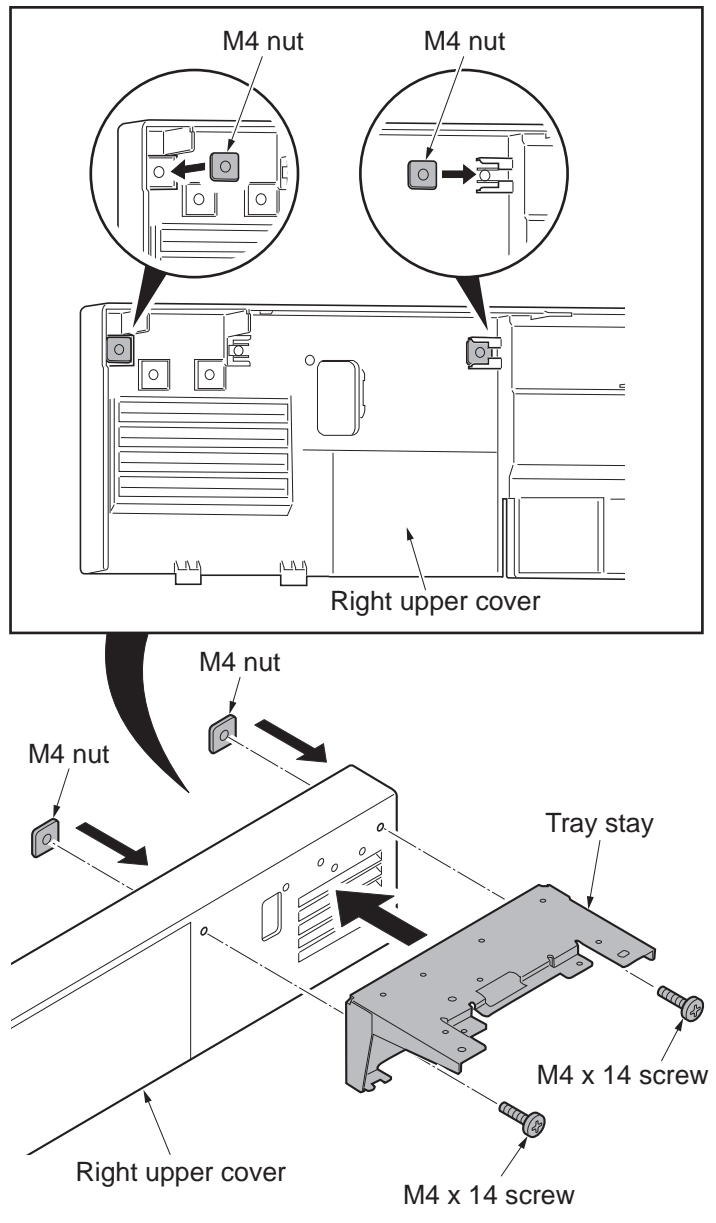
9. Remove five screws.
10. Unhook two hooks and then remove the controller box.

**Figure 1-2-54**

11. Cut out the aperture plate on the right upper cover using nippers.

**Figure 1-2-55**

12. Mount two M4 nuts at the back of the right upper cover.
13. Fit the tray stay to the right upper cover using two M4 x 14 screws.



\*: Secure the screws making sure that the nuts do not fall.

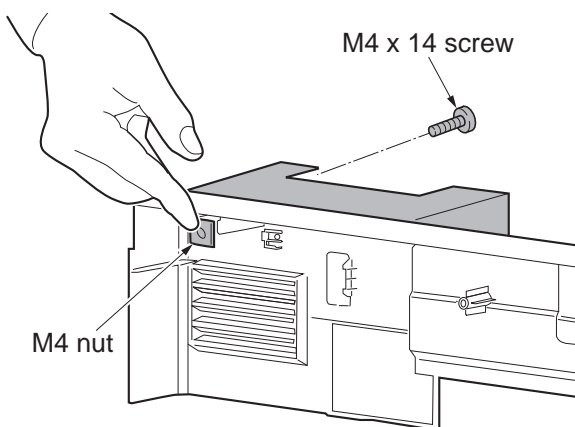
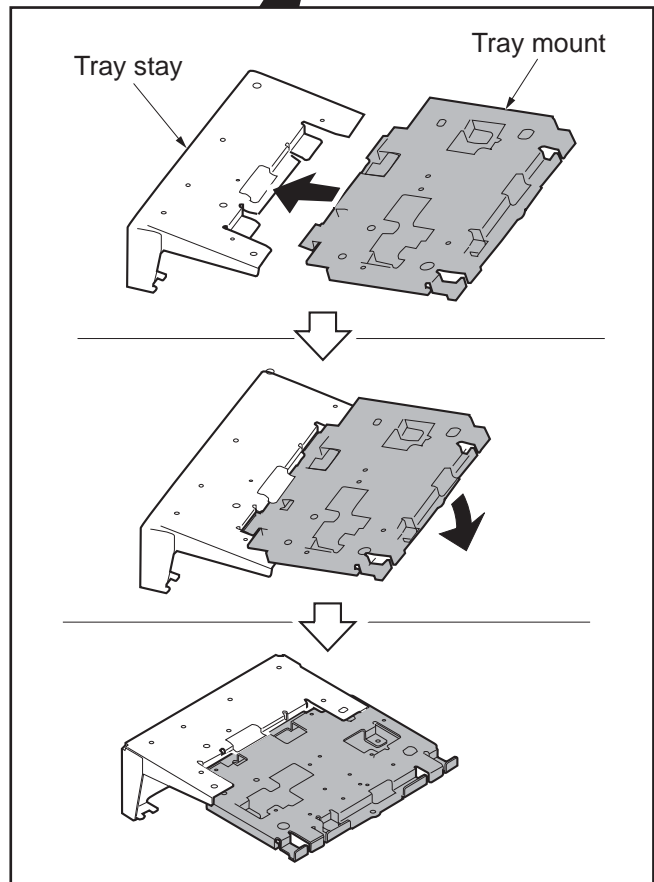
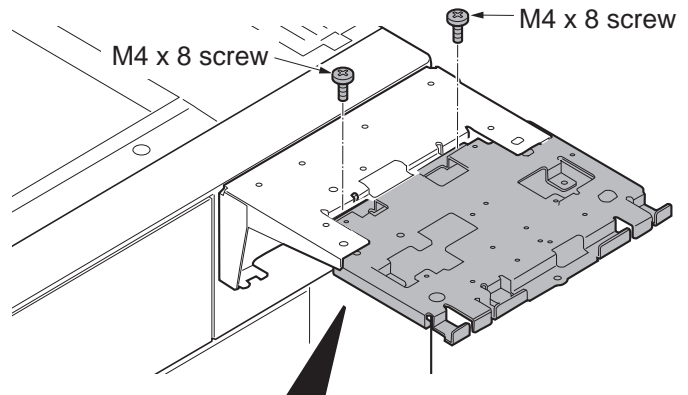


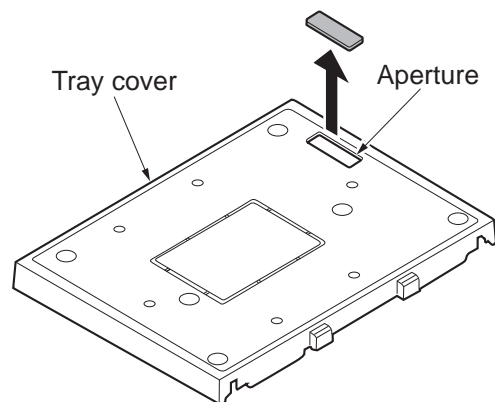
Figure 1-2-56

14. Snap in the tray mount to the tray stay and fix using two M4 x 8 screws.



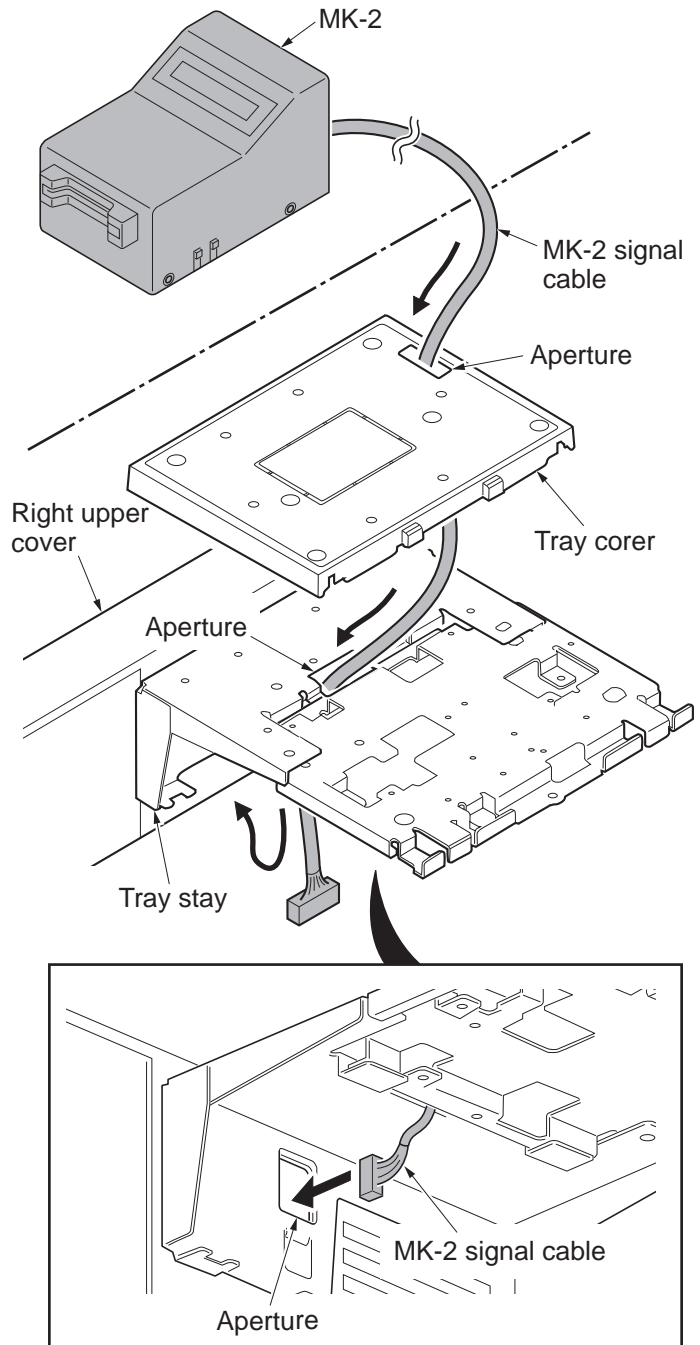
**Figure 1-2-57**

15. Cut out the aperture plate on the tray cover using nippers.



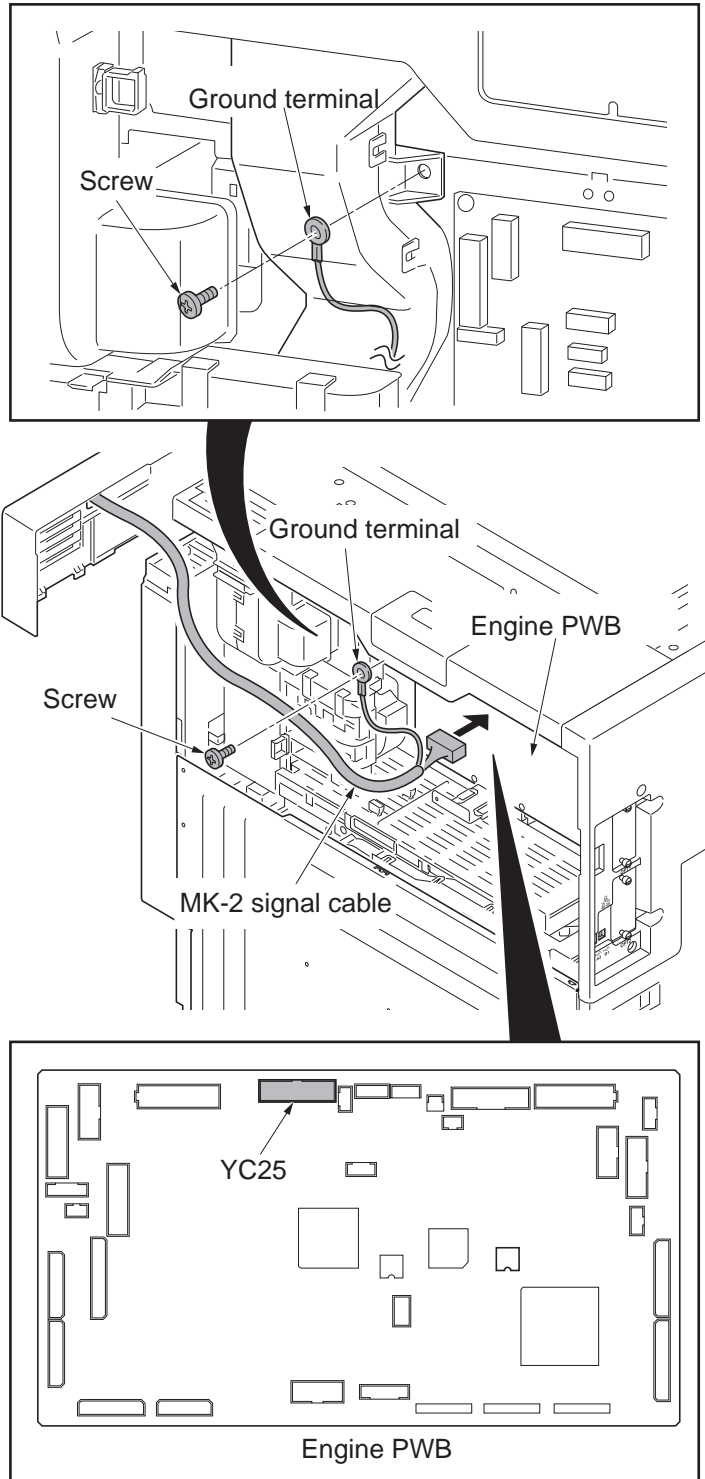
**Figure 1-2-58**

16. Pass the MK-2 signal cable through the aperture in the tray cover, tray stay and right upper cover.

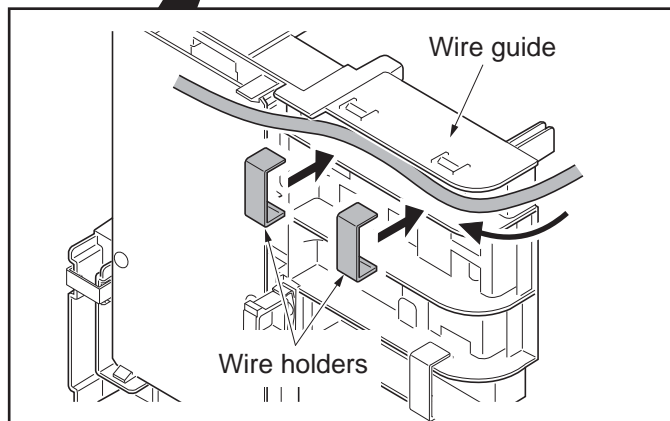
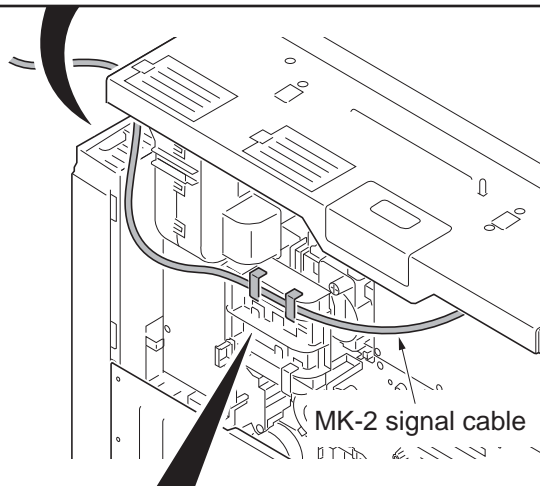
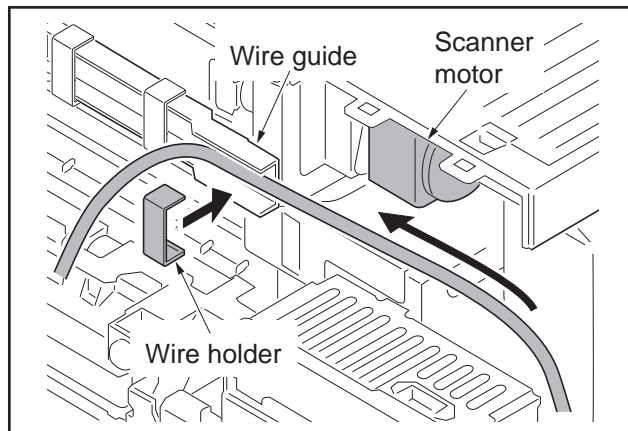


**Figure 1-2-59**

17. Connect the connector of the MK-2 signal cable to the connector YC25 on the engine PWB.
18. Remove the screw from the machine.
19. Fix the MK-2 signal cable to the ground terminal with the screw that was removed.

**Figure 1-2-60**

20. Remove three wire holders.
21. Route the MK-2 signal cable through the wire guide and fix it at three wire holders.
  - \*: Dress the MK-2 signal wire away from the scanner motor and fix.
22. Refit the controller box.
23. Refit the left upper cover and the rear upper cover.



**Figure 1-2-61**

24. Fit the tray retainer to the machine using the M4 x 8 screw.
- \*: The procedure described above is not required if an optional right job separator has been installed.

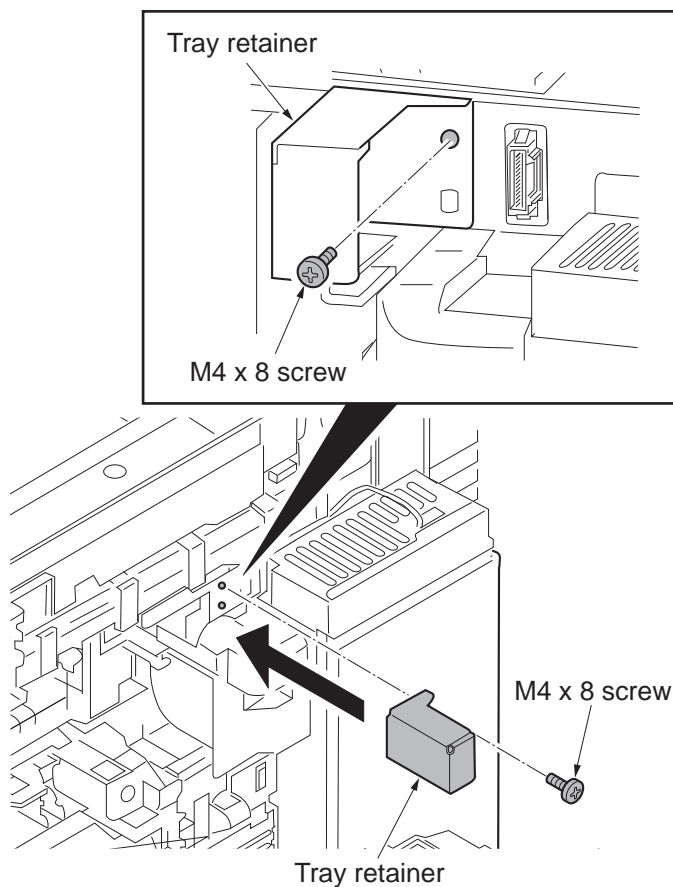


Figure 1-2-62

25. Refit the right upper cover.
26. Refit the ISU right cover.
27. Close the paper conveying unit.
28. Fit the tray cover to the tray stay using four M4 x 8 screws.

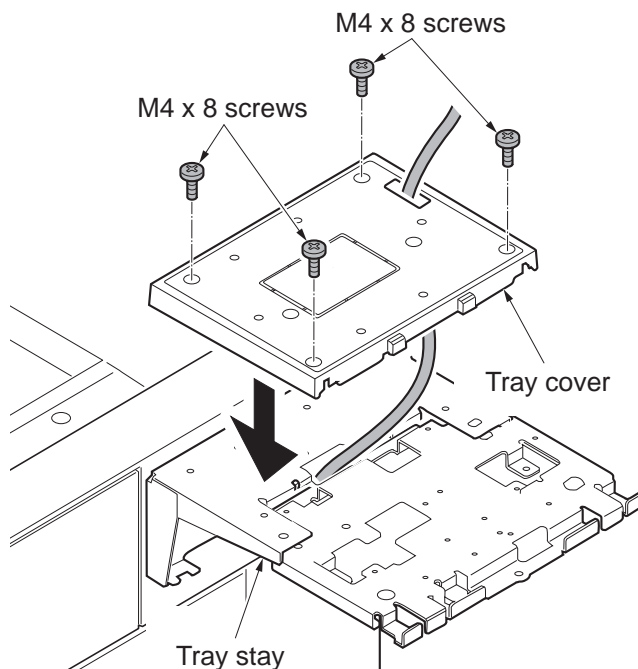
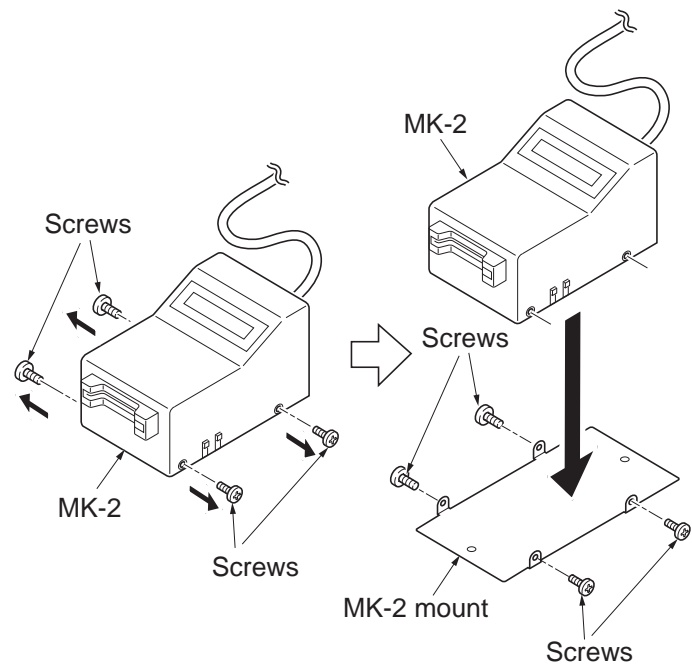


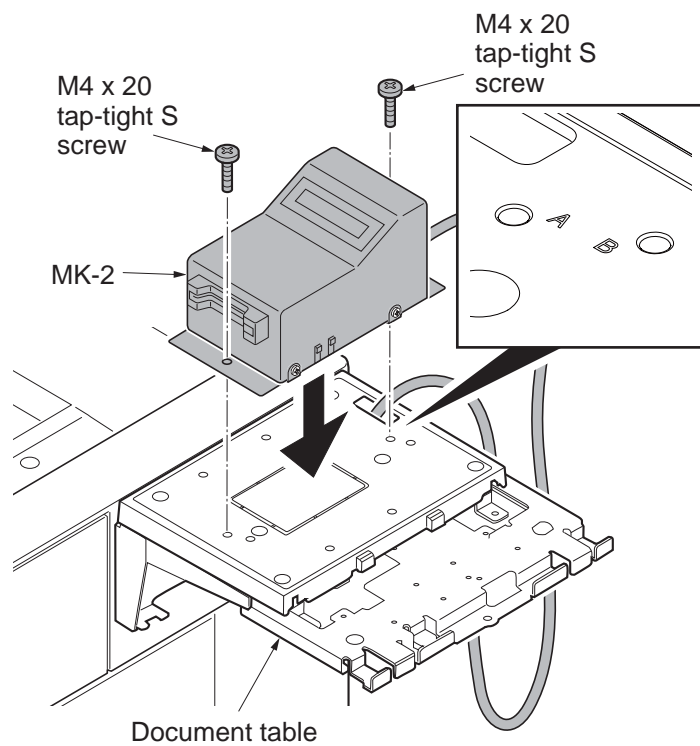
Figure 1-2-63

29. Remove the four screws securing the MK-2 cover; attach the MK-2 mount to the MK-2, and secure using the four screws.



**Figure 1-2-64**

30. Fit the MK-2 to the document table using two M4 x 20 tap-tight S screws.  
\*: Secure the screws to the location with mark "A".



**Figure 1-2-65**



- 31. Fit the tray lower cover.
- 32. Secure the tray lower cover with two pins.

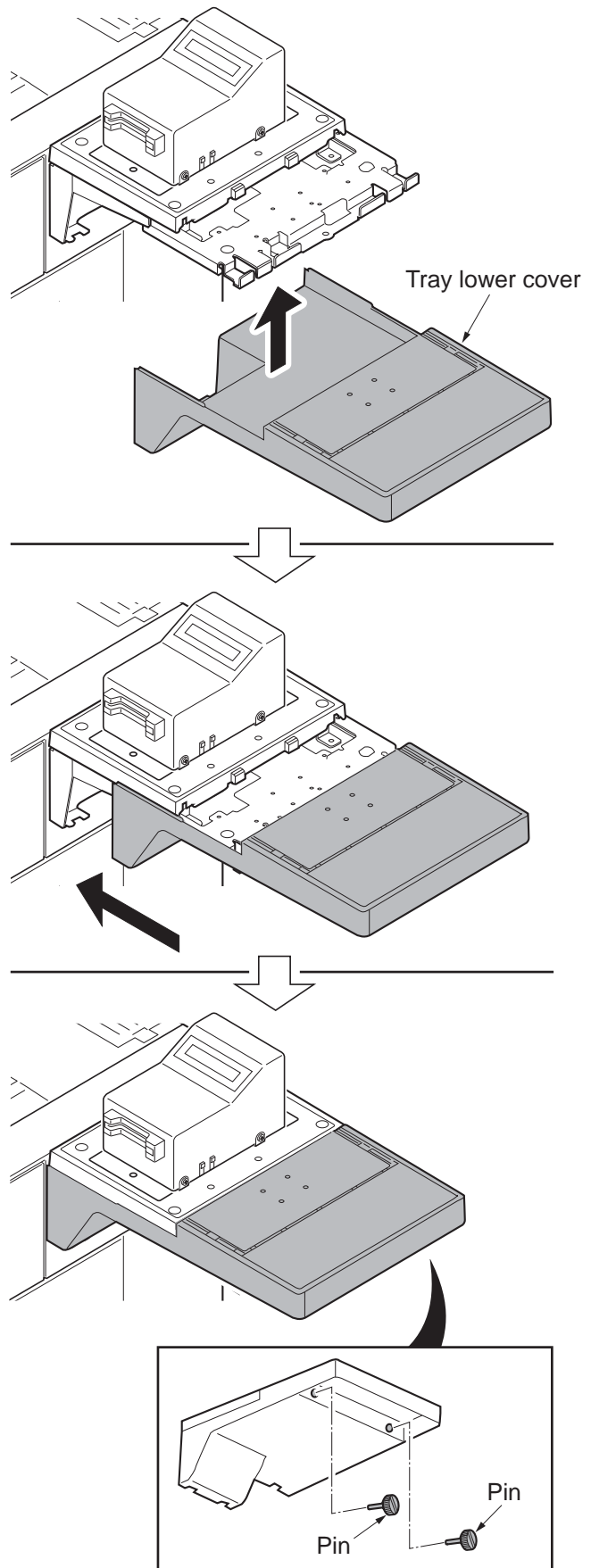
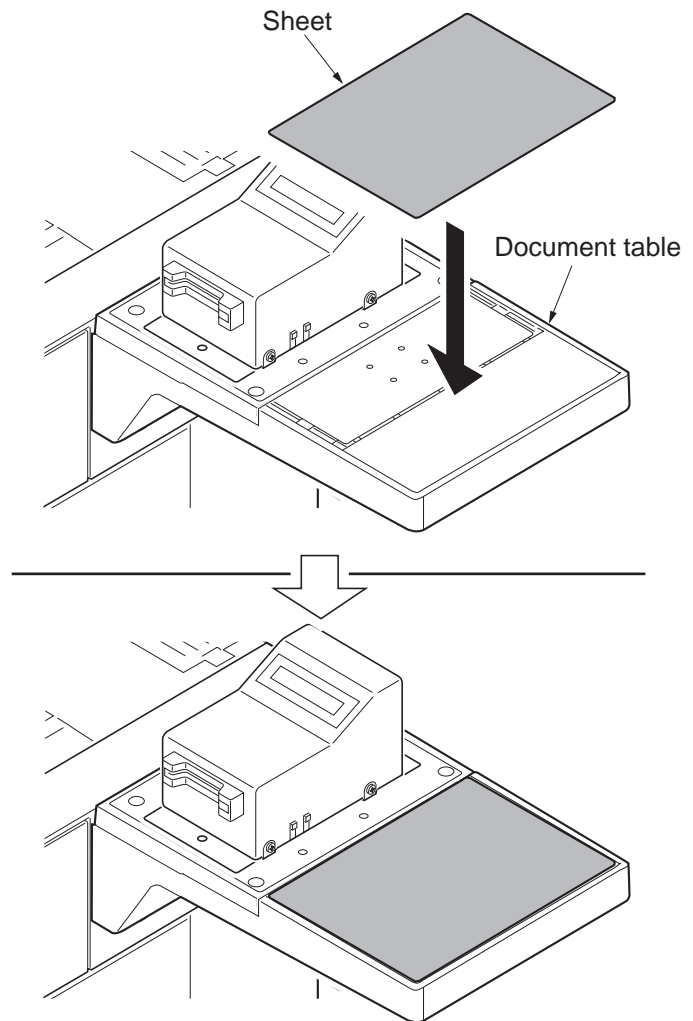


Figure 1-2-66

33. Adhere the sheet onto right side of the document table.
34. Turn the main power switch on and enter the maintenance mode.
35. Run maintenance item U204 and select [Key-Card] (see page 1-3-101).
36. Exit the maintenance mode.

**Figure 1-2-67**

## 1-2-5 Installing the KMAS (option for japan only)

KMAS installation requires the following parts:

### Using the PHS module

Parts	Quantity	Part.No.
PHS module	1	HM000080 (option)
PHS signal cable	1	023CK200 (option)
KMAS interface PWB	1	023CK000 (option)
M3 x 16 bronze binding screw	2	B3323160
Ferrite core	1	2A027770
Clamp	1	M2105910
KMAS wire set	1	302K994610

### Supplied parts of KMAS wire set (302K994610):

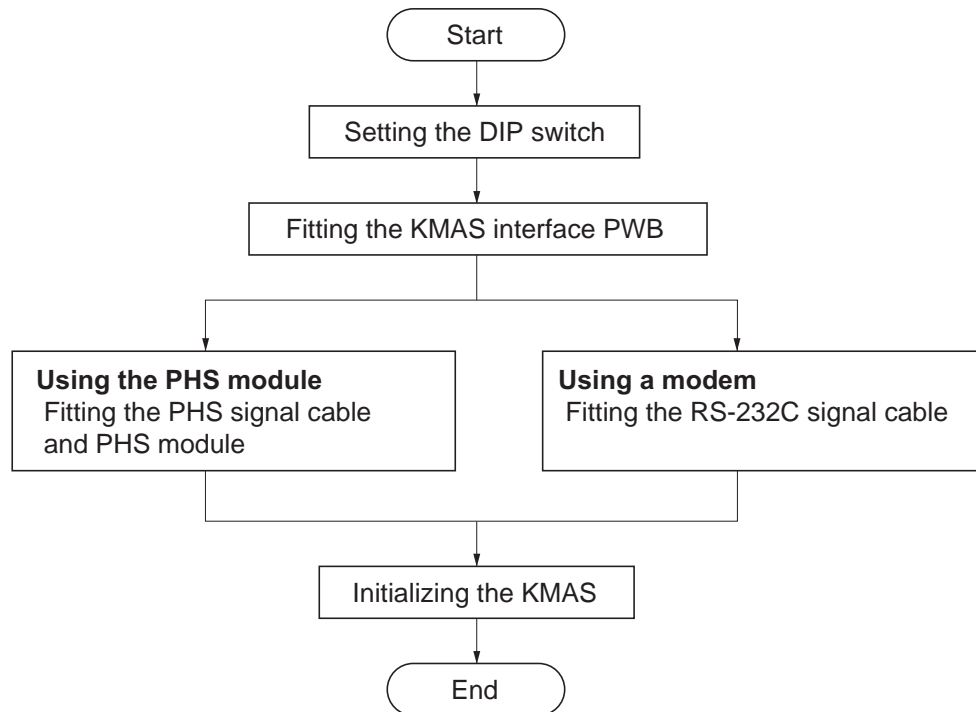
Parts	Quantity	Part.No.
KMAS wire	1	302K946AG0
Spacer A	1	7YZM510009++H01
Spacer B	3	7YZM510011++H01

### Using a modem

Parts	Quantity	Part.No.
RS-232C signal cable	1	303CK60011
RS-232C relay cable	1	303CK60041
KMAS interface PWB	1	023CK000 (option)

**Procedure**

To fix KMAS, perform the following procedure:



### Setting the DIP switch

1. Configure DIP switches 1 to 4 on the KMAS interface board as follows:

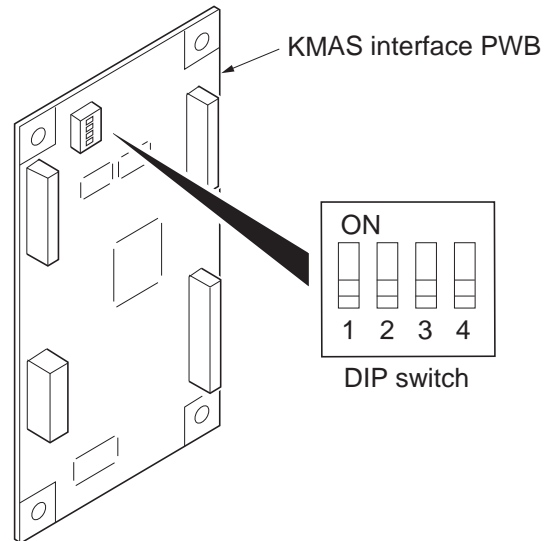
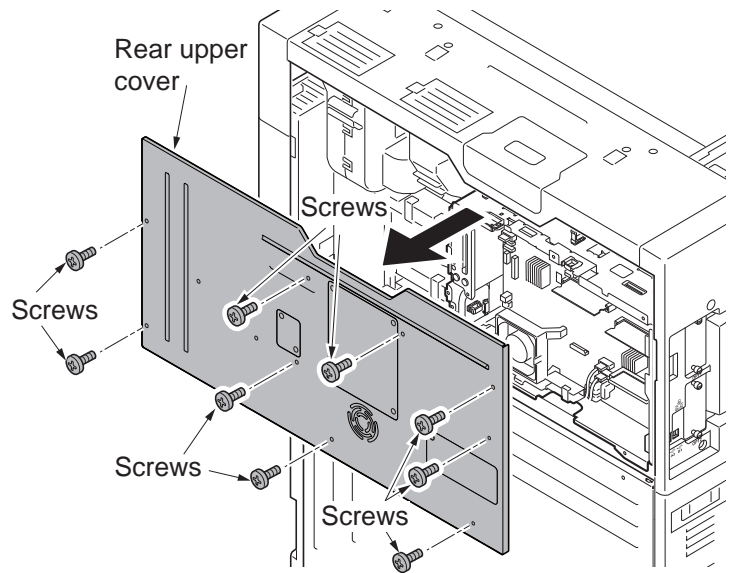


Figure 1-2-68

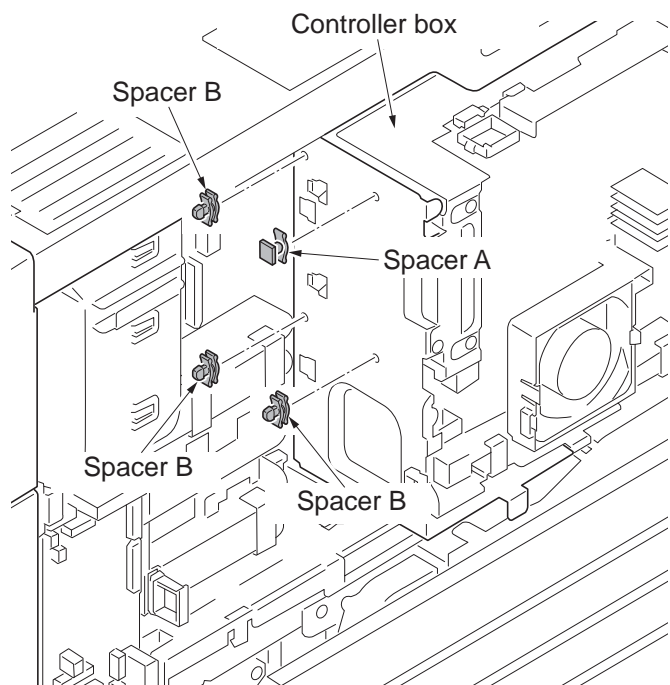
DIP SW No.	Description	Remarks
1	PHS module/modem switching ON: Use modem OFF: Use PHS module	
2	Modem outgoing switching ON: Pulse OFF: Tone	This is required when modem is used.
3	Communication speed switching with the device ON: 9600bps OFF: 19200bps	Set to OFF.
4	Communication log when automatically notifying service calls Switching messages ON: Message is fixed OFF: Normal message is used	When ON, the message is "Call a service representative." When OFF, the message will vary depending on communication status. To setup the system with automatic accounting only, ON may be set.

**Fitting the KMAS interface PWB**

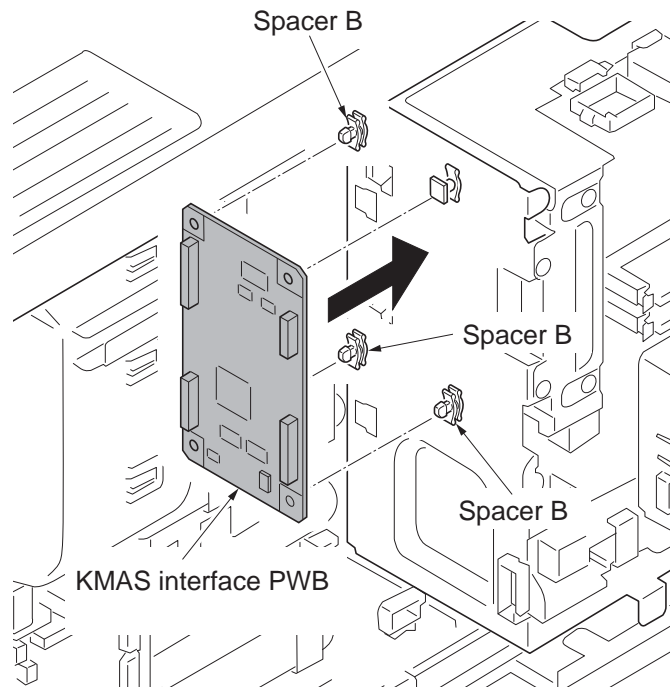
2. Remove nine screws and then remove the rear upper cover.

**Figure 1-2-69**

3. Attach one spacer A and three spacers B to the side of the controller box.

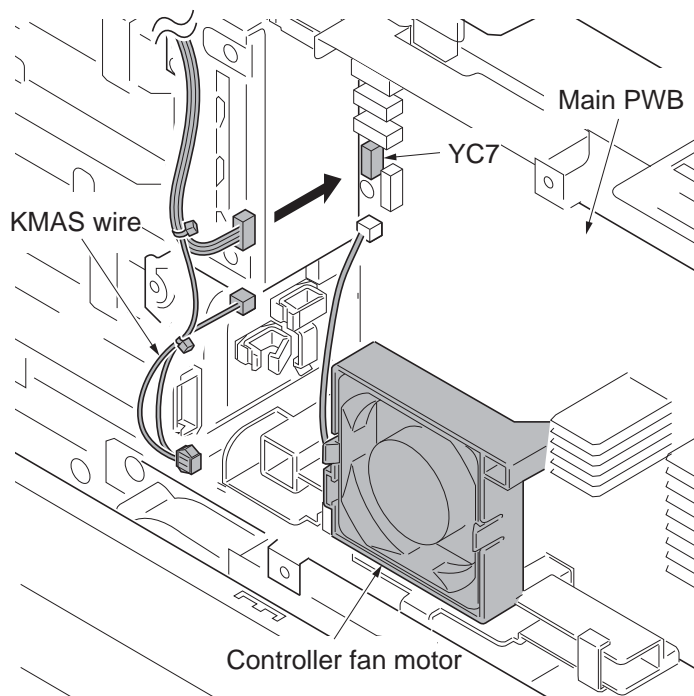
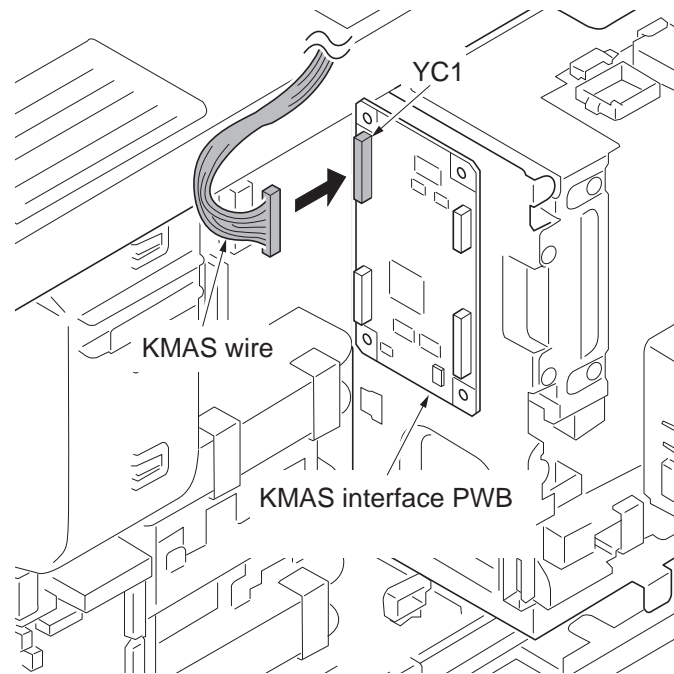
**Figure 1-2-70**

4. Insert the KMAS interface PWB to three spacers B.



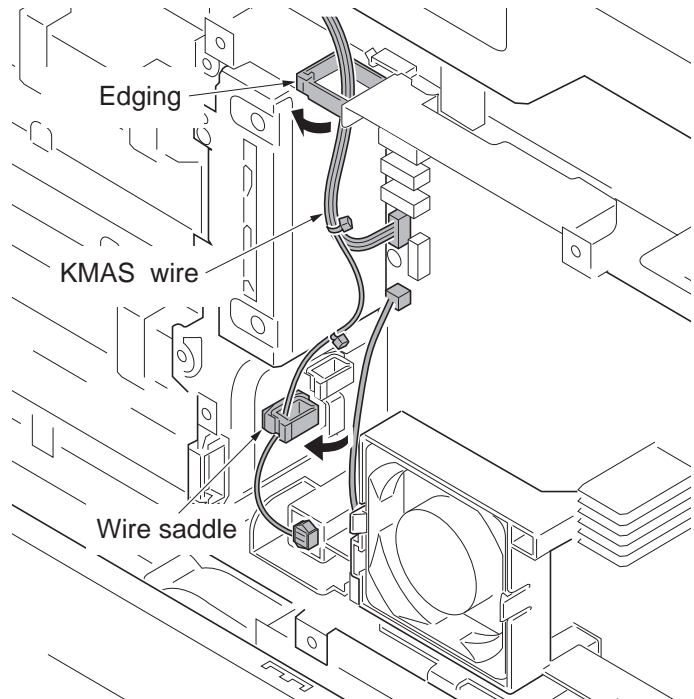
**Figure 1-2-71**

5. Connect the connector of the KMAS wire to the connector YC1 on the KMAS PWB.
6. Connect the connector of the KMAS wire to controller fan motor, YC7 on the main PWB.

**Figure 1-2-72**



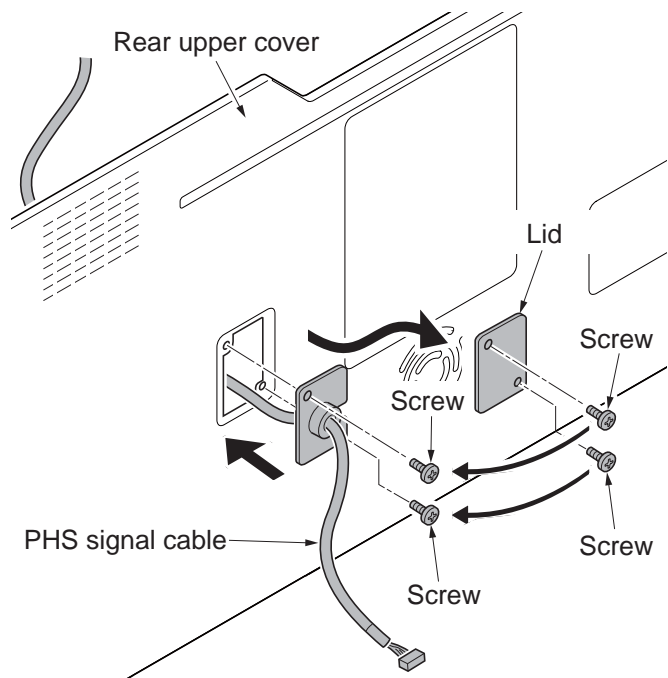
7. Pass the KMAS wire through the edging of the controller box and wire saddle and then fasten the KMAS wire.



**Figure 1-2-73**

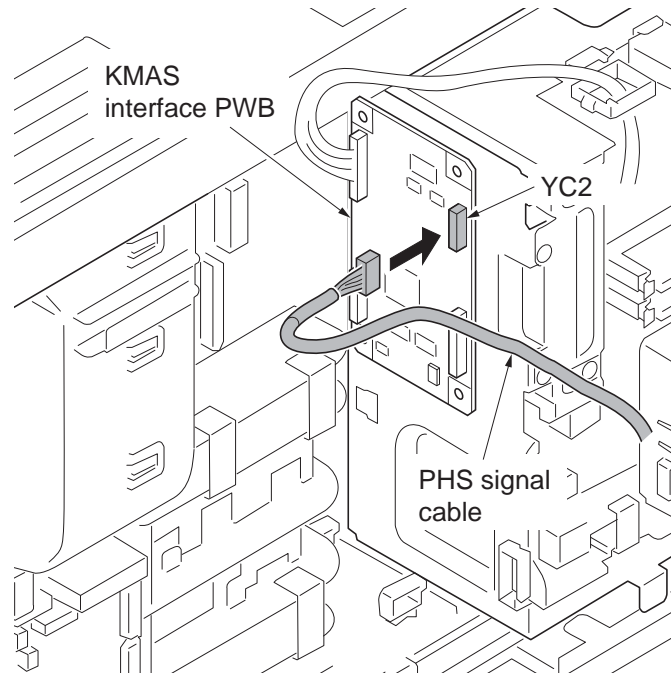
#### **Fitting the PHS signal cable and PHS module**

8. Remove two screws and then remove the lid from the rear upper cover.
9. Pass the PHS signal cable through the aperture in the rear upper cover.
10. Secure the PHS signal cable to rear upper cover with two screws.

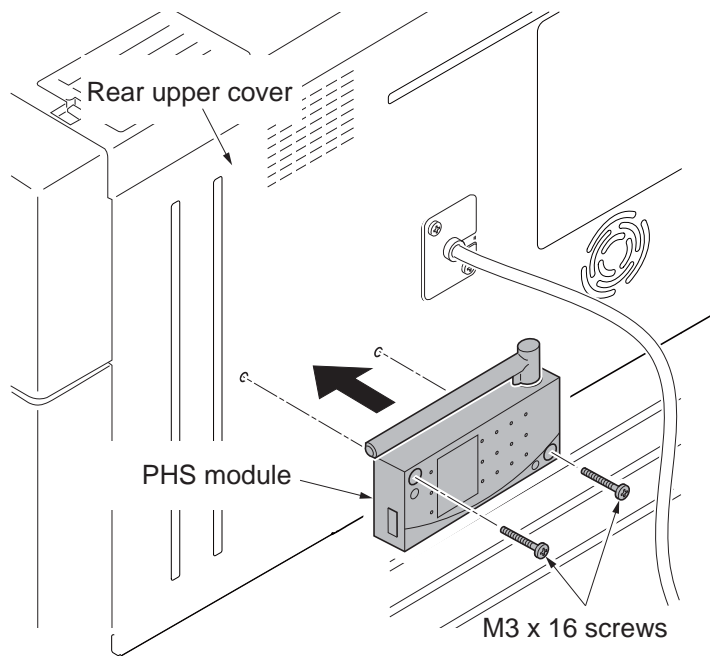


**Figure 1-2-74**

11. Connect the connector of the PHS signal cable to the connector YC2 on the KMAS interface PWB.
12. Refit the rear upper cover.

**Figure 1-2-75**

13. Fit the PHS module to rear upper cover using two M3 x 16 screws.

**Figure 1-2-76**

14. Wrap the PHS signal cable around the ferrite core a turn.
15. Connect the connector of the PHS signal cable to PHS module.
16. Fit the clamp to PHS signal cable.
17. After using alcohol to clean the rear upper cover, adhere the clamp to rear upper cover.

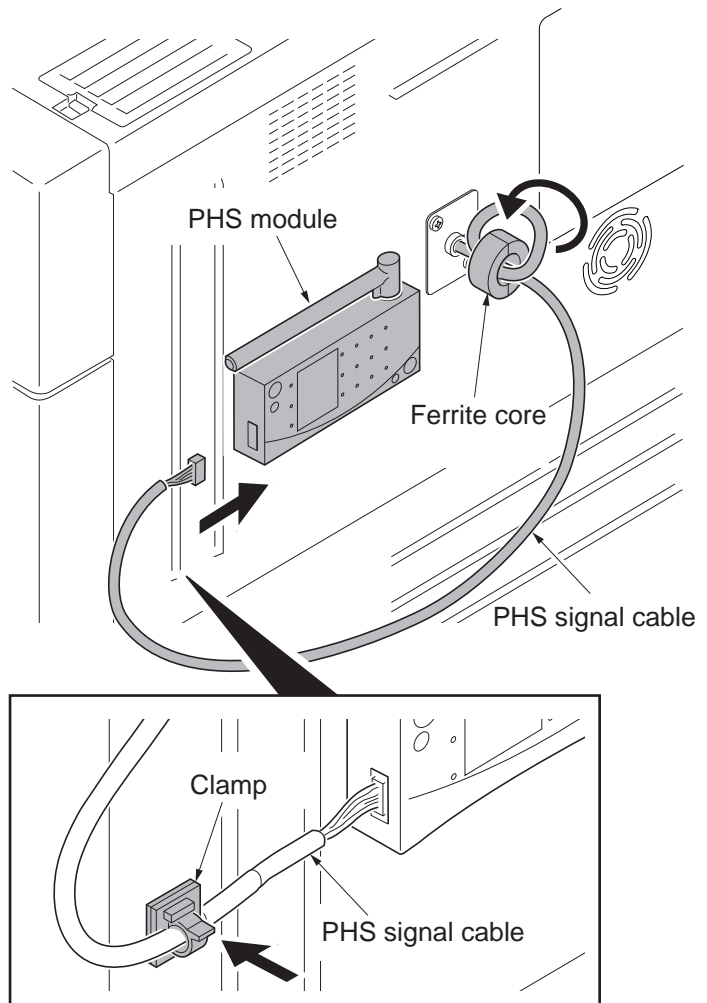


Figure 1-2-77

### Fitting the RS-232C signal cable

1. By referring to the instructions given to fix the PHS signal wire, insert the connector at the end of the RS-232C relay cable to the YC3 connector on the KMAS interface PWB.  
If the wire length is short, use a RS-232C extension cable.
2. Connect the RS-232C signal cable to the modem.

### Initializing the KMAS

1. Turn the main power switch on and enter the maintenance mode.
2. Run maintenance item U202 and Perform [Init/Set TEL No.] (see page 1-3-99).
3. Exit the maintenance mode.

## 1-2-6 Installing the coin vender (option for japan only)

Coin vender installation requires the following parts:

Parts	Quantity	Part.No.
Coin vender	1	1905H99JP0 (option)
Vender wire	1	Supplied with coin vender
Vender base	1	
M4 x 6 screw	4	
Ferrite core	1	
Clamp	1	
Vender signal cable	1	302K946AE0

### Procedure

1. Press the power key on the operation panel to off. Make sure that the power indicator and the memory indicator are off before turning off the main power switch. And then unplug the power cable from the wall outlet.
2. Fit the vender base to coin vender using four M4 x 6 screws.

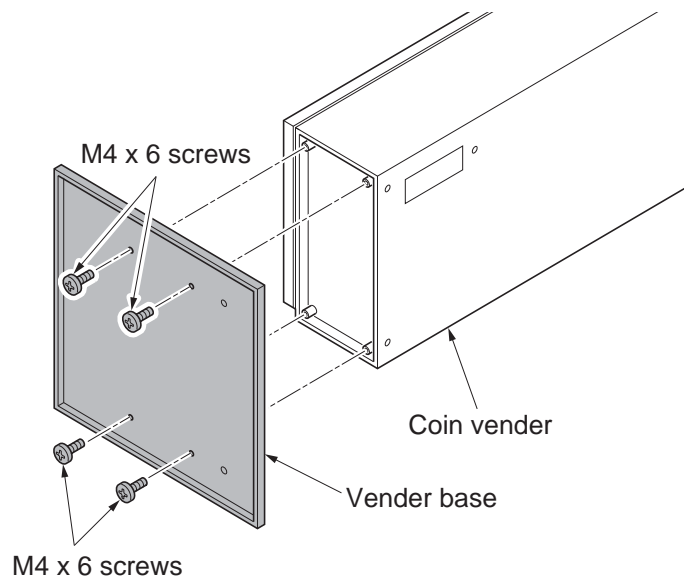
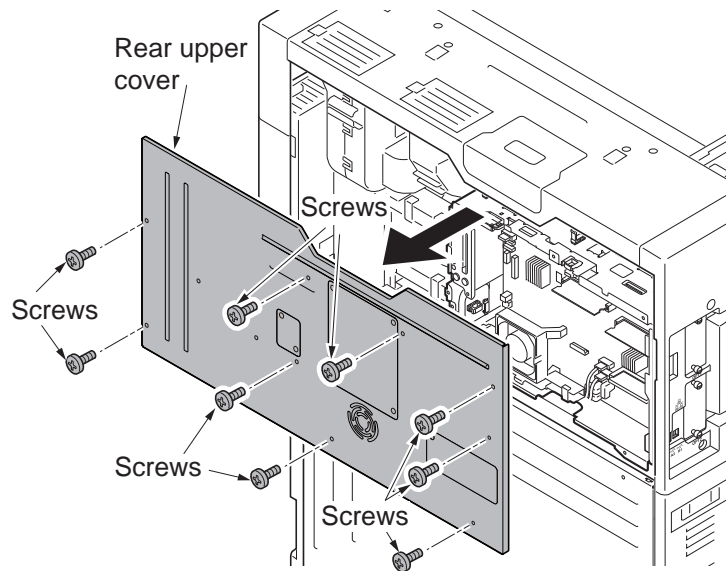
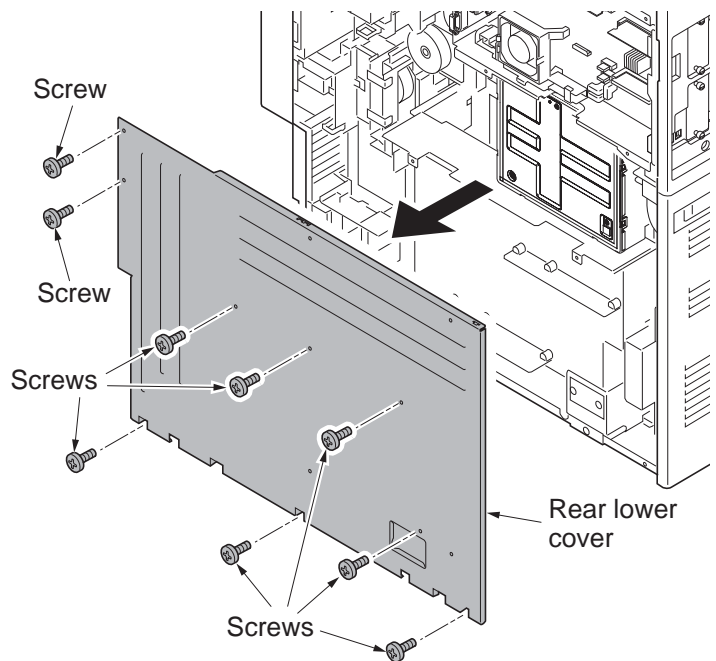


Figure 1-2-78

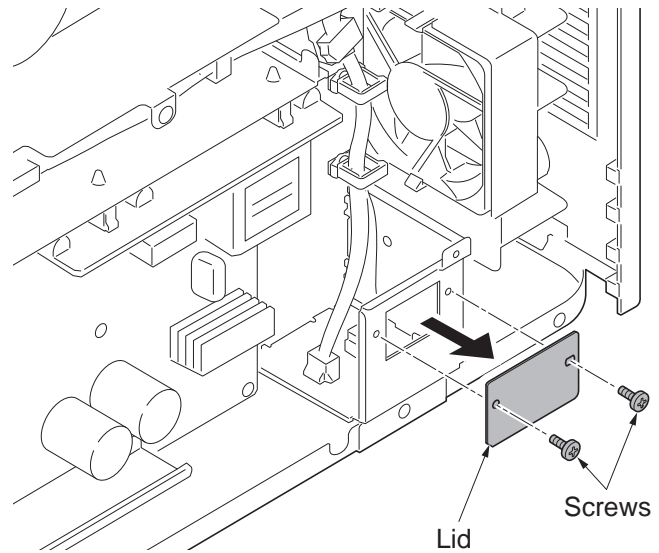
3. Remove nine screws and then remove the rear upper cover.

**Figure 1-2-79**

4. Remove nine screws.
5. Release two hanging parts and then remove the rear lower cover.

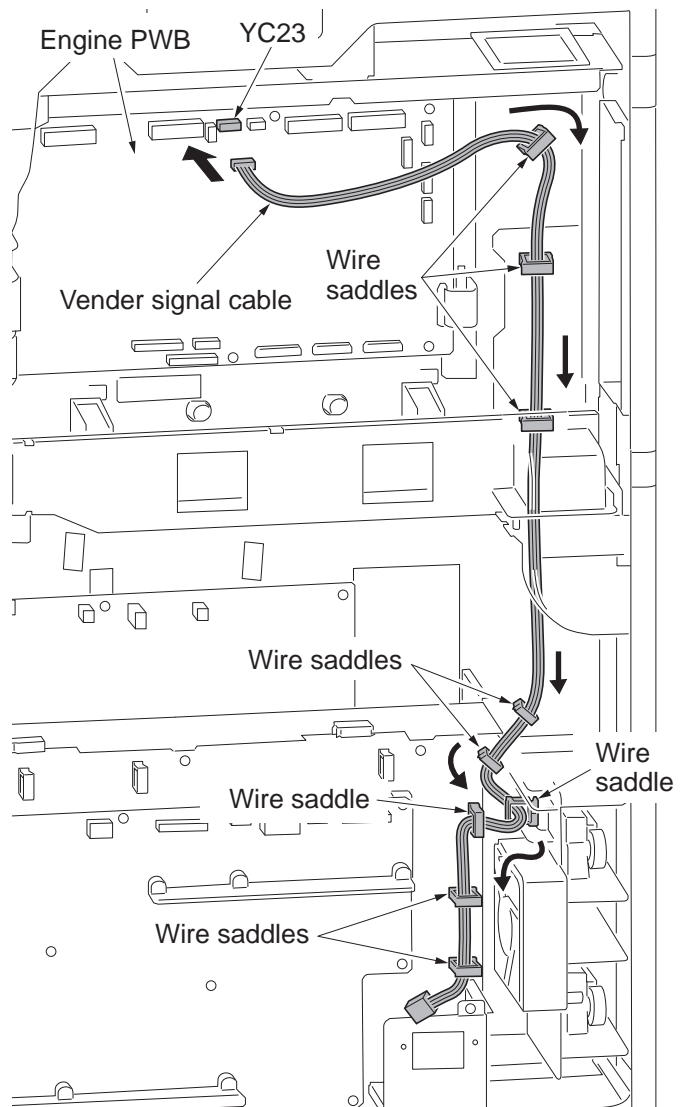
**Figure 1-2-80**

6. Remove two screws and then remove the lid.



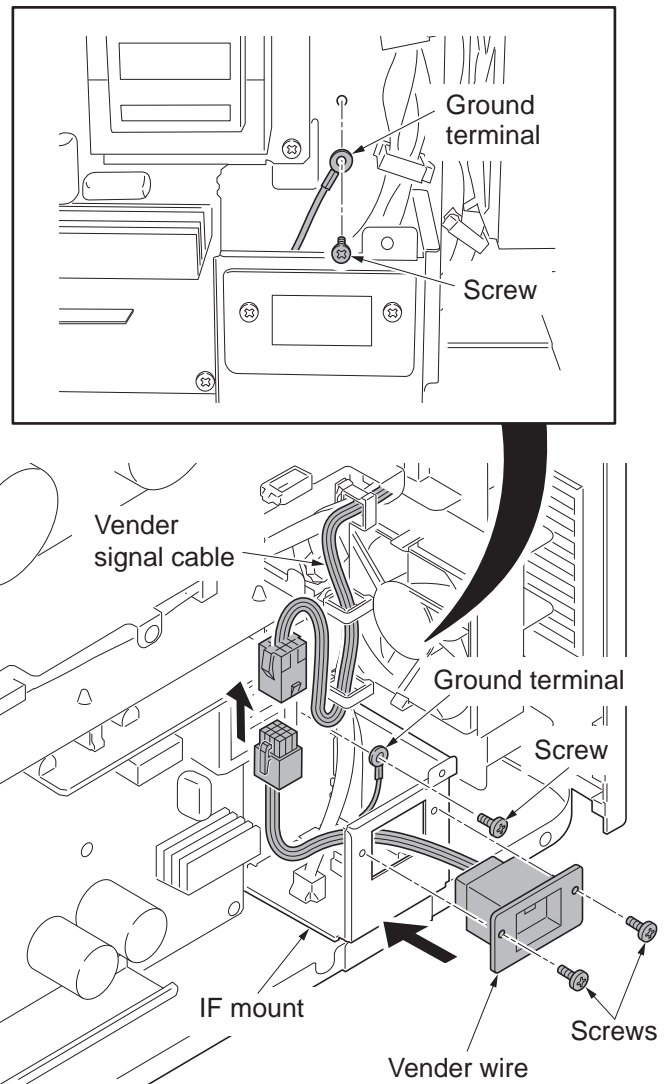
**Figure 1-2-81**

7. Connect the connector of the vender signal cable to the connector YC23 on the engine PWB.
8. Pass the vender signal cable through nine wire saddles and then fasten the cable.



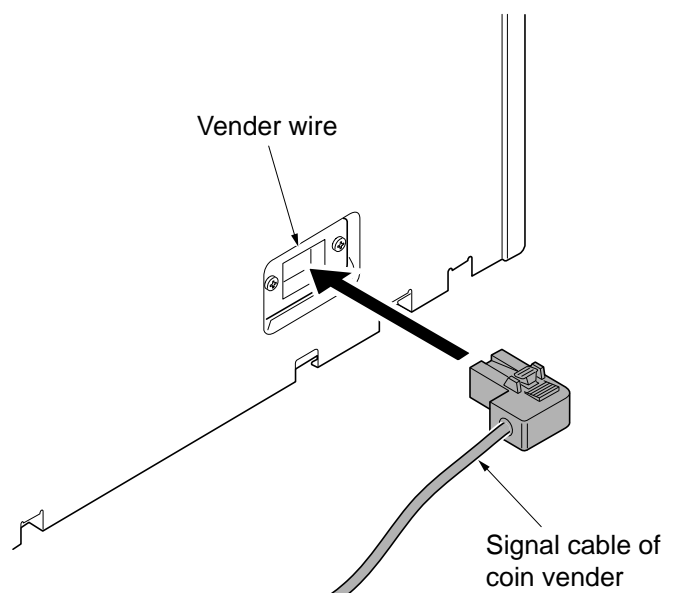
**Figure 1-2-82**

9. Pass the vender wire through the aperture in the IF mount.
10. Secure the vender wire with two screws removed in step 6.
11. Secure the ground terminal of the vender wire to rear frame with the screw.
12. Connect the connector of the vender wire to connector of the vender signal cable.



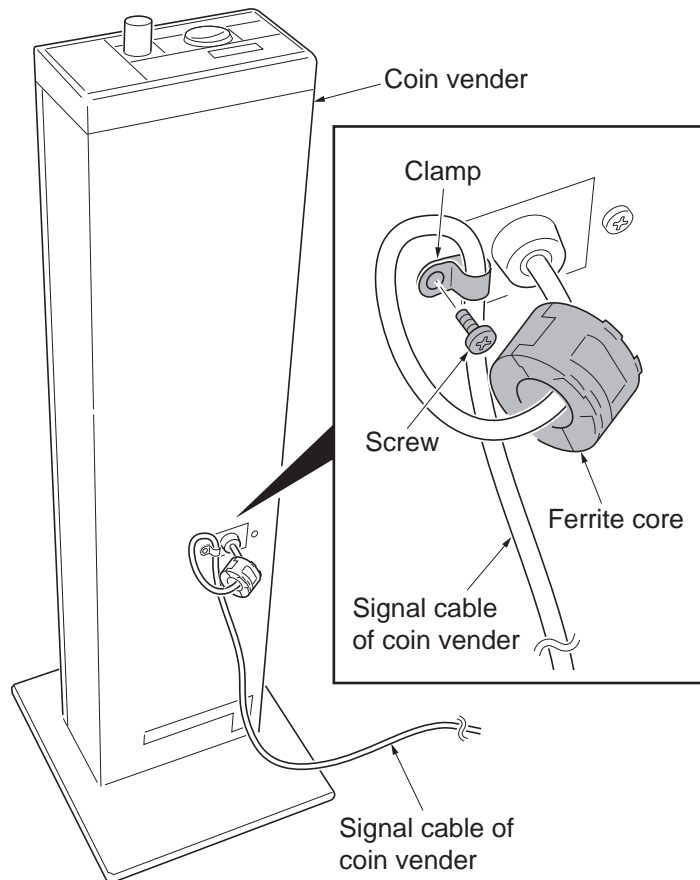
**Figure 1-2-83**

13. Refit the rear lower and upper covers.
14. Connect the signal cable of coin vender to connector of the vender wire.



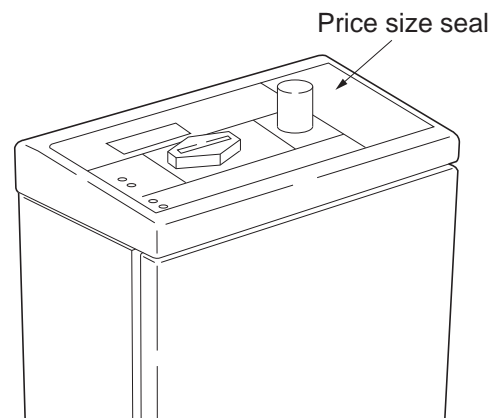
**Figure 1-2-84**

15. Fit the ferrite core to signal cable of coin vender.
16. Fit the clamp to signal cable of coin vender.
17. Remove a screw from the coin vender and fix the coin vender with a clamp.



**Figure 1-2-85**

18. Affix the price size decal at the right side of the coin vender operation panel.



**Figure 1-2-86**

19. Turn the main power switch on and enter the maintenance mode.
20. Run maintenance mode U206 and activate 'Coin vender is installed.' Continue configuring the coin vender required (see page **1-3-102**).
21. Exit the maintenance mode.



## 1-2-7 Installing the cassette heater (option)

Cassette heater installation requires the following parts:

Parts	Quantity	Part.No.
Cassette heater set (120V)	1	302K994931
Cassette heater set (240V)	1	302K994941

Supplied parts of cassette heater set (302K994931):

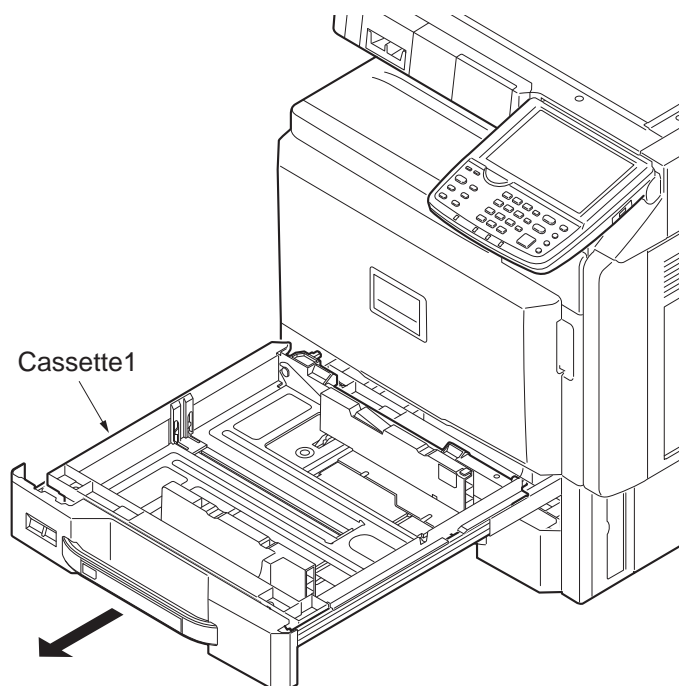
Parts	Quantity	Part.No.
Cassette heater (120V)	1	302H794620
Wire saddle	3	7YZM610001++H01
Caution label	1	302KP34220
Cover Connector	1	303NF04140
M3 x 8 tap-tight S screw	2	7BB700308H
M4 x 8 tap-tight S screw	1	7BB700408H

Supplied parts of cassette heater set (302K994941):

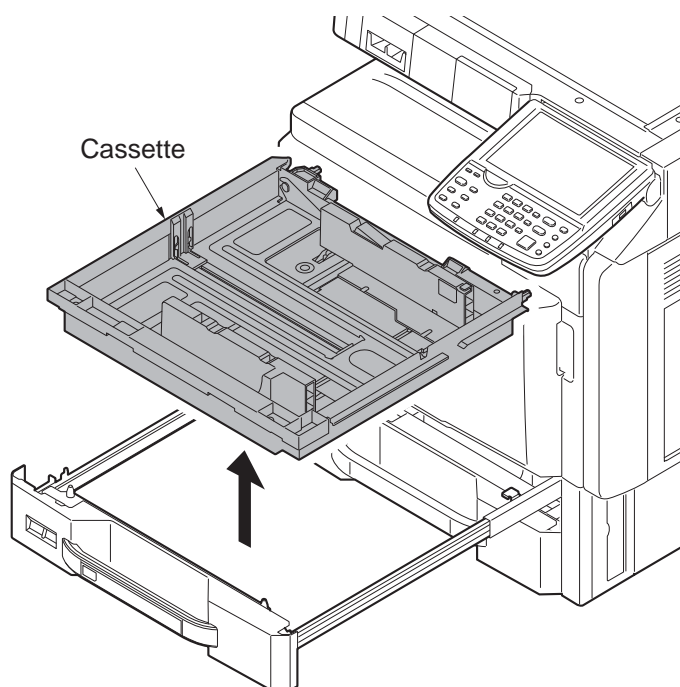
Parts	Quantity	Part.No.
Cassette heater (240V)	1	302H794610
Wire saddle	3	7YZM610001++H01
Caution label	1	302KP34220
Cover Connector	1	303NF04140
M3 x 8 tap-tight S screw	2	7BB700308H
M4 x 8 tap-tight S screw	1	7BB700408H

**Procedure**

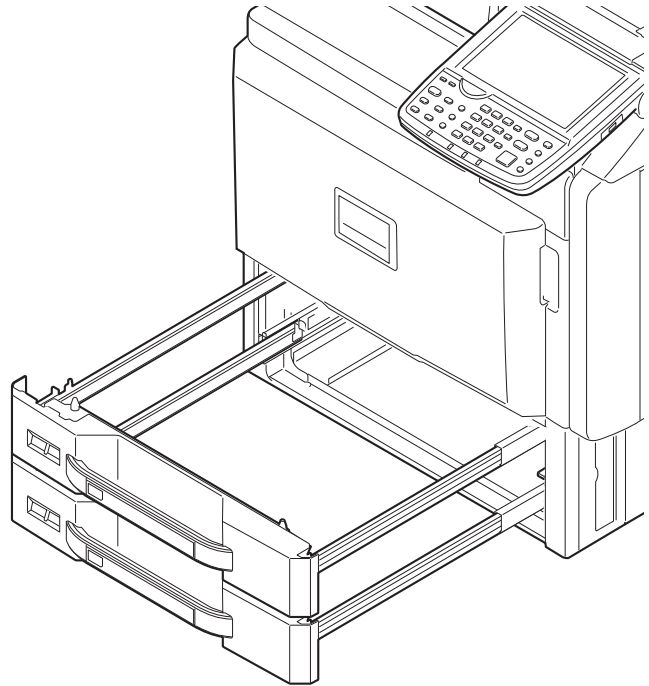
1. Press the power key on the operation panel to off. Make sure that the power indicator and the memory indicator are off before turning off the main power switch. And then unplug the power cable from the wall outlet.
2. Pull the cassette 1 forward.

**Figure 1-2-87**

3. Pull up the cassette.

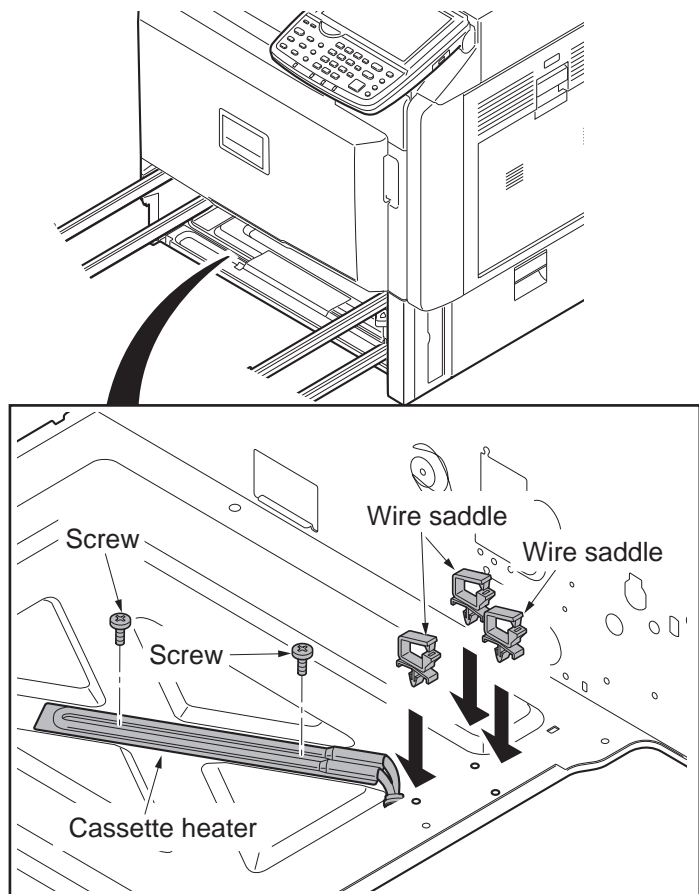
**Figure 1-2-88**

- Remove the cassette 2 in the same manner as above.



**Figure 1-2-89**

- Fit three wire saddles on the bottom frame of the machine.
- Fit the cassette heater using two M3 x 8 screws.



**Figure 1-2-90**

7. Pass the wire of the cassette heater through three wire saddles and then fasten the wire.
- \*: Route the wire so that it do not disturb opening and closing the cassettes.
8. Connect the connector of the cassette heater to the connector in the rear frame of the machine.

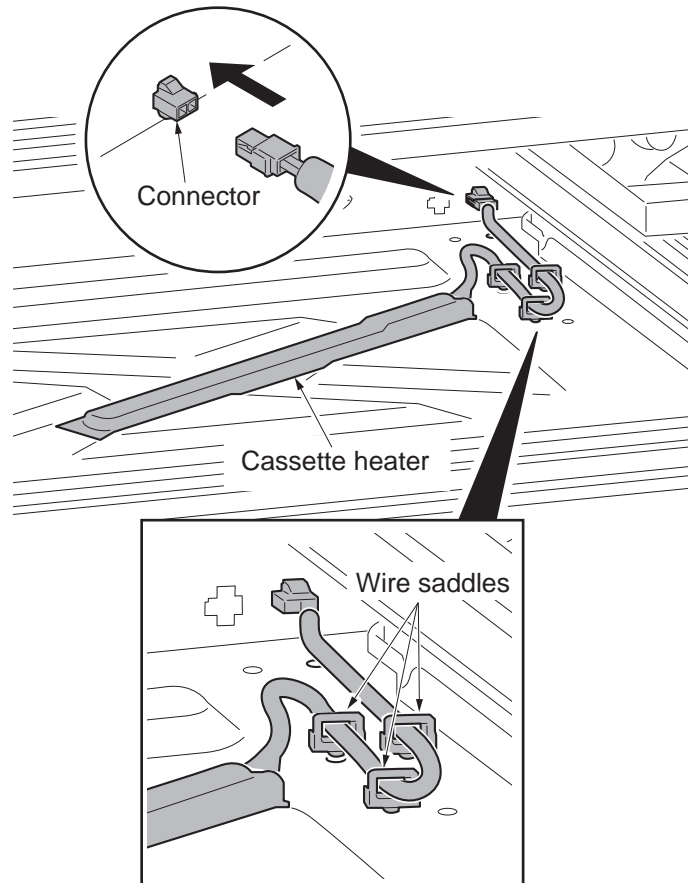


Figure 1-2-91

9. Insert two hooks of the connector cover to the holes of base of the machine each.
10. Install the connector cover by using a M4 x 8 screw.

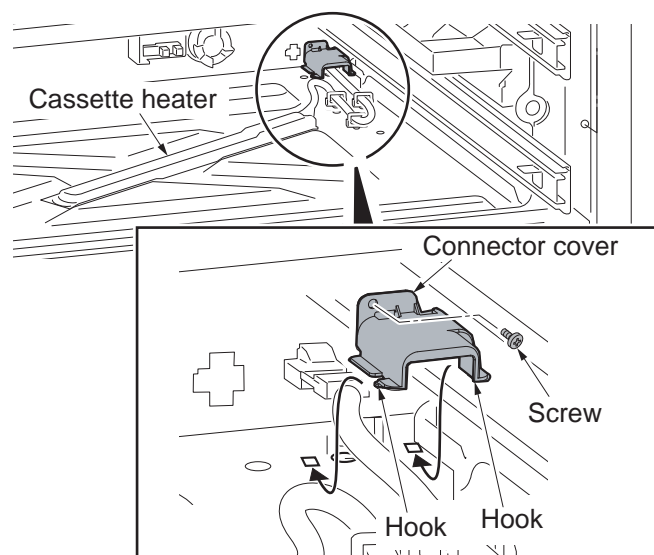
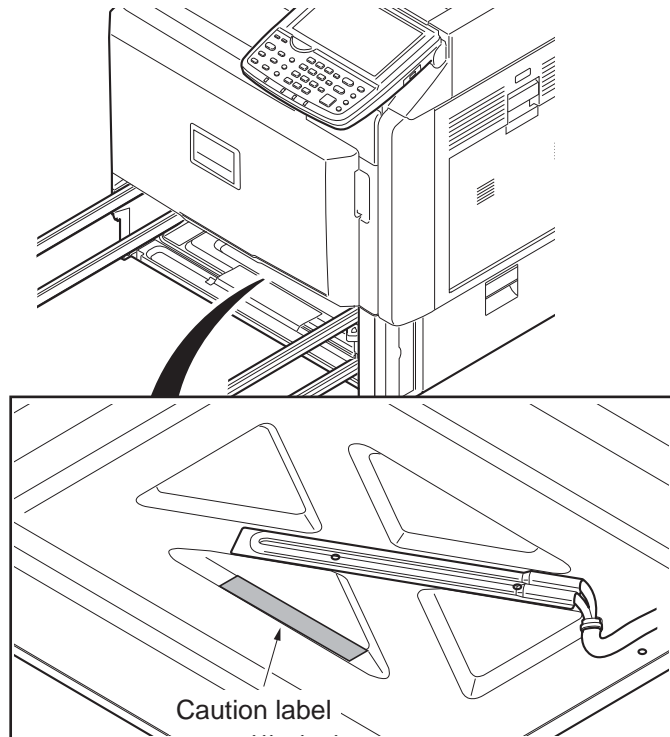


Figure 1-2-92

11. Adhere the caution label after wiping the bottom frame of this side of cassette heater with alcohol.



**Figure 1-2-93**

12. Replace the cassette 1 and the cassette 2.

\*: Perform the maintenance mode U327 to configure the cassette heater control settings after a cassette heater was installed.

## 1-2-8 Installing the gigabit ethernet board (option)

Gigabit ethernet board installation requires the following parts:

Parts	Quantity	Part.No.
Gigabit ethernet board	1	1505JV0UN0 (option)

### Procedure

1. Press the power key on the operation panel to off. Make sure that the power indicator and the memory indicator are off before turning off the main power switch. And then unplug the power cable from the wall outlet.
2. Remove two pins and then remove the slot cover of the OPT2.

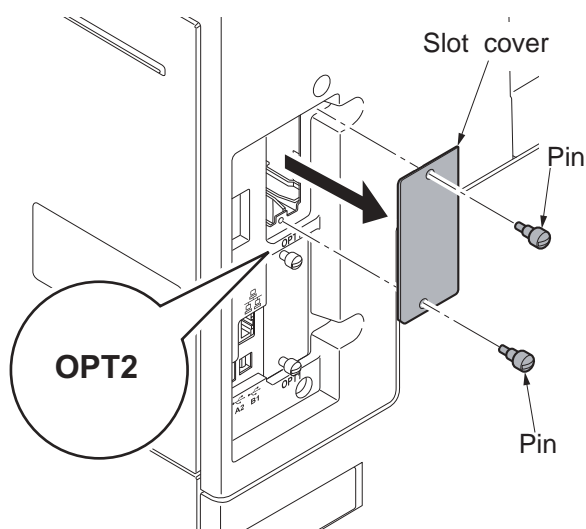


Figure 1-2-94

3. Insert the gigabit ethernet board along the groove in OPT2 and secure the board with two pins that have been removed in step 3.
- \*: Do not directly touch the gigabit ethernet board terminal.  
Hold the top and bottom of the gigabit ethernet board, or the projection of the board to insert the gigabit ethernet board.

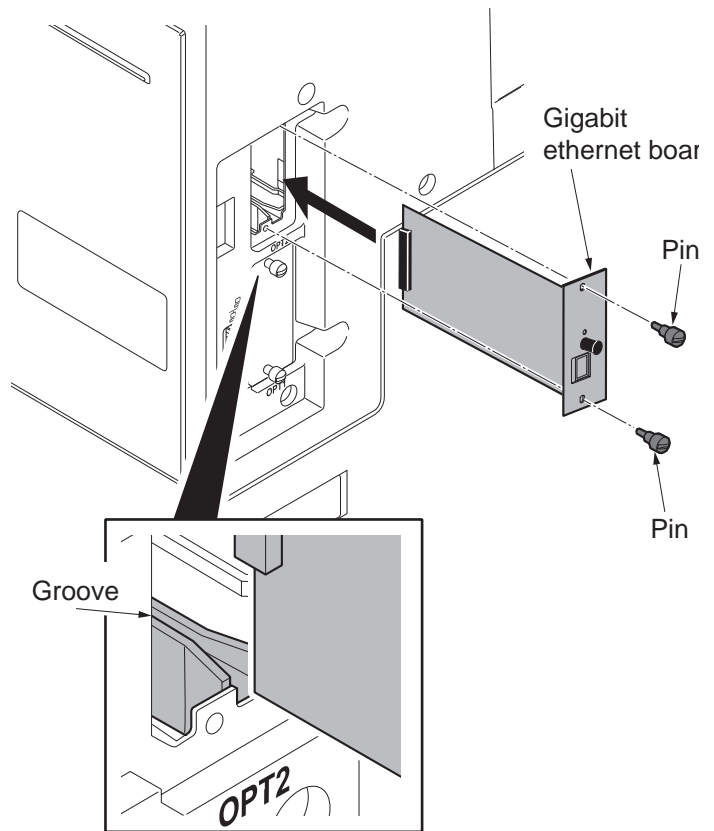


Figure 1-2-95

4. Plug the modular connector cable into the line terminal,

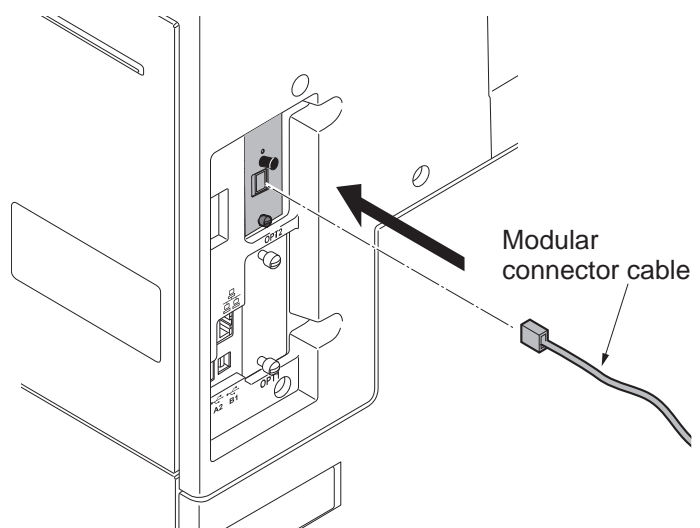


Figure 1-2-96

## 1-2-9 Installing the Wire-less interface kit (option)

Wire-less interface kit installation requires the following parts:

Parts	Quantity	Part.No.
Wire-less interface kit	1	1505J50UN0 (option)

### Procedure

1. Press the power key on the operation panel to off. Make sure that the power indicator and the memory indicator are off before turning off the main power switch. And then unplug the power cable from the wall outlet.
2. Remove two pins and then remove the slot cover of the OPT2.

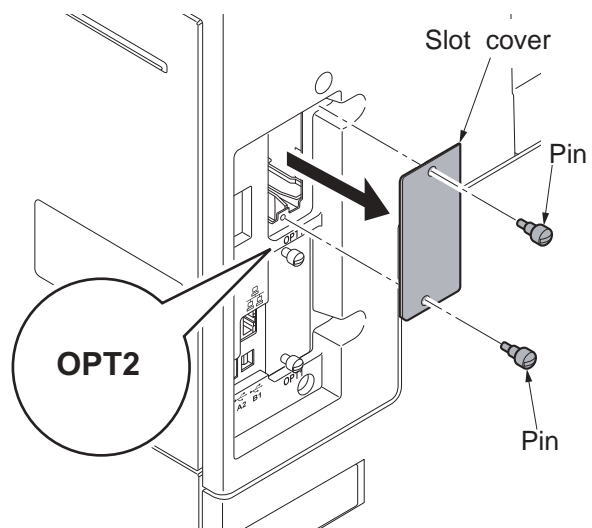


Figure 1-2-97



3. Insert the wire-less interface kit along the groove in OPT2 and secure the board with two pins that have been removed in step 2.

\*: Do not directly touch the wire-less interface kit terminal.

Hold the top and bottom of the wire-less interface kit, or the projection of the board to insert the wire-less interface kit.

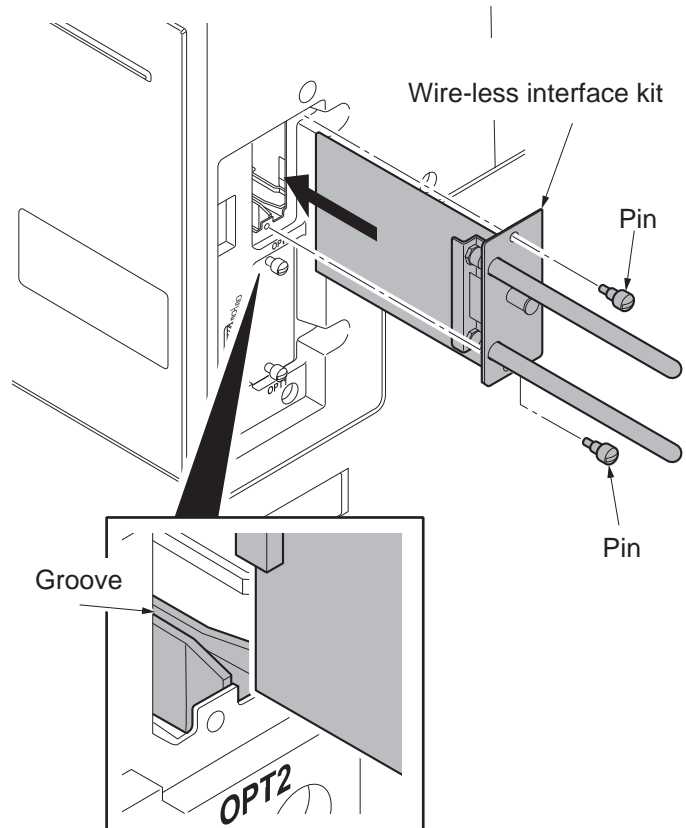


Figure 1-2-98

## 1-2-10 Installing the IC card reader holder (option)

IC card reader holder installation requires the following parts:

Parts	Quantity	Part.No.
IC card reader holder	1	1709AD0UN1 (option)

Supplied parts of IC card reader holder (1709AM0UN0):

Parts	Quantity	Part.No.
IC card reader holder	1	-
Label	1	-
Bundling band	1	-
Hook and loop fastener	2	-
Spacer	2	-

### Procedure

1. Press the power key on the operation panel to off. Make sure that the power indicator and the memory indicator are off before turning off the main power switch. And then unplug the power cable from the wall outlet.
2. Remove the staple holder.
3. Remove a screw and then remove the staple cover.

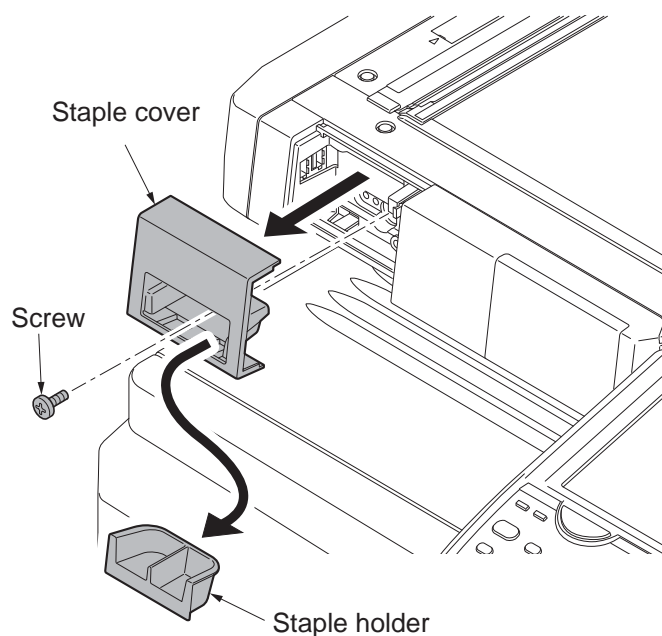
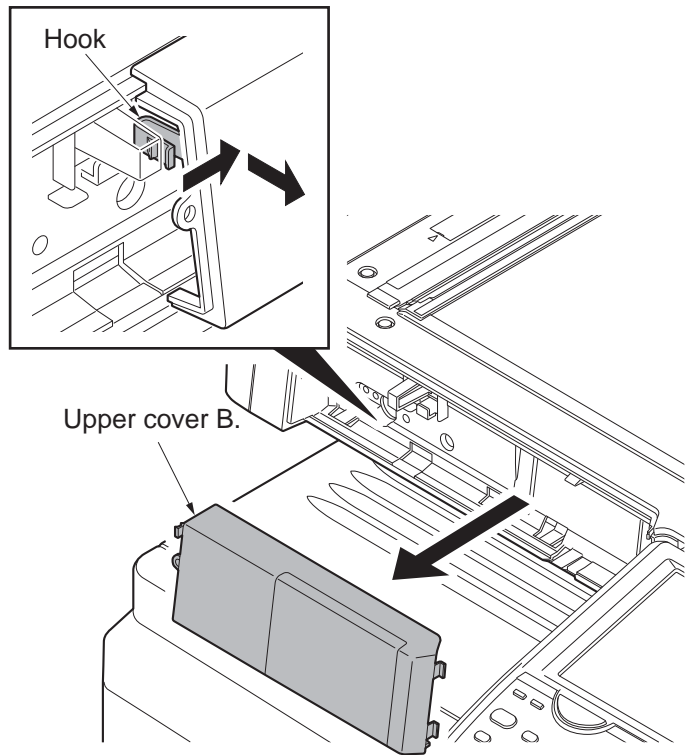


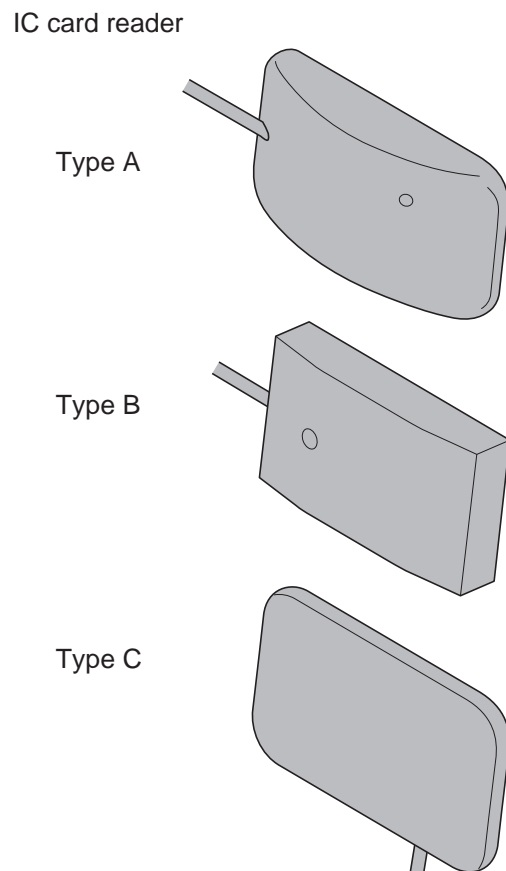
Figure 1-2-99

- Remove the hook and remove the upper cover B.



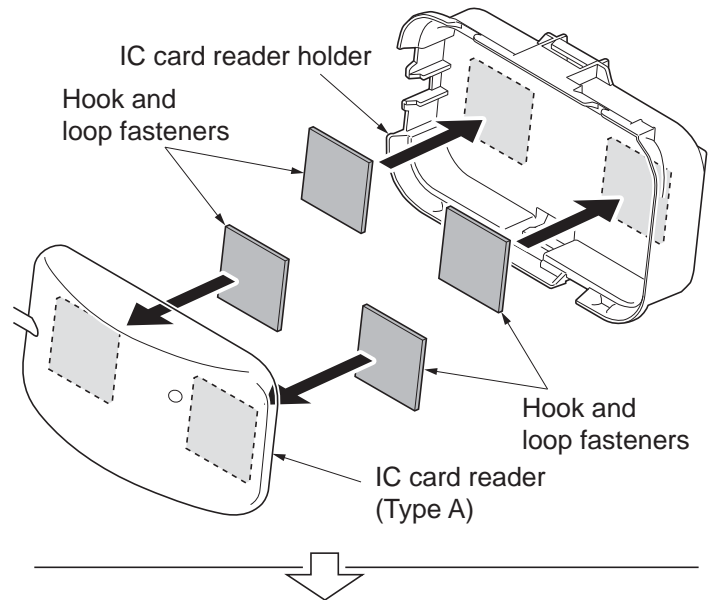
**Figure 1-2-100**

- The mounting procedure differs depending type of IC card readers.
  - Type A:  
Thicker and in the same size as its holder  
Continue to step 6.
  - Type B:  
Thicker but smaller than its holder  
Continue to step 8.
  - Type C:  
Thinner and in the same size as its holder  
Continue to step 11.



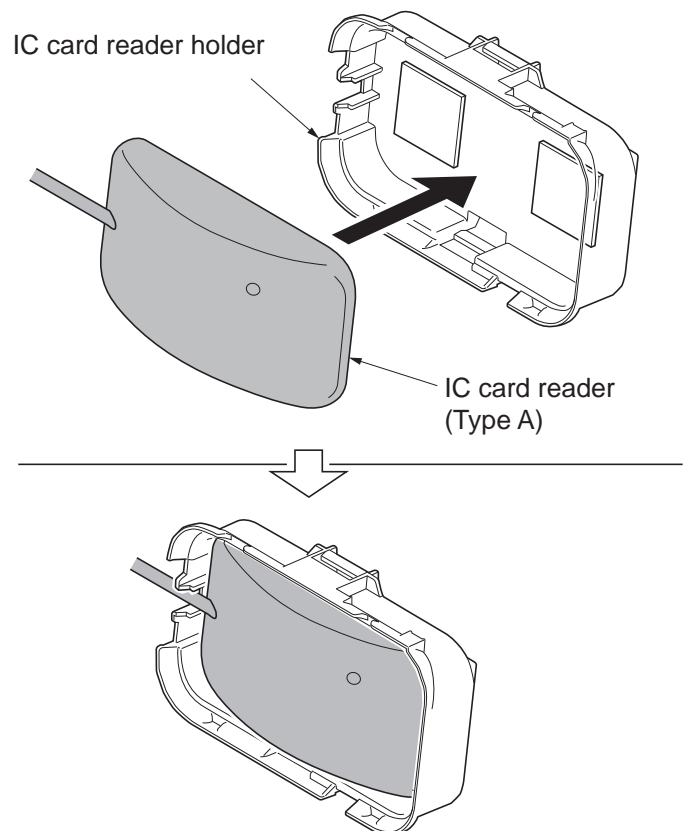
**Figure 1-2-101**

6. Affix two hook and loop fasteners to the IC card reader and IC card reader holder.



7. Mount the IC card reader to the IC card reader holder.

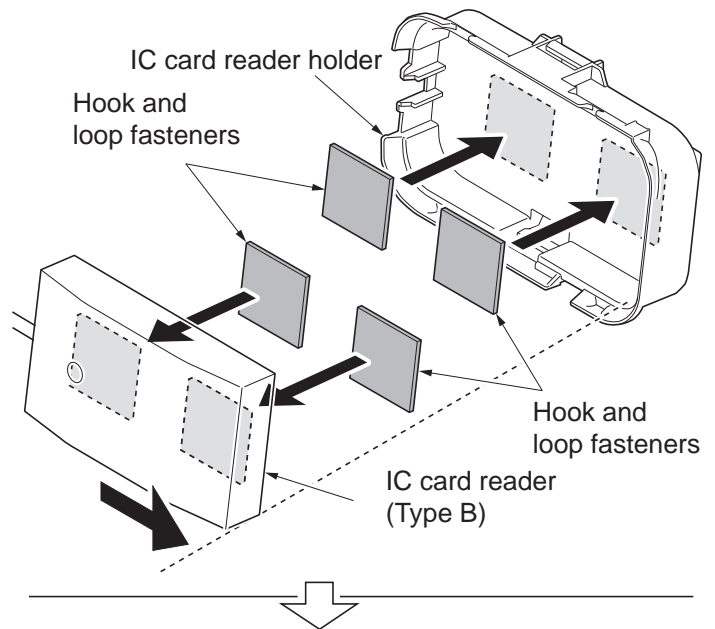
Proceed to step 10.



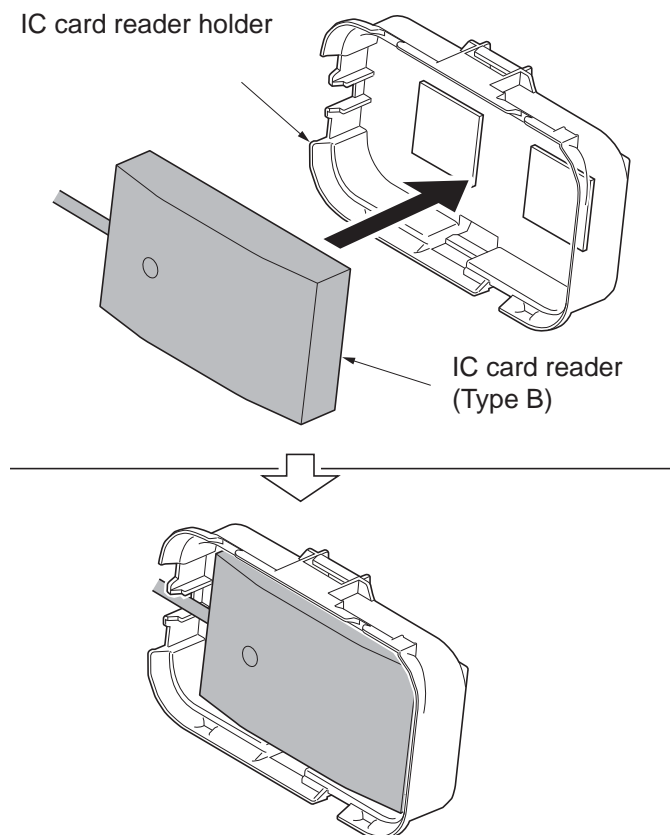
**Figure 1-2-102**

8. Affix two hook and loop fasteners to the IC card reader and IC card reader holder.

\*: Affix a hook and loop fastener onto the IC card reader so that it is mounted on the holder with both being flush with the right side edges.



9. Mount the IC card reader to the IC card reader holder.



**Figure 1-2-103**

10. Route the USB cable from the IC card reader through the IC card reader holder ribs, wind around its back and route through another rib.

\*: Make sure the cable will have a slack of more than 20 cm.

Proceed to step 15.

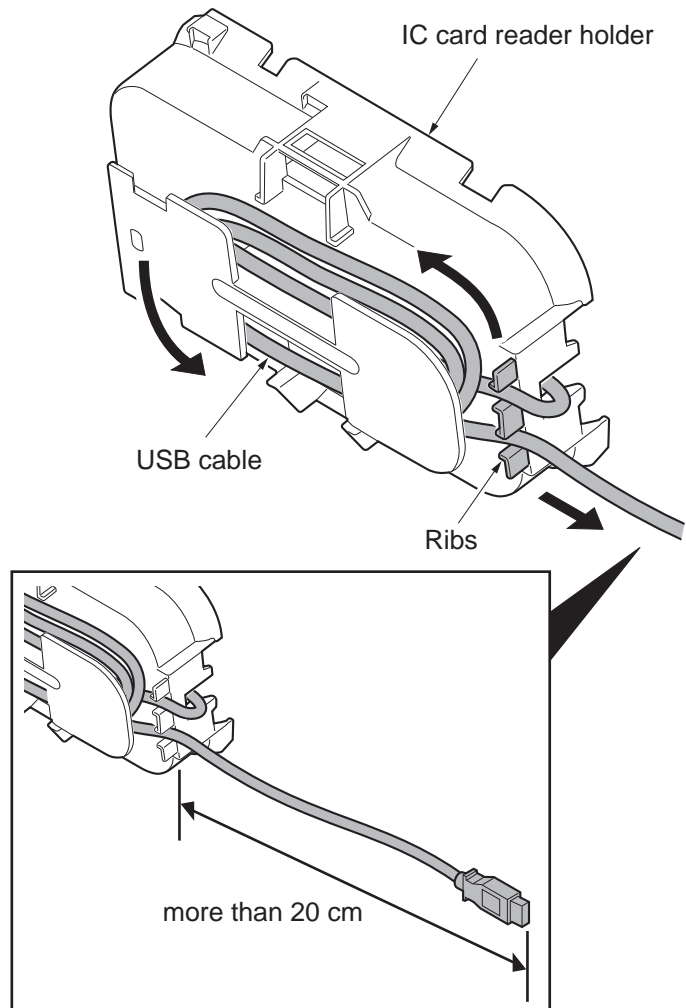
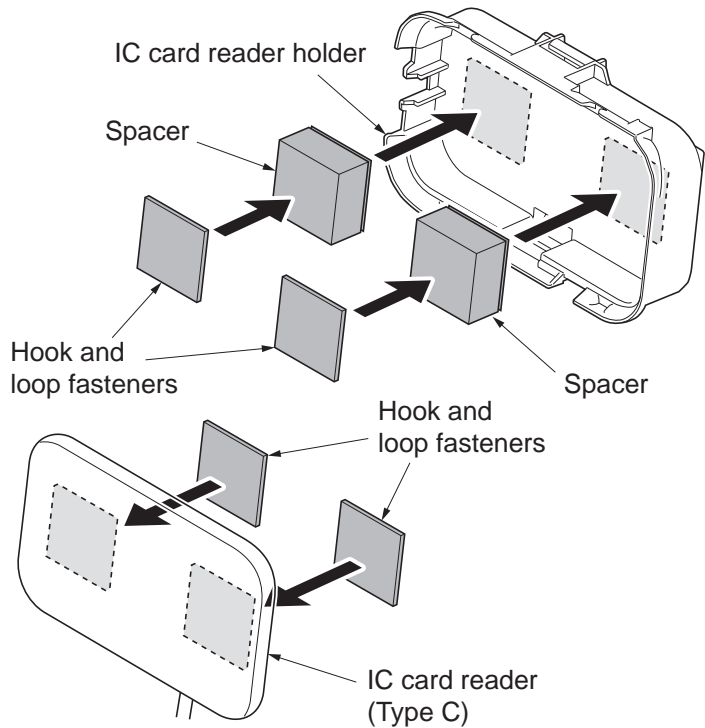
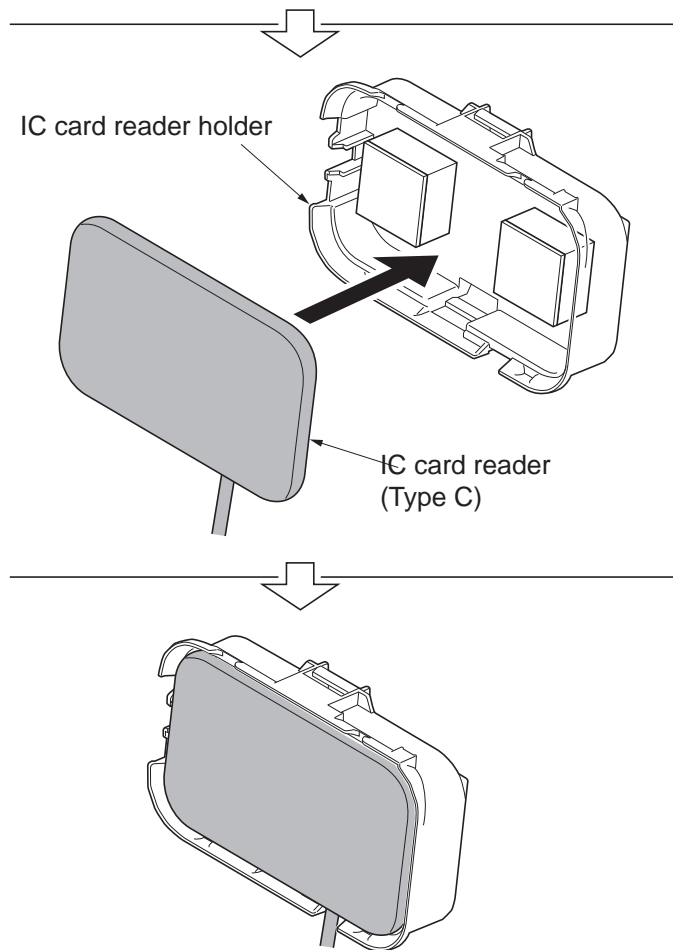


Figure 1-2-104

11. Affix two hook and loop fasteners to the IC card reader.
12. Affix a hook and loop fastener at the reverse side of the spacer where an adhesive tape has been affixed. Affix two spacers to the IC card reader.

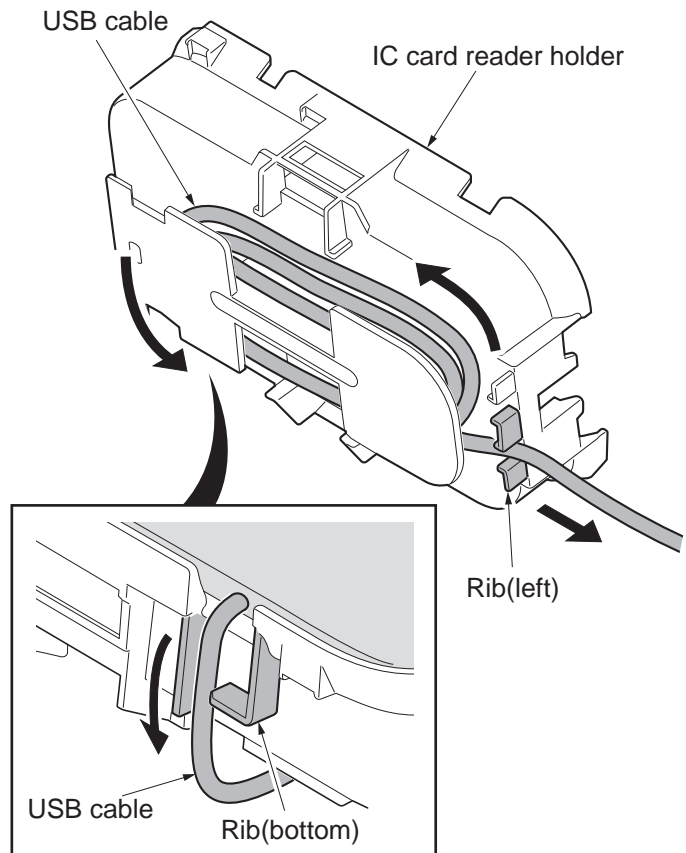


13. Mount the IC card reader to the IC card reader holder.



**Figure 1-2-105**

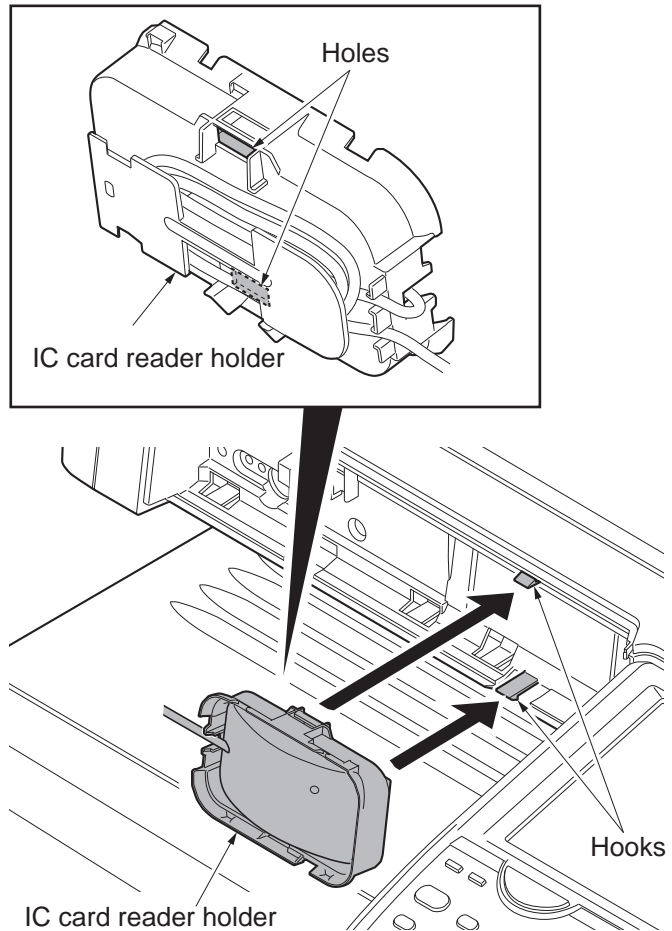
14. Route the USB cable from the IC card reader through the ribs at the bottom of the IC card reader holder, wind around its back a couple of turns, and route through the rib on the left hand side.



**Figure 1-2-106**

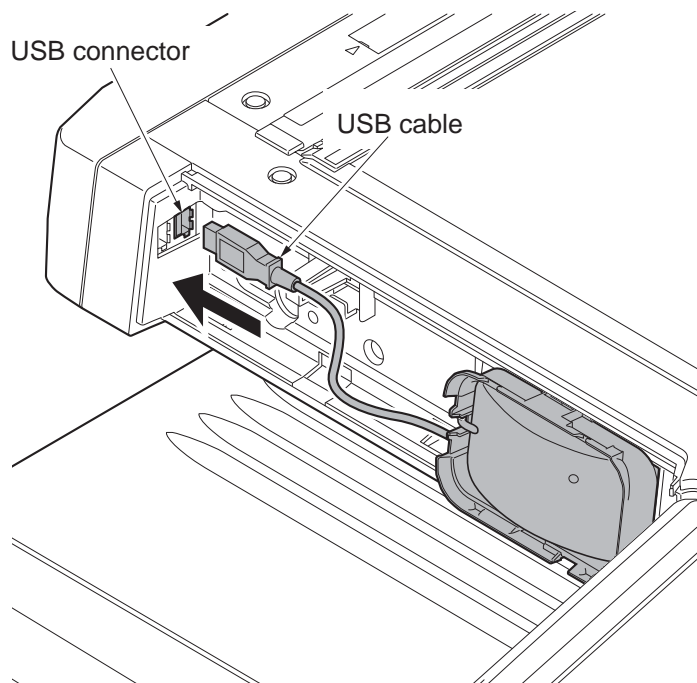


15. Hook the IC card reader holder onto the machine by mating the two holes on the holder with the hooks on the machine.



**Figure 1-2-107**

16. Connect the USB cable with the USB connector on the machine.  
If a keyboard holder is planned to be added, connect it to the connector on the far end.



**Figure 1-2-108**

17. For only type C of the IC card reader, bundle the surplus length of the cable with a bundling band and hook it on the hook.

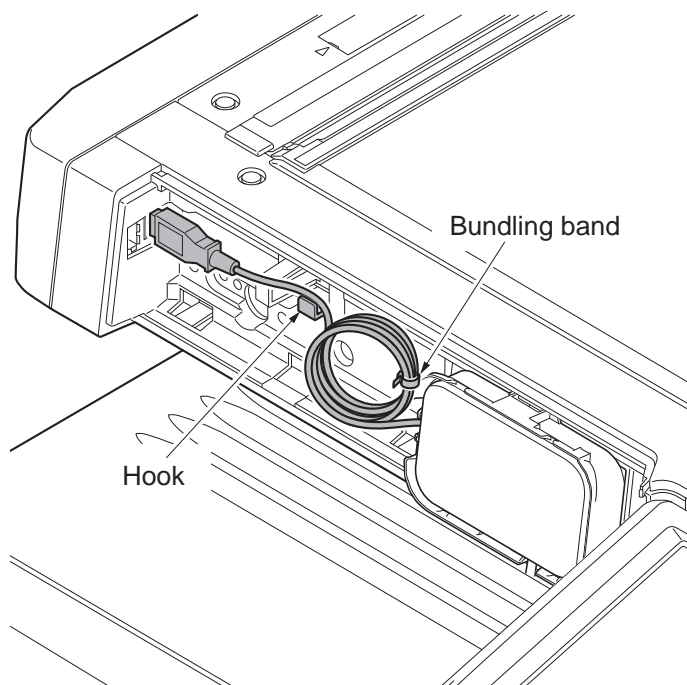


Figure 1-2-109

18. Affix a label on the upper cover B aligning it with the positioning mark.  
\*: Fix it by matching with a smoke of a different color.

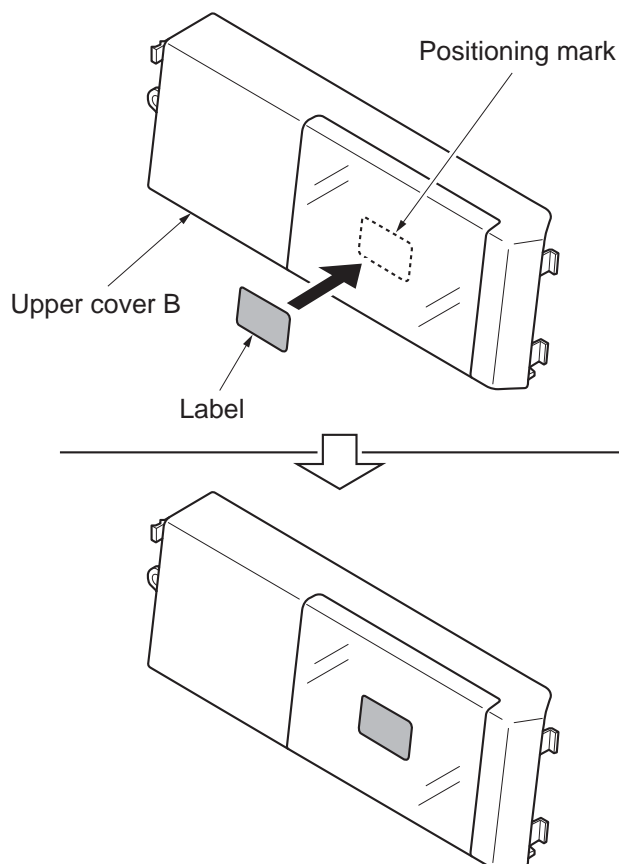
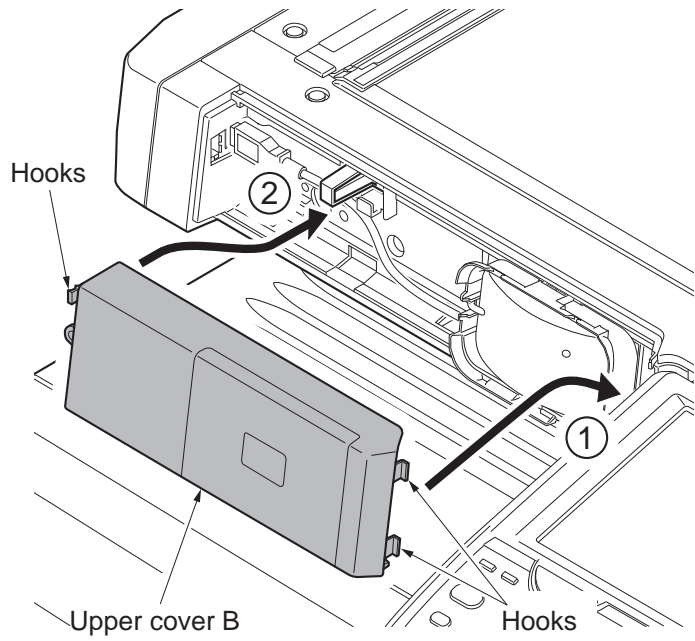


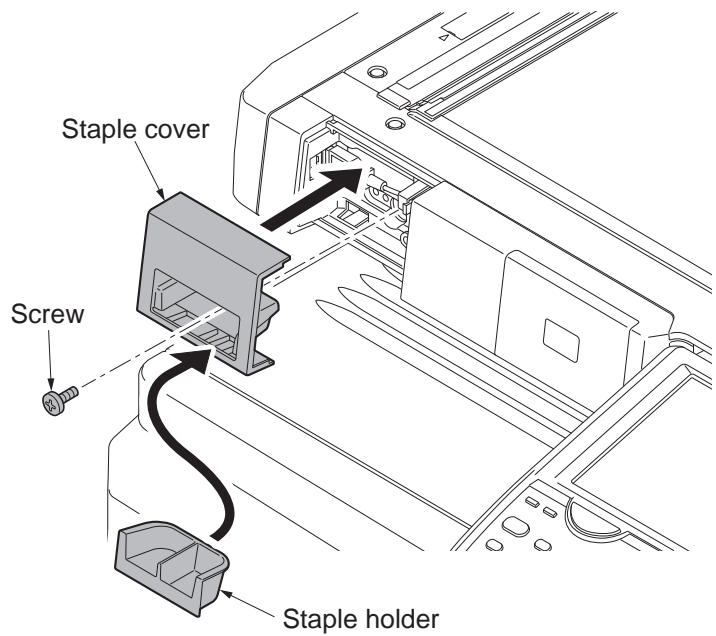
Figure 1-2-110

19. Replace the upper cover B.  
Insert the right-hand hook first, then the left-hand hook.



**Figure 1-2-111**

20. Replace the staple cover and the staple holder in their original positions.



**Figure 1-2-112**

## Enabling IC Card Authentication

### Precautions

To install the optional function, you need the License Key. Please access the designated website of your dealer or service representative, and register "Machine No." indicated on your machine and "Product ID" indicated on the License Certificate supplied with the product to issue the License Key.

1. Turn the main power switch on.
2. Press the System Menu key and then press [System/Network].  
If user login administration is disabled, the user authentication screen appears.  
Enter your login user name and password and then press [Login]. For this, you need to log in with administrator privileges.
3. Press [Next] of Optional Function.
4. Select CARD AUTHENTICATION KIT(B) and press [Activate].
5. The License Key entry screen is displayed.  
Enter the License Key using the numeric keys and press [Official].
6. Confirm the product name CARD AUTHENTICATION KIT(B) and press [Yes].
7. To use a SSFC card, run maintenance mode U222 and set SSFC.

\*: When the machine has entered sleep mode with Energy Saver ON, IC cards can not be recognized by the Card reader, since it does not wake from sleep mode. To enable the IC Card Reader in Sleep Mode, refer to the Operation Guide to change the Sleep level to OFF in the Sleep Rules at the Date/Timer/Energy Saver section of the System Menu.

\*: This setting is not necessary when the optional network interface kit is installed.

## 1-2-11 Installing the keyboard holder (option)

Keyboard holder installation requires the following parts:

Parts	Quantity	Part.No.
Keyboard holder (B)	1	1709AF0UN1 (option)

Supplied parts of keyboard holder (B) (1709AF0UN1):

Parts	Quantity	Part.No.
Upper keyboard holder	1	-
Lower keyboard holder	1	-
Upper keyboard cover	1	-
Lower keyboard cover	1	-
Cable cover	1	-
Upper lid	1	-
Lower lid	1	-
Hook and loop fastener	2	-
Bundling band	2	-
M4 x 12 tap-tight S screw	2	-
M3 x 8 tap-tight S screw	10	-
M3 x 8 tap-tight P screw	2	-

### Procedure

1. Press the power key on the operation panel to off. Make sure that the power indicator and the memory indicator are off before turning off the main power switch. And then unplug the power cable from the wall outlet.
2. Remove the staple holder.
3. Remove a screw.

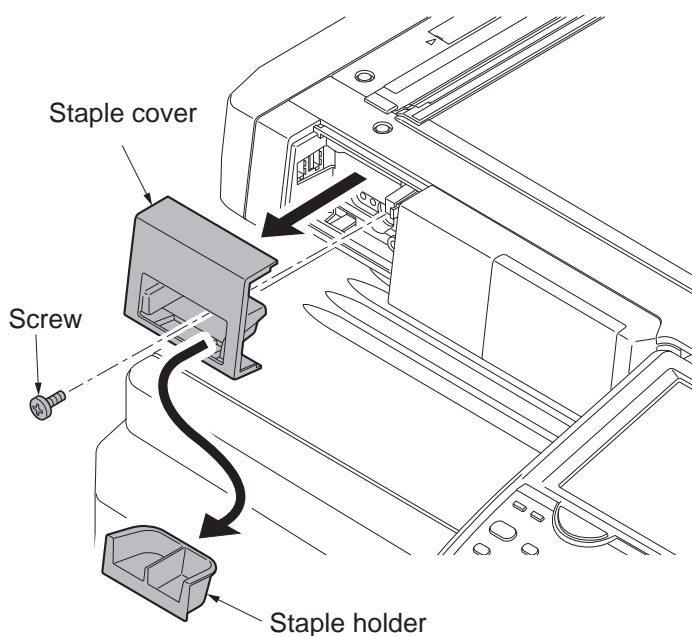
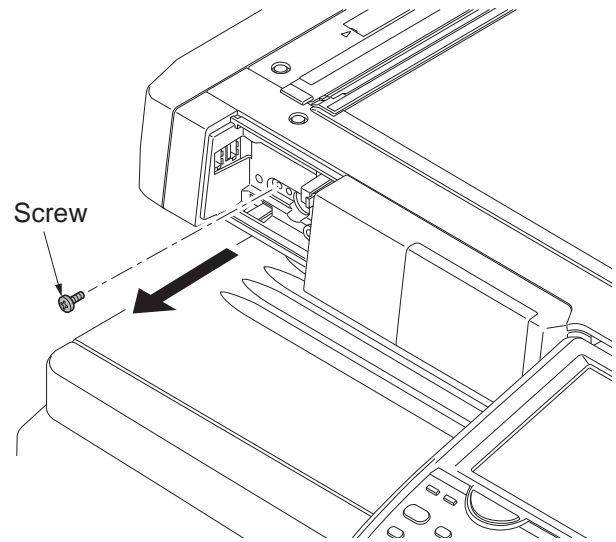


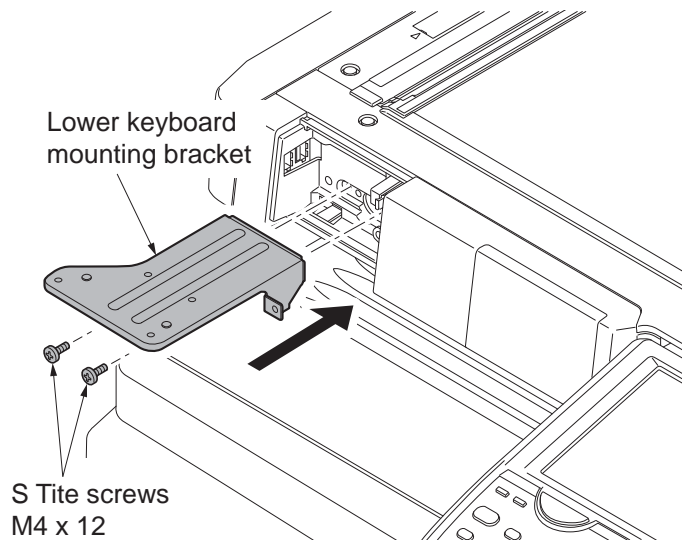
Figure 1-2-113

4. Remove a screw.



**Figure 1-2-114**

5. Fit the lower keyboard mounting bracket with the machine using the two S Tite screws M4 x 12.



**Figure 1-2-115**

6. Fix the upper keyboard mounting bracket onto the lower keyboard mounting bracket using the four S Tite screws M3 x 8. Align them with each other at the mark A.

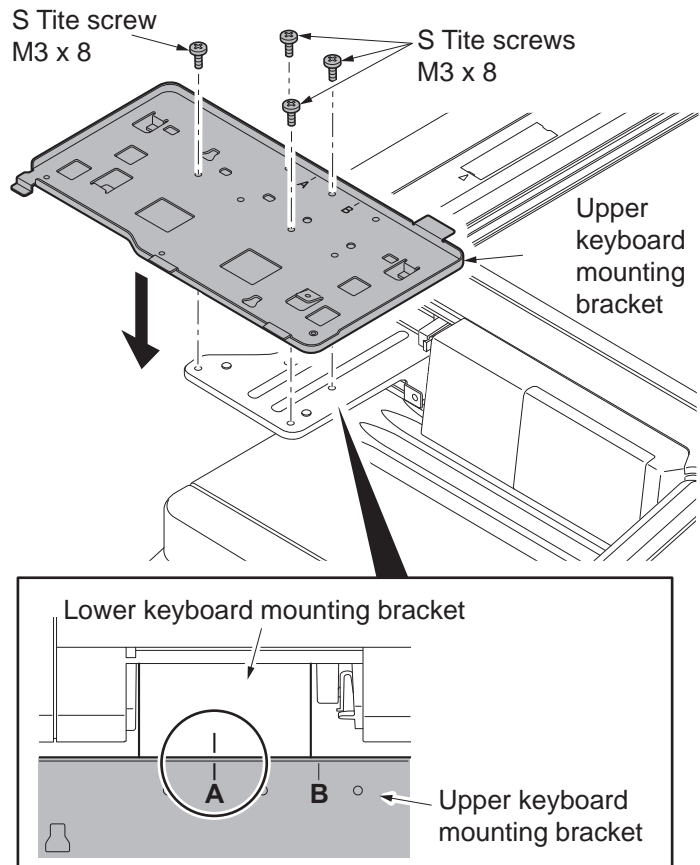


Figure 1-2-116

7. Cut out the cutaway portion of the lower keyboard cover by using a pair of nippers.

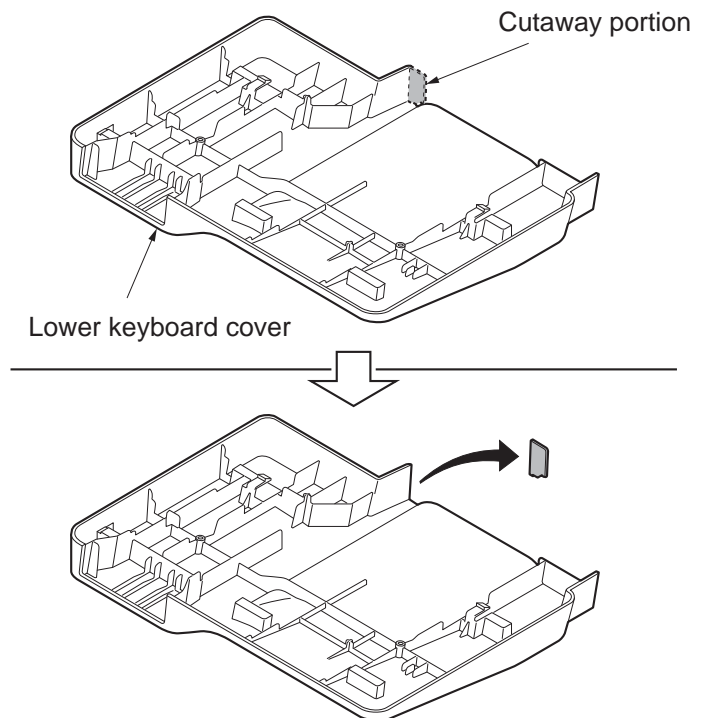


Figure 1-2-117

8. Insert the two positioning pins at the bottom of the lower keyboard cover in the holes on the keyboard mounting bracket, and slide towards the rear.
9. Latch the lower keyboard cover with the upper keyboard mount by the five hooks.

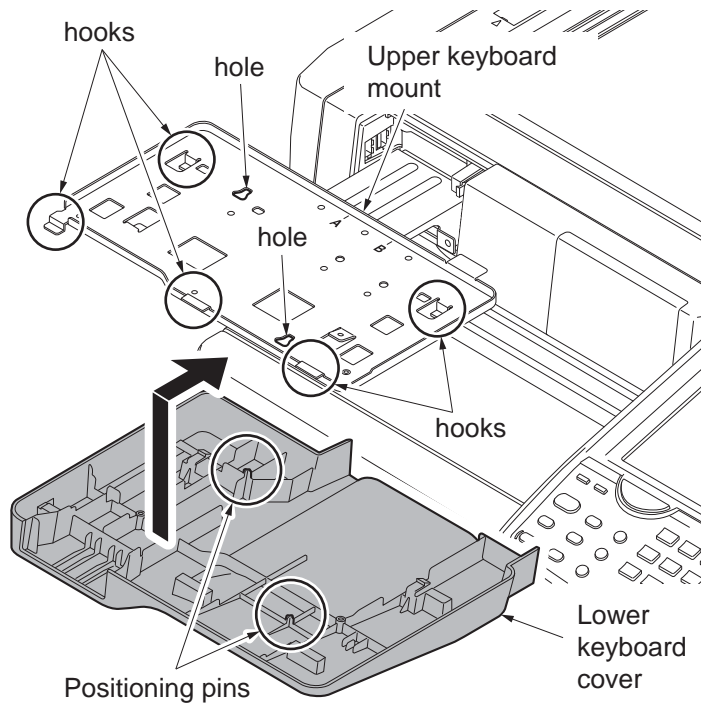


Figure 1-2-118

10. Fix the lower keyboard mounting bracket onto the upper keyboard mounting bracket using the two P Tite screws M3 x 8.

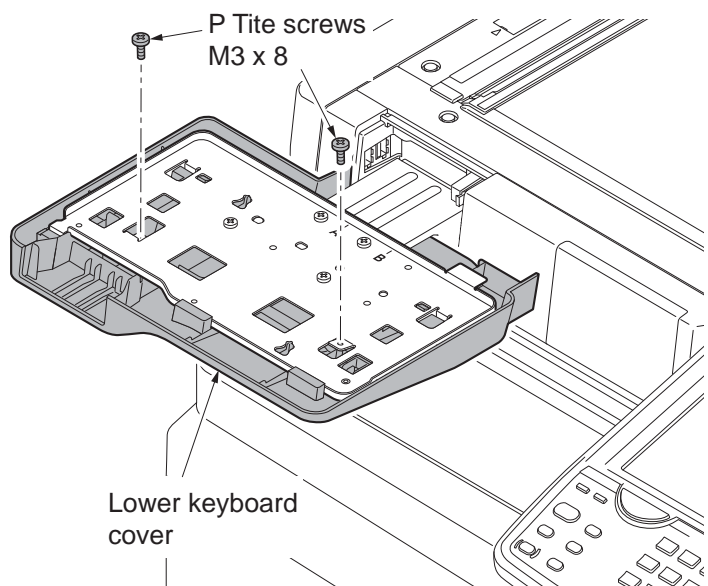
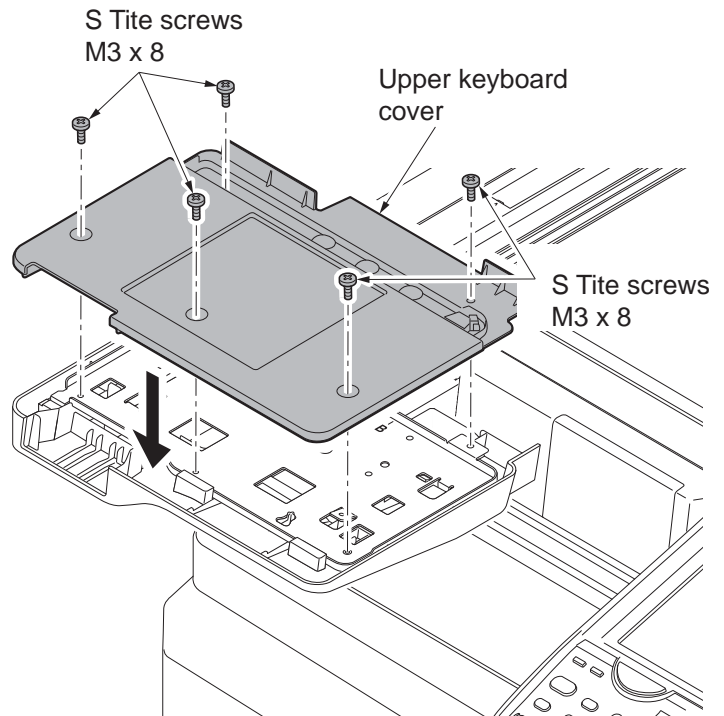


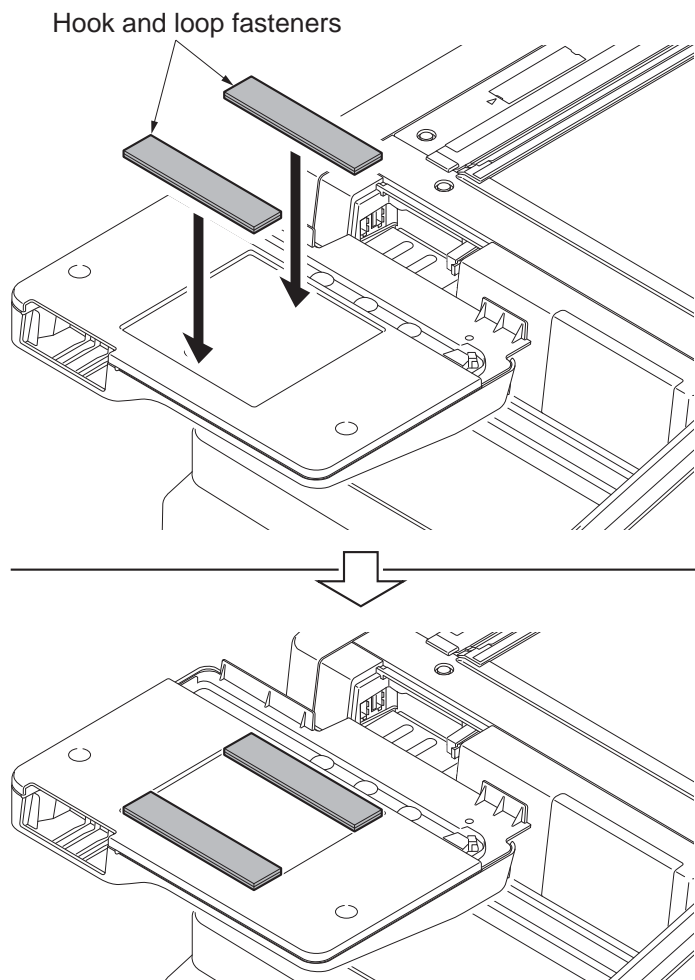
Figure 1-2-119



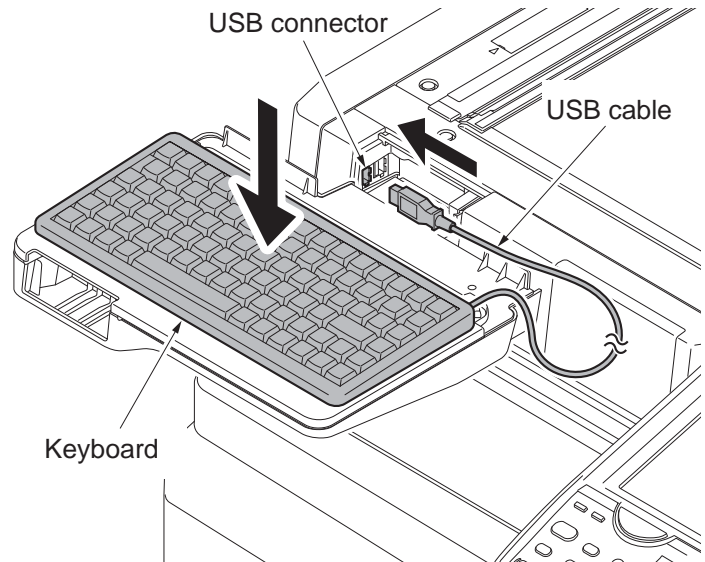
11. Fix the lower keyboard mounting bracket onto the upper keyboard mounting bracket using the two P Tite screws M3 x 8.

**Figure 1-2-120**

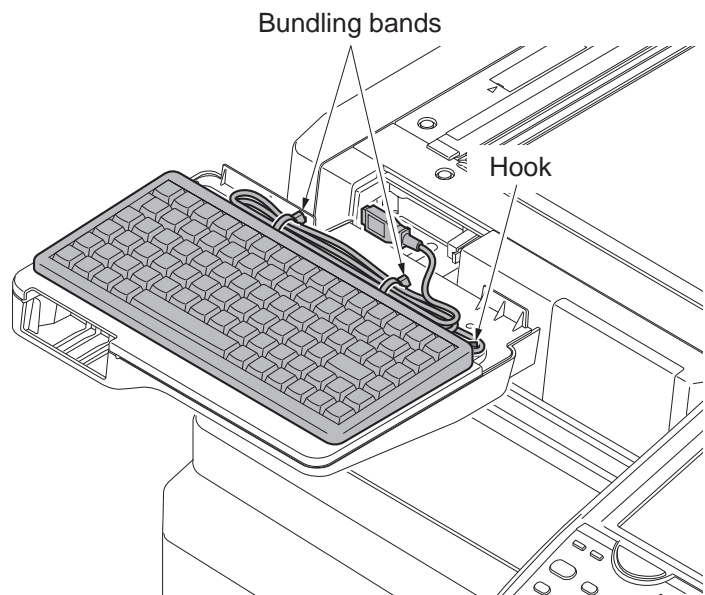
12. Affix two pieces of hook and loop fasteners on the upper keyboard cover.

**Figure 1-2-121**

13. Fix the keyboard with the hook and loop fasteners.
14. Connect the USB cable with the USB connector on the machine.

**Figure 1-2-122**

15. Bundle the surplus length of the cable with two bundling bands and hook it on the hook of the upper keyboard cover.

**Figure 1-2-123**

16. Slide the upper lid and fix in the machine.

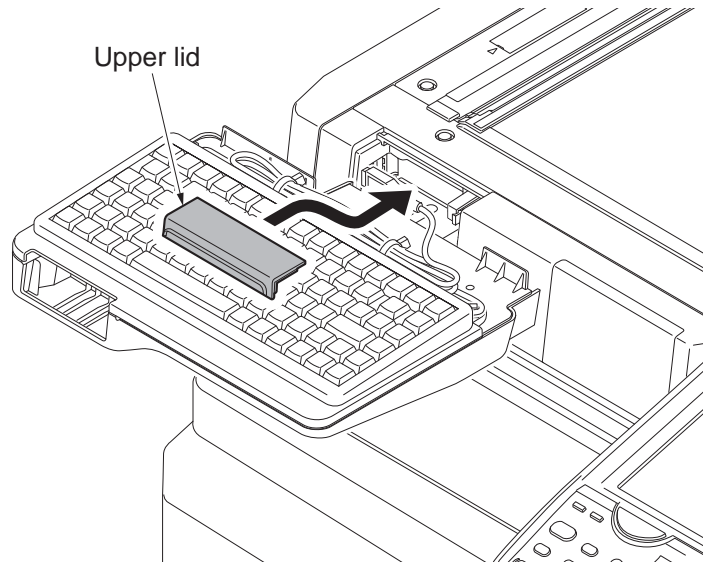


Figure 1-2-124

17. Fix the cable cover on the machine. Latch the three hooks at the near end and press the hooks downwards to mate with the holes at the far end.

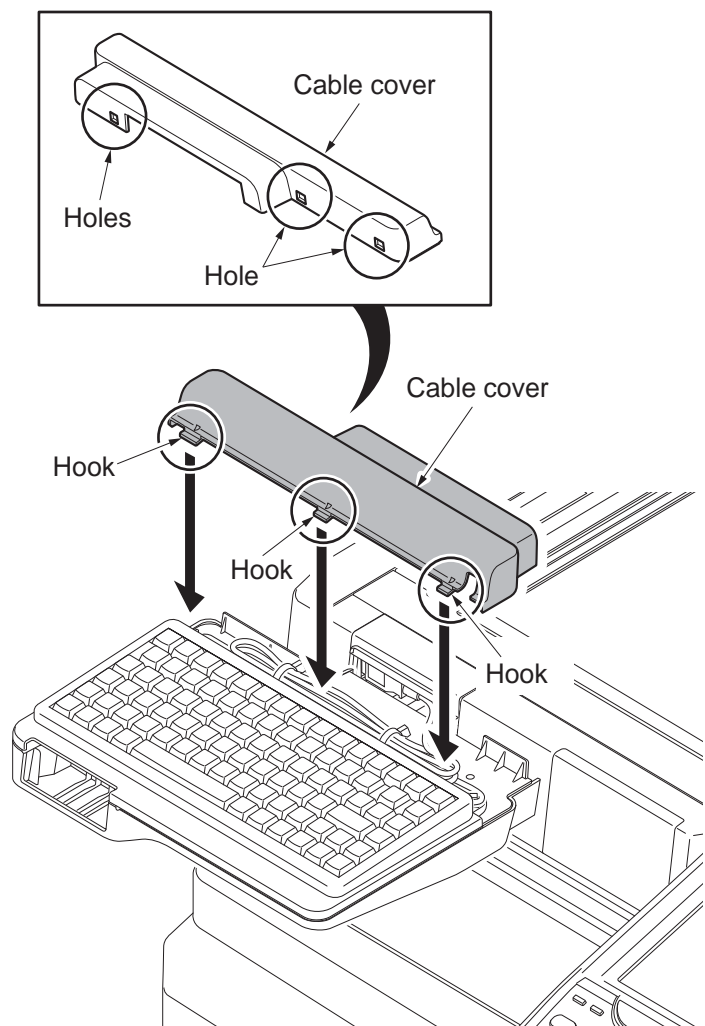
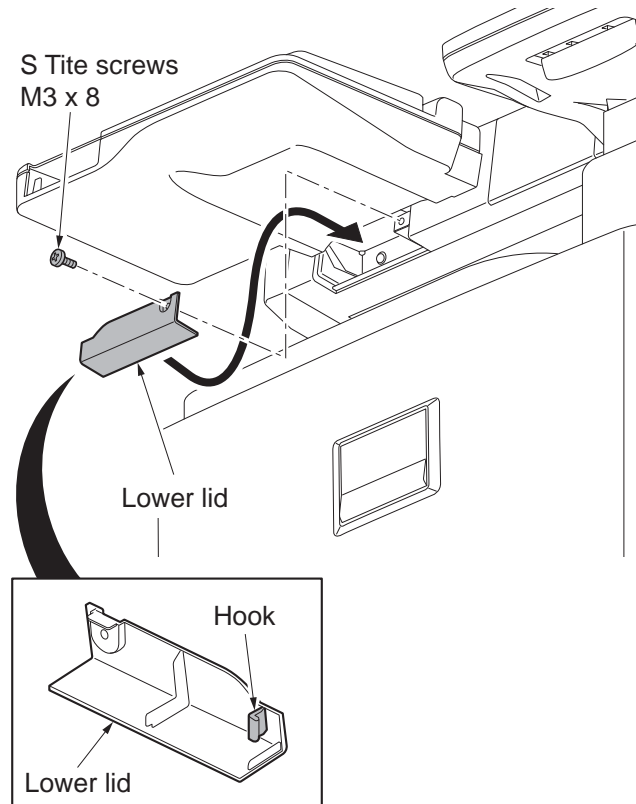
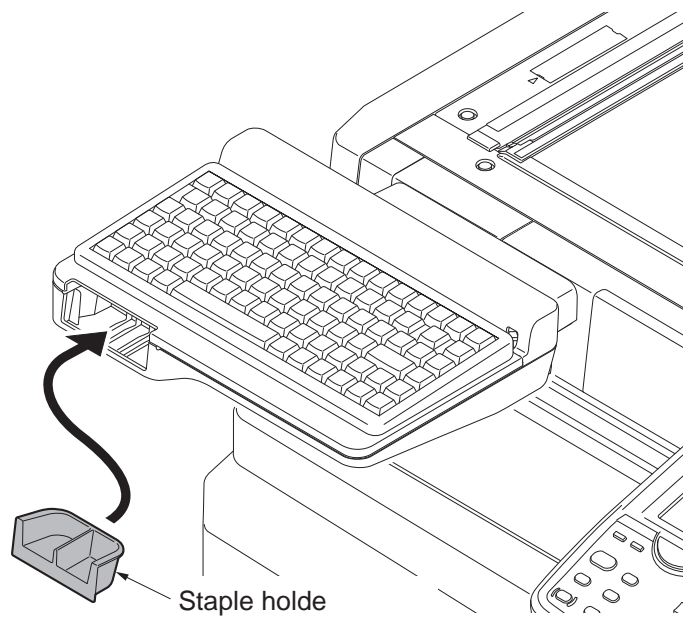


Figure 1-2-125

18. Latch the hook of the lower lid with the machine.
19. Fit the lower lid with the machine using a S Tite screws M3 x 8.

**Figure 1-2-126**

20. Replace the staple holder.

**Figure 1-2-127**

## 1-2-12 Installing the Printed Document Guard Kit (option)

Printed Document Guard Kit installation requires the following parts:

Parts	Quantity	Part.No.
Printed Document Guard Kit	1	1503P40UN0

Supplied parts of Printed Document Guard Kit :

Parts	Quantity	Part.No.
Copy guard PWB	1	-
FFC (short)	2	-
FFC (long)*1	2	-
Mount plate B*1	1	-
Screws M3 x 6*2	1	-

\*1: Not used in this model.

\*2: One piece is used in this model.

### Procedure

1. Press the power key on the operation panel to off. Make sure that the power indicator and the memory indicator are off before turning off the main power switch. And then unplug the power cable from the wall outlet.
2. Remove nine screws and then remove the rear upper cover.

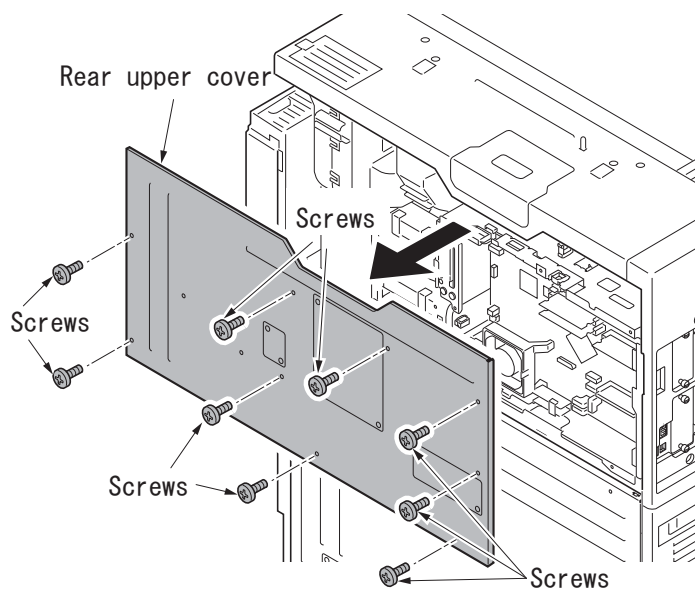


Figure 1-2-128

3. Insert the FFC (short) into the copy guard PWB until it clicks in.
- Without a DP relay circuit PWB  
A FFC is used at YC2 (serigraphed on MAIN)
  - With a DP relay circuit PWB  
Two FFCs are used at YC2 (serigraphed on MAIN)  
YC1 (Serigraphed on DP)

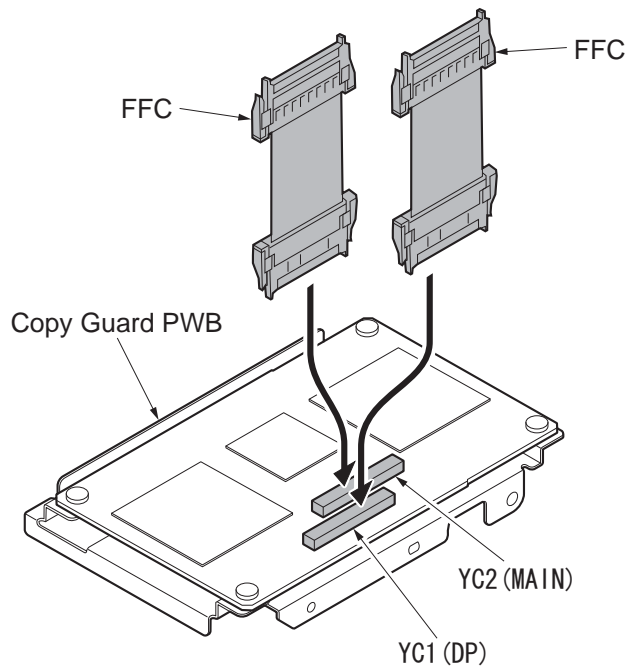


Figure 1-2-129

4. Insert the copy guard PWB to the side of the main-circuit PWB and fix with a S Tite screw M4 x 8.

\*: Mark the FFC cable by folding.

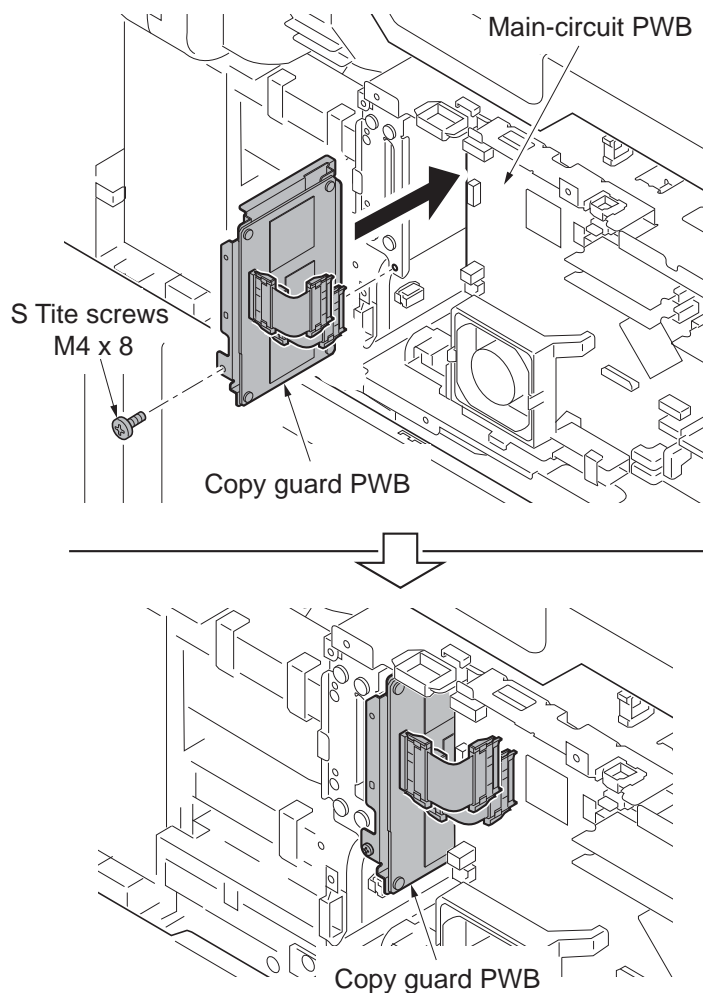
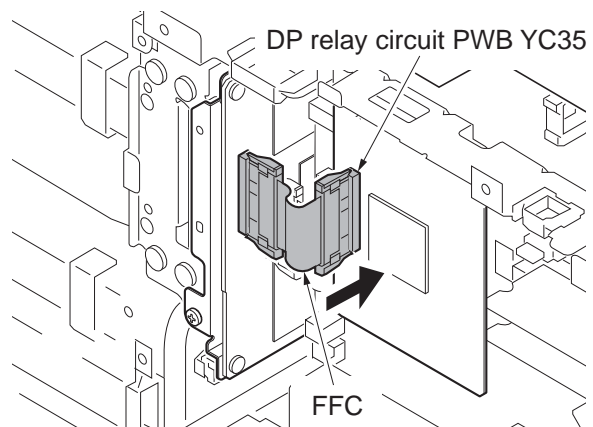
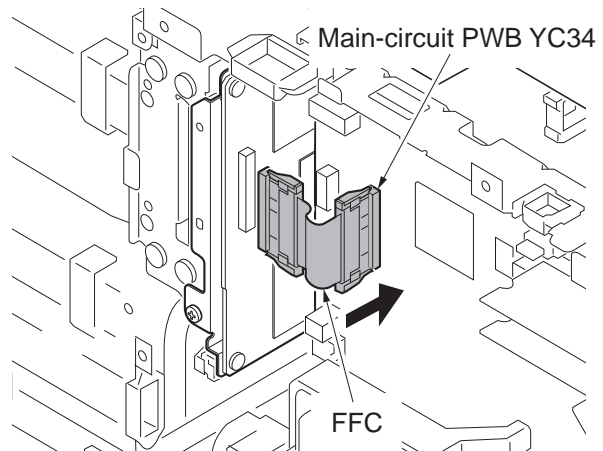


Figure 1-2-130

5. Connect the main-circuit PWB and the DP relay circuit PWB with the FFC.
- Without a DP relay circuit PWB Main-circuit PWB YC34
- With a DP relay circuit PWB Main-circuit PWB YC34  
DP relay circuit PWB YC35

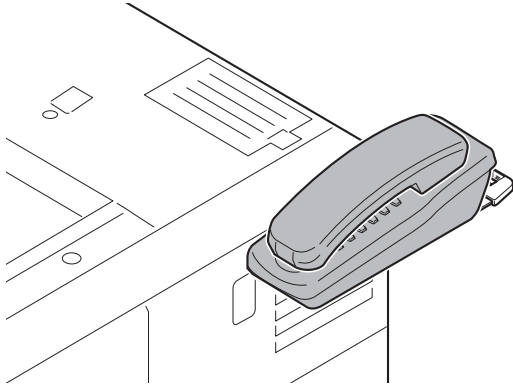


**Figure 1-2-131**

6. Replace the upper rear cover.
7. Confirm the settings.
- 1) Turn the main power switch on.
  - 2) Press the system menu key, then, System/Network.
  - 3) The user authentication dialog is shown if user authentication is not enabled.  
Enter the login user name and the login password, then, press Login.  
Use an administrator privilege for login.
  - 4) Confirm that the Confidential Guard is set to On.

## 1-2-13 Installing the handset (option for Japan only)

### (1) Installing directly on the device



Handset installation requires the following parts:

Parts	Quantity	Part.No.
Handset	1	1909AG9JP0 (option)

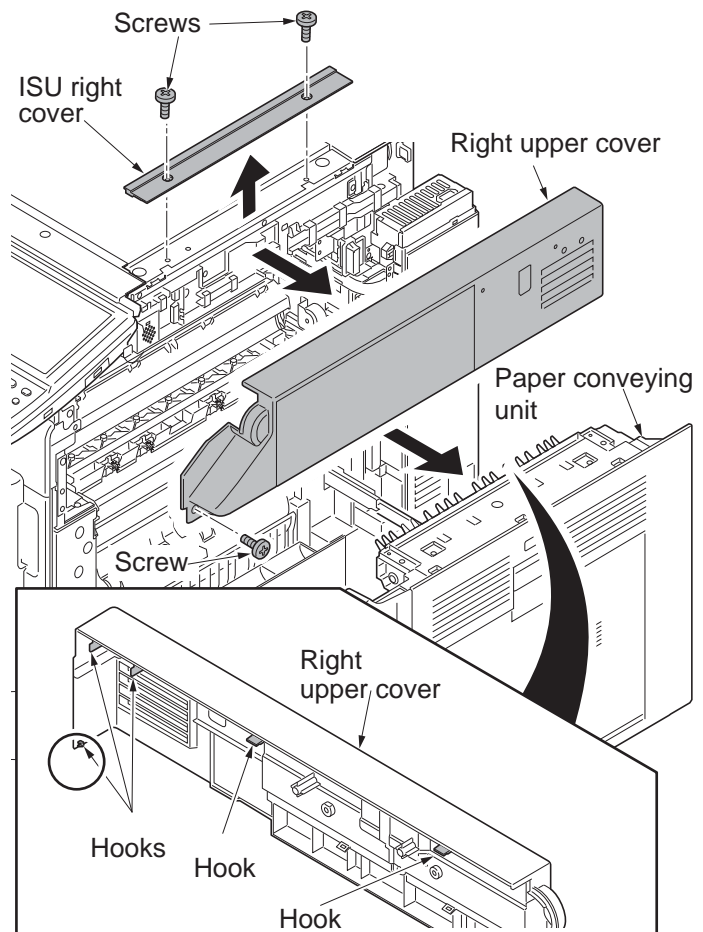
Supplied parts of handset (1909AG9JP0):

Parts	Quantity	Part.No.
Handset	1	-
Handset base	1	-
Handset mount	1	-
Protection cover	1	-
Pin	2	-
Telephone wire	1	-
Modular cable	1	-
M4 nut	2	3CY06030

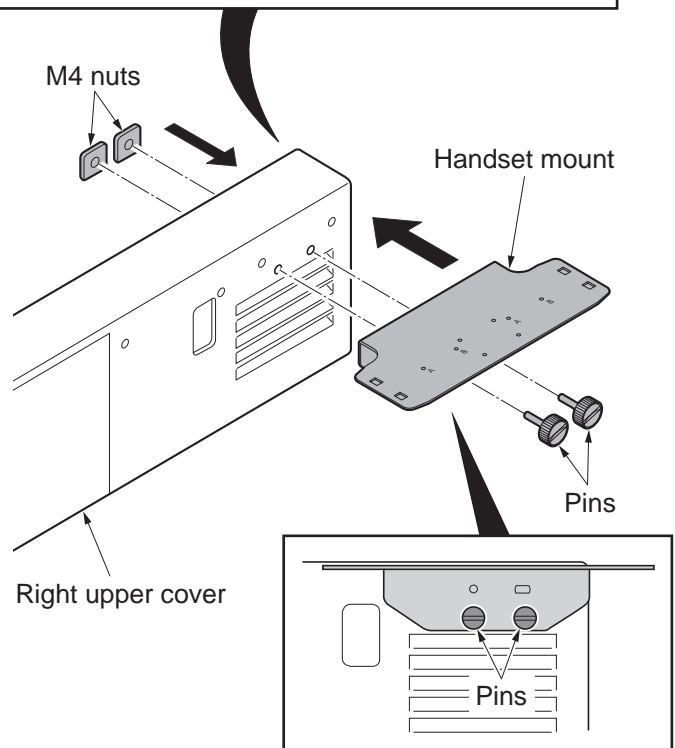
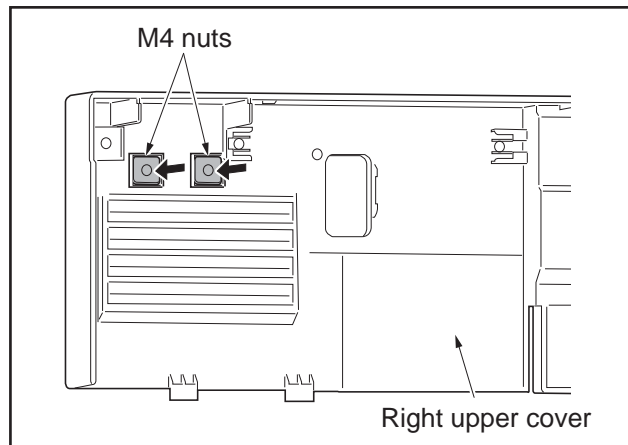


**Procedure**

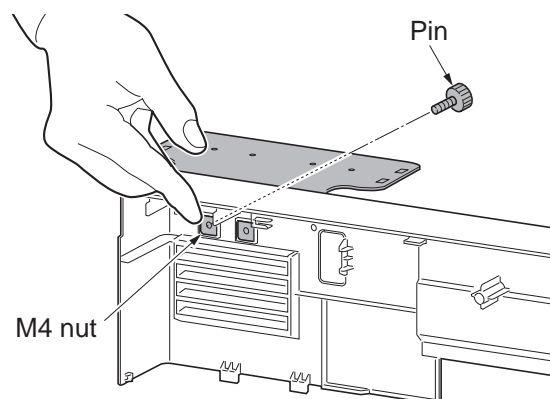
1. Press the power key on the operation panel to off. Make sure that the power indicator and the memory indicator are off before turning off the main power switch. And then unplug the power cable from the wall outlet.
  2. Pull the paper conveying unit out.
  3. Remove two screws and then remove the ISU right cover.
  4. Remove the screw and five hooks and then remove the right upper cover.
- \*: Unlatch the stoppers with the rear bottom one first.

**Figure 1-2-132**

5. Mount two M4 nuts at the back of the right upper cover.
6. Fit the handset mount to the right upper cover using two pins. Use the lower screw holes.



\*: Secure the screws making sure that the nuts do not fall.



**Figure 1-2-133**

7. Refit the right upper cover.
8. Refit the ISU right cover.
9. Close the paper conveying unit.
10. Remove two nuts and two pins from the handset mount and remount it at mark B.

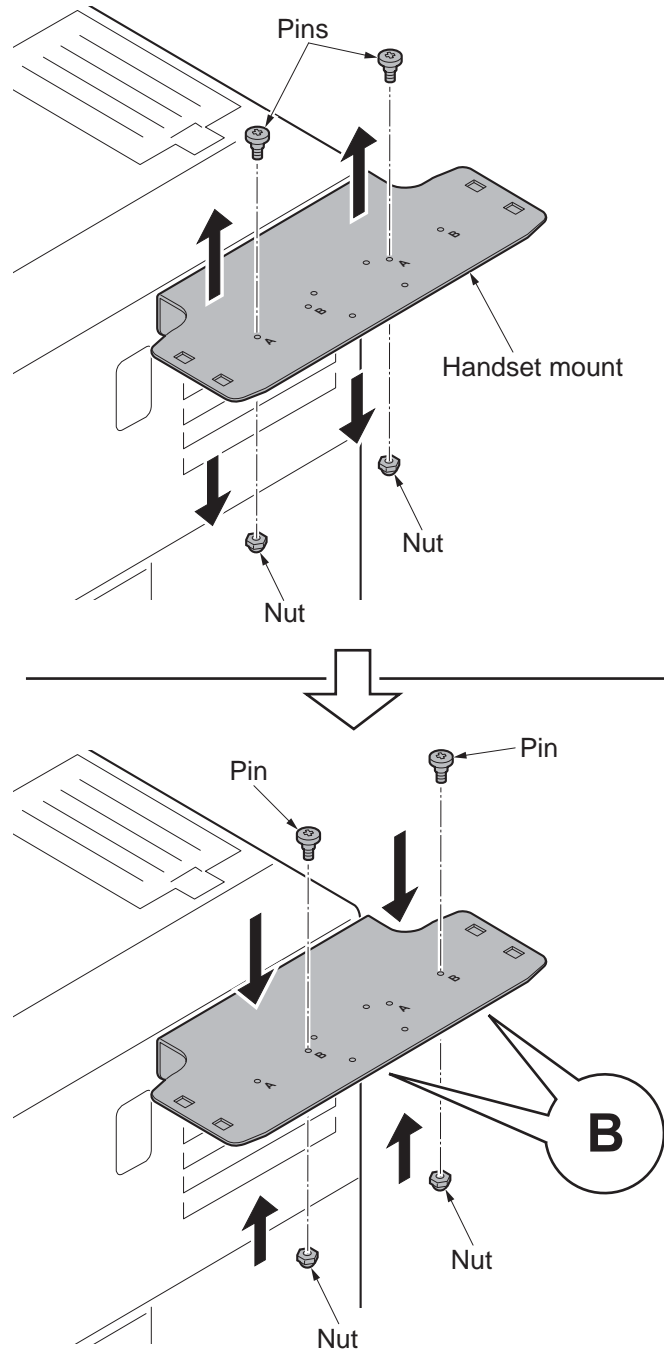
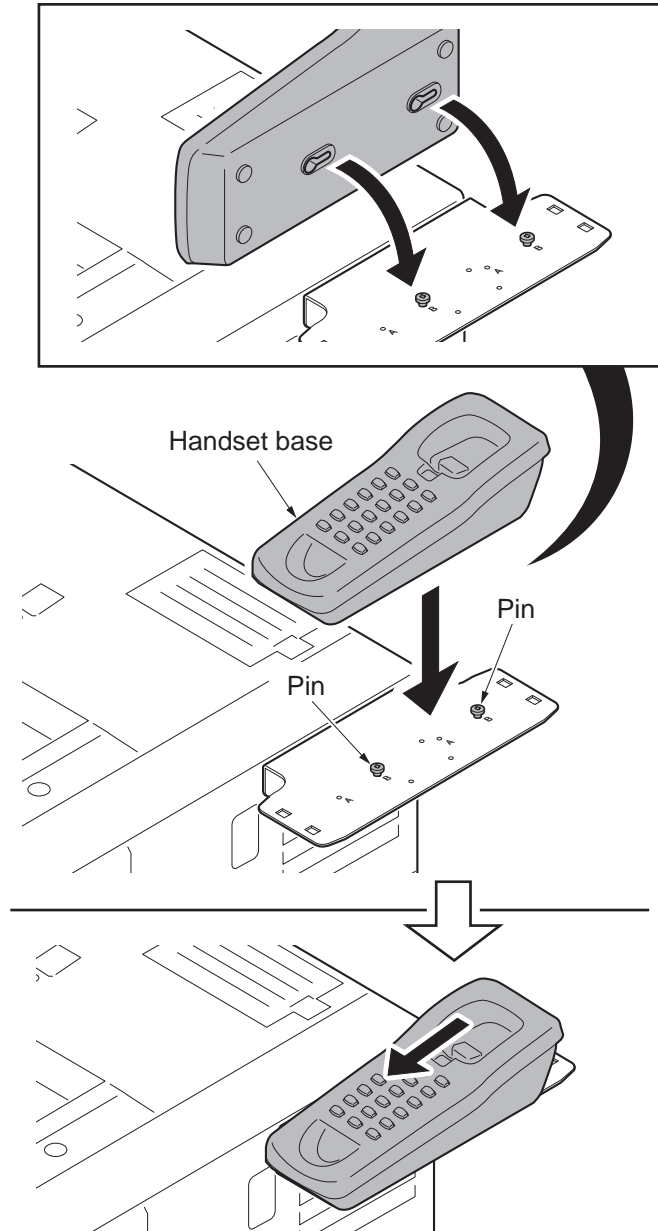


Figure 1-2-134

11. Insert the pins at the insert parts on the back of the handset base, and slide it towards you.



**Figure 1-2-135**

- 12. Fit the protection cover to the handset mount.

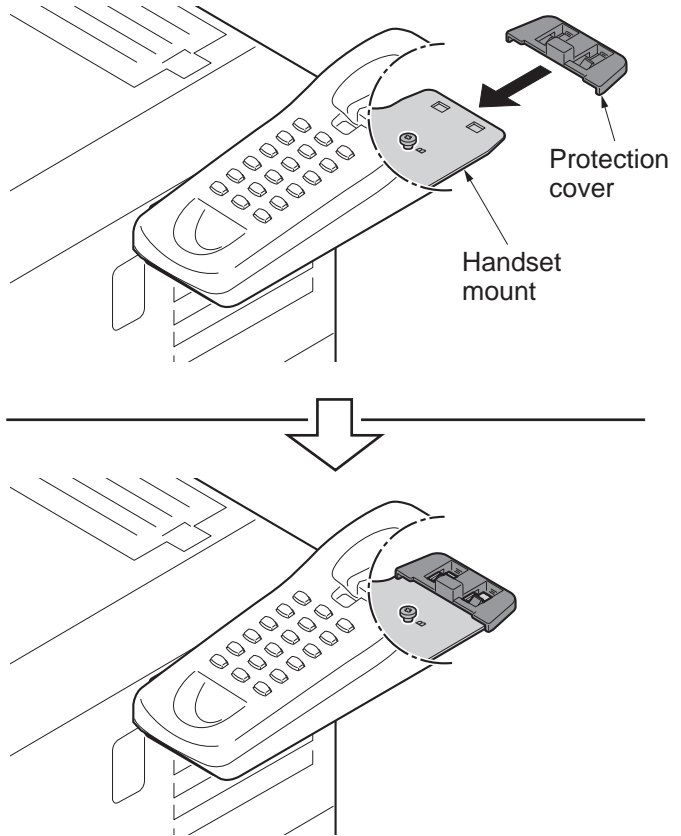


Figure 1-2-136

- 13. Connect the telephone wire to the handset and the handset base.

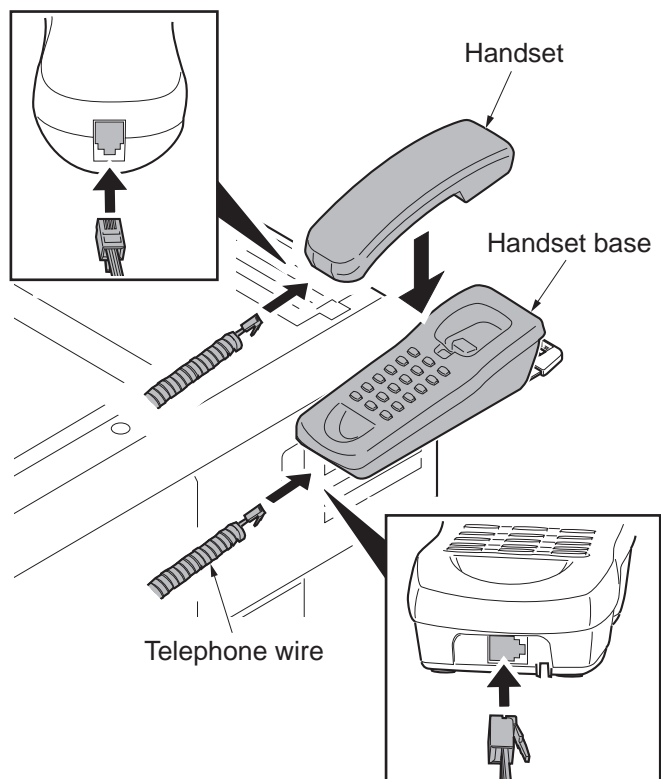


Figure 1-2-137

14. Connect the modular cable to the handset base and the machine.

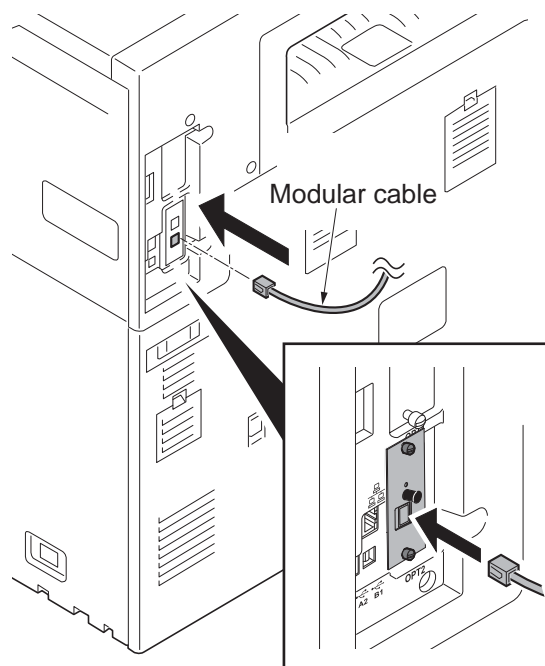
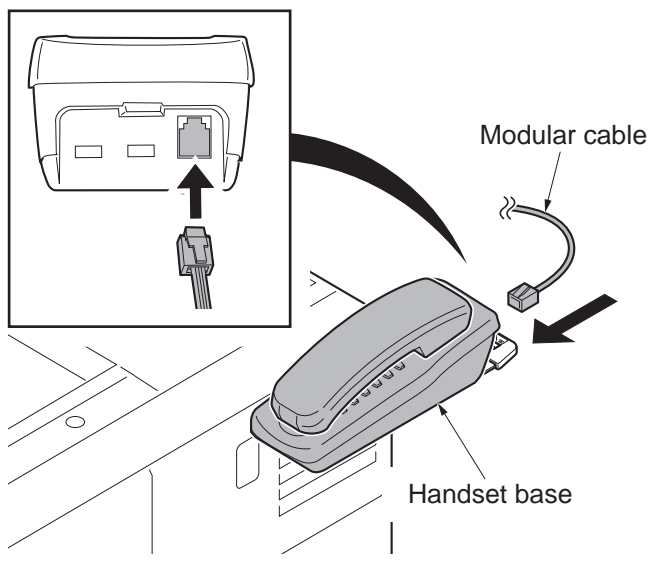
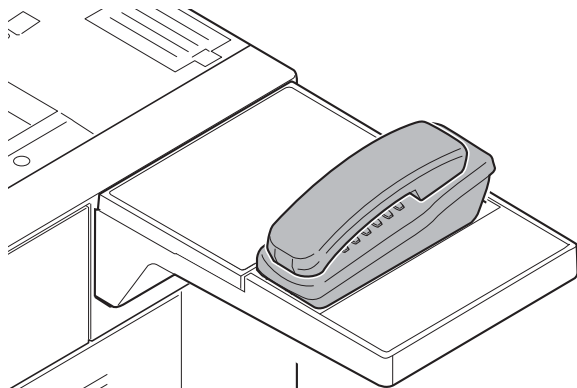


Figure 1-2-138

**(2) Mounting on the document table**

Handset installation requires the following parts:

Parts	Quantity	Part.No.
Handset	1	1909AG9JP0 (option)
Document table	1	1902LC0UN2 (option)

Supplied parts of handset (1909AG9JP0):

Parts	Quantity	Part.No.
Handset	1	-
Handset base	1	-
Handset mount	1*	-
Protection cover	1	-
Pin	2	-
Telephone wire	1	-
Modular cable	1	-
M4 nut	2*	3CY06030

\*: Not used in this model.

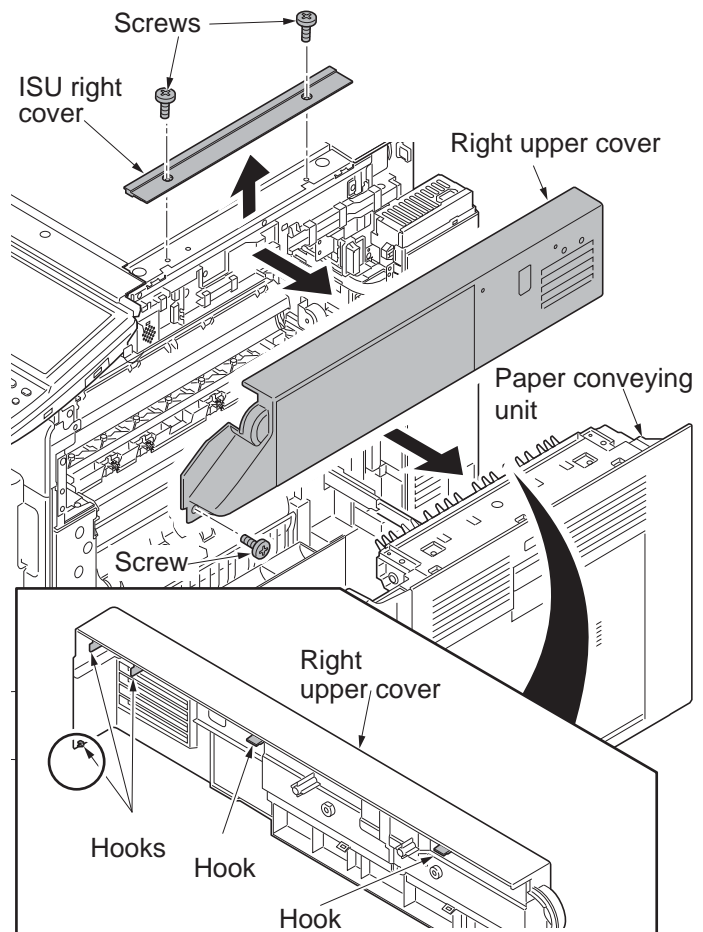
Supplied parts of document table (1902LC0UN2):

Parts	Quantity	Part.No.
Tray stay	1	-
Tray mount	1	-
Tray cover	1	302LC04601
Tray lower cover	1	302LC04710
Tray retainer	1	-
Sheet	2*	302LC04660
Pin	2	303NS24410
M4 nut	2	3CY06030
M4 x 8 screw	7	7BB180408H
M4 x 14 screw	2	7BB607414H

\*: Sheet x1 is not used.

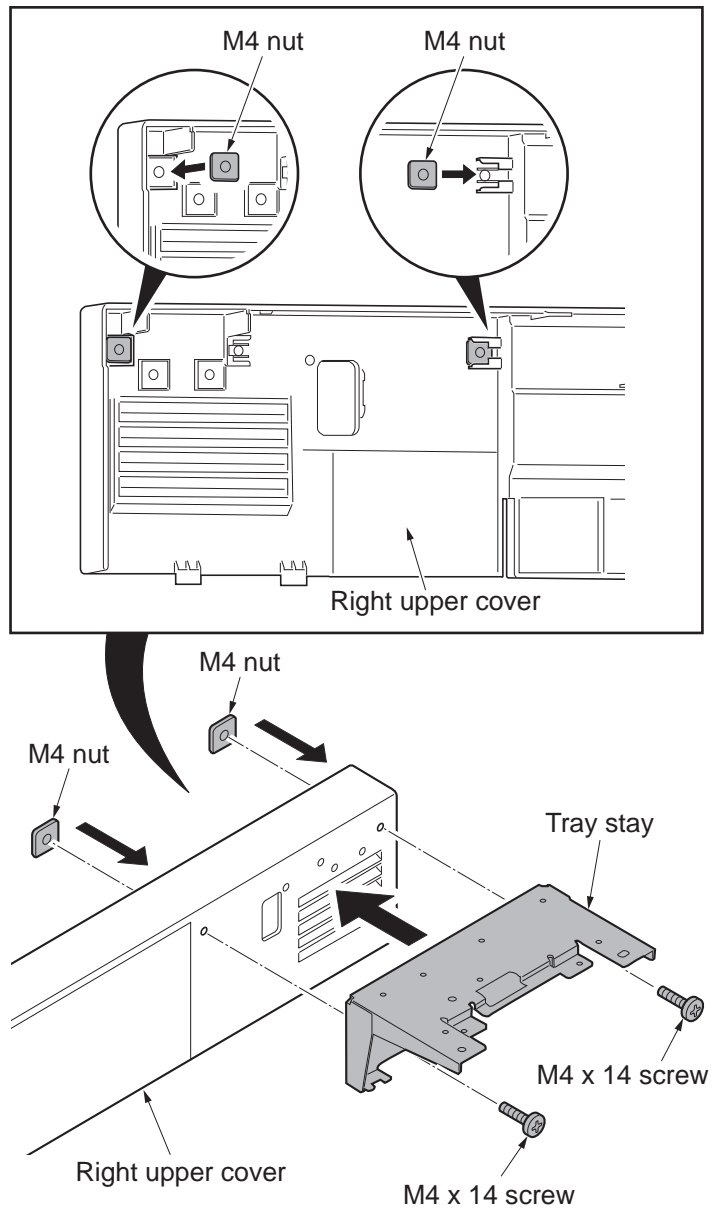
**Procedure**

1. Press the power key on the operation panel to off. Make sure that the power indicator and the memory indicator are off before turning off the main power switch. And then unplug the power cable from the wall outlet.
  2. Pull the paper conveying unit out.
  3. Remove two screws and then remove the ISU right cover.
  4. Remove the screw and five hooks and then remove the right upper cover.
- \*: Unlatch the stoppers with the rear bottom one first.

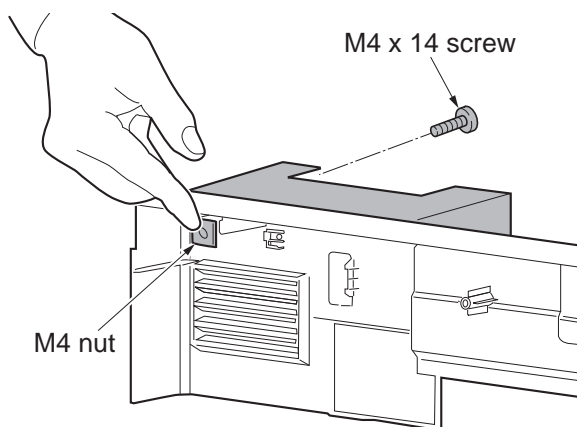
**Figure 1-2-139**



5. Mount two M4 nuts at the back of the right upper cover.
6. Fit the tray stay to the right upper cover using two M4 x 14 screws.



\*: Secure the screws making sure that the nuts do not fall.



**Figure 1-2-140**

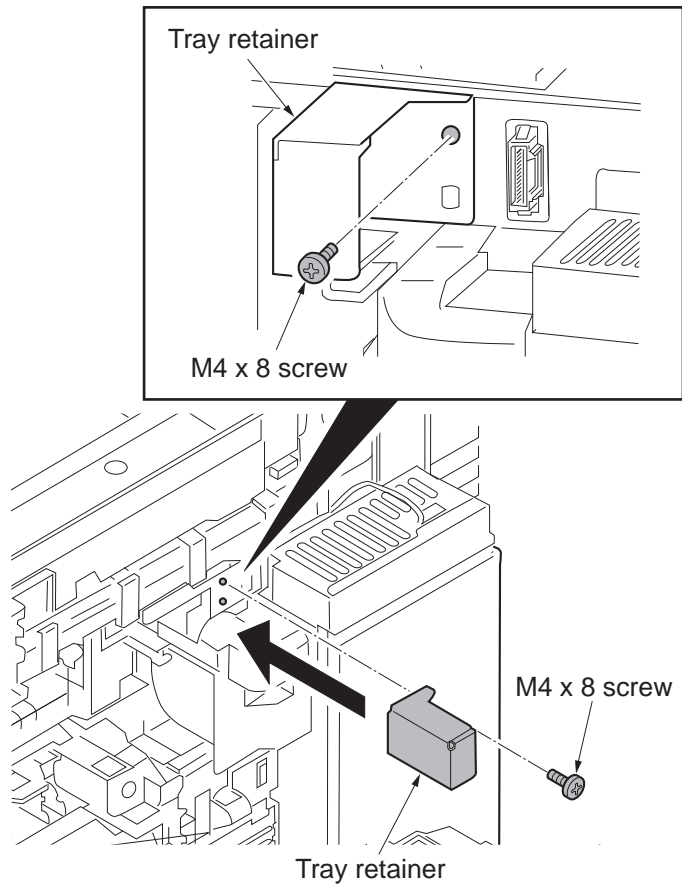
7. Fit the tray retainer to the machine using the M4 x 8 screw.

\*: The procedure described above is not required if an optional right job separator has been installed.

8. Refit the right upper cover.

9. Refit the ISU right cover.

10. Close the paper conveying unit.



**Figure 1-2-141**

11. Snap in the tray mount to the tray stay and fix using two M4 x 8 screws.

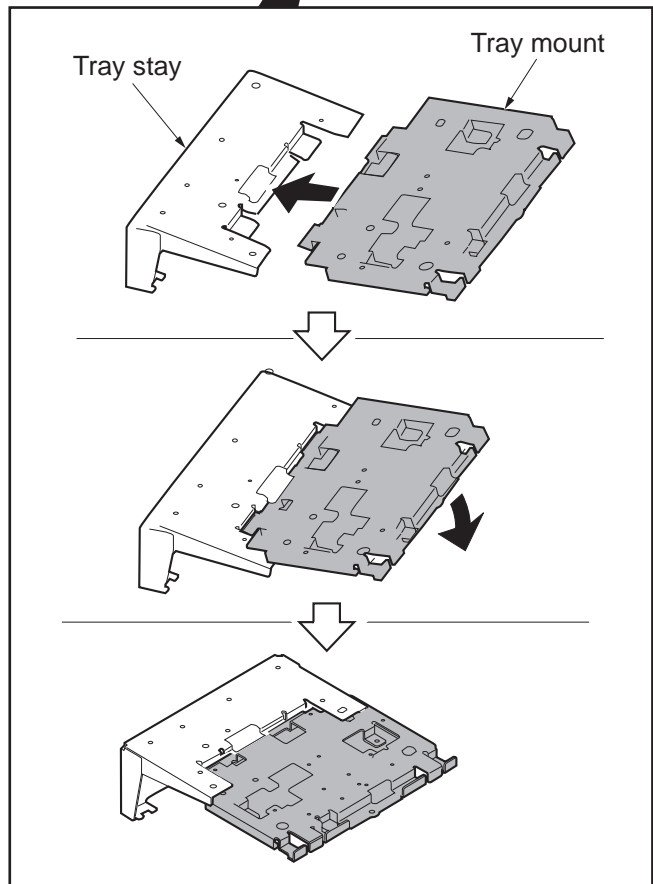
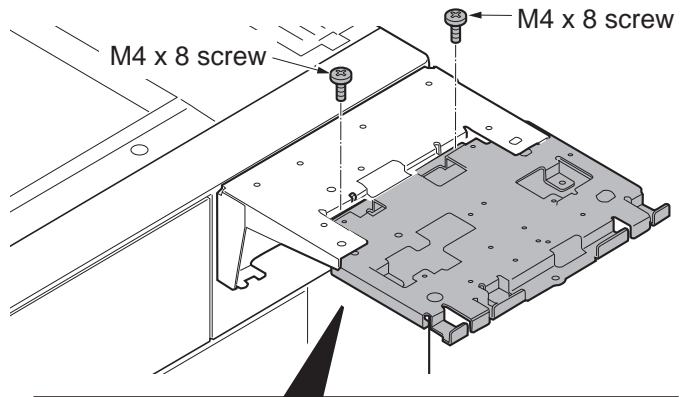


Figure 1-2-142

12. Fit the tray cover to the tray stay using four M4 x 8 screws.

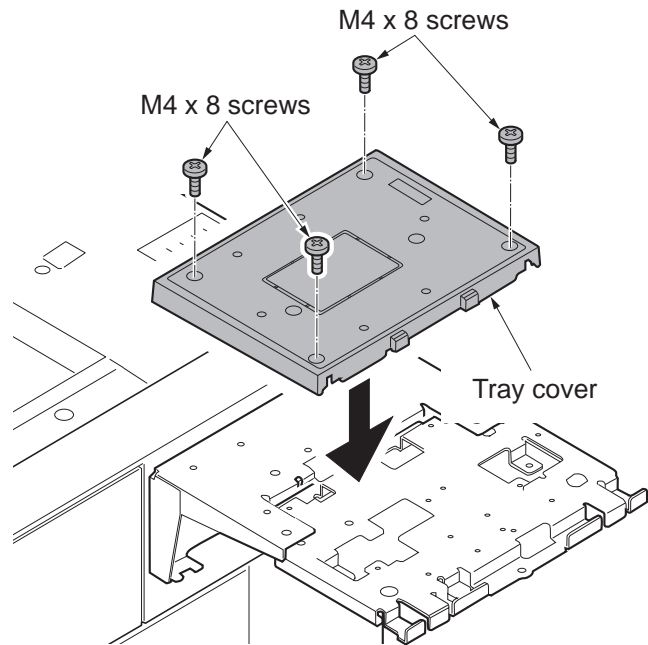


Figure 1-2-143

13. Remove two nuts and two pins from the handset mount.
14. Replace the two nuts and two pins which were removed at mark A on the tray mount.

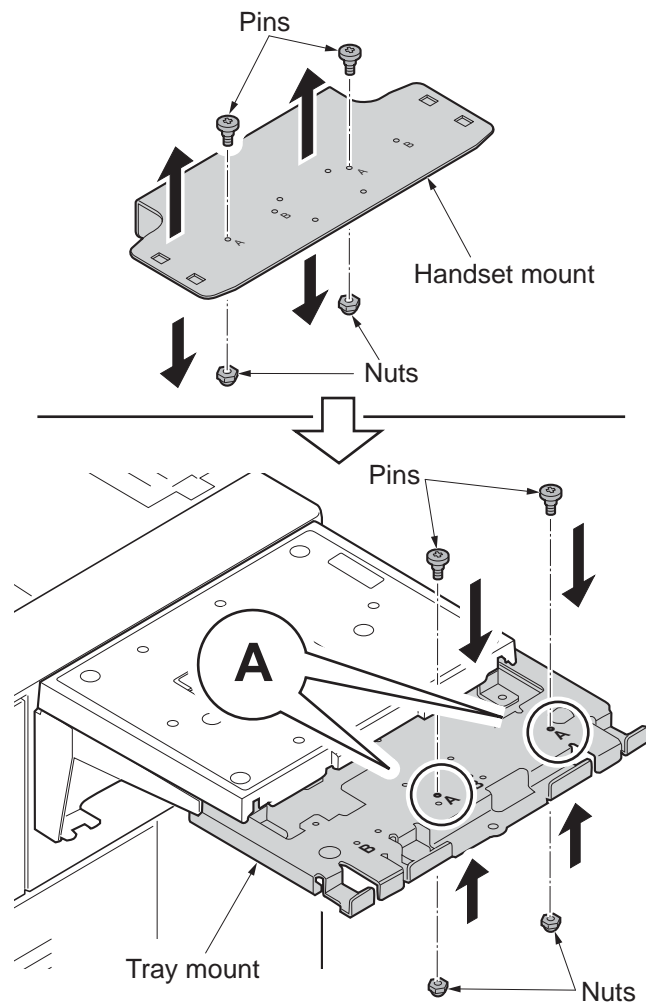
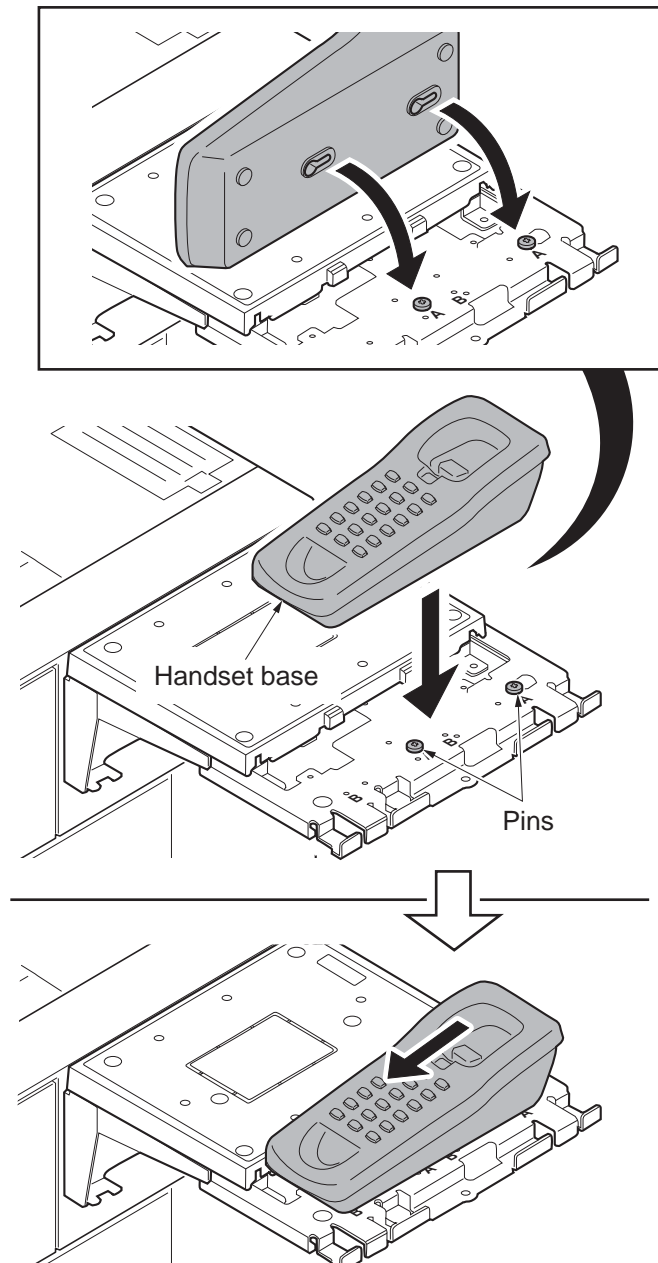


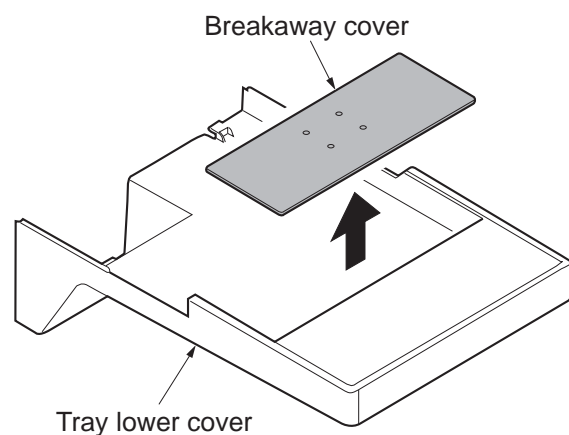
Figure 1-2-144

15. Insert the pins at the insert parts on the back of the handset base, and slide it towards you.



**Figure 1-2-145**

16. Cut out the breakaway cover on the tray lower cover using nippers.



**Figure 1-2-146**

- 17. Fit the tray lower cover.
- 18. Secure the tray lower cover with two pins.

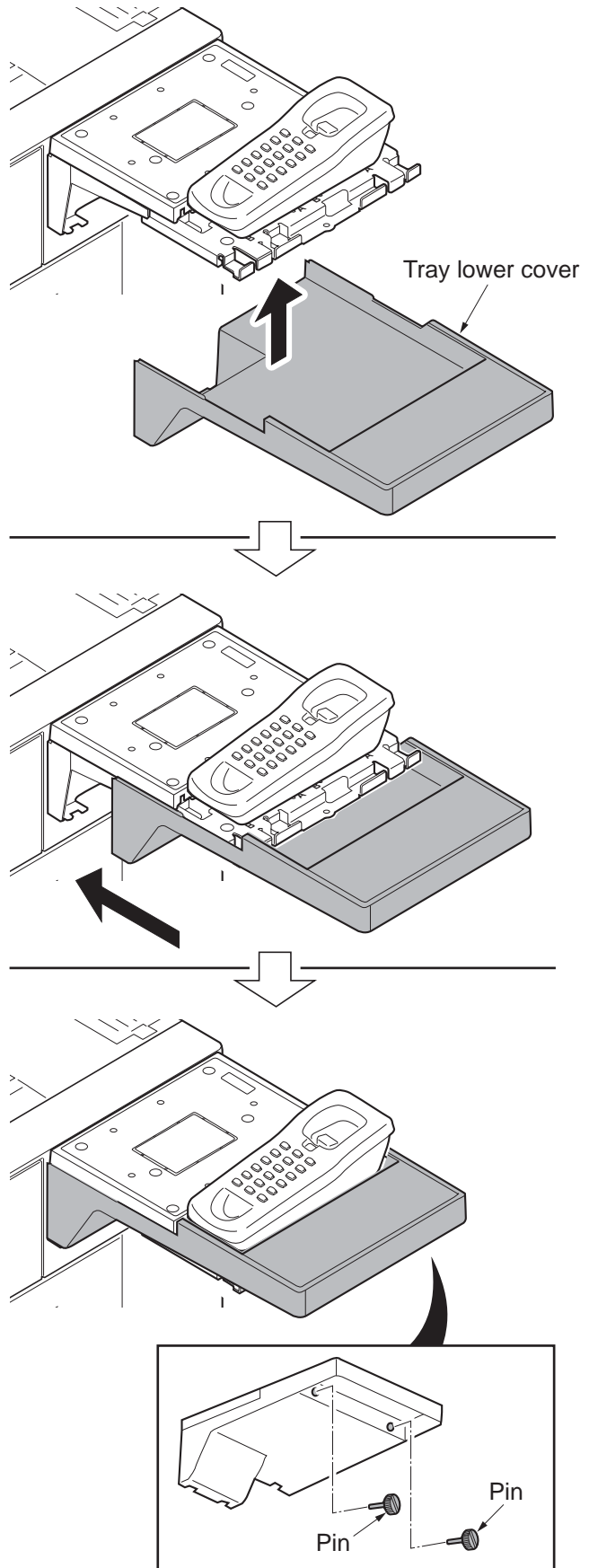
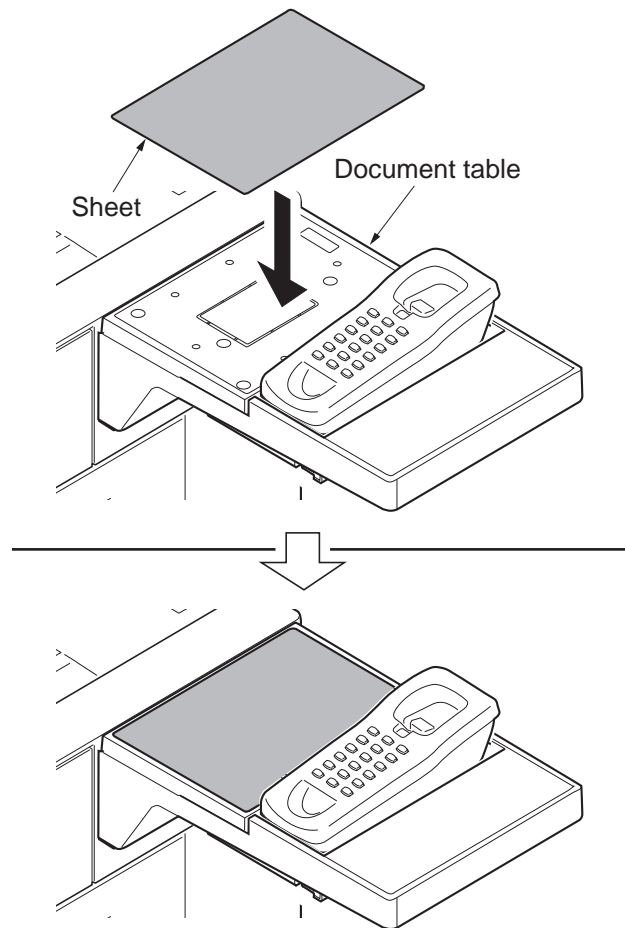


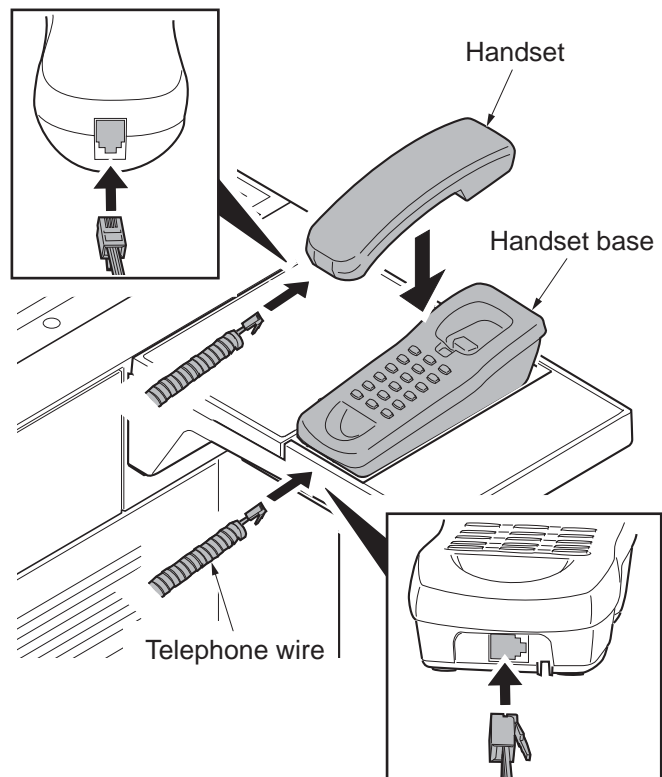
Figure 1-2-147

19. Adhere the sheet onto left side of the document table.



**Figure 1-2-148**

20. Connect the telephone wire to the handset and the handset base.



**Figure 1-2-149**

21. Connect the modular cable to the handset base and the machine.

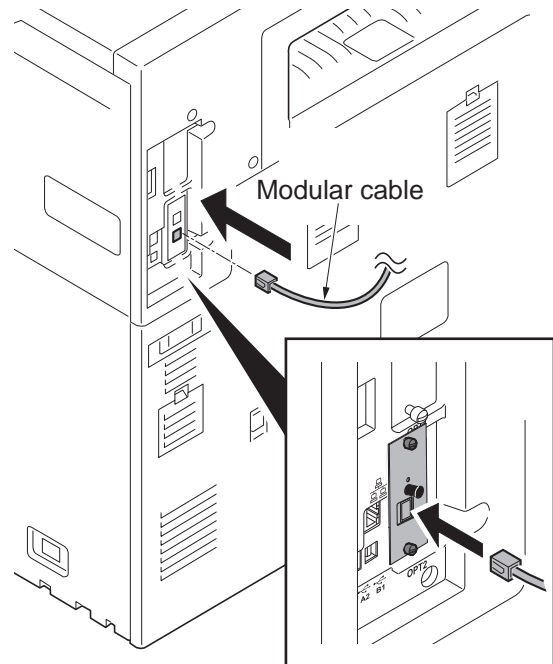
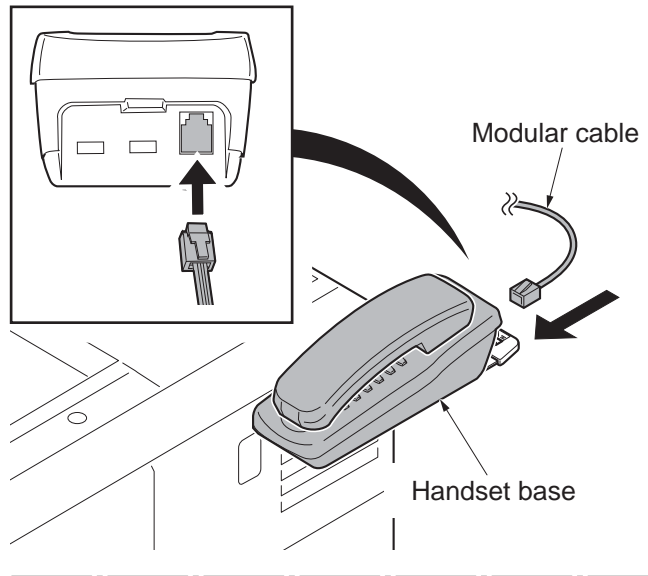


Figure 1-2-150



## 1-2-14 Optional Applications

### Overview of the Applications

The applications listed below are installed on this machine.

Applications	INstall page
Data Security Kit	page 1-2-114
Internet FAX Kit	page 1-2-115
Card Authentication Kit*	page 1-2-119
ThinPrint Option (UG-33)*	page 1-2-120
Emulation Upgrade Kit (UG-34)	page 1-2-121

\*: This can be used on a trial basis for a limited time.

### Guides (PDF) on the DVD (Product Library)

#### Operation Guide

Explains how to load paper and perform copy, print and scan operations, and indicates default settings and other information.

#### FAX Operation Guide

Explains how to use the fax function.

#### Card Authentication Kit (B) Operation Guide

Explains how to perform authentication using the ID card.

#### Data Security Kit (E) Operation Guide

Explains how to introduce and use the Data Security kit (E), and how to initialize the system.

#### Command Center RX User Guide

Explains how to access the machine from a Web browser on your computer to check and change settings.

#### Printer Driver User Guide

Explains how to install the printer driver and use the printer function.

## (1) Data Security Kit

The Data Security Kit overwrites all unnecessary data in the storage area of the hard disk so that it cannot be retrieved.

The Data Security Kit encrypts data before storing it in the hard disk. It guarantees higher security because no data cannot be decoded by ordinary output or operations.

### Precautions before Installation

Installing the Data Security Kit will delete all data stored in the hard disk by the customer. Before installation, confirm with the customer if the data can be deleted.

To install the optional function, you need the License Key.

Issue of License Key requires the "Machine No" indicated on your machine, and "product ID."

Be sure to login the machine with the administrator privilege.

### Installation Procedure

1. Press the System menu key and then press [System/Network]. If user login administration is disabled, the user authentication screen appears. Enter your login user name and password and then press [Login]. For this, you need to log in with administrator privileges.
2. Press [Next] of Optional Function.
3. The optional function screen is displayed. Select DATA SECURITY KIT(E) and press [Activate].
4. The license key entry screen is displayed. Enter the license key using the numeric keys and press [Official].
5. The confirmation screen appears. Confirm the product name DATA SECURITY KIT(E) and press [Yes]. Follow the onscreen instructions to turn the Main Power Switch off.
6. Turn the Main Power Switch on. The encryption code entry screen is displayed. Ask the customer to change the encryption code. Using the default value of the encryption code (00000000) will not affect the data security reliability. If the customer desires to change the code, lead the customer to follow the steps below.

Press [Encryption].

Press [Backspace] to delete 00000000. Enter the encryption code (8-digit alphanumeric characters) and then press [OK].

Remind the customer not to forget the encryption code entered.

7. Press [OK]. Hard disk formatting begins.
8. When formatting finishes, follow the onscreen instructions to turn the Main Power Switch off and on again.
9. After the opening screen is displayed, confirm that a hard disk icon (🖥️) is shown in the lower right corner of the screen.



Figure 1-2-151

\*: For details, refer to the Data Security Kit (E) Operation Guide.

## (2) Internet FAX Kit

Activating the Internet FAX Kit sends and receives faxes via the Internet without using a phone line. It can only be added when the FAX Kit is installed.

\*: To install the optional function, you need the License Key.

Issue of License Key requires the "Machine No" indicated on your machine, and "product ID."

### Installation Procedure

1. Press the System menu key and then press [System/Network]. If user login administration is disabled, the user authentication screen appears. Enter your login user name and password and then press [Login]. For this, you need to log in with administrator privileges.
2. Press [Next] of Optional Function.
3. The optional function screen is displayed. Select "INTERNET FAXKIT(A)" and press [Activate].
4. The license key entry screen is displayed. Enter the license key using the numeric keys and press [Official].
5. The confirmation screen appears. Confirm the product name "INTERNET FAXKIT(A)" and press [Yes]. Follow the onscreen instructions to turn the Main Power Switch off.

### i-FAX Settings

To send and receive Internet faxes, you must first specify the SMTP server and POP3 server settings.

Specify these settings using Command Center RX on a computer that is connected to this machine via a network.

Refer to the machine's Operation Guide for information on the network settings.

### Accessing Command Center RX

1. Launch your Web browser.
2. In the address or location bar, enter the machine's IP address or the host name.  
Examples: 192.168.48.21/ (for IP address)  
MFP001 (if the host name is "MFP001")



**Figure 1-2-152**

\*: When connecting to Command Center RX, a message may appear that reads "There is a problem with the security certificate of this website". To prevent this message from appearing, in "Protocol Settings", set "HTTP" to [On], or install the device certificate of this machine into your Web browser. For details, refer to the machine's Operation Guide.

3. Enter the user name and password of the administrator, and click Login.  
\*: Setting Administrator User Name, and Password restricts general users' access to pages other than the Start page. For security purposes, setting the Administrator password is highly recommended. The default Administrator password is factory-set as 'Admin'.
4. Click 'Function Settings' from the navigation bar on the left to view and set values for that particular category.
5. Click 'FAX / i-FAX'.  
The Transmit Settings dialog box will appear.  
\*: For details, refer to the Command Center RX User Guide.

## i-FAX Default Settings

Use this page to enable the internet faxing.

The settings available on the page are shown below.

Item			Description
Common Settings	Transmission	Local FAX Name	Enter the local fax name.
		TTI Selects	On or Off whether to send the TTI (Transmit Terminal Identifier) information to the other party.
		TTI Position	Selects the position of the TTI to be printed on the transmitted documents.
		Dept. Name Usage	Set to On to use the account name as the local FAX name. The account name appears in place of the local FAX name.
		Retry Times	Specify the number of redials from 0 to 14 times.
	Reception	Media Type	Sets the media type for printing the received documents.
		Use MP Tray	Selects whether or not to include the MP (multi purpose) tray for auto media selection when printing received documents. When turned [On], the MP tray will be included as an option for auto media selection, and when turned [Off], only the cassettes will be selected.
		Reduced RX Size	Specifies the printing configuration for printing a document, which is larger than the selected paper size. When [Same Size Override] is selected, the document will be printed on multiple sheets of paper without reducing the text. When [Reduction Override] is selected, the document will be printed on one sheet whenever possible.
		Receive Date/Time	Selects [On] or [Off] whether to print the reception information such as the received date, the received time, the transmitting party's information and the number of transmitted pages on the top of the received documents.
		Duplex Printing	Specifies whether or not to use the Duplex mode.
		2in1 Printing	Enables or disables 2 in1 reception.
	FAX Settings		
i-FAX Settings	TX/RX	i-FAX Protocol <sup>1</sup>	Display whether an i-FAX connection is available or not. Configure i-FAX in [i-FAX (SMTP & POP3)] on the Protocol Settings page.
	SMTP	SMTP Server Name <sup>2</sup>	Enter the SMTP server name or SMTP server IP address. You can enter up to 64 characters. If you enter the server name, you must specify the IP address of the DNS server. You can enter the DNS server IP address in the TCP/IP settings screen. Refer to the machine's Operation Guide for details.

Item		Description	
i-FAX Settings	SMTP	SMTP Port Number	Set the port number used by SMTP. Normally, 25 is used.
		SMTP Server Timeout	Enter the timeout period in seconds.
		Authentication Protocol	Specify whether SMTP authentication will be used or whether [POP before SMTP] will be used. This SMTP authentication is compatible with Microsoft Exchange 2000.
		SMTP POP before SMTP Timeout	If you selected [POP before SMTP] in the authentication setting, specify the timeout period in seconds.
		Connection Test	Tests to confirm that the settings on this page are correct. When the [Test] button is pressed, this machine tries to connect to the SMTP server.
		Domain Restriction	Activate or deactivate to restrict domains. Press the [Domain List] button to configure. Enter a domain name that is permitted or rejected. You can also specify the Email addresses.
	POP3	Check Interval	Displays the interval, in minutes, for connecting to the POP3 server to check for incoming e-mails at specific interval. Specify the interval in the range from 3 minutes to 60 minutes. The default is 15 minutes.
		Run once now	Click [Receive] to immediately connect to the POP3 server and check for incoming E-mail.
		Domain Restriction	Activate or deactivate to restrict domains. Press the [Domain List] button to configure. Enter a domain name that is permitted or rejected. You can also specify the Email addresses.
		POP3 User Settings	
		E-mail Address* <sup>1</sup>	Enter the i-FAX address (E-mail address). You can enter up to 64 characters.
		POP3 Server Name* <sup>1</sup>	If you enter the server name, you must specify the IP address of the DNS server. You can enter the DNS server IP address in the TCP/IP settings screen. Refer to the machine's Operation Guide for details.
		POP3 Port Number	Sets the port number used by POP3. Normally, 110 is used.
		POP3 Server Timeout	Enter the timeout period in seconds.
Login User Name* <sup>1</sup>	Enter the login name for the user account. You can enter up to 64 characters.		
Login Password* <sup>1</sup>	Enter the password for the user account. You can enter up to 64 characters.		
Use APOP	Specify whether to use APOP authentication. To use APOP authentication, select [On] in this setting.		

Item			Description
i-FAX Settings	POP3	Test	Runs a test to determine whether the settings specified in this page are correct.
		E-mail Size Limit	Enter the maximum size for E-mails that can be received in kilobytes. You can set up to 32,767 kilobytes. If 0 is entered, the setting does not limit the maximum size.
		Cover Page	Specify whether the E-mail messages are also printed. Select [On] to print faxes with a cover page attached. If the E-mail message includes text, the text is printed on the cover page.
	Transmission	Transmission Type	Allows to choose a method of sending from [Specify for Each Destination], [Via server - On], and [Via server - Off (Direct SMTP)].
		Direct SMTP Sender Address <sup>*1</sup>	Displays the sender address used for E-mails sent by Direct SMTP from this machine.
		Direct SMTP Port Number	Enter the port number used by Direct SMTP. Normally, 25 is used.
		Direct SMTP Timeout	Sets the timeout time in seconds during which this device retries to connect to the SMTP server.
	Reception	Direct SMTP Port Number	Enter the port number used by Direct SMTP. Normally, 25 is used.
		Direct SMTP Timeout	Sets the timeout time in seconds during which this device retries to connect to the SMTP server.
	E-mail Send Settings	E-mail Size Limit	Enter the maximum size of E-mail that can be sent in Kilobytes. When the value is 0, the limitation for E-mail size is disabled.
		Sender Address <sup>*2</sup>	Displays the sender address used for E-mails sent from this machine. Set in [E-mail Address] in POP3 User Settings.
		Signature	Displays the signature to be inserted in the end of the Email body. Set on the [E-mail Settings] page.
		Function Default	The default settings can be changed in [Common/Job Default Settings] page.

\*: After completing the settings, click [Submit] to save the settings.

\*1: When Direct SMTP is used, this must always be set.

\*2: When Internet FAX is used, this must always be set.

\*: For details, refer to the FAX Operation Guide.

### (3) Card Authentication Kit

This prevents the unauthorized copying and/or transmission of documents that contain important confidential or personal information. When a document is printed from a computer, this feature imprints a special pattern on the document. When anyone attempts to copy or send that document on this machine, the machine detects the pattern and protects the information by printing the document in blank and prohibiting transmission.

\*: To install the optional function, you need the License Key.

Issue of License Key requires the "Machine No" indicated on your machine, and "product ID."

#### Installation Procedure

1. Press the System menu key and then press [System/Network]. If user login administration is disabled, the user authentication screen appears. Enter your login user name and password and then press [Login]. For this, you need to log in with administrator privileges.
2. Press [Next] of Optional Function.
3. The optional function screen is displayed. Select "CARD AUTHENTICATIONKIT(B)" and press [Activate].
4. The license key entry screen is displayed. Enter the license key using the numeric keys and press [Official].
5. The confirmation screen appears. Confirm the product name "CARD AUTHENTICATIONKIT(B)" and press [Yes]. Follow the onscreen instructions to turn the Main Power Switch off.

\*: To use a SSFC card, run maintenance mode U222 and set SSFC.

#### Setting User Login

1. Make the settings of Local Authentication in User Login/Job Accounting or User Login on the machine.

\*: For User Login setting, refer to Management in the Operation Guide of the machine.

When you enable User Login on the machine, you need to make the setting of user account for the printer driver in order to print by the computer. For details, refer to the Printer Driver User Guide, Device Settings, and Administrator Settings.

#### Registering/deleting the ID card information

The procedures below are to register or delete the card information of a pre-registered user.

For new registration or change of user information on Local User List, refer to Management in the Operation Guide of the machine.

#### To register the ID card information

To login using the ID card, you need to register the ID card information in the user information.

Follow the steps below.

1. Press the System Menu key.
  - \*: If Local Authentication has been set in User Login, the ID Card Login screen appears. Refer to Login on the next page or the procedure of Keyboard Login, and login using the ID card registered with administrator privileges or using the login user name.
2. Press [User Login/Job Accounting].
  - \*: If User Login is disabled, the ID Card Login screen appears. Refer to Login on the next page or the procedure of Keyboard Login, and login using the ID card registered with administrator privileges or using the login user name.
3. In User Login Setting, press [Next] [Local User List], and then [Register/Edit].
4. Select the user for whom you wish to register the ID card information, and press [Detail].
5. Press [Change] in [ID Card information].
6. Hold the ID card to be registered over the card reader.
  - Completed. appears and the screen returns to the Detail menu.
7. In the Detail menu, press [Register]. The confirmation screen appears.
8. Press [Yes]. The ID card information is now registered.

## To register on the computer

The ID Register utility for registering/deleting ID card information on the computer is provided.

You can download the ID Register utility from the vendor's website.

## (4) ThinPrint Option

This application allows print data to be printed directly without a print driver.

\*: To install the optional function, you need the License Key.

Issue of License Key requires the "Machine No" indicated on your machine, and "product ID."

### Installation Procedure

1. Press the System menu key and then press [System/Network]. If user login administration is disabled, the user authentication screen appears. Enter your login user name and password and then press [Login]. For this, you need to log in with administrator privileges.
2. Press [Next] of Optional Function.
3. The optional function screen is displayed. Select "UG-33" and press [Activate].
4. The license key entry screen is displayed. Enter the license key using the numeric keys and press [Official].
5. The confirmation screen appears. Confirm the product name "UG-33" and press [Yes]. Follow the onscreen instructions to turn the Main Power Switch off.



## **(5) Emulation Upgrade Kit**

Enables emulation whereby the machine operates using commands for other printers. Installing this option enables IBM Proprinter, Line Printer, and EPSON LQ-850 emulation.

To install the optional function, you need the License Key.

Issue of License Key requires the "Machine No" indicated on your machine, and "product ID."

### **Installation Procedure**

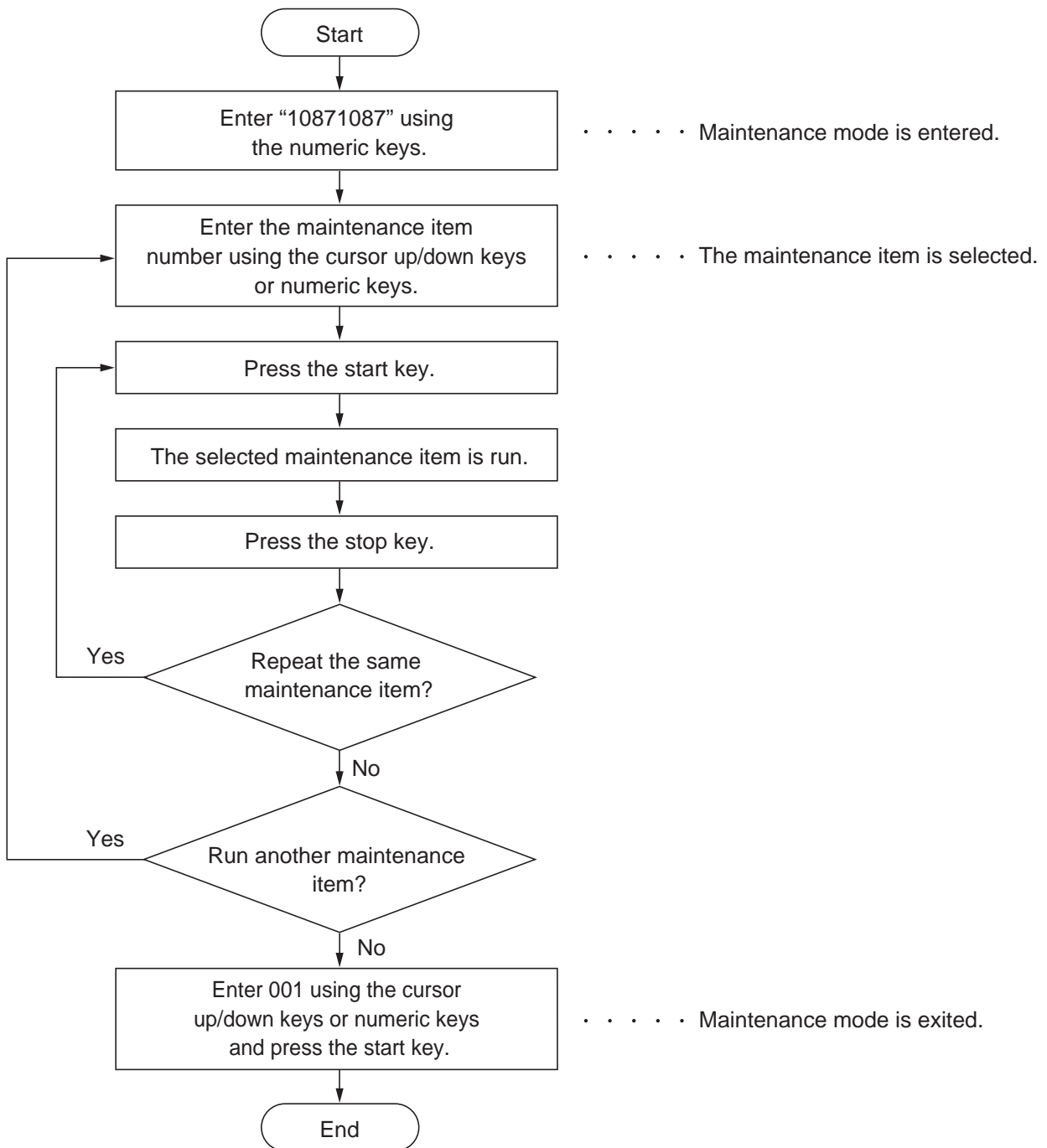
1. Press the System menu key and then press [System/Network]. If user login administration is disabled, the user authentication screen appears. Enter your login user name and password and then press [Login]. For this, you need to log in with administrator privileges.
2. Press [Next] of Optional Function.
3. The optional function screen is displayed. Select "UG-34" and press [Activate].
4. The license key entry screen is displayed. Enter the license key using the numeric keys and press [Official].
5. The confirmation screen appears. Confirm the product name "UG-34" and press [Yes]. Follow the onscreen instructions to turn the Main Power Switch off.

This page is intentionally left blank.

## 1-3-1 Maintenance mode

The machine is equipped with a maintenance function which can be used to maintain and service the machine.

### (1) Executing a maintenance item



**(2) Maintenance modes item list**

Section	Item No.	Content of maintenance item	Initial setting		
			35ppm	45ppm	55ppm
General	U000	Output Maintenance Report	-		
	U001	Exiting the maintenance mode	-		
	U002	Setting the factory default data	-		
	U003	Setting the service telephone number	-		
	U004	Setting the machine number	-		
	U010	Setting the maintenance mode ID	-		
	U019	Firmware Version	-		
Initializa- tion	U021	Memory initializing	-		
	U024	HDD formatting	-		
	U025	Firmware Update (Security)	-		
	U026	Pulling Backup Data	-		
Drive, paper feed and paper conveying system	U030	Checking the operation of the motors	-		
	U031	Checking switches and sensors for paper con- veying	-		
	U032	Checking the operation of the clutches	-		
	U033	Checking the operation of the solenoids	-		
	U034	Adjusting the print start timing			
		LSU Out Top	0/0/0/0/0/0/0/0/0/0/0		
		LSU Out Left	0/0/0/0/0/0/0		
	U035	Setting the printing area for folio paper	330/210		
	U037	Checking the operation of the fan motors	-		
	U051	Adjusting the deflection in the paper	1/1/1/1/1/1/	-5/0/-5/0/	-8/-1/-8/-1/
			1/1/1/1/1/1	-5/0/-5/0/	-8/-1/-8/-1/
				-5/0/-3/0	-8/-1/-6/-1
	U052	Setting the fuser motor control			
		Set Loop Sensor	-		
		Loop Sensor Control	On/On/On/On/On/On		
		Set Loop Sensor Valid	On		
	U053	Setting the adjustment of the motor speed			
		Motor1	0		
		Motor2	953/-/29	736/33/22	596/27/18
Motor3		18/-30/26/	13/-24/20/	10/-20/15/	
		26/66/35/	20/120/26/	15/97/19/	
	-/-/0/0/0/	72/-10/-10/	58/-8/-8/0/		
	0	0/0/0/0	0/0/0		
	Motor1 Half	0			

Section	Item No.	Content of maintenance item	Initial setting		
			35ppm	45ppm	55ppm
Drive, paper feed and paper conveying system	U053	Motor2 Half	1907/-/56	1473/66/ 44	1191/54/ 35
		Motor3 Half	106/0/112/ 112/132/ 210/ -/-	82/0/86/ 86/238/ 164/143/ -20/-20	66/0/70/ 70/194/ 133/116/ -16/-16
	U059	Setting fan mode			
		Fan Mode		Mode1	
		Cooling Mode		0	
Optical	U061	Checking the operation of the exposure lamp		-	
	U063	Adjusting the shading position		0	
	U065	Adjusting the scanner magnification		0/0	
	U066	Adjusting the scanner leading edge registration		0/0	
	U067	Adjusting the scanner center line		0/0	
	U068	Adjusting the scanning position for originals from the DP		0/0	
	U070	Adjusting the DP magnification		-	
	U071	Adjusting the DP scanning timing		-	
	U072	Adjusting the DP center line		-	
	U073	Checking the scanner operation		100/10200/1	
	U074	DP input response adjustment		1	
	U087	Setting DP reading position modification operation		125/125/125	
	U089	Outputting a MIP-PG pattern		-	
	U091	Setting the white line correction		112/112/112/75/0	
	U099	Adjusting original size detection		DP is not installed 20/30/40/20/30/40/20/30/40 DP is installed 50/50/50/50/50/50/50/50/50	
High voltage	U100	Adjusting main high voltage			
		Adj AC Bias		-	
		Set AC Auto Adj		On	
		Set DC Bias		-	
		Adj DC Bias		0/0	
		Set Low Temp		1	
		Set Charger Freq		9160	
		Chk Current		-	

Section	Item No.	Content of maintenance item	Initial setting		
			35ppm	45ppm	55ppm
High voltage	U106	Setting the voltage for the secondary transfer			
		Light/Normal1 1st	150/143/ 139	174/165/ 157	146/140/ 134
		Light/Normal1 2nd	146/139/ 124	160/153/ 135	133/130/ 120
		Normal2/3 1st	150/143/ 139	174/165/ 157	146/140/ 134
		Normal2/3 2nd	146/139/ 124	160/153/ 135	133/130/ 120
		Heavy1-3 1st Half	122/122/ 118	130/130/ 126	116/116/ 114
		Heavy1-3 2nd Half	115/115/ 105	122/122/ 109	121/121/ 109
		Heavy4/5 1st Half	118/118/ 110	126/126/ 115	114/114/ 107
		Heavy4/5 2nd Half	114/114/ 104	120/120/ 108	110/110/ 102
		OHP	108/108/ 101	112/112/ 104	105/105/ 101
	Bias	163/163/ 108/100	163/163/ 113/102	164/164/ 117/105	
	U110	Checking the drum count	-		
	U111	Checking the drum drive time	-		
U117	Checking the drum number	-			
U118	Displaying the drum history	-			
U119	Setting the drum	-			
U127	Checking/clearing the transfer count	-			
U128	Setting transfer high-voltage timing	-20/-/-13	-18/-/-15	-15/-/-18	
Developer	U130	Initial setting for the developer	-		
	U131	Adjusting the toner sensor control voltage	-		
		Manual	107	120	128
		Mode	Auto		
	U132	Replenishing toner forcibly	-		
	U135	Checking toner motor operation	-		
	U136	Setting toner near end detection	3		
U139	Displaying the temperature and humidity outside the machine	-			

Section	Item No.	Content of maintenance item	Initial setting		
			35ppm	45ppm	55ppm
Developer	U140	Displaying developer bias			
		Sleeve DC	62	62	70
		Sleeve AC	159	159	150
		Mag DC	148	148	180
		Mag AC	101	101	199
		Sleeve Freq	4580/5345	4580/5345	4580/5345
		Sleeve Duty	63	63	43
		Mag Duty	37	37	68
		AC Calib			
		Magnification			12
		High Altitude			Mode1
		Image Preference			
		Copy		0	
	U147	Setting for toner applying operation			
		Timing	35/8	45/8	55/8
		Mode		Mode1	
		Upper Limit		2.0	
		Minimum		10	
	U148	Setting drum refresh mode		2	
		Normal		2	
Dew Condensation			0		
U155	Checking sensors for toner		-		
U156	Setting the toner replenishment level				
	Supply		512		
	Empty		100		
U157	Checking the developer drive time		-		
U158	Checking the developer count		-		
Fuser	U161	Setting the fuser control temperature			
		Warm Up	110/110/ 155/150/ 155/160	110/110/ 160/155/ 160/160	110/110/ 170/165/ 170/160
		Print	160/170/0	165/175/0	175/185/0
		Jam Prevent Mode	0/-10/-10/ -10	0/-10/-10/ -10	0/-15/-15/ -10
		Toner Stain Reduce		Off	
	U167	Checking/clearing the fuser count		-	
	U199	Displaying fuser heater temperature		-	

Section	Item No.	Content of maintenance item	Initial setting		
			35ppm	45ppm	55ppm
Operation panel and support equipment	U200	Turning all LEDs on	-		
	U201	Initializing the touch panel	-		
	U202	Setting the KMAS host monitoring system	-		
	U203	Checking DP operation	-		
	U204	Setting the presence or absence of a key card or key counter	Off/Coin Vender		
	U206	Setting the presence or absence of a coin vender			
		On/Off Config	Off		
		No Coin Action	Off		
		Price	10/10/10/10/		
		Normal/AD/ Print/Apl	10/10/10/10, 10/10/10/10 10/10/10/10, 10/10/10/10/10		
		Boot Mode	Copy Service		
		Apl Charge Mode	Off		
	U207	Checking the operation panel keys	-		
	U208	Setting the paper size for the side deck	Letter (Inch)/A4 (Metric)		
	U209	Set RTC Date	-		
	U211	Setting the presence or absence of the job separator	Off		
	U221	Setting the USB host lock function	Off		
	U222	Setting the IC card type	Other		
	U223	Operation panel lock	Unlock		
	U224	Panel sheet extension	-		
	U234	Setting punch destination	Inch (Inch)/Europe Metric (Metric)		
	U237	Setting finisher stack quantity	0/0		
	U240	Checking the operation of the finisher	-		
	U241	Checking the operation of the switches of the finisher	-		
	U243	Checking the operation of the DP motors	-		
	U244	Checking the DP switches	-		
	U245	Checking messages	-		
	U246	Setting the finisher			
		Finisher	0/0/0/0/0/0/0/0		
		Booklet	0/0/0/0/0/0/0/0		
U247	Setting the paper feed device	-			
U249	Finisher operation test	-			



Section	Item No.	Content of maintenance item	Initial setting		
			35ppm	45ppm	55ppm
Mode setting	U250	Checking/clearing the maintenance cycle	600000/0/150000/150000/150000/ 150000/150000		
	U251	Checking/clearing the maintenance counter	0/0/0/0/0/0		
	U252	Setting the destination	-		
	U253	Switching between double and single counts	DBL(A3/Ledger)		
	U260	Selecting the timing for copy counting	Eject		
Mode setting	U265	Setting OEM purchaser code	-		
	U271	Setting the page count	2/3		
	U278	Setting the delivery date	-		
	U285	Setting service status page	On		
	U323	Setting abnormal temperature and humidity warning	On		
	U325	Setting the paper interval	Off/1		
	U326	Setting the black line cleaning indication	On/8		
	U327	Setting the cassette heater control	Off		
	U332	Setting the size conversion factor	1.0		
	U340	Setting the applied mode	50/1		
		Adj Memory	0		
		Adj Max Job	Copy:10 / Printer:50		
	U341	Specific paper feed location setting for printing function	Off		
	U343	Switching between duplex/simplex copy mode	Off		
U345	Setting the value for maintenance due indication	0			
Image processing	U402	Adjusting margins of image printing	4.0/3.0/3.0/3.9		
	U403	Adjusting margins for scanning an original on the contact glass	2.0/2.0/2.0/2.0		
	U404	Adjusting margins for scanning an original from the DP	3.0/2.5/3.0/4.0/3.0/2.5/3.0/4.0		
	U407	Adjusting the leading edge registration for memory image printing	0		
	U410	Adjusting the halftone automatically	Table1		
	U411	Adjusting the scanner automatically	-		
	U412	Adjusting the uneven density	-		
		On/Off Config	Off		
	U415	Adjusting the print position automatically	-		
U425	Setting the target	-			

Section	Item No.	Content of maintenance item	Initial setting		
			35ppm	45ppm	55ppm
Image processing	U464	Setting the ID correction operation			
		Permission		On	
		Time Interval		0	
		Mode		Normal	
		On/Sleep Out		On	
		AP/NE		On	
		Leaving Time		60	
		Driving Time		300	
		Timing		0	
		Target Value		145/330	
		Calib		-	
	U465	Data reference for ID correction		-	
	U470	Setting the JPEG compression ratio			
		Copy		90/90/90/90	
Send			30/40/51/70/90/30/40/51/70/90 30/40/51/70/90/30/40/51/70/90 15/25/90/15/25/90/ 15/25/90/15/25/90		
System			90/90		
U485	Setting the image processing mode		1/0		
Others	U520	Set TDRS		-	
	U901	Checking copy counts by paper feed locations		-	
	U903	Checking/clearing the paper jam counts		-	
	U904	Checking/clearing the call for service counts		-	
	U905	Checking counts by optional devices		-	
	U906	Resetting partial operation control		-	
	U908	Checking the total counter value		-	
	U910	Clearing the print coverage data		-	
	U911	Checking copy counts by paper sizes		-	
	U917	Setting backup data reading/writing		-	
	U920	Checking the copy counts		-	
	U927	Clearing the all copy counts and machine life counts (one time only)		-	
	U928	Checking machine life counts		-	
	U930	Checking/clearing the charger roller count		-	

Section	Item No.	Content of maintenance item	Initial setting		
			35ppm	45ppm	55ppm
Others	U935	Relay board maintenance	Mode0		
	U942	Setting of deflection for feeding from DP	0/0/0		
	U952	Maintenance mode workflow	-		
	U964	Checking of log	-		
	U969	Checking of toner area code	-		
	U977	Data capture mode	-		
	U978	Clear Optional Function	-		
	U984	Checking the developer unit number	-		
	U985	Displaying the developer unit history	-		
	U989	HDD Scan disk	-		
	U990	Checking the time for the exposure lamp to light	-		
	U991	Checking the scanner operation count	-		

**(3) Contents of the maintenance mode items**

Item No.	Description																								
U000	<p data-bbox="287 286 646 320"><b>Output Maintenance Report</b></p> <p data-bbox="287 353 438 387"><b>Description</b> Outputs lists of the current settings of the maintenance items, and paper jam and service call occurrences. Outputs the event log or service status page. Also sends output data to the USB memory.</p> <p data-bbox="287 495 399 528"><b>Purpose</b> To check the current setting of the maintenance items, or paper jam or service call occurrences. Before initializing or replacing the backup RAM, output a list of the current settings of the maintenance items to reenter the settings after initialization or replacement.</p> <p data-bbox="287 667 391 701"><b>Method</b></p> <ol data-bbox="303 705 1037 772" style="list-style-type: none"> <li>1. Press the start key.</li> <li>2. Select the item to be output using the cursor up/down keys.</li> </ol> <table border="1" data-bbox="335 779 1401 1120"> <thead> <tr> <th data-bbox="343 788 641 833">Display</th> <th data-bbox="641 788 1393 833">Output list</th> </tr> </thead> <tbody> <tr> <td data-bbox="343 833 641 878">Maintenance</td> <td data-bbox="641 833 1393 878">List of the current settings of the maintenance modes</td> </tr> <tr> <td data-bbox="343 878 641 922">User Status</td> <td data-bbox="641 878 1393 922">Outputs the user status page</td> </tr> <tr> <td data-bbox="343 922 641 967">Service Status</td> <td data-bbox="641 922 1393 967">Outputs the service status page</td> </tr> <tr> <td data-bbox="343 967 641 1012">Event</td> <td data-bbox="641 967 1393 1012">Outputs the event log</td> </tr> <tr> <td data-bbox="343 1012 641 1057">Network Status</td> <td data-bbox="641 1012 1393 1057">Outputs the network status page</td> </tr> <tr> <td data-bbox="343 1057 641 1102">All</td> <td data-bbox="641 1057 1393 1102">Outputs the all reports</td> </tr> </tbody> </table> <ol data-bbox="303 1131 1428 1299" style="list-style-type: none"> <li>3. Press the start key. A list is output.</li> <li>4. Press the start key. The interrupt print mode is entered and a list is output. When A4/Letter paper is available, a report of this size is output. If not, specify the paper feed location. The output status is displayed.</li> </ol> <table border="1" data-bbox="335 1310 1401 1556"> <thead> <tr> <th data-bbox="343 1319 641 1364">Display</th> <th data-bbox="641 1319 1393 1364">Description</th> </tr> </thead> <tbody> <tr> <td data-bbox="343 1364 641 1408">---</td> <td data-bbox="641 1364 1393 1408">List of the current settings of the maintenance modes</td> </tr> <tr> <td data-bbox="343 1408 641 1453">Active</td> <td data-bbox="641 1408 1393 1453">Outputs the user status page</td> </tr> <tr> <td data-bbox="343 1453 641 1498">OK</td> <td data-bbox="641 1453 1393 1498">Outputs the service status page</td> </tr> <tr> <td data-bbox="343 1498 641 1543">Error</td> <td data-bbox="641 1498 1393 1543">Outputs the event log</td> </tr> </tbody> </table>	Display	Output list	Maintenance	List of the current settings of the maintenance modes	User Status	Outputs the user status page	Service Status	Outputs the service status page	Event	Outputs the event log	Network Status	Outputs the network status page	All	Outputs the all reports	Display	Description	---	List of the current settings of the maintenance modes	Active	Outputs the user status page	OK	Outputs the service status page	Error	Outputs the event log
Display	Output list																								
Maintenance	List of the current settings of the maintenance modes																								
User Status	Outputs the user status page																								
Service Status	Outputs the service status page																								
Event	Outputs the event log																								
Network Status	Outputs the network status page																								
All	Outputs the all reports																								
Display	Description																								
---	List of the current settings of the maintenance modes																								
Active	Outputs the user status page																								
OK	Outputs the service status page																								
Error	Outputs the event log																								

Item No.	Description								
U000	<p><b>Method: Send to the USB memory</b></p> <ol style="list-style-type: none"> <li>1. Press the power key on the operation panel, and after verifying the main power indicator has gone off, switch off the main power switch.</li> <li>2. Insert USB memory in USB memory slot.</li> <li>3. Turn the main power switch on.</li> <li>4. Enter the maintenance item.</li> <li>5. Press the start key.</li> <li>6. Select the item to be send.</li> <li>7. Select [Text] or [HTML].</li> </ol> <table border="1" data-bbox="336 562 1401 754"> <thead> <tr> <th data-bbox="336 562 641 611">Display</th> <th data-bbox="641 562 1401 611">Output list</th> </tr> </thead> <tbody> <tr> <td data-bbox="336 611 641 660">Print</td> <td data-bbox="641 611 1401 660">Outputs the report</td> </tr> <tr> <td data-bbox="336 660 641 710">USB (Text)</td> <td data-bbox="641 660 1401 710">Sends output data to the USB memory (text type)</td> </tr> <tr> <td data-bbox="336 710 641 754">USB (HTML)</td> <td data-bbox="641 710 1401 754">Sends output data to the USB memory (HTML type)</td> </tr> </tbody> </table> <ol style="list-style-type: none"> <li>8. Press the start key. Output will be sent to the USB memory.</li> </ol> <p><b>Completion</b> Press the stop key. The screen for selecting a maintenance item No. is displayed.</p>	Display	Output list	Print	Outputs the report	USB (Text)	Sends output data to the USB memory (text type)	USB (HTML)	Sends output data to the USB memory (HTML type)
Display	Output list								
Print	Outputs the report								
USB (Text)	Sends output data to the USB memory (text type)								
USB (HTML)	Sends output data to the USB memory (HTML type)								

Item No.	Description																																																																																																																																																																																																																																																																																																																																																																																																																				
U000	<p data-bbox="288 241 414 271"><b>Event log</b></p> <div data-bbox="316 297 1398 1637" style="border: 1px solid black; padding: 10px;"> <h3 data-bbox="355 324 576 369">Event Log</h3> <p data-bbox="355 374 414 400">MFP</p> <p data-bbox="1155 374 1353 400">(2) 2013/01/31 08:40</p> <p data-bbox="347 430 1362 456">(1) Firmware version 2N9_2000.000.000 2013.01.27 [XXXXXXXX] [XXXXXXXX] [XXXXXXXX] [XXXXXXXX]</p> <table border="0" data-bbox="347 495 1342 929"> <tr> <td colspan="4" data-bbox="347 495 917 521"><b>(8) Paper Jam Log</b></td> <td colspan="4" data-bbox="917 495 1342 521"><b>(12) Counter Log</b></td> </tr> <tr> <th data-bbox="389 526 405 548">#</th> <th data-bbox="437 526 512 548">Count.</th> <th data-bbox="571 526 900 548">Event Descriptions</th> <th data-bbox="762 526 900 548">Date and Time</th> <th data-bbox="938 526 963 548">(f)</th> <th data-bbox="1043 526 1069 548"></th> <th data-bbox="1091 526 1117 548"></th> <th data-bbox="1203 526 1228 548">(g)</th> </tr> <tr> <td>16</td> <td>9999999</td> <td>0501.01.08.01.01</td> <td>2013/01/23 11:56</td> <td>J0000:</td> <td>0</td> <td>J0041:</td> <td>1</td> </tr> <tr> <td>15</td> <td>8888888</td> <td>4002.01.08.01.01</td> <td>2013/01/23 11:54</td> <td>J0001:</td> <td>1</td> <td>J0042:</td> <td>1</td> </tr> <tr> <td>14</td> <td>7777777</td> <td>0501.01.08.01.01</td> <td>2013/01/23 11:52</td> <td>J0002:</td> <td>11</td> <td>J0043:</td> <td>1</td> </tr> <tr> <td>13</td> <td>6666666</td> <td>4002.01.08.01.01</td> <td>2013/01/23 11:46</td> <td>J0003:</td> <td>2</td> <td>J0044:</td> <td>1</td> </tr> <tr> <td>12</td> <td>5555555</td> <td>0501.01.08.01.01</td> <td>2013/01/23 11:36</td> <td>J0004:</td> <td>1</td> <td>J0045:</td> <td>1</td> </tr> <tr> <td>11</td> <td>4444444</td> <td>4002.01.08.01.01</td> <td>2013/01/23 11:26</td> <td>J0005:</td> <td>1</td> <td>J0046:</td> <td>1</td> </tr> <tr> <td>10</td> <td>3333333</td> <td>0501.01.08.01.01</td> <td>2013/01/23 10:56</td> <td>J0006:</td> <td>1</td> <td>J0047:</td> <td>1</td> </tr> <tr> <td>9</td> <td>2222222</td> <td>4002.01.08.01.01</td> <td>2013/01/21 11:56</td> <td>J0007:</td> <td>1</td> <td>J0048:</td> <td>1</td> </tr> <tr> <td>8</td> <td>1111111</td> <td>0501.01.08.01.01</td> <td>2013/01/21 10:56</td> <td>J0008:</td> <td>1</td> <td>J0049:</td> <td>1</td> </tr> <tr> <td>7</td> <td>9999999</td> <td>4002.01.08.01.01</td> <td>2013/01/21 11:52</td> <td>J0009:</td> <td>1</td> <td>J0050:</td> <td>1</td> </tr> <tr> <td>6</td> <td>8888888</td> <td>0501.01.08.01.01</td> <td>2013/01/20 11:36</td> <td>J0010:</td> <td>1</td> <td></td> <td></td> </tr> <tr> <td>5</td> <td>7777777</td> <td>0501.01.08.01.01</td> <td>2013/01/20 10:26</td> <td>J0012:</td> <td>9</td> <td></td> <td></td> </tr> <tr> <td>4</td> <td>6666666</td> <td>0501.01.08.01.01</td> <td>2013/01/13 14:16</td> <td>J0013:</td> <td>1</td> <td></td> <td></td> </tr> <tr> <td>3</td> <td>5555555</td> <td>0501.01.08.01.01</td> <td>2013/01/13 11:56</td> <td>J0014:</td> <td>1</td> <td></td> <td></td> </tr> <tr> <td>2</td> <td>4444444</td> <td>0501.01.08.01.01</td> <td>2013/01/11 16:26</td> <td>J0015:</td> <td>1</td> <td></td> <td></td> </tr> <tr> <td>1</td> <td>3333333</td> <td>4002.01.08.01.01</td> <td>2013/01/10 11:56</td> <td>J0016:</td> <td>1</td> <td></td> <td></td> </tr> <tr> <td></td> <td></td> <td></td> <td></td> <td>J0017:</td> <td>1</td> <td></td> <td></td> </tr> <tr> <td></td> <td></td> <td></td> <td></td> <td>J0018:</td> <td>1</td> <td></td> <td></td> </tr> <tr> <td></td> <td></td> <td></td> <td></td> <td>J0019:</td> <td>1</td> <td></td> <td></td> </tr> <tr> <td></td> <td></td> <td></td> <td></td> <td>J0020:</td> <td>1</td> <td></td> <td></td> </tr> <tr> <td></td> <td></td> <td></td> <td></td> <td>J0021:</td> <td>1</td> <td></td> <td></td> </tr> <tr> <td></td> <td></td> <td></td> <td></td> <td>J0022:</td> <td>1</td> <td></td> <td></td> </tr> <tr> <td></td> <td></td> <td></td> <td></td> <td>J0023:</td> <td>1</td> <td></td> <td></td> </tr> <tr> <td></td> <td></td> <td></td> <td></td> <td>J0024:</td> <td>1</td> <td></td> <td></td> </tr> <tr> <td></td> <td></td> <td></td> <td></td> <td>J0025:</td> <td>1</td> <td></td> <td></td> </tr> <tr> <td></td> <td></td> <td></td> <td></td> <td>J0026:</td> <td>1</td> <td></td> <td></td> </tr> <tr> <td></td> <td></td> <td></td> <td></td> <td>J0027:</td> <td>1</td> <td></td> <td></td> </tr> <tr> <td></td> <td></td> <td></td> <td></td> <td>J0028:</td> <td>1</td> <td></td> <td></td> </tr> <tr> <td></td> <td></td> <td></td> <td></td> <td>J0029:</td> <td>1</td> <td></td> <td></td> </tr> <tr> <td></td> <td></td> <td></td> <td></td> <td>J0030:</td> <td>1</td> <td></td> <td></td> </tr> <tr> <td></td> <td></td> <td></td> <td></td> <td>J0031:</td> <td>1</td> <td></td> <td></td> </tr> <tr> <td></td> <td></td> <td></td> <td></td> <td>J0032:</td> <td>1</td> <td></td> <td></td> </tr> <tr> <td></td> <td></td> <td></td> <td></td> <td>J0033:</td> <td>1</td> <td></td> <td></td> </tr> <tr> <td></td> <td></td> <td></td> <td></td> <td>J0034:</td> <td>1</td> <td></td> <td></td> </tr> <tr> <td></td> <td></td> <td></td> <td></td> <td>J0035:</td> <td>1</td> <td></td> <td></td> </tr> <tr> <td></td> <td></td> <td></td> <td></td> <td>J0036:</td> <td>1</td> <td></td> <td></td> </tr> <tr> <td></td> <td></td> <td></td> <td></td> <td>J0037:</td> <td>1</td> <td></td> <td></td> </tr> <tr> <td></td> <td></td> <td></td> <td></td> <td>J0038:</td> <td>1</td> <td></td> <td></td> </tr> <tr> <td></td> <td></td> <td></td> <td></td> <td>J0039:</td> <td>1</td> <td></td> <td></td> </tr> <tr> <td></td> <td></td> <td></td> <td></td> <td>J0040:</td> <td>1</td> <td></td> <td></td> </tr> </table> <p data-bbox="347 958 558 985"><b>(9) Service Call Log</b></p> <table border="0" data-bbox="389 990 925 1198"> <thead> <tr> <th>#</th> <th>Count.</th> <th>Service Code</th> <th>Date and Time</th> </tr> </thead> <tbody> <tr> <td>8</td> <td>1111111</td> <td>01.6000</td> <td>2013/01/23 11:52</td> </tr> <tr> <td>7</td> <td>9999999</td> <td>01.2100</td> <td>2013/01/23 11:46</td> </tr> <tr> <td>6</td> <td>8888888</td> <td>01.4000</td> <td>2013/01/23 11:36</td> </tr> <tr> <td>5</td> <td>7777777</td> <td>01.6000</td> <td>2013/01/23 11:26</td> </tr> <tr> <td>4</td> <td>6666666</td> <td>01.2100</td> <td>2013/01/23 10:56</td> </tr> <tr> <td>3</td> <td>5555555</td> <td>01.4000</td> <td>2013/01/21 11:56</td> </tr> <tr> <td>2</td> <td>4444444</td> <td>01.6000</td> <td>2013/01/21 10:56</td> </tr> <tr> <td>1</td> <td>1</td> <td>01.2100</td> <td>2013/01/21 11:52</td> </tr> </tbody> </table> <p data-bbox="347 1227 566 1254"><b>(10) Maintenance Log</b></p> <table border="0" data-bbox="389 1258 900 1285"> <thead> <tr> <th>#</th> <th>Count.</th> <th>Item.</th> <th>Date and Time</th> </tr> </thead> <tbody> <tr> <td></td> <td></td> <td>Log Data Nothing...</td> <td></td> </tr> </tbody> </table> <p data-bbox="347 1361 593 1388"><b>(11) Unknown toner Log</b></p> <table border="0" data-bbox="389 1393 925 1534"> <thead> <tr> <th>#</th> <th>Count.</th> <th>Item.</th> <th>Date and Time</th> </tr> </thead> <tbody> <tr> <td>5</td> <td>1111111</td> <td>01.00</td> <td>2013/01/20 10:26</td> </tr> <tr> <td>4</td> <td>9999999</td> <td>01.00</td> <td>2013/01/13 14:16</td> </tr> <tr> <td>3</td> <td>8888888</td> <td>01.00</td> <td>2013/01/13 11:56</td> </tr> <tr> <td>2</td> <td>7777777</td> <td>01.00</td> <td>2013/01/11 16:26</td> </tr> <tr> <td>1</td> <td>6666666</td> <td>01.00</td> <td>2013/01/10 11:56</td> </tr> </tbody> </table> <p data-bbox="1085 1574 1353 1601">(7) [XXXXXXXXXXXXXXXXXXXXX]</p> </div>	<b>(8) Paper Jam Log</b>				<b>(12) Counter Log</b>				#	Count.	Event Descriptions	Date and Time	(f)			(g)	16	9999999	0501.01.08.01.01	2013/01/23 11:56	J0000:	0	J0041:	1	15	8888888	4002.01.08.01.01	2013/01/23 11:54	J0001:	1	J0042:	1	14	7777777	0501.01.08.01.01	2013/01/23 11:52	J0002:	11	J0043:	1	13	6666666	4002.01.08.01.01	2013/01/23 11:46	J0003:	2	J0044:	1	12	5555555	0501.01.08.01.01	2013/01/23 11:36	J0004:	1	J0045:	1	11	4444444	4002.01.08.01.01	2013/01/23 11:26	J0005:	1	J0046:	1	10	3333333	0501.01.08.01.01	2013/01/23 10:56	J0006:	1	J0047:	1	9	2222222	4002.01.08.01.01	2013/01/21 11:56	J0007:	1	J0048:	1	8	1111111	0501.01.08.01.01	2013/01/21 10:56	J0008:	1	J0049:	1	7	9999999	4002.01.08.01.01	2013/01/21 11:52	J0009:	1	J0050:	1	6	8888888	0501.01.08.01.01	2013/01/20 11:36	J0010:	1			5	7777777	0501.01.08.01.01	2013/01/20 10:26	J0012:	9			4	6666666	0501.01.08.01.01	2013/01/13 14:16	J0013:	1			3	5555555	0501.01.08.01.01	2013/01/13 11:56	J0014:	1			2	4444444	0501.01.08.01.01	2013/01/11 16:26	J0015:	1			1	3333333	4002.01.08.01.01	2013/01/10 11:56	J0016:	1							J0017:	1							J0018:	1							J0019:	1							J0020:	1							J0021:	1							J0022:	1							J0023:	1							J0024:	1							J0025:	1							J0026:	1							J0027:	1							J0028:	1							J0029:	1							J0030:	1							J0031:	1							J0032:	1							J0033:	1							J0034:	1							J0035:	1							J0036:	1							J0037:	1							J0038:	1							J0039:	1							J0040:	1			#	Count.	Service Code	Date and Time	8	1111111	01.6000	2013/01/23 11:52	7	9999999	01.2100	2013/01/23 11:46	6	8888888	01.4000	2013/01/23 11:36	5	7777777	01.6000	2013/01/23 11:26	4	6666666	01.2100	2013/01/23 10:56	3	5555555	01.4000	2013/01/21 11:56	2	4444444	01.6000	2013/01/21 10:56	1	1	01.2100	2013/01/21 11:52	#	Count.	Item.	Date and Time			Log Data Nothing...		#	Count.	Item.	Date and Time	5	1111111	01.00	2013/01/20 10:26	4	9999999	01.00	2013/01/13 14:16	3	8888888	01.00	2013/01/13 11:56	2	7777777	01.00	2013/01/11 16:26	1	6666666	01.00	2013/01/10 11:56
<b>(8) Paper Jam Log</b>				<b>(12) Counter Log</b>																																																																																																																																																																																																																																																																																																																																																																																																																	
#	Count.	Event Descriptions	Date and Time	(f)			(g)																																																																																																																																																																																																																																																																																																																																																																																																														
16	9999999	0501.01.08.01.01	2013/01/23 11:56	J0000:	0	J0041:	1																																																																																																																																																																																																																																																																																																																																																																																																														
15	8888888	4002.01.08.01.01	2013/01/23 11:54	J0001:	1	J0042:	1																																																																																																																																																																																																																																																																																																																																																																																																														
14	7777777	0501.01.08.01.01	2013/01/23 11:52	J0002:	11	J0043:	1																																																																																																																																																																																																																																																																																																																																																																																																														
13	6666666	4002.01.08.01.01	2013/01/23 11:46	J0003:	2	J0044:	1																																																																																																																																																																																																																																																																																																																																																																																																														
12	5555555	0501.01.08.01.01	2013/01/23 11:36	J0004:	1	J0045:	1																																																																																																																																																																																																																																																																																																																																																																																																														
11	4444444	4002.01.08.01.01	2013/01/23 11:26	J0005:	1	J0046:	1																																																																																																																																																																																																																																																																																																																																																																																																														
10	3333333	0501.01.08.01.01	2013/01/23 10:56	J0006:	1	J0047:	1																																																																																																																																																																																																																																																																																																																																																																																																														
9	2222222	4002.01.08.01.01	2013/01/21 11:56	J0007:	1	J0048:	1																																																																																																																																																																																																																																																																																																																																																																																																														
8	1111111	0501.01.08.01.01	2013/01/21 10:56	J0008:	1	J0049:	1																																																																																																																																																																																																																																																																																																																																																																																																														
7	9999999	4002.01.08.01.01	2013/01/21 11:52	J0009:	1	J0050:	1																																																																																																																																																																																																																																																																																																																																																																																																														
6	8888888	0501.01.08.01.01	2013/01/20 11:36	J0010:	1																																																																																																																																																																																																																																																																																																																																																																																																																
5	7777777	0501.01.08.01.01	2013/01/20 10:26	J0012:	9																																																																																																																																																																																																																																																																																																																																																																																																																
4	6666666	0501.01.08.01.01	2013/01/13 14:16	J0013:	1																																																																																																																																																																																																																																																																																																																																																																																																																
3	5555555	0501.01.08.01.01	2013/01/13 11:56	J0014:	1																																																																																																																																																																																																																																																																																																																																																																																																																
2	4444444	0501.01.08.01.01	2013/01/11 16:26	J0015:	1																																																																																																																																																																																																																																																																																																																																																																																																																
1	3333333	4002.01.08.01.01	2013/01/10 11:56	J0016:	1																																																																																																																																																																																																																																																																																																																																																																																																																
				J0017:	1																																																																																																																																																																																																																																																																																																																																																																																																																
				J0018:	1																																																																																																																																																																																																																																																																																																																																																																																																																
				J0019:	1																																																																																																																																																																																																																																																																																																																																																																																																																
				J0020:	1																																																																																																																																																																																																																																																																																																																																																																																																																
				J0021:	1																																																																																																																																																																																																																																																																																																																																																																																																																
				J0022:	1																																																																																																																																																																																																																																																																																																																																																																																																																
				J0023:	1																																																																																																																																																																																																																																																																																																																																																																																																																
				J0024:	1																																																																																																																																																																																																																																																																																																																																																																																																																
				J0025:	1																																																																																																																																																																																																																																																																																																																																																																																																																
				J0026:	1																																																																																																																																																																																																																																																																																																																																																																																																																
				J0027:	1																																																																																																																																																																																																																																																																																																																																																																																																																
				J0028:	1																																																																																																																																																																																																																																																																																																																																																																																																																
				J0029:	1																																																																																																																																																																																																																																																																																																																																																																																																																
				J0030:	1																																																																																																																																																																																																																																																																																																																																																																																																																
				J0031:	1																																																																																																																																																																																																																																																																																																																																																																																																																
				J0032:	1																																																																																																																																																																																																																																																																																																																																																																																																																
				J0033:	1																																																																																																																																																																																																																																																																																																																																																																																																																
				J0034:	1																																																																																																																																																																																																																																																																																																																																																																																																																
				J0035:	1																																																																																																																																																																																																																																																																																																																																																																																																																
				J0036:	1																																																																																																																																																																																																																																																																																																																																																																																																																
				J0037:	1																																																																																																																																																																																																																																																																																																																																																																																																																
				J0038:	1																																																																																																																																																																																																																																																																																																																																																																																																																
				J0039:	1																																																																																																																																																																																																																																																																																																																																																																																																																
				J0040:	1																																																																																																																																																																																																																																																																																																																																																																																																																
#	Count.	Service Code	Date and Time																																																																																																																																																																																																																																																																																																																																																																																																																		
8	1111111	01.6000	2013/01/23 11:52																																																																																																																																																																																																																																																																																																																																																																																																																		
7	9999999	01.2100	2013/01/23 11:46																																																																																																																																																																																																																																																																																																																																																																																																																		
6	8888888	01.4000	2013/01/23 11:36																																																																																																																																																																																																																																																																																																																																																																																																																		
5	7777777	01.6000	2013/01/23 11:26																																																																																																																																																																																																																																																																																																																																																																																																																		
4	6666666	01.2100	2013/01/23 10:56																																																																																																																																																																																																																																																																																																																																																																																																																		
3	5555555	01.4000	2013/01/21 11:56																																																																																																																																																																																																																																																																																																																																																																																																																		
2	4444444	01.6000	2013/01/21 10:56																																																																																																																																																																																																																																																																																																																																																																																																																		
1	1	01.2100	2013/01/21 11:52																																																																																																																																																																																																																																																																																																																																																																																																																		
#	Count.	Item.	Date and Time																																																																																																																																																																																																																																																																																																																																																																																																																		
		Log Data Nothing...																																																																																																																																																																																																																																																																																																																																																																																																																			
#	Count.	Item.	Date and Time																																																																																																																																																																																																																																																																																																																																																																																																																		
5	1111111	01.00	2013/01/20 10:26																																																																																																																																																																																																																																																																																																																																																																																																																		
4	9999999	01.00	2013/01/13 14:16																																																																																																																																																																																																																																																																																																																																																																																																																		
3	8888888	01.00	2013/01/13 11:56																																																																																																																																																																																																																																																																																																																																																																																																																		
2	7777777	01.00	2013/01/11 16:26																																																																																																																																																																																																																																																																																																																																																																																																																		
1	6666666	01.00	2013/01/10 11:56																																																																																																																																																																																																																																																																																																																																																																																																																		

Figure 1-3-1

Detail of event log

No.	Items	Description
(1)	System version	
(2)	System date	
(3)	Engine soft version	
(4)	Engine boot version	

Item No.	Description					
U000	<b>Detail of event log</b>					
	<b>No.</b>	<b>Items</b>	<b>Description</b>			
	(5)		Controller BROM version			
	(6)		Operation panel mask version			
	(7)		Machine serial number			
	(8)	Paper Jam Log	#	Count.	Event	
			Remembers 1 to 16 of occurrence. If the occurrence of the previous paper jam is less than 16, all of the paper jams are logged. When the occurrence exceeds 16, the oldest occurrence is removed.	The total page count at the time of the paper jam.	Log code (hexadecimal, 5 categories)  (a) Cause of a paper jam (b) Paper source (c) Paper size (d) Paper type (e) Paper eject	
			(a) Cause of paper jam (Hexadecimal)			
			For details on the case of paper jam, refer to Paper Misfeed Detection. (P.1-4-1)			
			(b) Detail of paper source (Hexadecimal)			
00: MP tray 01: Cassette 1 02: Cassette 2 03: Cassette 3 (paper feeder/large capacity feeder) 04: Cassette 4 (paper feeder/large capacity feeder) 05: Cassette 5 (side deck) 06 to 09: Reserved						
(c) Detail of paper size (Hexadecimal)						
00: (Not specified) 01: Monarch 02: Business 03: International DL 04: International C5 05: Executive 06: Letter-R 08: Letter-E 07: Legal 08: A4R 88: A4E 09: B5R 89: B5E 0A: A3	0B: B4 0C: Ledger 0D: A5R 0E: A6 0F: B6 10: Commercial #9 11: Commercial #6 12: ISO B5 13: Custom size 1E: C4 1F: Postcard 20: Reply-paid post-card 21: Oficio II	22: Special 1 23: Special 2 24: A3 wide 25: Ledger wide 26: Full bleed paper (12 x 8) 27: 8K 28: 16K-R A8: 16K-E 32: Statement-R B2: Statement-E 33: Folio 34: Western type 2 35: Western type 4				

Item No.	Description																							
U000																								
	(8) cont.	Paper Jam Log	<table border="1"> <thead> <tr> <th data-bbox="584 280 855 324">No.</th> <th data-bbox="855 280 1137 324">Items</th> <th data-bbox="1137 280 1441 324">Description</th> </tr> </thead> <tbody> <tr> <td colspan="3" data-bbox="584 324 1441 369">(d) Detail of paper type (Hexadecimal)</td> </tr> <tr> <td data-bbox="584 369 855 701">           01: Plain            02: Transparency            03: Preprinted            04: Labels            05: Bond            06: Recycled            07: Vellum            08: Rough            09: Letterhead         </td> <td data-bbox="855 369 1137 701">           0A: Color            0B: Prepunched            0C: Envelope            0D: Cardstock            0E: Coated            0F: 2nd side            10: Media 16            11: High quality         </td> <td data-bbox="1137 369 1441 701">           15: Custom 1            16: Custom 2            17: Custom 3            18: Custom 4            19: Custom 5            1A: Custom 6            1B: Custom 7            1C: Custom 8         </td> </tr> <tr> <td colspan="3" data-bbox="584 701 1441 745">(e) Detail of paper eject location (Hexadecimal)</td> </tr> <tr> <td colspan="3" data-bbox="584 745 1441 1870">           01: Face down (FD)            02: Face up (FU)/1000-sheet finisher face up (FU)/                  4000-sheet finisher left sub tray (FU)            03: 1000-sheet finisher face down (FD)                  4000-sheet finisher main tray (FD)            05: Job separator tray            06: 4000-sheet finisher right sub tray (FU)            07: 4000-sheet finisher left sub tray (FD)            09: 4000-sheet finisher right sub tray (FD)            0A: Center-folding unit tray            0B: Mailbox tray 1 (FD)            0C: Mailbox tray 1 (FU)            0F: 100-sheets Inner Job separator tray (FD)            15: Mailbox tray 2 (FD)            16: Mailbox tray 2 (FU)            1F: Mailbox tray 3 (FD)            20: Mailbox tray 3 (FU)            29: Mailbox tray 4 (FD)            2A: Mailbox tray 4 (FU)            33: Mailbox tray 5 (FD)            34: Mailbox tray 5 (FU)            3D: Mailbox tray 6 (FD)            3E: Mailbox tray 6 (FU)            47: Mailbox tray 7 (FD)            48: Mailbox tray 7 (FU)            04/0D/0E: Reserved         </td> </tr> <tr> <td colspan="2" data-bbox="584 1870 1137 1915">Date and Time</td> <td data-bbox="1137 1870 1441 1915"></td> </tr> <tr> <td colspan="3" data-bbox="584 1915 1441 1960">Date and time of the occurrence of paper jam.</td> </tr> </tbody> </table>	No.	Items	Description	(d) Detail of paper type (Hexadecimal)			01: Plain 02: Transparency 03: Preprinted 04: Labels 05: Bond 06: Recycled 07: Vellum 08: Rough 09: Letterhead	0A: Color 0B: Prepunched 0C: Envelope 0D: Cardstock 0E: Coated 0F: 2nd side 10: Media 16 11: High quality	15: Custom 1 16: Custom 2 17: Custom 3 18: Custom 4 19: Custom 5 1A: Custom 6 1B: Custom 7 1C: Custom 8	(e) Detail of paper eject location (Hexadecimal)			01: Face down (FD) 02: Face up (FU)/1000-sheet finisher face up (FU)/ 4000-sheet finisher left sub tray (FU) 03: 1000-sheet finisher face down (FD) 4000-sheet finisher main tray (FD) 05: Job separator tray 06: 4000-sheet finisher right sub tray (FU) 07: 4000-sheet finisher left sub tray (FD) 09: 4000-sheet finisher right sub tray (FD) 0A: Center-folding unit tray 0B: Mailbox tray 1 (FD) 0C: Mailbox tray 1 (FU) 0F: 100-sheets Inner Job separator tray (FD) 15: Mailbox tray 2 (FD) 16: Mailbox tray 2 (FU) 1F: Mailbox tray 3 (FD) 20: Mailbox tray 3 (FU) 29: Mailbox tray 4 (FD) 2A: Mailbox tray 4 (FU) 33: Mailbox tray 5 (FD) 34: Mailbox tray 5 (FU) 3D: Mailbox tray 6 (FD) 3E: Mailbox tray 6 (FU) 47: Mailbox tray 7 (FD) 48: Mailbox tray 7 (FU) 04/0D/0E: Reserved			Date and Time			Date and time of the occurrence of paper jam.		
	No.	Items	Description																					
	(d) Detail of paper type (Hexadecimal)																							
	01: Plain 02: Transparency 03: Preprinted 04: Labels 05: Bond 06: Recycled 07: Vellum 08: Rough 09: Letterhead	0A: Color 0B: Prepunched 0C: Envelope 0D: Cardstock 0E: Coated 0F: 2nd side 10: Media 16 11: High quality	15: Custom 1 16: Custom 2 17: Custom 3 18: Custom 4 19: Custom 5 1A: Custom 6 1B: Custom 7 1C: Custom 8																					
(e) Detail of paper eject location (Hexadecimal)																								
01: Face down (FD) 02: Face up (FU)/1000-sheet finisher face up (FU)/ 4000-sheet finisher left sub tray (FU) 03: 1000-sheet finisher face down (FD) 4000-sheet finisher main tray (FD) 05: Job separator tray 06: 4000-sheet finisher right sub tray (FU) 07: 4000-sheet finisher left sub tray (FD) 09: 4000-sheet finisher right sub tray (FD) 0A: Center-folding unit tray 0B: Mailbox tray 1 (FD) 0C: Mailbox tray 1 (FU) 0F: 100-sheets Inner Job separator tray (FD) 15: Mailbox tray 2 (FD) 16: Mailbox tray 2 (FU) 1F: Mailbox tray 3 (FD) 20: Mailbox tray 3 (FU) 29: Mailbox tray 4 (FD) 2A: Mailbox tray 4 (FU) 33: Mailbox tray 5 (FD) 34: Mailbox tray 5 (FU) 3D: Mailbox tray 6 (FD) 3E: Mailbox tray 6 (FU) 47: Mailbox tray 7 (FD) 48: Mailbox tray 7 (FU) 04/0D/0E: Reserved																								
Date and Time																								
Date and time of the occurrence of paper jam.																								



Item No.	Description								
U000	<table border="1"> <thead> <tr> <th data-bbox="295 280 375 324">No.</th> <th data-bbox="375 280 558 324">Items</th> <th colspan="3" data-bbox="558 280 1422 324">Description</th> </tr> </thead> </table>				No.	Items	Description		
	No.	Items	Description						
	(9)	Service Call Log	#	Count.	Service Code				
			Remembers 1 to 8 of occurrence of self diagnostics error. If the occurrence of the previous diagnostics error is less than 8, all of the diagnostics errors are logged.	The total page count at the time of the self diagnostics error.	Self diagnostic error code (See page 1-4-61)  0X:YYYY Where 0X is: 01: Service Call/ System error has occurred 02: after Service Call has occurred, power is turned on and off, and disconnection has been executed  YYYY is a self-diagnostics error code Example: 01.6000				
			Date and Time						
	Date and time of occurrence of self-diagnostic error.								
	(10)	Maintenance Log	#	Count.	Item				
			Remembers 1 to 8 of occurrence of replacement. If the occurrence of the previous replacement of toner container is less than 8, all of the occurrences of replacement are logged.	The total page count at the time of the replacement of the toner container.  * :The toner replacement log is triggered by toner empty. This record may contain such a reference as the toner container is inserted twice or a used toner container is inserted.	Code of maintenance replacing item (1 byte, 2 categories)  First byte (Replacing item) 01: Toner container Second byte (Type of replacing item) 00: Black  First byte (Replacing item) 02: Maintenance kit Second byte (Type of replacing item) 01: MK-6315A/ 6317A/ 6318A/ 6319A				
			Date and Time						
	Date and time of replacement of the maintenance items.								

Item No.	Description			
U000	<b>Description</b>			
	<b>No.</b>	<b>Items</b>	<b>Description</b>	
(11)	Unknown Toner Log	#	Count.	Item
		Remembers 1 to 5 of occurrence of unknown toner detection. If the occurrence of the previous unknown toner detection is less than 5, all of the unknown toner detection are logged.	The total page count at the time of the toner empty error with using an unknown toner container.	Unknown toner log code (1 byte, 2 categories)  First byte 01: Toner container (Fixed) Second byte 00: Black
		Date and Time		
		Date and time of occurrence of toner container replacement request display.		
(12)	Counter Log  Comprised of three log counters including paper jams, self diagnostics errors, and replacement of the toner container.	(f) Paper jam	(g) Self diagnostic error	(h) Maintenance item replacing
		Indicates the log counter of paper jams depending on location.  Refer to Paper Jam Log.  All instances including those are not occurred are displayed.	Indicates the log counter of self diagnostics errors depending on cause.  Example: C6000: 4  Self diagnostics error 6000 has happened four times.	Indicates the log counter depending on the maintenance item for maintenance.  T: Toner container 00: Black M: Maintenance kit 00: MK-6315A/ 6317A/ 6318A/ 6319A  Example: T00: 1 The toner container has been replaced once.  * :The toner replacement log is triggered by toner empty. This record may contain such a reference as the toner container is inserted twice or a used toner container is inserted.

Item No.	Description
U000	<p data-bbox="287 235 582 280"><b>Service status page (1)</b></p> <div data-bbox="295 302 1420 1803" style="border: 1px solid black; padding: 10px;"> <p data-bbox="327 324 766 369"><b>Service Status Page</b></p> <p data-bbox="327 369 391 403">MFP</p> <p data-bbox="1173 369 1372 403">(2) 2012/10/27 12:00</p> <p data-bbox="319 425 798 459">(1) Firmware version 2N9_2000.000.000 2012.10.27</p> <p data-bbox="1005 403 1380 459">(3) [XXXXXXXX] (4) [XXXXXXXX] (5) [XXXXXXXX]</p> <hr/> <p data-bbox="343 504 630 537"><b>Controller Information</b></p> <p data-bbox="343 548 494 571"><b>Memory status</b></p> <p data-bbox="319 571 662 593">(7) Total Size 2.0 GB</p> <p data-bbox="343 616 399 638"><b>Time</b></p> <p data-bbox="319 638 766 672">(8) Local Time Zone +01:00 Amsterdam</p> <p data-bbox="319 672 758 694">(9) Date and Time 27/10/2010 12:00</p> <p data-bbox="319 694 718 716">(10) Time Server 10.183.53.13</p> <p data-bbox="343 750 518 772"><b>Installed Options</b></p> <p data-bbox="303 772 766 1131">(11) Document Processor Installed  (12) Paper feeder Cassette (500 x 2)  (13) Side feeder Not Installed  (14) Finisher 1000-Finisher  (15) Job Separator Installed  (16) Document Guaeed (A) Installed  (17) Card Authentication Kit (B) Installed  (18) Internet FAX Kit (A) Installed  (19) Security Kit (E) Installed  Data Security Kit (E) Software Type I  (84) UG-33 Installed  (20) UG-34 Installed  (21) USB Keyboard Connected  (22) USB Keyboard Type US-English  (85) Scan ectension kit(A) Installed</p> <p data-bbox="343 1142 494 1164"><b>Print Coverage</b></p> <p data-bbox="303 1164 837 1198">(23) Average(%) / Usage Page(A4/Letter Conversion)</p> <p data-bbox="303 1198 622 1243">(24) Total K: 1.10 / 1111111.11</p> <p data-bbox="303 1243 622 1288">(25) Copy K: 1.10 / 1111111.11</p> <p data-bbox="303 1288 622 1332">(26) Printer K: 1.10 / 1111111.11</p> <p data-bbox="303 1332 622 1377">(27) FAX K: 1.10 / 1111111.11</p> <p data-bbox="303 1377 813 1411">(28) Period (27/10/2010 - 03/11/2010 08:40)</p> <p data-bbox="303 1411 774 1433">(29) Last Page K/C/M/Y(%) 1.00 / 2.22 / 3.33 / 4.44</p> <p data-bbox="861 504 1173 537"><b>(30) FAX Information Slot1/Slot2</b></p> <p data-bbox="861 537 1133 560">(31) Rings (Normal) 3</p> <p data-bbox="861 560 1133 582">(32) Rings (FAX/TEL) 3</p> <p data-bbox="861 582 1133 604">(33) Rings (TAD) 3</p> <p data-bbox="861 604 1173 627">(34) Option DIMM Size 16 MB</p> <p data-bbox="861 672 1029 694"><b>(35) FRPO Status</b></p> <p data-bbox="901 694 1348 728">User Top Margin A1+A2/100 0.00</p> <p data-bbox="901 728 1348 750">User Left Margin A3+A4/100 0.00</p> <p data-bbox="861 1366 989 1388">RP Code</p> <p data-bbox="861 1388 1053 1411">(36) 1234 5678 9012</p> <p data-bbox="861 1411 1053 1433">(37) 5678 9012 3456</p> <p data-bbox="861 1433 1053 1456">(38) 9012 3456 7890</p> <p data-bbox="861 1456 1053 1478">(39) 3456 7890 1234</p> <hr/> <p data-bbox="829 1736 845 1758">1</p> <p data-bbox="1117 1736 1380 1769">(6) [XXXXXXXXXXXXXXXXXXXX]</p> </div>

Figure 1-3-2



Item No.	Description		
<b>U000</b>	<b>Detail of service status page</b>		
	<b>No.</b>	<b>Description</b>	<b>Supplement</b>
	(1)	Firmware version	-
	(2)	System date	-
	(3)	Engine soft version	-
	(4)	Engine boot version	-
	(5)	Operation panel mask version	-
	(6)	Machine serial number	-
	(7)	Total memory size	-
	(8)	Local time zone	-
	(9)	Report output date	Day/Month/Year hour:minute
	(10)	NTP server name	-
	(11)	Presence or absence of the document processor	Installed/Not installed
	(12)	Presence or absence of the paper feeder	Paper feeder/Large capacity feeder/Not Installed
	(13)	Presence or absence of the side feeder	Side deck/Side multi tray/Side paper feeder/ Side large capacity feeder/Not Installed
	(14)	Presence or absence of the finisher	1000-sheet finisher/4000-sheet finisher/ Not Installed
	(15)	Presence or absence of the job separator	Installed/Not Installed
	(16)	Presence or absence of the printed document guard kit	Installed/Not Installed
	(17)	Presence or absence of the IC card authentication kit	Installed/Not Installed/Trial
	(18)	Presence or absence of the internet fax kit	Installed/Not Installed
	(19)	Presence or absence of the data security kit	Installed/Not Installed
	(20)	Presence or absence of the UG-34	Installed/Not Installed
	(21)	Presence or absence of the USB keyboard	Connected/Not connected
	(22)	USB keyboard setting display	US-English/US-English with Euro
	(23)	Page of relation to the A4/Letter	* :Print Coverage provides a close-matching reference of toner consumption and will not match with the actual toner consumption.
	(24)	Average coverage for total	-
	(25)	Average coverage for copy	-
(26)	Average coverage for printer	-	

Item No.	Description		
<b>U000</b>	<b>No.</b>	<b>Description</b>	<b>Supplement</b>
	(27)	Average coverage for fax	-
	(28)	Cleared date and output date	-
	(29)	Coverage on the final output page	-
	(30)	Fax kit information	This item is printed only when the fax kit is installed.
	(31)	Number of rings	0 to 15
	(32)	Number of rings before automatic switching	0 to 15
	(33)	Number of rings before connecting to answering machine	0 to 15
	(34)	Optional DIMM size	-
	(35)	FRPO setting	-
	(36)	RP code	Code the engine software version and the date of update.
	(37)	RP code	Code the main software version and the date of update.
	(38)	RP code	Code the engine software version and the date of the previous update.
	(39)	RP code	Code the main software version and the date of the previous update.
	(40)	NV RAM version	<p>_ 1F3 1225 _ 1F3 1225  (a) (b) (c) (d) (e) (f)</p> <p>(a) Consistency of the present software version and the database  _ (underscore): OK  * (Asterisk): NG</p> <p>(b) Database version  (c) The oldest time stamp of database version  (d) Consistency of the present software version and the ME firmware version  _ (underscore): OK  * (Asterisk): NG</p> <p>(e) ME firmware version  (f) The oldest time stamp of the ME database version</p> <p>Normal if (a) and (d) are underscored, and (b) and (e) are identical with (c) and (f).</p>
(41)	Scanner firmware version	-	
(42)	Fax firmware version	This item is printed only when the fax kit is	

Item No.	Description			
<b>U000</b>	<b>No.</b>	<b>Description</b>	<b>Supplement</b>	
	(43)	Mac address	-	
	(44)	The last sent date and time	-	
	(45)	Transmission address	-	
	(46)	Destination information	-	
	(47)	Area information	-	
	(48)	Margin settings	Top margin/Left margin	
	(49)	L settings	L Top margin integer part/ L Top margin decimal part/ L Left margin integer part/ L Left margin decimal part/	
	(50)	Life counter (The first line)	Machine life/MP tray/Cassette 1/Cassette 2/ Cassette 3/Cassette 4/Cassette 5/Duplex	
		Life counter (The second line)	Drum unit/Transfer belt unit/Developer unit/ Maintenance kit A	
	(51)	Panel lock information	0: Off 1: Partial lock 2: Full lock	
	(52)	USB information	U00: Not installed/U01: Full speed/U02: Hi speed	
	(53)	Paper handling information	0: Paper source unit select/1: Paper source unit	
	(54)	Black and white printing double count mode	0: All single counts 1: A3, Single count, Less than 420 mm (length) 2: Legal, Single count, 356 mm or less (length) 3: Folio, Single count, Less than 330 mm (length)	
	(55)	Billing counting timing	-	
	(56)	Temperature (machine outside)	-	
	(57)	Relative Humidity (machine outside)	-	
	(58)	Fixed assets number	-	
	(59)	Job end judgment time-out time	-	
	(60)	Job end detection mode	-	
	(61)	Prescribe environment reset	0: Off 1: On	
	(62)	Media type attributes 1 to 28 (Not used: 18, 19, 20) * : For details on settings, refer to MDAT Command in "Prescribe Commands Reference Manual.	Weight settings 0: Light 1: Normal 1 2: Normal 2 3: Normal 3 4: Heavy 1 5: Heavy 2 6: Heavy 3 7: Extra Heavy	Fuser settings 0: High 1: Middle 2: Low 3: Vellum Duplex settings 0: Disable 1: Enable

Item No.	Description																							
<b>U000</b>	<b>No.</b>	<b>Description</b>	<b>Supplement</b>																					
	(63)	Calibration information	-																					
	(64)	Calibration information	-																					
	(65)	Calibration information	-																					
	(66)	Calibration information	-																					
	(67)	Calibration information	-																					
	(68)	Calibration information	-																					
	(69)	Calibration information	-																					
	(70)	Calibration information	-																					
	(71)	Calibration information	-																					
	(72)	RFID information	-																					
	(73)	RFID reader/writer version information	-																					
	(74)	Maintenance information	-																					
	(75)	Altitude	0: Standard 1: High altitude 1 2: High altitude 2																					
	(76)	Charger roller correction	1 to 5																					
	(77)	Data Sanitization information	-																					
	(78)	Toner low setting	0: Enabled 1: Disabled																					
	(79)	Toner low detection level	0 to 100 (%)																					
	(80)	Limiting shifting for one-page document	0: Invalid (No shift limit) 1: Valid (Shift limit)																					
	(81)	Setting confirmation display for banner printing	0: Not shown 1: Shown on every page																					
	(82)	Full-page print mode	0: Normal mode (Fixed)																					
	(83)	Drum serial number	-																					
	(84)	Presence or absence of the UG-33	Installed/ Not Installed																					
	(85)	Presence or absence of the Scan extension kit(A)	Installed/ Not Installed																					
		<p style="text-align: center;">Code conversion</p> <table border="1" style="margin-left: auto; margin-right: auto;"> <tbody> <tr> <td style="text-align: center;">A</td> <td style="text-align: center;">B</td> <td style="text-align: center;">C</td> <td style="text-align: center;">D</td> <td style="text-align: center;">E</td> <td style="text-align: center;">F</td> <td style="text-align: center;">G</td> <td style="text-align: center;">H</td> <td style="text-align: center;">I</td> <td style="text-align: center;">J</td> </tr> <tr> <td style="text-align: center;">0</td> <td style="text-align: center;">1</td> <td style="text-align: center;">2</td> <td style="text-align: center;">3</td> <td style="text-align: center;">4</td> <td style="text-align: center;">5</td> <td style="text-align: center;">6</td> <td style="text-align: center;">7</td> <td style="text-align: center;">8</td> <td style="text-align: center;">9</td> </tr> </tbody> </table>			A	B	C	D	E	F	G	H	I	J	0	1	2	3	4	5	6	7	8	9
	A	B	C	D	E	F	G	H	I	J														
0	1	2	3	4	5	6	7	8	9															



Item No.	Description												
U001	<p><b>Exiting the maintenance mode</b></p> <p><b>Description</b> Exits the maintenance mode and return to the normal copy mode.</p> <p><b>Purpose</b> To exit the maintenance mode.</p> <p><b>Method</b> 1. Press the start key. The normal copy mode is entered.</p>												
U002	<p><b>Setting the factory default data</b></p> <p><b>Description</b> Restores the machine conditions to the factory default settings.</p> <p><b>Purpose</b> To move the mirror frame of the scanner to the position for transport. * : The parameter settings within the system menu will also be reset to the factory-set values.</p> <p><b>Method</b> 1. Press the start key. 2. Select [Mode1(All)]. 3. Press the start key. The mirror frame of the scanner return to the home position. 4. Turn the main power switch off and on. Allow more than 5 seconds between Off and On. * : An error code is displayed in case of an initialization error. When errors occurred, turn main power switch off then on, and execute initialization using maintenance item U002. * : Reset the following setting by using the system menu. [FAX] - Transmission - Local FAX Name Entry</p> <p><b>Error codes</b></p> <table border="1" data-bbox="336 1339 1401 1626"> <thead> <tr> <th data-bbox="336 1339 639 1384">Codes</th> <th data-bbox="639 1339 1401 1384">Description</th> </tr> </thead> <tbody> <tr> <td data-bbox="336 1384 639 1429">0001</td> <td data-bbox="639 1384 1401 1429">Entity error</td> </tr> <tr> <td data-bbox="336 1429 639 1473">0002</td> <td data-bbox="639 1429 1401 1473">Controller error</td> </tr> <tr> <td data-bbox="336 1473 639 1518">0003</td> <td data-bbox="639 1473 1401 1518">OS error</td> </tr> <tr> <td data-bbox="336 1518 639 1563">0020</td> <td data-bbox="639 1518 1401 1563">Engine error</td> </tr> <tr> <td data-bbox="336 1563 639 1626">0040</td> <td data-bbox="639 1563 1401 1626">Scanner error</td> </tr> </tbody> </table>	Codes	Description	0001	Entity error	0002	Controller error	0003	OS error	0020	Engine error	0040	Scanner error
Codes	Description												
0001	Entity error												
0002	Controller error												
0003	OS error												
0020	Engine error												
0040	Scanner error												

Item No.	Description										
U003	<p><b>Setting the service telephone number</b></p> <p><b>Description</b> Sets the telephone number to be displayed when a service call code is detected.</p> <p><b>Purpose</b> To set the telephone number to call service when installing the machine.</p> <p><b>Setting</b></p> <ol style="list-style-type: none"> <li>1. Press the start key. The keys to enter the number are displayed on the touch panel.</li> <li>2. Enter a telephone number (up to 15 digits).</li> <li>3. Press the start key. The setting is set.</li> </ol> <p><b>Completion</b> Press the stop key. The screen for selecting a maintenance item No. is displayed.</p>										
U004	<p><b>Setting the machine number</b></p> <p><b>Description</b> Sets or displays the machine number.</p> <p><b>Purpose</b> Performed to assign or confirm the machine ID when the EEPROM on the main PWB has been replaced.</p> <p><b>Method</b></p> <ol style="list-style-type: none"> <li>1. Press the start key. If the machine serial number of engine PWB matches with that of main PWB</li> </ol> <table border="1" data-bbox="336 1167 1401 1261"> <thead> <tr> <th data-bbox="336 1167 641 1211">Display</th> <th data-bbox="641 1167 1401 1211">Description</th> </tr> </thead> <tbody> <tr> <td data-bbox="336 1211 641 1261">Machine No.</td> <td data-bbox="641 1211 1401 1261">Displays the machine serial number</td> </tr> </tbody> </table> <p>If the machine serial number of engine PWB does not match with that of main PWB</p> <table border="1" data-bbox="336 1323 1401 1462"> <thead> <tr> <th data-bbox="336 1323 641 1368">Display</th> <th data-bbox="641 1323 1401 1368">Description</th> </tr> </thead> <tbody> <tr> <td data-bbox="336 1368 641 1413">Machine No.(Main)</td> <td data-bbox="641 1368 1401 1413">Displays the machine serial number of main</td> </tr> <tr> <td data-bbox="336 1413 641 1462">Machine No.(Eng)</td> <td data-bbox="641 1413 1401 1462">Displays the machine serial number of engine</td> </tr> </tbody> </table> <p><b>Setting</b> Carry out if the machine serial number does not match.</p> <ol style="list-style-type: none"> <li>1. Select [Execute].</li> <li>2. Press the start key. Writing of serial No. starts.</li> <li>3. Turn the main power switch off and on. Allow more than 5 seconds between Off and On.</li> </ol> <p><b>Completion</b> Press the stop key. The screen for selecting a maintenance item No. is displayed.</p>	Display	Description	Machine No.	Displays the machine serial number	Display	Description	Machine No.(Main)	Displays the machine serial number of main	Machine No.(Eng)	Displays the machine serial number of engine
Display	Description										
Machine No.	Displays the machine serial number										
Display	Description										
Machine No.(Main)	Displays the machine serial number of main										
Machine No.(Eng)	Displays the machine serial number of engine										

Item No.	Description								
<b>U010</b>	<p><b>Setting the maintenance mode ID</b></p> <p><b>Description</b> Sets the maintenance mode ID.</p> <p><b>Purpose</b> Modify maintenance mode ID for more security.</p> <p><b>Method</b> 1. Press the start key.</p> <table border="1" data-bbox="336 562 1401 757"> <thead> <tr> <th data-bbox="336 562 639 607">Display</th> <th data-bbox="639 562 1401 607">Description</th> </tr> </thead> <tbody> <tr> <td data-bbox="336 607 639 651">New ID</td> <td data-bbox="639 607 1401 651">Enter a new 8-digit ID</td> </tr> <tr> <td data-bbox="336 651 639 696">New ID(Reconfirm)</td> <td data-bbox="639 651 1401 696">Enter a new 8-digit ID (to confirm)</td> </tr> <tr> <td data-bbox="336 696 639 757">Initialize</td> <td data-bbox="639 696 1401 757">Initialize the ID</td> </tr> </tbody> </table> <p><b>Setting</b> 1. Select [New ID]. 2. Enter a new 8-digit ID on ten keys (0 – 9, *, #). * and # are mandatory to contain. 3. Select [New ID(Reconfirm)]. 4. Enter a new 8-digit ID on ten keys (0 – 9, *, #). 5. Press the start key. The setting is set.</p> <p><b>Method: [Initialize]</b> 1. Select [Initialize]. 2. Press the start key. ID is initialized.</p> <p><b>Completion</b> Press the stop key. The screen for selecting a maintenance item No. is displayed.</p>	Display	Description	New ID	Enter a new 8-digit ID	New ID(Reconfirm)	Enter a new 8-digit ID (to confirm)	Initialize	Initialize the ID
Display	Description								
New ID	Enter a new 8-digit ID								
New ID(Reconfirm)	Enter a new 8-digit ID (to confirm)								
Initialize	Initialize the ID								
<b>U018</b>	<p><b>Check Firmware Checksum</b></p> <p><b>Description</b> Investigate that the firmware has not been modified.</p> <p><b>Purpose</b> Investigate that the firmware has not been modified by re-calculate the checksum.</p> <p><b>Method</b> 1. Press the start key.</p> <table border="1" data-bbox="336 1653 1401 1848"> <thead> <tr> <th data-bbox="336 1653 639 1697">Display</th> <th data-bbox="639 1653 1401 1697">Description</th> </tr> </thead> <tbody> <tr> <td data-bbox="336 1697 639 1742">EXpected</td> <td data-bbox="639 1697 1401 1742">Displays the expected checksum.</td> </tr> <tr> <td data-bbox="336 1742 639 1787">Result</td> <td data-bbox="639 1742 1401 1787">Displays the calculated checksum.</td> </tr> <tr> <td data-bbox="336 1787 639 1848">Execute</td> <td data-bbox="639 1787 1401 1848">Perform the self-investigation.</td> </tr> </tbody> </table> <p>2. Select [Execute]. 3. Press the start key.</p>	Display	Description	EXpected	Displays the expected checksum.	Result	Displays the calculated checksum.	Execute	Perform the self-investigation.
Display	Description								
EXpected	Displays the expected checksum.								
Result	Displays the calculated checksum.								
Execute	Perform the self-investigation.								

Item No.	Description																																
<b>U018</b>	<p><b>If the verified result was incorrect, the following are displayed.</b></p> <table border="1" data-bbox="336 322 1401 609"> <thead> <tr> <th data-bbox="336 322 641 367">Display</th> <th data-bbox="641 322 1401 367">Description</th> </tr> </thead> <tbody> <tr> <td data-bbox="336 367 641 412">f001</td> <td data-bbox="641 367 1401 412">An expected-value file does not exist.</td> </tr> <tr> <td data-bbox="336 412 641 456">f002</td> <td data-bbox="641 412 1401 456">Reading the expected-value file failed.</td> </tr> <tr> <td data-bbox="336 456 641 501">f003</td> <td data-bbox="641 456 1401 501">Illegal data in the expected-value file (not 64-byte data)</td> </tr> <tr> <td data-bbox="336 501 641 546">s001t</td> <td data-bbox="641 501 1401 546">Failure to read the checksum</td> </tr> <tr> <td data-bbox="336 546 641 609">NG</td> <td data-bbox="641 546 1401 609">The expected value and the checksum do not match.</td> </tr> </tbody> </table> <p><b>Completion</b> Press the stop key. The screen for selecting a maintenance item No. is displayed.</p>	Display	Description	f001	An expected-value file does not exist.	f002	Reading the expected-value file failed.	f003	Illegal data in the expected-value file (not 64-byte data)	s001t	Failure to read the checksum	NG	The expected value and the checksum do not match.																				
Display	Description																																
f001	An expected-value file does not exist.																																
f002	Reading the expected-value file failed.																																
f003	Illegal data in the expected-value file (not 64-byte data)																																
s001t	Failure to read the checksum																																
NG	The expected value and the checksum do not match.																																
<b>U019</b>	<p><b>Firmware Version</b></p> <p><b>Description</b> Displays the part number of the firmware version to each PWB.</p> <p><b>Purpose</b> To check the part number or to decide, if the newest version of firmware is installed.</p> <p><b>Method</b></p> <ol style="list-style-type: none"> <li>1. Press the start key. The firmware version are displayed.</li> <li>2. Change the screen using the cursor up/down keys.</li> </ol> <table border="1" data-bbox="336 1128 1415 1895"> <thead> <tr> <th data-bbox="336 1128 655 1173">Display</th> <th data-bbox="655 1128 1415 1173">Description</th> </tr> </thead> <tbody> <tr> <td data-bbox="336 1173 655 1218">Main</td> <td data-bbox="655 1173 1415 1218">Main firmware</td> </tr> <tr> <td data-bbox="336 1218 655 1263">MMI</td> <td data-bbox="655 1218 1415 1263">Main operation firmware</td> </tr> <tr> <td data-bbox="336 1263 655 1308">Panel Main</td> <td data-bbox="655 1263 1415 1308">Operation firmware</td> </tr> <tr> <td data-bbox="336 1308 655 1352">Panel Boot</td> <td data-bbox="655 1308 1415 1352">Operation booting</td> </tr> <tr> <td data-bbox="336 1352 655 1397">Browser</td> <td data-bbox="655 1352 1415 1397">Browser firmware</td> </tr> <tr> <td data-bbox="336 1397 655 1442">Engine</td> <td data-bbox="655 1397 1415 1442">Engine firmware</td> </tr> <tr> <td data-bbox="336 1442 655 1487">Engine Boot</td> <td data-bbox="655 1442 1415 1487">Engine booting</td> </tr> <tr> <td data-bbox="336 1487 655 1532">Scanner</td> <td data-bbox="655 1487 1415 1532">Scanner firmware</td> </tr> <tr> <td data-bbox="336 1532 655 1576">Scanner Boot</td> <td data-bbox="655 1532 1415 1576">Scanner booting</td> </tr> <tr> <td data-bbox="336 1576 655 1621">RFID</td> <td data-bbox="655 1576 1415 1621">RFID firmware</td> </tr> <tr> <td data-bbox="336 1621 655 1666">Dictionary</td> <td data-bbox="655 1621 1415 1666">Dictionary software</td> </tr> <tr> <td data-bbox="336 1666 655 1711">Option Language</td> <td data-bbox="655 1666 1415 1711">Optional language software</td> </tr> <tr> <td data-bbox="336 1711 655 1756">OCR</td> <td data-bbox="655 1711 1415 1756">OCR software</td> </tr> <tr> <td data-bbox="336 1756 655 1800">DP</td> <td data-bbox="655 1756 1415 1800">Document processor firmware</td> </tr> <tr> <td data-bbox="336 1800 655 1895">DP Boot</td> <td data-bbox="655 1800 1415 1895">Document processor booting</td> </tr> </tbody> </table>	Display	Description	Main	Main firmware	MMI	Main operation firmware	Panel Main	Operation firmware	Panel Boot	Operation booting	Browser	Browser firmware	Engine	Engine firmware	Engine Boot	Engine booting	Scanner	Scanner firmware	Scanner Boot	Scanner booting	RFID	RFID firmware	Dictionary	Dictionary software	Option Language	Optional language software	OCR	OCR software	DP	Document processor firmware	DP Boot	Document processor booting
Display	Description																																
Main	Main firmware																																
MMI	Main operation firmware																																
Panel Main	Operation firmware																																
Panel Boot	Operation booting																																
Browser	Browser firmware																																
Engine	Engine firmware																																
Engine Boot	Engine booting																																
Scanner	Scanner firmware																																
Scanner Boot	Scanner booting																																
RFID	RFID firmware																																
Dictionary	Dictionary software																																
Option Language	Optional language software																																
OCR	OCR software																																
DP	Document processor firmware																																
DP Boot	Document processor booting																																

Item No.	Description	
<b>U019</b>	<b>Display</b>	<b>Description</b>
	PF1	Paper feeder / Large capacity feeder firmware
	PF1 Boot	Paper feeder / Large capacity feeder booting
	Side PF	Side deck firmware
	Side PF Boot	Side deck booting
	DF	1000-sheet finisher / 4000-sheet finisher firmware
	DF Boot	1000-sheet finisher / 4000-sheet finisher booting
	PH	Punch unit firmware
	PH Boot	Punch unit booting
	MT	Mailbox firmware
	MT Boot	Mailbox booting
	BF	Center-folding unit firmware
	BF Boot	Center-folding unit booting
	Fax APL1	Fax APL 1
	Fax Boot1	Fax booting 1
	Fax IPL1	Fax IPL 1
	Fax APL2	Fax APL 2 (dual Fax)
	Fax Boot2	Fax booting 2 (dual Fax)
	Fax IPL2	Fax IPL 2 (dual Fax)
	Application Name 01-16	Application software
	<p><b>Completion</b> Press the stop key. The screen for selecting a maintenance item No. is displayed.</p>	

Item No.	Description										
U021	<p data-bbox="287 241 534 275"><b>Memory initializing</b></p> <p data-bbox="287 309 438 342"><b>Description</b></p> <p data-bbox="287 344 1431 445">Initializes all settings, except those pertinent to the type of machine, namely each counter setting, service call history and mode setting. Also initializes backup RAM according to region specification selected in maintenance item U252 Setting the destination.</p> <p data-bbox="287 448 399 481"><b>Purpose</b></p> <p data-bbox="287 483 922 517">To return the machine settings to their factory default.</p> <p data-bbox="287 551 391 584"><b>Method</b></p> <ol data-bbox="303 586 1431 893" style="list-style-type: none"> <li data-bbox="303 586 566 620">1. Press the start key.</li> <li data-bbox="303 622 534 656">2. Select [Execute].</li> <li data-bbox="303 658 1431 759">3. Press the start key. * : All data other than that for adjustments due to variations between machines is initialized based on the destination setting.</li> <li data-bbox="303 761 1431 893">4. Turn the main power switch off and on. Allow more than 5 seconds between Off and On. * : An error code is displayed in case of an initialization error. When errors occurred, turn main power switch off then on, and execute initialization using maintenance item U021.</li> </ol> <p data-bbox="335 927 486 960"><b>Error codes</b></p> <table border="1" data-bbox="335 972 1399 1216"> <thead> <tr> <th data-bbox="343 983 641 1016">Codes</th> <th data-bbox="641 983 1391 1016">Description</th> </tr> </thead> <tbody> <tr> <td data-bbox="343 1028 641 1061">0001</td> <td data-bbox="641 1028 1391 1061">Entity error</td> </tr> <tr> <td data-bbox="343 1072 641 1106">0002</td> <td data-bbox="641 1072 1391 1106">Controller error</td> </tr> <tr> <td data-bbox="343 1117 641 1151">0020</td> <td data-bbox="641 1117 1391 1151">Engine error</td> </tr> <tr> <td data-bbox="343 1162 641 1196">0040</td> <td data-bbox="641 1162 1391 1196">Scanner error</td> </tr> </tbody> </table>	Codes	Description	0001	Entity error	0002	Controller error	0020	Engine error	0040	Scanner error
Codes	Description										
0001	Entity error										
0002	Controller error										
0020	Engine error										
0040	Scanner error										

Item No.	Description						
<b>U024</b>	<p><b>HDD formatting</b></p> <p><b>Description</b> Initializes the hard disk.</p> <p><b>Purpose</b> To initialize the hard disk when replacing the hard disk after shipping.</p> <p><b>Caution</b> In addition, the following settings are also initialized by initializing the hard disk. System menu (user login administration, job accounting, address book, one-touch keys and document box etc.), shortcuts and panel programs. When fully formatted, the following pre-installed software are removed. Option language, OCR dictionary software, HyPAS Application (FMU etc.).</p> <p><b>Method</b></p> <ol style="list-style-type: none"> <li>1. Press the start key.</li> <li>2. Select the item.</li> </ol> <table border="1" data-bbox="336 801 1401 949"> <thead> <tr> <th data-bbox="336 801 639 853">Display</th> <th data-bbox="639 801 1401 853">Description</th> </tr> </thead> <tbody> <tr> <td data-bbox="336 853 639 898">Full</td> <td data-bbox="639 853 1401 898">Full format</td> </tr> <tr> <td data-bbox="336 898 639 949">Data</td> <td data-bbox="639 898 1401 949">Data format (the application software are retained)</td> </tr> </tbody> </table> <ol style="list-style-type: none"> <li>3. Press [Execute].</li> <li>4. Press the start key to initialize the hard disk.</li> <li>5. Turn the main power switch off and on. Allow more than 5 seconds between Off and On.</li> </ol> <p>* : Software removed must be manually re-installed. Option language, OCR dictionary software: Install using a USB flash device. Install HyPAS applications (such as FMU) on the application dialog.</p> <p>* : If an OCT software does not exist, a warning dialog is displayed and OCR is deactivated.</p>	Display	Description	Full	Full format	Data	Data format (the application software are retained)
Display	Description						
Full	Full format						
Data	Data format (the application software are retained)						
<b>U025</b>	<p><b>Firmware Update (Security)</b></p> <p><b>Description</b> Used to execute FW-Update from the USB flash device while “Very High” is selected in the Security Level settings under the System Menu.</p> <p><b>Purpose</b> Firmware upgrading is initiated by a service person to conduct U025 while a USB flash device is inserted.</p> <p><b>Method</b></p> <ol style="list-style-type: none"> <li>1. Press the start key.</li> <li>2. Press [Execute].</li> <li>3. Firmware upgrading will begin when power is toggled off and on after the message to urge power toggling is displayed.</li> <li>4. After the firmware upgrade is completed normally, “FW-UPDATE Completed” will be displayed with the firmware version.</li> </ol> <p>* : This is not executable when a USB has not been installed.</p>						

Item No.	Description																																
<b>U026</b>	<p><b>Pulling Backup Data</b></p> <p><b>Description</b> Perform restoring of the backup data..</p> <p><b>Purpose</b> Restores the setting values that was backed up in the flash memory from the HDD.</p> <p><b>Method</b></p> <ol style="list-style-type: none"> <li>1. Press the start key.</li> <li>2. Press [Execute].</li> <li>3. Press the start key.</li> <li>4. Turn the main power switch off and on. Allow more than 5 seconds between Off and On. * : NG will be displayed when an error was resulted at completion.</li> </ol> <p>Saved data: U278 Setting the delivery date U402 Adjusting margins of image printing U952 Maintenance mode workflow</p>																																
<b>U030</b>	<p><b>Checking the operation of the motors</b></p> <p><b>Description</b> Drives each motor.</p> <p><b>Purpose</b> To check the operation of each motor.</p> <p><b>Method</b></p> <ol style="list-style-type: none"> <li>1. Press the start key.</li> <li>2. Select the motor to be operated.</li> <li>3. Press the start key. The operation starts.</li> </ol> <table border="1" data-bbox="336 1198 1385 1966"> <thead> <tr> <th data-bbox="336 1198 687 1243">Display</th> <th data-bbox="687 1198 1385 1243">Description</th> </tr> </thead> <tbody> <tr> <td data-bbox="336 1243 687 1288">Feed</td> <td data-bbox="687 1243 1385 1288">Paper feed motor (PFM) is turned on</td> </tr> <tr> <td data-bbox="336 1288 687 1332">DLP(K)</td> <td data-bbox="687 1288 1385 1332">Developer motor (DEVM) is turned on</td> </tr> <tr> <td data-bbox="336 1332 687 1377">Fuser</td> <td data-bbox="687 1332 1385 1377">Fuser motor (FUM) is turned on</td> </tr> <tr> <td data-bbox="336 1377 687 1422">SB(CW)</td> <td data-bbox="687 1377 1385 1422">Eject motor (EM) is turned on clockwise</td> </tr> <tr> <td data-bbox="336 1422 687 1467">SB(CCW)</td> <td data-bbox="687 1422 1385 1467">Eject motor (EM) is turned on counterclockwise</td> </tr> <tr> <td data-bbox="336 1467 687 1512">Job Separator</td> <td data-bbox="687 1467 1385 1512">JS eject motor (JSEM) is turned on</td> </tr> <tr> <td data-bbox="336 1512 687 1556">Regist*</td> <td data-bbox="687 1512 1385 1556">Registration motor (RM) is turned on</td> </tr> <tr> <td data-bbox="336 1556 687 1601">Decal</td> <td data-bbox="687 1556 1385 1601">Decal motor (BRDM) is turned on</td> </tr> <tr> <td data-bbox="336 1601 687 1646">Decal Guide</td> <td data-bbox="687 1601 1385 1646">Decal Guide motor (BRGM) is turned on</td> </tr> <tr> <td data-bbox="336 1646 687 1691">Bridge1</td> <td data-bbox="687 1646 1385 1691">BR conveying motor 1 (BRCM1) is turned on</td> </tr> <tr> <td data-bbox="336 1691 687 1736">Bridge2</td> <td data-bbox="687 1691 1385 1736">BR conveying motor 2 (BRCM2) is turned on</td> </tr> <tr> <td data-bbox="336 1736 687 1780">DU1*</td> <td data-bbox="687 1736 1385 1780">Duplex motor 1 (DUM1) is turned on</td> </tr> <tr> <td data-bbox="336 1780 687 1825">DU2*</td> <td data-bbox="687 1780 1385 1825">Duplex motor 2 (DUM2) is turned on</td> </tr> <tr> <td data-bbox="336 1825 687 1870">Mid Roller*</td> <td data-bbox="687 1825 1385 1870">Middle motor (RM) is turned on</td> </tr> <tr> <td data-bbox="336 1870 687 1915">Vibration</td> <td data-bbox="687 1870 1385 1915">Vibration motor is turned on</td> </tr> </tbody> </table> <p>*: 45 ppm/ 55 ppm model only</p>	Display	Description	Feed	Paper feed motor (PFM) is turned on	DLP(K)	Developer motor (DEVM) is turned on	Fuser	Fuser motor (FUM) is turned on	SB(CW)	Eject motor (EM) is turned on clockwise	SB(CCW)	Eject motor (EM) is turned on counterclockwise	Job Separator	JS eject motor (JSEM) is turned on	Regist*	Registration motor (RM) is turned on	Decal	Decal motor (BRDM) is turned on	Decal Guide	Decal Guide motor (BRGM) is turned on	Bridge1	BR conveying motor 1 (BRCM1) is turned on	Bridge2	BR conveying motor 2 (BRCM2) is turned on	DU1*	Duplex motor 1 (DUM1) is turned on	DU2*	Duplex motor 2 (DUM2) is turned on	Mid Roller*	Middle motor (RM) is turned on	Vibration	Vibration motor is turned on
Display	Description																																
Feed	Paper feed motor (PFM) is turned on																																
DLP(K)	Developer motor (DEVM) is turned on																																
Fuser	Fuser motor (FUM) is turned on																																
SB(CW)	Eject motor (EM) is turned on clockwise																																
SB(CCW)	Eject motor (EM) is turned on counterclockwise																																
Job Separator	JS eject motor (JSEM) is turned on																																
Regist*	Registration motor (RM) is turned on																																
Decal	Decal motor (BRDM) is turned on																																
Decal Guide	Decal Guide motor (BRGM) is turned on																																
Bridge1	BR conveying motor 1 (BRCM1) is turned on																																
Bridge2	BR conveying motor 2 (BRCM2) is turned on																																
DU1*	Duplex motor 1 (DUM1) is turned on																																
DU2*	Duplex motor 2 (DUM2) is turned on																																
Mid Roller*	Middle motor (RM) is turned on																																
Vibration	Vibration motor is turned on																																

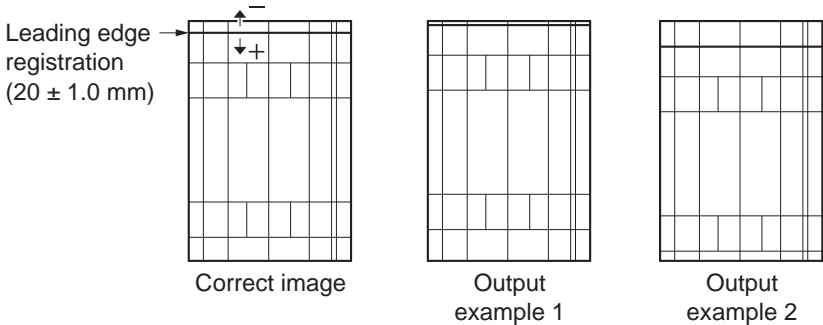
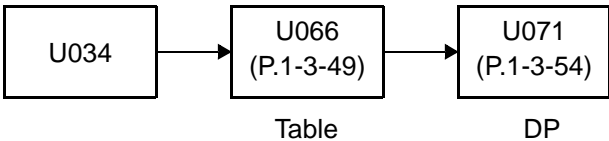


Item No.	Description																																				
U030	<p>4. To stop operation, press the stop key.</p> <p><b>Completion</b> Press the stop key. The screen for selecting a maintenance item No. is displayed.</p>																																				
U031	<p><b>Checking switches and sensors for paper conveying</b></p> <p><b>Description</b> Displays the on-off status of each paper detection switch or sensor on the paper path.</p> <p><b>Purpose</b> To check if the switches and sensors for paper conveying operate correctly.</p> <p><b>Method</b></p> <ol style="list-style-type: none"> <li>1. Press the start key.</li> <li>2. Turn each switch or sensor on and off manually to check the status. When the on-status of a switch or sensor is detected, that switch or sensor is displayed in reverse.</li> </ol> <table border="1" data-bbox="336 817 1401 1680"> <thead> <tr> <th data-bbox="336 817 641 862">Display</th> <th data-bbox="641 817 1401 862">Description</th> </tr> </thead> <tbody> <tr> <td data-bbox="336 862 641 907">MPT Jam</td> <td data-bbox="641 862 1401 907">MP feed sensor (MPFS)</td> </tr> <tr> <td data-bbox="336 907 641 952">Cassette1 Feed</td> <td data-bbox="641 907 1401 952">Feed sensor 1 (FS1)</td> </tr> <tr> <td data-bbox="336 952 641 996">Cassette2 Feed</td> <td data-bbox="641 952 1401 996">Feed sensor 2 (FS2)</td> </tr> <tr> <td data-bbox="336 996 641 1041">Feed2(Feed B)</td> <td data-bbox="641 996 1401 1041">Paper conveying sensor (PCS)</td> </tr> <tr> <td data-bbox="336 1041 641 1086">Regist</td> <td data-bbox="641 1041 1401 1086">Registration sensor (RS)</td> </tr> <tr> <td data-bbox="336 1086 641 1131">Decal</td> <td data-bbox="641 1086 1401 1131">Decal motor () is turned on</td> </tr> <tr> <td data-bbox="336 1131 641 1176">Decal Guide</td> <td data-bbox="641 1131 1401 1176">Decal Guide motor () is turned on</td> </tr> <tr> <td data-bbox="336 1176 641 1220">Belt Jam</td> <td data-bbox="641 1176 1401 1220">Loop sensor (LPS)</td> </tr> <tr> <td data-bbox="336 1220 641 1265">Exit Feed</td> <td data-bbox="641 1220 1401 1265">Switchback sensor (SBS)</td> </tr> <tr> <td data-bbox="336 1265 641 1310">DU1</td> <td data-bbox="641 1265 1401 1310">Duplex sensor 1 (DUS1)</td> </tr> <tr> <td data-bbox="336 1310 641 1355">DU2</td> <td data-bbox="641 1310 1401 1355">Duplex sensor 2 (DUS2)</td> </tr> <tr> <td data-bbox="336 1355 641 1400">Bridge2 Feed</td> <td data-bbox="641 1355 1401 1400">BR conveying sensor 2 (BRCS2)</td> </tr> <tr> <td data-bbox="336 1400 641 1444">Bridge Exit</td> <td data-bbox="641 1400 1401 1444">BR eject sensor (BRES)</td> </tr> <tr> <td data-bbox="336 1444 641 1489">Exit Paper</td> <td data-bbox="641 1444 1401 1489">Eject full sensor (EFS)</td> </tr> <tr> <td data-bbox="336 1489 641 1534">Fuser Feed</td> <td data-bbox="641 1489 1401 1534">Fuser eject sensor (FUES)</td> </tr> <tr> <td data-bbox="336 1534 641 1579">Feed1(Mid)</td> <td data-bbox="641 1534 1401 1579">Middle sensor (MS)</td> </tr> <tr> <td data-bbox="336 1579 641 1624">Exit Job Separator</td> <td data-bbox="641 1579 1401 1624">JS eject sensor (JSES)</td> </tr> </tbody> </table> <p><b>Completion</b> Press the stop key. The screen for selecting a maintenance item No. is displayed.</p>	Display	Description	MPT Jam	MP feed sensor (MPFS)	Cassette1 Feed	Feed sensor 1 (FS1)	Cassette2 Feed	Feed sensor 2 (FS2)	Feed2(Feed B)	Paper conveying sensor (PCS)	Regist	Registration sensor (RS)	Decal	Decal motor () is turned on	Decal Guide	Decal Guide motor () is turned on	Belt Jam	Loop sensor (LPS)	Exit Feed	Switchback sensor (SBS)	DU1	Duplex sensor 1 (DUS1)	DU2	Duplex sensor 2 (DUS2)	Bridge2 Feed	BR conveying sensor 2 (BRCS2)	Bridge Exit	BR eject sensor (BRES)	Exit Paper	Eject full sensor (EFS)	Fuser Feed	Fuser eject sensor (FUES)	Feed1(Mid)	Middle sensor (MS)	Exit Job Separator	JS eject sensor (JSES)
Display	Description																																				
MPT Jam	MP feed sensor (MPFS)																																				
Cassette1 Feed	Feed sensor 1 (FS1)																																				
Cassette2 Feed	Feed sensor 2 (FS2)																																				
Feed2(Feed B)	Paper conveying sensor (PCS)																																				
Regist	Registration sensor (RS)																																				
Decal	Decal motor () is turned on																																				
Decal Guide	Decal Guide motor () is turned on																																				
Belt Jam	Loop sensor (LPS)																																				
Exit Feed	Switchback sensor (SBS)																																				
DU1	Duplex sensor 1 (DUS1)																																				
DU2	Duplex sensor 2 (DUS2)																																				
Bridge2 Feed	BR conveying sensor 2 (BRCS2)																																				
Bridge Exit	BR eject sensor (BRES)																																				
Exit Paper	Eject full sensor (EFS)																																				
Fuser Feed	Fuser eject sensor (FUES)																																				
Feed1(Mid)	Middle sensor (MS)																																				
Exit Job Separator	JS eject sensor (JSES)																																				

Item No.	Description																								
<b>U032</b>	<p data-bbox="288 241 786 275"><b>Checking the operation of the clutches</b></p> <p data-bbox="288 311 440 340"><b>Description</b></p> <p data-bbox="288 344 533 374">Turn each clutch on.</p> <p data-bbox="288 380 400 409"><b>Purpose</b></p> <p data-bbox="288 414 740 443">To check the operation of each clutch.</p> <p data-bbox="288 483 387 512"><b>Method</b></p> <ol data-bbox="304 517 815 618" style="list-style-type: none"> <li>1. Press the start key.</li> <li>2. Select the clutch to be operated.</li> <li>3. Press the start key. The operation starts.</li> </ol> <table border="1" data-bbox="336 631 1401 1207"> <thead> <tr> <th data-bbox="336 631 639 676">Display</th> <th data-bbox="639 631 1401 676">Description</th> </tr> </thead> <tbody> <tr> <td data-bbox="336 676 639 721">Feed1</td> <td data-bbox="639 676 1401 721">Paper feed clutch 1 (PFCL1) is turned on</td> </tr> <tr> <td data-bbox="336 721 639 766">Feed2</td> <td data-bbox="639 721 1401 766">Paper feed clutch 2 (PFCL2) is turned on</td> </tr> <tr> <td data-bbox="336 766 639 810">Mid Roller*1</td> <td data-bbox="639 766 1401 810">Middle clutch (MCL) is turned on</td> </tr> <tr> <td data-bbox="336 810 639 855">MPT Feed</td> <td data-bbox="639 810 1401 855">MP paper feed clutch (MPPFCL) is turned on</td> </tr> <tr> <td data-bbox="336 855 639 900">Regist*1</td> <td data-bbox="639 855 1401 900">Registration clutch (RCL) is turned on</td> </tr> <tr> <td data-bbox="336 900 639 945">Feed</td> <td data-bbox="639 900 1401 945">Paper conveying clutch (PCCL) is turned on</td> </tr> <tr> <td data-bbox="336 945 639 990">DU1*1</td> <td data-bbox="639 945 1401 990">Duplex clutch 1 (DUCL1) is turned on</td> </tr> <tr> <td data-bbox="336 990 639 1034">DU2*1</td> <td data-bbox="639 990 1401 1034">Duplex clutch 2 (DUCL2) is turned on</td> </tr> <tr> <td data-bbox="336 1034 639 1079">Assist1*2</td> <td data-bbox="639 1034 1401 1079">Assist clutch 1 (ASCL1) is turned on</td> </tr> <tr> <td data-bbox="336 1079 639 1124">Assist2*2</td> <td data-bbox="639 1079 1401 1124">Assist clutch 2 (ASCL2) is turned on</td> </tr> <tr> <td data-bbox="336 1124 639 1207">Motor</td> <td data-bbox="639 1124 1401 1207">Motor is turned on</td> </tr> </tbody> </table> <p data-bbox="331 1225 994 1254">*1: 35 ppm model only. *2: 45 ppm/55 ppm model only.</p> <ol data-bbox="304 1258 780 1288" style="list-style-type: none"> <li>4. To stop operation, press the stop key.</li> </ol> <p data-bbox="288 1328 440 1357"><b>Completion</b></p> <p data-bbox="288 1361 1254 1391">Press the stop key. The screen for selecting a maintenance item No. is displayed.</p>	Display	Description	Feed1	Paper feed clutch 1 (PFCL1) is turned on	Feed2	Paper feed clutch 2 (PFCL2) is turned on	Mid Roller*1	Middle clutch (MCL) is turned on	MPT Feed	MP paper feed clutch (MPPFCL) is turned on	Regist*1	Registration clutch (RCL) is turned on	Feed	Paper conveying clutch (PCCL) is turned on	DU1*1	Duplex clutch 1 (DUCL1) is turned on	DU2*1	Duplex clutch 2 (DUCL2) is turned on	Assist1*2	Assist clutch 1 (ASCL1) is turned on	Assist2*2	Assist clutch 2 (ASCL2) is turned on	Motor	Motor is turned on
Display	Description																								
Feed1	Paper feed clutch 1 (PFCL1) is turned on																								
Feed2	Paper feed clutch 2 (PFCL2) is turned on																								
Mid Roller*1	Middle clutch (MCL) is turned on																								
MPT Feed	MP paper feed clutch (MPPFCL) is turned on																								
Regist*1	Registration clutch (RCL) is turned on																								
Feed	Paper conveying clutch (PCCL) is turned on																								
DU1*1	Duplex clutch 1 (DUCL1) is turned on																								
DU2*1	Duplex clutch 2 (DUCL2) is turned on																								
Assist1*2	Assist clutch 1 (ASCL1) is turned on																								
Assist2*2	Assist clutch 2 (ASCL2) is turned on																								
Motor	Motor is turned on																								

Item No.	Description												
U033	<p data-bbox="288 241 802 275"><b>Checking the operation of the solenoids</b></p> <p data-bbox="288 311 440 340"><b>Description</b></p> <p data-bbox="288 344 563 374">Turn each solenoid on.</p> <p data-bbox="288 383 400 412"><b>Purpose</b></p> <p data-bbox="288 416 770 445">To check the operation of each solenoid.</p> <p data-bbox="288 486 387 515"><b>Method</b></p> <ol data-bbox="308 519 815 620" style="list-style-type: none"> <li>1. Press the start key.</li> <li>2. Select the solenoid to be operated.z</li> <li>3. Press the start key. The operation starts.</li> </ol> <table border="1" data-bbox="336 631 1401 920"> <thead> <tr> <th data-bbox="336 631 639 676">Display</th> <th data-bbox="639 631 1401 676">Description</th> </tr> </thead> <tbody> <tr> <td data-bbox="336 676 639 721">Branch Left</td> <td data-bbox="639 676 1401 721">BR Feedshift solenoid (BRFSSOL) is turned on</td> </tr> <tr> <td data-bbox="336 721 639 766">Branch Exit</td> <td data-bbox="639 721 1401 766">Feedshift solenoid (FSSOL) is turned on</td> </tr> <tr> <td data-bbox="336 766 639 810">Job Separator</td> <td data-bbox="639 766 1401 810">JS feedshift solenoid (JSFSSOL) is turned on</td> </tr> <tr> <td data-bbox="336 810 639 855">ID Clean</td> <td data-bbox="639 810 1401 855">Cleaning solenoid (CLSOL) is turned on</td> </tr> <tr> <td data-bbox="336 855 639 920">Motor</td> <td data-bbox="639 855 1401 920">Motor is turned on</td> </tr> </tbody> </table> <ol data-bbox="308 972 780 1001" style="list-style-type: none"> <li>4. To stop operation, press the stop key.</li> </ol> <p data-bbox="288 1041 440 1070"><b>Completion</b></p> <p data-bbox="288 1075 1254 1104">Press the stop key. The screen for selecting a maintenance item No. is displayed.</p>	Display	Description	Branch Left	BR Feedshift solenoid (BRFSSOL) is turned on	Branch Exit	Feedshift solenoid (FSSOL) is turned on	Job Separator	JS feedshift solenoid (JSFSSOL) is turned on	ID Clean	Cleaning solenoid (CLSOL) is turned on	Motor	Motor is turned on
Display	Description												
Branch Left	BR Feedshift solenoid (BRFSSOL) is turned on												
Branch Exit	Feedshift solenoid (FSSOL) is turned on												
Job Separator	JS feedshift solenoid (JSFSSOL) is turned on												
ID Clean	Cleaning solenoid (CLSOL) is turned on												
Motor	Motor is turned on												

Item No.	Description																																																											
U034	<p data-bbox="288 241 683 275"><b>Adjusting the print start timing</b></p> <p data-bbox="288 311 440 340"><b>Description</b></p> <p data-bbox="288 344 895 376">Adjusts the leading edge registration or center line.</p> <p data-bbox="288 380 400 409"><b>Purpose</b></p> <p data-bbox="288 414 1425 479">Make the adjustment if there is a regular error between the leading edges of the copy image and original.</p> <p data-bbox="288 483 1401 548">Make the adjustment if there is a regular error between the center lines of the copy image and original.</p> <p data-bbox="288 584 387 613"><b>Method</b></p> <ol data-bbox="304 618 699 683" style="list-style-type: none"> <li>1. Press the start key.</li> <li>2. Select the item to be adjusted.</li> </ol> <table border="1" data-bbox="336 698 1401 1037"> <thead> <tr> <th data-bbox="336 698 603 743">Display</th> <th data-bbox="603 698 1401 743">Description</th> </tr> </thead> <tbody> <tr> <td data-bbox="336 743 603 788">LSU Out Top</td> <td data-bbox="603 743 1401 788">Leading edge registration adjustment</td> </tr> <tr> <td data-bbox="336 788 603 833">LSU Out Left</td> <td data-bbox="603 788 1401 833">Center line adjustment</td> </tr> <tr> <td data-bbox="336 833 603 878">Mode</td> <td data-bbox="603 833 1401 878">Sets the conveying timing verification mode.</td> </tr> <tr> <td data-bbox="336 878 603 922">Reset</td> <td data-bbox="603 878 1401 922">Resets the conveying timing verification data.</td> </tr> <tr> <td data-bbox="336 922 603 967">On Timing</td> <td data-bbox="603 922 1401 967">Verify the conveying timing (sensor on).</td> </tr> <tr> <td data-bbox="336 967 603 1037">Off Timing</td> <td data-bbox="603 967 1401 1037">Verify the conveying timing (sensor recovery).</td> </tr> </tbody> </table> <p data-bbox="288 1095 935 1124"><b>Adjustment: Leading edge registration adjustment</b></p> <ol data-bbox="304 1128 839 1261" style="list-style-type: none"> <li>1. Press the system menu key.</li> <li>2. Press the start key to output a test pattern.</li> <li>3. Press the system menu key.</li> <li>4. Select the item to be adjusted.</li> </ol> <p data-bbox="341 1265 525 1294"><b>[LSU Out Top]</b></p> <table border="1" data-bbox="336 1310 1393 1881"> <thead> <tr> <th data-bbox="336 1310 504 1391">Display</th> <th data-bbox="504 1310 959 1391">Description</th> <th data-bbox="959 1310 1110 1391">Setting range</th> <th data-bbox="1110 1310 1225 1391">Initial setting</th> <th data-bbox="1225 1310 1393 1391">Change in value per step</th> </tr> </thead> <tbody> <tr> <td data-bbox="336 1391 504 1435">MPT(L)</td> <td data-bbox="504 1391 959 1435">Paper feed from MP tray</td> <td data-bbox="959 1391 1110 1435">-3.0 to 3.0</td> <td data-bbox="1110 1391 1225 1435">0</td> <td data-bbox="1225 1391 1393 1435">0.1 mm</td> </tr> <tr> <td data-bbox="336 1435 504 1480">MPT Half(L)</td> <td data-bbox="504 1435 959 1480">Paper feed from MP tray</td> <td data-bbox="959 1435 1110 1480">-3.0 to 3.0</td> <td data-bbox="1110 1435 1225 1480">0</td> <td data-bbox="1225 1435 1393 1480">0.1 mm</td> </tr> <tr> <td data-bbox="336 1480 504 1525">Cassette(L)</td> <td data-bbox="504 1480 959 1525">Paper feed from cassette</td> <td data-bbox="959 1480 1110 1525">-3.0 to 3.0</td> <td data-bbox="1110 1480 1225 1525">0</td> <td data-bbox="1225 1480 1393 1525">0.1 mm</td> </tr> <tr> <td data-bbox="336 1525 504 1615">Cassette Half(L)</td> <td data-bbox="504 1525 959 1615">Paper feed from cassette</td> <td data-bbox="959 1525 1110 1615">-3.0 to 3.0</td> <td data-bbox="1110 1525 1225 1615">0</td> <td data-bbox="1225 1525 1393 1615">0.1 mm</td> </tr> <tr> <td data-bbox="336 1615 504 1659">Duplex(L)</td> <td data-bbox="504 1615 959 1659">Duplex mode (second)</td> <td data-bbox="959 1615 1110 1659">-3.0 to 3.0</td> <td data-bbox="1110 1615 1225 1659">0</td> <td data-bbox="1225 1615 1393 1659">0.1 mm</td> </tr> <tr> <td data-bbox="336 1659 504 1749">Duplex Half(L)</td> <td data-bbox="504 1659 959 1749">Duplex mode (second)</td> <td data-bbox="959 1659 1110 1749">-3.0 to 3.0</td> <td data-bbox="1110 1659 1225 1749">0</td> <td data-bbox="1225 1659 1393 1749">0.1 mm</td> </tr> <tr> <td data-bbox="336 1749 504 1794">MPT(S)</td> <td data-bbox="504 1749 959 1794">Paper feed from MP tray</td> <td data-bbox="959 1749 1110 1794">-3.0 to 3.0</td> <td data-bbox="1110 1749 1225 1794">0</td> <td data-bbox="1225 1749 1393 1794">0.1 mm</td> </tr> <tr> <td data-bbox="336 1794 504 1881">MPT Half(S)</td> <td data-bbox="504 1794 959 1881">Paper feed from MP tray</td> <td data-bbox="959 1794 1110 1881">-3.0 to 3.0</td> <td data-bbox="1110 1794 1225 1881">0</td> <td data-bbox="1225 1794 1393 1881">0.1 mm</td> </tr> </tbody> </table>	Display	Description	LSU Out Top	Leading edge registration adjustment	LSU Out Left	Center line adjustment	Mode	Sets the conveying timing verification mode.	Reset	Resets the conveying timing verification data.	On Timing	Verify the conveying timing (sensor on).	Off Timing	Verify the conveying timing (sensor recovery).	Display	Description	Setting range	Initial setting	Change in value per step	MPT(L)	Paper feed from MP tray	-3.0 to 3.0	0	0.1 mm	MPT Half(L)	Paper feed from MP tray	-3.0 to 3.0	0	0.1 mm	Cassette(L)	Paper feed from cassette	-3.0 to 3.0	0	0.1 mm	Cassette Half(L)	Paper feed from cassette	-3.0 to 3.0	0	0.1 mm	Duplex(L)	Duplex mode (second)	-3.0 to 3.0	0	0.1 mm	Duplex Half(L)	Duplex mode (second)	-3.0 to 3.0	0	0.1 mm	MPT(S)	Paper feed from MP tray	-3.0 to 3.0	0	0.1 mm	MPT Half(S)	Paper feed from MP tray	-3.0 to 3.0	0	0.1 mm
Display	Description																																																											
LSU Out Top	Leading edge registration adjustment																																																											
LSU Out Left	Center line adjustment																																																											
Mode	Sets the conveying timing verification mode.																																																											
Reset	Resets the conveying timing verification data.																																																											
On Timing	Verify the conveying timing (sensor on).																																																											
Off Timing	Verify the conveying timing (sensor recovery).																																																											
Display	Description	Setting range	Initial setting	Change in value per step																																																								
MPT(L)	Paper feed from MP tray	-3.0 to 3.0	0	0.1 mm																																																								
MPT Half(L)	Paper feed from MP tray	-3.0 to 3.0	0	0.1 mm																																																								
Cassette(L)	Paper feed from cassette	-3.0 to 3.0	0	0.1 mm																																																								
Cassette Half(L)	Paper feed from cassette	-3.0 to 3.0	0	0.1 mm																																																								
Duplex(L)	Duplex mode (second)	-3.0 to 3.0	0	0.1 mm																																																								
Duplex Half(L)	Duplex mode (second)	-3.0 to 3.0	0	0.1 mm																																																								
MPT(S)	Paper feed from MP tray	-3.0 to 3.0	0	0.1 mm																																																								
MPT Half(S)	Paper feed from MP tray	-3.0 to 3.0	0	0.1 mm																																																								

Item No.	Description				
U034	<b>Display</b>	<b>Description</b>	<b>Setting range</b>	<b>Initial setting</b>	<b>Change in value per step</b>
	Cassette(S)	Paper feed from cassette	-3.0 to 3.0	0	0.1 mm
	Cassette Half(S)	Paper feed from cassette	-3.0 to 3.0	0	0.1 mm
	Duplex(S)	Duplex mode (second)	-3.0 to 3.0	0	0.1 mm
	Duplex Half(S)	Duplex mode (second)	-3.0 to 3.0	0	0.1 mm
<p>* : (L): When large size paper is used (218 mm or more in width of paper).            (S): When small size paper is used.</p>					
<p>5. Change the setting value using the cursor +/- or numeric keys.            For output example 1, increase the value. For output example 2, decrease the value.</p>					
					
<b>Figure 1-3-4</b>					
<p>6. Press the start key. The value is set.</p>					
<b>Remark</b>					
<p>* : Transition of the test copy dialog            Test Copy is displayed as an item in the right bottom when a USB is not connected.            Test Box is displayed as an item in the right bottom when a USB is connected.            Pressing the system menu key causes transition to the dialog currently displayed.</p> <p>* : When changing the setting value of [Large] each item is modified, equal to amount of the value which is changed adds also the value of [Small] each item and is pulled.</p>					
<b>Caution</b>					
<p>Check the copy image after the adjustment. If the image is still incorrect, perform the following adjustments in maintenance mode.</p>					
					

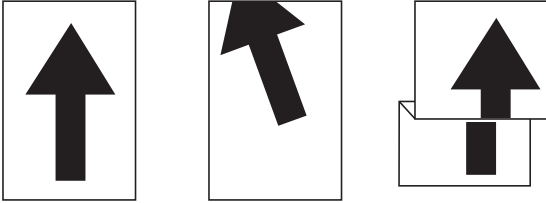
Item No.	Description																																								
U034	<p><b>Adjustment: LSU Out Left</b></p> <ol style="list-style-type: none"> <li>1. Press the system menu key.</li> <li>2. Press the start key to output a test pattern.</li> <li>3. Press the system menu key.</li> <li>4. Select the item to be adjusted.</li> </ol> <table border="1" data-bbox="335 421 1396 840"> <thead> <tr> <th>Display</th> <th>Description</th> <th>Setting range</th> <th>Initial setting</th> <th>Change in value per step</th> </tr> </thead> <tbody> <tr> <td>MPT</td> <td>Paper feed from MP tray</td> <td>-3.0 to 3.0</td> <td>0</td> <td>0.1 mm</td> </tr> <tr> <td>Cassette1</td> <td>Paper feed from cassette 1</td> <td>-3.0 to 3.0</td> <td>0</td> <td>0.1 mm</td> </tr> <tr> <td>Cassette2</td> <td>Paper feed from cassette 2</td> <td>-3.0 to 3.0</td> <td>0</td> <td>0.1 mm</td> </tr> <tr> <td>Cassette3</td> <td>Paper feed from optional cassette 3</td> <td>-3.0 to 3.0</td> <td>0</td> <td>0.1 mm</td> </tr> <tr> <td>Cassette4</td> <td>Paper feed from optional cassette 4</td> <td>-3.0 to 3.0</td> <td>0</td> <td>0.1 mm</td> </tr> <tr> <td>Cassette5</td> <td>Paper feed from optional cassette 5</td> <td>-3.0 to 3.0</td> <td>0</td> <td>0.1 mm</td> </tr> <tr> <td>Duplex</td> <td>Duplex mode (second)</td> <td>-3.0 to 3.0</td> <td>0</td> <td>0.1 mm</td> </tr> </tbody> </table> <p>5. Change the setting value using the +/- keys or numeric keys. For output example 1, increase the value. For output example 2, decrease the value.</p> <div data-bbox="534 1019 1189 1411" style="text-align: center;"> <p>Center line of printing (within <math>\pm 2.0</math> mm)</p> <p>Correct image      Output example 1      Output example 2</p> </div> <p><b>Figure 1-3-5</b></p> <p>6. Press the start key. The value is set.</p> <p><b>Caution</b> Check the copy image after the adjustment. If the image is still incorrect, perform the following adjustments in maintenance mode.</p> <div data-bbox="295 1691 901 1825" style="text-align: center;"> <pre> graph LR     U034[U034] --&gt; U067[U067 (P.1-3-50)]     U067 --&gt; U072[U072 (P.1-3-56)]     </pre> <p>Table      DP</p> </div> <p><b>Completion</b> Press the stop key. The screen for selecting a maintenance item No. is displayed.</p>	Display	Description	Setting range	Initial setting	Change in value per step	MPT	Paper feed from MP tray	-3.0 to 3.0	0	0.1 mm	Cassette1	Paper feed from cassette 1	-3.0 to 3.0	0	0.1 mm	Cassette2	Paper feed from cassette 2	-3.0 to 3.0	0	0.1 mm	Cassette3	Paper feed from optional cassette 3	-3.0 to 3.0	0	0.1 mm	Cassette4	Paper feed from optional cassette 4	-3.0 to 3.0	0	0.1 mm	Cassette5	Paper feed from optional cassette 5	-3.0 to 3.0	0	0.1 mm	Duplex	Duplex mode (second)	-3.0 to 3.0	0	0.1 mm
Display	Description	Setting range	Initial setting	Change in value per step																																					
MPT	Paper feed from MP tray	-3.0 to 3.0	0	0.1 mm																																					
Cassette1	Paper feed from cassette 1	-3.0 to 3.0	0	0.1 mm																																					
Cassette2	Paper feed from cassette 2	-3.0 to 3.0	0	0.1 mm																																					
Cassette3	Paper feed from optional cassette 3	-3.0 to 3.0	0	0.1 mm																																					
Cassette4	Paper feed from optional cassette 4	-3.0 to 3.0	0	0.1 mm																																					
Cassette5	Paper feed from optional cassette 5	-3.0 to 3.0	0	0.1 mm																																					
Duplex	Duplex mode (second)	-3.0 to 3.0	0	0.1 mm																																					

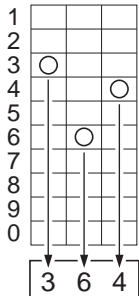
Item No.	Description												
U035	<p data-bbox="292 241 786 275"><b>Setting the printing area for folio paper</b></p> <p data-bbox="292 313 440 342"><b>Description</b></p> <p data-bbox="292 347 911 376">Changes the printing area for copying on folio paper.</p> <p data-bbox="292 383 400 412"><b>Purpose</b></p> <p data-bbox="292 416 1374 481">To prevent cropped images on the trailing edge or left/right side of copy paper by setting the actual printing area for folio paper.</p> <p data-bbox="292 519 384 548"><b>Setting</b></p> <ol data-bbox="308 555 858 654" style="list-style-type: none"> <li>1. Press the start key.</li> <li>2. Select the item to be set.</li> <li>3. Change the setting value using the +/- keys.</li> </ol> <table border="1" data-bbox="338 667 1401 810"> <thead> <tr> <th data-bbox="338 667 564 712">Display</th> <th data-bbox="564 667 944 712">Description</th> <th data-bbox="944 667 1171 712">Setting range</th> <th data-bbox="1171 667 1401 712">Initial setting</th> </tr> </thead> <tbody> <tr> <td data-bbox="338 712 564 757">Length</td> <td data-bbox="564 712 944 757">Length</td> <td data-bbox="944 712 1171 757">330 to 356 mm</td> <td data-bbox="1171 712 1401 757">330</td> </tr> <tr> <td data-bbox="338 757 564 810">Width</td> <td data-bbox="564 757 944 810">Width</td> <td data-bbox="944 757 1171 810">200 to 220 mm</td> <td data-bbox="1171 757 1401 810">210</td> </tr> </tbody> </table> <ol data-bbox="308 824 767 853" style="list-style-type: none"> <li>4. Press the start key. The value is set.</li> </ol> <p data-bbox="292 891 440 920"><b>Completion</b></p> <p data-bbox="292 925 1254 954">Press the stop key. The screen for selecting a maintenance item No. is displayed.</p>	Display	Description	Setting range	Initial setting	Length	Length	330 to 356 mm	330	Width	Width	200 to 220 mm	210
Display	Description	Setting range	Initial setting										
Length	Length	330 to 356 mm	330										
Width	Width	200 to 220 mm	210										

Item No.	Description																																	
U037	<p data-bbox="288 241 817 275"><b>Checking the operation of the fan motors</b></p> <p data-bbox="288 309 440 342"><b>Description</b></p> <p data-bbox="288 344 560 378">Drives each fan motor.</p> <p data-bbox="288 380 400 414"><b>Purpose</b></p> <p data-bbox="288 416 783 450">To check the operation of each fan motor.</p> <p data-bbox="288 483 387 517"><b>Method</b></p> <ol data-bbox="304 519 817 622" style="list-style-type: none"> <li>1. Press the start key.</li> <li>2. Select the fan motor to be operated.</li> <li>3. Press the start key. The operation starts.</li> </ol> <table border="1" data-bbox="336 633 1401 1160"> <thead> <tr> <th data-bbox="336 633 571 678">Display</th> <th data-bbox="571 633 1294 678">Description</th> <th data-bbox="1294 633 1401 678">Group</th> </tr> </thead> <tbody> <tr> <td data-bbox="336 678 571 723">Fuser Cooling</td> <td data-bbox="571 678 1294 723">Fuser rear fan motor (FURFM) is turned on</td> <td data-bbox="1294 678 1401 723">B</td> </tr> <tr> <td data-bbox="336 723 571 768">LSU Cooling*</td> <td data-bbox="571 723 1294 768">LSU fan motor (LSUFM) is turned on</td> <td data-bbox="1294 723 1401 768">B</td> </tr> <tr> <td data-bbox="336 768 571 813">Exit Cooling</td> <td data-bbox="571 768 1294 813">Eject front fan motor (EFFM) is turned on</td> <td data-bbox="1294 768 1401 813">B</td> </tr> <tr> <td data-bbox="336 813 571 857">Toner</td> <td data-bbox="571 813 1294 857">Toner fan motor (TFM) is turned on</td> <td data-bbox="1294 813 1401 857">A</td> </tr> <tr> <td data-bbox="336 857 571 902">Low Volt</td> <td data-bbox="571 857 1294 902">Power source fan motor (PSFM) is turned on</td> <td data-bbox="1294 857 1401 902">A</td> </tr> <tr> <td data-bbox="336 902 571 947">Exit Rear Cooling</td> <td data-bbox="571 902 1294 947">Eject rear fan motor (EFRM) is turned on</td> <td data-bbox="1294 902 1401 947">B</td> </tr> <tr> <td data-bbox="336 947 571 992">IH PWB</td> <td data-bbox="571 947 1294 992">Heater fan motor (HFM) is turned on</td> <td data-bbox="1294 947 1401 992">A</td> </tr> <tr> <td data-bbox="336 992 571 1037">Container Cooling</td> <td data-bbox="571 992 1294 1037">Exhaust motor 1and 2 (EXFM1, 2) is turned on</td> <td data-bbox="1294 992 1401 1037">A</td> </tr> <tr> <td data-bbox="336 1037 571 1081">GroupA</td> <td data-bbox="571 1037 1294 1081">Fan motors of group A are turned on</td> <td data-bbox="1294 1037 1401 1081"></td> </tr> <tr> <td data-bbox="336 1081 571 1160">GroupB</td> <td data-bbox="571 1081 1294 1160">Fan motors of group B are turned on</td> <td data-bbox="1294 1081 1401 1160"></td> </tr> </tbody> </table> <p data-bbox="336 1189 711 1223">* : 45 ppm/55 ppm model only.</p> <ol data-bbox="304 1225 783 1258" style="list-style-type: none"> <li>4. To stop operation, press the stop key.</li> </ol> <p data-bbox="288 1292 440 1326"><b>Completion</b></p> <p data-bbox="288 1328 1254 1361">Press the stop key. The screen for selecting a maintenance item No. is displayed.</p>	Display	Description	Group	Fuser Cooling	Fuser rear fan motor (FURFM) is turned on	B	LSU Cooling*	LSU fan motor (LSUFM) is turned on	B	Exit Cooling	Eject front fan motor (EFFM) is turned on	B	Toner	Toner fan motor (TFM) is turned on	A	Low Volt	Power source fan motor (PSFM) is turned on	A	Exit Rear Cooling	Eject rear fan motor (EFRM) is turned on	B	IH PWB	Heater fan motor (HFM) is turned on	A	Container Cooling	Exhaust motor 1and 2 (EXFM1, 2) is turned on	A	GroupA	Fan motors of group A are turned on		GroupB	Fan motors of group B are turned on	
Display	Description	Group																																
Fuser Cooling	Fuser rear fan motor (FURFM) is turned on	B																																
LSU Cooling*	LSU fan motor (LSUFM) is turned on	B																																
Exit Cooling	Eject front fan motor (EFFM) is turned on	B																																
Toner	Toner fan motor (TFM) is turned on	A																																
Low Volt	Power source fan motor (PSFM) is turned on	A																																
Exit Rear Cooling	Eject rear fan motor (EFRM) is turned on	B																																
IH PWB	Heater fan motor (HFM) is turned on	A																																
Container Cooling	Exhaust motor 1and 2 (EXFM1, 2) is turned on	A																																
GroupA	Fan motors of group A are turned on																																	
GroupB	Fan motors of group B are turned on																																	



Item No.	Description																																																																																					
U051	<p data-bbox="288 241 756 275"><b>Adjusting the deflection in the paper</b></p> <p data-bbox="288 311 440 340"><b>Description</b></p> <p data-bbox="288 344 983 376">Adjusts the deflection in the paper at the registration roller.</p> <p data-bbox="288 380 400 409"><b>Purpose</b></p> <p data-bbox="288 414 1426 479">Make the adjustment if the leading edge of the copy image is missing or varies randomly, or if the copy paper is Z-folded.</p> <p data-bbox="288 517 387 546"><b>Method</b></p> <ol data-bbox="304 553 699 618" style="list-style-type: none"> <li>1. Press the start key.</li> <li>2. Select the item to be adjusted.</li> </ol> <table border="1" data-bbox="336 631 1401 728"> <thead> <tr> <th data-bbox="336 631 679 678">Display</th> <th data-bbox="679 631 1401 678">Description</th> </tr> </thead> <tbody> <tr> <td data-bbox="336 678 679 728">Paper Loop Amount</td> <td data-bbox="679 678 1401 728">Deflection adjustment</td> </tr> </tbody> </table> <p data-bbox="288 772 440 801"><b>Adjustment</b></p> <ol data-bbox="304 808 1058 943" style="list-style-type: none"> <li>1. Press the system menu key.</li> <li>2. Place an original and press the start key to make a test copy.</li> <li>3. Press the system menu key.</li> <li>4. Select the item to be adjusted.</li> </ol> <table border="1" data-bbox="336 956 1401 1765"> <thead> <tr> <th data-bbox="336 956 520 1048" rowspan="2">Display</th> <th data-bbox="520 956 951 1048" rowspan="2">Description</th> <th data-bbox="951 956 1102 1048" rowspan="2">Setting range</th> <th colspan="3" data-bbox="1102 956 1401 994">Initial setting</th> </tr> <tr> <th data-bbox="1102 994 1203 1048">35ppm</th> <th data-bbox="1203 994 1303 1048">45ppm</th> <th data-bbox="1303 994 1401 1048">55ppm</th> </tr> </thead> <tbody> <tr> <td data-bbox="336 1048 520 1099">MPT(L)</td> <td data-bbox="520 1048 951 1099">Paper feed from MP tray</td> <td data-bbox="951 1048 1102 1099">-30 to 20</td> <td data-bbox="1102 1048 1203 1099">1</td> <td data-bbox="1203 1048 1303 1099">-5</td> <td data-bbox="1303 1048 1401 1099">-8</td> </tr> <tr> <td data-bbox="336 1099 520 1151">MPT Half(L)</td> <td data-bbox="520 1099 951 1151">Paper feed from MP tray</td> <td data-bbox="951 1099 1102 1151">-30 to 20</td> <td data-bbox="1102 1099 1203 1151">1</td> <td data-bbox="1203 1099 1303 1151">0</td> <td data-bbox="1303 1099 1401 1151">-1</td> </tr> <tr> <td data-bbox="336 1151 520 1202">Cassette(L)</td> <td data-bbox="520 1151 951 1202">Paper feed from cassette</td> <td data-bbox="951 1151 1102 1202">-30 to 20</td> <td data-bbox="1102 1151 1203 1202">1</td> <td data-bbox="1203 1151 1303 1202">-5</td> <td data-bbox="1303 1151 1401 1202">-8</td> </tr> <tr> <td data-bbox="336 1202 520 1254">Cassette Half(L)</td> <td data-bbox="520 1202 951 1254">Paper feed from cassette</td> <td data-bbox="951 1202 1102 1254">-30 to 20</td> <td data-bbox="1102 1202 1203 1254">1</td> <td data-bbox="1203 1202 1303 1254">0</td> <td data-bbox="1303 1202 1401 1254">-1</td> </tr> <tr> <td data-bbox="336 1254 520 1305">Duplex(L)</td> <td data-bbox="520 1254 951 1305">Duplex mode (second)</td> <td data-bbox="951 1254 1102 1305">-30 to 20</td> <td data-bbox="1102 1254 1203 1305">1</td> <td data-bbox="1203 1254 1303 1305">-5</td> <td data-bbox="1303 1254 1401 1305">-8</td> </tr> <tr> <td data-bbox="336 1305 520 1357">Duplex Half(L)</td> <td data-bbox="520 1305 951 1357">Duplex mode (second)</td> <td data-bbox="951 1305 1102 1357">-30 to 20</td> <td data-bbox="1102 1305 1203 1357">1</td> <td data-bbox="1203 1305 1303 1357">0</td> <td data-bbox="1303 1305 1401 1357">-1</td> </tr> <tr> <td data-bbox="336 1357 520 1408">MPT(S)</td> <td data-bbox="520 1357 951 1408">Paper feed from MP tray</td> <td data-bbox="951 1357 1102 1408">-30 to 20</td> <td data-bbox="1102 1357 1203 1408">1</td> <td data-bbox="1203 1357 1303 1408">-5</td> <td data-bbox="1303 1357 1401 1408">-8</td> </tr> <tr> <td data-bbox="336 1408 520 1460">MPT Half(S)</td> <td data-bbox="520 1408 951 1460">Paper feed from MP tray</td> <td data-bbox="951 1408 1102 1460">-30 to 20</td> <td data-bbox="1102 1408 1203 1460">1</td> <td data-bbox="1203 1408 1303 1460">0</td> <td data-bbox="1303 1408 1401 1460">-1</td> </tr> <tr> <td data-bbox="336 1460 520 1512">Cassette(S)</td> <td data-bbox="520 1460 951 1512">Paper feed from cassette</td> <td data-bbox="951 1460 1102 1512">-30 to 20</td> <td data-bbox="1102 1460 1203 1512">1</td> <td data-bbox="1203 1460 1303 1512">-5</td> <td data-bbox="1303 1460 1401 1512">-8</td> </tr> <tr> <td data-bbox="336 1512 520 1563">Cassette Half(S)</td> <td data-bbox="520 1512 951 1563">Paper feed from cassette</td> <td data-bbox="951 1512 1102 1563">-30 to 20</td> <td data-bbox="1102 1512 1203 1563">1</td> <td data-bbox="1203 1512 1303 1563">0</td> <td data-bbox="1303 1512 1401 1563">-1</td> </tr> <tr> <td data-bbox="336 1563 520 1615">Duplex(S)</td> <td data-bbox="520 1563 951 1615">Duplex mode (second)</td> <td data-bbox="951 1563 1102 1615">-30 to 20</td> <td data-bbox="1102 1563 1203 1615">1</td> <td data-bbox="1203 1563 1303 1615">-3</td> <td data-bbox="1303 1563 1401 1615">-6</td> </tr> <tr> <td data-bbox="336 1615 520 1666">Duplex Half(S)</td> <td data-bbox="520 1615 951 1666">Duplex mode (second)</td> <td data-bbox="951 1615 1102 1666">-30 to 20</td> <td data-bbox="1102 1615 1203 1666">1</td> <td data-bbox="1203 1615 1303 1666">0</td> <td data-bbox="1303 1615 1401 1666">-1</td> </tr> </tbody> </table> <p data-bbox="336 1776 740 1807">Change in value per step: 1.0 mm</p> <p data-bbox="336 1812 1174 1843">(L): When large size paper is used (218 mm or more in width of paper).</p> <p data-bbox="336 1848 756 1879">(S): When small size paper is used.</p>	Display	Description	Paper Loop Amount	Deflection adjustment	Display	Description	Setting range	Initial setting			35ppm	45ppm	55ppm	MPT(L)	Paper feed from MP tray	-30 to 20	1	-5	-8	MPT Half(L)	Paper feed from MP tray	-30 to 20	1	0	-1	Cassette(L)	Paper feed from cassette	-30 to 20	1	-5	-8	Cassette Half(L)	Paper feed from cassette	-30 to 20	1	0	-1	Duplex(L)	Duplex mode (second)	-30 to 20	1	-5	-8	Duplex Half(L)	Duplex mode (second)	-30 to 20	1	0	-1	MPT(S)	Paper feed from MP tray	-30 to 20	1	-5	-8	MPT Half(S)	Paper feed from MP tray	-30 to 20	1	0	-1	Cassette(S)	Paper feed from cassette	-30 to 20	1	-5	-8	Cassette Half(S)	Paper feed from cassette	-30 to 20	1	0	-1	Duplex(S)	Duplex mode (second)	-30 to 20	1	-3	-6	Duplex Half(S)	Duplex mode (second)	-30 to 20	1	0	-1
Display	Description																																																																																					
Paper Loop Amount	Deflection adjustment																																																																																					
Display	Description	Setting range	Initial setting																																																																																			
			35ppm	45ppm	55ppm																																																																																	
MPT(L)	Paper feed from MP tray	-30 to 20	1	-5	-8																																																																																	
MPT Half(L)	Paper feed from MP tray	-30 to 20	1	0	-1																																																																																	
Cassette(L)	Paper feed from cassette	-30 to 20	1	-5	-8																																																																																	
Cassette Half(L)	Paper feed from cassette	-30 to 20	1	0	-1																																																																																	
Duplex(L)	Duplex mode (second)	-30 to 20	1	-5	-8																																																																																	
Duplex Half(L)	Duplex mode (second)	-30 to 20	1	0	-1																																																																																	
MPT(S)	Paper feed from MP tray	-30 to 20	1	-5	-8																																																																																	
MPT Half(S)	Paper feed from MP tray	-30 to 20	1	0	-1																																																																																	
Cassette(S)	Paper feed from cassette	-30 to 20	1	-5	-8																																																																																	
Cassette Half(S)	Paper feed from cassette	-30 to 20	1	0	-1																																																																																	
Duplex(S)	Duplex mode (second)	-30 to 20	1	-3	-6																																																																																	
Duplex Half(S)	Duplex mode (second)	-30 to 20	1	0	-1																																																																																	

Item No.	Description
<b>U051</b>	<p data-bbox="304 241 1426 376">5. Change the setting value using the +/- keys or numeric keys. For output example 1, increase the value. For output example 2, decrease the value. The greater the value, the larger the deflection; the smaller the value, the smaller the deflection.</p> <div data-bbox="587 387 1134 656" style="text-align: center;"><p data-bbox="612 595 699 622">Original</p><p data-bbox="804 595 916 656">Copy example 1</p><p data-bbox="999 595 1110 656">Copy example 2</p></div> <p data-bbox="783 680 938 707"><b>Figure 1-3-6</b></p> <p data-bbox="304 748 767 775">6. Press the start key. The value is set.</p> <p data-bbox="288 819 440 846"><b>Completion</b></p> <p data-bbox="288 853 1246 880">Press the stop key. The indication for selecting a maintenance item No. appears.</p>

Item No.	Description																									
U052	<p><b>Setting the fuser motor control</b></p> <p><b>Description</b> Enters the sensor data values described on the supplied sheet provided when the loop sensor is replaced and Perform correction processing for the fuser motor.</p> <p><b>Purpose</b> To perform when replacing the loop sensor or paper conveying unit.</p> <p><b>Method</b></p> <ol style="list-style-type: none"> <li>1. Press the start key.</li> <li>2. Select the item.</li> </ol> <table border="1" data-bbox="336 631 1401 871"> <thead> <tr> <th>Display</th> <th>Description</th> </tr> </thead> <tbody> <tr> <td>Set Loop Sensor</td> <td>Enter the data value for loop sensor</td> </tr> <tr> <td>Loop Sensor Control</td> <td>Set the loop sensor detection control</td> </tr> <tr> <td>Set Loop Sensor Valid</td> <td>Sets the presence or absence of the loop sensor</td> </tr> <tr> <td>Chk Loop Sensor</td> <td>Display the data value for loop sensor</td> </tr> </tbody> </table> <p><b>Method: [Set Loop Sensor]</b></p> <ol style="list-style-type: none"> <li>1. Select [Scanning Board1].</li> <li>2. Enter the sensor data value of supplied sheet DATA1 using the +/- keys.</li> <li>3. Select [Scanning Board2].</li> <li>4. Enter the sensor data value of supplied sheet DATA2 using the +/- keys.</li> <li>5. Press the start key. The value is set.</li> </ol> <p>* : When replacing the conveying unit, enter the data specified on the maintenance report.</p> <p style="text-align: right;">How to read the sensor data value</p> <p>(e.g.)</p>  <p><b>Setting: [Loop Sensor Control]</b></p> <ol style="list-style-type: none"> <li>1. Select the item.</li> <li>2. Select On or Off.</li> </ol> <table border="1" data-bbox="336 1406 1401 2024"> <thead> <tr> <th>Display</th> <th>Description</th> <th>Initial setting</th> </tr> </thead> <tbody> <tr> <td>No.1</td> <td>Determines whether to attempt a correction in the fuser speed in reference to the transfer-separation speed, over the length of paper from the leading edge to 30mm.</td> <td>On</td> </tr> <tr> <td>No.2</td> <td>Determines whether to attempt a correction in the fuser speed in reference to the transfer-separation speed, over the length of paper from the leading edge to 30 to 60 mm</td> <td>On</td> </tr> <tr> <td>No.3</td> <td>Determines whether to attempt a correction in the fuser speed in reference to the transfer-separation speed, over the length of paper from the leading edge to 60 to 90 mm</td> <td>On</td> </tr> <tr> <td>No.4</td> <td>Determines whether to attempt a correction in the fuser speed in reference to the transfer-separation speed, over the length of paper from the leading edge to 90 to 120 mm</td> <td>On</td> </tr> </tbody> </table>	Display	Description	Set Loop Sensor	Enter the data value for loop sensor	Loop Sensor Control	Set the loop sensor detection control	Set Loop Sensor Valid	Sets the presence or absence of the loop sensor	Chk Loop Sensor	Display the data value for loop sensor	Display	Description	Initial setting	No.1	Determines whether to attempt a correction in the fuser speed in reference to the transfer-separation speed, over the length of paper from the leading edge to 30mm.	On	No.2	Determines whether to attempt a correction in the fuser speed in reference to the transfer-separation speed, over the length of paper from the leading edge to 30 to 60 mm	On	No.3	Determines whether to attempt a correction in the fuser speed in reference to the transfer-separation speed, over the length of paper from the leading edge to 60 to 90 mm	On	No.4	Determines whether to attempt a correction in the fuser speed in reference to the transfer-separation speed, over the length of paper from the leading edge to 90 to 120 mm	On
Display	Description																									
Set Loop Sensor	Enter the data value for loop sensor																									
Loop Sensor Control	Set the loop sensor detection control																									
Set Loop Sensor Valid	Sets the presence or absence of the loop sensor																									
Chk Loop Sensor	Display the data value for loop sensor																									
Display	Description	Initial setting																								
No.1	Determines whether to attempt a correction in the fuser speed in reference to the transfer-separation speed, over the length of paper from the leading edge to 30mm.	On																								
No.2	Determines whether to attempt a correction in the fuser speed in reference to the transfer-separation speed, over the length of paper from the leading edge to 30 to 60 mm	On																								
No.3	Determines whether to attempt a correction in the fuser speed in reference to the transfer-separation speed, over the length of paper from the leading edge to 60 to 90 mm	On																								
No.4	Determines whether to attempt a correction in the fuser speed in reference to the transfer-separation speed, over the length of paper from the leading edge to 90 to 120 mm	On																								

Item No.	Description														
U052	<table border="1" data-bbox="336 286 1401 636"> <thead> <tr> <th data-bbox="336 286 491 331">Display</th> <th data-bbox="491 286 1171 331">Description</th> <th data-bbox="1171 286 1401 331">Initial setting</th> </tr> </thead> <tbody> <tr> <td data-bbox="336 331 491 483">No.5</td> <td data-bbox="491 331 1171 483">Determines whether to attempt a correction in the fuser speed in reference to the transfer-separation speed, over the length of paper from the leading edge to 120 to 150 mm</td> <td data-bbox="1171 331 1401 483">On</td> </tr> <tr> <td data-bbox="336 483 491 636">No.6</td> <td data-bbox="491 483 1171 636">Determines whether to attempt a correction in the fuser speed in reference to the transfer-separation speed, over the length of paper from the leading edge to 150 to 180 mm</td> <td data-bbox="1171 483 1401 636">On</td> </tr> </tbody> </table> <p data-bbox="304 651 783 680">3. Press the start key. The setting is set.</p> <p data-bbox="288 719 700 748"><b>Setting: [Set Loop Sensor Valid]</b></p> <ol data-bbox="304 752 783 853" style="list-style-type: none"> <li>1. Select On or Off. Initial setting: On</li> <li>2. Press the start key. The setting is set.</li> </ol> <p data-bbox="288 891 440 920"><b>Completion</b></p> <p data-bbox="288 925 1246 954">Press the stop key. The indication for selecting a maintenance item No. appears.</p>	Display	Description	Initial setting	No.5	Determines whether to attempt a correction in the fuser speed in reference to the transfer-separation speed, over the length of paper from the leading edge to 120 to 150 mm	On	No.6	Determines whether to attempt a correction in the fuser speed in reference to the transfer-separation speed, over the length of paper from the leading edge to 150 to 180 mm	On					
Display	Description	Initial setting													
No.5	Determines whether to attempt a correction in the fuser speed in reference to the transfer-separation speed, over the length of paper from the leading edge to 120 to 150 mm	On													
No.6	Determines whether to attempt a correction in the fuser speed in reference to the transfer-separation speed, over the length of paper from the leading edge to 150 to 180 mm	On													
U053	<p data-bbox="288 976 831 1005"><b>Setting the adjustment of the motor speed</b></p> <p data-bbox="288 1043 440 1072"><b>Description</b></p> <p data-bbox="288 1077 916 1106">Perform fine adjustment of the speeds of the motors.</p> <p data-bbox="288 1144 400 1173"><b>Purpose</b></p> <p data-bbox="288 1178 1366 1245">Basically, the setting need not be changed. Modify settings by interlock setting only if faulty images occur.</p> <p data-bbox="288 1283 389 1312"><b>Method</b></p> <ol data-bbox="304 1317 692 1384" style="list-style-type: none"> <li>1. Press the start key.</li> <li>2. Select the item to be adjusted</li> </ol> <table border="1" data-bbox="336 1397 1401 1906"> <thead> <tr> <th data-bbox="336 1397 528 1442">Display</th> <th data-bbox="528 1397 1401 1442">Description</th> </tr> </thead> <tbody> <tr> <td data-bbox="336 1442 528 1487">Motor1</td> <td data-bbox="528 1442 1401 1487">Adjustment of drum motor speeds</td> </tr> <tr> <td data-bbox="336 1487 528 1576">Motor2</td> <td data-bbox="528 1487 1401 1576">Adjustment of developer motor, registration motor* and transfer motor speeds</td> </tr> <tr> <td data-bbox="336 1576 528 1666">Motor3</td> <td data-bbox="528 1576 1401 1666">Adjustment of eject motor, fuser motor, BR conveying motor 1/2, paper feed motor, JS eject motor, middle motor and duplex motor 1/2* speeds</td> </tr> <tr> <td data-bbox="336 1666 528 1711">Motor1 Half</td> <td data-bbox="528 1666 1401 1711">Adjustment of drum motor speeds in half speed</td> </tr> <tr> <td data-bbox="336 1711 528 1800">Motor2 Half</td> <td data-bbox="528 1711 1401 1800">Adjustment of developer motor, registration motor* and transfer motor speeds in half speed</td> </tr> <tr> <td data-bbox="336 1800 528 1906">Motor3 Half</td> <td data-bbox="528 1800 1401 1906">Adjustment of eject motor, fuser motor, BR conveying motor 1/2, paper feed motor, JS eject motor, middle motor and duplex motor 1/2* speeds in half speed</td> </tr> </tbody> </table> <p data-bbox="336 1917 639 1946">*: 45/ 55 ppm model only.</p> <p data-bbox="288 1984 509 2013"><b>Setting: [Motor1]</b></p>	Display	Description	Motor1	Adjustment of drum motor speeds	Motor2	Adjustment of developer motor, registration motor* and transfer motor speeds	Motor3	Adjustment of eject motor, fuser motor, BR conveying motor 1/2, paper feed motor, JS eject motor, middle motor and duplex motor 1/2* speeds	Motor1 Half	Adjustment of drum motor speeds in half speed	Motor2 Half	Adjustment of developer motor, registration motor* and transfer motor speeds in half speed	Motor3 Half	Adjustment of eject motor, fuser motor, BR conveying motor 1/2, paper feed motor, JS eject motor, middle motor and duplex motor 1/2* speeds in half speed
Display	Description														
Motor1	Adjustment of drum motor speeds														
Motor2	Adjustment of developer motor, registration motor* and transfer motor speeds														
Motor3	Adjustment of eject motor, fuser motor, BR conveying motor 1/2, paper feed motor, JS eject motor, middle motor and duplex motor 1/2* speeds														
Motor1 Half	Adjustment of drum motor speeds in half speed														
Motor2 Half	Adjustment of developer motor, registration motor* and transfer motor speeds in half speed														
Motor3 Half	Adjustment of eject motor, fuser motor, BR conveying motor 1/2, paper feed motor, JS eject motor, middle motor and duplex motor 1/2* speeds in half speed														

Item No.	Description																																																																																											
U053	1. Select the item to be adjusted																																																																																											
			<table border="1"> <thead> <tr> <th rowspan="2">Display</th> <th rowspan="2">Description</th> <th rowspan="2">Setting range</th> <th colspan="3">Initial setting</th> </tr> <tr> <th>35ppm</th> <th>45ppm</th> <th>55ppm</th> </tr> </thead> <tbody> <tr> <td>Drum(K)</td> <td>Drum motor (DRM)</td> <td>-5000 to 5000</td> <td>0</td> <td>0</td> <td>0</td> </tr> </tbody> </table>				Display	Description	Setting range	Initial setting			35ppm	45ppm	55ppm	Drum(K)	Drum motor (DRM)	-5000 to 5000	0	0	0																																																																							
	Display	Description	Setting range	Initial setting																																																																																								
				35ppm	45ppm	55ppm																																																																																						
	Drum(K)	Drum motor (DRM)	-5000 to 5000	0	0	0																																																																																						
	<b>Setting: [Motor2]</b>																																																																																											
	1. Select the item to be adjusted.																																																																																											
			<table border="1"> <thead> <tr> <th rowspan="2">Display</th> <th rowspan="2">Description</th> <th rowspan="2">Setting range</th> <th colspan="3">Initial setting</th> </tr> <tr> <th>35ppm</th> <th>45ppm</th> <th>55ppm</th> </tr> </thead> <tbody> <tr> <td>Dev(K)</td> <td>Developer motor (DEVM)</td> <td>-5000 to 5000</td> <td>953</td> <td>736</td> <td>596</td> </tr> <tr> <td>Regist*</td> <td>Registration motor (RM)</td> <td>-5000 to 5000</td> <td>-</td> <td>33</td> <td>27</td> </tr> <tr> <td>Sep Belt</td> <td>Transfer motor (TRM)</td> <td>-5000 to 5000</td> <td>29</td> <td>22</td> <td>18</td> </tr> </tbody> </table>				Display	Description	Setting range	Initial setting			35ppm	45ppm	55ppm	Dev(K)	Developer motor (DEVM)	-5000 to 5000	953	736	596	Regist*	Registration motor (RM)	-5000 to 5000	-	33	27	Sep Belt	Transfer motor (TRM)	-5000 to 5000	29	22	18																																																											
	Display	Description	Setting range	Initial setting																																																																																								
				35ppm	45ppm	55ppm																																																																																						
	Dev(K)	Developer motor (DEVM)	-5000 to 5000	953	736	596																																																																																						
	Regist*	Registration motor (RM)	-5000 to 5000	-	33	27																																																																																						
	Sep Belt	Transfer motor (TRM)	-5000 to 5000	29	22	18																																																																																						
	*: 45 ppm/55 ppm model only																																																																																											
	<b>Setting: [Motor3]</b>																																																																																											
1. Select the item to be adjusted.																																																																																												
		<table border="1"> <thead> <tr> <th rowspan="2">Display</th> <th rowspan="2">Description</th> <th rowspan="2">Setting range</th> <th colspan="3">Initial setting</th> </tr> <tr> <th>35ppm</th> <th>45ppm</th> <th>55ppm</th> </tr> </thead> <tbody> <tr> <td>SB</td> <td>Eject motor (EM)</td> <td>-5000 to 5000</td> <td>18</td> <td>13</td> <td>10</td> </tr> <tr> <td>Fixing</td> <td>Fuser motor (FUM)</td> <td>-5000 to 5000</td> <td>-30</td> <td>-24</td> <td>-20</td> </tr> <tr> <td>Bridge1</td> <td>BR conveying motor 1 (BRCM1)</td> <td>-5000 to 5000</td> <td>26</td> <td>20</td> <td>15</td> </tr> <tr> <td>Bridge2</td> <td>BR conveying motor 2 (BRCM2)</td> <td>-5000 to 5000</td> <td>26</td> <td>20</td> <td>15</td> </tr> <tr> <td>Feed</td> <td>Paper feed motor (PFM)</td> <td>-5000 to 5000</td> <td>66</td> <td>120</td> <td>97</td> </tr> <tr> <td>Job Separator</td> <td>JS eject motor (JSEM)</td> <td>-5000 to 5000</td> <td>35</td> <td>26</td> <td>19</td> </tr> <tr> <td>Mid Roller*</td> <td>Middle motor (MM)</td> <td>-5000 to 5000</td> <td>-</td> <td>72</td> <td>58</td> </tr> <tr> <td>DU1*</td> <td>Duplex motor 1 (DUM1)</td> <td>-5000 to 5000</td> <td>-</td> <td>-10</td> <td>-8</td> </tr> <tr> <td>DU2*</td> <td>Duplex motor 2 (DUM2)</td> <td>-5000 to 5000</td> <td>-</td> <td>-10</td> <td>-8</td> </tr> <tr> <td>Bridge1 DF High</td> <td>BR conveying motor 1 (BRCM1)</td> <td>-5000 to 5000</td> <td>0</td> <td>0</td> <td>0</td> </tr> <tr> <td>Bridge1 DF Low</td> <td>BR conveying motor 1 (BRCM1)</td> <td>-5000 to 5000</td> <td>0</td> <td>0</td> <td>0</td> </tr> <tr> <td>Bridge2 DF High</td> <td>BR conveying motor 2 (BRCM2)</td> <td>-5000 to 5000</td> <td>0</td> <td>0</td> <td>0</td> </tr> <tr> <td>Bridge2 DF Low</td> <td>BR conveying motor 2 (BRCM2)</td> <td>-5000 to 5000</td> <td>0</td> <td>0</td> <td>0</td> </tr> </tbody> </table>				Display	Description	Setting range	Initial setting			35ppm	45ppm	55ppm	SB	Eject motor (EM)	-5000 to 5000	18	13	10	Fixing	Fuser motor (FUM)	-5000 to 5000	-30	-24	-20	Bridge1	BR conveying motor 1 (BRCM1)	-5000 to 5000	26	20	15	Bridge2	BR conveying motor 2 (BRCM2)	-5000 to 5000	26	20	15	Feed	Paper feed motor (PFM)	-5000 to 5000	66	120	97	Job Separator	JS eject motor (JSEM)	-5000 to 5000	35	26	19	Mid Roller*	Middle motor (MM)	-5000 to 5000	-	72	58	DU1*	Duplex motor 1 (DUM1)	-5000 to 5000	-	-10	-8	DU2*	Duplex motor 2 (DUM2)	-5000 to 5000	-	-10	-8	Bridge1 DF High	BR conveying motor 1 (BRCM1)	-5000 to 5000	0	0	0	Bridge1 DF Low	BR conveying motor 1 (BRCM1)	-5000 to 5000	0	0	0	Bridge2 DF High	BR conveying motor 2 (BRCM2)	-5000 to 5000	0	0	0	Bridge2 DF Low	BR conveying motor 2 (BRCM2)	-5000 to 5000	0	0	0
Display	Description	Setting range	Initial setting																																																																																									
			35ppm	45ppm	55ppm																																																																																							
SB	Eject motor (EM)	-5000 to 5000	18	13	10																																																																																							
Fixing	Fuser motor (FUM)	-5000 to 5000	-30	-24	-20																																																																																							
Bridge1	BR conveying motor 1 (BRCM1)	-5000 to 5000	26	20	15																																																																																							
Bridge2	BR conveying motor 2 (BRCM2)	-5000 to 5000	26	20	15																																																																																							
Feed	Paper feed motor (PFM)	-5000 to 5000	66	120	97																																																																																							
Job Separator	JS eject motor (JSEM)	-5000 to 5000	35	26	19																																																																																							
Mid Roller*	Middle motor (MM)	-5000 to 5000	-	72	58																																																																																							
DU1*	Duplex motor 1 (DUM1)	-5000 to 5000	-	-10	-8																																																																																							
DU2*	Duplex motor 2 (DUM2)	-5000 to 5000	-	-10	-8																																																																																							
Bridge1 DF High	BR conveying motor 1 (BRCM1)	-5000 to 5000	0	0	0																																																																																							
Bridge1 DF Low	BR conveying motor 1 (BRCM1)	-5000 to 5000	0	0	0																																																																																							
Bridge2 DF High	BR conveying motor 2 (BRCM2)	-5000 to 5000	0	0	0																																																																																							
Bridge2 DF Low	BR conveying motor 2 (BRCM2)	-5000 to 5000	0	0	0																																																																																							
*: 45 ppm/55 ppm model only.																																																																																												
<b>Setting: [Motor1 Half]</b>																																																																																												
1. Select the item to be adjusted.																																																																																												


Item No.	Description																																																																		
U053	<table border="1"> <thead> <tr> <th rowspan="2">Display</th> <th rowspan="2">Description</th> <th rowspan="2">Setting range</th> <th colspan="3">Initial setting</th> </tr> <tr> <th>35ppm</th> <th>45ppm</th> <th>55ppm</th> </tr> </thead> <tbody> <tr> <td>Drum(K)</td> <td>Drum motor (DRM) in half speed</td> <td>-5000 to 5000</td> <td>0</td> <td>0</td> <td>0</td> </tr> </tbody> </table>					Display	Description	Setting range	Initial setting			35ppm	45ppm	55ppm	Drum(K)	Drum motor (DRM) in half speed	-5000 to 5000	0	0	0																																															
	Display	Description	Setting range	Initial setting																																																															
				35ppm	45ppm	55ppm																																																													
	Drum(K)	Drum motor (DRM) in half speed	-5000 to 5000	0	0	0																																																													
	<b>Setting: [Motor2 Half]</b> 1. Select the item to be adjusted.																																																																		
	<table border="1"> <thead> <tr> <th rowspan="2">Display</th> <th rowspan="2">Description</th> <th rowspan="2">Setting range</th> <th colspan="3">Initial setting</th> </tr> <tr> <th>35ppm</th> <th>45ppm</th> <th>55ppm</th> </tr> </thead> <tbody> <tr> <td>Dev(K)</td> <td>Developer motor (DEVM) in half speed</td> <td>-5000 to 5000</td> <td>1907</td> <td>1473</td> <td>1191</td> </tr> <tr> <td>Regist*</td> <td>Registration motor (RM) in half speed</td> <td>-5000 to 5000</td> <td>-</td> <td>66</td> <td>54</td> </tr> <tr> <td>Sep Belt</td> <td>Transfer motor (TRM) in half speed</td> <td>-5000 to 5000</td> <td>56</td> <td>44</td> <td>35</td> </tr> </tbody> </table>					Display	Description	Setting range	Initial setting			35ppm	45ppm	55ppm	Dev(K)	Developer motor (DEVM) in half speed	-5000 to 5000	1907	1473	1191	Regist*	Registration motor (RM) in half speed	-5000 to 5000	-	66	54	Sep Belt	Transfer motor (TRM) in half speed	-5000 to 5000	56	44	35																																			
	Display	Description	Setting range	Initial setting																																																															
				35ppm	45ppm	55ppm																																																													
	Dev(K)	Developer motor (DEVM) in half speed	-5000 to 5000	1907	1473	1191																																																													
	Regist*	Registration motor (RM) in half speed	-5000 to 5000	-	66	54																																																													
Sep Belt	Transfer motor (TRM) in half speed	-5000 to 5000	56	44	35																																																														
*: 45 ppm/55 ppm model only																																																																			
<b>Setting: [Motor3 Half]</b> 1. Select the item to be adjusted.																																																																			
<table border="1"> <thead> <tr> <th rowspan="2">Display</th> <th rowspan="2">Description</th> <th rowspan="2">Setting range</th> <th colspan="3">Initial setting</th> </tr> <tr> <th>35ppm</th> <th>45ppm</th> <th>55ppm</th> </tr> </thead> <tbody> <tr> <td>SB</td> <td>Eject motor (EM) in half speed</td> <td>-5000 to 5000</td> <td>106</td> <td>82</td> <td>66</td> </tr> <tr> <td>Fixing</td> <td>Fuser motor (FUM) in half speed</td> <td>-5000 to 5000</td> <td>0</td> <td>0</td> <td>0</td> </tr> <tr> <td>Bridge1</td> <td>BR conveying motor 1 (BRCM1) in half speed</td> <td>-5000 to 5000</td> <td>112</td> <td>86</td> <td>70</td> </tr> <tr> <td>Bridge2</td> <td>BR conveying motor 2 (BRCM2) in half speed</td> <td>-5000 to 5000</td> <td>112</td> <td>86</td> <td>70</td> </tr> <tr> <td>Feed</td> <td>Paper feed motor (PFM) in half speed</td> <td>-5000 to 5000</td> <td>132</td> <td>238</td> <td>194</td> </tr> <tr> <td>Job Separator</td> <td>JS eject motor (JSEM) in half speed</td> <td>-5000 to 5000</td> <td>210</td> <td>164</td> <td>133</td> </tr> <tr> <td>Mid Roller*</td> <td>Middle motor (MM) in half speed</td> <td>-5000 to 5000</td> <td>-</td> <td>143</td> <td>116</td> </tr> <tr> <td>DU1*</td> <td>Duplex motor 1 (DUM1) in half speed</td> <td>-5000 to 5000</td> <td>-</td> <td>-20</td> <td>-16</td> </tr> <tr> <td>DU2*</td> <td>Duplex motor 2 (DUM2) in half speed</td> <td>-5000 to 5000</td> <td>-</td> <td>-20</td> <td>-16</td> </tr> </tbody> </table>					Display	Description	Setting range	Initial setting			35ppm	45ppm	55ppm	SB	Eject motor (EM) in half speed	-5000 to 5000	106	82	66	Fixing	Fuser motor (FUM) in half speed	-5000 to 5000	0	0	0	Bridge1	BR conveying motor 1 (BRCM1) in half speed	-5000 to 5000	112	86	70	Bridge2	BR conveying motor 2 (BRCM2) in half speed	-5000 to 5000	112	86	70	Feed	Paper feed motor (PFM) in half speed	-5000 to 5000	132	238	194	Job Separator	JS eject motor (JSEM) in half speed	-5000 to 5000	210	164	133	Mid Roller*	Middle motor (MM) in half speed	-5000 to 5000	-	143	116	DU1*	Duplex motor 1 (DUM1) in half speed	-5000 to 5000	-	-20	-16	DU2*	Duplex motor 2 (DUM2) in half speed	-5000 to 5000	-	-20	-16
Display	Description	Setting range	Initial setting																																																																
			35ppm	45ppm	55ppm																																																														
SB	Eject motor (EM) in half speed	-5000 to 5000	106	82	66																																																														
Fixing	Fuser motor (FUM) in half speed	-5000 to 5000	0	0	0																																																														
Bridge1	BR conveying motor 1 (BRCM1) in half speed	-5000 to 5000	112	86	70																																																														
Bridge2	BR conveying motor 2 (BRCM2) in half speed	-5000 to 5000	112	86	70																																																														
Feed	Paper feed motor (PFM) in half speed	-5000 to 5000	132	238	194																																																														
Job Separator	JS eject motor (JSEM) in half speed	-5000 to 5000	210	164	133																																																														
Mid Roller*	Middle motor (MM) in half speed	-5000 to 5000	-	143	116																																																														
DU1*	Duplex motor 1 (DUM1) in half speed	-5000 to 5000	-	-20	-16																																																														
DU2*	Duplex motor 2 (DUM2) in half speed	-5000 to 5000	-	-20	-16																																																														
*: 45 ppm/55 ppm model only.																																																																			
<b>Completion</b> Press the stop key. The indication for selecting a maintenance item No. appears.																																																																			

Item No.	Description																								
U059	<p data-bbox="288 241 512 275"><b>Setting fan mode</b></p> <p data-bbox="288 311 440 340"><b>Description</b></p> <p data-bbox="288 344 778 374">Specifies mode for developer fan motors.</p> <p data-bbox="288 380 400 409"><b>Purpose</b></p> <p data-bbox="288 414 1318 443">Handling the lowering density [to suppress thermal stresses owing to the heated toner]</p> <p data-bbox="288 486 387 515"><b>Method</b></p> <ol data-bbox="304 519 564 582" style="list-style-type: none"> <li>1. Press the start key.</li> <li>2. Select the mode.</li> </ol> <table border="1" data-bbox="336 595 1401 801"> <thead> <tr> <th data-bbox="336 595 603 640">Display</th> <th data-bbox="603 595 1401 640">Description</th> </tr> </thead> <tbody> <tr> <td data-bbox="336 640 603 719">Fan Mode</td> <td data-bbox="603 640 1401 719">Sets threshold temperature at which developer fan motors operate.</td> </tr> <tr> <td data-bbox="336 719 603 801">Cooling Mode</td> <td data-bbox="603 719 1401 801">Sets temperature at which the developer fan motors are switched for controlling.</td> </tr> </tbody> </table> <p data-bbox="288 848 544 878"><b>Setting: [Fan Mode]</b></p> <ol data-bbox="304 882 539 911" style="list-style-type: none"> <li>1. Select the mode.</li> </ol> <table border="1" data-bbox="336 925 1401 1408"> <thead> <tr> <th data-bbox="336 925 564 969">Display</th> <th data-bbox="564 925 1401 969">Description</th> </tr> </thead> <tbody> <tr> <td data-bbox="336 969 564 1014">Mode1</td> <td data-bbox="564 969 1401 1014">Setting temperature:Normal</td> </tr> <tr> <td data-bbox="336 1014 564 1137">Mode2</td> <td data-bbox="564 1014 1401 1137">Setting temperature:Temperature threshold is raised from mode1 (WUP, temperature at READY : mode1 temperature -7(°C), Temperature at PRINT : mode1 temperature -3(°C).)</td> </tr> <tr> <td data-bbox="336 1137 564 1261">Mode3</td> <td data-bbox="564 1137 1401 1261">Setting temperature:Temperature threshold is raised from mode2 (WUP, temperature at READY : mode1 temperature -22(°C), Temperature at PRINT : mode1 temperature -8(°C).)</td> </tr> <tr> <td data-bbox="336 1261 564 1408">Auto</td> <td data-bbox="564 1261 1401 1408">Starting with Mode 2 at power up or recovery from sleep mode, and switches to Mode 3 when the termistor detects a developer temperature BK is equal to or higher than 38°C. The device never reverts from mode 2 from mode 3 while power is on.</td> </tr> </tbody> </table> <p data-bbox="336 1433 580 1462">Initial setting: Mode1</p> <ol data-bbox="304 1467 783 1496" style="list-style-type: none"> <li>2. Press the start key. The setting is set.</li> </ol> <p data-bbox="288 1538 595 1568"><b>Setting: [Cooling Mode]</b></p> <ol data-bbox="304 1572 858 1601" style="list-style-type: none"> <li>1. Change the setting value using the +/- keys.</li> </ol> <table border="1" data-bbox="336 1615 1385 1783"> <thead> <tr> <th data-bbox="336 1615 564 1693">Display</th> <th data-bbox="564 1615 1050 1693">Description</th> <th data-bbox="1050 1615 1219 1693">Setting range</th> <th data-bbox="1219 1615 1385 1693">Initial setting</th> </tr> </thead> <tbody> <tr> <td data-bbox="336 1693 564 1783">Cooling Mode</td> <td data-bbox="564 1693 1050 1783">Amount of shift from the initial standard temperature</td> <td data-bbox="1050 1693 1219 1783">-3 to 3 (°C)</td> <td data-bbox="1219 1693 1385 1783">0</td> </tr> </tbody> </table> <p data-bbox="336 1792 1217 1821">A larger value advances the operating timing, and a smaller value slows it.</p> <ol data-bbox="304 1825 767 1854" style="list-style-type: none"> <li>2. Press the start key. The value is set.</li> </ol> <p data-bbox="288 1897 440 1926"><b>Completion</b></p> <p data-bbox="288 1930 1246 1960">Press the stop key. The indication for selecting a maintenance item No. appears.</p>	Display	Description	Fan Mode	Sets threshold temperature at which developer fan motors operate.	Cooling Mode	Sets temperature at which the developer fan motors are switched for controlling.	Display	Description	Mode1	Setting temperature:Normal	Mode2	Setting temperature:Temperature threshold is raised from mode1 (WUP, temperature at READY : mode1 temperature -7(°C), Temperature at PRINT : mode1 temperature -3(°C).)	Mode3	Setting temperature:Temperature threshold is raised from mode2 (WUP, temperature at READY : mode1 temperature -22(°C), Temperature at PRINT : mode1 temperature -8(°C).)	Auto	Starting with Mode 2 at power up or recovery from sleep mode, and switches to Mode 3 when the termistor detects a developer temperature BK is equal to or higher than 38°C. The device never reverts from mode 2 from mode 3 while power is on.	Display	Description	Setting range	Initial setting	Cooling Mode	Amount of shift from the initial standard temperature	-3 to 3 (°C)	0
Display	Description																								
Fan Mode	Sets threshold temperature at which developer fan motors operate.																								
Cooling Mode	Sets temperature at which the developer fan motors are switched for controlling.																								
Display	Description																								
Mode1	Setting temperature:Normal																								
Mode2	Setting temperature:Temperature threshold is raised from mode1 (WUP, temperature at READY : mode1 temperature -7(°C), Temperature at PRINT : mode1 temperature -3(°C).)																								
Mode3	Setting temperature:Temperature threshold is raised from mode2 (WUP, temperature at READY : mode1 temperature -22(°C), Temperature at PRINT : mode1 temperature -8(°C).)																								
Auto	Starting with Mode 2 at power up or recovery from sleep mode, and switches to Mode 3 when the termistor detects a developer temperature BK is equal to or higher than 38°C. The device never reverts from mode 2 from mode 3 while power is on.																								
Display	Description	Setting range	Initial setting																						
Cooling Mode	Amount of shift from the initial standard temperature	-3 to 3 (°C)	0																						

Item No.	Description										
U061	<p><b>Checking the operation of the exposure lamp</b></p> <p><b>Description</b> Lights the exposure lamp.</p> <p><b>Purpose</b> To check whether the exposure lamp are turned on.</p> <p><b>Method</b></p> <ol style="list-style-type: none"> <li>1. Press the start key.</li> <li>2. Select the item.</li> </ol> <table border="1" data-bbox="336 595 1401 741"> <thead> <tr> <th data-bbox="336 595 603 640">Display</th> <th data-bbox="603 595 1401 640">Description</th> </tr> </thead> <tbody> <tr> <td data-bbox="336 640 603 685">CCD</td> <td data-bbox="603 640 1401 685">The exposure lamp lights</td> </tr> <tr> <td data-bbox="336 685 603 741">CIS</td> <td data-bbox="603 685 1401 741">The CIS lights (when dual scan DP is installed)</td> </tr> </tbody> </table> <ol style="list-style-type: none"> <li>3. Press the start key. The lamp lights.</li> <li>4. To turn the lamp off, press the stop key.</li> </ol> <p><b>Completion</b> Press the stop key. The screen for selecting a maintenance item No. is displayed.</p>	Display	Description	CCD	The exposure lamp lights	CIS	The CIS lights (when dual scan DP is installed)				
Display	Description										
CCD	The exposure lamp lights										
CIS	The CIS lights (when dual scan DP is installed)										
U063	<p><b>Adjusting the shading position</b></p> <p><b>Description</b> Changes the shading position of the scanner.</p> <p><b>Purpose</b> Used when the white line continue to appear longitudinally on the image after the shading plate is cleaned. This is due to flaws or stains inside the shading plate. To prevent this problem, the shading position should be changed so that shading is possible without being affected by the flaws or stains.</p> <p><b>Setting</b></p> <ol style="list-style-type: none"> <li>1. Press the start key.</li> <li>2. Change the setting value using the +/- keys or numeric keys.</li> </ol> <table border="1" data-bbox="336 1391 1401 1523"> <thead> <tr> <th data-bbox="336 1391 528 1473">Display</th> <th data-bbox="528 1391 922 1473">Description</th> <th data-bbox="922 1391 1082 1473">Setting range</th> <th data-bbox="1082 1391 1193 1473">Initial setting</th> <th data-bbox="1193 1391 1401 1473">Change in value per step</th> </tr> </thead> <tbody> <tr> <td data-bbox="336 1473 528 1523">Position</td> <td data-bbox="528 1473 922 1523">Shading position</td> <td data-bbox="922 1473 1082 1523">0 to 18</td> <td data-bbox="1082 1473 1193 1523">0</td> <td data-bbox="1193 1473 1401 1523">0.158 mm</td> </tr> </tbody> </table> <p>Increasing the value moves the shading position toward the machine left, and decreasing it moves the position toward the machine right.</p> <ol style="list-style-type: none"> <li>3. Press the start key. The value is set.</li> </ol> <p><b>Supplement</b> While this maintenance item is being executed, copying from an original is available in interrupt copying mode (which is activated by pressing the system menu key).</p> <p><b>Completion</b> Press the stop key. The screen for selecting a maintenance item No. is displayed.</p>	Display	Description	Setting range	Initial setting	Change in value per step	Position	Shading position	0 to 18	0	0.158 mm
Display	Description	Setting range	Initial setting	Change in value per step							
Position	Shading position	0 to 18	0	0.158 mm							




Item No.	Description															
<b>U065</b>	<p><b>Adjusting the scanner magnification</b></p> <p><b>Description</b> Adjusts the magnification of the original scanning.</p> <p><b>Purpose</b> Make the adjustment if the magnification in the main scanning direction is incorrect. Make the adjustment if the magnification in the auxiliary scanning direction is incorrect.</p> <p><b>Caution</b> The magnification adjustment along the main scanning direction could cause black streaks depending on the content of the original document. Adjust the magnification of the scanner in the following order.</p> <div data-bbox="523 674 1056 763" style="text-align: center;"> <pre> graph LR     A[U065 main scanning direction] --&gt; B[U065 auxiliary scanning direction]           </pre> </div> <p><b>Method</b></p> <ol style="list-style-type: none"> <li>1. Press the start key.</li> <li>2. Press the system menu key.</li> <li>3. Place an original and press the start key to make a test copy.</li> <li>4. Press the system menu key.</li> <li>5. Select the item to be adjusted.</li> </ol> <table border="1" data-bbox="336 1032 1401 1279"> <thead> <tr> <th>Display</th> <th>Description</th> <th>Setting range</th> <th>Initial setting</th> <th>Change in value per step</th> </tr> </thead> <tbody> <tr> <td>Main Scan</td> <td>Scanner magnification in the main scanning direction</td> <td>-75 to 75</td> <td>0</td> <td>0.02 %</td> </tr> <tr> <td>Sub Scan</td> <td>Scanner magnification in the auxiliary scanning direction</td> <td>-125 to 125</td> <td>0</td> <td>0.02 %</td> </tr> </tbody> </table> <p><b>Adjustment: [Main Scan]</b></p> <ol style="list-style-type: none"> <li>1. Change the setting value using the +/- keys or numeric keys. For copy example 1, increase the value. For copy example 2, decrease the value. Increasing the setting enlarges the image and decreasing it narrows the image.</li> </ol> <div data-bbox="667 1485 1056 1709" style="text-align: center;"> </div> <p style="text-align: center;"><b>Figure 1-3-7</b></p> <ol style="list-style-type: none"> <li>2. Press the start key. The value is set.</li> </ol>	Display	Description	Setting range	Initial setting	Change in value per step	Main Scan	Scanner magnification in the main scanning direction	-75 to 75	0	0.02 %	Sub Scan	Scanner magnification in the auxiliary scanning direction	-125 to 125	0	0.02 %
Display	Description	Setting range	Initial setting	Change in value per step												
Main Scan	Scanner magnification in the main scanning direction	-75 to 75	0	0.02 %												
Sub Scan	Scanner magnification in the auxiliary scanning direction	-125 to 125	0	0.02 %												


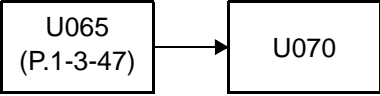
Item No.	Description
U065	<p data-bbox="288 241 596 275"><b>Adjustment: [Sub Scan]</b></p> <p data-bbox="308 280 1414 409">1. Change the setting value using the +/- keys or numeric keys. For copy example 1, increase the value. For copy example 2, decrease the value. Increasing the value makes the image longer, while decreasing the value makes the image shorter.</p> <div data-bbox="667 439 1054 658" style="text-align: center;"><p data-bbox="676 600 1054 658">Original      Copy example 1      Copy example 2</p></div> <p data-bbox="783 689 938 723" style="text-align: center;"><b>Figure 1-3-8</b></p> <p data-bbox="308 759 767 792">2. Press the start key. The value is set.</p> <p data-bbox="288 828 440 862"><b>Completion</b></p> <p data-bbox="288 866 1254 900">Press the stop key. The screen for selecting a maintenance item No. is displayed.</p>

Item No.	Description																				
U066	<p data-bbox="288 241 900 275"><b>Adjusting the scanner leading edge registration</b></p> <p data-bbox="288 309 440 342"><b>Description</b></p> <p data-bbox="288 344 1117 378">Adjusts the scanner leading edge registration of the original scanning.</p> <p data-bbox="288 380 400 414"><b>Purpose</b></p> <p data-bbox="288 416 1426 483">Make the adjustment if there is a regular error between the leading edges of the copy image and original.</p> <p data-bbox="288 517 440 551"><b>Adjustment</b></p> <ol data-bbox="304 553 1058 723" style="list-style-type: none"> <li>1. Press the start key.</li> <li>2. Press the system menu key.</li> <li>3. Place an original and press the start key to make a test copy.</li> <li>4. Press the system menu key.</li> <li>5. Select the item to be adjusted.</li> </ol> <table border="1" data-bbox="336 734 1401 981"> <thead> <tr> <th>Display</th> <th>Description</th> <th>Setting range</th> <th>Initial setting</th> <th>Change in value per step</th> </tr> </thead> <tbody> <tr> <td>Front</td> <td>Scanner leading edge registration</td> <td>-30 to 30</td> <td>0</td> <td>0.158 mm</td> </tr> <tr> <td>Rotate</td> <td>Scanner leading edge registration (rotate copying)</td> <td>-30 to 30</td> <td>0</td> <td>0.158 mm</td> </tr> </tbody> </table> <ol data-bbox="304 994 1406 1128" style="list-style-type: none"> <li>6. Change the setting value using the +/- keys or numeric keys. For copy example 1, increase the value. For copy example 2, decrease the value. Increasing the value moves the image forward and decreasing the value moves the image backward.</li> </ol> <div data-bbox="576 1151 1299 1458" style="text-align: center;"> <p>Leading edge registration of the copy image (+1.0/-1.5 mm or less)</p> <p>Original      Copy example 1      Copy example 2</p> </div> <p data-bbox="783 1491 938 1525"><b>Figure 1-3-9</b></p> <ol data-bbox="304 1561 767 1594" style="list-style-type: none"> <li>7. Press the start key. The value is set.</li> </ol> <p data-bbox="288 1628 392 1662"><b>Caution</b></p> <p data-bbox="288 1664 1426 1731">If the above adjustment does not optimize the leading edge registration, proceed with the following maintenance modes.</p> <div data-bbox="520 1744 1129 1839" style="text-align: center;"> <table border="1"> <tr> <td style="padding: 5px;">U034 (P.1-3-34)</td> <td style="text-align: center;">→</td> <td style="padding: 5px;">U065 (P.1-3-47)</td> <td style="text-align: center;">→</td> <td style="padding: 5px;">U066</td> </tr> </table> </div> <p data-bbox="288 1888 440 1921"><b>Completion</b></p> <p data-bbox="288 1924 1254 1957">Press the stop key. The screen for selecting a maintenance item No. is displayed.</p>	Display	Description	Setting range	Initial setting	Change in value per step	Front	Scanner leading edge registration	-30 to 30	0	0.158 mm	Rotate	Scanner leading edge registration (rotate copying)	-30 to 30	0	0.158 mm	U034 (P.1-3-34)	→	U065 (P.1-3-47)	→	U066
Display	Description	Setting range	Initial setting	Change in value per step																	
Front	Scanner leading edge registration	-30 to 30	0	0.158 mm																	
Rotate	Scanner leading edge registration (rotate copying)	-30 to 30	0	0.158 mm																	
U034 (P.1-3-34)	→	U065 (P.1-3-47)	→	U066																	

Item No.	Description																				
<b>U067</b>	<p><b>Adjusting the scanner center line</b></p> <p><b>Description</b> Adjusts the scanner center line of the original scanning.</p> <p><b>Purpose</b> Make the adjustment if there is a regular error between the center lines of the copy image and original.</p> <p><b>Adjustment</b></p> <ol style="list-style-type: none"> <li>1. Press the start key.</li> <li>2. Press the system menu key.</li> <li>3. Place an original and press the start key to make a test copy.</li> <li>4. Press the system menu key.</li> <li>5. Select the item to be adjusted.</li> </ol> <table border="1" data-bbox="336 734 1401 949"> <thead> <tr> <th>Display</th> <th>Description</th> <th>Setting range</th> <th>Initial setting</th> <th>Change in value per step</th> </tr> </thead> <tbody> <tr> <td>Front</td> <td>Scanner center line</td> <td>-60 to 60</td> <td>0</td> <td>0.085 mm</td> </tr> <tr> <td>Rotate</td> <td>Scanner center line (rotate copying)</td> <td>-40 to 40</td> <td>0</td> <td>0.085 mm</td> </tr> </tbody> </table> <ol style="list-style-type: none"> <li>6. Change the setting value using the +/- keys or numeric keys. For copy example 1, decrease the value. For copy example 2, increase the value. Increasing the value moves the image leftward and decreasing it moves the image rightward.</li> </ol> <div data-bbox="651 1088 1158 1384" style="text-align: center;"> <p>Center line of the copy image (within <math>\pm 2.0</math> mm)</p> <p>Original      Copy example 1      Copy example 2</p> </div> <p><b>Figure 1-3-10</b></p> <ol style="list-style-type: none"> <li>7. Press the start key. The value is set.</li> </ol> <p><b>Caution</b> If the above adjustment does not optimize the center line, proceed with the following maintenance modes.</p> <div data-bbox="293 1666 903 1760" style="text-align: center;"> <table border="1"> <tr> <td style="padding: 5px;">U034 (P.1-3-34)</td> <td style="padding: 5px; text-align: center;">→</td> <td style="padding: 5px;">U065 (P.1-3-47)</td> <td style="padding: 5px; text-align: center;">→</td> <td style="padding: 5px;">U067</td> </tr> </table> </div> <p><b>Completion</b> Press the stop key. The screen for selecting a maintenance item No. is displayed.</p>	Display	Description	Setting range	Initial setting	Change in value per step	Front	Scanner center line	-60 to 60	0	0.085 mm	Rotate	Scanner center line (rotate copying)	-40 to 40	0	0.085 mm	U034 (P.1-3-34)	→	U065 (P.1-3-47)	→	U067
Display	Description	Setting range	Initial setting	Change in value per step																	
Front	Scanner center line	-60 to 60	0	0.085 mm																	
Rotate	Scanner center line (rotate copying)	-40 to 40	0	0.085 mm																	
U034 (P.1-3-34)	→	U065 (P.1-3-47)	→	U067																	


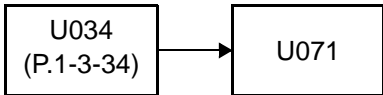
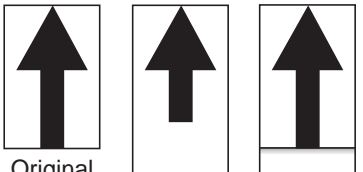
Item No.	Description															
U068	<p data-bbox="288 241 1021 275"><b>Adjusting the scanning position for originals from the DP</b></p> <p data-bbox="288 311 440 340"><b>Description</b></p> <p data-bbox="288 344 1426 412">Adjusts the position for scanning originals from the DP. Perform the test copy at the four scanning positions after adjusting.</p> <p data-bbox="288 416 400 445"><b>Purpose</b></p> <p data-bbox="288 450 1426 517">Used when the image fogging occurs because the scanning position is not proper when the DP is used. Run U071 to adjust the timing of DP leading edge when the scanning position is changed.</p> <p data-bbox="288 553 384 582"><b>Setting</b></p> <p data-bbox="304 586 571 616">1. Press the start key.</p> <table border="1" data-bbox="336 631 1399 880"> <thead> <tr> <th data-bbox="336 631 528 712">Display</th> <th data-bbox="528 631 922 712">Description</th> <th data-bbox="922 631 1082 712">Setting range</th> <th data-bbox="1082 631 1193 712">Initial setting</th> <th data-bbox="1193 631 1399 712">Change in value per step</th> </tr> </thead> <tbody> <tr> <td data-bbox="336 712 528 792">DP Read</td> <td data-bbox="528 712 922 792">Starting position adjustment for scanning originals</td> <td data-bbox="922 712 1082 792">-38 to 38</td> <td data-bbox="1082 712 1193 792">0</td> <td data-bbox="1193 712 1399 792">0.158 mm</td> </tr> <tr> <td data-bbox="336 792 528 880">Black Line</td> <td data-bbox="528 792 922 880">Scanning position for the test copy originals</td> <td data-bbox="922 792 1082 880">0 to 3</td> <td data-bbox="1082 792 1193 880">0</td> <td data-bbox="1193 792 1399 880">-</td> </tr> </tbody> </table> <p data-bbox="304 891 552 920">2. Select [DP Read].</p> <p data-bbox="304 925 983 954">3. Change the setting using the +/- keys or numeric keys.</p> <p data-bbox="333 958 1426 1025">When the setting value is increased, the scanning position moves to the right and it moves to the left when the setting value is decreased.</p> <p data-bbox="304 1030 767 1059">4. Press the start key. The value is set.</p> <p data-bbox="304 1064 564 1093">5. Select [Black Line].</p> <p data-bbox="304 1097 983 1126">6. Change the setting using the +/- keys or numeric keys.</p> <p data-bbox="304 1131 767 1160">7. Press the start key. The value is set.</p> <p data-bbox="304 1164 1418 1193">8. Set the original (the one which density is known) in the DP and press the system menu key.</p> <p data-bbox="304 1198 834 1227">9. Press the start key. Test copy is executed.</p> <p data-bbox="288 1232 1426 1299">10. Perform the test copy at each scanning position with the setting value from 0 to 3 and check that no black line appears and the image is normally scanned.</p> <p data-bbox="288 1335 440 1364"><b>Completion</b></p> <p data-bbox="288 1368 1254 1397">Press the stop key. The screen for selecting a maintenance item No. is displayed.</p>	Display	Description	Setting range	Initial setting	Change in value per step	DP Read	Starting position adjustment for scanning originals	-38 to 38	0	0.158 mm	Black Line	Scanning position for the test copy originals	0 to 3	0	-
Display	Description	Setting range	Initial setting	Change in value per step												
DP Read	Starting position adjustment for scanning originals	-38 to 38	0	0.158 mm												
Black Line	Scanning position for the test copy originals	0 to 3	0	-												

Item No.	Description																									
<b>U070</b>	<p><b>Adjusting the DP magnification</b></p> <p><b>Description</b> Adjusts the DP original scanning speed.</p> <p><b>Purpose</b> Make the adjustment if the magnification is incorrect in the auxiliary scanning direction when the DP is used. Make the adjustment if the magnification is incorrect in the main scanning direction when the CIS is used.</p> <p><b>Adjustment</b></p> <ol style="list-style-type: none"> <li>1. Press the start key.</li> <li>2. Press the system menu key.</li> <li>3. Place an original on the DP and press the start key to make a test copy.</li> <li>4. Press the system menu key.</li> <li>5. Select the item to be adjusted.</li> </ol> <table border="1" data-bbox="336 801 1401 1285"> <thead> <tr> <th>Display</th> <th>Description</th> <th>Setting range</th> <th>Initial setting</th> <th>Change in value per step</th> </tr> </thead> <tbody> <tr> <td>Sub Scan(F)</td> <td>Magnification in the auxiliary scanning direction of CCD (first side)</td> <td>-125 to 125</td> <td>0</td> <td>0.02 %</td> </tr> <tr> <td>Sub Scan(B)<sup>*1</sup></td> <td>Magnification in the auxiliary scanning direction of CCD (second side)</td> <td>-125 to 125</td> <td>0</td> <td>0.02 %</td> </tr> <tr> <td>Main Scan(CIS)<sup>*2</sup></td> <td>Magnification in the main scanning direction of CIS</td> <td>-100 to 100</td> <td>0</td> <td>0.02 %</td> </tr> <tr> <td>Sub Scan(CIS)<sup>*2</sup></td> <td>Magnification in the auxiliary scanning direction of CIS</td> <td>-125 to 125</td> <td>0</td> <td>0.02 %</td> </tr> </tbody> </table> <p>*1: Reversed DP only. *2: Dual scan DP only.</p> <p><b>Adjustment: [Sub Scan]</b></p> <ol style="list-style-type: none"> <li>1. Change the setting value using the +/- keys or numeric keys. For copy example 1, increase the value. For copy example 2, decrease the value. Increasing the value makes the image longer, while decreasing the value makes the image shorter.</li> </ol> <div data-bbox="667 1559 1054 1783" style="text-align: center;">  <p>Original      Copy example 1      Copy example 2</p> </div> <p style="text-align: center;"><b>Figure 1-3-11</b></p> <ol style="list-style-type: none"> <li>2. Press the start key. The value is set.</li> </ol>	Display	Description	Setting range	Initial setting	Change in value per step	Sub Scan(F)	Magnification in the auxiliary scanning direction of CCD (first side)	-125 to 125	0	0.02 %	Sub Scan(B) <sup>*1</sup>	Magnification in the auxiliary scanning direction of CCD (second side)	-125 to 125	0	0.02 %	Main Scan(CIS) <sup>*2</sup>	Magnification in the main scanning direction of CIS	-100 to 100	0	0.02 %	Sub Scan(CIS) <sup>*2</sup>	Magnification in the auxiliary scanning direction of CIS	-125 to 125	0	0.02 %
Display	Description	Setting range	Initial setting	Change in value per step																						
Sub Scan(F)	Magnification in the auxiliary scanning direction of CCD (first side)	-125 to 125	0	0.02 %																						
Sub Scan(B) <sup>*1</sup>	Magnification in the auxiliary scanning direction of CCD (second side)	-125 to 125	0	0.02 %																						
Main Scan(CIS) <sup>*2</sup>	Magnification in the main scanning direction of CIS	-100 to 100	0	0.02 %																						
Sub Scan(CIS) <sup>*2</sup>	Magnification in the auxiliary scanning direction of CIS	-125 to 125	0	0.02 %																						

Item No.	Description
U070	<p><b>Adjustment: [Main Scan]</b></p> <p>1. Change the setting value using the +/- keys or numeric keys. For copy example 1, increase the value. For copy example 2, decrease the value. Increasing the setting enlarges the image and decreasing it narrows the image.</p> <div data-bbox="667 405 1054 622" style="text-align: center;">  <p>Original      Copy example 1      Copy example 2</p> </div> <p style="text-align: center;"><b>Figure 1-3-12</b></p> <p>2. Press the start key. The value is set.</p> <p><b>Caution</b> If the above adjustment does not optimize the magnification, perform the following maintenance modes.</p> <div data-bbox="296 909 676 1003" style="text-align: center;">  <pre> graph LR     A["U065 (P.1-3-47)"] --&gt; B["U070"] </pre> </div> <p><b>Completion</b> Press the stop key. The screen for selecting a maintenance item No. is displayed.</p>

Item No.	Description																																																		
U071	<p data-bbox="287 241 721 275"><b>Adjusting the DP scanning timing</b></p> <p data-bbox="287 309 440 342"><b>Description</b></p> <p data-bbox="287 344 762 378">Adjusts the DP original scanning timing.</p> <p data-bbox="287 380 400 414"><b>Purpose</b></p> <p data-bbox="287 416 1423 483">Make the adjustment if there is a regular error between the leading or trailing edges of the original and the copy image when the DP is used.</p> <p data-bbox="287 517 387 551"><b>Method</b></p> <ol data-bbox="304 553 1185 723" style="list-style-type: none"> <li>1. Press the start key.</li> <li>2. Press the system menu key.</li> <li>3. Place an original on the DP and press the start key to make a test copy.</li> <li>4. Press the system menu key.</li> <li>5. Select the item to be adjusted.</li> </ol> <p data-bbox="336 725 496 759">Reversed DP</p> <table border="1" data-bbox="336 770 1401 1182"> <thead> <tr> <th>Display</th> <th>Description</th> <th>Setting range</th> <th>Initial setting</th> <th>Change in value per step</th> </tr> </thead> <tbody> <tr> <td>Front Head</td> <td>Leading edge registration of CCD (first side)</td> <td>-32 to 32</td> <td>0</td> <td>0.085 mm</td> </tr> <tr> <td>Front Tail</td> <td>Trailing edge registration of CCD (first side)</td> <td>-32 to 32</td> <td>0</td> <td>0.085 mm</td> </tr> <tr> <td>Back Head</td> <td>Leading edge registration of CCD (second side)</td> <td>-32 to 32</td> <td>0</td> <td>0.085 mm</td> </tr> <tr> <td>Back Tail</td> <td>Trailing edge registration of CCD (second side)</td> <td>-32 to 32</td> <td>0</td> <td>0.085 mm</td> </tr> </tbody> </table> <p data-bbox="336 1227 501 1261">Dual scan DP</p> <table border="1" data-bbox="336 1272 1401 1648"> <thead> <tr> <th>Display</th> <th>Description</th> <th>Setting range</th> <th>Initial setting</th> <th>Change in value per step</th> </tr> </thead> <tbody> <tr> <td>Front Head</td> <td>Leading edge registration of CCD (first side)</td> <td>-27 to 27</td> <td>0</td> <td>0.207 mm</td> </tr> <tr> <td>Front Tail</td> <td>Trailing edge registration of CCD (first side)</td> <td>-27 to 27</td> <td>0</td> <td>0.207 mm</td> </tr> <tr> <td>CIS Head</td> <td>Leading edge registration of CIS</td> <td>-27 to 27</td> <td>0</td> <td>0.207 mm</td> </tr> <tr> <td>CIS Tail</td> <td>Trailing edge registration of CIS</td> <td>-27 to 27</td> <td>0</td> <td>0.207 mm</td> </tr> </tbody> </table>	Display	Description	Setting range	Initial setting	Change in value per step	Front Head	Leading edge registration of CCD (first side)	-32 to 32	0	0.085 mm	Front Tail	Trailing edge registration of CCD (first side)	-32 to 32	0	0.085 mm	Back Head	Leading edge registration of CCD (second side)	-32 to 32	0	0.085 mm	Back Tail	Trailing edge registration of CCD (second side)	-32 to 32	0	0.085 mm	Display	Description	Setting range	Initial setting	Change in value per step	Front Head	Leading edge registration of CCD (first side)	-27 to 27	0	0.207 mm	Front Tail	Trailing edge registration of CCD (first side)	-27 to 27	0	0.207 mm	CIS Head	Leading edge registration of CIS	-27 to 27	0	0.207 mm	CIS Tail	Trailing edge registration of CIS	-27 to 27	0	0.207 mm
Display	Description	Setting range	Initial setting	Change in value per step																																															
Front Head	Leading edge registration of CCD (first side)	-32 to 32	0	0.085 mm																																															
Front Tail	Trailing edge registration of CCD (first side)	-32 to 32	0	0.085 mm																																															
Back Head	Leading edge registration of CCD (second side)	-32 to 32	0	0.085 mm																																															
Back Tail	Trailing edge registration of CCD (second side)	-32 to 32	0	0.085 mm																																															
Display	Description	Setting range	Initial setting	Change in value per step																																															
Front Head	Leading edge registration of CCD (first side)	-27 to 27	0	0.207 mm																																															
Front Tail	Trailing edge registration of CCD (first side)	-27 to 27	0	0.207 mm																																															
CIS Head	Leading edge registration of CIS	-27 to 27	0	0.207 mm																																															
CIS Tail	Trailing edge registration of CIS	-27 to 27	0	0.207 mm																																															



Item No.	Description
U071	<p><b>Adjustment: Leading edge registration</b></p> <p>1. Change the setting value using the +/- keys or numeric keys. For copy example 1, increase the value. For copy example 2, decrease the value. Increasing the value moves the image forward and decreasing the value moves the image backward.</p> <div data-bbox="655 434 1066 674" style="text-align: center;">  <p>Original      Copy example 1      Copy example 2</p> </div> <p style="text-align: center;"><b>Figure 1-3-13</b></p> <p>2. Press the start key. The value is set.</p> <p><b>Caution</b> If the first side is adjusted, check the second side and if adjustment is required, carry out the adjustment. If the above adjustment does not optimize the leading edge registration, proceed with the following maintenance modes.</p> <div data-bbox="520 1028 903 1122" style="text-align: center;">  <pre> graph LR     U034["U034 (P.1-3-34)"] --&gt; U071["U071"] </pre> </div> <p><b>Adjustment: Trailing edge registration</b></p> <p>1. Change the setting value using the +/- keys or numeric keys. For copy example 1, increase the value. For copy example 2, decrease the value.</p> <div data-bbox="679 1296 1043 1536" style="text-align: center;">  <p>Original      Copy example 1      Copy example 2</p> </div> <p style="text-align: center;"><b>Figure 1-3-14</b></p> <p>2. Press the start key. The value is set.</p> <p><b>Caution</b> If the first side is adjusted, check the second side and if adjustment is required, carry out the adjustment.</p> <p><b>Completion</b> Press the stop key. The screen for selecting a maintenance item No. is displayed.</p>




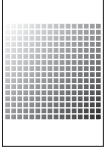



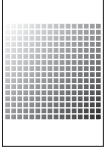



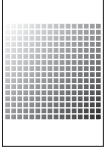
Item No.	Description																				
U072	<p data-bbox="287 241 651 273"><b>Adjusting the DP center line</b></p> <p data-bbox="287 309 440 340"><b>Description</b></p> <p data-bbox="287 342 927 374">Adjusts the scanning start position for the DP original.</p> <p data-bbox="287 376 400 407"><b>Purpose</b></p> <p data-bbox="287 409 1412 479">Make the adjustment if there is a regular error between the centers of the original and the copy image when the DP is used.</p> <p data-bbox="287 515 440 546"><b>Adjustment</b></p> <ol data-bbox="304 548 1185 719" style="list-style-type: none"> <li>1. Press the start key.</li> <li>2. Press the system menu key.</li> <li>3. Place an original on the DP and press the start key to make a test copy.</li> <li>4. Press the system menu key.</li> <li>5. Select the item to be adjusted.</li> </ol> <table border="1" data-bbox="336 734 1401 960"> <thead> <tr> <th>Display</th> <th>Description</th> <th>Setting range</th> <th>Initial setting</th> <th>Change in value per step</th> </tr> </thead> <tbody> <tr> <td>Front</td> <td>DP center line (first side)</td> <td>-60 to 60</td> <td>0</td> <td>0.085 mm</td> </tr> <tr> <td>Back</td> <td>DP center line (second side)</td> <td>-60 to 60</td> <td>0</td> <td>0.085 mm</td> </tr> <tr> <td>CIS*</td> <td>CIS center line</td> <td>-39 to 39</td> <td>0</td> <td>0.085 mm</td> </tr> </tbody> </table> <p data-bbox="333 967 585 999">*: Dual scan DP only</p> <ol data-bbox="304 1001 1431 1102" style="list-style-type: none"> <li>6. Change the setting value using the +/- keys or numeric keys. For copy example 1, increase the value. For copy example 2, decrease the value. Increasing the value moves the image rightward and decreasing it moves the image leftward.</li> </ol> <div data-bbox="646 1126 1074 1366" style="text-align: center;"> </div> <p data-bbox="775 1391 946 1422"><b>Figure 1-3-15</b></p> <ol data-bbox="304 1458 766 1489" style="list-style-type: none"> <li>7. Press the start key. The value is set.</li> </ol> <p data-bbox="287 1529 392 1561"><b>Caution</b></p> <p data-bbox="287 1563 1382 1632">If the first side is adjusted, check the second side and if adjustment is required, carry out the adjustment.</p> <p data-bbox="287 1635 1382 1704">If the above adjustment does not optimize the center line, proceed with the following maintenance modes.</p> <div data-bbox="292 1718 1129 1814" style="text-align: center;"> <pre> graph LR     U034["U034 (P.1-3-34)"] --&gt; U065["U065 (P.1-3-47)"]     U065 --&gt; U067["U067 (P.1-3-50)"]     U067 --&gt; U072["U072"] </pre> </div> <p data-bbox="287 1861 440 1892"><b>Completion</b></p> <p data-bbox="287 1895 1256 1926">Press the stop key. The screen for selecting a maintenance item No. is displayed.</p>	Display	Description	Setting range	Initial setting	Change in value per step	Front	DP center line (first side)	-60 to 60	0	0.085 mm	Back	DP center line (second side)	-60 to 60	0	0.085 mm	CIS*	CIS center line	-39 to 39	0	0.085 mm
Display	Description	Setting range	Initial setting	Change in value per step																	
Front	DP center line (first side)	-60 to 60	0	0.085 mm																	
Back	DP center line (second side)	-60 to 60	0	0.085 mm																	
CIS*	CIS center line	-39 to 39	0	0.085 mm																	

Item No.	Description																																																						
U073	<p data-bbox="288 241 702 275"><b>Checking the scanner operation</b></p> <p data-bbox="288 311 440 340"><b>Description</b></p> <p data-bbox="288 344 1037 376">Simulates the scanner operation under the arbitrary conditions.</p> <p data-bbox="288 380 400 409"><b>Purpose</b></p> <p data-bbox="288 414 1409 481">To check the scanner operation. This is also done to check the accumulation of dust on the slit glass.</p> <p data-bbox="288 517 387 546"><b>Method</b></p> <ol data-bbox="304 553 702 618" style="list-style-type: none"> <li>1. Press the start key.</li> <li>2. Select the item to be operated.</li> </ol> <table border="1" data-bbox="336 631 1401 871"> <thead> <tr> <th data-bbox="336 631 639 676">Display</th> <th data-bbox="639 631 1401 676">Description</th> </tr> </thead> <tbody> <tr> <td data-bbox="336 676 639 721">Scanner Motor</td> <td data-bbox="639 676 1401 721">Scanner operation</td> </tr> <tr> <td data-bbox="336 721 639 766">Home Position</td> <td data-bbox="639 721 1401 766">Home position operation</td> </tr> <tr> <td data-bbox="336 766 639 810">Dust Check</td> <td data-bbox="639 766 1401 810">Dust adhesion check operation with lamp on</td> </tr> <tr> <td data-bbox="336 810 639 855">DP Reading</td> <td data-bbox="639 810 1401 855">DP scanning position operation</td> </tr> </tbody> </table> <p data-bbox="288 913 606 943"><b>Setting: [Scanner Motor]</b></p> <ol data-bbox="304 947 786 1048" style="list-style-type: none"> <li>1. Select [Scanner Motor].</li> <li>2. Select the item.</li> <li>3. Change the setting using the +/- keys.</li> </ol> <table border="1" data-bbox="336 1061 1401 1254"> <thead> <tr> <th data-bbox="336 1061 563 1106">Display</th> <th data-bbox="563 1061 1094 1106">Operating conditions</th> <th data-bbox="1094 1061 1401 1106">Setting range</th> </tr> </thead> <tbody> <tr> <td data-bbox="336 1106 563 1151">Zoom</td> <td data-bbox="563 1106 1094 1151">Magnification</td> <td data-bbox="1094 1106 1401 1151">25 to 400 %</td> </tr> <tr> <td data-bbox="336 1151 563 1196">Size</td> <td data-bbox="563 1151 1094 1196">Original size</td> <td data-bbox="1094 1151 1401 1196">See below.</td> </tr> <tr> <td data-bbox="336 1196 563 1240">Lamp</td> <td data-bbox="563 1196 1094 1240">On and off of the exposure lamp</td> <td data-bbox="1094 1196 1401 1240">0 (off) or 1 (on)</td> </tr> </tbody> </table> <p data-bbox="336 1294 783 1323">Original sizes for each setting in SIZE</p> <table border="1" data-bbox="336 1337 1401 1722"> <thead> <tr> <th data-bbox="336 1337 603 1382">Setting</th> <th data-bbox="603 1337 869 1382">Paper size</th> <th data-bbox="869 1337 1136 1382">Setting</th> <th data-bbox="1136 1337 1401 1382">Paper size</th> </tr> </thead> <tbody> <tr> <td data-bbox="336 1382 603 1426">5000</td> <td data-bbox="603 1382 869 1426">A4</td> <td data-bbox="869 1382 1136 1426">5000</td> <td data-bbox="1136 1382 1401 1426">A5R</td> </tr> <tr> <td data-bbox="336 1426 603 1471">4300</td> <td data-bbox="603 1426 869 1471">B5</td> <td data-bbox="869 1426 1136 1471">7800</td> <td data-bbox="1136 1426 1401 1471">Folio</td> </tr> <tr> <td data-bbox="336 1471 603 1516">5100</td> <td data-bbox="603 1471 869 1516">11" x 8 1/2"</td> <td data-bbox="869 1471 1136 1516">10200</td> <td data-bbox="1136 1471 1401 1516">11" x 17"</td> </tr> <tr> <td data-bbox="336 1516 603 1561">10000</td> <td data-bbox="603 1516 869 1561">A3</td> <td data-bbox="869 1516 1136 1561">9000</td> <td data-bbox="1136 1516 1401 1561">11" x 15"</td> </tr> <tr> <td data-bbox="336 1561 603 1606">8600</td> <td data-bbox="603 1561 869 1606">B4</td> <td data-bbox="869 1561 1136 1606">8400</td> <td data-bbox="1136 1561 1401 1606">8 1/2" x 14"</td> </tr> <tr> <td data-bbox="336 1606 603 1650">7100</td> <td data-bbox="603 1606 869 1650">A4R</td> <td data-bbox="869 1606 1136 1650">6600</td> <td data-bbox="1136 1606 1401 1650">8 1/2" x 11"</td> </tr> <tr> <td data-bbox="336 1650 603 1695">6100</td> <td data-bbox="603 1650 869 1695">B5R</td> <td data-bbox="869 1650 1136 1695">5100</td> <td data-bbox="1136 1650 1401 1695">5 1/2" x 8 1/2"</td> </tr> </tbody> </table> <ol data-bbox="304 1733 1117 1865" style="list-style-type: none"> <li>4. Press the start key. The setting is set.</li> <li>5. Select [Execute].</li> <li>6. Press the start key. Scanning starts under the selected conditions.</li> <li>7. To stop operation, press the stop key.</li> </ol>	Display	Description	Scanner Motor	Scanner operation	Home Position	Home position operation	Dust Check	Dust adhesion check operation with lamp on	DP Reading	DP scanning position operation	Display	Operating conditions	Setting range	Zoom	Magnification	25 to 400 %	Size	Original size	See below.	Lamp	On and off of the exposure lamp	0 (off) or 1 (on)	Setting	Paper size	Setting	Paper size	5000	A4	5000	A5R	4300	B5	7800	Folio	5100	11" x 8 1/2"	10200	11" x 17"	10000	A3	9000	11" x 15"	8600	B4	8400	8 1/2" x 14"	7100	A4R	6600	8 1/2" x 11"	6100	B5R	5100	5 1/2" x 8 1/2"
Display	Description																																																						
Scanner Motor	Scanner operation																																																						
Home Position	Home position operation																																																						
Dust Check	Dust adhesion check operation with lamp on																																																						
DP Reading	DP scanning position operation																																																						
Display	Operating conditions	Setting range																																																					
Zoom	Magnification	25 to 400 %																																																					
Size	Original size	See below.																																																					
Lamp	On and off of the exposure lamp	0 (off) or 1 (on)																																																					
Setting	Paper size	Setting	Paper size																																																				
5000	A4	5000	A5R																																																				
4300	B5	7800	Folio																																																				
5100	11" x 8 1/2"	10200	11" x 17"																																																				
10000	A3	9000	11" x 15"																																																				
8600	B4	8400	8 1/2" x 14"																																																				
7100	A4R	6600	8 1/2" x 11"																																																				
6100	B5R	5100	5 1/2" x 8 1/2"																																																				

Item No.	Description
U073	<p><b>Method: [Home Position]</b></p> <ol style="list-style-type: none"><li>1. Select [Home Position].</li><li>2. Press the start key.</li></ol> <p>The mirror frame of the scanner moves to the home position.</p> <p><b>Method: [Dust Check]</b></p> <ol style="list-style-type: none"><li>1. Select [Dust Check].</li><li>2. Press the start key. The exposure lamp lights.</li><li>3. To turn the exposure lamp off, press the stop key.</li></ol> <p><b>Method: [DP Reading]</b></p> <ol style="list-style-type: none"><li>1. Select [DP Reading].</li><li>2. Press the start key.</li></ol> <p>The mirror frame of the scanner moves to the reading position.</p> <p><b>Completion</b></p> <p>Press the stop key when scanning stops. The screen for selecting a maintenance item No. is displayed.</p>

Item No.	Description								
U074	<p data-bbox="288 241 683 275"><b>DP input response adjustment</b></p> <p data-bbox="288 311 440 340"><b>Description</b></p> <p data-bbox="288 344 1023 376">Sets the density correction for scanning originals from the DP.</p> <p data-bbox="288 380 400 409"><b>Purpose</b></p> <p data-bbox="288 414 1394 479">Modify the setting only if a spotted background appears when a bluish original or a document with a background that is slightly colored is scanned from the DP.</p> <p data-bbox="288 483 1422 548">Perform adjustment if the page scanned using the table and the page scanned using DP do not match.</p> <p data-bbox="288 589 384 618"><b>Setting</b></p> <ol data-bbox="308 622 922 687" style="list-style-type: none"> <li>1. Press the start key.</li> <li>2. Change the setting using the +/- or numeric keys.</li> </ol> <table border="1" data-bbox="336 698 1385 864"> <thead> <tr> <th data-bbox="336 698 564 781">Display</th> <th data-bbox="564 698 1050 781">Description</th> <th data-bbox="1050 698 1219 781">Setting range</th> <th data-bbox="1219 698 1385 781">Initial setting</th> </tr> </thead> <tbody> <tr> <td data-bbox="336 781 564 864">Coefficient</td> <td data-bbox="564 781 1050 864">Compensating original document scanning density</td> <td data-bbox="1050 781 1219 864">0 to 3</td> <td data-bbox="1219 781 1385 864">1</td> </tr> </tbody> </table> <p data-bbox="336 871 1402 902">Settings 0: No correction / 1: Slight correction / 2: Medium correction / 3: Strong correction</p> <ol data-bbox="308 907 767 938" style="list-style-type: none"> <li>3. Press the start key. The value is set.</li> </ol> <p data-bbox="288 976 448 1005"><b>Supplement</b></p> <p data-bbox="288 1010 1418 1075">While this maintenance item is being executed, copying from an original is available in interrupt copying mode (which is activated by pressing the system menu key).</p> <p data-bbox="288 1115 440 1144"><b>Completion</b></p> <p data-bbox="288 1149 1257 1180">Press the stop key. The screen for selecting a maintenance item No. is displayed.</p>	Display	Description	Setting range	Initial setting	Coefficient	Compensating original document scanning density	0 to 3	1
Display	Description	Setting range	Initial setting						
Coefficient	Compensating original document scanning density	0 to 3	1						

Item No.	Description																						
U087	<p data-bbox="290 241 938 273"><b>Setting DP reading position modification operation</b></p> <p data-bbox="290 311 440 338"><b>Description</b></p> <p data-bbox="290 347 1426 479">The presence or absence of dust is determined by comparing the scan data of the original trailing edge and that taken after the original is conveyed past the DP original scanning position. If dust is identified, the DP original scanning position is adjusted for the following originals. Using image correction to reduce black streaks.</p> <p data-bbox="290 488 400 515"><b>Purpose</b></p> <p data-bbox="290 524 1385 584">When using DP, to solve the problem when black lines occurs due to the dust with respect to original reading position.</p> <p data-bbox="290 622 392 649"><b>Caution</b></p> <p data-bbox="290 658 1398 719">The coordinates of position where documents are scanned are modified when [System Menu] [Adjustment/Maintenance] [Correcting Black Line] is set to [Off].</p> <p data-bbox="290 757 387 784"><b>Method</b></p> <ol data-bbox="308 792 632 853" style="list-style-type: none"> <li>1. Press the start key.</li> <li>2. Select the item to be set.</li> </ol> <table border="1" data-bbox="336 871 1399 1016"> <thead> <tr> <th data-bbox="336 871 639 920">Display</th> <th data-bbox="639 871 1399 920">Description</th> </tr> </thead> <tbody> <tr> <td data-bbox="336 920 639 969">CCD</td> <td data-bbox="639 920 1399 969">Setting of standard data when dust is detected.</td> </tr> <tr> <td data-bbox="336 969 639 1016">Black Line</td> <td data-bbox="639 969 1399 1016">Initialization of original reading position.</td> </tr> </tbody> </table> <p data-bbox="290 1061 475 1088"><b>Setting: [CCD]</b></p> <ol data-bbox="308 1097 906 1158" style="list-style-type: none"> <li>1. Select the item to be set.</li> <li>2. Change the value using the +/- or numeric keys.</li> </ol> <table border="1" data-bbox="336 1171 1383 1400"> <thead> <tr> <th data-bbox="336 1171 489 1256">Display</th> <th data-bbox="489 1171 1050 1256">Description</th> <th data-bbox="1050 1171 1219 1256">Setting range</th> <th data-bbox="1219 1171 1383 1256">Initial setting</th> </tr> </thead> <tbody> <tr> <td data-bbox="336 1256 489 1305">R</td> <td data-bbox="489 1256 1050 1305">Lowest density of the R regard as the dust</td> <td data-bbox="1050 1256 1219 1305">0 to 255</td> <td data-bbox="1219 1256 1383 1305">125</td> </tr> <tr> <td data-bbox="336 1305 489 1355">G</td> <td data-bbox="489 1305 1050 1355">Lowest density of the G regard as the dust</td> <td data-bbox="1050 1305 1219 1355">0 to 255</td> <td data-bbox="1219 1305 1383 1355">125</td> </tr> <tr> <td data-bbox="336 1355 489 1400">B</td> <td data-bbox="489 1355 1050 1400">Lowest density of the B regard as the dust</td> <td data-bbox="1050 1355 1219 1400">0 to 255</td> <td data-bbox="1219 1355 1383 1400">125</td> </tr> </tbody> </table> <p data-bbox="339 1411 1433 1543">* : Decreasing the setting makes the objects with less density recognized as dusts, less dusts becomes detectable. Increasing the value allows more dusts to be detected and the cleaning prompts to be displayed more often.</p> <ol data-bbox="308 1552 767 1579" style="list-style-type: none"> <li>3. Press the start key. The value is set.</li> </ol> <p data-bbox="290 1619 555 1646"><b>Method: [Black Line]</b></p> <ol data-bbox="308 1655 831 1715" style="list-style-type: none"> <li>1. Select [Clear].</li> <li>2. Press the start key. The setting is cleared.</li> </ol> <p data-bbox="290 1756 440 1783"><b>Completion</b></p> <p data-bbox="290 1792 1254 1818">Press the stop key. The screen for selecting a maintenance item No. is displayed.</p>	Display	Description	CCD	Setting of standard data when dust is detected.	Black Line	Initialization of original reading position.	Display	Description	Setting range	Initial setting	R	Lowest density of the R regard as the dust	0 to 255	125	G	Lowest density of the G regard as the dust	0 to 255	125	B	Lowest density of the B regard as the dust	0 to 255	125
Display	Description																						
CCD	Setting of standard data when dust is detected.																						
Black Line	Initialization of original reading position.																						
Display	Description	Setting range	Initial setting																				
R	Lowest density of the R regard as the dust	0 to 255	125																				
G	Lowest density of the G regard as the dust	0 to 255	125																				
B	Lowest density of the B regard as the dust	0 to 255	125																				

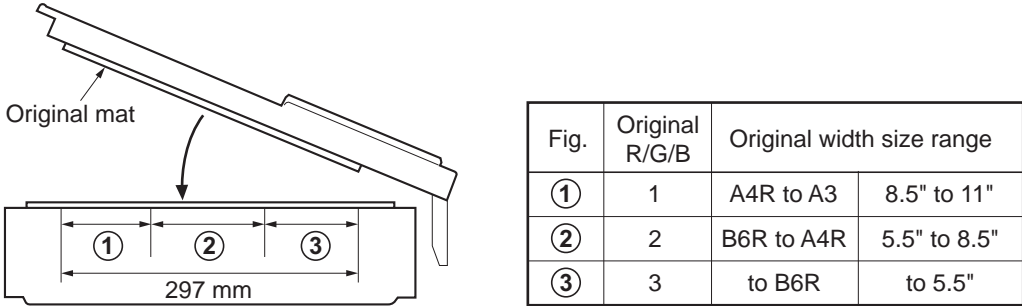
Item No.	Description															
U089	<p data-bbox="288 241 651 275"><b>Outputting a MIP-PG pattern</b></p> <p data-bbox="288 311 440 340"><b>Description</b></p> <p data-bbox="288 344 1050 376">Selects and outputs the MIP-PG pattern created in the machine.</p> <p data-bbox="288 383 400 412"><b>Purpose</b></p> <p data-bbox="288 416 1422 483">To check copier status other than scanner when adjusting image printing, using MIP-PG pattern output (with-out scanning).</p> <p data-bbox="288 519 387 548"><b>Method</b></p> <ol data-bbox="304 555 1082 622" style="list-style-type: none"> <li>1. Press the start key.</li> <li>2. Select the MIP-PG pattern to be output and press the start key.</li> </ol> <table border="1" data-bbox="336 629 1401 1518"> <thead> <tr> <th data-bbox="336 629 603 674">Display</th> <th data-bbox="603 629 922 674">PG pattern to be output</th> <th data-bbox="922 629 1401 674">Purpose</th> </tr> </thead> <tbody> <tr> <td data-bbox="336 674 603 887">Gray Scale</td> <td data-bbox="603 674 922 887">  </td> <td data-bbox="922 674 1401 887">To check the laser scanner unit engine output characteristics</td> </tr> <tr> <td data-bbox="336 887 603 1099">Mono1 (Output density: 0)</td> <td data-bbox="603 887 922 1099">  </td> <td data-bbox="922 887 1401 1099">To check the drum quality</td> </tr> <tr> <td data-bbox="336 1099 603 1312">Mono4 (Output density: 70)</td> <td data-bbox="603 1099 922 1312">  </td> <td data-bbox="922 1099 1401 1312">To check the drum quality</td> </tr> <tr> <td data-bbox="336 1312 603 1518">256-Level</td> <td data-bbox="603 1312 922 1518">  </td> <td data-bbox="922 1312 1401 1518">To check resolution reproducibility in printing</td> </tr> </tbody> </table> <ol data-bbox="304 1532 900 1599" style="list-style-type: none"> <li>3. Press the system menu key.</li> <li>4. Press the start key. A MIP-PG pattern is output.</li> </ol> <p data-bbox="288 1635 440 1664"><b>Completion</b></p> <p data-bbox="288 1668 1254 1700">Press the stop key. The screen for selecting a maintenance item No. is displayed.</p>	Display	PG pattern to be output	Purpose	Gray Scale		To check the laser scanner unit engine output characteristics	Mono1 (Output density: 0)		To check the drum quality	Mono4 (Output density: 70)		To check the drum quality	256-Level		To check resolution reproducibility in printing
Display	PG pattern to be output	Purpose														
Gray Scale		To check the laser scanner unit engine output characteristics														
Mono1 (Output density: 0)		To check the drum quality														
Mono4 (Output density: 70)		To check the drum quality														
256-Level		To check resolution reproducibility in printing														

Item No.	Description																				
U091	<p data-bbox="288 241 699 271"><b>Setting the white line correction</b></p> <p data-bbox="288 311 440 340"><b>Description</b></p> <p data-bbox="288 344 1422 409">Sets the error detection threshold value for white line correction and displays the count result of abnormal pixels.</p> <p data-bbox="288 414 400 443"><b>Purpose</b></p> <p data-bbox="288 448 1046 477">To perform when replacing the CIS, DP main PWB or CIS roller.</p> <p data-bbox="288 517 387 546"><b>Method</b></p> <ol data-bbox="304 551 564 616" style="list-style-type: none"> <li>1. Press the start key.</li> <li>2. Select the item.</li> </ol> <table border="1" data-bbox="336 629 1399 1144"> <thead> <tr> <th data-bbox="336 629 564 674">Display</th> <th data-bbox="564 629 1399 674">Description</th> </tr> </thead> <tbody> <tr> <td data-bbox="336 674 564 719">Calculation(R)</td> <td data-bbox="564 674 1399 719">Abnormal pixel count result for color R</td> </tr> <tr> <td data-bbox="336 719 564 763">Calculation(G)</td> <td data-bbox="564 719 1399 763">Abnormal pixel count result for color G</td> </tr> <tr> <td data-bbox="336 763 564 808">Calculation(B)</td> <td data-bbox="564 763 1399 808">Abnormal pixel count result for color B</td> </tr> <tr> <td data-bbox="336 808 564 853">Threshold(R)</td> <td data-bbox="564 808 1399 853">Abnormal pixel detection threshold value for color R</td> </tr> <tr> <td data-bbox="336 853 564 898">Threshold(G)</td> <td data-bbox="564 853 1399 898">Abnormal pixel detection threshold value for color G</td> </tr> <tr> <td data-bbox="336 898 564 943">Threshold(B)</td> <td data-bbox="564 898 1399 943">Abnormal pixel detection threshold value for color B</td> </tr> <tr> <td data-bbox="336 943 564 1032">Threshold (Abnormal)</td> <td data-bbox="564 943 1399 1032">Abnormal pixel threshold value setting</td> </tr> <tr> <td data-bbox="336 1032 564 1077">Mode</td> <td data-bbox="564 1032 1399 1077">Switching between white line correction mode ON/OFF</td> </tr> <tr> <td data-bbox="336 1077 564 1144">Execute</td> <td data-bbox="564 1077 1399 1144">Holding of white reference data</td> </tr> </tbody> </table> <p data-bbox="288 1189 663 1218"><b>Method: white line correction</b></p> <ol data-bbox="304 1223 1430 1803" style="list-style-type: none"> <li>1. Press [Execute].</li> <li>2. Press the start key. Holding of white reference data is started.</li> <li>3. The count result of abnormal pixels is displayed.</li> <li>4. Press the system menu key.</li> <li>5. Place a gray original on the DP with the gray side down. Load paper in the cassette. The paper should be the same size as the original.</li> <li>6. Press the start key. Two test pattern sheets will be printed.(1 st sheet: Approx. 60 mm black band, 2nd sheet: Blank or approx. 60 mm gray band)</li> <li>7. If vertical black lines appear on the blank (or gray band) page and vertical white lines appear on the black band in the same position, clean the CIS roller and the CIS glass and then repeat white line correction. If vertical black lines or vertical white lines appear on both sheets, white line correction has been completed normally. However, the cause of the vertical lines lies in the engine, and thus the engine must be checked.</li> <li>8. Press the system menu key. Mode is set to 1.</li> </ol>	Display	Description	Calculation(R)	Abnormal pixel count result for color R	Calculation(G)	Abnormal pixel count result for color G	Calculation(B)	Abnormal pixel count result for color B	Threshold(R)	Abnormal pixel detection threshold value for color R	Threshold(G)	Abnormal pixel detection threshold value for color G	Threshold(B)	Abnormal pixel detection threshold value for color B	Threshold (Abnormal)	Abnormal pixel threshold value setting	Mode	Switching between white line correction mode ON/OFF	Execute	Holding of white reference data
Display	Description																				
Calculation(R)	Abnormal pixel count result for color R																				
Calculation(G)	Abnormal pixel count result for color G																				
Calculation(B)	Abnormal pixel count result for color B																				
Threshold(R)	Abnormal pixel detection threshold value for color R																				
Threshold(G)	Abnormal pixel detection threshold value for color G																				
Threshold(B)	Abnormal pixel detection threshold value for color B																				
Threshold (Abnormal)	Abnormal pixel threshold value setting																				
Mode	Switching between white line correction mode ON/OFF																				
Execute	Holding of white reference data																				



Item No.	Description																																				
U091	<p data-bbox="335 241 638 275"><b>How to view test copies</b></p> <table border="1" data-bbox="335 286 1401 560"> <thead> <tr> <th data-bbox="343 297 526 331">blank sheet</th> <th data-bbox="526 297 710 331">black band</th> <th data-bbox="710 297 1018 331">Causes</th> <th data-bbox="1018 297 1393 331">Corrective measures</th> </tr> </thead> <tbody> <tr> <td data-bbox="343 331 526 376">No lines</td> <td data-bbox="526 331 710 376">No lines</td> <td data-bbox="710 331 1018 376">-</td> <td data-bbox="1018 331 1393 376">Complete</td> </tr> <tr> <td data-bbox="343 376 526 465">Black lines</td> <td data-bbox="526 376 710 465">White lines</td> <td data-bbox="710 376 1018 465">Dirty CIS roller or CIS glass</td> <td data-bbox="1018 376 1393 465">Clean CIS roller or CIS glass and then perform U091 again</td> </tr> <tr> <td data-bbox="343 465 526 510">Black lines</td> <td data-bbox="526 465 710 510">No lines</td> <td data-bbox="710 465 1018 510">Engine side</td> <td data-bbox="1018 465 1393 510">U091 ends, check engine</td> </tr> <tr> <td data-bbox="343 510 526 555">No lines</td> <td data-bbox="526 510 710 555">White lines</td> <td data-bbox="710 510 1018 555">Engine side</td> <td data-bbox="1018 510 1393 555">U091 ends, check engine</td> </tr> </tbody> </table> <p data-bbox="287 604 702 638"><b>Setting: Threshold value setting</b></p> <ol data-bbox="303 638 893 705" style="list-style-type: none"> <li>1. Select the item to be set.</li> <li>2. Change the value using the +/- or numeric keys.</li> </ol> <table border="1" data-bbox="335 716 1385 1086"> <thead> <tr> <th data-bbox="343 728 566 795">Display</th> <th data-bbox="566 728 1045 795">Description</th> <th data-bbox="1045 728 1228 795">Setting range</th> <th data-bbox="1228 728 1377 795">Initial setting</th> </tr> </thead> <tbody> <tr> <td data-bbox="343 795 566 884">Threshold (R)(G)(B)</td> <td data-bbox="566 795 1045 884">Displaying of abnormal pixel detection threshold value for color RGB</td> <td data-bbox="1045 795 1228 884">0 to 1023</td> <td data-bbox="1228 795 1377 884">112/112/112</td> </tr> <tr> <td data-bbox="343 884 566 974">Threshold (Abnormal)</td> <td data-bbox="566 884 1045 974">Abnormal pixel threshold value setting</td> <td data-bbox="1045 884 1228 974">0 to 8191</td> <td data-bbox="1228 884 1377 974">75</td> </tr> <tr> <td data-bbox="343 974 566 1075">Mode</td> <td data-bbox="566 974 1045 1075">Switching between white line correction mode ON/OFF</td> <td data-bbox="1045 974 1228 1075">0: OFF/ 1: ON/ 2: Test mode</td> <td data-bbox="1228 974 1377 1075">0</td> </tr> </tbody> </table> <p data-bbox="335 1097 1428 1232">* : Normally the Threshold (Com) value should not be changed from 112, the initial setting. If white lines appear even though the CIS roller and glass are not dirty, raise the set value. If fine lines in some originals disappear, lower the set value. Set within the range 50 to 200. (If set outside this range, the image may be affected.)</p> <ol data-bbox="303 1265 766 1299" style="list-style-type: none"> <li>3. Press the start key. The value is set.</li> </ol> <p data-bbox="287 1332 438 1366"><b>Completion</b></p> <p data-bbox="287 1366 1252 1400">Press the stop key. The screen for selecting a maintenance item No. is displayed.</p>	blank sheet	black band	Causes	Corrective measures	No lines	No lines	-	Complete	Black lines	White lines	Dirty CIS roller or CIS glass	Clean CIS roller or CIS glass and then perform U091 again	Black lines	No lines	Engine side	U091 ends, check engine	No lines	White lines	Engine side	U091 ends, check engine	Display	Description	Setting range	Initial setting	Threshold (R)(G)(B)	Displaying of abnormal pixel detection threshold value for color RGB	0 to 1023	112/112/112	Threshold (Abnormal)	Abnormal pixel threshold value setting	0 to 8191	75	Mode	Switching between white line correction mode ON/OFF	0: OFF/ 1: ON/ 2: Test mode	0
blank sheet	black band	Causes	Corrective measures																																		
No lines	No lines	-	Complete																																		
Black lines	White lines	Dirty CIS roller or CIS glass	Clean CIS roller or CIS glass and then perform U091 again																																		
Black lines	No lines	Engine side	U091 ends, check engine																																		
No lines	White lines	Engine side	U091 ends, check engine																																		
Display	Description	Setting range	Initial setting																																		
Threshold (R)(G)(B)	Displaying of abnormal pixel detection threshold value for color RGB	0 to 1023	112/112/112																																		
Threshold (Abnormal)	Abnormal pixel threshold value setting	0 to 8191	75																																		
Mode	Switching between white line correction mode ON/OFF	0: OFF/ 1: ON/ 2: Test mode	0																																		

Item No.	Description																																																												
U099	<p data-bbox="287 241 702 275"><b>Adjusting original size detection</b></p> <p data-bbox="287 309 438 342"><b>Description</b></p> <p data-bbox="287 342 1332 376">Checks the operation of the original size detection and sets the sensing threshold value.</p> <p data-bbox="287 376 399 409"><b>Purpose</b></p> <p data-bbox="287 409 1428 477">Modify the threshold of detection if documents are frequently mal-detected in size after scanning a wholly dark document or a document enclosed with dark objects on edges.</p> <p data-bbox="287 521 391 555"><b>Method</b></p> <ol data-bbox="303 555 566 622" style="list-style-type: none"> <li>1. Press the start key.</li> <li>2. Select the item.</li> </ol> <table border="1" data-bbox="335 633 1401 857"> <thead> <tr> <th>Display</th> <th>Description</th> </tr> </thead> <tbody> <tr> <td>Data1</td> <td>Displays the width of an Original Area colored original document</td> </tr> <tr> <td>B/W Level1</td> <td>Setting original size detection threshold value</td> </tr> <tr> <td>Data2</td> <td>Displays the width of an Original Area colored original document (when DP is installed)</td> </tr> </tbody> </table> <p data-bbox="287 902 574 936"><b>Method: [Data1/Data2]</b></p> <ol data-bbox="303 936 1428 1070" style="list-style-type: none"> <li>1. Place the original and close the original cover or DP</li> <li>2. The light source illuminates and the CCD sensor determines the width of the document. The original size sensor determines the document is vertical or horizontal. (The document is detected two times when the DP is installed.)</li> </ol> <table border="1" data-bbox="335 1081 1401 1373"> <thead> <tr> <th>Display</th> <th>Description</th> </tr> </thead> <tbody> <tr> <td>Original Area R</td> <td>Detected original width size for color R</td> </tr> <tr> <td>Original Area G</td> <td>Detected original width size for color G</td> </tr> <tr> <td>Original Area B</td> <td>Detected original width size for color B</td> </tr> <tr> <td>Original Area</td> <td>Detected original width size</td> </tr> <tr> <td>Size SW L</td> <td>Displays the original size sensor (OSS) ON/OFF</td> </tr> </tbody> </table> <p data-bbox="287 1373 558 1406"><b>Setting: [B/W Level1]</b></p> <ol data-bbox="303 1406 1061 1473" style="list-style-type: none"> <li>1. Select an item to be set.</li> <li>2. Change the setting value using the +/- keys or numeric keys.</li> </ol> <table border="1" data-bbox="335 1485 1401 2000"> <thead> <tr> <th>Display</th> <th>Description</th> <th>Setting range</th> <th>Initial setting*</th> </tr> </thead> <tbody> <tr> <td>Original R1</td> <td>Original threshold value for color R (near side)</td> <td>0 to 255</td> <td>20/50</td> </tr> <tr> <td>Original R2</td> <td>Original threshold value for color R (center)</td> <td>0 to 255</td> <td>30/50</td> </tr> <tr> <td>Original R3</td> <td>Original threshold value for color R (far side)</td> <td>0 to 255</td> <td>40/50</td> </tr> <tr> <td>Original G1</td> <td>Original threshold value for color G (near side)</td> <td>0 to 255</td> <td>20/50</td> </tr> <tr> <td>Original G2</td> <td>Original threshold value for color G (center)</td> <td>0 to 255</td> <td>30/50</td> </tr> <tr> <td>Original G3</td> <td>Original threshold value for color G (far side)</td> <td>0 to 255</td> <td>40/50</td> </tr> <tr> <td>Original B1</td> <td>Original threshold value for color B (near side)</td> <td>0 to 255</td> <td>20/50</td> </tr> <tr> <td>Original B2</td> <td>Original threshold value for color B (center)</td> <td>0 to 255</td> <td>30/50</td> </tr> <tr> <td>Original B3</td> <td>Original threshold value for color B (far side)</td> <td>0 to 255</td> <td>40/50</td> </tr> </tbody> </table> <p data-bbox="335 2011 742 2045">*:DP is not installed/DP is installed</p>	Display	Description	Data1	Displays the width of an Original Area colored original document	B/W Level1	Setting original size detection threshold value	Data2	Displays the width of an Original Area colored original document (when DP is installed)	Display	Description	Original Area R	Detected original width size for color R	Original Area G	Detected original width size for color G	Original Area B	Detected original width size for color B	Original Area	Detected original width size	Size SW L	Displays the original size sensor (OSS) ON/OFF	Display	Description	Setting range	Initial setting*	Original R1	Original threshold value for color R (near side)	0 to 255	20/50	Original R2	Original threshold value for color R (center)	0 to 255	30/50	Original R3	Original threshold value for color R (far side)	0 to 255	40/50	Original G1	Original threshold value for color G (near side)	0 to 255	20/50	Original G2	Original threshold value for color G (center)	0 to 255	30/50	Original G3	Original threshold value for color G (far side)	0 to 255	40/50	Original B1	Original threshold value for color B (near side)	0 to 255	20/50	Original B2	Original threshold value for color B (center)	0 to 255	30/50	Original B3	Original threshold value for color B (far side)	0 to 255	40/50
Display	Description																																																												
Data1	Displays the width of an Original Area colored original document																																																												
B/W Level1	Setting original size detection threshold value																																																												
Data2	Displays the width of an Original Area colored original document (when DP is installed)																																																												
Display	Description																																																												
Original Area R	Detected original width size for color R																																																												
Original Area G	Detected original width size for color G																																																												
Original Area B	Detected original width size for color B																																																												
Original Area	Detected original width size																																																												
Size SW L	Displays the original size sensor (OSS) ON/OFF																																																												
Display	Description	Setting range	Initial setting*																																																										
Original R1	Original threshold value for color R (near side)	0 to 255	20/50																																																										
Original R2	Original threshold value for color R (center)	0 to 255	30/50																																																										
Original R3	Original threshold value for color R (far side)	0 to 255	40/50																																																										
Original G1	Original threshold value for color G (near side)	0 to 255	20/50																																																										
Original G2	Original threshold value for color G (center)	0 to 255	30/50																																																										
Original G3	Original threshold value for color G (far side)	0 to 255	40/50																																																										
Original B1	Original threshold value for color B (near side)	0 to 255	20/50																																																										
Original B2	Original threshold value for color B (center)	0 to 255	30/50																																																										
Original B3	Original threshold value for color B (far side)	0 to 255	40/50																																																										

Item No.	Description																
U099	<p data-bbox="306 241 1404 412">3. Reducing the value increases the sensitivity of the sensor allowing a document with more density to be detected, however, the document mat could be detected as an original document. If the values vary excessively, mal-detection could occur depending on how a document is placed.</p> <div data-bbox="347 434 1372 739">  <table border="1" data-bbox="874 533 1372 739"> <thead> <tr> <th>Fig.</th> <th>Original R/G/B</th> <th colspan="2">Original width size range</th> </tr> </thead> <tbody> <tr> <td>①</td> <td>1</td> <td>A4R to A3</td> <td>8.5" to 11"</td> </tr> <tr> <td>②</td> <td>2</td> <td>B6R to A4R</td> <td>5.5" to 8.5"</td> </tr> <tr> <td>③</td> <td>3</td> <td>to B6R</td> <td>to 5.5"</td> </tr> </tbody> </table> </div> <p data-bbox="778 757 944 788"><b>Figure 1-3-16</b></p> <p data-bbox="306 824 766 855">4. Press the start key. The value is set.</p> <p data-bbox="290 896 440 927"><b>Completion</b></p> <p data-bbox="290 931 1117 963">Press the stop key. The screen for maintenance item No. is displayed.</p>	Fig.	Original R/G/B	Original width size range		①	1	A4R to A3	8.5" to 11"	②	2	B6R to A4R	5.5" to 8.5"	③	3	to B6R	to 5.5"
Fig.	Original R/G/B	Original width size range															
①	1	A4R to A3	8.5" to 11"														
②	2	B6R to A4R	5.5" to 8.5"														
③	3	to B6R	to 5.5"														

Item No.	Description																																		
U100	<p data-bbox="288 241 651 275"><b>Adjusting main high voltage</b></p> <p data-bbox="288 311 440 340"><b>Description</b></p> <p data-bbox="288 344 1086 376">Controls the charger roller voltage to optimize the surface potential.</p> <p data-bbox="288 380 400 409"><b>Purpose</b></p> <p data-bbox="288 414 1433 445">To change the setting value to adjust the image if an image failure (background blur, etc.) occurs.</p> <p data-bbox="288 483 387 512"><b>Method</b></p> <ol data-bbox="304 517 791 584" style="list-style-type: none"> <li>1. Press the start key.</li> <li>2. Select an item and press the start key.</li> </ol> <table border="1" data-bbox="336 595 1401 981"> <thead> <tr> <th data-bbox="336 595 639 640">Display</th> <th data-bbox="639 595 1401 640">Description</th> </tr> </thead> <tbody> <tr> <td data-bbox="336 640 639 685">Adj AC Bias</td> <td data-bbox="639 640 1401 685">Main charger AC bias for each color</td> </tr> <tr> <td data-bbox="336 685 639 730">Set AC Auto Adj</td> <td data-bbox="639 685 1401 730">Setting the AC bias auto adjustment</td> </tr> <tr> <td data-bbox="336 730 639 775">Set DC Bias</td> <td data-bbox="639 730 1401 775">Main charger DC bias for each color</td> </tr> <tr> <td data-bbox="336 775 639 819">Adj DC Bias</td> <td data-bbox="639 775 1401 819">Additional surface potential</td> </tr> <tr> <td data-bbox="336 819 639 864">Set Low Temp</td> <td data-bbox="639 819 1401 864">Pre-charge time at power supply ON</td> </tr> <tr> <td data-bbox="336 864 639 909">Set Charger Freq</td> <td data-bbox="639 864 1401 909">Setting the main charger frequency</td> </tr> <tr> <td data-bbox="336 909 639 981">Chk Current</td> <td data-bbox="639 909 1401 981">Rush current display</td> </tr> </tbody> </table> <p data-bbox="288 1021 571 1052"><b>Setting: [Adj AC Bias]</b></p> <ol data-bbox="304 1057 1350 1160" style="list-style-type: none"> <li>1. Change the value using the +/- or numeric keys. Increasing the setting makes the image lighter; decreasing it makes the image darker. The values set vary depending on environments.</li> </ol> <table border="1" data-bbox="336 1171 1401 1267"> <thead> <tr> <th data-bbox="336 1171 603 1216">Display</th> <th data-bbox="603 1171 1171 1216">Description</th> <th data-bbox="1171 1171 1401 1216">Setting range</th> </tr> </thead> <tbody> <tr> <td data-bbox="336 1216 603 1267">AC Bias(K)</td> <td data-bbox="603 1216 1171 1267">Main charger AC bias</td> <td data-bbox="1171 1216 1401 1267">0 to 255</td> </tr> </tbody> </table> <ol data-bbox="304 1279 767 1310" style="list-style-type: none"> <li>2. Press the start key. The value is set.</li> </ol> <p data-bbox="288 1346 624 1377"><b>Setting: [Set AC Auto Adj]</b></p> <ol data-bbox="304 1382 536 1413" style="list-style-type: none"> <li>1. Select On or Off.</li> </ol> <table border="1" data-bbox="336 1424 1401 1570"> <thead> <tr> <th data-bbox="336 1424 639 1469">Display</th> <th data-bbox="639 1424 1401 1469">Description</th> </tr> </thead> <tbody> <tr> <td data-bbox="336 1469 639 1514">On</td> <td data-bbox="639 1469 1401 1514">Turn auto adjustment ON</td> </tr> <tr> <td data-bbox="336 1514 639 1570">Off</td> <td data-bbox="639 1514 1401 1570">Turn auto adjustment OFF</td> </tr> </tbody> </table> <p data-bbox="336 1581 536 1612">Initial setting: On</p> <ol data-bbox="304 1617 783 1648" style="list-style-type: none"> <li>2. Press the start key. The setting is set.</li> </ol> <p data-bbox="288 1684 616 1715"><b>Displaying: [Set DC Bias]</b></p> <ol data-bbox="304 1720 715 1751" style="list-style-type: none"> <li>1. The current setting is displayed.</li> </ol> <table border="1" data-bbox="336 1762 1401 1908"> <thead> <tr> <th data-bbox="336 1762 639 1807">Display</th> <th data-bbox="639 1762 1401 1807">Description</th> </tr> </thead> <tbody> <tr> <td data-bbox="336 1807 639 1852">DC1 Bias(K)</td> <td data-bbox="639 1807 1401 1852">Main charger DC bias (full speed)</td> </tr> <tr> <td data-bbox="336 1852 639 1908">DC1 Bias Half(K)</td> <td data-bbox="639 1852 1401 1908">Main charger DC bias (half speed)</td> </tr> </tbody> </table>	Display	Description	Adj AC Bias	Main charger AC bias for each color	Set AC Auto Adj	Setting the AC bias auto adjustment	Set DC Bias	Main charger DC bias for each color	Adj DC Bias	Additional surface potential	Set Low Temp	Pre-charge time at power supply ON	Set Charger Freq	Setting the main charger frequency	Chk Current	Rush current display	Display	Description	Setting range	AC Bias(K)	Main charger AC bias	0 to 255	Display	Description	On	Turn auto adjustment ON	Off	Turn auto adjustment OFF	Display	Description	DC1 Bias(K)	Main charger DC bias (full speed)	DC1 Bias Half(K)	Main charger DC bias (half speed)
Display	Description																																		
Adj AC Bias	Main charger AC bias for each color																																		
Set AC Auto Adj	Setting the AC bias auto adjustment																																		
Set DC Bias	Main charger DC bias for each color																																		
Adj DC Bias	Additional surface potential																																		
Set Low Temp	Pre-charge time at power supply ON																																		
Set Charger Freq	Setting the main charger frequency																																		
Chk Current	Rush current display																																		
Display	Description	Setting range																																	
AC Bias(K)	Main charger AC bias	0 to 255																																	
Display	Description																																		
On	Turn auto adjustment ON																																		
Off	Turn auto adjustment OFF																																		
Display	Description																																		
DC1 Bias(K)	Main charger DC bias (full speed)																																		
DC1 Bias Half(K)	Main charger DC bias (half speed)																																		

Item No.	Description																																
U100	<p data-bbox="288 244 571 275"><b>Setting: [Adj DC Bias]</b></p> <p data-bbox="304 280 1358 378">1. Select the item to be set. 2. Change the value using the +/- or numeric keys. Increasing the setting makes the image lighter; decreasing it makes the image darker.</p> <table border="1" data-bbox="336 389 1385 568"> <thead> <tr> <th data-bbox="336 389 571 472">Display</th> <th data-bbox="571 389 1117 472">Description</th> <th data-bbox="1117 389 1270 472">Setting range</th> <th data-bbox="1270 389 1385 472">Initial setting</th> </tr> </thead> <tbody> <tr> <td data-bbox="336 472 571 517">DC2 Bias(K)</td> <td data-bbox="571 472 1117 517">Main charger DC bias (full speed)</td> <td data-bbox="1117 472 1270 517">128 to 127</td> <td data-bbox="1270 472 1385 517">0</td> </tr> <tr> <td data-bbox="336 517 571 568">DC2 Bias Half(K)</td> <td data-bbox="571 517 1117 568">Main charger DC bias (half speed)</td> <td data-bbox="1117 517 1270 568">128 to 127</td> <td data-bbox="1270 517 1385 568">0</td> </tr> </tbody> </table> <p data-bbox="304 584 767 616">3. Press the start key. The value is set.</p> <p data-bbox="288 651 596 683"><b>Setting: [Set Low Temp]</b></p> <p data-bbox="304 687 911 719">1. Change the value using the +/- or numeric keys.</p> <table border="1" data-bbox="336 730 1385 860"> <thead> <tr> <th data-bbox="336 730 571 813">Display</th> <th data-bbox="571 730 1050 813">Description</th> <th data-bbox="1050 730 1219 813">Setting range</th> <th data-bbox="1219 730 1385 813">Initial setting</th> </tr> </thead> <tbody> <tr> <td data-bbox="336 813 571 860">Set Low Temp</td> <td data-bbox="571 813 1050 860">Pre-charge time at power supply ON</td> <td data-bbox="1050 813 1219 860">0 to 6</td> <td data-bbox="1219 813 1385 860">1</td> </tr> </tbody> </table> <p data-bbox="304 871 767 902">2. Press the start key. The value is set.</p> <p data-bbox="288 938 635 969"><b>Setting: [Set Charger Freq]</b></p> <p data-bbox="304 974 927 1041">1. Select the item to be set. 2. Change the value using the +/- or numeric keys.</p> <table border="1" data-bbox="336 1050 1385 1180"> <thead> <tr> <th data-bbox="336 1050 571 1133">Display</th> <th data-bbox="571 1050 1018 1133">Description</th> <th data-bbox="1018 1050 1219 1133">Setting range</th> <th data-bbox="1219 1050 1385 1133">Initial setting</th> </tr> </thead> <tbody> <tr> <td data-bbox="336 1133 571 1180">Generally</td> <td data-bbox="571 1133 1018 1180">Main charger frequency</td> <td data-bbox="1018 1133 1219 1180">7500 to 11280</td> <td data-bbox="1219 1133 1385 1180">9160</td> </tr> </tbody> </table> <p data-bbox="304 1191 767 1223">3. Press the start key. The value is set.</p> <p data-bbox="288 1258 619 1290"><b>Displaying: [Chk Current]</b></p> <p data-bbox="304 1294 715 1326">1. The current setting is displayed.</p> <table border="1" data-bbox="336 1337 1401 1431"> <thead> <tr> <th data-bbox="336 1337 643 1384">Display</th> <th data-bbox="643 1337 1401 1384">Description</th> </tr> </thead> <tbody> <tr> <td data-bbox="336 1384 643 1431">K</td> <td data-bbox="643 1384 1401 1431">Rush current</td> </tr> </tbody> </table> <p data-bbox="288 1480 440 1512"><b>Completion</b></p> <p data-bbox="288 1516 1118 1547">Press the stop key. The screen for maintenance item No. is displayed.</p>	Display	Description	Setting range	Initial setting	DC2 Bias(K)	Main charger DC bias (full speed)	128 to 127	0	DC2 Bias Half(K)	Main charger DC bias (half speed)	128 to 127	0	Display	Description	Setting range	Initial setting	Set Low Temp	Pre-charge time at power supply ON	0 to 6	1	Display	Description	Setting range	Initial setting	Generally	Main charger frequency	7500 to 11280	9160	Display	Description	K	Rush current
Display	Description	Setting range	Initial setting																														
DC2 Bias(K)	Main charger DC bias (full speed)	128 to 127	0																														
DC2 Bias Half(K)	Main charger DC bias (half speed)	128 to 127	0																														
Display	Description	Setting range	Initial setting																														
Set Low Temp	Pre-charge time at power supply ON	0 to 6	1																														
Display	Description	Setting range	Initial setting																														
Generally	Main charger frequency	7500 to 11280	9160																														
Display	Description																																
K	Rush current																																

Item No.	Description																																																																										
U106	<p data-bbox="288 241 869 275"><b>Setting the voltage for the secondary transfer</b></p> <p data-bbox="288 311 440 340"><b>Description</b></p> <p data-bbox="288 344 1257 376">Sets the control voltage for the secondary transfer depending on each paper type.</p> <p data-bbox="288 380 400 409"><b>Purpose</b></p> <p data-bbox="288 414 1262 445">To change the setting when any density problems, such as too dark or light, occur.</p> <p data-bbox="288 483 387 512"><b>Method</b></p> <ol data-bbox="304 517 632 582" style="list-style-type: none"> <li>1. Press the start key.</li> <li>2. Select the item to be set.</li> </ol> <table border="1" data-bbox="336 595 1401 1070"> <thead> <tr> <th data-bbox="336 595 639 640">Display</th> <th data-bbox="639 595 1401 640">Description</th> </tr> </thead> <tbody> <tr> <td data-bbox="336 640 639 725">Light/Normal1</td> <td data-bbox="639 640 1401 725">Control voltage for the transfer bias on paper with thickness 52 g/m<sup>2</sup> to 64 g/m<sup>2</sup> and 65 g/m<sup>2</sup> to 75 g/m<sup>2</sup></td> </tr> <tr> <td data-bbox="336 725 639 810">Normal2/3</td> <td data-bbox="639 725 1401 810">Control voltage for the transfer bias on paper with thickness 76 g/m<sup>2</sup> to 105 g/m<sup>2</sup></td> </tr> <tr> <td data-bbox="336 810 639 896">Heavy1-3</td> <td data-bbox="639 810 1401 896">Control voltage for the transfer bias on paper with thickness 106 g/m<sup>2</sup> to 220 g/m<sup>2</sup></td> </tr> <tr> <td data-bbox="336 896 639 981">Heavy4/5</td> <td data-bbox="639 896 1401 981">Control voltage for the transfer bias on paper with thickness 221 g/m<sup>2</sup> to 300 g/m<sup>2</sup></td> </tr> <tr> <td data-bbox="336 981 639 1025">OHP</td> <td data-bbox="639 981 1401 1025">Control voltage for the transfer bias for transparencies</td> </tr> <tr> <td data-bbox="336 1025 639 1070">Bias</td> <td data-bbox="639 1025 1401 1070">Transfer bias value</td> </tr> </tbody> </table> <p data-bbox="288 1111 596 1142"><b>Setting: [Light/Normal1]</b></p> <ol data-bbox="304 1146 632 1178" style="list-style-type: none"> <li>1. Select the item to be set.</li> </ol> <table border="1" data-bbox="336 1191 1401 1335"> <thead> <tr> <th data-bbox="336 1191 564 1236">Display</th> <th data-bbox="564 1191 1401 1236">Description</th> </tr> </thead> <tbody> <tr> <td data-bbox="336 1236 564 1281">1st</td> <td data-bbox="564 1236 1401 1281">Control voltage for the transfer bias for the first side (full speed)</td> </tr> <tr> <td data-bbox="336 1281 564 1335">2nd</td> <td data-bbox="564 1281 1401 1335">Control voltage for the transfer bias for the second side (full speed)</td> </tr> </tbody> </table> <ol data-bbox="304 1339 906 1408" style="list-style-type: none"> <li>2. Select the paper width to be set.</li> <li>3. Change the value using the +/- or numeric keys.</li> </ol> <p data-bbox="336 1413 387 1444">[1st]</p> <table border="1" data-bbox="336 1458 1401 1695"> <thead> <tr> <th data-bbox="336 1458 520 1547" rowspan="2">Display</th> <th data-bbox="520 1458 916 1547" rowspan="2">Description</th> <th data-bbox="916 1458 1082 1547" rowspan="2">Setting range</th> <th colspan="3" data-bbox="1082 1458 1401 1503">Initial setting</th> </tr> <tr> <th data-bbox="1082 1503 1187 1547">35ppm</th> <th data-bbox="1187 1503 1292 1547">45ppm</th> <th data-bbox="1292 1503 1401 1547">55ppm</th> </tr> </thead> <tbody> <tr> <td data-bbox="336 1547 520 1592">Width=105</td> <td data-bbox="520 1547 916 1592">105 mm wide</td> <td data-bbox="916 1547 1082 1592">0 to 255</td> <td data-bbox="1082 1547 1187 1592">150</td> <td data-bbox="1187 1547 1292 1592">174</td> <td data-bbox="1292 1547 1401 1592">146</td> </tr> <tr> <td data-bbox="336 1592 520 1637">Width=210</td> <td data-bbox="520 1592 916 1637">210 mm wide</td> <td data-bbox="916 1592 1082 1637">0 to 255</td> <td data-bbox="1082 1592 1187 1637">143</td> <td data-bbox="1187 1592 1292 1637">165</td> <td data-bbox="1292 1592 1401 1637">140</td> </tr> <tr> <td data-bbox="336 1637 520 1695">Width=297</td> <td data-bbox="520 1637 916 1695">297 mm wide</td> <td data-bbox="916 1637 1082 1695">0 to 255</td> <td data-bbox="1082 1637 1187 1695">139</td> <td data-bbox="1187 1637 1292 1695">157</td> <td data-bbox="1292 1637 1401 1695">134</td> </tr> </tbody> </table> <p data-bbox="336 1704 395 1736">[2nd]</p> <table border="1" data-bbox="336 1749 1401 1986"> <thead> <tr> <th data-bbox="336 1749 520 1839" rowspan="2">Display</th> <th data-bbox="520 1749 916 1839" rowspan="2">Description</th> <th data-bbox="916 1749 1082 1839" rowspan="2">Setting range</th> <th colspan="3" data-bbox="1082 1749 1401 1794">Initial setting</th> </tr> <tr> <th data-bbox="1082 1794 1187 1839">35ppm</th> <th data-bbox="1187 1794 1292 1839">45ppm</th> <th data-bbox="1292 1794 1401 1839">55ppm</th> </tr> </thead> <tbody> <tr> <td data-bbox="336 1839 520 1883">Width=105</td> <td data-bbox="520 1839 916 1883">105 mm wide</td> <td data-bbox="916 1839 1082 1883">0 to 255</td> <td data-bbox="1082 1839 1187 1883">146</td> <td data-bbox="1187 1839 1292 1883">160</td> <td data-bbox="1292 1839 1401 1883">133</td> </tr> <tr> <td data-bbox="336 1883 520 1928">Width=210</td> <td data-bbox="520 1883 916 1928">210 mm wide</td> <td data-bbox="916 1883 1082 1928">0 to 255</td> <td data-bbox="1082 1883 1187 1928">139</td> <td data-bbox="1187 1883 1292 1928">153</td> <td data-bbox="1292 1883 1401 1928">130</td> </tr> <tr> <td data-bbox="336 1928 520 1986">Width=297</td> <td data-bbox="520 1928 916 1986">297 mm wide</td> <td data-bbox="916 1928 1082 1986">0 to 255</td> <td data-bbox="1082 1928 1187 1986">124</td> <td data-bbox="1187 1928 1292 1986">135</td> <td data-bbox="1292 1928 1401 1986">120</td> </tr> </tbody> </table> <ol data-bbox="304 1995 767 2027" style="list-style-type: none"> <li>4. Press the start key. The value is set.</li> </ol>	Display	Description	Light/Normal1	Control voltage for the transfer bias on paper with thickness 52 g/m <sup>2</sup> to 64 g/m <sup>2</sup> and 65 g/m <sup>2</sup> to 75 g/m <sup>2</sup>	Normal2/3	Control voltage for the transfer bias on paper with thickness 76 g/m <sup>2</sup> to 105 g/m <sup>2</sup>	Heavy1-3	Control voltage for the transfer bias on paper with thickness 106 g/m <sup>2</sup> to 220 g/m <sup>2</sup>	Heavy4/5	Control voltage for the transfer bias on paper with thickness 221 g/m <sup>2</sup> to 300 g/m <sup>2</sup>	OHP	Control voltage for the transfer bias for transparencies	Bias	Transfer bias value	Display	Description	1st	Control voltage for the transfer bias for the first side (full speed)	2nd	Control voltage for the transfer bias for the second side (full speed)	Display	Description	Setting range	Initial setting			35ppm	45ppm	55ppm	Width=105	105 mm wide	0 to 255	150	174	146	Width=210	210 mm wide	0 to 255	143	165	140	Width=297	297 mm wide	0 to 255	139	157	134	Display	Description	Setting range	Initial setting			35ppm	45ppm	55ppm	Width=105	105 mm wide	0 to 255	146	160	133	Width=210	210 mm wide	0 to 255	139	153	130	Width=297	297 mm wide	0 to 255	124	135	120
Display	Description																																																																										
Light/Normal1	Control voltage for the transfer bias on paper with thickness 52 g/m <sup>2</sup> to 64 g/m <sup>2</sup> and 65 g/m <sup>2</sup> to 75 g/m <sup>2</sup>																																																																										
Normal2/3	Control voltage for the transfer bias on paper with thickness 76 g/m <sup>2</sup> to 105 g/m <sup>2</sup>																																																																										
Heavy1-3	Control voltage for the transfer bias on paper with thickness 106 g/m <sup>2</sup> to 220 g/m <sup>2</sup>																																																																										
Heavy4/5	Control voltage for the transfer bias on paper with thickness 221 g/m <sup>2</sup> to 300 g/m <sup>2</sup>																																																																										
OHP	Control voltage for the transfer bias for transparencies																																																																										
Bias	Transfer bias value																																																																										
Display	Description																																																																										
1st	Control voltage for the transfer bias for the first side (full speed)																																																																										
2nd	Control voltage for the transfer bias for the second side (full speed)																																																																										
Display	Description	Setting range	Initial setting																																																																								
			35ppm	45ppm	55ppm																																																																						
Width=105	105 mm wide	0 to 255	150	174	146																																																																						
Width=210	210 mm wide	0 to 255	143	165	140																																																																						
Width=297	297 mm wide	0 to 255	139	157	134																																																																						
Display	Description	Setting range	Initial setting																																																																								
			35ppm	45ppm	55ppm																																																																						
Width=105	105 mm wide	0 to 255	146	160	133																																																																						
Width=210	210 mm wide	0 to 255	139	153	130																																																																						
Width=297	297 mm wide	0 to 255	124	135	120																																																																						

Item No.	Description																																																																																													
U106	<p data-bbox="288 241 547 275"><b>Setting: [Normal2/3]</b></p> <p data-bbox="288 277 632 311">1. Select the item to be set.</p> <table border="1" data-bbox="336 320 1401 465"> <thead> <tr> <th data-bbox="336 320 564 365">Display</th> <th data-bbox="564 320 1401 365">Description</th> </tr> </thead> <tbody> <tr> <td data-bbox="336 365 564 409">1st</td> <td data-bbox="564 365 1401 409">Control voltage for the transfer bias for the first side (full speed)</td> </tr> <tr> <td data-bbox="336 409 564 465">2nd</td> <td data-bbox="564 409 1401 465">Control voltage for the transfer bias for the second side (full speed)</td> </tr> </tbody> </table> <p data-bbox="288 474 719 508">2. Select the paper width to be set.</p> <p data-bbox="288 510 906 544">3. Change the value using the +/- or numeric keys.</p> <p data-bbox="333 546 389 580">[1st]</p> <table border="1" data-bbox="336 589 1401 828"> <thead> <tr> <th data-bbox="336 589 520 678" rowspan="2">Display</th> <th data-bbox="520 589 916 678" rowspan="2">Description</th> <th data-bbox="916 589 1082 678" rowspan="2">Setting range</th> <th colspan="3" data-bbox="1082 589 1401 633">Initial setting</th> </tr> <tr> <th data-bbox="1082 633 1189 678">35ppm</th> <th data-bbox="1189 633 1295 678">45ppm</th> <th data-bbox="1295 633 1401 678">55ppm</th> </tr> </thead> <tbody> <tr> <td data-bbox="336 678 520 723">Width=105</td> <td data-bbox="520 678 916 723">105 mm wide</td> <td data-bbox="916 678 1082 723">0 to 255</td> <td data-bbox="1082 678 1189 723">150</td> <td data-bbox="1189 678 1295 723">174</td> <td data-bbox="1295 678 1401 723">146</td> </tr> <tr> <td data-bbox="336 723 520 768">Width=210</td> <td data-bbox="520 723 916 768">210 mm wide</td> <td data-bbox="916 723 1082 768">0 to 255</td> <td data-bbox="1082 723 1189 768">143</td> <td data-bbox="1189 723 1295 768">165</td> <td data-bbox="1295 723 1401 768">140</td> </tr> <tr> <td data-bbox="336 768 520 828">Width=297</td> <td data-bbox="520 768 916 828">297 mm wide</td> <td data-bbox="916 768 1082 828">0 to 255</td> <td data-bbox="1082 768 1189 828">139</td> <td data-bbox="1189 768 1295 828">157</td> <td data-bbox="1295 768 1401 828">134</td> </tr> </tbody> </table> <p data-bbox="333 837 397 871">[2nd]</p> <table border="1" data-bbox="336 880 1401 1120"> <thead> <tr> <th data-bbox="336 880 520 969" rowspan="2">Display</th> <th data-bbox="520 880 916 969" rowspan="2">Description</th> <th data-bbox="916 880 1082 969" rowspan="2">Setting range</th> <th colspan="3" data-bbox="1082 880 1401 925">Initial setting</th> </tr> <tr> <th data-bbox="1082 925 1189 969">35ppm</th> <th data-bbox="1189 925 1295 969">45ppm</th> <th data-bbox="1295 925 1401 969">55ppm</th> </tr> </thead> <tbody> <tr> <td data-bbox="336 969 520 1014">Width=105</td> <td data-bbox="520 969 916 1014">105 mm wide</td> <td data-bbox="916 969 1082 1014">0 to 255</td> <td data-bbox="1082 969 1189 1014">146</td> <td data-bbox="1189 969 1295 1014">160</td> <td data-bbox="1295 969 1401 1014">133</td> </tr> <tr> <td data-bbox="336 1014 520 1059">Width=210</td> <td data-bbox="520 1014 916 1059">210 mm wide</td> <td data-bbox="916 1014 1082 1059">0 to 255</td> <td data-bbox="1082 1014 1189 1059">139</td> <td data-bbox="1189 1014 1295 1059">153</td> <td data-bbox="1295 1014 1401 1059">130</td> </tr> <tr> <td data-bbox="336 1059 520 1120">Width=297</td> <td data-bbox="520 1059 916 1120">297 mm wide</td> <td data-bbox="916 1059 1082 1120">0 to 255</td> <td data-bbox="1082 1059 1189 1120">124</td> <td data-bbox="1189 1059 1295 1120">135</td> <td data-bbox="1295 1059 1401 1120">120</td> </tr> </tbody> </table> <p data-bbox="288 1128 767 1162">4. Press the start key. The value is set.</p> <p data-bbox="288 1198 536 1232"><b>Setting: [Heavy1-3]</b></p> <p data-bbox="288 1234 632 1267">1. Select the item to be set.</p> <table border="1" data-bbox="336 1276 1401 1422"> <thead> <tr> <th data-bbox="336 1276 564 1321">Display</th> <th data-bbox="564 1276 1401 1321">Description</th> </tr> </thead> <tbody> <tr> <td data-bbox="336 1321 564 1366">1st Half</td> <td data-bbox="564 1321 1401 1366">Control voltage for the transfer bias for the first side (half speed)</td> </tr> <tr> <td data-bbox="336 1366 564 1422">2nd Half</td> <td data-bbox="564 1366 1401 1422">Control voltage for the transfer bias for the second side (half speed)</td> </tr> </tbody> </table> <p data-bbox="288 1431 719 1464">2. Select the paper width to be set.</p> <p data-bbox="288 1467 914 1500">3. Change the value using the +/- or numeric keys.</p> <p data-bbox="333 1503 445 1536">[1st Half]</p> <table border="1" data-bbox="336 1545 1401 1785"> <thead> <tr> <th data-bbox="336 1545 520 1635" rowspan="2">Display</th> <th data-bbox="520 1545 916 1635" rowspan="2">Description</th> <th data-bbox="916 1545 1082 1635" rowspan="2">Setting range</th> <th colspan="3" data-bbox="1082 1545 1401 1590">Initial setting</th> </tr> <tr> <th data-bbox="1082 1590 1189 1635">35ppm</th> <th data-bbox="1189 1590 1295 1635">45ppm</th> <th data-bbox="1295 1590 1401 1635">55ppm</th> </tr> </thead> <tbody> <tr> <td data-bbox="336 1635 520 1680">Width=105</td> <td data-bbox="520 1635 916 1680">105 mm wide</td> <td data-bbox="916 1635 1082 1680">0 to 255</td> <td data-bbox="1082 1635 1189 1680">122</td> <td data-bbox="1189 1635 1295 1680">130</td> <td data-bbox="1295 1635 1401 1680">116</td> </tr> <tr> <td data-bbox="336 1680 520 1724">Width=210</td> <td data-bbox="520 1680 916 1724">210 mm wide</td> <td data-bbox="916 1680 1082 1724">0 to 255</td> <td data-bbox="1082 1680 1189 1724">122</td> <td data-bbox="1189 1680 1295 1724">130</td> <td data-bbox="1295 1680 1401 1724">116</td> </tr> <tr> <td data-bbox="336 1724 520 1785">Width=297</td> <td data-bbox="520 1724 916 1785">297 mm wide</td> <td data-bbox="916 1724 1082 1785">0 to 255</td> <td data-bbox="1082 1724 1189 1785">118</td> <td data-bbox="1189 1724 1295 1785">126</td> <td data-bbox="1295 1724 1401 1785">114</td> </tr> </tbody> </table>	Display	Description	1st	Control voltage for the transfer bias for the first side (full speed)	2nd	Control voltage for the transfer bias for the second side (full speed)	Display	Description	Setting range	Initial setting			35ppm	45ppm	55ppm	Width=105	105 mm wide	0 to 255	150	174	146	Width=210	210 mm wide	0 to 255	143	165	140	Width=297	297 mm wide	0 to 255	139	157	134	Display	Description	Setting range	Initial setting			35ppm	45ppm	55ppm	Width=105	105 mm wide	0 to 255	146	160	133	Width=210	210 mm wide	0 to 255	139	153	130	Width=297	297 mm wide	0 to 255	124	135	120	Display	Description	1st Half	Control voltage for the transfer bias for the first side (half speed)	2nd Half	Control voltage for the transfer bias for the second side (half speed)	Display	Description	Setting range	Initial setting			35ppm	45ppm	55ppm	Width=105	105 mm wide	0 to 255	122	130	116	Width=210	210 mm wide	0 to 255	122	130	116	Width=297	297 mm wide	0 to 255	118	126	114
Display	Description																																																																																													
1st	Control voltage for the transfer bias for the first side (full speed)																																																																																													
2nd	Control voltage for the transfer bias for the second side (full speed)																																																																																													
Display	Description	Setting range	Initial setting																																																																																											
			35ppm	45ppm	55ppm																																																																																									
Width=105	105 mm wide	0 to 255	150	174	146																																																																																									
Width=210	210 mm wide	0 to 255	143	165	140																																																																																									
Width=297	297 mm wide	0 to 255	139	157	134																																																																																									
Display	Description	Setting range	Initial setting																																																																																											
			35ppm	45ppm	55ppm																																																																																									
Width=105	105 mm wide	0 to 255	146	160	133																																																																																									
Width=210	210 mm wide	0 to 255	139	153	130																																																																																									
Width=297	297 mm wide	0 to 255	124	135	120																																																																																									
Display	Description																																																																																													
1st Half	Control voltage for the transfer bias for the first side (half speed)																																																																																													
2nd Half	Control voltage for the transfer bias for the second side (half speed)																																																																																													
Display	Description	Setting range	Initial setting																																																																																											
			35ppm	45ppm	55ppm																																																																																									
Width=105	105 mm wide	0 to 255	122	130	116																																																																																									
Width=210	210 mm wide	0 to 255	122	130	116																																																																																									
Width=297	297 mm wide	0 to 255	118	126	114																																																																																									

Item No.	Description					
<b>U106</b>	[2nd Half]					
	<b>Display</b>	<b>Description</b>	<b>Setting range</b>	<b>Initial setting</b>		
				<b>35ppm</b>	<b>45ppm</b>	<b>55ppm</b>
	Width=105	105 mm wide	0 to 255	115	122	121
	Width=210	210 mm wide	0 to 255	115	122	121
	Width=297	297 mm wide	0 to 255	105	109	109
	4. Press the start key. The value is set.					
	<b>Setting: [Heavy4/5]</b>					
	1. Select the item to be set.					
	<b>Display</b>	<b>Description</b>				
	1st Half	Control voltage for the transfer bias for the first side (half speed)				
	2nd Half	Control voltage for the transfer bias for the second side (half speed)				
	2. Select the paper width to be set.					
	3. Change the value using the +/- or numeric keys.					
	[1st Half]					
<b>Display</b>	<b>Description</b>	<b>Setting range</b>	<b>Initial setting</b>			
			<b>35ppm</b>	<b>45ppm</b>	<b>55ppm</b>	
Width=105	105 mm wide	0 to 255	118	126	114	
Width=210	210 mm wide	0 to 255	118	126	114	
Width=297	297 mm wide	0 to 255	110	115	107	
[2nd Half]						
<b>Display</b>	<b>Description</b>	<b>Setting range</b>	<b>Initial setting</b>			
			<b>35ppm</b>	<b>45ppm</b>	<b>55ppm</b>	
Width=105	105 mm wide	0 to 255	114	120	110	
Width=210	210 mm wide	0 to 255	114	120	110	
Width=297	297 mm wide	0 to 255	104	108	102	
4. Press the start key. The value is set.						
<b>Setting: [OHP]</b>						
1. Select the item to be set.						
2. Change the value using the +/- or numeric keys.						
<b>Display</b>	<b>Description</b>	<b>Setting range</b>	<b>Initial setting</b>			
			<b>35ppm</b>	<b>45ppm</b>	<b>55ppm</b>	
Width=105	105 mm wide	0 to 255	108	112	105	
Width=210	210 mm wide	0 to 255	108	112	105	
Width=297	297 mm wide	0 to 255	101	104	101	
3. Press the start key. The value is set.						



Item No.	Description																																	
U106	<p data-bbox="288 241 475 271"><b>Setting: [Bias]</b></p> <ol data-bbox="304 277 906 338" style="list-style-type: none"> <li data-bbox="304 277 632 306">1. Select the item to be set.</li> <li data-bbox="304 311 906 338">2. Change the value using the +/- or numeric keys.</li> </ol> <table border="1" data-bbox="336 353 1401 779"> <thead> <tr> <th data-bbox="336 353 520 443" rowspan="2">Display</th> <th data-bbox="520 353 914 443" rowspan="2">Description</th> <th data-bbox="914 353 1082 443" rowspan="2">Setting range</th> <th colspan="3" data-bbox="1082 353 1401 394">Initial setting</th> </tr> <tr> <th data-bbox="1082 394 1187 443">35ppm</th> <th data-bbox="1187 394 1292 443">45ppm</th> <th data-bbox="1292 394 1401 443">55ppm</th> </tr> </thead> <tbody> <tr> <td data-bbox="336 443 520 533">Reverse</td> <td data-bbox="520 443 914 533">Transfer reverse bias (full speed)</td> <td data-bbox="914 443 1082 533">0 to 255</td> <td data-bbox="1082 443 1187 533">163</td> <td data-bbox="1187 443 1292 533">163</td> <td data-bbox="1292 443 1401 533">164</td> </tr> <tr> <td data-bbox="336 533 520 622">Reverse Half</td> <td data-bbox="520 533 914 622">Transfer reverse bias (half speed)</td> <td data-bbox="914 533 1082 622">0 to 255</td> <td data-bbox="1082 533 1187 622">163</td> <td data-bbox="1187 533 1292 622">163</td> <td data-bbox="1292 533 1401 622">164</td> </tr> <tr> <td data-bbox="336 622 520 712">Cleaning</td> <td data-bbox="520 622 914 712">Cleaning control value (full speed)</td> <td data-bbox="914 622 1082 712">0 to 255</td> <td data-bbox="1082 622 1187 712">108</td> <td data-bbox="1187 622 1292 712">113</td> <td data-bbox="1292 622 1401 712">117</td> </tr> <tr> <td data-bbox="336 712 520 779">Cleaning Half</td> <td data-bbox="520 712 914 779">Cleaning control value (half speed)</td> <td data-bbox="914 712 1082 779">0 to 255</td> <td data-bbox="1082 712 1187 779">100</td> <td data-bbox="1187 712 1292 779">102</td> <td data-bbox="1292 712 1401 779">105</td> </tr> </tbody> </table> <ol data-bbox="304 792 767 822" style="list-style-type: none"> <li data-bbox="304 792 767 822">3. Press the start key. The value is set.</li> </ol> <p data-bbox="288 862 448 891"><b>Supplement</b></p> <p data-bbox="288 898 1417 958">While this maintenance item is being executed, copying from an original is available in interrupt copying mode (which is activated by pressing the system menu key).</p> <p data-bbox="288 1001 440 1030"><b>Completion</b></p> <p data-bbox="288 1037 1254 1066">Press the stop key. The screen for selecting a maintenance item No. is displayed.</p>	Display	Description	Setting range	Initial setting			35ppm	45ppm	55ppm	Reverse	Transfer reverse bias (full speed)	0 to 255	163	163	164	Reverse Half	Transfer reverse bias (half speed)	0 to 255	163	163	164	Cleaning	Cleaning control value (full speed)	0 to 255	108	113	117	Cleaning Half	Cleaning control value (half speed)	0 to 255	100	102	105
Display	Description				Setting range	Initial setting																												
		35ppm	45ppm	55ppm																														
Reverse	Transfer reverse bias (full speed)	0 to 255	163	163	164																													
Reverse Half	Transfer reverse bias (half speed)	0 to 255	163	163	164																													
Cleaning	Cleaning control value (full speed)	0 to 255	108	113	117																													
Cleaning Half	Cleaning control value (half speed)	0 to 255	100	102	105																													

Item No.	Description				
<b>U110</b>	<p><b>Checking the drum count</b></p> <p><b>Description</b> Displays the drum counts for checking.</p> <p><b>Purpose</b> To check the drum status.</p> <p><b>Method</b> 1. Press the start key. The current drum counts is displayed.</p> <table border="1" data-bbox="338 562 1401 658"> <thead> <tr> <th data-bbox="338 562 641 607">Display</th> <th data-bbox="641 562 1401 607">Description</th> </tr> </thead> <tbody> <tr> <td data-bbox="338 607 641 658">K</td> <td data-bbox="641 607 1401 658">Drum count value</td> </tr> </tbody> </table> <p><b>Completion</b> Press the stop key. The screen for selecting a maintenance item No. is displayed.</p>	Display	Description	K	Drum count value
Display	Description				
K	Drum count value				
<b>U111</b>	<p><b>Checking the drum drive time</b></p> <p><b>Description</b> Displays the drum drive time for checking a figure, which is used as a reference when correcting the high voltage based on time.</p> <p><b>Purpose</b> To check the drum status.</p> <p><b>Method</b> 1. Press the start key. The drum drive time is displayed.</p> <table border="1" data-bbox="338 1140 1401 1236"> <thead> <tr> <th data-bbox="338 1140 641 1184">Display</th> <th data-bbox="641 1140 1401 1184">Description</th> </tr> </thead> <tbody> <tr> <td data-bbox="338 1184 641 1236">K</td> <td data-bbox="641 1184 1401 1236">Drum drive time</td> </tr> </tbody> </table> <p><b>Completion</b> Press the stop key. The screen for selecting a maintenance item No. is displayed.</p>	Display	Description	K	Drum drive time
Display	Description				
K	Drum drive time				
<b>U117</b>	<p><b>Checking the drum number</b></p> <p><b>Description</b> Displays the drum number.</p> <p><b>Purpose</b> To check the drum number.</p> <p><b>Method</b> 1. Press the start key. The drum number is displayed.</p> <table border="1" data-bbox="338 1682 1401 1778"> <thead> <tr> <th data-bbox="338 1682 641 1727">Display</th> <th data-bbox="641 1682 1401 1727">Description</th> </tr> </thead> <tbody> <tr> <td data-bbox="338 1727 641 1778">K</td> <td data-bbox="641 1727 1401 1778">Drum number</td> </tr> </tbody> </table> <p><b>Completion</b> Press the stop key. The screen for selecting a maintenance item No. is displayed.</p>	Display	Description	K	Drum number
Display	Description				
K	Drum number				

Item No.	Description										
U118	<p><b>Displaying the drum history</b></p> <p><b>Description</b> Displays the past record of machine number and the drum counter.</p> <p><b>Purpose</b> To check the count value of machine number and the drum counter.</p> <p><b>Method</b></p> <ol style="list-style-type: none"> <li>1. Press the start key.</li> <li>2. Select [K].</li> </ol> <table border="1" data-bbox="336 598 1401 694"> <thead> <tr> <th data-bbox="336 598 639 642">Display</th> <th data-bbox="639 598 1401 642">Description</th> </tr> </thead> <tbody> <tr> <td data-bbox="336 642 639 694">K</td> <td data-bbox="639 642 1401 694">Drum past record</td> </tr> </tbody> </table> <p>The history of a machine number and a drum counter for each color is displayed by three cases.</p> <table border="1" data-bbox="336 779 1401 925"> <thead> <tr> <th data-bbox="336 779 639 824">Display</th> <th data-bbox="639 779 1401 824">Description</th> </tr> </thead> <tbody> <tr> <td data-bbox="336 824 639 875">Machine History1 - 3</td> <td data-bbox="639 824 1401 875">Historical records of the machine number</td> </tr> <tr> <td data-bbox="336 875 639 925">Cnt History1 - 3</td> <td data-bbox="639 875 1401 925">Historical records of drum counter</td> </tr> </tbody> </table> <p><b>Completion</b> Press the stop key. The screen for selecting a maintenance item No. is displayed.</p>	Display	Description	K	Drum past record	Display	Description	Machine History1 - 3	Historical records of the machine number	Cnt History1 - 3	Historical records of drum counter
Display	Description										
K	Drum past record										
Display	Description										
Machine History1 - 3	Historical records of the machine number										
Cnt History1 - 3	Historical records of drum counter										
U119	<p><b>Setting the drum</b></p> <p><b>Description</b> Sets drum sensitivity.</p> <p><b>Purpose</b> To set the drum after replacing the drum unit or laser scanner unit. When completed, perform maintenance mode U464, Calibration. * : The U930 charging roller life counter will be cleared after execution.</p> <p><b>Method</b></p> <ol style="list-style-type: none"> <li>1. Press the start key.</li> <li>2. Select [Execute].</li> <li>3. Press the start key. Drum setup is commenced.</li> <li>4. Turn the main power switch off and on. Allow more than 5 seconds between Off and On.</li> </ol>										

Item No.	Description																					
U127	<p><b>Checking/clearing the transfer count</b></p> <p><b>Description</b> Displays and clears the counts of the transfer counter.</p> <p><b>Purpose</b> To check the count or drive time after replacement of the transfer belt unit. Also to clear the counts after replacing transfer belt unit.</p> <p><b>Method</b> 1. Press the start key. The current counts of the transfer counter is displayed.</p> <table border="1" data-bbox="336 595 1401 790"> <thead> <tr> <th>Display</th> <th>Description</th> </tr> </thead> <tbody> <tr> <td>Belt(Cnt)</td> <td>Transfer belt unit count value</td> </tr> <tr> <td>Belt(Time)</td> <td>Transfer belt unit drive time</td> </tr> <tr> <td>Clear</td> <td>All transfer count clear</td> </tr> </tbody> </table> <p><b>Clearing</b> 1. Select [Clear]. 2. Press the start key. The counter value is cleared.</p> <p><b>Completion</b> Press the stop key. The screen for selecting a maintenance item No. is displayed.</p>	Display	Description	Belt(Cnt)	Transfer belt unit count value	Belt(Time)	Transfer belt unit drive time	Clear	All transfer count clear													
Display	Description																					
Belt(Cnt)	Transfer belt unit count value																					
Belt(Time)	Transfer belt unit drive time																					
Clear	All transfer count clear																					
U128	<p><b>Setting transfer high-voltage timing</b></p> <p><b>Description</b> Adjusts the ON/OFF timing of transfer high-voltage output.</p> <p><b>Purpose</b> Basically, the setting need not be changed. If any problem such as faulty images or dirt on the back surface occurs, change the setting.</p> <p><b>Method</b> 1. Press the start key. 2. Select the item to set. 3. Change the value using the +/- keys or numeric keys.</p> <table border="1" data-bbox="336 1487 1401 1749"> <thead> <tr> <th rowspan="2">Display</th> <th rowspan="2">Description</th> <th rowspan="2">Setting range</th> <th colspan="3">Initial setting</th> </tr> <tr> <th>35ppm</th> <th>45ppm</th> <th>55ppm</th> </tr> </thead> <tbody> <tr> <td>On Timing 1st</td> <td>Transfer ON timing adjustment value (first side)</td> <td>-200 to 200</td> <td>-20</td> <td>-18</td> <td>-15</td> </tr> <tr> <td>Off Timing</td> <td>Transfer OFF timing adjustment value</td> <td>-200 to 200</td> <td>-13</td> <td>-15</td> <td>-18</td> </tr> </tbody> </table> <p>4. Press the start key. The value is set.</p> <p><b>Completion</b> Press the stop key. The screen for selecting a maintenance item No. is displayed.</p>	Display	Description	Setting range	Initial setting			35ppm	45ppm	55ppm	On Timing 1st	Transfer ON timing adjustment value (first side)	-200 to 200	-20	-18	-15	Off Timing	Transfer OFF timing adjustment value	-200 to 200	-13	-15	-18
Display	Description				Setting range	Initial setting																
		35ppm	45ppm	55ppm																		
On Timing 1st	Transfer ON timing adjustment value (first side)	-200 to 200	-20	-18	-15																	
Off Timing	Transfer OFF timing adjustment value	-200 to 200	-13	-15	-18																	

Item No.	Description				
U130	<p data-bbox="288 241 683 271"><b>Initial setting for the developer</b></p> <p data-bbox="288 311 440 340"><b>Description</b></p> <p data-bbox="288 344 1426 409">The toner sensor control bias is adjusted so that the sensor output is set as the target value with the initial developer.</p> <p data-bbox="288 414 400 443"><b>Purpose</b></p> <p data-bbox="288 448 1385 477">Automatically executed when the developer unit loaded with the initial developer is replaced.</p> <p data-bbox="288 517 387 546"><b>Method</b></p> <ol data-bbox="304 551 564 651" style="list-style-type: none"> <li>1. Press the start key.</li> <li>2. Select [Execute].</li> <li>3. Press the start key.</li> </ol> <p data-bbox="336 656 1294 685">Toner installation is started and the control value of the toner sensor is displayed.</p> <table border="1" data-bbox="336 698 1399 795"> <thead> <tr> <th data-bbox="336 698 639 743">Display</th> <th data-bbox="639 698 1399 743">Description</th> </tr> </thead> <tbody> <tr> <td data-bbox="336 743 639 795">K</td> <td data-bbox="639 743 1399 795">Toner sensor control voltage</td> </tr> </tbody> </table> <p data-bbox="288 835 440 864"><b>Completion</b></p> <p data-bbox="288 869 1254 898">Press the stop key. The screen for selecting a maintenance item No. is displayed.</p>	Display	Description	K	Toner sensor control voltage
Display	Description				
K	Toner sensor control voltage				

Item No.	Description																																			
U131	<p data-bbox="288 241 831 275"><b>Adjusting the toner sensor control voltage</b></p> <p data-bbox="288 311 440 340"><b>Description</b></p> <p data-bbox="288 344 767 376">Adjusts the toner sensor control voltage.</p> <p data-bbox="288 380 400 409"><b>Purpose</b></p> <p data-bbox="288 414 1398 481">If control values are not correctly retrievable due to the EEPROM of the developer unit failure, etc., use manual adjustment and obtain a temporary control value.</p> <p data-bbox="288 517 387 546"><b>Method</b></p> <ol data-bbox="304 553 783 620" style="list-style-type: none"> <li>1. Press the start key.</li> <li>2. Select the item to be set or displayed.</li> </ol> <table border="1" data-bbox="336 631 1398 824"> <thead> <tr> <th data-bbox="336 631 639 676">Display</th> <th data-bbox="639 631 1398 676">Description</th> </tr> </thead> <tbody> <tr> <td data-bbox="336 676 639 721">Manual</td> <td data-bbox="639 676 1398 721">Toner sensor control voltage manual adjustment</td> </tr> <tr> <td data-bbox="336 721 639 766">Auto</td> <td data-bbox="639 721 1398 766">Toner sensor control voltage auto adjustment</td> </tr> <tr> <td data-bbox="336 766 639 810">Mode</td> <td data-bbox="639 766 1398 810">Switching the manual adjustment and auto adjustment</td> </tr> </tbody> </table> <p data-bbox="288 869 509 898"><b>Setting: [Manual]</b></p> <ol data-bbox="304 902 903 934" style="list-style-type: none"> <li>1. Change the value using the +/- or numeric keys.</li> </ol> <table border="1" data-bbox="336 945 1398 1090"> <thead> <tr> <th data-bbox="336 945 520 1034" rowspan="2">Display</th> <th data-bbox="520 945 914 1034" rowspan="2">Description</th> <th data-bbox="914 945 1082 1034" rowspan="2">Setting range</th> <th colspan="3" data-bbox="1082 945 1398 990">Initial setting</th> </tr> <tr> <th data-bbox="1082 990 1187 1034">35ppm</th> <th data-bbox="1187 990 1292 1034">45ppm</th> <th data-bbox="1292 990 1398 1034">55ppm</th> </tr> </thead> <tbody> <tr> <td data-bbox="336 1034 520 1090">Control(K)</td> <td data-bbox="520 1034 914 1090">Toner sensor control voltage</td> <td data-bbox="914 1034 1082 1090">0 to 255</td> <td data-bbox="1082 1034 1187 1090">107</td> <td data-bbox="1187 1034 1292 1090">120</td> <td data-bbox="1292 1034 1398 1090">128</td> </tr> </tbody> </table> <ol data-bbox="304 1102 767 1133" style="list-style-type: none"> <li>2. Press the start key. The value is set.</li> </ol> <p data-bbox="288 1169 521 1198"><b>Displaying: [Auto]</b></p> <ol data-bbox="304 1202 715 1234" style="list-style-type: none"> <li>1. The current setting is displayed.</li> </ol> <table border="1" data-bbox="336 1245 1398 1391"> <thead> <tr> <th data-bbox="336 1245 639 1290">Display</th> <th data-bbox="639 1245 1398 1290">Description</th> </tr> </thead> <tbody> <tr> <td data-bbox="336 1290 639 1335">Default(K)</td> <td data-bbox="639 1290 1398 1335">Reference value for toner sensor control voltage</td> </tr> <tr> <td data-bbox="336 1335 639 1391">Control(K)</td> <td data-bbox="639 1335 1398 1391">Toner sensor control voltage after correction</td> </tr> </tbody> </table> <p data-bbox="288 1435 488 1464"><b>Setting: [Mode]</b></p> <ol data-bbox="304 1469 632 1500" style="list-style-type: none"> <li>1. Select the item to be set.</li> </ol> <table border="1" data-bbox="336 1512 1398 1657"> <thead> <tr> <th data-bbox="336 1512 639 1556">Display</th> <th data-bbox="639 1512 1398 1556">Description</th> </tr> </thead> <tbody> <tr> <td data-bbox="336 1556 639 1601">Manual</td> <td data-bbox="639 1556 1398 1601">Toner sensor control voltage manual adjustment</td> </tr> <tr> <td data-bbox="336 1601 639 1657">Auto</td> <td data-bbox="639 1601 1398 1657">Toner sensor control voltage auto adjustment</td> </tr> </tbody> </table> <p data-bbox="336 1668 557 1700">Initial setting: Auto</p> <ol data-bbox="304 1704 767 1736" style="list-style-type: none"> <li>2. Press the start key. The value is set.</li> </ol> <p data-bbox="288 1771 440 1800"><b>Completion</b></p> <p data-bbox="288 1805 1254 1836">Press the stop key. The screen for selecting a maintenance item No. is displayed.</p>	Display	Description	Manual	Toner sensor control voltage manual adjustment	Auto	Toner sensor control voltage auto adjustment	Mode	Switching the manual adjustment and auto adjustment	Display	Description	Setting range	Initial setting			35ppm	45ppm	55ppm	Control(K)	Toner sensor control voltage	0 to 255	107	120	128	Display	Description	Default(K)	Reference value for toner sensor control voltage	Control(K)	Toner sensor control voltage after correction	Display	Description	Manual	Toner sensor control voltage manual adjustment	Auto	Toner sensor control voltage auto adjustment
Display	Description																																			
Manual	Toner sensor control voltage manual adjustment																																			
Auto	Toner sensor control voltage auto adjustment																																			
Mode	Switching the manual adjustment and auto adjustment																																			
Display	Description	Setting range	Initial setting																																	
			35ppm	45ppm	55ppm																															
Control(K)	Toner sensor control voltage	0 to 255	107	120	128																															
Display	Description																																			
Default(K)	Reference value for toner sensor control voltage																																			
Control(K)	Toner sensor control voltage after correction																																			
Display	Description																																			
Manual	Toner sensor control voltage manual adjustment																																			
Auto	Toner sensor control voltage auto adjustment																																			

Item No.	Description						
U132	<p><b>Replenishing toner forcibly</b></p> <p><b>Description</b> Replenishes toner forcibly until the toner sensor output value reaches the toner feed start level.</p> <p><b>Purpose</b> Used when the toner empty is detected frequently.</p> <p><b>Method</b></p> <ol style="list-style-type: none"> <li>1. Press the start key.</li> <li>2. Select [Execute].</li> <li>3. Press the start key. Toner is replenished until the toner sensor output value reaches the toner feed start level.</li> </ol> <table border="1" data-bbox="336 667 1401 808"> <thead> <tr> <th data-bbox="336 667 641 712">Display</th> <th data-bbox="641 667 1401 712">Description</th> </tr> </thead> <tbody> <tr> <td data-bbox="336 712 641 757">Supply(K)</td> <td data-bbox="641 712 1401 757">Toner feed start level</td> </tr> <tr> <td data-bbox="336 757 641 808">Sensor(K)</td> <td data-bbox="641 757 1401 808">Toner sensor output value</td> </tr> </tbody> </table> <ol style="list-style-type: none"> <li>4. To stop operation, press the stop key.</li> </ol> <p><b>Completion</b> Press the stop key. The screen for selecting a maintenance item No. is displayed.</p>	Display	Description	Supply(K)	Toner feed start level	Sensor(K)	Toner sensor output value
Display	Description						
Supply(K)	Toner feed start level						
Sensor(K)	Toner sensor output value						
U135	<p><b>Checking toner motor operation</b></p> <p><b>Description</b> Drives toner motors.</p> <p><b>Purpose</b> To check the operation of toner motors.</p> <p><b>Remarks</b> When driving the toner motors long time or several times, developer section becomes the toner full and is locked.</p> <p><b>Method</b></p> <ol style="list-style-type: none"> <li>1. Press the start key.</li> <li>2. Select item.</li> <li>3. Press the start key. The operation starts.</li> </ol> <table border="1" data-bbox="336 1503 1401 1644"> <thead> <tr> <th data-bbox="336 1503 641 1547">Display</th> <th data-bbox="641 1503 1401 1547">Description</th> </tr> </thead> <tbody> <tr> <td data-bbox="336 1547 641 1592">Toner</td> <td data-bbox="641 1547 1401 1592">Toner motor (TM) is turned on</td> </tr> <tr> <td data-bbox="336 1592 641 1644">Hopper</td> <td data-bbox="641 1592 1401 1644">Toner hopper motor (THM) is turned on</td> </tr> </tbody> </table> <ol style="list-style-type: none"> <li>4. To stop the operation, press the stop key.</li> </ol> <p><b>Completion</b> Press the stop key after operation stops. The screen for selecting a maintenance item No. is displayed.</p>	Display	Description	Toner	Toner motor (TM) is turned on	Hopper	Toner hopper motor (THM) is turned on
Display	Description						
Toner	Toner motor (TM) is turned on						
Hopper	Toner hopper motor (THM) is turned on						

Item No.	Description								
U136	<p data-bbox="290 241 703 271"><b>Setting toner near end detection</b></p> <p data-bbox="290 311 440 340"><b>Description</b></p> <p data-bbox="290 344 1406 409">Sets the level that indicates the number of sheets that can be printed from occurrence of toner near end to toner empty.</p> <p data-bbox="290 414 400 443"><b>Purpose</b></p> <p data-bbox="290 448 1428 512">To change the setting to advance detection of near end if the interval from toner near end to toner empty seems too short.</p> <p data-bbox="290 553 384 582"><b>Setting</b></p> <ol data-bbox="304 586 906 651" style="list-style-type: none"> <li>1. Press the start key.</li> <li>2. Change the value using the +/- or numeric keys.</li> </ol> <table border="1" data-bbox="336 665 1401 795"> <thead> <tr> <th data-bbox="336 665 528 745">Display</th> <th data-bbox="528 665 1098 745">Description</th> <th data-bbox="1098 665 1249 745">Setting range</th> <th data-bbox="1249 665 1401 745">Initial setting</th> </tr> </thead> <tbody> <tr> <td data-bbox="336 745 528 795">K</td> <td data-bbox="528 745 1098 795">Setting the level of toner</td> <td data-bbox="1098 745 1249 795">0 to 9</td> <td data-bbox="1249 745 1401 795">3</td> </tr> </tbody> </table> <p data-bbox="336 806 1326 835">Increasing the setting makes the interval from toner near end to toner empty longer.</p> <p data-bbox="336 840 1347 869">Decreasing the setting makes the interval from toner near end to toner empty shorter.</p> <p data-bbox="336 873 879 902">If 0 is set, toner near end will not be detected.</p> <p data-bbox="336 907 959 936">* : Inch model (except for PH model) initial setting: 0</p> <ol data-bbox="304 940 767 969" style="list-style-type: none"> <li>3. Press the start key. The value is set.</li> </ol> <p data-bbox="290 1010 440 1039"><b>Completion</b></p> <p data-bbox="290 1043 1254 1072">Press the stop key. The screen for selecting a maintenance item No. is displayed.</p>	Display	Description	Setting range	Initial setting	K	Setting the level of toner	0 to 9	3
Display	Description	Setting range	Initial setting						
K	Setting the level of toner	0 to 9	3						



Item No.	Description																								
U139	<p data-bbox="288 241 1077 275"><b>Displaying the temperature and humidity outside the machine</b></p> <p data-bbox="288 309 438 342"><b>Description</b></p> <p data-bbox="288 344 1109 378">Displays the detected temperature and humidity outside the machine.</p> <p data-bbox="288 380 399 414"><b>Purpose</b></p> <p data-bbox="288 416 1005 450">To check the temperature and humidity outside the machine.</p> <p data-bbox="288 483 391 517"><b>Method</b></p> <ol data-bbox="304 519 566 586" style="list-style-type: none"> <li>1. Press the start key.</li> <li>2. Select the item.</li> </ol> <table border="1" data-bbox="336 598 1401 790"> <thead> <tr> <th data-bbox="336 598 639 642">Display</th> <th data-bbox="639 598 1401 642">Description</th> </tr> </thead> <tbody> <tr> <td data-bbox="336 642 639 687">Ext/Int</td> <td data-bbox="639 642 1401 687">Internal/External temperature (°C), External humidity (%)</td> </tr> <tr> <td data-bbox="336 687 639 732">LSU</td> <td data-bbox="639 687 1401 732">Internal temperature around the laser scanner unit (°C)</td> </tr> <tr> <td data-bbox="336 732 639 790">Developing</td> <td data-bbox="639 732 1401 790">Internal temperature around the developer section (°C)</td> </tr> </tbody> </table> <p data-bbox="288 835 502 869"><b>Method: [Ext/Int]</b></p> <ol data-bbox="304 871 957 904" style="list-style-type: none"> <li>1. The current temperature and humidity are displayed.</li> </ol> <table border="1" data-bbox="336 916 1401 1108"> <thead> <tr> <th data-bbox="336 916 639 960">Display</th> <th data-bbox="639 916 1401 960">Description</th> </tr> </thead> <tbody> <tr> <td data-bbox="336 960 639 1005">External Temp</td> <td data-bbox="639 960 1401 1005">External temperature (°C)</td> </tr> <tr> <td data-bbox="336 1005 639 1050">External Humidity</td> <td data-bbox="639 1005 1401 1050">External humidity (%)</td> </tr> <tr> <td data-bbox="336 1050 639 1108">Internal Temp</td> <td data-bbox="639 1050 1401 1108">Internal temperature (°C)</td> </tr> </tbody> </table> <p data-bbox="288 1153 470 1187"><b>Method: [LSU]</b></p> <ol data-bbox="304 1189 774 1223" style="list-style-type: none"> <li>1. The current temperature is displayed.</li> </ol> <table border="1" data-bbox="336 1234 1401 1328"> <thead> <tr> <th data-bbox="336 1234 639 1279">Display</th> <th data-bbox="639 1234 1401 1279">Description</th> </tr> </thead> <tbody> <tr> <td data-bbox="336 1279 639 1328">K</td> <td data-bbox="639 1279 1401 1328">Internal temperature around the laser scanner unit (°C)</td> </tr> </tbody> </table> <p data-bbox="288 1373 566 1406"><b>Method: [Developing]</b></p> <ol data-bbox="304 1408 774 1442" style="list-style-type: none"> <li>1. The current temperature is displayed.</li> </ol> <table border="1" data-bbox="336 1453 1401 1547"> <thead> <tr> <th data-bbox="336 1453 639 1498">Display</th> <th data-bbox="639 1453 1401 1498">Description</th> </tr> </thead> <tbody> <tr> <td data-bbox="336 1498 639 1547">K</td> <td data-bbox="639 1498 1401 1547">Internal temperature around the developer unit (°C)</td> </tr> </tbody> </table> <p data-bbox="288 1592 438 1626"><b>Completion</b></p> <p data-bbox="288 1628 1252 1662">Press the stop key. The screen for selecting a maintenance item No. is displayed.</p>	Display	Description	Ext/Int	Internal/External temperature (°C), External humidity (%)	LSU	Internal temperature around the laser scanner unit (°C)	Developing	Internal temperature around the developer section (°C)	Display	Description	External Temp	External temperature (°C)	External Humidity	External humidity (%)	Internal Temp	Internal temperature (°C)	Display	Description	K	Internal temperature around the laser scanner unit (°C)	Display	Description	K	Internal temperature around the developer unit (°C)
Display	Description																								
Ext/Int	Internal/External temperature (°C), External humidity (%)																								
LSU	Internal temperature around the laser scanner unit (°C)																								
Developing	Internal temperature around the developer section (°C)																								
Display	Description																								
External Temp	External temperature (°C)																								
External Humidity	External humidity (%)																								
Internal Temp	Internal temperature (°C)																								
Display	Description																								
K	Internal temperature around the laser scanner unit (°C)																								
Display	Description																								
K	Internal temperature around the developer unit (°C)																								

Item No.	Description																																																		
U140	<p data-bbox="288 241 624 275"><b>Displaying developer bias</b></p> <p data-bbox="288 311 440 340"><b>Description</b></p> <p data-bbox="288 344 906 376">Displays and changes various developer bias value.</p> <p data-bbox="288 383 400 412"><b>Purpose</b></p> <p data-bbox="288 416 842 448">To check or changes the developer bias value.</p> <p data-bbox="288 486 387 515"><b>Method</b></p> <ol data-bbox="304 519 632 584" style="list-style-type: none"> <li>1. Press the start key.</li> <li>2. Select the item to be set.</li> </ol> <table border="1" data-bbox="336 598 1401 1077"> <thead> <tr> <th data-bbox="336 598 639 642">Display</th> <th data-bbox="639 598 1401 642">Description</th> </tr> </thead> <tbody> <tr> <td data-bbox="336 642 639 687">Sleeve DC</td> <td data-bbox="639 642 1401 687">Developer sleeve roller DC bias</td> </tr> <tr> <td data-bbox="336 687 639 732">Sleeve AC</td> <td data-bbox="639 687 1401 732">Developer sleeve roller AC bias</td> </tr> <tr> <td data-bbox="336 732 639 777">Mag DC</td> <td data-bbox="639 732 1401 777">Developer magnet roller DC bias</td> </tr> <tr> <td data-bbox="336 777 639 822">Mag AC</td> <td data-bbox="639 777 1401 822">Developer magnet roller AC bias</td> </tr> <tr> <td data-bbox="336 822 639 866">Sleeve Freq</td> <td data-bbox="639 822 1401 866">Developer sleeve roller frequency</td> </tr> <tr> <td data-bbox="336 866 639 911">Sleeve Duty</td> <td data-bbox="639 866 1401 911">Developer sleeve roller duty</td> </tr> <tr> <td data-bbox="336 911 639 956">Mag Duty</td> <td data-bbox="639 911 1401 956">Developer magnet roller duty</td> </tr> <tr> <td data-bbox="336 956 639 1001">AC Calib</td> <td data-bbox="639 956 1401 1001">Executing or setting the AC calibration</td> </tr> <tr> <td data-bbox="336 1001 639 1077">Image Preference</td> <td data-bbox="639 1001 1401 1077">Toner density setting</td> </tr> </tbody> </table> <p data-bbox="288 1126 549 1158"><b>Setting: [Sleeve DC]</b></p> <ol data-bbox="304 1162 1054 1193" style="list-style-type: none"> <li>1. Change the setting value using the +/- keys or numeric keys.</li> </ol> <table border="1" data-bbox="336 1205 1401 1350"> <thead> <tr> <th data-bbox="336 1205 520 1294" rowspan="2">Display</th> <th data-bbox="520 1205 927 1294" rowspan="2">Description</th> <th data-bbox="927 1205 1082 1294" rowspan="2">Setting range</th> <th colspan="3" data-bbox="1082 1205 1401 1249">Initial setting</th> </tr> <tr> <th data-bbox="1082 1249 1187 1294">35ppm</th> <th data-bbox="1187 1249 1292 1294">45ppm</th> <th data-bbox="1292 1249 1401 1294">55ppm</th> </tr> </thead> <tbody> <tr> <td data-bbox="336 1294 520 1350">K</td> <td data-bbox="520 1294 927 1350">Developer sleeve roller DC bias</td> <td data-bbox="927 1294 1082 1350">0 to 255</td> <td data-bbox="1082 1294 1187 1350">62</td> <td data-bbox="1187 1294 1292 1350">62</td> <td data-bbox="1292 1294 1401 1350">70</td> </tr> </tbody> </table> <ol data-bbox="304 1361 767 1393" style="list-style-type: none"> <li>2. Press the start key. The value is set.</li> </ol> <p data-bbox="288 1429 549 1460"><b>Setting: [Sleeve AC]</b></p> <ol data-bbox="304 1464 1054 1496" style="list-style-type: none"> <li>1. Change the setting value using the +/- keys or numeric keys.</li> </ol> <table border="1" data-bbox="336 1507 1401 1653"> <thead> <tr> <th data-bbox="336 1507 520 1597" rowspan="2">Display</th> <th data-bbox="520 1507 927 1597" rowspan="2">Description</th> <th data-bbox="927 1507 1082 1597" rowspan="2">Setting range</th> <th colspan="3" data-bbox="1082 1507 1401 1552">Initial setting</th> </tr> <tr> <th data-bbox="1082 1552 1187 1597">35ppm</th> <th data-bbox="1187 1552 1292 1597">45ppm</th> <th data-bbox="1292 1552 1401 1597">55ppm</th> </tr> </thead> <tbody> <tr> <td data-bbox="336 1597 520 1653">K</td> <td data-bbox="520 1597 927 1653">Developer sleeve roller AC bias</td> <td data-bbox="927 1597 1082 1653">0 to 255</td> <td data-bbox="1082 1597 1187 1653">159</td> <td data-bbox="1187 1597 1292 1653">159</td> <td data-bbox="1292 1597 1401 1653">150</td> </tr> </tbody> </table> <ol data-bbox="304 1664 767 1695" style="list-style-type: none"> <li>2. Press the start key. The value is set.</li> </ol>	Display	Description	Sleeve DC	Developer sleeve roller DC bias	Sleeve AC	Developer sleeve roller AC bias	Mag DC	Developer magnet roller DC bias	Mag AC	Developer magnet roller AC bias	Sleeve Freq	Developer sleeve roller frequency	Sleeve Duty	Developer sleeve roller duty	Mag Duty	Developer magnet roller duty	AC Calib	Executing or setting the AC calibration	Image Preference	Toner density setting	Display	Description	Setting range	Initial setting			35ppm	45ppm	55ppm	K	Developer sleeve roller DC bias	0 to 255	62	62	70	Display	Description	Setting range	Initial setting			35ppm	45ppm	55ppm	K	Developer sleeve roller AC bias	0 to 255	159	159	150
Display	Description																																																		
Sleeve DC	Developer sleeve roller DC bias																																																		
Sleeve AC	Developer sleeve roller AC bias																																																		
Mag DC	Developer magnet roller DC bias																																																		
Mag AC	Developer magnet roller AC bias																																																		
Sleeve Freq	Developer sleeve roller frequency																																																		
Sleeve Duty	Developer sleeve roller duty																																																		
Mag Duty	Developer magnet roller duty																																																		
AC Calib	Executing or setting the AC calibration																																																		
Image Preference	Toner density setting																																																		
Display	Description	Setting range	Initial setting																																																
			35ppm	45ppm	55ppm																																														
K	Developer sleeve roller DC bias	0 to 255	62	62	70																																														
Display	Description	Setting range	Initial setting																																																
			35ppm	45ppm	55ppm																																														
K	Developer sleeve roller AC bias	0 to 255	159	159	150																																														

Item No.	Description							
U140	<b>Setting: [Mag DC]</b>							
	1. Change the setting value using the +/- keys or numeric keys.							
	<b>Display</b>		<b>Description</b>		<b>Setting range</b>	<b>Initial setting</b>		
						35ppm	45ppm	55ppm
	K		Developer magnet roller DC bias		0 to 255	148	148	180
	2. Press the start key. The value is set.							
	<b>Setting: [Mag AC]</b>							
	1. Change the setting value using the +/- keys or numeric keys.							
	<b>Display</b>		<b>Description</b>		<b>Setting range</b>	<b>Initial setting</b>		
						35ppm	45ppm	55ppm
	K		Developer magnet roller AC bias		0 to 255	101	101	199
	2. Press the start key. The value is set.							
<b>Setting: [Sleeve Freq]</b>								
1. Change the setting value using the +/- keys or numeric keys.								
<b>Display</b>		<b>Description</b>		<b>Setting range</b>	<b>Initial setting</b>			
					35ppm	45ppm	55ppm	
Normal		Developer sleeve roller frequency		0 to 6200	4580	4580	4580	
Half		Developer sleeve roller frequency (half speed)		0 to 6200	5345	5345	5345	
2. Press the start key. The value is set.								
<b>Setting: [Sleeve Duty]</b>								
1. Change the setting value using the +/- keys or numeric keys.								
<b>Display</b>		<b>Description</b>		<b>Setting range</b>	<b>Initial setting</b>			
					35ppm	45ppm	55ppm	
Normal		Developer sleeve roller duty		0 to 99	63	63	43	
2. Press the start key. The value is set.								
<b>Setting: [Mag Duty]</b>								
1. Change the setting value using the +/- keys or numeric keys.								
<b>Display</b>		<b>Description</b>		<b>Setting range</b>	<b>Initial setting</b>			
					35ppm	45ppm	55ppm	
Normal		Developer magnet roller duty		0 to 99	37	37	68	
2. Press the start key. The value is set.								

Item No.	Description																								
U140	<p data-bbox="288 241 738 275"><b>Method: [AC Calib] (55 ppm model)</b></p> <p data-bbox="288 277 520 311">1. Select the item.</p> <table border="1" data-bbox="336 320 1415 893"> <thead> <tr> <th data-bbox="336 320 550 365">Display</th> <th data-bbox="550 320 1415 365">Description</th> </tr> </thead> <tbody> <tr> <td data-bbox="336 365 550 589">Calibration</td> <td data-bbox="550 365 1415 589">           Executing the AC calibration (Developer AC calibration setting)  <b>Executing timing</b>            1. When the setup at high altitude place.            2. Execute when replacing the developer unit or drum unit            3. Execute at the time of developing leak outbreak            4. When the density of solid image is dropped after the AC calibration.         </td> </tr> <tr> <td data-bbox="336 589 550 745">Magnification</td> <td data-bbox="550 589 1415 745">           AC calibration target bias value setting  <b>Executing timing</b>            1. Developing bias setting when developing leak occurs after AC calibration practice         </td> </tr> <tr> <td data-bbox="336 745 550 893">High Altitude</td> <td data-bbox="550 745 1415 893">           Mode setting for AC calibration bias control  <b>Executing timing</b>            1. In case the density of solid image levels drop is not improved even if execute AC calibration (setting at high altitude)         </td> </tr> </tbody> </table> <p data-bbox="288 943 561 976"><b>Method: [Calibration]</b></p> <p data-bbox="288 978 743 1012">1. Turn the items to implement to on.</p> <table border="1" data-bbox="336 1021 1415 1214"> <thead> <tr> <th data-bbox="336 1021 550 1066">Display</th> <th data-bbox="550 1021 1415 1066">Description</th> </tr> </thead> <tbody> <tr> <td data-bbox="336 1066 550 1111">K</td> <td data-bbox="550 1066 1415 1111">Change On/Off of Black developer</td> </tr> <tr> <td data-bbox="336 1111 550 1155">Type</td> <td data-bbox="550 1111 1415 1155">Solid image density improvement mode</td> </tr> <tr> <td data-bbox="336 1155 550 1214">Execute</td> <td data-bbox="550 1155 1415 1214">Executing the Calibration</td> </tr> </tbody> </table> <p data-bbox="336 1223 1415 1290">* : When the density of solid image is dropped, select "Type" and chose "+1". (High altitude grain mode)</p> <p data-bbox="288 1330 1382 1464">           2. Select [Execute].            3. Press the start key. AC calibration is executed.            4. Turn the main power switch off and on. Allow more than 5 seconds between Off and On.            * : When an error occurs, an error code is displayed.         </p> <p data-bbox="288 1503 478 1536"><b>Setting: [Type]</b></p> <p data-bbox="288 1538 1054 1572">1. Change the setting value using the +/- keys or numeric keys.</p> <table border="1" data-bbox="336 1581 1415 1798"> <thead> <tr> <th data-bbox="336 1581 550 1626">Display</th> <th data-bbox="550 1581 1415 1626">Description</th> </tr> </thead> <tbody> <tr> <td data-bbox="336 1626 550 1671">0</td> <td data-bbox="550 1626 1415 1671">Continue the present setting and execute AC calibration</td> </tr> <tr> <td data-bbox="336 1671 550 1749">+1</td> <td data-bbox="550 1671 1415 1749">High altitude grain mode: Perform AC calibration in a high altitude installation and improve that image density becomes lighter</td> </tr> <tr> <td data-bbox="336 1749 550 1798">+2</td> <td data-bbox="550 1749 1415 1798">Cancel high altitude grain mode setting and execute AC calibration</td> </tr> </tbody> </table> <p data-bbox="288 1821 564 1888">           2. Select [Execute].            3. Press the start key.         </p>	Display	Description	Calibration	Executing the AC calibration (Developer AC calibration setting) <b>Executing timing</b> 1. When the setup at high altitude place. 2. Execute when replacing the developer unit or drum unit 3. Execute at the time of developing leak outbreak 4. When the density of solid image is dropped after the AC calibration.	Magnification	AC calibration target bias value setting <b>Executing timing</b> 1. Developing bias setting when developing leak occurs after AC calibration practice	High Altitude	Mode setting for AC calibration bias control <b>Executing timing</b> 1. In case the density of solid image levels drop is not improved even if execute AC calibration (setting at high altitude)	Display	Description	K	Change On/Off of Black developer	Type	Solid image density improvement mode	Execute	Executing the Calibration	Display	Description	0	Continue the present setting and execute AC calibration	+1	High altitude grain mode: Perform AC calibration in a high altitude installation and improve that image density becomes lighter	+2	Cancel high altitude grain mode setting and execute AC calibration
Display	Description																								
Calibration	Executing the AC calibration (Developer AC calibration setting) <b>Executing timing</b> 1. When the setup at high altitude place. 2. Execute when replacing the developer unit or drum unit 3. Execute at the time of developing leak outbreak 4. When the density of solid image is dropped after the AC calibration.																								
Magnification	AC calibration target bias value setting <b>Executing timing</b> 1. Developing bias setting when developing leak occurs after AC calibration practice																								
High Altitude	Mode setting for AC calibration bias control <b>Executing timing</b> 1. In case the density of solid image levels drop is not improved even if execute AC calibration (setting at high altitude)																								
Display	Description																								
K	Change On/Off of Black developer																								
Type	Solid image density improvement mode																								
Execute	Executing the Calibration																								
Display	Description																								
0	Continue the present setting and execute AC calibration																								
+1	High altitude grain mode: Perform AC calibration in a high altitude installation and improve that image density becomes lighter																								
+2	Cancel high altitude grain mode setting and execute AC calibration																								

Item No.	Description																																										
U140	<p><b>Setting: [Magnification]</b></p> <p>1. Change the setting value using the +/- keys or numeric keys.</p> <table border="1" data-bbox="336 320 1401 450"> <thead> <tr> <th>Display</th> <th>Description</th> <th>Setting range</th> <th>Initial setting</th> </tr> </thead> <tbody> <tr> <td>K</td> <td>When replacing the developer unit or drum unit</td> <td>-10 to 1 5</td> <td>12</td> </tr> </tbody> </table> <p>2. Press the start key. The value is set.</p> <p><b>Method: [High Altitude]</b></p> <p>1. Select Mode1 or Mode2.</p> <table border="1" data-bbox="336 607 1401 786"> <thead> <tr> <th>Display</th> <th>Description</th> </tr> </thead> <tbody> <tr> <td>Mode1</td> <td>Execute AC calibration by normal bias control</td> </tr> <tr> <td>Mode2</td> <td>If print density is low in an installation at high altitude, execute calibration by fixing the bias potential.</td> </tr> </tbody> </table> <p>Initial setting: Mode1</p> <p>2. Press the start key. The value is set.</p> <p>3. Turn the main power switch off and on. Allow more than 5 seconds between Off and On.</p> <p><b>Method: [AC Calib] (35 ppm model/45 ppm model)</b></p> <p>1. Select the item.</p> <table border="1" data-bbox="336 1014 1401 1111"> <thead> <tr> <th>Display</th> <th>Description</th> </tr> </thead> <tbody> <tr> <td>High Altitude</td> <td>Mode setting for AC calibration bias control</td> </tr> </tbody> </table> <p><b>Method: [High Altitude]</b></p> <p>1. Select mode.</p> <table border="1" data-bbox="336 1234 1401 1520"> <thead> <tr> <th>Display</th> <th>Description</th> <th>Display</th> <th>Description</th> </tr> </thead> <tbody> <tr> <td>Default</td> <td>Initial setting</td> <td>3000m</td> <td>Settings equivalent to the altitude of 3000 m</td> </tr> <tr> <td>1000m</td> <td>Settings equivalent to the altitude of 1000 m</td> <td>4000m</td> <td>Settings equivalent to the altitude of 4000 m</td> </tr> <tr> <td>2000m</td> <td>Settings equivalent to the altitude of 2000 m</td> <td></td> <td></td> </tr> </tbody> </table> <p>2. Press the start key. The value is set.</p> <p><b>Method: [Image Preference]</b></p> <p>1. Select the Copy.</p> <p>2. Change the value using the +/- or numeric keys.</p> <table border="1" data-bbox="336 1711 1401 1841"> <thead> <tr> <th>Display</th> <th>Description</th> <th>Setting range</th> <th>Initial setting</th> </tr> </thead> <tbody> <tr> <td>Copy</td> <td>Setting toner density at copying</td> <td>-1 to +1</td> <td>0</td> </tr> </tbody> </table> <p>* : 1: Low 0: Normal +1: Deep</p> <p><b>Completion</b></p> <p>Press the stop key. The screen for selecting a maintenance item No. is displayed.</p>	Display	Description	Setting range	Initial setting	K	When replacing the developer unit or drum unit	-10 to 1 5	12	Display	Description	Mode1	Execute AC calibration by normal bias control	Mode2	If print density is low in an installation at high altitude, execute calibration by fixing the bias potential.	Display	Description	High Altitude	Mode setting for AC calibration bias control	Display	Description	Display	Description	Default	Initial setting	3000m	Settings equivalent to the altitude of 3000 m	1000m	Settings equivalent to the altitude of 1000 m	4000m	Settings equivalent to the altitude of 4000 m	2000m	Settings equivalent to the altitude of 2000 m			Display	Description	Setting range	Initial setting	Copy	Setting toner density at copying	-1 to +1	0
Display	Description	Setting range	Initial setting																																								
K	When replacing the developer unit or drum unit	-10 to 1 5	12																																								
Display	Description																																										
Mode1	Execute AC calibration by normal bias control																																										
Mode2	If print density is low in an installation at high altitude, execute calibration by fixing the bias potential.																																										
Display	Description																																										
High Altitude	Mode setting for AC calibration bias control																																										
Display	Description	Display	Description																																								
Default	Initial setting	3000m	Settings equivalent to the altitude of 3000 m																																								
1000m	Settings equivalent to the altitude of 1000 m	4000m	Settings equivalent to the altitude of 4000 m																																								
2000m	Settings equivalent to the altitude of 2000 m																																										
Display	Description	Setting range	Initial setting																																								
Copy	Setting toner density at copying	-1 to +1	0																																								

Item No.	Description																																					
U147	<p data-bbox="287 241 746 275"><b>Setting for toner applying operation</b></p> <p data-bbox="287 309 438 342"><b>Description</b></p> <p data-bbox="287 344 1380 412">Sets the mode for removing charged toner in the developing unit (T7 control: Toner applying operation).</p> <p data-bbox="287 414 399 448"><b>Purpose</b></p> <p data-bbox="287 450 1141 517">The setting can be changed to reduce the toner applying quantity. If the charged toner stays inside the developing unit, density decreases.</p> <p data-bbox="287 551 391 584"><b>Method</b></p> <ol data-bbox="303 586 630 654" style="list-style-type: none"> <li>1. Press the start key.</li> <li>2. Select the item to be set.</li> </ol> <table border="1" data-bbox="335 667 1401 907"> <thead> <tr> <th data-bbox="343 678 566 723">Display</th> <th data-bbox="566 678 1393 723">Description</th> </tr> </thead> <tbody> <tr> <td data-bbox="343 725 566 770">Timing</td> <td data-bbox="566 725 1393 770">Setting timing to transit to toner applying</td> </tr> <tr> <td data-bbox="343 772 566 817">Mode</td> <td data-bbox="566 772 1393 817">Settings for toner applying operation</td> </tr> <tr> <td data-bbox="343 819 566 864">Upper Limit</td> <td data-bbox="566 819 1393 864">Upper limit printing ratio of toner applying quantity with each mode</td> </tr> <tr> <td data-bbox="343 866 566 911">Minimum</td> <td data-bbox="566 866 1393 911">Toner layer width when cleaning mode is selected</td> </tr> </tbody> </table> <p data-bbox="287 947 566 981"><b>Setting: [Upper Limit]</b></p> <ol data-bbox="303 983 1053 1016" style="list-style-type: none"> <li>1. Change the setting value using the +/- keys or numeric keys.</li> </ol> <table border="1" data-bbox="335 1028 1401 1290"> <thead> <tr> <th data-bbox="343 1039 491 1128" rowspan="2">Display</th> <th data-bbox="491 1039 930 1128" rowspan="2">Description</th> <th data-bbox="930 1039 1078 1128" rowspan="2">Setting range</th> <th colspan="3" data-bbox="1078 1039 1393 1084">Initial setting</th> </tr> <tr> <th data-bbox="1078 1084 1187 1128">35ppm</th> <th data-bbox="1187 1084 1295 1128">45ppm</th> <th data-bbox="1295 1084 1393 1128">55ppm</th> </tr> </thead> <tbody> <tr> <td data-bbox="343 1131 491 1220">Paper Int</td> <td data-bbox="491 1131 930 1220">Setting number of pages to transit to toner applying (between pages)</td> <td data-bbox="930 1131 1078 1220">0 to 100</td> <td data-bbox="1078 1131 1187 1220">35</td> <td data-bbox="1187 1131 1295 1220">45</td> <td data-bbox="1295 1131 1393 1220">55</td> </tr> <tr> <td data-bbox="343 1223 491 1290">Job End</td> <td data-bbox="491 1223 930 1290">Setting number of pages to transit to toner applying (job completed)</td> <td data-bbox="930 1223 1078 1290">0 to 100</td> <td data-bbox="1078 1223 1187 1290">8</td> <td data-bbox="1187 1223 1295 1290">8</td> <td data-bbox="1295 1223 1393 1290">8</td> </tr> </tbody> </table> <ol data-bbox="303 1301 766 1335" style="list-style-type: none"> <li>2. Press the start key. The value is set.</li> </ol> <p data-bbox="287 1368 486 1402"><b>Setting: [Mode]</b></p> <ol data-bbox="303 1404 534 1438" style="list-style-type: none"> <li>1. Select the mode.</li> </ol> <table border="1" data-bbox="335 1449 1401 1592"> <thead> <tr> <th data-bbox="343 1460 566 1505">Display</th> <th data-bbox="566 1460 1393 1505">Description</th> </tr> </thead> <tbody> <tr> <td data-bbox="343 1507 566 1552">Mode0</td> <td data-bbox="566 1507 1393 1552">Less consumption of toner than a regular toner applying operation</td> </tr> <tr> <td data-bbox="343 1554 566 1599">Mode1</td> <td data-bbox="566 1554 1393 1599">Executes toner applying with the regular amount of toner</td> </tr> </tbody> </table> <p data-bbox="335 1603 582 1637">Initial setting; Mode1</p> <ol data-bbox="303 1639 782 1673" style="list-style-type: none"> <li>2. Press the start key. The setting is set.</li> </ol>	Display	Description	Timing	Setting timing to transit to toner applying	Mode	Settings for toner applying operation	Upper Limit	Upper limit printing ratio of toner applying quantity with each mode	Minimum	Toner layer width when cleaning mode is selected	Display	Description	Setting range	Initial setting			35ppm	45ppm	55ppm	Paper Int	Setting number of pages to transit to toner applying (between pages)	0 to 100	35	45	55	Job End	Setting number of pages to transit to toner applying (job completed)	0 to 100	8	8	8	Display	Description	Mode0	Less consumption of toner than a regular toner applying operation	Mode1	Executes toner applying with the regular amount of toner
Display	Description																																					
Timing	Setting timing to transit to toner applying																																					
Mode	Settings for toner applying operation																																					
Upper Limit	Upper limit printing ratio of toner applying quantity with each mode																																					
Minimum	Toner layer width when cleaning mode is selected																																					
Display	Description	Setting range	Initial setting																																			
			35ppm	45ppm	55ppm																																	
Paper Int	Setting number of pages to transit to toner applying (between pages)	0 to 100	35	45	55																																	
Job End	Setting number of pages to transit to toner applying (job completed)	0 to 100	8	8	8																																	
Display	Description																																					
Mode0	Less consumption of toner than a regular toner applying operation																																					
Mode1	Executes toner applying with the regular amount of toner																																					

Item No.	Description																
U147	<p><b>Setting: [Upper Limit]</b></p> <p>1. Change the setting value using the +/- keys or numeric keys.</p> <table border="1" data-bbox="336 320 1401 488"> <thead> <tr> <th data-bbox="336 320 520 398">Display</th> <th data-bbox="520 320 1066 398">Description</th> <th data-bbox="1066 320 1233 398">Setting range</th> <th data-bbox="1233 320 1401 398">Initial setting</th> </tr> </thead> <tbody> <tr> <td data-bbox="336 398 520 488">Value</td> <td data-bbox="520 398 1066 488">Upper limit printing ratio of toner applying quantity with each mode (%)</td> <td data-bbox="1066 398 1233 488">0 to 2.0</td> <td data-bbox="1233 398 1401 488">2.0</td> </tr> </tbody> </table> <p>2. Press the start key. The value is set.</p> <p><b>Setting: [Minimum]</b></p> <p>1. Change the setting value using the +/- keys or numeric keys.</p> <table border="1" data-bbox="336 640 1401 808"> <thead> <tr> <th data-bbox="336 640 520 719">Display</th> <th data-bbox="520 640 1066 719">Description</th> <th data-bbox="1066 640 1233 719">Setting range</th> <th data-bbox="1233 640 1401 719">Initial setting</th> </tr> </thead> <tbody> <tr> <td data-bbox="336 719 520 808">Value</td> <td data-bbox="520 719 1066 808">Toner layer width when cleaning mode is selected (mm)</td> <td data-bbox="1066 719 1233 808">0 to 30</td> <td data-bbox="1233 719 1401 808">10</td> </tr> </tbody> </table> <p>2. Press the start key. The value is set.</p> <p><b>Completion</b></p> <p>Press the stop key. The screen for selecting a maintenance item No. is displayed.</p>	Display	Description	Setting range	Initial setting	Value	Upper limit printing ratio of toner applying quantity with each mode (%)	0 to 2.0	2.0	Display	Description	Setting range	Initial setting	Value	Toner layer width when cleaning mode is selected (mm)	0 to 30	10
Display	Description	Setting range	Initial setting														
Value	Upper limit printing ratio of toner applying quantity with each mode (%)	0 to 2.0	2.0														
Display	Description	Setting range	Initial setting														
Value	Toner layer width when cleaning mode is selected (mm)	0 to 30	10														
U148	<p><b>Setting drum refresh mode</b></p> <p><b>Description</b></p> <p>Selects the mode used in drum refreshing</p> <p><b>Purpose</b></p> <p>Change settings when drum refreshing is too frequently executed.</p> <p><b>Setting</b></p> <p>1. Press the start key.</p> <p>2. Select the mode.</p> <table border="1" data-bbox="336 1323 1401 1503"> <thead> <tr> <th data-bbox="336 1323 528 1368">Display</th> <th data-bbox="528 1323 1007 1368">Description</th> <th data-bbox="1007 1323 1198 1368">Setting range</th> <th data-bbox="1198 1323 1401 1368">Initial setting</th> </tr> </thead> <tbody> <tr> <td data-bbox="336 1368 528 1413">Normal*1</td> <td data-bbox="528 1368 1007 1413">Automatic drum refreshing setting</td> <td data-bbox="1007 1368 1198 1413">0 to 3</td> <td data-bbox="1198 1368 1401 1413">2</td> </tr> <tr> <td data-bbox="336 1413 528 1503">Dew Condensation*2</td> <td data-bbox="528 1413 1007 1503">Dew condensation drum refreshing setting</td> <td data-bbox="1007 1413 1198 1503">0 to 3</td> <td data-bbox="1198 1413 1401 1503">0</td> </tr> </tbody> </table> <p>* 1: 0: Off / 1: Short / 2: Standard / 3: Long</p> <p>* 2 : 0:Mode0/ 1:Mode1/ 2:Mode2/ 3:Mode3</p> <p>Larger the number, more the times of the refresh.</p> <p>3. Press the start key. The setting is set.</p> <p><b>Completion</b></p> <p>Press the stop key. The screen for selecting a maintenance item No. is displayed.</p>	Display	Description	Setting range	Initial setting	Normal*1	Automatic drum refreshing setting	0 to 3	2	Dew Condensation*2	Dew condensation drum refreshing setting	0 to 3	0				
Display	Description	Setting range	Initial setting														
Normal*1	Automatic drum refreshing setting	0 to 3	2														
Dew Condensation*2	Dew condensation drum refreshing setting	0 to 3	0														

Item No.	Description																		
U155	<p data-bbox="288 241 639 275"><b>Checking sensors for toner</b></p> <p data-bbox="288 311 440 342"><b>Description</b></p> <p data-bbox="288 344 754 376">Displays the toner sensor output value.</p> <p data-bbox="288 380 400 412"><b>Purpose</b></p> <p data-bbox="288 414 994 445">To check the output value when any image problems occur.</p> <p data-bbox="288 483 387 515"><b>Method</b></p> <ol data-bbox="304 517 679 584" style="list-style-type: none"> <li>1. Press the start key.</li> <li>2. Select the item to be display.</li> </ol> <table border="1" data-bbox="336 595 1401 741"> <thead> <tr> <th data-bbox="336 595 639 640">Display</th> <th data-bbox="639 595 1401 640">Description</th> </tr> </thead> <tbody> <tr> <td data-bbox="336 640 639 685">Waste Toner</td> <td data-bbox="639 640 1401 685">Control voltage value of the waste toner sensor</td> </tr> <tr> <td data-bbox="336 685 639 741">Toner</td> <td data-bbox="639 685 1401 741">Control voltage value and replenishment level of toner sensor</td> </tr> </tbody> </table> <p data-bbox="288 784 579 815"><b>Method: [Waste Toner]</b></p> <ol data-bbox="304 817 1027 848" style="list-style-type: none"> <li>1. Check the status of sensor. The current value is displayed.</li> </ol> <table border="1" data-bbox="336 860 1401 1005"> <thead> <tr> <th data-bbox="336 860 639 904">Display</th> <th data-bbox="639 860 1401 904">Description</th> </tr> </thead> <tbody> <tr> <td data-bbox="336 904 639 949">Full</td> <td data-bbox="639 904 1401 949">Waste toner sensor 1 (WTS1)</td> </tr> <tr> <td data-bbox="336 949 639 1005">Near Full</td> <td data-bbox="639 949 1401 1005">Waste toner sensor 2 (WTS2)</td> </tr> </tbody> </table> <p data-bbox="288 1052 496 1084"><b>Method: [Toner]</b></p> <ol data-bbox="304 1086 1027 1117" style="list-style-type: none"> <li>1. Check the status of sensor. The current value is displayed.</li> </ol> <table border="1" data-bbox="336 1128 1401 1274"> <thead> <tr> <th data-bbox="336 1128 639 1173">Display</th> <th data-bbox="639 1128 1401 1173">Description</th> </tr> </thead> <tbody> <tr> <td data-bbox="336 1173 639 1218">Sensor(K)</td> <td data-bbox="639 1173 1401 1218">Toner sensor output value</td> </tr> <tr> <td data-bbox="336 1218 639 1274">Supply(K)</td> <td data-bbox="639 1218 1401 1274">Toner replenishment level</td> </tr> </tbody> </table> <p data-bbox="288 1321 440 1352"><b>Completion</b></p> <p data-bbox="288 1355 1254 1386">Press the stop key. The screen for selecting a maintenance item No. is displayed.</p>	Display	Description	Waste Toner	Control voltage value of the waste toner sensor	Toner	Control voltage value and replenishment level of toner sensor	Display	Description	Full	Waste toner sensor 1 (WTS1)	Near Full	Waste toner sensor 2 (WTS2)	Display	Description	Sensor(K)	Toner sensor output value	Supply(K)	Toner replenishment level
Display	Description																		
Waste Toner	Control voltage value of the waste toner sensor																		
Toner	Control voltage value and replenishment level of toner sensor																		
Display	Description																		
Full	Waste toner sensor 1 (WTS1)																		
Near Full	Waste toner sensor 2 (WTS2)																		
Display	Description																		
Sensor(K)	Toner sensor output value																		
Supply(K)	Toner replenishment level																		



Item No.	Description																						
U156	<p data-bbox="290 241 762 271"><b>Setting the toner replenishment level</b></p> <p data-bbox="290 311 440 340"><b>Description</b> Sets the toner replenishment level for each color.</p> <p data-bbox="290 380 400 409"><b>Purpose</b> To change settings according to the original image.</p> <p data-bbox="290 486 387 515"><b>Method</b></p> <ol data-bbox="308 519 632 582" style="list-style-type: none"> <li>1. Press the start key.</li> <li>2. Select the item to be set.</li> </ol> <table border="1" data-bbox="336 595 1401 741"> <thead> <tr> <th data-bbox="336 595 641 640">Display</th> <th data-bbox="641 595 1401 640">Description</th> </tr> </thead> <tbody> <tr> <td data-bbox="336 640 641 685">Supply</td> <td data-bbox="641 640 1401 685">Setting the toner replenishment level</td> </tr> <tr> <td data-bbox="336 685 641 741">Empty</td> <td data-bbox="641 685 1401 741">Setting the toner empty level</td> </tr> </tbody> </table> <p data-bbox="290 786 512 815"><b>Method: [Supply]</b></p> <ol data-bbox="308 819 1350 882" style="list-style-type: none"> <li>1. Change the setting value using the +/- or numeric keys. Increasing the setting makes the image lighter; decreasing it makes the image darker.</li> </ol> <table border="1" data-bbox="336 898 1401 1030"> <thead> <tr> <th data-bbox="336 898 528 981">Display</th> <th data-bbox="528 898 1094 981">Description</th> <th data-bbox="1094 898 1249 981">Setting range</th> <th data-bbox="1249 898 1401 981">Initial setting</th> </tr> </thead> <tbody> <tr> <td data-bbox="336 981 528 1030">K</td> <td data-bbox="528 981 1094 1030">Toner replenishment level</td> <td data-bbox="1094 981 1249 1030">0 to 900</td> <td data-bbox="1249 981 1401 1030">512</td> </tr> </tbody> </table> <ol data-bbox="308 1043 767 1072" style="list-style-type: none"> <li>2. Press the start key. The value is set.</li> </ol> <p data-bbox="290 1113 504 1142"><b>Method: [Empty]</b></p> <ol data-bbox="308 1146 1362 1247" style="list-style-type: none"> <li>1. Change the setting value using the +/- or numeric keys. Increasing the setting makes 'toner empty' appear later and decreasing it makes 'toner empty' appear earlier.</li> </ol> <table border="1" data-bbox="336 1261 1401 1393"> <thead> <tr> <th data-bbox="336 1261 528 1344">Display</th> <th data-bbox="528 1261 1094 1344">Description</th> <th data-bbox="1094 1261 1249 1344">Setting range</th> <th data-bbox="1249 1261 1401 1344">Initial setting</th> </tr> </thead> <tbody> <tr> <td data-bbox="336 1344 528 1393">K</td> <td data-bbox="528 1344 1094 1393">Toner empty level</td> <td data-bbox="1094 1344 1249 1393">0 to 1023</td> <td data-bbox="1249 1344 1401 1393">100</td> </tr> </tbody> </table> <ol data-bbox="308 1406 767 1435" style="list-style-type: none"> <li>2. Press the start key. The value is set.</li> </ol> <p data-bbox="290 1471 440 1500"><b>Completion</b> Press the stop key. The screen for selecting a maintenance item No. is displayed.</p>	Display	Description	Supply	Setting the toner replenishment level	Empty	Setting the toner empty level	Display	Description	Setting range	Initial setting	K	Toner replenishment level	0 to 900	512	Display	Description	Setting range	Initial setting	K	Toner empty level	0 to 1023	100
Display	Description																						
Supply	Setting the toner replenishment level																						
Empty	Setting the toner empty level																						
Display	Description	Setting range	Initial setting																				
K	Toner replenishment level	0 to 900	512																				
Display	Description	Setting range	Initial setting																				
K	Toner empty level	0 to 1023	100																				

Item No.	Description				
U157	<p><b>Checking the developer drive time</b></p> <p><b>Description</b> Displays the developer drive time for checking a figure, which is used as a reference when correcting the toner control.</p> <p><b>Purpose</b> To check the developer drive time after replacing the developer unit.</p> <p><b>Method</b> 1. Press the start key. The developer drive time is displayed.</p> <table border="1" data-bbox="336 600 1401 696"> <thead> <tr> <th data-bbox="336 600 641 645">Display</th> <th data-bbox="641 600 1401 645">Description</th> </tr> </thead> <tbody> <tr> <td data-bbox="336 645 641 696">K</td> <td data-bbox="641 645 1401 696">Developer drive time</td> </tr> </tbody> </table> <p><b>Completion</b> Press the stop key. The screen for selecting a maintenance item No. is displayed.</p>	Display	Description	K	Developer drive time
Display	Description				
K	Developer drive time				
U158	<p><b>Checking the developer count</b></p> <p><b>Description</b> Displays the developer count for checking.</p> <p><b>Purpose</b> To check the developer unit status.</p> <p><b>Method</b> 1. Press the start key. The current developer counts is displayed.</p> <table border="1" data-bbox="336 1142 1401 1238"> <thead> <tr> <th data-bbox="336 1142 641 1187">Display</th> <th data-bbox="641 1142 1401 1187">Description</th> </tr> </thead> <tbody> <tr> <td data-bbox="336 1187 641 1238">K</td> <td data-bbox="641 1187 1401 1238">Developer count value</td> </tr> </tbody> </table> <p><b>Completion</b> Press the stop key. The screen for selecting a maintenance item No. is displayed.</p>	Display	Description	K	Developer count value
Display	Description				
K	Developer count value				

Item No.	Description																																																							
U161	<p data-bbox="288 241 766 275"><b>Setting the fuser control temperature</b></p> <p data-bbox="288 311 440 340"><b>Description</b></p> <p data-bbox="288 344 758 374">Changes the fuser control temperature.</p> <p data-bbox="288 380 400 409"><b>Purpose</b></p> <p data-bbox="288 414 1425 479">Normally no change is necessary. However, can be used to prevent curling or creasing of paper, or solve a fuser problem on thick paper.</p> <p data-bbox="288 517 387 546"><b>Method</b></p> <ol data-bbox="304 553 632 618" style="list-style-type: none"> <li>1. Press the start key.</li> <li>2. Select the item to be set.</li> </ol> <table border="1" data-bbox="336 631 1401 871"> <thead> <tr> <th data-bbox="336 631 639 676">Display</th> <th data-bbox="639 631 1401 676">Description</th> </tr> </thead> <tbody> <tr> <td data-bbox="336 676 639 721">Warm Up</td> <td data-bbox="639 676 1401 721">Control temperature except at printing</td> </tr> <tr> <td data-bbox="336 721 639 766">Print</td> <td data-bbox="639 721 1401 766">Control temperature during printing</td> </tr> <tr> <td data-bbox="336 766 639 810">Jam Prevent Mode</td> <td data-bbox="639 766 1401 810">Setting fuser separation mode</td> </tr> <tr> <td data-bbox="336 810 639 855">Toner Stain Reduce</td> <td data-bbox="639 810 1401 855">Reduce toner stain mode</td> </tr> </tbody> </table> <p data-bbox="288 918 533 947"><b>Setting: [Warm Up]</b></p> <ol data-bbox="304 954 858 1019" style="list-style-type: none"> <li>1. Select the item to be set.</li> <li>2. Change the setting value using the +/- keys.</li> </ol> <table border="1" data-bbox="336 1032 1401 1624"> <thead> <tr> <th data-bbox="336 1032 520 1122" rowspan="2">Display</th> <th data-bbox="520 1032 922 1122" rowspan="2">Description</th> <th data-bbox="922 1032 1102 1122" rowspan="2">Setting range</th> <th colspan="3" data-bbox="1102 1032 1401 1077">Initial setting</th> </tr> <tr> <th data-bbox="1102 1077 1203 1122">35ppm</th> <th data-bbox="1203 1077 1303 1122">45ppm</th> <th data-bbox="1303 1077 1401 1122">55ppm</th> </tr> </thead> <tbody> <tr> <td data-bbox="336 1122 520 1211">Ready (Center)</td> <td data-bbox="520 1122 922 1211">Control temperature at displaying Ready (Center)</td> <td data-bbox="922 1122 1102 1211">130 to 200 (°C)</td> <td data-bbox="1102 1122 1203 1211">110</td> <td data-bbox="1203 1122 1303 1211">110</td> <td data-bbox="1303 1122 1401 1211">110</td> </tr> <tr> <td data-bbox="336 1211 520 1301">Ready (Edge)</td> <td data-bbox="520 1211 922 1301">Control temperature at displaying Ready (Edge)</td> <td data-bbox="922 1211 1102 1301">100 to 200 (°C)</td> <td data-bbox="1102 1211 1203 1301">110</td> <td data-bbox="1203 1211 1303 1301">110</td> <td data-bbox="1303 1211 1401 1301">110</td> </tr> <tr> <td data-bbox="336 1301 520 1391">Drive (Center)</td> <td data-bbox="520 1301 922 1391">Stable temperature during driving (Center)</td> <td data-bbox="922 1301 1102 1391">130 to 200 (°C)</td> <td data-bbox="1102 1301 1203 1391">155</td> <td data-bbox="1203 1301 1303 1391">160</td> <td data-bbox="1303 1301 1401 1391">170</td> </tr> <tr> <td data-bbox="336 1391 520 1480">Drive (Edge)</td> <td data-bbox="520 1391 922 1480">Stable temperature during driving (Edge)</td> <td data-bbox="922 1391 1102 1480">100 to 200 (°C)</td> <td data-bbox="1102 1391 1203 1480">150</td> <td data-bbox="1203 1391 1303 1480">155</td> <td data-bbox="1303 1391 1401 1480">165</td> </tr> <tr> <td data-bbox="336 1480 520 1570">Wait (Center)</td> <td data-bbox="520 1480 922 1570">Stable temperature during halt (Center)</td> <td data-bbox="922 1480 1102 1570">130 to 200 (°C)</td> <td data-bbox="1102 1480 1203 1570">155</td> <td data-bbox="1203 1480 1303 1570">160</td> <td data-bbox="1303 1480 1401 1570">170</td> </tr> <tr> <td data-bbox="336 1570 520 1624">Wait (Edge)</td> <td data-bbox="520 1570 922 1624">Stable temperature during halt (Edge)</td> <td data-bbox="922 1570 1102 1624">100 to 200 (°C)</td> <td data-bbox="1102 1570 1203 1624">160</td> <td data-bbox="1203 1570 1303 1624">160</td> <td data-bbox="1303 1570 1401 1624">160</td> </tr> </tbody> </table> <ol data-bbox="304 1637 766 1666" style="list-style-type: none"> <li>3. Press the start key. The value is set.</li> </ol>	Display	Description	Warm Up	Control temperature except at printing	Print	Control temperature during printing	Jam Prevent Mode	Setting fuser separation mode	Toner Stain Reduce	Reduce toner stain mode	Display	Description	Setting range	Initial setting			35ppm	45ppm	55ppm	Ready (Center)	Control temperature at displaying Ready (Center)	130 to 200 (°C)	110	110	110	Ready (Edge)	Control temperature at displaying Ready (Edge)	100 to 200 (°C)	110	110	110	Drive (Center)	Stable temperature during driving (Center)	130 to 200 (°C)	155	160	170	Drive (Edge)	Stable temperature during driving (Edge)	100 to 200 (°C)	150	155	165	Wait (Center)	Stable temperature during halt (Center)	130 to 200 (°C)	155	160	170	Wait (Edge)	Stable temperature during halt (Edge)	100 to 200 (°C)	160	160	160
Display	Description																																																							
Warm Up	Control temperature except at printing																																																							
Print	Control temperature during printing																																																							
Jam Prevent Mode	Setting fuser separation mode																																																							
Toner Stain Reduce	Reduce toner stain mode																																																							
Display	Description	Setting range	Initial setting																																																					
			35ppm	45ppm	55ppm																																																			
Ready (Center)	Control temperature at displaying Ready (Center)	130 to 200 (°C)	110	110	110																																																			
Ready (Edge)	Control temperature at displaying Ready (Edge)	100 to 200 (°C)	110	110	110																																																			
Drive (Center)	Stable temperature during driving (Center)	130 to 200 (°C)	155	160	170																																																			
Drive (Edge)	Stable temperature during driving (Edge)	100 to 200 (°C)	150	155	165																																																			
Wait (Center)	Stable temperature during halt (Center)	130 to 200 (°C)	155	160	170																																																			
Wait (Edge)	Stable temperature during halt (Edge)	100 to 200 (°C)	160	160	160																																																			

Item No.	Description																																																																		
U161	<p><b>Setting: [Print]</b></p> <ol style="list-style-type: none"> <li>Select the item to be set.</li> <li>Change the setting value using the +/- keys.</li> </ol> <table border="1" data-bbox="336 353 1401 698"> <thead> <tr> <th rowspan="2">Display</th> <th rowspan="2">Description</th> <th rowspan="2">Setting range</th> <th colspan="3">Initial setting</th> </tr> <tr> <th>35ppm</th> <th>45ppm</th> <th>55ppm</th> </tr> </thead> <tbody> <tr> <td>Full Speed Print(Center)</td> <td>Temperature at maximum print speed (Center)</td> <td>130 to 200 (°C)</td> <td>160</td> <td>165</td> <td>175</td> </tr> <tr> <td>Full Speed Print(Edge)</td> <td>Temperature at maximum print speed (Edge)</td> <td>100 to 200 (°C)</td> <td>170</td> <td>175</td> <td>185</td> </tr> <tr> <td>Duplex Shift (Center)</td> <td>Temperature at duplex printing (Center)</td> <td>-20 to 20 (°C)</td> <td>0</td> <td>0</td> <td>0</td> </tr> </tbody> </table> <ol style="list-style-type: none"> <li>Press the start key. The value is set.</li> </ol> <p><b>Setting: [Jam Prevent Mode]</b></p> <ol style="list-style-type: none"> <li>Select On or Off.</li> </ol> <table border="1" data-bbox="336 855 1401 999"> <thead> <tr> <th>Display</th> <th>Description</th> </tr> </thead> <tbody> <tr> <td>On</td> <td>Turn the fuser separation mode to on.</td> </tr> <tr> <td>Off</td> <td>Turn the fuser separation mode to off.</td> </tr> </tbody> </table> <p>Initial setting: Off</p> <ol style="list-style-type: none"> <li>Select the item to be set.</li> <li>Change the setting value using the +/- keys.</li> </ol> <table border="1" data-bbox="336 1122 1401 1431"> <thead> <tr> <th rowspan="2">Display</th> <th rowspan="2">Description</th> <th rowspan="2">Setting range</th> <th colspan="3">Initial setting</th> </tr> <tr> <th>35ppm</th> <th>45ppm</th> <th>55ppm</th> </tr> </thead> <tbody> <tr> <td>Print</td> <td>Print compensation temperature</td> <td>-30 to 0 (°C)</td> <td>-10</td> <td>-10</td> <td>-15</td> </tr> <tr> <td>Ready</td> <td>Ready compensation temperature</td> <td>-30 to 0 (°C)</td> <td>-10</td> <td>-10</td> <td>-15</td> </tr> <tr> <td>Feed2</td> <td>Secondary feeding start compensation temperature</td> <td>-30 to 0 (°C)</td> <td>-10</td> <td>-10</td> <td>-10</td> </tr> </tbody> </table> <ol style="list-style-type: none"> <li>Press the start key. The value is set.</li> </ol> <p><b>Setting: [Toner Stain Reduce]</b></p> <ol style="list-style-type: none"> <li>Select On or Off.</li> </ol> <table border="1" data-bbox="336 1594 1401 1738"> <thead> <tr> <th>Display</th> <th>Description</th> </tr> </thead> <tbody> <tr> <td>On</td> <td>Reduce toner stain mode to on.</td> </tr> <tr> <td>Off</td> <td>Reduce toner stain mode to off.</td> </tr> </tbody> </table> <p>Initial setting: Off</p> <p>* : If it is enabled, the fuser is stopped for 3 seconds in every 50 continuous pages. Then, the claws contamination is reduced by ejecting the contamination at the time of feeding the next paper.</p> <ol style="list-style-type: none"> <li>Press the start key. The setting is set. Select the item to be set.</li> </ol> <p><b>Completion</b></p> <p>Press the stop key. The screen for selecting a maintenance item No. is displayed.</p>	Display	Description	Setting range	Initial setting			35ppm	45ppm	55ppm	Full Speed Print(Center)	Temperature at maximum print speed (Center)	130 to 200 (°C)	160	165	175	Full Speed Print(Edge)	Temperature at maximum print speed (Edge)	100 to 200 (°C)	170	175	185	Duplex Shift (Center)	Temperature at duplex printing (Center)	-20 to 20 (°C)	0	0	0	Display	Description	On	Turn the fuser separation mode to on.	Off	Turn the fuser separation mode to off.	Display	Description	Setting range	Initial setting			35ppm	45ppm	55ppm	Print	Print compensation temperature	-30 to 0 (°C)	-10	-10	-15	Ready	Ready compensation temperature	-30 to 0 (°C)	-10	-10	-15	Feed2	Secondary feeding start compensation temperature	-30 to 0 (°C)	-10	-10	-10	Display	Description	On	Reduce toner stain mode to on.	Off	Reduce toner stain mode to off.
Display	Description				Setting range	Initial setting																																																													
		35ppm	45ppm	55ppm																																																															
Full Speed Print(Center)	Temperature at maximum print speed (Center)	130 to 200 (°C)	160	165	175																																																														
Full Speed Print(Edge)	Temperature at maximum print speed (Edge)	100 to 200 (°C)	170	175	185																																																														
Duplex Shift (Center)	Temperature at duplex printing (Center)	-20 to 20 (°C)	0	0	0																																																														
Display	Description																																																																		
On	Turn the fuser separation mode to on.																																																																		
Off	Turn the fuser separation mode to off.																																																																		
Display	Description	Setting range	Initial setting																																																																
			35ppm	45ppm	55ppm																																																														
Print	Print compensation temperature	-30 to 0 (°C)	-10	-10	-15																																																														
Ready	Ready compensation temperature	-30 to 0 (°C)	-10	-10	-15																																																														
Feed2	Secondary feeding start compensation temperature	-30 to 0 (°C)	-10	-10	-10																																																														
Display	Description																																																																		
On	Reduce toner stain mode to on.																																																																		
Off	Reduce toner stain mode to off.																																																																		

Item No.	Description						
U167	<p><b>Checking/clearing the fuser count</b></p> <p><b>Description</b> Displays and clears the fuser count for checking.</p> <p><b>Purpose</b> To check the fuser count after replacement of the fuser unit. Also to clear the counts after replacing unit.</p> <p><b>Method</b> 1. Press the start key. The fuser count is displayed.</p> <table border="1" data-bbox="336 595 1401 741"> <thead> <tr> <th data-bbox="336 595 641 640">Display</th> <th data-bbox="641 595 1401 640">Description</th> </tr> </thead> <tbody> <tr> <td data-bbox="336 640 641 685">Cnt</td> <td data-bbox="641 640 1401 685">Fuser unit count value</td> </tr> <tr> <td data-bbox="336 685 641 741">Clear</td> <td data-bbox="641 685 1401 741">Clear the fuser unit count</td> </tr> </tbody> </table> <p><b>Clearing</b> 1. Press [Clear]. 2. Press the start key. The count is cleared.</p> <p><b>Completion</b> Press the stop key. The screen for selecting a maintenance item No. is displayed.</p>	Display	Description	Cnt	Fuser unit count value	Clear	Clear the fuser unit count
Display	Description						
Cnt	Fuser unit count value						
Clear	Clear the fuser unit count						
U199	<p><b>Displaying fuser heater temperature</b></p> <p><b>Description</b> Displays the detected fuser temperature.</p> <p><b>Purpose</b> To check the fuser temperature.</p> <p><b>Method</b> 1. Press the start key. The fuser temperature is displayed.</p> <table border="1" data-bbox="336 1323 1401 1469"> <thead> <tr> <th data-bbox="336 1323 641 1368">Display</th> <th data-bbox="641 1323 1401 1368">Description</th> </tr> </thead> <tbody> <tr> <td data-bbox="336 1368 641 1413">Heat Roller Edge1</td> <td data-bbox="641 1368 1401 1413">Heat roller edge temperature (°C)</td> </tr> <tr> <td data-bbox="336 1413 641 1469">Heat Roller Center</td> <td data-bbox="641 1413 1401 1469">Heat roller center temperature (°C)</td> </tr> </tbody> </table> <p><b>Completion</b> Press the stop key. The screen for selecting a maintenance mode No. is displayed.</p>	Display	Description	Heat Roller Edge1	Heat roller edge temperature (°C)	Heat Roller Center	Heat roller center temperature (°C)
Display	Description						
Heat Roller Edge1	Heat roller edge temperature (°C)						
Heat Roller Center	Heat roller center temperature (°C)						

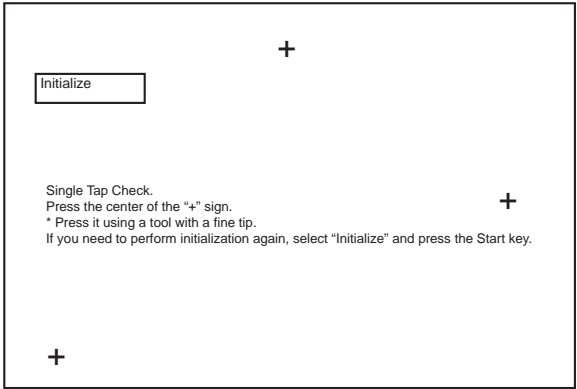
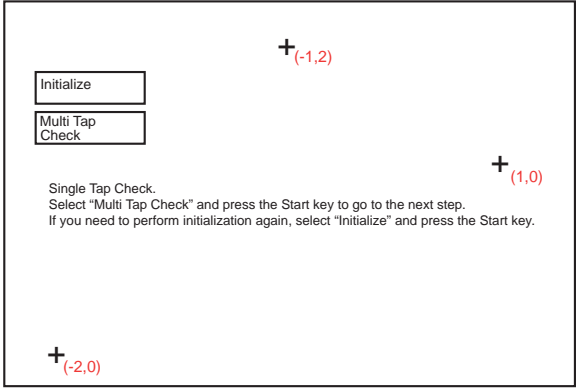
Item No.	Description
U200	<p data-bbox="288 241 544 275"><b>Turning all LEDs on</b></p> <p data-bbox="288 315 440 342"><b>Description</b></p> <p data-bbox="288 349 815 376">Turn all the LEDs on the operation panel on.</p> <p data-bbox="288 387 400 414"><b>Purpose</b></p> <p data-bbox="288 421 906 448">To check if all the LEDs on the operation panel light.</p> <p data-bbox="288 488 387 515"><b>Method</b></p> <ol data-bbox="308 521 1050 656" style="list-style-type: none"><li>1. Press the start key.</li><li>2. Select [Execute].</li><li>3. Press the start key. All the LEDs on the operation panel light.</li><li>4. Press the stop key. The LEDs Turn off.</li></ol> <p data-bbox="288 696 440 723"><b>Completion</b></p> <p data-bbox="288 730 1254 757">Press the stop key. The screen for selecting a maintenance item No. is displayed.</p>

Item No.	Description						
<p><b>U201</b></p>	<p><b>Initializing the touch panel</b></p> <p><b>Description</b> Adjust touch panel detecting positions.</p> <p><b>Purpose</b> When the panel PWB or the operation panel is replaced or if the detecting positions are not aligned, perform this simulation to correct and confirm.</p> <p><b>Method</b></p> <ol style="list-style-type: none"> <li>1. Press the start key.</li> <li>2. Select the [Initialize] or [Check].</li> </ol> <table border="1" data-bbox="336 633 1401 777"> <thead> <tr> <th data-bbox="336 633 641 678">Display</th> <th data-bbox="641 633 1401 678">Description</th> </tr> </thead> <tbody> <tr> <td data-bbox="336 678 641 723">Initialize</td> <td data-bbox="641 678 1401 723">Execute the correction of the touch panel display position.</td> </tr> <tr> <td data-bbox="336 723 641 777">Check</td> <td data-bbox="641 723 1401 777">Confirm the display position of touch panel.</td> </tr> </tbody> </table> <div data-bbox="839 844 1415 1236" style="border: 1px solid black; padding: 5px; margin: 10px 0;"> <p>Maintenance Mode Maintenance Mode Active U201 Initialize Touch Panel</p> <div style="border: 1px solid black; padding: 2px; width: fit-content; margin: 5px 0;">Initialize</div> <div style="border: 1px solid black; padding: 2px; width: fit-content; margin: 5px 0;">Check</div> </div> <p style="text-align: center;"><b>Figure 1-3-17</b></p> <p><b>Method: [Initialize]</b></p> <ol style="list-style-type: none"> <li>1. Press the start key.</li> <li>2. Tap the center of the + sign.</li> <li>3. Press the center of the [+] key displayed next.</li> </ol> <p>* : Press it using a tool with a fine tip.</p> <div data-bbox="839 1447 1415 1818" style="border: 1px solid black; padding: 10px; margin: 10px 0;"> <p style="text-align: center; font-size: 2em;">+</p> <p style="text-align: center; font-size: 0.8em;">Press the center of the "+" sign. * Press it using a tool with a fine tip.</p> </div> <p style="text-align: center;"><b>Figure 1-3-18</b></p>	Display	Description	Initialize	Execute the correction of the touch panel display position.	Check	Confirm the display position of touch panel.
Display	Description						
Initialize	Execute the correction of the touch panel display position.						
Check	Confirm the display position of touch panel.						

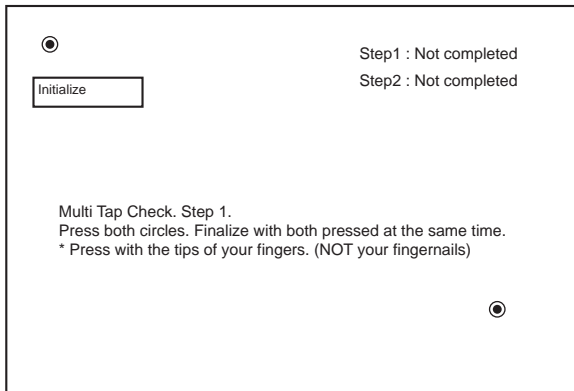
Item No.	Description
U201	<div data-bbox="839 259 1415 636" style="border: 1px solid black; padding: 10px; margin-bottom: 20px;"> <p style="text-align: center;">Press the center of the "+" sign. * Press it using a tool with a fine tip.</p> <p style="text-align: right; margin-right: 20px;">+</p> </div> <p style="text-align: center;"><b>Figure 1-3-19</b></p> <div data-bbox="304 835 810 1153" style="margin-bottom: 20px;"> <p>4. If two " ● " signs appear, press the both points at the same time. * : While pressing down one of " ● " sign, press the other " ● " sign. Setting values are obtained at the time when two " ● " signs are pressed at the same time. * : Press with the tip of your fingers (Not your fingernails).</p> </div> <div data-bbox="839 813 1415 1191" style="border: 1px solid black; padding: 10px; margin-bottom: 20px;"> <p style="text-align: center;">Press both circles. Finalize with both pressed at the same time. * Press with the tips of your fingers. (NOT your fingernails)</p> <p style="text-align: right; margin-right: 20px;">●</p> </div> <p style="text-align: center;"><b>Figure 1-3-20</b></p> <div data-bbox="304 1368 810 1435" style="margin-bottom: 20px;"> <p>5. Press the center of two " ● " signs displayed next at the same time.</p> </div> <div data-bbox="839 1346 1415 1724" style="border: 1px solid black; padding: 10px;"> <p style="text-align: center;">Press both circles. Finalize with both pressed at the same time. Press with the tips of your fingers. (NOT your fingernails)</p> <p style="text-align: right; margin-right: 20px;">●</p> <p style="text-align: left; margin-left: 20px;">●</p> </div> <p style="text-align: center;"><b>Figure 1-3-21</b></p>



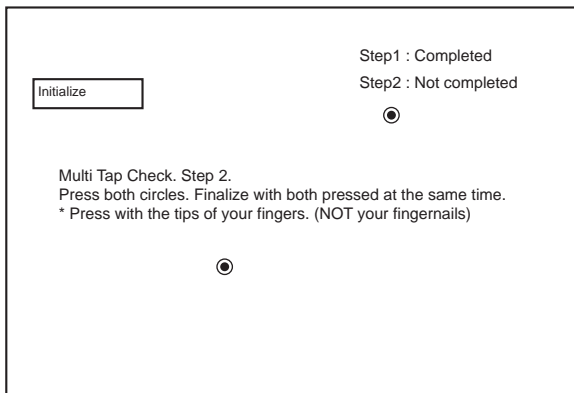
Item No.	Description
U201	<p data-bbox="304 277 788 376">6. Press the center of "+" sign displayed, as step 2 7. Repeat three times.</p> <div data-bbox="841 277 1415 647" style="border: 1px solid black; padding: 10px; margin: 10px 0;"> <p data-bbox="863 450 1374 510" style="text-align: center;">Press the center of the "+" sign. * Press it using a tool with a fine tip. If you cannot proceed to the next step, press the Stop key and try again.</p> <p data-bbox="879 607 895 629" style="text-align: center;">+</p> </div> <p data-bbox="1082 696 1246 719" style="text-align: center;"><b>Figure 1-3-22</b></p> <div data-bbox="841 792 1415 1164" style="border: 1px solid black; padding: 10px; margin: 10px 0;"> <p data-bbox="863 965 1374 1025" style="text-align: center;">Press the center of the "+" sign. * Press it using a tool with a fine tip. If you cannot proceed to the next step,press the Stop key and try again.</p> <p data-bbox="1337 949 1353 972" style="text-align: right;">+</p> </div> <p data-bbox="1082 1211 1246 1234" style="text-align: center;"><b>Figure 1-3-23</b></p> <div data-bbox="841 1341 1415 1713" style="border: 1px solid black; padding: 10px; margin: 10px 0;"> <p data-bbox="1102 1368 1118 1391" style="text-align: center;">+</p> <p data-bbox="863 1518 1374 1579" style="text-align: center;">Press the center of the "+" sign. * Press it using a tool with a fine tip. If you cannot proceed to the next step, press the Stop key and try again.</p> </div> <p data-bbox="1082 1765 1246 1787" style="text-align: center;"><b>Figure 1-3-24</b></p>

Item No.	Description
<p><b>U201</b></p>	<p>8. After completing the setting, "Initialize Completed." is displayed and entering Check mode.</p> <div data-bbox="839 271 1417 651" style="border: 1px solid black; padding: 10px; text-align: center; margin: 10px 0;"> <p>Initialize completed.</p> </div> <p style="text-align: center; margin: 10px 0;"><b>Figure 1-3-25</b></p> <p><b>Method: [Check Single Tap Check</b></p> <ol style="list-style-type: none"> <li>1. Press the start key.</li> <li>2. Press the center of three "+" signs and confirm the display positions.                     <ul style="list-style-type: none"> <li>* : Press it using a tool with a fine tip (touch panel pen etc).</li> </ul> </li> </ol> <div data-bbox="839 813 1417 1200" style="border: 1px solid black; padding: 10px; margin: 10px 0;">  </div> <p style="text-align: center; margin: 10px 0;"><b>Figure 1-3-26</b></p> <ol style="list-style-type: none"> <li>3. Make sure that the gap from coordinates X and Y is 6 or less, respectively.                     <ul style="list-style-type: none"> <li>* : If the setting values are not aligned, select "Initialize" and press the Start key to revert to step 1.</li> </ul> </li> </ol> <div data-bbox="839 1368 1417 1756" style="border: 1px solid black; padding: 10px; margin: 10px 0;">  </div> <p style="text-align: center; margin: 10px 0;"><b>Figure 1-3-27</b></p>

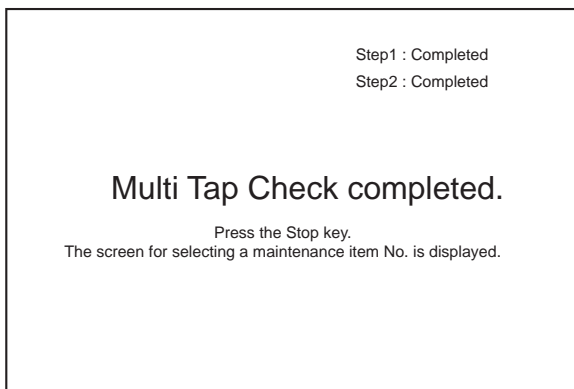
Item No.	Description
<p><b>U201</b></p>	<p><b>Multi Tap chek</b></p> <ol style="list-style-type: none"> <li>1. Select "Multi tap check", and press the start key.</li> <li>2. Press two " ● " signs at the same time. (Step1)                     <ul style="list-style-type: none"> <li>* : If the detecting values are not within the setting values, pressed detecting positions are displayed by red points.</li> </ul> </li> <li>3. Press two " ● " signs displayed next at the same time. (Step2)</li> <li>4. If the detecting values are within the setting values, Step1 and Step2 become "Completed".</li> <li>5. If "Multi tap check completed." is displayed, the checking process is completed successfully.</li> </ol>



**Figure 1-3-28**



**Figure 1-3-29**



**Figure 1-3-30**

Item No.	Description
U201	<p>* : If the detecting values are not within the setting values, pressed detecting positions are displayed by red points. And "Multi tap check Step 1" button is displayed.</p> <p>* : Select "Initialize" and press the Start key to revert to "Initialize".</p> <p>* : Select "Multi tap check Step 1" and press the Start key to revert to "Multi tap check".</p> <div data-bbox="842 253 1417 640" style="border: 1px solid black; padding: 5px;"> <p>Initialize</p> <p>Multi Tap Check Step1</p> <p>Step1 : Completed Step2 : Not completed</p> <p>Multi Tap Check, Step 2. Press both circles again. Select "Multi Tap Check Step 1" and press the Start key to try again from Multi Tap Check Step 1. If you need to perform initialization again, select "Initialize" and press the Start key. Press the Stop key to complete the setting.</p> </div> <p style="text-align: center;"><b>Figure 1-3-31</b></p> <p><b>Completion</b> Press the stop key. The screen for selecting a maintenance item No. is displayed.</p>

Item No.	Description																		
U202	<p data-bbox="288 241 826 275"><b>Setting the KMAS host monitoring system</b></p> <p data-bbox="288 311 440 340"><b>Description</b></p> <p data-bbox="288 344 962 374">Initializes or operates the KMAS host monitoring system.</p> <p data-bbox="288 378 1425 445">This is an optional device which is currently supported only by Japanese specification machines, so no setting is necessary.</p> <p data-bbox="288 450 400 479"><b>Purpose</b></p> <p data-bbox="288 483 1021 512">Performed at installation, periodic maintenance, and/or repair.</p> <p data-bbox="288 553 387 582"><b>Method</b></p> <ol data-bbox="304 586 564 651" style="list-style-type: none"> <li>1. Press the start key.</li> <li>2. Select the item.</li> </ol> <table border="1" data-bbox="336 665 1399 808"> <thead> <tr> <th data-bbox="336 665 641 710">Display</th> <th data-bbox="641 665 1399 710">Description</th> </tr> </thead> <tbody> <tr> <td data-bbox="336 710 641 754">Init/Set TEL No.</td> <td data-bbox="641 710 1399 754">Initialization/Phone Nbr. se</td> </tr> <tr> <td data-bbox="336 754 641 808">Call Service End</td> <td data-bbox="641 754 1399 808">Outgoing at the end of service activities</td> </tr> </tbody> </table> <p data-bbox="288 853 620 882"><b>Method: [Init/Set TEL No.]</b></p> <ol data-bbox="304 887 655 916" style="list-style-type: none"> <li>1. Select the item to be input.</li> </ol> <table border="1" data-bbox="336 929 1399 1072"> <thead> <tr> <th data-bbox="336 929 641 974">Display</th> <th data-bbox="641 929 1399 974">Description</th> </tr> </thead> <tbody> <tr> <td data-bbox="336 974 641 1019">TEL No. 1</td> <td data-bbox="641 974 1399 1019">Sales companies</td> </tr> <tr> <td data-bbox="336 1019 641 1072">TEL No. 2</td> <td data-bbox="641 1019 1399 1072">Call center</td> </tr> </tbody> </table> <ol data-bbox="304 1086 1128 1290" style="list-style-type: none"> <li>2. Input the telephone number using the numeric keys.</li> <li>3. Press the start key. The setting is set.</li> <li>4. Select [Initialize].</li> <li>5. Select [Execute].</li> <li>6. Press the start key. Communication with the host initiated.</li> <li>7. The result of communication will be displayed. (Refer to the result.)</li> </ol> <p data-bbox="288 1328 632 1357"><b>Method: [Call Service End]</b></p> <ol data-bbox="304 1361 1128 1462" style="list-style-type: none"> <li>1. Select [Execute].</li> <li>2. Press the start key. Communication with the host initiated.</li> <li>3. The result of communication will be displayed. (Refer to the result.)</li> </ol> <p data-bbox="336 1500 488 1529"><b>Result table</b></p> <table border="1" data-bbox="336 1543 1399 1879"> <thead> <tr> <th data-bbox="336 1543 641 1588">Display</th> <th data-bbox="641 1543 1399 1588">Description</th> </tr> </thead> <tbody> <tr> <td data-bbox="336 1588 641 1641">OK</td> <td data-bbox="641 1588 1399 1641">Communication properly terminated.</td> </tr> <tr> <td data-bbox="336 1641 641 1879">NG</td> <td data-bbox="641 1641 1399 1879">           Communication error (Nbr. of calls exceeded)            Communication error (Communication timeout)            Communication error (Communication trial timeout)            Communication error (Other)            KMAS unreachable         </td> </tr> </tbody> </table> <p data-bbox="288 1926 440 1955"><b>Completion</b></p> <p data-bbox="288 1960 1254 1989">Press the stop key. The screen for selecting a maintenance item No. is displayed.</p>	Display	Description	Init/Set TEL No.	Initialization/Phone Nbr. se	Call Service End	Outgoing at the end of service activities	Display	Description	TEL No. 1	Sales companies	TEL No. 2	Call center	Display	Description	OK	Communication properly terminated.	NG	Communication error (Nbr. of calls exceeded) Communication error (Communication timeout) Communication error (Communication trial timeout) Communication error (Other) KMAS unreachable
Display	Description																		
Init/Set TEL No.	Initialization/Phone Nbr. se																		
Call Service End	Outgoing at the end of service activities																		
Display	Description																		
TEL No. 1	Sales companies																		
TEL No. 2	Call center																		
Display	Description																		
OK	Communication properly terminated.																		
NG	Communication error (Nbr. of calls exceeded) Communication error (Communication timeout) Communication error (Communication trial timeout) Communication error (Other) KMAS unreachable																		

Item No.	Description																																
U203	<p data-bbox="287 241 587 275"><b>Checking DP operation</b></p> <p data-bbox="287 309 440 342"><b>Description</b></p> <p data-bbox="287 342 1046 376">Simulates the original conveying operation separately in the DP.</p> <p data-bbox="287 376 400 409"><b>Purpose</b></p> <p data-bbox="287 409 612 443">To check the DP operation.</p> <p data-bbox="287 477 387 510"><b>Method</b></p> <ol data-bbox="303 510 1085 622" style="list-style-type: none"> <li>1. Press the start key.</li> <li>2. Place an original in the DP if running this simulation with paper.</li> <li>3. Select the speed to be operated.</li> </ol> <table border="1" data-bbox="335 629 1401 920"> <thead> <tr> <th data-bbox="339 633 639 678">Display</th> <th data-bbox="639 633 1396 678">Description</th> </tr> </thead> <tbody> <tr> <td data-bbox="339 678 639 723">Normal Speed</td> <td data-bbox="639 678 1396 723">Normal reading (600 dpi)</td> </tr> <tr> <td data-bbox="339 723 639 768">High Speed</td> <td data-bbox="639 723 1396 768">High-speed reading</td> </tr> <tr> <td data-bbox="339 768 639 813">Mode</td> <td data-bbox="639 768 1396 813">Sets the conveying timing verification mode</td> </tr> <tr> <td data-bbox="339 813 639 857">Reset</td> <td data-bbox="639 813 1396 857">Resets the conveying timing verification data</td> </tr> <tr> <td data-bbox="339 857 639 902">Result</td> <td data-bbox="639 857 1396 902">Resets the conveying timing verification data</td> </tr> </tbody> </table> <ol data-bbox="303 931 702 965" style="list-style-type: none"> <li>4. Select the item to be operated.</li> </ol> <table border="1" data-bbox="335 976 1401 1417"> <thead> <tr> <th data-bbox="339 981 639 1025">Display</th> <th data-bbox="639 981 1396 1025">Description</th> </tr> </thead> <tbody> <tr> <td data-bbox="339 1025 639 1070">CCD ADP</td> <td data-bbox="639 1025 1396 1070">With paper, single-sided original of CCD</td> </tr> <tr> <td data-bbox="339 1070 639 1115">CCD RADP</td> <td data-bbox="639 1070 1396 1115">With paper, double-sided original of CCD</td> </tr> <tr> <td data-bbox="339 1115 639 1160">CIS</td> <td data-bbox="639 1115 1396 1160">With paper, double-sided original of CIS</td> </tr> <tr> <td data-bbox="339 1160 639 1249">CCD ADP (Non-P)</td> <td data-bbox="639 1160 1396 1249">Without paper, single-sided original of CCD (continuous operation)</td> </tr> <tr> <td data-bbox="339 1249 639 1339">CCD RADP (Non-P)</td> <td data-bbox="639 1249 1396 1339">Without paper, double-sided original of CCD (continuous operation)</td> </tr> <tr> <td data-bbox="339 1339 639 1417">CIS (Non-P)</td> <td data-bbox="639 1339 1396 1417">Without paper, double-sided original of CIS (continuous operation)</td> </tr> </tbody> </table> <ol data-bbox="303 1429 919 1496" style="list-style-type: none"> <li>5. Press the start key. The operation starts.</li> <li>6. To stop continuous operation, press the stop key.</li> </ol> <p data-bbox="287 1529 488 1563"><b>Setting: [Mode]</b></p> <ol data-bbox="303 1563 536 1597" style="list-style-type: none"> <li>1. Select On or Off.</li> </ol> <table border="1" data-bbox="335 1608 1401 1753"> <thead> <tr> <th data-bbox="339 1612 639 1657">Display</th> <th data-bbox="639 1612 1396 1657">Description</th> </tr> </thead> <tbody> <tr> <td data-bbox="339 1657 639 1702">On</td> <td data-bbox="639 1657 1396 1702">Sets the conveying timing verification mode on</td> </tr> <tr> <td data-bbox="339 1702 639 1753">Off</td> <td data-bbox="639 1702 1396 1753">Sets the conveying timing verification mode off</td> </tr> </tbody> </table> <ol data-bbox="303 1765 564 1798" style="list-style-type: none"> <li>2. Press the start key.</li> </ol> <p data-bbox="287 1832 491 1865"><b>Setting: [Reset]</b></p> <ol data-bbox="303 1865 564 1933" style="list-style-type: none"> <li>1. Select [Execute].</li> <li>2. Press the start key.</li> </ol>	Display	Description	Normal Speed	Normal reading (600 dpi)	High Speed	High-speed reading	Mode	Sets the conveying timing verification mode	Reset	Resets the conveying timing verification data	Result	Resets the conveying timing verification data	Display	Description	CCD ADP	With paper, single-sided original of CCD	CCD RADP	With paper, double-sided original of CCD	CIS	With paper, double-sided original of CIS	CCD ADP (Non-P)	Without paper, single-sided original of CCD (continuous operation)	CCD RADP (Non-P)	Without paper, double-sided original of CCD (continuous operation)	CIS (Non-P)	Without paper, double-sided original of CIS (continuous operation)	Display	Description	On	Sets the conveying timing verification mode on	Off	Sets the conveying timing verification mode off
Display	Description																																
Normal Speed	Normal reading (600 dpi)																																
High Speed	High-speed reading																																
Mode	Sets the conveying timing verification mode																																
Reset	Resets the conveying timing verification data																																
Result	Resets the conveying timing verification data																																
Display	Description																																
CCD ADP	With paper, single-sided original of CCD																																
CCD RADP	With paper, double-sided original of CCD																																
CIS	With paper, double-sided original of CIS																																
CCD ADP (Non-P)	Without paper, single-sided original of CCD (continuous operation)																																
CCD RADP (Non-P)	Without paper, double-sided original of CCD (continuous operation)																																
CIS (Non-P)	Without paper, double-sided original of CIS (continuous operation)																																
Display	Description																																
On	Sets the conveying timing verification mode on																																
Off	Sets the conveying timing verification mode off																																

Item No.	Description																				
U203	<p><b>Setting: [Result]</b> Press the start key. The value is set.</p> <p><b>Completion</b> Press the stop key. The screen for selecting a maintenance item No. is displayed.</p>																				
U204	<p><b>Setting the presence or absence of a key card or key counter</b></p> <p><b>Description</b> Sets the presence or absence of the optional key card or key counter.</p> <p><b>Purpose</b> To run this maintenance item if a key card or key counter is installed.</p> <p><b>Method</b></p> <ol style="list-style-type: none"> <li>1. Press the start key.</li> <li>2. Select the item to be set.</li> </ol> <table border="1" data-bbox="336 786 1401 927"> <thead> <tr> <th data-bbox="336 786 639 831">Display</th> <th data-bbox="639 786 1401 831">Description</th> </tr> </thead> <tbody> <tr> <td data-bbox="336 831 639 875">Device</td> <td data-bbox="639 831 1401 875">Sets the presence or absence of the key card or key counter</td> </tr> <tr> <td data-bbox="336 875 639 927">Message</td> <td data-bbox="639 875 1401 927">Sets the message when optional equipment is not installed</td> </tr> </tbody> </table> <p><b>Setting: [Device]</b></p> <ol style="list-style-type: none"> <li>1. Select the optional counter to be installed.</li> </ol> <table border="1" data-bbox="336 1050 1401 1240"> <thead> <tr> <th data-bbox="336 1050 639 1095">Display</th> <th data-bbox="639 1050 1401 1095">Description</th> </tr> </thead> <tbody> <tr> <td data-bbox="336 1095 639 1140">Key-Card</td> <td data-bbox="639 1095 1401 1140">The key card is installed</td> </tr> <tr> <td data-bbox="336 1140 639 1184">Key-Counter</td> <td data-bbox="639 1140 1401 1184">The key counter is installed</td> </tr> <tr> <td data-bbox="336 1184 639 1240">Off</td> <td data-bbox="639 1184 1401 1240">Not installed</td> </tr> </tbody> </table> <p>Initial setting: Off</p> <ol style="list-style-type: none"> <li>2. Press the start key. The setting is set.</li> <li>3. Turn the main power switch off and on. Allow more than 5 seconds between Off and On.</li> </ol> <p><b>Setting: [Message]</b></p> <ol style="list-style-type: none"> <li>1. Select the [Key Device] or [Coin Vender].</li> </ol> <table border="1" data-bbox="336 1476 1401 1688"> <thead> <tr> <th data-bbox="336 1476 639 1520">Display</th> <th data-bbox="639 1476 1401 1520">Description</th> </tr> </thead> <tbody> <tr> <td data-bbox="336 1520 639 1610">Key Device</td> <td data-bbox="639 1520 1401 1610">Select the prioritized display mode of the login dialog as the key device.</td> </tr> <tr> <td data-bbox="336 1610 639 1688">Coin Vender</td> <td data-bbox="639 1610 1401 1688">Select the coin vender as the prioritized display of the login dialog.</td> </tr> </tbody> </table> <p>* : Initial setting: Coin Vender</p> <ol style="list-style-type: none"> <li>2. Press the start key. The setting is set.</li> <li>3. Turn the main power switch off and on. Allow more than 5 seconds between Off and On.</li> </ol>	Display	Description	Device	Sets the presence or absence of the key card or key counter	Message	Sets the message when optional equipment is not installed	Display	Description	Key-Card	The key card is installed	Key-Counter	The key counter is installed	Off	Not installed	Display	Description	Key Device	Select the prioritized display mode of the login dialog as the key device.	Coin Vender	Select the coin vender as the prioritized display of the login dialog.
Display	Description																				
Device	Sets the presence or absence of the key card or key counter																				
Message	Sets the message when optional equipment is not installed																				
Display	Description																				
Key-Card	The key card is installed																				
Key-Counter	The key counter is installed																				
Off	Not installed																				
Display	Description																				
Key Device	Select the prioritized display mode of the login dialog as the key device.																				
Coin Vender	Select the coin vender as the prioritized display of the login dialog.																				

Item No.	Description																										
U206	<p data-bbox="288 241 917 275"><b>Setting the presence or absence of a coin vender</b></p> <p data-bbox="288 309 438 342"><b>Description</b></p> <p data-bbox="288 344 973 378">Sets the presence or absence of the optional coin vender.</p> <p data-bbox="288 380 1433 414">This is an optional device which is currently supported only by Japanese specification machines.</p> <p data-bbox="288 416 399 450"><b>Purpose</b></p> <p data-bbox="288 452 965 486">To run this maintenance item if a coin vender is installed.</p> <p data-bbox="288 519 391 553"><b>Method</b></p> <ol data-bbox="304 555 630 622" style="list-style-type: none"> <li>1. Press the start key.</li> <li>2. Select the item to be set.</li> </ol> <table border="1" data-bbox="336 633 1401 920"> <thead> <tr> <th data-bbox="336 633 639 678">Display</th> <th data-bbox="639 633 1401 678">Description</th> </tr> </thead> <tbody> <tr> <td data-bbox="336 678 639 723">On/Off Config</td> <td data-bbox="639 678 1401 723">Sets the presence or absence of the coin vender</td> </tr> <tr> <td data-bbox="336 723 639 768">No Coin Action</td> <td data-bbox="639 723 1401 768">Behavior when change runs out during copying</td> </tr> <tr> <td data-bbox="336 768 639 813">Price</td> <td data-bbox="639 768 1401 813">Charge per copy by size and color</td> </tr> <tr> <td data-bbox="336 813 639 857">Boot Mode</td> <td data-bbox="639 813 1401 857">Boot Mode setting</td> </tr> <tr> <td data-bbox="336 857 639 920">Apl Charge Mode</td> <td data-bbox="639 857 1401 920">Extended charge unit</td> </tr> </tbody> </table> <p data-bbox="288 976 598 1010"><b>Setting: [On/Off Config]</b></p> <ol data-bbox="304 1012 534 1046" style="list-style-type: none"> <li>1. Select On or Off.</li> </ol> <table border="1" data-bbox="336 1057 1401 1196"> <thead> <tr> <th data-bbox="336 1057 639 1102">Display</th> <th data-bbox="639 1057 1401 1102">Description</th> </tr> </thead> <tbody> <tr> <td data-bbox="336 1102 639 1146">On</td> <td data-bbox="639 1102 1401 1146">The coin vender is installed</td> </tr> <tr> <td data-bbox="336 1146 639 1196">Off</td> <td data-bbox="639 1146 1401 1196">The coin vender is not installed</td> </tr> </tbody> </table> <p data-bbox="336 1207 534 1240">Initial setting: Off</p> <ol data-bbox="304 1243 1380 1310" style="list-style-type: none"> <li>2. Press the start key. The setting is set.</li> <li>3. Turn the main power switch off and on. Allow more than 5 seconds between Off and On.</li> </ol> <p data-bbox="288 1344 614 1377"><b>Setting: [No Coin Action]</b></p> <ol data-bbox="304 1379 518 1413" style="list-style-type: none"> <li>1. Select the item.</li> </ol> <table border="1" data-bbox="336 1424 1401 1615"> <thead> <tr> <th data-bbox="336 1424 639 1469">Display</th> <th data-bbox="639 1424 1401 1469">Description</th> </tr> </thead> <tbody> <tr> <td data-bbox="336 1469 639 1514">All Clear</td> <td data-bbox="639 1469 1401 1514">All clear is performed</td> </tr> <tr> <td data-bbox="336 1514 639 1559">Auto Clear</td> <td data-bbox="639 1514 1401 1559">Auto clear is performed</td> </tr> <tr> <td data-bbox="336 1559 639 1615">Off</td> <td data-bbox="639 1559 1401 1615">Clear is not performed</td> </tr> </tbody> </table> <p data-bbox="336 1626 534 1659">Initial setting: Off</p> <ol data-bbox="304 1662 1380 1729" style="list-style-type: none"> <li>2. Press the start key. The setting is set.</li> <li>3. Turn the main power switch off and on. Allow more than 5 seconds between Off and On.</li> </ol>	Display	Description	On/Off Config	Sets the presence or absence of the coin vender	No Coin Action	Behavior when change runs out during copying	Price	Charge per copy by size and color	Boot Mode	Boot Mode setting	Apl Charge Mode	Extended charge unit	Display	Description	On	The coin vender is installed	Off	The coin vender is not installed	Display	Description	All Clear	All clear is performed	Auto Clear	Auto clear is performed	Off	Clear is not performed
Display	Description																										
On/Off Config	Sets the presence or absence of the coin vender																										
No Coin Action	Behavior when change runs out during copying																										
Price	Charge per copy by size and color																										
Boot Mode	Boot Mode setting																										
Apl Charge Mode	Extended charge unit																										
Display	Description																										
On	The coin vender is installed																										
Off	The coin vender is not installed																										
Display	Description																										
All Clear	All clear is performed																										
Auto Clear	Auto clear is performed																										
Off	Clear is not performed																										



Item No.	Description																																																										
U206	<p data-bbox="288 241 483 271"><b>Setting: [Price]</b></p> <p data-bbox="304 277 632 306">1. Select the item to be set.</p> <table border="1" data-bbox="336 318 1399 560"> <thead> <tr> <th data-bbox="336 318 639 362">Display</th> <th data-bbox="639 318 1399 362">Description</th> </tr> </thead> <tbody> <tr> <td data-bbox="336 362 639 407">Normal</td> <td data-bbox="639 362 1399 407">Charge setting: Normal</td> </tr> <tr> <td data-bbox="336 407 639 452">AD</td> <td data-bbox="639 407 1399 452">Charge setting: Commercial</td> </tr> <tr> <td data-bbox="336 452 639 497">Print</td> <td data-bbox="639 452 1399 497">Charge setting: Print</td> </tr> <tr> <td data-bbox="336 497 639 560">Apl</td> <td data-bbox="639 497 1399 560">Charge setting: Extended</td> </tr> </tbody> </table> <p data-bbox="288 602 571 631"><b>Setting: [Normal / AD]</b></p> <p data-bbox="304 674 632 703">1. Select the item to be set.</p> <table border="1" data-bbox="336 714 1399 813"> <thead> <tr> <th data-bbox="336 714 639 759">Display</th> <th data-bbox="639 714 1399 759">Description</th> </tr> </thead> <tbody> <tr> <td data-bbox="336 759 639 813">B/W</td> <td data-bbox="639 759 1399 813">Black &amp; White</td> </tr> </tbody> </table> <p data-bbox="304 826 858 891">2. Select the paper size to be set. 3. Change the setting value using the +/- keys.</p> <table border="1" data-bbox="336 902 1399 1178"> <thead> <tr> <th data-bbox="336 902 563 981">Display</th> <th data-bbox="563 902 1034 981">Description</th> <th data-bbox="1034 902 1219 981">Setting range</th> <th data-bbox="1219 902 1399 981">Initial setting</th> </tr> </thead> <tbody> <tr> <td data-bbox="336 981 563 1025">A3-Ledger</td> <td data-bbox="563 981 1034 1025">A3/Ledger size</td> <td data-bbox="1034 981 1219 1025">0 to 300</td> <td data-bbox="1219 981 1399 1025">10</td> </tr> <tr> <td data-bbox="336 1025 563 1070">B4</td> <td data-bbox="563 1025 1034 1070">B4 size</td> <td data-bbox="1034 1025 1219 1070">0 to 300</td> <td data-bbox="1219 1025 1399 1070">10</td> </tr> <tr> <td data-bbox="336 1070 563 1115">Card</td> <td data-bbox="563 1070 1034 1115">Post card</td> <td data-bbox="1034 1070 1219 1115">0 to 300</td> <td data-bbox="1219 1070 1399 1115">10</td> </tr> <tr> <td data-bbox="336 1115 563 1178">Other</td> <td data-bbox="563 1115 1034 1178">Other</td> <td data-bbox="1034 1115 1219 1178">0 to 300</td> <td data-bbox="1219 1115 1399 1178">10</td> </tr> </tbody> </table> <p data-bbox="336 1189 1209 1254">In 10-yen increments Value of 0 allows non-restricted copying. (At a periodic maintenance, etc.)</p> <p data-bbox="304 1261 1378 1326">4. Press the start key. The value is set. 5. Turn the main power switch off and on. Allow more than 5 seconds between Off and On.</p> <p data-bbox="288 1361 483 1391"><b>Setting: [Print ]</b></p> <p data-bbox="304 1397 632 1426">1. Select the item to be set.</p> <table border="1" data-bbox="336 1438 1399 1536"> <thead> <tr> <th data-bbox="336 1438 639 1482">Display</th> <th data-bbox="639 1438 1399 1482">Description</th> </tr> </thead> <tbody> <tr> <td data-bbox="336 1482 639 1536">B/W</td> <td data-bbox="639 1482 1399 1536">Black &amp; White</td> </tr> </tbody> </table> <p data-bbox="304 1552 858 1617">2. Select the paper size to be set. 3. Change the setting value using the +/- keys.</p> <table border="1" data-bbox="336 1628 1399 1904"> <thead> <tr> <th data-bbox="336 1628 563 1706">Display</th> <th data-bbox="563 1628 1034 1706">Description</th> <th data-bbox="1034 1628 1219 1706">Setting range</th> <th data-bbox="1219 1628 1399 1706">Initial setting</th> </tr> </thead> <tbody> <tr> <td data-bbox="336 1706 563 1751">A3-Ledger</td> <td data-bbox="563 1706 1034 1751">A3/Ledger size</td> <td data-bbox="1034 1706 1219 1751">0 to 300</td> <td data-bbox="1219 1706 1399 1751">10</td> </tr> <tr> <td data-bbox="336 1751 563 1796">B4</td> <td data-bbox="563 1751 1034 1796">B4 size</td> <td data-bbox="1034 1751 1219 1796">0 to 300</td> <td data-bbox="1219 1751 1399 1796">10</td> </tr> <tr> <td data-bbox="336 1796 563 1841">Card</td> <td data-bbox="563 1796 1034 1841">Post card</td> <td data-bbox="1034 1796 1219 1841">0 to 300</td> <td data-bbox="1219 1796 1399 1841">10</td> </tr> <tr> <td data-bbox="336 1841 563 1904">Other</td> <td data-bbox="563 1841 1034 1904">Other</td> <td data-bbox="1034 1841 1219 1904">0 to 300</td> <td data-bbox="1219 1841 1399 1904">10</td> </tr> </tbody> </table> <p data-bbox="336 1915 1209 1980">In 10-yen increments Value of 0 allows non-restricted copying. (At a periodic maintenance, etc.)</p>	Display	Description	Normal	Charge setting: Normal	AD	Charge setting: Commercial	Print	Charge setting: Print	Apl	Charge setting: Extended	Display	Description	B/W	Black & White	Display	Description	Setting range	Initial setting	A3-Ledger	A3/Ledger size	0 to 300	10	B4	B4 size	0 to 300	10	Card	Post card	0 to 300	10	Other	Other	0 to 300	10	Display	Description	B/W	Black & White	Display	Description	Setting range	Initial setting	A3-Ledger	A3/Ledger size	0 to 300	10	B4	B4 size	0 to 300	10	Card	Post card	0 to 300	10	Other	Other	0 to 300	10
Display	Description																																																										
Normal	Charge setting: Normal																																																										
AD	Charge setting: Commercial																																																										
Print	Charge setting: Print																																																										
Apl	Charge setting: Extended																																																										
Display	Description																																																										
B/W	Black & White																																																										
Display	Description	Setting range	Initial setting																																																								
A3-Ledger	A3/Ledger size	0 to 300	10																																																								
B4	B4 size	0 to 300	10																																																								
Card	Post card	0 to 300	10																																																								
Other	Other	0 to 300	10																																																								
Display	Description																																																										
B/W	Black & White																																																										
Display	Description	Setting range	Initial setting																																																								
A3-Ledger	A3/Ledger size	0 to 300	10																																																								
B4	B4 size	0 to 300	10																																																								
Card	Post card	0 to 300	10																																																								
Other	Other	0 to 300	10																																																								

Item No.	Description																																				
U206	<p data-bbox="304 241 1382 309">4. Press the start key. The value is set. 5. Turn the main power switch off and on. Allow more than 5 seconds between Off and On.</p> <p data-bbox="288 344 469 376"><b>Setting: [ Apl]</b></p> <p data-bbox="304 383 858 450">1. Select the item to be set. 2. Change the setting value using the +/- keys.</p> <table border="1" data-bbox="336 456 1361 745"> <thead> <tr> <th data-bbox="336 456 564 501">Display</th> <th data-bbox="564 456 944 501">Description</th> <th data-bbox="944 456 1150 501">Setting range</th> <th data-bbox="1150 456 1361 501">Initial setting</th> </tr> </thead> <tbody> <tr> <td data-bbox="336 501 564 546">Apl1</td> <td data-bbox="564 501 944 546">Expanded charging unit 1</td> <td data-bbox="944 501 1150 546">0 to 300</td> <td data-bbox="1150 501 1361 546">10</td> </tr> <tr> <td data-bbox="336 546 564 591">Apl2</td> <td data-bbox="564 546 944 591">Expanded charging unit 2</td> <td data-bbox="944 546 1150 591">0 to 300</td> <td data-bbox="1150 546 1361 591">10</td> </tr> <tr> <td data-bbox="336 591 564 636">Apl3</td> <td data-bbox="564 591 944 636">Expanded charging unit 3</td> <td data-bbox="944 591 1150 636">0 to 300</td> <td data-bbox="1150 591 1361 636">10</td> </tr> <tr> <td data-bbox="336 636 564 680">Apl4</td> <td data-bbox="564 636 944 680">Expanded charging unit 4</td> <td data-bbox="944 636 1150 680">0 to 300</td> <td data-bbox="1150 636 1361 680">10</td> </tr> <tr> <td data-bbox="336 680 564 745">Apl5</td> <td data-bbox="564 680 944 745">Expanded charging unit 5</td> <td data-bbox="944 680 1150 745">0 to 300</td> <td data-bbox="1150 680 1361 745">10</td> </tr> </tbody> </table> <p data-bbox="304 768 1382 835">3. Press the start key. The value is set. 4. Turn the main power switch off and on. Allow more than 5 seconds between Off and On.</p> <p data-bbox="288 871 555 902"><b>Setting: [Boot Mode]</b></p> <p data-bbox="304 909 520 940">1. Select the item.</p> <table border="1" data-bbox="336 947 1399 1093"> <thead> <tr> <th data-bbox="336 947 641 992">Display</th> <th data-bbox="641 947 1399 992">Description</th> </tr> </thead> <tbody> <tr> <td data-bbox="336 992 641 1037">Normal</td> <td data-bbox="641 992 1399 1037">Assign activation to normal mode.</td> </tr> <tr> <td data-bbox="336 1037 641 1093">Copy Service</td> <td data-bbox="641 1037 1399 1093">Assign activation to copy service display.</td> </tr> </tbody> </table> <p data-bbox="336 1115 660 1146">Initial setting: Copy Service</p> <p data-bbox="304 1153 783 1184">2. Press the start key. The setting is set.</p> <p data-bbox="288 1220 638 1252"><b>Setting: [Apl Charge Mode]</b></p> <p data-bbox="304 1258 520 1290">1. Select the item.</p> <table border="1" data-bbox="336 1296 1399 1442"> <thead> <tr> <th data-bbox="336 1296 641 1341">Display</th> <th data-bbox="641 1296 1399 1341">Description</th> </tr> </thead> <tbody> <tr> <td data-bbox="336 1341 641 1386">On</td> <td data-bbox="641 1341 1399 1386">The extended charge unit is used.</td> </tr> <tr> <td data-bbox="336 1386 641 1442">Off</td> <td data-bbox="641 1386 1399 1442">The extended charge unit is not used.</td> </tr> </tbody> </table> <p data-bbox="336 1464 539 1496">Initial setting: Off</p> <p data-bbox="304 1503 783 1534">2. Press the start key. The setting is set.</p> <p data-bbox="288 1570 440 1601"><b>Completion</b></p> <p data-bbox="288 1608 1254 1639">Press the stop key. The screen for selecting a maintenance item No. is displayed.</p>	Display	Description	Setting range	Initial setting	Apl1	Expanded charging unit 1	0 to 300	10	Apl2	Expanded charging unit 2	0 to 300	10	Apl3	Expanded charging unit 3	0 to 300	10	Apl4	Expanded charging unit 4	0 to 300	10	Apl5	Expanded charging unit 5	0 to 300	10	Display	Description	Normal	Assign activation to normal mode.	Copy Service	Assign activation to copy service display.	Display	Description	On	The extended charge unit is used.	Off	The extended charge unit is not used.
Display	Description	Setting range	Initial setting																																		
Apl1	Expanded charging unit 1	0 to 300	10																																		
Apl2	Expanded charging unit 2	0 to 300	10																																		
Apl3	Expanded charging unit 3	0 to 300	10																																		
Apl4	Expanded charging unit 4	0 to 300	10																																		
Apl5	Expanded charging unit 5	0 to 300	10																																		
Display	Description																																				
Normal	Assign activation to normal mode.																																				
Copy Service	Assign activation to copy service display.																																				
Display	Description																																				
On	The extended charge unit is used.																																				
Off	The extended charge unit is not used.																																				

Item No.	Description
<p><b>U207</b></p>	<p><b>Checking the operation panel keys</b></p> <p><b>Description</b> Checks operation of the operation panel keys.</p> <p><b>Purpose</b> To check operation of all the keys and LEDs on the operation panel.</p> <p><b>Method</b></p> <ol style="list-style-type: none"> <li>1. Press the start key. The screen for executing is displayed.</li> <li>2. [Count0] is displayed and the left most LED on the operation panel lights.</li> <li>3. As the keys lined up in the same line as the lit indicator are pressed in the order from the top to the bottom, the figure shown on the touch panel increases in increments of 1. When all the keys in that line are pressed and if there are any LEDs corresponding to the keys in the line on the immediate right, the top LED in that line will light.</li> <li>4. When all the keys on the operation panel have been pressed, all the LEDs light for up to 10 seconds.</li> </ol> <p><b>Completion</b> Press the stop key. The screen for selecting a maintenance item No. is displayed.</p>
<p><b>U208</b></p>	<p><b>Setting the paper size for the side deck</b></p> <p><b>Description</b> Sets the size of paper used in side deck.</p> <p><b>Purpose</b> To change the setting when installing the side deck or the size of paper used in the side deck is changed.</p> <p><b>Setting</b></p> <ol style="list-style-type: none"> <li>1. Press the start key.</li> <li>2. Select the paper size (A4, B5 or Letter). Initial setting: Letter (Inch specifications) A4 (Metric specifications)</li> <li>3. Press the start key. The setting is set.</li> <li>4. Turn the main power switch off and on. Allow more than 5 seconds between Off and On.</li> </ol>

Item No.	Description														
U209	<p data-bbox="288 244 464 271"><b>Set RTC Date</b></p> <p data-bbox="288 315 440 342"><b>Description</b></p> <p data-bbox="288 349 663 376">Assign a date and time to RTC.</p> <p data-bbox="288 383 400 409"><b>Purpose</b></p> <p data-bbox="288 416 1331 479">Used to assign a date and time to RTC when Maintenance T is displayed after C0840 is detected.</p> <p data-bbox="288 524 384 551"><b>Setting</b></p> <ol data-bbox="304 557 632 620" style="list-style-type: none"> <li data-bbox="304 557 564 584">1. Press the start key.</li> <li data-bbox="304 591 632 618">2. Select the item to be set.</li> </ol> <table border="1" data-bbox="336 633 1401 969"> <thead> <tr> <th data-bbox="344 645 643 678">Display</th> <th data-bbox="643 645 1393 678">Description</th> </tr> </thead> <tbody> <tr> <td data-bbox="344 689 643 723">Year</td> <td data-bbox="643 689 1393 723">Setting the year</td> </tr> <tr> <td data-bbox="344 734 643 768">Month</td> <td data-bbox="643 734 1393 768">Setting the month</td> </tr> <tr> <td data-bbox="344 779 643 813">Day</td> <td data-bbox="643 779 1393 813">Setting the day</td> </tr> <tr> <td data-bbox="344 824 643 857">Hour</td> <td data-bbox="643 824 1393 857">Setting the hour</td> </tr> <tr> <td data-bbox="344 869 643 902">Minute</td> <td data-bbox="643 869 1393 902">Setting the minute</td> </tr> <tr> <td data-bbox="344 913 643 947">Second</td> <td data-bbox="643 913 1393 947">Setting the second</td> </tr> </tbody> </table> <ol data-bbox="304 992 1193 1055" style="list-style-type: none"> <li data-bbox="304 992 767 1019">3. Press the start key. The value is set.</li> </ol> <p data-bbox="336 1025 1193 1052">* : Perform U906 to clear "Time for Maintenance T" after making setting.</p> <p data-bbox="288 1097 392 1124"><b>Caution</b></p> <ul data-bbox="336 1131 1430 1503" style="list-style-type: none"> <li data-bbox="336 1131 1318 1158">* : Pressing Current Time allows the system time to display a date and time of day.</li> <li data-bbox="336 1164 1430 1227">* : A message that prompts you to turn power off and on will be displayed after completion of the normal operation, deactivating the keys.</li> <li data-bbox="336 1234 1406 1296">* : The range allowed for normal use of RTC is 2013-01-01 00:00:00 (UTC) to 2038-01-19 3:14:07 (UTC).</li> <li data-bbox="336 1303 1422 1366">* : If a setting earlier than 2013-01-01 (UTC) is specified, C0840 will occur even a defective disconnection is released.</li> <li data-bbox="336 1373 1417 1435">* : If a setting earlier than 2000-01-01 00:00:00 (UTC) is specified, it will not affect RTC but will be recognized as a power off and on acknowledgement.</li> <li data-bbox="336 1442 1422 1505">* : If a setting later than 2038-01-19 3:14:07 (UTC) is specified, it will not affect RTC but will be recognized as a power off and on acknowledgement.</li> </ul>	Display	Description	Year	Setting the year	Month	Setting the month	Day	Setting the day	Hour	Setting the hour	Minute	Setting the minute	Second	Setting the second
Display	Description														
Year	Setting the year														
Month	Setting the month														
Day	Setting the day														
Hour	Setting the hour														
Minute	Setting the minute														
Second	Setting the second														

Item No.	Description						
<b>U211</b>	<p><b>Setting the presence or absence of the job separator</b></p> <p><b>Description</b> Sets the presence or absence of the inner job separator.</p> <p><b>Purpose</b> To run this maintenance item if the inner job separator is installed.</p> <p><b>Method</b></p> <ol style="list-style-type: none"> <li>1. Press the start key.</li> <li>2. Select [Inner Job Separator].</li> <li>3. Select On or Off.</li> </ol> <table border="1" data-bbox="336 633 1401 777"> <thead> <tr> <th data-bbox="336 633 641 678">Display</th> <th data-bbox="641 633 1401 678">Description</th> </tr> </thead> <tbody> <tr> <td data-bbox="336 678 641 723">On</td> <td data-bbox="641 678 1401 723">The inner job separator is installed</td> </tr> <tr> <td data-bbox="336 723 641 777">Off</td> <td data-bbox="641 723 1401 777">The inner job separator is not installed</td> </tr> </tbody> </table> <p>Initial setting: Off</p> <ol style="list-style-type: none"> <li>4. Press the start key. The setting is set.</li> <li>5. Turn the main power switch off and on. Allow more than 5 seconds between Off and On.</li> </ol>	Display	Description	On	The inner job separator is installed	Off	The inner job separator is not installed
Display	Description						
On	The inner job separator is installed						
Off	The inner job separator is not installed						
<b>U221</b>	<p><b>Setting the USB host lock function</b></p> <p><b>Description</b> Specifies ON/OFF the USB host lock function. Setting this to ON causes the machine to be unable to recognize the device connected to the USB host.</p> <p><b>Purpose</b> Set according to the preference of the user.</p> <p><b>Method</b></p> <ol style="list-style-type: none"> <li>1. Press the start key.</li> <li>2. Select [Host Lock].</li> <li>3. Select On or Off.</li> </ol> <table border="1" data-bbox="336 1395 1401 1538"> <thead> <tr> <th data-bbox="336 1395 641 1440">Display</th> <th data-bbox="641 1395 1401 1440">Description</th> </tr> </thead> <tbody> <tr> <td data-bbox="336 1440 641 1485">On</td> <td data-bbox="641 1440 1401 1485">USB host lock function ON</td> </tr> <tr> <td data-bbox="336 1485 641 1538">Off</td> <td data-bbox="641 1485 1401 1538">USB host lock function OFF</td> </tr> </tbody> </table> <p>Initial setting: Off</p> <ol style="list-style-type: none"> <li>4. Press the start key. The setting is set.</li> <li>5. Turn the main power switch off and on. Allow more than 5 seconds between Off and On.</li> </ol>	Display	Description	On	USB host lock function ON	Off	USB host lock function OFF
Display	Description						
On	USB host lock function ON						
Off	USB host lock function OFF						

Item No.	Description						
U222	<p data-bbox="288 241 592 275"><b>Setting the IC card type</b></p> <p data-bbox="288 309 440 342"><b>Description</b></p> <p data-bbox="288 344 579 378">Sets the type of IC card.</p> <p data-bbox="288 380 400 414"><b>Purpose</b></p> <p data-bbox="288 416 649 450">To change the type of IC card.</p> <p data-bbox="288 483 384 517"><b>Setting</b></p> <ol data-bbox="304 519 564 584" style="list-style-type: none"> <li>1. Press the start key.</li> <li>2. Select the item.</li> </ol> <table border="1" data-bbox="336 595 1401 741"> <thead> <tr> <th data-bbox="336 595 639 640">Display</th> <th data-bbox="639 595 1401 640">Description</th> </tr> </thead> <tbody> <tr> <td data-bbox="336 640 639 685">Other</td> <td data-bbox="639 640 1401 685">Sets the type of IC cards to other than SSFC</td> </tr> <tr> <td data-bbox="336 685 639 741">SSFC</td> <td data-bbox="639 685 1401 741">Sets the type of IC cards to SSFC</td> </tr> </tbody> </table> <p data-bbox="336 752 571 786">Initial setting: Other</p> <ol data-bbox="304 788 783 822" style="list-style-type: none"> <li>3. Press the start key. The setting is set.</li> </ol> <p data-bbox="288 855 440 889"><b>Completion</b></p> <p data-bbox="288 891 1257 925">Press the stop key. The screen for selecting a maintenance item No. is displayed.</p>	Display	Description	Other	Sets the type of IC cards to other than SSFC	SSFC	Sets the type of IC cards to SSFC
Display	Description						
Other	Sets the type of IC cards to other than SSFC						
SSFC	Sets the type of IC cards to SSFC						

Item No.	Description																																							
<b>U223</b>	<p data-bbox="290 241 558 275"><b>Operation panel lock</b></p> <p data-bbox="290 309 438 342"><b>Description</b></p> <p data-bbox="290 344 742 378">Sets the operation panel lock function.</p> <p data-bbox="290 380 399 414"><b>Purpose</b></p> <p data-bbox="290 416 1380 483">This is performed to inhibit operating and canceling the system menu on the operation panel which may be done by others then an administrator.</p> <p data-bbox="290 517 383 551"><b>Setting</b></p> <ol data-bbox="306 553 566 620" style="list-style-type: none"> <li>1. Press the start key.</li> <li>2. Select the item.</li> </ol> <table border="1" data-bbox="336 631 1399 1057"> <thead> <tr> <th data-bbox="336 631 639 676">Display</th> <th data-bbox="639 631 1399 676">Description</th> </tr> </thead> <tbody> <tr> <td data-bbox="336 676 639 721">Unlock</td> <td data-bbox="639 676 1399 721">Release the lock of the operation from the system menu</td> </tr> <tr> <td data-bbox="336 721 639 810">Partial Lock 1</td> <td data-bbox="639 721 1399 810">The system menu entry and input/output related settings are locked</td> </tr> <tr> <td data-bbox="336 810 639 900">Partial Lock 1</td> <td data-bbox="639 810 1399 900">The system menu entries, input/output related settings, and Job-execution-related settings are locked</td> </tr> <tr> <td data-bbox="336 900 639 1012">Partial Lock 1</td> <td data-bbox="639 900 1399 1012">The system menu entries, input/output related settings, Job-execution-related settings, and paper related settings are locked</td> </tr> <tr> <td data-bbox="336 1012 639 1057">Lock</td> <td data-bbox="639 1012 1399 1057">Lock the operation from the system menu and job cancel</td> </tr> </tbody> </table> <p data-bbox="336 1077 582 1111">Initial setting: Unlock</p> <ol data-bbox="306 1113 782 1146" style="list-style-type: none"> <li>3. Press the start key. The setting is set.</li> </ol> <table border="1" data-bbox="336 1189 1096 1688"> <thead> <tr> <th data-bbox="336 1189 791 1267">Item</th> <th data-bbox="791 1189 946 1267">Partial Lock 1</th> <th data-bbox="946 1189 1096 1267">Lock</th> </tr> </thead> <tbody> <tr> <td data-bbox="336 1267 791 1312">Entering maintenance mode</td> <td data-bbox="791 1267 946 1312">Prohibited</td> <td data-bbox="946 1267 1096 1312">Prohibited</td> </tr> <tr> <td data-bbox="336 1312 791 1357">Entering system menu</td> <td data-bbox="791 1312 946 1357">Prohibited</td> <td data-bbox="946 1312 1096 1357">Prohibited</td> </tr> <tr> <td data-bbox="336 1357 791 1447">Transmission/transmission from document boxes</td> <td data-bbox="791 1357 946 1447">Prohibited</td> <td data-bbox="946 1357 1096 1447">Prohibited</td> </tr> <tr> <td data-bbox="336 1447 791 1491">Entering Addressbook Add/Edit</td> <td data-bbox="791 1447 946 1491">Prohibited</td> <td data-bbox="946 1447 1096 1491">Prohibited</td> </tr> <tr> <td data-bbox="336 1491 791 1536">Entering Document box Add/Edit</td> <td data-bbox="791 1491 946 1536">Prohibited</td> <td data-bbox="946 1491 1096 1536">Prohibited</td> </tr> <tr> <td data-bbox="336 1536 791 1581">Pressing Stop key</td> <td data-bbox="791 1536 946 1581">Permitted</td> <td data-bbox="946 1536 1096 1581">Prohibited</td> </tr> <tr> <td data-bbox="336 1581 791 1626">Pressing Status/Job Cancel</td> <td data-bbox="791 1581 946 1626">Permitted</td> <td data-bbox="946 1581 1096 1626">Prohibited</td> </tr> <tr> <td data-bbox="336 1626 791 1688">Disconnecting FAX lines</td> <td data-bbox="791 1626 946 1688">Permitted</td> <td data-bbox="946 1626 1096 1688">Prohibited</td> </tr> </tbody> </table> <p data-bbox="290 1742 438 1776"><b>Completion</b></p> <p data-bbox="290 1778 1252 1812">Press the stop key. The screen for selecting a maintenance item No. is displayed.</p>	Display	Description	Unlock	Release the lock of the operation from the system menu	Partial Lock 1	The system menu entry and input/output related settings are locked	Partial Lock 1	The system menu entries, input/output related settings, and Job-execution-related settings are locked	Partial Lock 1	The system menu entries, input/output related settings, Job-execution-related settings, and paper related settings are locked	Lock	Lock the operation from the system menu and job cancel	Item	Partial Lock 1	Lock	Entering maintenance mode	Prohibited	Prohibited	Entering system menu	Prohibited	Prohibited	Transmission/transmission from document boxes	Prohibited	Prohibited	Entering Addressbook Add/Edit	Prohibited	Prohibited	Entering Document box Add/Edit	Prohibited	Prohibited	Pressing Stop key	Permitted	Prohibited	Pressing Status/Job Cancel	Permitted	Prohibited	Disconnecting FAX lines	Permitted	Prohibited
Display	Description																																							
Unlock	Release the lock of the operation from the system menu																																							
Partial Lock 1	The system menu entry and input/output related settings are locked																																							
Partial Lock 1	The system menu entries, input/output related settings, and Job-execution-related settings are locked																																							
Partial Lock 1	The system menu entries, input/output related settings, Job-execution-related settings, and paper related settings are locked																																							
Lock	Lock the operation from the system menu and job cancel																																							
Item	Partial Lock 1	Lock																																						
Entering maintenance mode	Prohibited	Prohibited																																						
Entering system menu	Prohibited	Prohibited																																						
Transmission/transmission from document boxes	Prohibited	Prohibited																																						
Entering Addressbook Add/Edit	Prohibited	Prohibited																																						
Entering Document box Add/Edit	Prohibited	Prohibited																																						
Pressing Stop key	Permitted	Prohibited																																						
Pressing Status/Job Cancel	Permitted	Prohibited																																						
Disconnecting FAX lines	Permitted	Prohibited																																						

Item No.	Description																																																
U224	<p data-bbox="288 241 574 271"><b>Panel sheet extension</b></p> <p data-bbox="288 311 440 340"><b>Description</b></p> <p data-bbox="288 344 1426 409">Changes the image data and the message of the opening screen at the machine startup and the image data and the message of the service call screen to user specified data.</p> <p data-bbox="288 414 400 443"><b>Purpose</b></p> <p data-bbox="288 448 805 477">Set according to the preference of the user.</p> <p data-bbox="288 517 383 546"><b>Setting</b></p> <ol data-bbox="304 551 1082 757" style="list-style-type: none"> <li>1. Write the image data or the message data to the USB memory.</li> <li>2. Insert USB memory in USB memory slot of the machine.</li> <li>3. Turn the main power switch on.</li> <li>4. Enter the maintenance item.</li> <li>5. Press the start key.</li> <li>6. Select the [Install] or [UnInstall].</li> </ol> <table border="1" data-bbox="336 768 1401 913"> <thead> <tr> <th data-bbox="336 768 639 813">Display</th> <th data-bbox="639 768 1401 813">Description</th> </tr> </thead> <tbody> <tr> <td data-bbox="336 813 639 857">Install</td> <td data-bbox="639 813 1401 857">Installs the image data or the message data</td> </tr> <tr> <td data-bbox="336 857 639 913">UnInstall</td> <td data-bbox="639 857 1401 913">Restores the original image data or message data</td> </tr> </tbody> </table> <ol data-bbox="304 925 520 954" style="list-style-type: none"> <li>7. Select the item.</li> </ol> <table border="1" data-bbox="336 965 1401 1256"> <thead> <tr> <th data-bbox="336 965 564 1010">Display</th> <th data-bbox="564 965 906 1010">Description</th> <th data-bbox="906 965 1401 1010">Display area</th> </tr> </thead> <tbody> <tr> <td data-bbox="336 1010 564 1055">Opening Img</td> <td data-bbox="564 1010 906 1055">Startup screen</td> <td data-bbox="906 1010 1401 1055">Entire start display</td> </tr> <tr> <td data-bbox="336 1055 564 1099">Call Img</td> <td data-bbox="564 1055 906 1099">Service call screen</td> <td data-bbox="906 1055 1401 1099">Graphic display area</td> </tr> <tr> <td data-bbox="336 1099 564 1144">Home Menu Img</td> <td data-bbox="564 1099 906 1144">Home Menu screen</td> <td data-bbox="906 1099 1401 1144">Home Menu display area</td> </tr> <tr> <td data-bbox="336 1144 564 1189">Call Msg Top</td> <td data-bbox="564 1144 906 1189">Service call message 1</td> <td data-bbox="906 1144 1401 1189">Message display area (top)</td> </tr> <tr> <td data-bbox="336 1189 564 1256">Call Msg Detail</td> <td data-bbox="564 1189 906 1256">Service call message 2</td> <td data-bbox="906 1189 1401 1256">Message display area (descriptive area)</td> </tr> </tbody> </table> <ol data-bbox="304 1279 1018 1344" style="list-style-type: none"> <li>8. Press the start key. Installation or uninstallation is started.</li> <li>9. When normally completed, [OK] is displayed.</li> </ol> <p data-bbox="288 1384 464 1413"><b>Supplement 1</b></p> <p data-bbox="288 1417 539 1447"><b>File information</b></p> <table border="1" data-bbox="336 1458 1401 1921"> <thead> <tr> <th data-bbox="336 1458 564 1503">Description</th> <th data-bbox="564 1458 927 1503">File name</th> <th data-bbox="927 1458 1233 1503">Image size (in pixels)</th> <th data-bbox="1233 1458 1401 1503">File format</th> </tr> </thead> <tbody> <tr> <td data-bbox="336 1503 564 1592">Startup screen</td> <td data-bbox="564 1503 927 1592">opening_ext_image.png</td> <td data-bbox="927 1503 1233 1592">Length: 480 Width : 800</td> <td data-bbox="1233 1503 1401 1592">PNG</td> </tr> <tr> <td data-bbox="336 1592 564 1682">Service call screen</td> <td data-bbox="564 1592 927 1682">callwin_ext_image.png</td> <td data-bbox="927 1592 1233 1682">Length: 200 Width : 180</td> <td data-bbox="1233 1592 1401 1682">PNG</td> </tr> <tr> <td data-bbox="336 1682 564 1771">Home Menu screen</td> <td data-bbox="564 1682 927 1771">menu_background.png</td> <td data-bbox="927 1682 1233 1771">Length: 480 Width : 800</td> <td data-bbox="1233 1682 1401 1771">PNG</td> </tr> <tr> <td data-bbox="336 1771 564 1839">Service call message 1</td> <td data-bbox="564 1771 927 1839">callwin_ext_mes_top.txt</td> <td data-bbox="927 1771 1233 1839">-</td> <td data-bbox="1233 1771 1401 1839">TEXT (Unicode)</td> </tr> <tr> <td data-bbox="336 1839 564 1921">Service call message 2</td> <td data-bbox="564 1839 927 1921">callwin_ext_mes_detail.txt</td> <td data-bbox="927 1839 1233 1921">-</td> <td data-bbox="1233 1839 1401 1921">TEXT (Unicode)</td> </tr> </tbody> </table>	Display	Description	Install	Installs the image data or the message data	UnInstall	Restores the original image data or message data	Display	Description	Display area	Opening Img	Startup screen	Entire start display	Call Img	Service call screen	Graphic display area	Home Menu Img	Home Menu screen	Home Menu display area	Call Msg Top	Service call message 1	Message display area (top)	Call Msg Detail	Service call message 2	Message display area (descriptive area)	Description	File name	Image size (in pixels)	File format	Startup screen	opening_ext_image.png	Length: 480 Width : 800	PNG	Service call screen	callwin_ext_image.png	Length: 200 Width : 180	PNG	Home Menu screen	menu_background.png	Length: 480 Width : 800	PNG	Service call message 1	callwin_ext_mes_top.txt	-	TEXT (Unicode)	Service call message 2	callwin_ext_mes_detail.txt	-	TEXT (Unicode)
Display	Description																																																
Install	Installs the image data or the message data																																																
UnInstall	Restores the original image data or message data																																																
Display	Description	Display area																																															
Opening Img	Startup screen	Entire start display																																															
Call Img	Service call screen	Graphic display area																																															
Home Menu Img	Home Menu screen	Home Menu display area																																															
Call Msg Top	Service call message 1	Message display area (top)																																															
Call Msg Detail	Service call message 2	Message display area (descriptive area)																																															
Description	File name	Image size (in pixels)	File format																																														
Startup screen	opening_ext_image.png	Length: 480 Width : 800	PNG																																														
Service call screen	callwin_ext_image.png	Length: 200 Width : 180	PNG																																														
Home Menu screen	menu_background.png	Length: 480 Width : 800	PNG																																														
Service call message 1	callwin_ext_mes_top.txt	-	TEXT (Unicode)																																														
Service call message 2	callwin_ext_mes_detail.txt	-	TEXT (Unicode)																																														



Item No.	Description										
<b>U224</b>	<p><b>Supplement 2</b></p> <p><b>Displaying start display</b> The pre-installed graphics file is displayed at power on or recovering from sleeping.</p> <p><b>Graphics display on service call display</b> The pre-installed graphics file is displayed at a service call.</p> <p><b>How to change the message</b> Entering #562 (4 letters) using the numeric keypad during a service call display will let service call messages 1 and 2.</p> <p><b>How to reset the message display</b> Reverting the maintenance mode will automatically reset the message to the previous.</p> <p><b>Caution</b> The graphics file for start display must be opaque. (To avoid the background from overlapping at recovering from sleeping.) The total size of the files installable is approximately 4 MB.</p> <p><b>Completion</b> Press the stop key. The screen for selecting a maintenance item No. is displayed.</p>										
<b>U234</b>	<p><b>Setting punch destination</b></p> <p><b>Description</b> Sets the destination of punch unit of 1000-sheet finisher or 4000-sheet finisher.</p> <p><b>Purpose</b> To be set when installing a different punch unit from the destination of the machine.</p> <p><b>Setting</b></p> <ol style="list-style-type: none"> <li>1. Press the start key.</li> <li>2. Select the destination.</li> </ol> <table border="1" data-bbox="336 1234 1401 1473"> <thead> <tr> <th data-bbox="336 1234 639 1279">Display</th> <th data-bbox="639 1234 1401 1279">Description</th> </tr> </thead> <tbody> <tr> <td data-bbox="336 1279 639 1323">Auto</td> <td data-bbox="639 1279 1401 1323">Conforms to destination settings.</td> </tr> <tr> <td data-bbox="336 1323 639 1368">Japan Metric</td> <td data-bbox="639 1323 1401 1368">Metric (Japan) specifications</td> </tr> <tr> <td data-bbox="336 1368 639 1413">Inch</td> <td data-bbox="639 1368 1401 1413">Inch (North America) specifications</td> </tr> <tr> <td data-bbox="336 1413 639 1458">Europe Metric</td> <td data-bbox="639 1413 1401 1458">Metric (Europe) specifications</td> </tr> </tbody> </table> <p>Initial setting: Inch (Inch specifications)/Europe Metric (Metric specifications)</p> <ol style="list-style-type: none"> <li>3. Press the start key. The setting is set.</li> <li>4. Turn the main power switch off and on. Allow more than 5 seconds between Off and On.</li> </ol>	Display	Description	Auto	Conforms to destination settings.	Japan Metric	Metric (Japan) specifications	Inch	Inch (North America) specifications	Europe Metric	Metric (Europe) specifications
Display	Description										
Auto	Conforms to destination settings.										
Japan Metric	Metric (Japan) specifications										
Inch	Inch (North America) specifications										
Europe Metric	Metric (Europe) specifications										

Item No.	Description																										
U237	<p data-bbox="288 241 675 275"><b>Setting finisher stack quantity</b></p> <p data-bbox="288 311 440 340"><b>Description</b></p> <p data-bbox="288 344 1412 409">Sets the number of sheets of each stack on the main tray and on the middle tray in 4000-sheet finisher.</p> <p data-bbox="288 414 400 443"><b>Purpose</b></p> <p data-bbox="288 448 1023 479">To change the setting when a stack malfunction has occurred.</p> <p data-bbox="288 515 387 544"><b>Method</b></p> <ol data-bbox="304 551 632 616" style="list-style-type: none"> <li>1. Press the start key.</li> <li>2. Select the item to be set.</li> </ol> <table border="1" data-bbox="336 629 1401 775"> <thead> <tr> <th data-bbox="336 629 639 680">Display</th> <th data-bbox="639 629 1401 680">Description</th> </tr> </thead> <tbody> <tr> <td data-bbox="336 680 639 725">Main Tray</td> <td data-bbox="639 680 1401 725">Number of sheets of stack on the main tray</td> </tr> <tr> <td data-bbox="336 725 639 775">Middle Tray</td> <td data-bbox="639 725 1401 775">Number of sheets of stack on the middle tray for staple mode</td> </tr> </tbody> </table> <p data-bbox="288 819 542 851"><b>Setting: [Main Tray]</b></p> <ol data-bbox="304 855 983 887" style="list-style-type: none"> <li>1. Change the setting using the +/- keys or numeric keys.</li> </ol> <table border="1" data-bbox="336 898 1401 1249"> <thead> <tr> <th data-bbox="336 898 639 949">Display</th> <th data-bbox="639 898 1401 949">Description</th> </tr> </thead> <tbody> <tr> <td data-bbox="336 949 639 1099">0</td> <td data-bbox="639 949 1401 1099">When stapling paper less than B4 size, paper full is detected when 4,000 sheets are output. When stapling B4 size paper, or larger, paper full is detected when 1500 sheets are output.</td> </tr> <tr> <td data-bbox="336 1099 639 1249">1</td> <td data-bbox="639 1099 1401 1249">When stapling 30 sheets or less, paper full is detected after 150 sets or 1500 sheets are output, whichever is faster.. When stapling 31 sheets or more, paper full is detected after 150 sets or 4,000 sheets are output, whichever is faster.</td> </tr> </tbody> </table> <p data-bbox="336 1267 517 1299">Initial setting: 0</p> <ol data-bbox="304 1303 1378 1368" style="list-style-type: none"> <li>2. Press the start key. The setting is set.</li> <li>3. Turn the main power switch off and on. Allow more than 5 seconds between Off and On.</li> </ol> <p data-bbox="288 1406 564 1438"><b>Setting: [Middle Tray]</b></p> <ol data-bbox="304 1442 983 1473" style="list-style-type: none"> <li>1. Change the setting using the +/- keys or numeric keys.</li> </ol> <table border="1" data-bbox="336 1485 1401 1724"> <thead> <tr> <th data-bbox="336 1485 639 1630" rowspan="2">Display</th> <th colspan="2" data-bbox="639 1485 1401 1536">Description</th> </tr> <tr> <th colspan="2" data-bbox="639 1536 1401 1581">Number of sheets of stack on the middle tray for staple mode</th> </tr> <tr> <td data-bbox="336 1581 639 1630"></td> <th data-bbox="639 1581 1018 1630">1000-sheet finisher</th> <th data-bbox="1018 1581 1401 1630">4000-sheet finisher</th> </tr> </thead> <tbody> <tr> <td data-bbox="336 1630 639 1675">0</td> <td data-bbox="639 1630 1018 1675">50 sheets</td> <td data-bbox="1018 1630 1401 1675">65 sheets</td> </tr> <tr> <td data-bbox="336 1675 639 1724">1</td> <td data-bbox="639 1675 1018 1724">30 sheets</td> <td data-bbox="1018 1675 1401 1724">30 sheets</td> </tr> </tbody> </table> <p data-bbox="336 1742 517 1774">Initial setting: 0</p> <p data-bbox="336 1778 1278 1809">Number of sheets of stack on the internal tray for non-staple copying: 10 sheets</p> <ol data-bbox="304 1814 1378 1879" style="list-style-type: none"> <li>2. Press the start key. The setting is set.</li> <li>3. Turn the main power switch off and on. Allow more than 5 seconds between Off and On.</li> </ol>	Display	Description	Main Tray	Number of sheets of stack on the main tray	Middle Tray	Number of sheets of stack on the middle tray for staple mode	Display	Description	0	When stapling paper less than B4 size, paper full is detected when 4,000 sheets are output. When stapling B4 size paper, or larger, paper full is detected when 1500 sheets are output.	1	When stapling 30 sheets or less, paper full is detected after 150 sets or 1500 sheets are output, whichever is faster.. When stapling 31 sheets or more, paper full is detected after 150 sets or 4,000 sheets are output, whichever is faster.	Display	Description		Number of sheets of stack on the middle tray for staple mode			1000-sheet finisher	4000-sheet finisher	0	50 sheets	65 sheets	1	30 sheets	30 sheets
Display	Description																										
Main Tray	Number of sheets of stack on the main tray																										
Middle Tray	Number of sheets of stack on the middle tray for staple mode																										
Display	Description																										
0	When stapling paper less than B4 size, paper full is detected when 4,000 sheets are output. When stapling B4 size paper, or larger, paper full is detected when 1500 sheets are output.																										
1	When stapling 30 sheets or less, paper full is detected after 150 sets or 1500 sheets are output, whichever is faster.. When stapling 31 sheets or more, paper full is detected after 150 sets or 4,000 sheets are output, whichever is faster.																										
Display	Description																										
	Number of sheets of stack on the middle tray for staple mode																										
	1000-sheet finisher	4000-sheet finisher																									
0	50 sheets	65 sheets																									
1	30 sheets	30 sheets																									

Item No.	Description																																																						
U240	<p data-bbox="288 241 774 275"><b>Checking the operation of the finisher</b></p> <p data-bbox="288 311 440 340"><b>Description</b></p> <p data-bbox="288 344 1230 374">Turn each motor and solenoid of 1000-sheet finisher or 4000-sheet finisher ON.</p> <p data-bbox="288 383 400 412"><b>Purpose</b></p> <p data-bbox="288 416 1418 479">To check the operation of each motor and solenoid of the 1000-sheet finisher or 4000-sheet finisher.</p> <p data-bbox="288 517 387 546"><b>Method</b></p> <ol data-bbox="304 555 695 618" style="list-style-type: none"> <li>1. Press the start key.</li> <li>2. Select the item to be checked.</li> </ol> <table border="1" data-bbox="336 631 1401 871"> <thead> <tr> <th data-bbox="336 631 639 676">Display</th> <th data-bbox="639 631 1401 676">Description</th> </tr> </thead> <tbody> <tr> <td data-bbox="336 676 639 721">Motor</td> <td data-bbox="639 676 1401 721">Checking the motor of the document finisher</td> </tr> <tr> <td data-bbox="336 721 639 766">Solenoid</td> <td data-bbox="639 721 1401 766">Checking the solenoid of the document finisher</td> </tr> <tr> <td data-bbox="336 766 639 810">Mail Box</td> <td data-bbox="639 766 1401 810">Checking the motor of the mailbox</td> </tr> <tr> <td data-bbox="336 810 639 855">Booklet</td> <td data-bbox="639 810 1401 855">Checking the motor of the center-folding unit</td> </tr> </tbody> </table> <p data-bbox="288 918 496 947"><b>Method: [Motor]</b></p> <ol data-bbox="304 952 815 1014" style="list-style-type: none"> <li>1. Select the item to be operated.</li> <li>2. Press the start key. The operation starts.</li> </ol> <table border="1" data-bbox="336 1028 1401 2018"> <thead> <tr> <th data-bbox="336 1028 639 1072">Display</th> <th data-bbox="639 1028 1401 1072">Description</th> </tr> </thead> <tbody> <tr> <td data-bbox="336 1072 639 1117">Feed In(H)</td> <td data-bbox="639 1072 1401 1117">DF paper entry motor (DFPEM) is turned on at high speed</td> </tr> <tr> <td data-bbox="336 1117 639 1162">Feed In(L)</td> <td data-bbox="639 1117 1401 1162">DF paper entry motor (DFPEM) is turned on at low speed</td> </tr> <tr> <td data-bbox="336 1162 639 1207">Middle(H)</td> <td data-bbox="639 1162 1401 1207">DF middle motor (DFMM) is turned on at high speed</td> </tr> <tr> <td data-bbox="336 1207 639 1252">Middle(L)</td> <td data-bbox="639 1207 1401 1252">DF middle motor (DFMM) is turned on at low speed</td> </tr> <tr> <td data-bbox="336 1252 639 1296">Eject(H)</td> <td data-bbox="639 1252 1401 1296">DF eject motor (DFEM) is turned on at high speed</td> </tr> <tr> <td data-bbox="336 1296 639 1341">Eject(L)</td> <td data-bbox="639 1296 1401 1341">DF eject motor (DFEM) is turned on at low speed</td> </tr> <tr> <td data-bbox="336 1341 639 1386">Save(H)</td> <td data-bbox="639 1341 1401 1386">DF drum motor (DFDRM) is turned on at high speed</td> </tr> <tr> <td data-bbox="336 1386 639 1431">Save(L)</td> <td data-bbox="639 1386 1401 1431">DF drum motor (DFDRM) is turned on at low speed</td> </tr> <tr> <td data-bbox="336 1431 639 1476">Tray</td> <td data-bbox="639 1431 1401 1476">DF tray motor (DFTM) is turned on</td> </tr> <tr> <td data-bbox="336 1476 639 1520"></td> <td data-bbox="639 1476 1401 1520">Operating sequences:</td> </tr> <tr> <td data-bbox="336 1520 639 1565"></td> <td data-bbox="639 1520 1401 1565">Ascends after descending to the bottom limit; descends again</td> </tr> <tr> <td data-bbox="336 1565 639 1610"></td> <td data-bbox="639 1565 1401 1610">in one second after the intermediate sensor is detected to be</td> </tr> <tr> <td data-bbox="336 1610 639 1655"></td> <td data-bbox="639 1610 1401 1655">off; ascends again after the intermediate sensor is detected to</td> </tr> <tr> <td data-bbox="336 1655 639 1700"></td> <td data-bbox="639 1655 1401 1700">be on; then halts at the top limit</td> </tr> <tr> <td data-bbox="336 1700 639 1744">Staple Move</td> <td data-bbox="639 1700 1401 1744">DF slide motor (DFSLM) is turned on</td> </tr> <tr> <td data-bbox="336 1744 639 1789">Staple</td> <td data-bbox="639 1744 1401 1789">DF staple motor (DFSTM) is turned on</td> </tr> <tr> <td data-bbox="336 1789 639 1834">Width Test(A3)</td> <td data-bbox="639 1789 1401 1834">DF side registration motor 1, 2 (DFSRM1, 2) is turned on</td> </tr> <tr> <td data-bbox="336 1834 639 1879">Width Test(LD)</td> <td data-bbox="639 1834 1401 1879">DF side registration motor 1, 2 (DFSRM1, 2) is turned on</td> </tr> <tr> <td data-bbox="336 1879 639 1924">Beat</td> <td data-bbox="639 1879 1401 1924">DF paddle motor (DFPDM) is turned on</td> </tr> <tr> <td data-bbox="336 1924 639 1968">Eject Unlock(HP)</td> <td data-bbox="639 1924 1401 1968">DF eject release motor (DFERM) is turned on to home position</td> </tr> <tr> <td data-bbox="336 1968 639 2013">Sort Test</td> <td data-bbox="639 1968 1401 2013">DF shift motor 1, 2 (DFSFM1, 2) is turned on</td> </tr> </tbody> </table>	Display	Description	Motor	Checking the motor of the document finisher	Solenoid	Checking the solenoid of the document finisher	Mail Box	Checking the motor of the mailbox	Booklet	Checking the motor of the center-folding unit	Display	Description	Feed In(H)	DF paper entry motor (DFPEM) is turned on at high speed	Feed In(L)	DF paper entry motor (DFPEM) is turned on at low speed	Middle(H)	DF middle motor (DFMM) is turned on at high speed	Middle(L)	DF middle motor (DFMM) is turned on at low speed	Eject(H)	DF eject motor (DFEM) is turned on at high speed	Eject(L)	DF eject motor (DFEM) is turned on at low speed	Save(H)	DF drum motor (DFDRM) is turned on at high speed	Save(L)	DF drum motor (DFDRM) is turned on at low speed	Tray	DF tray motor (DFTM) is turned on		Operating sequences:		Ascends after descending to the bottom limit; descends again		in one second after the intermediate sensor is detected to be		off; ascends again after the intermediate sensor is detected to		be on; then halts at the top limit	Staple Move	DF slide motor (DFSLM) is turned on	Staple	DF staple motor (DFSTM) is turned on	Width Test(A3)	DF side registration motor 1, 2 (DFSRM1, 2) is turned on	Width Test(LD)	DF side registration motor 1, 2 (DFSRM1, 2) is turned on	Beat	DF paddle motor (DFPDM) is turned on	Eject Unlock(HP)	DF eject release motor (DFERM) is turned on to home position	Sort Test	DF shift motor 1, 2 (DFSFM1, 2) is turned on
Display	Description																																																						
Motor	Checking the motor of the document finisher																																																						
Solenoid	Checking the solenoid of the document finisher																																																						
Mail Box	Checking the motor of the mailbox																																																						
Booklet	Checking the motor of the center-folding unit																																																						
Display	Description																																																						
Feed In(H)	DF paper entry motor (DFPEM) is turned on at high speed																																																						
Feed In(L)	DF paper entry motor (DFPEM) is turned on at low speed																																																						
Middle(H)	DF middle motor (DFMM) is turned on at high speed																																																						
Middle(L)	DF middle motor (DFMM) is turned on at low speed																																																						
Eject(H)	DF eject motor (DFEM) is turned on at high speed																																																						
Eject(L)	DF eject motor (DFEM) is turned on at low speed																																																						
Save(H)	DF drum motor (DFDRM) is turned on at high speed																																																						
Save(L)	DF drum motor (DFDRM) is turned on at low speed																																																						
Tray	DF tray motor (DFTM) is turned on																																																						
	Operating sequences:																																																						
	Ascends after descending to the bottom limit; descends again																																																						
	in one second after the intermediate sensor is detected to be																																																						
	off; ascends again after the intermediate sensor is detected to																																																						
	be on; then halts at the top limit																																																						
Staple Move	DF slide motor (DFSLM) is turned on																																																						
Staple	DF staple motor (DFSTM) is turned on																																																						
Width Test(A3)	DF side registration motor 1, 2 (DFSRM1, 2) is turned on																																																						
Width Test(LD)	DF side registration motor 1, 2 (DFSRM1, 2) is turned on																																																						
Beat	DF paddle motor (DFPDM) is turned on																																																						
Eject Unlock(HP)	DF eject release motor (DFERM) is turned on to home position																																																						
Sort Test	DF shift motor 1, 2 (DFSFM1, 2) is turned on																																																						

Item No.	Description																																																		
U240	<table border="1" data-bbox="336 286 1401 622"> <thead> <tr> <th data-bbox="336 286 639 331">Display</th> <th data-bbox="639 286 1401 331">Description</th> </tr> </thead> <tbody> <tr> <td data-bbox="336 331 639 376">Eject Unlock(30)</td> <td data-bbox="639 331 1401 376">DF eject release motor (DFERM) drive position 30-sheet stack</td> </tr> <tr> <td data-bbox="336 376 639 421">Eject Unlock(50)</td> <td data-bbox="639 376 1401 421">DF eject release motor (DFERM) drive position 50-sheet stack</td> </tr> <tr> <td data-bbox="336 421 639 465">Eject Unlock(Fix)</td> <td data-bbox="639 421 1401 465">DF eject release motor (DFERM) fixed drive position</td> </tr> <tr> <td data-bbox="336 465 639 510">Eject Unlock(Full)</td> <td data-bbox="639 465 1401 510">DF eject release motor (DFERM) full-open drive position</td> </tr> <tr> <td data-bbox="336 510 639 555">Punch</td> <td data-bbox="639 510 1401 555">Punch motor (PUM) is turned on</td> </tr> <tr> <td data-bbox="336 555 639 622">Punch Move</td> <td data-bbox="639 555 1401 622">Punch slide motor (PUSLM) is turned on</td> </tr> </tbody> </table> <p data-bbox="288 667 536 701"><b>Method: [Solenoid]</b></p> <ol data-bbox="304 701 815 768" style="list-style-type: none"> <li>1. Select the item to be operated.</li> <li>2. Press the start key. The operation starts.</li> </ol> <table border="1" data-bbox="336 779 1401 1070"> <thead> <tr> <th data-bbox="336 779 639 824">Display</th> <th data-bbox="639 779 1401 824">Description</th> </tr> </thead> <tbody> <tr> <td data-bbox="336 824 639 869">Sub Tray</td> <td data-bbox="639 824 1401 869">DF feedshift solenoid (DFFSSOL) is turned on</td> </tr> <tr> <td data-bbox="336 869 639 913">Save Drum</td> <td data-bbox="639 869 1401 913">DF drum solenoid (DFDRSOL) is turned on</td> </tr> <tr> <td data-bbox="336 913 639 958">Booklet</td> <td data-bbox="639 913 1401 958">DF center fold solenoid (DFCFSOL) is turned on</td> </tr> <tr> <td data-bbox="336 958 639 1003">Punch</td> <td data-bbox="639 958 1401 1003">Punch solenoid (PUSOL) is turned on</td> </tr> <tr> <td data-bbox="336 1003 639 1070">Three Fold</td> <td data-bbox="639 1003 1401 1070">CF feedshift solenoid (CFFSSOL) is turned on</td> </tr> </tbody> </table> <p data-bbox="288 1115 536 1149"><b>Method: [Mail Box]</b></p> <ol data-bbox="304 1149 815 1216" style="list-style-type: none"> <li>1. Select the item to be operated.</li> <li>2. Press the start key. The operation starts.</li> </ol> <table border="1" data-bbox="336 1227 1401 1373"> <thead> <tr> <th data-bbox="336 1227 564 1272">Display</th> <th data-bbox="564 1227 1401 1272">Description</th> </tr> </thead> <tbody> <tr> <td data-bbox="336 1272 564 1317">Conv</td> <td data-bbox="564 1272 1401 1317">MB drive motor (MBDM) is turned on at paper conveying</td> </tr> <tr> <td data-bbox="336 1317 564 1373">Branch</td> <td data-bbox="564 1317 1401 1373">MB drive motor (MBDM) is turned on at feedshift operation</td> </tr> </tbody> </table> <p data-bbox="288 1417 520 1451"><b>Method: [Booklet]</b></p> <ol data-bbox="304 1451 815 1518" style="list-style-type: none"> <li>1. Select the item to be operated.</li> <li>2. Press the start key. The operation starts.</li> </ol> <table border="1" data-bbox="336 1529 1401 1955"> <thead> <tr> <th data-bbox="336 1529 639 1574">Display</th> <th data-bbox="639 1529 1401 1574">Description</th> </tr> </thead> <tbody> <tr> <td data-bbox="336 1574 639 1619">Folding</td> <td data-bbox="639 1574 1401 1619">CF main motor (CFMM) is turned on</td> </tr> <tr> <td data-bbox="336 1619 639 1664">Blade</td> <td data-bbox="639 1619 1401 1664">CF blade motor (CFBM) is turned on</td> </tr> <tr> <td data-bbox="336 1664 639 1709">Bundle Up</td> <td data-bbox="639 1664 1401 1709">CF adjustment motor 2 (CFADM2) is turned on</td> </tr> <tr> <td data-bbox="336 1709 639 1753">Bundle Down</td> <td data-bbox="639 1709 1401 1753">CF adjustment motor 1 (CFADM1) is turned on</td> </tr> <tr> <td data-bbox="336 1753 639 1798">Staple</td> <td data-bbox="639 1753 1401 1798">CF staple motor (CFSTM) is turned on</td> </tr> <tr> <td data-bbox="336 1798 639 1843">Width Test(A3)</td> <td data-bbox="639 1798 1401 1843">CF side registration motor 1, 2 (CFSRM1, 2) is turned on</td> </tr> <tr> <td data-bbox="336 1843 639 1888">Width Test(LD)</td> <td data-bbox="639 1843 1401 1888">CF side registration motor 1, 2 (CFSRM1, 2) is turned on</td> </tr> <tr> <td data-bbox="336 1888 639 1955">Feed In</td> <td data-bbox="639 1888 1401 1955">CF paper entry motor (CFPEM) is turned on</td> </tr> </tbody> </table> <p data-bbox="288 1977 440 2011"><b>Completion</b></p> <p data-bbox="288 2011 1254 2036">Press the stop key. The screen for selecting a maintenance item No. is displayed.</p>	Display	Description	Eject Unlock(30)	DF eject release motor (DFERM) drive position 30-sheet stack	Eject Unlock(50)	DF eject release motor (DFERM) drive position 50-sheet stack	Eject Unlock(Fix)	DF eject release motor (DFERM) fixed drive position	Eject Unlock(Full)	DF eject release motor (DFERM) full-open drive position	Punch	Punch motor (PUM) is turned on	Punch Move	Punch slide motor (PUSLM) is turned on	Display	Description	Sub Tray	DF feedshift solenoid (DFFSSOL) is turned on	Save Drum	DF drum solenoid (DFDRSOL) is turned on	Booklet	DF center fold solenoid (DFCFSOL) is turned on	Punch	Punch solenoid (PUSOL) is turned on	Three Fold	CF feedshift solenoid (CFFSSOL) is turned on	Display	Description	Conv	MB drive motor (MBDM) is turned on at paper conveying	Branch	MB drive motor (MBDM) is turned on at feedshift operation	Display	Description	Folding	CF main motor (CFMM) is turned on	Blade	CF blade motor (CFBM) is turned on	Bundle Up	CF adjustment motor 2 (CFADM2) is turned on	Bundle Down	CF adjustment motor 1 (CFADM1) is turned on	Staple	CF staple motor (CFSTM) is turned on	Width Test(A3)	CF side registration motor 1, 2 (CFSRM1, 2) is turned on	Width Test(LD)	CF side registration motor 1, 2 (CFSRM1, 2) is turned on	Feed In	CF paper entry motor (CFPEM) is turned on
Display	Description																																																		
Eject Unlock(30)	DF eject release motor (DFERM) drive position 30-sheet stack																																																		
Eject Unlock(50)	DF eject release motor (DFERM) drive position 50-sheet stack																																																		
Eject Unlock(Fix)	DF eject release motor (DFERM) fixed drive position																																																		
Eject Unlock(Full)	DF eject release motor (DFERM) full-open drive position																																																		
Punch	Punch motor (PUM) is turned on																																																		
Punch Move	Punch slide motor (PUSLM) is turned on																																																		
Display	Description																																																		
Sub Tray	DF feedshift solenoid (DFFSSOL) is turned on																																																		
Save Drum	DF drum solenoid (DFDRSOL) is turned on																																																		
Booklet	DF center fold solenoid (DFCFSOL) is turned on																																																		
Punch	Punch solenoid (PUSOL) is turned on																																																		
Three Fold	CF feedshift solenoid (CFFSSOL) is turned on																																																		
Display	Description																																																		
Conv	MB drive motor (MBDM) is turned on at paper conveying																																																		
Branch	MB drive motor (MBDM) is turned on at feedshift operation																																																		
Display	Description																																																		
Folding	CF main motor (CFMM) is turned on																																																		
Blade	CF blade motor (CFBM) is turned on																																																		
Bundle Up	CF adjustment motor 2 (CFADM2) is turned on																																																		
Bundle Down	CF adjustment motor 1 (CFADM1) is turned on																																																		
Staple	CF staple motor (CFSTM) is turned on																																																		
Width Test(A3)	CF side registration motor 1, 2 (CFSRM1, 2) is turned on																																																		
Width Test(LD)	CF side registration motor 1, 2 (CFSRM1, 2) is turned on																																																		
Feed In	CF paper entry motor (CFPEM) is turned on																																																		

Item No.	Description																																																
U241	<p data-bbox="287 241 976 275"><b>Checking the operation of the switches of the finisher</b></p> <p data-bbox="287 309 440 342"><b>Description</b></p> <p data-bbox="287 344 1414 378">Displays the status of each switches and sensors of 1000-sheet finisher or 4000-sheet finisher.</p> <p data-bbox="287 380 400 414"><b>Purpose</b></p> <p data-bbox="287 416 1406 483">To check the operation of each switches and sensors of the 1000-sheet finisher or 4000-sheet finisher.</p> <p data-bbox="287 517 387 551"><b>Method</b></p> <ol data-bbox="304 553 695 620" style="list-style-type: none"> <li>1. Press the start key.</li> <li>2. Select the item to be checked.</li> </ol> <table border="1" data-bbox="336 631 1399 871"> <thead> <tr> <th data-bbox="336 631 639 676">Display</th> <th data-bbox="639 631 1399 676">Description</th> </tr> </thead> <tbody> <tr> <td data-bbox="336 676 639 721">Finisher</td> <td data-bbox="639 676 1399 721">Checking the switch and sensor of the document finisher</td> </tr> <tr> <td data-bbox="336 721 639 766">Mail Box</td> <td data-bbox="639 721 1399 766">Checking the switch and sensor of the mailbox</td> </tr> <tr> <td data-bbox="336 766 639 810">Booklet</td> <td data-bbox="639 766 1399 810">Checking the switch and sensor of the center-folding unit</td> </tr> <tr> <td data-bbox="336 810 639 855">Punch</td> <td data-bbox="639 810 1399 855">Checking the switch and sensor of the punch unit</td> </tr> </tbody> </table> <p data-bbox="287 913 528 947"><b>Method: [Finisher]</b></p> <ol data-bbox="304 949 1398 1050" style="list-style-type: none"> <li>1. Turn each switch or sensor on and off manually to check the status. When the on-status of a switch or sensor is detected, that switch or sensor is displayed in reverse.</li> </ol> <table border="1" data-bbox="336 1061 1399 1973"> <thead> <tr> <th data-bbox="336 1061 639 1106">Display</th> <th data-bbox="639 1061 1399 1106">Description</th> </tr> </thead> <tbody> <tr> <td data-bbox="336 1106 639 1151">Front Cover</td> <td data-bbox="639 1106 1399 1151">DF front cover switch (DFFCSW)</td> </tr> <tr> <td data-bbox="336 1151 639 1196">MPT<sup>*1</sup></td> <td data-bbox="639 1151 1399 1196">DF eject cover switch (DFECSW)</td> </tr> <tr> <td data-bbox="336 1196 639 1240">Top Cover<sup>*2</sup></td> <td data-bbox="639 1196 1399 1240">DF top cover switch (DFTCSW)</td> </tr> <tr> <td data-bbox="336 1240 639 1285">Tray U-Limit</td> <td data-bbox="639 1240 1399 1285">DF tray sensor 1 (DFTS1)</td> </tr> <tr> <td data-bbox="336 1285 639 1330">Tray HP2<sup>*1</sup></td> <td data-bbox="639 1285 1399 1330">DF tray sensor 2 (DFTS2)</td> </tr> <tr> <td data-bbox="336 1330 639 1375">Tray Middle</td> <td data-bbox="639 1330 1399 1375">DF tray sensor 3 (DFTS3)</td> </tr> <tr> <td data-bbox="336 1375 639 1420">Tray L-Limit</td> <td data-bbox="639 1375 1399 1420">DF tray sensor 4 (DFTS4)</td> </tr> <tr> <td data-bbox="336 1420 639 1464">Tray L-Limit(BL)<sup>*1</sup></td> <td data-bbox="639 1420 1399 1464">DF tray sensor 5 (DFTS5)</td> </tr> <tr> <td data-bbox="336 1464 639 1509">Tray Top</td> <td data-bbox="639 1464 1399 1509">DF tray upper surface sensor (DFTUSS)</td> </tr> <tr> <td data-bbox="336 1509 639 1554">HP</td> <td data-bbox="639 1509 1399 1554">DF paper entry sensor (DFPES)</td> </tr> <tr> <td data-bbox="336 1554 639 1599">Sub Tray Eject<sup>*1</sup></td> <td data-bbox="639 1554 1399 1599">DF sub eject sensor (DFSES)</td> </tr> <tr> <td data-bbox="336 1599 639 1644">Middle Tray Eject</td> <td data-bbox="639 1599 1399 1644">DF middle eject sensor (DFMES)</td> </tr> <tr> <td data-bbox="336 1644 639 1688">Drum<sup>*1</sup></td> <td data-bbox="639 1644 1399 1688">DF drum sensor (DFDRS)</td> </tr> <tr> <td data-bbox="336 1688 639 1733">Staple HP</td> <td data-bbox="639 1688 1399 1733">DF slide sensor (DFSLS)</td> </tr> <tr> <td data-bbox="336 1733 639 1778">Middle Tray</td> <td data-bbox="639 1733 1399 1778">DF middle tray sensor (DFMTS)</td> </tr> <tr> <td data-bbox="336 1778 639 1823">Width Front HP</td> <td data-bbox="639 1778 1399 1823">DF side registration sensor 1 (DFSRS1)</td> </tr> <tr> <td data-bbox="336 1823 639 1868">Width Tail HP</td> <td data-bbox="639 1823 1399 1868">DF side registration sensor 2 (DFSRS2)</td> </tr> <tr> <td data-bbox="336 1868 639 1912">Bundle Eject HP</td> <td data-bbox="639 1868 1399 1912">DF bundle discharge sensor (DFBDS)</td> </tr> </tbody> </table>	Display	Description	Finisher	Checking the switch and sensor of the document finisher	Mail Box	Checking the switch and sensor of the mailbox	Booklet	Checking the switch and sensor of the center-folding unit	Punch	Checking the switch and sensor of the punch unit	Display	Description	Front Cover	DF front cover switch (DFFCSW)	MPT <sup>*1</sup>	DF eject cover switch (DFECSW)	Top Cover <sup>*2</sup>	DF top cover switch (DFTCSW)	Tray U-Limit	DF tray sensor 1 (DFTS1)	Tray HP2 <sup>*1</sup>	DF tray sensor 2 (DFTS2)	Tray Middle	DF tray sensor 3 (DFTS3)	Tray L-Limit	DF tray sensor 4 (DFTS4)	Tray L-Limit(BL) <sup>*1</sup>	DF tray sensor 5 (DFTS5)	Tray Top	DF tray upper surface sensor (DFTUSS)	HP	DF paper entry sensor (DFPES)	Sub Tray Eject <sup>*1</sup>	DF sub eject sensor (DFSES)	Middle Tray Eject	DF middle eject sensor (DFMES)	Drum <sup>*1</sup>	DF drum sensor (DFDRS)	Staple HP	DF slide sensor (DFSLS)	Middle Tray	DF middle tray sensor (DFMTS)	Width Front HP	DF side registration sensor 1 (DFSRS1)	Width Tail HP	DF side registration sensor 2 (DFSRS2)	Bundle Eject HP	DF bundle discharge sensor (DFBDS)
Display	Description																																																
Finisher	Checking the switch and sensor of the document finisher																																																
Mail Box	Checking the switch and sensor of the mailbox																																																
Booklet	Checking the switch and sensor of the center-folding unit																																																
Punch	Checking the switch and sensor of the punch unit																																																
Display	Description																																																
Front Cover	DF front cover switch (DFFCSW)																																																
MPT <sup>*1</sup>	DF eject cover switch (DFECSW)																																																
Top Cover <sup>*2</sup>	DF top cover switch (DFTCSW)																																																
Tray U-Limit	DF tray sensor 1 (DFTS1)																																																
Tray HP2 <sup>*1</sup>	DF tray sensor 2 (DFTS2)																																																
Tray Middle	DF tray sensor 3 (DFTS3)																																																
Tray L-Limit	DF tray sensor 4 (DFTS4)																																																
Tray L-Limit(BL) <sup>*1</sup>	DF tray sensor 5 (DFTS5)																																																
Tray Top	DF tray upper surface sensor (DFTUSS)																																																
HP	DF paper entry sensor (DFPES)																																																
Sub Tray Eject <sup>*1</sup>	DF sub eject sensor (DFSES)																																																
Middle Tray Eject	DF middle eject sensor (DFMES)																																																
Drum <sup>*1</sup>	DF drum sensor (DFDRS)																																																
Staple HP	DF slide sensor (DFSLS)																																																
Middle Tray	DF middle tray sensor (DFMTS)																																																
Width Front HP	DF side registration sensor 1 (DFSRS1)																																																
Width Tail HP	DF side registration sensor 2 (DFSRS2)																																																
Bundle Eject HP	DF bundle discharge sensor (DFBDS)																																																

Item No.	Description																																						
U241	<table border="1" data-bbox="336 286 1401 669"> <thead> <tr> <th data-bbox="336 286 641 331">Display</th> <th data-bbox="641 286 1401 331">Description</th> </tr> </thead> <tbody> <tr> <td data-bbox="336 331 641 376">Match Paddle*1</td> <td data-bbox="641 331 1401 376">DF adjustment sensor (DFADS)</td> </tr> <tr> <td data-bbox="336 376 641 421">Lead Paddle</td> <td data-bbox="641 376 1401 421">DF paddle sensor (DFPDS)</td> </tr> <tr> <td data-bbox="336 421 641 465">Shift Front HP</td> <td data-bbox="641 421 1401 465">DF shift sensor 1 (DFSFS1)</td> </tr> <tr> <td data-bbox="336 465 641 510">Shift Tail HP</td> <td data-bbox="641 465 1401 510">DF shift sensor 2 (DFSFS2)</td> </tr> <tr> <td data-bbox="336 510 641 555">Shift Unlock HP</td> <td data-bbox="641 510 1401 555">DF shift release sensor (DFSFRS)</td> </tr> <tr> <td data-bbox="336 555 641 600">Sub Tray Full</td> <td data-bbox="641 555 1401 600">DF sub tray full sensor (DFSTFS)</td> </tr> <tr> <td data-bbox="336 600 641 669">Shift Set</td> <td data-bbox="641 600 1401 669">DF shift set sensor (DFSFS)</td> </tr> </tbody> </table> <p data-bbox="288 678 967 707">*1: 4000-sheet finisher only. *2: 1000-sheet finisher only.</p> <p data-bbox="288 712 533 741"><b>Method: [Mail Box]</b></p> <p data-bbox="304 745 1136 775">1. Turn each switch or sensor on and off manually to check the status.</p> <p data-bbox="333 779 1396 844">When the on-status of a switch or sensor is detected, that switch or sensor is displayed in reverse.</p> <table border="1" data-bbox="336 860 1401 1386"> <thead> <tr> <th data-bbox="336 860 641 904">Display</th> <th data-bbox="641 860 1401 904">Description</th> </tr> </thead> <tbody> <tr> <td data-bbox="336 904 641 949">Eject</td> <td data-bbox="641 904 1401 949">MB eject sensor (MBES)</td> </tr> <tr> <td data-bbox="336 949 641 994">Cover</td> <td data-bbox="641 949 1401 994">MB cover open/close switch (MBCOCSW)</td> </tr> <tr> <td data-bbox="336 994 641 1039">Over Flow1</td> <td data-bbox="641 994 1401 1039">MB overflow sensor 1 (MBOFS1)</td> </tr> <tr> <td data-bbox="336 1039 641 1084">Over Flow2</td> <td data-bbox="641 1039 1401 1084">MB overflow sensor 2 (MBOFS2)</td> </tr> <tr> <td data-bbox="336 1084 641 1128">Over Flow3</td> <td data-bbox="641 1084 1401 1128">MB overflow sensor 3 (MBOFS3)</td> </tr> <tr> <td data-bbox="336 1128 641 1173">Over Flow4</td> <td data-bbox="641 1128 1401 1173">MB overflow sensor 4 (MBOFS4)</td> </tr> <tr> <td data-bbox="336 1173 641 1218">Over Flow5</td> <td data-bbox="641 1173 1401 1218">MB overflow sensor 5 (MBOFS5)</td> </tr> <tr> <td data-bbox="336 1218 641 1263">Over Flow6</td> <td data-bbox="641 1218 1401 1263">MB overflow sensor 6 (MBOFS6)</td> </tr> <tr> <td data-bbox="336 1263 641 1308">Over Flow7</td> <td data-bbox="641 1263 1401 1308">MB overflow sensor 7 (MBOFS7)</td> </tr> <tr> <td data-bbox="336 1308 641 1386">Motor HP</td> <td data-bbox="641 1308 1401 1386">MB paper entry sensor (MBPES)</td> </tr> </tbody> </table>	Display	Description	Match Paddle*1	DF adjustment sensor (DFADS)	Lead Paddle	DF paddle sensor (DFPDS)	Shift Front HP	DF shift sensor 1 (DFSFS1)	Shift Tail HP	DF shift sensor 2 (DFSFS2)	Shift Unlock HP	DF shift release sensor (DFSFRS)	Sub Tray Full	DF sub tray full sensor (DFSTFS)	Shift Set	DF shift set sensor (DFSFS)	Display	Description	Eject	MB eject sensor (MBES)	Cover	MB cover open/close switch (MBCOCSW)	Over Flow1	MB overflow sensor 1 (MBOFS1)	Over Flow2	MB overflow sensor 2 (MBOFS2)	Over Flow3	MB overflow sensor 3 (MBOFS3)	Over Flow4	MB overflow sensor 4 (MBOFS4)	Over Flow5	MB overflow sensor 5 (MBOFS5)	Over Flow6	MB overflow sensor 6 (MBOFS6)	Over Flow7	MB overflow sensor 7 (MBOFS7)	Motor HP	MB paper entry sensor (MBPES)
Display	Description																																						
Match Paddle*1	DF adjustment sensor (DFADS)																																						
Lead Paddle	DF paddle sensor (DFPDS)																																						
Shift Front HP	DF shift sensor 1 (DFSFS1)																																						
Shift Tail HP	DF shift sensor 2 (DFSFS2)																																						
Shift Unlock HP	DF shift release sensor (DFSFRS)																																						
Sub Tray Full	DF sub tray full sensor (DFSTFS)																																						
Shift Set	DF shift set sensor (DFSFS)																																						
Display	Description																																						
Eject	MB eject sensor (MBES)																																						
Cover	MB cover open/close switch (MBCOCSW)																																						
Over Flow1	MB overflow sensor 1 (MBOFS1)																																						
Over Flow2	MB overflow sensor 2 (MBOFS2)																																						
Over Flow3	MB overflow sensor 3 (MBOFS3)																																						
Over Flow4	MB overflow sensor 4 (MBOFS4)																																						
Over Flow5	MB overflow sensor 5 (MBOFS5)																																						
Over Flow6	MB overflow sensor 6 (MBOFS6)																																						
Over Flow7	MB overflow sensor 7 (MBOFS7)																																						
Motor HP	MB paper entry sensor (MBPES)																																						

Item No.	Description																																												
U241	<p data-bbox="288 241 520 275"><b>Method: [Booklet]</b></p> <p data-bbox="304 277 1398 376">1. Turn each switch or sensor on and off manually to check the status. When the on-status of a switch or sensor is detected, that switch or sensor is displayed in reverse.</p> <table border="1" data-bbox="336 389 1401 1061"> <thead> <tr> <th data-bbox="336 389 639 439">Display</th> <th data-bbox="639 389 1401 439">Description</th> </tr> </thead> <tbody> <tr> <td data-bbox="336 439 639 483">HP</td> <td data-bbox="639 439 1401 483">CF paper entry sensor (CFPES)</td> </tr> <tr> <td data-bbox="336 483 639 528">Eject</td> <td data-bbox="639 483 1401 528">CF eject sensor (CFES)</td> </tr> <tr> <td data-bbox="336 528 639 573">Paper</td> <td data-bbox="639 528 1401 573">CF paper sensor (CFPS)</td> </tr> <tr> <td data-bbox="336 573 639 618">Tray Full</td> <td data-bbox="639 573 1401 618">CF tray full sensor (CFTFS)</td> </tr> <tr> <td data-bbox="336 618 639 663">Bundle Up HP</td> <td data-bbox="639 618 1401 663">CF adjustment sensor 1 (CFADS1)</td> </tr> <tr> <td data-bbox="336 663 639 707">Bundle Down HP</td> <td data-bbox="639 663 1401 707">CF adjustment sensor 2 (CFADS2)</td> </tr> <tr> <td data-bbox="336 707 639 752">Width Up HP</td> <td data-bbox="639 707 1401 752">CF side registration sensor 1 (CFSRS1)</td> </tr> <tr> <td data-bbox="336 752 639 797">Width Down HP</td> <td data-bbox="639 752 1401 797">CF side registration sensor 2 (CFSRS2)</td> </tr> <tr> <td data-bbox="336 797 639 842">Blade HP</td> <td data-bbox="639 797 1401 842">CF blade sensor (CFBLS)</td> </tr> <tr> <td data-bbox="336 842 639 887">Tray</td> <td data-bbox="639 842 1401 887">CF tray switch (CFTSW)</td> </tr> <tr> <td data-bbox="336 887 639 931">Set</td> <td data-bbox="639 887 1401 931">CF set switch (CFSSW)</td> </tr> <tr> <td data-bbox="336 931 639 976">Left Guide</td> <td data-bbox="639 931 1401 976">CF left guide switch (CFLGSW)</td> </tr> <tr> <td data-bbox="336 976 639 1021">Vertical Feed</td> <td data-bbox="639 976 1401 1021">CF paper conveying sensor (CFPCS)</td> </tr> </tbody> </table> <p data-bbox="288 1102 504 1135"><b>Method: [Punch]</b></p> <p data-bbox="304 1137 1398 1236">1. Turn each switch or sensor on and off manually to check the status. When the on-status of a switch or sensor is detected, that switch or sensor is displayed in reverse.</p> <table border="1" data-bbox="336 1249 1401 1630"> <thead> <tr> <th data-bbox="336 1249 639 1299">Display</th> <th data-bbox="639 1249 1401 1299">Description</th> </tr> </thead> <tbody> <tr> <td data-bbox="336 1299 639 1344">Punch HP</td> <td data-bbox="639 1299 1401 1344">Punch home position sensor (PUHPS)</td> </tr> <tr> <td data-bbox="336 1344 639 1388">Edge Face1</td> <td data-bbox="639 1344 1401 1388">Punch paper edge sensor (PUPES)</td> </tr> <tr> <td data-bbox="336 1388 639 1433">Edge Face2</td> <td data-bbox="639 1388 1401 1433">Punch paper edge sensor (PUPES)</td> </tr> <tr> <td data-bbox="336 1433 639 1478">Edge Face3</td> <td data-bbox="639 1433 1401 1478">Punch paper edge sensor (PUPES)</td> </tr> <tr> <td data-bbox="336 1478 639 1523">Edge Face4</td> <td data-bbox="639 1478 1401 1523">Punch paper edge sensor (PUPES)</td> </tr> <tr> <td data-bbox="336 1523 639 1568">Tank</td> <td data-bbox="639 1523 1401 1568">Punch tank set switch (PUTSSW)</td> </tr> <tr> <td data-bbox="336 1568 639 1630">Tank Full</td> <td data-bbox="639 1568 1401 1630">Punch tank full sensor (PUTFS)</td> </tr> </tbody> </table> <p data-bbox="288 1675 440 1709"><b>Completion</b></p> <p data-bbox="288 1711 1254 1744">Press the stop key. The screen for selecting a maintenance item No. is displayed.</p>	Display	Description	HP	CF paper entry sensor (CFPES)	Eject	CF eject sensor (CFES)	Paper	CF paper sensor (CFPS)	Tray Full	CF tray full sensor (CFTFS)	Bundle Up HP	CF adjustment sensor 1 (CFADS1)	Bundle Down HP	CF adjustment sensor 2 (CFADS2)	Width Up HP	CF side registration sensor 1 (CFSRS1)	Width Down HP	CF side registration sensor 2 (CFSRS2)	Blade HP	CF blade sensor (CFBLS)	Tray	CF tray switch (CFTSW)	Set	CF set switch (CFSSW)	Left Guide	CF left guide switch (CFLGSW)	Vertical Feed	CF paper conveying sensor (CFPCS)	Display	Description	Punch HP	Punch home position sensor (PUHPS)	Edge Face1	Punch paper edge sensor (PUPES)	Edge Face2	Punch paper edge sensor (PUPES)	Edge Face3	Punch paper edge sensor (PUPES)	Edge Face4	Punch paper edge sensor (PUPES)	Tank	Punch tank set switch (PUTSSW)	Tank Full	Punch tank full sensor (PUTFS)
Display	Description																																												
HP	CF paper entry sensor (CFPES)																																												
Eject	CF eject sensor (CFES)																																												
Paper	CF paper sensor (CFPS)																																												
Tray Full	CF tray full sensor (CFTFS)																																												
Bundle Up HP	CF adjustment sensor 1 (CFADS1)																																												
Bundle Down HP	CF adjustment sensor 2 (CFADS2)																																												
Width Up HP	CF side registration sensor 1 (CFSRS1)																																												
Width Down HP	CF side registration sensor 2 (CFSRS2)																																												
Blade HP	CF blade sensor (CFBLS)																																												
Tray	CF tray switch (CFTSW)																																												
Set	CF set switch (CFSSW)																																												
Left Guide	CF left guide switch (CFLGSW)																																												
Vertical Feed	CF paper conveying sensor (CFPCS)																																												
Display	Description																																												
Punch HP	Punch home position sensor (PUHPS)																																												
Edge Face1	Punch paper edge sensor (PUPES)																																												
Edge Face2	Punch paper edge sensor (PUPES)																																												
Edge Face3	Punch paper edge sensor (PUPES)																																												
Edge Face4	Punch paper edge sensor (PUPES)																																												
Tank	Punch tank set switch (PUTSSW)																																												
Tank Full	Punch tank full sensor (PUTFS)																																												

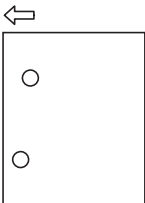
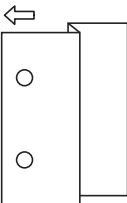
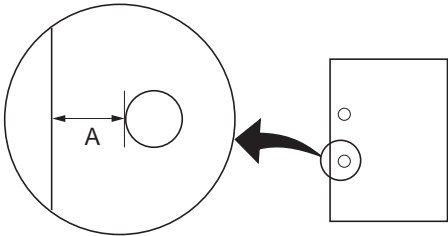
Item No.	Description																						
U243	<p data-bbox="288 241 813 275"><b>Checking the operation of the DP motors</b></p> <p data-bbox="288 313 438 342"><b>Description</b></p> <p data-bbox="288 347 794 376">Turn the motors or solenoids in the DP on.</p> <p data-bbox="288 383 400 412"><b>Purpose</b></p> <p data-bbox="288 416 948 445">To check the operation of the DP motors and solenoids.</p> <p data-bbox="288 488 387 517"><b>Method</b></p> <ol data-bbox="308 521 815 622" style="list-style-type: none"> <li>1. Press the start key.</li> <li>2. Select the item to be operated.</li> <li>3. Press the start key. The operation starts.</li> </ol> <table border="1" data-bbox="336 633 1401 1160"> <thead> <tr> <th data-bbox="336 633 639 678">Display</th> <th data-bbox="639 633 1401 678">Description</th> </tr> </thead> <tbody> <tr> <td data-bbox="336 678 639 723">Feed Motor</td> <td data-bbox="639 678 1401 723">DP original feed motor (DPOFM) is turned on</td> </tr> <tr> <td data-bbox="336 723 639 768">Conv Motor</td> <td data-bbox="639 723 1401 768">DP original conveying motor (DPOCM) is turned on</td> </tr> <tr> <td data-bbox="336 768 639 813">Rev Motor*1</td> <td data-bbox="639 768 1401 813">DP switchback motor (DPSBM) is turned on</td> </tr> <tr> <td data-bbox="336 813 639 857">Lift Motor</td> <td data-bbox="639 813 1401 857">DP lift motor (DPLM) is turned on</td> </tr> <tr> <td data-bbox="336 857 639 902">Rev Press Sol*1</td> <td data-bbox="639 857 1401 902">DP pressure solenoid (DPPSOL) is turned on</td> </tr> <tr> <td data-bbox="336 902 639 947">Rev Branch Sol*1</td> <td data-bbox="639 902 1401 947">DP feedshift solenoid (DPFSSOL) is turned on</td> </tr> <tr> <td data-bbox="336 947 639 992">Eject Motor*2</td> <td data-bbox="639 947 1401 992">DP eject motor (DPEM) is turned on</td> </tr> <tr> <td data-bbox="336 992 639 1037">Regist Motor*2</td> <td data-bbox="639 992 1401 1037">DP registration motor (DPRM) is turned on</td> </tr> <tr> <td data-bbox="336 1037 639 1081">DP Fan*2</td> <td data-bbox="639 1037 1401 1081">DP fan motor 1 (DPFM1) is turned on</td> </tr> <tr> <td data-bbox="336 1081 639 1160">CIS Fan*2</td> <td data-bbox="639 1081 1401 1160">DP fan motor 2 (DPFM2) is turned on</td> </tr> </tbody> </table> <p data-bbox="336 1171 879 1200">*1: Reversed DP only. *2: Dual scan DP only.</p> <ol data-bbox="308 1205 834 1234" style="list-style-type: none"> <li>4. To turn each motor off, press the stop key.</li> </ol> <p data-bbox="288 1272 438 1301"><b>Completion</b></p> <p data-bbox="288 1305 1433 1373">Press the stop key when operation stops. The screen for selecting a maintenance item No. is displayed.</p>	Display	Description	Feed Motor	DP original feed motor (DPOFM) is turned on	Conv Motor	DP original conveying motor (DPOCM) is turned on	Rev Motor*1	DP switchback motor (DPSBM) is turned on	Lift Motor	DP lift motor (DPLM) is turned on	Rev Press Sol*1	DP pressure solenoid (DPPSOL) is turned on	Rev Branch Sol*1	DP feedshift solenoid (DPFSSOL) is turned on	Eject Motor*2	DP eject motor (DPEM) is turned on	Regist Motor*2	DP registration motor (DPRM) is turned on	DP Fan*2	DP fan motor 1 (DPFM1) is turned on	CIS Fan*2	DP fan motor 2 (DPFM2) is turned on
Display	Description																						
Feed Motor	DP original feed motor (DPOFM) is turned on																						
Conv Motor	DP original conveying motor (DPOCM) is turned on																						
Rev Motor*1	DP switchback motor (DPSBM) is turned on																						
Lift Motor	DP lift motor (DPLM) is turned on																						
Rev Press Sol*1	DP pressure solenoid (DPPSOL) is turned on																						
Rev Branch Sol*1	DP feedshift solenoid (DPFSSOL) is turned on																						
Eject Motor*2	DP eject motor (DPEM) is turned on																						
Regist Motor*2	DP registration motor (DPRM) is turned on																						
DP Fan*2	DP fan motor 1 (DPFM1) is turned on																						
CIS Fan*2	DP fan motor 2 (DPFM2) is turned on																						

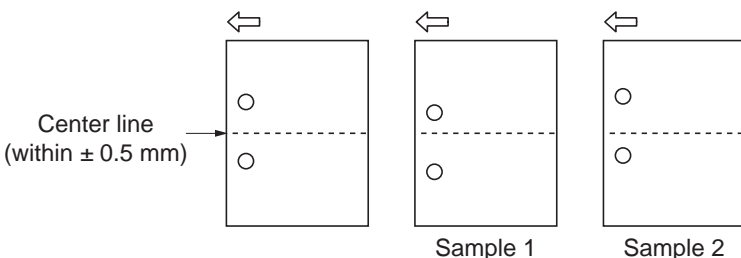


Item No.	Description																												
U244	<p data-bbox="288 241 627 271"><b>Checking the DP switches</b></p> <p data-bbox="288 311 440 340"><b>Description</b></p> <p data-bbox="288 344 1102 374">Displays the status of the respective switches and sensors in the DP.</p> <p data-bbox="288 380 400 409"><b>Purpose</b></p> <p data-bbox="288 414 1139 443">To check if respective switches and sensors in the DP operate correctly.</p> <p data-bbox="288 483 387 512"><b>Method</b></p> <ol data-bbox="304 517 1398 649" style="list-style-type: none"> <li>1. Press the start key.</li> <li>2. Turn each switch or sensor on and off manually to check the status. When the on-status of a switch or sensor is detected, that switch or sensor is displayed in reverse.</li> </ol> <table border="1" data-bbox="336 665 1398 1337"> <thead> <tr> <th data-bbox="336 665 639 710">Display</th> <th data-bbox="639 665 1398 710">Description</th> </tr> </thead> <tbody> <tr> <td data-bbox="336 710 639 754">Feed</td> <td data-bbox="639 710 1398 754">DP feed sensor (DPFS)</td> </tr> <tr> <td data-bbox="336 754 639 799">Regist<sup>*1</sup></td> <td data-bbox="639 754 1398 799">DP registration sensor (DPRS)</td> </tr> <tr> <td data-bbox="336 799 639 844">Timing</td> <td data-bbox="639 799 1398 844">DP timing sensor (DPTS)</td> </tr> <tr> <td data-bbox="336 844 639 889">CIS Head<sup>*2</sup></td> <td data-bbox="639 844 1398 889">DP CIS sensor (DPCS)</td> </tr> <tr> <td data-bbox="336 889 639 934">Tray<sup>*1</sup></td> <td data-bbox="639 889 1398 934">DP switchback sensor (DPSBS)</td> </tr> <tr> <td data-bbox="336 934 639 978">Set</td> <td data-bbox="639 934 1398 978">DP original sensor (DPOS)</td> </tr> <tr> <td data-bbox="336 978 639 1023">Longitudinal</td> <td data-bbox="639 978 1398 1023">DP original length switch (DPOLSW)</td> </tr> <tr> <td data-bbox="336 1023 639 1068">Lift U-Limit</td> <td data-bbox="639 1023 1398 1068">DP lift sensor 1 (DPLS1)</td> </tr> <tr> <td data-bbox="336 1068 639 1113">Lift L-Limit</td> <td data-bbox="639 1068 1398 1113">DP lift sensor 2 (DPLS2)</td> </tr> <tr> <td data-bbox="336 1113 639 1158">Cover Open</td> <td data-bbox="639 1113 1398 1158">DP interlock switch (DPILSW)</td> </tr> <tr> <td data-bbox="336 1158 639 1202">Open</td> <td data-bbox="639 1158 1398 1202">DP open/close switch (DPOCSW)</td> </tr> <tr> <td data-bbox="336 1202 639 1247">Eject</td> <td data-bbox="639 1202 1398 1247">DP eject sensor (DPES)</td> </tr> <tr> <td data-bbox="336 1247 639 1292">Slant<sup>*2</sup></td> <td data-bbox="639 1247 1398 1292">DP slant sensor (DPSS)</td> </tr> </tbody> </table> <p data-bbox="336 1346 879 1375">*1: Reversed DP only. *2: Dual scan DP only.</p> <p data-bbox="288 1415 440 1444"><b>Completion</b></p> <p data-bbox="288 1449 1254 1478">Press the stop key. The screen for selecting a maintenance item No. is displayed.</p>	Display	Description	Feed	DP feed sensor (DPFS)	Regist <sup>*1</sup>	DP registration sensor (DPRS)	Timing	DP timing sensor (DPTS)	CIS Head <sup>*2</sup>	DP CIS sensor (DPCS)	Tray <sup>*1</sup>	DP switchback sensor (DPSBS)	Set	DP original sensor (DPOS)	Longitudinal	DP original length switch (DPOLSW)	Lift U-Limit	DP lift sensor 1 (DPLS1)	Lift L-Limit	DP lift sensor 2 (DPLS2)	Cover Open	DP interlock switch (DPILSW)	Open	DP open/close switch (DPOCSW)	Eject	DP eject sensor (DPES)	Slant <sup>*2</sup>	DP slant sensor (DPSS)
Display	Description																												
Feed	DP feed sensor (DPFS)																												
Regist <sup>*1</sup>	DP registration sensor (DPRS)																												
Timing	DP timing sensor (DPTS)																												
CIS Head <sup>*2</sup>	DP CIS sensor (DPCS)																												
Tray <sup>*1</sup>	DP switchback sensor (DPSBS)																												
Set	DP original sensor (DPOS)																												
Longitudinal	DP original length switch (DPOLSW)																												
Lift U-Limit	DP lift sensor 1 (DPLS1)																												
Lift L-Limit	DP lift sensor 2 (DPLS2)																												
Cover Open	DP interlock switch (DPILSW)																												
Open	DP open/close switch (DPOCSW)																												
Eject	DP eject sensor (DPES)																												
Slant <sup>*2</sup>	DP slant sensor (DPSS)																												

Item No.	Description
U245	<p data-bbox="292 241 550 275"><b>Checking messages</b></p> <p data-bbox="292 311 440 340"><b>Description</b></p> <p data-bbox="292 344 1114 376">Displays a list of messages on the touch panel of the operation panel.</p> <p data-bbox="292 383 400 412"><b>Purpose</b></p> <p data-bbox="292 416 767 448">To check the messages to be displayed.</p> <p data-bbox="292 486 387 515"><b>Method</b></p> <ol data-bbox="308 519 1426 689" style="list-style-type: none"><li data-bbox="308 519 564 551">1. Press the start key.</li><li data-bbox="308 555 1426 654">2. Change the message using the cursor up/down keys. When a message number is entered with the numeric keys and then the start key is pressed, the message corresponding the specified number is displayed.</li><li data-bbox="308 658 820 689">3. Change the language using the +/- keys.</li></ol> <p data-bbox="292 728 440 757"><b>Completion</b></p> <p data-bbox="292 761 1254 792">Press the stop key. The screen for selecting a maintenance item No. is displayed.</p>

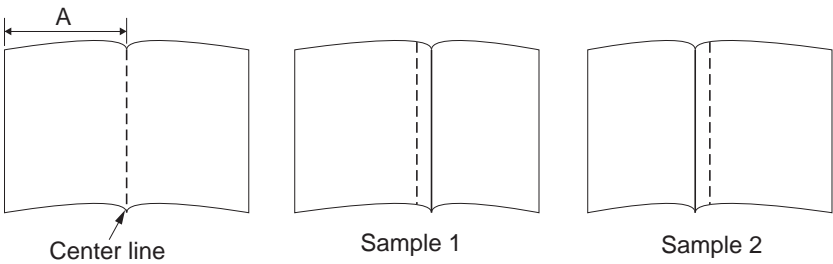
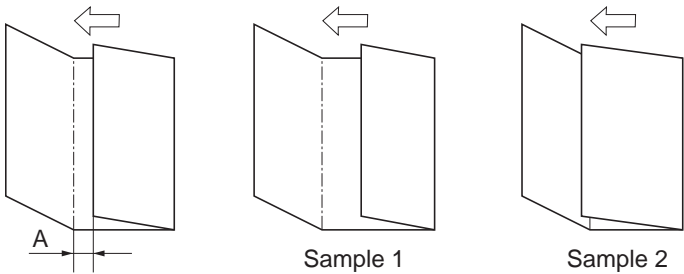
Item No.	Description																								
U246	<p><b>Setting the finisher</b></p> <p><b>Description</b> Provides various settings for the 1000-sheet finisher or 4000-sheet finisher, if furnished.</p> <p><b>Purpose</b></p> <p><b>Adjustment of registration stop timing in punch mode</b> Adjust if skewed paper conveying occurs or if the copy paper is Z-folded in punch mode.</p> <p><b>Adjustment of paper stop timing in the punch mode</b> To adjust this item when the position of a punch hole is different from the specified one.</p> <p><b>Adjustment of center position timing in the punch mode</b> Adjusts the center position of a punch hole in punch mode if the position is not proper.</p> <p><b>Adjustment of front/rear side registration home position</b> Provides optimization when paper jam occurs due to an inferior fitting of the side registration guides to paper.</p> <p><b>Adjustment of front/rear shift home position</b> Performed when adjustment is lost with the ejected paper</p> <p><b>Adjusting of front/back stapling home position</b> Adjusts the stapling position in the staple mode if the position is not proper.</p> <p><b>Adjustment of upper/lower side registration home position</b> Provides optimization when paper jam occurs due to an inferior fitting of the side registration guides to paper.</p> <p><b>Adjustment of booklet stapling position</b> Adjusts the booklet stapling position in the stitching mode if the position is not proper.</p> <p><b>Adjustment of center folding position</b> Adjusts the center folding position in the stitching mode if the position is not proper.</p> <p><b>Adjustment of tri- folding position</b> Adjusts the tri-folding position in the stitching mode if the position is not proper.</p> <p><b>Method</b></p> <ol style="list-style-type: none"> <li>1. Press the start key.</li> <li>2. Select the item to set.</li> </ol> <table border="1" data-bbox="336 1323 1401 1467"> <thead> <tr> <th>Display</th> <th>Description</th> </tr> </thead> <tbody> <tr> <td>Finisher</td> <td>Adjustment of 1000-sheet finisher and 4000-sheet finisher</td> </tr> <tr> <td>Booklet</td> <td>Adjustment of center-folding unit</td> </tr> </tbody> </table> <p><b>Method: [Finisher]</b></p> <ol style="list-style-type: none"> <li>1. Select the item to set.</li> </ol> <table border="1" data-bbox="336 1592 1401 2022"> <thead> <tr> <th>Display</th> <th>Description</th> </tr> </thead> <tbody> <tr> <td>Punch Regist</td> <td>Adjustment of registration stop timing in punch mode</td> </tr> <tr> <td>Punch Feed</td> <td>Adjustment of the paper stop timing in punch mode</td> </tr> <tr> <td>Punch Width</td> <td>Adjustment of the center position timing in punch mode</td> </tr> <tr> <td>Width Front HP</td> <td>Adjustment of front side registration home position</td> </tr> <tr> <td>Width Tail HP</td> <td>Adjustment of rear side registration home position</td> </tr> <tr> <td>Shift Front HP</td> <td>Adjustment of front shift home position</td> </tr> <tr> <td>Shift Tail HP</td> <td>Adjustment of rear shift home position</td> </tr> <tr> <td>Staple HP</td> <td>Adjustment of front and back stapling home position</td> </tr> </tbody> </table>	Display	Description	Finisher	Adjustment of 1000-sheet finisher and 4000-sheet finisher	Booklet	Adjustment of center-folding unit	Display	Description	Punch Regist	Adjustment of registration stop timing in punch mode	Punch Feed	Adjustment of the paper stop timing in punch mode	Punch Width	Adjustment of the center position timing in punch mode	Width Front HP	Adjustment of front side registration home position	Width Tail HP	Adjustment of rear side registration home position	Shift Front HP	Adjustment of front shift home position	Shift Tail HP	Adjustment of rear shift home position	Staple HP	Adjustment of front and back stapling home position
Display	Description																								
Finisher	Adjustment of 1000-sheet finisher and 4000-sheet finisher																								
Booklet	Adjustment of center-folding unit																								
Display	Description																								
Punch Regist	Adjustment of registration stop timing in punch mode																								
Punch Feed	Adjustment of the paper stop timing in punch mode																								
Punch Width	Adjustment of the center position timing in punch mode																								
Width Front HP	Adjustment of front side registration home position																								
Width Tail HP	Adjustment of rear side registration home position																								
Shift Front HP	Adjustment of front shift home position																								
Shift Tail HP	Adjustment of rear shift home position																								
Staple HP	Adjustment of front and back stapling home position																								

Item No.	Description																
<p><b>U246</b></p>	<p><b>Setting: [Punch Regist]</b></p> <ol style="list-style-type: none"> <li>1. Select [Punch Regist].</li> <li>2. Change the setting value using the +/- keys or numeric keys.</li> </ol> <table border="1" data-bbox="336 353 1401 488"> <thead> <tr> <th>Description</th> <th>Setting range</th> <th>Initial setting</th> <th>Change in value per step</th> </tr> </thead> <tbody> <tr> <td>Adjustment of registration stop timing</td> <td>-20 to 20</td> <td>0</td> <td>0.25 mm</td> </tr> </tbody> </table> <p>If skewed paper conveying occurs (sample 1), increase the setting value. If the copy paper is Z-folded (sample 2), decrease the setting value.</p> <div style="display: flex; justify-content: space-around; align-items: center;"> <div style="text-align: center;">  <p>Sample 1</p> </div> <div style="text-align: center;">  <p>Sample 2</p> </div> </div> <p style="text-align: center;"><b>Figure 1-3-32</b></p> <ol style="list-style-type: none"> <li>3. Press the start key. The value is set.</li> </ol> <p><b>Setting: [Punch Feed]</b></p> <ol style="list-style-type: none"> <li>1. Select [Punch Feed].</li> <li>2. Change the setting value using the +/- keys or numeric keys.</li> </ol> <table border="1" data-bbox="336 1093 1401 1227"> <thead> <tr> <th>Description</th> <th>Setting range</th> <th>Initial setting</th> <th>Change in value per step</th> </tr> </thead> <tbody> <tr> <td>Adjustment of the paper stop timing</td> <td>-10 to 10</td> <td>0</td> <td>0.52 mm</td> </tr> </tbody> </table> <p>If the distance of the position of a punch hole is smaller than the specified value A, increase the setting value. If the distance is larger than the value A, decrease the setting value.</p> <div style="display: flex; align-items: center; justify-content: center;">  <div style="margin-left: 20px;"> <p>Preset value A: 13 mm (metric) 9.5 mm (inch)</p> </div> </div> <p style="text-align: center;"><b>Figure 1-3-33</b></p> <ol style="list-style-type: none"> <li>3. Press the start key. The value is set.</li> </ol>	Description	Setting range	Initial setting	Change in value per step	Adjustment of registration stop timing	-20 to 20	0	0.25 mm	Description	Setting range	Initial setting	Change in value per step	Adjustment of the paper stop timing	-10 to 10	0	0.52 mm
Description	Setting range	Initial setting	Change in value per step														
Adjustment of registration stop timing	-20 to 20	0	0.25 mm														
Description	Setting range	Initial setting	Change in value per step														
Adjustment of the paper stop timing	-10 to 10	0	0.52 mm														

Item No.	Description																																
U246	<p><b>Setting: [Punch Width]</b></p> <ol style="list-style-type: none"> <li>1. Select [Punch Width].</li> <li>2. Change the setting value using the +/- keys or numeric keys.</li> </ol> <table border="1" data-bbox="335 347 1396 481"> <thead> <tr> <th>Description</th> <th>Setting range</th> <th>Initial setting</th> <th>Change in value per step</th> </tr> </thead> <tbody> <tr> <td>Adjustment of the punch center position timing</td> <td>-4 to 4</td> <td>0</td> <td>0.52 mm</td> </tr> </tbody> </table> <p>If the punch hole is too close to the front of the machine, increase the setting value. If the punch hole is too close to the rear of the machine, decrease the setting value.</p>  <p style="text-align: center;"><b>Figure 1-3-34</b></p> <ol style="list-style-type: none"> <li>3. Press the start key. The value is set.</li> </ol> <p><b>Setting: [Width Front HP/Width Tail HP]</b></p> <ol style="list-style-type: none"> <li>1. Select [Width Front HP] or [Width Tail HP].</li> <li>2. Change the setting value using the +/- keys or numeric keys.</li> </ol> <table border="1" data-bbox="335 1108 1396 1288"> <thead> <tr> <th>Description</th> <th>Setting range</th> <th>Initial setting</th> <th>Change in value per step</th> </tr> </thead> <tbody> <tr> <td>Adjustment of front side registration home position</td> <td>-15 to 15</td> <td>0</td> <td>0.19 mm</td> </tr> <tr> <td>Adjustment of rear side registration home position</td> <td>-15 to 15</td> <td>0</td> <td>0.19 mm</td> </tr> </tbody> </table> <ol style="list-style-type: none"> <li>3. Press the start key. The value is set.</li> <li>4. Press the stop key. The screen for selecting a maintenance item No. is displayed.</li> <li>5. Enter maintenance mode U240 and select [Motor], then [Width Test(A3)]. The width guides of the middle tray will move to A3-size position.</li> <li>6. Pull the middle tray, insert paper between the guides and check that paper is about the guides.</li> <li>7. Repeat the above adjustment until paper is properly in position.</li> </ol> <p><b>Setting: [Shift Front HP/Shift Tail HP]</b></p> <ol style="list-style-type: none"> <li>1. Select [Shift Front HP] or [Shift Tail HP].</li> <li>2. Change the setting value using the +/- keys or numeric keys.</li> </ol> <table border="1" data-bbox="335 1646 1396 1825"> <thead> <tr> <th>Description</th> <th>Setting range</th> <th>Initial setting</th> <th>Change in value per step</th> </tr> </thead> <tbody> <tr> <td>Adjustment of front shift home position</td> <td>-15 to 15</td> <td>0</td> <td>0.19 mm</td> </tr> <tr> <td>Adjustment of rear shift home position</td> <td>-15 to 15</td> <td>0</td> <td>0.19 mm</td> </tr> </tbody> </table> <ol style="list-style-type: none"> <li>3. Press the start key. The value is set.</li> <li>4. Press the stop key. The screen for selecting a maintenance item No. is displayed.</li> <li>5. Enter maintenance mode U240 and select [Motor], then [Sort Test].</li> <li>6. Repeat the above adjustment until eject paper is properly in position.</li> </ol>	Description	Setting range	Initial setting	Change in value per step	Adjustment of the punch center position timing	-4 to 4	0	0.52 mm	Description	Setting range	Initial setting	Change in value per step	Adjustment of front side registration home position	-15 to 15	0	0.19 mm	Adjustment of rear side registration home position	-15 to 15	0	0.19 mm	Description	Setting range	Initial setting	Change in value per step	Adjustment of front shift home position	-15 to 15	0	0.19 mm	Adjustment of rear shift home position	-15 to 15	0	0.19 mm
Description	Setting range	Initial setting	Change in value per step																														
Adjustment of the punch center position timing	-4 to 4	0	0.52 mm																														
Description	Setting range	Initial setting	Change in value per step																														
Adjustment of front side registration home position	-15 to 15	0	0.19 mm																														
Adjustment of rear side registration home position	-15 to 15	0	0.19 mm																														
Description	Setting range	Initial setting	Change in value per step																														
Adjustment of front shift home position	-15 to 15	0	0.19 mm																														
Adjustment of rear shift home position	-15 to 15	0	0.19 mm																														

Item No.	Description																												
<b>U246</b>	<p data-bbox="288 241 544 275"><b>Setting: [Staple HP]</b></p> <ol data-bbox="288 277 1054 342" style="list-style-type: none"> <li>1. Select [Staple HP].</li> <li>2. Change the setting value using the +/- keys or numeric keys.</li> </ol> <table border="1" data-bbox="336 353 1401 488"> <thead> <tr> <th data-bbox="336 353 975 439">Description</th> <th data-bbox="975 353 1110 439">Setting range</th> <th data-bbox="1110 353 1233 439">Initial setting</th> <th data-bbox="1233 353 1401 439">Change in value per step</th> </tr> </thead> <tbody> <tr> <td data-bbox="336 439 975 488">Adjustment of front and back stapling home position</td> <td data-bbox="975 439 1110 488">-15 to 15</td> <td data-bbox="1110 439 1233 488">0</td> <td data-bbox="1233 439 1401 488">0.19 mm</td> </tr> </tbody> </table> <p data-bbox="336 499 1417 595">When staple positions are off toward the front side of the machine (sample 1), increase the setting value. When staple positions are off toward the rear side of the machine (sample 2), decrease the setting value.</p> <div data-bbox="563 618 1158 875" style="text-align: center;"> <p data-bbox="635 846 735 875">Sample 1</p> <p data-bbox="995 846 1096 875">Sample 2</p> </div> <p data-bbox="778 898 943 931" style="text-align: center;"><b>Figure 1-3-35</b></p> <ol data-bbox="288 969 767 1003" style="list-style-type: none"> <li>3. Press the start key. The value is set.</li> </ol> <p data-bbox="288 1037 520 1070"><b>Method: [Booklet]</b></p> <ol data-bbox="288 1072 592 1106" style="list-style-type: none"> <li>1. Select the item to set.</li> </ol> <table border="1" data-bbox="336 1117 1401 1597"> <thead> <tr> <th data-bbox="336 1117 643 1167">Display</th> <th data-bbox="643 1117 1401 1167">Description</th> </tr> </thead> <tbody> <tr> <td data-bbox="336 1167 643 1211">Width Up HP</td> <td data-bbox="643 1167 1401 1211">Adjustment of upper side registration home position</td> </tr> <tr> <td data-bbox="336 1211 643 1256">Width Down HP</td> <td data-bbox="643 1211 1401 1256">Adjustment of lower side registration home position</td> </tr> <tr> <td data-bbox="336 1256 643 1301">Staple Pos1</td> <td data-bbox="643 1256 1401 1301">Adjustment of booklet stapling position for A4/Letter size</td> </tr> <tr> <td data-bbox="336 1301 643 1346">Staple Pos2</td> <td data-bbox="643 1301 1401 1346">Adjustment of booklet stapling position for B4/Legal size</td> </tr> <tr> <td data-bbox="336 1346 643 1391">Staple Pos3</td> <td data-bbox="643 1346 1401 1391">Adjustment of booklet stapling position for A3/Ledger/8K size</td> </tr> <tr> <td data-bbox="336 1391 643 1435">Booklet Pos1</td> <td data-bbox="643 1391 1401 1435">Adjustment of center folding position for A4/Letter size</td> </tr> <tr> <td data-bbox="336 1435 643 1480">Booklet Pos2</td> <td data-bbox="643 1435 1401 1480">Adjustment of center folding position for B4/Legal size</td> </tr> <tr> <td data-bbox="336 1480 643 1525">Booklet Pos3</td> <td data-bbox="643 1480 1401 1525">Adjustment of center folding position for A3/Ledger/8K size</td> </tr> <tr> <td data-bbox="336 1525 643 1597">Three Fold</td> <td data-bbox="643 1525 1401 1597">Adjustment of tri-folding position</td> </tr> </tbody> </table>	Description	Setting range	Initial setting	Change in value per step	Adjustment of front and back stapling home position	-15 to 15	0	0.19 mm	Display	Description	Width Up HP	Adjustment of upper side registration home position	Width Down HP	Adjustment of lower side registration home position	Staple Pos1	Adjustment of booklet stapling position for A4/Letter size	Staple Pos2	Adjustment of booklet stapling position for B4/Legal size	Staple Pos3	Adjustment of booklet stapling position for A3/Ledger/8K size	Booklet Pos1	Adjustment of center folding position for A4/Letter size	Booklet Pos2	Adjustment of center folding position for B4/Legal size	Booklet Pos3	Adjustment of center folding position for A3/Ledger/8K size	Three Fold	Adjustment of tri-folding position
Description	Setting range	Initial setting	Change in value per step																										
Adjustment of front and back stapling home position	-15 to 15	0	0.19 mm																										
Display	Description																												
Width Up HP	Adjustment of upper side registration home position																												
Width Down HP	Adjustment of lower side registration home position																												
Staple Pos1	Adjustment of booklet stapling position for A4/Letter size																												
Staple Pos2	Adjustment of booklet stapling position for B4/Legal size																												
Staple Pos3	Adjustment of booklet stapling position for A3/Ledger/8K size																												
Booklet Pos1	Adjustment of center folding position for A4/Letter size																												
Booklet Pos2	Adjustment of center folding position for B4/Legal size																												
Booklet Pos3	Adjustment of center folding position for A3/Ledger/8K size																												
Three Fold	Adjustment of tri-folding position																												

Item No.	Description																												
U246	<p><b>Setting: [Width Up HP/Width Down HP]</b></p> <ol style="list-style-type: none"> <li>1. Select [Width Up HP] or [Width Down HP].</li> <li>2. Change the setting value using the +/- keys or numeric keys.</li> </ol> <table border="1" data-bbox="336 353 1401 533"> <thead> <tr> <th>Description</th> <th>Setting range</th> <th>Initial setting</th> <th>Change in value per step</th> </tr> </thead> <tbody> <tr> <td>Adjustment of upper side registration home position</td> <td>-15 to 15</td> <td>0</td> <td>0.34 mm</td> </tr> <tr> <td>Adjustment of lower side registration home position</td> <td>-15 to 15</td> <td>0</td> <td>0.34 mm</td> </tr> </tbody> </table> <ol style="list-style-type: none"> <li>3. Press the start key. The value is set.</li> <li>4. Press the stop key. The screen for selecting a maintenance item No. is displayed.</li> <li>5. Enter maintenance mode U240 and select [Booklet], then [Width Test(A3)]. The width guides of the center-folding unit will move to A3-size position.</li> <li>6. Pull the center-folding unit, insert paper between the guides and check that paper is about the guides.</li> <li>7. Repeat the above adjustment until paper is properly in position.</li> </ol> <p><b>Setting: [Staple Pos]</b></p> <ol style="list-style-type: none"> <li>1. Select [Staple Pos1], [Staple Pos2] or [Staple Pos3].</li> <li>2. Change the setting value using the +/- keys or numeric keys.</li> </ol> <table border="1" data-bbox="336 929 1401 1261"> <thead> <tr> <th>Description</th> <th>Setting range</th> <th>Initial setting</th> <th>Change in value per step</th> </tr> </thead> <tbody> <tr> <td>Adjustment of booklet stapling position for A4/Letter size</td> <td>-15 to 15</td> <td>0</td> <td>0.32 mm</td> </tr> <tr> <td>Adjustment of booklet stapling position for B4/Legal size</td> <td>-15 to 15</td> <td>0</td> <td>0.32 mm</td> </tr> <tr> <td>Adjustment of booklet stapling position for A3/Ledger/8K size</td> <td>-15 to 15</td> <td>0</td> <td>0.32 mm</td> </tr> </tbody> </table> <p>When staples are placed too far right (sample 1), decrease the preset value. When staples are placed too far left (sample 2), increase the preset value. Reference value: within <math>\pm 2</math> mm</p> <div data-bbox="405 1397 1315 1671" style="text-align: center;"> <p style="display: flex; justify-content: space-around;"> <span>Sample 1</span> <span>Sample 2</span> </p> </div> <p><b>Figure 1-3-36</b></p> <ol style="list-style-type: none"> <li>3. Press the start key. The value is set.</li> </ol>	Description	Setting range	Initial setting	Change in value per step	Adjustment of upper side registration home position	-15 to 15	0	0.34 mm	Adjustment of lower side registration home position	-15 to 15	0	0.34 mm	Description	Setting range	Initial setting	Change in value per step	Adjustment of booklet stapling position for A4/Letter size	-15 to 15	0	0.32 mm	Adjustment of booklet stapling position for B4/Legal size	-15 to 15	0	0.32 mm	Adjustment of booklet stapling position for A3/Ledger/8K size	-15 to 15	0	0.32 mm
Description	Setting range	Initial setting	Change in value per step																										
Adjustment of upper side registration home position	-15 to 15	0	0.34 mm																										
Adjustment of lower side registration home position	-15 to 15	0	0.34 mm																										
Description	Setting range	Initial setting	Change in value per step																										
Adjustment of booklet stapling position for A4/Letter size	-15 to 15	0	0.32 mm																										
Adjustment of booklet stapling position for B4/Legal size	-15 to 15	0	0.32 mm																										
Adjustment of booklet stapling position for A3/Ledger/8K size	-15 to 15	0	0.32 mm																										

Item No.	Description																								
U246	<p><b>Setting: [Booklet Pos]</b></p> <ol style="list-style-type: none"> <li>1. Select [Booklet Pos1], [Booklet Pos2] or [Booklet Pos3].</li> <li>2. Change the setting value using the +/- keys or numeric keys.</li> </ol> <table border="1" data-bbox="336 353 1401 616"> <thead> <tr> <th>Description</th> <th>Setting range</th> <th>Initial setting</th> <th>Change in value per step</th> </tr> </thead> <tbody> <tr> <td>Adjustment of center folding position for A4/Letter size</td> <td>-15 to 15</td> <td>0</td> <td>0.32 mm</td> </tr> <tr> <td>Adjustment of center folding position for B4/Legal size</td> <td>-15 to 15</td> <td>0</td> <td>0.32 mm</td> </tr> <tr> <td>Adjustment of center folding position for A3/Ledger/8K size</td> <td>-15 to 15</td> <td>0</td> <td>0.32 mm</td> </tr> </tbody> </table> <p>When the centerfold position too far right (sample 1), increase the preset value. When the centerfold position too far left (sample 2), decrease the setting value.</p> <p>Reference value A: A4, Letter: Length of paper <math>\times 1/2 \pm 2</math> mm A3, Ledger, B4: Length of paper <math>\times 1/2 \pm 3</math> mm</p>  <p style="text-align: center;"><b>Figure 1-3-37</b></p> <ol style="list-style-type: none"> <li>3. Press the start key. The value is set.</li> </ol> <p><b>Setting: [Three Fold]</b></p> <ol style="list-style-type: none"> <li>1. Select [Three Fold].</li> <li>2. Change the setting value using the +/- keys or numeric keys.</li> </ol> <table border="1" data-bbox="336 1279 1401 1413"> <thead> <tr> <th>Description</th> <th>Setting range</th> <th>Initial setting</th> <th>Change in value per step</th> </tr> </thead> <tbody> <tr> <td>Adjustment of tri-folding position</td> <td>-15 to 15</td> <td>0</td> <td>0.32 mm</td> </tr> </tbody> </table> <p>When the tri-fold position too far right (sample 1), increase the preset value. When the tri-fold position too far left (sample 2), decrease the setting value.</p> <p>Reference value A: <math>7.0 \pm 2</math> mm</p>  <p style="text-align: center;"><b>Figure 1-3-38</b></p> <ol style="list-style-type: none"> <li>3. Press the start key. The value is set.</li> </ol> <p><b>Completion</b></p> <p>Press the stop key. The screen for selecting a maintenance item No. is displayed.</p>	Description	Setting range	Initial setting	Change in value per step	Adjustment of center folding position for A4/Letter size	-15 to 15	0	0.32 mm	Adjustment of center folding position for B4/Legal size	-15 to 15	0	0.32 mm	Adjustment of center folding position for A3/Ledger/8K size	-15 to 15	0	0.32 mm	Description	Setting range	Initial setting	Change in value per step	Adjustment of tri-folding position	-15 to 15	0	0.32 mm
Description	Setting range	Initial setting	Change in value per step																						
Adjustment of center folding position for A4/Letter size	-15 to 15	0	0.32 mm																						
Adjustment of center folding position for B4/Legal size	-15 to 15	0	0.32 mm																						
Adjustment of center folding position for A3/Ledger/8K size	-15 to 15	0	0.32 mm																						
Description	Setting range	Initial setting	Change in value per step																						
Adjustment of tri-folding position	-15 to 15	0	0.32 mm																						



Item No.	Description																												
U247	<p data-bbox="288 241 663 275"><b>Setting the paper feed device</b></p> <p data-bbox="288 309 440 342"><b>Description</b></p> <p data-bbox="288 344 895 378">Turn on motor and clutches of paper feeder device.</p> <p data-bbox="288 380 400 414"><b>Purpose</b></p> <p data-bbox="288 416 1078 450">To check the operation of motor and clutches of paper feed device.</p> <p data-bbox="288 483 387 517"><b>Method</b></p> <ol data-bbox="304 519 683 584" style="list-style-type: none"> <li>1. Press the start key.</li> <li>2. Select the paper feed device.</li> </ol> <table border="1" data-bbox="336 595 1399 790"> <thead> <tr> <th data-bbox="336 595 639 640">Display</th> <th data-bbox="639 595 1399 640">Description</th> </tr> </thead> <tbody> <tr> <td data-bbox="336 640 639 685">2PF</td> <td data-bbox="639 640 1399 685">Paper feeder</td> </tr> <tr> <td data-bbox="336 685 639 730">LCF</td> <td data-bbox="639 685 1399 730">Large capacity feeder</td> </tr> <tr> <td data-bbox="336 730 639 790">Side Deck</td> <td data-bbox="639 730 1399 790">Side deck</td> </tr> </tbody> </table> <p data-bbox="288 835 472 869"><b>Method: [2PF]</b></p> <ol data-bbox="304 871 863 904" style="list-style-type: none"> <li>1. Press [Motor] or [Clutch] and select the item.</li> </ol> <table border="1" data-bbox="336 916 1399 1294"> <thead> <tr> <th colspan="2" data-bbox="336 916 716 960">Display</th> <th data-bbox="716 916 1399 960">Description</th> </tr> </thead> <tbody> <tr> <td data-bbox="336 960 448 1055" rowspan="2">Motor</td> <td data-bbox="448 960 716 1005">Off</td> <td data-bbox="716 960 1399 1005">PF paper feed motor (PFPFM) is turned off</td> </tr> <tr> <td data-bbox="448 1005 716 1055">On</td> <td data-bbox="716 1005 1399 1055">PF paper feed motor (PFPFM) is turned on</td> </tr> <tr> <td data-bbox="336 1055 448 1249" rowspan="4">Clutch</td> <td data-bbox="448 1055 716 1099">C1 Clutch</td> <td data-bbox="716 1055 1399 1099">PF paper feed clutch 1 (PFPFCL1) is turned on</td> </tr> <tr> <td data-bbox="448 1099 716 1144">C2 Clutch</td> <td data-bbox="716 1099 1399 1144">PF paper feed clutch 2 (PFPFCL2) is turned on</td> </tr> <tr> <td data-bbox="448 1144 716 1189">V Feed(H) Clutch</td> <td data-bbox="716 1144 1399 1189">PF paper conveying clutch 1 (PFPCCL1) is turned on</td> </tr> <tr> <td data-bbox="448 1189 716 1249">V Feed(L) Clutch</td> <td data-bbox="716 1189 1399 1249">PF paper conveying clutch 2 (PFPCCL2) is turned on</td> </tr> <tr> <td colspan="2" data-bbox="336 1249 716 1294">Execute</td> <td data-bbox="716 1249 1399 1294">Executing the action</td> </tr> </tbody> </table> <ol data-bbox="304 1317 815 1417" style="list-style-type: none"> <li>2. Select [Execute].</li> <li>3. Press the start key. The operation starts.</li> <li>4. To stop operation, press the stop key.</li> </ol>	Display	Description	2PF	Paper feeder	LCF	Large capacity feeder	Side Deck	Side deck	Display		Description	Motor	Off	PF paper feed motor (PFPFM) is turned off	On	PF paper feed motor (PFPFM) is turned on	Clutch	C1 Clutch	PF paper feed clutch 1 (PFPFCL1) is turned on	C2 Clutch	PF paper feed clutch 2 (PFPFCL2) is turned on	V Feed(H) Clutch	PF paper conveying clutch 1 (PFPCCL1) is turned on	V Feed(L) Clutch	PF paper conveying clutch 2 (PFPCCL2) is turned on	Execute		Executing the action
Display	Description																												
2PF	Paper feeder																												
LCF	Large capacity feeder																												
Side Deck	Side deck																												
Display		Description																											
Motor	Off	PF paper feed motor (PFPFM) is turned off																											
	On	PF paper feed motor (PFPFM) is turned on																											
Clutch	C1 Clutch	PF paper feed clutch 1 (PFPFCL1) is turned on																											
	C2 Clutch	PF paper feed clutch 2 (PFPFCL2) is turned on																											
	V Feed(H) Clutch	PF paper conveying clutch 1 (PFPCCL1) is turned on																											
	V Feed(L) Clutch	PF paper conveying clutch 2 (PFPCCL2) is turned on																											
Execute		Executing the action																											

Item No.	Description																																						
U247	<p data-bbox="288 241 475 271"><b>Method: [LCF]</b></p> <p data-bbox="304 277 863 306">1. Press [Motor] or [Clutch] and select the item.</p> <table border="1" data-bbox="336 320 1401 752"> <thead> <tr> <th colspan="2" data-bbox="336 320 716 365">Display</th> <th data-bbox="716 320 1401 365">Description</th> </tr> </thead> <tbody> <tr> <td data-bbox="336 365 448 461" rowspan="2">Motor</td> <td data-bbox="448 365 716 409">Off</td> <td data-bbox="716 365 1401 409">PF paper feed motor (PFPFM) is turned off</td> </tr> <tr> <td data-bbox="448 409 716 461">On</td> <td data-bbox="716 409 1401 461">PF paper feed motor (PFPFM) is turned on</td> </tr> <tr> <td data-bbox="336 461 448 703" rowspan="5">Clutch</td> <td data-bbox="448 461 716 506">C1 Clutch</td> <td data-bbox="716 461 1401 506">PF paper feed clutch 1 (PFPFCL1) is turned on</td> </tr> <tr> <td data-bbox="448 506 716 551">C2 Clutch</td> <td data-bbox="716 506 1401 551">PF paper feed clutch 2 (PFPFCL2) is turned on</td> </tr> <tr> <td data-bbox="448 551 716 595">V Feed Clutch</td> <td data-bbox="716 551 1401 595">PF paper conveying clutch 1 (PFPCCL1) is turned on</td> </tr> <tr> <td data-bbox="448 595 716 640">H Feed1 Clutch</td> <td data-bbox="716 595 1401 640">PF paper conveying clutch 2 (PFPCCL2) is turned on</td> </tr> <tr> <td data-bbox="448 640 716 703">H Feed2 Clutch</td> <td data-bbox="716 640 1401 703">PF paper conveying clutch 3 (PFPCCL3) is turned on</td> </tr> <tr> <td colspan="2" data-bbox="336 703 716 752">Execute</td> <td data-bbox="716 703 1401 752">Executing the action</td> </tr> </tbody> </table> <p data-bbox="304 777 815 875">2. Select [Execute]. 3. Press the start key. The operation starts. 4. To stop operation, press the stop key.</p> <p data-bbox="288 913 549 943"><b>Method: [Side Deck]</b></p> <p data-bbox="304 949 863 978">1. Press [Motor] or [Clutch] and select the item.</p> <table border="1" data-bbox="336 992 1401 1279"> <thead> <tr> <th colspan="2" data-bbox="336 992 716 1037">Display</th> <th data-bbox="716 992 1401 1037">Description</th> </tr> </thead> <tbody> <tr> <td data-bbox="336 1037 448 1133" rowspan="2">Motor</td> <td data-bbox="448 1037 716 1081">Off</td> <td data-bbox="716 1037 1401 1081">SF paper feed motor (SFPFM) is turned off</td> </tr> <tr> <td data-bbox="448 1081 716 1133">On</td> <td data-bbox="716 1081 1401 1133">SF paper feed motor (SFPFM) is turned on</td> </tr> <tr> <td data-bbox="336 1133 448 1232" rowspan="2">Clutch</td> <td data-bbox="448 1133 716 1178">C1 Clutch</td> <td data-bbox="716 1133 1401 1178">SF paper feed clutch (SFPFCL) is turned on</td> </tr> <tr> <td data-bbox="448 1178 716 1232">Cassette1 Solenoid</td> <td data-bbox="716 1178 1401 1232">SF feed solenoid (PFPF SOL) is turned on</td> </tr> <tr> <td colspan="2" data-bbox="336 1232 716 1279">Execute</td> <td data-bbox="716 1232 1401 1279">Executing the action</td> </tr> </tbody> </table> <p data-bbox="304 1292 815 1391">2. Select [Execute]. 3. Press the start key. The operation starts. 4. To stop operation, press the stop key.</p> <p data-bbox="288 1429 440 1458"><b>Completion</b></p> <p data-bbox="288 1464 1254 1494">Press the stop key. The screen for selecting a maintenance item No. is displayed.</p>	Display		Description	Motor	Off	PF paper feed motor (PFPFM) is turned off	On	PF paper feed motor (PFPFM) is turned on	Clutch	C1 Clutch	PF paper feed clutch 1 (PFPFCL1) is turned on	C2 Clutch	PF paper feed clutch 2 (PFPFCL2) is turned on	V Feed Clutch	PF paper conveying clutch 1 (PFPCCL1) is turned on	H Feed1 Clutch	PF paper conveying clutch 2 (PFPCCL2) is turned on	H Feed2 Clutch	PF paper conveying clutch 3 (PFPCCL3) is turned on	Execute		Executing the action	Display		Description	Motor	Off	SF paper feed motor (SFPFM) is turned off	On	SF paper feed motor (SFPFM) is turned on	Clutch	C1 Clutch	SF paper feed clutch (SFPFCL) is turned on	Cassette1 Solenoid	SF feed solenoid (PFPF SOL) is turned on	Execute		Executing the action
Display		Description																																					
Motor	Off	PF paper feed motor (PFPFM) is turned off																																					
	On	PF paper feed motor (PFPFM) is turned on																																					
Clutch	C1 Clutch	PF paper feed clutch 1 (PFPFCL1) is turned on																																					
	C2 Clutch	PF paper feed clutch 2 (PFPFCL2) is turned on																																					
	V Feed Clutch	PF paper conveying clutch 1 (PFPCCL1) is turned on																																					
	H Feed1 Clutch	PF paper conveying clutch 2 (PFPCCL2) is turned on																																					
	H Feed2 Clutch	PF paper conveying clutch 3 (PFPCCL3) is turned on																																					
Execute		Executing the action																																					
Display		Description																																					
Motor	Off	SF paper feed motor (SFPFM) is turned off																																					
	On	SF paper feed motor (SFPFM) is turned on																																					
Clutch	C1 Clutch	SF paper feed clutch (SFPFCL) is turned on																																					
	Cassette1 Solenoid	SF feed solenoid (PFPF SOL) is turned on																																					
Execute		Executing the action																																					

Item No.	Description																																				
U249	<p><b>Finisher operation test</b></p> <p><b>Description</b> Perform operating tests on the 4000-sheet finisher.</p> <p><b>Purpose</b> To check the operation of the 4000-sheet finisher.</p> <p><b>Method</b></p> <ol style="list-style-type: none"> <li>1. Press the start key.</li> <li>2. Select the item.</li> </ol> <table border="1" data-bbox="336 595 1401 741"> <thead> <tr> <th data-bbox="336 595 639 640">Display</th> <th data-bbox="639 595 1401 640">Description</th> </tr> </thead> <tbody> <tr> <td data-bbox="336 640 639 685">Punch Position</td> <td data-bbox="639 640 1401 685">Check the stop position of punching</td> </tr> <tr> <td data-bbox="336 685 639 741">Booklet Pass</td> <td data-bbox="639 685 1401 741">Check the paper paths to the center-folding unit</td> </tr> </tbody> </table> <ol style="list-style-type: none"> <li>3. Press the start key.</li> <li>4. Press the system menu key to make a test copy.</li> </ol> <p><b>Completion</b> Press the stop key. The screen for selecting a maintenance item No. is displayed.</p>	Display	Description	Punch Position	Check the stop position of punching	Booklet Pass	Check the paper paths to the center-folding unit																														
Display	Description																																				
Punch Position	Check the stop position of punching																																				
Booklet Pass	Check the paper paths to the center-folding unit																																				
U250	<p><b>Checking/clearing the maintenance cycle</b></p> <p><b>Description</b> Changes preset values for maintenance cycle and automatic grayscale adjustment.</p> <p><b>Purpose</b> Provides changing the time when the message to acknowledge to conduct maintenance and automatic grayscale adjustment is periodically displayed.</p> <p><b>Setting</b></p> <ol style="list-style-type: none"> <li>1. Press the start key.</li> <li>2. Select the item to be set.</li> <li>3. Change the setting using the +/- keys or numeric keys.</li> </ol> <table border="1" data-bbox="336 1359 1423 1861"> <thead> <tr> <th data-bbox="336 1359 504 1442">Display</th> <th data-bbox="504 1359 1043 1442">Description</th> <th data-bbox="1043 1359 1233 1442">Setting range</th> <th data-bbox="1233 1359 1423 1442">Initial setting</th> </tr> </thead> <tbody> <tr> <td data-bbox="336 1442 504 1487">M.Cnt A</td> <td data-bbox="504 1442 1043 1487">Preset values for maintenance cycle (kit A)</td> <td data-bbox="1043 1442 1233 1487">0 to 9999999</td> <td data-bbox="1233 1442 1423 1487">600000</td> </tr> <tr> <td data-bbox="336 1487 504 1532">M.Cnt HT</td> <td data-bbox="504 1487 1043 1532">Preset values for automatic grayscale adjustment</td> <td data-bbox="1043 1487 1233 1532">0 to 9999999</td> <td data-bbox="1233 1487 1423 1532">0</td> </tr> <tr> <td data-bbox="336 1532 504 1576">Cassette 1</td> <td data-bbox="504 1532 1043 1576">Maintenance counter cassette1</td> <td data-bbox="1043 1532 1233 1576">0 to 9999999</td> <td data-bbox="1233 1532 1423 1576">150000</td> </tr> <tr> <td data-bbox="336 1576 504 1621">Cassette 2</td> <td data-bbox="504 1576 1043 1621">Maintenance counter cassette1</td> <td data-bbox="1043 1576 1233 1621">0 to 9999999</td> <td data-bbox="1233 1576 1423 1621">150000</td> </tr> <tr> <td data-bbox="336 1621 504 1666">Cassette 3</td> <td data-bbox="504 1621 1043 1666">Maintenance counter cassette1</td> <td data-bbox="1043 1621 1233 1666">0 to 9999999</td> <td data-bbox="1233 1621 1423 1666">150000</td> </tr> <tr> <td data-bbox="336 1666 504 1711">Cassette 4</td> <td data-bbox="504 1666 1043 1711">Maintenance counter cassette1</td> <td data-bbox="1043 1666 1233 1711">0 to 9999999</td> <td data-bbox="1233 1666 1423 1711">150000</td> </tr> <tr> <td data-bbox="336 1711 504 1756">Cassette 5</td> <td data-bbox="504 1711 1043 1756">Maintenance counter cassette5</td> <td data-bbox="1043 1711 1233 1756">0 to 9999999</td> <td data-bbox="1233 1711 1423 1756">150000</td> </tr> <tr> <td data-bbox="336 1756 504 1800">Clear</td> <td data-bbox="504 1756 1043 1800">Maintenance counter all clear</td> <td data-bbox="1043 1756 1233 1800">0 to 9999999</td> <td data-bbox="1233 1756 1423 1800">-</td> </tr> </tbody> </table> <ol style="list-style-type: none"> <li>4. Press the start key. The value is set.</li> </ol>	Display	Description	Setting range	Initial setting	M.Cnt A	Preset values for maintenance cycle (kit A)	0 to 9999999	600000	M.Cnt HT	Preset values for automatic grayscale adjustment	0 to 9999999	0	Cassette 1	Maintenance counter cassette1	0 to 9999999	150000	Cassette 2	Maintenance counter cassette1	0 to 9999999	150000	Cassette 3	Maintenance counter cassette1	0 to 9999999	150000	Cassette 4	Maintenance counter cassette1	0 to 9999999	150000	Cassette 5	Maintenance counter cassette5	0 to 9999999	150000	Clear	Maintenance counter all clear	0 to 9999999	-
Display	Description	Setting range	Initial setting																																		
M.Cnt A	Preset values for maintenance cycle (kit A)	0 to 9999999	600000																																		
M.Cnt HT	Preset values for automatic grayscale adjustment	0 to 9999999	0																																		
Cassette 1	Maintenance counter cassette1	0 to 9999999	150000																																		
Cassette 2	Maintenance counter cassette1	0 to 9999999	150000																																		
Cassette 3	Maintenance counter cassette1	0 to 9999999	150000																																		
Cassette 4	Maintenance counter cassette1	0 to 9999999	150000																																		
Cassette 5	Maintenance counter cassette5	0 to 9999999	150000																																		
Clear	Maintenance counter all clear	0 to 9999999	-																																		

Item No.	Description																																				
U250	<p><b>Clearing</b></p> <ol style="list-style-type: none"> <li>1. Select [Clear].</li> </ol> <p>Press the start key. The setting value is cleared.</p> <p><b>Completion</b></p> <p>Press the stop key. The screen for selecting a maintenance item No. is displayed.</p> <p>* : When the firmware is upgraded in the field, the standard counter value newly added should be set to 150000.</p>																																				
U251	<p><b>Checking/clearing the maintenance counter</b></p> <p><b>Description</b></p> <p>Displays and clears or changes the maintenance count and automatic grayscale adjustment count.</p> <p><b>Purpose</b></p> <p>To verify the maintenance counter count and automatic grayscale count. Also to clear the count during maintenance service.</p> <p><b>Setting</b></p> <ol style="list-style-type: none"> <li>1. Press the start key.</li> <li>2. Select the item to be changed.</li> <li>3. Change the setting using the +/- keys or numeric keys.</li> </ol> <table border="1" data-bbox="336 1059 1425 1525"> <thead> <tr> <th data-bbox="336 1059 491 1144">Display</th> <th data-bbox="491 1059 1043 1144">Description</th> <th data-bbox="1043 1059 1235 1144">Setting range</th> <th data-bbox="1235 1059 1425 1144">Initial setting</th> </tr> </thead> <tbody> <tr> <td data-bbox="336 1144 491 1189">M.Cnt A</td> <td data-bbox="491 1144 1043 1189">Count value for maintenance cycle (kit A)</td> <td data-bbox="1043 1144 1235 1189">0 to 9999999</td> <td data-bbox="1235 1144 1425 1189">0</td> </tr> <tr> <td data-bbox="336 1189 491 1234">M.Cnt HT</td> <td data-bbox="491 1189 1043 1234">Automatic grayscale adjustment count</td> <td data-bbox="1043 1189 1235 1234">0 to 9999999</td> <td data-bbox="1235 1189 1425 1234">0</td> </tr> <tr> <td data-bbox="336 1234 491 1279">Cassette 1</td> <td data-bbox="491 1234 1043 1279">Maintenance counter cassette1</td> <td data-bbox="1043 1234 1235 1279">0 to 9999999</td> <td data-bbox="1235 1234 1425 1279">0</td> </tr> <tr> <td data-bbox="336 1279 491 1323">Cassette 2</td> <td data-bbox="491 1279 1043 1323">Maintenance counter cassette2</td> <td data-bbox="1043 1279 1235 1323">0 to 9999999</td> <td data-bbox="1235 1279 1425 1323">0</td> </tr> <tr> <td data-bbox="336 1323 491 1368">Cassette 3</td> <td data-bbox="491 1323 1043 1368">Maintenance counter cassette3</td> <td data-bbox="1043 1323 1235 1368">0 to 9999999</td> <td data-bbox="1235 1323 1425 1368">0</td> </tr> <tr> <td data-bbox="336 1368 491 1413">Cassette 4</td> <td data-bbox="491 1368 1043 1413">Maintenance counter cassette4</td> <td data-bbox="1043 1368 1235 1413">0 to 9999999</td> <td data-bbox="1235 1368 1425 1413">0</td> </tr> <tr> <td data-bbox="336 1413 491 1458">Cassette 5</td> <td data-bbox="491 1413 1043 1458">Maintenance counter cassette5</td> <td data-bbox="1043 1413 1235 1458">0 to 9999999</td> <td data-bbox="1235 1413 1425 1458">0</td> </tr> <tr> <td data-bbox="336 1458 491 1525">Clear</td> <td data-bbox="491 1458 1043 1525">Maintenance counter all clear</td> <td data-bbox="1043 1458 1235 1525">0 to 9999999</td> <td data-bbox="1235 1458 1425 1525">-</td> </tr> </tbody> </table> <ol style="list-style-type: none"> <li>4. Press the start key. The value is set.</li> </ol> <p><b>Clearing</b></p> <ol style="list-style-type: none"> <li>1. Select [Clear].</li> <li>2. Press the start key. The setting value is cleared.</li> </ol> <p><b>Completion</b></p> <p>Press the stop key. The screen for selecting a maintenance item No. is displayed.</p> <p>* : When the firmware is upgraded in the field, input the counter value of U901 into the primary feed counter.</p> <p>If the counter value is larger than 150000, replace the primary feed roller and input "0".</p>	Display	Description	Setting range	Initial setting	M.Cnt A	Count value for maintenance cycle (kit A)	0 to 9999999	0	M.Cnt HT	Automatic grayscale adjustment count	0 to 9999999	0	Cassette 1	Maintenance counter cassette1	0 to 9999999	0	Cassette 2	Maintenance counter cassette2	0 to 9999999	0	Cassette 3	Maintenance counter cassette3	0 to 9999999	0	Cassette 4	Maintenance counter cassette4	0 to 9999999	0	Cassette 5	Maintenance counter cassette5	0 to 9999999	0	Clear	Maintenance counter all clear	0 to 9999999	-
Display	Description	Setting range	Initial setting																																		
M.Cnt A	Count value for maintenance cycle (kit A)	0 to 9999999	0																																		
M.Cnt HT	Automatic grayscale adjustment count	0 to 9999999	0																																		
Cassette 1	Maintenance counter cassette1	0 to 9999999	0																																		
Cassette 2	Maintenance counter cassette2	0 to 9999999	0																																		
Cassette 3	Maintenance counter cassette3	0 to 9999999	0																																		
Cassette 4	Maintenance counter cassette4	0 to 9999999	0																																		
Cassette 5	Maintenance counter cassette5	0 to 9999999	0																																		
Clear	Maintenance counter all clear	0 to 9999999	-																																		

Item No.	Description																								
U252	<p data-bbox="288 241 580 275"><b>Setting the destination</b></p> <p data-bbox="288 311 440 340"><b>Description</b></p> <p data-bbox="288 344 1254 376">Switches the operations and screens of the machine according to the destination.</p> <p data-bbox="288 383 400 412"><b>Purpose</b></p> <p data-bbox="288 416 1426 481">To be executed after initializing the backup RAM, in order to return the setting to the value before replacement or initialization.</p> <p data-bbox="288 517 387 546"><b>Method</b></p> <ol data-bbox="304 555 600 620" style="list-style-type: none"> <li>1. Press the start key.</li> <li>2. Select the destination.</li> </ol> <table border="1" data-bbox="336 631 1401 967"> <thead> <tr> <th data-bbox="336 631 641 676">Display</th> <th data-bbox="641 631 1401 676">Description</th> </tr> </thead> <tbody> <tr> <td data-bbox="336 676 641 721">Inch</td> <td data-bbox="641 676 1401 721">Inch (North America) specifications</td> </tr> <tr> <td data-bbox="336 721 641 766">Europe Metric</td> <td data-bbox="641 721 1401 766">Metric (Europe) specifications</td> </tr> <tr> <td data-bbox="336 766 641 810">Asia Pacific</td> <td data-bbox="641 766 1401 810">Metric (Asia Pacific) specifications</td> </tr> <tr> <td data-bbox="336 810 641 855">Australia</td> <td data-bbox="641 810 1401 855">Australia specifications</td> </tr> <tr> <td data-bbox="336 855 641 900">China</td> <td data-bbox="641 855 1401 900">China specifications</td> </tr> <tr> <td data-bbox="336 900 641 967">Korea</td> <td data-bbox="641 900 1401 967">Korea specifications</td> </tr> </tbody> </table> <ol data-bbox="304 987 1382 1052" style="list-style-type: none"> <li>3. Press the start key.</li> <li>4. Turn the main power switch off and on. Allow more than 5 seconds between Off and On.</li> </ol> <p data-bbox="336 1059 1059 1088">* : An error code is displayed in case of an initialization error.</p> <p data-bbox="371 1093 1426 1158">When errors occurred, turn main power switch off then on, and execute initialization using maintenance item U252.</p> <p data-bbox="336 1193 488 1223"><b>Error codes</b></p> <table border="1" data-bbox="336 1234 1401 1476"> <thead> <tr> <th data-bbox="336 1234 641 1279">Codes</th> <th data-bbox="641 1234 1401 1279">Description</th> </tr> </thead> <tbody> <tr> <td data-bbox="336 1279 641 1323">0001</td> <td data-bbox="641 1279 1401 1323">Entity error</td> </tr> <tr> <td data-bbox="336 1323 641 1368">0002</td> <td data-bbox="641 1323 1401 1368">Controller error</td> </tr> <tr> <td data-bbox="336 1368 641 1413">0020</td> <td data-bbox="641 1368 1401 1413">Engine error</td> </tr> <tr> <td data-bbox="336 1413 641 1476">0040</td> <td data-bbox="641 1413 1401 1476">Scanner error</td> </tr> </tbody> </table>	Display	Description	Inch	Inch (North America) specifications	Europe Metric	Metric (Europe) specifications	Asia Pacific	Metric (Asia Pacific) specifications	Australia	Australia specifications	China	China specifications	Korea	Korea specifications	Codes	Description	0001	Entity error	0002	Controller error	0020	Engine error	0040	Scanner error
Display	Description																								
Inch	Inch (North America) specifications																								
Europe Metric	Metric (Europe) specifications																								
Asia Pacific	Metric (Asia Pacific) specifications																								
Australia	Australia specifications																								
China	China specifications																								
Korea	Korea specifications																								
Codes	Description																								
0001	Entity error																								
0002	Controller error																								
0020	Engine error																								
0040	Scanner error																								

Item No.	Description														
U253	<p data-bbox="288 241 863 275"><b>Switching between double and single counts</b></p> <p data-bbox="288 309 440 342"><b>Description</b></p> <p data-bbox="288 344 1337 378">Switches the count system for the total counter and other counters for every color mode.</p> <p data-bbox="288 380 400 414"><b>Purpose</b></p> <p data-bbox="288 416 1374 483">Used to select, according to the preference of the user (copy service provider), if A3/Ledger paper is to be counted as one sheet (single count) or two sheets (double count).</p> <p data-bbox="288 517 384 551"><b>Setting</b></p> <ol data-bbox="304 553 595 620" style="list-style-type: none"> <li>1. Press the start key.</li> <li>2. Select the item to set.</li> </ol> <table border="1" data-bbox="336 631 1401 728"> <thead> <tr> <th data-bbox="336 631 639 676">Display</th> <th data-bbox="639 631 1401 676">Description</th> </tr> </thead> <tbody> <tr> <td data-bbox="336 676 639 728">B/W</td> <td data-bbox="639 676 1401 728">Count system of black/white mode</td> </tr> </tbody> </table> <p data-bbox="336 734 1254 768">Displayed only if the setting of U276 (Setting the copy count mode) is Mode1.</p> <ol data-bbox="304 770 632 804" style="list-style-type: none"> <li>3. Select the count system.</li> </ol> <table border="1" data-bbox="336 815 1401 1055"> <thead> <tr> <th data-bbox="336 815 639 860">Display</th> <th data-bbox="639 815 1401 860">Description</th> </tr> </thead> <tbody> <tr> <td data-bbox="336 860 639 904">SGL(All)</td> <td data-bbox="639 860 1401 904">Single count for all size paper</td> </tr> <tr> <td data-bbox="336 904 639 949">DBL(A3/Ledger)</td> <td data-bbox="639 904 1401 949">Double count for A3/Ledger size or larger</td> </tr> <tr> <td data-bbox="336 949 639 994">DBL(B4)</td> <td data-bbox="639 949 1401 994">Double count for B4 size or larger</td> </tr> <tr> <td data-bbox="336 994 639 1055">DBL(Folio)</td> <td data-bbox="639 994 1401 1055">Double count for Folio size or larger</td> </tr> </tbody> </table> <p data-bbox="336 1066 695 1099">Initial setting: DBL(A3/Ledger)</p> <ol data-bbox="304 1102 783 1135" style="list-style-type: none"> <li>4. Press the start key. The setting is set.</li> </ol> <p data-bbox="288 1169 440 1202"><b>Completion</b></p> <p data-bbox="288 1205 1254 1238">Press the stop key. The screen for selecting a maintenance item No. is displayed.</p>	Display	Description	B/W	Count system of black/white mode	Display	Description	SGL(All)	Single count for all size paper	DBL(A3/Ledger)	Double count for A3/Ledger size or larger	DBL(B4)	Double count for B4 size or larger	DBL(Folio)	Double count for Folio size or larger
Display	Description														
B/W	Count system of black/white mode														
Display	Description														
SGL(All)	Single count for all size paper														
DBL(A3/Ledger)	Double count for A3/Ledger size or larger														
DBL(B4)	Double count for B4 size or larger														
DBL(Folio)	Double count for Folio size or larger														

Item No.	Description						
<b>U260</b>	<p><b>Selecting the timing for copy counting</b></p> <p><b>Description</b> Changes the copy count timing for the total counter and other counters.</p> <p><b>Purpose</b> To be set according to user request.</p> <p><b>Setting</b></p> <ol style="list-style-type: none"> <li>1. Press the start key.</li> <li>2. Select the copy count timing.</li> </ol> <table border="1" data-bbox="336 598 1401 741"> <thead> <tr> <th data-bbox="336 598 641 642">Display</th> <th data-bbox="641 598 1401 642">Description</th> </tr> </thead> <tbody> <tr> <td data-bbox="336 642 641 687">Feed</td> <td data-bbox="641 642 1401 687">When secondary paper feed starts</td> </tr> <tr> <td data-bbox="336 687 641 741">Eject</td> <td data-bbox="641 687 1401 741">When the paper is ejected</td> </tr> </tbody> </table> <p>Initial setting: Eject</p> <ol style="list-style-type: none"> <li>3. Press the start key. The setting is set.</li> </ol> <p><b>Completion</b> Press the stop key. The screen for selecting a maintenance item No. is displayed.</p>	Display	Description	Feed	When secondary paper feed starts	Eject	When the paper is ejected
Display	Description						
Feed	When secondary paper feed starts						
Eject	When the paper is ejected						
<b>U265</b>	<p><b>Setting OEM purchaser code</b></p> <p><b>Description</b> Sets the OEM purchaser code.</p> <p><b>Purpose</b> Sets the code when replacing the main PWB and the like.</p> <p><b>Setting</b></p> <ol style="list-style-type: none"> <li>1. Press the start key.</li> <li>2. Change the setting value using the numeric keys.</li> <li>3. Press the start key. The setting is set.</li> <li>4. Turn the main power switch off and on. Allow more than 5 seconds between Off and On.</li> </ol>						

Item No.	Description												
<b>U271</b>	<p><b>Setting the page count</b></p> <p><b>Description</b> Banner counting</p> <p><b>Purpose</b> To change when modifying counting Banner * : If U253 is adjusted to double-counting, the value which is multiplied with this value will be the count value.</p> <p><b>Setting</b></p> <ol style="list-style-type: none"> <li>1. Press the start key.</li> <li>2. Select the item.</li> <li>3. Change the setting value using the +/- keys or numeric keys.</li> </ol> <table border="1" data-bbox="336 701 1401 949"> <thead> <tr> <th>Display</th> <th>Description</th> <th>Setting range</th> <th>Initial setting</th> </tr> </thead> <tbody> <tr> <td>Banner A</td> <td>Counting for Banner A (470.1mm to 915mm/18.51" to 36")</td> <td>2 to 30</td> <td>2</td> </tr> <tr> <td>Banner B</td> <td>Counting for Banner B (915.1mm to 1,220mm/36.01" to 48")</td> <td>2 to 30</td> <td>3</td> </tr> </tbody> </table> <ol style="list-style-type: none"> <li>4. Press the start key. The value is set.</li> </ol> <p><b>Completion</b> Press the stop key. The screen for selecting a maintenance item No. is displayed.</p>	Display	Description	Setting range	Initial setting	Banner A	Counting for Banner A (470.1mm to 915mm/18.51" to 36")	2 to 30	2	Banner B	Counting for Banner B (915.1mm to 1,220mm/36.01" to 48")	2 to 30	3
Display	Description	Setting range	Initial setting										
Banner A	Counting for Banner A (470.1mm to 915mm/18.51" to 36")	2 to 30	2										
Banner B	Counting for Banner B (915.1mm to 1,220mm/36.01" to 48")	2 to 30	3										
<b>U278</b>	<p><b>Setting the delivery date</b></p> <p><b>Description</b> Enter delivery date in month, day, and year.</p> <p><b>Purpose</b> To operate when installing the machine. Perform this to confirm the delivery date.</p> <p><b>Method</b></p> <ol style="list-style-type: none"> <li>1. Press the start key.</li> <li>2. Select [Today].</li> <li>3. Press the start key. The delivery date is set.</li> </ol> <p><b>Clearing</b></p> <ol style="list-style-type: none"> <li>1. Select [Clear].</li> <li>2. Press the start key. The delivery date is cleared.</li> </ol> <p><b>Completion</b> Press the stop key. The screen for selecting a maintenance item No. is displayed.</p>												



Item No.	Description						
<b>U285</b>	<p><b>Setting service status page</b></p> <p><b>Description</b> Determines displaying the print coverage report on reporting.</p> <p><b>Purpose</b> According to user request, changes the setting.</p> <p><b>Setting</b></p> <ol style="list-style-type: none"> <li>1. Press the start key.</li> <li>2. Select On or Off.</li> </ol> <table border="1" data-bbox="336 598 1401 741"> <thead> <tr> <th data-bbox="336 598 641 642">Display</th> <th data-bbox="641 598 1401 642">Description</th> </tr> </thead> <tbody> <tr> <td data-bbox="336 642 641 687">On</td> <td data-bbox="641 642 1401 687">Displays the print coverage</td> </tr> <tr> <td data-bbox="336 687 641 741">Off</td> <td data-bbox="641 687 1401 741">Not to display the print coverage</td> </tr> </tbody> </table> <p>Initial setting: On</p> <ol style="list-style-type: none"> <li>3. Press the start key. The setting is set.</li> </ol> <p><b>Completion</b> Press the stop key. The screen for selecting a maintenance item No. is displayed.</p>	Display	Description	On	Displays the print coverage	Off	Not to display the print coverage
Display	Description						
On	Displays the print coverage						
Off	Not to display the print coverage						
<b>U323</b>	<p><b>Setting abnormal temperature and humidity warning</b></p> <p><b>Description</b> Specify whether or not a notice is displayed on the operation panel when abnormal temperature and humidity is detected.</p> <p><b>Purpose</b> According to user request, changes the setting.</p> <p><b>Setting</b></p> <ol style="list-style-type: none"> <li>1. Press the start key.</li> <li>2. Select On or Off.</li> </ol> <table border="1" data-bbox="336 1328 1401 1471"> <thead> <tr> <th data-bbox="336 1328 641 1373">Display</th> <th data-bbox="641 1328 1401 1373">Description</th> </tr> </thead> <tbody> <tr> <td data-bbox="336 1373 641 1417">On</td> <td data-bbox="641 1373 1401 1417">Displays the abnormal temperature and humidity warning</td> </tr> <tr> <td data-bbox="336 1417 641 1471">Off</td> <td data-bbox="641 1417 1401 1471">Not to display the abnormal temperature and humidity warning</td> </tr> </tbody> </table> <p>Initial setting: On</p> <ol style="list-style-type: none"> <li>3. Press the start key. The setting is set.</li> </ol> <p><b>Completion</b> Press the stop key. The screen for selecting a maintenance item No. is displayed.</p>	Display	Description	On	Displays the abnormal temperature and humidity warning	Off	Not to display the abnormal temperature and humidity warning
Display	Description						
On	Displays the abnormal temperature and humidity warning						
Off	Not to display the abnormal temperature and humidity warning						

Item No.	Description																				
U325	<p data-bbox="288 241 612 271"><b>Setting the paper interval</b></p> <p data-bbox="288 311 440 340"><b>Description</b></p> <p data-bbox="288 344 1431 479">Due to the fact that, if toner consumption per driving time drastically lowers, the variation in coloring and low density and gray background become prominent, the print coverage that executes toner ejection according to the low density at a continued vertical printing with the low coverage data must be changed.</p> <p data-bbox="288 483 400 512"><b>Purpose</b></p> <p data-bbox="288 517 1406 584">The settings must be changed when printing an extensive volume with the vertical A4/Letter of low coverage contents or the toner consumption per driving time is extremely low.</p> <p data-bbox="288 624 387 654"><b>Method</b></p> <ol data-bbox="304 658 592 725" style="list-style-type: none"> <li>1. Press the start key.</li> <li>2. Select the item to set.</li> </ol> <table border="1" data-bbox="336 734 1399 880"> <thead> <tr> <th data-bbox="336 734 639 779">Display</th> <th data-bbox="639 734 1399 779">Description</th> </tr> </thead> <tbody> <tr> <td data-bbox="336 779 639 824">Interval</td> <td data-bbox="639 779 1399 824">On-Off control of Inter-paper toner ejection</td> </tr> <tr> <td data-bbox="336 824 639 880">Mode</td> <td data-bbox="639 824 1399 880">Setting mode of Inter-paper toner ejection</td> </tr> </tbody> </table> <p data-bbox="288 925 512 954"><b>Setting: [Interval]</b></p> <ol data-bbox="304 958 536 987" style="list-style-type: none"> <li>1. Select On or Off.</li> </ol> <table border="1" data-bbox="336 996 1399 1142"> <thead> <tr> <th data-bbox="336 996 639 1041">Display</th> <th data-bbox="639 996 1399 1041">Description</th> </tr> </thead> <tbody> <tr> <td data-bbox="336 1041 639 1086">On</td> <td data-bbox="639 1041 1399 1086">Inter-paper toner ejection is performed</td> </tr> <tr> <td data-bbox="336 1086 639 1142">Off</td> <td data-bbox="639 1086 1399 1142">Inter-paper toner ejection is not performed</td> </tr> </tbody> </table> <p data-bbox="336 1155 536 1184">Initial setting: Off</p> <ol data-bbox="304 1189 783 1218" style="list-style-type: none"> <li>2. Press the start key. The setting is set.</li> </ol> <p data-bbox="288 1263 488 1292"><b>Setting: [Mode]</b></p> <ol data-bbox="304 1296 1054 1326" style="list-style-type: none"> <li>1. Change the setting value using the +/- keys or numeric keys.</li> </ol> <table border="1" data-bbox="336 1335 1399 1469"> <thead> <tr> <th data-bbox="336 1335 528 1379">Display</th> <th data-bbox="528 1335 1094 1379">Description</th> <th data-bbox="1094 1335 1246 1379">Setting range</th> <th data-bbox="1246 1335 1399 1379">Initial setting</th> </tr> </thead> <tbody> <tr> <td data-bbox="336 1379 528 1469">Mode</td> <td data-bbox="528 1379 1094 1469">Inter-paper toner ejection mode</td> <td data-bbox="1094 1379 1246 1469">1 to 2</td> <td data-bbox="1246 1379 1399 1469">1</td> </tr> </tbody> </table> <p data-bbox="336 1514 927 1543">Mode 1 or Mode 2 is effective when Interval is on.</p> <p data-bbox="336 1547 1374 1615">Mode 1: For usages where the original date includes a low toner coverage or gray background is observed (T7 threshold is 3%).</p> <p data-bbox="336 1619 1422 1686">Mode 2: For environments where printing is seldom made but the machine toggles in warm-up mode. (Mostly scanning is used such as in a show room.)</p> <p data-bbox="336 1691 1350 1720">(T7 threshold 3% + simplified refreshing is implemented after the warm-up calibration)</p> <ol data-bbox="304 1765 783 1794" style="list-style-type: none"> <li>2. Press the start key. The setting is set.</li> </ol> <p data-bbox="288 1827 440 1856"><b>Completion</b></p> <p data-bbox="288 1861 1254 1890">Press the stop key. The screen for selecting a maintenance item No. is displayed.</p>	Display	Description	Interval	On-Off control of Inter-paper toner ejection	Mode	Setting mode of Inter-paper toner ejection	Display	Description	On	Inter-paper toner ejection is performed	Off	Inter-paper toner ejection is not performed	Display	Description	Setting range	Initial setting	Mode	Inter-paper toner ejection mode	1 to 2	1
Display	Description																				
Interval	On-Off control of Inter-paper toner ejection																				
Mode	Setting mode of Inter-paper toner ejection																				
Display	Description																				
On	Inter-paper toner ejection is performed																				
Off	Inter-paper toner ejection is not performed																				
Display	Description	Setting range	Initial setting																		
Mode	Inter-paper toner ejection mode	1 to 2	1																		

Item No.	Description																				
U326	<p data-bbox="288 241 810 275"><b>Setting the black line cleaning indication</b></p> <p data-bbox="288 311 440 340"><b>Description</b></p> <p data-bbox="288 344 1193 376">Sets whether to display the cleaning guidance when detecting the black line.</p> <p data-bbox="288 380 400 409"><b>Purpose</b></p> <p data-bbox="288 414 1425 481">Displays the cleaning guidance in order to make the call for service with the black line decrease by the rubbish on the contact glass when scanning from the DP.</p> <p data-bbox="288 517 387 546"><b>Method</b></p> <ol data-bbox="304 553 595 618" style="list-style-type: none"> <li>1. Press the start key.</li> <li>2. Select the item to set.</li> </ol> <table border="1" data-bbox="336 631 1401 777"> <thead> <tr> <th data-bbox="336 631 641 678">Display</th> <th data-bbox="641 631 1401 678">Description</th> </tr> </thead> <tbody> <tr> <td data-bbox="336 678 641 725">Black Line Mode</td> <td data-bbox="641 678 1401 725">Black line cleaning guidance ON/OFF setting</td> </tr> <tr> <td data-bbox="336 725 641 777">Black Line Cnt</td> <td data-bbox="641 725 1401 777">Setting counts of the cleaning guidance indication</td> </tr> </tbody> </table> <p data-bbox="288 819 628 851"><b>Setting: [Black Line Mode]</b></p> <ol data-bbox="304 855 536 887" style="list-style-type: none"> <li>1. Select On or Off.</li> </ol> <table border="1" data-bbox="336 898 1401 1043"> <thead> <tr> <th data-bbox="336 898 641 945">Display</th> <th data-bbox="641 898 1401 945">Description</th> </tr> </thead> <tbody> <tr> <td data-bbox="336 945 641 992">On</td> <td data-bbox="641 945 1401 992">Displays the cleaning guidance</td> </tr> <tr> <td data-bbox="336 992 641 1043">Off</td> <td data-bbox="641 992 1401 1043">Not to display the cleaning guidance</td> </tr> </tbody> </table> <p data-bbox="333 1052 537 1084">Initial setting: On</p> <ol data-bbox="304 1088 780 1120" style="list-style-type: none"> <li>2. Press the start key. The setting is set.</li> </ol> <p data-bbox="288 1158 603 1189"><b>Setting: [Black Line Cnt]</b></p> <ol data-bbox="304 1193 1053 1225" style="list-style-type: none"> <li>1. Change the setting value using the +/- keys or numeric keys.</li> </ol> <table border="1" data-bbox="336 1236 1401 1400"> <thead> <tr> <th data-bbox="336 1236 528 1317">Display</th> <th data-bbox="528 1236 1096 1317">Description</th> <th data-bbox="1096 1236 1248 1317">Setting range</th> <th data-bbox="1248 1236 1401 1317">Initial setting</th> </tr> </thead> <tbody> <tr> <td data-bbox="336 1317 528 1400">Cnt</td> <td data-bbox="528 1317 1096 1400">Setting counts of the cleaning guidance indication ( x 1000 sheets)</td> <td data-bbox="1096 1317 1248 1400">0 to 255</td> <td data-bbox="1248 1317 1401 1400">8</td> </tr> </tbody> </table> <p data-bbox="333 1411 1361 1476">When setting is 0, the black line cleaning indication is displayed only if the black line is detected.</p> <ol data-bbox="304 1480 766 1512" style="list-style-type: none"> <li>2. Press the start key. The value is set.</li> </ol> <p data-bbox="288 1550 440 1581"><b>Completion</b></p> <p data-bbox="288 1585 1256 1617">Press the stop key. The screen for selecting a maintenance item No. is displayed.</p>	Display	Description	Black Line Mode	Black line cleaning guidance ON/OFF setting	Black Line Cnt	Setting counts of the cleaning guidance indication	Display	Description	On	Displays the cleaning guidance	Off	Not to display the cleaning guidance	Display	Description	Setting range	Initial setting	Cnt	Setting counts of the cleaning guidance indication ( x 1000 sheets)	0 to 255	8
Display	Description																				
Black Line Mode	Black line cleaning guidance ON/OFF setting																				
Black Line Cnt	Setting counts of the cleaning guidance indication																				
Display	Description																				
On	Displays the cleaning guidance																				
Off	Not to display the cleaning guidance																				
Display	Description	Setting range	Initial setting																		
Cnt	Setting counts of the cleaning guidance indication ( x 1000 sheets)	0 to 255	8																		

Item No.	Description								
<b>U327</b>	<p><b>Setting the cassette heater control</b></p> <p><b>Description</b> Sets the cassette heater control.</p> <p><b>Purpose</b> To change the setting according to the machine installation environment.</p> <p><b>Setting</b></p> <ol style="list-style-type: none"> <li>1. Press the start key.</li> <li>2. Select the item to set.</li> </ol> <table border="1" data-bbox="336 595 1401 824"> <thead> <tr> <th>Display</th> <th>Description</th> </tr> </thead> <tbody> <tr> <td>Mode1</td> <td>Setting On when the humidity is 65%. (when sleep mode and waiting mode)</td> </tr> <tr> <td>Mode2</td> <td>Setting On in full-time. (when sleep mode and waiting mode)</td> </tr> <tr> <td>Off</td> <td>Cassette heater OFF</td> </tr> </tbody> </table> <p>Initial setting: Off</p> <ol style="list-style-type: none"> <li>3. Press the start key. The setting is set.</li> </ol> <p><b>Completion</b> Press the stop key. The screen for selecting a maintenance item No. is displayed.</p>	Display	Description	Mode1	Setting On when the humidity is 65%. (when sleep mode and waiting mode)	Mode2	Setting On in full-time. (when sleep mode and waiting mode)	Off	Cassette heater OFF
Display	Description								
Mode1	Setting On when the humidity is 65%. (when sleep mode and waiting mode)								
Mode2	Setting On in full-time. (when sleep mode and waiting mode)								
Off	Cassette heater OFF								
<b>U332</b>	<p><b>Setting the size conversion factor</b></p> <p><b>Description</b> Sets the coefficient of nonstandard sizes in relation to the A4/Letter size. The coefficient set here is used to convert the black ratio in relation to the A4/Letter size and to display the result in user simulation.</p> <p><b>Purpose</b> To set the coefficient for converting the black ratio for nonstandard sizes in relation to the A4/Letter size.</p> <p><b>Setting</b></p> <ol style="list-style-type: none"> <li>1. Press the start key.</li> <li>2. Change the setting using the +/-keys or numeric keys.</li> </ol> <table border="1" data-bbox="336 1485 1401 1619"> <thead> <tr> <th>Display</th> <th>Description</th> <th>Setting range</th> <th>Initial setting</th> </tr> </thead> <tbody> <tr> <td>Rate</td> <td>Size coefficient</td> <td>0.1 to 3.0</td> <td>1.0</td> </tr> </tbody> </table> <ol style="list-style-type: none"> <li>3. Press the start key. The value is set.</li> </ol> <p><b>Completion</b> Press the stop key. The screen for selecting a maintenance item No. is displayed.</p>	Display	Description	Setting range	Initial setting	Rate	Size coefficient	0.1 to 3.0	1.0
Display	Description	Setting range	Initial setting						
Rate	Size coefficient	0.1 to 3.0	1.0						

Item No.	Description																										
U340	<p data-bbox="287 241 614 273"><b>Setting the applied mode</b></p> <p data-bbox="287 309 438 340"><b>Description</b></p> <p data-bbox="287 344 1412 412">Allocates memory to ensure that there is sufficient memory available for the printer to use as a working area.</p> <p data-bbox="287 416 399 448"><b>Purpose</b></p> <p data-bbox="287 452 1428 519">Modify the memory allocation if insufficient memory for transparency support or XPS direct printing occurs.</p> <p data-bbox="287 555 391 586"><b>Method</b></p> <ol data-bbox="303 591 598 658" style="list-style-type: none"> <li>1. Press the start key.</li> <li>2. Select the item to set.</li> </ol> <table border="1" data-bbox="335 663 1401 810"> <thead> <tr> <th data-bbox="343 667 641 712">Display</th> <th data-bbox="641 667 1393 712">Description</th> </tr> </thead> <tbody> <tr> <td data-bbox="343 712 641 757">Adj Memory</td> <td data-bbox="641 712 1393 757">Setting the memory allocation</td> </tr> <tr> <td data-bbox="343 757 641 806">Adj Max Job</td> <td data-bbox="641 757 1393 806">Setting the maximum of multiple jobs</td> </tr> </tbody> </table> <p data-bbox="287 855 566 887"><b>Setting: [Adj Memory]</b></p> <ol data-bbox="303 891 981 922" style="list-style-type: none"> <li>1. Change the setting using the +/- keys or numeric keys.</li> </ol> <table border="1" data-bbox="335 927 1401 1097"> <thead> <tr> <th data-bbox="343 931 564 1012">Display</th> <th data-bbox="564 931 1066 1012">Description</th> <th data-bbox="1066 931 1248 1012">Setting range</th> <th data-bbox="1248 931 1393 1012">Initial setting</th> </tr> </thead> <tbody> <tr> <td data-bbox="343 1012 564 1097">Image</td> <td data-bbox="564 1012 1066 1097">Area temporarily used to create output image.</td> <td data-bbox="1066 1012 1248 1097">-50 to 50 (MB)</td> <td data-bbox="1248 1012 1393 1097">0</td> </tr> </tbody> </table> <p data-bbox="335 1111 1220 1178">Set the values below in case print failure occurs with the memory shortage. (recommended value)</p> <p data-bbox="335 1182 478 1214">Image : +50</p> <p data-bbox="335 1218 566 1249">Image(Detaile) : +1</p> <ol data-bbox="303 1254 1380 1321" style="list-style-type: none"> <li>2. Press the start key. The value is set.</li> <li>3. Turn the main power switch off and on. Allow more than 5 seconds between Off and On.</li> </ol> <p data-bbox="287 1357 446 1388"><b>Supplement</b></p> <p data-bbox="287 1393 1300 1424">The work area for copy is small and it may cause output failure if the values are large.</p> <p data-bbox="287 1460 574 1491"><b>Setting: [Adj Max Job]</b></p> <ol data-bbox="303 1496 973 1527" style="list-style-type: none"> <li>1. Change the setting using the +/-keys or numeric keys.</li> </ol> <table border="1" data-bbox="335 1532 1401 1711"> <thead> <tr> <th data-bbox="343 1536 564 1617">Display</th> <th data-bbox="564 1536 1094 1617">Description</th> <th data-bbox="1094 1536 1248 1617">Setting range</th> <th data-bbox="1248 1536 1393 1617">Initial setting</th> </tr> </thead> <tbody> <tr> <td data-bbox="343 1617 564 1662">Copy</td> <td data-bbox="564 1617 1094 1662">Maximum copy (Scan To Print) Jobs</td> <td data-bbox="1094 1617 1248 1662">10 to 50</td> <td data-bbox="1248 1617 1393 1662">10</td> </tr> <tr> <td data-bbox="343 1662 564 1711">Printer</td> <td data-bbox="564 1662 1094 1711">Maximum printer (Host To Print) Jobs</td> <td data-bbox="1094 1662 1248 1711">-</td> <td data-bbox="1248 1662 1393 1711">50</td> </tr> </tbody> </table> <p data-bbox="335 1724 1260 1756">The maximum Printer jobs should be (maximum jobs) – (maximum copy jobs).</p> <ol data-bbox="303 1760 766 1792" style="list-style-type: none"> <li>2. Press the start key. The value is set.</li> </ol> <p data-bbox="287 1827 438 1859"><b>Completion</b></p> <p data-bbox="287 1863 1252 1895">Press the stop key. The screen for selecting a maintenance item No. is displayed.</p>	Display	Description	Adj Memory	Setting the memory allocation	Adj Max Job	Setting the maximum of multiple jobs	Display	Description	Setting range	Initial setting	Image	Area temporarily used to create output image.	-50 to 50 (MB)	0	Display	Description	Setting range	Initial setting	Copy	Maximum copy (Scan To Print) Jobs	10 to 50	10	Printer	Maximum printer (Host To Print) Jobs	-	50
Display	Description																										
Adj Memory	Setting the memory allocation																										
Adj Max Job	Setting the maximum of multiple jobs																										
Display	Description	Setting range	Initial setting																								
Image	Area temporarily used to create output image.	-50 to 50 (MB)	0																								
Display	Description	Setting range	Initial setting																								
Copy	Maximum copy (Scan To Print) Jobs	10 to 50	10																								
Printer	Maximum printer (Host To Print) Jobs	-	50																								

Item No.	Description												
U341	<p><b>Specific paper feed location setting for printing function</b></p> <p><b>Description</b> Sets a paper feed location specified for printer output (only if a printer kit is installed).</p> <p><b>Purpose</b> To use a paper feed location only for printer output. A paper feed location specified for printer output cannot be used for copy output.</p> <p><b>Method</b></p> <ol style="list-style-type: none"> <li>1. Press the start key.</li> <li>2. Select the paper feed location for the printer. Two or more cassette can be selected.</li> </ol> <table border="1" data-bbox="336 667 1401 954"> <thead> <tr> <th data-bbox="336 667 639 712">Display</th> <th data-bbox="639 667 1401 712">Description</th> </tr> </thead> <tbody> <tr> <td data-bbox="336 712 639 757">Cassette1</td> <td data-bbox="639 712 1401 757">Cassette 1</td> </tr> <tr> <td data-bbox="336 757 639 801">Cassette2</td> <td data-bbox="639 757 1401 801">Cassette 2</td> </tr> <tr> <td data-bbox="336 801 639 846">Cassette3</td> <td data-bbox="639 801 1401 846">Cassette 3 (paper feeder/large capacity feeder)</td> </tr> <tr> <td data-bbox="336 846 639 891">Cassette4</td> <td data-bbox="639 846 1401 891">Cassette 4 (paper feeder/large capacity feeder)</td> </tr> <tr> <td data-bbox="336 891 639 954">Cassette5</td> <td data-bbox="639 891 1401 954">Cassette 5 (side deck)</td> </tr> </tbody> </table> <p>Initial setting: Off (Cassette1 to 5) * : When an optional paper feed device is not installed, the corresponding count is not displayed.</p> <ol style="list-style-type: none"> <li>3. Press the start key. The setting is set.</li> </ol> <p><b>Completion</b> Press the stop key. The screen for selecting a maintenance item No. is displayed.</p>	Display	Description	Cassette1	Cassette 1	Cassette2	Cassette 2	Cassette3	Cassette 3 (paper feeder/large capacity feeder)	Cassette4	Cassette 4 (paper feeder/large capacity feeder)	Cassette5	Cassette 5 (side deck)
Display	Description												
Cassette1	Cassette 1												
Cassette2	Cassette 2												
Cassette3	Cassette 3 (paper feeder/large capacity feeder)												
Cassette4	Cassette 4 (paper feeder/large capacity feeder)												
Cassette5	Cassette 5 (side deck)												
U343	<p><b>Switching between duplex/simplex copy mode</b></p> <p><b>Description</b> Switches the initial setting between duplex and simplex copy.</p> <p><b>Purpose</b> To be set according to frequency of use: set to the more frequently used mode.</p> <p><b>Setting</b></p> <ol style="list-style-type: none"> <li>1. Press the start key.</li> <li>2. Select On or Off.</li> </ol> <table border="1" data-bbox="336 1574 1401 1720"> <thead> <tr> <th data-bbox="336 1574 639 1619">Display</th> <th data-bbox="639 1574 1401 1619">Description</th> </tr> </thead> <tbody> <tr> <td data-bbox="336 1619 639 1664">On</td> <td data-bbox="639 1619 1401 1664">Duplex copy</td> </tr> <tr> <td data-bbox="336 1664 639 1720">Off</td> <td data-bbox="639 1664 1401 1720">Simplex copy</td> </tr> </tbody> </table> <p>Initial setting: Off</p> <ol style="list-style-type: none"> <li>3. Press the start key. The setting is set.</li> </ol> <p><b>Completion</b> Press the stop key. The screen for selecting a maintenance item No. is displayed.</p>	Display	Description	On	Duplex copy	Off	Simplex copy						
Display	Description												
On	Duplex copy												
Off	Simplex copy												

Item No.	Description										
U345	<p><b>Setting the value for maintenance due indication</b></p> <p><b>Description</b> Sets when to display a message notifying that the time for maintenance is about to be reached, by setting the number of copies that can be made before the current maintenance cycle ends. When the difference between the number of copies of the maintenance cycle and that of the maintenance count reaches the set value, the message is displayed.</p> <p><b>Purpose</b> To change the time for maintenance due indication.</p> <p><b>Setting</b></p> <ol style="list-style-type: none"> <li>1. Press the start key.</li> <li>2. Change the setting using the +/- keys or numeric keys.</li> </ol> <table border="1" data-bbox="336 674 1401 875"> <thead> <tr> <th>Display</th> <th>Description</th> <th>Setting range</th> <th>Initial setting</th> </tr> </thead> <tbody> <tr> <td>Cnt</td> <td>Time for maintenance due indication (Remaining number of copies that can be made before the current maintenance cycle ends)</td> <td>0 to 9999</td> <td>0</td> </tr> </tbody> </table> <ol style="list-style-type: none"> <li>3. Press the start key. The value is set.</li> </ol> <p><b>Completion</b> Press the stop key. The screen for selecting a maintenance item No. is displayed.</p>	Display	Description	Setting range	Initial setting	Cnt	Time for maintenance due indication (Remaining number of copies that can be made before the current maintenance cycle ends)	0 to 9999	0		
Display	Description	Setting range	Initial setting								
Cnt	Time for maintenance due indication (Remaining number of copies that can be made before the current maintenance cycle ends)	0 to 9999	0								
U346	<p><b>Selecting Sleep Mode</b></p> <p><b>Description</b> Switches configurations for sleep modes.</p> <p><b>Purpose</b> Use this to switch configurations for sleep modes.</p> <p><b>Method</b></p> <ol style="list-style-type: none"> <li>1. Press the start key.</li> <li>2. Select the item to set.</li> </ol> <table border="1" data-bbox="336 1429 1401 1525"> <thead> <tr> <th>Display</th> <th>Description</th> </tr> </thead> <tbody> <tr> <td>BAM</td> <td>Settings for BAM applicable countries</td> </tr> </tbody> </table> <p><b>Setting</b></p> <ol style="list-style-type: none"> <li>1. Press the start key.</li> <li>2. Select On or Off.</li> </ol> <table border="1" data-bbox="336 1693 1401 1839"> <thead> <tr> <th>Display</th> <th>Description</th> </tr> </thead> <tbody> <tr> <td>On</td> <td>Transition to sleep mode is deactivated from the system menu.</td> </tr> <tr> <td>Off</td> <td>Transition to sleep mode is activated from the system menu.</td> </tr> </tbody> </table> <p>Initial setting: On</p> <ol style="list-style-type: none"> <li>3. Press the start key. The setting is set.</li> </ol> <p><b>Completion</b> Press the stop key. The screen for selecting a maintenance item No. is displayed.</p>	Display	Description	BAM	Settings for BAM applicable countries	Display	Description	On	Transition to sleep mode is deactivated from the system menu.	Off	Transition to sleep mode is activated from the system menu.
Display	Description										
BAM	Settings for BAM applicable countries										
Display	Description										
On	Transition to sleep mode is deactivated from the system menu.										
Off	Transition to sleep mode is activated from the system menu.										




Item No.	Description																												
U402	<p data-bbox="288 241 751 275"><b>Adjusting margins of image printing</b></p> <p data-bbox="288 311 440 340"><b>Description</b></p> <p data-bbox="288 344 703 376">Adjusts margins for image printing.</p> <p data-bbox="288 380 400 409"><b>Purpose</b></p> <p data-bbox="288 414 826 445">Make the adjustment if margins are incorrect.</p> <p data-bbox="288 483 440 512"><b>Adjustment</b></p> <ol data-bbox="304 517 839 685" style="list-style-type: none"> <li>1. Press the start key.</li> <li>2. Press the system menu key.</li> <li>3. Press the start key to output a test pattern.</li> <li>4. Press the system menu key.</li> <li>5. Select the item to be adjusted.</li> </ol> <table border="1" data-bbox="336 701 1401 976"> <thead> <tr> <th>Display</th> <th>Description</th> <th>Setting range</th> <th>Initial setting</th> <th>Change in value per step</th> </tr> </thead> <tbody> <tr> <td>Lead</td> <td>Printer leading edge margin</td> <td>0.0 to 10.0</td> <td>4.0</td> <td>0.1 mm</td> </tr> <tr> <td>A Margin</td> <td>Printer left margin</td> <td>0.0 to 10.0</td> <td>3.0</td> <td>0.1 mm</td> </tr> <tr> <td>C Margin</td> <td>Printer right margin</td> <td>0.0 to 10.0</td> <td>3.0</td> <td>0.1 mm</td> </tr> <tr> <td>Trail</td> <td>Printer trailing edge margin</td> <td>0.0 to 10.0</td> <td>3.9</td> <td>0.1 mm</td> </tr> </tbody> </table> <ol data-bbox="304 987 1426 1055" style="list-style-type: none"> <li>6. Change the setting value using the +/- keys or numeric keys. Increasing the value makes the margin wider, and decreasing it makes the margin narrower.</li> </ol> <div data-bbox="528 1077 1190 1496" style="text-align: center;"> </div> <p data-bbox="775 1525 946 1554"><b>Figure 1-3-39</b></p> <ol data-bbox="304 1592 767 1624" style="list-style-type: none"> <li>7. Press the start key. The value is set.</li> </ol> <p data-bbox="288 1662 392 1691"><b>Caution</b></p> <p data-bbox="288 1695 1358 1762">If the above adjustment does not optimize the margins, perform the following maintenance modes.</p> <div data-bbox="520 1778 903 1872" style="text-align: center;"> <table border="1"> <tr> <td data-bbox="520 1778 676 1872">U034 (P.1-3-34)</td> <td data-bbox="676 1778 746 1872">→</td> <td data-bbox="746 1778 903 1872">U402</td> </tr> </table> </div> <p data-bbox="288 1921 440 1951"><b>Completion</b></p> <p data-bbox="288 1955 1254 1986">Press the stop key. The screen for selecting a maintenance item No. is displayed.</p>	Display	Description	Setting range	Initial setting	Change in value per step	Lead	Printer leading edge margin	0.0 to 10.0	4.0	0.1 mm	A Margin	Printer left margin	0.0 to 10.0	3.0	0.1 mm	C Margin	Printer right margin	0.0 to 10.0	3.0	0.1 mm	Trail	Printer trailing edge margin	0.0 to 10.0	3.9	0.1 mm	U034 (P.1-3-34)	→	U402
Display	Description	Setting range	Initial setting	Change in value per step																									
Lead	Printer leading edge margin	0.0 to 10.0	4.0	0.1 mm																									
A Margin	Printer left margin	0.0 to 10.0	3.0	0.1 mm																									
C Margin	Printer right margin	0.0 to 10.0	3.0	0.1 mm																									
Trail	Printer trailing edge margin	0.0 to 10.0	3.9	0.1 mm																									
U034 (P.1-3-34)	→	U402																											



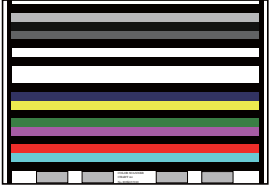
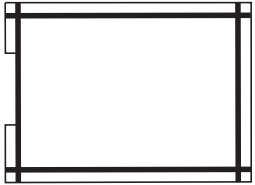

Item No.	Description																									
U403	<p data-bbox="290 241 1102 273"><b>Adjusting margins for scanning an original on the contact glass</b></p> <p data-bbox="290 311 440 338"><b>Description</b></p> <p data-bbox="290 344 1023 376">Adjusts margins for scanning the original on the contact glass.</p> <p data-bbox="290 383 400 409"><b>Purpose</b></p> <p data-bbox="290 416 826 448">Make the adjustment if margins are incorrect.</p> <p data-bbox="290 486 440 512"><b>Adjustment</b></p> <ol data-bbox="308 519 1054 685" style="list-style-type: none"> <li>1. Press the start key.</li> <li>2. Press the system menu key.</li> <li>3. Place an original and press the start key to make a test copy.</li> <li>4. Press the system menu key.</li> <li>5. Select the item to be adjusted.</li> </ol> <table border="1" data-bbox="336 701 1401 976"> <thead> <tr> <th>Display</th> <th>Description</th> <th>Setting range</th> <th>Initial setting</th> <th>Change in value per step</th> </tr> </thead> <tbody> <tr> <td>A Margin</td> <td>Scanner left margin</td> <td>0.0 to 10.0</td> <td>2.0</td> <td>0.5 mm</td> </tr> <tr> <td>B Margin</td> <td>Scanner leading edge margin</td> <td>0.0 to 10.0</td> <td>2.0</td> <td>0.5 mm</td> </tr> <tr> <td>C Margin</td> <td>Scanner right margin</td> <td>0.0 to 10.0</td> <td>2.0</td> <td>0.5 mm</td> </tr> <tr> <td>D Margin</td> <td>Scanner trailing edge margin</td> <td>0.0 to 10.0</td> <td>2.0</td> <td>0.5 mm</td> </tr> </tbody> </table> <ol data-bbox="308 987 1425 1055" style="list-style-type: none"> <li>6. Change the setting value using the +/- keys or numeric keys. Increasing the value makes the margin wider, and decreasing it makes the margin narrower.</li> </ol> <div data-bbox="528 1077 1190 1496" style="text-align: center;"> <p data-bbox="708 1077 1134 1137">Leading edge margin of the copy image (4.0 +1.5/-1.0 mm)</p> <p data-bbox="528 1234 730 1317">Left margin of the copy image (2.5 +1.5/-2.0 mm)</p> <p data-bbox="991 1234 1190 1317">Right margin of the copy image (2.5 +1.5/-2.0 mm)</p> <p data-bbox="708 1442 1126 1496">Trailing edge margin of the copy image (4.0 mm or less)</p> </div> <p data-bbox="775 1525 946 1556"><b>Figure 1-3-40</b></p> <ol data-bbox="308 1592 767 1624" style="list-style-type: none"> <li>7. Press the start key. The value is set.</li> </ol> <p data-bbox="290 1662 392 1688"><b>Caution</b></p> <p data-bbox="290 1695 1358 1762">If the above adjustment does not optimize the margins, perform the following maintenance modes.</p> <div data-bbox="520 1783 1131 1877" style="text-align: center;"> <pre> graph LR     U034["U034 (P.1-3-34)"] --&gt; U402["U402 (P.1-3-142)"]     U402 --&gt; U403["U403"]           </pre> </div> <p data-bbox="290 1924 440 1951"><b>Completion</b></p> <p data-bbox="290 1957 1246 1989">Press the stop key. The indication for selecting a maintenance item No. appears.</p>	Display	Description	Setting range	Initial setting	Change in value per step	A Margin	Scanner left margin	0.0 to 10.0	2.0	0.5 mm	B Margin	Scanner leading edge margin	0.0 to 10.0	2.0	0.5 mm	C Margin	Scanner right margin	0.0 to 10.0	2.0	0.5 mm	D Margin	Scanner trailing edge margin	0.0 to 10.0	2.0	0.5 mm
Display	Description	Setting range	Initial setting	Change in value per step																						
A Margin	Scanner left margin	0.0 to 10.0	2.0	0.5 mm																						
B Margin	Scanner leading edge margin	0.0 to 10.0	2.0	0.5 mm																						
C Margin	Scanner right margin	0.0 to 10.0	2.0	0.5 mm																						
D Margin	Scanner trailing edge margin	0.0 to 10.0	2.0	0.5 mm																						

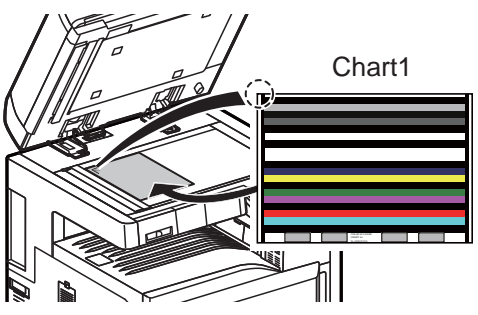
Item No.	Description																																													
U404	<p data-bbox="288 241 997 275"><b>Adjusting margins for scanning an original from the DP</b></p> <p data-bbox="288 311 440 340"><b>Description</b></p> <p data-bbox="288 344 927 376">Adjusts margins for scanning the original from the DP.</p> <p data-bbox="288 380 400 409"><b>Purpose</b></p> <p data-bbox="288 414 826 445">Make the adjustment if margins are incorrect.</p> <p data-bbox="288 483 440 512"><b>Adjustment</b></p> <ol data-bbox="304 517 1182 685" style="list-style-type: none"> <li>1. Press the start key.</li> <li>2. Press the system menu key.</li> <li>3. Place an original on the DP and press the start key to make a test copy.</li> <li>4. Press the system menu key.</li> <li>5. Select the item to be adjusted.</li> </ol> <table border="1" data-bbox="336 698 1401 1305"> <thead> <tr> <th>Display</th> <th>Description</th> <th>Setting range</th> <th>Initial setting</th> <th>Change in value per step</th> </tr> </thead> <tbody> <tr> <td>A Margin</td> <td>DP left margin</td> <td>0.0 to 10.0</td> <td>3.0</td> <td>0.5 mm</td> </tr> <tr> <td>B Margin</td> <td>DP leading edge margin</td> <td>0.0 to 10.0</td> <td>2.5</td> <td>0.5 mm</td> </tr> <tr> <td>C Margin</td> <td>DP right margin</td> <td>0.0 to 10.0</td> <td>3.0</td> <td>0.5 mm</td> </tr> <tr> <td>D Margin</td> <td>DP trailing edge margin</td> <td>0.0 to 10.0</td> <td>4.0</td> <td>0.5 mm</td> </tr> <tr> <td>A Margin (Back)*</td> <td>DP left margin (second side)</td> <td>0.0 to 10.0</td> <td>3.0</td> <td>0.5 mm</td> </tr> <tr> <td>B Margin (Back)*</td> <td>DP leading edge margin (second side)</td> <td>0.0 to 10.0</td> <td>2.5</td> <td>0.5 mm</td> </tr> <tr> <td>C Margin (Back)*</td> <td>DP right margin (second side)</td> <td>0.0 to 10.0</td> <td>3.0</td> <td>0.5 mm</td> </tr> <tr> <td>D Margin (Back)*</td> <td>DP trailing edge margin (second side)</td> <td>0.0 to 10.0</td> <td>4.0</td> <td>0.5 mm</td> </tr> </tbody> </table> <p data-bbox="336 1312 596 1344">* : Dual scan DP only</p> <ol data-bbox="304 1382 1426 1449" style="list-style-type: none"> <li>6. Change the setting value using the cursor left/right keys or numeric keys. Increasing the value makes the margin wider, and decreasing it makes the margin narrower.</li> </ol> <div data-bbox="564 1471 1230 1892" style="text-align: center;"> <p data-bbox="783 1471 1043 1532">DP leading edge margin (4.0 +1.5/-1.0 mm)</p> <p data-bbox="564 1626 767 1686">DP left margin (2.5 +1.5/-2.0 mm)</p> <p data-bbox="1023 1626 1230 1686">DP right margin (2.5 +1.5/-2.0 mm)</p> <p data-bbox="783 1834 1038 1895">DP trailing edge margin (4.0 mm or less)</p> </div> <p data-bbox="775 1915 943 1946"><b>Figure 1-3-41</b></p> <ol data-bbox="304 1984 767 2016" style="list-style-type: none"> <li>7. Press the start key. The value is set.</li> </ol>	Display	Description	Setting range	Initial setting	Change in value per step	A Margin	DP left margin	0.0 to 10.0	3.0	0.5 mm	B Margin	DP leading edge margin	0.0 to 10.0	2.5	0.5 mm	C Margin	DP right margin	0.0 to 10.0	3.0	0.5 mm	D Margin	DP trailing edge margin	0.0 to 10.0	4.0	0.5 mm	A Margin (Back)*	DP left margin (second side)	0.0 to 10.0	3.0	0.5 mm	B Margin (Back)*	DP leading edge margin (second side)	0.0 to 10.0	2.5	0.5 mm	C Margin (Back)*	DP right margin (second side)	0.0 to 10.0	3.0	0.5 mm	D Margin (Back)*	DP trailing edge margin (second side)	0.0 to 10.0	4.0	0.5 mm
Display	Description	Setting range	Initial setting	Change in value per step																																										
A Margin	DP left margin	0.0 to 10.0	3.0	0.5 mm																																										
B Margin	DP leading edge margin	0.0 to 10.0	2.5	0.5 mm																																										
C Margin	DP right margin	0.0 to 10.0	3.0	0.5 mm																																										
D Margin	DP trailing edge margin	0.0 to 10.0	4.0	0.5 mm																																										
A Margin (Back)*	DP left margin (second side)	0.0 to 10.0	3.0	0.5 mm																																										
B Margin (Back)*	DP leading edge margin (second side)	0.0 to 10.0	2.5	0.5 mm																																										
C Margin (Back)*	DP right margin (second side)	0.0 to 10.0	3.0	0.5 mm																																										
D Margin (Back)*	DP trailing edge margin (second side)	0.0 to 10.0	4.0	0.5 mm																																										

Item No.	Description
U404	<p data-bbox="288 241 392 271"><b>Caution</b></p> <p data-bbox="288 277 1358 342">If the above adjustment does not optimize the margins, perform the following maintenance modes.</p> <div data-bbox="520 360 1358 454"><pre data-bbox="520 360 1358 454">graph LR; A["U034 (P.1-3-34)"] --&gt; B["U402 (P.1-3-142)"]; B --&gt; C["U403 (P.1-3-143)"]; C --&gt; D["U404"]</pre></div> <p data-bbox="288 506 440 535"><b>Completion</b></p> <p data-bbox="288 542 1254 571">Press the stop key. The screen for selecting a maintenance item No. is displayed.</p>

Item No.	Description										
U407	<p data-bbox="290 241 1136 273"><b>Adjusting the leading edge registration for memory image printing</b></p> <p data-bbox="290 311 440 338"><b>Description</b></p> <p data-bbox="290 344 1018 376">Adjusts the leading edge registration during memory copying.</p> <p data-bbox="290 383 400 409"><b>Purpose</b></p> <p data-bbox="290 416 1398 479">Make the following adjustment if there is a regular error between the leading edge of the copy image on the front face and that on the reverse face during duplex switchback copying.</p> <p data-bbox="290 517 392 544"><b>Caution</b></p> <p data-bbox="290 551 1433 613">Before making this adjustment, ensure that the following adjustments have been made in maintenance mode</p> <div data-bbox="290 636 1433 842" style="border: 1px solid black; padding: 5px; margin: 10px 0;"> <pre> graph LR     U034["U034 (P.1-3-34)"] --&gt; U402["U402 (P.1-3-142)"]     U402 --&gt; U066["U066 (P.1-3-49)"]     U066 --&gt; U403["U403 (P.1-3-143)"]     U403 --&gt; U071["U071 (P.1-3-54)"]     U071 --&gt; Arrow1[ ]     U404["U404 (P.1-3-144)"] --&gt; U407["U407"]     style Arrow1 width:0px,height:0px </pre> </div> <p data-bbox="290 893 440 920"><b>Adjustment</b></p> <ol data-bbox="304 927 1058 1061" style="list-style-type: none"> <li>1. Press the start key.</li> <li>2. Press the system menu key.</li> <li>3. Place an original and press the start key to make a test copy.</li> <li>4. Press the system menu key.</li> </ol> <table border="1" data-bbox="336 1077 1401 1240" style="width: 100%; border-collapse: collapse; text-align: center;"> <thead> <tr> <th>Display</th> <th>Description</th> <th>Setting range</th> <th>Initial setting</th> <th>Change in value per step</th> </tr> </thead> <tbody> <tr> <td>Adj Data</td> <td>Leading edge registration for memory image printing</td> <td>-47 to 47</td> <td>0</td> <td>0.1 mm</td> </tr> </tbody> </table> <ol data-bbox="304 1256 1302 1319" style="list-style-type: none"> <li>5. Change the setting value using the +/- keys or numeric keys. For copy example 1, decrease the value. For copy example 2, increase the value.</li> </ol> <div data-bbox="655 1346 1066 1585" style="text-align: center; margin: 10px 0;"> <div style="display: flex; justify-content: space-around; width: 100%;"> <div style="text-align: center;">  Original         </div> <div style="text-align: center;">  Copy example 1         </div> <div style="text-align: center;">  Copy example 2         </div> </div> </div> <p data-bbox="775 1615 946 1641" style="text-align: center;"><b>Figure 1-3-42</b></p> <ol data-bbox="304 1682 767 1713" style="list-style-type: none"> <li>6. Press the start key. The value is set.</li> </ol> <p data-bbox="290 1751 440 1778"><b>Completion</b></p> <p data-bbox="290 1785 1254 1816">Press the stop key. The screen for selecting a maintenance item No. is displayed.</p>	Display	Description	Setting range	Initial setting	Change in value per step	Adj Data	Leading edge registration for memory image printing	-47 to 47	0	0.1 mm
Display	Description	Setting range	Initial setting	Change in value per step							
Adj Data	Leading edge registration for memory image printing	-47 to 47	0	0.1 mm							

Item No.	Description																																								
U410	<p data-bbox="288 241 753 275"><b>Adjusting the halftone automatically</b></p> <p data-bbox="288 311 440 340"><b>Description</b></p> <p data-bbox="288 344 1390 409">Carries out processing for the data acquisition that is required in order to perform either automatic adjustment of the halftone or the ID correction operation.</p> <p data-bbox="288 414 400 443"><b>Purpose</b></p> <p data-bbox="288 448 1069 479">Performed when the quality of reproduced halftones has dropped.</p> <p data-bbox="288 515 387 544"><b>Method</b></p> <ol data-bbox="304 551 1292 999" style="list-style-type: none"> <li>1. Press the start key.</li> <li>2. Select [Normal Mode].</li> <li>3. Press the start key. A test patterns 1 and 2 are outputted.</li> <li>4. Place the output test pattern 1 as the original. Place approximately 20 sheets of white paper on the test pattern 1 and set them.</li> <li>5. Press the start key. Adjustment is made (first time).</li> <li>6. Place the output test pattern 2 as the original. Place approximately 20 sheets of white paper on the test pattern 2 and set them.</li> <li>7. Press the start key. Adjustment is made (second time).</li> <li>8. When normally completed, [Finish] is displayed. If a problem occurs during auto adjustment, error code is displayed.</li> </ol> <p data-bbox="336 1037 488 1066"><b>Error codes</b></p> <table border="1" data-bbox="336 1081 1399 1514"> <thead> <tr> <th data-bbox="336 1081 488 1126">Codes</th> <th data-bbox="488 1081 869 1126">Description</th> <th data-bbox="869 1081 1019 1126">Codes</th> <th data-bbox="1019 1081 1399 1126">Description</th> </tr> </thead> <tbody> <tr> <td data-bbox="336 1126 488 1171">S001</td> <td data-bbox="488 1126 869 1171">Patch not detected</td> <td data-bbox="869 1126 1019 1171">E001</td> <td data-bbox="1019 1126 1399 1171">Engine status error</td> </tr> <tr> <td data-bbox="336 1171 488 1261">S002</td> <td data-bbox="488 1171 869 1261">Original deviation in the main scanning direction</td> <td data-bbox="869 1171 1019 1216">E002</td> <td data-bbox="1019 1171 1399 1216">Engine sensor error</td> </tr> <tr> <td data-bbox="336 1261 488 1350">S003</td> <td data-bbox="488 1261 869 1350">Original deviation in the auxiliary scanning direction</td> <td data-bbox="869 1216 1019 1261">EFFF</td> <td data-bbox="1019 1216 1399 1261">Engine other error</td> </tr> <tr> <td data-bbox="336 1350 488 1373">S004</td> <td data-bbox="488 1350 869 1373">Original inclination error</td> <td data-bbox="869 1261 1019 1305">C001</td> <td data-bbox="1019 1261 1399 1305">Controller error</td> </tr> <tr> <td data-bbox="336 1373 488 1395">S005</td> <td data-bbox="488 1373 869 1395">Original type error</td> <td data-bbox="869 1305 1019 1350">C100</td> <td data-bbox="1019 1305 1399 1350">Adjustment value error</td> </tr> <tr> <td data-bbox="336 1395 488 1417">SFFF</td> <td data-bbox="488 1395 869 1417">Scanner other error</td> <td data-bbox="869 1350 1019 1395">C200</td> <td data-bbox="1019 1350 1399 1395">Adjustment value error</td> </tr> <tr> <td data-bbox="336 1417 488 1440">SFFF</td> <td data-bbox="488 1417 869 1440">Scanner other error</td> <td data-bbox="869 1395 1019 1440">CFFF</td> <td data-bbox="1019 1395 1399 1440">Controller other error</td> </tr> <tr> <td data-bbox="336 1440 488 1462">SFFF</td> <td data-bbox="488 1440 869 1462">Scanner other error</td> <td data-bbox="869 1440 1019 1462">CFFF</td> <td data-bbox="1019 1440 1399 1462">Controller other error</td> </tr> <tr> <td data-bbox="336 1462 488 1485">SFFF</td> <td data-bbox="488 1462 869 1485">Scanner other error</td> <td data-bbox="869 1462 1019 1485">CFFF</td> <td data-bbox="1019 1462 1399 1485">Controller other error</td> </tr> </tbody> </table> <p data-bbox="288 1559 440 1588"><b>Completion</b></p> <p data-bbox="288 1592 1254 1624">Press the stop key. The screen for selecting a maintenance item No. is displayed.</p>	Codes	Description	Codes	Description	S001	Patch not detected	E001	Engine status error	S002	Original deviation in the main scanning direction	E002	Engine sensor error	S003	Original deviation in the auxiliary scanning direction	EFFF	Engine other error	S004	Original inclination error	C001	Controller error	S005	Original type error	C100	Adjustment value error	SFFF	Scanner other error	C200	Adjustment value error	SFFF	Scanner other error	CFFF	Controller other error	SFFF	Scanner other error	CFFF	Controller other error	SFFF	Scanner other error	CFFF	Controller other error
Codes	Description	Codes	Description																																						
S001	Patch not detected	E001	Engine status error																																						
S002	Original deviation in the main scanning direction	E002	Engine sensor error																																						
S003	Original deviation in the auxiliary scanning direction	EFFF	Engine other error																																						
S004	Original inclination error	C001	Controller error																																						
S005	Original type error	C100	Adjustment value error																																						
SFFF	Scanner other error	C200	Adjustment value error																																						
SFFF	Scanner other error	CFFF	Controller other error																																						
SFFF	Scanner other error	CFFF	Controller other error																																						
SFFF	Scanner other error	CFFF	Controller other error																																						

Item No.	Description				
U411	<b>Adjusting the scanner automatically</b>				
	<b>Description</b>				
	Uses a specified original and automatically adjusts the following items in the scanner and the DP scanning sections.				
	<b>Purpose</b>				
	To perform automatic adjustment of various items in the scanner and the DP scanning sections. Perform adjustments using a new test chart (chart 1) when replacing ISC PWB, LED lamp PWB, ISU, CIS and/or DP main PWB.				
	* : To automatically adjust the DP, to avoid damaging original documents, using a Chart 2-2 test chart is recommended.Method				
	<b>Method</b>				
	1. Press the start key. 2. Select the item.				
	<b>Display</b>		<b>Description</b>	<b>Original to be used for adjustment</b>	
	<b>P/N</b>		<b>Chart image</b>		
Table (Chart1)	Adjusting the scanner color and centering and timing for the leading edge	7505000005	Chart 1		
DP FaceUp (Chart1)	Adjusting color, centering, and timing for the leading edge of the reading unit (fore side) of the DP				
DP FaceDown (Chart1)	Adjusting color and retrieval of the target data of the reading unit (back side) of the DP (CIS)				
Table (Chart2)	Adjusting the scanner color and centering and timing for the leading edge	302FZ56990	Chart 2-1		
DP FaceUp (Chart2)	Adjusting the scanner centering and timing for the leading edge	302AC68243	Chart 2-2		
DP FaceDown (Chart2)	Adjusting retrieval of the target data of the reading unit (back side) of the DP (CIS)				
	Adjusting color and retrieval of the target data of the reading unit (back side) of the DP (CIS)	303JX57010	GAMMMA		
		303JX57020	MATRIX		
					

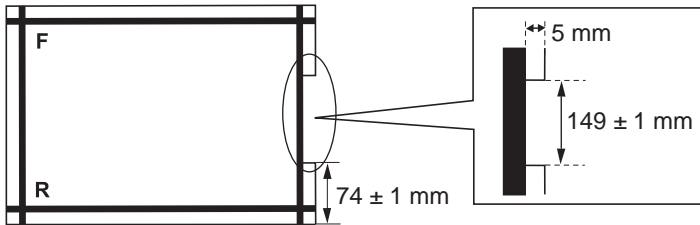
Item No.	Description		
U411			
	<b>Display</b>	<b>Description</b>	<b>Note</b>
	Target	Set-up for obtaining the target value	Select Auto to automatically read and enter the target values using the Chart 1 test chart Initial setting: U425
DP Auto Adj	Automatic adjustment of auto-matic document processor using the chart printed from the machine	Execute this mode when the Chart 2-2 (302AC68243) is not available	
<b>Method: [Table (Chart1)]</b>			
<b>To perform table adjustment using Chart1.</b>			
To automatically enter the target value			
* : Select this option for normal use.			
<ol style="list-style-type: none"> <li>1. Set a Chart1 original (P/N: 7505000005) on the platen.</li> <li>2. Enter maintenance item U411.</li> <li>3. Select [Target].</li> <li>4. Select [Auto] and press the start key.</li> <li>5. Select [Table (Chart1)].</li> <li>6. Select the item.</li> </ol> <p>* : Select All for normal use.</p>			
			
<b>Figure 1-3-43</b>			
<b>Display</b>		<b>Description</b>	
All	Executing the all scanner adjustment		
LED/AGC	Executing the adjustment for LED light quantity/AGC		
White	Executing the white reference compensation coefficient		
Input	Executing the adjustment for magnification, leading edge timing and center line		
C.A.	Executing the adjustment for chromatic aberration filter		
MTF	Executing the adjustment for MTF filter		
Gamma	Executing the adjustment for input gamma		
Matrix	Executing the adjustment for matrix		

Item No.	Description				
<p><b>U411</b></p>	<p>7. Press the start key. Auto adjustment starts.</p> <p>* : When automatic adjustment has normally completed, [OK] is displayed. If a problem occurs during auto adjustment, error code is displayed and operation stops. Should this happen, determine the details of the problem and repeat the procedure from the beginning ( P.1-3-155).</p> <p>* : If the target values are not obtainable automatically, manually enter the following target values in the following manner and perform adjustment.</p> <ol style="list-style-type: none"> <li>1. Enter the target values which are shown at the bottom of the chart1 original (P/N: 7505000005) executing maintenance item U425.</li> <li>2. Set a chart1 original on the platen.</li> <li>3. Enter maintenance item U411.</li> <li>4. Select [Target].</li> <li>5. Select [U425] and press the start key.</li> <li>6. Select [Table (Chart1)].</li> <li>7. Select the item.</li> </ol> <p>* : Select All for normal use.</p> <p>8. Press the start key. Auto adjustment starts.</p> <p><b>Method: [DP FaceUp (Chart1)]</b>  <b>To perform adjustment on the first side of the DP using Chart 1.</b>  To automatically enter the target value.</p> <ol style="list-style-type: none"> <li>1. Set a chart1 original (P/N: 7505000005) on the DP face up.</li> <li>2. Enter maintenance item U411.</li> <li>3. Select [Target].</li> <li>4. Select [Auto] and press the start key.</li> <li>5. Select [DP FaceUp (Chart1)].</li> <li>6. Select [Input].</li> </ol> <table border="1" data-bbox="336 1368 1401 1464"> <thead> <tr> <th data-bbox="336 1368 639 1413">Display</th> <th data-bbox="639 1368 1401 1413">Description</th> </tr> </thead> <tbody> <tr> <td data-bbox="336 1413 639 1464">Input</td> <td data-bbox="639 1413 1401 1464">Executing the adjustment for input gamma and matrix</td> </tr> </tbody> </table> <p>7. Press the start key. Auto adjustment starts.</p> <p>* : When automatic adjustment has normally completed, [OK] is displayed. If a problem occurs during auto adjustment, error code is displayed and operation stops. Should this happen, determine the details of the problem and repeat the procedure from the beginning ( P.1-3-155).</p>	Display	Description	Input	Executing the adjustment for input gamma and matrix
Display	Description				
Input	Executing the adjustment for input gamma and matrix				



Item No.	Description				
U411	<p>* : If the target values are not obtainable automatically, manually enter the following target values in the following manner and perform adjustment.</p> <ol style="list-style-type: none"> <li>1. Enter the target values which are shown at the bottom of the chart1original (P/N: 7505000005) executing maintenance item U425.</li> <li>2. Set a specified original on the DP face up.</li> <li>3. Enter maintenance item U411.</li> <li>4. Select [Target].</li> <li>5. Select [U425] and press the start key.</li> <li>6. Select [DP FaceUp (Chart1)].</li> <li>7. Select [Input].</li> <li>8. Press the start key. Auto adjustment starts.</li> </ol> <p><b>Method: [DP FaceDown (Chart1)]</b>  <b>To perform adjustment on the second side of the DP using Chart 1.</b>  To automatically enter the target value</p> <ol style="list-style-type: none"> <li>1. Set a specified original (P/N: 7505000005) on the DP face down.</li> <li>2. Enter maintenance item U411.</li> <li>3. Select [Target].</li> <li>4. Select [Auto] and press the start key.</li> <li>5. Select [DP FaceDown (Chart1)].</li> <li>6. Select [All].</li> </ol> <table border="1" data-bbox="336 1093 1401 1256"> <thead> <tr> <th data-bbox="336 1093 641 1137">Display</th> <th data-bbox="641 1093 1401 1137">Description</th> </tr> </thead> <tbody> <tr> <td data-bbox="336 1137 641 1256">All</td> <td data-bbox="641 1137 1401 1256">Executing the adjustment in the DP scanning section (second side) for magnification, leading edge timing, center line, MTF filter, input gamma and matrix</td> </tr> </tbody> </table> <ol style="list-style-type: none"> <li>7. Press the start key. Auto adjustment starts.</li> </ol> <p>* : When automatic adjustment has normally completed, [OK] is displayed. If a problem occurs during auto adjustment, error code is displayed and operation stops. Should this happen, determine the details of the problem and repeat the procedure from the beginning ( P.1-3-155).</p> <p>* : If the target values are not obtainable automatically, manually enter the following target values in the following manner and perform adjustment.</p> <ol style="list-style-type: none"> <li>1. Enter the target values which are shown at the bottom of the specified original (P/N: 7505000005) executing maintenance item U425.</li> <li>2. Set a specified original on the DP face down.</li> <li>3. Enter maintenance item U411.</li> <li>4. Select [Target].</li> <li>5. Select [U425] and press the start key.</li> <li>6. Select [DP FaceDown (Chart1)].</li> <li>7. Select [All].</li> <li>8. Press the start key. Auto adjustment starts.</li> </ol>	Display	Description	All	Executing the adjustment in the DP scanning section (second side) for magnification, leading edge timing, center line, MTF filter, input gamma and matrix
Display	Description				
All	Executing the adjustment in the DP scanning section (second side) for magnification, leading edge timing, center line, MTF filter, input gamma and matrix				

Item No.	Description														
U411	<p><b>Method: [Table (Chart2)]</b></p> <ol style="list-style-type: none"> <li>1. Enter the target values which are shown on the back of the Chart 2-1 original (P/N: 302FZ56990) executing maintenance item U425.</li> <li>2. Set a Chart 2-1 original on the platen.</li> <li>3. Enter maintenance item U411.</li> <li>4. Select [Target].</li> <li>5. Select [U425] and press the start key.</li> <li>6. Select [Table (Chart2)].</li> <li>7. Select the item.</li> </ol> <div data-bbox="938 322 1412 613" style="text-align: right;"> <p>Chart2-1</p> </div> <p style="text-align: center;"><b>Figure 1-3-44</b></p> <table border="1" data-bbox="336 734 1401 1106" style="width: 100%; border-collapse: collapse;"> <thead> <tr> <th style="width: 30%;">Display</th> <th>Description</th> </tr> </thead> <tbody> <tr> <td>All</td> <td>Executing the all scanner adjustment</td> </tr> <tr> <td>Input</td> <td>Executing the adjustment for magnification, leading edge timing and center line</td> </tr> <tr> <td>C.A.</td> <td>Executing the adjustment for chromatic aberration filter</td> </tr> <tr> <td>MTF</td> <td>Executing the adjustment for MTF filter</td> </tr> <tr> <td>Gamma</td> <td>Executing the adjustment for input gamma</td> </tr> <tr> <td>Matrix</td> <td>Executing the adjustment for matrix</td> </tr> </tbody> </table> <ol style="list-style-type: none"> <li>8. Press the start key. Auto adjustment starts. <ul style="list-style-type: none"> <li>* : When automatic adjustment has normally completed, [OK] is displayed. If a problem occurs during auto adjustment, error code is displayed and operation stops. Should this happen, determine the details of the problem and repeat the procedure from the beginning ( P.1-3-155).</li> </ul> </li> </ol>	Display	Description	All	Executing the all scanner adjustment	Input	Executing the adjustment for magnification, leading edge timing and center line	C.A.	Executing the adjustment for chromatic aberration filter	MTF	Executing the adjustment for MTF filter	Gamma	Executing the adjustment for input gamma	Matrix	Executing the adjustment for matrix
Display	Description														
All	Executing the all scanner adjustment														
Input	Executing the adjustment for magnification, leading edge timing and center line														
C.A.	Executing the adjustment for chromatic aberration filter														
MTF	Executing the adjustment for MTF filter														
Gamma	Executing the adjustment for input gamma														
Matrix	Executing the adjustment for matrix														

Item No.	Description				
U411	<p><b>Method: [DP FaceUp (Chart2)]</b></p> <p>1. Set a specified original (P/N: 302AC68243) on the DP. Cut the trailing edge of the original.</p>  <p style="text-align: center;"><b>Figure 1-3-45</b></p> <p>2. Enter maintenance item U411. 3. Select [Target]. 4. Select [U425] and press the start key. 5. Select [DP FaceUp (Chart2)]. 6. Select [INPUT].</p> <table border="1" data-bbox="336 869 1401 1003"> <thead> <tr> <th data-bbox="336 869 639 913">Display</th> <th data-bbox="639 869 1401 913">Description</th> </tr> </thead> <tbody> <tr> <td data-bbox="336 913 639 1003">Input</td> <td data-bbox="639 913 1401 1003">Executing the adjustment in the DP scanning section (first side) for magnification, leading edge timing and center line</td> </tr> </tbody> </table> <p>7. Press the start key. Auto adjustment starts. * : When automatic adjustment has normally completed, [OK] is displayed. If a problem occurs during auto adjustment, error code is displayed and operation stops. Should this happen, determine the details of the problem and repeat the procedure from the beginning ( P.1-3-155).</p> <p><b>Method: [DP FaceDown (Chart2)]</b></p> <p>1. Place the specified original for acquiring gamma target data (P/N: 303JX57010) on the platen, and press the start key. 2. Place the specified original for acquiring matrix target data (P/N: 303JX57020) on the platen, and press the start key. When normally completed, [OK] is displayed. 3. Select the item.</p>	Display	Description	Input	Executing the adjustment in the DP scanning section (first side) for magnification, leading edge timing and center line
Display	Description				
Input	Executing the adjustment in the DP scanning section (first side) for magnification, leading edge timing and center line				

Item No.	Description		
U411			
	All	Executing the adjustment in the DP scanning section (second side) for magnification, leading edge timing, center line, MTF filter, input gamma and matrix	302AC68243/ 303JX57010/ 303JX57020
	Input	Executing the adjustment in the DP scanning section (second side) for magnification, leading edge timing and center line	302AC68243
	MTF/Gamma	Executing the adjustment in the DP scanning section (second side) for MTF filter and input gamma	303JX57010
	Matrix	Executing the adjustment in the DP scanning section (second side) for matrix	303JX57020
<p><b>[Input]</b></p> <ol style="list-style-type: none"> <li>1. Select [Input].</li> <li>2. Set a Chart 2-2 original (P/N: 302AC6824) on the DP face down.</li> <li>3. Press the start key. Auto adjustment starts.</li> </ol>			
<p><b>[MTF/Gamma]</b></p> <ol style="list-style-type: none"> <li>1. Select [MTF/Gamma].</li> <li>2. Set a Gamma original (P/N: 303JX57010) on the DP face down.</li> <li>3. Press the start key. Auto adjustment starts.</li> </ol>			
<p><b>[Matrix]</b></p> <ol style="list-style-type: none"> <li>1. Select [Matrix].</li> <li>2. Set a Matrix original (P/N: 303JX57020) on the DP face down.</li> <li>3. Press the start key. Auto adjustment starts.</li> </ol>			
<p>When [ALL] is selected, the adjustment of [Input], [MTF/Gamma] and [Matrix] can be executed at once. When adjusting, place the three specified originals on the DP face down, and then press the start key.</p>			
<p>Set the original 303JX57020, and then place 303JX57010 and 302AC68243 in order on the top of the original.</p>			
<p>* : When automatic adjustment has normally completed, [OK] is displayed. If a problem occurs during auto adjustment, error code is displayed and operation stops. Should this happen, determine the details of the problem and repeat the procedure from the beginning ( P.1-3-155).</p>			

Item No.	Description																																												
U411	<p data-bbox="288 241 576 275"><b>Method: [DP Auto Adj]</b></p> <ol data-bbox="288 277 1102 584" style="list-style-type: none"> <li>1. Load A4/ letter paper.</li> <li>2. Press the start key to output the original for adjustment.</li> <li>3. Set the output the original for adjustment and press the start key.</li> <li>4. Set the output the original for adjustment on the DP face up.</li> <li>5. Press the start key to scan documents.</li> <li>6. Press the start key. Auto adjustment of first side starts.</li> <li>7. Set the output the original for adjustment on the DP face down.</li> <li>8. Press the start key to scan documents.</li> <li>9. Press the start key. Auto adjustment of second side starts.</li> </ol> <p data-bbox="336 586 1406 723">* : When automatic adjustment has normally completed, [OK] is displayed. If a problem occurs during auto adjustment, error code is displayed and operation stops. Should this happen, determine the details of the problem and repeat the procedure from the beginning.</p> <p data-bbox="336 763 491 790"><b>Error Codes</b></p> <table border="1" data-bbox="336 801 1399 1964"> <thead> <tr> <th data-bbox="336 801 451 846">Codes</th> <th data-bbox="451 801 1399 846">Description</th> </tr> </thead> <tbody> <tr> <td data-bbox="336 846 451 936">01</td> <td data-bbox="451 846 1399 936">Black band detection error (scanner auxiliary scanning direction leading edge skew )</td> </tr> <tr> <td data-bbox="336 936 451 981">02</td> <td data-bbox="451 936 1399 981">Black band detection error (scanner main scanning direction far end skew)</td> </tr> <tr> <td data-bbox="336 981 451 1025">03</td> <td data-bbox="451 981 1399 1025">Black band detection error (scanner main scanning direction near end skew)</td> </tr> <tr> <td data-bbox="336 1025 451 1115">03</td> <td data-bbox="451 1025 1399 1115">Black band detection error (scanner auxiliary scanning direction trailing edge skew)</td> </tr> <tr> <td data-bbox="336 1115 451 1160">04</td> <td data-bbox="451 1115 1399 1160">Black band is not detected (scanner auxiliary scanning direction leading edge)</td> </tr> <tr> <td data-bbox="336 1160 451 1205">05</td> <td data-bbox="451 1160 1399 1205">Black band is not detected (scanner main scanning direction far end)</td> </tr> <tr> <td data-bbox="336 1205 451 1249">06</td> <td data-bbox="451 1205 1399 1249">Black band is not detected (scanner main scanning direction near end)</td> </tr> <tr> <td data-bbox="336 1249 451 1294">07</td> <td data-bbox="451 1249 1399 1294">Black band is not detected (scanner auxiliary scanning direction trailing edge)</td> </tr> <tr> <td data-bbox="336 1294 451 1339">08</td> <td data-bbox="451 1294 1399 1339">Black band is not detected (DP main scanning direction far end)</td> </tr> <tr> <td data-bbox="336 1339 451 1384">09</td> <td data-bbox="451 1339 1399 1384">Black band is not detected (DP main scanning direction near end)</td> </tr> <tr> <td data-bbox="336 1384 451 1429">0a</td> <td data-bbox="451 1384 1399 1429">Black band is not detected (DP auxiliary scanning direction leading edge)</td> </tr> <tr> <td data-bbox="336 1429 451 1518">0b</td> <td data-bbox="451 1429 1399 1518">Black band is not detected (DP auxiliary scanning direction leading edge original check)</td> </tr> <tr> <td data-bbox="336 1518 451 1563">0c</td> <td data-bbox="451 1518 1399 1563">Black band is not detected (DP auxiliary scanning direction trailing edge)</td> </tr> <tr> <td data-bbox="336 1563 451 1608">0d</td> <td data-bbox="451 1563 1399 1608">White band is not detected (DP auxiliary scanning direction trailing edge)</td> </tr> <tr> <td data-bbox="336 1608 451 1653">0e</td> <td data-bbox="451 1608 1399 1653">DMA time out</td> </tr> <tr> <td data-bbox="336 1653 451 1697">0f</td> <td data-bbox="451 1653 1399 1697">Auxiliary scanning direction magnification error</td> </tr> <tr> <td data-bbox="336 1697 451 1742">10</td> <td data-bbox="451 1697 1399 1742">Auxiliary scanning direction leading edge error</td> </tr> <tr> <td data-bbox="336 1742 451 1787">11</td> <td data-bbox="451 1742 1399 1787">Auxiliary scanning direction trailing edge error</td> </tr> <tr> <td data-bbox="336 1787 451 1832">12</td> <td data-bbox="451 1787 1399 1832">DP uxiliary scanning direction skew error</td> </tr> <tr> <td data-bbox="336 1832 451 1877">13</td> <td data-bbox="451 1832 1399 1877">Maintenance request error</td> </tr> <tr> <td data-bbox="336 1877 451 1966">14</td> <td data-bbox="451 1877 1399 1966">Main scanning direction center line error</td> </tr> </tbody> </table>	Codes	Description	01	Black band detection error (scanner auxiliary scanning direction leading edge skew )	02	Black band detection error (scanner main scanning direction far end skew)	03	Black band detection error (scanner main scanning direction near end skew)	03	Black band detection error (scanner auxiliary scanning direction trailing edge skew)	04	Black band is not detected (scanner auxiliary scanning direction leading edge)	05	Black band is not detected (scanner main scanning direction far end)	06	Black band is not detected (scanner main scanning direction near end)	07	Black band is not detected (scanner auxiliary scanning direction trailing edge)	08	Black band is not detected (DP main scanning direction far end)	09	Black band is not detected (DP main scanning direction near end)	0a	Black band is not detected (DP auxiliary scanning direction leading edge)	0b	Black band is not detected (DP auxiliary scanning direction leading edge original check)	0c	Black band is not detected (DP auxiliary scanning direction trailing edge)	0d	White band is not detected (DP auxiliary scanning direction trailing edge)	0e	DMA time out	0f	Auxiliary scanning direction magnification error	10	Auxiliary scanning direction leading edge error	11	Auxiliary scanning direction trailing edge error	12	DP uxiliary scanning direction skew error	13	Maintenance request error	14	Main scanning direction center line error
Codes	Description																																												
01	Black band detection error (scanner auxiliary scanning direction leading edge skew )																																												
02	Black band detection error (scanner main scanning direction far end skew)																																												
03	Black band detection error (scanner main scanning direction near end skew)																																												
03	Black band detection error (scanner auxiliary scanning direction trailing edge skew)																																												
04	Black band is not detected (scanner auxiliary scanning direction leading edge)																																												
05	Black band is not detected (scanner main scanning direction far end)																																												
06	Black band is not detected (scanner main scanning direction near end)																																												
07	Black band is not detected (scanner auxiliary scanning direction trailing edge)																																												
08	Black band is not detected (DP main scanning direction far end)																																												
09	Black band is not detected (DP main scanning direction near end)																																												
0a	Black band is not detected (DP auxiliary scanning direction leading edge)																																												
0b	Black band is not detected (DP auxiliary scanning direction leading edge original check)																																												
0c	Black band is not detected (DP auxiliary scanning direction trailing edge)																																												
0d	White band is not detected (DP auxiliary scanning direction trailing edge)																																												
0e	DMA time out																																												
0f	Auxiliary scanning direction magnification error																																												
10	Auxiliary scanning direction leading edge error																																												
11	Auxiliary scanning direction trailing edge error																																												
12	DP uxiliary scanning direction skew error																																												
13	Maintenance request error																																												
14	Main scanning direction center line error																																												

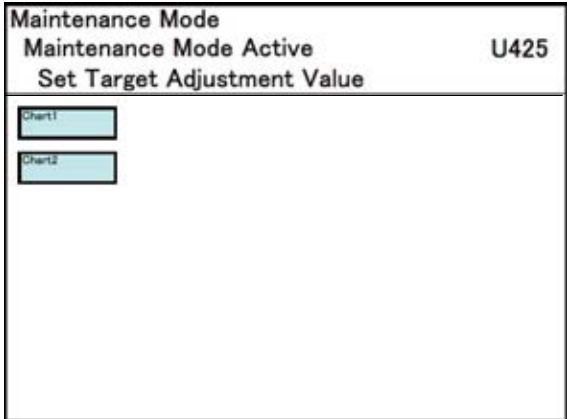
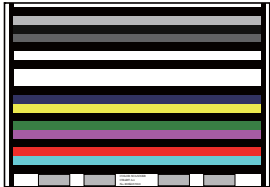

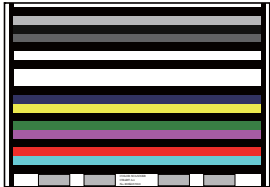

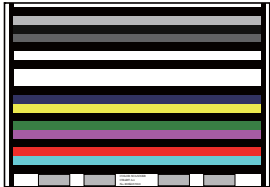

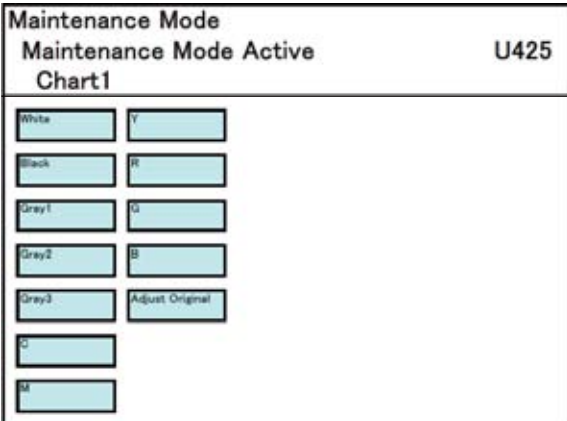
Item No.	Description																										
U411	<p data-bbox="335 241 494 273"><b>Error Codes</b></p> <table border="1" data-bbox="335 286 1401 909"> <thead> <tr> <th data-bbox="343 297 446 331">Codes</th> <th data-bbox="446 297 1393 331">Description</th> </tr> </thead> <tbody> <tr> <td data-bbox="343 342 446 376">15</td> <td data-bbox="446 342 1393 376">DP main scanning direction skew error</td> </tr> <tr> <td data-bbox="343 387 446 421">16</td> <td data-bbox="446 387 1393 421">Main scanning direction magnification error</td> </tr> <tr> <td data-bbox="343 432 446 465">17</td> <td data-bbox="446 432 1393 465">Service call error</td> </tr> <tr> <td data-bbox="343 477 446 510">18</td> <td data-bbox="446 477 1393 510">DP paper misfeed error</td> </tr> <tr> <td data-bbox="343 521 446 555">19</td> <td data-bbox="446 521 1393 555">PWB replacement error</td> </tr> <tr> <td data-bbox="343 566 446 600">1a</td> <td data-bbox="446 566 1393 600">Original error</td> </tr> <tr> <td data-bbox="343 611 446 645">1b</td> <td data-bbox="446 611 1393 645">Input gamma adjustment original error</td> </tr> <tr> <td data-bbox="343 656 446 689">1c</td> <td data-bbox="446 656 1393 689">Matrix adjustment original error</td> </tr> <tr> <td data-bbox="343 701 446 734">1d</td> <td data-bbox="446 701 1393 734">Original for the white reference compensation coefficient error</td> </tr> <tr> <td data-bbox="343 745 446 779">1e</td> <td data-bbox="446 745 1393 779">Lab value searching error</td> </tr> <tr> <td data-bbox="343 790 446 824">1f</td> <td data-bbox="446 790 1393 824">Lab value comparing error</td> </tr> <tr> <td data-bbox="343 835 446 869">63</td> <td data-bbox="446 835 1393 869">Completed to obtain a test RAW</td> </tr> </tbody> </table> <p data-bbox="287 1037 438 1068"><b>Completion</b></p> <p data-bbox="287 1070 1252 1102">Press the stop key. The screen for selecting a maintenance item No. is displayed.</p>	Codes	Description	15	DP main scanning direction skew error	16	Main scanning direction magnification error	17	Service call error	18	DP paper misfeed error	19	PWB replacement error	1a	Original error	1b	Input gamma adjustment original error	1c	Matrix adjustment original error	1d	Original for the white reference compensation coefficient error	1e	Lab value searching error	1f	Lab value comparing error	63	Completed to obtain a test RAW
Codes	Description																										
15	DP main scanning direction skew error																										
16	Main scanning direction magnification error																										
17	Service call error																										
18	DP paper misfeed error																										
19	PWB replacement error																										
1a	Original error																										
1b	Input gamma adjustment original error																										
1c	Matrix adjustment original error																										
1d	Original for the white reference compensation coefficient error																										
1e	Lab value searching error																										
1f	Lab value comparing error																										
63	Completed to obtain a test RAW																										

Item No.	Description						
U412	<p data-bbox="288 241 667 271"><b>Adjusting the uneven density</b></p> <p data-bbox="288 311 440 340"><b>Description</b></p> <p data-bbox="288 344 1426 409">Adjusts the uneven developer/transfer density in the drum axis direction by scanning directly the density distribution of test pattern with the scanner and adjusting LSU light quantity.</p> <p data-bbox="288 414 400 443"><b>Purpose</b></p> <p data-bbox="288 448 1027 477">To perform when replacing the drum unit or laser scanner unit.</p> <p data-bbox="288 481 1054 510">When completed, perform maintenance mode U464, Calibration.</p> <p data-bbox="288 551 387 580"><b>Method</b></p> <ol data-bbox="304 584 564 649" style="list-style-type: none"> <li>1. Press the start key.</li> <li>2. Select the item.</li> </ol> <table border="1" data-bbox="336 663 1399 808"> <thead> <tr> <th data-bbox="336 663 641 712">Display</th> <th data-bbox="641 663 1399 712">Description</th> </tr> </thead> <tbody> <tr> <td data-bbox="336 712 641 757">Normal Mode</td> <td data-bbox="641 712 1399 757">Executing the uneven density correction</td> </tr> <tr> <td data-bbox="336 757 641 808">On/Off Config</td> <td data-bbox="641 757 1399 808">Uneven density correction ON/OFF setting</td> </tr> </tbody> </table> <p data-bbox="288 848 592 878"><b>Method: [Normal Mode]</b></p> <ol data-bbox="304 882 1406 1469" style="list-style-type: none"> <li>1. Select [Default Value]. A test pattern is outputted with the initial light quantity setting. (1st sheet)</li> <li>2. Place approximately 20 sheets of white paper on the output test pattern and place as the original.</li> <li>3. Press the start key. the correction starts.</li> <li>4. After the correction is completed, and press the start key. A test pattern is outputted. (2nd sheet) A test pattern is outputted with light quantity setting lower than the 1st test pattern by 20%.</li> <li>5. Place approximately 20 sheets of white paper on the output test pattern and place as the original.</li> <li>6. Press the start key. the correction starts.</li> <li>7. After the correction is completed, and press the start key. A test pattern is outputted. (3rd sheet)</li> <li>8. Place approximately 20 sheets of white paper on the output test pattern and place as the original.</li> <li>9. Press the start key. The correction result is checked. When normally completed, [OK] is displayed.</li> </ol> <p data-bbox="288 1507 488 1536"><b>Retry (1st time)</b></p> <ol data-bbox="304 1541 1078 1606" style="list-style-type: none"> <li>10. If the correction is not completed normally, [Retry] is displayed.</li> <li>11. Repeat steps 4 and 9.</li> </ol> <p data-bbox="288 1644 496 1673"><b>Retry (2nd time)</b></p> <ol data-bbox="304 1677 1123 1780" style="list-style-type: none"> <li>12. If the correction is not completed normally, [Retry] is displayed.</li> <li>13. Repeat steps 4 and 9. If a problem occurs during auto correction, error code is displayed.</li> </ol>	Display	Description	Normal Mode	Executing the uneven density correction	On/Off Config	Uneven density correction ON/OFF setting
Display	Description						
Normal Mode	Executing the uneven density correction						
On/Off Config	Uneven density correction ON/OFF setting						

Item No.	Description																																	
U412	<b>Error codes</b>																																	
	<table border="1"> <thead> <tr> <th data-bbox="336 286 488 331">Codes</th> <th data-bbox="488 286 869 331">Description</th> </tr> </thead> <tbody> <tr> <td data-bbox="336 331 488 376">S001</td> <td data-bbox="488 331 869 376">Patch not detected</td> </tr> <tr> <td data-bbox="336 376 488 421">S002</td> <td data-bbox="488 376 869 421">Original deviation in the main scanning direction</td> </tr> <tr> <td data-bbox="336 421 488 465">S003</td> <td data-bbox="488 421 869 465">Original deviation in the auxiliary scanning direction</td> </tr> <tr> <td data-bbox="336 465 488 510">S004</td> <td data-bbox="488 465 869 510">Original inclination error</td> </tr> <tr> <td data-bbox="336 510 488 555">S005</td> <td data-bbox="488 510 869 555">Original type error</td> </tr> <tr> <td data-bbox="336 555 488 600">SFFF</td> <td data-bbox="488 555 869 600">Scanner other error</td> </tr> </tbody> </table>		Codes	Description	S001	Patch not detected	S002	Original deviation in the main scanning direction	S003	Original deviation in the auxiliary scanning direction	S004	Original inclination error	S005	Original type error	SFFF	Scanner other error	<table border="1"> <thead> <tr> <th data-bbox="869 286 1021 331">Codes</th> <th data-bbox="1021 286 1402 331">Description</th> </tr> </thead> <tbody> <tr> <td data-bbox="869 331 1021 376">E001</td> <td data-bbox="1021 331 1402 376">Engine status error</td> </tr> <tr> <td data-bbox="869 376 1021 421">E002</td> <td data-bbox="1021 376 1402 421">Spotted background error</td> </tr> <tr> <td data-bbox="869 421 1021 465">E003</td> <td data-bbox="1021 421 1402 465">Density error</td> </tr> <tr> <td data-bbox="869 465 1021 510">E004</td> <td data-bbox="1021 465 1402 510">Uneven density error</td> </tr> <tr> <td data-bbox="869 510 1021 555">EFFF</td> <td data-bbox="1021 510 1402 555">Engine other error</td> </tr> <tr> <td data-bbox="869 555 1021 600">C001</td> <td data-bbox="1021 555 1402 600">Controller error</td> </tr> <tr> <td data-bbox="869 600 1021 645">CFFF</td> <td data-bbox="1021 600 1402 645">Controller other error</td> </tr> </tbody> </table>		Codes	Description	E001	Engine status error	E002	Spotted background error	E003	Density error	E004	Uneven density error	EFFF	Engine other error	C001	Controller error	CFFF	Controller other error
	Codes	Description																																
	S001	Patch not detected																																
	S002	Original deviation in the main scanning direction																																
	S003	Original deviation in the auxiliary scanning direction																																
	S004	Original inclination error																																
	S005	Original type error																																
	SFFF	Scanner other error																																
	Codes	Description																																
E001	Engine status error																																	
E002	Spotted background error																																	
E003	Density error																																	
E004	Uneven density error																																	
EFFF	Engine other error																																	
C001	Controller error																																	
CFFF	Controller other error																																	
<b>Setting: [On/Off Config]</b>																																		
1. Select On or Off.																																		
<table border="1"> <thead> <tr> <th data-bbox="336 842 639 887">Display</th> <th data-bbox="639 842 1402 887">Description</th> </tr> </thead> <tbody> <tr> <td data-bbox="336 887 639 931">On</td> <td data-bbox="639 887 1402 931">Uneven density correction is enabled</td> </tr> <tr> <td data-bbox="336 931 639 987">Off</td> <td data-bbox="639 931 1402 987">Uneven density correction is disabled</td> </tr> </tbody> </table>				Display	Description	On	Uneven density correction is enabled	Off	Uneven density correction is disabled																									
Display	Description																																	
On	Uneven density correction is enabled																																	
Off	Uneven density correction is disabled																																	
* : Initial setting: Off																																		
* : ON is automatically set after the correction is complete.																																		
2. Press the start key. The setting is set.																																		
<b>Completion</b>																																		
Press the stop key. The screen for selecting a maintenance item No. is displayed.																																		



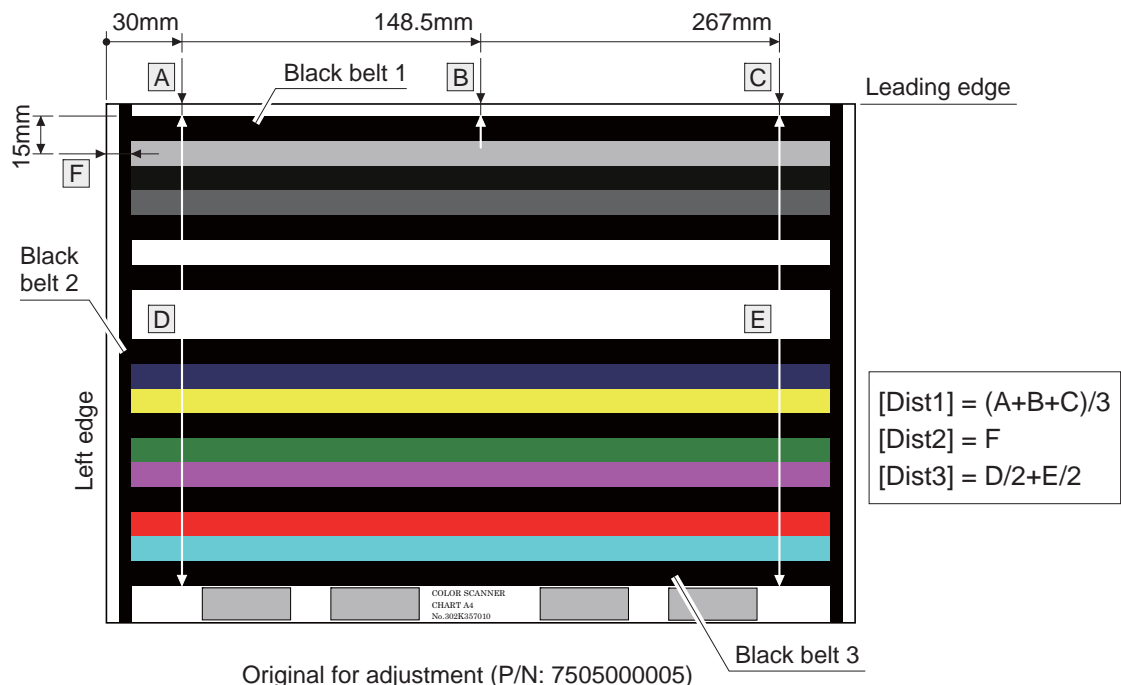
Item No.	Description																																						
U415	<p data-bbox="287 241 821 275"><b>Adjusting the print position automatically</b></p> <p data-bbox="287 309 438 342"><b>Description</b> Automatically adjusts timings at the print engine. Adjustment for leading edge timing, center line and margin.</p> <p data-bbox="287 409 399 443"><b>Purpose</b> Used to make respective auto adjustments for the print engine. * : Execute this mode when the Chart 2-2 (302AC68243) is not available.</p> <p data-bbox="287 510 391 544"><b>Method</b></p> <ol data-bbox="303 555 1133 896" style="list-style-type: none"> <li>1. Load A3/ledger paper. Load A4/Letter when the large capacity feeder is used.</li> <li>2. Press the start key.</li> <li>3. Select [Execute].</li> <li>4. Press the start key. A test pattern is outputted</li> <li>5. Set the output test pattern as the original.</li> <li>6. Press the start key. Automatically Perform adjustment from the top to bottom cassettes.</li> <li>7. When normally completed, [OK] is displayed. If a problem occurs during auto adjustment, error code is displayed.</li> </ol> <p data-bbox="335 929 494 963"><b>Error Codes</b></p> <table border="1" data-bbox="335 974 1396 1892"> <thead> <tr> <th data-bbox="343 981 550 1025">Codes</th> <th data-bbox="550 981 1388 1025">Description</th> </tr> </thead> <tbody> <tr><td>S001</td><td>Black band is not detected (main scanning direction far end)</td></tr> <tr><td>S002</td><td>Black band is not detected (main scanning direction near end)</td></tr> <tr><td>S003</td><td>Black band is not detected (auxiliary scanning direction leading edge)</td></tr> <tr><td>S004</td><td>Black band is not detected (auxiliary scanning direction trailing edge)</td></tr> <tr><td>S005</td><td>Auxiliary scanning direction skew error (1.5 mm or more)</td></tr> <tr><td>S006</td><td>Main scanning direction skew error (1.5 mm or more)</td></tr> <tr><td>S007</td><td>Original error (detection of reverse original paper)</td></tr> <tr><td>S008</td><td>Original error (page mismatch)</td></tr> <tr><td>SFFF</td><td>Scanner other error</td></tr> <tr><td>C101</td><td>Adjustment value error (main scanning direction magnification)</td></tr> <tr><td>C102</td><td>Adjustment value error (auxiliary scanning direction magnification)</td></tr> <tr><td>C103</td><td>Adjustment value error (leading edge timing)</td></tr> <tr><td>C104</td><td>Adjustment value error (center line)</td></tr> <tr><td>C105</td><td>Adjustment value error (B margin)</td></tr> <tr><td>C106</td><td>Adjustment value error (A margin)</td></tr> <tr><td>C107</td><td>Adjustment value error (C margin)</td></tr> <tr><td>C108</td><td>Adjustment value error (D margin)</td></tr> <tr><td>CFFF</td><td>Controller other error</td></tr> </tbody> </table> <p data-bbox="287 1926 438 1960"><b>Completion</b> Press the stop key. The screen for selecting a maintenance item No. is displayed.</p>	Codes	Description	S001	Black band is not detected (main scanning direction far end)	S002	Black band is not detected (main scanning direction near end)	S003	Black band is not detected (auxiliary scanning direction leading edge)	S004	Black band is not detected (auxiliary scanning direction trailing edge)	S005	Auxiliary scanning direction skew error (1.5 mm or more)	S006	Main scanning direction skew error (1.5 mm or more)	S007	Original error (detection of reverse original paper)	S008	Original error (page mismatch)	SFFF	Scanner other error	C101	Adjustment value error (main scanning direction magnification)	C102	Adjustment value error (auxiliary scanning direction magnification)	C103	Adjustment value error (leading edge timing)	C104	Adjustment value error (center line)	C105	Adjustment value error (B margin)	C106	Adjustment value error (A margin)	C107	Adjustment value error (C margin)	C108	Adjustment value error (D margin)	CFFF	Controller other error
Codes	Description																																						
S001	Black band is not detected (main scanning direction far end)																																						
S002	Black band is not detected (main scanning direction near end)																																						
S003	Black band is not detected (auxiliary scanning direction leading edge)																																						
S004	Black band is not detected (auxiliary scanning direction trailing edge)																																						
S005	Auxiliary scanning direction skew error (1.5 mm or more)																																						
S006	Main scanning direction skew error (1.5 mm or more)																																						
S007	Original error (detection of reverse original paper)																																						
S008	Original error (page mismatch)																																						
SFFF	Scanner other error																																						
C101	Adjustment value error (main scanning direction magnification)																																						
C102	Adjustment value error (auxiliary scanning direction magnification)																																						
C103	Adjustment value error (leading edge timing)																																						
C104	Adjustment value error (center line)																																						
C105	Adjustment value error (B margin)																																						
C106	Adjustment value error (A margin)																																						
C107	Adjustment value error (C margin)																																						
C108	Adjustment value error (D margin)																																						
CFFF	Controller other error																																						

Item No.	Description										
<p><b>U425</b></p>	<p><b>Setting the target</b></p> <p><b>Description</b>                      Enters the lab values that is indicated of the chart 1 (P/N: 7505000005) or chart 2 (P/N: 302FZ56990) used for adjustment.</p> <p><b>Purpose</b>                      Perform data input in order to correct for differences in originals during automatic adjustment.</p> <p><b>Method</b></p> <ol style="list-style-type: none"> <li>1. Press the start key.</li> <li>2. Select the chart to be used.</li> </ol>										
											
	<p><b>Figure 1-3-46</b></p>										
	<table border="1" style="width: 100%; border-collapse: collapse;"> <thead> <tr> <th data-bbox="336 976 489 1025">Display</th> <th data-bbox="489 976 1019 1025">Description</th> <th data-bbox="1019 976 1401 1025">Chart image</th> </tr> </thead> <tbody> <tr> <td data-bbox="336 1025 489 1263">Chart1</td> <td data-bbox="489 1025 1019 1263">Chart 1 (P/N: 7505000005)</td> <td data-bbox="1019 1025 1401 1263">                     Chart1   </td> </tr> <tr> <td data-bbox="336 1263 489 1514">Chart2</td> <td data-bbox="489 1263 1019 1514">Chart 2 (P/N: 302FZ56990)</td> <td data-bbox="1019 1263 1401 1514">                     Chart2-1   </td> </tr> </tbody> </table>		Display	Description	Chart image	Chart1	Chart 1 (P/N: 7505000005)	Chart1 	Chart2	Chart 2 (P/N: 302FZ56990)	Chart2-1 
Display	Description	Chart image									
Chart1	Chart 1 (P/N: 7505000005)	Chart1 									
Chart2	Chart 2 (P/N: 302FZ56990)	Chart2-1 									
	<p><b>Method: [Chart1]</b></p> <ol style="list-style-type: none"> <li>1. Press the start key.</li> <li>2. Select the item to be set.</li> </ol>										
											
	<p><b>Figure 1-3-47</b></p>										

Item No.	Description																																
<p><b>U425</b></p>	<table border="1" data-bbox="336 282 1401 907"> <thead> <tr> <th data-bbox="336 282 639 331">Display</th> <th data-bbox="639 282 1401 331">Description</th> </tr> </thead> <tbody> <tr> <td data-bbox="336 331 639 376">White</td> <td data-bbox="639 331 1401 376">Setting the white patch for the original for adjustment</td> </tr> <tr> <td data-bbox="336 376 639 421">Black</td> <td data-bbox="639 376 1401 421">Setting the black patch for the original for adjustment</td> </tr> <tr> <td data-bbox="336 421 639 465">Gray1</td> <td data-bbox="639 421 1401 465">Setting the Gray1 patch for the original for adjustment</td> </tr> <tr> <td data-bbox="336 465 639 510">Gray2</td> <td data-bbox="639 465 1401 510">Setting the Gray2 patch for the original for adjustment</td> </tr> <tr> <td data-bbox="336 510 639 555">Gray3</td> <td data-bbox="639 510 1401 555">Setting the Gray3 patch for the original for adjustment</td> </tr> <tr> <td data-bbox="336 555 639 600">C</td> <td data-bbox="639 555 1401 600">Setting the cyan patch for the original for adjustment</td> </tr> <tr> <td data-bbox="336 600 639 645">M</td> <td data-bbox="639 600 1401 645">Setting the magenta patch for the original for adjustment</td> </tr> <tr> <td data-bbox="336 645 639 689">Y</td> <td data-bbox="639 645 1401 689">Setting the yellow patch for the original for adjustment</td> </tr> <tr> <td data-bbox="336 689 639 734">R</td> <td data-bbox="639 689 1401 734">Setting the red patch for the original for adjustment</td> </tr> <tr> <td data-bbox="336 734 639 779">G</td> <td data-bbox="639 734 1401 779">Setting the green patch for the original for adjustment</td> </tr> <tr> <td data-bbox="336 779 639 824">B</td> <td data-bbox="639 779 1401 824">Setting the blue patch for the original for adjustment</td> </tr> <tr> <td data-bbox="336 824 639 907">Adjust Original</td> <td data-bbox="639 824 1401 907">Setting the main and auxiliary scanning directions</td> </tr> </tbody> </table> <p data-bbox="288 916 1050 949"><b>Setting: [White, Black, Gray1, Gray2, Gray3, C, M, Y, R, G, B]</b></p> <ol data-bbox="320 987 639 1093" style="list-style-type: none"> <li>1. Read the Lab values for the items selected on Chart 1.</li> </ol> <div data-bbox="839 958 1417 1384" data-label="Image"> </div> <p data-bbox="1082 1397 1251 1458"><b>Figure 1-3-48</b> Chart1</p> <ol data-bbox="304 1469 799 1608" style="list-style-type: none"> <li>3. Enters the value that is indicated on the face of the chart using the +/- keys or numeric keys.</li> <li>4. Press the start key. The value is set.</li> </ol> <div data-bbox="847 1458 1406 1973" data-label="Image"> <table border="1" data-bbox="1230 1765 1374 1861"> <tr> <td>L</td> <td>a</td> <td>b</td> </tr> <tr> <td>110</td> <td>1.1</td> <td>-1.3</td> </tr> </table> </div> <p data-bbox="1082 1984 1251 2018"><b>Figure 1-3-49</b></p>	Display	Description	White	Setting the white patch for the original for adjustment	Black	Setting the black patch for the original for adjustment	Gray1	Setting the Gray1 patch for the original for adjustment	Gray2	Setting the Gray2 patch for the original for adjustment	Gray3	Setting the Gray3 patch for the original for adjustment	C	Setting the cyan patch for the original for adjustment	M	Setting the magenta patch for the original for adjustment	Y	Setting the yellow patch for the original for adjustment	R	Setting the red patch for the original for adjustment	G	Setting the green patch for the original for adjustment	B	Setting the blue patch for the original for adjustment	Adjust Original	Setting the main and auxiliary scanning directions	L	a	b	110	1.1	-1.3
Display	Description																																
White	Setting the white patch for the original for adjustment																																
Black	Setting the black patch for the original for adjustment																																
Gray1	Setting the Gray1 patch for the original for adjustment																																
Gray2	Setting the Gray2 patch for the original for adjustment																																
Gray3	Setting the Gray3 patch for the original for adjustment																																
C	Setting the cyan patch for the original for adjustment																																
M	Setting the magenta patch for the original for adjustment																																
Y	Setting the yellow patch for the original for adjustment																																
R	Setting the red patch for the original for adjustment																																
G	Setting the green patch for the original for adjustment																																
B	Setting the blue patch for the original for adjustment																																
Adjust Original	Setting the main and auxiliary scanning directions																																
L	a	b																															
110	1.1	-1.3																															

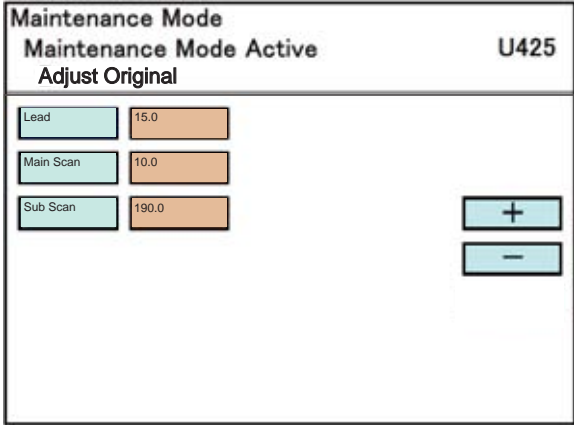
Item No.	Description																																			
U425	<table border="1" data-bbox="336 282 1401 474"> <thead> <tr> <th data-bbox="336 282 639 331">Display</th> <th data-bbox="639 282 1019 331">Description</th> <th data-bbox="1019 282 1401 331">Setting range</th> </tr> </thead> <tbody> <tr> <td data-bbox="336 331 639 376">L</td> <td data-bbox="639 331 1019 376">Setting the L value</td> <td data-bbox="1019 331 1401 376">0.0 to 100.0</td> </tr> <tr> <td data-bbox="336 376 639 421">a</td> <td data-bbox="639 376 1019 421">Setting the a value</td> <td data-bbox="1019 376 1401 421">-200.0 to 200.0</td> </tr> <tr> <td data-bbox="336 421 639 474">b</td> <td data-bbox="639 421 1019 474">Setting the b value</td> <td data-bbox="1019 421 1401 474">-200.0 to 200.0</td> </tr> </tbody> </table> <p data-bbox="288 640 611 674"><b>Setting: [Adjust Original]</b></p> <p data-bbox="336 678 798 712">* : This setting is usually unnecessary.</p> <p data-bbox="304 714 564 748">1. Press the start key.</p> <div data-bbox="837 658 1414 1084" data-label="Image"> </div> <p data-bbox="1082 1120 1251 1153" style="text-align: center;"><b>Figure 1-3-50</b></p> <table border="1" data-bbox="295 1200 1420 1650"> <thead> <tr> <th data-bbox="295 1200 432 1279">Display</th> <th data-bbox="432 1200 933 1279">Description</th> <th data-bbox="933 1200 1129 1279">Setting range</th> <th data-bbox="1129 1200 1252 1279">Initial setting</th> <th data-bbox="1252 1200 1420 1279">Change in value per step</th> </tr> </thead> <tbody> <tr> <td data-bbox="295 1279 432 1402">Dist1</td> <td data-bbox="432 1279 933 1402">Measure the distance from the leading edge to the top of black belt 1 of the original</td> <td data-bbox="933 1279 1129 1402">4.0 to 6.0</td> <td data-bbox="1129 1279 1252 1402">5.0</td> <td data-bbox="1252 1279 1420 1402"></td> </tr> <tr> <td data-bbox="295 1402 432 1525">Dist2</td> <td data-bbox="432 1402 933 1525">Measure the distance from the left edge to the right edge black belt 2 of the original</td> <td data-bbox="933 1402 1129 1525">9.0 to 11.0</td> <td data-bbox="1129 1402 1252 1525">10.0</td> <td data-bbox="1252 1402 1420 1525">0.1mm</td> </tr> <tr> <td data-bbox="295 1525 432 1650">Dist3</td> <td data-bbox="432 1525 933 1650">Measure the distance from the top edge of black belt 1 to the bottom of black belt 3 of the original</td> <td data-bbox="933 1525 1129 1650">189.0 to 191.0</td> <td data-bbox="1129 1525 1252 1650">190.0</td> <td data-bbox="1252 1525 1420 1650"></td> </tr> </tbody> </table>				Display	Description	Setting range	L	Setting the L value	0.0 to 100.0	a	Setting the a value	-200.0 to 200.0	b	Setting the b value	-200.0 to 200.0	Display	Description	Setting range	Initial setting	Change in value per step	Dist1	Measure the distance from the leading edge to the top of black belt 1 of the original	4.0 to 6.0	5.0		Dist2	Measure the distance from the left edge to the right edge black belt 2 of the original	9.0 to 11.0	10.0	0.1mm	Dist3	Measure the distance from the top edge of black belt 1 to the bottom of black belt 3 of the original	189.0 to 191.0	190.0	
Display	Description	Setting range																																		
L	Setting the L value	0.0 to 100.0																																		
a	Setting the a value	-200.0 to 200.0																																		
b	Setting the b value	-200.0 to 200.0																																		
Display	Description	Setting range	Initial setting	Change in value per step																																
Dist1	Measure the distance from the leading edge to the top of black belt 1 of the original	4.0 to 6.0	5.0																																	
Dist2	Measure the distance from the left edge to the right edge black belt 2 of the original	9.0 to 11.0	10.0	0.1mm																																
Dist3	Measure the distance from the top edge of black belt 1 to the bottom of black belt 3 of the original	189.0 to 191.0	190.0																																	

Item No.	Description
U425	<p>2. Measure the distance from the leading edge to the top of black belt 1 of the original at A, B and C.</p> <p>Measurement procedure</p> <ol style="list-style-type: none"> <li>1) Measure the distance from the leading edge to the top of black belt 1 of the original at A (30 mm from the left edge), B (148.5 mm from the left edge) and C (267 mm from the left edge), respectively.</li> <li>2) Apply the following formula for the values obtained: <math>((A + B + C) / 3)</math></li> </ol> <p>3. Enter the values solved using the cursor left/right keys or numeric keys in [Dist1].</p> <p>4. Press the start key. The value is set.</p> <p>5. Measure the distance from the left edge to the right edge black belt 2 of the original at F.</p> <p>Measurement procedure</p> <ol style="list-style-type: none"> <li>1) Measure the distance from the left edge to the right edge black belt 2 of the original at F (15 mm from the top edge of black belt 1).</li> </ol> <p>6. Enter the values using the cursor left/right keys or numeric keys in [Dist2].</p> <p>7. Press the start key. The value is set.</p> <p>8. Measure the distance from the top edge of black belt 1 to the bottom of black belt 3 of the original at D and E.</p> <ol style="list-style-type: none"> <li>1) Measure the distance from the top edge of black belt 1 to the bottom of black belt 3 of the original at D (30 mm from the left edge) and E (267 mm from the left edge), respectively.</li> <li>2) Apply the following formula for the values obtained: <math>(D/2 + E/2)</math></li> </ol> <p>9. Enter the measured value using the cursor left/right keys or numeric keys in [Dist3].</p> <p>10. Press the start key. The value is set.</p>



Item No.	Description								
<p><b>U425</b></p>	<p><b>Method: [Chart2]</b>                      1. Press the start key.                      2. Select the item.</p> <div data-bbox="842 259 1414 685" style="border: 1px solid black; padding: 5px; margin: 10px 0;"> <p>Maintenance Mode                          Maintenance Mode Active <span style="float: right;">U425</span>                          Chart 2</p> <p>CCD</p> <p>DP</p> <p>CIS</p> </div> <p style="text-align: center;"><b>Figure 1-3-52</b></p> <table border="1" data-bbox="336 797 1401 1059" style="width: 100%; border-collapse: collapse;"> <thead> <tr> <th style="width: 20%;">Display</th> <th>Description</th> </tr> </thead> <tbody> <tr> <td>CCD</td> <td>Entering the target values of the chart 2-1 (P/N: 302FZ56990) used for adjustment</td> </tr> <tr> <td>DP</td> <td>Entering the measurement value of the chart 2-2 (P/N: 302AC68243) used for adjustment</td> </tr> <tr> <td>CIS</td> <td>Execution is not required</td> </tr> </tbody> </table> <p><b>Method: [CCD]</b>                      1. Press the start key.                      2. Select the item to be set.</p> <div data-bbox="842 1162 1414 1588" style="border: 1px solid black; padding: 5px; margin: 10px 0;"> <p>Maintenance Mode                          Maintenance Mode Active <span style="float: right;">U425</span>                          CCD</p> <p>N875    B</p> <p>N475    Adjust Original</p> <p>C</p> <p>M</p> <p>Y</p> <p>R</p> <p>G</p> </div> <p style="text-align: center;"><b>Figure 1-3-53</b></p>	Display	Description	CCD	Entering the target values of the chart 2-1 (P/N: 302FZ56990) used for adjustment	DP	Entering the measurement value of the chart 2-2 (P/N: 302AC68243) used for adjustment	CIS	Execution is not required
Display	Description								
CCD	Entering the target values of the chart 2-1 (P/N: 302FZ56990) used for adjustment								
DP	Entering the measurement value of the chart 2-2 (P/N: 302AC68243) used for adjustment								
CIS	Execution is not required								

Item No.	Description																																																																												
<p><b>U425</b></p>	<table border="1" data-bbox="336 282 1401 808"> <thead> <tr> <th data-bbox="336 282 639 331">Display</th> <th data-bbox="639 282 1401 331">Description</th> </tr> </thead> <tbody> <tr> <td data-bbox="336 331 639 376">N875</td> <td data-bbox="639 331 1401 376">Setting the N875 patch for the original for adjustment</td> </tr> <tr> <td data-bbox="336 376 639 421">N475</td> <td data-bbox="639 376 1401 421">Setting the N475 patch for the original for adjustment</td> </tr> <tr> <td data-bbox="336 421 639 465">N125</td> <td data-bbox="639 421 1401 465">Setting the N125 patch for the original for adjustment</td> </tr> <tr> <td data-bbox="336 465 639 510">C</td> <td data-bbox="639 465 1401 510">Setting the cyan patch for the original for adjustment</td> </tr> <tr> <td data-bbox="336 510 639 555">M</td> <td data-bbox="639 510 1401 555">Setting the magenta patch for the original for adjustment</td> </tr> <tr> <td data-bbox="336 555 639 600">Y</td> <td data-bbox="639 555 1401 600">Setting the yellow patch for the original for adjustment</td> </tr> <tr> <td data-bbox="336 600 639 645">R</td> <td data-bbox="639 600 1401 645">Setting the red patch for the original for adjustment</td> </tr> <tr> <td data-bbox="336 645 639 689">G</td> <td data-bbox="639 645 1401 689">Setting the green patch for the original for adjustment</td> </tr> <tr> <td data-bbox="336 689 639 734">B</td> <td data-bbox="639 689 1401 734">Setting the blue patch for the original for adjustment</td> </tr> <tr> <td data-bbox="336 734 639 808">Adjust Original</td> <td data-bbox="639 734 1401 808">Setting the main and auxiliary scanning directions</td> </tr> </tbody> </table> <p data-bbox="288 860 839 893"><b>Setting: [N875, N475, N125, C, M, Y, R, G, B]</b></p> <ol data-bbox="304 936 775 1032" style="list-style-type: none"> <li>1. Read the Lab values for the items selected on the back of the Chart 2-1 test chart.</li> </ol> <div data-bbox="839 913 1417 1339" data-label="Image"> </div> <p data-bbox="1082 1373 1249 1406"><b>Figure 1-3-54</b></p> <ol data-bbox="304 1485 802 1619" style="list-style-type: none"> <li>2. Enters the value that is indicated on the back of the chart using the +/- keys or numeric keys.</li> <li>3. Press the start key. The value is set.</li> </ol> <div data-bbox="839 1473 1417 1921" data-label="Image"> <table border="1" data-bbox="847 1794 1409 1921"> <thead> <tr> <th colspan="2"></th> <th colspan="8">LAB(a,b) (Lab Value)</th> </tr> <tr> <th colspan="2"></th> <th>N875</th> <th>N475</th> <th>N125</th> <th>CYAN</th> <th>MAGENTA</th> <th>YELLOW</th> <th>RED</th> <th>GREEN</th> <th>BLUE</th> </tr> </thead> <tbody> <tr> <td>L*</td> <td></td> <td>85.5</td> <td>52.3</td> <td>21.6</td> <td>55.6</td> <td>46.3</td> <td>86.6</td> <td>45.8</td> <td>48.7</td> <td>23.2</td> </tr> <tr> <td>a*</td> <td></td> <td>-0.1</td> <td>-1.3</td> <td>-0.6</td> <td>-29.0</td> <td>71.4</td> <td>-10.2</td> <td>63.5</td> <td>-70.5</td> <td>22.9</td> </tr> <tr> <td>b*</td> <td></td> <td>0.5</td> <td>2.0</td> <td>2.4</td> <td>-45.9</td> <td>-2.3</td> <td>88.1</td> <td>43.5</td> <td>25.7</td> <td>-43.0</td> </tr> </tbody> </table> </div> <p data-bbox="1082 1955 1249 1989"><b>Figure 1-3-55</b></p>	Display	Description	N875	Setting the N875 patch for the original for adjustment	N475	Setting the N475 patch for the original for adjustment	N125	Setting the N125 patch for the original for adjustment	C	Setting the cyan patch for the original for adjustment	M	Setting the magenta patch for the original for adjustment	Y	Setting the yellow patch for the original for adjustment	R	Setting the red patch for the original for adjustment	G	Setting the green patch for the original for adjustment	B	Setting the blue patch for the original for adjustment	Adjust Original	Setting the main and auxiliary scanning directions			LAB(a,b) (Lab Value)										N875	N475	N125	CYAN	MAGENTA	YELLOW	RED	GREEN	BLUE	L*		85.5	52.3	21.6	55.6	46.3	86.6	45.8	48.7	23.2	a*		-0.1	-1.3	-0.6	-29.0	71.4	-10.2	63.5	-70.5	22.9	b*		0.5	2.0	2.4	-45.9	-2.3	88.1	43.5	25.7	-43.0
Display	Description																																																																												
N875	Setting the N875 patch for the original for adjustment																																																																												
N475	Setting the N475 patch for the original for adjustment																																																																												
N125	Setting the N125 patch for the original for adjustment																																																																												
C	Setting the cyan patch for the original for adjustment																																																																												
M	Setting the magenta patch for the original for adjustment																																																																												
Y	Setting the yellow patch for the original for adjustment																																																																												
R	Setting the red patch for the original for adjustment																																																																												
G	Setting the green patch for the original for adjustment																																																																												
B	Setting the blue patch for the original for adjustment																																																																												
Adjust Original	Setting the main and auxiliary scanning directions																																																																												
		LAB(a,b) (Lab Value)																																																																											
		N875	N475	N125	CYAN	MAGENTA	YELLOW	RED	GREEN	BLUE																																																																			
L*		85.5	52.3	21.6	55.6	46.3	86.6	45.8	48.7	23.2																																																																			
a*		-0.1	-1.3	-0.6	-29.0	71.4	-10.2	63.5	-70.5	22.9																																																																			
b*		0.5	2.0	2.4	-45.9	-2.3	88.1	43.5	25.7	-43.0																																																																			

Item No.	Description																					
U425	<table border="1"> <thead> <tr> <th data-bbox="335 286 641 331">Display</th> <th data-bbox="641 286 1019 331">Description</th> <th data-bbox="1019 286 1401 331">Setting range</th> </tr> </thead> <tbody> <tr> <td data-bbox="335 331 641 376">L</td> <td data-bbox="641 331 1019 376">Setting the L value</td> <td data-bbox="1019 331 1401 376">0.0 to 100.0</td> </tr> <tr> <td data-bbox="335 376 641 421">a</td> <td data-bbox="641 376 1019 421">Setting the a value</td> <td data-bbox="1019 376 1401 421">-200.0 to 200.0</td> </tr> <tr> <td data-bbox="335 421 641 477">b</td> <td data-bbox="641 421 1019 477">Setting the b value</td> <td data-bbox="1019 421 1401 477">-200.0 to 200.0</td> </tr> </tbody> </table>				Display	Description	Setting range	L	Setting the L value	0.0 to 100.0	a	Setting the a value	-200.0 to 200.0	b	Setting the b value	-200.0 to 200.0						
	Display	Description	Setting range																			
	L	Setting the L value	0.0 to 100.0																			
	a	Setting the a value	-200.0 to 200.0																			
b	Setting the b value	-200.0 to 200.0																				
<p><b>Setting: [Adjust Original]</b>  * : This setting is usually unnecessary.  1. Press the start key.</p>																						
																						
Figure 1-3-56																						
<table border="1"> <thead> <tr> <th data-bbox="295 1086 446 1198">Display</th> <th data-bbox="446 1086 997 1198">Description</th> <th data-bbox="997 1086 1189 1198">Setting range</th> <th data-bbox="1189 1086 1316 1198">Initial setting</th> <th data-bbox="1316 1086 1428 1198">Change in value per step</th> </tr> </thead> <tbody> <tr> <td data-bbox="295 1198 446 1288">Lead</td> <td data-bbox="446 1198 997 1288">Measure the distance from the left edge to the black belt (a) of the original</td> <td data-bbox="997 1198 1189 1288">14.0 to 16.0</td> <td data-bbox="1189 1198 1316 1288">15.0</td> <td data-bbox="1316 1198 1428 1288" rowspan="3">0.1mm</td> </tr> <tr> <td data-bbox="295 1288 446 1377">Main Scan</td> <td data-bbox="446 1288 997 1377">Measure the distance from the leading edge to the black belt (b) of the original</td> <td data-bbox="997 1288 1189 1377">9.0 to 11.0</td> <td data-bbox="1189 1288 1316 1377">10.0</td> </tr> <tr> <td data-bbox="295 1377 446 1467">Sub Scan</td> <td data-bbox="446 1377 997 1467">Measure the length from the edge of the black belt (a) to edge of N475 of the original</td> <td data-bbox="997 1377 1189 1467">189.0 to 191.0</td> <td data-bbox="1189 1377 1316 1467">190.0</td> </tr> </tbody> </table>					Display	Description	Setting range	Initial setting	Change in value per step	Lead	Measure the distance from the left edge to the black belt (a) of the original	14.0 to 16.0	15.0	0.1mm	Main Scan	Measure the distance from the leading edge to the black belt (b) of the original	9.0 to 11.0	10.0	Sub Scan	Measure the length from the edge of the black belt (a) to edge of N475 of the original	189.0 to 191.0	190.0
Display	Description	Setting range	Initial setting	Change in value per step																		
Lead	Measure the distance from the left edge to the black belt (a) of the original	14.0 to 16.0	15.0	0.1mm																		
Main Scan	Measure the distance from the leading edge to the black belt (b) of the original	9.0 to 11.0	10.0																			
Sub Scan	Measure the length from the edge of the black belt (a) to edge of N475 of the original	189.0 to 191.0	190.0																			



Item No.	Description
U425	<p>2. Measure the distance from the leading edge to the top of black belt 1 of the original at A, B and C.</p> <p>Measurement procedure</p> <ol style="list-style-type: none"> <li>1) Measure the distance from the leading edge to the top of black belt 1 of the original at A (30 mm from the left edge), B (148.5 mm from the left edge) and C (267 mm from the left edge), respectively.</li> <li>2) Apply the following formula for the values obtained: <math>((A + B + C) / 3)</math></li> </ol> <p>3. Enter the values solved using the cursor left/right keys or numeric keys in [Dist1].</p> <p>4. Press the start key. The value is set.</p> <p>5. Measure the distance from the left edge to the right edge black belt 2 of the original at F.</p> <p>Measurement procedure</p> <ol style="list-style-type: none"> <li>1) Measure the distance from the left edge to the right edge black belt 2 of the original at F (15 mm from the top edge of black belt 1).</li> </ol> <p>6. Enter the values using the cursor left/right keys or numeric keys in [Dist2].</p> <p>7. Press the start key. The value is set.</p> <p>8. Measure the distance from the top edge of black belt 1 to the bottom of black belt 3 of the original at D and E.</p> <ol style="list-style-type: none"> <li>1) Measure the distance from the top edge of black belt 1 to the bottom of black belt 3 of the original at D (30 mm from the left edge) and E (267 mm from the left edge), respectively.</li> <li>2) Apply the following formula for the values obtained: <math>(D/2 + E/2)</math></li> </ol> <p>9. Enter the measured value using the cursor left/right keys or numeric keys in [Dist3].</p> <p>10. Press the start key. The value is set.</p>

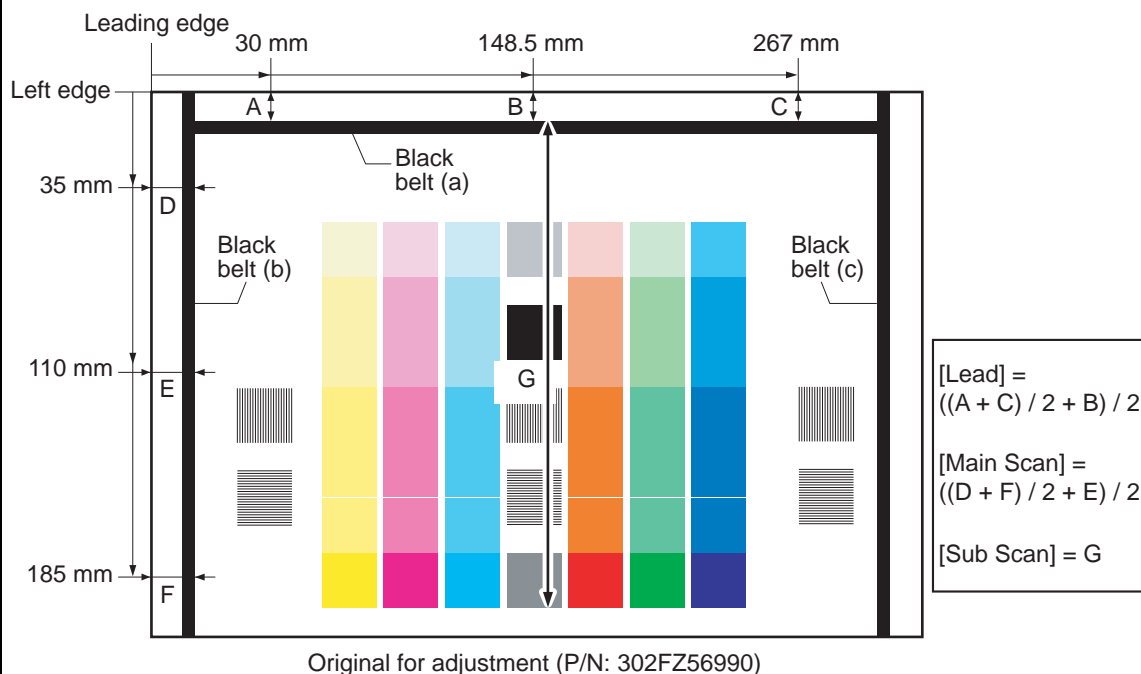
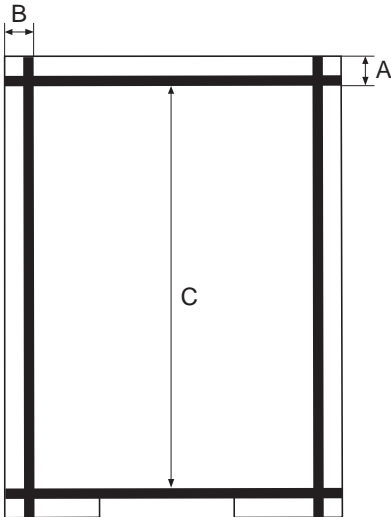


Figure 1-3-57

Item No.	Description																												
<p><b>U425</b></p> <p><b>Setting: [DP]</b></p> <p>* : This setting is usually unnecessary.</p> <p>1. Press the start key.</p> <p>2. Enters the value that is indicated on the face of the chart using the +/- keys or numeric keys.</p>	<p><b>Maintenance Mode</b></p> <p>Maintenance Mode Active <span style="float: right;">U425</span></p> <p>DP</p> <table border="1" style="width: 100%; border-collapse: collapse;"> <tr> <td style="width: 30%;">Lead</td> <td style="width: 30%;">15.0</td> <td style="width: 30%;"></td> </tr> <tr> <td>Main Scan</td> <td>15.0</td> <td></td> </tr> <tr> <td>Sub Scan</td> <td>390.0</td> <td style="text-align: right;"> <div style="border: 1px solid black; padding: 2px; display: inline-block;">+</div>  <div style="border: 1px solid black; padding: 2px; display: inline-block;">-</div> </td> </tr> </table>	Lead	15.0		Main Scan	15.0		Sub Scan	390.0	<div style="border: 1px solid black; padding: 2px; display: inline-block;">+</div> <div style="border: 1px solid black; padding: 2px; display: inline-block;">-</div>	<p style="text-align: center;"><b>Figure 1-3-58</b></p> <table border="1" style="width: 100%; border-collapse: collapse;"> <thead> <tr> <th data-bbox="295 792 448 909">Display</th> <th data-bbox="448 792 995 909">Description</th> <th data-bbox="995 792 1192 909">Setting range</th> <th data-bbox="1192 792 1315 909">Initial setting</th> <th data-bbox="1315 792 1426 909">Change in value per step</th> </tr> </thead> <tbody> <tr> <td data-bbox="295 909 448 994">Lead</td> <td data-bbox="448 909 995 994">Measure the distance from the leading edge to the black belt (inside) of the original</td> <td data-bbox="995 909 1192 994">14.0 to 16.0</td> <td data-bbox="1192 909 1315 994">15.0</td> <td data-bbox="1315 909 1426 994" rowspan="3" style="text-align: center; vertical-align: middle;">0.1mm</td> </tr> <tr> <td data-bbox="295 994 448 1079">Main Scan</td> <td data-bbox="448 994 995 1079">Measure the distance from the left edge to the black belt (inside) of the original</td> <td data-bbox="995 994 1192 1079">14.0 to 16.0</td> <td data-bbox="1192 994 1315 1079">15.0</td> </tr> <tr> <td data-bbox="295 1079 448 1211">Sub Scan</td> <td data-bbox="448 1079 995 1211">Measure the distance from the black belt of leading edge (inside) to the black belt of trailing edge (inside) of the original</td> <td data-bbox="995 1079 1192 1211">388.0 to 392.0</td> <td data-bbox="1192 1079 1315 1211">390.0</td> </tr> </tbody> </table> <p>3. Press the start key. The value is set.</p> <div style="text-align: center;">  <p>Original for adjustment (P/N: 302AC68243)</p> <p><b>Figure 1-3-59</b></p> </div> <p><b>Completion</b> Press the stop key. The screen for selecting a maintenance item No. is displayed.</p>	Display	Description	Setting range	Initial setting	Change in value per step	Lead	Measure the distance from the leading edge to the black belt (inside) of the original	14.0 to 16.0	15.0	0.1mm	Main Scan	Measure the distance from the left edge to the black belt (inside) of the original	14.0 to 16.0	15.0	Sub Scan	Measure the distance from the black belt of leading edge (inside) to the black belt of trailing edge (inside) of the original	388.0 to 392.0	390.0
Lead	15.0																												
Main Scan	15.0																												
Sub Scan	390.0	<div style="border: 1px solid black; padding: 2px; display: inline-block;">+</div> <div style="border: 1px solid black; padding: 2px; display: inline-block;">-</div>																											
Display	Description	Setting range	Initial setting	Change in value per step																									
Lead	Measure the distance from the leading edge to the black belt (inside) of the original	14.0 to 16.0	15.0	0.1mm																									
Main Scan	Measure the distance from the left edge to the black belt (inside) of the original	14.0 to 16.0	15.0																										
Sub Scan	Measure the distance from the black belt of leading edge (inside) to the black belt of trailing edge (inside) of the original	388.0 to 392.0	390.0																										

Item No.	Description																												
U464	<p data-bbox="288 241 734 275"><b>Setting the ID correction operation</b></p> <p data-bbox="288 311 440 340"><b>Description</b></p> <p data-bbox="288 344 1433 409">Turn ID correction (calibration) on or off. Also, this allows individual settings for calibration operation.</p> <p data-bbox="288 414 400 443"><b>Purpose</b></p> <p data-bbox="288 448 1425 515">Implements various settings of calibration when poor image quality is caused or to allow various settings of calibration depending on the user preference.</p> <p data-bbox="288 519 1027 548">To perform the calibration when replacing the maintenance kit.</p> <p data-bbox="288 589 387 618"><b>Method</b></p> <ol data-bbox="308 622 632 687" style="list-style-type: none"> <li>1. Press the start key.</li> <li>2. Select the item to be set.</li> </ol> <table border="1" data-bbox="336 698 1399 1538"> <thead> <tr> <th data-bbox="336 698 639 743">Display</th> <th data-bbox="639 698 1399 743">Description</th> </tr> </thead> <tbody> <tr> <td data-bbox="336 743 639 788">Permission</td> <td data-bbox="639 743 1399 788">Setting to turn calibration on/off</td> </tr> <tr> <td data-bbox="336 788 639 833">Time Interval</td> <td data-bbox="639 788 1399 833">Setting the interval time of calibration after printing</td> </tr> <tr> <td data-bbox="336 833 639 878">Mode</td> <td data-bbox="639 833 1399 878">Setting the calibration execution mode</td> </tr> <tr> <td data-bbox="336 878 639 967">On/Sleep Out*</td> <td data-bbox="639 878 1399 967">Setting execution parameters for calibration when powered up or reverted from auto-sleep</td> </tr> <tr> <td data-bbox="336 967 639 1057">AP/NE*</td> <td data-bbox="639 967 1399 1057">Paper interval calibration ON/OFF setting at the time of calibration/near end after toner feed</td> </tr> <tr> <td data-bbox="336 1057 639 1169">Leaving Time*</td> <td data-bbox="639 1057 1399 1169">Setting the standard time for judging whether or not to carry out calibration based on the sleep time when the machine recovers from the sleep mode</td> </tr> <tr> <td data-bbox="336 1169 639 1281">Driving Time*</td> <td data-bbox="639 1169 1399 1281">Setting the standard time for judging whether or not to carry out paper interval calibration based on the driving time during printing</td> </tr> <tr> <td data-bbox="336 1281 639 1393">Timing*</td> <td data-bbox="639 1281 1399 1393">Setting the standard time for judging whether or not to carry out calibration based on the continuous print driving time during printing</td> </tr> <tr> <td data-bbox="336 1393 639 1482">Target Value</td> <td data-bbox="639 1393 1399 1482">Setting the sensor target values for toner thick layer calibration and light amount calibration</td> </tr> <tr> <td data-bbox="336 1482 639 1538">Calib</td> <td data-bbox="639 1482 1399 1538">Executing the calibration</td> </tr> </tbody> </table> <p data-bbox="336 1550 813 1579">*: Enabled when Mode is set to Custom.</p> <p data-bbox="288 1619 563 1648"><b>Setting: [Permission]</b></p> <ol data-bbox="308 1653 536 1682" style="list-style-type: none"> <li>1. Select On or Off.</li> </ol> <table border="1" data-bbox="336 1693 1399 1841"> <thead> <tr> <th data-bbox="336 1693 639 1738">Display</th> <th data-bbox="639 1693 1399 1738">Description</th> </tr> </thead> <tbody> <tr> <td data-bbox="336 1738 639 1783">On</td> <td data-bbox="639 1738 1399 1783">Turn calibration ON</td> </tr> <tr> <td data-bbox="336 1783 639 1841">Off</td> <td data-bbox="639 1783 1399 1841">Turn calibration OFF</td> </tr> </tbody> </table> <p data-bbox="336 1852 539 1881">Initial setting: On</p> <ol data-bbox="308 1886 782 1915" style="list-style-type: none"> <li>2. Press the start key. The setting is set.</li> </ol>	Display	Description	Permission	Setting to turn calibration on/off	Time Interval	Setting the interval time of calibration after printing	Mode	Setting the calibration execution mode	On/Sleep Out*	Setting execution parameters for calibration when powered up or reverted from auto-sleep	AP/NE*	Paper interval calibration ON/OFF setting at the time of calibration/near end after toner feed	Leaving Time*	Setting the standard time for judging whether or not to carry out calibration based on the sleep time when the machine recovers from the sleep mode	Driving Time*	Setting the standard time for judging whether or not to carry out paper interval calibration based on the driving time during printing	Timing*	Setting the standard time for judging whether or not to carry out calibration based on the continuous print driving time during printing	Target Value	Setting the sensor target values for toner thick layer calibration and light amount calibration	Calib	Executing the calibration	Display	Description	On	Turn calibration ON	Off	Turn calibration OFF
Display	Description																												
Permission	Setting to turn calibration on/off																												
Time Interval	Setting the interval time of calibration after printing																												
Mode	Setting the calibration execution mode																												
On/Sleep Out*	Setting execution parameters for calibration when powered up or reverted from auto-sleep																												
AP/NE*	Paper interval calibration ON/OFF setting at the time of calibration/near end after toner feed																												
Leaving Time*	Setting the standard time for judging whether or not to carry out calibration based on the sleep time when the machine recovers from the sleep mode																												
Driving Time*	Setting the standard time for judging whether or not to carry out paper interval calibration based on the driving time during printing																												
Timing*	Setting the standard time for judging whether or not to carry out calibration based on the continuous print driving time during printing																												
Target Value	Setting the sensor target values for toner thick layer calibration and light amount calibration																												
Calib	Executing the calibration																												
Display	Description																												
On	Turn calibration ON																												
Off	Turn calibration OFF																												

Item No.	Description																														
U464	<p data-bbox="292 241 582 271"><b>Setting: [Time Interval]</b></p> <p data-bbox="308 277 1054 306">1. Change the setting value using the +/- keys or numeric keys.</p> <table border="1" data-bbox="336 318 1401 450"> <thead> <tr> <th data-bbox="336 318 564 398">Display</th> <th data-bbox="564 318 1066 398">Description</th> <th data-bbox="1066 318 1249 398">Setting range</th> <th data-bbox="1249 318 1401 398">Initial setting</th> </tr> </thead> <tbody> <tr> <td data-bbox="336 398 564 450">Time(sec)</td> <td data-bbox="564 398 1066 450">Setting the interval time of calibration</td> <td data-bbox="1066 398 1249 450">0 to 9999 (s)</td> <td data-bbox="1249 398 1401 450">0</td> </tr> </tbody> </table> <p data-bbox="308 461 767 490">2. Press the start key. The value is set.</p> <p data-bbox="292 528 488 557"><b>Setting: [Mode]</b></p> <p data-bbox="308 564 521 593">1. Select the item.</p> <table border="1" data-bbox="336 604 1401 846"> <thead> <tr> <th data-bbox="336 604 639 656">Display</th> <th data-bbox="639 604 1401 656">Description</th> </tr> </thead> <tbody> <tr> <td data-bbox="336 656 639 701">Short</td> <td data-bbox="639 656 1401 701">Setting the calibration execution mode: short</td> </tr> <tr> <td data-bbox="336 701 639 745">Normal</td> <td data-bbox="639 701 1401 745">Setting the calibration execution mode: normal</td> </tr> <tr> <td data-bbox="336 745 639 790">Long</td> <td data-bbox="639 745 1401 790">Setting the calibration execution mode: long</td> </tr> <tr> <td data-bbox="336 790 639 846">Custom</td> <td data-bbox="639 790 1401 846">Setting the calibration execution mode: custom</td> </tr> </tbody> </table> <p data-bbox="336 857 588 887">Initial setting: Normal</p> <p data-bbox="308 893 782 922">2. Press the start key. The setting is set.</p> <p data-bbox="292 960 587 990"><b>Setting: [On/Sleep Out]</b></p> <p data-bbox="308 996 537 1025">1. Select On or Off.</p> <table border="1" data-bbox="336 1037 1401 1254"> <thead> <tr> <th data-bbox="336 1037 639 1088">Display</th> <th data-bbox="639 1037 1401 1088">Description</th> </tr> </thead> <tbody> <tr> <td data-bbox="336 1088 639 1171">On</td> <td data-bbox="639 1088 1401 1171">Executes calibration if fuser temperature is less than 50°C/ 122°F at power-up or recovery from auto sleep mode</td> </tr> <tr> <td data-bbox="336 1171 639 1254">Off</td> <td data-bbox="639 1171 1401 1254">Not to execute calibration regardless of fuser temperature at power-up or recovery from auto sleep mode</td> </tr> </tbody> </table> <p data-bbox="336 1265 537 1294">Initial setting: On</p> <p data-bbox="308 1301 782 1330">2. Press the start key. The setting is set.</p> <p data-bbox="292 1368 499 1397"><b>Setting: [AP/NE]</b></p> <p data-bbox="308 1404 537 1433">1. Select On or Off.</p> <table border="1" data-bbox="336 1444 1401 1659"> <thead> <tr> <th data-bbox="336 1444 639 1496">Display</th> <th data-bbox="639 1444 1401 1496">Description</th> </tr> </thead> <tbody> <tr> <td data-bbox="336 1496 639 1579">On</td> <td data-bbox="639 1496 1401 1579">Paper interval calibration at the time of calibration/near end after toner feed is carried out</td> </tr> <tr> <td data-bbox="336 1579 639 1659">Off</td> <td data-bbox="639 1579 1401 1659">Paper interval calibration at the time of calibration/near end after toner feed is not carried out</td> </tr> </tbody> </table> <p data-bbox="336 1671 537 1700">Initial setting: On</p> <p data-bbox="308 1706 782 1736">2. Press the start key. The setting is set.</p>	Display	Description	Setting range	Initial setting	Time(sec)	Setting the interval time of calibration	0 to 9999 (s)	0	Display	Description	Short	Setting the calibration execution mode: short	Normal	Setting the calibration execution mode: normal	Long	Setting the calibration execution mode: long	Custom	Setting the calibration execution mode: custom	Display	Description	On	Executes calibration if fuser temperature is less than 50°C/ 122°F at power-up or recovery from auto sleep mode	Off	Not to execute calibration regardless of fuser temperature at power-up or recovery from auto sleep mode	Display	Description	On	Paper interval calibration at the time of calibration/near end after toner feed is carried out	Off	Paper interval calibration at the time of calibration/near end after toner feed is not carried out
Display	Description	Setting range	Initial setting																												
Time(sec)	Setting the interval time of calibration	0 to 9999 (s)	0																												
Display	Description																														
Short	Setting the calibration execution mode: short																														
Normal	Setting the calibration execution mode: normal																														
Long	Setting the calibration execution mode: long																														
Custom	Setting the calibration execution mode: custom																														
Display	Description																														
On	Executes calibration if fuser temperature is less than 50°C/ 122°F at power-up or recovery from auto sleep mode																														
Off	Not to execute calibration regardless of fuser temperature at power-up or recovery from auto sleep mode																														
Display	Description																														
On	Paper interval calibration at the time of calibration/near end after toner feed is carried out																														
Off	Paper interval calibration at the time of calibration/near end after toner feed is not carried out																														

Item No.	Description																																				
U464	<p data-bbox="288 241 587 275"><b>Setting: [Leaving Time]</b></p> <p data-bbox="288 277 1054 311">1. Change the setting value using the +/- keys or numeric keys.</p> <table border="1" data-bbox="336 320 1401 450"> <thead> <tr> <th data-bbox="336 320 564 398">Display</th> <th data-bbox="564 320 1066 398">Description</th> <th data-bbox="1066 320 1262 398">Setting range</th> <th data-bbox="1262 320 1401 398">Initial setting</th> </tr> </thead> <tbody> <tr> <td data-bbox="336 398 564 450">Time(min)</td> <td data-bbox="564 398 1066 450">Setting the standard time of sleep mode</td> <td data-bbox="1066 398 1262 450">0 to 480 (min)</td> <td data-bbox="1262 398 1401 450">60</td> </tr> </tbody> </table> <p data-bbox="288 459 767 492">2. Press the start key. The value is set.</p> <p data-bbox="288 526 579 560"><b>Setting: [Driving Time]</b></p> <p data-bbox="288 562 858 595">1. Change the setting value using the +/- keys.</p> <table border="1" data-bbox="336 604 1401 734"> <thead> <tr> <th data-bbox="336 604 564 683">Display</th> <th data-bbox="564 604 1035 683">Description</th> <th data-bbox="1035 604 1262 683">Setting range</th> <th data-bbox="1262 604 1401 683">Initial setting</th> </tr> </thead> <tbody> <tr> <td data-bbox="336 683 564 734">Time(sec)</td> <td data-bbox="564 683 1035 734">Setting the drive standard time</td> <td data-bbox="1035 683 1262 734">300 to 3000 (s)</td> <td data-bbox="1262 683 1401 734">300</td> </tr> </tbody> </table> <p data-bbox="288 743 767 777">2. Press the start key. The value is set.</p> <p data-bbox="288 810 504 844"><b>Setting: [Timing]</b></p> <p data-bbox="288 846 858 880">1. Change the setting value using the +/- keys.</p> <table border="1" data-bbox="336 889 1401 1055"> <thead> <tr> <th data-bbox="336 889 564 967">Display</th> <th data-bbox="564 889 1035 967">Description</th> <th data-bbox="1035 889 1262 967">Setting range</th> <th data-bbox="1262 889 1401 967">Initial setting</th> </tr> </thead> <tbody> <tr> <td data-bbox="336 967 564 1055">Time(sec)</td> <td data-bbox="564 967 1035 1055">Setting the drive standard time of continuous print</td> <td data-bbox="1035 967 1262 1055">0 to 3600 (s)</td> <td data-bbox="1262 967 1401 1055">0</td> </tr> </tbody> </table> <p data-bbox="288 1064 767 1097">2. Press the start key. The value is set.</p> <p data-bbox="288 1131 576 1164"><b>Setting: [Target Value]</b></p> <p data-bbox="288 1167 523 1200">1. Select the item.</p> <p data-bbox="288 1202 1054 1236">2. Change the setting value using the +/- keys or numeric keys.</p> <table border="1" data-bbox="336 1245 1401 1422"> <thead> <tr> <th data-bbox="336 1245 564 1323">Display</th> <th data-bbox="564 1245 1035 1323">Description</th> <th data-bbox="1035 1245 1262 1323">Setting range</th> <th data-bbox="1262 1245 1401 1323">Initial setting</th> </tr> </thead> <tbody> <tr> <td data-bbox="336 1323 564 1375">Thickness(K)</td> <td data-bbox="564 1323 1035 1375">Toner thick layer calibration</td> <td data-bbox="1035 1323 1262 1375">0 to 1000</td> <td data-bbox="1262 1323 1401 1375">145</td> </tr> <tr> <td data-bbox="336 1375 564 1422">Gamma(K)</td> <td data-bbox="564 1375 1035 1422">Light amount calibration</td> <td data-bbox="1035 1375 1262 1422">0 to 500</td> <td data-bbox="1262 1375 1401 1422">330</td> </tr> </tbody> </table> <p data-bbox="288 1431 767 1464">3. Press the start key. The value is set.</p> <p data-bbox="288 1498 488 1532"><b>Method: [Calib]</b></p> <p data-bbox="288 1534 539 1568">1. Select [Execute].</p> <p data-bbox="288 1570 850 1603">2. Press the start key. Calibration is executed.</p> <p data-bbox="336 1606 1305 1673">* : Duplicates selecting [System Menu] - [Adjustment/Maintenance] - [Calibration]. The same operation as System menu.</p> <p data-bbox="288 1706 440 1740"><b>Completion</b></p> <p data-bbox="288 1742 1257 1776">Press the stop key. The screen for selecting a maintenance item No. is displayed.</p>	Display	Description	Setting range	Initial setting	Time(min)	Setting the standard time of sleep mode	0 to 480 (min)	60	Display	Description	Setting range	Initial setting	Time(sec)	Setting the drive standard time	300 to 3000 (s)	300	Display	Description	Setting range	Initial setting	Time(sec)	Setting the drive standard time of continuous print	0 to 3600 (s)	0	Display	Description	Setting range	Initial setting	Thickness(K)	Toner thick layer calibration	0 to 1000	145	Gamma(K)	Light amount calibration	0 to 500	330
Display	Description	Setting range	Initial setting																																		
Time(min)	Setting the standard time of sleep mode	0 to 480 (min)	60																																		
Display	Description	Setting range	Initial setting																																		
Time(sec)	Setting the drive standard time	300 to 3000 (s)	300																																		
Display	Description	Setting range	Initial setting																																		
Time(sec)	Setting the drive standard time of continuous print	0 to 3600 (s)	0																																		
Display	Description	Setting range	Initial setting																																		
Thickness(K)	Toner thick layer calibration	0 to 1000	145																																		
Gamma(K)	Light amount calibration	0 to 500	330																																		

Item No.	Description																												
U465	<p data-bbox="287 241 694 275"><b>Data reference for ID correction</b></p> <p data-bbox="287 309 438 342"><b>Description</b> References the data related to ID correction.</p> <p data-bbox="287 376 399 409"><b>Purpose</b> To check the corresponding data.</p> <p data-bbox="287 488 391 521"><b>Method</b></p> <ol data-bbox="303 521 710 589" style="list-style-type: none"> <li>1. Press the start key.</li> <li>2. Select the item to be reference.</li> </ol> <table border="1" data-bbox="335 600 1401 835"> <thead> <tr> <th data-bbox="343 611 603 645">Display</th> <th data-bbox="603 611 1393 645">Description</th> </tr> </thead> <tbody> <tr> <td data-bbox="343 656 603 689">TCONT</td> <td data-bbox="603 656 1393 689">Developer bias control value after ID correction</td> </tr> <tr> <td data-bbox="343 701 603 734">Laser Power</td> <td data-bbox="603 701 1393 734">Scaling factor to the value determined in light amount calibration</td> </tr> <tr> <td data-bbox="343 745 603 779">Bias Calib</td> <td data-bbox="603 745 1393 779">Sensor value for toner thick layer calibration</td> </tr> <tr> <td data-bbox="343 790 603 824">T7 CTD</td> <td data-bbox="603 790 1393 824">T7 control value</td> </tr> </tbody> </table> <p data-bbox="287 880 574 913"><b>Displaying: [TCOUNT]</b></p> <ol data-bbox="303 913 925 947" style="list-style-type: none"> <li>1. Select [TCOUNT]. The current value is displayed.</li> </ol> <table border="1" data-bbox="335 958 1401 1104"> <thead> <tr> <th data-bbox="343 969 603 1003">Display</th> <th data-bbox="603 969 1393 1003">Description</th> </tr> </thead> <tbody> <tr> <td data-bbox="343 1014 603 1048">Before(K)</td> <td data-bbox="603 1014 1393 1048">Developer bias control value for black before ID correction</td> </tr> <tr> <td data-bbox="343 1059 603 1093">After(K)</td> <td data-bbox="603 1059 1393 1093">Developer bias control value for black after ID correction</td> </tr> </tbody> </table> <p data-bbox="287 1149 622 1182"><b>Displaying: [Laser Power]</b></p> <ol data-bbox="303 1182 965 1216" style="list-style-type: none"> <li>1. Select [Laser Power]. The current value is displayed.</li> </ol> <table border="1" data-bbox="335 1227 1401 1328"> <thead> <tr> <th data-bbox="343 1238 491 1272">Display</th> <th data-bbox="491 1238 1393 1272">Description</th> </tr> </thead> <tbody> <tr> <td data-bbox="343 1283 491 1317">K</td> <td data-bbox="491 1283 1393 1317">Scaling factor to the value determined in light amount calibration</td> </tr> </tbody> </table> <p data-bbox="287 1373 590 1406"><b>Displaying: [Bias Calib]</b></p> <ol data-bbox="303 1406 933 1440" style="list-style-type: none"> <li>1. Select [Bias Calib]. The current value is displayed.</li> </ol> <table border="1" data-bbox="335 1451 1401 1552"> <thead> <tr> <th data-bbox="343 1462 566 1496">Display</th> <th data-bbox="566 1462 1393 1496">Description</th> </tr> </thead> <tbody> <tr> <td data-bbox="343 1507 566 1541">K</td> <td data-bbox="566 1507 1393 1541">Sensor value for toner thick layer calibration</td> </tr> </tbody> </table> <p data-bbox="287 1597 558 1630"><b>Displaying: [T7 CTD]</b></p> <ol data-bbox="303 1630 901 1664" style="list-style-type: none"> <li>1. Select [T7 CTD]. The current value is displayed.</li> </ol> <table border="1" data-bbox="335 1675 1401 1776"> <thead> <tr> <th data-bbox="343 1686 566 1720">Display</th> <th data-bbox="566 1686 1393 1720">Description</th> </tr> </thead> <tbody> <tr> <td data-bbox="343 1731 566 1765">K</td> <td data-bbox="566 1731 1393 1765">T7 control value</td> </tr> </tbody> </table> <p data-bbox="287 1809 438 1843"><b>Completion</b> Press the stop key. The screen for selecting a maintenance item No. is displayed.</p>	Display	Description	TCONT	Developer bias control value after ID correction	Laser Power	Scaling factor to the value determined in light amount calibration	Bias Calib	Sensor value for toner thick layer calibration	T7 CTD	T7 control value	Display	Description	Before(K)	Developer bias control value for black before ID correction	After(K)	Developer bias control value for black after ID correction	Display	Description	K	Scaling factor to the value determined in light amount calibration	Display	Description	K	Sensor value for toner thick layer calibration	Display	Description	K	T7 control value
Display	Description																												
TCONT	Developer bias control value after ID correction																												
Laser Power	Scaling factor to the value determined in light amount calibration																												
Bias Calib	Sensor value for toner thick layer calibration																												
T7 CTD	T7 control value																												
Display	Description																												
Before(K)	Developer bias control value for black before ID correction																												
After(K)	Developer bias control value for black after ID correction																												
Display	Description																												
K	Scaling factor to the value determined in light amount calibration																												
Display	Description																												
K	Sensor value for toner thick layer calibration																												
Display	Description																												
K	T7 control value																												

Item No.	Description																										
U470	<p data-bbox="288 241 750 271"><b>Setting the JPEG compression ratio</b></p> <p data-bbox="288 311 440 340"><b>Description</b></p> <p data-bbox="288 344 1158 374">Sets the compression ratio for JPEG images in each image quality mode.</p> <p data-bbox="288 378 400 407"><b>Purpose</b></p> <p data-bbox="288 412 1418 582">To change the setting in accordance with the image that the user is copying. For example, in order to soften the coarseness of the image when making copies at over 200% magnification, change the level of compression by raising the value. Lowering the value will increase the compression and thereby lower the image quality; Raising the value will increase image quality but lower the image processing speed.</p> <p data-bbox="288 622 387 651"><b>Method</b></p> <ol data-bbox="304 656 632 719" style="list-style-type: none"> <li>1. Press the start key.</li> <li>2. Select the item to be set.</li> </ol> <table border="1" data-bbox="336 734 1399 927"> <thead> <tr> <th data-bbox="336 734 641 779">Display</th> <th data-bbox="641 734 1399 779">Description</th> </tr> </thead> <tbody> <tr> <td data-bbox="336 779 641 824">Copy</td> <td data-bbox="641 779 1399 824">Compression ratio for copying</td> </tr> <tr> <td data-bbox="336 824 641 869">Send</td> <td data-bbox="641 824 1399 869">Compression ratio for sending</td> </tr> <tr> <td data-bbox="336 869 641 927">System</td> <td data-bbox="641 869 1399 927">Compression ratio for temporary storage in system</td> </tr> </tbody> </table> <p data-bbox="288 972 485 1001"><b>Setting: [Copy]</b></p> <ol data-bbox="304 1005 632 1034" style="list-style-type: none"> <li>1. Select the item to be set.</li> </ol> <table border="1" data-bbox="336 1050 1399 1196"> <thead> <tr> <th data-bbox="336 1050 641 1095">Display</th> <th data-bbox="641 1050 1399 1095">Description</th> </tr> </thead> <tbody> <tr> <td data-bbox="336 1095 641 1140">Photo</td> <td data-bbox="641 1095 1399 1140">Compression ratio in the photo mode</td> </tr> <tr> <td data-bbox="336 1140 641 1196">Text</td> <td data-bbox="641 1140 1399 1196">Compression ratio in the text mode</td> </tr> </tbody> </table> <ol data-bbox="304 1207 1054 1270" style="list-style-type: none"> <li>2. Select the item to be set.</li> <li>3. Change the setting value using the +/- keys or numeric keys.</li> </ol> <table border="1" data-bbox="336 1285 1399 1462"> <thead> <tr> <th data-bbox="336 1285 564 1368">Display</th> <th data-bbox="564 1285 1067 1368">Description</th> <th data-bbox="1067 1285 1232 1368">Setting range</th> <th data-bbox="1232 1285 1399 1368">Initial setting</th> </tr> </thead> <tbody> <tr> <td data-bbox="336 1368 564 1413">Y</td> <td data-bbox="564 1368 1067 1413">Compression ratio of brightness</td> <td data-bbox="1067 1368 1232 1413">1 to 100</td> <td data-bbox="1232 1368 1399 1413">90</td> </tr> <tr> <td data-bbox="336 1413 564 1462">CbCr</td> <td data-bbox="564 1413 1067 1462">Compression ratio of color differential</td> <td data-bbox="1067 1413 1232 1462">1 to 100</td> <td data-bbox="1232 1413 1399 1462">90</td> </tr> </tbody> </table> <ol data-bbox="304 1473 767 1503" style="list-style-type: none"> <li>4. Press the start key. The value is set.</li> </ol>	Display	Description	Copy	Compression ratio for copying	Send	Compression ratio for sending	System	Compression ratio for temporary storage in system	Display	Description	Photo	Compression ratio in the photo mode	Text	Compression ratio in the text mode	Display	Description	Setting range	Initial setting	Y	Compression ratio of brightness	1 to 100	90	CbCr	Compression ratio of color differential	1 to 100	90
Display	Description																										
Copy	Compression ratio for copying																										
Send	Compression ratio for sending																										
System	Compression ratio for temporary storage in system																										
Display	Description																										
Photo	Compression ratio in the photo mode																										
Text	Compression ratio in the text mode																										
Display	Description	Setting range	Initial setting																								
Y	Compression ratio of brightness	1 to 100	90																								
CbCr	Compression ratio of color differential	1 to 100	90																								

Item No.	Description																																																												
U470	<p data-bbox="288 241 483 271"><b>Setting: [Send]</b></p> <p data-bbox="288 277 632 306">1. Select the item to be set.</p> <table border="1" data-bbox="336 320 1401 678"> <thead> <tr> <th data-bbox="336 320 639 365">Display</th> <th data-bbox="639 320 1401 365">Description</th> </tr> </thead> <tbody> <tr> <td data-bbox="336 365 639 409">Photo</td> <td data-bbox="639 365 1401 409">Compression ratio in the photo mode</td> </tr> <tr> <td data-bbox="336 409 639 454">Text</td> <td data-bbox="639 409 1401 454">Compression ratio in the text mode</td> </tr> <tr> <td data-bbox="336 454 639 499">HC-PDF(BG)</td> <td data-bbox="639 454 1401 499">Compression ratio of high compression PDF</td> </tr> <tr> <td data-bbox="336 499 639 589">HC-PDF(Char)</td> <td data-bbox="639 499 1401 589">Setting the compression rate of the high-compression PDF (text color)</td> </tr> <tr> <td data-bbox="336 589 639 678">HC-PDF(File Size)</td> <td data-bbox="639 589 1401 678">Setting the compression rate of the high-compression PDF (reduced file size priority )</td> </tr> </tbody> </table> <p data-bbox="288 719 632 748">2. Select the item to be set.</p> <p data-bbox="288 754 1054 784">3. Change the setting value using the +/- keys or numeric keys.</p> <p data-bbox="336 790 528 819">[Photo] or [Text]</p> <table border="1" data-bbox="336 833 1401 1010"> <thead> <tr> <th data-bbox="336 833 549 911">Display</th> <th data-bbox="549 833 1019 911">Description</th> <th data-bbox="1019 833 1187 911">Setting range</th> <th data-bbox="1187 833 1401 911">Initial setting</th> </tr> </thead> <tbody> <tr> <td data-bbox="336 911 549 956">Y1 to Y5</td> <td data-bbox="549 911 1019 956">Compression ratio of brightness</td> <td data-bbox="1019 911 1187 956">1 to 100</td> <td data-bbox="1187 911 1401 956">30/40/51/70/90</td> </tr> <tr> <td data-bbox="336 956 549 1010">CbCr1 to CbCr5</td> <td data-bbox="549 956 1019 1010">Compression ratio of color differential</td> <td data-bbox="1019 956 1187 1010">1 to 100</td> <td data-bbox="1187 956 1401 1010">30/40/51/70/90</td> </tr> </tbody> </table> <p data-bbox="336 1023 512 1052">[HC-PDF(BG)]</p> <table border="1" data-bbox="336 1066 1401 1243"> <thead> <tr> <th data-bbox="336 1066 549 1144">Display</th> <th data-bbox="549 1066 1019 1144">Description</th> <th data-bbox="1019 1066 1187 1144">Setting range</th> <th data-bbox="1187 1066 1401 1144">Initial setting</th> </tr> </thead> <tbody> <tr> <td data-bbox="336 1144 549 1189">Y3 to Y3</td> <td data-bbox="549 1144 1019 1189">Compression ratio of brightness</td> <td data-bbox="1019 1144 1187 1189">1 to 100</td> <td data-bbox="1187 1144 1401 1189">15/25/90</td> </tr> <tr> <td data-bbox="336 1189 549 1243">CbCr3 to CbCr3</td> <td data-bbox="549 1189 1019 1243">Compression ratio of color differential</td> <td data-bbox="1019 1189 1187 1243">1 to 100</td> <td data-bbox="1187 1189 1401 1243">15/25/90</td> </tr> </tbody> </table> <p data-bbox="336 1256 528 1285">[HC-PDF(Char)]</p> <table border="1" data-bbox="336 1299 1401 1476"> <thead> <tr> <th data-bbox="336 1299 549 1377">Display</th> <th data-bbox="549 1299 1019 1377">Description</th> <th data-bbox="1019 1299 1187 1377">Setting range</th> <th data-bbox="1187 1299 1401 1377">Initial setting</th> </tr> </thead> <tbody> <tr> <td data-bbox="336 1377 549 1422">Y3 to Y3</td> <td data-bbox="549 1377 1019 1422">Compression ratio of brightness</td> <td data-bbox="1019 1377 1187 1422">1 to 100</td> <td data-bbox="1187 1377 1401 1422">15/75/90</td> </tr> <tr> <td data-bbox="336 1422 549 1476">CbCr3 to CbCr3</td> <td data-bbox="549 1422 1019 1476">Compression ratio of color differential</td> <td data-bbox="1019 1422 1187 1476">1 to 100</td> <td data-bbox="1187 1422 1401 1476">15/75/90</td> </tr> </tbody> </table> <p data-bbox="336 1489 576 1518">[HC-PDF(File Size)]</p> <table border="1" data-bbox="336 1532 1401 1709"> <thead> <tr> <th data-bbox="336 1532 549 1610">Display</th> <th data-bbox="549 1532 1019 1610">Description</th> <th data-bbox="1019 1532 1187 1610">Setting range</th> <th data-bbox="1187 1532 1401 1610">Initial setting</th> </tr> </thead> <tbody> <tr> <td data-bbox="336 1610 549 1655">Y3 to Y3</td> <td data-bbox="549 1610 1019 1655">Compression ratio of brightness</td> <td data-bbox="1019 1610 1187 1655">1 to 100</td> <td data-bbox="1187 1610 1401 1655">15/25/75</td> </tr> <tr> <td data-bbox="336 1655 549 1709">CbCr3 to CbCr3</td> <td data-bbox="549 1655 1019 1709">Compression ratio of color differential</td> <td data-bbox="1019 1655 1187 1709">1 to 100</td> <td data-bbox="1187 1655 1401 1709">15/25/75</td> </tr> </tbody> </table> <p data-bbox="288 1758 767 1787">4. Press the start key. The value is set.</p>	Display	Description	Photo	Compression ratio in the photo mode	Text	Compression ratio in the text mode	HC-PDF(BG)	Compression ratio of high compression PDF	HC-PDF(Char)	Setting the compression rate of the high-compression PDF (text color)	HC-PDF(File Size)	Setting the compression rate of the high-compression PDF (reduced file size priority )	Display	Description	Setting range	Initial setting	Y1 to Y5	Compression ratio of brightness	1 to 100	30/40/51/70/90	CbCr1 to CbCr5	Compression ratio of color differential	1 to 100	30/40/51/70/90	Display	Description	Setting range	Initial setting	Y3 to Y3	Compression ratio of brightness	1 to 100	15/25/90	CbCr3 to CbCr3	Compression ratio of color differential	1 to 100	15/25/90	Display	Description	Setting range	Initial setting	Y3 to Y3	Compression ratio of brightness	1 to 100	15/75/90	CbCr3 to CbCr3	Compression ratio of color differential	1 to 100	15/75/90	Display	Description	Setting range	Initial setting	Y3 to Y3	Compression ratio of brightness	1 to 100	15/25/75	CbCr3 to CbCr3	Compression ratio of color differential	1 to 100	15/25/75
Display	Description																																																												
Photo	Compression ratio in the photo mode																																																												
Text	Compression ratio in the text mode																																																												
HC-PDF(BG)	Compression ratio of high compression PDF																																																												
HC-PDF(Char)	Setting the compression rate of the high-compression PDF (text color)																																																												
HC-PDF(File Size)	Setting the compression rate of the high-compression PDF (reduced file size priority )																																																												
Display	Description	Setting range	Initial setting																																																										
Y1 to Y5	Compression ratio of brightness	1 to 100	30/40/51/70/90																																																										
CbCr1 to CbCr5	Compression ratio of color differential	1 to 100	30/40/51/70/90																																																										
Display	Description	Setting range	Initial setting																																																										
Y3 to Y3	Compression ratio of brightness	1 to 100	15/25/90																																																										
CbCr3 to CbCr3	Compression ratio of color differential	1 to 100	15/25/90																																																										
Display	Description	Setting range	Initial setting																																																										
Y3 to Y3	Compression ratio of brightness	1 to 100	15/75/90																																																										
CbCr3 to CbCr3	Compression ratio of color differential	1 to 100	15/75/90																																																										
Display	Description	Setting range	Initial setting																																																										
Y3 to Y3	Compression ratio of brightness	1 to 100	15/25/75																																																										
CbCr3 to CbCr3	Compression ratio of color differential	1 to 100	15/25/75																																																										



Item No.	Description												
U470	<p data-bbox="288 244 512 275"><b>Setting: [System]</b></p> <ol data-bbox="304 280 1054 344" style="list-style-type: none"> <li data-bbox="304 280 632 311">1. Select the item to be set.</li> <li data-bbox="304 315 1054 344">2. Change the setting value using the +/- keys or numeric keys.</li> </ol> <table border="1" data-bbox="336 356 1401 535"> <thead> <tr> <th data-bbox="336 356 564 439">Display</th> <th data-bbox="564 356 1066 439">Description</th> <th data-bbox="1066 356 1233 439">Setting range</th> <th data-bbox="1233 356 1401 439">Initial setting</th> </tr> </thead> <tbody> <tr> <td data-bbox="336 439 564 488">Y</td> <td data-bbox="564 439 1066 488">Compression ratio of brightness</td> <td data-bbox="1066 439 1233 488">1 to 100</td> <td data-bbox="1233 439 1401 488">90</td> </tr> <tr> <td data-bbox="336 488 564 535">CbCr</td> <td data-bbox="564 488 1066 535">Compression ratio of color differential</td> <td data-bbox="1066 488 1233 535">1 to 100</td> <td data-bbox="1233 488 1401 535">90</td> </tr> </tbody> </table> <ol data-bbox="304 546 767 577" style="list-style-type: none"> <li data-bbox="304 546 767 577">3. Press the start key. The value is set.</li> </ol> <p data-bbox="288 613 448 645"><b>Supplement</b></p> <p data-bbox="288 649 1417 716">While this maintenance item is being executed, copying from an original is available in interrupt copying mode (which is activated by pressing the system menu key).</p> <p data-bbox="288 752 440 784"><b>Completion</b></p> <p data-bbox="288 788 1254 819">Press the stop key. The screen for selecting a maintenance item No. is displayed.</p>	Display	Description	Setting range	Initial setting	Y	Compression ratio of brightness	1 to 100	90	CbCr	Compression ratio of color differential	1 to 100	90
Display	Description	Setting range	Initial setting										
Y	Compression ratio of brightness	1 to 100	90										
CbCr	Compression ratio of color differential	1 to 100	90										

Item No.	Description																						
U485	<p data-bbox="288 241 746 275"><b>Setting the image processing mode</b></p> <p data-bbox="288 311 440 340"><b>Description</b></p> <p data-bbox="288 344 1382 412">Sets the detection level for scanning printed matter outputted with the confidential document guard function. Also, sets the process PDF images are rotated.</p> <p data-bbox="288 416 400 445"><b>Purpose</b></p> <p data-bbox="288 450 1433 517">To change the detection level when the confidential document guard is not printed well for detection in scanning. Also, changes the process of how PDF images are rotated.</p> <p data-bbox="288 553 387 582"><b>Method</b></p> <ol data-bbox="304 586 564 654" style="list-style-type: none"> <li>1. Press the start key.</li> <li>2. Select the item.</li> </ol> <table border="1" data-bbox="336 665 1401 808"> <thead> <tr> <th data-bbox="336 665 639 712">Display</th> <th data-bbox="639 665 1401 712">Description</th> </tr> </thead> <tbody> <tr> <td data-bbox="336 712 639 759">Conf. Doc. Detection</td> <td data-bbox="639 712 1401 759">Confidential document guard detection level</td> </tr> <tr> <td data-bbox="336 759 639 808">PDF Rotation</td> <td data-bbox="639 759 1401 808">Processing the rotation of PDF images</td> </tr> </tbody> </table> <p data-bbox="288 853 679 884"><b>Setting: [Conf. Doc. Detection]</b></p> <ol data-bbox="304 889 1010 920" style="list-style-type: none"> <li>1. Change the setting value using +/- keys or numeric keys.</li> </ol> <table border="1" data-bbox="336 931 1401 1097"> <thead> <tr> <th data-bbox="336 931 564 1014">Display</th> <th data-bbox="564 931 1066 1014">Description</th> <th data-bbox="1066 931 1233 1014">Setting range</th> <th data-bbox="1233 931 1401 1014">Initial setting</th> </tr> </thead> <tbody> <tr> <td data-bbox="336 1014 564 1097">Conf. Doc. Detection</td> <td data-bbox="564 1014 1066 1097">Confidential document guard detection level</td> <td data-bbox="1066 1014 1233 1097">1 to 5</td> <td data-bbox="1233 1014 1401 1097">1</td> </tr> </tbody> </table> <p data-bbox="333 1108 1436 1176">A smaller value raises the detection sensitivity but increases the possibility of false detection. A larger value lowers the detection sensitivity but decreases the possibility of false detection.</p> <ol data-bbox="304 1180 767 1211" style="list-style-type: none"> <li>2. Press the start key. The value is set.</li> </ol> <p data-bbox="288 1247 587 1279"><b>Setting: [PDF Rotation]</b></p> <ol data-bbox="304 1283 1010 1314" style="list-style-type: none"> <li>1. Change the setting value using +/- keys or numeric keys.</li> </ol> <table border="1" data-bbox="336 1326 1401 1552"> <thead> <tr> <th data-bbox="336 1326 639 1373">Display</th> <th data-bbox="639 1326 1401 1373">Description</th> </tr> </thead> <tbody> <tr> <td data-bbox="336 1373 639 1420">0</td> <td data-bbox="639 1373 1401 1420">Assigns the image rotation with the internal parameter</td> </tr> <tr> <td data-bbox="336 1420 639 1467">1</td> <td data-bbox="639 1420 1401 1467">Assigns the image rotation with the actual image</td> </tr> <tr> <td data-bbox="336 1467 639 1552">2</td> <td data-bbox="639 1467 1401 1552">Assigns the image rotation with the internal parameter (CTM rotation)</td> </tr> </tbody> </table> <p data-bbox="333 1563 517 1594">Initial setting: 0</p> <ol data-bbox="304 1599 767 1630" style="list-style-type: none"> <li>2. Press the start key. The value is set.</li> </ol> <p data-bbox="288 1666 440 1697"><b>Completion</b></p> <p data-bbox="288 1702 1254 1733">Press the stop key. The screen for selecting a maintenance item No. is displayed.</p>	Display	Description	Conf. Doc. Detection	Confidential document guard detection level	PDF Rotation	Processing the rotation of PDF images	Display	Description	Setting range	Initial setting	Conf. Doc. Detection	Confidential document guard detection level	1 to 5	1	Display	Description	0	Assigns the image rotation with the internal parameter	1	Assigns the image rotation with the actual image	2	Assigns the image rotation with the internal parameter (CTM rotation)
Display	Description																						
Conf. Doc. Detection	Confidential document guard detection level																						
PDF Rotation	Processing the rotation of PDF images																						
Display	Description	Setting range	Initial setting																				
Conf. Doc. Detection	Confidential document guard detection level	1 to 5	1																				
Display	Description																						
0	Assigns the image rotation with the internal parameter																						
1	Assigns the image rotation with the actual image																						
2	Assigns the image rotation with the internal parameter (CTM rotation)																						

Item No.	Description																																
U520	<p><b>Set TDRS</b></p> <p><b>Description</b> Perform TDRS settings and information views.</p> <p><b>Purpose</b> Perform TDRS settings and information views.</p> <p><b>Method</b></p> <ol style="list-style-type: none"> <li>1. Press the start key.</li> <li>2. Select the item.</li> </ol> <table border="1" data-bbox="336 595 1401 788"> <thead> <tr> <th>Display</th> <th>Description</th> </tr> </thead> <tbody> <tr> <td>Registration</td> <td>Transition to the TDRS Manager registering dialog</td> </tr> <tr> <td>Information</td> <td>Transition to the Device Agent description dialog</td> </tr> <tr> <td>On/Off Config</td> <td>Transition to the TDRS features dialog</td> </tr> </tbody> </table> <p><b>Setting: [Registration]</b></p> <ol style="list-style-type: none"> <li>1. Select the item.</li> </ol> <table border="1" data-bbox="336 911 1401 1055"> <thead> <tr> <th>Display</th> <th>Description</th> </tr> </thead> <tbody> <tr> <td>TDRS User</td> <td>Registering process using user and password</td> </tr> <tr> <td>Access Code</td> <td>Registering process using an Access Code</td> </tr> </tbody> </table> <p><b>Setting: [Access Code]</b></p> <ol style="list-style-type: none"> <li>1. Select the item.</li> </ol> <table border="1" data-bbox="336 1187 1401 1619"> <thead> <tr> <th>Display</th> <th>Description</th> </tr> </thead> <tbody> <tr> <td>Regist</td> <td>Performing registration to TDRS Manager</td> </tr> <tr> <td>TDRS Server</td> <td>TDRS Server URL</td> </tr> <tr> <td>TDRS User</td> <td>TDRS Username</td> </tr> <tr> <td>Access Code</td> <td>TDRS Access Code</td> </tr> <tr> <td>Proxy Server</td> <td>TDRS Proxy Server URL</td> </tr> <tr> <td>Proxy Port</td> <td>TDRS Proxy Port Number</td> </tr> <tr> <td>Proxy User</td> <td>TDRS Proxy Username</td> </tr> <tr> <td>Text</td> <td>TDRS Description</td> </tr> </tbody> </table> <p>* : The status of Online or Offline will be indicated at the right bottom depending on connection with TDRS Manager. The Regist button is inoperative if the USB is not installed. A normal completion will be indicated by Complete in the status of the item that was performed. An occurrence of an error is indicated by an error number in the status of the item that was performed. If [User/Processing Registration using a Password] is selected in the previous dialog, the TDRS User will be indicated. If [Processing Registration using an Access Code] is selected, the Access Code will be indicated.</p>	Display	Description	Registration	Transition to the TDRS Manager registering dialog	Information	Transition to the Device Agent description dialog	On/Off Config	Transition to the TDRS features dialog	Display	Description	TDRS User	Registering process using user and password	Access Code	Registering process using an Access Code	Display	Description	Regist	Performing registration to TDRS Manager	TDRS Server	TDRS Server URL	TDRS User	TDRS Username	Access Code	TDRS Access Code	Proxy Server	TDRS Proxy Server URL	Proxy Port	TDRS Proxy Port Number	Proxy User	TDRS Proxy Username	Text	TDRS Description
Display	Description																																
Registration	Transition to the TDRS Manager registering dialog																																
Information	Transition to the Device Agent description dialog																																
On/Off Config	Transition to the TDRS features dialog																																
Display	Description																																
TDRS User	Registering process using user and password																																
Access Code	Registering process using an Access Code																																
Display	Description																																
Regist	Performing registration to TDRS Manager																																
TDRS Server	TDRS Server URL																																
TDRS User	TDRS Username																																
Access Code	TDRS Access Code																																
Proxy Server	TDRS Proxy Server URL																																
Proxy Port	TDRS Proxy Port Number																																
Proxy User	TDRS Proxy Username																																
Text	TDRS Description																																

Item No.	Description													
<b>U520</b>	<b>Error Codes</b>													
	<b>Codes</b>	<b>Description</b>	<b>Codes</b>	<b>Description</b>										
	e0001	HDD is unavailable.	t0001	Fatal error.										
	e0002	USB memory is unavailable.	t0002	Error in processing the network.										
	e0003	The file to import does not exist in the USB.	t0003	An illegal parameter error.										
	e0004	Reading from the USB has failed.	t0004	Insufficient resource.										
	e0005	Unmounting USB has failed.	t0005	Communication error.										
	e0006	Moving or renaming the file has failed.	t0006	Error in processing communication.										
	e0007	Opening the file has failed.	t0007	Login error.										
	e0008	Closing the file has failed.	t0008	External error.										
	e0009	Error in reading the file.	t0009	Authentication error.										
	e000A	Copying the file has failed.	t000A	Request error.										
	e000B	Opening the directory has failed.	t000B	Error due to the server.										
	e00C	Creating a working directory has failed.	t00C	Error due to the client.										
	e00D	Deleting a working file has failed.												
	<b>Setting: [Information]</b>													
	1. Select the item.													
	<table border="1"> <thead> <tr> <th data-bbox="336 1180 639 1225">Display</th> <th data-bbox="639 1180 1399 1225">Description</th> </tr> </thead> <tbody> <tr> <td data-bbox="336 1225 639 1270">Agent ID</td> <td data-bbox="639 1225 1399 1270">Agent ID</td> </tr> <tr> <td data-bbox="336 1270 639 1314">Agent Type</td> <td data-bbox="639 1270 1399 1314">Agent Type</td> </tr> <tr> <td data-bbox="336 1314 639 1359">Model</td> <td data-bbox="639 1314 1399 1359">model name</td> </tr> <tr> <td data-bbox="336 1359 639 1420">Serial No</td> <td data-bbox="639 1359 1399 1420">Serial number</td> </tr> </tbody> </table>				Display	Description	Agent ID	Agent ID	Agent Type	Agent Type	Model	model name	Serial No	Serial number
	Display	Description												
	Agent ID	Agent ID												
	Agent Type	Agent Type												
	Model	model name												
	Serial No	Serial number												
	<b>Setting: [On/Off Config]</b>													
	1. Select the item.													
<table border="1"> <thead> <tr> <th data-bbox="336 1561 639 1606">Display</th> <th data-bbox="639 1561 1399 1606">Description</th> </tr> </thead> <tbody> <tr> <td data-bbox="336 1606 639 1650">On</td> <td data-bbox="639 1606 1399 1650">Enable TDRS</td> </tr> <tr> <td data-bbox="336 1650 639 1704">Off</td> <td data-bbox="639 1650 1399 1704">Disable TDRS</td> </tr> </tbody> </table>				Display	Description	On	Enable TDRS	Off	Disable TDRS					
Display	Description													
On	Enable TDRS													
Off	Disable TDRS													
<b>Completion</b>														
Press the stop key. The screen for selecting a maintenance item No. is displayed.														

Item No.	Description																
U901	<p data-bbox="290 241 884 273"><b>Checking copy counts by paper feed locations</b></p> <p data-bbox="290 309 440 340"><b>Description</b></p> <p data-bbox="290 344 1015 376">Displays or clears paper feed counts by paper feed locations.</p> <p data-bbox="290 380 1342 412">Perform backup when the counters on the engine PWB and PF main PWB do not match.</p> <p data-bbox="290 416 400 448"><b>Purpose</b></p> <p data-bbox="290 452 1418 515">To check the time to replace consumable parts. Also to clear the counts after replacing the consumable parts.</p> <p data-bbox="290 519 1433 551">Backup the counter values after completing changing the PF main PWB and the paper feed unit.</p> <p data-bbox="290 586 387 618"><b>Method</b></p> <p data-bbox="306 622 1161 654">1. Press the start key. The counts by paper feed locations are displayed.</p> <table border="1" data-bbox="336 667 1401 1048"> <thead> <tr> <th data-bbox="336 667 639 712">Display</th> <th data-bbox="639 667 1401 712">Description</th> </tr> </thead> <tbody> <tr> <td data-bbox="336 712 639 757">MPT</td> <td data-bbox="639 712 1401 757">MP tray</td> </tr> <tr> <td data-bbox="336 757 639 801">Cassette1</td> <td data-bbox="639 757 1401 801">Cassette 1</td> </tr> <tr> <td data-bbox="336 801 639 846">Cassette2</td> <td data-bbox="639 801 1401 846">Cassette 2</td> </tr> <tr> <td data-bbox="336 846 639 891">Cassette3</td> <td data-bbox="639 846 1401 891">Cassette 3 (paper feeder/large capacity feeder)</td> </tr> <tr> <td data-bbox="336 891 639 936">Cassette4</td> <td data-bbox="639 891 1401 936">Cassette 4 (paper feeder/large capacity feeder)</td> </tr> <tr> <td data-bbox="336 936 639 981">Cassette5</td> <td data-bbox="639 936 1401 981">Cassette 5 (side deck)</td> </tr> <tr> <td data-bbox="336 981 639 1048">Duplex</td> <td data-bbox="639 981 1401 1048">Duplex unit</td> </tr> </tbody> </table> <p data-bbox="336 1057 1370 1120">* : When an optional paper feed unit is not installed, the corresponding count is not displayed.</p> <p data-bbox="290 1160 400 1191"><b>Clearing</b></p> <p data-bbox="306 1196 1046 1330">1. Select the counts to be cleared. [Cassette3], [Cassette4] and [Cassette5] cannot be cleared. 2. Select the counts for all and press [Clear]. 3. Press the start key. The counts is cleared.</p> <p data-bbox="290 1366 397 1397"><b>Back up</b></p> <p data-bbox="306 1402 1380 1675">1. Select the paper feed location. 2. Select [Engine] when changing the PF main PWB. Backup the [Engine] counter values to [Enhancement]. Select [Enhancement] when changing the paper feed unit. Backup the [Enhancement] counter values to [Engine]. 3. Select [Execute]. 4. Press the start key. Back up the counter values. 5. Turn the main power switch off and on. Allow more than 5 seconds between Off and On.</p> <p data-bbox="336 1711 1326 1774">* : The values of cassette 4 counter vary in accordance with the cassette 3 counter. Select [None] if the counter values are not backed up.</p> <p data-bbox="290 1814 440 1845"><b>Completion</b></p> <p data-bbox="290 1850 1256 1881">Press the stop key. The screen for selecting a maintenance item No. is displayed.</p>	Display	Description	MPT	MP tray	Cassette1	Cassette 1	Cassette2	Cassette 2	Cassette3	Cassette 3 (paper feeder/large capacity feeder)	Cassette4	Cassette 4 (paper feeder/large capacity feeder)	Cassette5	Cassette 5 (side deck)	Duplex	Duplex unit
Display	Description																
MPT	MP tray																
Cassette1	Cassette 1																
Cassette2	Cassette 2																
Cassette3	Cassette 3 (paper feeder/large capacity feeder)																
Cassette4	Cassette 4 (paper feeder/large capacity feeder)																
Cassette5	Cassette 5 (side deck)																
Duplex	Duplex unit																

Item No.	Description						
U903	<p data-bbox="288 241 798 275"><b>Checking/clearing the paper jam counts</b></p> <p data-bbox="288 309 438 342"><b>Description</b></p> <p data-bbox="288 344 890 378">Displays or clears the jam counts by jam locations.</p> <p data-bbox="288 380 399 414"><b>Purpose</b></p> <p data-bbox="288 416 1393 450">To check the paper jam status. Also to clear the jam counts after replacing consumable parts.</p> <p data-bbox="288 483 387 517"><b>Method</b></p> <ol data-bbox="304 519 564 584" style="list-style-type: none"> <li>1. Press the start key.</li> <li>2. Select the item.</li> </ol> <table border="1" data-bbox="336 595 1401 741"> <thead> <tr> <th data-bbox="336 595 639 645">Display</th> <th data-bbox="639 595 1401 645">Description</th> </tr> </thead> <tbody> <tr> <td data-bbox="336 645 639 678">Cnt</td> <td data-bbox="639 645 1401 678">Displays/clears the jam counts</td> </tr> <tr> <td data-bbox="336 678 639 741">Total Cnt</td> <td data-bbox="639 678 1401 741">Displays the total jam counts</td> </tr> </tbody> </table> <p data-bbox="288 786 467 819"><b>Method: [Cnt]</b></p> <ol data-bbox="304 822 1002 1025" style="list-style-type: none"> <li>1. Select [Cnt]. The count of jam code by type is displayed. Codes for which the count value is 0 are not displayed.</li> <li>2. Change the screen using the cursor up/down keys.</li> <li>3. Select the count value for jam code and press [Clear]. The individual counter cannot be cleared.</li> <li>4. Press the start key. The counter value is cleared.</li> </ol> <p data-bbox="288 1061 536 1095"><b>Method: [Total Cnt]</b></p> <ol data-bbox="304 1097 1150 1198" style="list-style-type: none"> <li>1. Select [Total Cnt]. The total number of jam code by type is displayed.</li> <li>2. Change the screen using the cursor up/down keys. The total number of jam count cannot be cleared.</li> </ol> <p data-bbox="288 1270 807 1303"><b>How to display the history of paper jams</b></p> <p data-bbox="288 1305 432 1339"><b>[Function]</b></p> <p data-bbox="288 1341 1425 1375">To check the variation in the occurrences of paper jams as a consequence of firmware upgrade.</p> <p data-bbox="288 1408 451 1442"><b>[Procedure]</b></p> <ol data-bbox="304 1444 1414 1545" style="list-style-type: none"> <li>1. Retrieves versions of system and engine software at the timing of clearing.</li> <li>2. Displays comparison of the occurrences of paper jams before and after firmware upgrades.</li> <li>3. Displays the date of clearing.</li> </ol> <p data-bbox="288 1581 405 1615"><b>[Method]</b></p> <p data-bbox="288 1617 553 1650"><b>At firmware upgrade</b></p> <ol data-bbox="304 1653 1406 1753" style="list-style-type: none"> <li>1. Perform clearance of the counter following the above before performing firmware upgrade.</li> <li>2. Clearing the counter records the date of clearing.</li> <li>3. Perform firmware upgrade.</li> </ol> <p data-bbox="288 1789 569 1823"><b>At performing service</b></p> <p data-bbox="288 1825 1385 1890">Print a maintenance report using mode U000 and check the variance of occurrence of paper jams after firmware upgrade was done.</p>	Display	Description	Cnt	Displays/clears the jam counts	Total Cnt	Displays the total jam counts
Display	Description						
Cnt	Displays/clears the jam counts						
Total Cnt	Displays the total jam counts						

Item No.	Description																																					
U903	<p data-bbox="287 241 678 273">Detail of history of paper jams</p> <div data-bbox="316 302 1396 996" style="border: 1px solid black; padding: 10px;"> <p data-bbox="359 331 794 376"><b>Maintenance Report</b></p> <p data-bbox="359 380 414 407">MFP</p> <p data-bbox="1193 380 1353 407" style="text-align: right;">2013.01.17 08:17</p> <p data-bbox="386 439 829 461">Firmware version 2N9_2000.000.000 2012.11.17</p> <p data-bbox="997 439 1364 461" style="text-align: right;">[XXXXXXXX] [XXXXXXXX] [XXXXXXXX]</p> <hr/> <p data-bbox="359 506 651 528">Machine No.: SPXXX00001</p> <p data-bbox="901 506 1114 528" style="text-align: right;">Life Count : 001234</p> <hr/> <table data-bbox="411 577 997 795"> <tr> <td data-bbox="411 577 742 604">(a) Paper Jam Log</td> <td data-bbox="778 577 917 604">(b) 2012.12.12</td> <td></td> </tr> <tr> <td data-bbox="566 604 654 627">JAM0000</td> <td data-bbox="782 604 798 627">1</td> <td data-bbox="901 604 933 627">10</td> </tr> <tr> <td data-bbox="566 627 654 649">JAM0100</td> <td data-bbox="782 627 798 649">0</td> <td data-bbox="901 627 933 649">2</td> </tr> <tr> <td data-bbox="566 649 654 672">JAM0101</td> <td data-bbox="782 649 798 672">0</td> <td data-bbox="901 649 933 672">2</td> </tr> <tr> <td data-bbox="566 672 654 694">JAM0110</td> <td data-bbox="750 672 782 694">(c) 0</td> <td data-bbox="901 672 933 694">2</td> </tr> <tr> <td data-bbox="566 694 654 716">JAM0111</td> <td data-bbox="782 694 798 716">1</td> <td data-bbox="901 694 933 716">2</td> </tr> <tr> <td data-bbox="566 716 654 739">JAM0112</td> <td data-bbox="782 716 798 739">0</td> <td data-bbox="901 716 933 739">1</td> </tr> <tr> <td data-bbox="566 739 654 761">JAM0131</td> <td data-bbox="782 739 798 761">5</td> <td data-bbox="901 739 933 761">89</td> </tr> <tr> <td data-bbox="566 761 654 784">JAM0210</td> <td data-bbox="750 761 782 784">(d) 2</td> <td data-bbox="901 761 933 784">7</td> </tr> </table> </div> <p data-bbox="774 1037 949 1068" style="text-align: center;"><b>Figure 1-3-60</b></p> <table data-bbox="338 1149 1401 1388"> <thead> <tr> <th data-bbox="338 1149 411 1198">No.</th> <th data-bbox="411 1149 1401 1198">Description</th> </tr> </thead> <tbody> <tr> <td data-bbox="338 1198 411 1243">a</td> <td data-bbox="411 1198 1401 1243">Paper jam numbers</td> </tr> <tr> <td data-bbox="338 1243 411 1288">b</td> <td data-bbox="411 1243 1401 1288">Date of clearing counter records</td> </tr> <tr> <td data-bbox="338 1288 411 1332">c</td> <td data-bbox="411 1288 1401 1332">Occurrences of paper jams after clearing the paper jam counts</td> </tr> <tr> <td data-bbox="338 1332 411 1388">d</td> <td data-bbox="411 1332 1401 1388">Total number of paper jams</td> </tr> </tbody> </table> <p data-bbox="287 1438 534 1467"><b>Method: [Total Cnt]</b></p> <ol data-bbox="303 1473 1149 1572" style="list-style-type: none"> <li>1. Select [Total Cnt]. The total number of jam code by type is displayed.</li> <li>2. Change the screen using the cursor up/down keys. The total number of jam count cannot be cleared.</li> </ol> <p data-bbox="287 1612 438 1641"><b>Completion</b></p> <p data-bbox="287 1648 1252 1677">Press the stop key. The screen for selecting a maintenance item No. is displayed.</p>	(a) Paper Jam Log	(b) 2012.12.12		JAM0000	1	10	JAM0100	0	2	JAM0101	0	2	JAM0110	(c) 0	2	JAM0111	1	2	JAM0112	0	1	JAM0131	5	89	JAM0210	(d) 2	7	No.	Description	a	Paper jam numbers	b	Date of clearing counter records	c	Occurrences of paper jams after clearing the paper jam counts	d	Total number of paper jams
(a) Paper Jam Log	(b) 2012.12.12																																					
JAM0000	1	10																																				
JAM0100	0	2																																				
JAM0101	0	2																																				
JAM0110	(c) 0	2																																				
JAM0111	1	2																																				
JAM0112	0	1																																				
JAM0131	5	89																																				
JAM0210	(d) 2	7																																				
No.	Description																																					
a	Paper jam numbers																																					
b	Date of clearing counter records																																					
c	Occurrences of paper jams after clearing the paper jam counts																																					
d	Total number of paper jams																																					

Item No.	Description						
U904	<p data-bbox="290 241 861 275"><b>Checking/clearing the call for service counts</b></p> <p data-bbox="290 309 438 342"><b>Description</b></p> <p data-bbox="290 344 954 378">Displays or clears the service call code counts by types.</p> <p data-bbox="290 380 399 414"><b>Purpose</b></p> <p data-bbox="290 416 837 450">To check the service call code status by types.</p> <p data-bbox="290 452 1177 486">Also to clear the service call code counts after replacing consumable parts.</p> <p data-bbox="290 519 386 553"><b>Method</b></p> <ol data-bbox="306 555 564 622" style="list-style-type: none"> <li>1. Press the start key.</li> <li>2. Select the item.</li> </ol> <table border="1" data-bbox="336 633 1401 779"> <thead> <tr> <th data-bbox="336 633 641 678">Display</th> <th data-bbox="641 633 1401 678">Description</th> </tr> </thead> <tbody> <tr> <td data-bbox="336 678 641 723">Cnt</td> <td data-bbox="641 678 1401 723">Displays/clears the call for service counts</td> </tr> <tr> <td data-bbox="336 723 641 779">Total Cnt</td> <td data-bbox="641 723 1401 779">Displays the total call for service counts</td> </tr> </tbody> </table> <p data-bbox="290 824 466 857"><b>Method: [Cnt]</b></p> <ol data-bbox="306 860 1152 1061" style="list-style-type: none"> <li>1. Select [Cnt]. The count for service call detection by type is displayed. Codes for which the count value is 0 are not displayed.</li> <li>2. Change the screen using the cursor up/down keys.</li> <li>3. Select the count value for service call code and press [Clear]. The individual counter cannot be cleared.</li> <li>4. Press the start key. The counter value is cleared.</li> </ol> <p data-bbox="290 1099 534 1133"><b>Method: [Total Cnt]</b></p> <ol data-bbox="306 1135 1260 1236" style="list-style-type: none"> <li>1. Select [Total Cnt]. The total number of service call counts by type is displayed.</li> <li>2. Change the screen using the cursor up/down keys. The total number of service call count cannot be cleared.</li> </ol> <p data-bbox="290 1308 852 1341"><b>How to display the history of service counts</b></p> <p data-bbox="290 1344 430 1377"><b>[Function]</b></p> <p data-bbox="290 1379 1431 1413">To check the variation in the occurrences of service calls as a consequence of firmware upgrade.</p> <p data-bbox="290 1447 450 1480"><b>[Procedure]</b></p> <ol data-bbox="306 1482 1426 1583" style="list-style-type: none"> <li>1. Retrieves versions of system and engine software at the timing of clearing.</li> <li>2. Displays comparison of the occurrences of service calls before and after firmware upgrades.</li> <li>3. Displays the date of clearing.</li> </ol> <p data-bbox="290 1619 405 1653"><b>[Method]</b></p> <p data-bbox="290 1655 553 1688"><b>At firmware upgrade</b></p> <ol data-bbox="306 1691 1406 1789" style="list-style-type: none"> <li>1. Perform clearance of the counter following the above before performing firmware upgrade.</li> <li>2. Clearing the counter records the date of clearing.</li> <li>3. Perform firmware upgrade.</li> </ol> <p data-bbox="290 1825 569 1859"><b>At performing service</b></p> <ol data-bbox="306 1861 1406 1928" style="list-style-type: none"> <li>1. Print a maintenance report using mode U000 and check the variance of occurrence of service calls after firmware upgrade was done.</li> </ol>	Display	Description	Cnt	Displays/clears the call for service counts	Total Cnt	Displays the total call for service counts
Display	Description						
Cnt	Displays/clears the call for service counts						
Total Cnt	Displays the total call for service counts						



Item No.	Description																																																						
<p><b>U904</b></p>	<p><b>Detail of history of service counts</b></p> <div style="border: 1px solid black; padding: 10px; margin: 10px 0;"> <p style="text-align: center;"><b>Maintenance Report</b></p> <p>MFP <span style="float: right;">2013.01.17 08:17</span></p> <p>Firmware version 2N9_2000.000.000 2012.11.17 <span style="float: right;">[XXXXXXXX] [XXXXXXXX] [XXXXXXXX]</span></p> <hr/> <p><b>Machine No.: SPXXX00001</b> <span style="float: right;"><b>Life Count : 001234</b></span></p> <hr/> <table style="width: 100%; border-collapse: collapse;"> <tr> <td style="width: 40%;">Paper Jam Log</td> <td style="width: 20%; text-align: right;">2012.12.12</td> <td style="width: 20%;"></td> <td style="width: 20%;"></td> </tr> <tr> <td style="padding-left: 20px;">JAM0000</td> <td style="text-align: right;">10</td> <td style="text-align: right;">1</td> <td></td> </tr> <tr> <td><b>(a)</b> Service Call Log</td> <td><b>(b)</b> 2012.12.12</td> <td></td> <td></td> </tr> <tr> <td style="padding-left: 20px;">C0630</td> <td style="text-align: right;">1</td> <td style="text-align: right;">1</td> <td></td> </tr> <tr> <td style="padding-left: 20px;">C1000</td> <td style="text-align: right;">0</td> <td style="text-align: right;">50</td> <td></td> </tr> <tr> <td style="padding-left: 20px;">C1950</td> <td style="text-align: right;">0</td> <td style="text-align: right;">1</td> <td></td> </tr> <tr> <td style="padding-left: 20px;">C2840</td> <td style="text-align: right;">3</td> <td style="text-align: right;">17</td> <td></td> </tr> <tr> <td style="padding-left: 20px;">C4300</td> <td style="text-align: right;">1</td> <td style="text-align: right;">2</td> <td></td> </tr> <tr> <td style="padding-left: 20px;">C9000</td> <td style="text-align: right;">0</td> <td style="text-align: right;">1</td> <td></td> </tr> <tr> <td style="padding-left: 20px;">C9060</td> <td style="text-align: right;">5</td> <td style="text-align: right;">20</td> <td></td> </tr> <tr> <td style="padding-left: 20px;">C9080</td> <td style="text-align: right;">2</td> <td style="text-align: right;">1</td> <td></td> </tr> </table> </div> <p style="text-align: center;"><b>Figure 1-3-61</b></p> <table border="1" style="width: 100%; border-collapse: collapse; margin: 10px 0;"> <thead> <tr> <th style="width: 10%;">No</th> <th>Description</th> </tr> </thead> <tbody> <tr> <td>a</td> <td>Service call numbers</td> </tr> <tr> <td>b</td> <td>Date of clearing counter records</td> </tr> <tr> <td>c</td> <td>Occurrences of service calls after clearing the service call counts</td> </tr> <tr> <td>d</td> <td>Total number of service calls</td> </tr> </tbody> </table> <p><b>Method: [Total Cnt]</b></p> <ol style="list-style-type: none"> <li>1. Select [Total Cnt]. The total number of service call counts by type is displayed.</li> <li>2. Change the screen using the cursor up/down keys. The total number of service call count cannot be cleared.</li> </ol> <p><b>Completion</b></p> <p>Press the stop key. The screen for selecting a maintenance item No. is displayed.</p>	Paper Jam Log	2012.12.12			JAM0000	10	1		<b>(a)</b> Service Call Log	<b>(b)</b> 2012.12.12			C0630	1	1		C1000	0	50		C1950	0	1		C2840	3	17		C4300	1	2		C9000	0	1		C9060	5	20		C9080	2	1		No	Description	a	Service call numbers	b	Date of clearing counter records	c	Occurrences of service calls after clearing the service call counts	d	Total number of service calls
Paper Jam Log	2012.12.12																																																						
JAM0000	10	1																																																					
<b>(a)</b> Service Call Log	<b>(b)</b> 2012.12.12																																																						
C0630	1	1																																																					
C1000	0	50																																																					
C1950	0	1																																																					
C2840	3	17																																																					
C4300	1	2																																																					
C9000	0	1																																																					
C9060	5	20																																																					
C9080	2	1																																																					
No	Description																																																						
a	Service call numbers																																																						
b	Date of clearing counter records																																																						
c	Occurrences of service calls after clearing the service call counts																																																						
d	Total number of service calls																																																						

Item No.	Description																														
U905	<p data-bbox="288 241 762 275"><b>Checking counts by optional devices</b></p> <p data-bbox="288 311 440 340"><b>Description</b></p> <p data-bbox="288 344 1015 374">Displays the counts of DP, 1000-sheet or 4000-sheet finisher.</p> <p data-bbox="288 380 400 409"><b>Purpose</b></p> <p data-bbox="288 414 983 443">To check the use of DP, 1000-sheet or 4000-sheet finisher.</p> <p data-bbox="288 486 387 515"><b>Method</b></p> <ol data-bbox="304 519 979 618" style="list-style-type: none"> <li>1. Press the start key.</li> <li>2. Select the device, the count of which is to be checked. The count of the selected device is displayed.</li> </ol> <table border="1" data-bbox="336 631 1401 777"> <thead> <tr> <th data-bbox="336 631 639 676">Display</th> <th data-bbox="639 631 1401 676">Description</th> </tr> </thead> <tbody> <tr> <td data-bbox="336 676 639 721">DP</td> <td data-bbox="639 676 1401 721">Counts of DP</td> </tr> <tr> <td data-bbox="336 721 639 777">DF</td> <td data-bbox="639 721 1401 777">Counts of 1000-sheet or 4000-sheet finisher</td> </tr> </tbody> </table> <p data-bbox="288 822 459 851"><b>Method: [DP]</b></p> <table border="1" data-bbox="336 864 1401 1057"> <thead> <tr> <th data-bbox="336 864 639 909">Display</th> <th data-bbox="639 864 1401 909">Description</th> </tr> </thead> <tbody> <tr> <td data-bbox="336 909 639 954">ADP</td> <td data-bbox="639 909 1401 954">No. of single-sided originals that has passed through the DP</td> </tr> <tr> <td data-bbox="336 954 639 999">RADP</td> <td data-bbox="639 954 1401 999">No. of double-sided originals that has passed through the DP</td> </tr> <tr> <td data-bbox="336 999 639 1057">CIS</td> <td data-bbox="639 999 1401 1057">No. of dual scan originals that has passed through the DP</td> </tr> </tbody> </table> <p data-bbox="288 1102 459 1131"><b>Method: [DF]</b></p> <table border="1" data-bbox="336 1144 1401 1527"> <thead> <tr> <th data-bbox="336 1144 639 1189">Display</th> <th data-bbox="639 1144 1401 1189">Description</th> </tr> </thead> <tbody> <tr> <td data-bbox="336 1189 639 1234">Sorter</td> <td data-bbox="639 1189 1401 1234">No. of copies that has passed</td> </tr> <tr> <td data-bbox="336 1234 639 1279">Staple</td> <td data-bbox="639 1234 1401 1279">Frequency the stapler has been activated</td> </tr> <tr> <td data-bbox="336 1279 639 1323">Punch</td> <td data-bbox="639 1279 1401 1323">Frequency the punch has been activated</td> </tr> <tr> <td data-bbox="336 1323 639 1368">Stack*</td> <td data-bbox="639 1323 1401 1368">Frequency the main tray eject has been activated</td> </tr> <tr> <td data-bbox="336 1368 639 1413">Saddle*</td> <td data-bbox="639 1368 1401 1413">Frequency the saddle eject has been activated</td> </tr> <tr> <td data-bbox="336 1413 639 1458">Fold*</td> <td data-bbox="639 1413 1401 1458">Frequency the center folding has been activated</td> </tr> <tr> <td data-bbox="336 1458 639 1527">Three Fold*</td> <td data-bbox="639 1458 1401 1527">Frequency the tri-folding has been activated</td> </tr> </tbody> </table> <p data-bbox="336 1538 660 1568">* : 4000-sheet finisher only</p> <p data-bbox="288 1606 440 1635"><b>Completion</b></p> <p data-bbox="288 1639 1254 1668">Press the stop key. The screen for selecting a maintenance item No. is displayed.</p>	Display	Description	DP	Counts of DP	DF	Counts of 1000-sheet or 4000-sheet finisher	Display	Description	ADP	No. of single-sided originals that has passed through the DP	RADP	No. of double-sided originals that has passed through the DP	CIS	No. of dual scan originals that has passed through the DP	Display	Description	Sorter	No. of copies that has passed	Staple	Frequency the stapler has been activated	Punch	Frequency the punch has been activated	Stack*	Frequency the main tray eject has been activated	Saddle*	Frequency the saddle eject has been activated	Fold*	Frequency the center folding has been activated	Three Fold*	Frequency the tri-folding has been activated
Display	Description																														
DP	Counts of DP																														
DF	Counts of 1000-sheet or 4000-sheet finisher																														
Display	Description																														
ADP	No. of single-sided originals that has passed through the DP																														
RADP	No. of double-sided originals that has passed through the DP																														
CIS	No. of dual scan originals that has passed through the DP																														
Display	Description																														
Sorter	No. of copies that has passed																														
Staple	Frequency the stapler has been activated																														
Punch	Frequency the punch has been activated																														
Stack*	Frequency the main tray eject has been activated																														
Saddle*	Frequency the saddle eject has been activated																														
Fold*	Frequency the center folding has been activated																														
Three Fold*	Frequency the tri-folding has been activated																														

Item No.	Description
U906	<p><b>Resetting partial operation control</b></p> <p><b>Description</b> Resets the service call code for partial operation control.</p> <p><b>Purpose</b> To be reset after partial operation is performed due to problems in the cassettes or other sections, and the related parts are serviced.</p> <p><b>Method</b></p> <ol style="list-style-type: none"> <li>1. Press the start key.</li> <li>2. Press [Execute].</li> <li>3. Press the start key to reset partial operation control.</li> <li>4. Turn the main power switch off and on. Allow more than 5 seconds between Off and On.</li> </ol>
U908	<p><b>Checking the total counter value</b></p> <p><b>Description</b> Displays the total counter value.</p> <p><b>Purpose</b> To check the total counter value.</p> <p><b>Method</b></p> <ol style="list-style-type: none"> <li>1. Press the start key. The total count value is displayed.</li> </ol> <p><b>Completion</b> Press the stop key. The screen for selecting a maintenance item No. is displayed.</p>
U910	<p><b>Clearing the print coverage data</b></p> <p><b>Description</b> Clears the accumulated data for the print coverage per A4 size paper and its period of time (as shown on the service status report).</p> <p><b>Purpose</b> To clear data as required at times such as during maintenance service.</p> <p><b>Method</b></p> <ol style="list-style-type: none"> <li>1. Press the start key.</li> <li>2. Select [Execute].</li> <li>3. Press the start key. The print coverage data is cleared.</li> </ol> <p><b>Completion</b> Press the stop key. The screen for selecting a maintenance item No. is displayed.</p>

Item No.	Description																																
U911	<p data-bbox="288 241 767 275"><b>Checking copy counts by paper sizes</b></p> <p data-bbox="288 311 440 340"><b>Description</b></p> <p data-bbox="288 344 844 376">Displays the paper feed counts by paper sizes.</p> <p data-bbox="288 380 400 409"><b>Purpose</b></p> <p data-bbox="288 414 927 445">To check the counts after replacing consumable parts.</p> <p data-bbox="288 483 387 512"><b>Method</b></p> <p data-bbox="308 517 1329 548">1. Press the start key. The screen for the paper feed counts by paper size is displayed.</p> <table border="1" data-bbox="336 562 1399 1014"> <thead> <tr> <th data-bbox="336 562 491 645">Display (metric)</th> <th data-bbox="491 562 868 645">Description</th> <th data-bbox="868 562 1019 645">Display (inch)</th> <th data-bbox="1019 562 1399 645">Description</th> </tr> </thead> <tbody> <tr> <td data-bbox="336 645 491 689">A3</td> <td data-bbox="491 645 868 689">Paper feed counts for A3</td> <td data-bbox="868 645 1019 689">Ledger</td> <td data-bbox="1019 645 1399 689">Paper feed counts for Ledger</td> </tr> <tr> <td data-bbox="336 689 491 734">B4</td> <td data-bbox="491 689 868 734">Paper feed counts for B4</td> <td data-bbox="868 689 1019 734">Legal</td> <td data-bbox="1019 689 1399 734">Paper feed counts for Legal</td> </tr> <tr> <td data-bbox="336 734 491 779">A4</td> <td data-bbox="491 734 868 779">Paper feed counts for A4</td> <td data-bbox="868 734 1019 779">Letter</td> <td data-bbox="1019 734 1399 779">Paper feed counts for Letter</td> </tr> <tr> <td data-bbox="336 779 491 824">B5</td> <td data-bbox="491 779 868 824">Paper feed counts for B5</td> <td data-bbox="868 779 1019 824">Statement</td> <td data-bbox="1019 779 1399 824">Paper feed counts for State-</td> </tr> <tr> <td data-bbox="336 824 491 869">A5</td> <td data-bbox="491 824 868 869">Paper feed counts for A5</td> <td data-bbox="868 824 1019 869"></td> <td data-bbox="1019 824 1399 869">ment</td> </tr> <tr> <td data-bbox="336 869 491 913">Folio</td> <td data-bbox="491 869 868 913">Paper feed counts for Folio</td> <td data-bbox="868 869 1019 913">ETC</td> <td data-bbox="1019 869 1399 913">Paper feed counts for other</td> </tr> <tr> <td data-bbox="336 913 491 1014">ETC</td> <td data-bbox="491 913 868 1014">Paper feed counts for other size</td> <td data-bbox="868 913 1019 1014"></td> <td data-bbox="1019 913 1399 1014">size</td> </tr> </tbody> </table> <p data-bbox="288 1059 400 1088"><b>Clearing</b></p> <p data-bbox="308 1093 871 1124">1. Select the paper size of counts to be cleared.</p> <p data-bbox="308 1128 831 1160">2. Press the start key. The counts is cleared.</p> <p data-bbox="288 1198 440 1227"><b>Completion</b></p> <p data-bbox="288 1232 1254 1263">Press the stop key. The screen for selecting a maintenance item No. is displayed.</p>	Display (metric)	Description	Display (inch)	Description	A3	Paper feed counts for A3	Ledger	Paper feed counts for Ledger	B4	Paper feed counts for B4	Legal	Paper feed counts for Legal	A4	Paper feed counts for A4	Letter	Paper feed counts for Letter	B5	Paper feed counts for B5	Statement	Paper feed counts for State-	A5	Paper feed counts for A5		ment	Folio	Paper feed counts for Folio	ETC	Paper feed counts for other	ETC	Paper feed counts for other size		size
Display (metric)	Description	Display (inch)	Description																														
A3	Paper feed counts for A3	Ledger	Paper feed counts for Ledger																														
B4	Paper feed counts for B4	Legal	Paper feed counts for Legal																														
A4	Paper feed counts for A4	Letter	Paper feed counts for Letter																														
B5	Paper feed counts for B5	Statement	Paper feed counts for State-																														
A5	Paper feed counts for A5		ment																														
Folio	Paper feed counts for Folio	ETC	Paper feed counts for other																														
ETC	Paper feed counts for other size		size																														

Item No.	Description																																																			
U917	<p data-bbox="288 241 746 275"><b>Setting backup data reading/writing</b></p> <p data-bbox="288 311 440 340"><b>Description</b></p> <p data-bbox="288 344 1425 409">Retrieves the backup data to a USB memory from the machine; or writes the data from the USB memory to the machine.</p> <p data-bbox="288 414 400 443"><b>Purpose</b></p> <p data-bbox="288 448 1031 477">To store and write data when replacing the HDD or main PWB.</p> <p data-bbox="288 517 387 546"><b>Method</b></p> <ol data-bbox="304 553 1425 792" style="list-style-type: none"> <li>Press the power key on the operation panel, and after verifying the power indicator has gone off, switch off the main power switch.</li> <li>Insert USB memory in USB memory slot.</li> <li>Turn the main power switch on. Wait for 10 seconds to allow the machine to recognize the USB memory.</li> <li>Enter maintenance item U917.</li> <li>Select [Import] or [Export].</li> </ol> <table border="1" data-bbox="336 801 1401 949"> <thead> <tr> <th data-bbox="336 801 639 853">Display</th> <th data-bbox="639 801 1401 853">Description</th> </tr> </thead> <tbody> <tr> <td data-bbox="336 853 639 904">Import</td> <td data-bbox="639 853 1401 904">Writing data from the USB memory to the machine</td> </tr> <tr> <td data-bbox="336 904 639 949">Export</td> <td data-bbox="639 904 1401 949">Retrieving from the machine to a USB memory</td> </tr> </tbody> </table> <ol data-bbox="304 994 520 1023" style="list-style-type: none"> <li>Select the item.</li> </ol> <table border="1" data-bbox="336 1034 1425 1895"> <thead> <tr> <th data-bbox="336 1034 549 1086">Display</th> <th data-bbox="549 1034 890 1086">Description</th> <th data-bbox="890 1034 1425 1086">Depending data</th> </tr> </thead> <tbody> <tr> <td data-bbox="336 1086 549 1137">Address Book</td> <td data-bbox="549 1086 890 1137">Address book</td> <td data-bbox="890 1086 1425 1137">-</td> </tr> <tr> <td data-bbox="336 1137 549 1189">Job Account</td> <td data-bbox="549 1137 890 1189">Job accounting</td> <td data-bbox="890 1137 1425 1189">-</td> </tr> <tr> <td data-bbox="336 1189 549 1263">One Touch</td> <td data-bbox="549 1189 890 1263">Information on one-touch key</td> <td data-bbox="890 1189 1425 1263">Address Book</td> </tr> <tr> <td data-bbox="336 1263 549 1314">User</td> <td data-bbox="549 1263 890 1314">User managements</td> <td data-bbox="890 1263 1425 1314">Job Account</td> </tr> <tr> <td data-bbox="336 1314 549 1366">Document Box</td> <td data-bbox="549 1314 890 1366">Document box information</td> <td data-bbox="890 1314 1425 1366">Job Account, User</td> </tr> <tr> <td data-bbox="336 1366 549 1417">Shortcut</td> <td data-bbox="549 1366 890 1417">Shortcut information</td> <td data-bbox="890 1366 1425 1417">Job Account, User, Document Box</td> </tr> <tr> <td data-bbox="336 1417 549 1469">Fax Forward</td> <td data-bbox="549 1417 890 1469">FAX transfer information</td> <td data-bbox="890 1417 1425 1469">Job Account, User, Document Box</td> </tr> <tr> <td data-bbox="336 1469 549 1520">System</td> <td data-bbox="549 1469 890 1520">System information</td> <td data-bbox="890 1469 1425 1520">-</td> </tr> <tr> <td data-bbox="336 1520 549 1572">Network</td> <td data-bbox="549 1520 890 1572">Network information</td> <td data-bbox="890 1520 1425 1572">-</td> </tr> <tr> <td data-bbox="336 1572 549 1624">Job Setting</td> <td data-bbox="549 1572 890 1624">Job Setting information</td> <td data-bbox="890 1572 1425 1624">-</td> </tr> <tr> <td data-bbox="336 1624 549 1675">Printer</td> <td data-bbox="549 1624 890 1675">Printer information</td> <td data-bbox="890 1624 1425 1675">-</td> </tr> <tr> <td data-bbox="336 1675 549 1727">Fax Setting</td> <td data-bbox="549 1675 890 1727">Fax Setting information</td> <td data-bbox="890 1675 1425 1727">-</td> </tr> <tr> <td data-bbox="336 1727 549 1778">Program</td> <td data-bbox="549 1727 890 1778">Program information</td> <td data-bbox="890 1727 1425 1778">Address Book, Job Account, User, Document Box, Fax Forward, Fax Setting</td> </tr> <tr> <td data-bbox="336 1778 549 1895">Panel Setting</td> <td data-bbox="549 1778 890 1895">Panel Setting information</td> <td data-bbox="890 1778 1425 1895">Address Book, Job Account, User, Document Box, Fax Forward, Fax Setting, Program</td> </tr> </tbody> </table>	Display	Description	Import	Writing data from the USB memory to the machine	Export	Retrieving from the machine to a USB memory	Display	Description	Depending data	Address Book	Address book	-	Job Account	Job accounting	-	One Touch	Information on one-touch key	Address Book	User	User managements	Job Account	Document Box	Document box information	Job Account, User	Shortcut	Shortcut information	Job Account, User, Document Box	Fax Forward	FAX transfer information	Job Account, User, Document Box	System	System information	-	Network	Network information	-	Job Setting	Job Setting information	-	Printer	Printer information	-	Fax Setting	Fax Setting information	-	Program	Program information	Address Book, Job Account, User, Document Box, Fax Forward, Fax Setting	Panel Setting	Panel Setting information	Address Book, Job Account, User, Document Box, Fax Forward, Fax Setting, Program
Display	Description																																																			
Import	Writing data from the USB memory to the machine																																																			
Export	Retrieving from the machine to a USB memory																																																			
Display	Description	Depending data																																																		
Address Book	Address book	-																																																		
Job Account	Job accounting	-																																																		
One Touch	Information on one-touch key	Address Book																																																		
User	User managements	Job Account																																																		
Document Box	Document box information	Job Account, User																																																		
Shortcut	Shortcut information	Job Account, User, Document Box																																																		
Fax Forward	FAX transfer information	Job Account, User, Document Box																																																		
System	System information	-																																																		
Network	Network information	-																																																		
Job Setting	Job Setting information	-																																																		
Printer	Printer information	-																																																		
Fax Setting	Fax Setting information	-																																																		
Program	Program information	Address Book, Job Account, User, Document Box, Fax Forward, Fax Setting																																																		
Panel Setting	Panel Setting information	Address Book, Job Account, User, Document Box, Fax Forward, Fax Setting, Program																																																		

Item No.	Description																																																		
U917	<p>* : Since data are dependent with each other, data other than those assigned are also retrieved or written in.</p> <p>7. Press the start key. Starts reading or writing. The progress of selected item is displayed in %. When an error occurs, the operation is canceled and an error code is displayed.</p> <p>8. When normally completed, [Finish] is displayed.</p> <p>Turn the main power switch off and on after completing writing when selecting [Import].</p> <p><b>Error Codes</b></p> <table border="1" data-bbox="295 667 1093 1892"> <thead> <tr> <th data-bbox="295 667 561 712">Codes</th> <th data-bbox="561 667 1093 712">Description</th> </tr> </thead> <tbody> <tr><td data-bbox="295 712 561 757">e000</td><td data-bbox="561 712 1093 757">Unspecified error</td></tr> <tr><td data-bbox="295 757 561 801">e0001</td><td data-bbox="561 757 1093 801">Parameter error</td></tr> <tr><td data-bbox="295 801 561 846">e0002</td><td data-bbox="561 801 1093 846">Failed to generate a Dummy file</td></tr> <tr><td data-bbox="295 846 561 891">e0003</td><td data-bbox="561 846 1093 891">The target XML file to import does not exist</td></tr> <tr><td data-bbox="295 891 561 936">e0004</td><td data-bbox="561 891 1093 936">The exported file does not exist</td></tr> <tr><td data-bbox="295 936 561 981">e0100 to e01ff</td><td data-bbox="561 936 1093 981">Error in handling the addressbook</td></tr> <tr><td data-bbox="295 981 561 1025">e0200 to e02ff</td><td data-bbox="561 981 1093 1025">Error in handling One-touch</td></tr> <tr><td data-bbox="295 1025 561 1070">e0300 to e03ff</td><td data-bbox="561 1025 1093 1070">Error in handling user management</td></tr> <tr><td data-bbox="295 1070 561 1115">e0400 to e04ff</td><td data-bbox="561 1070 1093 1115">Error in handling panel-program data</td></tr> <tr><td data-bbox="295 1115 561 1160">e0500 to e05ff</td><td data-bbox="561 1115 1093 1160">Error in handling forwarding Fax data</td></tr> <tr><td data-bbox="295 1160 561 1205">e0600 to e06ff</td><td data-bbox="561 1160 1093 1205">Error in handling system configurations</td></tr> <tr><td data-bbox="295 1205 561 1249">e0700 to e07ff</td><td data-bbox="561 1205 1093 1249">Error in handling network parameters</td></tr> <tr><td data-bbox="295 1249 561 1294">e0800 to e08ff</td><td data-bbox="561 1249 1093 1294">Error in handling job accounting</td></tr> <tr><td data-bbox="295 1294 561 1339">e0900 to e09ff</td><td data-bbox="561 1294 1093 1339">Error in handling short-cuts</td></tr> <tr><td data-bbox="295 1339 561 1384">e0a00 to e0aff</td><td data-bbox="561 1339 1093 1384">Error in handling job information</td></tr> <tr><td data-bbox="295 1384 561 1429">e0b00 to e0bff</td><td data-bbox="561 1384 1093 1429">Error in handling Fax data</td></tr> <tr><td data-bbox="295 1429 561 1473">e0c00 to e0cff</td><td data-bbox="561 1429 1093 1473">Error in handling printer data</td></tr> <tr><td data-bbox="295 1473 561 1518">e0d00 to e0dff</td><td data-bbox="561 1473 1093 1518">Error in handling panel data</td></tr> <tr><td data-bbox="295 1518 561 1563">e0e00 to e0eff</td><td data-bbox="561 1518 1093 1563">Error in handling document boxes</td></tr> <tr><td data-bbox="295 1563 561 1608">e1000 to e1fff</td><td data-bbox="561 1563 1093 1608">Error in handling device-related information</td></tr> <tr><td data-bbox="295 1608 561 1653">e2000 to e2fff</td><td data-bbox="561 1608 1093 1653">Error in handling SOAP IF</td></tr> <tr><td data-bbox="295 1653 561 1697">e3000 to e3fff</td><td data-bbox="561 1653 1093 1697">Error in handling KM-WSDL IF</td></tr> <tr><td data-bbox="295 1697 561 1742">e4000 to e4fff</td><td data-bbox="561 1697 1093 1742">A file mandatory for importing is missing (e4002)/Invalid file header (e4008)</td></tr> <tr><td data-bbox="295 1742 561 1787">e5000 to e5fff</td><td data-bbox="561 1742 1093 1787">Error in handling rewriting SOAP data</td></tr> </tbody> </table> <p><b>Completion</b> Press the stop key. The screen for selecting a maintenance item No. is displayed.</p>	Codes	Description	e000	Unspecified error	e0001	Parameter error	e0002	Failed to generate a Dummy file	e0003	The target XML file to import does not exist	e0004	The exported file does not exist	e0100 to e01ff	Error in handling the addressbook	e0200 to e02ff	Error in handling One-touch	e0300 to e03ff	Error in handling user management	e0400 to e04ff	Error in handling panel-program data	e0500 to e05ff	Error in handling forwarding Fax data	e0600 to e06ff	Error in handling system configurations	e0700 to e07ff	Error in handling network parameters	e0800 to e08ff	Error in handling job accounting	e0900 to e09ff	Error in handling short-cuts	e0a00 to e0aff	Error in handling job information	e0b00 to e0bff	Error in handling Fax data	e0c00 to e0cff	Error in handling printer data	e0d00 to e0dff	Error in handling panel data	e0e00 to e0eff	Error in handling document boxes	e1000 to e1fff	Error in handling device-related information	e2000 to e2fff	Error in handling SOAP IF	e3000 to e3fff	Error in handling KM-WSDL IF	e4000 to e4fff	A file mandatory for importing is missing (e4002)/Invalid file header (e4008)	e5000 to e5fff	Error in handling rewriting SOAP data
Codes	Description																																																		
e000	Unspecified error																																																		
e0001	Parameter error																																																		
e0002	Failed to generate a Dummy file																																																		
e0003	The target XML file to import does not exist																																																		
e0004	The exported file does not exist																																																		
e0100 to e01ff	Error in handling the addressbook																																																		
e0200 to e02ff	Error in handling One-touch																																																		
e0300 to e03ff	Error in handling user management																																																		
e0400 to e04ff	Error in handling panel-program data																																																		
e0500 to e05ff	Error in handling forwarding Fax data																																																		
e0600 to e06ff	Error in handling system configurations																																																		
e0700 to e07ff	Error in handling network parameters																																																		
e0800 to e08ff	Error in handling job accounting																																																		
e0900 to e09ff	Error in handling short-cuts																																																		
e0a00 to e0aff	Error in handling job information																																																		
e0b00 to e0bff	Error in handling Fax data																																																		
e0c00 to e0cff	Error in handling printer data																																																		
e0d00 to e0dff	Error in handling panel data																																																		
e0e00 to e0eff	Error in handling document boxes																																																		
e1000 to e1fff	Error in handling device-related information																																																		
e2000 to e2fff	Error in handling SOAP IF																																																		
e3000 to e3fff	Error in handling KM-WSDL IF																																																		
e4000 to e4fff	A file mandatory for importing is missing (e4002)/Invalid file header (e4008)																																																		
e5000 to e5fff	Error in handling rewriting SOAP data																																																		

Item No.	Description								
<b>U920</b>	<p><b>Checking the copy counts</b></p> <p><b>Description</b> Checks the copy counts.</p> <p><b>Purpose</b> To check the copy counts.</p> <p><b>Method</b> 1. Press the start key. The current counts are displayed.</p> <table border="1" data-bbox="336 562 1401 757"> <thead> <tr> <th data-bbox="336 562 639 607">Display</th> <th data-bbox="639 562 1401 607">Description</th> </tr> </thead> <tbody> <tr> <td data-bbox="336 607 639 651">B/W Copy</td> <td data-bbox="639 607 1401 651">Count value of black/white copy</td> </tr> <tr> <td data-bbox="336 651 639 696">B/W Prn</td> <td data-bbox="639 651 1401 696">Count value of black/white print</td> </tr> <tr> <td data-bbox="336 696 639 741">B/W Fax</td> <td data-bbox="639 696 1401 741">Count value of black/white FAX</td> </tr> </tbody> </table> <p><b>Completion</b> Press the stop key. The screen for selecting a maintenance item No. is displayed.</p>	Display	Description	B/W Copy	Count value of black/white copy	B/W Prn	Count value of black/white print	B/W Fax	Count value of black/white FAX
Display	Description								
B/W Copy	Count value of black/white copy								
B/W Prn	Count value of black/white print								
B/W Fax	Count value of black/white FAX								
<b>U927</b>	<p><b>Clearing the all copy counts and machine life counts (one time only)</b></p> <p><b>Description</b> Resets all of the counts back to zero.</p> <p><b>Supplement</b> The total account counter and the machine life counter can be cleared only once if all count values are 1000 or less.</p> <p><b>Method</b> 1. Press the start key. 2. Select [Execute]. 3. Press the start key. All copy counts and machine life counts are cleared.</p> <p><b>Completion</b> Press the stop key. The screen for selecting a maintenance item No. is displayed.</p>								

Item No.	Description				
<b>U928</b>	<p><b>Checking machine life counts</b></p> <p><b>Description</b> Displays the machine life counts.</p> <p><b>Purpose</b> To check the machine life counts.</p> <p><b>Method</b> 1. Press the start key. The current machine life counts is displayed.</p> <table border="1" data-bbox="336 562 1401 658"> <thead> <tr> <th data-bbox="336 562 639 607">Display</th> <th data-bbox="639 562 1401 607">Description</th> </tr> </thead> <tbody> <tr> <td data-bbox="336 607 639 658">Cnt</td> <td data-bbox="639 607 1401 658">Machine life counts</td> </tr> </tbody> </table> <p><b>Completion</b> Press the stop key. The screen for selecting a maintenance item No. is displayed.</p>	Display	Description	Cnt	Machine life counts
Display	Description				
Cnt	Machine life counts				
<b>U930</b>	<p><b>Checking/clearing the charger roller count</b></p> <p><b>Description</b> Displays the counts of the charger roller counter for checking, setting or clearing.</p> <p><b>Purpose</b> To check the count after replacement of the charger roller unit. To clear the counter value when replacing the charger roller unit.</p> <p><b>Method</b> 1. Press the start key. The current counts of the charger roller count for each color is displayed.</p> <table border="1" data-bbox="336 1142 1401 1238"> <thead> <tr> <th data-bbox="336 1142 639 1187">Display</th> <th data-bbox="639 1142 1401 1187">Description</th> </tr> </thead> <tbody> <tr> <td data-bbox="336 1187 639 1238">K</td> <td data-bbox="639 1187 1401 1238">Count value of charger roller</td> </tr> </tbody> </table> <p><b>Setting</b> 1. Change the setting value using the +/- keys or numeric keys. 2. Press the start key. The value is set.</p> <p><b>Clearing</b> 1. Select [Clear]. 2. Press the start key. The counts is cleared.</p> <p><b>Completion</b> Press the stop key. The screen for selecting a maintenance item No. is displayed.</p>	Display	Description	K	Count value of charger roller
Display	Description				
K	Count value of charger roller				
<b>U933</b>	<p><b>Set Maintenance Mode Execute Log</b></p> <p><b>Description</b> Perform individual configuration or log file printing for the date when maintenance mode is entered and exited or for the feature which records the dates when maintenance mode numbers are executed.</p> <p><b>Purpose</b> Logs a history of execution of maintenance modes for an analysis of causes against the problems.</p>				



Item No.	Description						
<b>U933</b>	<p><b>Method</b></p> <ol style="list-style-type: none"> <li>1. Press the start key.</li> <li>2. Select the item.</li> </ol> <table border="1" data-bbox="336 353 1401 499"> <thead> <tr> <th data-bbox="336 353 639 398">Display</th> <th data-bbox="639 353 1401 398">Description</th> </tr> </thead> <tbody> <tr> <td data-bbox="336 398 639 443">Export</td> <td data-bbox="639 398 1401 443">Exports a maintenance log</td> </tr> <tr> <td data-bbox="336 443 639 499">Setting</td> <td data-bbox="639 443 1401 499">Configures maintenance logs to output</td> </tr> </tbody> </table> <p><b>Method: [Export]</b></p> <ol style="list-style-type: none"> <li>1. Press the start key.</li> <li>2. Select [Execute].</li> <li>3. Press the start key.</li> </ol> <p>Exports a maintenance log to a USB flash device.</p> <ul style="list-style-type: none"> <li>* : [Execute] is grayed out is a USB memory is not installed.</li> <li>* : Displays a OK or NG after execution.</li> </ul> <p><b>Setting: [Setting]</b></p> <ol style="list-style-type: none"> <li>1. Select the item. <ul style="list-style-type: none"> <li>* : Select the key that includes the number you want to configure as the logs are displayed block by block. ([U000-U019],[U020-U029], .... ,[U900-U999])</li> </ul> </li> <li>2. Enable or disable the number to configure.</li> </ol> <p><b>Completion</b></p> <p>Press the stop key. The screen for selecting a maintenance item No. is displayed.</p>	Display	Description	Export	Exports a maintenance log	Setting	Configures maintenance logs to output
Display	Description						
Export	Exports a maintenance log						
Setting	Configures maintenance logs to output						
<b>U935</b>	<p><b>Relay board maintenance</b></p> <p><b>Description</b></p> <p>Sets the mode when call for service (C0060) occurs.</p> <p><b>Purpose</b></p> <p>Sets the machine status temporarily when call for service (C0060) occurs. However, after the setting, call for service (C0060) occurs again when progress of period.</p> <p><b>Setting</b></p> <ol style="list-style-type: none"> <li>1. Press the start key.</li> <li>2. Select Mode using the +/- keys.</li> </ol> <table border="1" data-bbox="336 1608 1401 1753"> <thead> <tr> <th data-bbox="336 1608 639 1653">Display</th> <th data-bbox="639 1608 1401 1653">Description</th> </tr> </thead> <tbody> <tr> <td data-bbox="336 1653 639 1697">Mode0</td> <td data-bbox="639 1653 1401 1697">Setting mode: OFF</td> </tr> <tr> <td data-bbox="336 1697 639 1753">Mode1</td> <td data-bbox="639 1697 1401 1753">Setting mode: ON (Usable up to three times of use)</td> </tr> </tbody> </table> <ul style="list-style-type: none"> <li>* : Initial setting: Mode0</li> </ul> <ol style="list-style-type: none"> <li>3. Press the start key. The setting is set.</li> <li>4. Turn the main power switch off and on. Allow more than 5 seconds between Off and On.</li> </ol> <p><b>Supplement</b></p> <p>After removing the cause of the problem, be sure to change the setting in OFF.</p>	Display	Description	Mode0	Setting mode: OFF	Mode1	Setting mode: ON (Usable up to three times of use)
Display	Description						
Mode0	Setting mode: OFF						
Mode1	Setting mode: ON (Usable up to three times of use)						

Item No.	Description																				
U942	<p data-bbox="290 241 807 273"><b>Setting of deflection for feeding from DP</b></p> <p data-bbox="290 309 440 340"><b>Description</b></p> <p data-bbox="290 344 1139 376">Adjusts the deflection generated when the document processor is used.</p> <p data-bbox="290 380 400 412"><b>Purpose</b></p> <p data-bbox="290 416 1409 479">Use this mode if an original non-feed jam, oblique feed or wrinkling of original occurs when the document processor is used.</p> <p data-bbox="290 515 384 546"><b>Setting</b></p> <ol data-bbox="306 551 1182 757" style="list-style-type: none"> <li>1. Press the start key.</li> <li>2. Press the system menu key.</li> <li>3. Place an original on the DP and press the start key to make a test copy.</li> <li>4. Press the system menu key.</li> <li>5. Select the item to be adjusted.</li> <li>6. Change the setting value using the +/- keys or numeric keys.</li> </ol> <table border="1" data-bbox="336 770 1401 994"> <thead> <tr> <th data-bbox="344 779 504 846">Display</th> <th data-bbox="504 779 943 846">Description</th> <th data-bbox="943 779 1078 846">Setting range</th> <th data-bbox="1078 779 1193 846">Initial setting</th> <th data-bbox="1193 779 1393 846">Change in value per step</th> </tr> </thead> <tbody> <tr> <td data-bbox="344 853 504 884">Front</td> <td data-bbox="504 853 943 884">Deflection of single-sided original</td> <td data-bbox="943 853 1078 884">-31 to 31</td> <td data-bbox="1078 853 1193 884">0</td> <td data-bbox="1193 853 1393 884">0.17 mm</td> </tr> <tr> <td data-bbox="344 904 504 936">Back*</td> <td data-bbox="504 904 943 936">Deflection of double-sided original</td> <td data-bbox="943 904 1078 936">-31 to 31</td> <td data-bbox="1078 904 1193 936">0</td> <td data-bbox="1193 904 1393 936">0.17 mm</td> </tr> <tr> <td data-bbox="344 956 504 987">Mix</td> <td data-bbox="504 956 943 987">Deflection of mixed original</td> <td data-bbox="943 956 1078 987">-31 to 31</td> <td data-bbox="1078 956 1193 987">0</td> <td data-bbox="1193 956 1393 987">0.17 mm</td> </tr> </tbody> </table> <p data-bbox="336 1008 600 1039">*1: Reversed DP only.</p> <p data-bbox="336 1043 1377 1106">* : The greater the value, the larger the deflection; the smaller the value, the smaller the deflection.</p> <p data-bbox="373 1111 1417 1173">If an original non-feed jam or oblique feed occurs, increase the setting value. If wrinkling of original occurs, decrease the value.</p> <ol data-bbox="306 1178 767 1209" style="list-style-type: none"> <li>7. Press the start key. The value is set.</li> </ol> <p data-bbox="290 1245 440 1276"><b>Completion</b></p> <p data-bbox="290 1281 1254 1312">Press the stop key. The screen for selecting a maintenance item No. is displayed.</p>	Display	Description	Setting range	Initial setting	Change in value per step	Front	Deflection of single-sided original	-31 to 31	0	0.17 mm	Back*	Deflection of double-sided original	-31 to 31	0	0.17 mm	Mix	Deflection of mixed original	-31 to 31	0	0.17 mm
Display	Description	Setting range	Initial setting	Change in value per step																	
Front	Deflection of single-sided original	-31 to 31	0	0.17 mm																	
Back*	Deflection of double-sided original	-31 to 31	0	0.17 mm																	
Mix	Deflection of mixed original	-31 to 31	0	0.17 mm																	

Item No.	Description																																
U952	<p data-bbox="288 241 657 271"><b>Maintenance mode workflow</b></p> <p data-bbox="288 311 440 340"><b>Description</b></p> <p data-bbox="288 344 1426 409">The maintenance modes configured in the machine or a USB flash device as a workflow must be executed in succession.</p> <p data-bbox="288 414 400 443"><b>Purpose</b></p> <p data-bbox="288 448 983 477">This allows maintenance mode to be preset as a template.</p> <p data-bbox="288 517 384 546"><b>Setting</b></p> <ol data-bbox="304 551 564 616" style="list-style-type: none"> <li>1. Press the start key.</li> <li>2. Select the item.</li> </ol> <table border="1" data-bbox="336 629 1399 965"> <thead> <tr> <th data-bbox="336 629 603 674">Display</th> <th data-bbox="603 629 1399 674">Description</th> </tr> </thead> <tbody> <tr> <td data-bbox="336 674 603 719">Continue</td> <td data-bbox="603 674 1399 719">Restarting an abandoned workflow</td> </tr> <tr> <td data-bbox="336 719 603 763">Execute(USB)</td> <td data-bbox="603 719 1399 763">Executes a workflow housed in a USB flash device</td> </tr> <tr> <td data-bbox="336 763 603 808">Execute</td> <td data-bbox="603 763 1399 808">Executes a workflow stored in the machine</td> </tr> <tr> <td data-bbox="336 808 603 853">Entry(USB)</td> <td data-bbox="603 808 1399 853">Exports a workflow housed in a USB flash device to the machine</td> </tr> <tr> <td data-bbox="336 853 603 898">Entry</td> <td data-bbox="603 853 1399 898">Assigns a workflow in the machine manually</td> </tr> <tr> <td data-bbox="336 898 603 965">Log</td> <td data-bbox="603 898 1399 965">Displays a list of workflows recently executed</td> </tr> </tbody> </table> <p data-bbox="288 1010 523 1039"><b>Method: [Execute]</b></p> <ol data-bbox="304 1043 564 1108" style="list-style-type: none"> <li>1. Select [Execute].</li> <li>2. Select the workflow.</li> </ol> <p data-bbox="336 1113 1114 1142">* : The machine is preset with the following workflow at shipment.</p> <table border="1" data-bbox="336 1155 1399 1588"> <thead> <tr> <th data-bbox="336 1155 639 1200">Display</th> <th data-bbox="639 1155 1399 1200">Description</th> </tr> </thead> <tbody> <tr> <td data-bbox="336 1200 639 1245">SETUP</td> <td data-bbox="639 1200 1399 1245">U464/ U410/ U000/ U927/ U278</td> </tr> <tr> <td data-bbox="336 1245 639 1290">WARRANTY</td> <td data-bbox="639 1245 1399 1290">U089/ U000</td> </tr> <tr> <td data-bbox="336 1290 639 1335">MK-A</td> <td data-bbox="639 1290 1399 1335">U119/ U140*/ U127/ U167/ U464/ U412/ U410/ U251</td> </tr> <tr> <td data-bbox="336 1335 639 1379">EH SETUP</td> <td data-bbox="639 1335 1399 1379">U411/ U034/ U246/ U211</td> </tr> <tr> <td data-bbox="336 1379 639 1424">Data5</td> <td data-bbox="639 1379 1399 1424"></td> </tr> <tr> <td data-bbox="336 1424 639 1469">Data6</td> <td data-bbox="639 1424 1399 1469"></td> </tr> <tr> <td data-bbox="336 1469 639 1514">Data7</td> <td data-bbox="639 1469 1399 1514">-</td> </tr> <tr> <td data-bbox="336 1514 639 1588">Data8</td> <td data-bbox="639 1514 1399 1588">-</td> </tr> </tbody> </table> <p data-bbox="336 1610 608 1639">* : 55 ppm model only.</p> <ol data-bbox="304 1644 564 1673" style="list-style-type: none"> <li>3. Press the start key.</li> </ol> <p data-bbox="336 1677 1166 1706">* : Executes maintenance modes defined in a workflow in succession.</p>	Display	Description	Continue	Restarting an abandoned workflow	Execute(USB)	Executes a workflow housed in a USB flash device	Execute	Executes a workflow stored in the machine	Entry(USB)	Exports a workflow housed in a USB flash device to the machine	Entry	Assigns a workflow in the machine manually	Log	Displays a list of workflows recently executed	Display	Description	SETUP	U464/ U410/ U000/ U927/ U278	WARRANTY	U089/ U000	MK-A	U119/ U140*/ U127/ U167/ U464/ U412/ U410/ U251	EH SETUP	U411/ U034/ U246/ U211	Data5		Data6		Data7	-	Data8	-
Display	Description																																
Continue	Restarting an abandoned workflow																																
Execute(USB)	Executes a workflow housed in a USB flash device																																
Execute	Executes a workflow stored in the machine																																
Entry(USB)	Exports a workflow housed in a USB flash device to the machine																																
Entry	Assigns a workflow in the machine manually																																
Log	Displays a list of workflows recently executed																																
Display	Description																																
SETUP	U464/ U410/ U000/ U927/ U278																																
WARRANTY	U089/ U000																																
MK-A	U119/ U140*/ U127/ U167/ U464/ U412/ U410/ U251																																
EH SETUP	U411/ U034/ U246/ U211																																
Data5																																	
Data6																																	
Data7	-																																
Data8	-																																

Item No.	Description																				
U952	<p><b>Method: [Entry]</b></p> <ol style="list-style-type: none"> <li>1. Select [Entry].</li> <li>2. Select the area to store workflow.</li> </ol> <table border="1" data-bbox="338 353 1401 450"> <thead> <tr> <th data-bbox="338 353 641 398">Display</th> <th data-bbox="641 353 1401 398">Description</th> </tr> </thead> <tbody> <tr> <td data-bbox="338 398 641 450">Data1 - 8</td> <td data-bbox="641 398 1401 450">The area to store workflows in the machine</td> </tr> </tbody> </table> <ol style="list-style-type: none"> <li>3. Press the +/- keys or numeric keys to assign a maintenance Nbr. into a workflow.</li> </ol> <table border="1" data-bbox="338 504 1401 600"> <thead> <tr> <th data-bbox="338 504 641 548">Display</th> <th data-bbox="641 504 1401 548">Description</th> </tr> </thead> <tbody> <tr> <td data-bbox="338 548 641 600">Flow1 - 14</td> <td data-bbox="641 548 1401 600">Assign a maintenance Nbr.</td> </tr> </tbody> </table> <ol style="list-style-type: none"> <li>4. Press the start key. The setting is set.</li> <li>5. Press the start key. Executes maintenance modes defined in a workflow in succession.</li> </ol> <p><b>Method: [Execute(USB)]</b></p> <ol style="list-style-type: none"> <li>1. Press the power key on the operation panel, and after verifying the main power indicator has gone off, switch off the main power switch.</li> <li>2. Insert USB memory in USB memory slot.</li> <li>3. Turn the main power switch on.</li> <li>4. Enter maintenance item U952.</li> <li>5. Select [Execute(USB)].</li> <li>6. Select the workflow.</li> </ol> <table border="1" data-bbox="338 1032 1401 1128"> <thead> <tr> <th data-bbox="338 1032 641 1077">Display</th> <th data-bbox="641 1032 1401 1077">Description</th> </tr> </thead> <tbody> <tr> <td data-bbox="338 1077 641 1128">WorkFlowData01 - 07</td> <td data-bbox="641 1077 1401 1128">Workflow data in the USB flash device</td> </tr> </tbody> </table> <ol style="list-style-type: none"> <li>7. Press the start key. Executes maintenance modes defined in a workflow in succession.</li> </ol> <p><b>Method: [Entry(USB)]</b></p> <ol style="list-style-type: none"> <li>1. Press the power key on the operation panel, and after verifying the main power indicator has gone off, switch off the main power switch.</li> <li>2. Insert USB memory in USB memory slot.</li> <li>3. Turn the main power switch on.</li> <li>4. Enter maintenance item U952.</li> <li>5. Select [Entry(USB)].</li> <li>6. Select the workflow.</li> </ol> <table border="1" data-bbox="338 1527 1401 1624"> <thead> <tr> <th data-bbox="338 1527 641 1572">Display</th> <th data-bbox="641 1527 1401 1572">Description</th> </tr> </thead> <tbody> <tr> <td data-bbox="338 1572 641 1624">WorkFlowData01 - 07</td> <td data-bbox="641 1572 1401 1624">Workflow data in the USB flash device</td> </tr> </tbody> </table> <ol style="list-style-type: none"> <li>7. Select the work flow save area.</li> </ol> <table border="1" data-bbox="338 1677 1401 1774"> <thead> <tr> <th data-bbox="338 1677 641 1722">Display</th> <th data-bbox="641 1677 1401 1722">Description</th> </tr> </thead> <tbody> <tr> <td data-bbox="338 1722 641 1774">Data1 - 8</td> <td data-bbox="641 1722 1401 1774">The area to store workflows in the machine</td> </tr> </tbody> </table> <ol style="list-style-type: none"> <li>8. Select [Execute]. Exports a workflow housed in a USB flash device to the machine.</li> </ol>	Display	Description	Data1 - 8	The area to store workflows in the machine	Display	Description	Flow1 - 14	Assign a maintenance Nbr.	Display	Description	WorkFlowData01 - 07	Workflow data in the USB flash device	Display	Description	WorkFlowData01 - 07	Workflow data in the USB flash device	Display	Description	Data1 - 8	The area to store workflows in the machine
Display	Description																				
Data1 - 8	The area to store workflows in the machine																				
Display	Description																				
Flow1 - 14	Assign a maintenance Nbr.																				
Display	Description																				
WorkFlowData01 - 07	Workflow data in the USB flash device																				
Display	Description																				
WorkFlowData01 - 07	Workflow data in the USB flash device																				
Display	Description																				
Data1 - 8	The area to store workflows in the machine																				

Item No.	Description
U952	<p data-bbox="288 241 405 275"><b>Example</b></p> <p data-bbox="288 277 1382 344">Registration is feasible when a USB flash device that stores the commands and text/maintenance ID (editable) is inserted.</p> <p data-bbox="288 347 539 380">File Format: xxx.mwf</p> <p data-bbox="288 416 715 450">1, SET UP, 464, 410, 000, 927, 278</p> <p data-bbox="288 452 588 486">2, WARRANTY, 089, 000</p> <p data-bbox="288 488 919 521">3, MK-A, 119, 140, 127, 167, 464, 412, 464, 410, 251</p> <p data-bbox="288 591 440 624"><b>Completion</b></p> <p data-bbox="288 627 1254 660">Press the stop key. The screen for selecting a maintenance item No. is displayed.</p>

Item No.	Description																
U964	<p data-bbox="290 241 494 275"><b>Checking of log</b></p> <p data-bbox="290 311 440 340"><b>Description</b></p> <p data-bbox="290 344 925 374">Sends a log file saved on the HDD to a USB memory.</p> <p data-bbox="290 380 400 409"><b>Purpose</b></p> <p data-bbox="290 414 1412 479">To transfer a log file saved on the HDD to a USB memory as a means of investigating malfunctions.</p> <p data-bbox="290 517 387 546"><b>Method</b></p> <ol data-bbox="306 553 1426 719" style="list-style-type: none"> <li>1. Press the power key on the operation panel, and after verifying the main power indicator has gone off, switch off the main power switch.</li> <li>2. Insert USB memory in USB memory slot.</li> <li>3. Turn the main power switch on.</li> <li>4. Enter maintenance item U964.</li> </ol> <table border="1" data-bbox="336 768 1401 913"> <thead> <tr> <th data-bbox="336 768 639 813">Display</th> <th data-bbox="639 768 1401 813">Description</th> </tr> </thead> <tbody> <tr> <td data-bbox="336 813 639 857">Execute</td> <td data-bbox="639 813 1401 857">Executes transferring a log file.</td> </tr> <tr> <td data-bbox="336 857 639 913">Jam Log</td> <td data-bbox="639 857 1401 913"></td> </tr> </tbody> </table> <ol data-bbox="306 931 1378 1169" style="list-style-type: none"> <li>5. Select [Execute].</li> <li>6. Press the start key. Starts sending the log file saved on the HDD to the USB memory. Processing is displayed for approximately 3 to 5 minutes.</li> <li>7. When normally completed, [Completed] is displayed.</li> <li>8. Turn the main power switch off and on. Allow more than 5 seconds between Off and On. If a problem occurs during auto correction, error code is displayed.</li> </ol> <p data-bbox="290 1207 528 1236"><b>Setting: [Jam Log]</b></p> <ol data-bbox="306 1243 1048 1308" style="list-style-type: none"> <li>1. It is unnecessary to choose the Jam Log "On" / "Off" setting. * : Regardless of the setting, the Jam Log is acquired.</li> </ol> <p data-bbox="290 1346 446 1375"><b>Supplement</b></p> <p data-bbox="290 1382 1206 1411"><b>Instructions on how to obtain a log when the operation panel has frozen</b></p> <p data-bbox="290 1417 1382 1447">Simultaneously press and hold the *, 8, 6, and Clear keys for 3 to 6 seconds to start logging.</p> <p data-bbox="290 1453 1386 1482">The memory indicator keeps lighting during a log is generated and goes off when completed.</p> <p data-bbox="336 1588 488 1617"><b>Error codes</b></p> <table border="1" data-bbox="336 1630 1401 1870"> <thead> <tr> <th data-bbox="336 1630 639 1675">Display</th> <th data-bbox="639 1630 1401 1675">Description</th> </tr> </thead> <tbody> <tr> <td data-bbox="336 1675 639 1720">No Usb Storage</td> <td data-bbox="639 1675 1401 1720">USB memory is not inserted</td> </tr> <tr> <td data-bbox="336 1720 639 1765">No File</td> <td data-bbox="639 1720 1401 1765">File is not found</td> </tr> <tr> <td data-bbox="336 1765 639 1809">Mount Error</td> <td data-bbox="639 1765 1401 1809">USB memory mount error</td> </tr> <tr> <td data-bbox="336 1809 639 1870">File Delete Error</td> <td data-bbox="639 1809 1401 1870">File deletion error</td> </tr> </tbody> </table>	Display	Description	Execute	Executes transferring a log file.	Jam Log		Display	Description	No Usb Storage	USB memory is not inserted	No File	File is not found	Mount Error	USB memory mount error	File Delete Error	File deletion error
Display	Description																
Execute	Executes transferring a log file.																
Jam Log																	
Display	Description																
No Usb Storage	USB memory is not inserted																
No File	File is not found																
Mount Error	USB memory mount error																
File Delete Error	File deletion error																

Item No.	Description								
U964	<table border="1" data-bbox="336 286 1401 479"> <thead> <tr> <th data-bbox="336 286 639 331">Display</th> <th data-bbox="639 286 1401 331">Description</th> </tr> </thead> <tbody> <tr> <td data-bbox="336 331 639 376">Copy Error</td> <td data-bbox="639 331 1401 376">File copy error</td> </tr> <tr> <td data-bbox="336 376 639 421">Unmount Error</td> <td data-bbox="639 376 1401 421">USB memory unmount error</td> </tr> <tr> <td data-bbox="336 421 639 479">Other Error</td> <td data-bbox="639 421 1401 479">Other error</td> </tr> </tbody> </table>	Display	Description	Copy Error	File copy error	Unmount Error	USB memory unmount error	Other Error	Other error
Display	Description								
Copy Error	File copy error								
Unmount Error	USB memory unmount error								
Other Error	Other error								
U969	<p data-bbox="288 506 651 539"><b>Checking of toner area code</b></p> <p data-bbox="288 573 440 607"><b>Description</b> Displays the toner area code.</p> <p data-bbox="288 640 400 674"><b>Purpose</b> To check the toner area code.</p> <p data-bbox="288 752 384 786"><b>Method</b> 1. Press the start key. The toner area code is displayed.</p> <p data-bbox="288 853 440 887"><b>Completion</b> Press the stop/clear key. The screen for selecting a maintenance item No. is displayed.</p>								
U977	<p data-bbox="288 938 533 972"><b>Data capture mode</b></p> <p data-bbox="288 1005 440 1039"><b>Description</b> Store the print data sent to the machine into USB memory.</p> <p data-bbox="288 1072 400 1106"><b>Purpose</b> In case to occur the error at printing, check the print data sent to the machine.</p> <p data-bbox="288 1173 384 1207"><b>Method</b> 1. Press the power key on the operation panel, and after verifying the main power indicator has gone off, switch off the main power switch. 2. Insert USB memory in USB memory slot. 3. Turn the main power switch on. 4. Enter maintenance item U977. 5. Select [Execute]. 6. Press the start key. 7. Send the print data to the machine. Once the print data is stored into USB memory, [Finish] will be displayed.</p> <p data-bbox="288 1554 440 1588"><b>Completion</b> Press the stop key. The screen for selecting a maintenance item No. is displayed.</p> <p data-bbox="288 1666 440 1700"><b>Error codes</b></p> <table border="1" data-bbox="336 1704 1401 1933"> <thead> <tr> <th data-bbox="336 1704 639 1749">Error codes</th> <th data-bbox="639 1704 1401 1749">Description</th> </tr> </thead> <tbody> <tr> <td data-bbox="336 1749 639 1827">1</td> <td data-bbox="639 1749 1401 1827">A removable memory has been crushed. A removable memory was removed during processing or is write-protected.</td> </tr> <tr> <td data-bbox="336 1827 639 1883">2</td> <td data-bbox="639 1827 1401 1883">The removable memory is full.</td> </tr> <tr> <td data-bbox="336 1883 639 1933">50</td> <td data-bbox="639 1883 1401 1933">Other error</td> </tr> </tbody> </table>	Error codes	Description	1	A removable memory has been crushed. A removable memory was removed during processing or is write-protected.	2	The removable memory is full.	50	Other error
Error codes	Description								
1	A removable memory has been crushed. A removable memory was removed during processing or is write-protected.								
2	The removable memory is full.								
50	Other error								

Item No.	Description				
U978	<p><b>Clear Optional Function</b></p> <p><b>Description</b> Clear the optional function error.</p> <p><b>Purpose</b> Clear the optional function error.</p> <p><b>Method</b></p> <ol style="list-style-type: none"> <li>1. Press the start key.</li> <li>2. Select [Execute].</li> </ol> <p>* : A message that prompts you to turn power off and on will be displayed after completion of the normal operation, deactivating the keys.</p> <p>Object error : C9940 Confidential document guard uninstalled error.</p>				
U984	<p><b>Checking the developer unit number</b></p> <p><b>Description</b> Displays the developer unit number.</p> <p><b>Purpose</b> To check the developer unit number.</p> <p><b>Method</b></p> <ol style="list-style-type: none"> <li>1. Press the start key. The developer unit number for each color is displayed.</li> </ol> <table border="1" data-bbox="336 1061 1401 1158"> <thead> <tr> <th data-bbox="336 1061 641 1106">Display</th> <th data-bbox="641 1061 1401 1106">Description</th> </tr> </thead> <tbody> <tr> <td data-bbox="336 1106 641 1158">K</td> <td data-bbox="641 1106 1401 1158">Developer unit number</td> </tr> </tbody> </table> <p><b>Completion</b> Press the stop key. The screen for selecting a maintenance item No. is displayed.</p>	Display	Description	K	Developer unit number
Display	Description				
K	Developer unit number				



Item No.	Description										
<b>U985</b>	<p><b>Displaying the developer unit history</b></p> <p><b>Description</b> Displays the past record of machine number and the developer counter.</p> <p><b>Purpose</b> To check the count value of machine number and the developer counter.</p> <p><b>Method</b></p> <ol style="list-style-type: none"> <li>1. Press the start key.</li> <li>2. Select [K].</li> </ol> <table border="1" data-bbox="336 600 1401 696"> <thead> <tr> <th data-bbox="336 600 639 645">Display</th> <th data-bbox="639 600 1401 645">Description</th> </tr> </thead> <tbody> <tr> <td data-bbox="336 645 639 696">K</td> <td data-bbox="639 645 1401 696">Developer unit past record</td> </tr> </tbody> </table> <p>The history of a machine number and a developer counter for each color is displayed by three cases.</p> <table border="1" data-bbox="336 786 1401 929"> <thead> <tr> <th data-bbox="336 786 639 831">Display</th> <th data-bbox="639 786 1401 831">Description</th> </tr> </thead> <tbody> <tr> <td data-bbox="336 831 639 875">Machine History1 - 3</td> <td data-bbox="639 831 1401 875">Historical records of the machine number</td> </tr> <tr> <td data-bbox="336 875 639 929">Cnt History1 - 3</td> <td data-bbox="639 875 1401 929">Historical records of developer counter</td> </tr> </tbody> </table> <p><b>Completion</b> Press the stop key. The screen for selecting a maintenance item No. is displayed.</p>	Display	Description	K	Developer unit past record	Display	Description	Machine History1 - 3	Historical records of the machine number	Cnt History1 - 3	Historical records of developer counter
Display	Description										
K	Developer unit past record										
Display	Description										
Machine History1 - 3	Historical records of the machine number										
Cnt History1 - 3	Historical records of developer counter										
<b>U989</b>	<p><b>HDD Scan disk</b></p> <p><b>Description</b> Restores data in the hard disk by scanning the disk.</p> <p><b>Purpose</b> If power is turned off while accessing to the hard disk is performed, the control information in the hard disk drive may be damaged. Use this mode to restore the data.</p> <p><b>Method</b></p> <ol style="list-style-type: none"> <li>1. Press the start key.</li> <li>2. Select [Execute].</li> <li>3. Press the start key.</li> <li>4. Turn the main power switch off and on. Allow more than 5 seconds between Off and On.</li> </ol>										

Item No.	Description								
U990	<p><b>Checking the time for the exposure lamp to light</b></p> <p><b>Description</b> Displays the accumulated time for the CIS to light.</p> <p><b>Purpose</b> To check duration of use of the CIS.</p> <p><b>Method</b> 1. Press the start key. The accumulated time for the CIS to light is displayed in minutes.</p> <table border="1" data-bbox="336 598 1401 694"> <thead> <tr> <th data-bbox="336 598 639 642">Display</th> <th data-bbox="639 598 1401 642">Description</th> </tr> </thead> <tbody> <tr> <td data-bbox="336 642 639 694">CIS</td> <td data-bbox="639 642 1401 694">The accumulated time for the CIS to light</td> </tr> </tbody> </table> <p><b>Completion</b> Press the stop key. The screen for selecting a maintenance item No. is displayed.</p>	Display	Description	CIS	The accumulated time for the CIS to light				
Display	Description								
CIS	The accumulated time for the CIS to light								
U991	<p><b>Checking the scanner operation count</b></p> <p><b>Description</b> Displays the scanner operation count.</p> <p><b>Purpose</b> To check the status of use of the scanner.</p> <p><b>Method</b> 1. Press the start key. The current operation counts is displayed.</p> <table border="1" data-bbox="336 1140 1401 1332"> <thead> <tr> <th data-bbox="336 1140 639 1184">Display</th> <th data-bbox="639 1140 1401 1184">Description</th> </tr> </thead> <tbody> <tr> <td data-bbox="336 1184 639 1232">Copy Scan</td> <td data-bbox="639 1184 1401 1232">Scanner operation counts for copying</td> </tr> <tr> <td data-bbox="336 1232 639 1279">Fax Scan</td> <td data-bbox="639 1232 1401 1279">Scanner operation counts for fax</td> </tr> <tr> <td data-bbox="336 1279 639 1332">Other Scan</td> <td data-bbox="639 1279 1401 1332">Scanner operation counts except for copying</td> </tr> </tbody> </table> <p><b>Completion</b> Press the stop key. The screen for selecting a maintenance No. item is displayed.</p>	Display	Description	Copy Scan	Scanner operation counts for copying	Fax Scan	Scanner operation counts for fax	Other Scan	Scanner operation counts except for copying
Display	Description								
Copy Scan	Scanner operation counts for copying								
Fax Scan	Scanner operation counts for fax								
Other Scan	Scanner operation counts except for copying								

## 1-4-1 Paper misfeed detection

### (1) Paper misfeed indication

When a paper misfeed occurs, the machine immediately stops printing and displays the paper misfeed message on the operation panel. To remove paper misfed in the machine, pull out the cassette, open the paper conveying unit or paper conveying cover.

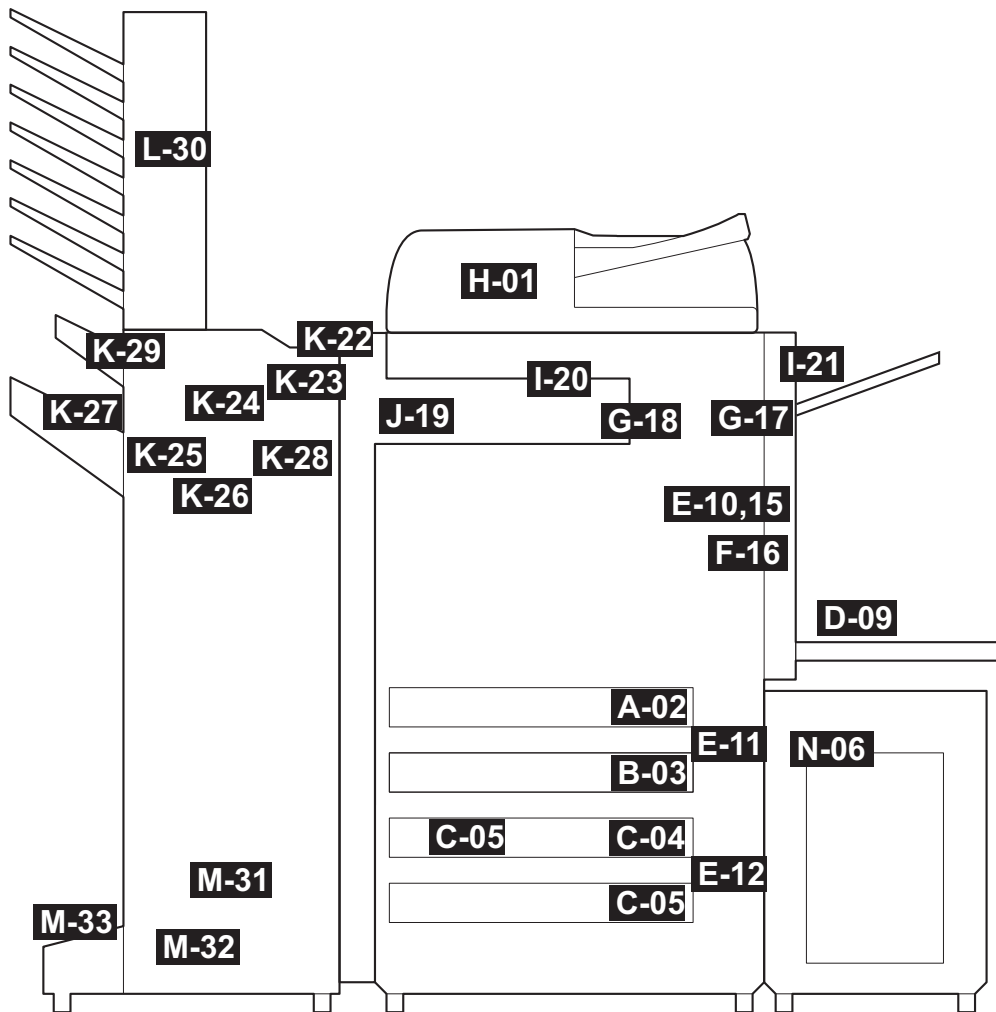
The positions and the corrective actions are displayed on the touch panel when a paper jam has occurred.

Jam code: Jam code suggesting the cause of jam

Position code: Code suggesting the place of jam



Figure 1-4-1



**A-02**  
 └─ Position code (displayed on the panel)  
 └─ Positions in the individual systems (See below.)

**Figure 1-4-2 Paper misfeed indication**

- A. Misfeed in cassette 1
- B. Misfeed in cassette 2
- C. Misfeed in cassette 3 or 4 (option)
- D. Misfeed in the MP tray
- E. Misfeed in paper conveying unit, paper conveying cover or PF paper conveying cover (option)
- F. Misfeed in the duplex section
- G. Misfeed in the fuser section
- H. Misfeed in document processor (option)
- I. Misfeed in job separator (option)
- J. Misfeed in bridge unit (option)
- K. Misfeed in document finisher (option)
- L. Misfeed in Mail box (option)
- M. Misfeed Center-folding unit (option)
- N. Misfeed in cassette 5 (option)





\* : This model does not support the following codes:

0211 /0212 /0214 /0215 /0505 /0506 /0507 /0515 /0516 /0517 /0525 /0526 /0527 /0535 /0536 /0537 /  
1306 /1307 /1316 /1317 /2106 /2107 /2116 /2117 /2307 /2317 /2606 /2607 /2616 /2617 /2707 /2717 /  
3106 /3107 /3116 /3117 /3307 /3317 /3405 /3406 /3407 /3415 /3416 /3417 /3505 /3506 /3507 /3515 /  
3516 /3517 /3605 /3606 /3607 /3615 /3616 /3617 /3705 /3706 /3707 /3715 /3716 /3717 /4006 /4007 /  
4016 /4017 /4106 /4107 /4116 /4117 /4206 /4207 /4216 /4217 /4306 /4307 /4316 /4317 /4406 /4407 /  
4416 /4417 /4606 /4607 /4616 /4617 /4706 /4707 /4716 /4717 /4906 /4907 /4916 /4917 /5006 /5007 /  
5016 /5017 /5106 /5107 /5116 /5117 /9030

#### List of JAM Code

Code	Contents	Conditions	Jam location*
0000	Initial jam	The power is turned on when a sensor in the conveying system is on.	-
0100	Secondary paper feed request time out	Secondary paper feed request given by the controller is unreachable.	-
0101	Waiting for process package to become ready	Process package won't become ready.	-
0102	Waiting for toner package to become ready	Toner package won't become ready.	-
0103	Waiting for the image-sustaining package to become ready	The image-sustaining package won't become ready.	-
0104	Waiting for conveying package to become ready	Conveying package won't become ready.	-
0106	Paper feeding request for duplex printing time out	Paper feeding request for duplex printing given by the controller is unreachable.	-
0107	Waiting for fuser package to become ready	Fuser package won't become ready.	-
0108	Waiting for option package to become ready	Option package won't become ready.	-
0110	Paper conveying unit open	The paper conveying unit is opened during printing.	E
0111	Front cover open	The front cover is opened during printing.	-
0112	Duplex cover open	The duplex cover is opened during printing.	F
0113	Paper conveying cover open	The paper conveying cover is opened during printing.	E
0114	BR conveying unit open	The BR conveying unit is opened during printing.	J
0115	BR eject cover open	The BR eject cover is opened during printing.	J
0131	MP lift sensor upper limit detection	MP lift sensor 1 (MPLS1) does not turn on within specified time of the MP lift plate rising.	D
0132	Rotary guide detection	Rotary sensor (RTS) does not turn on.	J
0200	Machine sequence error	A sequence error has occurred.	-
0210	PF paper conveying cover open	The PF paper conveying cover is opened during printing.	E
0213	SD cover open	The SD cover is opened during printing.	N

\*: Refer to figure 1-4-1 for paper misfeed indication (see page 1-4-1).

<b>Code</b>	<b>Contents</b>	<b>Conditions</b>	<b>Jam location*</b>
<b>0300</b>	Ejection uncompleted	An ejection-completed error has occurred.	-
<b>0501</b>	No paper feed from cassette 1	Feed sensor 1 (FS1) does not turn on during paper feed from cassette 1.	A
<b>0502</b>	No paper feed from cassette 2	Feed sensor 2 (FS2) does not turn on during paper feed from cassette 2.	B
<b>0503</b>	No paper feed from cassette 3	PF feed sensor 1 (PFFS1) does not turn on during paper feed from cassette 3 (paper feeder).	C
<b>0504</b>	No paper feed from cassette 4	PF feed sensor 2 (PFFS2) does not turn on during paper feed from cassette 4 (paper feeder).	C
<b>0508</b>	No paper feed from duplex section	Registration sensor (RS) does not turn on during paper feed from duplex section.	F
<b>0509</b>	No paper feed from MP tray	MP feed sensor (MPFS) does not turn on during paper feed from MP tray.	D
<b>0511</b>	Multiple sheets in cassette 1	Feed sensor 1 (FS1) does not turn off during paper feed from cassette 1.	A
<b>0512</b>	Multiple sheets in cassette 2	Feed sensor 2 (FS2) does not turn off during paper feed from cassette 2.	B
<b>0513</b>	Multiple sheets in cassette 3	PF feed sensor 1 (PFFS1) does not turn off during paper feed from cassette 3 (paper feeder).	C
<b>0514</b>	Multiple sheets in cassette 4	PF feed sensor 2 (PFFS2) does not turn off during paper feed from cassette 4 (paper feeder).	C
<b>0518</b>	Multiple sheets in duplex section	Registration sensor (RS) does not turn off during paper feed from duplex section.	F
<b>0519</b>	Multiple sheets in MP tray	MP feed sensor (MPFS) does not turn off during paper feed from MP tray.	D
<b>0523</b>	No paper feed from cassette 3	PF feed sensor 1 (PFFS1) does not turn on during paper feed from cassette 3 (large capacity feeder).	C
<b>0524</b>	No paper feed from cassette 4	PF feed sensor 2 (PFFS2) does not turn on during paper feed from cassette 4 (large capacity feeder).	C
<b>0533</b>	Multiple sheets in cassette 3	PF feed sensor 1 (PFFS1) does not turn off during paper feed from cassette 3 (large capacity feeder).	C
<b>0534</b>	Multiple sheets in cassette 4	PF feed sensor 2 (PFFS2) does not turn off during paper feed from cassette 4 (large capacity feeder).	C
<b>0545</b>	No paper feed from side deck	SD feed sensor (SDFS) does not turn on during paper feed from side deck.	N

\*: Refer to figure 1-4-1 for paper misfeed indication (see page 1-4-1).



Code	Contents	Conditions	Jam location*
0555	Multiple sheets in side deck	SD feed sensor (SDFS) does not turn off during paper feed from side deck.	N
1301	Middle sensor non arrival jam	Middle sensor (MS) does not turn on during paper feed from cassette 1.	A
1302		Middle sensor (MS) does not turn on during paper feed from cassette 2.	B
1303		Middle sensor (MS) does not turn on during paper feed from cassette 3 (paper feeder/large capacity feeder).	C
1304		Middle sensor (MS) does not turn on during paper feed from cassette 4 (paper feeder/large capacity feeder).	C
1305		Middle sensor (MS) does not turn on during paper feed from cassette 5 (side deck).	N
1311	Middle sensor stay jam	Middle sensor (MS) does not turn off during paper feed from cassette 1.	E
1312		Middle sensor (MS) does not turn off during paper feed from cassette 2.	E
1313		Middle sensor (MS) does not turn off during paper feed from cassette 3 (paper feeder/large capacity feeder).	E
1314		Middle sensor (MS) does not turn off during paper feed from cassette 4 (paper feeder/large capacity feeder).	E
1315		Middle sensor (MS) does not turn off during paper feed from cassette 5 (side deck).	E
1502	Paper conveying sensor non arrival jam	Paper conveying sensor (PCS) does not turn on during paper feed from cassette 2.	B
1503		Paper conveying sensor (PCS) does not turn on during paper feed from cassette 3 (paper feeder/large capacity feeder).	C
1504		Paper conveying sensor (PCS) does not turn on during paper feed from cassette 4 (paper feeder/large capacity feeder).	C

\*: Refer to figure 1-4-1 for paper misfeed indication (see page 1-4-1).

Code	Contents	Conditions	Jam location*
1512	Paper conveying sensor stay jam	Paper conveying sensor (PCS) does not turn off during paper feed from cassette 2.	E
1513		Paper conveying sensor (PCS) does not turn off during paper feed from cassette 3 (paper feeder/ large capacity feeder).	E
1514		Paper conveying sensor (PCS) does not turn off during paper feed from cassette 4 (paper feeder/ large capacity feeder).	E
1703	PF paper conveying sensor 1 non arrival jam	PF paper conveying sensor 1 (PFPCS1) does not turn on during paper feed from cassette 3 (paper feeder).	C
1704		PF paper conveying sensor 1 (PFPCS1) does not turn on during paper feed from cassette 4 (paper feeder).	C
1713	PF paper conveying sensor 1 stay jam	PF paper conveying sensor 1 (PFPCS1) does not turn off during paper feed from cassette 3 (paper feeder).	E
1714		PF paper conveying sensor 1 (PFPCS1) does not turn off during paper feed from cassette 4 (paper feeder).	E
1904	PF paper conveying sensor 2 non arrival jam	PF paper conveying sensor 2 (PFPCS2) does not turn on during paper feed from cassette 4 (paper feeder).	C
1914	PF paper conveying sensor 2 stay jam	PF paper conveying sensor 2 (PFPCS2) does not turn off during paper feed from cassette 4 (paper feeder).	C
2603	PF paper conveying sensor 1 non arrival jam	PF paper conveying sensor 1 (PFPCS1) does not turn on during paper feed from cassette 3 (large capacity feeder).	C
2604		PF paper conveying sensor 1 (PFPCS1) does not turn on during paper feed from cassette 4 (large capacity feeder).	C
2613	PF paper conveying sensor 1 stay jam	PF paper conveying sensor 1 (PFPCS1) does not turn off during paper feed from cassette 3 (large capacity feeder).	E
2614		PF paper conveying sensor 1 (PFPCS1) does not turn off during paper feed from cassette 4 (large capacity feeder).	E
2704	PF paper conveying sensor 2 non arrival jam	PF paper conveying sensor 2 (PFPCS2) does not turn on during paper feed from cassette 4 (large capacity feeder).	C

\*: Refer to figure 1-4-1 for paper misfeed indication (see page 1-4-1).

<b>Code</b>	<b>Contents</b>	<b>Conditions</b>	<b>Jam location*</b>
<b>2714</b>	PF paper conveying sensor 2 stay jam	PF paper conveying sensor 2 (PFPCS2) does not turn off during paper feed from cassette 4 (large capacity feeder).	C
<b>4001</b>	Registration sensor non arrival jam	Registration sensor (RS) does not turn on during paper feed from cassette 1.	E
<b>4002</b>		Registration sensor (RS) does not turn on during paper feed from cassette 2.	E
<b>4003</b>		Registration sensor (RS) does not turn on during paper feed from cassette 3 (paper feeder/large capacity feeder).	E
<b>4004</b>		Registration sensor (RS) does not turn on during paper feed from cassette 4 (paper feeder/large capacity feeder).	E
<b>4005</b>		Registration sensor (RS) does not turn on during paper feed from cassette 5 (side deck).	E
<b>4009</b>		Registration sensor (RS) does not turn on during paper feed from MP tray.	E

\*: Refer to figure 1-4-1 for paper misfeed indication (see page 1-4-1).

<b>Code</b>	<b>Contents</b>	<b>Conditions</b>	<b>Jam location*</b>
<b>4011</b>	Registration sensor stay jam	Registration sensor (RS) does not turn off during paper feed from cassette 1.	E
<b>4012</b>		Registration sensor (RS) does not turn off during paper feed from cassette 2.	E
<b>4013</b>		Registration sensor (RS) does not turn off during paper feed from cassette 3 (paper feeder/large capacity feeder).	E
<b>4014</b>		Registration sensor (RS) does not turn off during paper feed from cassette 4 (paper feeder/large capacity feeder).	E
<b>4015</b>		Registration sensor (RS) does not turn off during paper feed from cassette 5 (side deck).	E
<b>4019</b>		Registration sensor (RS) does not turn off during paper feed from MP tray.	E

\*: Refer to figure 1-4-1 for paper misfeed indication (see page 1-4-1).

<b>Code</b>	<b>Contents</b>	<b>Conditions</b>	<b>Jam location*</b>
<b>4101</b>	Loop sensor non arrival jam	Loop sensor (LPS) does not turn on during paper feed from cassette 1.	E
<b>4102</b>		Loop sensor (LPS) does not turn on during paper feed from cassette 2.	E
<b>4103</b>		Loop sensor (LPS) does not turn on during paper feed from cassette 3 (paper feeder/large capacity feeder).	E
<b>4104</b>		Loop sensor (LPS) does not turn on during paper feed from cassette 4 (paper feeder/large capacity feeder).	E
<b>4105</b>		Loop sensor (LPS) does not turn on during paper feed from cassette 5 (side deck).	E
<b>4108</b>		Loop sensor (LPS) does not turn on during paper feed from duplex section.	E
<b>4109</b>		Loop sensor (LPS) does not turn on during paper feed from MP tray.	E
<b>4111</b>	Loop sensor stay jam	Loop sensor (LPS) does not turn off during paper feed from cassette 1.	E
<b>4112</b>		Loop sensor (LPS) does not turn off during paper feed from cassette 2.	E
<b>4113</b>		Loop sensor (LPS) does not turn off during paper feed from cassette 3 (paper feeder/large capacity feeder).	E
<b>4114</b>		Loop sensor (LPS) does not turn off during paper feed from cassette 4 (paper feeder/large capacity feeder).	E
<b>4115</b>		Loop sensor (LPS) does not turn off during paper feed from cassette 5 (side deck).	E
<b>4118</b>		Loop sensor (LPS) does not turn off during paper feed from duplex section.	E
<b>4119</b>		Loop sensor (LPS) does not turn off during paper feed from MP tray.	E

\*: Refer to figure 1-4-1 for paper misfeed indication (see page 1-4-1).

<b>Code</b>	<b>Contents</b>	<b>Conditions</b>	<b>Jam location*</b>
<b>4201</b>	Fuser eject sensor non arrival jam	Fuser eject sensor (FUES) does not turn on during paper feed from cassette 1.	E
<b>4202</b>		Fuser eject sensor (FUES) does not turn on during paper feed from cassette 2.	E
<b>4203</b>		Fuser eject sensor (FUES) does not turn on during paper feed from cassette 3 (paper feeder/ large capacity feeder).	E
<b>4204</b>		Fuser eject sensor (FUES) does not turn on during paper feed from cassette 4 (paper feeder/ large capacity feeder).	E
<b>4205</b>		Fuser eject sensor (FUES) does not turn on during paper feed from cassette 5 (side deck).	E
<b>4208</b>		Fuser eject sensor (FUES) does not turn on during paper feed from duplex section.	E
<b>4209</b>		Fuser eject sensor (FUES) does not turn on during paper feed from MP tray.	E
<b>4211</b>	Fuser eject sensor stay jam	Fuser eject sensor (FUES) does not turn off during paper feed from cassette 1.	G
<b>4212</b>		Fuser eject sensor (FUES) does not turn off during paper feed from cassette 2.	G
<b>4213</b>		Fuser eject sensor (FUES) does not turn off during paper feed from cassette 3 (paper feeder/ large capacity feeder).	G
<b>4214</b>		Fuser eject sensor (FUES) does not turn off during paper feed from cassette 4 (paper feeder/ large capacity feeder).	G
<b>4215</b>		Fuser eject sensor (FUES) does not turn off during paper feed from cassette 5 (side deck).	G
<b>4218</b>		Fuser eject sensor (FUES) does not turn off during paper feed from duplex section.	G
<b>4219</b>		Fuser eject sensor (FUES) does not turn off during paper feed from MP tray.	G

\*: Refer to figure 1-4-1 for paper misfeed indication (see page 1-4-1).

Code	Contents	Conditions	Jam location*
4301	Duplex sensor 1 non arrival jam	Duplex sensor 1 (DUS1) does not turn on during paper feed from cassette 1.	G
4302		Duplex sensor 1 (DUS1) does not turn on during paper feed from cassette 2.	G
4303		Duplex sensor 1 (DUS1) does not turn on during paper feed from cassette 3 (paper feeder/large capacity feeder).	G
4304		Duplex sensor 1 (DUS1) does not turn on during paper feed from cassette 4 (paper feeder/large capacity feeder).	G
4305		Duplex sensor 1 (DUS1) does not turn on during paper feed from cassette 5 (side deck).	G
4309		Duplex sensor 1 (DUS1) does not turn on during paper feed from MP tray.	G
4311	Duplex sensor 1 stay jam	Duplex sensor 1 (DUS1) does not turn off during paper feed from cassette 1.	F
4312		Duplex sensor 1 (DUS1) does not turn off during paper feed from cassette 2.	F
4313		Duplex sensor 1 (DUS1) does not turn off during paper feed from cassette 3 (paper feeder/large capacity feeder).	F
4314		Duplex sensor 1 (DUS1) does not turn off during paper feed from cassette 4 (paper feeder/large capacity feeder).	F
4315		Duplex sensor 1 (DUS1) does not turn off during paper feed from cassette 5 (side deck).	F
4319		Duplex sensor 1 (DUS1) does not turn off during paper feed from MP tray.	F
4401	Duplex sensor 2 non arrival jam	Duplex sensor 2 (DUS2) does not turn on during paper feed from cassette 1.	F
4402		Duplex sensor 2 (DUS2) does not turn on during paper feed from cassette 2.	F
4403		Duplex sensor 2 (DUS2) does not turn on during paper feed from cassette 3 (paper feeder/large capacity feeder).	F
4404		Duplex sensor 2 (DUS2) does not turn on during paper feed from cassette 4 (paper feeder/large capacity feeder).	F
4405		Duplex sensor 2 (DUS2) does not turn on during paper feed from cassette 5 (side deck).	F
4409		Duplex sensor 2 (DUS2) does not turn on during paper feed from MP tray.	F

\*: Refer to figure 1-4-1 for paper misfeed indication (see page 1-4-1).

<b>Code</b>	<b>Contents</b>	<b>Conditions</b>	<b>Jam location*</b>
4411	Duplex sensor 2 stay jam	Duplex sensor 2 (DUS2) does not turn off during paper feed from cassette 1.	F
4412		Duplex sensor 2 (DUS2) does not turn off during paper feed from cassette 2.	F
4413		Duplex sensor 2 (DUS2) does not turn off during paper feed from cassette 3 (paper feeder/large capacity feeder).	F
4414		Duplex sensor 2 (DUS2) does not turn off during paper feed from cassette 4 (paper feeder/large capacity feeder).	F
4415		Duplex sensor 2 (DUS2) does not turn off during paper feed from cassette 5 (side deck).	F
4418		Duplex sensor 2 (DUS2) does not turn off during paper feed from duplex section.	F
4419		Duplex sensor 2 (DUS2) does not turn off during paper feed from MP tray.	F
4601	Eject full sensor non arrival jam	Eject full sensor (EFS) does not turn on during paper feed from cassette 1.	G
4602		Eject full sensor (EFS) does not turn on during paper feed from cassette 2.	G
4603		Eject full sensor (EFS) does not turn on during paper feed from cassette 3 (paper feeder/large capacity feeder).	G
4604		Eject full sensor (EFS) does not turn on during paper feed from cassette 4 (paper feeder/large capacity feeder).	G
4605		Eject full sensor (EFS) does not turn on during paper feed from cassette 5 (side deck).	G
4608		Eject full sensor (EFS) does not turn on during paper feed from duplex section.	G
4609		Eject full sensor (EFS) does not turn on during paper feed from MP tray.	G

\*: Refer to figure 1-4-1 for paper misfeed indication (see page 1-4-1).



<b>Code</b>	<b>Contents</b>	<b>Conditions</b>	<b>Jam location*</b>
<b>4611</b>	Eject full sensor stay jam	Eject full sensor (EFS) does not turn off during paper feed from cassette 1.	G
<b>4612</b>		Eject full sensor (EFS) does not turn off during paper feed from cassette 2.	G
<b>4613</b>		Eject full sensor (EFS) does not turn off during paper feed from cassette 3 (paper feeder/large capacity feeder).	G
<b>4614</b>		Eject full sensor (EFS) does not turn off during paper feed from cassette 4 (paper feeder/large capacity feeder).	G
<b>4615</b>		Eject full sensor (EFS) does not turn off during paper feed from cassette 5 (side deck).	G
<b>4618</b>		Eject full sensor (EFS) does not turn off during paper feed from duplex section.	G
<b>4619</b>		Eject full sensor (EFS) does not turn off during paper feed from MP tray.	G
<b>4701</b>	Switchback sensor non arrival jam	Switchback sensor (SBS) does not turn on during paper feed from cassette 1.	G
<b>4702</b>		Switchback sensor (SBS) does not turn on during paper feed from cassette 2.	G
<b>4703</b>		Switchback sensor (SBS) does not turn on during paper feed from cassette 3 (paper feeder/large capacity feeder).	G
<b>4704</b>		Switchback sensor (SBS) does not turn on during paper feed from cassette 4 (paper feeder/large capacity feeder).	G
<b>4705</b>		Switchback sensor (SBS) does not turn on during paper feed from cassette 5 (side deck).	G
<b>4708</b>		Switchback sensor (SBS) does not turn on during paper feed from duplex section.	G
<b>4709</b>		Switchback sensor (SBS) does not turn on during paper feed from MP tray.	G

\*: Refer to figure 1-4-1 for paper misfeed indication (see page 1-4-1).

<b>Code</b>	<b>Contents</b>	<b>Conditions</b>	<b>Jam location*</b>
<b>4711</b>	Switchback sensor stay jam	Switchback sensor (SBS) does not turn off during paper feed from cassette 1.	I
<b>4712</b>		Switchback sensor (SBS) does not turn off during paper feed from cassette 2.	I
<b>4713</b>		Switchback sensor (SBS) does not turn off during paper feed from cassette 3 (paper feeder/large capacity feeder).	I
<b>4714</b>		Switchback sensor (SBS) does not turn off during paper feed from cassette 4 (paper feeder/large capacity feeder).	I
<b>4715</b>		Switchback sensor (SBS) does not turn off during paper feed from cassette 5 (side deck).	I
<b>4718</b>		Switchback sensor (SBS) does not turn off during paper feed from duplex section.	I
<b>4719</b>		Switchback sensor (SBS) does not turn off during paper feed from MP tray.	I
<b>4901</b>	BR conveying sensor 1 non arrival jam	BR conveying sensor 1 (BRCS1) does not turn on during paper feed from cassette 1.	G
<b>4902</b>		BR conveying sensor 1 (BRCS1) does not turn on during paper feed from cassette 2.	G
<b>4903</b>		BR conveying sensor 1 (BRCS1) does not turn on during paper feed from cassette 3 (paper feeder/large capacity feeder).	G
<b>4904</b>		BR conveying sensor 1 (BRCS1) does not turn on during paper feed from cassette 4 (paper feeder/large capacity feeder).	G
<b>4905</b>		BR conveying sensor 1 (BRCS1) does not turn on during paper feed from cassette 5 (side deck).	G
<b>4908</b>		BR conveying sensor 1 (BRCS1) does not turn on during paper feed from duplex section.	G
<b>4909</b>		BR conveying sensor 1 (BRCS1) does not turn on during paper feed from MP tray.	G

\*: Refer to figure 1-4-1 for paper misfeed indication (see page 1-4-1).

<b>Code</b>	<b>Contents</b>	<b>Conditions</b>	<b>Jam location*</b>
<b>4911</b>	BR conveying sensor 1 stay jam	BR conveying sensor 1 (BRCS1) does not turn off during paper feed from cassette 1.	J
<b>4912</b>		BR conveying sensor 1 (BRCS1) does not turn off during paper feed from cassette 2.	J
<b>4913</b>		BR conveying sensor 1 (BRCS1) does not turn off during paper feed from cassette 3 (paper feeder/ large capacity feeder).	J
<b>4914</b>		BR conveying sensor 1 (BRCS1) does not turn off during paper feed from cassette 4 (paper feeder/ large capacity feeder).	J
<b>4915</b>		BR conveying sensor 1 (BRCS1) does not turn off during paper feed from cassette 5 (side deck).	J
<b>4918</b>		BR conveying sensor 1 (BRCS1) does not turn off during paper feed from duplex section.	J
<b>4919</b>		BR conveying sensor 1 (BRCS1) does not turn off during paper feed from MP tray.	J
<b>5001</b>	BR conveying sensor 2 non arrival jam	BR conveying sensor 2 (BRCS2) does not turn on during paper feed from cassette 1.	J
<b>5002</b>		BR conveying sensor 2 (BRCS2) does not turn on during paper feed from cassette 2.	J
<b>5003</b>		BR conveying sensor 2 (BRCS2) does not turn on during paper feed from cassette 3 (paper feeder/ large capacity feeder).	J
<b>5004</b>		BR conveying sensor 2 (BRCS2) does not turn on during paper feed from cassette 4 (paper feeder/ large capacity feeder).	J
<b>5005</b>		BR conveying sensor 2 (BRCS2) does not turn on during paper feed from cassette 5 (side deck).	J
<b>5008</b>		BR conveying sensor 2 (BRCS2) does not turn on during paper feed from duplex section.	J
<b>5009</b>		BR conveying sensor 2 (BRCS2) does not turn on during paper feed from MP tray.	J

\*: Refer to figure 1-4-1 for paper misfeed indication (see page 1-4-1).

Code	Contents	Conditions	Jam location*
5011	BR conveying sensor 2 stay jam	BR conveying sensor 2 (BRCS2) does not turn off during paper feed from cassette 1.	J
5012		BR conveying sensor 2 (BRCS2) does not turn off during paper feed from cassette 2.	J
5013		BR conveying sensor 2 (BRCS2) does not turn off during paper feed from cassette 3 (paper feeder/ large capacity feeder).	J
5014		BR conveying sensor 2 (BRCS2) does not turn off during paper feed from cassette 4 (paper feeder/ large capacity feeder).	J
5015		BR conveying sensor 2 (BRCS2) does not turn off during paper feed from cassette 5 (side deck).	J
5018		BR conveying sensor 2 (BRCS2) does not turn off during paper feed from duplex section.	J
5019		BR conveying sensor 2 (BRCS2) does not turn off during paper feed from MP tray.	J
5101	BR eject sensor non arrival jam	BR eject sensor (BRES) does not turn on during paper feed from cassette 1.	J
5102		BR eject sensor (BRES) does not turn on during paper feed from cassette 2.	J
5103		BR eject sensor (BRES) does not turn on during paper feed from cassette 3 (paper feeder/ large capacity feeder).	J
5104		BR eject sensor (BRES) does not turn on during paper feed from cassette 4 (paper feeder/ large capacity feeder).	J
5105		BR eject sensor (BRES) does not turn on during paper feed from cassette 5 (side deck/ large capacity feeder).	J
5108		BR eject sensor (BRES) does not turn on during paper feed from duplex section.	J
5109		BR eject sensor (BRES) does not turn on during paper feed from MP tray.	J

\*: Refer to figure 1-4-1 for paper misfeed indication (see page 1-4-1).

Code	Contents	Conditions	Jam location*
5111	BR eject sensor stay jam	BR eject sensor (BRES) does not turn off during paper feed from cassette 1.	J
5112		BR eject sensor (BRES) does not turn off during paper feed from cassette 2.	J
5113		BR eject sensor (BRES) does not turn off during paper feed from cassette 3 (paper feeder/large capacity feeder).	J
5114		BR eject sensor (BRES) does not turn off during paper feed from cassette 4 (paper feeder/large capacity feeder).	J
5115		BR eject sensor (BRES) does not turn off during paper feed from cassette 5 (side deck).	J
5118		BR eject sensor (BRES) does not turn off during paper feed from duplex section.	J
5119		BR eject sensor (BRES) does not turn off during paper feed from MP tray.	J
6000	DF paper entry error	DF paper entry sensor (DFPES) turn on before the eject signal is output from the machine (4000-sheet finisher).	K
6001		DF paper entry sensor (DFPES) turn on before the eject signal is output from the machine (1000-sheet finisher).	K
6020	DF front cover open	DF front upper cover is opened during operation (4000-sheet finisher).	K
6021		DF front cover is opened during operation (1000-sheet finisher).	K
6041	DF top cover open	DF top cover is opened during operation (1000-sheet finisher).	K
6050	CF eject cover open	CF eject cover is opened during operation (4000-sheet finisher).	M
6060	MB cover open	MB cover is opened during operation (4000-sheet finisher).	L
6070	Center folding unit open	Center folding unit is opened during operation (4000-sheet finisher).	M
6080	CF left guide open	CF left guide is opened during operation (4000-sheet finisher).	M

\*: Refer to figure 1-4-1 for paper misfeed indication (see page 1-4-1).

<b>Code</b>	<b>Contents</b>	<b>Conditions</b>	<b>Jam location*</b>
<b>6100</b>	DF paper entry sensor non arrival jam	DF paper entry sensor (DFPES) does not turned on even if a specified time has elapsed after the machine eject signal was received (4000-sheet finisher).	K
<b>6101</b>		DF paper entry sensor (DFPES) does not turned on even if a specified time has elapsed after the machine eject signal was received (1000-sheet finisher).	K
<b>6110</b>	DF paper entry sensor stay jam	DF paper entry sensor (DFPES) does not turned off within specified time of its turning on (4000-sheet finisher).	K
<b>6111</b>		DF paper entry sensor (DFPES) does not turned off within specified time of its turning on (1000-sheet finisher).	K
<b>6200</b>	DF sub eject sensor non arrival jam	DF sub eject sensor (DFSES) does not turn on within specified time of DF paper entry sensor (DFPES) turning on.	K
<b>6210</b>	DF sub eject sensor stay jam	DF sub eject sensor (DFSES) does not turned off within specified time of its turning on.	K
<b>6300</b>	DF middle eject sensor non arrival jam	DF middle eject sensor (DFMES) does not turn on within specified time of DF paper entry sensor (DFPES) turning on (4000-sheet finisher).	K
<b>6301</b>		DF middle eject sensor (DFMES) does not turn on within specified time of DF paper entry sensor (DFPES) turning on (1000-sheet finisher).	K
<b>6310</b>	DF middle eject sensor stay jam	DF middle eject sensor (DFMES) is not turned off within specified time of its turning on (4000-sheet finisher).	K
<b>6311</b>		DF middle eject sensor (DFMES) is not turned off within specified time of its turning on (1000-sheet finisher).	K
<b>6400</b>	DF tray upper surface sensor non arrival jam	DF tray upper surface sensor (DFTUSS) does not turn on within specified time of DF middle eject sensor (DFMES) turning on (4000-sheet finisher).	K
<b>6401</b>		DF tray upper surface sensor (DFTUSS) does not turn on within specified time of DF middle eject sensor (DFMES) turning on (1000-sheet finisher).	K

\*: Refer to figure 1-4-1 for paper misfeed indication (see page 1-4-1).

Code	Contents	Conditions	Jam location*
6410	DF tray upper surface sensor stay jam	DF tray upper surface sensor (DFTUSS) is not turned off within specified time of its turning on (4000-sheet finisher).	K
6411		DF tray upper surface sensor (DFTUSS) is not turned off within specified time of its turning on (1000-sheet finisher).	K
6500	DF eject paper sensor non arrival jam	DF bundle discharge sensor (DFBDS) does not turn on within specified time of DF middle eject sensor (DFMES) turning on.	K
6510	DF eject paper sensor stay jam	DF bundle discharge sensor (DFBDS) is not turned off since the bundle discharge starts (4000-sheet finisher).	K
6511		DF bundle discharge sensor (DFBDS) is not turned off since the bundle discharge starts (1000-sheet finisher).	K
6600	DF drum sensor non arrival jam	DF drum sensor (DFDRS) does not turn on within specified time of DF paper entry sensor (DFPES) turning on.	K
6610	DF drum sensor stay jam	DF drum sensor (DFDRS) is not turned off within specified time of its turning on.	K
6710	Center folding unit stay jam	During paper conveying to center folding unit, DF drum sensor (DFDRS) is not turned off within specified time of its turning on.	K
6810	DF side registration sensor 1 stay jam	DF side registration sensor 1 (DFSRS1) is not turned off within specified time after driving the DF side registration motor 1 (DFS RM1) (4000-sheet finisher).	K
6811		DF side registration sensor 1 (DFSRS1) is not turned off within specified time after driving the DF side registration motor 1 (DFS RM1) (1000-sheet finisher).	K
6910	DF side registration sensor 2 stay jam	DF side registration sensor 2 (DFSRS2) is not turned off within specified time after driving the DF side registration motor 2 (DFS RM2) (4000-sheet finisher).	K
6911		DF side registration sensor 2 (DFSRS2) is not turned off within specified time after driving the DF side registration motor 2 (DFS RM2) (1000-sheet finisher).	K

\*: Refer to figure 1-4-1 for paper misfeed indication (see page 1-4-1).

Code	Contents	Conditions	Jam location*
7000	DF staple operation error	DF staple sensor (DFSTS) is not turned on within specified time after driving the DF staple motor (DFSTM) (4000-sheet finisher).	K
7001		DF staple sensor (DFSTS) is not turned on within specified time after driving the DF staple motor (DFSTM) (1000-sheet finisher).	K
7100	CF paper entry sensor non arrival jam	CF paper entry sensor (CFPES) is not turned on even if a specified time has elapsed after the machine eject signal was received.	M
7110	CF paper entry sensor stay jam	CF paper entry sensor (CFPES) is not turned off within specified time of its turning on.	M
7200	CF eject sensor non arrival jam	CF eject sensor (CFES) is not turned on within specified time since centerfold operation starts.	M
7210	CF eject sensor stay jam	During centerfold operation, CF eject sensor (CFES) is not turned off within specified time of its turning on.	M
7300	CF eject sensor non arrival jam	CF eject sensor (CFES) is not turned on within specified time since three fold operation starts.	M
7310	CF eject sensor stay jam	During three fold operation, CF eject sensor (CFES) is not turned off within specified time of its turning on.	M
7400	CF side registration sensor 2 non arrival jam	CF side registration sensor 2 (CFSRS2) is not turned on within specified time after driving the CF side registration motor 2 (CFSRM2).	M
7500	CF side registration sensor 1 non arrival jam	CF side registration sensor 1 (CFSRS1) is not turned on within specified time after driving the CF side registration motor 1 (CFSRM1).	M
7600	CF staple operation error	CF staple sensor (CFSTS) is not turned on within specified time after driving the CF staple motor (CFSTM).	M
7700	CF paper conveying sensor non arrival jam	CF paper conveying sensor (CFPCS) is not turned on even if a specified time has elapsed after the machine eject signal was received.	M
7710	CF paper conveying sensor stay jam	CF paper conveying sensor (CFPCS) is not turned off within specified time of its turning on.	M

\*: Refer to figure 1-4-1 for paper misfeed indication (see page 1-4-1).



Code	Contents	Conditions	Jam location*
7800	MB eject sensor non arrival jam	MB eject sensor (MBES) is not turned on even if a specified time has elapsed after the machine eject signal was received.	L
7810	MB eject sensor stay jam	MB eject sensor (MBES) is not turned off within specified time of its turning on.	L
7900	Middle paddle error jam	DF paddle sensor (DFPDS) is not turned on within specified time after driving the DF middle motor (DFMM) (4000-sheet finisher).	K
7901		DF paddle sensor (DFPDS) is not turned on within specified time after driving the DF middle motor (DFMM) (1000-sheet finisher).	K
7950	Paper interval error jam	An illegal inter-page or inter-copy interval has occurred (4000-sheet finisher).	K
7951		An illegal inter-page or inter-copy interval has occurred (1000-sheet finisher).	K
9000	No original feed jam	DP feed sensor (DPFS) does not turn on within specified time during the first sheet feeding (Retry 5 times).	H
9001	DP original conveying jam	DP timing sensor (DPTS) turn off within the specified time since the sensor turn on.	H
9002	DP sensor stay jam	Sensor in the conveying system is on since original feeding starts.	H
9004	DP switchback jam 2	DP registration sensor (DPRS) is not turned on within specified time since original switchback operation starts.	H
9005	No original feed jam 2	DP lift sensor 1 (DPLS1) does not turn on within specified time of the lift plate rising.	H
9006	DP switchback jam 3	DP eject sensor (DPES) is not turned on within specified time since original switchback operation starts.	H
9007	DP switchback jam 4	DP eject sensor (DPES) is not turned off within specified time since original switchback operation starts.	H
9008	No original feed jam 3	DP CIS sensor (DPCS) does not turn on within specified time of the paper feed starting	H
9009	DP original conveying jam 2	Next feed original became the stand-by states of paper feed while reading the image.	H
9010	Document processor open	Document processor is opened during original feeding.	H
9011	DP top cover open	The DP top cover is opened during original feeding.	H

\*: Refer to figure 1-4-1 for paper misfeed indication (see page 1-4-1).

<b>Code</b>	<b>Contents</b>	<b>Conditions</b>	<b>Jam location*</b>
<b>9020</b>	Original skew feed jam	DP skew sensor (DPSS) does not turn on within specified time of DP registration sensor (DPRS) turning on.	H
<b>9110</b>	DP feed sensor stay jam	DP feed sensor (DPFS) does not turn off within specified time of DP timing sensor (DPTS) turning on.	H
<b>9200</b>	DP registration sensor non arrival jam	DP registration sensor (DPRS) does not turn on within specified time of DP feed sensor (DPFS) turning on.	H
<b>9210</b>	DP registration sensor stay jam	DP registration sensor (DPRS) does not turn off within specified time of DP timing sensor (DPTS) turning on.	H
<b>9300</b>	DP CIS sensor non arrival jam	DP CIS sensor (DPCS) does not turn on within specified time of DP registration sensor (DPFS) turning on.	H
<b>9310</b>	DP CIS sensor stay jam	DP CIS sensor (DPCS) does not turn off within specified time of DP registration sensor (DPFS) turning off.	H
<b>9400</b>	DP timing sensor non arrival jam	DP timing sensor (DPTS) does not turn on within specified time of DP feed sensor (DPFS) turning on.	H
<b>9410</b>	DP timing sensor stay jam	DP timing sensor (DPTS) does not turn off within specified time of DP feed sensor (DPFS) turning off.	H
<b>9500</b>	DP switchback sensor non arrival jam	DP switchback sensor (DPSBS) does not turn on within specified time of DP timing sensor (DPTS) turning on.	H
<b>9600</b>	DP eject sensor non arrival jam	DP eject sensor (DPES) does not turn on within specified time of DP timing sensor (DPTS) turning on.	H

\*: Refer to figure 1-4-1 for paper misfeed indication (see page 1-4-1).

<b>Code</b>	<b>Contents</b>	<b>Conditions</b>	<b>Jam location*</b>
<b>9610</b>	DP eject sensor stay jam	DP eject sensor (DPES) does not turn off within specified time of DP timing sensor (DPTS) turning off.	H

\*: Refer to figure 1-4-1 for paper misfeed indication (see page 1-4-1).

## 1-4-2 Troubleshooting

### (1) First check items

If the paper is fed askew, jammed, curled, or leading-edge dog-eared, first perform to check the following items.

Check items	Check description	Corrective measures
Paper	1. Check the paper delivered is dog-eared, skewed, ruffled, loosely fused, or curled.	If a dog-ear has happened, check there are no objects existing in the conveying paths and, if any, fix. If the paper is fed askew or crumpled, perform the following No.2.If an inferior fusing or curling is observed and the fuser temperature is set to a abnormal value, when measured by performing maintenance mode U161, reset to the default. (see page 1-3-89)
	2. Check how paper is loaded in the cassette (deck). Check that the paper has been properly aligned with width adjuster cursor and the rear guide; it has been loaded without skewing; or it is not damaged. (Crumpled paper, main unit/DF jam)	Adjust the cursors to the size of the paper. (If paper is fed askew, perform a skew cancellation adjustment of the width adjuster cursor.) (see page 1-5-108)
	3. Check how paper is loaded. Check if the cutting edge of the paper bundle inside is crumpled or bent.	If the cutting edge of the paper bundle is crumpled, fan the paper before loading. If the paper is folded, stretch before loading in the cassette
	4. If a large-capacity deck is being used, check how paper is loaded in the deck. Check if the paper inside the deck is placed above the guide.	Reload the paper so that its edges won't be situated above the platform.
	5. Check the paper is damp, wavy, or curled.	1. Load the paper bundle in the cassette upside down. 2. Load the paper bundle after rotating it 180°and reload. 3. Change the paper.
	6. Check if the paper loaded was stored in a continuously humid place.	Instruct the user to store paper in a dry, less humid place. Install a cassette heater and configure using U327. (see page 1-3-138)
	7. Check if the paper conforms to the requirements.	Isolate the cause of the problem by replacing the paper with the recommended paper. (see page 1-1-1)



Check items	Check description	Corrective measures
Paper	8. Check the paper ejected is dog-eared, skewed, ruffled, loosely fused, or curled.	If the maintenance mode U161 shows that the fuser temperature is set to an abnormal value, reset it to the default. (see page 1-3-89)
Settings/ Detection	1. Check if the margin is 4.0+1.5/-1.0mm from the leading edge of paper. 2. Perform U034 to check the reference mark is situated at 20mm±1mm from the edge. (Fuser jam) (see page 1-3-34)	If the check line is not situated at 20mm±1mm from the leading edge, adjust the leading margin by U402. (see page 1-3-142)
	3. Check the panel if the paper size is correctly detected and the cassette size is not fixed.(Paper jam caused by continuously fed paper, DF Jam J611X) Perform U000 to obtain a Event Log to check if the paper size and the size of the paper loaded are met when jam has occurred and if the size of the original document and the paper size are met. see page 1-3-10)	If the paper size is incorrectly displayed, adjust the positions of the paper set guide cursors in accordance with the paper size, making sure that the paper is not askew to activate the size detector switch.
	4. Check that paper settings are made in accordance with the paper being used. (Jam caused by faulty separation)	Select Original/ Paper settings under common settings in the system menu to set media type and weight of paper.
Conveying unit	Check the main unit vertical conveying unit or the front and back parts and right and left parts of the deck's horizontal conveying unit are slightly strained and closed.	To open, first open the right-side conveying unit and close firmly. (Check the position of the safety switch)

Check items	Check description	Corrective measures
Conveying guide, approaching guide, feed-shift guide	1. Check that the foreign objects including scrips, paper clips, etc., do not exist in the paper conveying paths.	If foreign objects such as scrips, etc., remain in the paper conveying path, remove.
	2. Check that the paper conveying guide and the separation needles are not contaminated with toner, paper dusts, etc.	If dirty, clean the guide, ribs (by a cloth), and the separation needles (by a cleaning brush). If the ribs of the conveying guides were broken or deposited with toner, replace.
	3. Check that the paper conveying guide has no bars, deformations, or abrasions; and it is properly mounted without being floated.	Clean the conveying guide or the paper approaching guide. Remove any protrusions including bars. If floated, fix it properly. If deformation or abrasion is observed, replace.
	4. Check that the guide. Check that the guide is smoothly operative when manipulated.	If the guide is inoperative or won't operate smoothly, replace the guide or the unit.
	5. Check that the guide. Perform U033 to check the operation of the solenoid to sight-check or audio-check its action. (see page 1-3-33)	If the guide is inoperative or won't operate smoothly, re-assemble the guide or replace the solenoid or the unit.

Check items	Check description	Corrective measures
Conveying roller, feed roller	1. Check the conveying rollers have no paper dusts, toner, or foreign objects stucked. Check a variation of the external diameter of the roller or abrasion is not observed with the conveying roller.	Clean the conveying rollers or the pulleys. If variation in the external diameter or abrasion is observed, replace.
	2. Turn the cover safety switch on and perform U030 - Motor, U032 - Clutch, and U240 - Finished, check they operate normally. * : At checking the clutch by U032, confirm that the roller won't turn when the motor is turned on. (see page 1-3-30, 1-3-32, 1-3-114)	If the conveying motor or the clutch is inoperative, replace. If stained, replace the clutch. If the clutch is kept turned on due to a tensioned wire, reroute wires.
	3. Check the conveying roller rotates without overloading. Check the axle holder or the roller shaft are not contaminated. Check that the spring has not fallen off and is mounted so that it is properly applying pressure against the rollers or pulleys.	Clean the roller axle or the axle holder. Re-assemble it while checking the pressure of the spring.
Sensor	1. Check if it does not operate with smoothness due to an abnormal move or dropping off of the actuator of the conveying switch.	Re-assemble the actuator or the return spring.
	2. Check that the surface of the sensor and the receptor black felt pieces are not contaminated with toner, paper dusts, etc.	If dirty, clean the sensor or the black felt piece.
	3. Perform U031 - Conveying switch and U241 - Finisher switch to check the sensors are normal without flickering, etc. (see page 1-3-31, 1-3-115)	If U031 has revealed that the sensor is inoperative, replace the switch.

Check items	Check description	Corrective measures
Static	Check if the location is susceptible to build static discharge at the conveying guide during printing.	Re-assemble and re-wire the static discharge sheet at the ejection unit or the metal guide at the transfer unit so that they are properly grounded.

## (2) Items and corrective actions relating to the device that will cause paper jam

Jam types	Check description	Corrective measures
No-paper-feed jam or the leading edge of paper is curled back at the position of the roller (J0501, J0502, J0503, J0504, J0505, J0506, J0507, J0509, J0523, J0524, J0525, J0526, J0527, J0545)	1. Check if the jammed paper or the printed paper has a tear caused by the roller at its leading edge.	Replace the primary feed roller. (Service life of rubber roller is 150k.) Increase the spring pressure to pinch the separation rollers if the component is undue to its expected life. Replace the spring.
	2. Check abrasion and paper dusts on the feed roller and forward rollers.	Clean the feed roller and the forward roller. Or, if not amended, replace.
	3. Perform U032 to check the forward roller and feed roller are rotating.	If disconnected or or stained, replace the primary feed clutch.
	4. Check if a primary feed roller of a wrong material of rubber is installed.	Distinguished by color: White x 2, black x 1 Check that the feed rollers are installed at (1) Feed Roller (Collar is white.), (2) Retard roller (black), and (3) Pickup Roller (white). 45-ppm/55-ppm devices * : If not, install then at the correct positions.
	5. Check that the conveying force of the pickup roller is sufficient.	Increase the conveying force during paper pickup by increasing the spring load of the pickup roller.
	6. Check the film is sufficiently protruded in front of approaching the feed roller and the nip. (Too wide a gap against the feed roller.)	Amount of protrusion of film in approaching (Gap: 0.2 - 0.5 mm) must be maintained after adjustment.

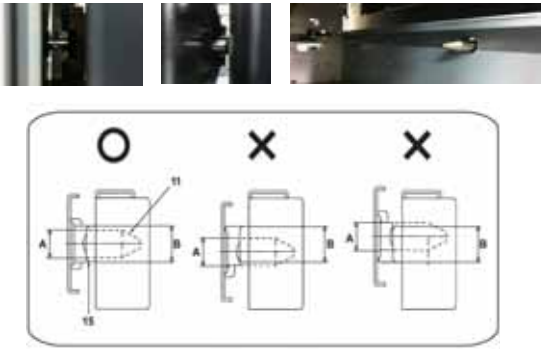
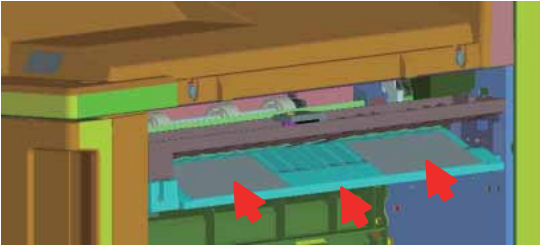
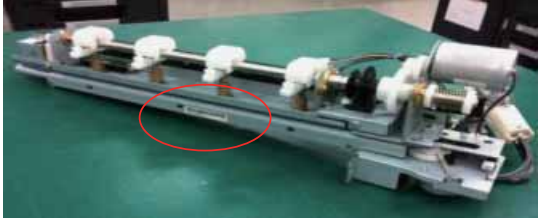



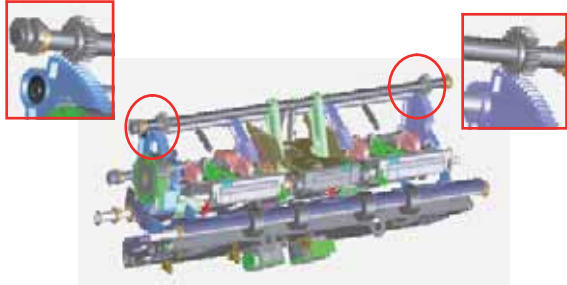

Jam types	Check description	Corrective measures
No-paper-feed jam or the leading edge of paper is curled back at the position of the roller (J0501,J0502, J0503,J0504, J0505, J0506, J0507, J0509, J0523, J0524, J0525, J0526, J0527, J0545)	7. Check the separation roller is not disturbed as a driving component is in contact with the frame during the separation roller is in motion.	If it gets in contact, replace the primary feed unit.
	8. Depress the release lever to release the pressure of the primary feed rollers to check that the retard holder falls.(The pressure by the retard roller to the feed roller is decreased.)	Modify mounting the retard holder fixing plate.


Jam types	Check description	Corrective measures
Multiple-feed Jam (J0511, J0512, J0513, J0514, J0516, J0517, J0519)	1. Check if the cutting edge of the paper bundle is crumpled or the cassette is loaded with multiple times of replenishing paper.	If the cutting edge of the paper bundle is crumpled or the cassette is loaded with multiple times of replenishing paper, load new paper.
	2. Checking paper size. Check that the size of the loaded paper and the paper size chosen on the operator panel are met.	If the paper size does not agree. 1. If the cassette cursors are open against the paper, set it properly. 2. Insert the cassette until the paper size detector switch is turned on. If the size is not detectable while automatic sizing is enabled, replace the size detection switch.
		If the paper size agrees 1. If paper other than complying the requirements such as coated paper, inkjet paper, etc., is used, replace the paper. 2. RE-assemble the pulley retard in the primary feed unit if it is mounted to the opposite direction. 3. Check if the spring retard has not been fallen off of the mounting position. * : If the spring retard is not dropped off of the mount position, decrease the spring pressure that is applied to the separation rollers. 4. Replace the primary feed unit.
	3. Check if paper dusts and abrasion are observed on the paper fanning roller and retard roller.	If the paper fanning roller is dirty, clean. If abrasion is observed, replace.
4. Select the motor by U032 and check the clutch rotates following the other component when the motor is turned on. (see page 1-3-32)	If the clutch rotates following the other component and its stain is observed, replace the clutch.	
Duplex No-original-feed Jam (J0508)/ Duplex Multiple-feed Jam (J0518)	Perform U031 to check if the duplex sensor 2 is detected. (see page 1-3-32)	If the duplex sensor 2 is not working, replace the duplex sensor 2.

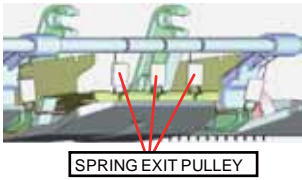
Jam types	Check description	Corrective measures
Intermediate/ conveying sensor stay jam (J1313, J1314, J1513, J1514)	1. Check to see if the actuator is operative without hinderance.	If it won't operate without hinderance, re-assemble or replace the actuator's return spring.
	2. Perform U031 to check the operation of the sensor.	If the sensor is inoperative, replace.
	3. Select the motor by U032 and check if the conveyng clutch rotates following the other component. (see page 1-3-33)	If stained, replace the clutch.Re-assmble the clutch so that it is not continuously energized. (Change of wirings, etc.)
	4. Check if the conveying guide is twisted to be mounted.(If the mounting parts of the guide is floated, the actuator won't protrude sufficiently.)	If the bracket is twisted to be mounted, remove the screw fixing the conveying guide and properly mount the bracket in the right position and fix again.
	5. Check no wrinkles are observed at the sluck of paper during paper feeding.	Adjust the cursors to the size of the paper. * : (If paper is fed askew, perform a skew cancellation adjustment of the width adjuster cursor.) (see page 1-5-108)
Conveying sensor non arrival jam (J1503/ J1504) SM conveying sensor 2 stay jam (J3415, J3416, J3417)	1. Check to see if the actuator is operative without hinderance.	Re-assemble or replace the actuator's return spring.
	2. Perform U030 to check the operation of the motor. Check the transmission of the gear drive using U032. * : Check the conveyng roller rotates and is movable in the direction of thrust without hinderance. (see page 1-3-30,1-3-32)	If the roller won't rotate without hinderance, loosen the screws for adjusting the position (at the gear train bracket) to mount the driving gears, and tighten so that a gap between the gears and frame is eliminated.

Jam types	Check description	Corrective measures
Loop sensor non arrival jam (J4101, J4102, J4103, J4104, J4105, J4106, J4107)	1. Check no wrinkles are observed at the sluck of paper during paper feeding.	Adjust the cursors to the size of the paper. * : (If paper is fed askew, perform a skew cancellation adjustment of the width adjuster cursor.) (see page 1-5-108)
	2. Check that the paper is entirely loaded inside the cassette without being skewed.	Reload paper.
Fuser eject sensor stay jam (J421X)  Ejection-full sensor non arrival jam (J460X)	1. If paper jam occurs at the feedshift guide in the eject unit, check if the guide is operative without hinderance.	If the distance between the housing and the feedshift guide is too small for the guide to move without hinderance, replace the eject unit.
Inversion sensor non arrival jam (J470X)	2. Perform U031 to check if the eject sensor does not show a false detection. (see page 1-3-31)	Replace the defective eject sensor or the eject unit.
Duplex sensors 1 and 2, stuck/ non arrival Jam (J43XX, J44XX)	1. Check that the duplex rollers cause slirage in feeding paper.	Clean or replace the duplex roller in the coveying unit.
	2. Perform U031 to check if the duplex sensors 1 and 2 do not show false detections.	Replace the defective duplex sensors 1 and 2 or the coveying unit.
	3. Check if the second side of plain paper is curled at its tail and slacked in the middle making the switch disguised as no existance of paper.	Replace the paper with new paper.Try feeding paper lengthwise.

Jam types	Check description	Corrective measures
BR conveying sensor 1/2 non arrival/stay jam (J49XX) Eject sensor non arrival jam (J50XX) Eject sensor stay jam (J51XX) DF paper entry error JAM (J600X)	1. Check contamination of the rollers of the bridge eject unit. 2. Check contamination or abrasion of the axle holders of the bridge eject unit. 3. Check the location the bridge relay conveying unit is mounted.	Clean or replace the rollers. Clean the axle holder or replace with a new axle holder. Re-mount.
DF conveying sensor non arrival jam (J610X) DF conveying sensor stay jam (J611X)	1. Check the main unit and the DF are vertically flush with each other. 2. Check if the jammed paper has a dog-ear. 3. Check if dog-ears are caused within the punch unit.	Perform the height adjustment by referring to the installation instructions.  2.If a down-curved sheet is jammed at the DF conveying guide ribs by being dog-eared, replace the DF conveying lower guide.  If a welding protrusion on the conveying side causes paper to be trapped, try replacing the punch unit. 

Jam types	Check description	Corrective measures
DF intermediate sensor stay jam (J631X) DF main tray ejection stay JAM (J641X) DF eject sensor non arrival jam (J6500) DF eject sensor stay jam (J651X)	<p>1. If there is not the jammed paper which is causing J631, at the paper processing area, check to see if the actuator (DF middle sensor) is operative.</p> 	Re-mount the actuator.
	<p>2. Check the range of the up and down movement of the ejection guide.            Check if the operating position after feeding in the first sheet is normal.</p> <p>(1) If it moves askew (due to the forward and backward shift of phase on the eject guide)</p> <p>(2) If the range of motion is too small            Check if the gap between the ejection roller and the ejection pulleys is approximately 3.5 - 5.5 mm.            (Check gaps while making paper still in the intermediate process tray.)</p>	<p>If the gap is not correct, fix balance of the bundle eject unit.</p> <p>If (1): Correct the phase shifting with meshing of the front and back gears.            (Turn on U240 - Motor-EjectUnlock (30) to check the balance of the front and back rollers with the bundle eject unit opened. see page 1-3-113)</p>  <p>If (2): Adjust the positioning of or replace the Mount PI upper guide.</p> 

Jam types	Check description	Corrective measures
DF intermediate sensor stay jam (J631X) DF main tray ejection stay JAM (J641X) DF eject sensor non arrival jam (J6500) DF eject sensor stay jam (J651X)	3. Execute maintenance mode U240 Motor - Width Test A3/LD to adjust the position of the width adjuster cursor of the process tray. Check if the cursor is located at 0 - +0.5 from the edge of is abnormally shifted. (The DF and the main unit paper sources) (see page 1-3-113)	If the width adjuster cursor is wrongly positioned, perform U246 Finisher - Width Front HP/Width Tail HP. (see page 1-3-121)  

Jam types	Check description	Corrective measures
DF intermediate sensor stay jam (J631X) DF main tray ejection stay JAM (J641X) DF eject sensor non arrival jam (J6500) DF eject sensor stay jam (J651X)	4. With stapling at one point with about 65 sheets, check for the failure on the bundle when it is delivered in the shape of an arc. 	1. If a wire from the ejection motor is pinched by other component or a connector is loosely connected, correct. If a loss of synchronism is observed with the ejection motor due to lack of torque, replace the motor. 2. If paper slippage occurs due to the lack of pressure by the ejection rollers, check the pressure rollers (3, at the center) to see if the pressure is insufficient and replace or re-assemble. If a malfunction to encumber the ejection rollers to generate pressure is observed, correct.
	5. With stapling set at 2 points and about 50 sheets, run a test print and check the print bundle delivered for the failure on the direction of ejection and the front and back side, abrupt alignment, and overall alignment.	If the paper is curled, change the direction of loading paper or replace the paper.
	6. Check if a floated staple, buckling, or stapling at a wrong position is occurred.	Configure each of the cassettes for the weight of the paper loaded. Replace the paper. Adjust the stapling home position by U246 - Staple HP. (see page 1-3-121)
	7. Check stapling has been properly done if the paper bundle cannot be ejected causing J-6510. * : 4000-sheets finisher	Provide instructions with the following points emphasized. <ol style="list-style-type: none"> <li>1. Tap the paper to align its ends and load all the way into the cassette.?</li> <li>2. After settings, let go off of the paper. (Allows automatic ejection after stapling.)</li> <li>3. Do not remove paper before the paper bundle is ejected once it is stapled.</li> </ol>
DF drum sensor non arrival jam (J6600)	Paper is jammed with its leading edge caught by the diversion solenoid 1 in the middle of conveying paths.	Check the axle of the diverting solenoid is inserted all the way into the lever of the DF diverting solenoid 1, and insert the lever firmly if it is not.



Jam types	Check description	Corrective measures
DF drum sensor stay jam (J6610)	1. Check if the size and orientation of the original document and the paper used match.	If not agreed, load the paper bundle in the size and orientation configured for the cassette or the manual feed tray.
	2. Check to see if the actuator (DF drum sensor) is operative without hinderance.	If the return spring has been fallen off of the fixing position, fix it properly.If the actuator won't operate smoothly, replace.
Center-folding unit conveying stay JAM (J6710) Center-folding unit conveying stay JAM (J7710)	If paper is jammed before reaching the center-folding unit, check that the drive train gears are in mesh.	If the drive transmission gears are not in mesh, replace the pivot pin of the CF lock lever and the DF fixing pin.

**(3) Paper jam at feeding from cassette 1****Electrical parts that could cause paper jam during paper travelling at the primary feeding (to regist roller)**

Timing of detection

Jam code
J0501,J0511,J1301,J1311,J4001,J4011

Measures

Related parts	
Paper feed motor(PFM)	Registration sensor (RS)
Paper feed clutch 1(PFCL1)	Engine PWB (EPWB)
Assist clutch 1 (ACSL1)*2	Feed PWB 2 (FPWB2)
Middle clutch (MCL)*1 Middle motor (MM) *2	Feed PWB 1 (FPWB1)
Registration clutch (RCL)*1 Registration motor (RM)*2	
Feed sensor 1 (FS1)	
Middle sensor (MS)	

\*1: 35 ppm model only. \*2: 45 ppm model /55 ppm model only.

Checking procedure at the occurrence of J0501	Corrective action at the occurrence of J0501	On/Off control signal output connector (terminal), point of checking connection
1	Items for Initial Checks	see page 1-4-26
2	Feed sensor 1 (FS1): Conduct connectivity check, mounting location check, operation check (U031)	Feed PWB 2 YC8-11
3	Paper feed clutch (PFCL1): Operation check (U032)	Feed PWB 2 YC4-1
4	Paper feed motor : Operation check (U030)	Feed PWB 2 YC2-3 (RDY), 1 (REM)
5	Feed PWB 2: Replace	
6	Engine PWB : Replace	

Checking procedure at the occurrence of J13X	Corrective action at the occurrence of J13X1	On/Off control signal output connector (terminal), point of checking connection
1	Items for Initial Checks	see page 1-4-26
2	Middle sensor (MS) : Conduct connectivity check, mounting location check, operation check (U031)	Feed PWB 2 YC8-9
3	Assist clutch 1 (ACSL1) <sup>*2</sup> :Operation check (U032)	Feed PWB 2 YC10-1
4	Middle clutch (MCL) <sup>*1</sup> : Middle motor (MM) <sup>*2</sup> :Operation check (U032/30)	Feed PWB 2 YC7-14 / YC7-1 to 4
5	Feed PWB 2: Replace	
6	Engine PWB : Replace	

\*1: 35 ppm model only. \*2: 45 ppm model /55 ppm model only.

Checking procedure at the occurrence of J40X1	Corrective action at the occurrence of J40X1	On/Off control signal output connector (terminal), point of checking connection
1	Items for Initial Checks	see page 1-4-26
2	Registration sensor (RS): Conduct connectivity check, mounting location check, operation check (U031) and U051 - Slack Margin Settings.	Feed PWB 2 YC7-12
3	Registration clutch (RCL) <sup>*1</sup> Registration motor (RM) <sup>*2</sup> : Operation check (U032/30)	Feed PWB 1 YC22-2 / YC25-1 to 4
4	Feed PWB 1 : Replace	
5	Engine PWB : Replace	

\*1: 35 ppm model only. \*2: 45 ppm model /55 ppm model only.

**(4) Paper jam at feeding from cassette 2****Electrical parts that could cause paper jam during paper travelling at the primary feeding ( to regist roller)**

Timing of detection

Jam code
J0502,J0512,J1502,J1512,J1302,J1312,J4002,J4012

Corrective Action

Related parts	
Paper feed motor(PFM)	Engine PWB (EPWB)
Paper feed clutch 2 (PFCL2)	Feed PWB 2 (FPWB2)
Assist clutch 2 (ACSL2)* <sup>2</sup>	Feed PWB 1 (FPWB1)
Middle clutch (MCL)* <sup>1</sup> Middle motor (MM)* <sup>2</sup>	
Registration clutch (RCL)* <sup>1</sup> Registration motor (RM)* <sup>2</sup>	
Vertical conveying clutch (PCCL)	
Feed sensor 2 (FS2)	
Paper conveying sensor (PCS)	
Middle sensor (MS)	
Registration sensor (RS)	

\*1: 35 ppm model only. \*2: 45 ppm model /55 ppm model only.

Checking procedure at the occurrence of J05X2	Corrective action at the occurrence of J05X2	On/Off control signal output connector (terminal), point of checking connection
1	Items for Initial Checks	see page 1-4-26
2	Feed sensor 2 (FS2): Conduct connectivity check, mounting location check, operation check (U031)	Feed PWB 2 YC8-23
3	Paper feed clutch (PFCL1): Operation check (U032)	Feed PWB 2 YC4-1
4	Paper feed motor : Operation check (U030)	Feed PWB 2 YC2-3(RDY), 5(REM)
5	Feed PWB 2: Replace	
6	Engine PWB : Replace	

Checking procedure at the occurrence of J13X2	Corrective action at the occurrence of J13X2	On/Off control signal output connector (terminal), point of checking connection
1	Items for Initial Checks	see page 1-4-26
2	Middle sensor (MS) : Conduct connectivity check, mounting location, check operation check (U031)	Feed PWB 2 YC8-9
3	Vertical conveying clutch (PCCL): Operation check (U032)	Feed PWB 2 YC5-3
4	Middle clutch (MCL) <sup>*1</sup> Middle motor (MM) <sup>*2</sup> : Operation check (U032/30)	Feed PWB 2 YC7-14 / YC7-1 to 4
5	Feed PWB 2: Replace	
6	Engine PWB : Replace	

\*1: 35 ppm model only. \*2: 45 ppm model /55 ppm model only

Checking procedure at the occurrence of J15X2	Corrective action at the occurrence of J15X2	On/Off control signal output connector (terminal), point of checking connection
1	Items for Initial Checks	see page 1-4-26
2	Conveying sensor (PCS) I/O check and sensor check (U031)	Feed PWB 2 YC6-3
3	Vertical conveying clutch (PCCL): Operation check (U032)	Feed PWB 2 YC5-3
4	Assist clutch 2 (ACSL2) <sup>*2</sup> ? Operation check (U032)	Feed PWB 2 YC12-1
5	Feed PWB 2: Replace	
6	Engine PWB : Replace	

\*2: 45 ppm model /55 ppm model only.

Checking procedure at the occurrence of J40X2	Corrective action at the occurrence of J40X2	On/Off control signal output connector (terminal), point of checking connection
1	Items for Initial Checks	see page 1-4-26
2	Registration sensor (RS): Conduct connectivity check, mounting location check, operation check U031 and U051 - Slack Margin Settings.	Feed PWB 2 YC7-12

Checking procedure at the occurrence of J40X2	Corrective action at the occurrence of J40X2	On/Off control signal output connector (terminal), point of checking connection
3	Registration clutch (RCL) <sup>*1</sup> Registration motor (RM) <sup>*2</sup> : Operation check (U032/30)	Feed PWB 1 YC22-2 / YC25-1 to 4
4	Feed PWB 1 : Replace	
5	Engine PWB : Replace	

\*1: 35 ppm model only. \*2: 45 ppm model /55 ppm model only.

### (5) Paper jam during manual feeding

#### Electrical parts that could cause paper jam during paper travelling at the primary feeding ( to regist roller)

Timing of detection

<b>Jam code</b>
<b>J0131,J0509,J0519,J4009,J4019</b>

#### Corrective Action

Related parts	
Paper feed motor(PFM)	Engine PWB (EPWB)
Manual feed clutch (MPPFCL)	Feed PWB 1 (FPWB1)
Middle clutch (MCL) <sup>*1</sup> Middle motor (MM) <sup>*2</sup>	Relay PWB (RYPWB) * : In paper conveying unit
Registration clutch (RCL) <sup>*1</sup> Registration motor (RM) <sup>*2</sup>	
MP feed sensor (MPFS)	
Registration sensor (RS)	
Manual feed lift motor (MPLM)	
MP lift sensor 1 (MPLS1)	
MP lift sensor 2 (MPLS2)	

\*1: 35 ppm model only. \*2: 45 ppm model /55 ppm model only.

Checking procedure at the occurrence of J05X9	Corrective action at the occurrence of J05X9	On/Off control signal output connector (terminal), point of checking connection
1	Items for Initial Checks	see page 1-4-26
2	MP feed sensor (MPFS): Conduct connectivity check, mounting location check, operation check (U031)	Feed PWB 1 YC17-9
3	Manual feed conveying clutch (CL): Operation check (U032)	Feed PWB 2 YC4-1
4	Middle clutch (MCL) <sup>*1</sup> Middle motor (MM) <sup>*2</sup> : Operation check (U032/30)	Feed PWB 2 YC7-14 / YC7-1 to 4
5	Feed PWB 2: Replace	
6	Engine PWB : Replace	

\*1: 35 ppm model only. \*2: 45 ppm model /55 ppm model only.

Checking procedure at the occurrence of J40X9	Corrective action at the occurrence of J40X9	On/Off control signal output connector (terminal), point of checking connection
1	Items for Initial Checks	see page 1-4-26
2	Registration sensor (RS): Conduct connectivity check, mounting location check, operation check (U031)	Feed PWB 2 YC7-12
3	Registration clutch (RCL) <sup>*1</sup> Registration motor (RM) <sup>*2</sup> : Operation check (U032/30)	Feed PWB 1 YC22-2 / YC25-1 to 4
4	Feed PWB 1 : Replace	
5	Engine PWB : Replace	

\*1: 35 ppm model only. \*2: 45 ppm model /55 ppm model only.

Checking procedure at the occurrence of J0131	Corrective action at the occurrence of J0131	On/Off control signal output connector (terminal), point of checking connection
1	Items for Initial Checks	see page 1-4-26
2	Manual feed lift base elevation check: 1. Up-and-down movability of the paper lift base of the manual feed tray. 2. Check if the lift lever is in contact with the lift motor cam (re-mount the manual feed table).	-

Checking procedure at the occurrence of J0131	Corrective action at the occurrence of J0131	On/Off control signal output connector (terminal), point of checking connection
3	MP lift sensors 1 and 2: Check for connection and the position of the sensor to be mounted.	Relay PWB (YC3-5, YC3-8) (YC12)
4	MP lift motor: Check if the paper lift base is raised as the motor rotates.	Relay PWB(YC3-11), (YC12)
5	Feed PWB 1 : Replace	Feed PWB 1(YC17),(YC1)
6	Engine PWB : Replace	Engine PWB (YC6)



**(6) Paper jam at the duplex re-feeding part****Electrical parts that could cause paper jam during paper travelling at the primary feeding ( to regist roller)**

Timing of detection

<b>Jam code</b>
<b>J0508,J0518</b>

## Corrective Action

Related parts	
Paper feed motor(PFM)	Engine PWB (EPWB)
Duplex clutch 2 (DUCL2)* <sup>1</sup> Duplex motor 2 (DUM2)* <sup>2</sup>	Feed PWB 1 (FPWB1)
Duplex sensor 2 (DUS2)	

\*1: 35 ppm model only. \*2: 45 ppm model /55 ppm model only.

Checking procedure at the occurrence of J05X8	Corrective action at the occurrence of J05X8	On/Off control signal output connector (terminal), point of checking connection
1	Items for Initial Checks	see page 1-4-26
2	Duplex sensor 2 (DUS2): Conduct connectivity check, mounting location check, operation check (U031)	Feed PWB 1 YC 14-5
3	Duplex clutch 2 (DUCL2)* <sup>1</sup> Duplex motor 2 (DUM2)* <sup>2</sup> : Operation check (U032/30)	Feed PWB 1 YC 14-12 / YC14-14 to 17
4	Check that the drive from the paper feed motor is transferred to the duplex roller. * : 35 ppm model only.	
5	Feed PWB 1 : Replace	
6	Engine PWB : Replace	

\*1: 35 ppm model only. \*2: 45 ppm model /55 ppm model only.

**(7) Electrical parts that could cause paper jam at the transfer part**

Timing of detection

<b>Jam code</b>
<b>J410x,J411x</b>

Corrective Action

Related parts	
Transfer belt drive	Engine PWB (EPWB)
Registration clutch (RCL) <sup>*1</sup> Registration motor (RM) <sup>*2</sup>	Feed PWB 1 (FPWB1)
Loop sensor (LPS)	Relay PWB (RYPWB)

\*1: 35 ppm model only. \*2: 45 ppm model /55 ppm model only.

Checking procedure at the occurrence of J41XX	Corrective action at the occurrence of J41XX	On/Off control signal output connector (terminal), point of checking connection
1	Items for Initial Checks	see page 1-4-26
2	Loop sensor (LPS) : Conduct connectivity check, mounting location check, operation check (U031)	Feed PWB 1 YC23-11
3	Registration clutch (RCL) <sup>*1</sup> Registration motor (RM) <sup>*2</sup> : Operation check (U032/30)	Feed PWB 1 YC25-1 to 4
4	Check that the drive from the transfer belt unit.	
5	Check how the conveying unit and the main unit drawer are connected (such as a fallen pin) and, if they are normal, replace the relay PWB.	
6	Feed PWB 1 : Replace	
7	Engine PWB : Replace	

\*1: 35 ppm model only. \*2: 45 ppm model /55 ppm model only.

**(8) Electrical parts that could cause paper jam at the fuser and eject parts**

Timing of detection

<b>Jam code</b>
<b>J420x,J421x,J460x,J461x,J470x,J471x</b>

Corrective Action

Related parts	
Fuser motor (FUM)	Engine PWB (EPWB)
Eject motor (EM)	Front PWB (FRPWB)
Feedshift solenoid (FSSOL)	
Fuser eject sensor (FUES)	
Eject full sensor (EFS)	
Switchback sensor (SBS)	
JS eject motor (JSEM) * : The job separator is installed.	

Checking procedure at the occurrence of J42XX	Corrective action at the occurrence of J42XX	On/Off control signal output connector (terminal), point of checking connection
1	Items for Initial Checks	see page 1-4-26
2	Fuser eject sensor (FUES) : Conduct connectivity check, mounting location check, operation check (U031)	Engine PWB YC26-A13
3	feedshift solenoid (FSSOL): feedshift guide check (U033)	Front PWB YC5-19
4	Fuser motor (FUM) : Operation check (U030)	Feed PWB 1 YC18-3(RDY), 5(REM)
5	Engine PWB : Replace	

Checking procedure at the occurrence of J46XX	Corrective action at the occurrence of J46XX	On/Off control signal output connector (terminal), point of checking connection
1	Items for Initial Checks	see page 1-4-26
2	Eject full sensor (EFS) : Conduct connectivity check, mounting location check, operation check (U031)	Front PWB YC5-16
3	feedshift solenoid (FSSOL): feedshift guide check (U033)	Front PWB YC5-19
4	Eject motor (EM) : Operation check (U030)	Front PWB YC5-8 to 11
5	Front PWB (FRPWB): Replace	
	Engine PWB : Replace	

Checking procedure at the occurrence of J47XX	Corrective action at the occurrence of J47XX	On/Off control signal output connector (terminal), point of checking connection
1	Items for Initial Checks	see page 1-4-26
2	Switchback sensor (SBS) : Conduct connectivity check, mounting location check, operation check (U031)	Front PWB YC5-13
3	feedshift solenoid (FSSOL): feedshift guide check (U033)	Front PWB YC5-19
4	Job separator eject motor (JSEM): Operational check (U030)	JS main circuit PWB: YC2-4, 5, 6, 7, YC-1 Feed PWB 1: YC20
5	Engine PWB : Replace	Engine PWB : YC7 Front PWB : YC3

**(9) Electrical parts that could cause paper jam at the duplex part**

Timing of detection

<b>Jam code</b>
<b>J430x,J431x,J440x,J441x</b>

Corrective Action

Related parts	
Paper feed motor(PFM)	Engine PWB (EPWB)
Duplex clutch 1 (DUCL1) <sup>*1</sup> Duplex motor 1 (DUM1) <sup>*2</sup>	Relay PWB (RYPWB) * : In paper conveying unit
Duplex clutch 2 (DUCL2) <sup>*1</sup> Duplex motor 2 (DUM2) <sup>*2</sup>	Feed PWB 1 (FPWB1) J440X
Duplex sensor 1 (DUS1)	
Duplex sensor 2 (DUS2)	

\*1: 35 ppm model only. \*2: 45 ppm model /55 ppm model only.

Checking procedure at the occurrence of J43XX	Corrective action at the occurrence of J43XX	On/Off control signal output connector (terminal), point of checking connection
1	Items for Initial Checks	see page 1-4-26
2	Duplex sensor 1 (DUS1) : Conduct connectivity check, mounting location check, operation check (U031)	Feed PWB 1 YC23-1
3	Duplex clutch 1 (DUCL1) <sup>*1</sup> Duplex motor 1 (DUM1) <sup>*2</sup> : Operation check (U032/30)	Feed PWB 1 YC23-4 /YC23-6 to 9
4	Is the drive from the paper feed motor chanded to the upper and lower duplex rollers.	
5	Check how the conveying unit and the main unit drawer are connected and, if they are normal, replace the feed circuit PWB1.	
6	Feed PWB 1(FPWB1) : relpace	
7	Engine PWB : Replace	

\*1: 35 ppm model only. \*2: 45 ppm model /55 ppm model only.

Checking procedure at the occurrence of J44XX	Corrective action at the occurrence of J44XX	On/Off control signal output connector (terminal), point of checking connection
1	Items for Initial Checks	see page 1-4-26
2	Duplex sensor 2 (DUS2) : Conduct connectivity check, mounting location check, operation check (U031)	Feed PWB 1 YC14-5
3	Duplex clutch 2 (DUCL2)*1 Duplex motor 2 (DUM2)*2: Operation check (U032/30)	Feed PWB 1 YC14-12 / YC14-14 to 17
4	Check how the conveying unit and the main unit drawer are connected and, if they are normal, replace the feed circuit PWB1.	
5	Feed PWB 1(FPWB1) : relpace	
6	Engine PWB : Replace	
7	Relay PWB (RYPWB) : Replace	

\*1: 35 ppm model only. \*2: 45 ppm model /55 ppm model only.

**(10) Electrical parts that could cause paper jam at the BR (bridge) part**

Timing of detection

<b>Jam code</b>
<b>J490x,J491x,J500x,J501x,J510x,J511x</b>

Corrective Action

Related parts	
BR conveying motor 1 (BRCM1)	Engine PWB (EPWB)
BR conveying motor 2 (BRCM2)	BR PWB (BRPWB)
BR conveying sensor 1 (BRCS1)	
BR conveying sensor 2 (BRCS2)	
BR eject sensor (BRES)	
BR feedshift solenoid (BRSOL)	

Checking procedure at the occurrence of J49XX	Corrective action at the occurrence of J49XX	On/Off control signal output connector (terminal), point of checking connection
1	Items for Initial Checks	see page 1-4-26
2	BR conveying sensor 1 (BRCS1) : Conduct connectivity check, mounting location check, operation check (U031)	BR PWB YC6-2
3	BR conveying motor 1 (BRCM1) : Operation check (U030)	BR PWB YC7-1 to 4
4	BR PWB (BRPWB) : Replace	
5	Engine PWB : Replace	

Checking procedure at the occurrence of J50XX	Corrective action at the occurrence of J50XX	On/Off control signal output connector (terminal), point of checking connection
1	Items for Initial Checks	see page 1-4-26
2	BR conveying sensor 2 (BRCS2) : Conduct connectivity check, mounting location check, operation check (U031)	BR PWB YC4-2
3	BR conveying motor 2 (BRCM2) : Operation check (U030)	BR PWB YC7-5 to 8
4	BR PWB (BRPWB) : Replace	

Checking procedure at the occurrence of J50XX	Corrective action at the occurrence of J50XX	On/Off control signal output connector (terminal), point of checking connection
5	Engine PWB : Replace	

Checking procedure at the occurrence of J51XX	Corrective action at the occurrence of J51XX	On/Off control signal output connector (terminal), point of checking connection
1	Items for Initial Checks	see page 1-4-26
2	BR eject sensor (BRES) : Conduct connectivity check, mounting location check, operation check (U031)	Engine PWB YC20-17
3	BR feedshift solenoid (BRSOL): Check for switching feedshift guide (U033)	Engine PWB YC20-17
4	BR PWB (BRPWB) : Replace	
5	Engine PWB : Replace	



## (11) Electrical parts that could cause paper jam at the DF paper entry, feedshift and subtray left eject part

Timing of detection

Jam code
J610x, J611x, J620x, J621x, J630x, J631x

### Corrective Action

Related parts	
DF paper entry motor (DFPEM)	DF feedshift solenoid 3 (DFSSOL)
DF middle motor (DFMM)	DP main PWB (DFMPWB)
DF eject motor (DFEM)	
BR conveying motor 1 (BRCM1)	
BR conveying motor 2 (BRCM2)	
DF paper entry sensor (DFPES)	
DF middle sensor (DFMES)	
DF sub eject sensor (DFSES)	

Checking procedure at the occurrence of J61XX	Corrective action at the occurrence of J61XX	On/Off control signal output connector (terminal), point of checking connection
1	Items for Initial Checks	see page 1-4-26
2	DF paper entry sensor (DFPES) : Conduct connectivity check, mounting location check, operation check (U241:Finisher HP)	DF main PWB YC21-9
3	DF feedshift solenoid 3 (DFSSOL): Check to see the feedshift guide 3 is switchable (U240 Solenoid - SubTray)	DF main PWB YC18-12,13
4	DF paper entry motor (DFPEM) : Operation check (U240 :Motor Feed In(H), Feed In(L))	DF main PWB YC12-13 to 16
5	BR conveying motor 1 (BRCM1) , BR conveying motor 2 (BRCM2) : Operation check (U030 Bridge1 , Bridge2)	
6	DF main PWB(DFMPWB) : Replace	

Checking procedure at the occurrence of J62XX	Corrective action at the occurrence of J62XX	On/Off control signal output connector (terminal), point of checking connection
1	Items for Initial Checks	see page 1-4-26
2	DF sub eject sensor (DFSES) : Conduct connectivity check, mounting location check, operation check (U241)	DF main PWB YC21-3
3	DF feedshift solenoid 3 (DFSSOL): Check to see the feedshift guide 3 is switchable (U240)	DF main PWB YC18-12,13
4	DF paper entry motor (DFPEM) : Operation check (U240)	DF main PWB YC12-13 to 16
5	DF eject motor (DFEM) : Operation check (U240)	DF main PWB YC12-5 to 8
6	DF main PWB(DFMPWB) : Replace	

Checking procedure at the occurrence of J63XX	Corrective action at the occurrence of J63XX	On/Off control signal output connector (terminal), point of checking connection
1	Items for Initial Checks	see page 1-4-26
2	DF middle sensor (DFMES):Conduct connectivity check, mounting location check, operation check (U241)	DF main PWB YC20-6
3	feedshift solenoid 3 (DFSSOL): Check to see the feedshift guide 3 is switchable (U240)	DF main PWB YC18-12,13
4	DF paper entry motor (DFPEM) : Operation check (U240)	DF main PWB YC12-13 to 16
5	DF middle motor (DFMM) : Operation check (U240)	DF main PWB YC10-5 to 8
6	DF main PWB(DFMPWB) : Replace	

**(12) Electrical parts that could cause paper jam at the DF process part**

Timing of detection

<b>Jam code</b>
<b>J6500,J651x,J6600,J6610</b>

Corrective Action

Related parts	
DF middle motor (DFMM)	DF main PWB(DFMPWB)
DF drum motor (DFDRM)	
DF bundle eject sensor (DFBDS)	
DF drum sensor (DFDRS)	
DF feedshift solenoid 1 (DFDRSOL)	

Checking procedure at the occurrence of J65XX	Corrective action at the occurrence of J65XX	On/Off control signal output connector (terminal), point of checking connection
1	Items for Initial Checks	see page 1-4-26
2	DF middle sensor (DFMES):Conduct connectivity check, mounting location check, operation check (U241)	DF main PWB YC20-6
3	DF bundle eject sensor (DFBDS) : Conduct connectivity check, mounting location, operation (U241)	DF main PWB YC22-27
4	DF middle motor (DFMM) : Operation check (U240)	DF main PWB YC12-9 to 12
5	DF main PWB(DFMPWB) : Replace	

Checking procedure at the occurrence of J66XX	Corrective action at the occurrence of J66XX	On/Off control signal output connector (terminal), point of checking connection
1	Items for Initial Checks	see page 1-4-26
2	DF drum sensor (DFDRS) : Conduct connectivity check, mounting location check, operation check (U241)	DF main PWB YC20-3
3	DF feedshift solenoid 1 (DFDRSOL): Check to see the feedshift guide 1 is switchable (U240)	DF main PWB YC18-12,13

Checking procedure at the occurrence of J66XX	Corrective action at the occurrence of J66XX	On/Off control signal output connector (terminal), point of checking connection
4	DF drum motor (DFDRM) : Operation check (U240)	DF main PWB YC18-1 to 4
5	DF main PWB(DFMPWB) : Replace	

### (13) Electrical parts that could cause paper jam at the DF eject tray part

Timing of detection

<b>Jam code</b>
<b>J640x,J641x</b>

Corrective Action

Related parts	
DF eject motor (DFEM)	DF main PWB(DFMPWB)
DF tray motor (DFTM)	
DF middle sensor (DFMES)	
DF tray upper sensor 1 and 2 (DFTUSS 1,2)	

Checking procedure at the occurrence of J64XX	Corrective action at the occurrence of J64XX	On/Off control signal output connector (terminal), point of checking connection
1	Items for Initial Checks	see page 1-4-26
2	DF middle sensor (DFMES):Conduct connectivity check, mounting location check, operation check (U241)	DF main PWB YC20-6
3	DF tray upper sensor 1 and 2 (DFTUSS1, 2) : Conduct connectivity check, mounting location, operation (U241)	DF main PWB YC21-19(DFTUSS1),YC13-3(DFTUSS2)
4	DF eject motor (DFEM): Operational check (U240)	DF main PWB YC12-5 to 8
5	DF tray motor (DFTM) : Operation check (U240)	DF main PWB YC19-4
6	DF main PWB(DFMPWB) : Replace	

**(14) Electrical parts that could cause paper jam at the CF conveying part**

Timing of detection

<b>Jam code</b>
<b>J6710,J7700,J7710</b>

## Corrective Action

Related parts	
DF drum motor (DFDRM)	DF main PWB(DFMPWB)
CF paper entry motor (CFPEM)	CF PWB (CFPWB)
DF drum sensor (DFDRS)	
CF conveying sensor (CFPCS)	

Checking procedure at the occurrence of J671X	Corrective action at the occurrence of J671X	On/Off control signal output connector (terminal), point of checking connection
1	Items for Initial Checks	see page 1-4-26
2	DF drum sensor (DFDRS) : Conduct connectivity check, mounting location check, operation check (U241)	DF main PWB YC20-3
3	DF drum motor (DFDRM) : Operation check (U240)	DF main PWB YC18-1 to 4
4	CF paper entry motor (CFPEM): Check if the gears can chain the drive.	CF PWB YC18-1 to 4
5	DF main PWB(DFMPWB) : Replace	
6	CF PWB (CFPWB): Replace	

Checking procedure at the occurrence of J77X0	Corrective action at the occurrence of J77X0	On/Off control signal output connector (terminal), point of checking connection
1	Items for Initial Checks	see page 1-4-26
2	CF conveying sensor (CFPCS) : Conduct connectivity check, mounting location check, operation check (U241)	CF PWB YC20-15
3	CF paper entry motor (CFPEM): Check if the gears can chain the drive.	CF PWB YC18-1 to 4
4	DF main PWB(DFMPWB) : Replace	
5	CF PWB (CFPWB): Replace	

## 1-4-3 Self-diagnostic function

### (1) Self-diagnostic function

1. This machine is equipped with self-diagnostic function. When a problem is detected, the machine stops printing and display the dialog to retrieve the relevant information in a log. (Self-diagnostic dialog)

\* : Be sure not to turn power off until the dialog has gone off.

\* : The logs retrieved can be downloaded in a flash memory device using U964 mode. (See page 1-3-196)

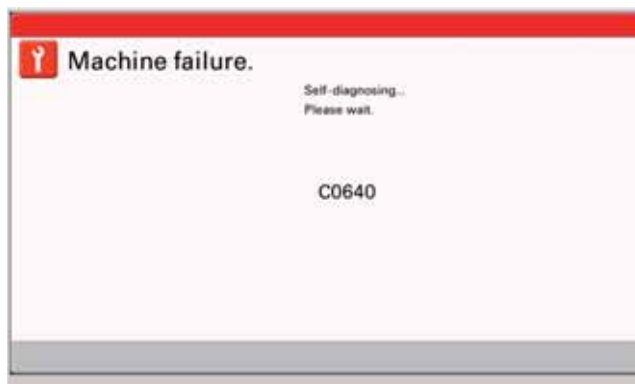


Figure 1-4-5

2. And then display an error message on the operation panel. An error message consists of a message prompting a contact to service personnel and a four-digit error code indicating the type of the error.

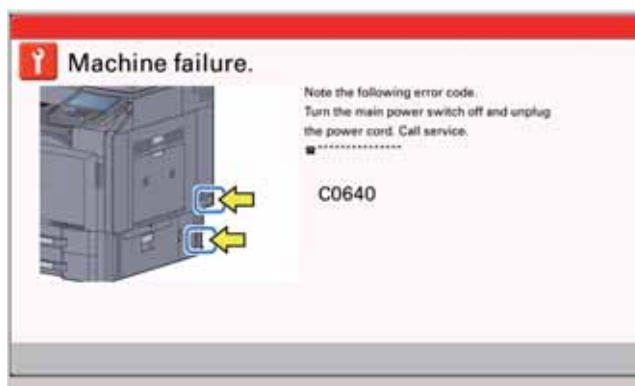


Figure 1-4-6

## (2) Self diagnostic codes

If the part causing the problem was not supplied, use the unit including the part for replacement

### Caution:

Before attempting to check the power supply, fuser unit, and the IH controller PWB, be sure to turn the power switch off and unplug the machine from power. Allow at least 5 seconds before starting to conduct service until the capacitors on the circuit boards have been completely discharged.

To reset a service call regarding the Maintenance T display and the DP, performing U906 Disconnection at Defect is required. (See page 1-3-185)

Code	Contents	Related parts	Check procedures/ corrective measures
0030	<b>FAX control PWB system error</b> Processing with the fax software was disabled due to a software problem.	FAX control PWB	<ol style="list-style-type: none"> <li>1. Turn the main power switch off and after 5 seconds, re-mount the FAX controller PWB, then turn power on.</li> <li>2. Reinstall the fax software.</li> <li>3. Replace the FAX control PWB.</li> </ol>
0060	<b>Engine PWB mismatch</b> Unmatching engine and engine sub boards. Defective engine subboard	Engine PWB	<ol style="list-style-type: none"> <li>1. Turn the main power switch off and after 5 seconds, then turn power on.</li> <li>2. Replace the engine PWB (see page 1-5-71).</li> </ol>
0070	<b>FAX control PWB incompatible detection error</b> Abnormal detection of FAX control PWB incompatibility In the initial communication with the FAX control PWB, any normal communication command is not transmitted.	FAX control PWB (The FAX PWB installed will not be the one designed for the machine.)	<ol style="list-style-type: none"> <li>1. Install the FAX system designed for the model.</li> <li>2. Reinstall the fax software.</li> </ol>
0100	<b>Backup memory device error</b>	EEPROM(main PWB)	<ol style="list-style-type: none"> <li>1. Turn the main power switch off and after 5 seconds, then turn power on.</li> <li>2. Check that the EEPROM on the main circuit PWB is properly installed on the main circuit PWB and, if not, re-install it.</li> <li>3. Replace the main PWB (see page 1-5-59).</li> </ol>
0120	<b>MAC address data error</b> For data in which the MAC address is invalid.	EEPROM(main PWB)	<ol style="list-style-type: none"> <li>1. Turn the main power switch off and after 5 seconds, then turn power on.</li> <li>2. Check the MAC address on the network status page.</li> <li>3. If it is blank, obtain an EEPROM with its MAC address written from the service support and install.</li> <li>4. Replace the main PWB (see page 1-5-59).</li> </ol>

Code	Contents	Related parts	Check procedures/ corrective measures
0150	<p><b>Backup memory read/write error (engine PWB)</b></p> <p>No response is issued from the device in reading/writing for 5 ms or more and this problem is repeated 5 times successively.</p> <p>Mismatch of reading data from 2 locations occurs 8 times successively.</p> <p>Mismatch between writing data and reading data occurs 8 times successively.</p>	EEPROM (engine PWB)	<ol style="list-style-type: none"> <li>1. Turn the main power switch off and after 5 seconds, then turn power on.</li> <li>2. Check that the EEPROM is properly installed on the engine PWB and re-install it.</li> <li>3. Replace the engine PWB (see page 1-5-71).</li> <li>4. Check the EEPROM and if the data are corrupted, contact the service support.</li> </ol>
0160	<p><b>Backup memory data error (engine PWB)</b></p> <p>Reading data from EEPROM is abnormal.</p>	EEPROM	<ol style="list-style-type: none"> <li>1. Turn the main power switch off and after 5 seconds, then turn power on.</li> <li>2. Execute U021 - memory initializing.(see page 1-3-28)</li> <li>3. If the EEPROM data are corrupted, contact the service support.</li> </ol>
0170	<p><b>Billing counting error</b></p> <p>The values on the main circuit PWB and on the engine do not match for any of charging counter, life counter, and scanner counter.</p>	EEPROM	<ol style="list-style-type: none"> <li>1. Check that the EEPROMs installed in the main PWB and the engine PWB are correct and, if not, use the correct EEPROM for the model.</li> <li>2. If the EEPROM data are corrupted, contact the service support.</li> </ol>
		Main PWB	Replace the main PWB (see page 1-5-59).
		Engine PWB	Replace the engine PWB (see page 1-5-67).
0180	<p><b>Machine number mismatch</b></p> <p>Machine number of main and engine does not match.</p>	Data damage of EEPROM.	<ol style="list-style-type: none"> <li>1. Confirm the machine data for the main and engine units by using U004 (see page 1-3-24).</li> <li>2. If the serial number data of different models is alternately displayed, install the correct EEPROM in the PWB of the wrong serial number data.</li> <li>3. Contact the Service Support.</li> </ol>
0350	<p><b>Panel PWB communication error (electronic volume I2C communication error)</b></p> <p>NACK is received during I2C communication -&gt; retried 5 times -&gt; rebooting command sent -&gt; retried 5 times If NACK is still received.</p>	Operation PWB	<ol style="list-style-type: none"> <li>1. Turn the main power switch off and after 5 seconds, then turn power on.</li> <li>2. Confirm that the wiring connector is firmly connected and, if necessary, connect the connector all the way in. Operation PWB (YC10) and Main PWB (YC6)</li> <li>3. If the wiring is disconnected, shorted or grounded, replace the wiring.</li> </ol>
		Main PWB	Replace the main PWB (see page 1-5-59).



Code	Contents	Related parts	Check procedures/ corrective measures
0620	<b>FAX image DIMM error</b> 1. The Fax image DIMM has not been installed. 2. Fax image DIMM access error.	FAX image DIMM	1. Install the FAX image DIMM supplied in the FAX system onto the main PWB. 2. Firmly install the FAX image DIMM again onto the main board. 3. Check the FAX image DIMM terminals and remove any foreign objects that may be adhered to it. 4. Replace with a new FAX image DIMM.
		Main PWB.	Replace the main PWB (see page 1-5-59).
0630	<b>DMA error</b> DMA transmission of image data does not complete within the specified period of time.	DP CIS	1. Reconnect the CIS signal line. 2. Confirm that the CIS connector terminals are firmly connected. Insert the connector all the way in. 3. If the wiring is disconnected, shorted or grounded, replace the wiring.
		DP main PWB Main PWB	1. Confirm that the wiring connector is firmly connected and, if necessary, connect the connector all the way in. 2. If the wiring is disconnected, shorted or grounded, replace the wiring. Wiring that connects the CIS and the DP controller PWB. Wiring that connects the DP main PWB and the main PWB. 3. Replace the DP main PWB. 4. Replace the main PWB (see page 1-5-59).
0640	<b>Hard disk error</b> The hard disk cannot be accessed.	HDD	1. If an abnormal noise is heard from the HDD, replace the HDD. 2. Check the SATA wiring between the HDD and the main circuit PWB for loose connection, disconnection and damages, and that it is connected into the correct terminal. Main PWB: YC1,YC27 3. Replace the SATA cable. 4. Execute U024 to initialize (FULL) the HDD (see page 1-3-29). 5. If an error is detected after executing U024, replace the HDD.
		Main PWB	Replace the main PWB (see page 1-5-59).

Code	Contents	Related parts	Check procedures/ corrective measures
0650	<b>FAX image DIMM check error</b> A fax image DIMM which was used with another machine is installed.	FAX DIMM.	<ol style="list-style-type: none"> <li>1. Confirm that a used FAX image DIMM was used instead of the FAX image DIMM contained in the FAX system.</li> <li>2. If a DIMM that was used with other unit has been installed, execute maintenance mode U671 - Recovery FAX DIMM.</li> <li>3. Check whether the Fax DIMM is properly inserted into the socket on the main PWB.</li> <li>4. Replace with a new FAX image DIMM.</li> </ol>
		Main PWB	Replace the main PWB (see page 1-5-59).
0660	<b>Hard disk encryption key error</b>	EEPROM	<ol style="list-style-type: none"> <li>1. Execute U004 if this occurs after the EEPROM has been changed.</li> </ol>
		HDD	<ol style="list-style-type: none"> <li>1. If an abnormal noise is heard from the HDD, replace the HDD.</li> <li>2. Check the SATA wiring between the HDD and the main circuit PWB for loose connection, disconnection and damages, and that it is connected into the correct terminal. Main PWB: YC1,YC27</li> <li>3. Replace the SATA cable.</li> <li>4. Execute U024 to initialize (FULL) the HDD (see page 1-3-29).</li> <li>5. If an error is detected after executing U024, replace the HDD.</li> </ol>
		Main PWB	Replace the main PWB (see page 1-5-59).
0670	<b>Hard disk overwriting erasure error</b>	HDD	<ol style="list-style-type: none"> <li>1. If an abnormal noise is heard from the HDD, replace the HDD.</li> <li>2. Check the SATA wiring between the HDD and the main circuit PWB for loose connection, disconnection and damages, and that it is connected into the correct terminal. Main PWB: YC1,YC27</li> <li>3. Replace the SATA cable.</li> <li>4. Execute U024 to initialize (FULL) the HDD (see page 1-3-29).</li> <li>5. If an error is detected after executing U024, replace the HDD.</li> </ol>
		Main PWB	Replace the main PWB (see page 1-5-59).

Code	Contents	Related parts	Check procedures/ corrective measures
0800	<b>Image processing error</b> JAM010X is detected twice.	Main PWB	Replace the main PWB (see page 1-5-59).
0830	<b>FAX control PWB flash program area checksum error</b> A checksum error occurred with the program of the FAX control PWB.	FAX software	1. Reinstall the fax software.
		FAX control PWB	1. Execute initializing by U600.(Refer to the FAX service manual) 2. Replace the FAX control PWB.
0840	<b>Faults of RTC</b> ("Time for maintenance T" is displayed) [Check at power up] The RTC setting has reverted to a previous state. The machine has not been powered for 5 years (compared to the settings stored periodically in the EEPROM). The RTC setting is older than 00:01 on January 1, 2000. [Checked periodically (in 5-minute interval) after powered up] The RTC setting has reverted to a state older than the last time it was checked. 10 minutes have been passed since the previous check.  After C840 is detected, the machine enters in disconnection mode after the main power switch has been switched on and off and indicates 'Maintenance T.'	Battery ( main PWB)	1. Make sure that the back-up batteries on the main PWB are not short-circuited. 2. Reset Maintenance T by executing U906 (see page 1-3-185). 3. If the same C call is displayed when power is switched on and off, replace the back up battery. 4. If communication error (due to a noise, etc.) is present with the RTC on the main circuit PWB, check the PWB is properly grounded.
		Main PWB	Replace the main PWB (see page 1-5-59).
0870	<b>PCFAX control PWB to main PWB high capacity data transfer error</b> High-capacity data transfer between the FAX control PWB and the main PWB of the machine was not normally performed even if the data transfer was retried the specified times.	FAX control PWB	1. Turn the main power swtch off and after 5 seconds, re-mount the FAX controller PWB, then turn power on. 2. Replace the FAX control PWB.
		HDD	Execute U024 to initialize the HDD (see page 1-3-29).
		Main PWB	Replace the main PWB (see page 1-5-59).

Code	Contents	Related parts	Check procedures/ corrective measures
0920	<b>Fax file system error</b> The backup data is not retained for file system abnormality of flash memory of the FAX control PWB.	FAX control PWB	1. Execute initializing by U600 (Refer to the FAX service manual). 2. Replace the FAX control PWB.
0980	<b>24 V power down detect</b> If a 24V power disconnection signal is observed and a 12V power disconnection signal is observed simultaneously for one second.	Power source PWB	1. Check the +24V output is given at YC12-1 to 3 of the power circuit PWB. 2. Replace the power source PWB (see page 1-5-71)

Code	Contents	Related parts	Check procedures/ corrective measures
1000	<b>MP lift motor error</b> If the MP lift sensor 1 (upper limit detect) or 2 (bottom detect) is not detectable to be turned on while the MP lift motor is ascending or descending.	Manual feed lift base elevating mechanism	<ol style="list-style-type: none"> <li>1. Check that the paper lift base of the manual feed tray can smoothly ascend and descent, if not, repair or replace.</li> <li>2. Check that the lift lever is located so that it can ascend or descend by the lift motor cam and that it not damaged and, if necessary, re-install or replace the manual feed table.</li> </ol>
		MP lift motor	<ol style="list-style-type: none"> <li>1. Check that the paper elevator has been ascended.</li> <li>2. Check the drive gear can rotate or they are not unusually loaded and, if necessary, replace.</li> <li>3. Confirm that the wiring connector is firmly connected and, if necessary, connect the connector all the way in. MP lift motor and Relay PWB (YC3) Relay PWB (YC12) and Feed PWB1 (YC17) Feed PWB1 (YC1) and Engine PWB (YC6)</li> <li>4. If the wiring is disconnected, shorted or grounded, replace the wiring.</li> <li>5. Replace the MP lift motor.</li> </ol>
		MP lift sensor1 MP lift sensor2	<ol style="list-style-type: none"> <li>1. Check that the sensor is correctly positioned.</li> <li>2. Confirm that the wiring connector is firmly connected and, if necessary, connect the connector all the way in. MP lift sensor1,2 and Relay PWB (YC3) Relay PWB (YC12) and Feed PWB1(YC17) Feed PWB1 (YC1) and Engine PWB (YC6)</li> <li>3. If the wiring is disconnected, shorted or grounded, replace the wiring.</li> <li>4. Replace the MP lift sensor1 or MP lift sensor2.</li> </ol>
		Feed PWB 2	Replace the Feed PWB 2.
		Engine PWB	<ol style="list-style-type: none"> <li>1. Check the engine software and upgrade to the latest, if necessary.</li> <li>2. Replace the engine PWB (see page 1-5-67).</li> </ol>

Code	Contents	Related parts	Check procedures/ corrective measures
<b>1010</b>	<b>Lift motor 1 error</b> After cassette 1 is inserted, lift sensor 1 does not turn on within 12 s. This error is detected 5 times successively. The lock signal of the motor is detected continuously for 1 s. This error is detected 5 times successively.	Cassette lift base elevating mechanism	Check that the cassette base can be manipulated smoothly, if not, repair or replace.
		Lift motor 1	<ol style="list-style-type: none"> <li>1. Check that the cassette base has been ascended.</li> <li>2. Check the drive gear can rotate or they are not unusually loaded and, if necessary, replace.</li> <li>3. Confirm that the wiring connector is firmly connected and, if necessary, connect the connector all the way in. Lift motor 1 and Feed PWB 2 (YC3) Feed PWB 2 (YC1) and Engine PWB (YC4)</li> <li>4. If the wiring is disconnected, shorted or grounded, replace the wiring.</li> <li>5. Replace the lift motor 1.</li> </ol>
		Lift sensor 1	<ol style="list-style-type: none"> <li>1. Check that the sensor is correctly positioned.</li> <li>2. Confirm that the wiring connector is firmly connected and, if necessary, connect the connector all the way in. Lift sensor 1 and Feed PWB 2 (YC8) Feed PWB 2 (YC1) and Engine PWB (YC4)</li> <li>3. If the wiring is disconnected, shorted or grounded, replace the wiring.</li> <li>4. Replace the lift sensor1.</li> </ol>
		Feed PWB 2	Replace the Feed PWB 2.
		Engine PWB	<ol style="list-style-type: none"> <li>1. Check the engine software and upgrade to the latest, if necessary.</li> <li>2. Replace the engine PWB (see page 1-5-67).</li> </ol>

Code	Contents	Related parts	Check procedures/ corrective measures
<b>1020</b>	<b>Lift motor 2 error</b> After cassette 2 is inserted, lift sensor 2 does not turn on within 12 s. This error is detected 5 times successively. The lock signal of the motor is detected continuously for 1 s. This error is detected 5 times successively.	Cassette lift base elevating mechanism	Check that the cassette base can be manipulated smoothly, if not, repair or replace.
		Lift motor 2	<ol style="list-style-type: none"> <li>1. Check that the cassette base has been ascended.</li> <li>2. Check the drive gear can rotate or they are not unusually loaded and, if necessary, replace.</li> <li>3. Confirm that the wiring connector is firmly connected and, if necessary, connect the connector all the way in. Lift motor 2 and Feed PWB 2 (YC3) Feed PWB 2 (YC1) and Engine PWB (YC4)</li> <li>4. If the wiring is disconnected, shorted or grounded, replace the wiring.</li> <li>5. Replace the lift motor 2.</li> </ol>
		Lift sensor 2	<ol style="list-style-type: none"> <li>1. Check that the sensor is correctly positioned.</li> <li>2. Confirm that the wiring connector is firmly connected and, if necessary, connect the connector all the way in. Lift sensor 2 and Feed PWB 2 (YC8) Feed PWB 2 (YC1) and Engine PWB (YC4)</li> <li>3. If the wiring is disconnected, shorted or grounded, replace the wiring.</li> <li>4. Replace the lift sensor2.</li> </ol>
		Feed PWB 2	Replace the Feed PWB 2.
		Engine PWB	<ol style="list-style-type: none"> <li>1. Check the engine software and upgrade to the latest, if necessary.</li> <li>2. Replace the engine PWB (see page 1-5-67).</li> </ol>

Code	Contents	Related parts	Check procedures/ corrective measures
1030	<b>PF lift motor 1 error (paper feeder)</b> After cassette 3 is inserted, PF lift sensor 1 does not turn on within 12 s. This error is detected 5 times successively. During driving the motor, the lift overcurrent protective monitor signal is detected for 1 s or more 5 times successively. However, the first 1 s after motor is turned on is excluded from detection.	Cassette lift base elevating mechanism	Check that the cassette base can be manipulated smoothly, if not, repair or replace.
		PF Lift motor 1	<ol style="list-style-type: none"> <li>1. Check that the cassette base has been ascended.</li> <li>2. Check the drive gear can rotate or they are not unusually loaded and, if necessary, replace.</li> <li>3. Confirm that the wiring connector is firmly connected and, if necessary, connect the connector all the way in. PF Lift motor 1 and main PWB (YC7)</li> <li>4. If the wiring is disconnected, shorted or grounded, replace the wiring.</li> <li>5. PF Replace the lift motor 1.</li> </ol>
		PF Lift sensor 1	<ol style="list-style-type: none"> <li>1. Check that the sensor is correctly positioned.</li> <li>2. Confirm that the wiring connector is firmly connected and, if necessary, connect the connector all the way in. PF Lift sensor 1 and PF main PWB (YC7)</li> <li>3. If the wiring is disconnected, shorted or grounded, replace the wiring.</li> <li>4. Replace the lift sensor 1.</li> </ol>
		PF main PWB	Replace the PF main PWB (Refer to the service manual for the paper feeder).



Code	Contents	Related parts	Check procedures/ corrective measures
1040	<b>PF lift motor 2 error (paper feeder)</b> After cassette 4 is inserted, PF lift sensor 2 does not turn on within 12 s. This error is detected 5 times successively. During driving the motor, the lift overcurrent protective monitor signal is detected for 1 s or more 5 times successively. However, the first 1 s after motor is turned on is excluded from detection.	Cassette lift base elevating mechanism	Check that the cassette base can be manipulated smoothly, if not, repair or replace.
		PF Lift motor 2	1. Check that the cassette base has been ascended. 2. Check the drive gear can rotate or they are not unusually loaded and, if necessary, replace. 3. Confirm that the wiring connector is firmly connected and, if necessary, connect the connector all the way in. PF Lift motor 2 and PF main PWB (YC7) 4. If the wiring is disconnected, shorted or grounded, replace the wiring. 5. Replace the PF Lift motor2.
		PF Lift sensor 2	1. Check that the sensor is correctly positioned. 2. Confirm that the wiring connector is firmly connected and, if necessary, connect the connector all the way in. PF Lift sensor 2 and PF main PWB (YC7) 3. If the wiring is disconnected, shorted or grounded, replace the wiring. 4. Replace the PF Lift sensor 2.
		PF main PWB	Replace the PF main PWB (Refer to the service manual for the paper feeder).

Code	Contents	Related parts	Check procedures/ corrective measures
1100	<p><b>PF lift motor 1 error (large capacity feeder)</b> After cassette 3 is inserted, PF lift sensor 1 does not turn on within 23 s. This error is detected 5 times successively. (Time to detect is 2 seconds at the second time and later.) During driving the motor, the lift overcurrent protective monitor signal is detected for 200 ms or more 5 times successively. However, the first 1 s after PF lift motor 1 is turned on is excluded from detection.</p>	Paper feeder lift base elevating mechanism	Check that the cassette base can be manipulated smoothly, if not, repair or replace.
		PF Lift motor1	<ol style="list-style-type: none"> <li>1. Check that the cassette base has been ascended.</li> <li>2. Check the drive gear can rotate or they are not unusually loaded and, if necessary, replace.</li> <li>3. Confirm that the wiring connector is firmly connected and, if necessary, connect the connector all the way in. PF Lift motor 1 and PF main PWB (YC7)</li> <li>4. If the wiring is disconnected, shorted or grounded, replace the wiring.</li> <li>5. Replace the PF lift motor1.</li> </ol>
		PF Lift sensor1	<ol style="list-style-type: none"> <li>1. Check that the sensor is correctly positioned.</li> <li>2. Confirm that the wiring connector is firmly connected and, if necessary, connect the connector all the way in. PF Lift sensor 1 and PF main PWB (YC5)</li> <li>3. If the wiring is disconnected, shorted or grounded, replace the wiring.</li> <li>4. Replace the PF lift sensor1.</li> </ol>
		PF main PWB	Replace the PF main PWB (Refer to the service manual for the paper feeder).

Code	Contents	Related parts	Check procedures/ corrective measures
1110	<p><b>PF lift motor 2 error (large capacity feeder)</b> After cassette 4 is inserted, PF lift sensor 2 does not turn on within 23 s. This error is detected 5 times successively. (Time to detect is 2 seconds at the second time and later.) During driving the motor, the lift overcurrent protective monitor signal is detected for 200 ms or more 5 times successively. However, the first 1 s after PF lift motor 2 is turned on is excluded from detection.</p>	Paper feeder lift base elevating mechanism	Check that the cassette base can be manipulated smoothly, if not, repair or replace.
		PF Lift motor 2	<ol style="list-style-type: none"> <li>1. Check that the cassette base has been ascended.</li> <li>2. Check the drive gear can rotate or they are not unusually loaded and, if necessary, replace.</li> <li>3. Confirm that the wiring connector is firmly connected and, if necessary, connect the connector all the way in. PF Lift motor 2 and PF main PWB (YC7)</li> <li>4. If the wiring is disconnected, shorted or grounded, replace the wiring.</li> <li>5. Replace the PF Lift motor2.</li> </ol>
		PF Lift sensor2	<ol style="list-style-type: none"> <li>1. Check that the sensor is correctly positioned.</li> <li>2. Confirm that the wiring connector is firmly connected and, if necessary, connect the connector all the way in. PF Lift sensor 2 and PF main PWB (YC4)</li> <li>3. If the wiring is disconnected, shorted or grounded, replace the wiring.</li> <li>4. Replace the PF Lift sensor 2.</li> </ol>
		PF main PWB	Replace the PF main PWB (Refer to the service manual for the paper feeder).

Code	Contents	Related parts	Check procedures/ corrective measures
<b>1140</b>	<b>SD lift motor error (side deck)</b> After cassette 5 is inserted, SD lift sensor does not turn on within 30 s. The lock signal of the motor is detected continuously for 200 ms.	Paper feeder lift base elevating mechanism	Check that the cassette base can be manipulated smoothly, if not, repair or replace.
		SD Lift motor	<ol style="list-style-type: none"> <li>1. Check that the cassette base has been ascended.</li> <li>2. Check the drive gear can rotate or they are not unusually loaded and, if necessary, replace.</li> <li>3. Confirm that the wiring connector is firmly connected and, if necessary, connect the connector all the way in. SD Lift motor and SD main PWB (YC8)</li> <li>4. If the wiring is disconnected, shorted or grounded, replace the wiring.</li> <li>5. Replace the SD Lift motor.</li> </ol>
		SD Lift sensor	<ol style="list-style-type: none"> <li>1. Check that the sensor is correctly positioned.</li> <li>2. Confirm that the wiring connector is firmly connected and, if necessary, connect the connector all the way in. SD Lift sensor and SD main PWB (YC5)</li> <li>3. If the wiring is disconnected, shorted or grounded, replace the wiring.</li> <li>4. Replace the SD Lift sensor.</li> </ol>
		SD main PWB	Replace the SD main PWB (Refer to the service manual for the paper feeder).
<b>1400</b>	<b>Rotary guide motor error</b> The guide sensor is not detected to be on at the home position detection with the rotary guide for three times in a row.	Rotary guide motor	<ol style="list-style-type: none"> <li>1. Check the rotary guide and drive gear can rotate or they are not unusually loaded and, if necessary, replace.</li> <li>2. Confirm that the wiring connector is firmly connected and, if necessary, connect the connector all the way in. Rotary guide motor and BR PWB (YC5)</li> <li>3. If the wiring is disconnected, shorted or grounded, replace the wiring.</li> <li>4. Replace the rotary guide motor.</li> </ol>
		BR PWB	Replace the BR PWB.

Code	Contents	Related parts	Check procedures/ corrective measures
1410	<b>Rotary de-curler error</b> If the de-curler won't turn On/Off despite it has been activated for 400 steps during waiting for the de-curler sensor to be On/Off three times in a row.	Rotary de-curler motor	<ol style="list-style-type: none"> <li>1. Check the rotary de-curler and drive gear can rotate or they are not unusually loaded and, if necessary, replace.</li> <li>2. Confirm that the wiring connector is firmly connected and, if necessary, connect the connector all the way in. Rotary de-curler motor and BR PWB (YC5)</li> <li>3. If the wiring is disconnected, shorted or grounded, replace the wiring.</li> <li>4. Replace the rotary de-curler motor.</li> </ol>
		BR PWB	Replace the BR PWB.
1710	<b>Side multi tray incompatible detection error</b> The side multi tray has been installed with a device to which it is incompatible.	The side multi tray is installed with a device to which it is incompatible.	Install the side multi-tray with the target model.
1800	<b>Paper feeder communication error</b> A communication error from paper feeder is detected 10 times in succession.	Paper feeder	Check the wiring connection status with the main unit and, if necessary, try connecting it again.
		PF main PWB	<ol style="list-style-type: none"> <li>1. Confirm that the wiring connector is firmly connected and, if necessary, connect the connector all the way in. PF main PWB (YC13) and Engine PWB (YC19)</li> <li>2. If the wiring is disconnected, shorted or grounded, replace the wiring.</li> <li>3. Replace the PF main PWB (Refer to the service manual for the paper feeder).</li> </ol>
		Engine PWB	<ol style="list-style-type: none"> <li>1. Check the engine software and upgrade to the latest, if necessary.</li> <li>2. Replace the engine PWB (see page 1-5-67).</li> </ol>
1900	<b>Paper feeder EEPROM error</b> When writing the data, read and write data does not match 3 times in succession.	PF main PWB (EEPROM)	<ol style="list-style-type: none"> <li>1. Confirm that the wiring connector is firmly connected and, if necessary, connect the connector all the way in.</li> <li>2. Replace the PF main PWB (Refer to the service manual for the paper feeder).</li> </ol>

Code	Contents	Related parts	Check procedures/ corrective measures
2101	<p><b>Developer motor error</b> After developer motor is driven, the ready signal does not turn to L within 5 s. After developer motor is stabilized, the ready signal is at the H level for 5 s continuously.</p>	Developer unit	<ol style="list-style-type: none"> <li>1. Check that the developer waste lock has been released and, if not, release the lock (see page 1-2-14).</li> <li>2. Check that the gears and spiral screw of the developer unit are not damaged.</li> <li>3. Confirm that the developer roller can rotate.</li> <li>4. If it won't rotate, replace the developer unit (see page 1-5-46).</li> </ol>
		Developer motor	<ol style="list-style-type: none"> <li>1. To check the motor operation, execute DLP(K) by U030 (see page 1-3-30).</li> <li>2. Check the drive gear can rotate or they are not unusually loaded and, if necessary, replace.</li> <li>3. Confirm that the wiring connector is firmly connected and, if necessary, connect the connector all the way in. Developer motor and Feed PWB 1 (YC8) Feed PWB 1 (YC2) and Engine PWB (YC5)</li> <li>4. If the wiring is disconnected, shorted or grounded, replace the wiring.</li> <li>5. Replace the Developer motor.</li> </ol>
		Engine PWB.	<ol style="list-style-type: none"> <li>1. Check the engine software and upgrade to the latest, if necessary.</li> <li>2. Replace the engine PWB (see page 1-5-67).</li> </ol>

Code	Contents	Related parts	Check procedures/ corrective measures
<b>2201</b> <b>drum motor steady-state error</b> After drum motor is stabilized, the ready signal is at the H level for 5 s continuously.		Drum unit	1. Confirm that the drum or the drum screw can rotate. 2. If it won't rotate, replace the drum unit. (see page 1-5-47)
		Drum motor	1. Check the drive gear can rotate or they are not unusually loaded and, if necessary, replace. 2. Confirm that the wiring connector is firmly connected and, if necessary, connect the connector all the way in. drum motor and Feed PWB 1 (YC9) Feed PWB 1 (YC2) and Engine PWB (YC5) 3. If the wiring is disconnected, shorted or grounded, replace the wiring. 4. Replace the drum motor (see page 1-5-88).
		Engine PWB	1. Check the engine software and upgrade to the latest, if necessary. 2. Replace the engine PWB (see page 1-5-67).
<b>2211</b> <b>Drum motor startup error</b> Drum motor is not stabilized within 5 s since the motor is activated.		Drum unit	1. Check the drive gear can rotate or they are not unusually loaded and, if necessary, replace. 2. Confirm that the drum or the drum screw can rotate. 3. If it won't rotate, replace the drum unit (see page 1-5-47).
		drum motor	1. Confirm that the wiring connector is firmly connected and, if necessary, connect the connector all the way in. drum motor and Feed PWB 1 (YC9) Feed PWB 1 (YC2) and Engine PWB (YC5) 2. If the wiring is disconnected, shorted or grounded, replace the wiring. 3. Replace the drum motor (see page 1-5-88).
		Engine PWB	1. Check the engine software and upgrade to the latest, if necessary. 2. Replace the engine PWB (see page 1-5-67).

Code	Contents	Related parts	Check procedures/ corrective measures
<b>2300</b>	<b>Fuser motor error</b> After fuser motor is driven, the ready signal does not turn to L within 2 s. After fuser motor is stabilized, the ready signal is at the H level for 1 s continuously.	Fuser motor	<ol style="list-style-type: none"> <li>1. To check the motor operation, execute U030 Fuser (Fuser motor) (see page 1-3-30).</li> <li>2. Check the drive gear can rotate or they are not unusually loaded and, if necessary, replace.</li> <li>3. Confirm that the wiring connector is firmly connected and, if necessary, connect the connector all the way in. Fuser motor and Feed PWB 1(YC18) Feed PWB 1(YC1) and Engine PWB (YC6)</li> <li>4. If the wiring is disconnected, shorted or grounded, replace the wiring.</li> <li>5. Replace the fuser motor (see page 1-5-91).</li> </ol>
		Engine PWB	<ol style="list-style-type: none"> <li>1. Check the engine software and upgrade to the latest, if necessary.</li> <li>2. Replace the engine PWB (see page 1-5-67).</li> </ol>
		Feed PWB 1	Replace the Feed PWB 1.
		Fuser unit	Replace the fuser unit (see page 1-5-57).
<b>2500</b>	<b>Paper feed motor error</b> After paper feed motor is driven, the ready signal does not turn to L within 2 s. After paper feed motor is stabilized, the ready signal is at the H level for 1 s continuously.	Paper feed motor	<ol style="list-style-type: none"> <li>1. To check the motor operation execute U030 Feed (paper feed motor) (see page 1-3-30).</li> <li>2. Check the paper feed roller and drive gear can rotate or they are not unusually loaded and, if necessary, replace.</li> <li>3. Confirm that the wiring connector is firmly connected and, if necessary, connect the connector all the way in. Paper feed motor and Feed PWB 2(YC2) Feed PWB 2(YC1) and Engine PWB (YC4)</li> <li>4. If the wiring is disconnected, shorted or grounded, replace the wiring.</li> <li>5. Replace the paper feed motor.</li> </ol>
		Engine PWB	<ol style="list-style-type: none"> <li>1. Check the engine software and upgrade to the latest, if necessary.</li> <li>2. Replace the engine PWB (see page 1-5-67).</li> </ol>



Code	Contents	Related parts	Check procedures/ corrective measures
2550	<b>Transfer motor error</b> After Transfer motor is driven, the ready signal does not turn to L within 2 s. After Transfer motor is stabilized, the ready signal is at the H level for 1 s continuously.	Transfer motor	<ol style="list-style-type: none"> <li>1. Check the drive gear can rotate or they are not unusually loaded and, if necessary, replace.</li> <li>2. Confirm that the wiring connector is firmly connected and, if necessary, connect the connector all the way in. Transfer motor and Relay PWB(YC6) Relay PWB(YC5) and Feed PWB 1 (YC13) Feed PWB 1 (YC2) and Engine PWB (YC5)</li> <li>3. If the wiring is disconnected, shorted or grounded, replace the wiring.</li> <li>4. Replace the Transfer motor.</li> </ol>
		Engine PWB	<ol style="list-style-type: none"> <li>1. Check the engine software and upgrade to the latest, if necessary.</li> <li>2. Replace the engine PWB (see page 1-5-67).</li> </ol>
2600	<b>PF paper feed motor error (large capacity feeder)</b> After PF paper feed motor is driven, the ready signal does not turn to L within 2 s.	PF paper feed motor	<ol style="list-style-type: none"> <li>1. To check the feed unit operation, execute U247 LCF- Motor ON (see page 1-3-127).</li> <li>2. Check the paper feed roller and drive gear can rotate or they are not unusually loaded and, if necessary, replace.</li> <li>3. Confirm that the wiring connector is firmly connected and, if necessary, connect the connector all the way in. PF paper feed motor and PF main PWB (YC16)</li> <li>4. If the wiring is disconnected, shorted or grounded, replace the wiring.</li> <li>5. Replace the paper feed motor.</li> </ol>
		PF main PWB	Replace the PF main PWB (Refer to the service manual for the paper feeder).

Code	Contents	Related parts	Check procedures/ corrective measures
2810	<p><b>Inner waste toner motor error</b></p> <p>Initialized when an error is constantly observed for 2 seconds after the inner waste toner motor is activated.</p> <p>An error is detected twice for 2.5 seconds after rebooting. The lock detect signal won't be H level three times in a row within 200 ms at 1.25 ms cycles after the waste toner motor has been driven.</p>	Waste toner box	<ol style="list-style-type: none"> <li>1. Rotate the waste toner spiral by the hand and check that they are not unusually loaded.</li> <li>2. If the spiral won't rotate, replace the waste toner tank.</li> </ol>
		Waste toner motor	<ol style="list-style-type: none"> <li>1. Rotate the drive gear by the hand and check that they are not unusually loaded.</li> <li>2. Clean the drive gears and the axle holder.</li> <li>3. Confirm that the wiring connector is firmly connected and, if necessary, connect the connector all the way in. Waste toner motor and Front PWB (YC13) Front PWB (YC3) and Engine PWB (YC7)</li> <li>4. If the wiring is disconnected, shorted or grounded, replace the wiring.</li> <li>5. Replace the waste toner motor.</li> </ol>
		Engine PWB	<ol style="list-style-type: none"> <li>1. Check the engine software and upgrade to the latest, if necessary.</li> <li>2. Replace the engine PWB (see page 1-5-67).</li> </ol>

Code	Contents	Related parts	Check procedures/ corrective measures
3100	<b>Scanner carriage error</b> The home position is not correct when the power is turned on, at the end of a reading process of the table and document processor.	The scanner mirror frame is being locked after setup.	Check whether the scanner mirror frame has been unlocked and unlock if necessary (see page 1-2-9).
		Scanner motor	1. To check the scanner motor, execute U073 (see page 1-3-57). 2. Move the scanner by the hand to check whether it is unusually difficult to move. 3. Check that the optical wire rope is not disengaged and engage the wire. 4. Confirm that the wiring connector is firmly connected and, if necessary, connect the connector all the way in. Scanner motor and ISC PWB (YC5) ISC PWB (YC3) and Main PWB (YC11) 5. If the wiring is disconnected, shorted or grounded, replace the wiring. 6. Replace the scanner motor.
		Home position sensor	1. Check that the sensor is correctly positioned. 2. Confirm that the wiring connector is firmly connected and, if necessary, connect the connector all the way in. Home position sensor and ISC PWB (YC8) 3. Replace the home position sensor.
		ISC PWB	Replace the ISC PWB and execute U411 (see page 1-3-148).
		Main PWB	Replace the main PWB (see page 1-5-59).

Code	Contents	Related parts	Check procedures/ corrective measures
3210	<b>CIS lamp error</b> When input value at the time of CIS illumination does not exceed the threshold value between 5 s.	CIS	<ol style="list-style-type: none"> <li>1. Execute U906 Separating Operation Release (see page 1-3-185).</li> <li>2. Execute CCD of U061 lamp check (see page 1-3-46).</li> <li>3. Confirm that the wiring connector is firmly connected and, if necessary, connect the connector all the way in. CIS and DPSHD PWB (YC2) DPSHD PWB (YC3) and DP relay PWB (YC2)</li> <li>4. If the wiring is disconnected, shorted or grounded, replace the wiring.</li> <li>5. Replace the CIS and execute U091 and U411 (see page 1-3-62,1-3-148).</li> </ol>
		DPSHD PWB	Replace the DPSHD PWB.
		DP relay PWB	Replace the DP relay PWB.
3220	<b>CCD lamp activation error</b> The threshold is calculated for colors at initialization and the pixel which does not exceed that value is greater than 1000.	CIS	<ol style="list-style-type: none"> <li>1. Execute U906 Separating Operation Release (see page 1-3-185).</li> <li>2. Confirm that the wiring connector is firmly connected and, if necessary, connect the connector all the way in. LED lamp PWB and ISC PWB (YC6) CCD PWB (YC2) and ISC PWB (YC9) ISC PWB (YC3) and Main PWB (YC11)</li> <li>3. If the wiring is disconnected, shorted or grounded, replace the wiring.</li> <li>4. If the LED lamp won't light, replace the LED PWB and execute U411 (see page 1-3-148).</li> </ol>
		ISC PWB	Replace the ISC PWB and execute U411 (see page 1-3-148).
		Main PWB	Replace the main PWB (see page 1-5-59).

Code	Contents	Related parts	Check procedures/ corrective measures
3300	<b>Optical system (AGC) error</b> One of the gains is FF or 00 during the CCD lamp AGC is being processed.	LED lamp PWB	<ol style="list-style-type: none"> <li>To check the lamp, execute U061 CCD (see page 1-3-46).</li> <li>Confirm that the wiring connector is firmly connected and, if necessary, connect the connector all the way in. LED lamp PWB and ISC PWB (YC6) CCD PWB (YC2) and ISC PWB (YC9) ISC PWB (YC3) and Main PWB (YC11)</li> <li>If the wiring is disconnected, shorted or grounded, replace the wiring.</li> <li>If the LED lamp won't light, replace the LED PWB and execute U411 (see page 1-3-148).</li> </ol>
		CCD PWB	Replace the ISU and execute U411 (see page 1-3-148).
		ISC PWB	Replace the ISC PWB and execute U411 (see page 1-3-148).
		Main PWB	Replace the main PWB (see page 1-5-59).
3310	<b>CIS AGC error</b> After AGC, correct input is not obtained at CIS.	CIS	<ol style="list-style-type: none"> <li>Execute U906 Separating Operation Release (see page 1-3-185).</li> <li>To check the lamp, execute U061 CCD (see page 1-3-148).</li> <li>Confirm that the wiring connector is firmly connected and, if necessary, connect the connector all the way in. DP CIS and DPSHD PWB (YC2) DPSHD PWB (YC3) and DP relay PWB (YC2)</li> <li>If the wiring is disconnected, shorted or grounded, replace the wiring.</li> <li>Replace the CIS and execute U091 and U411 (see page 1-3-62,1-3-148).</li> </ol>
		DPSHD PWB	Replace the DPSHD PWB.
3500	<b>Communication error between scanner and ASIC</b> An error code is detected.	ISC PWB	<ol style="list-style-type: none"> <li>Confirm that the wiring connector is firmly connected and, if necessary, connect the connector all the way in. ISC PWB (YC3) and Main PWB (YC11)</li> <li>If the wiring is disconnected, shorted or grounded, replace the wiring.</li> <li>Replace the ISC PWB and execute U411 (see page 1-3-148).</li> </ol>
		Main PWB	Replace the main PWB (see page 1-5-59).

Code	Contents	Related parts	Check procedures/ corrective measures
3600	<b>Scanner sequence error</b>	ISC PWB	<ol style="list-style-type: none"> <li>1. Execute U021 memory initializing (see page 1-3-28).</li> <li>2. Replace the ISC PWB and execute U411 (see page 1-3-148).</li> </ol>
3700	<b>Scanner device error</b>	CCD (ISU)	Since the ISU is mounted with a CCD of different type, install the ISU that matches with the model.
3800	<b>AFE error</b> When writing the data, read and write data does not match 3 times in succession. No response is received in 100 ms from AEF.	ISC PWB	<ol style="list-style-type: none"> <li>1. Confirm that the FFC wiring connector is not distorted and connect the FFC wiring all the way in. CCD PWB (YC2) and ISC PWB (YC9)</li> <li>2. If the FFC wiring is disconnected, replace the FFC wiring.</li> <li>3. Replace the ISC PWB and execute U411 (see page 1-5-37).</li> </ol>
		CCD PWB	Replace the ISU and execute U411 (see page 1-3-148).
3900	<b>Backup memory read/write error (ISC PWB)</b> Read and write data does not match.	Backup memory (ISC PWB)	<ol style="list-style-type: none"> <li>1. Turn the main power switch off and after 5 seconds, turn it on.</li> <li>2. Replace the ISC PWB and execute U411 (see page 1-3-148).</li> </ol>
4001	<b>Polygon motor synchronization error</b> After polygon motor is driven, the ready signal does not turn to L within 30 s. The polygon motor speed won't stabilize within 10 s.	Polygon motor (LSU)	<ol style="list-style-type: none"> <li>1. Confirm that the wiring connector is firmly connected and, if necessary, connect the connector all the way in. Polygon motor and Engine PWB (YC15)</li> <li>2. If the wiring is disconnected, shorted or grounded, replace the wiring.</li> <li>3. Replace the laser scanner unit (see page 1-5-42).</li> </ol>
		Engine PWB	<ol style="list-style-type: none"> <li>1. Check the engine software and upgrade to the latest, if necessary.</li> <li>2. Replace the engine PWB (see page 1-5-67).</li> </ol>

Code	Contents	Related parts	Check procedures/ corrective measures
4011	<b>Polygon motor steady-state error</b> After Polygon motor is stabilized, the ready signal is at the H level for 15 s continuously.	Polygon motor (LSU)	<ol style="list-style-type: none"> <li>1. Confirm that the wiring connector is firmly connected and, if necessary, connect the connector all the way in. Polygon motor and Engine PWB (YC15)</li> <li>2. If the wiring is disconnected, shorted or grounded, replace the wiring.</li> <li>3. Replace the laser scanner unit (see page 1-5-42).</li> </ol>
		Engine PWB	<ol style="list-style-type: none"> <li>1. Check the engine software and upgrade to the latest, if necessary.</li> <li>2. Replace the engine PWB (see page 1-5-67).</li> </ol>
4101	<b>BD initialization error K</b> After Polygon motor is driven, the BD signal is not detected for 1 s.	PD PWB K (LSU)	<ol style="list-style-type: none"> <li>1. Confirm that the FFC wiring connector is not distorted and connect the FFC wiring all the way in. Laser scanner unit and LSU relay PWB (YC3) LSU relay PWB (YC2) and Engine PWB (YC11)</li> <li>2. If the FFC wiring is disconnected, replace the FFC wiring.</li> <li>3. Replace the laser scanner unit (see page 1-5-42).</li> </ol>
		Engine PWB	<ol style="list-style-type: none"> <li>1. Check the engine software and upgrade to the latest, if necessary.</li> <li>2. Replace the engine PWB (see page 1-5-67).</li> </ol>
4201	<b>BD steady-state error K</b> The BD signal is not detected.	PD PWB K (LSU)	<ol style="list-style-type: none"> <li>1. Confirm that the FFC wiring connector is not distorted and connect the FFC wiring all the way in. Laser scanner unit and LSU relay PWB (YC3) LSU relay PWB (YC2) and Engine PWB (YC11)</li> <li>2. If the FFC wiring is disconnected, shorted or grounded, replace the FFC wiring.</li> <li>3. Replace the laser scanner unit (see page 1-5-42).</li> </ol>
		Engine PWB	<ol style="list-style-type: none"> <li>1. Check the engine software and upgrade to the latest, if necessary.</li> <li>2. Replace the engine PWB (see page 1-5-67).</li> </ol>

Code	Contents	Related parts	Check procedures/ corrective measures
5101	<b>Main high-voltage error K</b> Measure the inflowing current when Vpp is varied in 3 steps and verify if the difference of the currents of 0 and step 2 is less than 42 (51 if lower high-voltage board).	Drum unit	1. Confirm that the drum or the drum screw can rotate. 2. If it won't rotate, replace the drum unit. 3. Check that the discharger lamp is properly connected.
		Charger roller unit	1. Check that the high-voltage contacts are not distorted or adhered with foreign objects. 2. Reinstall the charger roller unit. Or, replace the charger roller unit (see page 1-5-49).
		High voltage PWB	1. Confirm that the wiring connector is firmly connected and, if necessary, connect the connector all the way in. High voltage PWB (YC2) and Engine PWB (YC16) 2. If the wiring is disconnected, shorted or grounded, replace the wiring. 3. Replace the High voltage PWB (see page 1-5-76).
		Engine PWB	1. Check the engine software and upgrade to the latest, if necessary. 2. Replace the engine PWB (see page 1-5-67).



Code	Contents	Related parts	Check procedures/ corrective measures
6000	<b>Broken fuser heater wire</b> Fuser thermistor 1 does not reach 100° C/212 °F even after 30 s during warming up. The detected temperature of fuser thermistor 1 does not reach the specified temperature (ready indication temperature) for 420 s in warming up after reached to 100° C/212 °F.	Fuser unit	<ol style="list-style-type: none"> <li>1. Check that no paper jam is present.</li> <li>2. Confirm that the wiring connector is firmly connected and, if necessary, connect the connector all the way in. Fuser unit and Engine PWB (YC26)</li> <li>3. If the wiring is disconnected, shorted or grounded, replace the wiring.</li> <li>4. Replace the Fuser unit and execute U167 counter clear (see page 1-3-91). (Deteriorated sensitivity due to the toner adhered to the center thermistor.)</li> </ol>
		Engine PWB	<ol style="list-style-type: none"> <li>1. Check the engine software and upgrade to the latest, if necessary.</li> <li>2. Replace the engine PWB (see page 1-5-67).</li> </ol>
		Power source PWB	<ol style="list-style-type: none"> <li>1. Confirm that the wiring connector is firmly connected and, if necessary, connect the connector all the way in. Power source PWB (YC3) and fuser heater PWB (YC3) Fuser heater PWB (YC2) and feed PWB 1 (YC27) Feed PWB 1 (YC1) and Engine PWB (YC6)</li> </ol>
		Fuser heater	<ol style="list-style-type: none"> <li>1. Replace the fuser unit (see page 1-5-57).</li> </ol>
6020	<b>Abnormally high fuser thermistor 1 temperature</b> Fuser thermistor 1 detects a temperature higher than 240°C/464°F for 1 s.	Fuser unit	<ol style="list-style-type: none"> <li>1. Confirm that the wiring connector is firmly connected and, if necessary, connect the connector all the way in. Fuser unit and Engine PWB (YC26)</li> <li>2. If the wiring is disconnected, shorted or grounded, replace the wiring.</li> <li>3. Replace the Fuser unit (see page 1-5-57).</li> </ol>
		Engine PWB	<ol style="list-style-type: none"> <li>1. Check the engine software and upgrade to the latest, if necessary.</li> <li>2. Replace the engine PWB (see page 1-5-67).</li> </ol>

Code	Contents	Related parts	Check procedures/ corrective measures
6030	<p><b>Broken fuser thermistor 1 wire</b></p> <p>Fuser thermistor 1 detects a lower than 30°C/86°F when the temperature at the fuser thermistor 2 is higher than 70°C/158°F for during warming up.</p> <p>Fuser thermistor 2 detects a lower than 50°C/122°F for 15s during warming up.</p>	Fuser unit	<ol style="list-style-type: none"> <li>1. Check that no paper jam is present.</li> <li>2. Confirm that the wiring connector is firmly connected and, if necessary, connect the connector all the way in. Fuser unit and Engine PWB (YC26)</li> <li>3. If the wiring is disconnected, shorted or grounded, replace the wiring.</li> <li>4. Replace the Fuser unit and execute U167 counter clear (see page 1-3-91). (Deteriorated sensitivity due to the toner adhered to the center thermistor.)</li> </ol>
		Engine PWB	<ol style="list-style-type: none"> <li>1. Check the engine software and upgrade to the latest, if necessary.</li> <li>2. Replace the engine PWB (see page 1-5-67).</li> </ol>
		Fuser thermistor 1	<ol style="list-style-type: none"> <li>1. Replace the Fuser unit and execute U167 counter clear (see page 1-3-91).</li> </ol>
		Fuser thermostat (triggered)	<ol style="list-style-type: none"> <li>1. Confirm that the wiring connector is firmly connected and, if necessary, connect the connector all the way in. Fuser unit and fuser heater PWB (YC1)</li> <li>2. If the wiring is disconnected, shorted or grounded, replace the wiring.</li> <li>3. Replace the Fuser unit and execute U167 counter clear (see page 1-3-91).</li> </ol>

Code	Contents	Related parts	Check procedures/ corrective measures
6040	<b>Fuser heater error</b> Input from fuser center thermistor 1 is abnormal value continuously for 1 s. CPU port PH1 to stay in H level for one second or more in all operating modes is judged that the connector is disconnected.	Fuser unit	1. Confirm that the wiring connector is firmly connected and, if necessary, connect the connector all the way in. Fuser unit and Engine PWB (YC26) 2. If the wiring is disconnected, shorted or grounded, replace the wiring.
		Engine PWB	1. Check the engine software and upgrade to the latest, if necessary. 2. Replace the engine PWB (see page 1-5-67).
		Center thermistor 1	1. Replace the Fuser unit and execute U167 counter clear (see page 1-3-91).
		Fuser thermostat (triggered)	1. Confirm that the wiring connector is firmly connected and, if necessary, connect the connector all the way in. Fuser unit and fuser heater PWB (YC1) 2. If the wiring is disconnected, shorted or grounded, replace the wiring. 3. Replace the Fuser unit and execute U167 counter clear (see page 1-3-91).

Code	Contents	Related parts	Check procedures/ corrective measures
6050	<p><b>Abnormally low fuser thermistor 1 temperature</b></p> <p>Fuser thermistor 1 detects a temperature lower than 100°C/212°F for 1 s after warming up, during ready or during print.</p> <p>The temperature of thermistor 1 is detected to be less than 70°C/158°F for more than one second during low-power mode.</p>	Power source	<ol style="list-style-type: none"> <li>1. Check that the operating voltage falls within +/-10%.</li> <li>2. Check no voltage drop is caused. The heater is deactivated at 70V or lower.</li> <li>3. Relocate the AC outlet that supplies power.</li> </ol>
		Fuser unit	<ol style="list-style-type: none"> <li>1. Confirm that the wiring connector is firmly connected and, if necessary, connect the connector all the way in. Fuser unit and Engine PWB (YC26)</li> <li>2. If the wiring is disconnected, shorted or grounded, replace the wiring.</li> <li>3. Replace the Fuser unit and execute U167 counter clear (see page 1-3-91).</li> </ol>
		Engine PWB	<ol style="list-style-type: none"> <li>1. Check the engine software and upgrade to the latest, if necessary.</li> <li>1. Replace the engine PWB (see page 1-5-67).</li> </ol>
		Fuser thermistor 1	<ol style="list-style-type: none"> <li>1. Replace the fuser unit and execute U167 counter clear (see page 1-3-91).</li> </ol>
		Fuser thermostat (triggered)	<ol style="list-style-type: none"> <li>1. Confirm that the wiring connector is firmly connected and, if necessary, connect the connector all the way in. Fuser unit and fuser heater PWB (YC1)</li> <li>2. If the wiring is disconnected, shorted or grounded, replace the wiring.</li> <li>3. Replace the Fuser unit and execute U167 counter clear (see page 1-3-91).</li> </ol>

Code	Contents	Related parts	Check procedures/ corrective measures
6200	<b>Broken fuser edge heater wire</b> Fuser thermistor 2 does not reach 100° C/212 °F even after 30 s during warming up. The detected temperature of fuser thermistor 2 does not reach the specified temperature (ready indication temperature) for 420 s in warming up after reached to 100° C/212 °F.	Fuser unit	1. Confirm that the wiring connector is firmly connected and, if necessary, connect the connector all the way in. Fuser unit and Engine PWB (YC26) 2. If the wiring is disconnected, shorted or grounded, replace the wiring. 3. Replace the Fuser unit and execute U167 counter clear (see page 1-3-91).
		Engine PWB	1. Check the engine software and upgrade to the latest, if necessary. 2. Replace the engine PWB (see page 1-5-67).
		Fuser center thermistor 1	1. Replace the Fuser unit and execute U167 counter clear (see page 1-3-91).
6220	<b>Abnormally high fuser edge thermistor temperature</b> Fuser thermistor 2 detects a temperature higher than 220°C/428°F for 1 s.	Fuser unit	1. Confirm that the wiring connector is firmly connected and, if necessary, connect the connector all the way in. Fuser unit and Engine PWB (YC26) 2. If the wiring is disconnected, shorted or grounded, replace the wiring. 3. Replace the Fuser unit and execute U167 counter clear (see page 1-3-91).
		Engine PWB	1. Check the engine software and upgrade to the latest, if necessary. 2. Replace the engine PWB (see page 1-5-67).
6230	<b>Broken fuser edge thermistor wire</b> The Input signal from the fuser thermistor 2 is 992 or more (A/D value) continuously for 1 s when the temperature at the fuser thermistor 1 is higher than 100°C/212°F. Fuser thermistor 2 detects a lower then 50°C/122°F for 15s during werming up.	Fuser unit	1. Confirm that the wiring connector is firmly connected and, if necessary, connect the connector all the way in. Fuser unit and Engine PWB (YC26) 2. If the wiring is disconnected, shorted or grounded, replace the wiring. 3. Replace the Fuser unit and execute U167 counter clear (see page 1-3-91).
		Engine PWB	1. Check the engine software and upgrade to the latest, if necessary. 2. Replace the engine PWB (see page 1-5-67).

Code	Contents	Related parts	Check procedures/ corrective measures
6250	<b>Abnormally low fuser edge thermistor temperature</b> Fuser thermistor 2 detects a temperature lower than 100°C/212°F for 1 s during ready or print. Fuser thermistor 2 detects a temperature lower than 50°C/122°F for 1 s during low power mode.	Fuser unit	<ol style="list-style-type: none"> <li>1. Confirm that the wiring connector is firmly connected and, if necessary, connect the connector all the way in.</li> <li>2. Fuser unit and Engine PWB (YC26) If the wiring is disconnected, shorted or grounded, replace the wiring.</li> <li>3. Replace the Fuser unit and execute U167 counter clear (see page 1-3-91).</li> </ol>
		Engine PWB	<ol style="list-style-type: none"> <li>1. Check the engine software and upgrade to the latest, if necessary.</li> <li>2. Replace the engine PWB (see page 1-5-67).</li> </ol>
6400	<b>Zero-cross signal error</b> While fuser heater ON/OFF control is performed, the zero-cross signal is not input within 3 s.	Fuser unit	<ol style="list-style-type: none"> <li>1. Confirm that the wiring connector is firmly connected and, if necessary, connect the connector all the way in. Fuser heater PWB (YC2) and feed PWB 1 (YC27)</li> <li>2. If the wiring is disconnected, shorted or grounded, replace the wiring.</li> <li>3. Replace the fuser heater PWB.</li> </ol>

Code	Contents	Related parts	Check procedures/ corrective measures
6610	<b>Fuser release sensor error</b> When the fuser release motor is driven, the fuser release sensor does not turn on/off for 8 s.	Fuser release motor	<ol style="list-style-type: none"> <li>1. To check the motor operation, execute U030 Fuser Release (see page 1-3-30).</li> <li>2. Check that the drive gear can be rotated and the separation is possible.</li> <li>3. If the motor won't rotate, confirm that the wiring connector is firmly connected and, if necessary, connect the connector all the way in. Fuser unit and Engine PWB (YC26)</li> <li>4. If the wiring is disconnected, shorted or grounded, replace the wiring.</li> <li>5. Replace the fuser unit and execute U167 counter clear (see page 1-3-91).</li> </ol>
		Fuser release sensor	<ol style="list-style-type: none"> <li>1. Check that the sensor is correctly positioned.</li> <li>2. Check that the sensor is not contaminated or damaged.</li> </ol>
		Engine PWB	<ol style="list-style-type: none"> <li>1. Check the engine software and upgrade to the latest, if necessary.</li> <li>2. Replace the engine PWB (see page 1-5-67).</li> </ol>
6910	<b>Engine software ready error</b> The device won't engage in ready state in 60 minutes after warming-up has began. (A previous timeout process has not been cancelled.)	Engine PWB	<ol style="list-style-type: none"> <li>1. Turn the main power switch off and after 5 seconds, turn it on.</li> <li>2. Reinstall the engine software.</li> <li>3. Replace the engine PWB (see page 1-5-67).</li> </ol>
6930	<b>Fuser rear fan motor error</b> When the fuser rear fan motor is driven, alarm signal is detected for 5 s continuously.	Fuser rear fan motor	<ol style="list-style-type: none"> <li>1. To check the fan motor operation, execute U037 Fuser Cooling (see page 1-3-38).</li> <li>2. Confirm that the wiring connector is firmly connected and, if necessary, connect the connector all the way in. Fuser rear fan motor and Engine PWB (YC26)</li> <li>3. If the wiring is disconnected, shorted or grounded, replace the wiring.</li> <li>4. Replace the fuser rear fan motor.</li> </ol>
		Engine PWB	<ol style="list-style-type: none"> <li>1. Check the engine software and upgrade to the latest, if necessary.</li> <li>2. Replace the engine PWB (see page 1-5-67).</li> </ol>

Code	Contents	Related parts	Check procedures/ corrective measures
<b>7001</b>	<b>Toner motor error</b> A state that a lock is detected 5 times in a row in 200ms cycle when the Toner motor is driven has occurred 30 times in total.	Toner container	<ol style="list-style-type: none"> <li>1. Check that the spiral screw of the toner container can be rotated by the hand.</li> <li>2. Check for broken gears and replace if any.</li> </ol>
		Toner motor	<ol style="list-style-type: none"> <li>1. Draw out the toner container and execute U135 to check the toner motor operation (see page 1-3-77).</li> <li>2. Check the drive gear can rotate or they are not unusually loaded and, if necessary, replace.</li> <li>3. Confirm that the wiring connector is firmly connected and, if necessary, connect the connector all the way in. Toner motor and Engine PWB (YC27)</li> <li>4. If the wiring is disconnected, shorted or grounded, replace the wiring.</li> <li>5. Replace the Toner motor.</li> </ol>
		Screw sensor	<ol style="list-style-type: none"> <li>1. Check that the sensor is correctly positioned.</li> <li>2. Confirm that the wiring connector is firmly connected and, if necessary, connect the connector all the way in. Screw sensor and Front PWB (YC5) Front PWB (YC2) and Engine PWB (YC7)</li> <li>3. Replace the Screw sensor.</li> </ol>
		Engine PWB	<ol style="list-style-type: none"> <li>1. Check the engine software and upgrade to the latest, if necessary.</li> <li>2. Replace the engine PWB (see page 1-5-67).</li> </ol>



Code	Contents	Related parts	Check procedures/ corrective measures
7101	<b>Toner sensor error</b> Sensor output value of 60 or less or 944 or more continued for 3 s.	Failure of locking the developer waste slot at setup.	If an abnormal noise is heard, check that the developer ejection outlet is released and, if not, release the outlet (see page 1-2-14).
		Toner sensor	<ol style="list-style-type: none"> <li>1. Check the toner sensor output by U155 (see page 1-3-66).</li> <li>2. Confirm that the wiring connector is firmly connected and, if necessary, connect the connector all the way in. Toner sensor and Front PWB (YC7) Front PWB (YC2) and Engine PWB (YC8)</li> <li>3. If the wiring is disconnected, shorted or grounded, replace the wiring.</li> <li>4. Check that the gears of the Developer unit are not damaged and the spiral can rotate.</li> <li>5. Replace the Developer unit (see page 1-5-46).</li> </ol>
		Toner motor	<ol style="list-style-type: none"> <li>1. Draw out the toner container and execute U135 to check the toner motor operation (see page 1-3-77).</li> <li>2. Check the drive gear can rotate or they are not unusually loaded and, if necessary, replace.</li> <li>3. Confirm that the wiring connector is firmly connected and, if necessary, connect the connector all the way in. Toner motor and Engine PWB (YC27)</li> <li>4. If the wiring is disconnected, shorted or grounded, replace the wiring.</li> <li>5. Replace the Toner motor.</li> </ol>
		Engine PWB	<ol style="list-style-type: none"> <li>1. Check the engine software and upgrade to the latest, if necessary.</li> <li>2. Replace the engine PWB (see page 1-5-67).</li> </ol>

Code	Contents	Related parts	Check procedures/ corrective measures
7200	<b>Broken outer temperature sensor 2 wire</b> The sensor input sampling is greater than 230.	Outer temperature sensor 2	<ol style="list-style-type: none"> <li>1. Confirm Ext/Int is displayed by U139 temperature and humidity (see page 1-3-79).</li> <li>2. Confirm that the wiring connector is firmly connected and, if necessary, connect the connector all the way in. Outer temperature sensor 2 and Front PWB (YC8) Front PWB (YC2) and Engine PWB (YC8)</li> <li>3. If the wiring is disconnected, shorted or grounded, replace the wiring.</li> <li>4. Replace the outer temperature sensor 2.</li> </ol>
		Front PWB	Replace the front PWB.
		Engine PWB	<ol style="list-style-type: none"> <li>1. Check the engine software and upgrade to the latest, if necessary.</li> <li>2. Replace the engine PWB (see page 1-5-67).</li> </ol>
7210	<b>Short-circuited outer temperature sensor 2</b> The sensor input sampling is less than 69.	Outer temperature sensor 2	<ol style="list-style-type: none"> <li>1. Confirm Ext/Int is displayed by U139 temperature and humidity (see page 1-3-79).</li> <li>2. Confirm that the wiring connector is firmly connected and, if necessary, connect the connector all the way in. Outer temperature sensor 2 and Front PWB (YC8) Front PWB (YC2) and Engine PWB (YC10)</li> <li>3. If the wiring is disconnected, shorted or grounded, replace the wiring.</li> <li>4. Replace the outer temperature sensor 2.</li> </ol>
		Front PWB	Replace the front PWB
		Engine PWB	<ol style="list-style-type: none"> <li>1. Check the engine software and upgrade to the latest, if necessary.</li> <li>2. Replace the engine PWB (see page 1-5-67).</li> </ol>

Code	Contents	Related parts	Check procedures/ corrective measures
7221	<b>Broken LSU thermistor wire</b> The sensor input sampling is greater than 230.	LSU thermistor	<ol style="list-style-type: none"> <li>1. Confirm LSU is displayed by U139 temperature and humidity (see page 1-3-79).</li> <li>2. Confirm that the wiring connector is firmly connected and, if necessary, connect the connector all the way in. Laser scanner unit and LSU relay PWB (YC3) LSU relay PWB (YC2) and Engine PWB (YC11)</li> <li>3. If the wiring is disconnected, shorted or grounded, replace the wiring.</li> <li>4. Replace the laser scanner unit (see page 1-5-42).</li> </ol>
		LSU relay PWB	REPLACE the LSU relay PWB.
		Engine PWB	<ol style="list-style-type: none"> <li>1. Check the engine software and upgrade to the latest, if necessary.</li> <li>2. Replace the engine PWB (see page 1-5-67).</li> </ol>
7231	<b>Short-circuited LSU thermistor K</b> The sensor input sampling is less than 69.	LSU thermistor	<ol style="list-style-type: none"> <li>1. Confirm LSU is displayed by U139 temperature and humidity (see page 1-3-79).</li> <li>2. Confirm that the wiring connector is firmly connected and, if necessary, connect the connector all the way in. Laser scanner unit and LSU relay PWB (YC3) LSU relay PWB (YC2) and Engine PWB (YC11)</li> <li>3. If the wiring is disconnected, shorted or grounded, replace the wiring.</li> <li>4. Replace the laser scanner unit (see page 1-5-42).</li> </ol>
		LSU relay PWB	Replace the LSU relay PWB.
		Engine PWB	<ol style="list-style-type: none"> <li>1. Check the engine software and upgrade to the latest, if necessary.</li> <li>2. Replace the engine PWB (see page 1-5-67).</li> </ol>

Code	Contents	Related parts	Check procedures/ corrective measures
7241	<b>Broken Developer thermistor wire</b> The sensor input sampling is greater than 230.	Developer thermistor	<ol style="list-style-type: none"> <li>1. Confirm Developing is displayed by U139 temperature and humidity (see page 1-3-79).</li> <li>2. Confirm that the wiring connector is firmly connected and, if necessary, connect the connector all the way in. Developer unit and Front PWB (YC7) Front PWB (YC2) and Engine PWB (YC8)</li> <li>3. If the wiring is disconnected, shorted or grounded, replace the wiring.</li> <li>4. Replace the Developer unit (see page 1-5-46).</li> </ol>
		Front PWB	Replace the front PWB
		Engine PWB	<ol style="list-style-type: none"> <li>1. Check the engine software and upgrade to the latest, if necessary.</li> <li>2. Replace the engine PWB (see page 1-5-67).</li> </ol>
7251	<b>Short-circuited Developer thermistor</b> The sensor input sampling is less than 69.	Developer thermistor	<ol style="list-style-type: none"> <li>1. Confirm Developing is displayed by U139 temperature and humidity (see page 1-3-79).</li> <li>2. Confirm that the wiring connector is firmly connected and, if necessary, connect the connector all the way in. Developer unit and Front PWB (YC7) Front PWB (YC2) and Engine PWB (YC8)</li> <li>3. If the wiring is disconnected, shorted or grounded, replace the wiring.</li> <li>4. Replace the Developer unit (see page 1-5-46).</li> </ol>
		Front PWB	Replace the front PWB
		Engine PWB	<ol style="list-style-type: none"> <li>1. Check the engine software and upgrade to the latest, if necessary.</li> <li>2. Replace the engine PWB (see page 1-5-67).</li> </ol>

Code	Contents	Related parts	Check procedures/ corrective measures
7301	<b>Toner hopper motor error</b> During the toner motor is driven, an event in which a locking was detected for 5 times in 200 ms intervals has occurred in 30 sets.	Tonner hopper motor	1. If the motor won't rotate, confirm that the wiring connector is firmly connected and, if necessary, connect the connector all the way in. Tonner hopper motor and Front PWB (YC5) Front PWB (YC3) and Engine PWB (YC7) 2. If the wiring is disconnected, shorted or grounded, replace the wiring. 3. Replace the tonner hopper motor .
		Screw sensor	1. Check that the sensor is correctly positioned. 2. Confirm that the wiring connector is firmly connected and, if necessary, connect the connector all the way in. Screw sensor and Front PWB (YC5) Front PWB (YC2) and Engine PWB (YC7) 3. Replace the Screw sensor.
		Engine PWB	1. Check the engine software and upgrade to the latest, if necessary. 2. Replace the engine PWB (see page 1-5-67).
7401	<b>Developer unit type mismatch error</b> Improper adaptation of the machine and developer unit is detected.	Different type of the developer unit is installed.	Install the developer unit of the correct type.
		Developer unit	1. Confirm that the wiring connector is firmly connected and, if necessary, connect the connector all the way in. Developer unit and Front PWB (YC7) Front PWB (YC2) and Engine PWB (YC8) 2. If the wiring is disconnected, shorted or grounded, replace the wiring.

Code	Contents	Related parts	Check procedures/ corrective measures
7460	<b>Developer shutter error</b> Power is turned on while the developer shutter is locked.	The developer shutter has been locked.	Release the developer shutter (see page 1-2-14).
		Developer shutter sensor	<ol style="list-style-type: none"> <li>1. Confirm that the wiring connector is firmly connected and, if necessary, connect the connector all the way in. Developer shutter sensor and Front PWB (YC4) Front PWB (YC3) and Engine PWB (YC7)</li> <li>2. If the wiring is disconnected, shorted or grounded, replace the wiring.</li> </ol>
7601	<b>ID sensor 1 error [Front]</b> Dark potential error FrontDarkP and FrontDarkS are greater than 0.80V. Light potential error FrontBrightS is smaller than FrontDarkS. FrontBrightP is smaller than [FrontDarkP + 0.5V].	ID sensor1	<ol style="list-style-type: none"> <li>1. Execute U464 Calib for setting ID compensation operation and check the displayed values by U465 Boas Calib for ID compensation reference (see page 1-3-172).</li> <li>2. Clean the ID sensor on its surface.</li> <li>3. Confirm that the wiring connector is firmly connected and, if necessary, connect the connector all the way in. ID sensor 1 (front) and relay PWB (YC10) Relay PWB (YC1) and Feed PWB 1 (YC14) Feed PWB 1 (YC1) and Engine PWB (YC6)</li> <li>4. If the wiring is disconnected, shorted or grounded, replace the wiring.</li> </ol>
		Feed PWB 1	Replace the Feed PWB 1.
		Engine PWB	<ol style="list-style-type: none"> <li>1. Check the engine software and upgrade to the latest, if necessary.</li> <li>2. Replace the engine PWB (see page 1-5-67).</li> </ol>

Code	Contents	Related parts	Check procedures/ corrective measures
7602	<b>ID sensor 2 error [Rear]</b> Dark potential error RearDarkP and RearDarkS are greater than 0.80V. Light potential error RearBrightS is smaller than RearDarkS. RearBrightP is smaller than [RearDarkP + 0.5V].	ID sensor 2	<ol style="list-style-type: none"> <li>1. Execute U464 Calib for setting ID compensation operation and check the displayed values by U465 Boas Calib for ID compensation reference (see page 1-3-172).</li> <li>2. Clean the ID sensor on its surface.</li> <li>3. Confirm that the wiring connector is firmly connected and, if necessary, connect the connector all the way in. ID sensor2 (rear) and relay PWB (YC10) Relay PWB (YC1) and Feed PWB 1 (YC14) Feed PWB 1 (YC1) and Engine PWB (YC6)</li> <li>4. If the wiring is disconnected, shorted or grounded, replace the wiring.</li> </ol>
		Feed PWB 1	Replace the Feed PWB 1.
		Engine PWB	<ol style="list-style-type: none"> <li>1. Check the engine software and upgrade to the latest, if necessary.</li> <li>2. Replace the engine PWB (see page 1-5-67).</li> </ol>
7800	<b>Broken outer temperature sensor wire</b> The device did not respond for more than 5 ms during reading, in 5 times.	Outer temperature sensor	<ol style="list-style-type: none"> <li>1. Confirm that the wiring connector is firmly connected and, if necessary, connect the connector all the way in. Outer temperature sensor and Front PWB (YC8) Front PWB (YC2) and Engine PWB (YC8)</li> <li>2. If the wiring is disconnected, shorted or grounded, replace the wiring.</li> <li>3. Replace the Outer temperature sensor.</li> </ol>
		Front PWB	Replace the front PWB
		Engine PWB	<ol style="list-style-type: none"> <li>1. Check the engine software and upgrade to the latest, if necessary.</li> <li>2. Replace the engine PWB (see page 1-5-67).</li> </ol>

Code	Contents	Related parts	Check procedures/ corrective measures
7901	<b>Drum EEPROM error</b> No response is issued from the device in reading/writing for 5 ms or more and this problem is repeated five times successively. Mismatch of reading data from two locations occurs 8 times successively. Mismatch between writing data and reading data occurs 8 times successively.	DR PWB	1. Confirm that the wiring connector is firmly connected and, if necessary, connect the connector all the way in. DR PWB and Front PWB (YC6) Front PWB (YC2) and Engine PWB (YC8) 2. If the wiring is disconnected, shorted or grounded, replace the wiring. 3. Replace the Drum unit (see page 1-5-47).
		Front PWB	Replace the front PWB
		Engine PWB	1. Check the engine software and upgrade to the latest, if necessary. 2. Replace the engine PWB (see page 1-5-67).
7911	<b>Developer unit EEPROM error</b> No response is issued from the device in reading/writing for 5 ms or more and this problem is repeated five times successively. Mismatch of reading data from two locations occurs 8 times successively. Mismatch between writing data and reading data occurs 8 times successively.	Developer unit	1. Confirm that the wiring connector is firmly connected and, if necessary, connect the connector all the way in. Developer unit and Front PWB (YC7) Front PWB (YC2) and Engine PWB (YC8) 2. If the wiring is disconnected, shorted or grounded, replace the wiring. 3. Replace the Developer unit (see page 1-5-46).
		Front PWB	Replace the front PWB
		Engine PWB	1. Check the engine software and upgrade to the latest, if necessary. 2. Replace the engine PWB (see page 1-5-67).



Code	Contents	Related parts	Check procedures/ corrective measures
7941	<b>Laser scanner unit EEPROM error</b> Mismatch of reading data from two locations occurs 8 times successively. Mismatch between writing data and reading data occurs 8 times successively.	APC PWB	1. Confirm that the FFC wiring connector is not distorted and connect the FFC wiring all the way in. APC PWB and LSU relay PWB (YC3) LSU relay PWB (YC2) and Engine PWB (YC11) 2. If the FFC wiring is disconnected, shorted or grounded, replace the FFC wiring. 3. Replace the laser scanner unit (see page 1-5-42).
		LSU relay PWB	Replace the LSU relay PWB.
		Engine PWB	1. Check the engine software and upgrade to the latest, if necessary. 2. Replace the engine PWB (see page 1-5-67).

Code	Contents	Related parts	Check procedures/ corrective measures
8010	<b>Punch motor 1 error</b> When the punch motor is driven, punch home position sensor does not turn on within 200 ms.	Punch motor	<ol style="list-style-type: none"> <li>1. Execute U240 Motor - Punch to check the finisher operation (see page 1-3-113).</li> <li>2. Manipulate the punch up and down to check it can smoothly move up and down.</li> <li>3. Check that the drive from the motor reaches the punch cam.</li> <li>4. Confirm that the wiring connector is firmly connected and, if necessary, connect the connector all the way in. Punch motor and Punch PWB (YC4)</li> <li>5. If the wiring is disconnected, shorted or grounded, replace the wiring.</li> <li>6. Replace the punch motor.</li> </ol>
		Punch home position sensor	<ol style="list-style-type: none"> <li>1. Execute U241 Punch - Punch HP to check the finisher switch (see page 1-3-115).</li> <li>2. Check that the sensor and its mounting bracket are correctly positioned.</li> <li>3. Confirm that the wiring connector is firmly connected and, if necessary, connect the connector all the way in. Punch home position sensor and Punch PWB (YC8)</li> <li>4. Replace the Punch home position sensor.</li> </ol>
		Punch PWB	<ol style="list-style-type: none"> <li>1. Confirm that the wiring connector is firmly connected and, if necessary, connect the connector all the way in. Punch PWB (YC1) and DF main PWB (YC7) (4000-sheet finisher) Punch PWB (YC1) and DF main PWB (YC8) (1000-sheet finisher)</li> <li>2. Replace the punch PWB.</li> </ol>
		DF main PWB	Replace the DF main PWB (Refer to the service manual for the document finisher).

Code	Contents	Related parts	Check procedures/ corrective measures
8020	<b>Punch motor 2 error</b> Home position is not obtained in 3 s after home position is initialized or in standby.	Punch motor	<ol style="list-style-type: none"> <li>1. Execute U240 Motor - Punch to check the finisher operation (see page 1-3-113).</li> <li>2. Manipulate the punch up and down to check it can smoothly move up and down.</li> <li>3. Check that the drive from the motor reaches the punch cam.</li> <li>4. Confirm that the wiring connector is firmly connected and, if necessary, connect the connector all the way in. Punch motor and Punch PWB (YC4)</li> <li>5. If the wiring is disconnected, shorted or grounded, replace the wiring.</li> <li>6. Replace the punch motor.</li> </ol>
		Punch PWB	<ol style="list-style-type: none"> <li>1. Confirm that the wiring connector is firmly connected and, if necessary, connect the connector all the way in. Punch PWB (YC1) and DF main PWB (YC7)(4000-sheet finisher) Punch PWB (YC1) and DF main PWB (YC8)(1000-sheet finisher)</li> <li>2. Replace the punch PWB.</li> </ol>
		DF main PWB	Replace the DF main PWB (Refer to the service manual for the document finisher).

Code	Contents	Related parts	Check procedures/ corrective measures
8030	<b>Punch motor 3 error</b> Home position does not turn from On to Off in 50 ms after home position has been initialized.	Punch motor	<ol style="list-style-type: none"> <li>1. Execute U240 Motor - Punch to check the finisher operation (see page 1-3-113).</li> <li>2. Manipulate the punch up and down to check it can smoothly move up and down.</li> <li>3. Check that the drive from the motor reaches the punch cam.</li> <li>4. Confirm that the wiring connector is firmly connected and, if necessary, connect the connector all the way in. Punch motor and Punch PWB (YC4)</li> <li>5. If the wiring is disconnected, shorted or grounded, replace the wiring.</li> <li>6. Replace the punch motor.</li> </ol>
		Punch PWB	<ol style="list-style-type: none"> <li>1. Confirm that the wiring connector is firmly connected and, if necessary, connect the connector all the way in. Punch PWB (YC1) and DF main PWB (YC7) (4000-sheet finisher) Punch PWB (YC1) and DF main PWB (YC8) (1000-sheet finisher)</li> <li>2. Replace the punch PWB.</li> </ol>
		DF main PWB	Replace the DF main PWB (Refer to the service manual for the document finisher).

Code	Contents	Related parts	Check procedures/ corrective measures
8090	<b>DF paddle motor error</b> When the DF paddle motor is driven, DF paddle sensor does not turn on within 1 s.	DF paddle motor	<ol style="list-style-type: none"> <li>1. Execute U240 Motor - Beat to check the finisher operation (see page 1-3-113).</li> <li>2. Check that the paddle can rotate.</li> <li>3. Check that the drive from the motor reaches the paddle.</li> <li>4. Confirm that the wiring connector is firmly connected and, if necessary, connect the connector all the way in. DF paddle motor and DF main PWB (YC15) (4000-sheet finisher) DF paddle motor and DF main PWB (YC11) (1000-sheet finisher)</li> <li>5. If the wiring is disconnected, shorted or grounded, replace the wiring.</li> <li>6. Replace the DF paddle motor.</li> </ol>
		DF paddle sensor	<ol style="list-style-type: none"> <li>1. Execute U241 Finisher - Bundle Eject HP to check the finisher switch (see page 1-3-115).</li> <li>2. Check that the sensor and its mounting bracket are correctly positioned.</li> <li>3. Confirm that the wiring connector is firmly connected and, if necessary, connect the connector all the way in. DF paddle sensor and DF main PWB (YC22) (4000-sheet finisher) DF paddle sensor and DF main PWB (YC20) (1000-sheet finisher)</li> <li>4. Replace the DF paddle sensor.</li> </ol>
		DF main PWB	Replace the DF main PWB (Refer to the service manual for the document finisher).

Code	Contents	Related parts	Check procedures/ corrective measures
8100	<b>DF eject release motor error</b> When the DF eject release motor is driven, DF bundle discharge sensor does not turn on within 1 s.	DF eject release motor DF bundle discharge unit sensor	<ol style="list-style-type: none"> <li>1. Execute U240 Motor - Eject Unlock (Full) to check the finisher operation (see page 1-3-113).</li> <li>2. Check that the eject guide of the process tray is opened and, if not, correct the guide.</li> <li>3. Check that the drive from the motor reaches the eject guide.</li> <li>4. Confirm that the wiring connector is firmly connected and, if necessary, connect the connector all the way in. DF bundle discharge unit sensor and DF main PWB (YC22)(4000-sheet finisher) DF bundle discharge unit sensor and DF main PWB (YC20)(1000-sheet finisher)</li> <li>5. If the wiring is disconnected, shorted or grounded, replace the wiring.</li> <li>6. Replace the DF eject release motor.</li> </ol>
		DF bundle discharge unit sensor	<ol style="list-style-type: none"> <li>1. Execute U241 Finisher - Bundle Eject HP to check the finisher switch (see page 1-3-115).</li> <li>2. Check that the sensor and its mounting bracket are correctly positioned.</li> <li>3. Confirm that the wiring connector is firmly connected and, if necessary, connect the connector all the way in. DF bundle discharge unit sensor and DF main PWB (YC22)(4000-sheet finisher) DF bundle discharge unit sensor and DF main PWB (YC20)(1000-sheet finisher)</li> <li>4. Replace the DF bundle eject unit sensor.</li> </ol>
		DF main PWB	Replace the DF main PWB (Refer to the service manual for the document finisher).

Code	Contents	Related parts	Check procedures/ corrective measures
8110	<b>DF shift motor 1 error</b> (4000-sheet finisher) DF shift sensor 1 won't turn on when it has travelled 160 mm after DF shift motor 1 is driven.	DF shift motor 1 [front]	<ol style="list-style-type: none"> <li>1. Execute U240 Motor - Sort Test to check the finisher operation (see page 1-3-113).</li> <li>2. Manipulate the front shift guide back and forth to check it is smoothly operable.</li> <li>3. Check that the drive from the motor reaches the front shift guide.</li> <li>4. Confirm that the wiring connector is firmly connected and, if necessary, connect the connector all the way in. DF shift motor 1[front] and DF main PWB (YC14)</li> <li>5. If the wiring is disconnected, shorted or grounded, replace the wiring.</li> <li>6. Replace the DF shift motor 1 [front].</li> </ol>
		DF shift sensor 1 [front]	<ol style="list-style-type: none"> <li>1. Execute U241 Finisher - Shift Front HP to check the finisher switch (see page 1-3-115).</li> <li>2. Check that the sensor and its mounting bracket are correctly positioned.</li> <li>3. Confirm that the wiring connector is firmly connected and, if necessary, connect the connector all the way in. DF shift sensor 1[front] and DF main PWB (YC23)</li> <li>4. Replace the DF shift sensor 1 [front].</li> </ol>
		DF main PWB	Replace the DF main PWB (Refer to the service manual for the document finisher).

Code	Contents	Related parts	Check procedures/ corrective measures
8120	<b>DF shift motor 2 error</b> (4000-sheet finisher) DF shift sensor 2 won't turn on when it has travelled 160 mm after DF shift motor 2 is driven.	DF shift motor 2 [rear]	<ol style="list-style-type: none"> <li>1. Execute U240 Motor - Sort Test to check the finisher operation (see page 1-3-113).</li> <li>2. Manipulate the rear shift guide back and forth to check it is smoothly operable.</li> <li>3. Check that the drive from the motor reaches the rear shift guide.</li> <li>4. Confirm that the wiring connector is firmly connected and, if necessary, connect the connector all the way in. DF shift motor 2 [rear] and DF main PWB (YC14)</li> <li>5. If the wiring is disconnected, shorted or grounded, replace the wiring.</li> <li>6. Replace the DF shift motor 2 [rear].</li> </ol>
		DF shift sensor 2 [rear]	<ol style="list-style-type: none"> <li>1. Execute U241 Finisher - Shift Tail HP to check the finisher switch (see page 1-3-115).</li> <li>2. Check that the sensor and its mounting bracket are correctly positioned.</li> <li>3. Confirm that the wiring connector is firmly connected and, if necessary, connect the connector all the way in. DF shift sensor 2 [rear] and DF main PWB (YC23)</li> <li>4. Replace the DF shift set sensor2 [rear].</li> </ol>
		DF main PWB	Replace the DF main PWB (Refer to the service manual for the document finisher).



Code	Contents	Related parts	Check procedures/ corrective measures
8130	<b>DF shift release motor error</b> (4000-sheet finisher) When the DF shift release motor is driven, DF shift release sensor does not turn on within 1 s.	DF shift release motor	<ol style="list-style-type: none"> <li>1. Check that cancelling the maintenance mode after executing U240 Motor - Sort for the finisher operation check lets the rear and forth cursors return to the home position (see page 1-3-113).</li> <li>2. Manipulate the front and rear shift guide to check it is smoothly operable.</li> <li>3. Check that the drive from the motor reaches the shift guide front and rear.</li> <li>4. Confirm that the wiring connector is firmly connected and, if necessary, connect the connector all the way in. DF shift release motor and DF main PWB (YC14)</li> <li>5. If the wiring is disconnected, shorted or grounded, replace the wiring.</li> <li>6. Replace the DF shift release motor.</li> </ol>
		DF shift release sensor	<ol style="list-style-type: none"> <li>1. Execute U241 Finisher - Shift Unlock HP to check the finisher switch (see page 1-3-115).</li> <li>2. Check that the sensor and its mounting bracket are correctly positioned.</li> <li>3. Confirm that the wiring connector is firmly connected and, if necessary, connect the connector all the way in. DF shift release sensor and DF main PWB (YC23)</li> <li>4. Replace the DF shift release sensor.</li> </ol>
		DF main PWB	Replace the DF main PWB (Refer to the service manual for the document finisher).

Code	Contents	Related parts	Check procedures/ corrective measures
8140	<b>DF tray error 1</b> When the main tray has ascended, DF tray sensor 1 or DF tray upper surface sensor does not turn on within 20 s.	DF tray motor	<ol style="list-style-type: none"> <li>1. Execute U240 Motor - Tray to check the finisher operation (see page 1-3-113).</li> <li>2. Manipulate the main tray up and down to check it is smoothly operable.</li> <li>3. Check that the drive from the motor reaches the main tray.</li> <li>4. Confirm that the wiring connector is firmly connected and, if necessary, connect the connector all the way in. DF tray motor and DF Main PWB(YC16) (4000-sheet finisher) DF tray motor and DF Main PWB(YC14) (1000-sheet finisher)</li> <li>5. If the wiring is disconnected, shorted or grounded, replace the wiring.</li> <li>6. Replace the DF tray motor.</li> </ol>
		DF tray sensor 1 DF tray upper surface sensor	<ol style="list-style-type: none"> <li>1. Execute U241 Finisher - Tray U-Limit, Tray Top to check the finisher switch (see page 1-3-115).</li> <li>2. Check that the sensor and its mounting bracket are correctly positioned.</li> <li>3. Confirm that the wiring connector is firmly connected and, if necessary, connect the connector all the way in. DF tray sensor 1 and DF Main PWB(YC22) (4000-sheet finisher) DF tray upper surface sensor and DF Main PWB(YC21, YC13) (4000-sheet finisher) DF tray sensor 1 and DF main PWB (YC20) (1000-sheet finisher) DF tray upper surface sensor and DF main PWB (YC18) (1000-sheet finisher)</li> <li>4. Replace the DF tray sensor 1 or DF tray upper surface sensor.</li> </ol>
		DF main PWB	Replace the DF main PWB (Refer to the service manual for the document finisher).

Code	Contents	Related parts	Check procedures/ corrective measures
8150	<b>DF tray error 2</b> When the main tray has descended, DF tray sensor 1 or DF tray upper surface sensor does not turn off within 5 s.	DF tray motor	<ol style="list-style-type: none"> <li>1. Execute U240 Motor - Tray to check the finisher operation (see page 1-3-113).</li> <li>2. Manipulate the main tray up and down to check it is smoothly operable.</li> <li>3. Check that the drive from the motor reaches the main tray.</li> <li>4. Confirm that the wiring connector is firmly connected and, if necessary, connect the connector all the way in. DF tray motor and DF main PWB (YC16) (4000-sheet finisher) DF tray motor and DF main PWB (YC14) (1000-sheet finisher)</li> <li>5. If the wiring is disconnected, shorted or grounded, replace the wiring.</li> <li>6. Replace the DF tray motor.</li> </ol>
		DF tray sensor 1 DF tray upper surface sensor	<ol style="list-style-type: none"> <li>1. Execute U241 Finisher - Tray U-Limit, Tray Top to check the finisher switch (see page 1-3-115).</li> <li>2. Check that the sensor and its mounting bracket are correctly positioned.</li> <li>3. Confirm that the wiring connector is firmly connected and, if necessary, connect the connector all the way in. DF tray sensor 1 and DF main PWB (YC22) (4000-sheet finisher) DF tray upper surface sensor and DF main PWB (YC21, YC13) (4000-sheet finisher) DF tray sensor 1 and DF main PWB (YC20) (1000-sheet finisher) DF tray upper surface sensor and DF main PWB (YC18) (1000-sheet finisher)</li> <li>4. Replace the DF tray sensor 1 or DF tray upper surface sensor.</li> </ol>
		DF main PWB	Replace the DF main PWB (Refer to the service manual for the document finisher).

Code	Contents	Related parts	Check procedures/ corrective measures
8160	<b>DF tray error 3</b> When the main tray has descended, DF tray sensor 4 does not turn on within 20 s.	DF tray motor	<ol style="list-style-type: none"> <li>1. Execute U240 Motor - Tray to check the finisher operation (see page 1-3-113).</li> <li>2. Manipulate the main tray up and down to check it is smoothly operable.</li> <li>3. Check that the drive from the motor reaches the main tray.</li> <li>4. Confirm that the wiring connector is firmly connected and, if necessary, connect the connector all the way in. DF tray motor and DF main PWB (YC16) (4000-sheet finisher) DF tray motor and DF main PWB (YC14) (1000-sheet finisher)</li> <li>5. If the wiring is disconnected, shorted or grounded, replace the wiring.</li> <li>6. Replace the DF tray motor.</li> </ol>
		DF tray sensor 4	<ol style="list-style-type: none"> <li>1. Execute U241 Finisher - Tray Middle to check the finisher switch (see page 1-3-115).</li> <li>2. Check that the sensor and its mounting bracket are correctly positioned.</li> <li>3. Confirm that the wiring connector is firmly connected and, if necessary, connect the connector all the way in. DF tray sensor 4 and DF main PWB (YC23) (4000-sheet finisher) DF tray sensor 4 and DF main PWB (YC20) (1000-sheet finisher)</li> <li>4. Replace the DF tray sensor 4.</li> </ol>
		DF main PWB	Replace the DF main PWB (Refer to the service manual for the document finisher).

Code	Contents	Related parts	Check procedures/ corrective measures
8170	<b>DF side registration motor 1 error 1</b> When initial operation, DF side registration sensor 1 does not turn on within 3 s.	DF side registration motor 1	<ol style="list-style-type: none"> <li>1. Execute U240 Motor - Width Test to check the finisher operation (see page 1-3-113).</li> <li>2. Manipulate the front side registration guide to check it is smoothly operable.</li> <li>3. Check that the drive from the motor reaches the front side registration guide.</li> <li>4. Confirm that the wiring connector is firmly connected and, if necessary, connect the connector all the way in. DF side registration motor 1 and DF main PWB (YC15) (4000-sheet finisher) DF side registration motor 1 and DF main PWB (YC11) (1000-sheet finisher)</li> <li>5. If the wiring is disconnected, shorted or grounded, replace the wiring.</li> <li>6. Replace the DF side registration motor 1.</li> </ol>
		DF side registration sensor 1	<ol style="list-style-type: none"> <li>1. Execute U241 Finisher - Width Front to check the finisher switch (see page 1-3-115).</li> <li>2. Check that the sensor and its mounting bracket are correctly positioned.</li> <li>3. Confirm that the wiring connector is firmly connected and, if necessary, connect the connector all the way in. DF side registration sensor 1. and DF main PWB (YC22) (4000-sheet finisher) DF side registration sensor 1. and DF main PWB (YC20) (1000-sheet finisher)</li> <li>4. Replace the DF side registration sensor 1.</li> </ol>
		DF main PWB	Replace the DF main PWB (Refer to the service manual for the document finisher).

Code	Contents	Related parts	Check procedures/ corrective measures
8180	<b>DF side registration motor 1 error 2</b> JAM6810 ( jam in front of width alignment) is detected twice.	DF side registration motor 1	<ol style="list-style-type: none"> <li>1. Execute U240 Motor - Width Test to check the finisher operation (see page 1-3-113).</li> <li>2. Manipulate the front side registration guide back and forth to check it is smoothly operable.</li> <li>3. Check that the drive from the motor reaches the front side registration guide.</li> <li>4. Confirm that the wiring connector is firmly connected and, if necessary, connect the connector all the way in. DF side registration motor 1 and DF main PWB (YC15) (4000-sheet finisher) DF side registration motor 1 and DF main PWB (YC11) (1000-sheet finisher)</li> <li>5. If the wiring is disconnected, shorted or grounded, replace the wiring.</li> <li>6. Replace the DF side registration motor 1.</li> </ol>
		DF side registration sensor 1.	<ol style="list-style-type: none"> <li>1. Execute U241 Finisher - Width Front to check the finisher switch (see page 1-3-115).</li> <li>2. Check that the sensor and its mounting bracket are correctly positioned.</li> <li>3. Confirm that the wiring connector is firmly connected and, if necessary, connect the connector all the way in. DF side registration sensor 1. and DF main PWB (YC22) (4000-sheet finisher) DF side registration sensor 1. and DF main PWB (YC20) (1000-sheet finisher)</li> <li>4. If the wiring is disconnected, shorted or grounded, replace the wiring.</li> <li>5. Replace the DF side registration sensor 1.</li> </ol>
		DF main PWB	Replace the DF main PWB (Refer to the service manual for the document finisher).

Code	Contents	Related parts	Check procedures/ corrective measures
8190	<b>DF side registration motor 2 error 1</b> When initial operation, DF side registration sensor 2 does not turn on within 3 s.	DF side registration motor 2	<ol style="list-style-type: none"> <li>1. Execute U240 Motor - Width Test to check the finisher operation (see page 1-3-113).</li> <li>2. Manipulate the rear side registration guide back and forth to check it is smoothly operable.</li> <li>3. Check that the drive from the motor reaches the rear side registration guide.</li> <li>4. Confirm that the wiring connector is firmly connected and, if necessary, connect the connector all the way in. DF side registration motor 2 and DF main PWB (YC15) (4000-sheet finisher) DF side registration motor 2 and DF main PWB (YC11) (1000-sheet finisher)</li> <li>5. If the wiring is disconnected, shorted or grounded, replace the wiring.</li> <li>6. Replace the DF side registration motor 2.</li> </ol>
		DF side registration sensor 2	<ol style="list-style-type: none"> <li>1. Execute U241 Finisher - Width tail HP to check the finisher switch (see page 1-3-115).</li> <li>2. Check that the sensor and its mounting bracket are correctly positioned.</li> <li>3. Confirm that the wiring connector is firmly connected and, if necessary, connect the connector all the way in. DF side registration sensor 2 and DF main PWB (YC22) (4000-sheet finisher) DF side registration sensor 2 and DF main PWB (YC20) (1000-sheet finisher)</li> <li>4. Replace the DF side registration sensor 2.</li> </ol>
		DF main PWB	Replace the DF main PWB (Refer to the service manual for the document finisher).

Code	Contents	Related parts	Check procedures/ corrective measures
8200	<b>DF side registration motor 2 error 2</b> JAM6910 (jam in rear of width alignment) is detected twice.	DF side registration motor 2	<ol style="list-style-type: none"> <li>1. Execute U240 Motor - Width Test to check the finisher operation (see page 1-3-113).</li> <li>2. Manipulate the rear side registration guide back and forth to check it is smoothly operable.</li> <li>3. Check that the drive from the motor reaches the rear side registration guide.</li> <li>4. Confirm that the wiring connector is firmly connected and, if necessary, connect the connector all the way in. DF side registration motor 2 and DF main PWB (YC15) (4000-sheet finisher) DF side registration motor 2 and DF main PWB (YC11) (1000-sheet finisher)</li> <li>5. If the wiring is disconnected, shorted or grounded, replace the wiring.</li> <li>6. Replace the DF side registration motor 2.</li> </ol>
		DF side registration sensor 2	<ol style="list-style-type: none"> <li>1. Execute U241 Finisher - Width tail HP to check the finisher switch (see page 1-3-115).</li> <li>2. Check that the sensor and its mounting bracket are correctly positioned.</li> <li>3. Confirm that the wiring connector is firmly connected and, if necessary, connect the connector all the way in. DF side registration sensor 2 and DF main PWB (YC22) (4000-sheet finisher) DF side registration sensor 2 and DF main PWB (YC20) (1000-sheet finisher)</li> <li>4. Replace the DF side registration sensor 2.</li> </ol>
		DF main PWB	Replace the DF main PWB (Refer to the service manual for the document finisher).



Code	Contents	Related parts	Check procedures/ corrective measures
8210	<b>DF slide motor error</b> When initial operation, DF staple sensor does not turn on within 3 s.	DF slide motor	<ol style="list-style-type: none"> <li>1. Execute U240 Motor - Staple Move to check the finisher operation (see page 1-3-113).</li> <li>2. Manipulate the staple unit back and forth to check it is smoothly operable.</li> <li>3. Check that the drive from the motor reaches the staple unit.</li> <li>4. Confirm that the wiring connector is firmly connected and, if necessary, connect the connector all the way in. DF slide motor and DF main PWB (YC12) (4000-sheet finisher) DF slide motor and DF main PWB (YC10) (1000-sheet finisher)</li> <li>5. If the wiring is disconnected, shorted or grounded, replace the wiring.</li> <li>6. Replace the DF slide motor.</li> </ol>
		DF staple sensor	<ol style="list-style-type: none"> <li>1. Execute U241 Finisher - Width Staple HP to check the finisher switch (see page 1-3-115).</li> <li>2. Check that the sensor and its mounting bracket are correctly positioned.</li> <li>3. Confirm that the wiring connector is firmly connected and, if necessary, connect the connector all the way in. DF staple sensor and DF main PWB (YC22) (4000-sheet finisher) DF staple sensor and DF main PWB (YC20) (1000-sheet finisher)</li> <li>4. If the wiring is disconnected, shorted or grounded, replace the wiring.</li> <li>5. Replace the DF staple sensor.</li> </ol>
		DF main PWB	Replace the DF main PWB (Refer to the service manual for the document finisher).

Code	Contents	Related parts	Check procedures/ corrective measures
8230	<b>DF staple motor error 1</b> Staple JAM (DF) has been detected twice in a row. (The second JAM detection condition fulfilled with the home position did not detected in 600 ms after the motor was driven.)	DF staple motor	1. Remove the staple unit and check that stapling is possible without a jam. 2. Confirm that the FFC wiring connector is not distorted and connect the FFC wiring all the way in. Staple unit and DF main PWB (YC17) (4000-sheet finisher) Staple unit and DF main PWB (YC11) (1000-sheet finisher) 3. If the wiring is disconnected, shorted or grounded, replace the wiring. 4. Replace the staple unit. (Refer to the service manual for the document finisher).
		DF staple sensor	Replace the staple unit.
		DF main PWB	Replace the DF main PWB (Refer to the service manual for the document finisher).
8240	<b>DF staple motor error 2</b> Staple JAM (DF) has been detected twice in a row. (The second JAM detection condition fulfilled with a lock detection signal maintained 1 V for 500 ms continuously, while the stapler motor was driven.)	DF staple motor	1. Remove the staple unit and check that stapling is possible without a jam. 2. Confirm that the FFC wiring connector is not distorted and connect the FFC wiring all the way in. Staple unit and DF main PWB (YC17) (4000-sheet finisher) Staple unit and DF main PWB (YC11) (1000-sheet finisher) 3. If the wiring is disconnected, shorted or grounded, replace the wiring. 4. Replace the staple unit. (Refer to the service manual for the document finisher).
		DF main PWB	Replace the DF main PWB (Refer to the service manual for the document finisher).

Code	Contents	Related parts	Check procedures/ corrective measures
8300	<b>CF unit communication error</b> (4000-sheet finisher) Communication with the center-folding unit is not possible.	CF unit set switch	<ol style="list-style-type: none"> <li>1. Execute U241 Booklet - Set to check the finisher switch (see page 1-3-115).</li> <li>2. Check that the switch and its mounting bracket are correctly positioned.</li> <li>3. Confirm that the wiring connector is firmly connected and, if necessary, connect the connector all the way in. CF main PWB (YC7) and DF main PWB (YC9)</li> <li>4. If the wiring is disconnected, shorted or grounded, replace the wiring.</li> <li>5. Replace the CF unit set switch.</li> </ol>
		CF main PWB	Replace the CF main PWB
		DF main PWB	Replace the DF main PWB (Refer to the service manual for the document finisher).
8310	<b>CF side registration motor 2 error</b> (4000-sheet finisher) When initial operation, CF side registration sensor 2 does not turn on within 1 s.	CF side registration motor 2	<ol style="list-style-type: none"> <li>1. Execute U240 Booklet - Width Test to check finisher operation check (see page 1-3-113).</li> <li>2. Manipulate the side registration upper guide back and forth to check it can smoothly move back and forth.</li> <li>3. Check that the drive from the motor reaches the side registration upper guide.</li> <li>4. Confirm that the wiring connector is firmly connected and, if necessary, connect the connector all the way in. CF side registration motor 2 and CF main PWB (YC10)</li> <li>5. If the wiring is disconnected, shorted or grounded, replace the wiring.</li> <li>6. Replace the CF side registration motor.</li> </ol>
		CF side registration sensor 2	<ol style="list-style-type: none"> <li>1. Execute U241 Booklet - Width Up HP to check the finisher switch (see page 1-3-115).</li> <li>2. Check that the sensor and its mounting bracket are correctly positioned.</li> <li>3. Confirm that the wiring connector is firmly connected and, if necessary, connect the connector all the way in. CF side registration sensor 2 and CF main PWB (YC20)</li> <li>4. Replace the CF side registration sensor 2.</li> </ol>
		CF main PWB	Replace the CF main PWB

Code	Contents	Related parts	Check procedures/ corrective measures
8320	<b>CF adjustment motor error</b> (4000-sheet finisher) When initial operation, CF adjustment sensor does not turn on within 2.5 s.	CF adjustment motor1,2	<ol style="list-style-type: none"> <li>1. Execute U240 Booklet - Bundle Up / Down to check the finisher operation (see page 1-3-113).</li> <li>2. Manipulate the fold moving belt up and down to check it is smoothly operable.</li> <li>3. Check that the drive from the motor reaches the fold moving belt. (Check if the belt is bent.)</li> <li>4. Confirm that the wiring connector is firmly connected and, if necessary, connect the connector all the way in. CF adjustment motor 1,2 and CF main PWB (YC10)</li> <li>5. If the wiring is disconnected, shorted or grounded, replace the wiring.</li> <li>6. Replace the CF adjustment motor1,2.</li> </ol>
		CF adjustment sensor1,2	<ol style="list-style-type: none"> <li>1. Execute U241 Booklet - bundle Up / Down HP to check the finisher switch (see page 1-3-115).</li> <li>2. Check that the sensor and its mounting bracket are correctly positioned.</li> <li>3. Confirm that the wiring connector is firmly connected and, if necessary, connect the connector all the way in. CF adjustment sensor 1,2 and CF main PWB (YC20)</li> <li>4. Replace the CF adjustment sensor1,2.</li> </ol>
		CF main PWB	Replace the CF main PWB.

Code	Contents	Related parts	Check procedures/ corrective measures
<b>8330</b> <b>CF blade motor error</b> (4000-sheet finisher) When initial operation, CF blade sensor does not turn on within 1500 ms.		CF blade motor	<ol style="list-style-type: none"> <li>1. Execute U240 Booklet - Blade to check the finisher operation (see page 1-3-113).</li> <li>2. Manipulate the fold blade up and down to check it is smoothly operable.</li> <li>3. Check that the drive from the motor reaches the fold blade.</li> <li>4. Confirm that the wiring connector is firmly connected and, if necessary, connect the connector all the way in. CF blade motor and CF main PWB (YC15)</li> <li>5. If the wiring is disconnected, shorted or grounded, replace the wiring.</li> <li>6. Replace the CF blade motor.</li> </ol>
		CF blade sensor	<ol style="list-style-type: none"> <li>1. Execute U241 Booklet - Blade HP to check the finisher switch (see page 1-3-115).</li> <li>2. Check that the sensor and its mounting bracket are correctly positioned.</li> <li>3. Confirm that the wiring connector is firmly connected and, if necessary, connect the connector all the way in. CF blade sensor and CF main PWB (YC20)</li> <li>4. Replace the CF blade sensor.</li> </ol>
		CF main PWB	Replace the CF main PWB
<b>8340</b> <b>CF staple motor error 1</b> (4000-sheet finisher) Staple JAM (center-folding unit) has been detected twice in a row. (The second JAM detection condition fulfilled with the home position did not detected in 600 ms after the motor was driven.)		CF staple motor	<ol style="list-style-type: none"> <li>1. Execute U240 Booklet - Staple to check the finisher operation (see page 1-3-113).</li> <li>2. Manipulate the staple up and down check it is smoothly operable.</li> <li>3. Check that the drive from the motor reaches the staple unit.</li> <li>4. Confirm that the wiring connector is firmly connected and, if necessary, connect the connector all the way in. CF staple unit and CF main PWB (YC13)</li> <li>5. If the wiring is disconnected, shorted or grounded, replace the wiring.</li> <li>6. Replace the CF staple motor.</li> </ol>
		CF staple sensor	Replace the CF staple unit.
		CF main PWB	Replace the CF main PWB.

Code	Contents	Related parts	Check procedures/ corrective measures
8350	<b>CF side registration motor 1 error</b> (4000-sheet finisher) When initial operation, CF side registration sensor 1 does not turn on within 1 s.	CF side registration motor 1	<ol style="list-style-type: none"> <li>1. Execute U240 Booklet - Width Test to check the finisher operation (see page 1-3-113).</li> <li>2. Manipulate the side registration lower guide back and forth to check it can smoothly operable.</li> <li>3. Check that the drive from the motor reaches the side registration lower guide.</li> <li>4. Confirm that the wiring connector is firmly connected and, if necessary, connect the connector all the way in. CF side registration motor 1 and CF main PWB (YC10)</li> <li>5. If the wiring is disconnected, shorted or grounded, replace the wiring.</li> <li>6. Replace the CF side registration motor 1.</li> </ol>
		CF side registration sensor 1	<ol style="list-style-type: none"> <li>1. Execute U241 Booklet - Width Down HP to check the finisher switch (see page 1-3-115).</li> <li>2. Check that the sensor and its mounting bracket are correctly positioned.</li> <li>3. Confirm that the wiring connector is firmly connected and, if necessary, connect the connector all the way in. CF side registration sensor 1 and CF main PWB (YC20)</li> <li>4. Replace the CF side registration sensor 1.</li> </ol>
		CF main PWB	Replace the CF main PWB

Code	Contents	Related parts	Check procedures/ corrective measures
8360	<p><b>CF main motor error</b> (4000-sheet finisher) During driving the motor, the lock signal is detected for 1 s continuously.</p>	CF main motor	<ol style="list-style-type: none"> <li>1. Execute U240 Booklet - Folding to check the finisher operation (see page 1-3-113).</li> <li>2. Manipulate the conveying roller to check it can smoothly rotate.</li> <li>3. Check that the drive from the motor reaches the conveying roller.</li> <li>4. Confirm that the wiring connector is firmly connected and, if necessary, connect the connector all the way in. CF main motor and CF main PWB (YC16)</li> <li>5. If the wiring is disconnected, shorted or grounded, replace the wiring.</li> <li>6. Replace the CF main motor.</li> </ol>
		CF main PWB	Replace the CF main PWB

Code	Contents	Related parts	Check procedures/ corrective measures
8410	<b>Punch slide motor error 1</b> The punch slide sensor won't turn On when home position has been moved by 30 mm.	Punch slide motor	<ol style="list-style-type: none"> <li>1. Execute U240 Booklet - Punch Move to check the finisher operation (see page 1-3-113).</li> <li>2. Manipulate the punch slide part of the punch unit back and forth to check it can smoothly move.</li> <li>3. Check that the drive from the motor reaches punch part.</li> <li>4. Confirm that the wiring connector is firmly connected and, if necessary, connect the connector all the way in. Punch slide motor and Punch PWB (YC3)</li> <li>5. If the wiring is disconnected, shorted or grounded, replace the wiring.</li> <li>6. Replace the punch slide motor.</li> </ol>
		Punch slide sensor	<ol style="list-style-type: none"> <li>1. Execute U241 Punch - Punch HP to check the finisher switch (see page 1-3-115).</li> <li>2. Check that the sensor and its mounting bracket are correctly positioned.</li> <li>3. Confirm that the wiring connector is firmly connected and, if necessary, connect the connector all the way in. Punch slide sensor and Punch PWB (YC6)</li> <li>4. Replace the punch slide sensor.</li> </ol>
		Punch PWB	<ol style="list-style-type: none"> <li>1. Confirm that the wiring connector is firmly connected and, if necessary, connect the connector all the way in. Punch PWB (YC1) and DF main PWB (YC7) (4000-sheet finisher) Punch PWB (YC1) and DF main PWB (YC8) (1000-sheet finisher)</li> <li>2. Replace the punch PWB.</li> </ol>
		DF main PWB	Replace the DF main PWB



Code	Contents	Related parts	Check procedures/ corrective measures
8420	<b>Punch slide motor error 2</b> In detection of paper edges, the paper edge cannot be detected in 30 mm move.	Punch slide motor	<ol style="list-style-type: none"> <li>1. Execute U240 Booklet - Punch Move to check the finisher operation (see page 1-3-113).</li> <li>2. Manipulate the punch slide part of the punch unit back and forth to check it can smoothly move.</li> <li>3. Check that the drive from the motor reaches punch part.</li> <li>4. Confirm that the wiring connector is firmly connected and, if necessary, connect the connector all the way in. Punch slide motor and Punch PWB (YC3)</li> <li>5. If the wiring is disconnected, shorted or grounded, replace the wiring.</li> <li>6. Replace the punch slide motor.</li> </ol>
		Punch paper edge sensor 1,2	<ol style="list-style-type: none"> <li>1. Execute U241 Punch - Edge Face 1,2,3,4 to check the finisher switch (see page 1-3-115).</li> <li>2. Check that the sensor and its mounting bracket are correctly positioned.</li> <li>3. Confirm that the wiring connector is firmly connected and, if necessary, connect the connector all the way in. Punch paper edge sensor 1,2 and Punch PWB (YC5,YC7)</li> <li>4. Replace the punch paper edge sensor 1,2.</li> </ol>
		Punch PWB	<ol style="list-style-type: none"> <li>1. Confirm that the wiring connector is firmly connected and, if necessary, connect the connector all the way in. Punch PWB (YC1) and DF main PWB (YC7) (4000-sheet finisher) Punch PWB (YC1) and DF main PWB (YC8) (1000-sheet finisher)</li> <li>2. Replace the Punch PWB.</li> </ol>
		DF main PWB	Replace the DF main PWB

Code	Contents	Related parts	Check procedures/ corrective measures
8430	<b>Punch unit communication error</b> Communication with the punch unit is not possible.	Punch PWB	<ol style="list-style-type: none"> <li>1. Confirm that the wiring connector is firmly connected and, if necessary, connect the connector all the way in. Punch PWB (YC1) and DF main PWB (YC7) (4000-sheet finisher) Punch PWB (YC1) and DF main PWB (YC8) (1000-sheet finisher)</li> <li>2. If the wiring is disconnected, shorted or grounded, replace the wiring.</li> <li>3. Replace the Punch PWB.</li> </ol>
		DF main PWB	Replace the DF main PWB
8500	<b>Mailbox communication error</b> (4000-sheet finisher) Communication failed to be established after the mailbox was hooked up.	MB main PWB	<ol style="list-style-type: none"> <li>1. Turn the main power switch off and after 5 seconds, turn it on.</li> <li>2. Confirm that the wiring connector is firmly connected and, if necessary, connect the connector all the way in. MB main PWB (YC3) and DF main PWB (YC6)</li> <li>3. If the wiring is disconnected, shorted or grounded, replace the wiring.</li> <li>4. Replace the MB main PWB</li> </ol>
		DF main PWB	Replace the DF main PWB
8510	<b>MB conveying motor error 1</b> (4000-sheet finisher) When initial operation, MB home position sensor does not turn on within 5 s.	MB conveying motor	<ol style="list-style-type: none"> <li>1. If the transfer roller won't rotate smoothly, repair its mechanism.</li> <li>2. Confirm that the wiring connector is firmly connected and, if necessary, connect the connector all the way in. MB conveying motor and MB main PWB (YC5)</li> <li>3. If the wiring is disconnected, shorted or grounded, replace the wiring.</li> <li>4. Replace the MB conveying motor.</li> </ol>
		MB home position sensor	<ol style="list-style-type: none"> <li>1. Execute U241 Mail Box - Motor HP to check the finisher switch (see page 1-3-115).</li> <li>2. Check that the sensor and its mounting bracket are correctly positioned.</li> <li>3. Confirm that the wiring connector is firmly connected and, if necessary, connect the connector all the way in. MB home position sensor and MB main PWB (YC2)</li> <li>4. Replace the MB home position sensor.</li> </ol>
		MB main PWB	Replace the MB main PWB

Code	Contents	Related parts	Check procedures/ corrective measures
8520	<b>MB conveying motor error 2</b> (4000-sheet finisher) When standby operation, MB home position sensor does not turn off within 1 s.	MB conveying motor	<ol style="list-style-type: none"> <li>1. Execute Mail Box - Conv of U240 finisher operation check (see page 1-3-113).</li> <li>2. Manipulate the conveying roller of the mailbox to check it can smoothly rotate.</li> <li>3. Check that the drive from the motor reaches the conveying roller.</li> <li>4. Confirm that the wiring connector is firmly connected and, if necessary, connect the connector all the way in. MB conveying motor and MB main PWB (YC5)</li> <li>5. If the wiring is disconnected, shorted or grounded, replace the wiring.</li> <li>6. Replace the MB conveying motor.</li> </ol>
		MB home position sensor	<ol style="list-style-type: none"> <li>1. Execute U241 Mail Box - Motor HP to check the finisher switch (see page 1-3-115).</li> <li>2. Check that the sensor and its mounting bracket are correctly positioned.</li> <li>3. Confirm that the wiring connector is firmly connected and, if necessary, connect the connector all the way in. MB home position sensor and MB main PWB (YC2)</li> <li>4. Replace the MB home position sensor.</li> </ol>
		MB main PWB	Replace the MB main PWB

Code	Contents	Related parts	Check procedures/ corrective measures
8800	<b>Document finisher main program error</b> Document finisher main program error at power up.	DF main PWB	1. Confirm that the wiring connector is firmly connected and, if necessary, connect the connector all the way in. DF main PWB (YC4) and Engine PWB (YC18) (4000-sheet finisher) DF main PWB (YC7) and Engine PWB (YC18) (1000-sheet finisher) 2. If the wiring is disconnected, shorted or grounded, replace the wiring. 3. Replace the DF main PWB
		Engine PWB	1. Check the engine software and upgrade to the latest, if necessary. 2. Replace the engine PWB (see page 1-5-67).
8900	<b>Document finisher backup error</b> Read and write data does not match 3 times in succession.	DF main PWB	1. Confirm that the wiring connector is firmly connected and, if necessary, connect the connector all the way in. DF main PWB (YC4) and Engine PWB (YC18) (4000-sheet finisher) DF main PWB (YC7) and Engine PWB (YC18) (1000-sheet finisher) 2. If the wiring is disconnected, shorted or grounded, replace the wiring. 3. Replace the DF main PWB
8930	<b>Center-folding unit backup error</b> (4000-sheet finisher) Read and write data does not match 3 times in succession.	CF main PWB	1. Confirm that the wiring connector is firmly connected and, if necessary, connect the connector all the way in. CF main PWB (YC7) and DF main PWB (YC9) 2. If the wiring is disconnected, shorted or grounded, replace the wiring. 3. Install the EEPROM properly. 4. Replace the CF main PWB

Code	Contents	Related parts	Check procedures/ corrective measures
9000	<b>Document processor communication error</b> Communication with the document processor is not possible.	DP main PWB	1. Check that the versions of the main unit firmware and the DP firmware are identical. 2. Confirm that the wiring connector is firmly connected and, if necessary, connect the connector all the way in. DP main PWB(YC1) and ISC PWB(YC12) ISC PWB (YC3) and Main PWB (YC11) 3. If the wiring is disconnected, shorted or grounded, replace the wiring. 4. Replace the DP main PWB
		ISC PWB	Replace the ISC PWB.
9010	<b>Coin vender communication error</b> A communication error from coin vender is detected 10 times in succession.	U206 setting	Set maintenance mode U206 to off when a coin vender is not installed (see page 1-3-102).
		Coin vender control PWB	1. Confirm that the wiring connector is firmly connected and, if necessary, connect the connector all the way in. Coin vender control PWB and Engine PWB (YC23) 2. If the wiring is disconnected, shorted or grounded, replace the wiring. 3. Replace the Coin vender control PWB.
		Engine PWB	1. Check the engine software and upgrade to the latest, if necessary. 2. Replace the engine PWB (see page 1-5-67).

Code	Contents	Related parts	Check procedures/ corrective measures
9040	<p><b>DP lift motor going up error</b> When the DP lift motor is driven, DP lift sensor 1 does not turn on within 1500 pulse. (Three recovery times.) The above has been detected 5 times.</p> <p>* : The number of detection should be weighted with one for the rise at job start and two for the irregular rise during transpotting. The accumulated number must be cleared at completion of a normal rise. The default threshold is 5.</p>	DP lift motor	<ol style="list-style-type: none"> <li>1. Execute U906 Separating Operation Release (see page 1-3-185).</li> <li>2. Execute U243 Lift Motor to check the DP motor operation (see page 1-3-118).</li> <li>3. Check that the original document lift guide can move upwards.</li> <li>4. Confirm that the wiring connector is firmly connected and, if necessary, connect the connector all the way in. DP lift motor and DP main PWB (YC5)</li> <li>5. If the wiring is disconnected, shorted or grounded, replace the wiring.</li> <li>6. Replace the DP lift motor.</li> </ol>
		DP lift sensor 1	<ol style="list-style-type: none"> <li>1. Execute U244 Lift L-Limit to check DP switch (see page 1-3-119).</li> <li>2. Check that the sensor and its mounting bracket are correctly positioned.</li> <li>3. Confirm that the wiring connector is firmly connected and, if necessary, connect the connector all the way in. DP lift sensor 1 and DP main PWB (YC4)</li> <li>4. Replace the DP lift sensor 1.</li> </ol>
		DP main PWB	Replace the DP main PWB

Code	Contents	Related parts	Check procedures/ corrective measures
<b>9050</b> <b>DP lift motor going down error</b> When the DP lift motor is driven, DP lift sensor 2 does not turn on within 1500 pulse. (Three recovery times.) The above has been detected 5 times.		DP lift motor	<ol style="list-style-type: none"> <li>1. Execute U906 Separating Operation Release (see page 1-3-185).</li> <li>2. Execute U243 Lift Motor to check the DP motor operation (see page 1-3-118).</li> <li>3. Check that the original document lift guide can move downwards.</li> <li>4. Confirm that the wiring connector is firmly connected and, if necessary, connect the connector all the way in. DP lift motor and DP main PWB (YC5) If the wiring is disconnected, shorted or grounded, replace the wiring.</li> <li>5. Replace the DP lift motor.</li> </ol>
		DP lift sensor 2	<ol style="list-style-type: none"> <li>1. Execute U244 Lift L-Limit to check DP switch (see page 1-3-119).</li> <li>2. Confirm that the DP lift sensor 2 has been firmly fitted.</li> <li>3. Confirm that the wiring connector is firmly connected and, if necessary, connect the connector all the way in. DP lift sensor 2 and DP main PWB (YC2)</li> <li>4. Replace the DP lift sensor2.</li> </ol>
		DP main PWB	Replace the DP main PWB
<b>9060</b> <b>DP EEPROM error</b> Mismatch of reading data from two locations occurs 3 times successively. Mismatch between writing data and reading data occurs 3 times successively.		DP main PWB	<ol style="list-style-type: none"> <li>1. Execute U906 Separating Operation Release (see page 1-3-185).</li> <li>2. Confirm that the EEPROM has been properly installed.</li> <li>3. Replace the DP main PWB</li> </ol>
		Device damage of EEPROM	Contact the Service Support.
<b>9070</b> <b>Communication error between DP and SHD</b> A communication error is detected.		DP SHD PWB	<ol style="list-style-type: none"> <li>1. Execute U906 Separating Operation Release (see page 1-3-185).</li> <li>2. Confirm that the wiring connector is firmly connected and, if necessary, connect the connector all the way in. DP SHD PWB (YC1) and DP main PWB (YC10)</li> <li>3. If the wiring is disconnected, shorted or grounded, replace the wiring.</li> <li>4. Replace the DP SHD PWB.</li> </ol>

Code	Contents	Related parts	Check procedures/ corrective measures
9080	<b>LED fault detection</b> A block is existent below a peak which was obtained by activating the LEDs in the four CIS blocks at power on, which is less than 80hex.	DP CIS	<ol style="list-style-type: none"> <li>Execute CIS automatic original document alignment by U411 (see page 1-3-148).</li> <li>Confirm that the wiring connector is firmly connected and, if necessary, connect the connector all the way in. CIS and DP SHD PWB (YC2) DP SHD PWB (YC1) and DP main PWB (YC10)</li> <li>If the wiring is disconnected, shorted or grounded, replace the wiring.</li> <li>Replace the CIS and execute U411.</li> </ol>
		DP SHD PWB	Replace the DP SHD PWB.
9100	<b>Coin vender control PWB error</b> Communication error has been detected at the coin mec of the coin vender control PWB.	Coin vender control PWB	Replace the coin mec.
9110	<b>Coin vender rejector error</b> Communication error has been detected in connection with the coin mec and the rejector.	Rejector	<ol style="list-style-type: none"> <li>Check that the rejector is firmly installed and, if not, install firmly.</li> <li>Replace the rejector.</li> </ol>
9120	<b>Sensor error in coin vender change (Yen 10)</b> Change is empty despite change is enough.	Coin jam in the change tube	Check visually and remedy.
		Contact in the connector	Check the connection of the empty change sensor.
		Change empty sensor	Replace the coin mec.
		Coin vender control PWB	Replace the coin mec.
9130	<b>Sensor error in coin vender change (Yen 50)</b> Change is empty despite change is enough.	Coin jam in the change tube	Check visually and remedy.
		Contact in the connector	Check the connection of the empty change sensor.
		Change empty sensor	Replace the coin mec.
		Coin vender control PWB	Replace the coin mec.



Code	Contents	Related parts	Check procedures/ corrective measures
9140	<b>Sensor error in coin vender change (Yen 100)</b> Change is empty despite change is enough.	Coin jam in the change tube	Check visually and remedy.
		Contact in the connector	Check the connection of the empty change sensor.
		Change empty sensor	Replace the coin mec.
		Coin vender control PWB	Replace the coin mec.
9150	<b>Sensor error in coin vender change (Yen 500)</b> Change is empty despite change is enough.	Change tube	Check no exchange jam is observed at the outlet and, if necessary, repair it.
		Contact in the connector	Check the connection of the empty change sensor.
		Change empty sensor	Replace the coin mec.
		Coin vender control PWB	Replace the coin mec.
9160	<b>Coin vender pay-out error</b> Coin is paid out despite the pay-out motor is determined not active.	Pay-out motor	Replace the coin mec.
9170	<b>Coin vender pay-out sensor error</b> Coin is paid out despite the pay-out motor is determined not active.	Pay-out area	Check no exchange jam is observed at the outlet and, if necessary, repair it.
		Pay-out motor	Replace the coin mec.
		Pay-out sensor	Replace the coin mec.
9500	<b>ISC PWB error A</b>	Main PWB ISC PWB	<ol style="list-style-type: none"> <li>1. Reinsert the connector if its connection is loose. Main PWB (YC25) and ISC PWB (YC4)</li> <li>2. Replace the main PWB (see page 1-5-59).</li> <li>3. Replace the ISC PWB</li> <li>4. Contact the Service Support.</li> </ol>
9510	<b>ISC PWB error B</b>	Main PWB DP SHD PWB	<ol style="list-style-type: none"> <li>1. Reinsert the connector if its connection is loose. DP relay PWB (YC2) and DP SHD PWB (YC3)</li> <li>2. Replace the main PWB (see page 1-5-59).</li> <li>3. Replace the DP SHD PWB.</li> <li>4. Contact the Service Support.</li> </ol>

Code	Contents	Related parts	Check procedures/ corrective measures
9520	<b>ISC PWB error C</b>	Main PWB ISC PWB	<ol style="list-style-type: none"> <li>1. Reinsert the connector if its connection is loose. Main PWB (YC25) and ISC PWB (YC4)</li> <li>2. Replace the main PWB (see page 1-5-59).</li> <li>3. Replace the ISC main PWB</li> <li>4. Contact the Service Support.</li> </ol>
9940	<b>Confidential document guard uninstalled error</b> The confidential document guard PWB is removed while the confidential document guard PWB is valid.	Confidential document guard PWB	<ol style="list-style-type: none"> <li>1. Check that the confidential document guard PWB is firmly installed and, if not, install firmly.</li> <li>2. Replace the confidential document guard PW.</li> </ol>
9950	<b>ISC PWB error C</b> FPGA configuration error CPU version information error This is caused when the PWB of a double-side scanning DP is connected, the confidential guard PWB is inserted, and the harness is not correctly connected	Confidential document guard PWB	<ol style="list-style-type: none"> <li>1. Replace the confidential document guard PW.</li> <li>2. Replace the main PWB (see page 1-5-59).</li> </ol>
F000	<b>Communication error between Main PWB and Operation PWB</b>	Main PWB	<ol style="list-style-type: none"> <li>1. Turn the main power switch off and after 5 seconds, then turn power on.</li> <li>2. Check that the wirings and connetors between the main PWB and the operation PWB and between the main PWB and the HDD are normal. Main PWB (YC12,YC17,YC30) and Operation PWB (YC1,YC2,YC3)</li> <li>3. Check that the DDR memories in the main PWB are well conducted and, if not, replace.</li> <li>4. Execute U024 to initialize (FULL) the HDD (see page 1-3-29).</li> <li>5. Execute U021initialize memory. (see page 1-3-28)</li> <li>6. Replace the Main PWB.</li> <li>7. Copy the log File saved in the HDD by U964 in USB memory and contact the service support (see page 1-3-196).</li> </ol>
		Operation PWB	Replace the operation PWB (see page 1-5-77).

Code	Contents	Related parts	Check procedures/ corrective measures
F010	Main PWB checksum error	Main PWB	<ol style="list-style-type: none"> <li>1. Turn the main power switch off and after 5 seconds, then turn power on.</li> <li>2. If not corrected, replace the main PWB (see page 1-5-59).</li> </ol>
F020 F021 F022 F023	System memory error Error occurs at start-up read/ write check of DIMM	Main PWB	<ol style="list-style-type: none"> <li>1. Turn the main power switch off and after 5 seconds, then turn power on.</li> <li>2. If not corrected, replace the main PWB (see page 1-5-59).</li> </ol>
F040	Communication error between Main PWB and Print engine	Main PWB	<ol style="list-style-type: none"> <li>1. Turn the main power switch off and after 5 seconds, then turn power on.</li> <li>2. Repair or replace the wire from the engine PWB, that may be grounded. (Check short-circuit between 5V and 3.3V.)</li> <li>3. Check that the FFC wire connecting between the Main PWB (YC3) and the engine PWB (YC46) is normal and, if necessary, re-insert. Or, replace the FFC wire.</li> <li>4. If not corrected, replace the main PWB (see page 1-5-59).</li> </ol>
		Engine PWB	<ol style="list-style-type: none"> <li>1. Check the engine software and upgrade to the latest, if necessary.</li> <li>2. Replace the engine PWB (see page 1-5-67).</li> </ol>
		HDD	Replace the HDD (see page 1-5-104).
F041	Communication error between Main PWB and Scanner engine	Main PWB	<ol style="list-style-type: none"> <li>1. Turn the main power switch off and after 5 seconds, then turn power on.</li> <li>2. Check that the wires between the main PWB and the ISC PWB are normal.</li> <li>3. If not corrected, replace the main PWB (see page 1-5-59).</li> </ol>
		ISC PWB	Replace the ISC PWB.
F050	Print engine ROM check- sum error	Engine software	Install the latest engine software.
		Engine PWB	<ol style="list-style-type: none"> <li>1. Turn the main power switch off and after 5 seconds, then turn power on.</li> <li>2. Confirm that the EEPROM has been properly installed.</li> <li>3. If not corrected, Replace the engine PWB (see page 1-5-67).</li> </ol>

Code	Contents	Related parts	Check procedures/ corrective measures
F051	Scanner engine ROM checksum error	Scanner software	Install the latest scanner software.
		ISC PWB	<ol style="list-style-type: none"> <li>1. Turn the main power switch off and after 5 seconds, then turn power on.</li> <li>2. Confirm that the EEPROM has been properly installed.</li> <li>3. If not corrected, Replace the ISC PWB.</li> </ol>
F278	Power supply in drive system error	The main power switch was turned off before the power switch is pressed. Shutdown due to a power failure	Turn the main power switch off and after 5 seconds, then turn power on. (Before turning power off, verify that the power key has been pressed and the power indicator has gone off, then switch the main power switch.)

### **(3) System Error (Fxxxx) Outline**

The document is subscribed to describe the outline of the factors of the Fxxx errors that are not described in the

service manual. Please utilize it to refer to checking the factors.

Please utilize it as the measures when the system is not recovered after power off/on or it frequently occurs.

It may be from the hardware factor while the error (Fxxx) is indicated.

Please initially check the following.

Check the DDR2 memory and neighboring parts:

Check the contact of YS1 or YS2 with the memory. Replace the memory if the error repeats.

Check the HDD if the error repeats after replacing the main board.

Take care, however, of handling the data when formatting or replacing the HDD.

Check the HDD : Replace the HDD if the error repeats after formatting the HDD.

No.	Content	Check procedure & check point	Team	Remark 1	Remark 2
-	Lock-up at Welcome display (The display unchanges after 60 seconds or more)	<ol style="list-style-type: none"> <li>1) Check connection of the harness (Panel to Main board), (Main board to HDD) and connectors and check function.</li> <li>2) Check contact of the DDR memory by detaching and reattaching, and check function. replace it if available and check function.</li> <li>3) Format the HDD and check function. (U024 FULL formatting)</li> <li>4) Execute the U021Memory initializing to initialize the controller backup memory and check function.</li> <li>5) Replace the panel board and check function.</li> <li>6) Replace the main board and check function.</li> <li>7) Retrieve the USBLOG and contact the Service Administrative Division.</li> </ol>	PSO/GUI	*User data and installed software is deleted if executing the U024. Reinstallation is required.	
F000	CF000 appears in 60 seconds after the Welcome display continues  Panel—Main board communication error  Panel core—Main core communication error	<ol style="list-style-type: none"> <li>1) Check connection of the harness (Panel to Main board), (Main board to HDD) and connectors and check function.</li> <li>2) Check contact of the DDR memory by detaching and reattaching, and check function. replace it if available and check function.</li> <li>3) Format the HDD and check function. (U024 FULL formatting)</li> <li>4) Execute the U021 Memory initializing to initialize the controller backup memory and check function.</li> <li>5) Replace the main board and check function.</li> <li>6) Replace the Panel board and check function.</li> <li>7) Retrieve the USBLOG and contact the Service Administrative Division.</li> </ol>	PSO/GUI/ OS/BMC		[Main-Panel Interface] Main board:YC12 Panel board:YC10
F12X	An error is detected at the Scan control section	<ol style="list-style-type: none"> <li>1) Check connection of the harness (Scan/DP - Main board) and connectors and check function.</li> <li>2) Format the HDD and check function. (U024 FULL formatting)</li> <li>3) Execute the U021 Memory initializing to initialize the controller backup memory and check function.</li> <li>4) Replace the Scan/DP board and check function.</li> <li>5) Replace the main board and check function.</li> <li>6) Retrieve the USBLOG and contact the Service Administrative Division.</li> </ol>	Scanner/ InputRIP		[Main-Scan Interface] Main board: YC11,YC25 ISC board: YC3,YC4  [Main-DP relay Interface] (Check if the boards are firmly connected via the board-to-board connector.) Main board:YC10 DP relay board:YC22
F13X	An error is detected at the Panel control section	<ol style="list-style-type: none"> <li>1) Check connection of the harness (Panel - Main board) and connectors and check function.</li> <li>2) Format the HDD and check function. (U024 FULL formatting)</li> <li>3) Execute the U021 Memory initializing to initialize the controller backup memory and check function.</li> <li>4) Replace the panel board and check function.</li> <li>5) Replace the main board and check function.</li> <li>6) Retrieve the USBLOG and contact the Service Administrative Division.</li> </ol>	PSO/GUI		[Main-Panel Interface] Main board:YC6,YC12 Panel board:YC10,YC17
F14X	An error is detected at the FAX control section	<ol style="list-style-type: none"> <li>1) Check connection of the harness (FAX - Main board) and connectors and check function.</li> <li>2) Format the HDD and check function. (U024 FULL formatting)</li> <li>3) Execute the U021 Memory initializing to initialize the controller backup memory and check function.</li> <li>4) Execute the U671 Clear FAX back up data (FAX DIMM clear) and check function. (Take cae of the received data since it is cleared)</li> <li>5) Replace the FAX_DIMM and check function.</li> <li>6) Replace the FAX board and check function.</li> <li>7) Replace the main board and check function.</li> <li>8) Retrieve the USBLOG and contact the Service Administrative Division.</li> </ol>	Job/Fax/ Service		[Main-KUIO Interface] Main board:YC8,YC9 KUIO board:YC3,YC4
F15X	An error is detected at the authentication device control section	<ol style="list-style-type: none"> <li>1) Check connection of the harness (Authentication device - Main board) and connectors and check function.</li> <li>2) Format the HDD and check function. (U024 FULL formatting)</li> <li>3) Execute the U021 Memory initializing to initialize the controller backup memory and check function.</li> <li>4) Replace the main board and check function.</li> <li>5) Replace the HDD and check function.</li> <li>6) Retrieve the USBLOG and contact the Service Administrative Division.</li> </ol>	SSM/PRC M/RPG/D CM/ESM/ Entity	Authentication device: Card Reader, etc.	[Main Interface] Main board: YC21,YC22,YC26
F17X	An error is detected at the print data control section	<ol style="list-style-type: none"> <li>1) Format the HDD and check function. (U024 FULL formatting)</li> <li>2) Execute the U021 Memory initializing to initialize the controller backup memory and check function.</li> <li>3) Replace the main board and check function.</li> <li>4) Replace the HDD and check function.</li> <li>5) Retrieve the USBLOG and contact the Service Administrative Division.</li> </ol>	OS/BMC		-
F18X	An error is detected at the Video control section	<ol style="list-style-type: none"> <li>1) Check connection of the harness (Engine - Main board) and connectors and check function.</li> <li>2) Format the HDD and check function. (U024 FULL formatting)</li> <li>3) Execute the U021 Memory initializing to initialize the controller backup memory and check function.</li> <li>4) Replace the engine board and check function.</li> <li>5) Replace the main board and check function.</li> <li>6) Retrieve the USBLOG and contact the Service Administrative Division.</li> </ol>	PrintSys/ GICL		[Main⇔ENGINE Interface] Main board:YC43 Engine board:YC46 or YC50
F1CX	An error is detected at the File System management section	<ol style="list-style-type: none"> <li>1) Format the HDD and check function. (U024 FULL formatting)</li> <li>2) Execute the U021 Memory initializing to initialize the controller backup memory and check function.</li> <li>3) Replace the main board and check function.</li> <li>4) Replace the HDD and check function.</li> <li>5) Retrieve the USBLOG and contact the Service Administrative Division.</li> </ol>	OS/BMC	*The F1C4 error appears with the HDD security kit at work.	-
F1DX	An error is detected at the Image memory management section	<ol style="list-style-type: none"> <li>1) Format the HDD and check function. (U024 FULL formatting)</li> <li>2) Execute the U021 Memory initializing to initialize the controller backup memory and check function.</li> <li>3) Replace the main board and check function.</li> <li>4) Replace the HDD and check function.</li> <li>5) Retrieve the USBLOG and contact the Service Administrative Division.</li> </ol>	OS/BMC	*The F1D4 error is RAM allocation error. 1Check it with the U340 2Initialize the setting valued with the U021	-

No.	Content	Check procedure & check point	Team	Remark 1	Remark 2
F21X	An error is detected at the Image processing section	1) Check contact of the DDR memory and check function. 2) Format the HDD and check function. (U024 FULL formatting) 3) Execute the U021 Memory initializing to initialize the controller backup memory and check function. 4) Replace the main board and check function. 5) Replace the HDD and check function. 6) Retrieve the USBLOG and contact the Service Administrative Division.	PrintSys/ GICL		[DDR2 memory contact check] Main board:YS1 or YS3 A certain part of the memory be faulty. The frequency of failure occurrence is dependent on the frequency of access to the faulty bit. The ASIC may be faulty if the memory is not sensitive.
F22X					
F23X					
F24X	An error is detected at the System management section	1) Check contact of the DDR memory and check function. 2) Format the HDD and check function. (U024 FULL formatting) 3) Execute the U021 Memory initializing to initialize the controller backup memory and check function. 4) Replace the main board and check function. 5) Replace the HDD and check function. 6) Retrieve the USBLOG and contact the Service Administrative Division.	SSM/PRC M/RPG/D CM/ESM/ Entity	*The F248 error is printer process error. if it repeats with a certain print data, retrieve the capture data and USBLOG.	[DDR2 memory contact check] Main board:YS1 or YS3 A certain part of the memory be faulty. The frequency of failure occurrence is dependent on the frequency of access to the faulty bit. The ASIC may be faulty if the memory is not sensitive.
F25X	An error is detected at the Network management section	1) Format the HDD and check function. (U024 FULL formatting) 2) Execute the U021 Memory initializing to initialize the controller backup memory and check function. 3) Replace the main board and check function. 4) Retrieve the USBLOG and contact the Service Administrative Division. (or retrieve the packet capture data depending on the result of analysis)	Network	*This may be owing to the users network environment.	-
F26X	An error is detected at the System management section	1) Format the HDD and check function. (U024 FULL formatting) 2) Execute the U021 Memory initializing to initialize the controller backup memory and check function. 3) Replace the main board and check function. 4) Replace the HDD and check function. 5) Retrieve the USBLOG and contact the Service Administrative Division.	SSM/PRC M/RPG/D CM/ESM/ Entity/KS F		-
F27X					
F28X					
F29X					
F2AX					
F33X	An error is detected at the Scan management section	1) Check connection of the harness (Scan/DP board - main board) and connectors and check function. 2) Format the HDD and check function. (U024 FULL formatting) 3) Execute the U021 Memory initializing to initialize the controller backup memory and check function. 4) Replace the Scan/DP board and check function. 5) Replace the main board and check function. 6) Retrieve the USBLOG and contact the Service Administrative Division.	Scanner/1 nputRIP		Main board: YC11,YC25 ISC board: YC3,YC4  [Main-DP relay Interface] (Check if the boards are firmly connected via the board-to-board connector.) Main board:YC10 DP relay board:YC22
F34X	An error is detected at the Panel management section	1) Format the HDD and check function. (U024 FULL formatting) 2) Execute the U021 Memory initializing to initialize the controller backup memory and check function. 3) Replace the main board and check function. 4) Retrieve the USBLOG and contact the Service Administrative Division.	PSO/GUI		[Main-Panel Interface] Main board:YC6,YC12 Panel board:YC10,YC17
F35X	An error is detected at the Print control section	1) Format the HDD and check function. (U024 FULL formatting) 2) Execute the U021 Memory initializing to initialize the controller backup memory and check function. 3) Replace the main board and check function. 4) Replace the HDD and check function. 5) Retrieve the USBLOG and contact the Service Administrative Division.	PrintSys/ GICL		-
F36X	An error is detected at the Print management section	1) Format the HDD and check function. (U024 FULL formatting) 2) Execute the U021 Memory initializing to initialize the controller backup memory and check function. 3) Replace the main board and check function. 4) Replace the HDD and check function. 5) Retrieve the USBLOG and contact the Service Administrative Division.	OS/BMC		-
F37X	An error is detected at the FAX management section	1) Format the HDD and check function. (U024 FULL formatting) 2) Execute the U021 Memory initializing to initialize the controller backup memory and check function. 3) Execute the U671 Clear FAX back up data (FAX DIMM clear) and check function. (Take care of the received data since it is cleared) 4) Replace the FAX_DIMM and check function. 5) Replace the main board and check function. 6) Replace the HDD and check function. 7) Retrieve the USBLOG and contact the Service Administrative Division.	Job/Fax/ Service		[FAX DIMM contact check] Main board: YC5
F38X	An error is detected at the Authentication/permit management section	1) Format the HDD and check function. (U024 FULL formatting) 2) Execute the U021 Memory initializing to initialize the controller backup memory and check function. 3) Replace the main board and check function. 4) Replace the HDD and check function. 5) Retrieve the USBLOG and contact the Service Administrative Division.	SSM/PRC M/RPG/D CM/ESM/ Entity		-
F3AX	An error is detected at the Entity management section	1) Format the HDD and check function. (U024 FULL formatting) 2) Execute the U021 Memory initializing to initialize the controller backup memory and check function. 3) Replace the main board and check function. 4) Replace the HDD and check function. 5) Retrieve the USBLOG and contact the Service Administrative Division.	SSM/PRC M/RPG/D CM/ESM/ Entity		-
F3BX					
F3CX					
F3DX					
F3EX					
F3FX					
F40X					
F41X					
F42X					
F43X					
F44X					
F45X					

No.	Content	Check procedure & check point	Team	Remark 1	Remark 2
F46X	An error is detected at the Print image process section	1) Replace the main board and check function. 2) Retrieve the USBLOG (or retrieve the print capture data by case)	PrintRIP/ Color	*The F46F is printer process error. if it repeats with a certain print data, retrieve the capture data and USBLOG.	-
F47X	An error is detected at the Image edit process control section	1) Format the HDD and check function. (U024 FULL formatting)	Job/Fax/ Service/In putRIP		
F48X		2) Execute the U021 Memory initializing to initialize the controller backup memory and check function.			
F49X		3) Replace the main board and check function. 4) Replace the HDD and check function. 5) Retrieve the USBLOG and contact the Service Administrative Division.			
F4AX	An error is detected at the Print image process section	1) Format the HDD and check function. (U024 FULL formatting)	PrintSys/ GICL		
F4CX		2) Execute the U021 Memory initializing to initialize the controller backup memory and check function. 3) Replace the main board and check function. 4) Replace the HDD and check function. 5) Retrieve the USBLOG and contact the Service Administrative Division.			
F4DX	An error is detected at the Entity control section	1) Format the HDD and check function. (U024 FULL formatting)	SSM/PRC M/RPG/D CM/ESM/ Entity		
F4EX		2) Execute the U021 Memory initializing to initialize the controller backup memory and check function. 3) Replace the main board and check function. 4) Replace the HDD and check function. 5) Retrieve the USBLOG and contact the Service Administrative Division.			
F4FX	An error is detected at the Job control section	1) Format the HDD and check function. (U024 FULL formatting) 2) Execute the U021 Memory initializing to initialize the controller backup memory and check function. 3) Replace the main board and check function. 4) Replace the HDD and check function. 5) Retrieve the USBLOG and contact the Service Administrative Division.	Job/Fax/ Service		
F50X	An error is detected at the FAX control section	1) Format the HDD and check function. (U024 FULL formatting) 2) Execute the U021 Memory initializing to initialize the controller backup memory and check function. 3) Replace the main board and check function. 4) Replace the HDD and check function. 5) Retrieve the USBLOG and contact the Service Administrative Division.	Job/Fax/ Service		
F51X	An error is detected at the Job execution section	1) Format the HDD and check function. (U024 FULL formatting)	Job/Fax/ Service		
F52X		2) Execute the U021 Memory initializing to initialize the controller backup memory and check function.			
F53X		3) Replace the main board and check function.			
F55X		4) Replace the HDD and check function.			
F56X		5) Retrieve the USBLOG and contact the Service Administrative Division.			
F57X					
F58X	An error is detected at the Service management section	1) Format the HDD and check function. (U024 FULL formatting)	Job/Fax/ Service		
F59X		2) Execute the U021 Memory initializing to initialize the controller backup memory and check function.			
F5AX		3) Replace the main board and check function.			
F5BX		4) Replace the HDD and check function.			
F5CX		5) Retrieve the USBLOG and contact the Service Administrative Division.			
F5DX					
F5EX					
F5FX	An error is detected at the Service execution section	1) Format the HDD and check function. (U024 FULL formatting) 2) Execute the U021 Memory initializing to initialize the controller backup memory and check function. 3) Replace the main board and check function. 4) Replace the HDD and check function. 5) Retrieve the USBLOG and contact the Service Administrative Division.	Job/Fax/ Service		
F60X	An error is detected at the Maintenance mode management section	1) Format the HDD and check function. (U024 FULL formatting) 2) Execute the U021 Memory initializing to initialize the controller backup memory and check function. 3) Replace the main board and check function. 4) Replace the HDD and check function. 5) Retrieve the USBLOG and contact the Service Administrative Division.	SSM/PRC M/RPG/D CM/ESM/ Entity		
F61X	An error is detected at the Report compiling section	1) Format the HDD and check function. (U024 FULL formatting) 2) Execute the U021 Memory initializing to initialize the controller backup memory and check function. 3) Replace the main board and check function. 4) Replace the HDD and check function. 5) Retrieve the USBLOG and contact the Service Administrative Division.	SSM/PRC M/RPG/D CM/ESM/ Entity		
F62X	An error is detected at the Service execution section	1) Format the HDD and check function. (U024 FULL formatting) 2) Execute the U021 Memory initializing to initialize the controller backup memory and check function. 3) Replace the main board and check function. 4) Replace the HDD and check function. 5) Retrieve the USBLOG and contact the Service Administrative Division.	Job/Fax/ Service		
F63X	An error is detected at the Device control section	1) Format the HDD and check function. (U024 FULL formatting) 2) Execute the U021 Memory initializing to initialize the controller backup memory and check function. 3) Replace the main board and check function. 4) Replace the HDD and check function. 5) Retrieve the USBLOG and contact the Service Administrative Division.	OS/BMC		



No.	Content	Check procedure & check point	Team	Remark 1	Remark 2
F64X	An error is detected at the Print image process section	1) Format the HDD and check function. (U024 FULL formatting)	PrintRIP/ Color		
F65X		2) Execute the U021 Memory initializing to initialize the controller backup memory and check function.			
F66X		3) Replace the main board and check function.			
F67X		4) Replace the HDD and check function.			
F67X		5) Retrieve the USBLOG and contact the Service Administrative Division.			
F68X	An error is detected at the Storage device control section	1) Format the HDD and check function. (U024 FULL formatting) 2) Execute the U021 Memory initializing to initialize the controller backup memory and check function. 3) Replace the main board and check function. 4) Replace the HDD and check function. 5) Retrieve the USBLOG and contact the Service Administrative Division.	OS/BMC	*F684 is Overwrite error with the HDD security kit	Please replace the FAX DIMM at the time of F684 occurrence when the Fax system is installed. Because FAX DIMM is an object of the data overwrite removal.
F69X	An error is detected at the HyPAS control section	1) Format the HDD and check function. (U024 FULL formatting)	Driver/Utility/ KSF		
F6AX		2) Execute the U021 Memory initializing to initialize the controller backup memory and check function.			
F6BX		3) Replace the main board and check function.			
F6CX		4) Replace the HDD and check function.			
F6CX		5) Retrieve the USBLOG and contact the Service Administrative Division.			
F6DX	An error is detected at the External Server management section	1) Check the external server and check function.	ConcordFW	*FieryOption related	[Main-FIERYBB Interface] Main board: YC33 FIERYBB board: YC2
F6EX		2) Check the connection to the external server and check function.			
F6FX		3) Check the network settings and check function.			
F70X		4) Replace the bridge board and check function.			
F71X		5) Replace the main board and check function.			
F72X		6) Retrieve the USBLOG and contact the Service Administrative Division.			
F73X					
F74X					
F75X					

## 1-4-4 Image formation problems

Isolate the component an image defect has occurred from.

<A guide to isolate the component of the cause.>

Run U089 to print a test page and check whether an image defect happens.

YES: Main unit as the cause of defect

NO: Scanner as the cause of defect

Perform enlarged or reduced copying and verify if the defective images are enlarged or reduced, accordingly.

YES: Scanner as the cause of defect

### 1. Scanner as the cause of defect:

If the defect occurs with copying or sending, refer to P.1-4-146.

(Defects caused by a reading error that occurs at the original (glass) LED lamp to CCD (DP: CIS).)

Isolate the problem at the location that the originals are scanned.

a. Single side DP (read by Main CCD)

b. On the contact glass (read by Main CCD)

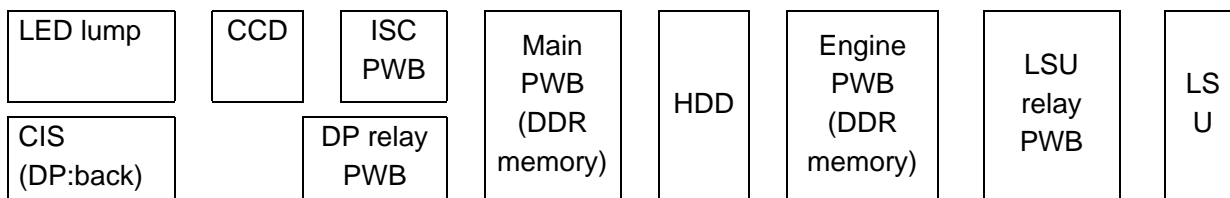
c. Back side DP (For DPs mounted with CIS)

### 2. Main unit as the cause of defect: refer to P. 1-4-146.

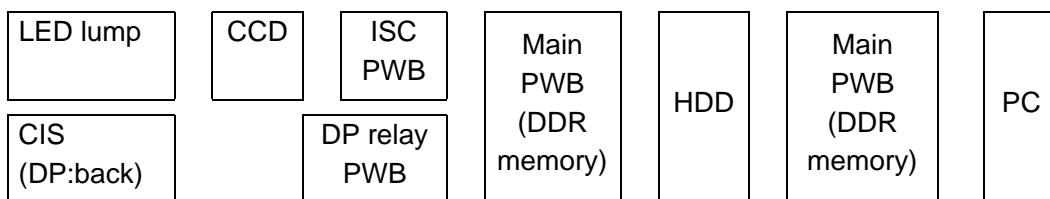
(A defect of image forming occurs from the rendering process that involves charging, drum, LSU, developer, and primary transferring.)

<Flow of image data>

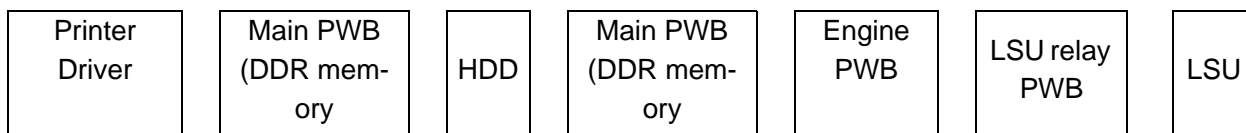
Copying :



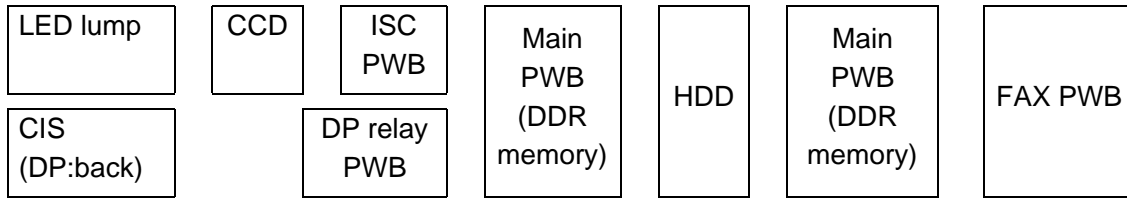
Sending :



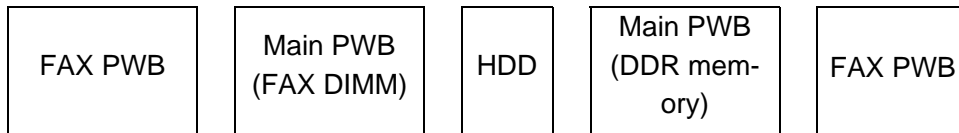
Printing data from PC :



FAX (send) :



FAX receive :



# 1-4-5 Poor image (due to DP and scanner reading)

(1) No image appears (entirely white).



See page1-4-147

(2) No image appears (entirely black).



See page1-4-150

(3) Image is too light.



See page1-4-152

(4) The background is colored.



See page1-4-156

(5) White streaks are printed vertically.



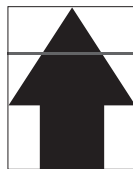
See page1-4-159

(6) Black streaks appear longitudinally.



See page1-4-162

(7) Streaks are printed horizontally.



See page1-4-166

(8) One side of the print image is darker or brighter than the other.



See page1-4-169

(9) Black dots appear on the image.



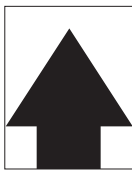
See page1-4-172

(10) Image is blurred.



See page1-4-174

(11) The leading edge of the image is consistently misaligned with the original.



See page1-4-177

(12) Part of image is missing.



See page1-4-179

(13) Image is out of focus.



See page1-4-182

(14) Image center does not align with the original center.



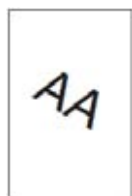
See page1-4-184

(15) Moires



See page1-4-185

(16) Skewed image

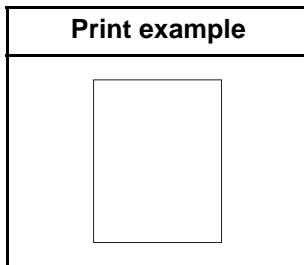


See page1-4-187

(17) Abnormal image



See page1-4-190

**(1) No image appears (entirely white).**

## 1. Table scanning

	Defective part	Check description	Corrective Action
1	Contact glass assy	Check the location the contact glass is mounted.	Re-mount the contact glass if it is hanged off.
2	FFC cable CCD	Check the FFC cable between the CCD sensor and ISC PWB is properly connected. Or, verify conduction of the wire.	Reinsert the connector if it its connection is loose. Or, if conduction is lot, replace the wire.
3	Home position sensor	Check the location the home position sensor is mounted.	Re-mount the home position sensor if it is hanged off.
4	Scanner wire drum	Check that the scanner drive gear is loosely mounted.	If the scanner wire drum is loosely mounted, secure the screws.
5	Scanner drive gear	Check that the scanner drive gear is loosely mounted.	If the scanner drive gear loosely mounted, secure the screw.
6	CCD PWB	The CCD PWB is defective.	Replace the ISU and perform U411. (see page 1-3-148)
7	ISC PWB	The ISC PWB is defective.	Replace the ISC PWB and perform U411. (see page 1-3-148)
8	Main PWB	The main PWB is defective.	Replace the main PWB.(see page 1-5-59)

## 2. DP-scanning first (front) page

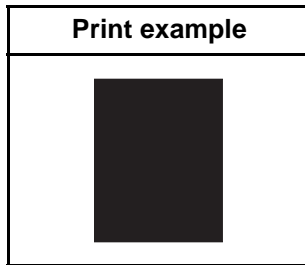
	Defective part	Check description	Corrective Action
1	Original document	Verify the sides of the original document.	If the sides of the original document are reversed, place the original document properly.
2	Contact glass assy	Check the location the contact glass is mounted.	Re-mount the contact glass if it is hanged off.
3	FFC cable CCD	Check the FFC cable between the CCD sensor and ISC PWB is properly connected. Or, verify conduction of the wire.	Reinsert the connector if its connection is loose. Or, if conduction is lot, replace the wire.
4	Home position sensor	Check the location the home position sensor is mounted.	Re-mount the home position sensor if it is hanged off.
5	Scanner wire drum	Check that the scanner wire drum is loosely mounted.	If the scanner wire drum is loosely mounted, secure the screws.
6	Scanner drive gear	Check that the scanner drive gear is loosely mounted.	If the scanner drive gear loosely mounted, secure the screw.
7	CCD PWB	The CCD PWB is defective.	Replace the ISU and perform U411. (see page 1-3-148)
8	ISC PWB	The ISC PWB is defective.	Replace the ISC PWB and perform U411. (see page 1-3-148)
9	Main PWB	The main PWB is defective.	Replace the main PWB.(see page 1-5-59)

## 3. DP-scanning second (back) page (with a dual scan DP installed)

	Defective part	Check description	Corrective Action
1	Original document	Verify the sides of the original document.	If the sides of the original document are reversed, place the original document properly.
2	White-reference roller(Counter the CIS)	Check that the white-reference roller is smoothly operative.	If the white-reference roller does not rotate smoothly, re-install.
3	White-reference roller(Counter the CIS)	Check if the white reference roller is contaminated on its surface or damaged.	If the white-reference roller is dirty, clean. Or, if the roller is damaged, replace.
4	DP_CIS unit	Check the location the CIS unit is mounted.	Re-mount the CIS unit if it is hanged off.
5	DP_SHD PWB	Check the CIS and the SHD PWB is properly connected.	Reinsert the connector if the PWB was loosely inserted.If not cured, replace the PWB.
6	DP_CIS	CIS is defective.	Replace the CIS and perform U091 and U411. (see page 1-3-62,1-3-148)
7	Main PWB	The main PWB is defective.	Replace the main PWB.(see page 1-5-59)

## 4. DP-scanning second (back) page (with a reversed DP installed)

	Defective part	Check description	Corrective Action
1	Original document	Verify the sides of the original document.	If the sides of the original document are reversed, place the original document properly.
2	Contact glass assy	Check the location the contact glass is mounted.	Re-mount the contact glass if it is hanged off.
3	FFC cable CCD	Check the FFC cable between the CCD sensor and ISC PWB is properly connected. Or, verify conduction of the wire.	Reinsert the connector if its connection is loose. Or, if conduction is lot, replace the wire.
4	Home position sensor	Check the location the home position sensor is mounted.	Re-mount the home position sensor if it is hanged off.
5	Scanner wire drum	Check that the scanner drive gear is loosely mounted.	If the scanner wire drum is loosely mounted, secure the screws.
6	Scanner drive gear	Check that the scanner drive gear is loosely mounted.	If the scanner drive gear loosely mounted, secure the screw.
7	CCD PWB	The CCD PWB is defective.	Replace the ISU and perform U411. (see page 1-3-148)
8	ISC PWB	The ISC PWB is defective.	Replace the ISC PWB and perform U411. (see page 1-3-148)
9	Main PWB	The main PWB is defective.	Replace the main PWB.(see page 1-5-59)

**(2) No image appears (entirely black).**

## 1. Table scanning

	Defective part	Check description	Corrective Action
1	FFC cable CCD	Check the FFC cable between the CCD sensor and ISC PWB is properly connected. Or, verify conduction of the wire.	Reinsert the connector if its connection is loose. Or, if conduction is lot, replace the wire.
2	SATA cable ISC	Check the SATA cable between the ISC PWB and main PWB is properly connected. Or, verify conduction of the wire.	Reinsert the connector if its connection is loose. Or, if conduction is lot, replace the wire.
3	CCD PWB	The CCD PWB is defective.	Replace the ISU and perform U411. (see page 1-3-148)
4	ISC PWB	The ISC PWB is defective.	Replace the ISC PWB and perform U411. (see page 1-3-148)
5	Main PWB	The main PWB is defective.	Replace the main PWB.(see page 1-5-59)

## 2. DP-scanning first (front) page

	Defective part	Check description	Corrective Action
1	Scanning position of the DP	Confirm the value using maintenance mode U068, DP Read.	If a large value is observed in maintenance mode U068, DP Read, perform adjustment.(see page 1-3-51)
2	FFC cable CCD	Check the FFC cable between the CCD sensor and ISC PWB is properly connected. Or, verify conduction of the wire.	Reinsert the connector if its connection is loose. Or, if conduction is lot, replace the wire.
3	SATA cable ISC	Check the SATA cable between the ISC PWB and main PWB is properly connected. Or, verify conduction of the wire.	Reinsert the connector if its connection is loose. Or, if conduction is lot, replace the wire.
4	CCD PWB	The CCD PWB is defective.	Replace the ISU and perform U411. (see page 1-3-148)
5	ISC PWB	The ISC PWB is defective.	replace the ISC PWB and perform U411. (see page 1-3-148)



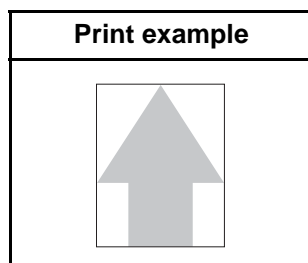
	Defective part	Check description	Corrective Action
6	Main PWB	The main PWB is defective.	Replace the main PWB.(see page 1-5-59)

## 3. DP-scanning second (back) page (with a dual scan DP installed)

	Defective part	Check description	Corrective Action
1	DP_CIS unit	Check the location the CIS unit is mounted.	Re-mount the CIS unit if it is hanged off.
2	DP_SHD PWB	Check the CIS and the SHD PWB is properly connected.	Reinsert the connector if the PWB was loosely inserted.If not cured, replace the PWB.
3	DP_CIS	CIS is defective.	Replace the CIS and perform U091 and U411. (see page 1-3-62,1-3-148)
4	Main PWB	The main PWB is defective.	Replace the main PWB.(see page 1-5-59)

## 4. DP-scanning second (back) page (with a reversed DP installed)

	Defective part	Check description	Corrective Action
1	Scanning position of the DP	Confirm the value using maintenance mode U068, DP Read.	If a large value is observed in maintenance mode U068, DP Read, perform adjustment.(see page 1-3-51)
2	FFC cable CCD	Check the FFC cable between the CCD sensor and ISC PWB is properly connected. Or, verify conduction of the wire.	Reinsert the connector if its connection is loose. Or, if conduction is lot, replace the wire.
3	SATA cable ISC	Check the SATA cable between the ISC PWB and main PWB is properly connected. Or, verify conduction of the wire.	Reinsert the connector if its connection is loose. Or, if conduction is lot, replace the wire.
4	CCD PWB	The CCD PWB is defective.	Replace the ISU and perform U411. (see page 1-3-148)
5	ISC PWB	The ISC PWB is defective.	replace the ISC PWB and perform U411. (see page 1-3-148)
6	Main PWB	The main PWB is defective.	Replace the main PWB.(see page 1-5-59)

**(3) Image is too light.**

## 1. Table scanning

	Defective part	Check description	Corrective Action
1	The settings of the adjustment of density	Check the settings of the adjustment of density.	1. Deactivate EcoPrint if it is activated. Or, if the density is too low, choose an image quality that suits the original document in type. 2. Increase density. 3. Perform the background color adjustment using the system menu.
2	Settings of anti-offset	Check the settings of anti-offset.	If anti-offset is set to on, set it to off.
3	Adjustment of the scanner	Check the automatic adjustment of the scanner.	Perform maintenance mode U411, table(Chart1)_All. (see page 1-3-148)
4	Contact glass	Check whether the contact glass is dirty.	If the contact glass is dirty, clean the contact glass, and the bottom part of the shading plate.
5	Home position sensor	Check the location the home position sensor is mounted.	Re-mount the home position sensor if it is hanged off.
6	FFC cable CCD	Check the FFC cable between the CCD sensor and ISC PWB is properly connected. Or, verify conduction of the wire.	Reinsert the connector if its connection is loose. Or, if conduction is lot, replace the wire.
7	FFC cable LED	Check the FFC cable between the LED PWB and ISC PWB is properly connected. Or, verify conduction of the wire.	Reinsert the connector if its connection is loose. Or, if conduction is lot, replace the wire.
8	Lamp unit	Check the location the lamp unit is mounted.	Re-mount the lamp unit if it is hanged off.
9	LED PWB	Check that the LED is lit.	If the LED is not lit, replace the LED PWB and perform U411.
10	ISC PWB	The ISC PWB is defective.	Replace the ISC PWB and perform U411. (see page 1-3-148)
11	CCD PWB	The CCD PWB is defective.	Replace the ISU and perform U411. (see page 1-3-148)

	Defective part	Check description	Corrective Action
12	Main PWB	The main PWB is defective.	Replace the main PWB.(see page 1-5-59)

## 2. DP-scanning first (front) page

	Defective part	Check description	Corrective Action
1	The settings of the adjustment of density	Check the settings of the adjustment of density.	1. Deactivate EcoPrint if it is activated. Or, if the density is too low, choose an image quality that suits the original document in type. 2. Increase density. 3. Perform the background color adjustment using the system menu.
2	Settings of anti-offset	Check the settings of anti-offset.	If anti-offset is set to on, set it to off.
3	Adjustment of the scanner	Check the automatic adjustment of the scanner.	Perform maintenance mode U411, DP FaceUp(Chart1)_Input(see page 1-3-148)
4	Contact glass	Check whether the contact glass is dirty.	If the contact glass is dirty, clean the contact glass, and the bottom part of the shading plate.
5	Home position sensor	Check the location the home position sensor is mounted.	Re-mount the home position sensor if it is hanged off.
6	Scanning position of the DP	Check whether the scanning position of the DP is wrong.	If the scanning position of the DP is shifted, perform maintenance mode U068, DP Read.(see page 1-3-51)
7	FFC cable CCD	Check the FFC cable between the CCD sensor and ISC PWB is properly connected. Or, verify conduction of the wire.	Reinsert the connector if its connection is loose. Or, if conduction is lot, replace the wire.
8	FFC cable LED	Check the FFC cable between the LED PWB and ISC PWB is properly connected. Or, verify conduction of the wire.	Reinsert the connector if its connection is loose. Or, if conduction is lot, replace the wire.
9	Lamp unit	Check the location the lamp unit is mounted.	Re-mount the lamp unit if it is hanged off.
10	LED PWB	Check that the LED is lit.	If the LED is not lit, replace the LED PWB and perform U411.
11	ISC PWB	The ISC PWB is defective.	replace the ISC PWB and perform U411. (see page 1-3-148)
12	CCD PWB	The CCD PWB is defective.	Replace the ISU and perform U411. (see page 1-3-148)
13	Main PWB	The main PWB is defective.	Replace the main PWB.(see page 1-5-59)

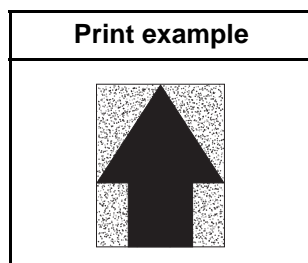
## 3. DP-scanning second (back) page (with a dual scan DP installed)

	Defective part	Check description	Corrective Action
1	The settings of the adjustment of density	Check the settings of the adjustment of density.	1. Deactivate EcoPrint if it is activated. Or, if the density is too low, choose an image quality that suits the original document in type. 2. Increase density. 3. Perform the background color adjustment using the system menu.
2	Settings of anti-offset	Check the settings of anti-offset.	If anti-offset is set to on, set it to off.
3	Adjustment of the scanner	Check the automatic adjustment of the scanner.	Perform maintenance mode U411, DP FaceDown(Char1)_All (see page 1-3-148)
4	White-reference roller(Counter the CIS)	Check that the white-reference roller is smoothly operative.	If the white-reference roller does not rotate smoothly, re-install.
5	White-reference roller(Counter the CIS)	Check if the white reference roller is contaminated on its surface or damaged.	If the white-reference roller is dirty, clean. Or, if the roller is damaged, replace.
6	DP_CIS unit	Check the location the CIS unit is mounted.	Re-mount the CIS unit if it is hanged off.
7	DP_SHD PWB	Check the CIS and the SHD PWB is properly connected.	Reinsert the connector if the PWB was loosely inserted.If not cured, replace the PWB.
8	DP_CIS	CIS is defective.	Replace the CIS and perform U091 and U411. (see page 1-3-62,1-3-148)
9	Main PWB	The main PWB is defective.	Replace the main PWB.(see page 1-5-59)

## 4. DP-scanning second (back) page (with a reversed DP installed)

	Defective part	Check description	Corrective Action
1	The settings of the adjustment of density	Check the settings of the adjustment of density.	1. Deactivate EcoPrint if it is activated. Or, if the density is too low, choose an image quality that suits the original document in type. 2. Increase density. 3. Perform the background color adjustment using the system menu.
2	Settings of anti-offset	Check the settings of anti-offset.	If anti-offset is set to on, set it to off.
3	Adjustment of the scanner	Check the automatic adjustment of the scanner.	Perform maintenance mode U411, DP FaceUp(Char1)_Input. (see page 1-3-148)

	Defective part	Check description	Corrective Action
4	Contact glass	Check whether the contact glass is dirty.	If the contact glass is dirty, clean the contact glass, and the bottom part of the shading plate.
5	Home position sensor	Check the location the home position sensor is mounted.	Re-mount the home position sensor if it is hanged off.
6	Scanning position of the DP	Check whether the scanning position of the DP is wrong.	If the scanning position of the DP is shifted, perform maintenance mode U068, DP Read.(see page 1-3-51)
7	FFC cable CCD	Check the FFC cable between the CCD sensor and ISC PWB is properly connected. Or, verify conduction of the wire.	Reinsert the connector if its connection is loose. Or, if conduction is lot, replace the wire.
8	FFC cable LED	Check the FFC cable between the LED PWB and ISC PWB is properly connected. Or, verify conduction of the wire.	Reinsert the connector if its connection is loose. Or, if conduction is lot, replace the wire.
9	Lamp unit	Check the location the lamp unit is mounted.	Re-mount the lamp unit if it is hanged off.
10	LED PWB	Check that the LED is lit.	If the LED is not lit, replace the LED PWB and perform U411.
11	ISC PWB	The ISC PWB is defective.	RSeplace the ISC PWB and perform U411. (see page 1-3-148)
12	CCD PWB	The CCD PWB is defective.	Replace the ISU and perform U411. (see page 1-3-148)
13	Main PWB	The main PWB is defective.	Replace the main PWB.(see page 1-5-59)

**(4) The background is colored.**

## 1. Table scanning

	Defective part	Check description	Corrective Action
1	Original document	1. Check if the background density of the original document is too dense. 2. Check if the original document is floated during scanning.	1. If the background density of the original document is too dense, perform automatic background adjustment. Or, adjust density with background adjustment. 2. If the original document is floated during scanning, press down the original document.
2	Adjustment of the scanner	Check the automatic adjustment of the scanner.	Perform maintenance mode U411, table(Chart1)_All. (see page 1-3-148)
3	Contact glass	Check whether the contact glass is dirty.	If the contact glass is dirty, clean the contact glass, and the bottom part of the shading plate.
4	Contact glass assy	Check the location the contact glass is mounted.	Re-mount the contact glass if it is hanged off.
5	Home position sensor	Check the location the home position sensor is mounted.	Re-mount the home position sensor if it is hanged off.
6	FFC cable CCD	Check the FFC cable between the CCD sensor and ISC PWB is properly connected. Or, verify conduction of the wire.	Reinsert the connector if its connection is loose. Or, if conduction is lot, replace the wire.
7	FFC cable LED	Check the FFC cable between the LED PWB and ISC PWB is properly connected. Or, verify conduction of the wire.	Reinsert the connector if its connection is loose. Or, if conduction is lot, replace the wire.
8	Lamp unit	Check the location the lamp unit is mounted.	Re-mount the lamp unit if it is hanged off.
9	LED PWB	Check that the LED is lit.	If the LED is not lit, replace the LED PWB and perform U411.
10	ISC PWB	The ISC PWB is defective.	Replace the ISC PWB and perform U411. (see page 1-3-148)
11	CCD PWB	The CCD PWB is defective.	Replace the ISU and perform U411. (see page 1-3-148)

	Defective part	Check description	Corrective Action
12	Main PWB	The main PWB is defective.	Replace the main PWB.(see page 1-5-59)

## 2. DP-scanning first (front) page

	Defective part	Check description	Corrective Action
1	Original document	1. Check if the background density of the original document is too dense. 2. Check if the original document is floated during scanning.	1. If the background density of the original document is too dense, perform automatic background adjustment.Or, adjust density with background adjustment. 2. Adjust the location the DP is mounted.
2	Adjustment of the scanner	Check the automatic adjustment of the scanner.	Perform maintenance mode U411, DP FaceDown(Chart1)_All. (see page 1-3-148)
3	Contact glass	Check whether the contact glass is dirty.	If the contact glass is dirty, clean the contact glass, and the bottom part of the shading plate.
4	Contact glass assy	Check the location the contact glass is mounted.	Re-mount the contact glass if it is hanged off.
5	Home position sensor	Check the location the Home position sensor is mounted.	Re-mount the Home position sensor if it is hanged off.
6	Installing DP	Check whether the DP frame is distorted or the hinges are damaged.	Replace the DP.
7	FFC cable CCD	Check the FFC cable between the CCD sensor and ISC PWB is properly connected. Or, verify conduction of the wire.	Reinsert the connector if it its connection is loose. Or, if conduction is lot, replace the wire.
8	FFC cable LED	Check the FFC cable between the LED PWB and ISC PWB is properly connected. Or, verify conduction of the wire.	Reinsert the connector if it its connection is loose. Or, if conduction is lot, replace the wire.
9	Lamp unit	Check the location the lamp unit is mounted.	Re-mount the lamp unit if it is hanged off.
10	LED PWB	Check that the LED is lit.	If the LED is not lit, replace the LED PWB and perform U411.
11	ISC PWB	The ISC PWB is defective.	Replace the ISC PWB and perform U411. (see page 1-3-148)
12	CCD PWB	The CCD PWB is defective.	Replace the ISU and perform U411. (see page 1-3-148)
13	Main PWB	The main PWB is defective.	Replace the main PWB.(see page 1-5-59)

## 3. DP-scanning second (back) page (with a dual scan DP installed)

	Defective part	Check description	Corrective Action
1	Original document	1. Check if the background density of the original document is too dense. 2. Check if the original document is floated during scanning.	1. If the background density of the original document is too dense, perform automatic background adjustment.Or, adjust density with background adjustment. 2. Adjust the location the CIS unit is mounted.
2	Adjustment of the scanner	Check the automatic adjustment of the scanner.	Perform maintenance mode U411, DP FaceUp(Char1)_All. (see page 1-3-148)
3	White-reference roller(Counter the CIS)	Check that the white-reference roller is smoothly operative.	If the white-reference roller does not rotate smoothly, re-install.
4	White-reference roller(Counter the CIS)	Check if the white reference roller is contaminated on its surface or damaged.	If the white-reference roller is dirty, clean. Or, if the roller is damaged, replace.
5	DP_CIS unit	Check the location the CIS unit is mounted.	Re-mount the CIS unit if it is hanged off.
6	DP_SHD PWB	Check the CIS and the SHD PWB is properly connected.	Reinsert the connector if the PWB was loosely inserted.If not cured, replace the PWB.
7	DP_CIS	CIS is defective.	Replace the CIS and perform U091 and U411. (see page 1-3-62,1-3-148)
8	Main PWB	The main PWB is defective.	Replace the main PWB.(see page 1-5-59)

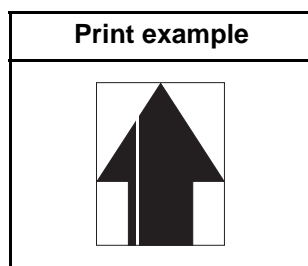
## 4. DP-scanning second (back) page (with a reversed DP installed)

	Defective part	Check description	Corrective Action
1	Original document	1. Check if the background density of the original document is too dense. 2. Check if the original document is floated during scanning.	1. If the background density of the original document is too dense, perform automatic background adjustment.Or, adjust density with background adjustment. 2. Adjust the location the DP is mounted.
2	Adjustment of the scanner	Check the automatic adjustment of the scanner.	Perform maintenance mode U411, DP FaceUp(Char1)_Input. (see page 1-3-148)
3	Contact glass	Check whether the contact glass is dirty.	If the contact glass is dirty, clean the contact glass, and the bottom part of the shading plate.
4	Contact glass assy	Check the location the contact glass is mounted.	Re-mount the contact glass if it is hanged off.
5	Home position sensor	Check the location the home position sensor is mounted.	Re-mount the home position sensor if it is hanged off.



	Defective part	Check description	Corrective Action
6	Installing DP	Check whether the DP frame is distorted or the hinges are damaged.	Replace the DP.
7	FFC cable CCD	Check the FFC cable between the CCD sensor and ISC PWB is properly connected. Or, verify conduction of the wire.	Reinsert the connector if its connection is loose. Or, if conduction is not, replace the wire.
8	Lamp unit	Check the location the lamp unit is mounted.	Re-mount the lamp unit if it is hanged off.
9	LED PWB	Check that the LED is lit.	If the LED is not lit, replace the LED PWB and perform U411.
10	ISC PWB	The ISC PWB is defective.	Replace the ISC PWB and perform U411. (see page 1-3-148)
11	CCD PWB	The CCD PWB is defective.	Replace the ISU and perform U411. (see page 1-3-148)
12	Main PWB	The main PWB is defective.	Replace the main PWB. (see page 1-5-59)

(5) White streaks are printed vertically.



#### 1. Table scanning

	Defective part	Check description	Corrective Action
1	Original document	Check whether the original document is dirty.	If the original document is dirty, replace.
2	Contact glass	Check whether the contact glass is dirty.	If the contact glass is dirty, clean the contact glass, and the bottom part of the shading plate.
3	Mirror	Check whether the mirrors are dirty.	If the mirrors are dirty, clean the three mirrors.
4	Lamp unit	Check that the lamp unit is contaminated with dusts.	If dusts are observed on the lamp unit, remove the dusts in the light paths.
5	Lamp unit	Check whether the LED cover is hanged off.	Re-mount the LED cover if it is hanged off.

	Defective part	Check description	Corrective Action
6	ISU	Check whether the lens cover is hanged off.	Re-mount the lens cover if it is hanged off.
7	Shading plate	Check whether the shading plate is dirty.	If the shading plate is dirty, perform maintenance mode U063 to modify the shading position. If it does not cure, replace the contact glass assembly. (see page 1-3-46)
8	ISC PWB	The ISC PWB is defective.	Replace the ISC PWB and perform U411. (see page 1-3-148)
9	CCD PWB	The CCD PWB is defective.	Replace the ISU and perform U411. (see page 1-3-148)
10	Main PWB	The main PWB is defective.	Replace the main PWB.(see page 1-5-59)

## 2. DP-scanning first (front) page

	Defective part	Check description	Corrective Action
1	Original document	Check whether the original document is dirty.	If the original document is dirty, replace.
2	Contact glass	Check whether the contact glass is dirty.	If the contact glass is dirty, clean the contact glass, and the bottom part of the shading plate.
3	Mirror	Check whether the mirrors are dirty.	If the mirrors are dirty, clean the three mirrors.
4	Lamp unit	Check that the lamp unit is contaminated with dusts.	If dusts are observed on the lamp unit, remove the dusts in the light paths.
5	Lamp unit	Check whether the LED cover is hanged off.	Re-mount the LED cover if it is hanged off.
6	ISU	Check whether the lens cover is hanged off.	Re-mount the lens cover if it is hanged off.
7	Shading plate	Check whether the shading plate is dirty.	If the shading plate is dirty, perform maintenance mode U063 to modify the shading position. If it does not cure, replace the contact glass assembly. (see page 1-3-46)
8	ISC PWB	The ISC PWB is defective.	Replace the ISC PWB and perform U411. (see page 1-3-148)
9	CCD PWB	The CCD PWB is defective.	Replace the ISU and perform U411. (see page 1-3-148)
10	Main PWB	The main PWB is defective.	Replace the main PWB.(see page 1-5-59)

## 3. DP-scanning second (back) page (with a dual scan DP installed)

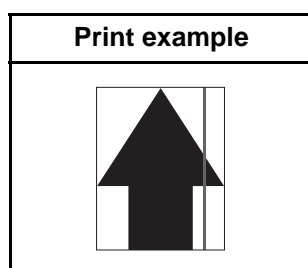
	Defective part	Check description	Corrective Action
1	White-reference roller (Counter the CIS)	Check if the white reference roller is contaminated on its surface or damaged.	If the white-reference roller is dirty, clean. Or, if the roller is damaged, replace.
2	DP_CIS glass	Check whether the CIS glass is contaminated.	If the CIS glass is contaminated, clean the CIS glass and conveying guide. If it has a scuff, replace.
3	White streaks compensation settings	Check the white streaks compensation settings.	Check the white streaks compensation settings.
4	DP_CIS unit	Check the location the CIS unit is mounted.	Re-mount the CIS unit if it is hanged off.
5	DP_SHD PWB	Check the CIS and the SHD PWB is properly connected.	Reinsert the connector if the PWB was loosely inserted.If not cured, replace the PWB.
6	DP_CIS	CIS is defective.	Replace the CIS and perform U091 and U411. (see page 1-3-62,1-3-148)
7	Main PWB	The main PWB is defective.	Replace the main PWB.(see page 1-5-59)

## 4. DP-scanning second (back) page (with a reversed DP installed)

	Defective part	Check description	Corrective Action
1	Original document	Check whether the original document is dirty.	If the original document is dirty, replace.
2	Contact glass	Check whether the contact glass is dirty.	If the contact glass is dirty, clean the contact glass, and the bottom part of the shading plate.
3	Mirror	Check whether the mirrors are dirty.	If the mirrors are dirty, clean the three mirrors.
4	Lamp unit	Check that the lamp unit is contaminated with dusts.	If dusts are observed on the lamp unit, remove the dusts in the light paths.
5	Lamp unit	Check whether the LED cover is hanged off.	Re-mount the LED cover if it is hanged off.
6	ISU	Check whether the lens cover is hanged off.	Re-mount the lens cover if it is hanged off.
7	Shading plate	Check whether the shading plate is dirty.	If the shading plate is dirty, perform maintenance mode U063 to modify the shading position. If it does not cure, replace the contact glass assembly. (see page 1-3-46)
8	ISC PWB	The ISC PWB is defective.	replace the ISC PWB and perform U411. (see page 1-3-148)

	Defective part	Check description	Corrective Action
9	CCD PWB	The CCD PWB is defective.	Replace the ISU and perform U411. (see page 1-3-148)
10	Main PWB	The main PWB is defective.	Replace the main PWB.(see page 1-5-59)

(6) Black streaks appear longitudinally.



1. Table scanning

	Defective part	Check description	Corrective Action
1	Original document	Check whether the original document is dirty.	If the original document is dirty, replace.
2	Original document	Check if the size of the original document and its reference size match.	If the size of the original document and its reference size do not match, set the correct document size or activate border erasure.
3	Contact glass assy	Check the location the contact glass is mounted.	Re-mount the contact glass if it is hanged off.
4	Adjustment of the scanner	Check whether the outer areas of the original document have streaks or lines.	1. Perform maintenance mode U067, Front.(see page 1-3-50) 2. Perform maintenance mode U411, table (Chart1)_Input. (see page 1-3-148)
5	Contact glass	Check whether the outer areas of the original document have streaks or lines.	If the contact glass is dirty, clean.
6	mirror	Check whether the mirrors are dirty.	If the mirrors are dirty, clean the three mirrors.
7	Lamp unit	Check that the lamp unit is contaminated with dusts.	If dusts are observed on the lamp unit, remove the dusts in the light paths.
8	CCD sensor	Check that the CCD sensor glass is contaminated with dusts.	If dusts are observed on the CCD sensor glass,remove the dusts by an air blower.

	Defective part	Check description	Corrective Action
9	Shading plate	Check whether the shading plate is dirty.	If the shading plate is dirty, perform maintenance mode U063 to modify the shading position. If it does not cure, replace the contact glass assembly. (see page 1-3-46)
10	ISC PWB	The ISC PWB is defective.	Replace the ISC PWB and perform U411. (see page 1-3-148)
11	CCD PWB	The CCD PWB is defective.	Replace the ISU and perform U411. (see page 1-3-148)
12	Main PWB	The main PWB is defective.	Replace the main PWB.(see page 1-5-59)

## 2. DP-scanning first (front) page

	Defective part	Check description	Corrective Action
1	Original document	Check whether the original document is dirty.	If the original document is dirty, replace.
2	Original document	Check if the size of the original document and its reference size match.	If the size of the original document and its reference size do not match, set the correct document size or activate border erasure.
3	Scanning position of the DP	Check whether the scanning position of the DP is wrong.	If the scanning position of the DP is shifted, perform maintenance mode U068, DP Read. (see page 1-3-51)
4	Adjustment of the scanner	Check whether the outer areas of the original document have streaks or lines.	1. Perform maintenance mode U072, Front. (see page 1-3-56) 2. Perform maintenance mode U411, DP Auto Adj. 3. Perform maintenance mode U411, DP FaceUp(Char2)_Input. (see page 1-3-148)
5	Slit glass, Contact glass	Check whether the slit glass and contact glass are dirty.	If the slit glass and contact glass are dirty, clean the contact glass, the slit glass, the bottom part of the shading plate, and the conveying guide.
6	Mirror	Check whether the mirrors are dirty.	If the mirrors are dirty, clean the three mirrors.
7	Lamp unit	Check that the lamp unit is contaminated with dusts.	If dusts are observed on the lamp unit, remove the dusts in the light paths.
8	CCD sensor	Check the dust on the CCD sensor glass.	Check whether the CCD sensor glass is stuck with dusts, and if necessary, remove the dusts by an air blower.

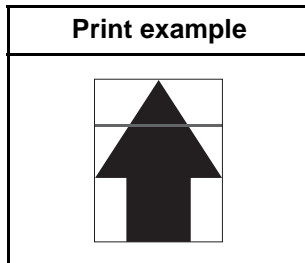
	Defective part	Check description	Corrective Action
9	Shading plate	Check whether the shading plate is dirty.	If the shading plate is dirty, perform maintenance mode U063 to modify the shading position. If it does not cure, replace the contact glass assembly. (see page 1-3-46)
10	ISC PWB	The ISC PWB is defective.	replace the ISC PWB and perform U411. (see page 1-3-148)
11	CCD PWB	The CCD PWB is defective.	Replace the ISU and perform U411. (see page 1-3-148)
12	Main PWB	The main PWB is defective.	Replace the main PWB.(see page 1-5-59)

### 3. DP-scanning second (back) page (with a dual scan DP installed)

	Defective part	Check description	Corrective Action
1	Adjustment of the scanner	Check if the outer areas of the original document have streaks or lines.	1. Perform maintenance mode U072, CIS. (see page 1-3-56) 2. Perform maintenance mode U411, DP Auto Adj. 3. Perform maintenance mode U411, DP FaceDown(Chart1)_All. (see page 1-3-148)
2	DP_CIS glass	Check whether the CIS glass of the DP is contaminated.	If the CIS glass of the DP is contaminated, clean. Or, if it has scuffs, replace.
3	DP guide plate	Check whether the DP guide plate is dirty.	If the guide plate is dirty, clean the guide plate and the conveying guide.
4	DP regist pulley	The DP regist pulley is contaminated.	Clean the DP regist pulley.
5	White-reference roller(Counter the CIS)	Check if the white reference roller is contaminated on its surface or damaged.	If the white-reference roller is dirty, clean. Or, if the roller is damaged, replace.
6	White streaks compensation settings	Check the white streaks compensation settings.	If the white streaks compensation is insufficient, perform maintenance mode U091.(see page 1-3-62)
7	DP_CIS unit	Check the location the CIS unit is mounted.	Re-mount the CIS unit if it is hanged off.
8	DP_SHD PWB	Check the CIS and the SHD PWB is properly connected.	Reinsert the connector if the PWB was loosely inserted.If not cured, replace the PWB.
9	DP_CIS	CIS is defective.	Replace the CIS and perform U091 and U411. (see page 1-3-62,1-3-148)
10	Main PWB	The main PWB is defective.	Replace the main PWB.(see page 1-5-59)

## 4. DP-scanning second (back) page (with a reversed DP installed)

	Defective part	Check description	Corrective Action
1	Original document	Check whether the original document is dirty.	If the original document is dirty, replace.
2	Original document	Check if the size of the original document and its reference size match.	If the size of the original document and its reference size do not match, set the correct document size or activate border erasure.
3	Adjustment of the scanner	Check if the outer areas of the original document have streaks or lines.	Perform maintenance mode U072, Front. (see page 1-3-56)
4	Scanning position of the DP	Check whether the scanning position of the DP is wrong.	If the scanning position of the DP is shifted, perform maintenance mode U068, DP Read. (see page 1-3-51)
5	Slit glass, contact glass	Check whether the slit glass and contact glass are dirty.	If the slit glass and contact glass are dirty, clean the contact glass, the slit glass, the bottom part of the shading plate, and the conveying guide.
6	Mirror	Check whether the mirrors are dirty.	If the mirrors are dirty, clean the three mirrors.
7	Lamp unit	Check that the lamp unit is contaminated with dusts.	If dusts are observed on the lamp unit, remove the dusts in the light paths.
8	CCD sensor	Check that the CCD sensor glass is contaminated with dusts.	If dusts are observed on the CCD sensor glass, remove the dusts by an air blower.
9	Shading plate	Check whether the shading plate is dirty.	If the shading plate is dirty, perform maintenance mode U063 to modify the shading position. If it does not cure, replace the contact glass assembly. (see page 1-3-46)
10	ISC PWB	The ISC PWB is defective.	Replace the ISC PWB and perform U411. (see page 1-3-148)
11	CCD PWB	The CCD PWB is defective.	Replace the ISU and perform U411. (see page 1-3-148)
12	Main PWB	The main PWB is defective.	Replace the main PWB. (see page 1-5-59)

**(7) Streaks are printed horizontally.**

## 1. Table scanning

	Defective part	Check description	Corrective Action
1	Original document	Check whether the original document is dirty.	If the original document is dirty, replace.
2	Contact glass	Check whether the contact glass is dirty.	If the contact glass is dirty, clean the contact glass, and the bottom part of the shading plate.
3	Ajusting scanner	Check that the image at the back of the size indicator has been rendered.	1. If the image at the back of the size indicator, has been rendered perform maintenance mode U066, Front. (see page 1-3-49) 2. Perform maintenance mode U411, Table(Char1)_Input.(see page 1-3-148)
4	FFC cable CCD	Check the FFC cable between the CCD sensor and ISC PWB is properly connected. Or, verify conduction of the wire.	Reinsert the connector if its connection is loose. Or, if conduction is lot, replace the wire.
5	FFC cable LED	Check the FFC cable between the LED PWB and ISC PWB is properly connected. Or, verify conduction of the wire.	Reinsert the connector if its connection is loose. Or, if conduction is lot, replace the wire.
6	SATA cable ISC	Check the SATA cable between the ISC PWB and main PWB is properly connected. Or, verify conduction of the wire.	Reinsert the connector if its connection is loose. Or, if conduction is lot, replace the wire.
7	LED PWB	Check that the LED is lit.	If the LED is not lit, replace the LED PWB and perform U411.
8	ISC PWB	The ISC PWB is defective.	Replace the ISC PWB and perform U411. (see page 1-3-148)
9	Main PWB	The main PWB is defective.	Replace the main PWB.(see page 1-5-59)



## 2. DP-scanning first (front) page

	Defective part	Check description	Corrective Action
1	Original document	Check whether the original document is dirty.	If the original document is dirty, replace.
2	Contact glass	Check whether the contact glass is dirty.	If the contact glass is dirty, clean the contact glass, and the bottom part of the shading plate.
3	FFC cable CCD	Check the FFC cable between the CCD sensor and ISC PWB is properly connected. Or, verify conduction of the wire.	Reinsert the connector if its connection is loose. Or, if conduction is lot, replace the wire.
4	FFC cable LED	Check the FFC cable between the LED PWB and ISC PWB is properly connected. Or, verify conduction of the wire.	Reinsert the connector if its connection is loose. Or, if conduction is lot, replace the wire.
5	SATA cable ISC	Check the SATA cable between the ISC PWB and main PWB is properly connected. Or, verify conduction of the wire.	Reinsert the connector if its connection is loose. Or, if conduction is lot, replace the wire.
6	LED PWB	Check that the LED is lit.	If the LED is not lit, replace the LED PWB and perform U411.
7	ISC PWB	The ISC PWB is defective.	Replace the ISC PWB and perform U411. (see page 1-3-148)
8	Main PWB	The main PWB is defective.	Replace the main PWB.(see page 1-5-59)

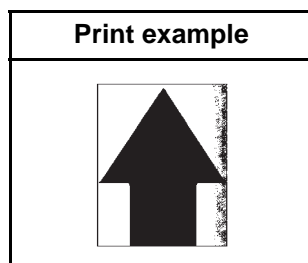
## 3. DP-scanning second (back) page (with a dual scan DP installed)

	Defective part	Check description	Corrective Action
1	Original document	Check whether the original document is dirty.	If the original document is dirty, replace.
2	DP_CIS glass	Check whether the CIS glass of the DP is contaminated.	If the CIS glass of the DP is contaminated, clean. Or, if it has scuffs, replace.
3	DP_CIS unit	Check the location the CIS unit is mounted.	Re-mount the CIS unit if it is hanged off.
4	DP_SHD PWB	Check the CIS and the SHD PWB is properly connected.	Reinsert the connector if the PWB was loosely inserted.If not cured, replace the PWB.
5	DP_SATA cable	Check the FFC cable between the SHD PWB and ISC PWB is properly connected. Or, verify conduction of the wire.	Reinsert the connector if its connection is loose. Or, if conduction is lot, replace the wire.
6	DP_CIS	CIS is defective.	Replace the CIS and perform U091 and U411. (see page 1-3-62,1-3-148)

	Defective part	Check description	Corrective Action
7	Main PWB	The main PWB is defective.	Replace the main PWB.(see page 1-5-59)

## 4. DP-scanning second (back) page (with a reversed DP installed)

	Defective part	Check description	Corrective Action
1	Original document	Check whether the original document is dirty.	If the original document is dirty, replace.
2	Contact glass	Check whether the contact glass is dirty.	If the contact glass is dirty, clean the contact glass, and the bottom part of the shading plate.
3	FFC cable CCD	Check the FFC cable between the CCD sensor and ISC PWB is properly connected. Or, verify conduction of the wire.	Reinsert the connector if its connection is loose. Or, if conduction is lot, replace the wire.
4	FFC cable LED	Check the FFC cable between the LED PWB and ISC PWB is properly connected. Or, verify conduction of the wire.	Reinsert the connector if its connection is loose. Or, if conduction is lot, replace the wire.
5	SATA cable ISC	Check the SATA cable between the ISC PWB and main PWB is properly connected. Or, verify conduction of the wire.	Reinsert the connector if its connection is loose. Or, if conduction is lot, replace the wire.
6	LED PWB	Check that the LED is lit.	If the LED is not lit, replace the LED PWB and perform U411.
7	ISC PWB	The ISC PWB is defective.	Replace the ISC PWB and perform U411. (see page 1-3-148)
8	Main PWB	The main PWB is defective.	Replace the main PWB.(see page 1-5-59)

**(8) One side of the print image is darker or brighter than the other.**

## 1. Table scanning

	Defective part	Check description	Corrective Action
1	Original document	Check whether the original document is dirty.	If the original document is dirty, replace.
2	Original document	Check if the original document has creases or foldings or wrinkles.	If the original document has foldings or creases, remove them.
3	Position of the mat of the platen	Check whether the position of the mat of the DP or the platen is wrong.	If the position of the mat of the DP or the platen is shifted, re-mount.
4	Contact glass	Check whether the contact glass is dirty.	If the contact glass is dirty, clean the contact glass, and the bottom part of the shading plate.
5	Contact glass assy	Check the location the contact glass is mounted.	If the light guide panel has been fallen off of the mounting position, fix it properly.
6	Lamp unit	Check the position at which the light guide panel is mounted.	If the contact part of the lamp unit and the rail is distorted, replace the lamp unit.
7	Mirror	Check whether the mirrors are dirty.	If the mirrors are dirty, clean the three mirrors.
8	ISU	Check the location the ISU unit is mounted.	Insert a spacer between the scanner unit and the ISU to change the height. (see page 1-5-37)
9	LED PWB	Check that the LED is lit.	If the LED is not lit, replace the LED PWB and perform U411.(see page 1-3-148)
10	LED Assy	Check the mounting position of the reflector board or if it is distorted.	If the LED assy is hanged off of the mounting position of the reflector or it is deformed, replace the LED assy.
11	Lamp unit	Check that the contact part of the lamp unit and the rail is distorted.	If the contact part of the lamp unit and the rail is distorted, replace the lamp unit.
12	Mirror unit	Check the location the mirror is mounted.	Re-mount the mirror if it is hanged off. Or, if the mirror is damaged, replace.

	Defective part	Check description	Corrective Action
13	Mirror unit	Check that the contact part of the mirror unit and the rail is distorted.	If the contact part of the mirror unit and the rail is distorted, replace the mirror unit.
14	ISC PWB	The ISC PWB is defective.	Replace the ISC PWB and perform U411. (see page 1-3-148)
15	CCD PWB	The CCD PWB is defective.	Replace the ISU and perform U411. (see page 1-3-148)
16	Main PWB	The main PWB is defective.	Replace the main PWB.(see page 1-5-59)

## 2. DP-scanning first (front) page

	Defective part	Check description	Corrective Action
1	Original document	Check whether the original document is dirty.	If the original document is dirty, replace.
2	Original document	Check if the original document has creases or foldings or wrinkles.	If the original document has foldings or creases, remove them.
3	DP scanning guide	Check that the scanning guide is smoothly operative.	If the scanning guide does not rotate smoothly, re-install.
4	Contact glass	Check whether the contact glass is dirty.	If the contact glass is dirty, clean the contact glass, and the bottom part of the shading plate.
5	Contact glass assy	Check the location the contact glass is mounted.	Re-mount the contact glass if it is hanged off.
6	LED PWB	Check that the LED is lit.	If the LED is not lit, replace the LED PWB and perform U411.
7	ISC PWB	The ISC PWB is defective.	replace the ISC PWB and perform U411. (see page 1-3-148)
8	CCD PWB	The CCD PWB is defective.	Replace the ISU PWB and perform U411. (see page 1-3-148)
9	Main PWB	The main PWB is defective.	Replace the main PWB.(see page 1-5-59)

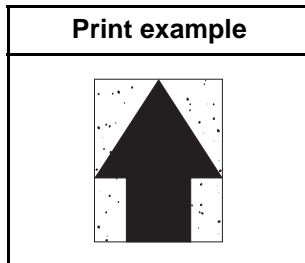
## 3. DP-scanning second (back) page (with a dual scan DP installed)

	Defective part	Check description	Corrective Action
1	Original document	Check whether the original document is dirty.	If the original document is dirty, replace.
2	Original document	Check if the original document has creases or foldings or wrinkles.	If the original document has foldings or creases, remove them.

	Defective part	Check description	Corrective Action
3	White-reference roller(Counter the CIS)	Check that the white-reference roller is smoothly operative.	If the white-reference roller does not rotate smoothly, re-install.
4	DP_CIS	CIS is defective.	Replace the CIS and perform U091 and U411. (see page 1-3-62,1-3-148)
5	Main PWB	The main PWB is defective.	Replace the main PWB.(see page 1-5-59)

## 4. DP-scanning second (back) page (with a reversed DP installed)

	Defective part	Check description	Corrective Action
1	Original document	Check whether the original document is dirty.	If the original document is dirty, replace.
2	Original document	Check if the original document has creases or foldings or wrinkles.	If the original document has foldings or creases, remove them.
3	DP scanning guide	Check that the scanning guide is smoothly operative.	If the scanning guide does not move smoothly, re-install.
4	Contact glass	Check whether the contact glass is dirty.	If the contact glass is dirty, clean the contact glass, and the bottom part of the shading plate.
5	Contact glass assy	Check the location the contact glass is mounted.	Re-mount the contact glass if it is hanged off.
6	LED PWB	Check that the LED is lit.	If the LED is not lit, replace the LED PWB and perform U411. (see page 1-3-148)
7	ISC PWB	The ISC PWB is defective.	Replace the ISC PWB and perform U411. (see page 1-3-148)
8	CCD PWB	The CCD PWB is defective.	Replace the ISU and perform U411. (see page 1-3-148)
9	Main PWB	The main PWB is defective.	Replace the main PWB.(see page 1-5-59)

**(9) Black dots appear on the image.**

## 1. Table scanning

	Defective part	Check description	Corrective Action
1	Original document	Check whether the original document is dirty.	If the original document is dirty, replace.
2	Contact glass	Check whether the contact glass is dirty.	If the contact glass is dirty, clean the contact glass, and the bottom part of the shading plate.
3	FFC cable CCD	Check the FFC cable between the CCD sensor and ISC PWB is properly connected. Or, verify conduction of the wire.	Reinsert the connector if its connection is loose. Or, if conduction is lot, replace the wire.
4	SATA cable ISC	Check the SATA cable between the ISC PWB and main PWB is properly connected. Or, verify conduction of the wire.	Reinsert the connector if its connection is loose. Or, if conduction is lot, replace the wire.
5	Main PWB	The main PWB is defective.	Replace the main PWB.(see page 1-5-59)

## 2. DP-scanning first (front) page

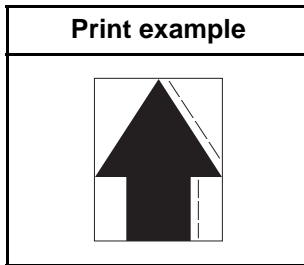
	Defective part	Check description	Corrective Action
1	Original document	Check whether the original document is dirty.	If the original document is dirty, replace.
2	Contact glass	Check whether the contact glass is dirty.	If the contact glass is dirty, clean the contact glass, and the bottom part of the shading plate.
3	FFC cable CCD	Check the FFC cable between the CCD sensor and ISC PWB is properly connected. Or, verify conduction of the wire.	Reinsert the connector if its connection is loose. Or, if conduction is lot, replace the wire.
4	SATA cable ISC	Check the SATA cable between the ISC PWB and main PWB is properly connected. Or, verify conduction of the wire.	Reinsert the connector if its connection is loose. Or, if conduction is lot, replace the wire.
5	Main PWB	The main PWB is defective.	Replace the main PWB.(see page 1-5-59)

## 3. DP-scanning second (back) page (with a dual scan DP installed)

	Defective part	Check description	Corrective Action
1	Original document	Check whether the original document is dirty.	If the original document is dirty, replace.
2	DP_SHD PWB	Check the CIS and the SHD PWB is properly connected.	Reinsert the connector if the PWB was loosely inserted.If not cured, replace the PWB.
3	DP_SATA cable	Check the FFC cable between the SHD PWB and I/F PWB is properly connected. Or, verify conduction of the wire.	Reinsert the connector if its connection is loose. Or, if conduction is lot, replace the wire.
4	DP_CIS	CIS is defective.	Replace the CIS and perform U091 and U411. (see page 1-3-62,1-3-148)
5	Main PWB	The main PWB is defective.	Replace the main PWB.(see page 1-5-59)

## 4. DP-scanning second (back) page (with a reversed DP installed)

	Defective part	Check description	Corrective Action
1	Original document	Check whether the original document is dirty.	If the original document is dirty, replace.
2	Contact glass	Check whether the contact glass is dirty.	If the contact glass is dirty, clean the contact glass, and the bottom part of the shading plate.
3	FFC cable CCD	Check the FFC cable between the CCD sensor and ISC PWB is properly connected. Or, verify conduction of the wire.	Reinsert the connector if its connection is loose. Or, if conduction is lot, replace the wire.
4	SATA cable ISC	Check the SATA cable between the ISC PWB and main PWB is properly connected. Or, verify conduction of the wire.	Reinsert the connector if its connection is loose. Or, if conduction is lot, replace the wire.
5	Main PWB	The main PWB is defective.	Replace the main PWB.(see page 1-5-59)

**(10) Image is blurred.**

## 1. Table scanning

	Defective part	Check description	Corrective Action
1	Rail	Check that the carriage is smoothly operative.	If the carriage does not travel smoothly, remove foreign objects on the front and back optical rails.
2	Lamp unit	Check that the carriage is smoothly operative.	If the carriage does not travel smoothly because the lamp unit contacts with the frame, rectify.
3	Scanner wire drum	Confirm that a foreign object exists between the wire rope and the scanner wire drum.	If a foreign object exists, remove.
4	Mirror unit	Check that a foreign object exists in the grooves of the pulley.	If a foreign object exists in the grooves of the pulleys, remove.
5	Pulley	Check that a foreign object exists in the grooves of the pulleys other than above.	If a foreign object exists in the grooves of the pulleys, remove.
6	Wire rope	Confirm that the wire rope has a foreign object stuck or has a scuff.	If a foreign object exists on the wire rope, remove the foreign object. Or, if it is damaged, replace.

## 2. DP-scanning first (front) page

	Defective part	Check description	Corrective Action
1	DP conveying pulley	Check that the conveying pulley is smoothly operative.	If the conveying pulley does not rotate smoothly, re-assemble the conveying roller and springs.
2	Adjustment height of the hinge portions of the DP	Check the height of the front and back portions of the DP.	If the front and back side of the DP is not leveled, adjust the hinge on the left side.
3	Install DP	Check how DP is mounted on the main unit.	If mounting to the main unit is improper, check positioning and secure the screws.
4	DP hinge	Check that the DP hinge is operative in both ascending and descending directions and kept open.	If the DP is not operative smoothly or is not held stably open, replace the hinges.



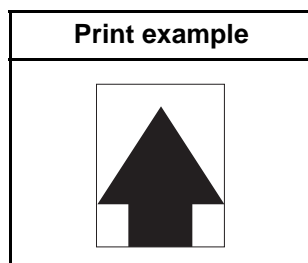
	Defective part	Check description	Corrective Action
5	DP document mat	Check the location the document mat of the DP is mounted.	Re-mount the document mat of the DP if it is hanged off.
6	Original document	Check that the leading edge of the original document is dog-eared.	If the leading edge of the original documet is dog-eared, straighten.
7	Scanning guide	Check if the scanning guide is distorted.	If the scanning guide deformed, replace.
8	Scopper guide	Check that the scopper guide is smoothly operative.	If the scopper guide does not rotate smoothly, re-install.
9	Conveying roller (before and after of scanning)	Check whether the conveying roller is dirty.	If the conveying roller is dirty, clean.
10	Drive belt	Check if the drive belt is jumping gear teeth.	If the drive belt is jumping gear teeth, re-mount the belt tensioner.

### 3. DP-scanning second (back) page (with a dual scan DP installed)

	Defective part	Check description	Corrective Action
1	DP conveying pulley	Check that the conveying pulley is smoothly operative.	If the conveying pulley does not rotate smoothly, re-assemble the conveying roller and springs.
2	Install DP	Check how DP is mounted on the main unit.	If mounting to the main unit is improper, check positioning and secure the screws.
3	DP hinge	Check that the DP hinge is operative in both ascending and descending directions and kept open.	If the DP is not operative smoothly or is not held stably open, replace the hinges.
4	DP document mat	Check the location the document mat of the DP is mounted.	Re-mount the document mat of the DP if it is hanged off.
5	Original document	Check that the leading edge of the original document is dog-eared.	If the leading edge of the original documet is dog-eared, straighten.
6	Scanning roller	Check if the scanning roller is floated.	If the scanning roller is floated, re-assemble.
7	Conveying roller (before and after of scanning)	Check whether the conveying roller is dirty.	If the conveying roller is dirty, clean.
8	Scanning glass	Check if the scanning glass is floated.	If the scanning glass is floated, re-assemble.
9	Drive belt	Check if the drive belt is jumping gear teeth.	If the drive belt is jumping gear teeth, re-mount the belt tensioner.

## 4. DP-scanning second (back) page (with a reversed DP installed)

	Defective part	Check description	Corrective Action
1	DP conveying pulley	Check that the conveying pulley is smoothly operative.	If the conveying pulley does not rotate smoothly, re-assemble the conveying roller and springs.
2	Adjustment height of the hinge portions of the DP	Check the height of the front and back portions of the DP.	If the front and back side of the DP is not leveled, adjust the hinge on the left side.
3	Install DP	Check how DP is mounted on the main unit.	If mounting to the main unit is improper, check positioning and secure the screws.
4	DP hinge	Check that the DP hinge is operative in both ascending and descending directions and kept open.	If the DP is not operative smoothly or is not held stably open, replace the hinges.
5	DP document mat	Check the location the document mat of the DP is mounted.	Re-mount the document mat of the DP if it is hanged off.
6	Original document	Check that the leading edge of the original document is dog-eared.	If the leading edge of the original document is dog-eared, straighten.
7	Scanning guide	Check if the scanning guide is distorted.	If the scanning guide deformed, replace.
8	Scopper guide	Check that the scopper guide is smoothly operative.	If the scopper guide does not rotate smoothly, re-install.
9	Conveying roller (before and after of scanning)	Check whether the conveying roller is dirty.	If the conveying roller is dirty, clean.
10	Drive belt	Check if the drive belt is jumping gear teeth.	If the drive belt is jumping gear teeth, re-mount the belt tensioner.

**(11) The leading edge of the image is consistently misaligned with the original.**

## 1. Table scanning

	Defective part	Check description	Corrective Action
1	Original document	Check if the original document is loaded correctly on the contact glass.	If the original document is not properly placed on the contact glass, place it correctly.
2	Secures the lamp unit	Confirm the orientation of the bracket that secures the wire rope and the lamp unit.	If the bracket that fixes the wire rope and the lamp unit is misaligned, align the bracket properly.
3	Adjustment of the scanner	Check the scanning adjustment of the scanner.	1. Perform maintenance mode U066, Front. (see page 1-3-49) 2. Perform maintenance mode U411, table(Char1)_Input. (see page 1-3-148)
4	Home position sensor	Check the location the home position sensor is mounted.	Re-mount the home position sensor if it is hanged off.
5	Drive belt	Check if the tension of the drive belt is insufficient.	If the tension of the drive belt is insufficient, tense the belt.
6	Scanner wire drum	Check if the optical wire drum is loosely fixed.	If the optical wire drum is loosely fixed, secure the screws.
7	Scanner drive gear	Check that the scanner drive gear is loosely mounted.	If the scanner drive gear loosely mounted, secure the screw.

## 2. DP-scanning first (front) page

	Defective part	Check description	Corrective Action
1	Adjustment of the scanner	Check the scanning adjustment of DP scanning.	1. Perform maintenance mode U071, CIS Head. (see page 1-3-54) 2. Perform maintenance mode U411, DP Auto Adj. (only a dual scan DP installed) 3. Perform maintenance mode U411, FaceUp(Char2)_Input. (see page 1-3-148)
2	Original conveying roller	Check if the conveyer roller is contaminated or worn.	If the conveying roller is dirty, clean the conveying roller and its axles. If the roller is worn out, replace.

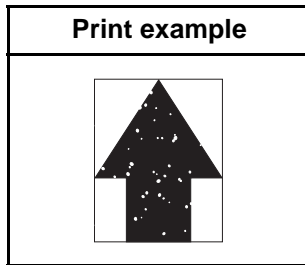
	Defective part	Check description	Corrective Action
3	DP drive motor	Check whether the DP drive motor is fluctuated in rotation.	If the DP motor is fluctuated in rotation, apply grease with the drive gear. If no improvement is observed, replace the motor.

## 3. DP-scanning second (back) page (with a dual scan DP installed)

	Defective part	Check description	Corrective Action
1	Adjustment of the scanner	Check the scanning adjustment of DP scanning.	<ol style="list-style-type: none"> <li>1. Perform maintenance mode U071, CIS Head. (see page 1-3-54)</li> <li>2. Perform maintenance mode U411, DP Auto Adj.</li> <li>3. Perform maintenance mode U411, FaceDown(Char1)_All. (see page 1-3-148)</li> </ol>

## 4. DP-scanning second (back) page (with a reversed DP installed)

	Defective part	Check description	Corrective Action
1	Adjustment of the scanner	Check the scanning adjustment of DP scanning.	<ol style="list-style-type: none"> <li>1. Perform maintenance mode U071, Back Head. (see page 1-3-54)</li> </ol>

**(12) Part of image is missing.**

## 1. Table scanning

	Defective part	Check description	Corrective Action
1	Original document	Check if the original document is loaded correctly on the contact glass.	If the original document is not properly placed on the contact glass, place it correctly.
2	Original document	<ol style="list-style-type: none"> <li>1. Check that the size of the original document and the paper size match on the panel.</li> <li>2. Check that the copying position has been automatically rotated.</li> </ol>	<ol style="list-style-type: none"> <li>1. If the sizes of the original document and the paper size do not match, manually set the proper paper size for the original document.</li> <li>2. Check the paper size automatic detection switch and replace if faulty.</li> <li>3. If the copying position is automatically rotated, deactivate automatic image</li> </ol>
3	Settings of Border removal	Check the value of border removal.	If a large value is given to bordere erasure, change it to a smaller value.
4	Contact glass	Check whether the contact glass is dirty.	If the contact glass is dirty, clean the contact glass, and the bottom part of the shading plate.
5	Contact glass assy	Check the location the contact glass is mounted.	Re-mount the contact glass if it is hanged off.
6	FFC cable CCD	Check the FFC cable between the CCD sensor and ISC PWB is properly connected. Or, verify conduction of the wire.	Reinsert the connector if its connection is loose. Or, if conduction is lot, replace the wire.
7	SATA cable ISC	Check the SATA cable between the ISC PWB and main PWB is properly connected. Or, verify conduction of the wire.	Reinsert the connector if its connection is loose. Or, if conduction is lot, replace the wire.
8	Lamp unit	Check the location the lamp unit is mounted.	Re-mount the lamp unit if it is hanged off.
9	ISC PWB	The ISC PWB is defective.	Replace the ISC PWB and perform U411. (see page 1-3-148)
10	CCD PWB	The CCD PWB is defective.	Replace the ISU and perform U411. (see page 1-3-148)
11	Main PWB	The main PWB is defective.	Replace the main PWB.(see page 1-5-59)

## 2. DP-scanning first (front) page

	Defective part	Check description	Corrective Action
1	Original document	Check if the original document is loaded correctly in the DP.	If the original document is not properly placed in the DP, place it correctly.
2	Original document	1. Check that the size of the original document and the paper size match on the panel. 2. Check that the copying position has been automatically rotated.	1. If the sizes of the original document and the paper size do not match, manually set the proper paper size for the original document. 2. Check the paper size automatic detection switch and replace if faulty. 3. If the copying position is automatically rotated, deactivate automatic image rotation by the system menu.
3	Settings of Border removal	Check the value of border removal.	If a large value is given to bordere erasure, change it to a smaller value.
4	Contact glass	Check whether the contact glass is dirty.	If the contact glass is dirty, clean the contact glass, and the bottom part of the shading plate.
5	FFC cable CCD	Check the FFC cable between the CCD sensor and ISC PWB is properly connected. Or, verify conduction of the wire.	Reinsert the connector if its connection is loose. Or, if conduction is lot, replace the wire.
6	SATA cable ISC	Check the SATA cable between the ISC PWB and main PWB is properly connected. Or, verify conduction of the wire.	Reinsert the connector if its connection is loose. Or, if conduction is lot, replace the wire.
7	ISC PWB	The ISC PWB is defective.	Replace the ISC PWB and perform U411. (see page 1-3-148)
8	CCD PWB	The CCD PWB is defective.	Replace the ISU and perform U411. (see page 1-3-148)
9	Main PWB	The main PWB is defective.	Replace the main PWB.(see page 1-5-59)

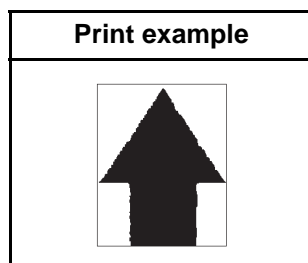
## 3. DP-scanning second (back) page (with a dual scan DP installed)

	Defective part	Check description	Corrective Action
1	Original document	Check if the original document is loaded correctly in the DP.	If the original document is not properly placed in the DP, place it correctly.
2	Original document	Check the size of the original document and its reference size.	If the size of the original document and its reference size do not match, manually set the document size.
3	Settings of Border removal	Check the value of border removal.	If a large value is given to bordere erasure, change it to a smaller value.

	Defective part	Check description	Corrective Action
4	DP_SATA cable	Check the FFC cable between the SHD PWB and I/F PWB is properly connected. Or, verify conduction of the wire.	Reinsert the connector if its connection is loose. Or, if conduction is lot, replace the wire.
5	DP_SHD PWB	Check the CIS and the SHD PWB is properly connected.	Reinsert the connector if the PWB was loosely inserted.If not cured, replace the PWB.
6	DP_CIS	CIS is defective.	Replace the CIS and perform U091 and U411. (see page 1-3-62,1-3-148)
7	Main PWB	The main PWB is defective.	Replace the main PWB.(see page 1-5-59)

## 4. DP-scanning second (back) page (with a reversed DP installed)

	Defective part	Check description	Corrective Action
1	Original document	Check if the original document is loaded correctly in the DP.	If the original document is not properly placed in the DP, place it correctly.
2	Original document	Check the size of the original document and its reference size.	If the size of the original document and its reference size do not match, manually set the document size.
3	Settings of Border removal	Check the value of border removal.	If a large value is given to bordere erasure, change it to a smaller value.
4	Contact glass	Check whether the contact glass is dirty.	If the contact glass is dirty, clean the contact glass, and the bottom part of the shading plate.
5	FFC cable CCD	Check the FFC cable between the CCD sensor and ISC PWB is properly connected. Or, verify conduction of the wire.	Reinsert the connector if its connection is loose. Or, if conduction is lot, replace the wire.
6	SATA cable ISC	Check the SATA cable between the ISC PWB and main PWB is properly connected. Or, verify conduction of the wire.	Reinsert the connector if its connection is loose. Or, if conduction is lot, replace the wire.
7	ISC PWB	The ISC PWB is defective.	Replace the ISC PWB and perform U411. (see page 1-3-148)
8	CCD PWB	The CCD PWB is defective.	Replace the ISU and perform U411. (see page 1-3-148)
9	Main PWB	The main PWB is defective.	Replace the main PWB.(see page 1-5-59)

**(13) Image is out of focus.**

## 1. Table scanning and DP-scanning first (front) page

	Defective part	Check description	Corrective Action
1	Original document	Check whether the original document is wavy.	If the original document is wavy, straighten.Or, replace the original document.
2	Contact glass	Check whether the contact glass is dew condensed.	If the contact glass is dew condensed, remove the dew.
3	Mirror	Check whether the mirror is dew condensed.	If the mirrors are dew-condensed, remove the dew.
4	Lens	Check whether the lens is dew condensed.	If the lens is dew condensed, remove the dew.
5	CCD sensor	Check whether the CCD sensor glass is dew condensed.	If the CCD sensor glass is dew condensed, remove the dew.
6	Adjustment of the scanner	Check the automatic adjustment of the scanner.	Perform maintenance mode U411, table(Chart1)_All. (see page 1-3-148)
7	ISU	Confirm the position of the lens and the CCD sensor.	If the lenses and the CCD sensor are misaligned, replace the ISU and perform U411.
8	ISC PWB	The ISC PWB is defective.	Replace the ISC PWB and perform U411. (see page 1-3-148)
9	Main PWB	The main PWB is defective.	Replace the main PWB.(see page 1-5-59)

## 2. DP-scanning second (back) page (with a dual scan DP installed)

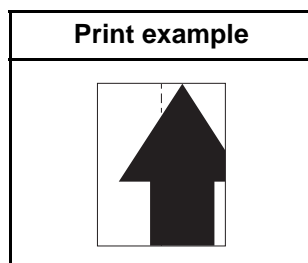
	Defective part	Check description	Corrective Action
1	DP_CIS glass	Check whether the CIS glass is dew condensed.	If the CIS glass is dew condensed, remove the dew.
2	DP_CIS glass	Check whether the CIS glass is contaminated.	If the CIS glass is contaminated, clean the CIS glass. If it has a scuff, replace.
3	White-reference roller(Counter the CIS)	Check that the white-reference roller is smoothly operative.	If the white-reference roller does not rotate smoothly, re-install.



	Defective part	Check description	Corrective Action
4	Adjustment of the scanner	Check the automatic adjustment of the scanner.	Perform maintenance mode U411, DP FaceDown(Chart1)_All. (see page 1-3-148)
5	DP_CIS unit	Check the location the CIS unit is mounted.	Re-mount the CIS unit if it is hanged off.
6	DP_CIS	CIS is defective.	Replace the CIS and perform U091 and U411. (see page 1-3-62,1-3-148)

### 3. DP-scanning second (back) page (with a reversed DP installed)

	Defective part	Check description	Corrective Action
1	Contact glass	Check whether the contact glass is dew condensed.	If the contact glass is dew condensed, remove the dew.
2	Mirror	Check whether the mirror is dew condensed.	If the mirrors are dew-condensed, remove the dew.
3	Lens	Check whether the lens is dew condensed.	If the lens is dew condensed, remove the dew.
4	CCD sensor	Check whether the CCD sensor glass is dew condensed.	If the CCD sensor glass is dew condensed, remove the dew.
5	Adjustment of the scanner	Check the automatic adjustment of the scanner.	Perform maintenance mode U411, Table(Chart1)_All. (see page 1-3-148)
6	ISU	Confirm the position of the lens and the CCD sensor.	If the lenses and the CCD sensor are misaligned, replace the ISU and perform U411. (see page 1-3-148)
7	ISC PWB	The ISC PWB is defective.	Replace the ISC PWB and perform U411. (see page 1-3-148)
8	Main PWB	The main PWB is defective.	Replace the main PWB.(see page 1-5-59)

**(14) Image center does not align with the original center.**

## 1. Table scanning

	Defective part	Check description	Corrective Action
1	Original document	Check if the original document is loaded correctly on the contact glass.	If the original document is not properly placed on the contact glass, place it correctly.
2	Contact glass assy	Check the location the contact glass is mounted.	Re-mount the contact glass if it is hanged off.
3	Adjustment of the scanner	Check the scanning adjustment of the scanner.	1. Perform maintenance mode U067, Front.(see page 1-3-50) 2. Perform maintenance mode U411, Table(Char1)_Input. (see page 1-3-148)

## 2. DP-scanning first (front) page

	Defective part	Check description	Corrective Action
1	Original document	Check if the original document is loaded correctly in the DP.	If the original document is not properly placed in the DP, place it correctly.
2	Adjustment of the scanner	Check the scanning adjustment of DP scanning.	1. Perform maintenance mode U072, Front. 2. Perform maintenance mode U411, DP Auto Adj. (If a duplex scanning DP is installed.) 3. Perform maintenance mode U411, DP FaceUp(Char2)_Input. (see page 1-3-148)

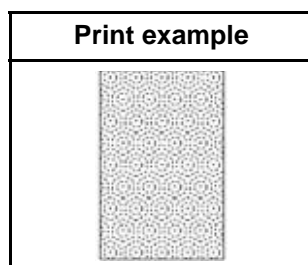
## 3. DP-scanning second (back) page (with a dual scan DP installed)

	Defective part	Check description	Corrective Action
1	Original document	Check if the original document is loaded correctly in the DP.	If the original document is not properly placed in the DP, place it correctly.

	Defective part	Check description	Corrective Action
2	Adjustment of the scanner	Check the scanning adjustment of DP scanning.	<ol style="list-style-type: none"> <li>1. Perform maintenance mode U072, CIS . (see page 1-3-66)</li> <li>2. Perform maintenance mode U411, DP Auto Adj.</li> <li>3. Perform maintenance mode U411, DP FaceDown (Chart1)_All. (see page 1-3-148)</li> </ol>

## 4. DP-scanning second (back) page (with a reversed DP installed)

	Defective part	Check description	Corrective Action
1	Original document	Check if the original document is loaded correctly in the DP.	If the original document is not properly placed in the DP, place it correctly.
2	Adjustment of the scanner	Check the scanning adjustment of DP scanning.	1. Perform maintenance mode U072, Back. (see page 1-3-56)

**(15) Moires**

## 1. Table scanning

	Defective part	Check description	Corrective Action
1	Settings of print quality mode	Confirm whether the moire varies depending on print quality mode.	Switch print quality mode if the moire varies depending on print quality mode. <ol style="list-style-type: none"> <li>1. Execute printing in text or print mode.</li> <li>2. Reduce the sharpness (to minus).</li> </ol>
2	Original document	Check if moire is observed along the direction of scanning of the original document.	If moire is observed, place the original document after rotating it 90-degree.
3	Scaling factor	Happens with the zoom ratio of 100%.	Reduce the real-size ratio of the main scan direction by U065.
4	Adjustment of the scanner	Check the automatic adjustment of the scanner.	Perform maintenance mode U411, Table(Chart1)_All. (see page 1-3-148)

## 2. DP-scanning first (front) page

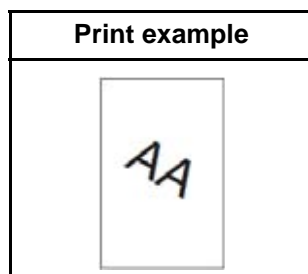
	Defective part	Check description	Corrective Action
1	Settings of print quality mode	Confirm whether the moire varies depending on print quality mode.	Switch print quality mode if the moire varies depending on print quality mode. 1. Execute printing in text or print mode. 2. Reduce the sharpness (to minus).
2	Adjustment of the scanner	Check the automatic adjustment of the scanner.	Perform maintenance mode U411, Table(Char1)_All. (see page 1-3-148)

## 3. DP-scanning second (back) page (with a dual scan DP installed)

	Defective part	Check description	Corrective Action
1	Settings of print quality mode	Confirm whether the moire varies depending on print quality mode.	Switch print quality mode if the moire varies depending on print quality mode. 1. Execute printing in text or print mode. 2. Reduce the sharpness (to minus).
2	Adjustment of the scanner	Check the automatic adjustment of the scanner.	Perform maintenance mode U411, DP FaceDown(Char1)_All. (see page 1-3-148)

## 4. DP-scanning second (back) page (with a reversed DP installed)

	Defective part	Check description	Corrective Action
1	Settings of print quality mode	Confirm whether the moire varies depending on print quality mode.	Switch print quality mode if the moire varies depending on print quality mode. 1. Execute printing in text or print mode. 2. Reduce the sharpness (to minus).
2	Adjustment of the scanner	Check the automatic adjustment of the scanner.	Perform maintenance mode U411, Table(Char1)_All. (see page 1-3-148)

**(16) Skewed image**

## 1. Table scanning

	Defective part	Check description	Corrective Action
1	Original document	Check if the original document is fed askew.	If the original document is not placed askew on the contact glass, place it correctly.
2	Adjustment of height of main unit and scanner unit	Check the scanner unit is quite level.	If the scanner unit is not quite level, perform the height adjustment of the entire scanner unit.
3	Lamp unit	Check the location the lamp unit is mounted.	Re-mount the lamp unit if it is hanged off.

## 2. DP-scanning first (front) page

	Defective part	Check description	Corrective Action
1	Original document	Check if the original document has creases or foldings or wrinkles.	If the original document has foldings or creases, remove them.
2	DP paper feed	Check if the original document is fed askew.	If the original document is fed askew, set the width guides correctly.
3	Lamp unit	Check the location the lamp unit is mounted.	Re-mount the lamp unit if it is hanged off.
4	DP feed roller	Check whether the feed roller is dirty.	If the feed roller is dirty, clean.Or, if not cured, replace the feed roller.
5	DP regist roller	Check whether the DP regist roller is dirty.	If the DP regist roller is dirty, clean.
6	DP regist pulley	Check that the DP regist pulley is smoothly operative.	If the DP regist pulley does not rotate smoothly, re-install.
7	Adjustment amount of slack of the original document	Check the amount of slack of the original document when it reaches at the regist.	If the amount of the slack of the original document roller improper is perform maintenance mode U942, DP slack settings.(see page 1-3-192)
8	Original document setting	Check that the cursor fits with the original document.	Align the cursor to fit with the original document, if necessary.

	Defective part	Check description	Corrective Action
9	Adjustment positions of the hinge	Check the front and back adjustment positions of the right hinge.	If the front and back adjustment positions of the right hinge are improper, perform adjustment.

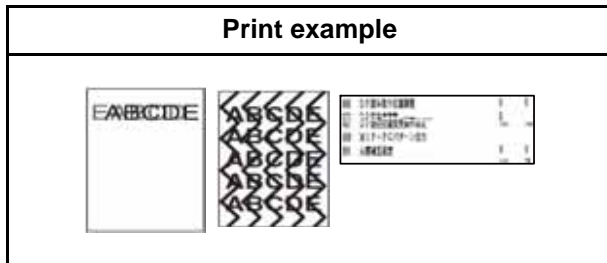
### 3. DP-scanning second (back) page (with a dual scan DP installed)

	Defective part	Check description	Corrective Action
1	Original document	Check if the original document has creases or foldings or wrinkles.	If the original document has foldings or creases, remove them.
2	DP feed roller	Check whether the DP feed roller is dirty.	If the DP feed roller is dirty, clean.
3	DP regist roller	Check whether the DP regist roller is dirty.	If the DP regist roller is dirty, clean.
4	DP regist pulley	Check that the DP regist pulley is smoothly operative.	If the DP regist pulley does not rotate smoothly, re-install.
5	Adjustment amount of slack of the original document	Check the amount of slack of the original document when it reaches at the regist.	If the amount of the slack of the original document roller improper is perform maintenance mode U942, DP slack settings.(see page 1-3-192)
6	Original document setting	Check that the cursor fits with the original document.	Align the cursor to fit with the original document, if necessary.
7	Install the CIS	Check whether CIS is loosely mounted.	Re-mount the CIS unit if it is hanged off.

### 4. DP-scanning second (back) page (with a reversed DP installed)

	Defective part	Check description	Corrective Action
1	Original document	Check if the original document has creases or foldings or wrinkles.	If the original document has foldings or creases, remove them.
2	Lamp unit	Check the location the lamp unit is mounted.	Re-mount the lamp unit if it is hanged off.
3	DP feed roller	Check whether the feed roller is dirty.	If the feed roller is dirty, clean.Or, if not cured, replace the feed roller.
4	DP regist roller	Check whether the DP regist roller is dirty.	If the DP regist roller is dirty, clean.
5	DP regist pulley	Check that the DP regist pulley is smoothly operative.	If the DP regist pulley does not rotate smoothly, re-install.

	Defective part	Check description	Corrective Action
6	Adjustment amount of slack of the original documen	Check the amount of slack of the original document when it reaches at the regist.	If the amount of the slack of the original document roller improper is perform maintenance mode U942, DP slack settings.(see page 1-3-192)
7	Original document setting	Check that the cursor fits with the original document.	Align the cursor to fit with the original document, if necessary.
8	Adjustment positions of the hinge	Check the front and back adjustment positions of the right hinge.	If the front and back adjustment positions of the right hinge are improper, perform adjustment.
9	Main PWB	The main PWB is defective.	Replace the main PWB.(see page 1-5-59)

**(17) Abnormal image**

## 1. Table scanning

	Defective part	Check description	Corrective Action
1	FFC cable CCD	Check the FFC cable between the CCD sensor and ISC PWB is properly connected. Or, verify conduction of the wire.	Reinsert the connector if its connection is loose. Or, if conduction is lot, replace the wire.
2	SATA cable ISC	Check the SATA cable between the ISC PWB and main PWB is properly connected. Or, verify conduction of the wire.	Reinsert the connector if its connection is loose. Or, if conduction is lot, replace the wire.
3	HDD	Check the wires to the HDD in conduction. Check the connector for connection. Check the connector pins for distortion.	<ol style="list-style-type: none"> <li>1. Reinsert the connector if its connection is loose.</li> <li>2. Check the wires and connectors, and replace if faulty.</li> <li>3. Replace the HDD or the SATA wire.</li> </ol>
4	ISC PWB	The ISC PWB is defective.	Replace the ISC PWB and perform U411. (see page 1-3-148)
5	CCD PWB	The CCD PWB is defective.	Replace the ISU and perform U411. (see page 1-3-148)
6	Main PWB	The main PWB is defective.	Replace the main PWB.(see page 1-5-59)

## 2. DP-scanning first (front) page

	Defective part	Check description	Corrective Action
1	FFC cable CCD	Check the FFC cable between the CCD sensor and ISC PWB is properly connected. Or, verify conduction of the wire.	Reinsert the connector if its connection is loose. Or, if conduction is lot, replace the wire.
2	SATA cable ISC	Check the SATA cable between the ISC PWB and main PWB is properly connected. Or, verify conduction of the wire.	Reinsert the connector if its connection is loose. Or, if conduction is lot, replace the wire.



	Defective part	Check description	Corrective Action
3	HDD	Check the wires to the HDD in conduction. Check the connector for connection. Check the connector pins for distortion.	1. Reinsert the connector if its connection is loose. 2. Check the wires and connectors, and replace if faulty. 3. Replace the HDD or the SATA wire.
4	ISC PWB	The ISC PWB is defective.	Replace the ISC PWB and perform U411. (see page 1-3-148)
5	CCD PWB	The CCD PWB is defective.	Replace the ISU and perform U411. (see page 1-3-148)
6	Main PWB	The main PWB is defective.	Replace the main PWB.(see page 1-5-59)

## 3. DP-scanning second (back) page (with a dual scan DP installed)

	Defective part	Check description	Corrective Action
1	DP_SHD PWB	Check the CIS and the SHD PWB is properly connected.	Reinsert the connector if the PWB was loosely inserted.If not cured, replace the PWB.
2	DP_SATA cable	Check the FFC cable between the SHD PWB and I/F PWB is properly connected. Or, verify conduction of the wire.	Reinsert the connector if its connection is loose. Or, if conduction is lot, replace the wire.
3	DP_CIS	CIS is defective.	Replace the CIS and perform U091 and U411. (see page 1-3-62,1-3-148)
4	Main PWB	The main PWB is defective.	Replace the main PWB.(see page 1-5-59)

## 4. DP-scanning second (back) page (with a reversed DP installed)

	Defective part	Check description	Corrective Action
1	FFC cable CCD	Check the FFC cable between the CCD sensor and ISC PWB is properly connected. Or, verify conduction of the wire.	Reinsert the connector if its connection is loose. Or, if conduction is lot, replace the wire.
2	SATA cable ISC	Check the SATA cable between the ISC PWB and main PWB is properly connected. Or, verify conduction of the wire.	Reinsert the connector if its connection is loose. Or, if conduction is lot, replace the wire.
3	HDD	Check the wires to the HDD in conduction. Check the connector for connection. Check the connector pins for distortion.	1. Reinsert the connector if its connection is loose. 2. Check the wires and connectors, and replace if faulty. 3. Replace the HDD or the SATA wire.
4	ISC PWB	The ISC PWB is defective.	Replace the ISC PWB and perform U411. (see page 1-3-148)

	Defective part	Check description	Corrective Action
5	CCD PWB	The CCD PWB is defective.	Replace the ISU and perform U411. (see page 1-3-148)
6	Main PWB	The main PWB is defective.	Replace the main PWB.(see page 1-5-59)

# 1-4-6 Poor image (Image rendering problems: printer engine)

(1) No image appears (entirely white).



See page1-4-195

(2) No image appears (entirely black).



See page1-4-196

(3) Image is too light.



See page1-4-196

(4) The background is colored.



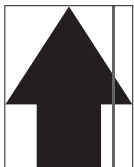
See page1-4-199

(5) White streaks are printed vertically.



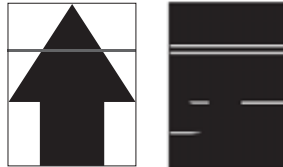
See page1-4-201

(6) Black streaks appear longitudinally.



See page1-4-202

(7) Black or white streaks appear horizontally.



See page1-4-203

(8) Uneven density longitudinally.



See page1-4-204

(9) Uneven density horizontally.



See page1-4-205

(10) Black dots appear on the image.



See page1-4-206

(11) Offset occurs.



See page1-4-207

(12) Image is partly missing.



See page1-4-208

(13) Image is out of focus.



See page1-4-208

(14) Poor grayscale reproducibility.



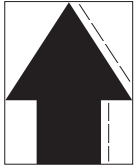
See page1-4-209

(15) Unevenly repeating horizontal streaks in the printed objects. Spots in the printed objects.



See page1-4-210

(16) Image is blurred (Shifted transferring).



See page1-4-211

(17) The leading edge of the image is consistently misaligned with the original.



See page1-4-212

(18) The leading edge of the image is sporadically misaligned with the original.



See page1-4-213

(19) Paper is wrinkled.



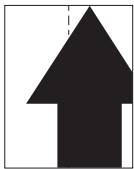
See page1-4-213

(20) Fusing is loose.



See page1-4-215

(21) Image center does not align with the original center.



See page1-4-216

(22) Dirty paper edges with toner.



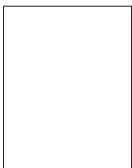
See page1-4-216

(23) Dirty reverse side of paper.




See page1-4-217

**(1) No image appears (entirely white).**

Print example	Cause of trouble
	<ol style="list-style-type: none"> <li>1. No or defective developing bias output.</li> <li>2. Failure of the rotation of the developing roller.</li> <li>3. Defective transfer.</li> <li>4. Laser is not dispersed from the laser scanner unit (LSU).</li> <li>5. The drum does not rotate.</li> </ol>

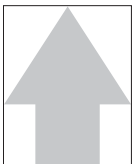
	Defective part	Check description	Corrective Action
1	Developing unit	Executing U089 to generate PGs and check the following :  Check whether the developer drive gear is damaged.  Check the developing roller is rotated by hand.  Check contamination and deformation on the terminals of developer unit or the high-voltage PWB1.	If the gear is damaged, replace the developer unit.  If the developer unit is in fault, replace the developer unit. (see page 1-5-46)  If the connecting terminals are dirty, clean. If the connecting terminals are deformed, correct for a proper conduction.
2	High-voltage PWB	Check the connection of the connector(s) and the high-voltage PWB. Or, verify conduction of the wires.  Check if developing bias value at its default by U140.	Reinsert the connector if its connection is loose. Replace the cable if it has no conduction. High voltage PWB (YC 1) and engine PWB (YC17) :Developer High voltage PWB (YC 2) and engine PWB (YC16) :Transfer  1. If the value obtained by U140 does not conform to the default value, reset it to the default. (see page 1-3-80) 2. Replace the high-voltage PWB.
3	Transfer belt unit	Check if the right side conveying unit is closed.	If the conveying unit has not been closed, check how the conveying guide is locked and open the conveying guide once, then close.
4	Laser scanner unit (LSU)	Check the connection of the connectors. Or, verify conduction of the wires.	1. Reinsert the FFC wire if its connection is loose. Replace the cable if it has no conduction. 2. Replace the LSU (see page 1-5-42)
5	Engine PWB	A control signal is not derived from the engine PWB.	Replace the engine PWB. (see page 1-5-67)

**(2) No image appears (entirely black).**

Print example	Cause of trouble
	<ol style="list-style-type: none"> <li>1. No main charging.</li> <li>2. The laser from the LSU is activated simultaneously.</li> </ol>

	Defective part	Check description	Corrective Action
1	Charging roller	Check whether the charging roller is properly mounted.	If the charging roller is not fixed properly, fix the roller properly.
		Check whether the connecting terminals of the charging roller and high-voltage PWB are deformed.	If the connecting terminals are deformed, correct for a proper conduction.
2	High-voltage PWB	Check the connection of the connectors. Or, verify conduction of the wires.	Reinsert the connector if its connection is loose. Replace the cable if it has no conduction. High voltage PWB (YC 2) and engine PWB (YC16) :Charger
		Main charging current supplied by the high-voltage PWB is faulty.	Replace the high-voltage PWB. (see page 1-5-76)
3	Laser scanner unit (LSU)	Switching on and off the laser diode on the LSU PWB is out of control.	Replace the LSU. (see page 1-5-42)
4	Engine PWB	The engine PWB is defective.	Replace the engine PWB.(see page 1-5-67)
5	Main PWB	The main PWB is defective.	Replace the main PWB.(see page 1-5-67)

**(3) Image is too light.**

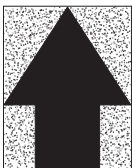
Print example	Cause of trouble
	<ol style="list-style-type: none"> <li>1. Variance in environments (dew formation).</li> <li>2. Toner is under supplied, or deteriorated in quality.(Under charged)</li> <li>3. The volatage of the developing bias is too low.</li> <li>4. The volatage of the transfer current is too low.</li> <li>5. The power of LSU laser is too low.</li> <li>6. The surface potential of the drum is too high.</li> <li>7. The contact pressure at the trasnfer belt and the drum is too low.</li> </ol>

	Defective part	Check description	Corrective Action
1	Paper	Check that the paper has moisture absorbed. Check that the paper has stored in a humid place.	<ol style="list-style-type: none"> <li>1. If the paper is damp, replace. Choose a dry place to store paper.</li> <li>2. If necessary, install a cassette heater. (see page 1-2-65)</li> </ol>
2	Drum unit	Check that the drum has dew condensation.	If a dew condensation is observed, perform drum refreshing. (System Menu >Adjustment / Maintenance)
		<ol style="list-style-type: none"> <li>1. Check if the discharging lamp is dirty.</li> <li>2. Check whether it is lit.</li> </ol>	<ol style="list-style-type: none"> <li>1. If the discharging lamp is dirty, clean.</li> <li>2. If not cured, or it does not light, replace the drum unit. (Perform U119)(see page 1-3-73)</li> </ol>
3	Developer unit	Executing U089 to generate PGs and check the following : (see page 1-3-61)	
		<ol style="list-style-type: none"> <li>1. Confirm the value from U155. (see page 1-3-86)</li> </ol>	<p>If the value is less than 542, perform U132 to forcibly replenish toner. (see page 1-3-77)</p> <p>Replace the developer unit if the output is kept too low.</p>
		<ol style="list-style-type: none"> <li>2. Check if the device executed a low-density printing for a prolonged period.</li> </ol>	<ol style="list-style-type: none"> <li>1. If the device was executing a low-density printing for a prolonged period, perform developing refreshing. (System Menu &gt;Adjustment / Maintenance)</li> <li>2. If developer refreshing does not correct the problem, perform the following Execute maintenance modes U464 Calibration and U410 Grayscale Adjustment. (see page 1-3-169,1-3-147)</li> </ol>
		<ol style="list-style-type: none"> <li>3. Check if the connecting terminals for developer bias are deformed.</li> </ol>	If the connecting terminals are deformed, correct for a proper conduction.
		Check the value of U140 MagDC. (see page 1-3-80)	If the MagDC value is in excess of the upper limit by U140, perform U464 to set the Thickness Target Value from 0 to +30. Execute maintenance modes U464 Calibration.(see page 1-3-169)

	Defective part	Check description	Corrective Action
4	Toner container	Shake the toner container up and down approx. 10 times, and check the following: 1. Check remaining toner by the indicator. 2. Check whether the toner supply inlet is open.	If the message prompting toner replenishing is shown, the toner inlet is not open, replace the toner container.
5	Toner supply motor	Execute U135 to check the revolution of the toner supply motor. (see page 1-3-77)	If the toner Conduct supply motor does not rotate, replace.
6	High-voltage PWB	Check the value of the U100. Check the value of the U140.	1. If the value obtained by U100 or U140 does not conform to the default value, reset it to the default. (see page 1-3-80) 2. Replace the high-voltage PWB.
7	Transfer belt unit	1. Check whether the connecting terminals. 2. Check the value of the U106. (see page 1-3-68)	1. If the connecting terminals are deformed, correct for a proper conduction. 2. If the value obtained after U106 does not conform to the default value, reset it to the default. 3. Replace transfer belt unit.
		1. Check if the contact between the transfer belut and durm is correct.	Re-mount the transfer belut unit.
8	LSU	1. The laser diode on the LSU APC PWB is out of control. 2. Check whether the internal mirrors are contaminated.	Replace the LSU. (Perform U119) (see page 1-3-73)
9	Engine PWB	The engine PWB is defective.	Replace the enging PWB. (see page 1-5-67)




**(4) The background is colored.**

Print example	要因
	<ol style="list-style-type: none"> <li>1. Toner is deteriorated in quality (under-charged).</li> <li>2. Toner is over-supplied.</li> <li>3. Developing bias is too high.</li> <li>4. The layer of toner is too thick on the developing roller (too much toner).</li> <li>5. The surface potential of the drum is too low (under low temperature environment).</li> </ol>

	Defective part	Check description	Corrective Action
1	Developer unit	Executing U089 to generate PGs and check the following : (see page 1-3-61) <ol style="list-style-type: none"> <li>1. Check whether the device was being continuously operated with high density, under a hot environment.</li> <li>2. Check the value of the U140 developer bias. (see page 1-3-80)</li> <li>3. Check contamination and deformation on the connecting terminals for developer bias.</li> <li>4. Check the toner sensor output by U155. (see page 1-3-86)</li> </ol>	If the device was being continuously operated with high density under a hot environment, perform developing refreshing. (System Menu >Adjustment / Maintenance)  If the density ID is too low at calibration, execute maintenance modes U464 Calibration and U410 Grayscale Adjustment. (see page 1-3-169,1-3-147)  If the connecting terminals for developer bias are dirty, clean.If the connecting terminals are deformed, correct for a proper conduction.  If the toner sensor output obtained by U155 is 100 or less, replace the developer unit. (see page 1-5-46)
2	Toner supply motor	Check the toner supply motor is continuously rotating.Check wires for shortcircuiting.	If the harnesses are short-circuited and the toner motor is continuously rotating, replace the toner supply motor.

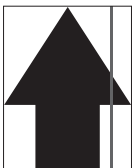
	Defective part	Check description	Corrective Action
3	Drum unit	1. Conduct U139 to check the internal temperature. (see page 1-3-79)	If the internal temperature is 16-degree C or less, continue printing until the temperature reaches 16-dgree C or higher.
		2. Check the value of the U100 main high voltage. (see page 1-3-66)	Fix the inner unit properly. (see page 1-5-44)
		3. Check that the ground terminal is not contaminated or the conductive grease is not applied with the connecting terminals.	If the connecting terminals are dirty, clean. If the amount of the grease applied is too small, apply conductive grease to the bearing on the receiver side of the drum drive axle. Replace the drum unit. (Perform U119)
		4. Check if the charging roller is dirty.	If the charging roller is dirty, clean.Or replace it. (Perform U930)(see page 1-3-190)
4	Transfer belt unit	1. Check if the belt is bleached on its surface. 2. Check the value of U140 MagDC after conducting calibration. 3. Check if the ground tab of the transfer belt unit is deformed.	1. If the connecting terminals are deformed, correct for a proper conduction. 2. If the value obtained by U106 does not conform to the default value, reset it to the default. 3. Increase the U140 MagDC value if the U140 MadDC value has not reached at its maximum even though the belt is bleached on its surface. 4. If the MadDC increased to its maximum won't cure, replace the transfer belt unit. (see page 1-5-55)
5	High-voltage PWB	The developing bias and charging current supplied by the high-voltage PWB is faulty.	Replace the high-voltage PWB. (see page 1-5-76)
6	Engine PWB	Defective the engine PWB	Replace the enging PWB. (see page 1-5-67)

**(5) White streaks are printed vertically.**

Print example	Cause of trouble
	<ol style="list-style-type: none"> <li>1. Dirty LSU slit glass.</li> <li>2. Foreign objects inside the developer unit.</li> <li>3. Internal contamination</li> <li>4. Dirty drum inside.</li> </ol>

	Defective part	Check description	Corrective Action
1	Developer unit	Executing U089 to generate PGs. (see page 1-3-61)	Replace the developer unit. (see page 1-5-46)
2	Light path between the LSU and the drum	Check if there are dusts, dirt, or toner obstructing the light paths.	If a foreign object exists on the frame or the sealings between the developer unit and the drum unit, remove.
3	Drum unit	Check if the charging roller is dirty.	If the charging roller is dirty, clean. Or replace it. (Perform U930) (see page 1-5-49)
		Check if the discharging lamp is dirty.	If the discharging lamp is dirty, clean.
4	LSU	Check if the LSU slit glass is dirty.	If the LSU slit glass is dirty, perform laser scanner cleaning.
5	Transfer belt unit	Check whether a white streak occurs at the same position as the smear on the transfer belt.	Clean the transfer belt if it is dirty. Replace the transfer belt unit. (see page 1-5-55)


**(6) Black streaks appear longitudinally.**

Print example	Cause of trouble
	<ol style="list-style-type: none"> <li>1. Dirty charging roller</li> <li>2. Flawed or dirty drum unit</li> <li>3. Damaged or paper dust bitten cleaning blade</li> </ol>

	Defective part	Check description	Corrective Action
1	Separation brush	Check if the separation brush is dirty with paper dusts and waste toner.	If the separation brush is dirty, clean it using a brush.
2	Drum unit	<p>Check if drum is dirty on its surface.</p> <ol style="list-style-type: none"> <li>1. Check if the drum has scratches.</li> <li>2. Check whether the edge of the cleaning blade is damaged.</li> <li>3. Check whether it is abraded or paper dusts are accumulated.</li> <li>4. Check whether toner is accumulated in the cleaning section.</li> </ol>	<p>Execute drum refreshing. (System Menu &gt; Adjustment / Maintenance)</p> <p>Replace the drum unit. (see page 1-5-47)</p>
3	Charging roller unit	Check if there is no toner streaks on the surface of the charging roller.	<p>If the charging roller has streaks on its surface, clean the charging roller. Replace the charging roller, if necessary. (Perform U930) (see page 1-3-190)</p>
4	Transfer belt unit	<ol style="list-style-type: none"> <li>1. Check if the transfer belt roller is contaminated on its surface or damaged.</li> <li>2. Check the cleaning bias connector or the connecting terminals of high voltage are not dirty or deformed.</li> </ol>	<p>If smears and scuff are observed on the transfer belt unit, replace the unit. (see page 1-5-55)</p> <p>If the connector or terminals are dirty, clean. If the connecting terminals are deformed, correct for a proper conduction. Replace the high-voltage PWB. (see page 1-5-76)</p>

	Defective part	Check description	Corrective Action
5	Fuser unit	Check if the paper separation puddle is contaminated with toner.	If the paper separation puddle is dirty, clean the paper separation puddle.
		Check the device is adjusted for a correct paper weight that matches the paper in use.	If the settings for paper weight and the paper being used do not match, make a proper configuration.
6	Eject guide	The Rib is contaminated with toner.	If it is dirty, clean.


### (7) Black or white streaks appear horizontally.

Print example	Cause of trouble
	<ol style="list-style-type: none"> <li>1. Dirty developer unit or terminals</li> <li>2. Flawed or dirty drum unit Improper grounding</li> <li>3. Dirty transfer roller terminals</li> </ol>

	Defective part	Check description	Corrective Action
1	Developer unit	<ol style="list-style-type: none"> <li>1. Check the print image on paper has a problem at an interval equivalent to the circumference of the developing roller.</li> <li>2. Check that the developing roller is dirty at its ends or at the developing bias tab.</li> </ol>	<ol style="list-style-type: none"> <li>1. If the ends of the developing roller and the connecting terminals for developer bias are dirty, clean.</li> <li>2. Replace the developer unit. (see page 1-5-46)</li> </ol>
2	Drum unit	1. Check the print image on paper has a problem at an interval equivalent to the circumference of the drum .	Execute drum refreshing. (System Menu >Adjustment / Maintenance)
		2. Check if the drum has scratches.	Replace the drum unit. (Perform U119) (see page 1-5-47)
		3. Check the grounding tab of the drum or the drum drive shaft.	<ol style="list-style-type: none"> <li>1. Check how the inner unit is mounted, and correct, if necessary.</li> <li>2. Replace the drum unit. (Perform U119) (see page 1-5-47)</li> </ol>

	Defective part	Check description	Corrective Action
3	Transfer belt unit	Check the print image that implies dirt, deformation, or scratches on the transfer belt, which will be appearing at an interval equal to its circumference .	If the print image has a problem, clean the transfer belt by a soft cloth.
		Check contamination and deformation on the terminals .	1. If the connecting terminals are deformed, correct for a proper conduction 2. Replace transfer belt unit.(see page 1-5-55)
4	Fuser unit	Check the print image on paper has a problem at an interval equivalent to the circumference of the fuser roller.	If the print image has a problem, clean the fuser roller.
5	High-voltage PWB	The bias voltage output supplied by the high-voltage PWB is not even.	Replace the high-voltage PWB. (see page 1-5-76)


### (8) Uneven density longitudinally.

Print example	Cause of trouble
	<ol style="list-style-type: none"> <li>1. Dirty LSU inside</li> <li>2. The transfer belt is not pressed against the drum properly.</li> <li>3. Drum condensation.</li> </ol>

	Defective part	Check description	Corrective Action
1	Transfer belt unit	Check that the transfer belt unit is properly fit.	<ol style="list-style-type: none"> <li>1. If it is not fixed properly, fix it properly.</li> <li>2. If the conveying unit has not been closed, check how the conveying guide is locked and open the conveying guide once, then close.</li> <li>3. Replace the transfer belt unit. (see page 1-5-55)</li> </ol>
2	Drum unit	<ol style="list-style-type: none"> <li>1. Check toner is evenly layered on its surface.</li> <li>2. Check whether the device has been operated under a highly humid environment.</li> </ol>	<ol style="list-style-type: none"> <li>1. Execute drum refreshing.</li> <li>2. Selects the Dew Mode by U148 Drum Refresh Mode. (see page 1-3-85)</li> <li>3. Install a cassette heater.</li> <li>4. Replace the drum unit. (Perform U119) (see page 1-5-47)</li> </ol>


	Defective part	Check description	Corrective Action
3	Developer unit	Check that toner is evenly layered on the developing roller.	Replace the developer unit. (see page 1-5-46)
4	LSU	The emission of laser dispersed from the LSU is not even. (Mirror is dropped off inside.)	Replace the LSU.(Perform U119)

### (9) Uneven density horizontally.

Print example	Cause of trouble
	<ol style="list-style-type: none"> <li>1. Defective laser scanner unit.</li> <li>2. Improper charging roller rotation</li> <li>3. Improper contact on the developer unit terminals</li> </ol>

	Defective part	Check description	Corrective Action
1	LSU	Check the emission of laser is even.	Replace the LSU. (see page 1-5-42)
2	Charging roller	Check if the charging roller is improperly mounted.	<ol style="list-style-type: none"> <li>1. Fix the charging roller properly.</li> <li>2. Replace the charging roller. (Perform U930) (see page 1-5-49)</li> </ol>
3	Developer unit	Check If the connecting terminals of the developing bias is contaminated by toner.	<ol style="list-style-type: none"> <li>1. If the connecting terminals is dirty.</li> <li>2. Replace the developer unit. (Perform U140) (see page 1-5-46)</li> </ol>
4	Transfer belt unit.	Check if the transfer belt is contaminated on its surface or damaged.	1. Replace the transfer belt unit.
		Check if the cleaning bias connector or the connecting terminals of high voltage are dirty or deformed.	<ol style="list-style-type: none"> <li>1. If the connector or terminals are dirty, clean.If the connecting terminals are deformed, correct for a proper conduction.</li> <li>2. Replace the high-voltage PWB.</li> </ol>
5	Fuser unit	Check that the roller, its driving unit, or the fusing pressure release mechanism is deformed, abraded, or damaged.	If the roller, its driving unit, or the fusing pressure release mechanism is deformed, abraded, or damaged, replace the fuser unit.

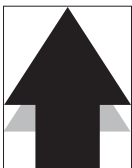
**(10) Black dots appear on the image.**

Print example	Cause of trouble
	<ol style="list-style-type: none"> <li>1. Dirty charging roller</li> <li>2. Flawed or dirty drum unit</li> <li>3. Damaged or paper dust bitten cleaning blade</li> </ol>

	Defective part	Check description	Corrective Action
1	Drum unit	Check the print image on paper has a problem at an interval equivalent to the circumference of the drum (126mm).	If the drum has scratches, replace the drum unit. (see page 1-5-47)
2	Charging roller	Check the print image on paper has a problem at an interval equivalent to the circumference of the charging roller (38mm).	A problem is observed at a constant interval of the charging roller (38 mm), replace the charging roller.(U930) (see page 1-3-190)
3	Developer unit	1. Check if that the developing bias is leaked.	Execute AC calibration by U140. (see page 1-3-80)
		2. Check the print image on paper has a problem at an interval equivalent to the circumference of the developing roller (39mm).	1. If the print image on paper has a problem at an interval equivalent to the circumference of the developer roller, clean the developer unit. 2. Replace the developer unit. (see page 1-5-36)
4	Transfer belt unit.	Check if the transfer belt is contaminated on its surface or damaged.	Replace the transfer belt unit.
		Check the cleaning bias connector or the connecting terminals of high voltage are not dirty or deformed.	1. If the connector or terminals are dirty, clean.If the connecting terminals are deformed, correct for a proper conduction. 2. Replace the high-voltage circuit PWB.
5	Fuser unit	Check the print image on paper has a problem at an interval equivalent to the circumference of the fuser roller.	1. If the print image has a problem, clean the fuser roller. 2. If cleaning does not help improve the symptom, replace the fuser unit.




**(11) Offset occurs.**

Print example	Cause of trouble
	1. Flawed or dirty drum unit 2. Developing bias leakage.


	Defective part	Check description	Corrective Action
1	Paper	Check that the type of the paper used falls within the range of specifications. Check the settings of the type and weight of the paper.	1. If the type of the paper being used falls outside the requirements, replace and use a suitable type of paper. 2. If the settings made for the paper being used is inadequate, configure the settings according to the paper being used.
2	Drum unit	Check the print image on paper has a problem at an interval equivalent to the circumference of the drum (126mm).	If the print image on paper has a problem at an interval equivalent to the circumference of the drum, replace the drum unit. (see page 1-5-47)
3	Developer unit	Check if offsets are observed at an constant interval of 39 mm, which is equivalent to the circumference of the developing roller.	If offsets are observed at an constant interval of 39 mm, which is equivalent to the circumference of the developing roller, replace the developer unit. (Waste toner is not properly swept from the developing roller.) (see page 1-5-46)
4	Transfer belt unit	Check the transfer cleaning volatage by U106. (see page 1-3-68)	1. If the transfer cleaning volatage by U106 is not its default, reset it to the default. 2. Replace the transfer belt unit. (see page 1-5-55)
Check if offsets are occurred at a pitch of the outer circumference of the transfer belt.		If an offset happens at a pitch of the outer circumference, clean the transfer belt.	
5	Fuser unit	Check the print image on paper has a problem at an interval equivalent to the circumference of the fuser roller.	If the fuser unit roller is dirty, replace the unit.
6	Fusing temperature setting	Check the fusing temperature value by U161. (see page 1-3-89)	If the fusing temperature value by U161 is not its default, reset it to the default.

**(12) Image is partly missing.**

Print example	Cause of trouble
	<ol style="list-style-type: none"> <li>1. Flawed or dirty drum unit.</li> <li>2. Deformed or dirty transfer roller on its surface.</li> </ol>

	Defective part	Check description	Corrective Action
1	Paper	<ol style="list-style-type: none"> <li>1. Check that the paper has moisture absorbed.</li> <li>2. Check that the paper has stored in a humid place.</li> </ol>	<ol style="list-style-type: none"> <li>1. If the paper is damp, replace. Choose a dry place to store paper.</li> <li>2. If necessary, install a cassette heater. (see page 1-2-65)</li> </ol>
2	Drum unit	Check the print image on paper has a problem at an interval equivalent to the circumference of the drum (126mm)	If the print image on paper has a problem at an interval equivalent to the circumference of the drum, execute drum refreshing (System Menu > Adjustment/Maintenance).
3	Transfer belt unit	Check if the transfer belt is deformed or contaminated on its surface.	If the transfer belt unit is deformed or contaminated, replace the intermediate transfer belt unit.
4	Fusing temperature setting	Check the value of the U161. (see page 1-3-89)	<ol style="list-style-type: none"> <li>1. Choose a paper weight appropriate for the weight of the paper actually being used, if the fusing temperature was set low using U161.</li> <li>2. Perform U161 for an appropriate fusing temperature.</li> </ol>

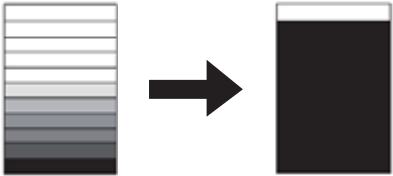
**(13) Image is out of focus.**

Print example	Cause of trouble
	<ol style="list-style-type: none"> <li>1. Drum condensation.</li> <li>2. Dirty LSU slit glass.</li> </ol>

	Defective part	Check description	Corrective Action
1	Paper	<ol style="list-style-type: none"> <li>1. Check that the paper has moisture absorbed.</li> <li>2. Check that the paper has stored in a humid place.</li> </ol>	<ol style="list-style-type: none"> <li>1. If the paper is damp, replace. Choose a dry place to store paper.</li> <li>2. If necessary, install a cassette heater. (see page 1-2-65)</li> </ol>


	Defective part	Check description	Corrective Action
2	Drum unit	Check that the surface of the drum has dew condensation.	Execute Drum refreshing. System Menu > Adjustment/Maintenance
3	LSU	Check whether the LSU slit glass is contaminated in its entirety.	1. If the LSU slit glass is dirty, execute Laser scanner cleaning. 2. Replace the LSU. (Perform U119) (see page 1-5-42)

#### (14) Poor grayscale reproducibility.

Print example	Cause of trouble
	1. Poor image adjustment.

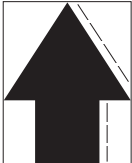
	Defective part	Check description	Corrective Action
1	Image adjustmen	Check if color adjustment is insufficient.	Execute U464 Calibration and U410 Grayscale Adjustment. (see page 1-3-80,1-3-147)

**(15) Unevenly repeating horizontal streaks in the printed objects. Spots in the printed objects.**

Print example	Cause of trouble
	<ol style="list-style-type: none"> <li>1. Installation at a high altitude.</li> <li>2. Using the paper with high surface resistance.</li> </ol>


	Defective part	Check description	Corrective Action
1	Developer unit	The device is installed in an altitude higher than 1500 m sea level.	<p>If the device is installed in an altitude greater than 1500 m sea level, perform the following.</p> <ol style="list-style-type: none"> <li>1. 35 ppm / 45 ppm devices Press maintenance mode U140 and select "AC Calib", after that select "High Altitude" in order to change the setting. (Default/ 1000m/ 2000m/ 3000m/ 4000m) (see page 1-3-80)</li> <li>2. 55 ppm devices               <ol style="list-style-type: none"> <li>1) Press maintenance mode U140 and execute "AC Calib" and "Calibration".</li> <li>2) Execute maintenance mode U140 and select "AC Calib", later "Magnification" in order to lower the setting value.(see page 1-3-80) (Initial setting K:12)</li> </ol> </li> </ol>
2	Paper	Check if paper is of high surface resistance.	Change the paper to another.

**(16) mage is blurred (Shifted transferring).**

Print example	Cause of trouble
	<ol style="list-style-type: none"> <li>1. The paper used does not conform to the requirement.</li> <li>2. Imbalanced fuser unit pressures.</li> </ol>

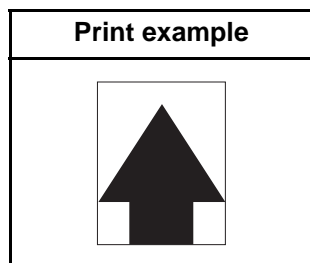
	Defective part	Check description	Corrective Action
1	Paper	<ol style="list-style-type: none"> <li>1. Check that the type of the paper used falls within the range of specifications.</li> <li>2. Check the settings of the type and weight of the paper.</li> </ol>	<ol style="list-style-type: none"> <li>1. If the type of the paper being used falls outside the requirements, replace and use a suitable type of paper.</li> <li>2. If the settings made for the paper being used is inadequate, configure the settings according to the paper being used.</li> </ol>
2	Fuser unit	<ol style="list-style-type: none"> <li>1. Check the fuser pressure balance.</li> <li>2. Check if the fuser paper-inserting guide is deformed.</li> </ol>	<ol style="list-style-type: none"> <li>1. If the pressures at the front and rear are unbalanced, replace the fuser unit. (see page 1-5-57)</li> <li>2. If the fuser unit is deformed, replace. (see page 1-5-57)</li> </ol>
3	Paper conveying motor	Check to see if the driving mechanism for paper conveying is operative without a hinderance.	If the drive does not operate normally, apply grease.
4	Paper conveying guide	The paper conveying guide is deformed.	If the paper conveying guide is deformed, replace the paper conveying guide.

**(17) The leading edge of the image is consistently misaligned with the original.**

Print example	Cause of trouble
	<ol style="list-style-type: none"> <li>1. Improperly adjusted leading edge timing.</li> <li>2. Improper amount of slack of the original document in front of the registration.</li> </ol>

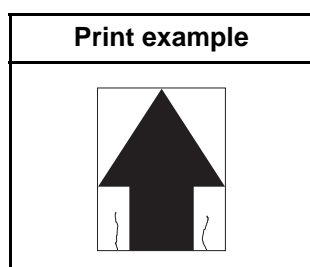
	Defective part	Check description	Corrective Action
1	Regist roller	1. Check whether the leading-edge timing is adequately adjusted.	If the adjustment is not sufficient, execute U034 to adjust the leading edge timing. (see page 1-3-34)
		2. Check whether the amount of slack of the original document when it reaches at the DP regist is adequate.	If the amount of the slack in front of the regist roller is insufficient, execute U051 to optimize the slack. (see page 1-3-39)

**(18) The leading edge of the image is sporadically misaligned with the original.**



	Defective part	Check description	Corrective Action
1	Paper feed clutch, Middle clutch, Reg- istration clutch, Duplex clutch	Check that the clutches are properly fit. Or, check they are operative without a hinderance. (35 ppm model)	1. If it is not fixed properly, fix it properly. 2. If it does not operate without a hinderance, replace the clutch.
2	Paper feed clutch, Middle motor, Reg- istration motor, Duplex motor	Check that the clutches and motors are properly fit. Or, check they are operative without a hinderance. (45 ppm/ 55 ppm model)	1. If it is not fixed properly, fix it properly. 2. If it does not operate without a hinderance, replace the clutch or motor.

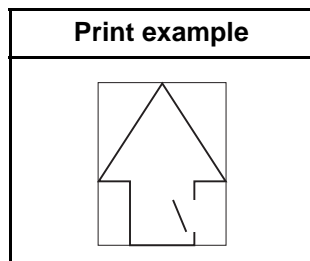
**(19) Paper is wrinkled.**



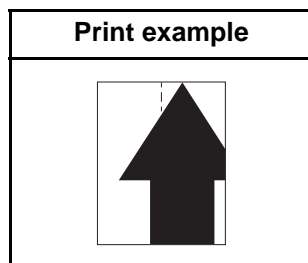
	Defective part	Check description	Corrective Action
1	Paper-width guides	Check the paper-width guides are flush with the paper.	If the width adjuster cursors are not flush with paper, set them correctly.
2	Paper	1. Check if paper is curled or wavy. 2. Check if paper is stored in a humid place.	1. If the paper is curled or wavy, replace. 2. Choose a dry place to store paper.

	Defective part	Check description	Corrective Action
3	Regist roller	The pressures at the front and back springs are unbalanced.	Replace the spring with the one having a correct pressure.
4	Fuser unit	The pressuring spring of the fuser unit is defective.	Replace the fuser unit. (see page 1-5-57)




**(20) Fusing is loose.**

	Defective part	Check description	Corrective Action
1	Paper	<ol style="list-style-type: none"> <li>1. Check that the type of the paper used falls within the range of specifications.</li> <li>2. Check the settings of the type and weight of the paper.</li> </ol>	<ol style="list-style-type: none"> <li>1. If the type of the paper being used falls outside the requirements, replace and use a suitable type of paper.</li> <li>2. If the settings made for the paper being used is inadequate, configure the settings according to the paper being used.</li> </ol>
2	Paper weight setting	Check If the weight of the paper is correctly set.	If the weight of the paper is not correctly set, choose the correct weight that matches the paper being used.
3	Fuser unit	Check the fuser pressure setting.	Replace the fuser unit. (see page 1-5-57)
4	Fusing temperature setting	Check the value of the U161. (see page 1-3-89)	<ol style="list-style-type: none"> <li>1. Choose a paper weight appropriate for the weight of the paper actually being used, if the fusing temperature was set low using U161.</li> <li>2. Perform U161 for an appropriate fusing temperature.</li> </ol>

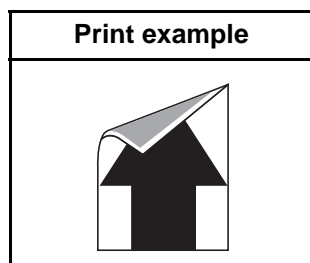
**(21) Image center does not align with the original center.**

	Defective part	Check description	Corrective Action
1	Paper setting	Check if paper is set correctly.	Reload paper if the paper was not loaded correctly.
2	Image position adjustment	Excute U034 to check the center alignment during writing images.	Perform adjustment if the value of U034 Center Line Adjustment is inadequate. (see page 1-3-34)

**(22) Dirty paper edges with toner.**

Print example	Cause of trouble
	1. Toner scattering due to an internal temperature increase.(Developer unit)

	Defective part	Check description	Corrective Action
1	Conveying guide	Check if the conveying guide is dirty with toner.	If the conveying guide is dirty with toner, clean the developer unit and the cooling ducts.
2	Internal temperature increase (Developer unit)	Check the device has been used for printing a large amount of data or for printing in duplex mode with a high density.	If the device has been used for printing a large amount of data or for printing in duplex mode with a high density, clean the developer unit.

**(23) Dirty reverse side of paper.**

	Defective part	Check description	Corrective Action
1	Conveying guide	Check if the conveying guide is dirty with toner.	If the conveying guide is dirty with toner, clean the conveying guide, the developer unit and the cooling ducts.
2	Fuser pressure roller	Check that a foreign object is stuck on the fuser pressure roller.	<ol style="list-style-type: none"> <li>1. If a foreign object exists, clean the fuser pressure roller.</li> <li>2. If the paper and the paper weight setting do not match, choose the proper paper weight setting.</li> </ol>
3	Transfer belt unit	Check if the transfer belt is dirty with toner on its surface.	<ol style="list-style-type: none"> <li>1. Clean the transfer belt.</li> <li>2. Reset U106 Bias settings to its default.</li> </ol>

## 1-4-7 Electric problems

If the part causing the problem was not supplied, use the unit including the part for replacement.  
Troubleshooting to each failure must be in the order of the numbered symptoms.

Problem	Causes	Check procedures/corrective measures
(1) The machine does not operate when the main power switch is turned on.	1. No electricity at the power outlet.	Measure the input voltage.
	2. The power cord is not plugged in properly.	Check the contact between the power plug and the outlet.
	3. Broken power cord.	Check for continuity. If none, replace the cord.
	4. Defective main power switch.	Check for continuity across the contacts. If none, replace the main power switch.
	5. Defective power source PWB.	Replace the power source PWB (see page 1-5-71).
(2) MP lift motor does not operate.	1. Defective connector cable or poor contact in the connector.	Reinsert the connector. Also check for continuity within the connector cable. If none, replace the cable. MP lift motor and relay PWB (YC3) Relay PWB (YC12) and feed PWB 1 (YC17) Feed PWB 1 (YC1) and engine PWB (YC6)
	2. Defective drive transmission system.	Check if the rollers and gears rotate smoothly. If not, grease the bushes and gears. Check for broken gears and replace if any.
	3. Defective motor.	Replace the MP lift motor.
	4. Defective PWB.	Replace the relay PWB, feed PWB 1 or engine PWB and check for correct operation (see page 1-5-67).
(3) Scanner motor does not operate.	1. Defective connector cable or poor contact in the connector.	Reinsert the connector. Also check for continuity within the connector cable. If none, replace the cable. Scanner motor and ISC PWB (YC5) ISC PWB (YC3) and main PWB (YC11)
	2. Defective drive transmission system.	Check if the rollers and gears rotate smoothly. If not, grease the bushes and gears. Check for broken gears and replace if any.
	3. Defective motor.	Replace the scanner motor.
	4. Defective PWB.	Replace the ISC PWB or main PWB and check for correct operation (see page 1-5-59).
(4) Registration motor does not operate (45 ppm/55 ppm model only).	1. Defective connector cable or poor contact in the connector.	Reinsert the connector. Also check for continuity within the connector cable. If none, replace the cable. Registration motor and feed PWB 1 (YC25) Feed PWB 1 (YC2) and engine PWB (YC5)
	2. Defective drive transmission system.	Check if the rollers and gears rotate smoothly. If not, grease the bushes and gears. Check for broken gears and replace if any.
	3. Defective motor.	Replace the registration motor.
	4. Defective PWB.	Replace the feed PWB 1 or engine PWB and check for correct operation (see page 1-5-67).

<b>Problem</b>	<b>Causes</b>	<b>Check procedures/corrective measures</b>
(5) Middle motor does not operate (45 ppm/55 ppm model only).	1. Defective connector cable or poor contact in the connector.	Reinsert the connector. Also check for continuity within the connector cable. If none, replace the cable. Middle motor and feed PWB 2 (YC7) Feed PWB 2 (YC1) and engine PWB (YC4)
	2. Defective drive transmission system.	Check if the rollers and gears rotate smoothly. If not, grease the bushes and gears. Check for broken gears and replace if any.
	3. Defective motor.	Replace the middle motor.
	4. Defective PWB.	Replace the feed PWB 2 or engine PWB and check for correct operation (see page 1-5-67).
(6) Inner motor does not operate.	1. Defective connector cable or poor contact in the connector.	Reinsert the connector. Also check for continuity within the connector cable. If none, replace the cable. Inner motor and front PWB (YC13) Front PWB (YC3) and engine PWB (YC7)
	2. Defective drive transmission system.	Check if the rollers and gears rotate smoothly. If not, grease the bushes and gears. Check for broken gears and replace if any.
	3. Defective motor.	Replace the inner motor.
	4. Defective PWB.	Replace the front PWB or engine PWB and check for correct operation (see page 1-5-71).
(7) Eject motor does not operate.	1. Defective connector cable or poor contact in the connector.	Reinsert the connector. Also check for continuity within the connector cable. If none, replace the cable. Eject motor and front PWB (YC5) Front PWB (YC3) and engine PWB (YC7)
	2. Defective drive transmission system.	Check if the rollers and gears rotate smoothly. If not, grease the bushes and gears. Check for broken gears and replace if any.
	3. Defective motor.	Replace the eject motor.
	4. Defective PWB.	Replace the front PWB or engine PWB and check for correct operation (see page 1-5-67).
(8) Duplex motor 1 does not operate (45 ppm/55 ppm model only).	1. Defective connector cable or poor contact in the connector.	Reinsert the connector. Also check for continuity within the connector cable. If none, replace the cable. Duplex motor 1 and relay PWB (YC16) Relay PWB (YC13) and feed PWB 1 (YC23) Feed PWB 1 (YC2) and engine PWB (YC5)
	2. Defective drive transmission system.	Check if the rollers and gears rotate smoothly. If not, grease the bushes and gears. Check for broken gears and replace if any.
	3. Defective motor.	Replace the duplex motor 1.
	4. Defective PWB.	Replace the relay PWB, feed PWB 1 or engine PWB and check for correct operation (see page 1-5-67).

<b>Problem</b>	<b>Causes</b>	<b>Check procedures/corrective measures</b>
(9) Duplex motor 2 does not operate (45 ppm/55 ppm model only).	1. Defective connector cable or poor contact in the connector.	Reinsert the connector. Also check for continuity within the connector cable. If none, replace the cable. Duplex motor 2 and relay PWB (YC7) Relay PWB (YC1) and feed PWB 1 (YC14) Feed PWB 1 (YC1) and engine PWB (YC6)
	2. Defective drive transmission system.	Check if the rollers and gears rotate smoothly. If not, grease the bushes and gears. Check for broken gears and replace if any.
	3. Defective motor.	Replace the duplex motor 2.
	4. Defective PWB.	Replace the relay PWB, feed PWB 1 or engine PWB and check for correct operation (see page 1-5-71).
(10) Toner fan motor does not operate.	1. Defective connector cable or poor contact in the connector.	Reinsert the connector. Also check for continuity within the connector cable. If none, replace the cable. Toner fan motor and engine PWB (YC19)
	2. Defective motor.	Replace the toner fan motor.
	3. Defective PWB.	Replace the engine PWB and check for correct operation (see page 1-5-67).
(11) Developer fan motor 1, 2* does not operate (*: 45 ppm/ 55 ppm model only).	1. Defective connector cable or poor contact in the connector.	Reinsert the connector. Also check for continuity within the connector cable. If none, replace the cable. Developer fan motor 1, 2 and front PWB (YC5) Front PWB (YC3) and engine PWB (YC7)
	2. Defective motor.	Replace the developer fan motor 1 or 2.
	3. Defective PWB.	Replace the front PWB or engine PWB and check for correct operation (see page 1-5-67).
(12) Exhaust fan motor does not operate.	1. Defective connector cable or poor contact in the connector.	Reinsert the connector. Also check for continuity within the connector cable. If none, replace the cable. Exhaust fan motor and engine PWB (YC19)
	2. Defective motor.	Replace the exhaust fan motor.
	3. Defective PWB.	Replace the engine PWB and check for correct operation (see page 1-5-67).
(13) LSU fan motor* does not operate (45 ppm/55 ppm model only).	1. Defective connector cable or poor contact in the connector.	Reinsert the connector. Also check for continuity within the connector cable. If none, replace the cable. LSU fan motor and front PWB (YC8) Front PWB (YC2) and engine PWB (YC8)
	2. Defective motor.	Replace the LSU fan motor.
	3. Defective PWB.	Replace the front PWB or engine PWB and check for correct operation (see page 1-5-67).
(14) Eject fan motor 1, 2 does not operate.	1. Defective connector cable or poor contact in the connector.	Reinsert the connector. Also check for continuity within the connector cable. If none, replace the cable. Eject fan motor 1, 2 and relay PWB (YC11) Relay PWB (YC13) and engine PWB (YC23)
	2. Defective motor.	Replace the eject fan motor 1 or 2.
	3. Defective PWB.	Replace the relay PWB or engine PWB and check for correct operation (see page 1-5-67).

<b>Problem</b>	<b>Causes</b>	<b>Check procedures/corrective measures</b>
(15) Eject front fan motor does not operate.	1. Defective connector cable or poor contact in the connector.	Reinsert the connector. Also check for continuity within the connector cable. If none, replace the cable. Eject front fan motor and front PWB (YC11) Front PWB (YC2) and engine PWB (YC8)
	2. Defective motor.	Replace the eject front fan motor.
	3. Defective PWB.	Replace the front PWB or engine PWB and check for correct operation (see page 1-5-67).
(16) Eject rear fan motor does not operate.	1. Defective connector cable or poor contact in the connector.	Reinsert the connector. Also check for continuity within the connector cable. If none, replace the cable. Eject rear fan motor and feed PWB 1 (YC19) Feed PWB 1 (YC1) and engine PWB (YC6)
	2. Defective motor.	Replace the eject rear fan motor.
	3. Defective PWB.	Replace the feed PWB 1 or engine PWB and check for correct operation (see page 1-5-67).
(17) Power source fan motor does not operate.	1. Defective connector cable or poor contact in the connector.	Reinsert the connector. Also check for continuity within the connector cable. If none, replace the cable. Power source fan motor and engine PWB (YC22)
	2. Defective motor.	Replace the power source fan motor.
	3. Defective PWB.	Replace the engine PWB and check for correct operation (see page 1-5-67).
(18) Controller fan motor does not operate.	1. Defective connector cable or poor contact in the connector.	Reinsert the connector. Also check for continuity within the connector cable. If none, replace the cable. Controller fan motor and main PWB (YC23)
	2. Defective motor.	Replace the controller fan motor.
	3. Defective PWB.	Replace the main PWB and check for correct operation (see page 1-5-59).
(19) Heater fan motor does not operate.	1. Defective connector cable or poor contact in the connector.	Reinsert the connector. Also check for continuity within the connector cable. If none, replace the cable. Heater fan motor and feed PWB 1 (YC11) Feed PWB 1 (YC2) and engine PWB (YC5)
	2. Defective motor.	Replace the heater fan motor.
	3. Defective PWB.	Replace the feed PWB 1 or engine PWB and check for correct operation (see page 1-5-67).
(20) Paper feed clutch 1, 2 does not operate.	1. Defective connector cable or poor contact in the connector.	Reinsert the connector. Also check for continuity within the connector cable. If none, replace the cable. Paper feed clutch 1, 2 and feed PWB 2 (YC4) Feed PWB 2 (YC1) and engine PWB (YC4)
	2. Defective clutch.	Replace the paper feed clutch 1 or 2.
	3. Defective PWB.	Replace the feed PWB 2 or engine PWB and check for correct operation (see page 1-5-67).

<b>Problem</b>	<b>Causes</b>	<b>Check procedures/corrective measures</b>
(21) Assist clutch 1, 2 does not operate (45 ppm/55 ppm model only).	1. Defective connector cable or poor contact in the connector.	Reinsert the connector. Also check for continuity within the connector cable. If none, replace the cable. Assist clutch 1 and feed PWB 2 (YC10) Assist clutch 2 and feed PWB 2 (YC12) Feed PWB 2 (YC1) and engine PWB (YC4)
	2. Defective clutch.	Replace the assist clutch 1 or 2.
	3. Defective PWB.	Replace the feed PWB 2 or engine PWB and check for correct operation (see page 1-5-67).
(22) Paper conveying clutch does not operate.	1. Defective connector cable or poor contact in the connector.	Reinsert the connector. Also check for continuity within the connector cable. If none, replace the cable. Paper conveying clutch and feed PWB 2 (YC5) Feed PWB 2 (YC1) and engine PWB (YC4)
	2. Defective clutch.	Replace the paper conveying clutch.
	3. Defective PWB.	Replace the feed PWB 2 or engine PWB and check for correct operation (see page 1-5-67).
(23) MP paper feed clutch does not operate.	1. Defective connector cable or poor contact in the connector.	Reinsert the connector. Also check for continuity within the connector cable. If none, replace the cable. MP paper feed clutch and relay PWB (YC3) Relay PWB (YC12) and feed PWB 1 (YC17) Feed PWB 1 (YC1) and engine PWB (YC6)
	2. Defective clutch.	Replace the MP paper feed clutch.
	3. Defective PWB.	Replace the relay PWB, feed PWB 1 or engine PWB and check for correct operation (see page 1-5-67).
(24) Registration clutch does not operate (35 ppm model only).	1. Defective connector cable or poor contact in the connector.	Reinsert the connector. Also check for continuity within the connector cable. If none, replace the cable. Registration clutch and feed PWB 1 (YC22) Feed PWB 1 (YC2) and engine PWB (YC5)
	2. Defective clutch.	Replace the registration clutch.
	3. Defective PWB.	Replace the feed PWB 1 or engine PWB and check for correct operation (see page 1-5-67).
(25) Middle clutch does not operate (35 ppm model only).	1. Defective connector cable or poor contact in the connector.	Reinsert the connector. Also check for continuity within the connector cable. If none, replace the cable. Middle clutch and feed PWB 2 (YC7) Feed PWB 2 (YC1) and engine PWB (YC4)
	2. Defective clutch.	Replace the middle clutch.
	3. Defective PWB.	Replace the feed PWB 2 or engine PWB and check for correct operation (see page 1-5-67).



<b>Problem</b>	<b>Causes</b>	<b>Check procedures/corrective measures</b>
(26) Duplex clutch 1 does not operate (35 ppm model only).	1. Defective connector cable or poor contact in the connector.	Reinsert the connector. Also check for continuity within the connector cable. If none, replace the cable. Duplex clutch 1 and relay PWB (YC11) Relay PWB (YC13) and feed PWB 1 (YC23) Feed PWB 1 (YC2) and engine PWB (YC5)
	2. Defective clutch.	Replace the duplex clutch 1.
	3. Defective PWB.	Replace the relay PWB, feed PWB 1 or engine PWB and check for correct operation (see page 1-5-67).
(27) Duplex clutch 2 does not operate (35 ppm model only).	1. Defective connector cable or poor contact in the connector.	Reinsert the connector. Also check for continuity within the connector cable. If none, replace the cable. Duplex clutch 2 and relay PWB (YC7) Relay PWB (YC1) and feed PWB 1 (YC14) Feed PWB 1 (YC1) and engine PWB (YC6)
	2. Defective clutch.	Replace the duplex clutch 2.
	3. Defective PWB.	Replace the relay PWB, feed PWB 1 or engine PWB and check for correct operation (see page 1-5-67).
(28) Feedshift solenoid does not operate.	1. Defective connector cable or poor contact in the connector.	Reinsert the connector. Also check for continuity within the connector cable. If none, replace the cable. Feedshift and front PWB (YC4) Front PWB (YC3) and engine PWB (YC7)
	2. Defective solenoid.	Replace the feedshift solenoid 1 or 2.
	3. Defective PWB.	Replace the front PWB or engine PWB and check for correct operation (see page 1-5-67).
(29) Cleaning solenoid does not operate.	1. Defective connector cable or poor contact in the connector.	Reinsert the connector. Also check for continuity within the connector cable. If none, replace the cable. Cleaning solenoid and relay PWB (YC4) Relay PWB (YC12) and Feed PWB 1 (YC17) Feed PWB 1 (YC2) and engine PWB (YC5)
	2. Defective solenoid.	Replace the cleaning solenoid.
	3. Defective PWB.	Replace the feed PWB 1 or engine PWB and check for correct operation (see page 1-5-67).

<b>Problem</b>	<b>Causes</b>	<b>Check procedures/corrective measures</b>
(30) The message requesting paper to be loaded is shown when paper is present on the cassette.	1. Defective connector cable or poor contact in the connector.	Reinsert the connector. Also check for continuity within the connector cable. If none, replace the cable. Paper sensor 1, 2 and feed PWB 2 (YC8) Feed PWB 2 (YC1) and engine PWB (YC4)
	2. Deformed actuator.	Check visually and replace if necessary.
	3. Defective sensor.	Replace the paper sensor 1 or 2.
	4. Defective PWB.	Replace the feed PWB 2 or engine PWB and check for correct operation (see page 1-5-67).
(31) The message requesting paper to be loaded is shown when paper is present on the MP tray.	1. Defective connector cable or poor contact in the connector.	Reinsert the connector. Also check for continuity within the connector cable. If none, replace the cable. MP paper sensor and relay PWB (YC3) Relay PWB (YC12) and feed PWB 1 (YC17) Feed PWB 1 (YC1) and engine PWB (YC6)
	2. Deformed actuator.	Check visually and replace if necessary.
	3. Defective sensor.	Replace the MP paper sensor.
	4. Defective PWB.	Replace the feed PWB 1 or engine PWB and check for correct operation (see page 1-5-67).
(32) The size of paper on the cassette is not displayed correctly.	1. Defective connector cable or poor contact in the connector.	Reinsert the connector. Also check for continuity within the connector cable. If none, replace the cable. Paper length switch 1, 2 and feed PWB 2 (YC3) Paper width switch 1, 2 and feed PWB 2 (YC3) Feed PWB 2 (YC1) and engine PWB (YC4)
	2. Defective switch.	Replace the paper length switch 1, 2 or paper width switch 1, 2.
	3. Defective PWB.	Replace the feed PWB 2 or engine PWB and check for correct operation (see page 1-5-67).
(33) The size of paper on the MP tray is not displayed correctly.	1. Defective connector cable or poor contact in the connector.	Reinsert the connector. Also check for continuity within the connector cable. If none, replace the cable. MP paper length switch and relay PWB (YC2) MP paper width switch and relay PWB (YC2) Relay PWB (YC12) and feed PWB 1 (YC17) Feed PWB 1 (YC1) and engine PWB (YC6)
	2. Defective switch.	Replace the MP paper length switch or MP paper width switch.
	3. Defective PWB.	Replace the relay PWB, feed PWB 1 or engine PWB and check for correct operation (see page 1-5-67).

Problem	Causes	Check procedures/corrective measures
(34) A paper jam in the paper feed, paper conveying or eject section is indicated when the main power switch is turned on.	1. A piece of paper torn from paper is caught around feed sensor 1, 2, MP feed sensor, middle sensor, paper conveying sensor, registration sensor, loop sensor, fuser eject sensor, duplex sensor 1, 2, eject full sensor or switch-back sensor.	Check visually and remove it, if any.
	2. Defective sensor.	Replace the feed sensor 1, 2, MP feed sensor, middle sensor, paper conveying sensor, registration sensor, loop sensor, fuser eject sensor, duplex sensor 1, 2, eject full sensor or switchback sensor.
(35) A message indicating cover open is displayed when the front cover is closed.	1. Defective connector cable or poor contact in the connector.	Reinsert the connector. Also check for continuity within the connector cable. If none, replace the cable. Front cover switch and front PWB (YC8) Front PWB (YC2) and engine PWB (YC8)
	2. Defective switch.	Replace the front cover switch.
(36) A message indicating unit open is displayed when the paper conveying unit is closed.	1. Defective connector cable or poor contact in the connector.	Reinsert the connector. Also check for continuity within the connector cable. If none, replace the cable. Paper conveying unit switch and feed PWB 1 (YC15) Feed PWB 1 (YC4) and power source PWB (YC12)
	2. Defective switch.	Replace the paper conveying unit switch.
(37) A message indicating cover open is displayed when the duplex cover is closed.	1. Defective connector cable or poor contact in the connector.	Reinsert the connector. Also check for continuity within the connector cable. If none, replace the cable. Duplex cover switch and relay PWB (YC7) Relay PWB (YC1) and feed PWB 1 (YC14) Feed PWB 1 (YC1)and engine PWB (YC6)
	2. Defective switch.	Replace the duplex cover switch.
(38) A message indicating cover open is displayed when the paper conveying cover is closed.	1. Defective connector cable or poor contact in the connector.	Reinsert the connector. Also check for continuity within the connector cable. If none, replace the cable. Paper conveying cover switch and feed PWB 2 (YC6) Feed PWB 2 (YC1) and power source PWB (YC4)
	2. Defective switch.	Replace the paper conveying cover switch.

## 1-4-8 Mechanical problems

If the part causing the problem was not supplied, use the unit including the part for replacement.

Problem	Causes/check procedures	Corrective measures
(1) No primary paper feed.	Check if the surfaces of the following rollers are dirty with paper powder. Forwarding pulley Paper feed pulley MP paper feed pulley	Clean with isopropyl alcohol.
	Check if the following rollers is deformed. Forwarding pulley Paper feed pulley MP paper feed pulley	Check visually and replace any deformed (see page 1-5-16, 1-5-25).
	Defective paper feed clutch 1, 2 or MP paper feed clutch installation.	Check visually and remedy if necessary.
(2) No secondary paper feed.	Check if the surfaces of the following rollers are dirty with paper powder. Right registration roller Left registration roller	Clean with isopropyl alcohol.
	Defective registration motor installation. (45 ppm/55 ppm model) Defective registration clutch installation. (35 ppm model)	Check visually and remedy if necessary.
(3) Skewed paper feed.	Paper width guide in a cassette installed incorrectly.	Check the paper width guide visually and remedy or replace if necessary.
(4) Multiple sheets of paper are fed.	Check if the paper is excessively curled.	Change the paper.
	Paper is loaded incorrectly.	Load the paper correctly.
	Check if the separation pulley is worn.	Replace the separation pulley if it is worn (see page 1-5-16, 1-5-19).
(5) Paper jams.	Check if the paper is excessively curled.	Change the paper.
	Check if the contact between the right and left registration rollers is correct.	Check visually and remedy if necessary.
	Check if the heat roller or press roller is extremely dirty or deformed.	Check visually and replace the fuser unit (see page 1-5-57).
(6) Toner drops on the paper conveying path.	Check if the drum unit or developer unit is extremely dirty.	Clean the drum unit or developer unit.

Problem	Causes/check procedures	Corrective measures
(7) Abnormal noise is heard.	Check if the rollers, pulleys and gears operate smoothly.	Grease the bushes and gears.
	Check if the following clutches are installed correctly. Paper feed clutch 1, 2 Assist clutch 1, 2 <sup>*1</sup> Paper conveying clutch MP paper feed clutch Registration clutch <sup>*2</sup> Middle clutch <sup>*2</sup> Duplex clutch 1, 2 <sup>*2</sup> *1: 45 ppm/55 ppm model only *2: 35 ppm model only	Check visually and remedy if necessary.

## 1-4-9 Send error code

This section describes the scanning errors and descriptions, preventive actions, as well as corrective actions. Error codes not described here could fall within software errors.

If such an error is encountered, turn power off then on, and advise the service representative.

### (1) Scan to SMB error codes

Code	Contents	Check procedures/corrective measures
1101	Host destined does not exist on the network.	<ol style="list-style-type: none"> <li>1. Confirm destined host.</li> <li>2. Confirm device's network parameters.</li> <li>3. Confirm the network parameters the device is connected.</li> </ol>
1102	Login to the host has failed.	<ol style="list-style-type: none"> <li>1. Confirm user name and password.</li> <li>2. Confirm the network parameters the device is connected.</li> <li>3. Check the host if the folder is properly shared.</li> </ol>
1103	Destined host, folder, and/or file names are invalid.	<ol style="list-style-type: none"> <li>1. Check illegal characters are not contained within these names.</li> <li>2. Check the name of the folder and files conform with the naming syntax.</li> <li>3. Confirm destined host and folder.</li> </ol>
1105	SMB protocol is not enabled.	<ol style="list-style-type: none"> <li>1. Confirm device's SMB protocols.</li> </ol>
2101	Login to the host has failed.	<ol style="list-style-type: none"> <li>1. Confirm destined host.</li> <li>2. Confirm that the LAN cable is properly connected to the device.</li> <li>3. Check the SMB port number.</li> <li>4. Confirm device's network parameters.</li> <li>5. Confirm the network parameters the device is connected.</li> </ol>
2201	Writing scanned data has failed.	<ol style="list-style-type: none"> <li>1. Check the scanning file name.</li> <li>2. Confirm device's network parameters.</li> <li>3. Confirm the network parameters the device is connected.</li> </ol>
2203	No response from the host during a certain period of time.	<ol style="list-style-type: none"> <li>1. Confirm the network parameters the device is connected.</li> <li>2. Confirm that the LAN cable is properly connected to the device.</li> </ol>

**(2) Scan to FTP error codes**

<b>Code</b>	<b>Contents</b>	<b>Check procedures/corrective measures</b>
<b>1101</b>	FTP server does not exist on the network.	<ol style="list-style-type: none"> <li>1. Check the FTP server name.</li> <li>2. Confirm device's network parameters.</li> <li>3. Confirm the network parameters the device is connected.</li> </ol>
<b>1102</b>	Login to the FTP server has failed.	<ol style="list-style-type: none"> <li>1. Confirm user name and password.</li> <li>2. Check the FTP server name.</li> </ol>
<b>1103</b>	Destined folder is invalid.	<ol style="list-style-type: none"> <li>1. Check illegal characters are not contained within these names.</li> <li>2. Check the FTP server name.</li> </ol>
<b>1105</b>	FTP protocol is not enabled.	<ol style="list-style-type: none"> <li>1. Confirm device's FTP protocols.</li> </ol>
<b>1131</b>	Initializing TLS has failed.	<ol style="list-style-type: none"> <li>1. Confirm device's security parameters.</li> </ol>
<b>1132</b>	TLS negotiation has failed.	<ol style="list-style-type: none"> <li>1. Confirm device's security parameters.</li> <li>2. Check the FTP server name.</li> </ol>
<b>2101</b>	Access to the FTP server has failed.	<ol style="list-style-type: none"> <li>1. Check the FTP server name.</li> <li>2. Confirm that the LAN cable is properly connected to the device.</li> <li>3. Check the FTP port number.</li> <li>4. Confirm device's network parameters.</li> <li>5. Confirm the network parameters the device is connected.</li> <li>6. Check the FTP server name.</li> </ol>
<b>2102</b>	Access to the FTP server has failed. (Connection timeout)	<ol style="list-style-type: none"> <li>1. Check the FTP server name.</li> <li>2. Check the FTP port number.</li> <li>3. Confirm device's network parameters.</li> <li>4. Confirm the network parameters the device is connected.</li> <li>5. Check the FTP server name.</li> </ol>
<b>2103</b>	The server cannot establish communication.	<ol style="list-style-type: none"> <li>1. Check the FTP server name.</li> <li>2. Check the FTP port number.</li> <li>3. Confirm device's network parameters.</li> <li>4. Confirm the network parameters the device is connected.</li> <li>5. Check the FTP server name.</li> </ol>
<b>2201</b>	Connection with the FTP server has failed.	<ol style="list-style-type: none"> <li>1. Confirm device's network parameters.</li> <li>2. Confirm the network parameters the device is connected.</li> <li>3. Confirm destined folder.</li> <li>4. Check the FTP server name.</li> </ol>
<b>2202</b>	Connection with the FTP server has failed. (Timeout)	<ol style="list-style-type: none"> <li>1. Confirm device's network parameters.</li> <li>2. Confirm the network parameters the device is connected.</li> </ol>
<b>2203</b>	No response from the server during a certain period of time.	<ol style="list-style-type: none"> <li>1. Confirm device's network parameters.</li> <li>2. Confirm the network parameters the device is connected.</li> </ol>

Code	Contents	Check procedures/corrective measures
2231	Connection with the FTP server has failed. (FTPS communication)	<ol style="list-style-type: none"> <li>1. Confirm device's network parameters.</li> <li>2. Confirm the network parameters the device is connected.</li> </ol>
3101	FTP server responded with an error.	<ol style="list-style-type: none"> <li>1. Confirm device's network parameters.</li> <li>2. Confirm the network parameters the device is connected.</li> <li>3. Check the FTP server.</li> </ol>

### (3) Scan to E-mail error codes

Code	Contents	Check procedures/corrective measures
1101	SMTP/POP3 server does not exist on the network.	<ol style="list-style-type: none"> <li>1. Check the SMTP/POP3 server name.</li> <li>2. Confirm device's network parameters.</li> <li>3. Confirm the network parameters the device is connected.</li> </ol>
1102	Login to the SMTP/POP3 server has failed.	<ol style="list-style-type: none"> <li>1. Confirm user name and password.</li> <li>2. Check the SMTP/POP3 server.</li> </ol>
1104	The domain the destined address belongs is prohibited by scanning restriction.	<ol style="list-style-type: none"> <li>1. Confirm device's SMTP parameters.</li> </ol>
1105	SMTP protocol is not enabled.	<ol style="list-style-type: none"> <li>1. Confirm device's SMTP protocols.</li> </ol>
1106	Sender's address is not specified.	<ol style="list-style-type: none"> <li>1. Confirm device's SMTP protocols.</li> </ol>
2101	Connection to the SMTP/POP3 server has failed.	<ol style="list-style-type: none"> <li>1. Check the SMTP/POP3 server name.</li> <li>2. Confirm that the LAN cable is properly connected to the device.</li> <li>3. Check the SMTP/POP3 port number.</li> <li>4. Confirm device's network parameters.</li> <li>5. Confirm the network parameters the device is connected.</li> <li>6. Check the SMTP/POP3 server.</li> </ol>
2102	Connection to the SMTP/POP3 server has failed. (Connection timeout)	<ol style="list-style-type: none"> <li>1. Check the SMTP/POP3 server name.</li> <li>2. Check the SMTP/POP3 port number.</li> <li>3. Confirm device's network parameters.</li> <li>4. Confirm the network parameters the device is connected.</li> <li>5. Check the SMTP/POP3 server.</li> </ol>
2103	The server cannot establish communication.	<ol style="list-style-type: none"> <li>1. Check the SMTP/POP3 server name.</li> <li>2. Check the SMTP/POP3 port number.</li> <li>3. Confirm device's network parameters.</li> <li>4. Confirm the network parameters the device is connected.</li> <li>5. Check the SMTP/POP3 server.</li> </ol>
2201	Connection to the SMTP/POP3 server has failed.	<ol style="list-style-type: none"> <li>1. Confirm device's network parameters.</li> <li>2. Confirm the network parameters the device is connected.</li> </ol>



<b>Code</b>	<b>Contents</b>	<b>Check procedures/corrective measures</b>
<b>2202</b>	Connection to the SMTP/POP3 server has failed. (Timeout)	<ol style="list-style-type: none"> <li>1. Confirm device's network parameters.</li> <li>2. Confirm the network parameters the device is connected.</li> </ol>
<b>2204</b>	The size of scanning exceeded its limit.	<ol style="list-style-type: none"> <li>1. Confirm device's network parameters.</li> <li>1.</li> </ol>
<b>3101</b>	SMTP/POP3 server responded with an error.	<ol style="list-style-type: none"> <li>1. Confirm device's network parameters.</li> <li>2. Confirm the network parameters the device is connected.</li> <li>3. Check the SMTP/POP3 server.</li> </ol>
<b>3102</b>	Error: Server Response.	<ol style="list-style-type: none"> <li>1. Check the SMTP/POP3 server.</li> <li>2. Wait a minute and try again.</li> </ol>
<b>3201</b>	No SMTP authentication is found.	<ol style="list-style-type: none"> <li>1. Check the SMTP server. The device supports SMTP authentication services including CRAM-MD5, DIGEST-MD5, PLAIN and LOGIN.</li> </ol>
<b>4803</b>	Failed to establish the SSL session.	<ol style="list-style-type: none"> <li>1. Verify the self certificate of the device.</li> <li>2. Check the server certificate of the SMTP/POP3 server.</li> <li>3. Check the SMTP/POP3 configuration of the device and the SMTP/POP3 server.</li> </ol>

## 1-4-10 Error codes

### (1) Error code

Error codes are listed on the communication reports, activity report, etc. The codes consist of an error code indication U followed by a 5-digit number. (Error codes for V34 communication errors start with an E indication, followed by five digits.)

The upper three of the five digits indicate general classification of the error and its cause, while the lower two indicate the detailed classification. Items for which detailed classification is not necessary have 00 as the last two digits.

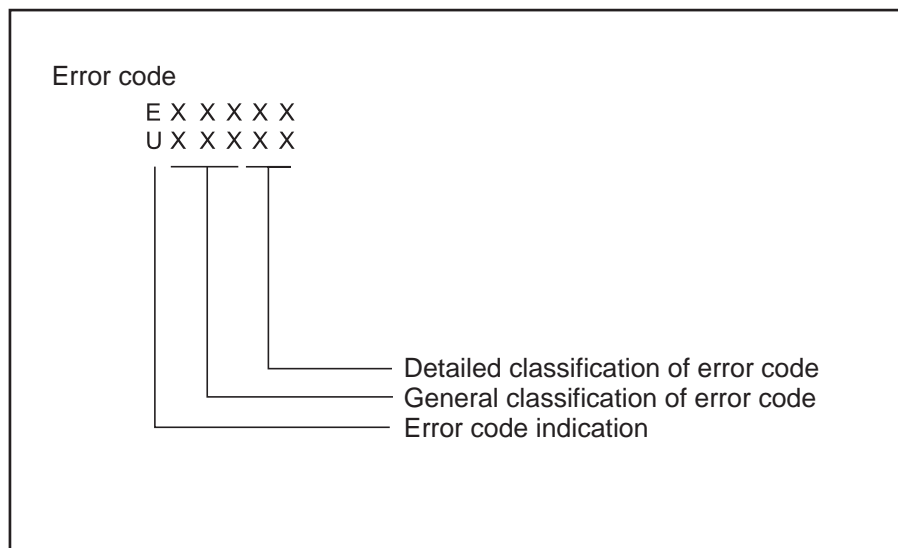


Figure 1-4-7

**(2) Table of general classification**

<b>Error code</b>	<b>Description</b>
U00000/E00000	No response or busy after the set number of redials.
U00100/E00100	Transmission was interrupted by a press of the stop/clear key.
U00200/E00200	Reception was interrupted by a press of the stop/clear key.
U00300/E00300	Recording paper on the destination unit has run out during transmission.
U004XX/E004XX	A connection was made but interrupted during handshake with the receiver unit (refer to P.1-4-235 U004XX error code table).
U006XX/E006XX	Communication was interrupted because of a machine problem (refer to P.1-4-235 U006XX error code table).
U00700/E00700	Communication was interrupted because of a problem in the destination unit.
U008XX/E008XX	A page transmission error occurred in G3 mode (refer to P.1-4-235 U008XX error code table).
U009XX/E009XX	A page reception error occurred in G3 mode (refer to P.1-4-235 U009XX error code table).
U010XX/E010XX	Transmission in G3 mode was interrupted by a signal error (refer to P.1-4-236 U010XX error code table).
U011XX/E011XX	Reception in G3 mode was interrupted by a signal error (refer to P.1-4-237 U011XX error code table).
U01400/E01400	An invalid one-touch key was specified during communication.
U01500/E01500	A communication error occurred when calling in V.8 mode.
U01600/E01600	A communication error occurred when called in V.8 mode.
U017XX/E017XX	A communication error occurred before starting T.30 protocol during transmission in V.34 mode (refer to P.1-4-238 U017XX error code table).
U018XX/E018XX	A communication error occurred before starting T.30 protocol during reception in V.34 mode (refer to P.1-4-238 U018XX error code table).
U03000/E03000	No document was present in the destination unit when polling reception started.
U03200/E03200	In interoffice subaddress-based bulletin board reception, data was not stored in the box specified by the destination unit.
U03300/E03300	In polling reception from a unit of our make, operation was interrupted due to a mismatch in permit ID or telephone number. Or, in interoffice subaddress-based bulletin board reception, operation was interrupted due to a mismatch in permit ID or telephone number.
U03400/E03400	Polling reception was interrupted because of a mismatch in individual numbers (destination unit is either of our make or by another manufacturer).
U03500/E03500	In interoffice subaddress-based bulletin board reception, the specified Subaddress confidential box number was not registered in the destination unit.
U03600/E03600	An interoffice subaddress-based bulletin board reception was interrupted because of a mismatch in the specified subaddress confidential box number.
U03700/E03700	Interoffice subaddress-based bulletin board reception failed because the destination unit had no subaddress-based bulletin board transmission capability, or data was not stored in any subaddress confidential box in the destination unit.

Error code	Description
U04000/E04000	In interoffice subaddress-based transmission mode, the specified subaddress box number was not registered in the destination unit.
U04100/E04100	Subaddress-based transmission failed because the destination unit had no subaddress-based reception capability.
U04200/E04200	In encrypted transmission, the specified encryption box was not registered in the destination unit.
U04300/E04300	Encrypted transmission failed because the destination unit had no encrypted communication capability.
U04400/E04400	Encrypted transmission was interrupted because encryption keys did not agree.
U04500/E04500	Encrypted reception was interrupted because of a mismatch in encryption keys.
U05100/E05100	Password check transmission or restricted transmission was interrupted because the permit ID's did not agree with.
U05200/E05200	Password check reception or restricted reception was interrupted because the permit ID's did not match, the rejected FAX number's did match, or the destination receiver did not return its phone number.
U05300/E05300	The password check reception or the restricted reception was interrupted because the permitted numbers did not match, the rejected numbers did match, or the machine in question did not acknowledge its phone number.
U14000/E14000	Memory overflowed during confidential reception. Or, in subaddress-based confidential reception, memory overflowed.
U14100/E14100	In interoffice subaddress-based transmission, memory overflowed in the destination unit.
U19000/E19000	Memory overflowed during memory reception.
U19100/E19100	Memory overflowed in the destination unit during transmission.
U19300/E19300	Transmission failed because an error occurred during JBIG encoding.

**(2-1) U004XX error code table: Interrupted phase B**

Error code	Description
U00430/E00430	Polling request was received but interrupted because of a mismatch in permit number. Or, subaddress-based bulletin board transmission request was received but interrupted because of a mismatch in permit ID in the transmitting unit.
U00431/E00431	An subaddress-based bulletin board transmission was interrupted because the specified subaddress confidential box was not registered.
U00432/E00432	An subaddress-based bulletin board transmission was interrupted because of a mismatch in Subaddress confidential box numbers.
U00433/E00433	Subaddress-based bulletin board transmission request was received but data was not present in the subaddress confidential box.
U00440/E00440	Subaddress-based confidential reception was interrupted because the specified subaddress box was not registered.
U00450/E00450	The destination transmitter disconnected because the permit ID's did not agree with while the destination transmitter is in password-check transmission or restricted transmission.
U00460/E00460	Encrypted reception was interrupted because the specified encryption box number was not registered.
U00462/E00462	Encrypted reception was interrupted because the encryption key for the specified encryption box was not registered.

**(2-2) U006XX error code table: Problems with the unit**

Error code	Description
U00601/E00601	Document jam or the document length exceeds the maximum.
U00613/E00613	Image writing section problem
U00656/E00656	Data was not transmitted to a modem error.
U00690/E00690	System error.

**(2-3) U008XX error code table: Page transmission error**

Error code	Description
U00800/E00800	A page transmission error occurred because of reception of a RTN or PIN signal.
U00811/E00811	A page transmission error reoccurred after retry of transmission in the ECM mode.

**(2-4) U009XX error code table: Page reception error**

Error code	Description
U00900/E00900	An RTN or PIN signal was transmitted because of a page reception error.
U00910/E00910	A page reception error remained after retry of transmission in the ECM mode.

**(2-5) U010XX error code table: G3 transmission**

<b>Error code</b>	<b>Description</b>
U01000/E01000	An FTT signal was received for a set number of times after TCF signal transmission at 2400 bps. Or, an RTN signal was received in response to a Q signal (excluding EOP) after transmission at 2400 bps.
U01001/E01001	Function of the unit differs from that indicated by a DIS signal.
U01016/E01016	An MCF signal was received but no DIS signal was received after transmission of an EOM signal, and T1 timeout was detected.
U01019/E01019	No relevant signal was received after transmission of a CNC signal, and the preset number of command retransfers was exceeded (between units of our make).
U01020/E01020	No relevant signal was received after transmission of a CTC signal, and the preset number of command retransfers was exceeded (ECM).
U01021/E01021	No relevant signal was received after transmission of an EOR.Q signal, and the preset number of command retransfers was exceeded (ECM).
U01022/E01022	No relevant signal was received after transmission of an RR signal, and the preset number of command retransfers was exceeded (ECM).
U01028/E01028	T5 time-out was detected during ECM transmission (ECM).
U01052/E01052	A DCN signal was received after transmission of an RR signal (ECM).
U01080/E01080	A PIP signal was received after transmission of a PPS.NULL signal.
U01092/E01092	During transmission in V.34 mode, communication was interrupted because of an impossible combination of the symbol speed and communication speed.
U01093/E01093	A DCN or other inappropriate signal was received during phase B of transmission.
U01094/E01094	The preset number of command retransfers for DCS/NSS signals was exceeded during phase B of transmission.
U01095/E01095	No relevant signal was received after transmission of a PPS (Q) signal during phase D of transmission, and the preset number of command transfers was exceeded.
U01096/E01096	A DCN signal or invalid command was received during phase D of transmission.
U01097/E01097	The preset number of command retransfers was exceeded after transmission of an RR signal or no response.

**(2-6) U011XX error code table: G3 reception**

<b>Error code</b>	<b>Description</b>
U01100/E01100	Function of the unit differs from that indicated by a DCS signal.
U01101/E01101	Function of the unit (excl. communication mode select) differs from that indicated by an NSS signal.
U01102/E01102	A DTC (NSC) signal was received when no transmission data was in the unit.
U01110/E01110	No response after transmission of a DIS signal.
U01111/E01111	No response after transmission of a DTC (NSC) signal.
U01113/E01113	No response after transmission of an FTT signal.
U01125/E01125	No response after transmission of a CNS signal (between units of our make).
U01129/E01129	No response after transmission of an SPA signal (short protocol).
U01141/E01141	A DCN signal was received after transmission of a DTC signal.
U01143/E01143	A DCN signal was received after transmission of an FTT signal.
U01155/E01155	A DCN signal was received after transmission of an SPA signal (short protocol).
U01160/E01160	During message reception, transmission time exceeded the maximum transmission time per line.
U01162/E01162	Reception was aborted due to a modem malfunction during message reception.
U01191/E01191	Communication was interrupted because an error occurred during an image data reception sequence in the V.34 mode.
U01193/E01193	There was no response, or a DCN signal or invalid command was received, during phase C/D of reception.
U01194/E01194	A DCN signal was received during phase B of reception.
U01195/E01195	No message was received during phase C of reception.
U01196/E01196	Error line control was exceeded and a decoding error occurred for the message being received.

**(2-7) U017XX error code table: V.34 transmission**

<b>Error code</b>	<b>Description</b>
U01700/E01700	A communication error occurred in phase 2 (line probing).
U01720/E01720	A communication error occurred in phase 4 (modem parameter exchange).
U01721/E01721	Operation was interrupted due to the absence of a common communication speed between units.

U01700/E01700:A communication error that occurs at the transmitting unit in the period after transmission of INFO0 before entering phase 3 (primary channel equivalent device training). For example, INFO0/A/Abar (B/Bbar, for polling transmission)/INFOh was not detected.

U01720/E01720:A communication error that occurs at the transmitting unit in the period after initiating the control channel before entering the T.30 process. For example, PPh/ALT/MPh/E was not detected.

U01721/E01721:In the absence of a common communication speed between units (including when an impossible combination of communication speed and symbol speed occurs) after MPh exchange; 1) a DCN signal was received from the destination unit, and the line was cut; or 2) a DIS (NSF, CSI) signal was received from the destination unit and, in response to the signal, the unit transmitted a DCN signal, and the line was cut.

**(2-8) U018XX error code table: V.34 reception**

<b>Error code</b>	<b>Description</b>
U01800/E01800	A communication error occurred in phase 2 (line probing).
U01810/E01810	A communication error occurred in phase 3 (primary channel equivalent device training).
U01820/E01820	A communication error occurred in phase 4 (modem parameter exchange).
U01821/E01821	Operation was interrupted due to the absence of a common communication speed between units.

U01800/E01800:A communication error that occurs at the receiver unit in the period after transmission of INFO0 before entering phase 3 (primary channel equivalent device training). For example, INFO0/B/Bbar (A/Abar, for polling reception)/probing tone was not detected.

U01810/E01810:A communication error that occurs at the receiver unit in phase 3 (primary channel equivalent device training). For example, S/Sbar/PP/TRN was not detected.

U01820/E01820:A communication error that occurs at the receiver unit in the period after initiating the control channel before entering the T.30 process. For example, PPh/ALT/MPh/E was not detected.

U01821/E01821:In the absence of a common communication speed between units (including when an impossible combination of communication speed and symbol speed occurs) after MPh exchange, a DCN signal was transmitted to the destination unit and the line was cut.



## 1-5-1 Precautions for assembly and disassembly

### (1) Precautions

Before starting disassembly, press the Power key on the operation panel to off. Make sure that the Power lamp is off before turning off the main power switch. And then unplug the power cable from the wall outlet.

When the fax kit is installed, be sure to disconnect the modular cable before starting disassembly.

When handling PWBs (printed wiring boards), do not touch parts with bare hands.

The PWBs are susceptible to static charge.

Do not touch any PWB containing ICs with bare hands or any object prone to static charge.

When removing the hook of the connector, be sure to release the hook.

Take care not to get the cables caught.

To reassemble the parts, use the original screws. If the types and the sizes of screws are not known, refer to the PARTS LIST.

### (2) Drum

Note the following when handling or storing the drum.

When removing the drum unit, never expose the drum surface to strong direct light.

Keep the drum at an ambient temperature between -20°C/-4°F and 40°C/104°F and at a relative humidity not higher than 85% RH. Avoid abrupt changes in temperature and humidity.

Avoid exposure to any substance which is harmful to or may affect the quality of the drum.

Do not touch the drum surface with any object. Should it be touched by hands or stained with oil, clean it.

### (3) Toner

Store the toner container in a cool, dark place.

Avoid direct light and high humidity.

#### (4) How to tell a genuine Kyocera toner container

As a means of brand protection, the Kyocera toner container utilizes an optical security technology to enable visual validation. A validation viewer is required to accomplish this.

Hold the validation viewer over the left side part of the brand protection seal on the toner container. Through each window of the validation viewer, the left side part of the seal should be seen as follows:

A black-colored band when seen through the left side window ( ● )

A shiny or gold-colored band when seen through the right side window ( ☼ )

The above will reveal that the toner container is a genuine Kyocera branded toner container, otherwise, it is a counterfeit.

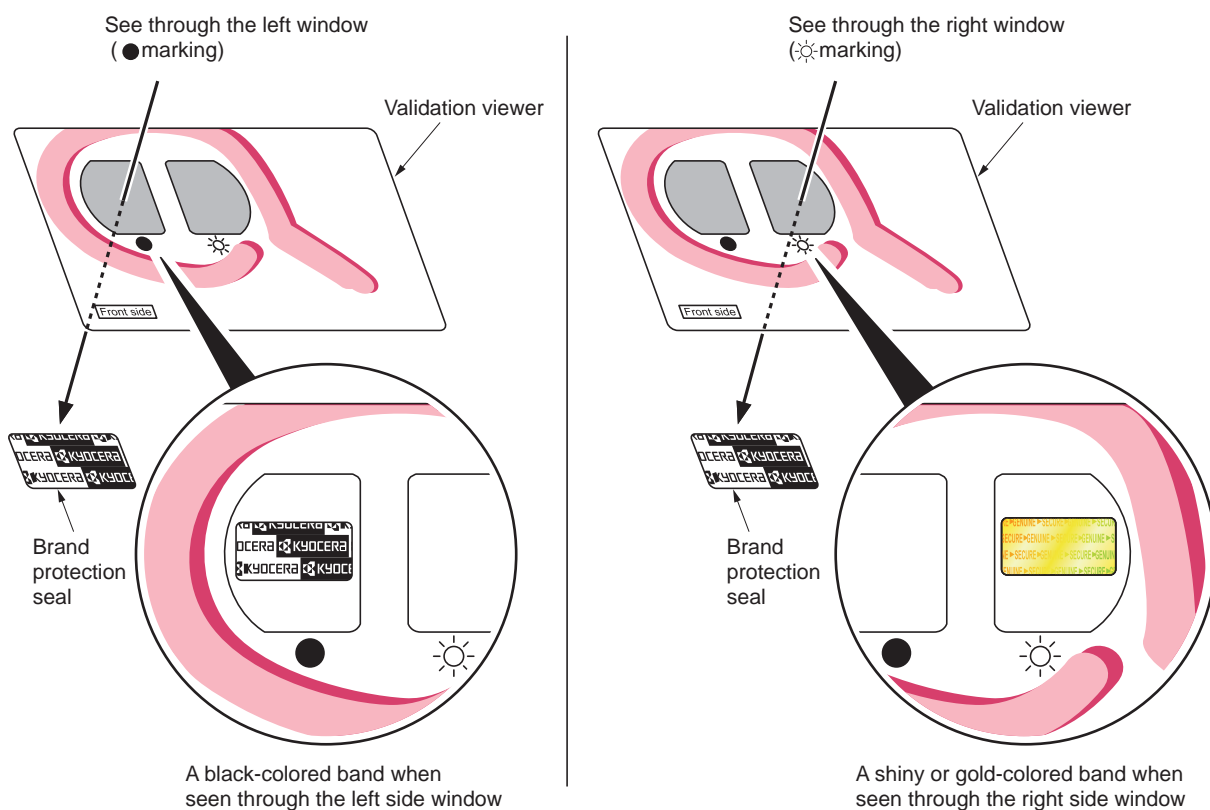


Figure 1-5-1

The brand protection seal has an incision as shown below to prohibit reuse.

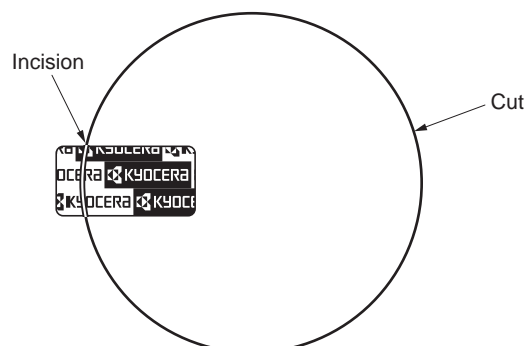


Figure 1-5-2

## 1-5-2 Outer covers

### (1) Detaching and refitting the rear upper cover

#### Procedure

1. Remove nine screws and then remove the rear upper cover.

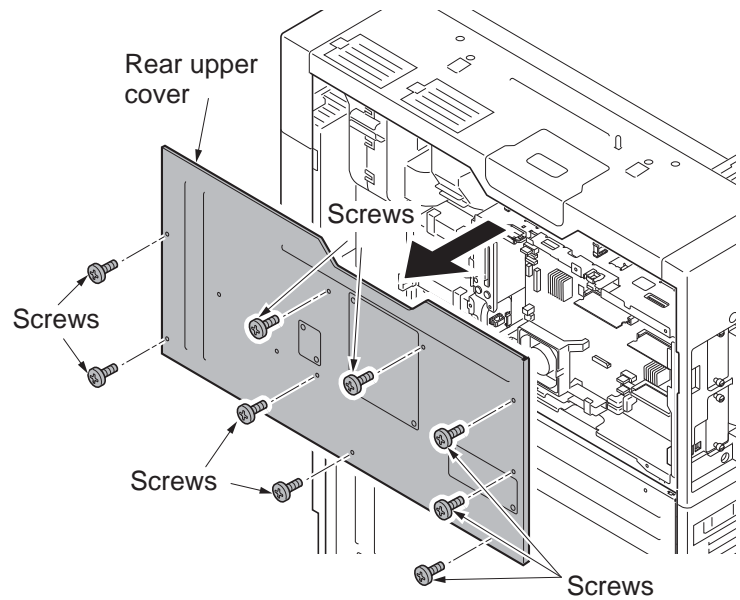


Figure 1-5-3

### (2) Detaching and refitting the rear lower cover

#### Procedure

2. Remove nine screws.
3. Release two hanging parts and then remove the rear lower cover.

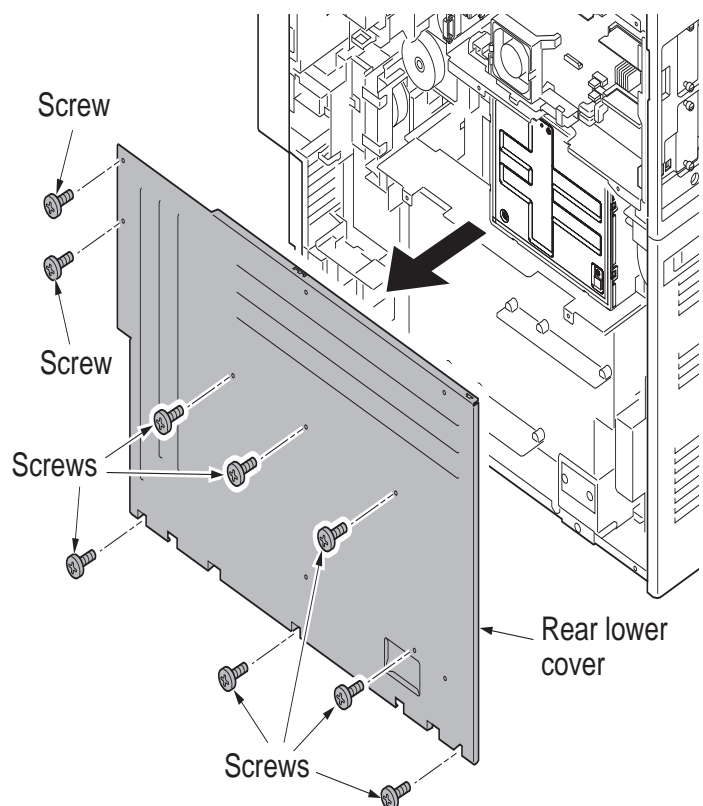


Figure 1-5-4

### (3) Detaching and refitting the left upper cover

#### Procedure

1. Remove four screws.
2. Unhook two hooks and then remove the left upper cover.

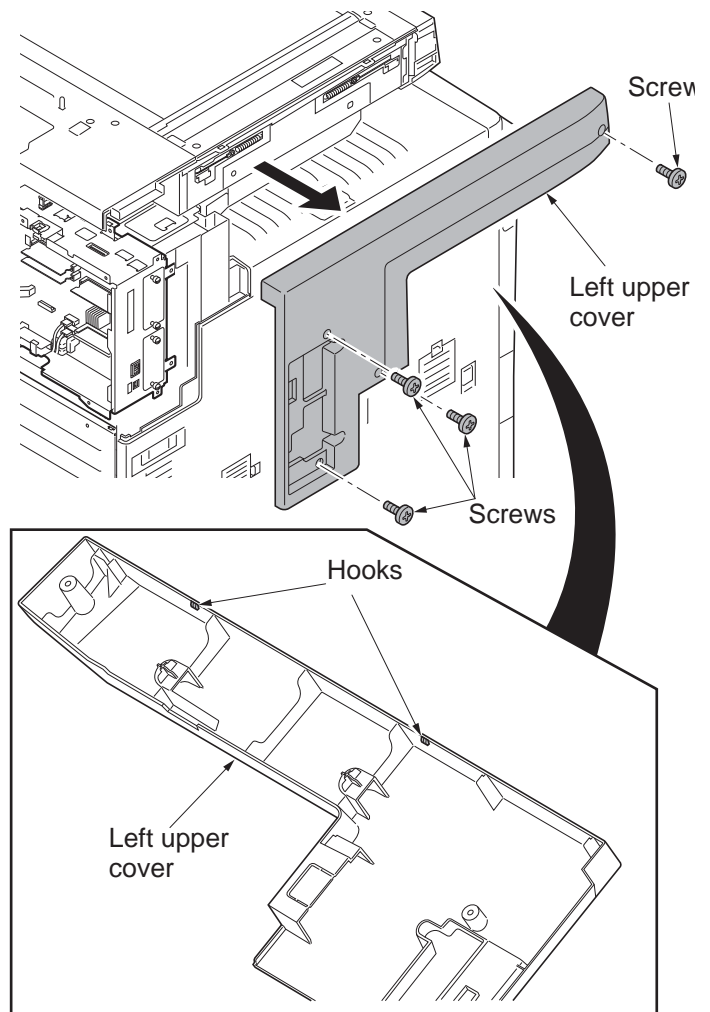


Figure 1-5-5

#### (4) Detaching and refitting the right lower cover

##### Procedure

1. Pull the cassette 1 and cassette 2 out completely.
2. Pull the paper conveying unit out.
3. Open the right lower cover.
4. Remove the strap and then remove the right lower cover.

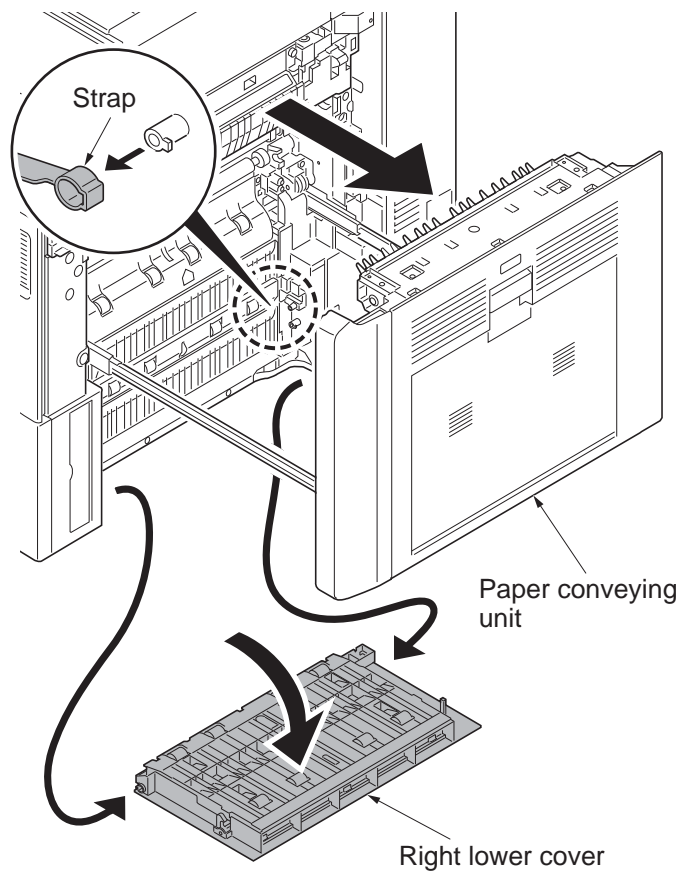


Figure 1-5-6

#### (5) Detaching and refitting the right lower rear cover

##### Procedure

1. Remove the rear upper cover and the rear lower cover (see page 1-5-3).
2. Pull the paper conveying unit out.
3. Remove three screws and then remove the right lower rear cover.

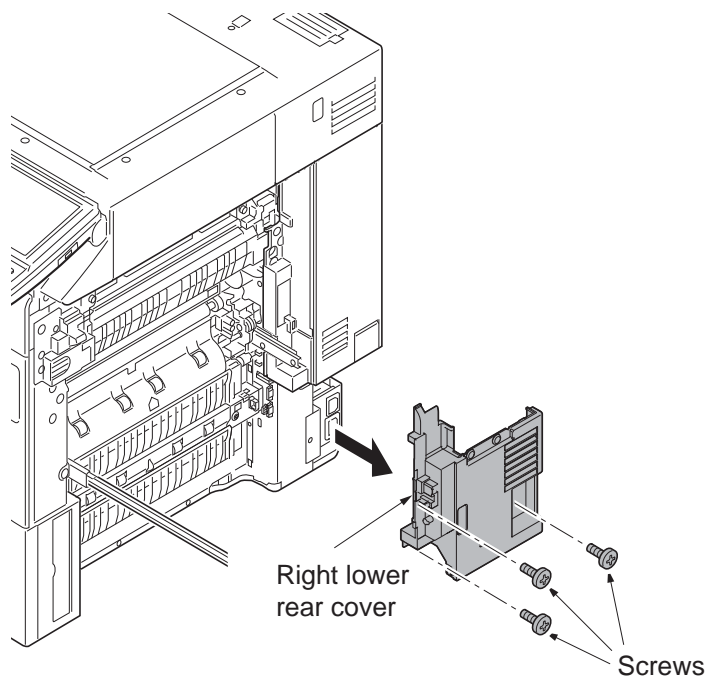
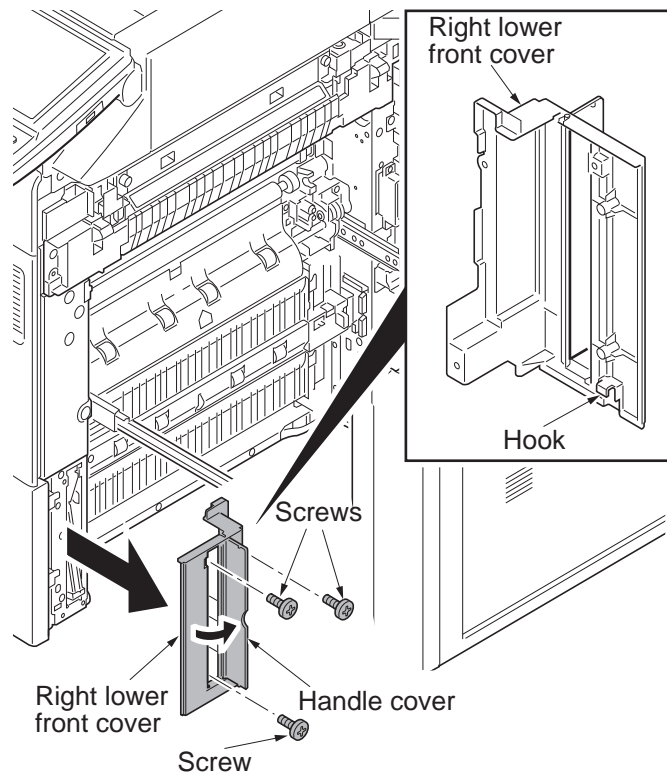


Figure 1-5-7

**(6) Detaching and refitting the right lower front cover**

1. Pull the paper conveying unit out.
2. Open the handle cover.
3. Remove three screws.
4. Unhook the hook and then remove the right lower front cover.

**Figure 1-5-8**

## (7) Detaching and refitting the ISU right cover and right upper cover

### Procedure

1. Remove two screws and then remove the ISU right cover.
2. Pull the paper conveying unit out.
3. Remove the screw and five hooks and then remove the right upper cover.

\*: Unlatch the stoppers with the rear bottom one first.

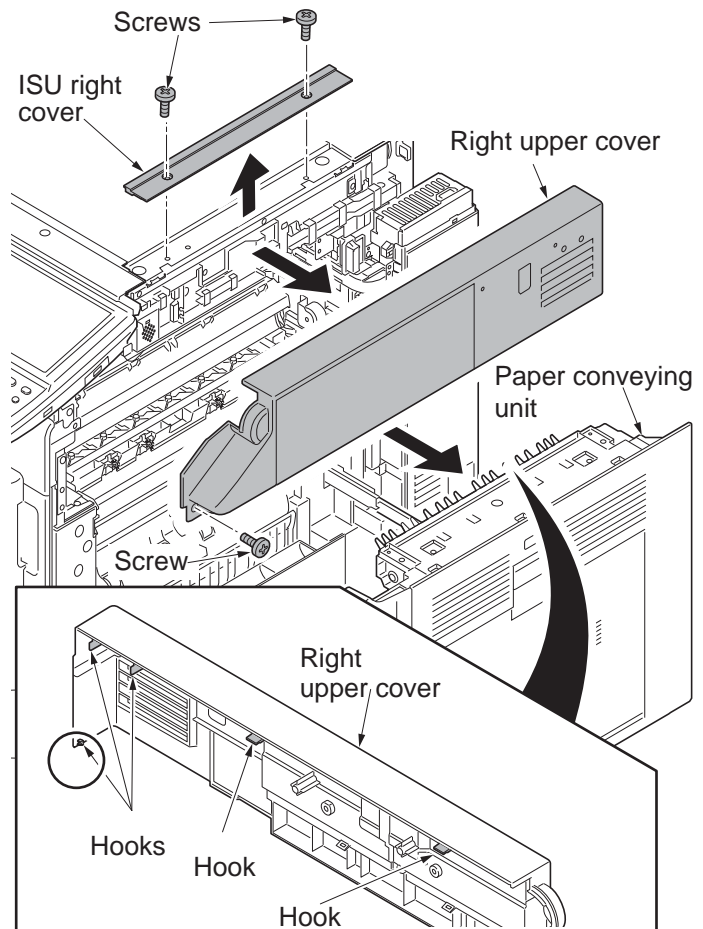


Figure 1-5-9

## (8) Detaching and refitting the right middle rear cover

### Procedure

1. Remove the ISU right cover and right upper cover (see page 1-5-7).
2. Remove the screw.
3. Unhook the two hooks and then remove the right middle rear cover.

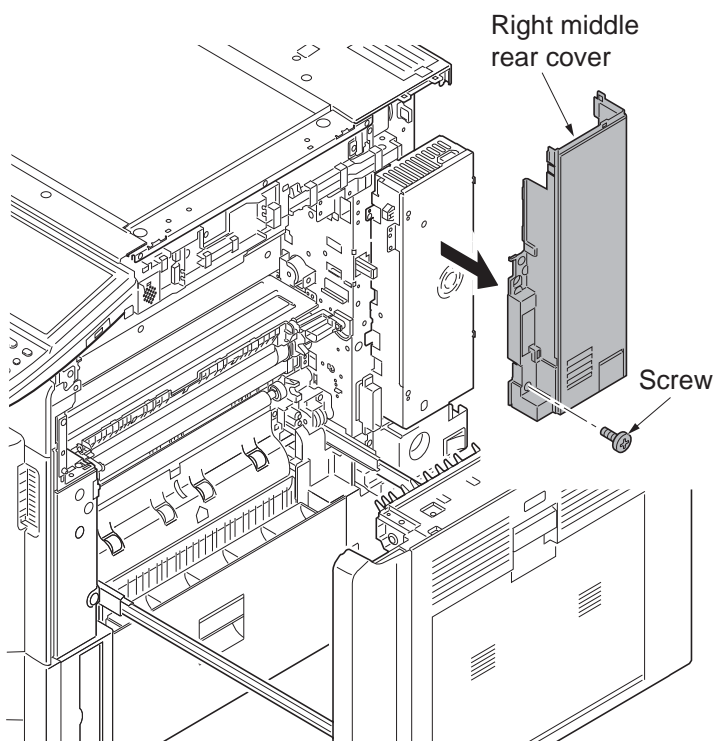


Figure 1-5-10

## (9) Detaching and refitting the MP tray paper feed unit

### Procedure

1. Pull the paper conveying unit out.
2. Open the MP tray.
3. Remove four screws.

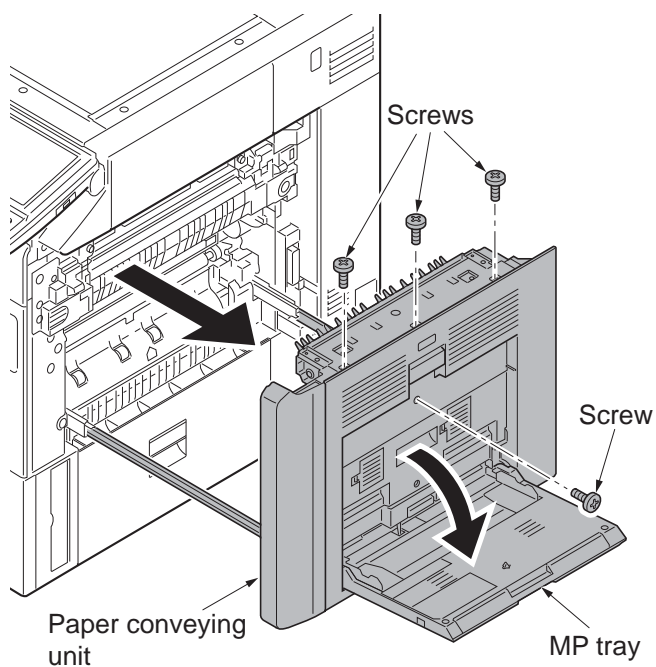


Figure 1-5-11



4. Unhook eight hooks and then remove the right cover and DU cover assembly.

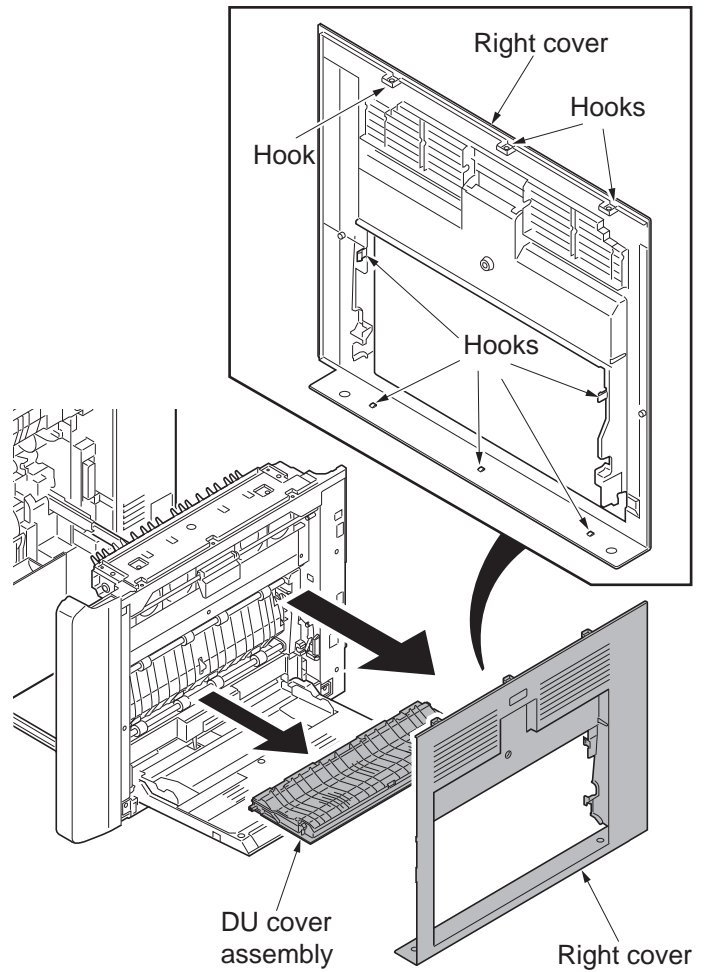


Figure 1-5-12

## (10) Detaching and refitting the paper conveying unit

### Procedure

1. Pull the paper conveying unit out.
2. Remove three screws.
3. Unhook three hooks and then remove the right front cover.

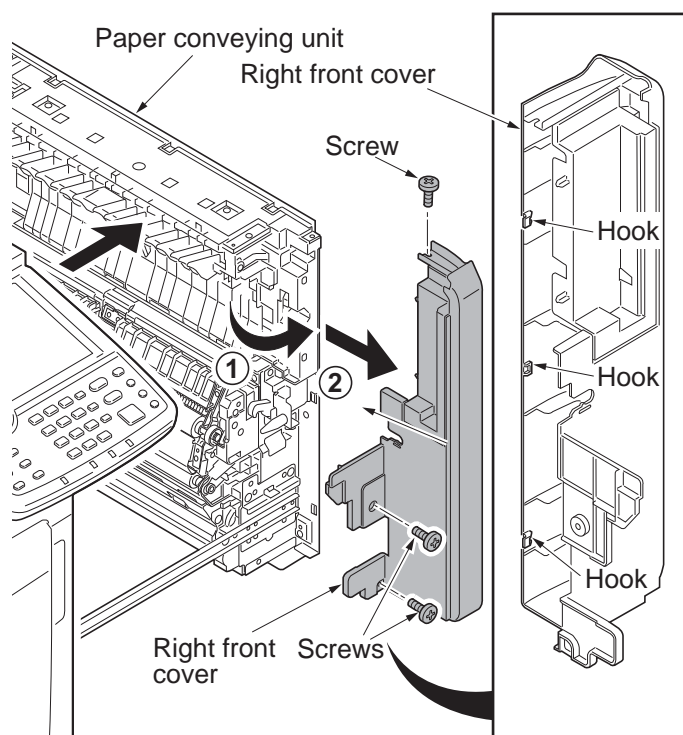


Figure 1-5-13

## (11) Detaching and refitting the ISU front cover and ISU right cover

### Procedure

1. Remove the original cover or the document processor.
2. Remove the the staple holder. Remove the screw and then remove the staple cover (see page 1-2-74).
3. Remove the hook and remove the upper cover B (see page 1-2-75).
4. Remove two pins and then remove the ISU front cover.
5. Remove two screws and then remove the ISU right cover.

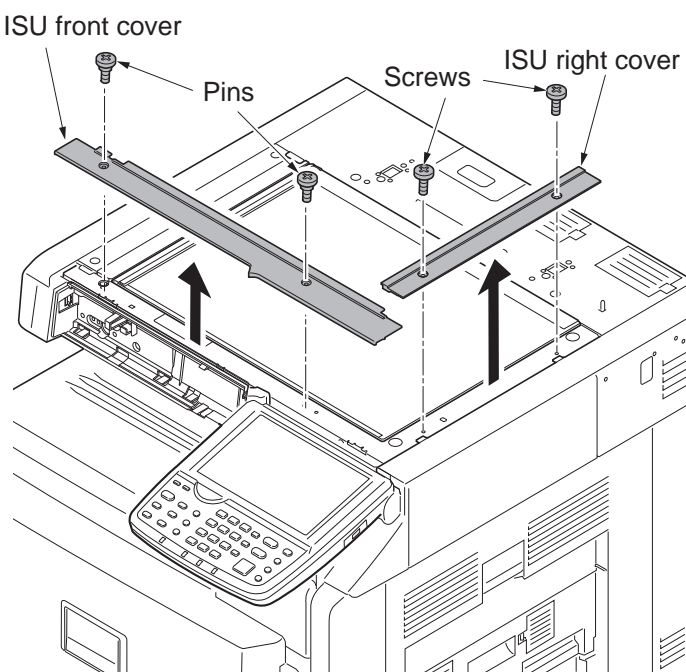


Figure 1-5-14

## (12) Detaching and refitting the ISU rear cover

### Procedure

1. Remove the left upper cover (see page 1-5-4).
2. Remove the right upper cover (see page 1-5-7).
3. Remove two screws and then remove the ISU rear cover.

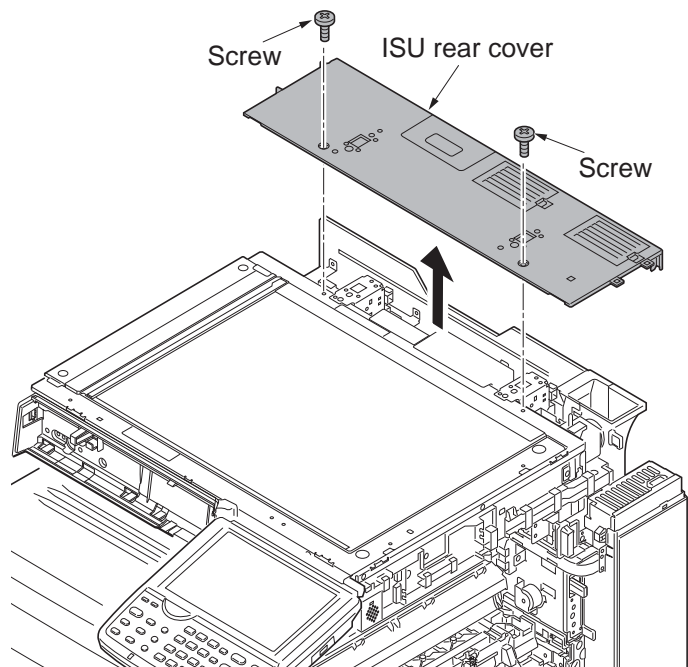


Figure 1-5-15

## 1-5-3 Paper feed section

### (1) Detaching and refitting the primary paper feed unit

#### Procedure

#### Remove the primary paper feed unit

1. Pull the cassette 1 and cassette 2 out completely.
2. Pull the paper conveying unit out.
3. Open the right lower cover.
4. Remove the strap and then remove the right lower cover.

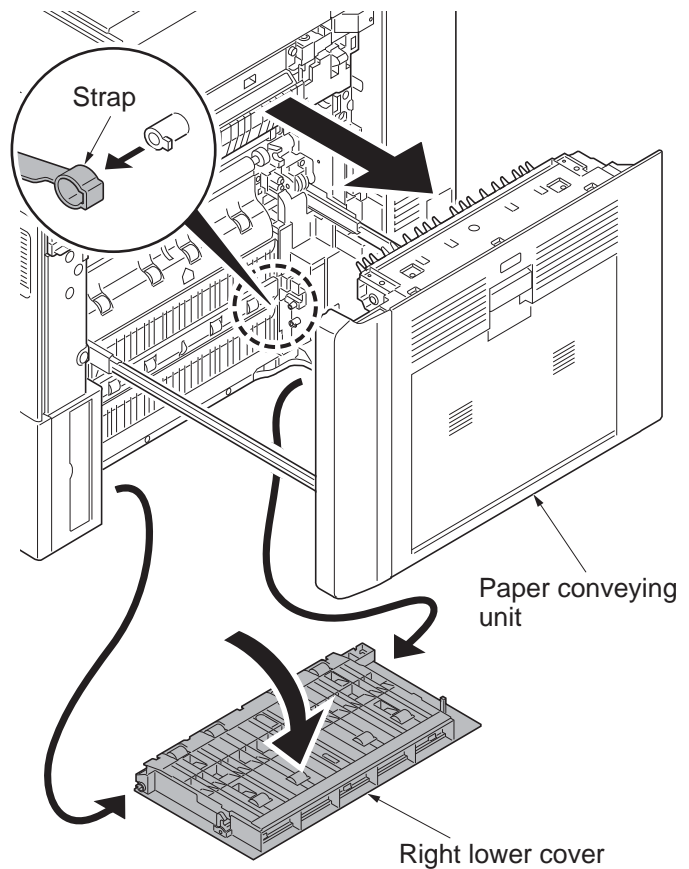


Figure 1-5-16

5. Remove the rear upper cover and the rear lower cover (see page 1-5-84).
6. Remove the screw A and then remove the right middle rear cover.
7. Remove three screws B and then remove the right lower rear cover.

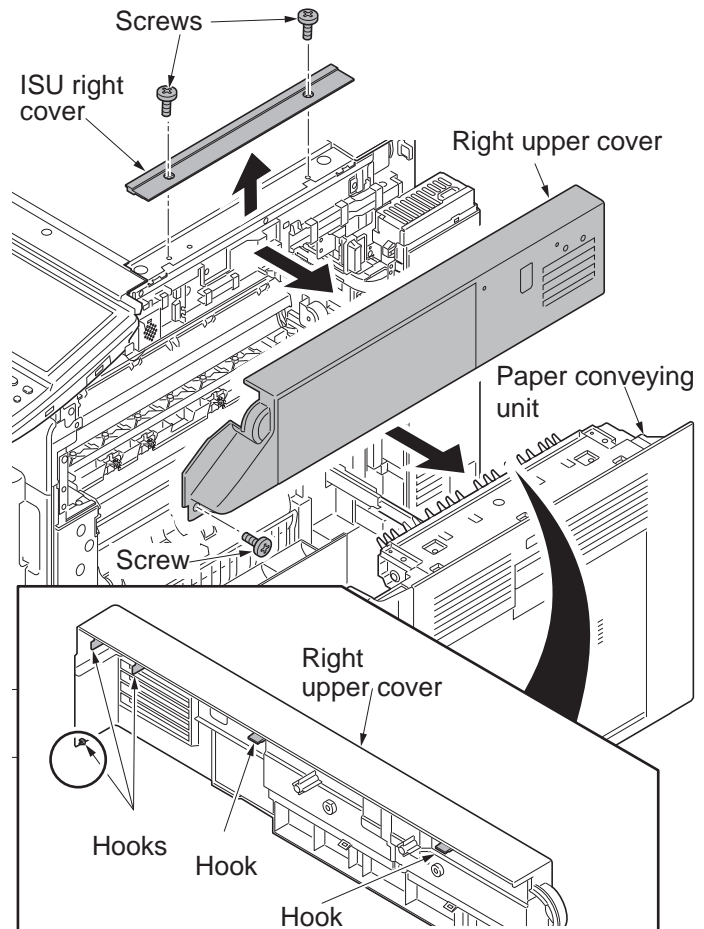


Figure 1-5-17

8. Open the handle cover.
9. Remove three screws.
10. Unhook the hook and then remove the right lower front cover.

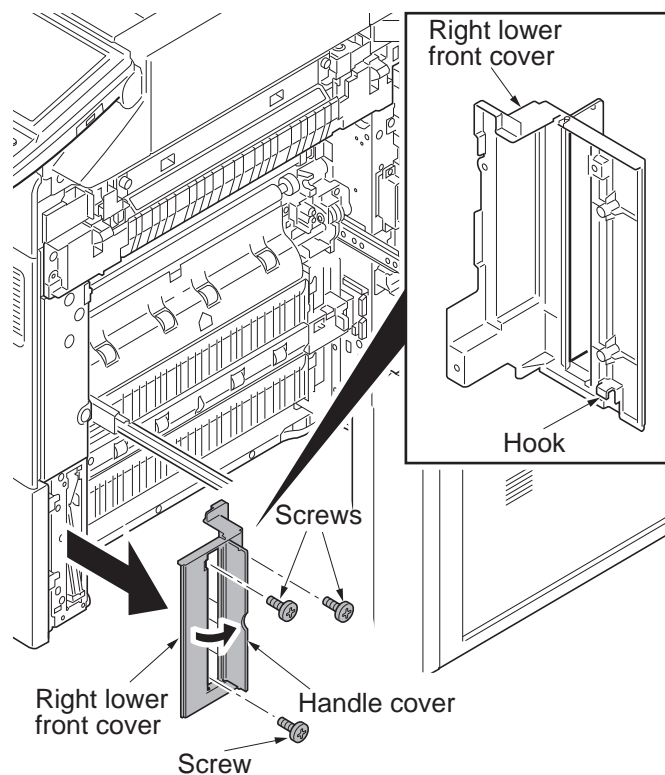


Figure 1-5-18

11. Release the two wire saddles.
12. Remove two connectors.

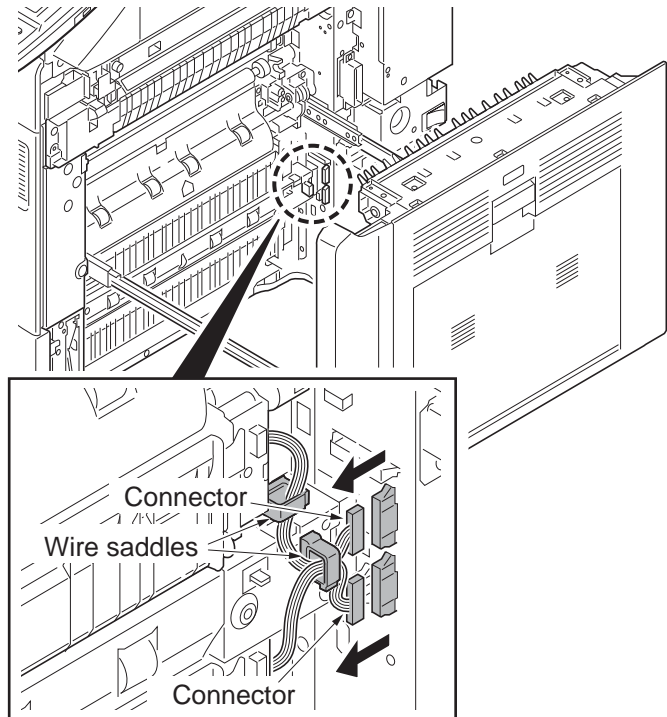


Figure 1-5-19

13. Remove two screws each from primary paper feed unit.
  14. Remove the primary paper feed unit.
- \*: Use the specific primary paper feed unit depending on model - 35 ppm or 45 ppm/55 ppm.

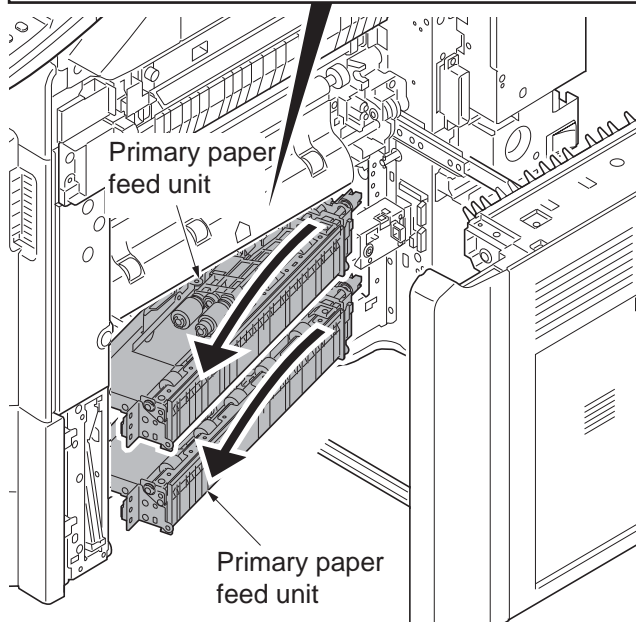
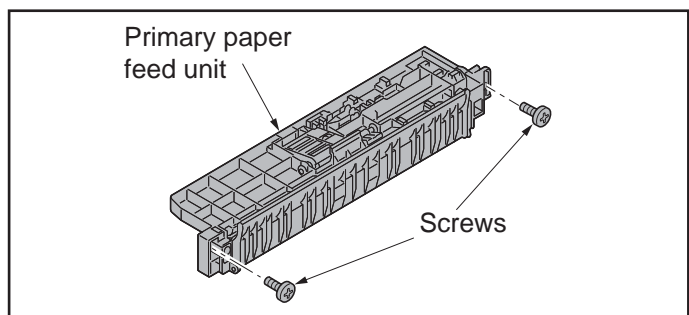
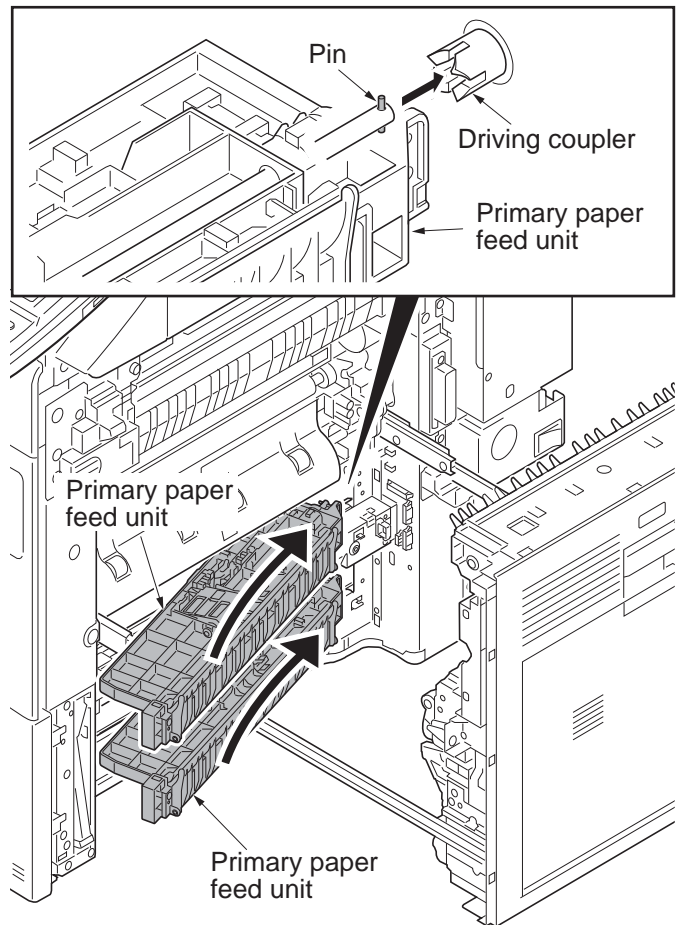


Figure 1-5-20

15. Check or replace the primary paper feed unit and refit all the removed parts.
- \*: When refit the primary paper feed unit, you must confirm the inserted pin to the driving coupler.
  - \*: For 45ppm/55ppm model, you must install the primary paper feed unit while pushing the retard release lever of the lower side, when the primary paper feed unit is refitted.
16. When the primary paper feed unit is replaced, perform maintenance mode U903 (clearing the jam counter) (see page 1-3-180).



**Figure 1-5-21**

## (2) Detaching and refitting the forwarding pulley, paper feed pulley and separation pulley. [35 ppm model]

### Procedure

1. Remove the primary paper feed unit  
(see page 1-5-12).

### Detaching the forwarding pulley and paper feed pulley

2. Remove four stop rings.

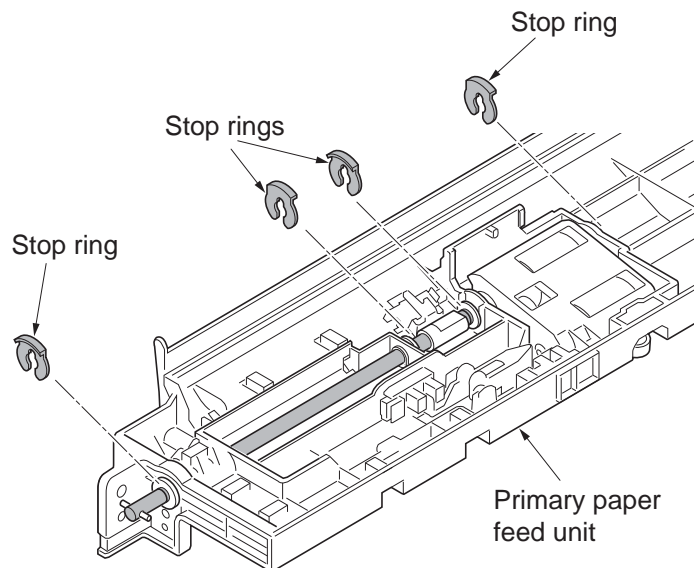


Figure 1-5-22

3. Slide the paper feed pulley shaft.
4. Remove the joint and three bushes.
5. Remove the spring and forwarding pulley holder assembly.

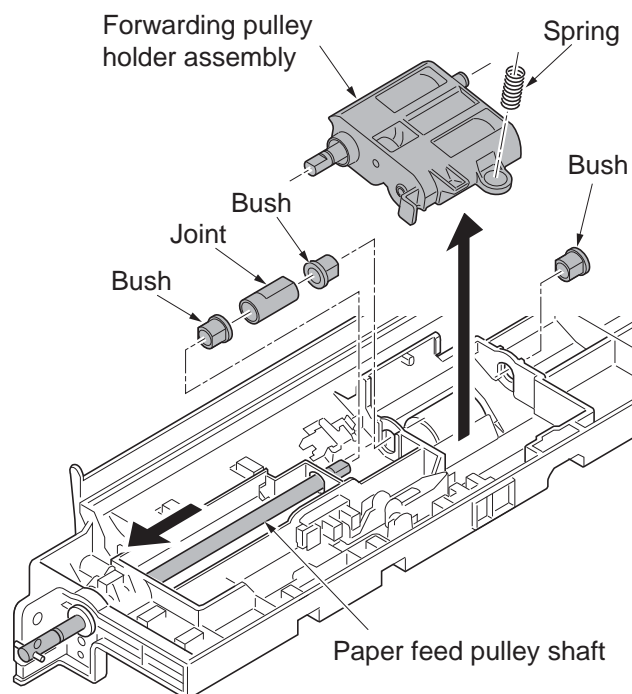


Figure 1-5-23



6. Pull the primary paper feed shaft out from the forwarding pulley holder.
  7. Remove the feed gear Z30H OW and paper feed pulley.
- \*: To refit the feed gear Z30H OW, be sure to correctly align it with the paper feed pulley, so that the on-way clutches meet each other.

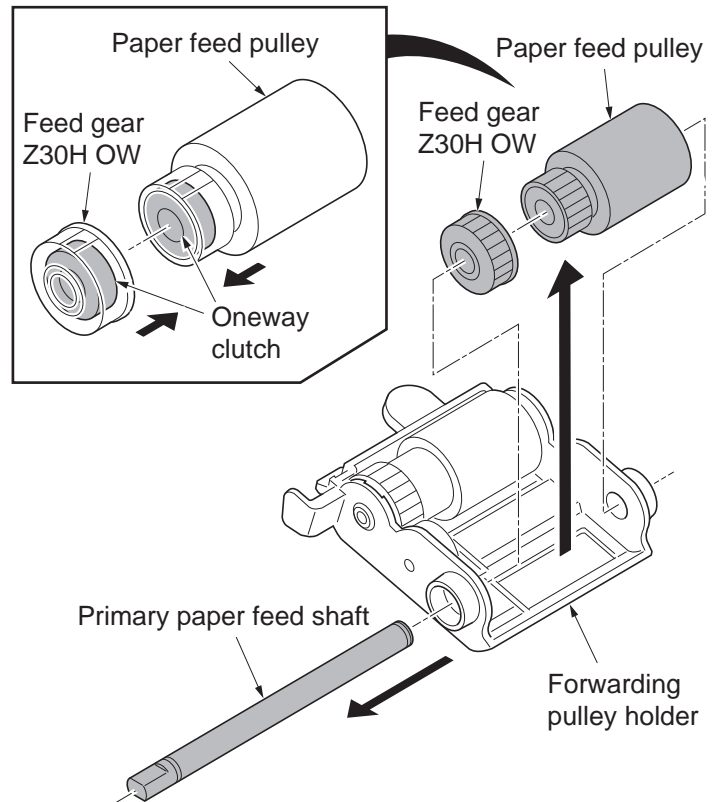


Figure 1-5-24

8. Pull the forwarding pulley from the axis hole of forwarding pulley holder.

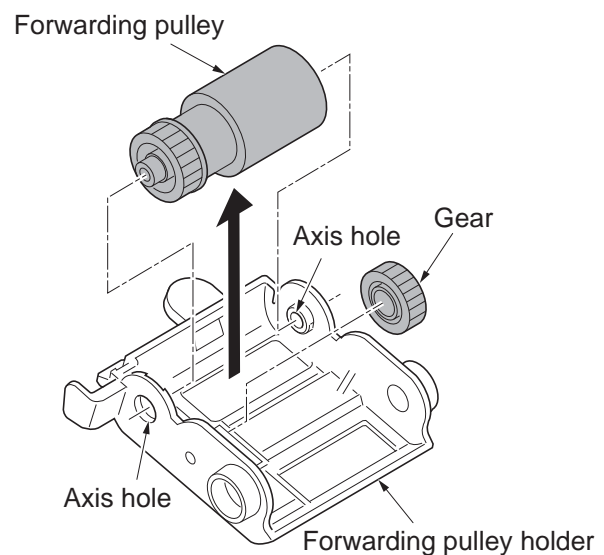
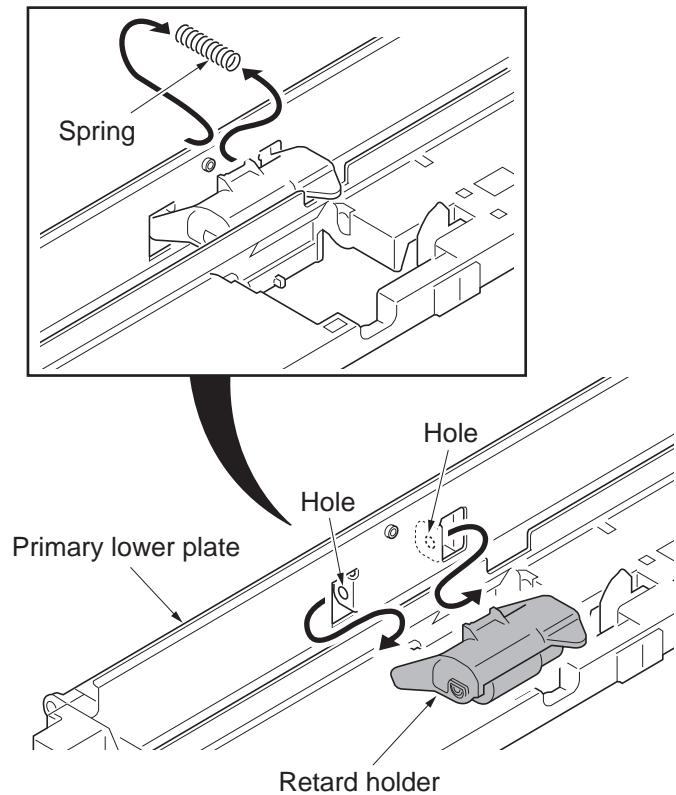


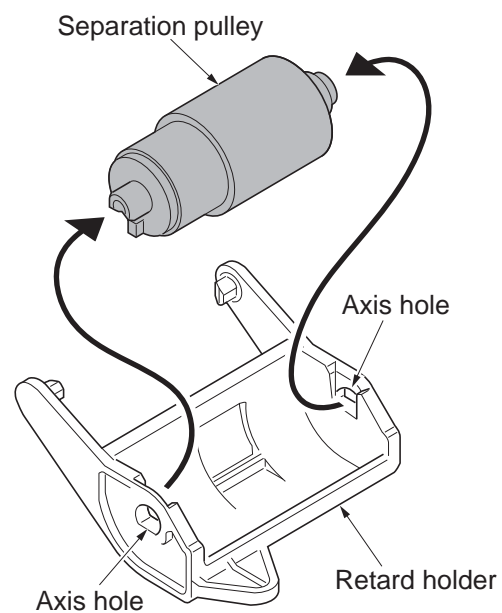
Figure 1-5-25

**Detaching the separation pulley**

9. Remove the spring.
10. Remove the retard holder from the primary lower plate.

**Figure 1-5-26**

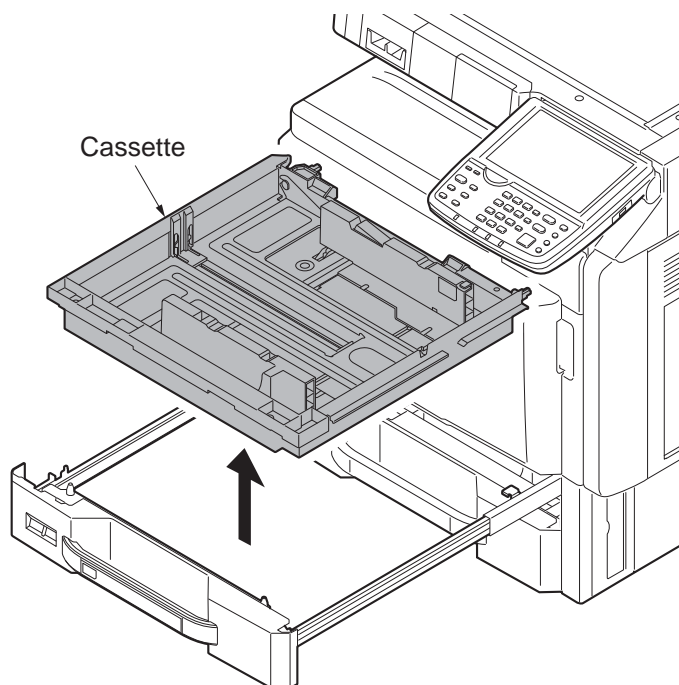
11. Remove the separation pulley from the retard holder.
12. Clean or replace the forwarding pulley, paper feed pulley and separation pulley.
13. Refit the forwarding pulley, paper feed pulley and separation pulley to the primary paper feed unit.
14. When the forwarding pulley, paper feed pulley or separation pulley is replaced, perform maintenance mode U903 (clearing the jam counter) (see page 1-3-180).

**Figure 1-5-27**

**(3) Detaching and refitting the forwarding pulley, paper feed pulley and separation pulley. [45 ppm model / 55 ppm model]**

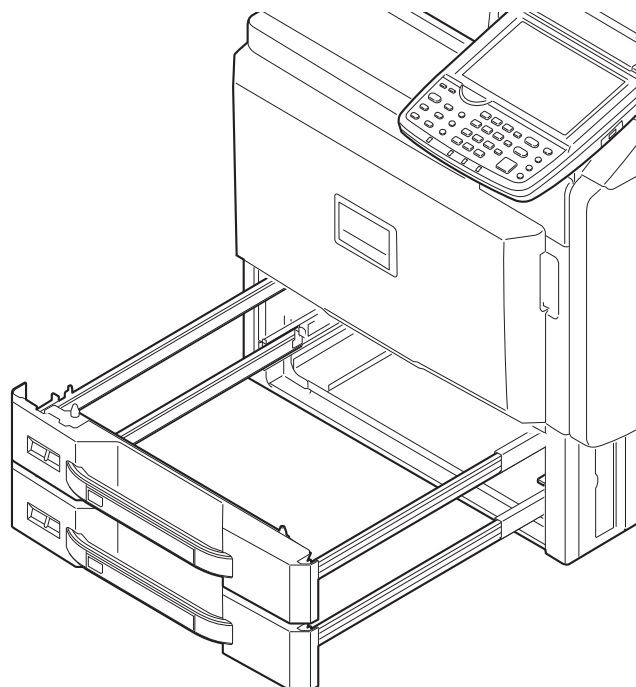
**Procedure**

1. Pull the cassette 1 completely.
2. Pull up the cassette.



**Figure 1-5-28**

3. Remove the cassette 2 in the same manner as above.



**Figure 1-5-29**

4. Remove the hook and remove the forward roller from the axle.
5. Remove the hook and remove the feed roller from the axle.

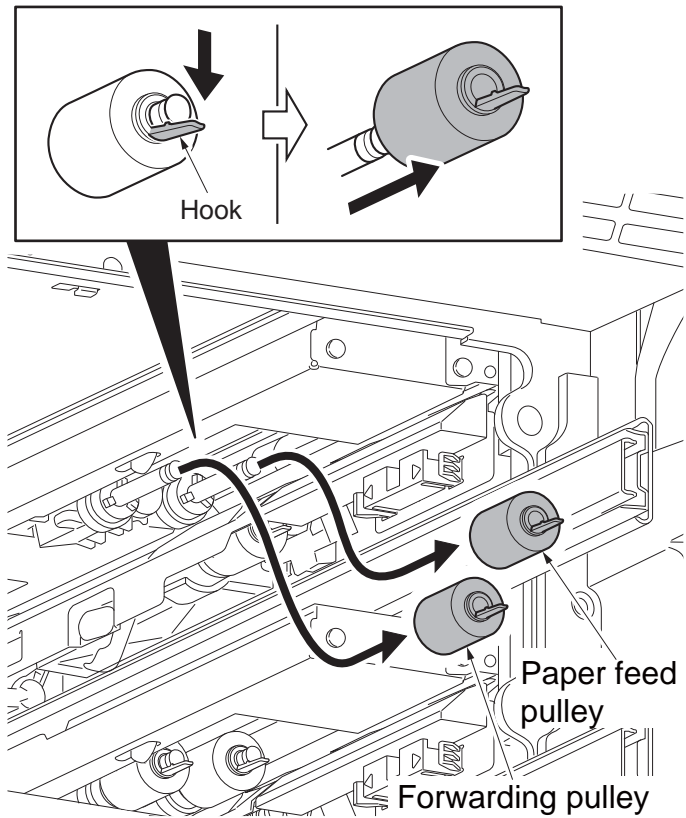


Figure 1-5-30

6. Unhook the two hooks and then remove the cover.

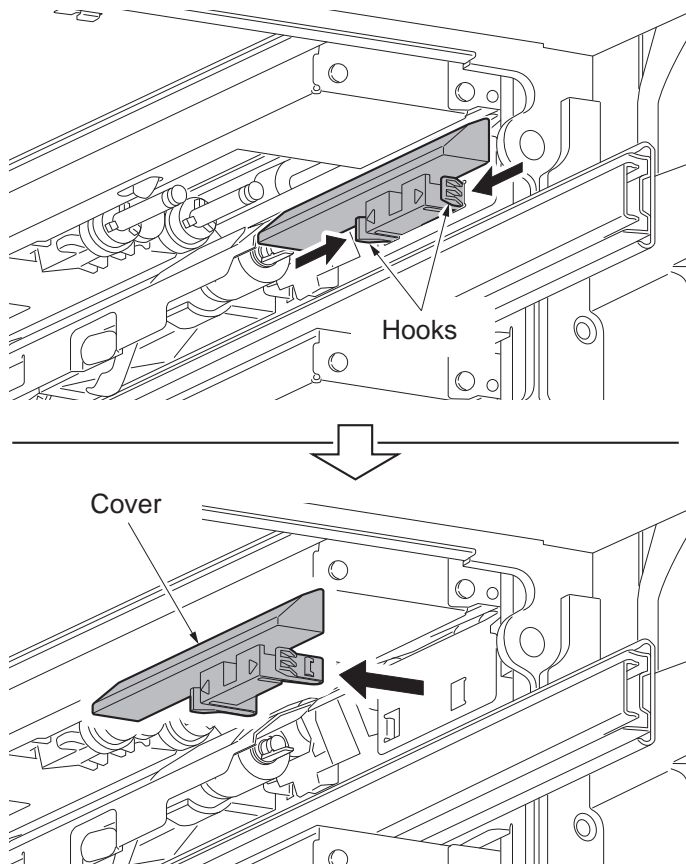


Figure 1-5-31

7. Remove the hook and remove the separation roller from the axle.
- \*: Confirm that the nipping between the feed roller and separation roller is released.
8. Clean or replace the forwarding pulley, paper feed pulley and separation pulley.
9. Refit the forwarding pulley, paper feed pulley and separation pulley to the primary paper feed unit.
- \*: Make sure that the collars are properly installed by checking its color.  
 Forwarding pulley (Collar is white.)  
 Paper feed pulley (Collar is white.)  
 Separation pulley (Collar is black.)
10. When the forwarding pulley, paper feed pulley or separation pulley is replaced, perform maintenance mode U903 (clearing the jam counter) (see page 1-3-180).  
 Execute Maintenance Counter - Cassette  
 - Counter Clear of U251 (Maintenance counter limits/clear) (see page 1-3-130).

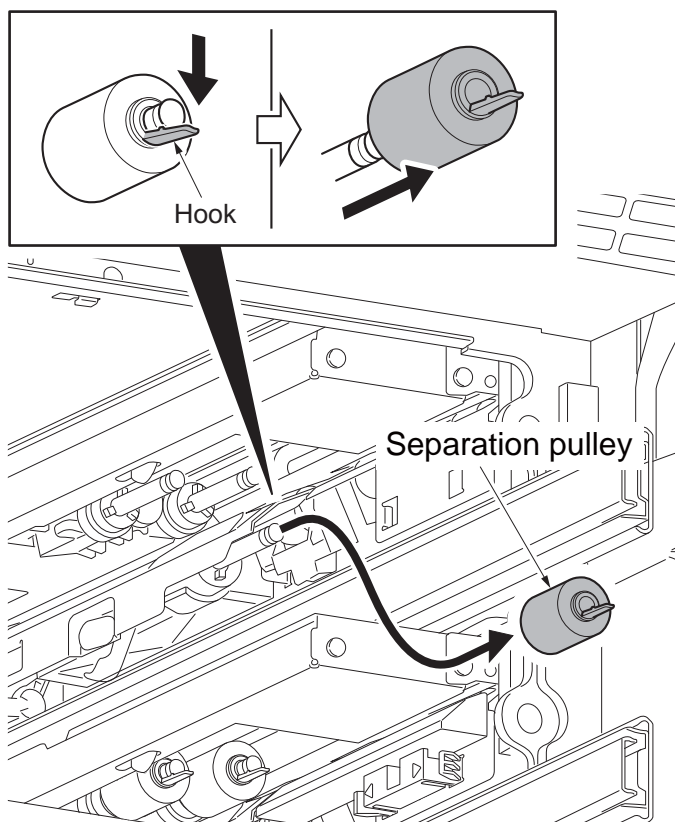


Figure 1-5-32

#### (4) Detaching and refitting the MP tray paper feed unit

##### Procedure

1. Pull the paper conveying unit out.
2. Open the MP tray.
3. Remove four screws.

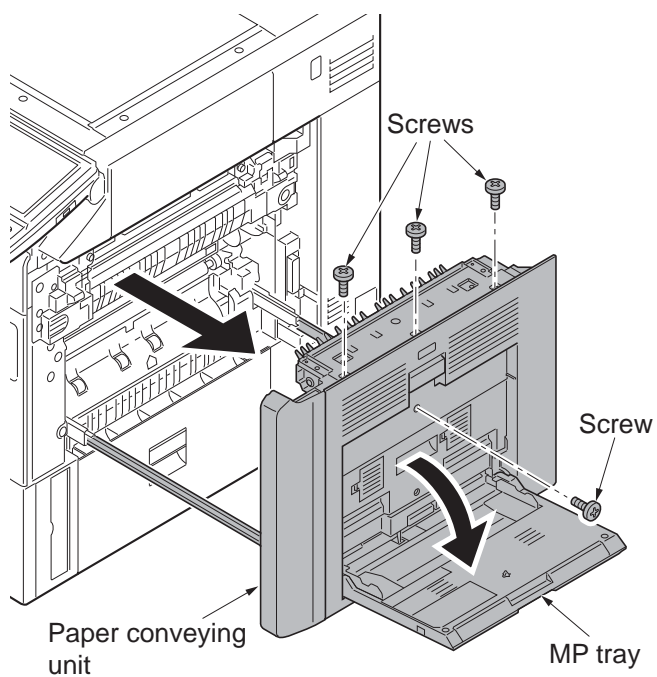


Figure 1-5-33

4. Unhook eight hooks and then remove the right cover and DU cover assembly.

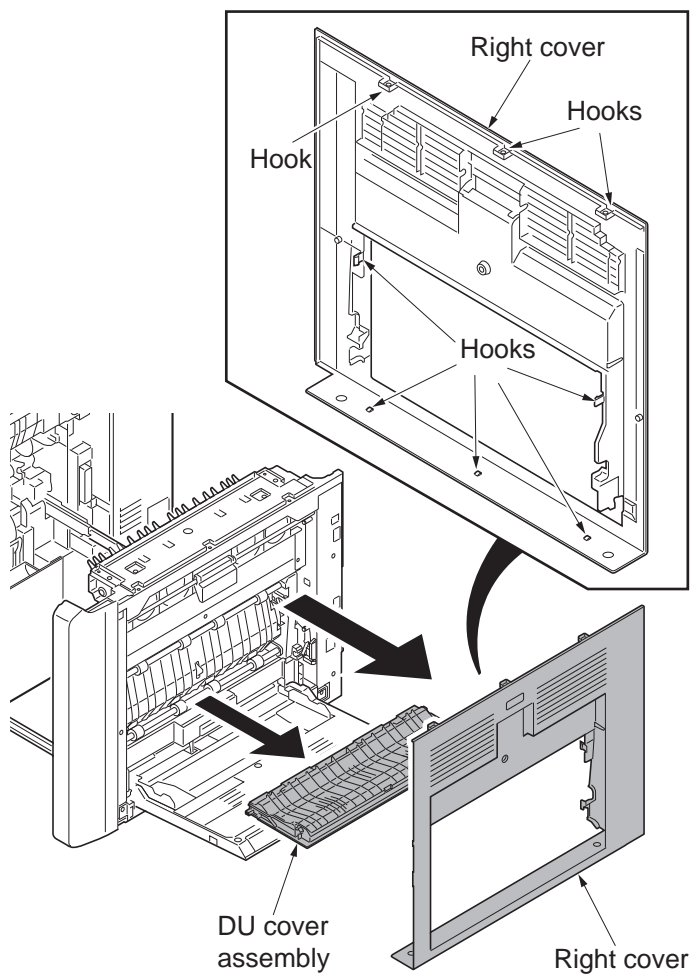


Figure 1-5-34

5. Remove two connectors.
  6. Release the wire saddle.
  7. Remove the wire saddle.
- \*: To refit the wire saddle, be sure to fit in the positioning hole that was previously used.

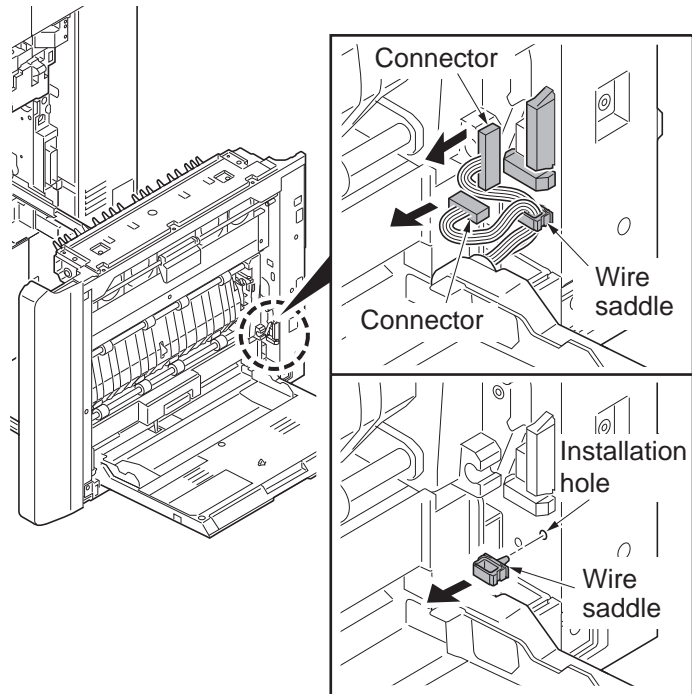


Figure 1-5-35

8. Remove the MP tray.
- \*: When refitting the MP tray, insert it in the MP tray paper feed unit side by turning the lift arm.

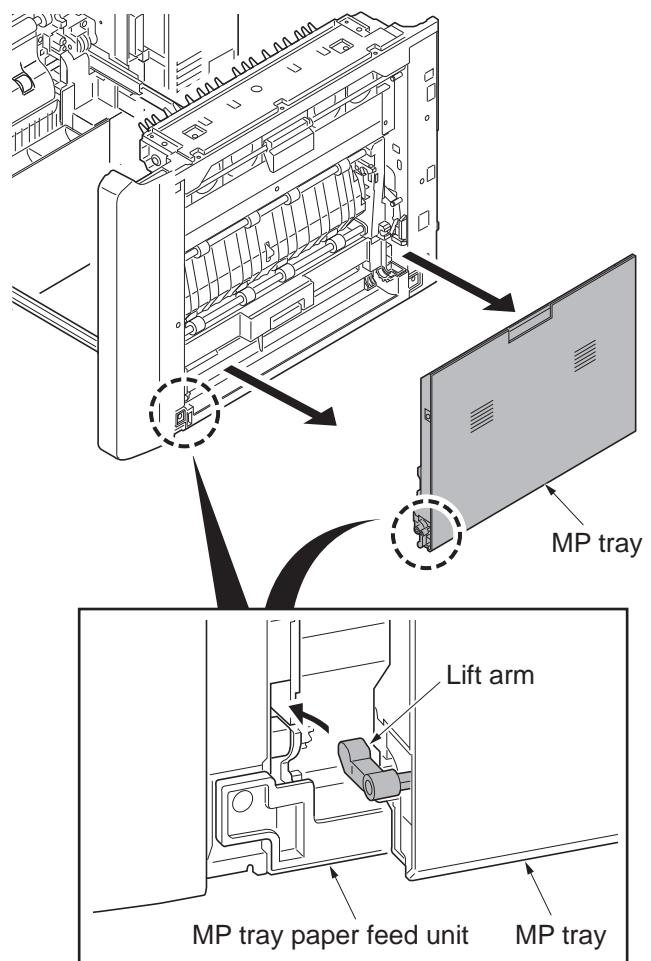


Figure 1-5-36

- 9. Remove two screws.
- 10. Remove the MP tray paper feed unit.

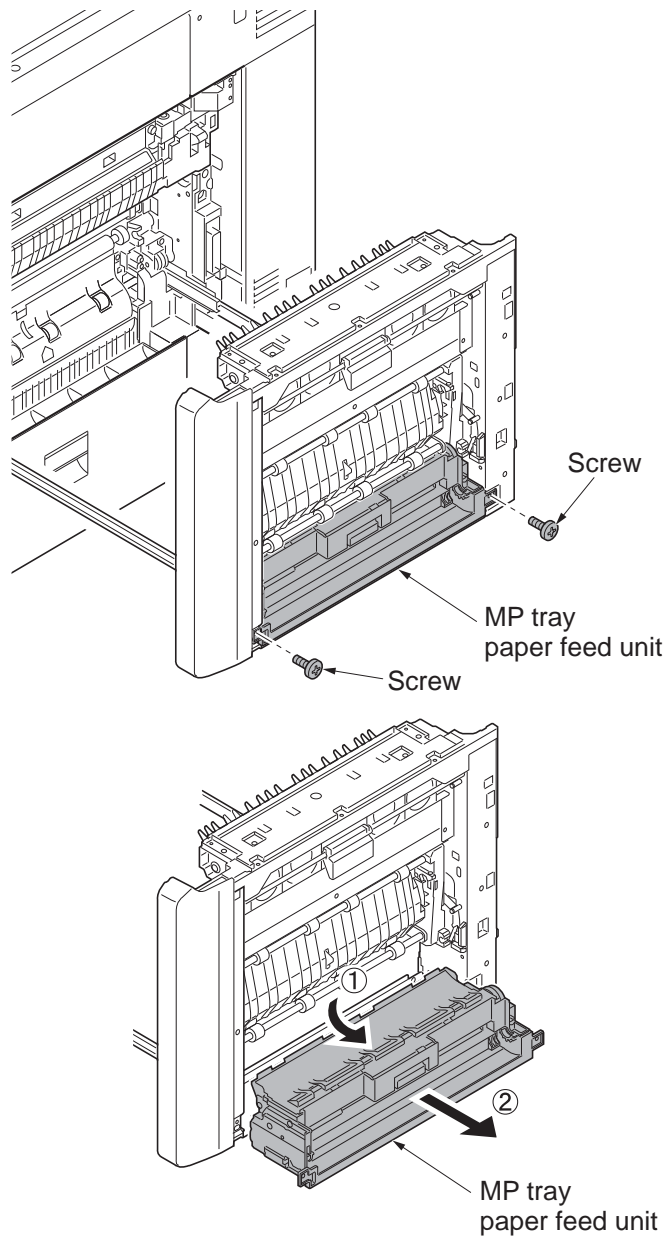


Figure 1-5-37



## (5) Detaching and refitting the MP forwarding pulley, MP paper feed pulley and MP separation pulley

### Procedure

1. Remove the MP tray paper feed unit (see page 1-5-22).

### Detaching forwarding pulley and paper feed pulley

2. Unhook three hooks and then remove the Du lower guide.
- \*: Remove the DU lower guide easy by bending the top base that the hook is hooking because the hook of the DU lower guide lacks flexibility.

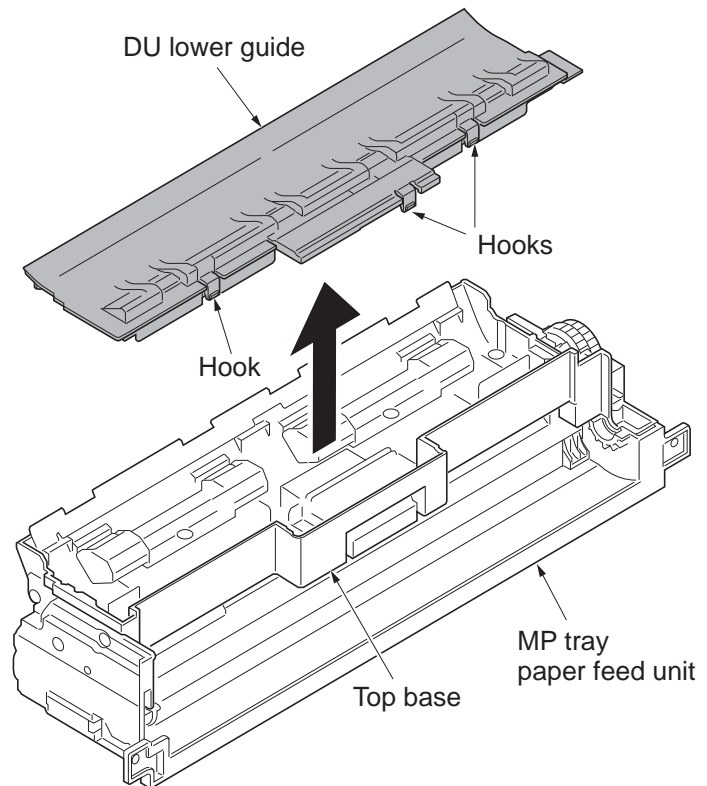


Figure 1-5-38

3. Remove the stop ring A and then slide the driving joint.
4. Slide the bush A.
5. Remove the stop ring B and then remove the bush B.

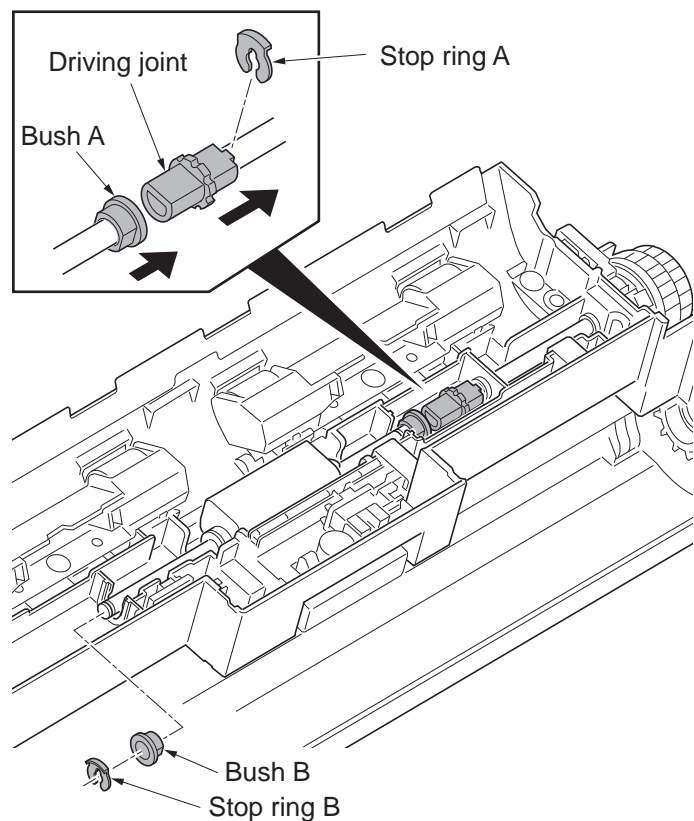


Figure 1-5-39

6. Unhook the hook of the feed holder assembly.
7. Remove the spring and the feed holder assembly from the top base.

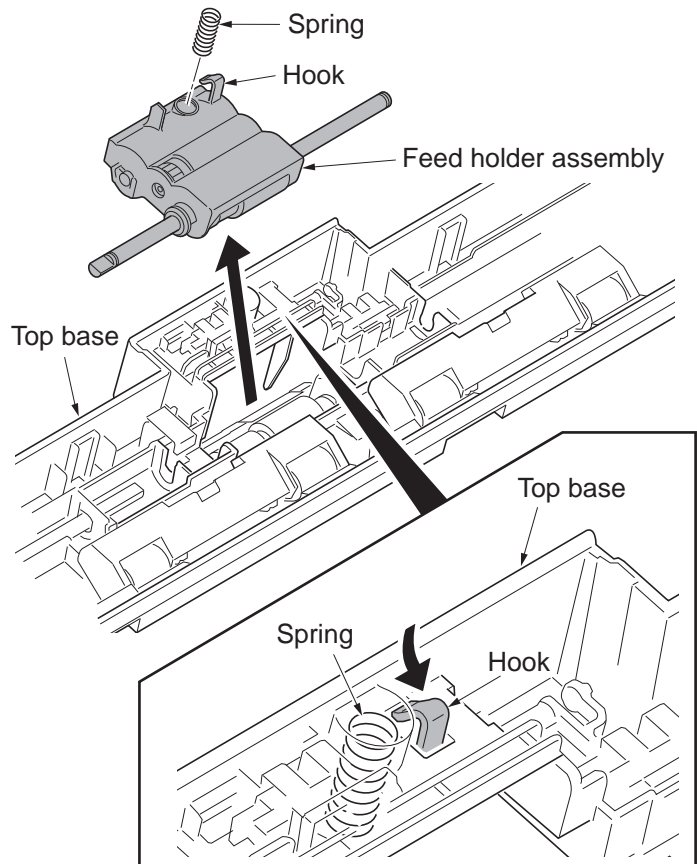


Figure 1-5-40

8. Remove two stop rings.
  9. Pull the feed MPF shaft out.
  10. Remove two bushes, one way gear Z30R and MP paper feed pulley.
- \*: To refit the one-way gear Z30R, mount the gear in the correct direction as shown.

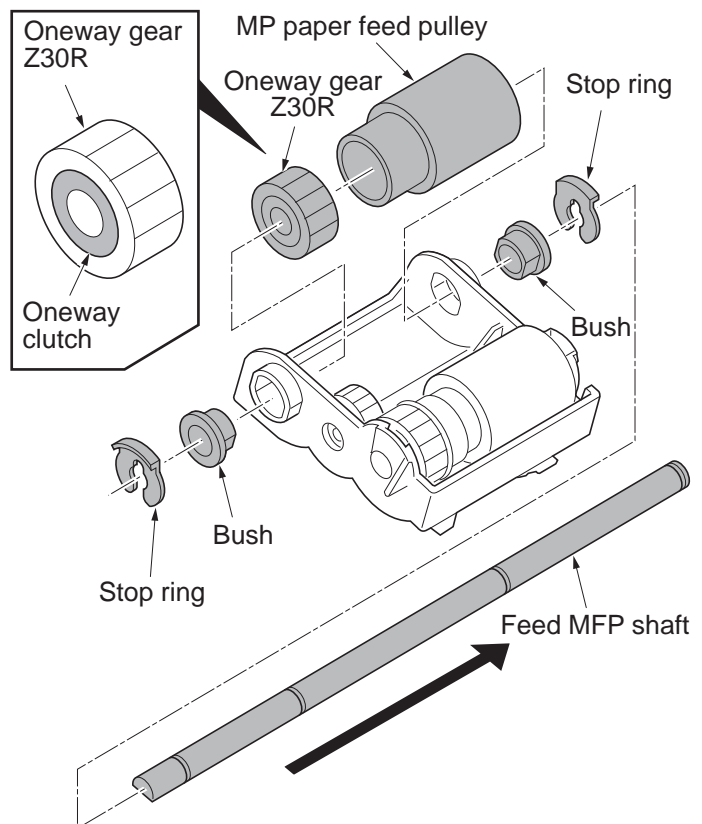


Figure 1-5-41

11. Remove the pickup MPF shaft from the axis holes of feed MPF holder.
12. Pull the pickup gear Z30R and MP forwarding pulley out from the pickup MPF shaft.

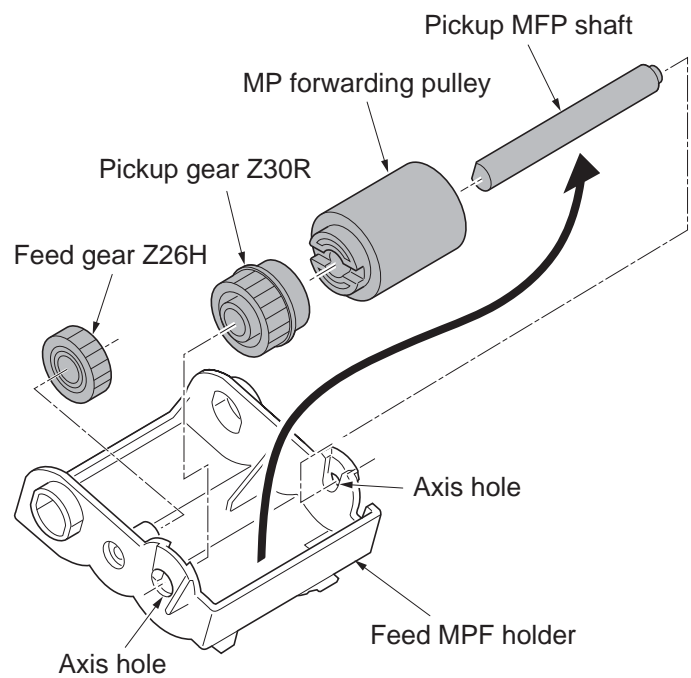


Figure 1-5-42

#### Detaching the MP separation pulley

13. Unhook two hooks and then remove the middle guide.

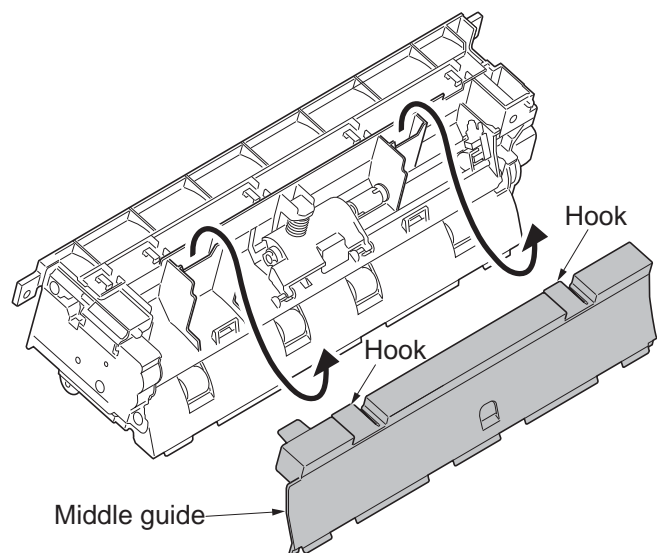
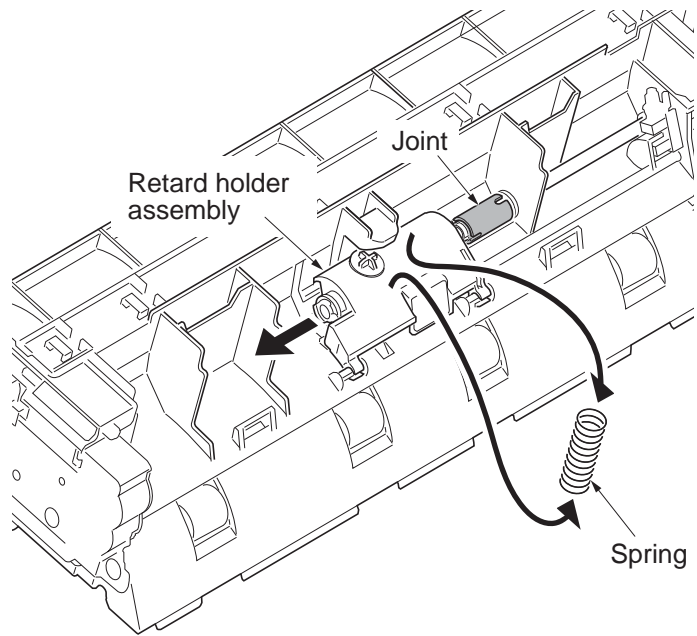
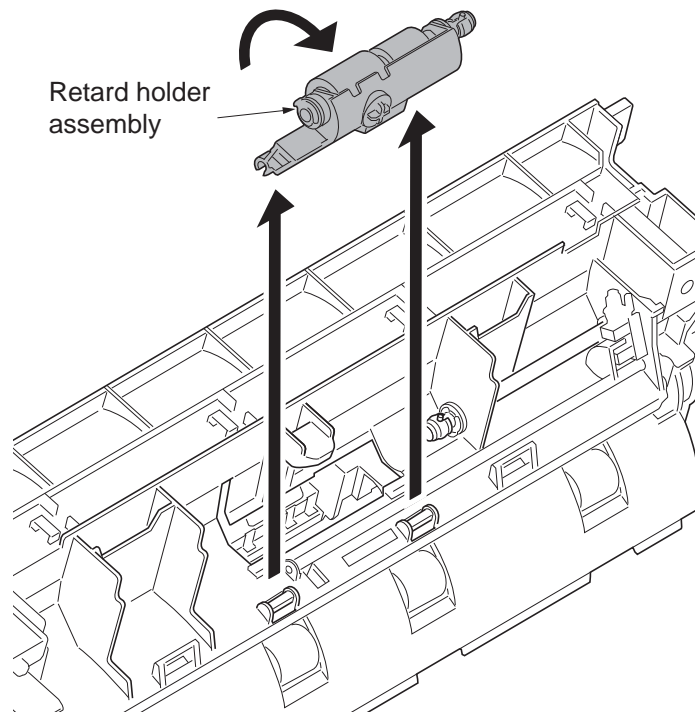


Figure 1-5-43

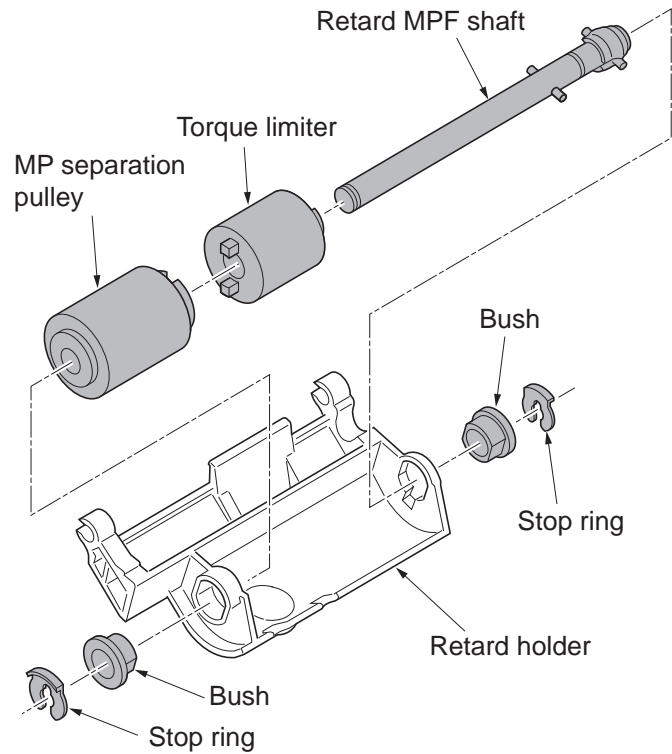
14. Remove the spring.
15. Release the uniting of joint by sliding the retard holder assembly.

**Figure 1-5-44**

16. Remove the retard holder assembly by turning it as shown.

**Figure 1-5-45**

17. Remove two stop rings.
18. Remove two bushes.
19. Pull the retard MPF shaft out and then remove the torque limiter and the MP separation pulley.
20. Clean or replace the MP forwarding pulley, MP paper feed pulley and MP separation pulley.
21. Refit the MP forwarding pulley, MP paper feed pulley and MP separation pulley to the MP tray paper feed unit.
22. When the MP forwarding pulley, MP paper feed pulley or MP separation pulley is replaced, perform maintenance mode U903 (clearing the jam counter) (see page 1-3-180).



**Figure 1-5-46**

## 1-5-4 Optical section

### (1) Detaching and refitting the exposure lamp

#### Notes on handling the LED mount assembly

Do not touch the diffusion seat and the light guiding plate.

Use air blow when you clean the diffusion seat, the light guiding plate, and reflector.

Do not clean it using a cleaning cloth that adheres the fiber easily.

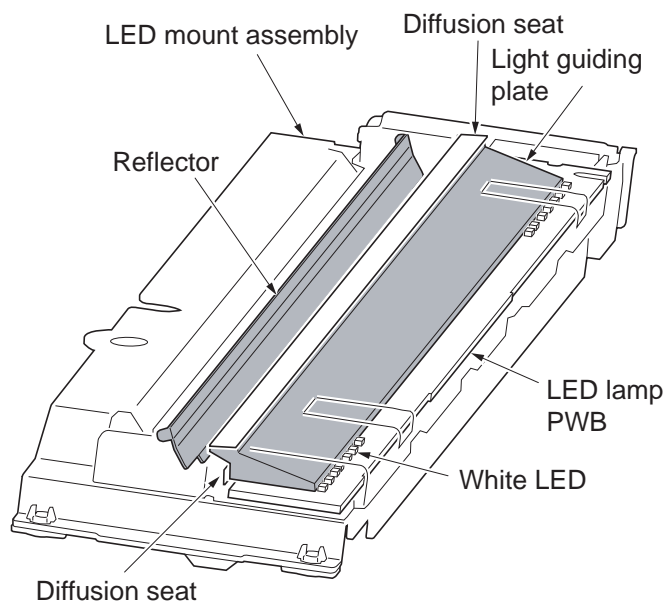


Figure 1-5-47

#### Procedure

1. Remove the original cover or the document processor.
2. Remove the the staple holder. Remove the screw and then remove the staple cover (see page 1-2-74).
3. Remove the hook and remove the upper cover B (see page 1-2-75).
4. Remove two pins and then remove the ISU front cover.
5. Remove two screws and then remove the ISU right cover.

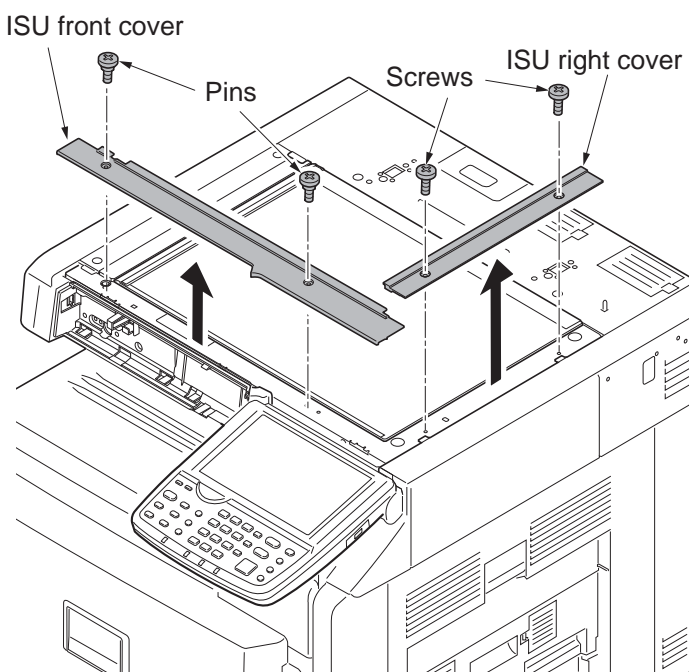


Figure 1-5-48

6. Remove the left upper cover (see page 1-5-4).
7. Remove the right upper cover (see page 1-5-31).
8. Remove two screws and then remove the ISU rear cover.

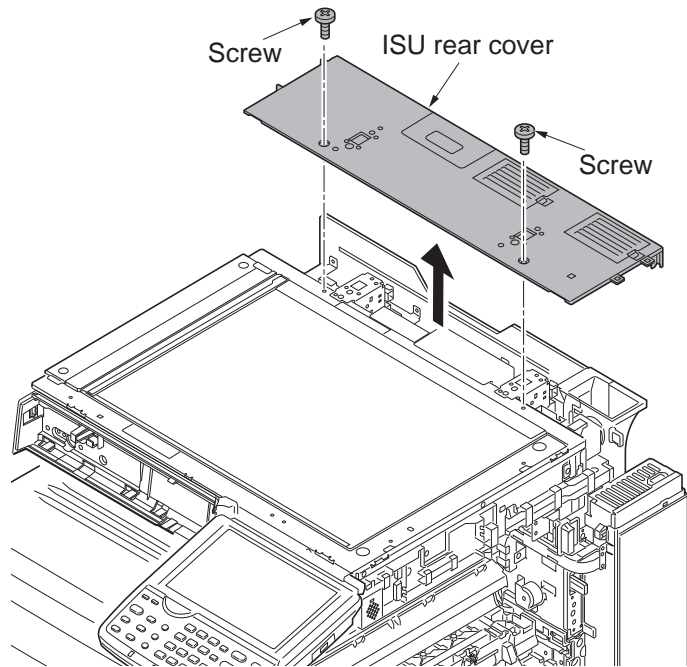


Figure 1-5-49

9. Remove the platen.
10. Peels two films off.

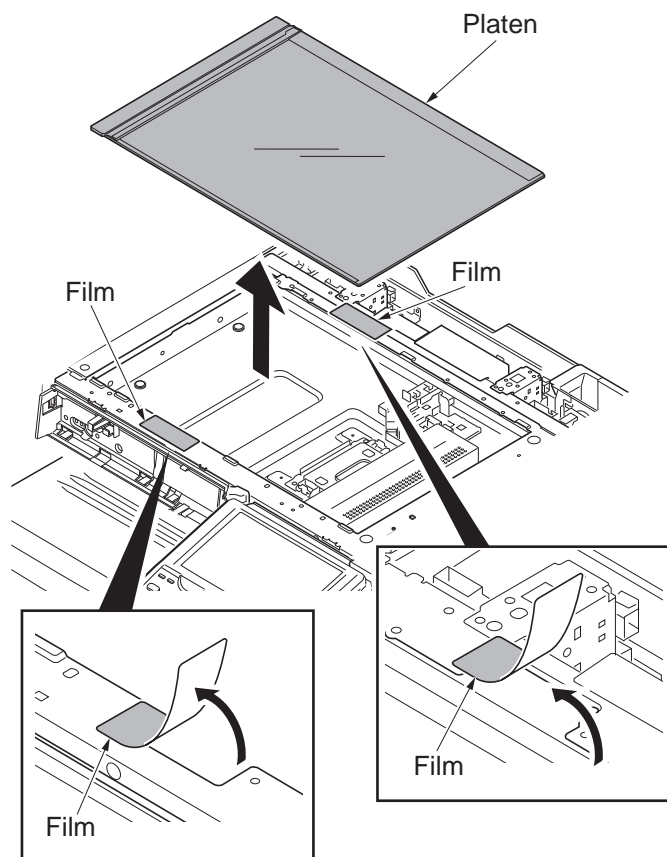


Figure 1-5-50

11. Move the LED mount assembly to the cutting lack part.
12. Unhook the hook and remove the FFC cover from LED mount assembly.
13. Remove the FFC from the FFC connector.
14. Unhook two hooks and remove the FFC guide from the LED mount assembly.

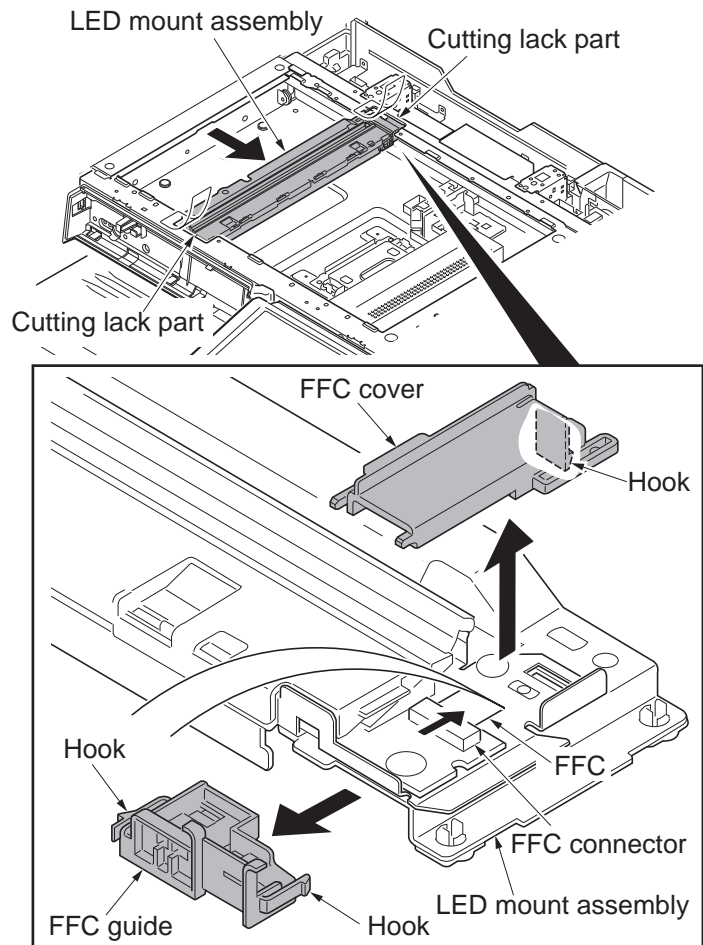


Figure 1-5-51

15. Remove two screws and then remove the LED mount assembly.
16. Check or replace the LED mount assembly and refit all the removed parts.

\*: When cleaning the reflector, the light guiding plate and the diffusion sheet of the LED mount assembly, clean it by air blow. Not to leave the hair dust.

17. When the LED mount assembly is replaced, perform maintenance mode U411 (Adjusting the scanner automatically) (see page 1-3-148).

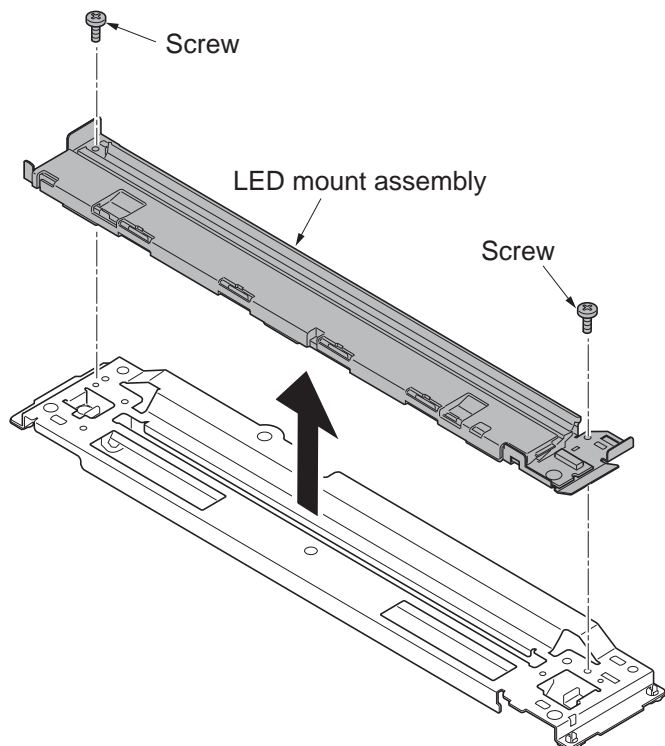


Figure 1-5-52



## (2) Detaching and refitting the scanner wires

### NOTE

When fitting the wires, be sure to use those specified below.

Machine front: (P/N: 302H717381), gray

Machine rear: (P/N: 302H717391), black

Fitting requires the following tools

Two frame securing tools (P/N 302FZ17100)

Two scanner wire stoppers (P/N 3596811)

### Procedure

1. Remove the exposure lamp  
(see page 1-5-30).
2. Remove each screw and then remove  
front and rear wire holder plates from  
mirror 1 frame.
3. Remove the mirror 1 frame.

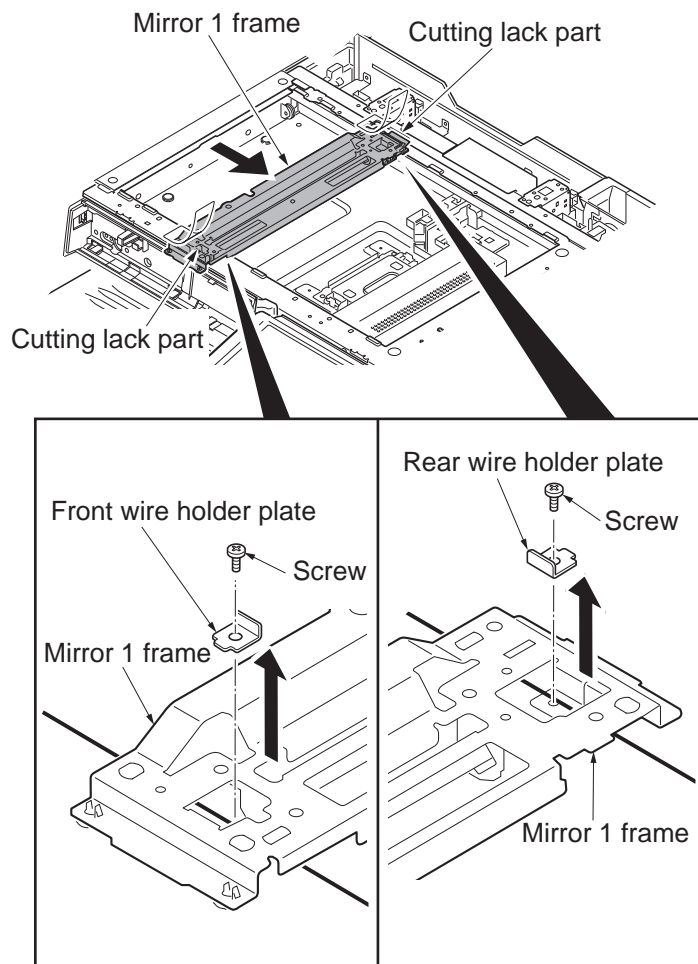


Figure 1-5-53

4. Remove the round terminals from the scanner wire springs on scanner unit left side.
5. Remove the scanner wire.

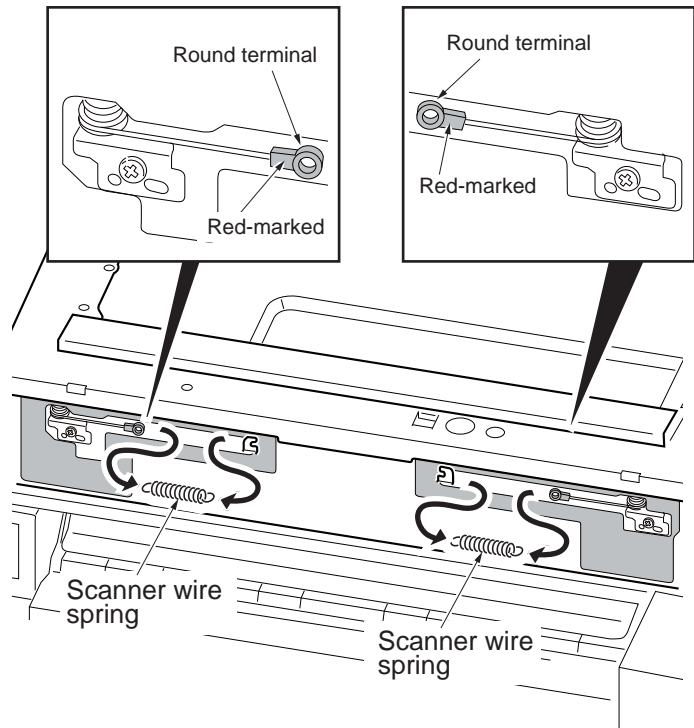


Figure 1-5-54

**Fitting the scanner wires**

6. Remove two screws each from scanner wire drum. .... (1)
7. Insert the locating ball on the scanner wire into the hole in the scanner wire drum..... (2)
8. Wind the scanner wires three turns inward and five turns outward.  
With the locating ball as the reference point,  
wind the shorter end of each of the wires outward. .... (3)(4)
9. Secure the scanner wires using the scanner wire stoppers..... (5)

10. Move the mirror 2 frame as shown in the figure and insert two frame securing tools into the positioning holes at the front and rear of the machine center to fix the mirror 2 frame in position.

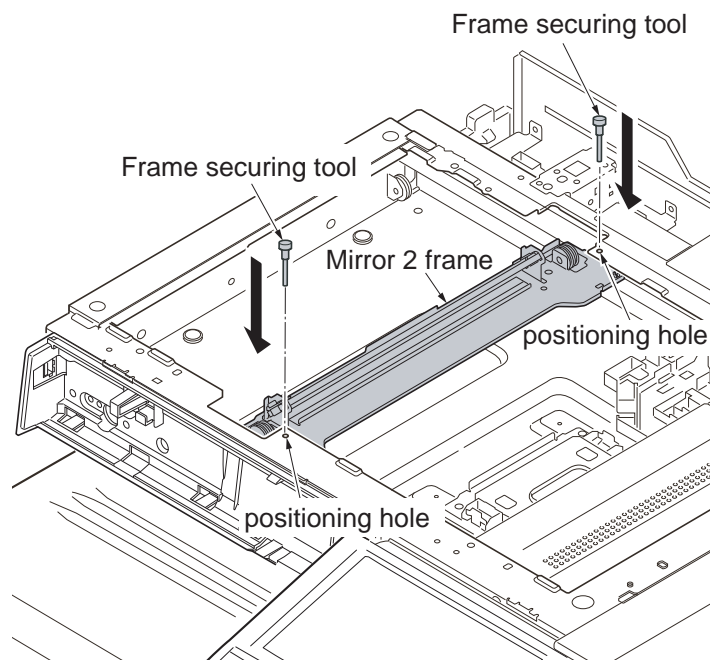


Figure 1-5-55

11. Wind the inner scanner wires around the grooves in the pulleys at the right of the scanner unit from below to above..... (6)
12. Wind the outer scanner wires around the outside grooves in the pulleys of the mirror frame 2 from above to below..... (7)
- \*: Align the scanner wires along the outside of the positioning pins.
13. Hook the round terminals to the catches inside the scanner unit. .... (8)
14. Wind the inner scanner wires around the grooves in the pulleys at the left of the scanner unit from below to above..... (9)
- \*: Align the scanner wires along the lower side of the mirror frame 2.
15. Wind the scanner wires around the inside grooves in the pulleys of the mirror frame 2 from below to above..... (10)
16. Wind the scanner wires around the grooves in the pulleys at the left of the scanner unit. .... (11)
17. Hook the round terminals to the scanner wire springs..... (12)
18. Apply the procedures 11 through 17 to another scanner wires.

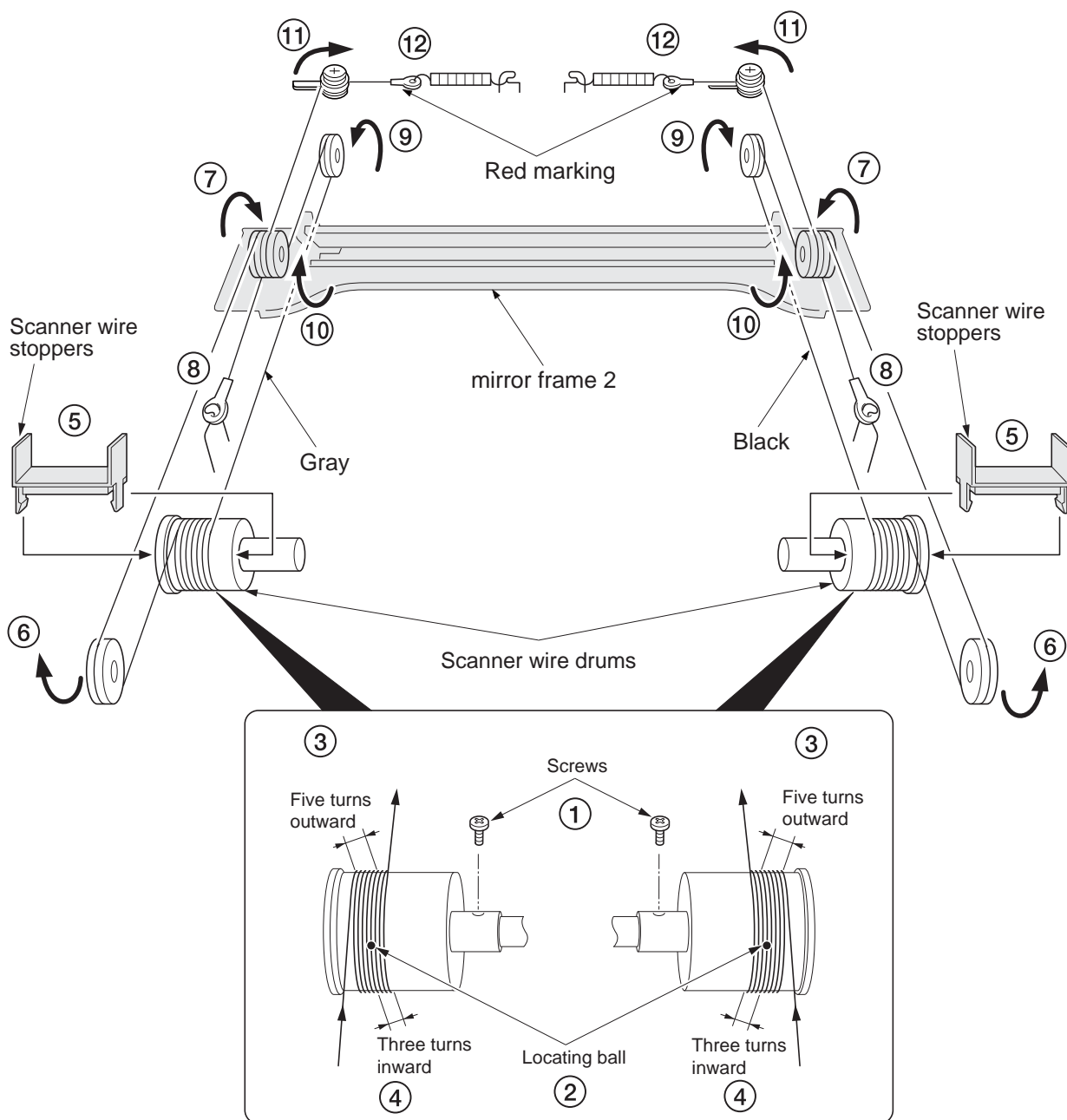


Figure 1-5-56

19. Refit the scanner wire drum with two screws.
20. Remove the two scanner wire stoppers and frame securing tools.
21. Focusing on the locating ball of the wire drum, align the scanner wires to the inside.
22. Move the mirror 2 frame from side to side to correctly locate the wires in position.
23. Refit the mirror 1 frame.
24. Move the mirror 1 and 2 frames to the machine left, and insert the two frame securing tools into the positioning holes at the front and rear of the scanner unit to secure the frames in position.
25. Hold the wires and fix each front and rear wire holder plate to mirror 1 frame with the screw.
26. Remove the two frame securing tools.
27. Refit the exposure lamp.

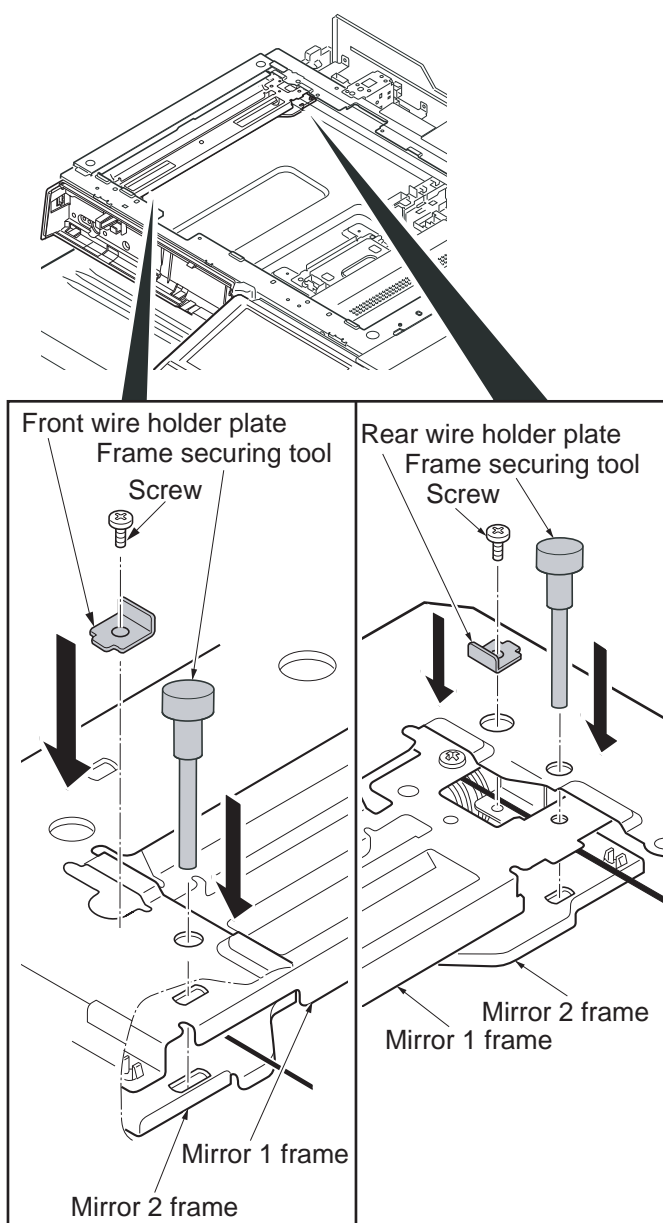


Figure 1-5-57

### (3) Detaching and refitting the ISU

#### Procedure

##### Detaching the ISU

1. Worn the electrostatic prevention band for the destruction prevention of the CCD board by static electricity.
2. Remove the platen (see page 1-5-30).
3. Remove six screws and then remove the lens cover.

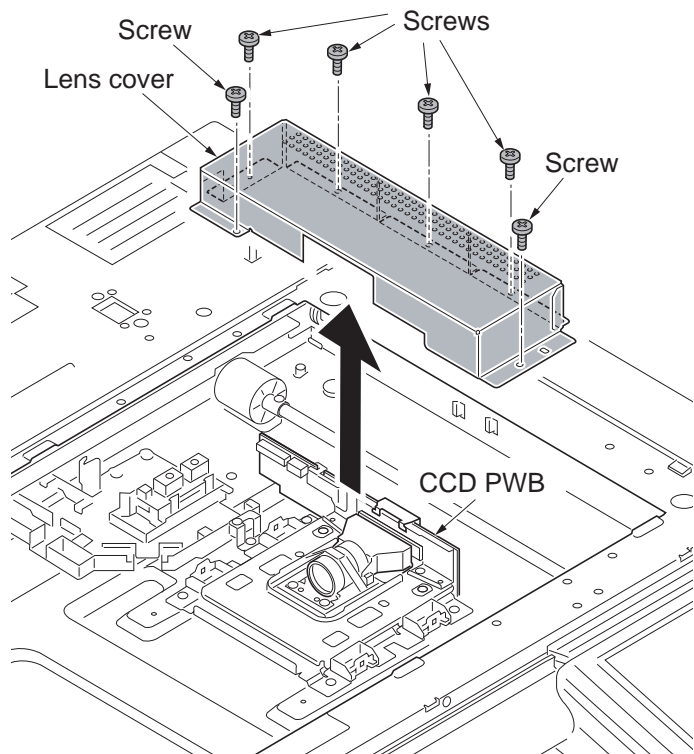


Figure 1-5-58

4. Remove the connector.
  5. Remove the FFC from the FFC connector with a lock.
- \*: When removing the FFC from the FFC connector with a lock, remove it after release the lock by lifting the lock lever up (see page 1-5-62).

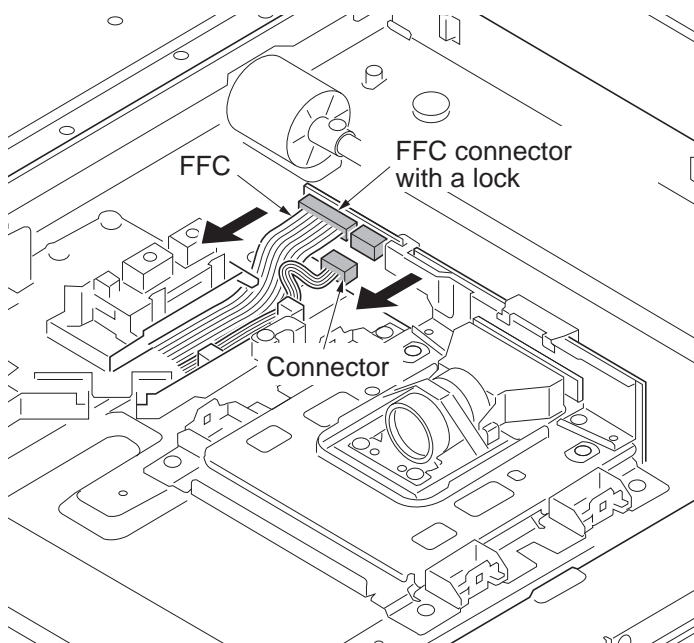


Figure 1-5-59

- Remove four screws and then remove the ISU.

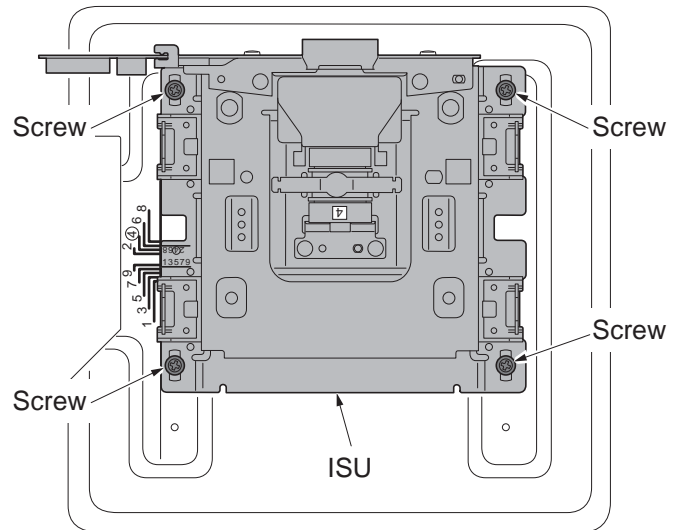


Figure 1-5-60

### Refitting the ISU

- Install the FFT.
  - \*: The FFT should be inserted while holding the position (A) shown in the illustration (A). Do not apply a pressure to the focus adjuster.

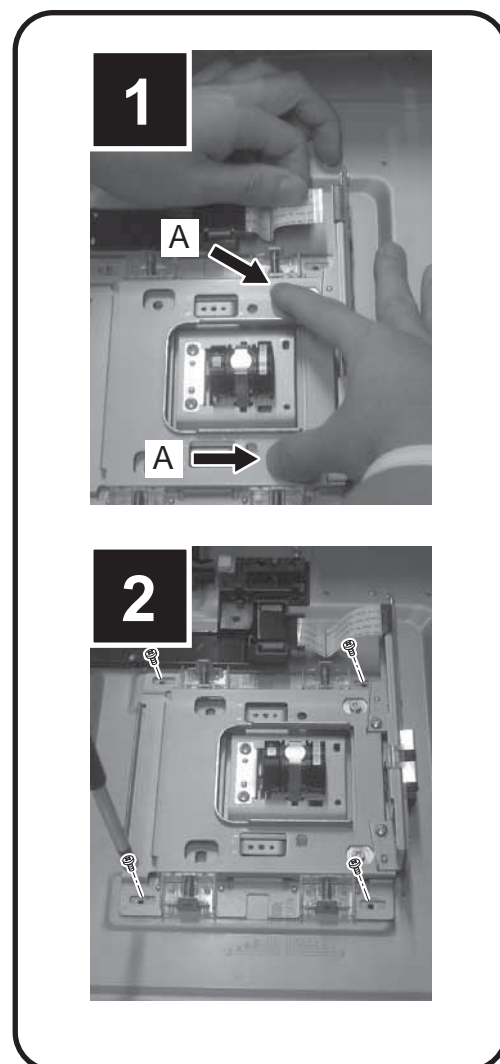


Figure 1-5-61

### Refitting the ISU

2. Decide the fix position of ISU by the following.

The right and left of machine:

Verify the number prefixed by a (a) mark.

Match the line (c) of ISU to the positioning line (b) of same number on frame side.

The rear and front of machine:

Match the edge (e) of ISU to the positioning line (d) on frame side.

3. Fix the ISU as before with four screws.

4. Refit all the removed parts.

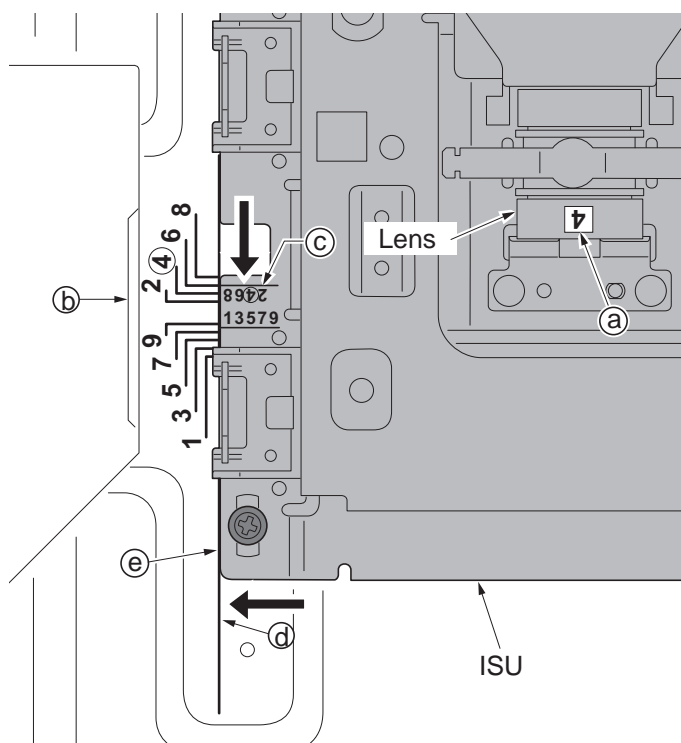


Figure 1-5-62

### Check the image

After replacing the CCD unit, check the copy image. According to the condition, execute the procedures below.

(1) In case of no problem on the image, go to "5. Image Adjustment"

(2) In case a part of the image is whitish from the leading edge or the background image appears like the illustration "a", go to "1. The CCD unit Height Adjustment 1".

(3) In case white vertical lines appear on the image like the illustration "b", go to "3. The CCD unit Height Adjustment 2".

\*: The CCD unit height adjustment is necessary for above 2 and 3 because an optical axis shifts and the light path is not secured.

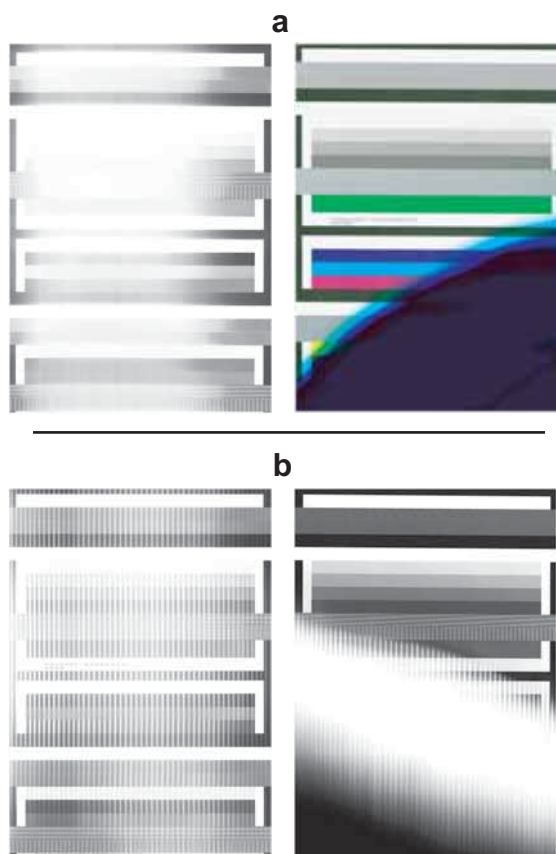


Figure 1-5-63

### 1. The CCD unit Height Adjustment 1

In case a part of the image is whitish from the leading edge or the background image appears like the illustration "a" .

The replacement ISU comes complete with a large spacer (B) and a small spacer (C).

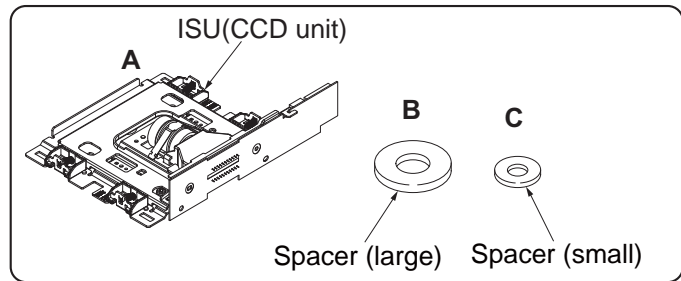


Figure 1-5-64

- (1) Set the spacer (large) (B) into the outside screw holes at the CCD sensor side.
- (2) Check the image.

In case of no problem on the image, go to "5. Image Adjustment".

In case of the problem on the image, go to "2. Re-adjustment 1".

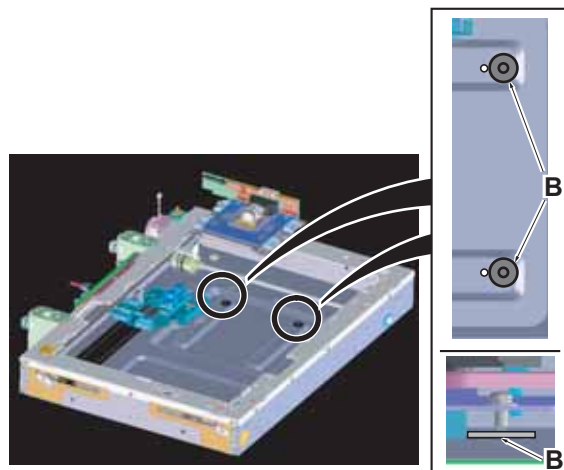


Figure 1-5-65

### 2. Re-adjustment 1

- (1) In case the whitish or background image still appears.

c: Insert the additional spacer (small) (C)

5. In case the white vertical lines appear.

d: Remove the spacer (large) (B) and insert the spacer (small) (C).

Check the image and go to "5. Image Adjustment".

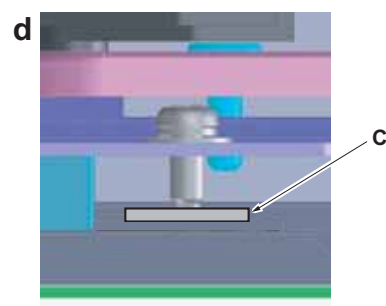
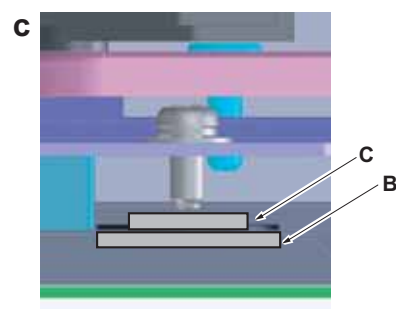


Figure 1-5-66



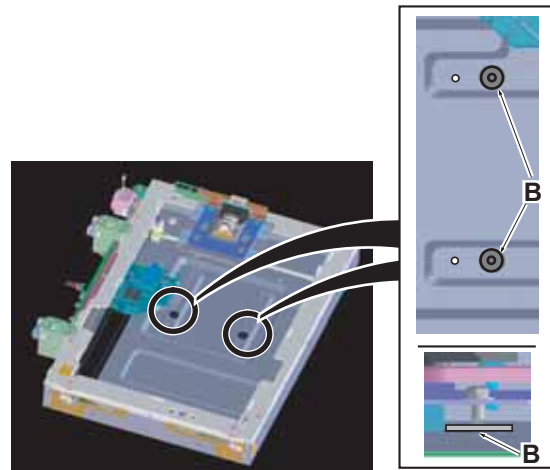
### 3. The CCD unit Height Adjustment 2

In case of white vertical lines appear like the illustration "b" on page 1.

1. Set the spacer (large)(B) into the inside screw holes at the lens side.
2. Check the image.

In case of no problem on the image, go to "5. Image Adjustment".

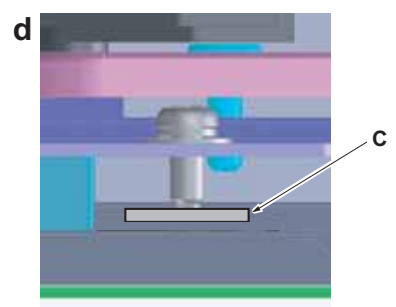
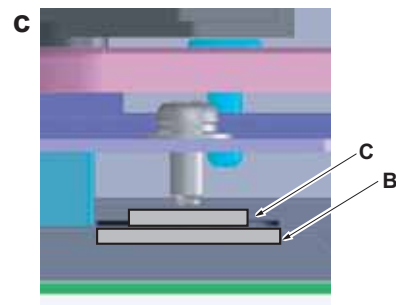
In case of the problem on the image, go to "4. Re-adjustment 2".



**Figure 1-5-67**

### 4. Re-adjustment 2

1. In case the white vertical lines still appear.  
c: Insert the additional spacer (small) (C)  
In case the whitish or background image appears.  
d: Remove the spacer (large) (B) and insert the spacer (small) (C).
2. Check the image and go to "5. Image Adjustment".



**Figure 1-5-68**

### 5. Image Adjustment

Execute the U411 Auto Adjustment (see page 1-3-148).

Set a new auto adjustment chart (part no. 7505000005) on the contact glass.

Execute the U411- Target – Auto –Table (chart1) - ALL.

6. Refit all the removed parts.

## (4) Detaching and refitting the LSU

### Procedure

1. Remove the inner unit (see page 1-5-45).
2. Remove two screws.
3. Remove the inner cover by releasing the hook through the round access.

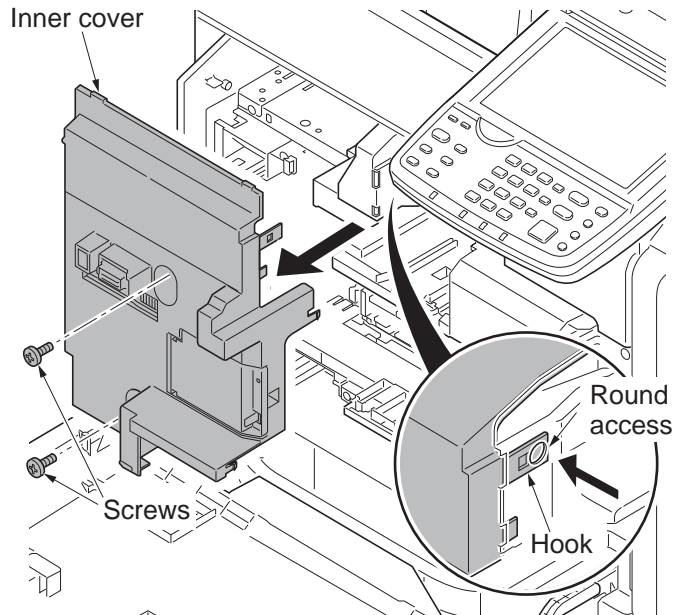


Figure 1-5-69

4. Remove two fixed screws of the container guide.
5. Pull the container guide out and remove the guide.

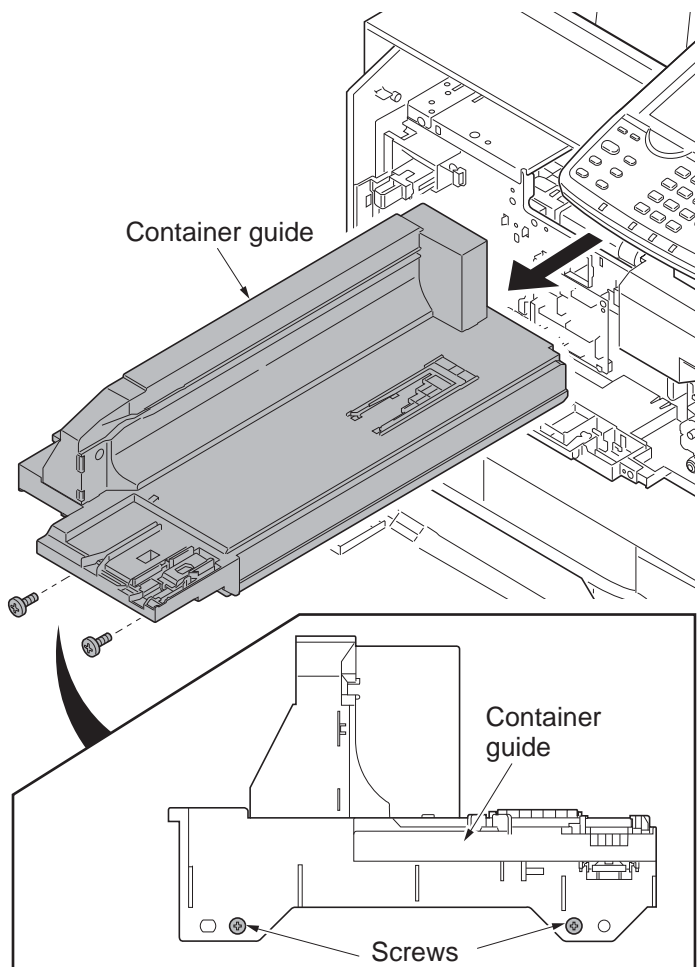
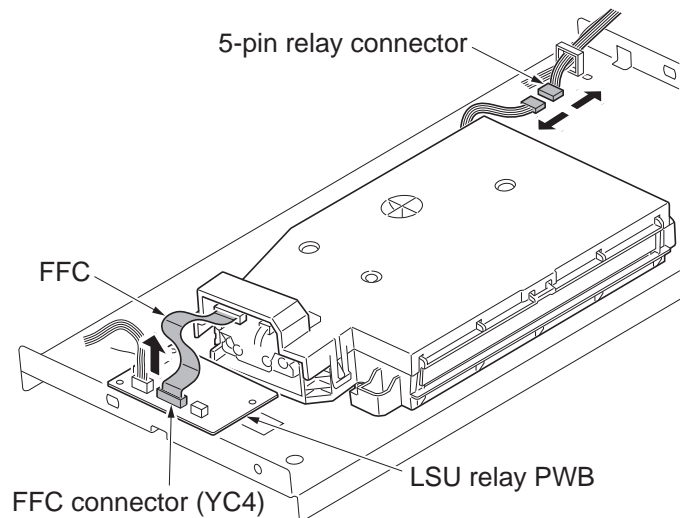


Figure 1-5-70

6. Remove the FFC from the FFC connector with a lock (YC4) of the LSU relay PWB.

\*: When removing the FFC from the FFC connector with a lock, remove it after release the lock by lifting the lock lever up.

7. Remove 5-pin relay connector at rear side of the LSU.



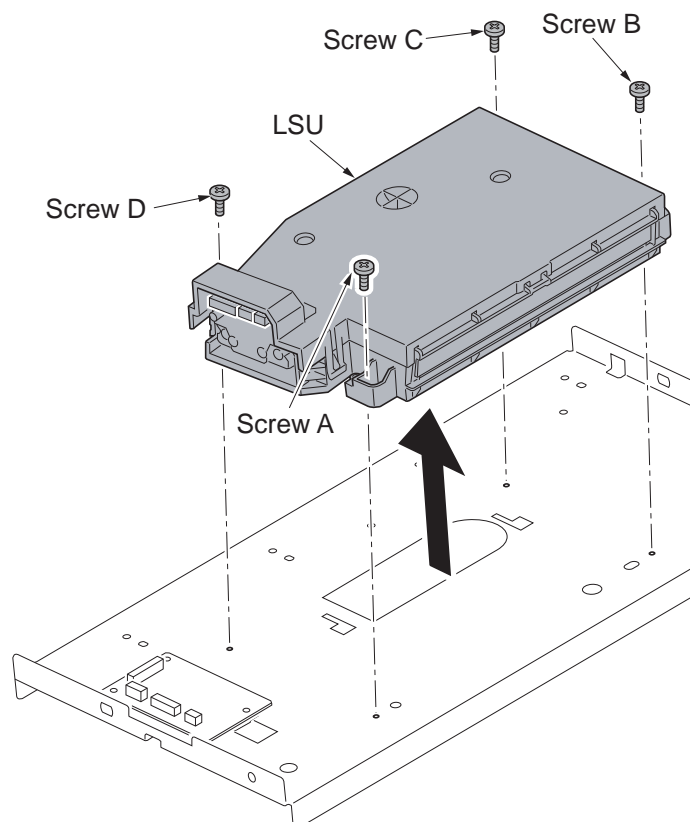
**Figure 1-5-71**

8. Remove four screws (A to D) and then remove the LSU.

9. Check or replace the LSU and refit all the removed parts.

\*: To re-mount the LSU, secure the screws in the order of A – B – C- D.

10. When replacing the new LSU, proceed as follows:
- 1) Perform maintenance mode U930 (checking/clearing the charger roller count) and checking the counter value (see page 1-3-190).
  - 2) Perform maintenance mode U119 (Setting the drum) (see page 1-3-73).
  - 3) Perform maintenance mode U930 (checking/clearing the charger roller count) and checking the counter value (see page 1-3-190).
  - 4) Perform maintenance mode U464 (Calibration) (see page 1-3-169).
  - 5) Perform maintenance mode U412 (Adjusting the uneven density) (see page 1-3-157).



**Figure 1-5-72**

- 6) Perform maintenance mode U464 (Calibration) (see page 1-3-169).
- 7) Perform maintenance mode U410 (Adjusting the halftone automatically) (see page 1-3-147).

## 1-5-5 Image formation section

### (1) Detaching and refitting the inner unit

#### Procedure

1. Open the front cover.
2. Remove toner container.
3. Remove the waste toner box tray by lifting upwards and from the right side.

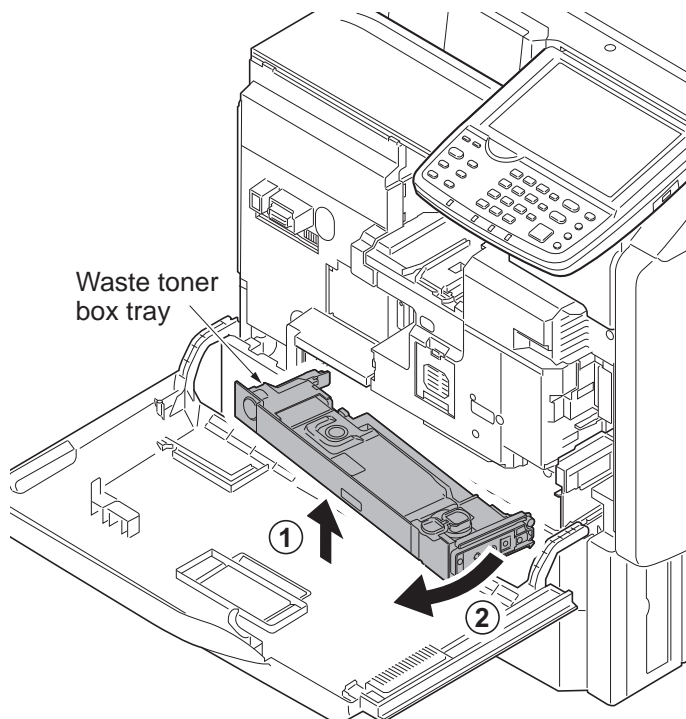


Figure 1-5-73

4. Remove the screw and then open the connector cover.
5. Release the wire saddle.
6. Remove the connector.

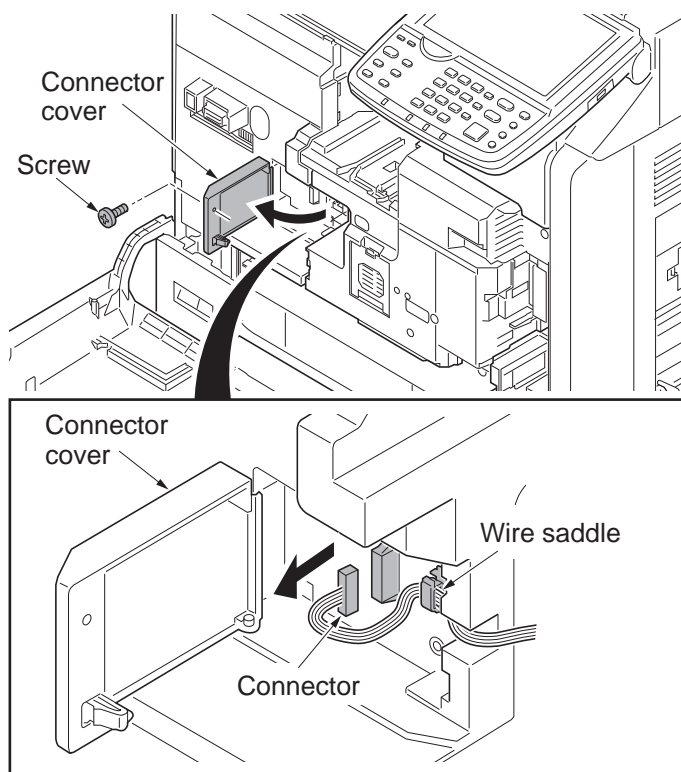


Figure 1-5-74

7. Remove four fixed screws of inner unit.

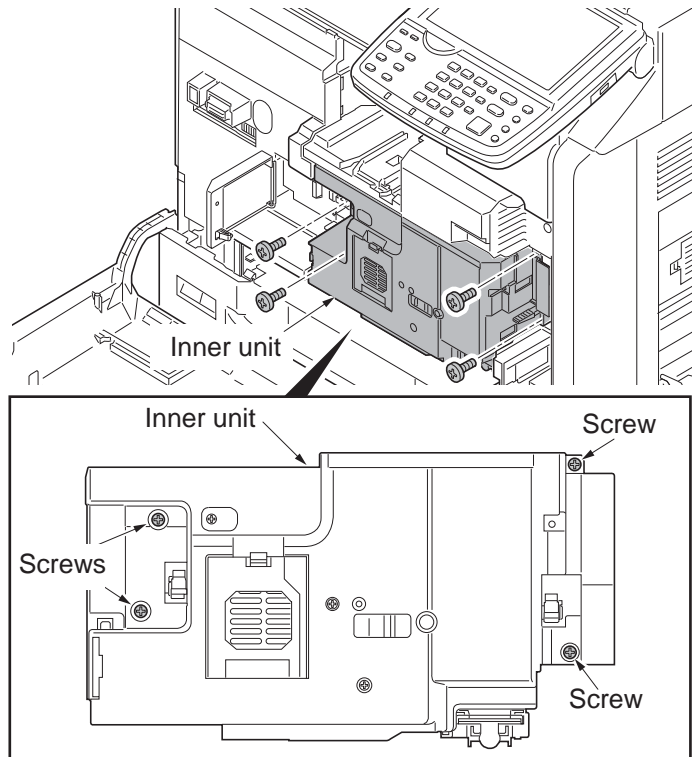


Figure 1-5-75

8. Remove the inner unit.
9. Release the lock by pushing the fixed levers at the right and left of inner unit.
10. Close the toner replenishment shutter of inner unit.

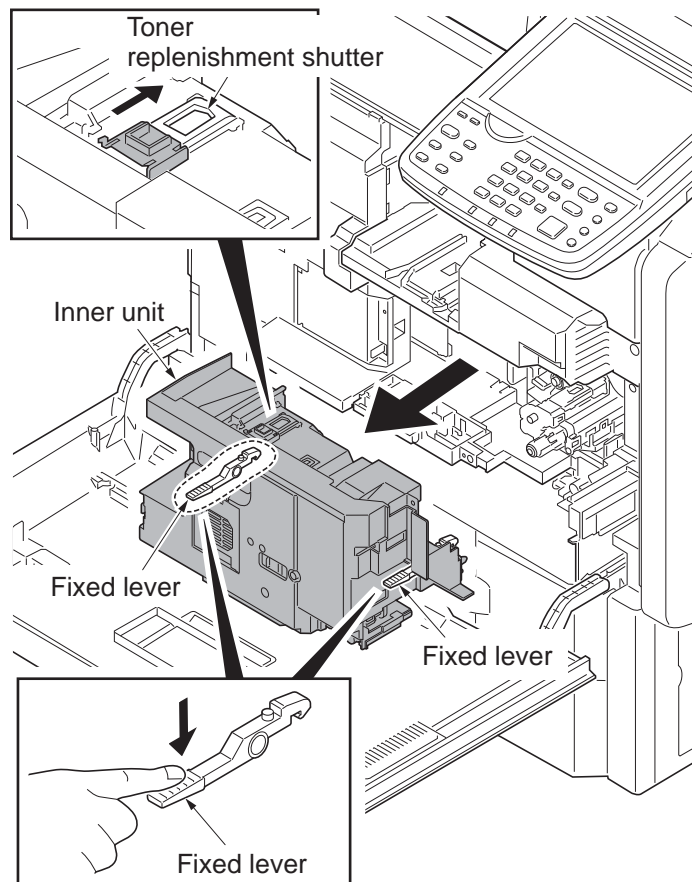


Figure 1-5-76

## (2) Detaching and refitting the developer unit

### Procedure

1. Remove the inner unit (see page 1-5-45).
2. Close the toner supply shutter.
3. Remove the connector.
4. Turn down the DLP rail lever.

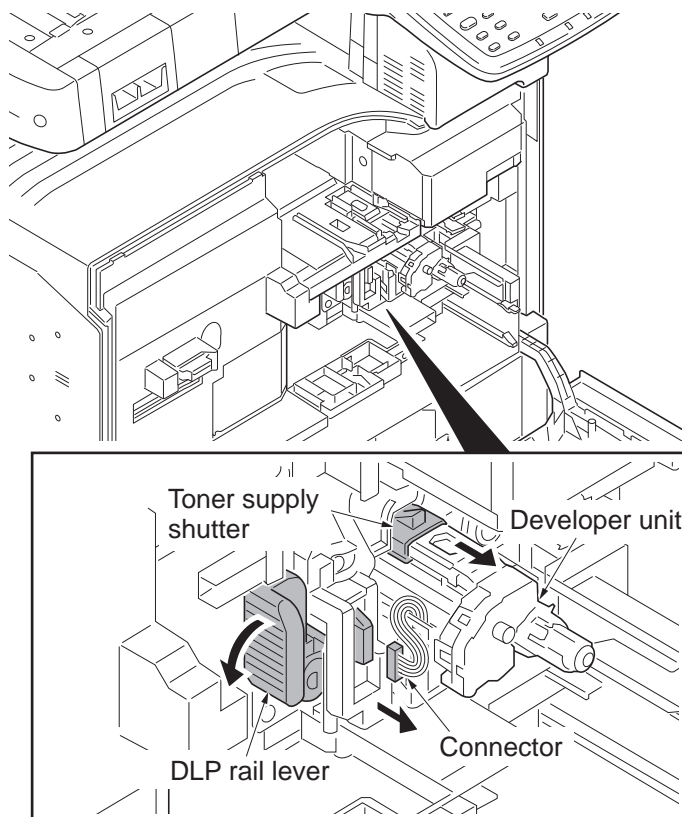


Figure 1-5-77

5. Release the lock lever at lower side of the developer unit and then pull out the developer unit.
6. Check or replace the developer unit and refit all the removed parts.
7. When replacing the new developer unit, proceed as follows:
  - 1) Perform maintenance mode U140 (AC calibration) for 55 ppm model only (see page 1-3-80).
  - 2) Perform maintenance mode U464 (Calibration) (see page 1-3-169).
  - 3) Perform maintenance mode U410 (Adjusting the halftone automatically) (see page 1-3-147).

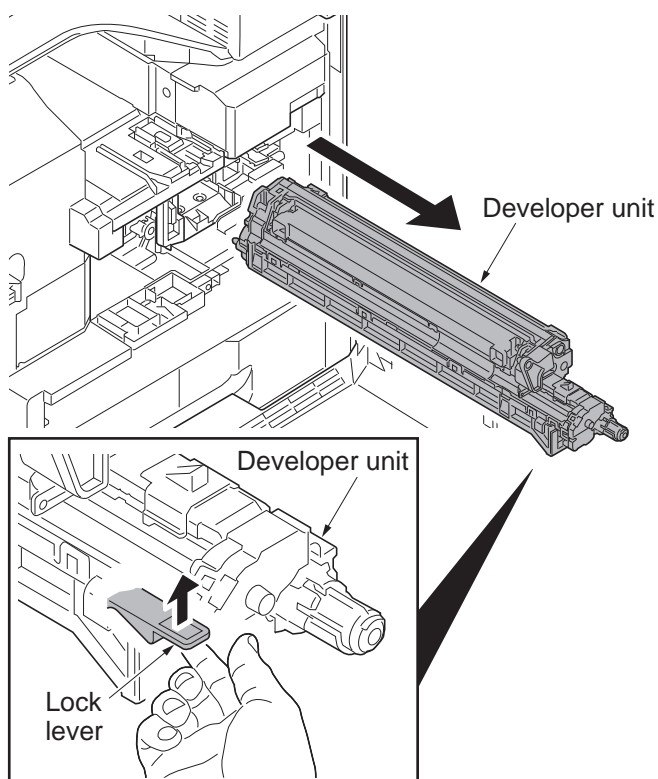


Figure 1-5-78

\*: When a new development unit is installed, the developing roller protective sheet must be removed.

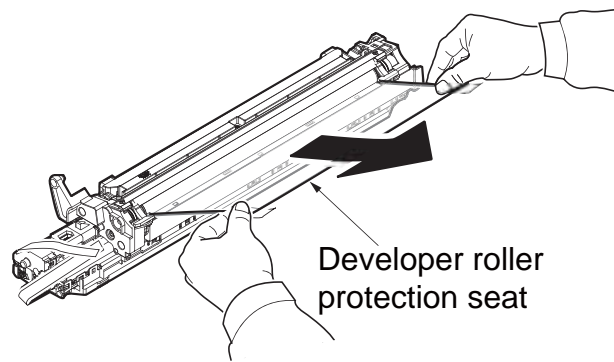


Figure 1-5-79

### (3) Detaching and refitting the drum unit

#### Procedure

1. Remove the inner unit (see page 1-5-45).
2. Remove the developer unit (see page 1-5-47).
3. Pull the paper conveying unit out.
4. Remove the connector.
5. Remove the screw.

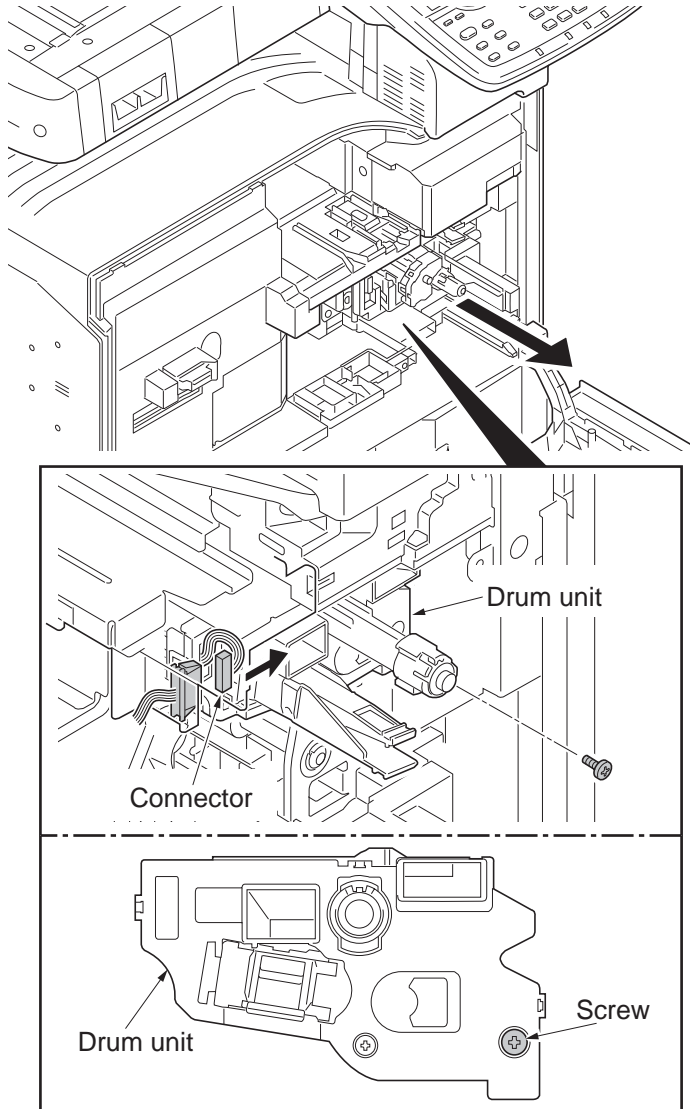
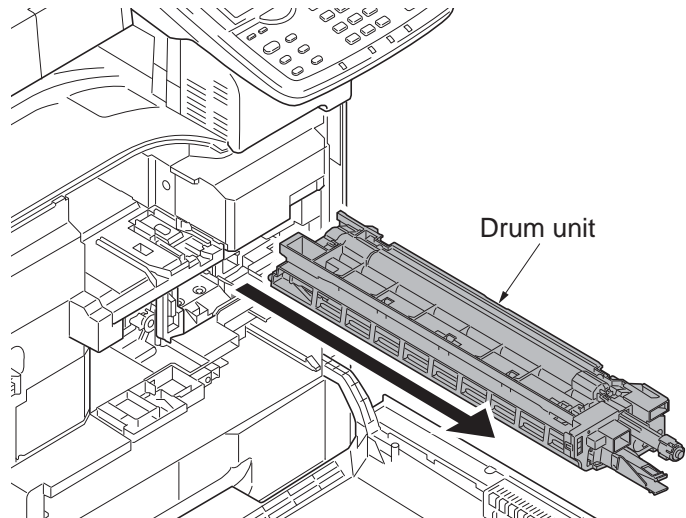


Figure 1-5-80



6. Pull out the drum unit.
7. Check or replace the drum unit and refit all the removed parts.



**Figure 1-5-81**

8. When replacing the new drum unit, proceed as follows:
  - 1) Perform maintenance mode U119 (drum setup) (see page 1-3-73).
  - 2) Perform maintenance mode U140 (AC calibration) for 55 ppm model only (see page 1-3-80).
  - 3) Perform maintenance mode U464 (Calibration) (see page 1-3-169).
  - 4) Perform maintenance mode U412 (Adjusting the uneven density) (see page 1-3-157).
  - 5) Perform maintenance mode U464 (Calibration) (see page 1-3-169).
  - 6) Perform maintenance mode U410 (Adjusting the halftone automatically) (see page 1-3-147).



## (4) Detaching and refitting the charger roller unit

### Procedure

1. Remove the inner unit (see page 1-5-45).
2. Pull out the charger roller unit by picking and releasing the MC lock lever.
3. Check or replace the charger roller unit and refit all the removed parts.

\*: When refitting the charger roller unit, that must hook the hook certain by operating the MC lock lever after inserting the charger roller unit until bumping.

4. When replacing the new charger roller unit, proceed as follows:  
Perform maintenance mode U930 (clearing the charger roller count) (see page 1-3-187).

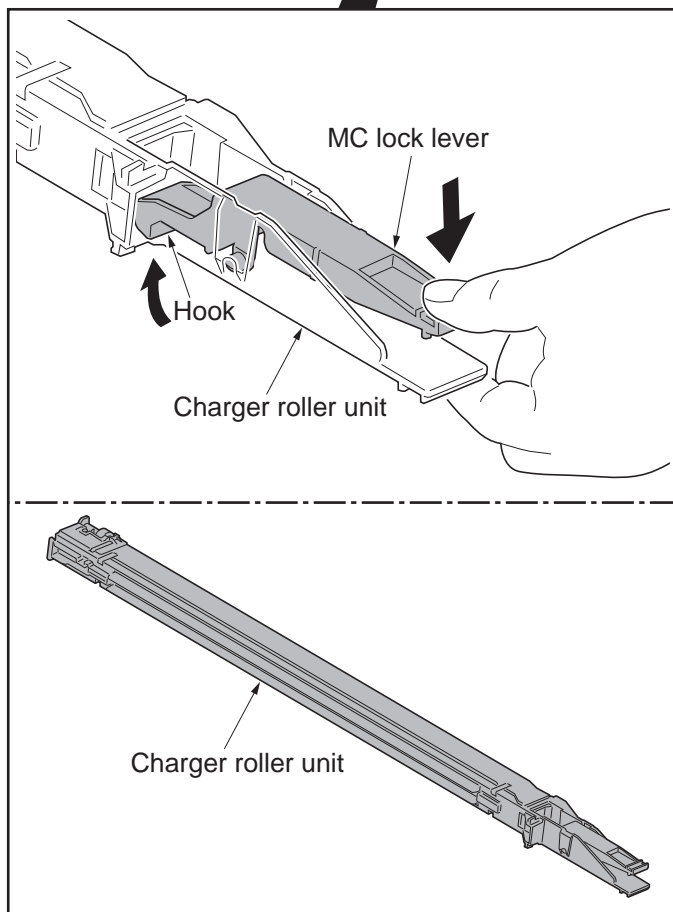
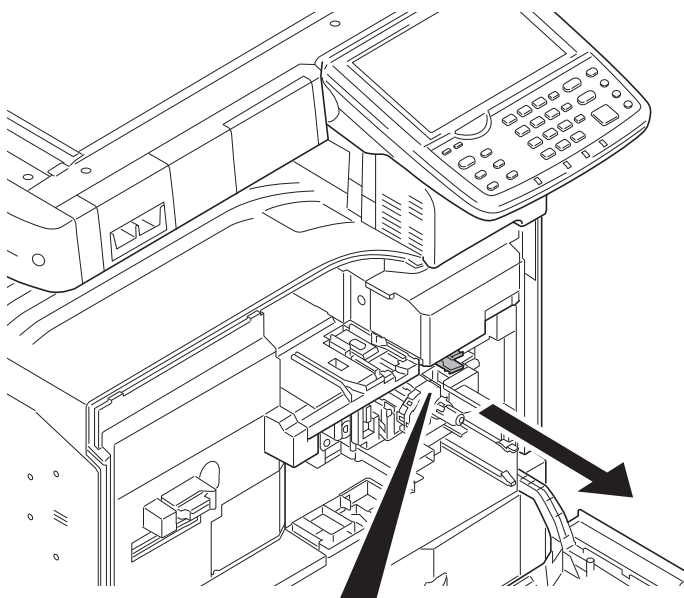
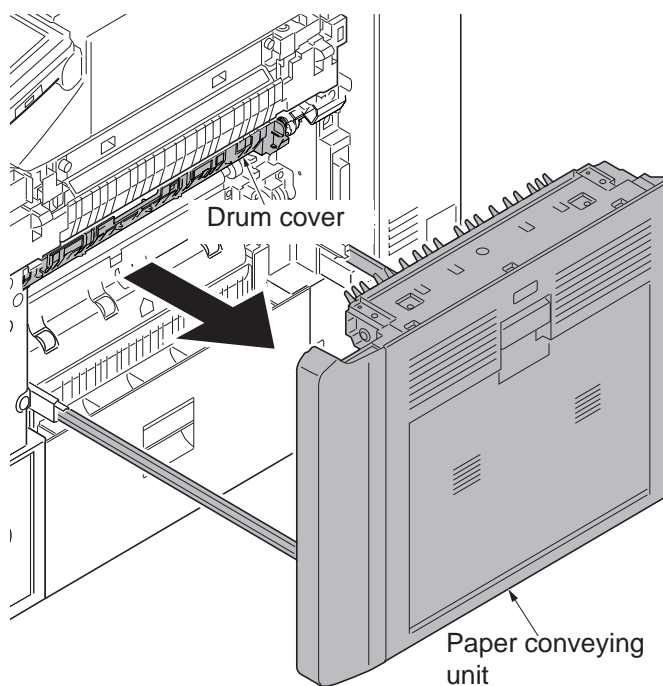


Figure 1-5-82

## (5) Removal and cleaning of the drum cover.

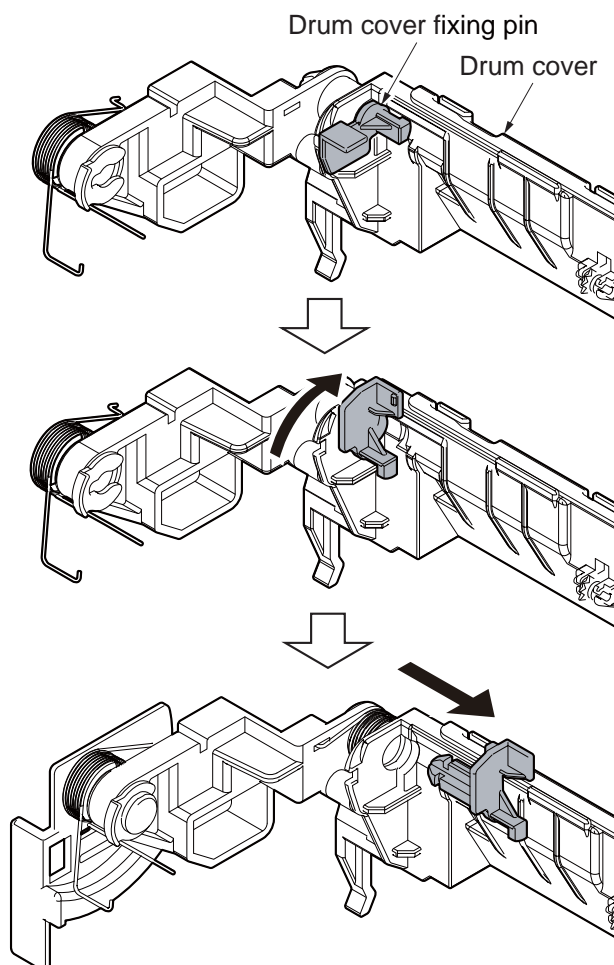
### Procedure

1. Pull out the paper conveying unit.



**Figure 1-5-83**

2. Turn the fixing pin at the front of the drum cover 90 degrees upwards.
3. Remove the drum cover fixing pin towards the far end



**Figure 1-5-84**

4. Remove the fixing pin on the drum cover from the cutout at the front drum cover arm by turning the drum cover upwards.

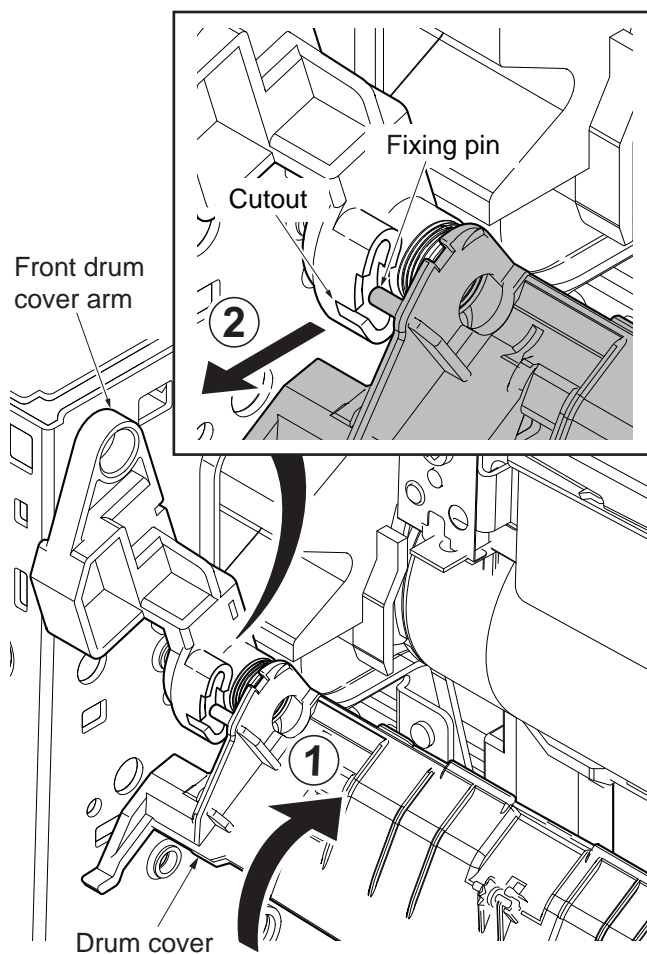


Figure 1-5-85

5. Pull the drum cover towards you to remove it from the rear drum cover arm.
6. Clean the drum cover and clamp all the parts back in place.

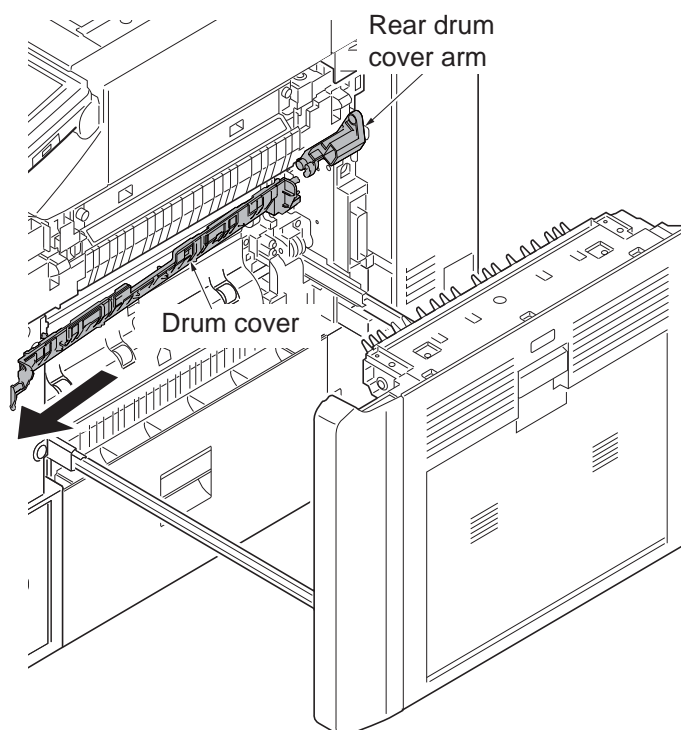


Figure 1-5-86

## Clamping the drum cover

1. Insert the axle at the end of the drum cover into the hole at the rear drum cover arm.  
\* : Be sure to insert the fixing pin into the guiding chase at the back of the drum cover.
2. In the same manner, insert the fixing pin at the front through the opening at the front drum cover arm into the guiding chase, fixing it using the drum cover fixing pin.  
\* : After fixing, confirm that the drum cover fixing pin won't drop by pulling it straight backwards.

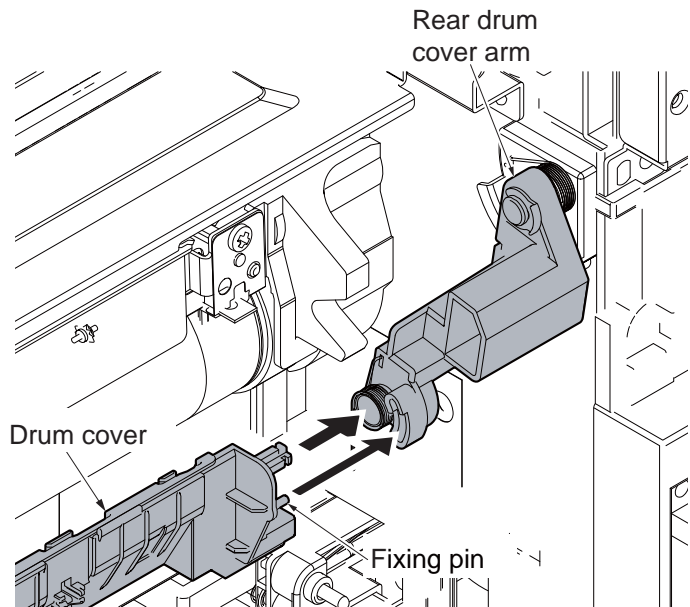


Figure 1-5-87

3. Hook the springs at the front and back of the drum cover arm onto the inside of the drum cover ribs.

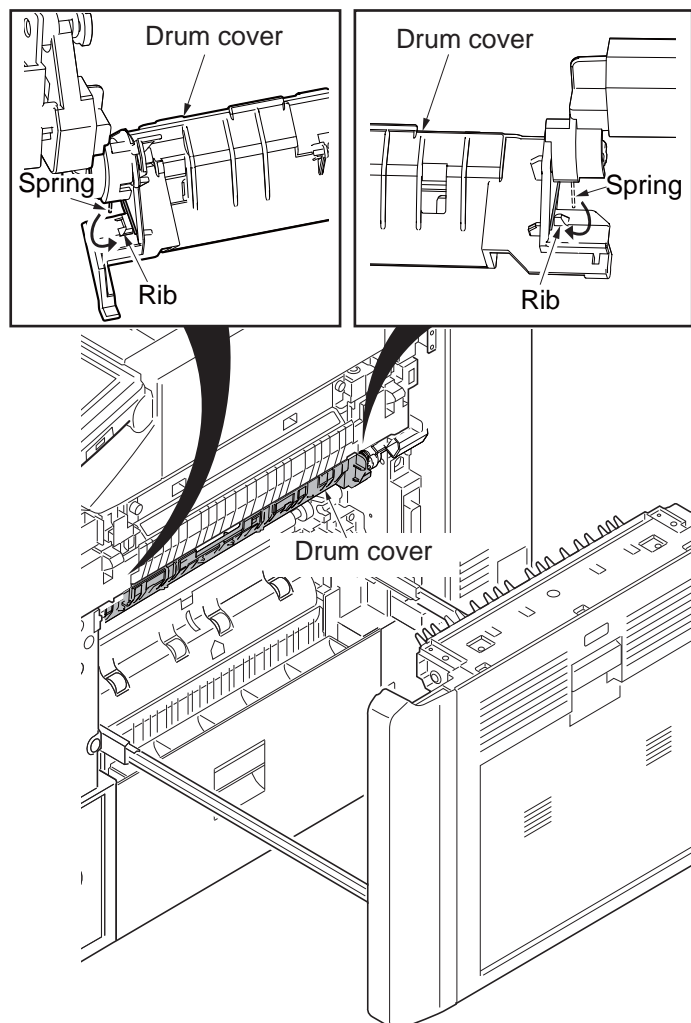


Figure 1-5-88

## 1-5-6 Transfer section

### (1) Detaching and refitting the paper conveying unit

#### Procedure

1. Pull the paper conveying unit out.
2. Remove three screws.
3. Unhook three hooks and then remove the right front cover.

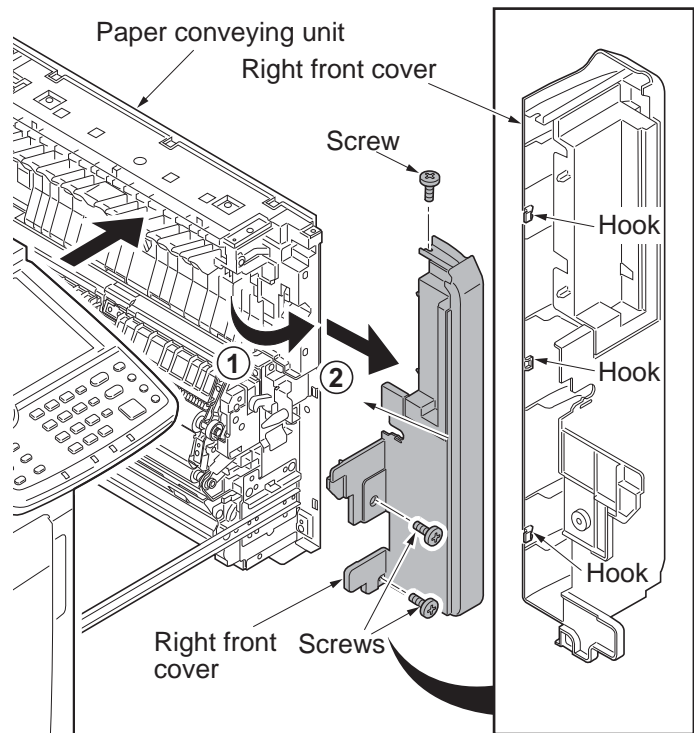


Figure 1-5-89

4. Unhook two hooks and then remove the conveying inner cover from the paper conveying unit.

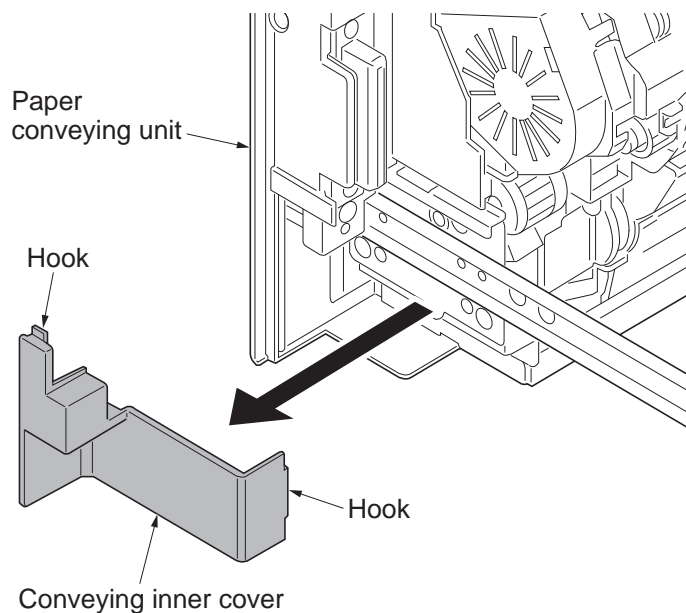


Figure 1-5-90

5. Remove four screws.
6. Remove the paper conveying unit by lifting upward.

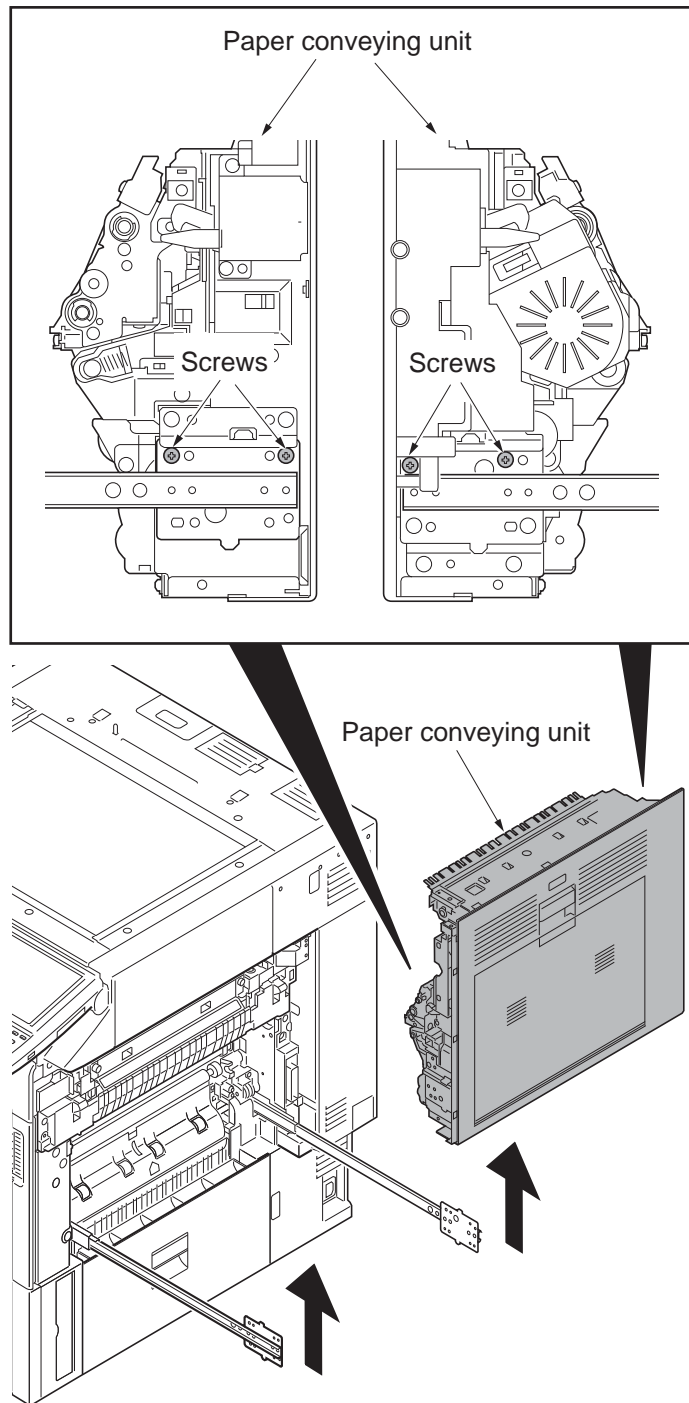


Figure 1-5-91

## (2) Detaching and refitting the transfer belt unit

### Procedure

1. Pull the paper conveying unit out.
2. Remove three screws and then remove the conveying rear middle cover.
3. Remove the connector.

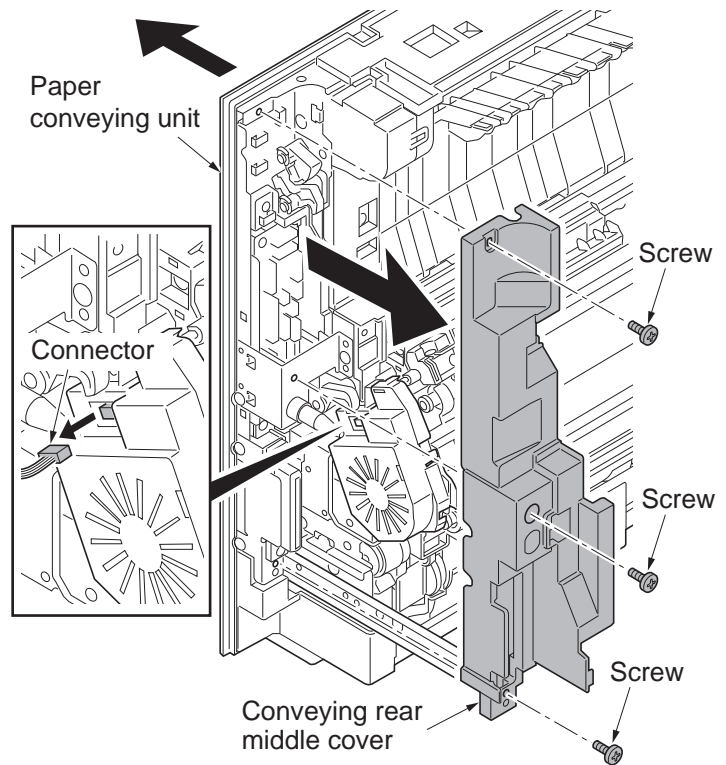


Figure 1-5-92

4. Unhook the two hooks by the tip of a screwdriver through the hole and then remove the front and rear transfer holders.

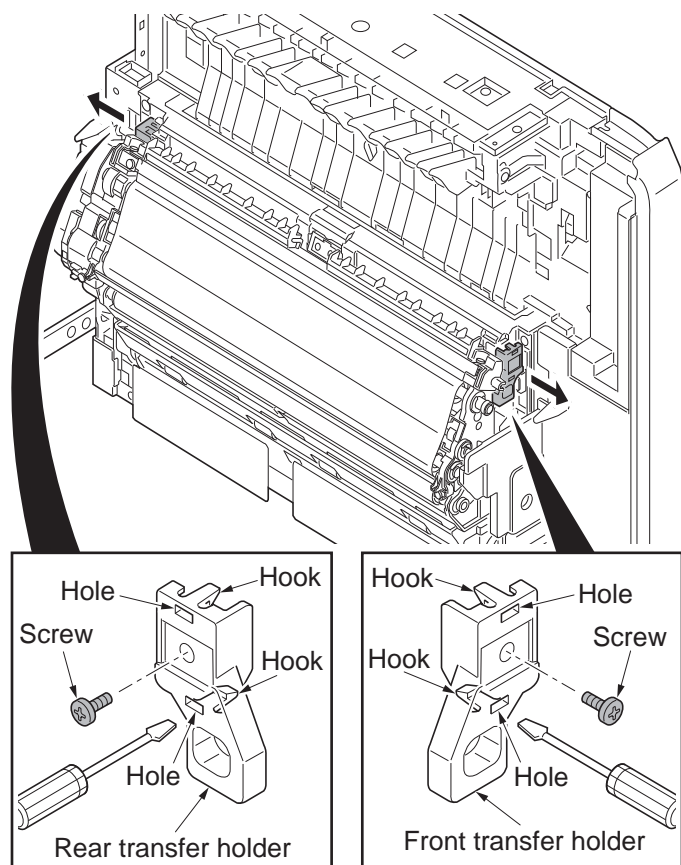


Figure 1-5-93

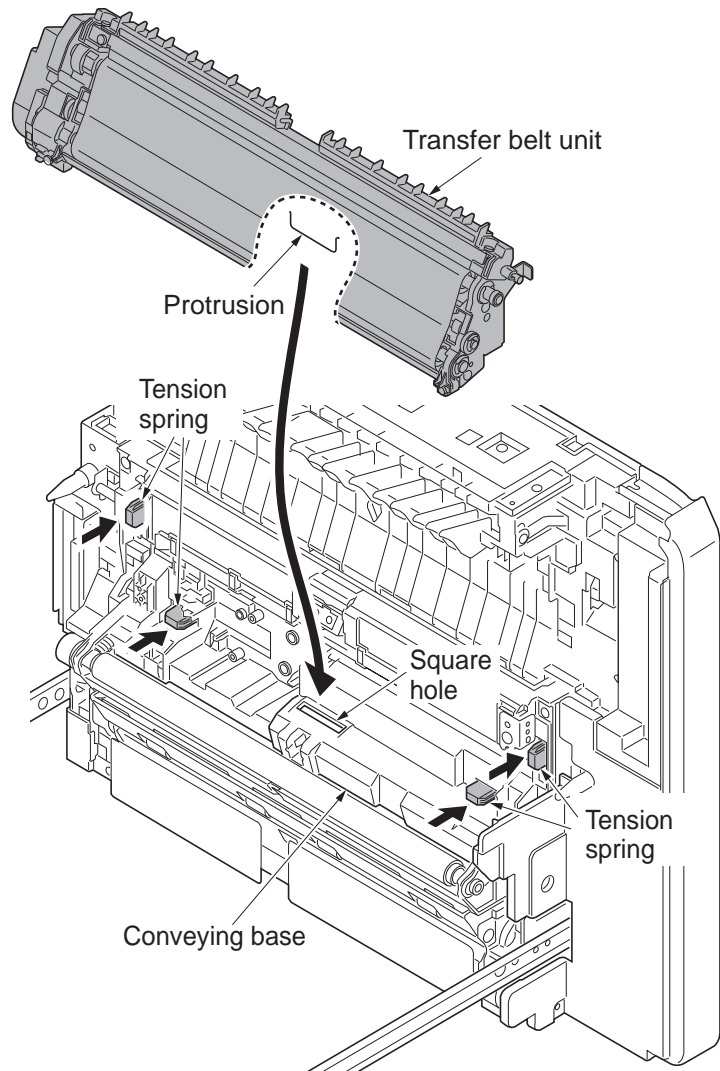


5. Remove the transfer belt unit.
6. Check or replace the transfer belt unit and refit all the removed parts.

\*: When refitting the transfer belt unit, observe the precautions in the following:

Insert the protrusion at the bottom of the transfer belt unit into the square hole on the conveying base.

7. When replacing the new transfer belt unit, proceed as follows:
  - 1) Perform maintenance mode U127 (clearing the transfer counter) (see page 1-3-74).
  - 2) Perform maintenance mode U464 (Calibration) (see page 1-3-169).
  - 3) Perform maintenance mode U410 (Adjusting the halftone automatically) (see page 1-3-147).



**Figure 1-5-94**



## 1-5-7 Fuser section

### (1) Detaching and refitting the fuser unit

#### Procedure

1. Pull out the paper conveying unit.
2. Remove the screw and then the fuser wire cover.
3. Remove two connectors

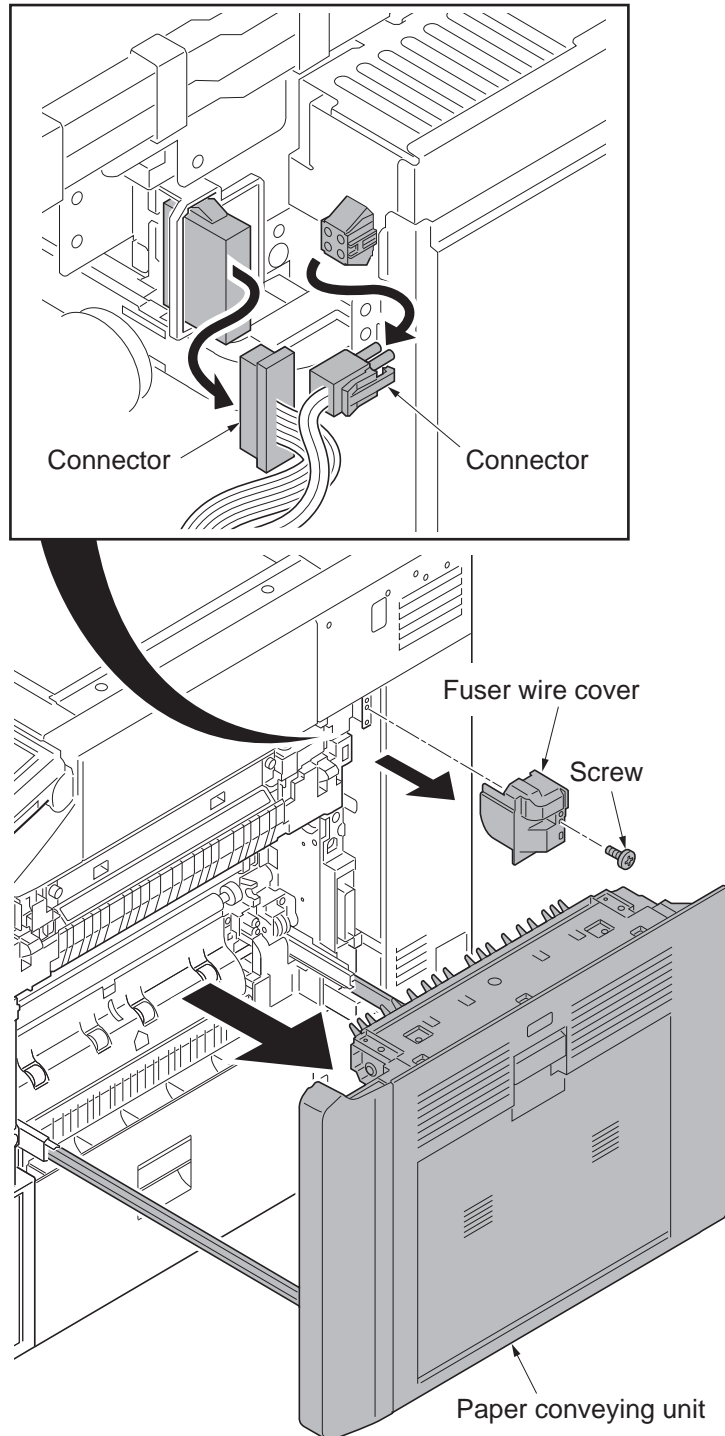
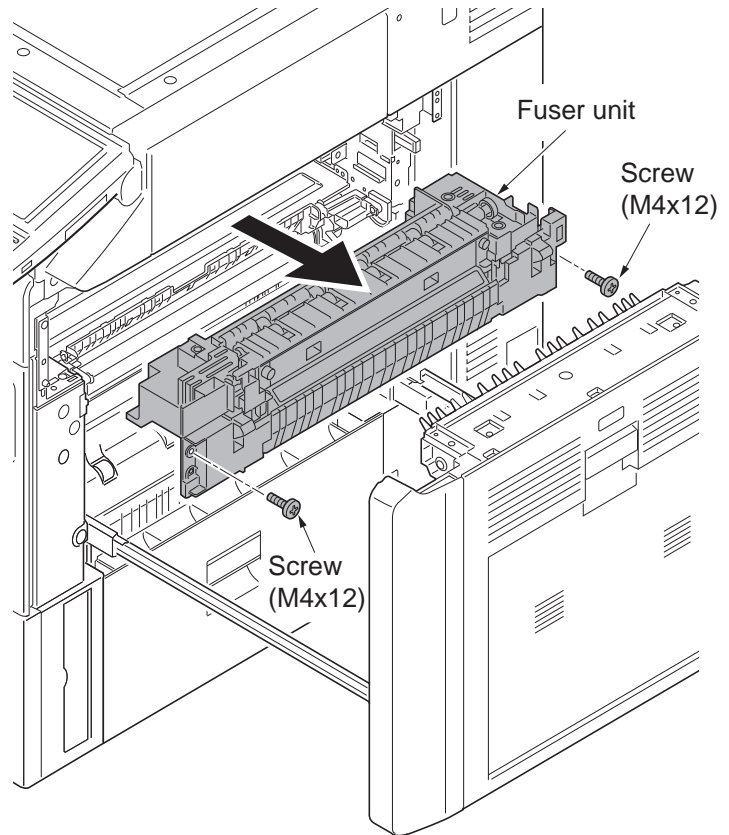


Figure 1-5-95

4. Remove two screws (M4 x 12) and then remove the fuser unit.
5. Check or replace the fuser unit and refit all the removed parts.
6. When replacing the new fuser unit, proceed as follows:
  - 1) Perform maintenance mode U167 (clearing the fuser count) (see page 1-3-91).
  - 2) Perform maintenance mode U464 (Calibration) (see page 1-3-169).
  - 3) Perform maintenance mode U410 (Adjusting the halftone automatically) (see page 1-3-147).

**Figure 1-5-96**

## 1-5-8 PWBs

### (1) Detaching and refitting the main PWB

#### Procedure

1. Remove the rear upper cover (see page 1-5-3).
2. Release seven wire saddles on the controller box.
3. Remove the wire holder.

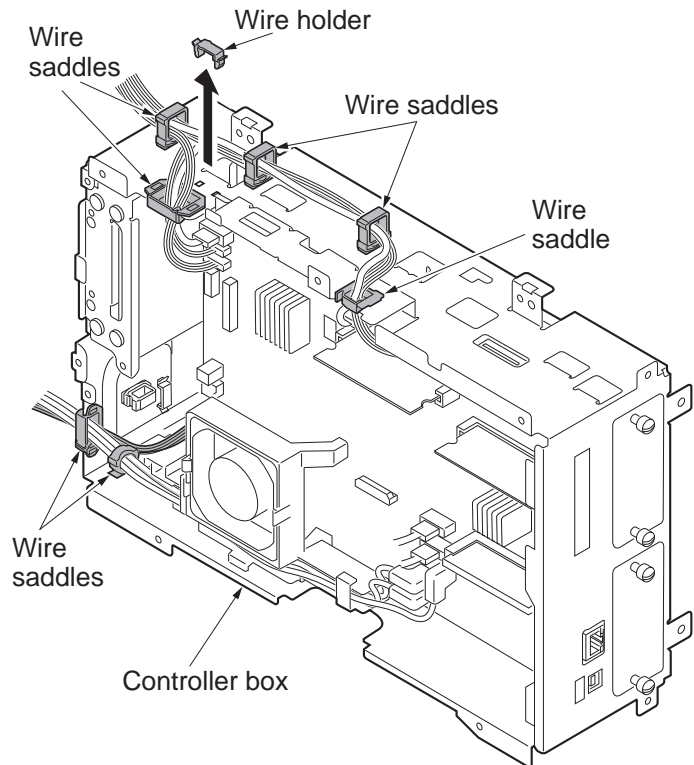
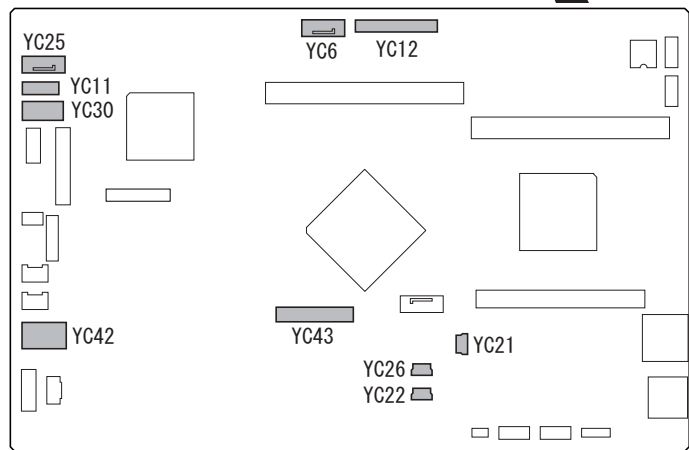
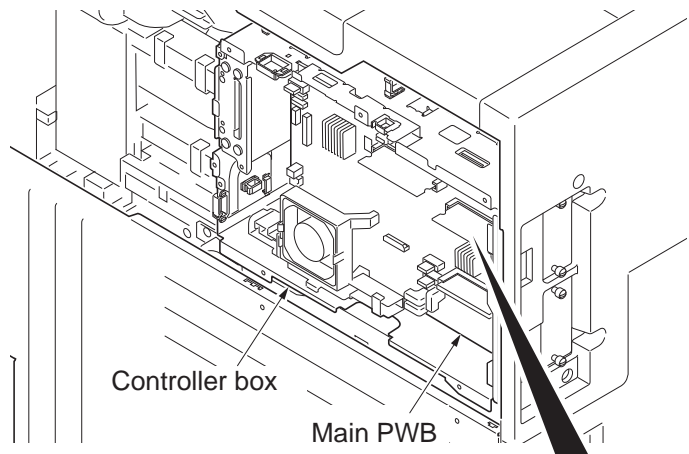


Figure 1-5-97

4. Remove the following connectors that connected to the main PWB from the outside of the control box.

- YC25
- YC11
- YC30
- YC42
- YC43(Connector type FFC)
- YC21(WH)
- YC22(WH)
- YC26(BK)
- YC6
- YC12

\*: Before removing the connector type FFC YC43, unlock the lock by pressing the lock levers at both ends.



Main PWB

Figure 1-5-98

- 5. Remove five screws.
- 6. Unhook two hooks and then remove the controller box.

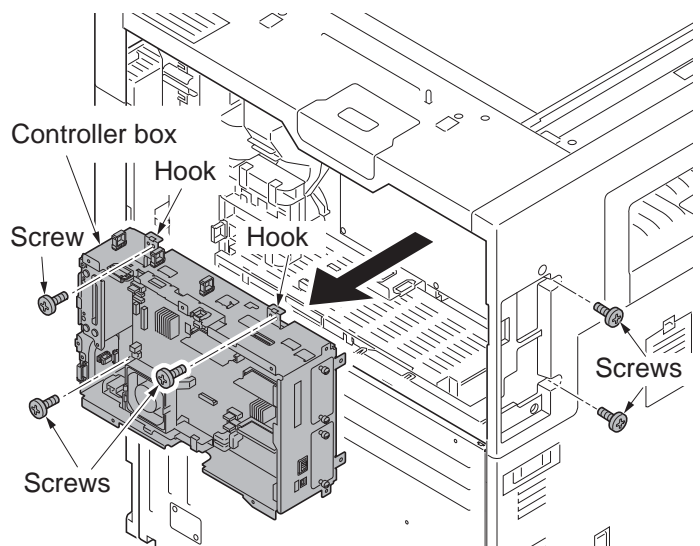


Figure 1-5-99

7. Remove the following connectors that connected to the main PWB.

- YC23
- YC27
- YC32
- YC8 (FFC connector with a lock)
- YC9
- YC1 [BLACK]

\*: When removing the FFC from the FFC connector with a lock, remove the FFC after released by lifting down the lock lever.

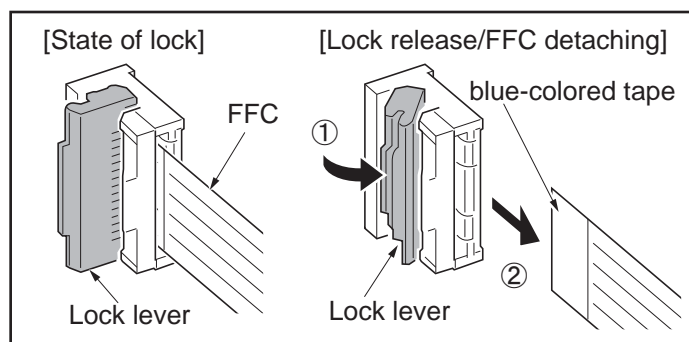
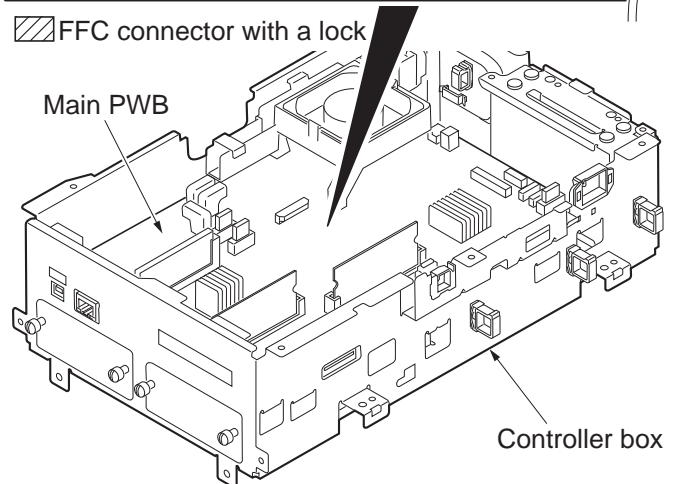
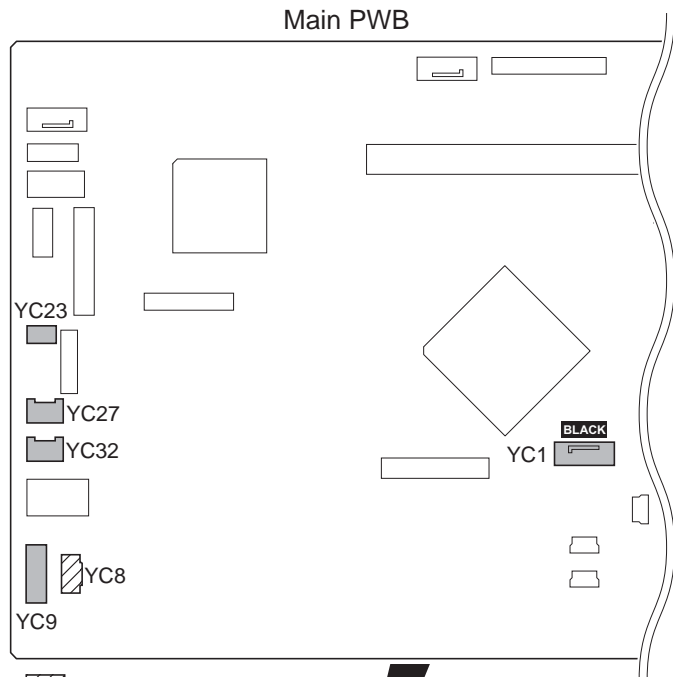


Figure 1-5-100

8. Release the wire saddle.
9. Remove two wire holders.
10. Remove two screws.
11. Remove the fan motor holder.

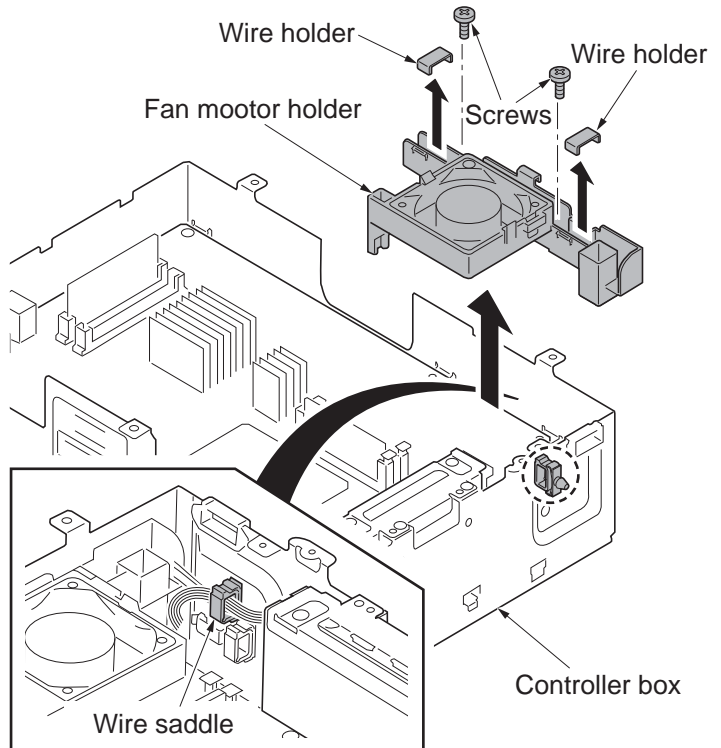


Figure 1-5-101

12. Remove seven screws from the main PWB.

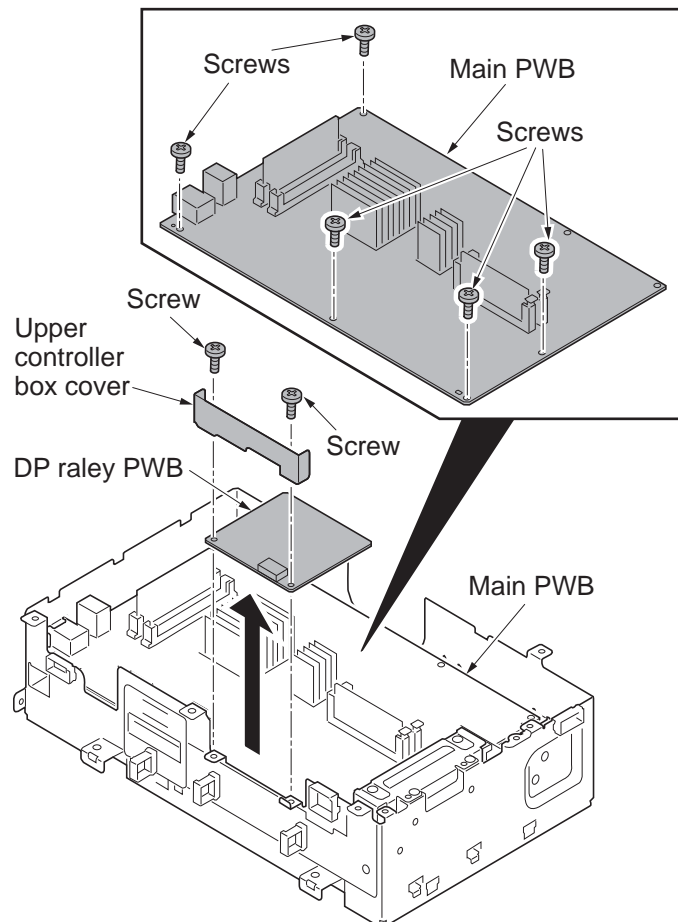


Figure 1-5-102

13. Remove the main PWB by releasing the projection of ground plate in the network connector.
14. Check or replace the main PWB and refit all the removed parts.

\*: When replacing the main PWB, remove the following devices from the main PWB and then reattach it to the new main PWB. (see page 1-5-72)

EEPROM (YC14)

Memory DDR (YS1,YS3)

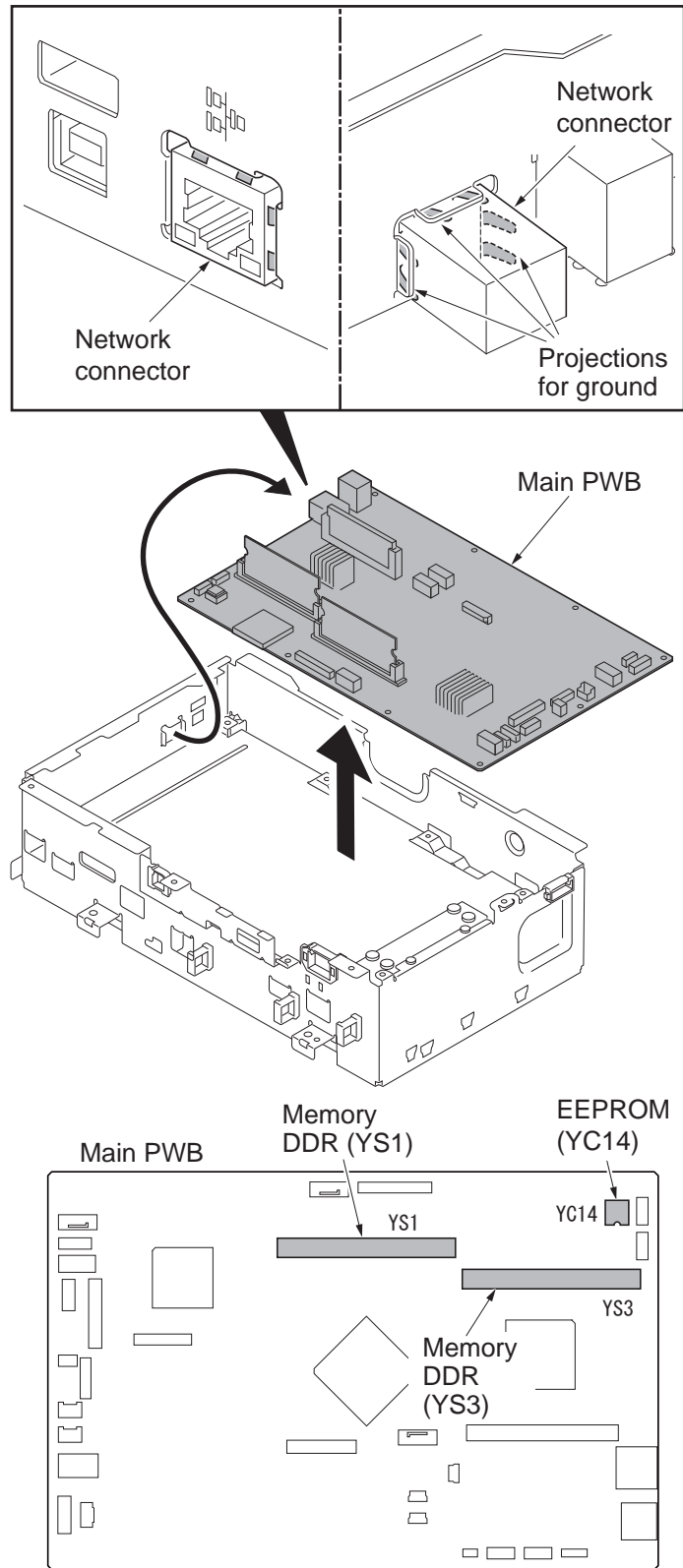


Figure 1-5-103

## (2) Remarks on main PWB replacement

When replacing the main PWB, remove the EEPROM (YC14) and DIMM (YS1,YS3) from the main PWB that has been removed and then reattach it to the new main PWB.

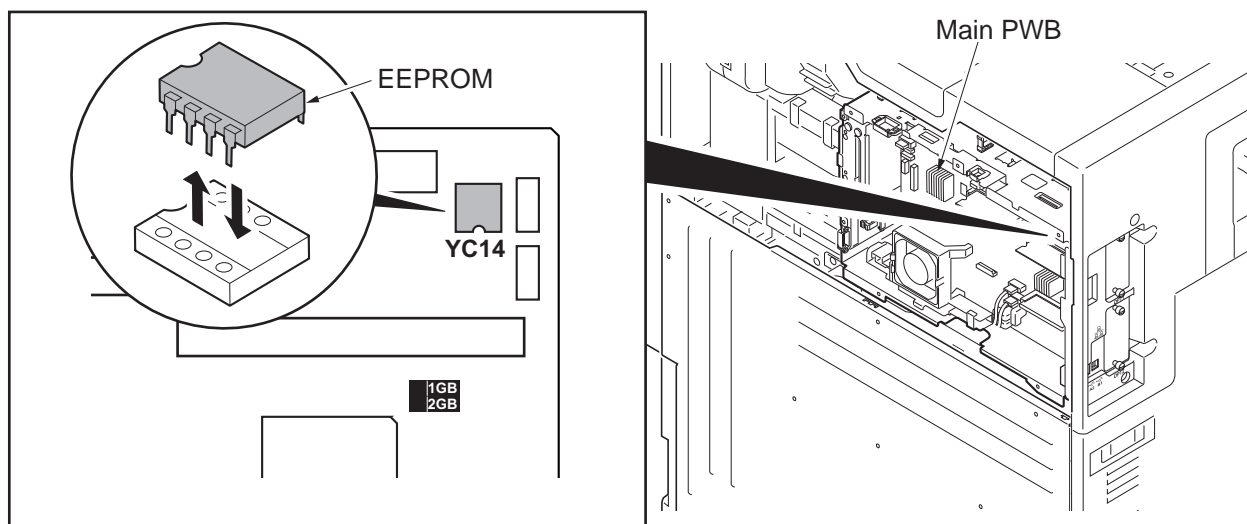


Figure 1-5-104

When refitting DIMM, Refit them to the original positions.

\* : YS1 :1GB YS3 :1GB

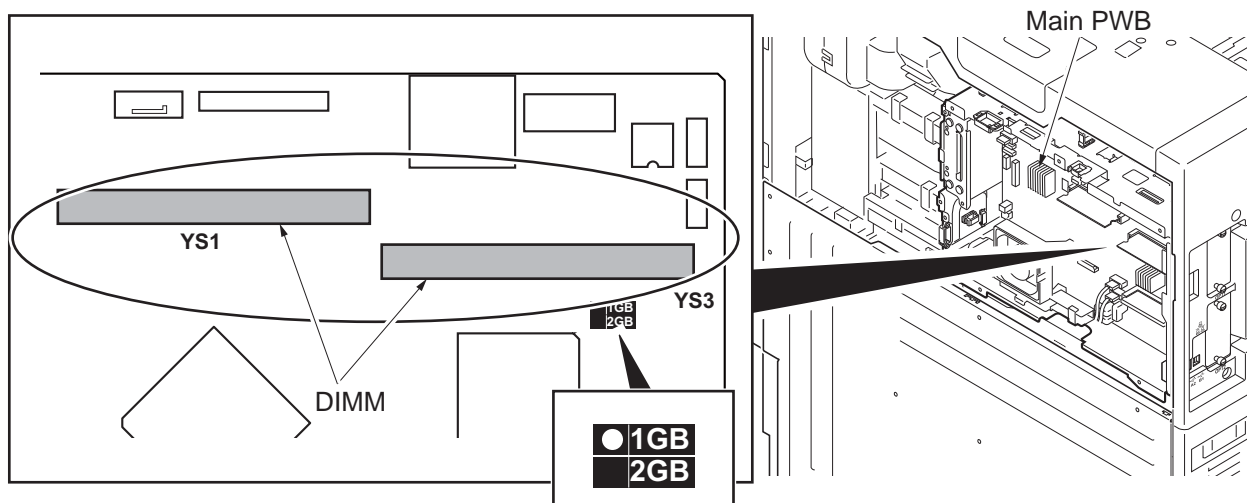


Figure 1-5-105

If the main PWB was replaced with a service supplied part, perform the following.

1. Insert the USB flash device in which an upgrade pack of the latest firmware or the Main/MMI/Browser and LANGUAGE BR (excluding Dictionary) were copied, into the slot on the machine and turn power on. (see page 1-6-1).
2. After the main-circuit PWB has been replaced, perform U026 to restore backed-up data.
  - \*: Do not replace the main-circuit PWB and the HDD at the same time. (Otherwise, the settings retained by U026 in the HDD will not become restorable.)
  - \*: Referring to the U000 maintenance report printed previously, enter the following values.
    - U278 Setting the delivery date
    - U402 Adjusting margins of image printing
    - U952 Maintenance mode workflow
  - \*: Since the U952 settings are not printed on the maintenance report, perform U952 to register settings again.



3. Reset machine settings. (Resets system menu settings modified at setup to their defaults.)  
If backup data is saved with the U917 maintenance mode, execute import of the backup data with the U917.  
Main items for settings  
[Date/Timer] - Date/Time settings  
[Date/Timer] - Timer settings (Sleep timer)  
[User/Job accounting] - Defaults for user authentication and job accounting only.  
Resettings are not required as the data are stored in harddisk.

#### Procedure to be followed after the EEPROM on the main PWB has been replaced

1. Run U004 – model number entry.  
The C0130 (mismatching model number) is displayed when the device is powered up after its EEPROM has been replaced. Restore the counter values and serial number that are stored in the engine EEPROM.
2. Referring to the maintenance report that was printed using U000 at setup, set the following maintenance modes:
  - 1) U252 - Setting the destination
  - 2) U265 - Setting OEM purchaser code
3. Reconfigure settings if the U250 maintenance counter preset value has been changed from the initial settings.
4. Run the following maintenance mode for image adjustment:
  - 1) U410 – Adjusting the halftone automatically

When connecting the hard disk cables (YC1) to the PWB, match "BLACK" marked on the PWB with the connector colors.

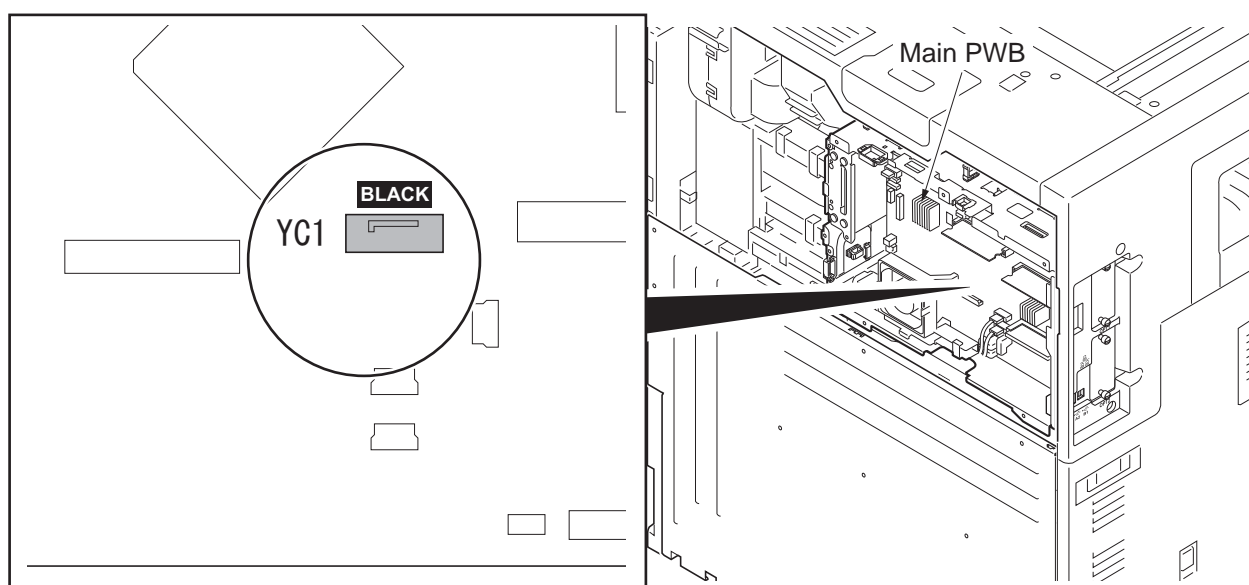


Figure 1-5-106

When connecting the USB cables (YC21, YC22, YC26) to the PWB, connect to the connectors which the cable length match.  
(Connecting to any connector is satisfactory.)

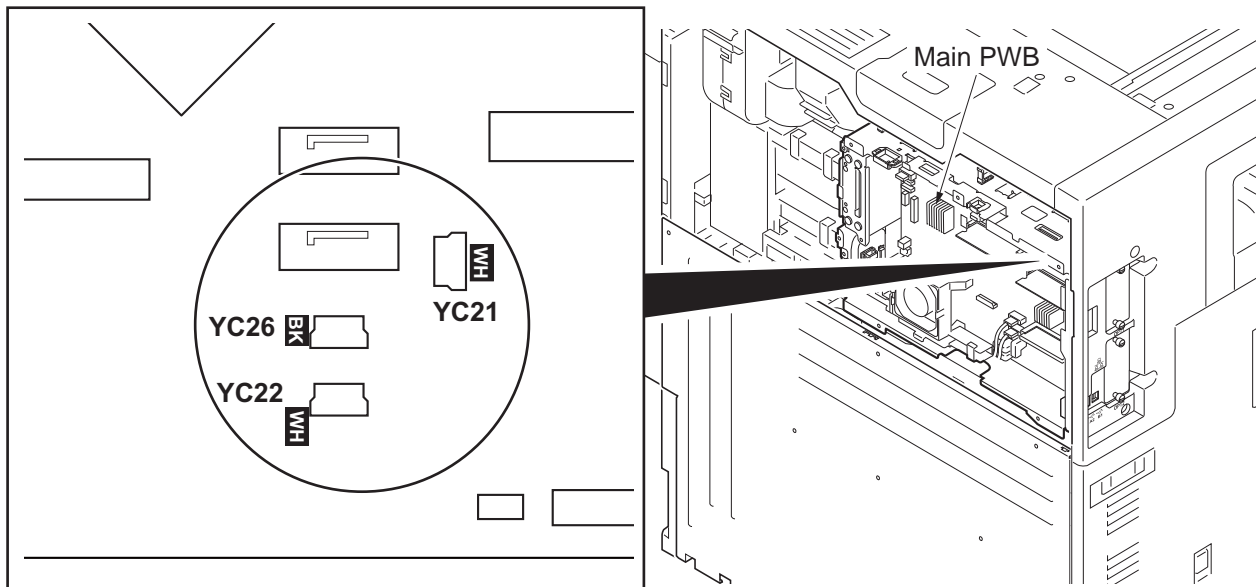


Figure 1-5-107

### (3) Detaching and refitting the engine PWB

#### Procedure

1. Remove the controller box (see page 1-5-60).
2. Remove twenty connectors of following from the engine PWB.  
 YC1, YC2, YC4(Connector type FFC),  
 YC5(Connector type FFC)  
 YC6(Connector type FFC), YC7(Connector type FFC),  
 YC11(Connector type FFC), YC13, YC26, YC9, YC8, YC46(Connector type FFC)  
 YC17, YC19, YC20, YC22, YC27

\*: To remove the FFC from the locked connector YC46, unlock the connector by pressing the lock lever at the triangular mark.

To insert an FCC cable, hold it at both ends and insert it all the way in.

\*: Before removing the connector type FFC YC43, unlock the lock by pressing the lock levers at both ends.

\*: Before removing the connector type FFCs of YC4-6 and YC11, unlock the lock by pressing the lock lever in its center.

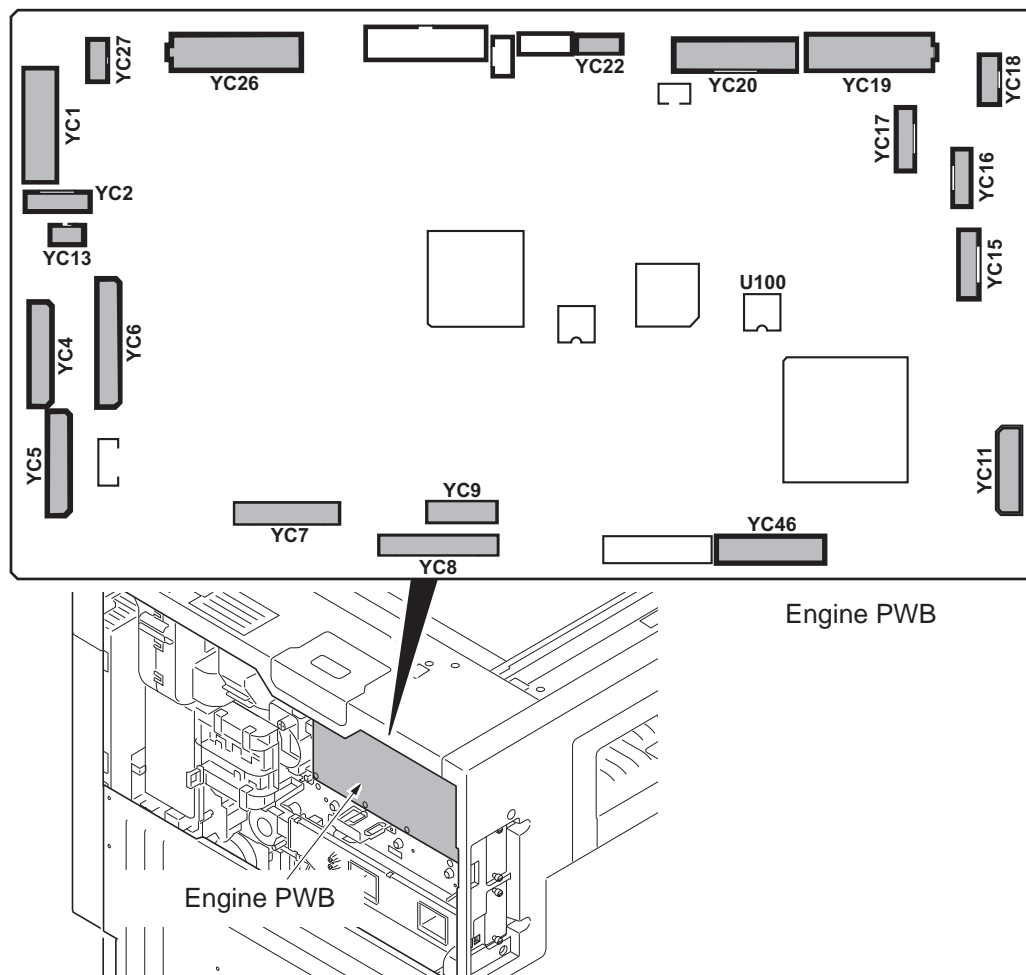
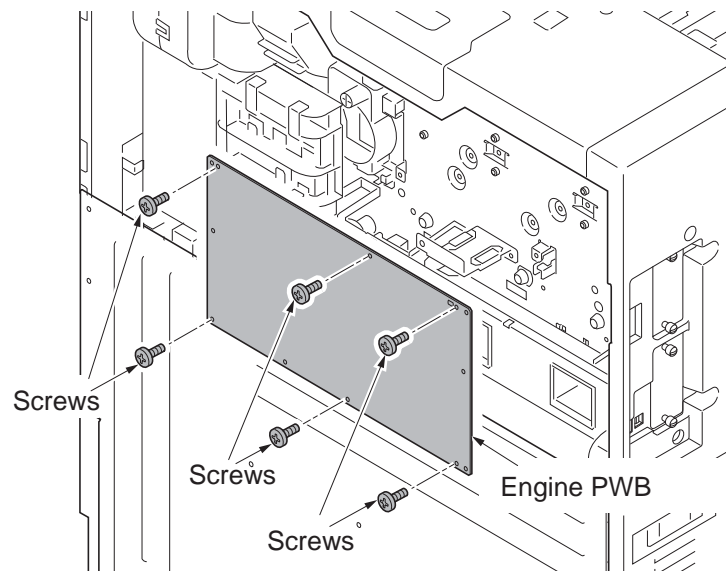


Figure 1-5-108

3. Remove six screws.
4. Remove the engine PWB.
5. Check or replace the engine PWB and refit all the removed parts.

\*: When replacing the engine PWB, remove the EEPROM (U100) from the engine PWB and then reattach it to the new engine PWB.



Engine PWB

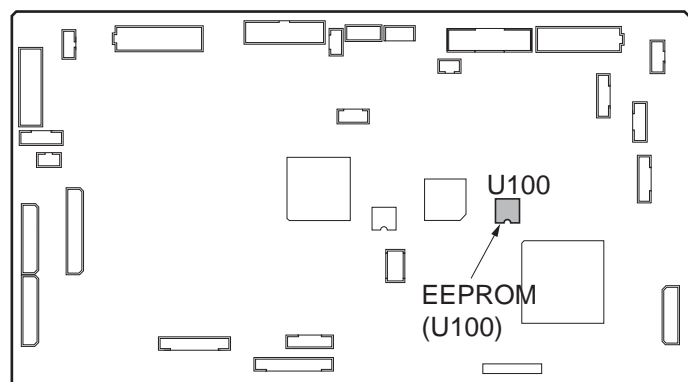


Figure 1-5-109

#### (4) Remarks on engine PWB replacement

When replacing the engine PWB, remove the EEPROM (U100) from the engine PWB that has been removed and then reattach it to the new engine PWB.

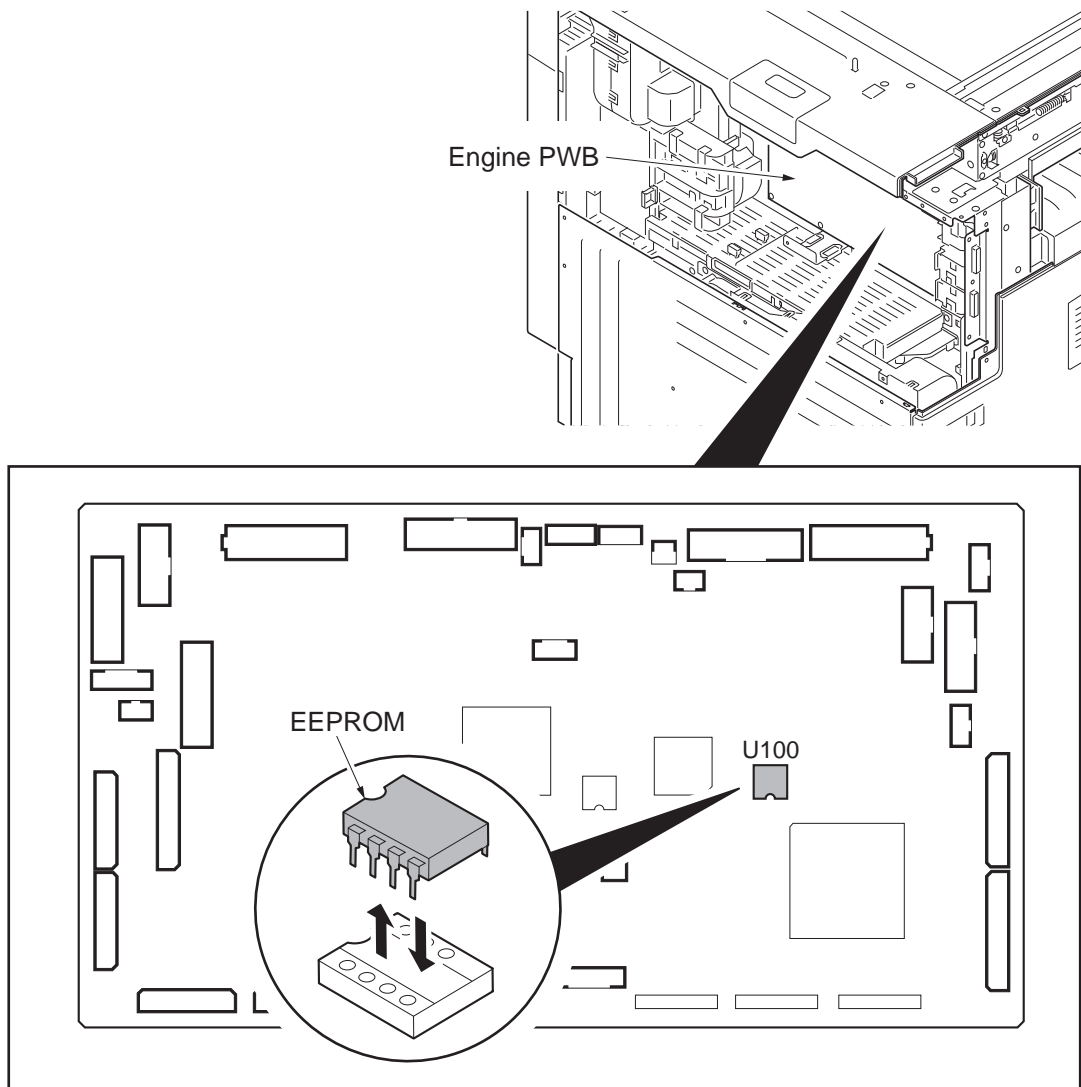
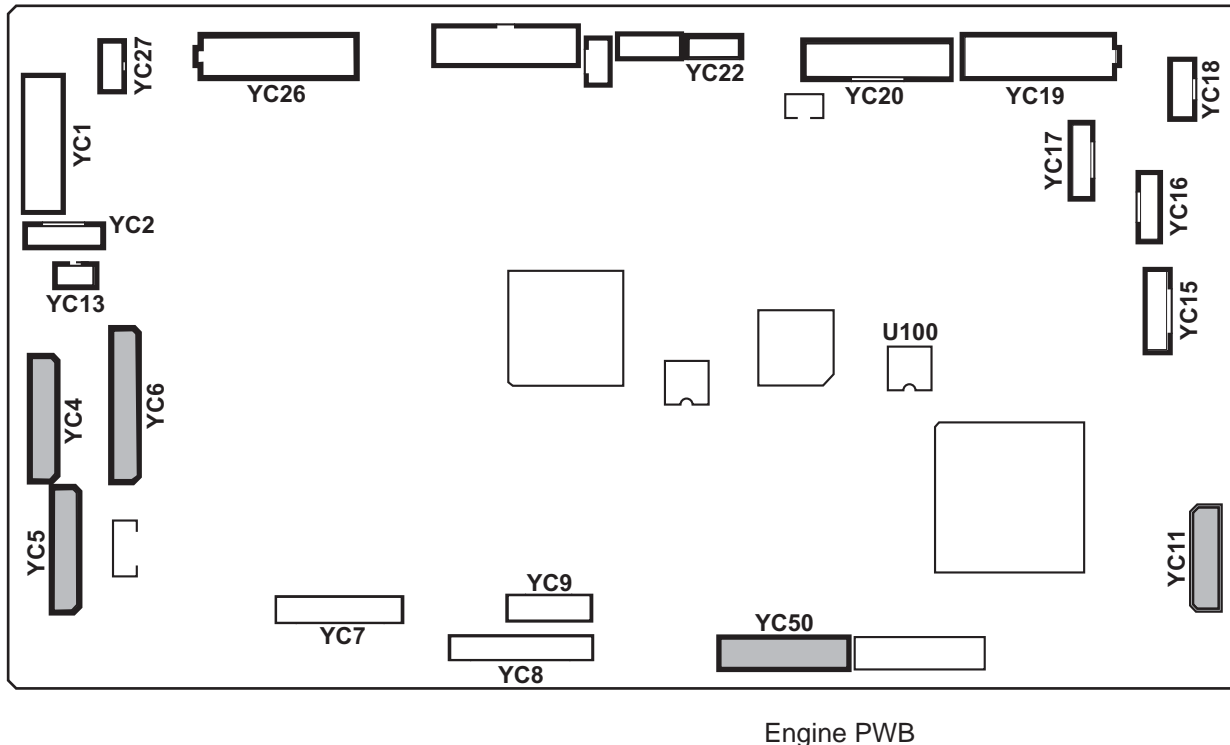


Figure 1-5-110

**(5) Error symptom at an erroneous insertion of the engine PWB FFC**

If an FFC is inserted improperly, the following symptom could be observed:



**Figure 1-5-111**

Engine PWB	Connect PWB	Occurrence
YC6	FEED1	[The cover is open](right cover1) [Machine failluer] (C2300)
YC5	FEED1	[Machine failluer] (C2211) [Paper jam] (JAM4101_15)
YC4	FEED2	[The cover is open] (right cover1) [Machine failluer] (C2500) [Paper jam] (JAM0000_02,03,10,15)
YC11	LSU	[System error] (4101) [Machine failluer] (C4101)
YC46	Main	[System error] (F040)

## (6) Detaching and refitting the power source PWB

### Procedure

1. Remove the rear lower cover (see page 1-5-3).
2. Remove the following nine connectors and three tabs from the power source PWB.  
 YC1  
 YC3  
 YC8  
 YC9  
 YC12  
 YC13  
 YC14  
 YC16  
 YC17  
 TB1  
 TB2  
 TB5

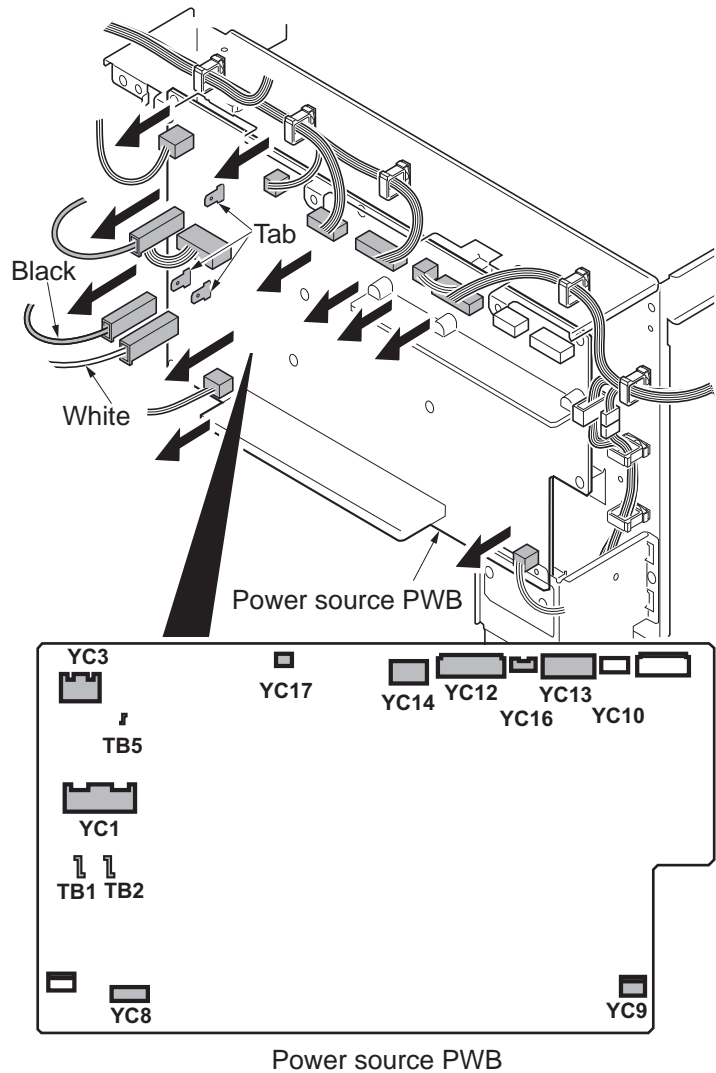


Figure 1-5-112

3. Remove eight screws.
4. Unhook the hook of the board support and then remove the power source PWB.
5. Check or replace the power source PWB and refit all the removed parts.

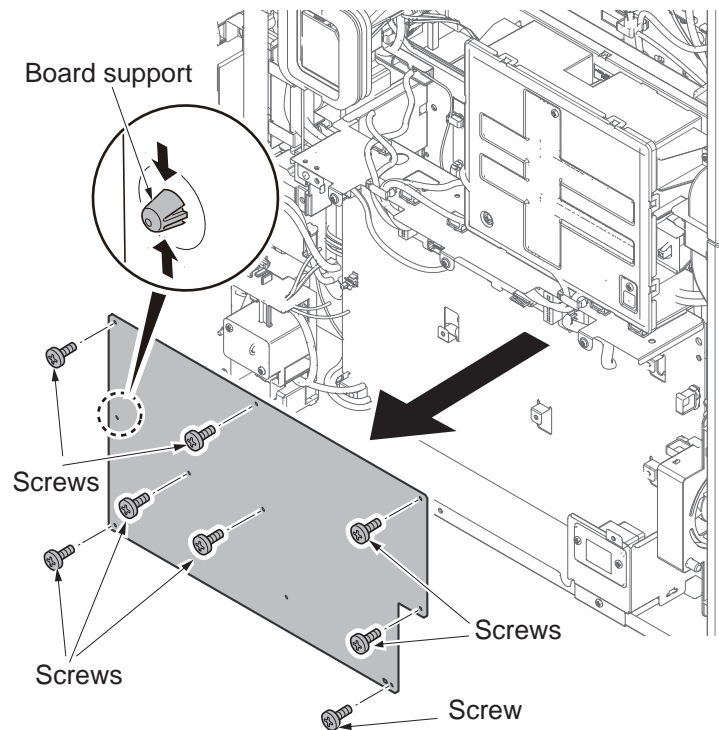


Figure 1-5-113

## (7) Detaching and refitting the power source assembly

### Procedure

1. Remove the connector.
2. Release two wire saddles.

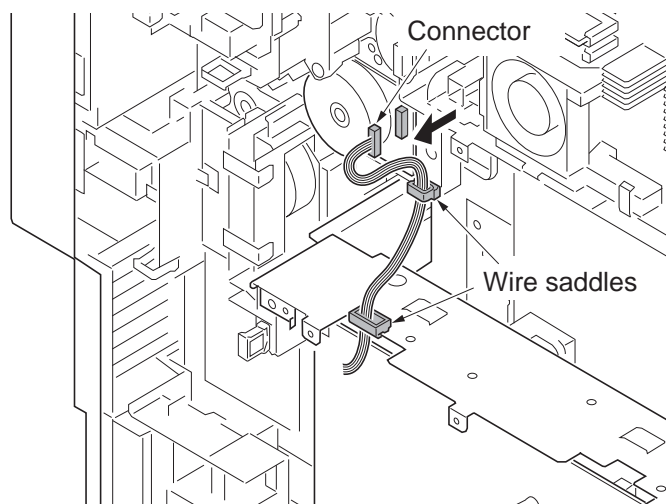
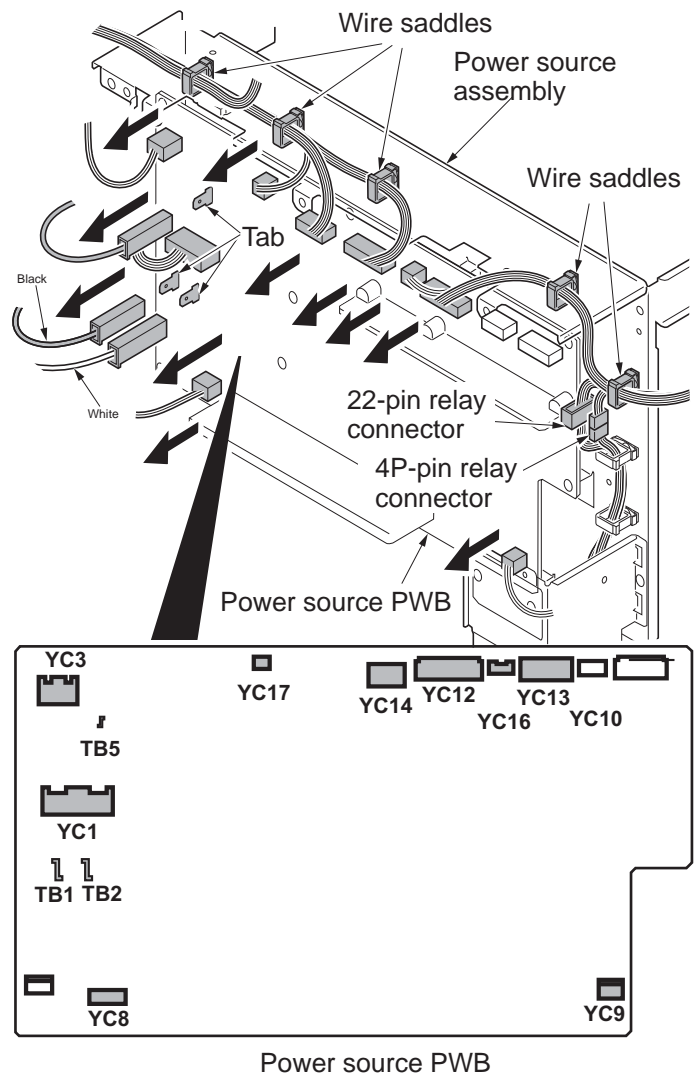


Figure 1-5-114



3. Release six wire saddles.
4. Remove the following nine connectors and three tabs from the power source PWB.
  - YC1
  - YC3
  - YC8
  - YC9
  - YC12
  - YC13
  - YC14
  - YC16
  - YC17
  - TB1
  - TB2
  - TB5

5. Remove 22-pin relay connector and 4-pin relay connector.



Power source PWB

Figure 1-5-115

6. Remove the connector.

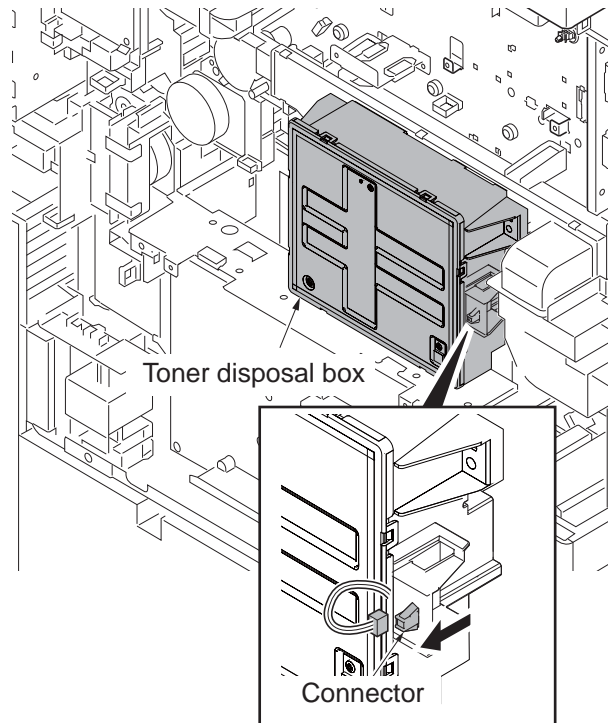


Figure 1-5-116

7. Remove two screws and then remove the toner disposal box.

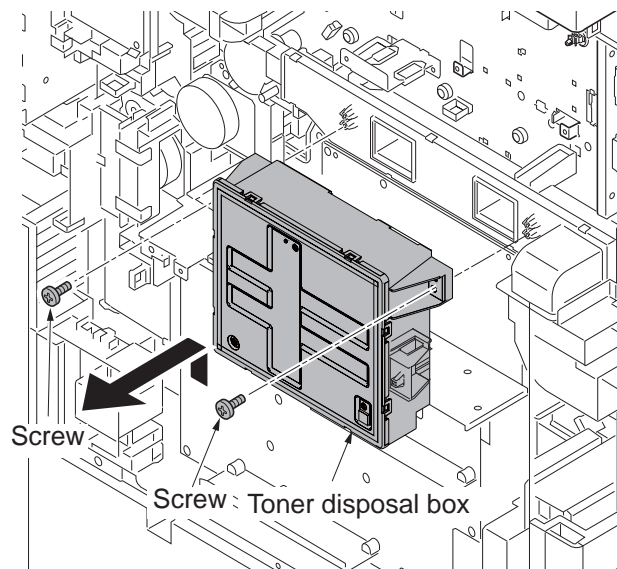
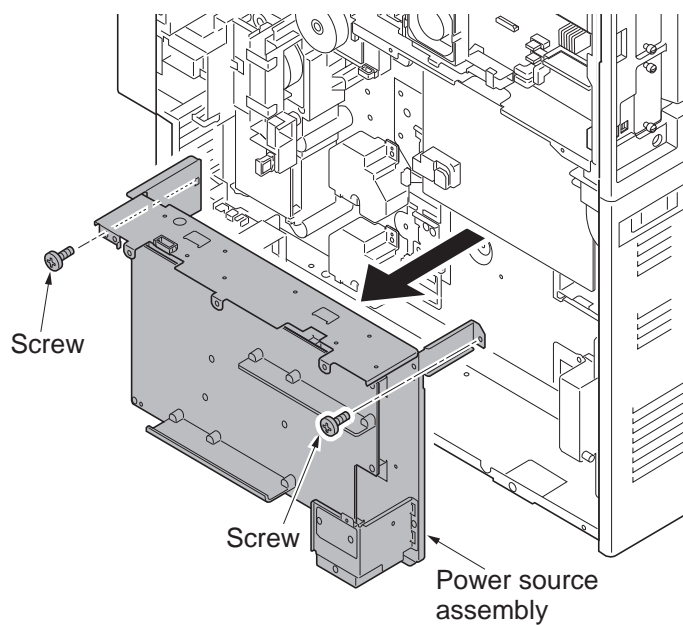


Figure 1-5-117

8. Remove two screws.

9. Remove the toner box.

10. Remove two screws.
11. Remove the power source assembly.
12. Check or replace the power source PWB and refit all the removed parts.



**Figure 1-5-118**

## (8) Detaching and refitting the high voltage PWB

### Procedure

1. Remove the power source assembly (see page 1-5-73).
2. Remove five connectors and four tabs from high voltage PWB.

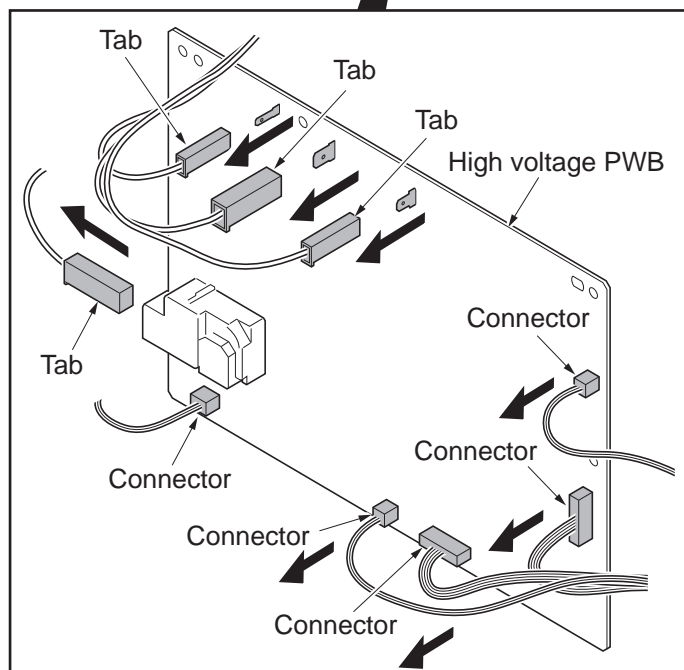
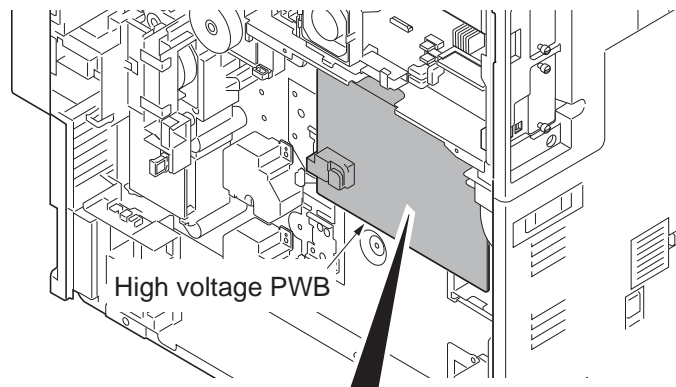


Figure 1-5-119

3. Remove four screws.
4. Unhook two hooks of PWB spacer and then remove the high voltage PWB.
5. Check or replace the high voltage PWB and refit all the removed parts.

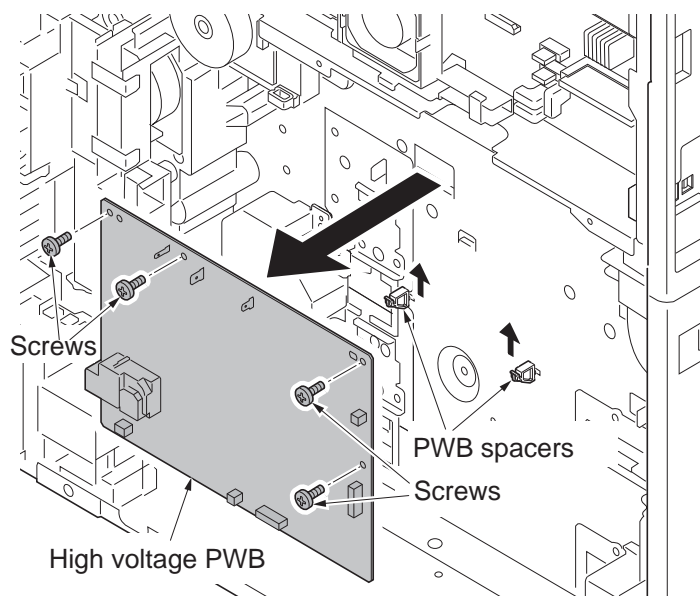


Figure 1-5-120

## (9) Detaching and refitting the operation PWB

### Procedure

1. Remove the original cover or the document processor.
2. Remove two screws and then remove the ISU front cover.
3. Remove two screws and then remove the ISU right cover.

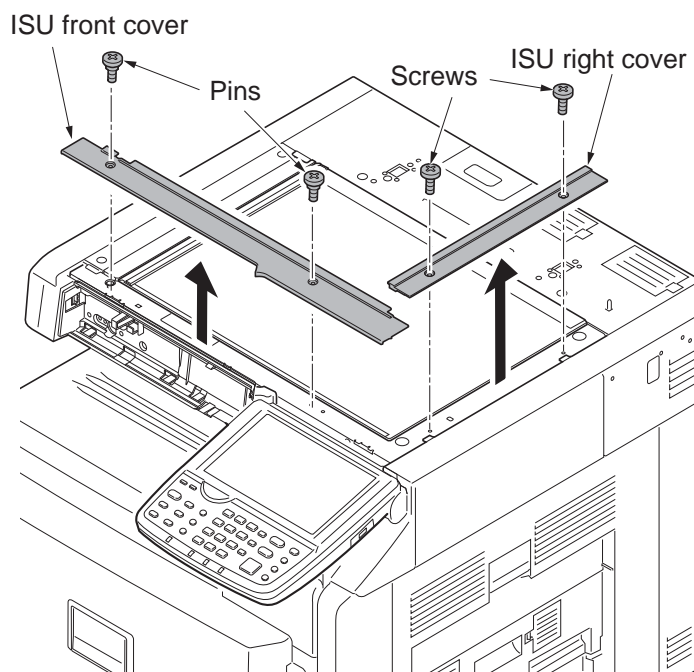


Figure 1-5-121

4. Pull the paper conveying unit out.
5. Remove the screw and five hooks and then remove the right upper cover.
  - \*: Unlatch the stoppers with the rear bottom one first.
  - \*: Unlatch the stoppers with the rear bottom one first.

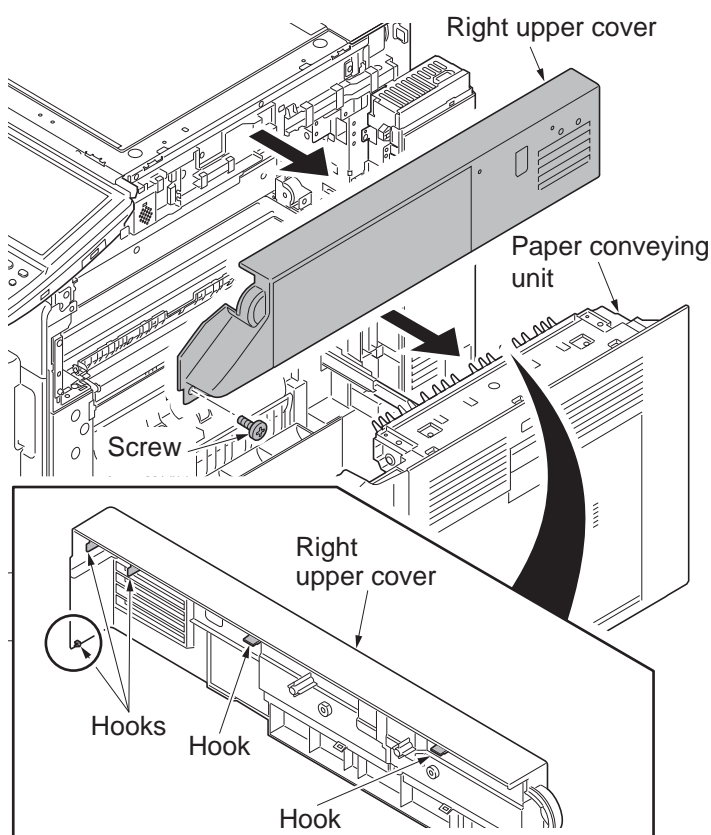


Figure 1-5-122

6. Remove the screw and then remove the operation panel cover.

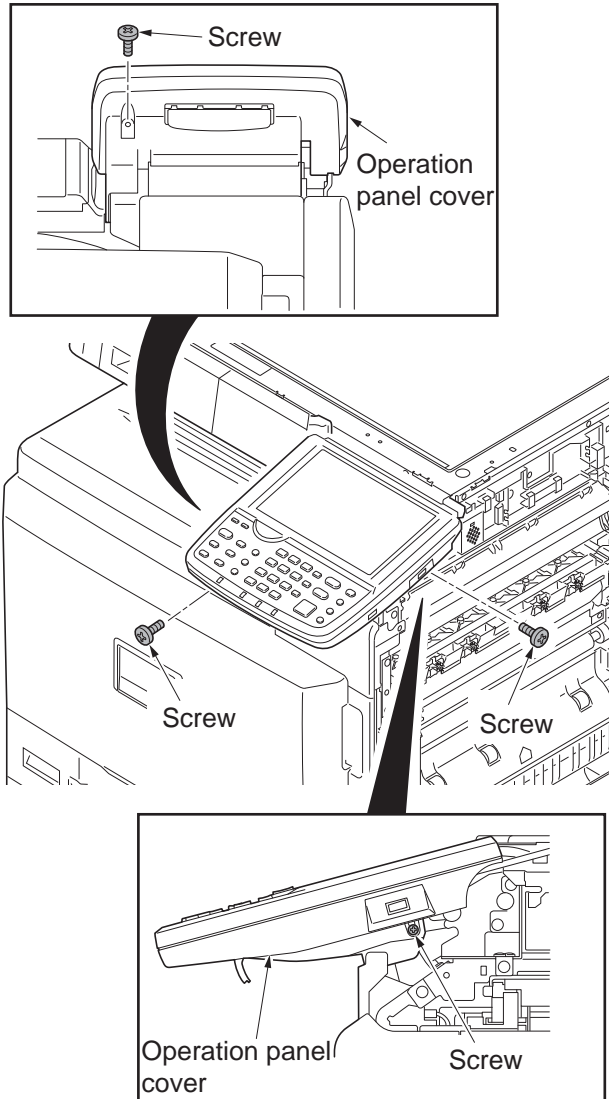


Figure 1-5-123

7. Remove two screws and then remove the USB wire (connector).

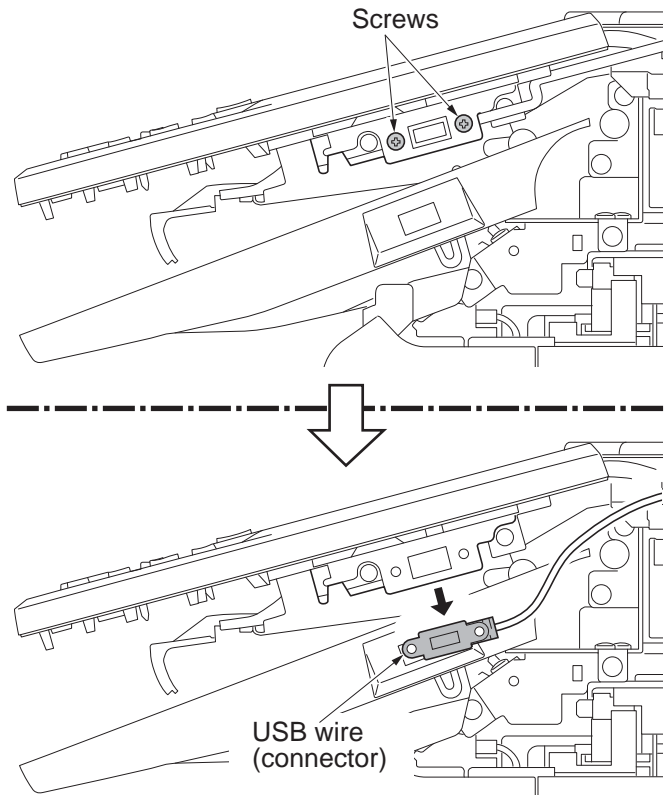


Figure 1-5-124

8. Remove four screws.

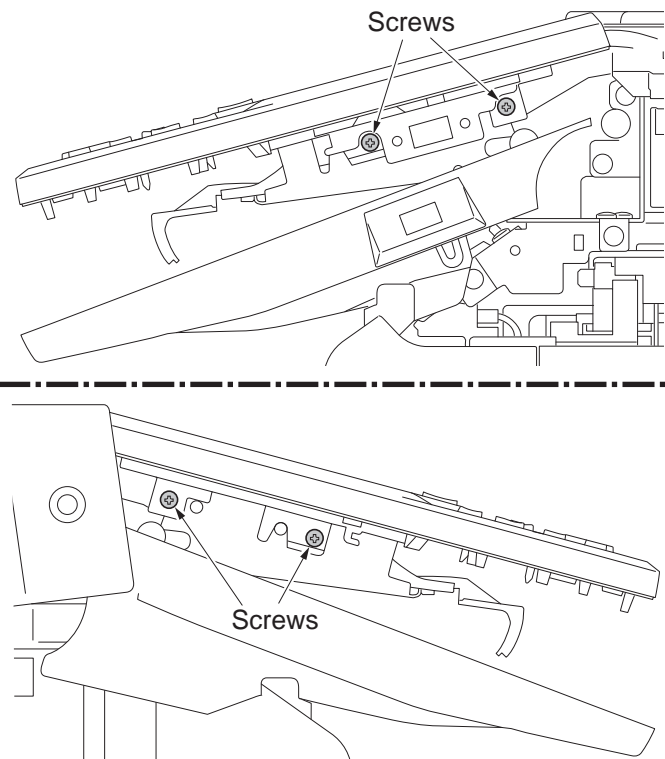


Figure 1-5-125

9. Pull the operation panel unit upward.
10. Release three wire saddles.
11. Remove four connectors from the operation PWB.
12. Remove the operation panel unit.

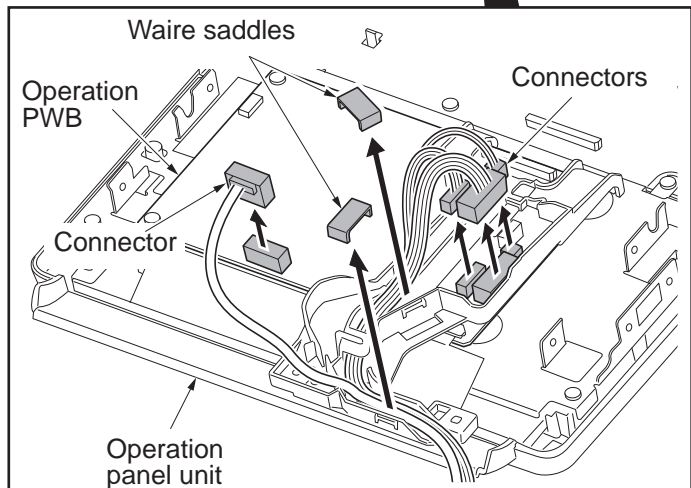
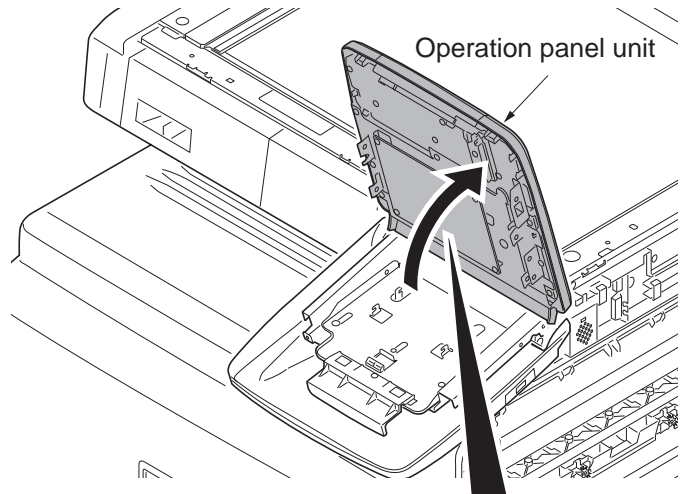


Figure 1-5-126

13. Remove two screws and then remove the wire guide.

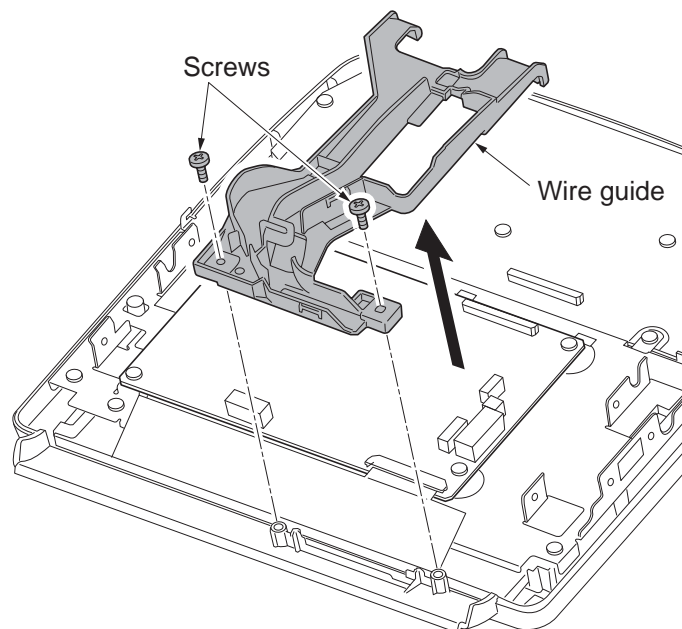


Figure 1-5-127



14. Remove the connectors, two FFC and the FPC from the operation PWB.

\*: To remove the FPC from the locked connector A, unlock the connector by raising the lock lever by 30 degrees. ( FPC: Flexible printed circuits )

15. To remove the FFC from the locked connector B, unlock the connector by sliding the stopper.

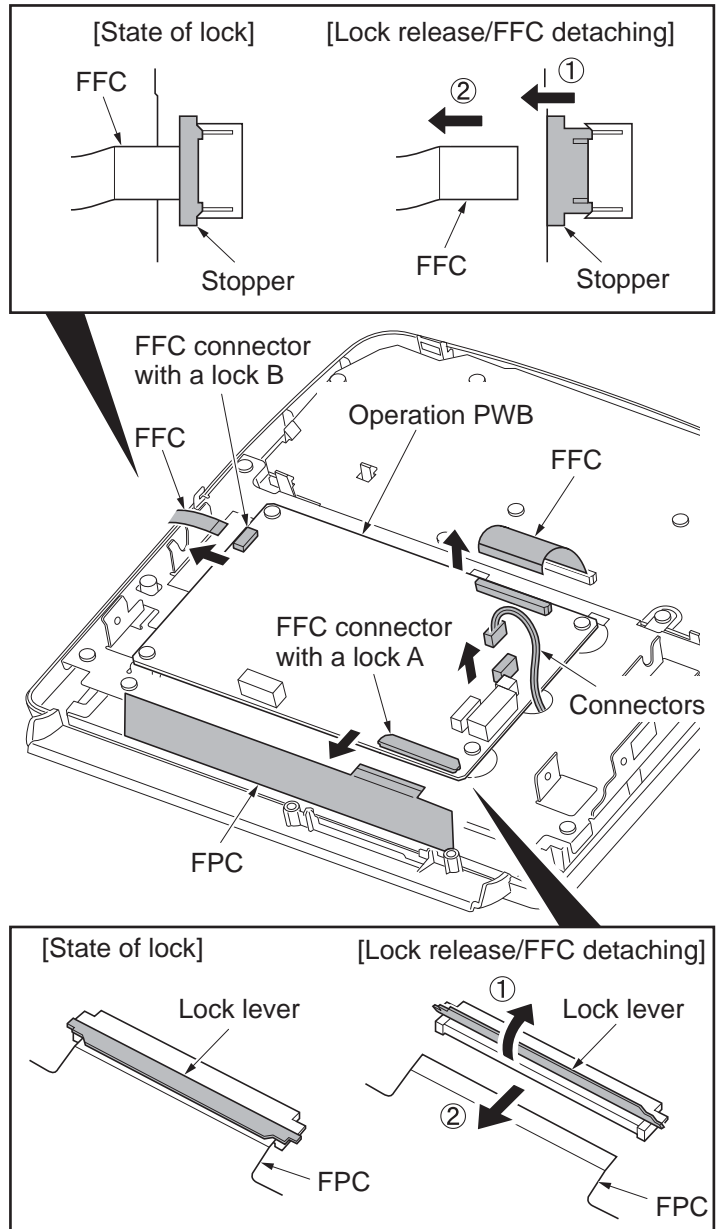
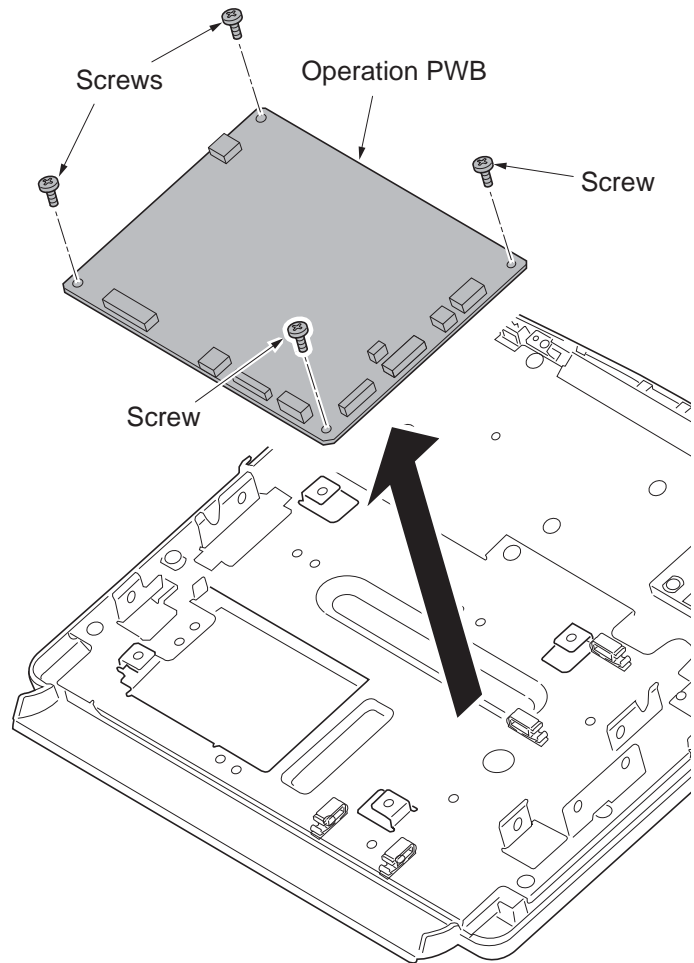


Figure 1-5-128

16. Remove six screws and then remove the operation PWB.
17. Check or replace the operation PWB and refit all the removed parts.



**Figure 1-5-129**

## (10) Detaching and refitting the fuser heater PWB

### Procedure

1. Remove nine screws and then remove the rear upper cover.

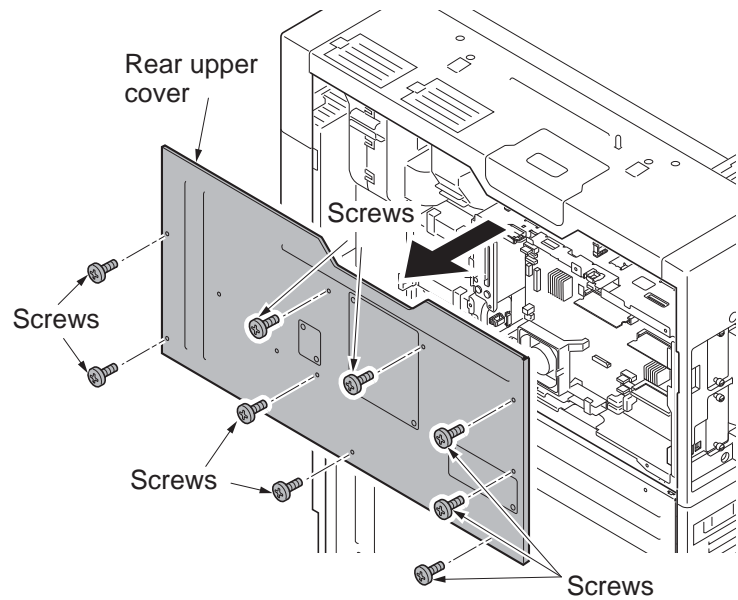


Figure 1-5-130

2. Remove nine screws.
3. Release two hanging parts and then remove the rear lower cover.
4. Remove the fuser unit (see page 1-5-58).

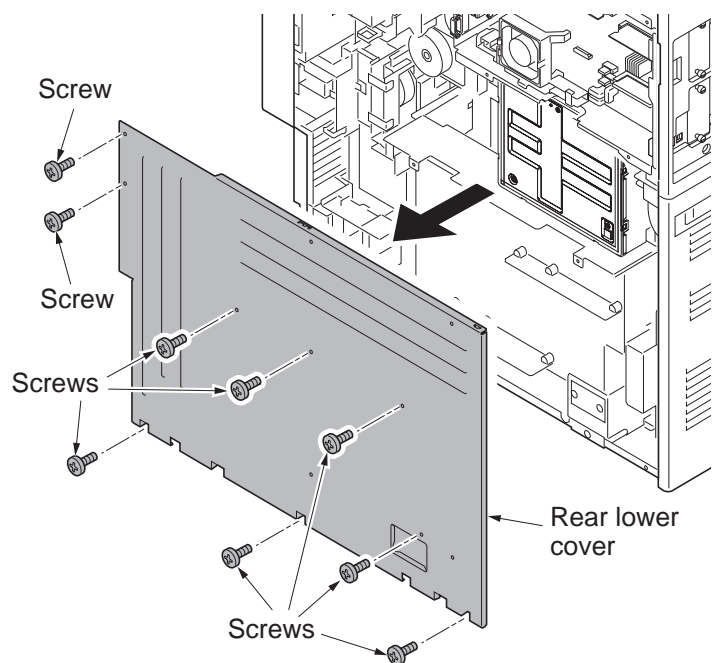


Figure 1-5-131

5. Remove two screws and then remove the ISU right cover.
  6. Remove the screw and five hooks and then remove the right upper cover.
- \*: Unlatch the stoppers with the rear bottom one first.

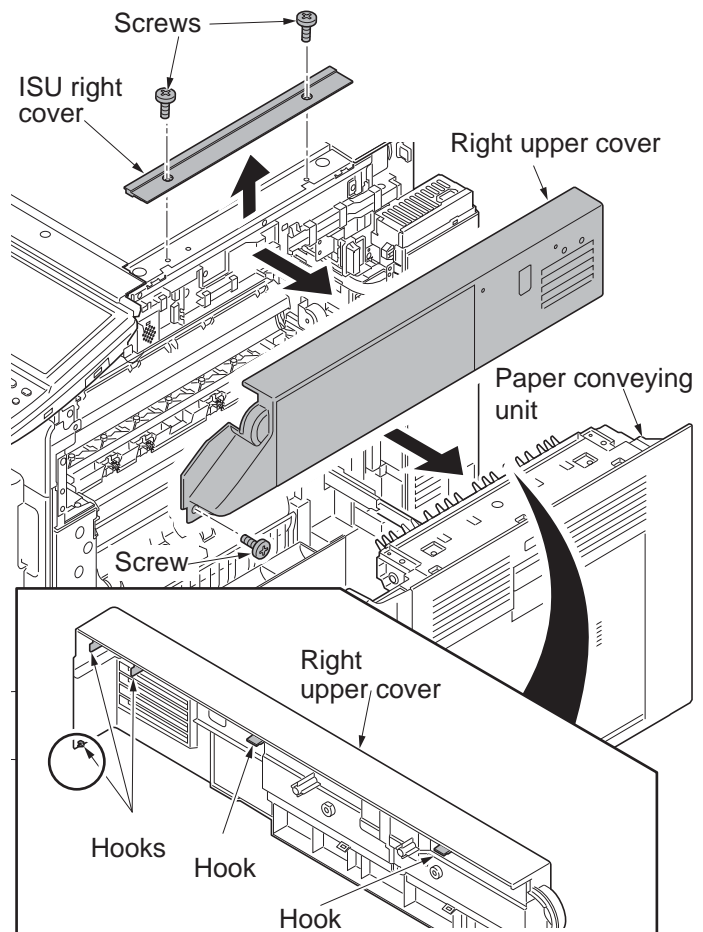


Figure 1-5-132

7. Remove the screw.
8. Unhook two hooks and then remove the right middle rear cover.

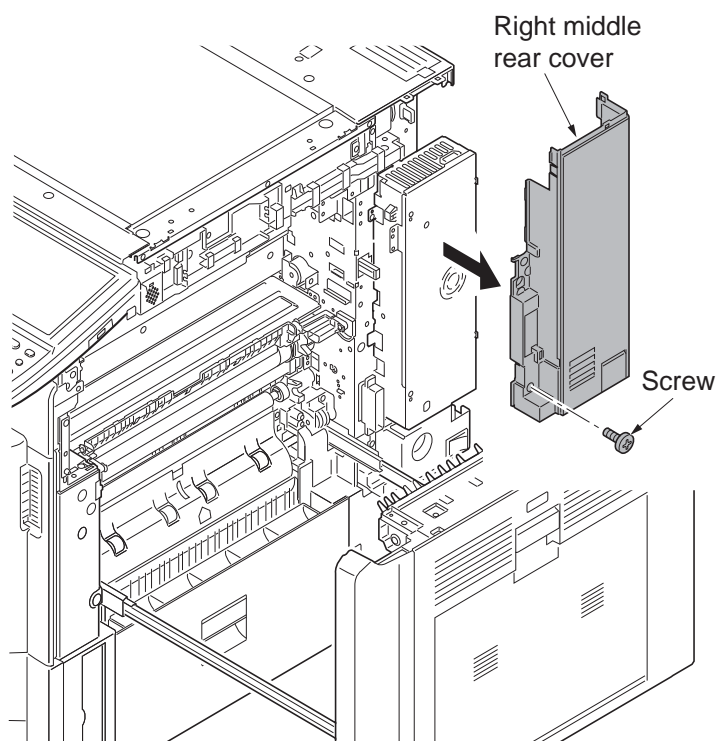
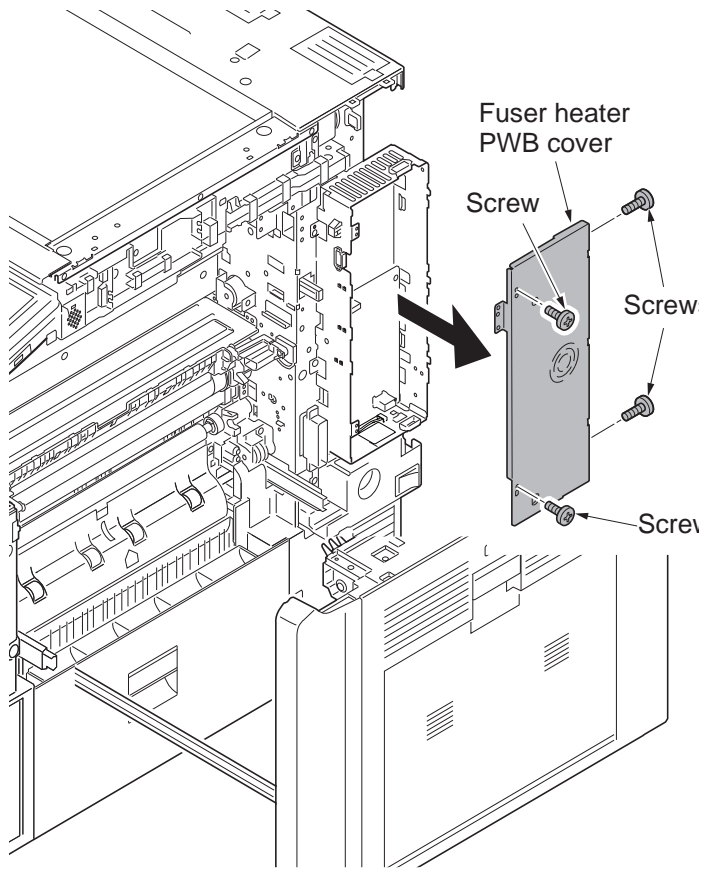


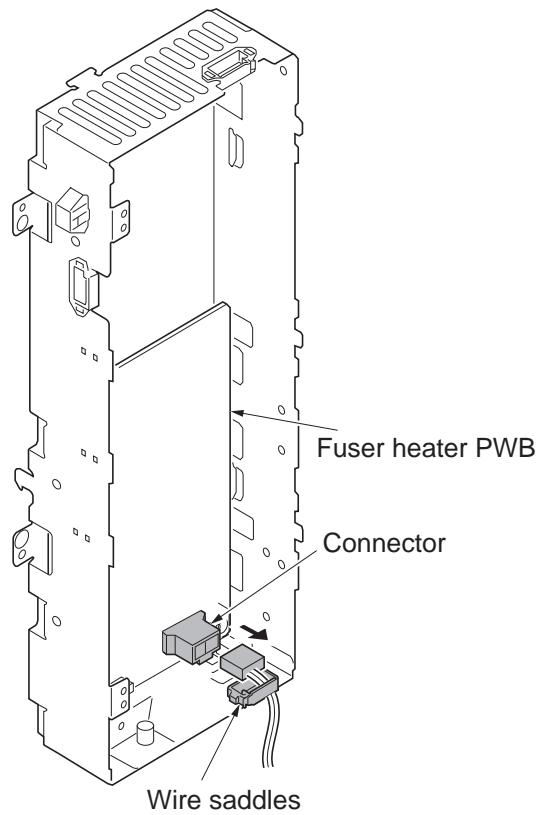
Figure 1-5-133

9. Remove four screws and the remove the fuser heater PWB cover.



**Figure 1-5-134**

10. Release wire saddles.
11. Remove the connector from the fuser heater PWB.



**Figure 1-5-135**

12. Remove two wire holders.
13. Remove the connector (YC27) from feed PWB 1.

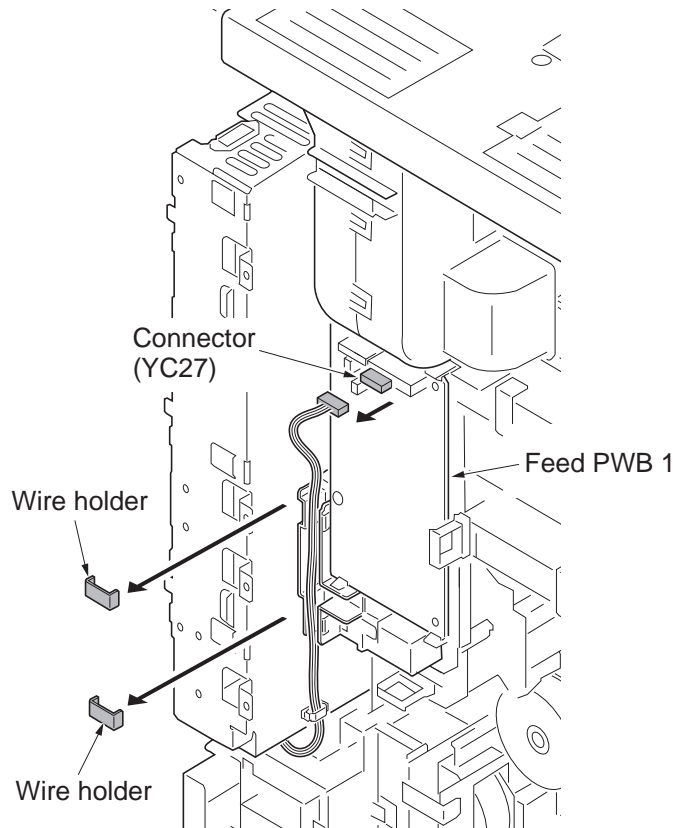


Figure 1-5-136

14. Remove three screws.
15. Unhook two hooks and then remove heater box assembly.

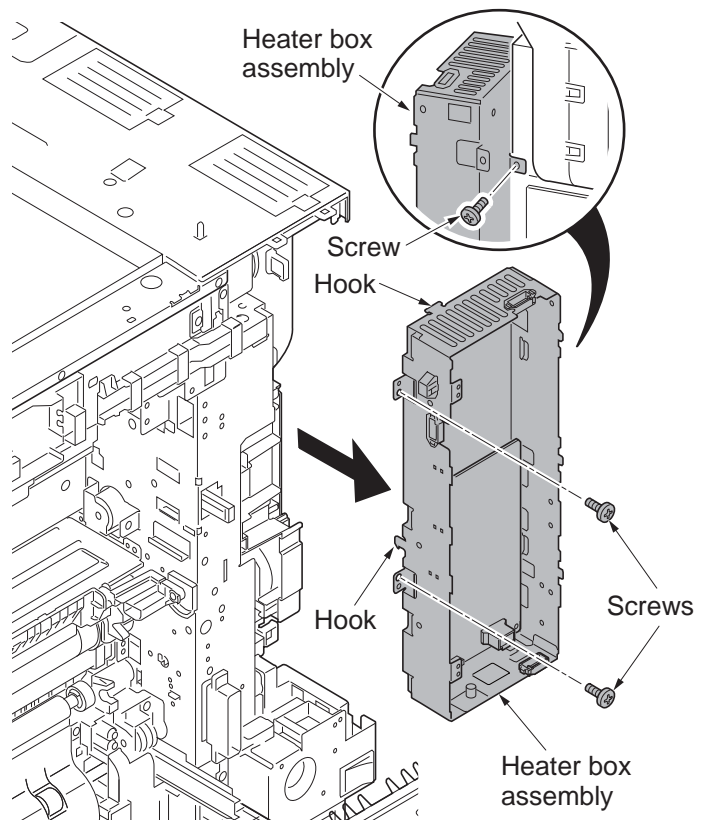
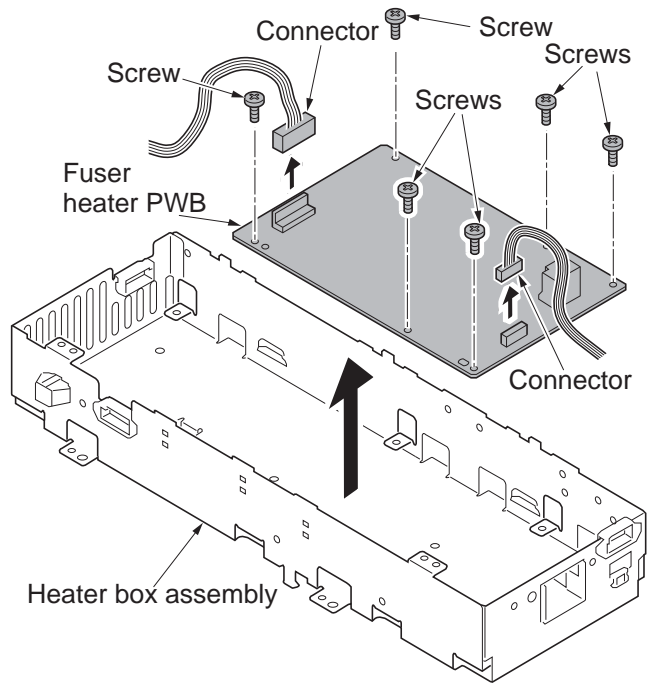


Figure 1-5-137

16. Remove two connectors.
17. Remove six screws and then remove fuser heater PWB.
18. Check or replace the fuser heater PWB and refit all the removed parts.

**Figure 1-5-138**

## 1-5-9 Drive section

### (1) Detaching and refitting the drum drive unit

#### Procedure

1. Remove the developer unit (see page 1-5-47).
2. Remove the drum unit (see page 1-5-48).
3. Remove the rear upper cover and the rear lower cover (see page 1-5-84).
4. Remove the feed PWB 1 assembly (see page 1-5-92).
5. Remove the connector.
6. Release the wire saddle.

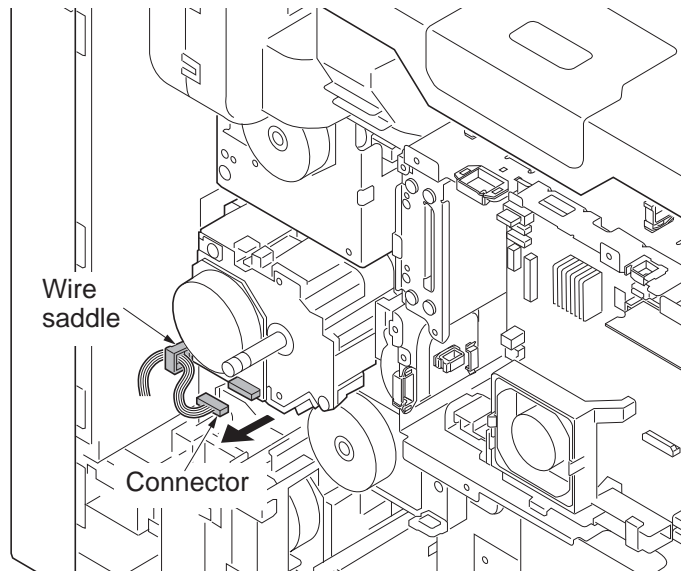


Figure 1-5-139

7. Remove three screws.
  8. Remove the drum drive unit.
- \*: Do not have a shaft part alone when you carry drum drive unit. (Have the housing.)
- \*: Put support on the tip of the shaft so that the shaft may become the horizontal when you put drum drive unit on the table etc.

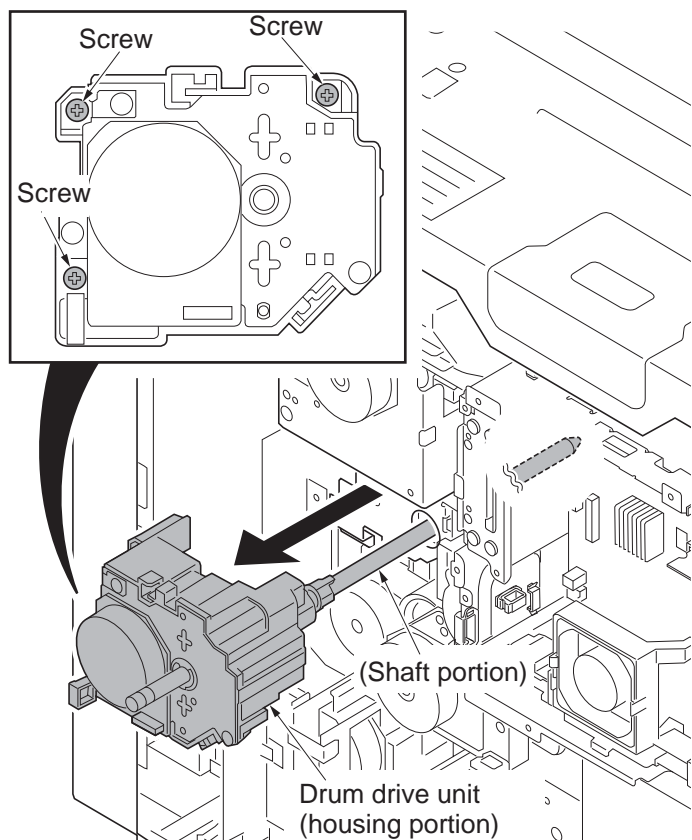
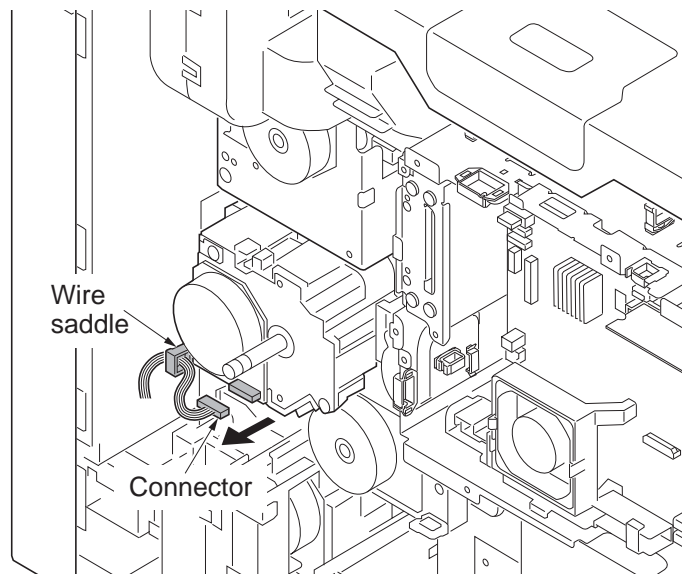


Figure 1-5-140



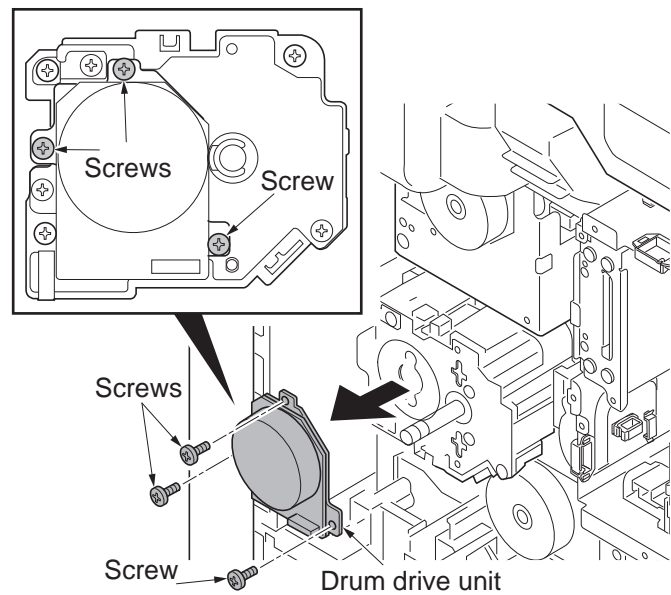
### Detaching the drum motor

1. Remove the rear upper cover and the rear lower cover (see page 1-5-84).
2. Remove the connector.
3. Release the wire saddle.



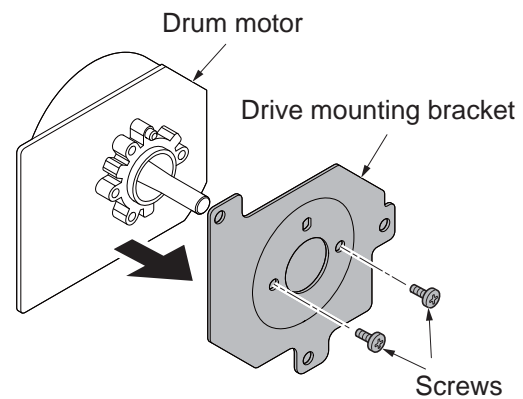
**Figure 1-5-141**

4. Remove three screws.
5. Remove the drum drive unit.



**Figure 1-5-142**

6. Remove two screws.
7. Remove the drive mounting bracket K.



**Figure 1-5-143**

## (2) Detaching and refitting the developer drive unit

### Procedure

1. Remove the rear upper cover and the rear lower cover (see page 1-5-84).
2. Unhook four hooks and then remove the duct.

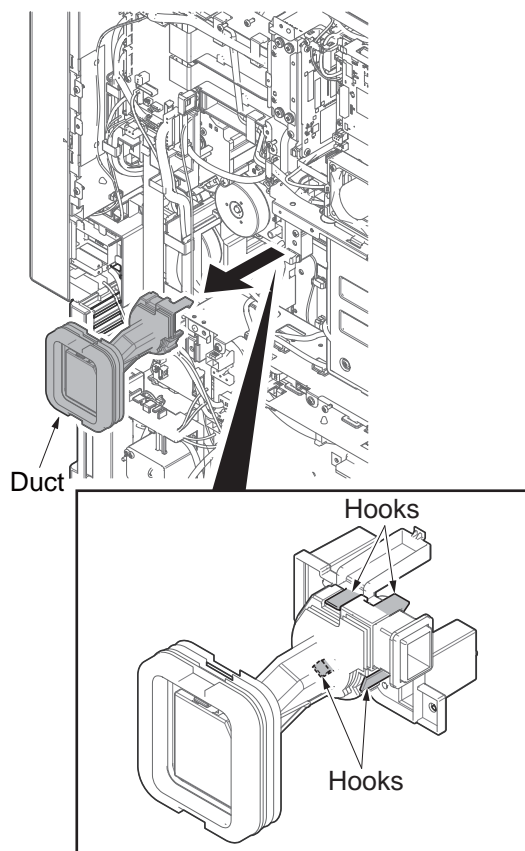


Figure 1-5-144

3. Remove the connector.
4. Release the wire saddle.
5. Remove two screws and then remove the developer drive unit.
6. Check or replace the developer drive unit and refit all the removed parts.

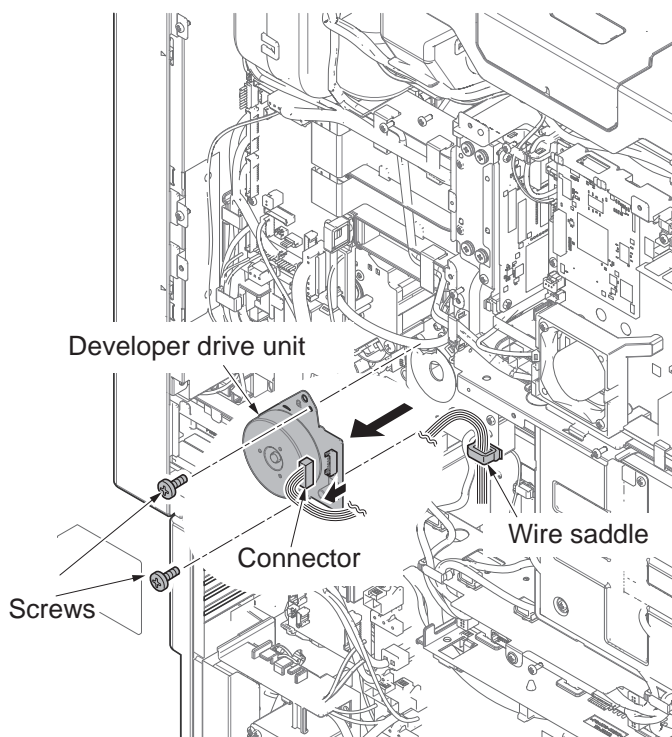


Figure 1-5-145

### (3) Detaching and refitting the fuser drive unit and feed drive unit

#### Procedure

##### Detaching the fuser drive unit

1. Remove the rear upper cover and the rear lower cover (see page 1-5-84).
2. Remove five wire holders of feed PWB 1 assembly.
3. Release two wire saddles.

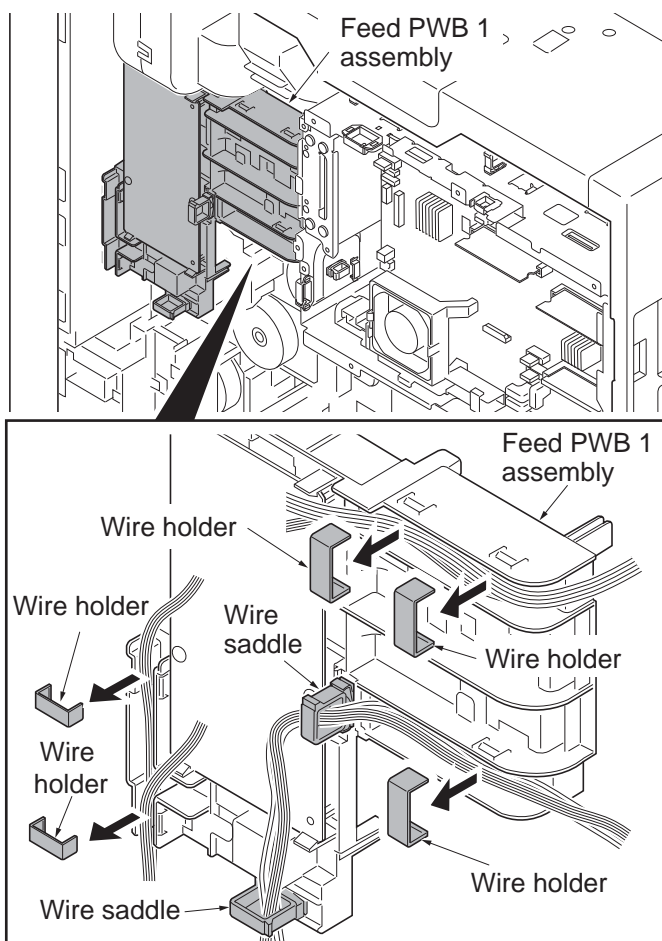


Figure 1-5-146

4. Remove the following twenty one connectors from the feed PWB 1.

YC18, YC19

YC20, YC27

YC26, YC3

YC17, YC14

YC16

YC13, YC12

YC23, YC25

YC15, YC11

YC5, YC4

YC1 (Connector type FFC)

YC2 (Connector type FFC)

YC8

YC9

- \*: Before removing the connector type FFCs of YC1 and YC2, unlock the lock by pressing the lock lever in its center.

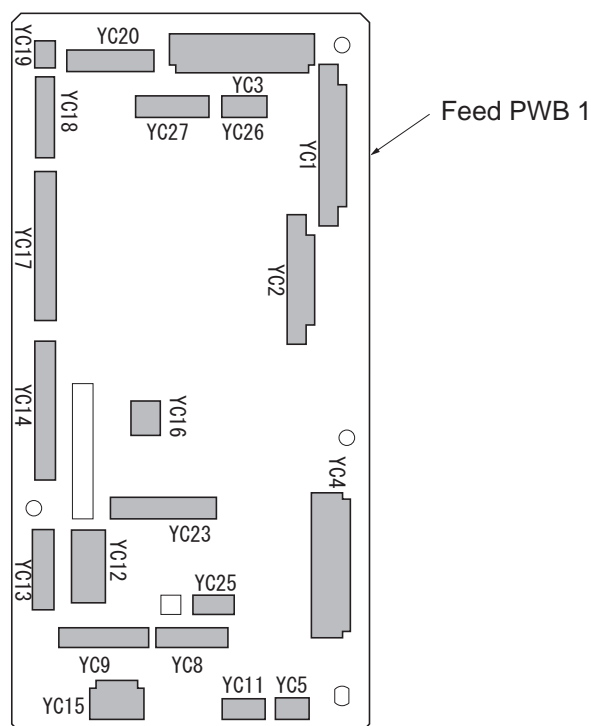
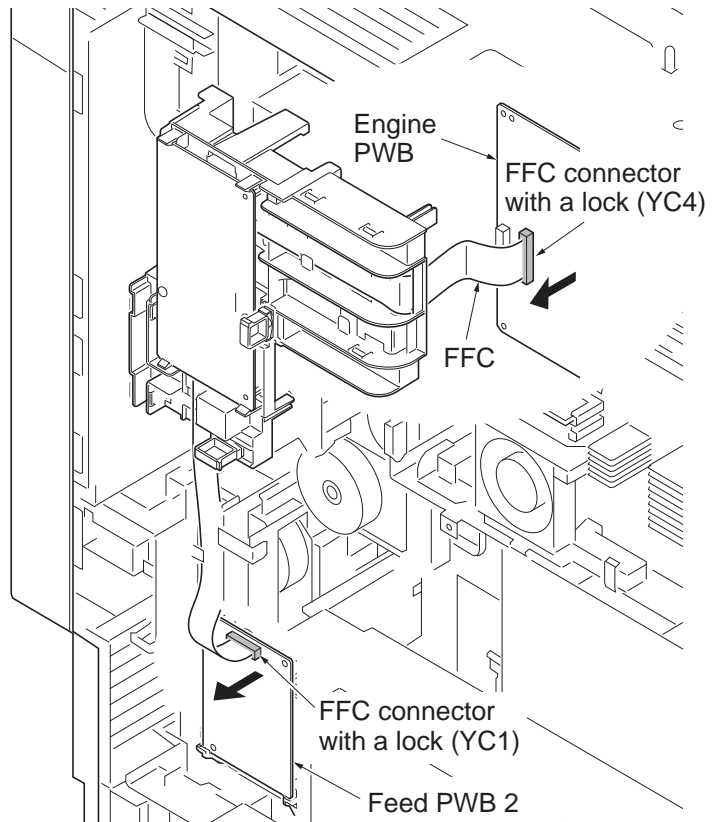


Figure 1-5-147

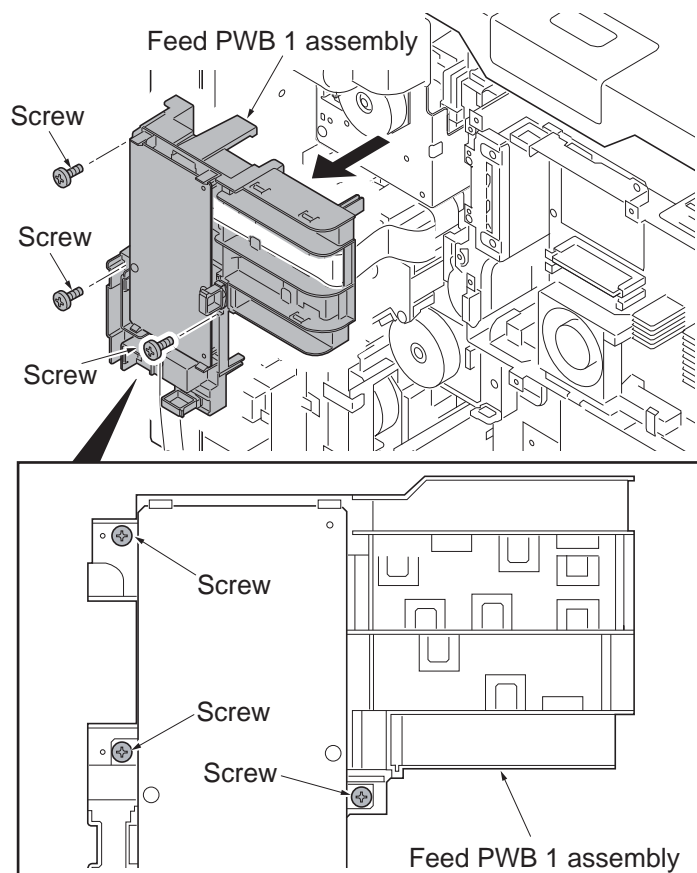
5. Remove the connector type FFC from the FFC connector (YC4) on the engine PWB.  
Remove the connector type FFC from the FFC connector (YC1) on the feed PWB 2.

\*: Before removing the connector type FFCs, unlock the lock by pressing the lock lever in its center.



**Figure 1-5-148**

6. Remove three screws.
7. Remove the feed PWB 1 assembly.



**Figure 1-5-149**

8. Remove the connector.
9. Remove three screws.
10. Remove the fuser drive unit.

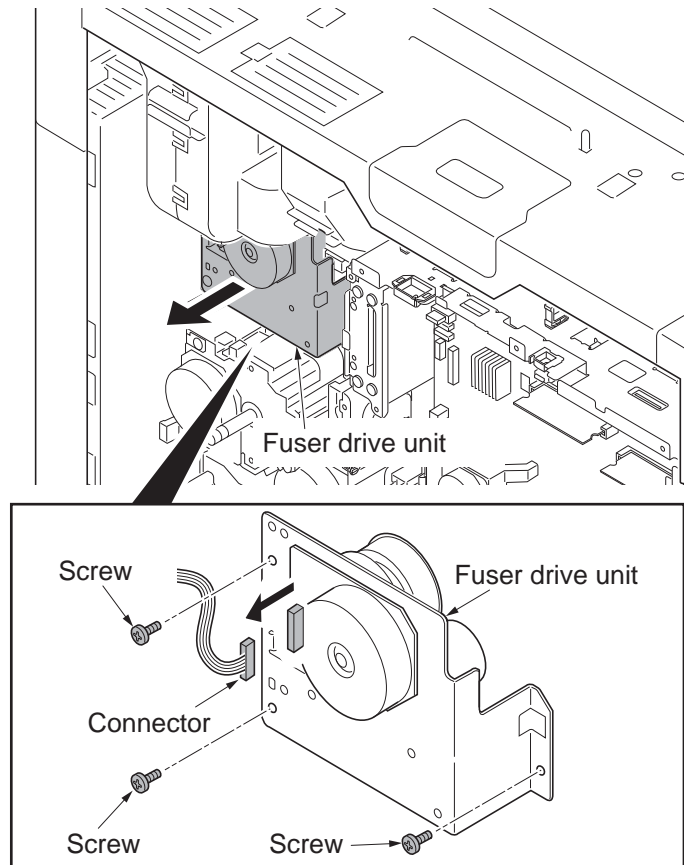


Figure 1-5-150

#### Detaching the feed drive unit

11. Remove three wire holders from the feed 2 FFC guide.

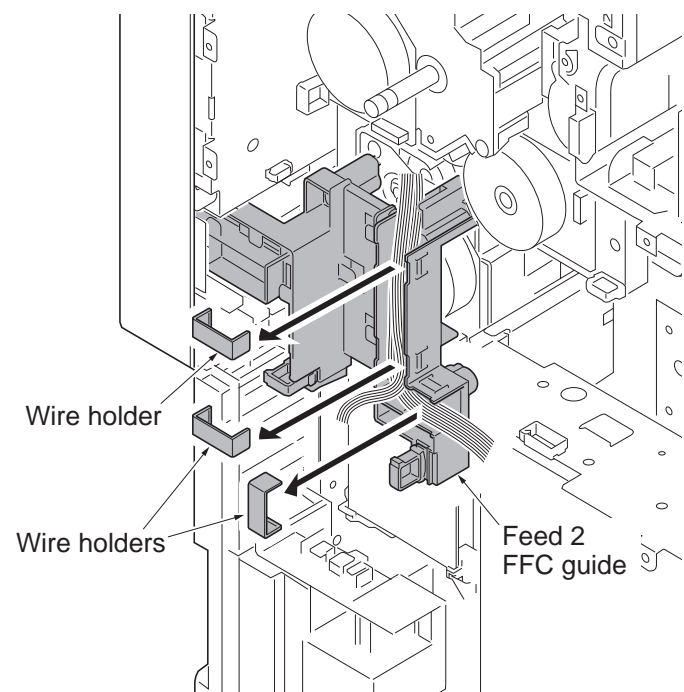


Figure 1-5-151

12. Remove two screws and then remove the feed 2 FFC guide.

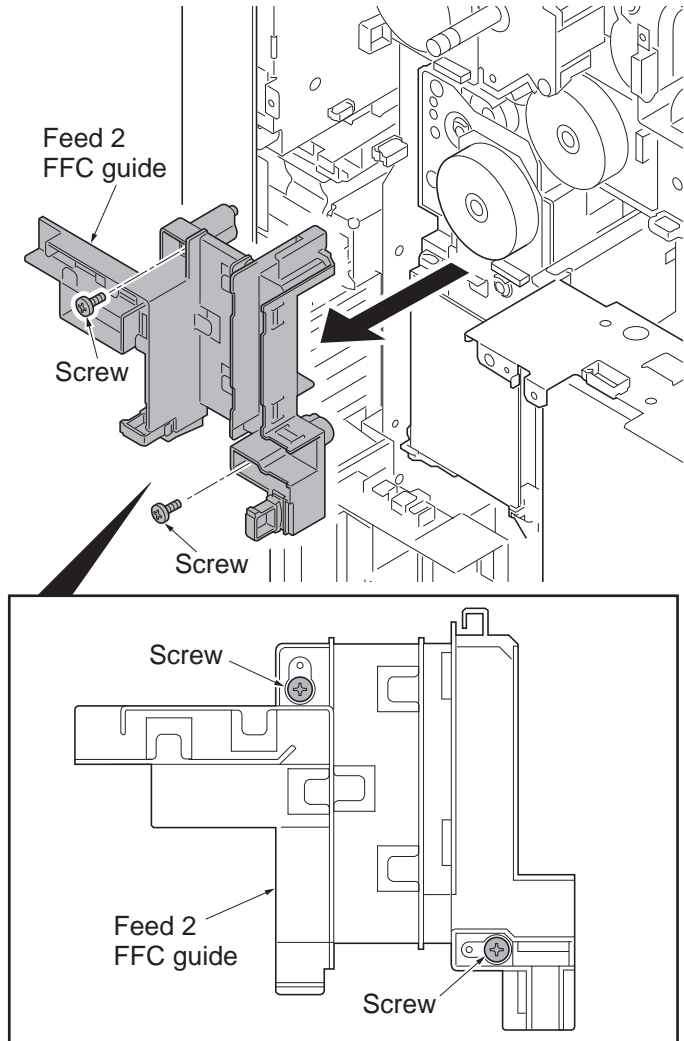


Figure 1-5-152

13. Remove the following five connectors from the feed PWB 2.

- YC7
- YC8
- YC3
- YC5
- YC6

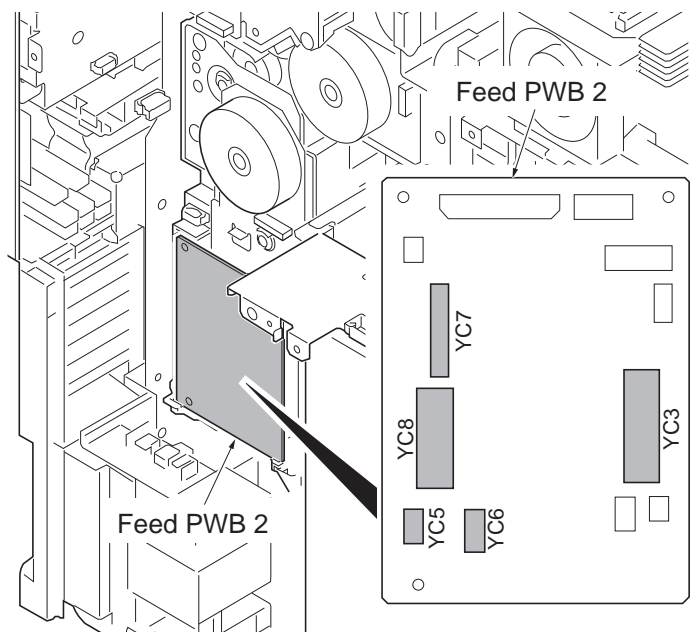


Figure 1-5-153

- 14. Remove three screws.
- 15. Remove the feed drive unit.

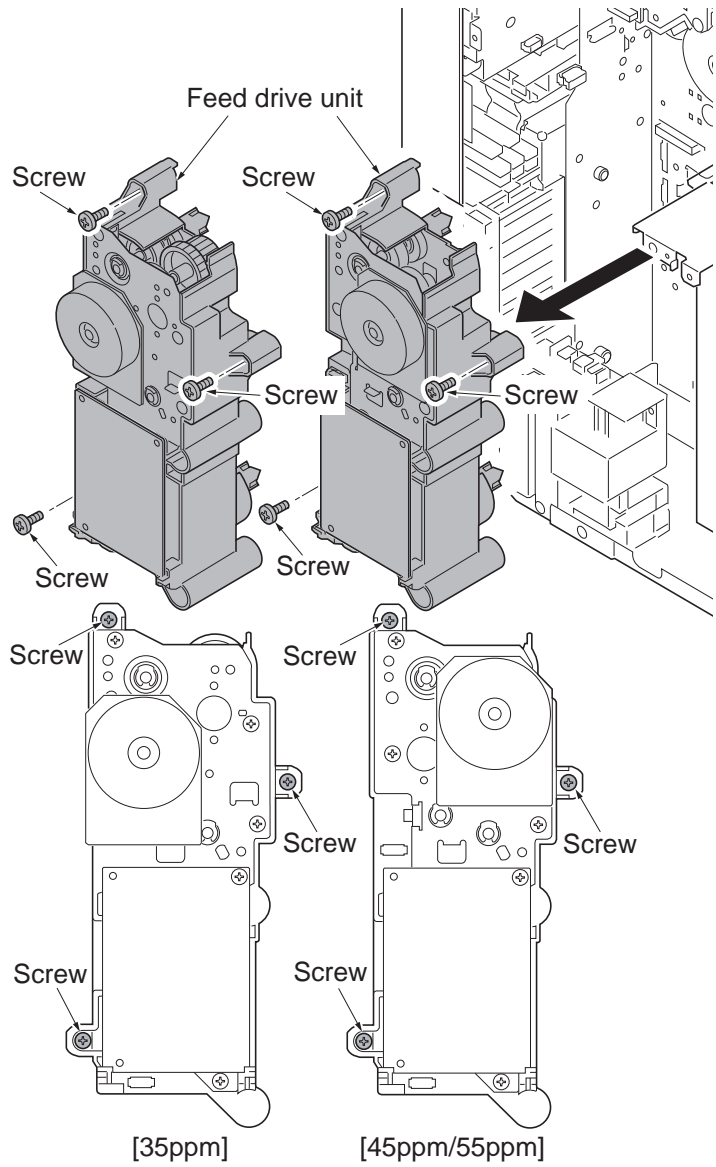


Figure 1-5-154

16. Check or replace the feed drive unit and refit all the removed parts.

\*: Connect the connector (yellow) to the connector of paper feed clutch 1 on stamp [YELLOW] side as before, when removing the connector of the paper feed clutch as the check of the feed drive unit etc.

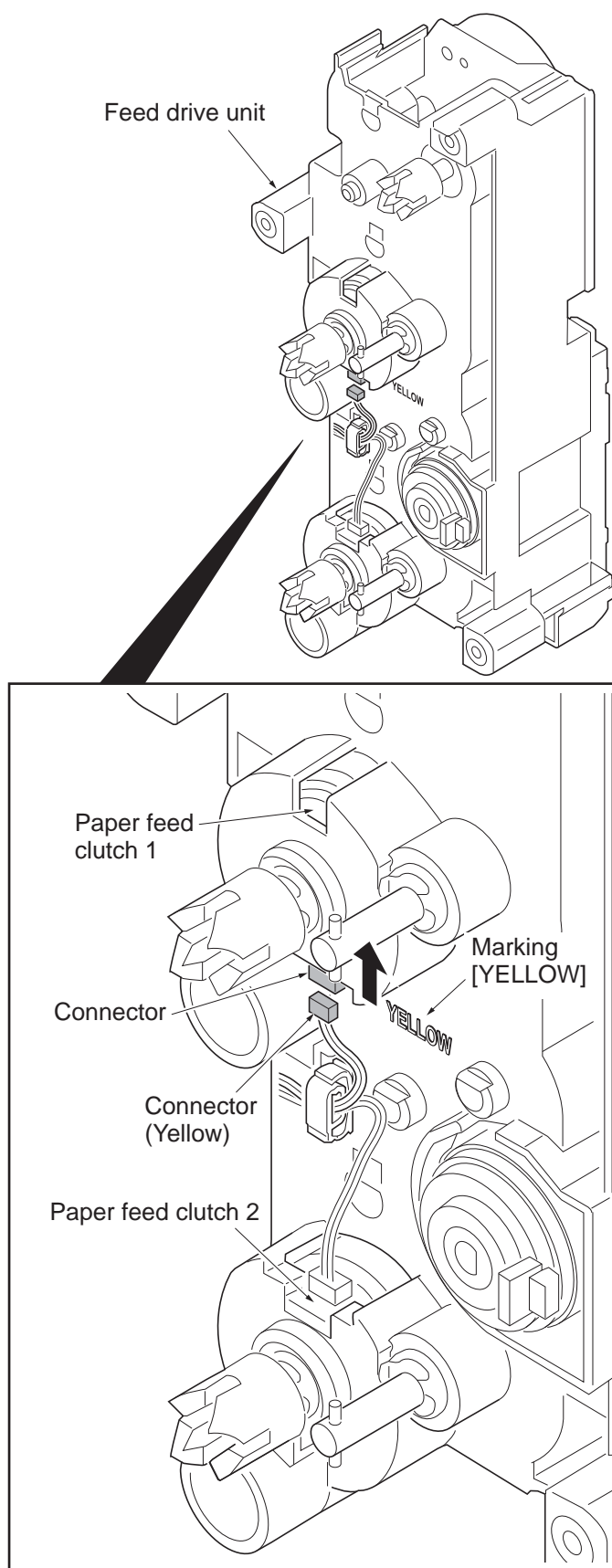


Figure 1-5-155



## (4) Detaching and refitting the lift motor 1 and 2

### Procedure

1. Remove the power source assembly (see page 1-5-73).
2. Remove the connector each.
3. Remove two screws each.
4. Remove the lift motor 1 and 2.
5. Check or replace the lift motor and refit all the removed parts.

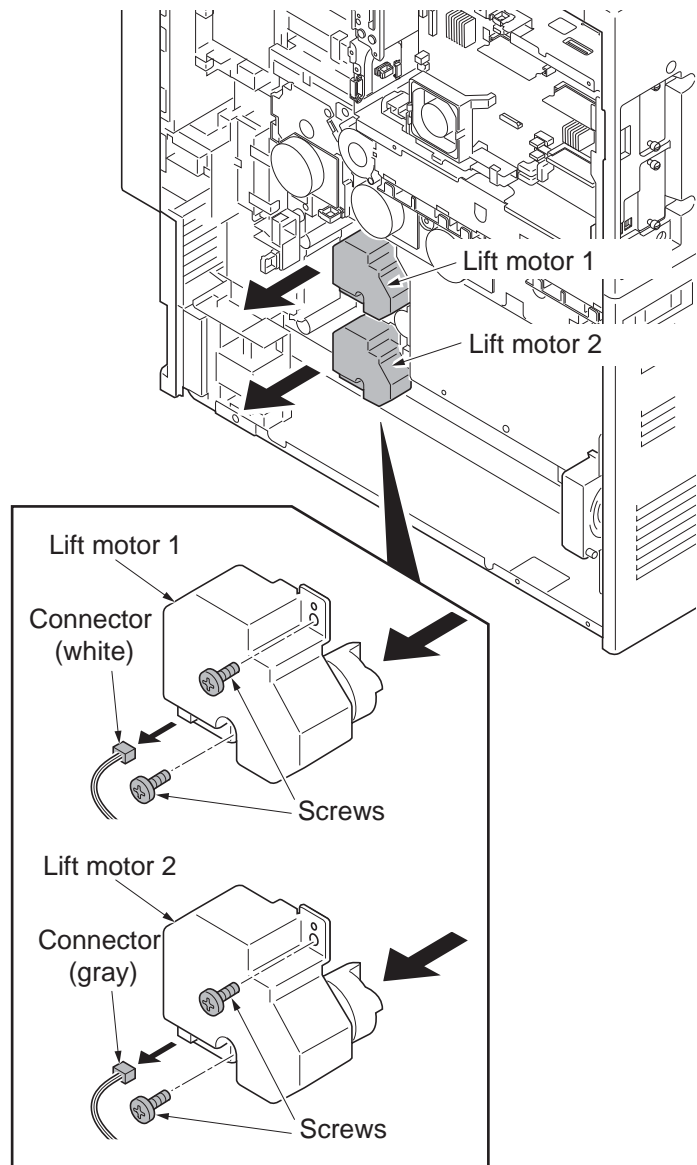


Figure 1-5-156

## 1-5-10 Others

### (1) Detaching the eject filter

#### Procedure

1. Unhook the hook each and remove two eject filter units.
2. Remove the eject filter from the eject cover.
3. Clean or replace the eject filter and refit the filter.

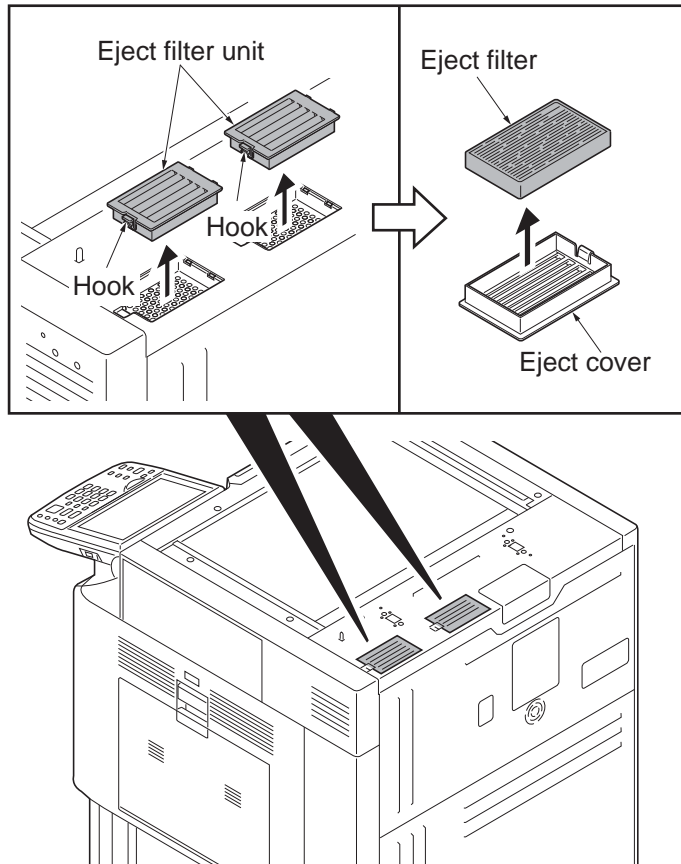


Figure 1-5-157

## (2) Detaching and refitting the toner filter

### Procedure

1. Remove the toner filter unit while gripping the levers.
2. Clean or replace the toner filter unit and refit the filter.

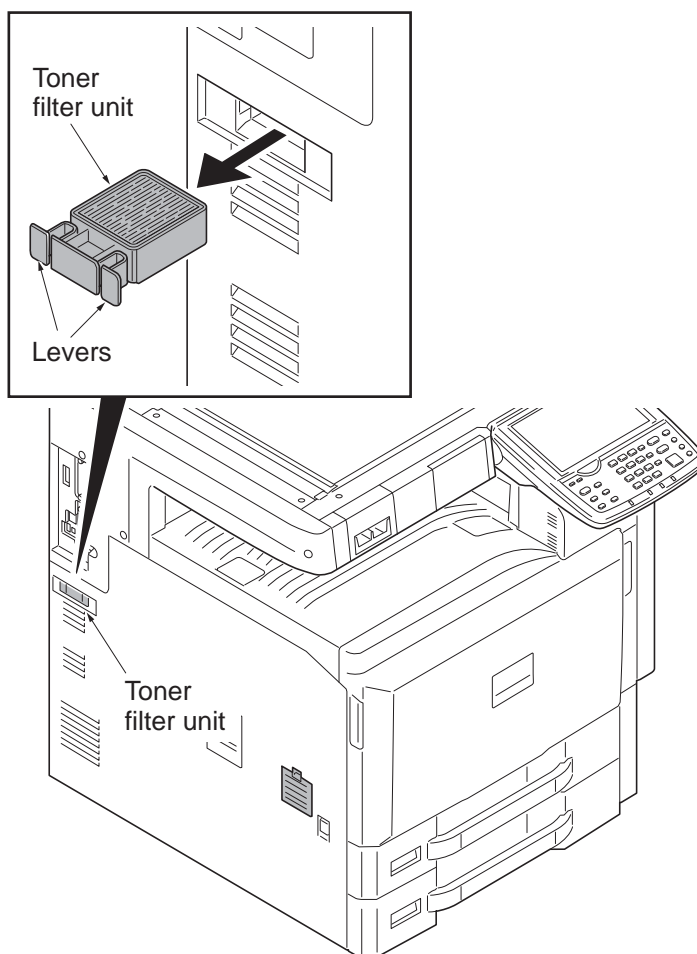


Figure 1-5-158

### (3) Detaching and refitting the left filter

#### Procedure

1. Remove the left filter cover and left filter by releasing the lever.
2. Clean or replace the left filter and refit the filter.

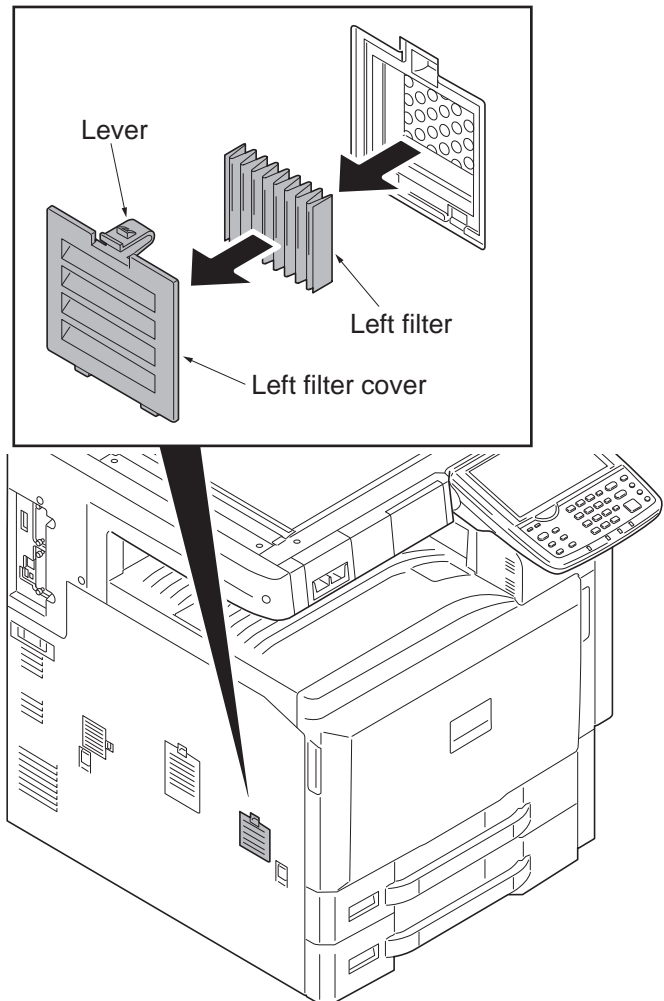


Figure 1-5-159

#### (4) Detaching and refitting the LSU filter and belt filter

##### Procedure

##### LSU filter

1. Remove the LSU filter by releasing the lever.
2. Clean or replace the LSU filter and refit the filter.

##### Belt filter

1. Remove the Belt filter by releasing the lever.
2. Clean or replace the Belt filter and refit the filter.

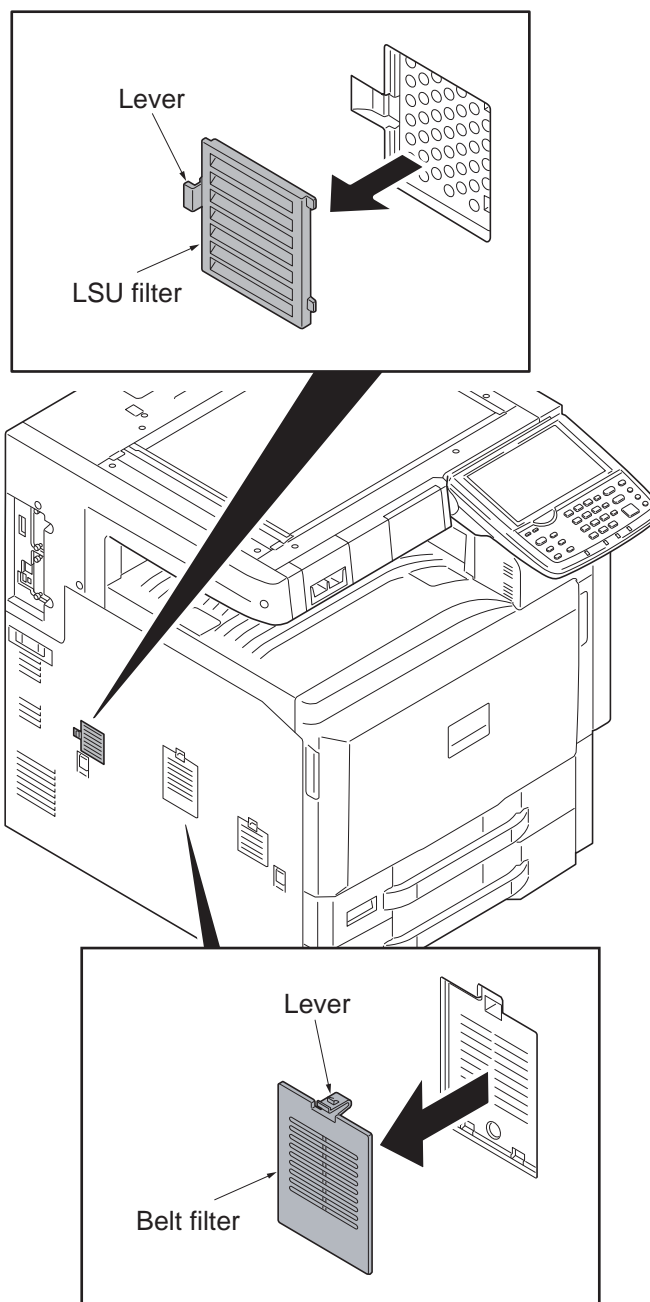


Figure 1-5-160

## (5) Detaching and refitting the drum filter and developer filter

### Procedure

1. Open the front cover.
2. Remove the drum filter and developer filter by releasing the lever.
3. Clean the drum filter and developer filter and refit the filter.

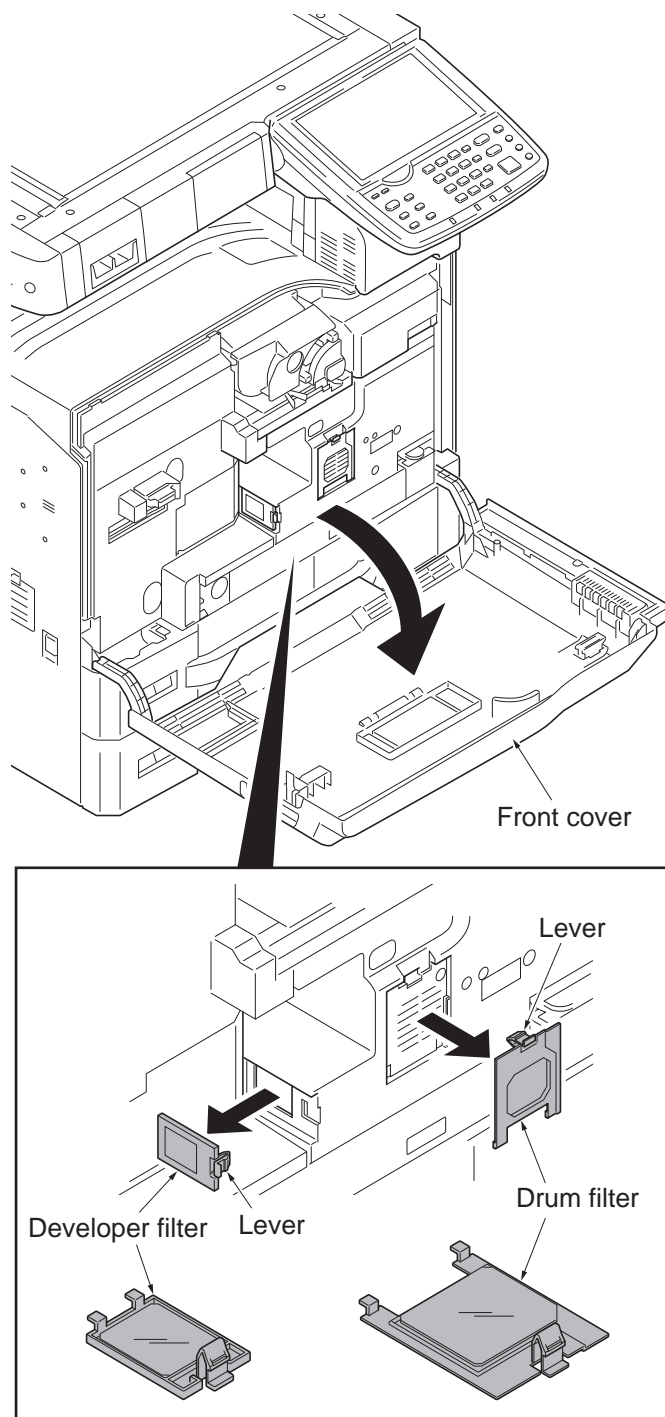


Figure 1-5-161

## (6) Detaching and refitting the toner disposal box

### Procedure

1. Remove the rear lower cover (see page 1-5-84).
2. Remove the connector.

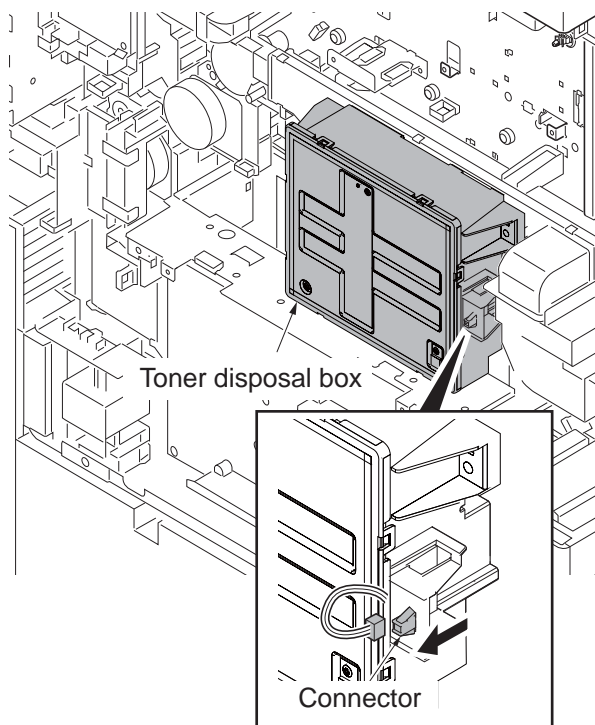


Figure 1-5-162

3. Remove two screws and then remove the toner disposal box.

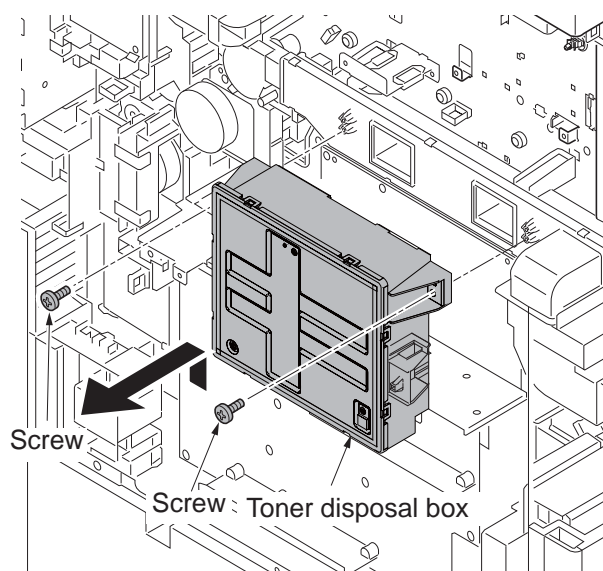


Figure 1-5-163

## (7) Detaching and refitting the hard disk unit

### Procedure

1. Perform maintenance mode U917 (backup data reading) (see page 1-3-187).
2. Remove the rear upper cover (see page 1-5-3).
3. Release the wire saddle.
4. Remove two screws.

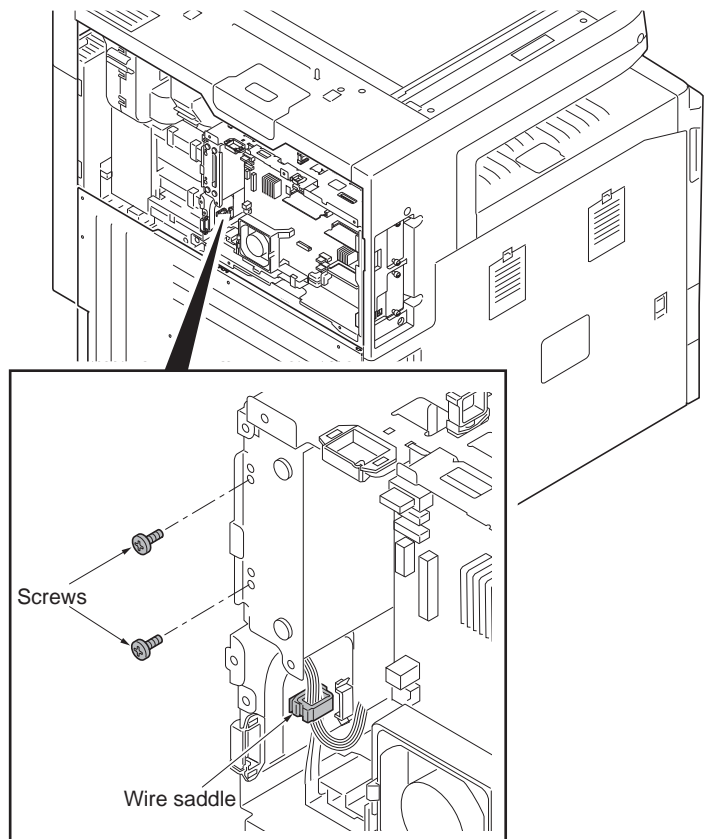


Figure 1-5-164

5. Unhook two hooks and pull out the HDD bracket a little.

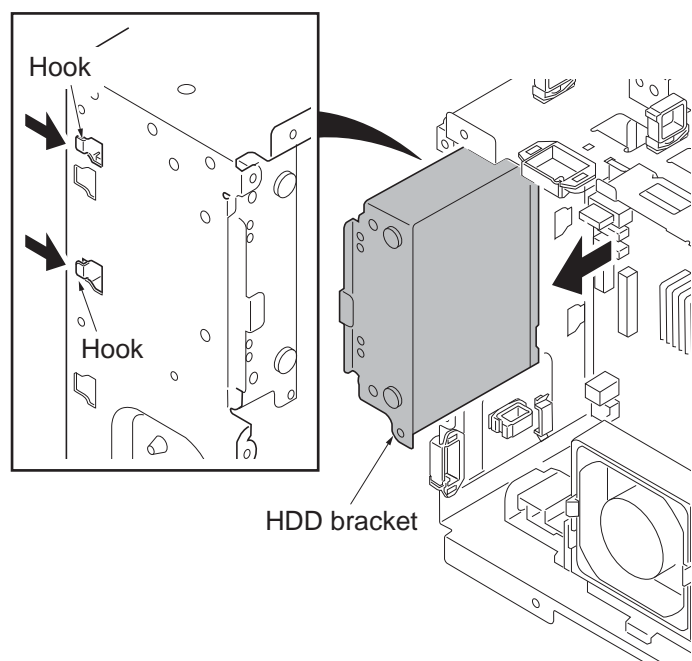
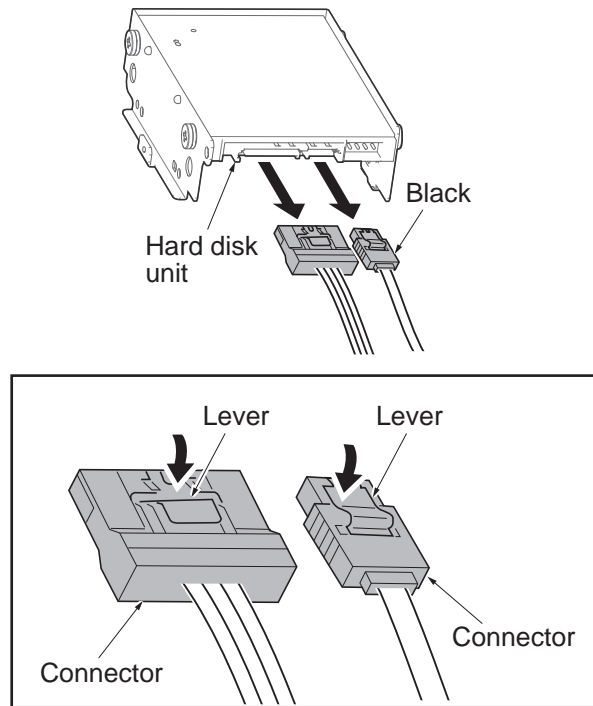


Figure 1-5-165



6. Remove two connectors from the hard disk unit while pushing the lock lever.

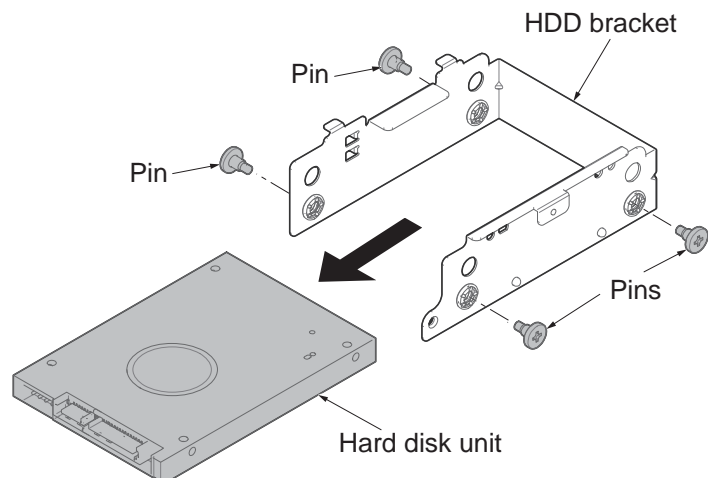


**Figure 1-5-166**

7. Remove four pins and then remove the hard disk unit from the HDD bracket.  
 8. Replace the hard disk unit and refit all the removed parts.  
 9. Perform maintenance mode U024 (HDD formatting) (see page 1-3-29).

\*: Handle the HDD so as not to drop or get it in touch with hard objects as it is susceptible to vibrations and impacts especially along the direction of disc rotation. Be careful not to apply shocks while securing the screws.

10. Perform maintenance mode U024 (HDD formatting) -Format - Full (see page 1-3-29).



**Figure 1-5-167**

11. Install the firmwares by the following procedure.
- 1) Connects to the machine the USB memory that preserved Software LANGUAGE BR (Opt Font, Opt Msg, opt Eweb) and option language.  
 The firmware is installed by switching the main power switch to ON/OFF.
  - 2) Connects to the machine the USB memory that preserved FMU application. Installs the firmware from the application screen of the system menu. (Refer to operation guide.)  
 \*: Confirm a kind of Hypas application displayed with an application screen before HDD exchange, and install it again.
  - 3) Reinstall the OCR dictionary software from a USB flash device by toggling power on and off.
12. If backup data is saved with the U917 maintenance mode, execute import of the backup data with the U917 (see page 1-3-198).

## (8) Detaching and refitting the eject unit

### Procedure

1. Remove the right upper cover (see page 1-5-85).
2. Remove the fuser unit (see page 1-5-58).
3. Remove the connector.
4. Remove two screws and then remove the eject unit.
5. Check or replace the eject unit and refit all the removed parts.

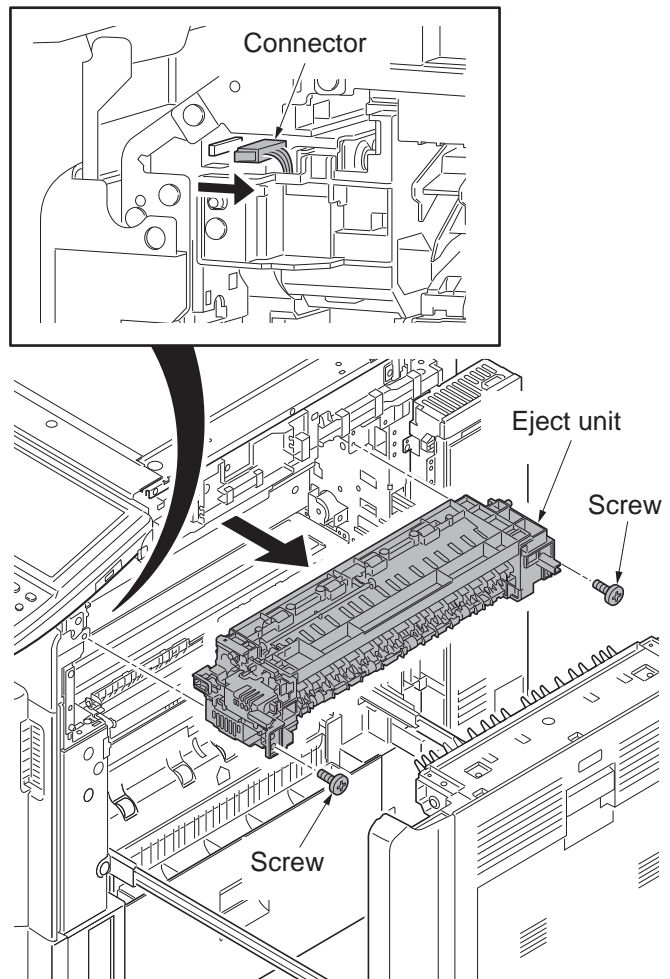


Figure 1-5-168

### Cautions on installing the eject unit

When inserting the eject unit into the device, use care that the eject unit does not get in contact with the eject guide, by keeping its actuator lifted while inserting.

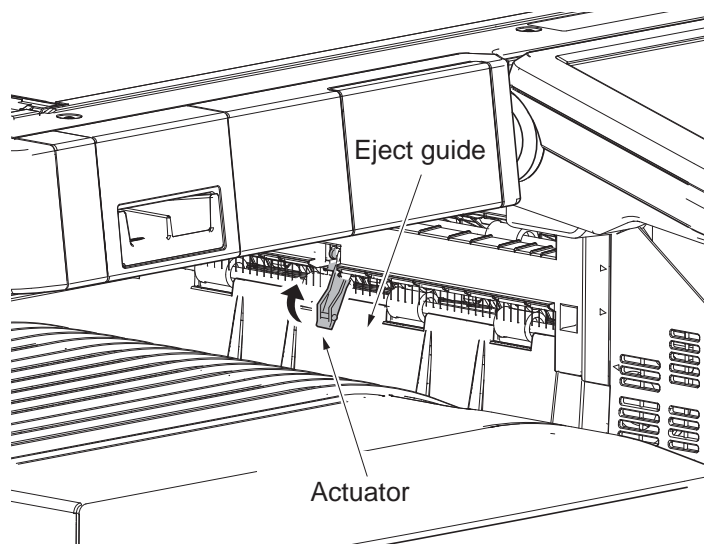


Figure 1-5-169

## (9) Direction of installing the principal fan motors

When detaching or refitting the fan motors, be careful of the airflow direction (intake or exhaust).

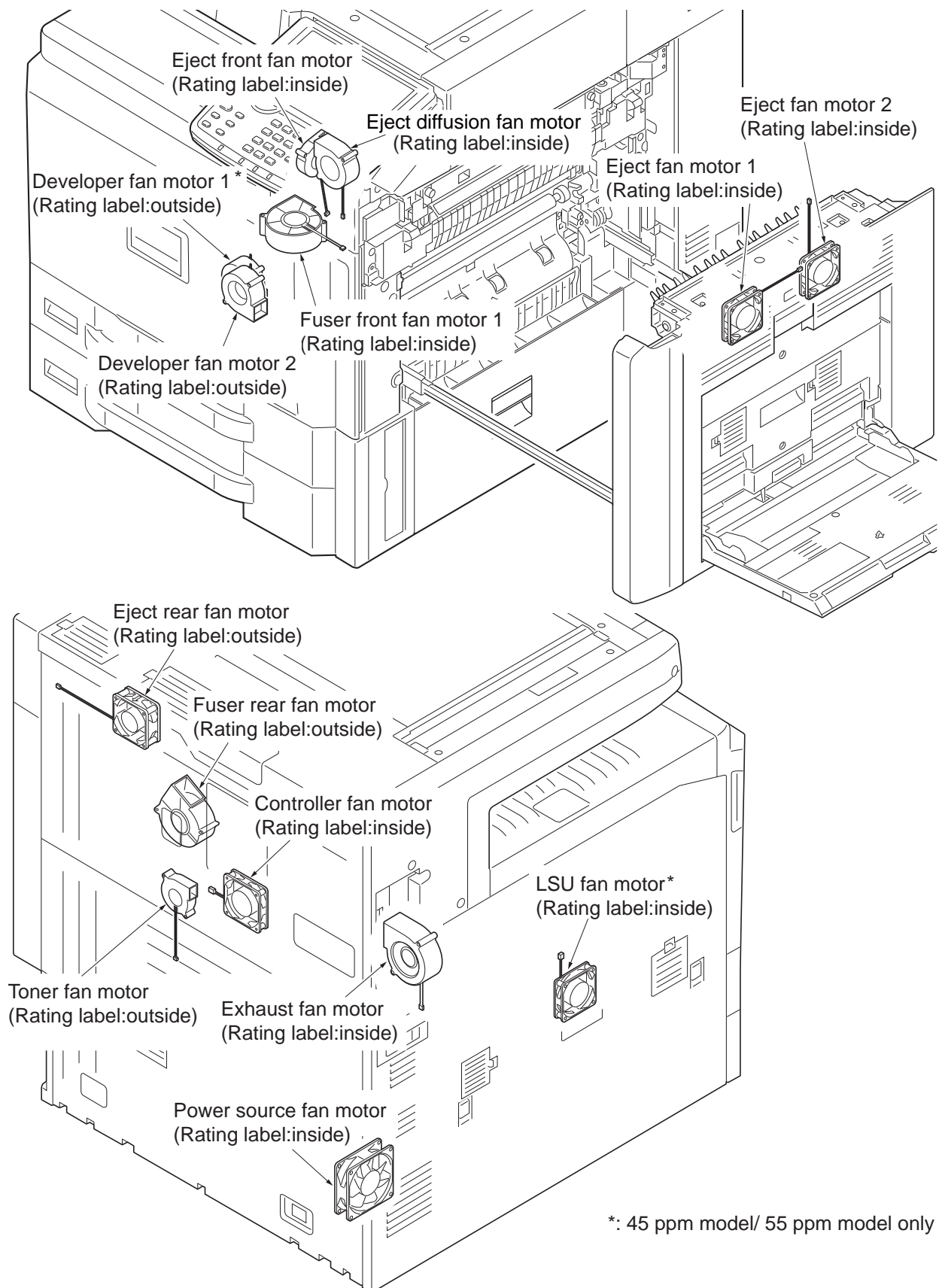


Figure 1-5-170

## (10) Skewed paper feeding check/adjustment

At the paper feed source which a sheet of wrinkled paper has caused, check how the paper is fed askew. Run U051 to reduce the curvature of paper at the regist roller and measure how the paper is fed askew.

1. Print a maintenance report and note the U051 value.
2. Reduce the value by 10 for the paper source in question.(See page -1-5-49.)

3. Press the system menu button to print a test chart.

Check the skew value (balance of left and right, B-A).

Less than 1mm: OK

1mm or more:

Correct the skew by using the paper angle adjusting mechanism (in cassette) that modifies the angle of the paper width guides.

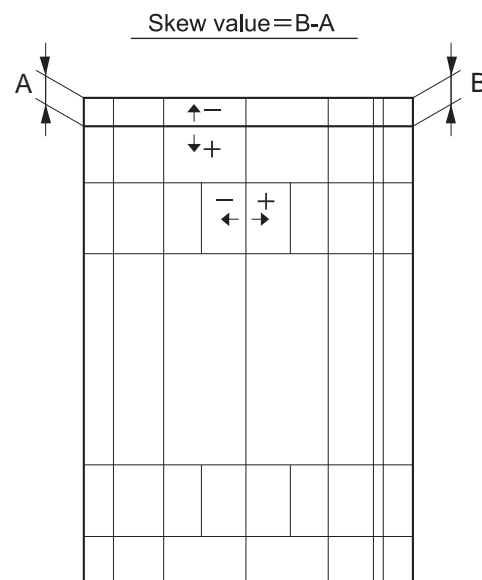


Figure 1-5-171

### Procedure

1. Unsecure the fixing screws (screw 1 to 4) and adjust the angle of the paper width guide by the skew feed adjustment screw.  
If the B-A is negative, rotate clockwise.  
If the B-A is positive, rotate counter-clockwise.
2. Tighten the four screw.  
\*: Secure the screws in the order of screws 1, 2, 3, then 4.
3. Run U051 and reset the curvature the regist roller.

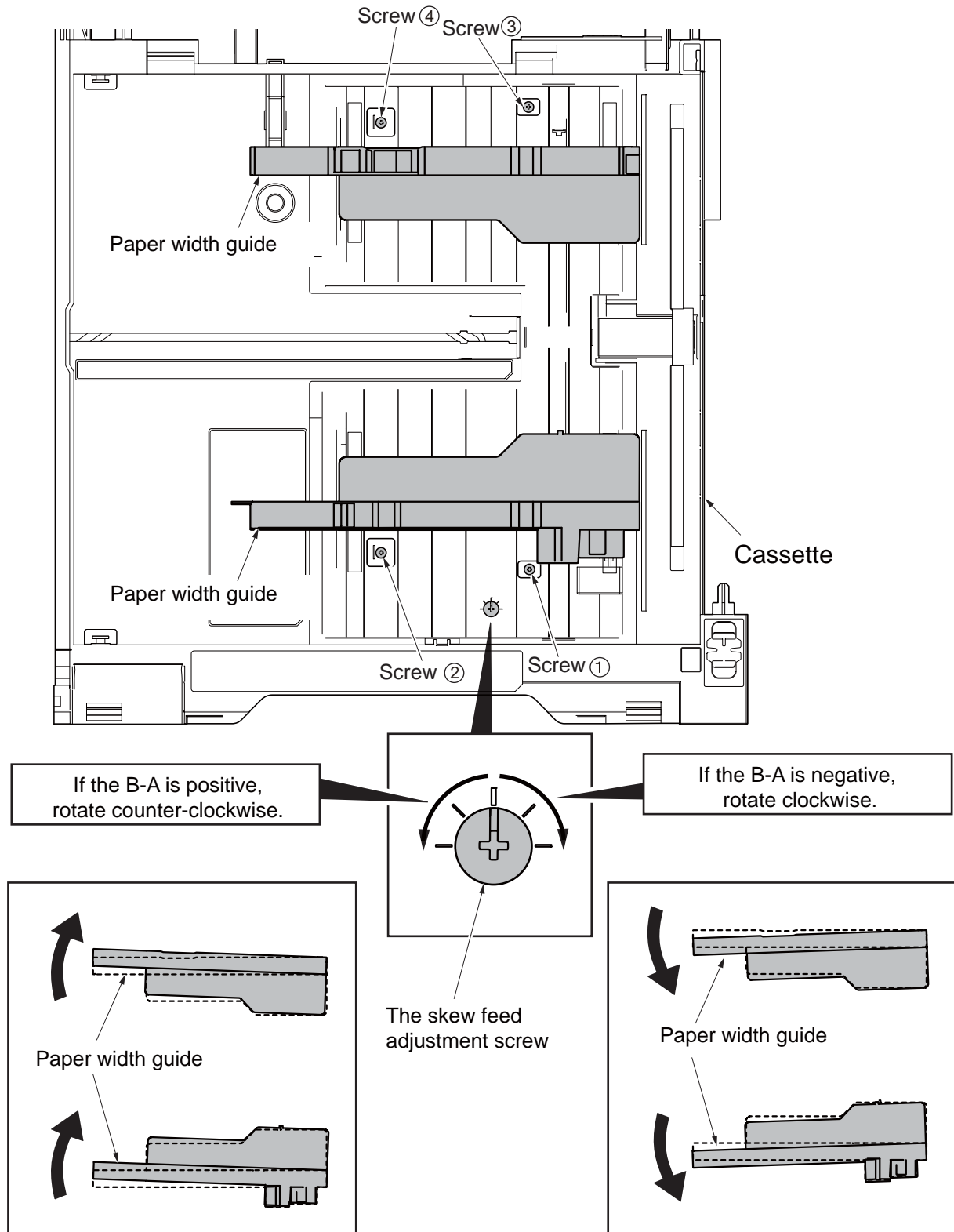


Figure 1-5-172

This page is intentionally left blank.

## 1-6-1 Upgrading the firmware

Follow the procedure below to upgrade the firmware of main PWB, operation PWB, engine PWB, ISC PWB, optional language and optional devices.

### Preparation

Extract the file that has the download firmware and put them in the USB flash device.

\* : Firmware upgrade must be preceded by an authentication using U025 if the security level is set to "Very High".

### Procedure

1. Perform maintenance item U000 (maintenance report output) and check U019 firmware version.
2. Press the power key on the operation panel, and after verifying the power indicator has gone off, switch off the main power switch.
3. Insert the USB flash device in which the firmware has been written into a notch hole of the machine.
4. Turn the main power switch on. Upgrading firmware starts (blinking the memory LED).

#### Caution:

Never turn off the power switch or remove the USB flash device during upgrading.

5. [FW-UPDATE] is displayed on the touch panel when upgrading is complete.
6. Switch off the main power switch.
7. Wait for several seconds and then remove the USB flash device from the machine.
8. Turn the main power switch on.
9. Perform maintenance item U000 (maintenance report output) and check that U019 firmware version has been upgraded.

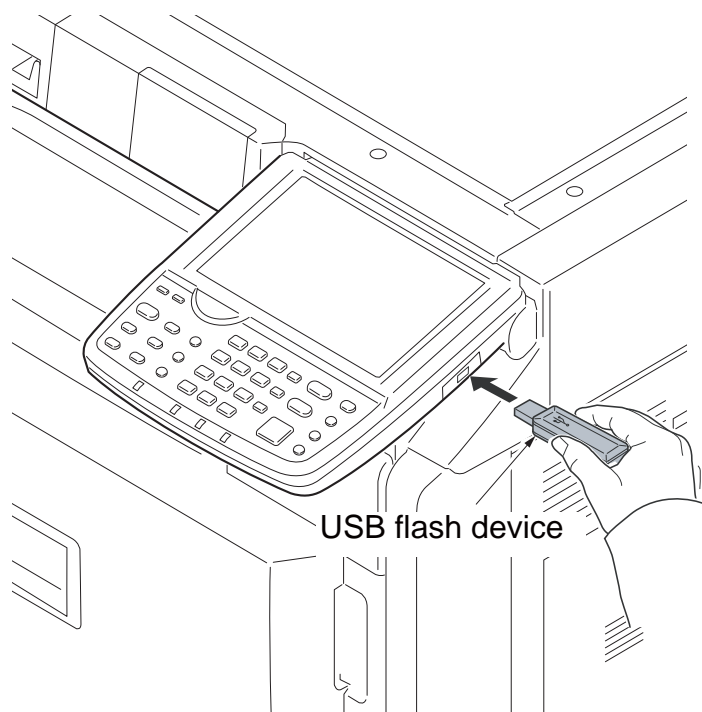


Figure 1-6-1

### Safe-UPDATE

If the device is accidentally switched off or the USB memory is disconnected and upgrading is incomplete, perform the following.

If the power is accidentally switched off, turn the power on without removing the USB memory and perform the above steps 4 through 9.

If the USB memory is disconnected, reinsert it, then turn the power on and perform the above steps 4 through 9.

In any case, complete the steps to the end.

## Emergency-UPDATE

If Safe Update is processed to the end, the firmware update is complete. In case the message below is indicated, update the firmware after recovery with the steps below.

FW-Update Error FFFF
-------------------------

Note that this is unoperable when the device is operating normally.

### Preparation

Use a USB flash device that meets the requirements and format it on a Windows PC if it has been used except for an emergency update. Format the USB flash device in FAT or FAT32 format.

Extract the main firmware to download from the file.

Rename the file which was extracted from the archive. [DL\_CTRL.2N9] to [KM\_EMRG.2N9]

Copy the all extracted files to the root of the USB flash device.

### Procedure

1. Turn the main power switch off.
2. Insert the USB flash device in which the firmware was copied into the USB flash device slot at the left of the machine.
3. Turn the main power switch on.
4. Rewriting of the PWB software will start for restoration.

(The LCD, memory LED, and attention LED on the operation panel will be showing the progress.)

5. The operation panel LCD will show "Completed" when rewriting has been finished.

\* : In case rewriting has been failed, "Error XXXX" (XXXX means an error code) will be shown.

6. Turn the main power switch off.
7. Wait for several seconds and then remove the USB flash device from the machine.

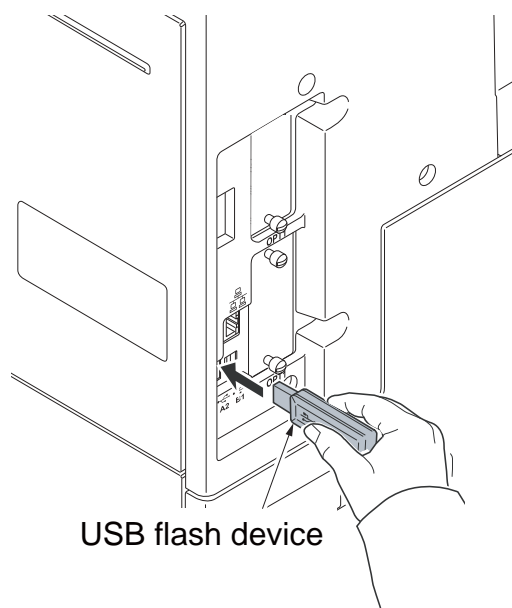


Figure 1-6-2

8. Insert the USB flash device in which an upgrade pack of the latest firmware or the Main/MMI/Browser and LANGUAGE BR (excluding Dictionary) were copied, into the slot on the machine and turn power on. (see page P.1-6-1).



## 2-1-1 Paper feed/conveying section

Paper feed/conveying section consists of the paper feed unit that feeds paper from the cassette and the MP tray paper feed unit that feeds paper from the MP tray, and the paper conveying section that conveys the fed paper to the transfer/separation section.

### (1) Cassette paper feed section

Cassette paper feed section consists of the paper holder with the cassette operation plate activated by lift motor 1 and 2, and the pulleys, such as the forwarding pulley, the paper feed pulley and the separation pulley, for extracting and conveying the paper. Paper is fed out of the cassette by the rotation of the forwarding pulley, paper feed pulley and separation pulley.

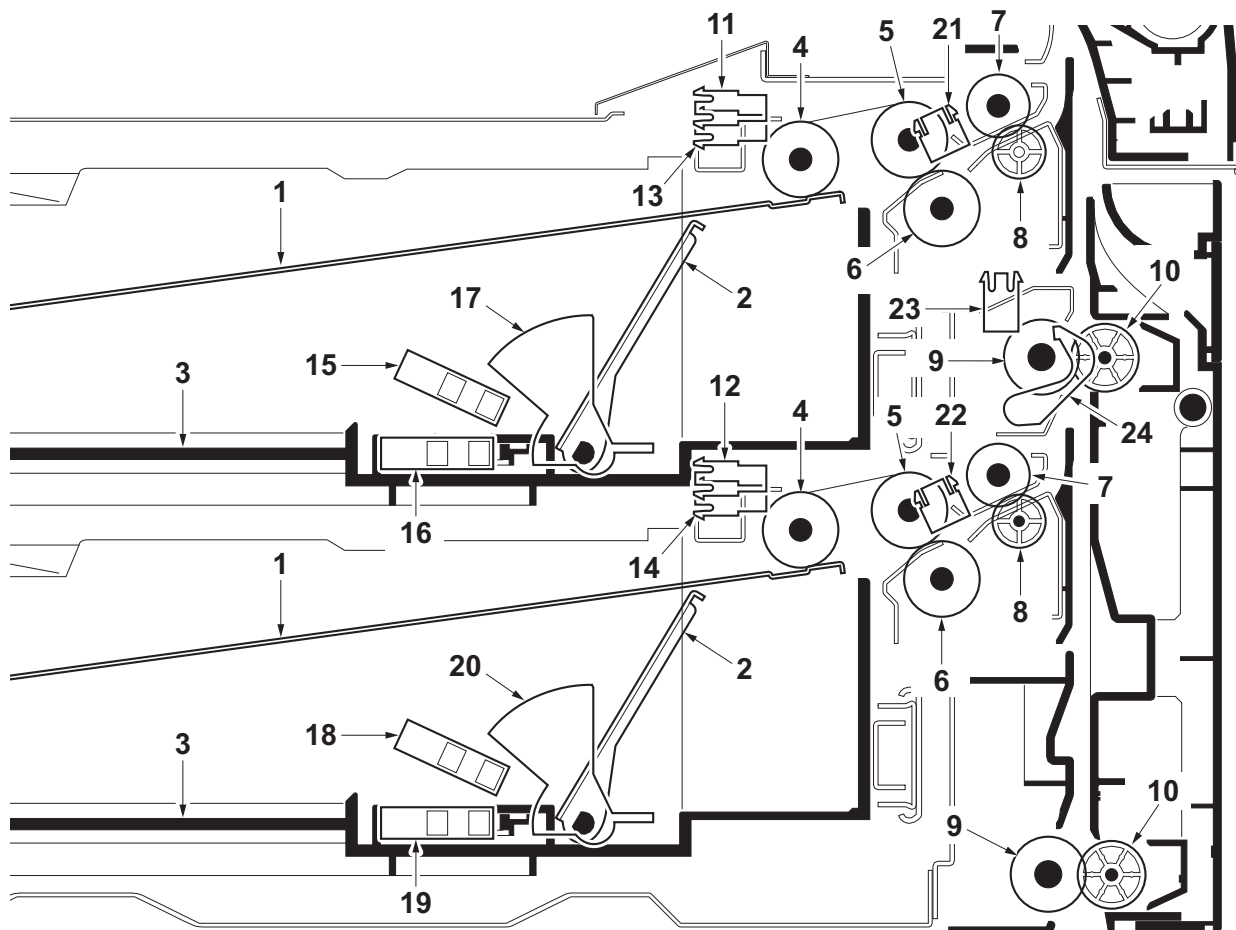


Figure 2-1-1 Cassette paper feed section

- |                             |   |   |
|-----------------------------|---|---|
| 1. Cassette base            | 12. Paper sensor 2 (PS2)                  | 19. Paper gauge sensor 2 (L)<br>(PGS2(L)) |
| 2. Cassette operation plate | 13. Lift sensor 1 (LS1)                   | 20. Actuator<br>(Paper gauge sensor 2)    |
| 3. Cassette                 | 14. Lift sensor 2 (LS2)                   | 21. Feed sensor 1 (FS1)                   |
| 4. Forwarding pulleys       | 15. Paper gauge sensor 1 (U)<br>(PGS1(U)) | 22. Feed sensor 2 (FS2)                   |
| 5. Paper feed pulleys       | 16. Paper gauge sensor 1 (L)<br>(PGS1(L)) | 23. Paper conveying sensor<br>(PCS)       |
| 6. Separation pulleys       | 17. Actuator<br>(Paper gauge sensor 1)    | 24. Actuator<br>(Paper conveying sensor)  |
| 7. Assist rollers           | 18. Paper gauge sensor 2 (U)<br>(PGS2(U)) |   |
| 8. Assist pulleys           |   |   |
| 9. Paper conveying roller   |   |   |
| 10. Paper conveying pulley  |   |   |
| 11. Paper sensor 1 (PS1)    |   |   |

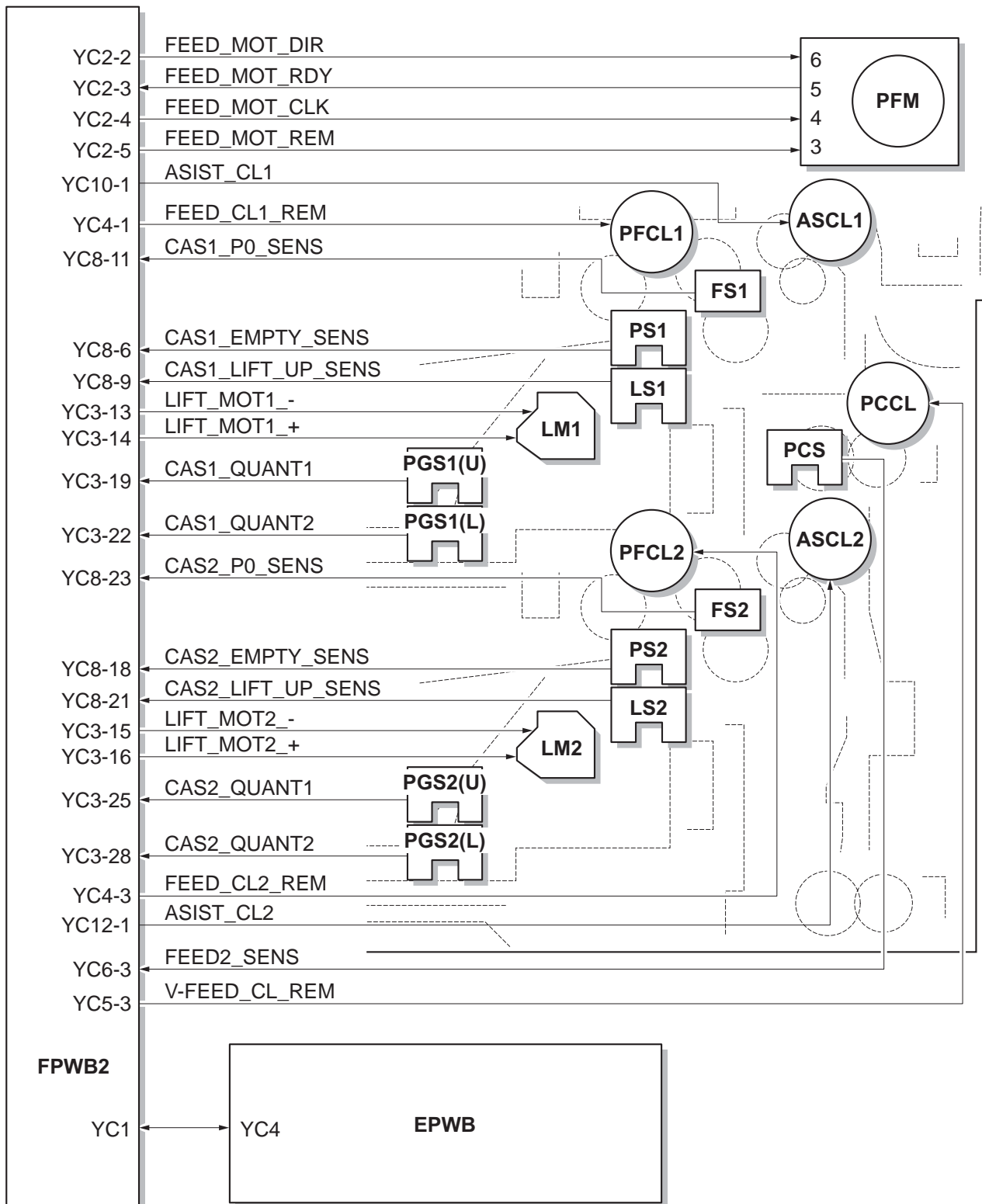


Figure 2-1-2 Cassette paper feed section block diagram

## (2) MP tray paper feed section

Paper is fed out of the MP tray by the rotation of the MP forwarding pulley, MP paper feed pulley and MP separation pulley. The MP separation pulley prevents multiple sheets from being fed at one time by the torque limiter.

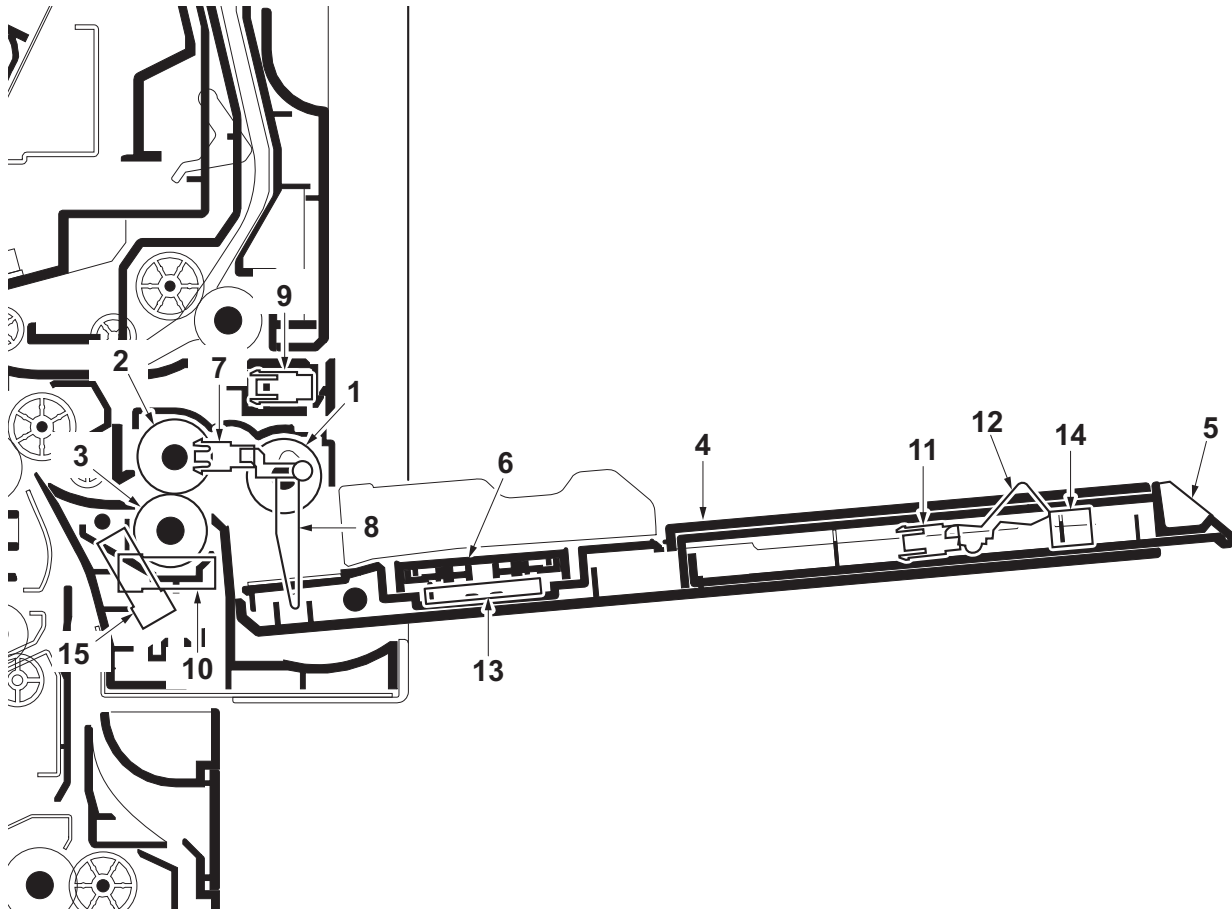


Figure 2-1-3 MP tray paper feed section

- |                               |                                       |
|-------------------------------|---------------------------------------|
| 1. MP forwarding pulley       | 10. MP lift sensor 2 (MPLS2)          |
| 2. MP paper feed pulley       | 11. MP paper length switch (MPPLSW)   |
| 3. MP separate pulley         | 12. Actuator (MP paper length switch) |
| 4. MP table                   | 13. MP paper width switch (MPPWSW)    |
| 5. MP support Tray            | 14. MP tray switch (MPTSW)            |
| 6. MP lift base               | 15. MP feed sensor (MPFS)             |
| 7. MP paper sensor (MPPS)     |                                       |
| 8. Actuator (MP paper sensor) |                                       |
| 9. MP lift sensor 1 (MPLS1)   |                                       |

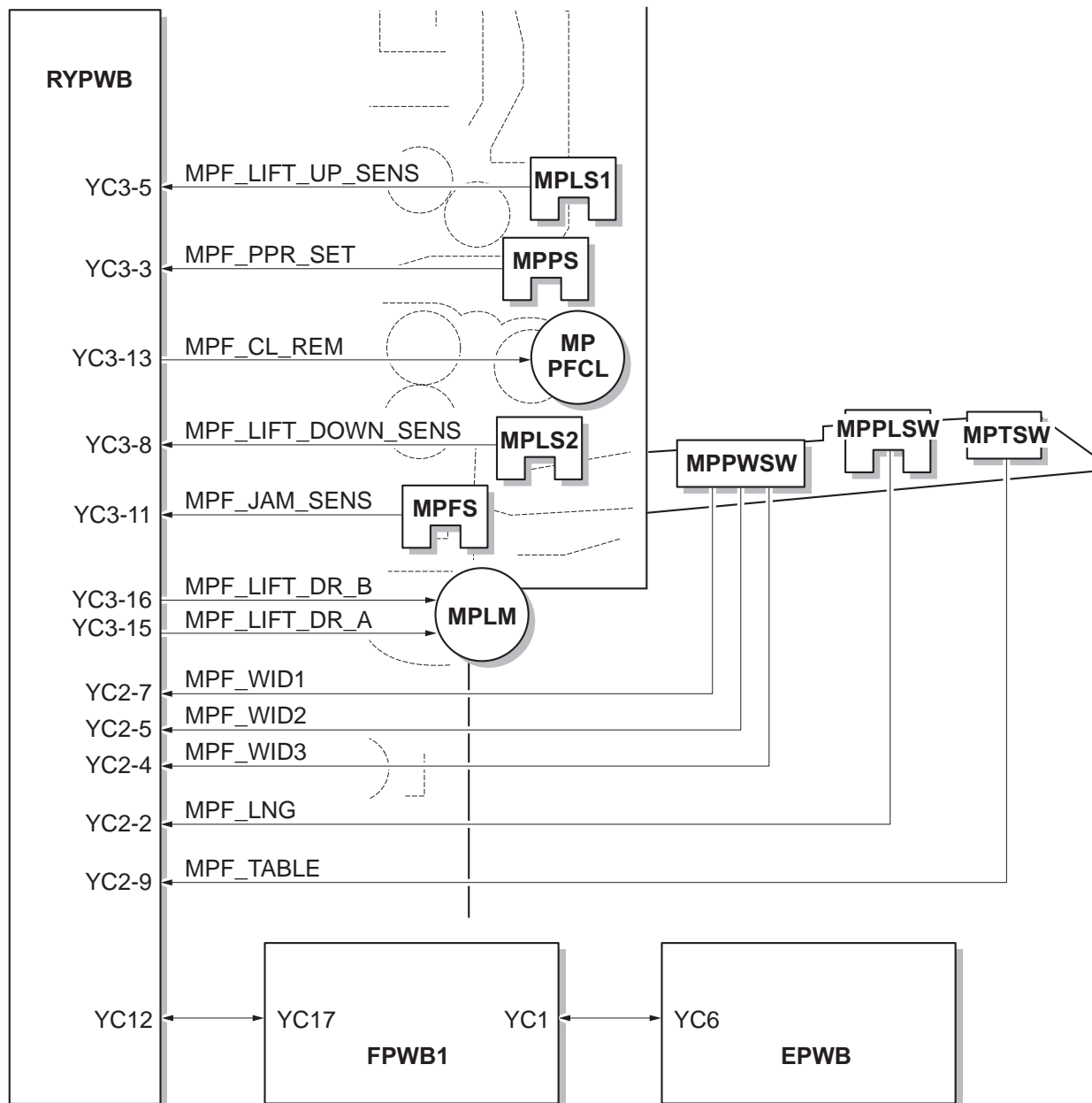


Figure 2-1-4 MP tray paper feed section block diagram

### (3) Paper conveying section

The paper conveying section conveys paper to the transfer/separation section as paper feeding from the cassette or MP tray, or as paper refeeding for duplex printing. Paper by feeding is conveyed by the middle roller to the position where the registration sensor (RS) is turned on, and then sent to the transfer/separation section by the right registration roller and left registration roller.

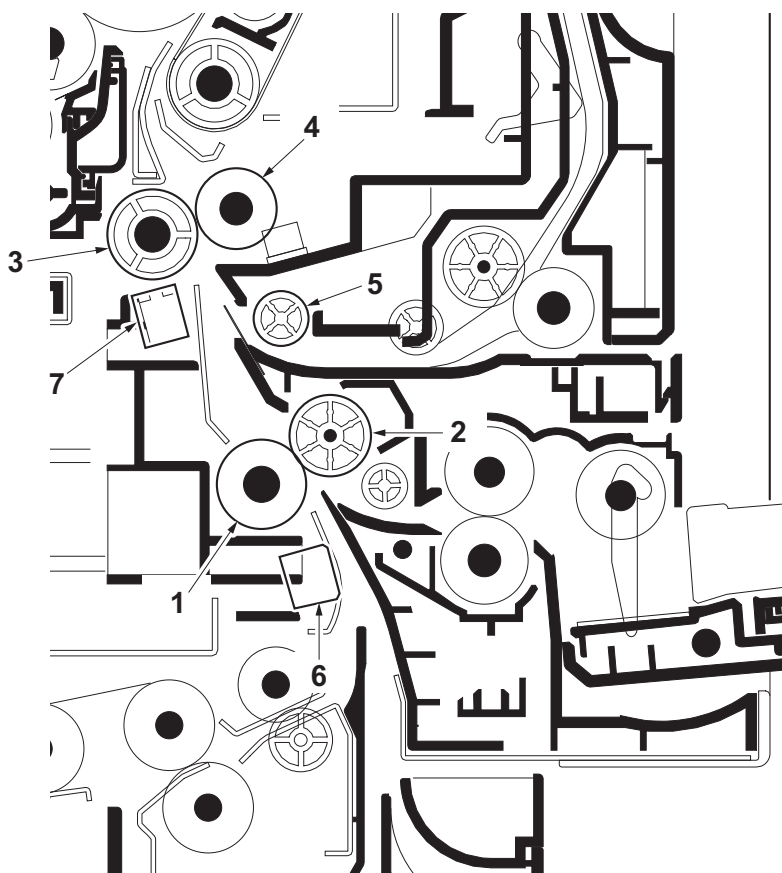


Figure 2-1-5 Paper conveying section

- |                              |                             |
|------------------------------|-----------------------------|
| 1. Middle roller             | 5. Paper conveying pulley   |
| 2. Middle pulley             | 6. Middle sensor (MS)       |
| 3. Left registration roller  | 7. Registration sensor (RS) |
| 4. Right registration roller |                             |

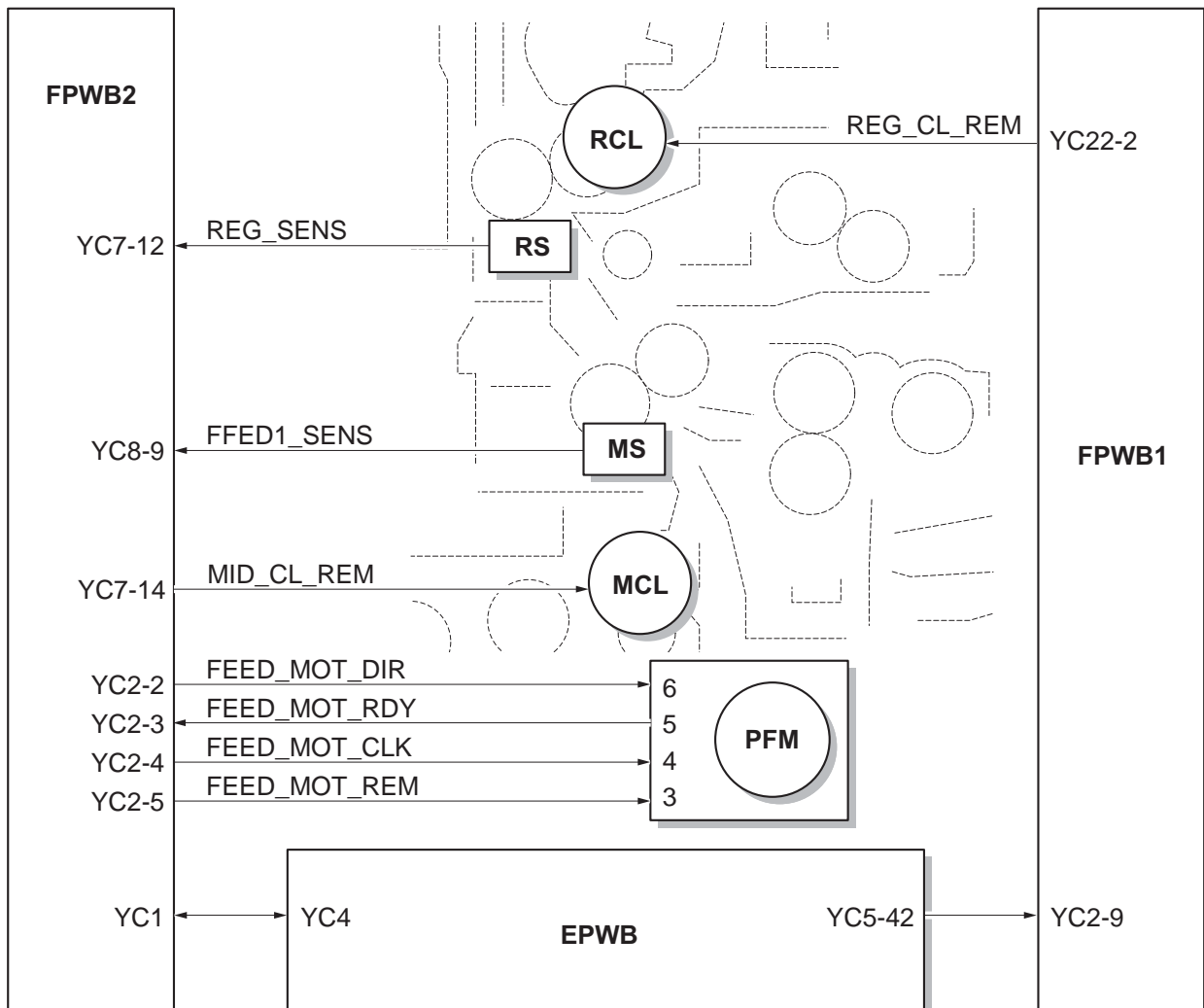


Figure 2-1-6 Paper conveying section block diagram (35 ppm model)

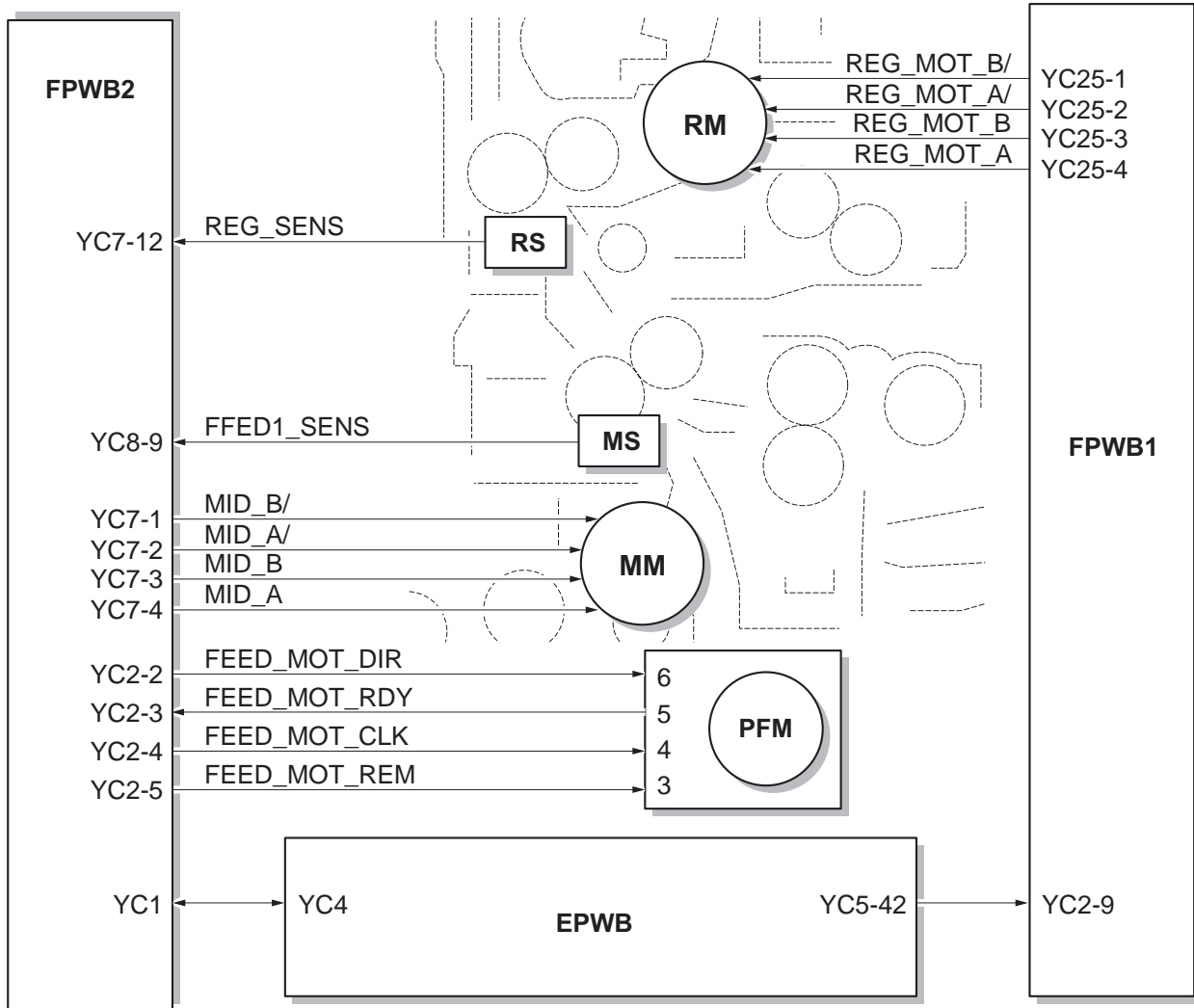


Figure 2-1-7 Paper conveying section block diagram (45 ppm/55 ppm model)

## 2-1-2 Drum section

The drum section consists of the charger roller unit, drum and cleaning section. The drum is electrically charged uniformly by means of a charger roller to form a latent image on the surface. The cleaning section consists of the cleaning blade and the cleaning roller which remove residual toner from the drum surface after transfer. The cleaning lamp (CL) consists of LEDs and removes residual charge on the drum before main charging.

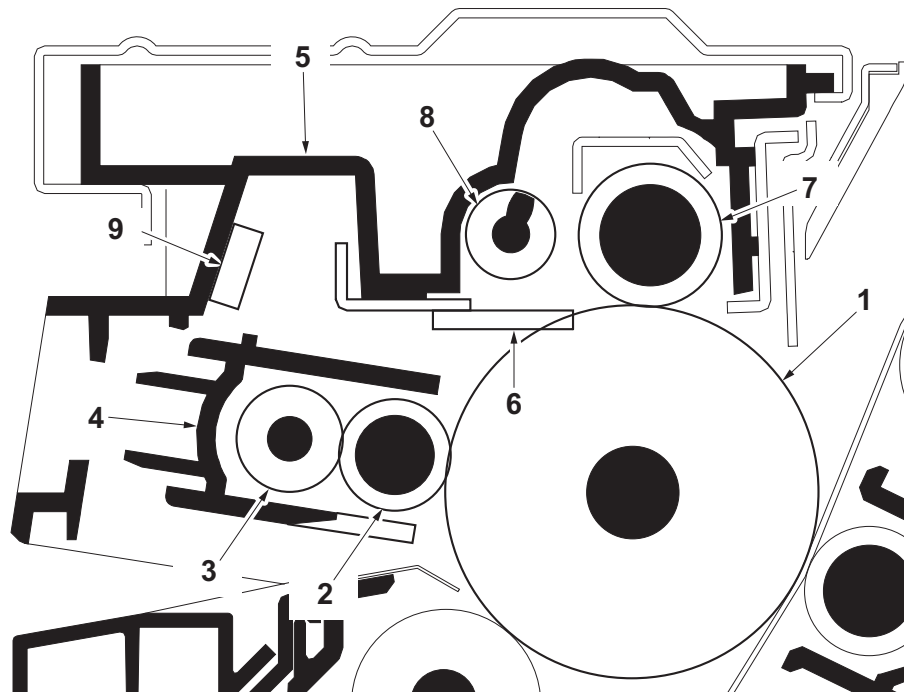


Figure 2-1-8 Drum section

- |                            |                       |
|----------------------------|-----------------------|
| 1. Drum                    | 6. Cleaning blade     |
| 2. Charger roller          | 7. Cleaning roller    |
| 3. Charger cleaning roller | 8. Drum screw         |
| 4. Charger case            | 9. Cleaning lamp (CL) |
| 5. Drum frame              |                       |



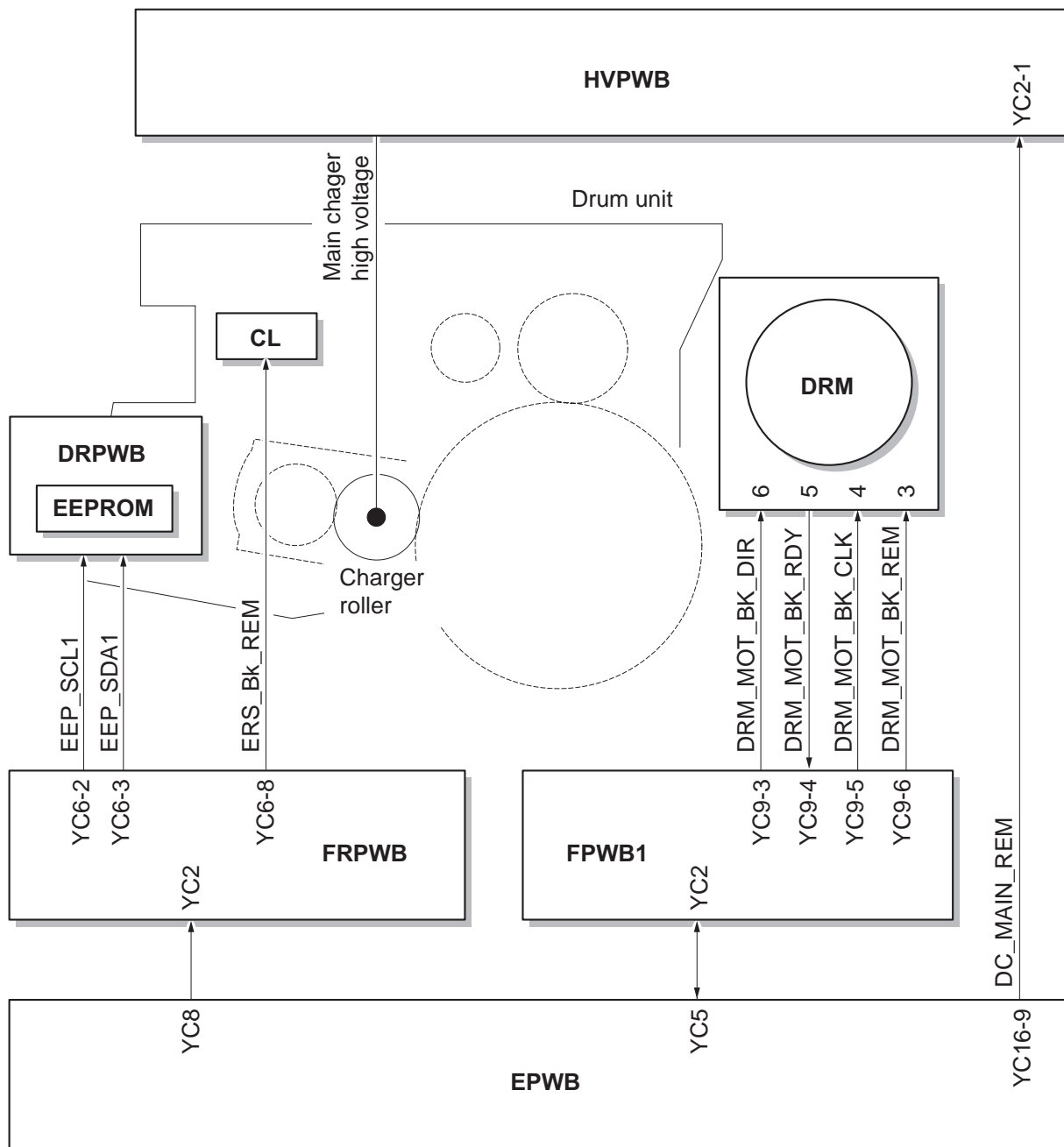


Figure 2-1-9 Drum section block diagram

## 2-1-3 Developer section

The developer unit consists of the sleeve roller that forms the magnetic brush, the magnet roller, the developer blade and the developer screws that agitate the toner. Also, the toner sensor (TS) checks whether or not toner remains in the developer unit.

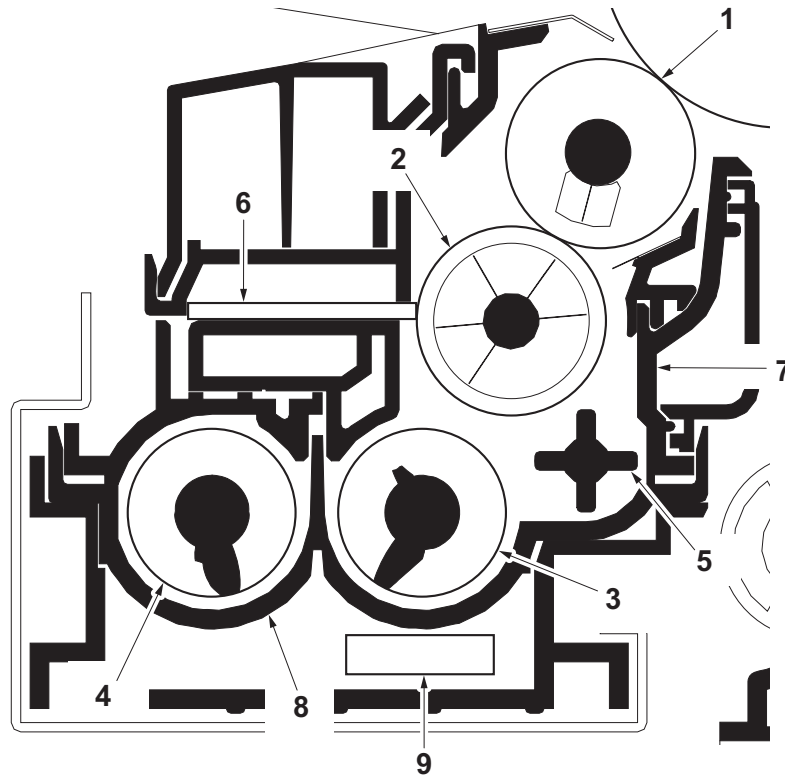


Figure 2-1-10 Developer section

- |                      |                      |
|----------------------|----------------------|
| 1. Sleeve roller     | 6. Developer blade   |
| 2. Magnet roller     | 7. Developer case    |
| 3. Developer screw A | 8. Developer cover   |
| 4. Developer screw B | 9. Toner sensor (TS) |
| 5. Developer paddle  |                      |



## 2-1-4 Optical section

The optical section consists of the image scanner section for scanning and the laser scanner section for printing.

### (1) Image scanner section

The original image is illuminated by the LED lamp and scanned by the CCD image sensor in the CCD PWB (CCDPWB) via the three mirrors and ISU lens, the reflected light being converted to an electrical signal. The mirror frame A and B travel to scan on the optical rails on the front and rear of the machine to scan from side to side. The speed of the mirror frame B is half the speed of the mirror frame A.

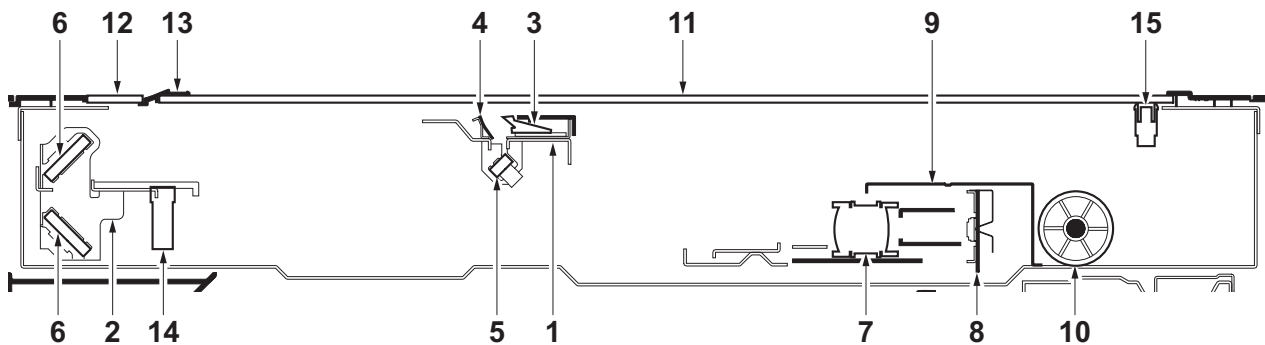


Figure 2-1-12 Image scanner section

- |                      |                                      |
|----------------------|--------------------------------------|
| 1. Mirror frame A    | 9. ISU cover                         |
| 2. Mirror frame B    | 10. Scanner wire drum                |
| 3. LED mount         | 11. Contact glass                    |
| 4. Scanner reflector | 12. Slit glass                       |
| 5. Mirror A          | 13. Original size indicator plate    |
| 6. Mirror B          | 14. Home position sensor (HPS)       |
| 7. ISU lens          | 15. Original detection switch (ODSW) |
| 8. CCD PWB (CCDPWB)  |                                      |

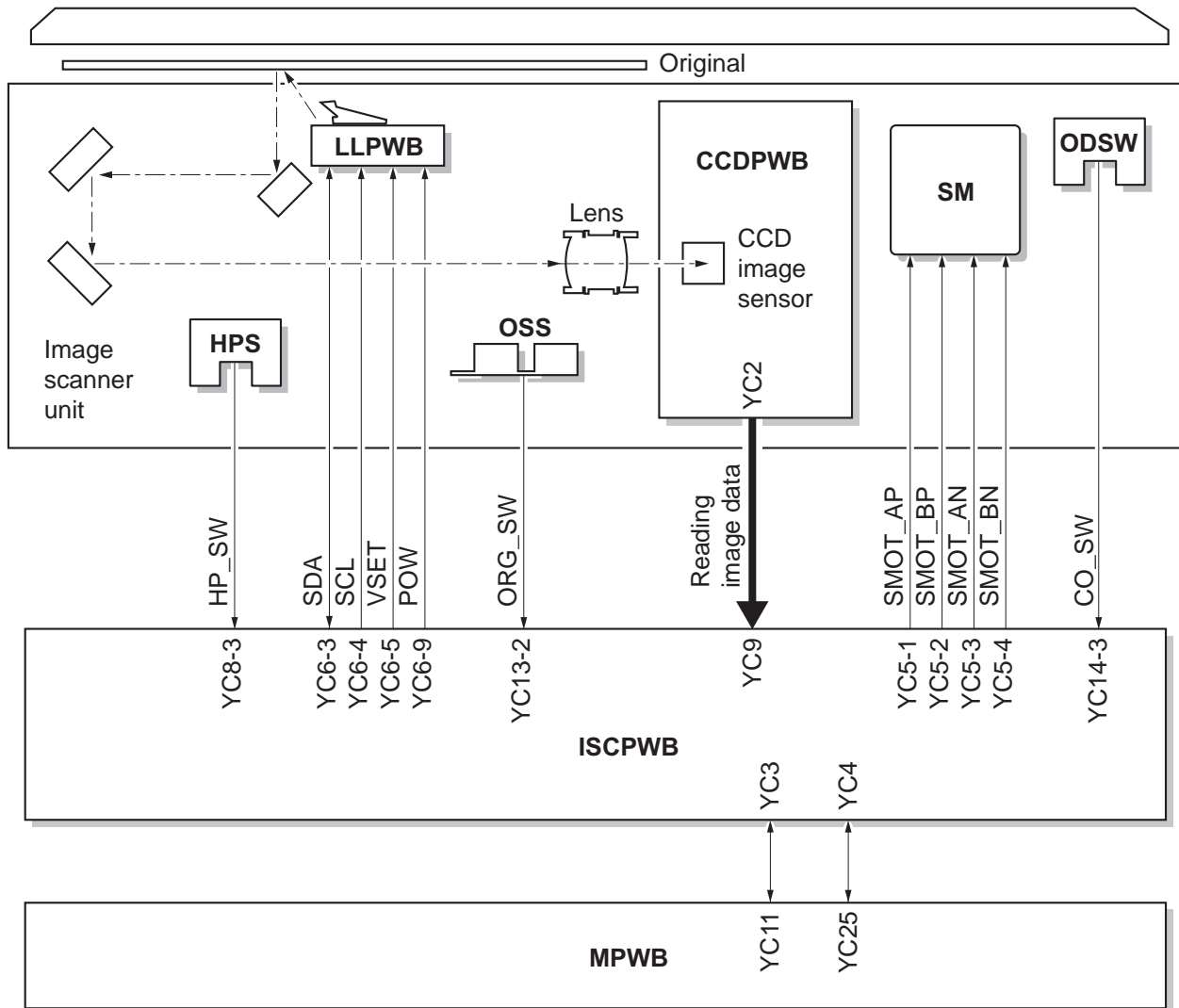


Figure 2-1-13 Image scanner section block diagram

## (2) Laser scanner section

The charged surface of the drum is then scanned by the laser beam from the laser scanner unit. The laser beam is dispersed as the polygon motor (PM) revolves to reflect the laser beam over the drum. Various lenses are housed in the laser scanner unit, adjust the diameter of the laser beam, and focalize it at the drum surface.

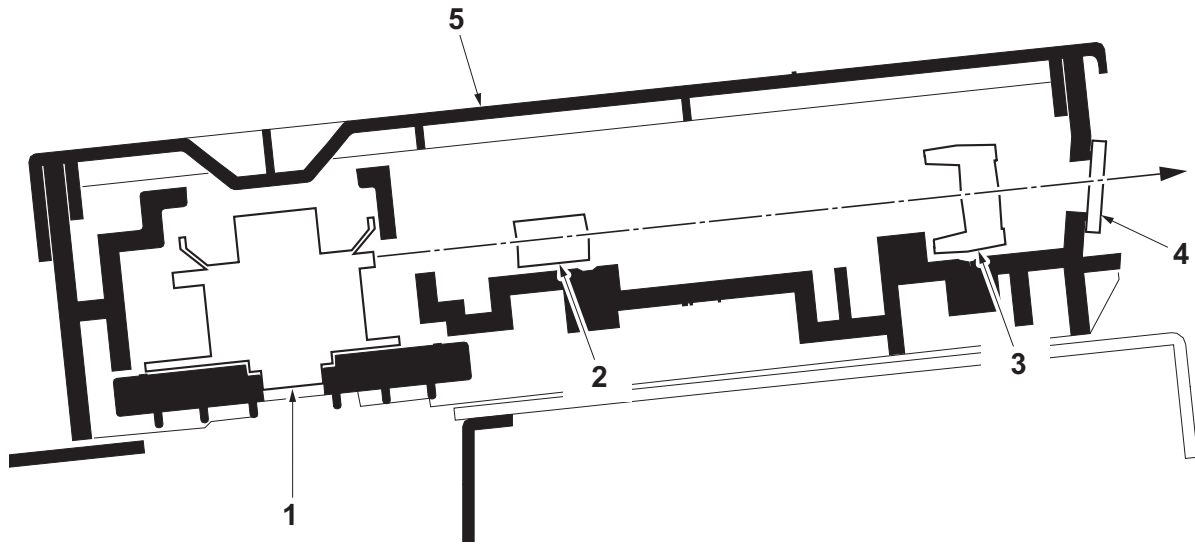
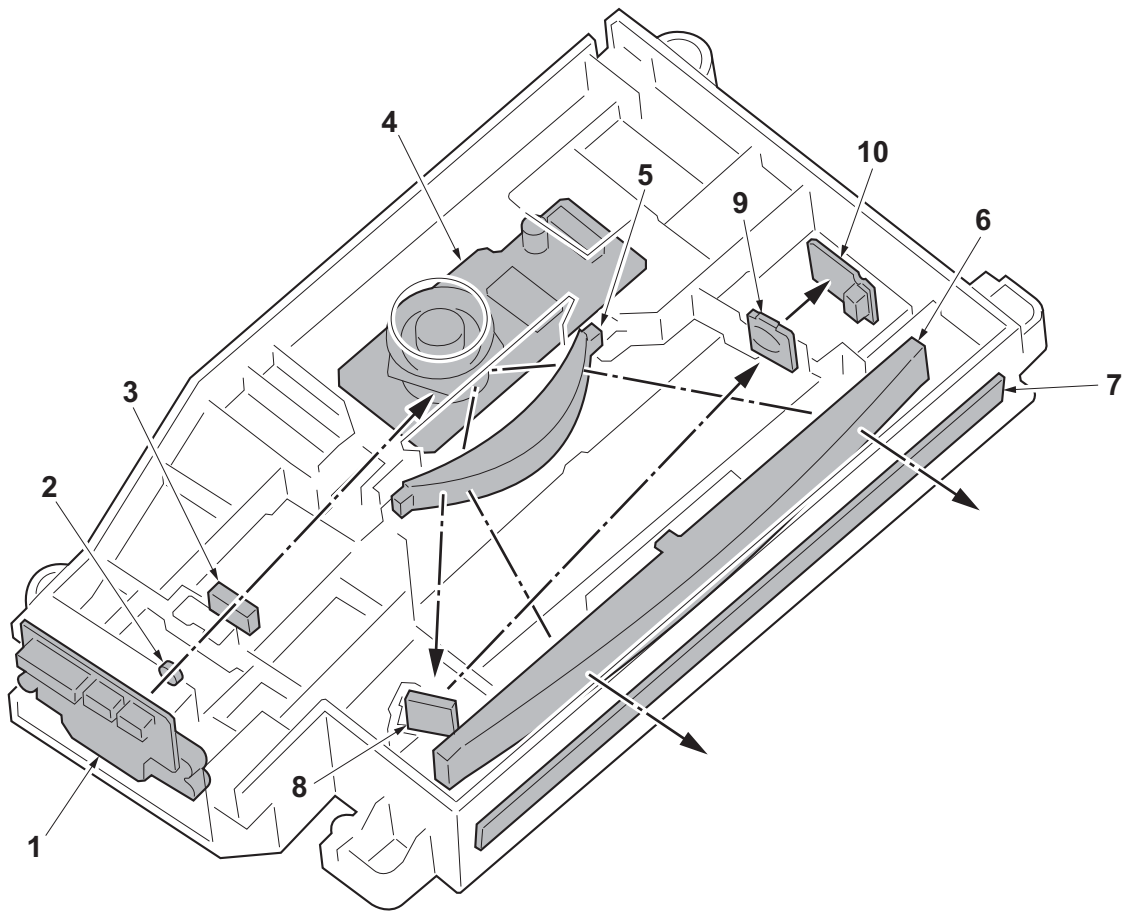


Figure 2-1-14 Laser scanner section

1. Polygon motor (PM)
2. f- $\theta$  lens A
3. f- $\theta$  lens B
4. LSU dust shield glass
5. LSU cover



**Figure 2-1-15 Laser scanner unit**

- |                       |                          |
|-----------------------|--------------------------|
| 1. APC PWB (APCPWB)   | 6. f-θ lens B            |
| 2. Collimate lens     | 7. LSU dust shield glass |
| 3. Cylindrical lens   | 8. Mirror lens           |
| 4. Polygon motor (PM) | 9. PD lens               |
| 5. f-θ lens A         | 10. PD PWB (PDPWB)       |

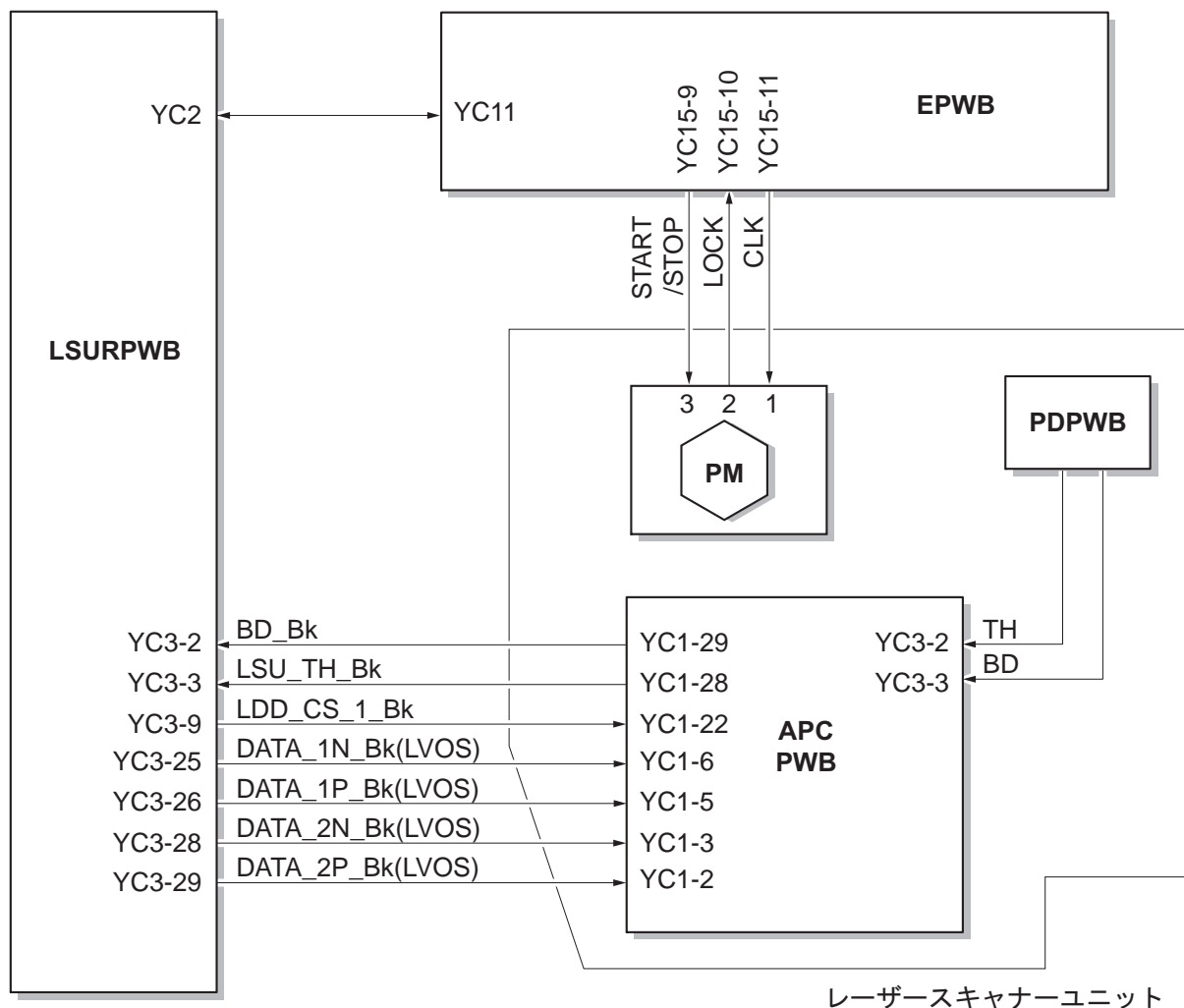


Figure 2-1-16 Laser scanner section block diagram



## 2-1-5 Transfer/Separation section

### (1) Transfer belt unit section

The transfer belt unit section consists of the transfer belt, transfer roller and the charge erasing brush. To the transfer roller, DC bias is applied from the high voltage PWB (HVPWB). The toner image formed on the drum is transferred to the paper by the potential difference and the paper is discharged with the discharging brush. Also with the ID sensors (IDS), the toner density on the transfer belt is measured.

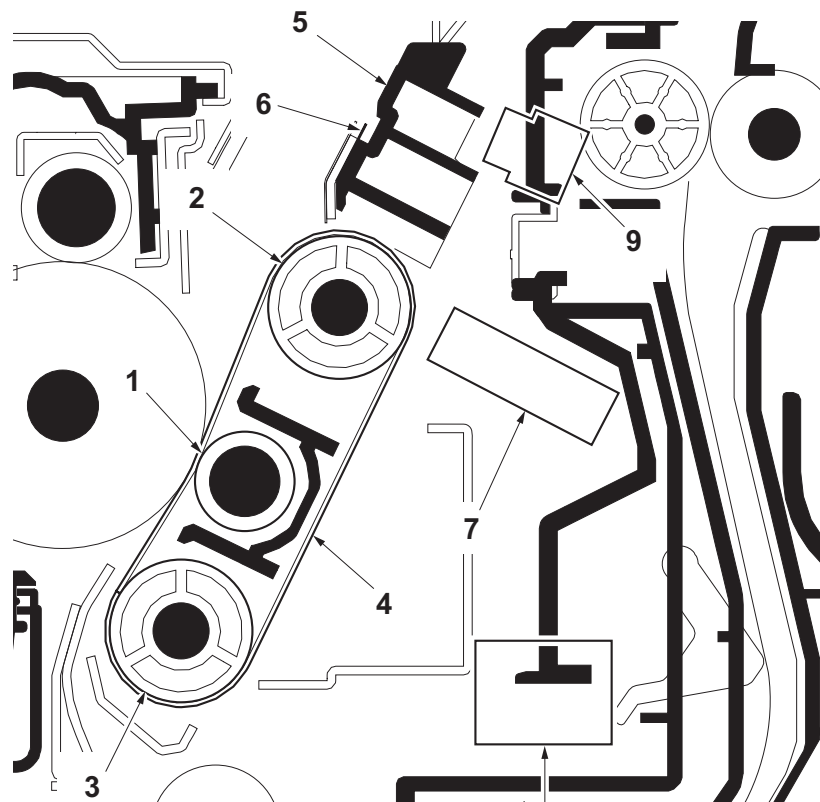


Figure 2-1-17 Transfer belt unit section

- |                        |                              |
|------------------------|------------------------------|
| 1. Transfer roller     | 6. Charge erasing brush      |
| 2. Idle roller         | 7. ID sensor (IDS)           |
| 3. Drive roller        | 8. Cleaning solenoid (CLSOL) |
| 4. Transfer belt       | 9. Loop sensor (LPS)         |
| 5. Transfer rear guide |                              |

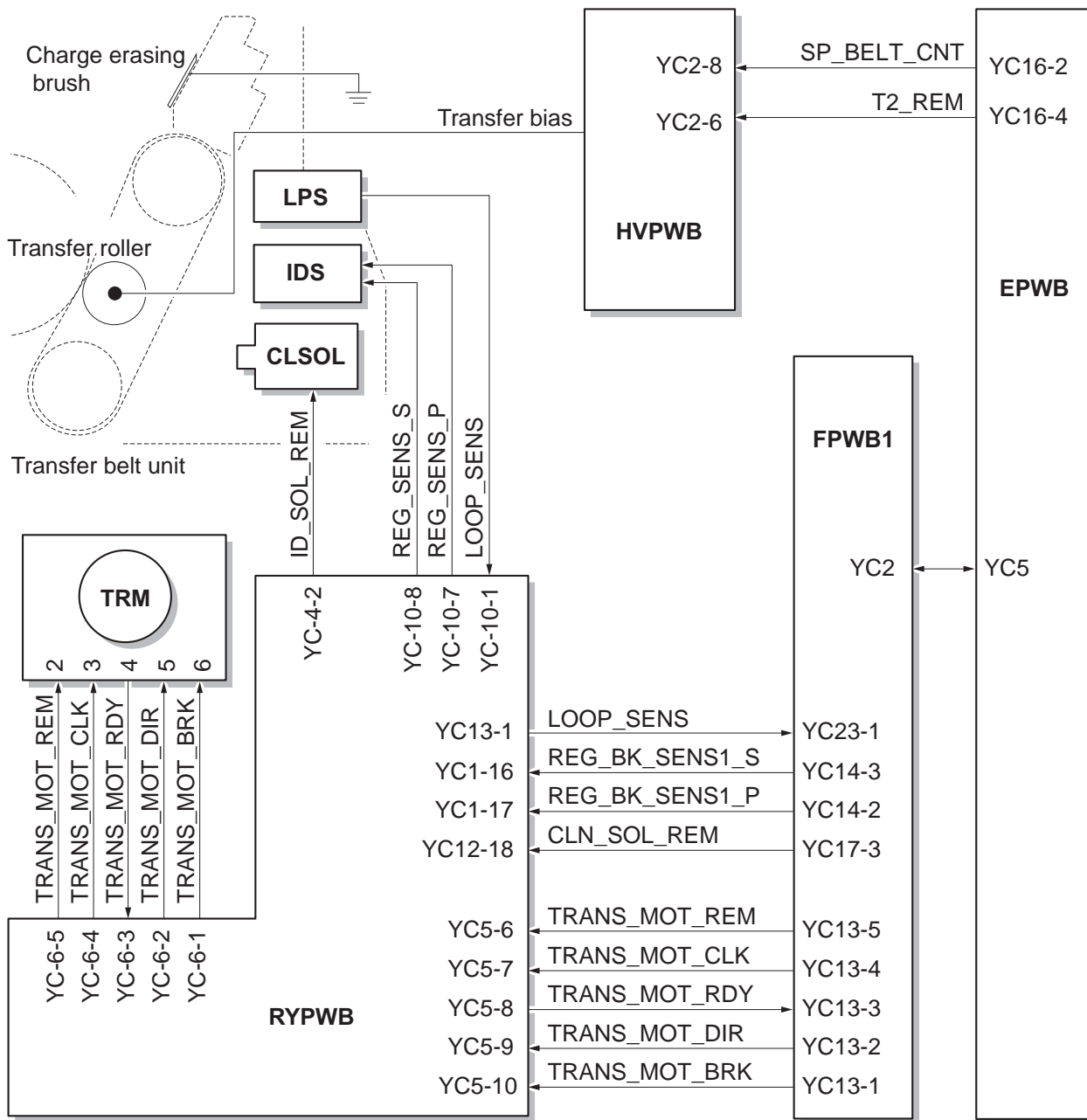


Figure 2-1-18 Transfer belt unit section block diagram

## 2-1-6 Fuser section

The paper sent from the transfer/separation section is interleaved between the heat roller and the press roller. The heat roller is heated by the fuser heater (FH), and the toner is fused by heat and pressure and fixed onto the paper because the press roller is pressed by the fuser press spring. The surface temperature of heat roller and press roller are detected by the fuser thermistor (FTH) and controlled by the engine PWB (EPWB).

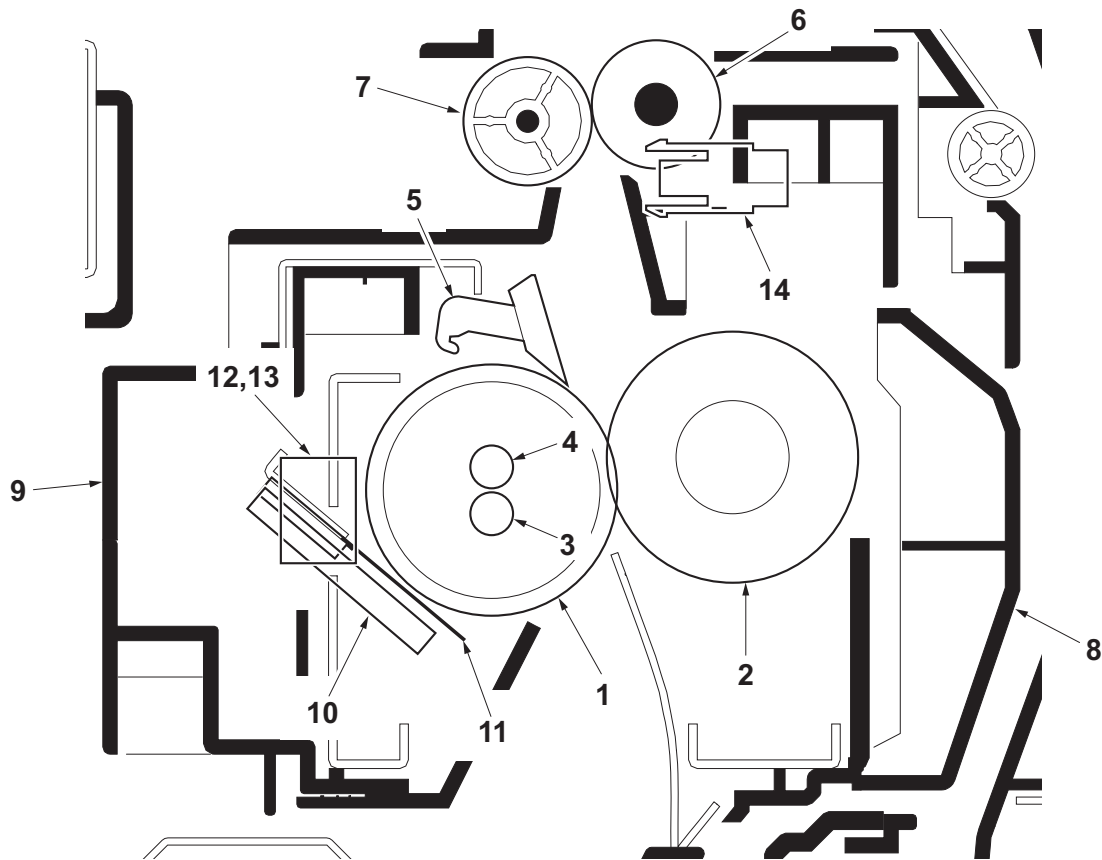


Figure 2-1-19 Fuser section

- |                         |                               |
|-------------------------|-------------------------------|
| 1. Heat roller          | 8. Right fuser cover          |
| 2. Press roller         | 9. Left fuser guide           |
| 3. Fuser heater 1 (FH1) | 10. Fuser thermistor 1 (FTH1) |
| 4. Fuser heater 2 (FH2) | 11. Fuser thermistor 2 (FTH2) |
| 5. Separators           | 12. Fuser thermostat 1 (FTH1) |
| 6. Fuser eject roller   | 13. Fuser thermostat 2 (FTH2) |
| 7. Fuser eject pulley   | 14. Fuser eject sensor (FTH2) |

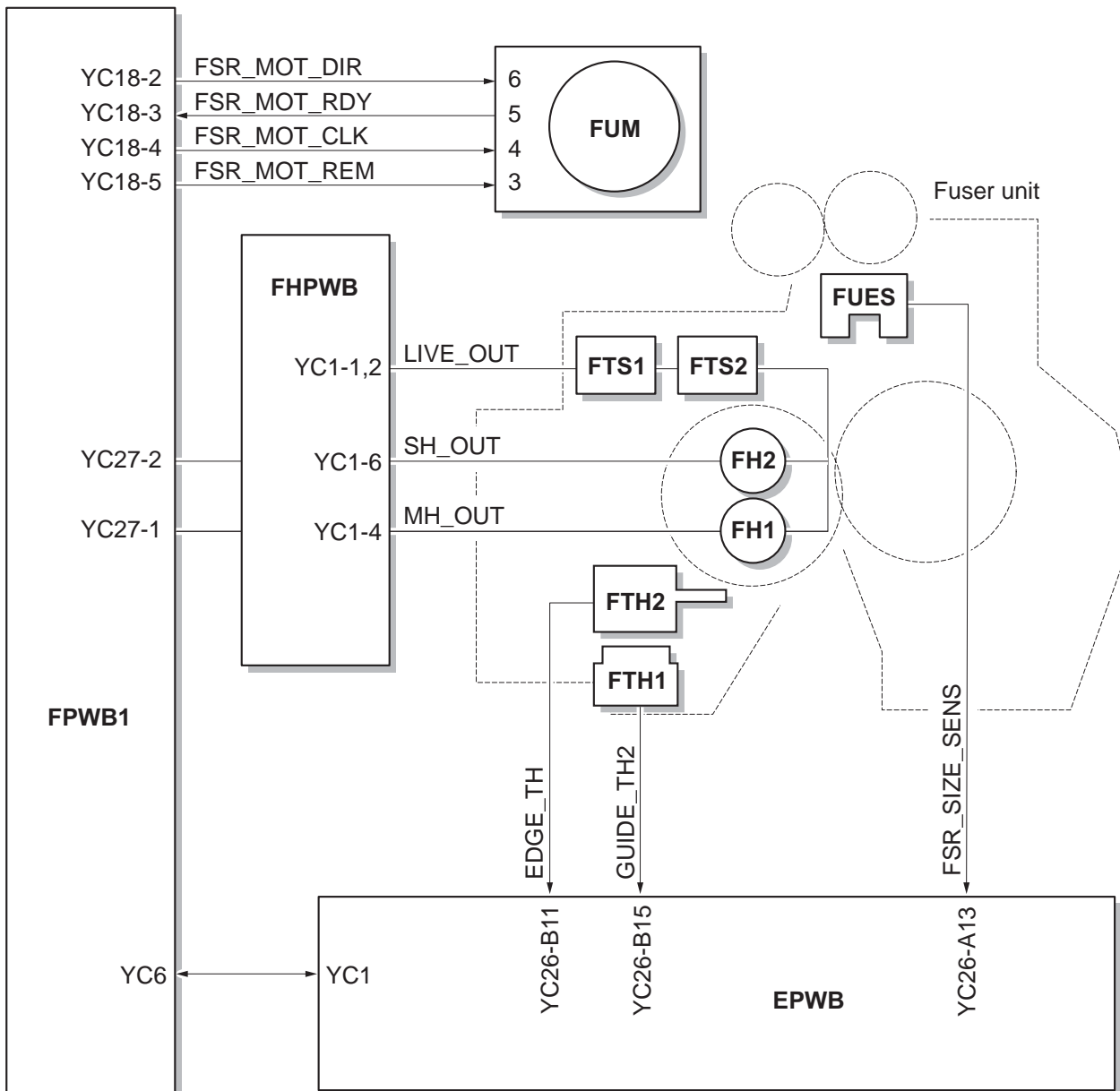


Figure 2-1-20 Fuser section block diagram

## 2-1-7 Eject/Feedshift section

The paper eject/feedshift section consists of the conveying path which sends the paper that has passed the fuser section to the top tray, duplex conveying section or job separator.

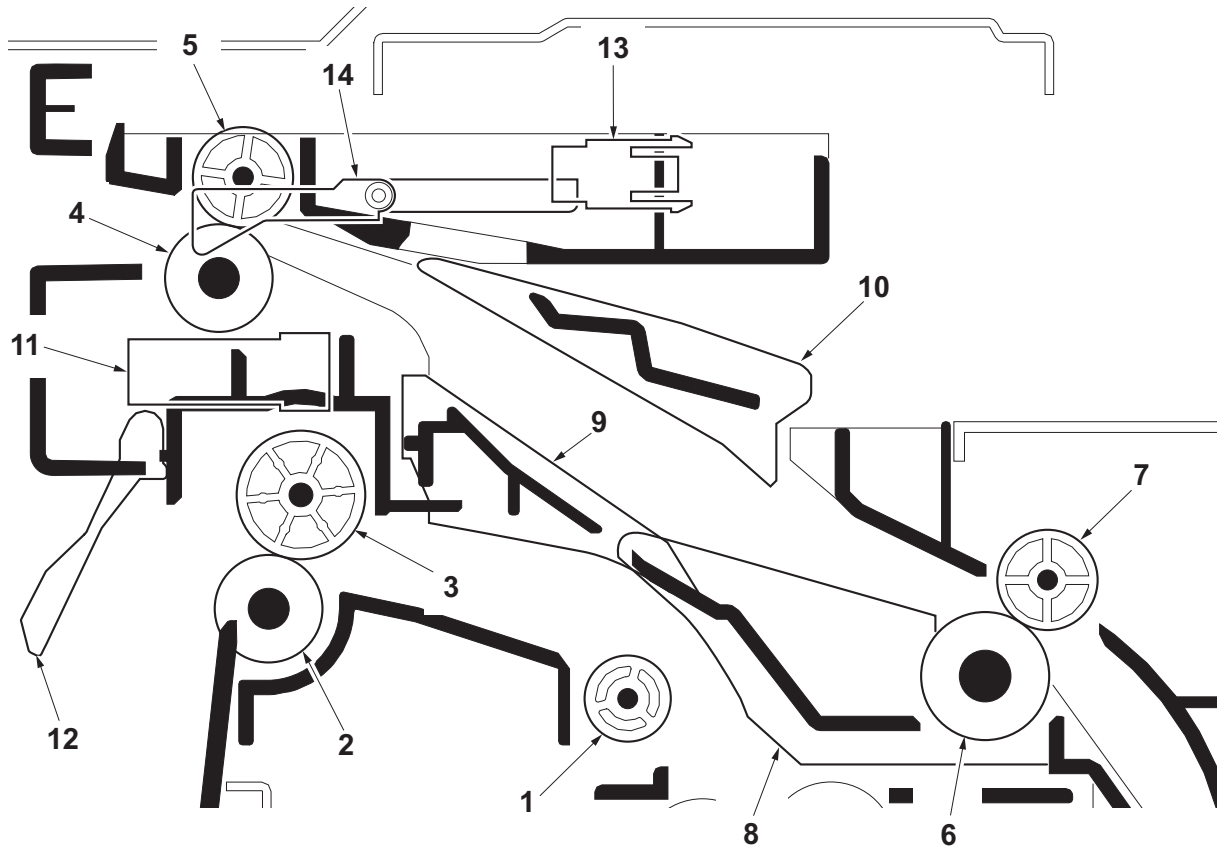


Figure 2-1-21 Eject/Feed shift section

- |                        |                                  |
|------------------------|----------------------------------|
| 1. Middle pulley       | 8. Lower duplex guide            |
| 2. Eject roller        | 9. Lower change guide            |
| 3. Eject pulley        | 10. Upper change guide           |
| 4. Eject roller B      | 11. Eject full sensor (EFS)      |
| 5. Eject pulley B      | 12. Actuator (eject full sensor) |
| 6. Upper duplex roller | 13. Switchback sensor (SBS)      |
| 7. Duplex pulley       | 14. Actuator (switchback sensor) |

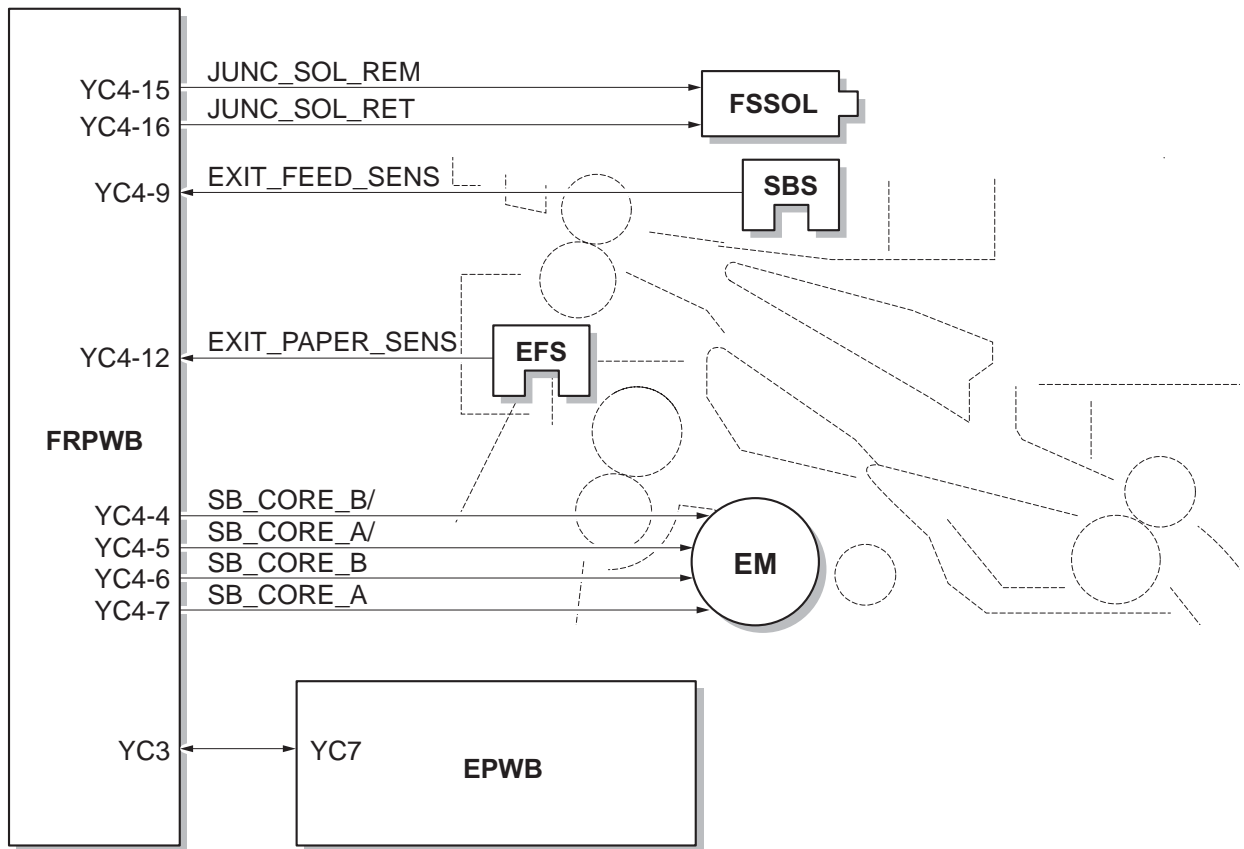


Figure 2-1-22 Eject/Feed shift section block diagram

## 2-1-8 Duplex conveying section

The duplex conveying section consists of conveying path which sends the paper sent from the eject/feedshift section to the paper feed/conveying section when duplex printing.

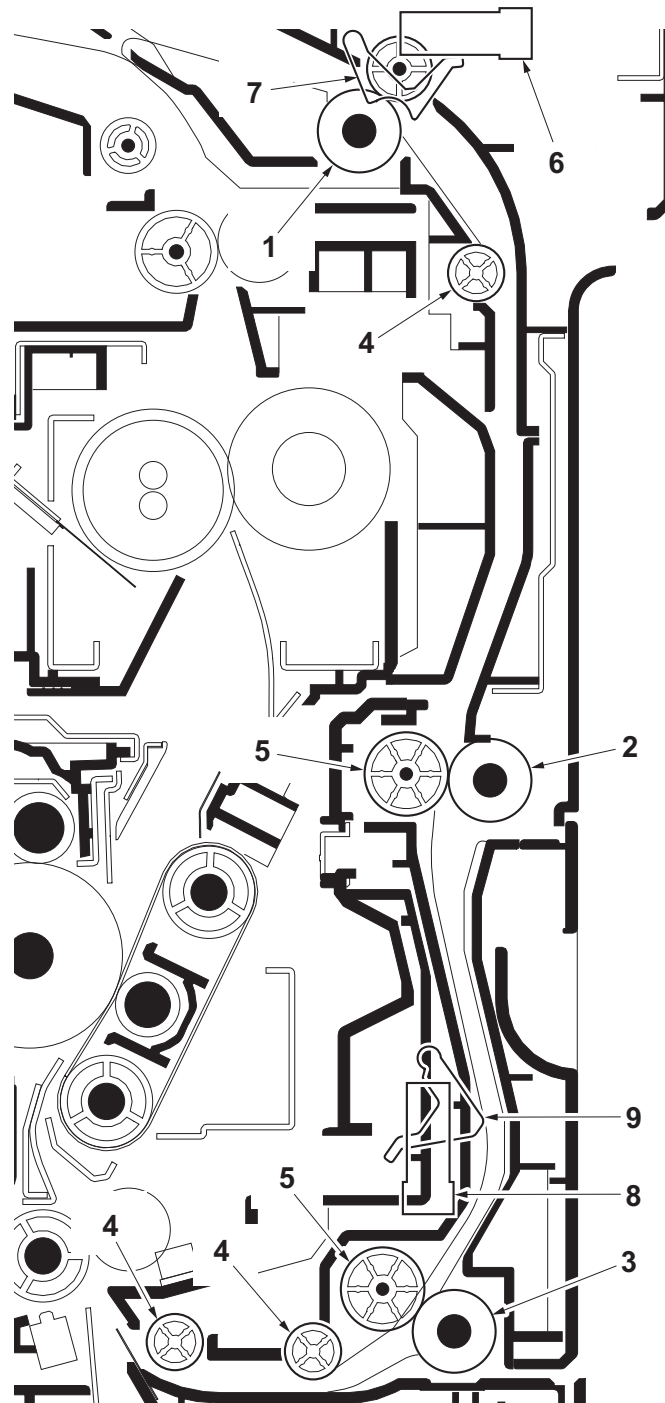


Figure 2-1-23 Duplex conveying section

- |                         |                               |
|-------------------------|-------------------------------|
| 1. Upper duplex roller  | 6. Duplex sensor 1 (DUS1)     |
| 2. Middle duplex roller | 7. Actuator (duplex sensor 1) |
| 3. Lower duplex roller  | 8. Duplex sensor 2 (DUS2)     |
| 4. Duplex pulleys A     | 9. Actuator (duplex sensor 2) |
| 5. Duplex pulleys B     |                               |

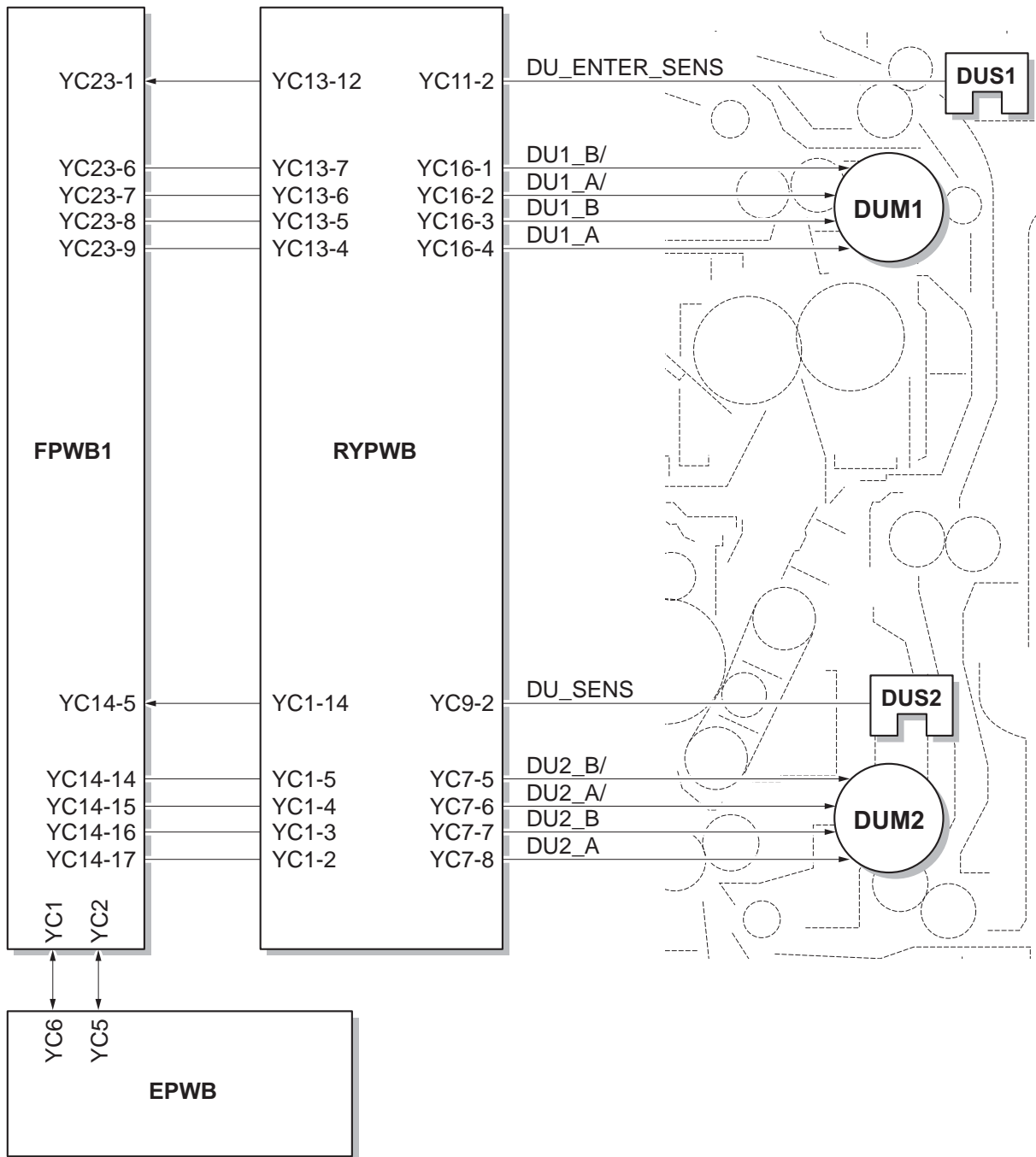
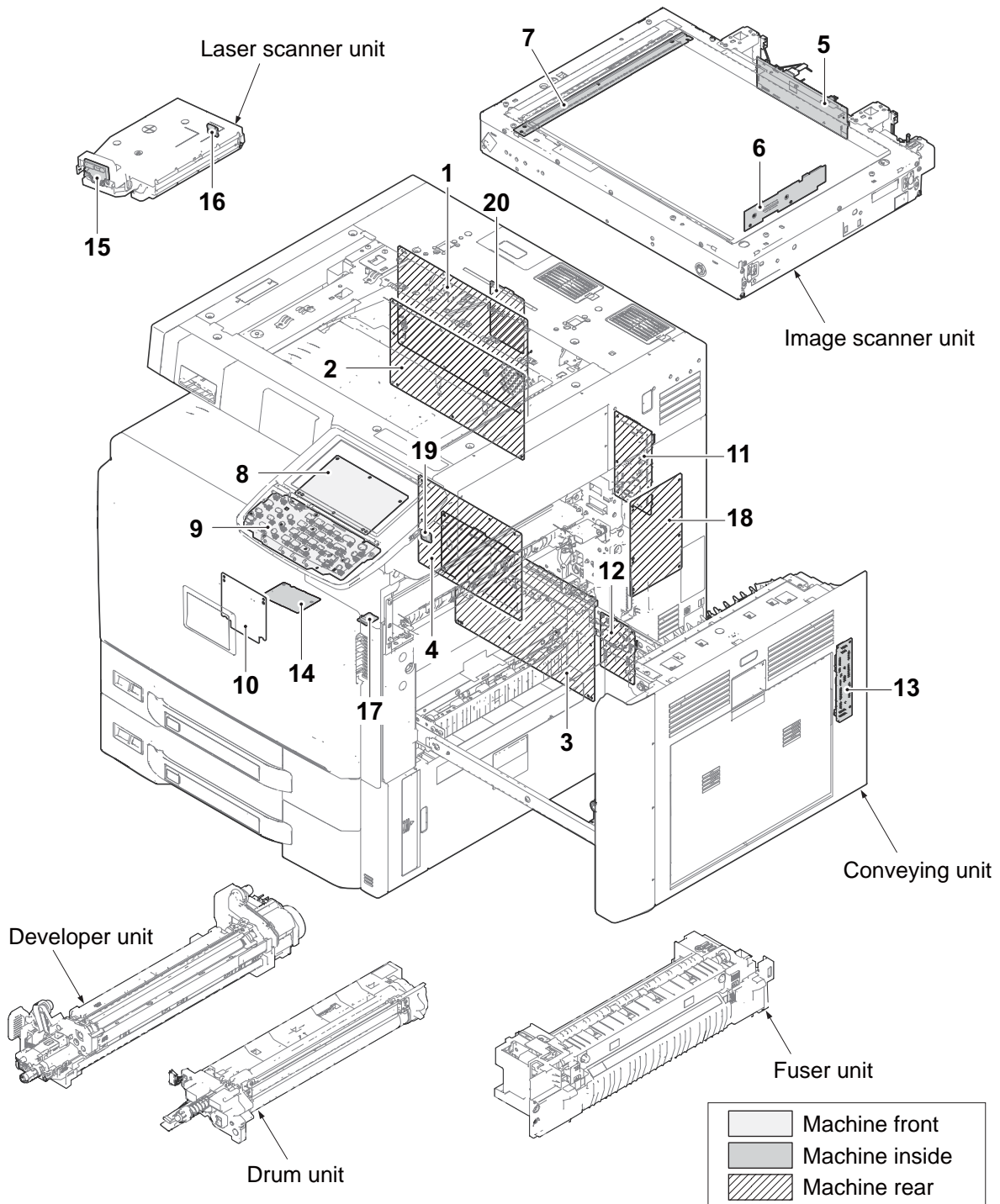


Figure 2-1-24 Duplex conveying section block diagram



## 2-2-1 Electrical parts layout

### (1) PWBs



**Figure 2-2-1 PWBs**

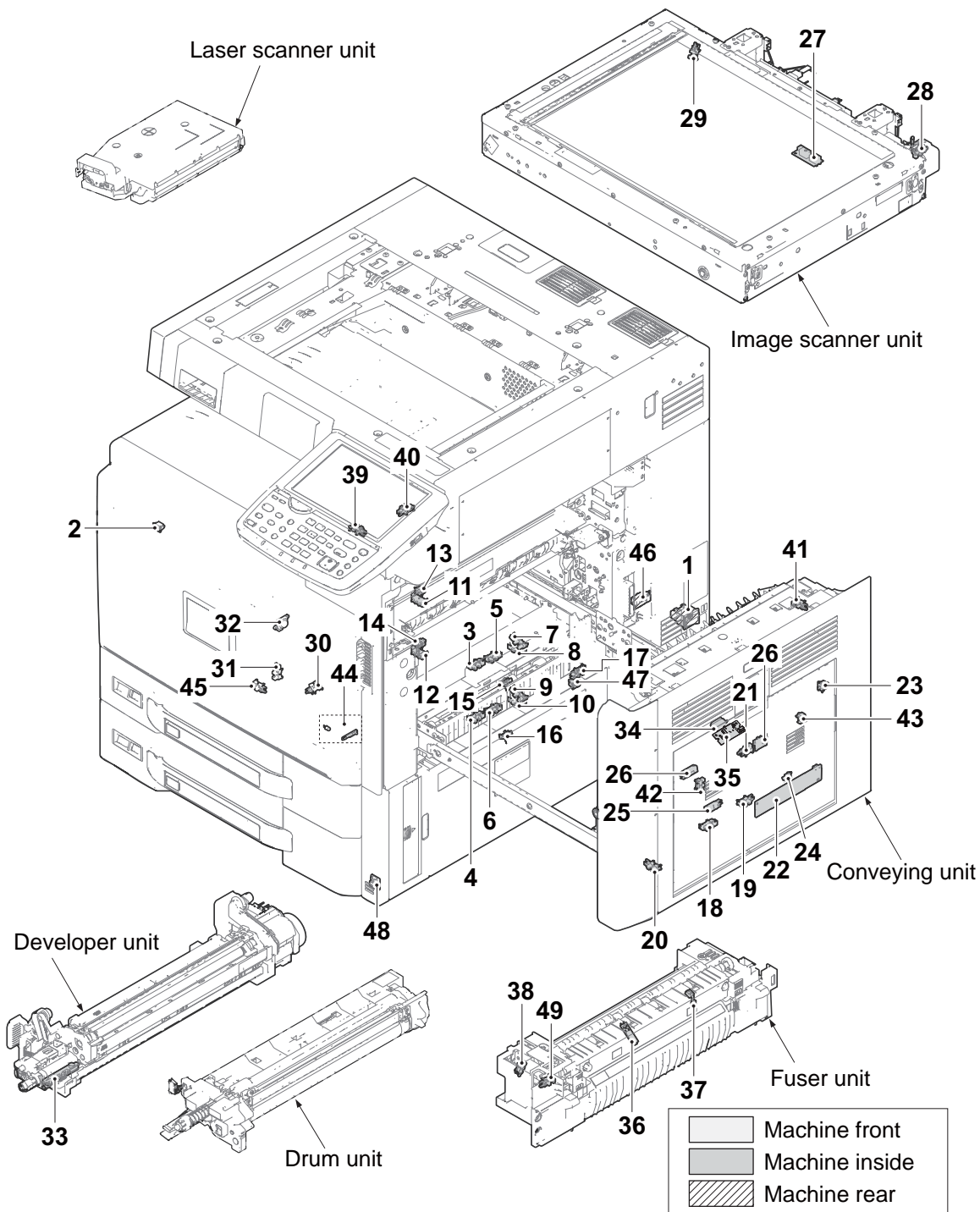
- 1. Main PWB (MPWB) ..... Controls the software such as the print data processing and provides the interface with computers.
- 2. Engine PWB (EPWB)..... Controls printer hardware such as high voltage/bias output control, paper conveying system control, and fuser temperature control, etc.

3. Power source PWB (PSPWB) ..... After full-wave rectification of AC power source input, switching for converting to 24 V DC and 5 V DC for output. Controls the fuser Heater.
4. High voltage PWB (HVPWB) ..... Generates main charging, developer bias, transfer bias and separation bias.
5. ISC PWB (ISCPWB) ..... Controls the scanner section.
6. CCD PWB (CCDPWB)..... Reads the image of originals.
7. LED lamp PWB (LLPWB) ..... Exposes originals.
8. Operation PWB 1 (OPWB1)..... Controls touch panel and LCD indication.
9. Operation PWB 2 (OPWB2)..... Consists of the LED indicators and key switches.
10. Front PWB (FRPWB) ..... Consists of wiring relay circuit between engine PWB and drum units, developer units, eject unit.
11. Feed PWB 1 (FPWB1)..... Consists of wiring relay circuit between engine PWB and fuser drive unit, relay PWB.
12. Feed PWB 2 (FPWB2)..... Consists of wiring relay circuit between engine PWB and paper conveying section, drive section.
13. Relay PWB (RPWB) ..... Consists of wiring relay circuit between feed PWB 1 and paper conveying unit.
14. LSU relay PWB (LSURPWB)..... Consists of wiring relay circuit between engine PWB and laser scanner unit.
15. APC PWB (APCPWB) ..... Generates and controls the laser beam.
16. PD PWB (PDPWB) ..... Controls horizontal synchronizing timing of laser beam.
17. Drum PWB(DRPWB) ..... Drum individual information in EEPROM storage.
18. Fuser heater PWB (FHPWB) ..... Controls the fuser heater.
19. RFID PWB (RFPWB) ..... Reads the container information.
20. Interface PWB (IFPWB) ..... Consists of wiring relay circuits between main PWB and Fax control PWB.

**List of correspondences of PWB names**

<b>No.</b>	<b>Name used in service manual</b>	<b>Name used in parts list</b>
1	Main PWB (MPWB)	PARTS PWB MAIN ASSY SP
2	Engine PWB (EPWB)	PARTS PWB ENGINE ASSY SP
3	Power source PWB (PSPWB)	PARTS UNIT LOW VOLTAGE SP
4	High voltage PWB (HVPWB)	PARTS UNIT HIGH VOLTAGE MAIN SP
5	ISC PWB (ISCPWB)	PARTS PWB ISC ASSY SP
6	CCD PWB (CCDPWB)	-
7	LED lamp PWB (LLPWB)	-
8	Operation PWB 1 (OPWB1)	PARTS PWB PANEL MAIN ASSY J SP
9	Operation PWB 2 (OPWB2)	PARTS PWB OPERATION ASSY SP
10	Front PWB (FRPWB)	PARTS PWB FRONT MONO ASSY SP
11	Feed PWB 1 (FPWB1)	PARTS PWB FEED 1 ASSY SP
12	Feed PWB 2 (FPWB2)	PARTS PWB FEED 2 ASSY SP
13	Relay PWB (RPWB)	PARTS PWB JUNCTION ASSY SP
14	LSU relay PWB (LSURPWB)	PARTS PWB LSU JUNC MONO ASSY SP
15	APC PWB (APCPWB)	-
16	PD PWB (PDPWB)	-
17	Drum PWB (DRPWB)	-
18	Fuser heater PWB (FHPWB)	PARTS PWB HEATER ASSY SP
19	RFID PWB (RFPWB)	PARTS PWB RFID ASSY SP
20	Interface PWB (IFPWB)	PARTS PWB KUIO ASSY SP

**(2) Switches and sensors**

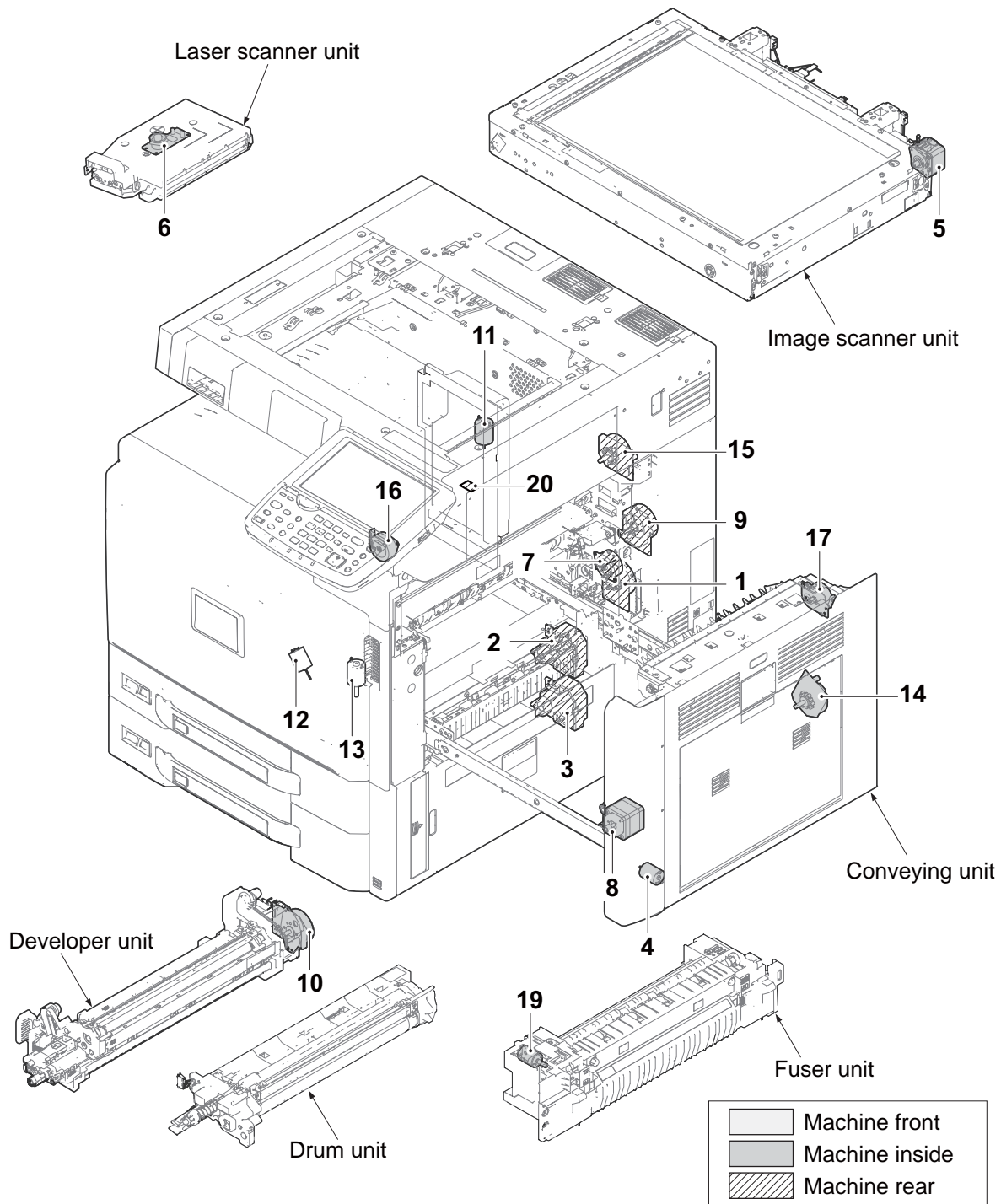


**Figure 2-2-2 Switches and sensors**

- 1. Main power switch (MSW) ..... Turns ON/OFF the AC power source.
- 2. Front cover switch (FRCSW) ..... Detects the opening and closing of the front cover.
- 3. Paper sensor 1 (PS1) ..... Detects the presence of paper (cassette 1).
- 4. Paper sensor 2 (PS2) ..... Detects the presence of paper (cassette 2).
- 5. Lift sensor 1 (LS1)..... Detects activation of upper limit of the bottom plate (cassette 1).
- 6. Lift sensor 2 (LS2)..... Detects activation of upper limit of the bottom plate (cassette 2).
- 7. Paper gauge sensor 1 (U) (PGS1(U))... Detects the paper gauge (cassette 1).
- 8. Paper gauge sensor 1 (L) (PGS1(L)).... Detects the paper gauge (cassette 1).

9. Paper gauge sensor 2 (U) (PGS2(U))... Detects the paper gauge (cassette 2).
10. Paper gauge sensor 2 (L) (PGS2(L)).... Detects the paper gauge (cassette 2).
11. Paper length switch 1 (PLSW1) ..... Detects the length of paper (cassette 1).
12. Paper length switch 2 (PLSW2) ..... Detects the length of paper (cassette 2).
13. Paper width switch 1 (PWSW1) ..... Detects the width of paper (cassette 1).
14. Paper width switch 2 (PWSW2) ..... Detects the width of paper (cassette 2).
15. Feed sensor 1 (FS1) ..... Detects a paper misfeed in the paper feed section (cassette 1).
16. Feed sensor 2 (FS2) ..... Detects a paper misfeed in the paper feed section (cassette 2).
17. Paper conveying sensor (PCS)..... Detects a paper misfeed in the vertical conveying section.
18. MP paper sensor (MPPS) ..... Detects the presence of paper (MP tray).
19. MP lift sensor 1 (MPLS1) ..... Detects activation of upper limit of the MP plate.
20. MP lift sensor 2 (MPLS2) ..... Detects activation of lower limit of the MP plate.
21. MP paper length switch (MPPLSW)..... Detects the length of paper (MP tray).
22. MP paper width switch (MPPWSW)..... Detects the width of paper (MP tray).
23. MP tray switch (MPTSW) ..... Detects the MP tray extension is extend.
24. MP feed sensor (MPFS) ..... Detects a paper misfeed in the MP paper feed section.
25. Middle sensor (MS) ..... Detects a paper misfeed in the paper conveying section.
26. Registration sensor (RS)..... Controls the secondary paper feed start timing.
27. Original size sensor (OSS) ..... Detects the size of the original.
28. Original detection switch (ODSW) ..... Detects the opening/closing of the document processor.
29. Home position sensor (HPS) ..... Detects the optical system in the home position.
30. Screw sensor (SRS) ..... Controls the toner replenishing for the toner container.
31. Developer shutter sensor (DEVSS) ..... Detects the opening and closing of the developer shutter.
32. Toner hopper sensor (THS) ..... Detects the quantity of toner in a toner hopper.
33. Toner sensor (TS) ..... Detects the toner density in the developer unit.
34. Loop sensor (LPS) ..... Detects a paper misfeed. Controls the fuser motor by detecting deflection in the paper.
35. ID sensor (IDS) ..... Measures image density for calibration.
36. Fuser thermistor 1 (FTH1) ..... Detects the heat roller temperature.
37. Fuser thermistor 2 (FTH2) ..... Detects the heat roller temperature.
38. Fuser release sensor (FURS) ..... Detects fuser pressure release setting (envelope mode).
39. Eject full sensor (EFS) ..... Detects a paper misfeed in the eject section. Detects when the inner tray is full.
40. Switchback sensor (SBS) ..... Detects a paper misfeed in the eject and switchback sections.
41. Duplex sensor 1 (DUS1) ..... Detects a paper misfeed in the duplex section.
42. Duplex sensor 2 (DUS2) ..... Detects a paper misfeed in the duplex section.
43. Duplex cover switch (DUCSW) ..... Detects the opening and closing of the duplex cover.
44. Waste toner sensor 1 (WTS1)..... Detects when the waste toner box is full.
45. Waste toner sensor 2 (WTS2)..... Detects when the waste toner box is near full.
46. Paper conveying unit switch  
(PCUSW) ..... Detects the opening and closing of the paper conveying unit.
47. Paper conveying cover switch  
(DUCSW) ..... Detects the opening and closing of the paper conveying cover.
48. Outer temperature sensor  
(OTEMS)..... Detects the outside temperature and humidity.
49. Fuser eject sensor (FUES) ..... Detects a paper misfeed in the fuser section.

**(3) Motors**



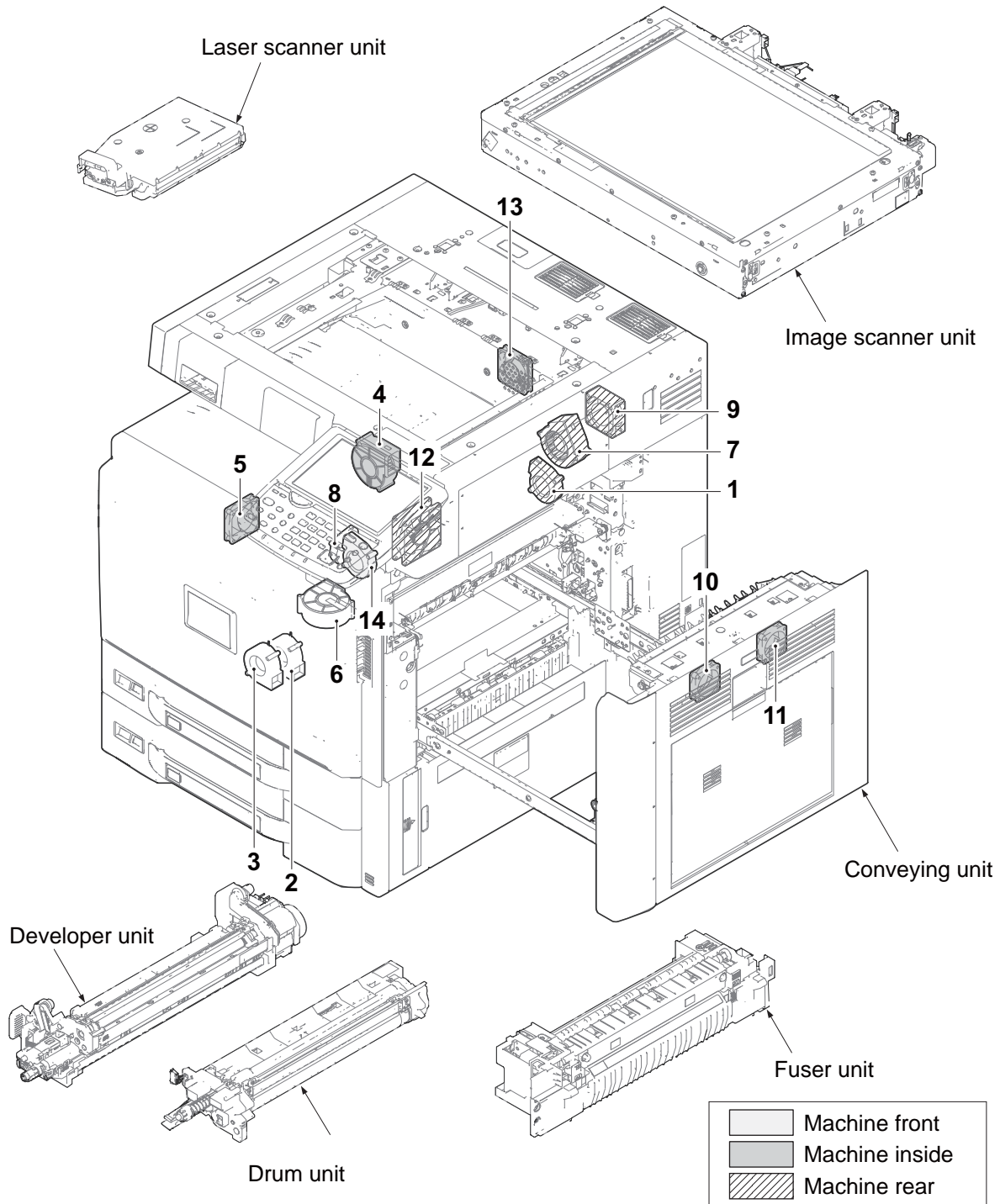
**Figure 2-2-3 Motors**

- 1. Paper feed motor (PFM) ..... Drives the paper feed section.
- 2. Lift motor 1 (LM1)..... Operates the bottom plate (cassette 1).
- 3. Lift motor 2 (LM2)..... Operates the bottom plate (cassette 2).
- 4. MP lift motor (MPLM) ..... Operates the MP plate.
- 5. Scanner motor (SM)..... Drives the optical system.
- 6. Polygon motor (PM) ..... Drives the polygon mirror.
- 7. Registration motor (RM)\* ..... Drives the registration section.
- 8. Middle motor (MM)\* ..... Drives the paper conveying section.

9. Drum motor (DRM) ..... Drives the drum unit.
10. Developer motor (DEV)..... Drives the developer unit.
11. Toner motor (TM) ..... Drives the toner container.
12. Toner hopper motor (THM) ..... Replenishes toner to the developer unit.
13. Inner motor (INM)..... Drives the inner unit.
14. Transfer motor (TRM) ..... Drives the transfer section.
15. Fuser motor (FUM) ..... Drives the fuser section.
16. Eject motor (EM) ..... Drives the eject section.
17. Duplex motor 1 (DUM1)\* ..... Drives the duplex section.
18. Duplex motor 2 (DUM2)\* ..... Drives the duplex section.
19. Fuser release motor (FURM) ..... Drives fuser pressure release.
20. Toner vibration motor (TVM) ..... Vibration of the filter inside the waste toner box.

\*: 45 ppm/ 55 ppm model only

**(4) Fan motors**



**Figure 2-2-4 Motors**

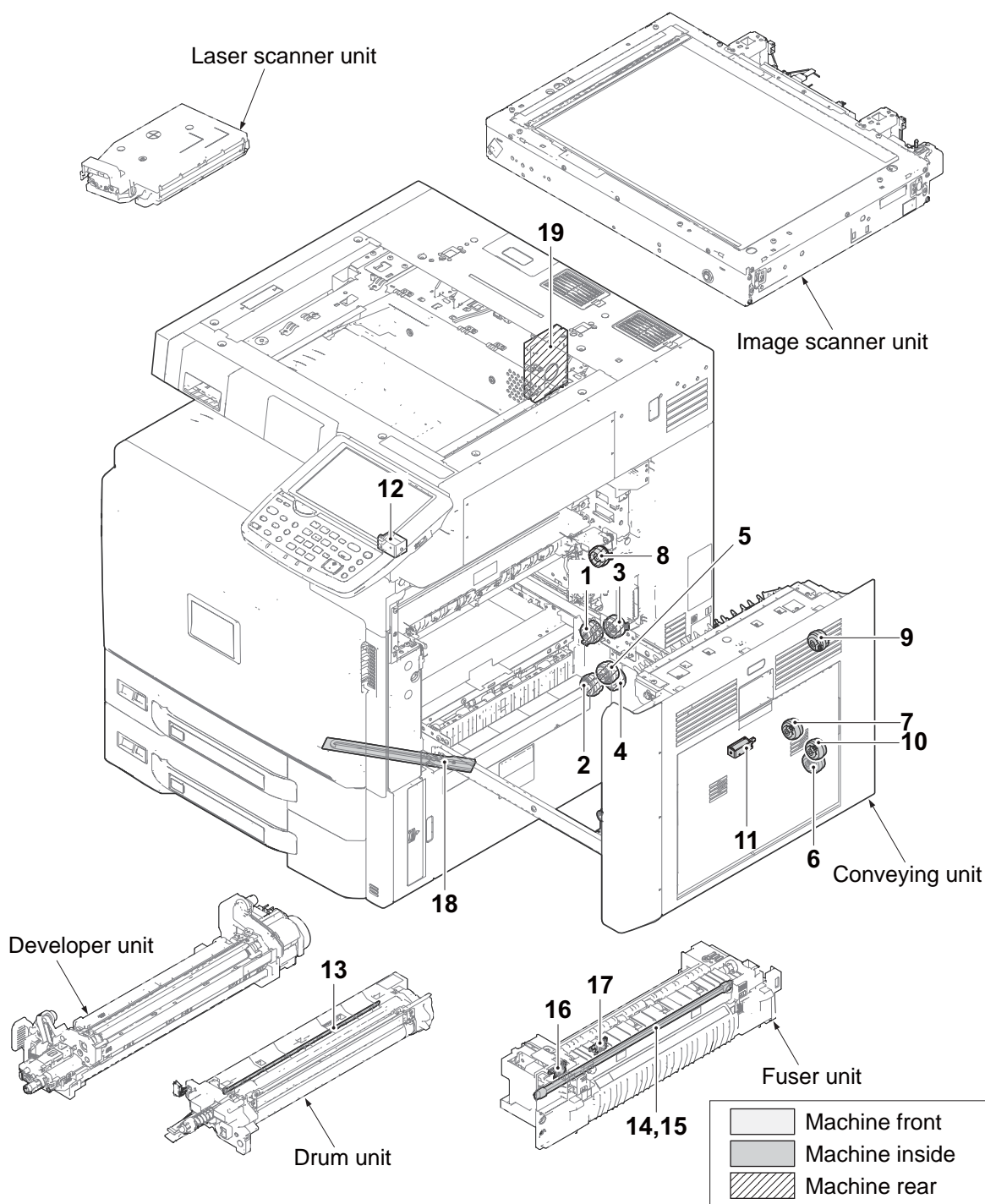
- 1. Toner fan motor (TFM) ..... Cools the toner container section.
- 2. Developer fan motor 1 (DEVM1)\* ..... Cools the developer section.
- 3. Developer fan motor 2 (DEVM2) ..... Cools the developer section.
- 4. Exhaust fan motor (EXFM) ..... Cools the machine inside.
- 5. LSU fan motor (LSUFM)\* ..... Cools the laser scanner unit section.
- 6. Fuser front fan motor (FUFFM) ..... Cools the fuser section (front side).
- 7. Fuser rear fan motor (FURFM) ..... Cools the fuser section (rear side).
- 8. Eject front fan motor (EFFM) ..... Cools the eject section (front side).



- 9. Eject rear fan motor (ERFM) ..... Cools the eject section (rear side).
- 10. Eject fan motor 1 (EFM1) ..... Cools the eject section.
- 11. Eject fan motor 2 (EFM2) ..... Cools the eject section.
- 12. Power source fan motor (PSFM) ..... Cools the power source section.
- 13. Controller fan motor (CONFM) ..... Cools the controller section.
- 14. Eject diffusion fan motor (EDFM) ..... Cools the eject section.

\*: 45 ppm/ 55 ppm model only

**(5) Others**



**Figure 2-2-5 Others**

- 1. Paper feed clutch 1 (PFCL1) ..... Primary paper feed from cassette 1.
- 2. Paper feed clutch 2 (PFCL2) ..... Primary paper feed from cassette 2.
- 3. Assist clutch 1 (ASCL1) ..... Controls the drive of the assist roller (cassette 1).
- 4. Assist clutch 2 (ASCL2) ..... Controls the drive of the assist roller (cassette 2).
- 5. Paper conveying clutch (PCCL) ..... Controls the drive of vertical conveying section.
- 6. MP paper feed clutch (MPPFCL) ..... Controls primary paper feed from the MP tray.
- 7. Middle clutch (MCL)\* ..... Controls the drive of paper conveying section.
- 8. Registration clutch (RCL)\* ..... Controls the secondary paper feed.

- 9. Duplex clutch 1 (DUCL1)\* ..... Controls the drive of duplex section.
- 10. Duplex clutch 2 (DUCL2)\* ..... Controls the drive of duplex section.
- 11. Cleaning solenoid (CLSOL) ..... Controls the ID sensor cleaning.
- 12. Feedshift solenoid (FSSOL)..... Controls the feedshift guide.
- 13. Cleaning lamp (CL) ..... Eliminates the residual electrostatic charge on the drum.
- 14. Fuser heater 1 (FH1) ..... Heats the heat roller.
- 15. Fuser heater 2 (FH2) ..... Heats the heat roller.
- 16. Fuser thermostat 1 (FTS1)..... Prevents overheating of the heat roller.
- 17. Fuser thermostat 2 (FTS2)..... Prevents overheating of the heat roller.
- 18. Cassette heater (CH) ..... Dehumidifies the cassette section (option).
- 19. Hard disk (HDD)..... Stores the image data and information of job accounting mode.

\*: 35 ppm model only

This page is intentionally left blank.



Connector	Pin	Signal	I/O	Voltage	Description
<b>YC1</b>	1	GND	-	-	Ground
Connected to hard disk1	2	TXP	O	-	HDD data signal
	3	TXN	O	-	HDD data signal
	4	GND	-	-	Ground
	5	RXN	I	-	HDD data signal
	6	RXP	I	-	HDD data signal
	7	GND	-	-	Ground
<b>YC2</b>	1	GND	-	-	Ground
Connected to hard disk2	2	TXP	O	-	HDD data signal
	3	TXN	O	-	HDD data signal
	4	GND	-	-	Ground
	5	RXN	I	-	HDD data signal
	6	RXP	I	-	HDD data signal
	7	GND	-	-	Ground
<b>YC5</b>	1	TD1+	O	0/3.3 V DC (pulse)	Transmission data
Connected to ethernet	2	TD1-	O	0/3.3 V DC (pulse)	Transmission data
	3	TD2+	O	0/3.3 V DC (pulse)	Transmission data
	4	TD2-	O	0/3.3 V DC (pulse)	Transmission data
	5	CT1	O	3.3 V DC	3.3 V DC power output
	6	CT2	O	3.3 V DC	3.3 V DC power output
	7	TD3+	O	0/3.3 V DC (pulse)	Transmission data
	8	TD3-	O	0/3.3 V DC (pulse)	Transmission data
	9	TD4+	O	0/3.3 V DC (pulse)	Transmission data
	10	TD4-	O	0/3.3 V DC (pulse)	Transmission data
	11	GRLED_A1	O	0/3.3 V DC	LED emitter signal
	12	GRLED_K1	O	0/3.3 V DC	LED emitter signal
	13	YWLED_A2	O	0/3.3 V DC	LED emitter signal
	14	YWLED_K2	O	0/3.3 V DC	LED emitter signal
	<b>YC6</b>	1	GND	-	-
Connected to operation panel PWB1	2	LCD_OFF	O	0/3.3 V DC	Control signal
	3	LOCKN	O	0/3.3 V DC	Lock signal
	4	GND	-	-	Ground
	5	TX0N	O	0/3.3 V DC (pulse)	Transmission data signal
	6	TX0P	O	0/3.3 V DC (pulse)	Transmission data signal
	7	GND	-	-	Ground

Connector	Pin	Signal	I/O	Voltage	Description
<b>YC7</b>	1	KMDET	I	0/3.3 V DC	KMAS set signal
Connected to KMAS	2	NC	-	-	Not used
	3	KMDREQ	I	0/3.3 V DC	KMAS control signal
	4	KMACK	O	0/3.3 V DC	KMAS control signal
	5	KMRXD	O	0/3.3 V DC (pulse)	KMAS received data signal
	6	SGND	-	-	Ground
	7	KMTXD	I	0/3.3 V DC (pulse)	KMAS transmission data signal
	8	SGND	-	-	Ground
	9	SGND	-	-	Ground
	10	SGND	-	-	Not used
	11	+5V	O	5 V DC	5 V DC power to KMAS
	12	NC	-	-	Not used
<b>YC8</b>	1	RESET0	I	0/3.3 V DC	Reset signal
Connected to interface PWB	2	WAKEUP0	O	0/3.3 V DC	Control signal
	3	AUDIO0	I	Analog	Audio signal
	4	GND	-	-	Ground
	5	USB_DP0	I/O	-	USB data signal
	6	USB_DN0	I/O	-	USB data signal
	7	VBUS0	O	3.3 V DC	3.3 V DC power to IFPWB
	8	GND	-	-	Ground
	9	RESET1	I	0/3.3 V DC	Reset signal
	10	WAKEUP1	O	0/3.3 V DC	Control signal
	11	AUDIO1	I	Analog	Audio signal
	12	GND	-	-	Ground
	13	USB_DP1	I/O	-	USB data signal
	14	USB_DN1	I/O	-	USB data signal
	15	VBUS1	O	3.3 V DC	3.3 V DC power to IFPWB
<b>YC9</b>	1	GND	-	-	Ground
Connected to interface PWB	2	5V_CUT0	I	0/3.3 V DC	5 V DC cut signal
	3	GND	-	-	Ground
	4	5V	O	5 V DC	5 V DC power to IFPWB
	5	GND	-	-	Ground
	6	5V_CUT1	I	0/3.3 V DC	5 V DC cut signal

Connector	Pin	Signal	I/O	Voltage	Description
<b>YC10</b>	1	DP_CONECTN	I	0/3.3 V DC	DPRPWB Control signal
Connected to DP relay PWB	2	DP_SYSCLKOUT	O	0/3.3 V DC (pulse)	DPRPWB clock signal
	3	PCIEN3_DP2A	I	0/3.3 V DC (pulse)	Image data signal
	4	GND	-	-	Ground
	5	PCIEP3_DP2A	I	0/3.3 V DC (pulse)	Image data signal
	6	GND	-	-	Ground
	7	GND	-	-	Ground
	8	PCIEN_REFCLK_ DP	O	0/3.3 V DC (pulse)	DPRPWB clock signal
	9	GND	-	-	Ground
	10	PCIEP_REFCLK_ DP	O	0/3.3 V DC (pulse)	DPRPWB clock signal
	11	PCIEN3_A2DP	O	0/3.3 V DC (pulse)	Image data signal
	12	GND	-	-	Ground
	13	PCIEP3_A2DP	O	0/3.3 V DC (pulse)	Image data signal
	14	GND	-	-	Ground
	15	GND	-	-	Ground
	16	URAN_RSTN	O	0/3.3 V DC	DPRPWB Control signal
	17	PCIEN2_DPA2	I	0/3.3 V DC (pulse)	Image data signal
	18	+3.3V3	-	3.3 V DC	3.3 V DC power to DPRPWB
	19	PCIEP2_DP2A	I	0/3.3 V DC (pulse)	Image data signal
	20	+3.3V3	-	3.3 V DC	3.3 V DC power to DPRPWB
	21	GND	-	-	Ground
	22	+3.3V3	-	3.3 V DC	3.3 V DC power to DPRPWB
	23	PCIEN2_A2DP	O	0/3.3 V DC (pulse)	Image data signal
	24	+3.3V3	-	3.3 V DC	3.3 V DC power to DPRPWB
	25	PCIEP2_A2DP	O	0/3.3 V DC (pulse)	Image data signal
	26	+3.3V3	-	3.3 V DC	3.3 V DC power to DPRPWB
	27	GND	-	-	Ground
	28	+3.3V3	-	3.3 V DC	3.3 V DC power to DPRPWB
	29	PCIEN1_DPA2	I	0/3.3 V DC (pulse)	Image data signal
	30	+3.3V3	-	3.3 V DC	3.3 V DC power to DPRPWB
	31	PCIEP1_DPA2	I	0/3.3 V DC (pulse)	Image data signal
	32	+3.3V3	-	3.3 V DC	3.3 V DC power to DPRPWB
	33	GND	-	-	Ground
	34	+3.3V3	-	3.3 V DC	3.3 V DC power to DPRPWB
	35	PCIEN1_A2DP	O	0/3.3 V DC (pulse)	Image data signal
	36	GND	-	-	Ground



Connector	Pin	Signal	I/O	Voltage	Description
YC10 Connected to DP relay PWB	37	PCIEP1_A2DP	O	0/3.3 V DC (pulse)	Image data signal
	38	GND	-	-	Ground
	39	GND	-	-	Ground
	40	GND	-	-	Ground
	41	PCIEN0_DPA2	I	0/3.3 V DC (pulse)	Image data signal
	42	GND	-	-	Ground
	43	PCIEN0_DPA2	I	0/3.3 V DC (pulse)	Image data signal
	44	GND	-	-	Ground
	45	GND	-	-	Ground
	46	PCIEN0_A2DP	O	0/3.3 V DC (pulse)	Image data signal
	47	GND	-	-	Ground
	48	PCIEP0_A2DP	O	0/3.3 V DC (pulse)	Image data signal
	49	PCIE3_SWRST_A2DP	O	0/3.3 V DC (pulse)	DPRPWB clock signal
	50	GND	-	-	Ground
YC11 Connected to ISC PWB	1	GND	-	-	Ground
	2	SC_IRN	O	0/3.3 V DC	Scanner interrupt signal
	3	SC_DIR	O	0/3.3 V DC	Scanner communication direction signal
	4	SC_HLDN	O	0/3.3 V DC	Scanner hold signal
	5	SC_BSY	O	0/3.3 V DC	Scanner busy signal
	6	SC_SI	O	0/3.3 V DC (pulse)	Serial communication data signal
	7	SC_SO	I	0/3.3 V DC (pulse)	Serial communication data signal
	8	SC_CLK	O	0/3.3 V DC (pulse)	Scanner clock signal
YC12 Connected to operation PWB 1	1	BEEP_POWERON	O	0/3.3 V DC	Sleep return signal
	2	ENERGY_SAVE	O	0/3.3 V DC	Energy save signal
	3	SUPND_POWER	O	3.3 V DC	3.3 V D C power to OPWB1
	4	LED_MEMORY_N	O	0/3.3 V DC	Memory LEDcontrol signal
	5	LED_ATTENTION_N	O	0/3.3 V DC	Attention LEDcontrol signal
	6	LED_PROCESSING_N	O	0/3.3 V DC	Processing LEDcontrol signal
	7	SHUT_DOWN	O	0/3.3 V DC	24V down signal
	8	LIGHTOFF_POWERON	O	0/3.3 V DC	Sleep return signal
	9	AUDIO	O	Analog	Audio output signal

Connector	Pin	Signal	I/O	Voltage	Description
<b>YC12</b> Connected to operation PWB 1	10	PANEL RESET	O	0/3.3 V DC	Reset signal
	11	INT_POWERKEY_N	I	0/3.3 V DC	Power key: On/Off
	12	PANEL_STATUS	I	0/3.3 V DC	Operation panel status signal
	13	GND	-	-	Ground
<b>YC20</b> Connected to USB	A1	VBUS_A	O	5 V DC	5 V DC power output
	A2	D-_A	I/O	-	USB data signal
	A3	D+_A	I/O	-	USB data signal
	A4	GND_A	-	-	Ground
	B1	VBUS_B	O	5 V DC	5 V DC power output
	B2	D-_B	I/O	-	USB data signal
	B3	D+_B	I/O	-	USB data signal
	B4	GND_B	-	-	Ground
<b>YC21</b> Connected to USB host	1	VBUS	O	5 V DC	5 V DC power output
	2	DATA -	I/O	-	USB data signal
	3	DATA +	I/O	-	USB data signal
	4	ID	-	-	Not used
	5	GND	-	-	Ground
<b>YC22</b> Connected to key board	1	VBUS	O	5 V DC	5 V DC power output
	2	DATA-	I/O	-	USB data signal
	3	DATA+	I/O	-	USB data signal
	4	ID	-	-	Not used
	5	GND	-	-	Ground
<b>YC23</b> Connected to controller fan motor	1	SPEED_CONTR OL	O	0/5 V DC	CONFM: On/Off
	2	GND	-	-	Ground
	3	5V	O	5 V D C	5 V DC power output
<b>YC25</b> Connected to ISC PWB	1	GND	-	-	Ground
	2	HTPDN	I	0/3.3 V DC	Control signal
	3	LOCKN	I	0/3.3 V DC	Lock signal
	4	GND	-	-	Ground
	5	RX0N	I	0/3.3 V DC (pulse)	Received data signal
	6	RX0P	I	0/3.3 V DC (pulse)	Received data signal
	7	GND	-	-	Ground

Connector	Pin	Signal	I/O	Voltage	Description
<b>YC26</b> Connected to card reader	1	VBUS	O	5 V DC	5 V DC power output
	2	DATA-	I/O	-	USB data signal
	3	DATA+	I/O	-	USB data signal
	4	ID	-	-	Not used
	5	GND	-	-	Ground
<b>YC27</b> Connected to hard disk 1	1	GND	-	-	Ground
	2	+5V_HDD	O	5 V DC	5 V DC power to HDD1
	3	GND	-	-	Ground
<b>YC30</b> Connected to operation PWB 1	1	+5V6	O	5 V DC	5 V DC power from OPWB1
	2	+5V6	O	5 V DC	5 V DC power from OPWB1
	3	+5V6	O	5 V DC	5 V DC power from OPWB1
	4	GND	-	-	Ground
	5	GND	-	-	Ground
	6	GND	-	-	Ground
<b>YC31</b> Connected to SD card	1	CD/DAT3	I/O	0/3.3 V DC	Control signal
	2	CMD	I/O	0/3.3 V DC	Control signal
	3	VSS	-	-	Ground
	4	VDD	-	0/3.3 V DC	Control signal
	5	CLK	-	0/3.3 V DC	Control signal
	6	VSS	-	-	Ground
	7	DAT0	I/O	0/3.3 V DC (pulse)	Data bus signal
	8	DAT1	I/O	0/3.3 V DC (pulse)	Data bus signal
	9	DAT2	I/O	0/3.3 V DC (pulse)	Data bus signal
	10	CD	I	0/3.3 V DC	Control signal
	11	COMMON	-	0/3.3 V DC	Control signal
	12	WP	I	0/3.3 V DC	Control signal
<b>YC32</b> Connected to hard disk 2	1	GND	-	-	Ground
	2	+5V_HDD	O	5 V DC	5 V DC power to HDD2
	3	GND	-	-	Ground

Connector	Pin	Signal	I/O	Voltage	Description
<b>YC42</b> Connected to power source PWB	1	5V1	I	5 V DC	5 V D C power from PSPWB
	2	GND	-	-	Ground
	3	5V1	I	5 V DC	5 V D C power from PSPWB
	4	GND	-	-	Ground
	5	5V1	I	5 V DC	5 V D C power from PSPWB
	6	GND	-	-	Ground
	7	5V1	I	5 V DC	5 V D C power from PSPWB
	8	GND	-	-	Ground
	9	5V1	I	5 V DC	5 V D C power from PSPWB
	10	GND	-	-	Ground
<b>YC43</b> Connected to engine PWB	1	SLEEP_INT	O	0/3.3 V DC	Engine sleep signal
	2	EGSCLK	O	0/3.3 V DC (pulse)	Engine clock signal
	3	EGSI	O	0/3.3 V DC (pulse)	Serial communication data signal
	4	EGSDIR	O	0/3.3 V DC	Engine communication direction signal
	5	EGSBSY	O	0/3.3 V DC	Engine busy signal
	6	EGSO	I	0/3.3 V DC (pulse)	Serial communication data signal
	7	EGIRN	O	0/3.3 V DC	Engine interrupt signal
	8	JS_LED	O	0/3.3 V DC	LED control signal
	9	ENG_OFF	O	0/3.3 V DC	Engine off signal
	10	HLDENG	O	0/3.3 V DC	Engine hold signal
	11	SLEEP	O	0/3.3 V DC	Sleep signal
	12	HSYNCD_P	O	0/3.3 V DC (pulse)	Image control signal
	13	HSYNCD_N	O	0/3.3 V DC (pulse)	Image control signal
	14	HSYNCC_P	O	0/3.3 V DC (pulse)	Image control signal
	15	HSYNCC_N	O	0/3.3 V DC (pulse)	Image control signal
	16	HSYNCB_P	O	0/3.3 V DC (pulse)	Image control signal
	17	HSYNCB_N	O	0/3.3 V DC (pulse)	Image control signal
	18	HSYNCA_P	O	0/3.3 V DC (pulse)	Image control signal
	19	HSYNCA_N	O	0/3.3 V DC (pulse)	Image control signal
	20	VSYNDD_P	O	0/3.3 V DC (pulse)	Image control signal
	21	VSYNDD_N	O	0/3.3 V DC (pulse)	Image control signal
	22	VSYNCC_P	O	0/3.3 V DC (pulse)	Image control signal
	23	VSYNCC_N	O	0/3.3 V DC (pulse)	Image control signal
	24	VSYNCB_P	O	0/3.3 V DC (pulse)	Image control signal
	25	VSYNCB_N	O	0/3.3 V DC (pulse)	Image control signal
	26	VSYNCA_P	O	0/3.3 V DC (pulse)	Image control signal

Connector	Pin	Signal	I/O	Voltage	Description
YC43	27	VSYNCA_N	O	0/3.3 V DC (pulse)	Image control signal
Connected to engine PWB	28	GND	-	-	Ground
	29	TCLKP	O	0/3.3 V DC (pulse)	Clock signal
	30	TCLKN	O	0/3.3 V DC (pulse)	Clock signal
	31	GND	-	-	Ground
	32	TCP	O	0/3.3 V DC (pulse)	Image control signal
	33	TCN	O	0/3.3 V DC (pulse)	Image control signal
	34	GND	-	-	Ground
	35	TBP	O	0/3.3 V DC (pulse)	Image control signal
	36	TBN	O	0/3.3 V DC (pulse)	Image control signal
	37	GND	-	-	Ground
	38	TAP	O	0/3.3 V DC (pulse)	Image control signal
	39	TAN	O	0/3.3 V DC (pulse)	Image control signal
	40	GND	-	-	Ground
	41	SGND	-	-	Not used
	42	SGND	-	-	Not used
	43	SGND	-	-	Not used
	44	SGND	-	-	Not used
	45	SGND	-	-	Not used
	46	SGND	-	-	Not used

### 2-3-2 Engine PWB

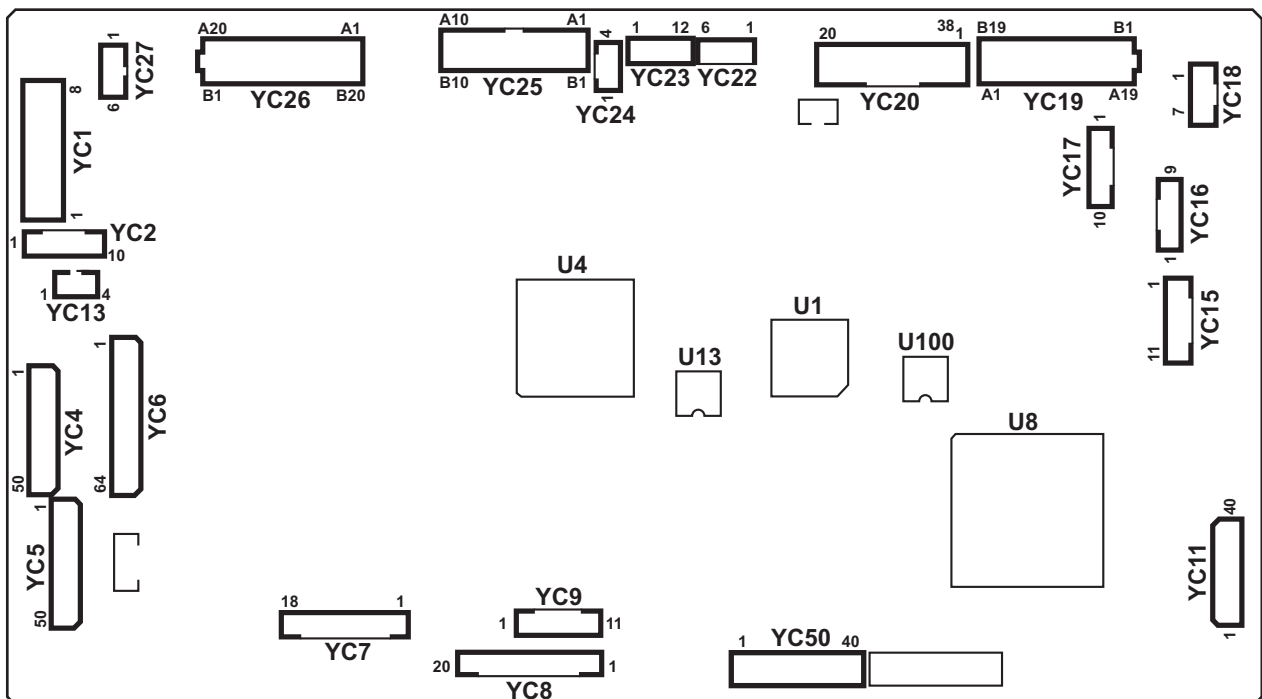


Figure 2-3-2 Engine PWB silk-screen diagram

Connector	Pin	Signal	I/O	Voltage	Description
<b>YC1</b> Connected to feed PWB 1	1	GND	-	-	Ground
	2	+5V	I	5 V DC	5 V DC power from FPWB1
	3	GND	-	-	Ground
	4	5V0	I	5V DC	5 V DC power from FPWB1
	5	GND	-	-	Ground
	6	GND	-	-	Ground
	7	+24V1	I	24 V DC	24 V DC power from FPWB1
	8	+24V1	I	24 V DC	24 V DC power from FPWB1
<b>YC2</b> Connected to front PWB	1	GND	-	-	Ground
	2	GND	-	-	Ground
	3	GND	-	-	Ground
	4	GND	-	-	Ground
	5	GND	-	-	Ground
	6	+24V	O	24 V DC	24 V DC power to FRPWB
	7	+24V	O	24 V DC	24 V DC power to FRPWB
	8	+5V	O	5 V DC	5 V DC power to FRPWB
	9	+3.3V2	O	3.3 V DC	3.3 V DC power to FRPWB
	10	+3.3V1	O	3.3 V DC	3.3 V DC power to FRPWB
<b>YC4</b> Connected to feed PWB 2	1	GND	-	-	Ground
	2	FEED_MOT_REM	O	0/3.3 V DC	PFM: On/Off
	3	FEED_MOT_CLK	O	0/3.3 V DC (pulse)	PFM clock signal
	4	FEED_MOT_RDY	I	0/3.3 V DC	PFM ready signal
	5	FEED_MOT_DIR	O	0/3.3 V DC	PFM drive switch signal
	6	FEED_CL1_REM	O	0/24 V DC	PFCL1: On/Off
	7	FEED_CL2_REM	O	0/24 V DC	PFCL2: On/Off
	8	ASIST_CL2	O	0/24 V DC	ASCL2: On/Off
	9	LIFT_MOT2_REM	O	0/24 V DC	LM2: On/Off
	10	GND	-	-	Ground
	11	LIFT_MOT1_REM1	O	0/24 V DC	LM1: On/Off
	12	CAS2_WID	I	0/3.3 V DC	PWSW2: On/Off
	13	CAS2_LNG3	I	0/3.3 V DC	PLSW2: On/Off
	14	CAS2_LNG2	I	0/3.3 V DC	PLSW2: On/Off
	15	CAS2_LNG1	I	0/3.3 V DC	PLSW2: On/Off
	16	CAS1_WID	I	0/3.3 V DC	PWSW1: On/Off
	17	CAS1_LNG3	I	0/3.3 V DC	PLSW1: On/Off

Connector	Pin	Signal	I/O	Voltage	Description
YC4	18	CAS1_LNG2	I	0/3.3 V DC	PLSW1: On/Off
Connected to feed PWB 2	19	CAS1_LNG1	I	0/3.3 V DC	PLSW1: On/Off
	20	GND	-	-	Ground
	21	CAS2_QUANT2	I	0/3.3 V DC	PGS2(L): On/Off
	22	CAS2_QUANT1	I	0/3.3 V DC	PGS2(U): On/Off
	23	CAS1_QUANT2	I	0/3.3 V DC	PGS1(L): On/Off
	24	CAS1_QUANT1	I	0/3.3 V DC	PGS1(U): On/Off
	25	LIFT_MOT1_LOCK	I	0/3.3 V DC	LM1 lock signal
	26	LIFT_MOT2_LOCK	I	0/3.3 V DC	LM2 lock signal
	27	CURRENT_SIG	I	0/3.3 V DC	Current signal
	28	V-FEED_CL	O	0/24 V DC	PCCL: On/Off
	29	COVER_OPEN	I	0/3.3 V DC	PCCSW: On/Off
	30	FEED2_SENS	I	0/3.3 V DC	PFPCS1: On/Off
	31	CAS1_P0	I	0/3.3 V DC	FS1: On/Off
	32	CAS1_LIFT_UP	I	0/3.3 V DC	LS1: On/Off
	33	GND	-	-	Ground
	34	CAS1_EMPTY	I	0/3.3 V DC	PS1: On/Off
	35	PICK_SOL1_RET	O	0/24 V DC	PUSOL1: On/Off (RET)
	36	PICK_SOL1_REM	O	0/24 V DC	PUSOL1: On/Off (ACT)
	37	CAS2_P0	I	0/3.3 V DC	FS2: On/Off
	38	CAS2_LIFT_UP	I	0/3.3 V DC	LS2: On/Off
	39	CAS2_EMPTY	I	0/3.3 V DC	PS2: On/Off
	40	PICK_SOL2_RET	O	0/24 V DC	PUSOL2: On/Off (RET)
	41	PICK_SOL2_REM	O	0/24 V DC	PUSOL2: On/Off (ACT)
	42	GND	-	-	Ground
	43	REG_SENS	I	0/3.3 V DC	RS: On/Off
	44	FEED1_SENS	I	0/3.3 V DC	PCS: On/Off
	45	BEND_SENS	I	0/3.3 V DC	RDS: On/Off
	46	MID_MOT_PH	O	0/3.3 V DC	MM control signal
	47	MID_MOT_REM(R OL_CL)	O	0/3.3 V DC	MM/MCL: On/Off
	48	MID_MOT_CLK	O	0/3.3 V DC (pulse)	MM clock signal
	49	MID_MOT_PD	O	0/3.3 V DC	MM control signal
	50	ASIST_CL1	O	0/24 V DC	ASCL1: On/Off



Connector	Pin	Signal	I/O	Voltage	Description
YC5	1	GND	-	-	Ground
Connected to feed PWB 1	2	M_TEMP	-	-	Not used
	3	LOOP_SENS	I	0/3.3 V DC	LPS: On/Off
	4	GND	-	-	Ground
	5	EDGE_FAN_H	O	0/24 V DC	FUFM: On/Off
	6	DU1_MOT_PD	O	0/3.3 V DC	DUM1 control signal
	7	DU1_MOT_CLK	O	0/3.3 V DC (pulse)	DUM1 clock signal
	8	DU1_MOT_REM(C L_H)	O	0/3.3 V DC	DUM1/DUCL1: On/Off
	9	GND	-	-	Ground
	10	EXIT_FAN	O	0/24 V DC	EFM: On/Off
	11	DU_ENTER_SENS	I	0/3.3 V DC	DUS1: On/Off
	12	TCON_SET	-	-	Not used
	13	GND	-	-	Ground
	14	TRANS_REM	O	0/3.3 V DC	TRCM:On/Off
	15	TRANS_CLK	O	0/3.3 V DC (pulse)	TRCM clock signal
	16	TRANS_RDY	I	0/3.3 V DC	TRCM ready signal
	17	TRANS_DIR	O	0/3.3 V DC	TRCM drive switch signal
	18	TRANS_BRK	O	0/3.3 V DC	TRCM break signal
	19	GND	-	-	Ground
	20	DRM_BK_REM	-	-	Not used
	21	DRM_BK_RDY	-	-	Not used
	22	DRM_MOT_BK_DI R	-	-	Not used
	23	DRM_MOT_BK_B RK	-	-	Not used
	24	GND	-	-	Ground
	25	DLP_BK_REM	-	-	Not used
	26	DLP_BK_CLK	-	-	Not used
	27	DLP_BK_RDY	-	-	Not used
	28	DLP_BK_DIR	-	-	Not used
	29	GND	-	-	Ground
	30	DRM_CLR_REM	-	-	Not used
	31	DRM_BK_CLR_CL K	-	-	Not used
	32	DRM_CLR_RDY	-	-	Not used
	33	DRM_CLR_DIR	-	-	Not used
	34	GND	-	-	Ground

Connector	Pin	Signal	I/O	Voltage	Description
YC5	35	DLP_CLR_REM	-	-	Not used
Connected to feed PWB 1	36	DLP_CLR_CLK	-	-	Not used
	37	DLP_CLR_RDY	-	-	Not used
	38	DLP_CLR_DIR	-	-	Not used
	39	GND	-	-	Ground
	40	REG_MOT_PD	O	0/3.3 V DC	RM control signal
	41	REG_MOT_CLK	O	0/3.3 V DC (pulse)	RM clock signal
	42	REG_MOT_REM(C L)	O	0/3.3 V DC	RM: On/Off
	43	GND	-	-	Ground
	44	IH_FAN_L	O	0/24 V DC	IHFM: On/Off
	45	IH_FAN_H	O	0/24 V DC	IHFM: On/Off
	46	IH_PWB_FAN_AL M(B)	I	0/3.3 V DC	IHFM alarm signal
	47	POWER_OFF_24V 1	O	0/3.3 V DC	Power off signal
	48	DRM_HEAT	-	-	Not used
	49	GND	-	-	Ground
	50	GND	-	-	Ground

Connector	Pin	Signal	I/O	Voltage	Description
YC6	1	GND	-	-	Ground
Connected to feed PWB 1	2	JOB_SET	I	0/3.3 V DC	Job separator set signal
	3	JOB_MOT_REM	O	0/3.3 V DC	JSEM: On/Off
	4	JOB_MOT_CLK	O	0/3.3 V DC (pulse)	JSEM clock signal
	5	JOB_MOT_DIR	O	0/3.3 V DC	JSEM drive switch signal
	6	JOB_OPEN_SENS	I	0/3.3 V DC	JSOCS: On/Off
	7	JOB_SOL_REM	O	0/24 V DC	JSFSSOL: On/Off
	8	GND	-	-	Ground
	9	MAIN_HEAT	O	0/3.3 V DC	FH1: On/Off
	10	PRESS_SUB_HEAT_REM	O	0/3.3 V DC	FH2: On/Off
	11	ZEROC	O	0/3.3 V DC (pulse)	zerocross signal
	12	FSR_RELAY	O	0/3.3 V DC	Fuser relay signal
	13	PRESS_REM	-	-	Not used
	14	EXIT_REAR_FAN_L	O	0/24 V DC	ERFM: On/Off
	15	EXIT_REAR_FAN_H	O	0/24 V DC	ERFM: On/Off
	16	GND	-	-	Ground
	17	GND	-	-	Ground
	18	FSR_MOT_REM	O	0/3.3 V DC	FUM: On/Off
	19	FSR_MOT_CLK	O	0/3.3 V DC (pulse)	FUM clock signal
	20	FSR_MOT_RDY	O	0/3.3 V DC	FUM ready signal
	21	FSR_MOT_DIR	O	0/3.3 V DC	FUM drive switch signal
	22	FSR_MOT_BRAKE	O	0/3.3 V DC	FUM break signal
	23	GND	-	-	Ground
	24	MPF_TABLE	I	0/3.3 V DC	MPTSW: On/Off
	25	MPF_WID1	I	0/3.3 V DC	MPPWSW: On/Off
	26	MPF_WID2	I	0/3.3 V DC	MPPWSW: On/Off
	27	MPF_WID3	I	0/3.3 V DC	MPPWSW: On/Off
	28	MPF_LNG	I	0/3.3 V DC	MPPLSW: On/Off
	29	GND	-	-	Ground
	30	MPF_PPR	I	0/3.3 V DC	MPPS: On/Off
	31	MPF_UP	I	0/3.3 V DC	MPLS1: On/Off
	32	MPF_DOWN	I	0/3.3 V DC	MPLS2: On/Off
	33	MPF_JAM	I	0/3.3 V DC	MPFS: On/Off
	34	MPF_CL	O	0/24 V DC	MPPFCL: On/Off
	35	MPF_LIF2	O	0/24 V DC	MPLM: On/Off

Connector	Pin	Signal	I/O	Voltage	Description
YC6	36	MPF_LIFT1	O	0/24 V DC	MPLM: On/Off
Connected to feed PWB 1	37	GND	-	-	Ground
	38	TC_MOT_LOCK	-	-	Not used
	39	TC_TONER_LED	-	-	Not used
	40	TONER_FULL	-	-	Not used
	41	TC_TONER_VCON T	-	-	Not used
	42	INTER_LOCK	-	-	Not used
	43	DU2_MOT_PD	O	0/3.3 V DC	DUM2 control signal
	44	DU2_MOT_CLK	O	0/3.3 V DC (pulse)	DUM2 clock signal
	45	DU2_MOT_REM	O	0/3.3 V DC	DUM2/DUCL2: On/Off
	46	GND	-	-	Ground
	47	DU_OPEN	I	0/3.3 V DC	DUCSW: On/Off
	48	DU_FAN	-	-	Not used
	49	PRESS_RLS_MOT _REM1	-	-	Not used
	50	PRESS_RLS_MOT _REM2	-	-	Not used
	51	PRESS_RLS_SEN S	-	-	Not used
	52	DU_SENS	I	0/3.3 V DC	DUS2: On/Off
	53	BELT_JAM_SENS	-	-	Not used
	54	GND	-	-	Ground
	55	CLN_SOL_RET	O	0/24 V DC	CLSOL: On/Off (RET)
	56	CLN_SOL_REM	O	0/24 V DC	CLSOL: On/Off (ACT)
	57	REG_SENS_R_S( BK)	I	Analog	IDS detection signal
	58	REG_SENS_R_P( BK)	I	Analog	IDS detection signal
	59	REG_R_LED	O	Analog	IDS control signal
	60	GND	-	-	Ground
	61	REG_SENS_F_S	I	Analog	IDS detection signal
	62	REG_SENS_F_P	I	Analog	IDS detection signal
	63	REG_F_LED	O	Analog	IDS detection signal
64	GND	-	-	Ground	

Connector	Pin	Signal	I/O	Voltage	Description
<b>YC7</b>	1	INTER_LOCK	-	-	Not used
Connected to front PWB	2	ROT_HP_SENS	I	0/3.3 V DC	DEVSS: On/Off
	3	DLP_FAN_L	O	0/24 V DC	DEVFM: On/Off
	4	DLP_FAN_H	O	0/24 V DC	DEVFM: On/Off
	5	THOP_MOT_DIR	O	0/3.3 V DC	THM drive switch signal
	6	THOP_MOT_REM	O	0/3.3 V DC	THM: On/Off
	7	THOP_Bk	I	0/3.3 V DC	THS: On/Off
	8	ENCODE_Bk	I	0/3.3 V DC	SRS: On/Off
	9	SB_MOT_PH	O	0/3.3 V DC	EM control signal
	10	SB_MOT_CLK	O	0/3.3 V DC (pulse)	EM clock signal
	11	SB_MOT_PD	O	0/3.3 V DC	EM control signal
	12	SB_MOT_DIR	O	0/3.3 V DC	EM drive switch signal
	13	SB_MOT_REM	O	0/3.3 V DC	EM: On/Off
	14	EXIT_FEED_SENS	I	0/3.3 V DC	SBS: On/Off
	15	EXIT_PAPER_SENS	I	0/3.3 V DC	EFS: On/Off
	16	GND	-	-	Ground
	17	JUNC_SOL_REM	O	0/24 V DC	FSSOL: On/Off (ACT)
	18	JUNC_SOL_RET	O	0/24 V DC	FSSOL: On/Off (RET)
<b>YC8</b>	1	WTNR_SET	I	Analog	WTS2 detection signal
Connected to front PWB	2	WTNR_FULL_VCON T	O	0/3.3 V DC	WTS1 control signal
	3	WTNR_FULL	I	Analog	WTS1 detection signal
	4	WTNR_NEAR_VC ONT	O	0/3.3 V DC	WTS2 control signal
	5	WTNR_NEAR	I	Analog	WTS2 detection signal
	6	WTNR_LED	O	0/3.3 V DC (pulse)	WTS1 LED emitter signal
	7	I2C_SDA	O	0/3.3 V DC (pulse)	EEPROM clock signal
	8	I2C_SCL	I/O	0/3.3 V DC (pulse)	EEPROM data signal
	9	FRONT_OPEN	I	0/3.3 V DC	FRCSW: On/Off
	10	LSU_FAN	O	0/24 V DC	LSUFM: On/Off
	11	TPD_TEMP_Bk	I	Analog	Developer thermistor detection signal
	12	DLP_VCONT_Bk_1	O	0/3.3 V DC	DEVPWB control signal
	13	TPD_Bk_1	I	Analog	DEVPWB detection signal
	14	TN_CLK	O	0/3.3 V DC (pulse)	Clock signal
	15	GND	-	-	Ground

Connector	Pin	Signal	I/O	Voltage	Description
<b>YC8</b> Connected to front PWB	16	EEP_SCL1	O	0/3.3 V DC (pulse)	EEPROM clock signal
	17	EEP_SDA1	I/O	0/3.3 V DC (pulse)	EEPROM data signal
	18	ERS_Bk_REM	O	0/24 V DC	CL: On/Off
	19	CONTAIN_FAN_REM	O	0/24 V DC	FUFFM: On/Off
	20	EXIT_FAN_REM	O	0/24 V DC	EFFM: On/Off
<b>YC9</b> Connected to front PWB	1	IH_CORE_MOT_REM	-	-	Not used
	2	IH_CORE_MOT_CLK	-	-	Not used
	3	IH_CORE_SENS	-	-	Not used
	4	IH_COIL_FAN_ALARM	-	-	Not used
	5	IH_COIL_FAN_L	-	-	Not used
	6	IH_COIL_FAN_H	-	-	Not used
	7	GND	-	-	Ground
	8	ROT_MOT_PD	-	-	Not used
	9	ROT_MOT_DIR	-	-	Not used
	10	ROT_MOT_CLK	-	-	Not used
	11	ROT_MOT_REM	-	-	Not used
<b>YC11</b> Connected to LSU relay PWB	1	GND	-	-	Ground
	2	DATA_2PBk(LVDS)	O	0/3.3 V DC (pulse)	Video data signal (P)
	3	DATA_2NBk(LVDS)	O	0/3.3 V DC (pulse)	Video data signal (N)
	4	GND	-	-	Ground
	5	DATA_1PBk(LVDS)	O	0/3.3 V DC (pulse)	Video data signal (P)
	6	DATA_1NBk(LVDS)	O	0/3.3 V DC (pulse)	Video data signal (N)
	7	GND	-	-	Ground
	8	GAIN_FIX_Bk	O	0/3.3 V DC	APCPWB control signal
	9	GND	-	-	Ground
	10	SDCLK_Bk	O	0/3.3 V DC (pulse)	APCPWB clock signal
	11	GND	-	-	Ground
	12	PARA_SIG_P4_Bk	O	0/3.3 V DC	APCPWB control signal
	13	PARA_SIG_P3_Bk	O	0/3.3 V DC	APCPWB control signal
	14	PARA_SIG_P2_Bk	O	0/3.3 V DC	APCPWB control signal
	15	PARA_SIG_P1_Bk	O	0/3.3 V DC	APCPWB control signal
	16	PARA_SIG_P0_Bk	O	0/3.3 V DC	APCPWB control signal
	17	INT_ST_1_Bk	O	0/3.3 V DC	APCPWB control signal

Connector	Pin	Signal	I/O	Voltage	Description
<b>YC11</b>	18	INT_ST_2_Bk	O	0/3.3 V DC	APCPWB control signal
Connected to LSU relay PWB	19	CUALM_BK	I	0/3.3 V DC	APCPWB alarm signal
	20	MSET_N	O	0/3.3 V DC	Control signal
	21	LDD_CS 1 Bk	O	0/3.3 V DC	APCPWB control signal
	22	LDD_CS 2 Bk	O	0/3.3 V DC	APCPWB control signal
	23	PARA_SIG_P3_2Bk	O	0/3.3 V DC	APCPWB control signal
	24	LSU_TH_Bk	I	Analog	LSU thermistor detection signal
	25	BD_Bk	I	0/3.3 V DC (pulse)	Horizontal synchronization signal
	26	GND	-	-	Ground
	27	DATA_4P_Bk(LVDS)	O	0/3.3 V DC (pulse)	Video data signal (P)
	28	DATA_4N_Bk(LVDS)	O	0/3.3 V DC (pulse)	Video data signal (N)
	29	GND	-	-	Ground
	30	DATA_3P_Bk(LVDS)	O	0/3.3 V DC (pulse)	Video data signal (P)
	31	DATA_3N_Bk(LVDS)	O	0/3.3 V DC (pulse)	Video data signal (N)
	32	GND	-	-	Ground
	33	EEPROM_CS_1_Bk	I/O	0/3.3 V DC (pulse)	APCPWB EEPROM data signal
	34	EEPROM_CS_2_Bk	I/O	0/3.3 V DC (pulse)	APCPWB EEPROM data signal
	35	GND	-	-	Ground
	36	SCLK	O	0/3.3 V DC (pulse)	Clock signal
	37	GND	-	-	Ground
	38	SDO	O	0/3.3 V DC (pulse)	Serial communication data signal
	39	GND	-	-	Ground
	40	SDI	O	0/3.3 V DC (pulse)	Serial communication data signal
	<b>YC13</b>	1	GND	-	-
Connected to feed PWB 1	2	GND	-	-	Ground
	3	3.3V3	I	3.3 V DC	3.3 V DC power from FPWB1
	4	3.3V2	I	3.3 V DC	3.3 V DC power from FPWB1
<b>YC15</b>	1	+5V_AN	O	5 V DC	5 V DC power to LSURPWB
Connected to LSU relay PWB and polygon motor	2	+5V_AN	O	5 V DC	5 V DC power to LSURPWB
	3	GND	-	-	Ground
	4	GND	-	-	Ground
	5	+3.3V2	O	3.3 V DC	3.3 V DC power to LSURPWB

Connector	Pin	Signal	I/O	Voltage	Description
<b>YC15</b> Connected to LSU relay PWB and polygon motor	6	GND	-	-	Ground
	7	+24V	O	24 V DC	24 V DC power to LSURPWB
	8	GND	-	-	Ground
	9	START/STOP	O	0/24 V DC	PM: On/Off
	10	LOCK	I	0/3.3 V DC	Lock signal
	11	CLK	O	0/3.3 V DC (pulse)	Clock signal
<b>YC16</b> Connected to high voltage PWB	1	SGND	-	-	Ground
	2	SP_BELT_CNT	O	Analog	Separation bias control voltage
	3	T2_CNT	O	Analog	Transfer bias control voltage
	4	T2_REM	O	0/3.3 V DC	Transfer bias: On/Off
	5	MAIN_IDC	O	PWM	DC charger roller control signal
	6	DC_MAIN_CNT	O	PWM	DC charger roller control signal
	7	AC_MAIN_CNT	O	PWM	AC charger roller control signal
	8	AC_MAIN_CLK	O	0/3.3 V DC (pulse)	AC charger roller clock signal
	9	DC_MAIN_REM	O	0/3.3 V DC	DC main charger: On/Off
<b>YC17</b> Connected to high voltage PWB	1	SGND	-	0/3.3 V DC (pulse)	PM-K clock signal
	2	DC_MAG_REM	O	0/3.3 V DC	DC main charger: On/Off
	3	DC_MAG_CNT	O	0/3.3 V DC (pulse)	DC magnet bias control voltage
	4	DC_SLV_CNT	O	PWM	DC sleeve bias control voltage
	5	AC_SLV_CLK	O	0/3.3 V DC (pulse)	AC sleeve bias clock signal
	6	AC_SLV_CNT	O	PWM	AC sleeve bias control voltage
	7	DISCHARGE	I	PWM	Main charger control signal
	8	AC_MAG_CLK	O	0/3.3 V DC (pulse)	AC magnet bias clock signal
	9	AC_MAG_CNT	O	0/3.3 V DC (pulse)	AC magnet bias control voltage
	10	DC_REC_CNT	O	PWM	DC bias control voltage
<b>YC18</b> Connected to 1000-sheet/ 4000-sheet finisher	1	DF_CLK	O	0/3.3 V DC (pulse)	DFMPWB clock signal
	2	DF_SDO	O	0/3.3 V DC (pulse)	DFMPWB serial communication data signal
	3	DF_SEL	O	0/3.3 V DC	DFMPWB select signal
	4	DF_SDI	O	0/3.3 V DC (pulse)	DFMPWB serial communication data signal
	5	DF_RDY	I	0/3.3 V DC	DFMPWB ready signal
	6	DF_DET	O	0/3.3 V DC	DFMPWB detection signal
	7	GND	-	-	Ground



Connector	Pin	Signal	I/O	Voltage	Description
YC19 Connected to paper feeder/ large capacity feeder, toner fan motor and exhaust fan motor	A1	PF_CLK	O	0/3.3 V DC (pulse)	PFMPWB clock signal
	A2	PF_SDO	O	0/3.3 V DC (pulse)	PFMPWB serial communication data signal
	A3	PF_SEL	O	0/3.3 V DC	PFMPWB select signal
	A4	PF_SDI	I	0/3.3 V DC (pulse)	PFMPWB serial communication data signal
	A5	PF_RDY	I	0/3.3 V DC	PFMPWB ready signal
	A6	PF_PAUSE	O	0/3.3 V DC	PFMPWB pause signal
	A7	PF_CAS1_OPEN	I	0/3.3 V DC	PFMPWB control signal
	A8	PF_CAS2_OPEN	I	0/3.3 V DC	PFMPWB control signal
	A9	+3.3V4	O	3.3 V DC	3.3 V DC power to PFMPWB
	A10	GND	-	-	Ground
	A11	GND	-	-	Ground
	A12	TN_FAN1	O	0/24 V DC	TFM: On/Off
	A13	+24V1	O	24 V DC	24 V DC power to TFM
	A14	TN_FAN2	-	-	Not used
	A15	+24V1	-	-	Not used
	A16	LVU_FAN1	-	-	Not used
	A17	+24V1	-	-	Not used
	A18	LVU_FAN2	-	-	Not used
	A19	+24V1	-	-	Not used
	B1	SIDE_CLK	O	0/3.3 V DC (pulse)	PFMPWB clock signal (side)
	B2	SIDE_SDO	O	0/3.3 V DC (pulse)	PFMPWB serial communication data signal (side)
	B3	SIDE_SEL	O	0/3.3 V DC	PFMPWB select signal (side)
	B4	SIDE_SDI	I	0/3.3 V DC (pulse)	PFMPWB serial communication data signal (side)
	B5	SIDE_RDY	I	0/3.3 V DC	PFMPWB ready signal (side)
	B6	SIDE_PAUSE	O	0/3.3 V DC	PFMPWB pause signal (side)
	B7	TANDEM_CAS1OPEN	I	0/3.3 V DC	PFMPWB control signal (side)
	B8	TANDEM_CAS2OPEN	I	0/3.3 V DC	PFMPWB control signal (side)
	B9	SIDE_MULTI_OPEN	O	0/3.3 V DC	PFMPWB control signal (side)
	B10	+3.3V4	O	3.3 V DC	3.3 V DC power to PFMPWB (side)
	B11	GND	-	-	Ground

Connector	Pin	Signal	I/O	Voltage	Description
<b>YC19</b>	B12	+24V1	-	-	Not used
Connected to paper feeder/ large capacity feeder, toner fan motor and exhaust fan motor	B13	BELT_FAN1	-	-	Not used
	B14	+24V1	-	-	Not used
	B15	BELT_FAN2	-	-	Not used
	B16	DLP_FAN1	-	-	Not used
	B17	+24V1	-	-	Not used
	B18	DLP_FAN2	O	0/24 V DC	EXFM: On/Off
	B19	+24V1	O	24 V DC	24 V DC power to EXFM
<b>YC20</b>	1	DECAL_HP_SENS	-	-	Not used
Connected to bridge unit	2	GUIDE_REM	-	-	Not used
	3	GUIDE_CLK	-	-	Not used
	4	GUIDE_PD	-	-	Not used
	5	GUIDE_DIR	-	-	Not used
	6	DECAL_REM	-	-	Not used
	7	DECAL_PH	-	-	Not used
	8	DECAL_CLK	-	-	Not used
	9	DECAL_PD	-	-	Not used
	10	DECAL_DIR	-	-	Not used
	11	+24V1	O	24 V DC	24 V DC power to BRSOL
	12	EXIT_SOL_REM	O	0/24 V DC	BRSOL: On/Off (ACT)
	13	EXIT_SOL_RET	O	0/24 V DC	BRSOL: On/Off (RET)
	14	GND	-	-	Ground
	15	EXIT_COV_OPEN	I	0/3.3 V DC	BRECSW: On/Off
	16	GND	-	-	Ground
	17	EXIT_SENS	I	0/3.3 V DC	BRES: On/Off
	18	5V4	O	5 V DC	5 V DC power to BRES
	19	N.C	-	-	Not used
	20	BRIDGE2 REM	O	0/3.3 V DC	BRCM2: On/Off
	21	BRIDGE2 PH	O	0/3.3 V DC	BRCM2 control signal
	22	BRIDGE2 CLK	O	0/3.3 V DC (pulse)	BRCM2 clock signal
	23	BRIDGE2 PD	O	0/3.3 V DC	BRCM2 control signal
	24	BRIDGE2 DIR	O	0/3.3 V DC	BRCM2 drive switch signal
	25	BRIDGE1 REM	O	0/3.3 V DC	BRCM2: On/Off
	26	BRIDGE1 PH	O	0/3.3 V DC	BRCM1 control signal
	27	BRIDGE1 CLK	O	0/3.3 V DC (pulse)	BRCM1 clock signal

Connector	Pin	Signal	I/O	Voltage	Description
<b>YC20</b> Connected to bridge unit	28	BRIDGE1 PD	O	0/3.3 V DC	BRCM1 control signal
	29	BRIDGE1 DIR	O	0/3.3 V DC	BRCM1 drive switch signal
	30	BRIDGE_SENS 2	I	0/3.3 V DC	BRCS2: On/Off
	31	BRIDGE_OPEN	I	0/3.3 V DC	BRCSW: On/Off
	32	BRIDGE_SENS 1	I	0/3.3 V DC	BRCS1: On/Off
	33	GND	-	-	Ground
	34	5V	O	5 V DC	5 V DC power to BRPWB
	35	GND	-	-	Ground
	36	GND	-	-	Ground
	37	+24V1	O	24 V DC	24 V DC power to BRPWB
	38	+24V1	O	24 V DC	24 V DC power to BRPWB
<b>YC22</b> Connected to power source fan motor	1	LVU_FAN	O	0/24 V DC	PSFM: On/Off
	2	+24V1	O	24 V DC	24 V DC power to PSFM
<b>YC23</b> Connected to coin vender	1	+24V	O	24 V DC	24 V DC power to coin vender
	2	GND	-	-	Ground
	3	GND	-	-	Ground
	4	COIN_EN	I	0/3.3 V DC	Coin vender enable signal
	5	FGND	-	-	Ground
	6	FEED_COUNT	O	0/3.3 V DC	Coin vender control signal
	7	EJECT_COUNT	O	0/3.3 V DC	Coin vender control signal
	8	COPYING_SIG	O	0/3.3 V DC	Coin vender control signal
	9	TXD_COIN	O	0/3.3 V DC (pulse)	Serial communication data signal
	10	GND	-	-	Serial communication data signal
	11	RXD_COIN	I	0/3.3 V DC (pulse)	MCL: On/Off
	12	GND	-	-	Ground

Connector	Pin	Signal	I/O	Voltage	Description
<b>YC24</b> Connected to key counter	1	GND	-	-	Ground
	2	DC1_SET	I	0/3.3 V DC	Key counter set signal
	3	DC1_COUNT	O	0/3.3 V DC	Key counter count signal
	4	+24V 1	O	24 V DC	24 V DC power to key card
<b>YC25</b> Connected to key card	A1	+5V	O	5 V DC	5 V DC power to key card
	A2	+5V	O	5 V DC	5 V DC power to key card
	A3	+5V	O	5 V DC	5 V DC power to key card
	A4	+5V	O	5 V DC	5 V DC power to key card
	A5	+5V	O	5 V DC	5 V DC power to key card
	A6	+5V	O	5 V DC	5 V DC power to key card
	A7	+5V	O	5 V DC	5 V DC power to key card
	A8	+5V	O	5 V DC	5 V DC power to key card
	A9	COPY_ENABLE	I	0/3.3 V DC	Key card enable signal
	A10	+24V	O	24 V DC	24 V DC power to key card
	B1	KEY7	O	0/3.3 V DC	Key card control signal
	B2	KEY6	O	0/3.3 V DC	Key card control signal
	B3	KEY5	O	0/3.3 V DC	Key card control signal
	B4	KEY4	O	0/3.3 V DC	Key card control signal
	B5	KEY3	O	0/3.3 V DC	Key card control signal
	B6	KEY2	O	0/3.3 V DC	Key card control signal
	B7	KEY1	O	0/3.3 V DC	Key card control signal
	B8	KEY0	O	0/3.3 V DC	Key card control signal
	B9	GND	-	-	Ground
	B10	COUNT	O	0/3.3 V DC	Key card count signal
<b>YC26</b> Connected to fuser unit	A1	EDGE_FAN		-	Not used
	A2	12V2		-	Not used
	A3	EDGE_FAN		-	Not used
	A4	12V2		-	Not used
	A5	MINICELFAN_REM		-	Not used
	A6	12V2		-	Not used
	A7	FSR_FAN_ALM	I	0/3.3 V DC	FURFM alarm signal
	A8	FSR_FAN	O	0/24 V DC	FURFM: On/Off
	A9	+24V1	O	24 V DC	24 V DC power to FURFM

Connector	Pin	Signal	I/O	Voltage	Description
<b>YC26</b>	A10	FSR_RLS_DR_CC W	-	-	Not used
Connected to fuser unit	A11	FSR_RLS_DR_CW	-	-	Not used
	A12	GND	-	-	Ground
	A13	FSR_SIZE_SENS	I	0/3.3 V DC	FUES: On/Off
	A14	+5V	O	5 V DC	5 V DC power to FUES
	A15	GND	-	-	Ground
	A16	FSR_RLS_SENS	-	-	Not used
	A17	+5V	-	-	Not used
	A18	GND	-	-	Not used
	A19	FSR_BLT_PLS	-	-	Not used
	A20	+5V	-	-	Not used
	B1	GND	-	-	Not used
	B2	IH_RXD	-	-	Not used
	B3	IH_TXD	-	-	Not used
	B4	ROTATION	-	-	Not used
	B5	IH_HEAT_REM	-	-	Not used
	B6	+3.3V2	-	-	Not used
	B7	GND	-	-	Not used
	B8	GND	-	-	Not used
	B9	PRESS_TH	-	-	Not used
	B10	GND	-	-	Ground
B11	EDGE_TH	I	Analog	FTH2 detection signal	
B12	GND	-	-	Not used	
B13	GUIDE_TH1	-	-	Not used	
B14	GND	-	-	Ground	
B15	GUIDE_TH2	I	Analog	FTH1 detection signal	
B16	MAIN_TH2	-	-	Not used	
B17	MAIN_TH1	-	-	Not used	
B18	GND	-	-	Not used	
B19	+24V1	-	-	Not used	
B20	BRIDGE_FAN	-	-	Not used	

Connector	Pin	Signal	I/O	Voltage	Description
<b>YC27</b>	1	GND	-	-	Ground
Connected to RFID PWB and toner motor	2	EEP_SDA2	I/O	0/3.3 V DC (pulse)	EEPROM data signal
	3	EEP_SCL2	I	0/3.3 V DC (pulse)	EEPROM clock signal
	4	3.3V2	O	3.3 V DC	3.3 V DC power to RFPWB
	5	+24V1	O	24 V DC	24 V DC power to TM-Y
	6	TMOT_Bk_DR	O	0/24 V DC	TM: On/Off
<b>YC46</b>	1	SLEEP_INT	I	0/3.3 V DC	Sleep signal
Connected to main PWB	2	G6_EG_SCLK	I	0/3.3 V DC (pulse)	Engine clock signal
	3	G6_EG_SI	I	0/3.3 V DC (pulse)	Serial communication data signal
	4	G6_EG_SDIR	I	0/3.3 V DC	Engine communication direction signal
	5	G6_EG_SBSY	I	0/3.3 V DC	Engine busy signal
	6	G6_EG_SO	O	0/3.3 V DC (pulse)	Serial communication data signal
	7	G6_EG_IRN	I	0/3.3 V DC	Engine interrupt signal
	8	JS_LED	I	0/3.3 V DC	LED control signal
	9	ENG_OFF	I	0/3.3 V DC	Engine off signal
	10	HLD_ENG	I	0/3.3 V DC	Engine hold signal
	11	SLEEP_ENG	I	0/3.3 V DC	Sleep signal
	12	HSYNC_DP	I	0/3.3 V DC (pulse)	Image control signal
	13	HSYNC_DN	I	0/3.3 V DC (pulse)	Image control signal
	14	HSYNC_CP	I	0/3.3 V DC (pulse)	Image control signal
	15	HSYNC_CN	I	0/3.3 V DC (pulse)	Image control signal
	16	HSYNC_BP	I	0/3.3 V DC (pulse)	Image control signal
	17	HSYNC_BN	I	0/3.3 V DC (pulse)	Image control signal
	18	HSYNC_AP	I	0/3.3 V DC (pulse)	Image control signal
	19	HSYNC_AN	I	0/3.3 V DC (pulse)	Image control signal
	20	VSYNC_DP	I	0/3.3 V DC (pulse)	Image control signal
	21	VSYNC_DN	I	0/3.3 V DC (pulse)	Image control signal
	22	VSYNC_CP	I	0/3.3 V DC (pulse)	Image control signal
	23	VSYNC_CN	I	0/3.3 V DC (pulse)	Image control signal
	24	VSYNC_BP	I	0/3.3 V DC (pulse)	Image control signal
	25	VSYNC_BN	I	0/3.3 V DC (pulse)	Image control signal
	26	VSYNC_AP	I	0/3.3 V DC (pulse)	Image control signal
	27	VSYNC_AN	I	0/3.3 V DC (pulse)	Image control signal
	28	GND	-	-	Ground
	29	SAR_VCLK_P	O	0/3.3 V DC (pulse)	Clock signal
	30	SAR_VCLK_N	O	0/3.3 V DC (pulse)	Clock signal

Connector	Pin	Signal	I/O	Voltage	Description
<b>YC46</b>	31	GND	-	-	Ground
Connected to main PWB	32	SAR_CH3_P	O	0/3.3 V DC (pulse)	Image control signal
	33	SAR_CH3_N	O	0/3.3 V DC (pulse)	Image control signal
	34	GND	-	-	Ground
	35	SAR_CH2_P	O	0/3.3 V DC (pulse)	Image control signal
	36	SAR_CH2_N	O	0/3.3 V DC (pulse)	Image control signal
	37	GND	-	-	Ground
	38	SAR_CH1_P	O	0/3.3 V DC (pulse)	Image control signal
	39	SAR_CH1_N	O	0/3.3 V DC (pulse)	Image control signal
	40	GND	-	-	Ground
<b>YC54</b>	1	3.3V2	O	3.3 V DC	3.3 V DC power to TVM
Connected to toner vibration motor	2	TN_VIB	O	0/3.3 V DC	TVM: On/Off

### 2-3-3 Power source PWB

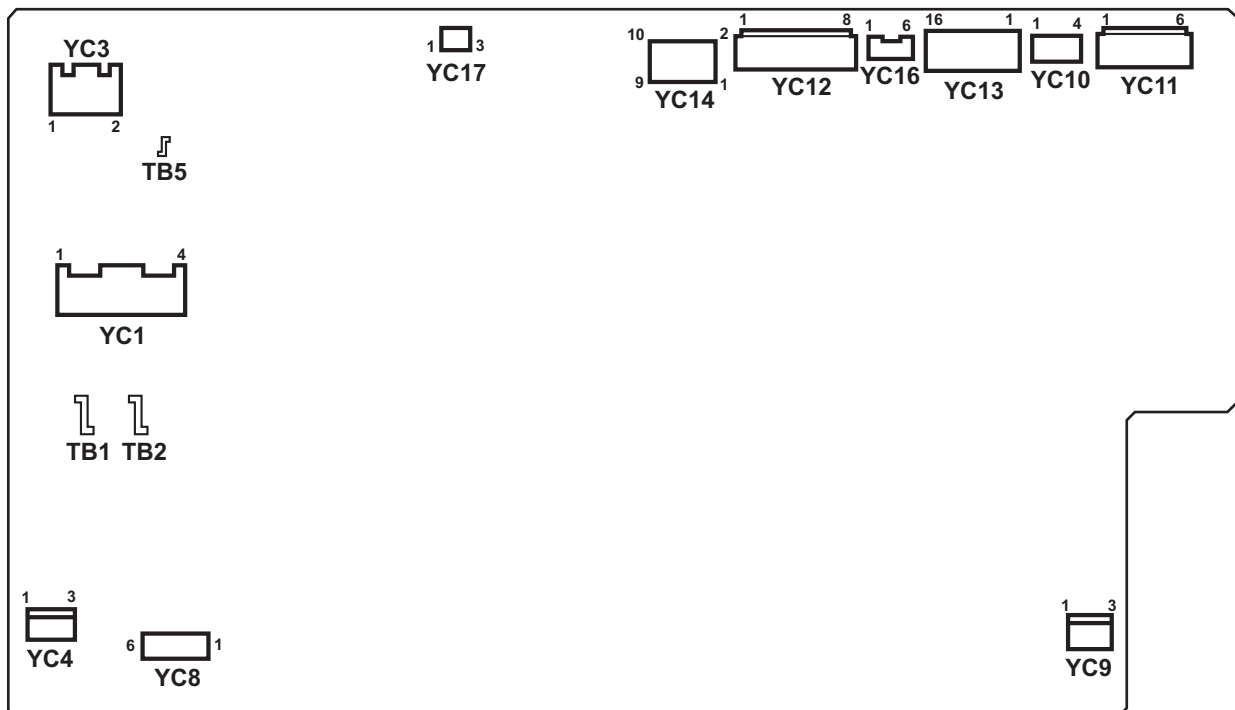
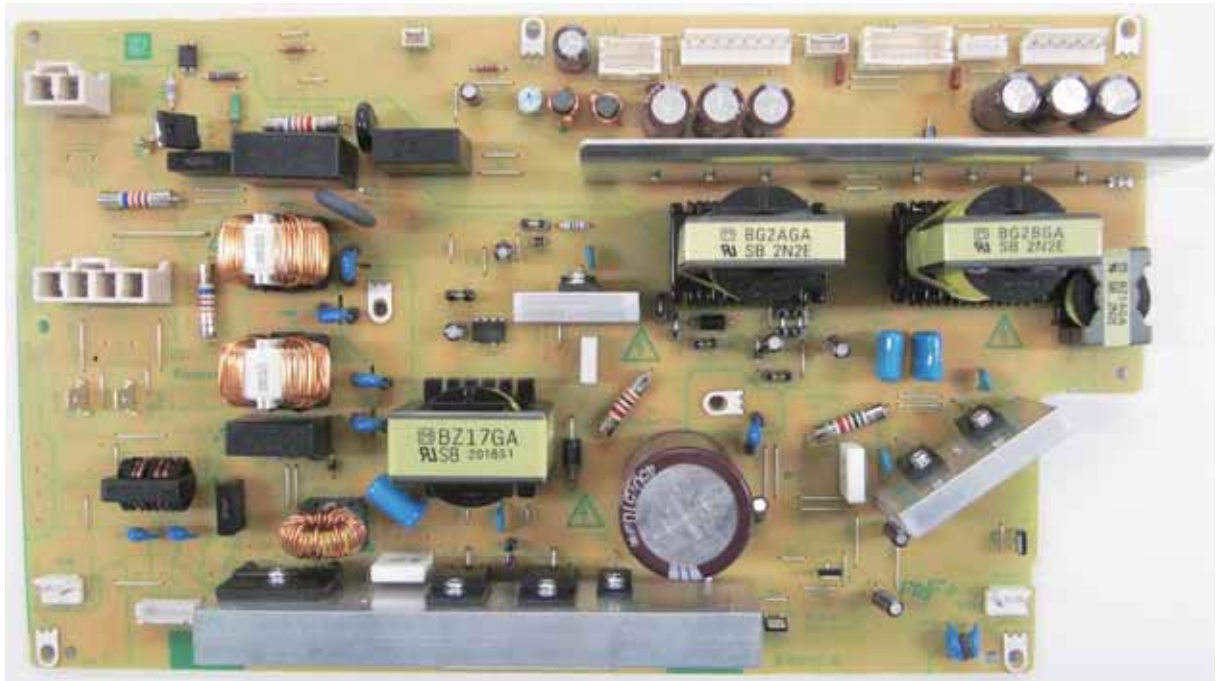


Figure 2-3-3 Power source PWB silk-screen diagram



Connector	Pin	Signal	I/O	Voltage	Description
<b>TB</b>  Connected to AC inlet and main power switch	1	LIVE	I	120 V AC 220-240 V AC	AC power input
	2	NEUTRAL	I	120 V AC 220-240 V AC	AC power input
	5	DH_LIVE	I	120 V AC 220-240 V AC	AC power input
<b>YC1</b>  Connected to main power switch	1	LIVE_IN	I	120 V AC 220-240 V AC	AC power input from MSW
	2	LIVE_OUT	O	120 V AC 220-240 V AC	AC power output to MSW
	3	NEUTRAL_OUT	O	120 V AC 220-240 V AC	AC power output to MSW
	4	NEUTRAL_IN	I	120 V AC 220-240 V AC	AC power input from MSW
<b>YC3</b>  Connected to fuser heater PWB	1	LIVE	O	120 V AC 220-240 V AC	AC power output to FHPWB
	2	NEUTRAL	O	120 V AC 220-240 V AC	AC power output to FHPWB
<b>YC8</b>  Connected to cassette heater	1	DH_LIVE	O	120 V AC 220-240 V AC	AC power output to CH
	2	NC	-	-	Not used
	3	NC	-	-	Not used
	4	NC	-	-	Not used
	5	NC	-	-	Not used
	6	DH_NEUTRAL	O	120 V AC 220-240 V AC	AC power output to CH
<b>YC9</b>  Connected to paper feeder /large capacity feeder	1	DH_LIVE	O	120 V AC 220-240 V AC	AC power output to PFCH
	3	DH_NEUTRAL	O	120 V AC 220-240 V AC	AC power output to PFCH
<b>YC12</b>  Connected to feed PWB 1	1	24V1	O	24 V DC	24 V DC power to FPWB1
	2	24V1	O	24 V DC	24 V DC power to FPWB1
	3	24V1	O	24 V DC	24 V DC power to FPWB1
	4	5V	O	5 V DC	5 V DC power to FPWB1
	5	GND	-	-	Ground
	6	GND	-	-	Ground
	7	GND	-	-	Ground
	8	GND	-	-	Ground

Connector	Pin	Signal	I/O	Voltage	Description
<b>YC13</b>	1	24V1	O	24 V DC	24 V DC power to paper feeder/large capacity feeder
Connected to paper feeder/ large capacity feeder, 1000-sheet/ 4000-sheet finisher and ISC PWB	2	24V1	O	24 V DC	24 V DC power to paper feeder/large capacity feeder
	3	24V1	O	24 V DC	24 V DC power to 1000-sheet/4000-sheet finisher
	4	24V1	O	24 V DC	24 V DC power to 1000-sheet/4000-sheet finisher
	5	24V1	O	24 V DC	24 V DC power to 1000-sheet/4000-sheet finisher
	6	24V1	O	24 V DC	24 V DC power to ISCPWB
	7	24V1	O	24 V DC	24 V DC power to ISCPWB
	8	24V1	O	24 V DC	24 V DC power to ISCPWB
	9	GND	-	-	Ground
	10	GND	-	-	Ground
	11	GND	-	-	Ground
	12	GND	-	-	Ground
	13	GND	-	-	Ground
	14	GND	-	-	Ground
	15	GND	-	-	Ground
	16	GND	-	-	Ground
<b>YC14</b>	1	5V1	O	5 V DC	5V DC power to MPWB
Connected to main PWB	2	GND	-	-	Ground
	3	5V1	O	5 V DC	5 V DC power to MPWB
	4	GND	-	-	Ground
	5	5V1	O	5 V DC	5 V DC power to MPWB
	6	GND	-	-	Ground
	7	5V1	O	5 V DC	5 V DC power to MPWB
	8	GND	-	-	Ground
	9	5V1	O	5 V DC	5 V DC power to MPWB
	10	GND	-	-	Ground
	<b>YC16</b>	1	+24V1	O	24 V DC
Connected to high voltage PWB 1	2	+24V1	-	-	Not used
	3	+24V1	O	24 V DC	24 V DC power to HVPWB1
	4	PGND	-	-	Ground
	5	PGND	-	-	Not used
	6	PGND	-	-	Ground

Connector	Pin	Signal	I/O	Voltage	Description
YC17	1	POWER_OFF_24 V1	I	0/3.3 V DC	Sleep mode signal: On/Off
Connected to feed PWB 1	2	DRUM_HEAT_RE M	I	0/3.3 V DC	FH: On/Off
	3	GND	-	-	Ground

### 2-3-4 ISC PWB

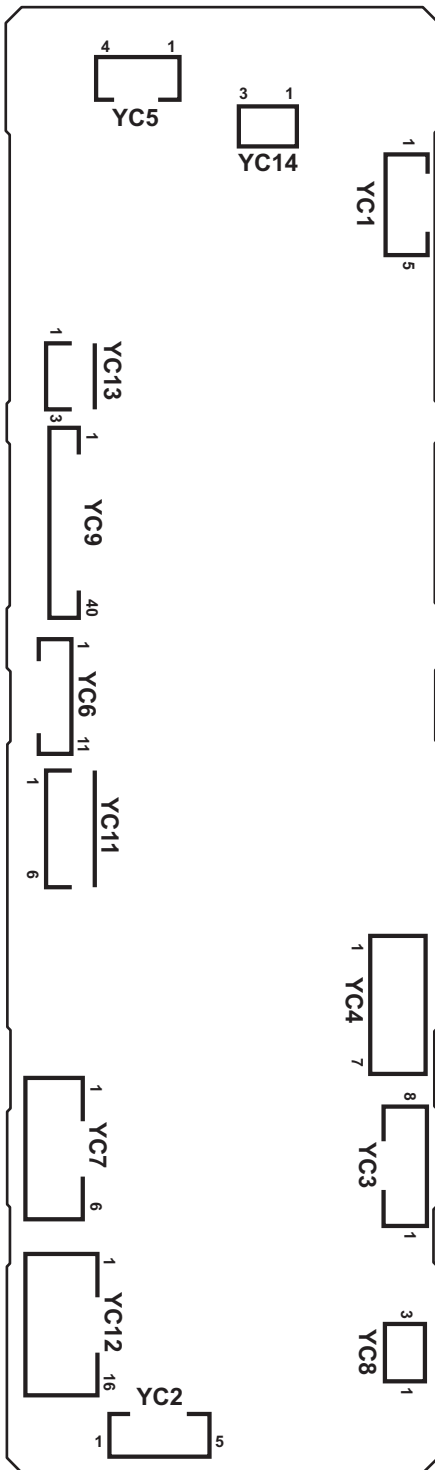


Figure 2-3-4 ISC PWB silk-screen diagram

Connector	Pin	Signal	I/O	Voltage	Description
<b>YC3</b> Connected to main PWB	1	SC_CLK	I	0/3.3 V DC (pulse)	Scanner clock signal
	2	SC_SO	O	0/3.3 V DC (pulse)	Serial communication data signal
	3	SC_SI	I	0/3.3 V DC (pulse)	Serial communication data signal
	4	SC_BSY	I	0/3.3 V DC	Scanner busy signal
	5	SC_HLDN	I	0/3.3 V DC	Scanner hold signal
	6	SC_DIR	I	0/3.3 V DC	Scanner communication direction signal
	7	SC_IRN	I	0/3.3 V DC	Scanner interrupt signal
	8	GND(SPARE)	-	-	Ground
<b>YC4</b> Connected to main PWB	1	GND	-	-	Ground
	2	HTPDN	O	0/3.3 V DC	Control signal
	3	LOCKN	O	0/3.3 V DC	Lock signal
	4	GND	-	-	Ground
	5	TX0N	O	0/3.3 V DC (pulse)	Transmission data signal
	6	TX0P	O	0/3.3 V DC (pulse)	Transmission data signal
	7	GND	-	-	Ground
<b>YC5</b> Connected to scanner motor	1	SMOT AP	O	0/24 V DC (pulse)	SM drive control signal
	2	SMOT BP	O	0/24 V DC (pulse)	SM drive control signal
	3	SMOT AN	O	0/24 V DC (pulse)	SM drive control signal
	4	SMOT BN	O	0/24 V DC (pulse)	SM drive control signal
<b>YC6</b> Connected to LED lamp PWB	1	+5V	O	5 V DC	5 V DC power to LLPWB
	2	FAIL	I	0/3.3 V DC	Error signal
	3	SDA	I/O	0/3.3 V DC	Data signal
	4	SCL	O	0/3.3 V DC (pulse)	Clock signal
	5	VSET	O	Analog	Analog voltage
	6	SGND	-	-	Ground
	7	PGND	-	-	Ground
	8	PWM	O	0/3.3 V DC	PWM signal
	9	POW	O	0/3.3 V DC	LED driver: On/Off
	10	+24V1	O	24 V DC	24 V DC power to LLPWB
	11	+24V1	O	24 V DC	24 V DC power to LLPWB
<b>YC7</b> Connected to power source PWB	1	+24V1	I	24 V DC	24 V DC power from PSPWB
	2	GND	-	-	Ground
	3	GND	-	-	Ground
	4	GND	-	-	Ground
	5	+24V2	I	24 V DC	24 V DC power from PSPWB
	6	+24V2	I	24 V DC	24 V DC power from PSPWB

Connector	Pin	Signal	I/O	Voltage	Description
YC8	1	+3.3V	O	3.3 V DC	3.3 V DC power to HPS
	2	GND	-	-	Ground
	3	HP_SW	I	0/3.3 V DC	HPS: On/Off
YC9	1	GND	-	-	Ground
	2	CCDCLK1	O	0/3.3 V DC (pulse)	Clock signal
	3	GND	-	-	Ground
	4	CCDCLK2	O	0/3.3 V DC (pulse)	Clock signal
	5	GND	-	-	Ground
	6	CP	O	0/3.3 V DC	Clamp signal
	7	GND	-	-	Ground
	8	RS	O	0/3.3 V DC	Reset signal
	9	VSG	O	0/3.3 V DC	Control signal
	10	TG	O	0/3.3 V DC	Control signal
	11	SH	O	0/3.3 V DC	Shift gate signal
	12	AFE_SI	I	0/3.3 V DC (pulse)	Serial communication data signal
	13	AFE_EN	O	0/3.3 V DC (pulse)	Enable signal
	14	AFE_SO	O	0/3.3 V DC (pulse)	Serial communication data signal
	15	AFE_CLK	O	0/3.3 V DC (pulse)	Clock signal
	16	GND	-	-	Ground
	17	DSI_CIS_1N	I	0/3.3 V DC (pulse)	Image data signal
	18	DSI_CIS_1P	I	0/3.3 V DC (pulse)	Image data signal
	19	GND	-	-	Ground
	20	DSI_CIS_2N	I	0/3.3 V DC (pulse)	Image data signal
	21	DSI_CIS_2P	I	0/3.3 V DC (pulse)	Image data signal
	22	GND	-	-	Ground
	23	DSI_CIS_3N	I	0/3.3 V DC (pulse)	Image data signal
	24	DSI_CIS_3P	I	0/3.3 V DC (pulse)	Image data signal
	25	GND	-	-	Ground
	26	DSI_CIS_4N	I	0/3.3 V DC (pulse)	Image data signal
	27	DSI_CIS_4P	I	0/3.3 V DC (pulse)	Image data signal
	28	GND	-	-	Ground
	29	DSI_CIS_5N	I	0/3.3 V DC (pulse)	Image data signal
	30	DSI_CIS_5P	I	0/3.3 V DC (pulse)	Image data signal
	31	GND	-	-	Ground
	32	DSI_CISCKN	O	0/3.3 V DC (pulse)	Clock signal
	33	DSI_CISCKP	O	0/3.3 V DC (pulse)	Clock signal

Connector	Pin	Signal	I/O	Voltage	Description
<b>YC9</b> Connected to CCD PWB	34	GND	-	-	Ground
	35	CCDSEL	O	0/3.3 V DC	Select signal
	36	GND	-	-	Ground
	37	AFE_MCLK	O	0/3.3 V DC (pulse)	Clock signal
	38	GND(AFE_SHD)	-	-	Ground
	39	CLPIN	O	0/3.3 V DC	Clamp signal
	40	GND(AFE_SHP)	-	-	Ground
<b>YC11</b> Connected to CCD PWB	1	+5.1V	O	5 V DC	5 V DC power to CCDPWB
	2	GND	-	-	Ground
	3	+10V	O	DC10V	10 V DC power to CCDPWB
	4	GND	-	-	Ground
	5	+3.3V	O	3.3 V DC	3.3 V DC power to CCDPWB
	6	GND	-	-	Ground
<b>YC12</b> Connected to DP main PWB	1	GND(SPARE)	-	-	Ground
	2	DP_TMG	I	0/3.3 V DC	DPTS: On/Off
	3	DP_RDY	I	0/3.3 V DC	Ready signal
	4	DP_SEL	O	0/3.3 V DC	Select signal
	5	DP_CLK	O	0/3.3 V DC (pulse)	Clock signal
	6	DP_SO	O	0/3.3 V DC (pulse)	Serial communication data signal
	7	DP_SI	I	0/3.3 V DC (pulse)	Serial communication data signal
	8	DP_OPEN	I	0/3.3 V DC	DPOCSW: On/Off
	9	Reserve	-	-	Not used
	10	GND	-	-	Ground
	11	GND	-	-	Ground
	12	GND	-	-	Ground
	13	Reserve	-	-	Not used
	14	+24V2	O	24 V DC	24 V DC power to DPMPWB
	15	+24V2	O	24 V DC	24 V DC power to DPMPWB
	16	+24V2	O	24 V DC	24 V DC power to DPMPWB
<b>YC13</b> Connected to original size sensor	1	GND	-	-	Ground
	2	ORG_SW	I	0/3.3 V DC	OSS: On/Off
	3	+5.1V	O	5 V DC	5 V DC power to OSS

Connector	Pin	Signal	I/O	Voltage	Description
<b>YC14</b>	1	+3.3V	O	3.3 V DC	3.3 V DC power to ODSW
Connected to original detection switch	2	GND	-	-	Ground
	3	CO_SW	I	0/3.3 V DC	ODSW: On/Off



### 2-3-5 Operation PWB 1

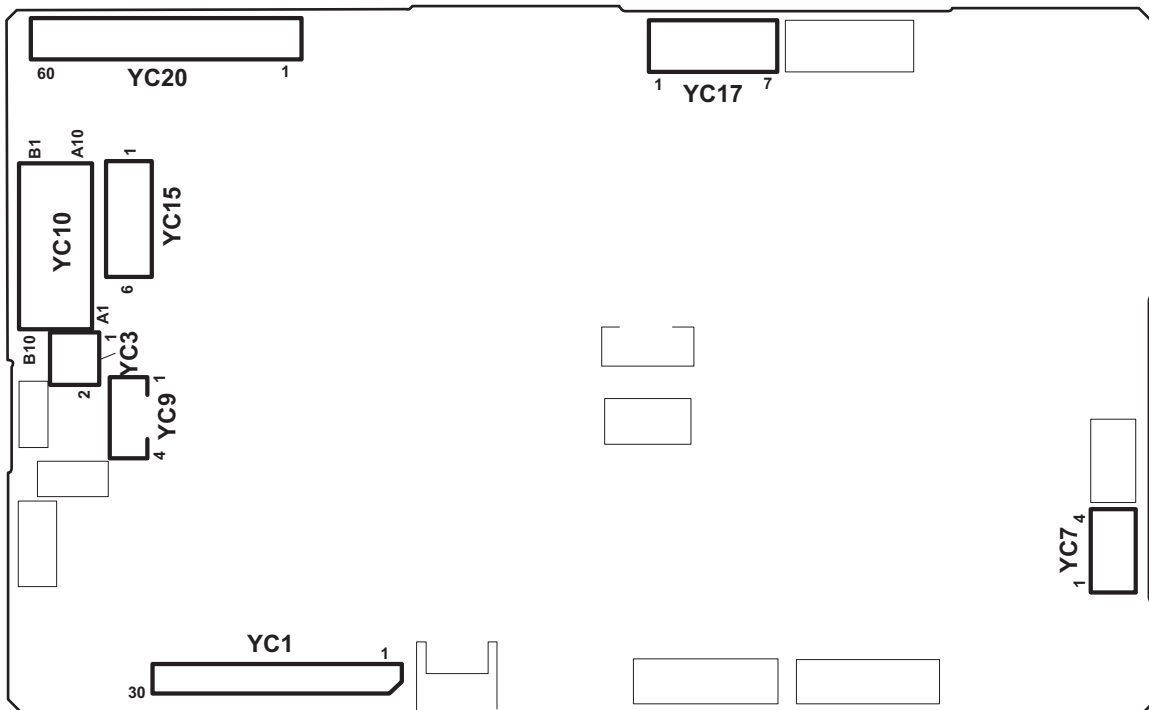


Figure 2-3-5 Operation PWB 1 silk-screen diagram

Connector	Pin	Signal	I/O	Voltage	Description
<b>YC1</b>	1	5V0	O	5 V DC	5 V DC power to OPWB2
Connected to operation panel PWB2	2	NC	-	-	Not used
	3	INT_POWERKEY_N	I	0/3.3 V DC	Power key: On/Off
	4	GND	-	-	Ground
	5	KEY6	I	0/3.3 V DC (pulse)	Operation panel key scan return signal 6
	6	NC	-	-	Not used
	7	LED3	O	0/3.3 V DC (pulse)	Operation panel LED display drive signal 3
	8	NC	-	-	Not used
	9	KEY5	I	0/3.3 V DC (pulse)	Operation panel key scan return signal 5
	10	KEY4	I	0/3.3 V DC (pulse)	Operation panel key scan return signal 4
	11	SCAN4	O	0/3.3 V DC (pulse)	Scan signal 4
	12	SCAN2	O	0/3.3 V DC (pulse)	Scan signal 2
	13	GND	-	-	Ground
	14	SCAN3	O	0/3.3 V DC (pulse)	Scan signal 3
	15	SCAN1	O	0/3.3 V DC (pulse)	Scan signal 1
	16	NC	-	-	Not used
	17	LED0	O	0/3.3 V DC (pulse)	Operation panel LED display drive signal 0
	18	LED1	O	0/3.3 V DC (pulse)	Operation panel LED display drive signal 1
	19	LED2	O	0/3.3 V DC (pulse)	Operation panel LED display drive signal 2
	20	NC	-	-	Not used
	21	KEY0	I	0/3.3 V DC (pulse)	Operation panel key scan return signal 0
	22	KEY1	I	0/3.3 V DC (pulse)	Operation panel key scan return signal 1
	23	KEY2	I	0/3.3 V DC (pulse)	Operation panel key scan return signal 2
	24	SCAN0	O	0/3.3 V DC (pulse)	Scan signal 0
	25	KEY3	I	0/3.3 V DC (pulse)	Operation panel key scan return signal 3
	26	GND	-	-	Ground
	27	ATTENTION	O	0/3.3 V DC	Attention LED control signal
	28	MEMORY	O	0/3.3 V DC	Memory LED control signal

Connector	Pin	Signal	I/O	Voltage	Description
<b>YC1</b> Connected to operation panel PWB2	29	PROCESSING	O	0/3.3 V DC	Processing LED control signal
	30	JOB_LED	O	0/3.3 V DC	JOB LED control signal
<b>YC3</b> Connected to speaker	1	VO2	O	Analog	Speaker sound signal (+)
	2	VO1	O	Analog	Speaker sound signal (-)
<b>YC7</b> Connected to touch panel	1	BOTTOM Y+	I	Analog	Touch panel Y+ position signal
	2	LEFT X-	I	Analog	Touch panel X- position signal
	3	TOP Y-	I	Analog	Touch panel Y- position signal
	4	RIGHT X+	I	Analog	Touch panel X+ position signal
<b>YC9</b> Connected to LCD	1	LED_A	O	Analog	LED control signal
	2	NC	-	-	Not used
	3	LED_C	I	Analog	LED control signal
	4	NC	-	-	Not used
<b>YC10</b> Connected to main PWB	A1	LIGHTOFF_POWERON	I	0/3.3 V DC	Sleep return signal
	A2	GND	-	-	Ground
	A3	INT_POWERKEY	O	0/3.3 V DC	Power key: On/Off
	A4	AUDIO	I	Analog	Audio output signal
	A5	LED_PROCESSING	I	0/3.3 V DC	Processing LED control signal
	A6	LED_ATTENTION	I	0/3.3 V DC	Attention LED control signal
	A7	LED_MEMORY	I	0/3.3 V DC	Memory LED control signal
	A8	BEEP_POWERON	I	0/3.3 V DC	Sleep return signal
	A9	PANEL RESET	I	0/3.3 V DC	Reset signal
	A10	GND	-	-	Ground
	B1	P2C_SDAT	O	0/3.3 V DC (pulse)	Serial communication data signal
	B2	C2P_SDAT	I	0/3.3 V DC (pulse)	Serial communication data signal
	B3	P2C_SDIR	O	0/3.3 V DC	Panel communication direction signal
	B4	P2C_SBSY	O	0/3.3 V DC	Panel busy signal
	B5	C2P_SCK	I	0/3.3 V DC (pulse)	Panel clock signal
	B6	ANY_KEY	O	0/3.3 V DC	ANY KEY return signal
	B7	HUMAN_SENS_NEAR	-	-	Not used
	B8	5V0	I	5 V DC	5 V DC power from MPWB

Connector	Pin	Signal	I/O	Voltage	Description
<b>YC10</b>	B9	JOB_LED	I	0/3.3 V DC	LED control signal
Connected to main PWB	B10	HUMAN_SENS_F AR	-	-	Not used
<b>YC15</b>	1	+5V6	I	5 V DC	5 V DC power from MPWB
Connected to main PWB	2	+5V6	I	5 V DC	5 V DC power from MPWB
	3	+5V6	I	5 V DC	5 V DC power from MPWB
	4	GND	-	-	Ground
	5	GND	-	-	Ground
	6	GND	-	-	Ground
<b>YC17</b>	1	GND	-	-	Ground
Connected to main PWB	2	LCD_OFF	I	0/3.3 V DC	Control signal
	3	LOCKN	I	0/3.3 V DC	Lock signal
	4	GND	-	-	Ground
	5	TX0N	I	0/3.3 V DC (pulse)	Transmission data signal
	6	TX0P	I	0/3.3 V DC (pulse)	Transmission data signal
	7	GND	-	-	Ground
<b>YC20</b>	1	VH	O	Analog	LCD control signal
Connected to LCD	2	3.3V2	O	0/3.3 V DC	3.3 V DC power to LCD
	3	3.3V2	O	0/3.3 V DC	3.3 V DC power to LCD
	4	CKG	O	0/3.3 V DC (pulse)	LCD clock signal
	5	STVD	I/O	0/3.3 V DC	LCD control signal
	6	GND	-	-	Ground
	7	GND	-	-	Ground
	8	VM	O	Analog	LCD control signal
	9	REV	O	0/3.3 V DC	LCD control signal
	10	UD	O	0/3.3 V DC	LCD control signal
	11	STVU	I/O	0/3.3 V DC	LCD control signal
	12	VLS	O	Analog	LCD control signal
	13	VLS	O	Analog	LCD control signal
	14	GND	-	-	Ground
	15	GND	-	-	Ground
	16	DIO2	I/O	0/3.3 V DC	LCD control signal
	17	DIO1	I/O	0/3.3 V DC	LCD control signal
	18	SHL	O	0/3.3 V DC	LCD control signal
	19	LD	O	0/3.3 V DC	LCD control signal

Connector	Pin	Signal	I/O	Voltage	Description
YC20	20	GND	-	-	Ground
Connected to LCD	21	CKS	O	0/3.3 V DC (pulse)	LCD clock signal
	22	GND	-	-	Ground
	23	V1	O	0/3.3 V DC	LCD control signal
	24	V2	O	0/3.3 V DC	LCD control signal
	25	V3	O	0/3.3 V DC	LCD control signal
	26	V4	O	0/3.3 V DC	LCD control signal
	27	V5	O	0/3.3 V DC	LCD control signal
	28	V6	O	0/3.3 V DC	LCD control signal
	29	V7	O	0/3.3 V DC	LCD control signal
	30	V8	O	0/3.3 V DC	LCD control signal
	31	V9	O	0/3.3 V DC	LCD control signal
	32	V10	O	0/3.3 V DC	LCD control signal
	33	V11	O	0/3.3 V DC	LCD control signal
	34	V12	O	0/3.3 V DC	LCD control signal
	35	V13	O	0/3.3 V DC	LCD control signal
	36	V14	O	0/3.3 V DC	LCD control signal
	37	GND	-	-	Ground
	38	RO0	O	0/3.3 V DC	LCD control signal
	39	RO1	O	0/3.3 V DC	LCD control signal
	40	RO2	O	0/3.3 V DC	LCD control signal
	41	RO3	O	0/3.3 V DC	LCD control signal
	42	RO4	O	0/3.3 V DC	LCD control signal
	43	RO5	O	0/3.3 V DC	LCD control signal
	44	GO0	O	0/3.3 V DC	LCD control signal
	45	GO1	O	0/3.3 V DC	LCD control signal
	46	GO2	O	0/3.3 V DC	LCD control signal
	47	GO3	O	0/3.3 V DC	LCD control signal
	48	GO4	O	0/3.3 V DC	LCD control signal
	49	GO5	O	0/3.3 V DC	LCD control signal
	50	BO0	O	0/3.3 V DC	LCD control signal
	51	BO1	O	0/3.3 V DC	LCD control signal
	52	BO2	O	0/3.3 V DC	LCD control signal
	53	BO3	O	0/3.3 V DC	LCD control signal
	54	BO4	O	0/3.3 V DC	LCD control signal
	55	BO5	O	0/3.3 V DC	LCD control signal
56	POL	O	0/3.3 V DC	LCD control signal	

Connector	Pin	Signal	I/O	Voltage	Description
YC20	57	OE	O	0/3.3 V DC	LCD control signal
Connected to LCD	58	VCOM	O	Analog	LCD control signal
	59	VCOM	O	Analog	LCD control signal
	60	VCOM	O	Analog	LCD control signal

### 2-3-6 Front PWB

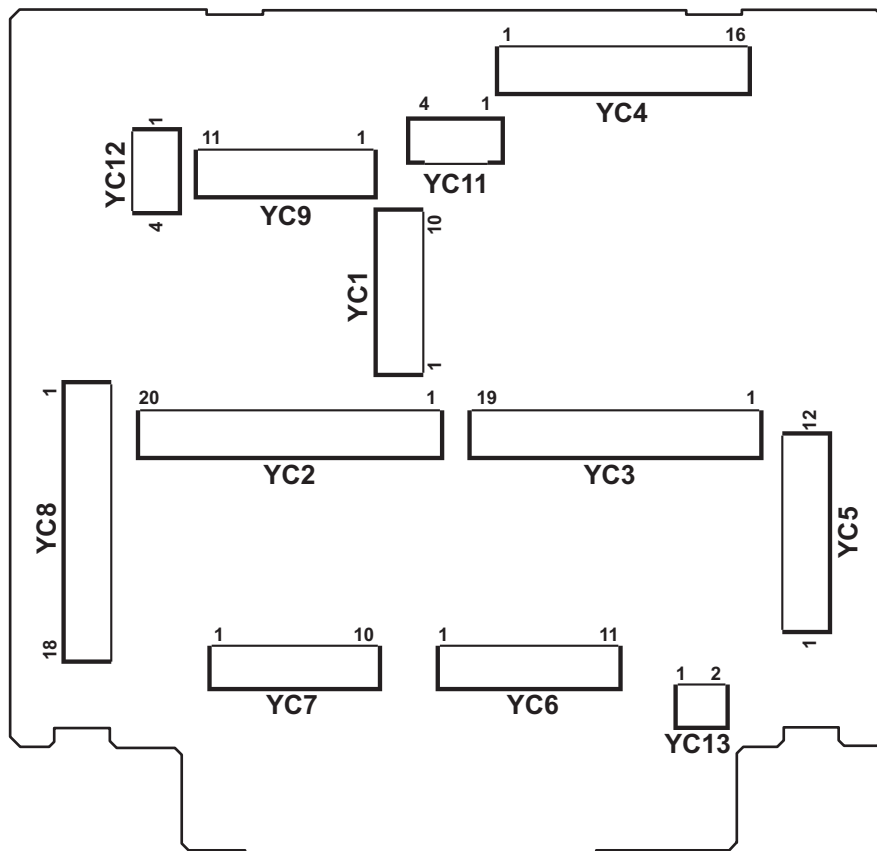
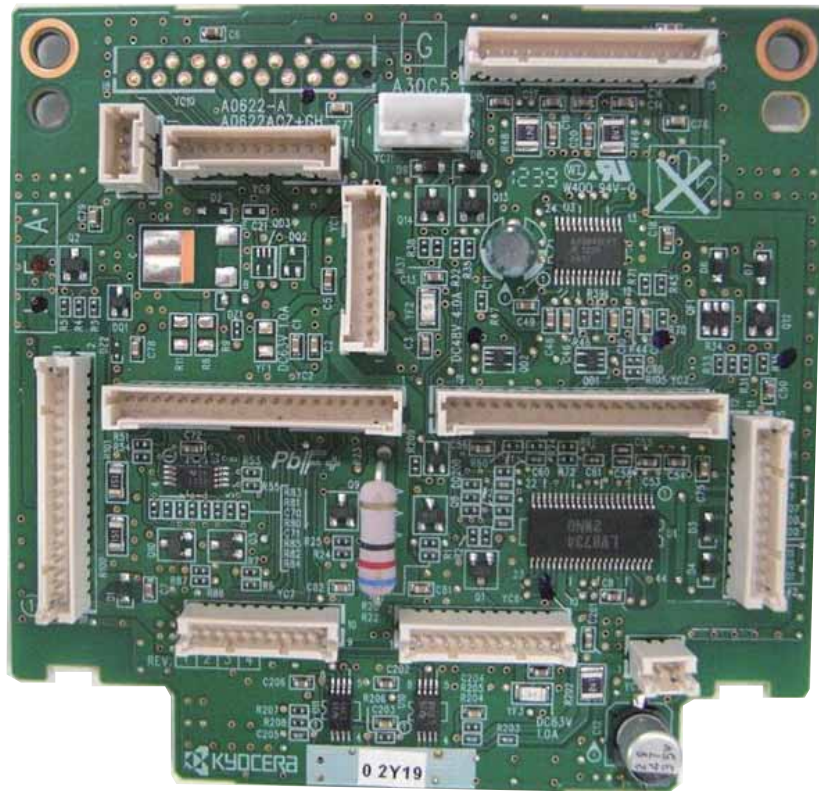


Figure 2-3-6 Front PWB silk-screen diagram

Connector	Pin	Signal	I/O	Voltage	Description
<b>YC1</b> Connected to engine PWB	1	+3.3V1	I	3.3 V DC	3.3 V DC power from EPWB
	2	+3.3V2	I	3.3 V DC	3.3 V DC power from EPWB
	3	+5V	I	5 V DC	5 V DC power from EPWB
	4	+24V	I	24 V DC	24 V DC power from EPWB
	5	+24V	I	24 V DC	24 V DC power from EPWB
	6	GND	-	-	Ground
	7	GND	-	-	Ground
	8	GND	-	-	Ground
	9	GND	-	-	Ground
	10	GND	-	-	Ground
<b>YC2</b> Connected to engine PWB	1	EXIT_FAN_REM	I	0/24 V DC	EFFM: On/Off
	2	CONTAIN_FAN_REM	I	0/24 V DC	FUFFM: On/Off
	3	ERS_Bk_REM	I	0/24 V DC	CL: On/Off
	4	EEP_SDA1	I/O	0/3.3 V DC (pulse)	EEPROM data signal
	5	EEP_SCL1	I	0/3.3 V DC (pulse)	EEPROM clock signal
	6	GND	-	-	Ground
	7	TN_CLK	I	0/3.3 V DC (pulse)	Clock signal
	8	TPD_Bk_1	O	Analog	DEVPWB detection signal
	9	DLP_VCONT_Bk_1	I	0/3.3 V DC	DEVPWB control signal
	10	TPD_TEMP_Bk	O	Analog	Developer thermistor detection signal
	11	LSU_FAN	I	0/24 V DC	LSUFM: On/Off
	12	FRONT_OPEN	O	0/3.3 V DC	FRCSW: On/Off
	13	I2C_SCL	I/O	0/3.3 V DC (pulse)	EEPROM data signal
	14	I2C_SDA	I	0/3.3 V DC (pulse)	EEPROM clock signal
	15	WTNR_LED	I	0/3.3 V DC (pulse)	WTS1 LED emitter signal
	16	WTNR_NEAR	O	Analog	WTS2 detection signal
	17	WTNR_NEAR_VCONT	I	0/3.3 V DC	WTS2 control signal
	18	WTNR_FULL	O	Analog	WTS1 detection signal
	19	WTNR_FULL_VCONT	I	0/3.3 V DC	WTS1 control signal
	20	WTNR_SET	O	Analog	WTS2 detection signal



Connector	Pin	Signal	I/O	Voltage	Description
<b>YC3</b>	1	JUNC_SOL_RET	I	0/24 V DC	FSSOL: On/Off (RET)
Connected to engine PWB	2	JUNC_SOL_REM	I	0/24 V DC	FSSOL: On/Off (ACT)
	3	GND	-	-	Ground
	4	EXIT_PAPER_SENS	O	0/3.3 V DC	EFS: On/Off
	5	EXIT_FEED_SENS	O	0/3.3 V DC	SBS: On/Off
	6	SB_MOT_REM	I	0/3.3 V DC	EM: On/Off
	7	SB_MOT_DIR	I	0/3.3 V DC	EM drive switch signal
	8	SB_MOT_PD	I	0/3.3 V DC	EM control signal
	9	SB_MOT_CLK	I	0/3.3 V DC (pulse)	EM clock signal
	10	SB_MOT_PH	I	0/3.3 V DC	EM control signal
	11	ENCODE_Bk	O	0/3.3 V DC	SRS: On/Off
	12	THOP_Bk	O	0/3.3 V DC	THS: On/Off
	13	THOP_MOT_REM	I	0/3.3 V DC	THM: On/Off
	14	THOP_MOT_DIR	I	0/3.3 V DC	THM drive switch signal
	15	DLP_FAN_H	I	0/24 V DC	DEVFM: On/Off
	16	DLP_FAN_L	I	0/24 V DC	DEVFM: On/Off
	17	ROT_HP_SENS	O	0/3.3 V DC	DEVSS: On/Off
	18	INTER_LOCK	-	-	Not used
	19	NC	-	-	Not used
<b>YC4</b>	1	GND	-	-	Ground
Connected to eject unit	2	ROT_HP_SENS	I	0/3.3 V DC	DEVSS: On/Off
	3	+5V	O	5 V DC	5 V DC power to DEVSS
	4	SB_CORE B/	O	0/24 V DC (pulse)	EM drive control signal
	5	SB_CORE A/	O	0/24 V DC (pulse)	EM drive control signal
	6	SB_CORE B	O	0/24 V DC (pulse)	EM drive control signal
	7	SB_CORE A	O	0/24 V DC (pulse)	EM drive control signal
	8	GND	-	-	Ground
	9	EXIT_FEED_SENS	I	0/3.3 V DC	SBS: On/Off
	10	5V	O	5 V DC	5 V DC power to SBS
	11	GND	-	-	Ground
	12	EXIT_PAPER_SENS	I	0/3.3 V DC	EFS: On/Off
	13	5V	O	5 V DC	5 V DC power to EFS
	14	+24V1	O	24 V DC	24 V DC power to FSSOL
	15	JUNC_SOL_REM	O	0/24 V DC	FSSOL: On/Off (REM)
	16	JUNC_SOL_RET	O	0/24 V DC	FSSOL: On/Off (RET)

Connector	Pin	Signal	I/O	Voltage	Description
<b>YC5</b> Connected to inner unit	1	+24V1	O	24 V DC	24 V DC power to DEVFM1
	2	DRUM_AIR_FAN	O	0/24 V DC	DEVFM1: On/Off
	3	+24V1	O	24 V DC	24 V DC power to DEVFM2
	4	DRUM_DLP_FAN	O	0/24 V DC	DEVFM2: On/Off
	5	THOP_MOT_BK	O	0/24 V DC	THM: On/Off
	6	+24V	O	24 V DC	24 V DC power to THM
	7	GND	-	-	Ground
	8	THOP_Bk	I	0/3.3 V DC	THS: On/Off
	9	+5V	O	5 V DC	5 V DC power to THS
	10	GND	-	-	Ground
	11	ENCODE_Bk	I	0/3.3 V DC	SRS: On/Off
	12	+5V	O	5 V DC	5 V DC power to SRS
<b>YC6</b> Connected to drum unit	1	3.3V2	O	3.3 V DC	3.3 V DC power to DRPWB
	2	EEP_SCL1	O	0/3.3 V DC (pulse)	EEPROM clock signal
	3	EEP_SDA1	I/O	0/3.3 V DC (pulse)	EEPROM data signal
	4	GND	-	-	Ground
	5	DRM_ADR0_Bk	-	-	Not used
	6	DRM_ADR1_Bk	-	-	Not used
	7	24V	O	24 V DC	24 V DC power to CL
	8	ERS_Bk_REM	O	0/24 V DC	CL: On/Off
	9	24V	-	-	Not used
	10	ERS_REM_PRE	-	-	Not used
	11	NC	-	-	Not used
<b>YC7</b> Connected to developer unit	1	TPD_TEMP_BK	I	Analog	Developer thermistor detection signal
	2	DLP_VCONT_BK_1	O	0/3.3 V DC	DEVPWB control signal
	3	TPD_BK_1	I	Analog	DEVPWB detection signal
	4	TN_CLK_BK	O	0/3.3 V DC (pulse)	Clock signal
	5	GND	-	-	Ground
	6	DLP_ADR1_BK	-	-	Not used
	7	DLP_ADR0_BK	-	-	Not used
	8	EEP_SDA1	I/O	0/3.3 V DC (pulse)	EEPROM data signal
	9	EEP_SCL1	O	0/3.3 V DC (pulse)	EEPROM clock signal
	10	3.3V2	O	3.3 V DC	3.3 V DC power to DEVPWB

Connector	Pin	Signal	I/O	Voltage	Description
<b>YC8</b>	1	WTNR_SET	I	Analog	WTS2 detection signal
Connected to outer temperature sensor, front cover switch, LSU fan motor and waste toner sensor	2	GND	-	-	Ground
	3	5V	O	5 V DC	5 V DC power to WTS1
	4	WTNR_FULL	I	Analog	WTS1 detection signal
	5	WTNR_LED	O	0/3.3 V DC (pulse)	WTS1 LED emitter signal
	6	5V_LED	O	5 V DC	5 V DC power to WTS1
	7	5V	O	5 V DC	5 V DC power to WTS2
	8	WTNR_NEAR	-	-	Not used
	9	WTNR_LED	-	-	Not used
	10	5V_LED	-	-	Not used
	11	3.3V1	O	3.3 V DC	3.3 V DC power to OTEM
	12	I2C_SDA	I	0/3.3 V DC (pulse)	EEPROM data signal
	13	GND	-	-	Ground
	14	I2C_SCL	O	0/3.3 V DC (pulse)	EEPROM clock signal
	15	FRONT_OPEN	O	0/3.3 V DC	FRCSW: On/Off
	16	GND	-	-	Ground
	17	24V	O	24 V DC	24 V DC power to LSUFM
	18	LSU_FAN	O	0V/24 V DC	LSUFM: On/Off
<b>YC9</b>	1	ROT_MOT_REM	-	-	Not used
Connected to engine PWB	2	ROT_MOT_CLK	-	-	Not used
	3	ROT_MOT_DIR	-	-	Not used
	4	ROT_MOT_PD	-	-	Not used
	5	GND	-	-	Ground
	6	IH_COIL_FAN_H	-	-	Not used
	7	IH_COIL_FAN_L	-	-	Not used
	8	IH_COIL_FAN_AL M	-	-	Not used
	9	IH_CORE_SENS	-	-	Not used
	10	IH_CORE_MOT_C LK	-	-	Not used
	11	IH_CORE_MOT_R EM	-	-	Not used

Connector	Pin	Signal	I/O	Voltage	Description
<b>YC11</b>	1	EXIT_FAN	O	0/24 V DC	EFFM: On/Off EDFM: On/Off
Connected to eject front fan motor, eject diffusion fan motor and fuser front fan motor	2	24V	O	24 V DC	24 V DC power to EFFM 24 V DC power to EDFM
	3	24V	O	24 V DC	24 V DC power to FUFFM
	4	CONTAINER_FAN	O	0/24 V DC	FUFFM: On/Off
<b>YC13</b>	1	24V	O	0/24 V DC	INM: On/Off
Connected to inner motor	2	LSU_FAN	O	0/24 V DC	INM: On/Off

### 2-3-7 Feed PWB 1

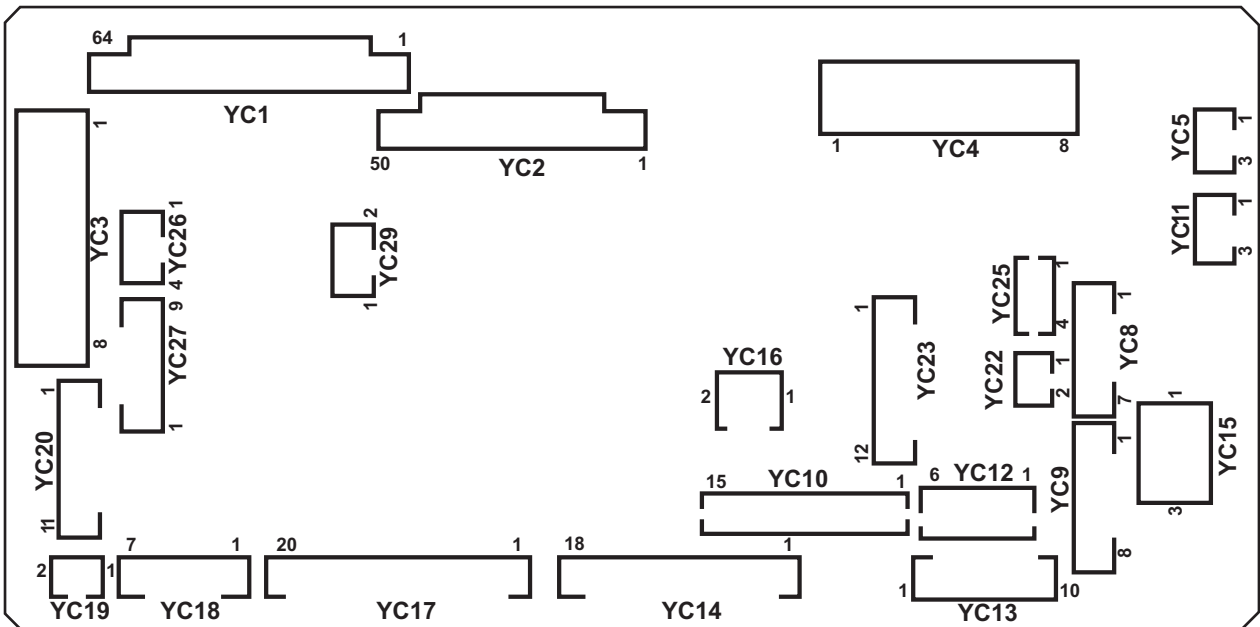


Figure 2-3-7 Feed PWB 1 silk-screen diagram

Connector	Pin	Signal	I/O	Voltage	Description
YC1	1	GND	-	-	Ground
Connected to engine PWB	2	REG_F_LED	I	Analog	IDS control signal
	3	REG_SENS_F_P	I	Analog	IDS detection signal
	4	REG_SENS_F_S	I	Analog	IDS detection signal
	5	GND	-	-	Ground
	6	REG_R_LED	O	Analog	IDS detection signal
	7	REG_SENS_R_P(BK)	I	Analog	IDS detection signal
	8	REG_SENS_R_S(BK)	I	Analog	IDS detection signal
	9	CLN_SOL_REM	I	0/24 V DC	CKSOL: On/Off (ACT)
	10	CLN_SOL_RET	I	0/24 V DC	CLSOL: On/Off (RET)
	11	GND	-	-	Ground
	12	BELT_JAM_SENS	-	-	Not used
	13	DU_SENS	I	0/3.3 V DC	DUS2: On/Off
	14	PRESS_RLS_SENS	-	-	Not used
	15	PRESS_RLS_MOT_REM2	-	-	Not used
	16	PRESS_RLS_MOT_REM1	-	-	Not used
	17	DU_FAN	-	-	Not used
	18	DU_OPEN	I	0/3.3 V DC	DUCSW: On/Off
	19	GND	-	-	Ground
	20	DU2_REM(CLLOW)	O	0/3.3 V DC	DUM2/DUCL2: On/Off
	21	DU2_CLK	O	0/3.3 V DC (pulse)	DUM2 clock signal
	22	DU2_PD	O	0/3.3 V DC	DUM2 control signal
	23	INTER_LOCK	-	-	Not used
	24	GND	-	-	Not used
	25	GND	-	-	Not used
	26	GND	-	-	Not used
	27	GND	-	-	Not used
	28	GND	-	-	Ground
	29	MPF_LIFT1	O	0/24 V DC	MPLM: On/Off
	30	MPF_LIF2	O	0/24 V DC	MPLM: On/Off
	31	MPF_CL	O	0/24 V DC	MPPFCL: On/Off
	32	MPF_JAM	I	0/3.3 V DC	MPFS: On/Off
	33	MPF_DOWN	I	0/3.3 V DC	MPLS2: On/Off

Connector	Pin	Signal	I/O	Voltage	Description
YC1	34	MPF_UP	I	0/3.3 V DC	MPLS1: On/Off
Connected to engine PWB	35	MPF_PPR	I	0/3.3 V DC	MPPS: On/Off
	36	GND	-	-	Ground
	37	MPF_LNG	I	0/3.3 V DC	MPPLSW: On/Off
	38	MPF_WID3	I	0/3.3 V DC	MPPWSW: On/Off
	39	MPF_WID2	I	0/3.3 V DC	MPPWSW: On/Off
	40	MPF_WID1	I	0/3.3 V DC	MPPWSW: On/Off
	41	MPF_TABLE	I	0/3.3 V DC	MPTSW: On/Off
	42	GND	-	-	Ground
	43	FSR_MOT_BRK	O	0/3.3 V DC	FUM break signal
	44	FSR_MOT_DIR	O	0/3.3 V DC	FUM drive switch signal
	45	FSR_MOT_RDY	O	0/3.3 V DC	FUM ready signal
	46	FSR_MOT_CLK	O	0/3.3 V DC (pulse)	FUM clock signal
	47	FSR_MOT_REM	O	0/3.3 V DC	FUM: On/Off
	48	GND	-	-	Ground
	49	GND	-	-	Ground
	50	EXIT_REAR_FAN_H	O	0/24 V DC	ERFM: On/Off
	51	EXIT_REAR_FAN_L	O	0/24 V DC	ERFM: On/Off
	52	PRESS_REM	-	-	Not used
	53	FSR_RELAY	I	0/3.3 V DC	Fuser relay signal
	54	ZEROC	O	0/3.3 V DC (pulse)	Zerocross signal
	55	SUB_HEAT_REM	O	0/3.3 V DC	FH2: On/Off
	56	MAIN_HEAT_REM	O	0/3.3 V DC	FH1: On/Off
	57	GND	-	-	Ground
	58	JOB_SOL_REM	O	0/24 V DC	JSFSSOL: On/Off
	59	JOB_OPEN_SENS	I	0/3.3 V DC	JSOCS: On/Off
	60	JOB_MOT_DIR	O	0/3.3 V DC	JSEM drive switch signal
	61	JOB_MOT_CLK	O	0/3.3 V DC (pulse)	JSEM clock signal
	62	JOB_MOT_REM	O	0/3.3 V DC	JSEM: On/Off
	63	JOB_SET	I	0/3.3 V DC	Job separator set signal
	64	GND	-	-	Ground

Connector	Pin	Signal	I/O	Voltage	Description
YC2	1	GND	-	-	Ground
Connected to engine PWB	2	GND	-	-	Ground
	3	DRM_HEAT_REM	-	-	Not used
	4	POWER_OFF	I	0/3.3 V DC	Power off signal
	5	IH_PWB_FAN(L)_ALM	O	0/3.3 V DC	IHFM alarm signal
	6	IH_PWB_FAN_H	I	0/24 V DC	IHFM: On/Off
	7	IH_PWB_FAN_L	I	0/24 V DC	IHFM: On/Off
	8	GND	-	-	Ground
	9	REG_MOT_REM(CL)	I	0/3.3 V DC	RM: On/Off
	10	REG_MOT_CLK	I	0/3.3 V DC (pulse)	RM clock signal
	11	REG_MOT_PD	I	0/3.3 V DC	RM control signal
	12	GND	-	-	Ground
	13	DLP_MOT_CLR_DIR	-	-	Not used
	14	DLP_MOT_CLR_RD	-	-	Not used
	15	DLP_MOT_CLR_CLK	-	-	Not used
	16	DLP_MOT_CLR_REM	-	-	Not used
	17	GND	-	-	Ground
	18	DRM_MOT_CLR_DIR	-	-	Not used
	19	DRM_MOT_CLR_RD	-	-	Not used
	20	DRM_MOT_BK_CLR_CLK	-	-	Not used
	21	DRM_MOT_CLR_REM	-	-	DRM clock signal
	22	GND	-	-	Ground
	23	DLP_MOT_BK_DIR	-	-	DEVM drive switch signal
	24	DLP_MOT_BK_READY	-	-	DEVM ready signal
	25	DLP_MOT_BK_CLK	-	-	DEVM clock signal
	26	DLP_MOT_BK_REM	-	-	DEVM: On/Off
	27	GND	-	-	Ground



Connector	Pin	Signal	I/O	Voltage	Description	
<b>YC2</b>	28	DRM_MOT_BK_B RK	-	-	DRM break signal	
Connected to engine PWB	29	DRM_MOT_BK_DI R	-	-	DRM drive switch signal	
	30	DRM_MOT_BK_R DY	-	-	DRM ready signal	
	31	DRM_MOT_BK_R EM	-	-	DRM: On/Off	
	32	GND	-	-	Ground	
	33	TRANS_MOT_BRK	I	0/3.3 V DC	TRCM break signal	
	34	TRANS_MOT_DIR	I	0/3.3 V DC	TRCM drive switch signal	
	35	TRANS_MOT_RDY	O	0/3.3 V DC	TRCM ready signal	
	36	TRANS_MOT_CLK	I	0/3.3 V DC (pulse)	TRCM clock signal	
	37	TRANS_MOT_RE M	I	0/3.3 V DC	TRCM:On/Off	
	38	GND	-	-	Ground	
	39	TCON_SET	-	-	Not used	
	40	DU_ENTER_SENS	O	0/3.3 V DC	DUS1: On/Off	
	41	EXIT_FAN	I	0/24 V DC	EFM: On/Off	
	42	GND	-	-	Ground	
	43	DU1_MOT_REM(C L_H)	I	0/3.3 V DC	DUM1/DUCL1: On/Off	
	44	DU1_MOT_CLK	I	0/3.3 V DC (pulse)	DUM1 clock signal	
	45	DU1_MOT_PD	I	0/3.3 V DC	DUM1 control signal	
	46	EDGE_FAN_H	I	0/24 V DC	FUFM: On/Off	
	47	GND	-	-	Ground	
		48	LOOP_SENS	O	0/3.3 V DC	LPS: On/Off
		49	M_TEMP	-	-	Not used
		50	GND	-	-	Ground
	<b>YC3</b>	1	+24V1	O	24 V DC	24 V DC power to EPWB
	Connected to engine PWB	2	+24V1	O	24 V DC	24 V DC power to EPWB
		3	GND	-	-	Ground
		4	GND	-	-	Ground
		5	+5 V0	O	5 V DC	5 V DC power to EPWB
6		GND	-	-	Ground	
7		+5V2	O	5 V DC	5 V DC power to EPWB	
8		GND	-	-	Ground	

Connector	Pin	Signal	I/O	Voltage	Description
<b>YC4</b> Connected to power source PWB	1	+24V1	I	24 V DC	24 V DC power from PSPWB
	2	+24V1	I	24 V DC	24 V DC power from PSPWB
	3	+24V1	I	24 V DC	24 V DC power from PSPWB
	4	+5 V	I	5 V DC	5 V DC power from PSPWB
	5	GND	-	-	Ground
	6	GND	-	-	Ground
	7	GND	-	-	Ground
	8	GND	-	-	Ground
<b>YC5</b> Connected to power source PWB	1	GND	-	-	Ground
	2	DRM_HEAT_REM	O	0/3.3 V DC	FH: On/Off
	3	POWER_OFF_24V1	O	0/3.3 V DC	Sleep mode signal: On/Off
<b>YC8</b> Connected to developer motor	1	NC	-	-	Not used
	2	DLP_MOT_Bk_DIR	O	0/3.3 V DC	DEVM drive switch signal
	3	DLP_MOT_Bk_RDY	I	0/3.3 V DC	DEVM ready signal
	4	DLP_MOT_Bk_CLK	O	0/3.3 V DC (pulse)	DEVM clock signal
	5	DLP_MOT_Bk_REM	O	0/24 V DC	DEVM: On/Off
	6	GND	-	-	Ground
	7	+24V1	O	24 V DC	24 V DC power to DEVM
<b>YC9</b> Connected to drum motor	1	NC	-	-	Not used
	2	DRM_MOT_Bk_BRK	O	0/3.3 V DC	DRM break signal
	3	DRM_MOT_Bk_DIR	O	0/3.3 V DC	DRM drive switch signal
	4	DRM_MOT_Bk_RDY	I	0/3.3 V DC	DRM ready signal
	5	DRM_MOT_Bk_CLK	O	0/3.3 V DC (pulse)	DRM clock signal
	6	DRM_MOT_Bk_REM	O	0/24 V DC	DRM: On/Off
	7	GND	-	-	Ground
	8	+24V1	O	24 V DC	24 V DC power to DRM

Connector	Pin	Signal	I/O	Voltage	Description
<b>YC11</b> Connected to heater fan motor	1	IH_PWB_FAN	O	0/24 V DC	HFM: On/Off
	2	GND	-	-	Ground
	3	IH_PWB_ALM	I	0/3.3 V DC	HFM alarm signal
<b>YC12</b> Connected to feed PWB 2	1	+24V2	O	24 V DC	24 V DC power to FPWB2
	2	+24V2	O	24 V DC	24 V DC power to FPWB2
	3	+5V	O	5 V DC	5 V DC power to FPWB2
	4	GND	-	-	Ground
	5	GND	-	-	Ground
	6	GND	-	-	Ground
<b>YC13</b> Connected to relay PWB	1	TRANS_MOT_BRK	O	0/3.3 V DC	TRM break signal
	2	TRANS_MOT_DIR	O	0/3.3 V DC	TRM drive switch signal
	3	TRANS_MOT_RDY	I	0/3.3 V DC	TRM ready signal
	4	TRANS_MOT_CLK	O	0/3.3 V DC (pulse)	TRM clock signal
	5	TRANS_MOT_RE M	O	0/24 V DC	TRM: On/Off
	6	GND	-	-	Ground
	7	24V2	O	24 V DC	24 V DC power to TRM
	8	GND	-	-	Not used
	9	24V2	-	-	Not used
	10	TANK_SET	-	-	Not used
<b>YC14</b> Connected to relay PWB	1	REG_BK_LED	O	Analog	IDS control signal
	2	REG_BK_SENS1_ P	I	Analog	IDS detection signal
	3	REG_BK_SENS1_ S	I	Analog	IDS detection signal
	4	BELT_JAM_SENS	-	-	Not used
	5	DU_SENS	I	0/3.3 V DC	DUS2: On/Off
	6	PRESS_RLS_SEN S	-	-	Not used
	7	5V	O	5 V DC	5 V DC power to RYPWB
	8	PRESS_RLSMOT2 1	-	-	Not used
	9	PRESS_RLSMOT2	-	-	Not used
	10	24V2	O	24 V DC	24 V DC power to RYPWB
	11	DU_FAN	-	-	Not used
	12	DU_CL_LOWER_R EM	O	0/24 V DC	DUCL2: On/Off

Connector	Pin	Signal	I/O	Voltage	Description
<b>YC14</b> Connected to relay PWB	13	DU_OPEN_SW	I	0/3.3 V DC	DUCSW: On/Off
	14	DU2_B/	O	0/24 V DC (pulse)	DUM2 drive control signal
	15	DU2_A/	O	0/24 V DC (pulse)	DUM2 drive control signal
	16	DU2_B	O	0/24 V DC (pulse)	DUM2 drive control signal
	17	DU2_A	O	0/24 V DC (pulse)	DUM2 drive control signal
	18	GND	-	-	Ground
<b>YC15</b> Connected to paper conveying unit switch	1	+24V1	O	24 V DC	24 V DC power to PCUSW
	2	N.C	-	-	Not used
	3	+24V2	I	24 V DC	24 V DC power from PCUSW
<b>YC16</b> Connected to high voltage PWB	1	+24V2	O	24 V DC	24 V DC power to HVPWB
	2	GND	-	-	Ground
<b>YC17</b> Connected to relay PWB	1	GND	-	-	Ground
	2	GND	-	-	Ground
	3	CL_SOL_REM	O	0/24 V DC	CLSOL: On/Off
	4	24V2	O	24 V DC	24 V dc power to CLSOL
	5	MPF_LIFT_MOT_B	O	0/24 V DC	MPLM: On/Off
	6	MPF_LIFT_MOT_A	O	0/24 V DC	MPLM: On/Off
	7	24V2	O	24 V DC	24 V dc power to RYPWB
	8	MPF_CL_REM	O	0/24 V DC	MPPFCL: On/Off
	9	MPF_JAM_SENS	I	0/3.3 V DC	MPFS: On/Off
	10	MPF_LIFT_DOWN_SENS	I	0/3.3 V DC	MPLS2: On/Off
	11	MPF_LIFT_UP_SENS	I	0/3.3 V DC	MPLS1: On/Off
	12	MPF_PPR_SET	I	0/3.3 V DC	MPPS: On/Off
	13	LED_3.3V3	O	3.3 V DC	3.3 V DC power to RYPWB
	14	MPF_LNG	I	0/3.3 V DC	MPPLSW: On/Off
	15	MPF_WID3	I	0/3.3 V DC	MPPWSW: On/Off
	16	MPF_WID2	I	0/3.3 V DC	MPPWSW: On/Off
	17	MPF_WID1	I	0/3.3 V DC	MPPWSW: On/Off
	18	MPF_TABLE	I	0/3.3 V DC	MPTSW: On/Off
	19	GND	-	-	Ground
	20	GND	-	-	Ground

Connector	Pin	Signal	I/O	Voltage	Description
<b>YC18</b> Connected to fuser motor	1	FSR_MOT_BRK	O	0/3.3 V DC	FUM break signal
	2	FSR_MOT_DIR	O	0/3.3 V DC	FUM drive switch signal
	3	FSR_MOT_RDY	I	0/3.3 V DC	FUM ready signal
	4	FSR_MOT_CLK	O	0/3.3 V DC (pulse)	FUM clock signal
	5	FSR_MOT_REM	O	0/24 V DC	FUM: On/Off
	6	GND	-	-	Ground
	7	24V2	O	24 V DC	24 V DC power to FUM
<b>YC19</b> Connected to eject rear fan motor	1	EXIT_REAR_FAN	O	0/24 V DC	ERFM: On/Off
	2	+24V1	O	24 V DC	24 V DC power to ERFM
<b>YC20</b> Connected to job separator	1	JOB_SET	I	0/3.3 V DC	Job separator set signal
	2	GND	-	-	Ground
	3	GND	-	-	Ground
	4	JOB_MOT_REM	O	0/24 V DC	JSEM: On/Off
	5	24V1	O	24 V DC	24 V DC power to JSMPWB
	6	JOB_MOT_CLK	O	0/3.3 V DC (pulse)	JSEM clock signal
	7	5V	O	5 V DC	5 V DC power to JSMPWB
	8	JOB_MOT_DIR	O	0/3.3 V DC	JSEM drive switch signal
	9	JOB_OPEN_SENS	I	0/3.3 V DC	JSOCS: On/Off
	10	JOB_SOL_REM	O	0/24 V DC	JSFSSOL: On/Off
	11	NC	-	-	Not used
<b>YC22</b> Connected to registration clutch (35 ppm model only)	1	24V2	O	24 V DC	24 V DC power to RCL
	2	REG_CL_REM	O	0/24 V DC	RCL: On/Off

Connector	Pin	Signal	I/O	Voltage	Description
<b>YC23</b> Connected to relay PWB	1	DU_ENTER_SENS	I	0/3.3 V DC	DUS1: On/Off
	2	EXIT_FAN	O	0/24 V DC	EFM: On/Off
	3	24V2	O	24 V DC	24 V DC power to RYPWB
	4	DU_CL_UPPER_REM	O	0/24 V DC	DUCL1: On/Off
	5	GND	-	-	Ground
	6	DU1_B/	O	0/24 V DC (pulse)	DUM1 drive control signal
	7	DU1_A/	O	0/24 V DC (pulse)	DUM1 drive control signal
	8	DU1_B	O	0/24 V DC (pulse)	DUM1 drive control signal
	9	DU1_A	O	0/24 V DC (pulse)	DUM1 drive control signal
	10	EDGE_FAN_REM	-	-	Not used
	11	LOOP_SENS	I	0/3.3 V DC	LPS: On/Off
	12	3.3V3	-	-	Not used
<b>YC25</b> Connected to registration motor (45/ 55 ppm model only)	1	REG_MOT_B/	O	0/24 V DC (pulse)	RM drive control signal
	2	REG_MOT_A/	O	0/24 V DC (pulse)	RM drive control signal
	3	REG_MOT_B	O	0/24 V DC (pulse)	RM drive control signal
	4	REG_MOT_A	O	0/24 V DC (pulse)	RM drive control signal
<b>YC26</b> Connected to engine PWB	1	3.3V2	O	3.3 V DC	3.3 V DC power to EPWB
	2	3.3V3	O	3.3 V DC	3.3 V DC power to EPWB
	3	GND	-	-	Ground
	4	GND	-	-	Ground
<b>YC27</b> Connected to fuser heater PWB	1	MAIN_HEAT_REM	O	0/3.3 V DC	FH1: On/Off
	2	SUB_HEAT_REM	O	0/3.3 V DC	FH2: On/Off
	3	24V2	O	24 V DC	24 V DC power to FHPWB
	4	ZEROC	O	0/3.3 V DC (pulse)	Zero-cross signal
	5	GND	-	-	Ground
	6	GND	-	-	Ground
	7	FSR_RELAY	O	0/3.3 V DC	Fuser relay signal
	8	+24V1	O	24 V DC	24 V DC power to FHPWB
	9	FSR_RELAY_24V	-	-	Not used

### 2-3-8 Feed PWB 2

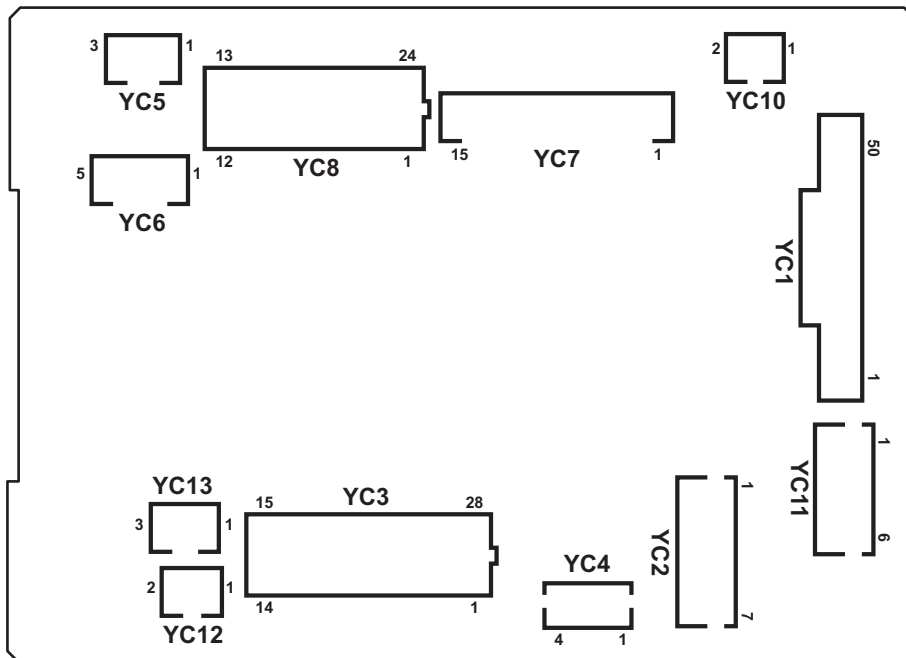
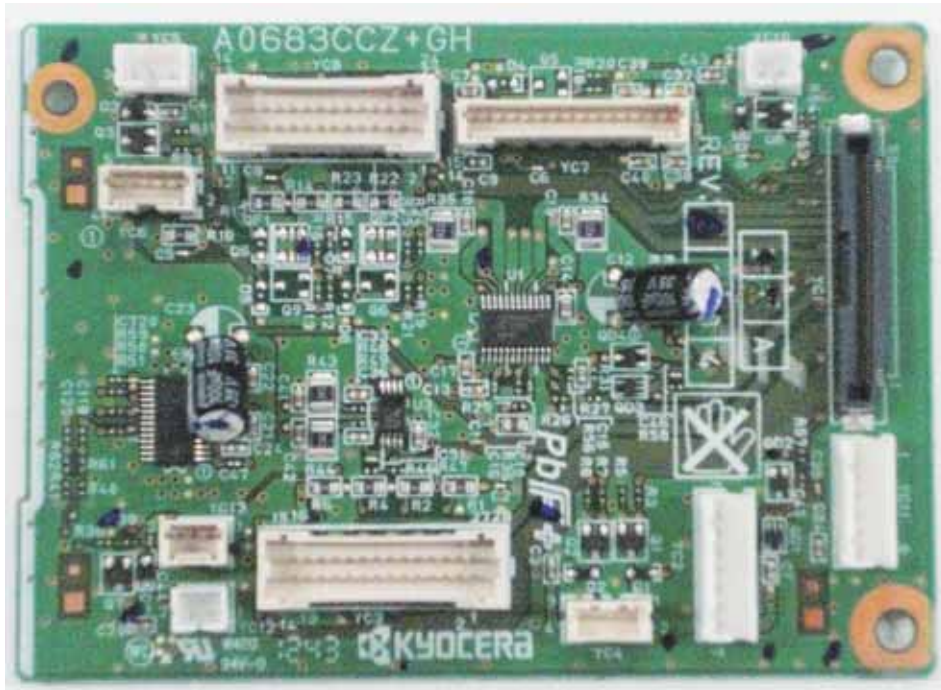


Figure 2-3-8 Feed PWB 2 silk-screen diagram

Connector	Pin	Signal	I/O	Voltage	Description
YC1	1	GND	-	-	Ground
Connected to engine PWB	2	FEED_MOT_REM	I	0/3.3 V DC	PFM: On/Off
	3	FEED_MOT_CLK	I	0/3.3 V DC (pulse)	PFM clock signal
	4	FEED_MOT_RDY	O	0/3.3 V DC	PFM ready signal
	5	FEED_MOT_DIR	I	0/3.3 V DC	PFM drive switch signal
	6	FEED_CL1_REM	I	0/24 V DC	PFCL1: On/Off
	7	FEED_CL2_REM	I	0/24 V DC	PFCL2: On/Off
	8	ASIST_CL2	I	0/24 V DC	ASCL2: On/Off
	9	LIFT_MOT2_REM	I	0/24 V DC	LM2: On/Off
	10	GND	-	-	Ground
	11	LIFT_MOT1_REM 1	I	0/24 V DC	LM1: On/Off
	12	CAS2_WID	O	0/3.3 V DC	PWSW2: On/Off
	13	CAS2_LNG3	O	0/3.3 V DC	PLSW2: On/Off
	14	CAS2_LNG2	O	0/3.3 V DC	PLSW2: On/Off
	15	CAS2_LNG1	O	0/3.3 V DC	PLSW2: On/Off
	16	CAS1_WID	O	0/3.3 V DC	PWSW1: On/Off
	17	CAS1_LNG3	O	0/3.3 V DC	PLSW1: On/Off
	18	CAS1_LNG2	O	0/3.3 V DC	PLSW1: On/Off
	19	CAS1_LNG1	O	0/3.3 V DC	PLSW1: On/Off
	20	GND	-	-	Ground
	21	CAS2_QUANT2	O	0/3.3 V DC	PGS2(L): On/Off
	22	CAS2_QUANT1	O	0/3.3 V DC	PGS2(U): On/Off
	23	CAS1_QUANT2	O	0/3.3 V DC	PGS1(L): On/Off
	24	CAS1_QUANT1	O	0/3.3 V DC	PGS1(U): On/Off
	25	LIFT_MOT1_LOCK	O	0/3.3 V DC	LM1 lock signal
	26	LIFT_MOT2_LOCK	O	0/3.3 V DC	LM2 lock signal
	27	CURRENT_SIG	O	0/3.3 V DC	Current signal
	28	V-FEED_CL	I	0/24 V DC	PCCL: On/Off
	29	COVER_OPEN	O	0/3.3 V DC	RLCSW: On/Off
	30	FEED2_SENS	O	0/3.3 V DC	PFPCS1: On/Off
	31	CAS1_P0	O	0/3.3 V DC	FS1: On/Off
	32	CAS1_LIFT_UP	O	0/3.3 V DC	LS1: On/Off
	33	GND	-	-	Ground
	34	CAS1_EMPTY	O	0/3.3 V DC	PS1: On/Off



Connector	Pin	Signal	I/O	Voltage	Description
<b>YC1</b> Connected to engine PWB	35	PICK_SOL1_RET	I	0/24 V DC	PUSOL1: On/Off (RET)
	36	PICK_SOL1_REM	I	0/24 V DC	PUSOL1: On/Off (ACT)
	37	CAS2_P0	O	0/3.3 V DC	FS2: On/Off
	38	CAS2_LIFT_UP	O	0/3.3 V DC	LS2: On/Off
	39	CAS2_EMPTY	O	0/3.3 V DC	PS2: On/Off
	40	PICK_SOL2_RET	I	0/24 V DC	PUSOL2: On/Off (RET)
	41	PICK_SOL2_REM	I	0/24 V DC	PUSOL2: On/Off (ACT)
	42	GND	-	-	Ground
	43	REG_SENS	O	0/3.3 V DC	RS: On/Off
	44	FEED1_SENS	O	0/3.3 V DC	PCS: On/Off
	45	BEND_SENS	O	0/3.3 V DC	RDS: On/Off
	46	MID_MOT_PH	I	0/3.3 V DC	MM control signal
	47	MID_MOT_REM(ROL_CL)	I	0/3.3 V DC	MM/MCL: On/Off
	48	MID_MOT_CLK	I	0/3.3 V DC (pulse)	MM clock signal
	49	MID_MOT_PD	I	0/3.3 V DC	MM control signal
50	ASIST_CL1	I	0/24 V DC	ASCL1: On/Off	
<b>YC2</b> Connected to paper feed motor	1	FEED_MOT_GAIN	-	-	Not used
	2	FEED_MOT_DIR	O	0/3.3 V DC	PFM drive switch signal
	3	FEED_MOT_RDY	I	0/3.3 V DC	PFM ready signal
	4	FEED_MOT_CLK	O	0/3.3 V DC (pulse)	PFM clock signal
	5	FEED_MOT_REM	O	0/24 V DC	PFM: On/Off
	6	GND	-	-	Ground
	7	24V2	O	24 V DC	24 V DC power to PFM
<b>YC3</b> Connected to paper length switch 1/2, paper width switch 1/2, lift motor 1/2, paper gauge sensor 1(U)/(L) and paper gauge sensor 2(U)/(L)	1	CAS1_LNG1	I	0/3.3 V DC	PLSW1: On/Off
	2	CAS1_LNG2	I	0/3.3 V DC	PLSW1: On/Off
	3	GND	-	-	Ground
	4	CAS1_LNG3	I	0/3.3 V DC	PLSW1: On/Off
	5	CAS1_WID	I	0/3.3 V DC	PWSW1: On/Off
	6	GND	-	-	Ground
	7	CAS2_LNG1	I	0/3.3 V DC	PLSW2: On/Off
	8	CAS2_LNG2	I	0/3.3 V DC	PLSW2: On/Off
	9	GND	-	-	Ground
	10	CAS2_LNG3	I	0/3.3 V DC	PLSW2: On/Off
	11	CAS2_WID	I	0/3.3 V DC	PWSW2: On/Off
	12	GND	-	-	Ground

Connector	Pin	Signal	I/O	Voltage	Description
<b>YC3</b>	13	LIFT_MOT1_RET	O	0/24 V DC	LM1: On/Off
Connected to paper length switch 1/2, paper width switch 1/2, lift motor 1/2, paper gauge sensor 1(U)/(L) and paper gauge sensor 2(U)/(L)	14	LIFT_MOT1_DR	O	0/24 V DC	LM1: On/Off
	15	LIFT_MOT2_RET	O	0/24 V DC	LM2: On/Off
	16	LIFT_MOT2_DR	O	0/24 V DC	LM2: On/Off
	17	LED_5V	O	5 V DC	5 V DC power to PGS1(U)
	18	GND	-	-	Ground
	19	CAS1_QUANT1	I	0/3.3 V DC	PGS1(U): On/Off
	20	LED_5V	O	5 V DC	5 V DC power to PGS1(L)
	21	GND	-	-	Ground
	22	CAS1_QUANT2	I	0/3.3 V DC	PGS1(L): On/Off
	23	LED_5V	O	5 V DC	5 V DC power to PGS2(U)
	24	GND	-	-	Ground
	25	CAS2_QUANT1	I	0/3.3 V DC	PGS2(U): On/Off
	26	LED_5V	O	5 V DC	5 V DC power to PGS2(L)
	27	GND	-	-	Ground
	28	CAS2_QUANT2	I	0/3.3 V DC	PGS2(L): On/Off
<b>YC4</b>	1	FEED_CL1_REM	O	0/24 V DC	PFCL1: On/Off
Connected to paper feed clutch 1/2	2	24V2	O	24 V DC	PFCL124 V DC power to PFCL1
	3	FEED_CL2_REM	O	0/24 V DC	PFCL2: On/Off
	4	24V2	O	24 V DC	24 V DC power to PFCL2
<b>YC5</b>	1	NC	-	-	Not used
Connected to paper conveying clutch	2	24V2	O	24 V DC	24 V DC power to PCCL
	3	V-FEED_CL_REM	O	0/24 V DC	PCCL: On/Off
<b>YC6</b>	1	LED_5V	O	5 V DC	5 V DC power to PCS
Connected to paper conveying sensor and paper conveying cover switch	2	GND	-	-	Ground
	3	FEED2_SENS	I	0/3.3 V DC	PCS: On/Off
	4	FEED_COVER_OPEN	I	0/3.3 V DC	PCCSW: On/Off
	5	GND	-	-	Ground

Connector	Pin	Signal	I/O	Voltage	Description
<b>YC7</b> Connected to middle motor* <sup>2</sup> , middle sensor, registration sensor and middle clutch* <sup>1</sup> (* <sup>1</sup> :35ppm model only * <sup>2</sup> :45ppm/55ppm model only)	1	MID_B/	O	0/24 V DC (pulse)	MM drive control signal
	2	MID_A/	O	0/24 V DC (pulse)	MM drive control signal
	3	MID_B	O	0/24 V DC (pulse)	MM drive control signal
	4	MID_A	O	0/24 V DC (pulse)	MM drive control signal
	5	BEND_SENS	I	0/3.3 V DC	RDS: On/Off
	6	GND	-	-	Ground
	7	5V	O	5 V DC	5 V DC power to RDS
	8	GND	-	-	Ground
	9	FEED1_SENS	I	0/3.3 V DC	MS: On/Off
	10	5V	O	5 V DC	5 V DC power to MS
	11	GND	-	-	Ground
	12	REG_SENS	I	0/3.3 V DC	RS: On/Off
	13	5V	O	5 V DC	5 V DC power to RS
	14	MID_CL_REM	O	0/24 V DC	MCL: On/Off
	15	24V2	O	24 V DC	24 V DC power to MCL
<b>YC8</b> Connected to primary paper feed unit	1	24V2	O	24 V DC	24 V DC power to PUSOL1
	2	PICK_SOL1_REM	O	0/24 V DC	PUSOL1: On/Off (ACT)
	3	PICK_SOL1_RET	O	0/24 V DC	PUSOL1: On/Off (RET)
	4	LED_5V	O	5 V DC	5 V DC power to PS1
	5	GND	-	-	Ground
	6	CAS1_EMPTY_SENS	I	0/3.3 V DC	PS1: On/Off
	7	LED_5V	O	5 V DC	5 V DC power to LS1
	8	GND	-	-	Ground
	9	CAS1_LIFT_UP_SENS	I	0/3.3 V DC	LS1: On/Off
	10	5V	O	5 V DC	5 V DC power to FS1
	11	CAS1_P0_SENS	I	0/3.3 V DC	FS1: On/Off
	12	GND	-	-	Ground
	13	24V2	O	24 V DC	24 V DC power to PUSOL2
	14	PICK_SOL2_REM	O	0/24 V DC	PUSOL2: On/Off (ACT)
	15	PICK_SOL2_RET	O	0/24 V DC	PUSOL2: On/Off (RET)
	16	LED_5V	O	5 V DC	5 V DC power to PS2
	17	GND	-	-	Ground
	18	CAS2_EMPTY_SENS	I	0/3.3 V DC	PS2: On/Off
	19	LED_5V	O	5 V DC	5 V DC power to LS2

Connector	Pin	Signal	I/O	Voltage	Description
<b>YC8</b> Connected to primary paper feed unit	20	GND	-	-	Ground
	21	CAS2_LIFT_UP_SENS	I	0/3.3 V DC	LS2: On/Off
	22	5V	O	5 V DC	5 V DC power to FS2
	23	CAS2_P0_SENS	I	0/3.3 V DC	FS2: On/Off
	24	GND	-	-	Ground
<b>YC10</b> Connected to assist clutch 1 (45ppm/55ppm model only)	1	ASIST_CL1	O	0/24 V DC	ASCL1: On/Off
	2	24V2	O	24 V DC	24 V DC power to ASCL1
<b>YC11</b> Connected to feed PWB 1	1	GND	-	-	Ground
	2	GND	-	-	Ground
	3	GND	-	-	Ground
	4	+5V	I	5 V DC	5 V DC power from FPWB1
	5	+24V2	I	24 V DC	24 V DC power from FPWB1
	6	+24V2	I	24 V DC	24 V DC power from FPWB1
<b>YC12</b> Connected to assist clutch 2 (45ppm/55ppm model only)	1	ASIST_CL2	O	0/24 V DC	ASCL2: On/Off
	2	24V2	O	24 V DC	24 V DC power to ASCL2
<b>YC13</b> Connected to current PWB	1	CURRENT_SIG	I	0/3.3 V DC	Current signal
	2	GND	-	-	Ground
	3	5V	I	5 V DC	5 V DC power from CRPWB

### 2-3-9 Relay PWB

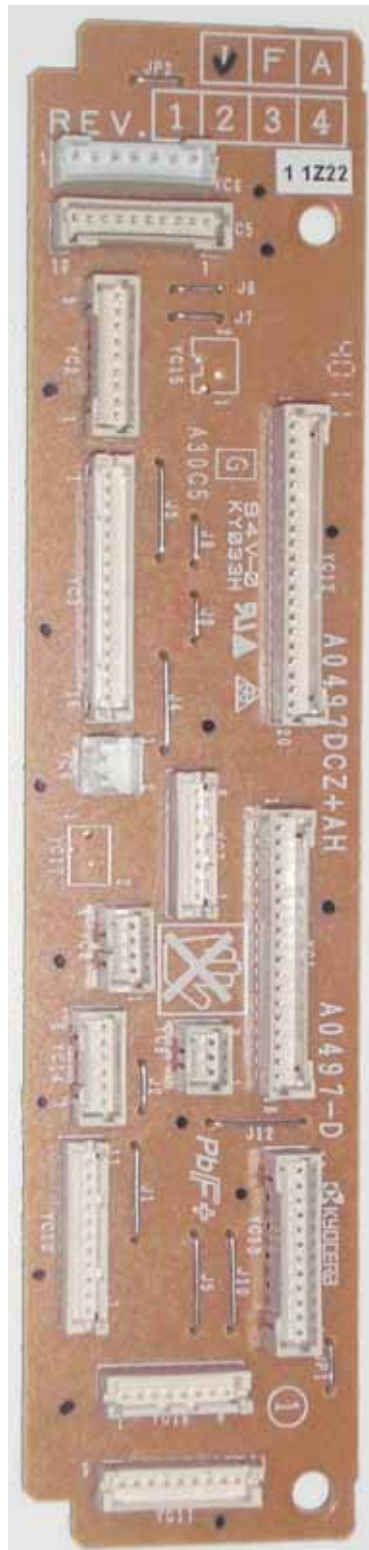
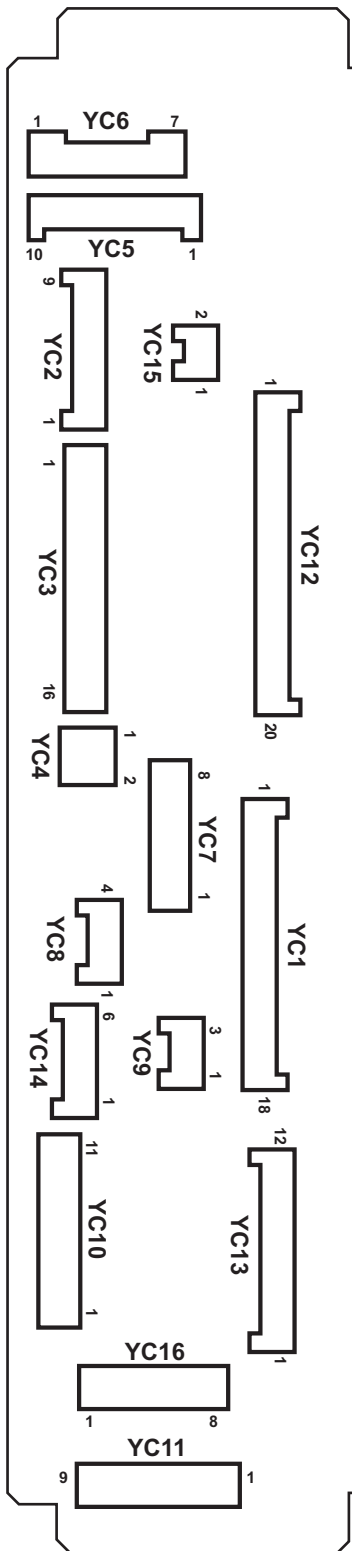


Figure 2-3-9 Relay PWB silk-screen diagram

Connector	Pin	Signal	I/O	Voltage	Description
<b>YC1</b>	1	GND	-	-	Ground
Connected to feed PWB 1	2	DU2_A	I	0/24 V DC (pulse)	DUM2 drive control signal
	3	DU2_B	I	0/24 V DC (pulse)	DUM2 drive control signal
	4	DU2_A/	I	0/24 V DC (pulse)	DUM2 drive control signal
	5	DU2_B/	I	0/24 V DC (pulse)	DUM2 drive control signal
	6	DU_OPEN_SW	O	0/3.3 V DC	DUCSW: On/Off
	7	DU_CL_LOWER_REM	I	0/24 V DC	DUCL2: On/Off
	8	DU_FAN	-	-	Not used
	9	24V2	I	24 V DC	24 V DC power from FPWB1
	10	PRESS_RLS_REM2	-	-	Not used
	11	PRESS_RLS_REM1	-	-	Not used
	12	5V	I	5 V DC	5 V DC power from FPWB1
	13	PRESS_RLS_SENS	-	-	Not used
	14	DU_SENS	O	0/3.3 V DC	DUS2: On/Off
	15	BELT_JAM_SENS	-	-	Not used
	16	REG_BK_SENS1_S	O	Analog	IDS detection signal
	17	REG_BK_SENS1_P	O	Analog	IDS detection signal
	18	REG_BK_LED	I	Analog	IDS control signal
<b>YC2</b>	1	GND	-	-	Ground
Connected to MP tray unit	2	MPF_LNG	I	0/3.3 V DC	MPPLSW: On/Off
	3	5V	O	5 V DC	5 V DC power to MPPLSW
	4	MPF_WID3	I	0/3.3 V DC	MPPWSW: On/Off
	5	MPF_WID2	I	0/3.3 V DC	MPPWSW: On/Off
	6	GND	-	-	Ground
	7	MPF_WID1	I	0/3.3 V DC	MPPWSW: On/Off
	8	GND	-	-	Ground
	9	MPF_TABLE	I	0/3.3 V DC	MPTSW: On/Off

Connector	Pin	Signal	I/O	Voltage	Description
<b>YC3</b>	1	LED_3.3V3	O	3.3 V DC	3.3 V DC power to MPPLSW
Connected to MP tray unit	2	GND	-	-	Ground
	3	MPF_PPR_SET	I	0/3.3 V DC	MPPS: On/Off
	4	GND	-	-	Ground
	5	MPF_LIFT_UP_SENS	I	0/3.3 V DC	MPLS1: On/Off
	6	5V	O	5 V DC	5 V DC power to MPLS1
	7	GND	-	-	Ground
	8	MPF_LIFT_DOWN_SENS	I	0/3.3 V DC	MPLS2: On/Off
	9	5V	O	5 V DC	5 V DC power to MPLS1
	10	GND	-	-	Ground
	11	MPF_JAM_SENS	I	0/3.3 V DC	MPFS: On/Off
	12	5V	O	5 V DC	5 V DC power to MPFS
	13	MPF_CL_REM	O	0/24 V DC	MPPFCL: On/Off
	14	24V2	O	24 V DC	24 V DC power to MPPFCL
	15	MPF_LIFT_DR_A	O	0/24 V DC	MPLM: On/Off
	16	MPF_LIFT_DR_B	O	0/24 V DC	MPLM: On/Off
<b>YC4</b>	1	24V2	O	24 V DC	24 V DC power to CLSOL
Connected to cleaning solenoid	2	ID_SOL_REM	O	0/24 V DC	CLSOL: On/Off
<b>YC5</b>	1	TANK_SET	-	-	Not used
Connected to feed PWB 1	2	24V2	-	-	Not used
	3	GND	-	-	Not used
	4	24V2	I	24 V DC	24 V DC power from FPWB1
	5	GND	-	-	Ground
	6	TRANS_MOT_REM	I	0/24 V DC	TRM: On/Off
	7	TRANS_MOT_CLK	I	0/3.3 V DC (pulse)	TRM clock signal
	8	TRANS_MOT_RDY	O	0/3.3 V DC	TRM ready signal
	9	TRANS_MOT_DIR	I	0/3.3 V DC	TRM drive switch signal
	10	TRANS_MOT_BRK	I	0/3.3 V DC	TRM break signal

Connector	Pin	Signal	I/O	Voltage	Description
<b>YC6</b> Connected to transfer motor	1	24V2	O	24 V DC	24 V DC power to TRM
	2	GND	-	-	Ground
	3	TRANS_MOT_REM	O	0/24 V DC	TRM: On/Off
	4	TRANS_MOT_CLK	O	0/3.3 V DC (pulse)	TRM clock signal
	5	TRANS_MOT_RDY	I	0/3.3 V DC	TRM ready signal
	6	TRANS_MOT_DIR	O	0/3.3 V DC	TRM drive switch signal
	7	TRANS_MOT_BRK	O	0/3.3 V DC	TRM break signal
<b>YC7</b> Connected to duplex clutch 2*1, duplex cover switch and duplex motor 2*2 *1:35ppm model only *2:45/ 55ppm model only)	1	24V2	O	24 V DC	24 V DC power to DUCL2
	2	DU_CL2_REM	O	0/24 V DC	DUCL2: On/Off
	3	DU_OPEN	I	0/3.3 V DC	DUCSW: On/Off
	4	GND	-	-	Ground
	5	DU2_B/	O	0/24 V DC (pulse)	DUM2 drive control signal
	6	DU2_A/	O	0/24 V DC (pulse)	DUM2 drive control signal
	7	DU2_B	O	0/24 V DC (pulse)	DUM2 drive control signal
	8	DU2_A	O	0/24 V DC (pulse)	DUM2 drive control signal
<b>YC9</b> Connected to duplex sensor 2	1	GND	-	-	Ground
	2	DU_SENS	I	0/3.3 V DC	DUS2: On/Off
	3	5V	O	5 V DC	5 V DC power to DUS2
<b>YC10</b> Connected to loop sensor and ID sensor	1	LOOP_SENS	I	0/3.3 V DC	LPS: On/Off
	2	GND	-	-	Ground
	3	5V	O	5 V DC	5 V DC power to LPS
	4	3.3V	O	3.3 V DC	3.3 V DC power to IDS
	5	REG_BK_LED	O	Analog	IDS control signal
	6	GND	-	-	Ground
	7	REG_BK_SENS1_P	I	Analog	IDS detection signal
	8	REG_BK_SENS1_S	I	Analog	IDS detection signal
	9	GND	-	-	Not used
	10	BELT_JAM_SENS	-	-	Not used
	11	5V	-	-	Not used



Connector	Pin	Signal	I/O	Voltage	Description
<b>YC11</b>	1	GND	-	-	Ground
Connected to duplex sensor 1, eject fan motor and duplex clutch 1* (35ppm model only)	2	DU_ENTER_SENS	I	0/3.3 V DC	DUS1: On/Off
	3	5V	O	5 V DC	5 V DC power to DUS1
	4	EXIT_FAN_REM	O	0/24 V DC	EFM1: On/Off
	5	24V2	O	24 V DC	24 V DC power to EFM1
	6	EXIT_FAN_REM	O	0/24 V DC	EFM2: On/Off
	7	24V2	O	24 V DC	24 V DC power to EFM2
	8	24V2	O	24 V DC	24 V DC power to DUCL1
	9	DU_CL_UPPER_REM	O	0/24 V DC	DUCL1: On/Off
<b>YC12</b>	1	GND	-	-	Ground
Connected to feed PWB 1	2	GND	-	-	Ground
	3	MPF_TABLE	O	0/3.3 V DC	MPTSW: On/Off
	4	MPF_WID1	O	0/3.3 V DC	MPPWSW: On/Off
	5	MPF_WID2	O	0/3.3 V DC	MPPWSW: On/Off
	6	MPF_WID3	O	0/3.3 V DC	MPPWSW: On/Off
	7	MPF_LNG	O	0/3.3 V DC	MPPLSW: On/Off
	8	LED_3.3V3	I	3.3 V DC	3.3 V DC power from FPWB1
	9	MPF_PPR_SET	O	0/3.3 V DC	MPPS: On/Off
	10	MPF_LIFT_UP_SENS	O	0/3.3 V DC	MPLS1: On/Off
	11	MPF_LIFT_DOWN_SENS	O	0/3.3 V DC	MPLS2: On/Off
	12	MPF_JAM_SENS	O	0/3.3 V DC	MPFS: On/Off
	13	MPF_CL_REM	I	0/24 V DC	MPPFCL: On/Off
	14	24V2	I	24 V DC	24 V DC power from FPWB1
	15	MPF_LIFT_MOT_A	I	0/24 V DC	MPLM: On/Off
	16	MPF_LIFT_MOT_B	I	0/24 V DC	MPLM: On/Off
	17	24V2	I	24 V DC	24 V DC power from FPWB1
	18	CLN_SOL_REM	O	0/24 V DC	CLSOL: On/Off
	19	GND	-	-	Ground
	20	GND	-	-	Ground

Connector	Pin	Signal	I/O	Voltage	Description
<b>YC13</b>	1	LOOP_SENS	O	0/3.3 V DC	LPS: On/Off
Connected to feed PWB 1	2	EDGE_FAN_REM	-	-	Not used
	3	EDGE_FAN_REM	-	-	Not used
	4	DU1_A	I	0/24 V DC (pulse)	DUM1 drive control signal
	5	DU1_B	I	0/24 V DC (pulse)	DUM1 drive control signal
	6	DU1_A/	I	0/24 V DC (pulse)	DUM1 drive control signal
	7	DU1_B/	I	0/24 V DC (pulse)	DUM1 drive control signal
	8	GND	-	-	Ground
	9	DU_CL_UPPER_REM	I	0/24 V DC	DUCL1: On/Off
	10	24V2	I	24 V DC	24 V DC power from FPWB1
	11	EXIT_FAN	I	0/24 V DC	EFM: On/Off
	12	DU_ENTER_SENS	O	0/3.3 V DC	DUS1: On/Off
<b>YC16</b>	1	DU1_B/	O	0/24 V DC (pulse)	DUM1 drive control signal
Connected to duplex motor 1 (45/ 55 ppm model only )	2	DU1_A/	O	0/24 V DC (pulse)	DUM1 drive control signal
	3	DU1_B	O	0/24 V DC (pulse)	DUM1 drive control signal
	4	DU1_A	O	0/24 V DC (pulse)	DUM1 drive control signal
	5	EDGE_FAN_REM	-	-	Not used
	6	24V2	-	-	Not used
	7	EDGE_FAN_REM	-	-	Not used
	8	24V2	-	-	Not used

### 2-3-10 LSU relay PWB

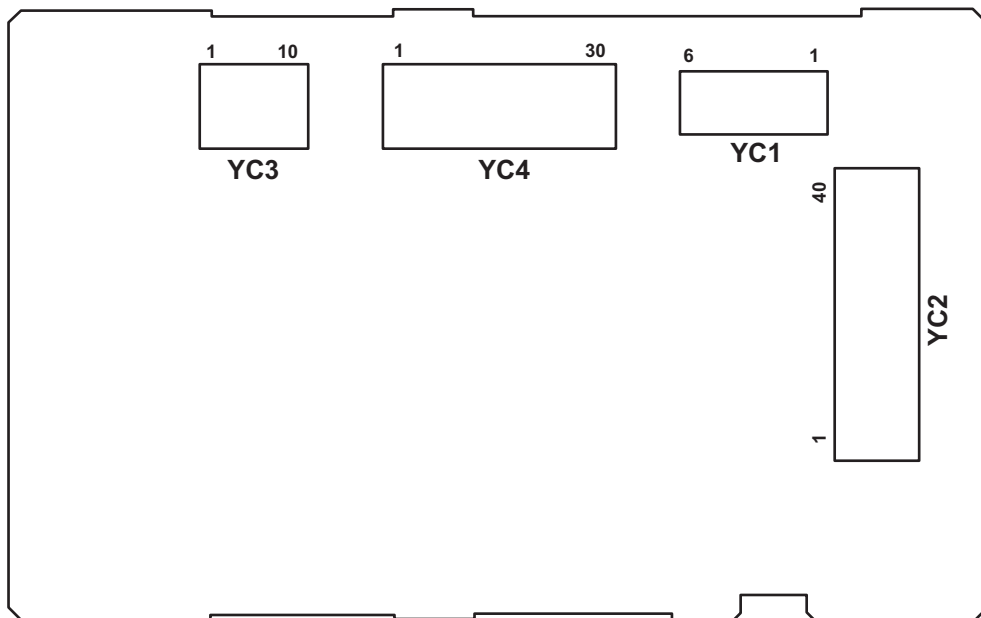
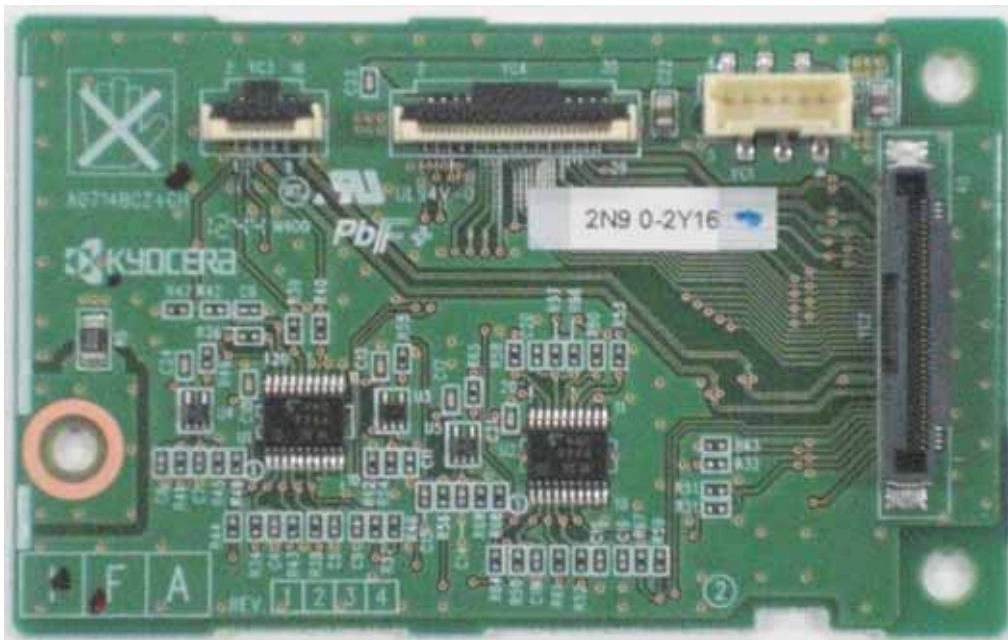


Figure 2-3-10 LSU relay PWB silk-screen diagram

Connector	Pin	Signal	I/O	Voltage	Description
<b>YC1</b> Connected to engine PWB	1	GND	-	-	Ground
	2	+3.3V2	O	3.3 V DC	3.3 V DC power from EPWB
	3	GND	-	-	Ground
	4	GND	-	-	Ground
	5	+5V AN	O	5 V DC	5 V DC power from EPWB
	6	+5V AN	O	5 V DC	5 V DC power from EPWB
<b>YC2</b> Connected to engine PWB	1	SDI	O	0/3.3 V DC (pulse)	Serial communication data signal
	2	GND	-	-	Ground
	3	SDO	I	0/3.3 V DC (pulse)	Serial communication data signal
	4	GND	-	-	Ground
	5	SCLK	I	0/3.3 V DC (pulse)	Clock signal
	6	GND	-	-	Ground
	7	EEPROM_CS_2_Bk	I/O	0/3.3 V DC (pulse)	APCPWB EEPROM data signal
	8	EEPROM_CS_1_Bk	I/O	0/3.3 V DC (pulse)	APCPWB EEPROM data signal
	9	GND	-	-	Ground
	10	DATA_3N_Bk(LVDS)	I	0/3.3 V DC (pulse)	Video data signal (N)
	11	DATA_3P_Bk(LVDS)	I	0/3.3 V DC (pulse)	Video data signal (P)
	12	GND	-	-	Ground
	13	DATA_4N_Bk(LVDS)	I	0/3.3 V DC (pulse)	Video data signal (N)
	14	DATA_4P_Bk(LVDS)	I	0/3.3 V DC (pulse)	Video data signal (P)
	15	GND	-	-	Ground
	16	BD_Bk	O	0/3.3 V DC (pulse)	Horizontal synchronization signal
	17	LSU_TH_Bk	O	Analog	LSU thermistor detection signal
	18	PARA_SIG_P3_2Bk	I	0/3.3 V DC	APCPWB control signal
	19	LDD_CS 2 Bk	I	0/3.3 V DC	APCPWB control signal
	20	LDD_CS 1 Bk	I	0/3.3 V DC	APCPWB control signal
	21	MSET_N	I	0/3.3 V DC	Control signal
	22	CUALM_BK	O	0/3.3 V DC	APCPWB alarm signal
	23	INT_ST_2_Bk	I	0/3.3 V DC	APCPWB control signal
	24	INT_ST_1_Bk	I	0/3.3 V DC	APCPWB control signal

Connector	Pin	Signal	I/O	Voltage	Description	
<b>YC2</b> Connected to engine PWB	25	PARA_SIG_P0_Bk	I	0/3.3 V DC	APCPWB control signal	
	26	PARA_SIG_P1_Bk	I	0/3.3 V DC	APCPWB control signal	
	27	PARA_SIG_P2_Bk	I	0/3.3 V DC	APCPWB control signal	
	28	PARA_SIG_P3_Bk	I	0/3.3 V DC	APCPWB control signal	
	29	PARA_SIG_P4_Bk	I	0/3.3 V DC	APCPWB control signal	
	30	GND	-	-	Ground	
	31	SDCLK_Bk	I	0/3.3 V DC (pulse)	APCPWB clock signal	
	32	GND	-	-	Ground	
	33	GAIN_FIX_Bk	I	0/3.3 V DC	APCPWB control signal	
	34	GND	-	-	Ground	
	35	DATA_1NBk(LVDS)	I	0/3.3 V DC (pulse)	Video data signal (N)	
	36	DATA_1PBk(LVDS)	I	0/3.3 V DC (pulse)	Video data signal (P)	
	37	GND	-	-	Ground	
	38	DATA_2NBk(LVDS)	I	0/3.3 V DC (pulse)	Video data signal (N)	
	39	DATA_2PBk(LVDS)	I	0/3.3 V DC (pulse)	Video data signal (P)	
	40	GND	-	-	Ground	
	<b>YC3</b> Connected to APC PWB	1	GND	-	-	Ground
		2	BD Bk	I	0/3.3 V DC (pulse)	Horizontal synchronization signal
		3	LSU_TH Bk	I	Analog	LSU thermistor detection signal
		4	PALA_SIG P3_2Bk	-	-	Not used
5		LDD_CS 2 Bk	-	-	Not used	
6		5V	O	5 V DC	5 V DC power to APCPWB	
7		5V	O	5 V DC	5 V DC power to APCPWB	
8		5V	O	5 V DC	5 V DC power to APCPWB	
9		LDD_CS 1 Bk	O	0/3.3 V DC	APCPWB control signal	
10		SDI1	I	0/3.3 V DC (pulse)	Serial communication data signal	
11		SDO1	O	0/3.3 V DC (pulse)	Serial communication data signal	
12		CLK1	O	0/3.3 V DC (pulse)	APCPWB clock signal	
13		EEPROM CS 1 Bk	I/O	0/3.3 V DC (pulse)	APCPWB EEPROM data signal	
14		MSET_N	O	0/3.3 V DC	APCPWB control signal	
15		CUALM Bk	I	0/3.3 V DC	APCPWB alarm signal	
16		INT_ST 2 Bk	O	0/3.3 V DC	APCPWB control signal	
17		INT_ST 1 Bk	O	0/3.3 V DC	APCPWB control signal	
18		PALA_SIG P0 Bk	O	0/3.3 V DC	APCPWB control signal	
19		PALA_SIG P1 Bk	O	0/3.3 V DC	APCPWB control signal	
20		PALA_SIG P2 Bk	O	0/3.3 V DC	APCPWB control signal	
21		PALA_SIG P3 Bk	O	0/3.3 V DC	APCPWB control signal	

Connector	Pin	Signal	I/O	Voltage	Description
<b>YC3</b>	22	PALA_SIG P4 Bk	O	0/3.3 V DC	APCPWB control signal
Connected to APC PWB	23	SDCLK Bk	O	0/3.3 V DC (pulse)	APCPWB clock signal
	24	GAIN FIX Bk	O	0/3.3 V DC	APCPWB control signal
	25	DATA_1NBk(LVDS)	O	0/3.3 V DC (pulse)	Video data signal (N)
	26	DATA_1PBk(LVDS)	O	0/3.3 V DC (pulse)	Video data signal (P)
	27	GND	-	-	Ground
	28	DATA_2NBk(LVDS)	O	0/3.3 V DC (pulse)	Video data signal (N)
	29	DATA_2PBk(LVDS)	O	0/3.3 V DC (pulse)	Video data signal (P)
	30	GND	-	-	Ground

## 2-4-1 Appendixes

### (1) List of maintenance parts

Maintenance part name		Part No.	Alternative part No.
Name used in service manual	Name used in parts list		
Paper feed pulley			
45/55 ppm model	PULLEY FEED	302N406030	2N406030
35 ppm model	PULLEY FEED ASSY	302F906230	2F906230
Separation pulley			
45/55 ppm model	PULLEY RETARD	302N406040	2N406040
35 ppm model	RETARD ROLLER ASSY	302F909171	2F909171
Forwarding pulley			
45/55 ppm model	PULLEY FEED	302N406030	2N406030
35 ppm model	PULLEY PICKUP ASSY	302HN06080	2HN06080
Left registration roller			
45/55 ppm model	PARTS ROLLER REGIST H SP	302K994A00	2K994A00
35 ppm model	PARTS ROLLER REGIST L SP	302K994450	2K994450
Regist cleaner L	PARTS CLEANER REGIST ASSY SP	302LF94160	2LF94160
Right registration roller	ROLLER REGIST R	302LF24150	2LF24150
Regist cleaner R	UNDER CLEANER REGIST	2BL07950	-
Middle roller	PARTS ROLLER MIDDLE L SP	302LC94550	2LC94550
Paper conveying roller	PARTS ROLLER FEED LOW SP	302K994430	2K994430
Assist roller			
45/55 ppm model	PARTS ROLLER ASSIST SP	302K994420	2K994420
Transfer belt unit	PARTS BELT ASSY SP	302LF94060	2LF94060
MP paper feed pulley	PULLEY, PAPER FEED	2AR07220	-
MP forwarding pulley	PULLEY, SEPARATION	2AR07230	

Maintenance part name		Part No.	Alternative part No.
Name used in service manual	Name used in parts list		
Contact glass for Metric for Inch	PARTS CONTACT-GLASS ASSY(C) SP	302K994040	2N994040
	PARTS CONTACT-GLASS ASSY(I) SP	302K994030	2K994030
LED mount	PARTS MOUNT LED ASSY SP	302N493040	2N493040
Original size sensor	SENSOR ORIGINAL	302H044110	2H044110
ISU	PARTS IMAGE SCANNER L SP	302N693020	2N693020
Lower duplex roller 45/55 ppm model 35 ppm model	PARTS ROLLER DU LOW SP	302K994470	2K994470
	PARTS ROLLER DU LOW SP	302LK94060	2LK94060
Middle duplex roller	PARTS ROLLER DU MID SP	302K994480	2K994480
Upper duplex roller 45/55 ppm model 35 ppm model	PARTS ROLLER DU UP SP	302K994491	2K994491
	PARTS ROLLER DU UP SP	302LK94071	2LK94071
Eject roller B	PARTS ROLLER EXIT SP	302LC94350	2LC94350
Eject roller	PARTS ROLLER EXIT SP	302LH94290	2LH94290
Drum filter	PARTS FILTER DRUM SP	302LF94310	2LF94310
Developer filter	PARTS FILTER DLP SP	302LF94320	2LF94320
LSU filter	PARTS FILTER FAN ASSY(Z) SP	302LF94300	2LF94300
Toner filter	FILTER LEFT SIDE	302LC33370	2LC33370
Left filter	FILTER LEFT SIDE	302LC33370	2LC33370
Eject filter	FILTER TOP	302N433010	2N433010
Belt filter	PARTS FILTER BELT UNIT(V) SP	302LC94130	2LC94130
Toner disposal box	PARTS DISPOSAL TONER UNIT SP	302N794020	2N794020



**(2) Maintenance kits**

Maintenance part name		Parts No.	Alternative part No.
Name used in service	Name used in parts list		
120 V specifications			
MK-6317A/ Maintenance kit (600,000 pages)	MK-6317/MAINTENANCE KIT	1702N97US1	072N97U1
Drum unit	DK-6306	-	-
Developer unit	DV-6305	-	-
Fuser unit	FK-6306B	-	-
Transfer belt unit	PARTS BELT ASSY SP	-	-
Toner disposal box	PARTS DISPOSAL TONER UNIT SP	-	-
Eject filter	FILTER TOP	-	-
Toner/Left filter	FILTER LEFT SIDE	-	-
220 - 240 V specifications			
MK-6315A/ Maintenance kit (600,000 pages)	MK-6315/MAINTENANCE KIT	1702N98NL1	072N98N1
Drum unit	DK-6306	-	-
Developer unit	DV-6305	-	-
Fuser unit	FK-6307B	-	-
Transfer belt unit	PARTS BELT ASSY SP	-	-
Toner disposal box	PARTS DISPOSAL TONER UNIT SP	-	-
Eject filter	FILTER TOP	-	-
Toner/Left filter	FILTER LEFT SIDE	-	-

### (3) Periodic maintenance procedures

CH: Check, CL: Clean, AD: Adjust, LU: Lubrication, RE: Replace

Section	Maintenance part/location	User call	Periodic maintenance (x1000 counts)				Points and cautions	Page
			300	600	900	1200		
Test copy and test print	Perform at the maximum copy size	CH AD	CH AD	CH AD	CH AD	CH AD	Test copy	



Section	Maintenance part/location	User call	Periodic maintenance (x1000 counts)				Points and cautions	Page
			300	600	900	1200		
Inner Cleaning	Cleaning the toner collection duct 1	CH CL	CH CL	CH CL	CH CL	CH CL	Vacuum.	P.2-4-10
	Cleaning the toner collection duct 2	CH CL	-	CH CL	-	CH CL	Vacuum.	P.2-4-11
	Cleaning the inner air duct Cleaning the back of the paper conveying plate	CH CL	CH CL	CH CL	CH CL	CH CL	Vacuum.	P.2-4-11
	Toner disposal box	CH RE	-	RE	-	RE	Replace: MK-6315A/ MK-6317A	P.1-5-103



Section	Maintenance part/location	User call	Periodic maintenance (x1000 counts)				Points and cautions	Page
			300	600	900	1200		
Developer section	Cleaning the duct at the back of the developer unit	CH CL	CH CL	-	CH CL	-	Vacuum.	P.2-4-12
	Developer unit	RE	CH CL	RE	CH CL	RE	Replace: MK-6315A/ MK-6317A	P.1-5-46



Section	Maintenance part/location	User call	Periodic maintenance (x1000 counts)				Points and cautions	Page
			300	600	900	1200		
Drum section	Drum unit	RE	CH CL	RE	CH CL	RE	Replace: MK-6315A/ MK-6317A	P.1-5-47
	Cleaning the inner unit	CH CL	CH CL	CH CL	CH CL	CH CL	Vacuum.	P.1-5-44
	Cleaning the drum cover	CH CL	CH CL	CH CL	CH CL	CH CL	Vacuum.	P.2-4-15



Section	Maintenance part/location	User call	Periodic maintenance (x1000 counts)				Points and cautions	Page
			300	600	900	1200		
Transfer section	Transfer belt unit	CH CL	CH CL	RE	CH CL	RE	Replace: MK-6315A/ MK-6317A	P.1-5-55



Section	Maintenance part/location	User call	Periodic maintenance (x1000 counts)				Points and cautions	Page
			300	600	900	1200		
Fuser section	Fuser unit	RE	CH CL	RE	CH CL	RE	Replace: MK-6315A/ MK-6317A	P.1-5-57



Section	Maintenance part/location	User call	Periodic maintenance (x1000 counts)				Points and cautions	Page
			150/ 300	450/ 600	750/ 900	1050/ 1200		
Paper feed , conveying section	Paper feed pulley	CH CL	CH RE	CH RE	CH RE	CH RE	Clean with alcohol or a dry cloth. CH: performing U901 and check feeding count: Target to replace at 150K.	P.1-5-16 P.1-5-19
	Separation pulley	CH CL	CH RE	CH RE	CH RE	CH RE		

Section	Maintenance part/location	User call	Periodic maintenance (x1000 counts)				Points and cautions	Page
			150/300	450/600	750/900	1050/1200		
Paper feed , conveying section	Forwarding pulley	CH CL	CH RE	CH RE	CH RE	CH RE	Clean with alcohol or a dry cloth. CH: performing U901 and check feeding count: Target to replace at 150K.	P.1-5-16 P.1-5-19
	Left registration roller	CL	- /CL	- /CL	- /CL	- /CL	Clean with alcohol or a dry cloth.	
	Regist cleaner L	CL	- /CL	- /CL	- /CL	- /CL	Vacuum.	P.1-5-57
	Right registration roller	CL	- /CL	- /CL	- /CL	- /CL	Clean with alcohol or a dry cloth.	
	Regist cleaner R	CL	- /CL	- /CL	- /CL	- /CL	Vacuum.	P.1-5-57
	Middle roller	CL	- /CL	- /CL	- /CL	- /CL	Clean with alcohol or a dry cloth.	
	Paper conveying roller	CL	- /CL	- /CL	- /CL	- /CL	Clean with alcohol or a dry cloth.	
	Assist roller	CL	- /CL	- /CL	- /CL	- /CL	Clean with alcohol or a dry cloth.	
	MP paper feed pulley	CH CL	CH RE	CH RE	CH RE	CH RE	Clean with alcohol or a dry cloth. CH:performing U901 and check feeding count: Target to replace at 150K.	P.1-5-25
	MP forwarding pulley	CH CL	CH RE	CH RE	CH RE	CH RE	Clean with alcohol or a dry cloth. CH:performing U901 and check feeding count: Target to replace at 150K.	P.1-5-25
	Guides	CH CL	CH CL	CH CL	CH CL	CH CL	Clean with alcohol or a dry cloth.	
Cleaning the separator	CL	- /CL	- /CL	- /CL	- /CL	Cleaning brush	P.2-4-13	



Section	Maintenance part/location	User call	Periodic maintenance (x1000 counts)				Points and cautions	Page
			300	600	900	1200		
Eject, Duplex section	Lower duplex roller	CL	CL	CL	CL	CL	Clean with alcohol or a dry cloth.	
	Middle duplex roller	CL	CL	CL	CL	CL	Clean with alcohol or a dry cloth.	
	Upper duplex roller	CL	CL	CL	CL	CL	Clean with alcohol or a dry cloth.	
	Eject roller B	CL	CL	CL	CL	CL	Clean with alcohol or a dry cloth.	
	Eject roller	CL	CL	CL	CL	CL	Clean with alcohol or a dry cloth.	
	Upper and lower feedshift guide	CL	CL	CL	CL	CL	Clean with alcohol or a dry cloth. Clean the lib.	



Section	Maintenance part/location	User call	Periodic maintenance (x1000 counts)				Points and cautions	Page
			300	600	900	1200		
Scanner Optical section	Contact glass	CL	CL	CL	CL	CL	DP slit glass: CL dry cloth or alcohol wet cloth is strictly prohibited. When installing DP, CL with dry cloth. Contact glass for original: CL alcohol or dry cloth. (Face Side) Only when unusual image (line or stain) appear, wipe the back side with dry cloth after cleaning with alcohol only. (Back side)	
	Mirror A/ B	CL	-	-	-	-	Clean: air blow after dry cloth only when unusual image (line) arises.	
	ISU lens	CH CL	-	-	-	-	Clean: air blow after dry cloth only when unusual image (line) arises.	
	LED mount	CH RE	-	-	-	-	Replace if there are image problems.	
	RAIL ISU R/F	LU	-	-	-	-	Apply grease if abnormal sound and jitter image appears. Optical rail grease PG-671 (P/N:60170000)	



Section	Maintenance part/location	User call	Periodic maintenance (x1000 counts)				Points and cautions	Page
			300	600	900	1200		
Outer, Cover	Outer Covers, Tray	CH CL	CL	CL	CL	CL	Clean with alcohol or a dry cloth.	



Section	Maintenance part/location	User call	Periodic maintenance (x1000 counts)				Points and cautions	Page
			300	600	900	1200		
Driving, Other	Drum filter	CL	CL	CL	CL	CL	Vacuum.	P.1-5-102
	Developer filter	CL	CL	CL	CL	CL	Vacuum.	P.1-5-102
	LSU filter	CL	CL	CL	CL	CL	Vacuum.	P.1-5-101
	Belt filter	CL	CL	CL	CL	CL	Vacuum.	P.1-5-101
	Left filter	RE	RE	RE	RE	RE	Replace: MK-6315A/ MK-6317A	P.1-5-100
	Toner filter	RE	RE	RE	RE	RE	Replace: MK-6315A/ MK-6317A	P.1-5-99
	Eject filter	RE	RE	RE	RE	RE	Replace: MK-6315A/ MK-6317A 3pcs	P.1-5-98
	Each Clutches	CH RE	CH	CH	CH	CH	Check the image registration and paper feed conveying condition on paper feed conveying	
	Sensors	CH RE	CH	CH	CH	CH	Clean with alcohol or a dry cloth. (lighting part and light reception part.)	
Image quality	CH AD	CH AD	CH AD	CH AD	CH AD	U464 (Calibration) U410 (Adjusting the half-tone automatically)	P.1-3-169 P.1-3-147	

\* : Please do not use spray containing flammable gas for air-blow or air-brush purposes.

**(4) Image adjustment after replacing the maintenance kit**

Perform the following maintenance mode after replacing the maintenance kit (MK-6315A/ MK-6317A):  
 Executable using preset-settings of the U952 maintenance mode workflow.

Maintenance kits	Maintenance mode
MK-A	U119/ U140*/ U127/ U167/ U464/ U412/ U410/ U251

\* : 55 ppm model only.

\* : When the forwarding pulley, paper feed pulley or separation pulley is replaced, perform maintenance mode U903 (clearing the jam counter) (see page P.1-3-180).  
 Execute Maintenance Counter - Cassette - Counter Clear of U251 (Maintenance counter limits/clear) (see page P.1-3-130).

## (5) Inner Cleaning

1. Cleaning the toner collection duct 1

### Procedure

1. Remove two screws.
2. Remove the rear cover lid.

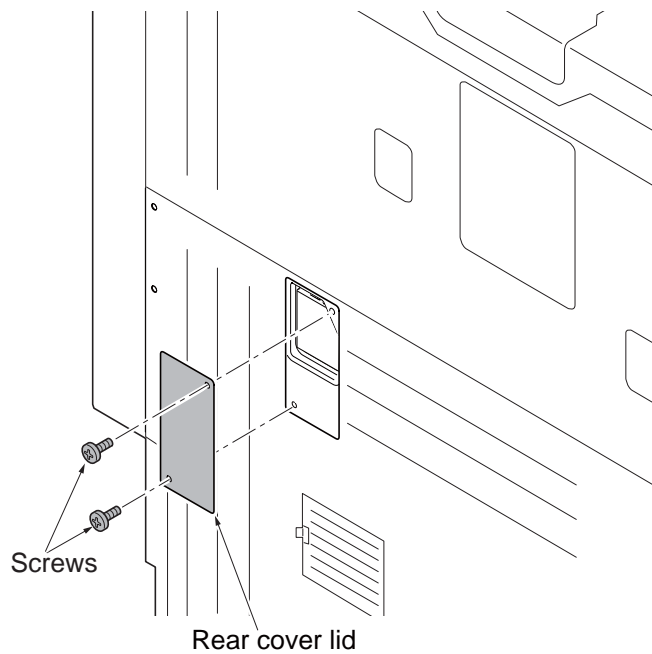


Figure 2-4-1

3. Remove the duct lid by releasing the lever.
4. Vacuum the main unit duct at its toner duct unit outtakes, using a vacuum cleaner.

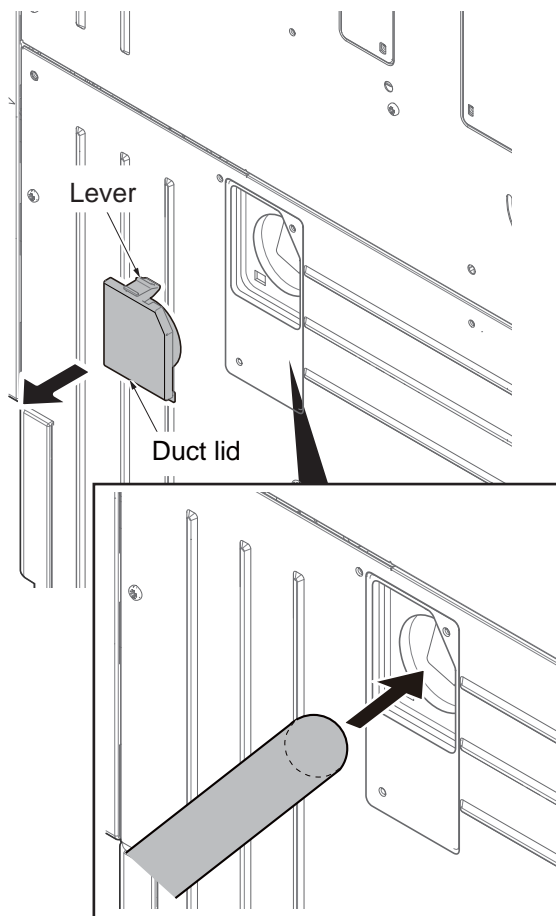


Figure 2-4-2



## 2. Cleaning the toner collection duct 2

### Procedure

1. Remove the toner disposal box.  
(see page P.1-5-103).
2. Insert the vacuum cleaner inlet from the opening at the toner duct, vacuum toner for 1 minutes.

\* : In order to fully vacuum toner, fill in the openings between the cleaner tip and the duct with a cloth.

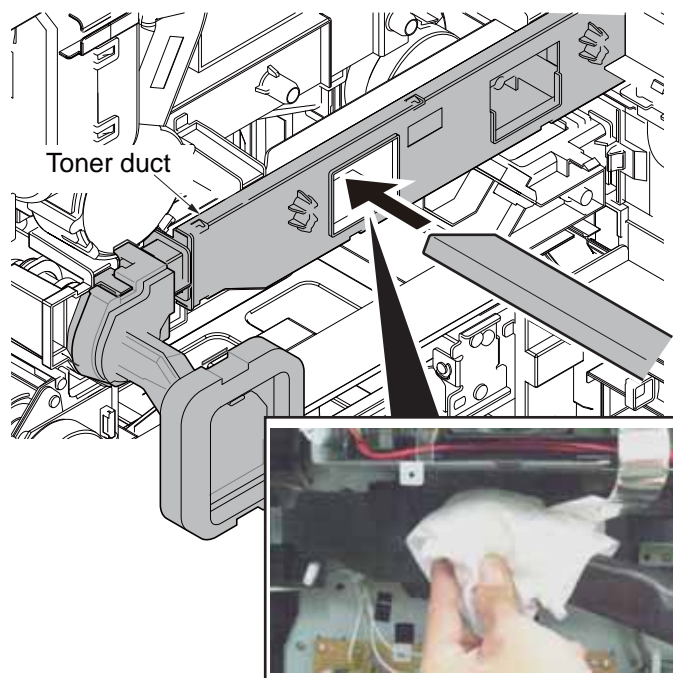


Figure 2-4-3

## 3. Cleaning the inner air duct and cleaning the back of the paper conveying plate

### Procedure

1. Remove the developer unit and the drum unit (see page P.1-5-90,P.1-5-88).
2. Pull out the paper conveying unit.
3. Clean the side of the conveying guide plate, which paper runs through (see page P.1-5-57).

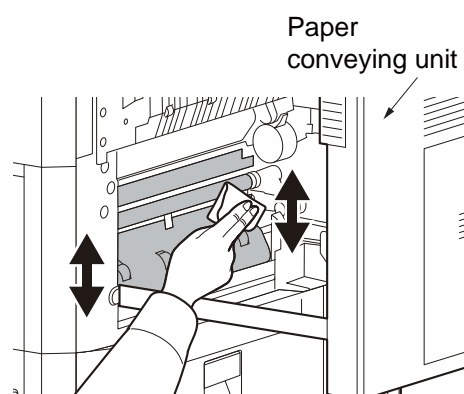


Figure 2-4-4

4. Remove the two screws holding the paper conveying plate.
5. Clean the back of the paper conveying plate.
  - \* : Use a dry, soft cloth for cleaning.
6. Check that the toner outlet, to which the cooling duct is joined in the developer unit, is not clogged with toner.
7. Remove toner accumulated in the duct by a vacuum cleaner via the toner outlet.
8. Refit all the removed parts.

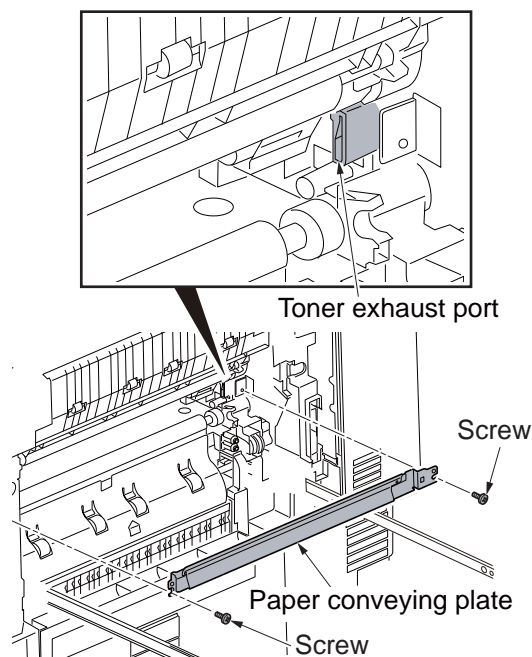


Figure 2-4-5

4. Cleaning the duct at the back of the developer unit
  - \* : Not required when a developer unit is replaced.

#### Procedure

1. Remove the developer unit (see page P.1-5-90).
2. Remove toner inside the cooling ducts using a vacuum cleaner.

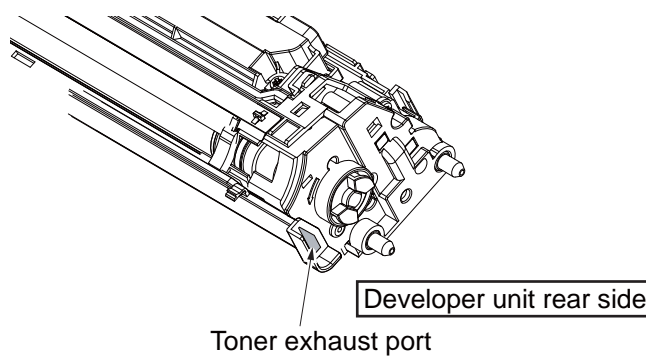
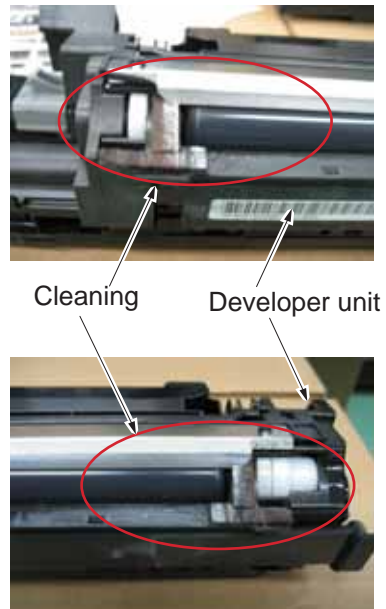


Figure 2-4-6

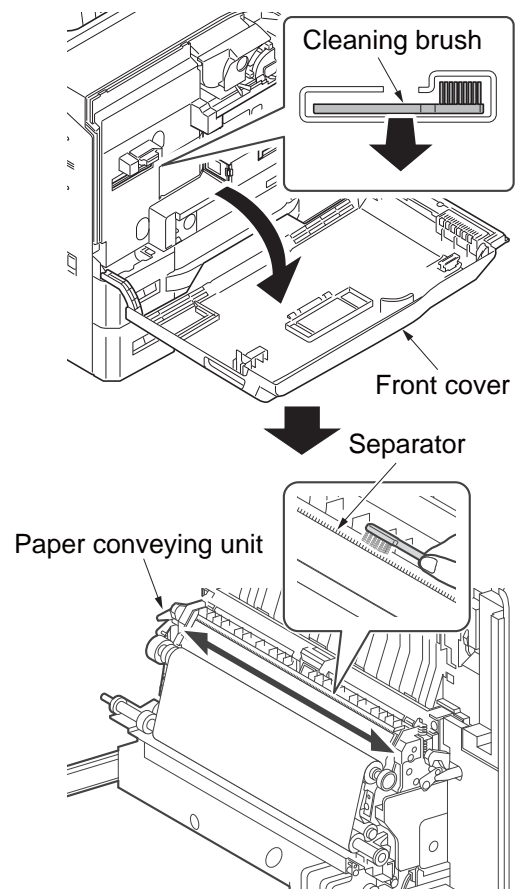
3. Cleaning the toner reservoir at the toner receiver in the developer unit.



**Figure 2-4-7**

5. Cleaning the separator

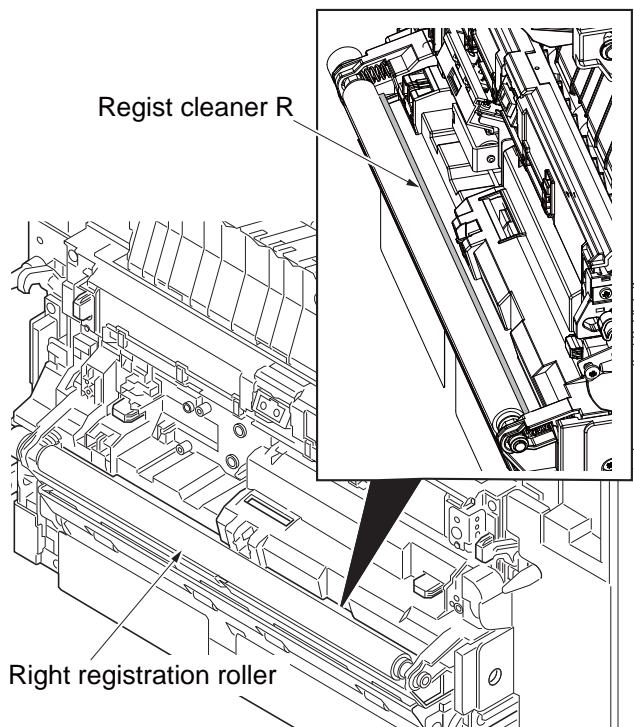
1. Open the front cover and remove the cleaning brush (blue colored).
2. As shown in the figure, clean dirt from the separator by moving the brush from side to side along the separator.



**Figure 2-4-8**

### 6. Cleaning the Right regist cleaner

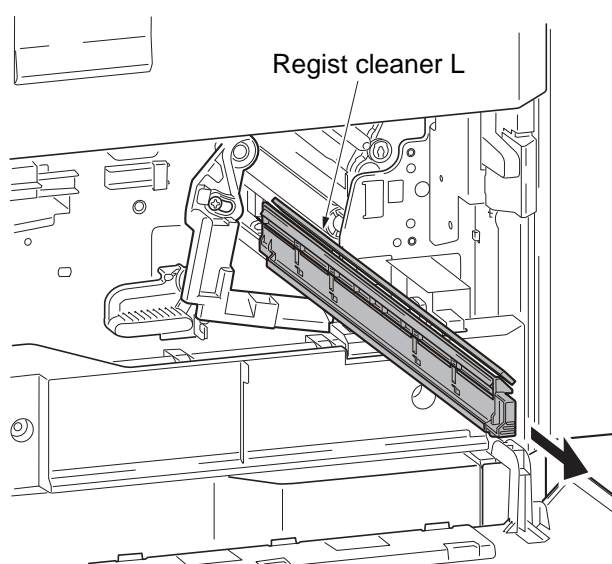
1. Remove the transfer belt unit.
2. Clean the regist cleaner R.



**Figure 2-4-9**

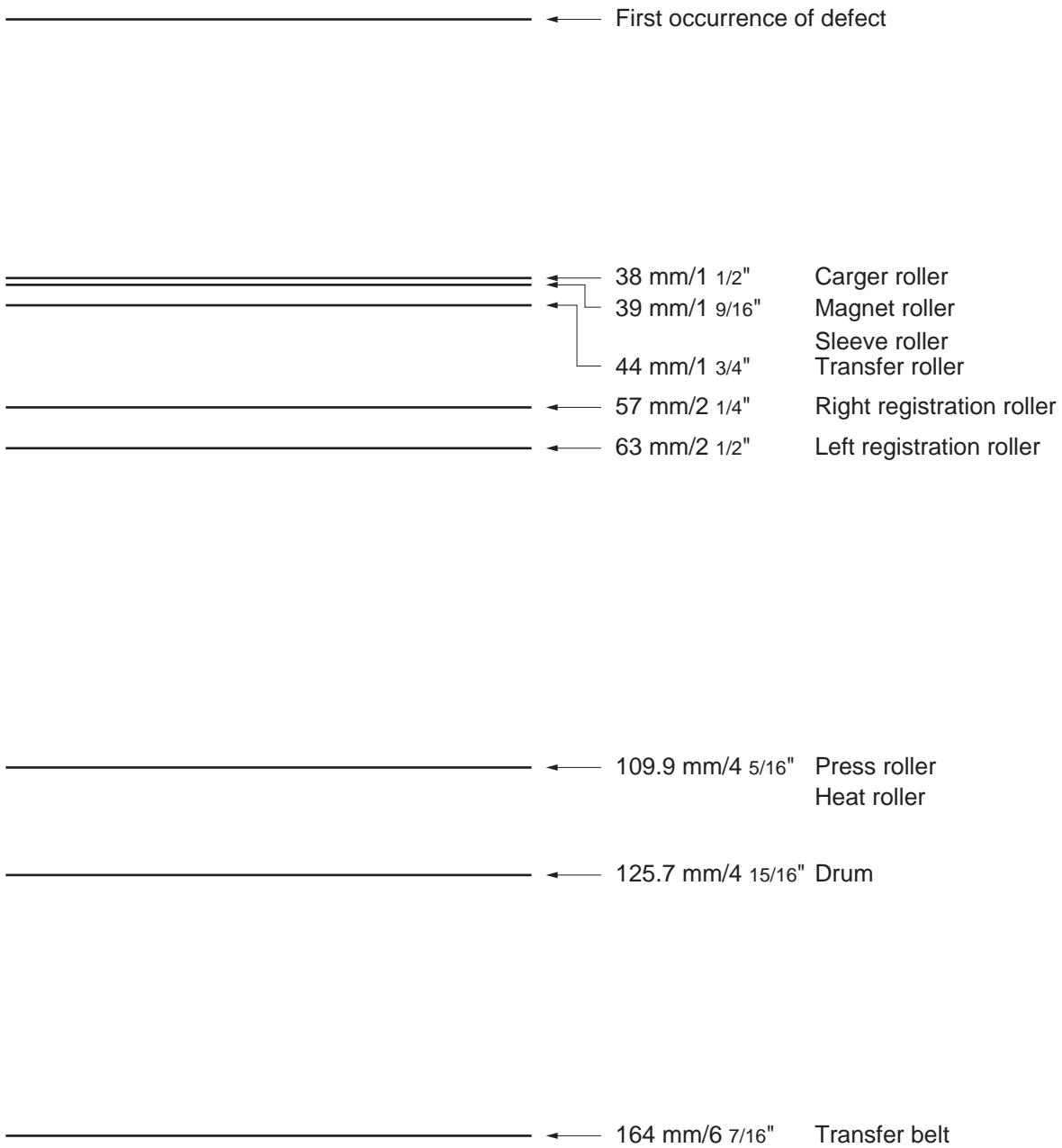
### 7. Cleaning the Left regist cleaner

1. Remove the developer unit.  
(see page P.1-5-46).
2. Remove the drum unit.  
(see page P.1-5-47).
3. Clean the cleaner unit by pulling out the regist cleaner L.



**Figure 2-4-10**

**(6) Repetitive defects gauge**



\* : The repetitive marks interval may vary depending on operating conditions.

## (7) Firmware environment commands

The printer maintains a number of printing parameters in its memory. These parameters may be changed permanently with the FRPO (Firmware RePrOgram) commands.

This section provides information on how to use the FRPO command and its parameters using examples.

### Using FRPO commands for reprogramming firmware

The current settings of the FRPO parameters are listed as optional values on the service status page.

Note: Before changing any FRPO parameter, print out a service status page, so you will know the parameter values before the changes are made. To return FRPO parameters to their factory default values, send the FRPO INIT (FRPO-INITialize) command.(!R! FRPO INIT; EXIT;)

The FRPO command is sent to the printer in the following sequence:

!R! FRPO parameter, value; EXIT;

Example: Changing emulation mode to PCL6

!R! FRPO P1, 6; EXIT;

### FRPO parameters

Item	FRPO	Setting values	Factory setting
Top margin	A1	Integer value in inches	0
	A2	Fraction value in 1/100 inches	0
Left margin	A3	Integer value in inches	0
	A4	Fraction value in 1/100 inches	0
Page length	A5	Integer value in inches	17
	A6	Fraction value in 1/100 inches	30
Page width	A7	Integer value in inches	17
	A8	Fraction value in 1/100 inches	30
Default pattern resolution	B8	0: 300 dpi 1: 600 dpi	0
Page orientation	C1	0: Portrait 1: Landscape	0
Default font No. *	C2	Middle two digits of power-up font	0
	C3	Last two digits of power-up font	0
	C5	First two digits of power-up font	0
PCL font switch	C8	0: HP compatibility mode 32: Conventional compatibility mode	0
Print density control parameter	D4	1: Pale 2: Relatively pale 3: Normal 4: Relevantly dark 6: Dark	4
Total host buffer size	H8	0 to 99 in units of the size defined by FRPO S5	5
Form feed time-out value	H9	Value in units of 5 seconds (1 to 99)	6 (30 s)

Item	FRPO	Setting values	Factory setting
Page reduction function	J0	0: 100 % 5: 70 % 6: 81 % 7: 86 % 8: 94 % 9: 98 %	0
KIR mode	N0	0: Off 2: On	2
Duplex mode	N4	0: Off 1: Long edge binding 2: Short edge binding	0
Sleep timer time-out time	N5	Value in units of 1 minute (1 to 240)	35 ppm: 45 45/55 ppm: 60
Ecoprint level	N6	0: Off 2: On	0
Default emulation mode	P1	6: PCL 6 9: KPDL	120V: 9 220-240V: 6
Carriage-return action	P2	0: Ignores 1: Carriage-return 2: Carriage-return + linefeed	1
Linefeed action	P3	0: Ignores 1: Linefeed 2: Linefeed + carriage-return	1
Automatic emulation switching	P4	0: AES disabled 1: AES enabled	120V: 1 220-240V: 0
Alternative emulation	P5	Same as the P1 values except that 9 is ignored.	6
Automatic emulation switching trigger	P7	0: Page eject commands 1: None 2: Page eject and prescribe EXIT commands 3: Prescribe EXIT commands 4: Formfeed (^L) commands 6: Prescribe EXIT and formfeed commands 10: Page eject commands; if AES fails, resolves to KPDL	120V: 11 220-240V: 10
Command recognition character	P9	ASCII code of 33 to 126	82 (R)
Default stacker	R0	1 (inner tray)	1

Item	FRPO	Setting values	Factory setting
Default paper size	R2	0: Size of the default paper cassette (See R4.) 1: Monarch (3-7/8 x 7-1/2 inches) 2: Business (4-1/8 x 9-1/2 inches) 3: International DL (11 x 22 cm) 4: International C5 (16.2 x 22.9 cm) 5: Executive (7-1/4 x 10-1/2 inches) 6: US Letter (8-1/2 x 11 inches) 7: US Legal (8-1/2 x 14 inches) 8: A4 (21.0 x 29.7 cm) 9: JIS B5 (18.2 x 25.7 cm) 10: A3 (29.7 x 42 cm) 11: B4 (25.7 x 36.4 cm) 12: US Ledger (11 x 17 inches) 13: ISO A5 14: A6 (10.5 x 14.8 cm) 15: JIS B6 (12.8 x 18.2 cm) 16: Commercial #9 (3-7/8 x 8-7/8 inches) 17: Commercial #6 (3-5/8 x 6-1/2 inches) 18: ISO B5 (17.6 x 25 cm) 19: Custom (11.7 x 17.7 inches) 20: B4toA4 21: A3toA4 22: A4toA4[98%] 23: STKtoA4 24: STKtoB4 30: C4 (22.9 x 32.4 cm) 31: Hagaki (10 x 14.8 cm) 32: Ofuku-hagaki (14.8 x 20 cm) 33: Officio II 38: 12 x 18 39: 8K 40: 16K 42: 8.5 x 13.5 inches 50: Statement 51: Folio 52: Youkei 2 53: Youkei 4	0
Default cassette	R4	0: MP tray 1: Cassette 1 2: Cassette 2 3: Cassette 3 4: Cassette 4 5: Cassette 5	1
Sorter full action	S3	0: Stop operation with detecting tray-full 1: Switching to the eject-able destinations when bin becomes tray full	0
A4/letter equation	S4	0: Off 1: On	1



Item	FRPO	Setting values	Factory setting
Host buffer size	S5	0: 10 KB 1: 100 KB 2: 1024 KB	1
Wide A4	T6	0: Off 1: On	0
Line spacing *	U0	Lines per inch (integer value)	6
	U1	Lines per inch (decimal value)	0
Character spacing *	U2	Characters per inch (integer value)	10
	U3	Characters per inch (decimal value)	0
Country code	U6	0: US-ASCII 1: France 2: Germany 3: UK 4: Denmark 5: Sweden 6: Italy 7: Spain 8: Japan 9: US Legal 10: IBM PC-850 (Multilingual) 11: IBM PC-860 (Portuguese) 12: IBM PC-863 (Canadian French) 13: IBM PC-865 (Norwegian) 14: Norway 15: Denmark 2 16: Spain 2 17: Latin America 50 - 99: HP PCL symbol set coding	41
Code set at power up in daisywheel emulation	U7	0: Same as the default emulation mode (P1) 1: IBM 6: PCL	53
Font pitch for fixedpitch scalable font *	U8	Default font pitch (integer value)	10
	U9	Default font pitch (decimal value)	0
Font height for the default scalable font *	V0	Integer value in 100 points: 0 to 9	0
	V1	Integer value in points: 0 to 99	12
	V2	decimal value in 1/100 points: 0, 25, 50, 75	0
Default scalable font *	V3	Name of typeface of up to 32 characters, enclosed with single or double quotation marks	Courier

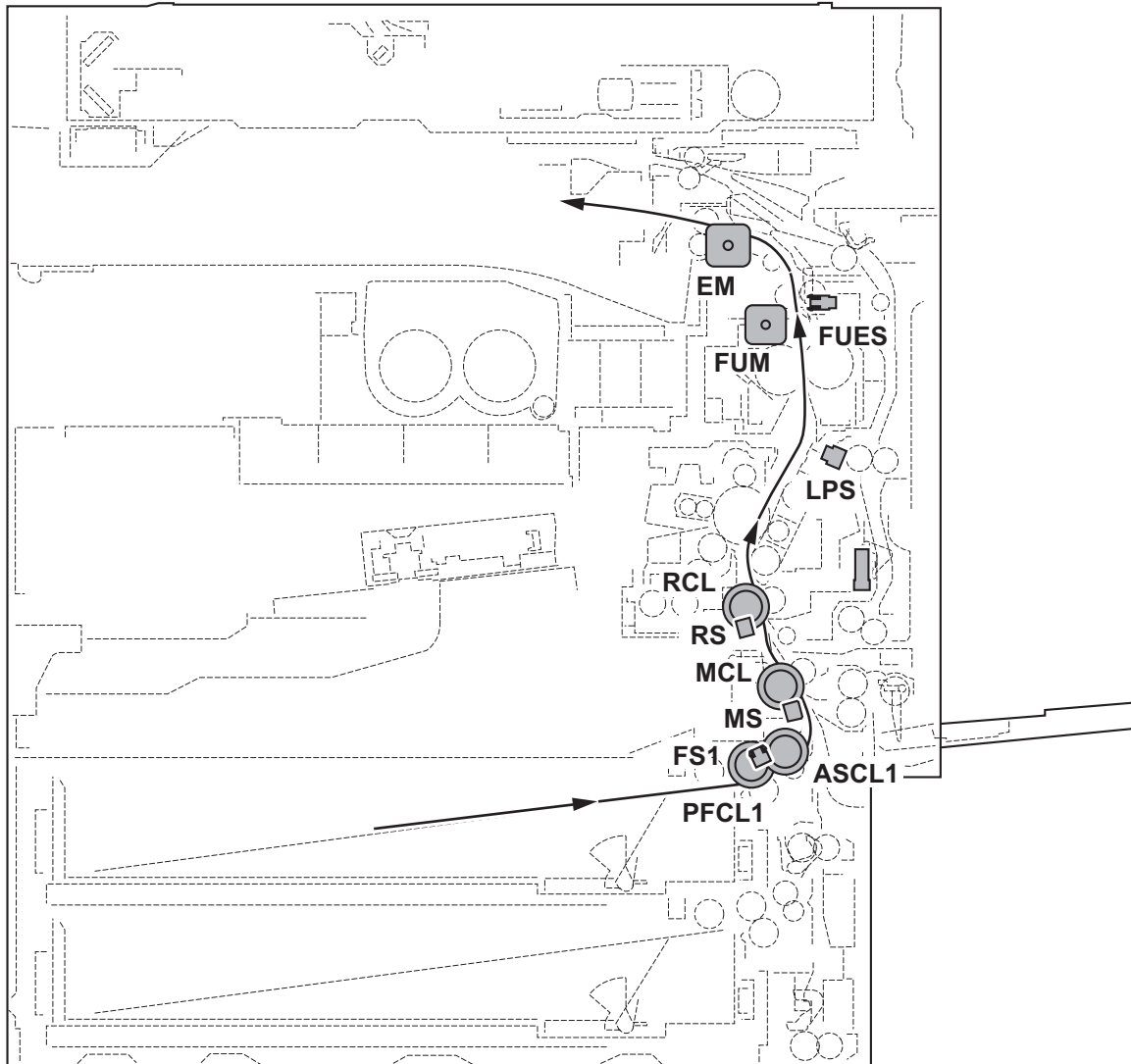
Item	FRPO	Setting values	Factory setting
Default weight (courier and letter Gothic)	V9	0: Courier = darkness Letter Gothic = darkness 1: Courier = regular Letter Gothic = darkness 4: Courier = darkness Letter Gothic = regular 5: Courier = regular Letter Gothic = regular	5
Paper type for the MP tray	X0	1: Plain 2: Transparency 3: Preprinted 4: Label 5: Bond 6: Recycle 7: Vellum 9: Letterhead 10: Color 11: Prepunched 12: Envelope 13: Cardstock 14: Coated 16: Thick 17: High quality 21 to 28: Custom1 to 8	1
Paper type for cassettes 1 and 2	X1 X2	1: Plain 3: Preprinted 5: Bond 6: Recycled 7: Vellum 9: Letterhead 10: Color 11: Prepunched 16: Thick 17: High quality 21 to 28: Custom1 to 8	1
Paper type for optional cas- settes 3 to 7	X3 X4 X5	1: Plain 3: Preprinted 5: Bond 6: Recycled 9: Letterhead 10: Color 11: Prepunched 17: High quality 21 to 28: Custom1 to 8	1
PCL paper source	X9	0: Paper selection depending on an escape sequence compatible with HP-LJ5Si. 2: Paper selection depending on an escape sequence compatible with HP-LJ8000.	0

Item	FRPO	Setting values	Factory setting
Automatic continue for 'Press GO'	Y0	0: Off 1: On	0
Automatic continue timer	Y1	Value in units of 5 seconds (1 to 99)	6 (30 s)
Error message for device error	Y3	0: Not detect 127: Detect	127
Duplex operation for specified paper type (Prepunched, Preprinted and Letterhead)	Y4	0: Off 1: On	0
Default operation for PDF direct printing	Y5	0: Enlarges or reduces the image to fit in the current paper size. Loads paper from the current paper cassette. 1: Through the image. Loads paper which is the same size as the image. 2: Enlarges or reduces the image to fit in the current paper size. Loads Letter, A4 size paper depending on the image size. 3: Through the image. Loads Letter, A4 size paper depending on the image size. 8: Through the image. Loads paper from the current paper cassette. 9: Through the image. Loads Letter, A4 size paper depending on the image size. 10: Enlarges or reduces the image to fit in the current paper size. Loads Letter, A4 size paper depending on the image size.	0
e-MPS error	Y6	0: Does not print the error report and display the error message. 1: Prints the error report. 2: Displays the error message. 3: Prints the error report and displays the error message.	3

\*: Ignored in some emulation modes.

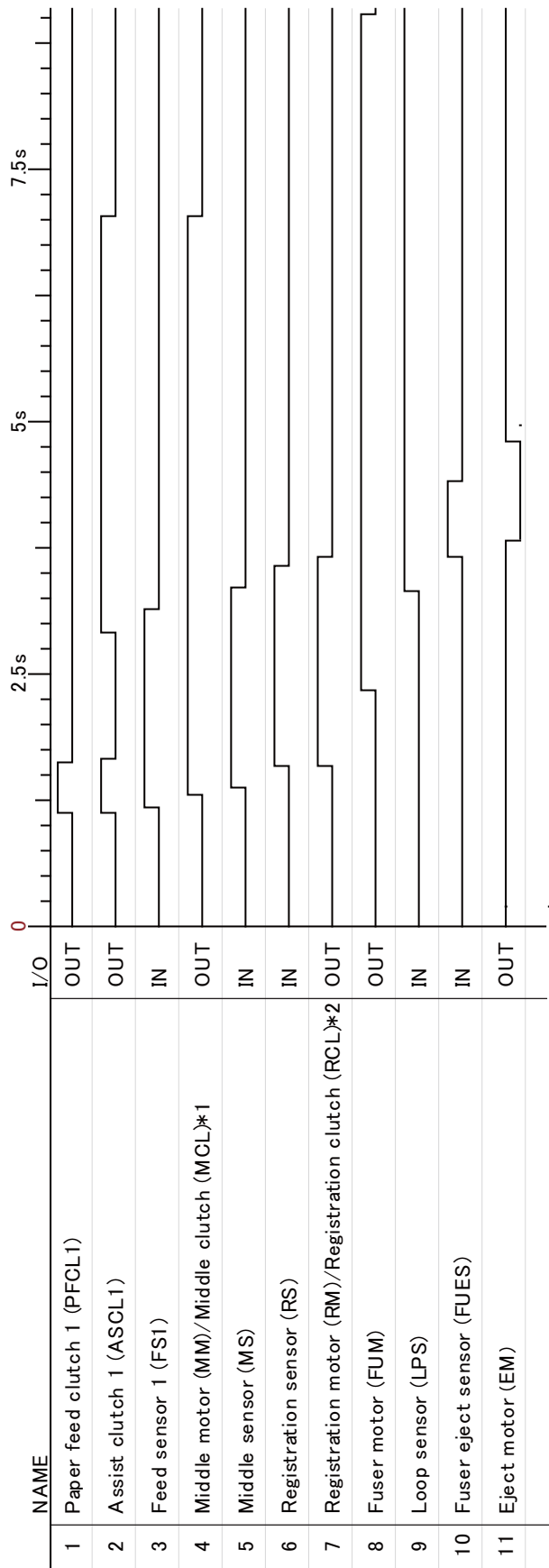
**(8) Timing chart**

1. Cassette1 paper feeding, Paper size A4, Simplex, Preset 1
  2. Cassette1 paper feeding, Paper size A4, Simplex, Preset 3
- 35 ppm model



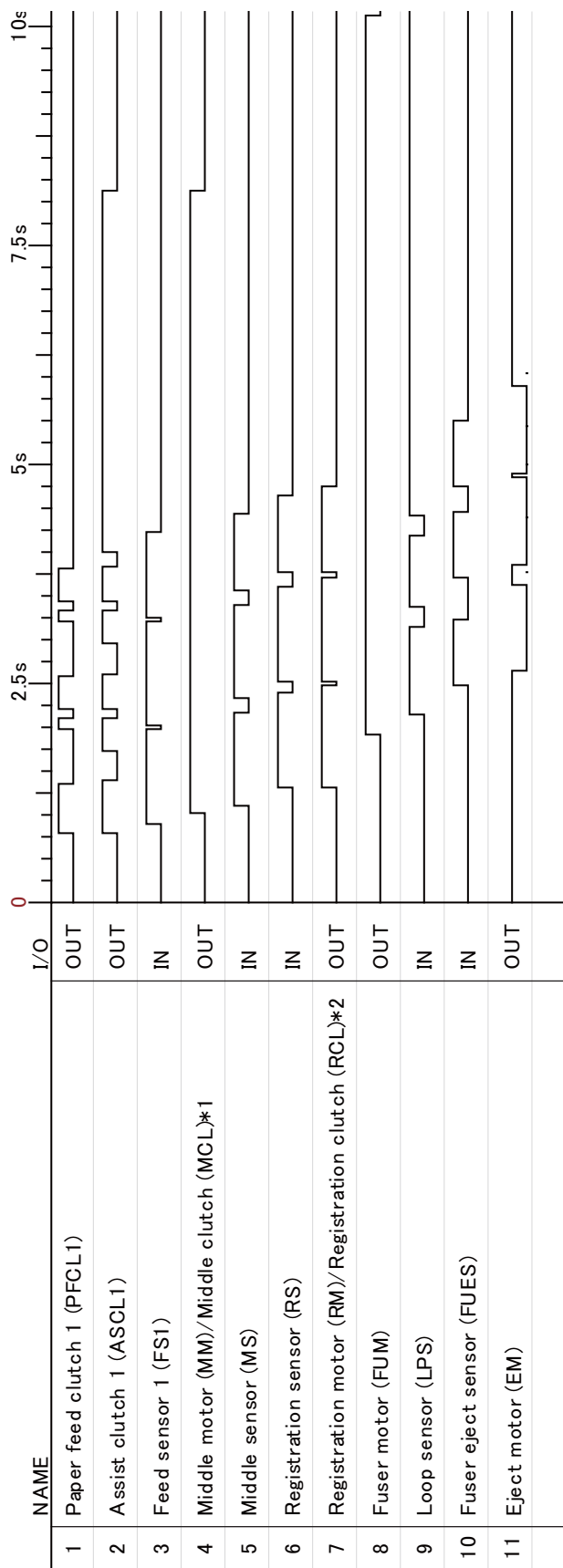


(1) Simplex\_Preset 1\_cassette1\_A4



\*1 Middle clutch (MCL): 35 ppm model, Middle motor (MM): 45 / 55 ppm model  
 \*2 Registration clutch (RCL): 35 ppm model, Registration motor (RM): 45 / 55 ppm model

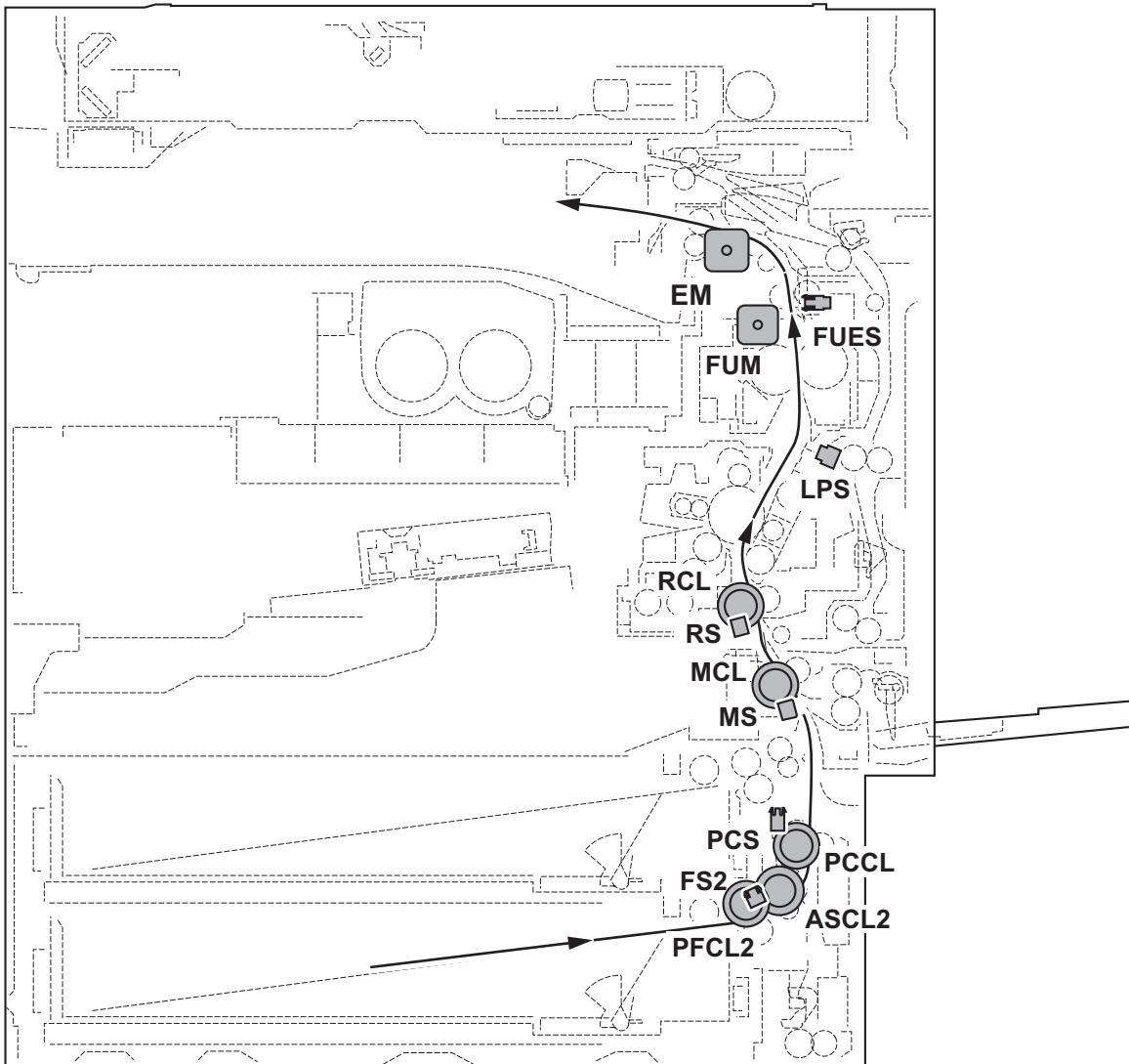
(2) Simplex\_Preset 3\_cassette1\_A4



\*1 Middle clutch (MCL): 35 ppm model, Middle motor (MM): 45 / 55 ppm model

\*2 Registration clutch (RCL): 35 ppm model, Registration motor (RM): 45 / 55 ppm model

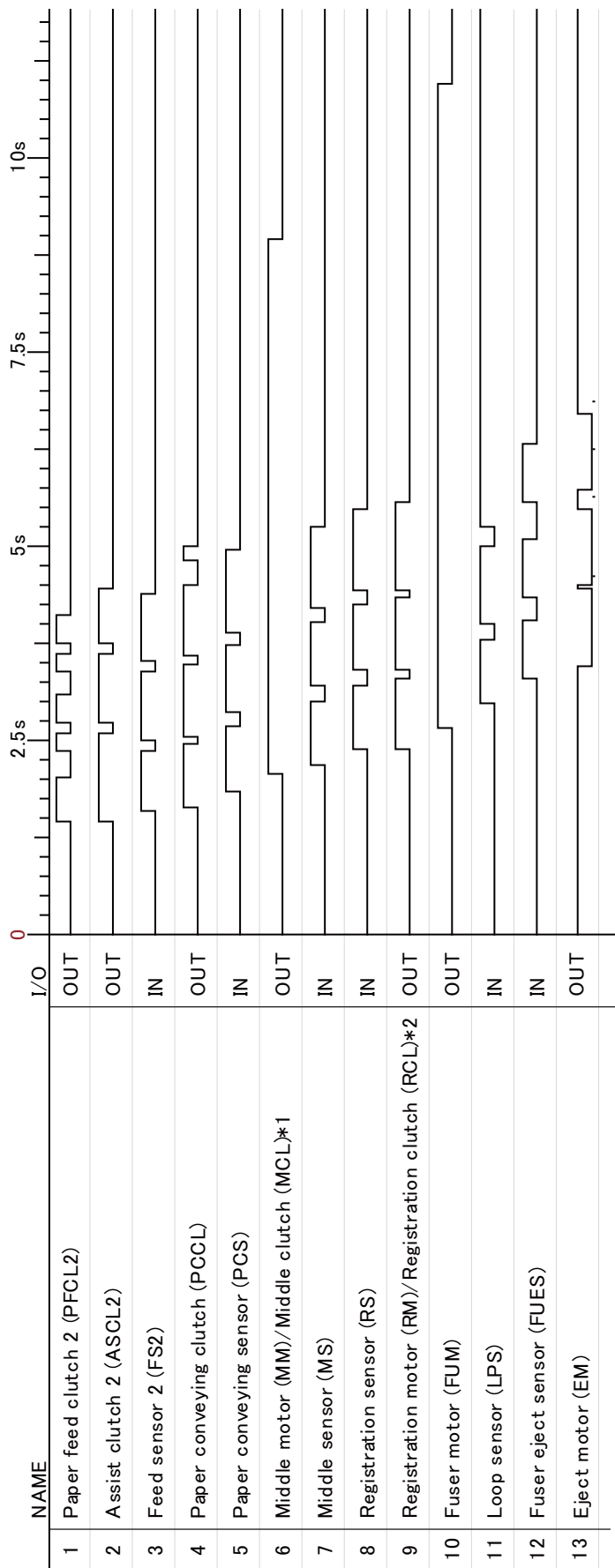
3. Cassette2 paper feeding, Paper size A4, Simplex, Preset 3  
35 ppm model







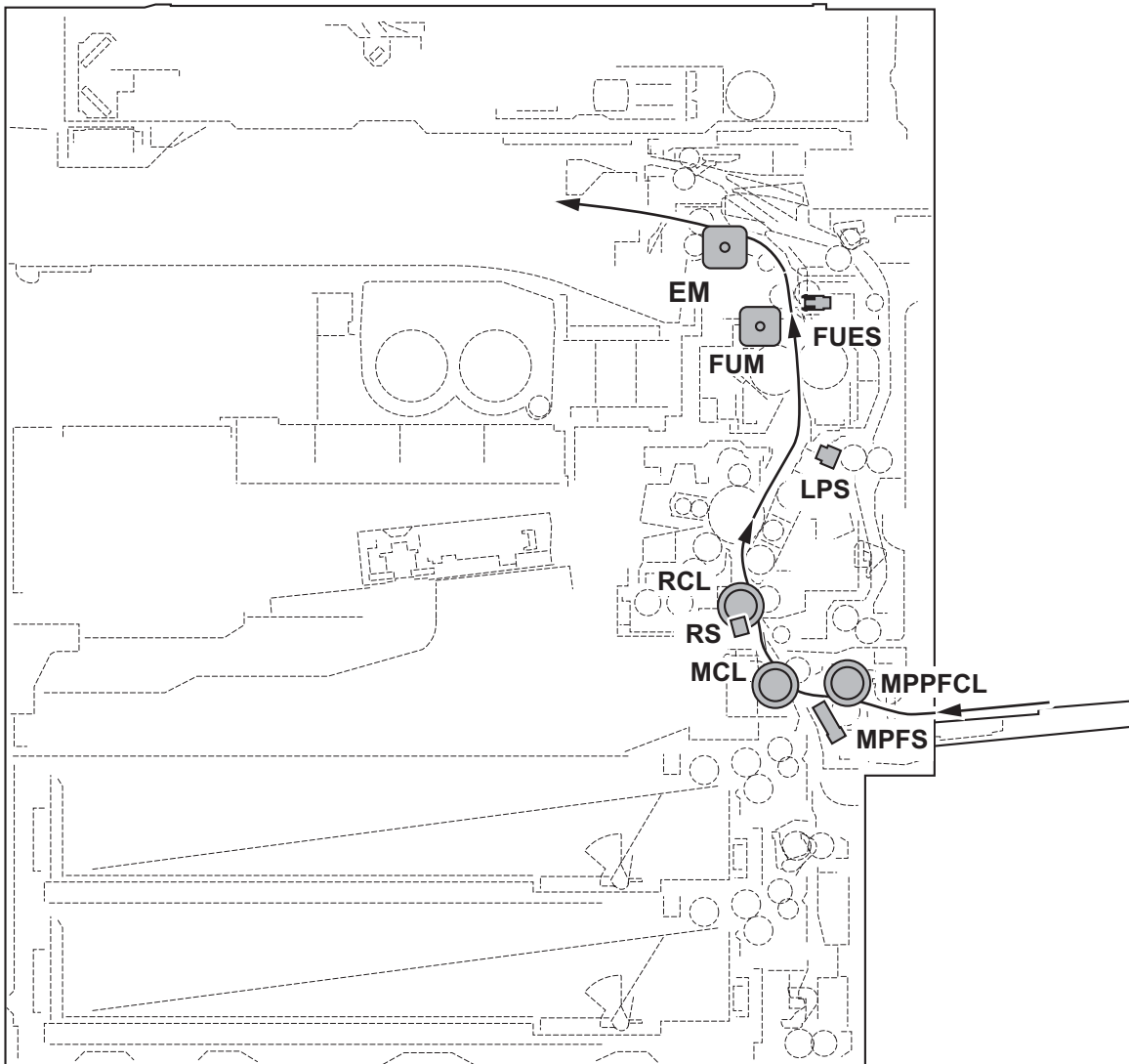
(3) Simplex\_Preset 3\_cassette2\_A4



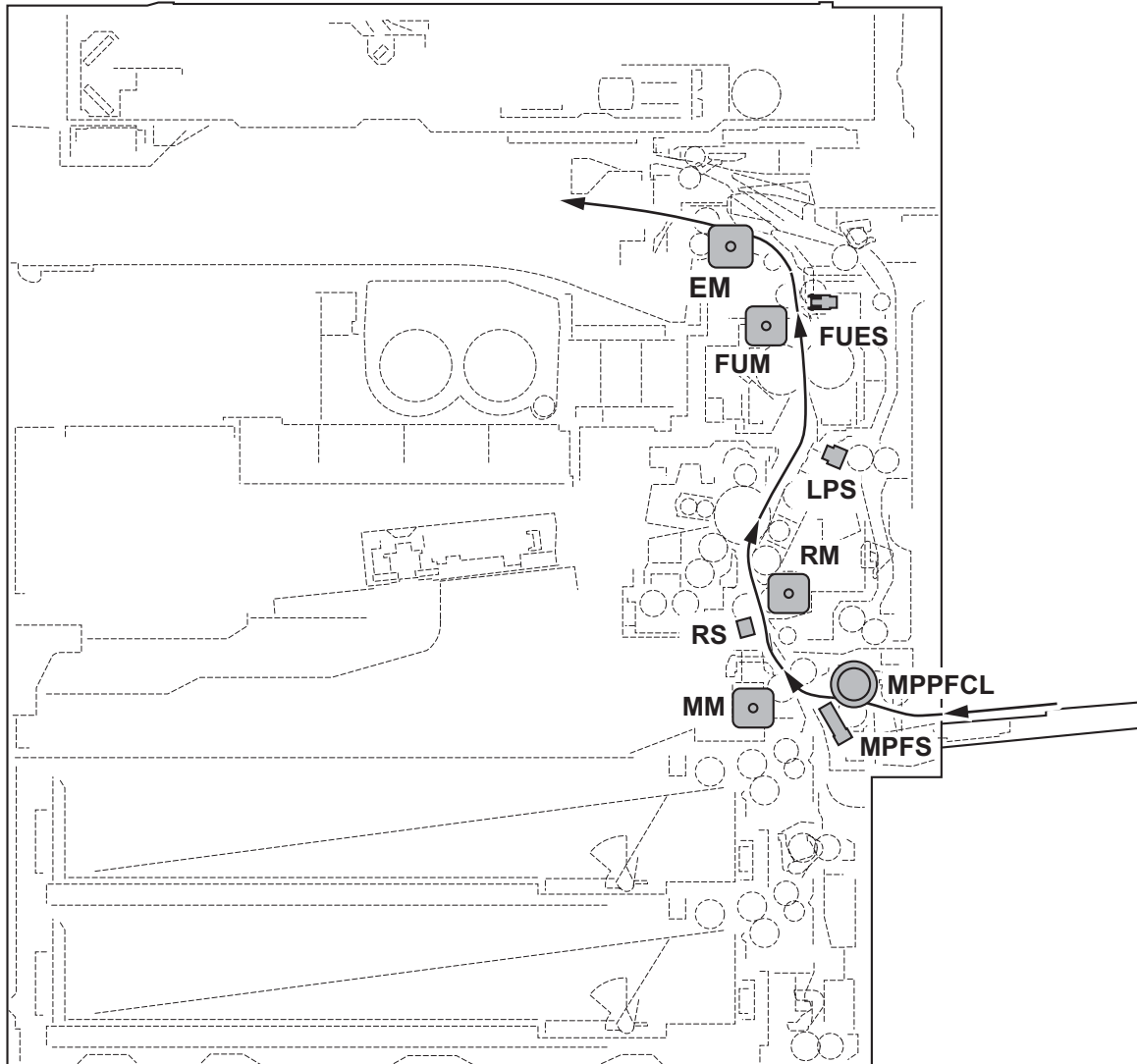
\*1 Middle clutch (MCL): 35 ppm model, Middle motor (MM): 45 / 55 ppm model

\*2 Registration clutch (RCL): 35 ppm model, Registration motor (RM): 45 / 55 ppm model

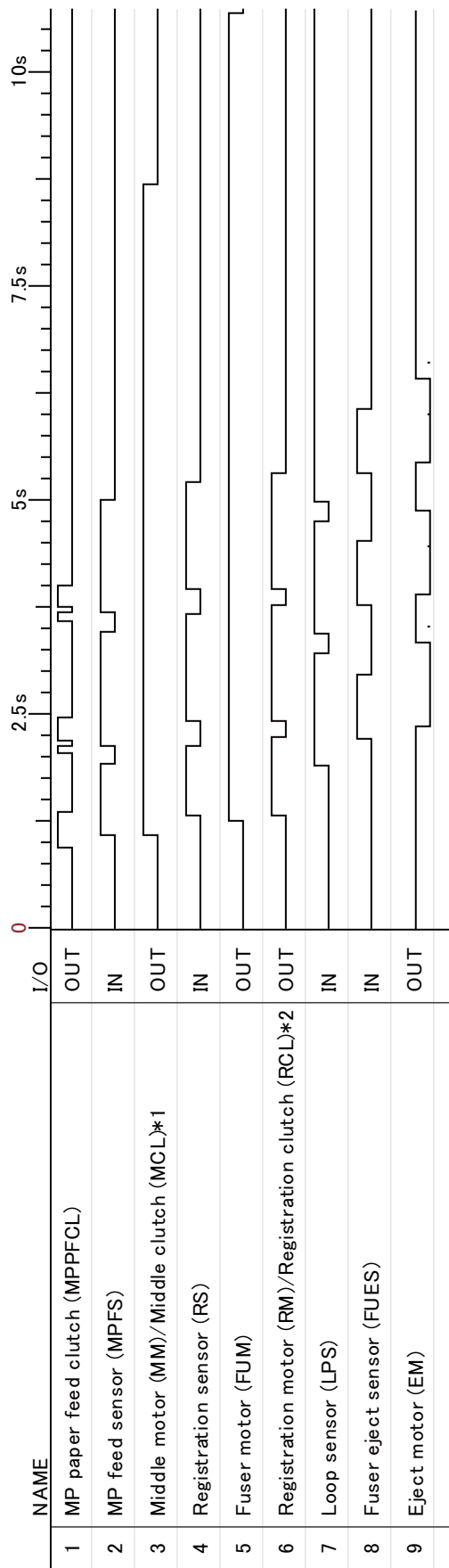
4. MPF paper feeding, Paper size A4, Simplex, Preset 1  
35 ppm model



45/55 ppm model



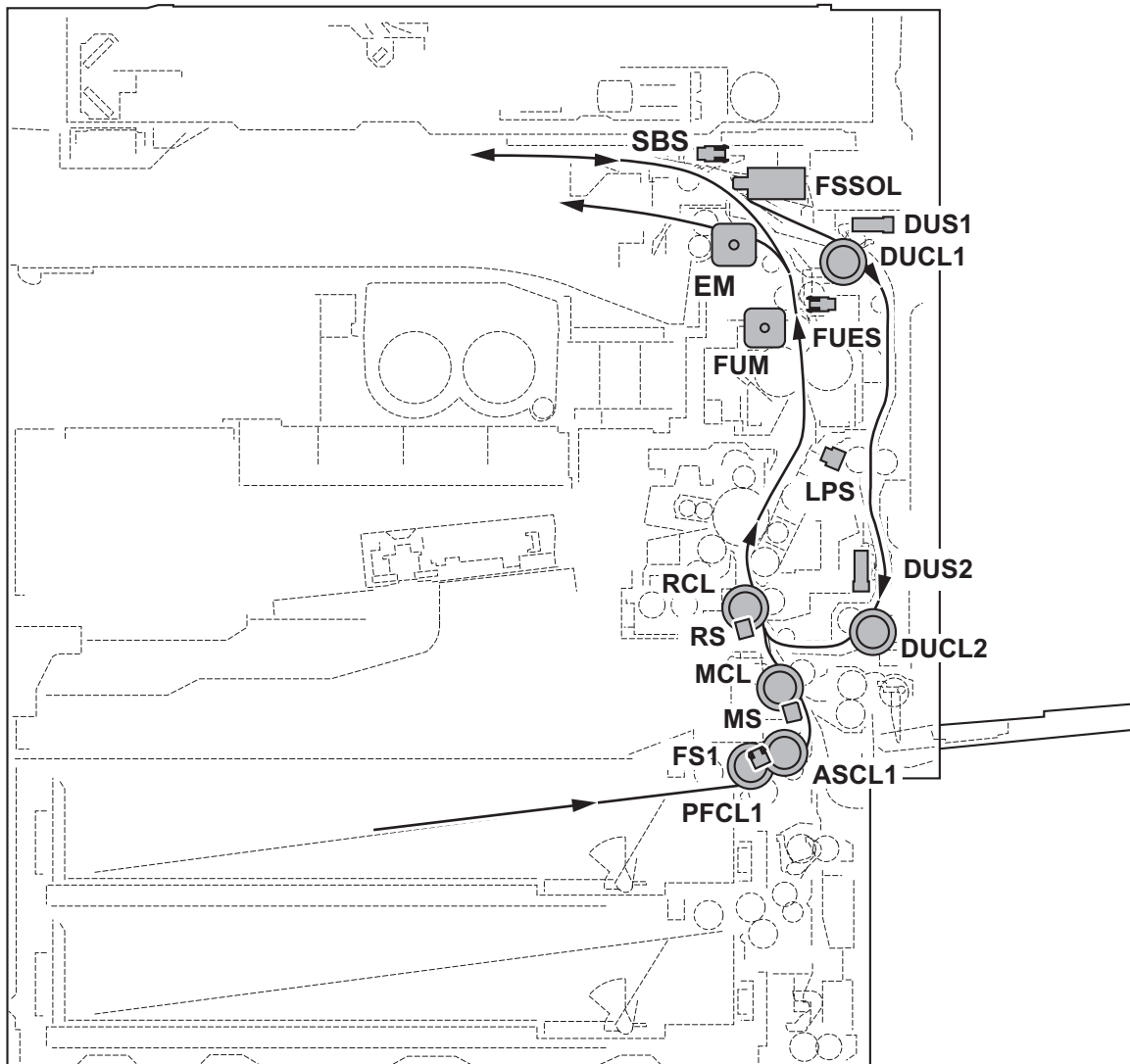
(4) Simplex\_Preset 3\_MPF\_A4



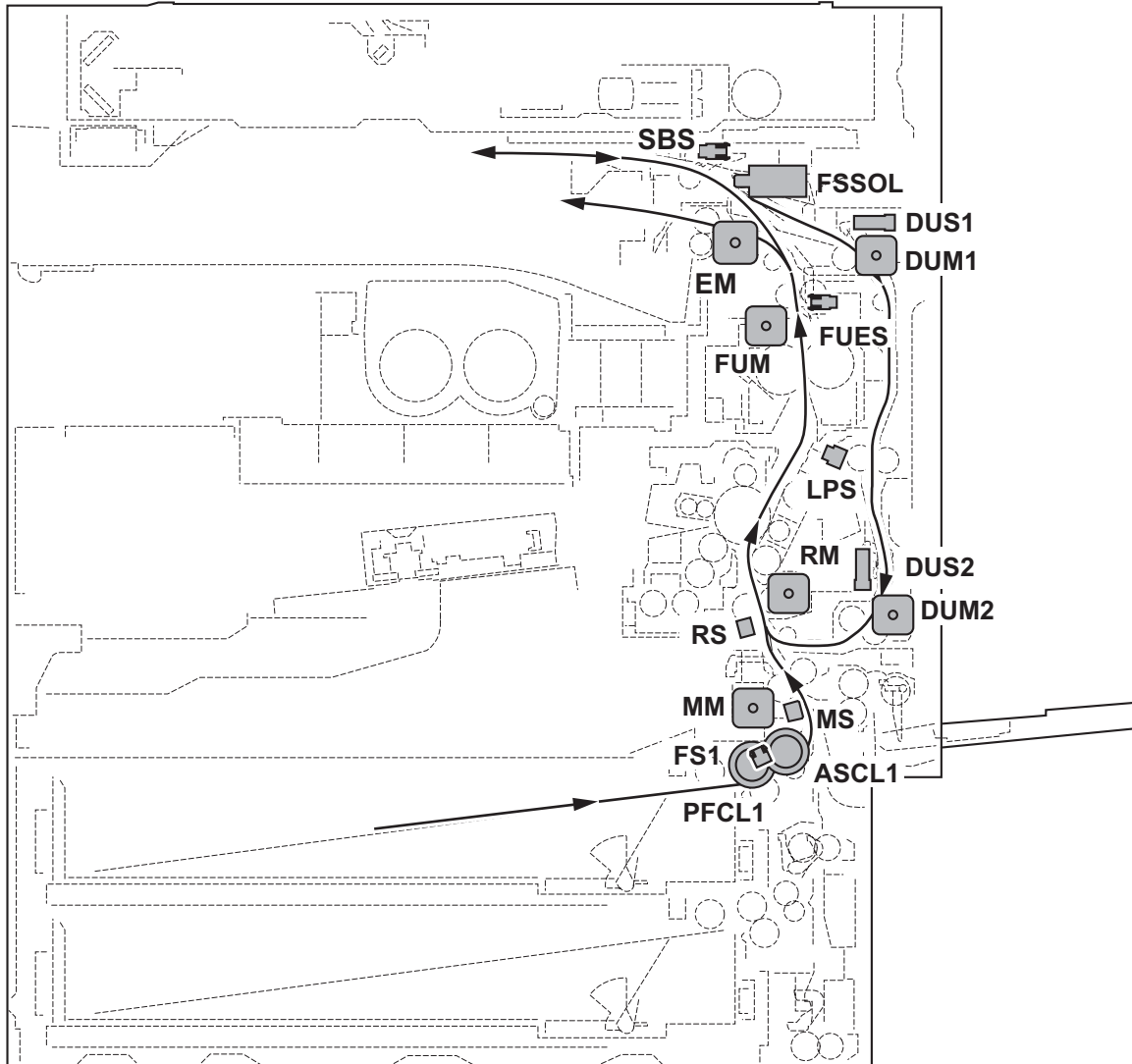
\*1 Middle clutch (MCL): 35 ppm model, Middle motor (MM): 45 / 55 ppm model

\*2 Registration clutch (RCL): 35 ppm model, Registration motor (RM): 45 / 55 ppm model

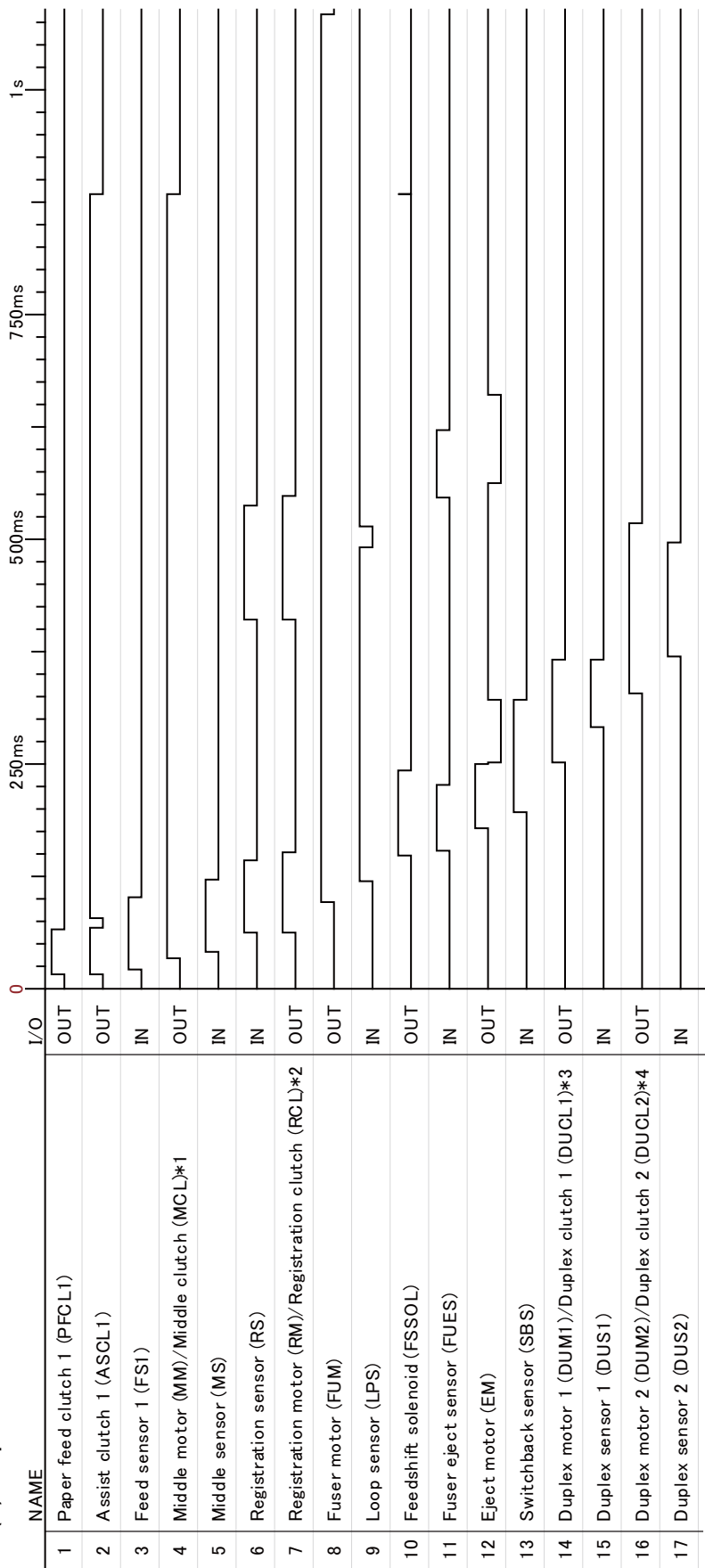
- 5. Cassette1 paper feeding, Paper size A4, Duplex, Preset 1
  - 6. Cassette1 paper feeding, Paper size A4, Duplex, Preset 3
- 35 ppm model**



45/55 ppm model



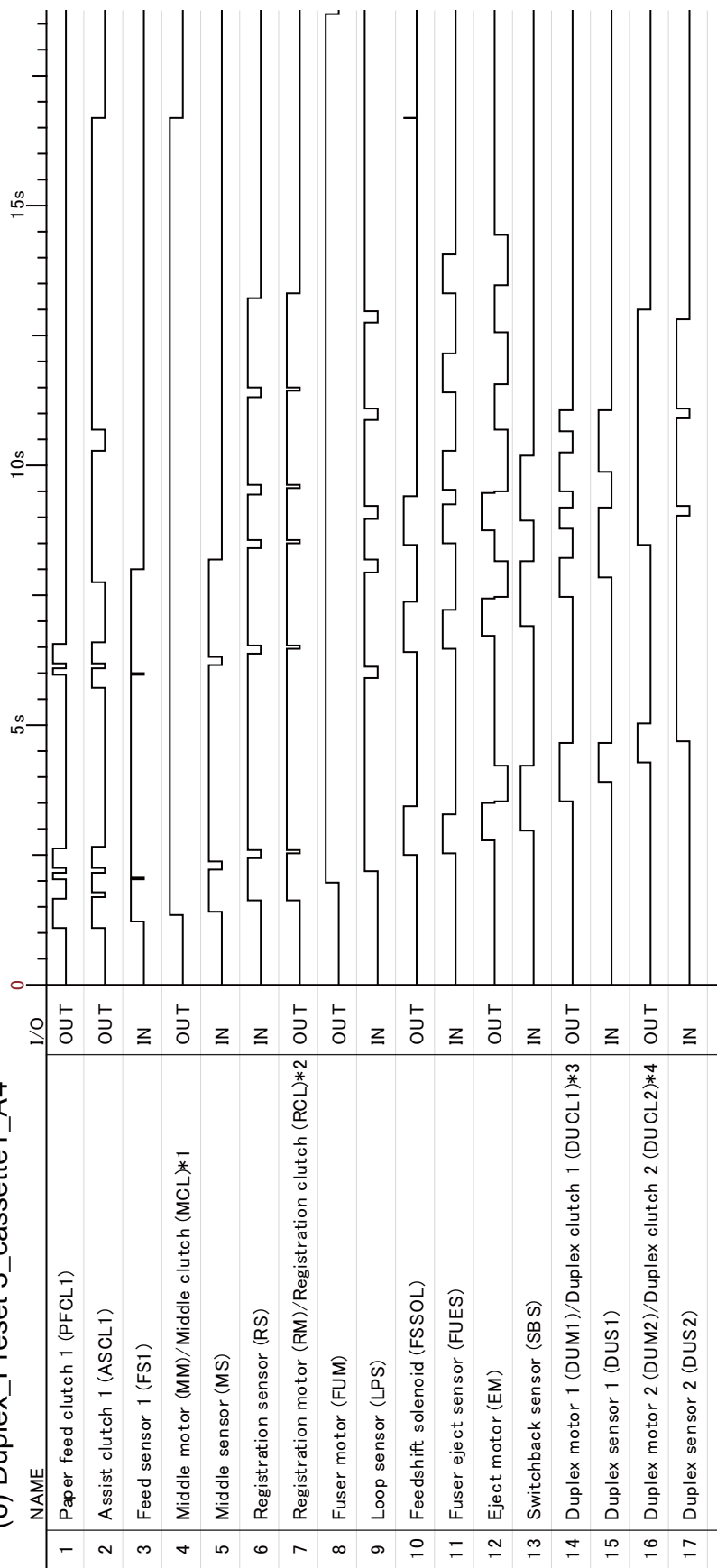
(5) Duplex\_Preset 1\_cassette1\_A4



- \*1 Middle clutch (MCL): 35 ppm model, Middle motor (MM): 45 / 55 ppm model
- \*2 Registration clutch (RCL): 35 ppm model, Registration motor (RM): 45 / 55 ppm model
- \*3 Duplex clutch 1 (DUCL1): 35 ppm model, Duplex motor 1 (DUM1): 45 / 55 ppm model
- \*4 Duplex clutch 2 (DUCL2): 35 ppm model, Duplex motor 2 (DUM2): 45 / 55 ppm model



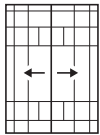
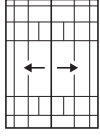
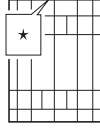
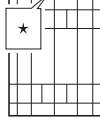
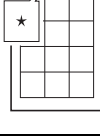
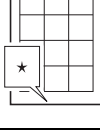
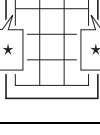
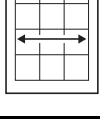
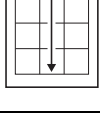
(6) Duplex\_Preset 3\_cassette1\_A4

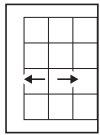
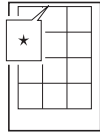
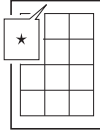
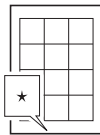
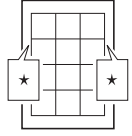


- \*1 Middle clutch (MCL): 35 ppm model, Middle motor (MM): 45 / 55 ppm model
- \*2 Registration clutch (RCL): 35 ppm model, Registration motor (RM): 45 / 55 ppm model
- \*3 Duplex clutch 1 (DUCL1): 35 ppm model, Duplex motor 1 (DUM1): 45 / 55 ppm model
- \*4 Duplex clutch 2 (DUCL2): 35 ppm model, Duplex motor 2 (DUM2): 45 / 55 ppm model

This page is intentionally left blank.

## (9) Chart of image adjustment procedures

Adjusting order	Item	Image	Description	Maintenance mode		Original	Page	Remarks
				Item No.	Mode			
1	Adjusting the center line of the MP tray (printing adjustment)		Adjusting the LSU print start timing	U034	LSU Out Left	U034 test pattern	P.1-3-34	To make an adjustment for duplex copying, select Duplex.
2	Adjusting the center line of the cassettes (printing adjustment)		Adjusting the LSU print start timing	U034	LSU Out Left	U034 test pattern	P.1-3-34	
3	Adjusting the leading edge registration of the MP tray (printing adjustment)		Registration motor turning on timing (secondary paper feed start timing)	U034	LSU Out Top	U034 test pattern	P.1-3-34	To make an adjustment for duplex copying, select Duplex.
4	Adjusting the leading edge registration of the cassette (printing adjustment)		Registration motor turning on timing (secondary paper feed start timing)	U034	LSU Out Top	U034 test pattern	P.1-3-34	
5	Adjusting the leading edge margin (printing adjustment)		LSU illumination start timing	U402	Lead	U402 test pattern	P.1-3-142	
6	Adjusting the trailing edge margin (printing adjustment)		LSU illumination end timing	U402	Trail	U402 test pattern	P.1-3-142	
7	Adjusting the left and right margins (printing adjustment)		LSU illumination start/end timing	U402	A Margin C Margin	U402 test pattern	P.1-3-142	
8	Adjusting magnification of the scanner in the main scanning direction (scanning adjustment)		Data processing	U065 U070	Main Scan Main Scan	Test chart	P.1-3-47 P.1-3-52	U065: For copying an original placed on the platen. U070: For copying originals from the DP.
9	Adjusting magnification of the scanner in the auxiliary scanning direction (scanning adjustment)		Original scanning speed	U065 U070	Sub Scan Sub Scan	Test chart	P.1-3-47 P.1-3-52	U065: For copying an original placed on the platen. U070: For copying originals from the DP.

Adjusting order	Item	Image	Description	Maintenance mode		Original	Page	Remarks
				Item No.	Mode			
10	Adjusting the center line (scanning adjustment)		Adjusting the original scan data (image adjustment)	U067	Front Rotate	Test chart	P.1-3-50	U067: For copying an original placed on the platen. To make an adjustment for rotate copying, select Rotate. U072: For copying originals from the DP. To make an adjustment for duplex copying, select Back.
				U072	Front Back		P.1-3-56	
11	Adjusting the leading edge registration (scanning adjustment)		Original scan start timing	U066	Front Rotate	Test chart	P.1-3-49	U066: For copying an original placed on the platen. To make an adjustment for trailing edge registration, select Rotate. U071: For copying originals from the DP. To make an adjustment for duplex copying, select Back Head.
				U071	Front Head Back Head		P.1-3-54	
12	Adjusting the leading edge margin (scanning adjustment)		Adjusting the original scan data (image adjustment)	U403	B Margin	Test chart	P.1-3-143	U403: For copying an original placed on the contact glass U404: For copying originals from the DP.
				U404	B Margin		P.1-3-144	
13	Adjusting the trailing edge margin (scanning adjustment)		Adjusting the original scan data (image adjustment)	U403	D Margin	Test chart	P.1-3-143	U403: For copying an original placed on the contact glass U404: For copying originals from the DP.
				U404	D Margin		P.1-3-144	
14	Adjusting the left and right margins (scanning adjustment)		Adjusting the original scan data (image adjustment)	U403	A Margin C Margin	Test chart	P.1-3-143	U403: For copying an original placed on the contact glass U404: For copying originals from the DP.
				U404	A Margin C Margin		P.1-3-144	

When maintenance item U411 (Automatic adjustment in the scanner) is run using the specified original (P/N 7505000005), the following adjustments are automatically made:

- Adjusting the scanner auxiliary scanning direction magnification (U065)
- Adjusting the scanner leading edge registration (U066)
- Adjusting the scanner center line (U067)
- Adjusting the DP magnification (U070)
- Adjusting the DP leading edge registration (U071)
- Adjusting the DP center line (U072)

When maintenance item U411 (Automatic adjustment in the scanner) is run using the specified original (P/N 302AC68243), the following adjustments are automatically made:

- Adjusting the DP magnification (U070)
- Adjusting the DP leading edge registration (U071)
- Adjusting the DP center line (U072)

When maintenance item U411 (Automatic adjustment in the scanner) is run using the chart printed from the machine, the following adjustments are automatically made:

- Adjusting the DP magnification (U070)
- Adjusting the DP leading edge registration (U071)
- Adjusting the DP center line (U072)
- Adjusting the DP magnification (U070)
- Adjusting the DP leading edge registration (U071)
- Adjusting the DP center line (U072)

When maintenance item U415 (Adjusting the print position automatically) is run, the following adjustments are automatically made:

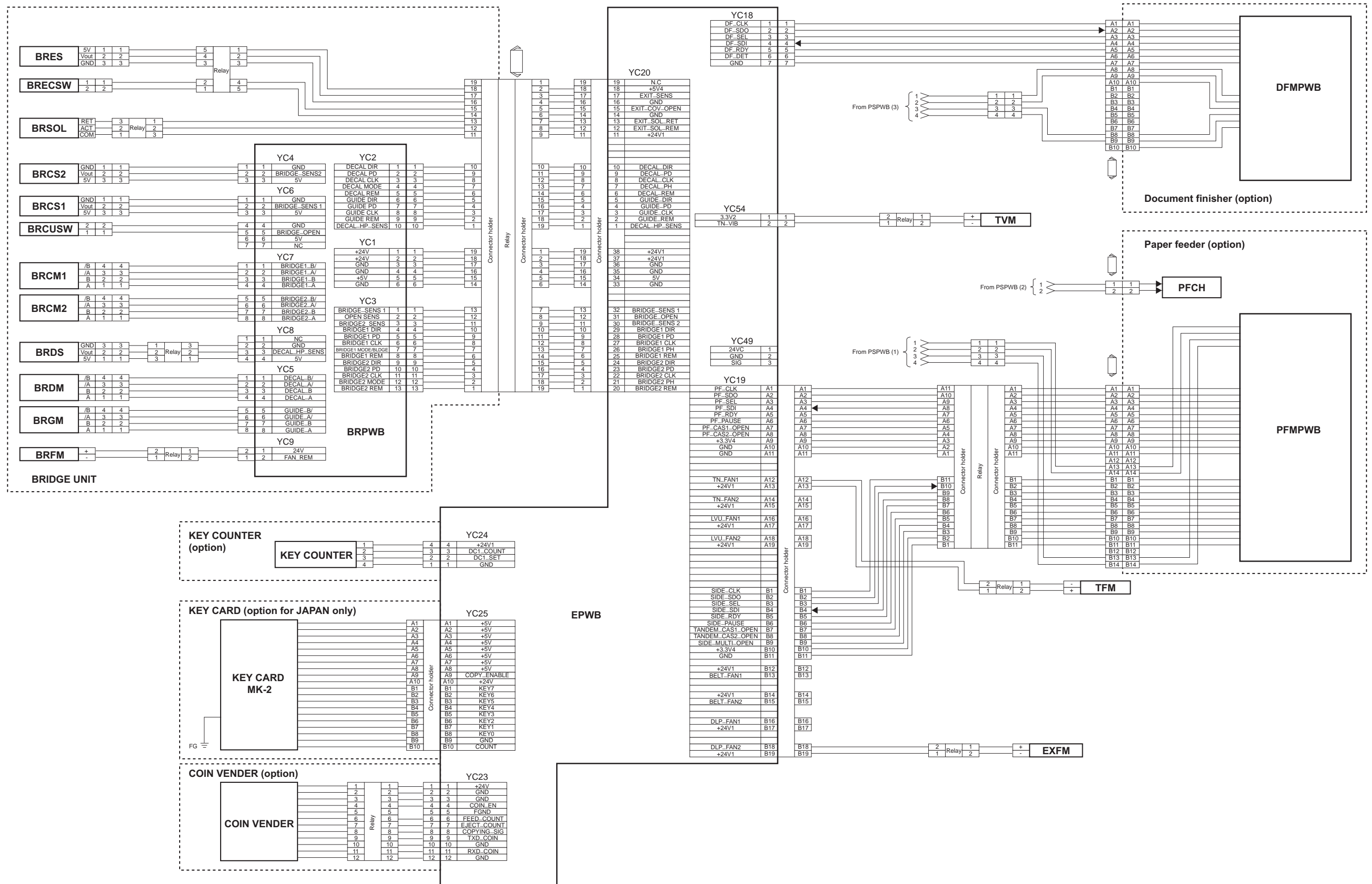
- Adjusting the printer leading edge registration (U034)
- Adjusting the printer center line (U034)
- Adjusting the printer margin (U402)

**Image quality**

Item	Specifications	Item	Specifications
100% magnification	Machine: ± 0.8 %	Leading edge registration	Cassette: +1.0/-1.5 mm
	Using DP: ± 1.5 %		MP tray: +1.0/-1.5 mm
Enlargement/reduction	Machine: ± 1.0 %		Duplex: +1.0/-1.5 mm
	Using DP: ± 1.5 %	Skewed paper feed (left-right difference)	Cassette: 1.5 mm or less
Lateral squareness	Machine: ± 1.5 mm/375 mm		MP tray: 1.5 mm or less
	Using DP: ± 3.0 mm/375 mm		Duplex: 2.0 mm or less
		Lateral image shifting	Cassette: ± 2.0 mm
			MP tray: ± 2.0 mm
			Duplex: ± 3.0 mm

(10) Wiring diagram

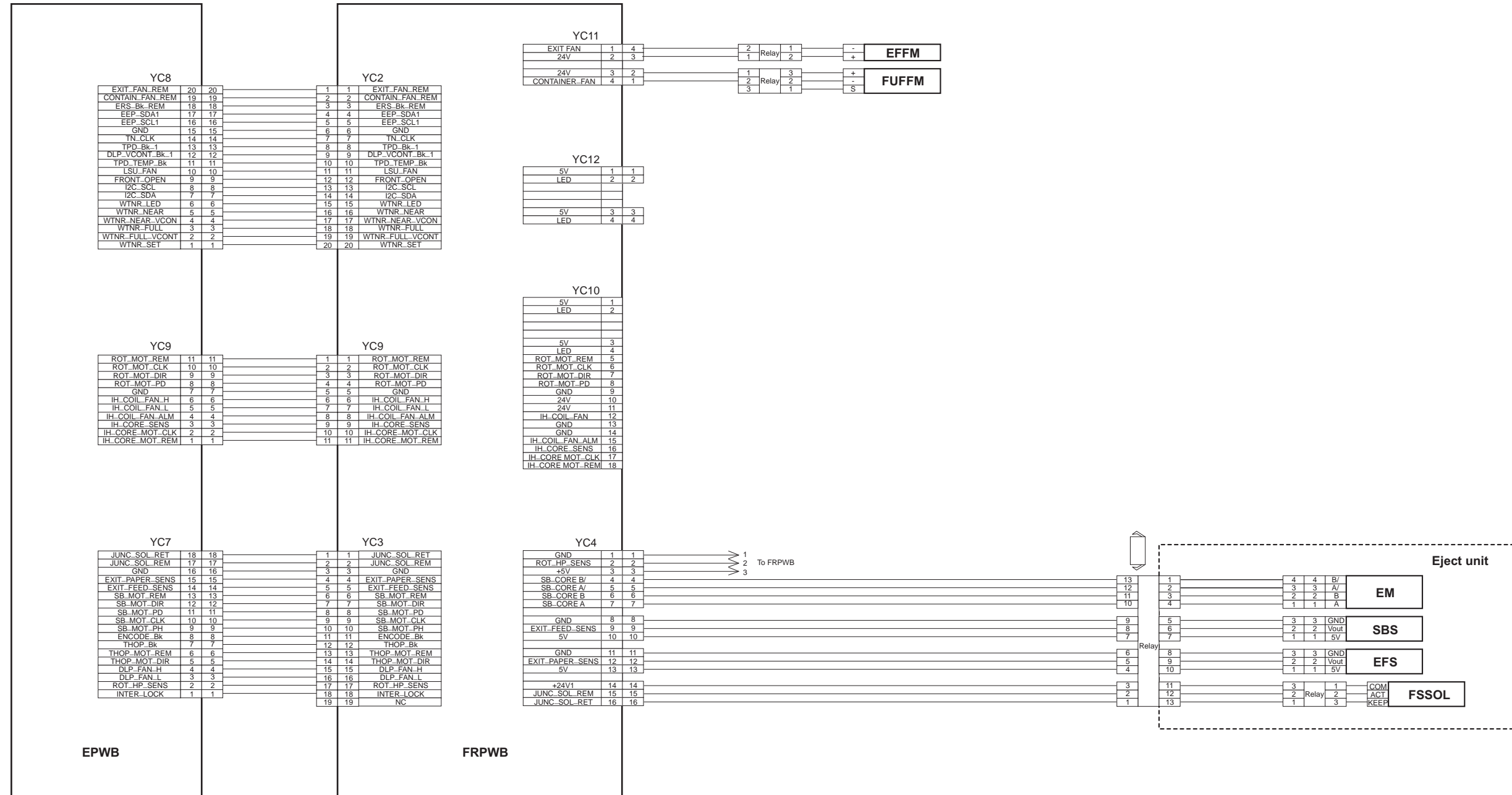
No.1





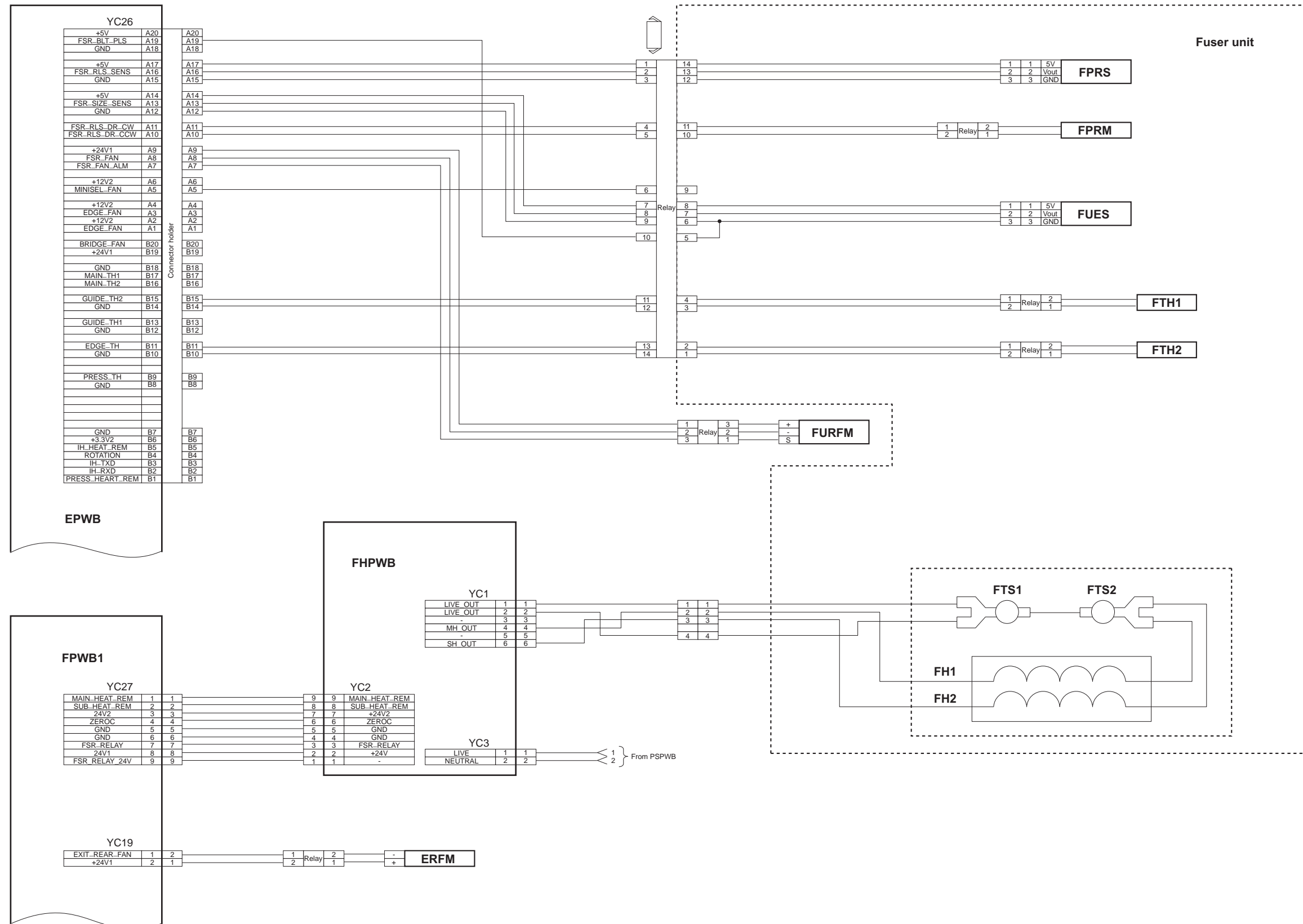


No.3

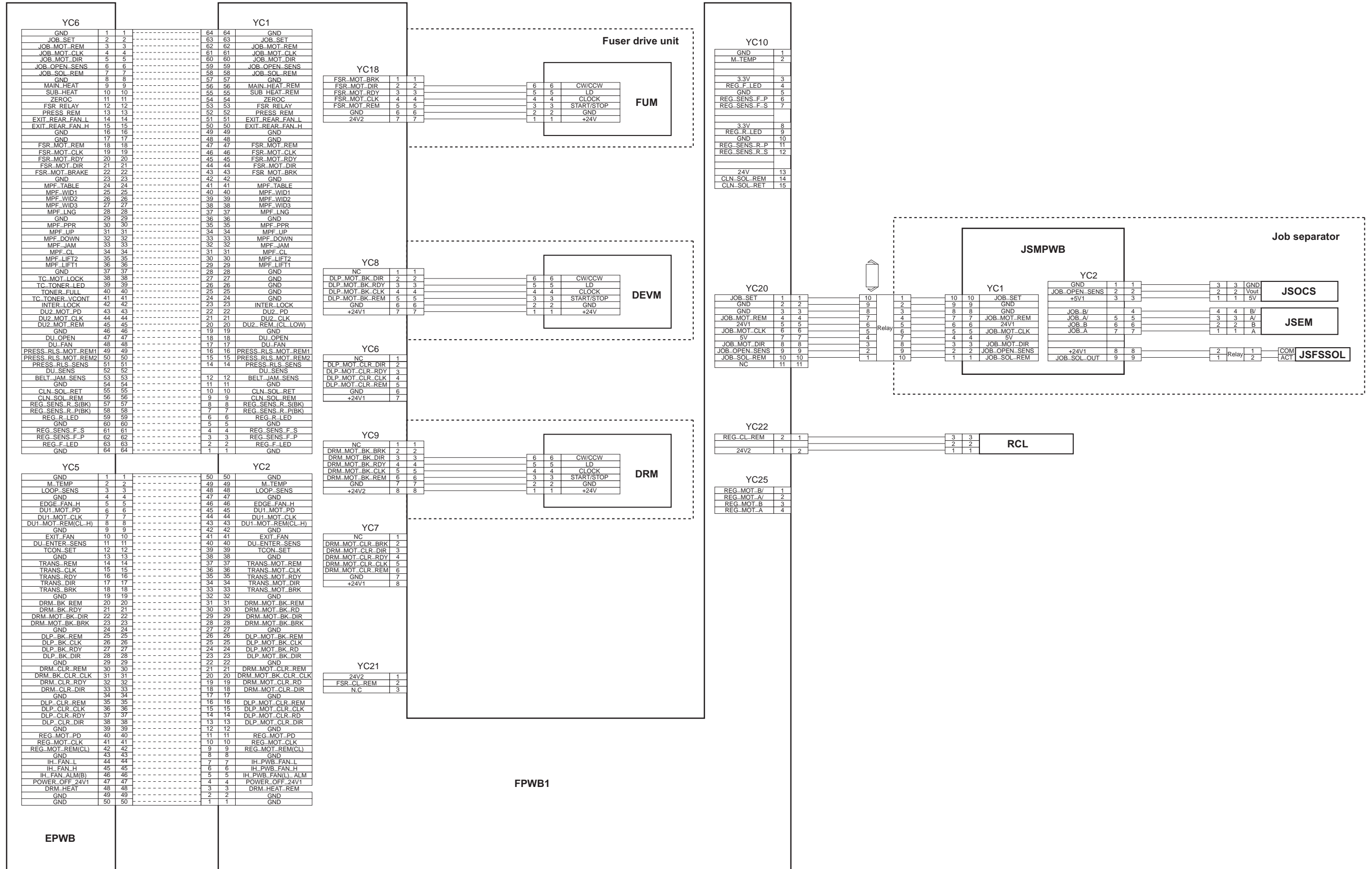




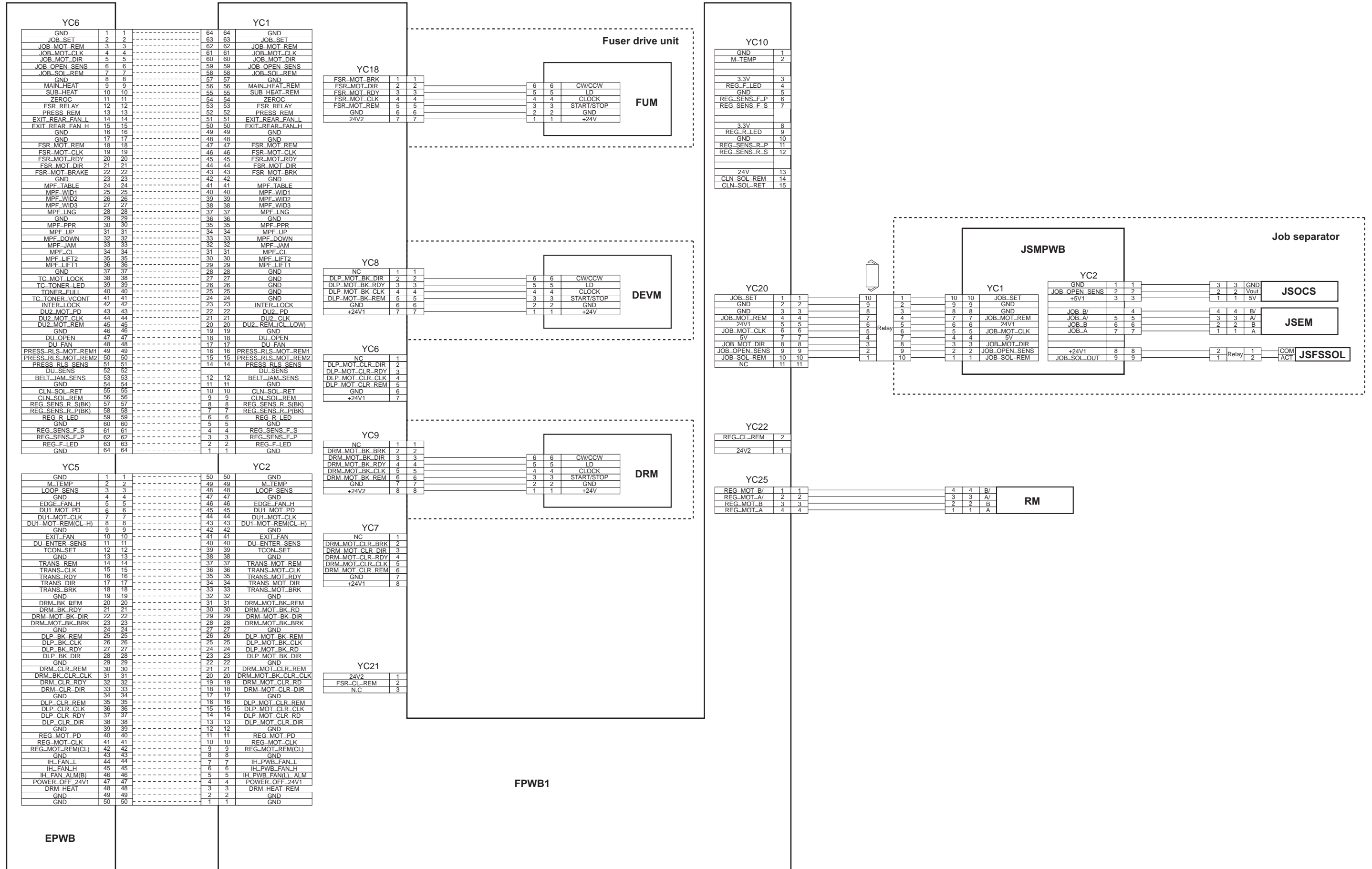
No.4



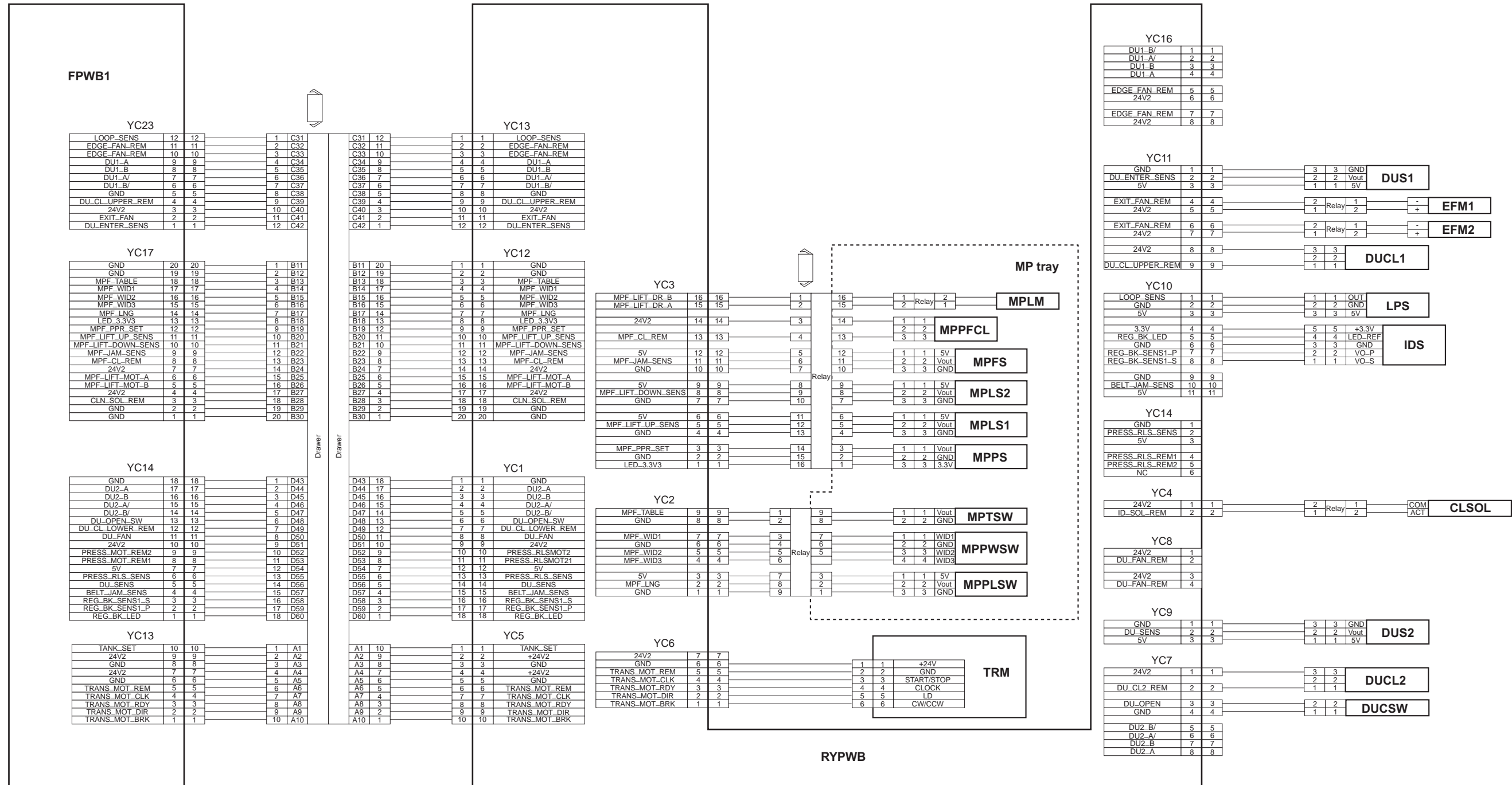
No.5 (35ppm)



No.5 (45 ppm/55 ppm)

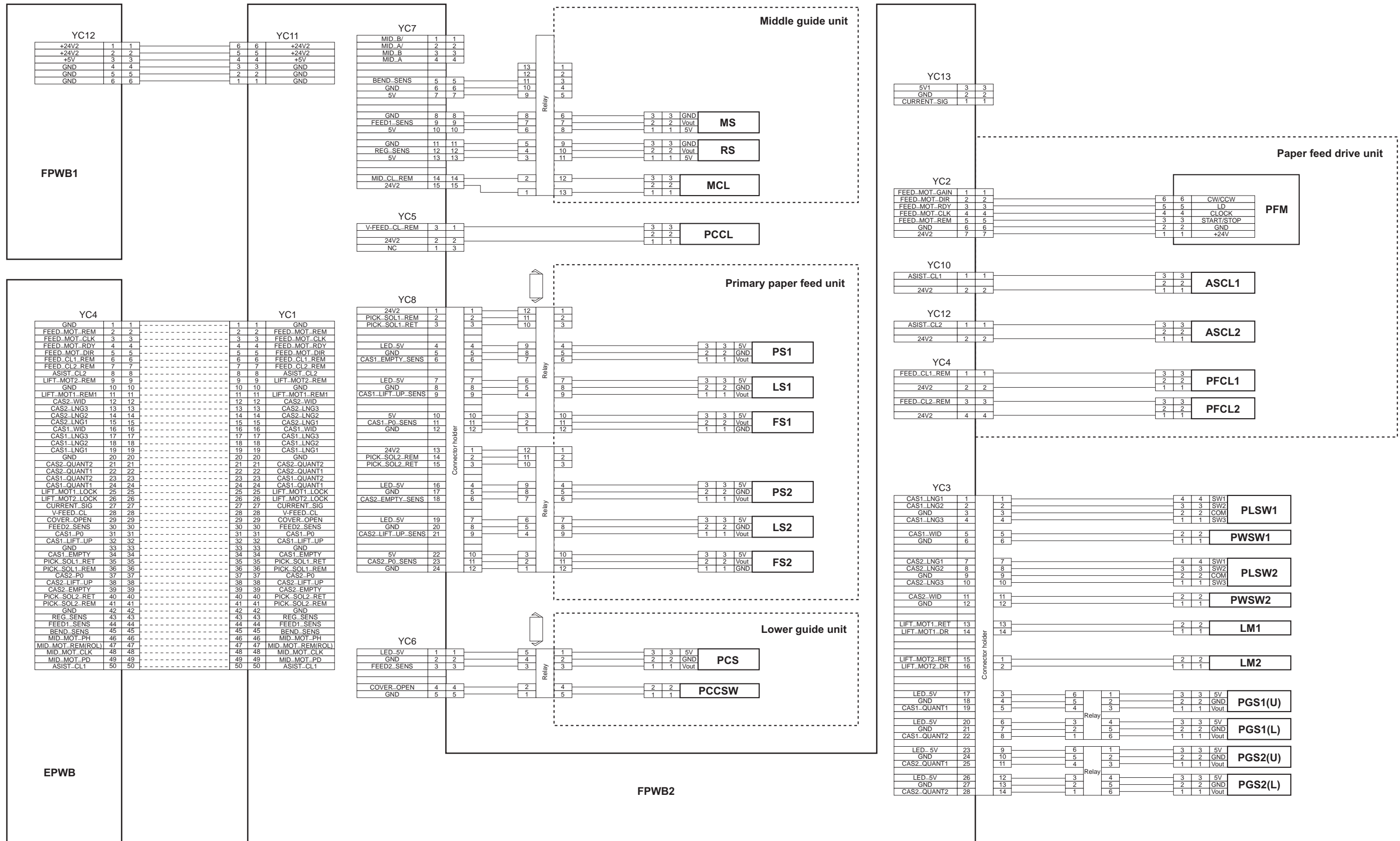


No.6 (35 ppm)



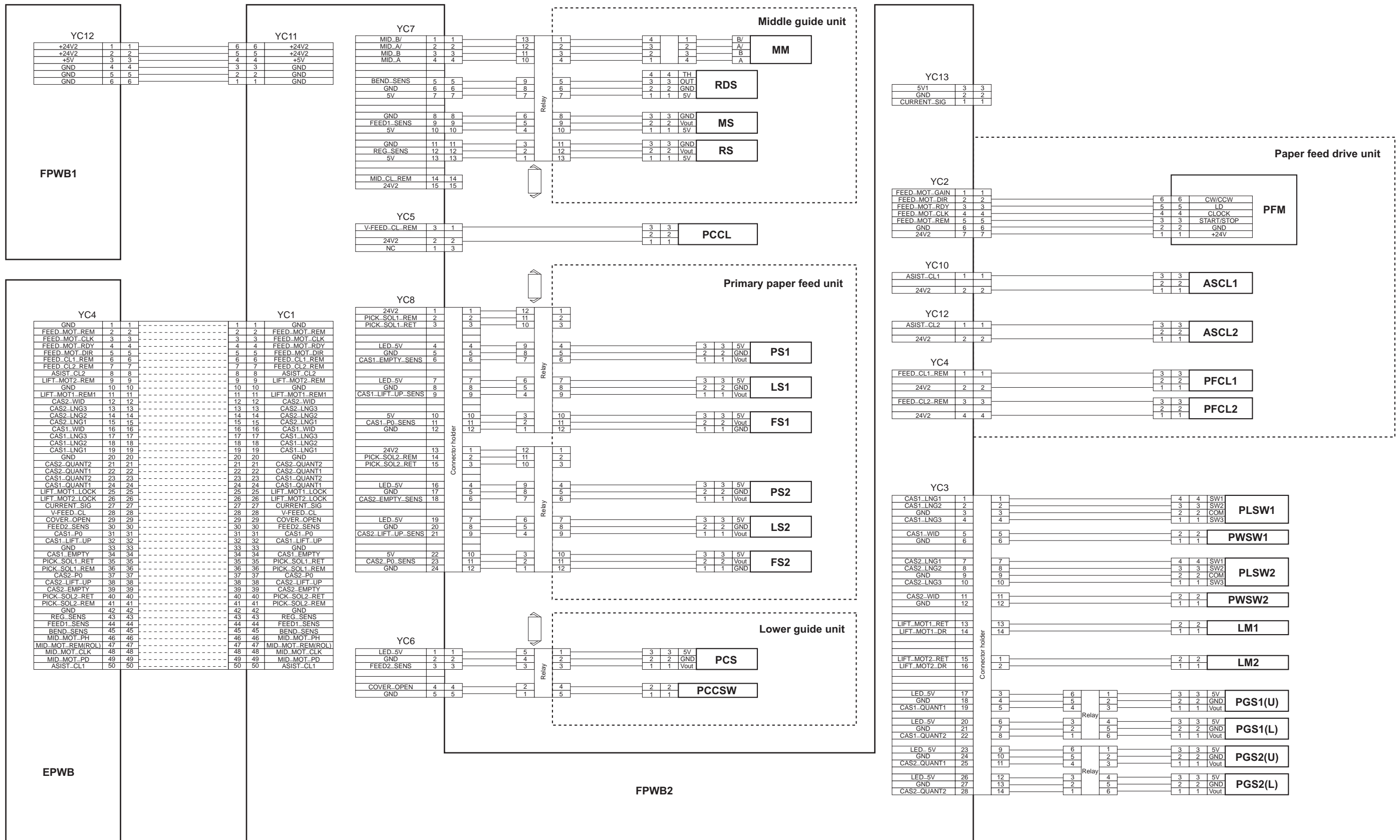


No.7 (35 ppm)

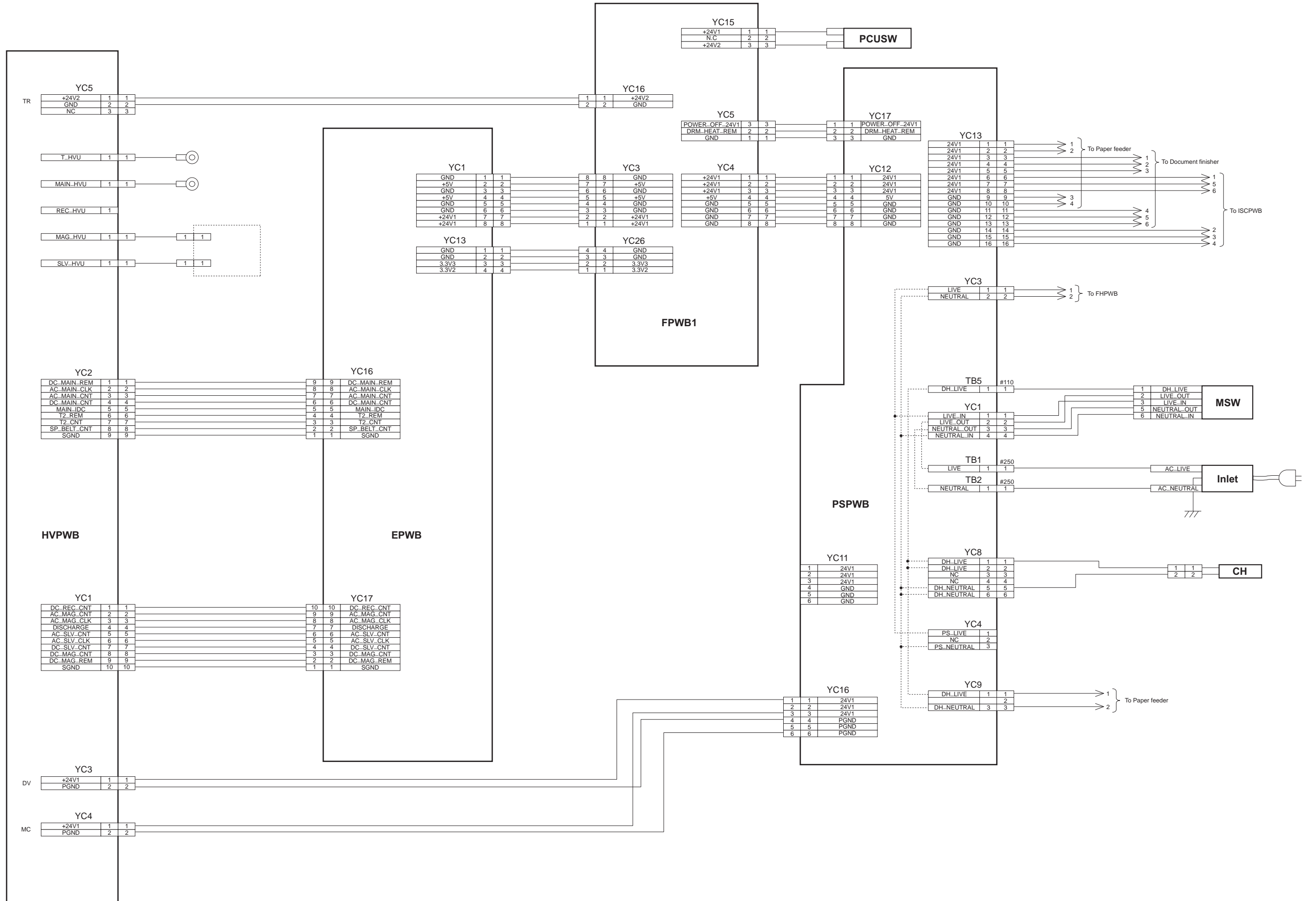




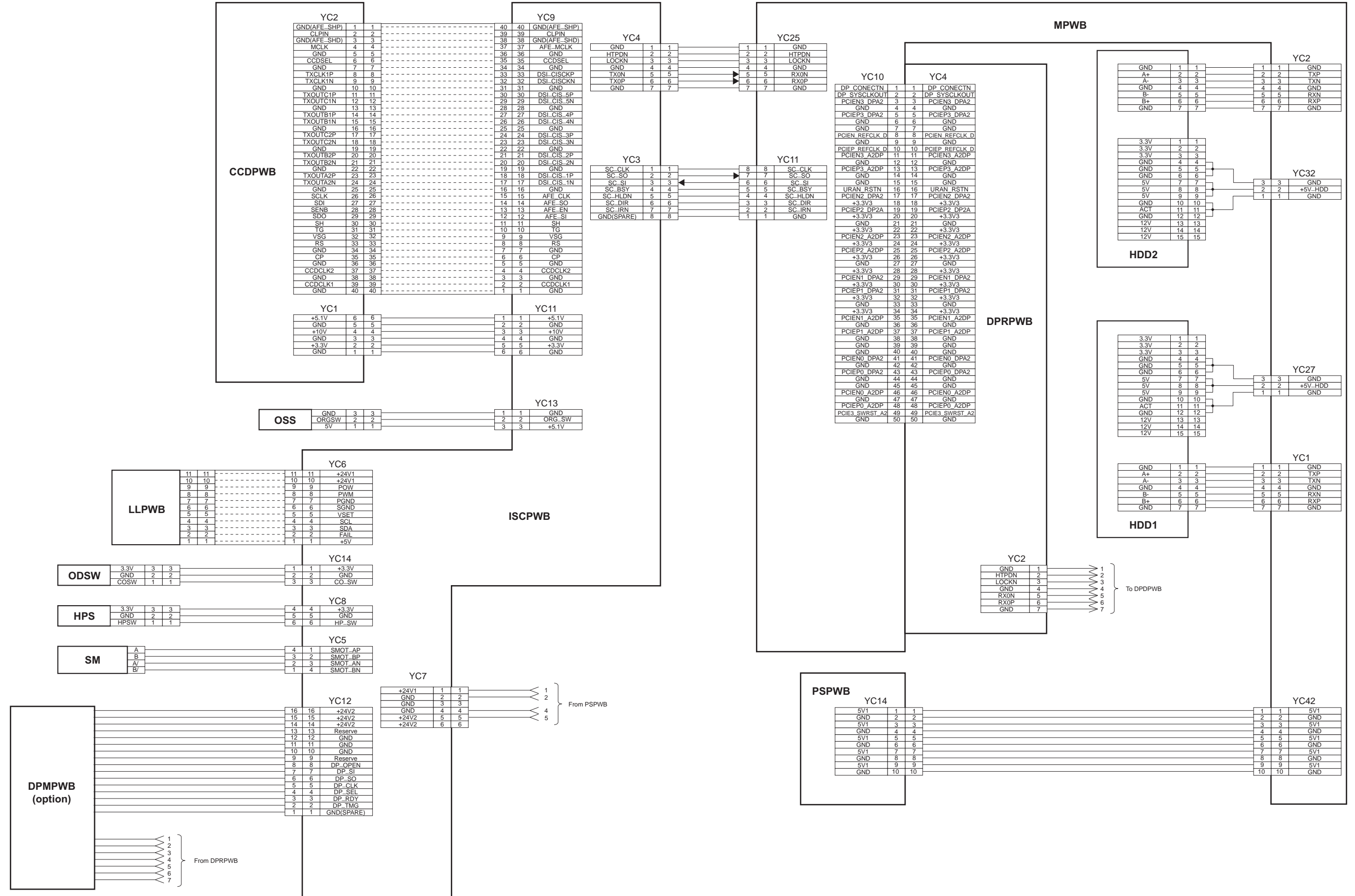
No.7 (45 ppm/55 ppm)



No.8

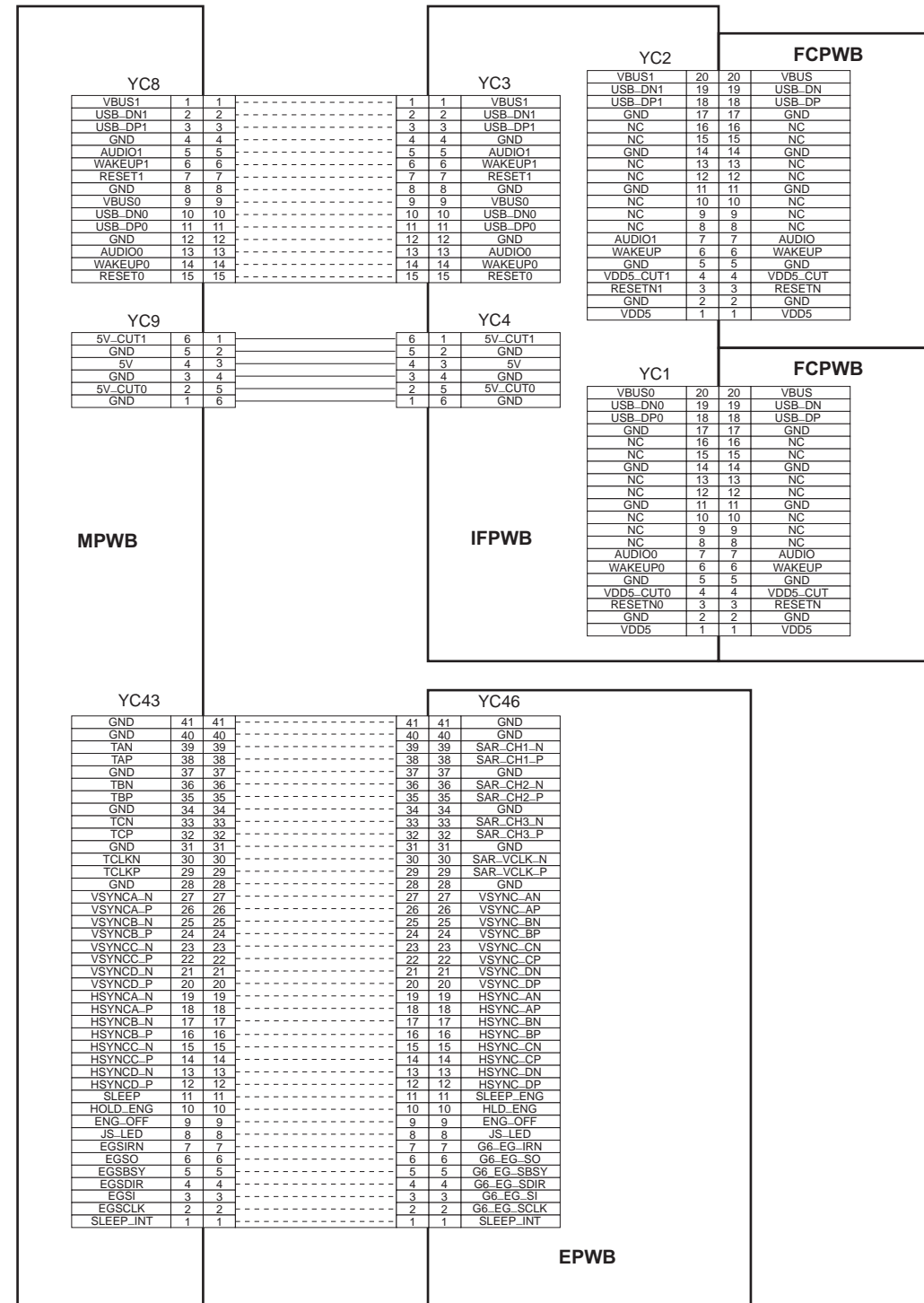




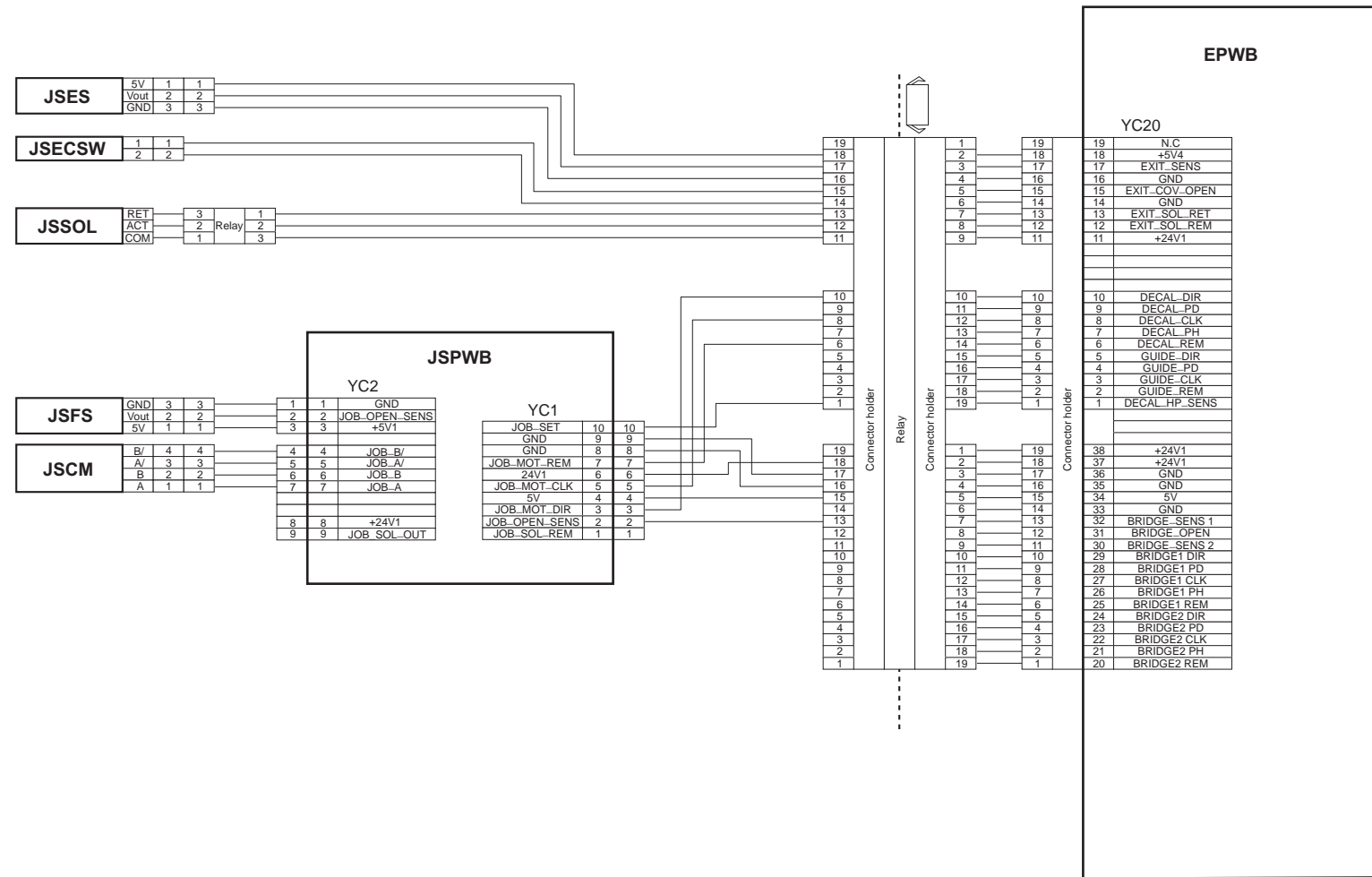




No.11



No.12



# **INSTALLATION GUIDE FOR DOCUMENT PROCESSOR**

---

**INSTALLATION GUIDE**

**GUIDE D'INSTALLATION**

**GUÍA DE INSTALACION**

**INSTALLATIONSANLEITUNG**

**GUIDA ALL'INSTALLAZIONE**

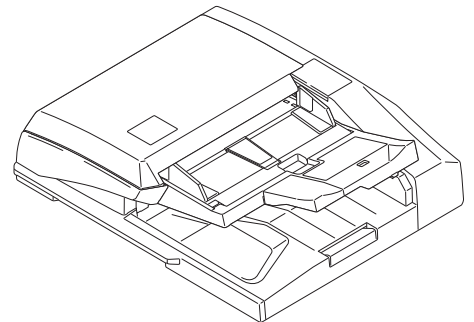
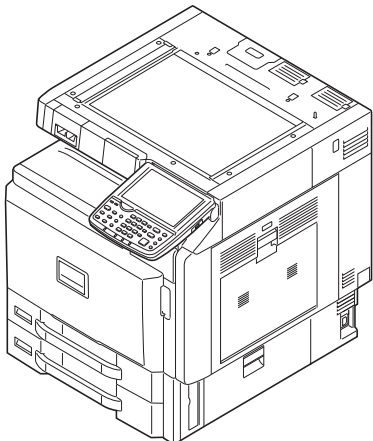
**安装手册**

**설치안내서**

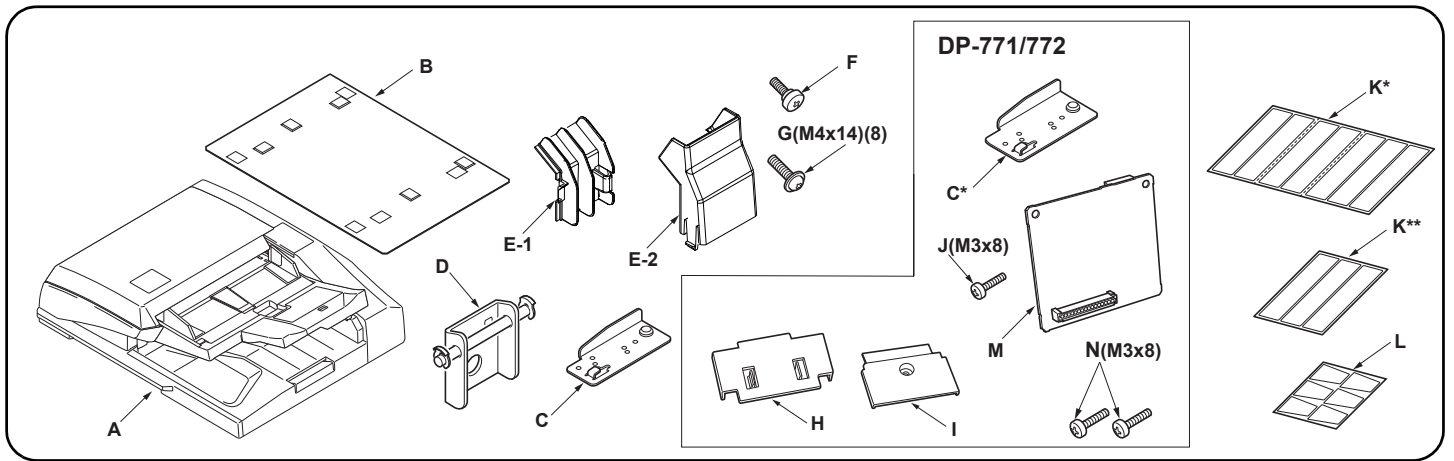
**設置手順書**

**DP-770(B)**  
**DP-771**  
**DP-772**

for Color MFP 30/30ppm,35/35ppm,45/45ppm,55/50ppm  
for Black & White MFP 35ppm,45ppm,55ppm

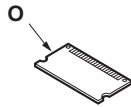






English		
<b>Supplied parts</b>		
A. DP.....	1	
B. Original mat.....	1	
C. Fixing fitting (width: 38.5 mm).....	2 (DP-770(B))	
	1 (DP-771/772)	
C*. Fixing fitting (width: 45 mm)*1.....	1	
D. Angle control fitting.....	1	
E-1. DP cable cover1.....	1	
E-2. DP cable cover2.....	1	
F. Pin.....	1	
G. M4 x 14TP screw.....	8	
H. Left hinge cover*1.....	1	
I. Right hinge cover*1.....	1	
J. M3 x 8 screw BLACK*1.....	1	
K. Label "Operation procedure".....	1	
	*1: for metric specification	
	**1: for inch specification	
L. Caution label "Original face up!".....	1	
M. DP relay PWB*1.....	1	
N. M3 x 8 screw*2.....	2	
	*1: DP-771/772 only, *2: DP-772 only	
Français		
<b>Pièces fournies</b>		
A. DP.....	1	
B. Plaque d'original.....	1	
C. Fixation (largeur: 38,5 mm).....	2 (DP-770(B))	
	1 (DP-771/772)	
C.*Fixation (largeur: 45 mm)*1.....	1	
D. Fixation d'angle.....	1	
E-1. Couverture du câble du DP1.....	1	
E-2. Couverture du câble du DP2.....	1	
F. Goupille.....	1	
G. Vis TP M4 x 14.....	8	
H. Couverture de charnière gauche*1.....	1	
I. Couverture de charnière droite*1.....	1	
J. Vis M3 x 8 NOIRE*1.....	1	
K. Étiquette relative à la procédure d'utilisation.....	1	
	*1: pour des spécifications métriques	
	**1: pour des spécifications anglo-saxonnes	
L. Étiquette d'avertissement relative à l'orientation vers le haut de la face de l'original.....	1	
M. Carte de circuit imprimé relais du DP*1.....	1	
N. Vis M3 x 8*2.....	2	
	*1: DP-771/772 uniquement, *2: DP-772 uniquement	
Español		
<b>Partes suministradas</b>		
A. DP.....	1	
B. Alfombrilla para originales.....	1	
C. Herraje de fijación (anchura: 38,5 mm).....	2 (DP-770(B))	
	1 (DP-771/772)	
C.*Herraje de fijación (anchura: 45 mm)*1.....	1	
D. Herraje de control de ángulo.....	1	
E-1. Cubierta del cable del DP1.....	1	
E-2. Cubierta del cable del DP2.....	1	
F. Pasador.....	1	
G. Tornillo TP M4 x 14.....	8	
H. Cubierta de la bisagra izquierda*1.....	1	
I. Cubierta de la bisagra derecha*1.....	1	
J. Tornillo M3 x 8 NEGRO*1.....	1	
K. Etiqueta "Procedimiento operativo".....	1	
	*1: para especificaciones en el sistema métrico	
	**1: para especificaciones en el sistema de pulgadas	
L. Etiqueta de precaución "Original cara arriba".....	1	
M. PWB del relé del DP*1.....	1	
N. Tornillo M3 x 8*2.....	2	
	*1: DP-771/772 solamente, *2: DP-772 solamente	
Deutsch		
<b>Enthaltene Teile</b>		
A. DP.....	1	
B. Originalmatte.....	1	
C. Befestigungshalterung (Breite: 38,5 mm).....	2 (DP-770(B))	
	1 (DP-771/772)	
C*. Befestigungshalterung (Breite: 45 mm)*1.....	1	
D. Winkeleinstellbefestigung.....	1	
E-1. DP-Kabelabdeckung1.....	1	
E-2. DP-Kabelabdeckung2.....	1	
F. Stift.....	1	
G. M4 x 14TP Schraube.....	8	
H. Linke Scharnierabdeckung*1.....	1	
I. Rechte Scharnierabdeckung*1.....	1	
J. M3 x 8 Schraube SCHWARZ*1.....	1	
K. Schild "Funktionsanweisung".....	1	
	*1: für metrische Angaben	
	**1: für Angaben in Zoll	
L. Warnschild "Originalschriftseite nach oben".....	1	
M. DP-Relaisleiterplatte *1.....	1	
N. M3 x 8 Schraube*2.....	2	
	*1: nur DP-771/772, *2: nur DP-772	
Italiano		
<b>Parti fornite</b>		
A. DP.....	1	
B. Tappetino originale.....	1	
C. Accessorio di fissaggio (larghezza: 38,5 mm).....	2 (DP-770(B))	
	1 (DP-771/772)	
C*. Accessorio di fissaggio (larghezza: 45 mm)*1.....	1	
D. Accessorio di regolazione angolare.....	1	
E-1. Coperchio del cavo DP1.....	1	
E-2. Coperchio del cavo DP2.....	1	
F. Perno.....	1	
G. Vite M4 x 14TP.....	8	
H. Coperchio cerniera sinistra*1.....	1	
I. Coperchio cerniera destra*1.....	1	
J. Vite M3 x 8 NERA*1.....	1	
K. Etichetta "Procedura di funzionamento".....	1	
	*1: per specifiche in unità del sistema metrico	
	**1: per specifiche in pollici	
L. Etichetta di avvertimento "Originale rivolto verso l'alto!".....	1	
M. Scheda a circuiti stampati di comunicazione DP*1.....	1	
N. Vite M3 x 8*2.....	2	
	*1: Solo DP-771/772, *2: Solo DP-772	
简体中文		
<b>附属品</b>		
A. DP.....	1	
B. 原稿垫.....	1	
C. 固定工具 (宽 38.5mm).....	2 (DP-770(B))	
	1 (DP-771/772)	
C*. 固定工具 (宽 45mm) *1.....	1	
D. 角度限制工具.....	1	
E-1. DP 电缆盖板 1.....	1	
E-2. DP 电缆盖板 2.....	1	
F. 销.....	1	
G. M4 x 14TP 螺丝.....	8	
H. 左部铰链盖板 *1.....	1	
I. 右部铰链盖板 *1.....	1	
J. M3 x 8 螺丝 BLACK *1.....	1	
M. DP 中继板 *1.....	1	
N. M3 x 8 螺丝 *2.....	2	
	*1: 仅限 DP-771/772	
	*2: 仅限 DP-772	
	(K) 和 (L) 并非附属品。	
한국어		
<b>동봉품</b>		
A. DP.....	1	
B. 원고매트.....	1	
C. 고정쇠 (38.5mm 폭).....	2 (DP-770(B))	
	1 (DP-771/772)	
C*. 고정쇠 (45mm 폭) *1.....	1	
D. 각도 고정쇠.....	1	
E-1. DP 케이블커버 1.....	1	
E-2. DP 케이블커버 2.....	1	
F. 핀.....	1	
G. 나사 M4 x 14TP.....	8	
H. 힌지커버 좌 *1.....	1	
I. 힌지커버 우 *1.....	1	
J. 나사 M3 x 8 BLACK *1.....	1	
M. DP 중계기판 *1.....	1	
N. 나사 M3 x 8 *2.....	2	
	*1: DP-771/772 만	
	*2: DP-772 만	
	(K) (L) 는 동봉되어 있지 않습니다.	
日本語		
<b>同梱品</b>		
A. DP.....	1	
B. 原稿マット.....	1	
C. 固定金具 (38.5mm 幅).....	2 (DP-770(B))	
	1 (DP-771/772)	
C*. 固定金具 (45mm 幅) *1.....	1	
D. 角度規制金具.....	1	
E-1. DP ケーブルカバー1.....	1	
E-2. DP ケーブルカバー2.....	1	
F. ピン.....	1	
G. ビス M4 x 14TP.....	8	
H. 左ヒンジカバー *1.....	1	
I. 右ヒンジカバー *1.....	1	
J. ビス M3 x 8 BLACK *1.....	1	
M. DP 中継基板 *1.....	1	
N. ビス M3 x 8 *2.....	2	
	*1: DP-771/772 のみ	
	*2: DP-772 のみ	
	(K) (L) は、同梱されていない。	





---

**O. Memory DIMM (1GB)**

(except 120V specification) ..... 1

The memory DIMM must be expanded separately before using the "Dual scan function" on the DP-771.

Order a memory DIMM in the service parts.

For details, see the instructions on page 12.

---

**O. Mémoire DIMM (1GB)**

(sauf spécifications 120V) ..... 1

La mémoire DIMM doit être expansée séparément avant utilisation de la "Fonction double balayage" du DP-771.

Commander une mémoire DIMM auprès du service des pièces de rechange.

Pour plus de précisions, se reporter aux instructions de la page 12.

---

**O. Memoria DIMM (1GB)**

(excepto especificaciones para 120V)..... 1

La memoria DIMM debe ampliarse de forma separada antes de utilizar la "Función de escaneado doble" del DP-771.

Realice un pedido de una memoria DIMM de repuesto.

Consulte las instrucciones de la página 12 para obtener información más detallada.

---

**O. Speicher-DIMM (1GB)**

(auser 120-V-Spezifikation) ..... 1

Die DIMM-Speichermodule müssen separat aufgerüstet werden, bevor man die "Dual Scan Funktion" des DP-771 benutzt.

Bestellen Sie ein DIMM-Speichermodul zusammen mit den Serviceteilen.

Einzelheiten hierzu finden Sie in den Anleitungen auf Seite 12.

---

**O. Memoria DIMM (1GB)**

(eccetto per i modelli con specifica 120V) .. 1

La memoria DIMM deve essere espansa separatamente prima di usare la "Funzione di scansione dual" sull'unità DP-771.

Ordinare una memoria DIMM dalle parti di servizio.

per maggiori informazioni in merito si prega di leggere le istruzioni riportate a pagina 12.

---

**O. 内存模组 DIMM (1GB)**

(120V 型号以外) ..... 1

在使用 DP-771 的「一次双面扫描功能」时，必需要增加内存卡。

请订购维修部件 DIMM 内存。

有关详情，请参阅第 12 页的说明。

---

**O. 메모리 DIMM (1GB)**

(120V 사양 이외) ..... 1

DP-771 의 「양면동시 스캔기능」을 사용하는 경우에는 별도 메모리 DIMM 의 증설이 필요합니다 .

서비스 부품으로 메모리 DIMM 을 발주해 주십시오 .

상세는 12 페이지를 참조해 주십시오 .

---

**O. メモリーDIMM(1GB)**

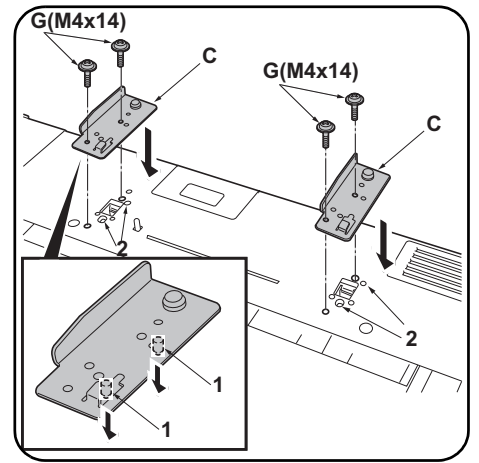
(120V仕様以外) ..... 1

DP-771 の「両面同時読み込み機能」を使用する場合は、別途メモリーDIMM の増設が必要です。

サービスパーツでメモリーDIMM を発注してください。

詳細は 12 ページ参照のこと

---



**NOTICE**

Be sure to remove any tape and/or cushioning materials from the parts supplied. The illustrations of the DP in the Installation Guide are for DP-771/772.

**Procedure**

Before starting installation, be sure to turn the main power switch of the machine off, and unplug the power plug from the wall outlet.

**Attach the fixing fitting (DP-770(B))**

1. Align projections (1) of each fixing fitting (C) with holes (2) on the MFP and insert the fixing fittings (C) into the MFP.
2. Secure each fixing fitting (C) with two M4 x 14TP screws (G).

**REMARQUE**

Veillez à retirer les morceaux de bande adhésive et/ou les matériaux de rembourrage des pièces fournies. Les schémas du DP dans le Guide d'installation concernent le DP-771/772.

**Procédure**

Avant de commencer l'installation, s'assurer de mettre la machine hors tension et de débrancher la fiche d'alimentation de la prise murale.

**Mettre en place la fixation (DP-770(B))**

1. Aligner les saillies (1) de chacune des pièces de fixation (C) avec les trous (2) sur le MFP et insérer ces pièces (C) dans le MFP.
2. Fixer chacune des pièces de fixation (C) avec deux vis M4 x 14TP (G).

**AVISO**

Asegúrese de quitar todas las cintas y/o material amortiguador de las partes suministradas. Las ilustraciones del DP en la Guía de instalación corresponden al DP-771/772.

**Procedimiento**

Antes de iniciar la instalación, asegúrese de apagar el interruptor de encendido de la máquina y desenchufar el cable de alimentación de la toma de pared.

**Monte el herraje de fijación (DP-770(B))**

1. Alinee las salientes (1) de cada herraje de fijación (C) con los orificios (2) del MFP e inserte los herrajes de fijación (C) en el MFP.
2. Asegure cada uno de los herrajes de fijación (C) con dos tornillos M4 x 14TP (G).

**ANMERKUNG**

Stellen Sie sicher, dass sämtliche Klebebänder und/oder Polstermaterial von den gelieferten Teilen entfernt wurden. Die Abbildungen des DP in der Installationsanleitung gelten für Modell DP-771/772.

**Vorgehensweise**

Bevor Sie mit der Installation beginnen überzeugen Sie sich, dass der Netzschalter des Geräts ausgeschaltet und das Stromkabel aus der Steckdose gezogen ist.

**Anbringen der Befestigungshalterung (DP-770(B))**

1. Die Zapfen (1) jeder Befestigungshalterung (C) mit den Öffnungen (2) am MFP ausrichten und die Befestigungshalterungen (C) in den MFP einsetzen.
2. Jede Befestigungshalterung (C) mit zwei M4 x 14TP Schrauben (G) befestigen.

**AVVISO**

Rimuovere tutti i nastri adesivi e/o i materiali di protezione dalle parti fornite. Le illustrazioni del DP nella Guida all'installazione sono per il modello DP-771/772.

**Procedura**

Prima di iniziare l'installazione, spegnere la macchina e scollegare la spina dalla presa di corrente.

**Applicazione dell'accessorio di fissaggio (DP-770(B))**

1. Allineare le sporgenze (1) di ogni accessorio di fissaggio (C) con i fori (2) sull'MFP, ed inserire gli accessori di fissaggio (C) nell'MFP.
2. Bloccare ogni accessorio di fissaggio (C) con le due viti M4 x 14TP (G).

**注意**

如果附属品上带有固定胶带, 缓冲材料时务必揭下。安装手册中关于 DP 的图示以 DP-771/772 为例。

**安装步骤**

安装前务必关闭机器的主电源开关, 并从墙壁插座拔下电源插头。

**安装固定工具 (DP-770(B))**

1. 将各固定工具 (C) 上的突出部分 (1) 与 MFP 上的孔 (2) 对齐, 然后将固定工具 (C) 插入 MFP 中。
2. 用两颗 M4 x 14TP 螺丝 (G) 固定各固定工具 (C)。

**주의**

동봉품에 고정 테이프, 완충재가 붙어 있는 경우에는 반드시 제거하십시오. 설치순서에 기재되어 있는 DP 일러스트는 DP-771/772 입니다.

**설치순서**

설치를 시작하기 전에 반드시 본체의 주 전원 스위치를 끄고 벽 콘센트에서 전원 플러그를 분리하십시오.

**고정쇠의 부착 (DP-770(B))**

1. 고정쇠 (C) 의 돌기 (1) 와 MFP 의 구멍 (2) 을 맞추고 MFP 에 고정쇠 (C) 를 꽂습니다.
2. 나사 M4 x 14TP (G) 각 2 개로 2 개의 고정쇠 (C) 를 고정합니다.

**注意**

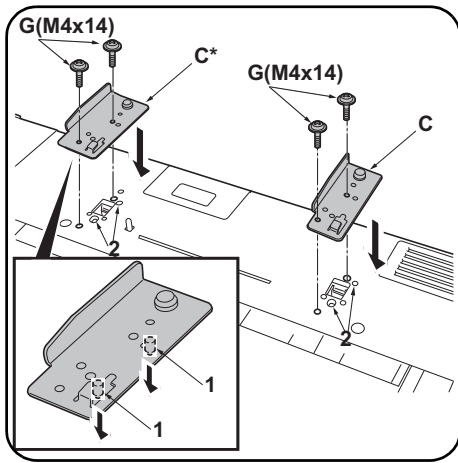
同梱品に固定テープ、緩衝材が付いている場合は必ず取り外すこと。設置手順書に記載している DP のイラストは、DP-771/772 です。

**取付手順**

必ず機械本体の主電源スイッチを OFF にし、機械本体の電源プラグを抜いてから作業すること。

**固定金具の取り付け (DP-770(B))**

1. 固定金具 (C) の突起 (1) と MFP の穴 (2) を合わせ、MFP に固定金具 (C) を差し込む。
2. ビス M4 x 14TP (G) 各 2 本で 2 つの固定金具 (C) を固定する。



#### Attach the fixing fitting (DP-771/772)

1. Align the projections (1) on the right fixing fitting (C) and on the wider left fixing fitting (C\*) with the respective holes (2) in the MFP and then insert the fixing fittings into the MFP.
2. Secure each of the fixing fittings (C) (C\*) with 2 M4 x 14TP screws (G).

#### Mettre en place la fixation (DP-771/772)

1. Aligner les saillies (1) de la fixation droite (C) et de la fixation gauche plus large (C\*) avec les trous correspondants (2) du MFP et insérer les fixations dans le MFP.
2. Fixer chaque des fixations (C) (C\*) avec 2 vis TP M4 x 14 (G).

#### Monte el herraje de fijación (DP-771/772)

1. Alinee los salientes (1) del herraje de fijación derecho (C) y del herraje de fijación izquierdo más ancho (C\*) con los orificios correspondientes (2) del MFP y, después, inserte los herrajes de fijación en el MFP.
2. Asegure cada uno de los herrajes de fijación (C) (C\*) con 2 tornillos TP M4 x 14 (G).

#### Anbringen der Befestigungshalterung (DP-771/772)

1. Die Zapfen (1) an der rechten Befestigungshalterung (C) und an der breiteren Befestigungshalterung (C\*) mit den entsprechenden Öffnungen (2) am MFP ausrichten und die Befestigungshalterungen in den MFP einsetzen.
2. Die Befestigungshalterungen (C) (C\*) mit den 2 M4 x 14TP Schrauben (G) befestigen.

#### Applicazione dell'accessorio di fissaggio (DP-771/772)

1. Allineare le sporgenze (1) sull'accessorio di fissaggio destro (C) e sull'accessorio di fissaggio sinistro più largo (C\*) con i rispettivi fori (2) nell'MFP, e quindi inserire gli accessori di fissaggio nell'MFP.
2. Fissare ciascuno degli accessori di fissaggio (C) (C\*) con 2 viti M4 x 14TP (G).

#### 安装固定工具 (DP-771/772)

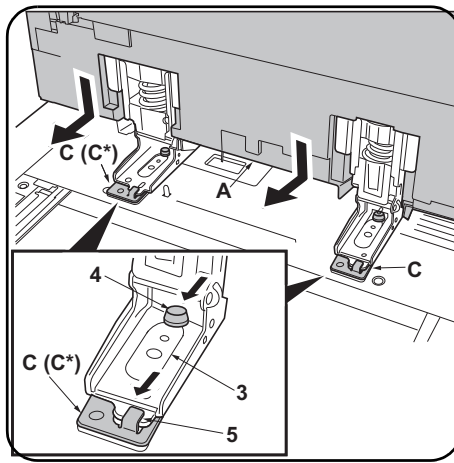
1. 将固定工具 (C) 从右侧、宽幅固定夹具 (C\*) 从左侧将各自的突出部分 (1) 与 MFP 的孔 (2) 对齐并插入到 MFP 中。
2. 使用各 2 颗 M4×14 螺丝 TP(G) 来固定固定工具 (C) 与固定工具 (C\*)

#### 고정쇠의 부착 (DP-771/772)

1. 우측에 고정쇠 (C), 좌측에 광폭 고정쇠 (C\*) 각각의 돌기 (1) 와 MFP 구멍 (2) 을 맞추고 MFP 에 끼웁니다 .
2. 나사 M4×14TP(G) 각 2 개로 고정쇠 (C) 와 고정쇠 (C\*) 를 고정합니다 .

#### 固定金具の取り付け(DP-771/772)

1. 右側に固定金具 (C)、左側に幅広の固定金具 (C\*) のそれぞれの突起 (1) と MFP の穴 (2) を合わせ、MFP に差し込む。
2. ビス M4×14TP(G) 各 2 本で固定金具 (C) と固定金具 (C\*) を固定する。



#### Install the DP

3. Align hinge hole (3) of DP (A) with pin (4) of fixing fitting (C), place DP (A) on the MFP.
4. Slide the DP (A) toward the front side and engage hinges into hooks (5) on fixing fittings (C).

#### Installer le DP

3. Aligner le trou de la charnière (3) du DP (A) sur la goupille (4) de la fixation (C) et placer le DP (A) sur le MFP.
4. Faire glisser le DP (A) vers l'avant et engager les charnières dans les crochets (5) sur les pièces de fixation (C).

#### Instale el DP

3. Alinee el orificio de bisagra (3) del DP (A) con el pasador (4) del herraje de fijación (C) y coloque el DP (A) en el MFP.
4. Deslice el DP (A) hacia el frente y enganche las bisagras en los ganchos (5) de los herrajes de fijación (C).

#### Installieren des DP

3. Scharnierloch (3) des DP (A) mit Stift (4) der Befestigungshalterung (C) ausrichten, und DP (A) auf den MFP stellen.
4. Den DP (A) nach vorne hin verschieben und die Scharniere in die Haken (5) an den Befestigungshalterungen (C) einsetzen.

#### Montaggio del DP

3. Allineare il foro della cerniera (3) del DP (A) con il perno (4) dell'accessorio di fissaggio (C), quindi posizionare il DP (A) sull'MFP.
4. Far scorrere il DP (A) verso il lato anteriore ed inserire le cerniere nei ganci (5) sugli accessori di fissaggio (C).

#### 安装 DP

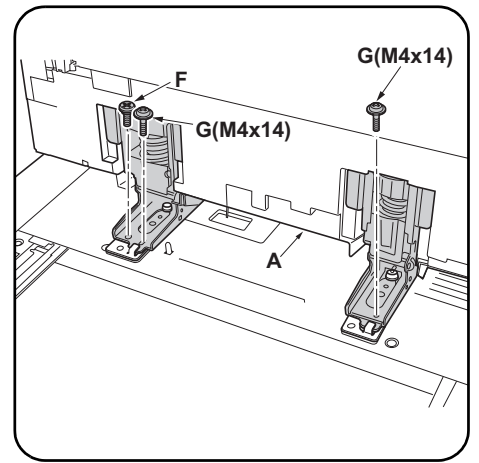
3. 将 DP (A) 的铰链孔 (3) 对准固定工具 (C) 的销 (4)，并将 DP (A) 放在 MFP 上。
4. 朝前侧滑动 DP (A)，然后将铰链与固定工具 (C) 上的卡扣 (5) 相啮合。

#### DP 부착

3. DP(A) 의 힌지부 구멍 (3) 과 고정쇠 (C) 핀 (4) 을 맞추고 MFP 에 DP(A) 를 올립니다 .
4. DP(A) 를 밀어 힌지부를 고정쇠 (C) 의 걸쇠 (5) 에 끼웁니다 .

#### DP の取り付け

3. DP (A) のヒンジ部の穴 (3) と固定金具 (C) のピン (4) を合わせ、MFP に DP (A) を乗せる。
4. DP (A) を手前にスライドさせ、ヒンジ部を固定金具 (C) の引っ掛け部 (5) にはめ込む。



#### 5. Install DP (A) onto the MFP securely with pin (F) and two M4 x 14TP screws (G).

#### 5. Installer le DP (A) sur le MFP en le fixant à l'aide de la goupille (F) et des deux vis TP M4 x 14 (G).

#### 5. Instale el DP (A) firmemente en el MFP con el pasador (F) y dos tornillos TP M4 x 14 (G).

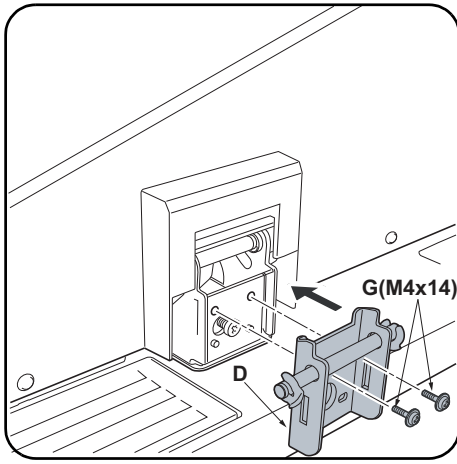
#### 5. DP (A) sicher mit einem Stift (F) und zwei M4 x 14TP Schrauben (G) am MFP befestigen.

#### 5. Montare il DP (A) sull'MFP assicurandolo con il perno (F) e due viti M4 x 14TP (G).

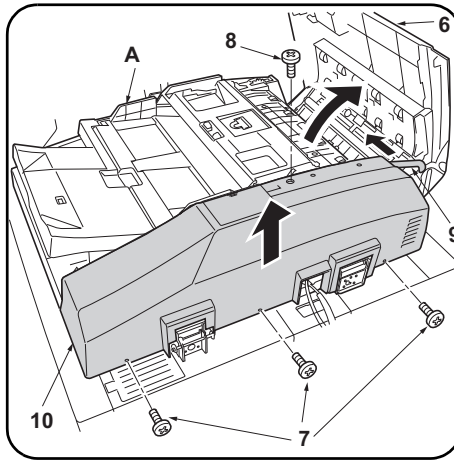
#### 5. 用销 (F) 和两颗 M4×14TP 螺丝 (G) 将 DP (A) 安装到 MFP 上。

#### 5. 핀 (F) 1 개와 나사 M4×14TP(G) 2 개로 DP(A) 를 MFP 에 고정합니다 .

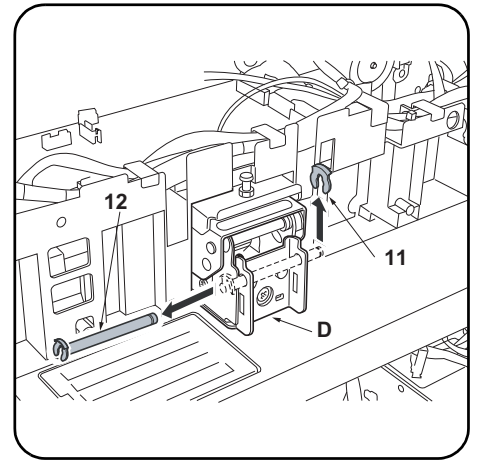
#### 5. ピン (F) 1 本とビス M4×14TP(G) 2 本で DP (A) を MFP に固定する。



**Install the angle control fitting**  
**To adjust DP open-close angle 60 degrees**  
 6. Install angle control fitting (D) at the rear side of the right hinge with two M4 x 14TP screws (G).



**To adjust DP open-close angle 30 degrees**  
 7. Open the upper cover (6) of the DP (A).  
 8. Remove the four screws (7) and (8). Remove the strap (9) from the rear cover (10). Remove the rear cover (10) of the DP (A).



9. Remove stop ring (11) of angle control fitting (D) that has been installed in step 6 to remove shaft (12).

**Installer la fixation d'angle**  
**Pour régler l'angle d'ouverture/de fermeture du DP de 60 degrés**  
 6. Placer la fixation d'angle (D) à l'arrière de la charnière droite à l'aide des deux vis TP M4 x 14 (G).

**Pour régler l'angle d'ouverture/de fermeture du DP de 30 degrés**  
 7. Ouvrir le couvercle supérieur (6) du DP (A).  
 8. Retirer les quatre vis (7) et (8). Retirer la courroie (9) du couvercle arrière (10). Retirer la couvercle arrière (10) du DP (A).

9. Retirer l'anneau de butée (11) de la fixation d'angle (D) installée à l'étape 6 pour enlever la tige (12).

**Instale el herraje de control de ángulo**  
**Para ajustar el DP, abra o cierre el ángulo 60 grados**  
 6. Instale el herraje de control de ángulo (D) en el lado trasero de la bisagra derecha con dos tornillos TP M4 x 14 (G).

**Para ajustar el DP, abra o cierre el ángulo 30 grados**  
 7. Abra la cubierta superior (6) del DP (A).  
 8. Quite los cuatro tornillos (7) y (8). Retire la correa (9) de la cubierta posterior (10). Quite la cubierta posterior (10) del DP (A).

9. Retire el anillo de retención (11) del herraje de control de ángulo (D) que se instaló en el paso 6 para retirar el eje (12).

**Installieren der Winkeleinstellbefestigung**  
**Einstellen des Öffnungs-/Schließungswinkels des DP um 60 Grad**  
 6. Winkeleinstellbefestigung (D) an der Rückseite des rechten Scharniers mit zwei M4 x 14TP Schrauben (G) befestigen.

**Einstellen des Öffnungs-/Schließungswinkels des DP um 30 Grad**  
 7. Die obere Abdeckung (6) des DP (A) öffnen.  
 8. Entfernen Sie die vier Schrauben (7) und (8). Entfernen Sie den Riemen (9) der hinteren Abdeckung (10). Entfernen Sie die hintere Abdeckung (10) des DP (A).

9. Anschlagring (11) von der Winkeleinstellbefestigung (D) abnehmen, die in Schritt 6 montiert wurde, um die Welle (12) zu entfernen.

**Montaggio dell'accessorio di regolazione angolare**  
**Per regolare l'angolo di chiusura / apertura del DP a 60 gradi**  
 6. Montare l'accessorio di regolazione angolare (D) sul lato posteriore della cerniera destra con due viti M4 x 14TP (G).

**Per regolare l'angolo di chiusura / apertura del DP a 30 gradi**  
 7. Aprire il pannello superiore (6) del DP (A).  
 8. Togliere le quattro viti (7) e (8). Rimuovere la cinghietta (9) dal coperchio posteriore (10). Rimuovere il coperchio posteriore (10) del DP (A).

9. Rimuovere l'anello di bloccaggio (11) dell'accessorio di regolazione angolare (D) che era stato installato al Punto 6 per rimuovere l'albero (12).

**安装角度限制工具**  
**若要将DP的开关角度调整为60度**  
 6. 在右部铰链的后部使用两颗M4×14TP螺丝(G)安装角度限制工具(D)。

**若要将DP的开关角度调整为30度**  
 7. 打开DP(A)的上盖板(6)。  
 8. 取下4颗螺丝(7),(8)。从后盖板(10)上取下塑料片(9)。取下DP(A)的后盖板(10)。

9. 拆下在第6步中安装的角度控制配件(D)的止动环(11),以将轴(12)拆下。

**각도 고정쇠의 부착**  
**DP 개폐각도를 60도로 설정하는 경우**  
 6. 우 힌지 뒷측에 나사 M4×14TP(G) 2 개로 각도 고정쇠(D)를 부착합니다.

**DP 개폐 각도를 30도로 설정하는 경우**  
 7. DP(A)의 DP 윗커버(6)를 엽니다.  
 8. 나사(7),(8) 4 개를 제거합니다. 스트랩(9)을 후면 커버(10)에서 제거합니다. DP(A)의 후면 커버(10)를 제거합니다.

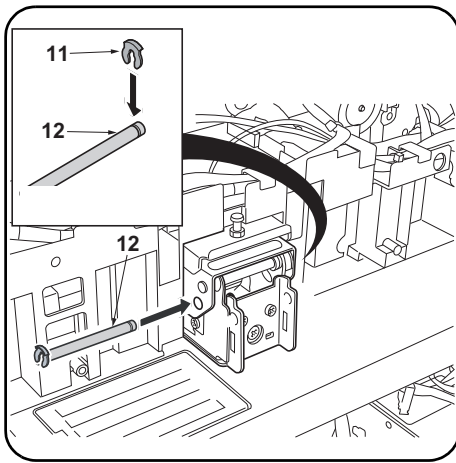
9. 스텝 6에서 부착한 각도 고정쇠(D)의 스톱링(11) 1 개를 제거하고 샤프트(12)를 제거합니다.

**角度規制金具の取り付け**  
**DP 開閉角度を60度に設定する場合**  
 6. 右ヒンジ後側にビスM4×14TP(G)2本で角度規制金具(D)を取り付ける。

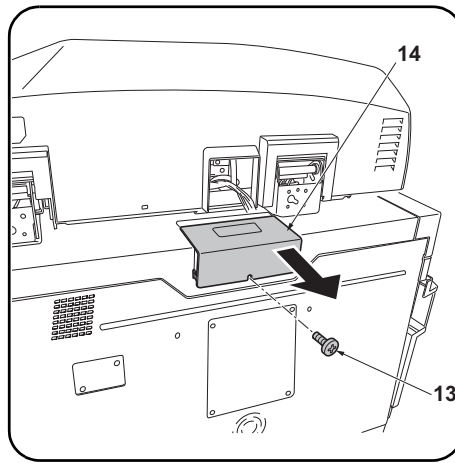
**DP 開閉角度を30度に設定する場合**  
 7. DP(A)のDP上カバー(6)を開く。  
 8. ビス(7),(8)4本を外す。ストラップ(9)を後カバー(10)から外す。DP(A)の後カバー(10)を取り外す。

9. 手順6で取り付けした角度規制金具(D)のストップリング(11)1個を外し、シャフト(12)を取り外す。

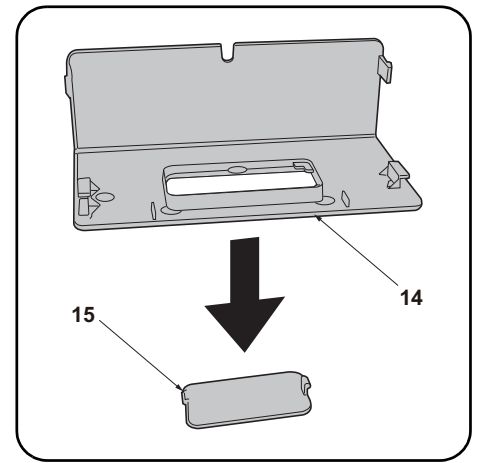




10. Insert shaft (12) into the rear side of the right hinge.
11. Attach stop ring (11) to the notch of shaft (12) and secure shaft (12).
12. Reinstall the rear cover (10) using the four screws (7) and (8) removed in step 8. Attach the strap (9) in the rear cover (10). Close the upper cover (6) of the DP (A).



13. Remove the screw (13) and remove the DP cable connection cover (14).



14. Remove the DP cable connection cap (15) from the DP cable connection cover (14).

10. Insérer la tige (12) à l'arrière de la charnière droite.
11. Fixer l'anneau de retenue (11) sur l'encoche de la tige (12) et mettre en place la tige (12).
12. Remonter la couvercle arrière (10) à l'aide des quatre vis (7) et (8) retirées à l'étape 8. Fixer la courroie (9) dans le couvercle arrière (10). Refermer le couvercle supérieur (6) du DP (A).

**Raccorder le circuit de transmission (DP-770(B) uniquement)**

13. Déposer la vis (13) et déposer le couvercle de la connexion du câble du DP (14).

14. Déposer le chapeau de la connexion du câble du DP (15) du couvercle de la connexion du câble du DP (14).

10. Inserte el eje (12) en el lado trasero de la bisagra derecha.
11. Fije el anillo de retención (11) a la muesca del eje (12) y asegure el eje (12).
12. Vuelva a colocar la cubierta posterior (10) con los cuatro tornillos (7) y (8) que quitó en el paso 8. Coloque la correa (9) de la cubierta posterior (10). Cierre la cubierta superior (6) del DP (A).

**Conecte la línea de señales del DP (DP-770(B) solamente)**

13. Quite el tornillo (13) y quite la cubierta de conexión del cable del DP (14).

14. Quite la tapa de conexión del cable del DP (15) de la cubierta de conexión del cable del DP (14)

10. Welle (12) in die Rückseite des rechten Scharniers einsetzen.
11. Anschlagring (11) an der Wellenkerbe (12) anbringen und Welle befestigen (12).
12. Bringen Sie die hintere Abdeckung (10) wieder an. Benutzen Sie die vier Schrauben (7) und (8) aus Schritt 8. Befestigen Sie den Riemen (9) der hinteren Abdeckung (10). Schließen Sie die obere Abdeckung (6) des DP (A).

**Anschließen der DP-Signalleitungen (nur DP-770(B))**

13. Die Schraube (13) entfernen und die Abdeckung (14) des DP-Kabelanschlusses abnehmen.

14. Die Kappe (15) des DP-Kabelanschlusses von der Abdeckung (14) des DP-Kabelanschlusses abnehmen.

10. Inserire l'albero (12) nella parte posteriore della cerniera destra.
11. Applicare l'anello di bloccaggio (11) nell'incavo dell'albero (12) e assicurare l'albero (12).
12. Rimontare il coperchio posteriore (10) utilizzando le quattro viti (7) e (8) rimosse al punto 8. Rimontare la cinghietta (9) sul coperchio posteriore (10). Chiudere il pannello superiore (6) del DP (A).

**Collegare la linea del segnale DP (solo DP-770(B))**

13. Rimuovere la vite (13) e quindi rimuovere il coperchio di la connessione del cavo DP (14).

14. Rimuovere il cappuccio (15) per la connessione del cavo DP dal coperchio di connessione del cavo DP (14).

10. 将轴 (12) 插入到右部铰链的后部。
11. 将止动环 (11) 安装到轴 (12) 的切口并将轴 (12) 固定。
12. 使用步骤 8 中取下的 4 颗螺丝 (7), (8) 来按原样安装后盖板 (10)。把塑料片 (9) 安装到后盖板 (10)。关闭 DP (A) 的 DP 上盖板 (6)。

**连接 DP 信号线 (仅限 DP-770 (B))**

13. 拆除 1 颗螺丝 (13), 拆下 DP 电缆连接盖板 (14)。

14. 从 DP 电缆连接盖板 (14) 上拆下 DP 电缆连接用盖 (15)。

10. 우 힌지 뒷측에 샤프트 (12) 를 삽입합니다 .
11. 스톱링 (11) 을 샤프트 (12) 의 노치에 부착하고 샤프트 (12) 를 고정합니다 .
12. 순서 8 에서 제거한 나사 (7), (8) 4 개를 사용하여 후면 커버 (10) 를 원래대로 부착합니다 . 스트랩 (9) 을 후면 커버 (10) 에 부착합니다 . DP (A) 의 DP 뒷 커버 (6) 를 닫습니다 .

**DP 신호선의 접속 (DP-770(B) 만)**

13. 나사 (13) 1 개를 빼고 DP 케이블 연결 커버 (14) 를 제거합니다 .

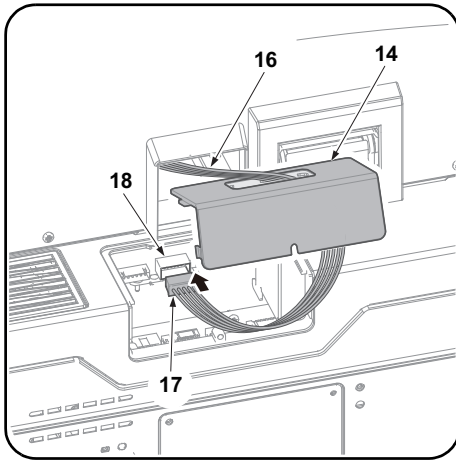
14. DP 케이블 연결 커버 (14) 에서 DP 케이블 연결 캡 (15) 을 제거합니다 .

10. 右ヒンジ後側にシャフト (12) を挿入する。
11. ストッピング (11) をシャフト (12) の溝に取り付け、シャフト (12) を固定する。
12. 手順 8 で外したビス (7)、(8) 4 本で後カバー (10) を元通り取り付け。ストラップ (9) を後カバー (10) に取り付ける。DP (A) の DP 上カバー (6) を閉じる。

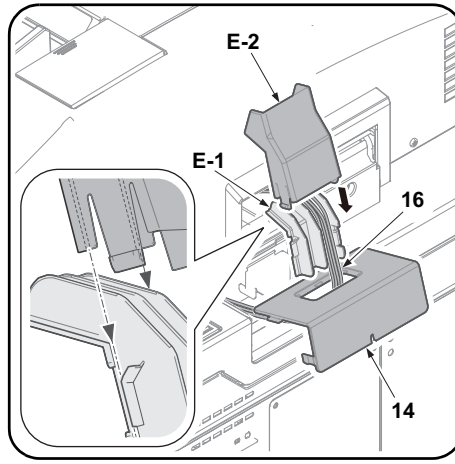
**DP 信号線の接続 (DP-770 (B) のみ)**

13. ビス (13) 1 本を外して、DP ケーブル接続カバー (14) を外す。

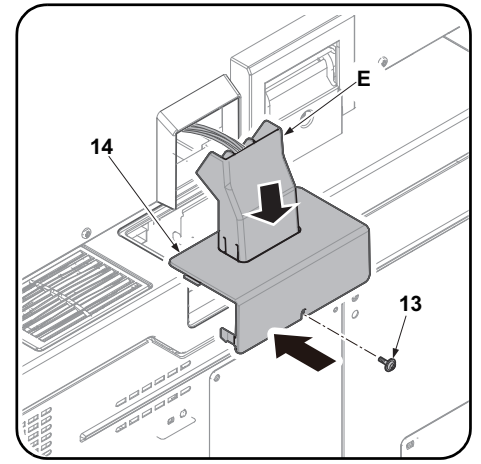
14. DP ケーブル接続カバー (14) から DP ケーブル接続用フタ (15) を取り外す。



**15.** Pass the DP signal line cable (16) through the hole in DP cable connection cover (14). Connect the DP signal line connector (17) to the connector (18) of the ISC PWB.



**16.** Pass the DP signal line cable (16) along the groove in the DP cable cover 1 (E-1). Install the DP cable cover 2 (E-2).



**17.** Attach the DP cable cover (E) to the DP cable connection cover (14) and install the DP cable connection cover (14) using the screw (13) removed in step 13. Proceed to step 27 on page 13

**15.** Passez le câble de la ligne du signal DP (16) dans le trou du couvercle de connexion du câble DP (14). Raccordez le connecteur de ligne de signal DP (17) sur le connecteur (18) de l'ISC PWB.

**16.** Passez le câble de la ligne du signal DP (16) dans la rainure du couvercle 1 du câble DP (E-1). Installez le couvercle 2 du câble DP (E-2).

**17.** Fixer le couvercle du câble du DP (E) sur le couvercle de la connexion du câble du DP (14) et installer le couvercle de la connexion du câble du DP (14) à l'aide de la vis (13) déposée à l'étape 13. Passer à l'étape 27 de la page 13.

**15.** Pase el cable de línea de señales del DP (16) por el orificio de la cubierta de conexión de cables del DP (14). Conecte el conector de línea de señales del DP (17) al conector (18) de ISC PWB.

**16.** Pase el cable de línea de señales del DP (16) a lo largo de la ranura de la cubierta de cables 1 del DP (E-1). Instale la cubierta de cables 2 del DP (E-2).

**17.** Fije la cubierta del cable del DP (E) a la cubierta de conexión del cable del DP (14) e instale la cubierta de conexión del cable del DP (14) usando el tornillo (13) quitado en el paso 13. Vaya al paso 27 de la página 13.

**15.** Führen Sie die Signalleitung (16) des DP durch die Öffnung der Steckerabdeckung (14) des DP. Verbinden Sie den Stecker der Signalleitung (17) des DP mit dem Steckverbinder (18) der ISC-Platine.

**16.** Führen Sie die Signalleitung (16) des DP durch die Nut der Steckerabdeckung 1 (E-1) des DP. Befestigen Sie die Steckerabdeckung 2 (E-2) des DP.

**17.** Die DP-Kabelabdeckung (E) an der Abdeckung (14) des DP-Kabelanschlusses anbringen und die Abdeckung (14) des DP-Kabelanschlusses mittels der in Schritt 13 entfernten Schraube (13) befestigen. Weitergehen zu Schritt 27 auf Seite 13.

**15.** Far passare il cavo di linea del segnale DP (16) nel foro presente sul coperchio del connettore cavo DP (14). Collegare il connettore di linea del segnale DP (17) al connettore (18) della scheda ISC PWB.

**16.** Far passare il cavo di linea del segnale DP (16) lungo la scanalatura sul coperchio del cavo DP 1 (E-1). Installare il coperchio del cavo DP 2 (E-2).

**17.** Fissare il coperchio del cavo DP (E) al coperchio di connessione del cavo DP (14), e quindi installare il coperchio di connessione del cavo DP (14) utilizzando la vite (13) rimossa nel passo 13. Procedere al passo 27 a pagina 13.

**15.** 将 DP 信号线 (16) 穿过 DP 电缆连接盖板 (14) 的孔。把 DP 信号线的接插件 (17) 和 ISC 电路板的接插件 (18) 相连接。

**16.** 将 DP 信号线 (16) 穿过 DP 电缆盖板 1 (E-1) 的槽中。安装 DP 电缆盖板 2 (E-2)。

**17.** 将 DP 电缆盖板 (E) 安装到 DP 电缆连接盖板 (14) 上, 使用步骤 13 中拆下的 1 颗螺丝 (13) 来安装 DP 电缆连接盖板 (14)。跳至 P13 的步骤 27。

**15.** DP 시그널 라인 케이블 (16) 을 DP 케이블 접속커버 (14) 의 구멍으로 통과시킵니다. DP 신호 신호선 커넥터 (17) 를 ISC PWB 의 커넥터 (18) 에 연결합니다.

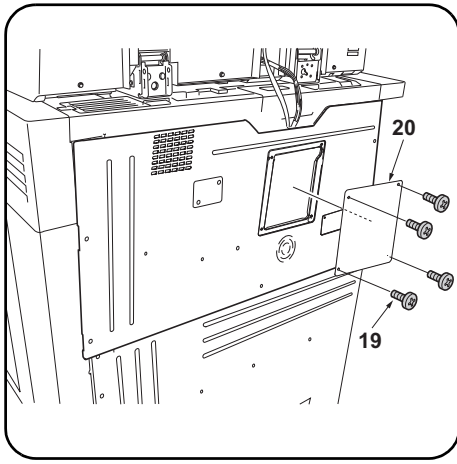
**16.** DP 케이블 커버 1 (E-1) 의 홈을 따라 DP 시그널 라인 케이블 (16) 을 통과시킵니다. DP 케이블 커버 2 (E-2) 를 설치합니다.

**17.** DP 케이블 커버 (E) 를 DP 케이블 접속커버 (14) 에 부착하고 순서 13 에서 제거한 나사 (13) 1 개로 DP 케이블 접속커버 (14) 를 부착합니다. P13 의 순서 27 로 진행.

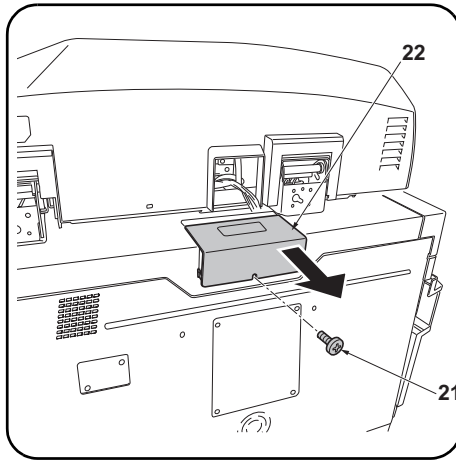
**15.** DP 케이블接続カバー (14) の穴に DP 信号線 (16) を通す。DP 信号線コネクタ (17) を ISC 基板のコネクタ (18) に接続する。

**16.** DP 케이블カバー 1 (E-1) の溝に DP 信号線 (16) を通す。DP 케이블カバー 2 (E-2) を取り付けする。

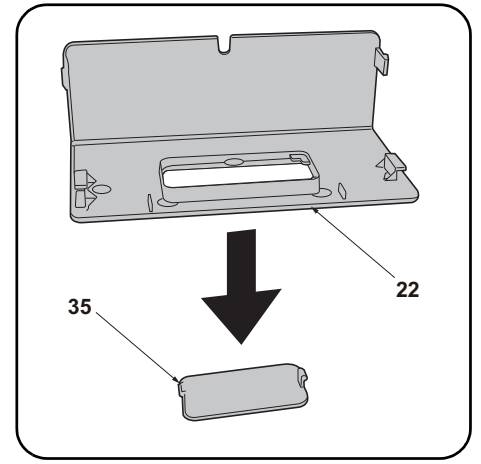
**17.** DP 케이블カバー (E) を DP 케이블接続カバー (14) に取り付け、手順 13 で外したビス (13) 1 本で DP 케이블接続カバー (14) を取り付ける。P13 の手順 27 へ進む。



**Connect the DP signal line (DP-771/772 only)**  
**13.** Remove the 4 screws (19). Remove the DP relay PWB cover (20).



**14.** Remove the screw (21) and remove the DP cable connection cover (22).



**15.** Remove the DP cable connection cap (35) from the DP cable connection cover (22).

**Raccorder le circuit de transmission (DP-771/772 uniquement)**

**13.** Retirez les 4 vis (19). Retirer le couvercle du circuit imprimé du relais du DP (20).

**14.** Déposer la vis (21) et déposer le couvercle de la connexion du câble du DP (22).

**15.** Déposer le chapeau de la connexion du câble du DP (35) du couvercle de la connexion du câble du DP (22).

**Conecte la línea de señales del DP (DP-771/772 solamente)**

**13.** Quite los 4 tornillos (19). Retire la cubierta de PWB del relé del DP (20).

**14.** Quite el tornillo (21) y quite la cubierta de conexión del cable del DP (22).

**15.** Quite la tapa de conexión del cable del DP (35) de la cubierta de conexión del cable del DP (22).

**Anschließen der DP-Signalleitungen (nur DP-771/772)**

**13.** Entfernen Sie die 4 Schrauben (19). Entfernen Sie die Abdeckung (20) der DP-Verbindungsplatine zum Vorlageneinzug.

**14.** Die Schraube (21) entfernen und die Abdeckung (22) des DP-Kabelanschlusses abnehmen.

**15.** Die Kappe (35) des DP-Kabelanschlusses von der Abdeckung (22) des DP-Kabelanschlusses abnehmen.

**Collegare la linea del segnale DP (solo DP-771/772)**

**13.** Togliere le 4 viti (19). Rimuovere la scheda a circuiti stampati di comunicazione DP (20).

**14.** Rimuovere la vite (21) e quindi rimuovere il coperchio di la connessione del cavo DP (22).

**15.** Rimuovere il cappuccio (35) per la connessione del cavo DP dal coperchio di connessione del cavo DP (22).

**连接 DP 信号线 (仅限 DP-771/772)**

**13.** 拆除 4 颗螺丝 (19)。取下 DP 中继板的盖板 (20)。

**14.** 拆除 1 颗螺丝 (21)，拆下 DP 电缆连接盖板 (22)。

**15.** 从 DP 电缆连接盖板 (22) 上拆下 DP 电缆连接用盖 (35)。

**DP 시그널 라인 연결 (DP-771/772 만)**

**13.** 나사 (19) 4 개를 제거합니다 . DP 중계기판 커버 (20) 를 제거합니다 .

**14.** 나사 (21) 1 개를 제거한 루 DP 케이블 연결 캡 (22) 을 제거합니다 .

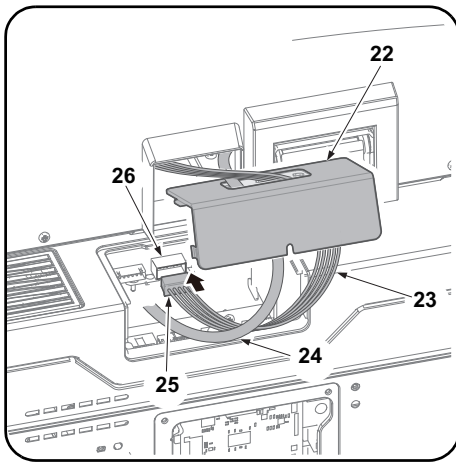
**15.** DP 케이블 연결 커버 (22) 에서 DP 케이블 연결 캡 (35) 을 제거합니다 .

**DP 信号線の接続 (DP-771/772 のみ)**

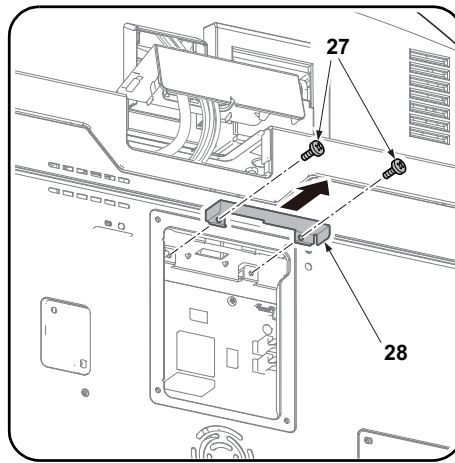
**13.** ビス (19) 4 本を外す。DP 中継基板カバー (20) を取り外す。

**14.** ビス (21) 1 本を外して、DP ケーブル接続カバー (22) を外す

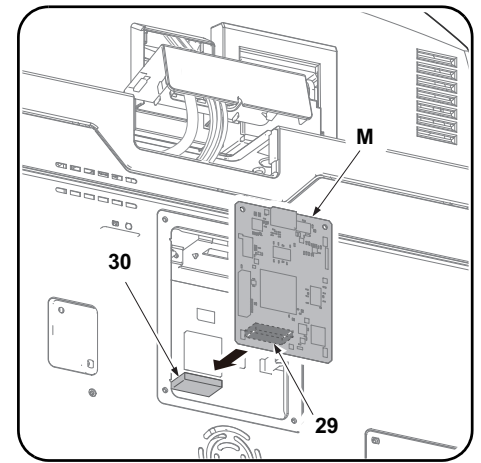
**15.** DP ケーブル接続カバー (22) から DP ケーブル接続用フタ (35) を取り外す。



**16.** Pass the DP signal line cable (23) and the CIS data line cable (24) through the hole in DP cable connection cover (22). Connect the DP signal line connector (25) to the connector (26) of the ISC PWB.



**DP-771 only**  
**17.** Remove the two screws (27). Remove the bracket (28).



**Installing the DP relay PWB**  
**18.** Connect connector (29) on the DP relay PWB (M) to connector (30) on the MFP.

**16.** Passez le câble de ligne de signal DP (23) et le câble de ligne de données CIS (24) dans le trou du couvercle de connexion du câble DP (22). Raccordez le connecteur de ligne de signal DP (25) sur le connecteur (26) de l'ISC PWB.

**DP-771 uniquement**  
**17.** Retirez les deux vis (27). Retirez le support (28).

**Installation de la carte de circuit imprimé relais du DP**  
**18.** Raccorder le connecteur (29) sur la carte de circuit imprimé relais du DP (M) au connecteur (30) sur le MFP.

**16.** Pase el cable de línea de señales del DP (23) y el cable de línea de datos de CIS (24) por el orificio de la cubierta de conexión de cables del DP (22). Conecte el conector de línea de señales del DP (25) al conector (26) de ISC PWB.

**DP-771 solamente**  
**17.** Quite los dos tornillos (27). Quite la abrazadera (28).

**Instalación del PWB del relé del DP**  
**18.** Conecte el conector (29) del PWB del relé del DP (M) al conector (30) del MFP.

**16.** Führen Sie die Signalleitung (23) des DP und die Datenleitung der CIS (24) durch die Öffnung der Steckerabdeckung (22) des DP. Verbinden Sie den Stecker der Signalleitung (25) des DP mit dem Steckverbinder (26) der ISC-Platine.

**nur DP-771**  
**17.** Entfernen Sie die beiden Schrauben (27). Entfernen Sie die Klammer (28).

**Installieren der DP-Relaisleiterplatte**  
**18.** Den Stecker (29) an der DP-Relaisleiterplatte (M) mit dem Stecker (30) am MFP verbinden

**16.** Far passare il cavo di linea del segnale DP (23) e il cavo di linea dei dati CIS (24) nel foro presente sul coperchio del connettore del cavo DP (22). Collegare il connettore di linea del segnale DP (25) al connettore (26) della scheda ISC PWB.

**Solo DP-771**  
**17.** Togliere le due viti (27). Rimuovere la staffa (28).

**Installazione della scheda a circuiti stampati di comunicazione DP**  
**18.** Collegare il connettore (29) sulla scheda a circuiti stampati di comunicazione DP (M) al connettore (30) sull'MFP.

**16.** 将 DP 信号线 (23) 和 CIS 数据线 (24) 穿过 DP 电缆连接盖板 (22) 的孔。把 DP 信号线的接插件 (25) 和 ISC 电路板的接插件 (26) 相连接。

**仅限 DP-771**  
**17.** 拆下 2 颗螺丝 (27)。卸下金属板 (28)。

**安装 DP 中继板**  
**18.** 将 DP 中继板 (M) 上的接插件 (29) 连接至 MFP 上的接插件 (30)。

**16.** DP 시그널 라인 케이블 (23) 과 CIS 데이터 라인 케이블 (24) 을 DP 케이블 연결 커버 (22) 의 구멍에 통과시킵니다 . DP 시그널 라인 커넥터 (25) 를 ISC PWB 의 커넥터 (26) 에 연결합니다 .

**DP-771 만**  
**17.** 나사 (27) 2 개를 제거합니다 . 브래킷 (28) 을 제거합니다 .

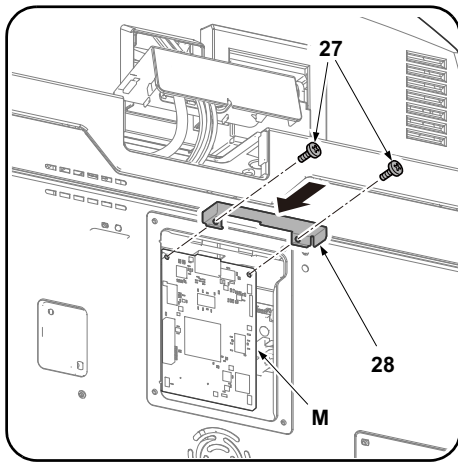
**DP 중계기판의 부착**  
**18.** DP 중계기판 (M) 의 커넥터 (29) 를 MFP 의 커넥터 (30) 에 연결합니다 .

**16.** DP 케이블接続カバー(22)の穴にDP信号線(23)とCISデータ線(24)を通す。DP信号線コネクタ(25)をISC基板のコネクタ(26)に接続する。

**DP-771のみ**  
**17.**ビス(27)2本を外す。板金(28)を外す。

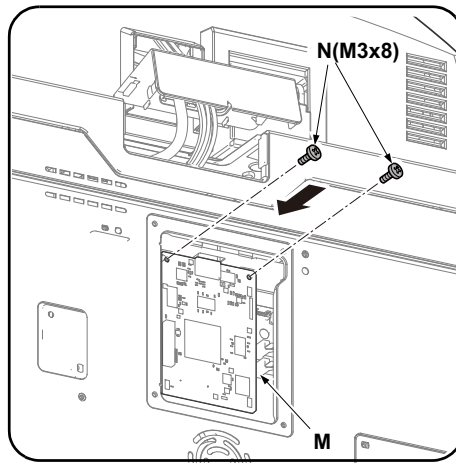
**DP 中継基板の取り付け**  
**18.** DP 中継基板 (M) のコネクタ (29) を、MFP のコネクタ (30) に接続する。





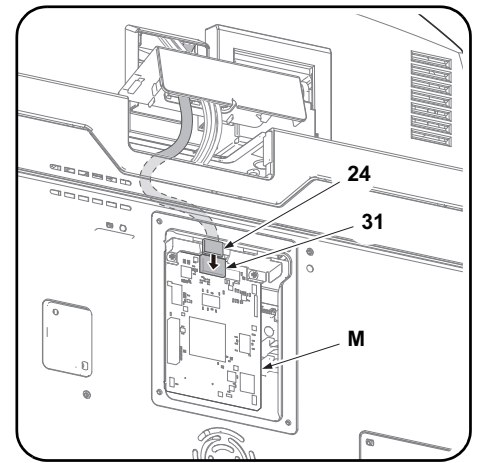
**DP-771 only**

19. Secure the DP relay PWB (M). Secure it with the bracket (28) and the two screws (27) removed in step 17.



**DP-772 only**

19. Secure the DP relay PWB (M). Secure it with the two M3 x 8 screws (N) supplied with the DP-772.



20. Plug the CIS data line (24) into the connector (31) on the DP relay PWB (M).

**DP-771 uniquement**

19. Fixez la DP relay PWB (M). Fixez-la avec le support (28) et les deux vis (27) retirés à l'étape 17.

**DP-772 uniquement**

19. Fixez la DP relay PWB (M). Fixez-la avec les deux vis M3 x 8 (N) fournies avec le DP-772.

20. Enficher le câble de la ligne des données du CIS (24) dans le connecteur (31) de la carte de circuit imprimé relais du DP (M).

**DP-771 solamente**

19. Fije el DP relay PWB (M). Fijelo con la abrazadera (28) y los dos tornillos (27) que quitó en el paso 17.

**DP-772 solamente**

19. Fije el DP relay PWB (M). Fijelo con los dos tornillos M3 x 8 (N) suministrados con DP-772.

20. Enchufe la línea de datos CIS (24) al conector (31) PWB del relé del DP (M).

**nur DP-771**

19. Befestigen Sie die DP Verbindungsplatine (M). Befestigen Sie die Klammer (28) und die beiden Schrauben (27), die in Schritt 17 entfernt wurden.

**nur DP-772**

19. Befestigen Sie die DP Verbindungsplatine (M). Befestigen Sie es mit den beiden M3 x 8 Schrauben (N), die sich im Lieferumfang des DP-772 befinden.

20. Die CIS-Datenleitung (24) an den Stecker(31) auf der DP-Relaisleiterplatte (M) anschließen.

**Solo DP-771**

19. Fissare la scheda DP Relay PWB (M). Fissarla con la staffa (28) e le due viti (27) rimosse al punto 17.

**Solo DP-772**

19. Fissare la scheda DP Relay PWB (M). Fissarla con le due viti M3 x 8 (N) fornite con l'alimentatore DP-772.

20. Inserire la linea dati CIS (24) nel connettore(31) sulla scheda a circuiti stampati di comunicazione DP (M).

**仅限 DP-771**

19. 固定 DP 中继板 (M)。使用在步骤 17 中取下的金属板 (28) 和 2 颗螺丝 (27) 来固定。

**仅限 DP-772**

19. 固定 DP 中继板 (M)。使用 DP-772 附带的 2 颗 M3X8 (N) 螺丝来固定。

20. 将 CIS 数据线 (24) 连接到 DP 中继电路板 (M) 上的接插件 (31) 上。

**DP-771 만**

19. DP 중계 PWB (M) 를 고정합니다 . 단계 17 에서 분리한 브래킷 (28) 과 나사 (27) 2 개로 고정합니다 .

**DP-772 만**

19. DP 중계 PWB (M) 를 고정합니다 . DP-772 와 함께 공급된 나사 M3x8(N) 2 개를 사용하여 고정합니다 .

20. DP 중계기판 (M) 상의 커넥터 (31) 에 CIS 데이터 라인 (24) 을 연결합니다 .

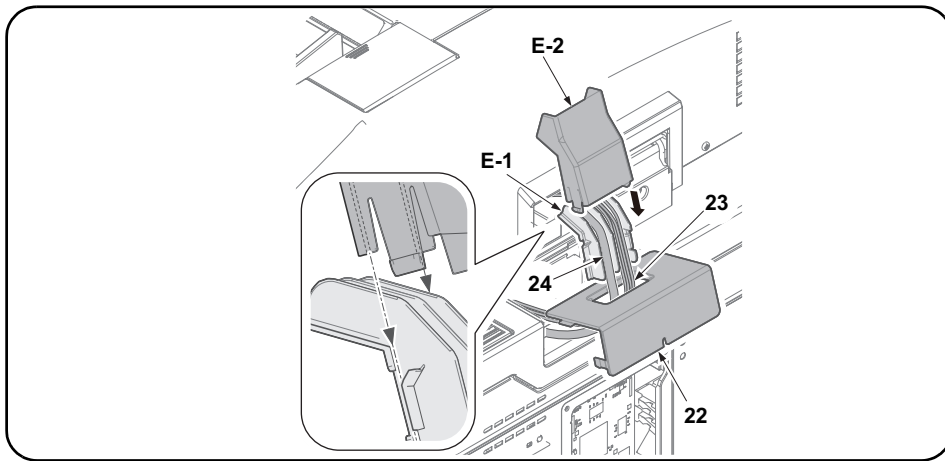
**DP-771のみ**

19. DP 中继基板 (M) を固定する。手順 17 で外した板金 (28) とビス (27) 2 本で固定する。

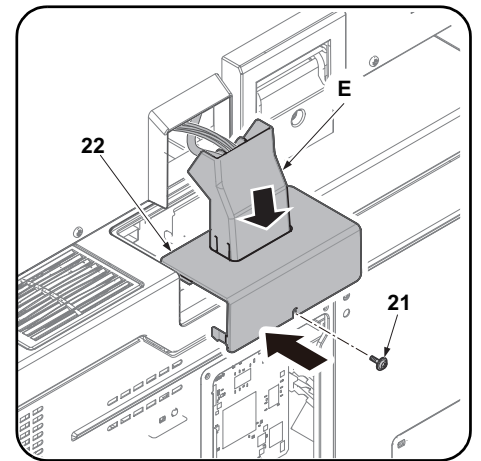
**DP-772のみ**

19. DP 中继基板 (M) を固定する。DP-772 に同梱のビス M3x8(N) 2 本で固定する。

20. DP 中继基板 (M) 上のコネクタ (31) に CIS データ線 (24) を接続する。



21. Pass the DP signal line cable (23) along the groove in the DP cable cover 1 (E-1). Pass the CIS data line cable (24) along the other groove. Install the DP cable cover 2 (E-2).



22. Attach the DP cable cover (E) to the DP cable connection cover (22) and install the DP cable connection cover (22) using the screw (21) removed in step 14.  
23. Install the DP relay PWB cover (20) using the four screws (19) removed in step 13.

**NOTICE**

To avoid image problems that may be caused when the both of the DP signal line cable (23) and CIS data line cable (24) were passed through in a same groove, be sure to slip the individual line in a separate groove as shown in the figure.

21. Passez le câble de la ligne du signal DP (23) dans la rainure du couvercle 1 du câble DP (E-1). Passez le câble de ligne de données CIS (24) dans l'autre rainure. Installez le couvercle 2 du câble DP (E-2).

22. Fixer le couvercle du câble du DP (E) sur le couvercle de la connexion du câble du DP (22) et installer le couvercle de la connexion du câble du DP (22) à l'aide de la vis (21) déposée à l'étape 14.  
23. Installez le couvercle du circuit imprimé du relais du DP (20) à l'aide des quatre vis (19) retirées à l'étape 13.

**REMARQUE**

Pour éviter les problèmes d'image pouvant être causés lorsque le câble de ligne de signal DP (23) et le câble de ligne de données CIS (24) ont été passé dans une même rainure, assurez-vous de glisser chaque ligne dans une rainure à part comme indiqué sur la figure.

21. Pase el cable de línea de señales del DP (23) a lo largo de la ranura de la cubierta de cables 1 del DP (E-1). Pase el cable de línea de datos de CIS (24) a lo largo de la otra ranura. Instale la cubierta de cables 2 del DP (E-2).

22. Fije la cubierta del cable del DP (E) a la cubierta de conexión del cable del DP (22) e instale la cubierta de conexión del cable del DP (22) usando el tornillo (21) quitado en el paso 14.  
23. Instale la cubierta de PWB del relé del DP (20) con los cuatro tornillos (19) que quitó en el paso 13.

**AVISO**

Para evitar posibles problemas de imagen como consecuencia de pasar tanto el cable de línea de señales del DP (23) como el cable de línea de datos de CIS (24) a lo largo de la misma ranura, asegúrese de pasar cada una de las líneas por una ranura distinta como se muestra en la imagen.

21. Führen Sie die Signalleitung (23) des DP durch die Nut der Steckerabdeckung 1 (E-1) des DP. Verlegen Sie die Datenleitung der CIS (24) durch die andere Nut. Befestigen Sie die Steckerabdeckung 2 (E-2) des DP.

22. Die DP-Kabelabdeckung (E) an der Abdeckung (22) des DP-Kabelanschlusses anbringen und die Abdeckung (22) des DP-Kabelanschlusses mittels der in Schritt 14 entfernten Schraube (21) befestigen.  
23. Bringen Sie die Abdeckung (20) der DP-Verbindungsplatine wieder an. Benutzen Sie die Schraube (19) aus Schritt 13.

**ANMERKUNG**

Um Probleme mit der Bildqualität zu vermeiden, die entstehen können, wenn die Signalleitung (23) des DP und die Datenleitung der CIS (24) durch die gleiche Nut geführt werden, stellen Sie sicher, dass jede Leitung in einer getrennten Nut geführt wird, wie in dem Bild gezeigt.

21. Far passare il cavo di linea del segnale DP (23) lungo la scanalatura sul coperchio del cavo DP 1 (E-1). Far passare il cavo di linea dei dati CIS (24) lungo l'altra scanalatura. Installare il coperchio del cavo DP 2 (E-2).

22. Fissare il coperchio del cavo DP (E) al coperchio di connessione del cavo DP (22), e quindi installare il coperchio di connessione del cavo DP (22) utilizzando la vite (21) rimossa nel passo 14.  
23. Installare il coperchio della scheda a circuiti stampati di comunicazione DP (20) utilizzando le quattro viti (19) rimosse al punto 13.

**AVVISO**

Per evitare i problemi di immagine che si verificano quando il cavo di linea del segnale DP (23) e il cavo di linea dei dati CIS (24) vengono fatti passare nella stessa scanalatura, ricordarsi di far passare questi due cavi in scanalature separate come indicato in figura.

21. 将 DP 信号线 (23) 穿过 DP 电缆盖板 1 (E-1) 的槽, 再把 CIS 数据线 (24) 穿过别的槽。安装 DP 电缆盖板 2 (E-2)。

22. 将 DP 电缆盖板 (E) 安装到 DP 电缆连接盖板 (22) 上, 使用步骤 14 中拆下的 1 颗螺丝 (21) 来安装 DP 电缆连接盖板 (22)。  
23. 使用在步骤 13 取下的 4 颗螺丝 (19) 来安装 DP 中继板的盖板 (20)。

**注意**

如将 DP 信号线 (23) 和 CIS 数据线 (24) 穿过同一个槽, 可能会出现图像异常, 因此必须如图所示分别穿过左右两侧的槽。

21. DP 케이블 커버 1(E-1) 의 홈을 따라 DP 시그널 라인 케이블 (23) 을 통과시킵니다 . 다른 홈을 따라 CIS 데이터 라인 케이블 (24) 을 통과시킵니다 . DP 케이블 커버 2(E-2) 를 설치합니다 .

22. DP 케이블 커버 (E) 를 DP 케이블 연결 커버 (22) 에 부착하고 스텝 14 에서 제거한 나사 (21) 1 개로 DP 케이블 연결 커버 (22) 를 부착합니다 .  
23. 13 단계에서 분리한 나사 (19) 4 개를 사용하여 DP 중계기판 커버 (20) 를 설치합니다 .

**주의**

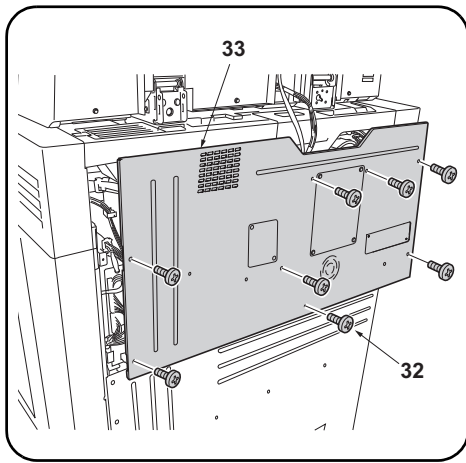
DP 시그널 라인 케이블 (23) 과 CIS 데이터 라인 케이블 (24) 을 같은 홈에 통과시키는 경우 화상 문제가 발생할 수 있으므로 그림과 같이 반드시 선을 따로 넣도록 하십시오 .

21. DP 케이블 커버 1(E-1) 의 홈에 DP 신호선 (23) 을 통과시킵니다 . 다른 홈에 CIS 데이터선 (24) 을 통과시킵니다 . DP 케이블 커버 2(E-2) 를取り付けます .

22. DP 케이블 커버 (E) 를 DP 케이블 연결 커버 (22) 에取り付けます . 手順 14 で外したビス (21) 1 本で DP 케이블 연결 커버 (22) を取り付けます .  
23. 手順 13 で外したビス (19) 4 本で, DP 中継基板 커버 (20) を取り付けます .

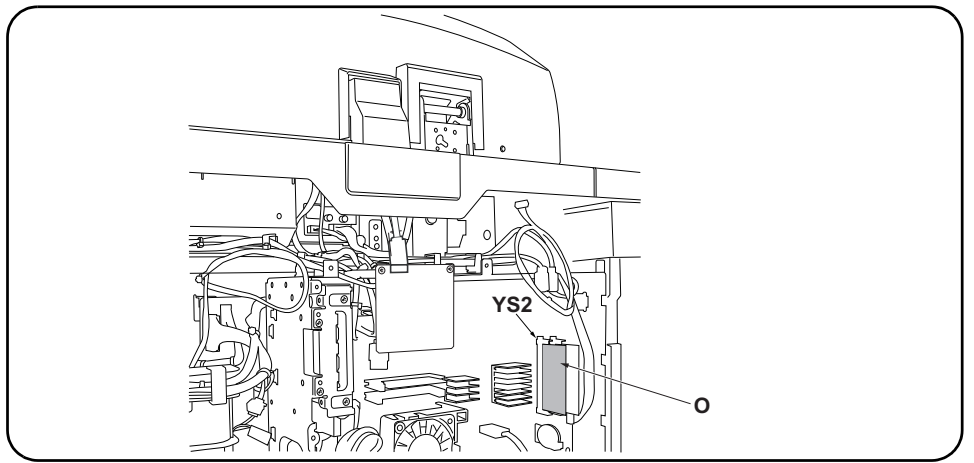
**注意**

DP 신호선 (23) と CIS 데이터선 (24) 을 同じ 홈에 통과시킵니다 는 異常画像が発生する可能性があるため, 図の様に左右の 홈에 別々に 入れること .



**Steps for expanding the memory DIMM (1GB)(35, 45 and 55 ppm monochrome machines only) (DP-771 only)**

24. Remove the 8 screws (32) and remove the upper rear cover (33) of the MFP.



25. Insert the memory DIMM (O) into the memory slot (YS2) of the main PWB.  
(Insert all the way until it clicks)  
26. Replace the upper rear cover (33) of the MFP using the 8 screws (32).

**Opérations pour l'expansion de la mémoire DIMM (1GB) (machines monochromes 35, 45 et 55 ppm uniquement)(DP-771 uniquement)**

24. Déposer les 8 vis (32) et déposer le couvercle arrière supérieur (33) du MFP.

25. Insérer la mémoire DIMM (O) dans la fente mémoire (YS2) de la carte de CI principale.  
(Insérer à fond jusqu'au clic)  
26. Reposer le couvercle arrière supérieur (33) sur le MFP à l'aide des 8 vis (32).

**Pasos para ampliar la memoria DIMM (1GB) (máquinas monocromáticas de 35, 45 y 55 ppm solamente) (DP-771 solamente)**

24. Quite los 8 tornillos (32) y quite la cubierta trasera superior (33) del MFP.

25. Inserte la memoria DIMM (O) en la ranura para memoria (YS2) en el PWB principal.  
(Insértela hasta escuchar un clic)  
26. Vuelva a colocar la cubierta trasera superior (33) del MFP usando los 8 tornillos (32).

**Schritte zur Aufrüstung der DIMM-Speichermodule (1GB) (nur 35, 45 und 55 ppm Monochrommaschinen) (nur DP-771)**

24. Die 8 Schrauben (32) entfernen und die obere hintere Abdeckung (33) des MFP abnehmen.

25. Setzen Sie das DIMM-Speichermodul (O) in die Speicherbank (YS2) der Hauptleiterplatte ein.  
(Drücken Sie sie bis zum Einrasten ein.)  
26. Die obere hintere Abdeckung (33) des MFP wieder mit den 8 Schrauben (32) anbringen.

**Passi per l'espansione della memoria DIMM (1GB) (solo per le macchine monocromatiche 35, 45 e 55 ppm) (solo DP-771)**

24. Rimuovere le 8 viti (32) e quindi rimuovere il coperchio superiore posteriore (33) dell'MFP.

25. Inserire la memoria DIMM (O) nello slot della memoria (YS2) sulla scheda principale PWB.  
(Inserire completamente finché non scatta in posizione con un clic)  
26. Ricollocare il coperchio superiore posteriore (33) dell'MFP utilizzando le 8 viti (32).

**内存卡 (1GB) 的增加步骤 (仅对于 35 张、45 张和 55 张的黑白机) (仅限 DP-771)**

24. 拆除 8 颗螺丝 (32), 拆下 MFP 的后上方盖板 (33)。

25. 把内存卡 (O) 插入主板的内存插槽 (YS2)。  
(插到底部, 直到发出咔嚓声为止)  
26. 使用 8 颗螺丝 (32) 按原样安装 MFP 的后上方盖板 (33)。

**메모리 DIMM (1GB) 의 증설순서 (흑백기 35매, 45매, 55매만) (DP-771만)**

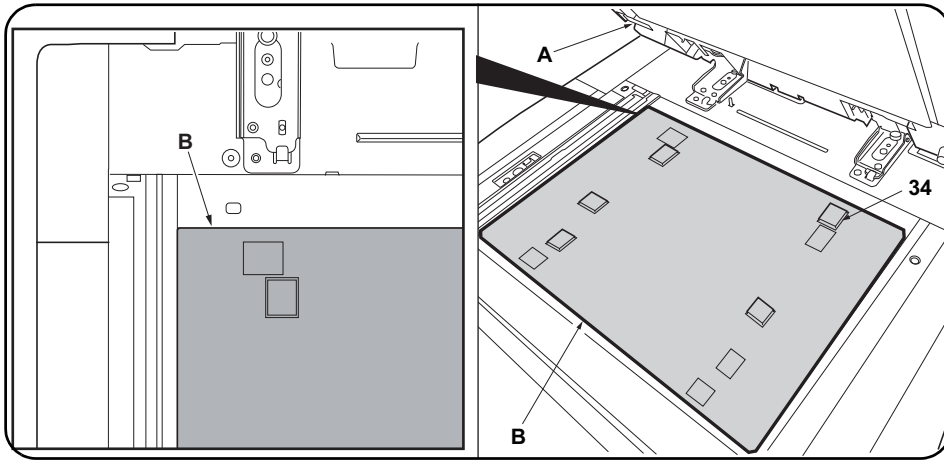
24. 나사 (32) 8 개를 제거하고 MFP 의 후면 상단커버 (33) 를 떼어 냅니다 .

25. 주 회로기판의 메모리 슬롯 (YS2) 에 메모리 DIMM(O) 을 삽입합니다 .  
(딸깍하고 소리가 날 때까지 삽입할 것 .)  
26. 나사 (32) 8 개로 MFP 후면 상단 커버 (33) 를 원래대로 부착합니다 .

**メモリーDIMM(1GB) の増設手順 (モノクロ機の 35 枚機、45 枚機、55 枚機のみ) (DP-771 のみ)**

24. ビス (32) 8 本を外し、MFP の後上カバー (33) を取り外す。

25. 主回路基板のメモリースロット (YS2) にメモリーDIMM(O) を挿入する。  
(カチッと音がするまで挿入すること)  
26. ビス (32) 8 本で、MFP の後上カバー (33) を元通り取り付けます。



#### Fasten the original mat.

27. Place original mat (B) with its Velcro (34) upward over the contact glass.

**Align original mat (B) corner that has 90 degrees of angle with the inner left corner of the original instruction panel.**

28. Close DP (A) and attach original mat (B) onto it with Velcro.

#### Fixer la plaque d'original.

27. Placer la plaque d'original (B) sur la vitre d'exposition, en orientant les bandes Velcro (34) vers le haut.

**Aligner le coin du plateau d'original (B) faisant un angle de 90 degrés avec le coin gauche interne du panneau d'instructions d'original.**

28. Abaisser le DP (A) et y fixer la plaque d'original (B) à l'aide des bandes Velcro.

#### Fije la alfombrilla para originales.

27. Coloque la alfombrilla para originales (B) con el velcro (34) hacia arriba sobre el cristal de contacto.

**Alinee la esquina que tiene un ángulo de 90 grados de la alfombrilla para originales (B) con la esquina interior izquierda del panel de instrucciones para el original.**

28. Cierre el DP (A) y fije la alfombrilla para originales (B) con el velcro.

#### Befestigen der Originalmatte.

27. Die Originalmatte (B) mit dem Klettband (34) nach oben über das Kontaktglas legen.

**Die Ecke der Originalmatte (B), die einen 90-Grad-Winkel aufweist, mit der linken, inneren Kante des Originalbedienfeldes ausrichten.**

28. Den DP (A) schließen und die Originalmatte (B) mit dem Klettband auf ihm befestigen.

#### Fissaggio del tappetino originale.

27. Posizionare il tappetino originale (B) con il velcro (34) rivolto verso l'alto sul vetro di appoggio.

**Allineare l'angolo di 90 gradi del coprioriginale (B) con l'angolo interno sinistro del pannello di controllo originale.**

28. Chiudere il DP (A) e applicarvi il tappetino originale (B) con il velcro.

#### 粘貼原稿墊。

27. 將原稿墊 (B) 放置在稿台玻璃上，并使魔术貼 (34) 向上。

**將原稿墊 (B) 的 90 度角對准原稿指示板的內部左角。**

28. 關閉 DP (A)，使原稿墊 (B) 粘貼到 DP 上。

#### 원고매트 부착

27. 벨크로 (34) 를 위로 향하게 하고 원고매트 (B) 를 원고대 유리판에 놓습니다 .

**원고매트 (B) 는 90° 가 되어 있는 각을 원고 안내판의 좌측 안에 맞출 것 .**

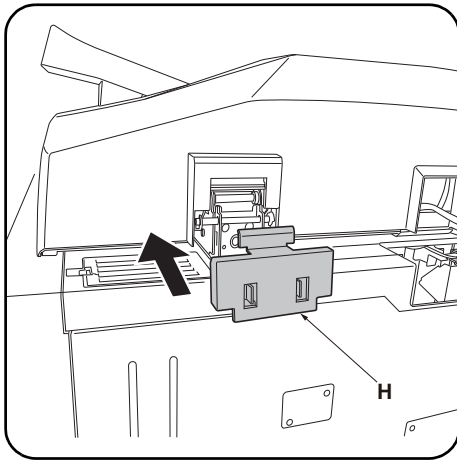
28. DP(A) 를 내리고 원고매트 (B) 를 DP(A) 에 부착합니다 .

#### 原稿マットの貼り付け

27.マジックテープ (34) を上に向けて、原稿マット (B) をコンタクトガラス上に置く。

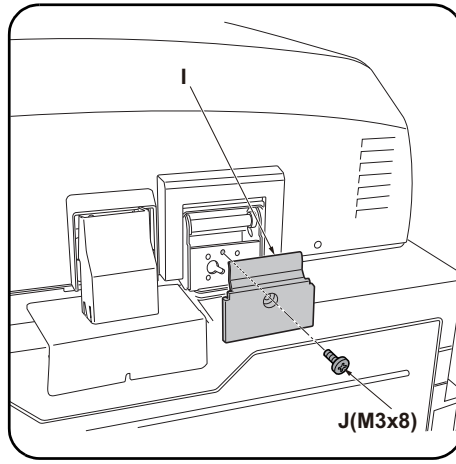
**原稿マット (B) は 90° になっている角を原稿指示板の左奥に合わせること。**

28. DP (A) を下ろし、原稿マット (B) を DP (A) に貼り付ける。



**Installing the hinge cover (DP-771/772 only)**  
For the DP-770(B), proceed to step 31 on page 15.

**29.** Install the left hinge cover (H).



**30.** Install the right hinge cover (I) using the M3 × 8 screw BLACK (J).

**Installation des couvercles de charnière (DP-771/772 uniquement)**

Pour le DP-770(B), passer à l'étape 31 de la page 15.

**29.** Installer le couvercle de la charnière gauche (H).

**30.** Installer le couvercle de la charnière droite (I) à l'aide de la vis M3 × 8 NOIRE (J).

**Instalación de la cubierta de las bisagras (DP-771/772 solamente)**

Para el DP-770(B), vaya al paso 31 de la página 15.

**29.** Instale la cubierta de la bisagra izquierda (H).

**30.** Instale la cubierta de la bisagra derecha (I) usando el tornillo M3 × 8 NEGRO (J).

**Installieren der Scharnierabdeckung (nur DP-771/772)**

Beim DP-770(B) gehen Sie zum Schritt 31 auf Seite 15 weiter.

**29.** Die linke Scharnierabdeckung (H) anbringen.

**30.** Die rechte Scharnierabdeckung (I) mit der M3 × 8 Schraube SCHWARZ (J) anbringen.

**Installazione del coperchio cerniera (solo DP-771/772)**

Per DP-770(B), procedere con il punto 31 a pagina 15.

**29.** Installare il coperchio cerniera sinistra (H).

**30.** Installare il coperchio cerniera destra (I) utilizzando la vite M3 × 8 NERA (J).

**安装铰链盖板 (仅限 DP-771/772)**

DP-770(B) 跳至 P15 的步骤 31。

**29.** 安装左部铰链盖板 (H)。

**30.** 使用 1 颗 M3×8 螺丝 BLACK (J) 来安装右部铰链盖板 (I)。

**힌지커버 부착 (DP-771/772 만)**

DP-770(B) 은 P15 의 순서 31 으로 진행 .

**29.** 좌측 힌지커버 (H) 를 부착합니다 .

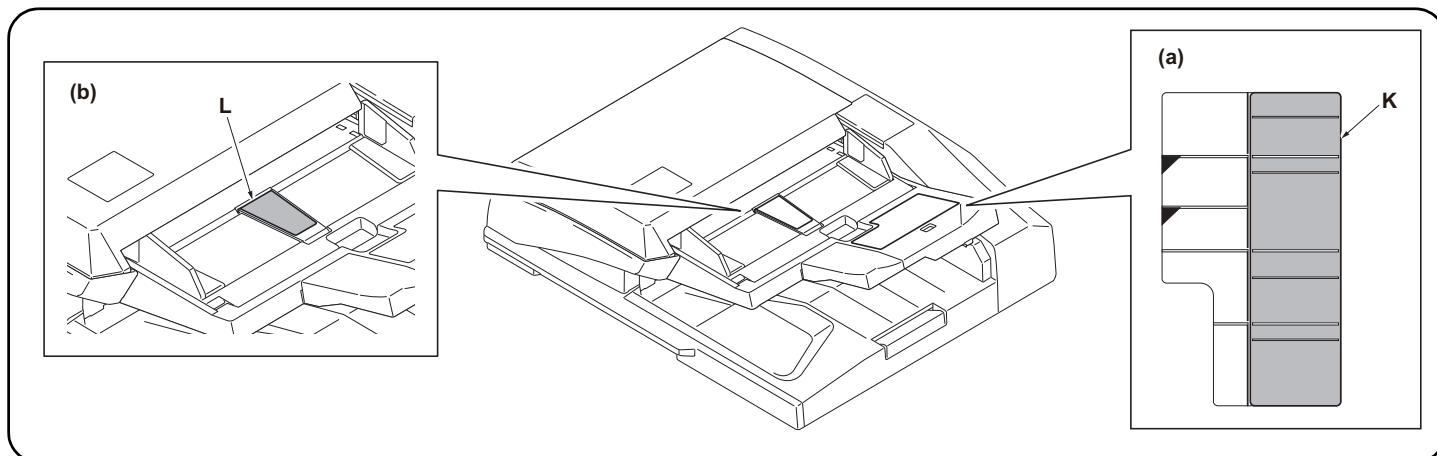
**30.** 나사 M3×8BLACK(J) 1 개로 우측 힌지커버 (I) 를 부착합니다 .

**ヒンジカバーの取り付け (DP-771/772 のみ)**

DP-770(B) は、P15 の手順 31 に進む。

**29.** 左ヒンジカバー (H) を取り付ける。

**30.** ビス M3×8BLACK (J) 1 本で右ヒンジカバー (I) を取り付ける。



#### Adhere the label

31. Clean the label on the original table with alcohol.

32. Adhere Label "Operation procedure" (K) of which the language corresponding to the destination of the MFP onto the existing label on the original table. Figure (a)

33. Adhere Caution label "Original face up!" (L) of which the language corresponding to the destination of the MFP onto the label on the original table. Figure (b)

#### Coller l'étiquette relative

31. Avec de l'alcool, nettoyer l'étiquette se trouvant sur le plateau d'original.

32. Coller l'étiquette "Processus opératoire" (K) dans la langue correspondant au destinataire du MFP sur l'étiquette existante sur le plateau d'original du DP. Figure (a)

33. Coller l'étiquette de mise en garde "Original en haut!" (L) dans la langue correspondant au destinataire du MFP sur l'étiquette du plateau d'original. Figure (b)

#### Pegue la etiqueta

31. Limpie con alcohol la etiqueta de la cubierta de originales.

32. Adhiera la etiqueta "Procedimiento operativo" (K) del idioma correspondiente al destino del MFP sobre la etiqueta que se encuentra sobre la cubierta de originales. Figura (a)

33. Pegue la etiqueta de precaución "¡La cara del original hacia arriba!" (L), del idioma que corresponde al destino del MFP, sobre la etiqueta en la cubierta de originales. Figura (b)

#### Anbringen des Schildes

31. Das Schild auf dem Originalbedienfeld mit Alkohol reinigen.

32. Das Schild „Funktionsanweisung“ (K) in der Sprache des jeweiligen Einsatzlandes des MFP auf das vorhandene Schild auf dem Originalbedienfeld aufkleben. Abbildung (a)

33. Das Warnschild „Originalschriftseite nach oben!“ (L) in der Sprache des jeweiligen Einsatzlandes des MFP auf das vorhandene Schild auf dem Originalbedienfeld aufkleben. Abbildung (b)

#### Applicazione dell'etichetta

31. Pulire con alcool l'etichetta sul piano originale.

32. Far aderire l'etichetta "Procedura di funzionamento" (K) corrispondente alla lingua di destinazione dell'MFP, sull'etichetta esistente sul piano originale. Figura (a)

33. Far aderire l'etichetta di avvertenza "Originale rivolto verso l'alto!" (L) corrispondente alla lingua di destinazione dell'MFP, sull'etichetta del piano originale. Figura (b)

#### 粘貼标签

31. 不需要本步骤。

32. 不需要本步骤。

33. 不需要本步骤。

#### 라벨 부착

31. 이 단계가 필요하지 않습니다 .

32. 이 단계가 필요하지 않습니다 .

33. 이 단계가 필요하지 않습니다 .

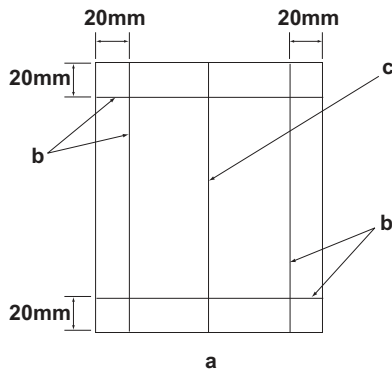
#### ラベルの貼り付け

31. この作業は不要。

32. この作業は不要。

33. この作業は不要。





#### [Operation check]

1. To check the machine operation, prepare original (a) where 4 lines (b) are drawn 20 mm from the edges of the A3 sheet and 1 line (c) is drawn at its center.
2. Connect the power plug of the MFP into the wall outlet and turn the main power switch on.
3. Set the original (a) on the DP and perform a test copy to check the operation and the copy example.

#### [Vérification du fonctionnement]

1. Pour vérifier le bon fonctionnement de l'appareil, préparer un original (a) sur lequel sont tracées 4 lignes (b) à 20 mm des bords de la feuille A3 et 1 ligne (c) en son axe.
2. Brancher la fiche d'alimentation du MFP sur la prise murale et mettre l'appareil sous tension.
3. Placer l'original (a) sur le DP et effectuer une copie de test pour vérifier le fonctionnement et l'exemple de copie.

#### [Verifique el funcionamiento]

1. Para comprobar el funcionamiento del aparato, prepare un original (a) que contenga 4 líneas (b) dibujadas a 20 mm de los bordes de la hoja A3 y 1 línea (c) dibujada en el centro.
2. Conecte el enchufe eléctrico del MFP en el tomacorriente de la pared y encienda el interruptor principal.
3. Coloque el original (a) en el DP y haga una copia de prueba para verificar el funcionamiento y el ejemplo de copia.

#### [Funktionsprüfung]

1. Zum Prüfen der Gerätefunktion das Original (a) vorbereiten, auf das 4 Linien (b) 20 mm von den Kanten des A3-Blattes und 1 Linie (c) in der Mitte gezeichnet sind.
2. Den Netzstecker am MFP in die Steckdose stecken und den Strom einschalten.
3. Das Original (a) auf den DP legen und eine Testkopie erstellen, um die Funktion und das Kopierbeispiel zu prüfen.

#### [Verifica del funzionamento]

1. Per verificare il funzionamento della macchina, preparare l'originale (a) tirando 4 linee (b) a 20 mm dai bordi del foglio A3 e una linea (c) al centro.
2. Inserire la spina dell'alimentazione dell'MFP nella presa a muro, quindi posizionare l'interruttore principale su On.
3. Posizionare l'originale(a) sul DP ed eseguire una copia di prova per verificare il funzionamento e l'esempio di copia.

#### [動作確認]

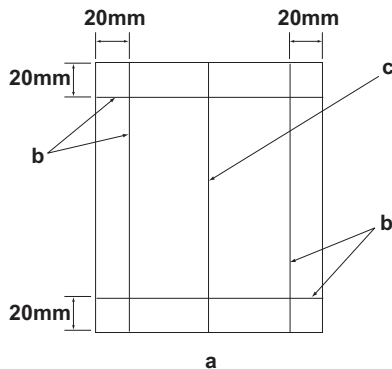
1. 若要检查机器动作, 准备一张 A3 原稿 (a), 距纸张边缘 20mm 画出 4 条线 (b) 并且在原稿中心画出 1 条线 (c)。
2. 将 MFP 的电源插头插入墙壁插座并打开主电源。
3. 在 DP 上设定原稿 (a) 并进行测试复印, 确认机器动作和复印样本。

#### [동작확인]

1. 기계 작동 확인을 위해서, A3 용지 선단에서 20mm 떨어진 곳에 4 개의 선 (b) 과 센터에 1 개의 선 (c) 이 그려진 원고 (a) 를 준비.
2. 콘센트에 MFP 전원플러그를 꽂고 메인 전원 스위치를 ON 으로 합니다.
3. DP 상에 원고 (a) 를 준비하고 테스트 카피를 확인하여 작동 상태와 카피 샘플을 확인합니다.

#### [動作確認]

1. A3 サイズ用紙の端から 20mm の位置に線 (b) 4 本と、用紙の中心に線 (c) 1 本を引いた、動作確認用の原稿 (a) を用意する。
2. MFP の電源プラグをコンセントに差し込み、主電源スイッチを ON にする。
3. 原稿 (a) を DP にセットし、テストコピーを行い、動作およびコピーサンプルを確認する。



4. Compare original (a) with the copy example. If the gap exceeds the reference value, perform the following adjustments according to the type of the gap.

**Check images of the DP after checking and adjusting images of the MFP. For details, see the service manual.**

**NOTICE:** If there is any image fogging, adjust the U068 DP scanning position. If you change the scanning position with U068, adjust the U071 DP leading edge timing.

4. Comparer l'original (a) avec l'exemple de copie. Si l'écart excède la valeur de référence, effectuer les réglages suivants en fonction du type d'écart.

**Vérifier les images du DP après avoir contrôlé et réglé les images du MFP. Pour plus de détails, se reporter au manuel d'entretien.**

**REMARQUE:** Si l'image est floue, régler la position de balayage de U068 du DP. Si la position de balayage de U068 est modifiée, régler la synchronisation du bord d'attaque de U071.

4. Compare el original (a) con el ejemplo de copia. Si la separación supera el valor de referencia, realice los siguientes ajustes según el tipo de separación.

**Compruebe las imágenes del DP después de comprobar y ajustar las imágenes del MFP. Para más detalles, lea el manual de servicio.**

**AVISO:** Si la imagen estuviera borrosa, ajuste la posición de escaneo U068 del DP. Si cambia la posición de escaneo con U068, ajuste la sincronización de borde superior U071 del DP

4. Das Original (a) mit dem Kopierbeispiel vergleichen. Wenn der Abstand größer als der Bezugswert ist, die folgenden Einstellungen gemäß dem Abstandstyp durchführen.

**Die Bilder des DP nach dem Prüfen und Einstellen der Bilder des MFP prüfen. Weitere Einzelheiten siehe Wartungsanleitung.**

**ANMERKUNG:** Falls das Bild verschwommen wirkt, ist die U068 DP Scan-Position zu verstellen. Wenn Sie die Scan-Position mit U068 verstellen, müssen Sie das U071 DP-Vorderkanten-Timing entsprechend verstellen.

4. Confrontare l'originale (a) con l'esempio di copia. Se lo scostamento supera il valore di riferimento, eseguire le seguenti regolazioni in funzione del tipo di scostamento.

**Controllare le immagini del DP dopo avere effettuato i controlli e le regolazioni delle immagini sull'MFP. Per ulteriori dettagli leggere il manuale d'istruzioni.**

**AVVISO:** Se è presente una qualsiasi sfocatura dell'immagine, regolare la posizione di scansione DP U068. Se si cambia la posizione di scansione con U068, regolare la sincronizzazione del bordo principale DP U071.

4. 对比复印样本和原稿(a), 如果偏移值在标准值以上时, 对偏移原稿进行调整。

对 MFP 的图像确认和调整后再对 DP 的图像进行确认。详细内容请参见维修手册。

(注意) 如果图像出现底灰, 用 U068 来调整 DP 的扫描位置。如果用 U068 更改了扫描位置, 则再用 U071 对 DP 的前端定时进行调整

4. 원고 (a) 와 카피 샘플을 비교하여 차이가 기준치를 벗어나는 경우, 차이 (틈) 의 형태에 따라 다음을 조정합니다 .

**MFP 의 화상확인 및 조정을 하고나서 DP 의 화상확인을 할 것 . 상세는 서비스 매뉴얼을 참조할 것 .**

(주의) 화상 카브리가 발생하는 경우 , U068DP 스캔위치 조정을 합니다 . U068 에서 스캔위치를 변경한 경우 U071DP 선단 타이밍 조정을 합니다 .

4. 原稿 (a) とコピーサンプルを比較し、基準値以上のずれがある場合、ずれ方に応じて調整を行う。

MFP の画像確認及び調整を行ってから DP の画像確認を行うこと。詳細はサービスマニュアルを参照のこと。

(注意)画像カブリが発生する場合、U068 DP 読み取り位置の調整を行う。U068 で読み取り位置を変更した場合、U071 DP 先端タイミング調整を行う。



Be sure to adjust in the following order. If not, the adjustment cannot be performed correctly.

For checking the angle of leading edge, see page 20. <Reference value> Simplex copying: within  $\pm 3.0$  mm; Duplex copying: within  $\pm 4.0$  mm

For checking the angle of trailing edge, see page 23. <Reference value> Simplex copying: within  $\pm 3.0$  mm; Duplex copying: within  $\pm 4.0$  mm

**When using the original for adjustment, automatic adjustment of magnification, leading edge timing and center line can be performed at a time.**

For the automatic adjustment using the original for adjustment, see page 26.

---

Veillez à effectuer le réglage en procédant dans l'ordre suivant. Sinon, il sera impossible d'obtenir un réglage correct.

Pour vérifier l'angle du bord avant, reportez-vous à la page 20. <Valeur de référence> Copie recto seul:  $\pm 3,0$  mm max.; copie recto verso:  $\pm 4,0$  mm max.

Pour vérifier l'angle du bord arrière, reportez-vous à la page 23. <Valeur de référence> Copie recto seul:  $\pm 3,0$  mm max.; copie recto verso:  $\pm 4,0$  mm max.

**Lorsque vous utilisez l'original pour effectuer le réglage, vous pouvez effectuer automatiquement le réglage de l'agrandissement, de la synchronisation du bord avant et de la ligne médiane en une seule fois.**

Pour le réglage automatique en utilisant l'original pour effectuer le réglage, reportez-vous à la page 26.

---

Asegúrese de ajustar en el siguiente orden. De lo contrario, el ajuste no puede hacerse correctamente.

Para verificar el ángulo del borde superior, vea la página 20. <Valor de referencia> Copia simple: dentro de  $\pm 3,0$  mm; Copia duplex: dentro de  $\pm 4,0$  mm

Para verificar el ángulo del borde inferior, vea la página 23. <Valor de referencia> Copia simple: dentro de  $\pm 3,0$  mm; Copia duplex: dentro de  $\pm 4,0$  mm

**Cuando utilice el original para el ajuste, puede hacerse un ajuste automático del cambio de tamaño, sincronización del borde superior y línea central al mismo tiempo.**

Para el ajuste automático utilizando el original para el ajuste, vea la página 26.

---

Die Einstellung in der folgenden Reihenfolge durchführen. Anderenfalls kann die Einstellung nicht korrekt durchgeführt werden.

Angaben zur Prüfung des Winkels der Vorderkante auf Seite 20. <Bezugswert> Simplexkopie: innerhalb  $\pm 3,0$  mm; Duplexkopie: innerhalb  $\pm 4,0$  mm

Angaben zur Prüfung des Winkels der Hinterkante auf Seite 23. <Bezugswert> Simplexkopie: innerhalb  $\pm 3,0$  mm; Duplexkopie: innerhalb  $\pm 4,0$  mm

**Bei Verwendung des Originals für die Einstellung können die automatischen Einstellungen für Vergrößerung, Vorderkanten-Timing und Mittellinie gleichzeitig durchgeführt werden.**

Angaben zur automatischen Einstellung mithilfe des Originals auf Seite 26.

---

Accertarsi di eseguire le regolazioni in questa sequenza: in caso contrario, la regolazione non può essere effettuata correttamente.

Per controllare l'angolo del bordo principale, vedere pagina 20. <Valore di riferimento> Copia simplex: entro  $\pm 3,0$  mm; Copia duplex: entro  $\pm 4,0$  mm

Per controllare l'angolo del bordo di uscita, vedere pagina 23. <Valore di riferimento> Copia simplex: entro  $\pm 3,0$  mm; Copia duplex: entro  $\pm 4,0$  mm

**Quando si utilizza l'originale per la regolazione, la regolazione automatica dell'ingrandimento, della sincronizzazione del bordo principale e della linea centrale possono essere eseguiti contemporaneamente.**

Per la regolazione automatica eseguita con l'originale, vedere pagina 26.

---

必须按照以下步骤进行调整, 否则不能达到准确调整的要求。

• 确认前端倾斜度 第 20 页 <标准值> 单面:  $\pm 3.0$ mm 以内, 双面:  $\pm 4.0$ mm 以内

• 确认后端倾斜度 第 23 页 <标准值> 单面:  $\pm 3.0$ mm 以内, 双面:  $\pm 4.0$ mm 以内

**使用调整用的原稿时, 可以同时自动进行等倍值, 前端定时以及中心线的调整。**

• 通过调整用原稿进行自动调整 第 26 页

---

반드시 하기의 순서로 조정을 할 것. 순서대로 조정을 하지 않는 경우 바른 조정을 할 수 없습니다.

• 선단경사확인 20 페이지 <기준치> 단면:  $\pm 3.0$ mm 이내, 양면:  $\pm 4.0$ mm 이내

• 후단경사확인 23 페이지 <기준치> 단면:  $\pm 3.0$ mm 이내, 양면:  $\pm 4.0$ mm 이내

**조정용 원고를 사용하는 경우, 등배도, 선단타이밍, 센터 라인의 자동조정이 한번에 수행됩니다.**

• 조정용 원고를 사용한 자동조정은 26 페이지 참조

---

必ず下記の順序で調整を行うこと。順序通りに調整を行わない場合、正しい調整ができない。

• 先端斜め確認 20 ページ <基準値> 片面:  $\pm 3.0$ mm 以内、両面:  $\pm 4.0$ mm 以内

• 後端斜め確認 23 ページ <基準値> 片面:  $\pm 3.0$ mm 以内、両面:  $\pm 4.0$ mm 以内

**調整用原稿を使用すると、等倍度調整、先端タイミング調整、センターライン調整の自動調整が一度におこなえる。**

• 調整用原稿による自動調整 26 ページ

For checking the magnification, see page 29. <Reference value> Within  $\pm 1.5\%$   
For checking the leading edge timing, see page 31. <Reference value> Within  $\pm 2.5$  mm  
For checking the center line, see page 33. <Reference value> Simplex copying: within  $\pm 2.0$  mm;  
Duplex copying: within  $\pm 3.0$  mm

---

Pour vérifier l'agrandissement, reportez-vous à la page 29. <Valeur de référence>  $\pm 1,5\%$  max.  
Pour vérifier la synchronisation du bord avant, reportez-vous à la page 31. <Valeur de référence>  $\pm 2,5$  mm max.  
Pour vérifier la ligne médiane, reportez-vous à la page 33. <Valeur de référence> Copie recto seul:  $\pm 2,0$  mm max.;  
Copie recto verso:  $\pm 3,0$  mm max.

---

Para verificar el cambio de tamaño, vea la página 29. <Valor de referencia> Dentro de  $\pm 1,5\%$   
Para verificar la sincronización del borde inferior, vea la página 31. <Valor de referencia> Dentro de  $\pm 2,5$  mm  
Para verificar la línea central, vea la página 33. <Valor de referencia> Copia simple: dentro de  $\pm 2,0$  mm;  
Copia duplex: dentro de  $\pm 3,0$  mm

---

Angaben zur Prüfung der Vergrößerung auf Seite 29. <Bezugswert> Innerhalb  $\pm 1,5\%$   
Angaben zur Prüfung des Vorderkanten-Timings auf Seite 31. <Bezugswert> Innerhalb  $\pm 2,5$  mm  
Angaben zur Prüfung der Mittellinie auf Seite 33. <Bezugswert> Simplexkopie: innerhalb  $\pm 2,0$  mm;  
Duplexkopie: innerhalb  $\pm 3,0$  mm

---

Per controllare l'ingrandimento, vedere pagina 29. <Valore di riferimento> Entro  $\pm 1,5\%$   
Per controllare la sincronizzazione del bordo principale, vedere pagina 31. <Valore di riferimento> Entro  $\pm 2,5$  mm  
Per controllare la linea centrale, vedere pagina 33. <Valore di riferimento> Copia simplex: entro  $\pm 2,0$  mm;  
Copia duplex: entro  $\pm 3,0$  mm

---

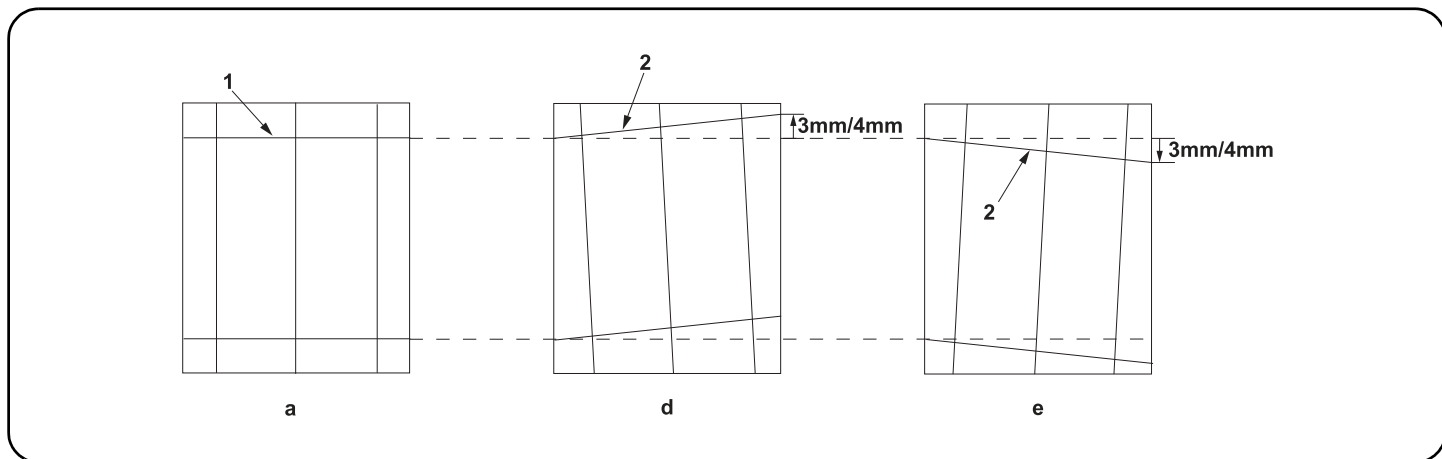
• 确认等倍值 第 29 页 <标准值>  $\pm 1.5\%$  以内  
• 确认前端定时调整 第 31 页 <标准值>  $\pm 2.5$ mm 以内  
• 确认中心线 第 33 页 <标准值> 单面:  $\pm 2.0$ mm 以内,  
双面:  $\pm 3.0$ mm 以内

---

• 등배도 확인 29 페이지 <기준치>  $\pm 1.5\%$  이내  
• 선단 타이밍 확인 31 페이지 <기준치>  $\pm 2.5$ mm 이내  
• 센터 라인 확인 33 페이지 <기준치> 단면:  $\pm 2.0$ mm 이내,  
양면:  $\pm 3.0$ mm 이내

---

• 等倍度確認 29 ページ <基準値>  $\pm 1.5\%$  以内  
• 先端タイミング確認 31 ページ <基準値>  $\pm 2.5$ mm 以内  
• センターライン確認 33 ページ <基準値> 片面:  $\pm 2.0$ mm 以内,  
両面:  $\pm 3.0$ mm 以内



#### [Checking the angle of leading edge]

1. Check the horizontal gap between line (1) of original (a) and line (2) of copy example positions. If the gap exceeds the reference value, adjust the gap according to the following procedure.

- <Reference value> For single copying: The horizontal gap of line (2) should be within  $\pm 3.0$  mm.  
For duplex copying: The horizontal gap of line (2) should be within  $\pm 4.0$  mm.

#### [Vérification de l'angle du bord avant]

1. Vérifier l'écart horizontal entre la position de la ligne (1) de l'original (a) et celle de la ligne (2) de l'exemple de copie. Si l'écart excède la valeur de référence, le régler selon la procédure suivante.

- <Valeur de référence> Pour la copie recto : l'écart horizontal de la ligne (2) doit être de  $\pm 3,0$  mm.  
Pour la copie recto-verso : l'écart horizontal de la ligne (2) doit être de  $\pm 4,0$  mm.

#### [Verificación del ángulo del borde superior]

1. Compruebe la separación horizontal entre la línea (1) del original (a) y la línea (2) de las posiciones del ejemplo de copia. Si la separación supera el valor de referencia, ajústela siguiendo este procedimiento.

- <Valor de referencia> Para el copiado por una cara: la separación horizontal de la línea (2) debe estar dentro de  $\pm 3,0$  mm.  
Para el copiado dúplex: la separación horizontal de la línea (2) debe estar dentro de  $\pm 4,0$  mm.

#### [Überprüfen des Winkels der Vorderkante]

1. Den horizontalen Abstand zwischen der Linie (1) des Originals (a) und der Linie (2) der Kopierbeispielspositionen prüfen. Wenn der Abstand größer als der Bezugswert ist, den Abstand mit dem folgenden Verfahren einstellen.

- <Bezugswert> Einzelkopie: Der horizontale Abstand der Linie (2) sollte innerhalb von  $\pm 3,0$  mm liegen.  
Duplexkopie: Der horizontale Abstand der Linie (2) sollte innerhalb von  $\pm 4,0$  mm liegen.

#### [Controllo dell'angolo del bordo principale]

1. Verificare lo scostamento orizzontale fra la linea (1) dell'originale (a) e la linea (2) delle posizioni dell'esempio di copia. Se lo scostamento supera il valore di riferimento, regolare lo scostamento stesso seguendo questa procedura.

- <Valore di riferimento> Per la copia singola: lo scostamento orizzontale della linea (2) deve limitarsi a  $\pm 3,0$  mm.  
Per la copia duplex: lo scostamento orizzontale della linea (2) deve limitarsi a  $\pm 4,0$  mm.

#### [ 确认前端倾斜度 ]

1. 确认原稿 (a) 上的线 (1) 和复印样本上的线 (2) 的左右偏移值。如果偏移值超过标准值，则按照下列步骤进行调整

- <标准值> 单面复印时，线 (2) 的左右偏移值： $\pm 3.0$ mm 以内。  
双面复印时，线 (2) 的左右偏移值： $\pm 4.0$ mm 以内。

#### [ 선단 경사확인 ]

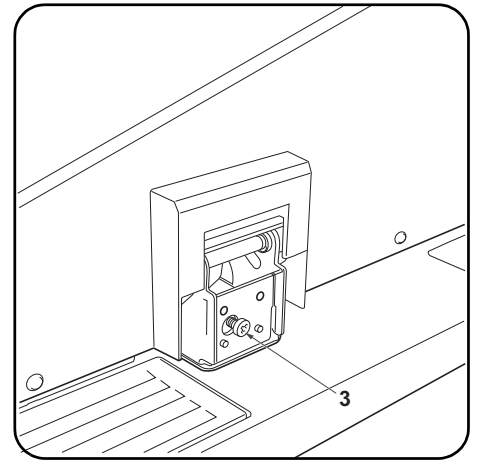
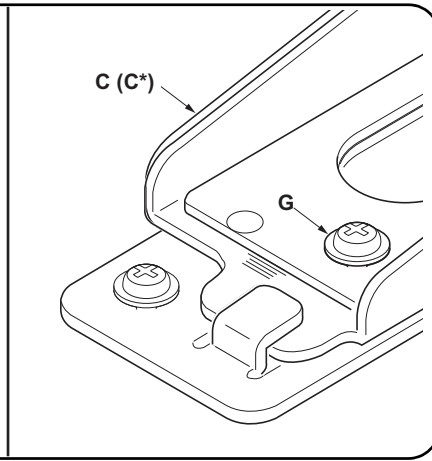
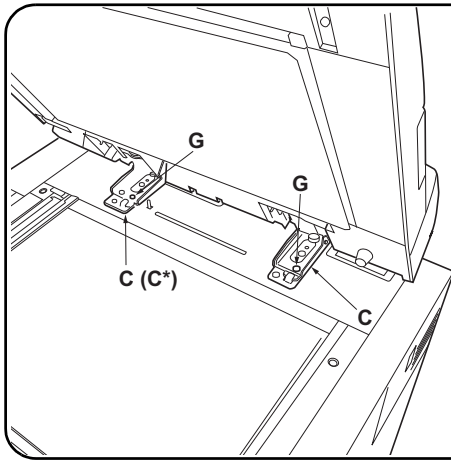
1. 원고 (a) 의 선 (1) 과 샘플 카피의 선 (2) 의 좌우 차이를 확인합니다. 차이가 기준치 외의 경우 다음의 순서대로 조정을 합니다.

- <기준치> 단면의 경우 선 (2) 의 좌우차이： $\pm 3.0$ mm 이내  
양면의 경우 선 (2) 의 좌우차이： $\pm 4.0$ mm 이내

#### [ 先端斜め確認 ]

1. 原稿 (a) の線 (1) とコピーサンプルの線 (2) の左右のずれを確認する。ずれが基準値外の場合、次の手順で調整を行う。

- <基準値> 片面の場合、線 (2) の左右ずれ： $\pm 3.0$ mm 以内  
両面の場合、線 (2) の左右ずれ： $\pm 4.0$ mm 以内



2. DP-770(B): Remove the angle control fitting (D). Loosen the 2 M4 x 14TP screws (G) on the left and right fixing fittings (C).  
DP-771/772: Remove the left hinge cover (H) and the angle control fitting (D). Loosen the 2 M4 x 14TP screws (G) on the left and right fixing fittings (C)(C\*)
3. Turn adjusting screw (3) at the rear side of the right hinge to adjust the DP position.  
For copy example (d): Turn the adjusting screw counterclockwise and move the DP to the inner side.  
For copy example (e): Turn the adjusting screw clockwise and move the DP to the front side.  
Amount of change per scale: Approx. 1.0 mm
4. Perform a test copy.

2. DP-770(B): Déposer la fixation d'angle (assurant le contrôle de l'ouverture) (D). Desserrer les 2 vis TP M4 x 14 (G) sur les fixations gauche et droite (C).  
DP-771/772: Déposer le couvercle de la charnière gauche (H) et la fixation d'angle (assurant le contrôle de l'ouverture) (D). Desserrer les 2 vis TP M4 x 14 (G) sur les fixations gauche et droite (C)(C\*).
3. Tourner la vis de réglage (3) à l'arrière de la charnière droite pour régler la position du DP.  
Pour l'exemple de copie (d) : tourner la vis de réglage dans le sens inverse des aiguilles d'une montre et déplacer le DP vers l'intérieur.  
Pour l'exemple de copie (e) : tourner la vis de réglage dans le sens des aiguilles d'une montre et déplacer le DP vers l'avant.  
Changement par graduation d'échelle : environ 1,0 mm
4. Effectuer une copie de test.

2. DP-770(B): quite el herraje de control de ángulo (D). Afloje los 2 tornillos TP M4 x 14 (G) de los herrajes de fijación izquierdo y derecho (C).  
DP-771/772: quite la cubierta de la bisagra izquierda (H) y el herraje de control de ángulo (D). Afloje los 2 tornillos TP M4 x 14 (G) de los herrajes de fijación izquierdo y derecho (C)(C\*).
3. Gire el tornillo de ajuste (3) en el lado trasero de la bisagra derecha para ajustar la posición del DP.  
Para el ejemplo de copia (d): gire el tornillo de ajuste en sentido antihorario y mueva el DP al lado interno.  
Para el ejemplo de copia (e): gire el tornillo de ajuste en sentido horario y mueva el DP al lado frontal.  
Magnitud del cambio por escala: aprox. 1,0 mm
4. Haga una copia de prueba.

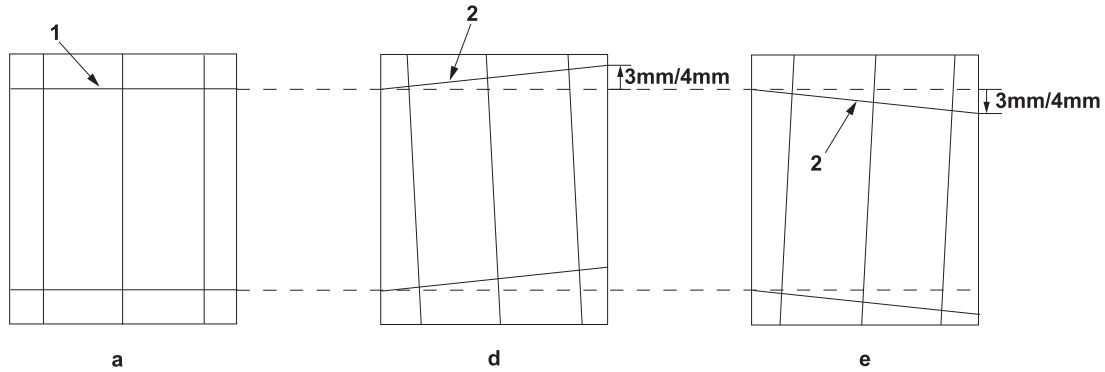
2. DP-770(B): Die Winkeleinstellbefestigung (D) entfernen. Die 2 M4 x 14TP Schrauben (G) an den linken und rechten Befestigungshalterung (C) lösen.  
DP-771/772: Die linke Scharnierabdeckung (H) und die Winkeleinstellbefestigung (D) entfernen. Die 2 M4 x 14TP Schrauben (G) an den linken und rechten Befestigungshalterungen (C)(C\*) lösen.
3. Die Einstellschraube (3) an der Rückseite des rechten Scharniers einstellen, um die DP-Position einzustellen.  
Kopierbeispiel (d): Die Einstellschraube nach links drehen und den DP nach innen schieben.  
Kopierbeispiel (e): Die Einstellschraube nach rechts drehen und den DP nach vorne schieben.  
Änderung pro Maßstab: Ungefähr 1,0 mm
4. Eine Testkopie erstellen.

2. DP-770(B): Rimuovere l'accessorio di regolazione angolare (D). Allentare le 2 viti M4 x 14TP (G) sugli accessori di fissaggio (C) destro e sinistro.  
DP-771/772: Rimuovere il coperchio cerniera sinistra (H) e l'accessorio di regolazione angolare (D). Allentare le 2 viti M4 x 14TP (G) sui lati destro e sinistro degli accessori di fissaggio (C)(C\*) destro e sinistro.
3. Ruotare la vite di regolazione (3) sul lato posteriore della cerniera destra per regolare la posizione del DP.  
Per l'esempio di copia (d): ruotare la vite di regolazione in senso antiorario e spostare il DP verso l'interno.  
Per l'esempio di copia (e): ruotare la vite di regolazione in senso orario e spostare il DP in avanti.  
Entità modifica per scala: circa 1,0 mm
4. Eseguire una copia di prova.

2. DP-770(B) 時: 拆下角限制工具 (D)。拧松左右固定工具 (C) 的 2 顆 M4x14TP(G) 螺絲。  
DP-771/772 時: 拆下左部鉸鏈蓋板 (H) 以及角限制工具 (D)。拧松左右固定工具 (C)(C\*) 的 2 顆 M4x14TP(G) 螺絲。
3. 旋轉右部鉸鏈的後部的調整螺釘 (3) 以調整 DP 位置。  
對於復印樣本 (d): 逆時針旋轉調整螺釘並將 DP 移動到內側。  
對於復印樣本 (e): 順時針旋轉調整螺釘並將 DP 移動到正面。  
按比例尺的更改量: 約 1.0mm
4. 進行測試復印。

2. DP-770(B) 의 경우: 각도 고정쇠 (D) 를 제거합니다. 좌우의 고정쇠 (C) 나사 M4x14TP(G) 2 개를 느슨하게 합니다.  
DP-771/772 의 경우: 좌 힌지커버 (H) 및 각도 고정쇠 (D) 를 제거합니다. 좌우의 고정쇠 (C)(C\*) 의 나사 M4x14TP(G) 2 개를 느슨하게 합니다.
3. 우 힌지 뒷측 조정나사 (3) 를 돌려 DP 의 위치를 조정합니다.  
샘플 카피 (d) 의 경우: 조정나사를 좌로 돌려 DP 를 안으로 넣습니다.  
샘플 카피 (e) 의 경우: 조정나사를 오른쪽으로 돌려 DP 를 앞으로 뺍니다.  
1 개 변화량: 약 1.0mm
4. 테스트 카피를 합니다.

2. DP-770(B) の場合: 角度規制金具 (D) を取り外す。左右の固定金具 (C) のビス M4x14TP(G) 2 本を緩める  
DP-771/772 の場合: 左ヒンジカバー (H) および角度規制金具 (D) を取り外す。左右の固定金具 (C)(C\*) のビス M4x14TP(G) 2 本を緩める。
3. 右ヒンジ後側の調整ビス (3) を回し、DP の位置を調整する。  
コピーサンプル (d) の場合: 調整ビスを左に回し、DP を奥へ動かす。  
コピーサンプル (e) の場合: 調整ビスを右に回し、DP を手前へ動かす。  
1 目盛り当たりの変化量: 約 1.0mm
4. テストコピーを行う。



5. Repeat the steps above until the gap of line (2) of copy example shows the following reference values.

<Reference value> For single copying: The horizontal gap of line (2) should be within  $\pm 3.0$  mm.

For duplex copying: The horizontal gap of line (2) should be within  $\pm 4.0$  mm.

6. After adjustment is completed, retighten two M4  $\times$  14TP screws (G) that have been loosened in step 2.

7. Remove the original mat (B) and refit it (see steps 27 and 28 on page 13).

5. Répéter les étapes ci-dessus jusqu'à ce que l'écart de la ligne (2) de l'exemple de copie indique les valeurs de référence suivantes.

<Valeur de référence> Pour la copie recto : l'écart horizontal de la ligne (2) doit être de  $\pm 3,0$  mm.

Pour la copie recto-verso : l'écart horizontal de la ligne (2) doit être de  $\pm 4,0$  mm.

6. Une fois le réglage effectué, resserrer les deux vis TP M4  $\times$  14 (G) desserrées à l'étape 2.

7. Retirez le tapis d'original (B) et remettez-le en place. (Reportez-vous aux étapes 27 et 28 à la page 13.)

5. Repita los pasos anteriores hasta que la separación de la línea (2) del ejemplo de copia presente los siguientes valores de referencia.

<Valor de referencia> Para el copiado por una cara: la separación horizontal de la línea (2) debe estar dentro de  $\pm 3,0$  mm.

Para el copiado dúplex: la separación horizontal de la línea (2) debe estar dentro de  $\pm 4,0$  mm.

6. Una vez hecho el ajuste, vuelva a apretar los dos tornillos TP M4  $\times$  14 (G) que ha aflojado en el paso 2.

7. Desmonte la plancha de original (B) y vuelva a colocar (vea los pasos 27 y 28 en la página 13).

5. Die obigen Schritte wiederholen, bis der Abstand der Linie (2) des Kopierbeispiels die folgenden Bezugswerte aufweist.

<Bezugswert> Einzelkopie: Der horizontale Abstand der Linie (2) sollte innerhalb von  $\pm 3,0$  mm liegen.

Duplexkopie: Der horizontale Abstand der Linie (2) sollte innerhalb von  $\pm 4,0$  mm liegen.

6. Nach der Einstellung die zwei M4  $\times$  14TP Schrauben (G), die in Schritt 2 gelöst wurden, wieder festziehen.

7. Die Originalmatte (B) abnehmen und wieder anbringen (siehe Schritte 27 und 28 auf Seite 13).

5. Ripetere le operazioni sopra descritte fino a quando lo scostamento della linea (2) dell'esempio di copia riporterà i valori di riferimento seguenti.

<Valore di riferimento> Per la copia singola: lo scostamento orizzontale della linea (2) deve limitarsi a  $\pm 3,0$  mm.

Per la copia duplex: lo scostamento orizzontale della linea (2) deve limitarsi a  $\pm 4,0$  mm.

6. Una volta conclusa la regolazione, serrare nuovamente le viti M4  $\times$  14TP (G) che erano state allentate al Punto 2.

7. Rimuovere il coprioriginale (B) e reinserirlo (vedere i passi 27 e 28 a pagina 13).

5. 重复上述步骤直至复印样本上的线(2)的偏移值达到标准值范围内。

<标准值> 单面时, 线(2)的左右偏移值:  $\pm 3.0$ mm 以内

双面时, 线(2)的左右偏移值:  $\pm 4.0$ mm 以内

6. 调整完成后, 重新拧紧在步骤2中松开的一颗M4 $\times$ 14TP螺丝(G)。

7. 拆下原稿垫(B), 参照第13页的步骤27和28再次装上。

5. 샘플 카피 선 (2) 차이가 기준치내가 될 때까지 조정을 반복합니다 .

<기준치> 단면의 경우 선 (2) 의 좌우차이:  $\pm 3.0$ mm 이내

양면의 경우 선 (2) 의 좌우차이:  $\pm 4.0$ mm 이내

6. 조정 완료 후 스텝 2 에서 느슨하게 한 나사 M4 $\times$ 14TP(G) 2 개를 조입니다 .

7. 원고매트 (B) 를 제거하고 13 페이지 순서 27, 28 을 참고로 다시 부착합니다 .

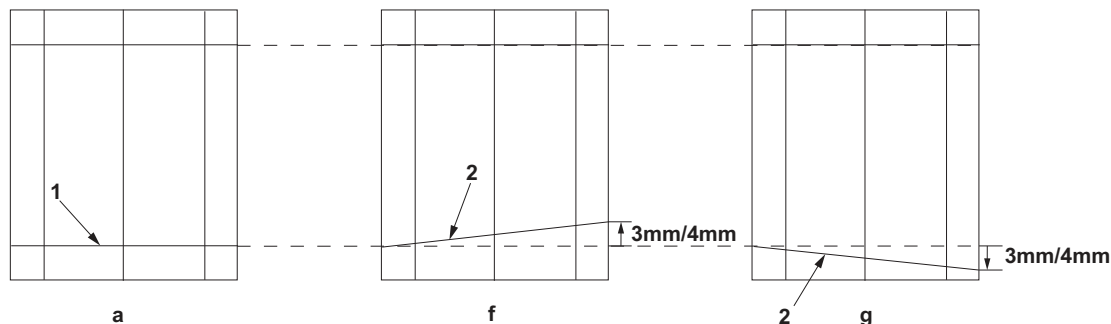
5. コピーサンプルの線 (2) のずれが基準値内になるまで、調整を繰り返す。

<基準値> 片面の場合、線 (2) の左右ずれ:  $\pm 3.0$ mm 以内

両面の場合、線 (2) の左右ずれ:  $\pm 4.0$ mm 以内

6. 調整終了後、手順2で緩めたビスM4 $\times$ 14TP(G)2本を締め付ける。

7. 原稿マット (B) を取り外し、13ページの手順27、28を参考に再度取り付ける。



#### [Checking the angle of trailing edge]

1. Check the gap between line (1) of original (a) and line (2) of copy example. If the gap exceeds the reference value, perform the following adjustment.  
 <Reference value> For simplex copying: Within  $\pm 3.0$  mm  
 For duplex copying: Within  $\pm 4.0$  mm

#### [Vérification de l'angle du bord arrière]

1. Vérifiez l'écart entre la ligne (1) de l'original (a) et la ligne (2) de l'exemple de copie. Si l'écart est supérieur à la valeur de référence, effectuez le réglage suivant.  
 <Valeur de référence> Copie recto seul:  $\pm 3,0$  mm max.  
 Copie recto verso:  $\pm 4,0$  mm max.

#### [Verificación del ángulo del borde inferior]

1. Verifique la separación entre la línea (1) del original (a) y la línea (2) de la copia de muestra. Si la superación supera el valor de referencia, haga el siguiente ajuste.  
 <Valor de referencia> Para copia simple: Dentro de  $\pm 3,0$  mm  
 Para copia duplex: Dentro de  $\pm 4,0$  mm

#### [Überprüfen des Winkels der Hinterkante]

1. Die Abweichung der Linie (1) des Originals (a) und der Linie (2) des Kopienmusters prüfen. Überschreitet die Abweichung den Bezugswert, ist die folgende Einstellung durchzuführen.  
 <Bezugswert> Für Simplexkopie: Innerhalb  $\pm 3,0$  mm  
 Für Duplexkopie: Innerhalb  $\pm 4,0$  mm

#### [Controllo dell'angolo del bordo di uscita]

1. Controllare la differenza tra la linea (1) dell'originale (a) e la linea (2) della copia di esempio. Se la differenza supera il valore di riferimento, effettuare la seguente regolazione.  
 <Valore di riferimento> Per copia simplex: Entro  $\pm 3,0$  mm  
 Per copia duplex: Entro  $\pm 4,0$  mm

#### [ 确认后端倾斜度 ]

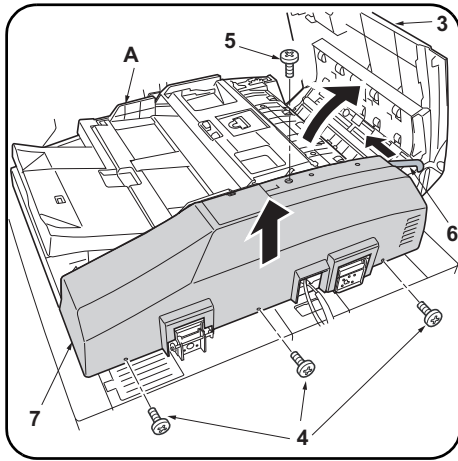
1. 确认原稿 (a) 上的线 (1) 和复印样本上的线 (2) 的偏移值。如果超过标准值时, 必须进行调整。  
 <标准值> 单面时:  $\pm 3.0$ mm 以内  
 双面时:  $\pm 4.0$ mm 以内

#### [ 후단 경사확인 ]

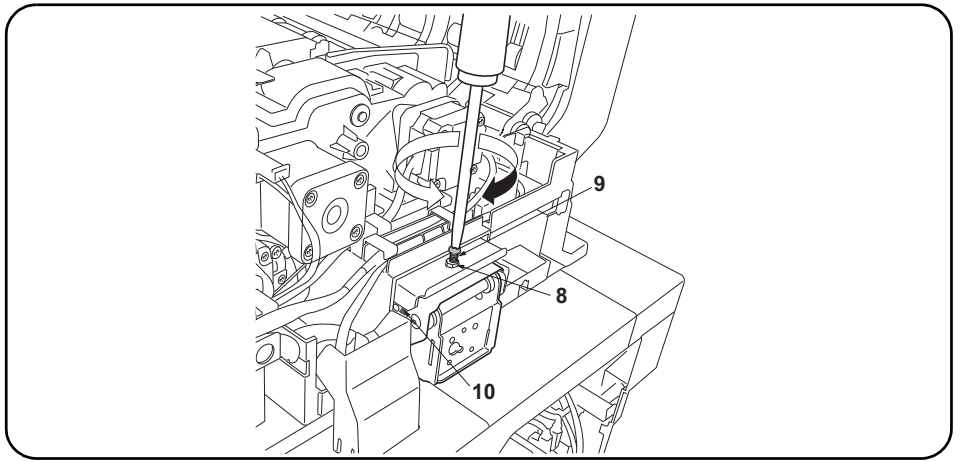
1. 원고 (a) 의 선 (1) 과 샘플 카피 선 (2) 의 차이를 확인합니다. 차이가 기준치 외의 경우에는 조정을 합니다.  
 <기준치> 단면의 경우:  $\pm 3.0$ mm 이내  
 양면의 경우:  $\pm 4.0$ mm 이내

#### [ 後端斜め確認 ]

1. 原稿 (a) の線 (1) とコピーサンプルの線 (2) のずれを確認する。ずれが基準値外の場合は調整をおこなう。  
 <基準値> 片面の場合:  $\pm 3.0$ mm 以内  
 両面の場合:  $\pm 4.0$ mm 以内



2. Open the upper cover (3) of the DP (A).
3. Remove the 3 TP screws (4) and the screw (5), and remove the strap (6) from the rear cover (7). Then remove the DP (A) rear cover (7).



4. Adjust the height of DP.  
Loosen the nut (8).  
For copy example (f): Loosen the adjusting screw (9).  
For copy example (g): Tighten the adjusting screw (9).

- Amount of change per scale: Approx. 0.5 mm (10)  
Retighten the nut (8).
5. Refit the rear cover (7) removed in step 3.
  6. Remove the original mat (B) and refit it (see steps 27 and 28 on page 13).

2. Ouvrir le couvercle supérieur (3) du DP (A).
3. Déposer les 3 vis TP (4) et la vis (5) puis déposer la courroie (6) du couvercle arrière (7). Déposer ensuite le couvercle arrière (7) du DP (A).

4. Réglez la hauteur du DP.  
Desserrez l'écrou (8).  
Pour l'exemple de copie (f): Desserrez la vis de réglage (9).  
Pour l'exemple de copie (g): Serrez la vis de réglage (9).

- Quantité de changement par pas: Environ 0,5 mm (10)  
Resserrez l'écrou (8).
5. Reposer le couvercle arrière (7) déposé à l'étape 3.
  6. Retirez le tapis d'original (B) et remettez-le en place. (Reportez-vous aux étapes 27 et 28 à la page 13).

2. Abra la cubierta superior (3) del DP (A).
3. Quite los 3 tornillos TP (4) y el tornillo (5) y quite la correa (6) de la cubierta trasera (7). Después, quite la cubierta trasera (7) del DP (A).

4. Ajuste la altura del DP.  
Afloje la tuerca (8).  
Para la copia de muestra (f): Afloje el tornillo de ajuste (9).  
Para la copia de muestra (g): Apriete el tornillo de ajuste (9).

- Cantidad de cambio de escala: Aprox. 0,5 mm (10)  
Vuelva a apretar la tuerca (8).
5. Vuelva a colocar la cubierta (7) desmontada en el paso 3.
  6. Desmonte la plancha de original (B) y vuelva a colocar (vea los pasos 27 y 28 en la página 13).

2. Die obere Abdeckung (3) des DP (A) öffnen.
3. Die 3 TP-Schrauben (4) und die Schraube (5) entfernen und den Riemen (6) von der hinteren Abdeckung (7) abnehmen. Dann die hintere Abdeckung (7) des DP (A) abnehmen.

4. Die Höhe des DP einstellen.  
Lösen Sie die Mutter (8).  
Für Kopienmuster (f): Lösen Sie die Einstellschraube (9).  
Für Kopienmuster (g): Die Einstellschraube (9) festziehen.

- Änderungsbetrag pro Skalenstrich: Ca. 0,5 mm (10)  
Ziehen Sie die Mutter (8) wieder fest.
5. Die in Schritt 3 entfernte hintere Abdeckung (7) wieder anbringen.
  6. Die Originalmatte (B) abnehmen und wieder anbringen (siehe Schritte 27 und 28 auf Seite 13).

2. Aprire il pannello superiore (3) del DP (A).
3. Rimuovere le 3 viti TP (4) e la vite (5), e quindi rimuovere la cinghietta (6) dal coperchio posteriore (7). Quindi rimuovere il coperchio posteriore (7) del DP (A).

4. Regolazione dell'altezza del DP  
Allentare il dado (8).  
Per un esempio di copia (f): Allentare la vite di regolazione (9).  
Per un esempio di copia (g): Stringere la vite di regolazione (9).

- Variatione graduale: Circa 0,5 mm (10)  
Stringere di nuovo il dado (8).
5. Reinserrire il coperchio posteriore (7) rimosso nel passo 3.
  6. Rimuovere il coprioriginale (B) e reinserirlo (vedere i passi 27 e 28 a pagina 13).

2. 打开 DP (A) 的上盖板 (3)。
3. 拆除 3 颗 TP 螺丝 (4) 和 1 颗螺丝 (5)，将塑料片 (6) 从后盖板 (7) 上拆除，拆下 DP 主机 (A) 的后盖板 (7)。

4. 调整 DP 的高度。  
松弛螺母 (8)。  
复印样张 (f) 时：松弛调整螺丝 (9)。  
复印样张 (g) 时：紧固调整螺丝 (9)。

- 每 1 格的移动量：约 0.5mm (10)  
将螺母 (8) 按原样紧固好。
5. 重新安装在步骤 3 中拆下的后盖板 (7)。
  6. 拆下原稿垫 (B)，参照第 13 页的步骤 27 和 28 再次装上。

2. DP(A) 의 DP 윗 커버 (3) 를 엽니다 .
3. TP 나사 (4) 3 개와 나사 (5) 1 개를 제거하고 스트랩 (6) 을 뒷면 커버 (7) 에서 제거해 DP(A) 의 후면 커버 (7) 를 제거합니다 .

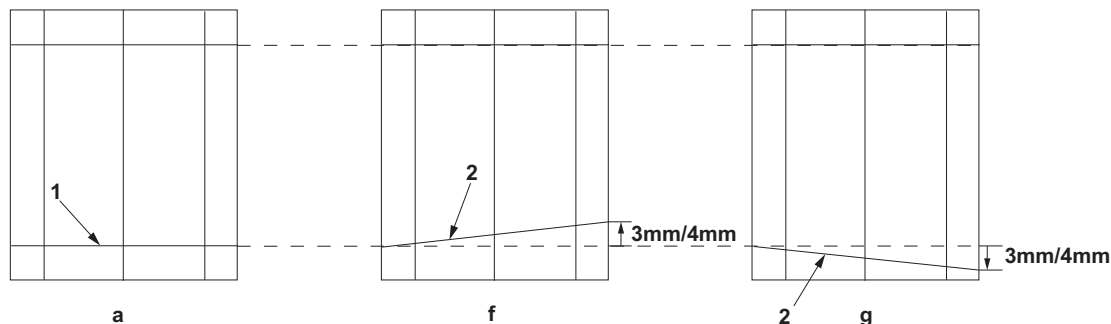
4. DP 의 높이를 조정합니다 .  
너트 (8) 를 느슨하게 합니다 .  
샘플 카피 (f) 의 경우 : 조정나사 (9) 를 느슨하게 합니다 .  
샘플 카피 (g) 의 경우 : 조정나사 (9) 를 조입니다 .

- 1 개 변화량 : 약 0.5mm(10)  
너트 (8) 를 원래대로 조입니다 .
5. 순서 3 에서 제거한 윗 커버 (7) 를 원래대로 장착합니다 .
  6. 원고 매트 (B) 를 제거하고 13 페이지 순서 27, 28 을 참고로 다시 부착합니다 .

2. DP (A) の DP 上カバー (3) を開く。
3. TP ビス (4) 3 本とビス (5) 1 本を外し、ストラップ (6) を後カバー (7) から外して、DP (A) の後カバー (7) を取り外す。

4. DP の高さを調整する。  
ナット (8) をゆるめる。  
コピーサンプル (f) の場合 : 調整ビス (9) をゆるめる。  
コピーサンプル (g) の場合 : 調整ビス (9) を締める。

- 1 目盛り当たりの変化量 : 約 0.5mm (10)  
ナット (8) を元通り締める。
5. 手順 3 で取り外した後カバー (7) を元通り取り付ける。
  6. 原稿マット (B) を取り外し、13 ページの手順 27, 28 を参考に再度取り付ける。



7. Make a proof copy again.  
 8. Repeat steps 1 to 6 until line (2) of copy example shows the following the reference values.  
 <Reference value> For simplex copying: Within  $\pm 3.0$  mm  
 For duplex copying: Within  $\pm 4.0$  mm

7. Effectuez à nouveau une copie de test.  
 8. Répétez les étapes 1 à 6 jusqu'à ce que la ligne (2) de l'exemple de copie corresponde aux valeurs de référence suivantes.  
 <Valeur de référence> Copie recto seul:  $\pm 3,0$  mm max.  
 Copie recto verso:  $\pm 4,0$  mm max.

7. Haga otra copia de prueba.  
 8. Repita los pasos 1 a 6 hasta que la línea (2) de la copia de muestra tenga los siguientes valores de referencia.  
 <Valor de referencia> Para copia simple: Dentro de  $\pm 3,0$  mm  
 Para copia duplex: Dentro de  $\pm 4,0$  mm

7. Eine erneute Probekopie anfertigen.  
 8. Die Schritte 1 bis 6 wiederholen, bis die Linie (2) des Kopienmusters die folgenden Bezugswerte aufweist.  
 <Bezugswert> Für Simplexkopie: Innerhalb  $\pm 3,0$  mm  
 Für Duplexkopie: Innerhalb  $\pm 4,0$  mm

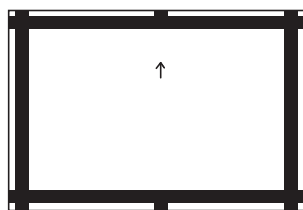
7. Eseguire di nuovo una prova di copia.  
 8. Ripetere i passi da 1 a 6 fino a che la linea (2) dell'esempio di copia non mostra i seguenti valori di riferimento.  
 <Valore di riferimento> Per copia simplex: Entro  $\pm 3,0$  mm  
 Per copia duplex: Entro  $\pm 4,0$  mm

7. 再次进行测试复印。  
 8. 反复操作步骤 1~6, 直至 复印样张的线 (2) 为标准值内。  
 <标准值> 单面时:  $\pm 3.0$ mm 以内  
 双面时:  $\pm 4.0$ mm 以内

7. 다시 테스트 카피를 합니다.  
 8. 샘플 카피 선 (2) 이 기준치내로 될 때까지 순서 1 ~ 6 을 반복합니다.  
 <기준치> 단면의 경우:  $\pm 3.0$ mm 이내  
 양면의 경우:  $\pm 4.0$ mm 이내

7. 再度テストコピーをおこなう。  
 8. コピーサンプルの線 (2) が基準値内になるまで、手順 1 ~ 6 を繰り返す。  
 <基準値> 片面の場合:  $\pm 3.0$ mm 以内  
 両面の場合:  $\pm 4.0$ mm 以内





**[Automatic adjustment using the original for adjustment]  
If there is no DP auto adjustment original.**

1. Set the maintenance mode U411, select [DP Auto Adj] and press the Start key to print an original.
2. Set the printed original on the contact glass and press the Start key.
3. Set the original on the DP face up and press the Start key to carry out surface adjustment.

4. Set the original on the DP face down and press the Start key to carry out rear-side adjustment. (DP-771/772 only)
5. If OK appears on the display, the adjustment is completed. If ERROR XX appears, the adjustment failed. Check the original set position and repeat steps 2 and 4 until OK appears. For details, see the service manual.

**[Réglage automatique en utilisant l'original pour effectuer le réglage]  
Si la machine n'est pas pourvue de la fonction réglage automatique d'original du DP**

1. Régler le mode maintenance U411, sélectionner [DP Auto Adj] et appuyer sur la touche Start pour imprimer un original.
2. Placer l'original qui vient d'être imprimé sur la vitre d'exposition et appuyer sur la touche Start.
3. Placer l'original sur le DP côté imprimé en haut et appuyer sur la touche Start pour procéder au réglage de la surface.

4. Placer l'original sur le DP côté imprimé en bas et appuyer sur la touche Start pour procéder au réglage du côté arrière. (DP-771/772 uniquement)
5. Si le message OK apparaît sur l'affichage, le réglage est terminé. Si le message ERROR XX (erreur XX) s'affiche, le réglage a échoué. Vérifier la position de l'original et recommencer les opérations 2 et 4 jusqu'à ce que le message OK apparaisse. Pour plus de détails, se reporter au manuel d'entretien.

**[Ajuste automático utilizando el original para el ajuste]  
Si no existe el original de ajuste automático del DP**

1. Entre al modo de mantenimiento U411, seleccione [DP Auto Adj] y pulse la tecla de Start para imprimir un original.
2. Coloque el original impreso sobre el cristal de contacto y pulse la tecla de Start.
3. Coloque el original en el DP cara arriba y pulse la tecla de Start para realizar un ajuste de anverso.

4. Coloque el original en el DP cara abajo y pulse la tecla de Start para realizar un ajuste de reverso. (DP-771/772 solamente)
5. Si aparece OK en la pantalla significa que el ajuste ha sido realizado. Si aparece ERROR XX, el ajuste ha fallado. Compruebe la posición ajustada del original y repita los pasos 2 y 4 hasta que aparezca OK en la pantalla. Para más detalles, lea el manual de servicio.

**[Automatische Einstellung mithilfe des Originals]**

**Falls keine automatische Einstellung des Originals des DP vorhanden ist**

1. Den Wartungsmodus U411 einschalten. [DP Auto Adj] wählen und die Start-Taste betätigen, um ein Original auszudrucken.
2. Das ausgedruckte Original auf das Kontaktglas legen und die Start-Taste betätigen.
3. Das Original mit der Druckseite nach oben einlegen und die Start-Taste betätigen, um die Oberflächeneinstellung ausführen zu lassen.

4. Das Original mit der Druckseite nach unten einlegen und die Start-Taste betätigen, um die Rückseiteneinstellung ausführen zu lassen. (nur DP-771/772)
5. Wenn am Display OK angezeigt wird, ist die Einstellung abgeschlossen. Wenn ERROR XX (FEHLER XX) angezeigt wird, ist die Einstellung fehlgeschlagen. Überprüfen Sie die Originalpositionierung und wiederholen Sie Schritte 2 und 4, bis OK angezeigt wird. Weitere Einzelheiten siehe Wartungsanleitung.

**[Regolazione automatica eseguita con l'originale]**

**Se non è presente l'autoregolazione originale DP**

1. Impostare la modalità manutenzione U411, selezionare [DP Auto Adj] e premere il tasto di Start per stampare un originale.
2. Posizionare l'originale stampato sul vetro di appoggio e premere il tasto di Start.
3. Posizionare l'originale sul DP rivolto verso l'alto e premere il tasto di Start per eseguire la regolazione della superficie.

4. Posizionare l'originale sul DP rivolto verso il basso e premere il tasto di Start per eseguire la regolazione del lato posteriore. (Solo DP-771/772)
5. Se OK appare sul display, la regolazione è completata. Se compare ERROR XX (ERRORE XX), la regolazione non è riuscita. Verificare la posizione di impostazione dell'originale e ripetere le operazioni 2 e 4 fino a quando appare OK. Per ulteriori dettagli leggere il manuale d'istruzioni.

**[通过调整用原稿进行自动调整]**

**没有 DP 调整用原稿时**

1. 设置维护模式 U411, 按 [DP Auto Adj]、Start 键以输出原稿。
2. 将输出的原稿放在稿台上, 按 Start 键。
3. 将原稿面朝上放在 DP 主机上, 按 Start 键以进行正面的调整。

4. 将原稿面朝下放在 DP 主机上, 按 Start 键以进行反面的调整。(仅限 DP-771/772)
5. 如果屏幕上出现 OK (完成), 则表示调整完成。如果出现 ERROR XX (错误 XX), 则表示调整失败。检查原稿设定位置并重复步骤 2 和 4, 直到 OK (完成) 出现。详细内容请参考维修手册。

**[조정용 원고를 이용한 자동조정]**

**DP 조정용 원고가 없는 경우**

1. 메인テナンス 모드 U411 을 세트하고 [DP Auto Adj], 시작키를 눌러 원고를 출력합니다.
2. 출력한 원고를 원고 유리에 장착하고 시작키를 누릅니다.
3. 원고를 FaceUp 으로 DP 로 세트하고 시작키를 눌러 표면조정을 합니다.

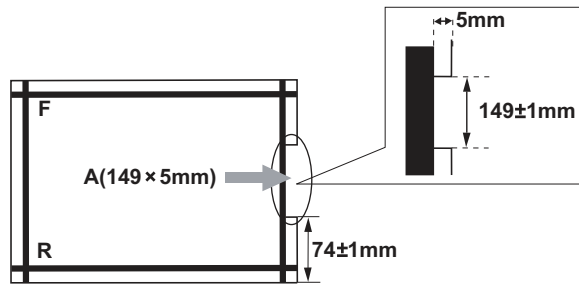
4. 원고를 FaceDown 으로 DP 에 장착하고 시작키를 눌러 뒷면조정을 합니다. (DP-771/772 만)
5. 디스플레이에 OK 가 표시되면 조정완료가 됩니다. ERROR XX 가 표시된 경우에는 조정실패입니다. 원고 장착위치를 확인하고 OK 가 표시될 때까지 순서 2 ~ 4 를 반복합니다. 상세는 서비스 매뉴얼을 참조

**[調整用原稿による自動調整]**

**DP 調整用原稿が無い場合**

1. メンテナンスモード U411 をセットし、[DP Auto Adj]、Start キーを押し原稿を出力する。
2. 出力した原稿をコンタクトガラス上にセットし、Start キーを押す。
3. 原稿を FaceUp で DP へセットし、Start キーを押し、表面の調整を行う。

4. 原稿を FaceDown で DP へセットし、Start キーを押し、裏面の調整を行う。(DP-771/772 のみ)
5. ディスプレイに OK が表示されれば調整完了となる。ERROR XX が表示された場合は調整失敗である。原稿のセット位置を確認し、OK が表示されるまで手順 2 ~ 4 を繰り返す。詳細はサービスマニュアルを参照のこと。



### Using a DP auto adjustment original

1. Direct F and R of the DP auto adjustment original upward, and set the original from the place where F and R are marked.
2. Set the maintenance mode U411. Press the [DP FaceUp (Chart2)], [Input] and the Start key in that order to carry out surface adjustment.

3. If OK appears on the display, the adjustment is completed. If ERROR XX appears, the adjustment failed. Check the original set position and repeat steps 1 and 2 until OK appears. For details, see the service manual.

### Avec la fonction réglage automatique d'original du DP

1. Diriger F (avant) et R (arrière) de la fonction de réglage automatique d'original du DP vers le haut, puis placer l'original à partir de l'emplacement des repères F et R.
2. Passer au mode maintenance U411. Appuyer sur les touches [DP FaceUp (Chart2)], [Input] et Start dans cet ordre pour procéder au réglage de la surface.

3. Si le message OK apparaît sur l'affichage, le réglage est terminé. Si le message ERROR XX (erreur XX) s'affiche, le réglage a échoué. Vérifier la position de l'original et recommencer les opérations 1 et 2 jusqu'à ce que le message OK apparaisse. Pour plus de détails, se reporter au manuel d'entretien.

### Uso del original de ajuste automático del DP

1. Dirija F y R del original de ajuste automático del DP hacia arriba, y coloque el original a partir del sitio en que están marcados F y R.
2. Entre en el modo de mantenimiento U411. Pulse las teclas [DP FaceUp (Chart2)], [Input] y la tecla de Start, en ese orden, para realizar el ajuste de anverso.

3. Si aparece OK en la pantalla significa que el ajuste ha sido realizado. Si aparece ERROR XX, el ajuste ha fallado. Compruebe la posición ajustada del original y repita los pasos 1 y 2 hasta que aparezca OK en la pantalla. Para más detalles, lea el manual de servicio.

### Gebrauch der automatischen Einstellung des Originals des DP

1. F und R der automatischen Einstellung des Originals des DP nach oben zeigen und das Original an die mit F und R markierte Stelle setzen.
2. Den Wartungsmodus U411 einschalten. [DP Faceup (Chart2)], [Input] und die Start-Taste in dieser Reihenfolge betätigen, um die Oberflächeneinstellung ausführen zu lassen.

3. Wenn am Display OK angezeigt wird, ist die Einstellung abgeschlossen. Wenn ERROR XX (FEHLER XX) angezeigt wird, ist die Einstellung fehlgeschlagen. Überprüfen Sie die Originalpositionierung und wiederholen Sie Schritte 1 und 2, bis OK angezeigt wird. Weitere Einzelheiten siehe Wartungsanleitung.

### Uso di un'autoregolazione originale DP

1. Orientare F e R dell'autoregolazione originale DP verso l'alto e disporre l'originale rispetto ai punti in cui sono contrassegnati F e R.
2. Impostare la modalità manutenzione U411. Premere nell'ordine [DP FaceUp (Chart2)], [Input] e il tasto di Start, per eseguire la regolazione della superficie.

3. Se OK appare sul display, la regolazione è completata. Se compare ERROR XX (ERRORE XX), la regolazione non è riuscita. Verificare la posizione di impostazione dell'originale e ripetere le operazioni 1 e 2 fino a quando appare OK. Per ulteriori dettagli leggere il manuale d'istruzioni.

### 使用 DP 自动调整原稿时

1. 将 DP 自动调整原稿的 F 和 R 向上, 并把标有 F 和 R 的一侧插入 DP 来设定原稿。
2. 设置维护模式 U411, 按顺序按 [DP FaceUp(Chart2)], [Input]、Start 键以进行正面的调整。

3. 如果屏幕上出现 OK (完成), 则表示调整完成。如果出现 ERROR XX (错误 XX), 则表示调整失败。检查原稿设定位置并重复步骤 1 和 2, 直到 OK (完成) 出现。详细内容请参照维修手册。

### DP 자동조정용 원고를 사용하는 경우

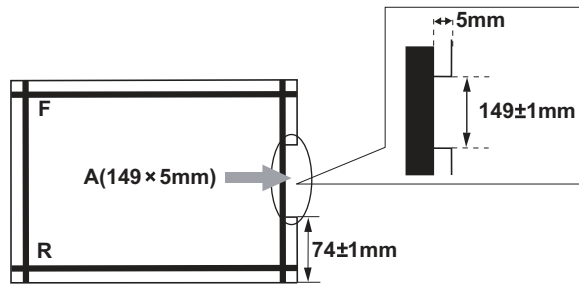
1. DP 자동 조정 원고를 F, R 을 위로 향하게 하고 F, R 이라고 표시된 곳에서 부터 원고를 셋팅합니다.
2. 메인テナンス 모드 U411 을 세트하고 [DP FaceUp(Chart2)], [Input], 시작키의 순서로 눌러 표면 조정을 합니다.

3. 디스플레이에 OK 가 표시되면 조정완료가 됩니다. ERROR XX 가 표시된 경우에는 조정실패입니다. 원고 장착위치를 확인하고 OK 가 표시될 때까지 순서 1 ~ 2 를 반복합니다. 상세는 서비스 매뉴얼을 참조.

### DP 自動調整原稿を使用する場合

1. DP 自動調整原稿の F、R を上に向け、F、R が書かれている方から DP へセットする。
2. メンテナンスモード U411 をセットし、[DP FaceUp(Chart2)]、[Input]、Start キーの順に押し、表面の調整を行う。

3. ディスプレイに OK が表示されれば調整完了となる。ERROR XX が表示された場合は調整失敗である。原稿のセット位置を確認し、OK が表示されるまで手順 1 ~ 2 を繰り返す。詳細はサービスマニュアルを参照のこと。



4. After completing the surface adjustment, direct F and R of the DP auto adjustment original downward and set the original by inserting the side where the F and R are marked into the DP first.(DP-771/772 only)
5. Set the maintenance mode U411. Press the [DP FaceDown (Chart2)], [Normal Target], [Input] and the Start key in that order to carry out rear-side adjustment.(DP-771/772 only)

6. If OK appears on the display, the adjustment is completed.(DP-771/772 only)  
If ERROR XX appears, the adjustment failed. Check the original set position and repeat steps 4 and 5 until OK appears.  
For details, see the service manual.

4. Une fois le réglage de la surface effectué, diriger F (avant) et R (arrière) de la fonction de réglage automatique d'original du DP vers le bas et placer l'original en introduisant en premier dans le DP le côté sur lequel F et R sont indiqués.( DP-771/772 uniquement)
5. Passer au mode maintenance U411. Appuyer sur les touches [DP FaceDown (Chart2)], [Normal Target], [Input] et Start dans cet ordre pour procéder au réglage du côté arrière.( DP-771/772 uniquement)

6. Si le message OK apparaît sur l'affichage, le réglage est terminé. ( DP-771/772 uniquement)  
Si le message ERROR XX (erreur XX) s'affiche, le réglage a échoué. Vérifier la position de l'original et recommencer les opérations 4 et 5 jusqu'à ce que le message OK apparaisse.  
Pour plus de détails, se reporter au manuel d'entretien.

4. Una vez hecho el ajuste del anverso, dirija F y R del original de ajuste automático del DP hacia abajo y coloque el original insertando en el DP, en primer lugar, el lado en el que están marcados F y R.(DP-771/772 solamente )
5. Entre en el modo de mantenimiento U411. Pulse las teclas [DP FaceDown (Chart2)], [Normal Target], [Input] y la tecla de Start, en ese orden, para realizar el ajuste de reverso.(DP-771/772 solamente )

6. Si aparece OK en la pantalla significa que el ajuste ha sido realizado.(DP-771/772 solamente )  
Si aparece ERROR XX, el ajuste ha fallado. Compruebe la posición ajustada del original y repita los pasos 4 y 5 hasta que aparezca OK en la pantalla.  
Para mas detalles, lea el manual de servicio.

4. Nach dem Abschluss der Oberflächeneinstellung F und R der automatischen Einstellung des Originals des DP nach unten zeigen und das Original einstellen, indem die mit F und R markierte Seite zuerst in den DP eingeführt wird.(nur DP-771/772)
5. Den Wartungsmodus U411 einschalten. [DP FaceDown (Chart2)], [Normal Target], [Input] und die Start-Taste in dieser Reihenfolge betätigen, um die Rückseiteneinstellung ausführen zu lassen.(nur DP-771/772)

6. Wenn am Display OK angezeigt wird, ist die Einstellung abgeschlossen.(nur DP-771/772)  
Wenn ERROR XX (FEHLER XX) angezeigt wird, ist die Einstellung fehlgeschlagen. Überprüfen Sie die Originalpositionierung und wiederholen Sie Schritte 4 und 5, bis OK angezeigt wird.  
Weitere Einzelheiten siehe Wartungsanleitung.

4. Una volta conclusa la regolazione della superficie, orientare F e R dell'autoregolazione originale DP verso il basso e disporre l'originale inserendo nel DP prima il lato su cui sono contrassegnati F e R.( Solo DP-771/772 )
5. Impostare la modalità manutenzione U411. Premere nell'ordine [DP FaceDown (Chart2)], [Normal Target], [Input] e il tasto di Start, per eseguire la regolazione del lato posteriore.( Solo DP-771/772 )

6. Se OK appare sul display, la regolazione è completata.( Solo DP-771/772 )  
Se compare ERROR XX (ERRORE XX), la regolazione non è riuscita. Verificare la posizione di impostazione dell'originale e ripetere le operazioni 4 e 5 fino a quando appare OK.  
Per ulteriori dettagli leggere il manuale d'istruzioni.

4. 完成正面调整后,将 DP 自动调整原稿的 F 和 R 向下,并首先将标有 F 和 R 的一侧插入 DP 来设定原稿。(仅限 DP-771/772)
5. 设置维护模式 U411,按顺序按 [DP FaceDown(Chart2)], [Normal Target]、[Input]、Start 键以进行反面的调整。(仅限 DP-771/772)

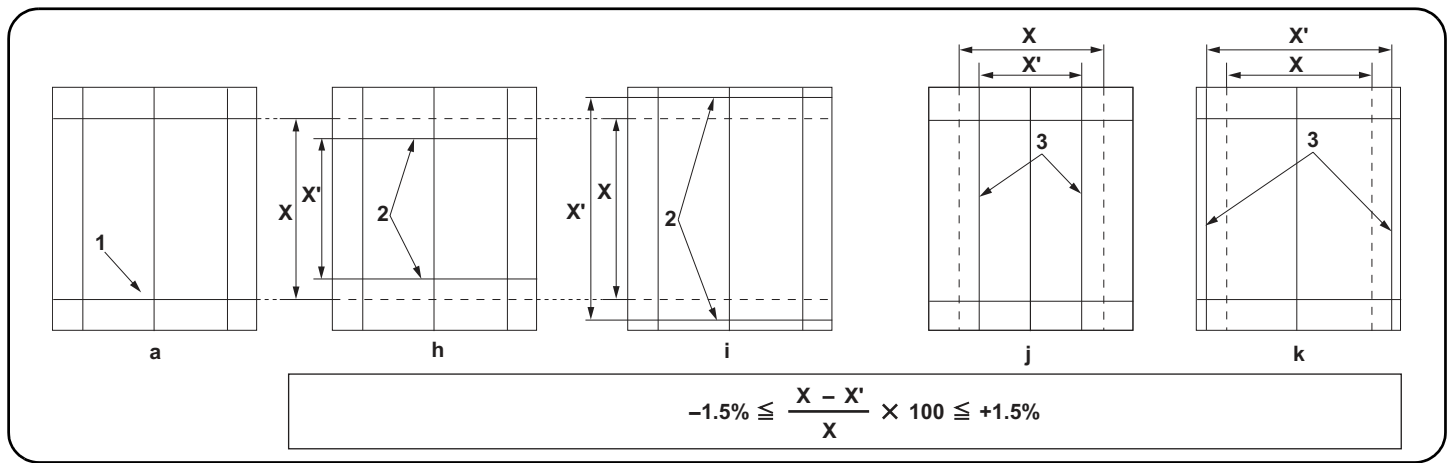
6. 如果屏幕上出现 OK (完成),则表示调整完成。(仅限 DP-771/772)  
如果出现 ERROR XX (错误 XX),则表示调整失败。检查原稿设定位置并重复步骤 4 和 5,直到 OK (完成)出现。  
详细内容请参照维修手册。

4. 표면의 조정완료 후 DP 자동조정원고의 F, R 을 아래로 향하게 해 F, R 이 쓰여져 있는 쪽에서 DP 로 세트합니다 . (DP-771/772 만 )
5. 메인テナンス 모드 U411 을 세트하고 [DP FaceDown(Chart2)], [Normal Taget], [Input], 시작키 순서로 뒷면조정을 합니다 . (DP-771/772 만 )

6. 디스플레이에 OK 가 표시되면 조정완료가 됩니다 . (DP-771/772 만 )  
ERROR XX 가 표시된 경우에는 조정실패입니다 . 원고 장착위치를 확인하고 OK 가 표시될 때까지 순서 4 ~ 5 를 반복합니다 .  
상세는 서비스 매뉴얼을 참조

4. 表面の調整完了後、DP 自動調整原稿の F、R を下に向け、F、R が書かれている方から DP へセットする。(DP-771/772 のみ)
5. メンテナンスモード U411 をセットし、[DP FaceDown (Chart2)], [Normal Taget]、[Input]、Start キーの順に押し、裏面の調整を行う。(DP-771/772 のみ)

6. ディスプレイに OK が表示されれば調整完了となる。(DP-771/772 のみ)  
ERROR XX が表示された場合は調整失敗である。原稿のセット位置を確認し、OK が表示されるまで手順 4 ~ 5 を繰り返す。  
詳細はサービスマニュアルを参照のこと。



**[Checking the magnification]**

1. Check the gap between line (1) of original (a) and line (2) (3) of copy example. If the gap exceeds the reference value, adjust the gap according to the following procedure.  
<Reference value>  
For the sub-scan direction, vertical gap of line (2): within ±1.5%  
For the main-scan direction, horizontal gap of line (3): within ±1.5%

2. Use the maintenance mode U070 to adjust the magnification.  
Sub Scan(F): Adjusts the scanner sub-scan magnification (surface)  
Sub Scan(B): Adjusts the scanner sub-scan magnification (rear side) (DP-770(B))  
Main Scan(CIS): Adjusts the scanner CIS main-scan magnification (DP-771/772)  
Scan (CIS): Adjusts the scanner CIS sub-scan magnification (DP-771/772)

**[Vérification de l'agrandissement]**

1. Vérifier l'écart entre la ligne (1) de l'original (a) et la ligne (2) (3) de l'exemple de copie. Si l'écart excède la valeur de référence, le régler selon la procédure suivante.  
<Valeur de référence>  
Pour la direction du balayage secondaire, l'écart vertical de la ligne (2) est de ±1,5%  
Pour la direction du balayage principal, l'écart horizontal de la ligne (3) est de ±1,5%

2. Pour régler l'agrandissement, utilisez le mode entretien U070.  
Sub Scan(F): Permet de régler l'agrandissement du balayage secondaire du scanner(surface)  
Sub Scan(B): Permet de régler l'agrandissement du balayage secondaire du scanner (arrière)(DP-770(B))  
Main Scan (CIS): Permet de régler l'agrandissement du balayage principal du CIS du scanner (DP-771/772)  
Sub Scan (CIS): Permet de régler l'agrandissement du balayage secondaire du CIS du scanner (DP-771/772)

**[Verificación del cambio de tamaño]**

1. Compruebe la separación entre la línea (1) del original (a) y la línea (2) (3) del ejemplo de copia. Si la separación supera el valor de referencia, ajústela siguiendo este procedimiento.  
<Valor de referencia>  
Para la dirección de exploración secundaria, separación vertical de la línea (2): dentro de ±1,5%  
Para la dirección de exploración principal, separación horizontal de la línea (3): dentro de ±1,5%

2. Para ajustar la ampliación utilice el modo de mantenimiento U070.  
Sub Scan(F): ajusta el cambio de tamaño de la dirección de exploración secundaria del escáner.(anverso)  
Sub Scan(B): ajusta el cambio de tamaño de la dirección de exploración secundaria del escáner (reverso) (DP-770(B))  
Main Scan(CIS): Ajusta el cambio de tamaño de la dirección de exploración principal CIS del escáner (DP-771/772)  
Sub Scan (CIS): ajusta el cambio de tamaño de la dirección de exploración secundaria CIS del escáner (DP-771/772)

**[Überprüfen der Vergrößerung]**

1. Den Abstand zwischen der Linie (1) des Originals (a) und der Linie (2) (3) des Kopierbeispiels prüfen. Wenn der Abstand größer als der Bezugswert ist, den Abstand mit dem folgenden Verfahren einstellen.  
<Bezugswert>  
Subscanrichtung: Vertikaler Abstand der Linie (2): Innerhalb ±1,5%  
Hauptscanrichtung: Horizontaler Abstand der Linie (3): Innerhalb ±1,5%

2. Zum Einstellen der Vergrößerung den Wartungsmodus U070 verwenden.  
Sub Scan(F): Zur Einstellung der Subscan-Vergrößerung(Oberfläche)  
Sub Scan(B): Zur Einstellung der Subscan-Vergrößerung(Rückseite)(DP-770(B))  
Main Scan(CIS): Zur Einstellung der Scanner-CIS-Mainscan-Vergrößerung (DP-771/772)  
Sub Scan (CIS): Zur Einstellung der Scanner-CIS-Subscan-Vergrößerung (DP-771/772)

**[Controllo dell'ingrandimento]**

1. Verificare lo scostamento fra la linea (1) dell'originale (a) e la linea (2) (3) dell'esempio di copia. Se lo scostamento supera il valore di riferimento, regolare lo scostamento stesso seguendo questa procedura.  
<Valore di riferimento>  
Per l'orientamento della scansione ausiliare, lo scostamento verticale della linea (2) deve essere compreso fra ±1,5%

2. Usare la modalità di manutenzione U070 per regolare l'ingrandimento.  
Sub Scan(F): Regola l'ingrandimento della scansione ausiliare dello scanner(superficie)  
Sub Scan(B): Regola l'ingrandimento della scansione ausiliare dello scanner(lato posteriore)(DP-770(B))  
Main Scan (CIS): Regola l'ingrandimento della scansione principale CIS dello scanner (DP-771/772)  
Sub Scan (CIS): Regola l'ingrandimento della scansione ausiliare CIS dello scanner (DP-771/772)

**[ 确认等倍値 ]**

1. 确认原稿 (a) 上的线 (1) 和复印样本上的线 (2)、(3) 之间的偏移值。如果偏移值超过标准值, 则按照下列步骤进行调整。  
<标准值>  
对于副扫描方向, 线 (2) 的上下偏移值: ±1.5% 以内  
对于主扫描方向, 线 (3) 的左右偏移值: ±1.5% 以内

2. 使用维修模式 U070 调整等倍值。  
Sub Scan(F): 读取副扫描等倍度的调整 (正面)  
Sub Scan(B): 读取副扫描等倍度的调整 (反面) (DP-770(B))  
Main Scan(CIS): CIS 的读取主扫描等倍度的调整 (DP-771/772)  
Sub Scan(CIS): CIS 的读取副扫描等倍度的调整 (DP-771/772)

**[ 등배도확인 ]**

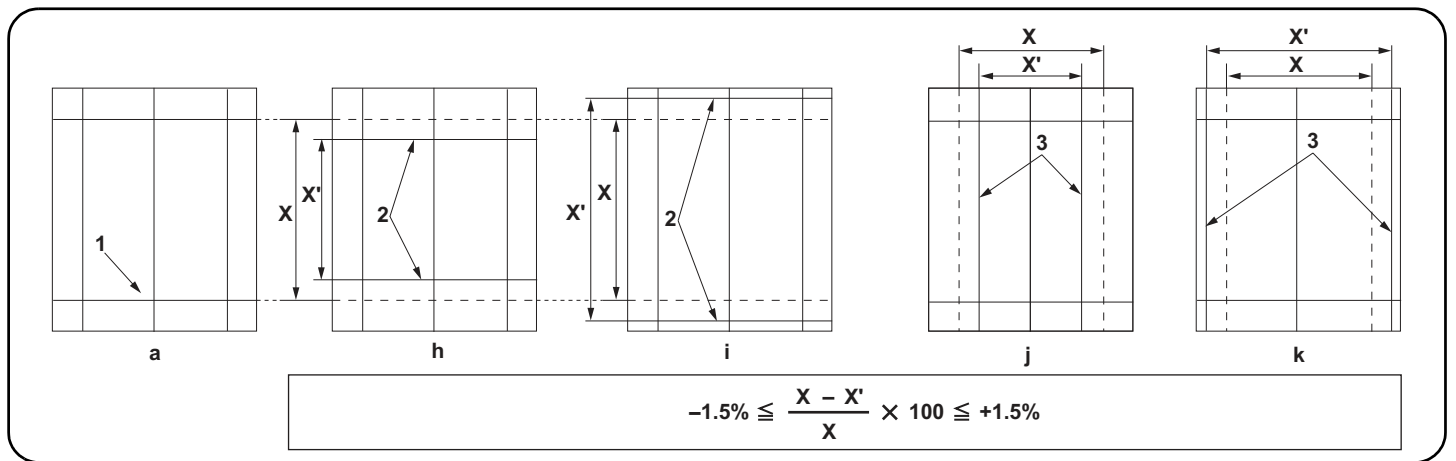
1. 원고 (a) 선 (1) 과 샘플 카피의 선 (2)(3) 의 차이를 확인합니다. 차이가 기준이외의 경우, 다음 순서로 조정을 합니다.  
<기준치>  
부주사 방향의 경우 선 (2) 의 상하차이: ±1.5% 이내  
주주사 방향의 경우 선 (3) 의 좌우차이: ±1.5% 이내

2. 메인テナンス 모드 U070 을 세트하고 조정을 합니다.  
Sub Scan(F): 스캔 부주사등배도의 조정 (표면)  
Sub Scan(B): 스캔 부주사등배도의 조정 (뒷면) (DP-770(B))  
Main Scan(CIS): CIS 의 스캔 주주사등배도의 조정 (DP-771/772)  
Sub Scan(CIS): CIS 의 스캔 부주사등배도의 조정 (DP-771/772)

**[ 等倍度確認 ]**

1. 原稿 (a) の線 (1) とコピーサンプルの線 (2) (3) のずれを確認する。ずれが基準値外の場合、次の手順で調整を行う。  
<基準値>  
副走査方向の場合、線 (2) の上下ずれ: ±1.5% 以内  
主走査方向の場合、線 (3) の左右ずれ: ±1.5% 以内

2. メンテナンスモード U070 をセットし、調整を行う。  
Sub Scan(F): 読み取り副走査等倍度の調整 (表面)  
Sub Scan(B): 読み取り副走査等倍度の調整 (裏面) (DP-770(B))  
Main Scan(CIS): CIS の読み取り主走査等倍度の調整 (DP-771/772)  
Sub Scan(CIS): CIS の読み取り副走査等倍度の調整 (DP-771/772)



**3. Adjust the values.**

For the shorter length copy example (h)(j): Increases the value.  
 For the longer length copy example (i)(k): Decreases the value.  
 Amount of change per step: 0.10 %

**4. Perform a test copy.**

**5. Repeat the steps 2 to 4 above until the gap of line (2) (3) of copy example shows the reference value.**

<Reference value>

For the sub-scan direction, vertical gap of line (2): within ±1.5%

For the main-scan direction, horizontal gap of line (3): within ±1.5%

**3. Régler les valeurs.**

Pour l'exemple de copie dont la longueur est plus courte (h)(j) : augmenter la valeur.

Pour l'exemple de copie dont la longueur est plus longue (i)(k) : diminuer la valeur.

Changement par graduation d'échelle : 0,10 %

**4. Effectuer une copie de test.**

**5. Répéter les étapes 2 à 4 jusqu'à ce que l'écart de la ligne (2) (3) de l'exemple de copie indique la valeur de référence.**

<Valeur de référence>

Pour la direction du balayage secondaire, l'écart vertical de la ligne (2) est de ±1,5%

Pour la direction du balayage principal, l'écart horizontal de la ligne (3) est de ±1,5%

**3. Ajuste los valores.**

Para el ejemplo de copia más corto (h)(j): aumenta el valor.

Para el ejemplo de copia más largo (i)(k): disminuye el valor.

Magnitud del cambio por incremento: 0,10 %

**4. Haga una copia de prueba.**

**5. Repita los pasos 2 a 4 anteriores hasta que la separación de la línea (2) (3) del ejemplo de copia presente el valor de referencia.**

<Valor de referencia>

Para la dirección de exploración secundaria, separación vertical de la línea (2): dentro de ±1,5%

Para la dirección de exploración principal, separación horizontal de la línea (3): dentro de ±1,5%

**3. Die Werte einstellen.**

Für die kürzere Länge des Kopierbeispiels (h)(j): Den Wert erhöhen.

Für die längere Länge des Kopierbeispiels (i)(k): Den Wert verringern.

Änderung pro Schritt: 0,10 %

**4. Eine Testkopie erstellen.**

**5. Die Schritte 2 bis 4 wiederholen, bis der Abstand der Linie (2) (3) des Kopierbeispiels den Bezugswert aufweist.**

<Bezugswert>

Subscanrichtung: Vertikaler Abstand der Linie (2): Innerhalb ±1,5%

Hauptscanrichtung: Horizontaler Abstand der Linie (3): Innerhalb ±1,5%

**3. Regolare i valori.**

Per l'esempio di copia di lunghezza inferiore (h)(j): aumenta il valore.

Per l'esempio di copia di lunghezza superiore (i)(k): riduce il valore.

Entità modifica per passo: 0,10 %

**4. Eseguire una copia di prova**

**5. Ripetere le operazioni sopra descritte da 2 a 4 fino a quando lo scostamento della linea (2) (3) dell'esempio di copia riporterà i valori di riferimento.**

<Valore di riferimento>

Per l'orientamento della scansione ausiliare, lo scostamento verticale della linea (2) deve essere compreso fra ±1,5%

Per l'orientamento della scansione principale, lo scostamento orizzontale della linea (3) deve essere compreso fra ±1,5%

**3. 調整設定値。**

在长度偏短时 复印样本 (h) (j) : 调高设定值

在长度偏长时 复印样本 (i) (k) : 调低设定值

设定值的一个调整单位变化量 : 0.10%

**4. 进行测试复印。**

**5. 重复上述步骤 2 到 4, 直至复印样本上的线 (2)、(3) 之间的偏移值达到标准值范围内。**

<标准值>

对于副扫描方向, 线 (2) 的上下偏移值 : ±1.5% 以内

对于主扫描方向, 线 (3) 的左右偏移值 : ±1.5% 以内

**3. 설정치를 조정합니다 .**

길이가 짧은 경우 샘플 카피 (h)(j): 설정치를 높입니다 .

길이가 긴 경우 샘플 카피 (i)(k): 설정치를 내립니다 .

1 스텝당 변화량: 0.10%

**4. 테스트 카피를 합니다 .**

**5. 샘플 카피 선 (2)(3) 의 차이가 기준치내가 될 때까지 2 ~ 4 를 반복합니다 .**

< 기준치 >

부주사 방향의 경우 선 (2) 의 상하차이: ±1.5% 이내

주주사 방향의 경우 선 (3) 의 좌우차이: ±1.5% 이내

**3. 設定値を調整する。**

長さが短い場合コピーサンプル (h) (j) : 設定値を上げる

長さが長い場合コピーサンプル (i) (k) : 設定値を下げる

1 ステップ当たりの変化量: 0.10%

**4. テストコピーを行う。**

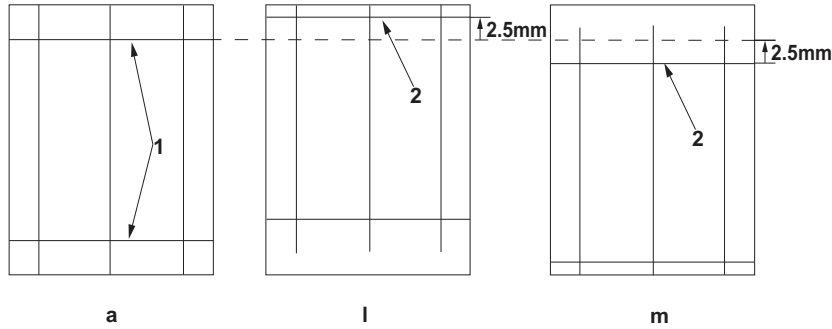
**5. コピーサンプルの線 (2) (3) のずれが基準値内になるまで手順 2 ~ 4 を繰り返す。**

< 基準値 >

副走査方向の場合、線 (2) の上下ずれ: ±1.5% 以内

主走査方向の場合、線 (3) の左右ずれ: ±1.5% 以内





#### [Checking the leading edge timing]

1. Check the gap between line (1) on original (a) and line (2) of copy example. If the gap exceeds the reference value, adjust the gap according to the following procedure.  
<Reference value>  
Vertical gap of line (2): within  $\pm 2.5$  mm

2. Use the maintenance mode U071 to adjust the timing.

Front Head: Adjusts the leading edge timing (surface)  
Front Tail: Adjusts the trailing edge timing (surface)  
CIS Head: Adjusts the leading edge timing for CIS scanning.(DP-771/772)  
CIS Tail: Adjusts the trailing edge timing for CIS scanning.(DP-771/772)  
Back Head: Adjusts the leading edge timing (rear side)(DP-770(B))  
Back Tail: Adjusts the trailing edge timing (rear side)(DP-770(B))

#### [Vérification de la synchronisation du bord avant]

1. Vérifier l'écart entre la ligne (1) de l'original (a) et la ligne (2) de l'exemple de copie. Si l'écart excède la valeur de référence, le régler selon la procédure suivante.  
<Valeur de référence>  
Écart vertical de la ligne (2) :  $\pm 2,5$  mm

2. Pour régler la synchronisation, utilisez le mode entretien U071.

Front Head: Permet de régler la synchronisation du bord de tête (surface)  
Front Tail: Permet de régler la synchronisation du bord arrière (surface)  
CIS Head: Permet de régler la synchronisation du bord de tête pour le balayage par le CIS.(DP-771/772)  
CIS Tail: Permet de régler la synchronisation du bord arrière pour le balayage par le CIS.(DP-771/772)  
Back Head: Permet de régler la synchronisation du bord de tête (arrière)(DP-770(B))  
Back Tail: Permet de régler la synchronisation du bord arrière (arrière)(DP-770(B))

#### [Cambio de la sincronización de borde superior]

1. Compruebe la separación entre la línea (1) del original (a) y la línea (2) del ejemplo de copia. Si la separación supera el valor de referencia, ajústela siguiendo este procedimiento.  
<Valor de referencia>  
Separación vertical de la línea (2): dentro de  $\pm 2,5$  mm

2. Para ajustar la sincronización utilice el modo de mantenimiento U071.

Front Head: Ajusta la sincronización del borde superior (anverso).  
Front Tail: Ajusta la sincronización del borde inferior (anverso).  
CIS Head: Ajusta la sincronización del borde superior para exploración CIS.(DP-771/772)  
CIS Tail: Ajusta la sincronización del borde inferior para exploración CIS.(DP-771/772)  
Back Head: Ajusta la sincronización del borde superior (reverso).(DP-770(B))  
Back Tail: Ajusta la sincronización del borde inferior (reverso).(DP-770(B))

#### [Überprüfen des Vorderkanten-Timings]

1. Den Abstand zwischen der Linie (1) des Originals (a) und der Linie (2) des Kopierbeispiels prüfen. Wenn der Abstand größer als der Bezugswert ist, den Abstand mit dem folgenden Verfahren einstellen.  
<Bezugswert>  
Vertikaler Abstand der Linie (2): Innerhalb  $\pm 2,5$  mm

2. Zum Einstellen des Timing den Wartungsmodus U071 verwenden.

Front Head: Zur Einstellung des Vorderkanten-Timing (Oberfläche)  
Front Tail: Zur Einstellung des Hinterkanten-Timing (Oberfläche)  
CIS Head: Zur Einstellung des Vorderkanten-Timing für CIS-Scannen.(DP-771/772)  
CIS Tail: Zur Einstellung des Hinterkanten-Timing für CIS-Scannen.(DP-771/772)  
Back Head: Zur Einstellung des Vorderkanten-Timing (Rückseite)(DP-770(B))  
Back Tail: Zur Einstellung des Hinterkanten-Timing (Rückseite)(DP-770(B))

#### [Controllo della sincronizzazione del bordo principale]

1. Verificare lo scostamento fra la linea (1) sull'originale (a) e la linea (2) dell'esempio di copia. Se lo scostamento supera il valore di riferimento, regolare lo scostamento stesso seguendo questa procedura.  
<Valore di riferimento>  
Scostamento verticale della linea (2) compreso fra  $\pm 2,5$  mm

2. Usare la modalità di manutenzione U071 per regolare la sincronizzazione.

Front Head: Regola la sincronizzazione del bordo principale (superficie)  
Front Tail: Regola la sincronizzazione del bordo di uscita (superficie)  
CIS Head: Regola la sincronizzazione del bordo principale per scansione CIS.(DP-771/772)  
CIS Tail: Regola la sincronizzazione del bordo di uscita per scansione CIS.(DP-771/772)  
Back Head: Regola la sincronizzazione del bordo principale (lato posteriore)(DP-770(B))  
Back Tail: Regola la sincronizzazione del bordo di uscita (lato posteriore)(DP-770(B))

#### [ 确认前端定时调整 ]

1. 确认原稿 (a) 上的线 (1) 和复印样本上的线 (2) 之间的偏移值。如果偏移值超过标准值, 则按照下列步骤进行调整。  
<标准值>  
线 (2) 的上下偏移值:  $\pm 2.5$  mm 以内

2. 使用维修模式 U071 调整定时。

Front Head: 调整前端定时 (正面)  
Front Tail: 调整后端定时 (正面)  
CIS Head: 调整 CIS 读取时的前段对位 (DP-771/772)  
CIS Tail: 调整 CIS 读取时的后段定时 (DP-771/772)  
Back Head: 调整前端定时 (反面) (DP-770 (B))  
Back Tail: 调整后端定时 (反面) (DP-770 (B))

#### [ 선단 타이밍확인 ]

1. 원고 (a) 선 (1) 과 샘플 카피 선 (2) 의 차이를 확인합니다. 차이가 기준치 외의 경우 다음 순서로 조정을 합니다.  
<기준치>  
선 (2) 의 상하차이:  $\pm 2.5$ mm 이내

2. 메인テナンス 모드 U071 을 세트하고 조정을 합니다.

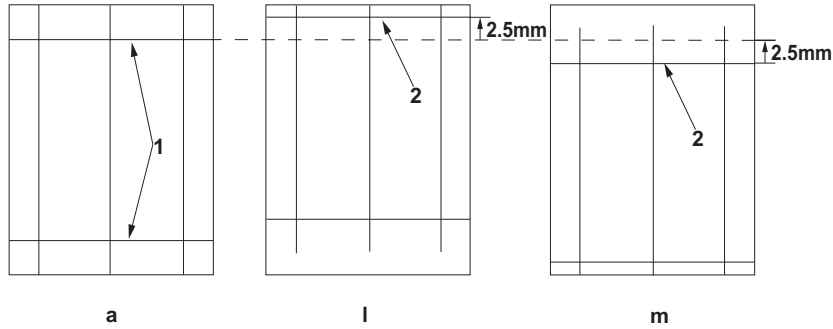
Front Head: 선단 타이밍 (표면) 을 조정합니다.  
Front Tail: 후단 타이밍 (표면) 을 조정합니다.  
CIS Head: CIS 스캔 시의 선단 타이밍을 조정합니다.(DP-771/772)  
CIS Tail: CIS 스캔 시의 후단 타이밍을 조정합니다.(DP-771/772)  
Back Head: 선단 타이밍 (뒷면) 을 조정합니다.(DP-770(B))  
Back Tail: 후단 타이밍 (뒷면) 을 조정합니다.(DP-770(B))

#### [ 先端タイミン確認 ]

1. 原稿 (a) の線 (1) とコピーサンプルの線 (2) のずれを確認する。ずれが基準値外の場合、次の手順で調整を行う。  
<基準値>  
線 (2) の上下ずれ:  $\pm 2.5$ mm 以内

2. メンテナンスモード U071 をセットし、調整を行う。

Front Head: 先端タイミング (表面) を調整する  
Front Tail: 後端タイミング (表面) を調整する  
CIS Head: CIS 読み込み時の先端タイミングを調整する (DP-771/772)  
CIS Tail: CIS 読み込み時の後端タイミングを調整する (DP-771/772)  
Back Head: 先端タイミング (裏面) を調整する (DP-770 (B))  
Back Tail: 後端タイミング (裏面) を調整する (DP-770 (B))



**3. Adjust the values.**

For the faster leading edge timing, copy examples (l): Decreases the value.

For the slower leading edge timing, copy examples (m): Increases the value.

Amount of change per step: 0.17 mm

**4. Perform a test copy.**

**5. Repeat the steps 2 to 4 above until the gap of line (2) of copy example shows the reference value.**

<Reference value>

Vertical gap of line (2): within  $\pm 2.5$  mm

**3. Régler les valeurs.**

Pour les exemples de copie dont la synchronisation du bord avant est plus rapide (l) : diminuer la valeur.

Pour les exemples de copie dont la synchronisation du bord avant est plus lente (m) : augmenter la valeur.

Changement par graduation d'échelle : 0,17 mm

**4. Effectuer une copie de test.**

**5. Répéter les étapes 2 à 4 jusqu'à ce que l'écart de la ligne (2) de l'exemple de copie indique la valeur de référence.**

<Valeur de référence>

Écart vertical de la ligne (2) :  $\pm 2,5$  mm

**3. Ajuste los valores.**

Para una sincronización más rápida de extremo guía, ejemplos de copia (l): disminuye el valor.

Para una sincronización más lenta de extremo guía, ejemplos de copia (m): aumenta el valor.

Magnitud del cambio por incremento: 0,17 mm

**4. Haga una copia de prueba.**

**5. Repita los pasos 2 a 4 anteriores hasta que la separación de la línea (2) del ejemplo de copia presente el valor de referencia.**

<Valor de referencia>

Separación vertical de la línea (2): dentro de  $\pm 2,5$  mm

**3. Die Werte einstellen.**

Für den schnelleren Vorderkantentakt, Kopierbeispiel (l): Den Wert verringern.

Für den langsameren Vorderkantentakt, Kopierbeispiel (m): Den Wert erhöhen.

Änderung pro Schritt: 0,17 mm

**4. Eine Testkopie erstellen.**

**5. Die Schritte 2 bis 4 wiederholen, bis der Abstand der Linie (2) des Kopierbeispiels den Bezugswert aufweist.**

<Bezugswert>

Vertikaler Abstand der Linie (2): Innerhalb  $\pm 2,5$  mm

**3. Regolare i valori.**

Per accelerare la fasatura del bordo di entrata, esempi di copia (l): riduce il valore.

Per rallentare la fasatura del bordo di entrata, esempi di copia (m): aumenta il valore.

Entità modifica per passo: 0,17 mm

**4. Eseguire una copia di prova**

**5. Ripetere le operazioni sopra descritte da 2 a 4 fino a quando lo scostamento della linea (2) dell'esempio di copia riporterà i valori di riferimento.**

<Valore di riferimento>

Scostamento verticale della linea (2) compreso fra  $\pm 2,5$  mm

**3. 調整設定値。**

在前端定时偏快时 复印样本(1): 调低设定值

在前端定时偏慢时 复印样本(m): 调高设定值

设定值的一个调整单位变化量: 0.17mm

**4. 进行测试复印。**

**5. 重复上述步骤 2 到 4, 直至复印样本上的线(2)的偏移值达到标准值范围内。**

<标准值>

线(2)的上下偏移值:  $\pm 2.5$ mm 以内

**3. 설정치를 조정합니다.**

선단 타이밍이 빠른 경우 샘플 카피 (l): 설정치를 내립니다.

선단 타이밍이 늦은 경우 샘플 카피 (m): 설정치를 올립니다.

1 스텝당 변화량: 0.17mm

**4. 테스트 카피를 합니다.**

**5. 샘플 카피 선 (2) 의 차이가 기준치내가 될 때까지 2 ~ 4 를 반복합니다.**

<기준치>

선 (2) 의 상하차이:  $\pm 2.5$ mm 이내

**3. 設定値を調整する。**

先端タイミングが早い場合コピーサンプル (1): 設定値を下げる。

先端タイミングが遅い場合コピーサンプル (m): 設定値を上げる。

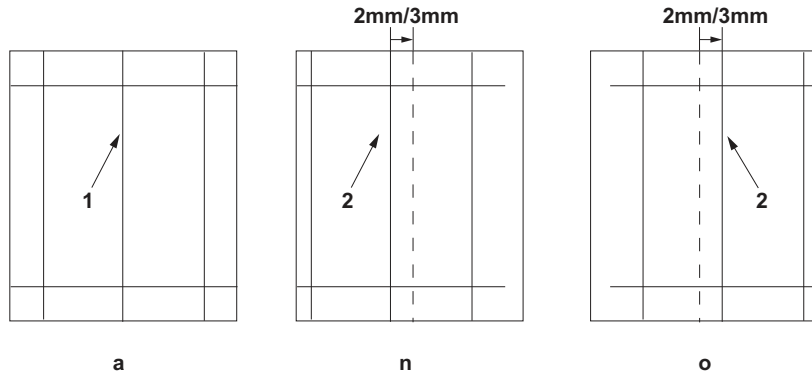
1 ステップ当たりの変化量: 0.17mm

**4. テストコピーを行う。**

**5. コピーサンプルの線 (2) のずれが基準値内になるまで手順 2 ~ 4 を繰り返す。**

<基準値>

線 (2) の上下ずれ:  $\pm 2.5$ mm 以内



#### [Checking the center line]

1. Check the gap between center line (1) on original (a) and center line (2) of copy example. If the gap exceeds the reference value, adjust the gap according to the following procedure.

<Reference value>

Horizontal difference of center line (2) for the single copying:  $\pm 2.0$  mm  
Horizontal difference of center line (2) for the duplex copying:  $\pm 3.0$  mm

2. Use the maintenance mode U072 to adjust the timing.

Front: Adjusts the center line (surface)

Back: Adjusts the center line (rear side)

CIS: Adjusts the CIS center line (DP-771/772)

#### [Vérification de la ligne médiane]

1. Vérifier l'écart entre l'axe (1) de l'original (a) et l'axe (2) de l'exemple de copie. Si l'écart excède la valeur de référence, le régler selon la procédure suivante.

<Valeur de référence>

Différence horizontale de l'axe (2) pour la copie recto :  $\pm 2,0$  mm

Différence horizontale de l'axe (2) pour la copie recto-verso :  $\pm 3,0$  mm

2. Pour régler la ligne médiane, utiliser le mode entretien U072.

Front: Permet de régler l'axe (surface)

Back: Permet de régler l'axe (arrière)

CIS: Permet de régler l'axe du CIS (DP-771/772)

#### [Verificación de la línea central]

1. Compruebe la separación entre la línea de centro (1) del original (a) y la línea de centro (2) del ejemplo de copia. Si la separación supera el valor de referencia, ajústela siguiendo este procedimiento.

<Valor de referencia>

Diferencia horizontal de la línea de centro (2) para el copiado por una cara:  $\pm 2,0$  mm

Diferencia horizontal de la línea de centro (2) para el copiado dúplex:  $\pm 3,0$  mm

2. Para ajustar la línea central utilice el modo de mantenimiento U072.

Front: ajusta la línea central (anverso)

Back: ajusta la línea central (reverso)

CIS: ajusta la línea central CIS (DP-771/772)

#### [Überprüfen der Mittellinie]

1. Den Abstand zwischen der Mittellinie (1) des Originals (a) und der Mittellinie (2) des Kopierbeispiels prüfen. Wenn der Abstand größer als der Bezugswert ist, den Abstand mit dem folgenden Verfahren einstellen.

<Bezugswert>

Horizontaler Unterschied der Mittellinie (2) für die Einzelkopie:  $\pm 2,0$  mm

Horizontaler Unterschied der Mittellinie (2) für die Duplexkopie:  $\pm 3,0$  mm

2. Zum Einstellen der Mittellinie den Wartungsmodus U072 verwenden.

Front: Zur Einstellung der Mittellinie (Oberfläche)

Back: Zur Einstellung der Mittellinie (Rückseite)

CIS: Zur Einstellung der CIS-Mittellinie (DP-771/772)

#### [Controllo della linea centrale]

1. Verificare lo scostamento fra la linea centrale (1) sull'originale (a) e la linea centrale (2) dell'esempio di copia. Se lo scostamento supera il valore di riferimento, regolare lo scostamento stesso seguendo questa procedura.

<Valore di riferimento>

Differenza orizzontale della linea centrale (2) per la copia singola:  $\pm 2,0$  mm

Differenza orizzontale della linea centrale (2) per la copia duplex:  $\pm 3,0$  mm

2. Usare la modalità di manutenzione U072 per regolare la linea centrale.

Front: Regola la linea centrale (superficie)

Back: Regola la linea centrale (lato posteriore)

CIS: Regola la linea centrale CIS (DP-771/772)

#### [ 确认中心线 ]

1. 确认原稿 (a) 中心线 (1) 和复印样本中心线 (2) 之间的偏移值。如果偏移值超过标准值, 则按照下列步骤进行调整。

<标准值> 单面复印时, 中心线 (2) 的左右偏移值:  $\pm 2.0$  mm 以内

双面复印时, 中心线 (2) 的左右偏移值:  $\pm 3.0$  mm 以内

2. 使用维修模式 U072 调整中心线。

Front: 中心位置 (正面) 的调整

Back: 中心位置 (反面) 的调整

CIS: CIS 的中心位置的调整 (DP-771/772)

#### [ 센터 라인 확인 ]

1. 원고 (a) 센터라인 (1) 과 샘플 카피 센터라인 (2) 의 차이를 확인합니다 . 차이가 기준치 외의 경우 다음 순서로 조정합니다 .

<기준치> 단면의 경우 센터라인 (2) 의 좌우차이:  $\pm 2.0$ mm 이내

양면의 경우 센터라인 (2) 의 좌우차이:  $\pm 3.0$ mm 이내

2. 메인テナンス 모드 U072 을 세트하고 조정을 합니다 .

Front: 센터 위치 (표면) 의 조정

Back: 센터 위치 (뒷면) 의 조정

CIS: CIS 의 센터 위치조정 ((DP-771/772)

#### [ センターライン確認 ]

1. 原稿 (a) の中心線 (1) とコピーサンプルの中心線 (2) のずれを確認する。ずれが基準値外の場合、次の手順で調整を行う。

<基準値> 片面の場合、中心線 (2) の左右ずれ:  $\pm 2.0$  mm 以内

両面の場合、中心線 (2) の左右ずれ:  $\pm 3.0$  mm 以内

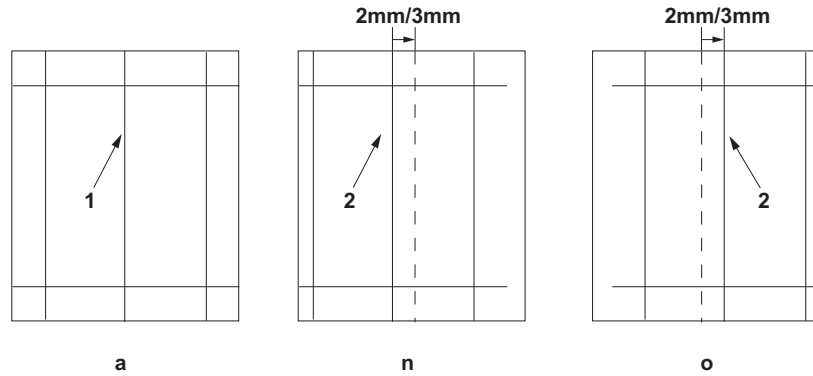
2. メンテナンスモード U072 をセットし、調整を行う。

Front: センター位置 (表面) の調整

Back: センター位置 (裏面) の調整

CIS: CIS のセンター位置の調整 (DP-771/772)





**3. Adjust the values.**

If the center moves more front, copy example (n): Increases the value.  
 If the center moves inner, copy sample (o): Decreases the value.  
 Amount of change per step: 0.085 mm

**4. Perform a test copy.**

**5. Repeat the steps 2 to 4 above until the gap of line (2) of copy example shows the reference value.**

<Reference value>

Horizontal difference of center line (2) for the single copying:  $\pm 2.0$  mm

Horizontal difference of center line (2) for the duplex copying:  $\pm 3.0$  mm

**3. Régler les valeurs.**

Pour l'exemple de copie (n) dont l'axe se déplace davantage vers l'avant : augmenter la valeur.

Pour l'exemple de copie (o) dont l'axe se déplace vers l'intérieur : diminuer la valeur.

Changement par graduation d'échelle : 0,085 mm

**4. Effectuer une copie de test.**

**5. Répéter les étapes 2 à 4 jusqu'à ce que l'écart de la ligne (2) de l'exemple de copie indique la valeur de référence.**

<Valeur de référence>

Différence horizontale de l'axe (2) pour la copie recto :  $\pm 2,0$  mm

Différence horizontale de l'axe (2) pour la copie recto-verso :  $\pm 3,0$  mm

**3. Ajuste los valores.**

Si el centro se desplaza más hacia el frente, ejemplo de copia (n): aumenta el valor.

Si el centro se desplaza hacia dentro, ejemplo de copia (o): disminuye el valor.

Magnitud del cambio por incremento: 0,085 mm

**4. Haga una copia de prueba.**

**5. Repita los pasos 2 a 4 anteriores hasta que la separación de la línea (2) del ejemplo de copia presente el valor de referencia.**

<Valor de referencia>

Diferencia horizontal de la línea de centro (2) para el copiado por una cara:  $\pm 2,0$  mm

Diferencia horizontal de la línea de centro (2) para el copiado dúplex:  $\pm 3,0$  mm

**3. Die Werte einstellen.**

Wenn die Mitte nach vorne verlagert ist, Kopierbeispiel (n): Den Wert erhöhen.

Wenn die Mitte nach innen verlagert ist, Kopierbeispiel (o): Den Wert verringern.

Änderung pro Schritt: 0,085 mm

**4. Eine Testkopie erstellen.**

**5. Die Schritte 2 bis 4 wiederholen, bis der Abstand der Linie (2) des Kopierbeispiels den Bezugswert aufweist.**

<Bezugswert>

Horizontaler Unterschied der Mittellinie (2) für die Einzelkopie:  $\pm 2,0$  mm

Horizontaler Unterschied der Mittellinie (2) für die Duplexkopie:  $\pm 3,0$  mm

**3. Regolare i valori.**

Se il centro si sposta più avanti, esempio di copia (n): aumenta il valore.

Se il centro si sposta verso l'interno, esempio di copia (o): riduce il valore.

Entità modifica per passo: 0,085 mm

**4. Eseguire una copia di prova**

**5. Ripetere le operazioni sopra descritte da 2 a 4 fino a quando lo scostamento della linea (2) dell'esempio di copia riporterà i valori di riferimento.**

<Valore di riferimento>

Differenza orizzontale della linea centrale (2) per la copia singola:  $\pm 2,0$  mm

Differenza orizzontale della linea centrale (2) per la copia duplex:  $\pm 3,0$  mm

**3. 調整設定値。**

当中心向前偏移时 复印样本 (n) : 调高设定值

当中心向内偏移时 复印样本 (o) : 调低设定值

设定值的一个调整单位变化量 : 0.085mm

**4. 进行测试复印。**

**5. 重复上述步骤 2 到 4, 直至复印样本上的线 (2) 的偏移值达到标准值范围内。**

<标准值>

单面复印时, 中心线 (2) 的左右偏移值 :  $\pm 2.0$ mm 以内

双面复印时, 中心线 (2) 的左右偏移值 :  $\pm 3.0$ mm 以内

**3. 설정치를 조정합니다 .**

센터가 바로 앞으로 틀려 있는 경우 샘플 카피 (n) : 설정치를 높입니다 .

센터가 안으로 틀려 있는 경우 샘플 카피 (o) : 설정치를 내립니다 .

1 스텝당 변화량 : 0.085mm

**4. 테스트 카피를 합니다 .**

**5. 샘플 카피 센터라인 (2) 차이가 기준치 내가 될 때까지 순서 2 ~ 4 를 반복합니다 .**

< 기준치 >

단면의 경우 센터라인 (2) 의 좌우차이 :  $\pm 2.0$ mm 이내

양면의 경우 센터라인 (2) 의 좌우차이 :  $\pm 3.0$ mm 이내

**3. 設定値を調整する。**

センターが手前にずれている場合コピーサンプル (n) : 設定値を上げる。

センターが奥にずれている場合コピーサンプル (o) 設定値を下げる。

1 ステップ当たりの変化量 : 0.085mm

**4. テストコピーを行う。**

**5. コピーサンプルの中心線 (2) ずれが基準値内になるまで手順 2 ~ 4 を繰り返す。**

<基準値>

片面の場合、中心線 (2) の左右ずれ :  $\pm 2.0$ mm 以内

両面の場合、中心線 (2) の左右ずれ :  $\pm 3.0$ mm 以内

# MEMO

# MEMO





303NW5673001

2013. 7  
303NW56730-01

# **INSTALLATION GUIDE FOR PAPER FEEDER**

---

**INSTALLATION GUIDE**

**GUIDE D'INSTALLATION**

**GUÍA DE INSTALACION**

**INSTALLATIONSANLEITUNG**

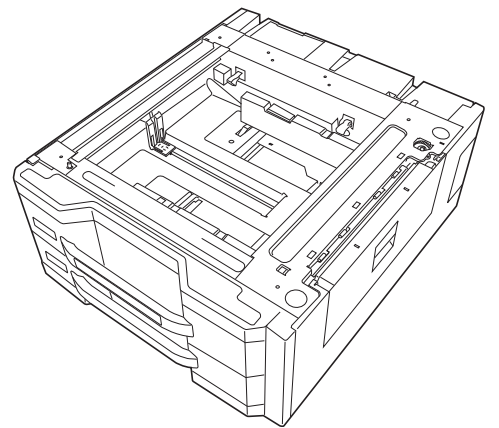
**GUIDA ALL'INSTALLAZIONE**

**安装手册**

**설치안내서**

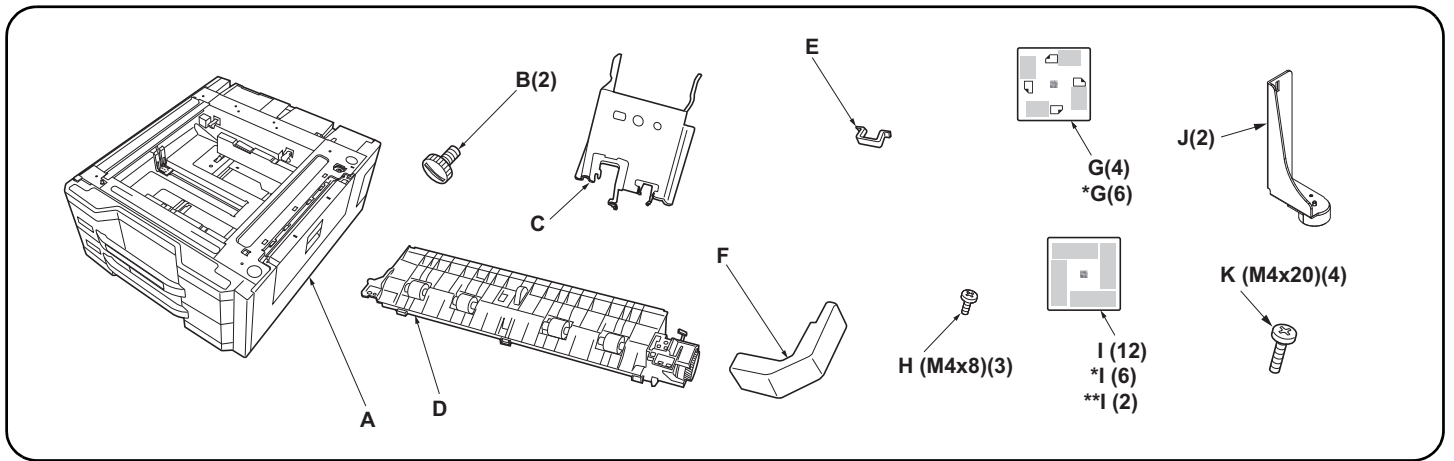
**設置手順書**

**PF-730(B)**

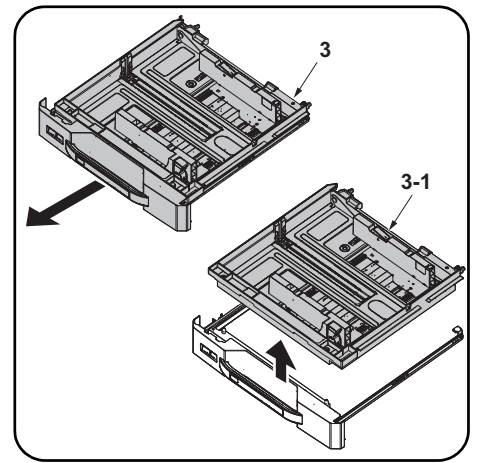
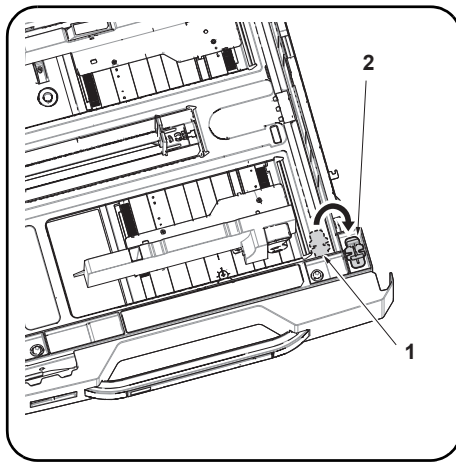








English		E. Clamp ..... 1		I. Media type plate (except for above models).....12	
<b>Supplied parts</b>		<b>F. Wire cover..... 1</b>		<b>J. Stopper ..... 2</b>	
A. Paper feeder..... 1		<b>G. Paper size plate..... 4</b>		<b>K. S Tite screws M4 x 20 ..... 4</b>	
B. Pin ..... 2		<b>H. S Tite screw M4 x 8..... 3</b>		Be sure to remove any tape and/or cushioning materials from the parts supplied.	
C. Retainer ..... 1		<b>*I. Media type plate(120V model only) ..... 6</b>			
D. Intermediate paper conveying unit..... 1		<b>**I. Media type plate(110V model only) ..... 2</b>			
<b>Français</b>		<b>E. Collier..... 1</b>		Veillez à retirer les morceaux de bande adhésive et/ou les matériaux de rembourrage des pièces fournies.	
<b>Pièces fournies</b>		<b>F. Couvercle de câble..... 1</b>			
A. Chargeur de papier..... 1		<b>G. Plaquette du format de papier ..... 4</b>			
B. Broche ..... 2		<b>H. Vis S Tite M4 x 8 ..... 3</b>			
C. Élément de retenue ..... 1		<b>I. Plaquette du type de support..... 12</b>			
D. Unité de transport du papier intermédiaire 1		<b>J. Butée ..... 2</b>			
<b>Español</b>		<b>K. Vis S Tite M4 x 20 ..... 4</b>			
<b>Partes suministradas</b>		<b>E. Sujetador ..... 1</b>		Asegúrese de despegar todas las cintas y/o material amortiguador de las partes suministradas.	
A. Depósito de papel..... 1		<b>F. Cubierta para el cable..... 1</b>			
B. Clavija..... 2		<b>G. Placa de tamaño de papel ..... 4</b>			
C. Retén ..... 1		<b>H. Tornillo S Tite M4 x 8 ..... 3</b>			
D. Unidad de transporte de papel intermedia. 1		<b>I. Placa de tipo de medio ..... 12</b>			
<b>Deutsch</b>		<b>J. Tope ..... 2</b>			
<b>Enthaltene Teile</b>		<b>K. Tornillos S Tite M4 x 20 ..... 4</b>		Stellen Sie sicher, dass sämtliche Klebebänder und/oder Polstermaterial von den gelieferten Teilen entfernt wurden.	
A. Papiereinzug..... 1		<b>E. Klemme..... 1</b>			
B. Stift..... 2		<b>F. Kabelabdeckung..... 1</b>			
C. Halterung..... 1		<b>G. Papierformatkarte ..... 4</b>			
D. Eingesetzte Papierfördereinheit ..... 1		<b>H. S-Tite-Schraube M4 x 8..... 3</b>			
<b>Italiano</b>		<b>I. Medientypkarte ..... 12</b>			
<b>Parti fornite</b>		<b>J. Anschlag..... 2</b>		Rimuovere tutti i nastri adesivi e/o i materiali di protezione dalle parti fornite.	
A. Unità di alimentazione della carta ..... 1		<b>K. S-Tite-Schrauben M4 x 20..... 4</b>			
B. Perno ..... 2		<b>E. Morsetto..... 1</b>			
C. Fermo ..... 1		<b>F. Coperchio cavi..... 1</b>			
D. Unità intermediale di trasporto carta..... 1		<b>G. Piastra formato carta ..... 4</b>			
<b>简体中文</b>		<b>H. Vite S Tite M4 x 8 ..... 3</b>			
<b>附属品</b>		<b>I. Piastra tipo carta..... 12</b>		K. 紧固型 S 螺丝 M4×20 ..... 4	
A. 供纸工作台..... 1		<b>J. Fermo ..... 2</b>		如果附属品上带有固定胶带, 缓冲材料时务必揭下。	
B. 固定插销..... 2		<b>K. Vite S Tite M4 x 20 ..... 4</b>			
C. 安装板..... 1		<b>E. 束线夹 ..... 1</b>			
D. 中间搬运单元..... 1		<b>F. 电线盖板 ..... 1</b>			
<b>한국어</b>		<b>*G. 纸张尺寸标识片 ..... 6</b>			
<b>동봉품</b>		<b>H. 紧固型 S 螺丝 M4×8 ..... 3</b>		동봉품에 고정 테이프, 완충재가 붙어 있는 경우에는 반드시 제거할 것 .	
A. 급지대..... 1		<b>**I. 纸张种类标识片 ..... 2</b>			
B. 핀..... 2		<b>J. 限位器 ..... 2</b>			
C. 부착판..... 1		<b>E. 크램프 ..... 1</b>			
D. 중간반송유닛..... 1		<b>F. 전선커버..... 1</b>			
<b>日本語</b>		<b>G. 用紙サイズプレート ..... 4</b>		K. ナサ M4×20 S タイト..... 4	
<b>同梱品</b>		<b>H. ビス M4×8 S タイト ..... 3</b>		同梱品に固定テープ、緩衝材が付いている場合は必ず取り外すこと。	
A. ペーパーフィーダー..... 1		<b>*I. 用紙種類プレート ..... 2</b>			
B. ピン..... 2		<b>J. 転倒防止金具 ..... 2</b>			
C. 取付板..... 1		<b>K. ビス M4×20 S タイト ..... 4</b>			
D. 中間搬送ユニット..... 1					



### Procedure

Before starting installation, be sure to turn the main power switch of the machine off, and unplug the power plug from the wall outlet.

1. Pull each cassette out from the paper feeder (A). Remove the lift plate stopper (1) from each cassette and attach it to the storage location (2).
2. Gently close each cassette.

3. Pull out the lower paper cassette (3) from the machine.
4. Remove the paper cassette (3-1).

### Procédure

Avant de commencer l'installation, s'assurer de mettre la machine hors tension et de débrancher la fiche d'alimentation de la prise murale.

1. Sortez chaque magasin du chargeur de papier (A). Retirez la butée de la plaque de levage (1) de chaque magasin et fixez-la dans l'emplacement de stockage (2).
2. Refermez progressivement chaque tiroir.

3. Sortez le magasin de papier inférieur (3) de la machine.
4. Retirez le magasin de papier (3-1).

### Procedimiento

Antes de iniciar la instalación, asegúrese de apagar el interruptor de encendido de la máquina y desenchufar el cable de alimentación de la toma de pared.

1. Saque cada uno de los depósitos del depósito de papel (A). Quite el tope de placa de elevación (1) de cada depósito y póngalo en el espacio reservado para guardarlo (2).
2. Cierre suavemente cada bandeja.

3. Extraiga el depósito inferior (3) de la máquina.
4. Quite el depósito de papel (3-1).

### Verfahren

Bevor Sie mit der Installation beginnen überzeugen Sie sich, dass der Netzschalter des Geräts ausgeschaltet und das Stromkabel aus der Steckdose gezogen ist.

1. Ziehen Sie jede Kasette aus dem Papierreinzug (A) heraus. Entfernen Sie die Verriegelung des Papierlifts (1) aus jeder Kasette und setzen Sie die Verriegelung in die Parkposition (2) ein.
2. Alle Kassetten sanft schließen.

3. Ziehen Sie die untere Kasette (3) aus dem Gerät heraus.
4. Nehmen Sie die Papierkasette (3-1) heraus.

### Procedura

Prima di iniziare l'installazione, spegnere la macchina e scollegare la spina dalla presa di corrente.

1. Estrarre ciascun cassetto dall'unità di alimentazione carta (A). Rimuovere il fermo della piastra di sollevamento (1) da ogni cassetto e fissarlo sulla posizione a riposo (2).
2. Chiudere delicatamente ciascun cassetto.

3. Estrarre il cassetto carta inferiore (3) dalla macchina.
4. Rimuovere il cassetto carta (3-1).

### 安装步骤

安装前务必关闭机器的主电源开关, 并从墙壁插座拔下电源插头。

1. 拉出供纸工作台 (A) 的各个供纸盒, 拆下各 1 个升降板限位器 (1), 并安装在保管场所 (2) 上。
2. 轻轻地推入各供纸盒。

3. 拉出机器的下部供纸盒 (3)。
4. 取下纸盒 (3-1)。

### 설치순서

설치를 시작하기 전에 반드시 본체의 주 전원 스위치를 끄고 벽 콘센트에서 전원 플러그를 분리하십시오.

1. 급지대 (A) 의 각 카세트를 빼냅니다. 리프트판 스톱퍼 (1) 각 1 개를 빼내 보관장소 (2) 에 부착합니다.
2. 각 카세트를 조용히 밀어 넣습니다.

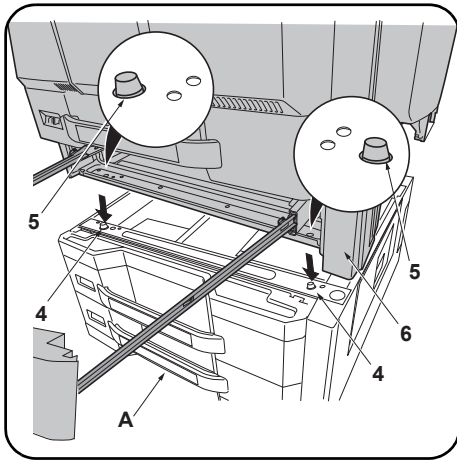
3. 본체의 하단 용지 카세트 (3) 를 빼냅니다.
4. 용지 카세트 (3-1) 를 제거합니다.

### 取付手順

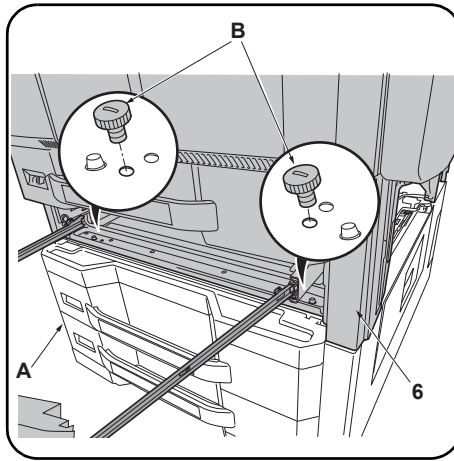
必ず機械本体の主電源スイッチをOFFにし、機械本体の電源プラグを抜いてから作業すること。

1. ペーパーフィーダー(A) の各カセットを引き出す。リフト板ストッパー(1) 各 1 個を外して保管場所(2) に取り付ける。
2. 各カセットを静かに押し込む。

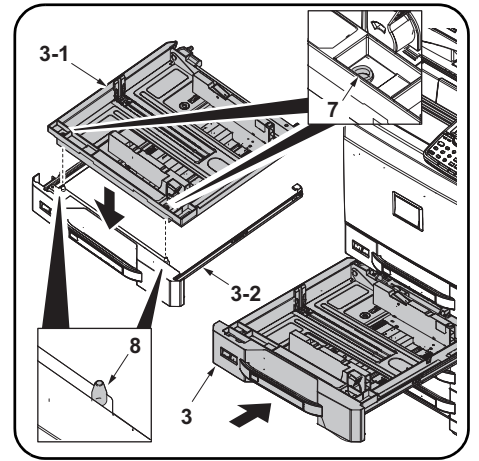
3. 機械本体の下段カセット(3) を引き出す。
4. カセット(3-1) を取り外す。



5. Place the machine (6) on the paper feeder (A) so that the pins (4) at the front left and front right of the paper feeder (A) are aligned with the holes (5) in the base of the machine.



6. Secure the machine (6) to the paper feeder (A) with the 2 pins (B).



7. Align the holes (7) of the lower cassette (3-1) for the machine with the pins (8) in the cassette slider (3-2). Put the paper cassette (3-1).

8. Push the lower paper cassette (3) in fully.

5. Monter la machine (6) sur le chargeur de papier (A) de sorte que les broches (4) à l'avant gauche et à l'avant droit du chargeur de papier (A) soient alignés avec les trous (5) dans la base du machine.

6. Fixer la machine (6) au chargeur de papier (A) avec les 2 broches (B).

7. Alignez les trous (7) du magasin inférieur (3-1) pour la machine avec les ergots (8) dans le tiroir du magasin (3-2). Placez le magasin de papier (3-1).

8. Enfoncez à fond le magasin de papier inférieur (3).

5. Coloque la máquina (6) sobre el depósito de papel (A) de forma que los pasadores (4) en los lados frontales izquierdo y derecho del depósito de papel (A) estén alineados con los orificios (5) de la base de la máquina.

6. Fije la máquina (6) al depósito de papel (A) con los dos pasadores (B).

7. Alinee los orificios (7) del depósito inferior (3-1) de la máquina con los pasadores (8) del deslizador del depósito (3-2). Coloque el depósito de papel (3-1).

8. Ejercer presión sobre el depósito de papel inferior (3) hasta introducirlo por completo.

5. Setzen Sie das Gerät (6) so auf den Papiereinzug (A), dass die Stifte (4) vorne links und vorne rechts am Papiereinzug (A) auf die Öffnungen (5) im Boden des Geräts ausgerichtet sind.

6. Sichern Sie das Gerät (6) mit den 2 Stiften (B) am Papiereinzug (A).

7. Richten Sie die Löcher (7) der Kassette (3-1) des Geräts mit den Stiften (8) im Kassettenanschlag (3-2) aus. Setzen Sie die Papierkassette (3-1) wieder ein.

8. Schieben Sie die Papierkassette (3) bis zum Anschlag ein.

5. Posizionare la macchina (6) sull'alimentatore carta (A) in modo che i perni (4) sul lato destro e sinistro anteriore dell'alimentatore carta (A) siano allineati con i fori (5) presenti sulla base della macchina..

6. Fissare la macchina (6) sull'alimentatore carta (A) con i 2 perni (B).

7. Allineare i fori (7) del cassetto inferiore (3-1) per la macchina con perni (8) della guida cassetto (3-2). Inserire il cassetto carta (3-1).

8. Spingere il cassetto carta inferiore (3) fino in fondo.

5. 供紙工作台 (A) の左右前側の各挿销 (4) 分别对准机器 主机底面的孔 (5) 后, 将机器 (6) 放在供纸工作台 (A) 上。

6. 用 2 个固定插销 (B) 将机器 主机 (6) 固定在供纸工作台 (A) 上。

7. 将机器下部供纸盒 (3-1) 的孔 (7) 和供纸盒导轨 (3-2) 的插销 (8) 对齐。放置纸盒 (3-1)。

8. 完全推入下部供纸盒 (3)。

5. 금지대 (A) 의 전면 좌측과 전면 우측에 있는 각 핀 (4) 이 본체의 바닥면에 있는 구멍 (5) 에 맞도록 본체 (6) 를 금지대 (A) 위에 놓습니다 .

6. 핀 (B) 2 개로 본체 (6) 를 금지대 (A) 에 고정 합니다 .

7. 본체의 하단 용지 카세트 (3-1) 의 구멍 (7) 과 카세트 슬라이더 (3-2) 의 핀 (8) 을 맞춥니다 . 용지 카세트 (3-1) 를 배치합니다 .

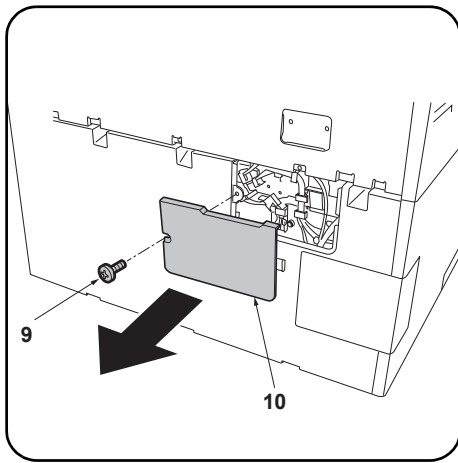
8. 하단 용지 카세트 (3) 를 완전히 밀어 넣습니다 .

5. ペーパーフィーダー(A)の左右前方の各ピン(4)と機械本体のベースの穴(5)が合うように、ペーパーフィーダー(A)に機械本体(6)を載せる。

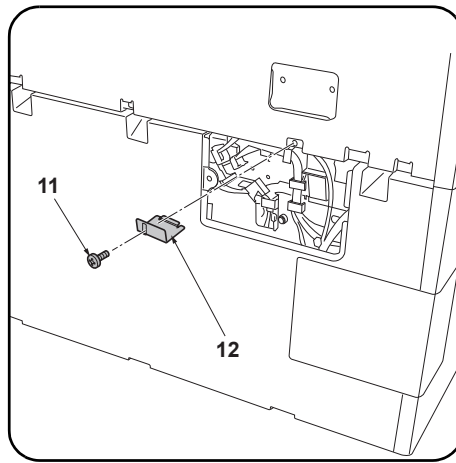
6. ピン(B)2本で 機械本体(6)をペーパーフィーダー(A)に固定する。

7. 機械本体の下段カセット(3-1)の穴(7)とカセットスライダ(3-2)のピン(8)を合わせる。カセット(3-1)を置く。

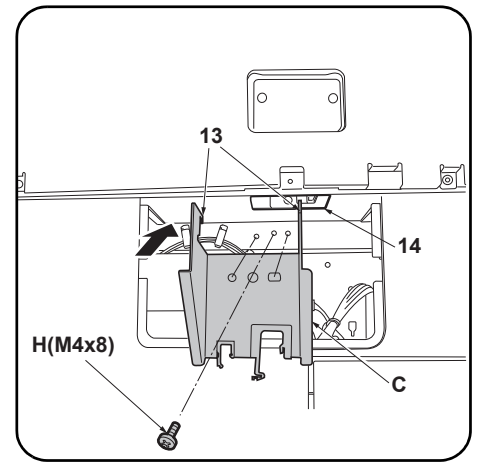
8. 下段カセット(3)を奥まで押し込む。



9. Remove the screw (9) in the rear of the paper feeder and remove the cover (10).



10. Remove the screw (11) to remove the metal plate (12).



11. Fit the hook (13) on the mounting plate (C) into the opening (14) and then align the 2 positioning projections.  
12. Secure the mounting plate (C) with the S Tite screw M4 x 8 (H).

9. Déposer la vis (9) à l'arrière du chargeur de papier et déposer le couvercle (10).

10. Déposer la vis (11) pour enlever la plaque métallique (12).

11. Insérer le crochet (13) du plateau de montage (C) dans l'ouverture (14) et aligner les 2 saillies de positionnement.  
12. Fixer le plateau de montage (C) avec la vis S Tite M4 x 8 (H).

9. Quite el tornillo (9) del lado trasero del depósito de papel y quite la cubierta (10).

10. Quite el tornillo (11) para desmontar la placa de metal (12).

11. Coloque el gancho (13) de la placa de montaje (C) en la abertura (14) y, después, alinee los 2 resaltes de posición.  
12. Asegure la placa de montaje (C) con el tornillo S Tite M4 x 8 (H).

9. Die Schraube (9) an der Rückseite des Papiereinzugs entfernen und die Abdeckung (10) abnehmen.

10. Die Schraube (11) herausdrehen, um die Metallplatte (12) abzunehmen.

11. Den Haken (13) auf der Montageplatte (C) in die Öffnung (14) einpassen und dann die 2 Positionierungsnasen ausrichten.  
12. Die Montageplatte (C) mit der S-Tite-Schraube M4 x 8 verwenden (H) befestigen.

9. Rimuovere la vite (9) nel retro dell'unità di alimentazione della carta e quindi rimuovere il coperchio (10).

10. Rimuovere la vite (11), per rimuovere la piastra di metallo (12).

11. Inserire il gancio (13) sulla piastra di montaggio (C) nell'apertura (14) e quindi allineare le 2 sporgenze di posizionamento.  
12. Fissare la piastra di montaggio (C) con la vite S Tite M4 x 8 (H).

9. 拆除供紙工作台后部的 1 顆螺絲 (9)，拆下盖板 (10)。

10. 拆除 1 顆螺絲 (11)，拆下金屬件 (12)。

11. 將安裝板 (C) 的掛鉤 (13) 挂在開口部 (14) 上，并与定位用的 2 处突出部对齐。  
12. 使用 1 顆緊固型 S 螺絲 M4×8 (H) 來固定安裝板 (C)。

9. 금지대 후면의 뒤쪽 나사 (9) 1 개를 제거하고 커버 (10) 를 떼어 냅니다 .

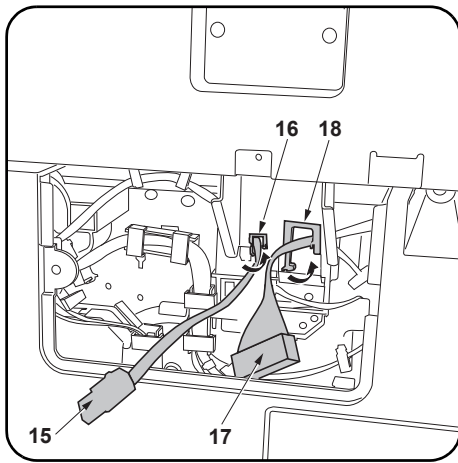
10. 나사 (11) 1 개를 제거하고 쇠 (12) 를 제거합니다 .

11. 부착판 (C) 의 후크 (13) 를 개구부 (14) 에 걸고 위치조정 돌기 2 곳을 맞춥니다 .  
12. 나사 M4×8 S 타이트 (H) 1 개로 부착판 (C) 을 고정합니다 .

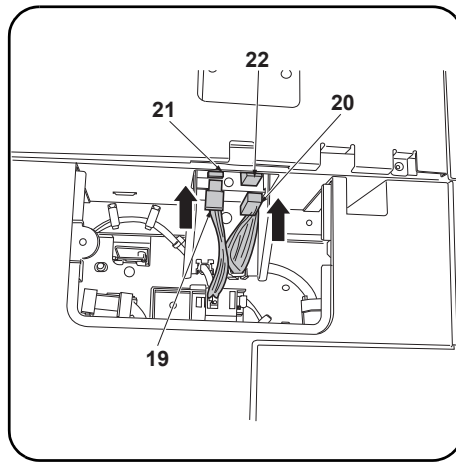
9. ペーパーフィーダー後側のビス (9) 1 本を外し、カバー (10) を取り外す。

10. ビス (11) 1 本を外し、金具 (12) を取り外す。

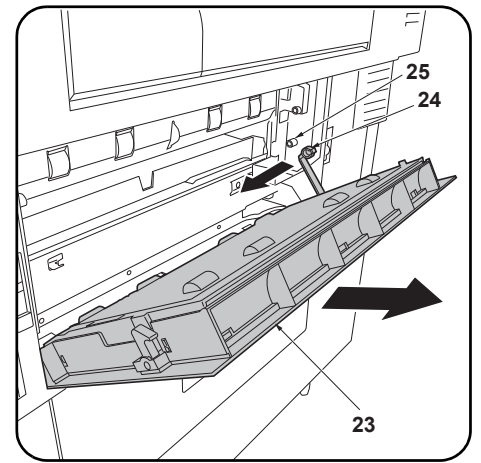
11. 取付板 (C) のフック (13) を開口部 (14) に引っ掛けてから、位置決め突起 2 箇所を合わせる。  
12. ビス M4×8 S タイト (H) 1 本で取付板 (C) を固定する。



**13.** Pass the power cord (15) through the edging (small) (16) and the signal cable (17) through the edging (large) (18) and then close the edging



**14.** Connect the power cord (19) and the signal cable (20) to connectors (21) (22) respectively on the machine.  
**15.** Replace the cover (10) using the screw (9) removed in step 9.



**16.** Open the lower right cover (23) on the machine.  
Remove the strap (24) from the shaft (25) and remove lower right cover (23).

**13.** Faire passer le cordon d'alimentation (15) dans le (petit) passage (16) et le câble du signal (17) dans le (grand) passage (18) puis fermer le passage.

**14.** Raccorder respectivement le cordon d'alimentation (19) et le câble de signal (20) aux connecteurs (21) (22) de la machine.  
**15.** Reposer le couvercle (10) à l'aide de la vis (9) déposée à l'étape 9.

**16.** Ouvrir le capot inférieur droit (23) de la machine.  
Déposer la courroie (24) de l'arbre (25) et déposer le couvercle inférieur droit (23).

**13.** Pase el cable de alimentación (15) a través de la pestaña (pequeña) (16) y el cable de señales (17) a través de la pestaña (grande) (18) y, después, cierre la pestaña.

**14.** Conecte el cable de alimentación (19) y el cable de señal (20) a los conectores (21) (22) respectivamente de la máquina.  
**15.** Vuelva a colocar la cubierta (10) usando el tornillo (9) quitado en el paso 9.

**16.** Abra la cubierta derecha inferior (23) de la máquina.  
Quite la correa (24) del eje (25) y quite la cubierta frontal inferior (23).

**13.** Das Netzkabel (15) durch den Kantenschutz (klein) (16) und das Signalkabel (17) durch den Kantenschutz (groß) (18) führen und dann den Kantenschutz schließen.

**14.** Schließen Sie das Netzkabel (19) und das Signalkabel (20) an den entsprechenden Steckverbindern (21) (22) des Geräts an.  
**15.** Die Abdeckung (10) mittels der in Schritt 9 entfernten Schraube (9) wieder anbringen.

**16.** Öffnen Sie die untere rechte Abdeckung (23) des Geräts.  
Den Riemen (24) von der Welle (25) abnehmen und dann die untere rechte Abdeckung (23) abnehmen.

**13.** Passare il cavo di alimentazione (15) attraverso il bordo (piccolo) (16) e il cavo del segnale (17) attraverso il bordo (grande) (18), e quindi chiudere il bordo.

**14.** Collegare il cavo di alimentazione (19) e il cavo del segnale (20) ai connettori della macchina (21) e (22), rispettivamente.  
**15.** Ricollocare il coperchio (10) utilizzando la vite (9) rimossa nel passo 9.

**16.** Aprire il pannello destro inferiore (23) sulla macchina.  
Rimuovere la cinghietta (24) dall'asta (25) e quindi rimuovere il pannello destro inferiore (23).

**13.** 将 AC 电线 (15) 从束线孔 (小) (16), 信号线 (17) 从束线孔 (大) (18) 中分别穿过, 关闭束线孔。

**14.** 将 AC 电线 (19) 以及信号线 (20) 分别与主机的接插件 (21)、(22) 连接。  
**15.** 使用在步骤 9 中拆除的 1 颗螺丝 (9) 按原样安装盖板 (10)。

**16.** 打开机器的右下部盖板 (23)。  
将带子 (24) 从轴 (25) 上拆除, 拆下右下部盖板 (23)。

**13.** AC 전선 (15) 을 에징 (소) (16) 에, 신호선 (17) 을 에징 (대) (18) 에 각각 지나가게 하고 에징을 닫습니다.

**14.** 전원 코드 (19) 및 신호 케이블 (20) 을 본체 커넥터 (21), (22) 에 각각 연결합니다.  
**15.** 순서 9 에서 제거한 나사 (9) 1 개로 커버 (10) 를 원래대로 부착합니다.

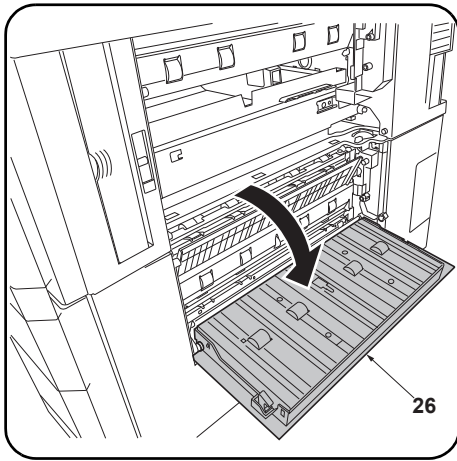
**16.** 본체의 오른쪽 하단 커버 (23) 를 엽니다.  
스트랩 (24) 를 축 (25) 에서 떼어내 오른쪽 아래 커버 (23) 를 제거합니다.

**13.** AC 電線 (15) をエッジング (小) (16) に、信号線 (17) をエッジング (大) (18) にそれぞれ通し、エッジングを閉じる。

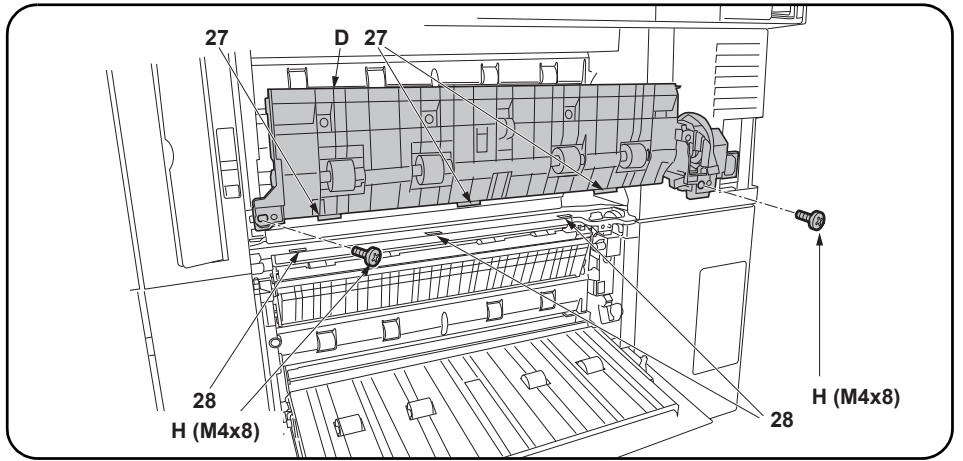
**14.** AC 電線 (19) および信号線 (20) を本体のコンネクター (21)、(22) にそれぞれ接続する。  
**15.** 手順 9 で取り外したビス (9) 1 本でカバー (10) を元通りに取り付ける。

**16.** 機械本体の右下カバー (23) を開く。  
ストラップ (24) を軸 (25) から外し、右下カバー (23) を取り外す。





17. Open the paper feeder right cover (26).



18. Fit the 3 hooks (27) on the intermediate paper conveying unit (D) into the 3 holes (28) in the guide.

19. Secure the intermediate paper conveying unit (D) with the 2 S Tite screw M4 x 8 (H).

**NOTICE**

Be sure to use S Tite screw M4 x 8.

Using longer screws, such as S Tite screws M4 x 20, may damage wires.

17. Ouvrir le couvercle droit du chargeur de papier (26).

18. Insérer les 3 crochets (27) de l'unité de transport du papier intermédiaire (D) dans les 3 trous (28) du guide.

19. Fixer l'unité de transport du papier intermédiaire (D) à l'aide des 2 Vis S Tite M4 x 8 (H).

**REMARQUE**

S'assurer d'utiliser la vis S Tite M4 x 8.

L'utilisation de vis plus longues, comme les vis S Tite M4 x 20, peut endommager les fils.

17. Abra la cubierta derecha del depósito de papel (26).

18. Coloque los 3 ganchos (27) de la unidad de transporte de papel intermedia (D) en los 3 orificios (28) de la guía.

19. Asegure la unidad de transporte de papel intermedia (D) con los 2 Tornillo S Tite M4 x 8 (H).

**AVISO**

Asegúrese de usar tornillos S Tite M4 x 8.

El uso de tornillos más largos, como tornillos S Tite M4 x 20, puede dañar los cables.

17. Die rechte Abdeckung (26) des Papierinzugs öffnen.

18. Die 3 Haken (27) an der eingesetzten Papierfördereinheit (D) in die 3 Öffnungen (28) in der Führung einpassen.

19. Die eingesetzte Papierfördereinheit (D) mit den 2 S-Tite-Schraube M4 x 8 (H) sichern.

**ANMERKUNG**

Stellen Sie sicher, dass Sie die S-Tite-Schraube M4 x 8 verwenden.

Die Verwendung von längeren Schrauben als den S-Tite-Schrauben M4 x 20 kann Kabel beschädigen.

17. Aprire il pannello destro (26) dell'unità di alimentazione della carta.

18. Inserire i 3 ganci (27) sull'unità intermediale di trasporto carta (D) nei 3 fori (28) nella guida.

19. Fixare l'unità intermediale di trasporto carta (D) con le 2 Vite S Tite M4 x 8 (H).

**AVVISO**

Utilizzare solo la vite S Tite M4 x 8.

Se si utilizzano viti più lunghe, come le viti S Tite M4 x 20, si possono danneggiare i fili.

17. 打开供纸工作台的右部盖板 (26)。

18. 将中间搬运单元 (D) 的 3 个挂钩 (27) 嵌入导向板的 3 个孔 (28) 中。

19. 使用 2 颗紧固型 S 螺丝 M4x8(H) 来固定中间搬运单元 (D)。

**注意**

必须使用紧固型 S 螺丝 M4x8。

如使用长螺丝 (紧固型 S 螺丝 M4x20), 可能会使电线受到损伤。

17. 금지대 오른쪽 커버 (26) 를 엽니다 .

18. 중간반송유닛 (D) 의 후크 (27) 3 개를 가이드 구멍 (28) 3 곳에 꽂습니다 .

19. 나사 M4x8 S 타이트 (H) 2 개로 중간반송유닛 (D) 를 고정합니다 .

**주의**

반드시 나사 M4x8 S 타이트를 사용하십시오 .

더 긴 나사 ( 예 : 나사 M4x20 S 타이트 ) 를 사용할 경우 와이어가 손상될 수 있습니다 .

17. ペーパーフィーダーの右カバー (26) を開く。

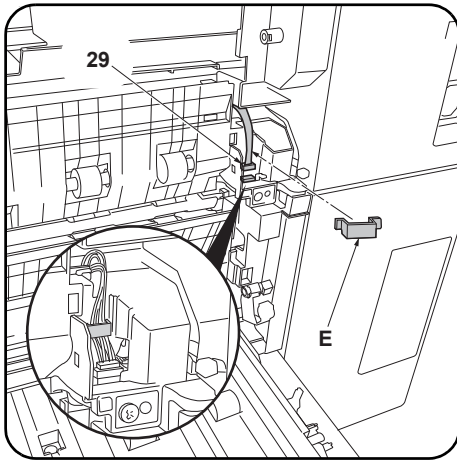
18. 中間搬送ユニット (D) のフック (27) 3 個をガイドの穴 (28) 3 カ所にはめ込む。

19. ビス M4x8 S タイト (H) 2 本で中間搬送ユニット (D) を固定する。

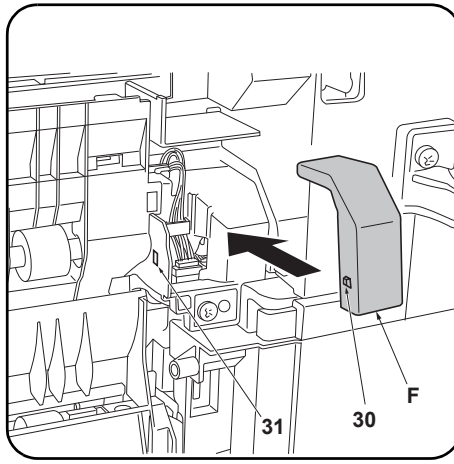
**注意**

必ずビス M4x8 S タイトを使用すること。

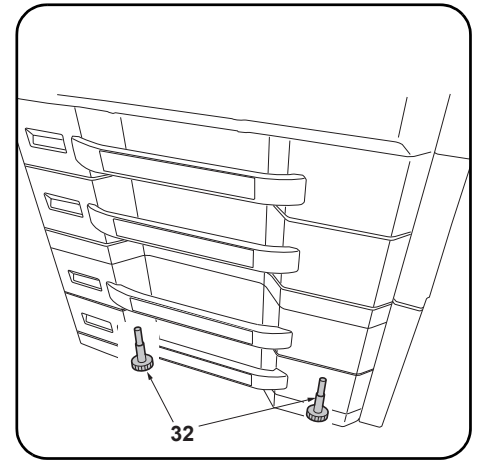
長いビス (M4x20 S タイト) を使用すると電線を傷付けることがあります。



20. Connect the intermediate paper conveying unit connector (29).  
 21. Attach the clamp (E) and secure the connector wire.



22. Insert the projection (30) on the wire cover (F) into the hole (31) in the paper feeder and install the wire cover (F).  
 23. Close the paper feeder right cover (26) and replace the lower right cover (23) on the machine.



24. Turn the adjusters on each corner (32) until they reach the floor and then secure the paper feeder.

20. Raccorder le connecteur (29) de l'unité de transport de papier intermédiaire.  
 21. Monter le collier (E) et fixer le câble du connecteur.

22. Insérer la saillie (30) du couvercle du câble (F) dans le trou (31) du chargeur de papier et reposer le couvercle du câble (F).  
 23. Fermer le couvercle droit du chargeur de papier (26) et reposer le capot inférieur droit (23) sur la machine.

24. Faire tourner les dispositifs de réglage de chacun des coins (32) jusqu'à ce qu'ils touchent le sol et fixer ensuite le chargeur de papier.

20. Conecte el conector de la unidad de transporte de papel intermedia (29).  
 21. Fije el sujetador (E) y asegure el cable del conector.

22. Inserte el resalto (30) de la cubierta para el cable (F) en el orificio (31) del depósito de papel e instale la cubierta para el cable (F).  
 23. Cierre la cubierta derecha del depósito de papel (26) y vuelva a colocar la cubierta derecha inferior (23) en la máquina.

24. Gire los reguladores en cada esquina (32) hasta que lleguen al piso y, a continuación, asegure el depósito de papel.

20. Den Steckverbinder (29) der eingesetzten Papierfördereinheit anschließen.  
 21. Die Klemme (E) anbringen und das Kabel des Steckverbinders sichern.

22. Die Nase (30) der Kabelabdeckung (F) in die Öffnung (31) des Papiereinzugs einsetzen und die Kabelabdeckung (F) anbringen.  
 23. Schließen Sie die rechte Abdeckung (26) des Papiereinzugs und setzen Sie die untere rechte Abdeckung (23) wieder im Gerät ein.

24. Die Einsteller an jeder Ecke (32) drehen, bis sie den Boden berühren, und dann den Papiereinzug sichern.

20. Collegare il connettore (29) dell'unità intermediale di trasporto carta.  
 21. Applicare il morsetto (E) e fissare il cavo del connettore.

22. Inserire la sporgenza (30) del coperchio cavi (F) nel foro (31) nell'unità di alimentazione della carta ed installare il coperchio cavi (F).  
 23. Chiudere il pannello destro (26) dell'alimentatore carta e rimontare il pannello destro inferiore (23) sulla macchina.

24. Ruotare i regolatori (32) presenti su ciascun angolo finché vengano a contatto con il pavimento, e quindi fissare l'unità di alimentazione della carta.

20. 连接中间搬运单元的接插件 (29)。  
 21. 安装束线夹 (E)，以固定接插件电线。

22. 将电线盖板 (F) 的突出部 (30) 插入供纸工作台的孔 (31) 中，安装电线盖板 (F)。  
 23. 关闭供纸工作台的右部盖板 (26)，按原样安装机器的右下部盖板 (23)。

24. 转动四角上的调节器 (32) 直至与地面接触，然后再固定供纸工作台。

20. 중간반송유닛의 커넥터 (29) 를 접속합니다.  
 21. 클램프 (E) 를 부착, 커넥터 전선을 고정합니다.

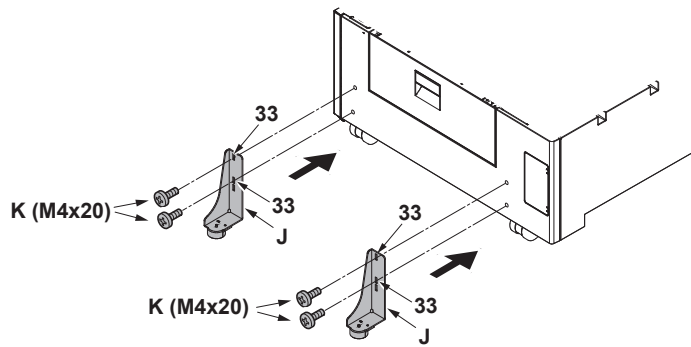
22. 전선커버 (F) 의 돌기 (30) 를 급지대의 구멍 (31) 에 넣고 전선커버 (F) 를 부착합니다.  
 23. 급지대 오른쪽 커버 (26) 를 닫고 본체의 오른쪽 하단 커버 (23) 를 다시 부착합니다.

24. 네 곳의 어저스터 (32) 를 맨 밑에 닿을 위치까지 돌려 급지대를 고정합니다.

20. 中間搬送ユニットのコネクター (29) を接続する。  
 21. クランプ (E) を取り付け、コネクター電線を固定する。

22. 電線カバー (F) の突起 (30) をペーパーフィーダーの穴 (31) に入れて、電線カバー (F) を取り付ける。  
 23. ペーパーフィーダーの右カバー (26) を閉じ、機械本体の右下カバー (23) を元通りに取り付ける。

24. 四隅のアジャスター (32) を床に接触する位置まで回し、ペーパーフィーダーを固定する。



25. Select holes (33) and install each stopper (J) with 2 S Tite screws M4 x 20 (K) so that the stoppers will be grounded on the floor.

25. Sélectionner les trous (33) et installer chaque butée (J) avec 2 vis S Tite M4 x 20 (K) de sorte que les butées reposent sur le sol.

25. Seleccione los orificios (33) e instale cada tope (J) con los 2 tornillos S Tite M4 x 20 (K) de manera que los topes se conecten a tierra en el suelo.

25. Wählen Sie die Öffnungen (33) und befestigen Sie jeden Anschlag (J) mit den 2 S-Tite-Schrauben M4 x 20 (K) so an, dass die Anschläge am Boden aufsitzen.

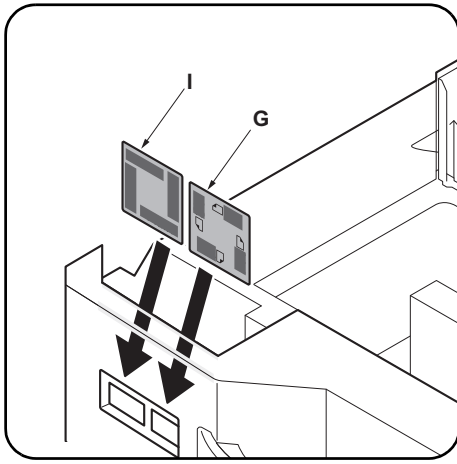
25. Selezionare i fori (33) ed installare ogni fermo (J) con le 2 viti S Tite M4 x 20 (K) in modo che i fermi siano posti a terra sul pavimento.

25. 在孔(33)处各用2颗M4×20紧固型S螺丝(K)安装限位器(J),使之和地板接触。

25. 전도방지쇠(J)가 바닥면에 접지될 수 있도록 구멍(33)을 선택해 나사 M4×20 S 타이트(K) 각 2개로 설치합니다.

25. 転倒防止金具(J)が床面に接地するように、穴(33)を選択してビス M4×20 S タイト(K) 各2本で取り付けます。





### Setting the paper size plate and media type plate

Insert the paper size plate (G) and media type plate (I) into the each slots respectively.

### Skewed paper feed adjustment

1. Connect the machine power plug to the wall outlet and turn the machine main power switch on.
2. Load paper into the cassette and make a test copy to check the image.
3. If the image is skewed (skewed paper feed), make the adjustments described below.  
<Reference value> Left-right difference of 1.5 mm or less

### Disposition des plaquettes du format de papier et du type de support

Introduire la plaquette du format de papier (G) et la plaquette du type de support (I) dans leur logement respectif.

### Réglage de l'entraînement du papier en biais

1. Insérer la fiche d'alimentation de la machine dans la prise murale et mettre la machine sous tension.
2. Mettre du papier dans le tiroir et effectuer une copie d'essai pour vérifier l'image.
3. Si l'image est en biais (entraînement du papier en biais), régler en procédant comme décrit ci-dessous.  
<Valeur de référence> Différence de droite à gauche de 1,5 mm ou moins.

### Ajuste de la placa de tamaño de papel y la placa de tipo de medio

Inserte la placa de tamaño de papel (G) y la placa de tipo de medio (I) en cada uno de las ranuras, respectivamente.

### Ajuste de alimentación de papel torcida

1. Conecte el enchufe de la máquina en el receptáculo de pared y encienda el interruptor principal de la máquina.
2. Introduzca papel en el cajón y haga una copia de prueba para verificar la imagen.
3. Si la imagen está torcida (alimentación del papel torcida) haga los ajustes que se describen a continuación.  
<Valor de referencia> diferencia izquierda-derecha de 1,5 mm o menor.

### Einsetzen der Papierformatkarte und der Medientypkarte

Setzen Sie die Papierformatkarte (G) und die Medientypkarte (I) in die jeweiligen Führungen.

### Einstellung bei verkantetem Papiereinzug

1. Stecken Sie den Netzstecker des Geräts in die Wandsteckdose und schalten Sie das Gerät am Hauptschalter ein.
2. Legen Sie Papier in die Papierlade ein und machen Sie eine Testkopie, um das Bild zu prüfen.
3. Nehmen Sie nachstehende Einstellungen vor, falls das Bild verkantet ist (verkanteter Papiereinzug).  
<Bezugswert> Links-rechts-Differenz maximal 1,5 mm.

### Impostazione della piastra di formato carta e della piastra del tipo di supporto

Inserire la piastra del formato carta (G) e la piastra del tipo di supporto (I) nei rispettivi alloggiamenti.

### Regolazione alimentazione obliqua carta

1. Collegare la spina della macchina alla presa di corrente a muro e accendere l'interruttore di alimentazione della macchina.
2. Caricare carta nel cassetto ed eseguire una copia di prova per controllare l'immagine.
3. Se l'immagine risulta obliqua (alimentazione obliqua della carta), eseguire le regolazioni descritte sotto.  
<Valore di riferimento> Differenza tra destra e sinistra di 1,5 mm o inferiore

### 纸张尺寸标识片和纸张种类标识片的安装

将纸张尺寸标识片 (G) 和纸张种类标识片 (I) 分别插入到图示的插槽中。

### 歪斜进纸调节

1. 将机器上的电源插头插入电源插座中，打开主电源开关。
2. 在纸盒中放入纸张。进行测试复印以确认图像。
3. 图像倾斜（歪斜进纸）时进行以下调节。  
<基准值> 左右差 1.5mm 以下

### 용지크기 플레이트와 용지종류 플레이트의 세트

용지크기 플레이트 (G) 와 용지종류 플레이트 (I) 를 각 표시 슬롯에 각각 삽입한다.

### 경사급지 조정

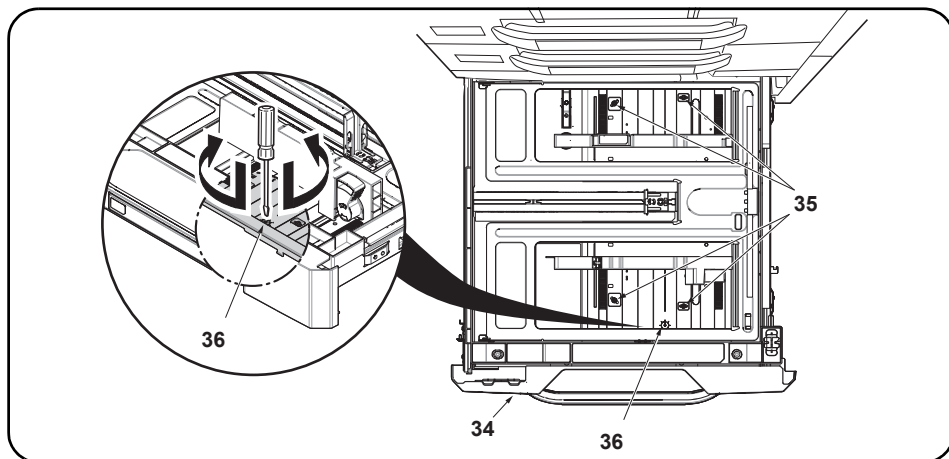
1. 본체 전원 플러그를 벽 콘센트에 연결하고 본체의 주 전원 스위치를 켭니다.
2. 카세트에 용지를 장착합니다. 시험복사를 하고 화상을 확인합니다.
3. 화상이 기울어져 있는 (경사급지) 경우에는 다음 조정을 합니다.  
<기준치> 좌우차 1.5mm 이하

### 用紙サイズプレートと用紙種類プレートのセット

用紙サイズプレート (G) と用紙種類プレート (I) を各表示スロットにそれぞれ挿入する。

### 斜め給紙調整

1. 機械本体の電源プラグをコンセントに差し込み、主電源スイッチを ON にする。
2. カセットに用紙をセットする。テストコピーをおこない、画像を確認する。
3. 画像が傾いている(斜め給紙)場合は次の調整をおこなう。  
<基準値> 左右差 1.5mm 以下



4. Pull out the cassette (34) in the paper feeder and loosen the 4 screws (35).
5. Turn the adjusting screw (36) to adjust the cursor skew.
6. Retighten the 4 screws (35).
7. Make another test copy to check the image.

- 
4. Sortir le tiroir (34) du chargeur de papier et desserrer les 4 vis (35).
  5. Faire tourner la vis de réglage (36) pour régler la déviation du curseur.
  6. Resserrer les 4 vis (35).
  7. Faire une autre copie d'essai pour vérifier l'image.

- 
4. Extraiga el cajón (34) del depósito de papel y afloje los 4 tornillos (35).
  5. Gire el tornillo de ajuste (36) para ajustar la desviación del cursor.
  6. Vuelva a apretar los 4 tornillos (35).
  7. Haga otra copia de prueba para verificar la imagen.

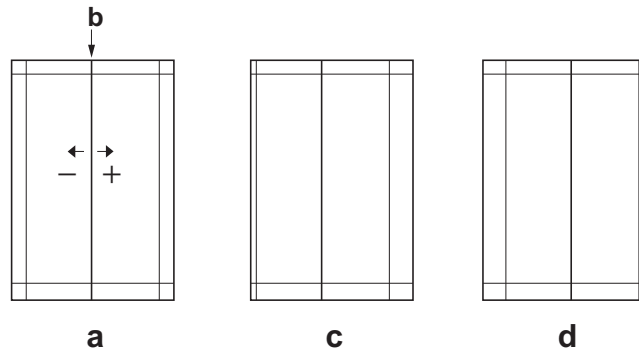
- 
4. Ziehen Sie die Papierlade (34) aus dem Papiereinzug und lösen Sie die 4 Schrauben (35).
  5. Drehen Sie die Einstellschraube (36), um die Cursor-Verkantung zu korrigieren.
  6. Ziehen Sie die 4 Schrauben (35) wieder an
  7. Erstellen Sie zur Überprüfung des Bilds noch einmal eine Testkopie.

- 
4. Estrarre il cassetto (34) dell'unità di alimentazione della carta e quindi allentare le 4 viti (35).
  5. Ruotare la vite di regolazione (36) per regolare l'inclinazione del cursore.
  6. Ristringere le 4 viti (35).
  7. Eseguire un'altra copia di prova per controllare l'immagine.

- 
4. 拉出供纸盒 (34)，拧松 4 颗螺丝 (35)。
  5. 旋转调节螺丝 (36)，以调节游标的倾斜。
  6. 拧紧 4 颗螺丝 (35)。
  7. 再次进行测试复印，确认图像。

- 
4. 금지 카세트 (34) 를 빼 내어 나사 (35) 4 개를 느슨하게 합니다 .
  5. 조정나사 (36) 을 돌려 커서 경사조정을 합니다 .
  6. 나사 (35) 4 개를 조입니다 .
  7. 다시 시험복사를 하고 화상을 확인합니다 .

- 
4. ペーパーフィーダーのカセット (34) を引き出し、ビス (35) 4 本を緩める。
  5. 調整ネジ (36) を回し、カーソルの傾き調整をおこなう。
  6. ビス (35) 4 本を締め付ける。
  7. 再度、テストコピーをおこない、画像を確認する。



### Adjusting the center line

The reference value for the center line is  $\pm 0.5$  mm or less at position (b) in the correct image (a). If the center line position is outside this range, perform the following adjustment.

1. Set maintenance mode U034, select LSU Out Left and Cassette3 or Cassette4.
2. Adjust the values.  
Test pattern (c): Increase the setting value. Test pattern (d): Decrease the setting value.
3. Press the Start key to confirm the setting value.

### Réglage de l'axe

La valeur de référence pour l'axe est de  $\pm 0,5$  mm ou moins à la position (b) d'une image correcte (a). Si la position de l'axe est hors de cette plage, effectuez le réglage suivant.

1. Passer en mode maintenance U034, sélectionner LSU Out Left et Cassette3 ou Cassette4.
2. Régler les valeurs.  
Mire d'essai (c): Augmentez la valeur de réglage. Mire d'essai (d): Diminuez la valeur de réglage.
3. Appuyer sur la touche de Start pour confirmer la valeur de réglage.

### Ajuste de la línea central

El valor de referencia de la línea central es de  $\pm 0,5$  mm o menor, en la posición (b) de la imagen correcta (a). Si la posición de la línea central estuviera fuera de este rango, haga el siguiente ajuste.

1. Entre al modo de mantenimiento U034, seleccione LSU Out Left y Cassette3 o Cassette4.
2. Ajuste los valores.  
Patrón de prueba (c): Aumente el valor de configuración. Patrón de prueba (d): Reduzca el valor de configuración.
3. Pulse la tecla de Start para confirmar el valor de configuración.

### Einstellen der Mittelinie

Der Bezugswert für die Mittelinie ist  $\pm 0,5$  mm oder weniger an Position (b) des korrekten Bilds (a). Falls die Mittelinie außerhalb dieses Bereichs liegt, ist folgende Einstellung vorzunehmen.

1. Schalten Sie in den Wartungsmodus U034, wählen Sie LSU Out Left und Cassette3 oder Cassette4.
2. Die Werte einstellen.  
Testmuster (c): Den Einstellwert erhöhen. Testmuster (d): Den Einstellwert verringern.
3. Den Einstellwert durch Drücken der Start-Taste bestätigen.

### Regolazione della linea centrale

Il valore di riferimento per la linea centrale è  $\pm 0,5$  mm o inferiore alla posizione (b) nell'immagine corretta (a). Se la posizione della linea centrale è all'infuori di questa gamma, effettuare la regolazione seguente.

1. Impostare la modalità manutenzione U034, selezionare LSU Out Left e Cassette3 o Cassette4.
2. Regolare i valori.  
Modello di prova (c): Aumentare il valore dell'impostazione. Modello di prova (d): Diminuire il valore dell'impostazione.
3. Premere il tasto di Start per confermare il valore dell'impostazione.

### 中心线调节

中心线的基准值在矫正图像 (a) 的 (b) 位置为  $\pm 0.5$ mm 以内。超出该范围时，须进行以下调节。

1. 设置维护模式 U034，选择 LSU Out Left、Cassette3 或 Cassette4。
2. 调整设定值。  
测试图案 (c)：调高设定值。测试图案 (d)：调低设定值。
3. 按 Start 键，以确定设定值。

### 센터라인 조정

센터라인은 적정화상 (a) 의 (b) 위치에서 기준치는  $\pm 0.5$ mm 이내 . 여기에서 벗어나는 것은 이하의 조정을 합니다 .

1. 메인テナンス 모드 U034 를 세트하고 LSU Out Left, Cassette3 또는 Cassette4 를 선택합니다 .
2. 설정치를 조정합니다 .  
테스트 패턴 (c) : 설정치를 높입니다 . 테스트 패턴 (d) : 설정치를 내립니다 .
3. 시작키를 누르고 설정치를 확인합니다 .

### センターライン調整

センターラインは、適正画像 (a) の (b) の位置で基準値は  $\pm 0.5$ mm 以内。これから外れるときは以下の調整をおこなう。

1. メンテナンスモード U034 をセットし、LSU Out Left、Cassette3 または Cassette4 を選択する。
2. 設定値を調整する。  
テストパターン (c) : 設定値を上げる。 テストパターン (d) : 設定値を下げる。
3. スタートキーを押し、設定値を確定する。

# MEMO

# MEMO



303NJ5674001

2013. 1  
303NJ56740-01

# **INSTALLATION GUIDE FOR LARGE CAPACITY FEEDER**

---

**INSTALLATION GUIDE**

**GUIDE D'INSTALLATION**

**GUÍA DE INSTALACION**

**INSTALLATIONSANLEITUNG**

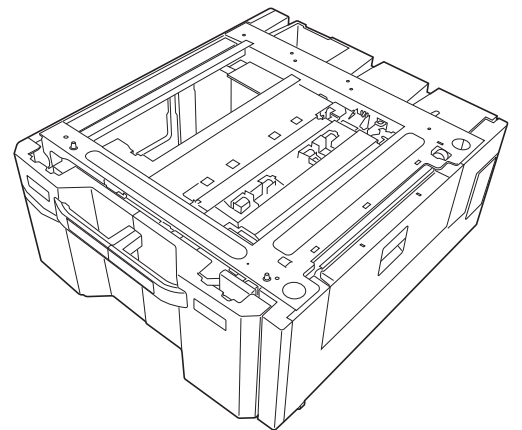
**GUIDA ALL'INSTALLAZIONE**

**安装手册**

**설치안내서**

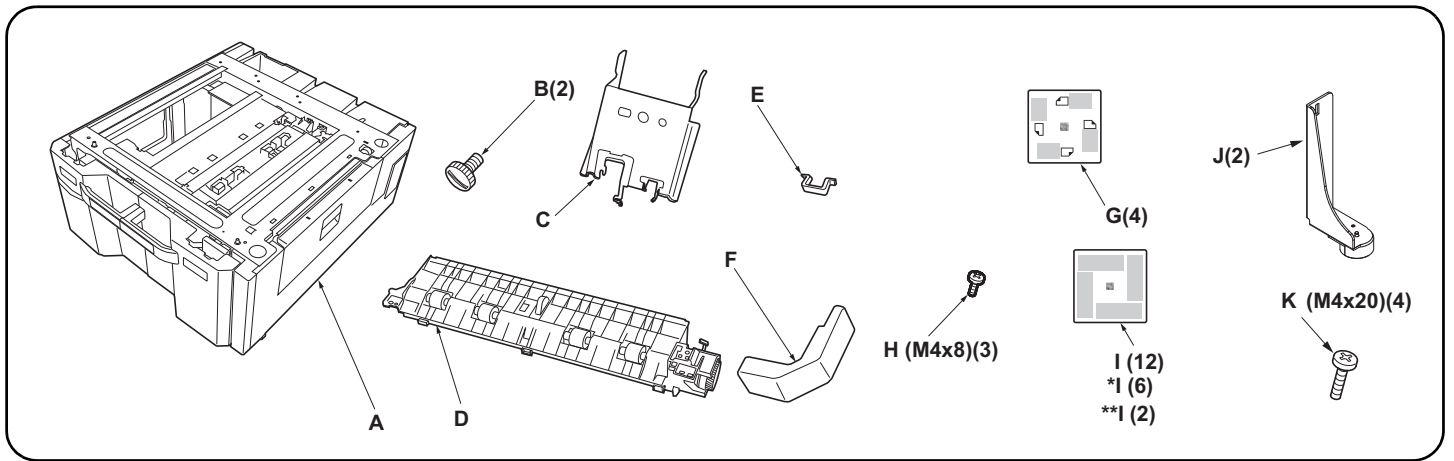
**設置手順書**

**PF-740(B)**

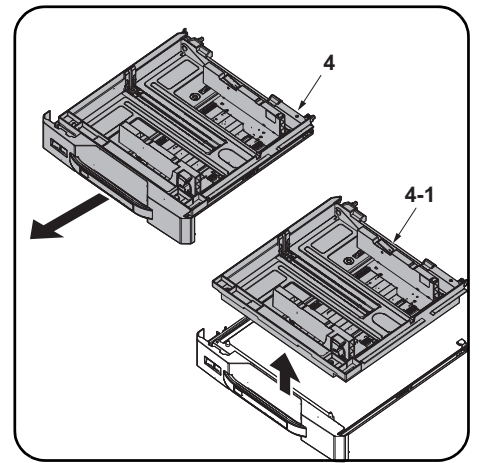
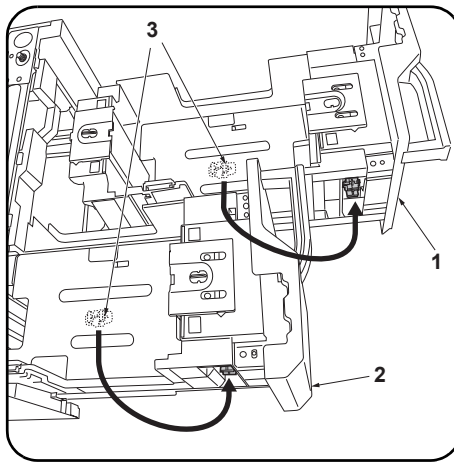








<p><b>English</b></p> <p><b>Supplied parts</b></p> <p>A. Paper feeder ..... 1</p> <p>B. Pin ..... 2</p> <p>C. Retainer ..... 1</p> <p>D. Intermediate paper conveying unit..... 1</p>	<p>E. Clamp ..... 1</p> <p>F. Wire cover..... 1</p> <p>G. Paper size plate ..... 4</p> <p>H. S Tite screw M4 x 8 ..... 3</p> <p>I. Media type plate(except for 120V model) 12</p> <p>*I. Media type plate(120V model only) ..... 6</p> <p>J. Stopper ..... 2</p>	<p>K. S Tite screws M4 x 20 ..... 4</p> <p>Be sure to remove any tape and/or cushioning materials from the parts supplied.</p>
<p><b>Français</b></p> <p><b>Pièces fournies</b></p> <p>A. Chargeur de papier..... 1</p> <p>B. Broche ..... 2</p> <p>C. Élément de retenue ..... 1</p> <p>D. Unité de transport du papier intermédiaire 1</p>	<p>E. Collier..... 1</p> <p>F. Couverture de câble ..... 1</p> <p>G. Plaquette du format de papier ..... 4</p> <p>H. Vis S Tite M4 x 8 ..... 3</p> <p>I. Plaquette du type de support..... 12</p> <p>J. Butée ..... 2</p> <p>K. Vis S Tite M4 x 20 ..... 4</p>	<p>Veillez à retirer les morceaux de bande adhésive et/ou les matériaux de rembourrage des pièces fournies.</p>
<p><b>Español</b></p> <p><b>Partes suministradas</b></p> <p>A. Depósito de papel..... 1</p> <p>B. Clavija..... 2</p> <p>C. Retén ..... 1</p> <p>D. Unidad de transporte de papel intermedia. 1</p>	<p>E. Sujetador ..... 1</p> <p>F. Cubierta para el cable..... 1</p> <p>G. Placa de tamaño de papel ..... 4</p> <p>H. Tornillo S Tite M4 x 8 ..... 3</p> <p>I. Placa de tipo de medio ..... 12</p> <p>J. Tope ..... 2</p> <p>K. Tornillos S Tite M4 x 20 ..... 4</p>	<p>Asegúrese de despegar todas las cintas y/o material amortiguador de las partes suministradas.</p>
<p><b>Deutsch</b></p> <p><b>Enthaltene Teile</b></p> <p>A. Papiereinzug..... 1</p> <p>B. Stift..... 2</p> <p>C. Halterung..... 1</p> <p>D. Eingesetzte Papierfördereinheit ..... 1</p>	<p>E. Klemme..... 1</p> <p>F. Kabelabdeckung..... 1</p> <p>G. Papierformatkarte ..... 4</p> <p>H. S-Tite-Schraube M4 x 8..... 3</p> <p>I. Medientypkarte ..... 12</p> <p>J. Anschlag..... 2</p> <p>K. S-Tite-Schrauben M4 x 20..... 4</p>	<p>Stellen Sie sicher, dass sämtliche Klebebänder und/oder Polstermaterial von den gelieferten Teilen entfernt wurden.</p>
<p><b>Italiano</b></p> <p><b>Parti fornite</b></p> <p>A. Unità di alimentazione della carta ..... 1</p> <p>B. Perno ..... 2</p> <p>C. Fermo ..... 1</p> <p>D. Unità intermediale di trasporto carta..... 1</p>	<p>E. Morsetto..... 1</p> <p>F. Coperchio cavi..... 1</p> <p>G. Piastra formato carta ..... 4</p> <p>H. Vite S Tite M4 x 8 ..... 3</p> <p>I. Piastra tipo carta..... 12</p> <p>J. Fermo ..... 2</p> <p>K. Vite S Tite M4 x 20 ..... 4</p>	<p>Rimuovere tutti i nastri adesivi e/o i materiali di protezione dalle parti fornite.</p>
<p><b>简体中文</b></p> <p><b>附属品</b></p> <p>A. 供纸工作台..... 1</p> <p>B. 固定插销..... 2</p> <p>C. 安装板..... 1</p> <p>D. 中间搬运单元..... 1</p>	<p>E. 束线夹 ..... 1</p> <p>F. 电线盖板 ..... 1</p> <p>G. 纸张尺寸标识片 ..... 4</p> <p>H. 紧固型 S 螺丝 M4x8 ..... 3</p> <p>**I. 纸张种类标识片 ..... 2</p> <p>J. 限位器 ..... 2</p>	<p>K. 紧固型 S 螺丝 M4x20 ..... 4</p> <p>如果附属品上带有固定胶带, 缓冲材料时务必揭下。</p>
<p><b>한국어</b></p> <p><b>동봉품</b></p> <p>A. 급지대..... 1</p> <p>B. 핀..... 2</p> <p>C. 부착판..... 1</p> <p>D. 중간반송유닛..... 1</p>	<p>E. 크램프..... 1</p> <p>F. 전선커버..... 1</p> <p>G. 용지크기 플레이트..... 4</p> <p>H. 나사 M4x8 S 타이트..... 3</p> <p>**I. 용지종류 플레이트..... 2</p> <p>J. 전도방지쇠..... 2</p>	<p>K. 나사 M4x20 S 타이트..... 4</p> <p>동봉품에 고정 테이프, 완충재가 붙어 있는 경우에는 반드시 제거할 것 .</p>
<p><b>日本語</b></p> <p><b>同梱品</b></p> <p>A. ペーパーフィーダー..... 1</p> <p>B. ピン..... 2</p> <p>C. 取付板..... 1</p> <p>D. 中間搬送ユニット..... 1</p>	<p>E. クランプ ..... 1</p> <p>F. 電線カバー ..... 1</p> <p>G. 用紙サイズプレート ..... 4</p> <p>H. ビス M4x8 S タイト ..... 3</p> <p>**I. 用紙種類プレート ..... 2</p> <p>J. 転倒防止金具 ..... 2</p> <p>K. ビス M4x20 S タイト ..... 4</p>	<p>同梱品に固定テープ、緩衝材が付いている場合は必ず取り外すこと。</p>



### Procédure

Before starting installation, be sure to turn the main power switch of the machine off, and unplug the power plug from the wall outlet.

1. Pull out the right cassette (1) and the left cassette (2) from the paper feeder (A). Remove the lift plate stopper (3) from each cassette and attach it to the storage location.
2. Gently close each cassette.

3. Pull out the lower paper cassette (4) from the machine.
4. Remove the paper cassette (4-1).

### Procédure

Avant de commencer l'installation, s'assurer de mettre la machine hors tension et de débrancher la fiche d'alimentation de la prise murale.

1. Sortez le magasin droit (1) et le magasin gauche (2) du chargeur de papier (A). Retirez la butée de la plaque de levage (3) de chaque magasin et fixez-la dans l'emplacement de stockage.
2. Refermer progressivement chaque tiroir.

3. Sortez le magasin de papier inférieur (4) de la machine.
4. Retirez le magasin de papier (4-1).

### Procedimiento

Antes de iniciar la instalación, asegúrese de apagar el interruptor de encendido de la máquina y desenchufar el cable de alimentación de la toma de pared.

1. Extraiga el depósito derecho (1) y el depósito izquierdo (2) del depósito de papel (A). Quite el tope de placa de elevación (3) de cada depósito y póngalo en el espacio reservado para guardarlo.
2. Cierre suavemente cada bandeja.

3. Extraiga el depósito inferior (4) de la máquina.
4. Quite el depósito de papel (4-1).

### Verfahren

Bevor Sie mit der Installation beginnen überzeugen Sie sich, dass der Netzschalter des Geräts ausgeschaltet und das Stromkabel aus der Steckdose gezogen ist.

1. Ziehen Sie die rechte Kassette (1) und die linke Kassette (2) aus dem Papiereinzug (A) heraus. Entfernen Sie die Verriegelung des Papierlifts (3) aus jeder Kassette und setzen Sie die Verriegelung in die Parkposition ein.
2. Alle Kassetten sanft schließen.

3. Ziehen Sie die untere Kassette (4) aus dem Gerät heraus.
4. Nehmen Sie die Papierkassette (4-1) heraus.

### Procedura

Prima di iniziare l'installazione, spegnere la macchina e scollegare la spina dalla presa di corrente.

1. Estrarre il cassetto destro (1) e il cassetto sinistro (2) dall'unità di alimentazione carta (A). Rimuovere il fermo della piastra di sollevamento (3) da ogni cassetto e fissarlo sulla posizione a riposo.
2. Chiudere delicatamente ciascun cassetto.

3. Estrarre il cassetto carta inferiore (4) dalla macchina.
4. Nehmen Sie die Papierkassette (4-1) heraus.

### 安装步骤

安装前务必关闭机器的主电源开关, 并从墙壁插座拔下电源插头。

1. 拉出供纸工作台 (A) 的右侧供纸盒 (1) 以及左侧供纸盒 (2)。拆下各 1 个升降板限位器 (3), 并安装在保管场所上。
2. 轻轻地推入各供纸盒。

3. 拉出机器主机的下部供纸盒 (4)。
4. 取下纸盒 (4-1)。

### 설치순서

설치를 시작하기 전에 반드시 본체의 주 전원 스위치를 끄고 벽 콘센트에서 전원 플러그를 분리하십시오.

1. 급지대 (A) 의 카세트 오른쪽 (1) 및 카세트 왼쪽 (2) 을 꺼내십시오. 리프트판 스톱퍼 (3) 각 1 개를 제거하고 보관장소에 부착합니다.
2. 각 카세트를 조용히 밀어 넣습니다.

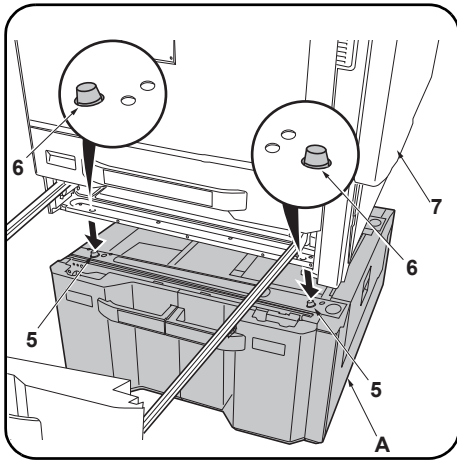
3. 본체의 하단 용지 카세트 (4) 를 빼냅니다.
4. 용지 카세트 (4-1) 를 제거합니다.

### 取付手順

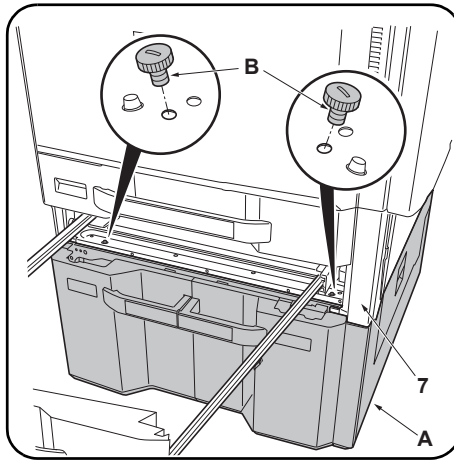
必ず機械本体の主電源スイッチをOFFにし、機械本体の電源プラグを抜いてから作業すること。

1. ペーパーフィーダー(A) のカセット右 (1) およびカセット左 (2) を引き出す。リフト板 ストッパー (3) 各 1 個を取り外し、保管場所に取り付ける。
2. 各カセットを静かに押し込む。

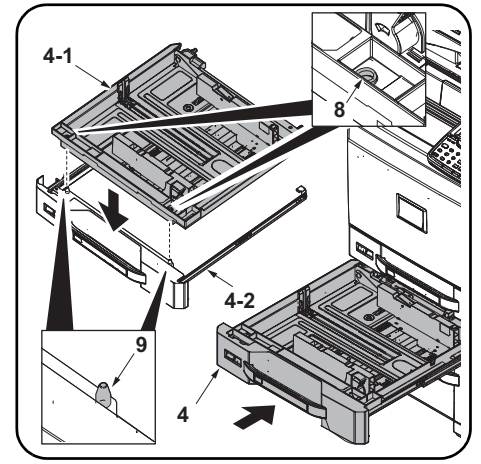
3. 機械本体の下段カセット (4) を引き出す。
4. カセット (4-1) を取り外す。



5. Place the machine (7) on the paper feeder (A) so that the pins (5) at the front left and front right of the paper feeder (A) are aligned with the holes (6) in the base of the machine.



6. Secure the machine (7) to the paper feeder (A) with the 2 pins (B).



7. Align the holes (8) of the lower cassette (4-1) for the machine with the pins (9) in the cassette slider (4-2). Put the paper cassette (4-1).

8. Push the lower paper cassette (4) in fully.

5. Monter la machine (7) sur le chargeur de papier (A) de sorte que les broches (5) à l'avant gauche et à l'avant droit du chargeur de papier (A) soient alignés avec les trous (6) dans la base du machine.

6. Fixer la machine (7) au chargeur de papier (A) avec les 2 broches (B).

7. Alignez les trous (8) du magasin inférieur (4-1) pour la machine avec les ergots (9) dans le tiroir du magasin (4-2). Placez le magasin de papier (4-1).

8. Enfoncez à fond le magasin de papier inférieur (4).

5. Coloque la máquina (7) sobre el depósito de papel (A) de forma que los pasadores (5) en los lados frontales izquierdo y derecho del depósito de papel (A) estén alineados con los orificios (6) de la base de la máquina.

6. Fije la máquina (7) al depósito de papel (A) con los dos pasadores (B).

7. Alinee los orificios (8) del depósito inferior (4-1) de la máquina con los pasadores (9) del deslizador del depósito (4-2). Coloque el depósito de papel (4-1).

8. Ejercer presión sobre el depósito de papel inferior (4) hasta introducirlo por completo.

5. Setzen Sie das Gerät (7) so auf den Papiereinzug (A), dass die Stifte (5) vorne links und vorne rechts am Papiereinzug (A) auf die Öffnungen (6) im Boden des Geräts ausgerichtet sind.

6. Sichern Sie das Gerät (7) mit den 2 Stiften (B) am Papiereinzug (A).

7. Richten Sie die Löcher (8) der Kassette (4-1) des Geräts mit den Stiften (9) im Kassettenanschlag (4-2) aus. Setzen Sie die Papierkassette (4-1) wieder ein.

8. Schieben Sie die Papierkassette (4) bis zum Anschlag ein.

5. Posizionare la macchina (7) sull'alimentatore carta (A) in modo che i perni (5) sul lato destro e sinistro anteriore dell'alimentatore carta (A) siano allineati con i fori (6) presenti sulla base della macchina.

6. Fissare la macchina (7) sull'alimentatore carta (A) con i 2 perni (B).

7. Allineare i fori (8) del cassetto inferiore (4-1) per la macchina con perni (9) della guida cassetto (4-2). Inserire il cassetto carta (4-1).

8. Spingere il cassetto carta inferiore (4) fino in fondo.

5. 供紙工作台 (A) の左右前側の各挿销 (5) 分别对准机器 主机底面的孔 (6) 后, 将机器主机 (7) 放在供纸工作台 (A) 上。

6. 用 2 个固定插销 (B) 将机器主机 (7) 固定在供纸工作台 (A) 上。

7. 将机器下部供纸盒 (4-1) 的孔 (8) 和供纸盒导轨 (4-2) 的插销 (9) 对齐。放置纸盒 (4-1)。

8. 完全推入下部供纸盒 (4)。

5. 금지대 (A) 의 전면 좌측과 전면 우측에 있는 각 핀 (5) 이 본체의 바닥면에 있는 구멍 (6) 에 맞도록 본체 (7) 를 금지대 (A) 위에 놓습니다 .

6. 핀 (B) 2 개로 본체 (7) 를 금지대 (A) 에 고정 합니다 .

7. 본체의 하단 용지 카세트 (4-1) 의 구멍 (8) 과 카세트 슬라이더 (4-2) 의 핀 (9) 을 맞춥니다 . 용지 카세트 (4-1) 를 배치합니다 .

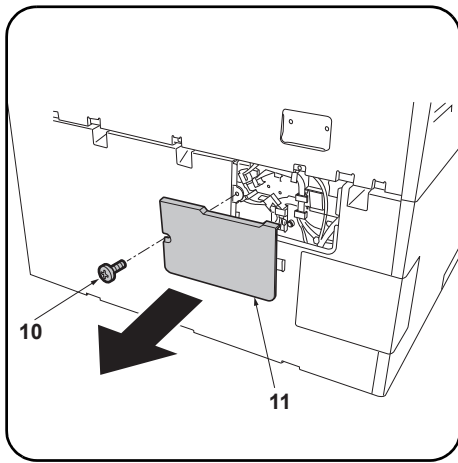
8. 하단 용지 카세트 (4) 를 완전히 밀어 넣습니다 .

5. ペーパーフィーダー(A) の左右前方の各ピン (5) と機械本体のベースの穴 (6) が合うように、ペーパーフィーダー(A) に機械本体 (7) を載せる。

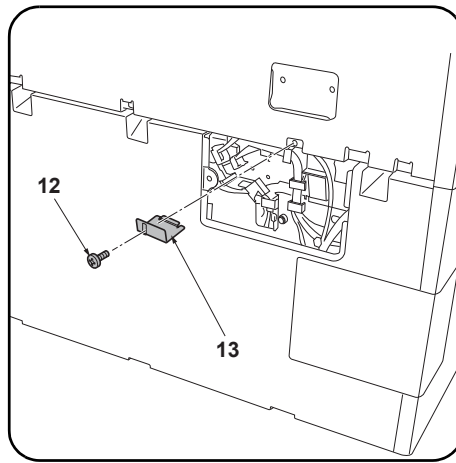
6. ピン (B) 2 本で機械本体 (7) をペーパーフィーダー(A) に固定する。

7. 機械本体の下段カセット (4-1) の穴 (8) とカセットスライダ (4-2) のピン (9) を合わせる。カセット (4-1) を置く。

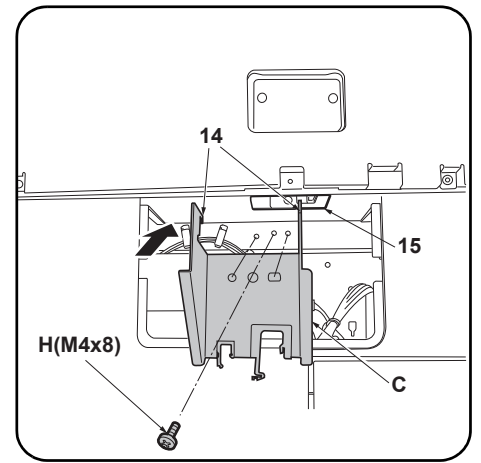
8. 下段カセット (4) を奥まで押し込む。



9. Remove the screw (10) in the rear of the paper feeder and remove the cover (11).



10. Remove the screw (12) to remove the metal plate (13).



11. Fit the hook (14) on the mounting plate (C) into the opening (15) and then align the 2 positioning projections.  
12. Secure the mounting plate (C) with the S Tite screw M4 x 8 (H).

9. Déposer la vis (10) à l'arrière du chargeur de papier et déposer le couvercle (11).

10. Déposer la vis (12) pour enlever la plaque métallique (13).

11. Insérer le crochet (14) du plateau de montage (C) dans l'ouverture (15) et aligner les 2 saillies de positionnement.  
12. Fixer le plateau de montage (C) avec la vis S Tite M4 x 8 (H).

9. Quite el tornillo (10) del lado trasero del depósito de papel y quite la cubierta (11).

10. Quite el tornillo (12) para desmontar la placa de metal (13).

11. Coloque el gancho (14) de la placa de montaje (C) en la abertura (15) y, después, alinee los 2 resaltes de posición.  
12. Asegure la placa de montaje (C) con el tornillo S Tite M4 x 8 (H).

9. Die Schraube (10) an der Rückseite des Papiereinzugs entfernen und die Abdeckung (11) abnehmen.

10. Die Schraube (12) herausdrehen, um die Metallplatte (13) abzunehmen.

11. Den Haken (14) auf der Montageplatte (C) in die Öffnung (15) einpassen und dann die 2 Positionierungsnasen ausrichten.  
12. Die Montageplatte (C) mit der S-Tite-Schraube M4 x 8 verwenden (H) befestigen.

9. Rimuovere la vite (10) nel retro dell'unità di alimentazione della carta e quindi rimuovere il coperchio (11).

10. Rimuovere la vite (12), per rimuovere la piastra di metallo (13).

11. Inserire il gancio (14) sulla piastra di montaggio (C) nell'apertura (15) e quindi allineare le 2 sporgenze di posizionamento.  
12. Fissare la piastra di montaggio (C) con la vite S Tite M4x8 (H).

9. 拆除供紙工作台后部的 1 顆螺絲 (10)，拆下蓋板 (11)。

10. 拆除 1 顆螺絲 (12)，拆下金屬件 (13)。

11. 將安裝板 (C) 的掛鉤 (14) 挂在開口部 (15) 上，并与定位用的 2 处突出部对齐。  
12. 使用 1 顆緊固型 S 螺絲 M4×8 (H) 來固定安裝板 (C)。

9. 금지대 후면의 뒤쪽 나사 (10) 1 개를 제거하고 커버 (11) 를 떼어 냅니다 .

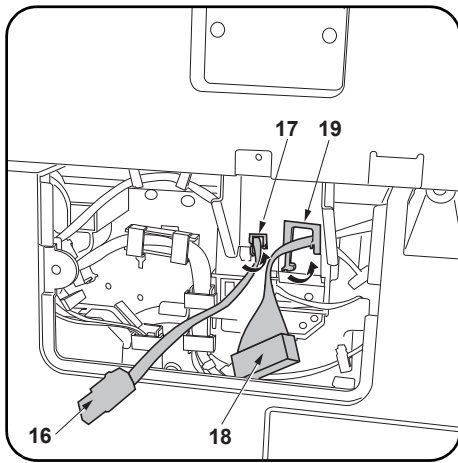
10. 나사 (12) 1 개를 제거하고 쇠 (13) 를 제거합니다 .

11. 부착판 (C) 의 후크 (14) 를 개구부 (15) 에 걸고 위치조정 돌기 2 곳을 맞춥니다 .  
12. 나사 M4×8 S 타이트 (H) 1 개로 부착판 (C) 을 고정합니다 .

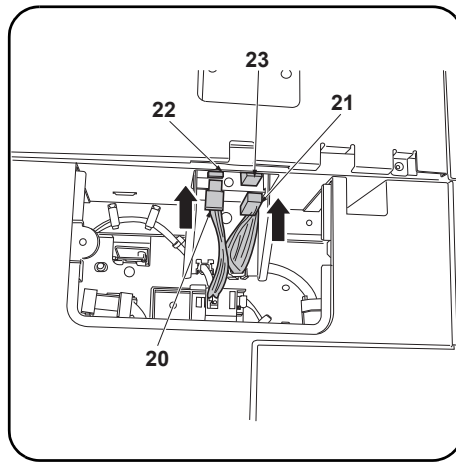
9. ペーパーフィーダー後側のビス (10) 1 本を外し、カバー (11) を取り外す。

10. ビス (12) 1 本を外し、金具 (13) を取り外す。

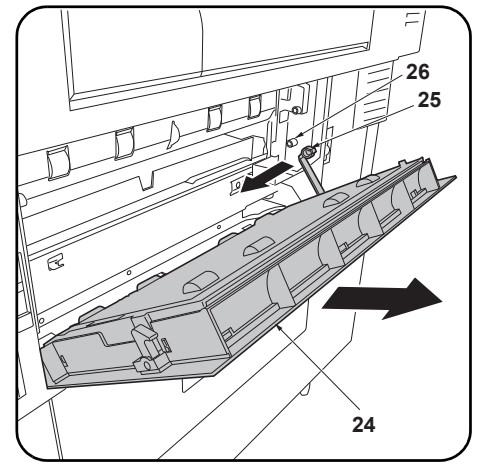
11. 取付板 (C) のフック (14) を開口部 (15) に引っ掛けてから、位置決め突起 2 箇所を合わせる。  
12. ビス M4×8 S タイト (H) 1 本で取付板 (C) を固定する。



**13.** Pass the power cord (16) through the edging (small) (17) and the signal cable (18) through the edging (large) (19) and then close the edging



**14.** Connect the power cord (20) and the signal cable (21) to connectors (22) (23) respectively on the machine.  
**15.** Replace the cover (11) using the screw (10) removed in step 9.



**16.** Open the lower right cover (24) on the machine.  
Remove the strap (25) from the shaft (26) and remove lower right cover (24).

**13.** Faire passer le cordon d'alimentation (16) dans le (petit) passage (17) et le câble du signal (18) dans le (grand) passage (19) puis fermer le passage.

**14.** Raccorder respectivement le cordon d'alimentation (20) et le câble de signal (21) aux connecteurs (22) (23) de la machine.  
**15.** Reposer le couvercle (11) à l'aide de la vis (10) déposée à l'étape 9.

**16.** Ouvrir le capot inférieur droit (24) de la machine.  
Déposer la courroie (25) de l'arbre (26) et déposer le couvercle inférieur droit (24).

**13.** Pase el cable de alimentación (16) a través de la pestaña (pequeña) (17) y el cable de señales (18) a través de la pestaña (grande) (19) y, después, cierre la pestaña.

**14.** Conecte el cable de alimentación (20) y el cable de señal (21) a los conectores (22) (23) respectivamente de la máquina.  
**15.** Vuelva a colocar la cubierta (11) usando el tornillo (10) quitado en el paso 9.

**16.** Abra la cubierta derecha inferior (24) de la máquina.  
Quite la correa (25) del eje (26) y quite la cubierta frontal inferior (24).

**13.** Das Netzkabel (16) durch den Kantenschutz (klein) (17) und das Signalkabel (18) durch den Kantenschutz (groß) (19) führen und dann den Kantenschutz schließen.

**14.** Schließen Sie das Netzkabel (20) und das Signalkabel (21) an den entsprechenden Steckverbindern (22) (23) des Geräts an.  
**15.** Die Abdeckung (11) mittels der in Schritt 9 entfernten Schraube (10) wieder anbringen.

**16.** Öffnen Sie die untere rechte Abdeckung (24) des Geräts.  
Den Riemen (25) von der Welle (26) abnehmen und dann die untere rechte Abdeckung (24) abnehmen.

**13.** Passare il cavo di alimentazione (16) attraverso il bordo (piccolo) (17) e il cavo del segnale (18) attraverso il bordo (grande) (19), e quindi chiudere il bordo.

**14.** Collegare il cavo di alimentazione (20) e il cavo del segnale (21) ai connettori della macchina (22) e (23), rispettivamente.  
**15.** Ricollocare il coperchio (11) utilizzando la vite (10) rimossa nel passo 9.

**16.** Aprire il pannello destro inferiore (24) sulla macchina.  
Rimuovere la cinghietta (25) dall'asta (26) e quindi rimuovere il pannello destro inferiore (24).

**13.** 将 AC 电线 (16) 从束线孔 (小) (17), 信号线 (18) 从束线孔 (大) (19) 中分别穿过, 关闭束线孔。

**14.** 将 AC 电线 (20) 以及信号线 (21) 分别与主机的接插件 (22)、(23) 连接。  
**15.** 使用在步骤 9 中拆除的 1 颗螺丝 (10) 按原样安装盖板 (11)。

**16.** 打开机器主机的右下部盖板 (24)。  
将带子 (25) 从轴 (26) 上拆除, 拆下右下部盖板 (24)。

**13.** AC 전선 (16) 을 에징 (소) (17) 에, 신호선 (18) 을 에징 (대) (19) 에 각각 지나가게 하고 에징을 닫습니다.

**14.** 전원 코드 (20) 및 신호 케이블 (21) 을 본체 커넥터 (22), (23) 에 각각 연결합니다.  
**15.** 순서 9 에서 제거한 나사 (10) 1 개로 커버 (11) 를 원래대로 부착합니다.

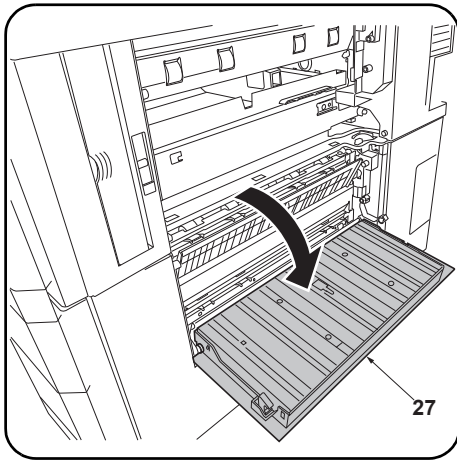
**16.** 본체의 오른쪽 하단 커버 (24) 를 엽니다.  
스트랩 (25) 를 축 (26) 에서 떼어내 오른쪽 아래 커버 (24) 를 제거합니다.

**13.** AC 電線 (16) をエッジング(小) (17) に、信号線 (18) をエッジング(大) (19) にそれぞれ通し、エッジングを閉じる。

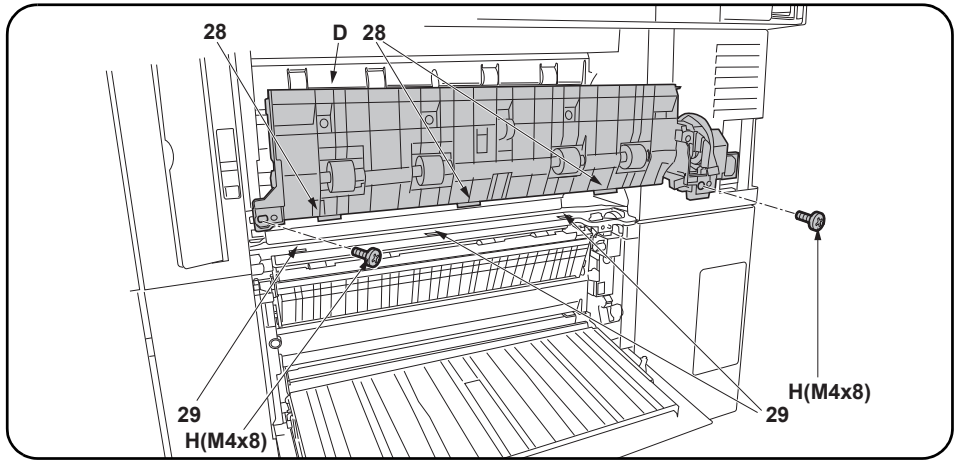
**14.** AC 電線 (20) および信号線 (21) を本体のコネクタ (22)、(23) にそれぞれ接続する。  
**15.** 手順 9 で取り外したビス (10) 1 本でカバー (11) を元通りに取り付ける。

**16.** 機械本体の右下カバー (24) を開く。  
ストラップ (25) を軸 (26) から外し、右下カバー (24) を取り外す。





17. Open the paper feeder right cover (27).



18. Fit the 3 hooks (28) on the intermediate paper conveying unit (D) into the 3 holes (29) in the guide.

19. Secure the intermediate paper conveying unit (D) with the 2 S Tite screw M4 x 8 (H).

**NOTICE**

Be sure to use S Tite screw M4 x 8.

Using longer screws, such as S Tite screws M4 x 20, may damage wires.

17. Ouvrir le couvercle droit du chargeur de papier (27).

18. Insérer les 3 crochets (28) de l'unité de transport du papier intermédiaire (D) dans les 3 trous (29) du guide.

19. Fixer l'unité de transport du papier intermédiaire (D) à l'aide des 2 Vis S Tite M4 x 8 (H).

**REMARQUE**

S'assurer d'utiliser la vis S Tite M4 x 8.

L'utilisation de vis plus longues, comme les vis S Tite M4 x 20, peut endommager les fils.

17. Abra la cubierta derecha del depósito de papel (27).

18. Coloque los 3 ganchos (28) de la unidad de transporte de papel intermedia (D) en los 3 orificios (29) de la guía.

19. Asegure la unidad de transporte de papel intermedia (D) con los 2 Tornillo S Tite M4 x 8 (H).

**AVISO**

Asegúrese de usar tornillos S Tite M4 x 8.

El uso de tornillos más largos, como tornillos S Tite M4 x 20, puede dañar los cables.

17. Die rechte Abdeckung (27) des Papierinzugs öffnen.

18. Die 3 Haken (28) an der eingesetzten Papierfördereinheit (D) in die 3 Öffnungen (29) in der Führung einpassen.

19. Die eingesetzte Papierfördereinheit (D) mit den 2 S-Tite-Schraube M4 x 8 (H) sichern.

**ANMERKUNG**

Stellen Sie sicher, dass Sie die S-Tite-Schraube M4 x 8 verwenden.

Die Verwendung von längeren Schrauben als den S-Tite-Schrauben M4 x 20 kann Kabel beschädigen.

17. Aprire il pannello destro (27) dell'unità di alimentazione della carta.

18. Inserire i 3 ganci (28) sull'unità intermediale di trasporto carta (D) nei 3 fori (29) nella guida.

19. Fixare l'unità intermediale di trasporto carta (D) con le 2 Vite S Tite M4 x 8 (H).

**AVVISO**

Utilizzare solo la vite S Tite M4 x 8.

Se si utilizzano viti più lunghe, come le viti S Tite M4 x 20, si possono danneggiare i fili.

17. 打开供纸工作台的右部盖板 (27)。

18. 将中间搬运单元 (D) 的 3 个挂钩 (28) 嵌入导向板的 3 个孔 (29) 中。

19. 使用 2 颗紧固型 S 螺丝 M4x8(H) 来固定中间搬运单元 (D)。

**注意**

必须使用紧固型 S 螺丝 M4x8。

如使用长螺丝 (紧固型 S 螺丝 M4x20), 可能会使电线受到损伤。

17. 금지대 오른쪽 커버 (27) 를 엽니다 .

18. 중간반송유닛 (D) 의 후크 (28) 3 개를 가이드 구멍 (29) 3 곳에 꽂습니다 .

19. 나사 M4x8 S 타이트 (H) 2 개로 중간반송유닛 (D) 를 고정합니다 .

**주의**

반드시 나사 M4x8 S 타이트를 사용하십시오 .

더 긴 나사 ( 예 : 나사 M4x20 S 타이트 ) 를 사용할 경우 와이어가 손상될 수 있습니다 .

17. 베어퍼피더의右カバー(27)を開く。

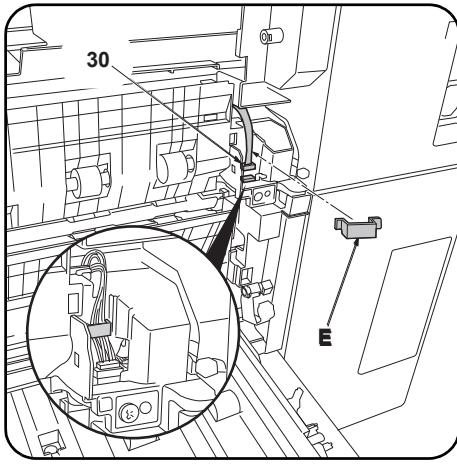
18. 中間搬送ユニット (D) のフック (28) 3 個をガイドの穴 (29) 3 カ所にはめ込む。

19. ビス M4x8 S タイト (H) 2 本で中間搬送ユニット (D) を固定する。

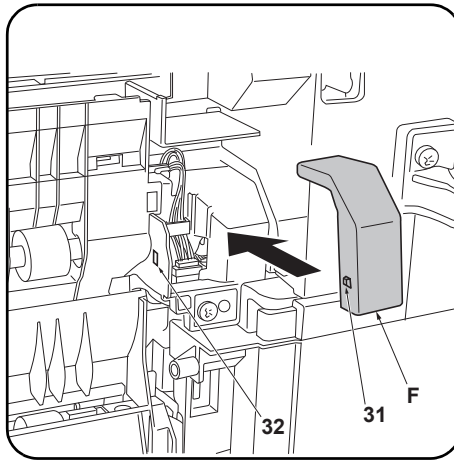
**注意**

必ずビス M4x8 S タイトを使用すること。

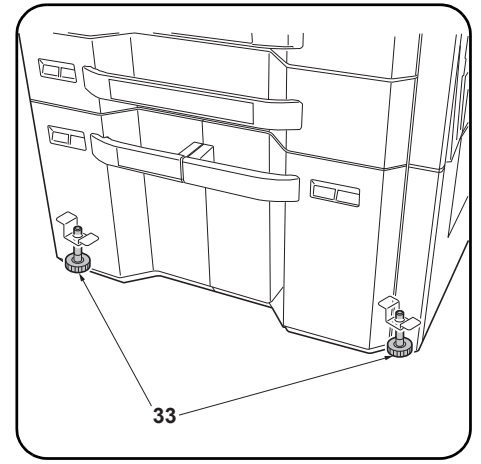
長いビス (M4x20 S タイト) を使用すると電線を傷付けることがあります。



20. Connect the intermediate paper conveying unit connector (30).  
 21. Attach the clamp (E) and secure the connector wire.



22. Insert the projection (31) on the wire cover (F) into the hole (32) in the paper feeder and install the wire cover (F).  
 23. Close the paper feeder right cover (27) and replace the lower right cover (24) on the machine.



24. Turn the adjusters on each corner (33) until they reach the floor and then secure the paper feeder.

20. Raccorder le connecteur (30) de l'unité de transport du papier intermédiaire.  
 21. Monter le collier (E) et fixer le câble du connecteur.

22. Insérer la saillie (31) du couvercle du câble (F) dans le trou (32) du chargeur de papier et reposer le couvercle du câble (F).  
 23. Fermer le couvercle droit du chargeur de papier (27) et reposer le capot inférieur droit (24) sur la machine.

24. Faire tourner les dispositifs de réglage de chacun des coins (33) jusqu'à ce qu'ils touchent le sol et fixer ensuite le chargeur de papier.

20. Conecte el conector de la unidad de transporte de papel intermedia (30).  
 21. Fije el sujetador (E) y asegure el cable del conector.

22. Inserte el resalto (31) de la cubierta para el cable (F) en el orificio (32) del depósito de papel e instale la cubierta para el cable (F).  
 23. Cierre la cubierta derecha del depósito de papel (27) y vuelva a colocar la cubierta derecha inferior (24) en la máquina.

24. Gire los reguladores en cada esquina (33) hasta que lleguen al piso y, a continuación, asegure el depósito de papel.

20. Den Steckverbinder (30) der eingesetzten Papierfördereinheit anschließen.  
 21. Die Klemme (E) anbringen und das Kabel des Steckverbinders sichern.

22. Die Nase (31) der Kabelabdeckung (F) in die Öffnung (32) des Papiereinzugs einsetzen und die Kabelabdeckung (F) anbringen.  
 23. Schließen Sie die rechte Abdeckung (27) des Papiereinzugs und setzen Sie die untere rechte Abdeckung (24) wieder im Gerät ein.

24. Die Einsteller an jeder Ecke (33) drehen, bis sie den Boden berühren, und dann den Papiereinzug sichern.

20. Collegare il connettore (30) dell'unità intermediale di trasporto carta.  
 21. Applicare il morsetto (E) e fissare il cavo del connettore.

22. Inserire la sporgenza (31) del coperchio cavi (F) nel foro (32) nell'unità di alimentazione della carta ed installare il coperchio cavi (F).  
 23. Chiudere il pannello destro (27) dell'alimentatore carta e rimontare il pannello destro inferiore (24) sulla macchina.

24. Ruotare i regolatori (33) presenti su ciascun angolo finché vengano a contatto con il pavimento, e quindi fissare l'unità di alimentazione della carta.

20. 连接中间搬运单元的接插件 (30)。  
 21. 安装束线夹 (E), 以固定接插件电线。

22. 将电线盖板 (F) 的突出部 (31) 插入供纸工作台的孔 (32) 中, 安装电线盖板 (F)。  
 23. 关闭供纸工作台的右部盖板 (27), 按原样安装机器主机的右下部盖板 (24)。

24. 转动四角上的调节器 (33) 直至与地面接触, 然后再固定供纸工作台。

20. 중간반송유닛의 커넥터 (30) 를 접속합니다.  
 21. 클램프 (E) 를 부착, 커넥터 전선을 고정합니다.

22. 전선커버 (F) 의 돌기 (31) 를 급지대의 구멍 (32) 에 넣고 전선커버 (F) 를 부착합니다.  
 23. 급지대 오른쪽 커버 (27) 를 닫고 본체의 오른쪽 하단 커버 (24) 를 다시 부착합니다.

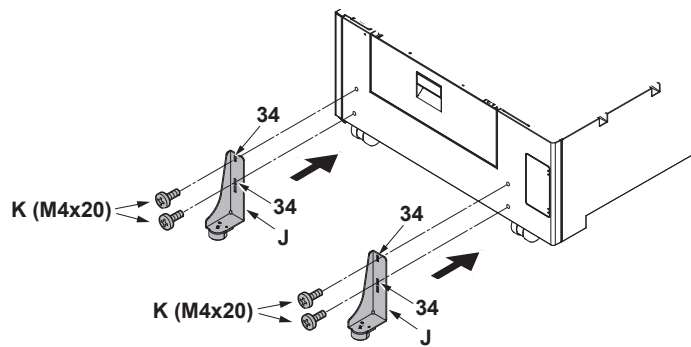
24. 네 곳의 어저스터 (33) 를 맨 밑에 닿을 위치까지 돌려 급지대를 고정합니다.

20. 中間搬送ユニットのコネクター (30) を接続する。  
 21. クランプ (E) を取り付け、コネクター電線を固定する。

22. 電線カバー (F) の突起 (31) をペーパーフィーダーの穴 (32) に入れて、電線カバー (F) を取り付ける。  
 23. ペーパーフィーダーの右カバー (27) を閉じ、機械本体の右下カバー (24) を元通りに取り付ける。

24. 四隅のアジャスター (33) を床に接触する位置まで回し、ペーパーフィーダーを固定する。





25. Select holes (34) and install each stopper (J) with 2 S Tite screws M4 x 20 (K) so that the stoppers will be grounded on the floor.

25. Sélectionner les trous (34) et installer chaque butée (J) avec 2 vis S Tite M4 x 20 (K) de sorte que les butées reposent sur le sol.

25. Seleccione los orificios (34) e instale cada tope (J) con los 2 tornillos S Tite M4 x 20 (K) de manera que los topes se conecten a tierra en el suelo.

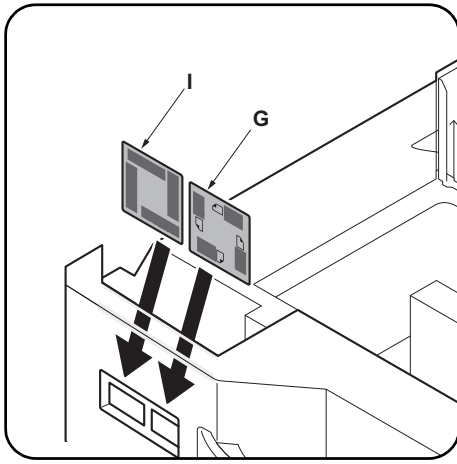
25. Wählen Sie die Öffnungen (34) und befestigen Sie jeden Anschlag (J) mit den 2 S-Tite-Schrauben M4 x 20 (K) so an, dass die Anschläge am Boden aufsitzen.

25. Selezionare i fori (34) ed installare ogni fermo (J) con le 2 viti S Tite M4 x 20 (K) in modo che i fermi siano posti a terra sul pavimento.

25. 在孔(34)处各用2颗M4×20紧固型S螺丝(K)安装限位器(J),使之和地板接触。

25. 전도방지쇠(J)가 바닥면에 접지될 수 있도록 구멍(34)을 선택해 나사 M4×20 S 타이트(K) 각 2개로 설치합니다.

25. 転倒防止金具(J)が床面に接地するように、穴(34)を選択してビス M4×20 S タイト(K) 各2本で取り付けます。



### Setting the paper size plate and media type plate

Insert the paper size plate (G) and media type plate (I) into the each slots respectively.

### Disposition des plaquettes du format de papier et du type de support

Introduire la plaquette du format de papier (G) et la plaquette du type de support (I) dans leur logement respectif.

### Ajuste de la placa de tamaño de papel y la placa de tipo de medio

Insere la placa de tamaño de papel (G) y la placa de tipo de medio (I) en cada uno de las ranuras, respectivamente.

### Einsetzen der Papierformatkarte und der Medientypkarte

Setzen Sie die Papierformatkarte (G) und die Medientypkarte (I) in die jeweiligen Führungen.

### Impostazione della piastra di formato carta e della piastra del tipo di supporto

Inserire la piastra del formato carta (G) e la piastra del tipo di supporto (I) nei rispettivi alloggiamenti.

### 纸张尺寸标识片和纸张种类标识片的安装

将纸张尺寸标识片 (G) 和纸张种类标识片 (I) 分别插入到图示的插槽中。

### 용지크기 플레이트와 용지종류 플레이트의 세트

용지크기 플레이트 (G) 와 용지종류 플레이트 (I) 를 각 표시 슬롯에 각각 삽입한다.

用紙サイズプレートと用紙種類プレートのセット  
用紙サイズプレート (G) と用紙種類プレート (I) を各表示スロットにそれぞれ挿入する。

### Changing paper size (metric specifications only)

At shipment, Letter is set for inch models and A4 is set for metric models. Use the procedure below to change the size to B5.

### Modification du format du papier (pour spécifications métriques seulement)

À expédition, les modèles à mesure en pouces sont réglés sur le format Letter et les modèles à mesure métrique sur le format A4. Pour passer au format B5, procéder de la manière suivante.

### Cómo cambiar el tamaño de papel (sólo para las especificaciones métricas)

En el momento de salida de fábrica, se configura Carta para los modelos en pulgadas y A4 para los modelos en sistema métrico. Siga este procedimiento para cambiar el tamaño a B5.

### Ändern des Papierformats (nur metrische Spezifikationen)

Beim Werksversand ist bei Modellen mit Zollmaß das Format Letter voreingestellt und bei Modellen mit metrischem Maß das Format A4. Das Format kann wie folgend auf B5 umgeschaltet werden.

### Cambio del formato della carta (solo per le specifiche metriche)

Al momento della spedizione, Letter è impostato per le specifiche in pollici e A4 è impostato per le specifiche metriche. Usare la procedura riportata sotto per cambiare il formato a B5.

### 纸张尺寸更改 (仅限公制规格)

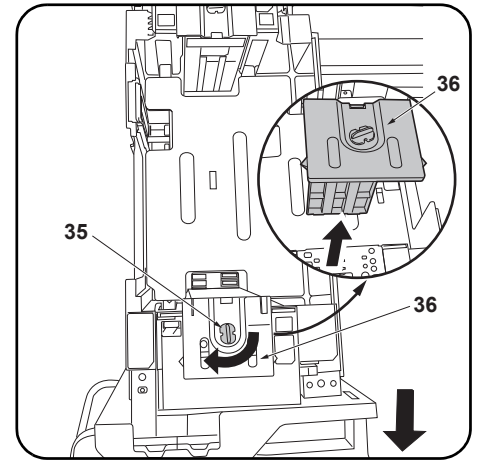
产品出厂时, 英制规格设定为 Letter、公制规格设定为 A4。要将尺寸更改为 B5 时, 请按以下步骤进行操作。

### 용지크기 변경 (센치 사양만)

출하시, 인치사양은 Letter, 센치사양은 A4 로 설정되어 있습니다. 크기를 B5 로 변경하는 경우에는 다음 순서를 진행해 주십시오.

### 用紙サイズ変更 (センチ仕様のみ)

出荷時、インチ仕様は Letter、センチ仕様は A4 に設定されています。サイズを B5 に変更する場合は次の手順をおこなってください。



1. Pull out the cassette of the paper feeder.
2. Turn the front lock lever (35) 90° and remove the front deck cursor (36).

1. Tirer le magasin du chargeur de papier vers soi.
2. Faire tourner le levier de verrouillage avant (35) de 90° et déposer le curseur de platine avant (36).

1. Abra el casete del depósito de papel.
2. Gire la palanca de bloqueo frontal (35) 90° y quite el cursor frontal de la plataforma (36).

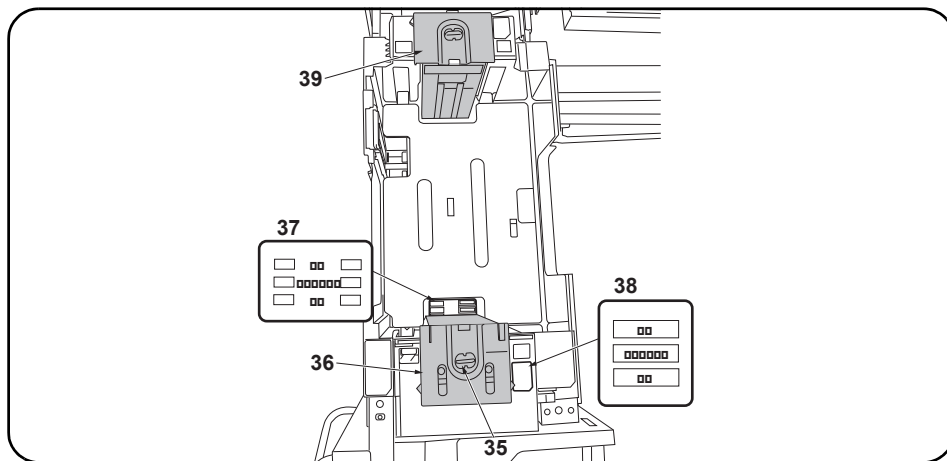
1. Ziehen Sie die Papierlade aus dem Papiereinzug.
2. Den vorderen Verriegelungshebel (35) um 90° drehen und den vorderen Konsole-Cursor (36) abnehmen.

1. Estrarre il cassetto dell'unità di alimentatore della carta.
2. Ruotare la leva frontale di blocco (35) di 90° e rimuovere il cursore frontale del deck (36).

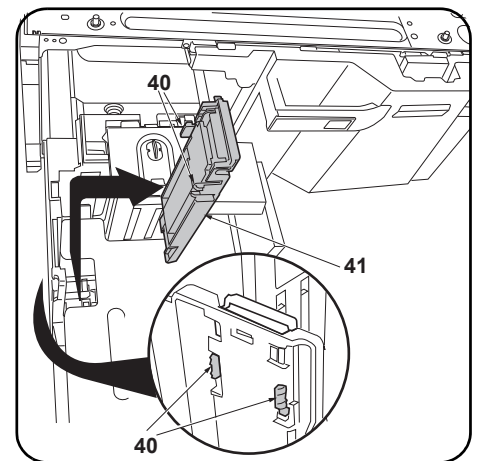
1. 拉出供纸工作台的供纸盒。
2. 将前部锁定杆 (35) 旋转 90°, 拆下堆纸板前部游标 (36)。

1. 금지대 카세트를 빼 냅니다.
2. 잠금레버 앞 (35) 을 90° 회전시켜 데스크커서 앞 (36) 을 제거합니다.

1. ペーパーフィーダーのカセットを引き出す。
2. ロックレバー前 (35) を 90° 回転させ、デッキカーソル前 (36) を取り外す。



3. Move the front deck cursor (36) so that it is aligned with the size indicators on the top (38) and bottom (37) of the cassette.
4. Turn the front lock lever (35) 90° to lock it.
5. Move the rear deck cursor (39) in the same way.



6. Release the hook (40) and remove the deck trailing edge cursor (41).

3. Déplacer le curseur de platine avant (36) de sorte qu'il soit aligné avec les indicateurs de format en haut (38) et en bas (37) du tiroir.
4. Faire tourner le levier de verrouillage avant (35) de 90° pour le verrouiller.
5. Déplacer le curseur de platine arrière (39) en procédant de la même manière.

6. Libérer le crochet (40) et déposer le curseur du bord arrière de la platine (41).

3. Mueva el cursor frontal de la plataforma (36) para que quede alineado con las indicadores de tamaño de la parte superior (38) e inferior (37) del cajón.
4. Gire la palanca de bloqueo frontal (35) 90° para bloquearla.
5. Mueva el cursor trasero de la plataforma (39) de la misma forma.

6. Libere el gancho (40) y quite el cursor del borde inferior de la plataforma (41).

3. Den vorderen Konsole-Cursor (36) so verschieben, dass er mit den Formatanzeigen oben (38) und unten (37) an der Kassette fluchtet.
4. Den vorderen Verriegelungshebel (35) zum Verriegeln um 90° drehen.
5. Den hinteren Konsole-Cursor (39) auf gleiche Weise verschieben.

6. Den Haken (40) lösen und den Hinterkante-Cursor (41) der Konsole abnehmen.

3. Spostare il cursore frontale del deck (36) in modo che esso risulti allineato con gli indicatori di formato sulla parte superiore (38) e inferiore (37) del cassetto.
4. Ruotare la leva frontale di blocco (35) di 90°, per bloccarla.
5. Spostare il cursore posteriore del deck (39) allo stesso modo.

6. Rilasciare il gancio (40) e rimuovere il cursore del bordo di uscita del deck (41).

3. 移动堆纸板前部游标 (36), 使供纸盒下部的尺寸标记 (37) 与供纸盒上部的尺寸标记 (38) 对齐。
4. 将前部锁定杆 (35) 旋转 90° 以固定。
5. 按同样方式移动后部堆纸板后部游标 (39)。

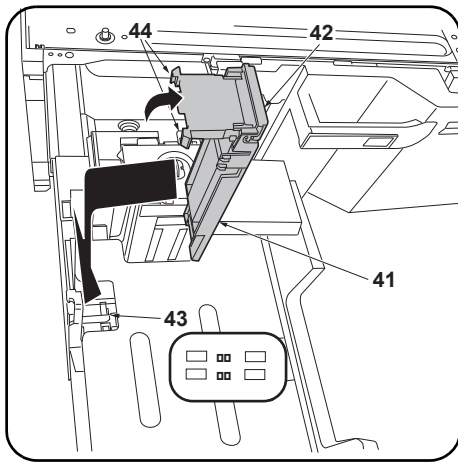
6. 解除挂钩 (40), 拆下堆纸板后部游标 (41)。

3. 카세트 밑의 크기표시 (37) 와 카세트 위의 크기 표시 (38) 에 맞춰 데크커서 앞 (36) 을 이동시킵니다 .
4. 잠금레버 앞 (35) 을 90° 회전시켜 고정합니다 .
5. 똑같이 데크커서 뒤 (39) 를 이동시킵니다 .

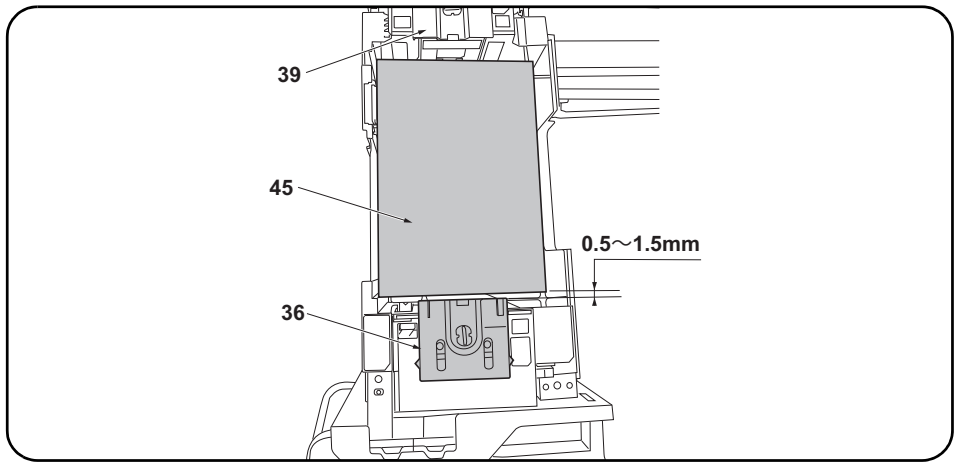
6. 후크 (40) 를 해제하고 데크 뒷단커서 (41) 를 제거합니다 .

3. カセット下のサイズ表示 (37) とカセット上のサイズ表示 (38) に合わせてデッキカーソル前 (36) を移動させる。
4. ロックレバー前 (35) を 90° 回転させ固定する。
5. 同様にデッキカーソル後 (39) を移動させる。

6. フック (40) を解除し、デッキ後端カーソル (41) を取り外す。



7. Lift up the sub-cursor (42).
8. Align with the size indicator (43), engage the hook (44) and install the deck trailing edge cursor (41).



#### Adjusting the cursor width

1. Load paper in the cassettes.
2. If the gap between the front deck cursor (36) and the paper (45) is outside the 0.5 to 1.5 mm range when the paper (45) is touching up against the rear deck cursor (39), perform the following adjustment.
  - \* A cursor width that is too small can hinder paper feeding, while a cursor width that is too large can lead to problems such as skewed paper feed.

7. Lever le curseur secondaire (42).
8. Aligner avec l'indicateur de format (43), engager le crochet (44) et reposer le curseur du bord arrière de la platine (41).

#### Réglage de la largeur du curseur

1. Charger les tiroirs en papier.
2. Si l'écartement entre le curseur de platine avant (36) et le papier (45) est hors des limites de 0,5 à 1,5 mm quand le papier (45) touche le curseur de platine arrière (39), procéder au réglage suivant.
  - \* Une largeur trop faible du curseur risque d'empêcher l'entraînement du papier et une largeur trop grande risque d'entraîner des problèmes du type entraînement du papier de biais.

7. Levante el cursor secundario (42).
8. Alinee con el indicador de tamaño (43), enganche el gancho (44) e instale el cursor del borde inferior de la plataforma. (41).

#### Cómo ajustar la anchura del cursor

1. Cargue papel en los cajones.
2. Si la separación entre el cursor frontal de la plataforma (36) y el papel (45) está fuera del rango de 0,5 a 1,5 mm cuando el papel (45) toca el cursor trasero de la plataforma (39), haga el siguiente ajuste.
  - \* Una anchura del cursor demasiado pequeña puede impedir la alimentación de papel; una anchura del cursor demasiado grande puede provocar problemas con la alimentación torcida de papel.

7. Den Unter-Cursor (42) anheben.
8. Auf die Formatanzeige (43) ausrichten, den Haken (44) einsetzen und den Hinterkante-Cursor (41) der Konsole anbringen.

#### Einstellen der Cursor-Breite

1. Papier in die Papierladen einlegen.
2. Falls der Abstand zwischen dem vorderen Konsole-Cursor (36) und dem Papier (45) außerhalb des Bereichs 0,5 bis 1,5 mm liegt, wenn das Papier (45) am hinteren Konsole-Cursor (39) anliegt, ist folgende Einstellung vorzunehmen.
  - \* Eine zu kleine Cursor-Breite kann den Papiereinzug behindern, wogegen eine zu große Cursor-Breite verkanteten Papiereinzug und ähnliche Probleme verursachen kann.

7. Sollevare il cursore secondario (42).
8. Allineare con l'indicatore formato (43), fissare il gancio (44) e installare il cursore del bordo di uscita del deck (41).

#### Regolazione della larghezza del cursore

1. Caricare carta nei cassetti.
2. Se lo spazio tra il cursore frontale del deck (36) e la carta (45) è fuori della gamma da 0,5 a 1,5 mm quando la carta (45) tocca il cursore posteriore del deck (39), eseguire la regolazione seguente.
  - \* Una larghezza dei cursori troppo piccola può ostacolare l'alimentazione della carta, mentre un'alarghezza dei cursori troppo grande può essere causa di problemi, come ad esempio l'alimentazione obliqua della carta.

7. 抬起副游标 (42)。
8. 对齐尺寸标记 (43)，将挂钩 (44) 嵌入以安装堆纸板后部游标 (41)。

#### 游标宽度的调节

1. 在供纸盒中装入纸张。
2. 在堆纸板后部游标 (39) 与纸张 (45) 接触的状态下，如果堆纸板前部游标 (36) 与纸张 (45) 的间隙超出了 0.5 ~ 1.5mm 的范围，须进行以下调节。
  - ※ 如果游标宽度过小，可能造成不供纸，游标宽度过大，则可能发生歪斜进纸等情况。

7. 서브커서 (42) 를 세웁니다 .
8. 크기표시 (43) 에 맞춰 후크 (44) 를 판백데크 후단커서 (41) 를 부착합니다 .

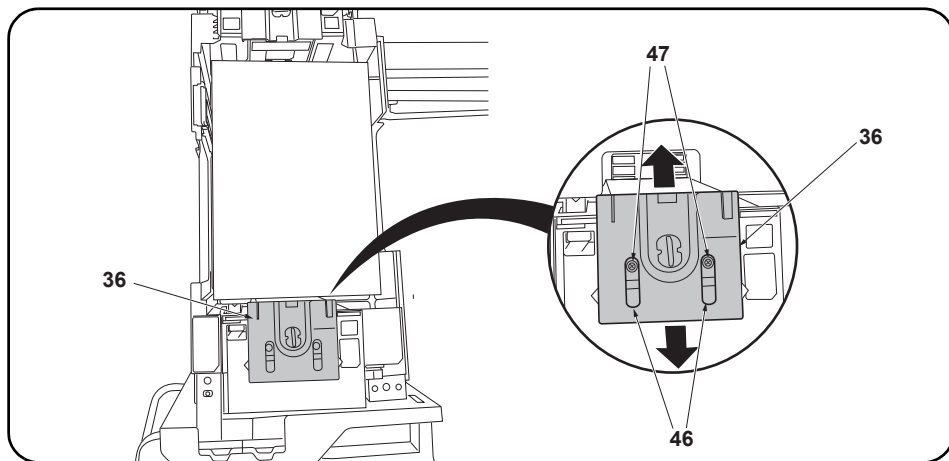
#### 커서 폭 조정

1. 카세트에 용지를 장착합니다 .
2. 데크커서 뒤 (39) 에 용지 (45) 가 접하고 있는 상태에서 데크커서 앞 (36) 과 용지 (45) 의 틈이 0.5 ~ 1.5mm 의 범위외의 경우에는 이하의 조정을 합니다 .
  - ※ 커서 폭이 작으면 무급지, 커서 폭이 크면 경사급지 등이 발생할 가능성이 있습니다 .

7. サブカーソル (42) を起こす。
8. サイズ表示 (43) に合わせて、フック (44) をはめデッキ後端カーソル (41) を取り付ける。

#### カーソル幅の調整

1. カセットに用紙をセットする。
2. デッキカーソル後 (39) に用紙 (45) が接している状態で、デッキカーソル前 (36) と用紙 (45) の隙間が 0.5 ~ 1.5mm の範囲外の場合は、以下の調整をおこなう。
  - ※ カーソル幅が小さいと無給紙、カーソル幅が大きいと斜め給紙などが発生する可能性がある。



3. Insert a Philips-head screwdriver into the 2 long slots (46) in the front deck cursor (36) and loosen the 2 adjusting screws (47). Then move the front deck cursor (36).

4. Retighten the 2 adjusting screws (47).  
5. Check that the gap between the front deck cursor (36) and the paper is between 0.5 and 1.5 mm.

3. Insérer un tournevis cruciforme dans les 2 longues fentes (46) du curseur de platine avant (36) et desserrer les 2 vis de réglage (47). Déplacer ensuite le curseur de platine avant (36).

4. Resserrer les 2 vis de réglage (47).  
5. Vérifier que l'écartement entre le curseur de platine avant (36) et le papier est entre 0,5 et 1,5 mm.

3. Inserte un destornillador de cabeza Philips en las dos ranuras largas (46) en el cursor frontal de la plataforma (36) y afloje los 2 tornillos de ajuste (47). Después, mueva el cursor frontal de la plataforma (36).

4. Vuelva a apretar los 2 tornillos de ajuste (47).  
5. Verifique que la separación entre el cursor frontal de la plataforma (36) y el papel sea de entre 0,5 y 1,5 mm.

3. Einen Kreuzschlitzschraubendreher in die 2 langen Öffnungen (46) im vorderen Konsole-Cursor (36) stecken und die 2 Einstellschrauben (47) lösen. Danach den vorderen Konsole-Cursor (36) verschieben.

4. Die 2 Einstellschrauben (47) wieder anziehen.  
5. Vergewissern Sie sich, dass der Abstand zwischen dem vorderen Konsole-Cursor (36) und dem Papier im Bereich 0,5 bis 1,5 mm liegt.

3. Inserire un cacciavite con testa a croce tipo Philips nelle 2 fessure lunghe (46) nel cursore frontale del deck (36) e allentare le 2 viti di regolazione (47). Quindi spostare il cursore frontale del deck (36).

4. Ristringere le 2 viti di regolazione (47).  
5. Controllare che lo spazio tra il cursore frontale del deck (36) e la carta sia compreso nella gamma tra 0,5 e 1,5 mm.

3. 将十字螺丝刀从堆纸板前部游标 (36) 的 2 处长孔 (46) 处插入, 拧松 2 颗调节螺丝 (47), 移动堆纸板前部游标 (36)。

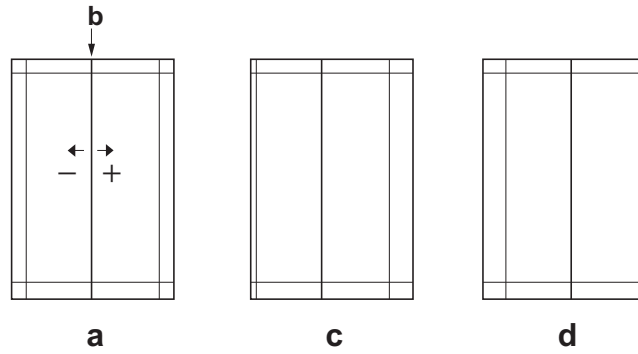
4. 拧紧 2 颗调节螺丝 (47)。  
5. 确认堆纸板前部游标 (36) 与纸张的间隙在 0.5 ~ 1.5mm 的范围内。

3. 데크커서 앞 (36) 2 곳의 긴 구멍 (46) 에서 플러스 드라이버를 넣어 조정나사 (47) 2 개를 느슨하게 하고 데크커서 앞 (46) 을 이동시킵니다 .

4. 조정나사 (47) 2 개를 조입니다 .  
5. 데크커서 앞 (36) 과 용지의 틈이 0.5 ~ 1.5 mm 범위내가 되어 있는 것을 확인합니다 .

3. デッキカーソル前 (36) の 2 箇所 の長穴 (46) からプラスドライバー挿入し、調整ビス (47) 2 本を緩め、デッキカーソル前 (36) を移動させる。

4. 調整ビス (47) 2 本を締め付ける。  
5. デッキカーソル前 (36) と用紙の隙間が 0.5 ~ 1.5mm の範囲内になっていることを確認する



### Adjusting the center line

The reference value for the center line is  $\pm 0.5$  mm or less at position (b) in the correct image (a). If the center line position is outside this range, perform the following adjustment.

1. Set maintenance mode U034, select LSU Out Left and Cassette3 or Cassette4.
2. Adjust the values.  
Test pattern (c): Increase the setting value. Test pattern (d): Decrease the setting value.
3. Press the Start key to confirm the setting value.

### Réglage de l'axe

La valeur de référence pour l'axe est de  $\pm 0,5$  mm ou moins à la position (b) d'une image correcte (a). Si la position de l'axe est hors de cette plage, effectuez le réglage suivant.

1. Passer en mode maintenance U034, sélectionner LSU Out Left et Cassette3 ou Cassette4.
2. Régler les valeurs.  
Mire d'essai (c): Augmentez la valeur de réglage. Mire d'essai (d): Diminuez la valeur de réglage.
3. Appuyer sur la touche de Start pour confirmer la valeur de réglage.

### Ajuste de la línea central

El valor de referencia de la línea central es de  $\pm 0,5$  mm o menor, en la posición (b) de la imagen correcta (a). Si la posición de la línea central estuviera fuera de este rango, haga el siguiente ajuste.

1. Entre al modo de mantenimiento U034, seleccione LSU Out Left y Cassette3 o Cassette4.
2. Ajuste los valores.  
Patrón de prueba (c): Aumente el valor de configuración. Patrón de prueba (d): Reduzca el valor de configuración.
3. Pulse la tecla de Start para confirmar el valor de configuración.

### Einstellen der Mittelinie

Der Bezugswert für die Mittelinie ist  $\pm 0,5$  mm oder weniger an Position (b) des korrekten Bilds (a). Falls die Mittelinie außerhalb dieses Bereichs liegt, ist folgende Einstellung vorzunehmen.

1. Schalten Sie in den Wartungsmodus U034, wählen Sie LSU Out Left und Cassette3 oder Cassette4.
2. Die Werte einstellen.  
Testmuster (c): Den Einstellwert erhöhen. Testmuster (d): Den Einstellwert verringern.
3. Den Einstellwert durch Drücken der Start-Taste bestätigen.

### Regolazione della linea centrale

Il valore di riferimento per la linea centrale è  $\pm 0,5$  mm o inferiore alla posizione (b) nell'immagine corretta (a). Se la posizione della linea centrale è all'infuori di questa gamma, effettuare la regolazione seguente.

1. Impostare la modalità manutenzione U034, selezionare LSU Out Left e Cassette3 o Cassette4.
2. Regolare i valori.  
Modello di prova (c): Aumentare il valore dell'impostazione. Modello di prova (d): Diminuire il valore dell'impostazione.
3. Premere il tasto di Start per confermare il valore dell'impostazione.

### 中心线调节

中心线的基准值在矫正图像 (a) 的 (b) 位置为  $\pm 0.5$ mm 以内。超出该范围时，须进行以下调节。

1. 设置维护模式 U034，选择 LSU Out Left、Cassette3 或 Cassette4。
2. 调整设定值。  
测试图案 (c)：调高设定值。测试图案 (d)：调低设定值。
3. 按 Start 键，以确定设定值。

### 센터라인 조정

센터라인은 적정화상 (a) 의 (b) 위치에서 기준치는  $\pm 0.5$ mm 이내 . 여기에서 벗어나는 것은 이하의 조정을 합니다 .

1. 메인テナンス 모드 U034 를 세트하고 LSU Out Left, Cassette3 또는 Cassette4 를 선택합니다 .
2. 설정치를 조정합니다 .  
테스트 패턴 (c) : 설정치를 높입니다 . 테스트 패턴 (d) : 설정치를 내립니다 .
3. 시작키를 누르고 설정치를 확인합니다 .

### センターライン調整

センターラインは、適正画像 (a) の (b) の位置で基準値は  $\pm 0.5$ mm 以内。これから外れるときは以下の調整をおこなう。

1. メンテナンスモード U034 をセットし、LSU Out Left、Cassette3 または Cassette4 を選択する。
2. 設定値を調整する。  
テストパターン (c) : 設定値を上げる。 テストパターン (d) : 設定値を下げる。
3. スタートキーを押し、設定値を確定する。



303NF5673001

2013. 1  
303NF56730-01

# **INSTALLATION GUIDE FOR SIDE DECK**



---

**INSTALLATION GUIDE**

**GUIDE D'INSTALLATION**

**GUÍA DE INSTALACION**

**INSTALLATIONSANLEITUNG**

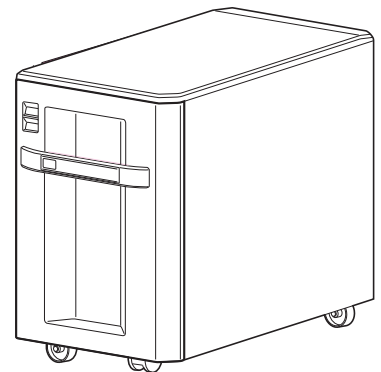
**GUIDA ALL'INSTALLAZIONE**

**安装手册**

**설치안내서**

**設置手順書**

**PF-770**



## English

References to medium-speed MFPs in this document denote 30/30, 35/35, 45/45 and 55/50 ppm color machines, and 35, 45 and 55 ppm monochrome machines.

References to high-speed MFPs in this document denote 65/65 and 75/70 ppm color machines, and 65 and 80 ppm monochrome machines.

---

## Français

Dans le présent document, les références aux MFP à vitesse moyenne renvoient aux machines couleurs 30/30, 35/35, 45/45 et 55/50 ppm et aux machines monochromes 35, 45 et 55 ppm.

Dans le présent document, les références aux MFP à grande vitesse renvoient aux machines couleurs 65/65 et 75/70 ppm et aux machines monochromes 65 et 80 ppm.

---

## Español

Las referencias a las MFP de velocidad media de este documento corresponden a las máquinas a color de 30/30, 35/35, 45/45 y 55/50 ppm y a las máquinas monocromáticas de 35, 45 y 55 ppm.

Las referencias a las MFP de alta velocidad de este documento corresponden a las máquinas a color de 65/65 y 75/70 ppm y a las máquinas monocromáticas de 65 y 80 ppm.

---

## Deutsch

Angaben für MFP der mittleren Leistungsklasse in dieser Anleitung gelten für die 30/30, 35/35, 45/45 und 55/50 ppm Vollfarbenkopierer sowie für die 35, 45 und 55 ppm Monochrommaschinen.

Angaben für MFP der Hochleistungsklasse in dieser Anleitung gelten für die 65/65 und 75/70 ppm Vollfarbenkopierer sowie für die 65 und 80 ppm Monochrommaschinen.

---

## Italiano

I riferimenti per le MFP a velocità media riportati in questo documento indicano le macchine a colori 30/30, 35/35, 45/45 e 55/50 ppm, e le macchine monocromatiche 35, 45 e 55 ppm.

I riferimenti per le MFP a velocità alta riportati in questo documento indicano le macchine a colori 65/65 e 75/70 ppm, e le macchine monocromatiche 65 e 80 ppm.

---

## 简体中文

本文中的中速 MFP 代表彩色 30/30 页机型、35/35 页机型、45/45 页机型、55/50 页机型、黑白 35 页机型、45 页机型、55 页机型。

本文中的高速 MFP 代表彩色 65/65 页机型、75/70 页机型、黑白 65 页机型、80 页机型。

---

## 한국어

본문 중 중속 MFP 는 컬러 30/30 매기, 35/35 매기, 45/45 매기, 55/50 매기, 흑백 35 매기, 45 매기, 55 매기를 나타냅니다.

본문 중 고속 MFP 는 컬러 65/65 매기, 75/70 매기, 흑백 65 매기, 80 매기를 나타냅니다.

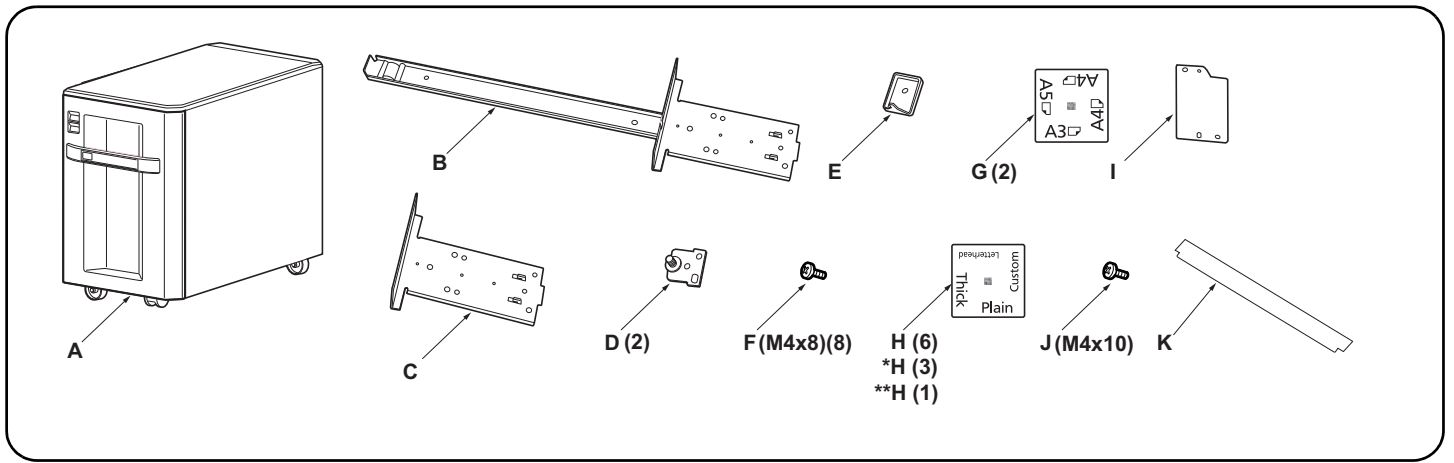
---

## 日本語

本文中の中速 MFP はカラー機の 30/30 枚機、35/35 枚機、45/45 枚機、55/50 枚機、モノクロ機の 35 枚機、45 枚機、55 枚機を表す。

本文中の高速 MFP はカラー機の 65/65 枚機、75/70 枚機、モノクロ機の 65 枚機、80 枚機を表す。

---



### Supplied parts

A. Side feeder .....	1
B. Large base slider .....	1
C. Small base slider .....	1
D. Lock pin .....	2
E. Switch press plate .....	1
F. M4 x 8 screw .....	8

G. Paper size plate .....	2
H. Media type plate(except for 120V model) ..	6
*H. Media type plate(120V model only) .....	3
I. Cover plate .....	1
J. M4 x 10 tapping screw.....	1
K. Film .....	1

Be sure to remove any tape and/or cushioning material from supplied parts.

### Pièces fournies

A. Plateau d'alimentation latéral.....	1
B. Grande règle de base.....	1
C. Petite règle de base.....	1
D. Broche de verrouillage.....	2
E. Plaque de pression de l'interrupteur .....	1
F. Vis M4 x 8.....	8

G. Plaquette du format de papier .....	2
H. Plaquette du type de support.....	6
I. Capot .....	1
J. Vis de connexion M4 x 10 .....	1
K. Film .....	1

Veillez à retirer les morceaux de bande adhésive et/ou les matériaux de rembourrage des pièces fournies.

### Partes suministradas

A. Alimentador lateral.....	1
B. Deslizador de base grande.....	1
C. Deslizador de base pequeño .....	1
D. Clavija de bloqueo .....	2
E. Placa de presión del interruptor.....	1
F. Tornillo M4 x 8 .....	8

G. Placa de tamaño de papel .....	2
H. Placa de tipo de medio .....	6
I. Tapa .....	1
J. Tornillo de roscado M4 x 10 .....	1
K. Película .....	1

Asegúrese de despegar todas las cintas y/o material amortiguador de las partes suministradas.

### Gelieferte Teile

A. Seitlicher Einzug.....	1
B. Großer Basis-Schieber .....	1
C. Kleiner Basis-Schieber .....	1
D. Arretierstift .....	2
E. Schalterdruckplatte .....	1
F. M4 x 8 Schraube .....	8

G. Papierformatkarte .....	2
H. Medientypkarte .....	6
I. Abdeckplatte .....	1
J. M4 x 10 Schneidschraube.....	1
K. Film .....	1

Entfernen Sie Klebeband und/oder Dämpfungsmaterial vollständig von den mitgelieferten Teilen.

### Parti di forniture

A. Unità di alimentazione laterale.....	1
B. Scivolo di base grande .....	1
C. Scivolo di base piccolo .....	1
D. Perno di bloccaggio .....	2
E. Piastra spingi interruttore.....	1
F. Vite M4 x 8 .....	8

G. Piastra formato carta .....	2
H. Piastra tipo carta.....	6
I. Coperchio .....	1
J. Vite autofilettante M4 x 10 .....	1
K. Pellicola .....	1

Accertarsi di rimuovere tutti i nastri adesivi e/o il materiale di imbottitura dalle parti fornite.

### 附属品

A. 侧供纸盒 .....	1
B. 底座滑板(大).....	1
C. 底座滑板(小).....	1
D. 锁定插销 .....	2
E. 开关挡板 .....	1

F. M4x8 螺丝 .....	8
G. 纸张尺寸标示 .....	2
**H. 纸张种类标示 .....	1
I. 盖板 .....	1
J. M4x10 自攻螺丝 .....	1
K. 胶片 .....	1

如果附属品上带有固定胶带,缓冲材料时必须揭下。

### 동봉품

A. 사이드피더.....	1
B. 베이스 슬라이더 대 .....	1
C. 베이스 슬라이더 소 .....	1
D. 잠금 핀 .....	2
E. 스위치 판 .....	1

F. 나사 M4x8.....	8
G. 용지크기 플레이트.....	2
**H. 용지종류 플레이트 .....	1
I. 커버 플레이트.....	1
J. 탭핑 나사 M4x10.....	1
K. 필름 .....	1

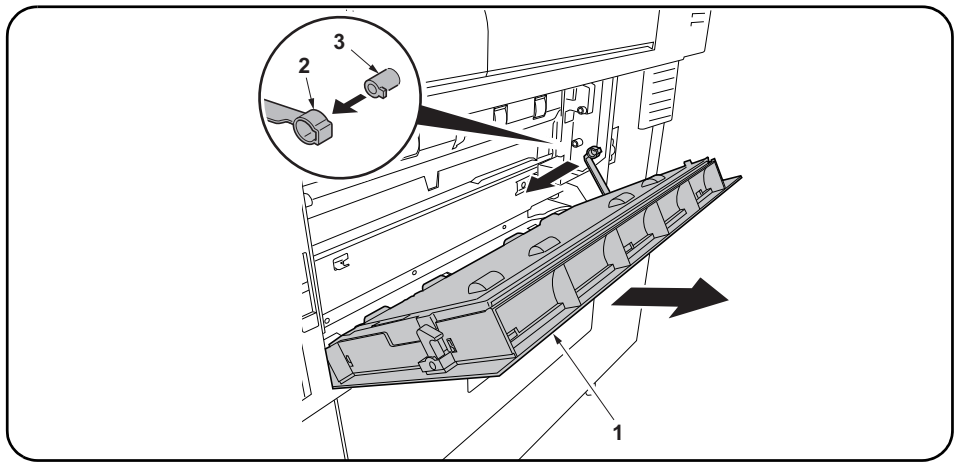
동봉품에 고정 테이프, 완충재가 붙어 있는 경우에는 반드시 제거할 것.

### 同梱品

A. サイドフィーダー.....	1
B. ベーススライダ-大.....	1
C. ベーススライダ-小.....	1
D. ロックピン.....	2
E. スイッチ当たり板.....	1
F. ビス M4x8 .....	8

G. 用紙サイズプレート .....	2
**H. 用紙種類プレート .....	1
I. カバープレート .....	1
J. タッピングビス M4x10 .....	1
K. フィルム .....	1

同梱品に固定テープ、緩衝材がついている場合は、必ず取り外すこと。



### Procédure

Be sure to turn the MFP main power switch off and disconnect the MFP power plug from the wall outlet before starting to install the side feeder.

### Installation on medium-speed MFPs

If installing on a high-speed MFP, proceed to step 10.

1. Open the lower right cover (1) on the MFP.  
Remove the strap (2) from the shaft (3) and remove lower right cover (1).

### Procédure

Veiller à bien mettre l'interrupteur principal du MFP hors tension et à débrancher la fiche d'alimentation du MFP de la prise murale avant de commencer l'installation du plateau d'alimentation latéral.

### Montage sur des MFP à vitesse moyenne

Si le montage est fait sur un MFP à grande vitesse, passer à l'étape 10.

1. Ouvrir le couvercle inférieur droit (1) du MFP.  
Déposer la courroie (2) de l'arbre (3) et déposer le couvercle inférieur droit (1).

### Procedimiento

Asegúrese de apagar el interruptor principal del MFP y de desconectar el enchufe del MFP del receptáculo de pared antes de empezar a instalar el alimentador lateral.

### Instalación en las MFP de velocidad media

Si se instala en una MFP de alta velocidad, vaya al paso 10.

1. Abra la cubierta frontal inferior (1) del MFP.  
Quite la correa (2) del eje (3) y quite la cubierta frontal inferior (1).

### Verfahren

Schalten Sie unbedingt den Hauptschalter des MFP aus, und ziehen Sie den Netzstecker des MFP von der Netzsteckdose ab, bevor Sie mit der Installation des seitlichen Einzugs beginnen.

### Installation an MFP der mittleren Leistungsklasse

Gehen Sie zur Installation an einem MFP der Hochleistungsklasse weiter zu Schritt 10.

1. Die untere rechte Abdeckung (1) am MFP öffnen.  
Den Riemen (2) von der Welle (3) abnehmen und dann die untere rechte Abdeckung (1) abnehmen.

### Procedura

Prima di iniziare la procedura di installazione dell'unità di alimentazione laterale, assicurarsi di spegnere l'interruttore principale di alimentazione dell'MFP, e di scollegare la spina del cavo di alimentazione dalla presa elettrica a muro.

### Installazione sulle MFP a velocità media

Se si installa su una MFP a velocità alta, procedere al passo 10.

1. Aprire il coperchio destro inferiore (1) sull'MFP.  
Rimuovere la cinghietta (2) dall'asta (3) e quindi rimuovere il coperchio destro inferiore (1).

### 安装步骤

安装侧供纸盒时，必须先关闭 MFP 主机上的主电源开关，并拔出电源插头后方可进行工作。

### 安装于中速 MFP 上时

安装于高速 MFP 上时，进至步骤 10。

1. 打开 MFP 主机的右下部盖板 (1)。  
将带子 (2) 从轴 (3) 上拆除，拆下右下部盖板 (1)。

### 설치순서

사이드피더를 설치할 때에는 반드시 MFP 본체의 주전원 스위치를 OFF 로 하고 전원 플러그를 뽑아 후 작업을 할 것 .

### 중속 MFP 에 설치하는 경우

고속 MFP 에 설치하는 경우에는 순서 10 로 진행합니다 .

1. MFP 본체의 오른쪽 아래 커버 (1) 를 엽니다 .  
스트랩 (2) 를 축 (3) 에서 떼어내 오른쪽 아래 커버 (1) 를 제거합니다 .

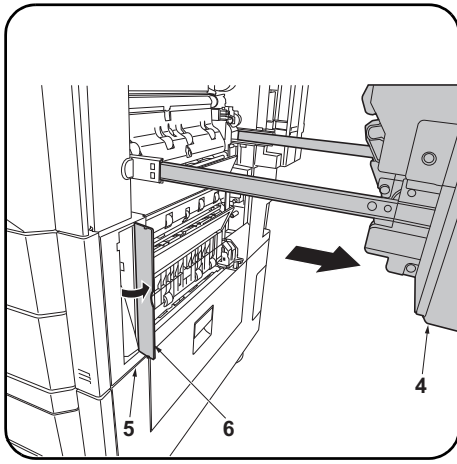
### 取付手順

サイドフィーダーを設置するときは、必ず MFP 本体の主電源スイッチを OFF にし、電源プラグを抜いてから作業すること。

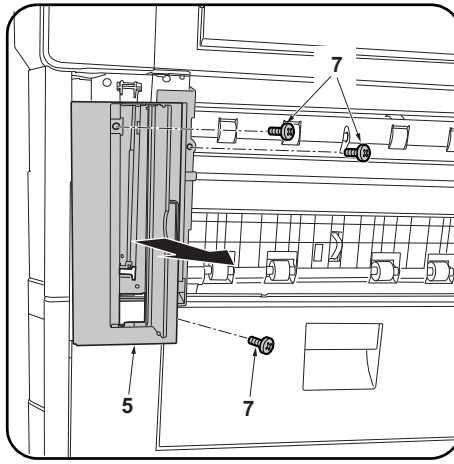
### 中速 MFP に設置の場合

高速 MFP に設置の場合は手順 10 に進む。

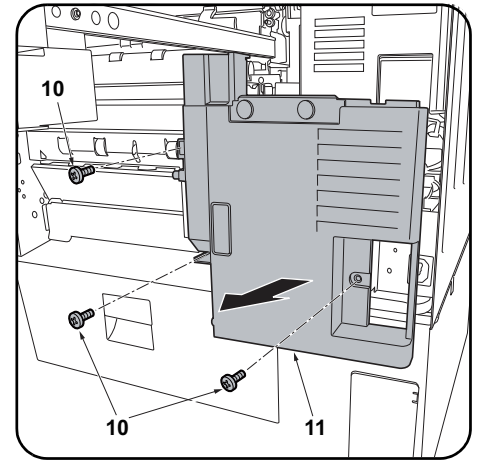
1. MFP 本体の右下カバー (1) を開く。  
ストラップ (2) を軸 (3) から外し、右下カバー (1) を取り外す。



2. Open the MFP paper conveying cover (4).
3. Open the panel (6) on the MFP front right cover (5).



4. Remove 3 screws (7) and remove the front right cover (5).



5. Remove 3 screws (10). Remove the lower right rear cover (11).

2. Ouvrir le capot du transport du papier du MFP (4).
3. Ouvrir le panneau (6) sur le capot avant droit du MFP (5).

4. Déposer les 3 vis (7) et déposer le capot avant droit (5).

5. Déposer les 3 vis (10). Déposer le capot arrière droit inférieur (11).

2. Abra la cubierta de transporte del papel del MFP (4).
3. Abra el panel (6) en la cubierta delantera derecha (5).

4. Quite los 3 tornillos (7) y quite la cubierta delantera derecha (5).

5. Quite los 3 tornillos (10). Quite la cubierta trasera inferior derecha (11).

2. Öffnen Sie die Papierförderabdeckung (4) des MFP.
3. Öffnen Sie die Platte (6) der vorderen rechten Abdeckung (5) des MFP.

4. Entfernen Sie 3 Schrauben (7) und nehmen Sie die vordere rechte Abdeckung (5) ab.

5. Entfernen Sie 3 Schrauben (10). Nehmen Sie die untere rechte hintere Abdeckung (11) ab.

2. Aprire il coperchio (4) dell'unità di trasporto carta dell'MFP.
3. Aprire il pannello (6) sul coperchio destro anteriore (5) dell'MFP.

4. Rimuovere le 3 viti (7), e quindi rimuovere il coperchio destro posteriore (5).

5. Rimuovere le 3 viti (10). Rimuovere il coperchio posteriore inferiore destro (11).

2. 打开 MFP 主机的供纸盖板 (4)。
3. 打开 MFP 主机的右前部盖板 (5) 的盖子 (6)。

4. 拆除 3 颗螺丝 (7)，拆下右前部盖板 (5)。

5. 拆除 3 颗螺丝 (10)。拆下右下后部盖板 (11)。

2. MFP 본체의 반송커버 (4) 를 엽니다 .
3. MFP 본체의 우측 전면커버 (5) 의 뚜껑 (6) 을 엽니다 .

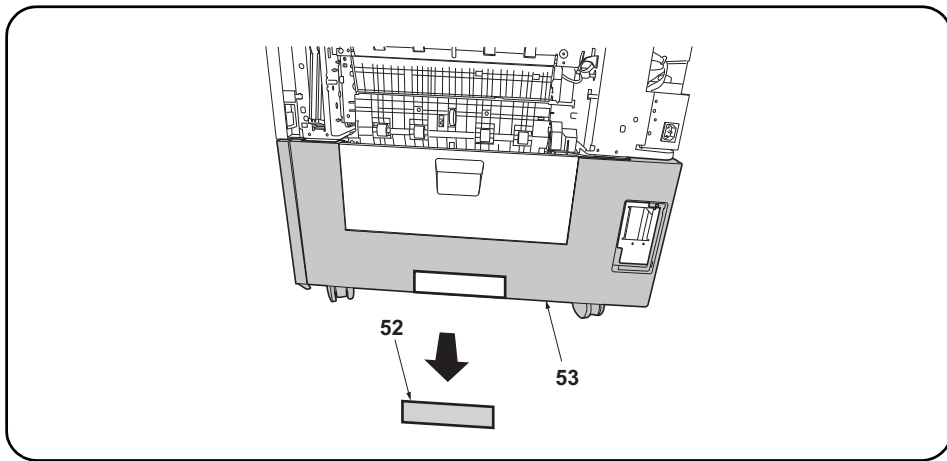
4. 나사 (7) 3 개를 제거하고 우측 전면커버 (5) 를 떼어 냅니다 .

5. 나사 (10) 3 개를 제거합니다 . 우측 하단 뒷 커버 (11) 를 제거합니다 .

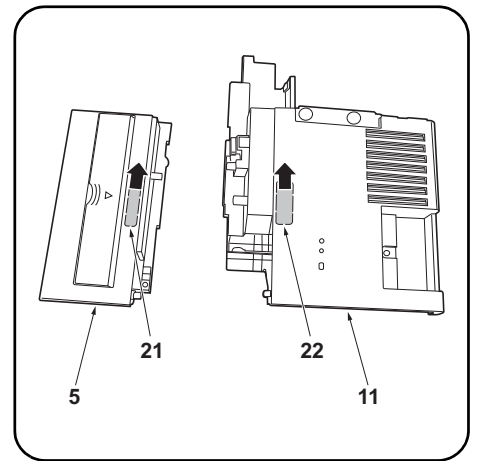
2. MFP 本体の搬送カバー (4) を開く。
3. MFP 本体の右前カバー (5) のふた (6) を開く。

4. ビス (7) 3 本を外し、右前カバー (5) を取り外す。

5. ビス (10) 3 本を外す。右下後カバー (11) を取り外す。



6. Remove the breakaway cover (52) from the paper feeder lower right cover (53).



7. Remove the breakaway cover (21) from the front right cover (5) and the breakaway cover (22) from the lower right rear cover (11).

6. Retirez le capot détachable (52) du capot inférieur droit du chargeur de papier (53).

7. Déposer le couvercle amovible (21) du capot avant droit (5) et le couvercle amovible (22) du capot arrière inférieur droit (11).

6. Quite la cubierta de separación (52) de la cubierta inferior derecha del depósito de papel (53).

7. Quite la cubierta divisoria (21) de la cubierta delantera derecha (5) y la cubierta divisoria (22) de la cubierta trasera inferior derecha (11).

6. Nehmen Sie die Ablösungsabdeckung (52) von der untere rechte Abdeckung (53) des Papiereinzugs ab.

7. Nehmen Sie die Ablösungsabdeckung (21) von der vorderen rechten Abdeckung (5) ab und die Ablösungsabdeckung (22) von der unteren rechten hinteren Abdeckung (11).

6. Rimuovere il coperchio di distacco (52) dal coperchio destro inferiore (53) dell'unità di alimentazione carta.

7. Rimuovere il coperchio di distacco (21) dal coperchio destro anteriore (5), e il coperchio di distacco (22) dal coperchio posteriore inferiore destro (11).

6. 去除供纸盒的右下部盖板(53)上的可去除部(52)。

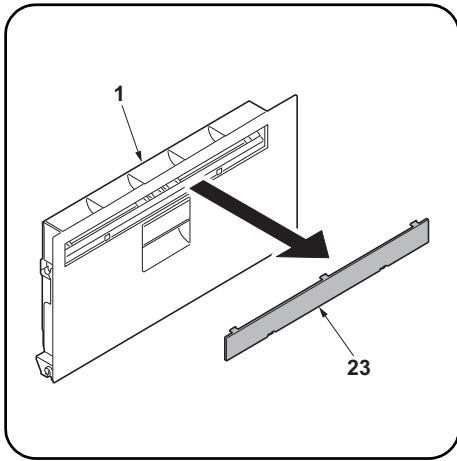
7. 切除右前部盖板(5)的切割盖板(21)和右下后部盖板(11)的切割盖板(22)。

6. 용지 급지대의 우측 하단커버(53)의 분할커버부(52)를 떼어 냅니다.

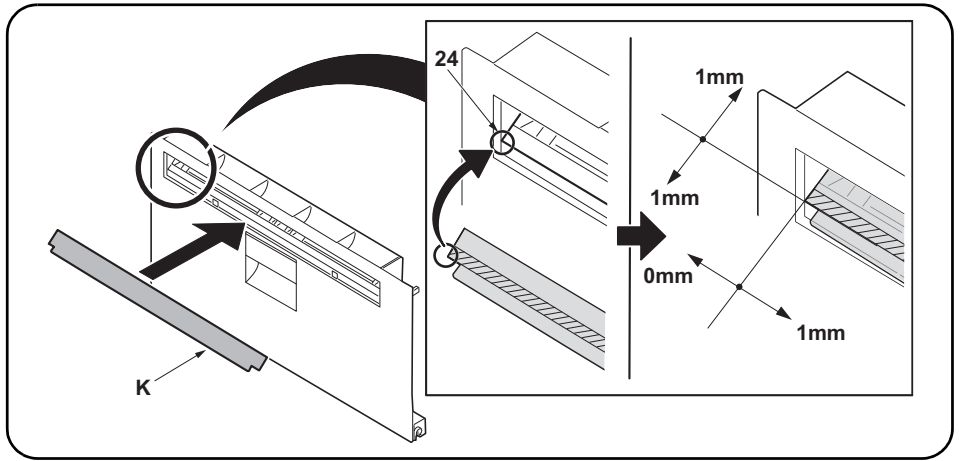
7. 우측 전면커버(5)의 분할커버(21)와 오른쪽 하단 뒷커버(11)의 분할커버(22)를 떼어 냅니다.

6. ペーパーフィーダーの右下カバー(53)の割りカバー部(52)を切り取る。

7. 右前カバー(5)の割りカバー(21)と右下後カバー(11)の割りカバー(22)を切り取る。



8. Remove the panel (23) from the MFP lower right cover (1) with a flat blade screwdriver.



9. After using alcohol to clean place adhering the film, adhere the film (K) in the position (24) indicated in the illustration. Proceed to step 21.

8. Déposer le panneau (23) du capot inférieur droit du MFP (1) en procédant à l'aide d'un tournevis à lame.

9. Coller le film (K) sur l'emplacement (24) indiqué dans l'illustration, après avoir soigneusement nettoyé cet emplacement à l'alcool. Passer à l'étape 21.

8. Extraiga el panel (23) de la cubierta derecha inferior del MFP (1) con un destornillador de pala plana.

9. Después de utilizar alcohol para limpiar la zona donde se va a pegar la película, pegue la película (K) en el lugar (24) que se indica en la ilustración. Vaya al paso 21.

8. Nehmen Sie mit einem flachen Schraubendreher die Platte (23) von der unteren rechten Abdeckung (1) des MFP ab.

9. Zum Anbringen des Films (K) die Stelle zuvor mit Alkohol reinigen und den Film (K) dann in der in der Abbildung angegebenen Position (24) anbringen. Gehen Sie weiter zu Schritt 21.

8. Rimuovere il pannello (23) dal coperchio destro inferiore (1) dell'MFP con un cacciavite a testa piana.

9. Dopo aver utilizzato alcol per pulire la piastra che aderisce alla pellicola, far aderire la pellicola (K) nella posizione (24) indicata nell'illustrazione. Procedere al passo 21.

8. 使用一字螺丝刀将 MFP 主机的右下部盖板 (1) 的盖子 (23) 拆下。

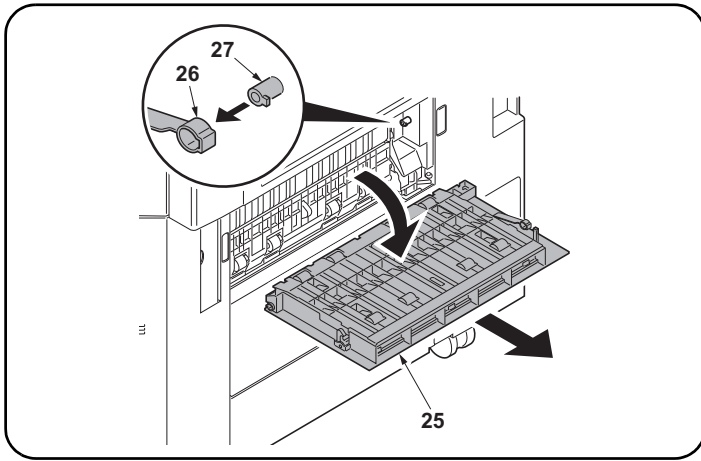
9. 使用酒精对薄膜粘贴位置进行清洁后, 按插图位置 (24) 粘贴薄膜 (K)。进至步骤 21。

8. MFP 본체의 우측 뒷커버 (1) 의 뚜껑 (23) 을 마이너스 드라이버로 제거합니다 .

9. 필름 부착위치를 알코올 청소 후, 일러스트의 위치 (24) 에 맞춰 필름 (K) 을 부착합니다 . 순서 21 로 진행합니다 .

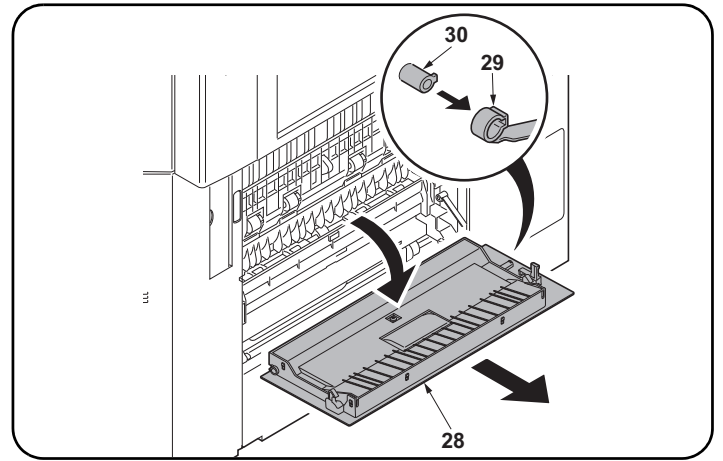
8. MFP 本体の右下カバー(1) のふた (23) をマイナスドライバーで取り外す。

9. フィルム貼り付け位置をアルコール清掃後、イラストの位置 (24) にあわせて、フィルム(K)を貼り付ける。手順 21 に進む。



#### Installation on high-speed MFPs

10. Open the right cover 1 (25) on the MFP.  
Remove the strap (26) from the shaft (27) and remove right cover 1 (25).



11. Open the right cover 2 (28) on the MFP.  
Remove the strap (29) from the right cover shaft (30) and remove the right cover 2 (28).

#### Montage sur des MFP à grande vitesse

10. Ouvrir le capot droit 1 (25) du MFP.  
Déposer la courroie (26) de l'arbre (27) et déposer le capot droit 1 (25).

11. Ouvrir le capot droit 2 (28) du MFP.  
Déposer la courroie (29) de l'axe du capot droit (30) et déposer le capot droit 2 (28).

#### Instalación en las MFP de alta velocidad

10. Abra la cubierta derecha 1 (25) del MFP.  
Quite la correa (26) del eje (27) y quite la cubierta derecha 1 (25).

11. Abra la cubierta derecha 2 (28) del MFP.  
Quite la correa (29) del eje de la cubierta derecha (30) y quite la cubierta derecha 2 (28).

#### Installation an MFP der Hochleistungsklasse

10. Die rechte Abdeckung 1 (25) am MFP öffnen.  
Den Riemen (26) von der Welle (27) abnehmen und dann die rechte Abdeckung 1 (25) abnehmen.

11. Die rechte Abdeckung 2 (28) am MFP öffnen.  
Nehmen Sie den Riemen (29) von der Welle (30) der rechten Abdeckung und dann die rechte Abdeckung 2 (28) ab.

#### Installazione sulle MFP a velocità alta

10. Aprire il coperchio destro 1 (25) sull'MFP.  
Rimuovere la cinghietta (26) dall'asta (27) e quindi rimuovere il coperchio destro 1 (25).

11. Aprire il coperchio destro 2 (28) sull'MFP.  
Rimuovere la cinghietta (29) dall'asta (30) del coperchio destro e quindi rimuovere il coperchio destro 2 (28).

#### 安装于高速 MFP 上时

10. 打开 MFP 主机的右部盖板 1 (25)。  
将带子 (26) 从轴 (27) 上拆除，拆下右部盖板 1 (25)。

11. 打开 MFP 主机的右部盖板 2 (28)。  
从右盖板的轴 (30) 上拆除挂绳 (29)，拆下右盖板 2 (28)。

#### 고속 MFP 에 설치하는 경우

10. MFP 본체의 우측커버 1 (25) 를 엽니다.  
스트랩 (26) 를 축 (27) 에서 떼어내 우측커버 1 (25) 를 제거합니다.

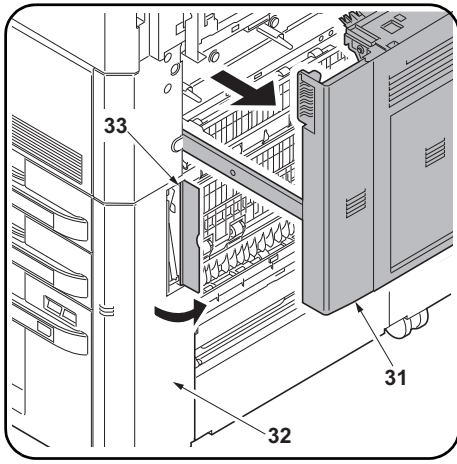
11. MFP 본체의 우측커버 2 (28) 를 엽니다.  
스트랩 (29) 을 우측커버의 축 (30) 에서 떼어내고 우측커버 2 (28) 를 제거합니다.

#### 高速 MFP に設置の場合

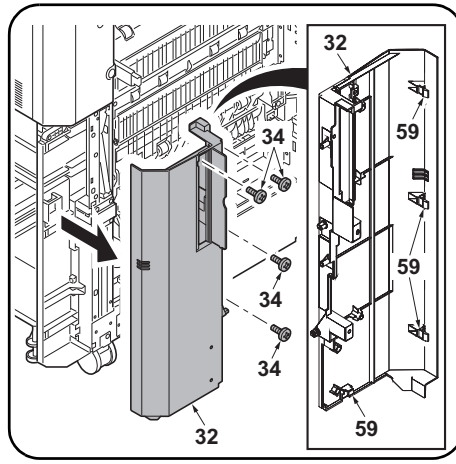
10. MFP 本体の右カバー1 (25) を開く。  
ストラップ (26) を軸 (27) から外し、右カバー1 (25) を取り外す。

11. MFP 本体の右カバー2 (28) を開く。  
ストラップ (29) を右カバーの軸 (30) から外し、右カバー2 (28) を取り外す。

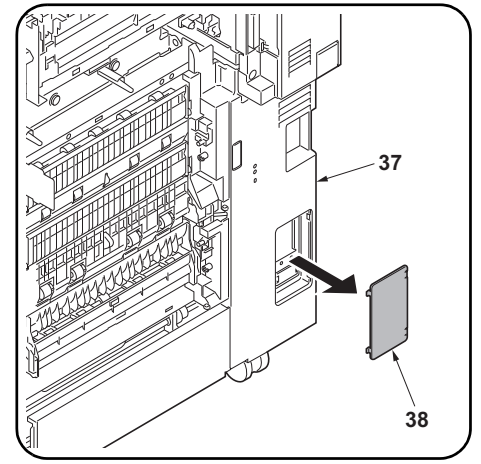




12. Open the MFP paper conveying cover (31).  
13. Open the panel (33) on the MFP front right cover (32).



14. Remove the 4 screws (34) and release the 4 hooks (59). Then remove the front right cover (32).



15. Remove the panel (38) from the lower right rear cover (37) with a flat blade screwdriver.

12. Ouvrir le capot du transport du papier du MFP (31).  
13. Ouvrir le panneau (33) sur le capot avant droit du MFP (32).

14. Retirer les 4 vis (34) et libérer les 4 crochets (59). Retirer ensuite le capot avant droit (32).

15. Déposer le panneau (38) du capot arrière inférieur droit (37) en procédant à l'aide d'un tournevis à lame.

12. Abra la cubierta de transporte del papel del MFP (31).  
13. Abra el panel (33) en la cubierta delantera derecha (32).

14. Quite los 4 tornillos (34) y libere los 4 ganchos (59). Después, quite la cubierta frontal derecha (32).

15. Extraiga el panel (38) de la cubierta trasera inferior derecha (37) con un destornillador de pala plana.

12. Öffnen Sie die Papierförderabdeckung (31) des MFP.  
13. Öffnen Sie die Platte (33) der vorderen rechten Abdeckung (32) des MFP.

14. Entfernen Sie die 4 Schrauben (34) und lösen Sie die 4 Haken (59). Danach nehmen Sie die rechte vordere Abdeckung (32) ab.

15. Nehmen Sie mit einem flachen Schraubendreher die Platte (38) von der unteren rechten hinteren Abdeckung (37) ab.

12. Aprire il coperchio (31) dell'unità di trasporto carta dell'MFP.  
13. Aprire il pannello (33) sul coperchio destro anteriore (32) dell'MFP.

14. Rimuovere le 4 viti (34) e rilasciare i 4 ganci (59). Rimuovere quindi il coperchio anteriore destro (32).

15. Rimuovere il pannello (38) dal coperchio posteriore inferiore destro (37) con un cacciavite a testa piana.

12. 打开 MFP 主机的供纸盖板 (31)。  
13. 打开 MFP 主机的右前部盖板 (32) 的盖子 (33)。

14. 卸下 4 颗螺丝 (34) 并松开 4 个卡扣 (59)。然后卸下右前盖板 (32)。

15. 用一字螺丝刀等取下右下盖板 (37) 的盖子 (38)。

12. MFP 본체의 반송커버 (31) 를 엽니다 .  
13. MFP 본체의 우측 전면커버 (32) 의 뚜껑 (33) 을 엽니다 .

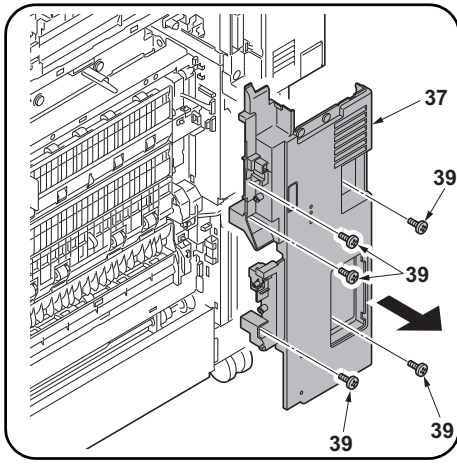
14. 나사 (34) 4 개를 제거하고 후크 (59) 4 개를 풀니다 . 그런 다음 우측 전면 커버 (32) 를 제거합니다 .

15. 우측 아래면 커버 (37) 의 뚜껑 (38) 을 마이너스 드라이버 등으로 풀니다 .

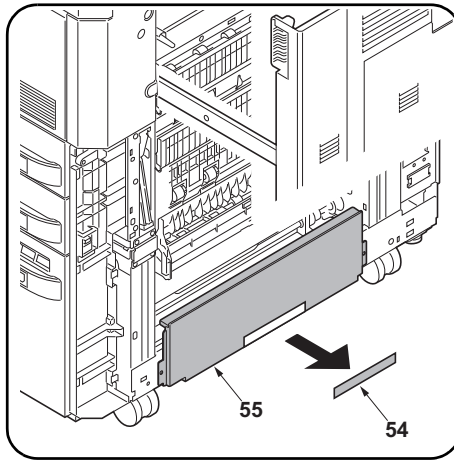
12. MFP 本体の搬送カバー (31) を開く。  
13. MFP 本体の右前カバー (32) のふた (33) を開く。

14. ビス (34) 4 本およびフック (59) 4 箇所を外し、右前カバー (32) を取り外す。

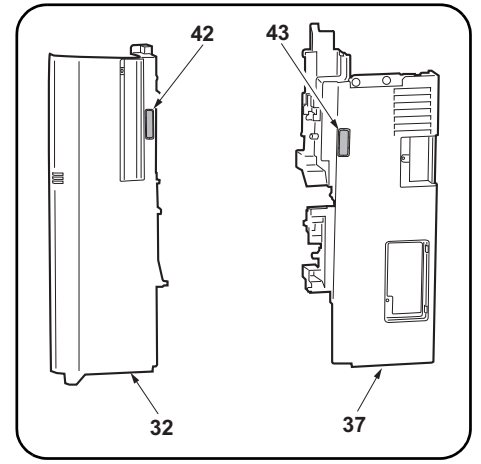
15. 右下後カバー (37) のふた (38) をマイナスドライバーなどで取る。



16. Remove 5 screws (39). Remove the lower right rear cover (37).



17. Remove the breakaway cover (54) from the lower right cover (55).



18. Remove the breakaway cover (42) from the front right cover (32) and the breakaway cover (43) from the lower right rear cover (37).

16. Déposer les 5 vis (39). Déposer le capot arrière inférieur droit (37).

17. Retirez le capot détachable (54) du capot inférieur droit (55).

18. Déposer le couvercle amovible (42) du capot avant droit (32) et le couvercle amovible (43) du capot arrière inférieur droit (37).

16. Quite los 5 tornillos (39). Quite la cubierta trasera inferior derecha (37).

17. Quite la cubierta de separación (54) de la cubierta inferior derecha (55).

18. Quite la cubierta divisoria (42) de la cubierta delantera derecha (32) y la cubierta divisoria (43) de la cubierta trasera inferior derecha (37).

16. Entfernen Sie 5 Schrauben (39). Nehmen Sie die untere rechte hintere Abdeckung (37) ab.

17. Nehmen Sie die Ablösungsabdeckung (54) von untere rechte Abdeckung (55) ab.

18. Nehmen Sie die Ablösungsabdeckung (42) von der vorderen rechten Abdeckung (32) ab und die Ablösungsabdeckung (43) von der unteren rechten hinteren Abdeckung (37).

16. Rimuovere le 5 viti (39). Rimuovere il coperchio posteriore inferiore destro (37).

17. Rimuovere il coperchio di distacco (54) dal coperchio destro inferiore (55).

18. Rimuovere il coperchio di distacco (42) dal coperchio destro anteriore (32), e il coperchio di distacco (43) dal coperchio posteriore inferiore destro (37).

16. 拆除 5 顆螺絲 (39)。拆下右下後部蓋板 (37)。

17. 去除右下部蓋板 (55) 上的可去除部 (54)。

18. 切除右前部蓋板 (32) 的切割蓋板 (42) 和右下後部蓋板 (37) 的切割蓋板 (43)。

16. 나사 (39) 5 개를 제거합니다. 우측 하단 뒷 커버 (37) 를 제거합니다.

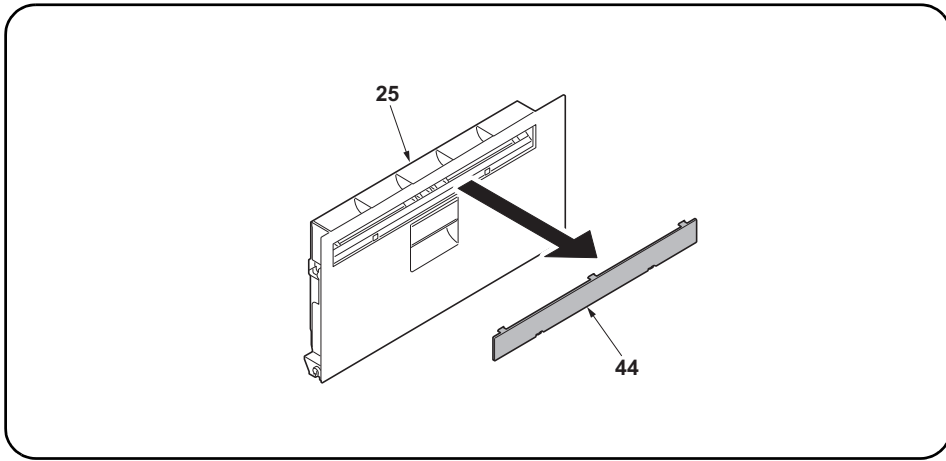
17. 우측 하단 커버 (55) 의 분할커버부 (54) 를 떼어 냅니다.

18. 우측 전면커버 (32) 의 분할커버 (42) 와 오른쪽 하단 뒷커버 (37) 의 분할커버 (43) 를 떼어 냅니다.

16. ビス (39) 5 本を外す。右下後カバー (37) を取り外す。

17. 右下カバー (55) の割りカバー部 (54) を切り取る。

18. 右前カバー (32) の割りカバー (42) と右下後カバー (37) の割りカバー (43) を切り取る。



19. Remove the panel (44) from the MFP right cover 1 (25) with a flat blade screwdriver.

---

19. Déposer le panneau (44) du capot droit 1 du MFP (25) en procédant à l'aide d'un tournevis à lame.

---

19. Extraiga el panel (44) de la cubierta derecha 1 del MFP (25) con un destornillador de pala plana.

---

19. Nehmen Sie mit einem flachen Schraubendreher die Platte (44) von der rechten Abdeckung 1 (25) des MFP ab.

---

19. Rimuovere il pannello (44) dal coperchio destro 1 (25) dell'MFP con un cacciavite a testa piana.

---

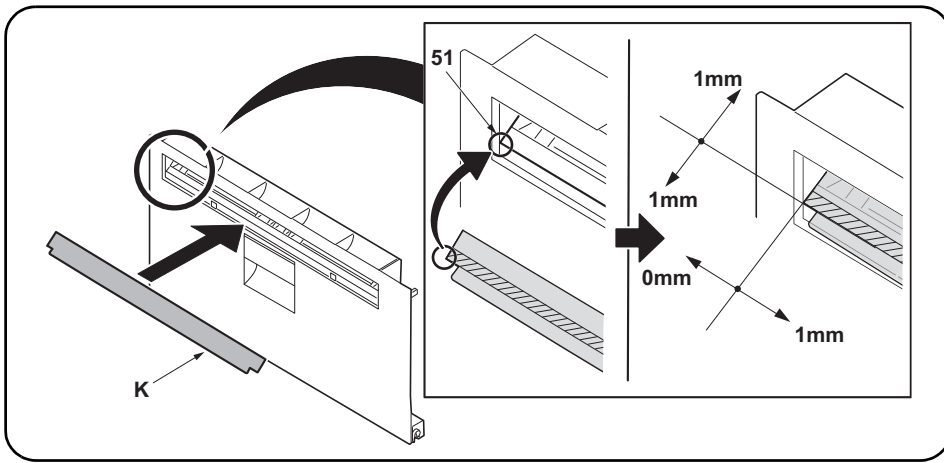
19. 使用一字螺丝刀将 MFP 主机的右部盖板 1 (25) 的盖子 (44) 拆下。

---

19. MFP 본체의 우측커버 1 (25) 의 뚜껑 (44) 을 마이너스 드라이버로 제거합니다 .

---

19. MFP 本体の右カバー1(25) のふた (44) をマイナスドライバーで取り外す。



20. After using alcohol to clean place adhering the film, adhere the film (K) in the position (51) indicated in the illustration.

20. Coller le film (K) sur l'emplacement (51) indiqué dans l'illustration, après avoir soigneusement nettoyé cet emplacement à l'alcool.

20. Después de utilizar alcohol para limpiar la zona donde se va a pegar la película, pegue la película (K) en el lugar (51) que se indica en la ilustración.

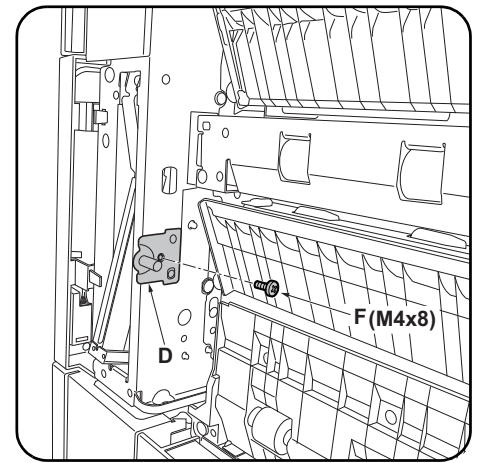
20. Zum Anbringen des Films (K) die Stelle zuvor mit Alkohol reinigen und den Film (K) dann in der in der Abbildung angegebenen Position (51) anbringen.

20. Dopo aver utilizzato alcol per pulire la piastra che aderisce alla pellicola, far aderire la pellicola (K) nella posizione (51) indicata nell'illustrazione.

20. 使用酒精对薄膜粘贴位置进行清洁后,按插图位置(51)粘贴薄膜(K)。

20. 필름 부착위치를 알코올 청소 후, 일러스트의 위치 (51) 에 맞춰 필름 (K) 을 부착합니다 .

20. フィルム貼り付け位置をアルコール清掃後、イラストの位置(51)にあわせて、フィルム(K)を貼り付ける。



21. Install a lock pin (D) on the front right of the MFP using an M4 x 8 screw (F).

21. Monter une broche de verrouillage (D) à droite et à l'avant du MFP en procédant à l'aide d'une vis M4 x 8 (F).

21. Instale una clavija de bloqueo (D) en la parte derecha frontal del MFP usando un tornillo M4 x 8 (F).

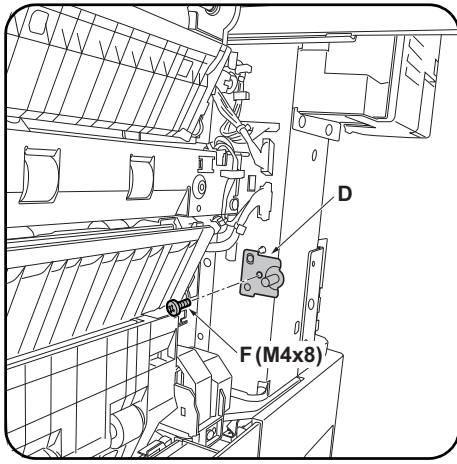
21. Bringen Sie mit einer M4 x 8 Schraube (F) den Arretierungsstift (D) vorne rechts am MFP an.

21. Installare un perno di bloccaggio (D) sulla parte anteriore destra dell'MFP utilizzando una vite M4 x 8 (F).

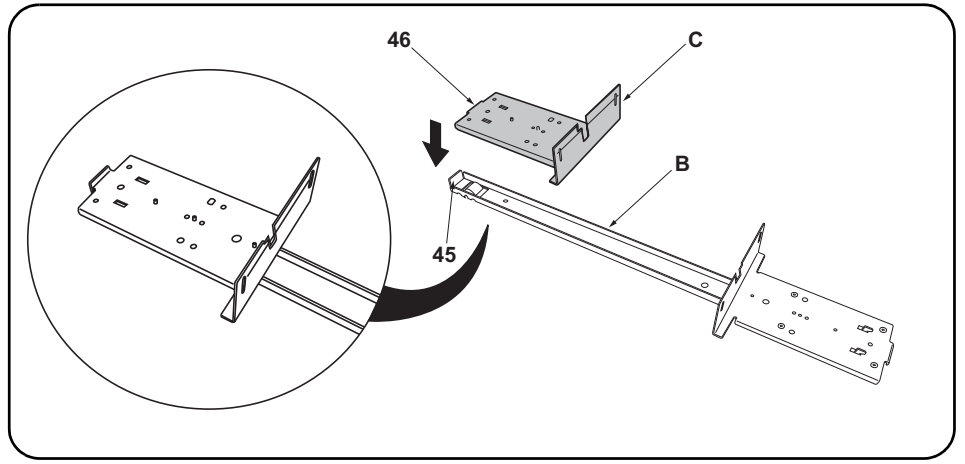
21. 使用 1 颗 M4×8 螺丝 (F) 将锁定插销 (D) 安装到 MFP 主机的前右侧。

21. 나사 M4×8(F) 1 개로 잠금 핀 (D) 을 MFP 본체 우측 전면쪽에 설치합니다 .

21. ビス M4×8(F) 1 本で、ロックピン (D) を MFP 本体右前側に取り付ける。



22. Install a lock pin (D) on the rear right of the MFP using an M4 x 8 screw (F) in the same way.



23. Place the small base slider (C) on the large base slider (B). Place so that the bend (46) on the small base slider (C) abuts inside the rest (45) at the end of the large base slider (B).

22. Monter une broche de verrouillage (D) à droite et à l'arrière du MFP en procédant de la même manière à l'aide d'une vis M4 x 8 (F).

23. Placer la petite règle de base (C) sur la grande règle de base (B). Disposer la petite règle de base (C) de sorte que son extrémité repliée (46) s'encastre dans la butée (45) à l'extrémité de la grande règle de base (B).

22. Instale una clavija de bloqueo (D) en la parte derecha frontal del MFP usando un tornillo M4 x 8 (F).

23. Coloque el deslizador de base pequeño (C) sobre el deslizador de base grande (B). Haga que la dobladura (46) del deslizador de base pequeño (C) quede en el interior del apoyo (45) del extremo del deslizador de base grande (B).

22. Bringen Sie auf gleiche Weise mit einer M4 x 8 Schraube (F) den Arretierungsstift (D) hinten rechts am MFP an.

23. Setzen Sie den kleinen Basis-Schieber (C) auf den großen Basis-Schieber (B). Setzen Sie ihn so auf, dass die Biegung (46) am kleinen Basis-Schieber (C) innerhalb der Auflage (45) am Ende des großen Basis-Schiebers (B) anliegt.

22. Installare un perno di bloccaggio (D) sulla parte posteriore destra dell'MFP utilizzando una vite M4 x 8 (F) alla stessa maniera.

23. Posizionare lo scivolo di base piccolo (C) sullo scivolo di base grande (B). Posizionare in modo che la piegatura (46) sullo scivolo di base piccolo (C) si attesti all'interno del sostegno (45) all'estremità dello scivolo di base grande (B).

22. 按相同方法, 使用 1 顆 M4×8 螺丝 (F) 将锁定插销 (D) 安装到 MFP 主机的右后侧。

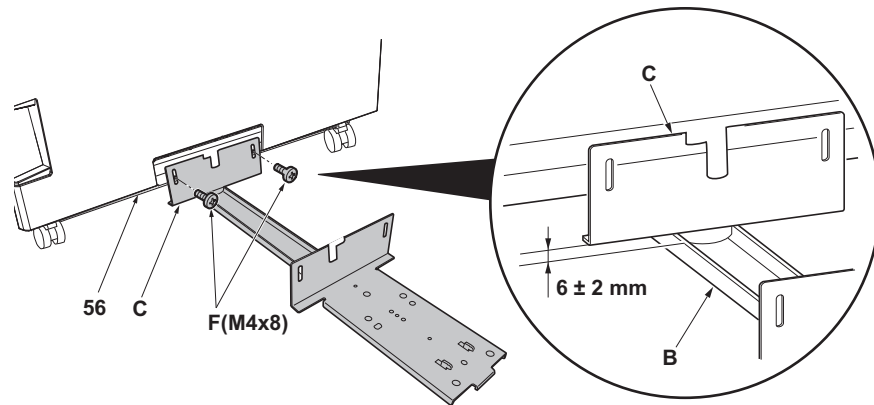
23. 将底座滑板 (小) (C) 放在底座滑板 (大) (B)。此时底座滑板 (小) (C) 的弯曲部 (46) 应处于底座滑板 (大) (B) 的前端折弯部 (45) 的内侧。

22. 같은 방식으로 나사 M4×8(F) 1 개로 잠금 핀 (D) 을 MFP 본체 우측 뒤쪽에 설치합니다 .

23. 베이스 슬라이더 대 (B) 의 위에 베이스 슬라이더 소 (C) 를 엽습니다 . 그 때 , 베이스 슬라이더 소 (C) 의 곡선부 (46) 가 베이스 슬라이더 대 (B) 의 맨 앞쪽의 꺾이고 구부러진 부분 (45) 의 안쪽으로 오도록 세웁니다 .

22. 同様にビス M4×8(F) 1 本で、ロックピン (D) を MFP 本体右後側に取り付ける。

23. ベーススライダ大 (B) の上にベーススライダ小 (C) を乗せる。その際、ベーススライダ小 (C) の曲げ (46) がベーススライダ大 (B) の先端折り曲げ部 (45) の内側にくるようにセットする。



**24.** Insert the small base slider (C) under the paper feeder. Install to the base (56) using 2 M4 × 8 screws (F) so that the gap between the small base slider (C) and the large base slider (B) is  $6 \pm 2$  mm.

\* For PF-730, install to the screw holes marked "R".

**24.** Insérer la petite règle de base (C) sous le bureau papier. Fixer à la base (56) à l'aide de 2 vis M4 × 8 (F) de sorte que le battement entre la petite règle de base (C) et la grande règle de base (B) soit de  $6 \pm 2$  mm.

\* Pour le PF-730, fixer aux trous de vis marqués "R".

**24.** Inserte el deslizador de base pequeño (C) debajo del alimentador de papel. Instálalo en la base (56) usando 2 tornillos M4 × 8 (F) de manera tal que el huelgo entre el deslizador de base pequeño (C) y el deslizador de base grande (B) sea de  $6 \pm 2$  mm.

\* En el caso de PF-730, instale en los orificios para tornillo "R".

**24.** Stecken Sie den kleinen Basis-Schieber (C) unter den Papiereinzug. Befestigen Sie ihn mit 2 M4 × 8 Schrauben (F) so an der Basis (56), dass der Abstand zwischen dem kleinen Basis-Schieber (C) und dem großen Basis-Schieber (B)  $6 \pm 2$  mm beträgt.

\* Bei Modell PF-730 an den mit "R" markierten Schraublöchern befestigen.

**24.** Inserire lo scivolo di base piccolo (C) sotto l'unità di alimentazione carta. Installare alla base (56) utilizzando 2 viti M4 × 8 (F) in modo che lo spazio tra lo scivolo di base piccolo (C) e lo scivolo di base grande (B) sia di  $6 \pm 2$  mm.

\* Per PF-730, installare ai fori per viti segnalati con "R".

**24.** 将底座滑板(小)(C)装入供纸盒的下方。使用2颗M4×8(F)螺丝将底座滑板(小)(C)安装到底板(56)上,确保底座滑板(小)(C)与底座滑板(大)(B)之间的间隙为 $6 \pm 2$ mm。

※PF-730时,安装到带有R刻印的螺纹孔上。

**24.** 베이스 슬라이더 소 (C) 를 용지 급지대 밑에 넣습니다 . 베이스 슬라이더 소 (C) 와 베이스 슬라이더 대 (B) 의 틈이  $6 \pm 2$ mm 가 되도록 나사 M4×8(F) 2 개로 바닥판 (56) 에 장착합니다 .

※PF-730 은 R 의 각인이 있는 나사구멍에 장착합니다 .

**24.** ベーススライダ小 (C) をペーパーフィーダーの下に入れる。ベーススライダ小 (C) とベーススライダ大 (B) の隙間が、 $6 \pm 2$ mm になるようにビス M4×8(F) 2 本で底板 (56) に取り付ける。

※PF-730 は R の刻印のあるビス穴に取り付ける。

### Installation on medium-speed MFPs

If installing on a high-speed MFP, proceed to step 28.

25. Reinstall the lower right rear cover (11).
  26. Reinstall the front right cover (5).
  27. Reinstall the lower right cover (1).
- Proceed to step 32.

### Installation on high-speed MFPs

28. Reinstall the lower right rear cover (37).
29. Reinstall the front right cover (32).
30. Reinstall the right cover 2 (28).
31. Reinstall the right cover 1 (25).

### Montage sur des MFP à vitesse moyenne

Si le montage est fait sur un MFP à grande vitesse, passer à l'étape 28.

25. Reposer le capot arrière inférieur droit (11).
  26. Reposer le capot avant droit (5).
  27. Reposer le capot inférieur droit (1).
- Passer à l'étape 32.

### Montage sur des MFP à grande vitesse

28. Reposer le capot arrière inférieur droit (37).
29. Reposer le capot avant droit (32).
30. Reposer le capot droit 2 (28).
31. Reposer le capot droit 1 (25).

### Instalación en las MFP de velocidad media

Si se instala en una MFP de alta velocidad, vaya al paso 28.

25. Reinstale la cubierta trasera inferior derecha (11).
  26. Reinstale la cubierta delantera derecha (5).
  27. Reinstale la cubierta derecha inferior (1).
- Vaya al paso 32.

### Instalación en las MFP de alta velocidad

28. Reinstale la cubierta trasera inferior derecha (37).
29. Reinstale la cubierta delantera derecha (32).
30. Reinstale la cubierta derecha 2 (28).
31. Reinstale la cubierta derecha 1 (25).

### Installation an MFP der mittleren Leistungsklasse

Gehen Sie zur Installation an einem MFP der Hochleistungsklasse weiter zu Schritt 28.

25. Bringen Sie die untere rechte hintere Abdeckung (11) wieder an.
  26. Bringen Sie die vordere rechte Abdeckung (5) wieder an.
  27. Bringen Sie die untere rechte Abdeckung (1) wieder an.
- Gehen Sie weiter zu Schritt 32.

### Installation an MFP der Hochleistungsklasse

28. Bringen Sie die untere rechte hintere Abdeckung (37) wieder an.
29. Bringen Sie die vordere rechte Abdeckung (32) wieder an.
30. Bringen Sie die rechte Abdeckung 2 (28) wieder an.
31. Bringen Sie die rechte Abdeckung 1 (25) wieder an.

### Installazione sulle MFP a velocità media

Se si installa su una MFP a velocità alta, procedere al passo 28.

25. Reinstallare il coperchio posteriore inferiore destro (11).
  26. Reinstallare il coperchio destro anteriore (5).
  27. Reinstallare il coperchio destro inferiore (1).
- Procedere al passo 32.

### Installazione sulle MFP a velocità alta

28. Reinstallare il coperchio posteriore inferiore destro (37).
29. Reinstallare il coperchio destro anteriore (32).
30. Reinstallare il coperchio destro 2 (28).
31. Reinstallare il coperchio destro 1 (25).

### 安装于中速 MFP 上时

安装于高速 MFP 上时, 进至步骤 28。

25. 按原样安装右下后部盖板 (11)。
  26. 按原样安装右前部盖板 (5)。
  27. 按原样安装右下部盖板 (1)。
- 进至步骤 32。

### 安装于高速 MFP 上时

28. 按原样安装右下后部盖板 (37)。
29. 按原样安装右前部盖板 (32)。
30. 按原样安装右部盖板 2 (28)。
31. 按原样安装右部盖板 1 (25)。

### 중속 MFP 에 설치하는 경우

고속 MFP 에 설치하는 경우에는 순서 28 로 진행합니다 .

25. 우측하단 뒷커버 (11) 를 원래대로 장착합니다 .
  26. 우측 전면커버 (5) 를 원래대로 장착합니다 .
  27. 우측 하단커버 (1) 를 원래대로 장착합니다 .
- 순서 32 로 진행합니다 .

### 고속 MFP 에 설치하는 경우

28. 우측하단 뒷커버 (37) 를 원래대로 장착합니다 .
29. 우측 전면커버 (32) 를 원래대로 장착합니다 .
30. 우측커버 2 (28) 를 원래대로 장착합니다 .
31. 우측커버 1 (25) 를 원래대로 장착합니다 .

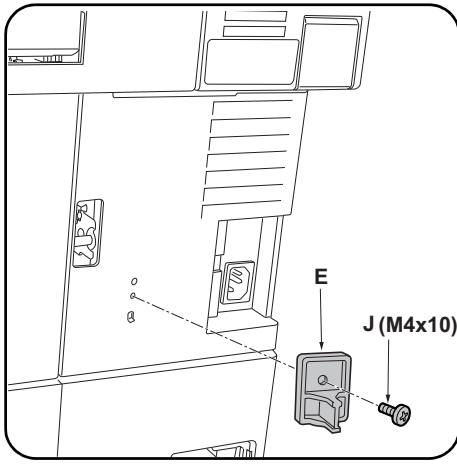
### 中速 MFP に設置の場合

高速 MFP に設置の場合は手順 28 に進む。

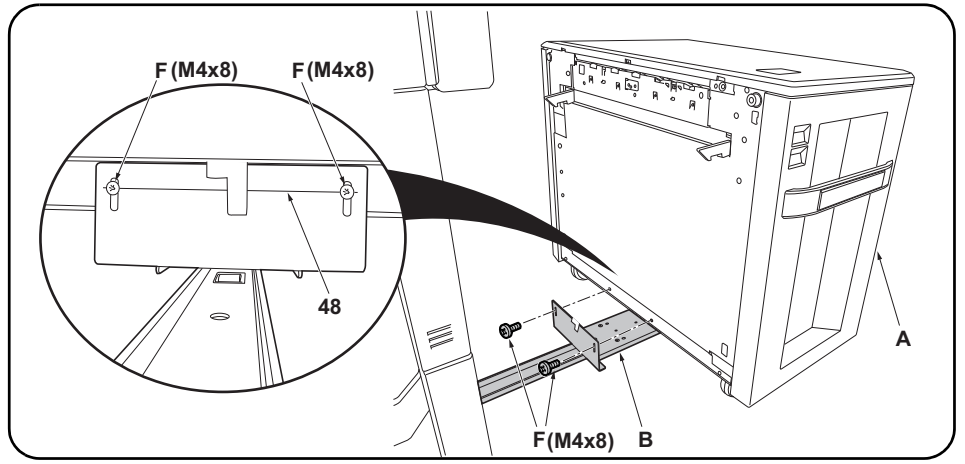
25. 右下後カバー (11) を元通り取り付け。
  26. 右前カバー (5) を元通り取り付け。
  27. 右下カバー (1) を元通り取り付け。
- 手順 32 に進む。

### 高速 MFP に設置の場合

28. 右下後カバー (37) を元通り取り付け。
29. 右前カバー (32) を元通り取り付け。
30. 右カバー 2 (28) を元通り取り付け。
31. 右カバー 1 (25) を元通り取り付け。



32. Install the switch press plate (E) using the M4 x 10 tapping screw (J).



33. Install the side feeder (A) to the large base slider (B) using 2 M4 x 8 screws (F). Install so that the center of the M4 x 8 screws (F) comes over the horizontal line (48) of the mounting plate on the large base slider (B).

32. Fixer la plaque de pression du contacteur (E) à l'aide d'une vis de connexion M4 x 10 (J).

33. Fixer le dispositif du plateau d'alimentation latéral (A) à la grande règle de base (B) à l'aide de 2 vis M4 x 8 (F). Procéder de sorte que l'axe des vis M4 x 8 (F) recouvre la ligne horizontale (48) du plateau de montage sur la grande règle de base (B).

32. Instale la placa de presión del interruptor (E) usando el tornillo de roscado M4 x 10 (J).

33. Instale el alimentador lateral (A) en el deslizador de base grande (B) usando 2 tornillos M4 x 8 (F). Instale de manera que el centro de los tornillos M4 x 8 (F) queden sobre la línea horizontal (48) de la placa de montaje del deslizador de base (B) grande.

32. Befestigen Sie mit der M4 x 10 Schreidschraube (J) die Schalterdruckplatte (E).

33. Befestigen Sie den seitlichen Einzug (A) mit 2 M4 x 8 Schrauben (F) am großen Basis-Schieber (B). Befestigen Sie ihn so, dass die Mitte der M4 x 8 Schrauben (F) über der Waagrechtlinie (48) der Montageplatte am großen Basis-Schieber (B) liegt.

32. Installare la piastra spingi interruttore (E) utilizzando la vite autofilettante M4 x 10 (J).

33. Installare l'unità di alimentazione laterale (A) allo scivolo di base grande (B) utilizzando 2 viti M4 x 8 (F). Installare in modo che il centro delle viti M4 x 8 (F) sia sulla linea orizzontale (48) della piastra di montaggio sullo scivolo di base grande (B).

32. 使用 1 顆 M4×10 自攻螺絲 (J) 安裝開關擋板 (E)。

33. 使用 2 顆 M4×8 螺絲 (F) 將側供紙盒 (A) 安裝到底座滑板 (大) (B) 上。此時，應確保 M4×8 螺絲 (F) 的中心處於底座滑板 (大) (B) 的安裝板的平行線 (48) 上。

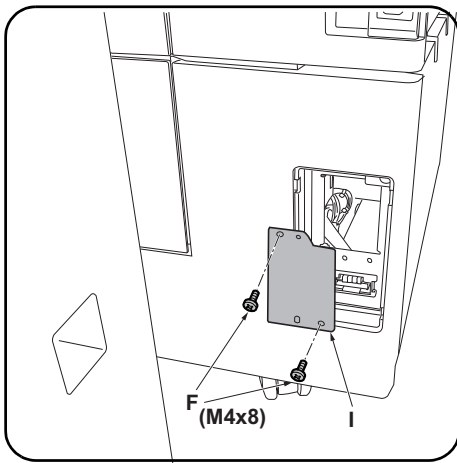
32. 탐핑나사 M4×10(J) 1 개로 스위치 판 (E) 을 장착합니다 .

33. 나사 M4×8(F) 2 개로 베이스 슬라이더 대 (B) 에 사이드 피더 (A) 를 장착합니다 . 그 때 , 베이스 슬라이더 대 (B) 의 설치판의 평행선 (48) 에 나사 M4×8(F) 의 센터가 오도록 장착합니다 .

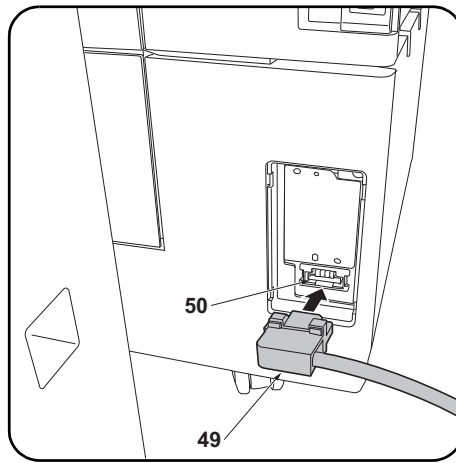
32. タッピングビス M4×10(J) 1 本でスイッチ当たり板 (E) を取り付けます。

33. ビス M4×8(F) 2 本でベーススライダ大 (B) にサイドフィーダー (A) を取り付けます。その際、ベーススライダ大 (B) の取付板の平行線 (48) にビス M4×8(F) のセンターがくるように取り付けます。



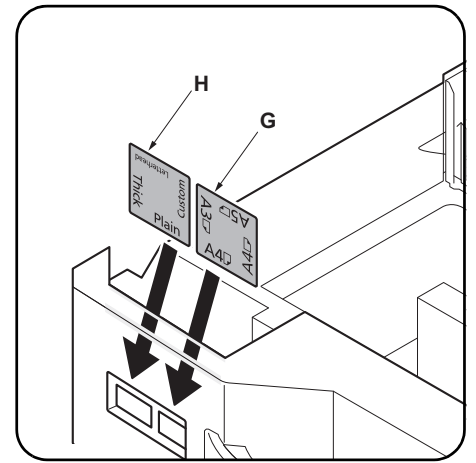


34. Install the cover plate (I) using 2 M4 x 8 screws (F).



35. Plug the signal cable (49) for the side feeder into the paper feeder connector (50).

36. Push the side feeder to connect it to the MFP.



**Setting the paper size plate and media type plate**

Insert the paper size plate (G) and media type plate (H) into the each slots respectively

34. Fixer le capot (I) à l'aide de 2 vis M4 x 8 (F).

35. Enfiler le câble de signal (49) du dispositif du plateau d'alimentation latéral dans le connecteur (50) du bureau papier.

36. Pousser le dispositif du plateau d'alimentation latéral pour le raccorder au MFP.

**Disposition des plaquettes du format de papier et du type de support**

Introduire la plaquette du format de papier (G) et la plaquette du type de support (H) dans leur logement respectif.

34. Instale la tapa (I) usando los 2 tornillos M4 x 8 (F).

35. Conecte el cable de señal (49) del alimentador lateral en el conector del alimentador de papel (50).

36. Empuje el alimentador lateral para conectarlo al MFP.

**Ajuste de la placa de tamaño de papel y la placa de tipo de medio**

Inserte la placa de tamaño de papel (G) y la placa de tipo de medio (H) en cada uno de las ranuras, respectivamente.

34. Bringen Sie die Abdeckungsplatte (I) mit 2 M4 x 8 Schrauben (F) an.

35. Schließen Sie das Signalkabel (49) für den seitlichen Einzug am Papiereinzug-Steckverbinder (50) an.

36. Drücken Sie auf den seitlichen Einzug, um ihn mit dem MFP zu verbinden.

**Einsetzen der Papierformatkarte und der Medientypkarte**

Setzen Sie die Papierformatkarte (G) und die Medientypkarte (H) in die jeweiligen Führungen.

34. Installare il coperchio (I) utilizzando 2 viti M4 x 8 (F).

35. Collegare il cavo del segnale (49) per l'unità di alimentazione laterale nel connettore dell'unità di alimentazione carta (50).

36. Spingere l'unità di alimentazione laterale per collegarla all'MFP.

**Impostazione della piastra di formato carta e della piastra del tipo di supporto**

Inserire la piastra del formato carta (G) e la piastra del tipo di supporto (H) nei rispettivi alloggiamenti.

34. 使用 2 顆 M4×8 螺絲 (F) 安裝盖板 (I)。

35. 將側供紙盒的訊号线 (49) 连接到供紙盒的接口 (50) 上。

36. 按住側供紙盒，將其與 MFP 主機連接。

纸张尺寸标示和纸张种类标示的安装  
将纸张尺寸标示 (G) 和纸张种类标示 (H) 分别插入到图示的插槽中。

34. 나사 M4×8(F) 2 개로 커버 플레이트 (I) 를 장착합니다 .

35. 사이드 피더의 신호선 (49) 을 용지 급지대의 커넥터 (50) 에 접속합니다 .

36. 사이드 피더를 밀어 MFP 본체에 접속합니다

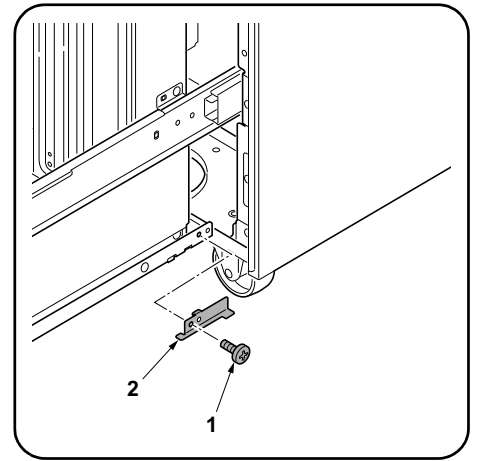
용지크기 플레이트와 용지종류 플레이트의 세트  
용지크기 플레이트 (G) 와 용지종류 플레이트 (H) 를 각표시 슬롯에 각각 삽입한다 .

34. ビス M4×8(F) 2 本でカバープレート (I) を取り付ける。

35. サイドフィーダーの信号線 (49) をペーパーフィーダーのコネクター (50) に接続する。

36. サイドフィーダーを押し、MFP 本体に接続する。

用紙サイズプレートと用紙種類プレートのセット  
用紙サイズプレート (G) と用紙種類プレート (H) を各表示スロットにそれぞれ挿入する。



#### Changing paper size (metric specifications only)

At shipment, Letter is set for inch models and A4 is set for metric models. Use the procedure below to change the size to B5.

1. Pull out the side feeder cassette.
2. Remove a screw (1) and remove the stopper (2).

#### Modification du format du papier (pour spécifications métriques seulement)

À expédition, les modèles à mesure en pouces sont réglés sur le format Letter et les modèles à mesure métrique sur le format A4. Pour passer au format B5, procéder de la manière suivante.

1. Sortir le tiroir du dispositif du plateau d'alimentation latéral.
2. Déposer la vis (1) et la butée (2).

#### Cómo cambiar el tamaño de papel (sólo para las especificaciones métricas)

En el momento de salida de fábrica, se configura Carta para los modelos en pulgadas y A4 para los modelos en sistema métrico. Siga este procedimiento para cambiar el tamaño a B5.

1. Extraiga el cajón del alimentador lateral.
2. Quite el tornillo (1) y quite el tope (2).

#### Ändern des Papierformats (nur metrische Spezifikationen)

Beim Werksversand ist bei Modellen mit Zollmaß das Format Letter voreingestellt und bei Modellen mit metrischem Maß das Format A4. Das Format kann wie folgend auf B5 umgeschaltet werden.

1. Ziehen Sie die Papierlade des seitlichen Einzugs heraus.
2. Entfernen Sie eine Schraube (1) und nehmen Sie den Anschlag (2) heraus.

#### Cambio del formato della carta (solo per le specifiche metriche)

Al momento della spedizione, Letter è impostato per le specifiche in pollici e A4 è impostato per le specifiche metriche. Usare la procedura riportata sotto per cambiare il formato a B5.

1. Estrarre il cassetto dell'unità di alimentazione laterale.
2. Rimuovere la vite (1) e quindi rimuovere il fermo (2).

#### 纸张尺寸更改 (仅限公制规格)

产品出厂时, 英制规格设定为 Letter、公制规格设定为 A4。要将尺寸更改为 B5 时, 请按以下步骤进行操作。

1. 拉出侧供纸盒的纸盒。
2. 拆除 1 颗螺丝 (1), 拆下挡块 (2)。

#### 용지크기 변경 (센치 사양만)

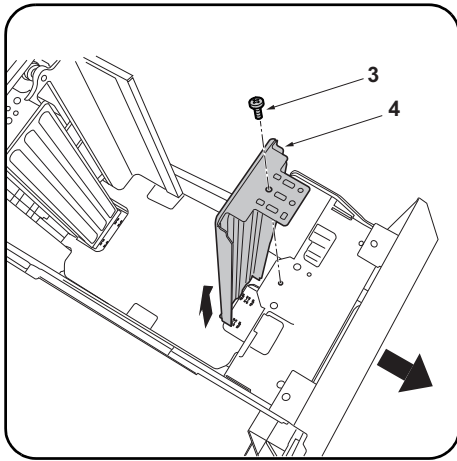
출하시, 인치사양은 Letter, 센치사양은 A4 로 설정되어 있습니다. 크기를 B5 로 변경하는 경우에는 다음 순서를 진행해 주십시오.

1. 사이드 피더의 카셋트를 빼 냅니다.
2. 나사 (1) 1 개를 제거하고 스톱퍼 (2) 를 떼어 냅니다.

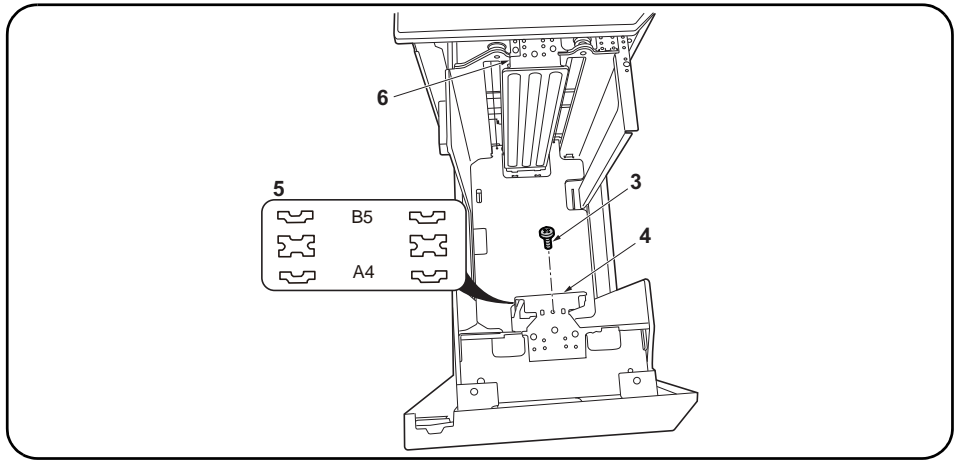
#### [用紙サイズ変更(センチ仕様のみ)]

出荷時、インチ仕様は Letter、センチ仕様は A4 に設定されています。サイズを B5 に変更する場合は次の手順をおこなってください。

1. サイドフィーダーのカセットを引き出す。
2. ビス (1) 1 本を外し、ストップ (2) を取り外す。



3. Remove a screw (3) and remove the front deck cursor (4).



4. Move the front deck cursor (4) to match the size marking (5) (the outermost is A4, the innermost is B5) at the bottom of the cassette.  
5. Fix the front deck cursor (4) using the screw (3).  
6. Move the rear deck cursor (6) in the same way.

3. Déposer la vis (3) et le curseur de platine avant (4).

4. Déplacer le curseur de platine avant (4) en fonction du repère de format papier (5) (le repère le plus à l'extérieur est celui du format A4, celui le plus à l'intérieur, celui du format B5) se trouvant au fond de le tiroir.  
5. Fixer le curseur de platine avant (4) à l'aide de la vis (3).  
6. Déplacer le curseur de platine arrière (6) en procédant de la même manière.

3. Quite el tornillo (3) y quite el cursor frontal de la plataforma (4).

4. Mueva el cursor frontal de la plataforma (4) para que corresponda con la marca de tamaño (5) (la más externa es A4, la más interna es B5) en la parte inferior del cajón.  
5. Fije el cursor frontal de la plataforma (4) usando el tornillo (3).  
6. Mueva el cursor trasero de la plataforma (6) de la misma forma.

3. Entfernen Sie eine Schraube (3) und nehmen Sie den vorderen Konsole-Cursor (4) heraus.

4. Versetzen Sie den vorderen Konsole-Cursor (4), um die Formatmarkierung (5) am Boden der Papierlade anzupassen (die äußerste ist A4, die innerste ist B5).  
5. Befestigen Sie den vorderen Konsole-Cursor (4) mit der Schraube (3).  
6. Versetzen Sie den hinteren Konsole-Cursor (6) auf gleiche Weise.

3. Rimuovere la vite (3) e quindi rimuovere il cursore frontale del deck (4).

4. Spostare il cursore frontale del deck (4) per farlo corrispondere al segno del formato (5) (il più esterno è A4, il più interno è B5) alla parte inferiore del cassetto.  
5. Fissare il cursore frontale del deck (4) utilizzando la vite (3).  
6. Spostare il cursore posteriore del deck (6) alla stessa maniera.

3. 拆除 1 顆螺絲 (3)，拆下前部紙張長度調節片 (4)。

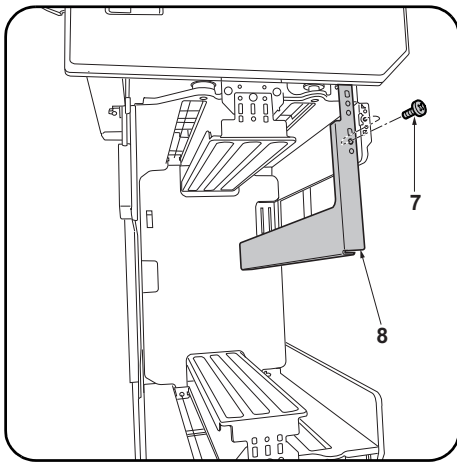
4. 根據紙盒下部的刻印 (5) (最外側為 A4、最內側為 B5) 移動前部紙張長度調節片 (4)。  
5. 使用 1 顆螺絲 (3) 固定前部紙張長度調節片 (4)。  
6. 按相同方法移動後部紙張長度調節片 (6)。

3. 나사 (3) 1 개를 제거하고 데크커서앞 (4) 을 제거합니다 .

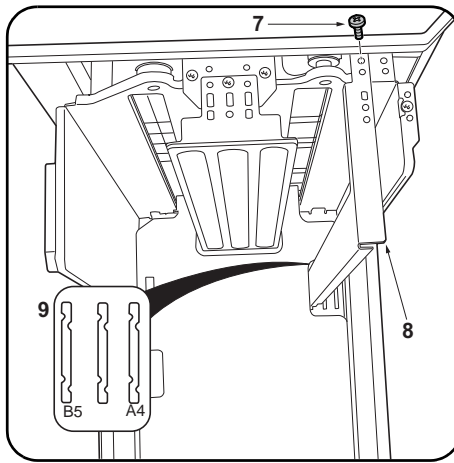
4. 카세트 아래의 사이즈각인 (5) (가장 바깥쪽이 A4, 가장 안쪽이 B5) 에 맞춰 데크커서앞 (4) 을 이동시킵니다 .  
5. 나사 (3) 1 개로 데크커서앞 (4) 을 고정합니다 .  
6. 같은 방식으로 데크커서뒤 (6) 를 이동시킵니다 .

3. ビス (3) 1 本を外し、デッキカーソル前 (4) を取り外す。

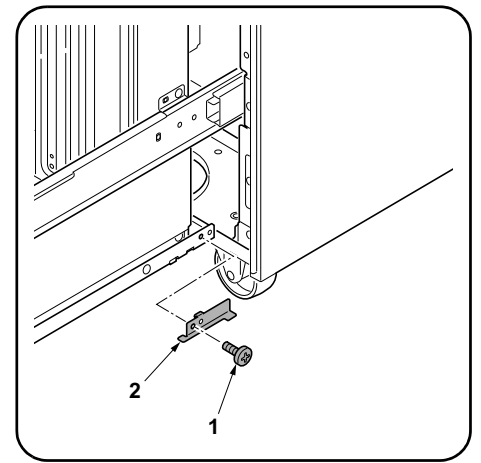
4. カセット下のサイズ刻印 (5) (一番外側が A4、一番内側が B5) に合わせてデッキカーソル前 (4) を移動させる。  
5. ビス (3) 1 本で、デッキカーソル前 (4) を固定する。  
6. 同様にデッキカーソル後 (6) を移動させる。



7. Remove a screw (7) and remove the deck trailing edge cursor (8).



8. Move the deck trailing edge cursor (8) to match the size marking (9) at the bottom of the cassette.  
9. Fix the deck trailing edge cursor (8) with the screw (7).



10. Reinstall the stopper (2) using the screw (1).  
11. Run maintenance mode U208 and set the paper size.

7. Déposer la vis (7) et déposer le curseur du bord arrière de la platine (8).

8. Déplacer le curseur du bord arrière de la platine (8) en fonction du repère de format papier (9) se trouvant au fond de le tiroir.  
9. Fixer le curseur du bord arrière de la platine (8) à l'aide de la vis (7).

10. Reposer la butée (2) à l'aide de la vis (1).  
11. Exécuter le mode maintenance U208 et définir le format du papier.

7. Quite el tornillo (7) y quite el cursor del borde inferior de la plataforma (8).

8. Mueva el cursor del borde inferior de la plataforma (8) para que corresponda con la marca de tamaño (9) en la parte inferior del cajón.  
9. Fije el cursor del borde inferior de la plataforma (8) con el tornillo (7).

10. Reinstale el tope (2) usando el tornillo (1).  
11. Active el modo de mantenimiento U208 y ajuste el tamaño de papel.

7. Entfernen Sie eine Schraube (7) und nehmen Sie den Hinterkante-Cursor (8) heraus.

8. Versetzen Sie den Hinterkante-Cursor (8), um die Formatmarkierung (9) am Boden der Papierlade anzupassen.  
9. Befestigen Sie den Hinterkante-Cursor (8) mit der Schraube (7).

10. Bringen Sie den Anschlag (2) wieder mit der Schraube (1) an.  
11. Führen Sie den Wartungsmodus U208 aus und stellen Sie das Papierformat ein.

7. Rimuovere la vite (7) e quindi rimuovere il cursore del bordo finale del deck (8).

8. Spostare il cursore del bordo finale del deck (8) per farlo corrispondere al segno di formato (9) alla parte inferiore del cassetto.  
9. Fissare il cursore del bordo finale del deck (8) con la vite (7).

10. Reinstallare il fermo (2) utilizzando la vite (1).  
11. Eseguire la modalità manutenzione U208 e impostare il formato carta.

7. 拆除 1 顆螺絲 (7)，拆下后端紙張長度調節片 (8)。

8. 根據紙盒下部的刻印 (9) 移動后端紙張長度調節片 (8)。  
9. 使用 1 顆螺絲 (7) 固定后端紙張長度調節片 (8)。

10. 使用 1 顆螺絲 (1)，按原樣安裝擋塊 (2)。  
11. 執行維修模式 U208，進行紙張尺寸的設定。

7. 나사 (7) 1 개를 제거하고 데크뒤커서 (8) 를 제거합니다 .

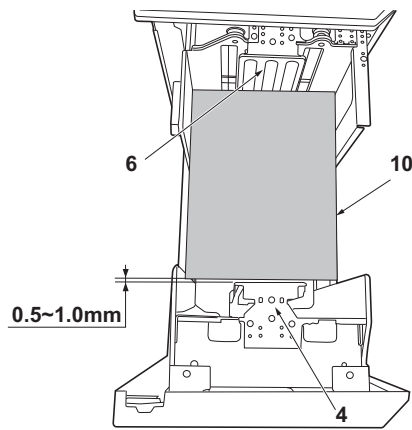
8. 카세트 아래의 사이즈각인 (9) 에 맞춰서 데크뒤커서 (8) 를 이동시킵니다 .  
9. 나사 (7) 1 개로 데크뒤커서 (8) 를 고정합니다 .

10. 나사 (1) 1 개로 스톱퍼 (2) 를 원래대로 장착합니다 .  
11. 메인テナンス 모드 U208 을 실행해 용지크기 설정을 합니다 .

7. ビス (7) 1 本を外し、デッキ後端カーソル (8) を取り外す。

8. カセット下のサイズ刻印 (9) に合わせて、デッキ後端カーソル (8) を移動させる。  
9. ビス (7) 1 本で、デッキ後端カーソル (8) を固定する。

10. ビス (1) 1 本で、ストップ (2) を元通り取り付ける。  
11. メンテナンスモード U208 を実行し、用紙サイズの設定をおこなう。



#### Adjusting the cursor width

1. Load paper in the cassettes.
2. If the gap between the front deck cursor (4) and the paper (10) is outside the 0.5 to 1.0 mm range when the paper (10) is touching up against the rear deck cursor (6), perform the following adjustment.  
\* A cursor width that is too small can hinder paper feeding, while a cursor width that is too large can lead to problems such as skewed paper feed.

#### Réglage de la largeur du curseur

1. Charger les tiroirs en papier.
2. Si l'écartement entre le curseur de platine avant (4) et le papier (10) est hors des limites de 0,5 à 1,0 mm quand le papier (10) touche le curseur de platine arrière (6), procéder au réglage suivant.  
\* Une largeur trop faible du curseur risque d'empêcher l'entraînement du papier et une largeur trop grande risque d'entraîner des problèmes du type entraînement du papier de biais.

#### Cómo ajustar la anchura del cursor

1. Cargue papel en los cajones.
2. Si la separación entre el cursor frontal de la plataforma (4) y el papel (10) está fuera del rango de 0,5 a 1,0 mm cuando el papel (10) toca el cursor trasero de la plataforma (6), haga el siguiente ajuste.  
\* Una anchura del cursor demasiado pequeña puede impedir la alimentación de papel; una anchura del cursor demasiado grande puede provocar problemas con la alimentación torcida de papel.

#### Einstellen der Cursor-Breite

1. Papier in die Papierladen einlegen.
2. Falls der Abstand zwischen dem vorderen Konsole-Cursor (4) und dem Papier (10) außerhalb des Bereichs 0,5 bis 1,0 mm liegt, wenn das Papier (10) am hinteren Konsole-Cursor (6) anliegt, ist folgende Einstellung vorzunehmen.  
\* Eine zu kleine Cursor-Breite kann den Papiereinzug behindern, wogegen eine zu große Cursor-Breite verkanteten Papiereinzug und ähnliche Probleme verursachen kann.

#### Regolazione della larghezza del cursore

1. Caricare carta nei cassetti.
2. Se lo spazio tra il cursore frontale del deck (4) e la carta (10) è fuori della gamma da 0,5 a 1,0 mm quando la carta (10) tocca il cursore posteriore del deck (6), eseguire la regolazione seguente.  
\* Una larghezza dei cursori troppo piccola può ostacolare l'alimentazione della carta, mentre unalarghezza dei cursori troppo grande può essere causa di problemi, come ad esempio l'alimentazione obliqua della carta.

#### 游标宽度的调节

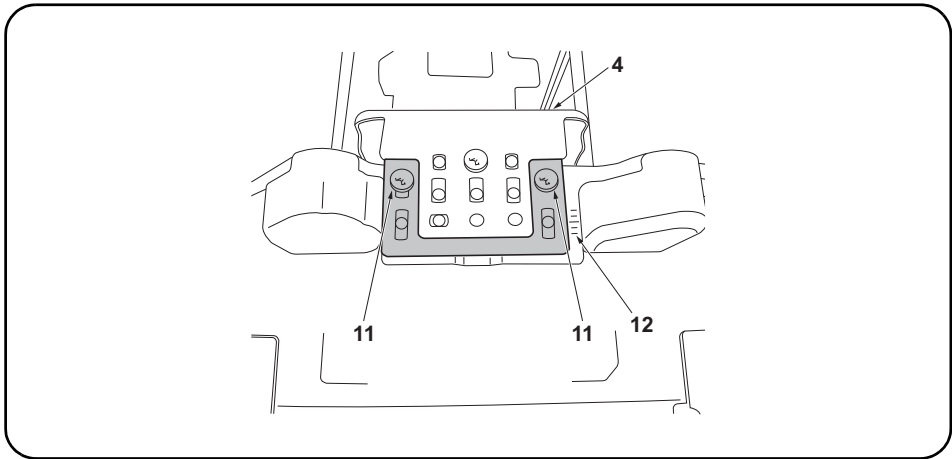
1. 在供纸盒中装入纸张。
2. 在堆纸板后部游标 (6) 与纸张 (10) 接触的状态下, 如果堆纸板前部游标 (4) 与纸张 (10) 的间隙超出了 0.5 ~ 1.0mm 的范围, 须进行以下调节。  
※ 如果游标宽度过小, 可能造成不供纸, 游标宽度过大, 则可能发生歪斜进纸等情况。

#### 커서 폭 조정

1. 카세트에 용지를 장착합니다.
2. 데크커서 뒤 (6) 에 용지 (10) 가 접하고 있는 상태에서 데크커서 앞 (4) 과 용지 (10) 의 틈이 0.5 ~ 1.0mm 의 범위외의 경우에는 이하의 조정을 합니다.  
※ 커서 폭이 작으면 무급지, 커서 폭이 크면 경사급지 등이 발생할 가능성이 있습니다.

#### [カーソル幅の調整]

1. カセットに用紙をセットする。
2. デッキカーソル後 (6) に用紙 (10) が接している状態で、デッキカーソル前 (4) と用紙 (10) の隙間が 0.5 ~ 1.0mm の範囲外の場合は、以下の調整をおこなう。  
※ カーソル幅が小さいと無給紙、カーソル幅が大きいと斜め給紙などが発生する可能性がある。



3. Loosen 2 adjusting screws (11) on the front deck cursor (4) and move the cursor (4) while checking with the scale (12).
4. Retighten the 2 adjusting screws (11).
5. Check that the gap between the front deck cursor (4) and the paper is between 0.5 and 1.0 mm.

- 
3. Desserrer les 2 vis de réglage (11) sur le curseur de platine avant (4) et déposer le curseur (4) tout en vérifiant à l'aide de l'échelle (12).
  4. Resserrer les 2 vis de réglage (11).
  5. Vérifier que l'écartement entre le curseur de platine avant (4) et le papier est entre 0,5 et 1,0 mm.

- 
3. Afloje 2 tornillos de ajuste (11) en el cursor frontal de la plataforma (4) y mueva el cursor (4) mientras verifica con la escala (12).
  4. Vuelva a apretar los 2 tornillos de ajuste (11).
  5. Verifique que la separación entre el cursor frontal de la plataforma (4) y el papel sea de entre 0,5 y 1,0 mm.

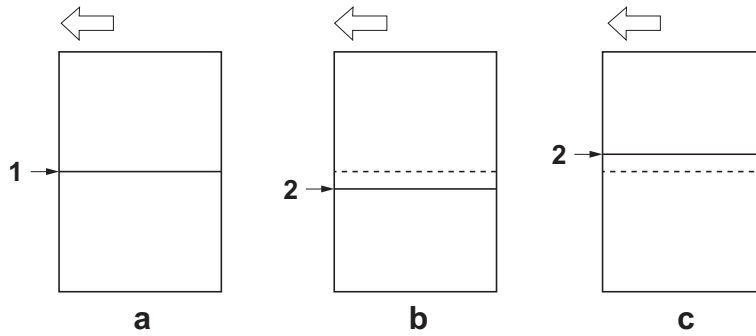
- 
3. Lösen Sie 2 Einstellschrauben (11) am vorderen Konsole-Cursor (4) und versetzen Sie den Cursor (4) unter Beobachtung der Skale (12).
  4. Die 2 Einstellschrauben (11) wieder anziehen.
  5. Vergewissern Sie sich, dass der Abstand zwischen dem vorderen Konsole-Cursor (4) und dem Papier im Bereich 0,5 bis 1,0 mm liegt.

- 
3. Allentare le 2 viti di regolazione (11) sul cursore frontale del deck (4), e quindi rimuovere il cursore (4) controllando la scala (12).
  4. Ristringere le 2 viti di regolazione (11).
  5. Controllare che lo spazio tra il cursore frontale del deck (4) e la carta sia compreso nella gamma tra 0,5 e 1,0 mm.

- 
3. 拧松前部纸张长度调节片 (4) 的 2 颗调节螺丝 (11), 边确认刻度 (12) 边移动前部纸张长度调节片 (4)。
  4. 拧紧 2 颗调节螺丝 (11)。
  5. 确认堆纸板前部游标 (4) 与纸张的间隙在 0.5 ~ 1.0mm 的范围内。

- 
3. 데크커서앞 (4) 의 조정나사 (11) 2 개를 풀어 눈금 (12) 을 확인하면서 데크커서앞 (4) 을 이동시킵니다 .
  4. 조정나사 (11) 2 개를 조입니다 .
  5. 데크커서 앞 (4) 과 용지의 틈이 0.5 ~ 1.0 mm 범위내가 되어 있는 것을 확인합니다 .

- 
- 3.デッキカーソル前 (4) の調整ビス (11) 2 本を緩め、目盛り (12) を確認しながらデッキカーソル前 (4) を移動させる。
  4. 調整ビス (11) 2 本を締め付ける。
  5. デッキカーソル前 (4) と用紙の隙間が 0.5 ~ 1.0mm の範囲内になっていることを確認する。



### Adjusting the center line

Check the deviation between the center (1) of a correct image (a) and the center (2) of a test pattern.

<Reference value> Within  $\pm 2.0$  mm

1. Set the maintenance mode U034. Select LSU Out Left and Cassette5.

2. Adjust the values.

Test pattern (b): Increase the setting value.

Test pattern (c): Decrease the setting value.

3. Press the Start key to confirm the setting value.

### Réglage de l'axe

Vérifier la déviation entre l'axe (1) d'une image correcte (a) et l'axe (2) d'une forme d'essai.

<Valeur de référence>  $\pm 2,0$  mm max.

1. Passer au mode maintenance U034. Sélectionner LSU Out Left et Cassette5.

2. Régler les valeurs.

Mire d'essai (b): Augmentez la valeur de réglage.

Mire d'essai (c): Diminuez la valeur de réglage.

3. Appuyer sur la touche de Start pour confirmer la valeur de réglage.

### Ajuste de la línea central

Compruebe la desviación entre el centro (1) de una imagen correcta (a) y el centro (2) de un patrón de prueba.

<Valor de referencia> Dentro de  $\pm 2,0$  mm

1. Entre en el modo de mantenimiento U034. Seleccione LSU Out Left y Cassette5.

2. Ajuste los valores.

Patrón de prueba (b): Aumente el valor de configuración.

Patrón de prueba (c): Reduzca el valor de configuración.

3. Pulse la tecla de Start para confirmar el valor de configuración.

### Einstellen der Mittelinie

Überprüfen Sie die Abweichung zwischen der Mitte (1) eines korrekten Bilds (a) und der Mitte (2) eines Prüfmusters.

<Bezugswert> Innerhalb  $\pm 2,0$  mm

1. Stellen Sie den Wartungsmodus U034 ein. Wählen Sie LSU Out Left und Cassette5.

2. Die Werte einstellen.

Testmuster (b): Den Einstellwert erhöhen.

Testmuster (c): Den Einstellwert verringern.

3. Den Einstellwert durch Drücken der Start-Taste bestätigen.

### Regolazione della linea centrale

Controllare la deviazione tra il centro (1) di un'immagine corretta (a) e il centro (2) di un modello di prova.

<Valore di riferimento> Entro  $\pm 2,0$  mm

1. Impostare la modalità manutenzione U034. Selezionare LSU Out Left e Cassette5.

2. Regolare i valori.

Modello di prova (b): Aumentare il valore dell'impostazione.

Modello di prova (c): Diminuire il valore dell'impostazione.

3. Premere il tasto di Start per confermare il valore dell'impostazione.

### 中心线调节

确认标准图像 (a) 的中心位置 (1) 与测试图案的中心位置 (2) 的偏移。

<标准值>  $\pm 2.0$ mm 以内

1. 设置维修模式 U034, 选择 LSU Out Left、Cassette5。

2. 调整设定值。

测试图案 (b): 调高设定值。

测试图案 (c): 调低设定值。

3. 按 Start 键, 以确定设定值。

### 센터라인 조정

적정화상 (a) 의 센터 (1) 와 테스트패턴의 센터 (2) 의 차이를 확인합니다.

<기준치>  $\pm 2.0$ mm 이내

1. 메인テナンス 모드 U034 을 세트하고 LSU Out Left, Cassette5 를 선택합니다.

2. 설정치를 조정합니다.

테스트 패턴 (b): 설정치를 높입니다.

테스트 패턴 (c): 설정치를 내립니다.

3. 시작키를 누르고 설정치를 확인합니다.

### センターライン調整

適正画像 (a) のセンター (1) とテストパターン (2) のずれを確認する。ずれが基準値外の場合は調整をおこなう。

<基準値>  $\pm 2.0$ mm 以内。

1. メンテナンスモード U034 をセットし、LSU Out Left、Cassette5 を選択する。

2. 設定値を調整する。

テストパターン (b): 設定値を上げる。

テストパターン (c): 設定値を下げる。

3. スタートキーを押し、設定値を確定する。



303NG5671202

2013. 4  
303NG56712-02



# **INSTALLATION GUIDE FOR 1000-SHEETS FINISHER**

---

**INSTALLATION GUIDE**

**GUIDE D'INSTALLATION**

**GUÍA DE INSTALACION**

**INSTALLATIONSANLEITUNG**

**GUIDA ALL'INSTALLAZIONE**

**安装手册**

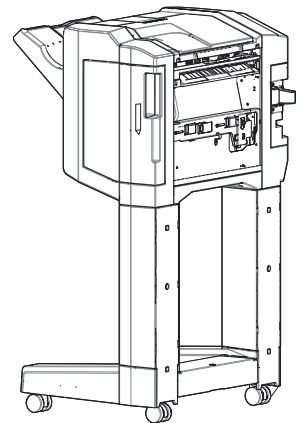
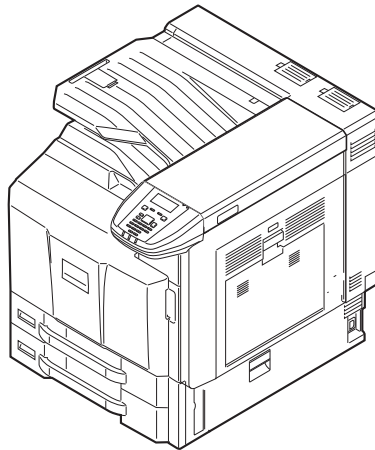
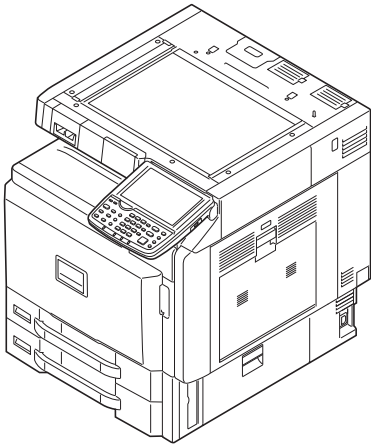
**설치안내서**

**設置手順書**

**DF-770(D)**

for Color MFP 30/30ppm,35/35ppm,  
45/45ppm,55/50ppm  
for Black & White MFP  
35ppm,45ppm,55ppm

for Color Printer 45/45ppm,55/50ppm



**English** A different procedure is required depending on the product which is installed with this unit. Each procedure is described in the following pages.  
For installation with a MFP, see Page 1 to Page 6.  
For installation with a Printer, see Page 7 to Page 13.

**Français** Une procédure différente est requise selon le produit qui est installé avec cette unité. Chaque procédure est décrite dans les pages suivantes.  
Pour l'installation avec une imprimante multifonction, voir Page 1 à Page 6.  
Pour l'installation avec une imprimante, voir Page 7 à Page 13.

**Español** El procedimiento es diferente según el producto que se instale con esta unidad. En las siguientes páginas, se describe cada procedimiento.  
Para la instalación con un MFP, consulte las páginas de la 1 a la 6.  
Para la instalación con una impresora, consulte las páginas de la 7 a la 13.

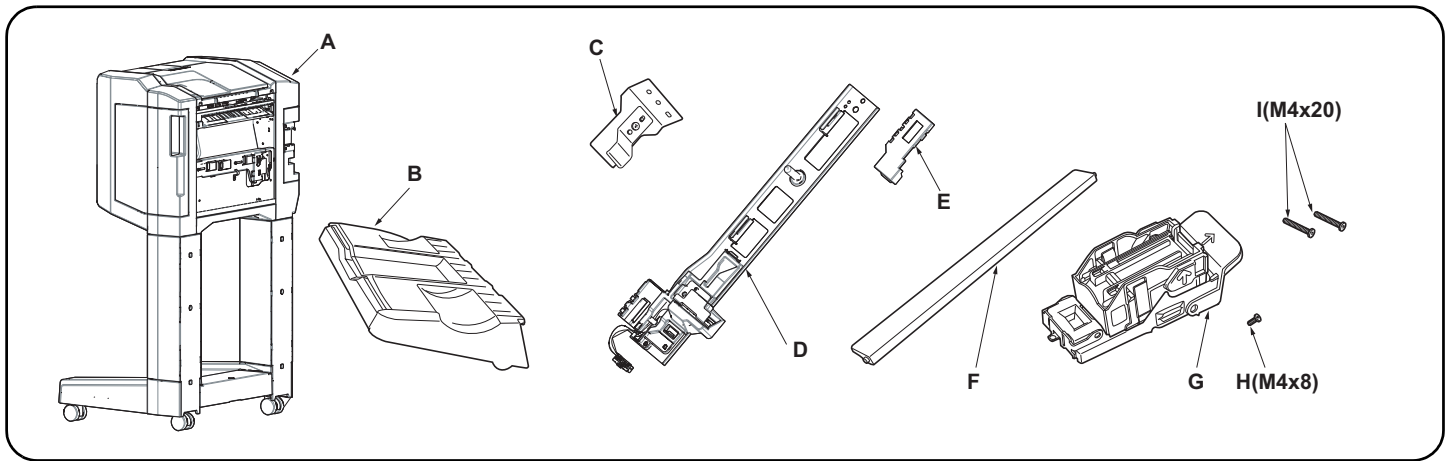
**Deutsch** Je nach verwendetem Modell ist eine andere Vorgehensweise zur Installation dieses Teils erforderlich. Die unterschiedlichen Vorgehensweisen werden auf den folgenden Seiten erläutert.  
Bei Installation an einem MFP siehe Seiten 1 bis 6.  
Bei Installation an einem Drucker siehe Seiten 7 bis 13.

**Italiano** Si richiede una procedura diversa in funzione del prodotto su cui è installata l'unità. Le singole procedure sono descritte nelle pagine seguenti.  
Per l'installazione con un MFP, vedere le pagine da 1 a 6.  
Per l'installazione con una stampante, vedere le pagine da 7 a 13.

**简体中文** 根据安装对象, 安装步骤略有不同。各个步骤记载在下面的页面。  
安装到 MFP 上时, 请参见 P1-P6。  
安装到打印机上时, 请参见 P7-P13。

**한국어** 이 장치에 설치되는 제품에 따라 절차가 다릅니다. 다음 페이지에서 각 절차를 설명합니다.  
MFP 에 설치하는 경우 1 페이지 ~6 페이지를 참조하십시오.  
프린터에 설치하는 경우 7 페이지 ~13 페이지를 참조하십시오.

**日本語** 装着する対象によって、取付手順は異なります。それぞれ、以下のページに記載しています。  
MFP に設置する場合; 1 ページ ~ 6 ページ  
プリンターに設置する場合; 7 ページ ~ 13 ページ



**Supplied parts**

A. Document finisher.....	1
B. Eject tray.....	1
C. Lower earth plate.....	1
D. Connecting plate.....	1
E. Connector cover.....	1
F. Eject guide.....	1

G. Staple cartridge.....	1
H. M4 x 8 screw.....	1
I. M4 x 20 screw.....	2

Be sure to remove any tape and/or cushioning materials from the parts supplied.

**Pièces fournies**

A. Finisseur de document.....	1
B. Bac d'éjection.....	1
C. Plaque de terre inférieure.....	1
D. Plaque de connexion.....	1
E. Cache de connecteur.....	1
F. Guide d'éjection.....	1

G. Cartouche d'agrafes.....	1
H. Vis M4 x 8.....	1
I. Vis M4 x 20.....	2

Veillez à retirer les morceaux de bande adhésive et/ou les matériaux de rembourrage des pièces fournies.

**Partes suministradas**

A. Finalizador de documentos.....	1
B. Bandeja de salida.....	1
C. Placa de conexión a tierra inferior.....	1
D. Placa de conexión.....	1
E. Cubierta del conector.....	1
F. Guía de salida.....	1

G. Cartucho de grapas.....	1
H. Tornillo M4 x 8.....	1
I. Tornillo M4 x 20.....	2

Asegúrese de despegar todas las cintas y/o material amortiguador de las partes suministradas.

**Enthaltene Teile**

A. Finisher.....	1
B. Auswerffach.....	1
C. Untere Grundplatte.....	1
D. Verbindungsplatte.....	1
E. Stecker-Abdeckung.....	1
F. Ausgabeführung.....	1

G. Heftklammer-Magazin.....	1
H. M4 x 8 Schraube.....	1
I. M4 x 20 Schraube.....	2

Stellen Sie sicher, dass sämtliche Klebebänder und/oder Polstermaterial von den gelieferten Teilen entfernt wurden.

**Parti fornite**

A. Finisher documenti.....	1
B. Vassoio di espulsione.....	1
C. Piastra di messa a terra inferiore.....	1
D. Piastra di connessione.....	1
E. Copri connettore.....	1
F. Guida di espulsione.....	1

G. Contenitore punti.....	1
H. Vite M4 x 8.....	3
I. Vite M4 x 20.....	2

Rimuovere tutti i nastri adesivi e/o i materiali di protezione dalle parti fornite.

**附属品**

A. 装订器.....	1
B. 排纸托盘.....	1
C. 下部接地板.....	1
D. 连接板.....	1
E. 接插件盖板.....	1

F. 排纸导向板.....	1
G. 装订针盒.....	1
H. M4x8 螺丝.....	1
I. M4x20 螺丝.....	2

如果附属品上带有固定胶带, 缓冲材料时务必揭下。

**동봉품**

A. 도큐먼트 피니셔.....	1
B. 배출 트레이.....	1
C. 접지판 하.....	1
D. 연결판.....	1
E. 커넥터 커버.....	1

F. 배출 가이드.....	1
G. 스테이플 카트리지.....	1
H. 나사 M4x8.....	1
I. 나사 M4x20.....	2

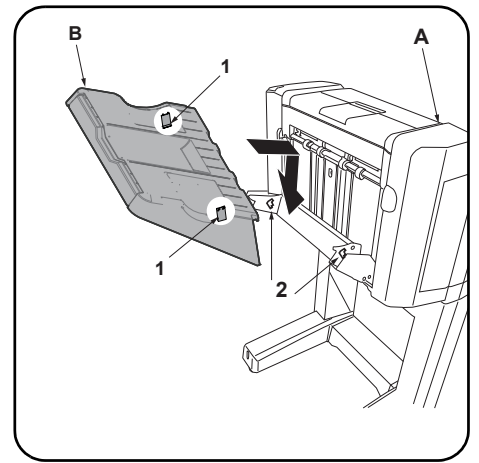
동봉품에 고정 테이프, 완충재가 붙어 있는 경우에는 반드시 제거하십시오.

**同梱品**

A. ドキュメントフィニッシャー.....	1
B. 排出トレイ.....	1
C. アース板下.....	1
D. 連結板.....	1
E. コネクターカバー.....	1
F. 排出ガイド.....	1

G. ステープルカートリッジ.....	1
H. ビス M4x8.....	1
I. ビス M4x20.....	2

同梱品に固定テープ、緩衝材がついている場合は、必ず取り外すこと。



#### NOTICE

The Attachment Kit (AK-730 or AK-731) must be installed before the document finisher is installed.

#### Procedure

Before starting installation, be sure to turn the main power switch of the machine off, and unplug the power plug from the wall outlet.

1. Install eject tray (B) to document finisher (A) by inserting the 2 hooks (1) on the back of the tray in the holes (2) of the finisher lift plate.

#### REMARQUE

Le kit de fixation (AK-730 ou AK-731) doit être installé avant d'installer le finisseur de document.

#### Procédure

Avant de commencer l'installation, s'assurer de mettre la machine hors tension et de débrancher la fiche d'alimentation de la prise murale.

1. Installez le bac d'éjection (B) sur le finisseur de document (A) en insérant les 2 crochets (1) au dos du bac d'éjection (B) dans les trous (2) du dispositif de levage du finisseur.

#### AVISO

El Kit de conexión (AK-730 o AK-731) se debe instalar antes de instalarse el finalizador de documentos.

#### Procedimiento

Antes de iniciar la instalación, asegúrese de apagar el interruptor de encendido de la máquina y desenchufar el cable de alimentación de la toma de pared.

1. Instale la bandeja de salida (B) en el finalizador de documentos (A); para ello, inserte los 2 enganches (1) de la parte posterior de la bandeja en los orificios (2) de la placa de elevación del finalizador.

#### ANMERKUNG

Das Attachment Kit (AK-730 oder AK-731) muss installiert werden, bevor der Finisher installiert wird.

#### Vorgehensweise

Bevor Sie mit der Installation beginnen überzeugen Sie sich, dass der Netzschalter des Geräts ausgeschaltet und das Stromkabel aus der Steckdose gezogen ist.

1. Setzen Sie das Ausgabefach (B) in den Finisher (A), indem Sie die 2 Haken (1) auf der Rückseite des Fachs in die beiden Löcher (2) der Finisher-Lift-Platte einsetzen.

#### AVVISO

Installare l'unità Attachment Kit (AK-730 o AK-731) prima di collegare il finisher documenti.

#### Procedura

Prima di iniziare l'installazione, spegnere la macchina e scollegare la spina dalla presa di corrente.

1. Installare il vassoio di uscita (B) sul finisher documenti (A) inserendo i 2 ganci (1) sul retro del vassoio nei fori (2) della piastra di elevazione del finisher.

#### 注意

安装装订器前，必须先安装连接组件 (AK-730 或 AK-731)。

#### 安装步骤

安装前务必关闭机器的主电源开关，并从墙壁插座拔下电源插头。

1. 将排纸托盘 (B) 内侧的 2 个挂钩 (1) 装入装订器 (A) 的升降板的孔 (2) 中。

#### 주의

도큐먼트 피니셔를 설치하기 전에 어태치먼트 키트 (AK-730 또는 AK-731) 를 설치해야 합니다.

#### 장착순서

설치를 시작하기 전에 반드시 본체의 주 전원 스위치를 끄고 벽 콘센트에서 전원 플러그를 분리하십시오.

1. 배출 트레이 (B) 의 후면 후크 (1) 2 개를 문서 피니셔 (A) 의 리프트 플레이트 구멍 (2) 에 장착합니다.

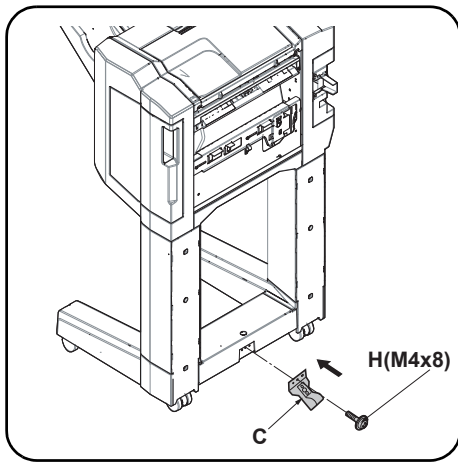
#### 注意

ドキュメントフィニッシャーを取り付ける前に、アタッチメントキット (AK-730 または AK-731) の取り付けをおこなうこと。

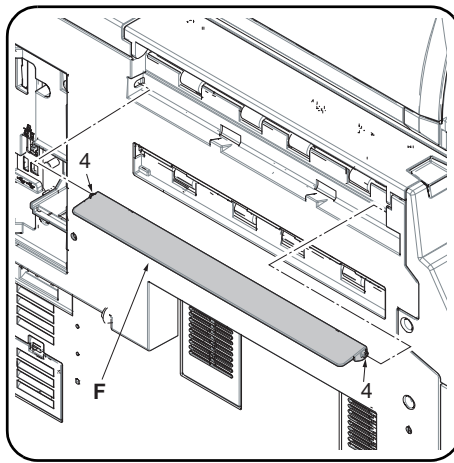
#### 取付手順

必ず機械本体の主電源スイッチを OFF にし、機械本体の電源プラグを抜いてから作業すること。

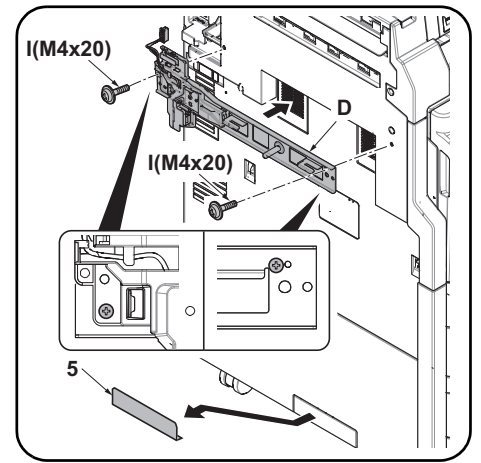
1. 排出トレイ (B) の裏側のフック (1) 2 個をドキュメントフィニッシャー (A) の昇降板の穴 (2) に入れて、取り付け。



2. Secure the lower earth plate (C) with M4 x 8 screws (H).



3. Install the eject guide (F) by fitting the 2 eject guide pins (4) into the holes in the machine.



4. Attach the connecting plate (D) to the machine using 2 M4 x 20 screws (I). Attach them at the point as shown above.  
5. Remove the breakaway cover (5) from the left cover.

2. Fixez la plaque de terre inférieure (C) avec des vis M4 x 8 (H).

3. Installer le guide d'éjection (F) en insérant les 2 ergots du guide d'éjection (4) dans les trous de la machine.

4. Fixez la plaque de connexion (D) à la machine à l'aide de 2 vis M4 x 20 (I). Raccordez-les au point indiqué ci-dessus.  
5. Déposer le capot amovible (5) du capot gauche.

2. Fije la placa de conexión a tierra inferior (C) con tornillos M4 x 8 (H).

3. Instale la guía de salida (F) encajando los 2 clavijas de la guía de salida (4) en los orificios de la máquina.

4. Fije la placa de conexión (D) a la máquina mediante 2 tornillos M4 x 20 (I). Conéctelas en el punto que se muestra arriba.  
5. Quite la cubierta divisoria (5) de la cubierta izquierda.

2. Befestigen Sie die untere Grundplatte (C) mit den M4 x 8 Schrauben (H).

3. Installieren Sie die Ausgabeführung (F), indem Sie die beiden Stifte (4) der Auswerfführung in die Aufnahmen des Geräts einsetzen.

4. Bringen Sie die Verbindungsplatte (D) mit 2 M4 x 20 Schrauben (I) am Gerät an. Bringen Sie diese an der in der Abbildung gezeigten Stelle an.  
5. Nehmen Sie die Ablösungsabdeckung (5) von der linken Abdeckung ab.

2. Fissare la piastra di messa a terra inferiore (C) con le viti M4 x 8 (H).

3. Installare la guida di espulsione (F) inserendo i 2 perni (4) della guida di espulsione nei fori della macchina.

4. Applicare la piastra di connessione (D) alla macchina utilizzando le 2 viti M4 x 20 (I). Fissare nella posizione sopra indicata.  
5. Rimuovere il coperchio di distacco (5) dal coperchio sinistro.

2. 使用 M4×8(H) 螺丝来固定下部接地板 (C)。

3. 将排纸导向板 (F) 的 2 根销钉 (4) 插入机器的孔中。

4. 使用 2 颗 M4×20(I) 螺丝将连接板 (D) 安装到机器上。按图示位置来安装。  
5. 去除左侧盖板上的可去除部 (5)。

2. 지판 하 (C) 를 나사 M4×8(H) 로 고정합니다 .

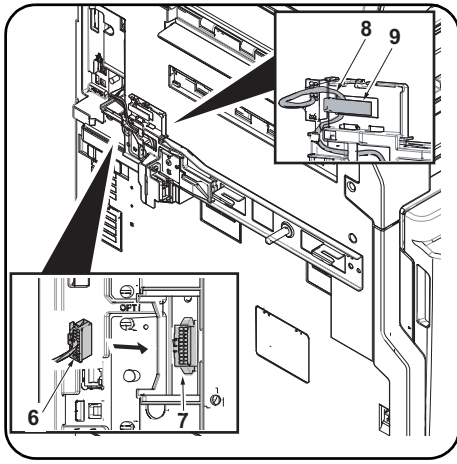
3. 배출 가이드 (F) 의 핀 (4) 2 개를 본체의 구멍에 맞추어 끼워서 부착합니다 .

4. 나사 M4 × 20(I) 2 개를 사용하여 연결판 (D) 을 본체에 부착합니다 . 위에 표시된 위치에 부착합니다 .  
5. 좌측 커버의 분할커버부 (5) 를 떼어 냅니다 .

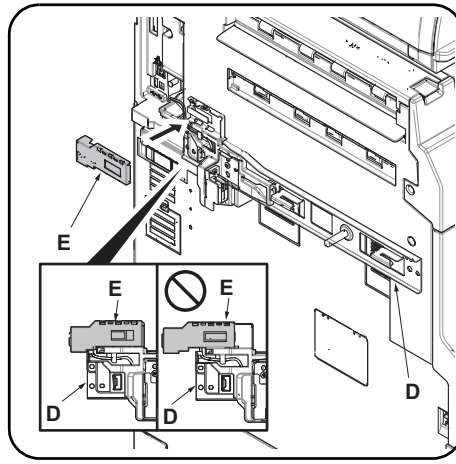
2. アース板下 (C) をビス M4×8(H) で固定する。

3. 排出ガイド (F) のピン (4) 2 本を機械本体の穴に差し込み取り付ける。

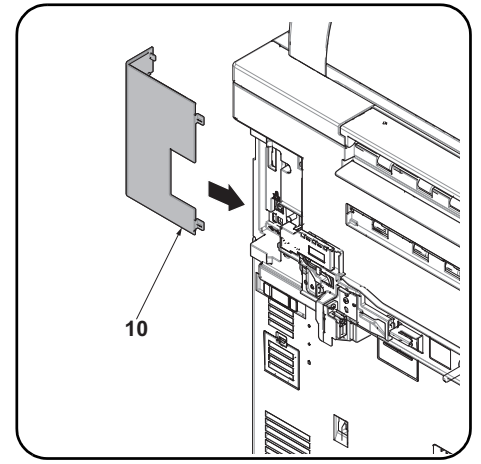
4. 連結板 (D) をビス M4×20(I) 2 本で、機械本体に取り付ける。図の位置で取り付けること。  
5. 左カバーの割りカバー部 (5) を切り取る。



6. Connect the signal line connector (6) to the connector (7) on the machine. Hook the signal line wire (8) onto the hook (9).



7. Fit the connector cover (E) in the connecting plate (D). Take care not to get the cable pinched by objects. Attach it at the point as shown above. Check that the signal line connector is covered by the connector cover (E).



8. Attach the interface cover (10)\* on the machine.  
\* The cover which was removed while installing the AK-730 or AK-731.

6. Raccorder le connecteur de ligne de signal (6) sur le connecteur (7) de la machine. Accrocher le fil de ligne de signal (8) sur le crochet (9).

7. Placer le cache de connecteur (E) dans la plaque de connexion (D). Prendre soin à ne pas pincer le câble. Raccordez-les au point indiqué ci-dessus. Vérifier que le connecteur de ligne de signal est couvert par le cache de connecteur (E).

8. Raccordez le capot d'interface (10)\* à la machine.  
\* Le cache qui a été retiré lors de l'installation de l'AK-730 ou AK-731.

6. Conecte el conector de línea de señales (6) al conector (7) de la máquina. Enganche el cable de la línea de señales (8) en el enganche (9).

7. Acople la cubierta del conector (E) en la placa de conexión (D). Tenga cuidado de que el cable no quede atrapado por objetos. Conéctelas en el punto que se muestra arriba. Compruebe que el conector de la línea de señales quede cubierto por la cubierta del conector (E).

8. Conecte la cubierta de interfaz (10)\* de la máquina.  
\* La cubierta que se quitó al instalar el kit AK-730 o AK-731.

6. Verbinden Sie den Stecker der Signalleitung (6) mit dem Steckverbinder im Gerät (7). Hängen Sie das Kabel der Signalleitung (8) in den Befestigungshaken (9) ein.

7. Setzen Sie die Stecker-Abdeckung (E) in die Verbindungsplatte (D) ein. Stellen Sie sicher, dass das Kabel nicht eingeklemmt wird. Bringen Sie diese an der in der Abbildung gezeigten Stelle an. Überprüfen Sie, ob der Stecker der Signalleitung von der Stecker-Abdeckung (E) abgedeckt ist.

8. Bringen Sie die Schnittstellenabdeckung (10)\* am Gerät an.  
\* Die Abdeckung, die zur Installation des AK-730 oder AK-731 entfernt wurde

6. Collegare il connettore di linea del segnale (6) al connettore (7) sulla periferica. Agganciare il cavo di linea del segnale (8) al gancio (9).

7. Inserire il copri connettore (E) nella piastra di connessione (D). Fare attenzione a non impigliare il cavo. Fissare nella posizione sopra indicata. Controllare che il connettore della linea del segnale sia coperto dal copri connettore (E).

8. Fissare la copertura di interfaccia (10)\* sulla macchina.  
\* Il coperchio che è stato rimosso per installare il kit AK-730 o AK-731

6. 把信号线的接插件 (6) 和机器本体的接插件 (7) 相连接。把信号线 (8) 挂到挂钩 (9) 上。

7. 将接插件盖板 (E) 嵌入到连接板 (D)。请注意不要夹住电线。按图示位置来安装。请确认信号线的接插件是否完全隐藏在接插件盖板中 (E)。

8. 将接口盖板 (10)\* 安装到机器主机。  
\* 安装 AK-730 或 AK-731 时, 取下的盖板

6. 시그널 라인 연결커넥터 (6) 를 본체의 커넥터 (7) 에 연결합니다. 시그널 라인 와이어 (8) 를 후크 (9) 에 겁니다.

7. 커넥터 커버 (E) 를 연결판 (D) 에 맞추어 끼웁니다. 케이블이 커넥터 커버 (E) 에 끼이지 않도록 주의합니다. 위에 표시된 위치에 부착합니다. 시그널라인 커넥터가 커넥터 커버 (E) 에 덮여있는지 확인합니다.

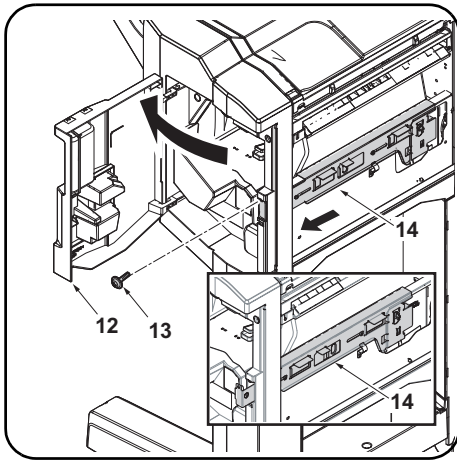
8. 인터페이스 커버 (10)\* 를 본체에 부착합니다.  
\* AK-730 또는 AK-731 설치 시 분리한 커버.

6. 信号線のコネクタ (6) を機械本体のコネクタ (7) に接続する。信号線 (8) は、フック (9) に掛けること。

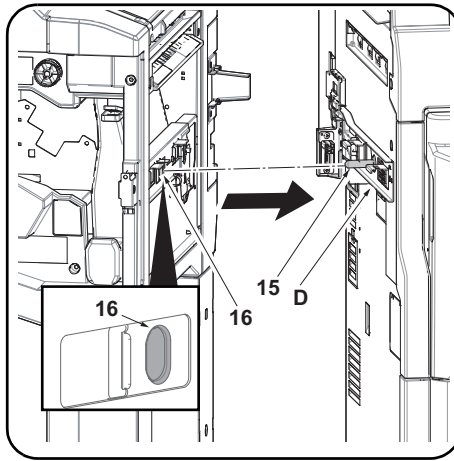
7. コネクタカバー (E) を連結板 (D) にはめ込む。電線を挟み込まない様注意すること。図の位置で取り付けること。信号線のコネクタがコネクタカバー (E) で隠れていることを確認する。

8. 機械本体にインターフェイスカバー (10)\* を取り付ける。  
\* AK-730 または AK-731 設置時に取り外したカバー

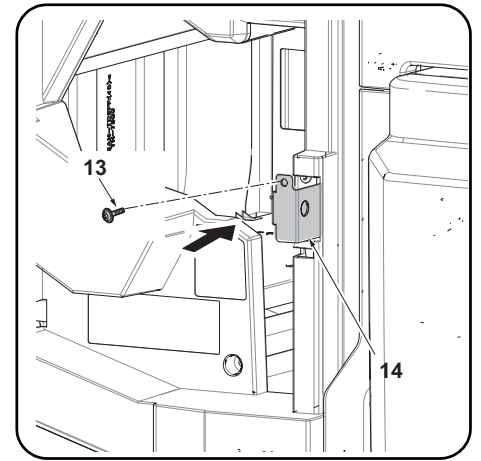




9. Open the document finisher front cover (12). Remove the screw (13). Pull the lock frame (14) frontwards.



10. Insert the pin (15) on the connecting plate (D) into the hole (16) on the document finisher. Connect the document finisher to the machine.  
\* If the document finisher doesn't comply with the reference of the height as described on page 14, adjust the height.



11. Slowly push the lock frame (14) fully into the machine so that the connectors at the far end are connected.  
12. Secure the lock frame (14) using the screw (13) removed in step 9.

9. Ouvrir le capot avant du finisseur de document (12). Retirez la vis (13). Tirer le cadre de verrouillage (14) vers le bas.

10. Introduire l'ergot (15) sur la plaque de connexion (D) dans le trou (16) sur le finisseur de document. Connecter le finisseur de document sur la machine.  
\* Si le finisseur de document n'est pas conforme à la référence de hauteur comme décrit à la page 14, ajustez la hauteur.

11. Pousser doucement le cadre de verrouillage (14) à fond dans la machine de sorte que les connecteurs à l'extrémité soient raccordés.  
12. Fixez le bâti de verrouillage (14) à l'aide de la vis (13) déposée à l'étape 9.

9. Abra la cubierta frontal del finalizador de documentos (12). Quite el tornillo (13). Empuje el marco de cierre (14) hacia delante.

10. Inserte la clavija (15) de la placa de conexión (D) en el orificio (16) del finalizador de documentos. Conecte el finalizador de documentos a la máquina.  
\* Si el finalizador de documentos no cumple con la referencia de altura como se describe en la página 14, ajuste la altura.

11. Empuje lentamente y hasta el fondo el marco del cierre (14) hacia la máquina de modo que se conecten los conectores en el extremo más lejano.  
12. Asegure la carcasa de bloqueo (14) por medio del tornillo (13) quitado en el paso 9.

9. Öffnen Sie die vordere Abdeckung des Finishers (12). Entfernen Sie die Schraube (13). Ziehen Sie die Verriegelung (14) nach vorne.

10. Setzen Sie den Stift (15) der Verbindungssplatte (D) in die Öffnung (16) des Finishers. Verbinden Sie den Finisher mit dem Gerät.  
\* Falls die Höhe des Finishers nicht mit der auf Seite 14 in der Referenz beschriebenen Höhe übereinstimmt, justieren Sie die Höhe.

11. Schieben Sie die Verriegelung (14) wieder langsam ins Gerät, so dass die Verbindungen am anderen Ende des Geräts geschlossen werden.  
12. Befestigen Sie den Fixierahmen (14) mit der in Schritt 9 entfernten Schraube (13).

9. Aprire il coperchio frontale del finisher documenti (12). Togliere la vite (13). Tirare in avanti la frame di blocco (14).

10. Inserire il perno (15) della piastra di connessione (D) nel foro (16) del finisher documenti. Collegare il finisher documenti alla macchina.  
\* Se il finisher documenti non è conforme con il riferimento altezza come descritto a pagina 14, regolare l'altezza.

11. Spingere lentamente la frame di blocco (14) nella macchina in modo che i connettori all'estremità risultino collegati.  
12. Fissare il telaio di bloccaggio (14) utilizzando la vite (13) rimossa nel passo 9.

9. 打开装订器的前盖板(12)。取下螺丝(13)。向身体前侧拉出固定架(14)。

10. 将连接板(D)的销钉(15)插入装订器的孔(16)中。把装订器连接到机器本体。  
※ 若不符合P14的【高度调整】的基准时, 执行【高度调整】。

11. 慢慢的把固定架(14)完全推入机器, 这样机器里侧的接插件就可以顺利连接。  
12. 使用步骤9中取下的1颗螺丝(13)来固定锁框(14)。

9. 도큐먼트 피니셔의 상단 프론트 커버(12)를 엽니다. 나사(13)를 제거합니다. 잠금 프레임(14)을 앞으로 뺍니다.

10. 연결판(D)의 핀(15)을 도큐먼트 피니셔의 구멍(16)에 삽입합니다. 도큐먼트 피니셔를 본체에 연결합니다.  
\* 연결할 도큐먼트 피니셔가 14 페이지에 설명된 높이 기준에 부합하지 않으면 높이를 조정하십시오.

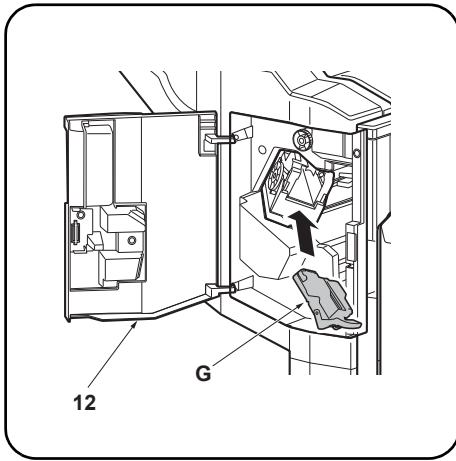
11. 본체 뒷쪽의 커넥터가 연결되도록 잠금 프레임(14)을 본체 안으로 천천히 밀어 넣습니다.  
12. 스텝 9에서 뺀 나사(13)1개로 잠금 프레임(14)을 고정합니다.

9. ドキュメントフィニッシャーの前カバー(12)を開く。ビス(13)を外す。ロックフレーム(14)を手前に引く。

10. 連結板(D)のピン(15)をドキュメントフィニッシャーの穴(16)に挿入する。ドキュメントフィニッシャーを機械本体に接続する。  
※P14の「高さ調整」の基準に適合しない場合は、「高さ調整」を行う。

11. 機械奥側のコネクタが接続されるように、ロックフレーム(14)をゆっくり奥に押す。  
12. 手順9で外したビス(13)で、ロックフレーム(14)を固定する。





13. Install the staple cartridge (G).  
14. Close the front cover (12).

Proceed to adjusting the stapling position on page 18.

13. Installer la cartouche d'agrafes (G).  
14. Refermer le capot avant (12).

Passez à l'ajustement de la position d'agrafage page 18.

13. Instale el cartucho de grapas (G).  
14. Cierre la cubierta frontal (12).

Proceda al ajuste de la posición de grapado en la página 18.

13. Installieren Sie das Heftklammer-Magazin (G).  
14. Schließen Sie die vordere Abdeckung (12).

Fahren Sie mit der Justage der Heftposition auf Seite 18 fort.

13. Installare il contenitore punti (G).  
14. Chiudere il pannello anteriore (12).

Proseguire con la regolazione della posizione di pinzatura a pagina 18.

13. 安装装订针盒 (G)。  
14. 关闭前盖板 (12)。

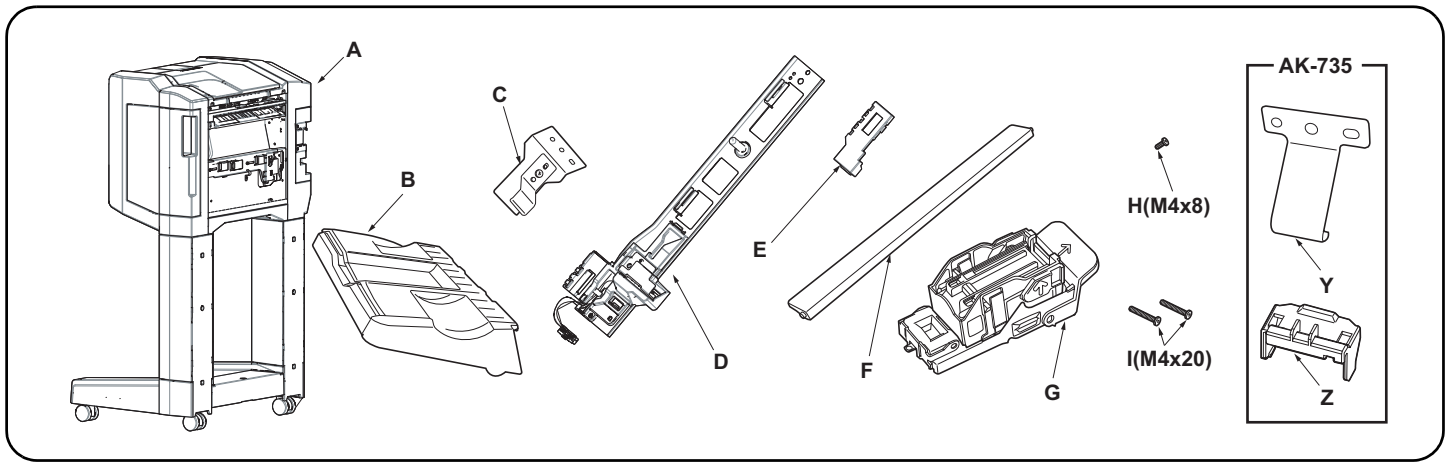
跳至 P18「调节装订位置」。

13. 스테이플 카트리지를 (G) 를 설치합니다 .  
14. 상단 프론트 커버 (12) 를 닫습니다 .

18 페이지의 스테이플 위치 조정을 진행합니다 .

13. ステープルカートリッジ (G) を取り付ける。  
14. 前カバー (12) を閉じる。

P18「ステープル位置の調整」に進む。



**Supplied parts**

A. Document finisher.....	1
B. Eject tray.....	1
C. Lower earth plate.....	1
D. Connecting plate.....	1
E. Connector cover.....	1
F. Eject guide.....	1

G. Staple cartridge.....	1
H. M4 x 8 screw.....	1
I. M4 x 20 screw.....	2
Y. Earth Plate.....	1
Z. Cover.....	1

(C) and (Z) are not used.

Be sure to remove any tape and/or cushioning materials from the parts supplied.

**Pièces fournies**

A. Finisseur de document.....	1
B. Bac d'éjection.....	1
C. Plaque de terre inférieure.....	1
D. Plaque de connexion.....	1
E. Cache de connecteur.....	1
F. Guide d'éjection.....	1

G. Cartouche d'agrafes.....	1
H. Vis M4 x 8.....	1
I. Vis M4 x 20.....	2
Y. Plaque de terre.....	1
Z. Capot.....	1

(C) et (Z) ne sont pas utilisés.

Veillez à retirer les morceaux de bande adhésive et/ou les matériaux de rembourrage des pièces fournies.

**Partes suministradas**

A. Finalizador de documentos.....	1
B. Bandeja de salida.....	1
C. Placa de conexión a tierra inferior.....	1
D. Placa de conexión.....	1
E. Cubierta del conector.....	1
F. Guía de salida.....	1

G. Cartucho de grapas.....	1
H. Tornillo M4 x 8.....	1
I. Tornillo M4 x 20.....	2
Y. Placa de conexión a tierra.....	1
Z. Cubierta.....	1

(C) y (Z) no se utilizan.

Asegúrese de despegar todas las cintas y/o material amortiguador de las partes suministradas.

**Enthaltene Teile**

A. Finisher.....	1
B. Auswerffach.....	1
C. Untere Grundplatte.....	1
D. Verbindungsplatte.....	1
E. Stecker-Abdeckung.....	1
F. Ausgabeführung.....	1

G. Heftklammer-Magazin.....	1
H. M4 x 8 Schraube.....	1
I. M4 x 20 Schraube.....	2
Y. Grundplatte.....	1
Z. Abdeckung.....	1

(C) und (Z) werden nicht benötigt.

Stellen Sie sicher, dass sämtliche Klebebänder und/oder Polstermaterial von den gelieferten Teilen entfernt wurden.

**Parti fornite**

A. Finisher documenti.....	1
B. Vassoio di espulsione.....	1
C. Piastra di messa a terra inferiore.....	1
D. Piastra di connessione.....	1
E. Copri connettore.....	1
F. Guida di espulsione.....	1

G. Contenitore punti.....	1
H. Vite M4 x 8.....	1
I. Vite M4 x 20.....	2
Y. Piastra di messa a terra.....	1
Z. Coperchio.....	1

(C) e (Z) non sono utilizzati.

Rimuovere tutti i nastri adesivi e/o i materiali di protezione dalle parti fornite.

**附属品**

A. 装订器.....	1
B. 排纸托盘.....	1
C. 下部接地板.....	1
D. 连接板.....	1
E. 接插件盖板.....	1

F. 排纸导向板.....	1
G. 装订针盒.....	1
H. M4x8 螺丝.....	1
I. M4x20 螺丝.....	2
Y. 接地板.....	1
Z. 盖板.....	1

不使用 (C) 和 (Z)。

如果附属品上带有固定胶带, 缓冲材料时务必揭下。

**동봉품**

A. 도큐먼트 피니셔.....	1
B. 배출 트레이.....	1
C. 접지판 하.....	1
D. 연결판.....	1
E. 커넥터 커버.....	1

F. 배출 가이드.....	1
G. 스테이플 카트리지.....	1
H. 나사 M4x8.....	1
I. 나사 M4x20.....	2
Y. 접지판.....	1
Z. 커버.....	1

(C) 와 (Z) 는 사용되지 않습니다 .

동봉품에 고정 테이프, 완충재가 붙어 있는 경우에는 반드시 제거하십시오 .

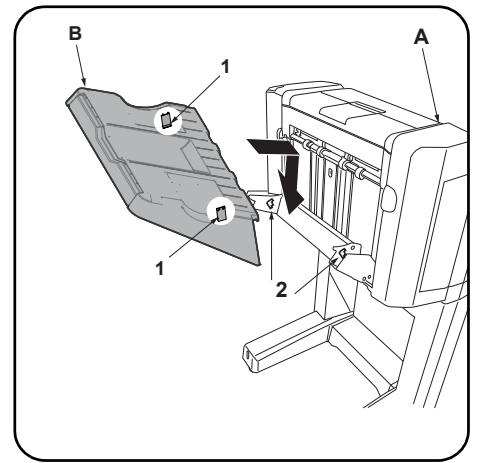
**同梱品**

A. ドキュメントフィニッシャー.....	1
B. 排出トレイ.....	1
C. アース板下.....	1
D. 連結板.....	1
E. コネクターカバー.....	1
F. 排出ガイド.....	1

G. ステープルカートリッジ.....	1
H. ビス M4x8.....	1
I. ビス M4x20.....	2
Y. アース板.....	1
Z. カバー.....	1

(C), (Z) は使用しない。

同梱品に固定テープ、緩衝材がついている場合は、必ず取り外すこと。



#### NOTICE

The Attachment Kit (AK-735) must be installed before the document finisher is installed.

#### Procedure

Before starting installation, be sure to turn the main power switch of the machine off, and unplug the power plug from the wall outlet.

1. Install eject tray (B) to document finisher (A) by inserting the 2 hooks (1) on the back of the tray in the holes (2) of the finisher lift plate.

#### REMARQUE

Le kit de fixation (AK-735) doit être installé avant d'installer le finisseur de document.

#### Procédure

Avant de commencer l'installation, s'assurer de mettre la machine hors tension et de débrancher la fiche d'alimentation de la prise murale.

1. Installez le bac d'éjection (B) sur le finisseur de document (A) en insérant les 2 crochets (1) au dos du bac d'éjection (B) dans les trous (2) du dispositif de levage du finisseur.

#### AVISO

El Kit de conexión (AK-735) se debe instalar antes de instalarse el finalizador de documentos.

#### Procedimiento

Antes de iniciar la instalación, asegúrese de apagar el interruptor de encendido de la máquina y desenchufar el cable de alimentación de la toma de pared.

1. Instale la bandeja de salida (B) en el finalizador de documentos (A); para ello, inserte los 2 enganches (1) de la parte posterior de la bandeja en los orificios (2) de la placa de elevación del finalizador.

#### ANMERKUNG

Das Attachment Kit (AK-735) muss installiert werden, bevor der Finisher installiert wird.

#### Verfahren

Bevor Sie mit der Installation beginnen überzeugen Sie sich, dass der Netzschalter des Geräts ausgeschaltet und das Stromkabel aus der Steckdose gezogen ist.

1. Setzen Sie das Ausgabefach (B) in den Finisher (A), indem Sie die 2 Haken (1) auf der Rückseite des Fachs in die beiden Löcher (2) der Finisher-Lift-Platte einsetzen.

#### AVVISO

Installare l'unità Attachment Kit (AK-735) prima di collegare il finisher documenti.

#### Procedura

Prima di iniziare l'installazione, spegnere la macchina e scollegare la spina dalla presa di corrente.

1. Installare il vassoio di uscita (B) sul finisher documenti (A) inserendo i 2 ganci (1) sul retro del vassoio nei fori (2) della piastra di elevazione del finisher.

#### 注意

安装装订器之前，必须先安装连接组件 (AK-735)。

#### 安装步骤

安装前务必关闭机器的主电源开关，并从墙壁插座拔下电源插头。

1. 将排纸托盘 (B) 内侧的 2 个挂钩 (1) 装入装订器 (A) 的升降板的孔 (2) 中。

#### 주의

도큐먼트 피니셔를 설치하기 전에 어태치먼트 키트 (AK-735) 를 설치해야 합니다 .

#### 장착순서

설치를 시작하기 전에 반드시 본체의 주 전원 스위치를 끄고 벽 콘센트에서 전원 플러그를 분리하십시오 .

1. 배출 트레이 (B) 의 후면 후크 (1) 2 개를 문서 피니셔 (A) 의 리프트 플레이트 구멍 (2) 에 장착합니다 .

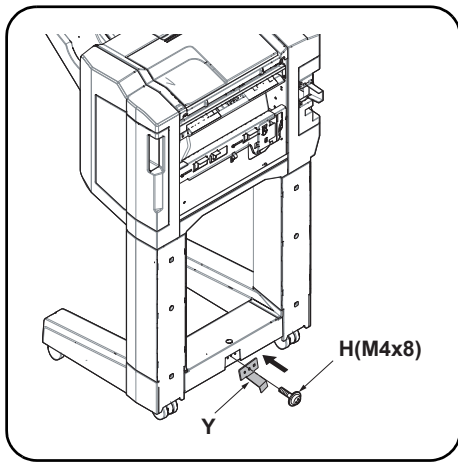
#### 注意

ドキュメントフィニッシャーを取り付ける前に、アタッチメントキット (AK-735) の取り付けをおこなうこと。

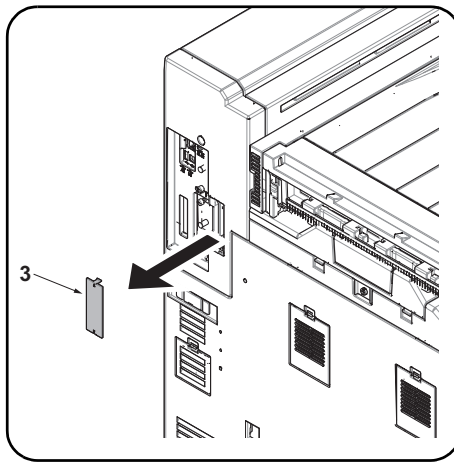
#### 取付手順

必ず機械本体の主電源スイッチを OFF にし、機械本体の電源プラグを抜いてから作業すること。

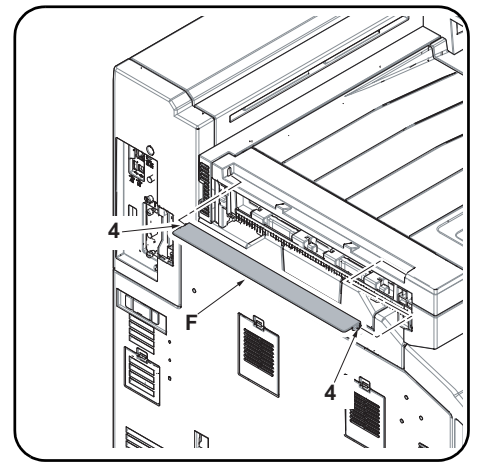
1. 排出トレイ (B) の裏側のフック (1) 2 個をドキュメントフィニッシャー (A) の昇降板の穴 (2) に入れて、取り付けます。



2. Secure the earth plate (Y)\* with M4 x 8 screws (H).  
\*The part was supplied with the AK-735.



3. Remove the machine interface cover (3).



4. Install the eject guide (F) by fitting the 2 eject guide pins (4) into the holes in the machine.

2. Fixez la plaque de terre (Y)\* avec des vis M4 x 8 (H).  
\*La pièce a été fournie avec l'AK-735

3. Déposer le couvercle d'interface (3) de la machine.

4. Installer le guide d'éjection (F) en insérant les 2 ergots du guide d'éjection (4) dans les trous de la machine.

2. Fije la placa de conexión a tierra (Y)\* con tornillos M4 x 8 (H).  
\*La pieza se proporcionó con AK-735

3. Quite la cubierta de la interfaz (3) de la máquina.

4. Instale la guía de salida (F) encajando los 2 clavijas de la guía de salida (4) en los orificios de la máquina.

2. Befestigen Sie die Grundplatte (Y)\* mit den M4 x 8 Schrauben (H).  
\*Dieses Teil ist im AK-735 enthalten.

3. Nehmen Sie die Schnittstellenabdeckung (3) des Geräts ab.

4. Installieren Sie die Ausgabeführung (F), indem Sie die beiden Stifte (4) der Auswerfführung in die Aufnahmen des Geräts einsetzen.

2. Fissare la piastra di messa a terra (Y)\* con le viti M4 x 8 (H).  
\*Parte fornita con AK-735

3. Rimuovere la copertura di interfaccia (3) della macchina.

4. Installare la guida di espulsione (F) inserendo i 2 perni (4) della guida di espulsione nei fori della macchina.

2. 使用 M4×8(H) 螺丝来固定接地板 (Y)\*。  
\*AK-735 的附属品

3. 拆下机器的接口盖板 (3)。

4. 将排纸导向板 (F) 的 2 根销钉 (4) 插入机器的孔中。

2. 나사 M4 × 8(H) 로 접지판 (Y)\* 을 고정합니다.  
\*AK-735 동봉 부품

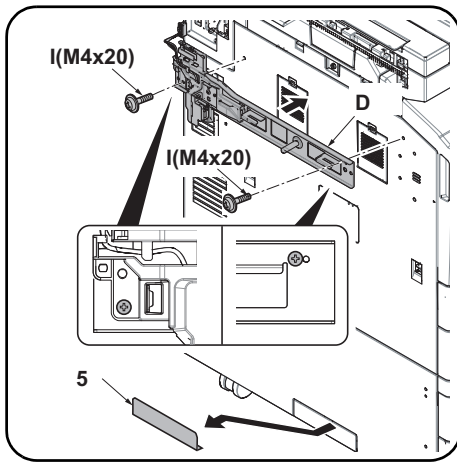
3. 본체의 인터페이스 커버 (3) 를 제거합니다 .

4. 배출 가이드 (F) 의 핀 (4) 2 개를 본체의 구멍에 맞추어 끼워서 부착합니다 .

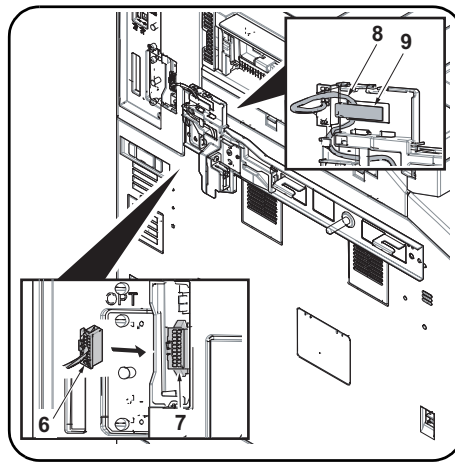
2. アース板 (Y)\* をビス M4×8(H) で固定する。  
\*AK-735 の同梱品

3. 機械本体のインターフェイスカバー (3) を取り外す。

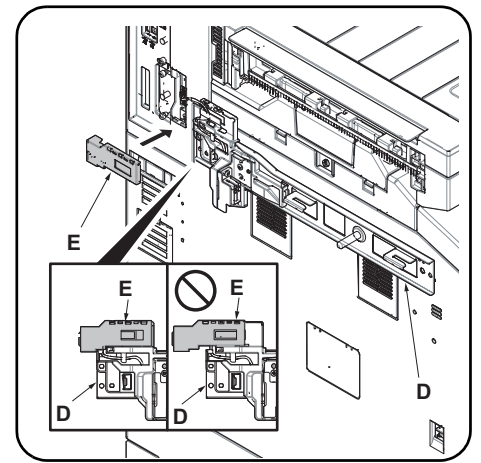
4. 排出ガイド (F) のピン (4) 2 本を機械本体の穴に差し込み取り付けする。



- Attach the connecting plate (D) to the machine using 2 M4 x 20 screws (I). Attach them at the point as shown above.
- Remove the breakaway cover (5) from the left cover.



- Connect the signal line connector (6) to the connector (7) on the machine. Hook the signal line wire (8) onto the hook (9).



- Fit the connector cover (D) in the connecting plate (E). Take care not to get the cable pinched by objects. Attach it at the point as shown above. Check that the signal line connector is covered by the connector cover (E).

- Fixez la plaque de connexion (D) à la machine à l'aide de 2 vis M4 x 20 (I). Raccordez-les au point indiqué ci-dessus.
- Déposer le capot amovible (5) du capot gauche.

- Raccorder le connecteur de ligne de signal (6) sur le connecteur (7) de la machine. Accrocher le fil de ligne de signal (8) sur le crochet (9).

- Placer le cache de connecteur (D) dans la plaque de connexion (E). Prendre soin de ne pas pincer le câble. Raccordez-les au point indiqué ci-dessus. Vérifier que le connecteur de ligne de signal est couvert par le cache de connecteur (E).

- Fije la placa de conexión (D) a la máquina mediante 2 tornillos M4 x 20 (I). Conéctelas en el punto que se muestra arriba.
- Quite la cubierta divisoria (5) de la cubierta izquierda.

- Conecte el conector de línea de señales (6) al conector (7) de la máquina. Enganche el cable de la línea de señales (8) en el enganche (9).

- Acople la cubierta del conector (D) en la placa de conexión (E). Tenga cuidado de que el cable no quede atrapado por objetos. Conéctelas en el punto que se muestra arriba. Compruebe que el conector de la línea de señales quede cubierto por la cubierta del conector (E).

- Bringen Sie die Verbindungsplatte (D) mit 2 M4 x 20 Schrauben (I) am Gerät an. Bringen Sie diese an der in der Abbildung gezeigten Stelle an.
- Nehmen Sie die Ablösungsabdeckung (5) von der linken Abdeckung ab.

- Verbinden Sie den Stecker der Signalleitung (6) mit dem Steckverbinder im Gerät (7). Hängen Sie das Kabel der Signalleitung (8) in den Befestigungshaken (9) ein.

- Setzen Sie die Stecker-Abdeckung (D) in die Verbindungsplatte (E) ein. Stellen Sie sicher, dass das Kabel nicht eingeklemmt wird. Bringen Sie diese an der in der Abbildung gezeigten Stelle an. Überprüfen Sie, ob der Stecker der Signalleitung von der Stecker-Abdeckung (E) abgedeckt ist.

- Applicare la piastra di connessione (D) alla macchina utilizzando le 2 viti M4 x 20 (I). Fissare nella posizione sopra indicata.
- Rimuovere il coperchio di distacco (5) dal coperchio sinistro.

- Collegare il connettore di linea del segnale (6) al connettore (7) sulla periferica. Agganciare il cavo di linea del segnale (8) al gancio (9).

- Inserire il copri connettore (D) nella piastra di connessione (E). Fare attenzione a non impigliare il cavo. Fissare nella posizione sopra indicata. Controllare che il connettore della linea del segnale sia coperto dal copri connettore (E).

- 使用 2 顆 M4×20 (I) 螺丝將連接板 (D) 安裝到機器上。按圖示位置來安裝。
- 去除左側蓋板上的可去除部 (5)。

- 把信號線的接插件 (6) 和機器本體的接插件 (7) 相連接。把信號線 (8) 掛到掛鉤 (9) 上。

- 將接插件蓋板 (E) 嵌入到連接板 (D)。請注意不要夾住電線。按圖示位置來安裝。請確認信號線的接插件是否完全隱藏在接插件蓋板中 (E)。

- 나사 M4 x 20 (I) 2 개를 사용하여 연결판 (D) 을 본체에 부착합니다. 위에 표시된 위치에 부착합니다.
- 좌측 커버의 분할커버부 (5) 를 떼어 냅니다.

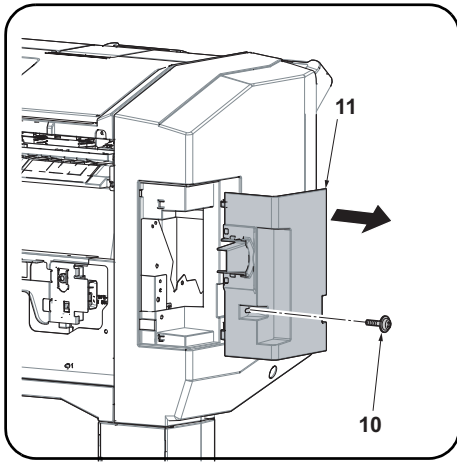
- 시그널 라인 연결커넥터 (6) 를 본체의 커넥터 (7) 에 연결합니다. 시그널 라인 와이어 (8) 를 후크 (9) 에 걸립니다.

- 커넥터 커버 (E) 를 연결판 (D) 에 맞추어 끼웁니다. 케이블이 커넥터 커버 (E) 에 끼이지 않도록 주의합니다. 위에 표시된 위치에 부착합니다. 시그널라인 커넥터가 커넥터 커버 (E) 에 덮여있는지 확인합니다.

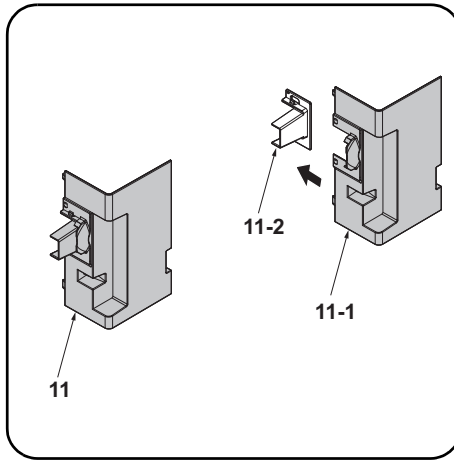
- 連結板 (D) をビス M4×20 (I) 2 本で、機械本体に取り付ける。図の位置で取り付けること。
- 左カバーの割りカバー部 (5) を切り取る。

- 信號線のコネクター (6) を機械本体のコネクター (7) に接続する。信號線 (8) は、フック (9) に掛けること。

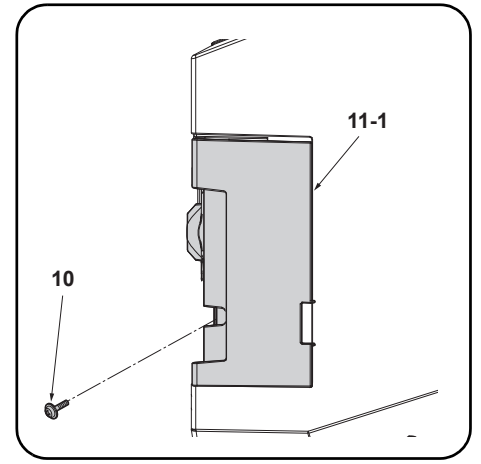
- コネクターカバー (E) を連結板 (D) にはめ込む。電線を挟み込まない様注意すること。図の位置で取り付けること。信號線のコネクターがコネクターカバー (E) で隠れていることを確認する。



**9.** Remove the screw (10). Remove the rear cover (11).



**10.** Separate the rear cover(11) into the two covers(11-1,11-2).  
The cover (11-2) is not used.



**11.** Install the cover (11-1) using the screw (10) removed in step 9.

**9.** Retirez la vis (10). Retirez le capot arrière (11).

**10.** Séparez le capot arrière (11) en deux capots (11-1, 11-2).  
Le capot (11-2) n'est pas utilisé.

**11.** Installez le capot (11-1) à l'aide de la vis (10) déposée à l'étape 9.

**9.** Quite el tornillo (10). Quite la cubierta posterior (11).

**10.** Separe la cubierta posterior (11) en las dos cubiertas (11-1, 11-2).  
La cubierta (11-2) no se utiliza.

**11.** Instale la cubierta (11-1) con un tornillo (10) quitado en el paso 9.

**9.** Entfernen Sie die Schraube (10). Entfernen Sie die hintere Abdeckung (11).

**10.** Teilen Sie die hintere Abdeckung (11) in zwei Abdeckungen (11-1, 11-2) auf.  
Die Abdeckung (11-2) wird nicht benötigt.

**11.** Installieren Sie die Abdeckung (11-1) mit der in Schritt 9 entfernten Schrauben (10).

**9.** Togliere la vite (10). Rimuovere il coperchio posteriore (11).

**10.** Separare il coperchio posteriore (11) in due coperchi (11-1,11-2).  
Il coperchio (11-2) non viene utilizzato.

**11.** Installare il coperchio (11-1) utilizzando la vite (10) rimossa nel passo 9.

**9.** 取下螺丝 (10)。取下后盖板 (11)。

**10.** 将后盖板 (11) 分成 2 个盖板 (11-1, 11-2)。不需要盖板 (11-2)。

**11.** 使用在步骤 9 中取下的螺丝 (10) 来安装盖板 (11-1)。

**9.** 나사 (10) 를 제거합니다 . 후면 커버 (11) 를 제거합니다 .

**10.** 후면 커버 (11) 를 2 개의 커버 (11-1, 11-2) 로 분리합니다 .  
커버 (11-2) 는 사용되지 않습니다 .

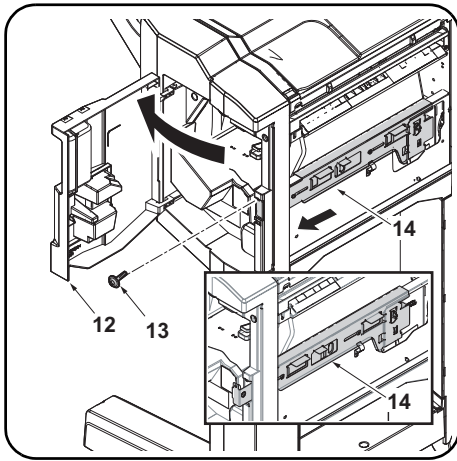
**11.** 순서 9 에서 뺀 나사 (10) 를 사용하여 커버 (11-1) 를 장착합니다 .

**9.** ビス (10) を外す。後カバー (11) を取り外す。

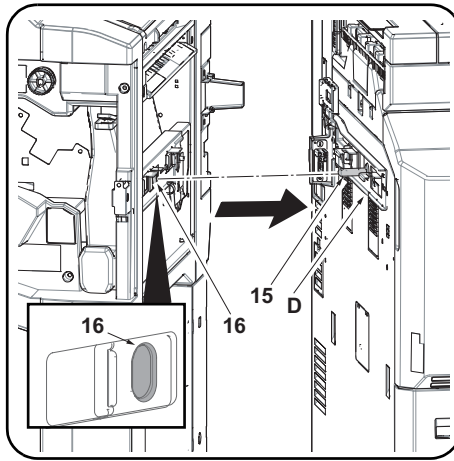
**10.** 後カバー (11) を 2 つのカバー (11-1, 11-2) に分ける。  
カバー (11-2) は不要。

**11.** 手順 9 で外したビス (10) でカバー (11-1) を取り付けます。

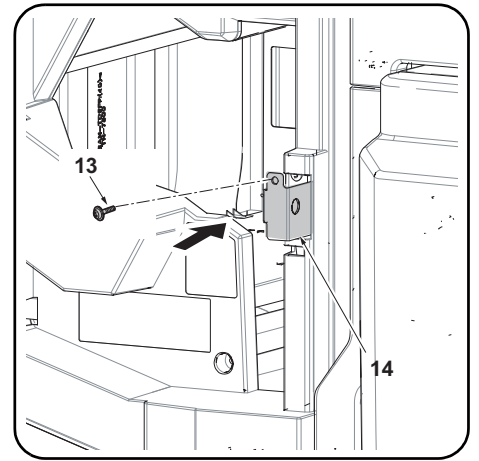




**12.** Open the document finisher front cover (12). Remove the screw (13). Pull the lock frame (14) frontwards.



**13.** Insert the pin (15) on the connecting plate (D) into the hole (16) on the document finisher. Connect the document finisher to the machine.  
\* If the document finisher doesn't comply with the reference of the height as described on page 14, adjust the height.



**14.** Slowly push the lock frame (14) fully into the machine so that the connectors at the far end are connected.  
**15.** Secure the lock frame (14) using the screw (13) removed in step 12.

**12.** Ouvrir le capot avant du finisseur de document (12). Retirez la vis (13). Tirer le cadre de verrouillage (14) vers le bas.

**13.** Introduire l'ergot (15) sur la plaque de connexion (D) dans le trou (16) sur le finisseur de document. Connecter le finisseur de document sur la machine.  
\* Si le finisseur de document n'est pas conforme à la référence de hauteur comme décrit à la page 14, ajustez la hauteur.

**14.** Pousser doucement le cadre de verrouillage (14) à fond dans la machine de sorte que les connecteurs à l'extrémité soient raccordés.  
**15.** Fixez le bâti de verrouillage (14) à l'aide de la vis (13) déposée à l'étape 12.

**12.** Abra la cubierta frontal del finalizador de documentos (12). Quite el tornillo (13). Empuje el marco de cierre (14) hacia delante.

**13.** Inserte la clavija (15) de la placa de conexión (D) en el orificio (16) del finalizador de documentos. Conecte el finalizador de documentos a la máquina.  
\* Si el finalizador de documentos no cumple con la referencia de altura como se describe en la página 14, ajuste la altura.

**14.** Empuje lentamente y hasta el fondo el marco del cierre (14) hacia la máquina de modo que se conecten los conectores en el extremo más lejano.  
**15.** Asegure la carcasa de bloqueo (14) por medio del tornillo (13) quitado en el paso 12.

**12.** Öffnen Sie die vordere Abdeckung des Finishers (12). Entfernen Sie die Schraube (13). Ziehen Sie die Verriegelung (14) nach vorne.

**13.** Setzen Sie den Stift (15) der Verbindungssplatte (D) in die Öffnung (16) des Finishers. Verbinden Sie den Finisher mit dem Gerät.  
\* Falls die Höhe des Finishers nicht mit der auf Seite 14 in der Referenz beschriebenen Höhe übereinstimmt, justieren Sie die Höhe.

**14.** Schieben Sie die Verriegelung (14) wieder langsam ins Gerät, so dass die Verbindungen am anderen Ende des Geräts geschlossen werden.  
**15.** Befestigen Sie den Fixierahmen (14) mit der in Schritt 12 entfernten Schraube (13).

**12.** Aprire il coperchio frontale del finisher documenti (12). Togliere la vite (13). Tirare in avanti la frame di blocco (14).

**13.** Inserire il perno (15) della piastra di connessione (D) nel foro (16) del finisher documenti. Collegare il finisher documenti alla macchina.  
\* Se il finisher documenti non è conforme con il riferimento altezza come descritto a pagina 14, regolare l'altezza.

**14.** Spingere lentamente la frame di blocco (14) nella macchina in modo che i connettori all'estremità risultino collegati.  
**15.** Fissare il telaio di bloccaggio (14) utilizzando la vite (13) rimossa nel passo 12.

**12.** 打开装订器的前盖板(12)。取下螺丝(13)。向身体前侧拉出固定架(14)。

**13.** 将连接板(D)的销钉(15)插入装订器的孔(16)中。把装订器连接到机器本体。  
※若不符合P14的【高度调整】的基准时,执行【高度调整】。

**14.** 慢慢的把固定架(14)完全推入机器,这样机器里侧的接插件就可以顺利连接。  
**15.** 使用步骤12中取下的1颗螺丝(13)来固定锁框(14)。

**12.** 도큐먼트 피니셔의 상단 프론트 커버(12)를 엽니다. 나사(13)를 제거합니다. 잠금 프레임(14)을 앞으로 뺍니다.

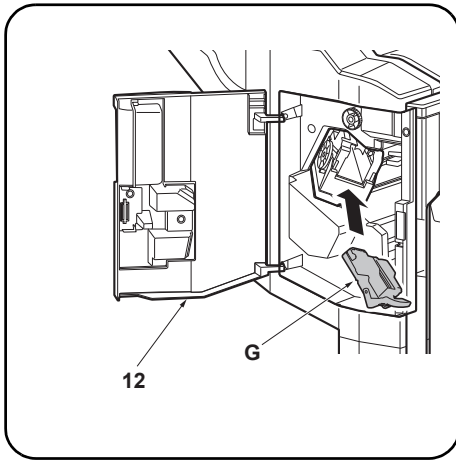
**13.** 연결판(D)의 핀(15)을 도큐먼트 피니셔의 구멍(16)에 삽입합니다. 도큐먼트 피니셔를 본체에 연결합니다.  
\* 연결할 도큐먼트 피니셔가 14 페이지에 설명된 높이 기준에 부합하지 않으면 높이를 조정하십시오.

**14.** 본체 뒷쪽의 커넥터가 연결되도록 잠금 프레임(14)을 본체 안으로 천천히 밀어 넣습니다.  
**15.** 스텝 12에서 뺀 나사(13) 1개로 잠금 프레임(14)을 고정합니다.

**12.** ドキュメントフィニッシャーの前カバー(12)を開く。ビス(13)を外す。ロックフレーム(14)を手前に引く。

**13.** 連結板(D)のピン(15)をドキュメントフィニッシャーの穴(16)に挿入する。ドキュメントフィニッシャーを機械本体に接続する。  
※P14の「高さ調整」の基準に適合しない場合は、「高さ調整」を行う。

**14.** 機械奥側のコネクタが接続されるように、ロックフレーム(14)をゆっくり奥に押す。  
**15.** 手順12で外したビス(13)で、ロックフレーム(14)を固定する。



- 16.** Install the staple cartridge (G).  
**17.** Close the front cover (12).

Proceed to adjusting the stapling position on page 18.

- 16.** Installer la cartouche d'agrafes (G).  
**17.** Refermer le capot avant (12).

Passez à l'ajustement de la position d'agrafage page 18.

- 16.** Instale el cartucho de grapas (G).  
**17.** Cierre la cubierta frontal (12).

Proceda al ajuste de la posición de grapado en la página 18.

- 16.** Installieren Sie das Heftklammer-Magazin (G).  
**17.** Schließen Sie die vordere Abdeckung (12).

Fahren Sie mit der Justage der Heftposition auf Seite 18 fort.

- 16.** Installare il contenitore punti (G).  
**17.** Chiudere il pannello anteriore (12).

Proseguire con la regolazione della posizione di pinzatura a pagina 18.

- 16.** 安装装订针盒 (G)。  
**17.** 关闭前盖板 (12)。

跳至 P18「调节装订位置」。

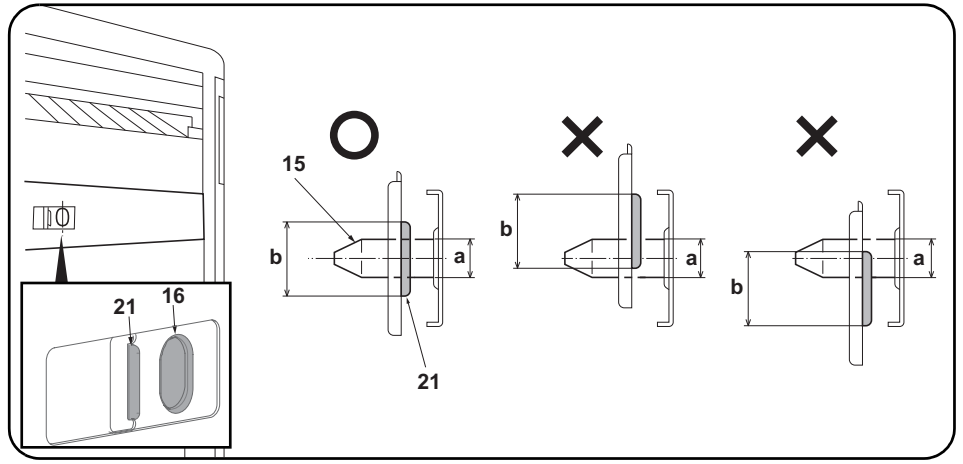
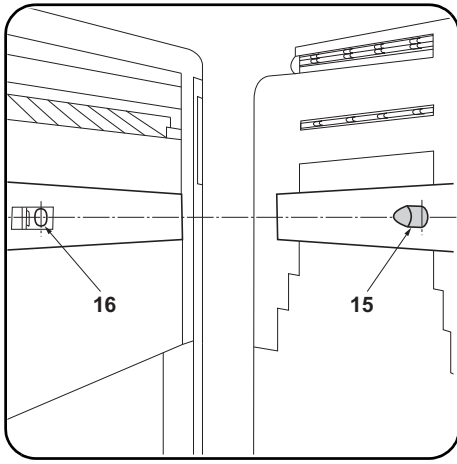
- 16.** 스테이플 카트리지를 (G) 를 설치합니다 .  
**17.** 상단 프론트 커버 (12) 를 닫습니다 .

18 페이지의 스테이플 위치 조정을 진행합니다 .

- 16.** ステープルカートリッジ (G) を取り付ける。  
**17.** 前カバー (12) を閉じる。

P18「ステープル位置の調整」に進む。





### Adjusting the height

1. Check that the respective heights of the pins (15) on the connecting plate installed on the machine and the connecting holes (16) on the document finisher comply with the standards below.

Compliant: The diameter (a) of the pin (15) is within the height range (b) of the curved section (21).  
 Non-compliant: The diameter (a) of the pin (15) extends beyond the height range (b) of the curved section (21).  
 If the heights are non-compliant, use the procedure below to adjust the height.

### Réglage de la hauteur

1. Vérifiez que les hauteurs respectives des ergots (15) sur la plaque de connexion installée sur la machine et les trous de connexion (16) sur le finisseur de document sont conformes aux références ci-dessous.

Bon : Le diamètre (a) de l'ergot (15) est dans les limites de hauteur (b) de la partie courbée (21).  
 Mauvais : Le diamètre (a) de l'ergot (15) dépasse les limites de hauteur (b) de la partie courbée (21).  
 Si la hauteur n'est pas conforme, l'ajuster en procédant comme indiqué ci-dessous.

### Ajuste de la altura

1. Compruebe que las alturas correspondientes de las clavijas (15) de la placa de fijación instaladas en la máquina y los orificios de conexión (16) del finalizador de documentos cumplen las referencias de abajo.

Cumple: el diámetro (a) de la clavija (15) está dentro del rango de altura (b) de la sección curvada (21).  
 No cumple: el diámetro (a) de la clavija (15) sobrepasa el rango de altura (b) de la sección curvada (21).  
 Si las alturas no cumplen con las especificaciones, utilice el siguiente procedimiento para ajustar la altura.

### Einstellen der Höhe

1. Überprüfen Sie, dass die jeweilige Höhe der Stifte (15) der am Gerät installierten Verbindungsplatte und Verbindungsöffnungen (16) des Finishers mit den unten angegebenen Werten übereinstimmen.

Korrekt: Der Durchmesser (a) des Stifts (15) befindet sich im Höhenbereich (b) des Kurvenabschnitts (21).  
 Nicht korrekt: Der Durchmesser (a) des Stifts (15) ragt über den Höhenbereich (b) des Kurvenabschnitts (21) hinaus.  
 Falls die Höhen nicht korrekt sind, müssen Sie sie wie folgend einstellen.

### Regolazione dell'altezza

1. Controllare che le rispettive altezze dei perni (15) sulla piastra di connessione installata sulla macchina e i fori di connessione (16) sulla finisher documenti corrispondano ai riferimenti mostrati sotto.

Conformità: Il diametro (a) del perno (15) è compreso nella gamma di altezza (b) della sezione curvata (21).  
 Non conformità: Il diametro (a) del perno (15) si estende oltre la gamma di altezza (b) della sezione curvata (21).  
 Se le altezze sono non corrispondenti, utilizzare la procedura riportata sotto per regolare l'altezza.

### 高度调节

1. 确认机器主机上安装的连接板的销钉 (15) 和装订器的连接用的孔 (16) 的高度是否符合以下标准。

符合: 销钉 (15) 的直径 a 在弯曲部 (21) 的高度 b 的范围内。  
 不符合: 销钉 (15) 的直径 a 超出了弯曲部 (21) 的高度 b 的范围。  
 不符合时, 通过以下步骤进行调节。

### 높이조절

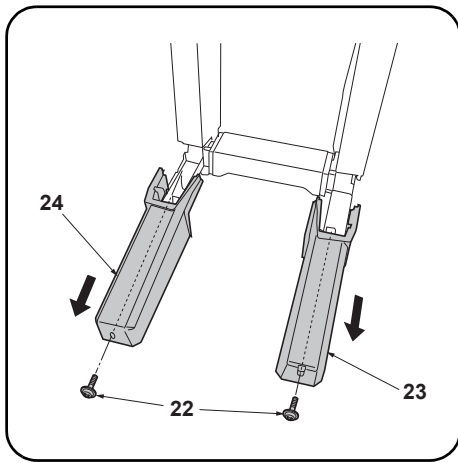
1. 본체에 설치된 연결판의 핀 (15) 과 도큐먼트 피니셔의 연결용 구멍 (16) 의 각 높이가 아래의 기준에 부합하는지 확인합니다.

적합 : 핀 (15) 의 직경 a 가 곡선부 (21) 의 높이 b 의 범위에 들어간다.  
 부적합: 핀 (15) 의 직경 a 가 곡선부 (21) 의 높이 b 의 범위를 넘는다.  
 부적합의 경우에는 이하의 순서대로 조정합니다.

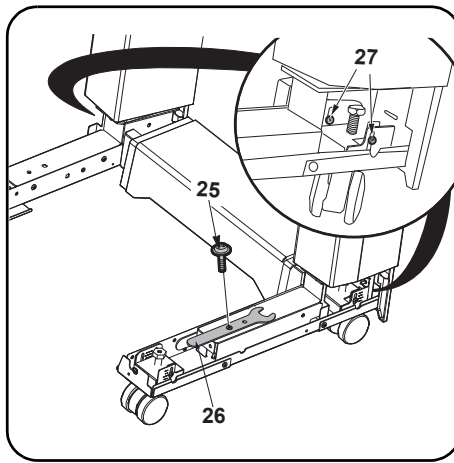
### 高さ調整

1. 機械本体に取り付けた連結板のピン (15) とドキュメントフィニッシャーの連結用の穴 (16) の高さが以下の基準に適合するか確認する。

適合: ピン (15) の直径 (a) が曲げ部 (21) の高さ (b) の範囲に収まっている。  
 不適合: ピン (15) の直径 (a) が曲げ部 (21) の高さ (b) の範囲からはみだしている。  
 不適合の場合は、以下の手順で調整する。



2. Remove each of the screws (22) and remove the front foot cover (23) and rear foot cover (24).



3. Remove the screw (25) to remove the spanner (26).  
4. Loosen the 2 screws (27) on the front right and on the rear right of the document finisher.

2. Déposer toutes les vis (22) puis le capot du pied avant (23) et le capot du pied arrière (24).

3. Déposer la vis (25) pour libérer la clé (26).  
4. Desserrer les 2 vis (27) du côté avant droit et arrière droit du finisseur de document.

2. Quite cada uno de los tornillos (22) y quite la cubierta de la pata frontal (23) y la cubierta de la pata posterior (24).

3. Quite el tornillo (25) para extraer la llave inglesa (26).  
4. Afloje los 2 tornillos (27) en los lados derecho frontal y derecho posterior del finalizador de documentos.

2. Entfernen Sie sämtliche Schrauben (22) und nehmen Sie die Vorderfußabdeckung (23) und die Hinterfußabdeckung (24).

3. Entfernen Sie die Schraube (25), um den Schlüssel (26) abzunehmen  
4. Lösen Sie die 2 Schrauben (27) vorne rechts und hinten rechts am Finisher.

2. Rimuovere ciascuna delle viti (22) e quindi rimuovere la copertura del piede anteriore (23) e la copertura del piede posteriore (24).

3. Rimuovere la vite (25) per rimuovere la chiave (26).  
4. Allentare le 2 viti (27) sulla parte anteriore destra e posteriore destra della finisher documenti.

2. 拆除各 1 顆螺丝 (22), 取下前脚座盖板 (23)、后脚座盖板 (24)。

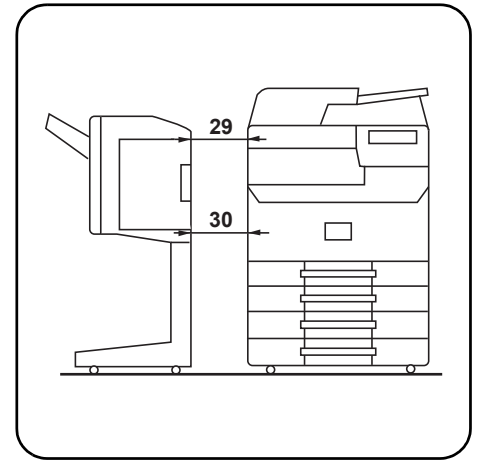
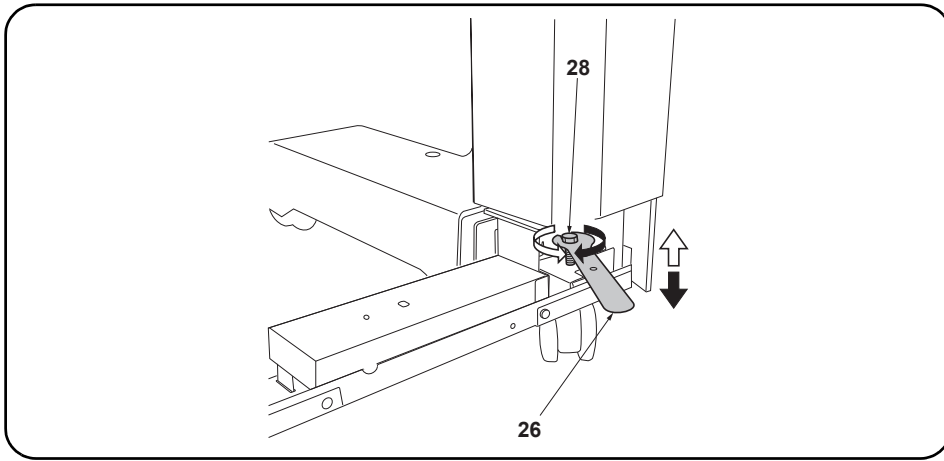
3. 取下螺丝 (25) 以便拆下扳手 (26)。  
4. 拧松装订器右前侧与右后侧的各 2 顆螺丝 (27)。

2. 나사 (22) 각 1 개를 빼고 풋커버 앞 (23), 풋커버 뒤 (24) 를 뺍니다 .

3. 나사 (25) 1 개를 빼고 , 스패너 (26) 를 떼어 냅니다 .  
4. 도큐먼트 피니셔 우측 앞과 뒤의 나사 (27) 각 2 개를 느슨하게 합니다 .

2. ビス (22) 各 1 本を外し、フットカバー前 (23)、フットカバー後 (24) を取り外す。

3. ビス (25) 1 本を外し、スパナー (26) を取り外す。  
4. ドキュメントフィニッシャー右前と右後のビス (27) 各 2 本を緩める。



5. Turn the adjustment bolts (28) with the spanner (26) to adjust the height of the document finisher. Turning the adjustment bolt clockwise lifts the document finisher, and turning it counterclockwise lowers the document finisher.
6. Retighten each of the 2 screws (27) and replace the spanner (26).

7. If the distances between the document finisher and the machine (29, 30) are unequal, use the procedure below to adjust the spacing.

5. Faire tourner les boulons de réglage (28) avec la clé (26) pour ajuster la hauteur du finisseur de document. Tourner le boulon de réglage dans le sens horloger pour lever le finisseur de document, et dans le sens contraire au sens horloger pour le descendre.
6. Resserrer les 2 vis (27) et repositionner la clé (26) au même endroit.

7. Si les distances entre le finisseur de document et la machine (29, 30) sont inégales, régler l'espacement en procédant de la manière suivante.

5. Gire los pernos de ajuste (28) con la llave inglesa (26) para ajustar la altura del finalizador de documentos. Al girar el perno de ajuste en la dirección de las manecillas del reloj se levanta el finalizador de documentos y al girar en sentido contrario a las manecillas del reloj baja el finalizador de documentos.
6. Vuelva a apretar los 2 tornillos (27) y coloque la llave inglesa en su lugar (26).

7. Si las distancias entre el finalizador de documentos y la máquina (29, 30) no son iguales, utilice el siguiente procedimiento para ajustar la separación.

5. Drehen Sie die Einstellschrauben (28) mit dem Schlüssel (26), um die Höhe des Finishers einzustellen. Durch Drehen der Einstellschraube im Uhrzeigersinn wird der Finisher angehoben, während er durch Drehen entgegen dem Uhrzeigersinn abgesenkt wird.
6. Ziehen Sie die 2 Schrauben (27) wieder an und verstauen Sie den Schlüssel (26) wieder.

7. Falls die Abstände zwischen dem Finisher und dem Gerät (29, 30) ungleich sind, führen Sie die unten angegebenen Schritte aus, um den Abstand zu korrigieren.

5. Ruotare i bulloni di regolazione (28) con la chiave (26) per regolare l'altezza della finisher documenti. Ruotando il bullone di regolazione in senso orario si solleva la finisher documenti, mentre ruotandolo in senso antiorario si abbassa la finisher documenti.
6. Ristringere ciascuna delle 2 viti (27) e riporre la chiave (26).

7. Se le distanze tra la finisher documenti e la macchina (29, 30) sono diverse, attenersi alla sottostante procedura per regolare la spaziatura.

5. 使用扳手 (26) 旋转调节螺栓 (28), 以调节装订器的高度。将调节螺栓向顺时针方向旋转, 装订器的高度升高, 逆时针方向旋转则装订器的高度降低。
6. 拧紧各 2 颗螺丝 (27), 按原样安装扳手 (26)。

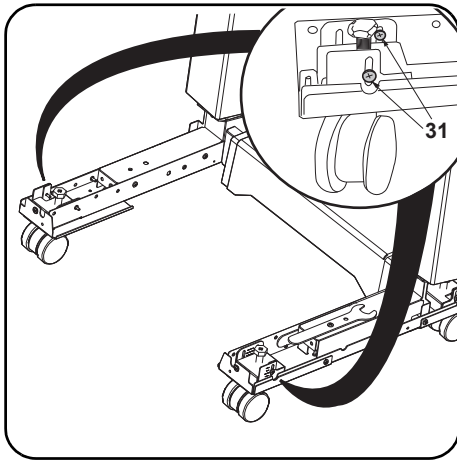
7. 装订器与机器的间隙 (29、30) 不等时, 按以下步骤进行调节。

5. 스패너 (26) 로 조정 볼트 (28) 를 돌려 도큐먼트 피니셔의 높이를 조정한다. 조정 볼트를 시계방향으로 돌리면 도큐먼트 피니셔의 높이가 높아지고, 반 시계방향으로 돌리면 낮아 집니다.
6. 나사 (27) 각 2 개를 조이고 스패너 (26) 를 원래 자리에 장착합니다.

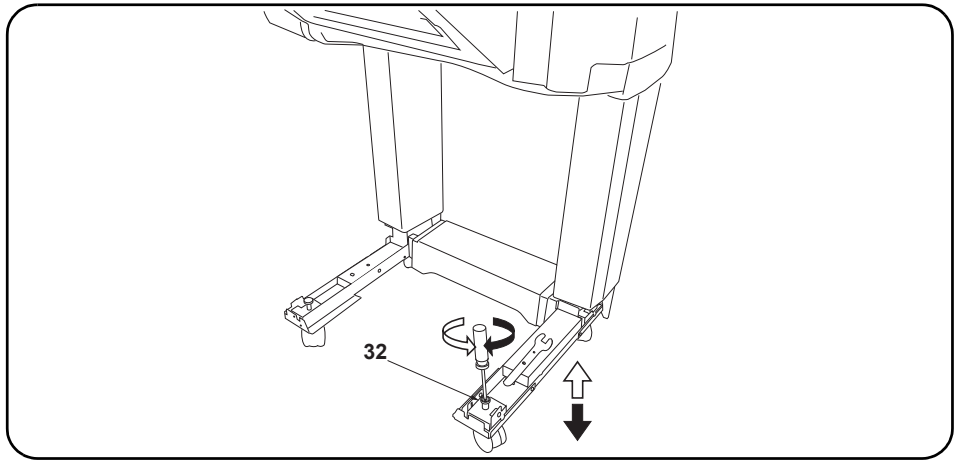
7. 도큐먼트 피니셔와 본체의 거리 (29, 30) 가 동일하지 않는 경우 아래의 절차에 따라 간격을 조정합니다.

5. スパナー (26) で調整ボルト (28) を回し、ドキュメントフィニッシャーの高さを調整する。調整ボルトを時計方向に回すとドキュメントフィニッシャーの高さが高くなり、反時計方向に回すと低くなる。
6. ビス (27) 各 2 本を締め付け、スパナー (26) を元通り取り付ける。

7. ドキュメントフィニッシャーと機械本体の間隔 (29, 30) が等しくない場合は、以下の手順で調整を行う。



8. Loosen the 2 screws (31) on the front left and on the rear left of the document finisher.



9. Turn the adjustment bolts (32) with a Philips-head screwdriver to adjust the height of the document finisher.  
Turning the adjustment bolt clockwise lifts the document finisher, and turning it counterclockwise lowers the document finisher.

10. Retighten each of the 2 screws (31).

11. Replace the front foot cover (23) and rear foot cover (24).

8. Desserrer les 2 vis (31) du côté avant gauche et arrière gauche du finisseur de document.

9. Faire tourner les boulons de réglage (32) à l'aide d'un tournevis cruciforme pour ajuster la hauteur du finisseur de document.  
Tourner le boulon de réglage dans le sens horloger pour lever le finisseur de document, et dans le sens contraire au sens horloger pour le descendre.

10. Resserrer les 2 vis (31).

11. Reposer le capot du pied avant (23) et le capot du pied arrière (24).

8. Afloje los 2 tornillos (31) en los lados izquierdo frontal e izquierdo posterior del finalizador de documentos.

9. Gire los pernos de ajuste (32) con un destornillador de cabeza Philips para ajustar la altura del finalizador de documentos.  
Al girar el perno de ajuste en la dirección de las manecillas del reloj se levanta el finalizador de documentos y al girar en sentido contrario a las manecillas del reloj baja el finalizador de documentos.

10. Vuelva a apretar los 2 tornillos (31).

11. Vuelva a colocar la cubierta de la pata frontal (23) y la cubierta de la pata posterior (24).

8. Lösen Sie die 2 Schrauben (31) vorne links und hinten links am Finisher.

9. Stellen Sie die Einstellschrauben (32) mit einem Kreuzschlitzschraubendreher ein, um die Höhe des Finishers zu korrigieren.  
Durch Drehen der Einstellschraube im Uhrzeigersinn wird der Finisher angehoben, während er durch Drehen entgegen dem Uhrzeigersinn abgesenkt wird.

10. Ziehen Sie die 2 Schrauben (31) nach.

11. Setzen Sie die Vorderfußabdeckung (23) und die Hinterfußabdeckung (24) wieder ein.

8. Allentare le 2 viti (31) sulla parte anteriore sinistra e posteriore sinistra della finisher documenti.

9. Ruotare i bulloni di regolazione (32) con un cacciavite con testa a croce tipo Philips per regolare l'altezza della finisher documenti.  
Ruotando il bullone di regolazione in senso orario si solleva la finisher documenti, mentre ruotandolo in senso antiorario si abbassa la finisher documenti.

10. Ristringere ciascuna delle 2 viti (31).

11. Ricollocare la copertura del piede anteriore (23) e la copertura del piede posteriore (24).

8. 拧松装订器左前侧与左后侧的各 2 颗螺丝 (31)。

9. 使用十字螺丝刀旋转调节螺栓 (32)，以调节装订器的高度。  
将调节螺栓向顺时针方向旋转，装订器的高度升高，逆时针方向旋转则装订器的高度降低。

10. 拧紧各 2 颗螺丝 (31)。

11. 将前脚座盖板 (23)、后脚座盖板 (24) 按原样安装

8. 도큐먼트 피니셔 좌측 앞과 뒤의 나사 (31) 각 2 개를 느슨하게 합니다 .

9. 플러스 드라이버로 조정 볼트 (32) 를 돌려 도큐먼트 피니셔 높이를 조정합니다 .  
조정 볼트를 시계방향으로 돌리면 도큐먼트 피니셔의 높이가 높아지고, 반 시계방향으로 돌리면 낮아 집니다 .

10. 나사 (31) 각 2 개를 조입니다 .

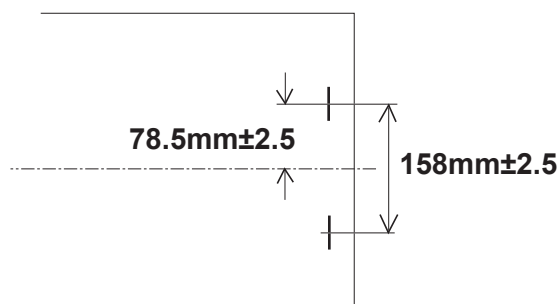
11. 풋커버 앞 (23), 풋커버 뒤 (24) 를 원래대로 장착합니다 .

8. ドキュメントフィニッシャー左前と左後のビス (31) 各 2 本を緩める。

9. プラスドライバーで調整ボルト (32) を回し、ドキュメントフィニッシャーの高さを調整する。  
調整ボルトを時計方向に回すとドキュメントフィニッシャーの高さが高くなり、反時計方向に回すと低くなる。

10. ビス (31) 各 2 本を締め付ける。

11. フットカバー前 (23)、フットカバー後 (24) を元通りに取り付ける。



### Adjusting the stapling position

1. Connect the machine power plug to the wall outlet and turn the machine main power switch on.
2. Make a test copy using staple mode (double stapled).
3. Check whether the stapling position is off-center. If the staple position is off-center, follow the procedure below to adjust the position.  
<Reference value> 78.5 mm  $\pm$ 2.5 mm from the center of the paper

### Ajustement de la position d'agrafage

1. Insérer la fiche d'alimentation de la machine dans la prise murale et mettre la machine sous tension.
2. Procéder à une copie d'essai en mode agrafage (double agrafage).
3. Vérifier que la position d'agrafage n'est pas en décalage. Si la position d'agrafage est décalée, la régler en procédant de la manière suivante.  
<Valeur de référence> 78,5 mm  $\pm$ 2,5 mm depuis le milieu de la feuille de papier.

### Ajuste de la posición de grapado

1. Conecte el enchufe de la máquina al receptáculo de pared y encienda el interruptor principal de la máquina.
2. Haga una copia de prueba en el modo de grapado (grapado doble).
3. Compruebe si la posición de grapado está descentrada. Si la posición de grapado está descentrada, realice el siguiente procedimiento para ajustar la posición.  
<Valor de referencia> 78,5 mm  $\pm$  2,5 mm del centro del papel

### Justage der Heftposition

1. Stecken Sie den Netzstecker des Geräts in die Wandsteckdose und schalten Sie das Gerät am Gauptschalter ein.
2. Erstellen Sie eine Probekopie im Heftmodus (doppelt geheftet).
3. Prüfen Sie, ob die Heftposition außermittig ist. Falls die Heftposition außermittig ist, müssen Sie sie wie folgend einstellen.  
<Bezugswert> 78,5 mm  $\pm$ 2,5 mm von der Blattmitte

### Regolazione della posizione di pinzatura

1. Collegare la spina alla presa di corrente a muro e accendere l'interruttore di alimentazione della macchina.
2. Eseguire una copia di prova utilizzando la modalità di spillatura con punti metallici (spillatura doppia).
3. Verificare che la posizione di spillatura non sia fuori centro. Se la posizione di spillatura è fuori centro, seguire la procedura riportata sotto per regolare la posizione.  
<Valore di riferimento> 78,5 mm  $\pm$  2,5 mm dal centro del foglio

### 调节装订位置

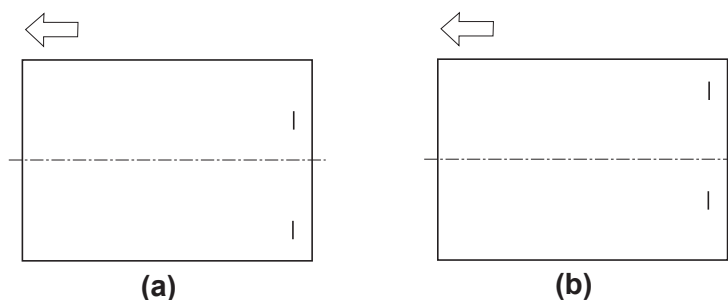
1. 将机器上的电源插头插入电源插座中，打开主电源开关。
2. 在装订模式（2点固定）下进行测试复印。
3. 确认装订位置的偏差。装订位置偏离中心时，按以下步骤进行调节。  
<基准值> 距离纸张中心 78.5mm  $\pm$  2.5mm

### 스태이플 위치 조정

1. 본체 전원플러그를 콘센트에 꽂고 주 전원 스위치를 ON 으로 합니다.
2. 스타이플 모드 (2 점) 에서 시험복사를 합니다.
3. 스타이플 위치의 센터 어긋남을 확인합니다. 스타이플 위치가 중심에서 벗어난 경우다음 순서로 조정을 합니다.  
<기준치> 용지 센터에서 78.5mm  $\pm$  2.5mm

### ステーブル位置の調整

1. 機械本体の電源プラグをコンセントに差し込み、主電源スイッチをONにする。
2. ステーブルモード(2箇所止め)でテストコピーを行う。
3. ステーブル位置のセンターずれを確認する。ステーブル位置が中心からずれていた場合、次の手順で調整を行う。  
<基準値> 用紙センターより 78.5mm  $\pm$  2.5mm



4. Set maintenance mode U246, select [Finisher] and [Staple HP].  
 5. Adjust the values.  
 If the paper is stapled too close to the front of the machine (a): Increase the setting value.  
 If the paper is stapled too close to the rear of the machine (b): Decrease the setting value.

6. Perform a test copy.  
 7. Repeat steps 4 to 6 until the staple position is within the reference value.  
 <Reference value> 78.5 mm  $\pm$ 2.5 mm from the center of the paper

4. Passer en mode maintenance U246, sélectionner [Finisher] et [Staple HP].  
 5. Régler les valeurs.  
 Si le papier est agrafé trop près de l'avant de la machine (a): augmenter la valeur de réglage.  
 Si le papier est agrafé trop près de l'arrière de la machine (b): réduire la valeur de réglage.

6. Effectuer une copie de test.  
 7. Recommencer les étapes 4 à 6 jusqu'à ce que la position d'agrafe soit conforme à la valeur de référence  
 <Valeur de référence> 78,5 mm  $\pm$ 2,5 mm depuis le milieu de la feuille de papier.

4. Entre en el modo de mantenimiento U246, seleccione [Finisher] y [Staple HP].  
 5. Ajuste los valores.  
 Si el grapado del papel se encuentra demasiado cerca del frente de la máquina (a): aumente el valor de configuración.  
 Si el grapado del papel se encuentra demasiado cerca de la parte posterior de la máquina (b): disminuya el valor de configuración.

6. Haga una copia de prueba.  
 7. Repita los pasos 4 a 6 hasta que la posición de grapado se encuentre dentro del valor de referencia.  
 <Valor de referencia> 78,5 mm  $\pm$  2,5 mm del centro del pape

4. Schalten Sie in den Wartungsmodus U246, wählen Sie [Finisher] und [Staple HP].  
 5. Die Werte einstellen.  
 Falls das Papier zu nahe am vorderen Rand des Geräts (a) abgestapelt wird: Vergrößern Sie den Stellwert.  
 Falls das Papier zu nahe am hinteren Rand des Geräts (b) abgestapelt wird: Verkleinern Sie den Stellwert.

6. Eine Testkopie erstellen.  
 7. Wiederholen Sie die Schritte 4 bis 6, bis die Heftposition im Bereich des Bezugswerts liegt.  
 <Bezugswert> 78,5 mm  $\pm$ 2,5 mm von der Blattmitte

4. Impostare la modalità manutenzione U246, selezionare [Finisher] e [Staple HP].  
 5. Regolare i valori.  
 Se il foglio viene spillato troppo vicino alla parte anteriore della macchina (a): Aumentare il valore di impostazione.  
 Se il foglio viene spillato troppo vicino alla parte posteriore della macchina (b): Diminuire il valore di impostazione.

6. Eseguire una copia di prova.  
 7. Ripetere i passi 4 to 6 finché la posizione di spillatura risulta all'interno del valore di riferimento.  
 <Valore di riferimento> 78,5 mm  $\pm$  2,5 mm dal centro del foglio

4. 设置维护模式 U246, 选择 [Finisher]、[Staple HP]。  
 5. 调整设定值。  
 装订位置向机器前部偏移时 (a): 调高设定值。  
 装订位置向机器后部偏移时 (b): 调低设定值。

6. 进行测试复印。  
 7. 重复步骤 4 ~ 6, 直到装订位置在基准范围内为止。  
 <基准值> 距离纸张中心 78.5mm  $\pm$  2.5mm

4. 메인テナンス 모드 U246 을 세트하고 [Finisher], [Staple HP] 를 선택합니다.  
 5. 설정치를 조정합니다.  
 스테이플 위치가 기기앞측으로 벗어난 경우 (a): 설정치를 높입니다.  
 스테이플 위치가 기기뒷측으로 벗어난 경우 (b): 설정치를 내입니다.

6. 시험복사를 합니다.  
 7. 스테이플 위치가 기준치내가 될 때까지 순서 4 ~ 6 을 반복합니다.  
 <기준치> 용지 센터에서 78.5mm  $\pm$  2.5mm

4. メンテナンスモード U246 をセットし、[Finisher]、[Staple HP] を選択する。  
 5. 設定値を調整する。  
 ステープル位置が機械前側にずれている場合 (a): 設定値を上げる。  
 ステープル位置が機械後側にずれている場合 (b): 設定値を下げる。

6. テストコピーを行う。  
 7. ステープル位置が基準値内になるまで、手順 4 ~ 6 を繰り返す。  
 <基準値> 用紙センターより 78.5mm  $\pm$  2.5mm

**MEMO**







303NC5676001

2013. 7  
303NC56760-01

# **INSTALLATION GUIDE FOR 4000-SHEETS FINISHER**

---

**INSTALLATION GUIDE**

**GUIDE D'INSTALLATION**

**GUÍA DE INSTALACION**

**INSTALLATIONSANLEITUNG**

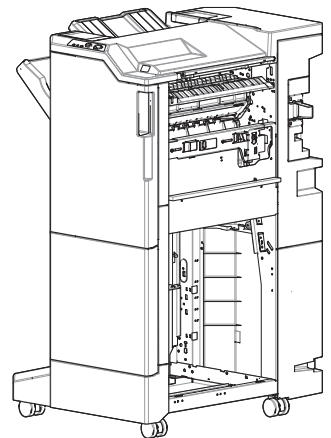
**GUIDA ALL'INSTALLAZIONE**

**安装手册**

**설치안내서**

**設置手順書**

**DF-790(C)**



**English** A different procedure is required depending on the product which is installed with this unit. Each procedure is described in the following pages. For installation with a MFP, see Page 1 to Page 7.  
For installation with a Printer, see Page 8 to Page 14.  
References to medium-speed MFPs in this document denote 30/30, 35/35, 45/45 and 55/50 ppm color machines, and 35, 45 and 55 ppm monochrome machines.  
References to high-speed MFPs in this document denote 65/65 and 75/70 ppm color machines, and 65 and 80 ppm monochrome machines.

**Français** Une procédure différente est requise selon le produit qui est installé avec cette unité. Chaque procédure est décrite dans les pages suivantes. Pour l'installation avec une imprimante multifonction, voir Page 1 à Page 7.  
Pour l'installation avec une imprimante, voir Page 8 à Page 14.  
Dans le présent document, les références aux MFP à vitesse moyenne renvoient aux machines couleurs 30/30, 35/35, 45/45 et 55/50 ppm et aux machines monochromes 35, 45 et 55 ppm.  
Dans le présent document, les références aux MFP à grande vitesse renvoient aux machines couleurs 65/65 et 75/70 ppm et aux machines monochromes 65 et 80 ppm.

**Español** El procedimiento es diferente según el producto que se instale con esta unidad. En las siguientes páginas, se describe cada procedimiento. Para la instalación con un MFP, consulte las páginas de la 1 a la 7.  
Para la instalación con una impresora, consulte las páginas de la 8 a la 14.  
Las referencias a las MFP de velocidad media de este documento corresponden a las máquinas a color de 30/30, 35/35, 45/45 y 55/50 ppm y a las máquinas monocromáticas de 35, 45 y 55 ppm.  
Las referencias a las MFP de alta velocidad de este documento corresponden a las máquinas a color de 65/65 y 75/70 ppm y a las máquinas

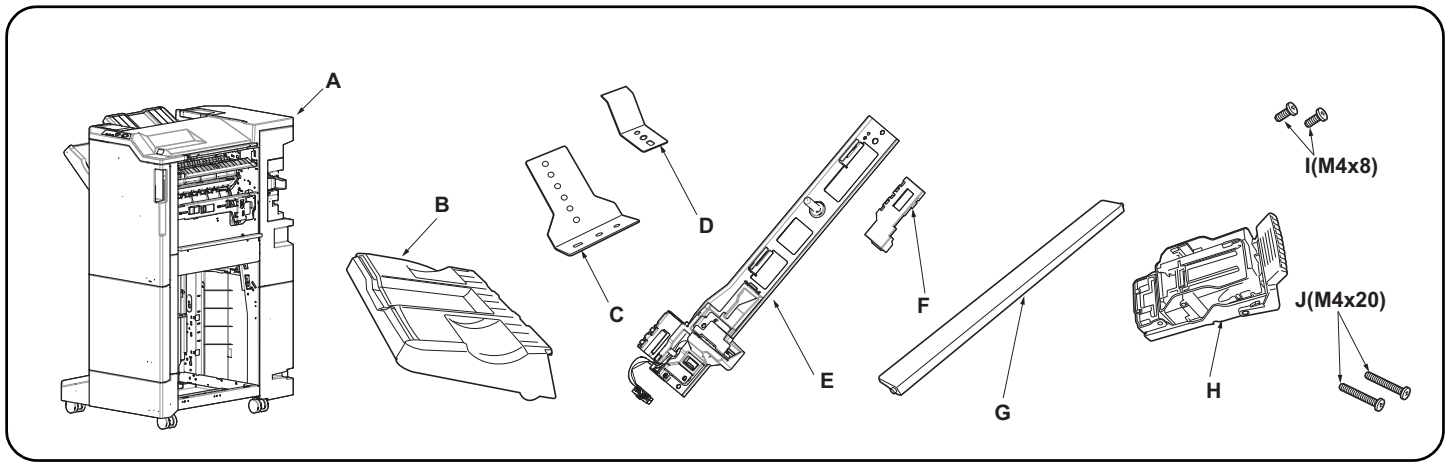
**Deutsch** Je nach verwendetem Modell ist eine andere Vorgehensweise zur Installation dieses Teils erforderlich. Die unterschiedlichen Vorgehensweisen werden auf den folgenden Seiten erläutert.  
Bei Installation an einem Dokumentenfinisher siehe Seiten 1 bis 7.  
Bei Installation an einem Drucker siehe Seiten 8 bis 14.  
Angaben für MFP der mittleren Leistungsklasse in dieser Anleitung gelten für die 30/30, 35/35, 45/45 und 55/50 ppm Vollfarbentkopierer sowie für die 35, 45 und 55 ppm Monochrommaschinen.  
Angaben für MFP der Hochleistungsklasse in dieser Anleitung gelten für die 65/65 und 75/70 ppm Vollfarbentkopierer sowie für die 65 und 80 ppm Monochrommaschinen.

**Italiano** Si richiede una procedura diversa in funzione del prodotto su cui è installata l'unità. Le singole procedure sono descritte nelle pagine seguenti. Per l'installazione con un MFP, vedere le pagine da 1 a 7.  
Per l'installazione con una stampante, vedere le pagine da 8 a 14.  
I riferimenti per le MFP a velocità media riportati in questo documento indicano le macchine a colori 30/30, 35/35, 45/45 e 55/50 ppm, e le macchine monocromatiche 35, 45 e 55 ppm.  
I riferimenti per le MFP a velocità alta riportati in questo documento indicano le macchine a colori 65/65 e 75/70 ppm, e le macchine monocromatiche 65 e 80 ppm.

**简体中文** 根据安装对象, 安装步骤略有不同。各个步骤记载在下面的页面。  
安装到 MFP 上时, 请参见 P1-P7。  
安装到打印机上时, 请参见 P8-P14。  
本文中的中速 MFP 代表彩色 30/30 页机型、35/35 页机型、45/45 页机型、55/50 页机型、黑白 35 页机型、45 页机型、55 页机型。  
本文中的高速 MFP 代表彩色 65/65 页机型、75/70 页机型、黑白 65 页机型、80 页机型。

**한국어** 이 장치에 설치되는 제품에 따라 절차가 다릅니다. 다음 페이지에서 각 절차를 설명합니다.  
MFP 에 설치하는 경우 1 페이지 ~7 페이지를 참조하십시오.  
프린터에 설치하는 경우 8 페이지 ~14 페이지를 참조하십시오.  
본문 중 중속 MFP 는 컬러 30/30 매기, 35/35 매기, 45/45 매기, 55/50 매기, 흑백 35 매기, 45 매기, 55 매기를 나타냅니다.  
본문 중 고속 MFP 는 컬러 65/65 매기, 75/70 매기, 흑백 65 매기, 80 매기를 나타냅니다.

**日本語** 装着する対象によって、取付手順は異なります。それぞれ、以下のページに記載しています。  
MFP に設置する場合; 1 ページ ~ 7 ページ  
プリンターに設置する場合; 8 ページ ~ 14 ページ  
本文中の中速 MFP はカラー機の 30/30 枚機、35/35 枚機、45/45 枚機、55/50 枚機、モノクロ機の 35 枚機、45 枚機、55 枚機を表す。  
本文中の高速 MFP はカラー機の 65/65 枚機、75/70 枚機、モノクロ機の 65 枚機、80 枚機を表す。



**Supplied parts**

A. Document finisher.....	1
B. Eject tray.....	1
C. Earth connection plate.....	1
D. Earth spring.....	1
E. Connecting plate.....	1
F. Connector cover.....	1

G. Eject guide.....	1
H. Staple cartridge.....	1
I. M4 x 8 screw.....	2
J. M4 x 20 screw.....	2

Be sure to remove any tape and/or cushioning materials from the parts supplied.

**Pièces fournies**

A. Finisseur de document.....	1
B. Bac d'éjection.....	1
C. Plaque de raccordement de mise à terre.....	1
D. Ressort de mise à la terre.....	1
E. Plaque de connexion.....	1
F. Cache de connecteur.....	1

G. Guide d'éjection.....	1
H. Cartouche d'agrafes.....	1
I. Vis M4 x 8.....	2
J. Vis M4 x 20.....	2

Veillez à retirer les morceaux de bande adhésive et/ou les matériaux de rembourrage des pièces fournies.

**Partes suministradas**

A. Finalizador de documentos.....	1
B. Bandeja de salida.....	1
C. Placa de conexión a tierra.....	1
D. Resorte de conexión a tierra.....	1
E. Placa de conexión.....	1
F. Cubierta del conector.....	1

G. Guía de salida.....	1
H. Cartucho de grapas.....	1
I. Tornillo M4 x 8.....	2
J. Tornillo M4 x 20.....	2

Asegúrese de despegar todas las cintas y/o material amortiguador de las partes suministradas.

**Enthaltene Teile**

A. Finisher.....	1
B. Auswerffach.....	1
C. Grundanschlussplatte.....	1
D. Grundfeder.....	1
E. Verbindungsplatte.....	1
F. Stecker-Abdeckung.....	1

G. Ausgabeführung.....	1
H. Heftklammermagazin.....	1
I. M4 x 8 Schraube.....	2
J. M4 x 20 Schraube.....	2

Stellen Sie sicher, dass sämtliche Klebebänder und/oder Polstermaterial von den gelieferten Teilen entfernt wurden.

**Parti fornite**

A. Finisher documenti.....	1
B. Vassoio di espulsione.....	1
C. Piastra di connessione per messa a terra.....	1
D. Molla di messa a terra.....	1
E. Piastra di connessione.....	1
F. Copri connettore.....	1

G. Guida di espulsione.....	1
H. Contenitore punti.....	1
I. Vite M4 x 8.....	2
J. Vite M4 x 20.....	2

Rimuovere tutti i nastri adesivi e/o i materiali di protezione dalle parti fornite.

**附属品**

A. 装订器.....	1
B. 排纸托盘.....	1
C. 接地安装板.....	1
D. 接地弹簧.....	1
E. 连接板.....	1

F. 接插件盖板.....	1
G. 排纸导向板.....	1
H. 装订针盒.....	1
I. M4x8 螺丝.....	2
J. M4x20 螺丝.....	2

如果附属品上带有固定胶带, 缓冲材料时务必卸下。

**동봉품**

A. 문서 피니셔.....	1
B. 배출 트레이.....	1
C. 접지 부착판.....	1
D. 접지 스프링.....	1
E. 연결판.....	1

F. 커넥터 커버.....	1
G. 배출 가이드.....	1
H. 스테이플 카트리지.....	1
I. 나사 M4x8.....	2
J. 나사 M4x20.....	2

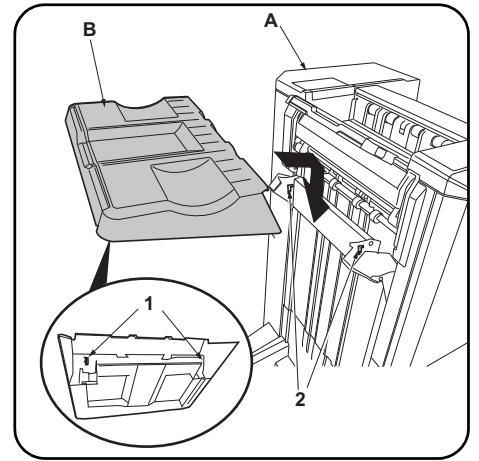
동봉품에 고정 테이프, 완충재가 붙어 있는 경우에는 반드시 제거할 것.

**同梱品**

A. ドキュメントフィニッシャー.....	1
B. 排出トレイ.....	1
C. アース取付板.....	1
D. アースパネ.....	1
E. 連結板.....	1
F. コネクターカバー.....	1

G. 排出ガイド.....	1
H. ステープルカートリッジ.....	1
I. ビス M4x8.....	2
J. ビス M4x20.....	2

同梱品に固定テープ、緩衝材がついている場合は、必ず取り外すこと。



**NOTICE**

When installing on a medium-speed MFP, the Attachment Kit (AK-730 or AK-731) must be installed before the document finisher is installed.

**Procedure**

Before starting installation, be sure to turn the main power switch of the machine off, and unplug the power plug from the wall outlet.

1. Install by inserting the 2 hooks (1) on the back of the eject tray (B) into the holes (2) in the document finisher (A) lift.

**REMARQUE**

Lors de l'installation sur une imprimante multifonction à vitesse moyenne, le kit de fixation (AK-730 ou AK-731) doit être installé avant d'installer le finisseur de document.

**Procédure**

Avant de commencer l'installation, s'assurer de mettre la machine hors tension et de débrancher la fiche d'alimentation de la prise murale.

1. Procéder en insérant les 2 crochets (1) au dos du bac d'éjection (B) dans les trous (2) du dispositif de levage du finisseur de document (A).

**AVISO**

Si se instala en un MFP de velocidad media, el Kit de conexión (AK-730 o AK-731) se debe instalar antes de instalarse el finalizador de documentos.

**Procedimiento**

Antes de iniciar la instalación, asegúrese de apagar el interruptor de encendido de la máquina y desenchufar el cable de alimentación de la toma de pared.

1. Instale insertando los 2 ganchos (1) de la parte posterior de la bandeja de salida (B) en los orificios (2) del elevador del finalizador de documentos (A).

**ANMERKUNG**

Bei der Installation an einem mittelschnellen MFP muss das Attachment-Kit (AK-730 oder AK-731) vor dem Finisher installiert werden.

**Verfahren**

Bevor Sie mit der Installation beginnen überzeugen Sie sich, dass der Netzschalter des Geräts ausgeschaltet und das Stromkabel aus der Steckdose gezogen ist.

1. Setzen Sie die 2 Haken (1) zur Befestigung an der Rückseite des Auswerffachs (B) in die Öffnungen (2) an der Hebeplatte des Finishers (A) ein.

**AVVISO**

Quando si installa un MFP di fascia media, prima di installare il finisher documenti occorre installare l'unità Attachment Kit (AK-730 o AK-731).

**Procedura**

Prima di iniziare l'installazione, spegnere la macchina e scollegare la spina dalla presa di corrente.

1. Installare inserendo i 2 ganci (1) sul retro del vassoio di espulsione (B) nei fori (2) sul sollevatore della finisher documenti (A).

**注意**

安装到中速 MFP 上时, 在安装装订器前, 请先安装连接组件 (AK-730 或 AK-731)。

**安装步骤**

安装前务必关闭机器的主电源开关, 并从墙壁插座拔下电源插头。

1. 将排纸托盘 (B) 内侧的 2 个挂钩 (1) 装入装订器 (A) 的升降板的孔 (2) 中。

**주의**

중속 MFP 에 설치하는 경우 문서 피니셔를 장착하기 전에 부착 키트 (AK-730 또는 AK-731) 를 설치해야 합니다 .

**장착순서**

설치를 시작하기 전에 반드시 본체의 주 전원 스위치를 끄고 벽 콘센트에서 전원 플러그를 분리하십시오 .

1. 배출 트레이 (B) 의 후면 후크 (1) 2 개를 문서 피니셔 (A) 의 승강판 구멍 (2) 에 넣고 장착합니다 .

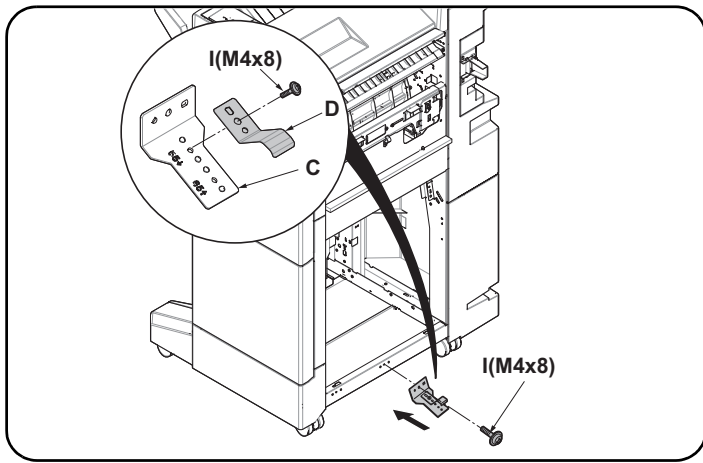
**注意**

中速 MFP に設置する場合、ドキュメントフィニッシャーを取り付ける前に、アタッチメントキット (AK-730 または AK-731) の取り付けをおこなうこと。

**取付手順**

必ず機械本体の主電源スイッチを OFF にし、機械本体の電源プラグを抜いてから作業すること。

1. 排出トレイ (B) の裏側のフック (1) 2 個をドキュメントフィニッシャー (A) の昇降板の穴 (2) に入れて、取り付ける。



### Installation on medium-speed MFPs

- Using an M4 x 8 screw (I), secure the earth spring (D) in the location indicated by the "55" marking on the earth connection plate (C).
- Attach the earth connection plate (C) to the center of the bottom of the document finisher using an M4 x 8 screw (I). Proceed to step 6. The procedure for installing the kit on a high-speed MFP is described on the following steps.

### Montage sur des MFP à vitesse moyenne

- En procédant à l'aide d'une vis M4 x 8 (I), fixez le ressort de mise à la terre (D) à l'endroit indiqué par la marque "55" sur la plaque de raccordement de mise à la terre (C).
- Fixez la plaque de raccordement de mise à la terre (C) au milieu de la partie inférieure du finisseur de document avec une vis M4 x 8 (I). Passer à l'étape 6. La procédure d'installation du kit sur l'imprimante multifonction à grande vitesse est décrite dans les étapes suivantes.

### Instalación en las MFP de velocidad media

- Con un tornillo M4 x 8 (I), asegure el resorte de conexión a tierra (D) en el lugar indicado por la marca "55" de la placa de conexión a tierra (C).
- Fije la placa de conexión a tierra (C) en el centro de la parte inferior del finalizador de documentos usando un tornillo M4 x 8 (I). Vaya al paso 6. En los siguientes pasos se describe el procedimiento de instalación del kit en un MFP de velocidad alta.

### Installation an MFP der mittleren Leistungsklasse

- Befestigen Sie die Grundfeder (D) mit einer M4 x 8 Schraube (I) an der mit "55" bezeichneten Stelle der Grundanschlussplatte (C).
- Bringen Sie die Grundanschlussplatte (C) mit einer M4 x 8 Schraube (I) mitig an der Unterseite des Finishers an. Gehen Sie weiter zu Schritt 6. Die Vorgehensweise zur Installation des Kits an einem schnellen MFP wird in den folgenden Schritten beschrieben.

### Installazione sulle MFP a velocità media

- Utilizzando una vite M4 x 8 (I), fissare la molla di messa a terra (D) nella posizione indicata dal segno "55" sulla piastra di connessione per messa a terra (C).
- Applicare la piastra di connessione per messa a terra (C) al centro in basso della finisher documenti utilizzando una vite M4 x 8 (I). Procedere al passo 6. La procedura di installazione del Kit su un MFP di fascia alta è descritta nelle pagine successive.

### 安装于中速 MFP 上时

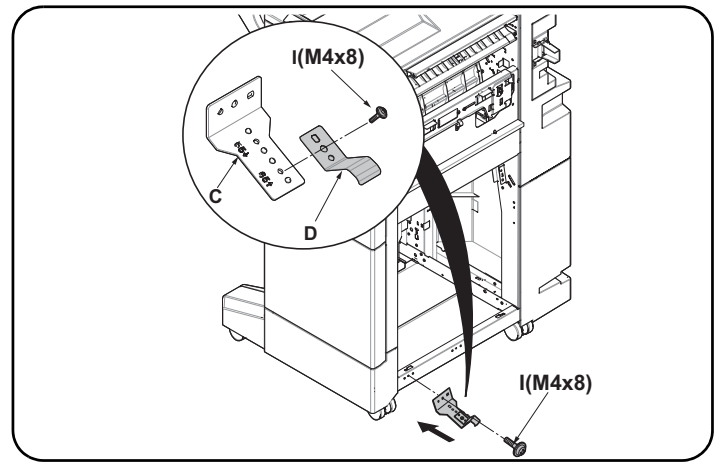
- 在接地安装板 (C) 上刻有 55 ↓ 的位置使用 1 颗 M4×8(I) 螺丝来固定接地弹簧 (D)。
- 使用 M4×8(I) 螺丝将接地安装板 (C) 安装到装订器下部中心位置。进至步骤 6。安装到高速 MFP 时, 请参照下面的内容。

### 중속 MFP 에 설치하는 경우

- 접지 부착판 (C) 의 각인 55 ↓ 의 위치에 나사 M4×8(I) 1 개로 접지스프링 (D) 을 고정합니다 .
- 나사 M4×8(I) 로 접지 부착판 (C) 을 문서 피니셔 하부중앙에 부착합니다 . 순서 6 로 진행합니다 . 고속 MFP 에 키트를 설치하는 절차는 다음 단계에 설명되어 있습니다 .

### 中速 MFP に設置の場合

- アース取付板 (C) の刻印 55 ↓ の位置にビス M4×8(I) でアースバネ (D) を固定する。
- ビス M4×8(I) でアース取付板 (C) をドキュメントフィニッシャー下部センターに取り付ける。手順 6 に進む。高速 MFP に設置の場合は次に記載しています。



### Installation on high-speed MFPs

- Using an M4 x 8 screw (I), secure the earth spring (D) in the location indicated by the "65" marking on the earth connection plate (C).
- Attach the earth connection plate (C) to the front side of the bottom of the document finisher using an M4 x 8 screw (I).

### Montage sur des MFP à grande vitesse

- En procédant à l'aide d'une vis M4 x 8 (I), fixez le ressort de mise à la terre (D) à l'endroit indiqué par la marque "65" sur la plaque de raccordement de mise à la terre (C).
- Fixez la plaque de raccordement de mise à la terre (C) à l'avant de la partie inférieure du finisseur de document avec une vis M4 x 8 (I).

### Instalación en las MFP de alta velocidad

- Con un tornillo M4 x 8 (I), asegure el resorte de conexión a tierra (D) en el lugar indicado por la marca "65" de la placa de conexión a tierra (C).
- Fije la placa de conexión a tierra (C) en el lado frontal de la parte inferior del finalizador de documentos usando un tornillo M4 x 8 (I).

### Installation an MFP der Hochleistungsklasse

- Befestigen Sie die Grundfeder (D) mit einer M4 x 8 Schraube (I) an der mit "65" bezeichneten Stelle der Grundanschlussplatte (C).
- Bringen Sie die Grundanschlussplatte (C) mit einer M4 x 8 Schraube (I) vorne an der Unterseite des Finishers an.

### Installazione sulle MFP a velocità alta

- Utilizzando una vite M4 x 8 (I), fissare la molla di messa a terra (D) nella posizione indicata dal segno "65" sulla piastra di connessione per messa a terra (C).
- Applicare la piastra di connessione per messa a terra (C) al lato anteriore in basso della finisher documenti utilizzando una vite M4 x 8 (I).

### 安装于高速 MFP 上时

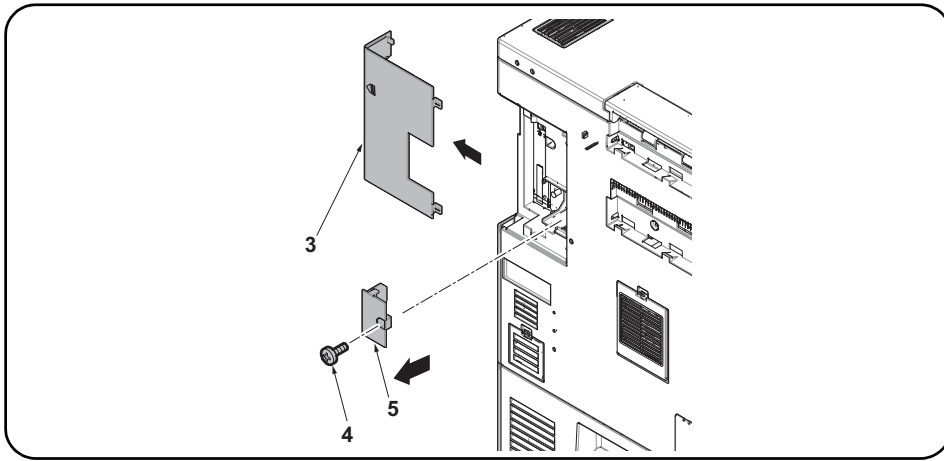
- 在接地安装板 (C) 上刻有 65 ↑ 的位置使用 1 颗 M4×8(I) 螺丝来固定接地弹簧 (D)。
- 使用 M4×8(I) 螺丝将接地安装板 (C) 安装到装订器下部前侧位置。

### 고속 MFP 에 설치하는 경우

- 접지 부착판 (C) 의 각인 65 ↑ 의 위치에 나사 M4×8(I) 1 개로 접지스프링 (D) 을 고정합니다 .
- 나사 M4×8(I) 로 접지 부착판 (C) 을 문서 피니셔 하부앞측에 부착합니다 .

### 高速 MFP に設置の場合

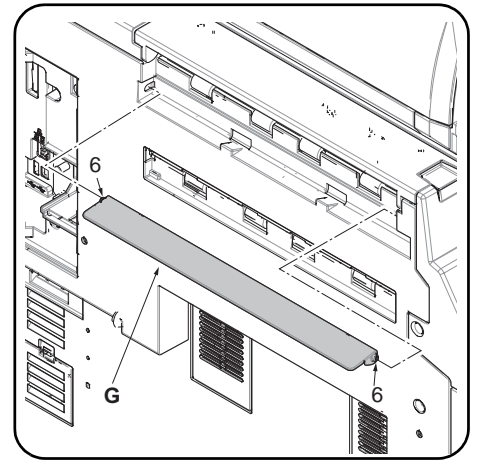
- アース取付板 (C) の刻印 65 ↑ の位置にビス M4×8(I) でアースバネ (D) を固定する。
- ビス M4×8(I) でアース取付板 (C) をドキュメントフィニッシャー下部前側に取り付ける。



**Only for installation on high-speed MFPs**

If installing on a medium-speed MFP, proceed to step 6.

- 4. Remove the machine interface cover (3).
- 5. Remove the screw (4) and remove the controller cover (5).



- 6. Install the eject guide (G) by fitting the 2 eject guide pins (6) into the holes in the machine.

**Pour montage sur des MFP à grande vitesse uniquement**

Si le montage est fait sur un MFP à vitesse moyenne, passer à l'étape 6.

- 4. Déposer le couvercle d'interface (3) de la machine.
- 5. Déposer la vis (4) puis le couvercle du contrôleur (5).

- 6. Installer le guide d'éjection (G) en insérant les 2 ergots du guide d'éjection (6) dans les trous de la machine.

**Solo para la instalación en las MFP de alta velocidad**

Si se instala en una MFP de velocidad media, vaya al paso 6.

- 4. Quite la cubierta de la interfaz (3) de la máquina.
- 5. Quite el tornillo (4) y quite la cubierta del controlador (5).

- 6. Instale la guía de salida (G) encajando los 2 pasadores de la guía de salida (6) en los orificios de la máquina.

**Nur bei Installation an MFP der Hochleistungsklasse**

Gehen Sie zur Installation an einem MFP der mittleren Leistungsklasse weiter zu Schritt 6.

- 4. Nehmen Sie die Schnittstellenabdeckung (3) des Geräts ab.
- 5. Entfernen Sie die Schraube (4) und nehmen Sie die Controller-Abdeckung (5) ab.

- 6. Installieren Sie die Ausgabeführung (G), indem Sie die beiden Stifte (6) der Auswerfführung in die Aufnahmen des Geräts einsetzen.

**Solo per l'installazione sulle MFP a velocità alta**

Se si installa su una MFP a velocità media, procedere al passo 6.

- 4. Rimuovere la copertura di interfaccia (3) della macchina.
- 5. Rimuovere la vite (4) e quindi rimuovere il coperchio del controller (5).

- 6. Installare la guida di espulsione (G) inserendo i 2 perni (6) della guida di espulsione nei fori della macchina.

**仅限安装于高速 MFP 上时**

安装于中速 MFP 上时，进至步骤 6。

- 4. 拆下机器的接口盖板 (3)。
- 5. 拆除 1 颗螺丝 (4)，拆下控制器盖板 (5)。

- 6. 将排纸导向板 (G) 的 2 根销钉 (6) 插入机器的孔中。

**고속 MFP 에 설치하는 경우만**

중속 MFP 에 설치하는 경우에는 순서 6 로 진행합니다 .

- 4. 본체의 인터페이스 커버 (3) 를 제거합니다 .
- 5. 나사 (4) 1 개를 빼고 컨트롤러덮개 (5) 를 제거합니다 .

- 6. 배출 가이드 (G) 핀 (6) 2 개를 본체의 구멍에 맞추어 끼워서 부착합니다 .

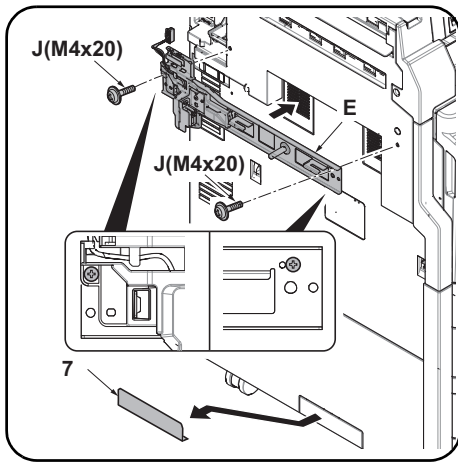
**高速 MFP に設置の場合のみ**

中速 MFP に設置の場合は手順 6 に進む。

- 4. 機械本体のインターフェイスカバー (3) を取り外す。
- 5. ビス (4) を外し、コントローラーフタ (5) を取り外す。

- 6. 排出ガイド (G) のピン (6) 2 本を機械本体の穴に差し込み取り付け。



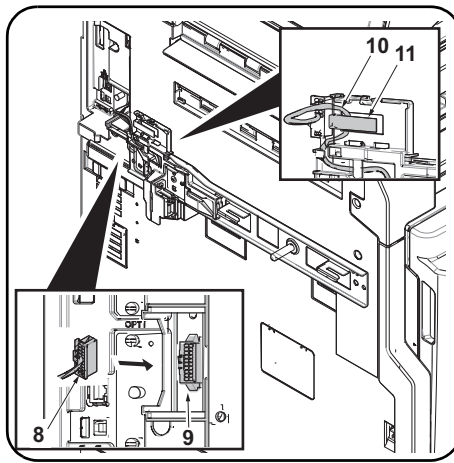


7. Attach the connecting plate (E) to the machine using 2 M4 x 20 screws (J). Attach them at the point as shown above.

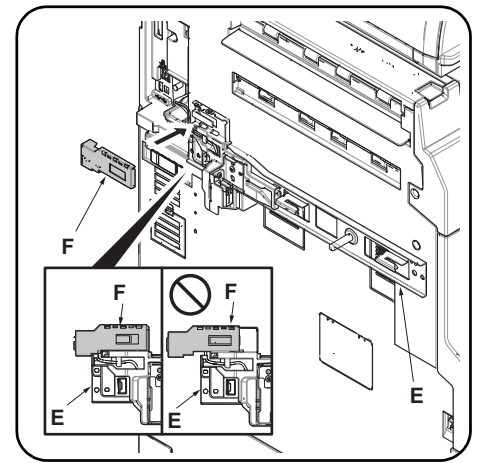
**Only if installing to a medium-speed MFP**

If installing on a high-speed MFP, proceed to step 9.

8. Remove the breakaway cover (7) from the left cover.



9. Connect the signal line connector (8) to the connector (9) on the machine. Hook the signal line wire (10) onto the hook (11).



10. Fit the connector cover (F) in the connecting plate (E). Take care not to get the cable pinched by objects. Attach it at the point as shown above. Check that the signal line connector is covered by the connector cover (F).

7. Fixez la plaque de connexion (E) à la machine à l'aide de 2 vis M4 x 20 (J). Raccordez-les au point indiqué ci-dessus.

**Uniquement en cas d'installation sur un MFP à vitesse moyenne**

Si le montage est fait sur un MFP à grande vitesse, passer à l'étape 9.

8. Déposer le couvercle amovible (7) du couvercle gauche.

9. Raccorder le connecteur de ligne de signal (8) sur le connecteur (9) de la machine. Accrocher le fil de ligne de signal (10) sur le crochet (11).

10. Placer le cache de connecteur (F) dans la plaque de connexion (E). Prendre soin à ne pas pincer le câble. Raccordez-les au point indiqué ci-dessus. Vérifier que le connecteur de ligne de signal est couvert par le cache de connecteur (F).

7. Fije la placa de conexión (E) a la máquina mediante 2 tornillos M4 x 20 (J). Conéctelas en el punto que se muestra arriba.

**Solo si instala en una MFP de velocidad media**

Si se instala en una MFP de alta velocidad, vaya al paso 9.

8. Quite la cubierta divisoria (7) de la cubierta izquierda.

9. Conecte el conector de línea de señales (8) al conector (9) de la máquina. Enganche el cable de la línea de señales (10) en el enganche (11).

10. Acople la cubierta del conector (F) en la placa de conexión (E). Tenga cuidado de que el cable no quede atrapado por objetos. Conéctelas en el punto que se muestra arriba. Compruebe que el conector de la línea de señales quede cubierto por la cubierta del conector (F).

7. Bringen Sie die Verbindungsplatte (E) mit 2 M4 x 20 Schrauben (J) am Gerät an. Bringen Sie diese an der in der Abbildung gezeigten Stelle an.

**Nur bei Installation eines MFP der mittleren Leistungsklasse**

Gehen Sie zur Installation an einem MFP der Hochleistungsklasse weiter zu Schritt 9.

8. Nehmen Sie die Ablösungsabdeckung (7) von der linken Abdeckung ab.

9. Verbinden Sie den Stecker der Signalleitung (8) mit dem Steckverbinder im Gerät (9). Hängen Sie das Kabel der Signalleitung (10) in den Befestigungshaken (11) ein.

10. Setzen Sie die Stecker-Abdeckung (F) in die Verbindungsplatte (E) ein. Stellen Sie sicher, dass das Kabel nicht eingeklemmt wird. Bringen Sie diese an der in der Abbildung gezeigten Stelle an. Überprüfen Sie, ob der Stecker der Signalleitung von der Stecker-Abdeckung (F) abgedeckt ist.

7. Applicare la piastra di connessione (E) alla macchina utilizzando le 2 viti M4 x 20 (J). Fissare nella posizione sopra indicata.

**Solo se si installa ad un MFP a velocità media**

Se si installa su una MFP a velocità alta, procedere al passo 9.

8. Rimuovere il coperchio di distacco (7) dal coperchio sinistro.

9. Collegare il connettore di linea del segnale (8) al connettore (9) sulla periferica. Agganciare il cavo di linea del segnale (10) al gancio (11).

10. Inserire il copri connettore (F) nella piastra di connessione (E). Fare attenzione a non impigliare il cavo. Fissare nella posizione sopra indicata. Controllare che il connettore della linea del segnale sia coperto dal copri connettore (F).

7. 使用 2 顆 M4×20 (J) 螺絲將連接板 (E) 安裝到機器上。按圖示位置來安裝。

**仅限安裝於中速機上時**

安裝於高速 MFP 上時，請進步驟 9。

8. 去除左側蓋板上的可去除部 (7)。

9. 把信號線的接插件 (8) 和機器本體的接插件 (9) 相連接。把信號線 (10) 掛到掛鉤 (11) 上。

10. 將接插件蓋板 (F) 嵌入到連接板 (E)。請注意不要夾住電線。按圖示位置來安裝。請確認信號線的接插件是否完全隱藏在接插件蓋板中 (F)。

7. 나사 M4 x 20 (J) 2 개를 사용하여 연결판 (E) 을 본체에 부착합니다. 위에 표시된 위치에 부착합니다. 위에 표시된 위치에 부착합니다.

**중속 MFP 에 설치할 경우만**

고속 MFP 에 설치하는 경우에는 순서 9 로 진행합니다.

8. 좌측커버의 분할커버부 (7) 를 떼어 냅니다.

9. 신호선 커넥터 (8) 를 본체의 커넥터 (9) 에 연결합니다. 신호선 와이어 (10) 를 후크 (11) 에 걸립니다.

10. 커넥터 커버 (F) 를 연결판 (E) 에 맞추어 끼웁니다. 전선이 커넥터 커버 (F) 에 끼이지 않도록 주의합니다. 위에 표시된 위치에 부착합니다. 신호선 커넥터가 커넥터 커버 (F) 에 덮여있는지 확인합니다.

7. 連結板 (E) をビス M4×20 (J) 2 本で、機械本体に取り付ける。図の位置で取り付けること。

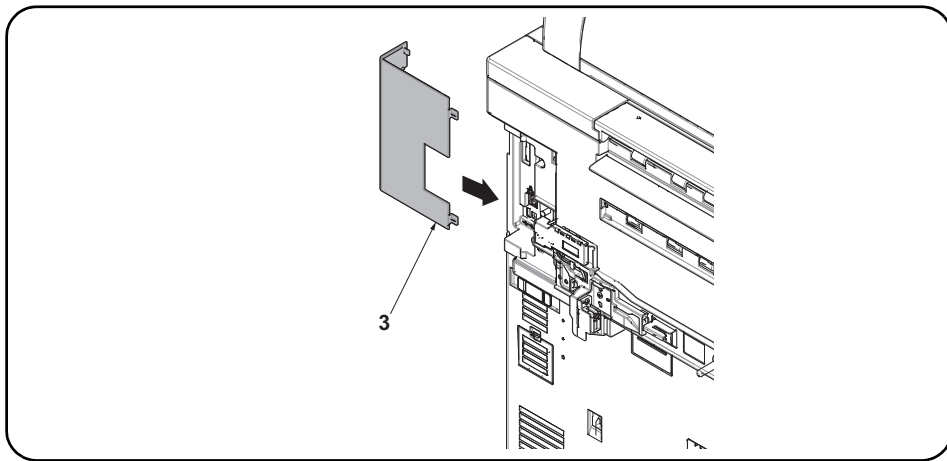
**中速 MFP に設置の場合のみ**

高速 MFP に設置の場合には手順 9 に進む。

8. 左カバーの割りカバー部 (7) を切り取る。

9. 信号線のコネクター (8) を機械本体のコネクター (9) に接続する。信号線 (10) は、フック (11) に掛けること。

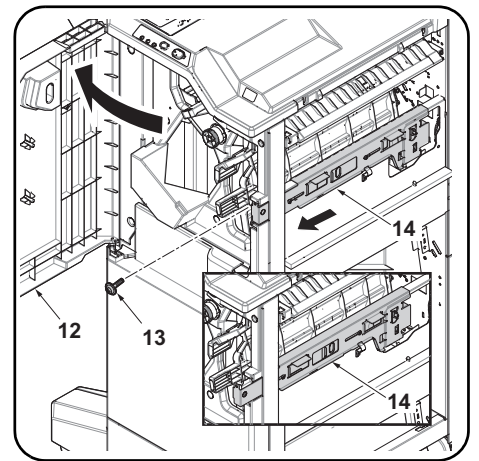
10. コネクターカバー (F) を連結板 (E) にはめ込む。電線を挟み込まない様注意すること。図の位置で取り付けること。信号線のコネクターがコネクターカバー (F) で隠れていることを確認する。



**11. Attach the interface cover (3)\* on the machine.**

\* Installing with a high-speed MFP : the cover which was removed in step 4.

Installing with a medium-speed MFP : the cover which was removed while installing the AK-730 or AK-731.



**12. Open the document finisher upper front cover (12). Remove the screw (13). Pull the lock frame (14) frontwards.**

Remove the screw (13). Pull the lock frame (14) frontwards.

**11. Raccordez le couvercle d'interface (3)\* à la machine.**

\* Installation avec une imprimante multifonction à grande vitesse : le cache qui a été retiré à l'étape 4.

Installation avec une imprimante multifonction à moyenne vitesse : le cache qui a été retiré lors de l'installation de l'AK-730 ou AK-731.

**12. Ouvrir le couvercle avant supérieur du finisseur de document (12). Retirez la vis (13). Tirer le cadre de verrouillage (14) vers le bas.**

Tirer le cadre de verrouillage (14) vers le bas.

**11. Conecte la cubierta de interfaz (3)\* de la máquina.**

\* Instalación con un MFP de velocidad alta : la cubierta que se quitó en el paso 4.

Instalación con un MFP de velocidad media : la cubierta que se quitó al instalar el kit AK-730 o AK-731.

**12. Abra la cubierta frontal superior del finalizador de documentos (12). Quite el tornillo (13). Empuje el marco de cierre (14) hacia delante.**

Empuje el marco de cierre (14) hacia delante.

**11. Bringen Sie die Schnittstellenabdeckung (3)\* am Gerät an.**

\* Installation an einem MFP der Hochleistungs-kategorie : die Abdeckung, die in Schritt 4 entfernt wurde

Installation an einem MFP der mittleren Leistungs-kategorie : die Abdeckung, die zur Installation des AK-730 oder AK-731 entfernt wurde

**12. Öffnen Sie die obere vordere Abdeckung des Finishers (12). Entfernen Sie die Schraube (13). Ziehen Sie die Verriegelung (14) nach vorne.**

Ziehen Sie die Verriegelung (14) nach vorne.

**11. Fissare la copertura di interfaccia (3)\* sulla macchina.**

\* Installazione su un MFP di fascia alta : il coperchio che è stato rimosso al punto 4

Installazione su un MFP di fascia media : il coperchio che è stato rimosso per installare il kit AK-730 o AK-731

**12. Aprire il coperchio frontale superiore del finisher documenti (12). Togliere la vite (13). Tirare in avanti la frame di blocco (14).**

Tirare in avanti la frame di blocco (14).

**11. 将接口盖板 (3)\* 安装到机器主机。**

\* 安装到高速 MFP 时 : 在步骤 4 中取下的盖板

安装到中速 MFP 时 : 在安装 AK-730 或 AK-731 时取下的盖板

**12. 打开装订器的前上盖板 (12)。取下螺丝 (13)。向身体前侧拉出固定架 (14)。**

向身体前侧拉出固定架 (14)。

**11. 인터페이스 커버 (3)\* 를 본체에 부착합니다 .**

\* 고속 MFP 설치의 경우 : 순서 4 에서 제거한 커버

중속 MFP 설치의 경우 : AK-730 또는 AK-731 설치 시 분리한 커버

**12. 문서 피니셔의 전면 상커버 (12) 를 엽니다 .**

나사 (13) 를 제거합니다 . 잠금 프레임 (14) 을 앞으로 뺍니다 .

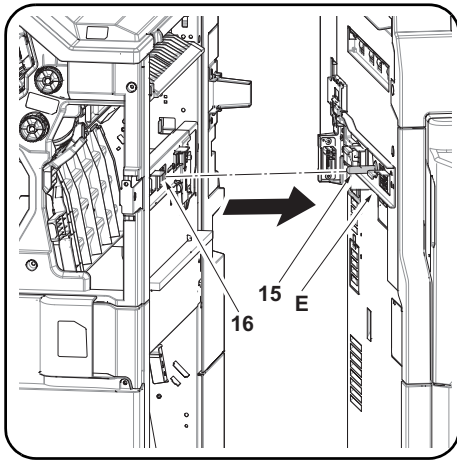
**11. 機械本体にインターフェイスカバー (3)\* を取り付けます。**

\* 高速 MFP に設置の場合 : 手順 4 で外したカバー

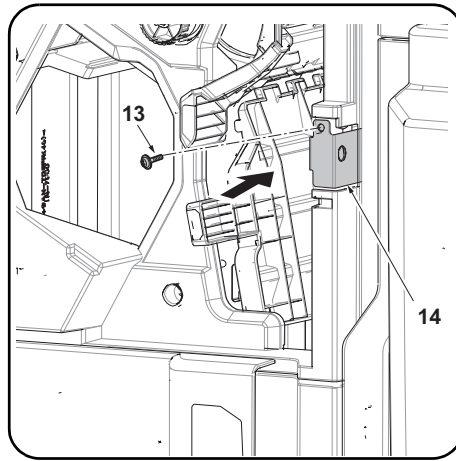
中速 MFP に設置の場合 : AK-730 または AK-731 設置時に取り外したカバー

**12. ドキュメントフィニッシャーの前上カバー (12) を開く。ビス (13) を外す。ロックフレーム (14) を手前に引く。**

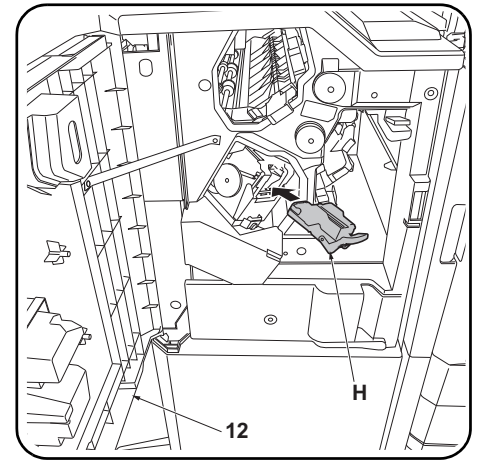
ロックフレーム (14) を手前に引く。



- 13.** Insert the pin (15) on the connecting plate (E) into the hole (16) on the document finisher. Connect the document finisher to the machine.  
\* If you cannot connect the document finisher, adjust the height as described on page 15.



- 14.** Slowly push the lock frame (14) fully into the machine so that the connectors at the far end are connected.  
**15.** Secure the lock frame (14) using the screw (13) removed in step 12.



- 16.** Install the staple cartridge (H).  
**17.** Close the upper front cover (12).  
Proceed to adjusting the stapling position on page 20.

- 13.** Introduire la broche (15) sur la plaque de connexion (E) dans le trou (16) sur le finisseur de document. Connecter le finisseur de document sur la machine.  
\* S'il s'avère impossible de connecter le finisseur de document, en régler la hauteur comme décrit en page 15.

- 14.** Pousser doucement le cadre de verrouillage (14) à fond dans la machine de sorte que les connecteurs à l'extrémité soient raccordés.  
**15.** Fixez le bâti de verrouillage (14) à l'aide de la vis (13) déposée à l'étape 12.

- 16.** Installer la cartouche d'agrafes (H).  
**17.** Refermer le couvercle avant supérieur (12).  
Passez à l'ajustement de la position d'agrafage page 20.

- 13.** Inserte el pasador (15) de la placa de conexión (E) en el orificio (16) del finalizador de documentos. Conecte el finalizador de documentos a la máquina.  
\* Si no puede conectar el finalizador de documentos, ajuste la altura como se describe en la página 15.

- 14.** Empuje lentamente y hasta el fondo el marco del cierre (14) hacia la máquina de modo que se conecten los conectores en el extremo más lejano.  
**15.** Asegure la carcasa de bloqueo (14) por medio del tornillo (13) quitado en el paso 12.

- 16.** Instale el cartucho de grapas (H).  
**17.** Cierre la cubierta frontal superior (12).  
Proceda al ajuste de la posición de grapado en la página 20.

- 13.** Setzen Sie den Stift (15) der Verbindungsplatte (E) in die Öffnung (16) des Finishers. Verbinden Sie den Finisher mit dem Gerät.  
\* Falls Sie den Finisher nicht anschließen können, sollten Sie die Höhe wie auf Seite 15 beschrieben einstellen.

- 14.** Schieben Sie die Verriegelung (14) wieder langsam ins Gerät, so dass die Verbindungen am anderen Ende des Geräts geschlossen werden.  
**15.** Befestigen Sie den Fixierahmen (14) mit der in Schritt 12 entfernten Schraube (13).

- 16.** Installieren Sie das Heftklammer-Magazin (H).  
**17.** Schließen Sie die obere vordere Abdeckung (12).  
Fahren Sie mit der Justage der Heftposition auf Seite 20 fort.

- 13.** Inserire il perno (15) della piastra di connessione (E) nel foro (16) del finisher documenti. Collegare il finisher documenti alla macchina.  
\* Se non è possibile collegare la finisher documenti, regolare l'altezza come descritto a pagina 15.

- 14.** Spingere lentamente la frame di blocco (14) nella macchina in modo che i connettori all'estremità risultino collegati.  
**15.** Fissare il telaio di bloccaggio (14) utilizzando la vite (13) rimossa nel passo 12.

- 16.** Installare il contenitore punti (H).  
**17.** Chiudere il coperchio superiore anteriore (12).  
Proseguire con la regolazione della posizione di pinzatura a pagina 20.

- 13.** 将连接板 (E) 的销钉 (15) 插入装订器的孔 (16) 中。把装订器连接到机器本体。  
※ 如果无法连接, 请进行 P15 的“高度调节”。

- 14.** 慢慢的把固定架 (14) 完全推入机器, 这样机器里侧的接插件就可以顺利连接。  
**15.** 使用在步骤 12 中取下的 1 颗螺丝 (13) 来固定锁框 (14)。

- 16.** 安装装订针盒 (H)。  
**17.** 关闭前部上盖板 (12)。  
跳至 P20「调节装订位置」。

- 13.** 연결판 (E) 의 핀 (15) 을 문서 피니셔의 구멍 (16) 에 삽입합니다. 문서 피니셔를 본체에 연결합니다.  
※ 연결할 수 없는 경우에는 P15 의 「높이조정」을 할 것.

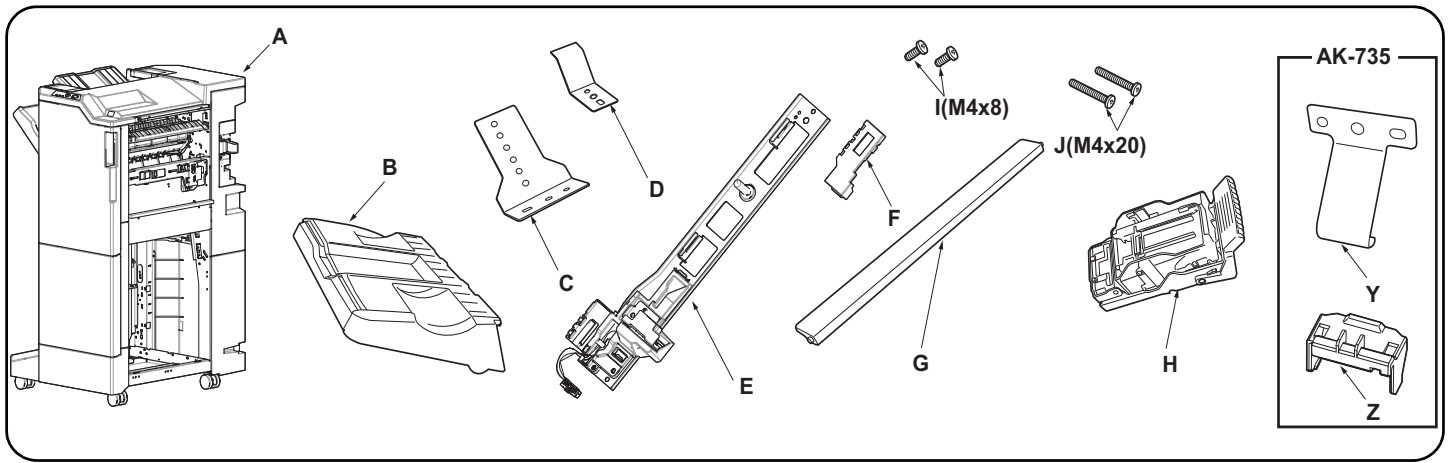
- 14.** 본체 뒷쪽의 커넥터가 연결되도록 잠금 프레임 (14) 을 본체 안으로 천천히 밀어 넣습니다.  
**15.** 순서 12 에서 뺀 나사 (13) 1 개로 잠금 프레임 (14) 을 고정합니다.

- 16.** 스테이플 카트리지를 (H) 를 설치합니다.  
**17.** 앞 상커버 (12) 를 닫습니다.  
20 페이지의 스테이플 위치 조정으로 진행합니다.

- 13.** 連結板 (E) のピン (15) をドキュメントフィニッシャーの穴 (16) に挿入する。ドキュメントフィニッシャーを機械本体に接続する。  
※ 連結できない場合は、P15 の「高さ調整」を行う。

- 14.** 機械奥側のコネクタが接続されるように、ロックフレーム (14) をゆっくり奥に押す。  
**15.** 手順 12 で外したビス (13) で、ロックフレーム (14) を固定する。

- 16.** ステープルカートリッジ (H) を取り付ける。  
**17.** 前上カバー (12) を閉じる。  
P20「ステープル位置の調整」に進む。



**Supplied parts**

A. Document finisher.....	1
B. Eject tray.....	1
C. Earth connection plate.....	1
D. Earth spring.....	1
E. Connecting plate.....	1
F. Connector cover.....	1

G. Eject guide.....	1
H. Staple cartridge.....	1
I. M4 x 8 screw.....	3
J. M4 x 20 screw.....	2
K. Earth Plate.....	1
L. Cover.....	1

C ,D and Z are not used.

Be sure to remove any tape and/or cushioning materials from the parts supplied.

**Pièces fournies**

A. Finisseur de document.....	1
B. Bac d'éjection.....	1
C. Plaque de raccordement de mise à terre.....	1
D. Ressort de mise à la terre.....	1
E. Plaque de connexion.....	1
F. Cache de connecteur.....	1

G. Guide d'éjection.....	1
H. Cartouche d'agrafes.....	1
I. Vis M4 x 8.....	2
J. Vis M4 x 20.....	2
Y. Plaque de terre.....	1
Z. Couverture.....	1

C, D et Z ne sont pas utilisés.

Veillez à retirer les morceaux de bande adhésive et/ou les matériaux de rembourrage des pièces fournies.

**Partes suministradas**

A. Finalizador de documentos.....	1
B. Bandeja de salida.....	1
C. Placa de conexión a tierra.....	1
D. Resorte de conexión a tierra.....	1
E. Placa de conexión.....	1
F. Cubierta del conector.....	1

G. Guía de salida.....	1
H. Cartucho de grapas.....	1
I. Tornillo M4 x 8.....	2
J. Tornillo M4 x 20.....	2
Y. Placa de conexión a tierra.....	1
Z. Cubierta.....	1

C, D y Z no se utilizan.

Asegúrese de despegar todas las cintas y/o material amortiguador de las partes suministradas.

**Enthaltene Teile**

A. Finisher.....	1
B. Auswerffach.....	1
C. Grundanschlussplatte.....	1
D. Grundfeder.....	1
E. Verbindungsplatte.....	1
F. Stecker-Abdeckung.....	1

G. Ausgabeführung.....	1
H. Heftklammermagazin.....	1
I. M4 x 8 Schraube.....	2
J. M4 x 20 Schraube.....	2
Y. Grundplatte.....	1
Z. Abdeckung.....	1

C, D und Z werden nicht benötigt.

Stellen Sie sicher, dass sämtliche Klebebänder und/oder Polstermaterial von den gelieferten Teilen entfernt wurden.

**Parti fornite**

A. Finisher documenti.....	1
B. Vassoio di espulsione.....	1
C. Piastra di connessione per messa a terra.....	1
D. Molla di messa a terra.....	1
E. Piastra di connessione.....	1
F. Copri connettore.....	1

G. Guida di espulsione.....	1
H. Contenitore punti.....	1
I. Vite M4 x 8.....	2
J. Vite M4 x 20.....	2
Y. Piastra di messa a terra.....	1
Z. Coperchio.....	1

C, D e Z non sono utilizzati.

Rimuovere tutti i nastri adesivi e/o i materiali di protezione dalle parti fornite.

**附属品**

A. 装订器.....	1
B. 排纸托盘.....	1
C. 接地安装板.....	1
D. 接地弹簧.....	1
E. 连接板.....	1
F. 接插件盖板.....	1

G. 排纸导向板.....	1
H. 装订针盒.....	1
I. M4x8 螺丝.....	2
J. M4x20 螺丝.....	2
Y. 接地板.....	1
Z. 盖板.....	1

不使用 C、D 和 Z。

如果附属品上带有固定胶带，缓冲材料时务必揭下。

**동봉품**

A. 문서 피니셔.....	1
B. 배출 트레이.....	1
C. 접지 부착판.....	1
D. 접지 스프링.....	1
E. 연결판.....	1
F. 커넥터 커버.....	1

G. 배출 가이드.....	1
H. 스테이플 카트리지.....	1
I. 나사 M4x8.....	2
J. 나사 M4x20.....	2
Y. 접지판.....	1
Z. 커버.....	1

C, D 와 Z 는 사용되지 않습니다 .

동봉품에 고정 테이프, 완충재가 붙어 있는 경우에는 반드시 제거할 것 .

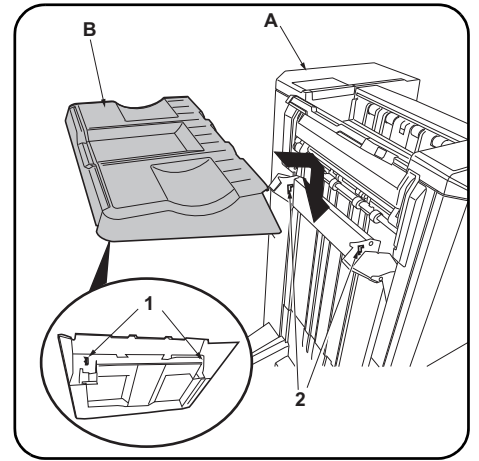
**同梱品**

A. ドキュメントフィニッシャー.....	1
B. 排出トレイ.....	1
C. アース取付板.....	1
D. アースパネ.....	1
E. 連結板.....	1
F. コネクターカバー.....	1

G. 排出ガイド.....	1
H. ステープルカートリッジ.....	1
I. ビス M4x8.....	2
J. ビス M4x20.....	2
Y. アース板.....	1
Z. カバー.....	1

C, D, Z は使用しない。

同梱品に固定テープ、緩衝材がついている場合は、必ず取り外すこと。



**NOTICE**  
The Attachment Kit (AK-735) must be installed before the document finisher is installed.

**Procedure**  
Before starting installation, be sure to turn the main power switch of the machine off, and unplug the power plug from the wall outlet.

1. Install by inserting the 2 hooks (1) on the back of the eject tray (B) into the holes (2) in the document finisher (A) lift.

**REMARQUE**  
Le gabarit de fixation (AK-735) doit être en place avant de procéder à l'installation du finisseur de document.

**Procédure**  
Avant de commencer l'installation, s'assurer de mettre la machine hors tension et de débrancher la fiche d'alimentation de la prise murale.

1. Procéder en insérant les 2 crochets (1) au dos du bac d'éjection (B) dans les trous (2) du dispositif de levage du finisseur document (A).

**AVISO**  
El Kit de instalación (AK-735) debe instalarse antes de instalar el finalizador de documentos.

**Procedimiento**  
Antes de iniciar la instalación, asegúrese de apagar el interruptor de encendido de la máquina y desenchufar el cable de alimentación de la toma de pared.

1. Instale insertando los 2 ganchos (1) de la parte posterior de la bandeja de salida (B) en los orificios (2) del elevador del finalizador de documentos (A).

**ANMERKUNG**  
Das Gerätezusatz (AK-735) muss installiert werden, bevor man den Finisher installiert.

**Verfahren**  
Bevor Sie mit der Installation beginnen überzeugen Sie sich, dass der Netzschalter des Geräts ausgeschaltet und das Stromkabel aus der Steckdose gezogen ist.

1. Setzen Sie die 2 Haken (1) zur Befestigung an der Rückseite des Auswerffachs (B) in die Öffnungen (2) an der Hebeplatte des Finishers (A) ein.

**AVVISO**  
Il kit accessorio (AK-735) deve essere installato prima che sia installata la finisher documenti.

**Procedura**  
Prima di iniziare l'installazione, spegnere la macchina e scollegare la spina dalla presa di corrente.

1. Installare inserendo i 2 ganci (1) sul retro del vassoio di espulsione (B) nei fori (2) sul sollevatore della finisher documenti (A).

**注意**  
安装装订器之前，必须先安装连接组件 (AK-735)。

**安装步骤**  
安装前务必关闭机器的主电源开关，并从墙壁插座拔下电源插头。

1. 将排纸托盘 (B) 内侧的 2 个挂钩 (1) 装入装订器 (A) 的升降板的孔 (2) 中。

**주의**  
문서 피니셔를 장착하기 전에 연결킷 (AK-735) 의 장착을 선행할 것 .

**장착순서**  
설치를 시작하기 전에 반드시 본체의 주 전원 스위치를 끄고 벽 콘센트에서 전원 플러그를 분리하십시오 .

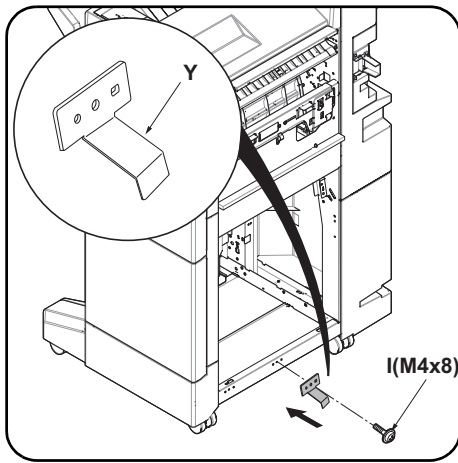
1. 배출 트레이 (B) 의 후면 후크 (1) 2 개를 문서 피니셔 (A) 의 승강판 구멍 (2) 에 넣고 장착합니다 .

**注意**  
ドキュメントフィニッシャーを取り付ける前に、アタッチメントキット (AK-735) の取り付けをおこなうこと。

**取付手順**  
必ず機械本体の主電源スイッチを OFF にし、機械本体の電源プラグを抜いてから作業すること。

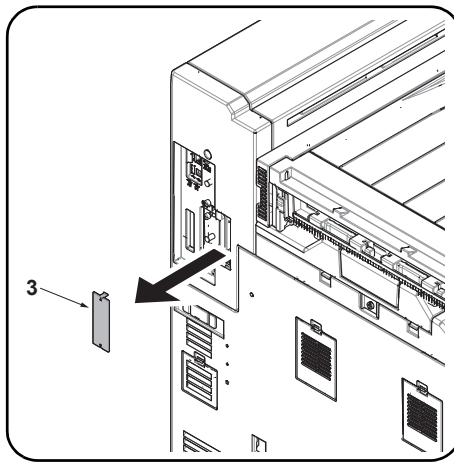
1. 排出トレイ (B) の裏側のフック (1) 2 個をドキュメントフィニッシャー (A) の昇降板の穴 (2) に入れて、取り付ける。



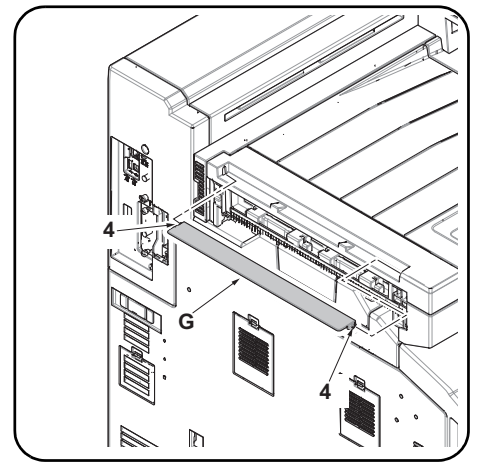


2. Attach the earth plate (Y)\* to the center of the bottom of the document finisher using an M4 x 8 screw (I).

\*The part was supplied with AK-735



3. Remove the cover (3) from the machine.



4. Install the eject guide (G) by fitting the 2 eject guide pins (4) into the holes in the machine.

2. Raccordez la plaque de terre (Y)\* en bas au centre du finisseur de document en utilisant une vis M4 x 8 (I).

\*La pièce a été fournie avec l'AK-735

3. Retirer le couvercle (3) de la machine.

4. Installer le guide d'éjection (G) en insérant les 2 ergots du guide d'éjection (4) dans les trous de la machine.

2. Conecte la placa de conexión a tierra (Y)\* al centro de la parte inferior del finalizador de documentos con un tornillo M4 x 8 (I).

\*La pieza se proporcionó con AK-735

3. Quite la cubierta (3) de la máquina.

4. Instale la guía de salida (G) encajando los 2 pasadores de la guía de salida (4) en los orificios de la máquina.

2. Bringen Sie die Grundplatte (Y)\* in der Mitte des Bodens des Finishers mit den M4 x 8 Schrauben (I) an.

\*Dieses Teil ist im AK-735 enthalten.

3. Entfernen Sie die Abdeckung (3) vom Gerät.

4. Installieren Sie die Ausgabeführung (G), indem Sie die beiden Stifte (4) der Auswerfführung in die Aufnahmen des Geräts einsetzen.

2. Applicare la piastra di messa a terra (Y)\* al centro dell'area inferiore della finisher documenti utilizzando una vite M4 x 8 (I).

\*Parte fornita con AK-735

3. Rimuovere il coperchio (3) dalla macchina.

4. Installare la guida di espulsione (G) inserendo i 2 perni (4) della guida di espulsione nei fori della macchina.

2. 使用 M4×8(I) 螺丝将接地板 (Y)\* 安装到装订器下部中央。

\*AK-735 的附属品

3. 从机器上拆下盖板 (3)。

4. 将排纸导向板 (G) 的 2 根销钉 (4) 插入机器的孔中。

2. 나사 M4 x 8(I) 를 사용하여 접지판 (Y)\* 을 문서 피니셔의 하단 중앙에 부착합니다 .

\*AK-735 동봉 부품

3. 본체에서 커버 (3) 를 분리합니다 .

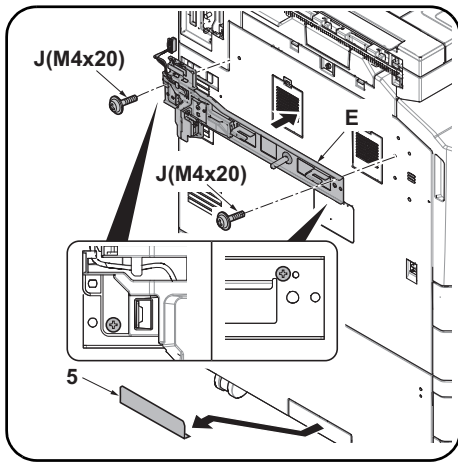
4. 배출 가이드 (G) 의 핀 (4) 2 개를 본체의 구멍에 맞추어 끼워서 부착합니다 .

2. ビス M4×8(I) でアース板 (Y)\* をドキュメントフィニッシャー下部センターに取り付ける。

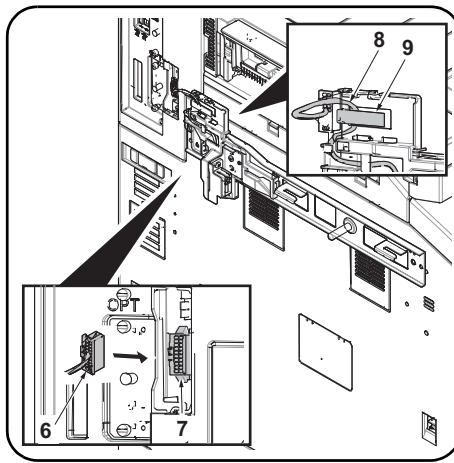
\*AK-735 の同梱品

3. 機械本体からカバー (3) を取り外す。

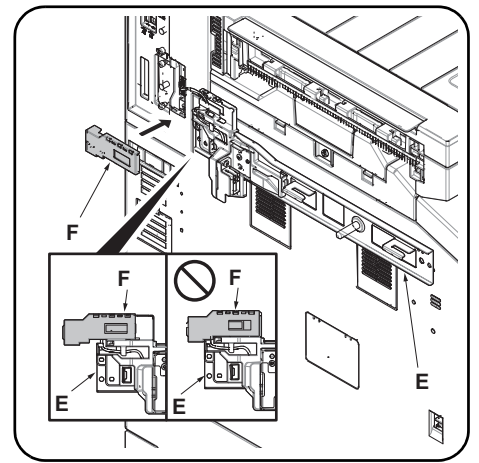
4. 排出ガイド (G) のピン (4) 2 本を機械本体の穴に差し込み取り付け。



5. Attach the connecting plate (E) to the machine using 2 M4 x 20 screws (J). Attach them at the point as shown above.
6. Remove the breakaway cover (5) from the left cover.



7. Connect the signal line connector (6) to the connector (7) on the machine. Hook the signal line wire (8) onto the hook (9).



8. Fit the connector cover (F) in the connecting plate (E). Take care not to get the cable pinched by objects. Attach it at the point as shown above. Check that the signal line connector is covered by the connector cover (F).

5. Fixez la plaque de connexion (E) à la machine à l'aide de 2 vis M4 x 20 (J). Raccordez-les au point indiqué ci-dessus.
6. Déposer le couvercle amovible (5) du couvercle gauche.

7. Raccorder le connecteur de ligne de signal (6) sur le connecteur (7) de la machine. Accrocher le fil de ligne de signal (8) sur le crochet (9).

8. Placer le cache de connecteur (F) dans la plaque de connexion (E). Prendre soin à ne pas pincer le câble. Raccordez-les au point indiqué ci-dessus. Vérifier que le connecteur de ligne de signal est couvert par le cache de connecteur (F).

5. Fije la placa de conexión (E) a la máquina mediante 2 tornillos M4 x 20 (J). Conéctelas en el punto que se muestra arriba.
6. Quite la cubierta divisoria (5) de la cubierta izquierda.

7. Conecte el conector de línea de señales (6) al conector (7) de la máquina. Enganche el cable de la línea de señales (8) en el enganche (9).

8. Acople la cubierta del conector (F) en la placa de conexión (E). Tenga cuidado de que el cable no quede atrapado por objetos. Conéctelas en el punto que se muestra arriba. Compruebe que el conector de la línea de señales quede cubierto por la cubierta del conector (F).

5. Bringen Sie die Verbindungsplatte (E) mit 2 M4 x 20 Schrauben (J) am Gerät an. Bringen Sie diese an der in der Abbildung gezeigten Stelle an.
6. Nehmen Sie die Ablösungsabdeckung (5) von der linken Abdeckung ab.

7. Verbinden Sie den Stecker der Signalleitung (6) mit dem Steckverbinder im Gerät (7). Hängen Sie das Kabel der Signalleitung (8) in den Befestigungshaken (9) ein.

8. Setzen Sie die Stecker-Abdeckung (F) in die Verbindungsplatte (E) ein. Stellen Sie sicher, dass das Kabel nicht eingeklemmt wird. Bringen Sie diese an der in der Abbildung gezeigten Stelle an. Überprüfen Sie, ob der Stecker der Signalleitung von der Stecker-Abdeckung (F) abgedeckt ist.

5. Applicare la piastra di connessione (E) alla macchina utilizzando le 2 viti M4 x 20 (J). Fissare nella posizione sopra indicata.
6. Rimuovere il coperchio di distacco (5) dal coperchio sinistro.

7. Collegare il connettore di linea del segnale (6) al connettore (7) sulla periferica. Agganciare il cavo di linea del segnale (8) al gancio (9).

8. Inserire il copri connettore (F) nella piastra di connessione (E). Fare attenzione a non impigliare il cavo. Fissare nella posizione sopra indicata. Controllare che il connettore della linea del segnale sia coperto dal copri connettore (F).

5. 使用 2 顆 M4×20 (J) 螺絲將連接板 (E) 安裝到機器上。按圖示位置來安裝。
6. 去除左側蓋板上的可去除部 (5)。

7. 把信號線的接插件 (6) 和機器本體的接插件 (7) 相連接。把信號線 (8) 掛到掛鉤 (9) 上。

8. 將接插件蓋板 (F) 嵌入到連接板 (E)。請注意不要夾住電線。按圖示位置來安裝。請確認信號線的接插件是否完全隱藏在接插件蓋板中 (F)。

5. 나사 M4 x 20 (J) 2 개를 사용하여 연결판 (E) 을 본체에 부착합니다. 위에 표시된 위치에 부착합니다.
6. 좌측커버의 분할커버부 (5) 를 떼어 냅니다.

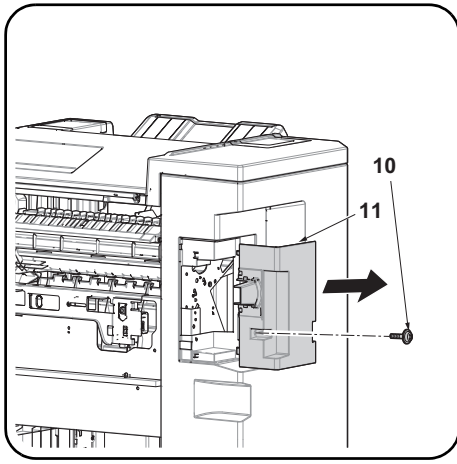
7. 신호선 커넥터 (6) 를 본체의 커넥터 (7) 에 연결합니다. 신호선 와이어 (8) 를 후크 (9) 에 걸립니다.

8. 커넥터 커버 (F) 를 연결판 (E) 에 맞추어 끼웁니다. 전선이 커넥터 커버 (F) 에 끼이지 않도록 주의합니다. 위에 표시된 위치에 부착합니다. 신호선 커넥터가 커넥터 커버 (F) 에 덮여있는지 확인합니다.

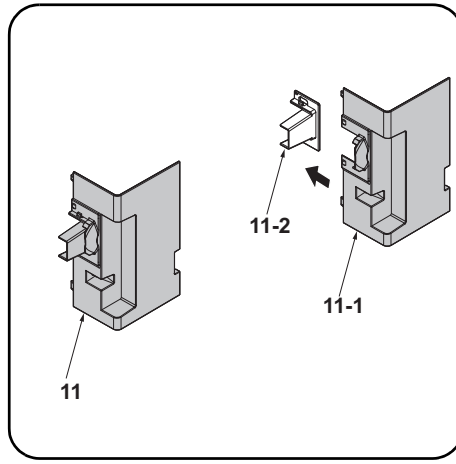
5. 連結板 (E) をビス M4×20 (J) 2 本で、機械本体に取り付ける。図の位置で取り付けること。
6. 左カバーの割りカバー部 (5) を切り取る。

7. 信号線のコネクター (6) を機械本体のコネクター (7) に接続する。信号線 (8) は、フック (9) に掛けること。

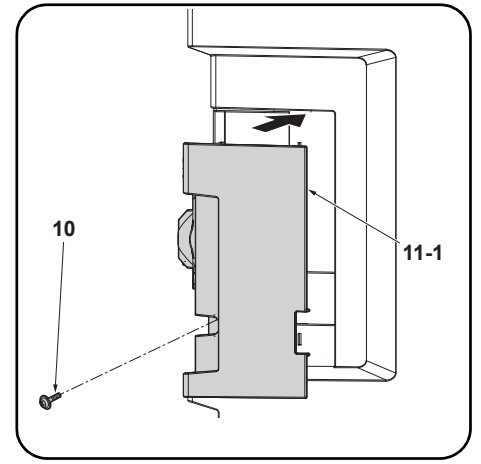
8. コネクターカバー (F) を連結板 (E) にはめ込む。電線を挟み込まない様注意すること。図の位置で取り付けること。信号線のコネクターがコネクターカバー (F) で隠れていることを確認する。



**9.** Remove the screw (10). Remove the rear cover (11).



**10.** Separate the rear cover (11) into the two covers (11-1, 11-2).  
The cover (11-2) is not used.



**11.** Install the cover (11-1) using the screw (10).

**9.** Retirez la vis (10). Retirez le capot arrière (11).

**10.** Séparez le couvercle arrière (11) en deux couvercles (11-1, 11-2).  
Le couvercle (11-2) n'est pas utilisé.

**11.** Installez le couvercle (11-1) à l'aide de la vis (10).

**9.** Quite el tornillo (10). Quite la cubierta posterior (11).

**10.** Separe la cubierta posterior (11) en las dos cubiertas (11-1, 11-2).  
La cubierta (11-2) no se utiliza.

**11.** Instale la cubierta (11-1) con un tornillo (10).

**9.** Entfernen Sie die Schraube (10). Entfernen Sie die hintere Abdeckung (11).

**10.** Teilen Sie die hintere Abdeckung (11) in zwei Abdeckungen (11-1, 11-2) auf.  
Die Abdeckung (11-2) wird nicht benötigt.

**11.** Installieren Sie die Abdeckung (11-1) mit den Schrauben (10).

**9.** Togliere la vite (10). Rimuovere il coperchio posteriore (11).

**10.** Separare il coperchio posteriore (11) in due coperchi (11-1, 11-2).  
Il coperchio (11-2) non viene utilizzato.

**11.** Installare il coperchio (11-1) utilizzando la vite (10).

**9.** 取下螺丝 (10)。取下后盖板 (11)。

**10.** 将后盖板 (11) 分成 2 个盖板 (11-1, 11-2)。不需要盖板 (11-2)。

**11.** 使用螺丝 (10) 来安装盖板 (11-1)。

**9.** 나사 (10) 를 제거합니다 . 후면 커버 (11) 를 제거합니다 .

**10.** 후면 커버 (11) 를 2개의 커버 (11-1, 11-2) 로 분리합니다 .  
커버 (11-2) 는 사용되지 않습니다 .

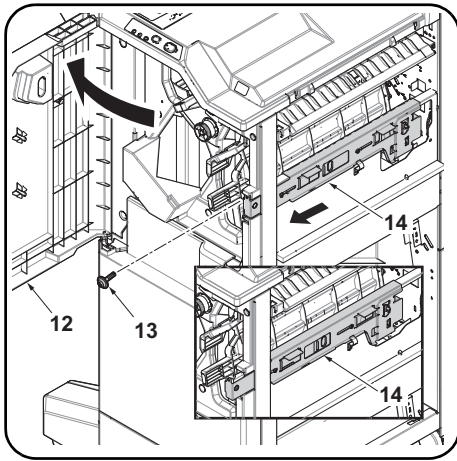
**11.** 나사 (10) 를 사용하여 커버 (11-1) 를 장착합니다 .

**9.** ビス (10) を外す。後カバー (11) を取り外す。

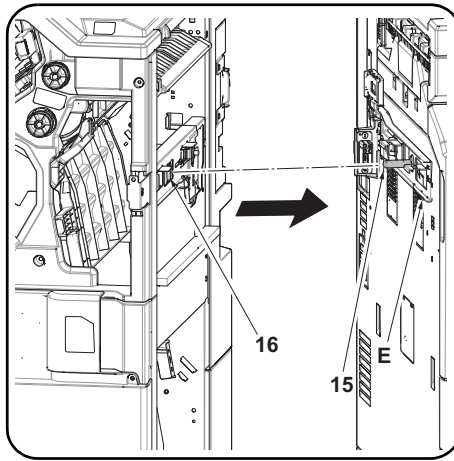
**10.** 後カバー (11) を 2つのカバー (11-1, 11-2) に分ける。  
カバー (11-2) は不要。

**11.** ビス (10) でカバー (11-1) を取り付ける。

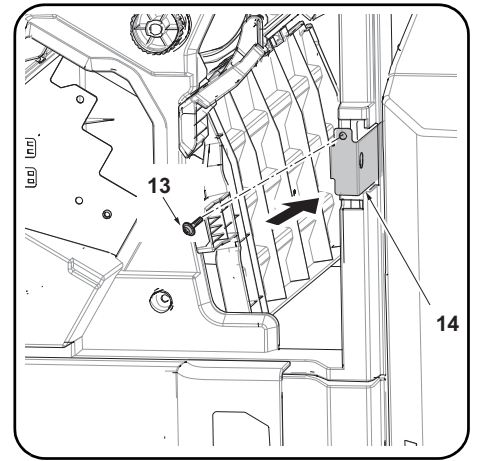




**12.** Open the document finisher upper front cover (12). Remove the screw (13). Pull the lock frame (14) frontwards.



**13.** Insert the pin (15) on the connecting plate (E) into the hole (16) on the document finisher. Connect the document finisher to the machine.  
\* If you cannot connect the document finisher, adjust the height as described on page 15.



**14.** Slowly push the lock frame (14) fully into the machine so that the connectors at the far end are connected.  
**15.** Secure the lock frame (14) using the screw (13) removed in step 12.

**12.** Ouvrir le couvercle avant supérieur du finisseur de document (12). Retirez la vis (13). Tirer le cadre de verrouillage (14) vers le bas.

**13.** Introduire la broche (15) sur la plaque de connexion (E) dans le trou (16) sur le finisseur de document. Connecter le finisseur de document sur la machine.  
\* S'il s'avère impossible de connecter le finisseur de document, en régler la hauteur comme décrit en page 15.

**14.** Pousser doucement le cadre de verrouillage (14) à fond dans la machine de sorte que les connecteurs à l'extrémité soient raccordés.  
**15.** Fixez le bâti de verrouillage (14) à l'aide de la vis (13) déposée à l'étape 12.

**12.** Abra la cubierta frontal superior del finalizador de documentos (12). Quite el tornillo (13). Empuje el marco de cierre (14) hacia delante.

**13.** Inserte el pasador (15) de la placa de conexión (E) en el orificio (16) del finalizador de documentos. Conecte el finalizador de documentos a la máquina.  
\* Si no puede conectar el finalizador de documentos, ajuste la altura como se describe en la página 15.

**14.** Empuje lentamente y hasta el fondo el marco del cierre (14) hacia la máquina de modo que se conecten los conectores en el extremo más lejano.  
**15.** Asegure la carcasa de bloqueo (14) por medio del tornillo (13) quitado en el paso 12.

**12.** Öffnen Sie die obere vordere Abdeckung des Finishers (12). Entfernen Sie die Schraube (13). Ziehen Sie die Verriegelung (14) nach vorne.

**13.** Setzen Sie den Stift (15) der Verbindungsplatte (E) in die Öffnung (16) des Finishers. Verbinden Sie den Finisher mit dem Gerät.  
\* Falls Sie den Finisher nicht anschließen können, sollten Sie die Höhe wie auf Seite 15 beschrieben einstellen.

**14.** Schieben Sie die Verriegelung (14) wieder langsam ins Gerät, so dass die Verbindungen am anderen Ende des Geräts geschlossen werden.  
**15.** Befestigen Sie den Fixierahmen (14) mit der in Schritt 12 entfernten Schraube (13).

**12.** Aprire il coperchio frontale superiore del finisher documenti (12). Togliere la vite (13). Tirare in avanti la frame di blocco (14).

**13.** Inserire il perno (15) della piastra di connessione (E) nel foro (16) del finisher documenti. Collegare il finisher documenti alla macchina.  
\* Se non è possibile collegare la finisher documenti, regolare l'altezza come descritto a pagina 15.

**14.** Spingere lentamente la frame di blocco (14) nella macchina in modo che i connettori all'estremità risultino collegati.  
**15.** Fissare il telaio di bloccaggio (14) utilizzando la vite (13) rimossa nel passo 12.

**12.** 打开装订器的前上盖板(12)。取下螺丝(13)。向身体前侧拉出固定架(14)。

**13.** 将连接板(E)的销钉(15)插入装订器的孔(16)中。把装订器连接到机器本体。  
※ 如果无法连接, 请进行 P15 的“高度调节”。

**14.** 慢慢的把固定架(14)完全推入机器, 这样机器里侧的接插件就可以顺利连接。  
**15.** 使用在步骤 12 中取下的 1 颗螺丝(13)来固定锁框(14)。

**12.** 문서 피니셔의 전면 상커버(12)를 엽니다. 나사(13)를 제거합니다. 잠금 프레임(14)을 앞으로 뺍니다.

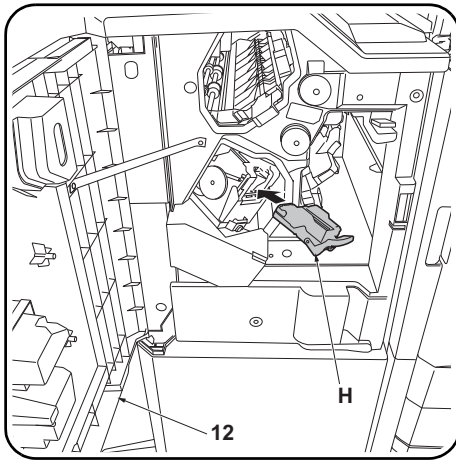
**13.** 연결판(E)의 핀(15)을 문서 피니셔의 구멍(16)에 삽입합니다. 문서 피니셔를 본체에 연결합니다.  
※ 연결할 수 없는 경우에는 P15의 「높이조정」을 할 것.

**14.** 본체 뒷쪽의 커넥터가 연결되도록 잠금 프레임(14)을 본체 안으로 천천히 밀어 넣습니다.  
**15.** 순서 12에서 뺀 나사(13) 1개로 잠금 프레임(14)을 고정합니다.

**12.** ドキュメントフィニッシャーの前上カバー(12)を開く。ビス(13)を外す。ロックフレーム(14)を手前に引く。

**13.** 連結板(E)のピン(15)をドキュメントフィニッシャーの穴(16)に挿入する。ドキュメントフィニッシャーを機械本体に接続する。  
※ 連結できない場合は、P15の「高さ調整」を行う。

**14.** 機械奥側のコネクタが接続されるように、ロックフレーム(14)をゆっくり奥に押す。  
**15.** 手順 12 で外したビス(13)で、ロックフレーム(14)を固定する。



16. Install the staple cartridge (H).
17. Close the upper front cover (12).

Proceed to adjusting the stapling position on page 20.

- 
16. Installer la cartouche d'agrafes (H).
  17. Refermer le couvercle avant supérieur (12).

Passez à l'ajustement de la position d'agrafage page 20.

- 
16. Instale el cartucho de grapas (H).
  17. Cierre la cubierta frontal superior (12).

Proceda al ajuste de la posición de grapado en la página 20.

- 
16. Installieren Sie das Heftklammer-Magazin (H).
  17. Schließen Sie die obere vordere Abdeckung (12).

Fahren Sie mit der Justage der Heftposition auf Seite 20 fort.

- 
16. Installare il contenitore punti (H).
  17. Chiudere il coperchio superiore anteriore (12).

Proseguire con la regolazione della posizione di pinzatura a pagina 20.

- 
16. 安装装订针盒 (H)。
  17. 关闭前部上盖板 (12)。

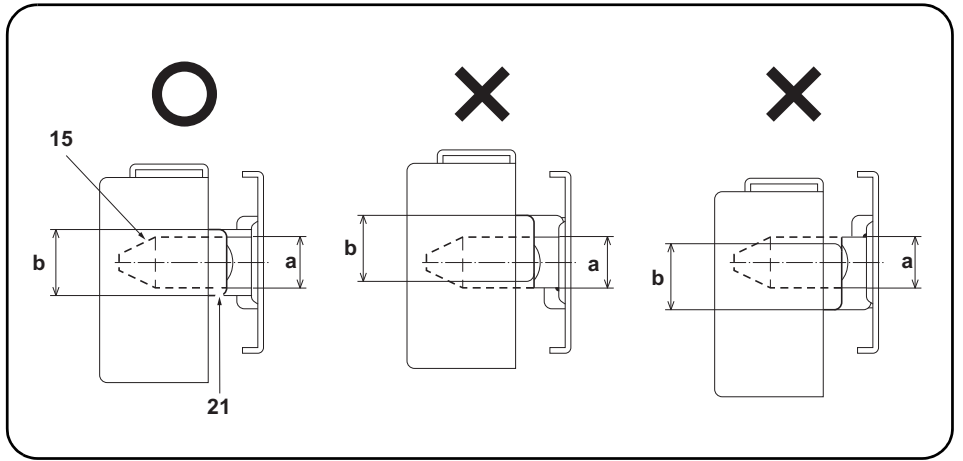
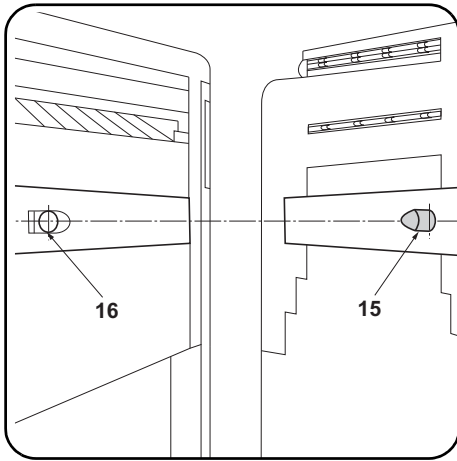
跳至 P20「调节装订位置」。

- 
16. 스테이플 카트리지를 (H) 를 설치합니다 .
  17. 앞 상커버 (12) 를 닫습니다 .

20 페이지의 스테이플 위치 조정으로 진행합니다 .

- 
16. 스테이플카트리지를 (H) 을取り付けます。
  17. 前上カバー(12) を閉じます。

P20「ステイブル位置の調整」に進む。



### Adjusting the height

1. Check that the respective heights of the pins (15) on the connecting plate installed on the machine and the connecting holes (16) on the document finisher comply with the references below.

Compliant: The diameter (a) of the pin (15) is within the height range (b) of the curved section (21).  
 Non-compliant: The diameter (a) of the pin (15) extends beyond the height range (b) of the curved section (21).  
 If the heights are non-compliant, use the procedure below to adjust the height.

### Réglage de la hauteur

1. Vérifiez que les hauteurs respectives des ergots (15) sur la plaque de connexion installée sur la machine et les trous de connexion (16) sur le finisseur de document sont conformes aux références ci-dessous.

Bon : Le diamètre (a) de l'ergot (15) est dans les limites de hauteur (b) de la partie courbée (21).  
 Mauvais : Le diamètre (a) de l'ergot (15) dépasse les limites de hauteur (b) de la partie courbée (21).  
 Si la hauteur n'est pas conforme, l'ajuster en procédant comme indiqué ci-dessous.

### Ajuste de la altura

1. Compruebe que las alturas correspondientes de los pasadores (15) de la placa de fijación instalados en la máquina y los orificios de conexión (16) del finalizador de documentos cumplen las referencias de abajo.

Cumple: el diámetro (a) del pasador (15) está dentro del rango de altura (b) de la sección curvada (21).  
 No cumple: el diámetro (a) del pasador (15) sobrepasa el rango de altura (b) de la sección curvada (21).  
 Si las alturas no cumplen con las especificaciones, utilice el siguiente procedimiento para ajustar la altura.

### Einstellen der Höhe

1. Überprüfen Sie, dass die jeweilige Höhe der Stifte (15) der am Gerät installierten Verbindungsplatte und Verbindungsöffnungen (16) des Finishers mit den unten angegebenen Werten übereinstimmen.

Korrekt: Der Durchmesser (a) des Stifts (15) befindet sich im Höhenbereich (b) des Kurvenabschnitts (21).  
 Nicht korrekt: Der Durchmesser (a) des Stifts (15) ragt über den Höhenbereich (b) des Kurvenabschnitts (21) hinaus.  
 Falls die Höhen nicht korrekt sind, müssen Sie sie wie folgend einstellen.

### Regolazione dell'altezza

1. Controllare che le rispettive altezze dei perni (15) sulla piastra di connessione installata sulla macchina e i fori di connessione (16) sulla finisher documenti corrispondano ai riferimenti mostrati sotto.

Conformità: Il diametro (a) del perno (15) è compreso nella gamma di altezza (b) della sezione curvata (21).  
 Non conformità: Il diametro (a) del perno (15) si estende oltre la gamma di altezza (b) della sezione curvata (21).  
 Se le altezze sono non corrispondenti, utilizzare la procedura riportata sotto per regolare l'altezza.

### 高度調節

1. 确认机器主机上安装的连接板的销钉 (15) 和装订器的连接用的孔 (16) 的高度是否符合以下标准。

符合: 销钉 (15) 的直径 (a) 在弯曲部 (21) 的高度 (b) 的范围内。  
 不符合: 销钉 (15) 的直径 (a) 超出了弯曲部 (21) 的高度 (b) 的范围。  
 不符合时, 通过以下步骤进行调节。

### 높이조절

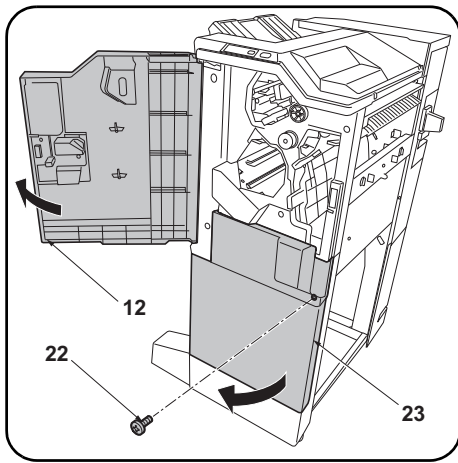
1. 본체에 설치된 연결판의 핀 (15) 과 문서 피니셔의 연결용 구멍 (16) 의 각 높이가 아래의 기준에 부합하는지 확인합니다.

적합 : 핀 (15) 의 직경 (a) 가 곡선부 (21) 의 높이 (b) 의 범위에 들어간다.  
 부적합: 핀 (15) 의 직경 (a) 가 곡선부 (21) 의 높이 (b) 의 범위를 넘는다.  
 부적합의 경우에는 이하의 순서대로 조정합니다.

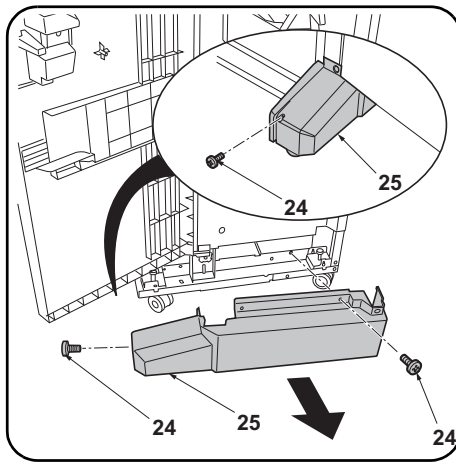
### 高さ調整

1. 機械本体に取り付けた連結板のピン (15) とドキュメントフィニッシャーの連結用の穴 (16) の高さが以下の基準に適合するか確認する。

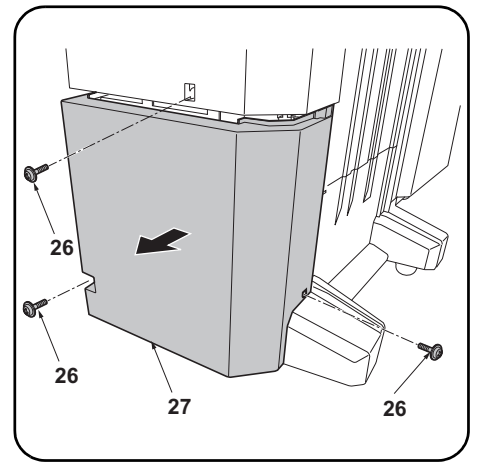
適合: ピン (15) の直径 (a) が曲げ部 (21) の高さ (b) の範囲に収まっている。  
 不適合: ピン (15) の直径 (a) が曲げ部 (21) の高さ (b) の範囲からはみだしている。  
 不適合の場合は、以下の手順で調整する。



2. Open the upper front cover (12) of the document finisher.
3. Remove the screw (22) and open the lower front cover (23).



4. Remove the 2 screws (24) and remove the foot cover (25).



5. Remove the 3 screws (26) and remove the lower rear cover (27).

2. Ouvrir le couvercle avant supérieur (12) du finisseur de document.
3. Déposer la vis (22) et ouvrir le couvercle avant inférieur (23).

4. Déposer les 2 vis (24) puis le couvercle du pied (25).

5. Déposer les 3 vis (26) puis le couvercle arrière inférieur (27).

2. Abra la cubierta frontal superior (12) del finalizador de documentos.
3. Quite el tornillo (22) y abra la cubierta frontal inferior (23).

4. Quite los 2 tornillos (24) y quite la cubierta de la pata (25).

5. Quite los 3 tornillos (26) y quite la cubierta posterior inferior (27).

2. Öffnen Sie die obere vordere Abdeckung (12) des Finishers.
3. Entfernen Sie die Schraube (22) und öffnen Sie die untere vordere Abdeckung (23).

4. Entfernen Sie die 2 Schrauben (24) und nehmen Sie die Fußabdeckung (25) ab.

5. Entfernen Sie die 3 Schrauben (26) und nehmen Sie die untere hintere Abdeckung (27) ab.

2. Aprire il coperchio superiore anteriore (12) della finisher documenti.
3. Rimuovere la vite (22) ed aprire il coperchio inferiore anteriore (23).

4. Rimuovere le 2 viti (24) e quindi rimuovere la copertura del piede (25).

5. Rimuovere le 3 viti (26) e quindi rimuovere il coperchio inferiore posteriore (27).

2. 打开装订器的前部上盖板 (12)。
3. 拆除 1 颗螺丝 (22)，打开前部下盖板 (23)。

4. 拆除 2 颗螺丝 (24)，拆下脚座盖板 (25)。

5. 拆除 3 颗螺丝 (26)，拆下后部下盖板 (27)。

2. 문서 피니셔 앞 상커버 (12) 를 엽니다 .
3. 나사 (22) 1 개를 제거하고 앞 하커버 (23) 를 엽니다 .

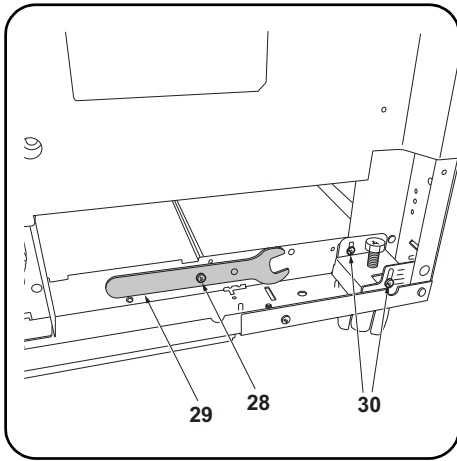
4. 나사 (24) 2 개를 제거하고 , 풋커버 (25) 를 제거합니다 .

5. 나사 (26) 3 개를 제거하고 , 뒤 하커버 (27) 를 제거합니다 .

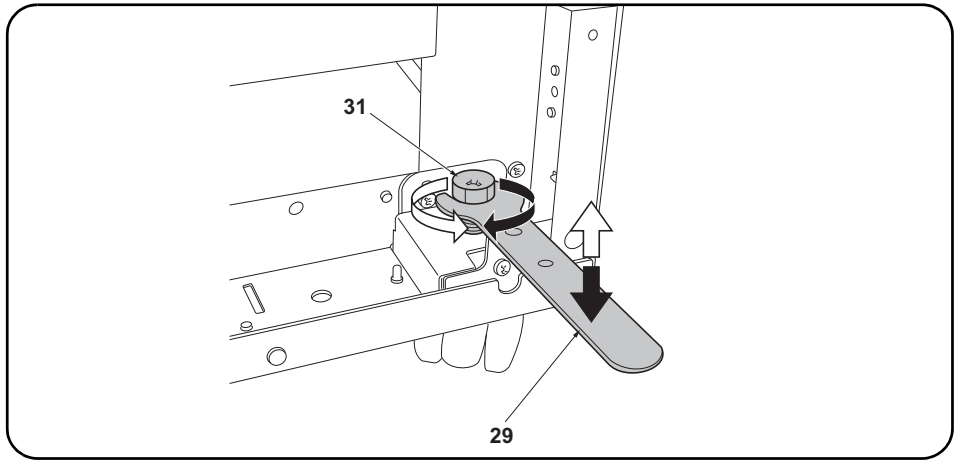
2. ドキュメントフィニッシャーの前上カバー (12) を開く。
3. ビス (22) 1 本を外し、前下カバー (23) を開く。

4. ビス (24) 2 本を外し、フットカバー (25) を取り外す。

5. ビス (26) 3 本を外し、後下カバー (27) を取り外す。



6. Remove the screw (28) to remove the spanner (29).
7. Loosen the 2 screws (30) on the front right and on the rear right of the document finisher.



8. Turn the adjustment bolts (31) with the spanner (29) to adjust the height of the document finisher. Turning the adjustment bolt clockwise lifts the document finisher, and turning it counterclockwise lowers the document finisher.
9. Retighten each of the 2 screws (30) and replace the spanner (29).

6. Déposer la vis (28) pour libérer la clé (29).
7. Desserrer les 2 vis (30) du côté avant droit et arrière droit du finisseur de document.

8. Faire tourner les boulons de réglage (31) avec la clé (29) pour ajuster la hauteur du finisseur de document. Tourner le boulon de réglage dans le sens horloger pour lever le finisseur de document, et dans le sens contraire au sens horloger pour le descendre.
9. Resserrer les 2 vis (30) et repositionner la clé (29) au même endroit.

6. Quite el tornillo (28) para extraer la llave inglesa (29).
7. Afloje los 2 tornillos (30) en los lados derecho frontal y derecho posterior del finalizador de documentos.

8. Gire los pernos de ajuste (31) con la llave inglesa (29) para ajustar la altura del finalizador de documentos. Al girar el perno de ajuste en la dirección de las manecillas del reloj se levanta el finalizador de documentos y al girar en sentido contrario a las manecillas del reloj baja el finalizador de documentos.
9. Vuelva a apretar los 2 tornillos (30) y coloque la llave inglesa en su lugar (29).

6. Entfernen Sie die Schraube (28), um den Schlüssel (29) abzunehmen
7. Lösen Sie die 2 Schrauben (30) vorne rechts und hinten rechts am Finisher.

8. Drehen Sie die Einstellschrauben (31) mit dem Schlüssel (29), um die Höhe des Finishers einzustellen. Durch Drehen der Einstellschraube im Uhrzeigersinn wird der Finisher angehoben, während er durch Drehen entgegen dem Uhrzeigersinn abgesenkt wird.
9. Ziehen Sie die 2 Schrauben (30) wieder an und verstauen Sie den Schlüssel (29) wieder.

6. Rimuovere la vite (28) per rimuovere la chiave (29).
7. Allentare le 2 viti (30) sulla parte anteriore destra e posteriore destra della finisher documenti.

8. Ruotare i bulloni di regolazione (31) con la chiave (29) per regolare l'altezza della finisher documenti. Ruotando il bullone di regolazione in senso orario si solleva la finisher documenti, mentre ruotandolo in senso antiorario si abbassa la finisher documenti.
9. Ristringere ciascuna delle 2 viti (30) e riporre la chiave (29).

6. 取下螺丝 (28) 以便拆下扳手 (29)。
7. 拧松装订器右前侧与右后侧的各 2 颗螺丝 (30)。

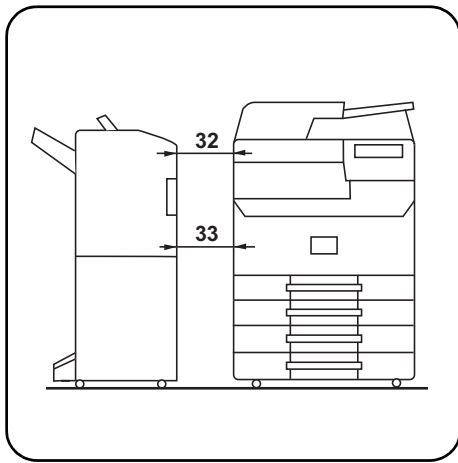
8. 使用扳手 (29) 旋转调节螺栓 (31), 以调节装订器的高度。将调节螺栓向顺时针方向旋转, 装订器的高度升高, 逆时针方向旋转则装订器的高度降低。
9. 拧紧各 2 颗螺丝 (30), 按原样安装扳手 (29)。

6. 나사 (28) 1 개를 빼고, 스패너 (29) 를 떼어 냅니다.
7. 문서 피니셔 우측 앞과 뒤의 나사 (30) 각 2 개를 느슨하게 합니다.

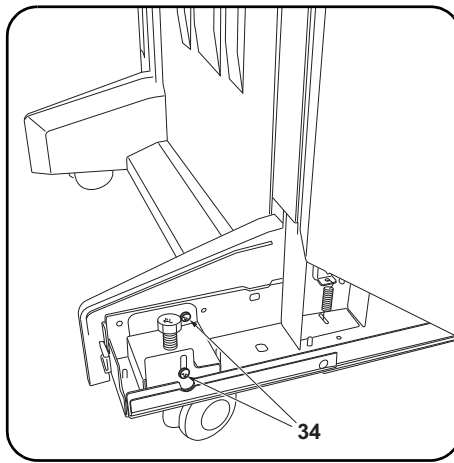
8. 스패너 (29) 로 조정 볼트 (31) 를 돌려 문서 피니셔의 높이를 조정한다. 조정 볼트를 시계방향으로 돌리면 문서 피니셔의 높이가 높아지고, 반 시계방향으로 돌리면 낮아 집니다.
9. 나사 (30) 각 2 개를 조이고 스패너 (29) 를 원래 자리에 장착합니다.

6. 비스 (28) 1 본を外し、スパナー (29) を取り外す。
7. ドキュメントフィニッシャー右前と右後のビス (30) 各 2 本を緩める。

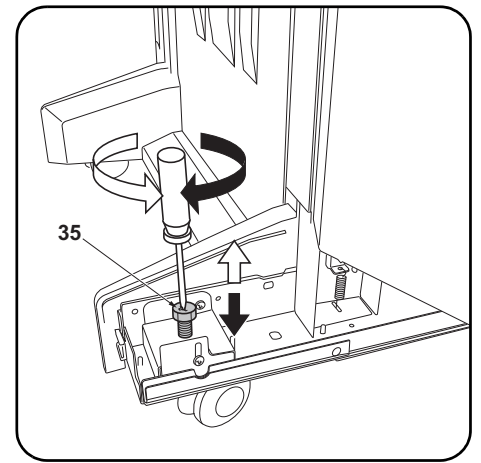
8. 스패너 (29) で調整볼트 (31) を回し、ドキュメントフィニッシャーの高さを調整する。調整볼트를時計方向に回すとドキュメントフィニッシャーの高さが高くなり、反時計方向に回すと低くなる。
9. 비스 (30) 各 2 本を締め付け、スパナー (29) を元通り取り付ける。



10. If the distances between the document finisher and the machine (32, 33) are unequal, use the procedure below to adjust the spacing.



11. Loosen the 2 screws (34) on the front left and on the rear left of the document finisher.



12. Turn the adjustment bolts (35) with a Philips-head screwdriver to adjust the height of the document finisher. Turning the adjustment bolt clockwise lifts the document finisher, and turning it counter-clockwise lowers the document finisher.

10. Si les distances entre le finisseur de document et la machine (32, 33) sont inégales, régler l'espacement en procédant de la manière suivante.

11. Desserrer les 2 vis (34) du côté avant gauche et arrière gauche du finisseur de document.

12. Faire tourner les boulons de réglage (35) à l'aide d'un tournevis cruciforme pour ajuster la hauteur du finisseur de document. Tourner le boulon de réglage dans le sens horloger pour lever le finisseur de document, et dans le sens contraire au sens horloger pour le descendre.

10. Si las distancias entre el finalizador de documentos y la máquina (32, 33) no son iguales, utilice el siguiente procedimiento para ajustar la separación.

11. Afloje los 2 tornillos (34) en los lados izquierdo frontal e izquierdo posterior del finalizador de documentos.

12. Gire los pernos de ajuste (35) con un destornillador de cabeza Philips para ajustar la altura del finalizador de documentos. Al girar el perno de ajuste en la dirección de las manecillas del reloj se levanta el finalizador de documentos y al girar en sentido contrario a las manecillas del reloj baja el finalizador de documentos.

10. Falls die Abstände zwischen dem Finisher und dem Gerät (32, 33) ungleich sind, führen Sie die unten angegebenen Schritte aus, um den Abstand zu korrigieren.

11. Lösen Sie die 2 Schrauben (34) vorne links und hinten links am Finisher.

12. Stellen Sie die Einstellschrauben (35) mit einem Kreuzschlitzschraubendreher ein, um die Höhe des Finishers zu korrigieren. Durch Drehen der Einstellschraube im Uhrzeigersinn wird der Finisher angehoben, während er durch Drehen entgegen dem Uhrzeigersinn abgesenkt wird.

10. Se le distanze tra la finisher documenti e la macchina (32, 33) sono diverse, attenersi alla sottostante procedura per regolare la spaziatura.

11. Allentare le 2 viti (34) sulla parte anteriore sinistra e posteriore sinistra della finisher documenti.

12. Ruotare i bulloni di regolazione (35) con un cacciavite con testa a croce tipo Philips per regolare l'altezza della finisher documenti. Ruotando il bullone di regolazione in senso orario si solleva la finisher documenti, mentre ruotandolo in senso antiorario si abbassa la finisher documenti.

10. 装订器与机器的间隙 (32, 33) 不等时, 按以下步骤进行调节。

11. 拧松装订器左前侧与左后侧的各 2 颗螺丝 (34)。

12. 使用十字螺丝刀旋转调节螺栓 (35), 以调节装订器的高度。将调节螺栓向顺时针方向旋转, 装订器的高度升高, 逆时针方向旋转则装订器的高度降低。

10. 문서 피니셔와 본체의 거리 (32, 33) 가 동일하지 않는 경우 아래의 절차에 따라 간격을 조정합니다.

11. 문서 피니셔 좌측 앞과 뒤의 나사 (34) 각 2 개를 느슨하게 합니다.

12. 플러스 드라이버로 조정 볼트 (35) 를 돌려 문서 피니셔 높이를 조정합니다. 조정 볼트를 시계방향으로 돌리면 문서 피니셔의 높이가 높아지고, 반 시계방향으로 돌리면 낮아 집니다.

10. ドキュメントフィニッシャーと機械本体の間隔 (32, 33) が等しくない場合は、以下の手順で調整を行う。

11. ドキュメントフィニッシャー左前と左後のビス (34) 各 2 本を緩める。

12. プラスドライバーで調整ボルト (35) を回し、ドキュメントフィニッシャーの高さを調整する。調整ボルトを時計方向に回すとドキュメントフィニッシャーの高さが高くなり、反時計方向に回すと低くなる。

13. Retighten each of the 2 screws (34).  
14. Reinstall the foot cover (25) and lower rear cover (27).
- 

13. Resserrer les 2 vis (34).  
14. Reposer le couvercle du pied (25) et le couvercle arrière inférieur (27).
- 

13. Vuelva a apretar los 2 tornillos (34).  
14. Vuelva a instalar la cubierta de la pata (25) y la cubierta posterior inferior (27).
- 

13. Ziehen Sie die 2 Schrauben (34) nach.  
14. Setzen Sie die Fußabdeckung (25) und die untere hintere Abdeckung (27) wieder ein.
- 

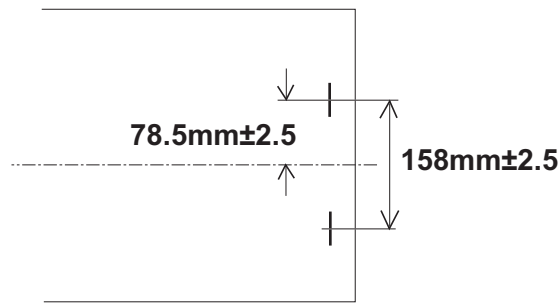
13. Ristringere ciascuna delle 2 viti (34).  
14. Reinstallare la copertura del piede (25) e il coperchio inferiore posteriore (27).
- 

13. 拧紧各 2 颗螺丝 (34)。  
14. 按原样安装脚座盖板 (25)、后部下盖板 (27)。
- 

13. 나사 (34) 각 2 개를 조입니다 .  
14. 풋커버 (25), 뒤 하커버 (27) 를 원래대로 제거합니다 .
- 

13. ビス (34) 各 2 本を締め付ける。  
14. フットカバー (25)、後下カバー (27) を元通りに取り付ける。
-





### Adjusting the stapling position

1. Connect the machine power plug to the wall outlet and turn the machine main power switch on.
2. Make a test copy using staple mode (double stapled).
3. Check whether the stapling position is off-center. If the staple position is off-center, follow the procedure below to adjust the position.  
<Reference value> 78.5 mm  $\pm$ 2.5 mm from the center of the paper

### Ajustement de la position d'agrafage

1. Insérer la fiche d'alimentation de la machine dans la prise murale et mettre la machine sous tension.
2. Procéder à une copie d'essai en mode agrafage (double agrafage).
3. Vérifier que la position d'agrafage n'est pas en décalage. Si la position d'agrafage est décalée, la régler en procédant de la manière suivante.  
<Valeur de référence> 78,5 mm  $\pm$ 2,5 mm depuis le milieu de la feuille de papier.

### Ajuste de la posición de grapado

1. Conecte el enchufe de la máquina al receptáculo de pared y encienda el interruptor principal de la máquina.
2. Haga una copia de prueba en el modo de grapado (grapado doble).
3. Compruebe si la posición de grapado está descentrada. Si la posición de grapado está descentrada, realice el siguiente procedimiento para ajustar la posición.  
<Valor de referencia> 78,5 mm  $\pm$  2,5 mm del centro del papel

### Justage der Heftposition

1. Stecken Sie den Netzstecker des Geräts in die Wandsteckdose und schalten Sie das Gerät am Hauptschalter ein.
2. Erstellen Sie eine Probekopie im Heftmodus (doppelt geheftet).
3. Prüfen Sie, ob die Heftposition außermittig ist. Falls die Heftposition außermittig ist, müssen Sie sie wie folgend einstellen.  
<Bezugswert> 78,5 mm  $\pm$ 2,5 mm von der Blattmitte

### Regolazione della posizione di pinzatura

1. Collegare la spina alla presa di corrente a muro e accendere l'interruttore di alimentazione della macchina.
2. Eseguire una copia di prova utilizzando la modalità di spillatura con punti metallici (spillatura doppia).
3. Verificare che la posizione di spillatura non sia fuori centro. Se la posizione di spillatura è fuori centro, seguire la procedura riportata sotto per regolare la posizione.  
<Valore di riferimento> 78,5 mm  $\pm$  2,5 mm dal centro del foglio

### 调节装订位置

1. 将机器上的电源插头插入电源插座中，打开主电源开关。
2. 在装订模式（2点固定）下进行测试复印。
3. 确认装订位置的偏差。装订位置偏离中心时，按以下步骤进行调节。  
<基准值> 距离纸张中心 78.5mm  $\pm$  2.5mm

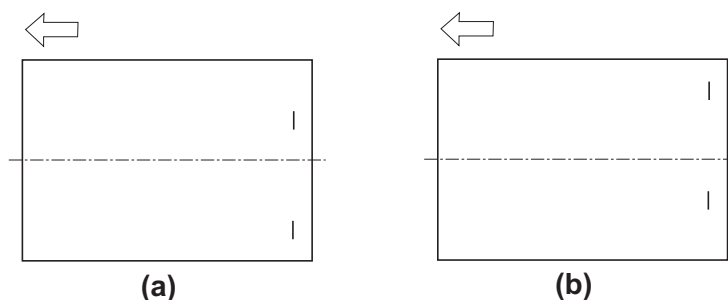
### 스태이플 위치 조정

1. 본체 전원플러그를 콘센트에 꽂고 주 전원 스위치를 ON 으로 합니다 .
2. 스타이플 모드 (2 곳) 에서 시험복사를 합니다 .
3. 스타이플 위치의 센터 어긋남을 확인합니다 . 스타이플 위치가 중심에서 벗어난 경우다음 순서로 조정을 합니다 .  
<기준치> 용지 센터에서 78.5mm  $\pm$  2.5mm

### ステーブル位置の調整

1. 機械本体の電源プラグをコンセントに差し込み、主電源スイッチをONにする。
2. ステーブルモード(2箇所止め)でテストコピーを行う。
3. ステーブル位置のセンターずれを確認する。ステーブル位置が中心からずれていた場合、次の手順で調整を行う。  
<基準値> 用紙センターより 78.5mm  $\pm$  2.5mm





4. Set maintenance mode U246, select Finisher and Staple HP.  
 5. Adjust the values.  
 If the paper is stapled too close to the front of the machine (a): Increase the setting value.  
 If the paper is stapled too close to the rear of the machine (b): Decrease the setting value.

6. Perform a test copy.  
 7. Repeat steps 4 to 6 until the staple position is within the reference value.  
 <Reference value> 78.5 mm  $\pm$ 2.5 mm from the center of the paper

4. Passer en mode maintenance U246, sélectionner Finisher et Staple HP.  
 5. Régler les valeurs.  
 Si le papier est agrafé trop près de l'avant de la machine (a): augmenter la valeur de réglage.  
 Si le papier est agrafé trop près de l'arrière de la machine (b): réduire la valeur de réglage.

6. Effectuer une copie de test.  
 7. Recommencer les étapes 4 à 6 jusqu'à ce que la position d'agrafe soit conforme à la valeur de référence  
 <Valeur de référence> 78,5 mm  $\pm$ 2,5 mm depuis le milieu de la feuille de papier.

4. Entre en el modo de mantenimiento U246, seleccione Finisher y Staple HP.  
 5. Ajuste los valores.  
 Si el grapado del papel se encuentra demasiado cerca del frente de la máquina (a): aumente el valor de configuración.  
 Si el grapado del papel se encuentra demasiado cerca de la parte posterior de la máquina (b): disminuya el valor de configuración.

6. Haga una copia de prueba.  
 7. Repita los pasos 4 a 6 hasta que la posición de grapado se encuentre dentro del valor de referencia.  
 <Valor de referencia> 78,5 mm  $\pm$  2,5 mm del centro del papel

4. Schalten Sie in den Wartungsmodus U246, wählen Sie Finisher und Staple HP.  
 5. Die Werte einstellen.  
 Falls das Papier zu nahe am vorderen Rand des Geräts (a) abgestapelt wird: Vergrößern Sie den Stellwert.  
 Falls das Papier zu nahe am hinteren Rand des Geräts (b) abgestapelt wird: Verkleinern Sie den Stellwert.

6. Eine Testkopie erstellen.  
 7. Wiederholen Sie die Schritte 4 bis 6, bis die Heftposition im Bereich des Bezugswerts liegt.  
 <Bezugswert> 78,5 mm  $\pm$ 2,5 mm von der Blattmitte

4. Impostare la modalità manutenzione U246, selezionare Finisher e Staple HP.  
 5. Regolare i valori.  
 Se il foglio viene spillato troppo vicino alla parte anteriore della macchina (a): Aumentare il valore di impostazione.  
 Se il foglio viene spillato troppo vicino alla parte posteriore della macchina (b): Diminuire il valore di impostazione.

6. Eseguire una copia di prova.  
 7. Ripetere i passi 4 to 6 finché la posizione di spillatura risulta all'interno del valore di riferimento.  
 <Valore di riferimento> 78,5 mm  $\pm$  2,5 mm dal centro del foglio

4. 设置维护模式 U246, 选择 Finisher、Staple HP。  
 5. 调整设定值。  
 装订位置向机器前部偏移时 (a): 调高设定值。  
 装订位置向机器后部偏移时 (b): 调低设定值。

6. 进行测试复印。  
 7. 重复步骤 4 ~ 6, 直到装订位置在基准范围内为止。  
 <基准值> 距离纸张中心 78.5mm  $\pm$  2.5mm

4. 메인テナンス 모드 U246 을 세트하고 Finisher, Staple HP 를 선택합니다.  
 5. 설정치를 조정합니다.  
 스테이플 위치가 기기앞측으로 벗어난 경우 (a): 설정치를 높입니다.  
 스테이플 위치가 기기뒷측으로 벗어난 경우 (b): 설정치를 내입니다.

6. 시험복사를 합니다.  
 7. 스테이플 위치가 기준치내가 될 때까지 순서 4 ~ 6 을 반복합니다.  
 <기준치> 용지 센터에서 78.5mm  $\pm$  2.5mm

4. メンテナンスモード U246 をセットし、Finisher、Staple HP を選択する。  
 5. 設定値を調整する。  
 ステープル位置が機械前側にずれている場合 (a): 設定値を上げる。  
 ステープル位置が機械後側にずれている場合 (b): 設定値を下げる。

6. テストコピーを行う。  
 7. ステープル位置が基準値内になるまで、手順 4 ~ 6 を繰り返す。  
 <基準値> 用紙センターより 78.5mm  $\pm$  2.5mm



303NB5676001

2013. 1  
303NB56760-01

# **INSTALLATION GUIDE FOR FINISHER ATTACHMENT KIT**

---

**INSTALLATION GUIDE**

**GUIDE D'INSTALLATION**

**GUÍA DE INSTALACION**

**INSTALLATIONSANLEITUNG**

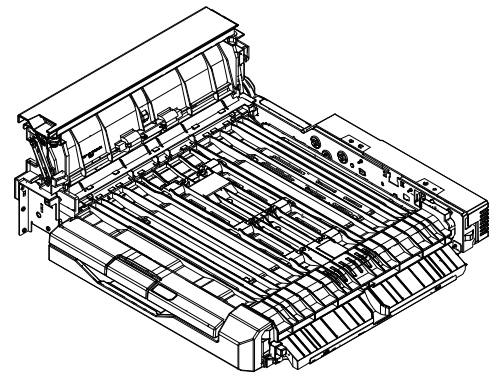
**GUIDA ALL'INSTALLAZIONE**

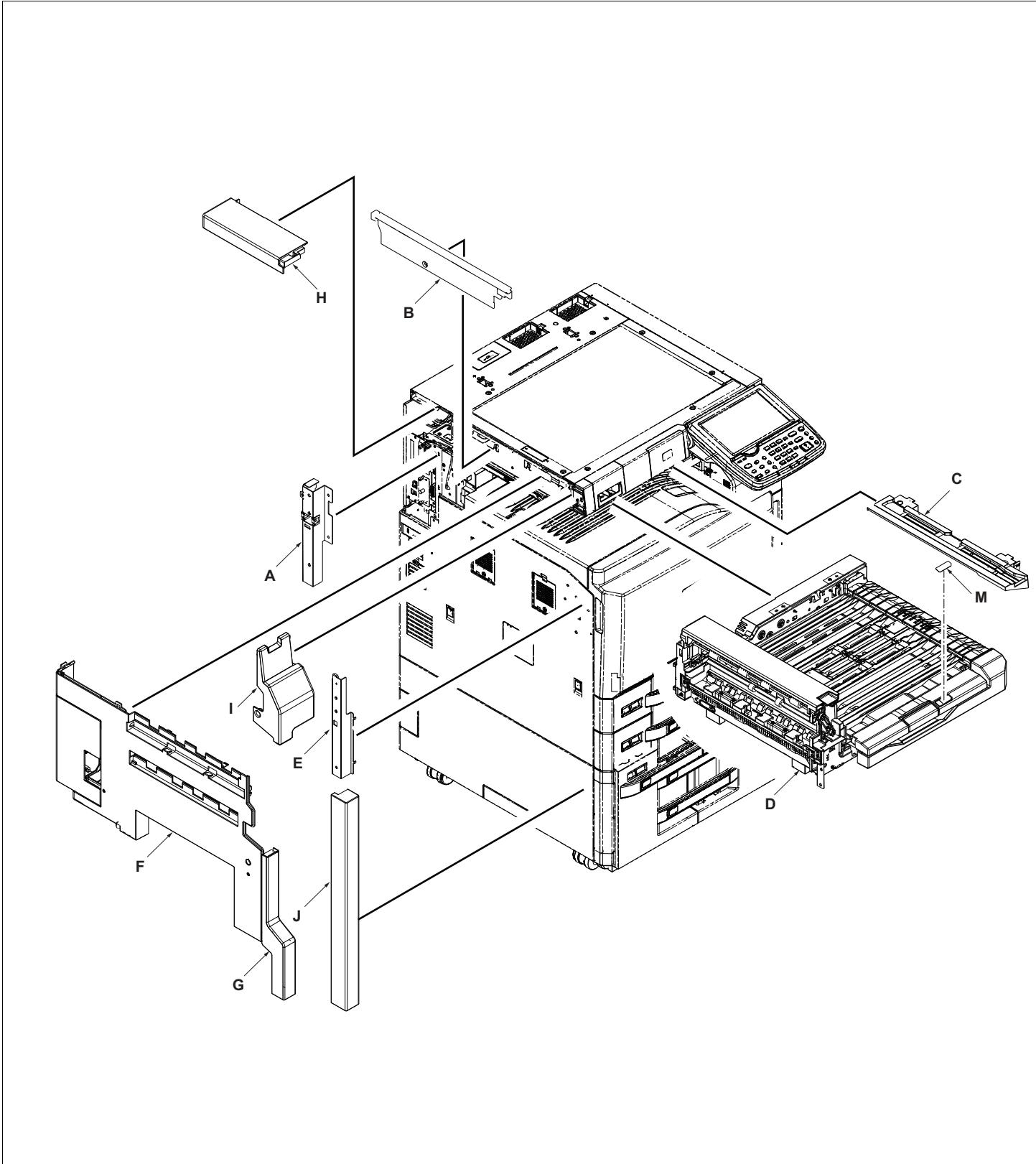
**安装手册**

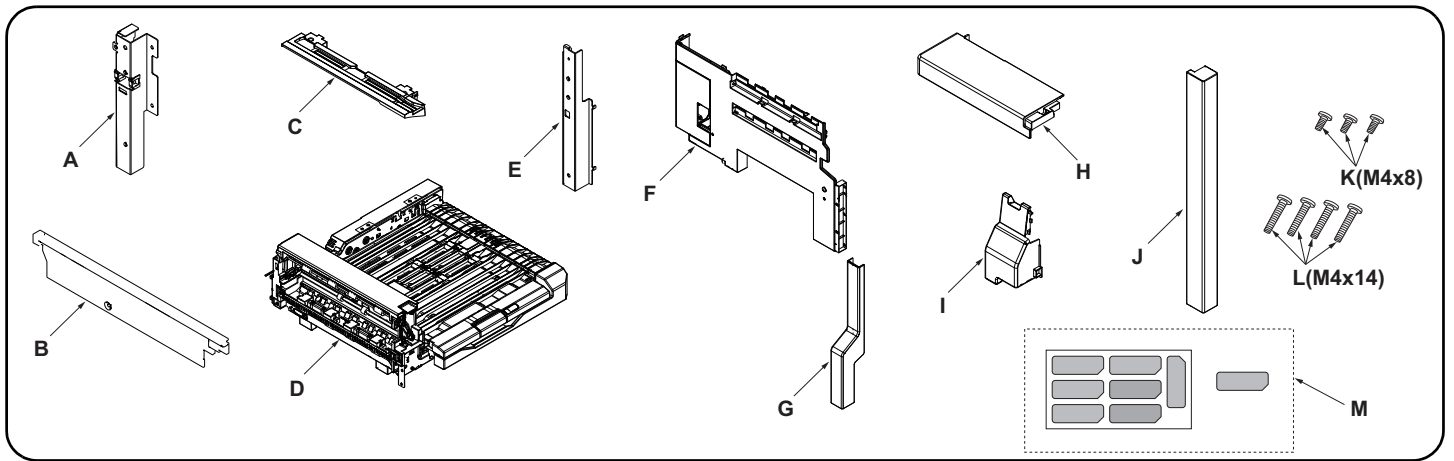
**설치안내서**

**設置手順書**

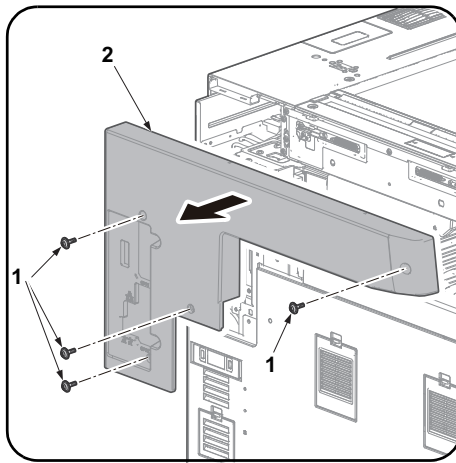
**AK-731**







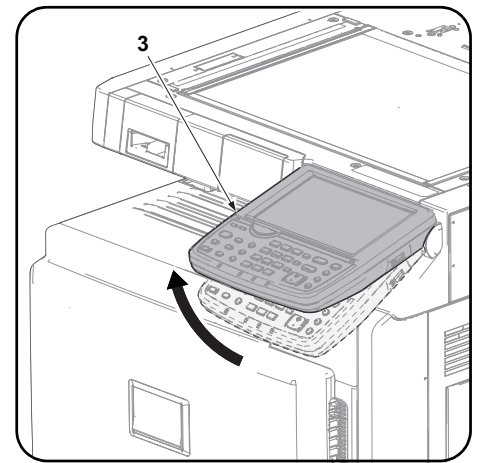
<p><b>English</b></p> <p><b>Supplied parts</b></p> <p>A. Rear left stay..... 1</p> <p>B. Left scanner cover ..... 1</p> <p>C. Rail AK..... 1</p> <p>D. AK unit ..... 1</p>	<p>E. Front left stay ..... 1</p> <p>F. Left cover ..... 1</p> <p>G. Front cover..... 1</p> <p>H. Left upper cover ..... 1</p> <p>I. Left front cover ..... 1</p> <p>J. Lower connection cover..... 1</p>	<p>K. M4 × 8 screw ..... 3</p> <p>L. M4 × 14 screw ..... 4</p> <p>M. Label ..... 1</p> <p>Be sure to remove any tape and/or cushioning material from supplied parts.</p>
<p><b>Français</b></p> <p><b>Pièces fournies</b></p> <p>A. Support arrière gauche..... 1</p> <p>B. Capot de scanner gauche ..... 1</p> <p>C. Rail AK..... 1</p> <p>D. Unité AK ..... 1</p>	<p>E. Support avant gauche..... 1</p> <p>F. Capot gauche ..... 1</p> <p>G. Capot avant ..... 1</p> <p>H. Capot supérieur gauche ..... 1</p> <p>I. Capot avant gauche..... 1</p> <p>J. Capot de connexion inférieur..... 1</p>	<p>K. Vis M4 × 8..... 3</p> <p>L. Vis M4 × 14..... 4</p> <p>M. Étiquette..... 1</p> <p>Veillez à retirer les morceaux de bande adhésive et/ou les matériaux de rembourrage des pièces fournies.</p>
<p><b>Español</b></p> <p><b>Partes suministradas</b></p> <p>A. Soporte izquierdo trasero ..... 1</p> <p>B. Cubierta izquierda del escáner..... 1</p> <p>C. Kit AK del rail..... 1</p> <p>D. Unidad de AK ..... 1</p>	<p>E. Soporte frontal izquierdo..... 1</p> <p>F. Cubierta izquierda..... 1</p> <p>G. Cubierta frontal ..... 1</p> <p>H. Cubierta superior izquierda..... 1</p> <p>I. Cubierta frontal izquierda..... 1</p> <p>J. Cubierta de conexiones inferior ..... 1</p>	<p>K. Tornillo M4 × 8 ..... 3</p> <p>L. Tornillo M4 × 14 ..... 4</p> <p>M. Etiqueta..... 1</p> <p>Asegúrese de despegar todas las cintas y/o material amortiguador de las partes suministradas.</p>
<p><b>Deutsch</b></p> <p><b>Gelieferte Teile</b></p> <p>A. Hintere linke Stütze..... 1</p> <p>B. Linke Scanner-Abdeckung ..... 1</p> <p>C. AK Schiene..... 1</p> <p>D. AK Baugruppe ..... 1</p>	<p>E. Vordere linke Stütze..... 1</p> <p>F. Linke Abdeckung ..... 1</p> <p>G. Vordere Abdeckung ..... 1</p> <p>H. Linke obere Abdeckung ..... 1</p> <p>I. Linke vordere Abdeckung ..... 1</p> <p>J. Untere Verbindungsabdeckung ..... 1</p>	<p>K. M4 × 8 Schraube ..... 3</p> <p>L. M4 × 14 Schraube ..... 4</p> <p>M. Aufkleber..... 1</p> <p>Entfernen Sie Klebeband und/oder Dämpfungsmaterial vollständig von den mitgelieferten Teilen.</p>
<p><b>Italiano</b></p> <p><b>Parti di forniture</b></p> <p>A. Supporto posteriore sinistro..... 1</p> <p>B. Coperchio sinistro dello scanner ..... 1</p> <p>C. Binario AK..... 1</p> <p>D. Unità AK ..... 1</p>	<p>E. Supporto anteriore sinistro..... 1</p> <p>F. Coperchio sinistro ..... 1</p> <p>G. Coperchio frontale ..... 1</p> <p>H. Coperchio superiore sinistro ..... 1</p> <p>I. Coperchio frontale sinistro ..... 1</p> <p>J. Coperchio connessione inferior ..... 1</p>	<p>K. Vite M4 × 8..... 3</p> <p>L. Vite M4 × 14..... 4</p> <p>M. Etichetta ..... 1</p> <p>Accertarsi di rimuovere tutti i nastri adesivi e/o il materiale di imbottitura dalle parti fornite.</p>
<p><b>简体中文</b></p> <p><b>附属品</b></p> <p>A. 左后部支架..... 1</p> <p>B. 扫描仪左盖板..... 1</p> <p>C. 导轨 AK..... 1</p> <p>D. AK 组件..... 1</p>	<p>E. 左前部支架 ..... 1</p> <p>F. 左盖板 ..... 1</p> <p>G. 前盖板 ..... 1</p> <p>H. 左上部盖板 ..... 1</p> <p>I. 左前盖板 ..... 1</p> <p>J. 连接下盖板 ..... 1</p>	<p>K. M4×8 螺丝 ..... 3</p> <p>L. M4×14 螺丝 ..... 4</p> <p>(M) 并非附属品。 如果附属品上带有固定胶带, 缓冲材料时务必揭下。</p>
<p><b>한국어</b></p> <p><b>동봉품</b></p> <p>A. 좌측 뒷 받침대..... 1</p> <p>B. 스캐너 좌측 커버..... 1</p> <p>C. 레일 AK..... 1</p> <p>D. AK 유닛..... 1</p>	<p>E. 좌측 뒷 받침대..... 1</p> <p>F. 좌측 커버..... 1</p> <p>G. 전면 커버..... 1</p> <p>H. 좌측 상커버..... 1</p> <p>I. 좌측 전면 커버..... 1</p> <p>J. 연결 하커버..... 1</p>	<p>K. 나사 M4×8..... 3</p> <p>L. 나사 M4×14..... 4</p> <p>(M) 는 동봉되어 있지 않습니다. 동봉품에 고정 테이프, 완충재가 붙어 있는 경우에는 반드시 제거할 것.</p>
<p><b>日本語</b></p> <p><b>同梱品</b></p> <p>A. 左後ステー..... 1</p> <p>B. スキャナー左カバー..... 1</p> <p>C. レール AK..... 1</p> <p>D. AK ユニット ..... 1</p>	<p>E. 左前ステー ..... 1</p> <p>F. 左カバー ..... 1</p> <p>G. 前カバー ..... 1</p> <p>H. 左上カバー ..... 1</p> <p>I. 左前カバー ..... 1</p> <p>J. 連結下カバー ..... 1</p>	<p>K. ビス M4×8..... 3</p> <p>L. ビス M4×14..... 4</p> <p>M. ラベル ..... 1</p> <p>同梱品に固定テープ、緩衝材がついている場合は、必ず取り外すこと。</p>



Before starting installation, be sure to turn the main power switch of the machine off, and unplug the power plug from the wall outlet.

**Procedure**

1. Remove the four screws (1). Remove the left upper cover (2).



2. If the operation panel (3) is lowered, raise it to the top position.

Avant de commencer l'installation, s'assurer de mettre la machine hors tension et de débrancher la fiche d'alimentation de la prise murale.

**Procédure**

1. Retirez les quatre vis (1). Retirez le capot supérieur gauche (2).

2. Si le panneau de commande (3) est abaissé, le relever dans sa position maximum.

Antes de iniciar la instalación, asegúrese de apagar el interruptor de encendido de la máquina y desenchufar el cable de alimentación de la toma de pared.

**Procedimiento**

1. Quite los cuatro tornillos (1). Quite la cubierta superior izquierda (2).

2. Si el panel de trabajo (3) está bajo, levántelo hasta la posición superior.

Bevor Sie mit der Installation beginnen überzeugen Sie sich, dass der Netzschalter des Geräts ausgeschaltet und das Stromkabel aus der Steckdose gezogen ist.

**Verfahren**

1. Entfernen Sie die vier Schrauben (1). Entfernen Sie die linke obere Abdeckung (2).

2. Heben Sie das Bedienfeld (3) in die oberste Position, falls es gesenkt ist.

Prima di iniziare l'installazione, spegnere la macchina e scollegare la spina dalla presa di corrente.

**Procedura**

1. Togliere le quattro viti (1). Rimuovere il coperchio superiore sinistro (2).

2. Se il pannello operativo (3) è abbassato, sollevarlo alla posizione in alto.

安装前务必关闭机器的主电源开关, 并从墙壁插座拔下电源插头。

**安装步骤**

1. 取下 4 颗螺丝 (1)。取下左上盖板 (2)。

2. 操作面板 (3) 处于低位时, 将其升到最高位置。

설치를 시작하기 전에 반드시 본체의 주 전원 스위치를 끄고 벽 콘센트에서 전원 플러그를 분리하십시오.

**설치순서**

1. 나사 (1) 4 개를 제거합니다. 좌측 상커버 (2) 를 제거합니다.

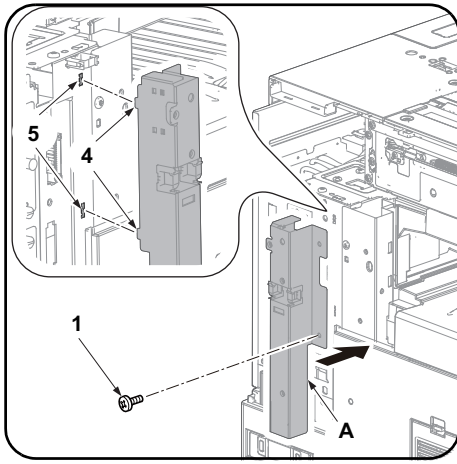
2. 조작판넬 (3) 이 내려가 있는 경우에는 위로 올립니다.

必ず機械本体の主電源スイッチをOFFにし、機械本体の電源プラグを抜いてから作業すること。

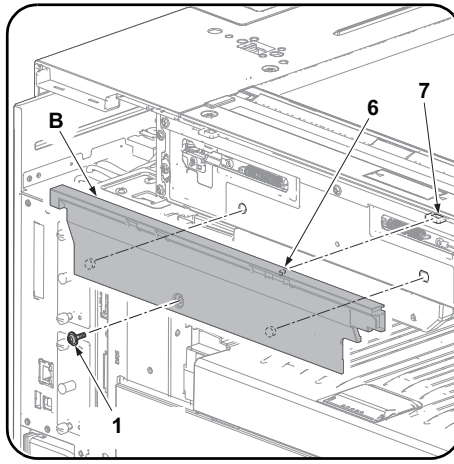
**取付手順**

1. ビス (1) 4 本を外す。左上カバー (2) を取り外す。

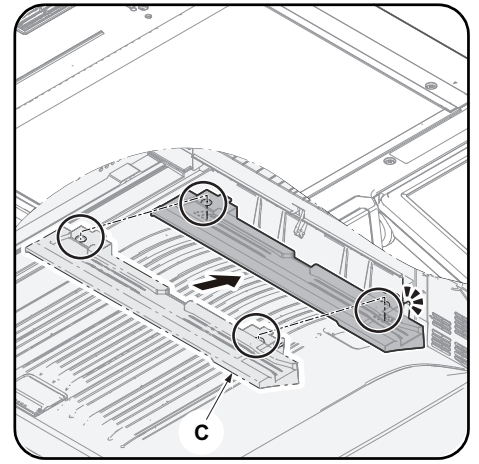
2. 操作パネル (3) が下がっている場合は上位位置に上げる。



3. Insert the two projections(4) on the left rear stay(A) into the holes(5) in the frame. Secure the left rear stay(A) with the screw(1) removed in step 1.



4. Insert the hook(6) on the left cover of the scanner(B) into the hole(7) in the frame. Secure the left cover(B) of the scanner with the screw(1) removed in step 1.



5. Align the projection of the rail AK(C) with the hole of the tray cover. (Fit it until it clicks into place.)

3. Introduire les deux ergots (4) du support arrière gauche (A) dans les trous (5) du cadre. Fixer le support arrière gauche (A) avec la vis (1) retirée à l'étape 1.

4. Introduire le crochet (6) sur le capot gauche du scanner (B) dans le trou (7) du cadre. Fixer le capot gauche (B) du scanner avec la vis (1) retirée à l'étape 1.

5. Aligner l'ergot du rail AK (C) avec le trou du capot de bac. (Un dé clic indique que la pièce est en position.)

3. Inserte las dos proyecciones (4) de la estancia izquierda posterior (A) en los orificios (5) del marco. Fije la estancia izquierda posterior (A) con el tornillo (1) que quitó en el paso 1.

4. Inserte el enganche (6) de la cubierta izquierda del escáner (B) en el orificio (7) del marco. Fije la cubierta izquierda (B) del escáner con el tornillo (1) que quitó en el paso 1.

5. Alinee la proyección del AK del raíl (C) con el orificio de la cubierta de la bandeja. (Ajustela hasta que escuche un clic de posicionamiento.)

3. Setzen Sie die beiden Nasen (4) des linken hinteren Anschlags (A) in die Öffnungen (5) der seitlichen Platte. Befestigen Sie den linken hinteren Anschlag (A). Benutzen Sie die Schraube (1) aus Schritt 1.

4. Setzen Sie die Haken (6) der linken Scanner-Abdeckung (B) in die Öffnung (7) der seitlichen Platte. Befestigen Sie die linke Scanner-Abdeckung (B). Benutzen Sie die Schraube (1) aus Schritt 1.

5. Richten Sie die Nase der AK Schiene (C) mit den Öffnungen der Abdeckung der Ablage aus. (Bewegen Sie es so lange, bis es in der richtigen Position einrastet.)

3. Inserire le due sporgenze (4) sul tirante posteriore sinistro (A) nei fori (5) sul telaio. Fissare il tirante posteriore sinistro (A) con la vite (1) rimossa al punto 1.

4. Inserire il gancio (6) presente sul coperchio sinistro dello scanner (B) nel foro (7) sul telaio. Fissare il coperchio sinistro (B) dello scanner con la vite (1) rimossa al punto 1.

5. Allineare la sporgenza del binario AK (C) al foro del coperchio vassoio. (Inserire fino a sentire il clic di blocco in posizione.)

3. 把左后部支架 (A) 的 2 处突起部 (4) 插入侧板的孔 (5) 中。使用步骤 1 中取下的 1 颗螺丝 (1) 来固定左后部支架 (A)。

4. 把扫描仪左盖板 (B) 的挂钩 (6) 插入侧板的孔 (7) 中。使用步骤 1 中取下的 1 颗螺丝 (1) 来固定扫描仪左盖板 (B)。

5. 使导轨 AK (C) 的凸起部和托盘盖板的凹处对齐后安装。(插入, 直至其卡入到位)

3. 좌측 뒷 받침대 (A) 에 있는 2 개의 돌기 (4) 를 프레임의 구멍 (5) 에 삽입합니다. 순서 1 에서 제거한 나사 (1) 로 좌측 뒷 받침대 (A) 를 고정합니다.

4. 스캐너 좌측 커버 (B) 에 있는 후크 (6) 를 프레임의 구멍 (7) 에 삽입합니다. 순서 1 에서 제거한 나사 (1) 로 스캐너 좌측 커버 (B) 를 고정합니다.

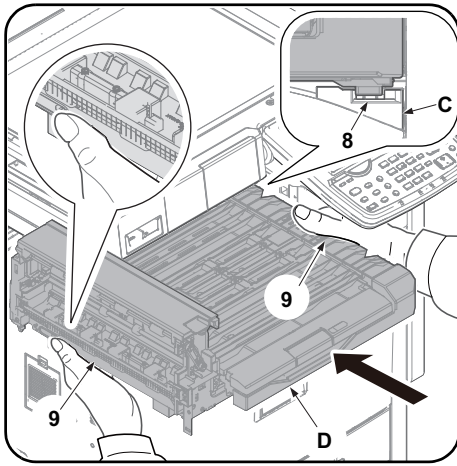
5. 레일 AK (C) 의 돌출부를 트레이 커버의 구멍에 맞춥니다. (찰칵 소리가 나서 제자리에 장착될 때까지 삽입합니다.)

3. 左後ステー (A) の 2 個の突起 (4) を側板の穴 (5) に入れる。手順 1 で外したビス (1) 1 本で左後ステー (A) を固定する。

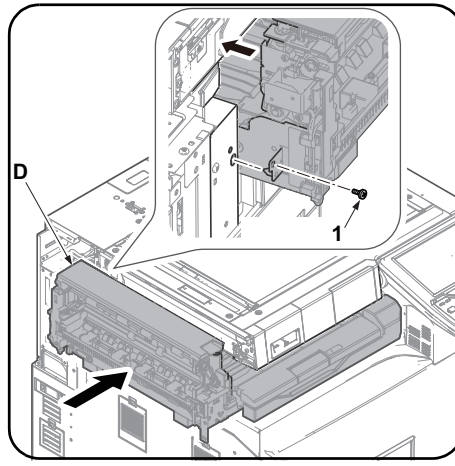
4. スキャナー左カバー (B) のフック (6) を側板の穴 (7) に入れる。手順 1 で外したビス (1) 1 本でスキャナー左カバー (B) を固定する。

5. レール AK (C) の凸部と、トレイカバーの凹部を、あわせて取り付け。 (カチッと音がするまで挿入する)

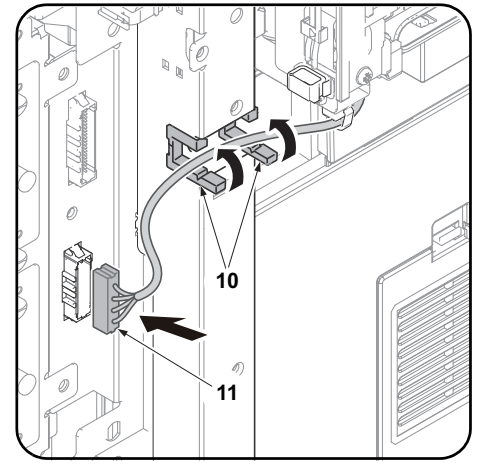




6. Align the AK unit(D) with the groove(8) of the rail AK(C). Push it from the front of machine as far as it will go.  
\*Both ends(9) of the AK unit(D) should be lifted.



7. Slide the AK unit(D) to the right.  
8. Secure the AK unit(D) with the screw(1) removed in step 1.



9. Run the cable from the AK unit(D) through the two edgings(10). Plug the connector(11) into the machine.

6. Aligner l'unité AK (D) avec la rainure (8) du rail AK (C). Poussez à fond depuis l'avant de la machine.  
\*Les deux extrémités (9) de l'unité AK (D) doivent être soulevées.

7. Faire glisser l'unité AK (D) vers la droite.  
8. Fixer l'unité AK (D) avec la vis (1) retirée à l'étape 1.

9. Faire passer le câble depuis l'unité AK (D) à travers les deux bords (10). Brancher le connecteur (11) dans la machine.

6. Alinee la unidad AK (D) con la ranura (8) del AK del rail (C). Empújela desde la parte frontal de la máquina hasta el máximo.  
\*Ambos extremos (9) de la unidad AK (D) se deben levantar.

7. Deslice la unidad AK (D) a la derecha.  
8. Con el tornillo (1) que quitó en el paso 1, fije la unidad AK (D).

9. Pase el cable de la unidad AK (D) a través de los dos bordes (10). Enchufe el conector (11) a la máquina.

6. Richten Sie die AK Baugruppe (D) mit der Nut (8) der AK Schiene (C) aus. Drücken Sie sie von der Vorderseite des Geräts so weit es geht hinein.  
\*Beide Enden (9) der AK Baugruppe (D) sollten angehoben werden.

7. Schwenken Sie die AK Baugruppe (D) nach rechts.  
8. Befestigen Sie die AK Baugruppe (D). Benutzen Sie die Schraube (1) aus Schritt 1.

9. Legen Sie die Kabel der AK Baugruppe (D) durch die beiden Einfassungen (10). Stecken Sie den Stecker (11) ins Gerät.

6. Allineare l'unità AK (D) alla scanalatura (8) del binario AK (C). Dal fronte della macchina, spingere per inserire a fondo.  
\*Entrambe le unità (9) dell'unità AK (D) devono essere sollevate.

7. Inserire l'unità AK (D) sulla destra.  
8. Fissare l'unità AK (D) con la vite (1) rimossa al punto 1.

9. Tirare il cavo dall'unità AK (D) attraverso i due spigoli (10). Collegare il connettore (11) sulla macchina.

6. 使 AK 组件 (D) 和导轨 AK (C) 的沟槽 (8) 对齐。从机器前侧向内侧插入到底。  
※ 必须拿在 AK 组件 (D) 的两端 (9)。

7. 使 AK 组件 (D) 向右侧滑动。  
8. 使用步骤 1 中取下的 1 颗螺丝 (1) 来固定 AK 组件 (D)。

9. 使 AK 组件 (D) 的电线穿过 2 处束线夹 (10)。把接插件 (11) 连接到机器本体。

6. AK 유닛 (D) 를 레일 AK (C) 의 홈 (8) 에 맞춥니다. 본체 전면에서 가능한 한 멀리 밀어 넣습니다.  
※ AK 유닛 (D) 의 양 끝 (9) 을 들어 올려야 합니다.

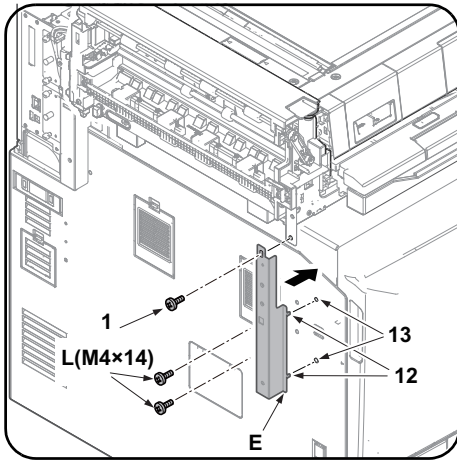
7. AK 유닛 (D) 를 오른쪽으로 밀니다.  
8. 순서 1 에서 제거한 나사 (1) 로 AK 유닛 (D) 를 고정합니다.

9. AK 유닛 (D) 의 전선을 2 가장자리 (10) 를 통과하도록 합니다. 커넥터 (11) 를 본체에 연결합니다.

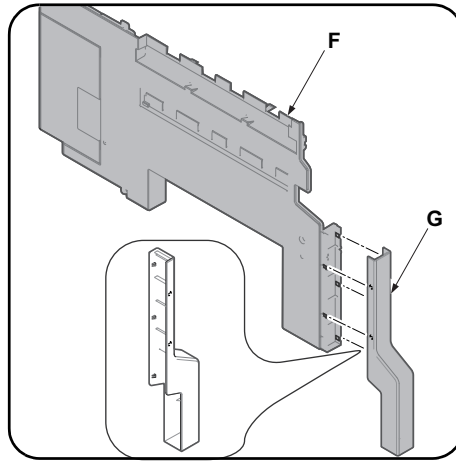
6. AK 유닛 (D) 을, 레일 AK (C) 의溝 (8) にあわせる。機械前側から奥まで挿入する。  
※AK 유닛 (D) は、必ず両端部 (9) を持つこと。

7. AK 유닛 (D) 을, 右側にスライドさせる。  
8. 手順 1 で外したビス (1) 1 本で AK 유닛 (D) を固定する。

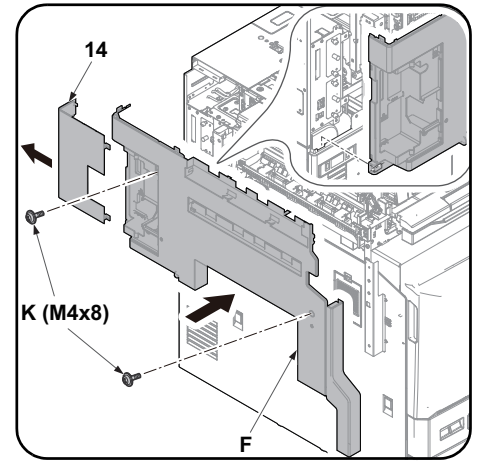
9. AK 유닛 (D) の電線を、2 箇所のエッジング (10) に通す。コネクタ (11) を機械本体に接続する。



10. Insert the two projections (12) on the left front stay (E) into the holes (13) of the left cover in the machine. Secure the left front stay (E) using the two screws M4x14 (L) and the screw (1) removed in step 1.



11. Attach the front cover (G) to the left cover (F).



12. Remove the interface cover (14).  
\* After installing the document finisher, re-attach the interface cover (14).  
13. Install the left cover (F) using the two screws M4x8 (K).

10. Introduire les deux ergots (12) du support avant gauche (E) dans les trous (13) du capot gauche de la machine. Fixer le support avant gauche (E) à l'aide des deux vis M4x14 (L) et de la vis (1) retirée à l'étape 1

11. Installer le capot avant (G) sur le capot gauche (F).

12. Déposer le Capot d'interface (14).  
\* Après avoir installé le retoucheur de document, reposer le Capot d'interface (14).  
13. Installer le capot gauche (F) à l'aide des deux vis M4x8 (K).

10. Inserte las dos proyecciones (12) de la estancia izquierda frontal (E) en los orificios (13) de la cubierta izquierda de la máquina. Fije la estancia frontal izquierda (E) con los dos tornillos M4x14 (L) con el tornillo (1) que quitó en el paso 1.

11. Conecte la cubierta frontal (G) a la cubierta izquierda (F).

12. Quite la cubierta de la interfaz (14).  
\* Después de instalar el finalizador de documentos, vuelva a colocar la cubierta de la interfaz (14).  
13. Instale la cubierta izquierda (F) con los dos tornillos M4x8 (K).

10. Setzen Sie die beiden Nasen (12) des linken vorderen Anschlags (E) in die Öffnungen (13) der linken Abdeckung ins Gerät ein. Befestigen Sie den linken vorderen Anschlag (E). Benutzen Sie die zwei Schrauben M4x14 (L) und die Schraube (1) aus Schritt 1.

11. Befestigen Sie die vordere Abdeckung (G) an der linken Abdeckung (F).

12. Entfernen Sie die Schnittstellenabdeckung (14).  
\* Bringen Sie nach der Installation des Dokument-Finishers wieder die Schnittstellenabdeckung (14) an.  
13. Installieren Sie die linke Abdeckung (F) mit den beiden Schrauben M4x8 (K).

10. Inserire le due sporgenze (12) del tirante frontale sinistro (E) nei fori (13) del coperchio sinistro sulla macchina. Fissare il tirante frontale sinistro (E) con le due viti M4x14 (L) e la vite (1) rimossa al punto 1.

11. Montare il coperchio frontale (G) sul coperchio sinistro (F).

12. Rimuovere il coperchio interfaccia (14).  
\* Dopo l'installazione della finitrice di documenti, fissare di nuovo il coperchio interfaccia (14).  
13. Installare il coperchio sinistro (F) utilizzando le due viti M4x8 (K).

10. 把左前部支架 (E) 的 2 处突起部 (12) 插入机器本体的左盖板的孔 (13) 中。使用 2 颗螺丝 M4x14 (L) 和步骤 1 中取下的 1 颗螺丝 (1) 来固定左前部支架 (E)。

11. 把前盖板 (G) 安装到左盖板 (F) 上。

12. 拆下接口盖板 (14)。  
※ 在装订器设置完成后, 按原样安装接口盖板 (14)。  
13. 使用 2 颗螺丝 M4x8 (K) 来安装左盖板 (F)。

10. 좌측 전면 받침대 (E) 의 두 돌기 (12) 를 본체의 좌측 커버의 구멍 (13) 에 삽입합니다. 나사 M4 x 14 (L) 2 개와 순서 1 에서 제거한 나사 (1) 를 사용하여 좌측 전면 받침대 (E) 를 고정합니다.

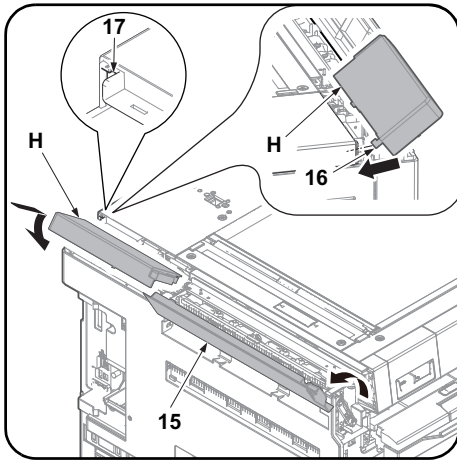
11. 전면 커버 (G) 를 좌측 커버 (F) 에 부착합니다.

12. 인터페이스 커버 (14) 를 제거합니다.  
※ 인터페이스 커버 (14) 는 문서 피니셔 설치 후에 원래대로 장착합니다.  
13. 나사 M4x8 (K) 2 개를 사용하여 좌측 커버 (F) 를 장착합니다.

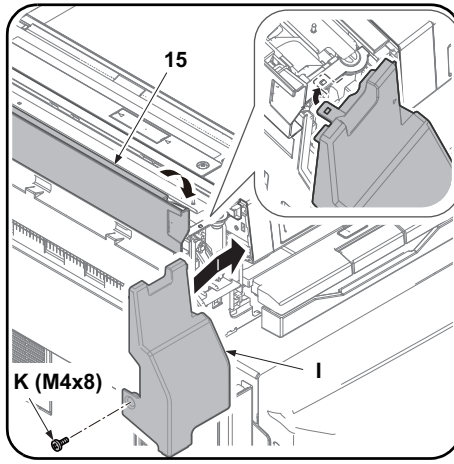
10. 左前ステー (E) の 2箇所の突起 (12) を機械本体の左カバーの穴 (13) に入れる。ビス M4x14 (L) 2本と手順 1 で外したビス (1) 1本で左前ステー (E) を固定する。

11. 左カバー (F) に前カバー (G) を取り付ける。

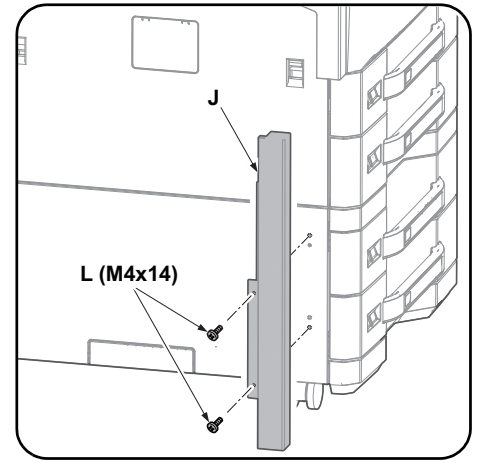
12. インターフェイスカバー (14) を取り外す。  
※ インターフェイスカバー (14) はドキュメントフィニッシャー設置後に、元通り取り付け。  
13. ビス M4x8 (K) 2本で左カバー (F) を取り付け。



14. Open the eject cover (15).  
15. Insert the hook (16) of the left top cover (H) into the notched section (17) of the cover in the machine.



16. Attach the left front cover (I). Secure it using the screw M4 x 8 (K).  
17. Close the eject cover (15).



18. Attach the lower connection cover (J) with the 2 M4 x 14 screws (L).

14. Ouvrir le capot de sortie (15).  
15. Introduire le crochet (16) du capot supérieur gauche (H) dans la section à encoche (17) du capot de la machine.

16. Installer le capot avant gauche (I). Le fixer avec la vis M4x8 (K).  
17. Fermer le capot de sortie (15).

18. Fixer le Capot de connexion inférieur (J) à l'aide de 2 vis M4 x 14 (L).

14. Abra la cubierta de salida (15).  
15. Inserte el enganche (16) de la cubierta superior izquierda (H) en la sección con muescas (17) de la cubierta de la máquina.

16. Conecte la cubierta frontal izquierda (I). Fijela con el tornillo M4x8 (K).  
17. Cierre la cubierta de salida (15).

18. Fije la cubierta de conexiones inferior (J) con los 2 tornillos M4 x 14 (L).

14. Öffnen Sie die Abdeckung des Ausgabefachs (15).  
15. Richten Sie den Haken (16) der oberen linken Abdeckung (H) mit den Einkerbungen (17) der Abdeckung des Geräts aus.

16. Befestigen Sie die linke vordere Abdeckung (I). Befestigen Sie sie mit der Schraube M4x8 (K).  
17. Schließen Sie die Abdeckung des Ausgabefachs (15).

18. Bringen Sie die untere Verbindungsabdeckung (J) mit den 2 M4 x 14 Schrauben (L) an.

14. Aprire il coperchio di uscita (15).  
15. Inserire il gancio (16) del coperchio superiore sinistro (H) nella sezione con incavo (17) del coperchio sulla macchina.

16. Montare il coperchio frontale sinistro (I). Fissarlo utilizzando la vite M4x8 (K).  
17. Chiudere il coperchio di uscita (15).

18. Fissare il coperchio connessione inferiore (J) con le 2 viti M4 x 14 (L).

14. 打开排纸盖板 (15)。  
15. 使左上盖板 (H) 的 1 处挂钩 (16) 插入盖板的缺口部 (17) 后, 再安装。

16. 安装左前盖板 (I)。使用螺丝 M4×8 (K) 来固定。  
17. 关闭排纸盖板 (15)。

18. 使用 2 颗 M4×14 螺丝 (L) 来安装连接下盖板 (J)。

14. 배출 커버 (15) 를 엽니다.  
15. 좌측 상단 커버 (H) 의 후크 (16) 를 본체 안에 있는 커버의 홈 부분 (17) 에 삽입합니다.

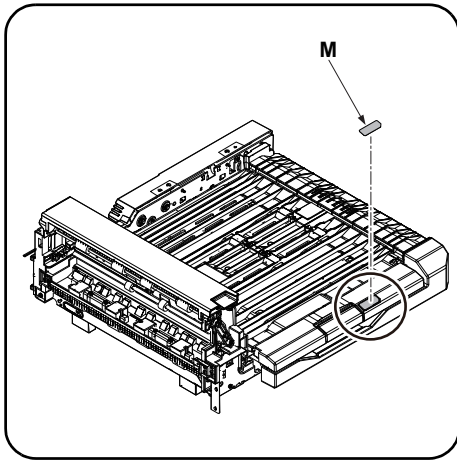
16. 좌측 전면 커버 (I) 를 장착합니다. 나사 M4 x 8 (K) 를 사용하여 고정합니다.  
17. 배출 커버 (15) 를 닫습니다.

18. 나사 M4×14 (L) 2 개로 연결 하커버 (J) 를 장착합니다.

14. 排出カバー (15) を開く。  
15. 左上カバー (H) のフック (16) 1箇所をカバーの切り欠き部 (17) に入れて、取り付ける。

16. 左前カバー (I) を取り付ける。ビス M4×8 (K) 1本 1本で固定する。  
17. 排出カバー (15) を閉じる。

18. ビス M4×14 (L) 2本で連結下カバー (J) を取り付ける。



19. Wipe the label surface shown in the figure with alcohol and adhere the label (M) of the corresponding language.

---

19. Essuyer avec de l'alcool la surface pour l'étiquette montrée sur l'illustration, et apposer l'étiquette (M) de la langue correspondante.

---

19. Limpie la superficie de la etiqueta mostrada en la ilustración con alcohol y pegue la etiqueta (M) del idioma correspondiente.

---

19. Reinigen Sie die in der Abbildung gezeigte Klebefläche des Aufklebers mit Alkohol und bringen den Aufkleber (M) der entsprechenden Sprache an.

---

19. Pulire con alcol la superficie dell'etichetta indicata nella figura e applicare l'etichetta (M) della lingua corrispondente.

---

19. 不需要本步骤。

---

19. 이 단계가 필요하지 않습니다 .

---

19. イラストの位置のラベル上面をアルコール清掃後、該当する言語のラベル (M) を貼り付ける。

# MEMO





303P05671003

2013. 1  
303P056710-03

# **INSTALLATION GUIDE FOR CENTER-FOLDING UNIT**



---

**INSTALLATION GUIDE**

**GUIDE D'INSTALLATION**

**GUÍA DE INSTALACION**

**INSTALLATIONSANLEITUNG**

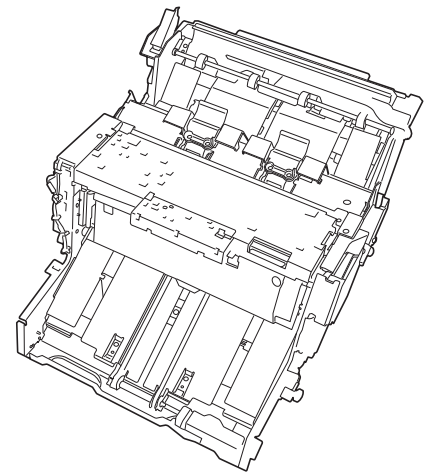
**GUIDA ALL'INSTALLAZIONE**

**安装手册**

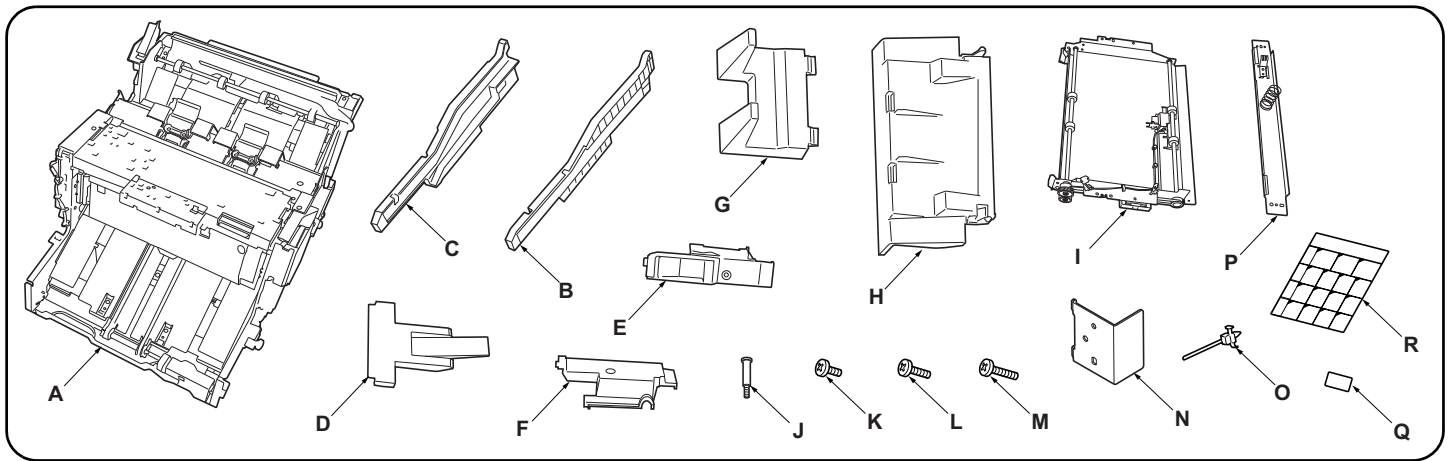
**설치안내서**

**設置手順書**

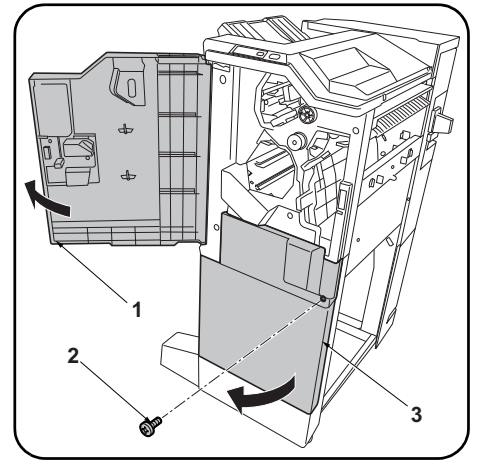
**BF-730**







<b>English</b>			
<b>Supplied parts</b>			
A. Center-Folding unit.....	1	E. Front side cover.....	1
B. Front rail.....	1	F. Rear side cover.....	1
C. Rear rail.....	1	G. Output stock tray.....	1
D. Output stopper.....	1	H. Output tray.....	1
		I. Relay paper conveying unit.....	1
		J. Pin.....	1
		K. M4 x 8 screw.....	11
		L. M4 x 10 screw (black).....	2
		M. M4 x 12 screw.....	4
		N. Lock plate.....	2
		O. Binding band.....	1
		P. Guide.....	1
		Q. D7 label.....	1
		R. Operation label.....	1
<b>Français</b>			
<b>Pièces fournies</b>			
A. Plieuse.....	1	E. Capot latéral avant.....	1
B. Glissière avant.....	1	F. Capot latéral arrière.....	1
C. Glissière arrière.....	1	G. Plateau de sortie du papier.....	1
D. Butée de sortie.....	1	H. Plateau de sortie.....	1
		I. Unité de transport du papier de relais.....	1
		J. Goupille.....	1
		K. Vis M4 x 8.....	11
		L. Vis M4 x 10 (noire).....	2
		M. Vis M4 x 12.....	4
		N. Plaque de verrouillage.....	2
		O. Collier de fixation.....	1
		P. Guide.....	1
		Q. Étiquette D7.....	1
		R. Étiquette de fonctionnement.....	1
<b>Español</b>			
<b>Partes suministradas</b>			
A. Unidad de plegado.....	1	E. Cubierta lateral frontal.....	1
B. Carril frontal.....	1	F. Cubierta lateral posterior.....	1
C. Carril posterior.....	1	G. Bandeja de recolección de papel de salida.....	1
D. Tope de salida.....	1	H. Bandeja de salida.....	1
		I. Unidad de transporte de papel por relevador.....	1
		J. Pasador.....	1
		K. Tornillo M4 x 8.....	11
		L. Tornillo M4 x 10 (negro).....	2
		M. Tornillo M4 x 12.....	4
		N. Placa de cierre.....	2
		O. Correa de sujeción.....	1
		P. Guía.....	1
		Q. Etiqueta D7.....	1
		R. Etiqueta de funcionamiento.....	1
<b>Deutsch</b>			
<b>Gelieferte Teile</b>			
A. Mittenfalteinheit.....	1	E. Vordere Seitenabdeckung.....	1
B. Vordere Schiene.....	1	F. Hintere Seitenabdeckung.....	1
C. Hintere Schiene.....	1	G. Ausgabestapel Fach.....	1
D. Ausgabeanschlag.....	1	H. Ausgabefach.....	1
		I. Eingesetzte Papierfördereinheit.....	1
		J. Stift.....	1
		K. M4 x 8 Schraube.....	11
		L. M4 x 10 Schraube (schwarz).....	2
		M. M4 x 12 Schraube.....	4
		N. Sperrplatte.....	2
		O. Schellenband.....	1
		P. Führung.....	1
		Q. D7 Aufkleber.....	1
		R. Bedienungsaufkleber.....	1
<b>Italiano</b>			
<b>Parti di forniture</b>			
A. Unità di piegatura centrale.....	1	E. Coperchio laterale anteriore.....	1
B. Rotaia anteriore.....	1	F. Coperchio laterale posteriore.....	1
C. Rotaia posteriore.....	1	G. Vassoio di uscita stoccaggio.....	1
D. Fermo di uscita.....	1	H. Vassoio di uscita.....	1
		I. Unità relay di trasporto carta.....	1
		J. Perno.....	1
		K. Vite M4 x 8.....	11
		L. Vite M4 x 10 (nera).....	2
		M. Vite M4 x 12.....	4
		N. Piastra di bloccaggio.....	2
		O. Fascetta di legatura.....	1
		P. Guida.....	1
		Q. Etichetta D7.....	1
		R. Etichetta di operazione.....	1
<b>简体中文</b>			
<b>附属品</b>			
A. 中缝装订一折页单元.....	1	E. 前部侧盖板.....	1
B. 前部导轨.....	1	F. 后部侧盖板.....	1
C. 后部导轨.....	1	G. 堆纸托盘.....	1
D. 排纸挡板.....	1	H. 排纸托盘.....	1
		I. 中间搬运单元.....	1
		J. 销钉.....	1
		K. M4x8 螺丝.....	11
		L. M4x10 螺丝 (黑).....	2
		M. M4x12 螺丝.....	4
		N. 锁定板.....	2
		O. 束线带.....	1
		P. 导板.....	1
		Q. D7 标签.....	1
		R. 操作标签.....	1
<b>한국어</b>			
<b>동봉품</b>			
A. 접기 유닛.....	1	E. 사이드 커버 앞.....	1
B. 레일 앞.....	1	F. 사이드 커버 뒤.....	1
C. 레일 뒤.....	1	G. 배지 저장 트레이.....	1
D. 배지 스톱퍼.....	1	H. 배지 트레이.....	1
		I. 중계 반송 유닛.....	1
		J. 핀.....	1
		K. 나사 M4x8.....	11
		L. 나사 M4x10 (흑).....	2
		M. 나사 M4x12.....	4
		N. 잠금 플레이트.....	2
		O. 결속 밴드.....	1
		P. 가이드.....	1
		Q. D7 라벨.....	1
		R. 조작라벨.....	1
<b>日本語</b>			
<b>同梱品</b>			
A. 中折りユニット.....	1	E. サイドカバー前.....	1
B. レール前.....	1	F. サイドカバー後.....	1
C. レール後.....	1	G. 排紙ストックトレイ.....	1
D. 排紙ストッパー.....	1	H. 排紙トレイ.....	1
		I. 中継搬送ユニット.....	1
		J. ピン.....	1
		K. ビス M4x8.....	11
		L. ビス M4x10(黒).....	2
		M. ビス M4x12.....	4
		N. ロックプレート.....	2
		O. 結束バンド.....	1
		P. ガイド.....	1
		Q. D7 ラベル.....	1
		R. 操作ラベル.....	1



Be sure to remove any tape and/or cushioning material from supplied parts.

**Procedure**

Before installing the center-folding unit, turn the MFP's main power switch off and unplug the power cable from the power supply. Install the document finisher, and then install the center-folding unit.

1. Open the upper front cover (1) of the document finisher.
2. Remove the screw (2) and open the lower front cover (3).  
**(NOTICE)**  
Discard the screw (2) and do not fasten the lower front cover (3).

Veillez à retirer les morceaux de bande adhésive et/ou les matériaux de rembourrage des pièces fournies.

**Procédure**

Avant d'installer la plieuse mettre l'interrupteur d'alimentation principal du MFP hors tension et débrancher le câble d'alimentation de la prise de courant. Installer le finisseur de document, puis installer la plieuse.

1. Ouvrir le couvercle avant supérieur (1) du retoucheur de document.
2. Déposer la vis (2) et ouvrir le couvercle avant inférieur (3).  
**(AVIS)**  
Jeter la vis (2) et ne pas fixer le capot inférieur avant (3).

Asegúrese de despegar todas las cintas y/o material amortiguador de las partes suministradas.

**Procedimiento**

Antes de instalar la unidad de plegado, desconecte el interruptor de alimentación principal de la MFP y desenchufe el cable de alimentación de la toma de corriente. Instale primero el finalizador de documentos y luego instale la unidad de plegado.

1. Abra la cubierta frontal superior (1) del finalizador de documentos.
2. Quite el tornillo (2) y abra la cubierta frontal inferior (3).  
**(AVISO)**  
Descarte el tornillo (2) y no ajuste la cubierta frontal inferior (3).

Entfernen Sie Klebeband und/oder Dämpfungsmaterial vollständig von den mitgelieferten Teilen.

**Verfahren**

Bevor Sie mit dem Einbau der Mittenfalteinheit beginnen, stellen Sie sicher, dass der Hauptschalter des Kopierers ausgeschaltet und das Netzkabel aus der Steckdose gezogen ist. Bringen Sie den Dokument-Finisher zuerst und dann erst die Mittenfalteinheit an.

1. Öffnen Sie die obere vordere Abdeckung (1) des Dokument-Finishers.
2. Entfernen Sie die Schraube (2) und öffnen Sie die untere vordere Abdeckung (3).  
**(HINWEIS)**  
Entsorgen Sie die Schraube (2) und befestigen Sie nicht die untere vordere Abdeckung (3).

Accertarsi di rimuovere tutti i nastri adesivi e/o il materiale di imbottitura dalle parti fornite.

**Procedura**

Prima di installare l'unità di piegatura centrale, assicurarsi che l'interruttore principale della fotocopiatrice sia spento e che il cavo di alimentazione non sia inserito nella presa. Installare prima la finitrice e poi procedere all'installazione dell'unità di piegatura centrale.

1. Aprire il coperchio superiore anteriore (1) della finitrice di documenti.
2. Rimuovere la vite (2) ed aprire il coperchio inferiore anteriore (3).  
**(NOTIFICA)**  
Eliminare le viti (2) e non fissare il coperchio inferiore anteriore (3).

如果附属品上带有固定胶带, 缓冲材料时务必揭下。

**安装步骤**

安装中缝装订一折页单元前, 请关闭 MFP 的主电源开关并从电源拔下电源线。安装装订器, 然后安装中缝装订一折页单元。

1. 打开装订器的前部下盖板 (1)。
2. 拆除 1 颗螺丝 (2), 打开前部下盖板 (3)。  
**(注意)**  
废除螺丝 (2), 前部下盖板 (3) 不需固定。

동봉품에 고정 테이프, 완충재가 붙어 있는 경우에는 반드시 제거할 것 .

**장착순서**

중철 유닛을 설치할 때에는 반드시 MFP 본체의 주전원 스위치를 OFF 로 하고 전원플러그를 뺀 후 작업을 할 것 . 문서 피니셔를 설치 후, 중철 유닛을 설치 할 것 .

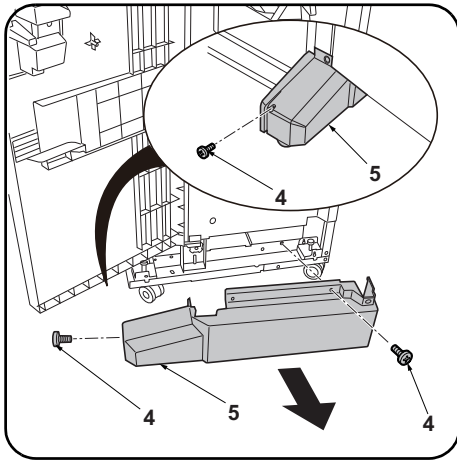
1. 문서 피니셔 앞 상커버 (1) 를 엽니다 .
2. 나사 (2) 1 개를 제거하고 앞 하커버 (3) 를 엽니다 .  
**( 주의 )**  
나사 (2) 는 폐기하고 전면 아래커버 (3) 는 고정하지 않습니다 .

同梱品に固定テープ、緩衝材がついている場合は、必ず取り外すこと。

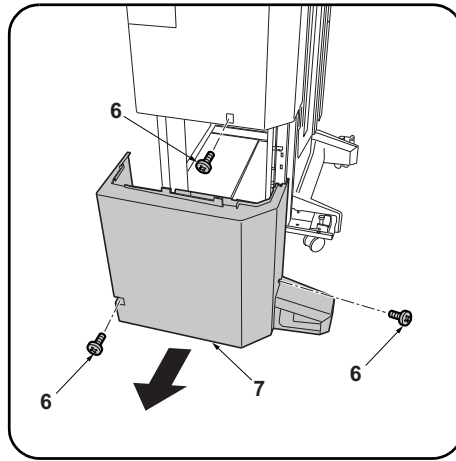
**取付手順**

中折りユニットを設置するときは、必ず MFP 本体の主電源スイッチを OFF にし、電源プラグを抜いてから作業すること。ドキュメントフィニッシャーを設置後、中折りユニットを設置すること。

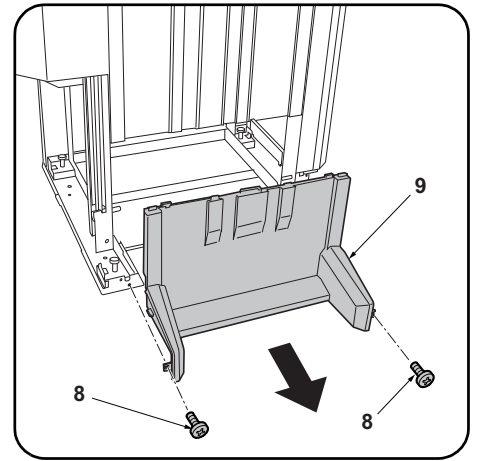
1. ドキュメントフィニッシャーの前上カバー (1) を開く。
2. ビス (2) 1 本を外し、前下カバー (3) を開く。  
**(注意)**  
ビス (2) は廃棄とし、前下カバー (3) は固定しない。



3. Remove the 2 screws (4) and remove the foot cover (5).



4. Remove the 3 screws (6) and remove the lower rear cover (7).



5. Remove 2 screws (8) and remove the lower middle cover (9).

3. Déposer les 2 vis (4) puis le couvercle du pied (5).

4. Déposer les 3 vis (6) puis le couvercle arrière inférieur (7).

5. Déposer les 2 vis (8) et le couvercle intermédiaire inférieur (9).

3. Quite los 2 tornillos (4) y quite la cubierta de la pata (5).

4. Quite los 3 tornillos (6) y quite la cubierta posterior inferior (7).

5. Quite los 2 tornillos (8) y quite la cubierta intermedia inferior (9).

3. Entfernen Sie die 2 Schrauben (4) und nehmen Sie die Fußabdeckung (5) ab.

4. Entfernen Sie die 3 Schrauben (6) und nehmen Sie die untere hintere Abdeckung (7) ab.

5. Entfernen Sie die 2 Schrauben (8) und nehmen Sie die untere mittlere Abdeckung (9) ab.

3. Rimuovere le 2 viti (4) e quindi rimuovere la copertura del piede (5).

4. Rimuovere le 3 viti (6) e quindi rimuovere il coperchio inferiore posteriore (7).

5. Rimuovere le 2 viti (8) e quindi rimuovere il pannello centrale inferiore (9).

3. 拆除 2 顆螺絲 (4)，拆下腳座蓋板 (5)。

4. 拆除 3 顆螺絲 (6)，拆下後部下蓋板 (7)。

5. 拆除 2 顆螺釘 (8)，拆下中部下蓋板 (9)。

3. 나사 (4) 2 개를 제거하고, 풋커버 (5) 를 제거합니다 .

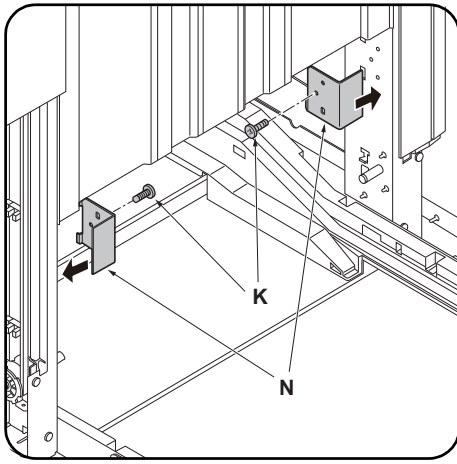
4. 나사 (6) 3 개를 제거하고, 뒤 하커버 (7) 를 제거합니다 .

5. 나사 (8) 2 개를 제거하고 중하 커버 (9) 를 떼어 냅니다 .

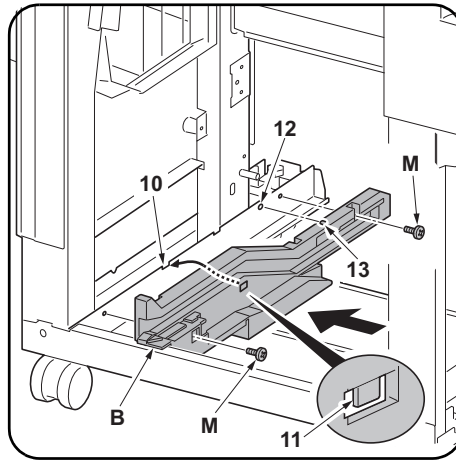
3. ビス (4) 2 本を外し、フットカバー (5) を取り外す。

4. ビス (6) 3 本を外し、後下カバー (7) を取り外す。

5. ビス (8) 2 本を外し、中下カバー (9) を取り外す。

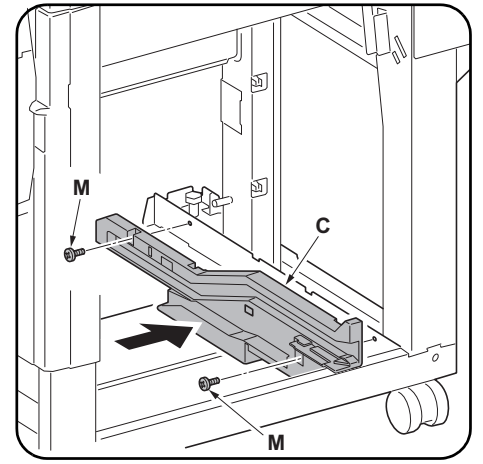


6. Install the lock plates (N) on the front and rear supports using an M4 x 8 screw (K) each.



7. Place the hook (11) of the front rail (B) on the notch (10) at the front of the document finisher, at the same time inserting the projection (13) on the front rail (B) in the hole (12) in the document finisher.

8. Fix the front rail (B) using 2 M4 x 12 screws (M).



9. Install the rear rail (C) at the rear of the document finisher using 2 M4 x 12 screws (M) in the same way.

6. Monter les plaques de verrouillage (N) sur les supports avant et arrière en procédant à l'aide d'une vis M4 x 8 (K) dans les deux cas.

7. Placer le crochet (11) de la glissière avant (B) dans l'encoche (10) à l'avant du retoucheur de document tout en insérant la saillie (13) de la glissière avant (B) dans le trou (12) du retoucheur de document.

8. Fixer la glissière avant (B) à l'aide de 2 vis M4 x 12 (M).

9. Monter la glissière arrière (C) au dos du retoucheur de document en procédant de la même façon et à l'aide de 2 vis M4 x 12 (M).

6. Instale las placas de cierre (N) en los soportes frontal y posterior usando un tornillo M4 x 8 (K) en cada uno.

7. Coloque el gancho (11) del carril frontal (B) en la muesca (10) de la parte frontal del finalizador de documentos al mismo tiempo que inserta el resalto (13) del carril frontal (B) en el orificio (12) del finalizador de documentos.

8. Fije el carril frontal (B) usando 2 tornillos M4 x 12 (M).

9. Instale el carril posterior (C) en la parte posterior del finalizador de documentos usando 2 tornillos M4 x 12 (M) de la misma forma.

6. Montieren Sie die Sperrplatten (N) an den vorderen und hinteren Stützen mit jeweils einer M4 x 8 Schraube (K).

7. Setzen Sie den Haken (11) der vorderen Schiene (B) in die Aussparung (10) vorne am Dokument-Finisher ein, und setzen Sie dabei auch den Vorsprung (13) an der vorderen Schiene (B) in die Öffnung (12) des Dokument-Finishers ein.

8. Befestigen Sie die vordere Schiene (B) mit den 2 M4 x 12 Schrauben (M).

9. Montieren Sie die hintere Schiene (C) auf gleiche Weise mit 2 M4 x 12 Schrauben (M) an der Rückseite des Dokument-Finishers.

6. Installare le piastre di bloccaggio (N) sui supporti anteriore e posteriore utilizzando una vite M4 x 8 (K) ciascuna.

7. Posizionare il gancio (11) della rotaia anteriore (B) sull'incavo (10) alla parte anteriore della finitrice di documenti, contemporaneamente inserire la sporgenza (13) sulla rotaia anteriore (B) nel foro (12) nella finitrice di documenti.

8. Fissare la rotaia anteriore (B) utilizzando 2 viti M4 x 12 (M).

9. Installare la rotaia posteriore (C) alla parte posteriore della finitrice di documenti utilizzando 2 viti M4 x 12 (M) alla stessa maniera.

6. 使用各 1 顆 M4×8(K) 螺釘將鎖定板 (N) 安裝在前後的支柱上。

7. 將前部導軌 (B) 的掛鉤 (11) 嵌入裝訂器前部的缺口 (10)，同時將前部導軌 (B) 的卡銷 (13) 插入到裝訂器的孔 (12) 中。

8. 使用 2 顆 M4×12(M) 螺釘來固定前部導軌 (B)。

9. 按相同方法，使用 2 顆 M4×12(M) 螺釘將後部導軌 (C) 安裝在裝訂器後部。

6. 잠금 플레이트 (N) 를 앞뒤 지주에 나사 M4×8(K) 각 1 개로 장착합니다 .

7. 문서 피니셔 앞의 이음부분 (10) 에 레일 앞 (B) 의 후크 (11) 를 걸고 동시에 문서 피니셔 구멍 (12) 에 레일 앞 (B) 의 보스 (13) 를 넣습니다 .

8. 나사 M4×12(M) 2 개로 레일 앞 (B) 을 고정합니다 .

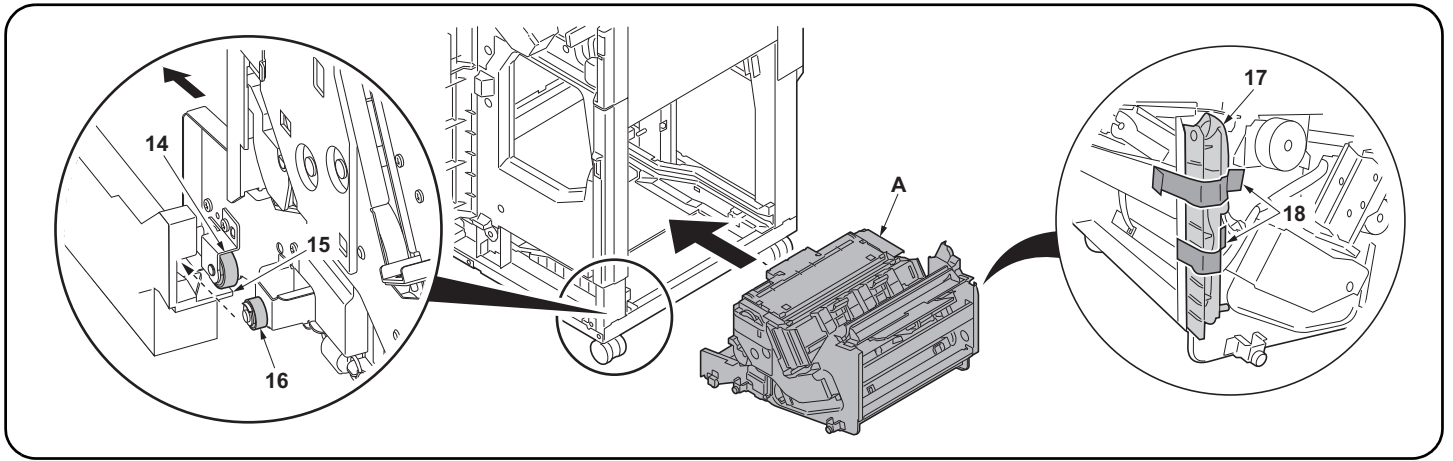
9. 같은 방식으로 나사 M4×12(M) 2 개로 문서 피니셔 뒤에 레일 뒤 (C) 를 장착합니다 .

6. ロックプレート (N) を前後の支柱にビス M4×8(K) 各 1 本で取り付け。

7. ドキュメントフィニッシャー前の切り欠き (10) にレール前 (B) のフック (11) を引っかけ、同時にドキュメントフィニッシャーの穴 (12) にレール前 (B) のボス (13) を入れる。

8. ビス M4×12(M) 2 本でレール前 (B) を固定する。

9. 同様に、ビス M4×12(M) 2 本で、ドキュメントフィニッシャー後にレール後 (C) を取り付け。



10. Place the left rollers (14) at the front and rear of the center-folding unit (A) on the tracks (15) on the inner sides of the rails, and roll in the direction shown. The middle rollers (16) will roll onto the rails.

11. Insert the center-folding unit (A) into the document finisher along the rails.

**(NOTICE)**

Insert without removing the fixing tape (18) for the wire guide (17). (The fixing tape (18) is removed at step 15)

10. Disposer les rouleaux gauche (14) à l'avant et à l'arrière de la plieuse (A) sur les voies (15) de côté interne des glissières et faire rouler dans la direction indiquée. Les rouleaux intermédiaires (16) vont se placer d'eux-mêmes sur les glissières.

11. Insérer la plieuse (A) dans le retoucheur de document le long des glissières.

**(AVIS)**

Insérer sans enlever la bande adhésive de fixation (18) pour le guide câble (17). (La bande adhésive de fixation (18) est enlevée à l'étape 15).

10. Coloque los rodillos izquierdos (14) en las partes frontal y posterior de la unidad de plegado (A) en las pistas (15) de los lados internos de los carriles y hágalos rodar en la dirección de la ilustración. Los rodillos intermedios (16) rodarán sobre los carriles.

11. Inserte la unidad de plegado (A) en el finalizador de documentos a lo largo de los carriles.

**(AVISO)**

Inserte sin quitar la cinta de fijación (18) de la guía para el cable (17). (La cinta de fijación (18) se quita en el paso 15.)

10. Setzen Sie die linken Rollen (14) an der Vorderseite und Rückseite der Mittenfalteinheit (A) auf die Bahnen (15) an den Innenseiten der Schienen, und rollen Sie sie in der dargestellten Richtung. Die mittleren Rollen (16) rollen nun auf die Schienen.

11. Schieben Sie die Mittenfalteinheit (A) entlang den Schienen in den Dokument-Finisher ein.

**(HINWEIS)**

Schieben Sie sie ein, ohne das Klebeband (18) für die Kabelführung (17) zu entfernen. (Das Klebeband (18) wird bei Schritt 15 entfernt.)

10. Posizionare i rulli di sinistra (14) alla parte anteriore e posteriore dell'unità di piegatura centrale (A) sulle piste (15) sui lati interni delle rotaie, e farli scorrere nella direzione mostrata. I rulli intermedi (16) scorreranno sulle rotaie.

11. Inserire l'unità di piegatura centrale (A) nella finitrice di documenti lungo le rotaie.

**(NOTIFICA)**

Inserire senza rimuovere il nastro di fissaggio (18) per la guida cavi (17). (Il nastro di fissaggio (18) viene rimosso al punto 15)

10. 将中缝装订一折页单元 (A) 前后的左侧滑轮 (14) 放在导轨内侧的转动部 (15) 上, 并按箭头方向转动。将中间滑轮 (16) 插入到导轨上。

11. 将中缝装订一折页单元 (A) 沿着导轨插入到装订器中。

**(注意)**

插入时不需剥除电线导板 (17) 的固定胶带 (18)。(在步骤 15 时剥除固定胶带 (18))

10. 접기 유닛 (A) 의 앞뒤에 있는 좌측 코로 (14) 를 레일 내측에 있는 굴림부 (15) 에 얹고 화살표 방향으로 굴립니다. 중간코로 (16) 가 레일에 삽입됩니다.

11. 접기 유닛 (A) 를 레일에 붙여 문서 피니셔에 삽입합니다.

**(주의)**

전선 가이드 (17) 의 고정 테이프 (18) 를 떼어 내지 않고 삽입할 것. (고정 테이프 (18) 는 순서 15 에서 떼어 냅니다.)

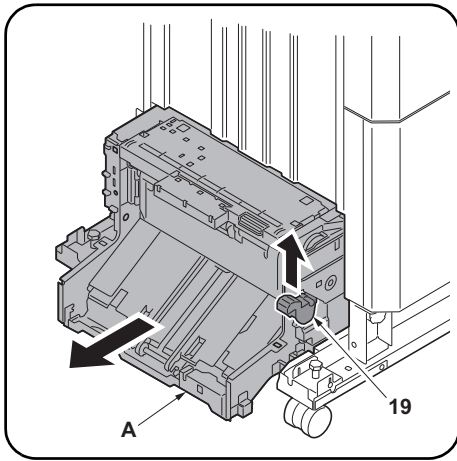
10. 中折りユニット (A) の前後にある左コロ (14) を、レールより内側にある転がし部 (15) に乗せ、矢印方向に転がす。中間コロ (16) がレールに挿入される。

11. 中折りユニット (A) をレールに沿ってドキュメントフィニッシャーに挿入する。

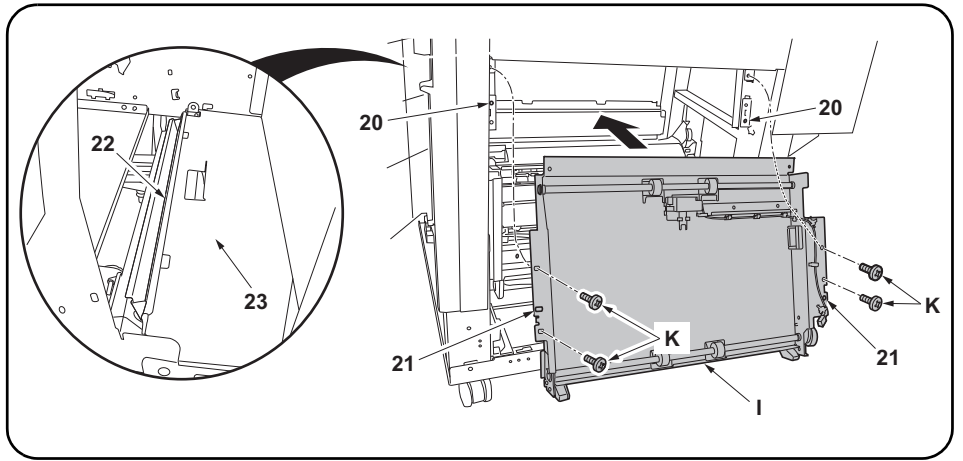
**(注意)**

電線ガイド (17) の固定テープ (18) を剥がさずに挿入すること。(固定テープ (18) は手順 15 で剥がす)





**12.** Release the lock lever (19) and pull out the center-folding unit (A) to the left of the document finisher.



**13.** Align the holes (21) in the relay paper conveying unit (I) with the 2 projections (20) on the document finisher. Install so that the lip (22) on the top frame of the relay paper conveying unit rests on the document finisher's frame (23).

**14.** Install the relay paper conveying unit (I) using 4 M4 × 8 screws (K).

**12.** Libérer le levier de verrouillage (19) et sortir la plieuse (A) par la gauche du retoucheur de document.

**13.** Aligner les trous (21) de l'unité de transport de relais (I) avec les 2 saillies (20) du retoucheur de document. Procéder de sorte que la lèvre (22) du châssis supérieur de l'unité de transport de relais repose sur le châssis du retoucheur de document (23).

**14.** Installer l'unité de transport de relais (I) à l'aide de 4 vis M4 × 8 (K).

**12.** Libere la palanca de bloqueo (19) y extraiga la unidad de plegado (A) hacia la izquierda del finalizador de documentos.

**13.** Alinee los orificios (21) de la unidad de transporte de papel (I) con los dos resaltes (20) del finalizador de documentos. Instale de forma tal que el reborde (22) del marco superior de la unidad de transporte de papel apoye en el marco del finalizador de documentos (23).

**14.** Instale la unidad de transporte de papel por relevador (I) usando 4 tornillos M4 × 8 (K).

**12.** Lösen Sie den Verriegelungshebel (19) und ziehen Sie die Mittenfalteinheit (A) zur linken Seite des Dokument-Finishers heraus.

**13.** Richten Sie die Öffnungen (21) der eingesetzten Papierfördereinheit (I) auf die 2 Vorsprünge (20) des Dokument-Finishers aus. Montieren Sie so, dass die Lippe (22) am oberen Rahmen der eingesetzten Papierfördereinheit auf dem Rahmen des Dokument-Finishers (23) ruht.

**14.** Montieren Sie die eingesetzte Papierfördereinheit (I) mit 4 M4 × 8 Schrauben (K).

**12.** Rilasciare la leva di blocco (19) e quindi estrarre l'unità di piegatura centrale (A) alla sinistra della finitrice di documenti.

**13.** Allineare i fori (21) nell'unità relay di trasporto carta (I) con le 2 sporgenze (20) sulla finitrice di documenti. Installare in modo che il bordo (22) sulla struttura superiore dell'unità relay di trasporto carta rimanga sulla struttura (23) della finitrice di documenti.

**14.** Installare l'unità relay di trasporto carta (I) utilizzando 4 viti M4 × 8 (K).

**12.** 解除锁定杆 (19), 将中缝装订 - 折页单元 (A) 从文档整理器的左侧拉出。

**13.** 将装订器的 2 处突出部 (20) 与中间搬运单元 (I) 的孔 (21) 对齐。将中间搬运单元上部框架的弯曲部 (22) 放在装订器的框架上 (23) 以进行安装。

**14.** 使用 4 颗 M4×8(K) 螺钉来安装后中间搬运单元 (I)。

**12.** 잠금레버 (19) 를 해제하고 중첩 유니트 (A) 를 문서 피니셔 좌측으로 이동시킵니다 .

**13.** 문서 피니셔의 돌기 (20) 2 개로 중계반송 유니트 (I) 의 구멍 (21) 을 맞춥니다 . 중계반송 유니트 상부 프레임의 구부러진 부분 (22) 이 문서 피니셔의 프레임 (23) 에 얹히게 장착합니다 .

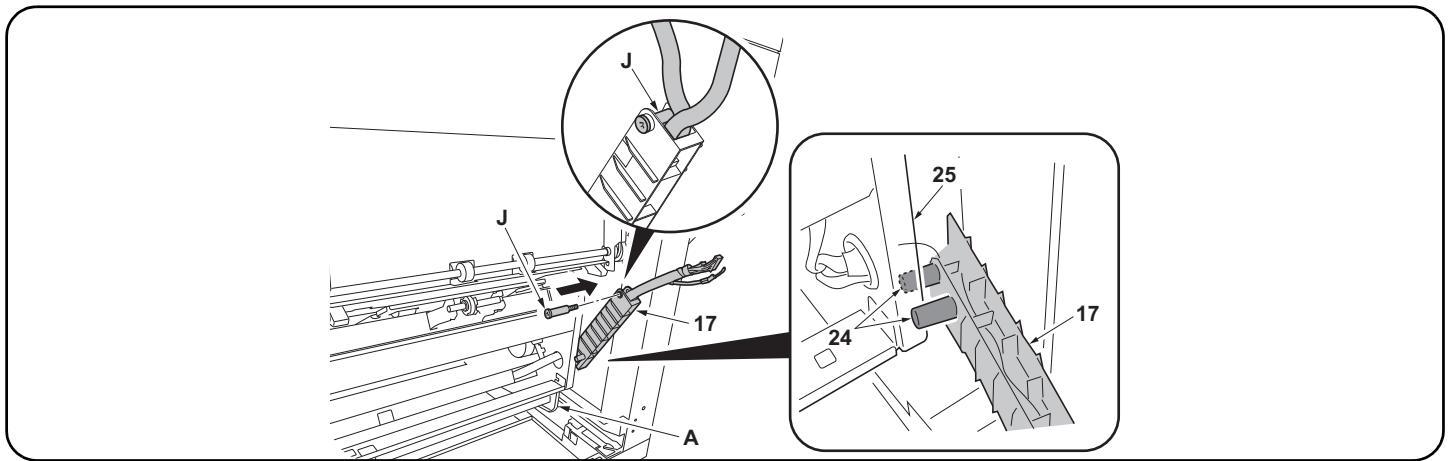
**14.** 나사 M4×8(K) 4 개로 중계반송 유니트 (I) 를 장착합니다 .

**12.** ロックレバー (19) を解除し、中折りユニット (A) をドキュメントフィニッシャー左側へ引き出す。

**13.** ドキュメントフィニッシャーの突起 (20) 2 個に中継搬送ユニット (I) の穴 (21) を合わせる。中継搬送ユニット上部フレームの折曲がり部 (22) がドキュメントフィニッシャーのフレーム (23) に乗るように取り付ける。

**14.** ビス M4×8(K) 4 本で、中継搬送ユニット (I) を取り付ける。





15. Remove the fixing tape (18) for the wire guide (17) and insert the pin (J) into the wire guide (17), with the 2 projections (24) on either side of the frame (25).

**(NOTICE)**

Insert the pin (J) to keep wires in the wire guide (17).

16. Screw the pin (J) into the document finisher to anchor the wire guide (17).

15. Enlever la bande adhésive de fixation (18) du guide câble (17) et insérer la goupille (J) dans le guide câble (17) avec les 2 saillies (24) de chaque côté du bâti (25).

**(AVIS)**

Insérer la goupille (J) pour que les câbles demeurent dans le guide câble (17).

16. Visser la goupille (J) dans le retoucheur de document pour fixer le guide câble (17) en place.

15. Quite la cinta de fijación (18) de la guía para el cable (17) e inserte el pasador (J) en la guía para el cable (17) con los 2 resaltos (24) a cada lado del marco (25).

**(AVISO)**

Inserte el pasador (J) para mantener los cables en la guía para el cable (17).

16. Atornille el pasador (J) en el finalizador de documentos para anclar la guía para el cable (17).

15. Entfernen Sie das Klebeband (18) für die Kabelführung (17) und stecken Sie die Rändelschraube (J) in die Kabelführung (17), wobei der Rahmen (25) zwischen den 2 Vorsprüngen (24) liegen muss.

**(HINWEIS)**

Stecken Sie die Rändelschraube (J) ein, um die Kabel in der Kabelführung (17) zu halten.

16. Schrauben Sie die Rändelschraube (J) in den Dokument-Finisher, um die Kabelführung (17) zu verankern.

15. Rimuovere il nastro di fissaggio (18) per la guida cavi (17) e quindi inserire il perno (J) nella guida cavi (17), con le 2 sporgenze (24) su ciascun lato della struttura (25).

**(NOTIFICA)**

Inserire il perno (J) per mantenere i cavi nella guida cavi (17).

16. Avvitare il perno (J) nella finitrice di documenti per ancorare la guida cavi (17).

15. 剥除电线导板 (17) 的固定胶带 (18)，使框架 (25) 处于 2 个卡销 (24) 之间，将 1 个销子 (J) 从电线导板 (17) 上穿过。

**(注意)**

将销钉 (J) 穿过电线导板 (17) 时，注意避免电线露出电线导板 (17) 外。

16. 将销钉 (J) 的螺纹部分安装到装订器上，以固定电线导板 (17)。

15. 전선 가이드 (17) 의 고정 테이프 (18) 를 떼어 내고 보스 (24) 2 개의 사이에 프레임 (25) 이 들어 있는 상태에서 핀 (J) 1 개를 전선 가이드 (17) 에 통과시킵니다 .

**(주의)**

핀 (J) 은 전선이 전선 가이드 (17) 에서 나오지 않도록 통하게 합니다 .

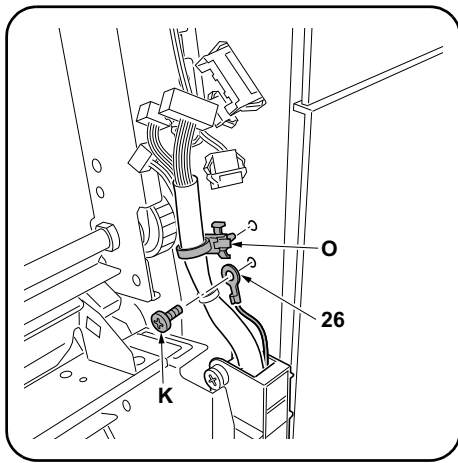
16. 핀 (J) 의 나사부분을 문서 피니셔에 장착하고 전선 가이드 (17) 를 고정합니다 .

15. 電線ガイド (17) の固定テープ (18) を剥がし、ボス (24) 2 本の中にフレーム (25) が入っている状態で、ピン (J) 1 本を電線ガイド (17) に通す。

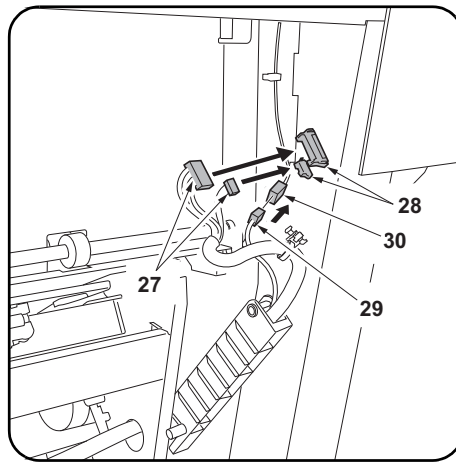
**(注意)**

ピン (J) は電線が電線ガイド (17) から出ないように通す。

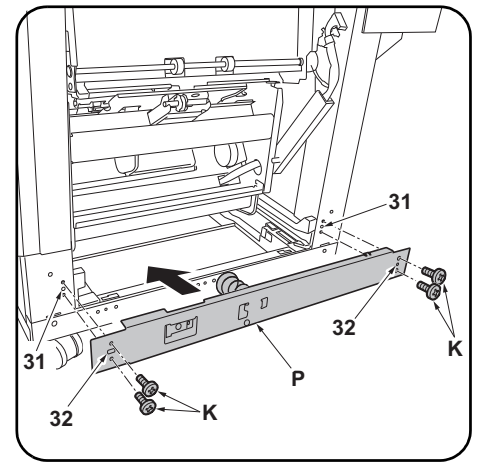
16. ピン (J) のネジ部分をドキュメントフィニッシャーに取り付け、電線ガイド (17) を固定する。



17. Install the ground wire (26) to the frame using an M4 × 8 screw (K).  
18. Install the binding band (O) to the wires and fit the band into the frame.



19. Plug the 2 connectors (27) into the connectors (28) on the document finisher.  
20. Plug the connector (29) into the connector (30) on the relay paper conveying unit (I).



21. Align holes (32) at 2 locations in the guide (P) with projections (31) on the document finisher.  
22. Install the guide (P) on the document finisher using 4 M4 × 8 screws (K).

17. Fixer le câble de terre (26) au châssis en procédant à l'aide d'une vis M4 × 8 (K).  
18. Monter le collier de fixation (O) sur les câbles et assujettir le collier au châssis.

19. Enfiler les 2 connecteurs (27) dans les connecteurs (28) du retoucheur de document.  
20. Enfiler le connecteur (29) dans le connecteur (30) de l'unité de transport de papier (I).

21. Aligner les trous (32) en 2 endroits du guide (P) avec les saillies (31) du retoucheur de document.  
22. Monter le guide (P) sur le retoucheur de document à l'aide de 4 vis M4 × 8 (K).

17. Instale el cable de conexión a tierra (26) en el marco usando un tornillo M4 × 8 (K).  
18. Instale la correa de sujeción (O) en los cables y coloque la correa en el marco.

19. Enchufe los 2 conectores (27) en los conectores (28) del finalizador de documentos.  
20. Enchufe el conector (29) en el conector (30) de la unidad de transporte de papel por relevarador (I).

21. Alinee los orificios (32) de los 2 lugares de la guía (P) con los resaltes (31) del finalizador de documentos.  
22. Instale la guía (P) en el finalizador de documentos usando 4 tornillos M4 × 8 (K).

17. Montieren Sie das Massekabel (26) mit einer M4 × 8 Schraube (K) an den Rahmen.  
18. Bringen Sie das Schellenband (O) an den Kabeln an und setzen Sie das Band in den Rahmen ein.

19. Verbinden Sie die 2 Steckverbinder (27) mit den Steckverbindern (28) des Dokument-Finishers.  
20. Verbinden Sie den Steckverbinder (29) mit dem Steckverbinder (30) der eingesetzten Papierfördereinheit (I).

21. Richten Sie die Öffnungen (32) an 2 Stellen in der Führung (P) auf die Vorsprünge (31) des Dokument-Finishers aus.  
22. Montieren Sie die Führung (P) mit 4 M4 × 8 Schrauben (K) am Dokument-Finisher.

17. Installare il cavo di terra (26) alla struttura utilizzando una vite M4 × 8 (K).  
18. Installare la fascetta di legatura (O) ai cavi e quindi fissare la fascetta nella struttura.

19. Inserire i 2 connettori (27) nei connettori (28) sulla finitrice di documenti.  
20. Inserire il connettore (29) nel connettore (30) sull'unità relay di trasporto carta (I).

21. Allineare i fori (32) alle 2 posizioni nella guida (P) con le sporgenze (31) sulla finitrice di documenti.  
22. Installare la guida (P) sulla finitrice di documenti utilizzando 4 viti M4 × 8 (K).

17. 使用 M4×8(K) 螺钉将装接地线 (26) 安装到框架上。  
18. 在电线上安装束线带 (O), 将束线带 (O) 嵌入到框架上。

19. 将 2 个连接器 (27) 与装订器的连接器 (28) 相连接。  
20. 将连接器 (29) 与中间搬运单元 (I) 的连接器 (30) 相连接。

21. 将装订器的 2 处突出部 (31) 与导板 (P) 的孔 (32) 对齐。  
22. 使用 4 颗螺钉 M4×8(K) 将导板 (P) 安装到装订器上。

17. 나사 M4×8(K) 로 접지선 (26) 을 프레임에 장착합니다.  
18. 전선에 결속 밴드 (O) 를 장착하고 프레임에 결속 밴드 (O) 를 끼웁니다.

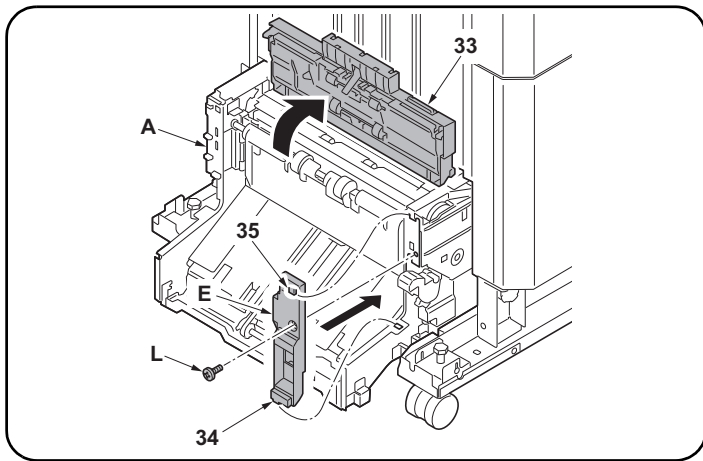
19. 커넥터 (27) 2 개를 문서 피니셔의 커넥터 (28) 에 접속합니다.  
20. 커넥터 (29) 를 중계 유니트 (I) 의 커넥터 (30) 에 접속합니다.

21. 문서 피니셔의 돌기 (31) 2 곳을 가이드 (P) 의 구멍 (32) 에 맞춥니다.  
22. 나사 M4×8(K) 4 개로 문서 피니셔에 가이드 (P) 를 장착합니다.

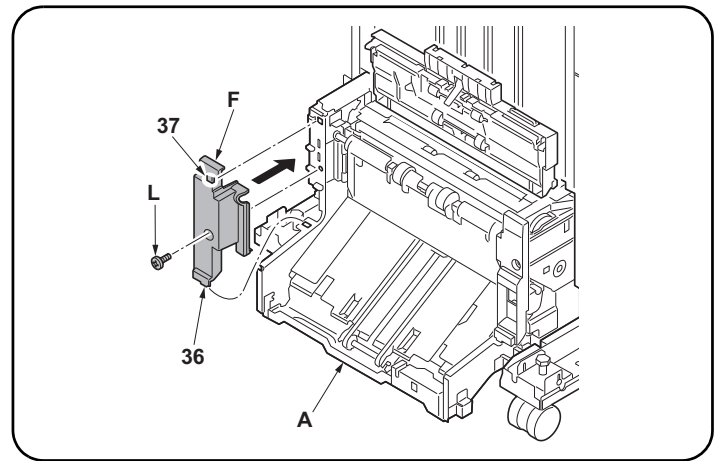
17. ビス M4×8(K) でアース線 (26) をフレームに取り付ける。  
18. 電線に結束バンド (O) を取り付け、フレームに結束バンド (O) をはめ込む。

19. コネクター (27) 2 個をドキュメントフィニッシャーのコネクター (28) に接続する。  
20. コネクター (29) を中継搬送ユニット (I) のコネクター (30) に接続する。

21. ドキュメントフィニッシャーの突起 (31) 2 箇所ガイド (P) の穴 (32) に合わせる。  
22. ビス M4×8(K) 4 本でドキュメントフィニッシャーにガイド (P) を取り付け。



23. Open the eject cover (33).  
 24. Engage the projection (34) and hook (35) on the front side cover (E) with the center-folding unit (A). Complete installation of the front side cover (E) using an M4 × 10 screw (black) (L).



25. Engage the projection (36) and hook (37) on the rear side cover (F) with the center-folding unit (A). Complete installation of the rear side cover (F) using an M4 × 10 screw (black) (L).

23. Ouvrir le capot d'éjection (33).  
 24. Engager la saillie (34) et le crochet (35) du capot latéral avant (E) dans la plieuse (A). Finaliser l'installation du capot latéral avant (E) à l'aide d'une vis M4 × 10 (noire) (L).

25. Engager la saillie (36) et le crochet (37) du capot latéral arrière (F) dans la plieuse (A). Finaliser l'installation du capot latéral arrière (F) à l'aide d'une vis M4 × 10 (noire) (L).

23. Abra la cubierta de expulsión (33).  
 24. Enganche el resalto (34) y el gancho (35) de la cubierta lateral frontal (E) con la unidad de plegado (A). Complete la instalación de la cubierta lateral frontal (E) usando un tornillo M4 × 10 (negro) (L).

25. Enganche el resalto (36) y el gancho (37) de la cubierta lateral posterior (F) con la unidad de plegado (A). Complete la instalación de la cubierta lateral posterior (F) usando un tornillo M4 × 10 (negro) (L).

23. Öffnen Sie die Auswurfabdeckung (33).  
 24. Hängen Sie den Vorsprung (34) und den Haken (35) der vorderen Seitenabdeckung (E) in die Mittenfalteinheit (A) ein. Befestigen Sie die vordere Seitenabdeckung (E) mit einer M4 × 10 Schraube (schwarz) (L).

25. Hängen Sie den Vorsprung (36) und den Haken (37) der hinteren Seitenabdeckung (F) in die Mittenfalteinheit (A) ein. Befestigen Sie die hintere Seitenabdeckung (F) mit einer M4 × 10 Schraube (schwarz) (L).

23. Aprire il coperchio di espulsione carta (33).  
 24. Innestare la sporgenza (34) e il gancio (35) sul coperchio laterale anteriore (E) con l'unità di piegatura centrale (A). Completare l'installazione del coperchio laterale anteriore (E) utilizzando una vite M4 × 10 (nera) (L).

25. Innestare la sporgenza (36) e il gancio (37) sul coperchio laterale posteriore (F) con l'unità di piegatura centrale (A). Completare l'installazione del coperchio laterale posteriore (F) utilizzando una vite M4 × 10 (nera) (L).

23. 打开排纸盖板 (33)。  
 24. 将前部侧盖板 (E) 的突出部 (34) 以及挂钩 (35) 嵌入到中缝装订一折页单元 (A) 中, 使用 1 颗 M4×10 (黑) (L) 螺钉来安装前部侧盖板 (E)。

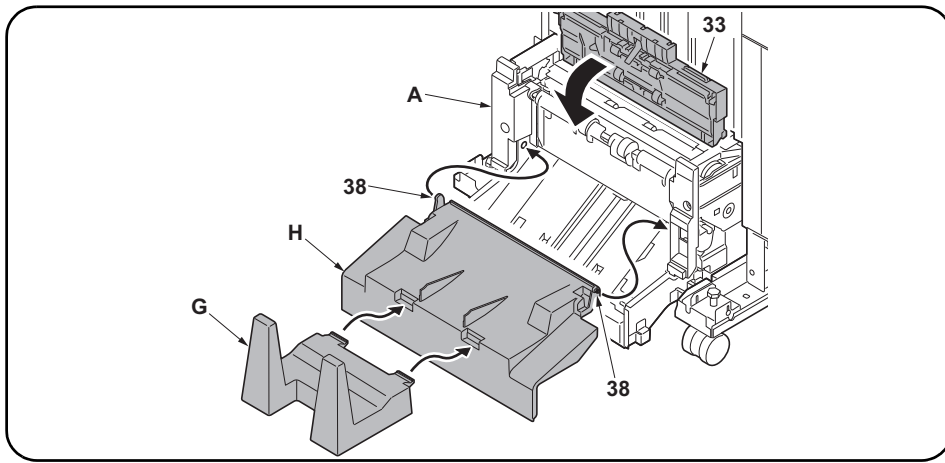
25. 将后部侧盖板 (F) 的突出部 (36) 以及挂钩 (37) 嵌入到中缝装订一折页单元 (A) 中, 使用 1 颗 M4×10 (黑) (L) 螺钉来安装后部侧盖板 (F)。

23. 배출 커버 (33) 를 엽니다.  
 24. 사이드 커버 앞 (E) 의 돌기 (34) 및 후크 (35) 를 접기 유닛 (A) 에 끼웁니다. 나사 M4×10 (흑) (L) 1 개로 사이드 커버 앞 (E) 을 장착합니다.

25. 사이드 커버 뒤 (F) 의 돌기 (36) 및 후크 (37) 를 접기 유닛 (A) 에 끼웁니다. 나사 M4×10 (흑) (L) 1 개로 사이드 커버 뒤 (F) 를 장착합니다.

23. 排出カバー (33) を開く。  
 24. サイドカバー前 (E) の突起 (34) およびフック (35) を、中折りユニット (A) にはめ込む。  
 ビス M4×10(黒) (L) 1 本で、サイドカバー前 (E) を取り付け。

25. サイドカバー後 (F) の突起 (36) およびフック (37) を、中折りユニット (A) にはめ込む。  
 ビス M4×10(黒) (L) 1 本で、サイドカバー後 (F) を取り付け。



26. Insert the 2 pins (38) on the output tray (H) in the holes in the center-folding unit (A) to install the tray.
27. Install the output stock tray (G) on the output tray (H).
28. Close the eject cover (33).

26. Insérer les 2 goupilles (38) du plateau de sortie (H) dans les trous de la plieuse (A) pour installer le plateau.
27. Installer la butée de sortie du papier (G) sur le plateau de sortie (H).
28. Fermer le capot d'éjection (33).

26. Inserte los 2 pasadores (38) de la bandeja de salida (H) en los orificios de la unidad de plegado (A) para instalar la bandeja.
27. Instale la bandeja de recolección de papel de salida (G) en la bandeja de salida (H).
28. Cierre la cubierta de expulsión (33).

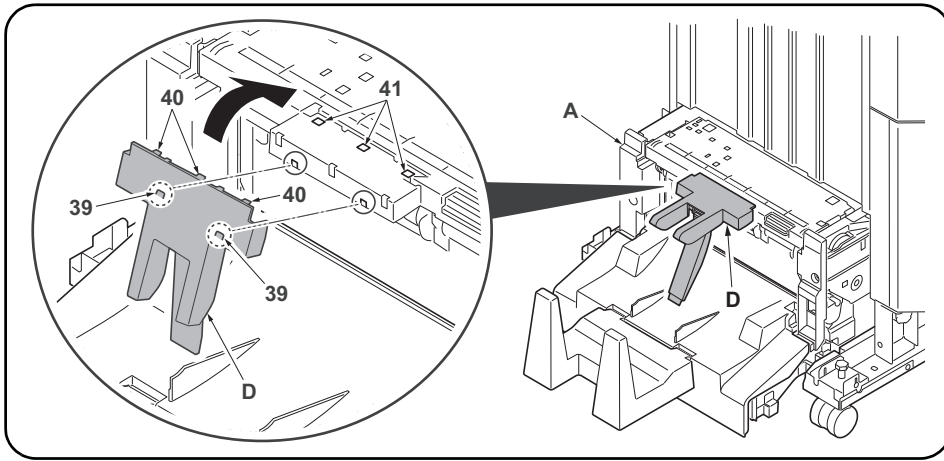
26. Stecken Sie die 2 Rändelschrauben (38) des Ausgabefachs (H) in die Öffnungen der Mittenfalteinheit (A) ein, um das Fach zu installieren.
27. Bringen Sie das Ausgabestapelfach (G) am Ausgabefach (H) an.
28. Schließen Sie die Auswurfabdeckung (33).

26. Inserire i 2 perni (38) sul vassoio di uscita (H) nei fori sull'unità di piegatura centrale (A) per installare il vassoio.
27. Installare il vassoio di uscita stoccaggio (G) sul vassoio di uscita (H).
28. Chiudere il coperchio di espulsione carta (33).

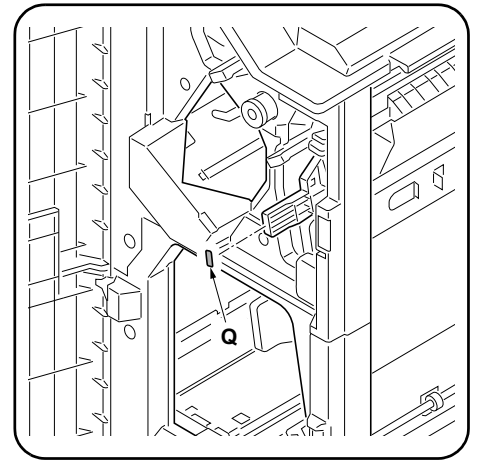
26. 将排纸托盘 (H) 的 2 根销钉 (38) 插入中缝装订—折页单元 (A) 的孔中, 以安装排纸托盘 (H)。
27. 将堆纸托盘 (G) 安装到排纸托盘 (H) 上。
28. 关闭排纸盖板 (33)。

26. 배지 트레이 (H) 의 핀 (38) 2 개를 접기 유닛 (A) 의 구멍에 넣고 배지 트레이 (H) 를 장착합니다.
27. 배지 저장 트레이 (G) 를 배지 트레이 (H) 에 장착합니다.
28. 배출커버 (33) 를 닫습니다.

26. 排紙トレイ (H) のピン (38) 2 本を中折りユニット (A) の穴に入れ、排紙トレイ (H) を取り付ける。
27. 排紙ストックトレイ (G) を排紙トレイ (H) に取り付ける。
28. 排出カバー (33) を閉じる。



**29.** Insert the 2 projections (39) on the back of the output stopper (D) in the portions circled on the center-folding unit (A).  
Fit the 3 hooks (40) on the output stopper (D) in the holes (41) in the center-folding unit (A).



**30.** Adhere the D7 label (Q) at the location shown in the figure.

**29.** Insérer les 2 saillies (39) au dos de la butée de sortie (D) dans les parties encadrées de la pliouse (A).  
Assujettir les 3 crochets (40) de la butée de sortie (D) dans les trous (41) de la pliouse (A).

**30.** Apposer l'étiquette D7 (Q) à l'endroit repéré sur la figure.

**29.** Inserte los 2 resaltos (39) de la parte posterior del tope de salida (D) en las porciones marcadas con un círculo de la unidad de plegado (A).  
Coloque los 3 ganchos (40) del tope de salida (D) en los orificios (41) de la unidad de plegado (A).

**30.** Adhiera la etiqueta D7 (Q) en el lugar que se muestra en la ilustración.

**29.** Setzen Sie die 2 Vorsprünge (39) auf der Rückseite des Ausgabeanschlags (D) in die mit Kreis bezeichneten Positionen der Mittenfalteinheit (A) ein.  
Setzen Sie die 3 Haken (40) des Ausgabeanschlags (D) in die Öffnungen (41) der Mittenfalteinheit (A) ein.

**30.** Kleben Sie den D7 Aufkleber (Q) an der abgebildeten Stelle an.

**29.** Inserire le 2 sporgenze (39) sulla parte posteriore del fermo di uscita (D) nelle porzioni cerchiate sull'unità di piegatura centrale (A).  
Fissare i 3 ganci (40) sul fermo di uscita (D) nei fori (41) nell'unità di piegatura centrale (A).

**30.** Far aderire l'etichetta D7 (Q) alla posizione mostrata nella figura.

**29.** 将排纸挡板 (D) 内侧的 2 处突出部 (39) 插入到中缝装订—折页单元 (A) 的圆框部。  
将排纸挡板 (D) 的 3 个挂钩 (40) 嵌入到中缝装订—折页单元 (A) 的孔 (41) 中。

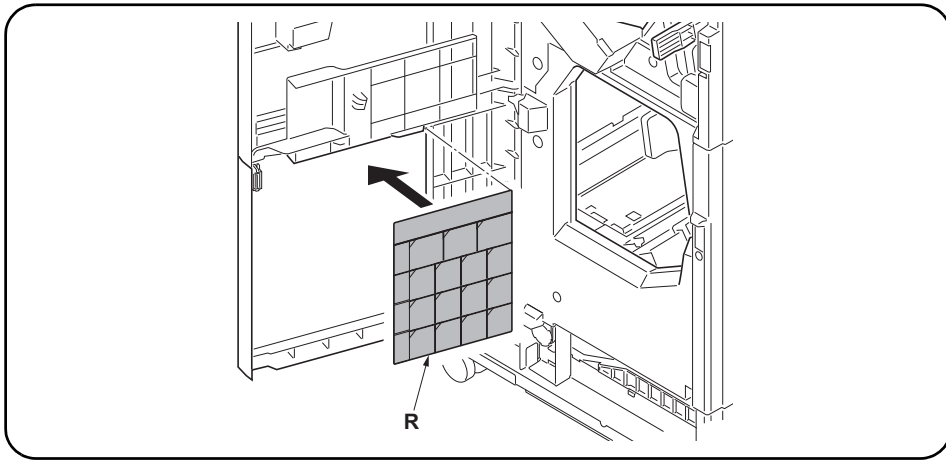
**30.** 在图示位置黏贴 D7 标签 (Q)。

**29.** 배지 스톱퍼 (D) 의 안쪽에 있는 돌기 (39) 2 곳을 접기 유닛 (A) 의에 삽입합니다 .  
배지 스톱퍼 (D) 의 후크 (40) 3 곳을 접기 유닛 (A) 의 구멍 (41) 에 끼웁니다 .

**30.** D7 라벨 (Q) 을 그림의 위치에 붙입니다 .

**29.** 排紙ストッパー (D) の裏側にある突起 (39) 2箇所を中折ユニット (A) の丸枠部に挿入する。  
排紙ストッパー (D) のフック (40) 3箇所を中折ユニット (A) の穴 (41) にはめ込む。

**30.** D7 ラベル (Q) を図の位置に貼り付ける。



31. Adhere the Operation label (R) at the location shown in the figure.  
 32. Reinstall the foot cover (5) and lower rear cover (7).  
 33. Close the lower front cover (3) and the upper front cover (1).

31. Apposer l'étiquette de fonctionnement (R) à l'endroit repéré sur la figure.  
 32. Reposer le couvercle du pied (5) et le couvercle arrière inférieur (7).  
 33. Fermer le capot inférieur avant (3) et le couvercle avant supérieur (1).

31. Adhiera la etiqueta de funcionamiento (R) en el lugar que se muestra en la ilustración.  
 32. Vuelva a instalar la cubierta de la pata (5) y la cubierta posterior inferior (7).  
 33. Cierre la cubierta frontal inferior (3) y la cubierta frontal superior (1).

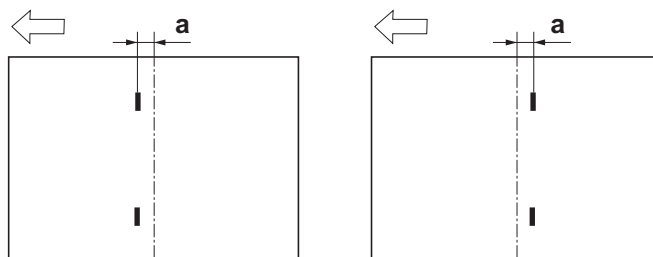
31. Kleben Sie den Bedienungsaufkleber (R) an der abgebildeten Stelle an.  
 32. Bringen Sie die Fußabdeckung (5) und die untere hintere Abdeckung (7) wieder an.  
 33. Schließen Sie die untere vordere Abdeckung (3) und die obere vordere Abdeckung (1).

31. Far aderire l'etichetta di operazione (R) alla posizione mostrata nella figura.  
 32. Reinstallare la copertura del piede (5) e il coperchio inferiore posteriore (7).  
 33. Chiudere il coperchio inferiore anteriore (3) e il coperchio superiore anteriore (1).

31. 在图示位置黏贴操作标签 (R)。  
 32. 按原样安装脚座盖板 (5) 和后部下盖板 (7)。  
 33. 关闭前部下盖板 (3) 和前部上盖板 (1)。

31. 조작 라벨 (R) 을 그림의 위치에 붙입니다 .  
 32. 풋커버 (5) 및 뒤하 커버 (7) 를 원래대로 장착합니다 .  
 33. 전면 아래커버 (3) 및 전면 윗커버 (1) 를 닫습니다 .

31. 操作ラベル (R) を図の位置に貼り付ける。  
 32. フットカバー (5) および後下カバー (7) を元通りに取り付ける。  
 33. 前下カバー (3) および前上カバー (1) を閉じる。



#### Adjustment of centerfold-stapling position

Check the distance (a) from the stapling position to the center of the paper. If the distance (a) is over the reference value, follow the procedure below to adjust the position.

<Reference value (a)>  $\pm 2$  mm

1. Set maintenance mode U246, select Booklet and Staple Pos.
2. Adjust the values.
3. Press the Start key to confirm the setting value.

#### Réglage de la position d'agrafage des pages centrales dépliées

Vérifier la distance (a) entre la position d'agrafage et le milieu de la feuille de papier. Si cette distance (a) est supérieure à la valeur de référence, régler la position en procédant de la manière suivante.

<Valeur de référence (a)>  $\pm 2$  mm

1. Passer en mode maintenance U246, sélectionner Booklet et Staple Pos.
2. Régler les valeurs.
3. Appuyer sur la touche de Start pour confirmer la valeur de réglage.

#### Ajuste de la posición de grapado de la unidad de plegado

Compruebe la distancia (a) desde la posición de grapado con respecto al centro del papel. Si dicha distancia (a) supera el valor de referencia, realice el siguiente procedimiento para ajustar la posición.

<Valor de referencia (a)>  $\pm 2$  mm

1. Entre en el modo de mantenimiento U246, seleccione Booklet y Staple Pos.
2. Ajuste los valores.
3. Pulse la tecla de Start para confirmar el valor de configuración.

#### Einstellung der Mittenfalt-Heftposition

Überprüfen Sie den Abstand (a) zwischen der Heftposition und der Papiermitte. Falls der Abstand (a) größer als der Bezugswert ist, ist die Position gemäß der nachstehenden Prozedur nachzustellen.

<Bezugswert (a)>  $\pm 2$  mm

1. Schalten Sie in den Wartungsmodus U246, wählen Sie Booklet und Staple Pos.
2. Die Werte einstellen.
3. Den Einstellwert durch Drücken der Start-Taste bestätigen.

#### Regolazione della posizione di cucitura dell'unità di piegatura centrale

Controllare la distanza (a) dalla posizione di spillatura al centro del foglio. Se la distanza (a) è superiore al valore di riferimento, seguire la procedura riportata sotto per regolare la posizione.

<Valore di riferimento (a)>  $\pm 2$  mm

1. Impostare la modalità manutenzione U246, selezionare Booklet e Staple Pos.
2. Regolare i valori.
3. Premere il tasto di Start per confermare il valore dell'impostazione.

#### 中缝装订位置调整

检查从装订位置到纸张中心的距离 (a)。如果距离 (a) 超出标准值范围，按照下列步骤调节装订位置。

<标准值 (a) >  $\pm 2$ mm

1. 设置维护模式 U246，选择 Booklet、Staple Pos。
2. 调整设定值。
3. 按 Start 键，以确定设定值。

#### 접기 스테이플 위치조정

스테이플 위치에서 용지 중앙까지의 거리 (a) 를 확인합니다 . 거리 (a) 가 기준치 외의 경우에는 다음 순서로 조정을 합니다 .

< 기준치 (a) >  $\pm 2$ mm

1. 메인テナンス 모드 U246 을 세트하고 Booklet, Staple Pos 를 선택합니다 .
2. 설정치를 조정합니다 .
3. 시작키를 누르고 설정치를 확인합니다 .

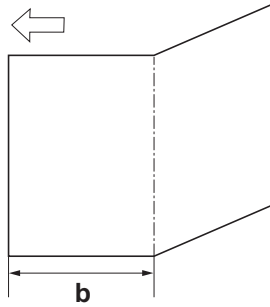
#### 中とじステーブル位置調整

ステーブル位置から用紙センターまでの距離 (a) を確認する。距離 (a) が基準値外の場合、次の手順で調整を行う。

<基準値 (a) >  $\pm 2$ mm

1. メンテナンスモード U246 をセットし、Booklet、Staple Pos を選択する。
2. 設定値を調整する。
3. スタートキーを押し、設定値を確定する。





#### Adjustment of center folding position

Check the distance (b) from the edge of the paper to the center folding position. If the distance (b) is over the reference value, follow the procedure below to adjust the position.

<Reference value (b)>

A4, Letter: Length of paper  $\times 1/2 \pm 2$  mm

A3, Ledger, B4: Length of paper  $\times 1/2 \pm 3$  mm

1. Set maintenance mode U246, select Booklet and Booklet Pos.
2. Adjust the values.
3. Press the Start key to confirm the setting value.

#### Réglage de la position de pliage central

Vérifier la distance (b) entre le bord de la feuille de papier et la position de pliage central. Si cette distance (b) est supérieure à la valeur de référence, régler la position en procédant de la manière suivante.

<Valeur de référence (b)>

A4, Letter : Longueur de la feuille  $\times 1/2 \pm 2$  mm

A3, Ledger, B4: Longueur de la feuille  $\times 1/2 \pm 3$  mm

1. Passer en mode maintenance U246, sélectionner Booklet et Booklet Pos.
2. Régler les valeurs.
3. Appuyer sur la touche de Start pour confirmer la valeur de réglage.

#### Ajuste de la posición de plegado

Compruebe la distancia (b) desde el borde del papel a la posición de plegado. Si dicha distancia (b) supera el valor de referencia, realice el siguiente procedimiento para ajustar la posición.

<Valor de referencia (b)>

A4, Letter: Longitud del papel  $\times 1/2 \pm 2$  mm

A3, Ledger, B4: Longitud del papel  $\times 1/2 \pm 3$  mm

1. Entre en el modo de mantenimiento U246, seleccione Booklet y Booklet Pos.
2. Ajuste los valores.
3. Pulse la tecla de Start para confirmar el valor de configuración.

#### Einstellung der Mittenfaltposition

Überprüfen Sie den Abstand (b) zwischen der Papierkante und der Mittenfaltposition. Falls der Abstand (b) größer als der Bezugswert ist, ist die Position gemäß der nachstehenden Prozedur nachzustellen.

<Bezugswert (b)>

A4, Letter: Papierlänge  $\times 1/2 \pm 2$  mm

A3, Ledger, B4: Papierlänge  $\times 1/2 \pm 3$  mm

1. Schalten Sie in den Wartungsmodus U246, wählen Sie Booklet und Booklet Pos.
2. Die Werte einstellen.
3. Den Einstellwert durch Drücken der Start-Taste bestätigen.

#### Regolazione della posizione centrale di piegatura

Controllare la distanza (b) dal bordo della carta alla posizione centrale di piegatura. Se la distanza (b) è superiore al valore di riferimento, seguire la procedura riportata sotto per regolare la posizione.

<Valore di riferimento (b)>

A4, Letter: Lunghezza carta  $\times 1/2 \pm 2$  mm

A3, Ledger, B4: Lunghezza carta  $\times 1/2 \pm 3$  mm

1. Impostare la modalità manutenzione U246, selezionare Booklet e Booklet Pos.
2. Regolare i valori.
3. Premere il tasto di Start per confermare il valore dell'impostazione.

#### 中缝折叠位置调整

检查从纸张头部到折叠位置的距离 (b)。如果距离 (b) 超出标准值范围, 按照下列步骤调节折叠位置。

<标准值 (b) >

A4, Letter: 纸张长度  $\times 1/2 \pm 2$  mm

A3, Ledger, B4: 纸张长度  $\times 1/2 \pm 3$  mm

1. 设置维护模式 U246, 选择 Booklet、Booklet Pos。
2. 调整设定值。
3. 按 Start 键, 以确定设定值。

#### 접기 위치조정

용지 끝에서 접기 위치까지의 거리 (b) 를 확인합니다 . 거리 (b) 가 기준치 외의 경우에는 다음 순서로 조정을 합니다 .

<기준치 (b) >

A4, Letter: 용지길이  $\times 1/2 \pm 2$  mm

A3, Ledger, B4: 용지길이  $\times 1/2 \pm 3$  mm

1. 메인テナンス 모드 U246 을 세트하고 Booklet, Booklet Pos 를 선택합니다 .
2. 설정치를 조정합니다 .
3. 시작키를 누르고 설정치를 확인합니다 .

#### 中折り位置調整

用紙端から中折り位置までの距離 (b) を確認する。距離 (b) が基準値外の場合、次の手順で調整を行う。

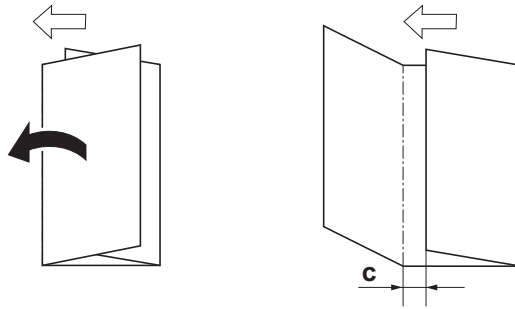
<基準値 (b) >

A4, Letter: 用紙長  $\times 1/2 \pm 2$  mm

A3, Ledger, B4: 用紙長  $\times 1/2 \pm 3$  mm

1. メンテナンスモード U246 をセットし、Booklet、Booklet Pos を選択する。
2. 設定値を調整する。
3. スタートキーを押し、設定値を確定する。





#### Adjustment of tri-folding position

Check the distance (c) from the edge of the paper to the second folding position. If the distance (c) is over the reference value, follow the procedure below to adjust the position.

<Reference value (c)> 7.0 ±2 mm

1. Set maintenance mode U246, select Booklet and Three Fold.
2. Adjust the values.
3. Press the Start key to confirm the setting value.

#### Réglage de la position de triple pliage

Vérifier la distance (c) entre le bord de la feuille de papier et la position du deuxième pliage. Si cette distance (c) est supérieure à la valeur de référence, régler la position en procédant de la manière suivante.

<Valeur de référence (c)> 7,0 ±2 mm

1. Passer en mode maintenance U246, sélectionner Booklet et Three Fold.
2. Régler les valeurs.
3. Appuyer sur la touche de Start pour confirmer la valeur de réglage.

#### Ajuste de la posición de plegado tríptico

Compruebe la distancia (c) desde el borde del papel a la segunda posición de plegado. Si dicha distancia (c) supera el valor de referencia, realice el siguiente procedimiento para ajustar la posición.

<Valor de referencia (c)> 7,0 ±2 mm

1. Entre en el modo de mantenimiento U246, seleccione Booklet y Three Fold.
2. Ajuste los valores.
3. Pulse la tecla de Start para confirmar el valor de configuración.

#### Einstellung der Dreilagenfaltposition

Überprüfen Sie den Abstand (c) zwischen der Papierkante und der zweiten Faltposition. Falls der Abstand (c) größer als der Bezugswert ist, ist die Position gemäß der nachstehenden Prozedur nachzustellen.

<Bezugswert (c)> 7,0 ±2 mm

1. Schalten Sie in den Wartungsmodus U246, wählen Sie Booklet und Three Fold.
2. Die Werte einstellen.
3. Den Einstellwert durch Drücken der Start-Taste bestätigen.

#### Regolazione della posizione di piegatura tripla

Controllare la distanza (c) dal bordo della carta alla posizione della seconda piegatura. Se la distanza (c) è superiore al valore di riferimento, seguire la procedura riportata sotto per regolare la posizione.

<Valore di riferimento (c)> 7,0 ±2 mm

1. Impostare la modalità manutenzione U246, selezionare Booklet e Three Fold.
2. Regolare i valori.
3. Premere il tasto di Start per confermare il valore dell'impostazione.

#### 三折位置調整

检查从纸张头部到第2个折叠位置的距离(c)。如果距离(c)超出标准值范围,按照下列步骤调节折叠位置。

<标准(c) > 7.0±2mm

1. 设置维护模式 U246, 选择 Booklet、Three Fold。
2. 调整设定值。
3. 按 Start 键, 以确定设定值。

#### 두번 접기 위치 조정

용지끝과 두번째 접히는 위치까지의 거리(c)를 확인합니다. 거리(c)가 기준치 외의 경우에는 다음 순서로 조절을 합니다.

<기준치(c) > 7.0±2mm

1. 메인テナンス 모드 U246 을 세트하고 Booklet, Three Fold 를 선택합니다.
2. 설정치를 조정합니다.
3. 시작키를 누르고 설정치를 확인합니다.

#### 三折り位置調整

用紙端と二つ目の折り位置までの距離(c)を確認する。距離(c)が基準値外の場合、次の手順で調整を行う。

<基準値(c) > 7.0±2mm

1. メンテナンスモードU246 をセットし、Booklet、Three Fold を選択する。
2. 設定値を調整する。
3. スタートキーを押し、設定値を確定する。

**NOTICE**

This accessory is for use only with the following Applicant's Listed Machine.  
Machine: DF-790,DF-7110

---

**AVIS**

Cet accessoire est utilisable uniquement avec le copieur figurant dans la liste du demandeur suivant.  
Modèle: DF-790,DF-7110

---

**AVISO**

Este accesorio es sólo para usar en las siguientes fotocopiadoras de la lista de solicitantes.  
Modelo: DF-790,DF-7110

---

**HINWEIS**

Dieses Zubehör ist nur für den Einsatz mit der folgenden Antragstellerlisten-Kopiermaschine vorgesehen.  
Modell: DF-790,DF-7110

---

**NOTIFICA**

Questo accessorio deve essere usato solo con le seguenti fotocopiatrici nella lista dell'applicante.  
Modello: DF-790,DF-7110

---

**注意**

本产品适用于以下机型。  
机型：DF-790,DF-7110

---

**주의**

본 제품은 이하의 기종에 적용됩니다.  
기종: DF-790,DF-7110

---

**注意**

本製品は、以下の機種に適用します。  
機種：DF-790,DF-7110

---

**MEMO**



303ND5671002

2016. 3  
303ND56710-02

# **INSTALLATION GUIDE FOR MAILBOX**

---

**INSTALLATION GUIDE**

**GUIDE D'INSTALLATION**

**GUÍA DE INSTALACION**

**INSTALLATIONSANLEITUNG**

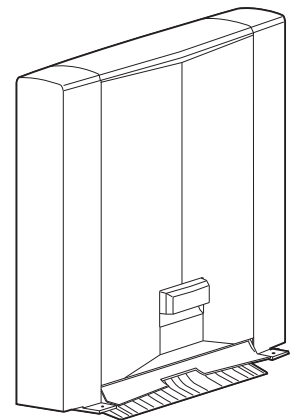
**GUIDA ALL'INSTALLAZIONE**

**安装手册**

**설치안내서**

**設置手順書**

**MT-730(B)**



---

### English

A different procedure is required depending on the product which is installed with this unit. Each procedure is described in the following pages.  
When installing to a document finisher, see Page 1 to Page 6.  
When installing to a Printer, see Page 7 to Page 12.

---

### Français

Une procédure différente est requise selon le produit qui est installé avec cette unité. Chaque procédure est décrite dans les pages suivantes.  
Lors de l'installation sur un module finition de documents, voir Page 1 à Page 6.  
Lors de l'installation sur une imprimante, voir Page 7 à Page 12.

---

### Español

El procedimiento es diferente según el producto que se instale con esta unidad. En las siguientes páginas, se describe cada procedimiento.  
Para la instalación con un finalizador de documentos, consulte las páginas de la 1 a la 6.  
Para la instalación con una impresora, consulte las páginas de la 7 a la 12.

---

### Deutsch

Je nach verwendetem Modell ist eine andere Vorgehensweise zur Installation dieses Teils erforderlich. Die unterschiedlichen Vorgehensweisen werden auf den folgenden Seiten erläutert.  
Bei Installation an einem Dokumentenfinisher siehe Seiten 1 bis 6.  
Bei Installation an einem Drucker siehe Seiten 7 bis 12.

---

### Italiano

Si richiede una procedura diversa in funzione del prodotto su cui è installata l'unità. Le singole procedure sono descritte nelle pagine seguenti.  
Quando si installa un finisher documenti, vedere le pagine da 1 a 6.  
Quando si installa una stampante, vedere le pagine da 7 a 12.

---

### 简体中文

根据安装对象，安装步骤略有不同。各个步骤记载在下面的页面。  
安装到装订器时，请参见第1～6页。  
安装到打印机时，请参见第7～12页。

---

### 한국어

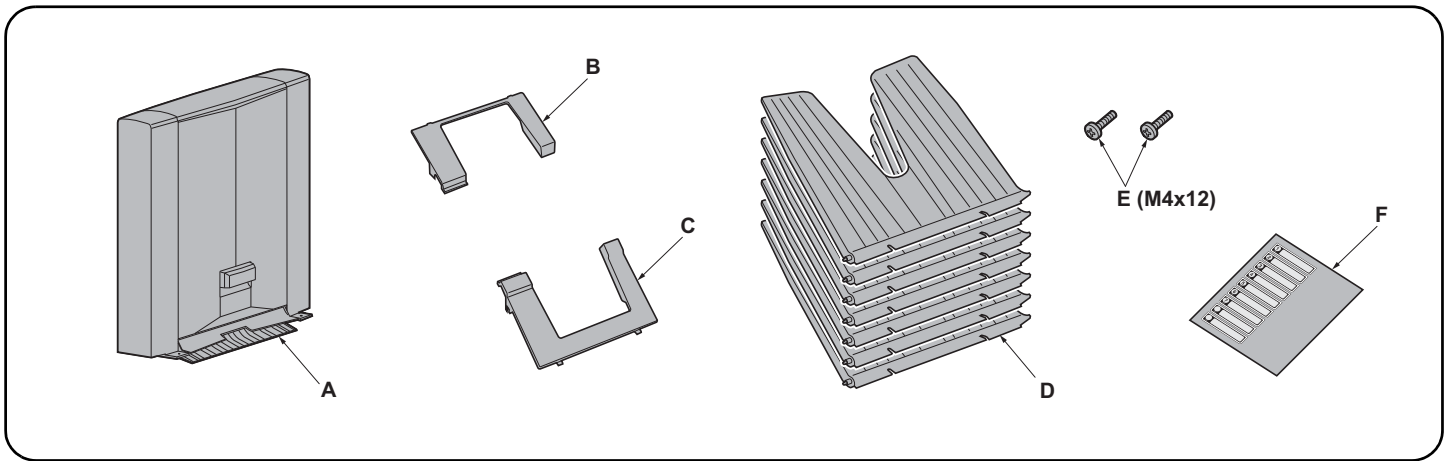
이 장치에 설치되는 제품에 따라 절차가 다릅니다. 다음 페이지에서 각 절차를 설명합니다.  
문서 피니셔에 설치하는 경우 1 페이지 ~6 페이지를 참조하십시오.  
프린터에 설치하는 경우 7 페이지 ~12 페이지를 참조하십시오.

---

### 日本語

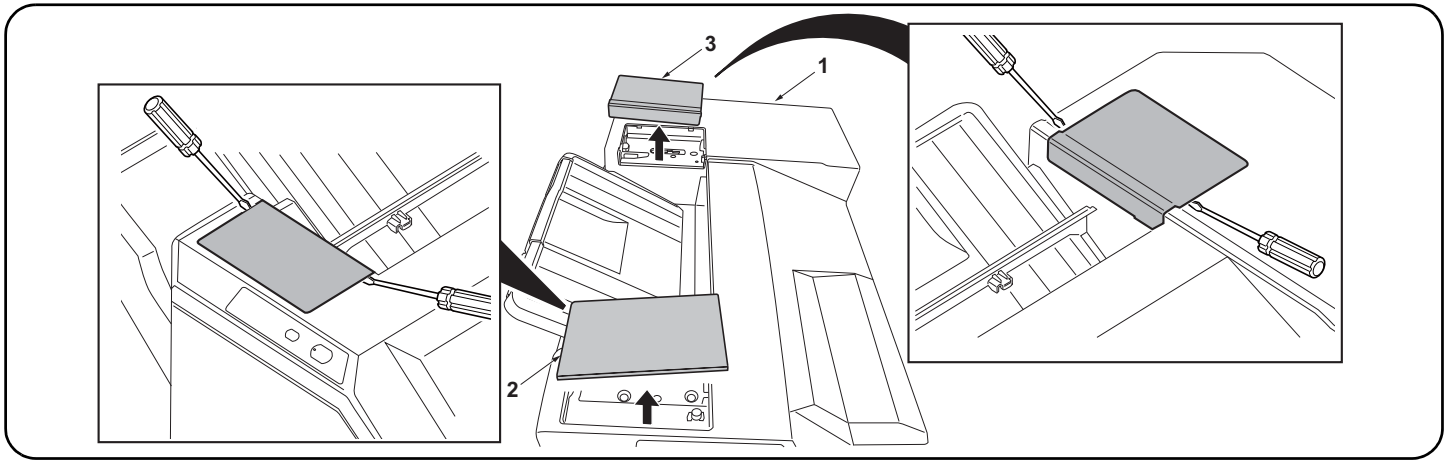
装着する対象によって、取付手順は異なります。それぞれ、以下のページに記載しています。  
ドキュメントフィニッシャーに設置する場合;1 ページ～6 ページ  
プリンターに設置する場合;7 ページ～12 ページ

---



<p><b>English</b></p> <p><b>Supplied parts</b></p> <p>A. Mailbox ..... 1</p> <p>B. Front mounting plate cover..... 1</p> <p>C. Rear mounting plate cover ..... 1</p> <p>D. Copy eject bins ..... 7</p>	<p>E. M4 × 12 screw ..... 2</p> <p>F. Tray name label (for users)..... 1</p>	<p>Be sure to remove any tape and/or cushioning materials from the parts supplied.</p>
<p><b>Français</b></p> <p><b>Pièces fournies</b></p> <p>A. Boîte à lettres ..... 1</p> <p>B. Couverture de la plaque de montage avant..... 1</p> <p>C. Couverture de la plaque de montage arrière ... 1</p> <p>D. Case d'éjection de copies..... 7</p>	<p>E. Vis M4 × 12..... 2</p> <p>F. Étiquette de nom de plateau (pour les utilisateurs) ..... 1</p>	<p>Veillez à retirer les morceaux de bande adhésive et/ou les matériaux de rembourrage des pièces fournies.</p>
<p><b>Español</b></p> <p><b>Partes suministradas</b></p> <p>A. Buzón de correo ..... 1</p> <p>B. Cubierta de la placa de montaje frontal ..... 1</p> <p>C. Cubierta de la placa de montaje trasera..... 1</p> <p>D. Bandejas de expulsión de copias ..... 7</p>	<p>E. Tornillo M4 × 12 ..... 2</p> <p>F. Etiqueta de nombre de la bandeja (para usuarios)..... 1</p>	<p>Asegúrese de quitar todas las cintas y/o material amortiguador de las partes suministradas.</p>
<p><b>Deutsch</b></p> <p><b>Enthaltene Teile</b></p> <p>A. Mailbox ..... 1</p> <p>B. Vordere Abdeckung der Montageplatte ..... 1</p> <p>C. Hintere Abdeckung der Montageplatte ..... 1</p> <p>D. Kopienausgabefächer..... 7</p>	<p>E. Schraube M4 × 12 ..... 2</p> <p>F. Fachnamenaufkleber (für Benutzer) ..... 1</p>	<p>Stellen Sie sicher, dass sämtliche Klebebänder und/oder Polstermaterial von den gelieferten Teilen entfernt wurden.</p>
<p><b>Italiano</b></p> <p><b>Parti fornite</b></p> <p>A. Mailbox ..... 1</p> <p>B. Coperchio della piastra di montaggio anteriore .. 1</p> <p>C. Coperchio della piastra di montaggio posteriore. 1</p> <p>D. Scomparti di espulsione delle copie ..... 7</p>	<p>E. Vite M4 × 12..... 2</p> <p>F. Etichetta di nome del vassoio (per utenti) ..... 1</p>	<p>Rimuovere tutti i nastri adesivi e/o i materiali di protezione dalle parti fornite.</p>
<p><b>简体中文</b></p> <p><b>附属品</b></p> <p>A. 邮箱..... 1</p> <p>B. 支撑板前盖板..... 1</p> <p>C. 支撑板后盖板..... 1</p> <p>D. 接纸盘..... 7</p>	<p>E. M4×12 螺丝 ..... 2</p> <p>F. 托盘名称标贴（用户用）..... 1</p>	<p>如果附属品上带有固定胶带，缓冲材料时必须揭下。</p>
<p><b>한국어</b></p> <p><b>동봉품</b></p> <p>A. 메일박스..... 1</p> <p>B. 부착판커버 앞..... 1</p> <p>C. 부착판커버 뒤..... 1</p> <p>D. 배출핀..... 7</p>	<p>E. 나사 M4 × 12..... 2</p> <p>F. 트레이 명칭 스티 (사용자용) ..... 1</p>	<p>동봉품에 고정 테이프, 완충재가 붙어 있는 경우에는 반드시 제거하십시오.</p>
<p><b>日本語</b></p> <p><b>同梱品</b></p> <p>A. メールボックス..... 1</p> <p>B. 取付板カバー前..... 1</p> <p>C. 取付板カバー後..... 1</p> <p>D. 排出ピン..... 7</p>	<p>E. ビス M4×12 ..... 2</p> <p>F. トレイ名称シール(ユーザー用) ..... 1</p>	<p>同梱品に固定テープ、緩衝材が付いている場合は必ず取り外すこと。</p>





#### Procedure

Before starting installation, be sure to turn the main power switch of the machine off, and unplug the power plug from the wall outlet.

1. Remove the front top cover (2) and rear top cover (3) at the top of the finisher (1) using a flat-blade screwdriver or the like.

#### Procédure

Avant de commencer l'installation, s'assurer de mettre la machine hors tension et de débrancher la fiche d'alimentation de la prise murale.

1. Retirer le couvercle supérieur avant (2) et le couvercle supérieur arrière (3) situés en haut du retoucheur (1) à l'aide d'un tournevis à tête plate ou d'un outil équivalent.

#### Procedimiento

Antes de iniciar la instalación, asegúrese de apagar el interruptor de encendido de la máquina y desenchufar el cable de alimentación de la toma de pared.

1. Remueva la cubierta superior delantera (2) y la cubierta superior trasera (3) en la parte superior del finalizador (1) utilizando un destornillador de punta plana o similar.

#### Verfahren

Bevor Sie mit der Installation beginnen überzeugen Sie sich, dass der Netzschalter des Geräts ausgeschaltet und das Stromkabel aus der Steckdose gezogen ist.

1. Entfernen Sie die vordere obere Abdeckung (2) und die hintere obere Abdeckung (3) an der Oberseite des Finishers (1) mit einem Klingenschraubendreher oder dergleichen.

#### Procedura

Prima di iniziare l'installazione, spegnere la macchina e scollegare la spina dalla presa di corrente.

1. Rimuovere il coperchio superiore anteriore (2) e il coperchio superiore posteriore (3) dalla parte superiore del finitore (1) utilizzando un cacciavite a punta piatta, o un attrezzo simile.

#### 安装步骤

安装前务必关闭机器的主电源开关，并从墙壁插座拔下电源插头。

1. 用一字形螺丝刀拆下装订器 (1) 上部的顶罩前盖板 (2) 和顶罩后盖板 (3)。

#### 설치순서

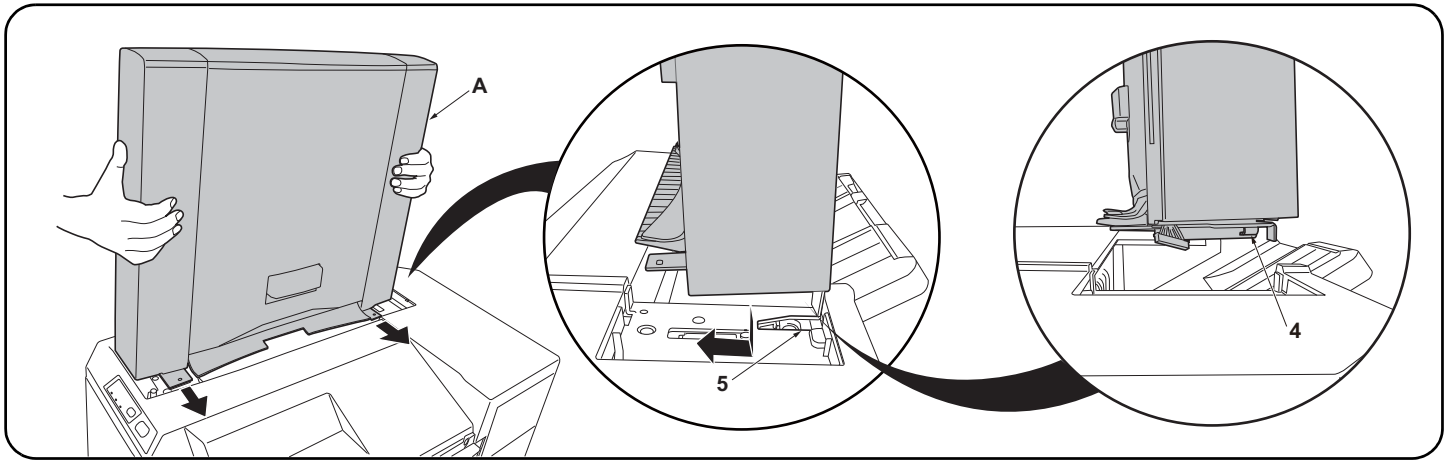
설치를 시작하기 전에 반드시 본체의 주 전원 스위치를 끄고 벽 콘센트에서 전원 플러그를 분리하십시오.

1. 피니셔 (1) 상부의 윗커버 앞 덮개 (2), 윗커버 뒤 덮개 (3) 를 마이너스 드라이버 등으로 제거합니다.

#### 取付手順

必ず機械本体の主電源スイッチをOFFにし、機械本体の電源プラグを抜いてから作業すること。

1. フィニッシャー (1) 上部の天カバー前フタ (2)、天カバー後フタ (3) をマイナスドライバーなどで取り外す。



2. Fit the hooks (4) located at the front and rear of the bottom of the mailbox (A) into the notches (5) located at the front and rear of the top of the finisher (1) as shown in the illustration and attach the mailbox (A) to the finisher (1).

**Note:**

Lift the front and rear of the mailbox (A) lightly upward to make sure that no gap is made between the mailbox (A) and the machine.

2. Insérer les crochets (4) se trouvant à l'avant et à l'arrière au fond de la boîte à lettres (A) dans les encoches (5) situées à l'avant et à l'arrière en haut du retoucheur (1) comme illustré ici, puis fixer la boîte à lettres (A) au retoucheur (1).

**Remarque:**

Lever légèrement l'avant et l'arrière de la boîte à lettres (A) de sorte qu'il n'y ait aucun interstice entre la boîte à lettres (A) et la machine.

2. Coloque los ganchos (4) ubicados en la parte inferior frontal y trasera del buzón de correo (A) en las muescas (5) ubicadas en la parte superior frontal y trasera del finalizador (1), como se muestra en la ilustración, y coloque el buzón de correo (A) en el finalizador (1).

**Nota:**

Levante ligeramente la parte frontal y trasera del buzón de correo (A) para asegurarse de que no queda espacio entre el buzón de correo (A) y la máquina.

2. Setzen Sie die Haken (4) an der Vorder- und Rückseite der Mailbox (A) in die Öffnungen (5) vorne und hinten an der Oberseite des Finishers (1) ein, wie in der Abbildung dargestellt, und bringen Sie die Mailbox (A) am Finisher (1) an.

**Hinweis:**

Heben Sie die Vorder- und Rückseite der Mailbox (A) ein wenig an, damit sich kein Spalt zwischen der Mailbox (A) und dem Gerät bildet.

2. Inserire i ganci (4) posizionati sul davanti e sul dietro della parte di fondo della mailbox (A), negli incavi (5) posizionati sul davanti e sul dietro della parte superiore del finitore (1) come mostrato nell'illustrazione, e fissare la mailbox (A) al finitore (1).

**Nota:**

Sollevarle leggermente la parte anteriore e posteriore della mailbox (A) verso l'alto per accertarsi che non vi sia dello spazio tra la mailbox (A) e la macchina.

2. 如图所示, 将位于邮箱 (A) 底部前后侧的卡扣 (4) 嵌入位于装订器 (1) 顶部前后侧的凹口 (5), 并将邮箱 (A) 安装至装订器 (1)。

**注:**

轻轻向上提升邮箱 (A) 的前后侧, 确保邮箱 (A) 未处于悬浮状态。

2. 메일박스 (A) 하부의 앞뒤에 있는 후크 (4) 를 피니셔 (1) 상부의 앞뒤에 있는 파인 홈에 (5) 에 일러스트와 같이 삽입하고 메일박스 (A) 를 피니셔측에 장착합니다 .

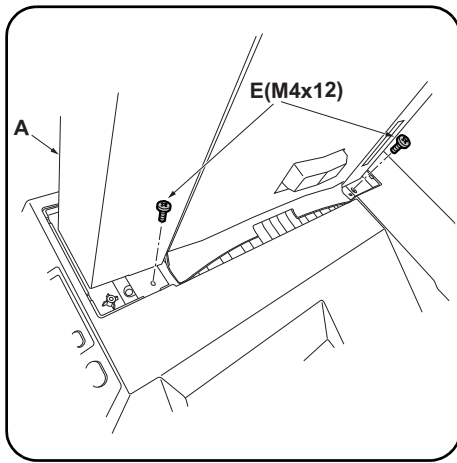
**주**

메일박스 (A) 의 앞뒤를 각각 상방향으로 가볍게 들어 메일박스 (A) 가 떠 있지 않은 것을 확인합니다 .

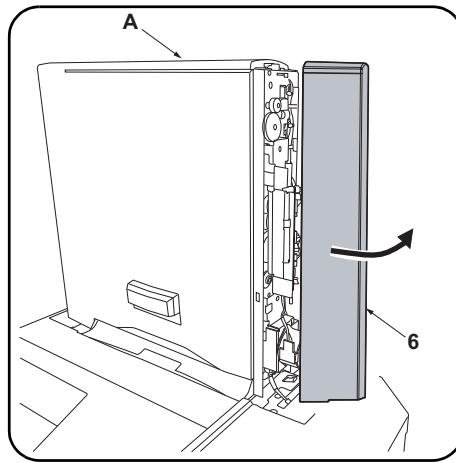
2. メールボックス (A) 下部の前後にあるフック (4) をフィニッシャー(1) 上部の前後にある切り欠き部 (5) にイラストのように挿入し、メールボックス (A) をフィニッシャー(1) に取り付ける。

**注意**

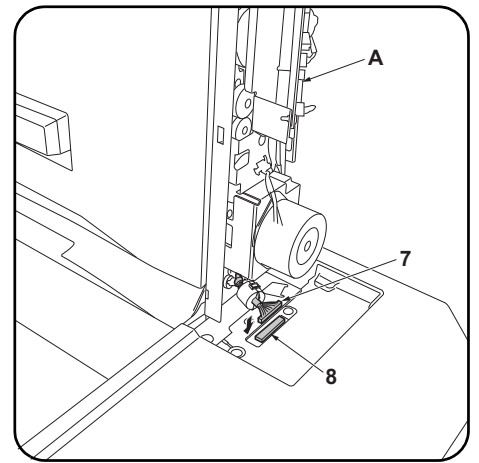
メールボックス (A) の前後をそれぞれ上方向に軽く持ち上げ、メールボックス (A) が浮かないことを確認する。



3. Secure the mailbox (A) using the two screws M4x12 (E).



4. Remove the rear cover (6) of the mailbox (A).



5. Plug the connector (7) of the mailbox (A) into the connector (8) of the machine body.  
6. Reinstall the rear cover (6) of the mailbox (A).

3. Fixer la boîte à lettres (A) à l'aide de deux vis M4x12 (E).

4. Retirer le couvercle arrière (6) de la boîte à lettres (A).

5. Brancher le connecteur (7) de la boîte à lettres (A) dans le connecteur (8) du corps de la machine.  
6. Remonter le couvercle arrière (6) de la boîte à lettres (A).

3. Fije el buzón de correo (A) con dos tornillos M4x12 (E).

4. Quite la cubierta posterior (6) del buzón de correo (A).

5. Enchufe el conector (7) del buzón de correo (A) al conector (8) del cuerpo de la máquina.  
6. Vuelva a instalar la cubierta posterior (6) del buzón de correo (A).

3. Sichern Sie die Mailbox (A) mit zwei Schrauben M4x12 (E).

4. Entfernen Sie die hintere Abdeckung (6) der Mailbox (A).

5. Stecken Sie den Stecker (7) der Mailbox (A) in die Steckbuchse (8) des Gerätegehäuses.  
6. Bringen Sie die hintere Abdeckung (6) der Mailbox (A) wieder an.

3. Fissare la mailbox (A) utilizzando le due viti M4x12 (E).

4. Rimuovere il coperchio posteriore (6) della mailbox (A).

5. Collegare il connettore (7) della mailbox (A) al connettore (8) del corpo macchina.  
6. Reinstallare il coperchio posteriore (6) della mailbox (A).

3. 使用两个螺丝 M4x12 (E) 固定邮箱 (A)。

4. 拆下邮箱 (A) 的后部盖板 (6)。

5. 将邮箱 (A) 的接插件 (7) 插入机器的接插件 (8)。  
6. 重新安装邮箱 (A) 的后盖板 (6)。

3. M4x12 나사 (E) 두 개를 사용하여 메일박스 (A) 를 고정합니다 .

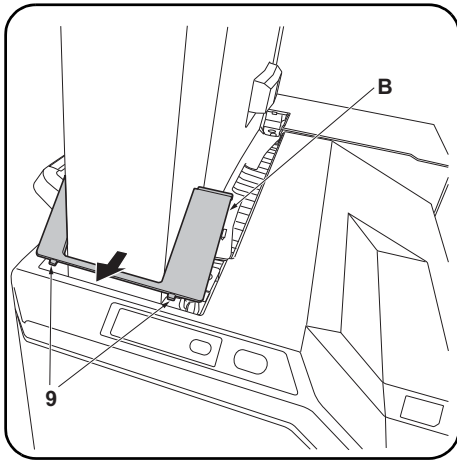
4. 메일박스 (A) 의 뒤커버 (6) 를 떼어냅니다 .

5. 메일박스 (A) 의 커넥터 (7) 를 본체의 커넥터 (8) 에 연결합니다  
6. 메일박스 (A) 의 뒤커버 (6) 를 다시 장착합니다 .

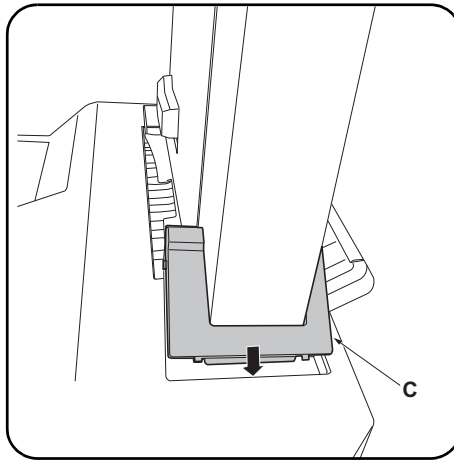
3. ビス M4×12(E)2 本で、メールボックス (A) を固定する。

4. メールボックス (A) の後カバー (6) を取り外す。

5. メールボックス (A) のコネクタ (7) を機械本体のコネクタ (8) に接続する。  
6. メールボックス (A) の後カバー (6) を元通りに取り付ける。



7. Insert the 2 hooks (9) on the front mounting plate cover (B) for the mailbox into the finisher to install the cover (B).



8. Install the rear mounting plate cover (C) on the finisher in the same way.

7. Insérer les 2 crochets (9) du couvercle de la plaque de montage avant (B) de la boîte à lettres dans le retourneur pour installer ce couvercle (B).

8. Installer le couvercle de la plaque de montage arrière (C) sur le retourneur en procédant de la même manière.

7. Para instalar la cubierta (B), inserte los 2 ganchos (9) de la cubierta de la placa de montaje frontal (B) para el buzón de correo en el finalizador.

8. Instale de la misma manera la cubierta de la placa de montaje trasera (C) en el finalizador.

7. Setzen Sie die 2 Haken (9) an der vorderen Abdeckung der Montageplatte (B) für die Mailbox in den Finisher ein, um die Abdeckung (B) zu installieren.

8. Bringen Sie auf gleiche Weise die hintere Abdeckung der Montageplatte (C) am Finisher an.

7. Inserire nel finitore i 2 ganci (9) posizionati sul coperchio della piastra di montaggio anteriore (B) per la mailbox, per installare il coperchio (B).

8. Installare il coperchio della piastra di montaggio posteriore (C) sul finitore nella stessa maniera.

7. 将邮箱的安装板前部盖板 (B) 的 2 个卡扣 (9) 插入到装订器中, 以安装安装板前部盖板 (B)。

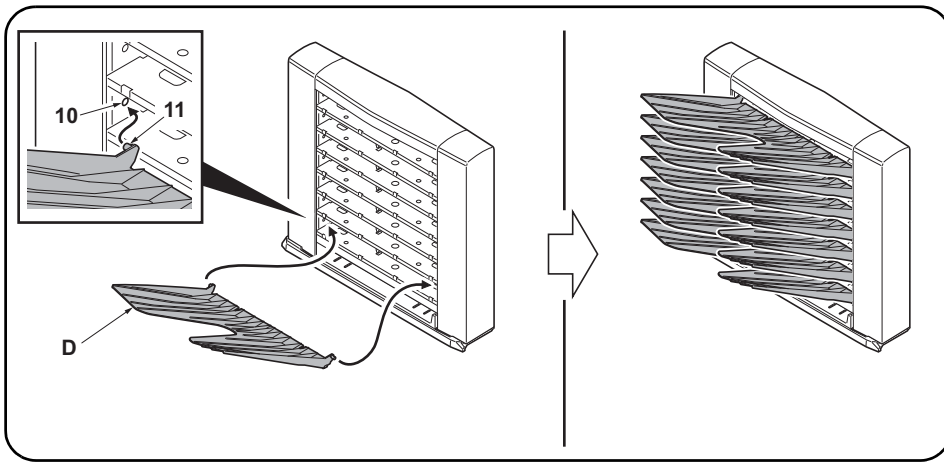
8. 按相同方法将安装板后部盖板 (C) 安装到装订器上。

7. 메일박스의 부착판 커버 앞 (B) 의 후크 (9) 2 곳을 피니셔에 삽입하고 부착판 커버 앞 (B) 을 장착합니다 .

8. 같은 방식으로 부착판 커버 뒤 (C) 를 피니셔에 장착합니다 .

7. メールボックスの取付板カバー前 (B) のフック (9) 2箇所をフィニッシャーに挿入し、取付板カバー前 (B) を取り付ける。

8. 同様に取付板カバー後 (C) をフィニッシャーに取り付ける。



**9.** Fit the seven copy eject bins (D) to the ejection section of the mailbox (A) from the lowest bin to the highest.  
Press both ends of each copy eject bin (D) to bend it a little, then fit the bin by inserting the front and rear pins (10) into the round holes (11) at the front and rear of the mailbox.

**10.** Insert the power plug from the machine into the outlet, turn the main power switch on, and verify the machine operates normally.

**9.** Fixer les sept cases d'éjection de copies (D) sur la section d'éjection de la boîte à lettres (A), en procédant de la case située tout en bas à celle située tout en haut.  
Appuyer sur les deux extrémités de chaque case d'éjection des copies (D) pour cintrer légèrement cette pièce, puis monter la case en insérant les broches avant et arrière (10) dans les trous ronds (11) à l'avant et à l'arrière de la boîte à lettres.

**10.** Insérer la fiche d'alimentation de la machine dans la prise et mettre la machine sous tension, puis vérifier qu'elle fonctionne correctement.

**9.** Presione ambos extremos de cada bandeja de expulsión de copias (D) para doblarlas un poco; después, coloque la bandeja insertando los pasadores delantero y trasero (10) en los orificios redondos (11) en la parte frontal y posterior del buzón de correo.

**10.** Enchufe el cable de alimentación de la máquina en la toma de corriente y encienda el interruptor principal para comprobar que la máquina funciona correctamente.

**9.** Setzen Sie die sieben Kopienausgabefächer (D) in die Ausgabeöffnungen der Mailbox (A) ein, beginnend vom untersten Fach zum höchsten.  
Drücken Sie beide Enden jedes Kopienausgabefachs (D) zusammen, um es etwas zu biegen. Setzen Sie das Fach ein, indem Sie die vorderen und hinteren Stifte (10) in die Rundlöcher (11) vorne und hinten an der Mailbox einsetzen.

**10.** Stecken Sie den Netzstecker des Geräts in eine Steckdose und schalten Sie den Hauptschalter des Geräts ein, um den Betrieb zu prüfen.

**9.** Installare i sette scomparti di espulsione delle copie (D) nella sezione di espulsione della mailbox (A), iniziando dallo scomparto più in basso fino a quello più in alto.  
Premere le due estremità di ciascuno scomparto di espulsione delle copie (D) in modo da piegarlo leggermente, quindi installare lo scomparto inserendo i perni anteriore e posteriore (10) nei fori rotondi (11) presenti sul fronte e sul retro della mailbox.

**10.** Inserire la spina nella presa di corrente, accendere la macchina e controllare che funzioni correttamente.

**9.** 从邮箱 (A) 的排出部下面起按顺序安装 7 个接纸盘 (D)。  
按住接纸盘 (D) 的左右两侧并使其稍稍下垂, 通过将前后的销钉 (10) 插入邮箱前后的圆孔 (11) 中来安装接纸盘。

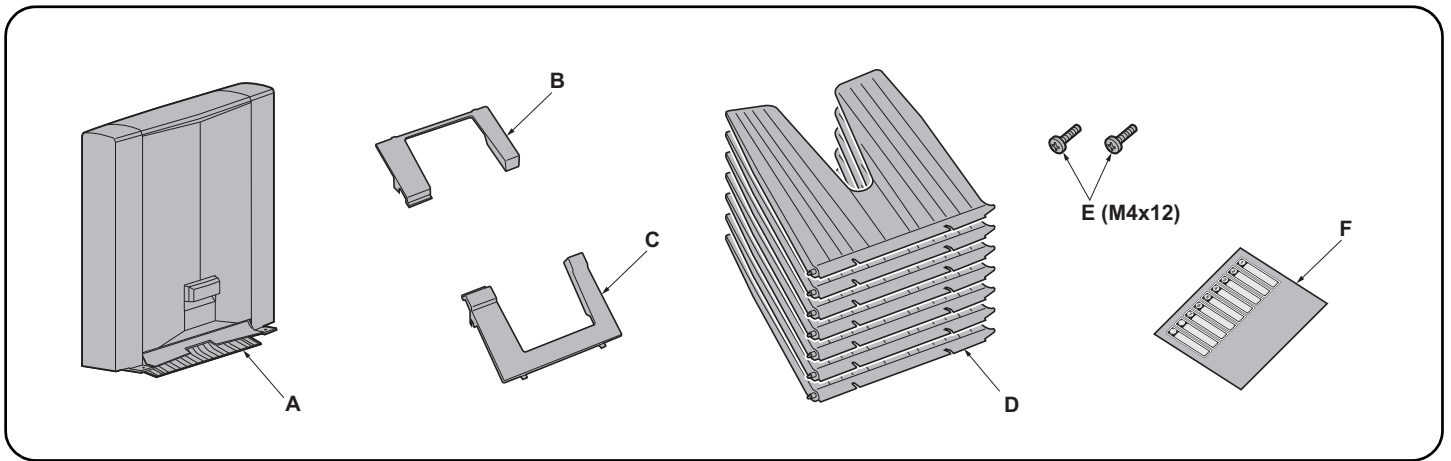
**10.** 将机器的电源插头插入插座, 然后打开主电源开关并确认机器能否正常操作。

**9.** 배출핀 (D) 7 개를 메일박스 (A) 의 배출부에 밑에서부터 순서대로 장착합니다 .  
배출핀 (D) 의 좌우를 밀어 조금 휘게해 앞뒤의 핀 (10) 을 메일박스의 앞뒤의 둥근 구멍 (11) 에 삽입합니다 .

**10.** 기기본체의 전원 플러그를 콘센트에 꽂고 주 전원 스위치를 ON 으로 해서 동작을 확인 합니다 .

**9.** 排出ビン (D) 7 枚をメールボックス (A) の排出部に下から順番に取り付ける。  
排出ビン (D) の左右を押し少したわませ、前後のピン (10) をメールボックスの前後の丸穴 (11) に挿入する。

**10.** 機械本体の電源プラグをコンセントに差し込み、主電源スイッチを ON にして動作を確認する。



<p><b>English</b></p> <p><b>Supplied parts</b></p> <p>A. Mailbox ..... 1</p> <p>B. Front mounting plate cover..... 1</p> <p>C. Rear mounting plate cover ..... 1</p> <p>D. Copy eject bins ..... 7</p>	<p>E. M4 × 12 screw ..... 2</p> <p>F. Tray name label (for users)..... 1</p> <p>B and C are not used.</p>	<p>Be sure to remove any tape and/or cushioning materials from the parts supplied.</p>
<p><b>Français</b></p> <p><b>Pièces fournies</b></p> <p>A. Boîte à lettres ..... 1</p> <p>B. Couvercle de la plaque de montage avant..... 1</p> <p>C. Couvercle de la plaque de montage arrière ... 1</p> <p>D. Case d'éjection de copies..... 7</p>	<p>E. Vis M4 × 12..... 2</p> <p>F. Étiquette de nom de plateau (pour les utilisateurs) ..... 1</p> <p>B et C ne sont pas utilisés.</p>	<p>Veillez à retirer les morceaux de bande adhésive et/ou les matériaux de rembourrage des pièces fournies.</p>
<p><b>Español</b></p> <p><b>Partes suministradas</b></p> <p>A. Buzón de correo ..... 1</p> <p>B. Cubierta de la placa de montaje frontal .... 1</p> <p>C. Cubierta de la placa de montaje trasera.... 1</p> <p>D. Bandejas de expulsión de copias ..... 7</p>	<p>E. Tornillo M4 × 12 ..... 2</p> <p>F. Etiqueta de nombre de la bandeja (para usuarios)..... 1</p> <p>B y C no se utilizan.</p>	<p>Asegúrese de quitar todas las cintas y/o material amortiguador de las partes suministradas.</p>
<p><b>Deutsch</b></p> <p><b>Enthaltene Teile</b></p> <p>A. Mailbox ..... 1</p> <p>B. Vordere Abdeckung der Montageplatte..... 1</p> <p>C. Hintere Abdeckung der Montageplatte ..... 1</p> <p>D. Kopienausgabefächer..... 7</p>	<p>E. Schraube M4 × 12 ..... 2</p> <p>F. Fachnamenaufkleber (für Benutzer) ..... 1</p> <p>B und C werden nicht benötigt.</p>	<p>Stellen Sie sicher, dass sämtliche Klebebänder und/oder Polstermaterial von den gelieferten Teilen entfernt wurden.</p>
<p><b>Italiano</b></p> <p><b>Parti fornite</b></p> <p>A. Mailbox ..... 1</p> <p>B. Coperchio della piastra di montaggio anteriore .. 1</p> <p>C. Coperchio della piastra di montaggio posteriore. 1</p> <p>D. Scomparti di espulsione delle copie ..... 7</p>	<p>E. Vite M4 × 12..... 2</p> <p>F. Etichetta di nome del vassoio (per utenti) ..... 1</p> <p>B e C non sono utilizzati.</p>	<p>Rimuovere tutti i nastri adesivi e/o i materiali di protezione dalle parti fornite.</p>
<p><b>简体中文</b></p> <p><b>附属品</b></p> <p>A. 邮箱..... 1</p> <p>B. 支撑板前盖板..... 1</p> <p>C. 支撑板后盖板..... 1</p> <p>D. 接纸盘..... 7</p>	<p>E. M4×12 螺丝 ..... 2</p> <p>F. 托盘名称标贴 (用户用) ..... 1</p> <p>不使用 B 和 C。</p>	<p>如果附属品上带有固定胶带, 缓冲材料时必须揭下。</p>
<p><b>한국어</b></p> <p><b>동봉품</b></p> <p>A. 메일박스..... 1</p> <p>B. 부착판커버 앞..... 1</p> <p>C. 부착판커버 뒤..... 1</p> <p>D. 배출핀..... 7</p>	<p>E. 나사 M4 × 12..... 2</p> <p>F. 트레이 명칭 스티 (사용자용) ..... 1</p> <p>B 와 C 는 사용되지 않습니다 .</p>	<p>동봉품에 고정 테이프, 완충재가 붙어 있는 경우에는 반드시 제거하십시오 .</p>
<p><b>日本語</b></p> <p><b>同梱品</b></p> <p>A. メールボックス..... 1</p> <p>B. 取付板カバー前..... 1</p> <p>C. 取付板カバー後..... 1</p> <p>D. 排出ピン..... 7</p>	<p>E. ビス M4×12 ..... 2</p> <p>F. トレイ名称シール(ユーザー用) ..... 1</p> <p>B, C は使用しない。</p>	<p>同梱品に固定テープ、緩衝材がついている場合は、必ず取り外すこと。</p>

**Note**  
The Attachment Kit(AK-736) must be installed before the mailbox is installed.

**Procedure**  
Before starting installation, be sure to turn the main power switch of the machine off, and unplug the power plug from the wall outlet.

---

**Remarque**  
L'Attachment Kit (AK-736) doit être installé avant d'installer la boîte à lettres.

**Procédure**  
Avant de commencer l'installation, s'assurer de mettre la machine hors tension et de débrancher la fiche d'alimentation de la prise murale.

---

**Nota**  
El Attachment Kit (AK-736) se debe instalar antes de la instalación del buzón de correo.

**Procedimiento**  
Antes de iniciar la instalación, asegúrese de apagar el interruptor de encendido de la máquina y desenchufar el cable de alimentación de la toma de pared.

---

**Hinweis**  
Das Attachment Kit (AK-736) muss vor der Installation der Mailbox installiert werden.

**Vorgehensweise**  
Bevor Sie mit der Installation beginnen überzeugen Sie sich, dass der Netzschalter des Geräts ausgeschaltet und das Stromkabel aus der Steckdose gezogen ist.

---

**Nota**  
Installare l'Attachment Kit (AK-736) prima di installare il vassoio mailbox.

**Procedura**  
Prima di iniziare l'installazione, spegnere la macchina e scollegare la spina dalla presa di corrente.

---

**注**  
在安装邮箱前, 请先安装连接组件 (AK-736)。

**安装步骤**  
安装前务必关闭机器的主电源开关, 并从墙壁插座拔下电源插头。

---

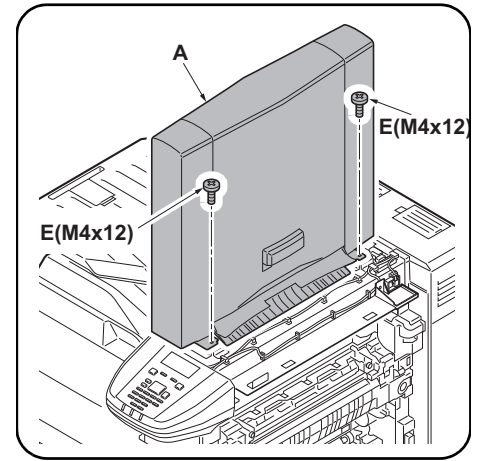
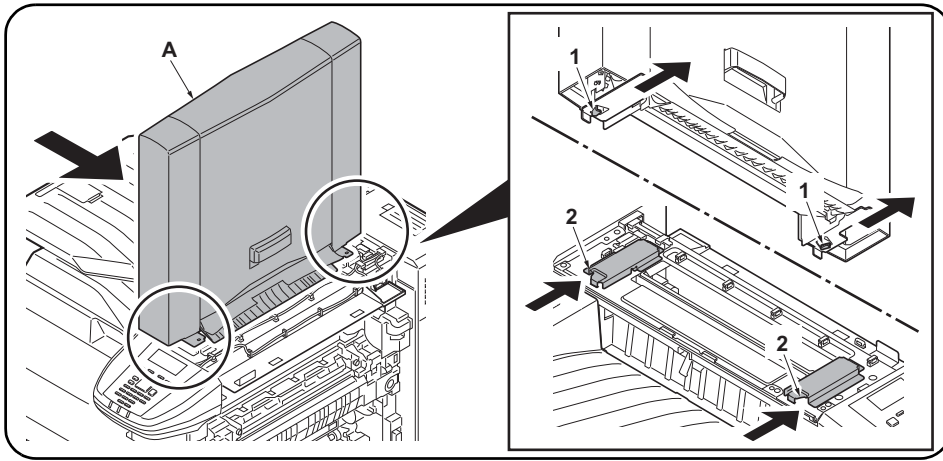
**주**  
메일박스를 설치하기 전에 부착 키트 (AK-736) 를 설치해야 합니다 .

**설치순서**  
설치를 시작하기 전에 반드시 본체의 주 전원 스위치를 끄고 벽 콘센트에서 전원 플러그를 분리하십시오 .

---

**注意**  
メールボックスを取付ける前にアタッチメントキット (AK-736) の取付けをおこなうこと。

**取付手順**  
必ず機械本体の主電源スイッチを OFF にし、機械本体の電源プラグを抜いてから作業すること。



1. Insert the hooks (1) located at the front and rear of the bottom of the mailbox (A) into the notches (2) of the machine and attach the mailbox (A) to the machine.

2. Secure the mailbox (A) using the two screws M4x12 (E).

**Note**

Lift the front and rear of the mailbox (A) lightly upward to make sure that no gap is made between the mailbox (A) and the machine.

1. Insérer les crochets (1) situés à l'avant et à l'arrière du fond de la boîte à lettres (A) dans les encoches (2) de la machine et fixer la boîte aux lettres (A) à la machine.

2. Fixer la boîte à lettres (A) à l'aide de deux vis M4x12 (E).

**Remarque**

Lever légèrement l'avant et l'arrière de la boîte à lettres (A) de sorte qu'il n'y ait aucun interstice entre la boîte à lettres (A) et la machine.

1. Inserte los enganches (1) que se encuentran en la parte frontal y trasera de la parte inferior del buzón de correo (A) en las hendiduras (2) de la máquina y acople el buzón de correo (A) a la máquina.

2. Fije el buzón de correo (A) con dos tornillos M4x12 (E).

**Nota**

Levante ligeramente la parte frontal y trasera del buzón de correo (A) para asegurarse de que no queda espacio entre el buzón de correo (A) y la máquina.

1. Führen Sie die Haken (1), die sich hinten und vorne an der Unterseite der Mailbox (A) befinden, in die Aufnahmen (2) des Geräts ein und befestigen Sie die Mailbox (A) am Gerät.

2. Sichern Sie die Mailbox (A) mit zwei Schrauben M4x12 (E).

**Hinweis**

Heben Sie die Vorder- und Rückseite der Mailbox (A) ein wenig an, damit sich kein Spalt zwischen der Mailbox (A) und dem Gerät bildet.

1. Inserire i ganci (1) posti sul fronte e sul retro della sezione inferiore della mailbox (A) negli incavi (2) presenti sulla macchina e fissare la mailbox (A) sulla macchina.

2. Fissare la mailbox (A) utilizzando le due viti M4x12 (E).

**Nota**

Sollevarle leggermente la parte anteriore e posteriore della mailbox (A) verso l'alto per accertarsi che non vi sia dello spazio tra la mailbox (A) e la macchina.

1. 将位于邮箱 (A) 底部前、后侧的挂钩 (1) 插入机器的凹槽 (2)，然后将邮箱 (A) 安装至机器。

2. 使用两个螺丝 M4x12 (E) 固定邮箱 (A)。

**注**

轻轻向上提升邮箱 (A) 的前后侧，确保邮箱 (A) 未处于悬浮状态。

1. 메일박스 (A) 의 전후면 하단에 있는 후크 (1) 를 본체의 노치 (2) 에 삽입하여 메일박스 (A) 를 본체에 부착합니다.

2. M4x12 나사 (E) 두 개를 사용하여 메일박스 (A) 를 고정합니다.

**주**

메일박스 (A) 의 앞뒤를 각각 상방향으로 가볍게 들어 메일박스 (A) 가 떠 있지 않은 것을 확인합니다.

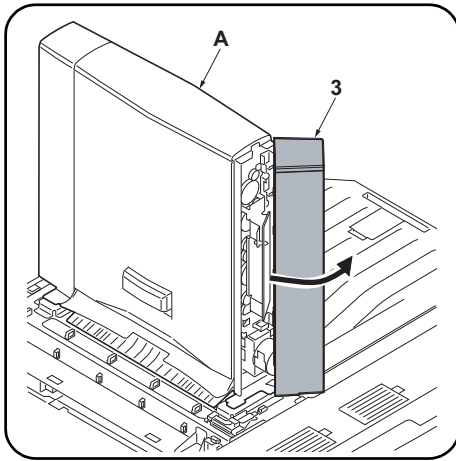
1. 메일박스 (A) 下部の前後にあるフック (1) を機械本体の切り欠き (2) に挿入し、メールボックス (A) を機械本体に取り付ける。

2. ビス M4×12 (E) 2 本で、メールボックス (A) を固定する。

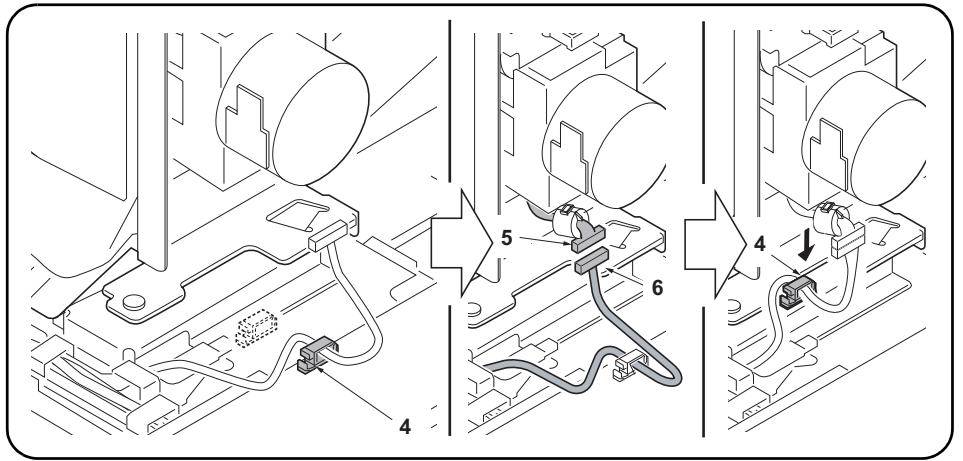
**注意**

メールボックス (A) の前後をそれぞれ上方向に軽く持ち上げ、メールボックス (A) が浮かないことを確認する。





3. Remove the rear cover (3) of the mailbox (A).



4. Remove the wire saddle (4).  
 5. Plug the connector (5) of the mailbox (A) into the connector (6) of the machine body.  
 6. Install the wire saddle (4) in the position as shown in the figure.  
 7. Reinstall the rear cover (3) of the mailbox (A).

3. Retirer le couvercle arrière (3) de la boîte à lettres (A).

4. Retirer le serre-câble (4).  
 5. Brancher le connecteur (5) de la boîte à lettres (A) dans le connecteur (6) du corps de la machine.  
 6. Installer le serre-câble (4) dans la position illustrée sur la figure.  
 7. Remonter le couvercle arrière (3) de la boîte à lettres (A).

3. Quite la cubierta posterior (3) del buzón de correo (A).

4. Retire la abrazadera del cable (4).  
 5. Enchufe el conector (5) del buzón de correo (A) al conector (6) del cuerpo de la máquina.  
 6. Instale la abrazadera del cable (4) en la posición que se muestra en la imagen.  
 7. Vuelva a instalar la cubierta posterior (3) del buzón de correo (A).

3. Entfernen Sie die hintere Abdeckung (3) der Mailbox (A).

4. Entfernen Sie die Kabelbefestigung (4).  
 5. Stecken Sie den Stecker (5) der Mailbox (A) in die Steckbuchse (6) des Gerätegehäuses.  
 6. Installieren Sie die Kabelbefestigung (4) an der im Bild gezeigten Position.  
 7. Bringen Sie die hintere Abdeckung (3) der Mailbox (A) wieder an.

3. Rimuovere il coperchio posteriore (3) della mailbox (A).

4. Rimuovere l'unità sella (4).  
 5. Collegare il connettore (5) della mailbox (A) al connettore (6) del corpo macchina.  
 6. Installare l'unità sella (4) nella posizione indicata in figura.  
 7. Reinstallare il coperchio posteriore (3) della mailbox (A).

3. 拆下邮箱 (A) 的后部盖板 (3)。

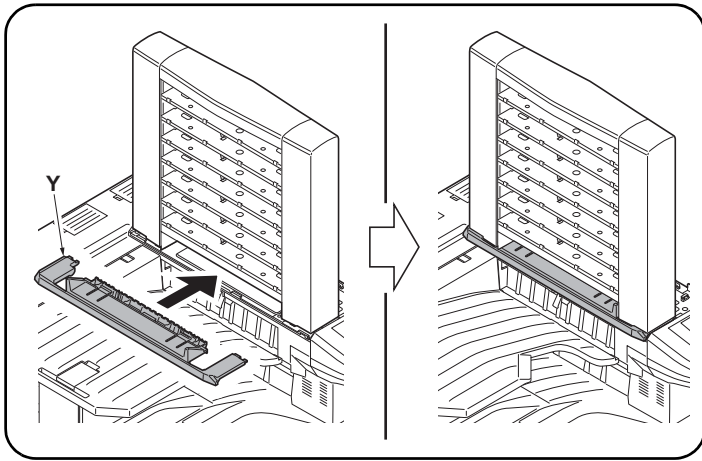
4. 取下束线夹 (4)。  
 5. 将邮箱 (A) 的接插件 (5) 插入机器的接插件 (6)。  
 6. 把束线夹 (4) 安装到图示位置。  
 7. 重新安装邮箱 (A) 的后盖板 (3)。

3. 메일박스 (A) 의 뒤커버 (3) 를 떼어냅니다 .

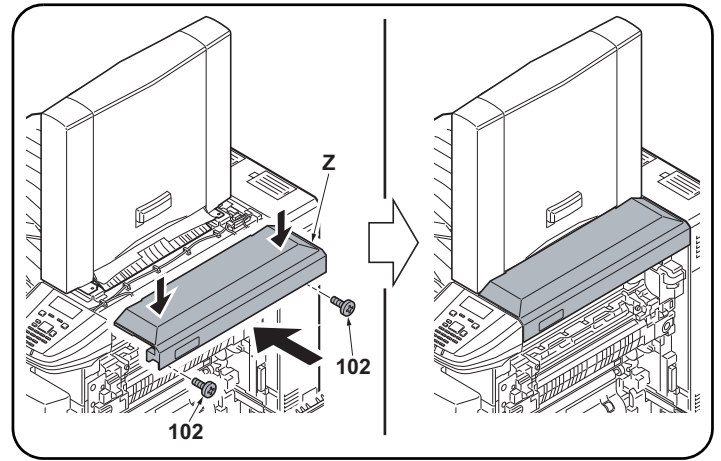
4. 와이어 새들 (4) 을 분리합니다 .  
 5. 메일박스 (A) 의 커넥터 (5) 를 본체의 커넥터 (6) 에 연결합니다 .  
 6. 와이어 새들 (4) 을 그림에 표시된 위치에 설치합니다 .  
 7. 메일박스 (A) 의 뒤커버 (3) 를 다시 장착합니다 .

3. メールボックス (A) の後カバー (3) を取り外す。

4. ワイヤースドル (4) を外す。  
 5. メールボックス (A) のコネクタ (5) を機械本体のコネクタ (6) に接続する。  
 6. ワイヤースドル (4) を図の位置に取り付ける。  
 7. メールボックス (A) の後カバー (3) を元通りに取り付ける。



8. Install the left cover (Y) in place.



9. Using the two screws (102) removed in step 2 in the installation guide for the AK-736, install the right cover (Z).  
\*While pressing the right cover (Z) downwards, fix the right cover (Z).

8. Monter le couvercle gauche (Y) en position.

9. À l'aide des deux vis (102) retirées à l'étape 2 du guide d'installation pour l'AK-736, installez le capot droit (Z).  
\*Fixer le capot droit (Z) en le maintenant enfoncé vers le bas.

8. Instale la cubierta izquierda (Y) en la ubicación prevista.

9. Con los dos tornillos (102) que quitó en el paso 2 de la guía de instalación para AK-736, instale la cubierta derecha (Z).  
\*A la vez que ejerce presión sobre la cubierta derecha (Z), fije la cubierta derecha (Z).

8. Installieren Sie die linke Abdeckung (Y).

9. Mit den zwei Schrauben (102), die Sie in Schritt 2 der Installationsanleitung für das AK-736 entfernt haben, bringen Sie die rechte Abdeckung (Z) wieder an.  
\*Drücken Sie die rechte Abdeckung (Z) leicht nach unten, während Sie diese befestigen.

8. Installare il coperchio di sinistra (Y) in posizione.

9. Utilizzando le due viti (102) rimosse al punto 2 della procedura descritta nella guida di installazione del kit AK-736, installare il coperchio destro (Z).  
\*Premere verso il basso il coperchio destro (Z) per fissarlo in posizione.

8. 将左盖板 (Y) 安装到位。

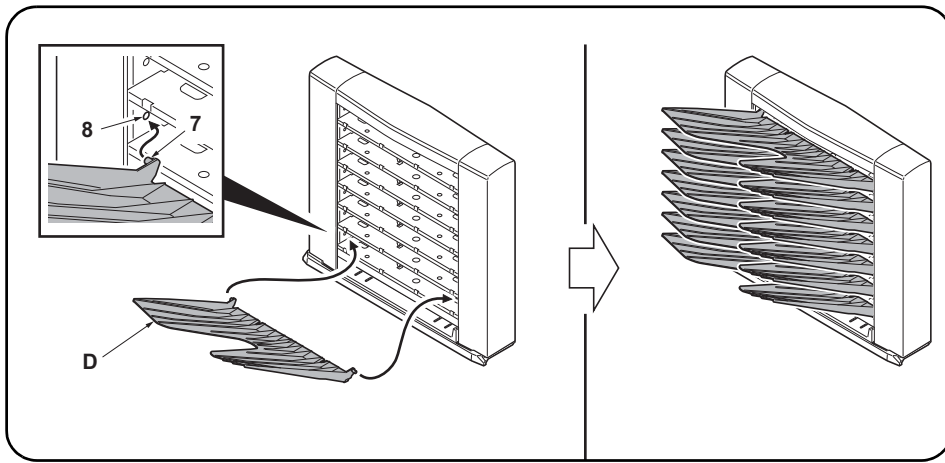
9. 请用 AK-736 安装手册步骤 2 中取下的 2 颗螺丝 (102) 来安装右盖板 (Z)。  
\*把右盖板 (Z) 边向下按, 边固定。

8. 좌측 커버 (Y) 를 제자리에 장착합니다 .

9. AK-736 설치 설명서의 2 단계에서 분리한 나사 (102) 두 개를 사용하여 우측 커버 (Z) 를 장착합니다 .  
\* 우측 커버 (Z) 를 아래쪽으로 누르는 동시에 우측 커버 (Z) 를 고정하십시오 .

8. 左カバー (Y) を取り付ける。

9. AK-736 設置手順書の手順 2 で外したビス (102) 2 本で、右カバー (Z) を取付ける。  
\* 右カバー (Z) を下方向に押さえながら、固定する。



- 10.** Fit the seven copy eject bins (D) to the ejection section of the mailbox (A) from the lowest bin to the highest.  
Press both ends of each copy eject bin (D) to bend it a little, then fit the bin by inserting the front and rear pins (7) into the round holes (8) at the front and rear of the mailbox.

- 10.** Fixer les sept cases d'éjection de copies (D) sur la section d'éjection de la boîte à lettres (A), en procédant de la case située tout en bas à celle située tout en haut.  
Appuyer sur les deux extrémités de chaque case d'éjection des copies (D) pour cintrer légèrement cette pièce, puis monter la case en insérant les broches avant et arrière (7) dans les trous ronds (8) à l'avant et à l'arrière de la boîte à lettres.

- 10.** Presione ambos extremos de cada bandeja de expulsión de copias (D) para doblarlas un poco; después, coloque la bandeja insertando los pasadores delantero y trasero (7) en los orificios redondos (8) en la parte frontal y posterior del buzón de correo.

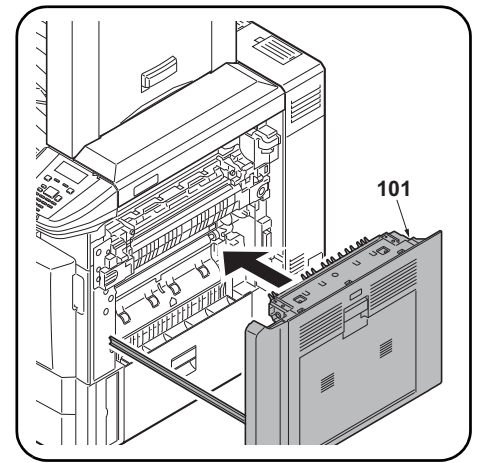
- 10.** Setzen Sie die sieben Kopienausgabefächer (D) in die Ausgabeöffnungen der Mailbox (A) ein, beginnend vom untersten Fach zum höchsten.  
Drücken Sie beide Enden jedes Kopienausgabefachs (D) zusammen, um es etwas zu biegen. Setzen Sie das Fach ein, indem Sie die vorderen und hinteren Stifte (7) in die Rundlöcher (8) vorne und hinten an der Mailbox einsetzen.

- 10.** Installare i sette scomparti di espulsione delle copie (D) nella sezione di espulsione della mailbox (A), iniziando dallo scomparto più in basso fino a quello più in alto.  
Premere le due estremità di ciascuno scomparto di espulsione delle copie (D) in modo da piegarlo leggermente, quindi installare lo scomparto inserendo i perni anteriore e posteriore (7) nei fori rotondi (8) presenti sul fronte e sul retro della mailbox.

- 10.** 从邮箱 (A) 的排出部下面起按顺序安装 7 个接纸盘 (D)。  
按住接纸盘 (D) 的左右两侧并使其稍稍下垂, 通过将前后的销钉 (7) 插入邮箱前后的圆孔 (8) 中来安装接纸盘。

- 10.** 배출핀 (D) 7 개를 메일박스 (A) 의 배출부에 밑에서부터 순서대로 장착합니다 .  
배출핀 (D) 의 좌우를 밀어 조금 휘게해 앞뒤의 핀 (7) 을 메일박스의 앞뒤의 둥근 구멍 (8) 에 삽입합니다 .

- 10.** 排出ビン (D) 7 枚をメールボックス (A) の排出部に下から順番に取り付ける。  
排出ビン (D) の左右を押し少したわませ、前後のピン (7) をメールボックスの前後の丸穴 (8) に挿入する。



- 11.** Close the paper conveying unit (101).  
**12.** Insert the power plug from the machine into the outlet, turn the main power switch on, and verify the machine operates normally.

- 11.** Fermer l'unité de transport du papier (101).  
**12.** Insérer la fiche d'alimentation de la machine dans la prise et mettre la machine sous tension, puis vérifier qu'elle fonctionne correctement.

- 11.** Cierre la unidad de transporte de papel (101).  
**12.** Enchufe el cable de alimentación de la máquina en la toma de corriente y encienda el interruptor principal para comprobar que la máquina funciona correctamente.

- 11.** Schließen Sie die Papierführung (101).  
**12.** Stecken Sie den Netzstecker des Geräts in eine Steckdose und schalten Sie den Hauptschalter des Geräts ein, um den Betrieb zu prüfen.

- 11.** Chiudere l'unità trasporto carta (101).  
**12.** Inserire la spina nella presa di corrente, accendere la macchina e controllare che funzioni correttamente.

- 11.** 关闭纸张传输单元 (101)。  
**12.** 将机器的电源插头插入插座, 然后打开主电源开关并确认机器能否正常操作。

- 11.** 반송 유닛 (101) 를 닫습니다 .  
**12.** 기기본체의 전원 플러그를 콘센트에 꽂고 주 전원 스위치를 ON 으로 해서 동작을 확인 합니다 .

- 11.** 搬送ユニット (101) を閉じる。  
**12.** 機械本体の電源プラグをコンセントに差し込み、主電源スイッチを ON にして動作を確認する。

# MEMO



303N05673001

2012. 4  
303N056730-01

# **INSTALLATION GUIDE FOR PUNCH UNIT**

---

**INSTALLATION GUIDE**

**GUIDE D'INSTALLATION**

**GUÍA DE INSTALACION**

**INSTALLATIONSANLEITUNG**

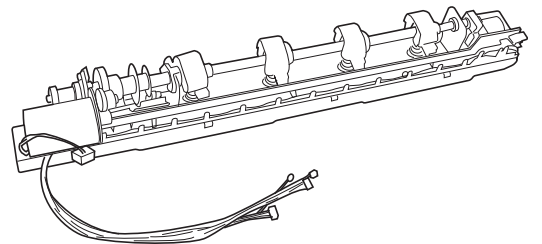
**GUIDA ALL'INSTALLAZIONE**

**安装手册**

**설치안내서**

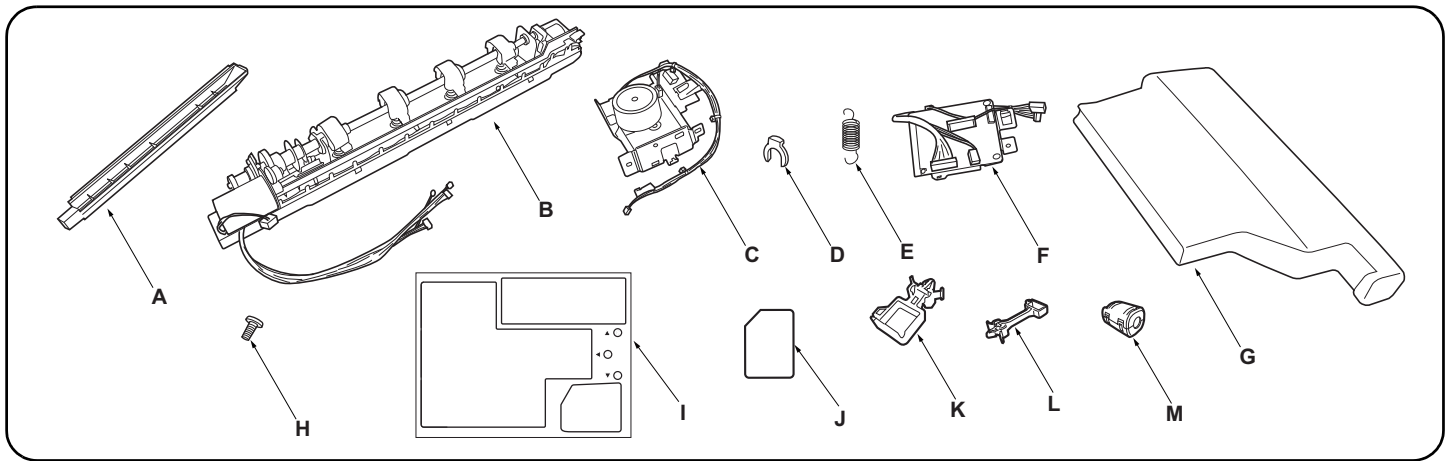
**設置手順書**

**PH-7A/PH-7B/PH-7C/PH-7D**

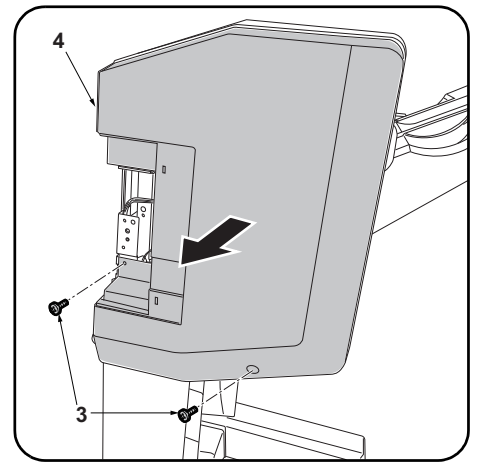
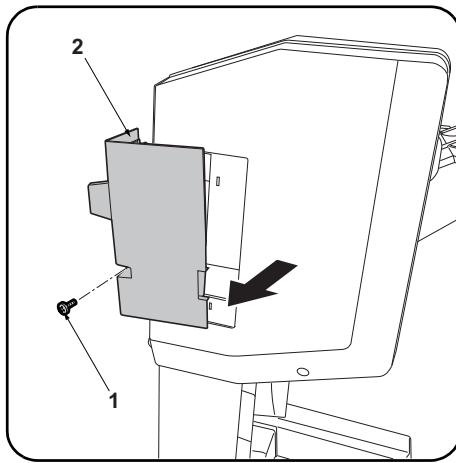








<b>English</b>		<b>E. Spring</b> ..... 1	<b>L. Large clamp (for DF-790/DF-791)</b> ..... 1
<b>Supplied parts</b>		<b>F. Punch PWB</b> ..... 1	<b>M. Ferrite core</b> ..... 1
<b>A. Punch guide</b> ..... 1	<b>G. Waste hole punch box</b> ..... 1	<b>H. M3 x 8 tap Tight S screw</b> ..... 3	Be sure to remove any tape and/or cushioning material from supplied parts.
<b>B. Hole punch unit</b> ..... 1	<b>I. Label sheet</b> ..... 1	<b>J. Film</b> ..... 1	
<b>C. Motor unit</b> ..... 1	<b>K. Small clamp (for DF-770)</b> ..... 1		
<b>D. Stop ring</b> ..... 1			
<b>Français</b>		<b>E. Ressort</b> ..... 1	<b>L. Grand collier (pour DF-790/DF-791)</b> ..... 1
<b>Pièces fournies</b>		<b>F. PWB de la perforatrice</b> ..... 1	<b>M. Noyau de ferrite</b> ..... 1
<b>A. Guide de perforatrice</b> ..... 1	<b>G. Bac de récupération de la perforatrice</b> ..... 1	<b>H. Vis S taraudée M3 x 8</b> ..... 3	Veillez à retirer les morceaux de bande adhésive et/ou les matériaux de rembourrage des pièces fournies.
<b>B. Perforatrice</b> ..... 1	<b>I. Feuillet d'étiquettes</b> ..... 1	<b>J. Film</b> ..... 1	
<b>C. Moteur</b> ..... 1	<b>K. Petit collier (pour DF-770)</b> ..... 1		
<b>D. Bague d'arrêt</b> ..... 1			
<b>Español</b>		<b>E. Resorte</b> ..... 1	<b>L. Sujetador grande (para DF-790/DF-791)</b> ... 1
<b>Partes suministradas</b>		<b>F. PWB de perforación</b> ..... 1	<b>M. Núcleo de ferrita</b> ..... 1
<b>A. Guía de perforación</b> ..... 1	<b>G. Caja para desechos de la perforación</b> ..... 1	<b>H. Tornillo de ajuste M3 x 8</b> ..... 3	Asegúrese de despegar todas las cintas y/o material amortiguador de las partes suministradas.
<b>B. Perforadora</b> ..... 1	<b>I. Hoja con etiqueta</b> ..... 1	<b>J. Película</b> ..... 1	
<b>C. Unidad motriz</b> ..... 1	<b>K. Sujetador pequeño (para DF-770)</b> ..... 1		
<b>D. Anillo de tope</b> ..... 1			
<b>Deutsch</b>		<b>E. Feder</b> ..... 1	<b>L. Große Klemme (für DF-790/DF-791)</b> ..... 1
<b>Gelieferte Teile</b>		<b>F. Locher-PWB</b> ..... 1	<b>M. Ferritkern</b> ..... 1
<b>A. Locherführung</b> ..... 1	<b>G. Lochungsabfallbehälter</b> ..... 1	<b>H. M3 x 8 Passstift-Verbandschrauben</b> ..... 3	Entfernen Sie Klebeband und/oder Dämpfungsmaterial vollständig von den mitgelieferten Teilen.
<b>B. Lochereinheit</b> ..... 1	<b>I. Aufkleberbogen</b> ..... 1	<b>J. Film</b> ..... 1	
<b>C. Motoreinheit</b> ..... 1	<b>K. Kleine Klemme (für DF-770)</b> ..... 1		
<b>D. Anschlagring</b> ..... 1			
<b>Italiano</b>		<b>E. Molla</b> ..... 1	<b>L. Morsetto grande (per DF-790/DF-791)</b> ..... 1
<b>Parti di forniture</b>		<b>F. Scheda a circuiti stampati di perforazione</b> .... 1	<b>M. Nucleo di ferrite</b> ..... 1
<b>A. Guida perforazione</b> ..... 1	<b>G. Scarto perforazione</b> ..... 1	<b>H. Viti con testa a croce S M3 x 8</b> ..... 3	Accertarsi di rimuovere tutti i nastri adesivi e/o il materiale di imbottitura dalle parti fornite.
<b>B. Unità di perforazione</b> ..... 1	<b>I. Foglio di etichette</b> ..... 1	<b>J. Pellicola</b> ..... 1	
<b>C. Unità motore</b> ..... 1	<b>K. Morsetto piccolo (per DF-770)</b> ..... 1		
<b>D. Anello di bloccaggio</b> ..... 1			
<b>简体中文</b>		<b>E. 弹簧</b> ..... 1	<b>K. 固定夹 小 (DF-770 用)</b> ..... 1
<b>附属品</b>		<b>F. 打孔单元电路板</b> ..... 1	<b>L. 固定夹 大 (DF-790/DF-791 用)</b> ..... 1
<b>A. 打孔导向板</b> ..... 1	<b>G. 打孔纸屑盒</b> ..... 1	<b>H. M3 X 8 攻丝紧固型 S 螺丝</b> ..... 3	<b>M. 磁环</b> ..... 1
<b>B. 打孔单元</b> ..... 1	<b>I. 标签纸</b> ..... 1	<b>J. 胶片</b> ..... 1	如果附属品上带有固定胶带, 缓冲材料时务必揭下。
<b>C. 电机单元</b> ..... 1			
<b>D. 止动环</b> ..... 1			
<b>한국어</b>		<b>E. 스프링</b> ..... 1	<b>K. 클램프 소 (DF-770 용)</b> ..... 1
<b>동봉품</b>		<b>F. 펀치기판</b> ..... 1	<b>L. 클램프 대 (DF-790/DF-791 용)</b> ..... 1
<b>A. 펀치가이드</b> ..... 1	<b>G. 펀치폐기박스</b> ..... 1	<b>H. 나사 M3x8 탭타이트 S</b> ..... 3	<b>M. 페라이트 코어</b> ..... 1
<b>B. 펀치유닛</b> ..... 1	<b>I. 라벨 시트</b> ..... 1	<b>J. 필름</b> ..... 1	동봉품에 고정 테이프, 완충재가 붙어 있는 경우에는 반드시 제거할 것.
<b>C. 모터유닛</b> ..... 1			
<b>D. 스톱링</b> ..... 1			
<b>日本語</b>		<b>E. バネ</b> ..... 1	<b>L. クランプ大 (DF-790/DF-791 用)</b> ..... 1
<b>同梱品</b>		<b>F.パンチ基板</b> ..... 1	<b>M. フェライトコア</b> ..... 1
<b>A.パンチガイド</b> ..... 1	<b>G.パンチくずボックス</b> ..... 1	<b>H.ビス M3×8 タップタイト S</b> ..... 3	同梱品に固定テープ、緩衝材が付いている場合は必ず取り外すこと。
<b>B.パンチユニット</b> ..... 1	<b>I.ラベルシート</b> ..... 1	<b>J.フィルム</b> ..... 1	
<b>C.モーターユニット</b> ..... 1	<b>K.クランプ小 (DF-770 用)</b> ..... 1		
<b>D.ストップリング</b> ..... 1			



**Procedure**

Before installing the hole punch unit, make sure the MFP's main power switch is turned off and that its power cord is unplugged from the power outlet.

Install the document finisher first and then install the hole punch unit.

**Removing the cover (DF-770)**

If installing on the DF-790/DF-791, proceed to step 1 on page 3.

1. Remove the screw (1) and remove the small rear cover (2).

2. Remove the 2 screws (3) and remove the upper rear cover (4).

**Procédure**

Avant d'installer la perforatrice, s'assurer que l'interrupteur d'alimentation principal du MFP est hors tension et que le câble d'alimentation est débranché de la prise secteur.

Installer d'abord le finisseur de document, puis installer la perforatrice.

**Dépose du couvercle (DF-770)**

Pour l'installation sur le modèle DF-790/DF-791, passer à l'étape 1 de la page 3.

1. Déposer la vis (1) et déposer le petit couvercle arrière (2).

2. Déposer les 2 vis (3) et déposer le couvercle supérieur arrière (4).

**Procedimiento**

Antes de instalar la perforadora, asegúrese de que el interruptor principal de la alimentación del MFP esté desconectado y de que el cable de alimentación esté desenchufado de la toma de corriente de la pared.

Instale primero el finalizador de documentos y luego instale la perforadora.

**Extracción de la cubierta (DF-770)**

Si realiza la instalación en el DF-790/DF-791, vaya al paso 1 de la página 3.

1. Quite el tornillo (1) y, después, quite la cubierta trasera pequeña (2).

2. Quite los 2 tornillos (3) y, después, quite la cubierta trasera superior (4).

**Verfahren**

Bevor Sie mit dem Einbau der Lochereinheit beginnen, stellen Sie sicher, dass der Hauptschalter des Kopierers ausgeschaltet und das Netzkabel aus der Steckdose gezogen ist. Bringen Sie den Dokument-Finisher zuerst und dann erst die Lochereinheit an.

**Entfernen der Abdeckung (DF-770)**

Zur Installation des DF-790/DF-791 weitergehen zu Schritt 1 auf Seite 3.

1. Die Schraube (1) entfernen und die kleine hintere Abdeckung (2) abnehmen.

2. Die 2 Schrauben (3) entfernen und die obere hintere Abdeckung (4) abnehmen.

**Procedura**

Prima di installare l'unità di perforazione, assicurarsi che l'interruttore principale dell'MFP sia spento e che il cavo di alimentazione sia scollegato dalla presa di corrente.

Installare prima la finitrice e poi procedere all'installazione dell'unità di perforazione.

**Rimozione del coperchio (DF-770)**

Se si installa sull'unità DF-790/DF-791, procedere al passo 1 a pagina 3.

1. Rimuovere la vite (1) e quindi rimuovere il pannello posteriore piccolo (2).

2. Rimuovere le 2 viti (3) e quindi rimuovere il pannello superiore posteriore (4).

**安装步骤**

安装打孔单元时，必须事先关闭 MFP 主机的主电源开关，并拔下电源插头后再进行作业。首先安装装订器，然后安装打孔单元。

**拆下盖板 (DF-770 时)**

安装到 DF-790/DF-791 上时，跳至 P3 的步骤 1。

1. 拆除 1 颗螺丝 (1)，拆下后部小盖板 (2)。

2. 拆除 2 颗螺丝 (3)，拆下后上部盖板 (4)。

**설치순서**

펀치유니트를 부착할 때에는 반드시 MFP 본체의 주 전원 스위치를 OFF 로 하고 전원플러그를 뺀 다음 작업을 할 것 . 문서 피니셔를 설치 후 , 펀치유니트를 설치 할 것 .

**커버제거 (DF-770 의 경우)**

DF-790/DF-791 에 장착하는 경우에는 P3 의 순서 1 로 진행합니다 .

1. 나사 (1) 1 개를 제거하고 뒷 소커버 (2) 를 제거합니다 .

2. 나사 (3) 2 개를 제거하고 뒷 상커버 (4) 를 제거합니다 .

**取付手順**

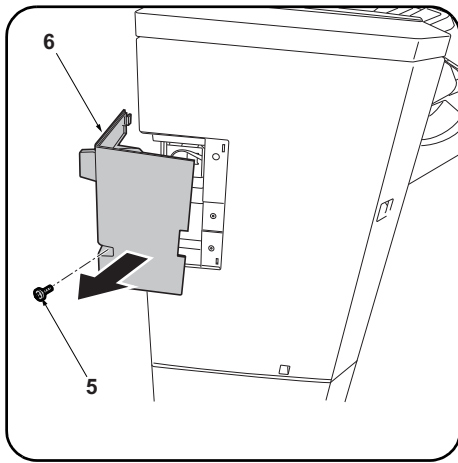
パンチユニットを設置するときは、必ず MFP 本体の主電源スイッチを OFF にし、電源プラグを抜いてから作業すること。ドキュメントフィニッシャーを設置後、パンチユニットを設置すること。

**カバーの取り外し (DF-770 の場合)**

DF-790/DF-791 に装着の場合は、P3 の手順 1 へ進む。

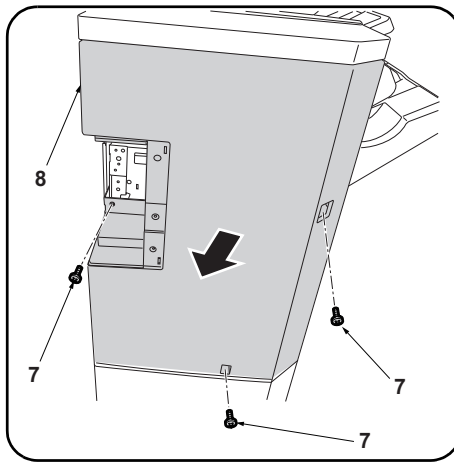
1. ビス (1) 1 本を外し、後小カバー (2) を取り外す。

2. ビス (3) 2 本を外し、後上カバー (4) を取り外す。

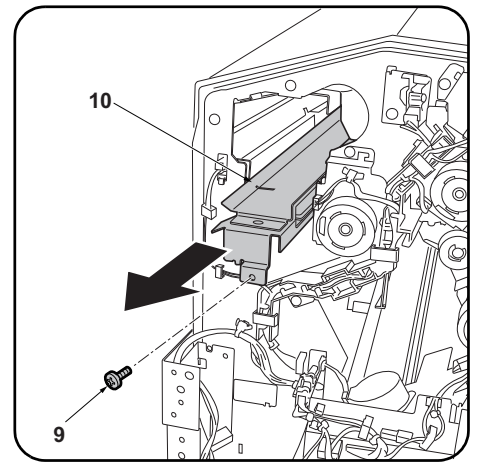


**Removing the cover (DF-790/DF-791)**

1. Remove the screw (5) and remove the small rear cover (6).



2. Remove the 3 screws (7) and remove the upper rear cover (8).



**Installing the hole punch unit**

3. Remove the screw (9) and pull the guide (10) outwards.

**Dépose du couvercle (DF-790/DF-791)**

1. Déposer la vis (5) et déposer le petit couvercle arrière (6).

2. Déposer les 3 vis (7) et déposer le couvercle supérieur arrière (8).

**Installation de la perforatrice**

3. Déposer la vis (9) et tirer le guide (10) vers l'extérieur.

**Extracción de la cubierta (DF-790/DF-791)**

1. Quite el tornillo (5) y, después, quite la cubierta trasera pequeña (6).

2. Quite los 3 tornillos (7) y, después, quite la cubierta trasera superior (8).

**Instalación de la perforadora**

3. Quite el tornillo (9) y tire de la guía (10) hacia fuera.

**Entfernen der Abdeckung (DF-790/DF-791)**

1. Die Schraube (5) entfernen und die kleine hintere Abdeckung (6) abnehmen.

2. Die 3 Schrauben (7) entfernen und die obere hintere Abdeckung (8) abnehmen.

**Anbringen der Lochereinheit**

3. Die Schraube (9) entfernen und die Führung (10) nach außen ziehen.

**Rimozione del coperchio (DF-790/DF-791)**

1. Rimuovere la vite (5) e quindi rimuovere il pannello posteriore piccolo (6).

2. Rimuovere le 3 viti (7) e quindi rimuovere il pannello superiore posteriore (8).

**Installare l'unità di perforazione**

3. Rimuovere la vite (9) ed estrarre la guida (10) verso l'esterno.

**拆下盖板 (DF-790/DF-791 时)**

1. 拆除 1 颗螺丝 (5), 拆下后部小盖板 (6)。

2. 拆除 3 颗螺丝 (7), 拆下后上部盖板 (8)。

**安装打孔单元**

3. 拆除 1 颗螺丝 (9), 将导向板 (10) 向外拉出。

**커버제거 (DF-790/DF-791 의 경우)**

1. 나사 (5) 1 개를 제거하고 뒷 소커버 (6) 를 제거합니다 .

2. 나사 (7) 3 개를 제거하고 뒷 상커버 (8) 를 제거합니다 .

**펀치유닛 부착**

3. 나사 (9) 1 개를 제거하고 가이드 (10) 을 앞으로 끌어 당깁니다 .

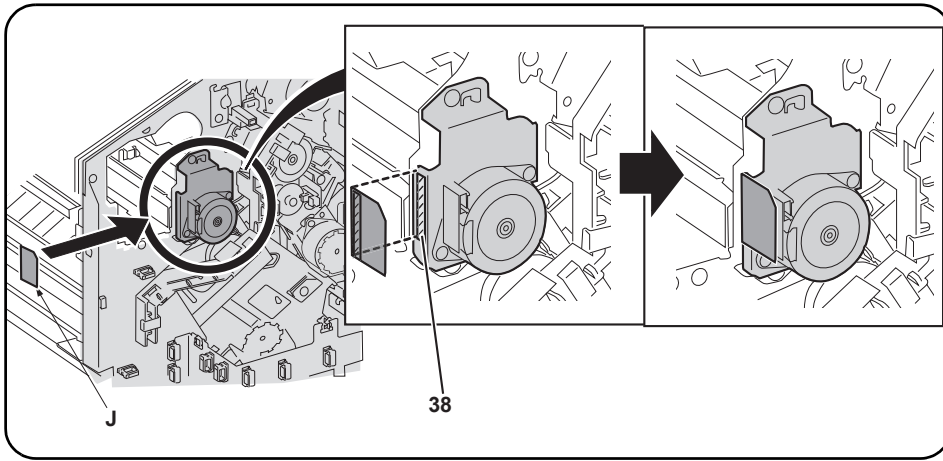
**カバーの取り外し (DF-790/DF-791 の場合)**

1. ビス (5) 1 本を外し、後小カバー (6) を取り外す。

2. ビス (7) 3 本を外し、後上カバー (8) を取り外す。

**パンチユニットの取り付け**

3. ビス (9) 1 本を外し、ガイド (10) を手前に引き出す。



4. After using alcohol to clean the shaded portion (38) of the motor shown for adhering the film (J), adhere the film.

---

4. Après avoir utilisé de l'alcool pour nettoyer la partie du moteur hachurée (38) sur laquelle le film (J) est apposé, coller ce film.

---

4. Después de utilizar alcohol para limpiar la parte sombreada (38) del motor mostrada en la ilustración para pegar la película (J), pegue la película.

---

4. Den in der Abbildung grau dargestellten Teil (38) des Motors zum Anbringen des Films (J) mit Alkohol reinigen und dann den Film anbringen.

---

4. Dopo aver usato l'alcool per pulire la parte ombreggiata (38) del motore, illustrata per l'adesione della pellicola (J), far aderire la pellicola.

---

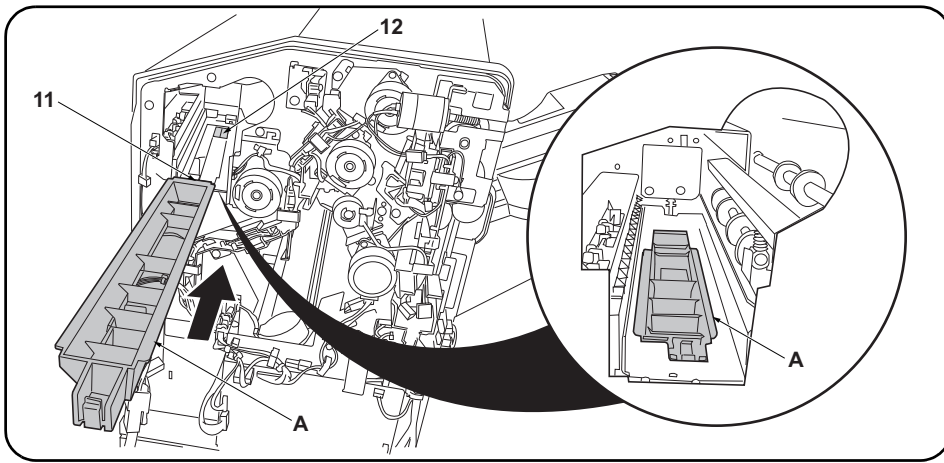
4. 用酒精清洁电机斜侧处(38)的粘贴位置后, 粘贴胶片(J)。

---

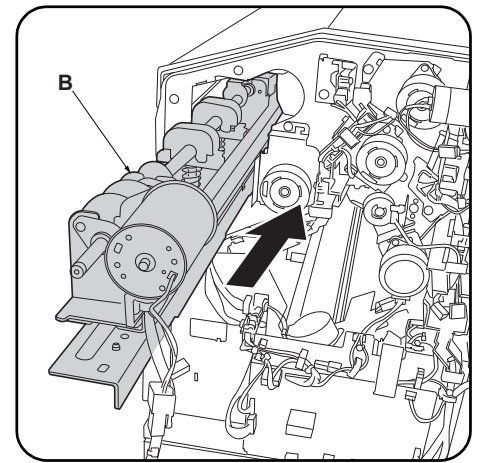
4. 모터 사선부(38)의 부착위치를 알코올 청소 후, 필름(J)을 부착합니다.

---

4. モーター斜線部(38)の貼り付け位置をアルコール清掃後、フィルム(J)を貼り付ける。



5. Install the punch guide (A) so that the leading edge of the guide (11) is below the document finisher frame (12).



6. Insert the hole punch unit (B) into the document finisher.

5. Monter le guide de la perforatrice (A) de sorte que le bord d'attaque du guide (11) se trouve sous le bâti du retoucheur de document (12).

6. Insérer la perforatrice (B) dans le retoucheur de document.

5. Instale la guía de perforación (A) de forma tal que el borde delantero de la guía (11) quede debajo de la carcasa del finalizador de documentos (12).

6. Inserte la perforadora (B) en el finalizador de documentos.

5. Die Locherführung (A) so einsetzen, dass die Vorderkante der Führung (11) unter dem Rahmen (12) des Dokument-Finishers liegt.

6. Die Lochereinheit (B) in den Dokument-Finisher einsetzen.

5. Installare la guida perforazione (A) in modo che il bordo principale della guida (11) sia sotto il telaio (12) della finitrice di documenti.

6. Inserire l'unità di perforazione (B) nella finitrice di documenti.

5. 将打孔导向板 (A) 的前端 (11) 安装在装订器的框架 (12) 的下部。

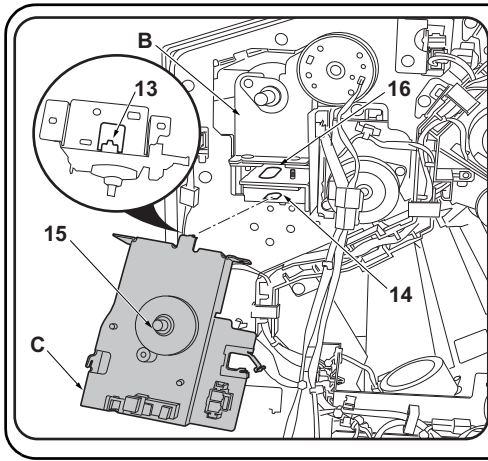
6. 将打孔单元 (B) 插入到装订器中。

5. 펀치가이드 (A) 의 끝 (11) 이 문서 피니셔의 프레임 (12) 밑으로 되도록 장착합니다 .

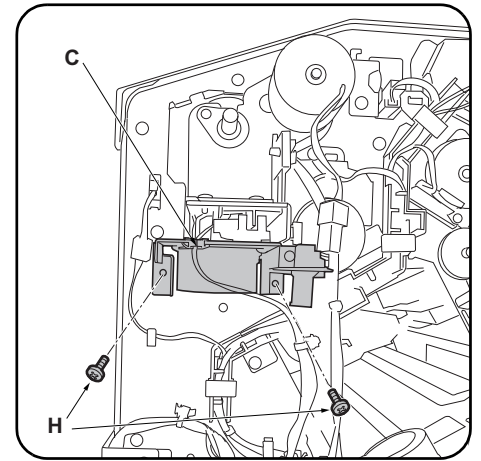
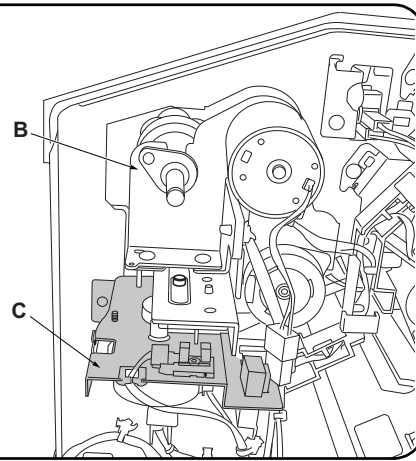
6. 펀치유닛 (B) 를 문서 피니셔에 삽입합니다 .

5.パンチガイド (A) の先端 (11) がドキュメントフィニッシャーのフレーム (12) の下になるように取り付ける。

6.パンチユニット (B) をドキュメントフィニッシャーに挿入する。



7. Raise the hole punch unit (B) slightly and fit the hook (13) on the motor unit (C) into the groove (14) in the document finisher. At the same time, insert the rod (15) on the motor unit (C) into the hole (16) in the hole punch unit (B).



8. Secure the motor unit (C) with the 2 screws (H).

7. Lever légèrement la perforatrice (B) et insérer le crochet (13) du moteur (C) dans la rainure (14) du retoucheur de document. Insérer en même temps la tige (15) du moteur (C) dans le trou (16) de la perforatrice (B).

8. Fixer le moteur (C) à l'aide de 2 vis (H).

7. Levante ligeramente la perforadora (B) y encaje el gancho (13) de la unidad motriz (C) en la ranura (14) del finalizador de documentos. Al mismo tiempo, inserte la varilla (15) de la unidad motriz (C) en el orificio (16) de la perforadora (B).

8. Asegure la unidad motriz (C) con los 2 tornillos (H).

7. Die Lochereinheit (B) leicht anheben und den Haken (13) an der Motoreinheit (C) in die Nut (14) des Dokument-Finishers einsetzen. Dabei auch die Stange (15) an der Motoreinheit (C) in die Öffnung (16) der Lochereinheit (B) einstecken.

8. Die Motoreinheit (C) mit den 2 Schrauben (H) sichern.

7. Sollevare leggermente l'unità di perforazione (B) ed inserire il gancio (13) sull'unità motore (C) nella scanalatura (14) della finitrice di documenti. Contemporaneamente, inserire l'asta (15) sull'unità motore (C) nel foro (16) dell'unità di perforazione (B).

8. Fissare l'unità motore (C) con le 2 viti (H).

7. 稍稍抬起打孔单元 (B), 将电机单元 (C) 的卡扣 (13) 嵌入装订器的沟槽 (14) 内。与此同时, 将电机单元 (C) 的轴 (15) 插入打孔单元 (B) 的孔 (16) 中。

8. 使用 2 颗螺丝 (H) 来固定电机单元 (C)。

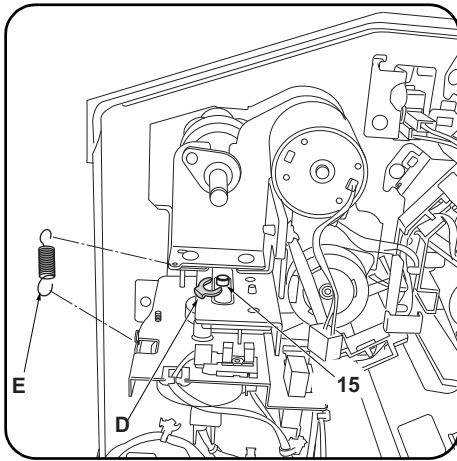
7. 펀치유닛 (B) 를 조금 들면서 모터유닛 (C) 후크 (13) 를 문서 피니셔의 구 (14) 에 꽂습니다. 이것과 동시에 모터유닛 (C) 의 축 (15) 을 펀치유닛 (B) 구멍 (16) 에 삽입합니다.

8. 나사 (H) 2 개로 모터유닛 (C) 를 고정합니다.

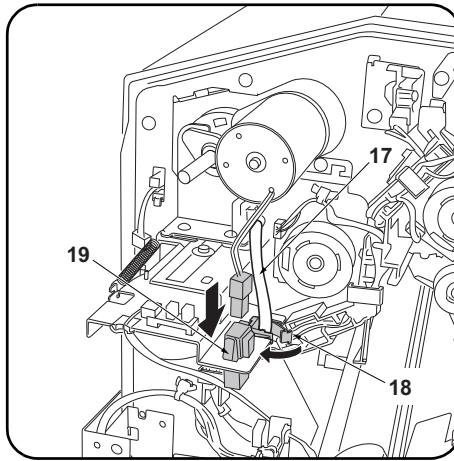
7.パンチユニット (B) を少し持ち上げながら、モーターユニット (C) のフック (13) をドキュメントフィニッシャーの溝 (14) にはめ込む。これと同時に、モーターユニット (C) の軸 (15) をパンチユニット (B) の穴 (16) に挿入する。

8.ビス (H) 2 本で、モーターユニット (C) を固定する。





**9.** Fit the stop ring (D) over the motor unit rod (15) and fit the spring (E) between the hole punch unit and motor unit.



**10.** Run the hole punch unit wire (17) through the motor unit edging (18).

**11.** Plug the wire from the hole punch unit motor into the connector on the motor unit (19).

**9.** Monter la bague d'arrêt (D) sur la tige du moteur (15) et insérer le ressort (E) entre la perforatrice et le moteur.

**10.** Faire passer le câble de la perforatrice (17) dans le passage de câbles du moteur (18)  
**11.** Raccorder le câble du moteur de la perforatrice au connecteur du moteur (19).

**9.** Coloque el anillo de tope (D) sobre la varilla de la unidad motriz (15) y coloque el resorte (E) entre la perforadora y la unidad motriz.

**10.** Tienda el cable de la perforadora (17) a través de la pestaña de la unidad motriz (18).  
**11.** Enchufe el cable del motor de la perforadora al conector de la unidad motriz (19).

**9.** Den Anschlagring (D) auf die Stange (15) der Motoreinheit setzen und die Feder (E) zwischen Lochereinheit und Motoreinheit einsetzen.

**10.** Das Kabel (17) der Lochereinheit durch den Kantenschutz (18) der Motoreinheit führen.  
**11.** Das Kabel vom Motor der Lochereinheit an den Steckverbinder der Motoreinheit (19) anschließen.

**9.** Inserire l'anello di bloccaggio (D) sull'asta (15) dell'unità motore ed inserire molla (E) tra l'unità di perforazione e l'unità motore.

**10.** Far passare il cavo dell'unità di perforazione (17) attraverso il bordo (18) dell'unità motore.  
**11.** Collegare il cavo dal motore dell'unità di perforazione nel connettore sull'unità motore (19).

**9.** 将止动环 (D) 嵌入到电机单元的轴 (15) 上, 在打孔单元与电机单元之间安装弹簧 (E)。

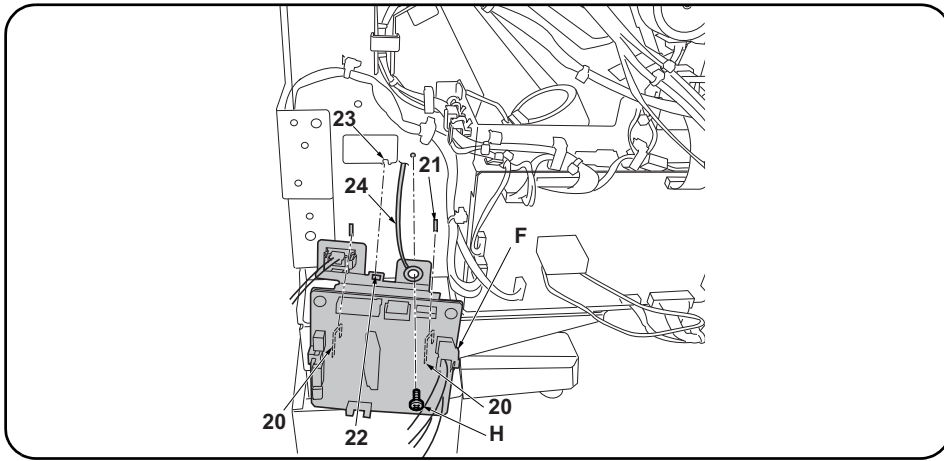
**10.** 将打孔单元的电线 (17) 穿过电机单元的包边孔 (18)。  
**11.** 将来自打孔单元的电机的电线与电机单元的接插件 (19) 相连接。

**9.** 모터유닛 축 (15) 에 스톱링 (D) 을 끼고 펀치유닛과 모터유닛 사이에 스프링 (E) 을 설치합니다 .

**10.** 펀치유닛의 전선 (17) 을 모터유닛의 에징 (18) 에 지나가게 합니다 .  
**11.** 펀치유닛 모터에서의 전선을 모터유닛 커넥터 (19) 에 접속합니다 .

**9.** 모터유닛의 축 (15) にストップ링 (D) をはめ、パンチユニットとモーターユニットの間にバネ (E) を取り付けます。

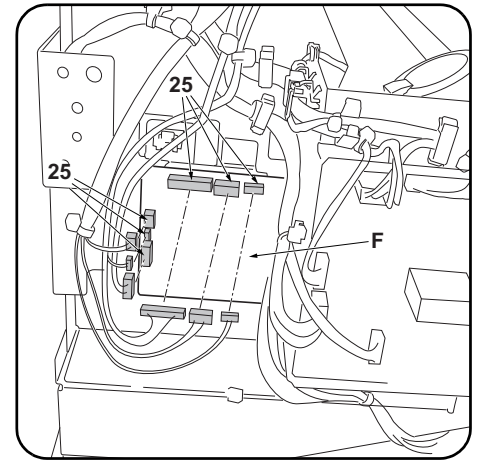
**10.** パンチユニットの電線 (17) をモーターユニットのエッジング (18) に通す。  
**11.** パンチユニットのモーターからの電線をモーターユニットのコネクタ (19) に接続する。



#### Installing the punch PWB and waste hole punch box (DF-770)

If installing on the DF-790/DF-791, proceed to step 12 on page 12.

- Fit the 2 hooks (20) in the punch PWB (F) into the cut (21) in the document finisher. At the same time, insert the projection (23) on the document finisher into the hole (22) in the punch PWB (F).
- Using the screw (H), tighten the hole punch unit ground wire (24) and the punch PWB (F) together.



- Plug the 6 hole punch unit wires into the connectors (25) on the punch PWB (F).

#### Installation de la PWB de la perforatrice et du bac de récupération de la perforatrice (DF-770).

Pour une installation sur le modèle DF-790/DF-791, passer à l'étape 12 en page 12.

- Insérer les 2 crochets (20) de la PWB de la perforatrice (F) dans la découpe (21) du retoucheur de document. Insérer en même temps la saillie (23) du retoucheur de document dans le trou (22) de la PWB de la perforatrice (F).
- Fixer le câble de terre de la perforatrice (24) à la PWB de la perforatrice (F) à l'aide d'une vis (H).

- Raccorder les 6 câbles de la perforatrice aux connecteurs (25) de la PWB de la perforatrice (F).

#### Instalación del PWB de perforación y la caja para desechos de la perforación (DF-770)

Si realiza la instalación en el DF-790/DF-791, vaya al paso 12 de la página 12.

- Coloque los 2 ganchos (20) del PWB de perforación (F) en el corte (21) del finalizador de documentos. Al mismo tiempo, inserte el resalto (23) del finalizador de documentos en el orificio (22) del PWB de perforación (F).
- Usando el tornillo (H), apriete juntos el cable de conexión a tierra de la perforadora (24) y el PWB de perforación (F).

- Enchufe los 6 cables de la perforadora a los conectores (25) del PWB de perforación (F).

#### Installation der Locher-PWB und des Lochungsabfallbehälters (DF-770)

Zur Installation des DF-790/DF-791 weitergehen zu Schritt 12 auf Seite 12.

- Die 2 Haken (20) in der Locher-PWB (F) in die Aussparung (21) am Dokument-Finisher einsetzen. Dabei auch den Vorsprung (23) am Dokument-Finisher in die Öffnung (22) auf der Locher-PWB (F) einsetzen.
- Mit der Schraube (H) das Massekabel (24) der Lochereinheit an der Locher-PWB (F) festziehen.

- Die 6 Kabel der Lochereinheit an die Steckverbinder (25) der Locher-PWB (F) anschließen.

#### Installazione della scheda a circuiti stampati di perforazione e dello scarto perforazione (DF-770)

Se si installa sull'unità DF-790/DF-791, procedere al passo 12 a pagina 12.

- Inserire i 2 ganci (20) della scheda a circuiti stampati di perforazione (F) nell'incisione (21) della finitrice di documenti. Contemporaneamente, inserire la sporgenza (23) sulla finitrice di documenti nel foro (22) della scheda a circuiti stampati di perforazione (F).
- Utilizzando la vite (H), stringere insieme il cavo di terra (24) dell'unità di perforazione e la scheda a circuiti stampati di perforazione (F).

- Collegare i 6 cavi dell'unità di perforazione nei connettori (25) sulla scheda a circuiti stampati di perforazione (F).

#### 安装电路板与打孔纸屑盒 (DF-770 时)

安装到 DF-790/DF-791 上时, 跳至 P12 的步骤 12。

- 将打孔电路板 (F) 的 2 个卡扣 (20) 挂在装订器的缺口 (21) 上。同时, 将打孔电路板 (F) 的孔 (22) 卡入装订器的突出部 (23)。
- 使用 1 颗螺丝 (H) 将打孔单元的接地线 (24) 与打孔电路板 (F) 一起固定。

- 将打孔单元的 6 根电线与打孔电路板 (F) 的接插件 (25) 相连接。

#### 기판과 펀치폐기박스의 부착 (DF-770 의 경우)

DF-790/DF-791 에 장착하는 경우에는 P12 의 순서 12 로 진행합니다 .

- 펀치기판 (F) 의 후크 (20) 2 곳을 문서 피니셔의 구멍 (21) 에 걸립니다 . 동시에 펀치기판 (F) 구멍 (22) 을 문서 피니셔의 돌기 (23) 에 넣습니다 .
- 나사 (H) 1 개로 펀치유닛의 접지선 (24) 과 펀치기판 (F) 을 함께 조입니다 .

- 펀치유닛의 전선 6 선을 펀치기판 (F) 커넥터 (25) 에 접속합니다 .

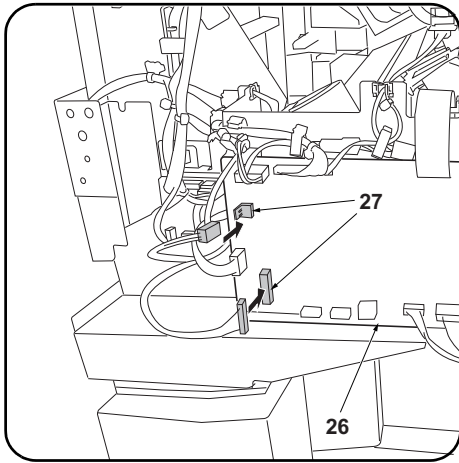
#### 基板とパンチくずボックスの取り付け (DF-770 の場合)

DF-790/DF-791 に装着の場合は、P12 の手順 12 へ進む。

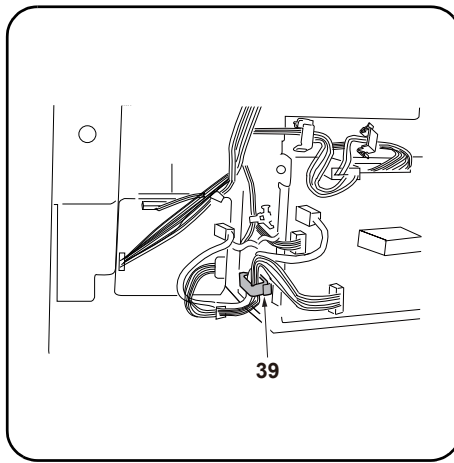
- パンチ基板 (F) のフック (20) 2箇所をドキュメントフィニッシャーの切り欠き (21) に引っ掛ける。同時に、パンチ基板 (F) の穴 (22) をドキュメントフィニッシャーの突起 (23) に入れる。
- ビス (H) 1本で、パンチユニットのアース線 (24) とパンチ基板 (F) を共締めする。

- パンチユニットの電線 6本を、パンチ基板 (F) のコネクタ (25) に接続する。

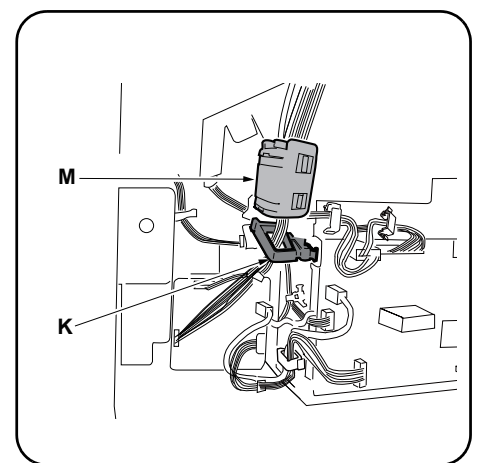




**15.** Plug the 2 punch PWB wires into the connectors (27) on the DF main PWB (26).



**16.** Fasten two wires which were connected in step 15 with the clamp (39).



**17.** Install the small clamp (K) on the finisher, then pass and fasten the wires from the motor unit and hole punch unit.  
**18.** Attach the ferrite core (M) to the wire.

**15.** Raccorder les 2 câbles de la PWB de la perforatrice aux connecteurs (27) de la PWB principale du DF (26).

**16.** Attacher les deux fils qui ont été connectés à l'étape 15 avec le collier (39).

**17.** Monter le petit collier (K) sur le retoucheur puis faire passer les câbles du moteur et de la perforatrice dans ce collier pour les fixer en place.

**18.** Fixer le noyau en ferrite (M) au câble.

**15.** Enchufe los 2 cables del PWB de perforación a los conectores (27) del PWB principal del DF (26).

**16.** Apriete los dos cables que conectó en el paso 15 con la abrazadera (39).

**17.** Instale el sujetador pequeño (K) en el finalizador, después tienda y ajuste los cables de la unidad motriz y la perforadora.

**18.** Fije el núcleo de ferrita (M) al cable.

**15.** Die 2 Kabel der Locher-PWB an die Steckverbinder (27) der DF-Haupt-PWB (26) anschließen.

**16.** Befestigen Sie die beiden Kabel, die in Schritt 15 verbunden wurden, mit der Schelle (39).

**17.** Die kleine Klemme (K) am Finisher anbringen, dann die Kabel von der Motoreinheit und der Lochereinheit hindurchführen und befestigen.

**18.** Den Ferritkern (M) am Kabel befestigen.

**15.** Collegare i 2 cavi della scheda a circuiti stampati di perforazione nei connettori (27) sulla scheda principale PWB (26) della DF.

**16.** Fissare i due cavi collegati al punto 15 con il morsetto (39).

**17.** Installare il morsetto piccolo (K) sul finitore, e quindi passare e fissare i cavi dall'unità motore e dall'unità di perforazione.

**18.** Applicare il nucleo in ferrite (M) al cavo.

**15.** 将打孔电路板的 2 根电线与 DF 主电路板 (26) 的接插件 (27) 连接。

**16.** 使用固定夹 (39) 来固定步骤 15 中连接的 2 根电线。

**17.** 把小固定夹 (K) 安装在装订器上, 从电机单元和打孔单元出来的导线穿过固定夹来固定。

**18.** 用磁环 (M) 套住导线。

**15.** 펀치기판의 전선 2 선을 DF 주 회로기판 (26) 의 커넥터 (27) 에 접속합니다 .

**16.** 순서 15 로 접속한 2 개의 전선을 클램프 (39) 로 고정해 주십시오 .

**17.** 클램프 소 (K) 를 피니셔에 장착, 모터 유니트와 펀치 유니트에서부터 전선을 통과시키고 고정합니다 .

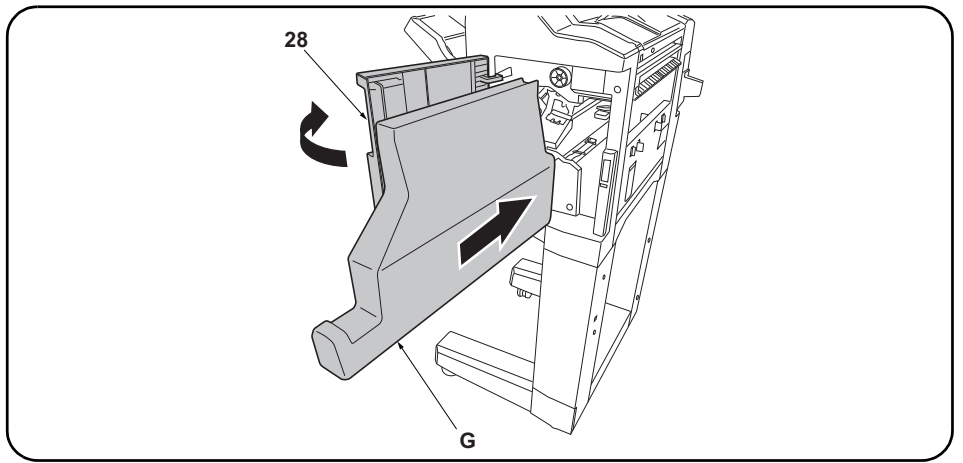
**18.** 페라이트 코어 (M) 를 전선으로 장착합니다 .

**15.**パンチ基板の電線 2 本を DF 主回路基板 (26) のコネクタ (27) に接続する。

**16.**手順 15 で接続した 2 本の電線をクランプ (39) で固定する。

**17.**クランプ小 (K) をフィニッシャーに取り付け、モーターユニットとパンチユニットからの電線を通し、固定する。

**18.**フェライトコア (M) を電線に取り付ける。



19. Replace the upper rear cover (4) and small rear cover (2).

20. Open the upper front cover (28) and insert the waste hole punch box (G).

19. Reposer le couvercle supérieur arrière (4) et le petit couvercle arrière (2).

20. Ouvrir le couvercle supérieur avant (28) et insérer le bac de récupération de la perforatrice (G).

19. Vuelva a colocar la cubierta trasera superior (4) y la cubierta trasera pequeña (2).

20. Abra la cubierta delantera superior (28) e inserte la caja para desechos de la perforación (G).

19. Die obere hintere Abdeckung (4) und die kleine hintere Abdeckung (2) wieder einsetzen.

20. Die obere vordere Abdeckung (28) öffnen und den Lochungsabfallbehälter (G) einsetzen.

19. Ricollocare il pannello superiore posteriore (4) e il pannello posteriore piccolo (2).

20. Aprire il pannello superiore anteriore (28) ed inserire lo scarto perforazione (G).

19. 按原样安装后上部盖板 (4) 与后部小盖板 (2)。

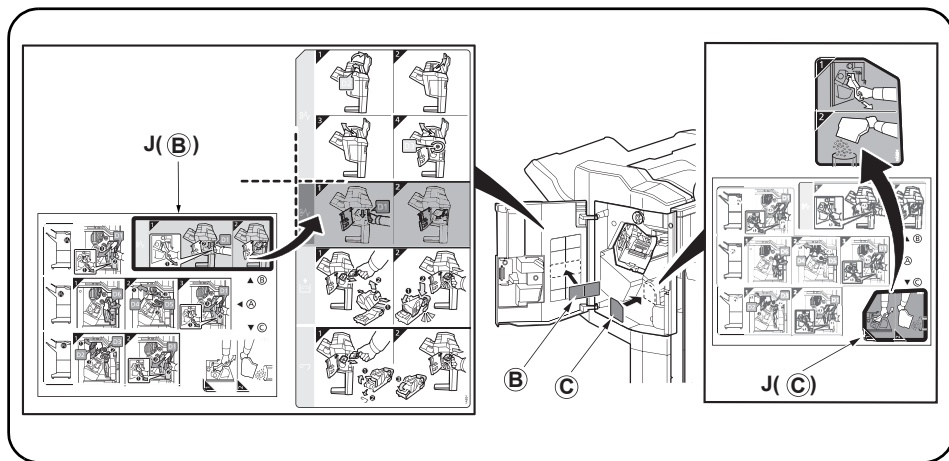
20. 打开前上部盖板 (28)，插入打孔纸屑盒 (G)。

19. 뒤 상커버 (4) 와 후 소커버 (2) 를 원래대로 부착합니다 .

20. 앞 상커버 (28) 를 열고 펀치폐기박스 (G) 를 삽입합니다 .

19. 後上カバー (4) と後小カバー (2) を元通り取り付ける。

20. 前上カバー (28) を開き、パンチくずボックス (G) を挿入する。



21. After cleaning each area with alcohol, adhere the following labels from the label sheet (J) at the locations shown in the illustration: B, C.

22. Close the upper front cover (28).

21. Après avoir nettoyé chaque zone à l'alcool, apposer les étiquettes suivantes du feuillet d'étiquettes (J) aux emplacements indiqués dans l'illustration : B, C.

22. Fermer le couvercle supérieur avant (28).

21. Después de limpiar todas las zonas con alcohol, despegue de la hoja de etiquetas (J) las etiquetas siguientes, y péguelas en los sitios que se indican en la ilustración: B, C.

22. Cierre la cubierta delantera superior (28).

21. Nachdem Sie alle Flächen mit Alkohol gereinigt haben, kleben Sie bitte die folgenden Aufkleber vom Aufkleberbogen (J) an die in der Abbildung angegebenen Stellen: B, C.

22. Die obere vordere Abdeckung (28) schließen.

21. Dopo aver pulito ciascuna zona con alcol, applicare le seguenti etichette del foglio di etichette (J) sui punti mostrati nell'illustrazione: B, C.

22. Chiudere il pannello superiore anteriore (28).

21. 用酒精清洁各区域后, 请在如图所示位置粘贴从标签纸上 (J) 撕下的下列标签 B, C。

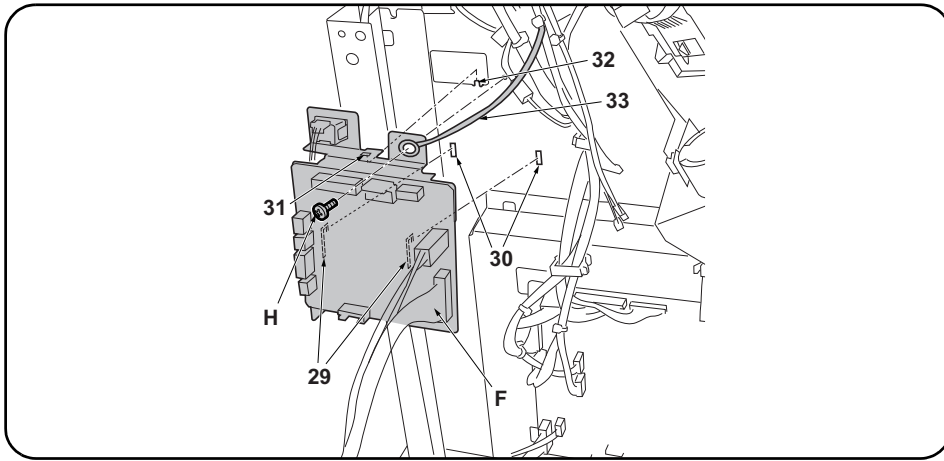
22. 关闭前上部盖板 (28)。

21. 라벨 시트 ( J ) 내의 하기 라벨을 일러스트의 위치에 알코올청소 후 붙입니다: B, C .

22. 앞 상커버 (28) 를 닫습니다 .

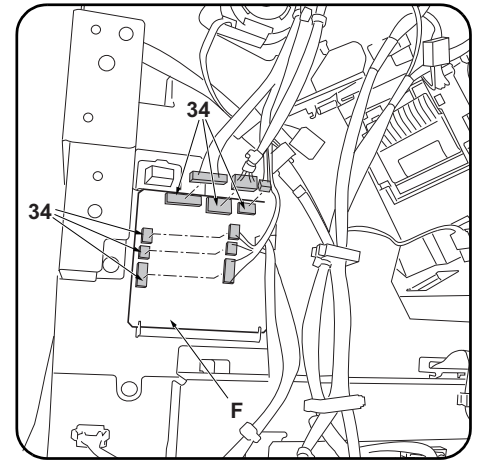
21. ラベルシート (J) 内の B、C をイラストの位置にアルコール清掃後貼り付ける。

22. 前上カバー (28) を閉じる。



**Installing the punch PWB and waste hole punch box (DF-790/DF-791)**

12. Fit the 2 hooks (29) in the punch PWB (F) into the cut (30) in the document finisher. At the same time, insert the projection (32) on the document finisher into the hole (31) in the punch PWB (F).  
 13. Using the screw (H), tighten the hole punch unit ground wire (33) and the punch PWB (F) together.



14. Plug the 6 hole punch unit wires into the connectors (34) on the punch PWB (F).

**Installation de la PWB de la perforatrice et du bac de récupération de la perforatrice (DF-790/DF-791).**

12. Insérer les 2 crochets (29) de la PWB de la perforatrice (F) dans la découpe (30) du retoucheur de document. Insérer en même temps la saillie (32) du retoucheur de document dans le trou (31) de la PWB de la perforatrice (F).  
 13. Fixer le câble de terre de la perforatrice (33) à la PWB de la perforatrice (F) à l'aide d'une vis (H).

14. Raccorder les 6 câbles de la perforatrice aux connecteurs (34) de la PWB de la perforatrice (F).

**Instalación del PWB de perforación y la caja para desechos de la perforación (DF-790/DF-791)**

12. Coloque los 2 ganchos (29) del PWB de perforación (F) en el corte (30) del finalizador de documentos. Al mismo tiempo, inserte el resalto (32) del finalizador de documentos en el orificio (31) del PWB de perforación (F).  
 13. Usando el tornillo (H), apriete juntos el cable de conexión a tierra de la perforadora (33) y el PWB de perforación (F).

14. Enchufe los 6 cables de la perforadora a los conectores (34) del PWB de perforación (F).

**Installation der Locher-PWB und des Lochungsabfallbehälters (DF-790/DF-791)**

12. Die 2 Haken (29) in der Locher-PWB (F) in die Aussparung (30) am Dokument-Finisher einsetzen. Dabei auch den Vorsprung (32) am Dokument-Finisher in die Öffnung (31) auf der Locher-PWB (F) einsetzen.  
 13. Mit der Schraube (H) das Massekabel (33) der Lochereinheit an der Locher-PWB (F) festziehen.

14. Die 6 Kabel der Lochereinheit an die Steckverbinder (34) der Locher-PWB (F) anschließen.

**Installazione della scheda a circuiti stampati di perforazione e dello scarto perforazione (DF-790/DF-791)**

12. Inserire i 2 ganci (29) della scheda a circuiti stampati di perforazione (F) nell'incisione (30) della finitrice di documenti. Contemporaneamente, inserire la sporgenza (32) sulla finitrice di documenti nel foro (31) della scheda a circuiti stampati di perforazione (F).  
 13. Utilizzando la vite (H), stringere insieme il cavo di terra (33) dell'unità di perforazione e la scheda a circuiti stampati di perforazione (F).

14. Collegare i 6 cavi dell'unità di perforazione nei connettori (34) sulla scheda a circuiti stampati di perforazione (F).

**安装电路板与打孔纸屑盒 (DF-790/DF-791 时)**

12. 将打孔电路板 (F) 的 2 个卡扣 (29) 挂在装订器的缺口 (30) 上。同时, 将打孔电路板 (F) 的孔 (31) 卡入装订器的突出部 (32)。  
 13. 使用 1 颗螺丝 (H) 将打孔单元的接地线 (33) 与打孔电路板 (F) 一起固定。

14. 将打孔单元的 6 根电线与打孔电路板 (F) 的接插件 (34) 相连接。

**기판과 펀치폐기박스의 부착 (DF-790/DF-791 의 경우)**

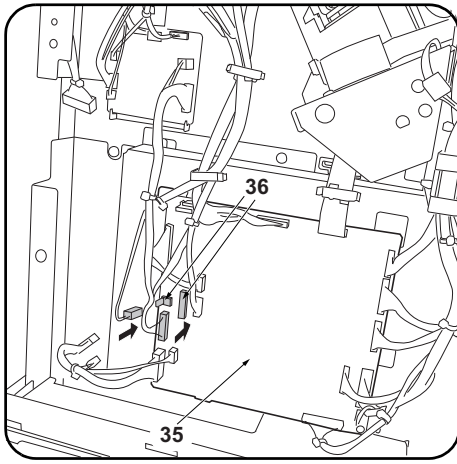
12. 펀치기판 (F) 의 후크 (29) 2 곳을 문서 피니셔의 구멍 (30) 에 걸립니다. 동시에 펀치기판 (F) 구멍 (31) 을 문서 피니셔의 돌기 (32) 에 넣습니다.  
 13. 나사 (H) 1 개로 펀치유닛의 접지선 (33) 과 펀치기판 (F) 을 함께 조입니다.

14. 펀치유닛의 전선 6 선을 펀치기판 (F) 커넥터 (34) 에 접속합니다.

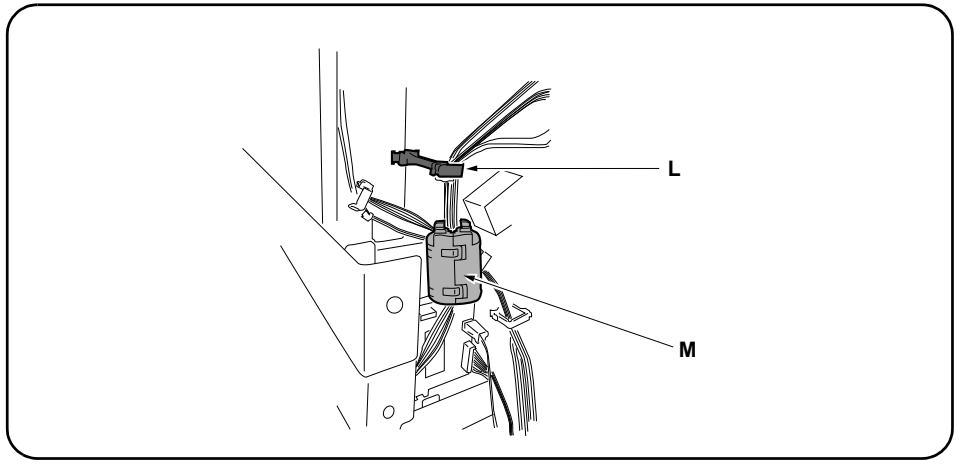
**基板とパンチくずボックスの取り付け (DF-790/DF-791 の場合)**

- 12.パンチ基板 (F) のフック (29) 2箇所をドキュメントフィニッシャーの切り欠き (30) に引っ掛ける。同時に、パンチ基板 (F) の穴 (31) をドキュメントフィニッシャーの突起 (32) に入れる。  
 13.ビス (H) 1本で、パンチユニットのアース線 (33) とパンチ基板 (F) を共締めする。

- 14.パンチユニットの電線 6本を、パンチ基板 (F) のコネクタ (34) に接続する。



15. Plug the 2 punch PWB wires into the connectors (36) on the DF main PWB (35).



16. Install the small clamp (L) on the finisher, then pass and fasten the wires from the motor unit and hole punch unit.  
17. Attach the ferrite core (M) to the wire.

15. Raccorder les 2 câbles de la PWB de la perforatrice aux connecteurs (36) de la PWB principale du DF (35).

16. Installer le grand collier (L) sur le retoucheur puis faire passer les câbles du moteur et de la perforatrice dans ce collier pour les fixer en place.  
17. Fixer le noyau en ferrite (M) au câble.

15. Enchufe los 2 cables del PWB de perforación a los conectores (36) del PWB principal del DF (35).

16. Instale el sujetador grande (L) en el finalizador, después tienda y ajuste los cables de la unidad motriz y la perforadora.  
17. Fije el núcleo de ferrita (M) al cable.

15. Die 2 Kabel der Locher-PWB an die Steckverbinder (36) der DF-Haupt-PWB (35) anschließen.

16. Die große Klemme (L) am Finisher anbringen, dann die Kabel von der Motoreinheit und der Lochereinheit hindurchführen und befestigen.  
17. Den Ferritkern (M) am Kabel befestigen.

15. Collegare i 2 cavi della scheda a circuiti stampati di perforazione nei connettori (36) sulla scheda principale PWB (35) della DF.

16. Installare il morsetto grande (L) sul finitore, e quindi passare e fissare i cavi dall'unità motore e dall'unità di perforazione.  
17. Applicare il nucleo in ferrite (M) al cavo.

15. 将打孔电路板的2根电线与DF主电路板(35)的接插件(36)连接。

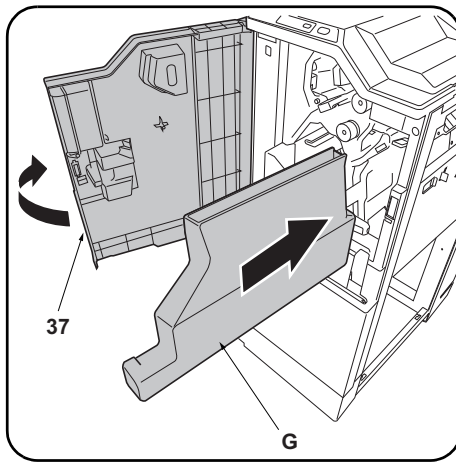
16. 把大固定夹(L)安装在装订器上,从电机单元和打孔单元出来的导线穿过固定夹来固定。  
17. 用磁环(M)套住导线。

15. 펀치기판의 전선 2 선을 DF 주 회로기판(35)의 커넥터(36)에 접속합니다.

16. 클램프 대(L)를 피니셔에 장착, 모터 유닛과 펀치 유닛에서부터 전선을 통과시키고 고정합니다.  
17. 페라이트 코어(M)를 전선으로 장착합니다.

15. パンチ基板の電線2本をDF主回路基板(35)のコネクター(36)に接続する。

16. クランプ大(L)をフィニッシャーに取り付け、モーターユニットとパンチユニットからの電線を通し、固定する。  
17. フェライトコア(M)を電線に取り付ける。



18. Replace the upper rear cover (8) and small rear cover (6).

19. Open the upper front cover (37) and insert the waste hole punch box (G).

18. Reposer le couvercle supérieur arrière (8) et le petit couvercle arrière (6).

19. Ouvrir le couvercle supérieur avant (37) et insérer le bac de récupération de la perforatrice (G).

18. Vuelva a colocar la cubierta trasera superior (8) y la cubierta trasera pequeña (6).

19. Abra la cubierta delantera superior (37) e inserte la caja para desechos de la perforación (G).

18. Die obere hintere Abdeckung (8) und die kleine hintere Abdeckung (6) wieder einsetzen.

19. Die obere vordere Abdeckung (37) öffnen und den Lochungsabfallbehälter (G) einsetzen.

18. Ricollocare il pannello superiore posteriore (8) e il pannello posteriore piccolo (6).

19. Aprire il pannello superiore anteriore (37) ed inserire lo scarto perforazione (G).

18. 按原样安装后上部盖板 (8) 与后部小盖板 (6)。

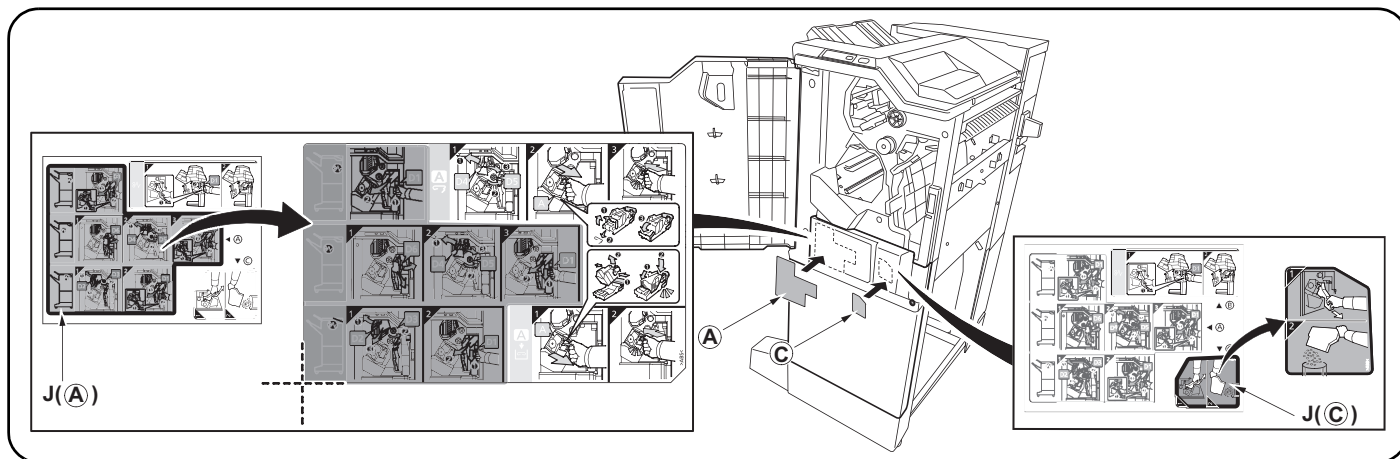
19. 打开前上部盖板 (37)，插入打孔纸屑盒 (G)。

18. 뒤 상커버 (8) 와 후 소커버 (6) 를 원래대로 부착합니다 .

19. 앞 상커버 (37) 를 열고 펀치폐기박스 (G) 를 삽입합니다 .

18. 後上カバー (8) と後小カバー (6) を元通り取り付ける。

19. 前上カバー (37) を開き、パンチくずボックス (G) を挿入する。



20. After cleaning each area with alcohol, adhere the following labels from the label sheet (J) at the locations shown in the illustration: A, C.  
 21. Close the upper front cover (37).

20. Après avoir nettoyé chaque zone à l'alcool, apposer les étiquettes suivantes du feuillet d'étiquettes (J) aux emplacements indiqués dans l'illustration :  
 A, C.  
 21. Fermer le couvercle supérieur avant (37).

20. Después de limpiar todas las zonas con alcohol, despegue de la hoja de etiquetas (J) las etiquetas siguientes, y péguelas en los sitios que se indican en la ilustración: A, C.  
 21. Cierre la cubierta delantera superior (37).

20. Nachdem Sie alle Flächen mit Alkohol gereinigt haben, kleben Sie bitte die folgenden Aufkleber vom Aufkleberbogen (J) an die in der Abbildung angegebenen Stellen: A, C.  
 21. Die obere vordere Abdeckung (37) schließen.

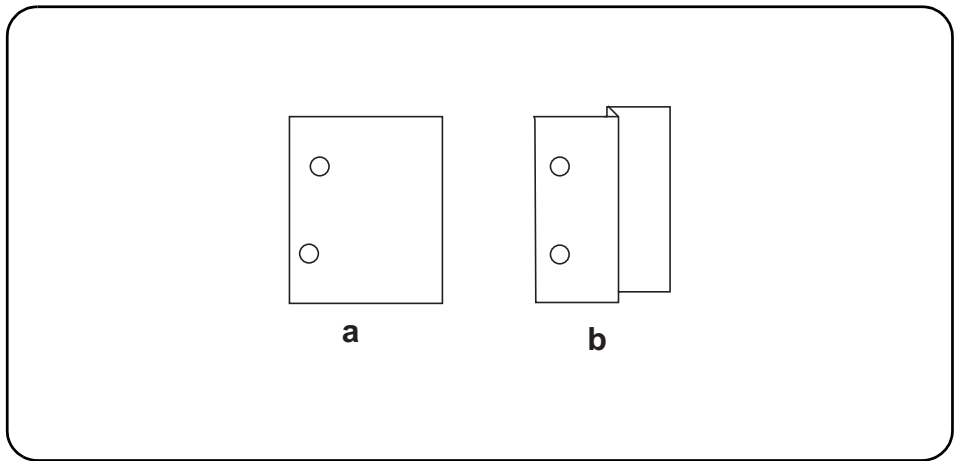
20. Dopo aver pulito ciascuna zona con alcol, applicare le seguenti etichette del foglio di etichette (J) sui punti mostrati nell'illustrazione: A, C.  
 21. Chiudere il pannello superiore anteriore (37).

20. 用酒精清洁各区域后, 请在如图所示位置粘贴从标签纸上(J)撕下的下列标签 A, C。  
 21. 关闭前上部盖板(37)。

20. 라벨 시트(J) 내의 하기 라벨을 일러스트의 위치에 알코올청소 후 붙입니다:A, C.  
 21. 앞 상커버(37) 를 닫습니다.

20. ラベルシート(J)内のA,Cをイラストの位置にアルコール清掃後貼り付ける。  
 21. 前上カバー(37)を閉じる。





#### [Adjusting the hole punch position]

1. Connect the MFP power plug to the wall outlet and turn the MFP main power switch on.
2. Make a test copy in punch mode.
3. If any off-centering is observed, follow the procedure below to adjust the hole position.

#### Adjusting the hole punch entry registration

1. Enter the maintenance mode U246, select Finisher and Punch Regist.
2. Adjust the values.  
When the paper fed in skewed copy example (a): Increase the setting value.  
When the paper crimped copy example (b): Decrease the setting value.
3. Press the Start key to confirm the setting value.

#### [Réglage de la position des perforations]

1. Insérer la fiche d'alimentation du MFP dans la prise murale et mettre l'interrupteur principal du MFP sous tension.
2. Effectuer une copie d'essai en mode perforation.
3. Si les perforations sont décentrées, suivre la procédure ci-dessous pour ajuster la position de perforation.

#### Réglage de l'enregistrement de l'entrée des perforations

1. Passer en mode maintenance U246, sélectionner Finisher et Punch Regist.
2. Régler les valeurs.  
Si le papier est alimenté de travers exemple de copie (a): Augmentez la valeur de réglage.  
Si le papier est froissé exemple de copie (b): Diminuez la valeur de réglage.
3. Appuyer sur la touche de Start pour confirmer la valeur de réglage.

#### [Ajuste de la posición de perforación]

1. Conecte el enchufe del MFP en el receptáculo de pared y encienda el interruptor principal del MFP.
2. Haga una copia de prueba en el modo de perforación.
3. Si observa descentrado, siga el procedimiento de abajo para ajustar la posición del agujero.

#### Ajuste del registro de entrada de perforación

1. Entre en el modo de mantenimiento U246, seleccione Finisher y Punch Regist.
2. Ajuste los valores.  
Cuando el papel alimentado está torcido copia de muestra (a): Aumente el valor de configuración.  
Cuando el papel se dobló copia de muestra (b): Reduzca el valor de configuración.
3. Pulse la tecla de Start para confirmar el valor de configuración.

#### [Einstellen der Lochungsposition]

1. Stecken Sie den Netzstecker des MFP in die Wandsteckdose und schalten Sie den MFP am Hauptschalter ein.
2. Eine Testkopie im Lochungsmodus erstellen.
3. Falls eine außermittige Lochung erfolgte, ist die Lochungsposition wie folgend nachzustellen.

#### Einstellen der Lochungsregistrierung

1. Schalten Sie in den Wartungsmodus U246, wählen Sie Finisher und Punch Regist.
2. Die Werte einstellen.  
Wenn Papier verkantet eingezogen wird Kopiebeispiel (a): Den Einstellwert erhöhen.  
Wenn Papier verknittert wird Kopiebeispiel (b): Den Einstellwert verringern.
3. Den Einstellwert durch Drücken der Start-Taste bestätigen.

#### [Regolazione di posizione dei fori di perforazione]

1. Collegare la spina del cavo di alimentazione dell'MFP alla presa a muro della rete elettrica e accendere l'interruttore principale di alimentazione.
2. Eseguire una copia di prova in modalità di perforazione.
3. Nel caso in cui non lo siano, eseguire la procedura indicata qui di seguito per regolarne la posizione.

#### Regolazione del registro del foro di perforazione

1. Entrare in modalità manutenzione U246, selezionare Finisher e Punch Regist.
2. Regolare i valori.  
Quando l'alimentazione della carta risulta obliqua esempio di copia (a): Aumentare il valore dell'impostazione.  
Quando la carta risulta increspata esempio di copia (b): Diminuire il valore dell'impostazione.
3. Premere il tasto di Start per confermare il valore dell'impostazione.

#### [打孔位置的调节]

1. 将 MFP 主机上的电源插头插入电源插座中，打开主电源开关。
2. 在打孔模式下进行测试复印。
3. 打孔位置有偏差时，按以下步骤进行调节。

#### 打孔装入定位调节

1. 设置维护模式 U246，选择 Finisher、Punch Regist。
2. 调整设定值。  
纸张斜向搬运时的复印样本 (a)：调高设定值。  
纸张作 Z 字折时的复印样本 (b)：调低设定值。
3. 按 Start 键，以确定设定值。

#### [핀치위치의 조정]

1. MFP 본체 전원플러그를 콘센트에 꽂고 주 전원 스위치를 ON으로 합니다.
2. 핀치모드에서 시험복사를 합니다.
3. 핀치위치가 벗어난 경우에는 다음 순서로 조정합니다.

#### 핀치반입 레지스트 조정

1. 메인テナンス 모드 U246 를 세트하고 Finisher, Punch Regist 를 선택합니다.
2. 설정치를 조정합니다.  
용지가 경사로 반송되는 경우의 복사샘플 (a): 설정치를 높입니다.  
용지가 Z 꺾임이 있는 경우의 복사샘플 (b): 설정치를 내립니다.
3. 시작키를 누르고 설정치를 확인합니다.

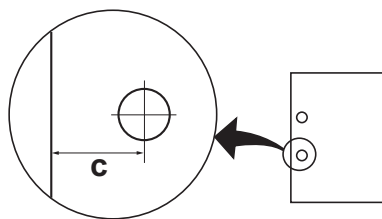
#### [パンチ位置の調整]

1. MFP 本体の電源プラグをコンセントに差し込み、主電源スイッチを ON にする。
2. パンチモードでテストコピーを行う。
3. パンチ位置がずれていた場合、次の手順で調整を行う。

#### パンチ搬入レジスト調整

1. メンテナンスモード U246 をセットし、Finisher、Punch Regist を選択する。
2. 設定値を調整する。  
用紙が斜めに搬送される場合コピーサンプル (a)：設定値を上げる。  
用紙が Z 折れする場合コピーサンプル (b)：設定値を下げる。
3. スタートキーを押し、設定値を確定する。





### Adjusting the hole punch position feed

1. Enter the maintenance mode U246, select Finisher and Punch Feed.
2. Adjust the values.  
If the punch hole position is closer to the edge than the reference value (c): Increase the setting value.  
If the punch hole position is further from the edge than the reference value (c): Decrease the setting value.

3. Press the Start key to confirm the setting value.  
<Reference value (c)>  
Metric specification: 13 mm; Inch specification: 9.5 mm

### Réglage de la position du point de perforation

1. Passer en mode maintenance U246, sélectionner Finisher et Punch Feed.
2. Régler les valeurs.  
Si la perforation est plus proche du bord de la feuille que défini par la valeur de référence (c): Augmentez la valeur de réglage.  
Si la perforation est plus loin du bord de la feuille que défini par la valeur de référence (c): Diminuez la valeur de réglage.

3. Appuyer sur la touche de Start pour confirmer la valeur de réglage.  
<Valeur de référence (c)>  
Spécifications métriques: 13 mm; Spécifications en pouces: 9,5 mm

### Ajuste de la alimentación de la posición de perforación

1. Entre en el modo de mantenimiento U246, seleccione Finisher y Punch Feed.
2. Ajuste los valores.  
Si la posición de perforación está más cerca del borde que el valor de referencia (c): Aumente el valor de configuración.  
Si la posición de perforación está más alejada del borde que el valor de referencia (c): Reduzca el valor de configuración.

3. Pulse la tecla de Start para confirmar el valor de configuración.  
<Valor de referencia (c)>  
Sistema métrico: 13 mm; en pulgadas: 9,5 mm

### Einstellen des Transports der Lochungsposition

1. Schalten Sie in den Wartungsmodus U246, wählen Sie Finisher und Punch Feed.
2. Die Werte einstellen.  
Falls die Lochungsposition näher an der Kante liegt als der Bezugswert (c) erlaubt: Den Einstellwert erhöhen.  
Falls die Lochungsposition ferner von der Kante liegt als der Bezugswert (c) erlaubt: Den Einstellwert verringern.

3. Den Einstellwert durch Drücken der Start-Taste bestätigen.  
<Bezugswert (c)>  
Metrischer Abstand: 13 mm; Abstand in Zoll: 9,5 mm

### Regolazione spostamento di posizione dei fori di perforazione

1. Entrare in modalità manutenzione U246, selezionare Finisher e Punch Feed.
2. Regolare i valori.  
Se la posizione dei fori di perforazione è più vicina al bordo rispetto al valore di riferimento (c): Aumentare il valore dell'impostazione.  
Se la posizione dei fori di perforazione è più lontana dal bordo rispetto al valore di riferimento (c): Diminuire il valore dell'impostazione.

3. Premere il tasto di Start per confermare il valore dell'impostazione.  
<Valore di riferimento (c)>  
Specificazione in unità metrica: 13 mm; Specificazione in pollici: 9,5 mm

### 打孔位置搬送调节

1. 设置维护模式 U246, 选择 Finisher、Punch Feed。
2. 调整设定值。  
打孔位置比基准值 (c) 短时: 调高设定值。  
打孔位置比基准值 (c) 长时: 调低设定值。

3. 按 Start 键, 以确定设定值。  
<基准值 (c) >  
公制规格: 13mm、英制规格: 9.5mm

### 핀치위치 반송조정

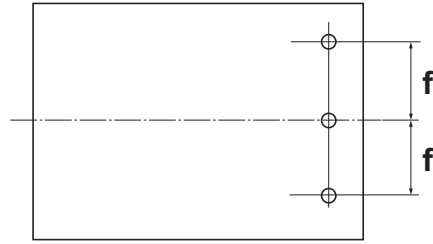
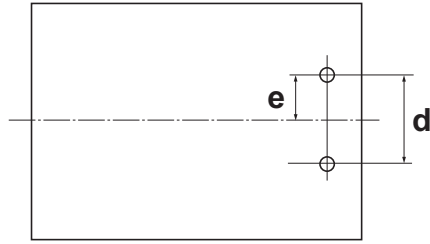
1. 메인터너스 모드 U246 를 세트하고 Finisher, Punch Feed 를 선택합니다.
2. 설정치를 조정합니다.  
핀치구멍의 위치가 기준치 (c) 보다 짧은 경우: 설정치를 높입니다.  
핀치구멍의 위치가 기준치 (c) 보다 긴 경우: 설정치를 내립니다.

3. 시작키를 누르고 설정치를 확인합니다.  
<기준치 (c) >  
센치사양: 13mm, 인치사양: 9.5mm

### パンチ位置搬送調整

1. メンテナンスモード U246 をセットし、Finisher、Punch Feed を選択する。
2. 設定値を調整する。  
パンチ穴の位置が基準値 (c) より短い場合: 設定値を上げる。  
パンチ穴の位置が基準値 (c) より長い場合: 設定値を下げる。

3. スタートキーを押し、設定値を確定する。  
<基準値 (c) >  
センチ仕様: 13mm、インチ仕様: 9.5mm



### Centering the hole punch position

1. Enter the maintenance mode U246, select Finisher and Punch Width.
2. Adjust the values.  
If the punch hole is too close to the front of the machine: Decrease the setting value.  
If the punch hole is too close to the rear of the machine: Increase the setting value.

3. Press the Start key to confirm the setting value.

<Reference value>

Metric specification:  $d = 80 \text{ mm} \pm 0.5$ ,  $e = 40 \text{ mm} \pm 2$   
Inch specification:  $d = 2.75 \text{ inch} \pm 0.5$ ,  $e = 1.375 \text{ inch} \pm 2$ ,  
 $f = 4.25 \text{ inch} \pm 0.5$

### Centrage de la position de perforation

1. Passer en mode maintenance U246, sélectionner Finisher et Punch Width.
2. Régler les valeurs.  
Si la perforation est trop proche de l'avant de la machine: Diminuez la valeur de réglage.  
Si la perforation est trop proche de l'arrière de la machine: Augmentez la valeur de réglage.

3. Appuyer sur la touche de Start pour confirmer la valeur de réglage.

<Valeur de référence>

Spécifications métriques:  $d = 80 \text{ mm} \pm 0.5$ ,  $e = 40 \text{ mm} \pm 2$   
Spécifications en pouces:  $d = 2,75 \text{ pouces} \pm 0,5$ ,  $e = 1,375 \text{ pouces} \pm 2$ ,  
 $f = 4.25 \text{ pouces} \pm 0,5$

### Centrado de la posición de perforación

1. Entre en el modo de mantenimiento U246, seleccione Finisher y Punch Width.
2. Ajuste los valores.  
Si la perforación se encuentra demasiado cerca del frente de la máquina: Reduzca el valor de configuración.  
Si la perforación se encuentra demasiado cerca de la parte trasera de la máquina: Aumente el valor de configuración.

3. Pulse la tecla de Start para confirmar el valor de configuración.

<Valor de referencia>

Sistema métrico:  $d = 80 \text{ mm} \pm 0,5$ ,  $e = 40 \text{ mm} \pm 2$   
En pulgadas:  $d = 2,75 \text{ pulgada} \pm 0,5$ ,  $e = 1,375 \text{ pulgada} \pm 2$ ,  
 $f = 4.25 \pm 0,5 \text{ pulgada}$

### Zentrieren der Stanzlochposition

1. Schalten Sie in den Wartungsmodus U246, wählen Sie Finisher und Punch Width.
2. Die Werte einstellen.  
Falls die Lochung zu nah an der Gerätefront liegt: Den Einstellwert verringern.  
Falls die Lochung zu weit weg von der Gerätefront liegt: Den Einstellwert erhöhen.

3. Den Einstellwert durch Drücken der Start-Taste bestätigen.

<Bezugswert>

Metrischer Abstand:  $d = 80 \text{ mm} \pm 0,5$ ;  $e = 40 \text{ mm} \pm 2$   
Abstand in Zoll:  $d = 2,75 \text{ Zoll} \pm 0,5$ ,  $e = 1,375 \text{ Zoll} \pm 2$ ,  
 $f = 4.25 \text{ Zoll} \pm 0,5$

### Centrata della posizione dei fori di perforazione

1. Entrare in modalità manutenzione U246, selezionare Finisher e Punch Width.
2. Regolare i valori.  
Se la posizione dei fori di perforazione è troppo vicina alla parte anteriore della macchina: Diminuire il valore dell'impostazione.  
Se la posizione dei fori di perforazione è troppo vicina alla parte posteriore della macchina: Aumentare il valore dell'impostazione.

3. Premere il tasto di Start per confermare il valore dell'impostazione.

<Valore di riferimento>

Specificazione in unità metrica:  $d = 80 \text{ mm} \pm 0,5$ ,  $e = 40 \text{ mm} \pm 2$   
Specificazione in pollici:  $d = 2,75 \text{ pollici} \pm 0,5$ ,  $e = 1,375 \text{ pollici} \pm 2$ ,  
 $f = 4.25 \text{ pollici} \pm 0,5$

### 打孔位置中心调节

1. 设置维护模式 U246, 选择 Finisher、Punch Width。
2. 调整设定值。  
打孔位置向机器前部偏移时: 调低设定值。  
打孔位置向机器后部偏移时: 调高设定值。

3. 按 Start 键, 以确定设定值。

<基准值>

公制规格:  $d=80\text{mm} \pm 0.5$ 、 $e=40\text{mm} \pm 2$   
英制规格:  $d=2.75\text{inch} \pm 0.5$ 、 $e=1.375\text{inch} \pm 2$ 、 $f=4.25\text{inch} \pm 0.5$

### 펀치위치 센터조정

1. 메인터넌스 모드 U246 를 세트하고 Finisher, Punch Width 를 선택합니다.
2. 설정치를 조정합니다.  
펀치구멍이 기기 앞측으로 벗어난 경우: 설정치를 내립니다.  
펀치구멍의 위치가 기기 뒷측으로 벗어난 경우: 설정치를 높입니다.

3. 시작키를 누르고 설정치를 확인합니다.

<기준치>

센치 사양:  $d=80\text{mm} \pm 0.5$ ,  $e=40\text{mm} \pm 2$   
인치 사양:  $d=2.75\text{inch} \pm 0.5$ ,  $e=1.375\text{inch} \pm 2$ ,  $f=4.25\text{inch} \pm 0.5$

### パンチ位置センター調整

1. メンテナンスモード U246 をセットし、Finisher、Punch Width を選択する。
2. 設定値を調整する。  
パンチ穴の位置が機械前側にずれている場合: 設定値を下げる。  
パンチ穴の位置が機械後側にずれている場合: 設定値を上げる。

3. スタートキーを押し、設定値を確定する。

<基準値>

センチ仕様:  $d=80\text{mm} \pm 0.5$ 、 $e=40\text{mm} \pm 2$   
インチ仕様:  $d=2.75\text{inch} \pm 0.5$ 、 $e=1.375\text{inch} \pm 2$ 、 $f=4.25\text{inch} \pm 0.5$

**MEMO**

# MEMO

# MEMO



303NK5671103

2014. 8  
303NK56711-03

# **INSTALLATION GUIDE FOR INNER JOB SEPARATOR**

**INSTALLATION GUIDE**

**GUIDE D'INSTALLATION**

**GUÍA DE INSTALACION**

**INSTALLATIONSANLEITUNG**

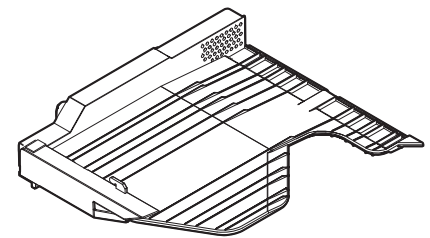
**GUIDA ALL'INSTALLAZIONE**

**安装手册**

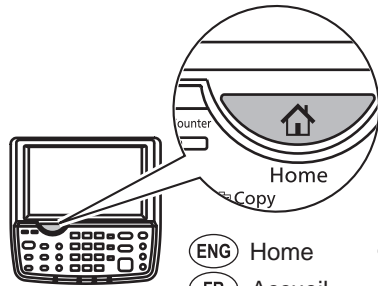
**설치안내서**

**設置手順書**

**JS-730**



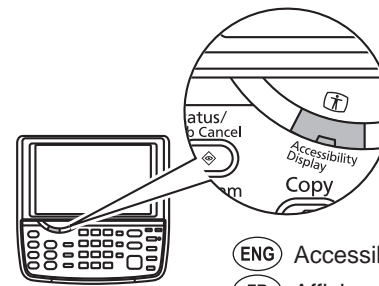




- |                 |           |
|-----------------|-----------|
| (ENG) Home      | (IT) Home |
| (FR) Accueil    | (CN) 主界面  |
| (ES) Inicio     | (KO) 홈    |
| (DE) Startseite | (JP) ホーム  |



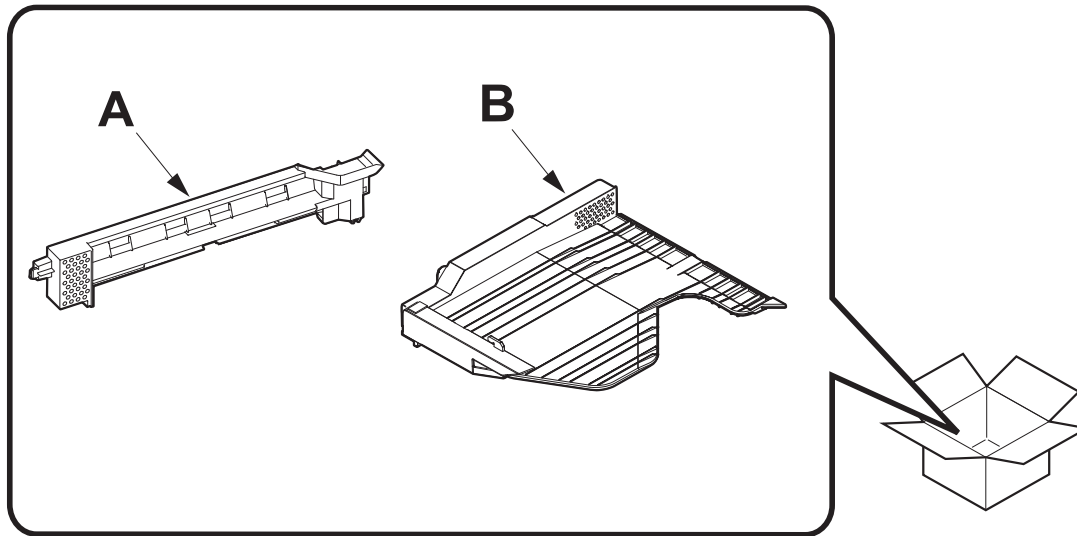
- (ENG) see Page 1 to Page 6  
 (FR) voir Page 1 à Page 6  
 (ES) consulte las páginas de la 1 a la 6  
 (DE) siehe Seiten 1 bis 6  
 (IT) vedere le pagine da 1 a 6  
 (CN) 请参见P1-P6  
 (KO) 1페이지~6페이지를 참조하십시오  
 (JP) 1ページ~6ページ



- |                             |                            |
|-----------------------------|----------------------------|
| (ENG) Accessibility Display | (IT) Visual. Accessibilità |
| (FR) Affich. accessibilité  | (CN) 扩大显示                  |
| (ES) Pantalla acceso        | (KO) 유니버설                  |
| (DE) Zugriffsanzeige        | (JP) ユニバーサル                |



- (ENG) see Page 7 to Page 13  
 (FR) voir Page 7 à Page 13  
 (ES) consulte las páginas de la 7 a la 13  
 (DE) siehe Seiten 7 bis 13  
 (IT) vedere le pagine da 7 a 13  
 (CN) 请参见P7-P13  
 (KO) 7페이지~13페이지를 참조하십시오  
 (JP) 7ページ~13ページ



**(ENG) Precautions**

The illustrations of the machine in the Installation Guide are for color MFP.

**(FR) Précautions**

L'appareil représenté dans les illustrations du présent guide d'installation est le MFP couleur.

**(ES) Precauciones**

Las ilustraciones de la máquina que aparecen en la Guía de instalación corresponden a una MFP en color.

**(DE) Vorsichtsmaßnahmen**

Die Abbildungen der Maschine in der Installationsanleitung gelten für den Farb-MFP.

**(IT) Precauzioni**

Le illustrazioni della macchina nella guida di installazione sono per colore MFP.

**(CN) 注意事项**

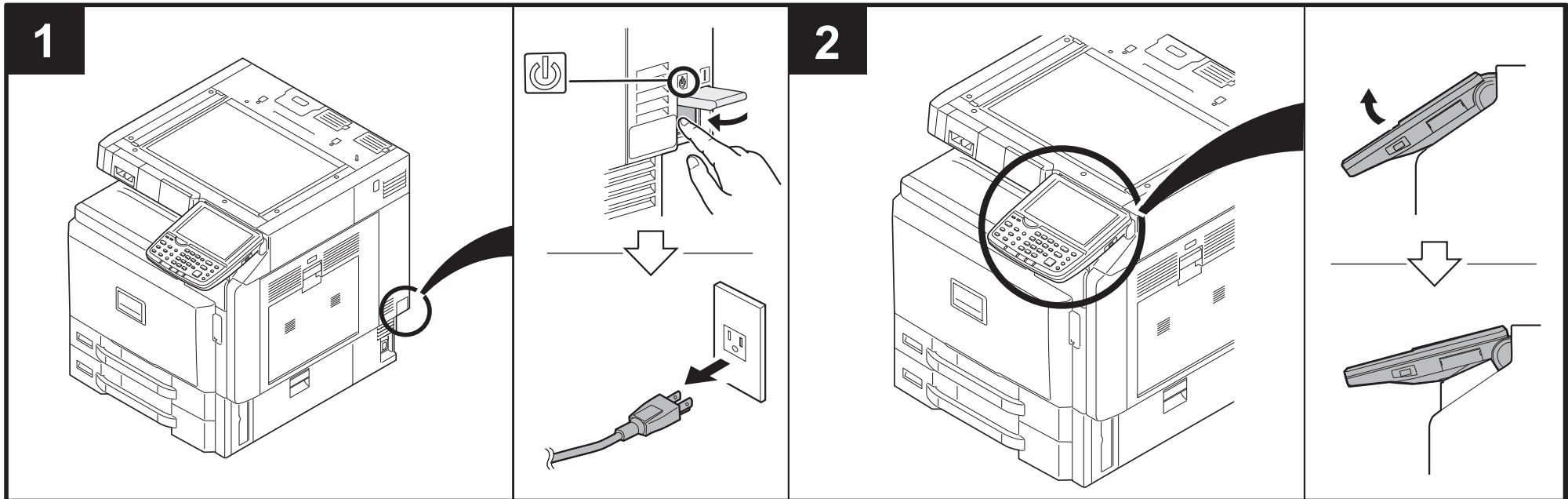
安装手册中记载的机器主机的插图是彩色机。

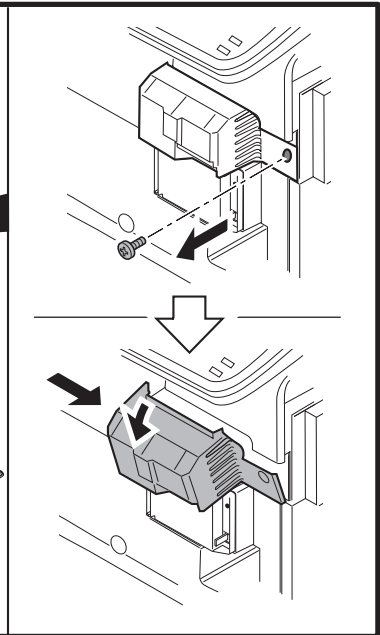
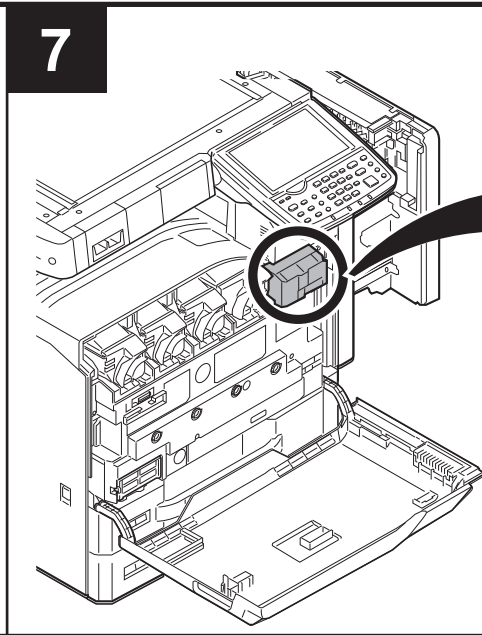
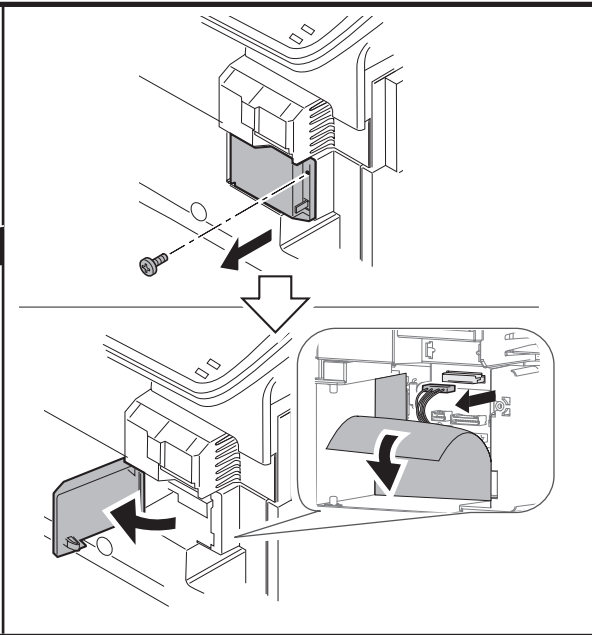
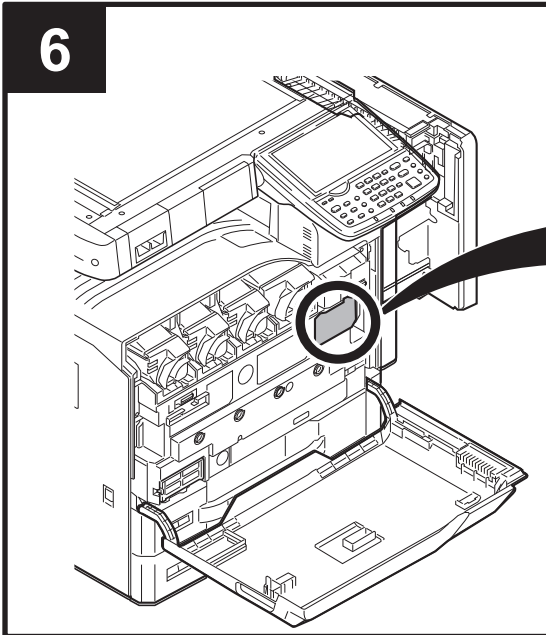
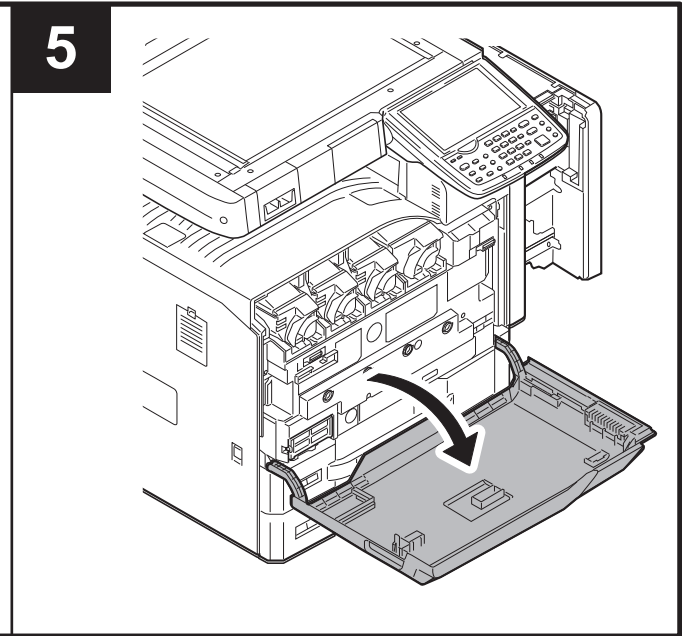
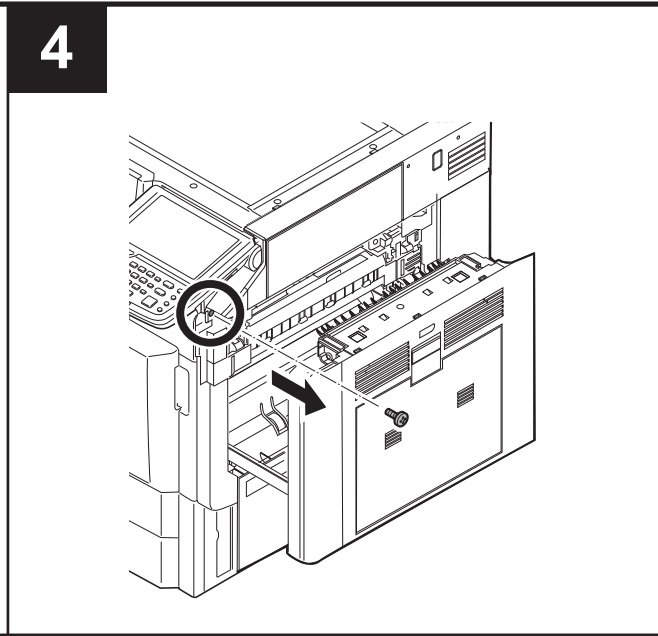
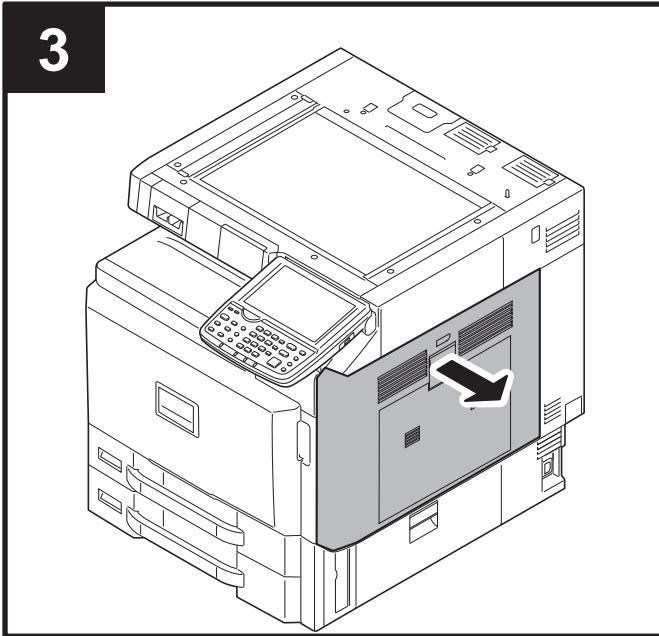
**(KO) 주의사항**

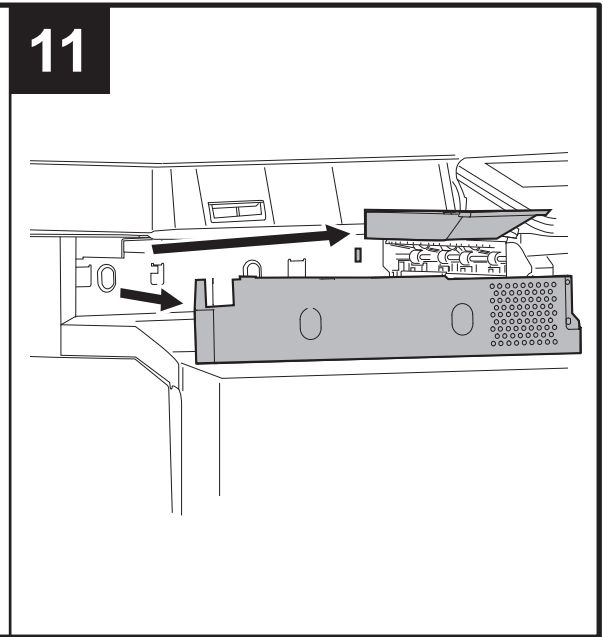
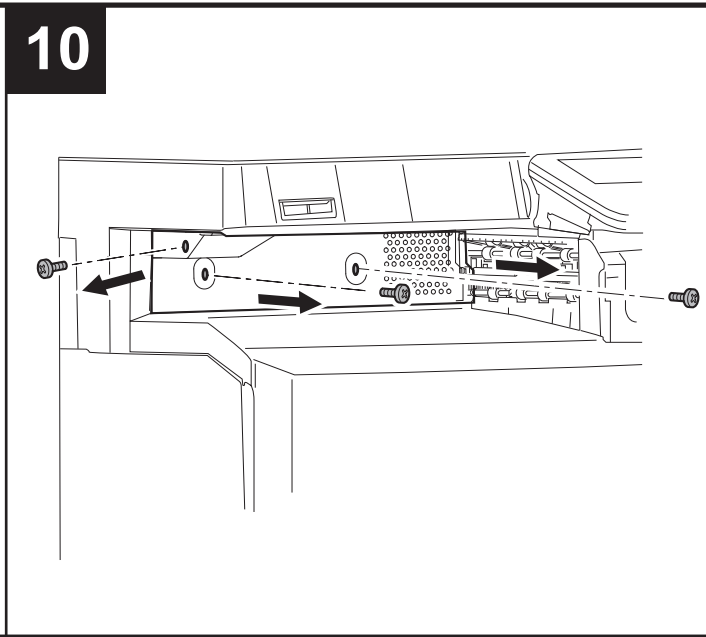
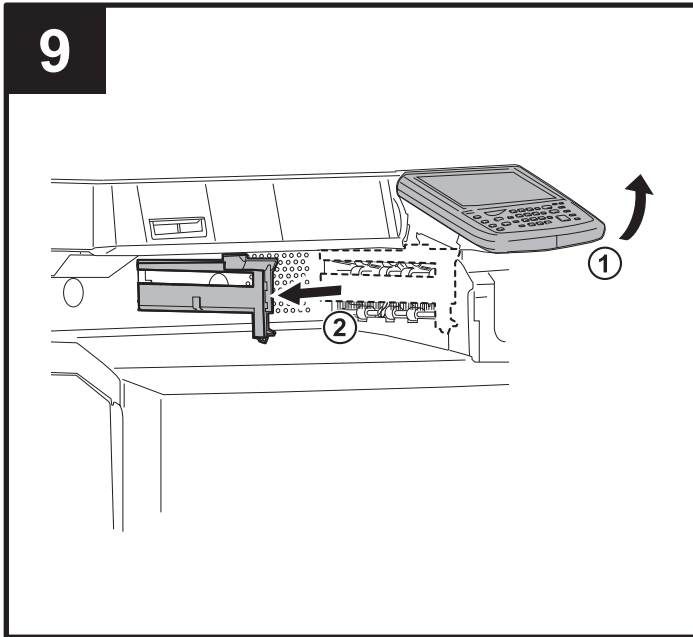
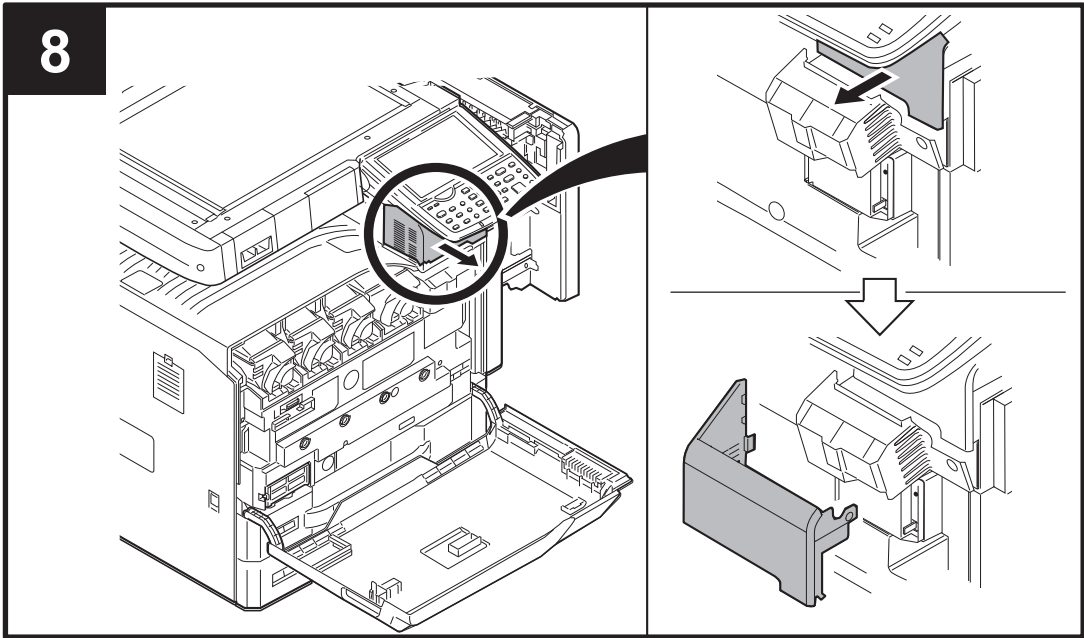
설치순서에 기재되어 있는 기기본체 일러스트는 컬러기입니다.

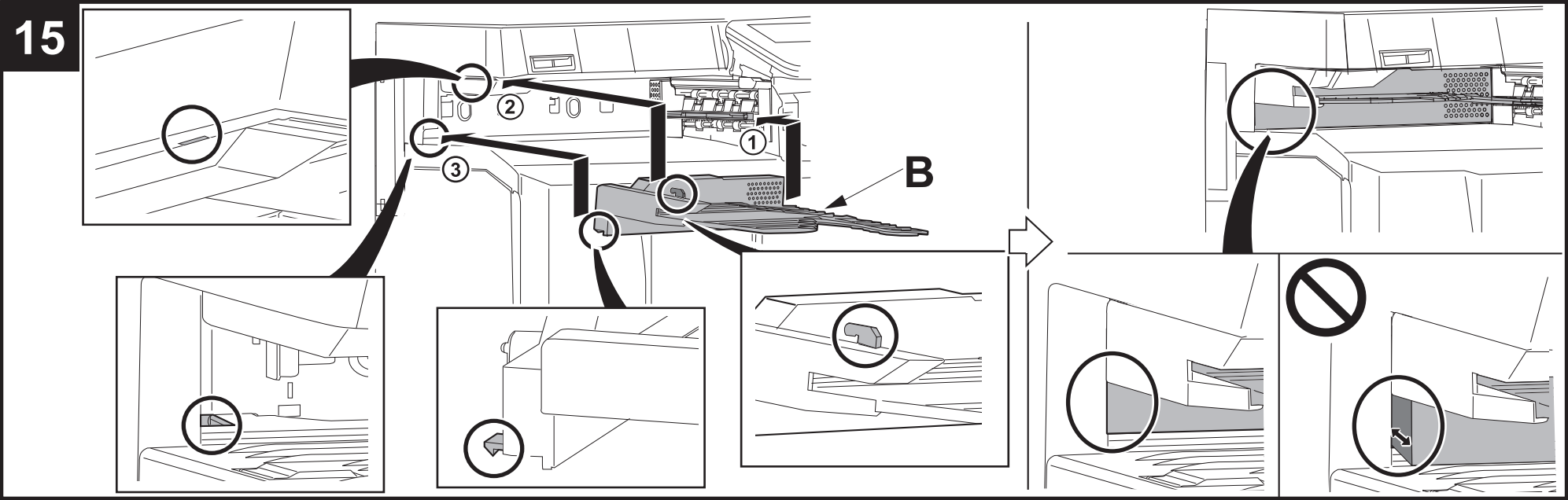
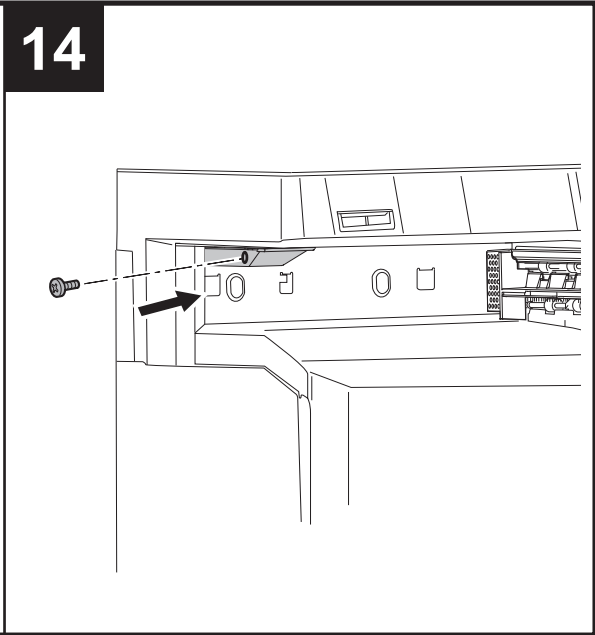
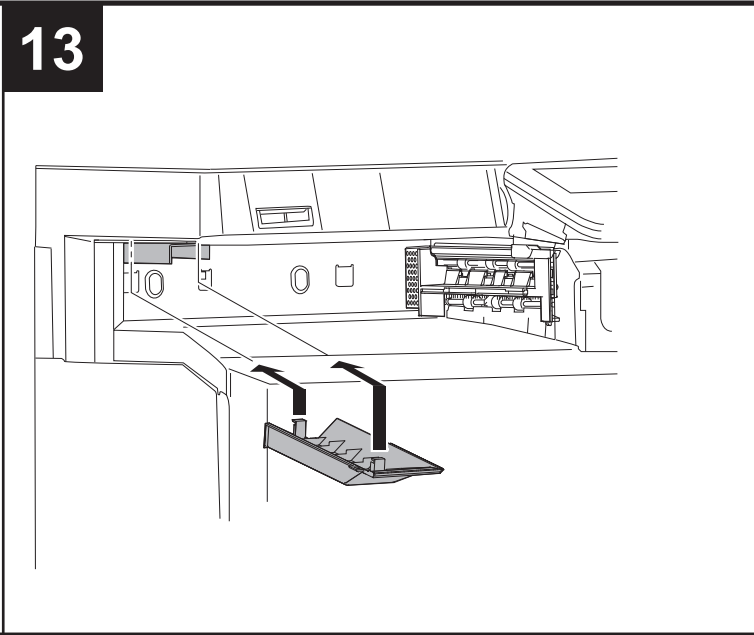
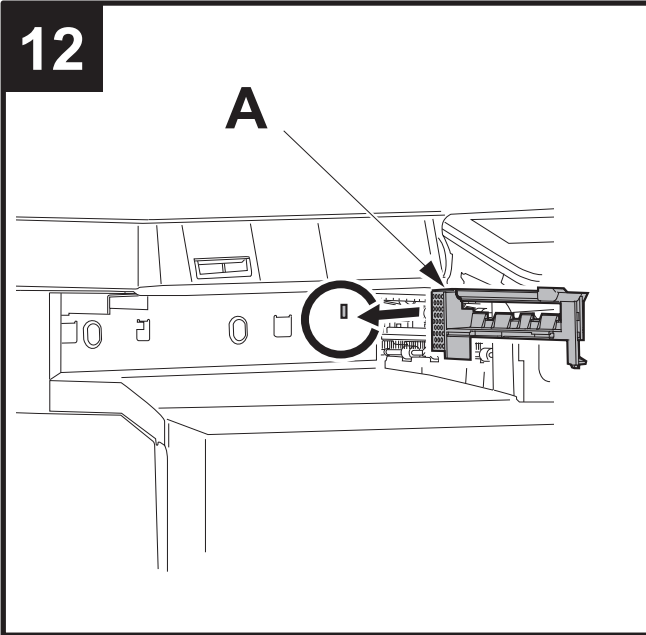
**(JP) 注意事項**

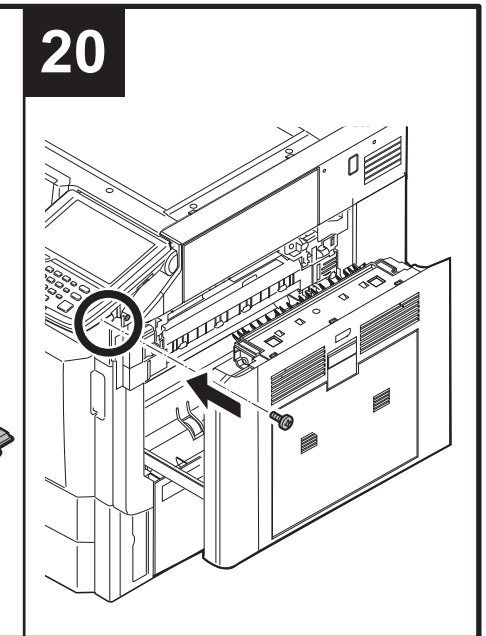
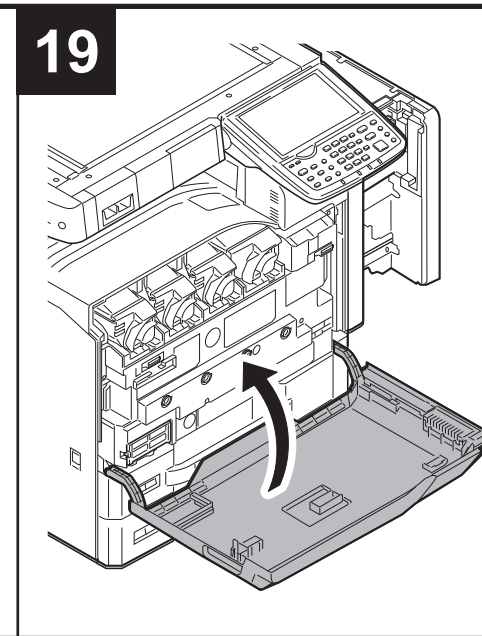
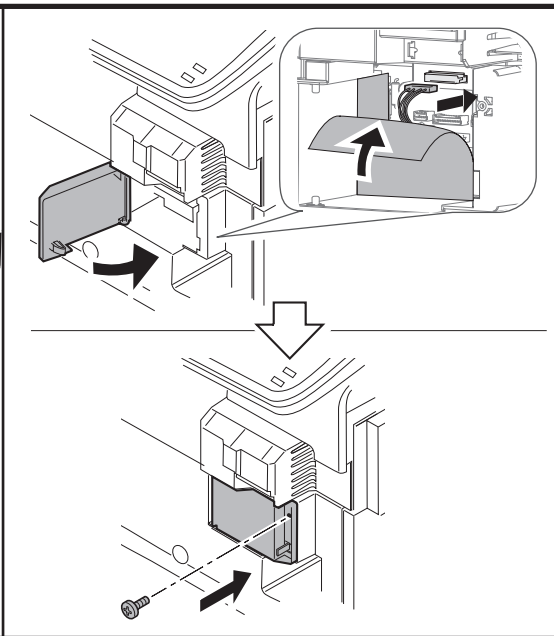
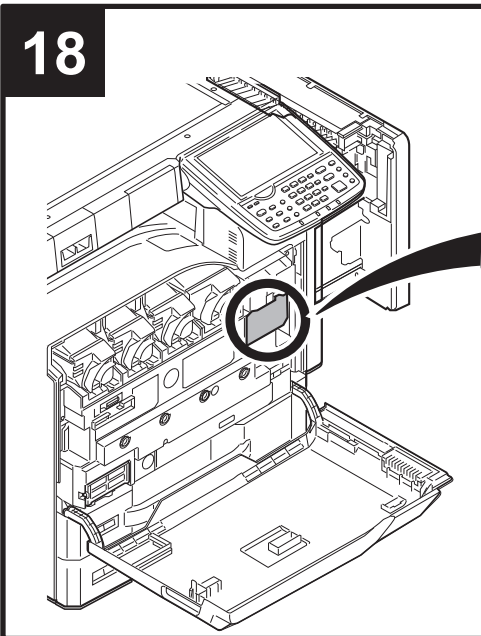
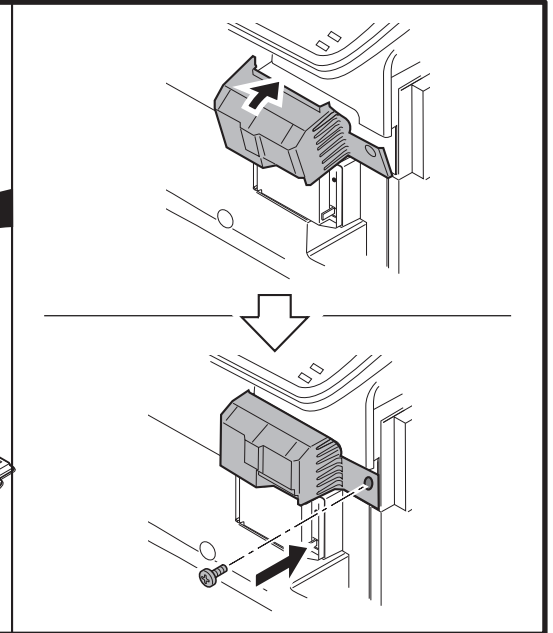
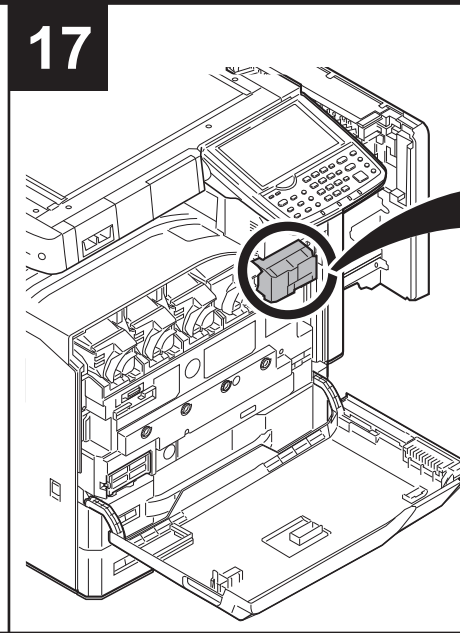
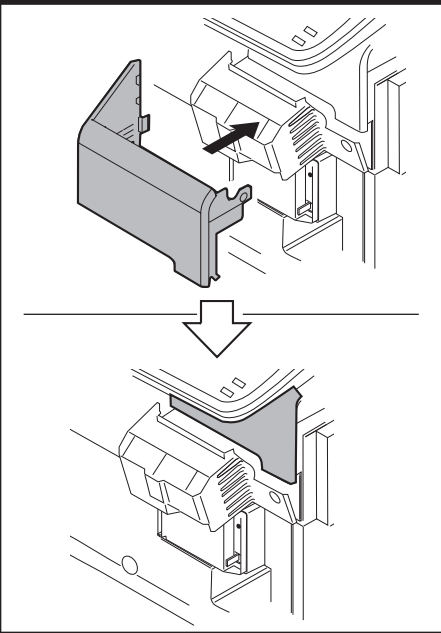
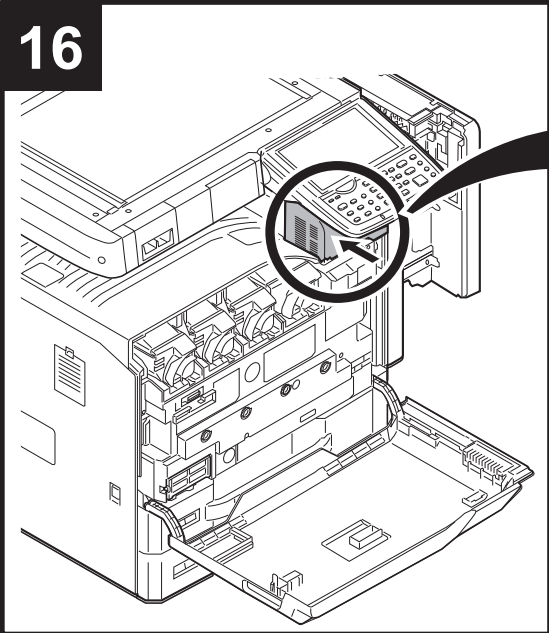
設置手順書に記載している機械本体のイラストはカラー機です。



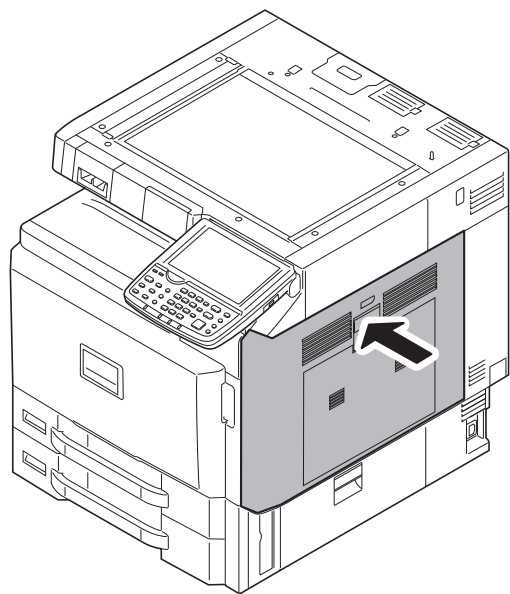
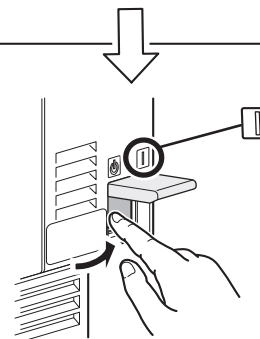
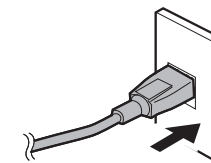
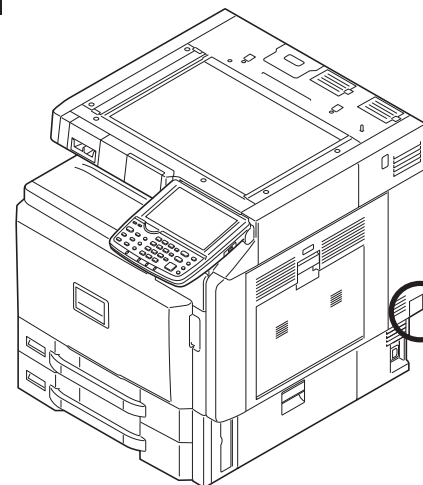




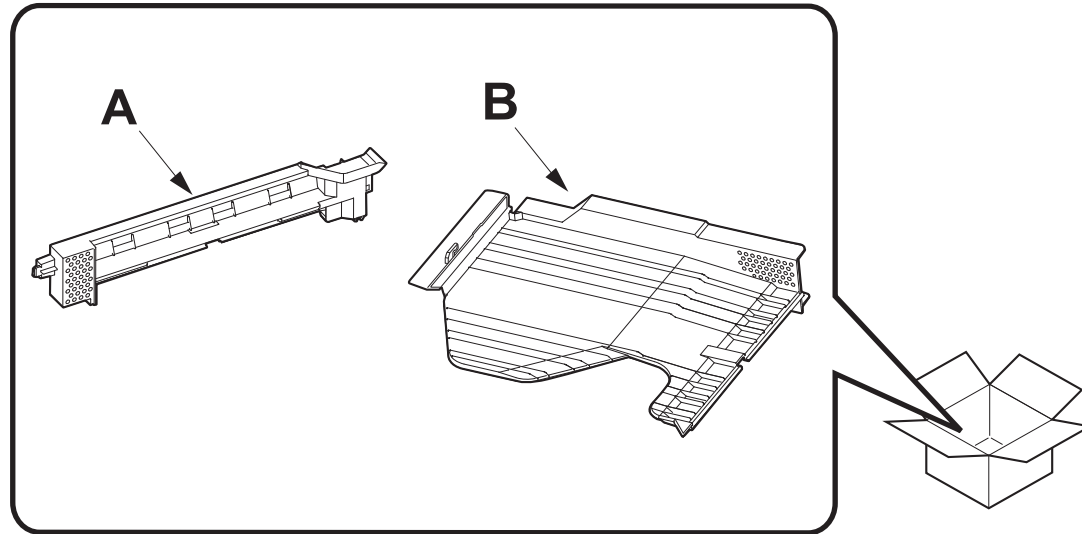






**21****22****23**

- Ⓔ **ENG** Enter maintenance mode U211 "Set Enhance connection", and select Inner Job Separator.
- Ⓕ **FR** Passer en mode maintenance U211, cliquer sur "Set Enhance connection" et sélectionner Inner Job Separator.
- Ⓖ **ES** Entre en el modo de mantenimiento U211 "Set Enhance connection" y seleccione Inner Job Separator.
- Ⓗ **DE** Schalten Sie in den Wartungsmodus U211 „Set Enhance connection“ und wählen Sie Inner Job Separator.
- Ⓐ **IT** Introdurre la modalità manutenzione U211 "Set Enhance connection", e selezionare Inner Job Separator.
- Ⓒ **CN** 进入维护模式，在U211 Set Enhance connection 中选择Inner Job Separator。
- Ⓚ **KO** 메인テナンス 모드에 들어가 U211 Set Enhance connection에서 Inner Job Separator를 선택합니다.
- Ⓜ **JP** メンテナンスモードに入り、U211エンハンス接続設定にてInner Job Separatorを選択する。



**(ENG) Precautions**

The illustrations of the machine in the Installation Guide are for color MFP.

**(FR) Précautions**

L'appareil représenté dans les illustrations du présent guide d'installation est le MFP couleur.

**(ES) Precauciones**

Las ilustraciones de la máquina que aparecen en la Guía de instalación corresponden a una MFP en color.

**(DE) Vorsichtsmaßnahmen**

Die Abbildungen der Maschine in der Installationsanleitung gelten für den Farb-MFP.

**(IT) Precauzioni**

Le illustrazioni della macchina nella guida di installazione sono per colore MFP.

**(CN) 注意事项**

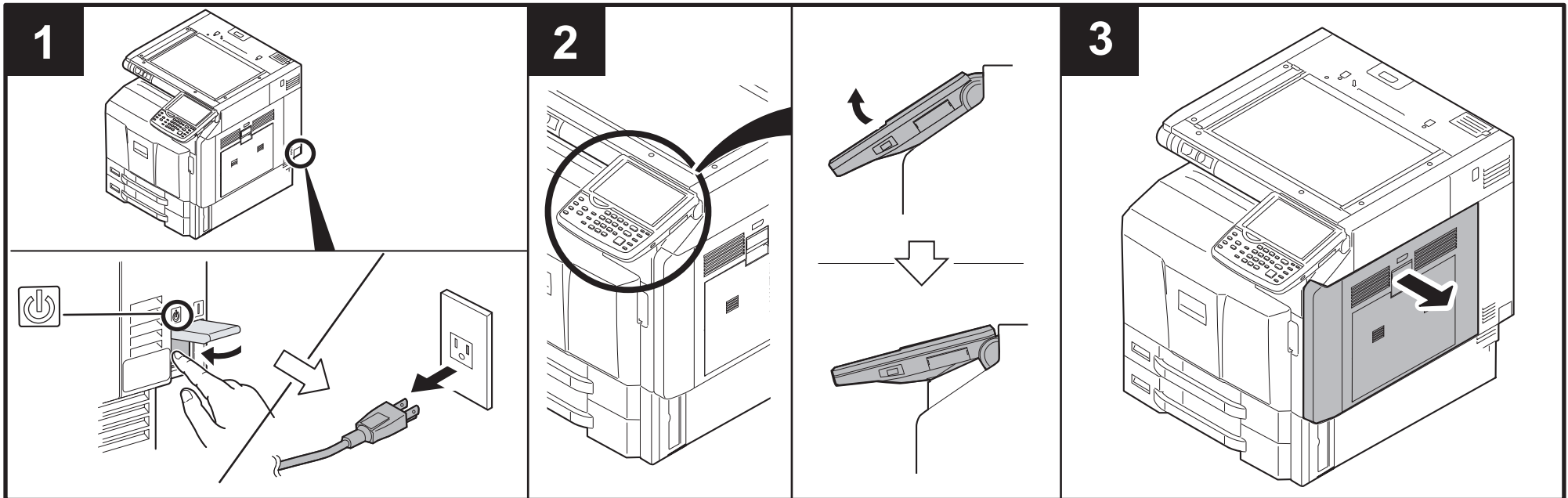
安装手册中记载的机器主机的插图是彩色机。

**(KO) 주의사항**

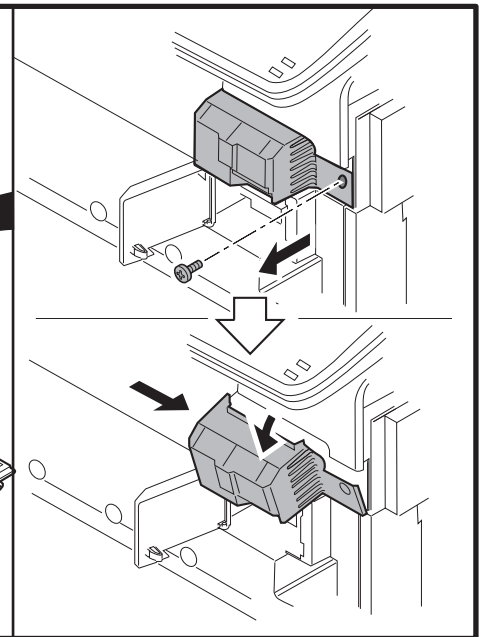
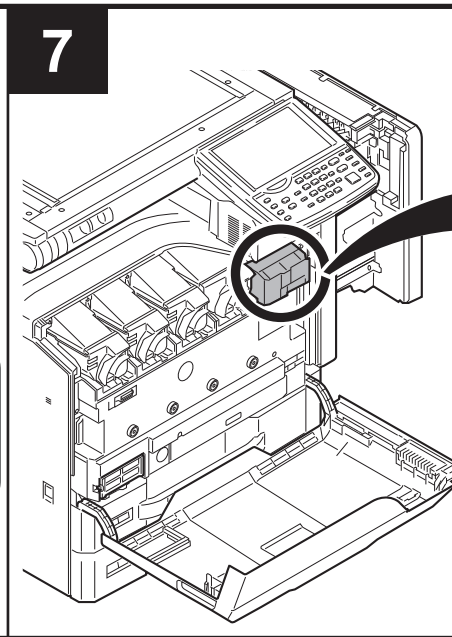
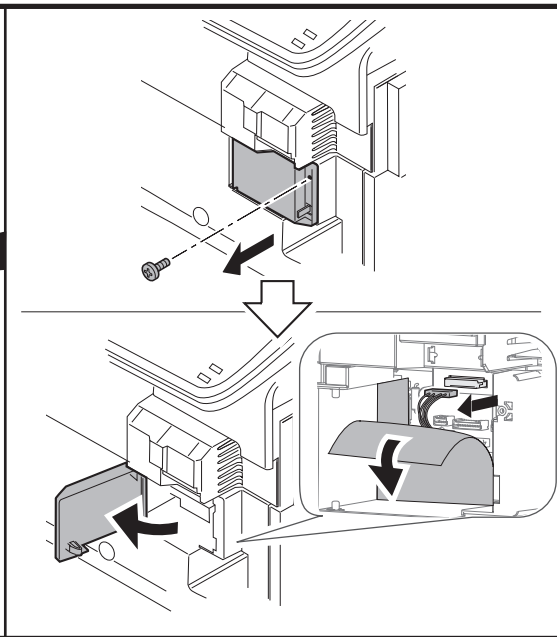
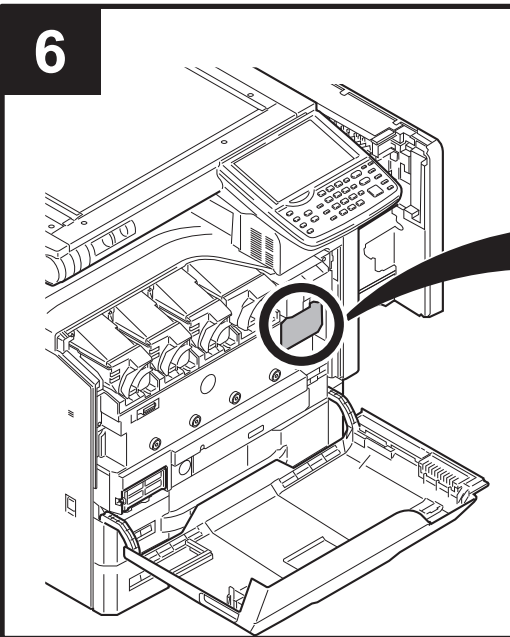
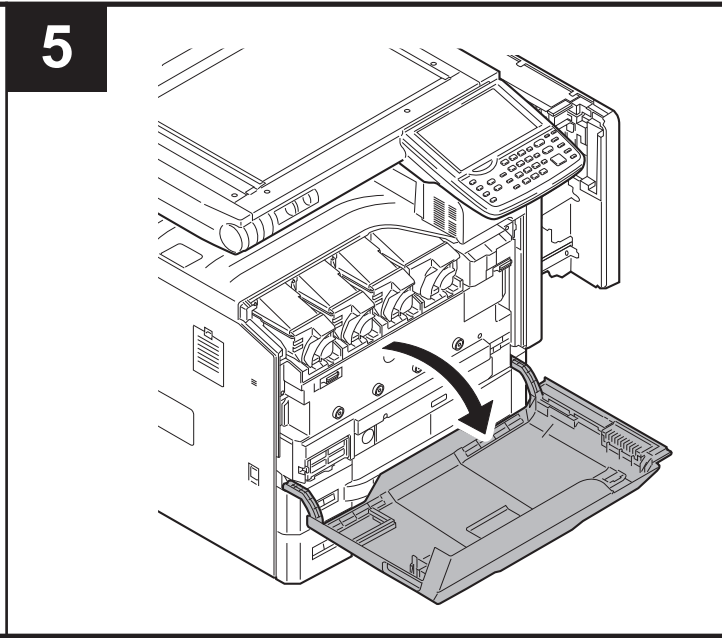
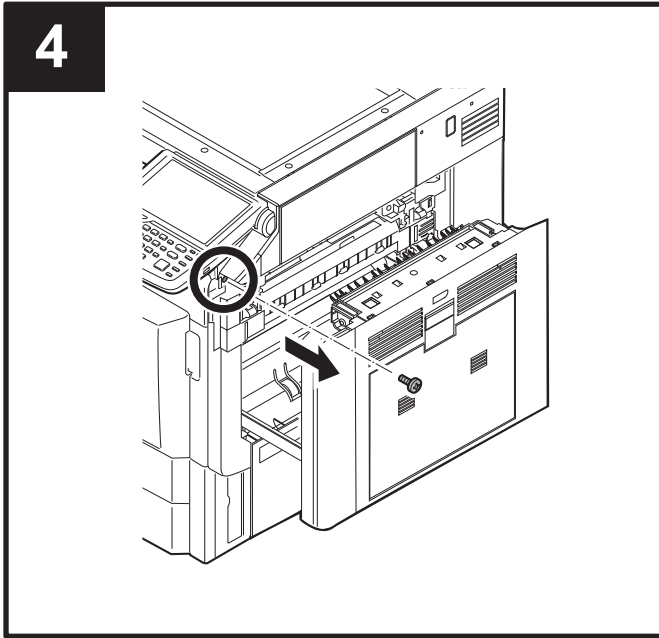
설치순서에 기재되어 있는 기기본체 일러스트는 컬러기입니다.

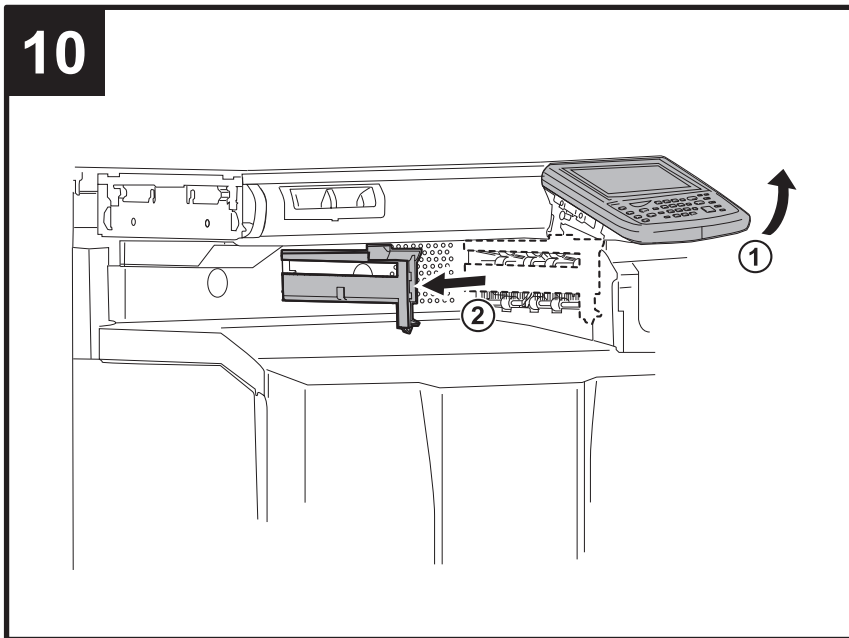
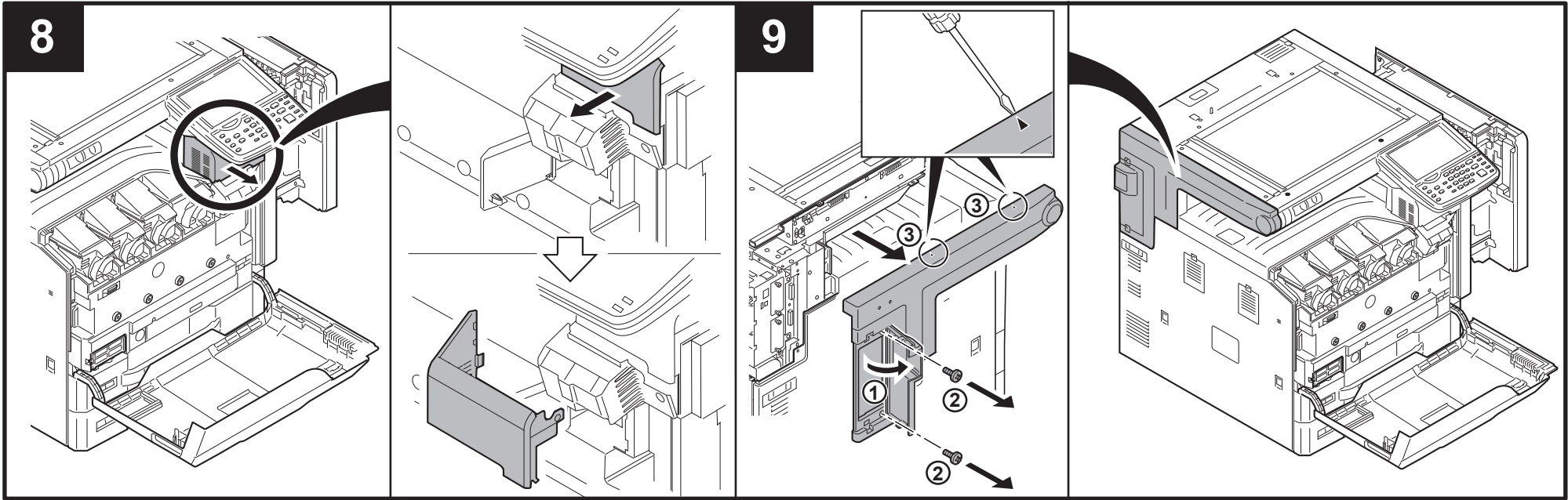
**(JP) 注意事項**

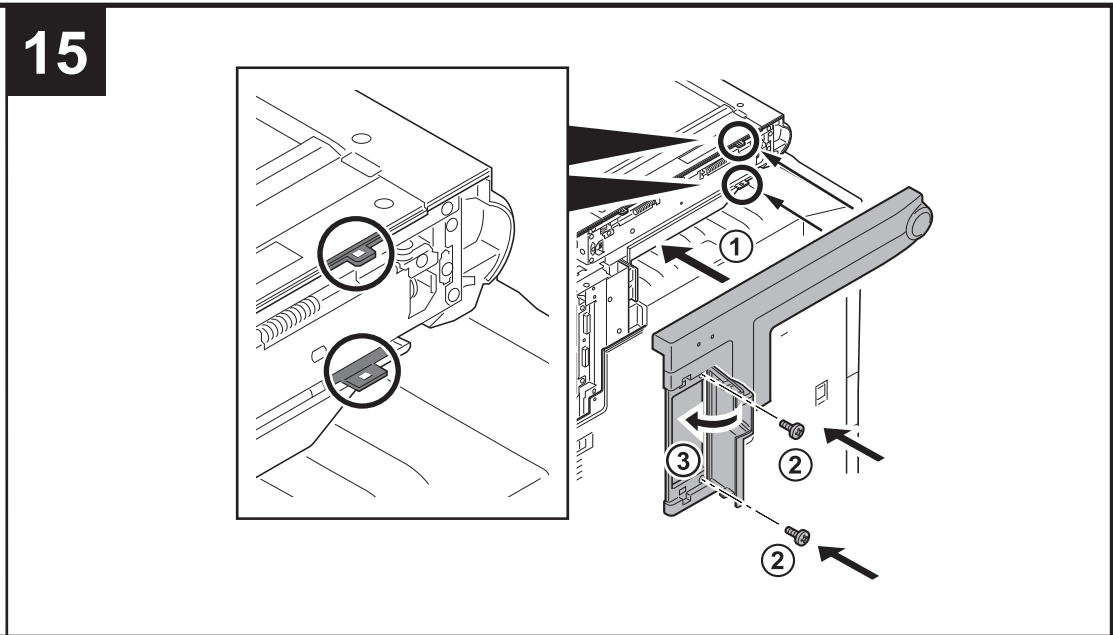
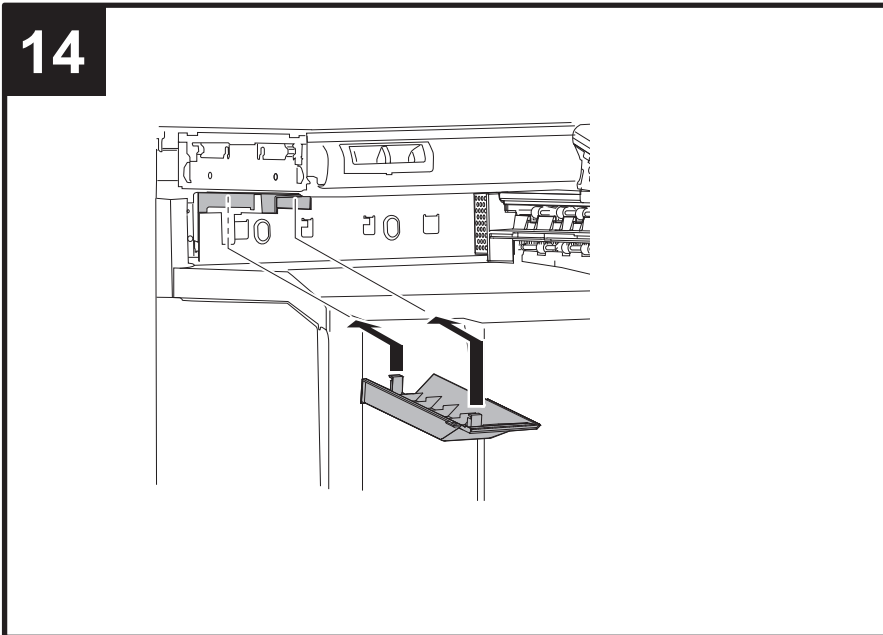
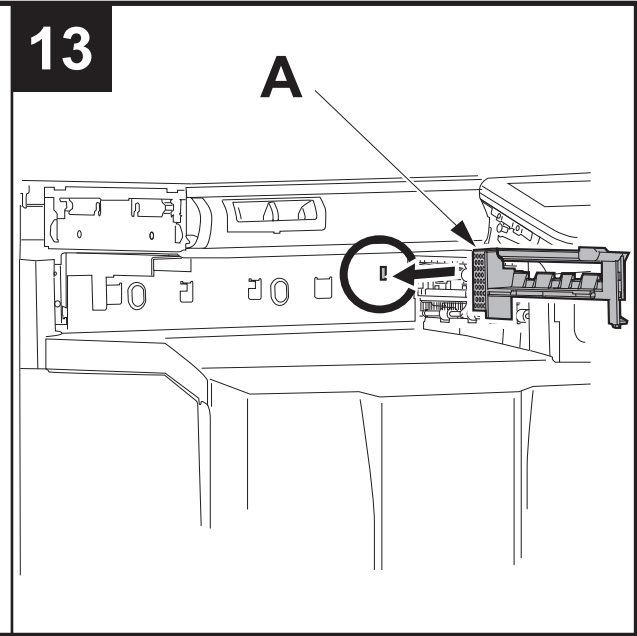
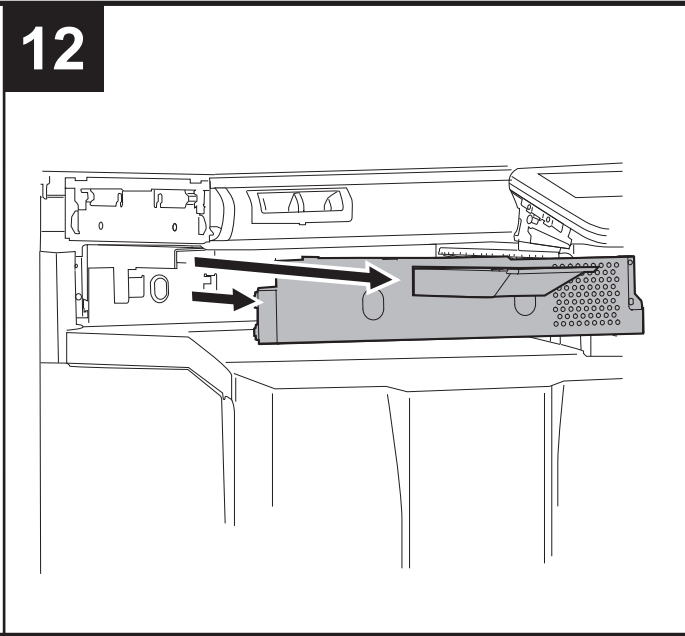
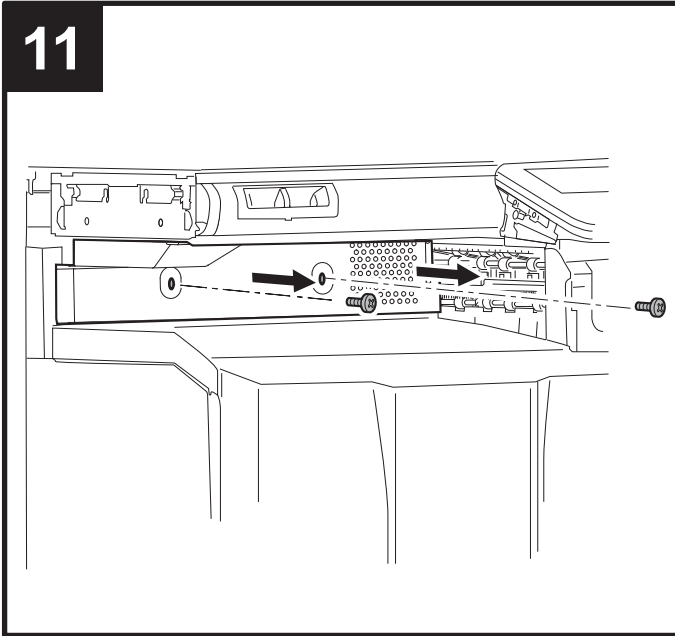
設置手順書に記載している機械本体のイラストはカラー機です。

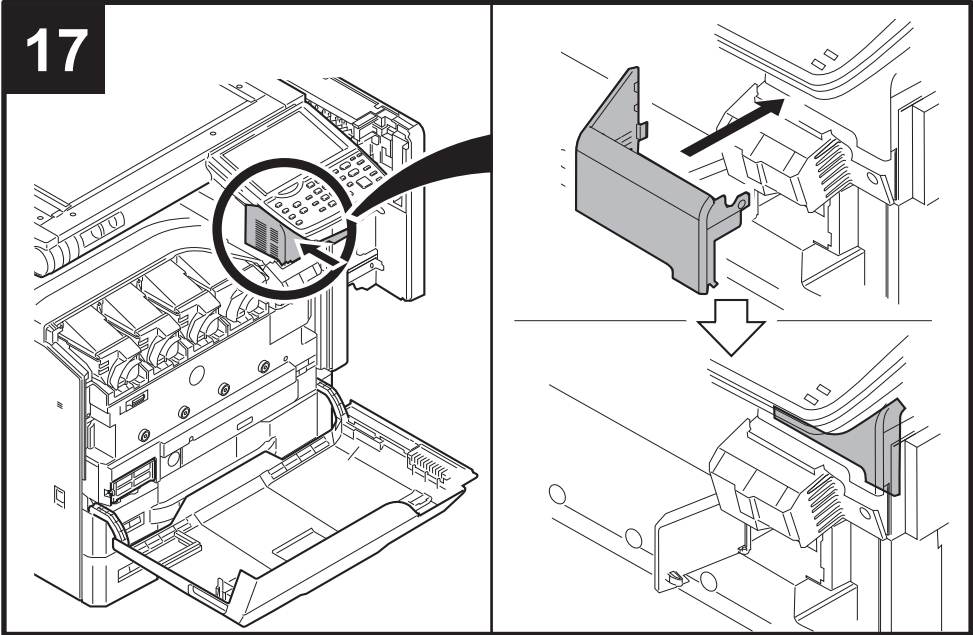
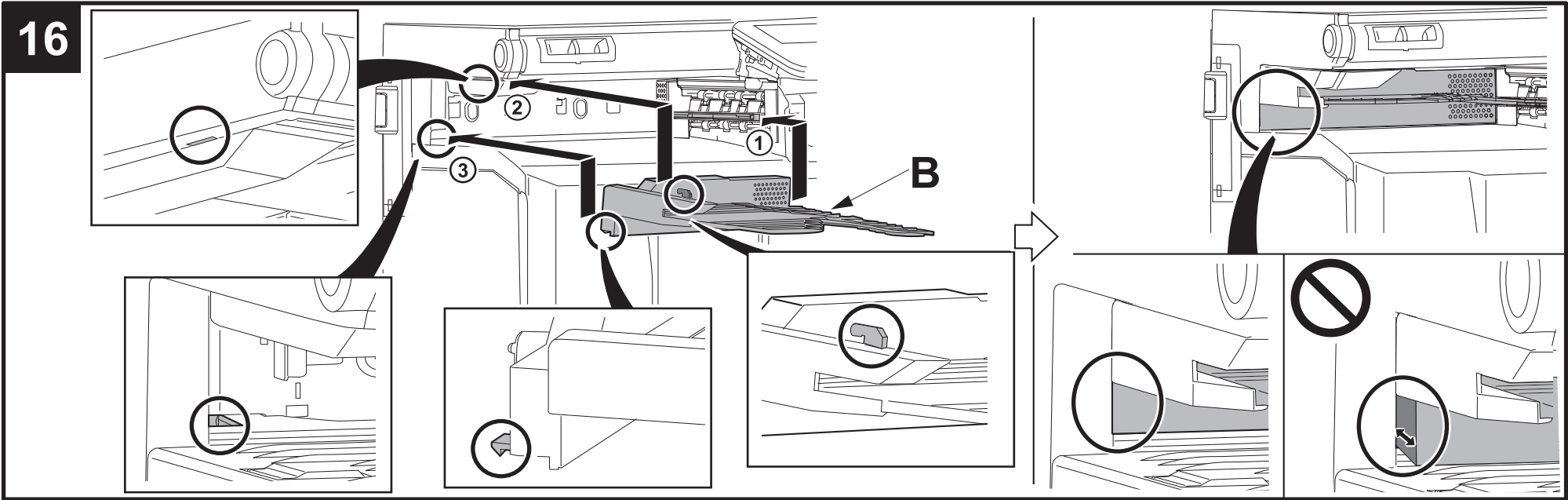


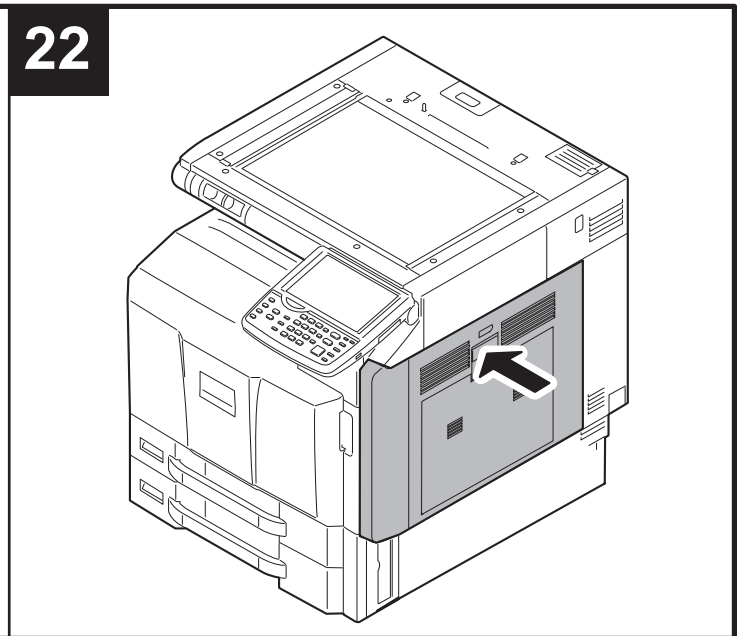
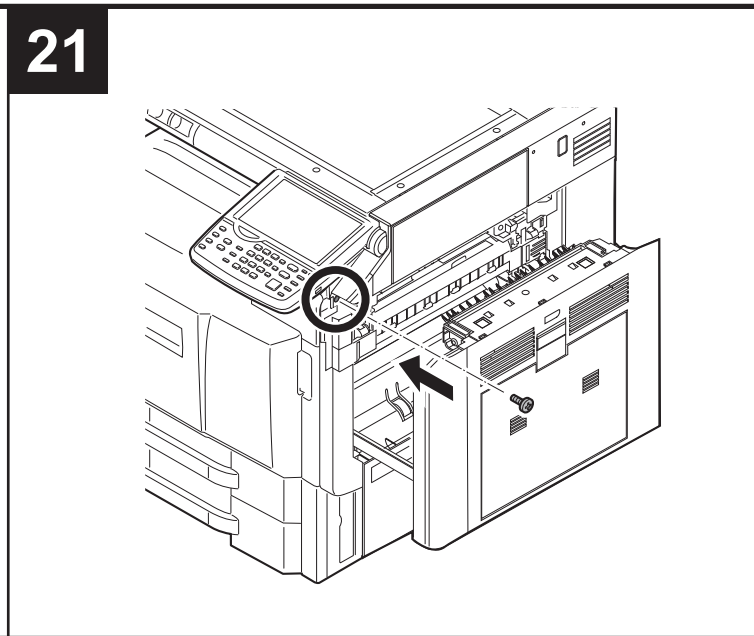
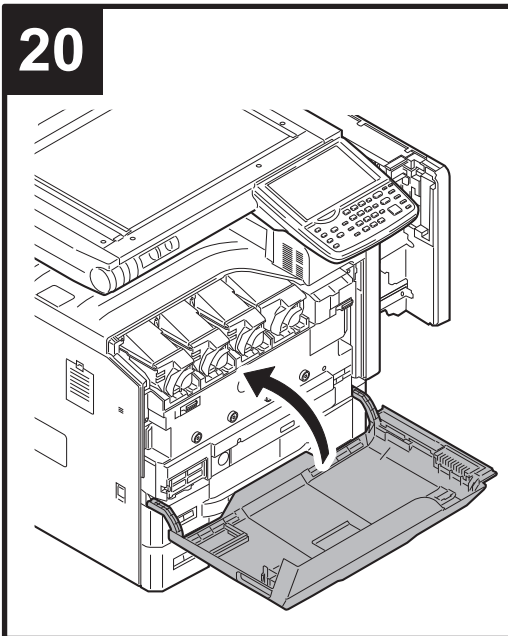
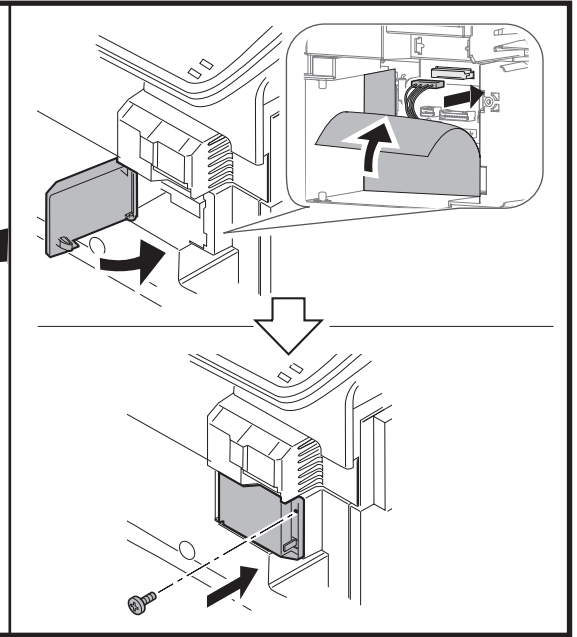
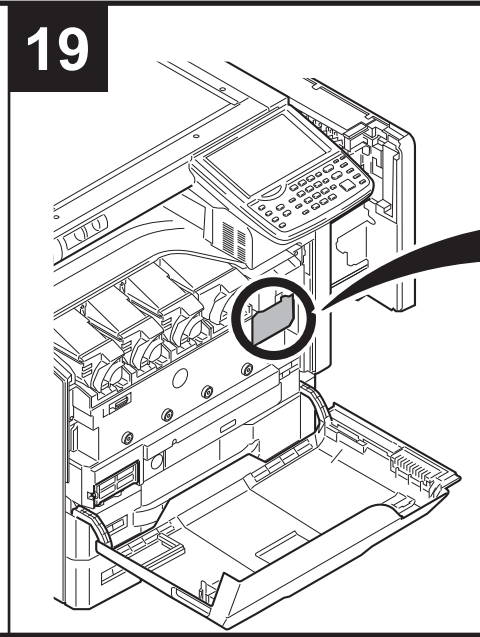
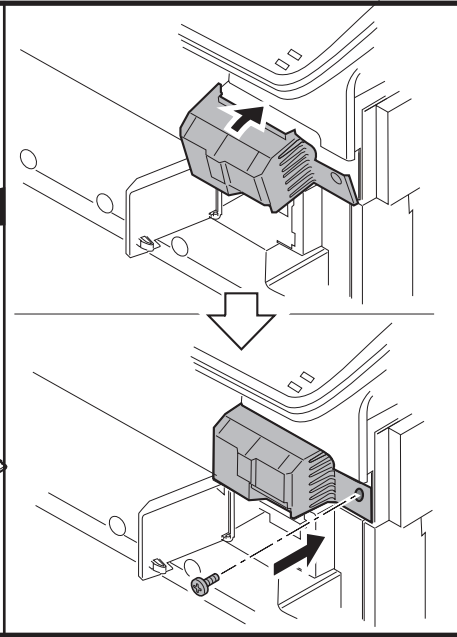
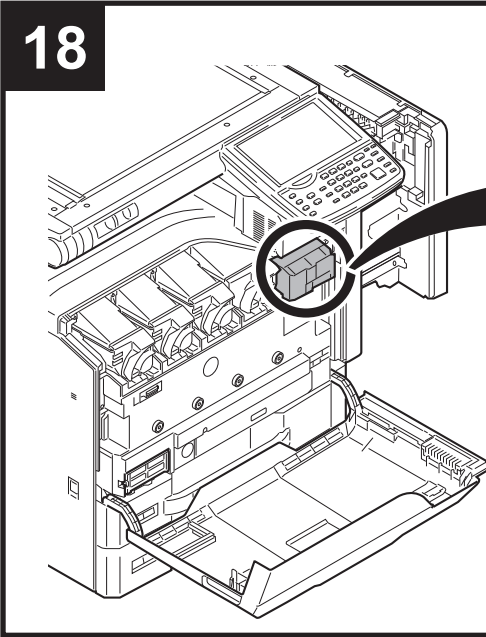


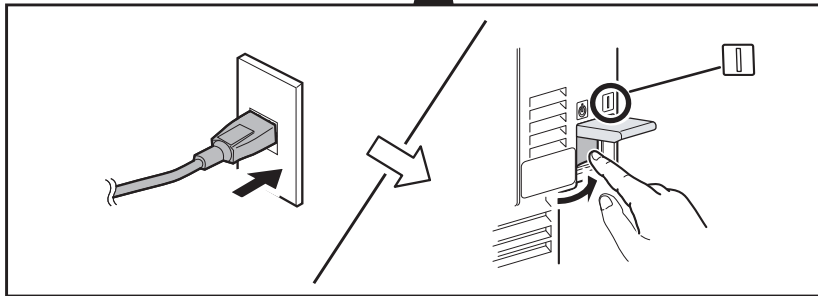
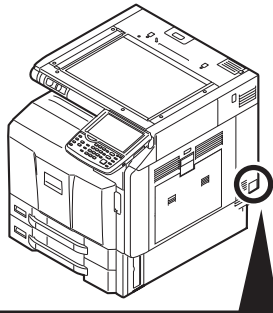










**23****24**

- Ⓔ **ENG** Enter maintenance mode U211 "Set Enhance connection", and select Inner Job Separator.
- Ⓔ **FR** Passer en mode maintenance U211, cliquer sur "Set Enhance connection" et sélectionner Inner Job Separator.
- Ⓔ **ES** Entre en el modo de mantenimiento U211 "Set Enhance connection" y seleccione Inner Job Separator.
- Ⓔ **DE** Schalten Sie in den Wartungsmodus U211 „Set Enhance connection“ und wählen Sie Inner Job Separator.
- Ⓔ **IT** Introdurre la modalità manutenzione U211 "Set Enhance connection", e selezionare Inner Job Separator.
- Ⓔ **CN** 进入维护模式，在U211 Set Enhance connection 中选择Inner Job Separator。
- Ⓔ **KO** 메인テナンス 모드에 들어가 U211 Set Enhance connection에서 Inner Job Separator를 선택합니다.
- Ⓔ **JP** メンテナンスモードに入り、U211エンハンス接続設定にてInner Job Separatorを選択する。



303NZ5671004

2013.5  
303NZ56710-04

**INSTALLATION GUIDE FOR  
100-SHEETS INNER JOB  
SEPARATOR**



---

**INSTALLATION GUIDE**

**GUIDE D'INSTALLATION**

**GUÍA DE INSTALACION**

**INSTALLATIONSANLEITUNG**

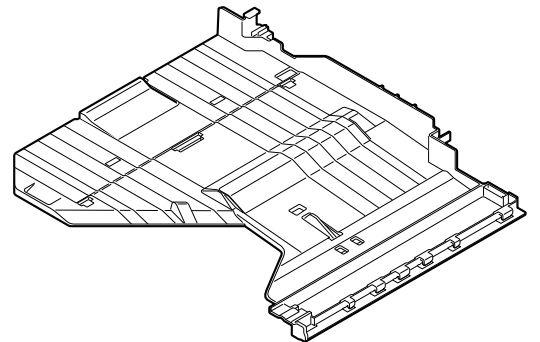
**GUIDA ALL'INSTALLAZIONE**

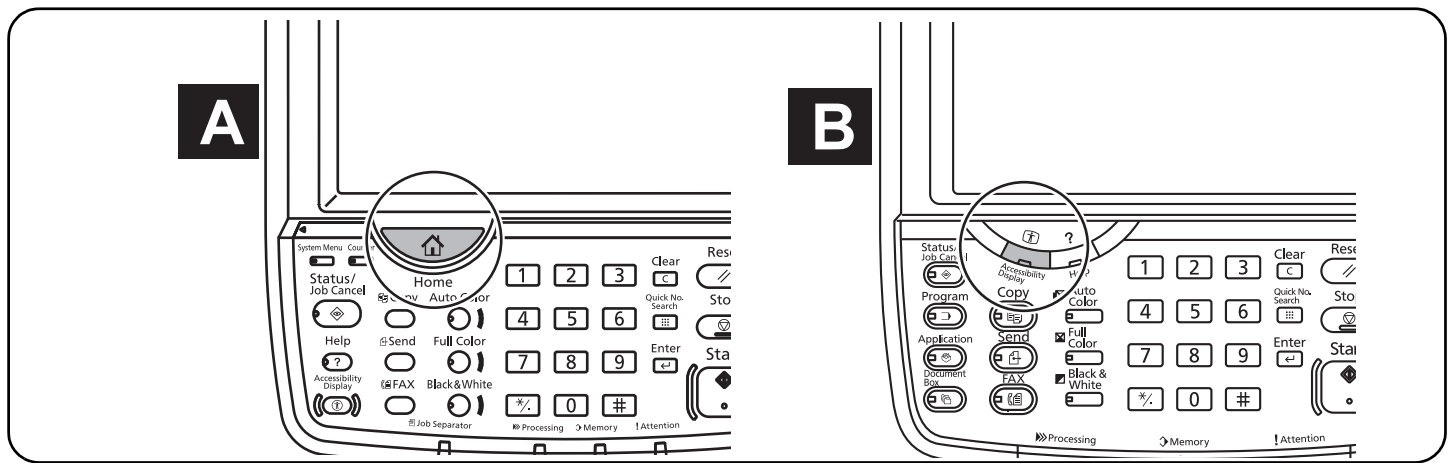
**安装手册**

**설치안내서**

**設置手順書**

**JS-732**





**English** A different procedure is required depending on the product which is installed with this unit. Each procedure is described in the following pages.

**A:** When installing on a machine which has the 'HOME' key in the operation panel, see Page 1 to Page 10.

**B:** When installing on a machine which has the 'Accessibility Display' key in the operation panel, see Page 11 to Page 21.

**Français** Une procédure différente est requise selon le produit qui est installé avec cette unité. Chaque procédure est décrite dans les pages suivantes.

**A:** Lors de l'installation sur une machine disposant de la touche 'Accueil' sur le panneau de commande, voir Page 1 à Page 10.

**B:** Lors de l'installation sur une machine disposant de la touche 'Affich. accessibilité' sur le panneau de commande, voir Page 11 à Page 21.

**Español** El procedimiento es diferente según el producto que se instale con esta unidad. En las siguientes páginas, se describe cada procedimiento.

**A:** Instalación en una máquina que dispone de la tecla 'Inicio' en el panel de controles, consulte las páginas de la 1 a la 10.

**B:** Instalación en una máquina que dispone de la tecla 'Pantalla acceso' en el panel de controles, consulte las páginas de la 11 a la 21.

**Deutsch** Je nach verwendetem Modell ist eine andere Vorgehensweise zur Installation dieses Teils erforderlich. Die unterschiedlichen Vorgehensweisen werden auf den folgenden Seiten erläutert.

**A:** Bei Installation an einem Gerät mit der Taste 'Startseite' im Bedienfeld siehe Seiten 1 bis 10.

**B:** Bei Installation an einem Gerät mit der Taste 'Zugriffsanzeige' im Bedienfeld siehe Seiten 11 bis 21.

**Italiano** Si richiede una procedura diversa in funzione del prodotto su cui è installata l'unità. Le singole procedure sono descritte nelle pagine seguenti.

**A:** Installazione su una macchina con tasto 'Home' sul pannello comandi, vedere le pagine da 1 a 10.

**B:** Installazione su una macchina con tasto 'Visual. Accessibilità' sul pannello comandi, vedere le pagine da 11 a 21.

**简体中文** 根据安装对象, 安装步骤略有不同。各个步骤记载在下面的页面。

**A:** 安装操作面板上有 '主界面' 按键的机器时; 请参见 P1-P10。

**B:** 安装操作面板上有 '扩大显示' 按键的机器时; 请参见 P11-P21。

**한국어** 이 장치에 설치되는 제품에 따라 절차가 다릅니다. 다음 페이지에서 각 절차를 설명합니다.

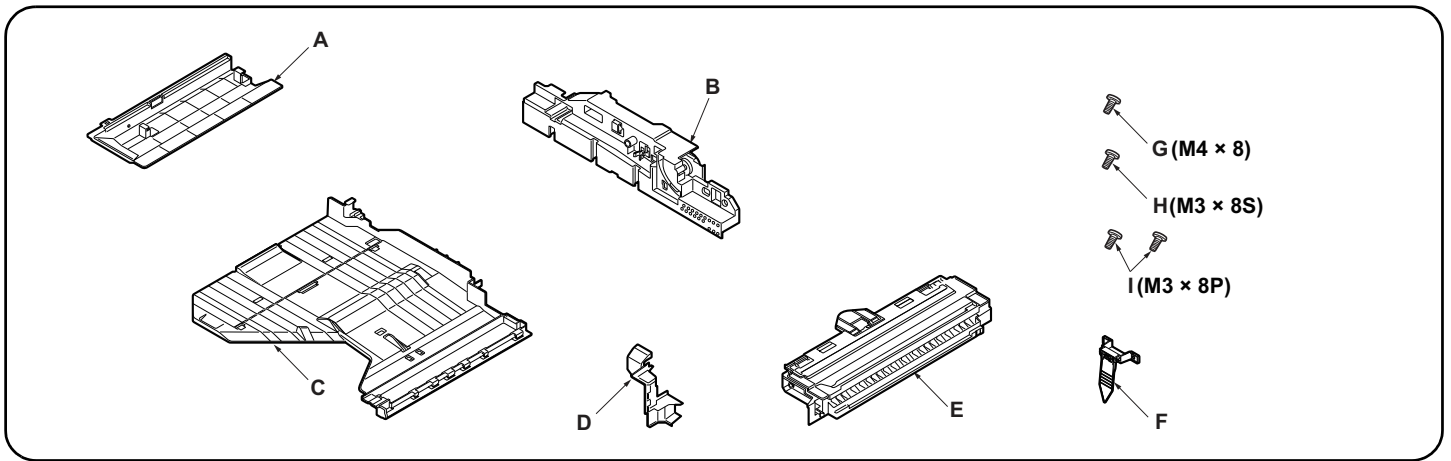
**A:** 조작판넬에 '홈' 키가 있는 기기에 설치하는 경우 1 페이지 ~ 10 페이지를 참조하십시오.

**B:** 조작판넬에 '유니버설' 키가 있는 기기에 설치하는 경우 11 페이지 ~ 21 페이지를 참조하십시오.

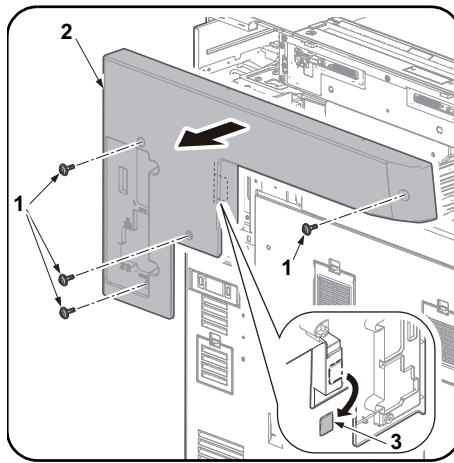
**日本語** 装着する対象によって、取付手順は異なります。それぞれ、以下のページに記載しています。

**A:** 操作パネルに 'ホーム' キーがある機械に設置する場合; 1 ページ ~ 10 ページ

**B:** 操作パネルに 'ユニバーサル' キーがある機械に設置する場合; 11 ページ ~ 21 ページ



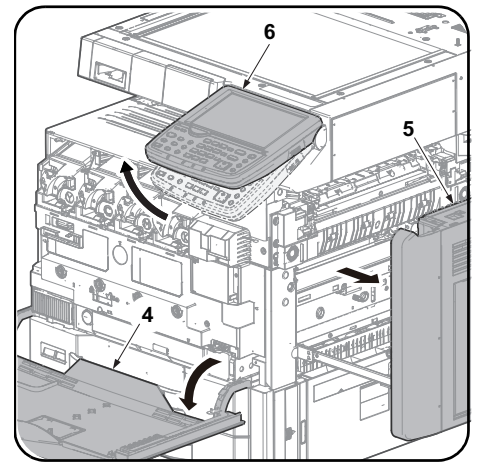
English			
<b>Supplied parts</b>			
A. Scanner bottom cover	.....	1	
B. Drive unit	.....	1	
C. Inner tray	.....	1	
D. Eject unit cover	.....	1	
E. Eject unit	.....	1	
F. Stopper paper	.....	1	
G. M4 x 8 screw	.....	1	
H. S Tite screw M3 x 8	.....	1	
I. P Tite screw M3 x 8	.....	2	
			Be sure to remove any tape and/or cushioning materials from the parts supplied.
			* (G) is not used.
Français			
<b>Pièces fournies</b>			
A. Capot inférieur du scanner	.....	1	
B. Unité d'entraînement	.....	1	
C. Bac intérieur	.....	1	
D. Capot de l'unité d'éjection	.....	1	
E. Unité d'éjection	.....	1	
F. Butée de papier	.....	1	
G. Vis M4 x 8	.....	1	
H. Vis S Tite M3 x 8	.....	1	
I. Vis P Tite M3 x 8	.....	2	
			Veillez à retirer les morceaux de bande adhésive et/ou les matériaux de rembourrage des pièces fournies.
			* (G) n'est pas utilisé.
Español			
<b>Partes suministradas</b>			
A. Cubierta inferior del escáner	.....	1	
B. Unidad de accionamiento	.....	1	
C. Bandeja interna	.....	1	
D. Cubierta de la unidad de salida	.....	1	
E. Unidad de salida	.....	1	
F. Tope de papel	.....	1	
G. Tornillo M4 x 8	.....	1	
H. Tornillo S Tite M3 x 8	.....	1	
I. Tornillo P Tite M3 x 8	.....	2	
			Asegúrese de despegar todas las cintas y/o material amortiguador de las partes suministradas.
			* (G) no se utiliza.
Deutsch			
<b>Gelieferte Teile</b>			
A. Untere Abdeckung des Scanners	.....	1	
B. Antriebseinheit	.....	1	
C. Innere Ablage	.....	1	
D. Abdeckung der Ausgabereinheit	.....	1	
E. Ausgabereinheit	.....	1	
F. Papieranschlag	.....	1	
G. Schraube M4 x 8	.....	1	
H. S-Tite-Schraube M3 x 8	.....	1	
I. P-Tite-Schraube M3 x 8	.....	2	
			Stellen Sie sicher, dass sämtliche Klebebänder und/oder Polstermaterial von den gelieferten Teilen entfernt wurden.
			* (G) wird nicht benötigt.
Italiano			
<b>Parti di forniture</b>			
A. Coperchio inferiore dello scanner	.....	1	
B. Unità guida	.....	1	
C. Vassoio interno	.....	1	
D. Coperchio dell'unità di espulsione	.....	1	
E. Unità di espulsione	.....	1	
F. Fermo carta	.....	1	
G. Vite M4 x 8	.....	1	
H. Vite S Tite M3 x 8	.....	1	
I. Vite P Tite M3 x 8	.....	2	
			Rimuovere tutti i nastri adesivi e/o i materiali di protezione dalle parti fornite.
			* (G) non è utilizzato.
简体中文			
<b>附属品</b>			
A. 扫描仪底部盖板	.....	1	
B. 驱动单元	.....	1	
C. 内部托盘	.....	1	
D. 出纸单元盖板	.....	1	
E. 出纸单元	.....	1	
F. 纸张挡板	.....	1	
G. M4x8 螺丝	.....	1	
H. 紧固型 S 螺丝 M3x8	.....	1	
I. 紧固型 P 螺丝 M3x8	.....	2	
			如果附属品上带有固定胶带, 缓冲材料时必须揭下。
			※ 不使用 (G)
한국어			
<b>동봉품</b>			
A. 스캐너 밑커버	.....	1	
B. 구동 유닛	.....	1	
C. 내부 트레이	.....	1	
D. 배출 유닛 커버	.....	1	
E. 배출 유닛	.....	1	
F. 스톱퍼 용지	.....	1	
G. 나사 M4x8	.....	1	
H. 나사 M3x8S 타이트	.....	1	
I. 나사 M3x8P 타이트	.....	2	
			동봉품에 고정 테이프, 완충재가 붙어 있는 경우에는 반드시 제거하십시오.
			※ (G) 는 사용되지 않습니다.
日本語			
<b>同梱品</b>			
A. スキャナー底カバー	.....	1	
B. 駆動ユニット	.....	1	
C. 内部トレイ	.....	1	
D. 排出ユニットカバー	.....	1	
E. 排出ユニット	.....	1	
F. ペーパーストップパー	.....	1	
G. ビス M4x8	.....	1	
H. ビス M3x8S タイト	.....	1	
I. ビス M3x8P タイト	.....	2	
			同梱品に固定テープ、緩衝材がついている場合は、必ず取り外すこと。
			※ (G) は、使用しません。



Before installing the JS-732, make sure that the MFP's main power switch is turned off and that its power cord is unplugged from the power outlet.

#### Procedure

1. Remove the four screws (1). Remove the left upper cover (2).
2. Remove the breakaway cover (3) from the left upper cover (2).



3. Open the front cover (4) on the MFP.
4. Pull out the paper conveyor cover (5).
5. If the operation panel (6) is lowered, raise it to the top position.

Avant d'installer l'JS-732, s'assurer que l'interrupteur d'alimentation principal du MFP est coupé et que le cordon d'alimentation est débranché de la prise secteur.

#### Procédure

1. Retirez les quatre vis (1). Retirer le capot supérieur gauche (2).
2. Retirez le capot détachable (3) du capot supérieur gauche (2).

3. Ouvrir le capot avant (4) sur le MFP.
4. Sortir le capot du transporteur du papier (5).
5. Si le panneau de commande (6) est abaissé, le relever dans sa position maximum.

Antes de instalar el JS-732, asegúrese de que el interruptor principal de la alimentación de la MFP esté desconectado y que su cable de alimentación esté desenchufado de la toma de corriente.

#### Procedimiento

1. Quite los cuatro tornillos (1). Quite la cubierta superior izquierda (2).
2. Quite la cubierta de separación (3) de la cubierta superior izquierda (2).

3. Abra la cubierta frontal (4) en la MFP.
4. Extraiga la cubierta de la unidad de transporte de papel (5).
5. Si el panel de trabajo (6) está bajo, levántelo hasta la posición superior.

Vor dem Einbau des JS-732 muss der MFP-Hauptschalter ausgeschaltet und das Netzkabel von der Steckdose abgezogen sein.

#### Verfahren

1. Entfernen Sie die vier Schrauben (1). Entfernen Sie die linke obere Abdeckung (2).
2. Entfernen Sie die Abdeckung mit der Sollbruchstelle (3) aus der linken oberen Abdeckung (2).

3. Öffnen Sie die vordere Abdeckung (4) des MFP.
4. Entfernen Sie die Abdeckung des Papiertransports (5).
5. Falls das Bedienfeld (6) abgesenkt ist, bringen Sie es in die oberste Position.

Prima di installare l'unità JS-732, assicurarsi che l'interruttore principale dell'MFP sia spento e che il suo cavo di alimentazione sia scollegato presa di corrente.

#### Procedura

1. Rimuovere le quattro viti (1). Rimuovere il coperchio superiore sinistro (2).
2. Rimuovere il coperchio ad aggancio rapido (3) dal coperchio superiore sinistro (2).

3. Aprire il pannello anteriore (4) sull'MFP.
4. Estrarre il coperchio di trasporto carta (5).
5. Se il pannello operativo (6) è abbassato, sollevarlo alla posizione in alto.

安装 JS-732 时, 请务必将 MFP 主机电源关闭, 关闭下电源插头再进行安装作业。

#### 安装步骤

1. 取下 4 颗螺丝 (1)。取下左上盖板 (2)。
2. 取下左上盖板 (2) 的组合盖板 (3)。

3. 打开 MFP 主机的前盖板 (4)。
4. 拉出输纸盖板 (5)。
5. 操作面板 (6) 处于低位时, 将其升到最高位置。

JS-732 을 부착할 때에는 반드시 MFP 본체의 주 전원 스위치를 OFF 로 하고 전원 플러그를 제거하고 작업을 할 것 .

#### 설치순서

1. 나사 (1) 4 개를 제거합니다 . 좌측 상커버 (2) 를 제거합니다 .
2. 좌측 상 커버 (2) 에서 분리 커버 (3) 를 제거합니다 .

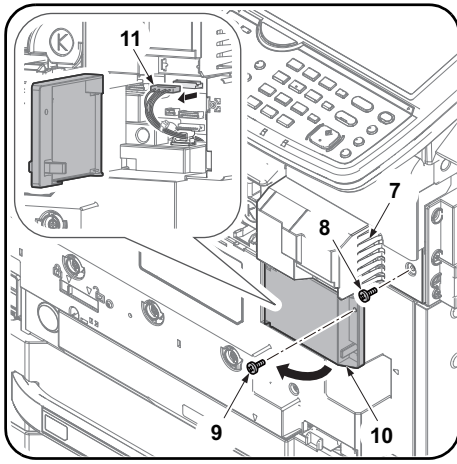
3. MFP 본체의 전면커버 (4) 를 엽니다 .
4. 반송커버 (5) 를 당겨 냅니다 .
5. 조작판넬 (6) 이 내려가 있는 경우에는 위로 올립니다 .

JS-732 を取り付ける際は、必ず MFP 本体の主電源スイッチを OFF にし、電源プラグを外して作業をおこなうこと。

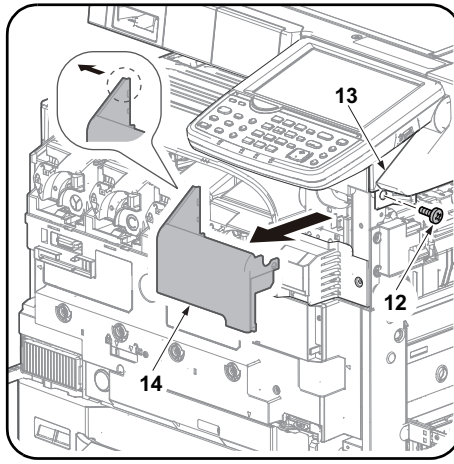
#### 取付手順

1. ビス (1) 4 本を外す。左上カバー (2) を取り外す。
2. 左上カバー (2) の割りカバー (3) を切り取る。

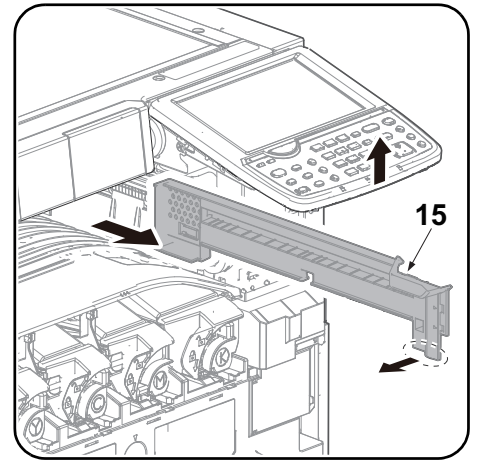
3. MFP 本体の前カバー (4) を開く。
4. 搬送カバー (5) を引き出す。
5. 操作パネル (6) が下がっている場合は上位置に上げる。



6. Remove the screw (8) from the fan cover (7).  
**Full-color machines only**  
 7. Remove the screw (9). Open the inner cover (10). Unplug the connector (11).  
 \*Take care not to get the wire saddle fallen off.



8. Remove the screw (12) and pull the upper right cover (13) outwards slightly while removing the front right cover (14). Remove the right front cover (14) by pulling the part in the dotted circle outwards.



9. Remove the eject cover (15).  
 \*Release the operation panel lock. Lift up the operation panel.  
 \* Pull the lower front side to the left before removing the cover.  
 \*The eject cover (15) which was removed is not used.

6. Retirez la vis (8) du capot du ventilateur (7).  
**Machines entièrement en couleurs uniquement**  
 7. Retirez la vis (9). Ouvrez le capot interne (10). Débranchez le connecteur (11).  
 \*Prendre soin à ne pas faire tomber le serre-câble.

8. Retirez la vis (12) et tirez légèrement le capot supérieur droit (13) vers l'extérieur tout en déposant le capot avant droit (14). Retirez le capot avant droit (14) en tirant la partie dans le cercle en pointillés.

9. Retirez le capot d'éjection (15).  
 \*Libérez le verrou du panneau de commande. Soulevez le panneau de commande.  
 \* Tirer le côté avant inférieur sur la gauche avant de retirer le capot.  
 \*Le capot de sortie (15) qui a été retiré n'est pas utilisé.

6. Quite el tornillo (8) de la cubierta del ventilador (7).  
**Maquinas a todo color solamente**  
 7. Quite el tornillo (9). Abra la cubierta interna (10). Desenchufe el conector (11).  
 \*Tenga cuidado de que no se caiga el pasador de cables.

8. Quite el tornillo (12) y saque la cubierta superior derecha (13) ligeramente mientras quita la cubierta frontal derecha (14). Quite la cubierta frontal derecha (14) tirando hacia afuera de la parte en el círculo punteado.

9. Quite la cubierta de expulsión (15).  
 \*Libere el bloqueo del panel de controles. Levante el panel de controles.  
 \* Tire del lado frontal inferior hacia la izquierda antes de quitar la cubierta.  
 \*No se utiliza la cubierta de expulsión (15) que se quitó.

6. Entfernen Sie die Schraube (8) der Lüfterabdeckung (7).  
**nur Farbgeräte**  
 7. Entfernen Sie die Schraube (9). Öffnen Sie die innere Abdeckung (10). Ziehen Sie den Stecker (11) ab.  
 \*Stellen Sie sicher, dass der Kabelsattel nicht herunterfällt.

8. Entfernen Sie die Schraube (12) und ziehen Sie die obere rechte Abdeckung (13) vorsichtig nach außen, während Sie gleichzeitig die vordere rechte Abdeckung (14) entfernen. Entfernen Sie die rechte vordere Abdeckung (14), indem Sie das Teil, das in der Zeichnung mit einem gepunkteten Kreis markiert ist, nach außen ziehen.

9. Entfernen Sie die Abdeckung der Ausgabeinheit (15).  
 \*Lösen Sie die Verriegelung des Bedienfelds. Heben Sie das Bedienfeld nach oben an.  
 \* Bevor Sie die Abdeckung entfernen, ziehen Sie die untere Vorderseite nach links.  
 \*Die gerade entfernte Abdeckung des Papierauslaufs (15) wird nicht mehr benötigt.

6. Rimuovere la vite (8) dal coperchio ventola (7).  
**Solo dispositivi a colori**  
 7. Rimuovere la vite (9). Aprire il coperchio interno (10). Scollegare il connettore (11).  
 \*Attenzione a non fare cadere la sella di supporto filo.

8. Rimuovere la vite (12) e tirare il coperchio superiore destro (13) leggermente verso l'esterno mentre si rimuove il coperchio anteriore destro (14). Rimuovere il coperchio anteriore destro (14) tirando verso l'esterno la parte nel cerchio tratteggiato.

9. Rimuovere il coperchio di espulsione carta (15).  
 \*Sbloccare il pannello comandi. Sollevare il pannello comandi.  
 \* Tirare il lato anteriore in basso a sinistra prima di rimuovere il coperchio.  
 \*Il coperchio di uscita (15) rimosso non viene utilizzato.

6. 卸下风扇盖板 (7) 的 1 颗螺丝 (8)。  
**仅限彩色机器**  
 7. 取下 1 颗螺丝 (9)。打开内侧盖板 (10)。取下接插件 (11)。  
 ※ 请注意不要让束线夹脱落。

8. 卸下 1 颗螺丝 (12)，稍稍拉出右上部盖板 (13) 的同时，拆下右前部盖板 (14)。通过向外拉虚线圈出的部分卸下右前盖板 (14)。

9. 拆下排纸盖板 (15)。  
 ※ 解除操作部的锁定。把操作面板向上抬起。  
 ※ 将盖板前下部向左侧拉出以拆卸。  
 ※ 请不要使用取下的排纸盖板 (15)。

6. 팬커버 (7) 의 나사 (8) 1 개를 제거합니다.  
**컬러기 만**  
 7. 나사 (9) 를 제거합니다. 내부 커버 (10) 를 엽니다. 커넥터 (11) 를 분리합니다.  
 ※ 와이어 새들이 빠지지 않도록 주의합니다.

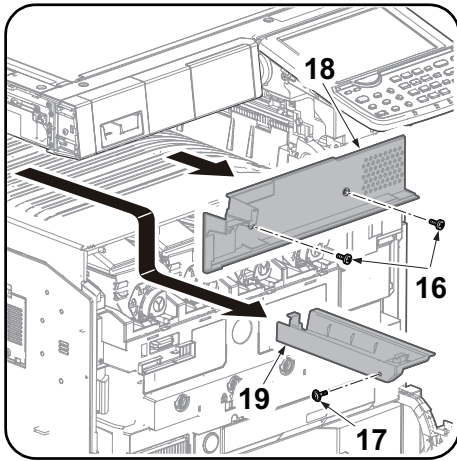
8. 나사 (12) 1 개를 제거하고 오른쪽 상커버 (13) 를 조금 당기면서 오른쪽 전면 커버 (14) 를 제거합니다. 점선 원으로 표시된 부분을 바깥 방향으로 당겨서 오른쪽 전면커버 (14) 를 제거합니다.

9. 배출커버 (15) 를 제거합니다.  
 ※ 조작판넬의 잠금을 해제합니다. 조작판넬을 위로 들어 올립니다.  
 ※ 전면 아래쪽을 좌측으로 당겨서 제거합니다.  
 ※ 분리한 배출 커버 (15) 는 사용되지 않습니다.

6. ファンカバー (7) のビス (8) 1 本を外す。  
**カラー機 のみ**  
 7. ビス (9) 1 本を外す。インナーカバー (10) を開ける。コネクタ (11) を抜く。  
 ※ ワイヤースドルが外れないよう注意すること。

8. ビス (12) 1 本を外し、右上カバー (13) を少し外に引っ張りながら右前カバー (14) を取り外す。  
 右前カバー (14) は、破線部を外側に引っ張るようにして外す。

9. 排出カバー (15) を取り外す。  
 ※ 操作部のロックを解除する。操作パネルを上方向に上げる。  
 ※ 前下側を左側に引いてから取り外す。  
 ※ 取り外した排出カバー (15) は使用しない。



10. Remove the two screws (16). Remove the screw (17). Remove the rear tray cover (18) and scanner bottom cover (19).  
\*The scanner bottom cover (19) which was removed is not used.

10. Retirez les deux vis (16). Retirez la vis (17). Retirez le capot du support arrière (18) et le capot inférieur du scanner (19).  
\*Le capot inférieur du scanner (19) qui a été retiré n'est pas utilisé.

10. Quite los dos tornillos (16). Quite el tornillo (17). Quite la cubierta izquierda de la bandeja (18) y la cubierta inferior del escáner (19).  
\*No se utiliza la cubierta inferior del escáner (19) que se quitó.

10. Entfernen Sie die beiden Schrauben (16). Entfernen Sie die Schraube (17). Entfernen Sie die Abdeckung des hinteren Fachs (18) und die untere Abdeckung des Scanners (19).  
\*Die gerade entfernte untere Scannerabdeckung (19) wird nicht mehr benötigt.

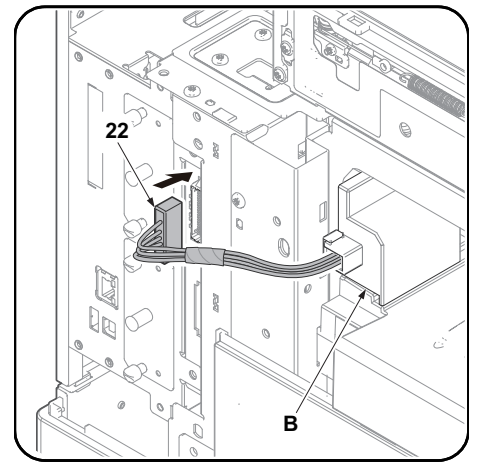
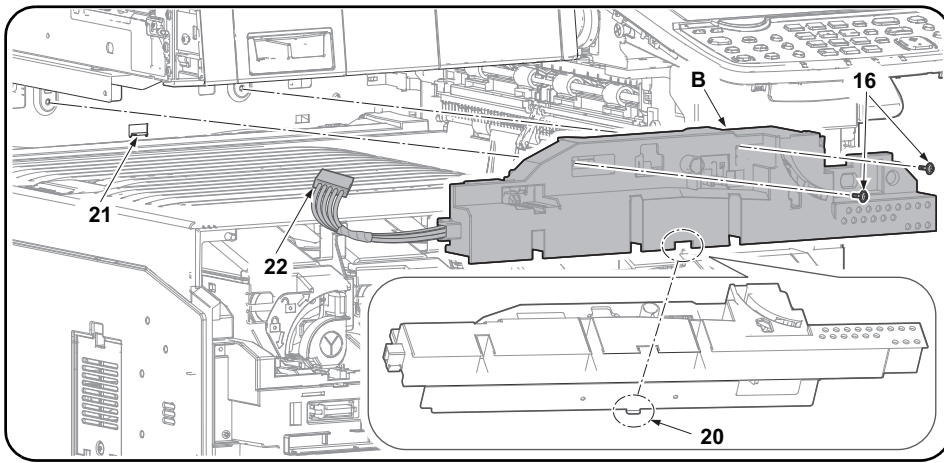
10. Rimuovere le due viti (16). Rimuovere la vite (17).  
Rimuovere il coperchio posteriore del vassoio (18) e il coperchio inferiore dello scanner (19).  
\*Il coperchio inferiore dello scanner (19) rimosso non viene utilizzato.

10. 取下 2 顆螺絲 (16)。取下螺絲 (17)。拆下托盤後部蓋板 (18) 以及掃描儀底部蓋板 (19)。  
※ 請不要使用取下的掃描儀底部蓋板 (19)。

10. 나사 (16) 두 개를 제거합니다. 나사 (17) 를 제거합니다. 트레이 뒷커버 (18) 및 스캐너 밑커버 (19) 를 제거합니다.  
※ 분리한 스캐너 밑커버 (19) 는 사용되지 않습니다.

10. ビス (16) 2 本を外す。ビス (17) 1 本を外す。  
トレイ後カバー (18) およびスキャナー底カバー (19) を取り外す。  
※ 取り外したスキャナー底カバー (19) は使用しない。





11. Insert the hook (20) on the underside of the drive unit (B) into the respective positioning hole (21) in the back plate, using the location of the notch on the front as a guide. Then secure the drive unit using the 2 M4 x 8 screws (black) (16) removed in step 10.

**NOTICE**

When installing the drive unit (B), take care not to rub it against the ribs on the top of the MFP tray.

Hold the connector (22) out of the way so that it does not become trapped.

12. Plug the connector (22) from the drive unit (B) into the MFP.

11. Insérer le crochet (20) sous l'unité d'entraînement (B) dans le trou de positionnement approprié (21) sur la plaque arrière, en prenant comme guide l'encoche à l'avant. Puis fixer l'unité d'entraînement avec les 2 vis M4 x 8 (noires) (16) retirées au point 10.

**REMARQUE**

À l'installation de l'unité d'entraînement (B), veiller à ne pas le frotter contre les nervures sur le haut du bac MFP.

Écarter le connecteur (22) de sorte qu'il ne soit pas coincé.

12. Bancher le connecteur (22) de l'unité d'entraînement (B) sur le MFP.

11. Inserte el gancho (20) del lado inferior de la unidad de accionamiento (B) en el orificio de posición respectivo (21) de la placa posterior, con la ubicación de la muesca en el frente como guía. Después, fije la unidad de accionamiento con los 2 tornillos M4 x 8 (negros) (16) quitados en el paso 11.

**AVISO**

Durante la instalación de la unidad de accionamiento (B), tenga cuidado de no rozar las nervaduras de la parte superior de la bandeja de la MFP. Mantenga el conector (22) alejado para no atraparlo.

12. Enchufe el conector (22) de la unidad de accionamiento (B) en la MFP.

11. Setzen Sie die Haken (20) auf der Unterseite der Antriebseinheit (B) in die entsprechenden Aufnahmen (21) der Rückwand. Benutzen Sie die Aussparungen auf der Vorderseite als Orientierung. Befestigen Sie die Antriebseinheit mit den 2 M4 x 8 Schrauben (schwarz) (16), die Sie in Schritt 10 gelöst haben.

**ANMERKUNG**

Beim Einsetzen der Antriebseinheit (B) achten Sie darauf, dass Sie diese nicht an den Nasen oben in der Ablage des MFP scheuern. Führen Sie den Stecker (22) so, dass dieser nicht eingeklemmt werden kann.

12. Stecken Sie den Stecker (22) in die Antriebseinheit (B) des MFP.

11. Inserire il gancio (20) sul lato inferiore dell'unità guida (B) nel rispettivo foro di posizionamento (21) sulla piastra posteriore, usando la posizione dell'intaglio sulla parte frontale come guida. Quindi fissare l'unità guida usando le 2 viti M4 x 8 (neri) (16) rimosse nel passo 10.

**AVVISO**

Quando si installa l'unità guida (B), fare attenzione a non sfregarla contro i rilievi sulla parte superiore del vassoio MFP.

Mantenere il connettore (22) all'esterno in modo che esso non rimanga intrappolato.

12. Inserire il connettore (22) dall'unità guida (B) nell'MFP.

11. 以前部の槽口位置を参考、将驱动单元 (B) 下部的卡扣 (20) 插入背板上各自的定位孔 (21)。然后使用步骤 10 中卸下的 2 颗螺丝 M4 x 8 (黑) (16) 固定驱动单元。

**注意**

安装驱动单元 (B) 时, 请小心勿触碰 MFP 托盘顶部的肋片。

避开接插件 (22) 以免其被卡住。

12. 将从驱动单元 (B) 引出的接插件 (22) 插入 MFP。

11. 전면의 노치 위치를 기준으로 활용하여 구동 유닛 (B) 아래쪽에 있는 후크 (20) 를 후면판의 해당 위치고정 구멍 (21) 에 삽입합니다 . 그런 다음 단계 10 에서 제거한 나사 M4 x 8 ( 흑 ) (16) 2 개로 구동 유닛을 고정합니다 .

**주의**

구동 유닛 (B) 를 설치할 때 이 장치가 MFP 트레이 상단의 리브 부위에 닿아서 스키지 않도록 주의하십시오 . 막히지 않도록 커넥터 (22) 를 잡습니다 .

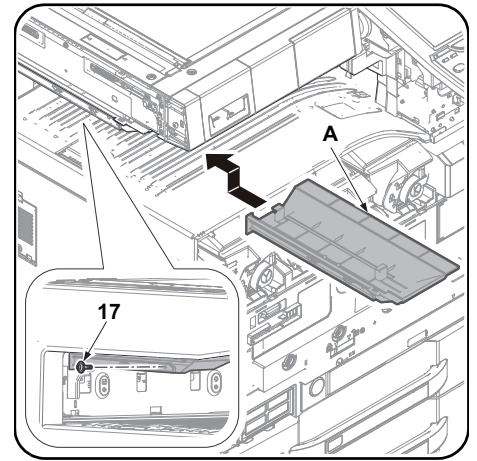
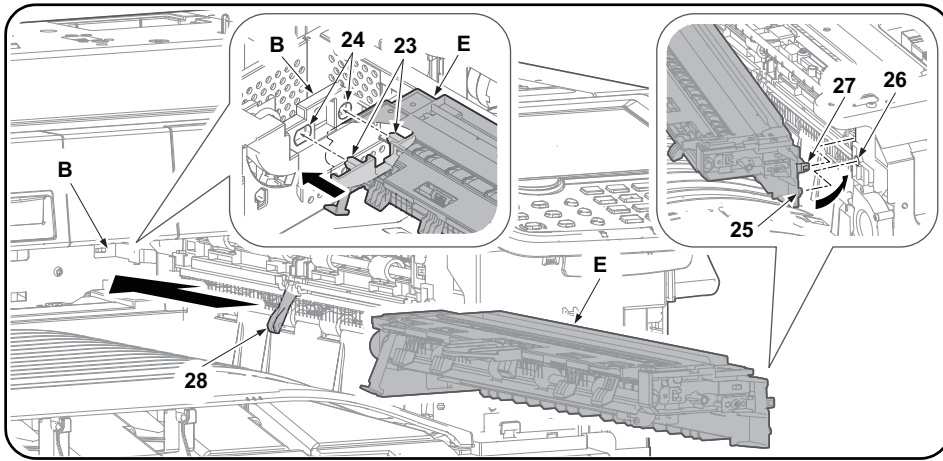
12. 구동 유닛 (B) 의 커넥터 (22) 를 MFP 에 연결합니다 .

11. 駆動ユニット (B) 下側のフック (20) を前側の切り欠き位置を目安に後側板の位置決め穴 (21) に入れ、手順 10 のビス M4x8(黒) (16) 2 本で固定する。

**注意**

駆動ユニット (B) を取り付ける時は、本体トレイ上のリブをこすらないように作業をすること。コネクタ (22) を挟まないように外に出しておくこと。

12. 駆動ユニット (B) からのコネクタ (22) を MFP 本体に接続する。



13. Insert the projection (23) on the back of the eject unit (E) into the hole (24) in the drive unit (B) and insert the projection on the front (25) into the hole (26) in the MFP frame to attach the eject unit (E).

Push the eject unit (E) to the right and fit the hook (27) in so that it clicks into place.

**NOTICE**

When installing the eject unit, take care not to dislodge the paper eject actuator (28).

After installing the unit, check the operation of the actuator.

14. Insert the 2 hooks on the scanner bottom cover (A) into the notches of the machine. Secure it with the screw (17) removed in step 10.

**NOTICE**

Take particular care to check that the hooks on the rear are securely engaged before tightening the screws.

13. Insérer la projection (23) à l'arrière de l'unité d'éjection (E) dans le trou (24) de l'unité d'entraînement (B) et insérer la projection à l'avant (25) dans le trou (26) du châssis de MFP pour attacher l'unité d'éjection (E). Pousser l'unité d'éjection (E) vers la droite et emboîter le crochet (27) jusqu'au déclic.

**REMARQUE**

À l'installation de l'unité d'éjection, veiller à ne pas déplacer l'actionneur d'éjection du papier (28). Après avoir installé l'unité, vérifier le bon fonctionnement de l'actuateur.

14. Introduisez les 2 crochets du capot inférieur du scanner (A) dans les encoches de la machine. Fixez-les avec la vis (17) retirée à l'étape 10.

**REMARQUE**

S'assurer tout particulièrement que les crochets à l'arrière sont bien engagés avant de serrer les vis.

13. Inserte el saliente (23) de la parte posterior de la unidad de salida (E) en el orificio (24) de la unidad de accionamiento (B) e inserte el saliente del frente (25) en el orificio (26) de la carcasa de la MFP para fijar la unidad de salida (E). Presione la unidad de salida (E) hacia la derecha y encaje el gancho (27) hasta que escuche un clic.

**AVISO**

Durante la instalación de la unidad de salida, tenga cuidado de no desplazar el actuador de expulsión de papel (28). Después de instalar la unidad, compruebe el funcionamiento del actuador.

14. Inserte los 2 enganches en la cubierta inferior del escáner (A) en las ranuras de la máquina. Fijelo con el tornillo (17) que quitó en el paso 10.

**AVISO**

Antes de apretar los tornillos, tenga especial cuidado de comprobar si los ganchos en la parte posterior están enganchados de forma segura.

13. Setzen Sie die Nase (23) an der Rückseite der Ausgabeeinheit (E) in das Loch (24) der Antriebseinheit (B). Dann setzen Sie die Nase (25) vorne in das Loch (26) des MFP-Rahmens, um die Ausgabeeinheit (E) anzubringen. Schieben Sie die Ausgabeeinheit (E) nach rechts und drücken Sie auf die Haken (27), damit diese einrasten.

**ANMERKUNG**

Achten Sie beim Einsetzen der Ausgabeeinheit darauf, dass der Papierausgabesensor (28) in der korrekten Position verbleibt. Nachdem die Ausgabeeinheit installiert ist, prüfen Sie die korrekte Arbeitsweise des Sensors.

14. Setzen Sie die beiden Nasen der unteren Scannerabdeckung (A) in die Aussparungen im Gerät. Befestigen Sie diese mit der Schraube (17) aus Schritt 10.

**ANMERKUNG**

Prüfen Sie sorgfältig, ob die Haken auf der Rückseite richtig eingerastet sind, bevor Sie die Schrauben festziehen.

13. Inserire la parte sporgente (23) sul retro dell'unità di espulsione (E) nel foro (24) dell'unità guida (B), e inserire la parte sporgente sul lato anteriore (25) nel foro (26) del telaio dell'MFP per fissare l'unità di espulsione (E). Spingere l'unità di espulsione (E) alla destra e inserire il gancio (27) in modo che esso scatti in posizione.

**AVVISO**

Quando si installa l'unità di espulsione, fare attenzione a non rimuovere l'attuatore (28) di espulsione carta. Dopo l'installazione dell'unità, controllare il funzionamento dell'attuatore.

14. Inserire i 2 ganci presenti sul coperchio inferiore dello scanner (A) negli incavi previsti sulla macchina. Fissare con la vite (17) rimossa al punto 10.

**AVVISO**

Fare particolare attenzione per controllare che i ganci sul retro siano agganciati in modo sicuro prima di stringere le viti.

13. 通过将出纸单元 (E) 背部的突出部分 (23) 插入驱动单元 (B) 中的孔 (24) 中, 并将前部的突出部分 (25) 插入 MFP 框架中的孔 (26) 中来安装出纸单元 (E)。向右按出纸单元 (E) 并扣好卡扣 (27) 以使其固定到位。

**注意**

安装出纸单元时, 请小心勿使出纸致动器 (28) 外露。安装好该单元后, 请检查致动器的操作。

14. 把扫描仪底部盖板 (A) 的 2 处挂钩插入到机器本体的缺口处。使用步骤 10 取下的 1 颗螺丝 (17) 来固定。

**注意**

拧紧该螺丝前, 请特别注意要检查后部的卡扣是否牢固衔接。

13. 배출 유닛 (E) 후면의 프로젝션 (23) 을 구동 유닛 (B) 의 구멍 (24) 에 삽입하고 전면의 프로젝션 (25) 을 MFP 프레임의 구멍 (26) 에 삽입하여 배출 유닛 (E) 를 부착합니다. 배출 유닛 (E) 를 오른쪽으로 밀고 제자리에 장착되도록 후크 (27) 를 맞춥니다.

**주의**

배출 유닛을 설치할 때 용지 배출 액추에이터 (28) 를 제거하지 않도록 주의하십시오. 유닛을 설치한 후 액추에이터의 작동을 확인하십시오.

14. 스캐너 밑커버 (A) 의 후크 2 개를 본체의 홈에 삽입합니다. 단계 10 에서 분리한 나사 (17) 로 고정합니다.

**주의**

나사를 조이기 전에 후면의 후크가 단단히 결합되어 있는지 각별히 주의하여 확인하십시오.

13. 排出ユニット (E) 後側の突起 (23) を駆動ユニット (B) の穴 (24) に入れ, 前側の突起 (25) を本体フレームの穴 (26) に入れて排出ユニット (E) を取り付ける。排出ユニット (E) を右側に押し, フック (27) がカチッと音がするまではめ込むこと。

**注意**

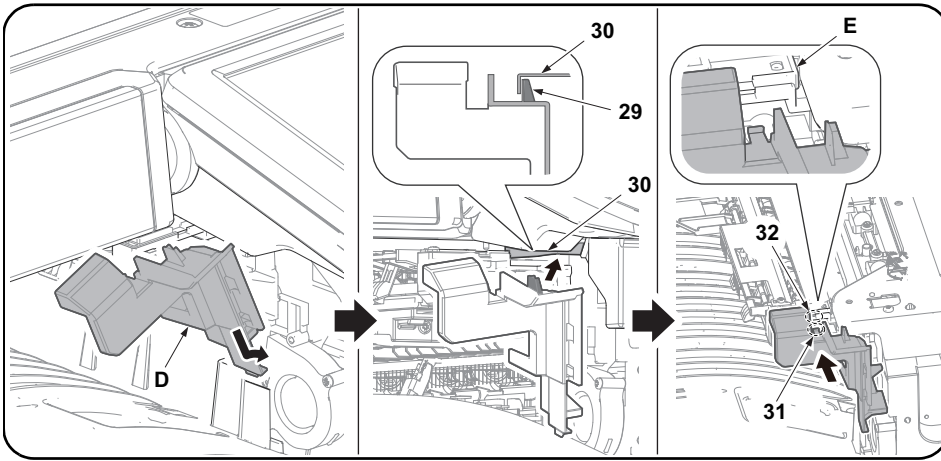
排出ユニットを取り付ける時は, 排出のアクチュエーター (28) を外さないように作業をする。取付後, アクチュエーターの動作確認を行うこと。

14. スキャナー底カバー (A) のフック 2 カ所を機械本体の切り欠きに挿入する。手順 10 で外したビス (17) 1 本で固定する。

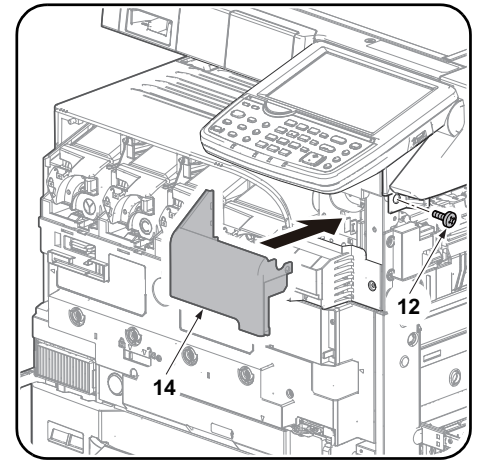
**注意**

特に後側のフックが確実に掛かっている事を確認した後, ビス固定をすること。





15. Insert the lower portion of the eject unit cover (D) into the right side of the MFP.  
 16. Insert the ribs (29) at the top into the right side of the MFP main unit frame (30).  
 17. Install the eject unit cover (D) by inserting its hook (31) into the hole (32) on the eject unit (E).



18. Install the front right cover (14) using the screw (12) removed in step 8.

15. Insérer la portion inférieure du capot de l'unité d'éjection (D) dans le côté droit de l'imprimante.  
 16. Insérer les nervures (29) au-dessus dans le côté droit du châssis de l'unité principale de l'imprimante (30).  
 17. Installer le capot de l'unité d'éjection (D) en insérant son crochet (31) dans le trou (32) sur l'unité d'éjection (E).

18. Installer le capot avant droit (14) à l'aide de la vis (12) déposée à l'étape 8.

15. Inserte la parte inferior de la cubierta de la unidad de expulsión (D) en el lado derecho del MFP.  
 16. Inserte las nervaduras (29) en la parte superior del lado derecho de la estructura (30) de la unidad principal del MFP.  
 17. Instale la cubierta (D) de la unidad de expulsión introduciendo su gancho (31) en el orificio (32) de la unidad de expulsión (E).

18. Instale la cubierta frontal derecha (14) usando el tornillo (12) quitado en el paso 8.

15. Setzen Sie den unteren Teil der Abdeckung der Ausgabereinheit (D) auf der rechten Seite des MFP ein.  
 16. Setzen Sie die Lamellen (29) oben in den Rahmen (30) des MFP auf der rechten Seite ein.  
 17. Installieren Sie die Abdeckung der Ausgabereinheit (D), indem Sie die Haken (31) in die Löcher (32) der Ausgabereinheit (E) einsetzen.

18. Bringen Sie die vordere rechte Abdeckung (14) wieder an. Benutzen Sie die Schraube (12) aus Schritt 8.

15. Inserire la parte inferiore del coperchio dell'unità di espulsione (D) sul lato destro dell'MFP.  
 16. Inserire le nervature (29) presenti sulla parte superiore, nel lato destro del telaio dell'unità principale dell'MFP (30).  
 17. Installare il coperchio dell'unità di espulsione (D) inserendo i relativi ganci (31) nel foro (32) sull'unità di espulsione (E).

18. Installare il coperchio anteriore destro (14) utilizzando la vite (12) rimossa nel punto 8.

15. 把出纸单元盖板 (D) 的下侧插入机器右侧。  
 16. 把上侧的肋片 (29) 插入机器框架 (30) 的右侧。  
 17. 把出纸单元盖板 (D) 的挂钩 (31) 装到出纸单元 (E) 的洞 (32) 中。

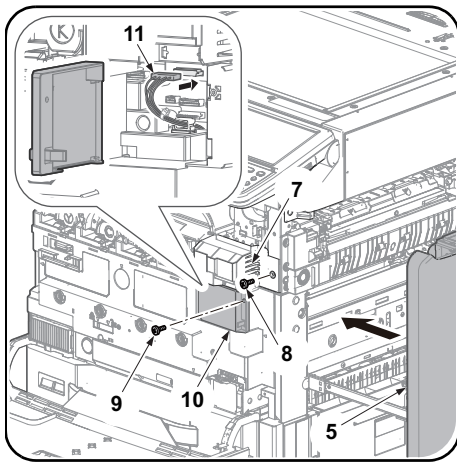
18. 使用在步骤 8 中卸下的 1 颗螺丝 (12) 来固定右前盖板 (14)。

15. 배출 유닛 커버 (D) 의 하단 부분을 MFP 의 우측에 삽입합니다 .  
 16. 상단의 리브 (29) 를 MFP 본체 프레임 (30) 의 우측에 장착합니다 .  
 17. 배출 유닛 (E) 의 구멍 (32) 에 후크 (31) 를 삽입하여 배출 유닛 커버 (D) 를 설치합니다 .

18. 단계 8 에서 제거한 나사 (12) 1 개로 오른쪽 전면커버 (14) 를 부착합니다 .

15. 排出ユニットカバー (D) の下側をMFP本体右側に差し込む。  
 16. 上側のリブ (29) をMFP本体フレーム (30) の右側に差し込む。  
 17. 排出ユニットカバー (D) のフック (31) を排出ユニット (E) の穴 (32) に入れて取り付ける。

18. 手順 8 で取り外したビス (12) 1 本で右前カバー (14) を取り付ける。



#### Full-color machines only

19. Plug in the connector (11) which was unplugged in step 7. Secure the inner cover (10) with the screw (9).
20. Secure the fan cover (7) using the screw (8) removed in step 6.  
Close the paper conveyor cover (5).

#### Machines entièrement en couleurs uniquement

19. Branchez le connecteur (11) qui a été débranché à l'étape 7. Fixez le capot interne (10) avec la vis (9).
20. Fixer le capot du ventilateur (7) à l'aide de la vis (8) déposée à l'étape 6.  
Réfermer le capot du transporteur du papier (5).

#### Maquinas a todo color solamente

19. Enchufe el conector (11) que desconectó en el paso 7. Fije la cubierta interna (10) con el tornillo (9).
20. Asegure la cubierta del ventilador (7) usando el tornillo (8) quitado en el paso 6.  
Cierre la unidad de transporte de papel (5).

#### nur Farbgeräte

19. Stecken Sie den Stecker (11) wieder ein, der in Schritt 7 gelöst wurde. Befestigen Sie die innere Abdeckung (10) mit der Schraube (9).
20. Bringen Sie die Lüfterabdeckung (7) wieder an. Benutzen Sie die Schraube (8) aus Schritt 6. Schließen Sie die Abdeckung des Papiertransports (5).

#### Solo dispositivi a colori

19. Collegare il connettore (11) scollegato al punto 7. Fissare il coperchio interno (10) con la vite (9).
20. Fissare il coperchio ventola (7) utilizzando la vite (8) rimossa nel punto 6.  
Chiudere il coperchio di trasporto carta (5).

#### 仅限彩色机器

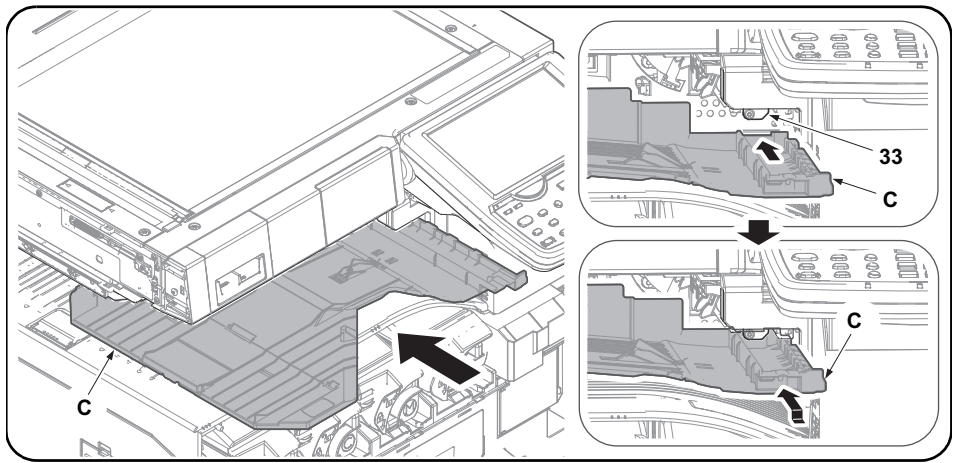
19. 连接步骤 7 取下的接插件 (11)。使用 1 颗螺丝 (9) 来固定内侧盖板 (10)。
20. 使用在步骤 6 中卸下的 1 颗螺丝 (8) 来固定风扇盖板 (7)。  
关闭输纸盖板 (5)

#### 컬러기 만

19. 단계 7 에서 분리한 커넥터 (11) 를 연결합니다 . 나사 (9) 로 내부 커버 (10) 를 고정합니다 .
20. 순서 6 에서 제거한 나사 (8) 1 개로 팬커버 (7) 를 고정합니다 .  
반송커버 (5) 를 닫습니다 .

#### カラー機 のみ

19. 手順 7 で外したコネクタ (11) を接続する。ビス (9) 1 本でインナーカバー (10) を固定する。
20. 手順 6 で外したビス (8) 1 本でファンカバー (7) を固定する。  
搬送カバー (5) を閉める。



21. Insert the right side portion of the inner tray (C) in the main unit.
22. While lowering the wall at the far end of the inner tray (C) so that it does not hit the rail (33), insert the inner tray (C) in the main unit.
23. Raise and hold the wall at the far end of the inner tray (C) above the front side of the rail (33), slide the inner tray (C) all the way in.

21. Insérer la portion de droite du bac intérieur (C) dans l'unité principale.
22. Abaisser la cloison de l'extrémité la plus éloignée du bac intérieur (C) afin qu'elle ne heurte pas le rail (33) et insérer le bac intérieur (C) dans l'unité principale.
23. Soulever et maintenir la cloison de l'extrémité la plus éloignée du bac intérieur (C) au-dessus de l'avant du rail (33) et faire coulisser le bac intérieur (C) jusqu'au fond.

21. Inserte el lado derecho de la bandeja interna (C) en la unidad principal.
22. Mientras baja la pared en el extremo más lejano de la bandeja interna (C) para que no golpee el rail (33), inserte la bandeja interna (C) en la unidad principal.
23. Levante y sujete la pared en el extremo más lejano de la bandeja interna (C) sobre la parte frontal del rail (33), deslice la bandeja interna (C) hasta introducirla hasta el fondo.

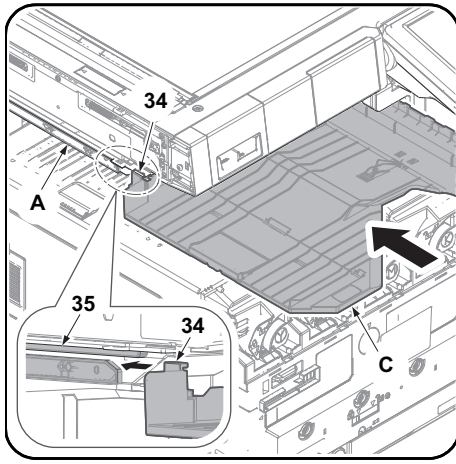
21. Setzen Sie den rechten Teil der inneren Ablage (C) in das Gerät ein.
22. Senken Sie die Rückwand am hinteren Ende der inneren Ablage (C) ein wenig ab, so dass diese nicht die Schiene (33) berührt. Gleichzeitig setzen Sie die innere Ablage (C) in das Gerät ein.
23. Senken Sie die Rückwand am hinteren Ende der inneren Ablage (C) ein wenig ab, halten diese gleichzeitig über der Vorderseite der Schiene (33) und setzen die innere Ablage (C) in das Gerät ein.

21. Inserire la parte lato destro del vassoio interno (C) nell'unità principale.
22. Tenendo abbassata la parete sull'estremità distante del vassoio interno (C), in modo da non colpire la guida (33), inserire il vassoio interno (C) nell'unità principale.
23. Sollevare e reggere la parete sull'estremità distante del vassoio interno (C) sopra il lato frontale della guida (33), quindi inserire a fondo il vassoio interno (C).

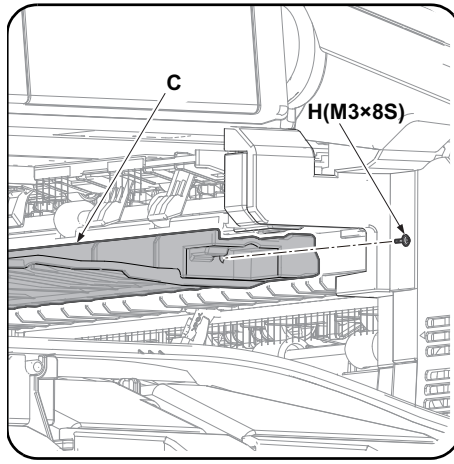
21. 把内部接纸盘 (C) 的右侧插入机器内。
22. 插入机器时, 请不要让内部接纸盘 (C) 的里侧壁碰到导轨 (33)。
23. 在超过导轨 (33) 前的位置, 抬起内部接纸盘 (C) 的里侧壁后, 把内部接纸盘向里侧滑动。

21. 내부 트레이 (C) 의 우측 부분을 본체에 삽입합니다 .
22. 레일 (33) 에 부딪히지 않도록 내부 트레이 (C) 의 안쪽의 칸막이 부분을 낮추면서 본체에 내부 트레이 (C) 를 삽입합니다 .
23. 내부 트레이 (C) 의 안쪽의 칸막이 부분을 레일 (33) 의 전면 위로 올려서 유지하고 내부 트레이 (C) 를 안으로 최대한 밀습니다 .

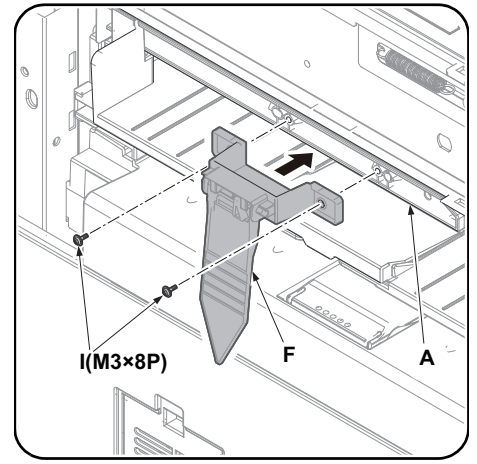
21. 内部トレイ (C) の右側を本体に挿入する。
22. 内部トレイ (C) の奥側の壁がレール (33) に当たらないように下げて挿入する。
23. 内部トレイ (C) の奥側の壁がレール (33) 前面を越えた位置で上に上げ、その後内部トレイ (C) を奥にスライドさせる。



**24.** Raise the rear left corner of the inner tray (C) and insert the hook (34) into the rail (35) on the scanner bottom cover (A).



**25.** Firmly slide the inner tray (C) all the way in.  
**26.** Attach the inner tray (C) using the S Tite screw M3 x 8 (H).



**27.** Install the stopper paper (F) onto the scanner bottom cover (A) with the two P Tite screw M3 x 8 (I).

**24.** Soulever le coin arrière gauche du bac intérieur (C) et insérer le crochet (34) dans le rail (35) sur le capot inférieur du scanner (A).

**25.** Faire coulisser fermement le bac intérieur (C) jusqu'au fond.  
**26.** Attacher le bac intérieur (C) à l'aide de la vis S Tite M3 x 8 (H).

**27.** Installer la butée de papier (F) sur le capot inférieur du scanner (A) avec les deux vis P Tite M3 x 8 (I).

**24.** Levante la cubierta izquierda posterior de la bandeja interna (C) e inserte el enganche (34) en el raíl (35) en la cubierta inferior (A) del escáner.

**25.** Deslice firmemente la bandeja interna (C) hasta introducirla hasta el fondo.  
**26.** Fije la bandeja interna (C) con el tornillo S Tite M3 x 8 (H).

**27.** Instale el tope de papel (F) en la cubierta inferior del escáner (A) con los dos tornillos P Tite M3 x 8 (I).

**24.** Heben Sie die hintere linke Ecke der inneren Ablage (C) an und setzen Sie den Haken (34) in die Schiene (35) an der unteren Abdeckung des Scanners (A) ein.

**25.** Setzen Sie die innere Ablage (C) vorsichtig komplett ein.  
**26.** Bringen Sie die innere Ablage (C) mit der S-Tite-Schraube M3 x 8 (H) an.

**27.** Installieren Sie den Papieranschlag (F) an der unteren Abdeckung des Scanners (A) mit 2 P-Tite-Schrauben M3 x 8 (I).

**24.** Sollevare l'angolo sinistro posteriore del vassoio interno (C) e inserire il gancio (34) nella guida (35) sul coperchio inferiore dello scanner (A).

**25.** Inserire saldamente il vassoio interno (C) fino a fine corsa.  
**26.** Fissare il vassoio interno (C) utilizzando la vite S Tite M3 x 8 (H).

**27.** Installare il fermo carta (F) sul coperchio inferiore dello scanner (A) con le due viti P Tite M3 x 8 (I).

**24.** 抬起内部接纸盘 (C) 的左后侧, 把挂钩 (34) 插入扫描仪底部盖板 (A) 的导轨 (35) 上。

**25.** 把内部接纸盘 (C) 完全插到底。  
**26.** 使用 1 颗紧固型 S 螺丝 M3x8 (H) 来固定内部接纸盘 (C)。

**27.** 使用 2 颗紧固型 P 螺丝 M3x8 (I), 把纸张挡板 (F) 固定到扫描仪底部盖板 (A) 上。

**24.** 내부 트레이 (C) 의 왼쪽 후면 모서리를 위로 올리고 후크 (34) 를 스캐너 하단 커버 (A) 의 레일 (35) 에 삽입합니다 .5

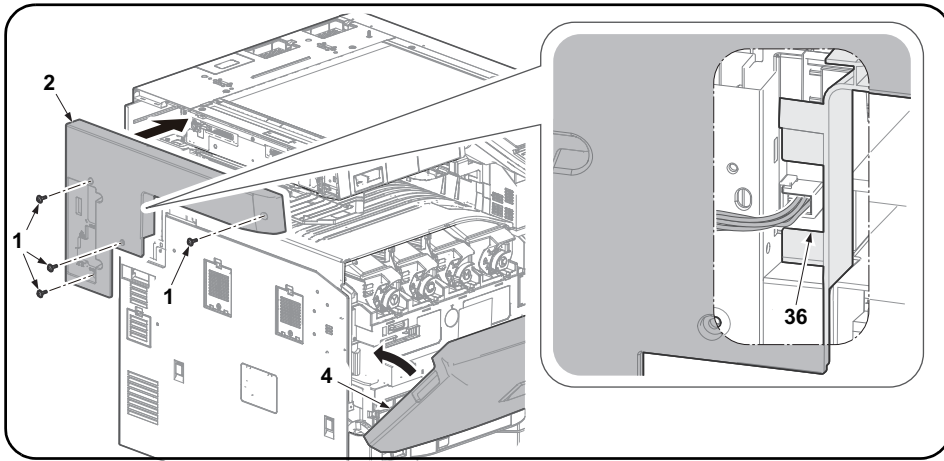
**25.** 내부 트레이 (C) 를 안쪽으로 힘껏 밀니다 .  
**26.** 나사 M3x8S 타이트 (H) 를 사용하여 내부 트레이 (C) 를 부착합니다 .

**27.** 나사 M3x8P 타이트 (I) 두 개를 사용하여 스캐너 하단 커버 (A) 에 스톱퍼 용지 (F) 를 장착합니다 .

**24.** 内部トレイ (C) の左後側を持ち上げ、フック (34) をスキャナー底カバー (A) のレール (35) に挿入する。

**25.** 内部トレイ (C) を奥までしっかり挿入する。  
**26.** 内部トレイ (C) をビス M3x8S タイト (H) 1 本で固定する。

**27.** ペーパーstopper (F) をスキャナー底カバー (A) にビス M3x8P タイト (I) 2 本で固定する。



28. Close the front cover (4).

29. Install the left upper cover (2) using the 4 screws (1) removed in step 1.

\*Take care to pass the cable through the breakaway part (36) of the left upper cover (2).

**NOTICE**

The left upper cover (2) will not fit in, if the breakaway cover (3) was not removed in step 2.

28. Refermer le capot avant (4).

29. Installez le capot supérieur gauche (2) à l'aide des 4 vis (1) retirées à l'étape 1.

\*Veillez à passer le câble à travers la partie détachable (36) du capot supérieur gauche (2).

**REMARQUE**

Le capot supérieur gauche (2) ne rentre pas si le capot détachable (3) n'a pas été retiré à l'étape 2.

28. Cierre la cubierta frontal (4).

29. Instale la cubierta superior izquierda (2) con los 4 tornillos (1) que quitó en el paso 1.

\*Tenga cuidado de pasar el cable a través de la pieza de separación (36) de la cubierta superior izquierda (2).

**AVISO**

La cubierta superior izquierda (2) no entrará si no se ha quitado la cubierta de separación (3) en el paso 2.

28. Schließen Sie die vordere Abdeckung (4).

29. Bringen Sie die linke obere Abdeckung (2) wieder an. Benutzen Sie die 4 Schrauben (1) aus Schritt 1.

\*Stellen Sie sicher, dass das Kabel durch die Öffnung der Sollbruchstelle (36) der linken oberen Abdeckung (2) geführt wird.

**ANMERKUNG**

Die linke obere Abdeckung (2) wird nicht passen, wenn die Abdeckung der Sollbruchstelle (3) in Schritt 2 nicht entfernt wurde.

28. Chiudere il pannello anteriore (4).

29. Installare il coperchio superiore sinistro (2) utilizzando le 4 viti (1) rimosse al punto 1.

\*Prestare attenzione a far passare il cavo attraverso la parte ad aggancio rapido (36) del coperchio superiore sinistro (2).

**AVVISO**

Se non è stato rimosso il coperchio ad aggancio rapido (3) al punto 2, non sarà possibile montare il coperchio superiore sinistro (2).

28. 关闭前盖板 (4)。

29. 使用步骤 1 中卸下的 4 颗螺丝 (1) 安装左上盖板 (2)。

※ 使电线穿过左上盖板 (2) 的组合部 (36)。

**注意**

如忘记取下步骤 2 的组合盖板 (3)，将不能安装左上盖板 (2)。

28. 전면 커버 (4) 를 닫습니다 .

29. 단계 1 에서 제거한 나사 (1) 4 개를 사용하여 좌측 상 커버 (2) 를 부착합니다 .

※ 케이블이 좌측 상 커버 (2) 의 분리된 부분 (36) 을 통과하도록 합니다 .

**주의**

단계 2 에서 분리 커버 (3) 를 제거하지 않은 경우 좌측 상 커버 (2) 를 달 수 없습니다 .

28. 前カバー (4) 閉める。

29. 手順 1 で外したビス (1) 4 本で左上カバー (2) を取り付ける。

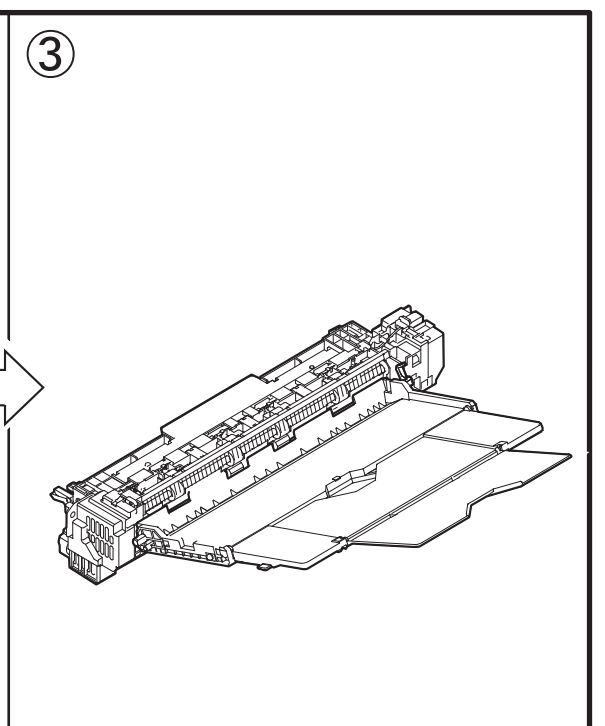
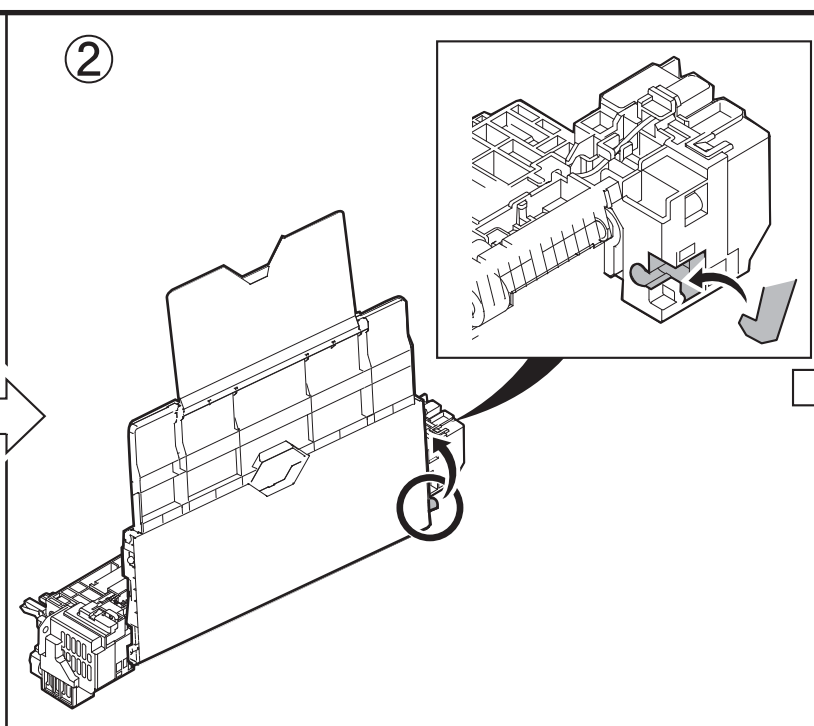
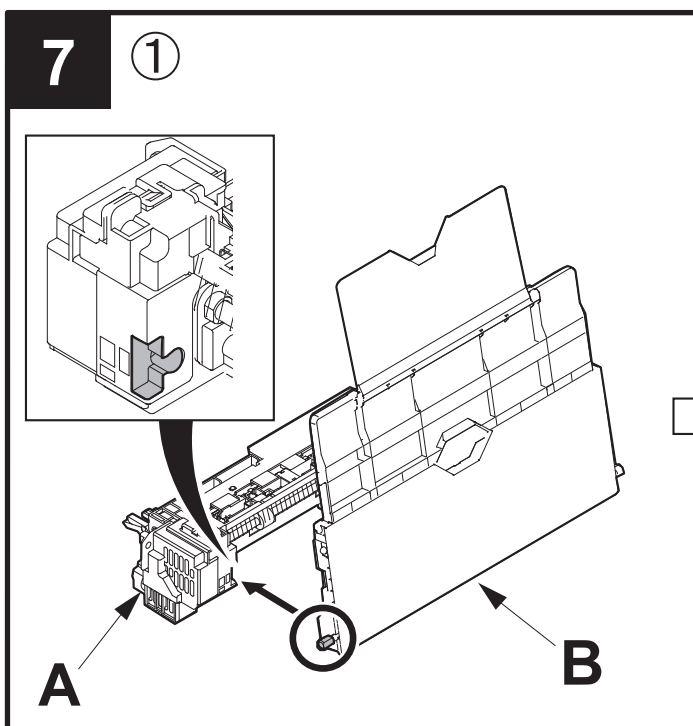
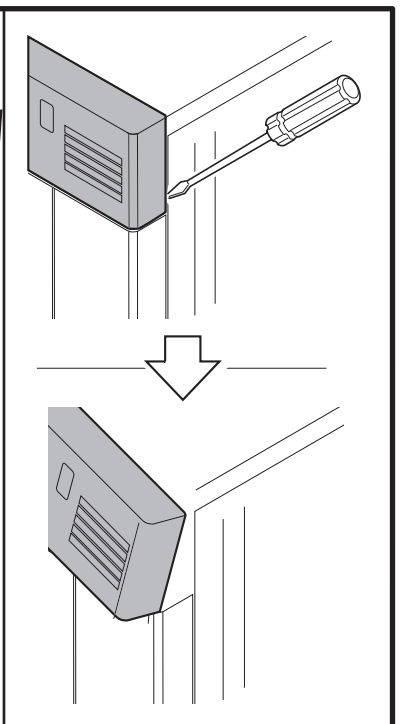
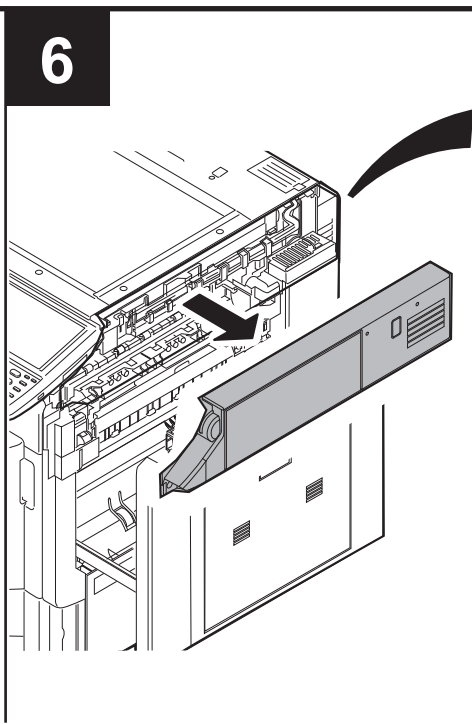
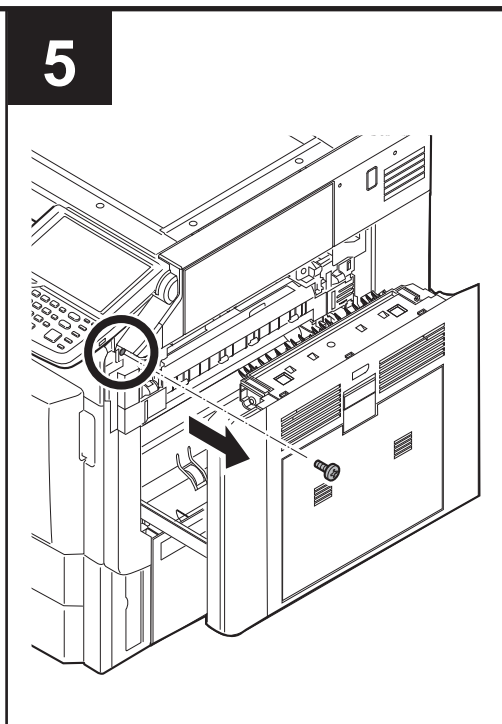
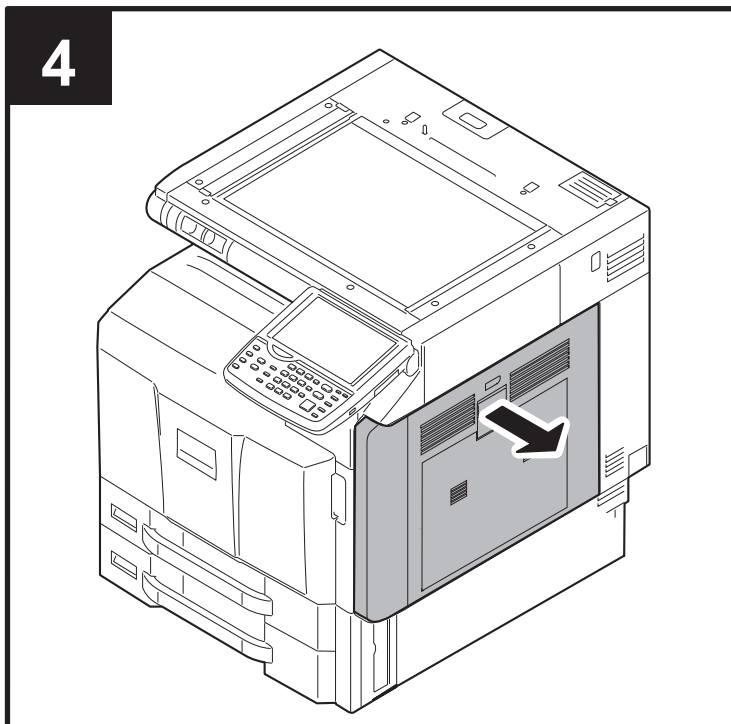
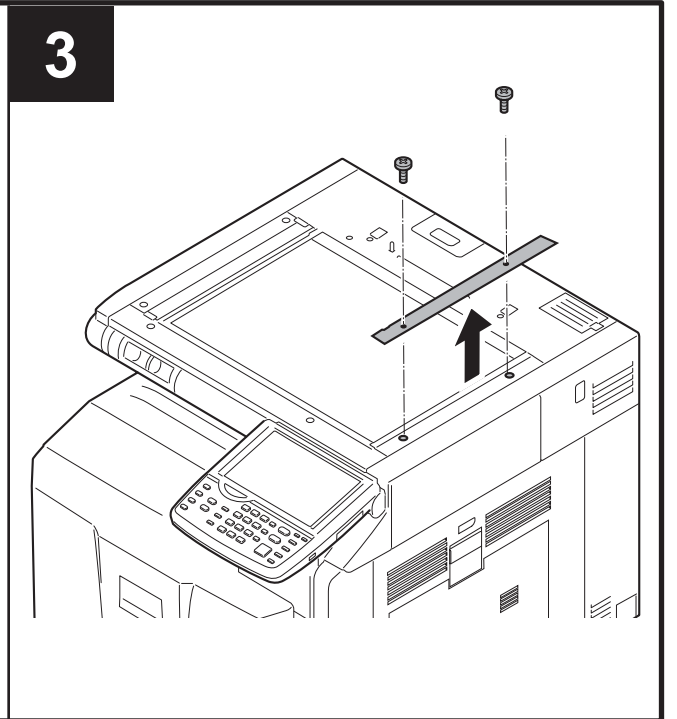
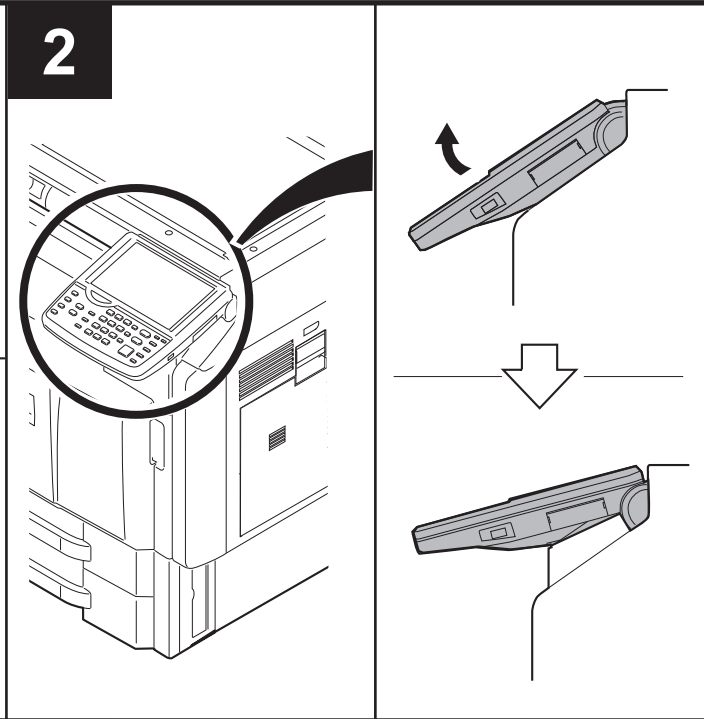
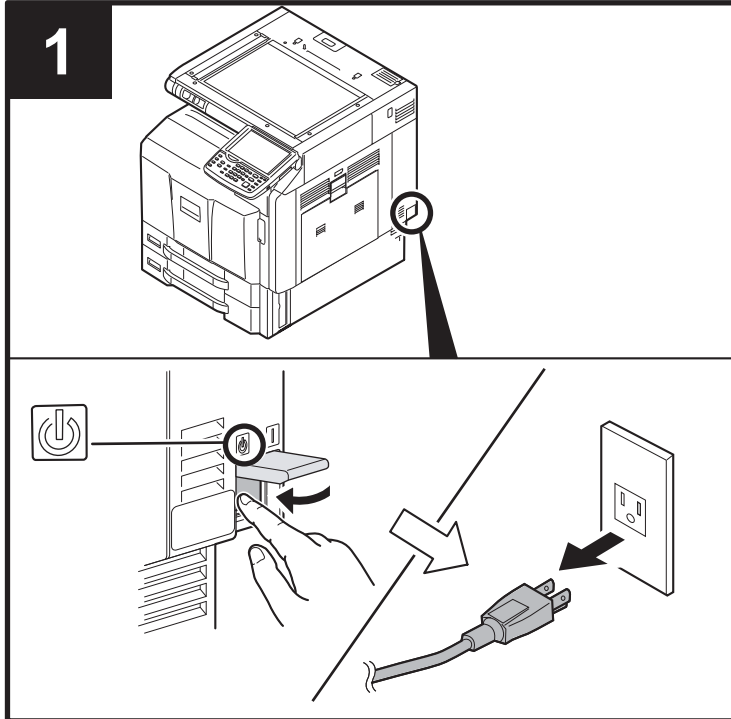
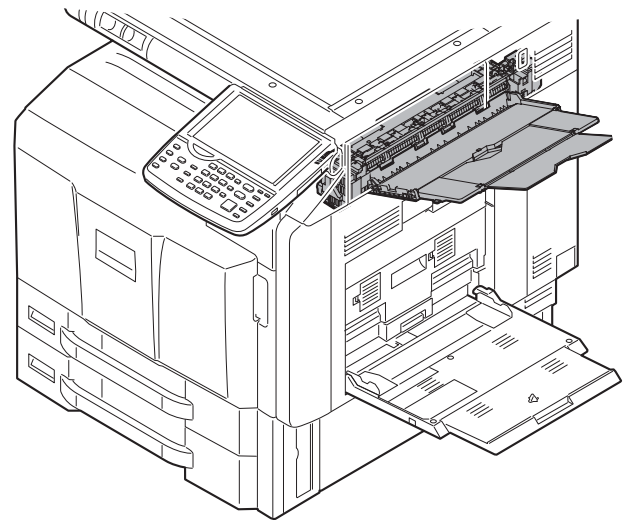
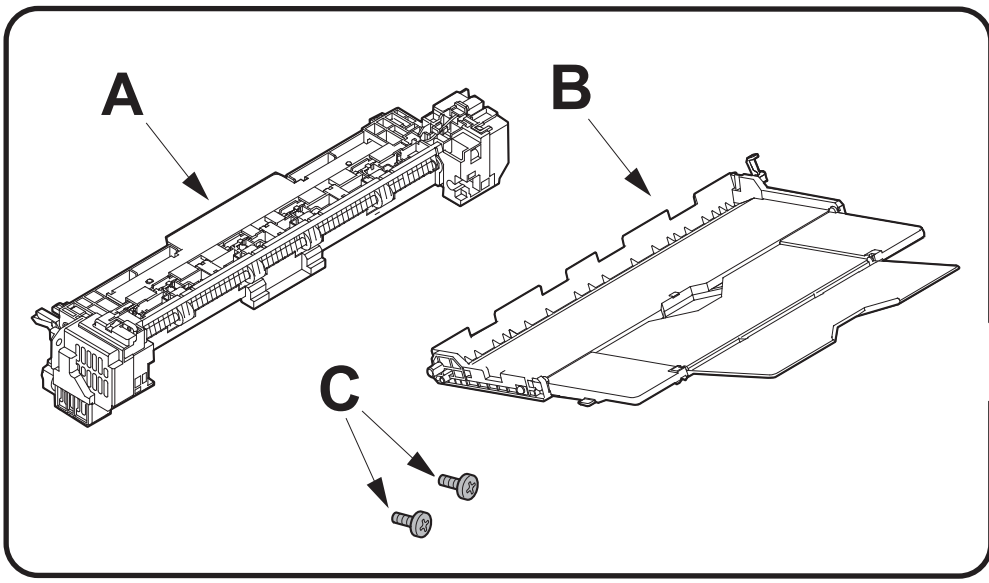
※ 左上カバー (2) の割り部 (36) に電線が通っていること。

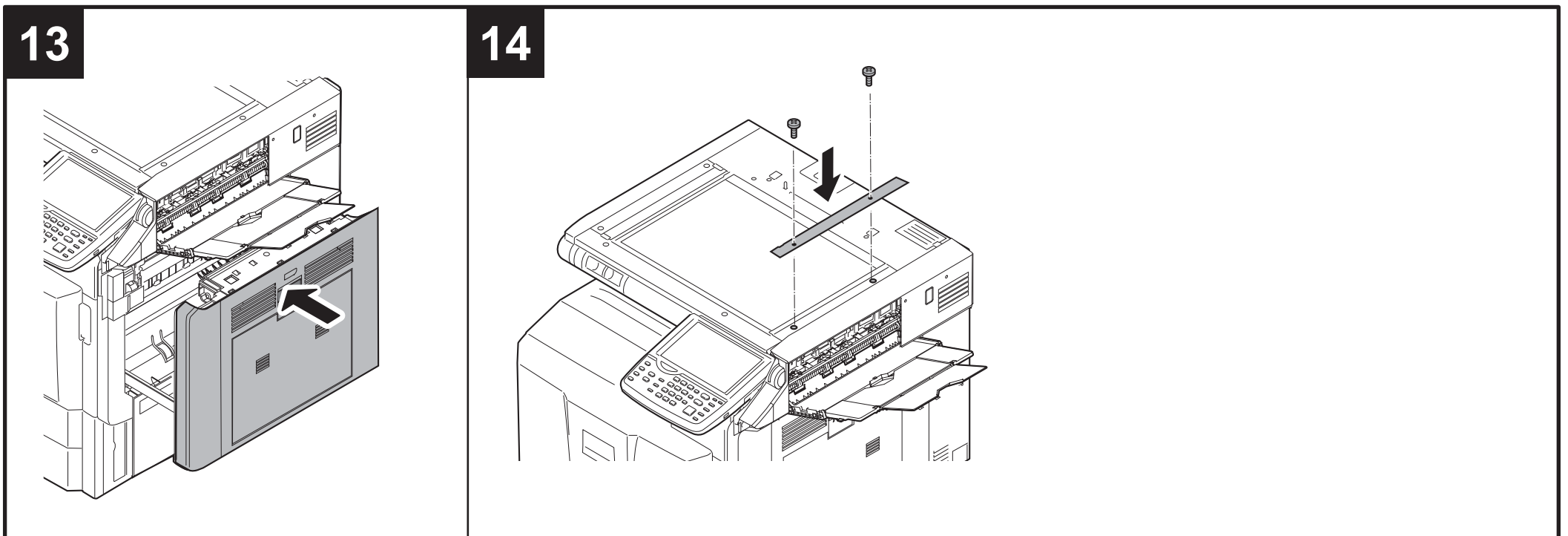
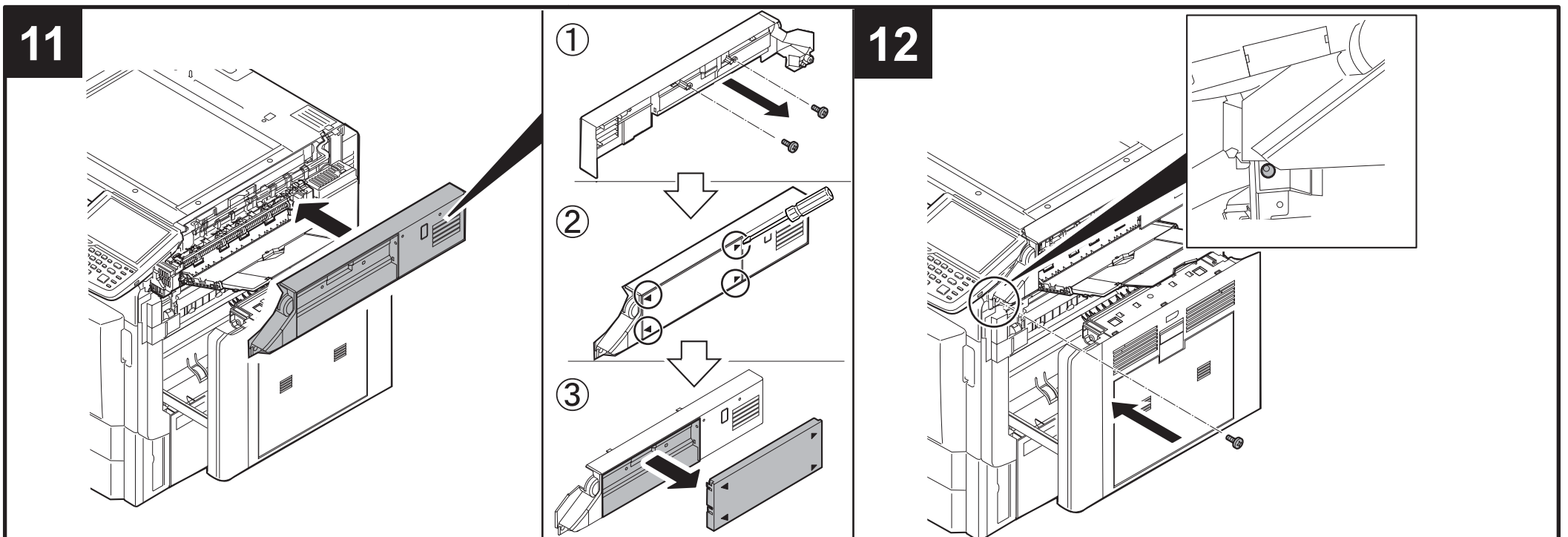
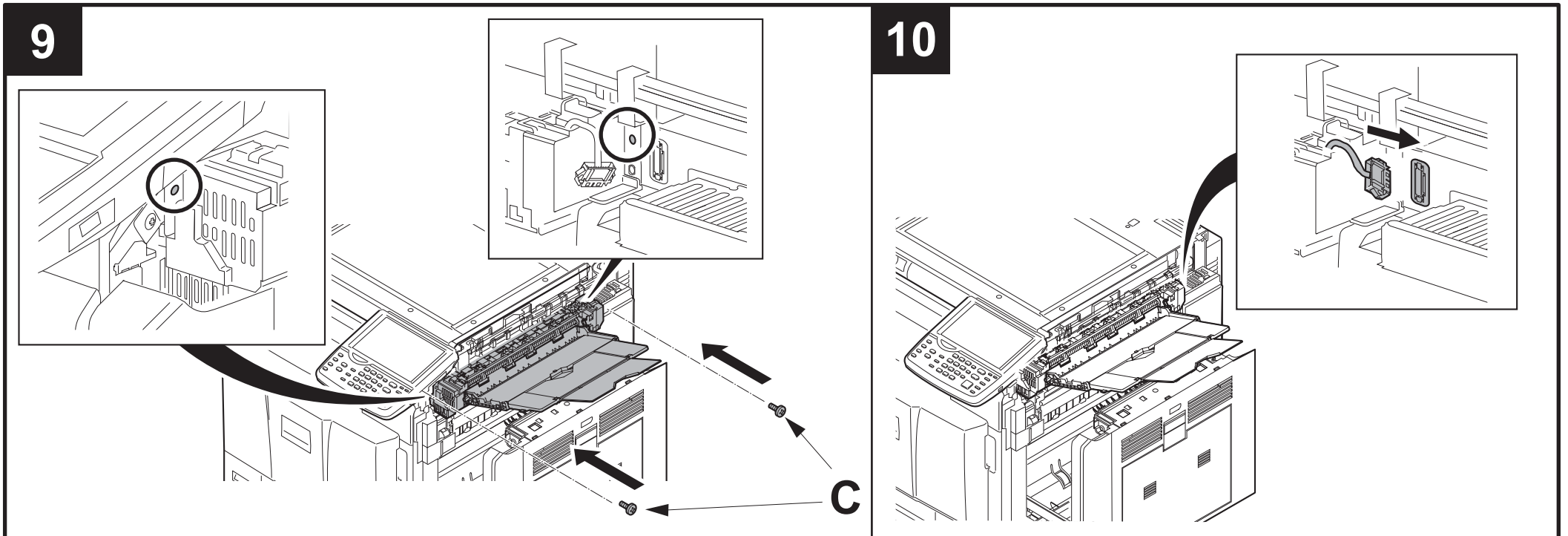
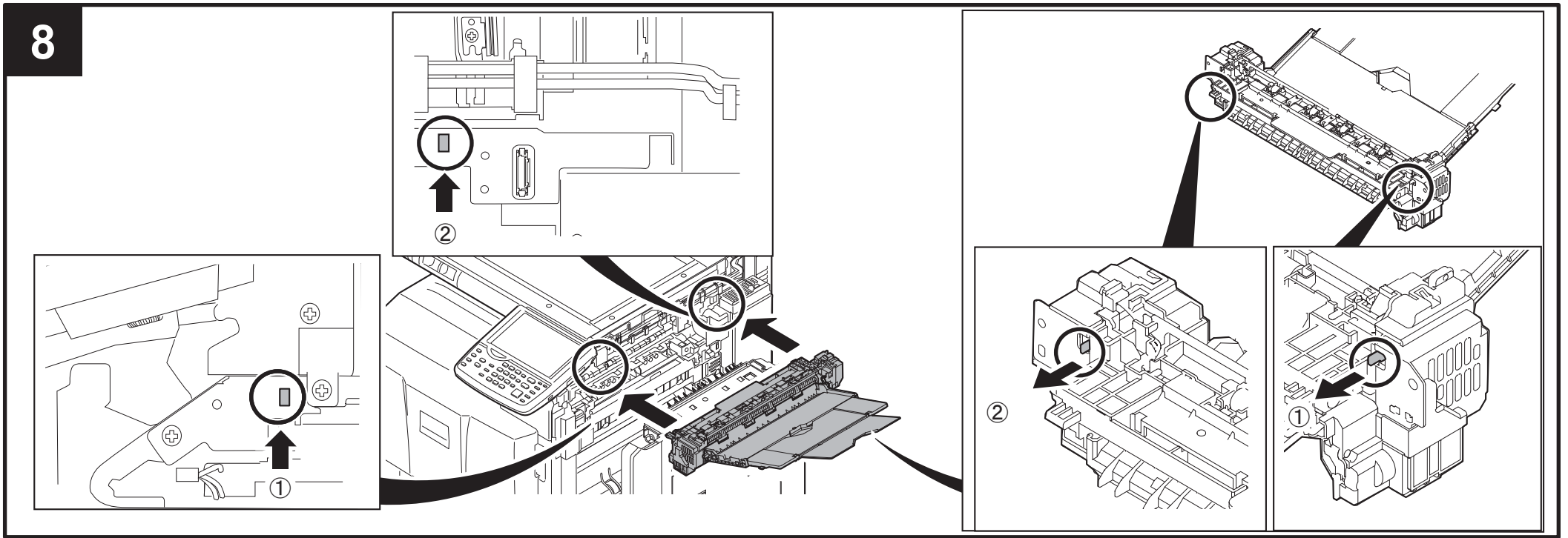
**注意**

手順 2 の割りカバー (3) の切り取りを忘れた場合は、左上カバー (2) を取り付ける事ができません。

# **INSTALLATION GUIDE FOR RIGHT JOB SEPARATOR**







# **INSTALLATION GUIDE FOR BANNER GUIDE**



# INSTALLATION GUIDE

## GUIDE D'INSTALLATION

## GUÍA DE INSTALACION

## INSTALLATIONSANLEITUNG

## GUIDA ALL'INSTALLAZIONE

## 安装手册

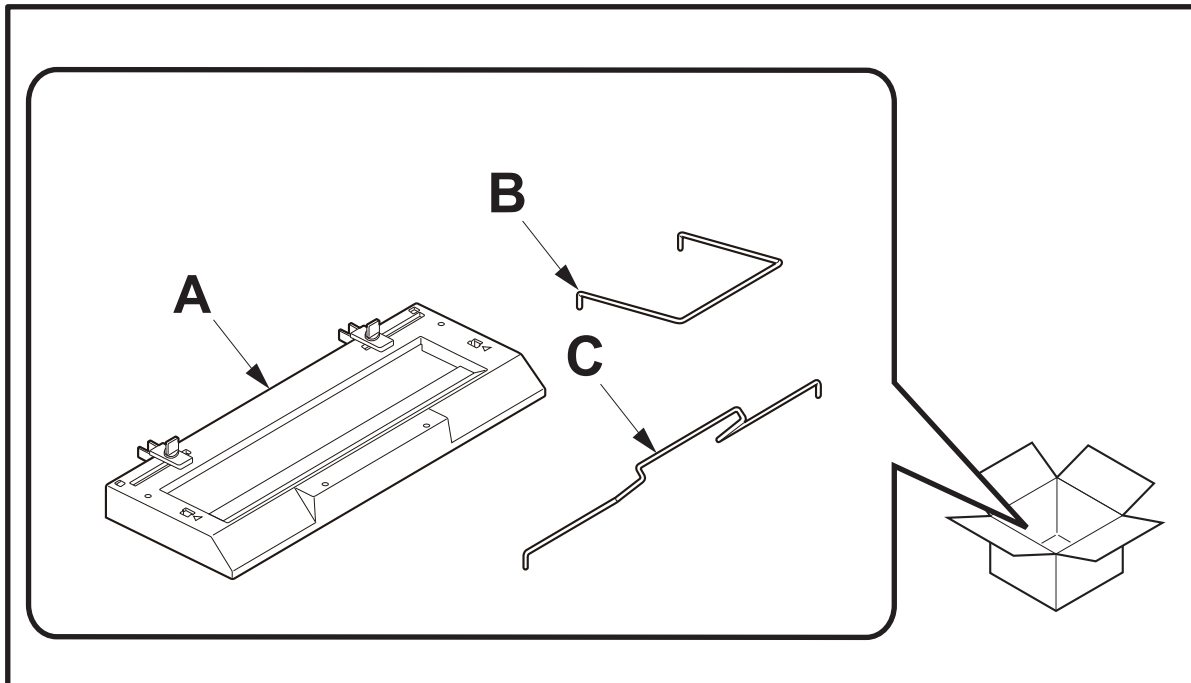
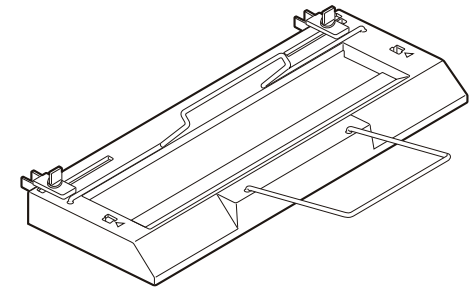
## 설치안내서

## 設置手順書

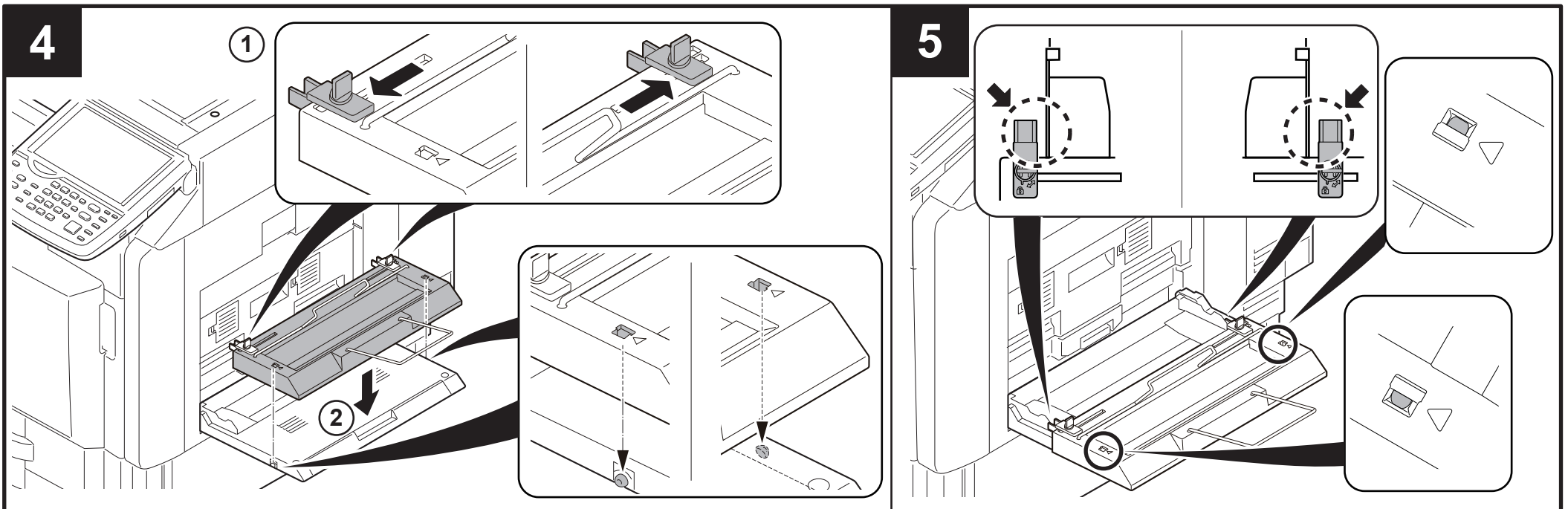
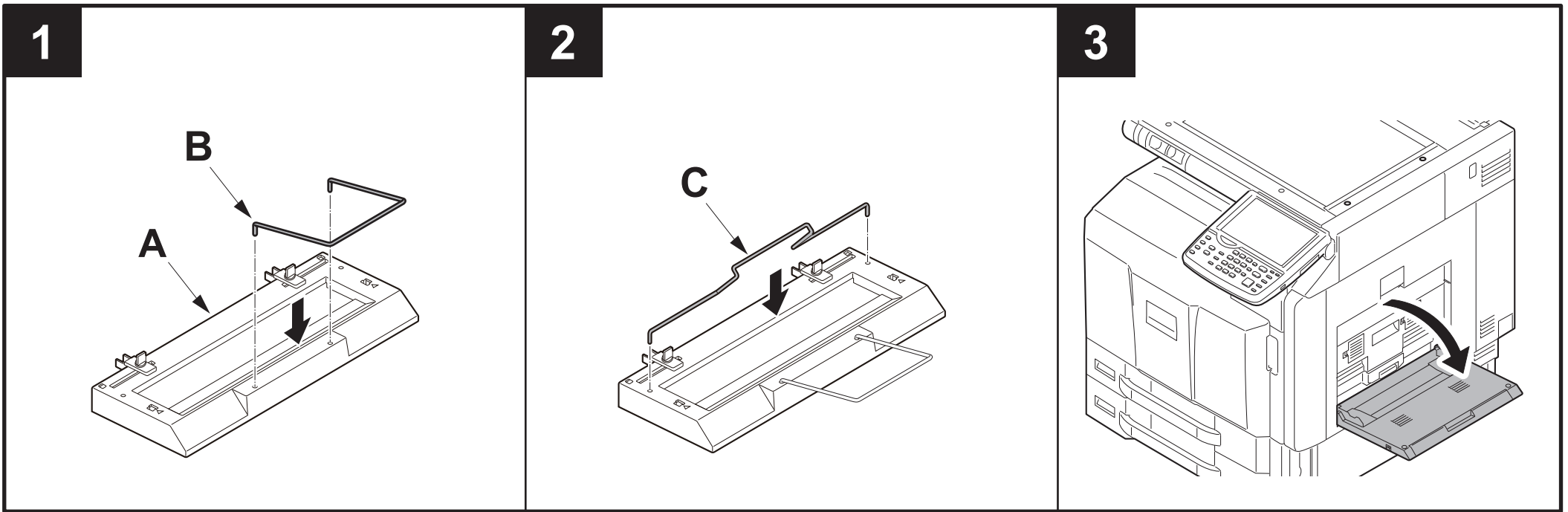


302K95672001

# Banner Guide(A)



- (ENG) Precautions**  
The illustrations of the machine in the Installation Guide are for color MFP. (30,35,45,55ppm)
- (FR) Précautions**  
L'appareil représenté dans les illustrations du présent guide d'installation est le MFP couleur. (30,35,45,55ppm)
- (ES) Precauciones**  
Las ilustraciones de la máquina que aparecen en la Guía de instalación corresponden a una MFP en color. (30,35,45,55ppm)
- (DE) Vorsichtsmaßnahmen**  
Die Abbildungen der Maschine in der Installationsanleitung gelten für den Farb-MFP. (30,35,45,55ppm)
- (IT) Precauzioni**  
Le illustrazioni della macchina nella guida di installazione sono per colore MFP. (30,35,45,55ppm)
- (CN) 注意事项**  
安装手册中记载的机器主机的插图是彩色机。(30, 35, 45, 55 页机型)
- (KO) 주의사항**  
설치순서에 기재되어 있는 기기본체 일러스트는 컬러기 입니다. (30,35,45,55매기)
- (JP) 注意事項**  
設置手順書に記載している機械本体のイラストはカラー機 (30, 35, 45, 55枚機) です。



# **INSTALLATION GUIDE FOR FAX System**

---

**INSTALLATION GUIDE**

**GUIDE D'INSTALLATION**

**GUÍA DE INSTALACION**

**INSTALLATIONSANLEITUNG**

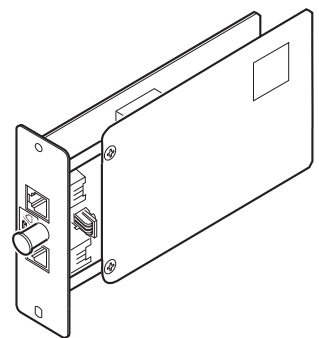
**GUIDA ALL'INSTALLAZIONE**

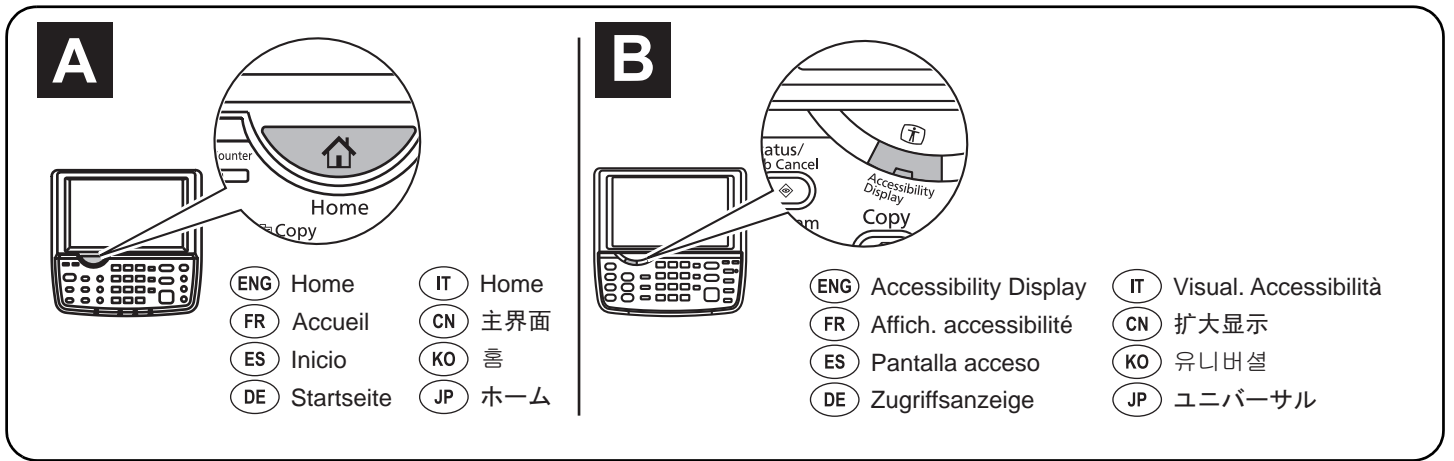
**安装手册**

**설치안내서**

**設置手順書**

# **FAX System(W)**





### English

A different procedure is required depending on the product which is installed with this unit. Each procedure is described in the following pages.

When installing the Fax system on a machine (A) which has the 'Home' key in the operation panel, see Page 1 to Page 13.

When installing the multiport on a machine (A) which has the 'Home' key in the operation panel, see Page 14 to Page 21.

When installing the Fax system on a machine (B) which has the 'Accessibility Display' key in the operation panel, see Page 22 to Page 34.

When installing the multiport on a machine (B) which has the 'Accessibility Display' key in the operation panel, see Page 35 to Page 41.

### Français

Une procédure différente est requise selon le produit qui est installé avec cette unité. Chaque procédure est décrite dans les pages suivantes.

Lors de l'installation du fax sur une machine (A) disposant de la touche 'Accueil' sur le panneau de commande, voir de Page 1 à Page 13.

Lors de l'installation du port multiple sur une machine (A) disposant de la touche 'Accueil' sur le panneau de commande, voir Page 14 à Page 21.

Lors de l'installation du fax sur une machine (B) disposant de la touche 'Affich. accessibilité' sur le panneau de commande, voir de Page 22 à Page 34.

Lors de l'installation du port multiple sur une machine (B) disposant de la touche 'Affich. accessibilité' sur le panneau de commande, voir Page 35 à Page 41.

### Español

El procedimiento es diferente según el producto que se instale con esta unidad. En las siguientes páginas, se describe cada procedimiento.

Al instalar el sistema de fax en una máquina (A) que dispone de la tecla 'Inicio' en el panel de controles, consulte las páginas de la 1 a la 13.

Al instalar un puerto múltiple en una máquina (A) que dispone de la tecla 'Inicio' en el panel de controles, consulte las páginas de la 14 a la 21.

Al instalar el sistema de fax en una máquina (B) que dispone de la tecla 'Pantalla acceso' en el panel de controles, consulte las páginas de la 22 a la 34.

Al instalar un puerto múltiple en una máquina (B) que dispone de la tecla 'Pantalla acceso' en el panel de controles, consulte las páginas de la 35 a la 41.

### Deutsch

Je nach verwendetem Modell ist eine andere Vorgehensweise zur Installation dieses Teils erforderlich. Die unterschiedlichen Vorgehensweisen werden auf den folgenden Seiten erläutert.

Bei Installation des FAX-Systems in einem Gerät (A), das über die Taste 'Startseite' im Bedienfeld verfügt, siehe Seite 1 bis 13.

Bei Installation einer zweiten Leitung in einem Gerät (A), das über die Taste 'Startseite' im Bedienfeld verfügt, siehe Seite 14 bis 21.

Bei Installation des FAX-Systems in einem Gerät (B), das über die Taste 'Zugriffsanzeige' im Bedienfeld verfügt, siehe Seite 22 bis 34.

Bei Installation einer zweiten Leitung in einem Gerät (B), das über die Taste 'Zugriffsanzeige' im Bedienfeld verfügt, siehe Seite 35 bis 41.

### Italiano

Si richiede una procedura diversa in funzione del prodotto su cui è installata l'unità. Le singole procedure sono descritte nelle pagine seguenti.

Per l'installazione del modulo FAX su una macchina (A) dotata di tasto 'Home' sul pannello comandi, vedere le istruzioni da Pagina 1 a Pagina 13.

Per l'installazione di una porta multipla su una macchina (A) dotata di tasto 'Home' sul pannello comandi, vedere le istruzioni da Pagina 14 a Pagina 21.

Per l'installazione del modulo FAX su una macchina (B) dotata di tasto 'Visual. Accessibilità' sul pannello comandi, vedere le istruzioni da Pagina 22 a Pagina 34.

Per l'installazione di una porta multipla su una macchina (B) dotata di tasto 'Visual. Accessibilità' sul pannello comandi, vedere le istruzioni da Pagina 35 a Pagina 41.

### 简体中文

根据安装对象, 安装步骤略有不同。各个步骤记载在下面的页面。

当安装传真系统到那些操作面板上有 '主界面' 按键的机器 (A) 时, 请参见 P1-P13。

当安装双路传真系统到那些操作面板上有 '主界面' 按键的机器 (A) 时, 请参见 P14-P21。

当安装传真系统到那些操作面板上有 '扩大显示' 按键的机器 (B) 时, 请参见 P22-P34。

当安装双路传真系统到那些操作面板上有 '扩大显示' 按键的机器 (B) 时, 请参见 P35-P41。

### 한국어

이 장치를 설치하는 제품에 따라 절차가 다릅니다. 다음 페이지에서 각 절차를 설명합니다.

조작판넬에 '홈' 키가 있는 본체 (A) 에 팩스 시스템을 설치하는 경우 1 페이지 ~ 13 페이지를 참조하십시오.

조작판넬에 '홈' 키가 있는 본체 (A) 에 멀티 포트를 설치하는 경우 14 페이지 ~ 21 페이지를 참조하십시오.

조작판넬에 '유니버설' 키가 있는 본체 (B) 에 팩스 시스템을 설치하는 경우 22 페이지 ~ 34 페이지를 참조하십시오.

조작판넬에 '유니버설' 키가 있는 본체 (B) 에 멀티 포트를 설치하는 경우 35 페이지 ~ 41 페이지를 참조하십시오.

### 日本語

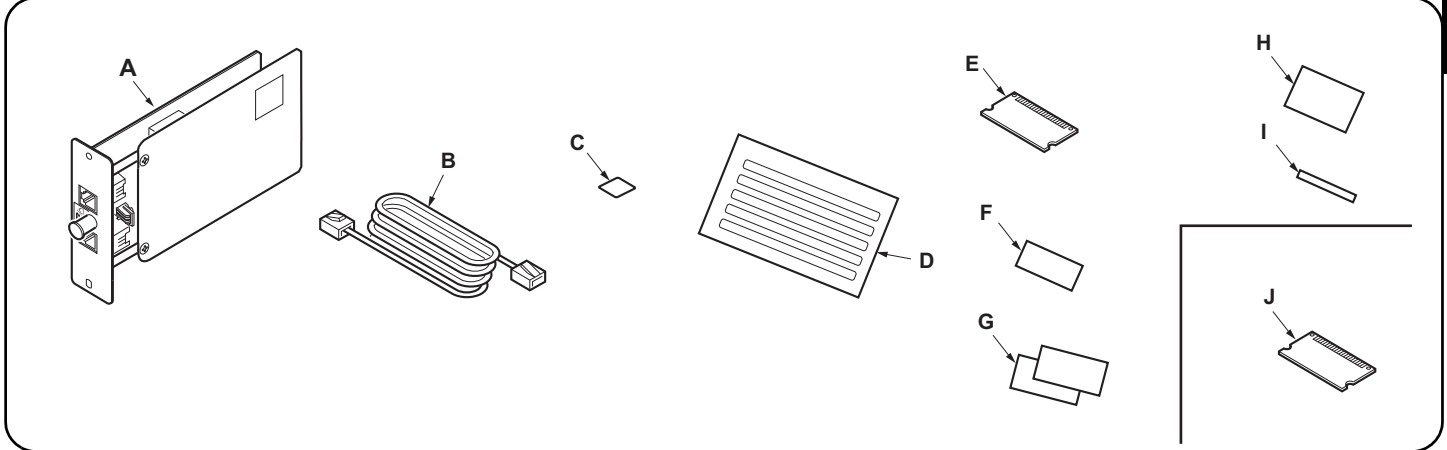
装着する対象によって、取付手順は異なります。それぞれ、以下のページに記載しています。

操作パネルに 'ホーム' キーがある機械 (A) にファクスシステムを設置する場合; 1 ページ ~ 13 ページ

操作パネルに 'ホーム' キーがある機械 (A) にマルチポートを設置する場合; 14 ページ ~ 21 ページ

操作パネルに 'ユニバーサル' キーがある機械 (B) にファクスシステムを設置する場合; 22 ページ ~ 34 ページ

操作パネルに 'ユニバーサル' キーがある機械 (B) にマルチポートを設置する場合; 35 ページ ~ 41 ページ



**When installing the Fax system on a machine (A) which has the 'Home' key in the operation panel**

<b>Supplied parts</b>		<b>Option</b>
A. FAX circuit board ..... 1	C. Terminal seal..... 1	J. Memory DIMM (128 MB) ..... 1
B. Modular connector cable (120 V/Australian model only) PJJWC0016Z (UL Listed.HUAN HSIN Type TL:120 V only) ..... 1	D. Alphabet label ..... 1	(H) and (I) are not supplied.
	E. Memory DIMM (16 MB) ..... 1	Be sure to remove any tape and/or cushioning materials from the parts supplied.
	F. PTT label (110V model only) ..... 1	
	G. Approval label (Australian/New Zealand models only) ..... 2	

**Lors de l'installation du fax sur une machine (A) disposant de la touche 'Accueil' sur le panneau de commande**

<b>Pièces fournies</b>		<b>Option</b>
A. Carte à circuits FAX..... 1	E. Mémoire DIMM (16 MB) ..... 1	Veillez à retirer les morceaux de bande adhésive et/ou les matériaux de rembourrage des pièces fournies.
B. Câble du connecteur modulaire (modèles pour l'Australie/120 V seulement)..... 1	J. Mémoire DIMM (128 MB) ..... 1	
C. Joint de borne..... 1	(F),(G),(H) et (I) ne sont pas fournis.	
D. Etiquette de l'alphabet..... 1		

**Al instalar el sistema de fax en una máquina (A) que dispone de la tecla 'Inicio' en el panel de controles**

<b>Partes suministradas</b>		<b>Opción</b>
A. Tarjeta de circuitos de fax..... 1	E. Memoria DIMM (16 MB) ..... 1	Asegúrese de quitar todas las cintas y/o material amortiguador de las partes suministradas.
B. Cable conector modular (sólo para modelos de 120 V/Australianos)..... 1	J. Memoria DIMM (128 MB) ..... 1	
C. Sello del terminal..... 1	(F) ,(G) ,(H) y (I) no se suministran.	
D. Etiqueta de alfabeto..... 1		

**Bei Installation des FAX-Systems in einem Gerät (A), das über die Taste 'Startseite' im Bedienfeld verfügt**

<b>Enthaltene Teile</b>		<b>Option</b>
A. FAX-Leiterplatte ..... 1	J. Speicher-DIMM (128 MB) ..... 1	Stellen Sie sicher, dass sämtliche Klebebänder und/oder Polstermaterial von den gelieferten Teilen entfernt wurden.
C. Verschlusskappe ..... 1	(B), (F), (G), (H) und (I) liegen nicht bei.	
D. Alphabetaufkleber..... 1		
E. Speicher-DIMM (16 MB) ..... 1		

**Per l'installazione del modulo FAX su una macchina (A) dotata di tasto 'Home' sul pannello comandi**

<b>Parti fornite</b>		<b>Opzioni</b>
A. Scheda a circuiti FAX ..... 1	J. Memoria DIMM (128 MB) ..... 1	Rimuovere tutti i nastri adesivi e/o i materiali di protezione dalle parti fornite.
C. Guarnizione terminale ..... 1	(B),(F), (G), (H) e (I) non sono in dotazione.	
D. Etichetta alfabetica ..... 1		
E. Memoria DIMM (16 MB) ..... 1		

**当安装传真系统到那些操作面板上有 '主界面' 按键的机器 (A) 时**

<b>附属品</b>		<b>选购件</b>
A. 传真电路板..... 1	F. 规格标签 ..... 1	J. 内存模组 DIMM (128MB) ..... 1
B. 电话线..... 1	H. 贴片 ..... 1	(G) 并非附属品。
C. 端子密封..... 1	I. 名称标签 ..... 1	如果附属品上带有固定胶带, 缓冲材料时务必揭下。
D. 英文字母标签..... 1		
E. 内存模组 DIMM (16MB) ..... 1		

**조작판넬에 '홈' 키가 있는 본체 (A) 에 팩스 시스템을 설치하는 경우**

<b>동봉품</b>		<b>옵션</b>
A. FAX 기관 ..... 1	J. 메모리 DIMM (128MB) ..... 1	동봉품에 고정 테이프, 완충재가 붙어 있는 경우에는 반드시 제거하십시오.
C. 단자씰 ..... 1	(B), (F), (G), (H), (I) 는 동봉되어 있지 않습니다.	
D. 알파벳 라벨..... 1		
E. 메모리 DIMM (16MB) ..... 1		

**操作パネルに 'ホーム' キーがある機械 (A) にファクスシステムを設置する場合**

<b>同梱品</b>		<b>オプション</b>
A. FAX 基板 ..... 1	J. メモリーDIMM(128MB) ..... 1	同梱品に固定テープ、緩衝材が付いている場合は必ず取り外すこと。
B. モジュラーコード..... 1	(D), (F), (G), (H), (I) は、同梱されていない。	
C. 端子シール..... 1		
E. メモリーDIMM(16MB)..... 1		

**NOTICE**

References to medium-speed MFPs in this document denote 25/25, 30/30, 35/35, 45/45 and 55/50 ppm color machines, and 30, 35, 45 and 55 ppm monochrome machines.

References to high-speed MFPs in this document denote 65/65 and 75/70 ppm color machines, and 65 and 80 ppm monochrome machines.

(The generic procedure figures in this document show medium-speed MFPs.)

If the finisher is already installed, remove the finisher before installing FAX System(W).

Before starting installation, be sure to turn the main power switch of the machine off, and unplug the power plug from the wall outlet.

**REMARQUE**

Dans le présent document, les références aux MFP à vitesse moyenne renvoient aux machines couleurs 25/25, 30/30, 35/35, 45/45 et 55/50 ppm et aux machines monochromes 30, 35, 45 et 55 ppm.

Dans le présent document, les références aux MFP à grande vitesse renvoient aux machines couleurs 65/65 et 75/70 ppm et aux machines monochromes 65 et 80 ppm. (Dans ce document, les chiffres des processus génériques renvoient aux MFP à vitesse moyenne.)

Si le retoucheur est déjà en place, le déposer avant de monter le FAX System(W).

Avant de commencer l'installation, s'assurer de mettre la machine hors tension et de débrancher la fiche d'alimentation de la prise murale.

**AVISO**

Las referencias a las MFP de velocidad media de este documento corresponden a las máquinas a color de 25/25, 30/30, 35/35, 45/45 y 55/50 ppm y a las máquinas monocromáticas de 30, 35, 45 y 55 ppm.

Las referencias a las MFP de alta velocidad de este documento corresponden a las máquinas a color de 65/65 y 75/70 ppm y a las máquinas monocromáticas de 65 y 80 ppm. (Las ilustraciones de procedimientos genéricos de este documento muestran las MFP de velocidad media.)

Si el finalizador ya se encuentra instalado, desmóntelo antes de instalar el FAX System(W).

Antes de iniciar la instalación, asegúrese de apagar el interruptor de encendido de la máquina y desenchufar el cable de alimentación de la toma de pared.

**ANMERKUNG**

Angaben für MFP der mittleren Leistungsklasse in dieser Anleitung gelten für die 25/25, 30/30, 35/35, 45/45 und 55/50 ppm Vollfarbenkopierer sowie für die 30, 35, 45 und 55 ppm Monochrommaschinen.

Angaben für MFP der Hochleistungsklasse in dieser Anleitung gelten für die 65/65 und 75/70 ppm Vollfarbenkopierer sowie für die 65 und 80 ppm Monochrommaschinen. (Die Abbildungen der allgemeinen Prozeduren zeigen MFP der mittleren Leistungsklasse.)

Falls der Finisher schon installiert ist, müssen Sie ihn ausbauen, bevor Sie das FAX System(W) installieren.

Bevor Sie mit der Installation beginnen überzeugen Sie sich, dass der Netzschalter des Geräts ausgeschaltet und das Stromkabel aus der Steckdose gezogen ist.

**AVVISO**

I riferimenti per le MFP a velocità media riportati in questo documento indicano le macchine a colori 25/25, 30/30, 35/35, 45/45 e 55/50 ppm, e le macchine monocromatiche 30, 35, 45 e 55 ppm.

I riferimenti per le MFP a velocità alta riportati in questo documento indicano le macchine a colori 65/65 e 75/70 ppm, e le macchine monocromatiche 65 e 80 ppm. (Le figure della procedura generica riportate in questo documento mostrano le MFP a velocità media.)

Se la finitrice è già installata, rimuovere la finitrice prima di installare il FAX System(W).

Prima di iniziare l'installazione, spegnere la macchina e scollegare la spina dalla presa di corrente.

**注意**

本文中の中速 MFP 代表彩色 25/25 页机型、30/30 页机型、35/35 页机型、45/45 页机型、55/50 页机型、黑白 30 页机型、35 页机型、45 页机型、55 页机型。

本文中的高速 MFP 代表彩色 65/65 页机型、75/70 页机型、黑白 65 页机型、80 页机型。(本文中的通用步骤的插图为中速 MFP。)

已安装装订器时，必须先拆下装订器再安装 FAX System(W)。

安装前务必关闭机器的主电源开关，并从墙壁插座拔下电源插头。

**주의**

본문 중 중속 MFP 는 컬러 25/25, 30/30, 35/35, 45/45, 55/50 ppm 기종 , 흑백 30, 35, 45, 55 ppm 기종을 나타냅니다 .

본문 내 고속 MFP 는 컬러 65/65, 75/70 ppm 기종 , 흑백 65, 80 ppm 기종을 나타냅니다 . (본문에있는 일반적인 순서 일러스트는 중속 MFP 가 보여 집니다 .)

피니셔가 이미 장착되어 있는 경우에는 피니셔를 제거하고 FAX System(W) 를 설치할 것 .

설치 시작하기 전에 반드시 본체의 주 전원 스위치를 끄고 벽 콘센트에서 전원 플러그를 분리하십시오 .

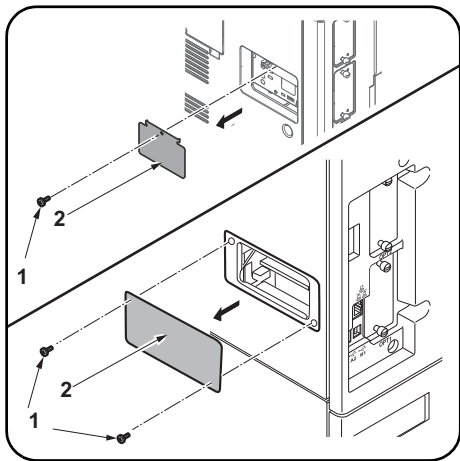
**注意**

本文中の中速 MFP はカラー機の 25/25 枚機、30/30 枚機、35/35 枚機、45/45 枚機、55/50 枚機、モノクロ機の 30 枚機、35 枚機、45 枚機、55 枚機を表す。

本文中の高速 MFP はカラー機の 65/65 枚機、75/70 枚機、モノクロ機の 65 枚機、80 枚機を表す。(本文中の共通手順イラストは中速 MFP とする。)

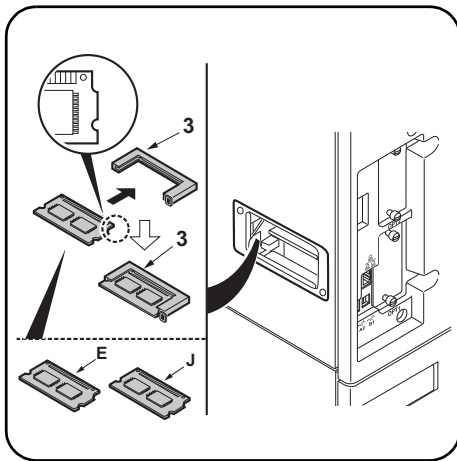
フィニッシャーがすでに装着されている場合は、フィニッシャーを取り外してから、FAX System(W) を取り付けること。

必ず機械本体の主電源スイッチを OFF にし、機械本体の電源プラグを抜いてから作業すること。



**Procedure**  
**Installing the memory DIMM**

1. Remove 1 or 2 screws (1), and then remove the cover (2).



2. Install the memory DIMM (E) or the optional memory DIMM (J) into the memory slot (3). Install it with the IC side facing up. Insert it in the direction of the arrow until it clicks.

3. Reinstall the cover (2) using the 1 or 2 screws (1).

**Procédure**  
**Installation de la mémoire DIMM**

1. Déposer 1 ou 2 vis (1), puis retirez le couvercle (2).

2. Installer la mémoire DIMM (E) ou la mémoire DIMM en option (J) dans la fente mémoire (3). L'installer avec le côté IC vers le haut. L'insérer dans la direction de la flèche jusqu'au clic.

3. Reposez le couvercle (2) en position à l'aide de 1 ou 2 vis (1).

**Procedimiento**  
**Instalación de la memoria DIMM**

1. Quite 1 o 2 tornillos (1) y después retire la cubierta (2).

2. Instale la memoria DIMM (E) o la memoria DIMM opcional (J) en la ranura para memoria (3). Instálela con la cara IC hacia arriba. Insértela en la dirección que indica la flecha hasta que escuche un clic.

3. Vuelva a colocar la cubierta (2) con 1 o 2 tornillos (1).

**Vorgehensweise**  
**Installation der DIMM-Speichermodule**

1. Entfernen Sie 1 oder 2 Schrauben (1) und entfernen dann die Abdeckung (2).

2. Setzen Sie den DIMM-Speicher (E) oder den optionalen DIMM-Speicher (J) in der Speichersteckplatz (3). Installieren Sie die Platine mit den Speicherbausteinen nach oben. Schieben Sie das Modul in Pfeilrichtung, bis es hörbar einrastet.

3. Setzen Sie die Abdeckung (2) mit 1 oder 2 Schrauben (1) wieder ein.

**Procedura**  
**Installazione della memoria DIMM**

1. Rimuovere 1 o 2 viti (1) per rimuovere il coperchio (2).

2. Installare la memoria DIMM (E) oppure la memoria opzionale DIMM (J) nello slot memoria (3). Installarla con il lato IC rivolto verso l'alto. Inserirli nella direzione della freccia finché non scatta in posizione.

3. Reinstallare il coperchio (2) utilizzando 1 o 2 viti (1).

**安装步骤**  
**安装内存模组 DIMM**

1. 取下 1 颗或 2 颗螺丝 (1)，然后取下盖板 (2)。

2. 将内存模块 (E) 或选购件内存模块 (J) 安装到内存插槽 (3)。  
将 IC 侧正面向上来安装。  
沿箭头方向将其插入到底直至发出喀嗒声。

3. 使用 1 颗或 2 颗螺丝 (1) 重新安装盖板 (2)。

**설치순서**  
**메모리 DIMM 설치**

1. 나사 (1) 1 또는 2 개를 제거하고 커버 (2) 를 제거합니다 .

2. 메모리 DIMM(E) 또는 옵션 메모리 DIMM(J) 을 메모리 슬롯 (3) 에 장착합니다 .  
IC 면을 위로 향하게 하여 설치합니다 .  
딸깍하고 소리가 날 때까지 화살표 방향으로 삽입합니다 .

3. 나사 (1) 1 또는 2 개로 커버 (2) 를 원래대로 장착합니다 .

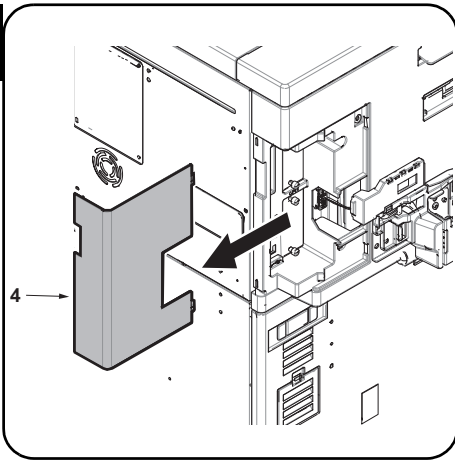
**取付手順**  
**メモリーDIMMの取り付け**

1. ビス (1) 1 本または 2 本を外し、カバー (2) を取り外す。

2. メモリーDIMM(E)または、オプションのメモリーDIMM(J) をメモリースロット (3) に取り付ける。  
IC面を上向きに取り付けること。  
カチッと音がするまで矢印方向に挿入する。

3. ビス (1) 1 本または 2 本で、カバー (2) を元通り取り付ける。

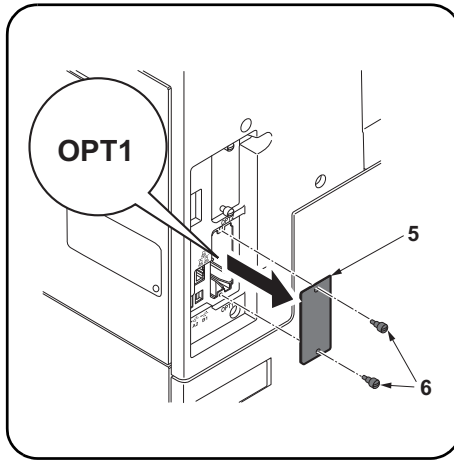




#### Removing the slot cover

##### 4. Remove the cover (4).

\* For high-speed MFPs with/without the finisher and for medium-speed MFPs with the finisher installed.



##### 5. Remove 2 screws (6) and then remove the OPT1 slot cover (5).

\* Do not use OPT2.

#### Dépose du couvercle de la fente

##### 4. Déposer le couvercle (4).

\* Pour les imprimantes multifonction à grande vitesse avec/sans module de finition et pour les imprimantes multifonction à vitesse moyenne avec le module de finition installé.

##### 5. Déposer les 2 vis (6) puis le couvercle de la fente OPT1 (5).

\* Ne pas utiliser OPT2.

#### Desmontaje de la cubierta de la ranura

##### 4. Quite la cubierta (4).

\* Para los MFP de velocidad alta con/sin finalizador y para los MFP de velocidad media con el finalizador instalado.

##### 5. Quite 2 tornillos (6) y, después, quite la cubierta de la ranura OPT1 (5).

\* No utilice OPT2.

#### Entfernen der Einschubabdeckung

##### 4. Die Abdeckung (4) entfernen.

\* Bei schnellen MFPs mit/ohne Finisher oder mittelschnellen MFPs mit installiertem Finisher.

##### 5.2 Schrauben (6) entfernen und dann die Abdeckung (5) des Einschubs OPT1 entfernen.

\* OPT2 nicht verwenden.

#### Rimozione del coperchio vano

##### 4. Rimuovere il coperchio (4).

\* Per dispositivi MFP di fascia alta con/senza finisher e per dispositivi di fascia media con finisher installato.

##### 5. Rimuovere le 2 viti (6) e quindi rimuovere il coperchio (5) del vano OPT1.

\* Non utilizzare OPT2.

#### 拆下插槽盖板

##### 4. 拆下盖板 (4)。

※ 对于高速机来说装订器可装可不装，对于中速机来说要安装。

##### 5. 拆除 2 颗螺丝 (6)，拆下 OPT1 的插槽盖板 (5)。

※ 不使用 OPT2。

#### 슬롯커버 제거

##### 4. 커버 (4) 를 제거합니다 .

※ 피니셔 장착 및 비장착 고속 MFP 및 피니셔 장착 중속 MFP.

##### 5. 나사 (6) 2 개를 제거하고 OPT1 의 슬롯커버 (5) 를 제거합니다 .

※ OPT2 는 사용하지 말 것 .

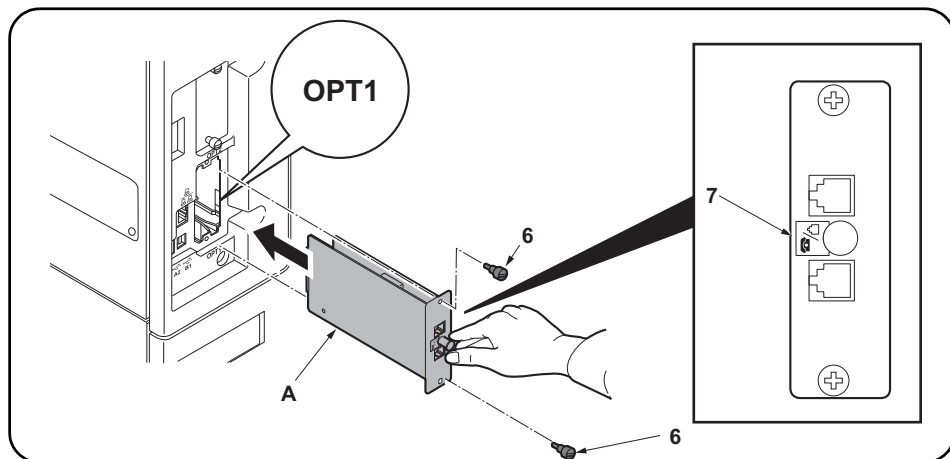
#### スロットカバーの取り外し

##### 4. カバー (4) を取り外す。

※ 高速 MFP の場合および中速 MFP にフィニッシャー装着時の場合。

##### 5. ビス (6) 2 本を外し、OPT1 のスロットカバー (5) を取り外す。

※ OPT2 は使用しないこと。



#### Install the FAX circuit board.

6. Insert the FAX circuit board (A) along the groove in OPT1 and secure the board with two screws (6) that have been removed in step 5.  
Do not directly touch the FAX circuit board (A) terminal. Hold the top and bottom of the FAX circuit board, or the projection of the board to insert the FAX circuit board (A).  
Direct the label (7) on to the FAX circuit board (A) as indicated in the illustration and insert the board along the groove.

#### Installer la carte à circuits FAX.

6. Insérer la carte à circuits FAX (A) le long de la rainure dans l'OPT1 et la fixer à l'aide des deux vis (6) retirées à l'étape 5.  
Ne pas toucher directement la borne de la carte à circuits FAX (A). Tenir les parties inférieure et supérieure de la carte à circuits FAX ou la saillie de la carte pour insérer la carte à circuits FAX (A). Orienter l'étiquette (7) de la carte à circuits FAX (A) comme illustré et insérer la plaquette le long de la rainure.

#### Instale la tarjeta de circuitos de fax.

6. Inserte la tarjeta de circuitos de fax (A) a lo largo de la ranura de OPT1 y asegúrela con los dos tornillos (6) que ha quitado en el paso 5.  
No toque directamente el terminal de la tarjeta de circuitos del fax (A). Sujete las partes superior e inferior de la tarjeta de circuitos de fax o la saliente de la tarjeta para insertar la tarjeta de circuitos de fax (A). Oriente la etiqueta (7) en la tarjeta de circuitos del FAX (A) como se indica en la ilustración e inserte la tarjeta a lo largo de la ranura.

#### Installieren der FAX-Leiterplatte.

6. FAX-Leiterplatte (A) in die Nut des Einbauschachts OPT1 einsetzen und Leiterplatte mit den in Schritt 5 ausgebauten Schrauben (6) befestigen.  
Berühren Sie die Anschlüsse der FAX-Platine (A) nicht mit den Fingern. Die FAX-Leiterplatte (A) beim Einsetzen oben und unten oder an dem Vorsprung festhalten.  
Die FAX-Leiterplatte (A) so in die Nut einsetzen, dass der Aufkleber (7) wie abgebildet zur Leiterplatte zeigt.

#### Installare la scheda a circuiti FAX.

6. Inserire la scheda a circuiti FAX (A) lungo l'incavo nell'OPT1 e fissare la scheda con le due viti (6) rimosse nell'operazione 5.  
Non toccare direttamente il terminale della scheda a circuiti FAX (A). Per inserire il circuito FAX (A), tenere l'estremità superiore e la base della scheda a circuiti FAX, o la sporgenza della scheda a circuiti FAX. Orientare l'etichetta (7) sulla scheda a circuiti FAX (A) come indicato nell'illustrazione e inserire la scheda lungo l'incavo.

#### 安装传真电路板

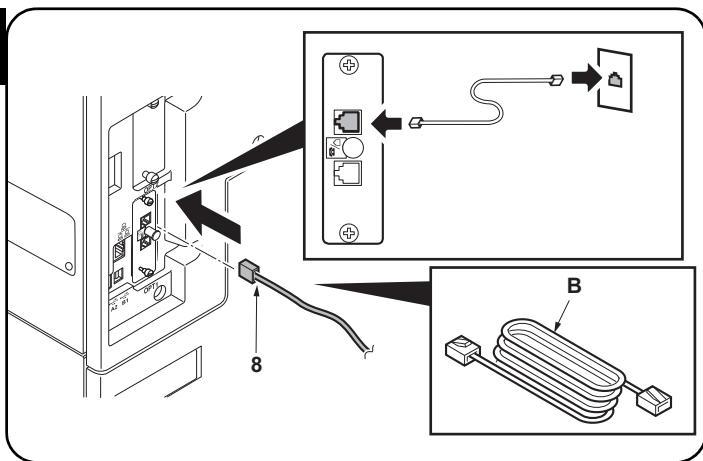
6. 沿着 OPT1 的沟槽插入传真电路板 (A) 并用步骤 5 中拆下的两颗螺钉 (6) 固定电路板。  
请勿直接接触传真电路板 (A) 端子。  
按住传真电路板的顶部和底部, 或者按住电路板的突出部将传真电路板 (A) 插入。  
将传真电路板 (A) 上的标签 (7) 保持图示中的方向, 将电路板沿着沟槽方向插入。

#### FAX 회로기판 장착

6. OPT1 의 홈을 따라 FAX 회로기판 (A) 를 삽입하고 앞 순서 5 에서 제거한 나사 (6) 2 개 로 고정합니다.  
FAX 회로기판 (A) 의 단자에 직접 닿지 않도록 할 것.  
FAX 회로기판 (A) 삽입 시, 회로기판의 상하 또는 돌출부를 잡을 것.  
FAX 회로기판 (A) 를 부착된 라벨 (7) 그림 표기 방향으로 삽입할 것.

#### FAX 基板の取り付け

6. OPT1 の溝に沿って FAX 基板 (A) を挿入し、手順 5 で外したビス (6) 2 本で固定する。  
FAX 基板 (A) の端子に直接触れないこと。  
FAX 基板 (A) の挿入時は基板の上下か突起を持つこと。  
FAX 基板 (A) は、貼り付けられているラベル (7) が図に示す方向になるように、挿入すること。



#### Connect the MFP to the telephone line.

7. Plug the modular connector cable (8) into the line terminal, and then connect the other end to the telephone line.

For 100 V/120 V/Australian or Chinese models, use the supplied modular connector cable (B).

#### Connecter le MFP à la ligne de téléphone.

7. Brancher le câble du connecteur modulaire (8) à la borne de la ligne, puis connecter l'autre extrémité à la ligne de téléphone.

Pour les modèles 100 V/120 V/Australie ou Chine, utilisez le câble à connecteur modulaire (B) fourni.

#### Conecte el MFP a la línea telefónica.

7. Enchufe el cable del conector modular (8) en el terminal de línea y, a continuación, conecte el otro extremo a la línea telefónica.

Para los modelos de 100 V/120 V/Australiano o Chino, utilice el cable conector modular (B) suministrado.

#### Anschließen des MFP an die Telefonleitung.

7. Telefonmodulkabel (8) in die Gerätebuchse einstecken und das Kabel an der Telefondose anschließen.

Das mitgelieferte Modularsteckerkabel (B) für die 100-V/120-V/Australien- oder China-Modelle verwenden.

#### Collegamento dell'MFP alla linea del telefono.

7. Inserire il cavo connettore modulare (8) nel terminale della linea, e quindi collegare l'altro terminale alla linea del telefono.

Per modelli da 100 V/120 V/Australia o Cina, utilizzare il cavo connettore modulare (B) in dotazione.

#### 将 MFP 连接到电话线

7. 将模块接插件电缆 (8) 插入电话线端子, 然后将另一端与电话线连接。

对于 100V/120V/ 澳大利亚或中国机型, 请使用随附的模块接插件电缆 (B)。

#### 전화회선 연결

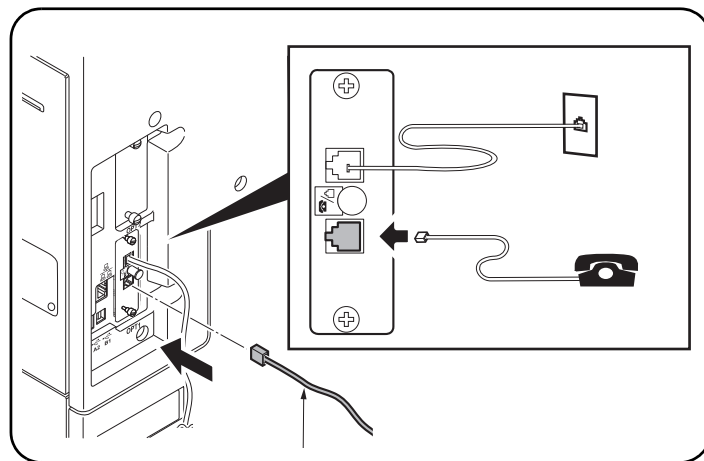
7. 모듈 코드 (8) 을 선 단자에 꽂는다 . 다른 쪽 플러그는 전화선에 연결한다 .

100V/120V/ 오스트레일리아 / 중국 스펙은 부속 모듈 코드 (B) 를 사용할 것 .

#### 電話回線との接続

7. モジュラーコード (8) をライン端子に差し込む。もう片方のプラグは、電話回線へ接続する。

100V/120V/ オーストラリア / 中国仕様は付属のモジュラーコード (B) を使用すること。



#### Connect the MFP to the separate phone (except for New Zealand model).

8. Plug the modular connector cable (9) into the telephone terminal, and then connect the other end to the separate phone.

#### Connecter le MFP au téléphone séparé.

8. Brancher le câble du connecteur modulaire (9) à la borne du téléphone, puis connecter l'autre extrémité au téléphone séparé.

#### Conecte el MFP al teléfono separado.

8. Enchufe el cable del conector modular (9) en el terminal del teléfono y, a continuación, conecte el otro extremo al teléfono separado.

#### Anschließen des MFP an das separate Telefon.

8. Das Telefonmodulkabel (9) in die Telefonbuchse einstecken und das andere Ende an das separate Telefon anschließen.

#### Collegamento dell'MFP al telefono separato.

8. Inserire il cavo connettore modulare (9) nel terminale del telefono, e quindi collegare l'altro terminale al telefono separato.

#### 将 MFP 连接到其它电话

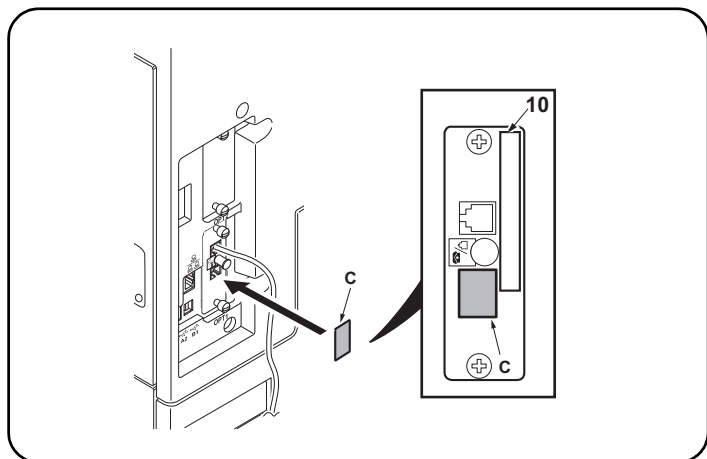
8. 将模块接插件电缆 (9) 插入电话端子, 然后将另一端与其他电话连接。

#### 외부 전화에 연결

8. 모듈 코드 (9) 를 TEL 단자에 꽂습니다 . 다른 한 쪽의 플러그는 외부 전화에 연결합니다 .

#### 外付け電話との接続

8. モジュラーコード (9) を TEL 端子に差し込む。もう片方のプラグは、外付け電話と接続する。



If you don't connect the MFP to the separate phone, wipe the surface of the telephone terminal with alcohol and adhere the terminal seal (C) upon the customer's request.

On 120 V models, be sure that it is not attached over the top of the approval label (10).

Si le MFP n'est pas connecté au téléphone séparé à la demande du client, nettoyer la surface de la borne de téléphone avec de l'alcool et apposer le joint de borne (C).

Sur les modèles 120 V, attention à ne pas installer en recouvrant le haut de l'étiquette d'approbation (10).

Si no conecta el MFP a un teléfono separado, limpie la superficie del terminal del teléfono con alcohol y pegue el sello del terminal (C), a solicitud del cliente.

En los modelos de 120 V, asegúrese de que no se fije sobre la etiqueta de aprobación (10).

Wenn der MFP nicht an das separate Telefon angeschlossen wird, die Oberfläche der Telefonbuchse mit Alkohol abwischen und Verschlusskappe (C) einsetzen, falls vom Kunden gewünscht.

Bei 120-V-Modellen darauf achten, dass der Aufkleber nicht den Genehmigungsaufkleber (10) verdeckt.

Nel caso in cui non si colleghi l'MFP al telefono separato, pulire la superficie del terminale del telefono con dell'alcol e applicare la guarnizione terminale (C) a richiesta del cliente.

Sui modelli da 120 V, assicurarsi che essa non venga applicata sopra l'etichetta di approvazione (10).

如果您没有将 MFP 连接至其他电话，请用酒精擦拭电话端子表面，并按照客户要求粘上端子密封 (C)。

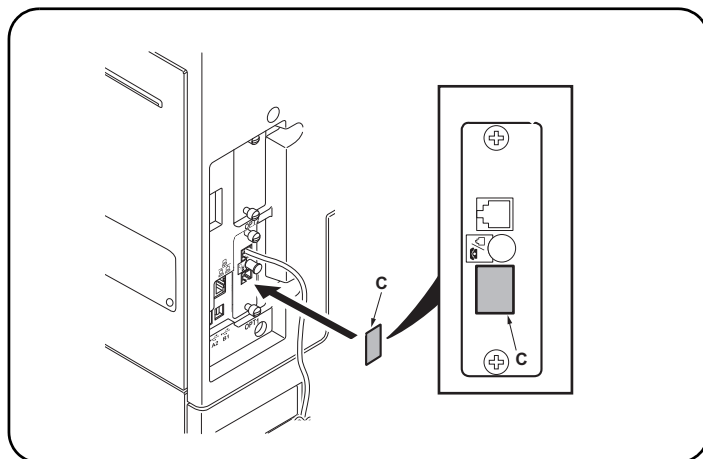
120V 规格在粘贴时注意不要与认可标签 (10) 重叠。

외부 전화에 연결하지 않는 경우, 고객의 요청에 따라 TEL 단자 주위를 알코올 청소하고 단자씰 (C) 을 붙입니다.

120V 사양은 허가 라벨 (10) 에 겹치지 않도록 붙일 것.

外付け電話と接続しない場合、お客様の要望により、TEL 端子周囲をアルコール清掃し、端子シール (C) を貼り付ける。

120V 仕様は認可ラベル (10) に重ならないように、貼りつけること。



#### Seal the terminal (for New Zealand model).

9. Wipe the surface of the telephone terminal with alcohol and adhere the terminal seal (C).

Perform this procedure for New Zealand model only.

#### Fermer hermétiquement la borne (modèle pour la Nouvelle-Zélande).

9. Cette étape est superflue.

#### Selle el terminal (para el modelo Nuevo Zelandés).

9. Este paso no es necesario.

#### Versiegeln der Anschlussbuchse (für Neuseeland-Modell).

9. Dieser Schritt ist nicht erforderlich.

#### Sigillare il terminale (per il modello Nuova Zelanda).

9. Questo passo non è richiesto.

#### 安装端子密封 (仅适用于新西兰型号)

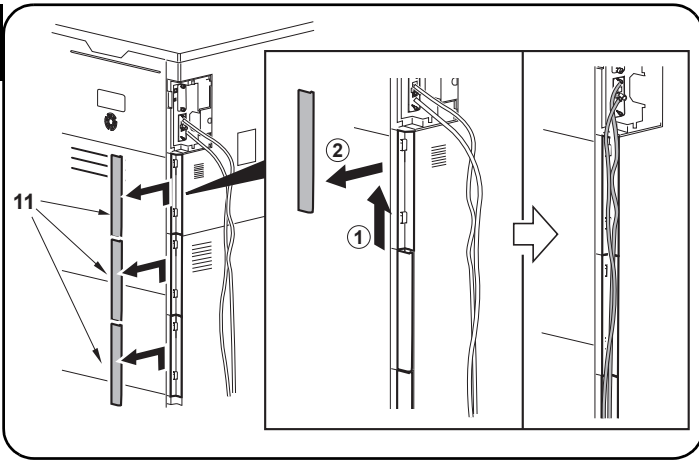
9. 不需要本步骤。

#### 단자씰의 부착 (뉴질랜드 사양만)

9. 작업 불필요.

#### 端子シールの貼り付け (ニュージーランド仕様のみ)

9. この作業は不要。



#### Wiring the modular connector cable (High-speed MFPs only)

10. Remove the covers (11) and run the modular connector cable as shown in the figure.
11. Reinstall the covers (11).

#### Câblage du câble à connecteur modulaire (MFP à grande vitesse uniquement)

10. Déposer les couvercles (11) et implanter le câble à connecteur modulaire comme illustré par la figure.
11. Reposer les couvercles (11).

#### Tendido del cable conector modular (Solo para las MFP de alta velocidad)

10. Quite las cubiertas (11) y tienda el cable conector modular como se muestra en la ilustración.
11. Vuelva a instalar las cubiertas (11).

#### Verlegung des Modularsteckerkabels (Nur MFP der Hochleistungsklasse)

10. Die Abdeckungen (11) entfernen und das Modularsteckerkabel gemäß der Abbildung verlegen.
11. Die Abdeckungen (11) wieder anbringen.

#### Cablaggio del cavo connettore modulare (Solo per MFP a velocità alta)

10. Rimuovere i coperchi (11) e far passare il cavo connettore modulare come indicato nella figura.
11. Reinstallare i coperchi (11).

#### 电话线的配线(仅限高速 MFP 时)

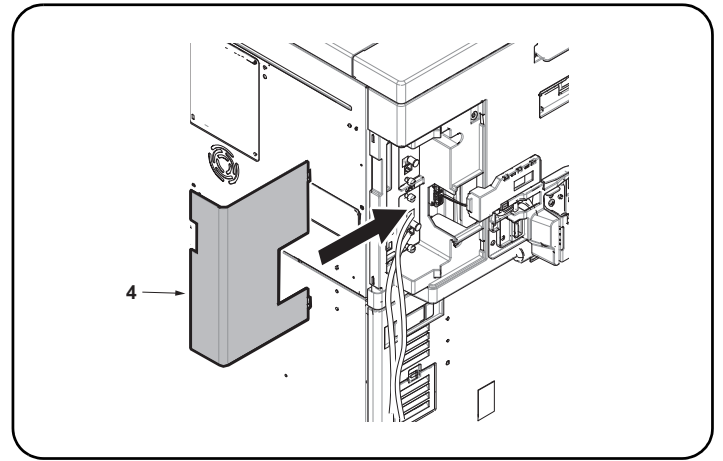
10. 拆下盖板(11),将电话线如图所示穿过。
11. 安装盖板(11)。

#### 모듈러 코드의 배선(고속 MFP 의 경우만)

10. 커버(11)를 떼어 내고 모듈러 코드를 그림과 같이 지나가게 합니다.
11. 커버(11)을 장착합니다.

#### モジュラーコードの配線(高速 MFP の場合のみ)

10. カバー(11)を取り外し、モジュラーコードを図のように通す。
11. カバー(11)を取り付ける。



12. Install the cover (4) which was removed in step 4.

\* For high-speed MFPs with/without the finisher and for medium-speed MFPs with the finisher installed.  
\* This work is not required if a multiport is installed along with the fax system (OPT1).

12. Installer le cache (4) qui a été retiré à l'étape 4.

\* Pour les imprimantes multifonction à grande vitesse avec/sans module de finition et pour les imprimantes multifonction à vitesse moyenne avec le module de finition installé.  
\* Cette opération n'est pas nécessaire si un port multiple est installé avec le fax (OPT1).

12. Instale la cubierta (4) que se quitó en el paso 4.

\* Para los MFP de velocidad alta con/sin finalizador y para los MFP de velocidad media con el finalizador instalado.  
\* Esto no es necesario realizarlo si hay instalado un puerto múltiple con el sistema de fax (OPT1).

12. Installieren Sie die Abdeckung (4), die in Schritt 4 entfernt wurde.

\* Bei schnellen MFPs mit/ohne Finisher oder mittelschnellen MFPs mit installiertem Finisher.  
\* Dies ist nicht nötig, wenn eine zweite Leitung zusammen mit dem FAX-System (OPT1) installiert ist.

12. Installare il coperchio (4) rimosso al punto 4.

\* Per dispositivi MFP di fascia alta con/senza finisher e per dispositivi di fascia media con finisher installato.  
\* Questa operazione non è richiesta quando con il modulo fax (OPT1) viene installata una porta multipla.

12. 安装在步骤 4 中取下的盖板(4)。

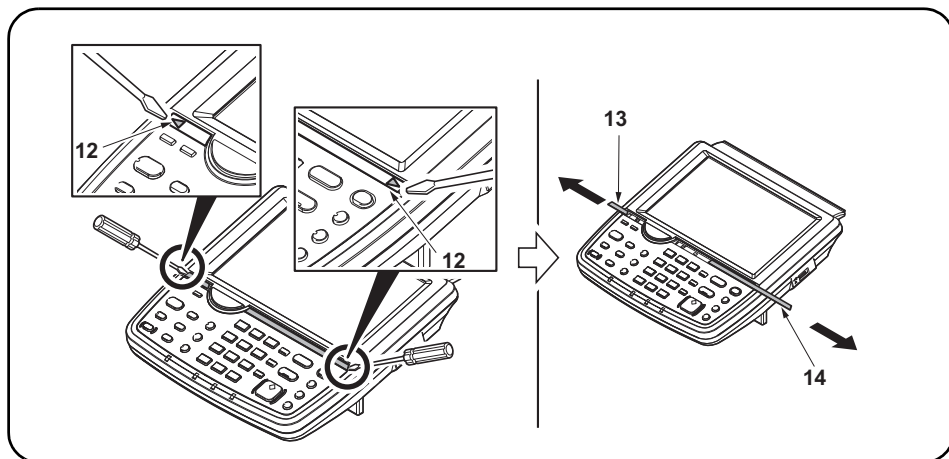
※ 对于高速机来说装订器可装可不装,对于中速机来说要安装。  
※ 双路传真系统和传真系统(OPT1)同时安装时,不需要此步骤。

12. 4 단계에서 분리한 커버(4)를 설치합니다.

※ 피니셔 장착 및 비장착의 고속 MFP 및 피니셔 장착 중속 MFP.  
※ 이 작업은 멀티 포트가 팩스 시스템(OPT1)과 함께 설치되어 있는 경우에는 필요하지 않습니다.

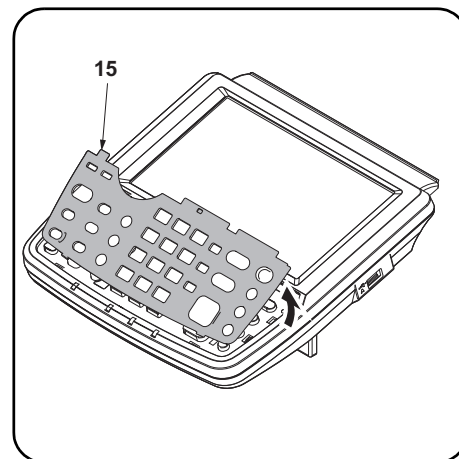
12. 手順 4 で取り外したカバー(4)を取り付ける。

※ 高速 MFP の場合および中速 MFP にフィニッシャー装着時の場合。  
※ ファクスシステム(OPT1)と同時にマルチポートを設置する場合この作業は不要。



**Attach the alphabet labels (excluding 100 V models).**

13. Insert a flat-head screwdriver at the tip indicated by the arrows (12) as shown on the left, and slide the operation panel covers (13) (14) to remove them.



14. Remove the clear panel (15).

**Apposer les étiquettes de l'alphabet (Sauf sur les modèles 100 V).**

13. Insérer un tournevis à lame à l'endroit repéré par les flèches (12) comme illustré ci-contre à gauche et faire glisser les couvercles du panneau de commande (13) (14) pour les déposer.

14. Déposer le panneau transparent (15).

**Fije las etiquetas de alfabeto (a excepción de los modelos de 100 V).**

13. Inserte un destornillador de pala plana en la punta que indican las flechas (12) como se muestra a la izquierda y deslice las cubiertas del panel de trabajo (13) (14) para quitarlas.

14. Quite el panel transparente (15).

**Anbringen der Alphetaufkleber (ausgenommen 100-V-Modelle).**

13. Einen flachen Schraubendreher an der links mit Pfeilen (12) bezeichneten Spitze einschieben und die Bedienfeldabdeckungen (13) (14) verschieben, um sie dann abzunehmen.

14. Die durchsichtige Platte (15) entfernen.

**Applicare le etichette alfabetiche (esclusi i modelli da 100 V).**

13. Inserire un cacciavite a testa piana nel punto indicato dalla freccia (12) come mostrato sulla sinistra, e slittare i coperchi (13) (14) del pannello operativo per rimuoverli.

14. Rimuovere il pannello trasparente (15).

**粘貼英文字母标签 (100V 规格以外)**

13. 如图所示, 在▲箭头(12)前方插入一字螺丝刀, 滑动并取下操作面板的盖板(13)(14)。

14. 拆下透明面板(15)。

**알파벳 라벨의 부착 (100V 사양 이외)**

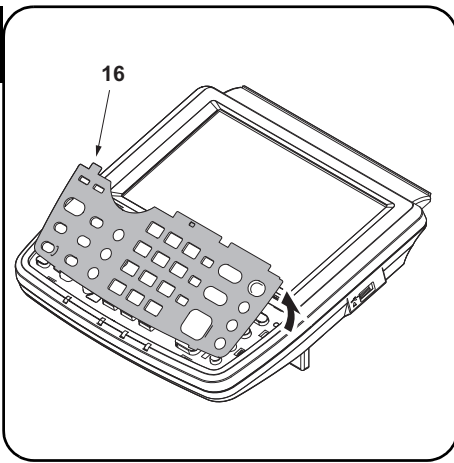
13. 그림과 같이 ▲ 표시 (12) 앞에 마이너스 드라이버를 삽입해 조작 패널의 커버 (13) (14) 를 미끄러트리면서 떼어 냅니다 .

14. 클리어 판넬 (15) 을 제거합니다 .

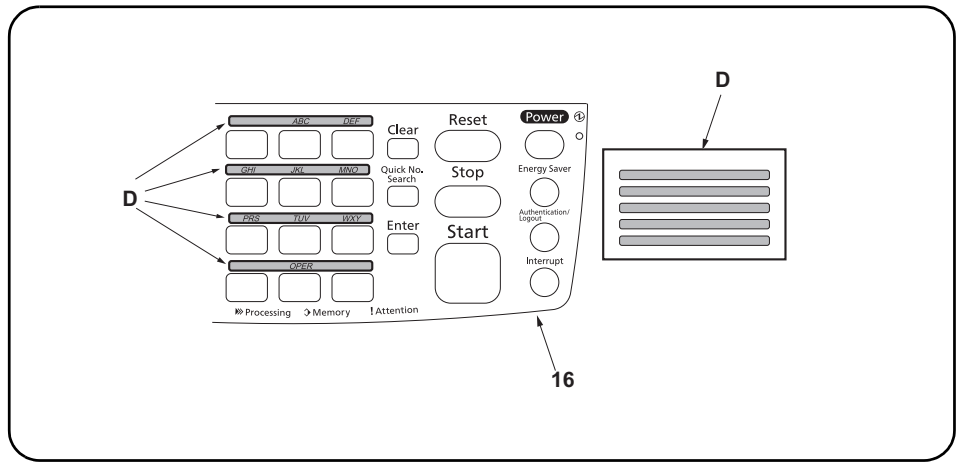
**アルファベットラベルの貼り付け (100V仕様以外)**

13. この作業は不要。

14. この作業は不要。



15. Remove the operation panel sheet (16).



16. Wipe the area above the numeric keys on the operation panel sheet (16) with alcohol and attach the alphabet labels (D).  
In Asia and Oceania, use PQRS TUV WXYZ label, and do not use PRS TUV WXY and OPER labels.

15. Déposer la tôle du panneau de commande (16).

16. Nettoyer à l'alcool la surface au-dessus des touches numériques sur la tôle du panneau de commande (16) et apposer les étiquettes alphabétiques (D).  
En Asie et Océanie, utiliser l'étiquette PQRS TUV WXYZ et pas les étiquettes PRS TUV WXY et OPER.

15. Quite la hoja del panel de trabajo (16).

16. Limpie el área sobre las teclas numéricas de la hoja del panel de trabajo (16) con alcohol y fije las etiquetas de alfabeto (D).  
En Asia y Oceanía, utilice la etiqueta PQRS TUV WXYZ y no use las PRS TUV WXY ni las OPER.

15. Die Bedienfeldfolie (16) entfernen.

16. Den Bereich über den Zifferntasten an der Bedienfeldfolie (16) mit Alkohol abwischen und die Alphabetaufkleber (D) hier anbringen.  
In Asien und Ozeanien den Aufkleber PQRS TUV WXYZ verwenden; nicht die Aufkleber PRS TUV WXY und OPER verwenden.

15. Rimuovere il foglio (16) del pannello operativo.

16. Pulire l'area sopra i tasti numerici sul foglio del pannello operativo (16) con alcool ed applicare le etichette alfabetiche (D).  
In Asia ed Oceania, utilizzare l'etichetta PQRS TUV WXYZ e non utilizzare le etichette PRS TUV WXY e OPER.

15. 拆下操作面板页 (16)。

16. 使用酒精清洁操作面板页 (16) 的数字键上部, 粘贴英文字母标签 (D)。  
在亚洲和大洋州, 请使用 PQRS TUV WXYZ 标签, 而不要使用 PRS TUV WXY 和 OPER 标签。

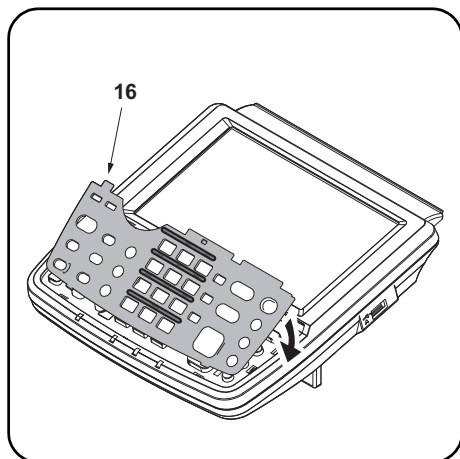
15. 조작판넬시트 (16) 를 제거합니다 .

16. 조작판넬시트 (16) 상에 숫자키 윗측을 알코올을 청소하고 알파벳 라벨 (D) 을 붙입니다 . 아시아 / 오세아니아에서는 「PRS TUV WXY」 및 「OPER」 라벨을 사용하지 말고 「PQRS TUV WXYZ」의 라벨을 사용할 것 .

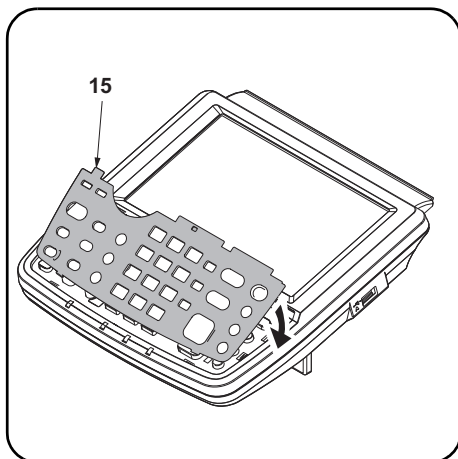
15. この作業は不要。

16. この作業は不要。

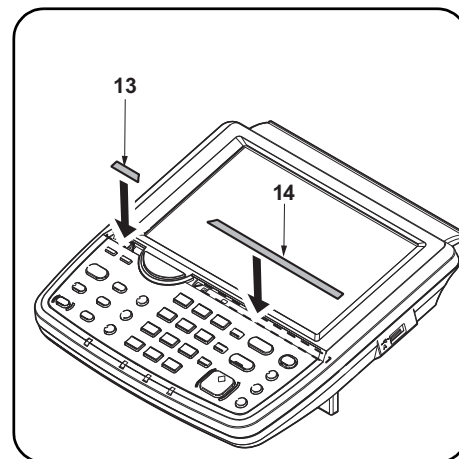




17. Attach the operation panel sheet (16).



18. Reinstall the clear panel (15).



19. Reinstall the operation panel covers (13) (14).

17. Fixer la tôle du panneau de commande (16).

18. Reposer le panneau transparent (15).

19. Reposer les couvercles du panneau de commande (13) (14).

17. Fije la hoja del panel de trabajo (16).

18. Vuelva a instalar el panel transparente (15).

19. Vuelva a instalar las cubiertas del panel de trabajo (13) (14).

17. Die Bedienfeldfolie (16) anbringen.

18. Die durchsichtige Platte (15) wieder anbringen.

19. Die Bedienfeldabdeckungen (13) (14) wieder anbringen.

17. Applicare il foglio del pannello operativo (16).

18. Reinstallare il pannello trasparente (15).

19. Reinstallare i coperchi (13) (14) del pannello operativo.

17. 安装操作面板页 (16)。

18. 安装透明面板 (15)。

19. 安装操作面板的盖板 (13) (14)。

17. 조작판넬시트 (16) 를 붙입니다 .

18. 클리어판넬 (15) 를 부착합니다 .

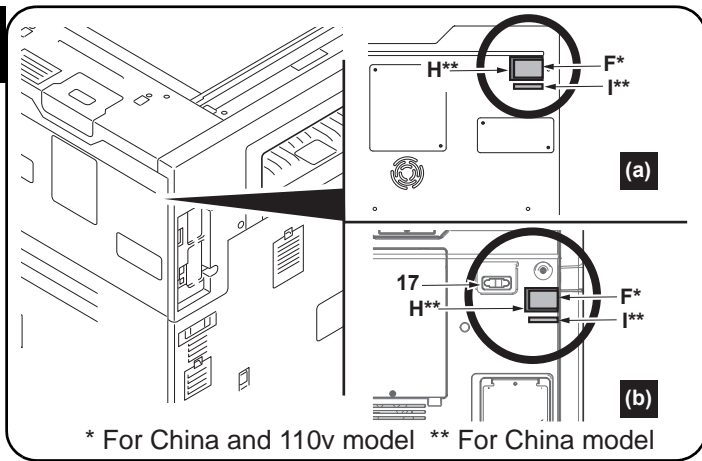
19. 조작판넬 커버 (13) (14) 을 부착합니다 .

17. この作業は不要。

18. この作業は不要。

19. この作業は不要。





**Attach the PTT label (for 110 V models only).**

20. Wiping with alcohol in the position as shown above. Attach the PTT label (F) at the point as shown above.

If there isn't a connector(17),see the figure(a).

If there is a connector(17),see the figure(b).

**Fixer l'étiquette d'approbation (pour la Chine, modèles 110 V seulement).**

20. Cette étape est superflue.

**Coloque la etiqueta de aprobación (para China, solo para los modelos de 110 V).**

20. Este paso no es necesario.

**Den Genehmigungsaufkleber anbringen (für China nur 110-V-Modelle).**

20. Dieser Schritt ist nicht erforderlich.

**Applicare l'etichetta di approvazione (per Cina, solo per i modelli da 110 V).**

20. Questo passo non è richiesto.

**粘貼規格標籤 ( 仅限中国规格 )**

20. 在粘貼標籤或貼片前, 請用酒精清潔粘貼位置。按照圖示位置來粘貼貼片(H)。把規格標籤(F)粘貼在貼片(H)上面。按照圖示位置來粘貼名稱標籤(I)。

如沒有連接端子(17), 請參照圖(a)

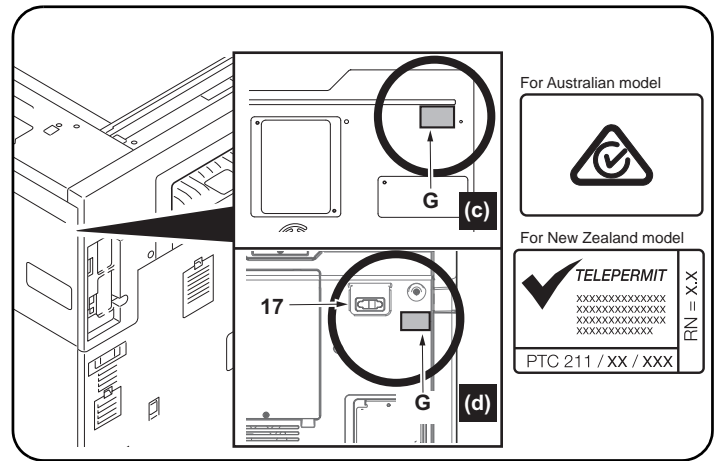
如有連接端子(17), 請參照圖(b)

**규격라벨의 부착 (중국, 110V 사양만)**

20. 이 단계가 필요하지 않습니다.

**規格ラベルの貼り付け (中国、110V仕様のみ)**

20. この作業は不要。



**Attach the approval label (for Australian/New Zealand model only).**

21. Wiping with alcohol in the position as shown above. Attach the approval label (G) at the point as shown above.

If there isn't a connector(17),see the figure(c).

If there is a connector(17),see the figure(d).

Perform this procedure for Australian/New Zealand model only.

**Fixer l'étiquette d'approbation (modèle pour l'Australie/Nouvelle-Zélande seulement).**

21. Cette étape est superflue.

**Coloque la etiqueta de aprobación (sólo para los modelos Australiano/Nuevo Zelandés)**

21. Este paso no es necesario

**Den Genehmigungsaufkleber anbringen (nur für Australien/Neuseeland-Modell).**

21. Dieser Schritt ist nicht erforderlich.

**Applicare l'etichetta di approvazione (solo per il modello Australia/ Nuova Zelanda).**

21. Questo passo non è richiesto.

**粘貼規格標籤 ( 仅适用于澳大利亚 / 新西兰型号 )**

21. 不需要本步骤。

**규격라벨의 부착 (오스트레일리아 / 뉴질랜드 사양만)**

21. 이 단계가 필요하지 않습니다.

**規格ラベルの貼り付け (オーストラリア / ニュージーランド仕様のみ)**

21. この作業は不要。

**Initialize the FAX circuit board.**

1. Plug the MFP into a power outlet, and turn on the main power.
2. Perform the maintenance mode U600 to initialize the FAX PWBs

---

**Initialiser la carte à circuits FAX.**

1. Brancher le MFP sur une prise d'alimentation et le mettre sous tension.
2. Exécuter le mode maintenance U600 pour initialiser les cartes de circuit imprimé du fax .

---

**Inicialice la tarjeta de circuitos FAX.**

1. Conecte el MFP a un receptáculo de pared y encienda el interruptor principal.
2. Ejecute el modo de mantenimiento U600 para inicializar los FAX PWB.

---

**Initialisieren der FAX-Leiterplatte.**

1. Netzstecker des MFP in eine Steckdose stecken und Hauptschalter einschalten.
2. Führen Sie den Wartungsmodus U600 aus, um die FAX-Karte zu initialisieren.

---

**Inizializzare la scheda a circuiti FAX.**

1. Collegare l'MFP ad una presa di corrente e portare l'interruttore principale su On.
2. Eseguire il modo manutenzione U600 per inizializzare le schede PWB FAX.

---

**传真电话板的初始化**

1. 将 MFP 的电源插头插入电源插座，打开主电源。
2. 执行维修保养模式 U600，初始化传真电路板。

---

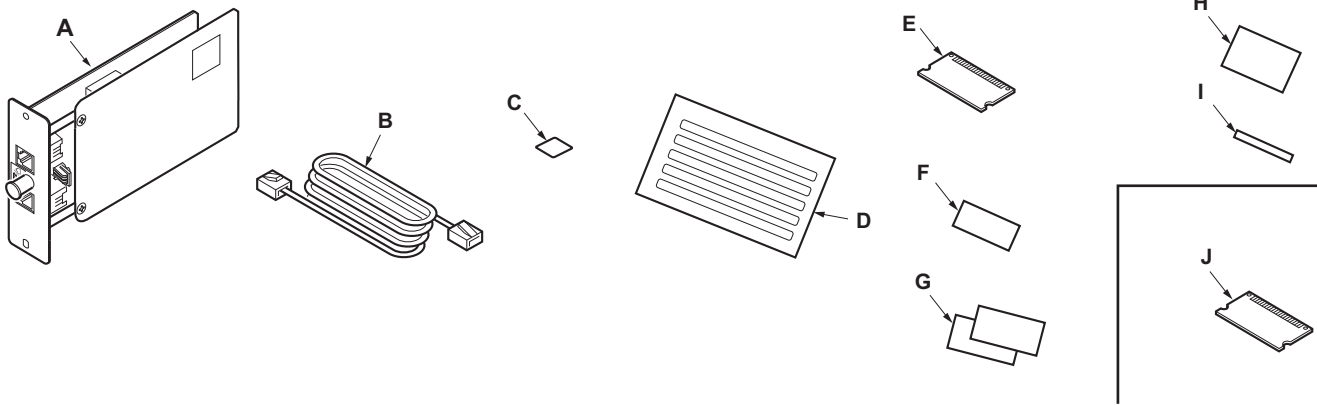
**FAX 회로기판 초기화**

1. MFP 본체 전원플러그를 콘센트에 꽂고 주 전원 스위치를 ON 으로 한다 .
2. 메인テナンス 모드 U600 을 실행하여 FAX 회로기판을 초기화합니다 .

---

**FAX 基板の初期化**

1. MFP 本体の電源プラグをコンセントに差し込み、主電源スイッチを ON にする。
2. メンテナンスモード U600 を実行し、FAX 基板を初期化する。



### When installing the multiport on a machine (A) which has the 'Home' key in the operation panel

#### Supplied parts

A. FAX circuit board .....	1
B. Modular connector cable (120 V/Australian model only) PJJWC0016Z (UL Listed.HUAN HSIN Type TL:120 V only) .....	1

C. Terminal seal.....	1
D. Alphabet label .....	1
E. Memory DIMM (16 MB) .....	1
F. PTT label (110V model only) .....	1
G. Approval label (Australian/New Zealand models only) .....	2

#### Option

J. Memory DIMM (128 MB) .....	1
-------------------------------	---

(H) and (I) are not supplied.  
(D), (E), (F), (G) and (J) are not used.  
Be sure to remove any tape and/or cushioning materials from the parts supplied.

### Lors de l'installation du port multiple sur une machine (A) disposant de la touche 'Accueil' sur le panneau de commande

#### Pièces fournies

A. Carte à circuits FAX.....	1
B. Câble du connecteur modulaire (modèles pour l'Australie/120 V seulement).....	1
C. Joint de borne.....	1
D. Etiquette de l'alphabet.....	1

E. Mémoire DIMM (16 MB) .....	1
J. Mémoire DIMM (128 MB) .....	1

#### Option

(F), (G), (H) et (I) ne sont pas fournis.  
(D), (E) et (J) ne sont pas utilisés.

Veillez à retirer les morceaux de bande adhésive et/ou les matériaux de rembourrage des pièces fournies.

### Al instalar un puerto múltiple en una máquina (A) que dispone de la tecla 'Inicio' en el panel de controles

#### Partes suministradas

A. Tarjeta de circuitos de fax.....	1
B. Cable conector modular (sólo para modelos de 120 V/Australianos).....	1
C. Sello del terminal.....	1
D. Etiqueta de alfabeto.....	1

E. Memoria DIMM (16 MB) .....	1
J. Memoria DIMM (128 MB) .....	1

#### Opción

(F), (G), (H) y (I) no se suministran.  
(D), (E) y (J) no se utilizan.

Asegúrese de quitar todas las cintas y/o material amortiguador de las partes suministradas.

### Bei Installation einer zweiten Leitung in einem Gerät (A), das über die Taste 'Startseite' im Bedienfeld verfügt

#### Enthaltene Teile

A. FAX-Leiterplatte.....	1
C. Verschlusskappe .....	1
D. Alphabetaufkleber.....	1
E. Speicher-DIMM (16 MB) .....	1

#### Option

J. Speicher-DIMM (128 MB) .....	1
---------------------------------	---

(B), (F), (G), (H) und (I) liegen nicht bei.  
(D), (E) und (J) werden nicht benötigt.

Stellen Sie sicher, dass sämtliche Klebebänder und/oder Polstermaterial von den gelieferten Teilen entfernt wurden.

### Per l'installazione di una porta multipla su una macchina (A) dotata di tasto 'Home' sul pannello comandi

#### Parti fornite

A. Scheda a circuiti FAX .....	1
C. Guarnizione terminale .....	1
D. Etichetta alfabetica .....	1
E. Memoria DIMM (16 MB) .....	1

#### Opzioni

J. Memoria DIMM (128 MB) .....	1
--------------------------------	---

(B), (F), (G), (H) e (I) non sono in dotazione.  
(D), (E) e (J) non sono utilizzati.

Rimuovere tutti i nastri adesivi e/o i materiali di protezione dalle parti fornite.

### 当安装双路传真系统到那些操作面板上有 '主界面' 按键的机器 (A) 时

#### 附属品

A. 传真电路板.....	1
B. 电话线.....	1
C. 端子密封.....	1
D. 英文字母标签.....	1
E. 内存模组 DIMM (16MB) .....	1

F. 规格标签 .....	1
H. 贴片 .....	1
I. 名称标签 .....	1

#### 选购件

J. 内存模组 DIMM (128MB) .....	1
----------------------------	---

(G) 并非附属品。  
不使用 (D), (E), (F), (H), (I) 和 (J)。

如果附属品上带有固定胶带, 缓冲材料时务必揭下。

### 조작판넬에 '홈' 키가 있는 본체 (A) 에 멀티 포트를 설치하는 경우

#### 동봉품

A. FAX 기관 .....	1
C. 단자씰 .....	1
D. 알파벳 라벨.....	1
E. 메모리 DIMM (16MB) .....	1

#### 옵션

J. 메모리 DIMM (128MB) .....	1
---------------------------	---

(B), (F), (G), (H), (I) 는 동봉되어 있지 않습니다.  
(D), (E), (J) 는 사용되지 않습니다.

동봉품에 고정 테이프, 완충재가 붙어 있는 경우에는 반드시 제거하십시오.

### 操作パネルに 'ホーム' キーがある機械 (A) にマルチポートを設置する場合

#### 同梱品

A. FAX 基板 .....	1
B. モジュラーコード.....	1
C. 端子シール.....	1
E. メモリーDIMM(16MB).....	1

#### オプション

J. メモリーDIMM(128MB) .....	1
--------------------------	---

(D), (F), (G), (H), (I) は、同梱されていない。  
(E), (J) は、使用しない。

同梱品に固定テープ、緩衝材が付いている場合は必ず取り外すこと。

**NOTICE**

References to medium-speed MFPs in this document denote 25/25, 30/30, 35/35, 45/45 and 55/50 ppm color machines, and 30, 35, 45 and 55 ppm monochrome machines.

References to high-speed MFPs in this document denote 65/65 and 75/70 ppm color machines, and 65 and 80 ppm monochrome machines. (The generic procedure figures in this document show medium-speed MFPs.)

If the finisher is already installed, remove the finisher before installing FAX System(W). Before starting installation, be sure to turn the main power switch of the machine off, and unplug the power plug from the wall outlet.

**REMARQUE**

Dans le présent document, les références aux MFP à vitesse moyenne renvoient aux machines couleurs 25/25, 30/30, 35/35, 45/45 et 55/50 ppm et aux machines monochromes 30, 35, 45 et 55 ppm.

Dans le présent document, les références aux MFP à grande vitesse renvoient aux machines couleurs 65/65 et 75/70 ppm et aux machines monochromes 65 et 80 ppm. (Dans ce document, les chiffres des processus génériques renvoient aux MFP à vitesse moyenne.)

Si le retoucheur est déjà en place, le déposer avant de monter le FAX System(W).

Avant de commencer l'installation, s'assurer de mettre la machine hors tension et de débrancher la fiche d'alimentation de la prise murale.

**AVISO**

Las referencias a las MFP de velocidad media de este documento corresponden a las máquinas a color de 25/25, 30/30, 35/35, 45/45 y 55/50 ppm y a las máquinas monocromáticas de 30, 35, 45 y 55 ppm.

Las referencias a las MFP de alta velocidad de este documento corresponden a las máquinas a color de 65/65 y 75/70 ppm y a las máquinas monocromáticas de 65 y 80 ppm. (Las ilustraciones de procedimientos genéricos de este documento muestran las MFP de velocidad media.)

Si el finalizador ya se encuentra instalado, desmóntelo antes de instalar el FAX System(W).

Antes de iniciar la instalación, asegúrese de apagar el interruptor de encendido de la máquina y desenchufar el cable de alimentación de la toma de pared.

**ANMERKUNG**

Angaben für MFP der mittleren Leistungsklasse in dieser Anleitung gelten für die 25/25, 30/30, 35/35, 45/45 und 55/50 ppm Vollfarbepkopierer sowie für die 30, 35, 45 und 55 ppm Monochrommaschinen.

Angaben für MFP der Hochleistungsklasse in dieser Anleitung gelten für die 65/65 und 75/70 ppm Vollfarbepkopierer sowie für die 65 und 80 ppm Monochrommaschinen. (Die Abbildungen der allgemeinen Prozeduren zeigen MFP der mittleren Leistungsklasse.)

Falls der Finisher schon installiert ist, müssen Sie ihn ausbauen, bevor Sie das FAX System(W) installieren.

Bevor Sie mit der Installation beginnen überzeugen Sie sich, dass der Netzschalter des Geräts ausgeschaltet und das Stromkabel aus der Steckdose gezogen ist.

**AVVISO**

I riferimenti per le MFP a velocità media riportati in questo documento indicano le macchine a colori 25/25, 30/30, 35/35, 45/45 e 55/50 ppm, e le macchine monocromatiche 30, 35, 45 e 55 ppm.

I riferimenti per le MFP a velocità alta riportati in questo documento indicano le macchine a colori 65/65 e 75/70 ppm, e le macchine monocromatiche 65 e 80 ppm. (Le figure della procedura generica riportate in questo documento mostrano le MFP a velocità media.)

Se la finitrice è già installata, rimuovere la finitrice prima di installare il FAX System(W).

Prima di iniziare l'installazione, spegnere la macchina e scollegare la spina dalla presa di corrente.

**注意**

本文中の中速 MFP 代表彩色 25/25 页机型、30/30 页机型、35/35 页机型、45/45 页机型、55/50 页机型、黑白 30 页机型、35 页机型、45 页机型、55 页机型。

本文中的高速 MFP 代表彩色 65/65 页机型、75/70 页机型、黑白 65 页机型、80 页机型。(本文中的通用步骤的插图为中速 MFP。)

已安装装订器时，必须先拆下装订器再安装 FAX System(W)。

安装前务必关闭机器的主电源开关，并从墙壁插座拔下电源插头。

**주의**

본문 중 중속 MFP 는 컬러 25/25, 30/30, 35/35, 45/45, 55/50 ppm 기종, 흑백 30, 35, 45, 55 ppm 기종을 나타냅니다 .

본문 내 고속 MFP 는 컬러 65/65, 75/70 ppm 기종, 흑백 65, 80 ppm 기종을 나타냅니다 . (본문에있는 일반적인 순서 일러스트는 중속 MFP 가 보여 집니다 .)

피니셔가 이미 장착되어 있는 경우에는 피니셔를 제거하고 FAX System(W) 를 설치할 것 .

설치 시작하기 전에 반드시 본체의 주 전원 스위치를 끄고 벽 콘센트에서 전원 플러그를 분리하십시오 .

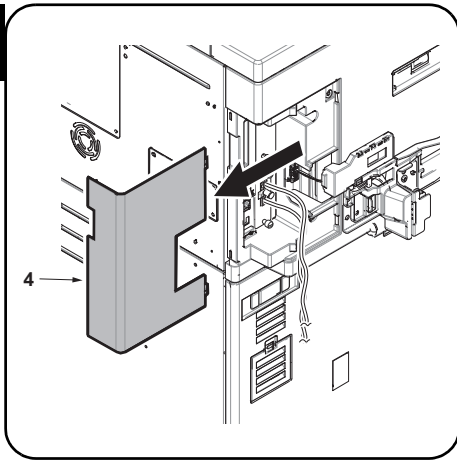
**注意**

本文中の中速 MFP はカラー機の 25/25 枚機、30/30 枚機、35/35 枚機、45/45 枚機、55/50 枚機、モノクロ機の 30 枚機、35 枚機、45 枚機、55 枚機を表す。

本文中の高速 MFP はカラー機の 65/65 枚機、75/70 枚機、モノクロ機の 65 枚機、80 枚機を表す。(本文中の共通手順イラストは中速 MFP とする。)

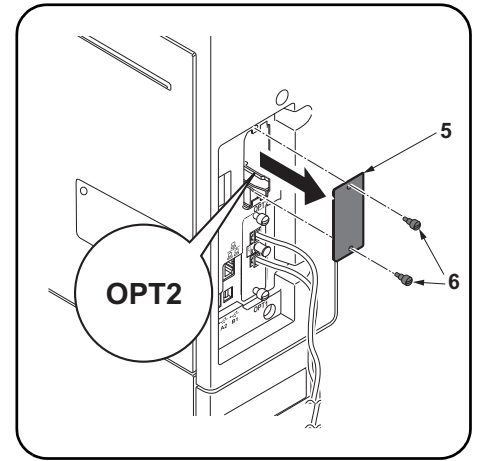
フィニッシャーがすでに装着されている場合は、フィニッシャーを取り外してから、FAX System(W) を取り付けること。

必ず機械本体の主電源スイッチを OFF にし、機械本体の電源プラグを抜いてから作業すること。



**Procedure**  
**Removing the slot cover**

1. Remove the cover (4).
  - \* For high-speed MFPs with/without the finisher and for medium-speed MFPs with the finisher installed.
  - \* This work is not required if a multiport is installed along with the fax system (OPT1).



2. Remove 2 screws (6) and then remove the OPT2 slot cover (5).

**Procédure**  
**Dépose du couvercle de la fente**

1. Déposer le couvercle (4).
  - \* Pour les imprimantes multifonction à grande vitesse avec/sans module de finition et pour les imprimantes multifonction à vitesse moyenne avec le module de finition installé.
  - \* Cette opération n'est pas nécessaire si un port multiple est installé avec le fax (OPT1).

2. Déposer les 2 vis (6) puis le couvercle de la fente OPT2 (5).

**Procedimiento**  
**Desmontaje de la cubierta de la ranura**

1. Quite la cubierta (4).
  - \* Para los MFP de velocidad alta con/sin finalizador y para los MFP de velocidad media con el finalizador instalado.
  - \* Esto no es necesario realizarlo si hay instalado un puerto múltiple con el sistema de fax (OPT1).

2. Quite 2 tornillos (6) y, después, quite la cubierta de la ranura OPT2 (5).

**Vorgehensweise**  
**Entfernen der Einschubabdeckung**

1. Die Abdeckung (4) entfernen.
  - \* Bei schnellen MFPs mit/ohne Finisher oder mittelschnellen MFPs mit installiertem Finisher.
  - \* Dies ist nicht nötig, wenn eine zweite Leitung zusammen mit dem FAX-System (OPT1) installiert ist.

- 2.2 Schrauben (6) entfernen und dann die Abdeckung (5) des Einschubs OPT2 entfernen.

**Procedura**  
**Rimozione del coperchio vano**

1. Rimuovere il coperchio (4).
  - \* Per dispositivi MFP di fascia alta con/senza finisher e per dispositivi di fascia media con finisher installato.
  - \* Questa operazione non è richiesta quando con il modulo fax (OPT1) viene installata una porta multipla.

2. Rimuovere le 2 viti (6) e quindi rimuovere il coperchio (5) del vano OPT2.

**安装步骤**  
**拆下插槽盖板**

1. 拆下盖板 (4)。
  - ※ 对于高速机来说装订器可装可不装，对于中速机来说要安装。
  - ※ 双路传真系统和传真系统 (OPT1) 同时安装时，不需要此步骤。

2. 拆除 2 颗螺丝 (6)，拆下 OPT2 的插槽盖板 (5)。

**설치순서**  
**슬롯커버 제거**

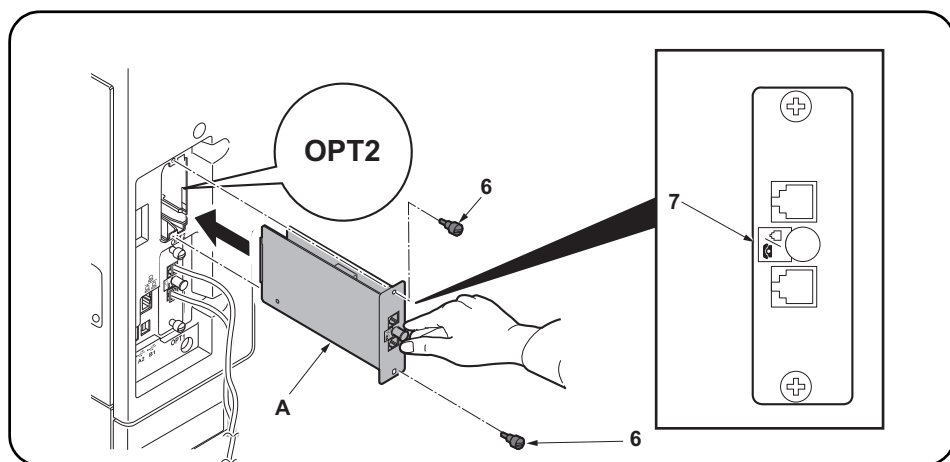
1. 커버 (4) 를 제거합니다.
  - ※ 피니셔 장착 또는 비장착의 고속 MFP 및 피니셔 장착 중속 MFP.
  - ※ 이 작업은 멀티 포트가 팩스 시스템 (OPT1) 과 함께 설치되어 있는 경우에는 필요하지 않습니다.

2. 나사 (6) 2 개를 제거하고 OPT2 의 슬롯커버 (5) 를 제거합니다 .

**取付手順**  
**スロットカバーの取り外し**

1. カバー (4) を取り外す。
  - ※ 高速 MFP の場合および中速 MFP にフィニッシャー装着時の場合
  - ※ ファクスシステム (OPT1) と同時にマルチポートを設置する場合この作業は不要。

2. ビス (6) 2 本を外し、OPT2 のスロットカバー (5) を取り外す。



### Install the FAX circuit board.

3. Insert the FAX circuit board (A) along the groove in OPT2 and secure the board with two screws (6) that have been removed in step 2.  
Do not directly touch the FAX circuit board (A) terminal.  
Hold the top and bottom of the FAX circuit board, or the projection of the board to insert the FAX circuit board (A).  
Direct the label (7) on to the FAX circuit board (A) toward left side and insert the board along the groove.

### Installer la carte à circuits FAX.

3. Insérer la carte à circuits FAX (A) le long de la rainure dans l'OPT2 et la fixer à l'aide des deux vis (6) retirées à l'étape 2.  
Ne pas toucher directement la borne de la carte à circuits FAX (A).  
Tenir les parties inférieure et supérieure de la carte à circuits FAX ou la saillie de la carte pour insérer la carte à circuits FAX (A).  
Orienter l'étiquette (7) de la carte à circuits FAX (A) comme illustré et insérer la plaquette le long de la rainure.

### Instale la tarjeta de circuitos de FAX.

3. Inserte la tarjeta de circuitos de fax (A) a lo largo de la ranura de OPT2 y asegúrela con los dos tornillos (6) que ha quitado en el paso 2.  
No toque directamente el terminal de la tarjeta de circuitos del FAX (A).  
Sujete las partes superior e inferior de la tarjeta de circuitos de FAX o la saliente de la tarjeta para insertar la tarjeta de circuitos de FAX (A).  
Oriente la etiqueta (7) en la tarjeta de circuitos del FAX (A) como se indica en la ilustración e inserte la tarjeta a lo largo de la ranura.

### Installieren der FAX-Leiterplatte.

3. FAX-Leiterplatte (A) in die Nut des Einbauschachts OPT2 einsetzen und Leiterplatte mit den in Schritt 2 ausgebauten Schrauben (6) befestigen.  
Berühren Sie die Anschlüsse der FAX-Platine (A) nicht mit den Fingern.  
Die FAX-Leiterplatte (A) beim Einsetzen oben und unten oder an dem Vorsprung festhalten.  
Die FAX-Leiterplatte (A) so in die Nut einsetzen, dass der Aufkleber (7) wie abgebildet zur Leiterplatte zeigt.

### Installare la scheda a circuiti FAX.

3. Inserire la scheda a circuiti FAX (A) lungo l'incavo nell'OPT2 e fissare la scheda con le due viti (6) rimosse nell'operazione 2.  
Non toccare direttamente il terminale della scheda a circuiti FAX (A),  
Per inserire il circuito FAX (A), tenere l'estremità superiore e la base della scheda a circuiti FAX, o la sporgenza della scheda a circuiti FAX.  
Orientare l'etichetta (7) sulla scheda a circuiti FAX (A) come indicato nell'illustrazione e inserire la scheda lungo l'incavo.

### 安装传真电路板

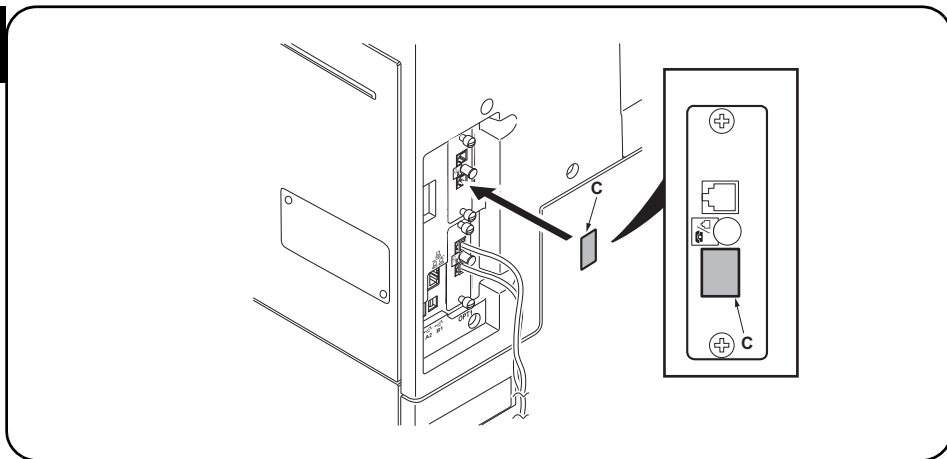
3. 沿着 OPT2 的沟槽插入传真电路板 (A) 并用步骤 2 中拆下的两颗螺钉 (6) 固定电路板。  
请勿直接触摸传真电路板 (A) 端子。  
按住传真电路板的顶部和底部, 或者按住电路板的突出部将传真电路板 (A) 插入。  
将传真电路板 (A) 上的标签 (7) 保持图示中的方向, 将电路板沿着沟槽方向插入。

### FAX 회로기판 장착

3. OPT2 의 홈을 따라 FAX 회로기판 (A) 를 삽입하고 앞 순서 2 에서 제거한 나사 (6) 2 개로 고정합니다 .  
FAX 회로기판 (A) 의 단자에 직접 닿지 않도록 할 것 .  
FAX 회로기판 (A) 삽입 시 , 회로기판의 상하 또는 돌출부를 잡을 것 .  
FAX 회로기판 (A) 를 부착된 라벨 (7) 그림 표기 방향으로 삽입할 것 .

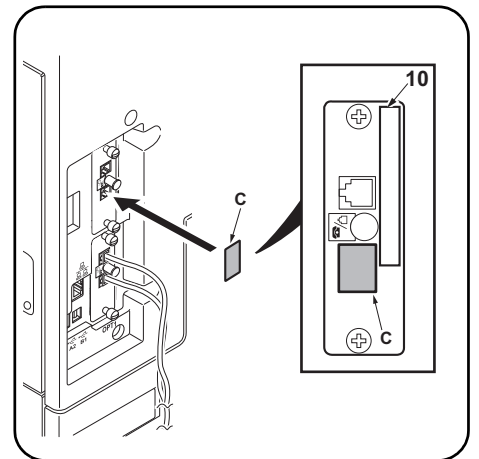
### FAX 基板の取り付け

3. OPT2 の溝に沿って FAX 基板 (A) を挿入し、手順 2 で外したビス (6) 2 本で固定する。  
FAX 基板 (A) の端子に直接触れないこと。  
FAX 基板 (A) の挿入時は基板の上下か突起を持つこと。  
FAX 基板 (A) は、貼り付けられているラベル (7) が図に示す方向になるように、挿入すること。



#### Seal the terminal.

4. Wipe the surface of the telephone terminal with alcohol and adhere the terminal seal (C).  
The telephone terminal on the FAX circuit board installed to OPT2 is unavailable (invalid). Seal the terminal securely to prevent a user from connecting a separate phone.



On 120 V models, be sure that it is not attached over the top of the approval label (10).

#### Fermer hermétiquement la borne.

4. Nettoyer la surface de la borne de téléphone avec de l'alcool, et apposer le joint de borne (C).  
La borne de téléphone de la carte à circuits FAX installée sur l'OPT2 n'est pas utilisable (invalide). Fermer hermétiquement la borne pour empêcher tout utilisateur de connecter un téléphone séparé.

Sur les modèles 120 V, attention à ne pas installer en recouvrant le haut de l'étiquette d'approbation (10).

#### Selle el terminal.

4. Limpie la superficie del terminal de teléfono con alcohol y pegue el sello de terminal (C).  
El terminal de teléfono de la tarjeta de circuitos de FAX instalado en el OPT2 no está disponible (inválido). Selle firmemente el terminal para evitar que un usuario conecte un teléfono por separado.

En los modelos de 120 V, asegúrese de que no se fije sobre la etiqueta de aprobación (10).

#### Versiegeln der Anschlussbuchse.

4. Die Oberfläche der Telefonanschlussbuchse mit Alkohol abwischen und die Verschlusskappe (C) anbringen.  
Die Telefonanschlussbuchse der in OPT2 installierten FAX-Leiterplatte ist nicht verfügbar (ungültig). Die Anschlussbuchse vollkommen versiegeln, um den Anschluss eines separaten Telefons zu verhindern.

Bei 120-V-Modellen darauf achten, dass der Aufkleber nicht den Genehmigungsaufkleber (10) verdeckt.

#### Sigillare il terminale.

4. Pulire la superficie del terminale del telefono con alcol e fare aderire la guarnizione terminale (C).  
Il terminale del telefono sulla scheda a circuiti FAX installata su OPT2 non è disponibile (invalido). Sigillare il terminale saldamente per prevenire a un utente di collegare un telefono separato.

Sui modelli da 120 V, assicurarsi che essa non venga applicata sopra l'etichetta di approvazione (10).

#### 安装端子密封

4. 用酒精擦拭电话端子表面并粘上端子密封 (C)。  
安装在 OPT2 上的传真电路板的电话端子不可使用 (无效)。为了避免用户错误与其它电话连接, 必须确实粘贴好端子密封。

120V 规格在粘贴时注意不要与认可标签 (10) 重叠。

#### 단자씰의 부착

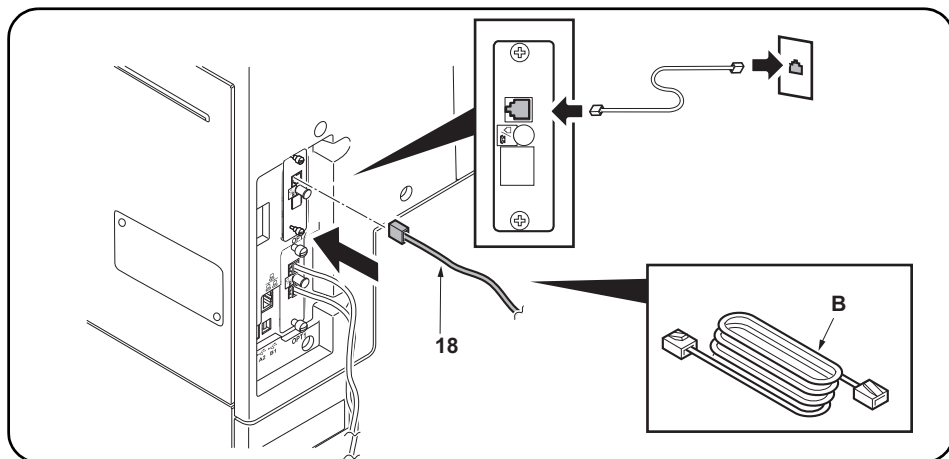
4. TEL 단자주위를 알코올청소하고 단자씰 (C) 을 부착합니다.  
OPT2 에 부착한 FAX 회로기판의 TEL 단자는 사용불가 (무효) 가 됩니다. 사용자의 실수로 외부 전화에 연결하지 않도록 확실히 부착할 것.

120V 사양은 허가 라벨 (10) 에 겹치지 않도록 붙일 것.

#### 端子シールの貼り付け

4. TEL 端子周囲をアルコール清掃し、端子シール (C) を貼り付ける。  
OPT2 に取り付けした FAX 基板の TEL 端子は使用不可 (無効) となる。ユーザーが誤って外付け電話を接続しないよう確実に貼り付けること。

120V 仕様は認可ラベル (10) に重ならないように、貼り付けること。



#### Connect the MFP to the telephone line.

5. Plug the modular connector cable (18) into the line terminal, and then connect the other end to the telephone line.

For 100 V/120 V/Australian or Chinese models, use the supplied modular connector cable (B).

#### Connecter le MFP à la ligne de téléphone.

5. Brancher le câble du connecteur modulaire (18) à la borne de la ligne, puis connecter l'autre extrémité à la ligne de téléphone.

Pour les modèles 100 V/120 V/Australie ou Chine, utilisez le câble à connecteur modulaire (B) fourni.

#### Conecte el MFP a la línea telefónica.

5. Enchufe el cable del conector modular (18) en el terminal de línea y, a continuación, conecte el otro extremo a la línea telefónica.

Para los modelos de 100 V/120 V/Australiano o Chino, utilice el cable conector modular (B) suministrado.

#### Anschließen des MFP an die Telefonleitung.

5. Telefonmodulkabel (18) in die Gerätebuchse einstecken und das Kabel an der Telefondose anschließen.

Das mitgelieferte Modularsteckerkabel (B) für die 100-V/120-V/Australien- oder China-Modelle verwenden.

#### Collegamento dell'MFP alla linea del telefono.

5. Inserire il cavo connettore modulare (18) nel terminale della linea, e quindi collegare l'altro terminale alla linea del telefono.

Per modelli da 100 V/120 V/Australia o Cina, utilizzare il cavo connettore modulare (B) in dotazione.

#### 将 MFP 连接到电话线

5. 将模块接插件电缆 (18) 插入电话线端子, 然后将另一端与电话线连接。

对于 100V/120V/ 澳大利亚或中国机型, 请使用随附的模块接插件电缆 (B)。

#### 전화회선과의 연결

5. 모듈러 코드 (18) 를 라인단자에 꽂습니다. 다른 한 쪽의 플러그는 전화회선과 연결합니다.

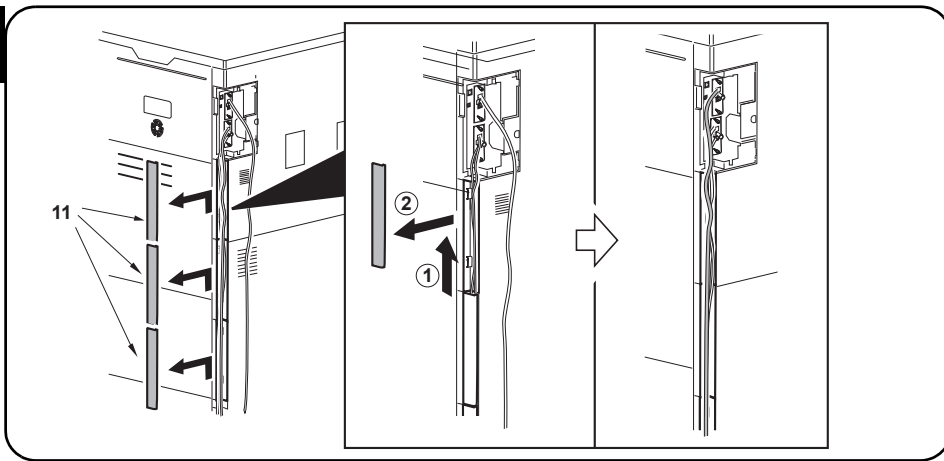
100V/120V/ 오스트레일리아 / 중국사양은 부속 모듈코드 (B) 를 사용할 것.

#### 電話回線との接続

5. モジュラーコード (18) をライン端子に差し込む。もう片方のプラグは、電話回線へ接続する。

100V/120V/ オーストラリア / 中国仕様は付属のモジュラーコード (B) を使用すること。

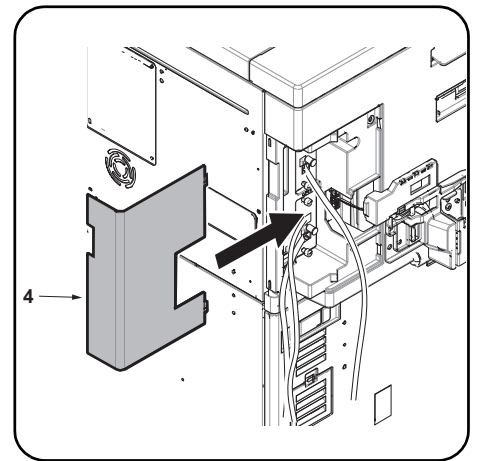




#### Wiring the modular connector cable (High-speed MFPs only)

6. Remove the covers (11) and run the modular connector cable as shown in the figure.  
\*Run it by binding with the modular cords from the Fax System (OPT1).

7. Reinstall the covers (11).



8. Install the cover (4) which was removed in step 1.

- \* For high-speed MFPs with/without the finisher and for medium-speed MFPs with the finisher installed.

#### Câblage du câble à connecteur modulaire (MFP à grande vitesse uniquement)

6. Déposer les couvercles (11) et implanter le câble à connecteur modulaire comme illustré par la figure.  
\*Le faire passer avec les cordons modulaires du fax (OPT1).

7. Reposer les couvercles (11).

8. Installer le cache (4) qui a été retiré à l'étape 1.

- \* Pour les imprimantes multifonction à grande vitesse avec/sans module de finition et pour les imprimantes multifonction à vitesse moyenne avec le module de finition installé.

#### Tendido del cable conector modular (Solo para las MFP de alta velocidad)

6. Quite las cubiertas (11) y tienda el cable conector modular como se muestra en la ilustración.  
\* Tiéndalo uniéndolo con los cables modulares del sistema de fax (OPT1).

7. Vuelva a instalar las cubiertas (11).

8. Instale la cubierta (4) que se quitó en el paso 1.

- \* Para los MFP de velocidad alta con/sin finalizador y para los MFP de velocidad media con el finalizador instalado.

#### Verlegung des Modularsteckerkabels (Nur MFP der Hochleistungsklasse)

6. Die Abdeckungen (11) entfernen und das Modularsteckerkabel gemäß der Abbildung verlegen.  
\*Führen Sie es zusammen mit dem Kabel des FAX-Systems (OPT1).

7. Die Abdeckungen (11) wieder anbringen.

8. Installieren Sie die Abdeckung (4), die in Schritt 1 entfernt wurde.

- \* Bei schnellen MFPs mit/ohne Finisher oder mittelschnellen MFPs mit installiertem Finisher.

#### Cablaggio del cavo connettore modulare (Solo per MFP a velocità alta)

6. Rimuovere i coperchi (11) e far passare il cavo connettore modulare come indicato nella figura.  
\*Infilarlo collegandolo ai cavi modulari del modulo fax (OPT1).

7. Reinstallare i coperchi (11).

8. Installare il coperchio (4) rimosso al punto 1.

- \* Per dispositivi MFP di fascia alta con/senza finisher e per dispositivi di fascia media con finisher installato.

#### 电话线的配线 (仅限高速 MFP 时)

6. 拆下盖板 (11), 将电话线如图所示穿过。  
※ 将传真系统 (OPT1) 的连接线整理成束。

7. 安装盖板 (11)。

8. 安装在步骤 1 中取下的盖板 (4)。

- ※ 对于高速机来说装订器可装可不装, 对于中速机来说要安装。

#### 모듈러 코드의 배선 (고속 MFP 의 경우만)

6. 커버 (11) 를 떼어 내고 모듈러 코드를 그림과 같이 지나가게 합니다.  
※ 팩스 시스템 (OPT1) 의 모듈러 코드와 묶어서 실행합니다.

7. 커버 (11) 을 장착합니다.

8. 1 단계에서 분리한 커버 (4) 를 설치합니다.

- ※ 피니셔 장착 및 비장착의 고속 MFP 및 피니셔 장착 중속 MFP.

#### モジュラーコードの配線 (高速 MFP の場合のみ)

6. カバー (11) を取り外し、モジュラーコードを図のように通す。  
※ ファクスシステム (OPT1) のモジュラーコードと束ねて通す。

7. カバー (11) を取り付ける。

8. 手順 1 で取り外したカバー (4) を取り付ける。

- ※ 高速 MFP の場合および中速 MFP にフィニッシャー装着時の場合。

**Initialize the FAX circuit board.**

1. Plug the MFP into a power outlet, and turn on the main power.
2. If the FAX PWBs were installed simultaneously to OPT1 and OPT2 (all Fax PWBs are initialized), perform the maintenance mode U600 to initialize the FAX PWBs.

**3. If the FAX circuit board has been added to OPT2 (to initialize the FAX circuit board in OPT2)**

Initialize OPT2 by pressing [PORT2], and the Start key in this order in the maintenance mode U698 and executing the maintenance mode U600. If [ALL] is selected in U698, both OPT1 and OPT2 are initialized. For details, see the service manual.

**Initialiser la carte à circuits FAX.**

1. Brancher le MFP sur une prise d'alimentation et le mettre sous tension.
2. Si les cartes de circuit imprimé du fax ont été installées en même temps que OPT1 et OPT2 (toutes les cartes de circuit imprimé du fax sont initialisées), exécuter le mode maintenance U600 pour initialiser les cartes de circuit imprimé du fax.

**3. Si la carte à circuits FAX a été ajoutée à l'OPT2 (pour initialiser la carte à circuits FAX dans l'OPT2)**

Initialiser l'OPT2 en appuyant sur [PORT2] et la touche Départ dans cet ordre en mode de maintenance U698, et exécuter le mode de maintenance U600. Si [ALL] est sélectionné dans U698, l'OPT1 et l'OPT2 sont tous deux initialisés. Pour plus de détails, se reporter au manuel d'entretien.

**Inicialice la tarjeta de circuitos FAX.**

1. Conecte el MFP a un receptáculo de pared y encienda el interruptor principal.
2. Si se instalaron FAX PWB simultáneamente a OPT1 y OPT2 (se inicializan todos los FAX PWB), ejecute el modo de mantenimiento U600 para inicializar los FAX PWB.

**3. Si la tarjeta de circuitos de FAX se agregó a OPT2 (para inicializar la tarjeta de circuitos de FAX en OPT2)**

Inicialice el OPT2 presionando [PORT2] y la tecla de Inicio en ese orden en el modo de mantenimiento U698 y ejecutando el modo de mantenimiento U600. Si se selecciona [ALL] en U698, se inicializan ambos OPT1 y OPT2. Para más detalles, lea el manual de servicio.

**Initialisieren der FAX-Leiterplatte.**

1. Netzstecker des MFP in eine Steckdose stecken und Hauptschalter einschalten.
2. Falls die FAX-Karten gleichzeitig in OPT1 und OPT2 installiert werden (alle FAX-Karten werden initialisiert), führen Sie den Wartungsmodus U600 aus, um die FAX-Karten zu initialisieren.

**3. Wenn die FAX-Leiterplatte zu OPT2 hinzugefügt worden ist (um die FAX-Leiterplatte in OPT2 zu initialisieren)**

OPT2 initialisieren. Dazu [PORT2] und die Start-Taste im Wartungsmodus U698 in dieser Reihenfolge drücken und den Wartungsmodus U600 ausführen. Wenn [ALL] in U698 gewählt wird, werden OPT1 und OPT2 initialisiert. Weitere Einzelheiten siehe Wartungsanleitung.

**Inizializzare la scheda a circuiti FAX.**

1. Collegare l'MFP ad una presa di corrente e portare l'interruttore principale su On.
2. Se sono state installate simultaneamente le schede FAX PWB su OPT1 e OPT2 (tutte le schede FAX PWB sono inizializzate), eseguire il modo manutenzione U600 per inizializzare le schede FAX PWB.

**3. Se la scheda a circuiti è stata aggiunta all'OPT2 (per inizializzare la scheda a circuiti FAX nell'OPT2)**

Inizializzare OPT2 premendo [PORT2] e il tasto Avvio in questo ordine nel modo di manutenzione U698 ed eseguendo il modo di manutenzione U600. Se viene selezionato [ALL] nel modo U698, entrambi OPT1 e OPT2 sono inizializzati. Per ulteriori dettagli leggere il manuale d'istruzioni.

**传真电话板的初始化**

1. 将 MFP 的电源插头插入电源插座，打开主电源。
2. 当把传真电路板同时安装到 OPT1 和 OPT2 时（全部的传真电路板初始化），执行维修保养模式 U600，初始化传真电路板。

**3. 在 OPT2 上增设时**

（OPT2 的传真电路板初始化）只进行 OPT2 初始化时，在维修保养模式 U698 状态下，按顺序按下“PORT2”、开始键，执行维修保养模式 U600。在 U698 状态下设定“ALL”时，会使 OPT1 和 OPT2 均初始化。有关详细信息，请参见维修手册。

**FAX 회로기판의 초기화**

1. MFP 본체 전원플러그를 콘센트에 꼽고 주 전원 스위치를 ON 으로 한다.
2. OPT1 과 OPT2 에 FAX 회로기판을 동시에 설치한 경우 ( 모든 FAX 회로기판이 초기화됨 ), 메인テナンス 모드 U600 을 수행하여 FAX 회로기판을 초기화합니다.

**3. OPT2 에 증설한 경우 (OPT2 의 FAX 기판을 초기화)**

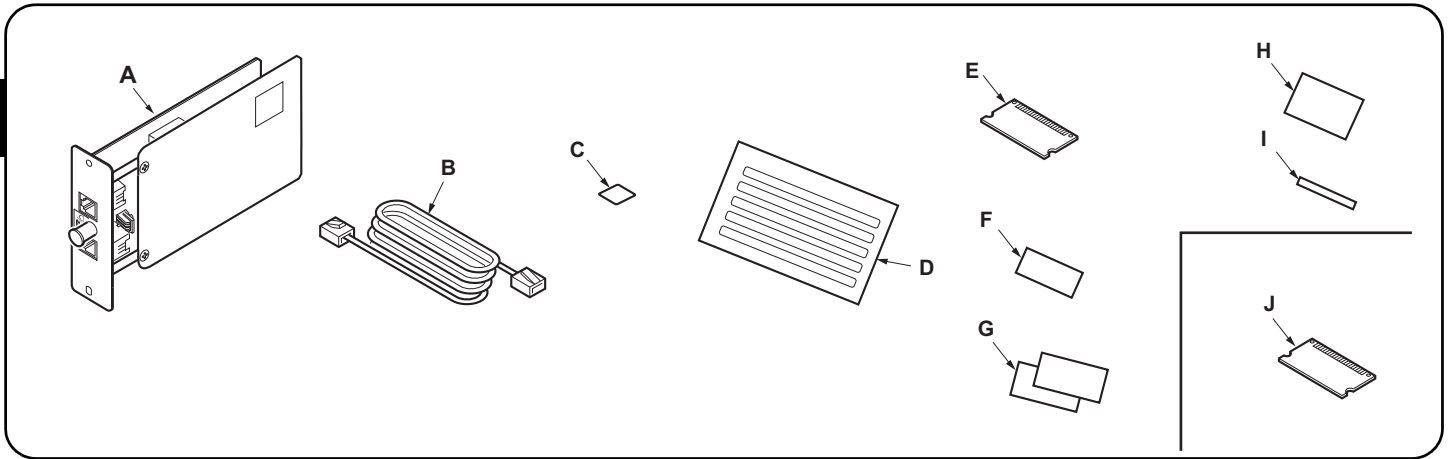
메인テナンス모드 U698 에서 「PORT2」, 시작키 순으로 누릅니다. 메인テナンス 모드 U600 을 실행하고 FAX 회로기판을 초기화합니다. U698 에서 「ALL」을 설정하면 OPT1 과 OPT2 양쪽을 초기화하기 때문에 주의할 것. 상세는 서비스 매뉴얼을 참조할 것.

**FAX 基板の初期化**

1. MFP 本体の電源プラグをコンセントに差し込み、主電源スイッチを ON にする。
2. OPT1 と OPT2 に FAX 基板を同時に設置した場合（すべての FAX 基板を初期化）メンテナンスモード U600 を実行し、FAX 基板を初期化する。

**3. OPT2 に増設した場合 (OPT2 の FAX 基板を初期化)**

メンテナンスモード U698 で「PORT2」、スタートキーの順に押す。メンテナンスモード U600 を実行し、FAX 基板を初期化する。U698 で「ALL」を設定すると OPT1 と OPT2 両方を初期化するので注意すること。詳細はサービスマニュアルを参照のこと。



**When installing the Fax system on a machine (B) which has the 'Accessibility Display' key in the operation panel**

**Supplied parts**

- A. FAX circuit board ..... 1
- B. Modular connector cable  
(120 V/Australian model only)  
PJJWC0016Z (UL Listed.HUAN HSIN  
Type TL:120 V only) ..... 1

- C. Terminal seal..... 1
- D. Alphabet label ..... 1
- E. Memory DIMM (16 MB) ..... 1
- F. PTT label (110V model only) ..... 1
- G. Approval label  
(Australian/New Zealand models only) ..... 2

**Option**

- J. Memory DIMM (128 MB) ..... 1  
(H) and (I) are not supplied.

Be sure to remove any tape and/or cushioning materials from the parts supplied.

**Lors de l'installation du fax sur une machine (B) disposant de la touche 'Affich. accessibilité' sur le panneau de commande**

**Pièces fournies**

- A. Carte à circuits FAX..... 1
- B. Câble du connecteur modulaire (modèles pour l'Australie/120 V seulement)..... 1
- C. Joint de borne..... 1
- D. Etiquette de l'alphabet..... 1

- E. Mémoire DIMM (16 MB) ..... 1
- Option**
- J. Mémoire DIMM (128 MB) ..... 1

Veillez à retirer les morceaux de bande adhésive et/ou les matériaux de rembourrage des pièces fournies.

(F),(G),(H) et (I) ne sont pas fournis.

**Al instalar el sistema de fax en una máquina (B) que dispone de la tecla 'Pantalla acceso' en el panel de controles**

**Partes suministradas**

- A. Tarjeta de circuitos de fax..... 1
- B. Cable conector modular (sólo para modelos de 120 V/Australianos)..... 1
- C. Sello del terminal..... 1
- D. Etiqueta de alfabeto..... 1

- E. Memoria DIMM (16 MB) ..... 1
- Opción**
- J. Memoria DIMM (128 MB) ..... 1

Asegúrese de quitar todas las cintas y/o material amortiguador de las partes suministradas.

(F),(G),(H) y (I) no se suministran.

**Bei Installation des FAX-Systems in einem Gerät (B), das über die Taste 'Zugriffsanzeige' im Bedienfeld verfügt**

**Enthaltene Teile**

- A. FAX-Leiterplatte ..... 1
- C. Verschlusskappe ..... 1
- D. Alphabetaufkleber..... 1
- E. Speicher-DIMM (16 MB) ..... 1

- Option**
- J. Speicher-DIMM (128 MB) ..... 1

Stellen Sie sicher, dass sämtliche Klebebänder und/oder Polstermaterial von den gelieferten Teilen entfernt wurden.

(B), (F), (G), (H) und (I) liegen nicht bei.

**Per l'installazione del modulo FAX su una macchina (B) dotata di tasto 'Visual. Accessibilità' sul pannello comandi**

**Parti fornite**

- A. Scheda a circuiti FAX ..... 1
- C. Guarnizione terminale ..... 1
- D. Etichetta alfabetica ..... 1
- E. Memoria DIMM (16 MB) ..... 1

- Opzioni**
- J. Memoria DIMM (128 MB) ..... 1

Rimuovere tutti i nastri adesivi e/o i materiali di protezione dalle parti fornite.

(B), (F), (G), (H) e (I) non sono in dotazione.

**当安装传真系统到那些操作面板上有 '扩大显示' 按键的机器 (B) 时**

**附属品**

- A. 传真电路板..... 1
- B. 电话线..... 1
- C. 端子密封..... 1
- D. 英文字母标签..... 1
- E. 内存模组 DIMM (16MB) ..... 1

- F. 规格标签 ..... 1
- H. 贴片 ..... 1
- I. 名称标签 ..... 1

(G) 并非附属品。不使用 (I)。

**选购件**

- J. 内存模组 DIMM (128MB) ..... 1

如果附属品上带有固定胶带, 缓冲材料时务必揭下。

**조작판넬에 '유니버설' 키가 있는 본체 (B) 에 팩스 시스템을 설치하는 경우**

**동봉품**

- A. FAX 기관 ..... 1
- C. 단자씰 ..... 1
- D. 알파벳 라벨..... 1
- E. 메모리 DIMM (16MB) ..... 1

- 옵션**
- J. 메모리 DIMM (128MB) ..... 1

동봉품에 고정 테이프, 완충재가 붙어 있는 경우에는 반드시 제거하십시오.

(B),(F),(G),(H),(I) 는 동봉되어 있지 않습니다.

**操作パネルに 'ユニバーサル' キーがある機械 (B) にファクスシステムを設置する場合**

**同梱品**

- A. FAX 基板 ..... 1
- B. モジュラーコード..... 1
- C. 端子シール..... 1
- E. メモリーDIMM(16MB)..... 1

- オプション**
- J. メモリーDIMM(128MB) ..... 1

同梱品に固定テープ、緩衝材がついている場合は、必ず取り外すこと。

(D), (F), (G), (H), (I) は、同梱されていない。

**NOTICE**

If the finisher is already installed, remove the finisher before installing FAX System(W).

Before starting installation, be sure to turn the main power switch of the machine off, and unplug the power plug from the wall outlet.

---

**REMARQUE**

Si le retoucheur est déjà en place, le déposer avant de monter le FAX System(W).

Avant de commencer l'installation, s'assurer de mettre la machine hors tension et de débrancher la fiche d'alimentation de la prise murale.

---

**AVISO**

Si el finalizador ya se encuentra instalado, desmóntelo antes de instalar el FAX System(W).

Antes de iniciar la instalación, asegúrese de apagar el interruptor de encendido de la máquina y desenchufar el cable de alimentación de la toma de pared.

---

**ANMERKUNG**

Falls der Finisher schon installiert ist, müssen Sie ihn ausbauen, bevor Sie das FAX System(W) installieren.

Bevor Sie mit der Installation beginnen überzeugen Sie sich, dass der Netzschalter des Geräts ausgeschaltet und das Stromkabel aus der Steckdose gezogen ist.

---

**AVVISO**

Se la finitrice è già installata, rimuovere la finitrice prima di installare il FAX System(W).

Prima di iniziare l'installazione, spegnere la macchina e scollegare la spina dalla presa di corrente.

---

**注意**

已安装装订器时，必须先拆下装订器再安装 FAX System(W)。

安装前务必关闭机器的主电源开关，并从墙壁插座拔下电源插头。

---

**주의**

피니셔가 이미 장착되어 있는 경우에는 피니셔를 제거하고 FAX System(W) 를 설치할 것 .

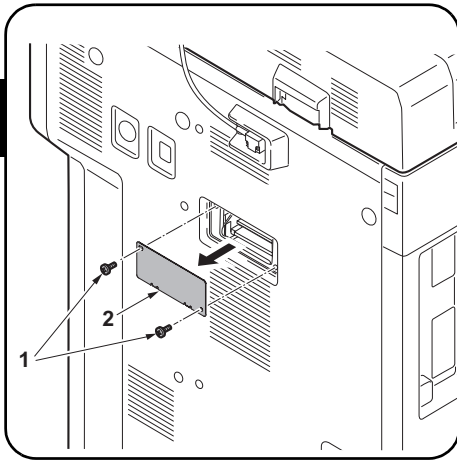
설치를 시작하기 전에 반드시 본체의 주 전원 스위치를 끄고 벽 콘센트에서 전원 플러그를 분리하십시오 .

---

**注意**

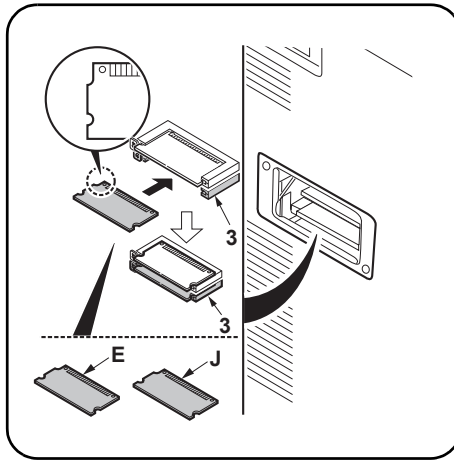
フィニッシャーがすでに装着されている場合は、フィニッシャーを取り外してから、FAX System(W) を取り付けること。

必ず機械本体の主電源スイッチをOFFにし、機械本体の電源プラグを抜いてから作業すること。



### Procedure Installing the memory DIMM

1. Remove 2 screws (1), and then remove the cover (2).



2. Install the memory DIMM (E) or the optional memory DIMM (J) into the memory slot (3) on the lower level (FLS).

Install it with the IC side facing down.

Insert it in the direction of the arrow until it clicks.

3. Reinstall the cover (2) using the 2 screws (1).

### Procédure Installation de la mémoire DIMM

1. Déposer les 2 vis (1) puis enlevez le couvercle (2).

2. Installer la mémoire DIMM (E) ou la mémoire DIMM en option (J) dans la fente mémoire (3) se trouvant au niveau inférieur (FLS).

L'installer avec le côté IC en bas.

L'insérer dans la direction de la flèche jusqu'au clic.

3. Reposez le couvercle (2) à l'aide des 2 vis (1).

### Procedimiento Instalación de la memoria DIMM

1. Quite 2 tornillos (1) y, después, desmonte la cubierta (2).

2. Instale la memoria DIMM (E), o la memoria DIMM opcional (J), en la ranura para memoria (3) en el nivel inferior (FLS).

Instálolo con el lado IC hacia abajo.

Insértela en la dirección que indica la flecha hasta que escuche un clic.

3. Vuelva a colocar la cubierta (2) utilizando los 2 tornillos (1).

### Vorgehensweise Installation der DIMM-Speichermodule

1. Entfernen Sie 2 Schrauben (1) und nehmen Sie dann die Abdeckung (2) ab.

2. Setzen Sie das DIMM-Speichermodul (E) oder das optionale DIMM-Speichermodul (J) in die untere Position (FLS) der Speicherbank (3) ein.

Mit der IC-Seite nach untenweisend installieren.

Schieben Sie das Modul in Pfeilrichtung, bis es hörbar einrastet.

3. Setzen Sie die Abdeckung (2) wieder mit den 2 Schrauben (1) an.

### Procedura Installazione della memoria DIMM

1. Rimuovere 2 viti (1), e quindi rimuovere il coperchio (2).

2. Installare la memoria DIMM (E) o la memoria DIMM opzionale (J) nello slot della memoria (3) al livello inferiore (FLS).

Installare con il lato IC rivolto verso il basso.

Inserirla nella direzione della freccia finché non scatta in posizione.

3. Reinstallare il coperchio (2) utilizzando le 2 viti (1).

### 安装步骤 安装内存模组 DIMM

1. 取下 2 个螺丝 (1)，然后取下盖板 (2)。

2. 将内存模组 DIMM (E) 或选购件内存模组 DIMM (J) 安装至下层 (FLS) 的内存插槽 (3)。安装时，将 IC 侧正面朝下。沿箭头方向将其插入到底直至发出喀嗒声。

3. 使用 2 个螺丝 (1) 重新安装盖板 (2)。

### 설치순서 메모리 DIMM 설치

1. 나사 (1) 2 개를 제거하고 커버 (2) 를 제거합니다.

2. 메모리 DIMM (E) 또는 옵션 메모리 DIMM (J) 를 하단 (FLS) 의 메모리 슬롯 (3) 에 장착합니다. IC 면을 밑으로 할 것. 딸깍하고 소리가 날 때까지 화살표 방향으로 삽입합니다.

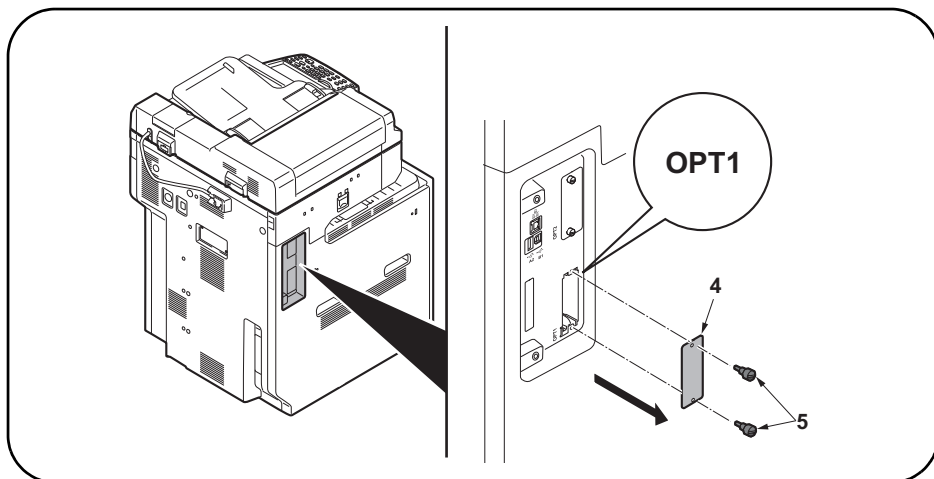
3. 나사 (1) 2 개로 커버 (2) 를 원래대로 장착합니다.

### 取付手順 メモリーDIMMの取り付け

1. ビス (1) 2 本を外し、カバー (2) を取り外す。

2. メモリーDIMM (E) または、オプションのメモリーDIMM (J) を下段 (FLS) のメモリースロット (3) に取り付ける。IC面を下向きに取り付けること。カチッと音がするまで矢印方向に挿入する。

3. ビス (1) 2 本で、カバー (2) を元通り取り付け。



#### Removing the slot cover

4. Remove 2 screws (5) and then remove the OPT1 slot cover (4).

\* Do not use OPT2.

#### Dépose du couvercle de la fente

4. Déposer les 2 vis (5) puis le couvercle de la fente OPT1 (4).

\* Ne pas utiliser OPT2.

#### Desmontaje de la cubierta de la ranura

4. Quite 2 tornillos (5) y, después, quite la cubierta de la ranura OPT1 (4).

\* No utilice OPT2.

#### Entfernen der Einschubabdeckung

4.2 Schrauben (5) entfernen und dann die Abdeckung (4) des Einschubs OPT1 entfernen.

\* OPT2 nicht verwenden.

#### Rimozione del coperchio vano

4. Rimuovere le 2 viti (5) e quindi rimuovere il coperchio (4) del vano OPT1.

\* Non utilizzare OPT2.

#### 拆下插槽盖板

4. 拆除 2 颗螺丝 (5)，拆下 OPT1 的插槽盖板 (4)。

※ 不使用 OPT2。

#### 슬롯커버 제거

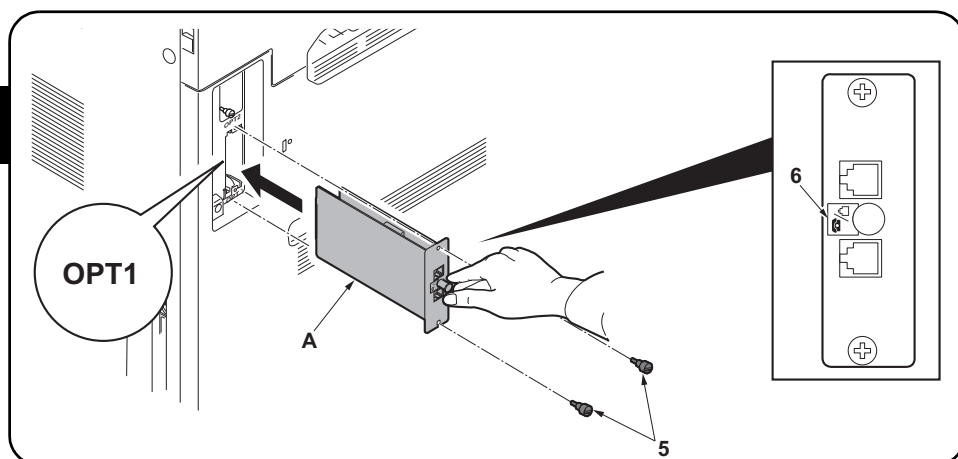
4. 나사 (5) 2 개를 제거하고 OPT1 의 슬롯커버 (4) 를 제거합니다 .

※ OPT2 는 사용하지 말 것 .

#### スロットカバーの取り外し

4. ビス (5) 2 本を外し、OPT1 のスロットカバー (4) を取り外す。

※OPT2 は使用しないこと。



#### Install the FAX circuit board.

5. Insert the FAX circuit board (A) along the groove in OPT1 and secure the board with two screws (5) that have been removed in step 4.

Do not directly touch the FAX circuit board (A) terminal. Hold the top and bottom of the FAX circuit board, or the projection of the board to insert the FAX circuit board (A).

Direct the label (6) on to the FAX circuit board (A) as indicated in the illustration and insert the board along the groove.

#### Installer la carte à circuits FAX.

5. Insérer la carte à circuits FAX (A) le long de la rainure dans l'OPT1 et la fixer à l'aide des deux vis (5) retirées à l'étape 4.

Ne pas toucher directement la borne de la carte à circuits FAX (A). Tenir les parties inférieure et supérieure de la carte à circuits FAX ou la saillie de la carte pour insérer la carte à circuits FAX (A). Orienter l'étiquette (6) de la carte à circuits FAX (A) comme illustré et insérer la plaquette le long de la rainure.

#### Instale la tarjeta de circuitos de fax.

5. Inserte la tarjeta de circuitos de fax (A) a lo largo de la ranura de OPT1 y asegúrela con los dos tornillos (5) que ha quitado en el paso 4.

No toque directamente el terminal de la tarjeta de circuitos del fax (A). Sujete las partes superior e inferior de la tarjeta de circuitos de fax o la saliente de la tarjeta para insertar la tarjeta de circuitos de fax (A). Oriente la etiqueta (6) en la tarjeta de circuitos del FAX (A) como se indica en la ilustración e inserte la tarjeta a lo largo de la ranura.

#### Installieren der FAX-Leiterplatte.

5. FAX-Leiterplatte (A) in die Nut des Einbauschachts OPT1 einsetzen und Leiterplatte mit den in Schritt 4 ausgebauten Schrauben (5) befestigen.

Berühren Sie die Anschlüsse der FAX-Platine (A) nicht mit den Fingern. Die FAX-Leiterplatte (A) beim Einsetzen oben und unten oder an dem Vorsprung festhalten.

Die FAX-Leiterplatte (A) so in die Nut einsetzen, dass der Aufkleber (6) wie abgebildet zur Leiterplatte zeigt.

#### Installare la scheda a circuiti FAX.

5. Inserire la scheda a circuiti FAX (A) lungo l'incavo nell'OPT1 e fissare la scheda con le due viti (5) rimosse nell'operazione 4.

Non toccare direttamente il terminale della scheda a circuiti FAX (A). Per inserire il circuito FAX (A), tenere l'estremità superiore e la base della scheda a circuiti FAX, o la sporgenza della scheda a circuiti FAX. Orientare l'etichetta (6) sulla scheda a circuiti FAX (A) come indicato nell'illustrazione e inserire la scheda lungo l'incavo.

#### 安装传真电路板

5. 沿着 OPT1 的沟槽插入传真电路板 (A) 并用步骤 4 中拆下的两颗螺钉 (5) 固定电路板。

请勿直接接触传真电路板 (A) 端子。

按住传真电路板的顶部和底部, 或者按住电路板的突出部将传真电路板 (A) 插入。

将传真电路板 (A) 上的标签 (6) 保持图示中的方向, 将电路板沿着沟槽方向插入。

#### FAX 회로기판 장착

5. OPT1 의 홈을 따라 FAX 회로기판 (A) 를 삽입하고 앞 순서 4 에서 제거한 나사 (5) 2 개로 고정합니다.

FAX 회로기판 (A) 의 단자에 직접 닿지 않도록 할 것.

FAX 회로기판 (A) 삽입 시, 회로기판의 상하 또는 돌출부를 잡을 것.

FAX 회로기판 (A) 를 부착된 라벨 (6) 그림 표기 방향으로 삽입할 것.

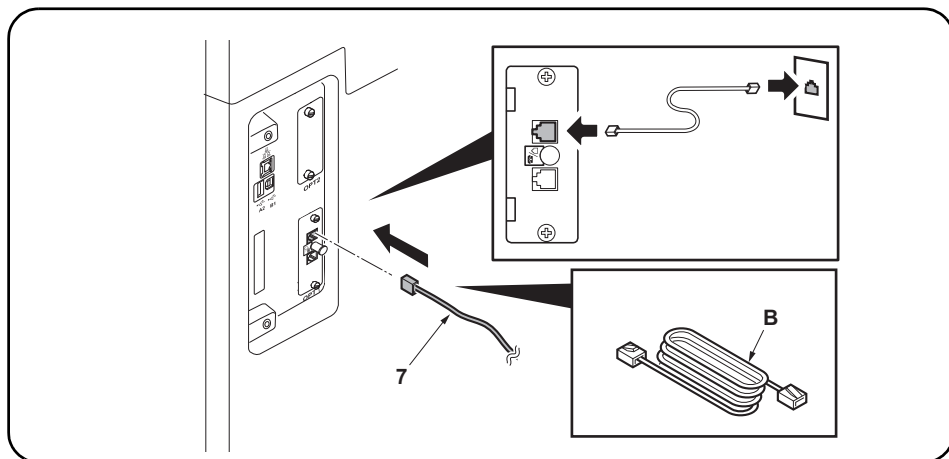
#### FAX 基板の取り付け

5. OPT1 の溝に沿って FAX 基板 (A) を挿入し、手順 4 で外したビス (5) 2 本で固定する。

FAX 基板 (A) の端子に直接触れないこと。

FAX 基板 (A) の挿入時は基板の上下か突起を持つこと。

FAX 基板 (A) は、貼り付けられているラベル (6) が図に示す方向になるように、挿入すること。



#### Connect the MFP to the telephone line.

6. Plug the modular connector cable (7) into the line terminal, and then connect the other end to the telephone line.

For 100 V/120 V/Australian or Chinese models, use the supplied modular connector cable (B).

#### Connecter le MFP à la ligne de téléphone.

6. Brancher le câble du connecteur modulaire (7) à la borne de la ligne, puis connecter l'autre extrémité à la ligne de téléphone.

Pour les modèles 100 V/120 V/Australie ou Chine, utilisez le câble à connecteur modulaire (B) fourni.

#### Conecte el MFP a la línea telefónica.

6. Enchufe el cable del conector modular (7) en el terminal de línea y, a continuación, conecte el otro extremo a la línea telefónica.

Para los modelos de 100 V/120 V/Australiano o Chino, utilice el cable conector modular (B) suministrado.

#### Anschließen des MFP an die Telefonleitung.

6. Telefonmodulkabel (7) in die Gerätebuchse einstecken und das Kabel an der Telefondose anschließen.

Das mitgelieferte Modularsteckerkabel (B) für die 100-V/120-V/Australien- oder China-Modelle verwenden.

#### Collegamento dell'MFP alla linea del telefono.

6. Inserire il cavo connettore modulare (7) nel terminale della linea, e quindi collegare l'altro terminale alla linea del telefono.

Per modelli da 100 V/120 V/Australia o Cina, utilizzare il cavo connettore modulare (B) in dotazione.

#### 将 MFP 连接到电话线

6. 将模块接插件电缆 (7) 插入电话线端子, 然后将另一端与电话线连接。

对于 100V/120V/ 澳大利亚或中国机型, 请使用随附的模块接插件电缆 (B)。

#### 전화회선 연결

6. 모듈 코드 (7) 을 라인단자에 꽂습니다. 다른 한 쪽의 플러그는 전화회선과 연결합니다.

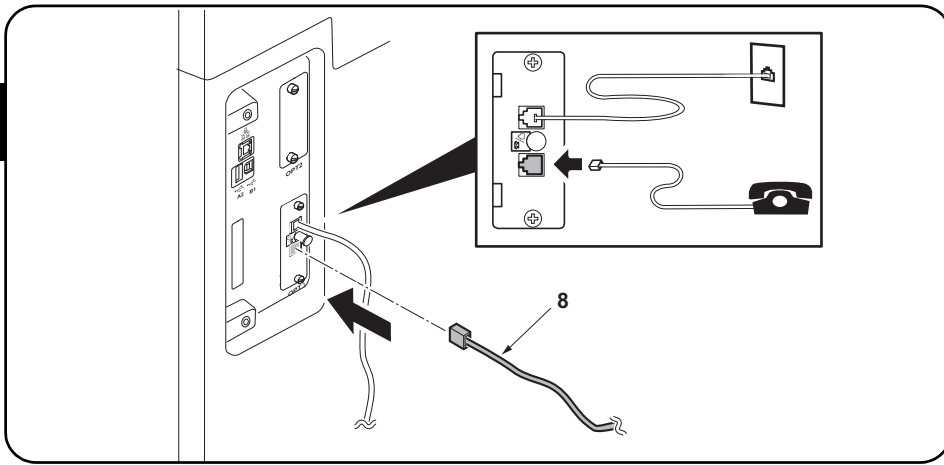
100V/120V/ 오스트레일리아 / 중국사양은 부속 모듈러 코드 (B) 를 사용할 것.

#### 電話回線との接続

6. モジュラーコード (7) をライン端子に差し込む。もう片方のプラグは、電話回線へ接続する。

100V/120V/ オーストラリア / 中国仕様は付属のモジュラーコード (B) を使用すること。





**Connect the MFP to the separate phone ).**

7. Plug the modular connector cable (8) into the telephone terminal, and then connect the other end to the separate phone.

**Connecter le MFP au téléphone séparé.**

7. Brancher le câble du connecteur modulaire (8) à la borne du téléphone, puis connecter l'autre extrémité au téléphone séparé.

**Conecte el MFP al teléfono separado.**

7. Enchufe el cable del conector modular (8) en el terminal del teléfono y, a continuación, conecte el otro extremo al teléfono separado.

**Anschließen des MFP an das separate Telefon.**

7. Das Telefonmodulkabel (8) in die Telefonbuchse einstecken und das andere Ende an das separate Telefon anschließen.

**Collegamento dell'MFP al telefono separato.**

7. Inserire il cavo connettore modulare (8) nel terminale del telefono, e quindi collegare l'altro terminale al telefono separato.

**将 MFP 连接到其它电话**

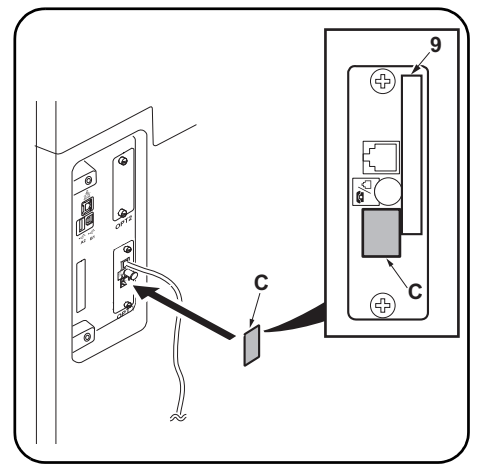
7. 将模块接插件电缆 (8) 插入电话端子, 然后将另一端与其他电话连接。

**외부 전화와 연결**

7. 모듈코드 (8) 를 TEL 단자에 꽂습니다. 다른 한 쪽의 플러그는 외부 전화와 연결합니다.

**外付け電話との接続**

7. モジュラーコード (8) を TEL 端子に差し込む。もう片方のプラグは、外付け電話と接続する。



If you don't connect the MFP to the separate phone, wipe the surface of the telephone terminal with alcohol and adhere the terminal seal (C) upon the customer's request.

On 120 V models, be sure that it is not attached over the top of the approval label (9).

Si le MFP n'est pas connecté au téléphone séparé à la demande du client, nettoyer la surface de la borne de téléphone avec de l'alcool et apposer le joint de borne (C).

Sur les modèles 120 V, attention à ne pas installer en recouvrant le haut de l'étiquette d'approbation (9).

Si no conecta el MFP a un teléfono separado, limpie la superficie del terminal del teléfono con alcohol y pegue el sello del terminal (C), a solicitud del cliente.

En los modelos de 120 V, asegúrese de que no se fije sobre la etiqueta de aprobación (9).

Wenn der MFP nicht an das separate Telefon angeschlossen wird, die Oberfläche der Telefonbuchse mit Alkohol abwischen und Verschlusskappe (C) einsetzen, falls vom Kunden gewünscht.

Bei 120-V-Modellen darauf achten, dass der Aufkleber nicht den Genehmigungsaufkleber (9) verdeckt.

Nel caso in cui non si colleghi l'MFP al telefono separato, pulire la superficie del terminale del telefono con dell'alcol e applicare la guarnizione terminale (C) a richiesta del cliente.

Sui modelli da 120 V, assicurarsi che essa non venga applicata sopra l'etichetta di approvazione (9).

如果您没有将 MFP 连接至其他电话, 请用酒精擦拭电话端子表面, 并按照客户要求粘上端子密封 (C)。

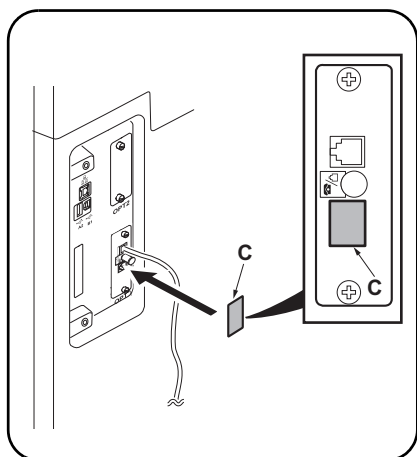
120V 规格在粘贴时注意不要与认可标签 (9) 重叠。

외부 전화와 연결하지 않는 경우 고객의 요청에 따라 TEL 단자 주위를 알코올 청소하고 단자씰 (C) 을 붙입니다.

120V 사양은 허가 라벨 (9) 에 겹치지 않도록 붙일 것.

外付け電話と接続しない場合、お客様の要望により、TEL 端子周囲をアルコール清掃し、端子シール (C) を貼り付ける。

120V仕様は認可ラベル (9) に重ならないように、貼りつけること。



**Seal the terminal  
(for New Zealand model)**

8. Wipe the surface of the telephone terminal with alcohol and adhere the terminal seal (C).  
Perform this procedure for New Zealand model only.

**Fermer hermétiquement la borne  
(modèle pour la Nouvelle-Zélande)**

8. Cette étape est superflue.

**Selle el terminal  
(para el modelo Nuevo Zelandés)**

8. Este paso no es necesario.

**Versiegeln der Anschlussbuchse  
(für Neuseeland-Modell)**

8. Dieser Schritt ist nicht erforderlich.

**Sigillare il terminale  
(per il modello Nuova Zelanda)**

8. Questo passo non è richiesto.

**安装端子密封（仅适用于新西兰型号）**

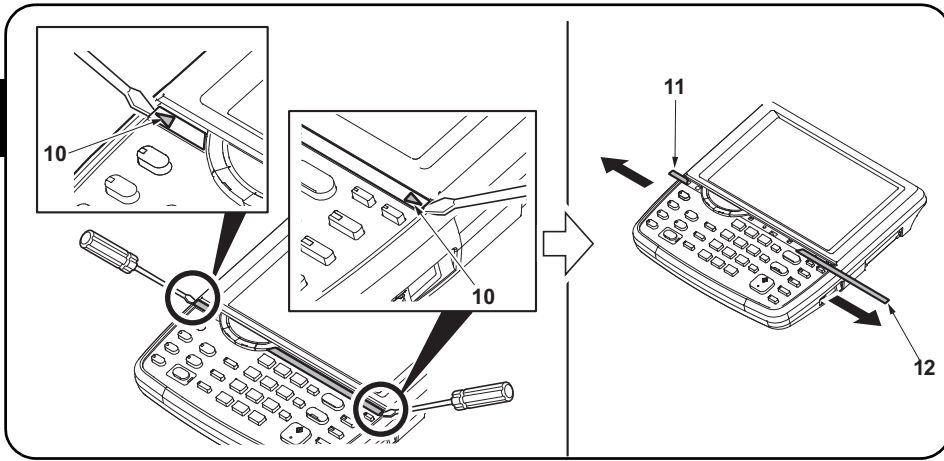
8. 不需要本步骤。

**단자씰의 부착 (뉴질랜드 사양만)**

8. 이 단계가 필요하지 않습니다.

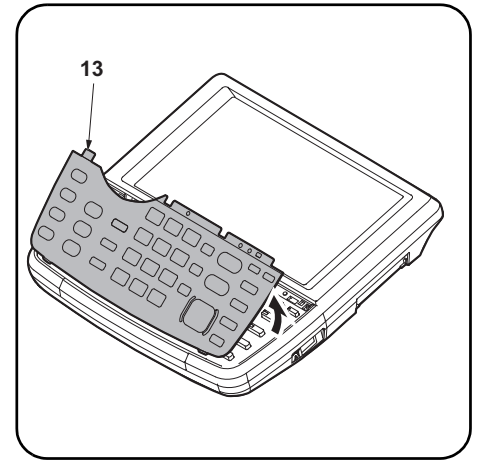
**端子シールの貼り付け  
(ニュージーランド仕様のみ)**

8. この作業は不要。



**Attach the alphabet labels (excluding 100 V models).**

9. Insert a flat-head screwdriver at the tip indicated by the arrows (10) as shown on the left, and slide the operation panel covers (11) (12) to remove them.



10. Remove the clear panel (13).

**Apposer les étiquettes de l'alphabet (Sauf sur les modèles 100 V).**

9. Insérer un tournevis à lame à l'endroit repéré par les flèches (10) comme illustré ci-contre à gauche et faire glisser les couvercles du panneau de commande (11) (12) pour les déposer.

10. Déposer le panneau transparent (13).

**Fije las etiquetas de alfabeto (a excepción de los modelos de 100 V).**

9. Inserte un destornillador de pala plana en la punta que indican las flechas (10) como se muestra a la izquierda y deslice las cubiertas del panel de trabajo (11) (12) para quitarlas.

10. Quite el panel transparente (13).

**Anbringen der Alphetaufkleber (ausgenommen 100-V-Modelle).**

9. Einen flachen Schraubendreher an der links mit Pfeilen (10) bezeichneten Spitze einschieben und die Bedienfeldabdeckungen (11) (12) verschieben, um sie dann abzunehmen.

10. Die durchsichtige Platte (13) entfernen.

**Applicare le etichette alfabetiche (esclusi i modelli da 100 V).**

9. Inserire un cacciavite a testa piana nel punto indicato dalla freccia (10) come mostrato sulla sinistra, e slittare i coperchi (11) (12) del pannello operativo per rimuoverli.

10. Rimuovere il pannello trasparente (13).

**粘貼英文字母标签 (100V 规格以外)**

9. 如图所示, 在▲箭头(10)前方插入一字螺丝刀, 滑动并取下操作面板的盖板(11)(12)。

10. 拆下透明面板(13)。

**알파벳 라벨의 부착 (100V 사양 이외)**

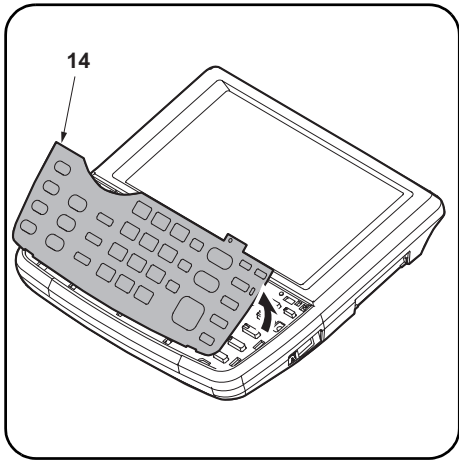
9. 그림과 같이 ▲ 표시 (10) 앞에 일자 드라이버를 삽입해 조작 판넬의 커버 (11) (12) 를 밀면서 떼어 냅니다 .

10. 클리어 판넬 (13) 을 제거합니다 .

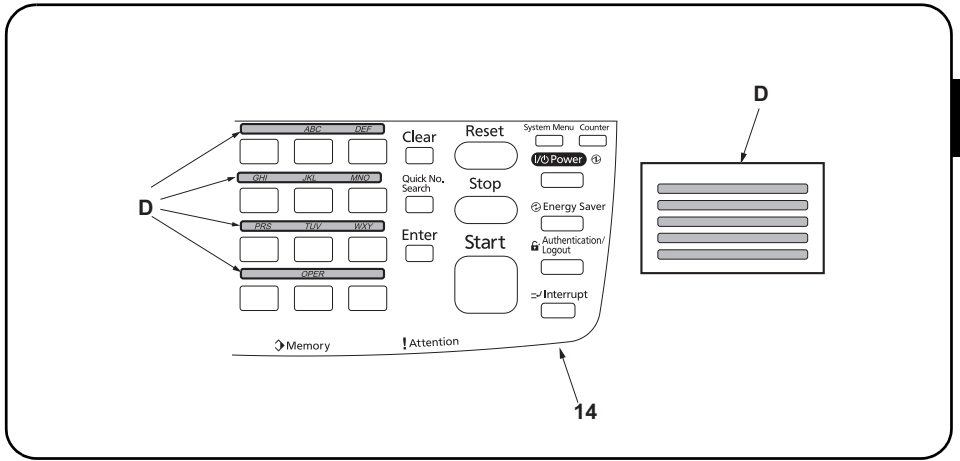
**アルファベットラベルの貼り付け (100V仕様以外)**

9. この作業は不要。

10. この作業は不要。



11. Remove the operation panel sheet (14).



12. Wipe the area above the numeric keys on the operation panel sheet (14) with alcohol and attach the alphabet labels (D).  
In Asia and Oceania, use PQRS TUV WXYZ label, and do not use PRS TUV WXY and OPER labels.

11. Déposer la tôle du panneau de commande (14).

12. Nettoyer à l'alcool la surface au-dessus des touches numériques sur la tôle du panneau de commande (14) et apposer les étiquettes alphabétiques (D).  
En Asie et Océanie, utiliser l'étiquette PQRS TUV WXYZ et pas les étiquettes PRS TUV WXY et OPER.

11. Quite la hoja del panel de trabajo (14).

12. Limpie el área sobre las teclas numéricas de la hoja del panel de trabajo (14) con alcohol y fije las etiquetas de alfabeto (D).  
En Asia y Oceanía, utilice la etiqueta PQRS TUV WXYZ y no use las PRS TUV WXY ni las OPER.

11. Die Bedienfeldfolie (14) entfernen.

12. Den Bereich über den Zifferntasten an der Bedienfeldfolie (14) mit Alkohol abwischen und die Alphabetaufkleber (D) hier anbringen.  
In Asien und Ozeanien den Aufkleber PQRS TUV WXYZ verwenden; nicht die Aufkleber PRS TUV WXY und OPER verwenden.

11. Rimuovere il foglio (14) del pannello operativo.

12. Pulire l'area sopra i tasti numerici sul foglio del pannello operativo (14) con alcool ed applicare le etichette alfabetiche (D).  
In Asia ed Oceania, utilizzare l'etichetta PQRS TUV WXYZ e non utilizzare le etichette PRS TUV WXY e OPER.

11. 拆下操作面板页 (14)。

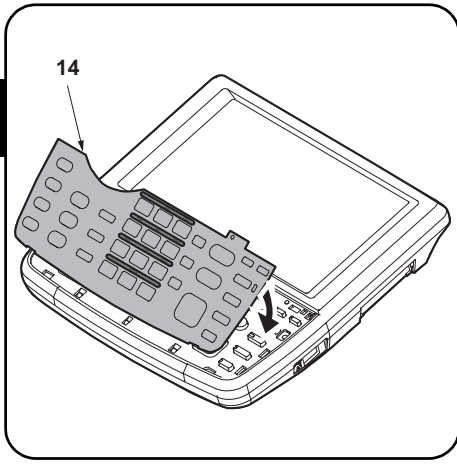
12. 使用酒精清洁操作面板页 (14) 的数字键上部, 粘贴英文字母标签 (D)。  
在亚洲和大洋州, 请使用 PQRS TUV WXYZ 标签, 而不要使用 PRS TUV WXY 和 OPER 标签。

11. 조작판넬시트 (14) 를 제거합니다 .

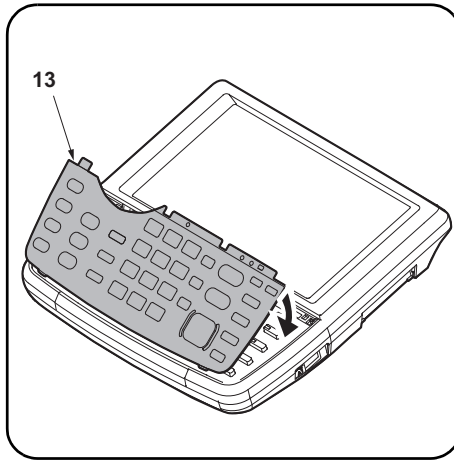
12. 조작판넬시트 (14) 상에 숫자키 윗측을 알코올을 청소하고 알파벳 라벨 (D) 을 붙입니다 .  
아시아 / 오세아니아에서는 「PRS TUV WXY」 및 「OPER」 라벨을 사용하지 말고 「PQRS TUV WXYZ」의 라벨을 사용할 것 .

11. この作業は不要。

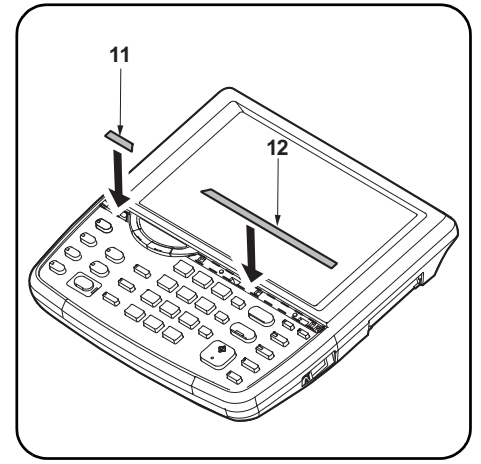
12. この作業は不要。



13. Attach the operation panel sheet (14).



14. Reinstall the clear panel (13).



15. Reinstall the operation panel covers (11) (12).

13. Fixer la tôle du panneau de commande (14).

14. Reposer le panneau transparent (13).

15. Reposer les couvercles du panneau de commande (11) (12).

13. Fije la hoja del panel de trabajo (14).

14. Vuelva a instalar el panel transparente (13).

15. Vuelva a instalar las cubiertas del panel de trabajo (11) (12).

13. Die Bedienfeldfolie (14) anbringen.

14. Die durchsichtige Platte (13) wieder anbringen.

15. Die Bedienfeldabdeckungen (11) (12) wieder anbringen.

13. Applicare il foglio del pannello operativo (14).

14. Reinstallare il pannello trasparente (13).

15. Reinstallare i coperchi (11) (12) del pannello operativo.

13. 安装操作面板页 (14)。

14. 安装透明面板 (13)。

15. 安装操作面板的盖板 (11) (12)。

13. 조작판넬시트 (14) 를 붙입니다 .

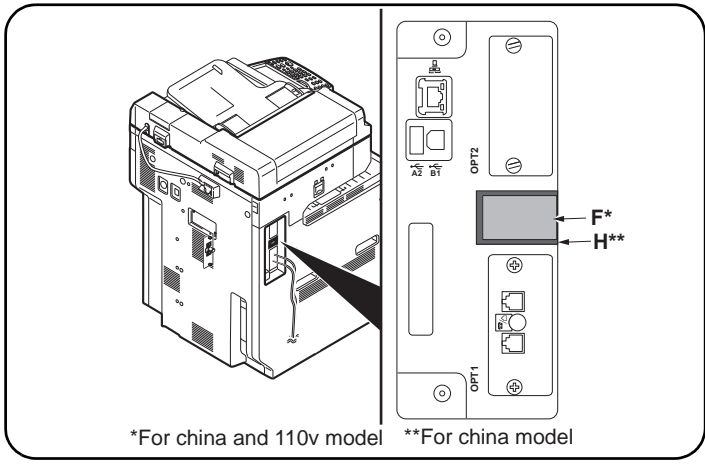
14. 클리어판넬 (13) 를 부착합니다 .

15. 조작판넬 커버 (11) (12) 을 부착합니다 .

13. この作業は不要。

14. この作業は不要。

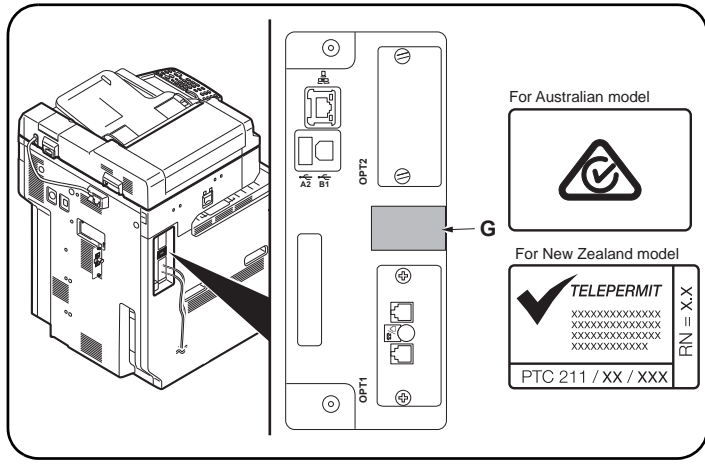
15. この作業は不要。



\*For china and 110v model \*\*For china model

**Attach the PTT label (for 110 V model only).**

16. Attach the PTT label (F) at the point as shown above after wiping with alcohol.



**Attach the approval label (for Australian/New Zealand model only).**

17. Attach the approval label (G) at the point as shown above after wiping with alcohol.

Perform this procedure for Australian/New Zealand model only.

**Fixer l'étiquette d'approbation (pour la Chine, modèles 110 V seulement).**

16. Cette étape est superflue.

**Fixer l'étiquette d'approbation (modèle pour l'Australie/Nouvelle-Zélande seulement).**

17. Cette étape est superflue.

**Coloque la etiqueta de aprobación (para China, solo para los modelos de 110 V).**

16. Este paso no es necesario.

**Coloque la etiqueta de aprobación (sólo para los modelos Australiano/Nuevo Zelandés)**

17. Este paso no es necesario.

**Den Genehmigungsaufkleber anbringen (für China nur 110-V-Modelle).**

16. Dieser Schritt ist nicht erforderlich.

**Den Genehmigungsaufkleber anbringen (nur für Australien/Neuseeland-Modell).**

17. Dieser Schritt ist nicht erforderlich.

**Applicare l'etichetta di approvazione (per Cina, solo per i modelli da 110 V).**

16. Questo passo non è richiesto.

**Applicare l'etichetta di approvazione (solo per il modello Australia/ Nuova Zelanda)**

17. Questo passo non è richiesto.

**粘貼規格標籤 ( 仅限中国规格 )**

16. 在粘貼標籤或貼片前，請用酒精清潔粘貼位置。按照圖示位置來粘貼貼片 (H)。把規格標籤 (F) 粘貼在貼片 (H) 上面。

**粘貼規格標籤 ( 仅适用于澳大利亚 / 新西兰型号 )**

17. 不需要本步驟。

**규격라벨의 부착 ( 중국 , 110V 사양만 )**

16. 이 단계가 필요하지 않습니다 .

**규격라벨의 부착 ( 오스트레일리아 / 뉴질랜드 사양만 )**

17. 이 단계가 필요하지 않습니다 .

**規格ラベルの貼り付け ( 中国、110V 仕様のみ )**

16. この作業は不要。

**規格ラベルの貼り付け ( オーストラリア / ニュージーランド仕様のみ )**

17. この作業は不要。

**Initialize the FAX circuit board.**

1. Plug the MFP into a power outlet, and turn on the main power.
2. Perform the maintenance mode U600 to initialize the FAX PWBs

---

**Initialiser la carte à circuits FAX.**

1. Brancher le MFP sur une prise d'alimentation et le mettre sous tension.
2. Exécuter le mode maintenance U600 pour initialiser les cartes de circuit imprimé du fax .

---

**Inicialice la tarjeta de circuitos FAX.**

1. Conecte el MFP a un receptáculo de pared y encienda el interruptor principal.
2. Ejecute el modo de mantenimiento U600 para inicializar los FAX PWB.

---

**Initialisieren der FAX-Leiterplatte.**

1. Netzstecker des MFP in eine Steckdose stecken und Hauptschalter einschalten.
2. Führen Sie den Wartungsmodus U600 aus, um die FAX-Karte zu initialisieren.

---

**Questo passo non è richiesto. Inizializzare la scheda a circuiti FAX.**

1. Collegare l'MFP ad una presa di corrente e portare l'interruttore principale su On.
2. Eseguire il modo manutenzione U600 per inizializzare le schede PWB FAX.

---

**传真电话板的初始化**

1. 将 MFP 的电源插头插入电源插座，打开主电源。
2. 执行维修保养模式 U600，初始化传真电路板。

---

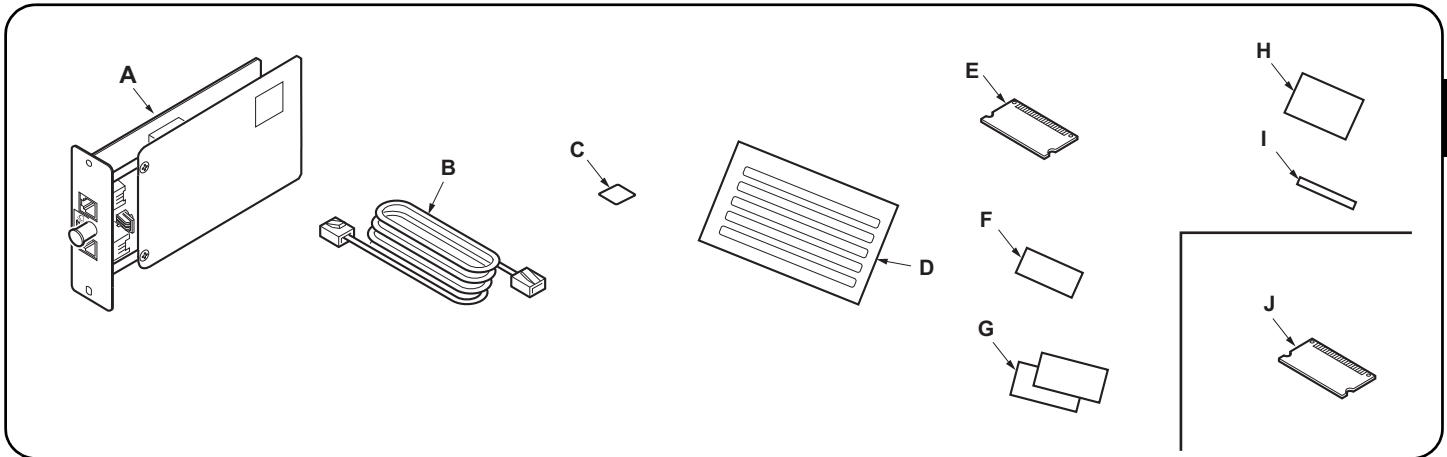
**FAX 회로기판의 초기화**

1. MFP 본체 전원플러그를 콘센트에 꽂고 주 전원 스위치를 ON 으로 한다 .
2. 메인テナンス 모드 U600 을 수행하여 FAX 회로기판을 초기화합니다 .

---

**FAX 基板の初期化**

1. MFP 本体の電源プラグをコンセントに差し込み、主電源スイッチを ON にする。
2. メンテナンスモード U600 を実行し、FAX 基板を初期化する。



**When installing the multiport on a machine (B) which has the 'Accessibility Display' key in the operation panel**

<b>Supplied parts</b>		<b>Option</b>
A. FAX circuit board ..... 1	C. Terminal seal..... 1	J. Memory DIMM (128 MB) ..... 1
B. Modular connector cable (120 V/Australian model only) PJJWC0016Z (UL Listed.HUAN HSIN Type TL:120 V only) ..... 1	D. Alphabet label ..... 1	(H) and (I) are not supplied.
	E. Memory DIMM (16 MB) ..... 1	(D), (E), (F), (G) and (J) are not used.
	F. PTT label (110V model only) ..... 1	Be sure to remove any tape and/or cushioning materials from the parts supplied.
	G. Approval label (Australian/New Zealand models only) ..... 2	

**Lors de l'installation du port multiple sur une machine (B) disposant de la touche 'Affich. accessibilité' sur le panneau de commande**

<b>Pièces fournies</b>		<b>Option</b>
A. Carte à circuits FAX..... 1	E. Mémoire DIMM (16 MB) ..... 1	(D), (E) et (J) ne sont pas utilisés.
B. Câble du connecteur modulaire (modèles pour l'Australie/120 V seulement)..... 1	J. Mémoire DIMM (128 MB) ..... 1	Veillez à retirer les morceaux de bande adhésive et/ou les matériaux de rembourrage des pièces fournies.
C. Joint de borne..... 1	(F), (G), (H) et (I) ne sont pas fournis.	
D. Etiquette de l'alphabet..... 1		

**Al instalar un puerto múltiple en una máquina (B) que dispone de la tecla 'Pantalla acceso' en el panel de controles**

<b>Partes suministradas</b>		<b>Opción</b>
A. Tarjeta de circuitos de fax..... 1	E. Memoria DIMM (16 MB) ..... 1	(D), (E) y (J) no se utilizan.
B. Cable conector modular (sólo para modelos de 120 V/Australianos)..... 1	J. Memoria DIMM (128 MB) ..... 1	Asegúrese de quitar todas las cintas y/o mate- rial amortiguador de las partes suministradas.
C. Sello del terminal..... 1	(F), (G), (H) y (I) no se suministran.	
D. Etiqueta de alfabeto..... 1		

**Bei Installation einer zweiten Leitung in einem Gerät (B), das über die Taste 'Zugriffsanzeige' im Bedienfeld verfügt**

<b>Enthaltene Teile</b>		<b>Option</b>
A. FAX-Leiterplatte..... 1	J. Speicher-DIMM (128 MB) ..... 1	Stellen Sie sicher, dass sämtliche Klebebänder und/oder Polstermaterial von den gelieferten Teilen entfernt wurden.
C. Verschlusskappe ..... 1	(B), (F), (G), (H) und (I) liegen nicht bei.	
D. Alphabetaufkleber..... 1	(D), (E) und (J) werden nicht benötigt.	
E. Speicher-DIMM (16 MB) ..... 1		

**Per l'installazione di una porta multipla su una macchina (B) dotata di tasto 'Visual. Accessibilità' sul pannello comandi**

<b>Parti fornite</b>		<b>Opzioni</b>
A. Scheda a circuiti FAX ..... 1	J. Memoria DIMM (128 MB) ..... 1	Rimuovere tutti i nastri adesivi e/o i materiali di protezione dalle parti fornite.
C. Guarnizione terminale ..... 1	(B), (F), (G), (H) e (I) non sono in dotazione.	
D. Etichetta alfabetica ..... 1	(D), (E) e (J) non sono utilizzati.	
E. Memoria DIMM (16 MB) ..... 1		

**当安装双路传真系统到那些操作面板上有 '扩大显示' 按键的机器 (B) 时**

<b>附属品</b>		<b>选购件</b>
A. 传真电路板..... 1	F. 规格标签 ..... 1	J. 内存模组 DIMM (128MB) ..... 1
B. 电话线..... 1	H. 贴片 ..... 1	(G) 并非附属品。
C. 端子密封..... 1	I. 名称标签 ..... 1	不使用 (D), (E), (F), (H), (I), 和 (J)。
D. 英文字母标签..... 1		
E. 内存模组 DIMM (16MB) ..... 1		

**조작판넬에 '유니버설' 키가 있는 본체 (B) 에 멀티 포트를 설치하는 경우**

<b>동봉품</b>		<b>옵션</b>
A. FAX 기관 ..... 1	J. 메모리 DIMM (128MB) ..... 1	동봉품에 고정 테이프, 완충재가 붙어 있는 경 우에는 반드시 제거하십시오 .
C. 단자씰 ..... 1	(B), (F), (G), (H), (I) 는 동봉되어 있지 않습 니다 .	
D. 알파벳 라벨..... 1	(D), (E), (J) 는 사용되지 않습니다 .	
E. 메모리 DIMM (16MB) ..... 1		

**操作パネルに 'ユニバーサル' キーがある機械 (B) にマルチポートを設置する場合**

<b>同梱品</b>		<b>オプション</b>
A. FAX 基板 ..... 1	J. メモリーDIMM(128MB) ..... 1	同梱品に固定テープ、緩衝材がついている場合 は、必ず取り外すこと。
B. モジュラーコード..... 1	(D), (F), (G), (H), (I) は、同梱されていない。	
C. 端子シール..... 1	(E), (J) は、使用しない。	
E. メモリーDIMM(16MB)..... 1		



**NOTICE**

If the finisher is already installed, remove the finisher before installing FAX System(W).

Before starting installation, be sure to turn the main power switch of the machine off, and unplug the power plug from the wall outlet.

---

**REMARQUE**

Si le retoucheur est déjà en place, le déposer avant de monter le FAX System(W).

Avant de commencer l'installation, s'assurer de mettre la machine hors tension et de débrancher la fiche d'alimentation de la prise murale.

---

**AVISO**

Si el finalizador ya se encuentra instalado, desmóntelo antes de instalar el FAX System(W).

Antes de iniciar la instalación, asegúrese de apagar el interruptor de encendido de la máquina y desenchufar el cable de alimentación de la toma de pared.

---

**ANMERKUNG**

Falls der Finisher schon installiert ist, müssen Sie ihn ausbauen, bevor Sie das FAX System(W) installieren.

Bevor Sie mit der Installation beginnen überzeugen Sie sich, dass der Netzschalter des Geräts ausgeschaltet und das Stromkabel aus der Steckdose gezogen ist.

---

**AVVISO**

Se la finitrice è già installata, rimuovere la finitrice prima di installare il FAX System(W).

Prima di iniziare l'installazione, spegnere la macchina e scollegare la spina dalla presa di corrente.

---

**注意**

已安装装订器时，必须先拆下装订器再安装 FAX System(W)。

安装前务必关闭机器的主电源开关，并从墙壁插座拔下电源插头。

---

**주의**

피니셔가 이미 장착되어 있는 경우에는 피니셔를 제거하고 FAX System(W) 를 설치할 것 .

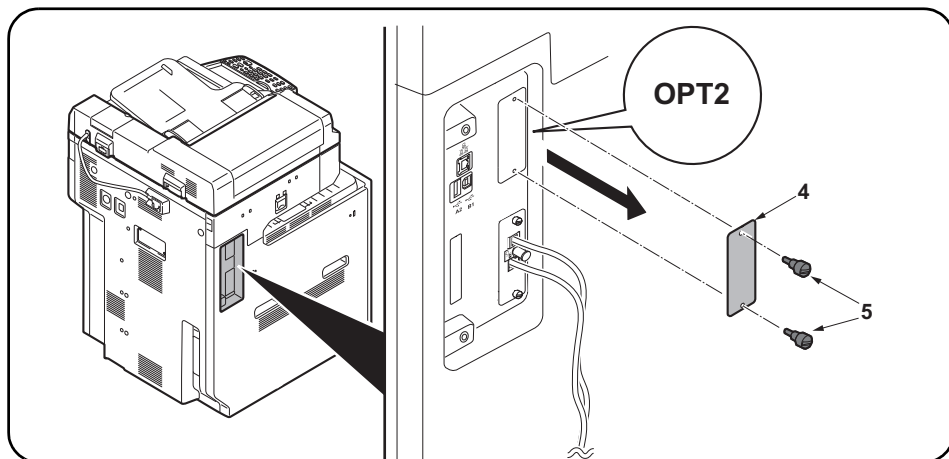
설치를 시작하기 전에 반드시 본체의 주 전원 스위치를 끄고 벽 콘센트에서 전원 플러그를 분리하십시오 .

---

**注意**

フィニッシャーがすでに装着されている場合は、フィニッシャーを取り外してから、FAX System(W) を取り付けること。

必ず機械本体の主電源スイッチをOFFにし、機械本体の電源プラグを抜いてから作業すること。



#### Procedure

##### Removing the slot cover

1. Remove 2 screws (5) and then remove the OPT2 slot cover (4).

#### Procédure

##### Dépose du couvercle de la fente

1. Déposer les 2 vis (5) puis le couvercle de la fente OPT2 (4).

#### Procedimiento

##### Desmontaje de la cubierta de la ranura

1. Quite 2 tornillos (5) y, después, quite la cubierta de la ranura OPT2 (4).

#### Vorgehensweise

##### Entfernen der Einschubabdeckung

- 1.2 Schrauben (5) entfernen und dann die Abdeckung (4) des Einschubs OPT2 entfernen.

#### Procedura

##### Rimozione del coperchio vano

1. Rimuovere le 2 viti (2) e quindi rimuovere il coperchio (1) del vano OPT2.

#### 安装步骤

##### 拆下插槽盖板

1. 拆除 2 颗螺丝 (5)，拆下 OPT2 的插槽盖板 (4)。

#### 설치순서

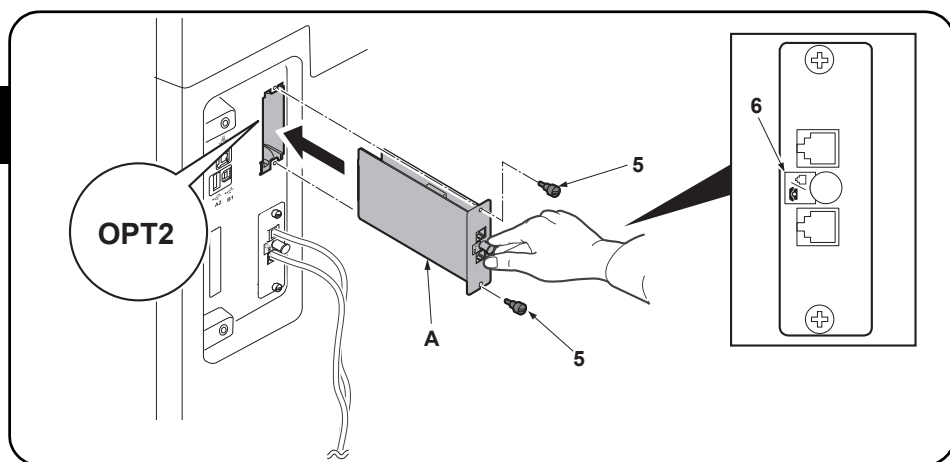
##### 슬롯커버 제거

1. 나사 (5) 2 개를 제거하고 OPT2 의 슬롯커버 (4) 를 제거합니다 .

#### 取付手順

##### スロットカバーの取り外し

1. ビス (5) 2 本を外し、OPT2 のスロットカバー (4) を取り外す。



#### Install the FAX circuit board.

2. Insert the FAX circuit board (A) along the groove in OPT2 and secure the board with two screws (5) that have been removed in step 1.  
Do not directly touch the FAX circuit board (A) terminal.  
Hold the top and bottom of the FAX circuit board, or the projection of the board to insert the FAX circuit board (A).  
Direct the label (6) on to the FAX circuit board (A) toward left side and insert the board along the groove.

#### Installer la carte à circuits FAX.

2. Insérer la carte à circuits FAX (A) le long de la rainure dans l'OPT2 et la fixer à l'aide des deux vis (5) retirées à l'étape 1.  
Ne pas toucher directement la borne de la carte à circuits FAX (A).  
Tenir les parties inférieure et supérieure de la carte à circuits FAX ou la saillie de la carte pour insérer la carte à circuits FAX (A).  
Orienter l'étiquette (6) de la carte à circuits FAX (A) comme illustré et insérer la plaquette le long de la rainure.

#### Instale la tarjeta de circuitos de FAX.

2. Inserte la tarjeta de circuitos de fax (A) a lo largo de la ranura de OPT2 y asegúrela con los dos tornillos (5) que ha quitado en el paso 1.  
No toque directamente el terminal de la tarjeta de circuitos del FAX (A).  
Sujete las partes superior e inferior de la tarjeta de circuitos de FAX o la saliente de la tarjeta para insertar la tarjeta de circuitos de FAX (A).  
Oriente la etiqueta (6) en la tarjeta de circuitos del FAX (A) como se indica en la ilustración e inserte la tarjeta a lo largo de la ranura.

#### Installieren der FAX-Leiterplatte.

2. FAX-Leiterplatte (A) in die Nut des Einbauschachts OPT2 einsetzen und Leiterplatte mit den in Schritt1 ausgebauten Schrauben (5) befestigen.  
Berühren Sie die Anschlüsse der FAX-Platine (A) nicht mit den Fingern.  
Die FAX-Leiterplatte (A) beim Einsetzen oben und unten oder an dem Vorsprung festhalten.  
Die FAX-Leiterplatte (A) so in die Nut einsetzen, dass der Aufkleber (6) wie abgebildet zur Leiterplatte zeigt.

#### Installare la scheda a circuiti FAX.

2. Inserire la scheda a circuiti FAX (A) lungo l'incavo nell'OPT2 e fissare la scheda con le due viti (5) rimosse nell'operazione 1.  
Non toccare direttamente il terminale della scheda a circuiti FAX (A),  
Per inserire il circuito FAX (A), tenere l'estremit superiore e la base della scheda a circuiti FAX, o la sporgenza della scheda a circuiti FAX.  
Orientare l'etichetta (6) sulla scheda a circuiti FAX (A) come indicato nell'illustrazione e inserire la scheda lungo l'incavo.

#### 安装传真电路板

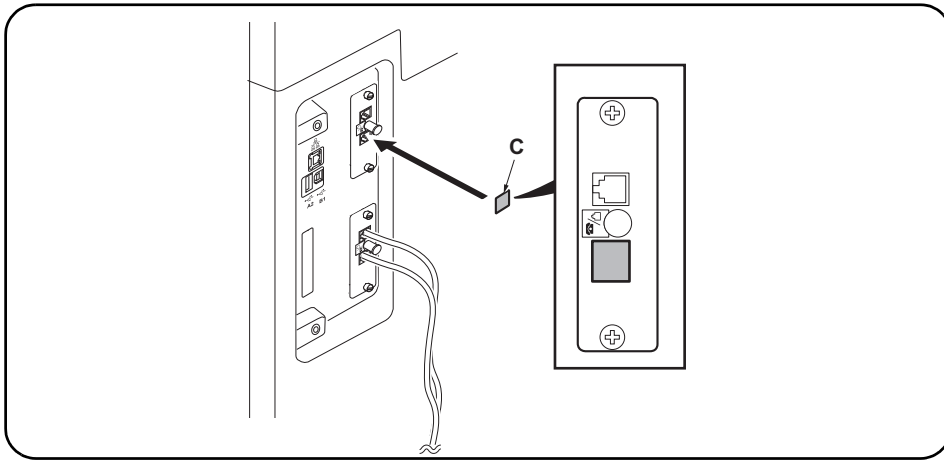
2. 沿着 OPT2 的沟槽插入传真电路板 (A) 并用步骤 1 中拆下的两颗螺钉 (5) 固定电路板。  
请勿直接接触传真电路板 (A) 端子。  
按住传真电路板的顶部和底部, 或者按住电路板的突出部将传真电路板 (A) 插入。  
将传真电路板 (A) 上的标签 (6) 保持图示中的方向, 将电路板沿着沟槽方向插入。

#### FAX 회로기판 장착

2. OPT2 의 홈을 따라 FAX 회로기판 (A) 를 삽입하고 앞 순서 1 에서 제거한 나사 (5) 2 개로 고정합니다 .  
FAX 회로기판 (A) 의 단자에 직접 닿지 않도록 할 것 .  
FAX 회로기판 (A) 삽입 시 , 회로기판의 상하 또는 돌출부를 잡을 것 .  
FAX 회로기판 (A) 를 부착된 라벨 (6) 그림 표기 방향으로 삽입할 것 .

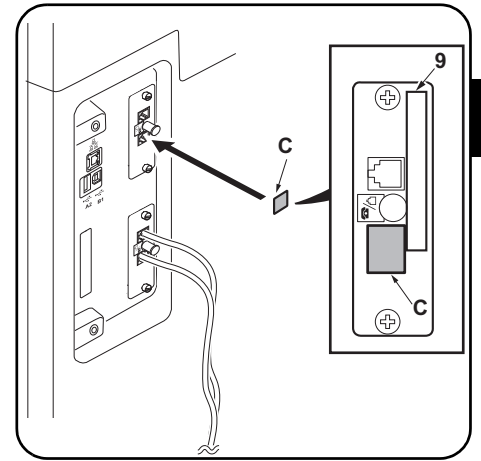
#### FAX 基板の取り付け

2. OPT2 の溝に沿って FAX 基板 (A) を挿入し、手順 1 で外したビス (5) 2 本で固定する。  
FAX 基板 (A) の端子に直接触れないこと。  
FAX 基板 (A) の挿入時は基板の上下か突起を持つこと。  
FAX 基板 (A) は、貼り付けられているラベル (6) が図に示す方向になるように、挿入すること。



### Seal the terminal.

3. Wipe the surface of the telephone terminal with alcohol and adhere the terminal seal (C).  
The telephone terminal on the FAX circuit board installed to OPT2 is unavailable (invalid). Seal the terminal securely to prevent a user from connecting a separate phone.



On 120 V models, be sure that it is not attached over the top of the approval label (9).

### Fermer hermétiquement la borne.

3. Nettoyer la surface de la borne de téléphone avec de l'alcool, et apposer le joint de borne (C).  
La borne de téléphone de la carte à circuits FAX installée sur l'OPT2 n'est pas utilisable (invalide). Fermer hermétiquement la borne pour empêcher tout utilisateur de connecter un téléphone séparé.

Sur les modèles 120 V, attention à ne pas installer en recouvrant le haut de l'étiquette d'approbation (9).

### Selle el terminal.

3. Limpie la superficie del terminal de teléfono con alcohol y pegue el sello de terminal (C).  
El terminal de teléfono de la tarjeta de circuitos de FAX instalado en el OPT2 no está disponible (inválido). Selle firmemente el terminal para evitar que un usuario conecte un teléfono por separado.

En los modelos de 120 V, asegúrese de que no se fije sobre la etiqueta de aprobación (9).

### Versiegeln der Anschlussbuchse.

3. Die Oberfläche der Telefonanschlussbuchse mit Alkohol abwischen und die Verschlusskappe (C) anbringen.  
Die Telefonanschlussbuchse der in OPT2 installierten FAX-Leiterplatte ist nicht verfügbar (ungültig). Die Anschlussbuchse vollkommen versiegeln, um den Anschluss eines separaten Telefons zu verhindern.

Bei 120-V-Modellen darauf achten, dass der Aufkleber nicht den Genehmigungsaufkleber (9) verdeckt.

### Sigillare il terminale.

3. Pulire la superficie del terminale del telefono con alcol e fare aderire la guarnizione terminale (C).  
Il terminale del telefono sulla scheda a circuiti FAX installata su OPT2 non è disponibile (invalido). Sigillare il terminale saldamente per prevenire a un utente di collegare un telefono separato.

Sui modelli da 120 V, assicurarsi che essa non venga applicata sopra l'etichetta di approvazione (9).

### 安装端子密封

3. 用酒精擦拭电话端子表面并粘上端子密封 (C)。  
安装在 OPT2 上的传真电路板的电话端子不可使用 (无效)。为了避免用户错误与其它电话连接, 必须确实粘贴好端子密封。

120V 规格在粘贴时注意不要与认可标签 (9) 重叠。

### 단자씰의 부착

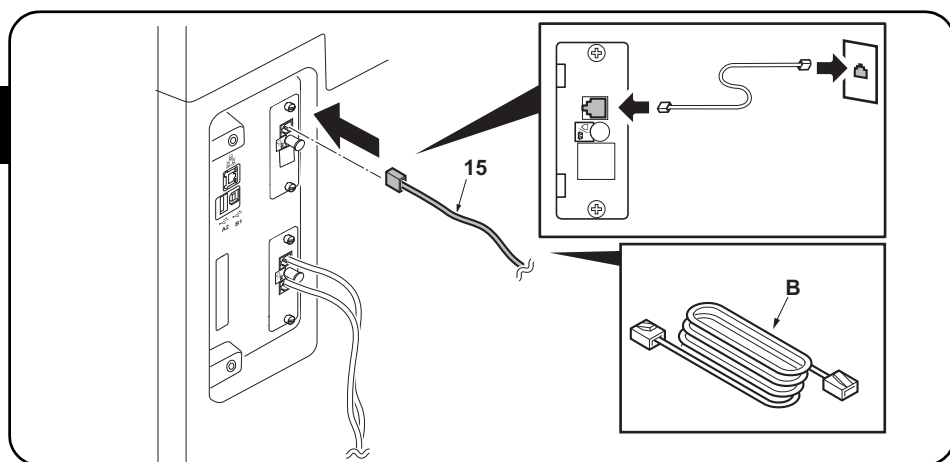
3. TEL 단자주위를 알코올청소하고 단자씰 (C) 을 부착합니다.  
OPT2 에 부착한 FAX 기판의 TEL 단자는 사용불가 (무효) 가 됩니다. 사용자가 잘못해 외부 전화를 연결하지 않도록 확실히 부착할 것.

120V 사양은 허가 라벨 (9) 에 겹치지 않도록 붙일 것.

### 端子シールの貼り付け

3. TEL 端子周围をアルコール清掃し、端子シール (C) を貼り付ける。  
OPT2 に取り付けした FAX 基板の TEL 端子は使用不可 (無効) となる。ユーザーが誤って外付け電話を接続しないよう確実に貼り付けること。

120V仕様は認可ラベル(9)に重ならないように、貼り付けること。



#### Connect the MFP to the telephone line.

4. Plug the modular connector cable (15) into the line terminal, and then connect the other end to the telephone line.  
For 100 V/120 V/Australian or Chinese models, use the supplied modular connector cable (B).

#### Connecter le MFP à la ligne de téléphone.

4. Brancher le câble du connecteur modulaire (15) à la borne de la ligne, puis connecter l'autre extrémité à la ligne de téléphone.  
Pour les modèles 100 V/120 V/Australie ou Chine, utilisez le câble à connecteur modulaire (B) fourni.

#### Conecte el MFP a la línea telefónica.

4. Enchufe el cable del conector modular (15) en el terminal de línea y, a continuación, conecte el otro extremo a la línea telefónica.  
Para los modelos de 100 V/120 V/Australiano o Chino, utilice el cable conector modular (B) suministrado.

#### Anschließen des MFP an die Telefonleitung.

4. Telefonmodulkabel (15) in die Gerätebuchse einstecken und das Kabel an der Telefondose anschließen.  
Das mitgelieferte Modularsteckerkabel (B) für die 100-V/120-V/Australien- oder China-Modelle verwenden.

#### Collegamento dell'MFP alla linea del telefono.

4. Inserire il cavo connettore modulare (15) nel terminale della linea, e quindi collegare l'altro terminale alla linea del telefono.  
Per modelli da 100 V/120 V/Australia o Cina, utilizzare il cavo connettore modulare (B) in dotazione.

#### 将 MFP 连接到电话线

4. 将模块接插件电缆 (15) 插入电话线端子，然后将另一端与电话线连接。  
对于 100V/120V/ 澳大利亚或中国机型，请使用随附的模块接插件电缆 (B)。

#### 전화회선과의 연결

4. 모듈러 코드 (15) 를 라인단자에 꽂습니다. 다른 한 쪽의 플러그는 전화회선과 연결합니다.  
100V/120V/ 오스트레일리아 / 중국사양은 부속 모듈러 코드 (B) 를 사용할 것.

#### 電話回線との接続

4. モジュラーコード (15) をライン端子に差し込む。もう片方のプラグは、電話回線へ接続する。  
100V/120V/ オーストラリア / 中国仕様は付属のモジュラーコード (B) を使用すること。

**(Initialize the FAX circuit board.**

1. Plug the MFP into a power outlet, and turn on the main power.
2. If the FAX PWBs were installed simultaneously to OPT1 and OPT2 (all Fax PWBs are initialized), perform the maintenance mode U600 to initialize the FAX PWBs.

3. If the FAX circuit board has been added to OPT2 (to initialize the FAX circuit board in OPT2)

Initialize OPT2 by pressing [PORT2], and the Start key in this order in the maintenance mode U698 and executing the maintenance mode U600. If [ALL] is selected in U698, both OPT1 and OPT2 are initialized. For details, see the service manual.

**Initialiser la carte à circuits FAX.**

1. Brancher le MFP sur une prise d'alimentation et le mettre sous tension.
2. Si les cartes de circuit imprimé du fax ont été installées en même temps que OPT1 et OPT2 (toutes les cartes de circuit imprimé du fax sont initialisées), exécuter le mode maintenance U600 pour initialiser les cartes de circuit imprimé du fax.

3. Si la carte à circuits FAX a été ajoutée à l'OPT2 (pour initialiser la carte à circuits FAX dans l'OPT2)

Initialiser l'OPT2 en appuyant sur [PORT2] et la touche Départ dans cet ordre en mode de maintenance U698, et exécuter le mode de maintenance U600. Si [ALL] est sélectionné dans U698, l'OPT1 et l'OPT2 sont tous deux initialisés. Pour plus de détails, se reporter au manuel d'entretien.

**Inicialice la tarjeta de circuitos FAX.**

1. Conecte el MFP a un receptáculo de pared y encienda el interruptor principal.
2. Si se instalaron FAX PWB simultáneamente a OPT1 y OPT2 (se inicializan todos los FAX PWB), ejecute el modo de mantenimiento U600 para inicializar los FAX PWB.

3. Si la tarjeta de circuitos de FAX se agregó a OPT2 (para inicializar la tarjeta de circuitos de FAX en OPT2)

Inicialice el OPT2 presionando [PORT2] y la tecla de Inicio en ese orden en el modo de mantenimiento U698 y ejecutando el modo de mantenimiento U600. Si se selecciona [ALL] en U698, se inicializan ambos OPT1 y OPT2. Para más detalles, lea el manual de servicio.

**Initialisieren der FAX-Leiterplatte.**

1. Netzstecker des MFP in eine Steckdose stecken und Hauptschalter einschalten.
2. Falls die FAX-Karten gleichzeitig in OPT1 und OPT2 installiert werden (alle FAX-Karten werden initialisiert), führen Sie den Wartungsmodus U600 aus, um die FAX-Karten zu initialisieren.

3. Wenn die FAX-Leiterplatte zu OPT2 hinzugefügt worden ist (um die FAX-Leiterplatte in OPT2 zu initialisieren)

OPT2 initialisieren. Dazu [PORT2] und die Start-Taste im Wartungsmodus U698 in dieser Reihenfolge drücken und den Wartungsmodus U600 ausführen. Wenn [ALL] in U698 gewählt wird, werden OPT1 und OPT2 initialisiert. Weitere Einzelheiten siehe Wartungsanleitung.

**Inizializzare la scheda a circuiti FAX.**

1. Collegare l'MFP ad una presa di corrente e portare l'interruttore principale su On.
2. Se sono state installate simultaneamente le schede FAX PWB su OPT1 e OPT2 (tutte le schede FAX PWB sono inizializzate), eseguire il modo manutenzione U600 per inizializzare le schede FAX PWB.

3. Se la scheda a circuiti è stata aggiunta all'OPT2 (per inizializzare la scheda a circuiti FAX nell'OPT2)

Inizializzare OPT2 premendo [PORT2] e il tasto Avvio in questo ordine nel modo di manutenzione U698 ed eseguendo il modo di manutenzione U600. Se viene selezionato [ALL] nel modo U698, entrambi OPT1 e OPT2 sono inizializzati. Per ulteriori dettagli leggere il manuale d'istruzioni.

**传真电话板的初始化**

1. 将 MFP 的电源插头插入电源插座，打开主电源。
2. 当把传真电路板同时安装到 OPT1 和 OPT2 时（全部的传真电路板初始化），执行维修保养模式 U600，初始化传真电路板。

3. 在 OPT2 上增设时

（OPT2 的传真电路板初始化）只进行 OPT2 初始化时，在维修保养模式 U698 状态下，按顺序按下“PORT2”、开始键，执行维修保养模式 U600。在 U698 状态下设定“ALL”时，会使 OPT1 和 OPT2 均初始化。有关详细信息，请参见维修手册。

**FAX 회로기판의 초기화**

1. MFP 본체 전원플러그를 콘센트에 꼽고 주 전원 스위치를 ON 으로 한다.
2. OPT1 과 OPT2 에 FAX 회로기판을 동시에 설치한 경우 ( 모든 FAX 회로기판이 초기화됨 ), 메인터너스 모드 U600 을 수행하여 FAX 회로기판을 초기화합니다 .

3. OPT2 에 증설한 경우 (OPT2 의 FAX 기판을 초기화 )

메인터너스모드 U698 에서 「PORT2」, 시작키 순으로 누릅니다 . 메인터너스 모드 U600 을 실행하고 FAX 회로기판을 초기화합니다 . U698 에서 「ALL」을 설정하면 OPT1 과 OPT2 양쪽을 초기화하기 때문에 주의할 것 . 상세는 서비스 매뉴얼을 참조할 것 .

**FAX 基板の初期化**

1. MFP 本体の電源プラグをコンセントに差し込み、主電源スイッチを ON にする。
2. OPT1 と OPT2 に FAX 基板を同時に設置した場合（すべての FAX 基板を初期化）メンテナンスモード U600 を実行し、FAX 基板を初期化する。

3. OPT2 に増設した場合 (OPT2 の FAX 基板を初期化 )

メンテナンスモード U698 で「PORT2」、スタートキーの順に押す。メンテナンスモード U600 を実行し、FAX 基板を初期化する。U698 で「ALL」を設定すると OPT1 と OPT2 両方を初期化するので注意すること。詳細はサービスマニュアルを参照のこと。



303N65673201

2015.11  
303N656732-01

# **INSTALLATION GUIDE FOR DOCUMENT TABLE**



**INSTALLATION GUIDE**

**GUIDE D'INSTALLATION**

**GUÍA DE INSTALACION**

**INSTALLATIONSANLEITUNG**

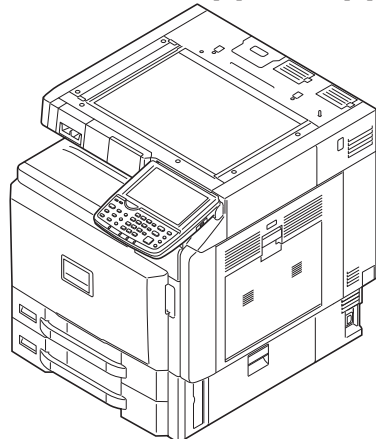
**GUIDA ALL'INSTALLAZIONE**

**安装手册**

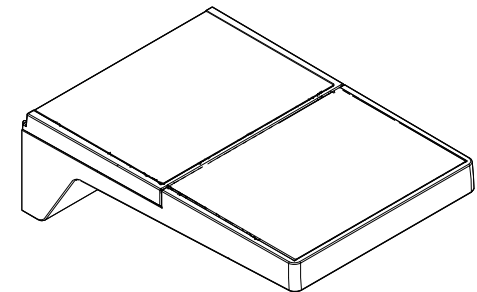
**설치안내서**

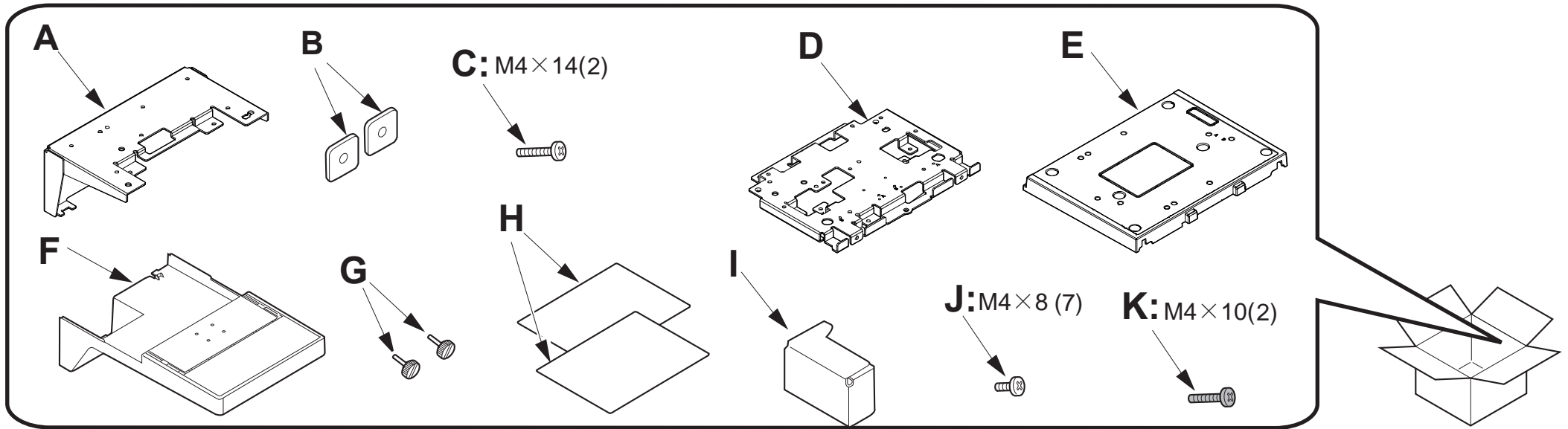
**設置手順書**

**for Color MFP 30/30ppm,35/35ppm,45/45ppm,55/50ppm  
for Black & White MFP 35ppm,45ppm,55ppm**



**DT-730(B)**





ENG (K) is not used.

FR (K) n'est pas utilisé.

ES (K) no se utiliza.

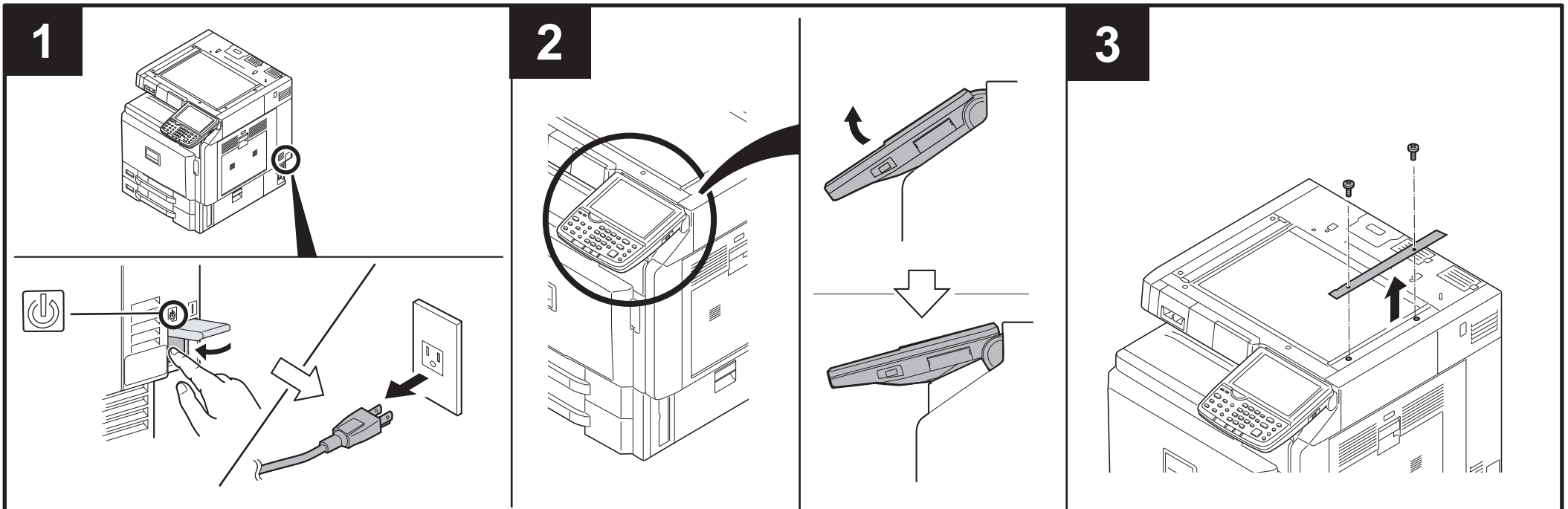
DE (K) wird nicht verwendet.

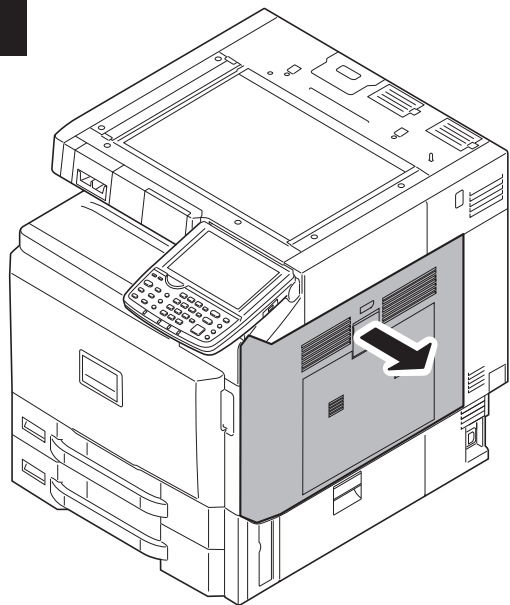
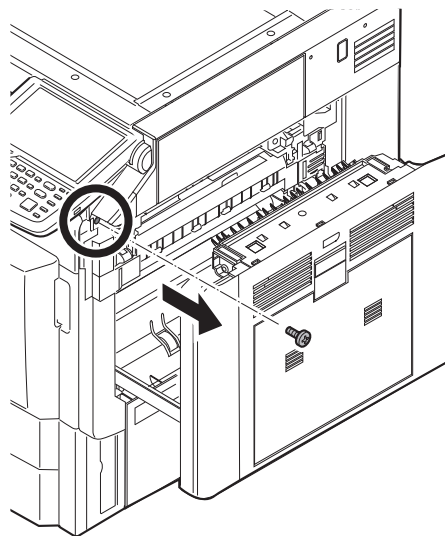
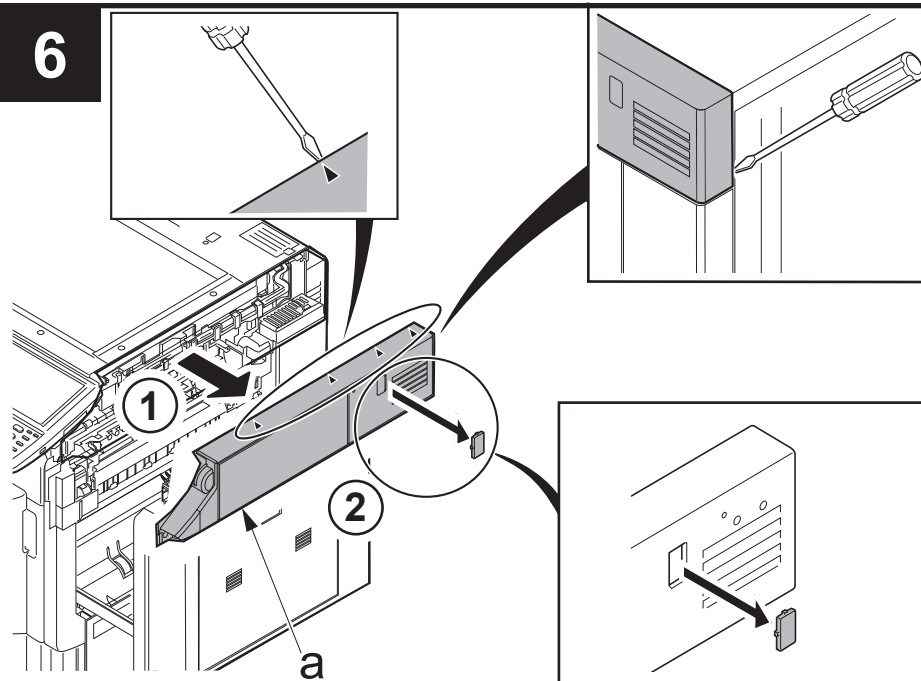
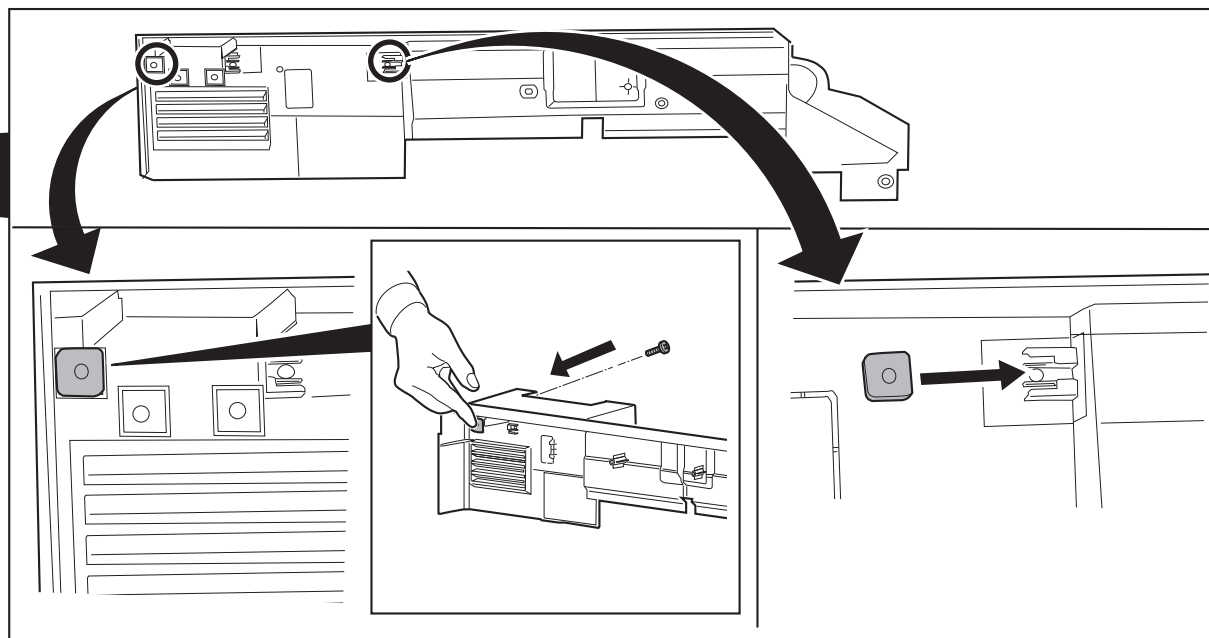
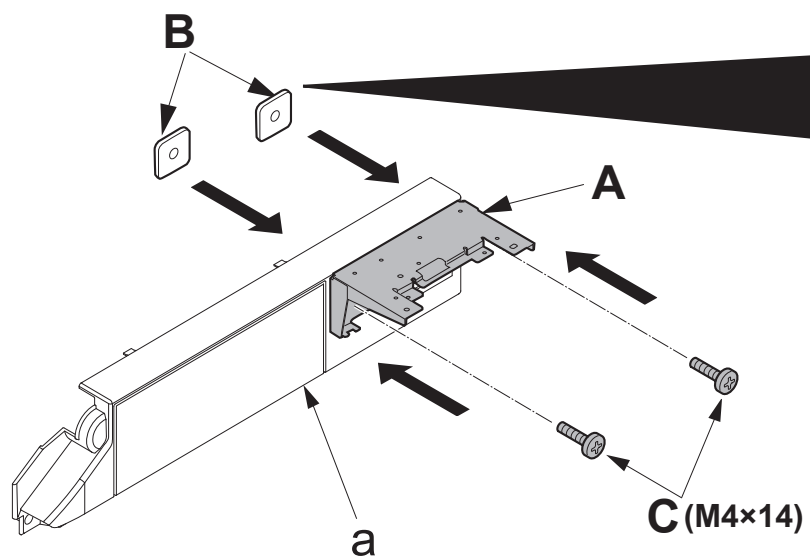
IT (K) non viene utilizzata.

CN 不使用 (K)。

KO (K)는 사용되지 않습니다.

JP (K)は使用しません。



**4****5****6****7**

(ENG) If the right job separator is not installed, proceed to step 8.

(FR) Si le séparateur de travaux correspondant n'est pas installé, passer à l'étape 8.

(ES) Si no está instalado el separador de trabajos derecho, vaya al paso 8.

(DE) Gehen Sie weiter zu Schritt 8, falls der rechte Job-Separator nicht installiert ist.

(IT) Se il separatore lavori destro non è installato, procedere al punto 8.

(CN) 如果没有安装右作业分离器，请进入步骤8。

(KO) 우측 작업 분류기가 설치되어 있지 않은 경우 순서 8로 진행합니다.

(JP) 右ジョブセパレーターが設置されていない場合、手順8へ進む。

(ENG) If the right job separator is installed, proceed to step 10.

(FR) Si le séparateur de travaux correspondant est installé, passer à l'étape 10.

(ES) Si está instalado el separador de trabajos derecho, vaya al paso 10.

(DE) Gehen Sie weiter zu Schritt 10, falls der rechte Job-Separator installiert ist.

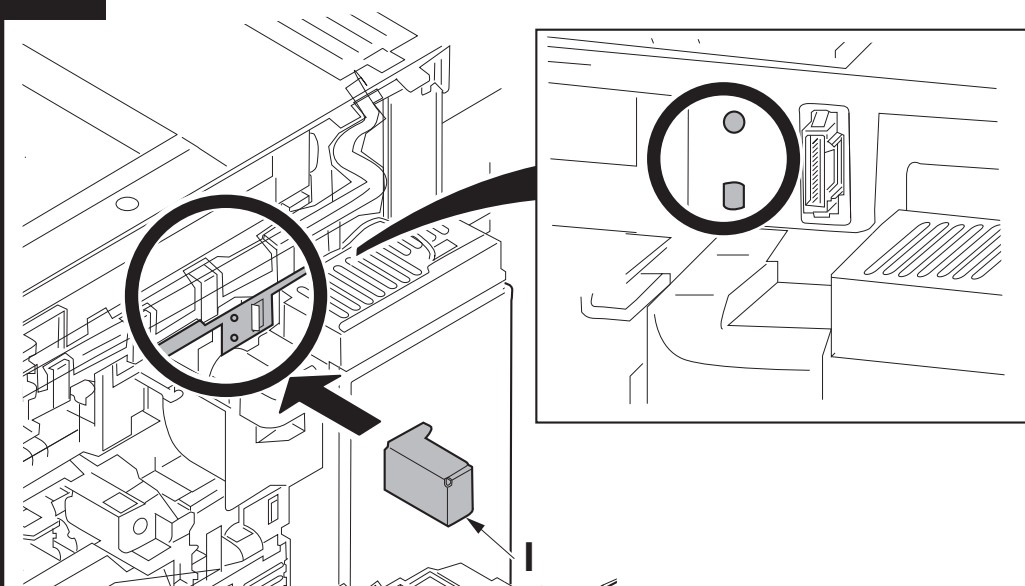
(IT) Se il separatore lavori destro è installato, procedere al punto 10.

(CN) 如果安装了右作业分离器，请进入步骤10。

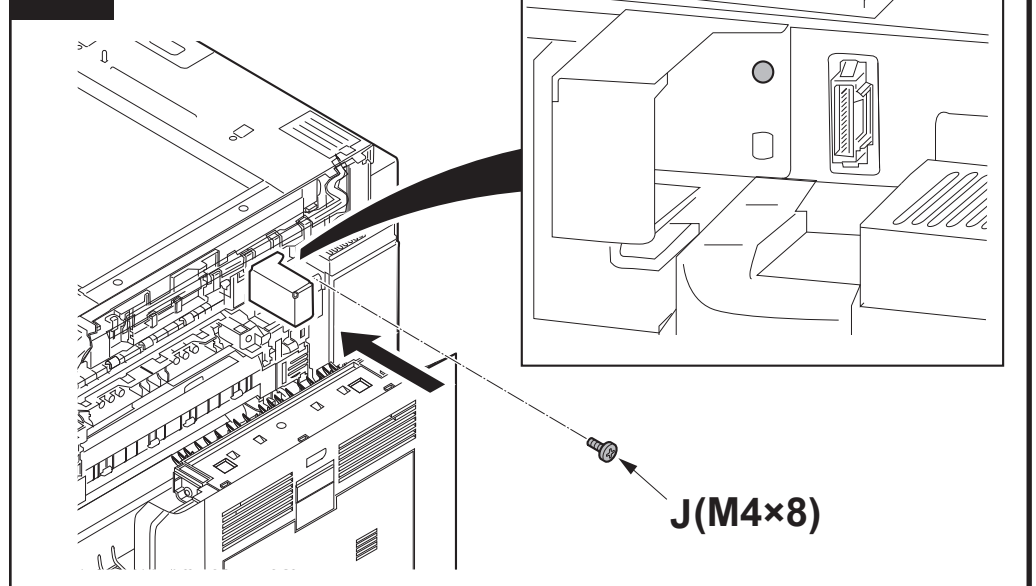
(KO) 우측 작업 분류기가 설치되어 있는 경우 순서 10로 진행합니다.

(JP) 右ジョブセパレーターが設置されている場合、手順10へ進む。

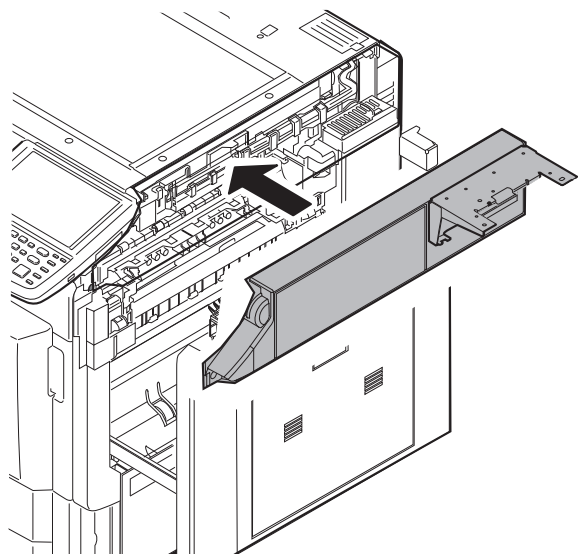
8



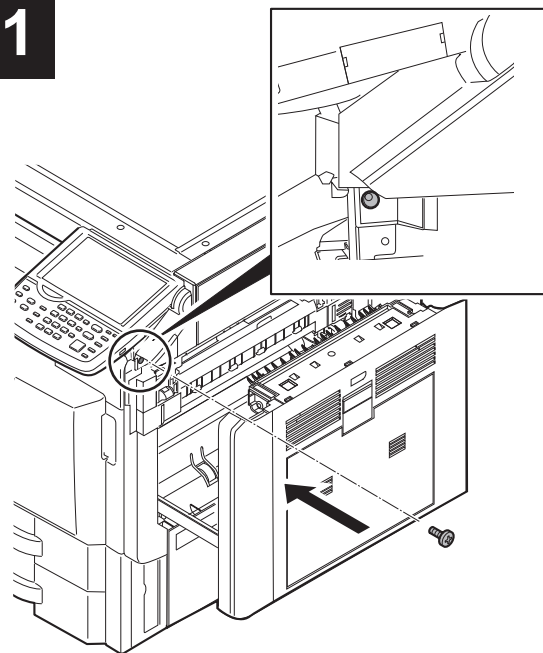
9



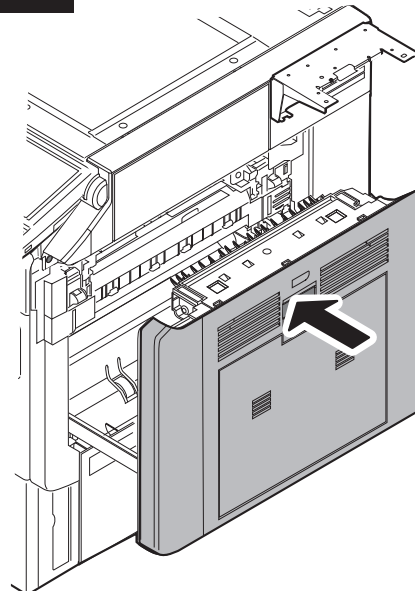
10



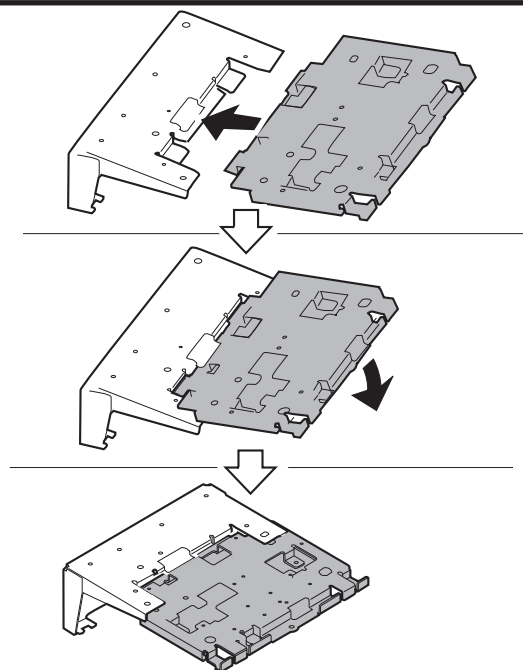
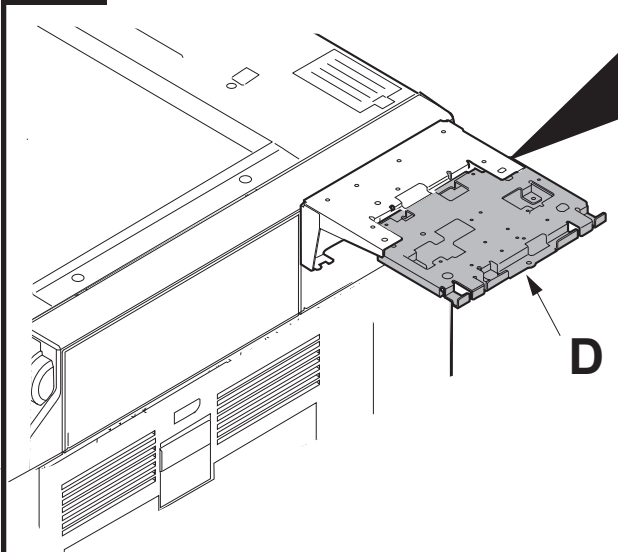
11



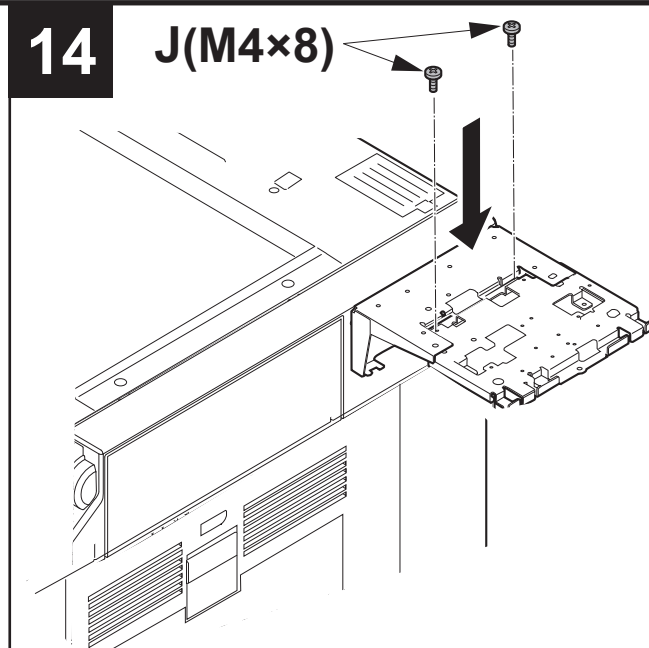
12



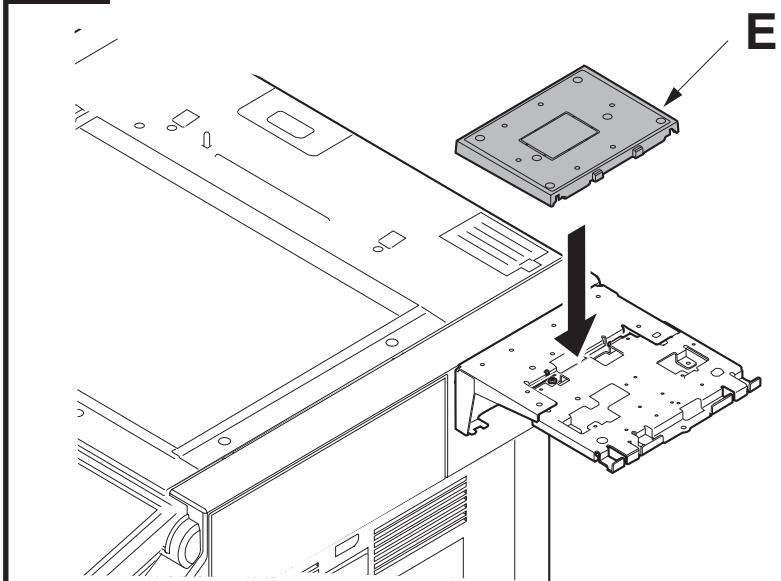
13



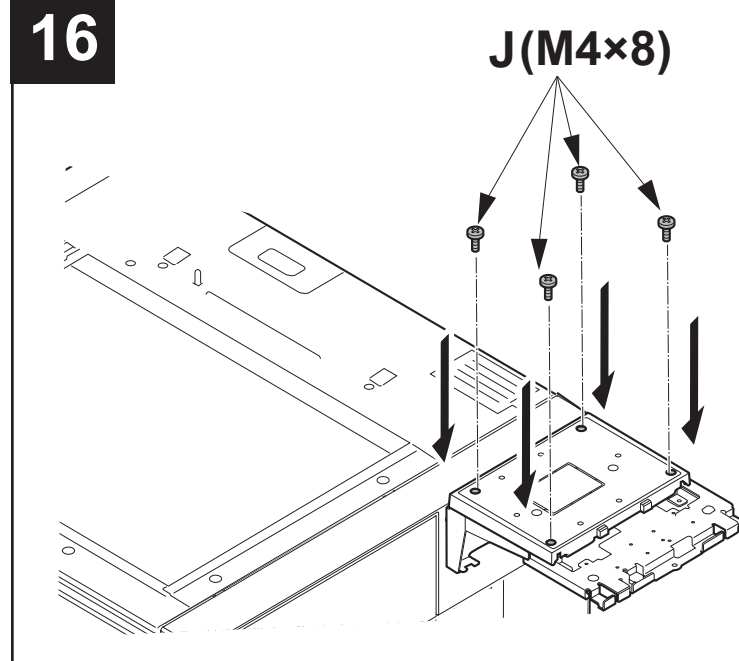
14



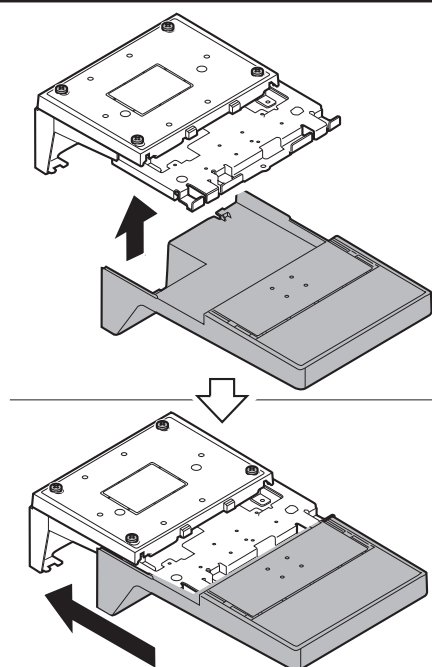
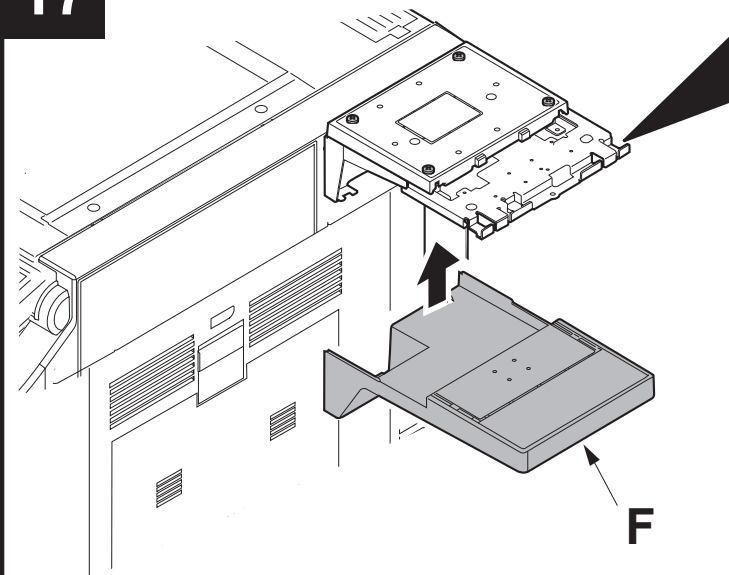
15



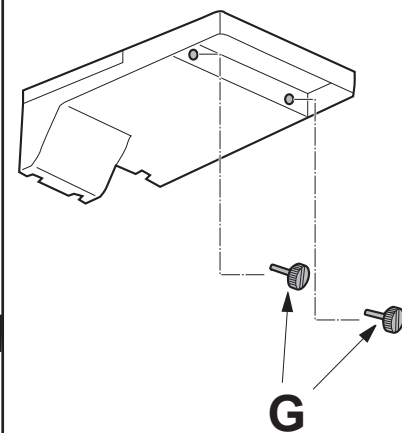
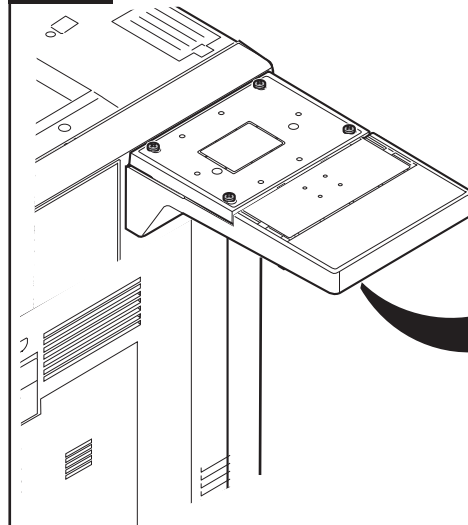
16



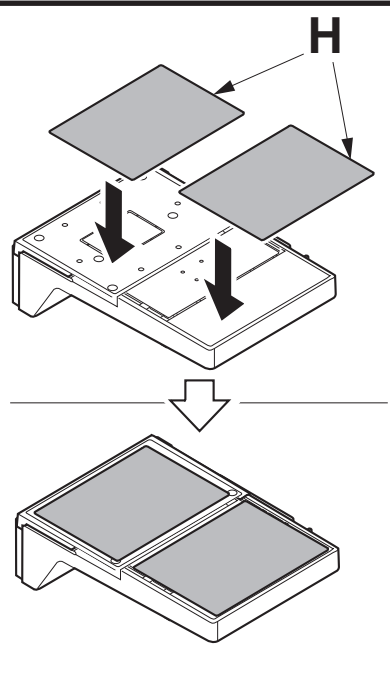
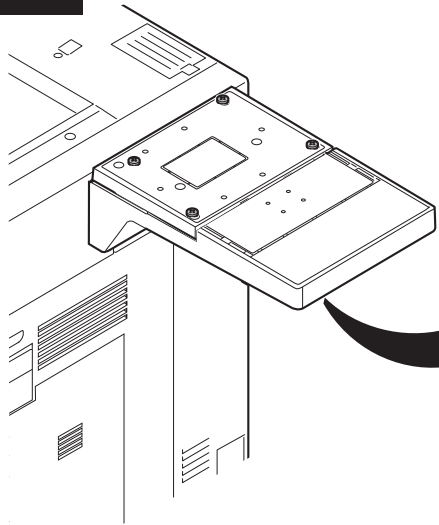
17



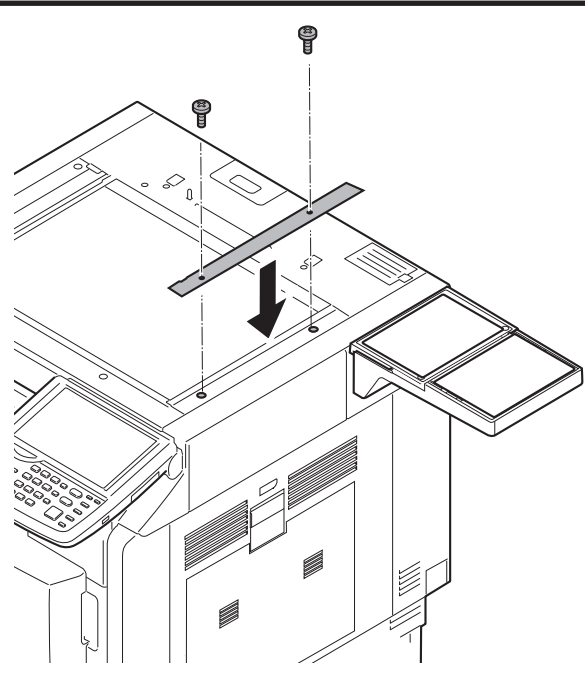
18



19



20





302LC5674001

2013. 5  
302LC56740-01



**KYOCERA Document Solutions America, Inc.****Headquarters**

225 Sand Road,  
Fairfield, New Jersey 07004-0008, USA  
Phone: +1-973-808-8444  
Fax: +1-973-882-6000

**Latin America**

8240 NW 52nd Terrace Dawson Building, Suite 100  
Miami, Florida 33166, USA  
Phone: +1-305-421-6640  
Fax: +1-305-421-6666

**KYOCERA Document Solutions Canada, Ltd.**

6120 Kestrel Rd., Mississauga, ON L5T 1S8,  
Canada  
Phone: +1-905-670-4425  
Fax: +1-905-670-8116

**KYOCERA Document Solutions****Mexico, S.A. de C.V.**

Calle Arquimedes No. 130, 4 Piso, Colonia Polanco  
Chapultepec, Delegacion Miguel Hidalgo,  
Distrito Federal, C.P. 11560, México  
Phone: +52-555-383-2741  
Fax: +52-555-383-7804

**KYOCERA Document Solutions Brazil, Ltda.**

Alameda África, 545, Pólo Empresarial Consbrás,  
Tamboré, Santana de Parnaíba, State of São Paulo, CEP  
06543-306, Brazil  
Phone: +55-11-2424-5353  
Fax: +55-11-2424-5304

**KYOCERA Document Solutions Chile SpA**

Jose Ananias 505, Macul. Santiago, Chile  
Phone: +562-2350-7000  
Fax: +562-2350-7150

**KYOCERA Document Solutions****Australia Pty. Ltd.**

Level 3, 6-10 Talavera Road North Ryde N.S.W., 2113,  
Australia  
Phone: +61-2-9888-9999  
Fax: +61-2-9888-9588

**KYOCERA Document Solutions****New Zealand Ltd.**

Ground Floor, 19 Byron Avenue, Takapuna, Auckland,  
New Zealand  
Phone: +64-9-415-4517  
Fax: +64-9-415-4597

**KYOCERA Document Solutions Asia Limited**

Unit 3 & 5, 16/F., Mita Centre, 552-566, Castle Peak Road  
Tsuen Wan, New Territories, Hong Kong  
Phone: +852-2496-5678  
Fax: +852-2610-2063

**KYOCERA Document Solutions****(China) Corporation**

8F, No. 288 Nanjing Road West, Huangpu District,  
Shanghai, 200003, China  
Phone: +86-21-5301-1777  
Fax: +86-21-5302-8300

**KYOCERA Document Solutions****(Thailand) Corp., Ltd.**

335 Ratchadapisek Road, Wongsawang, Bangsue,  
Bangkok 10800,  
Thailand  
Phone: +66-2-586-0333  
Fax: +66-2-586-0278

**KYOCERA Document Solutions****Singapore Pte. Ltd.**

12 Tai Seng Street #04-01A,  
Luxasia Building, Singapore 534118  
Phone: +65-6741-8733  
Fax: +65-6748-3788

**KYOCERA Document Solutions****Hong Kong Limited**

Unit 1,2,4,6,8 & 10, 16/F., Mita Centre, 552-566, Castle  
Peak Road Tsuen Wan, New Territories, Hong Kong  
Phone: +852-3582-4000  
Fax: +852-3185-1399

**KYOCERA Document Solutions****Taiwan Corporation**

6F., No.37, Sec. 3, Minquan E. Rd.,  
Zhongshan Dist., Taipei 104, Taiwan R.O.C.  
Phone: +886-2-2507-6709  
Fax: +886-2-2507-8432

**KYOCERA Document Solutions Korea Co., Ltd.**

#3F Daewoo Foundation Bldg 18, Toegye-ro, Jung-gu,  
Seoul, Korea  
Phone: +822-6933-4050  
Fax: +822-747-0084

**KYOCERA Document Solutions****India Private Limited**

Second Floor, Centrum Plaza, Golf Course Road,  
Sector-53, Gurgaon, Haryana 122002, India  
Phone: +91-0124-4671000  
Fax: +91-0124-4671001

**KYOCERA Document Solutions Europe B.V.**

Bloemlaan 4, 2132 NP Hoofddorp,  
The Netherlands  
Phone: +31-20-654-0000  
Fax: +31-20-653-1256

**KYOCERA Document Solutions Nederland B.V.**

Beechavenue 25, 1119 RA Schiphol-Rijk,  
The Netherlands  
Phone: +31-20-5877200  
Fax: +31-20-5877260

**KYOCERA Document Solutions (U.K.) Limited**

Eldon Court, 75-77 London Road,  
Reading, Berkshire RG1 5BS,  
United Kingdom  
Phone: +44-118-931-1500  
Fax: +44-118-931-1108

**KYOCERA Document Solutions Italia S.p.A.**

Via Monfalcone 15, 20132, Milano, Italy,  
Phone: +39-02-921791  
Fax: +39-02-92179-600

**KYOCERA Document Solutions Belgium N.V.**

Sint-Martinusweg 199-201 1930 Zaventem,  
Belgium  
Phone: +32-2-7209270  
Fax: +32-2-7208748

**KYOCERA Document Solutions France S.A.S.**

Espace Technologique de St Aubin  
Route de l'Orme 91195 Gif-sur-Yvette CEDEX,  
France  
Phone: +33-1-69852600  
Fax: +33-1-69853409

**KYOCERA Document Solutions Espana, S.A.**

Edificio Kyocera, Avda. de Manacor No.2,  
28290 Las Matas (Madrid), Spain  
Phone: +34-91-6318392  
Fax: +34-91-6318219

**KYOCERA Document Solutions Finland Oy**

Atomitie 5C, 00370 Helsinki,  
Finland  
Phone: +358-9-47805200  
Fax: +358-9-47805390

**KYOCERA Document Solutions  
Europe B.V., Amsterdam (NL) Zürich Branch**

Hohlstrasse 614, 8048 Zürich,  
Switzerland  
Phone: +41-44-9084949  
Fax: +41-44-9084950

**KYOCERA Bilgitas Document Solutions  
Turkey A.S.**

Gülbahar Mahallesi Otello Kamil Sk. No:6 Mecidiyeköy  
34394 i li stanbul, Turkey  
Phone: +90-212-356-7000  
Fax: +90-212-356-6725

**KYOCERA Document Solutions****Deutschland GmbH**

Otto-Hahn-Strasse 12, 40670 Meerbusch,  
Germany  
Phone: +49-2159-9180  
Fax: +49-2159-918100

**KYOCERA Document Solutions Austria GmbH**

Altmannsdorferstraße 91, Stiege 1, 2. OG, Top 1, 1120,  
Wien, Austria  
Phone: +43-1-863380  
Fax: +43-1-86338-400

**KYOCERA Document Solutions Nordic AB**

Esbogatan 16B 164 75 Kista, Sweden  
Phone: +46-8-546-550-00  
Fax: +46-8-546-550-10

**KYOCERA Document Solutions Norge Nuf**

Olaf Helsetsv. 6, 0619 Oslo, Norway  
Phone: +47-22-62-73-00  
Fax: +47-22-62-72-00

**KYOCERA Document Solutions Danmark A/S**

Ejby Industrivej 60, DK-2600 Glostrup,  
Denmark  
Phone: +45-70223880  
Fax: +45-45765850

**KYOCERA Document Solutions Portugal Lda.**

Rua do Centro Cultural, 41 (Alvalade) 1700-106 Lisboa,  
Portugal  
Phone: +351-21-843-6780  
Fax: +351-21-849-3312

**KYOCERA Document Solutions****South Africa (Pty) Ltd.**

KYOCERA House, Hertford Office Park,  
90 Bekker Road (Cnr. Allandale), Midrand, South Africa  
Phone: +27-11-540-2600  
Fax: +27-11-466-3050

**KYOCERA Document Solutions Russia LLC.**

Building 2, 51/4, Schepkina St., 129110, Moscow,  
Russia  
Phone: +7(495)741-0004  
Fax: +7(495)741-0018

**KYOCERA Document Solutions Middle East**

Dubai Internet City, Bldg. 17,  
Office 157 P.O. Box 500817, Dubai,  
United Arab Emirates  
Phone: +971-04-433-0412

**KYOCERA Document Solutions Inc.**

2-28, 1-chome, Tamatsukuri, Chuo-ku  
Osaka 540-8585, Japan  
Phone: +81-6-6764-3555  
<http://www.kyoceradocumentsolutions.com>