



PF-35
PF-30A

**SERVICE
MANUAL**

Published in Feb.'02
845CY111
Revision 1

CAUTION

Danger of explosion if battery is incorrectly replaced. Replace only with the same or equivalent type recommended by the manufacturer. Dispose of used batteries according to the manufacturer's instructions.

CAUTION

Double-pole/neutral fusing.





Safety precautions

This booklet provides safety warnings and precautions for our service personnel to ensure the safety of their customers, their machines as well as themselves during maintenance activities. Service personnel are advised to read this booklet carefully to familiarize themselves with the warnings and precautions described here before engaging in maintenance activities.

Safety warnings and precautions

Various symbols are used to protect our service personnel and customers from physical danger and to prevent damage to their property. These symbols are described below:

 **DANGER:** High risk of serious bodily injury or death may result from insufficient attention to or incorrect compliance with warning messages using this symbol.

 **WARNING:** Serious bodily injury or death may result from insufficient attention to or incorrect compliance with warning messages using this symbol.

 **CAUTION:** Bodily injury or damage to property may result from insufficient attention to or incorrect compliance with warning messages using this symbol.

Symbols

The triangle () symbol indicates a warning including danger and caution. The specific point of attention is shown inside the symbol.



General warning.



Warning of risk of electric shock.



Warning of high temperature.

 indicates a prohibited action. The specific prohibition is shown inside the symbol.



General prohibited action.



Disassembly prohibited.

 indicates that action is required. The specific action required is shown inside the symbol.



General action required.



Remove the power plug from the wall outlet.



Always ground the copier.

1. Installation Precautions

WARNING

• Do not use a power supply with a voltage other than that specified. Avoid multiple connections to one outlet: they may cause fire or electric shock. When using an extension cable, always check that it is adequate for the rated current.



• Connect the ground wire to a suitable grounding point. Not grounding the copier may cause fire or electric shock. Connecting the earth wire to an object not approved for the purpose may cause explosion or electric shock. Never connect the ground cable to any of the following: gas pipes, lightning rods, ground cables for telephone lines and water pipes or faucets not approved by the proper authorities.



CAUTION:

• Do not place the copier on an infirm or angled surface: the copier may tip over, causing injury.



• Do not install the copier in a humid or dusty place. This may cause fire or electric shock.



• Do not install the copier near a radiator, heater, other heat source or near flammable material. This may cause fire.



• Allow sufficient space around the copier to allow the ventilation grills to keep the machine as cool as possible. Insufficient ventilation may cause heat buildup and poor copying performance.



• Always handle the machine by the correct locations when moving it.



• Always use anti-toppling and locking devices on copiers so equipped. Failure to do this may cause the copier to move unexpectedly or topple, leading to injury.



• Avoid inhaling toner or developer excessively. Protect the eyes. If toner or developer is accidentally ingested, drink a lot of water to dilute it in the stomach and obtain medical attention immediately. If it gets into the eyes, rinse immediately with copious amounts of water and obtain medical attention.













• Advise customers that they must always follow the safety warnings and precautions in the copier's instruction handbook.







2. Precautions for Maintenance

WARNING

- Always remove the power plug from the wall outlet before starting machine disassembly. 
- Always follow the procedures for maintenance described in the service manual and other related brochures. 
- Under no circumstances attempt to bypass or disable safety features including safety mechanisms and protective circuits. 
- Always use parts having the correct specifications. 
- Always use the thermostat or thermal fuse specified in the service manual or other related brochure when replacing them. Using a piece of wire, for example, could lead to fire or other serious accident. 
- When the service manual or other serious brochure specifies a distance or gap for installation of a part, always use the correct scale and measure carefully. 
- Always check that the copier is correctly connected to an outlet with a ground connection. 
- Check that the power cable covering is free of damage. Check that the power plug is dust-free. If it is dirty, clean it to remove the risk of fire or electric shock. 
- Never attempt to disassemble the optical unit in machines using lasers. Leaking laser light may damage eyesight. 
- Handle the charger sections with care. They are charged to high potentials and may cause electric shock if handled improperly. 

CAUTION

- Wear safe clothing. If wearing loose clothing or accessories such as ties, make sure they are safely secured so they will not be caught in rotating sections. 
- Use utmost caution when working on a powered machine. Keep away from chains and belts. 
- Handle the fixing section with care to avoid burns as it can be extremely hot. 
- Check that the fixing unit thermistor, heat and press rollers are clean. Dirt on them can cause abnormally high temperatures. 
- Do not remove the ozone filter, if any, from the copier except for routine replacement. 

• Do not pull on the AC power cord or connector wires on high-voltage components when removing them; always hold the plug itself.



• Do not route the power cable where it may be stood on or trapped. If necessary, protect it with a cable cover or other appropriate item.



• Treat the ends of the wire carefully when installing a new charger wire to avoid electric leaks.



• Remove toner completely from electronic components.



• Run wire harnesses carefully so that wires will not be trapped or damaged.



• After maintenance, always check that all the parts, screws, connectors and wires that were removed, have been refitted correctly. Special attention should be paid to any forgotten connector, trapped wire and missing screws.



• Check that all the caution labels that should be present on the machine according to the instruction handbook are clean and not peeling. Replace with new ones if necessary.



• Handle greases and solvents with care by following the instructions below:



- Use only a small amount of solvent at a time, being careful not to spill. Wipe spills off completely.
- Ventilate the room well while using grease or solvents.
- Allow applied solvents to evaporate completely before refitting the covers or turning the main switch on.
- Always wash hands afterwards.

• Never dispose of toner or toner bottles in fire. Toner may cause sparks when exposed directly to fire in a furnace, etc.



• Should smoke be seen coming from the copier, remove the power plug from the wall outlet immediately.



3. Miscellaneous

WARNING

• Never attempt to heat the drum or expose it to any organic solvents such as alcohol, other than the specified refiner; it may generate toxic gas.



Chapter 1

General Information

Chapter 1 Contents

1-1 General	1-3
1-2 Product description	1-4
1-2-1 Unpacking	1-5
1-2-2 Caster kit	1-5
1-2-3 Installing the paper feeder	1-6
(1) Installing the paper feeder to the copier	1-6
(2) Installing the paper feeder to the printer	1-10
(3) Place the paper size indicator plate	1-13
1-2-4 Names of parts	1-14
1-3 Precautions concerning service and maintenance	1-16
1-3-1 Precautions	1-16
1-3-2 Replacement parts	1-17
1-3-3 Notes concerning paper storage	1-17
1-4 Specifications	1-18
1-4-1 Mechanical specifications	1-18
1-4-2 Paper specifications	1-19

1-1 General

This chapter explains basic information and precautions to be observed when repairing, maintaining and inspecting the paper feeder. Topics covered in this chapter are:

- Product description
- Precautions
- Specifications

1-2 Product description

The paper feeder is for the copier/page printers. One paper feeder is attached to the copier/printer as a standard equipment. Furthermore, as an option, one can be installed to the copier and two can be installed to the printer. Each paper feeder is provided with two paper feed cassettes and there is the type (the total capacity of approximately 500 sheets) can be set approximately 250 sheets, and the other type (the total capacity of approximately 1000 sheets) can be set approximately 500 sheets. The combination of the copier/printer and paper feeder(s) is as follows.

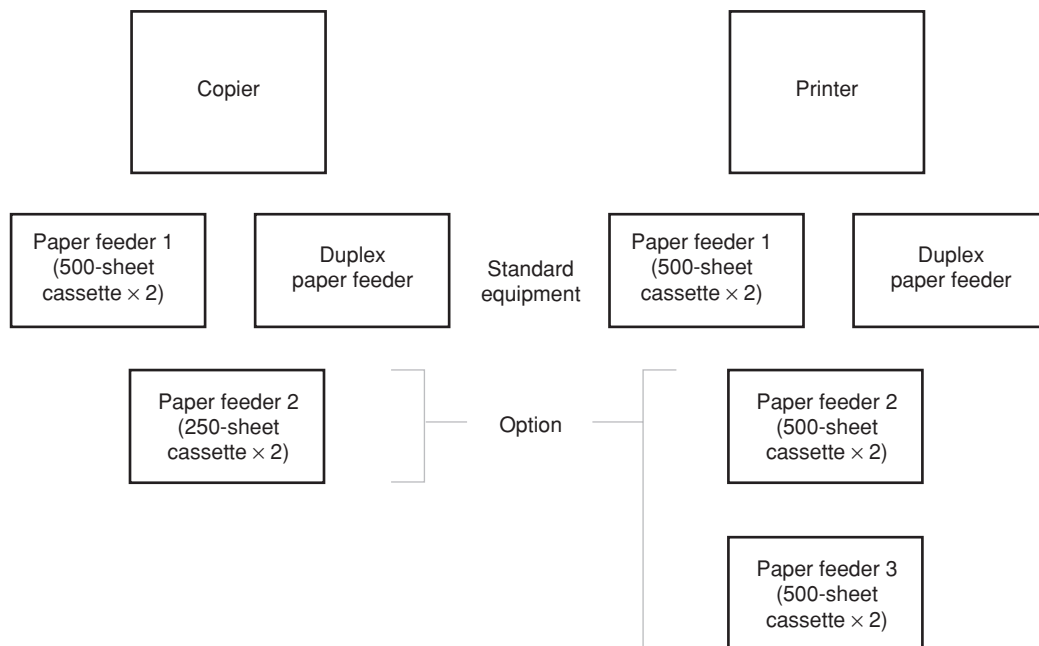

Figure 1-2-1

The paper feeder includes a motor and rollers to feed paper into the copier/printer, and the built-in electronics for controlling them. Technical explanation for the electronics circuits is made in chapter 4, Mechanical Construction.

1-2-1 Unpacking

To unpack the paper feeder, proceed as diagrammed below.

WARNING The paper feeder weighs approximately 20 kg (44 lbs.).

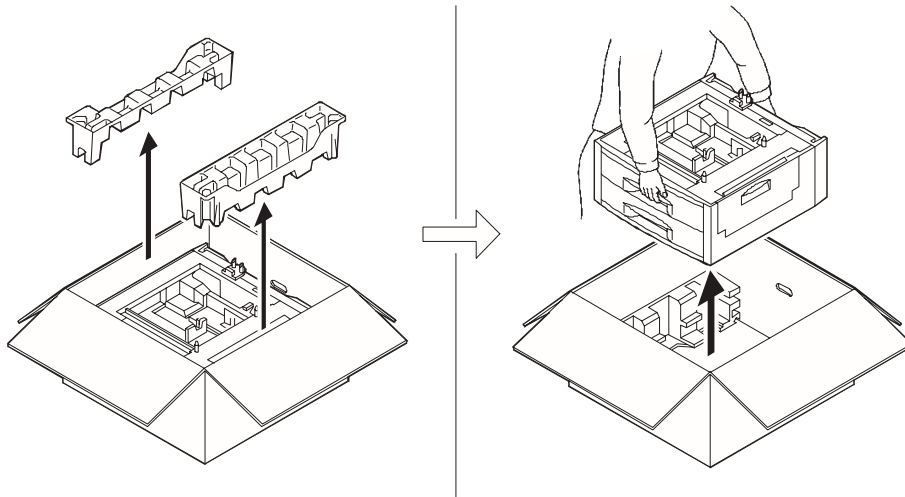

Figure 1-2-2 Unpacking

Place the paper feeder on a stable, level surface (table, floor, etc.).

The paper feeder package contains each of the following items in the indicated quantities.

Paper feeder × 1

*250-sheet cassette paper feeder is equipped with the caster kit as standard.

Paper feed cassette (A5 size up to ledger size) × 2

Paper size indicator plate × 2

Installation guide × 1

1-2-2 Caster kit

These casters are mounted at the bottom of the bottom feeder for moving or fixing the printer.

The caster kit is the topple-resistant, heavy-duty caster kit. The caster kit must be installed when the printer is installed with one or more extra paper feeders.

WARNING The manufacturer is not liable for any damages or injuries that may be caused when the caster kit is not used to support the printer having more than one paper feeders.

1-2-3 Installing the paper feeder

(1) Installing the paper feeder to the copier

Fitting the shield gaskets (220-240 V specifications only)

1. Remove the release coated paper of the double-faced tape located on the rear face of the shield gaskets.
2. Stick two shield gaskets to the top surface of the paper feeder as shown in the diagram.

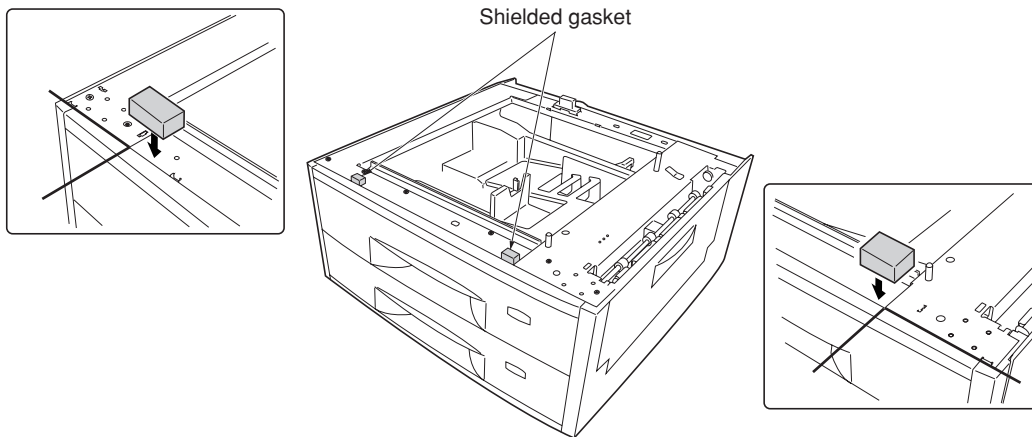

Figure 1-2-3 Installing the shield gaskets

Joining the copier and paper feeder(s)

1. When installing the optional paper feeder, stack and join paper feeder and optional paper feeder using the clamp.

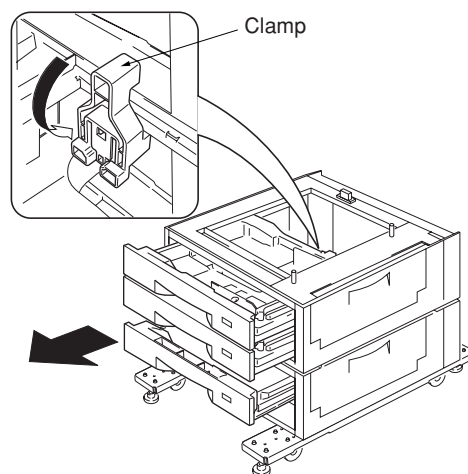

Figure 1-2-4 Joining the paper feeders

2. Place the copier on top of the paper feeder.
3. Join the copier and paper feeder(s) with the junction plate using the binding tap tight screw M4 × 8.

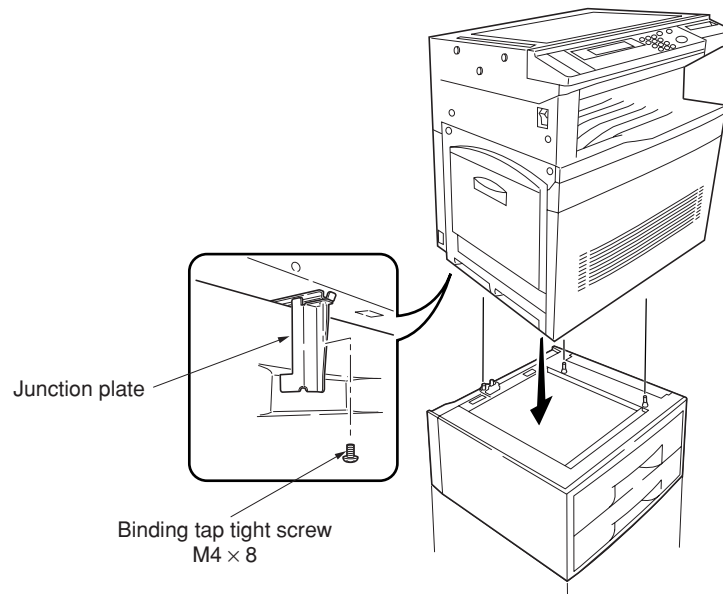

Figure 1-2-5 Joining the copier and paper feeder(s)

Fixation of the copier

1. Turn the adjusters to adjust the level of the overall machine.

Caution: To prevent the possibility of accidents due to tilting the copier body, turn the adjusters until they make firm contact with the floor.

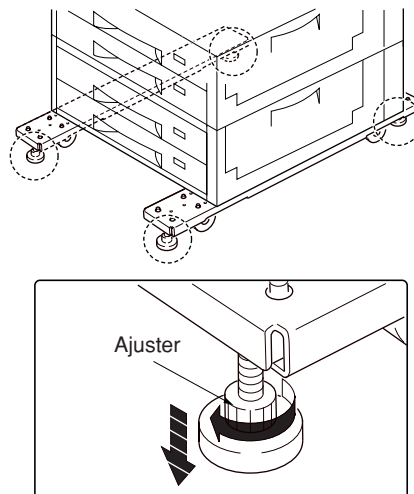

Figure 1-2-6 Fixation of the copier

Installing the desk stay covers and attaching the labels

1. Attach the two desk stay covers to the front part of the two caster stays using the two M4 × 8 chrome screws (1 screw for each cover).

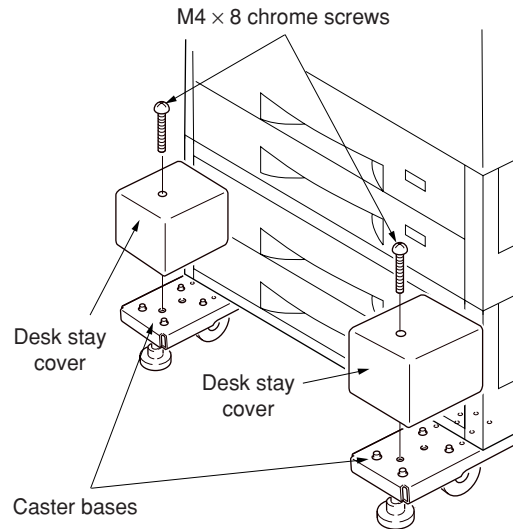

Figure 1-2-7 Installing the desk stay covers

2. Attach the four labels at the locations shown in the diagram.

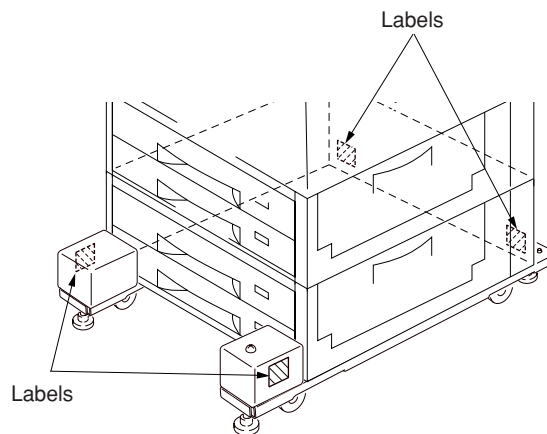

Figure 1-2-8 Attaching the labels

3. Attach the caution label at the shown in the diagram.

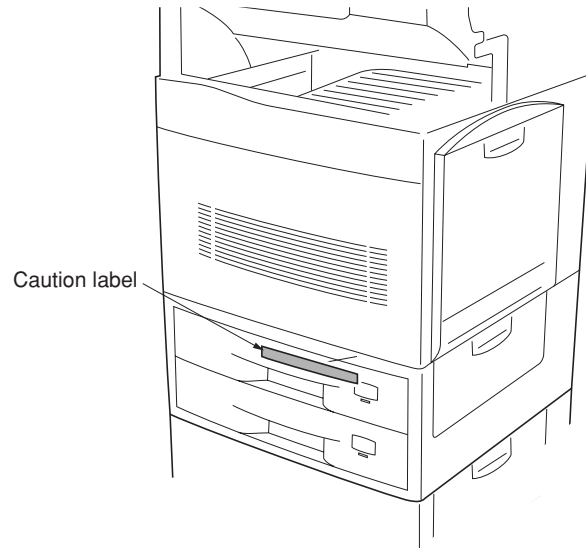

Figure 1-2-9 Attaching the caution label

(2) Installing the paper feeder to the printer

Attaching the casters (option)

Caution

To prevent the printer from tipping over because of weight of the printer and the paper cassettes, the caster kit must be installed at the bottom-most paper feeder, when an optional paper feeder or duplex unit is installed with the printer.

Caution labels have been attached to the paper feeder and the duplex unit.

1. Stand the paper feeder with the rear side on the floor.
2. Remove each one screw to remove four feet.
3. Install two optional caster bases onto the bottom of the paper feeder by using four screws for each. Be sure to face the longer end towards the front of the paper feeder.

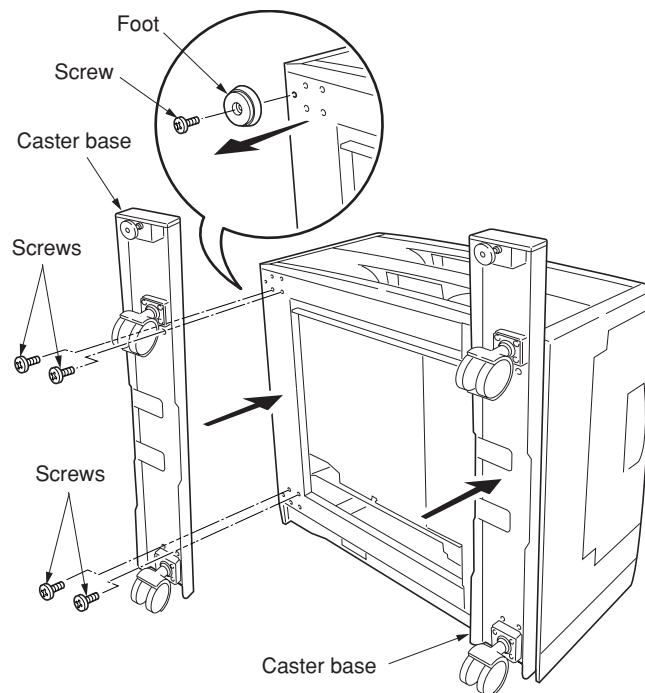

Figure 1-2-10 Attaching the optional caster kit

Joining the printer and paper feeder(s)

1. Using the topple-resistant bracket (supplied with the caster kit), stack and join the bottom and middle paper feeders.

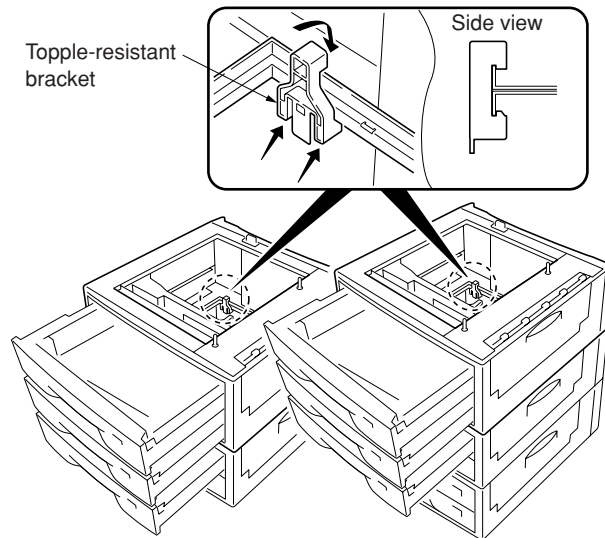

Figure 1-2-11 Joining the paper feeders

2. Place the printer on top of the paper feeders (by more than two persons).
3. Join the printer and topmost paper feeder with the joint jig provided using one screw.

Warning:

Lift the printer by more than two persons. The printer weighs approx. 76 kg.

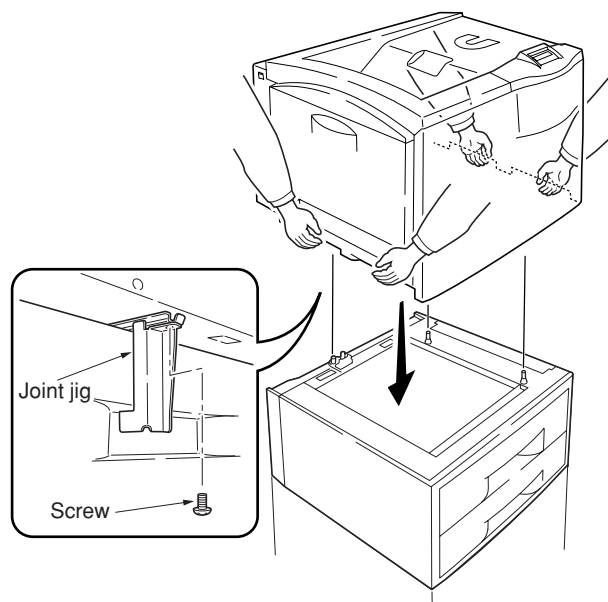

Figure 1-2-12 Joining the printer and paper feeder(s)

4. Place the printer in a proper location.
5. Lock the stopper for each caster and turn the height adjuster clockwise until the adjuster reaches the floor. This fixes the printer in place.

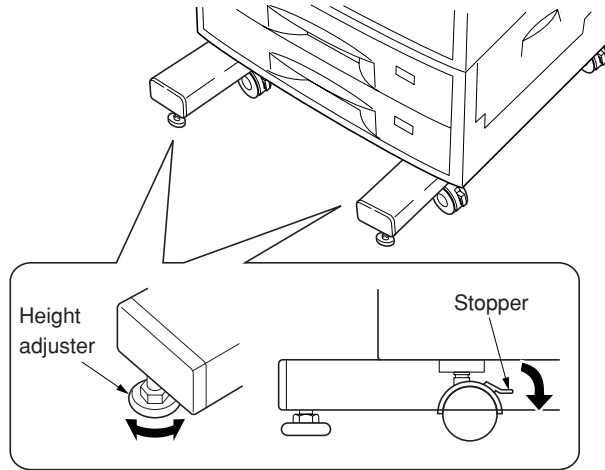

Figure 1-2-13 Fixation of the printer

(3) Place the paper size indicator plate

Place these on the front of the cassette according to the paper size inside to make it easy to know the current paper size.

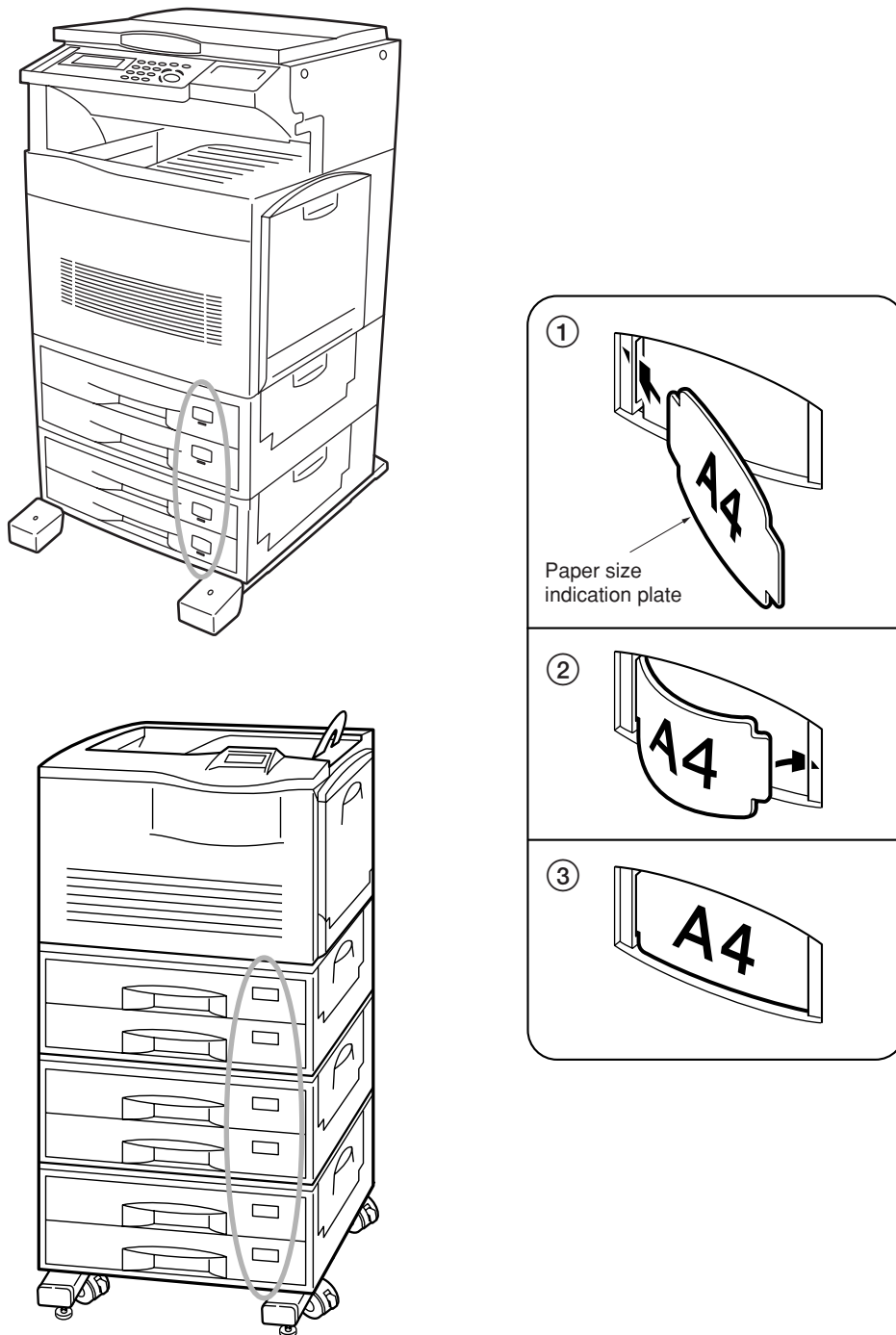

Figure 1-2-14 Place the paper size indicator plate

1-2-4 Names of parts

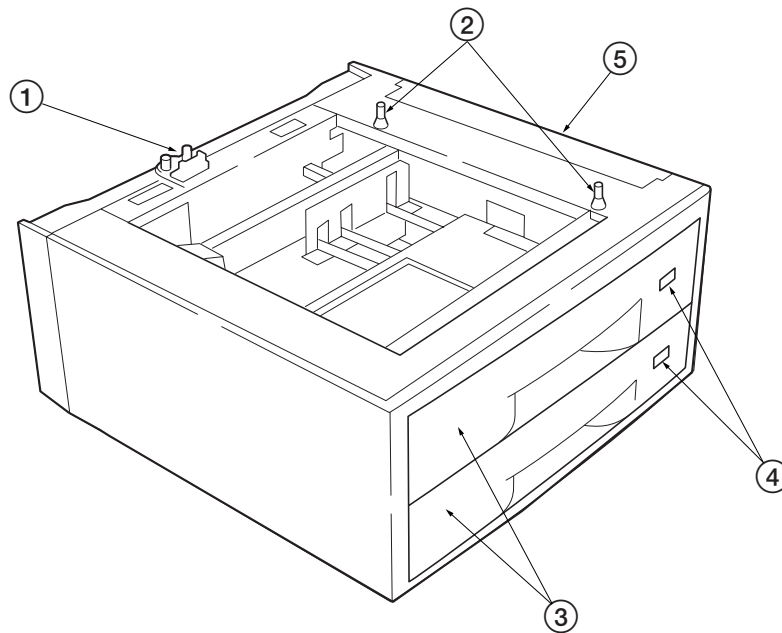

Figure 1-2-15 Paper feeder

- ① Connector Plugs into a connector located inside the bottom of the copier/printer. When using 2 or 3 paper feeders, this connector plugs into a connector located inside the bottom of the upper feeder.
- ② Positioning pins These pins fit into two holes in the bottom of the copier/printer. When using 2 or 3 paper feeders, these pins fit into holes in the bottom of the upper feeder.
- ③ Paper feed cassette By adjusting the paper guides inside the paper feed cassette, this cassette accommodates standard paper from A5 size up to ledger size. It holds up to 500 sheets of paper (0.1 mm thickness per sheet).
- ④ LED Indicates the state of the paper feeder's paper feed cassette. The included (Paper size indicator plate location) paper size indicator plates are attached here (See page 1-7).
- ⑤ Side cover Opens to allow clearing paper jams.

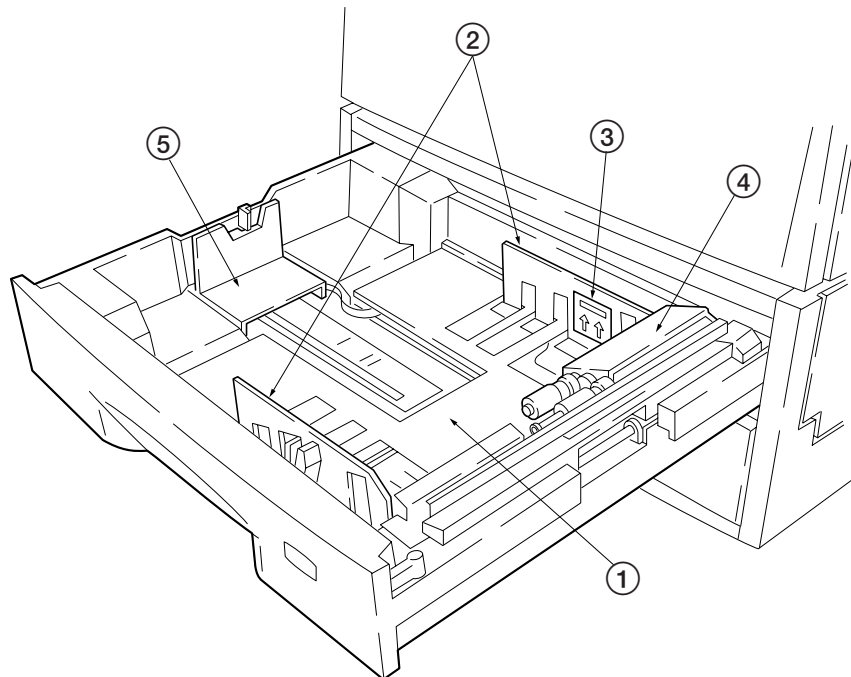

Figure 1-2-16 Paper feed cassette

- | | |
|-------------------------|---|
| ① Bottom plate | Paper is placed on top of this. After the paper feed cassette is inserted into the feeder, the bottom plate rises as the paper stack decreases. |
| ② Paper guides | Keeps the sides of the paper aligned. The paper guides should be repositioned for different paper size. |
| ③ Paper limit indicator | The tip of the arrow indicates the upper limit for the paper stack height when loading paper. |
| ④ Paper feed roller | Feeds paper to be printed to the copier/printer. Raise the paper feed roller before loading paper. |
| ⑤ Paper stopper | Keeps the back edges of the paper aligned. |

1-3 Precautions concerning service and maintenance

Only a qualified technician should perform service on the equipment, who is familiar with fundamental safety countermeasures as dictated for all electronics technicians. Observe the following precautions during service and maintenance of the paper feeder. These are to prevent the possible personal injuries to the technician and the damage to the equipment.

1-3-1 Precautions

Always observe the following precautions when maintaining or inspecting the paper feeder.

- When performing any maintenance or inspection procedure, first unplug the power cord. Make sure that the copier/printer power is turned off before replacing circuit boards or electrical components in the paper feeder.
- To prevent electrostatic discharge damage to electrical circuits, be sure to wear an antistatic band when handling the circuit boards.
- Be particularly careful when reconnecting the power after having repaired or replaced a component that has the potential for causing an electric shock.
- If the paper feeder is to be transported or stored for a lengthy period of time, the unit should be packed in its original packaging.
- Store the paper feeder in a cool, dark, dry area. Avoid storage in dusty areas.

1-3-2 Replacement parts

Be sure to use only the recommended supplies and components. We assume no liability in the event of damage resulting from the use of unauthorized components.

1-3-3 Notes concerning paper storage

Use of paper with a high moisture content in the paper feeder can adversely affect printing quality through the occurrence of paper jams, wrinkling, and other difficulties. Observe the following paper handling precautions.

- Store paper in a dry place. Do not place paper directly on a damp floor.
- Do not stand paper on end for storage. Stack paper horizontally on a flat surface.
- After loading paper in the paper cassette, store any leftover paper in the original wrapping or a plastic bag.

1-4 Specifications

1-4-1 Mechanical specifications

Table 1-4-1 Mechanical specifications

Item	Specification
Applicable paper standard paper	See next page.
Paper feed cassette	Universal cassette × 2
Loadable paper size	ISO A3 (297 mm × 420 mm) ISO A4 (210 mm × 297 mm) ISO A5 (148 mm × 210 mm) JIS B4 (257 mm × 364 mm) JIS B5 (182 mm × 257 mm) Ledger (11" × 17") Letter (8½" × 11") Legal (8½" × 14")
Sheet capacity	1000 sheets (500 sheets × 2) (paper thickness: 0.1 mm/sheet) 500 sheets (250 sheets × 2) (paper thickness: 0.1 mm/sheet)
Operating environment	Temperature: 10 to 32.5 °C Humidity: 20 to 80 % RH Optimal conditions: 20 °C, 65 % RH Altitude: Max. 2000 m
Dimensions (W × D × H)	250-sheet cassette: 560 mm × 713 mm × 281 mm [22" × 28½" × 11½"] (including the caster kit) 500-sheet cassette: 560 mm × 566 mm × 251 mm [22" × 22¼" × 9⅞"]
Weight	Approx. 20 kg (44 lbs.)
Power s	From copier/printer

1-4-2 Paper specifications

Table 1-4-2 Paper specifications

Item	Specification
Weight	64 to 90 g/m ² (17 to 24 lbs/ream)
Thickness	0.086 to 0.110 mm (3.4 to 4.3 mils)
Dimensional accuracy	±0.7 mm (±0.0276 inches)
Squareness of corners	90° ±0.2°
Moisture content	4 to 6 %
Direction of grain	Long
Pulp content	80 % or more

Notes on types of paper

With the following types of paper, paper feed performance should be tested prior to purchase even if the above specifications are fulfilled. If possible, use of these paper types should be avoided.

- Glossy paper
- Translucent paper
- Paper with a texture surface finish
- Perforated paper
- Paper with punched holes

For more detailed explanation of paper handling, see chapter 3, section 3-2, Paper specifications.

Chapter 2 Assembly and Disassembly

Chapter 2 Contents

2-1 Introduction	2-3
2-2 Disassembly procedures	2-4
2-2-1 Precautions	2-4
2-2-2 Disassembly	2-5
(1) Removing the rear cover	2-5
(2) Removing the main board	2-6
(3) Removing the feed roller and pickup roller	2-7
(4) Removing the retard roller	2-8
(5) Removing the upper and lower cassette base elevation motors (250-sheet cassette paper feeder)	2-9
(6) Removing the upper and lower cassette base elevation motors (500-sheet cassette paper feeder)	2-11

2-1 Introduction

This chapter explains the disassembly procedures required to replace parts.

Note that the paper feeder requires no lubrication at any part.

2-2 Disassembly procedures

This section provides procedures for disassembling of the paper feeder. When replacing parts for which there is no specific procedure described, refer to the exploded view shown in the *Parts List* (separate).

2-2-1 Precautions

Before beginning disassembly, be sure to read the precautions below.

- Before removing the paper feeder from the copier/printer, be sure to turn off copier/printer power.
- Be sure to use the correct screws when installing a component. Using incorrect screws can result in the threads of the screws being stripped, which may lead in turn to other problems. Frequent insertion and removal of self-tapping screws can cause damage to screw holes.
- Do not tighten screws excessively.
- When removing or installing circuit boards, wear a grounded wrist strap to protect against damage due to discharge of static electricity.
- Before proceeding, make sure copier/printer power is switched off.

2-2-2 Disassembly

(1) Removing the rear cover

Remove four screws (1). Remove the rear cover (2).

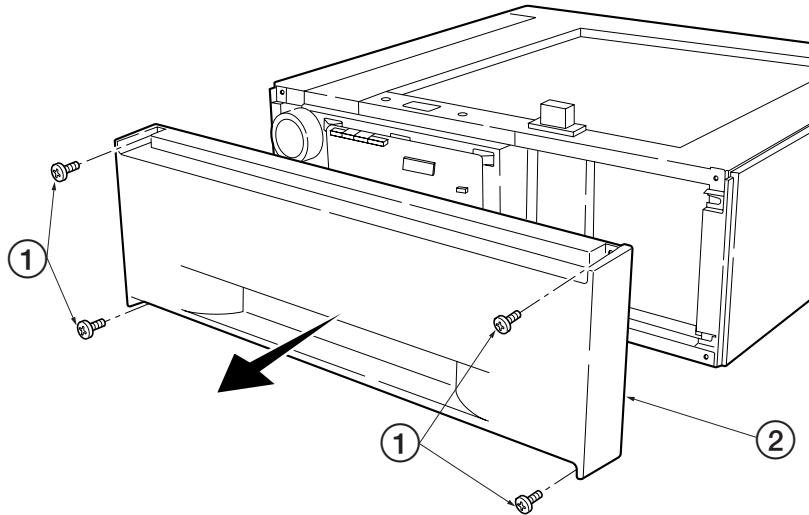

**Figure 2-1-1a Removing the rear cover
(250-sheet cassette paper feeder)**

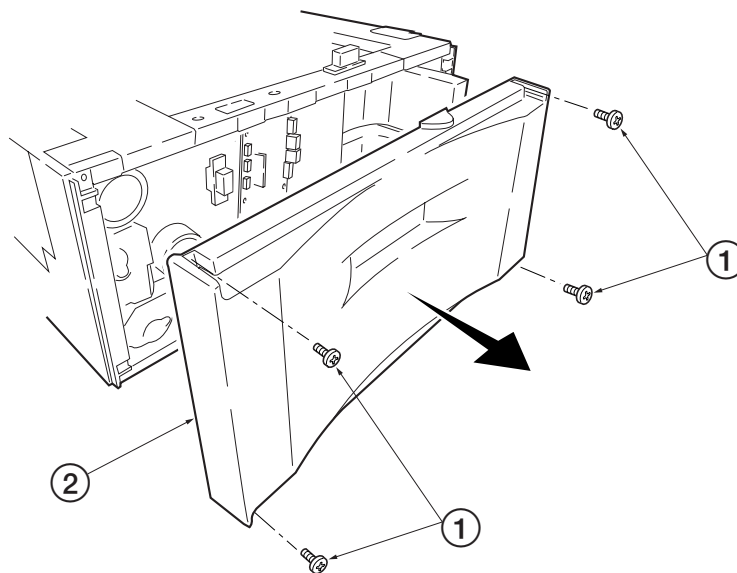

**Figure 2-1-1b Removing the rear cover
(500-sheet cassette paper feeder)**

(2) Removing the main board

Remove the rear cover (See page 2-5). Remove the all connectors from the main board ①. Remove five screws ②. Remove the main board ①.

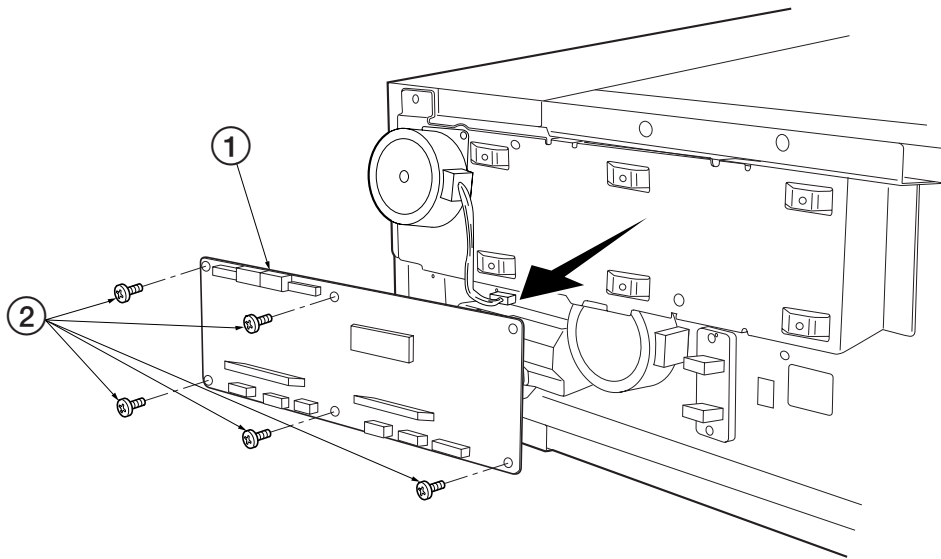

**Figure 2-1-2a Removing the main board
(250-sheet cassette paper feeder)**

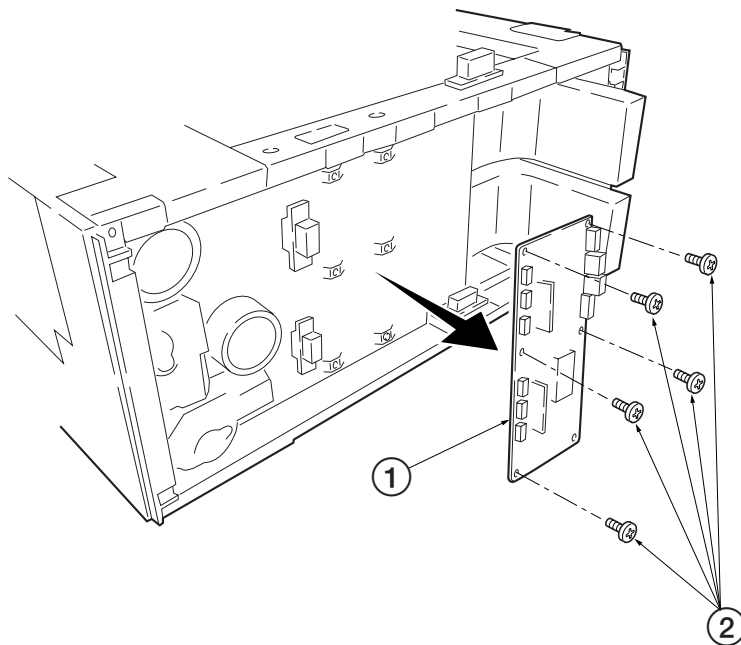

**Figure 2-1-2b Removing the main board
(500-sheet cassette paper feeder)**

(3) Removing the feed roller and pickup roller

Remove the four E-rings ① from the feed roller's shaft ②. Remove the feed roller ③ from the feed roller's shaft ②. Remove the one E-ring ④ from the pickup roller's shaft ⑤. Remove the pickup roller ⑥.

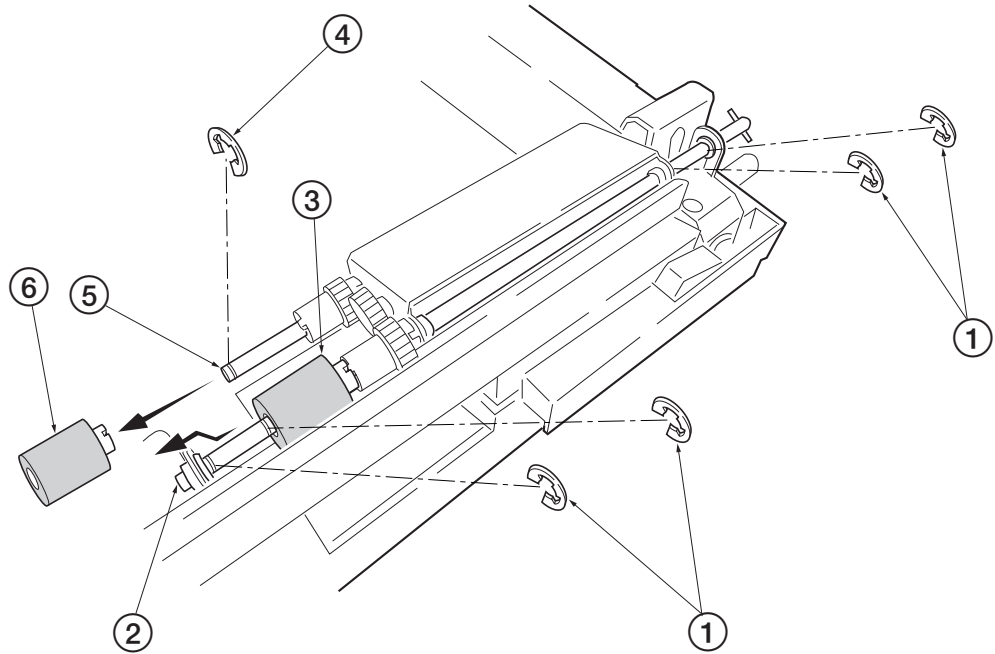

Figure 2-1-3 Removing the feed roller and pickup roller

(4) Removing the retard roller

Remove the four screws (1). Remove the feed stay (2). Remove the retard plate (3). Remove the retard roller (4).

NOTE

Use care not forget the retard springs lost.

Be sure to fit the red-colored retard spring on the front side of the retard roller.

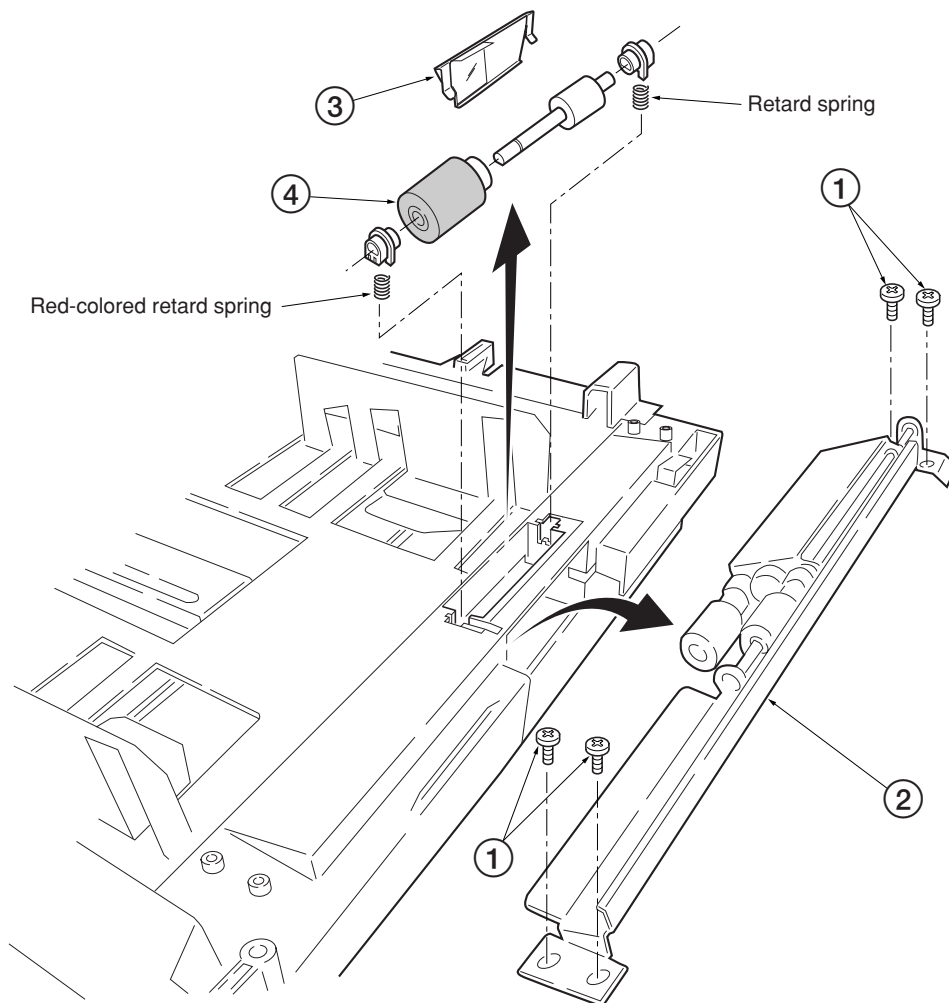

Figure 2-1-4 Removing the retard roller

**(5) Removing the upper and lower cassette base elevation motors
(250-sheet cassette paper feeder)**

Remove the rear cover (See page 2-5). Open the side cover ①. Remove four screws ②. Remove the right cover ③.

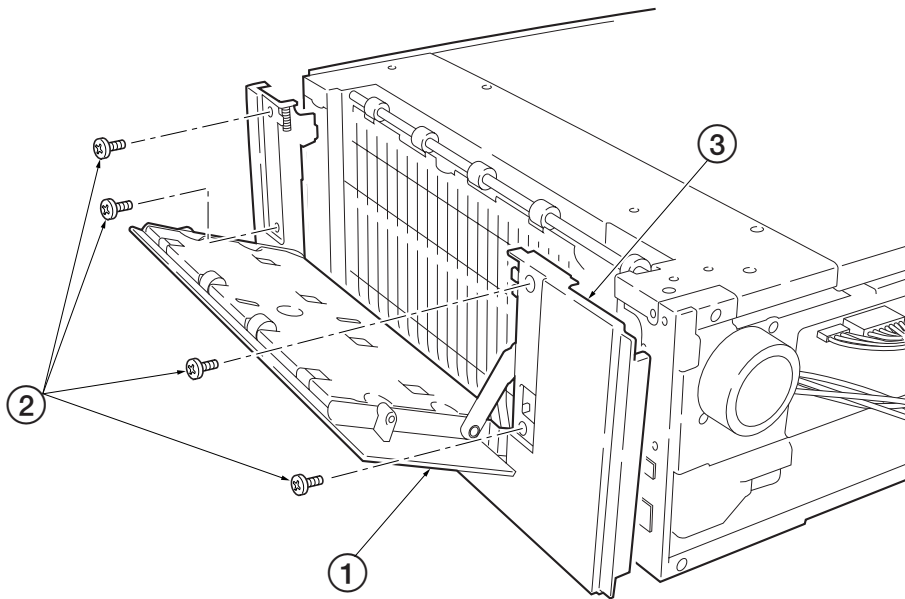

Figure 2-1-5 Removing the right cover

Remove one connector ④. Remove two screws ⑤. Remove the intermediate stepping motor ⑥.

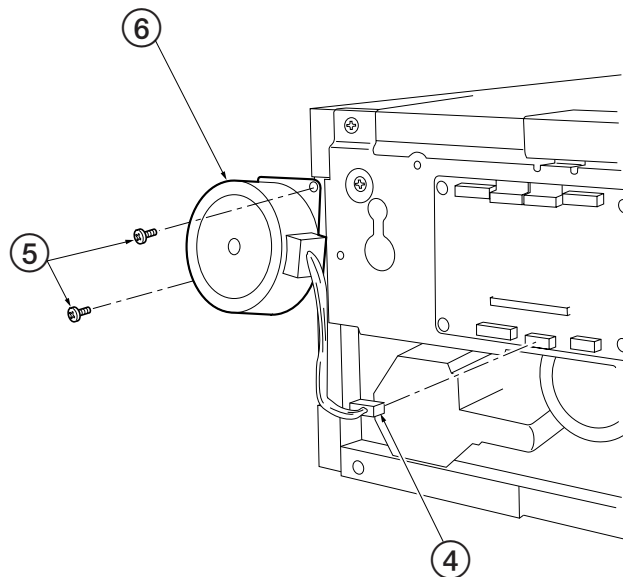

Figure 2-1-6 Removing the intermediate stepping motor

Remove six screws (7). Remove the mount plate (8).

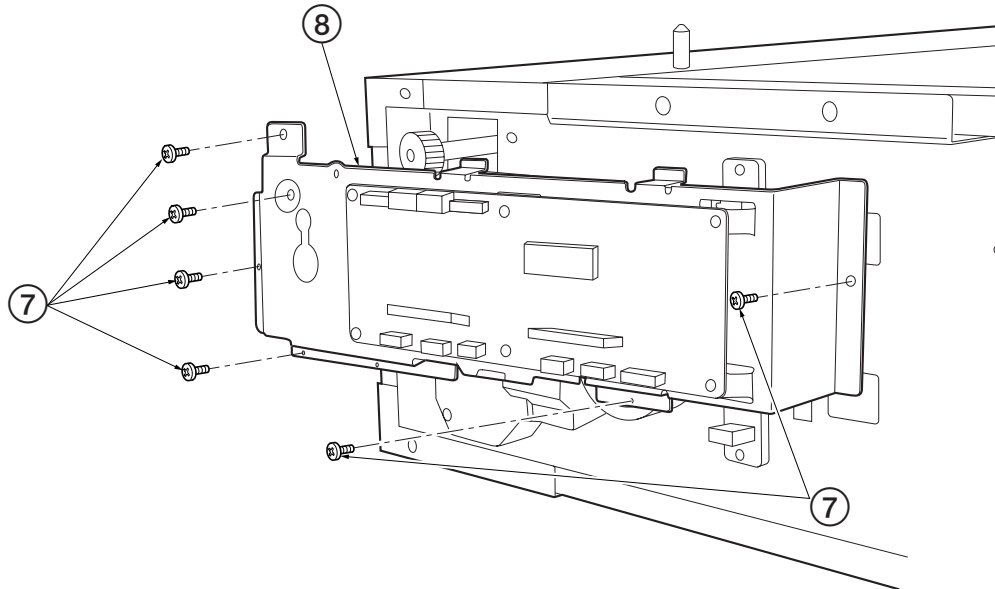

Figure 2-1-7 Removing the mount plate

Remove one connector (9). Remove two screws (10). Remove the upper cassette base elevation motor (11). Remove one connector (12). Remove two screws (13). Remove the lower cassette base elevation motor (14).

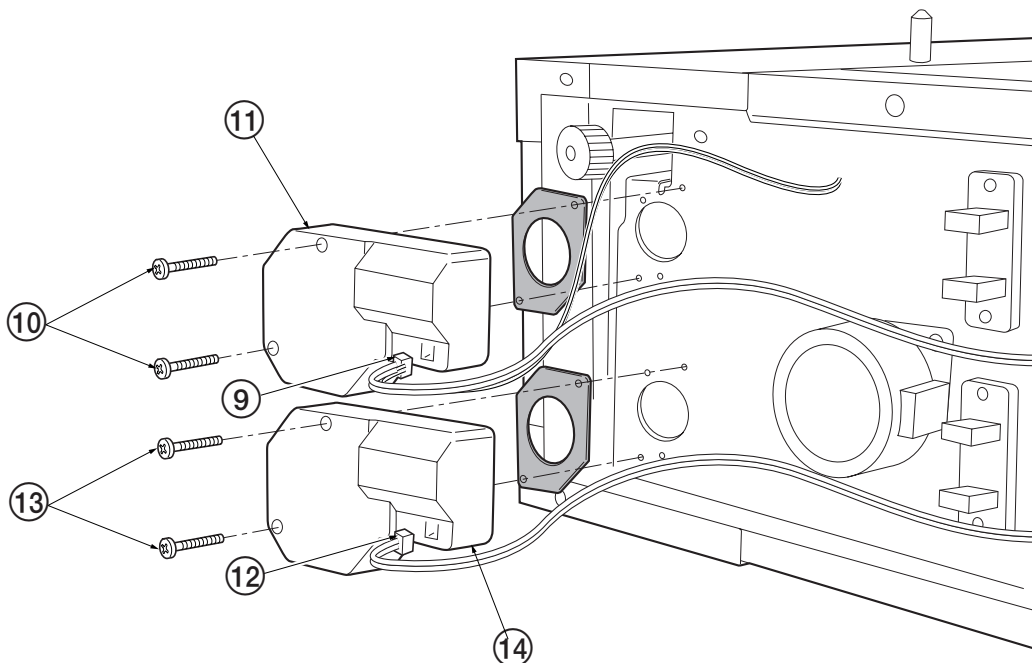

Figure 2-1-8 Removing the upper and lower cassette base elevation motors

**(6) Removing the upper and lower cassette base elevation motors
(500-sheet cassette paper feeder)**

Remove the rear cover (See page 2-5). Remove one connector ①. Remove two screws ②. Remove the upper cassette base elevation motor ③. Remove one connector ④. Remove two screws ⑤. Remove the lower cassette base elevation motor ⑥.

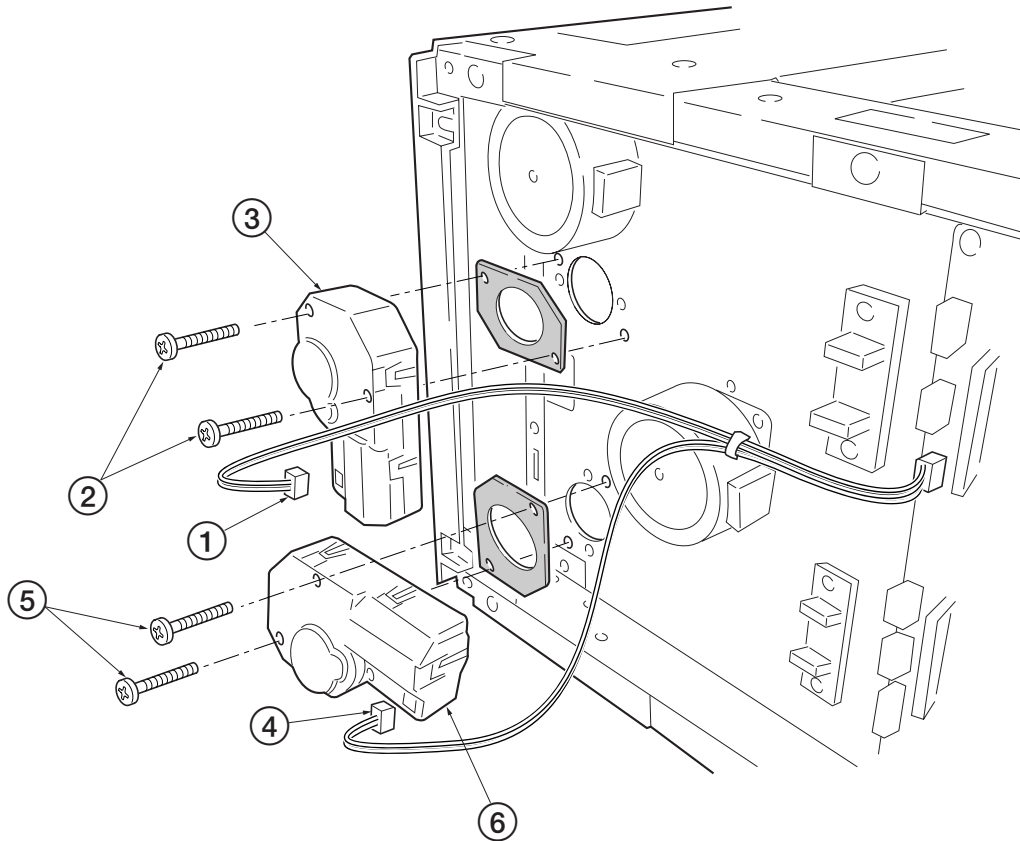

Figure 2-1-9 Removing the upper and lower cassette base elevation motors

Chapter 3

Paper Specifications

Chapter 3 Contents

3-1 General guidelines	3-3
3-1-1 Paper availability	3-3
3-1-2 Selecting the right paper	3-4
3-2 Paper specifications	3-5
3-2-1 Points of consideration	3-5
(1) Condition of the paper	3-5
(2) Composition	3-5
(3) Paper size	3-6
(4) Smoothness	3-6
(5) Basis weight	3-6
(6) Thickness (Caliper)	3-6
(7) Moisture content	3-7
(8) Paper grain	3-7
3-2-2 Other paper properties	3-8
(1) Porosity	3-8
(2) Stiffness	3-8
(3) Curl	3-8
(4) Electrostatic properties	3-8
(5) Whiteness	3-8
(6) Quality control	3-8
(7) Packaging	3-8
3-2-3 Special paper	3-9
(1) Colored paper	3-9
(2) Preprinted paper	3-9

3-1 General guidelines

The paper feeder may not be used to print on paper not satisfying the requirements below. Also, special types of print media such as overhead projection (OHP) film, envelopes, adhesive backed labels, and paper containing watermarks must not be used with printing with the paper feeder.

These types can result in jams, misfeeds, and paper waste, and in extreme cases can damage the paper feeder.

NOTE We assumes no liability for problems that occur when paper not satisfying these requirements is used with the paper feeder.

Selection of the right paper is important. The wrong paper can result in jams, misfeeds, curl, poor print quality, and paper waste, and in extreme cases can damage the paper feeder and the copier/printer. The guidelines given below will increase the productivity of your office by ensuring efficient, trouble-free printing and reducing wear and tear on the paper feeder and the copier/printer.

3-1-1 Paper availability

Most types of paper are compatible with a variety of machines. Paper intended for xerographic copiers can also be used with the paper feeder and the copier/printer.

Differences between paper from different suppliers can also affect the paper feeder's performance. A high-quality copier/printer cannot produce high-quality results when the wrong paper is used. Low-priced paper is not economical in the long run if causes printing problems.

3-1-2 Selecting the right paper

Copier/printer printing is a process involving laser light, electrostatic discharge, toner, and heat. In addition, as the paper passes through the copier/printer it undergoes considerable sliding, bending, and twisting motions. A high-quality printing paper matching the requirements withstands all these stresses, enabling the paper feeder and the copier/printer to turn out clean, crisp printed copy consistently.

Remember that all paper is not the same. Some of the factors to consider when selecting paper is as following in the next section.

3-2 Paper specifications

The following table summarizes the basic paper specifications that should be applied to the paper used with the paper feeder. Details are given following the table.

Table 3-2-1 Specifications

Item	Specification
Weight	64 to 90 g/m ² (17 to 24 lbs./ream)
Thickness	0.086 to 0.110 mm (3.4 to 4.3 mils)
Dimensional accuracy	±0.7 mm (±0.0276 inches)
Squareness	90° ±0.2°
Moisture content	4 to 6 %
Direction of grain	Long grain
Pulp content	80 % or more

3-2-1 Points of consideration

The following section provides general information which should be considered when selecting paper for using with the paper feeder.

(1) Condition of the paper

Avoid using paper that is bent at edges, curled, dirty, torn, or contaminated with lint, clay, or paper shreds.

Used of paper in these conditions can lead to illegible printing, misfeeding, and paper jams, and can shorten the life of the paper feeder and the copier/printer. In particular, avoid using paper with a surface coating or other surface treatment. The paper should have as smooth and even a surface as possible.

(2) Composition

Do not use paper that has been coated or surface-treated and contains plastic or carbon. The heat of fusing can cause such paper to give off harmful fumes.

Bond paper should contain at least 80% pulp. Not more than 20% of the total paper content should consist of cotton or other fibers.

(3) Paper size

The paper feeder is usable with the paper sizes as tabled below.

Table 3-2-1 Paper size

Paper size	Dimension
ISO A3	297 mm × 420 mm
ISO A4	210 mm × 297 mm
JIS A5	148 mm × 210 mm
JIS B4	257 mm × 364 mm
JIS B5	182 mm × 257 mm
Ledger	11" × 17"
Letter	8½" × 11"
Legal	8½" × 14"

(4) Smoothness

The paper should have a smooth, uncoated surface. Paper with a rough or sandy surface can cause voids in the printed output. Paper that is too smooth, however, can cause multiple feeding and fogging problems. (Fogging is a gray background effect.)

(5) Basis weight

Paper that is too light or too heavy can cause misfeeding, jams, and premature wear of the paper feeder and the copier/printer. Uneven paper weight can cause multiple feeds, print defects, poor toner fusing, blurring, and other print quality problems. The proper weight is 64 to 90 g/m² (17 to 24 lbs/ream).

(6) Thickness (Caliper)

Thick paper is referred to as high-caliper paper and thin paper as low-caliper paper. The paper used with the paper feeder should be neither extremely thick nor extremely thin. If you are having problems with paper jams, multiple feeds, and faint printing, the paper may be too thin. If you are having problems with paper jams, and blurred printing the paper may be too thick. The proper thickness is 0.086 to 0.110 mm (3.4 to 4.3 mils).

(7) Moisture content

Moisture content is defined as the percent ratio of moisture to the dry mass of the paper. Moisture can affect the paper's appearance, feedability, curl, electrostatic properties, and toner fusing characteristics.

The moisture content of the paper varies with the relative humidity in the room. When the relative humidity is high and the paper absorbs moisture, the paper edges expand, becoming wavy in appearance. When the relative humidity is low and paper loses moisture, the edges shrink and tighten, and print contrast may suffer.

Wavy or tight edges can cause misfeeding and alignment anomalies.

The moisture content of the paper should be 4 % to 6 %.

To ensure the proper moisture content it is important to store the paper in a controlled environment.

Some tips on moisture control are:

- Store paper in a cool, dry location.

- Keep the paper in its wrapping as long as possible. Rewrap paper that is not in use.

- Store paper in its original carton. Place a pallet etc. under the carton to separate it from the floor.

- After removing paper from storage, let it stand in the same room as the copier/printer for 48 hours before use.

- Avoid leaving paper where it is exposed to heat, sunlight, or damp.

(8) Paper grain

When paper is manufactured, it is cut into sheets with the grain running parallel to the length (long grain) or parallel to width (short grain).

Short grain paper can cause feeding problems in the paper feeder and the copier/printer. All paper used in the paper feeder and the copier/printer should be long grain.

3-2-2 Other paper properties

(1) Porosity

Refers to the density of the paper structure; that is, to how openly or compactly the fibers are bonded.

(2) Stiffness

Limp paper can buckle inside the paper feeder and the copier/printer, while paper that is too stiff may bind. Either way the result is a paper jam.

(3) Curl

Most paper has a natural tendency to curl in one direction. The paper should be loaded so that the natural curl is downward, to counteract the upward curl imparted by the copier/printer. Printed sheets will then come out flat. Most paper also has a top and bottom surface. Loading instructions are usually given on the paper package.

(4) Electrostatic properties

During the printing process the paper is electrostatically charged to attract the toner. The paper must be able to release this charge so that printed sheets do not cling together in the output tray.

(5) Whiteness

The contrast of the printed page depends on the whiteness of the paper. Whiter paper provides a sharper, brighter appearance.

(6) Quality control

Uneven sheet size, corners that are not square, ragged edges, welded (uncut) sheets, and crushed edged and corners can cause the paper feeder and the copier/printer and the copier/printer to malfunction in various ways. A quality paper supplier should take considerable care to ensure that these problems do not occur.

(7) Packaging

Paper should be packed in a sturdy carton to protect it from damage during transport. Quality paper obtained from a reputable supplier is usually properly packaged.

3-2-3 Special paper

The following types of special paper can be used:

Colored paper
Preprinted paper

Use paper that is sold specifically for use with photocopies and/or laser printers.

Since the composition and quality of special paper vary considerably, special paper is more likely than white bond paper to give trouble during printing. No liability will be assumed if moisture etc. given off in printing on special paper causes harm to the machine or operator.

NOTE Before purchasing any type of special paper, test a sample on the paper feeder and the copier/printer and check that printing quality is satisfactory.

Specifications for each type of special paper are given on next page.

(1) Colored paper

Colored paper should satisfy the same conditions as Table 3-2-1 of page 3-5, listed in used in the paper must be able to withstand the heat of fusing during the printing process (up to 200 °C or 392 °F).

(2) Preprinted paper

Preprinted paper should satisfy the same conditions as Table 3-2-1 of page 3-5. The preprinted ink must be able to withstand the heat of fusing during the printing process, and must not be affected by silicone oil.

Do not use paper with any kind of surface treatment, such as the type of paper commonly used for calendars.

Chapter 4 Mechanical Construction

Chapter 4 Contents

4-1 Introduction	4-3
4-2 Main board	4-4
4-3 Feeder interface	4-5
4-3-1 Connector configuration	4-5
4-4 Paper feeding system	4-7
4-4-1 Paper control signals	4-9
4-4-2 Electrical components	4-10
4-4-3 Paper cassette feeding	4-14
4-4-4 Paper cassette feeding drive system	4-16
4-4-5 Paper size sensing	4-17
4-4-6 Paper gauge sensing	4-18
4-4-7 Paper feeder identifying system	4-22

4-1 Introduction

This chapter describes the operation of the electrical circuits in the paper feeder.

General diagram is provided in Appendix A.

4-2 Main board

The main board includes the driver circuits for motors and LEDs, reset circuit (U3), and other circuits diagrammed in Figure 4-2-1 below, that are controlled by CPU (U1). CPU incorporates a ROM that includes the program to operate the paper feeder which in turn provides control over the entire feeder system according to the program. CPU also exchanges control signals between the engine board of the copier/printer and itself in serial communication method; accepts inputs given by the switches and sensors for detection of paper; and delivers outputs to drive the motor driver circuits. The reset circuit (U3) is to monitor the 5 V DC operating power supply and delivers RESET signal at power up and in case of voltage drop to CPU.

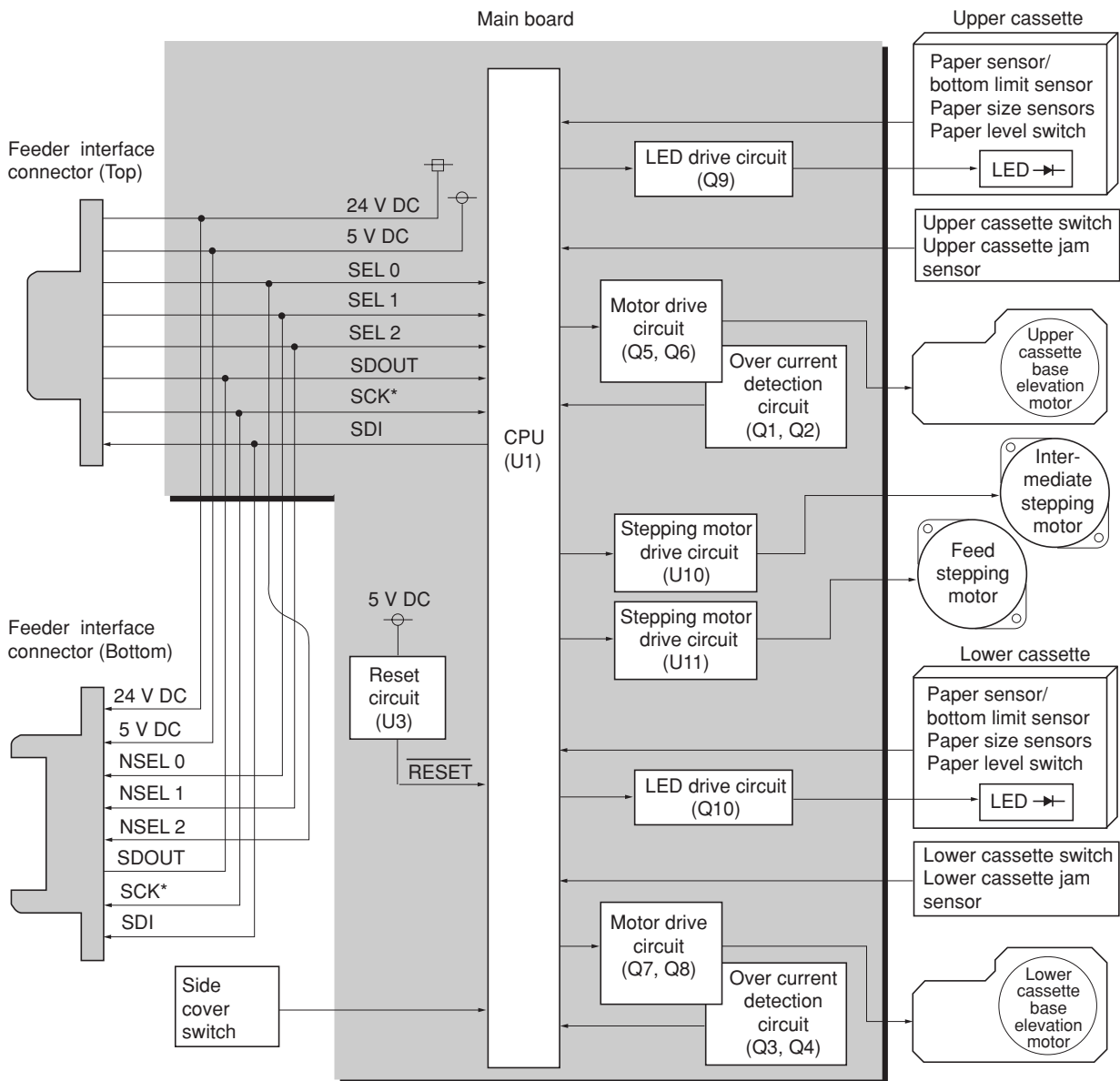

Fig 4-2-1 Main board block diagram

4-3 Feeder interface

4-3-1 Connector configuration

The paper feeder and the copier/printer exchange signals between them through feeder interface connector which is provided on top of the paper feeder. The other end of the connector appears on the bottom of the paper feeder and exchanges the same signals with other paper feeder(s) that is installed with the copier/printer. The names and functions of these signals are tabled on next page.

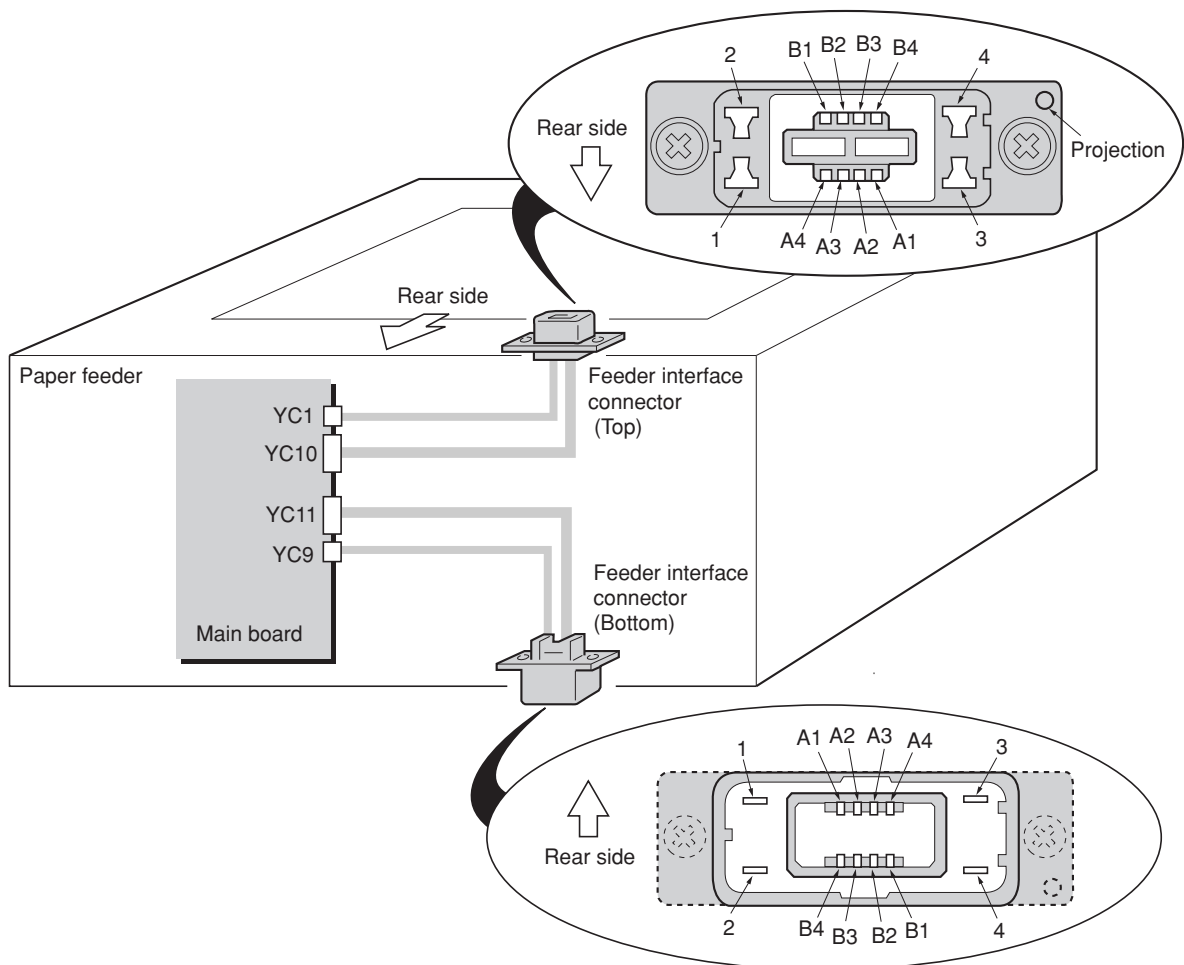

Figure 4-3-1 Connector configuration

Table 4-3-1 Feeder interface connector (Top) pin assignment

PinNo.	Signal	Description
1	GND	Ground
2	GND	Ground
3	OP24V	+24V power
4	OP24V	+24V power
A-1	SDOUT	Serial communication input data
A-2	SEL2	Select bit 2
A-3	SEL1	Select bit 1
A-4	SEL0	Select bit 0
B-1	OP5V	+5 V power
B-2	OP5V	+5 V power
B-3	SDI	Serial communication output data
B-4	SCK*	Serial communication synchronous clock

Table 4-3-2 Feeder interface connector (Bottom) pin assignment

PinNo.	Signal	Description
1	GND	Ground
2	GND	Ground
3	OP24V	+24V power
4	OP24V	+24V power
A-1	NSEL0	Select bit 0
A-2	NSEL1	Select bit 1
A-3	NSEL2	Select bit 2
A-4	SOUT	Serial communication output data
B-1	SCK*	Serial communication synchronous clock
B-2	SDI	Serial communication output data
B-3	OP5V	+5 V power
B-4	OP5V	+5 V power

4-4 Paper feeding system

The paper feeding system picks up paper from the paper cassette. At a precise timing, it feeds it to the copier/printer. The printed page is finally delivered to the internal tray/face-down tray, eject tray/face-up tray, or optional document finisher/sorter, document finisher and stacker.

The figure below shows the components in the paper path within the copier/printer and paper feeder. The sensors, clutches, motors, etc., are also described in the following pages.

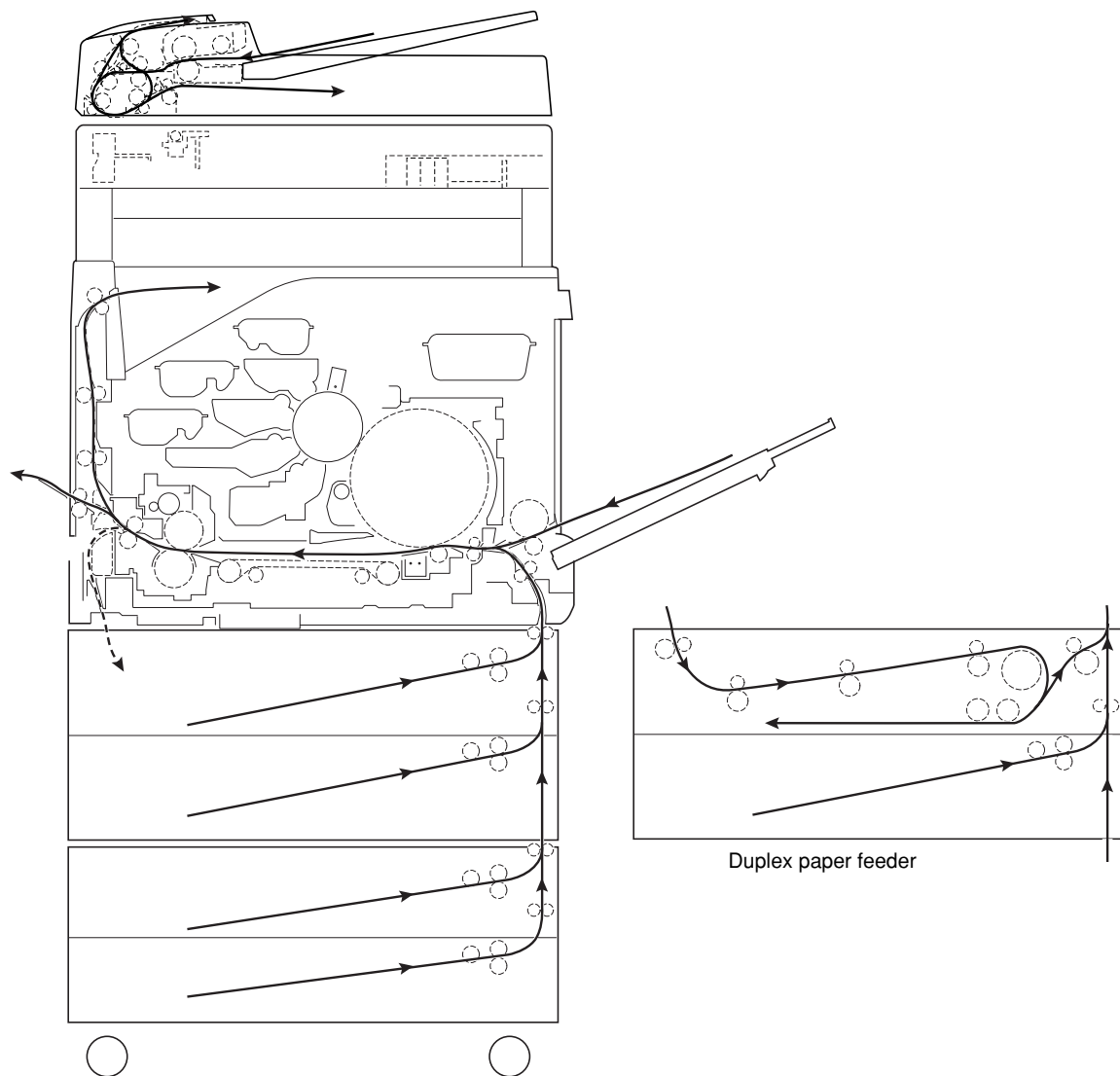

Figure 4-4-1a Paper path (copier and paper feeders)

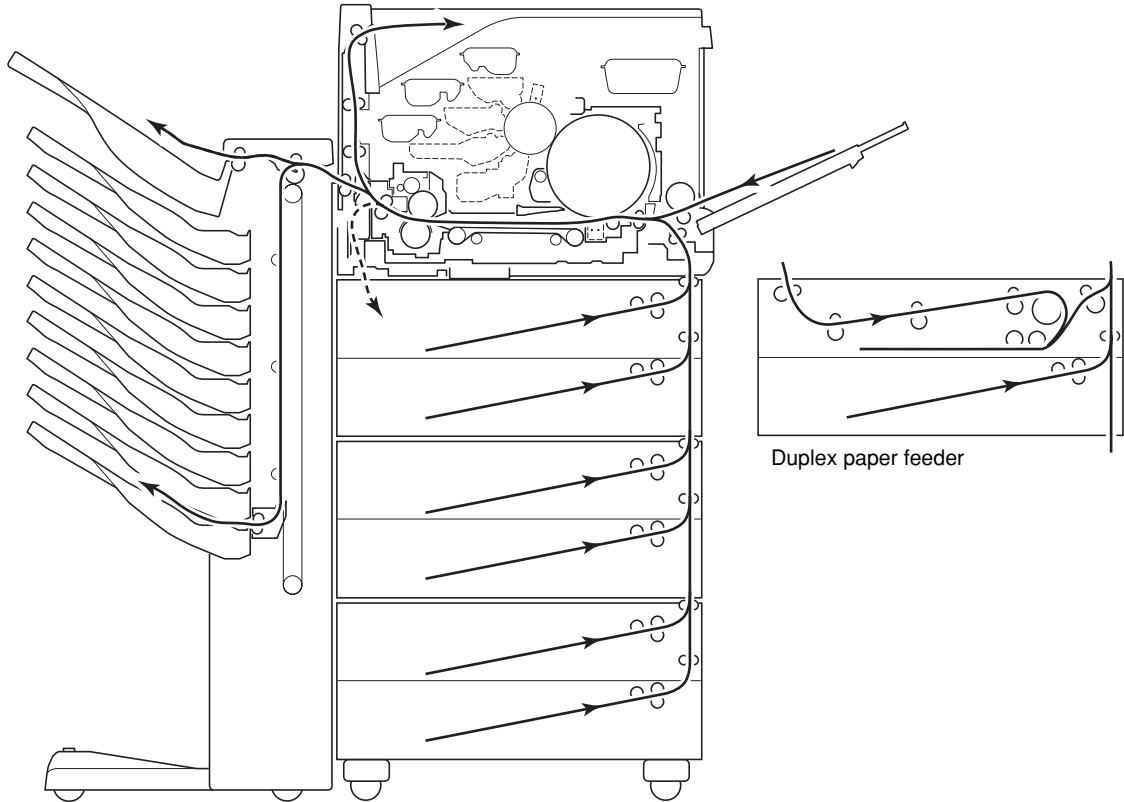

Figure 4-4-1b Paper path (printer and paper feeders)

4-4-1 Paper control signals

The following diagram shows the signals that control the sensors and the rollers for guiding paper.

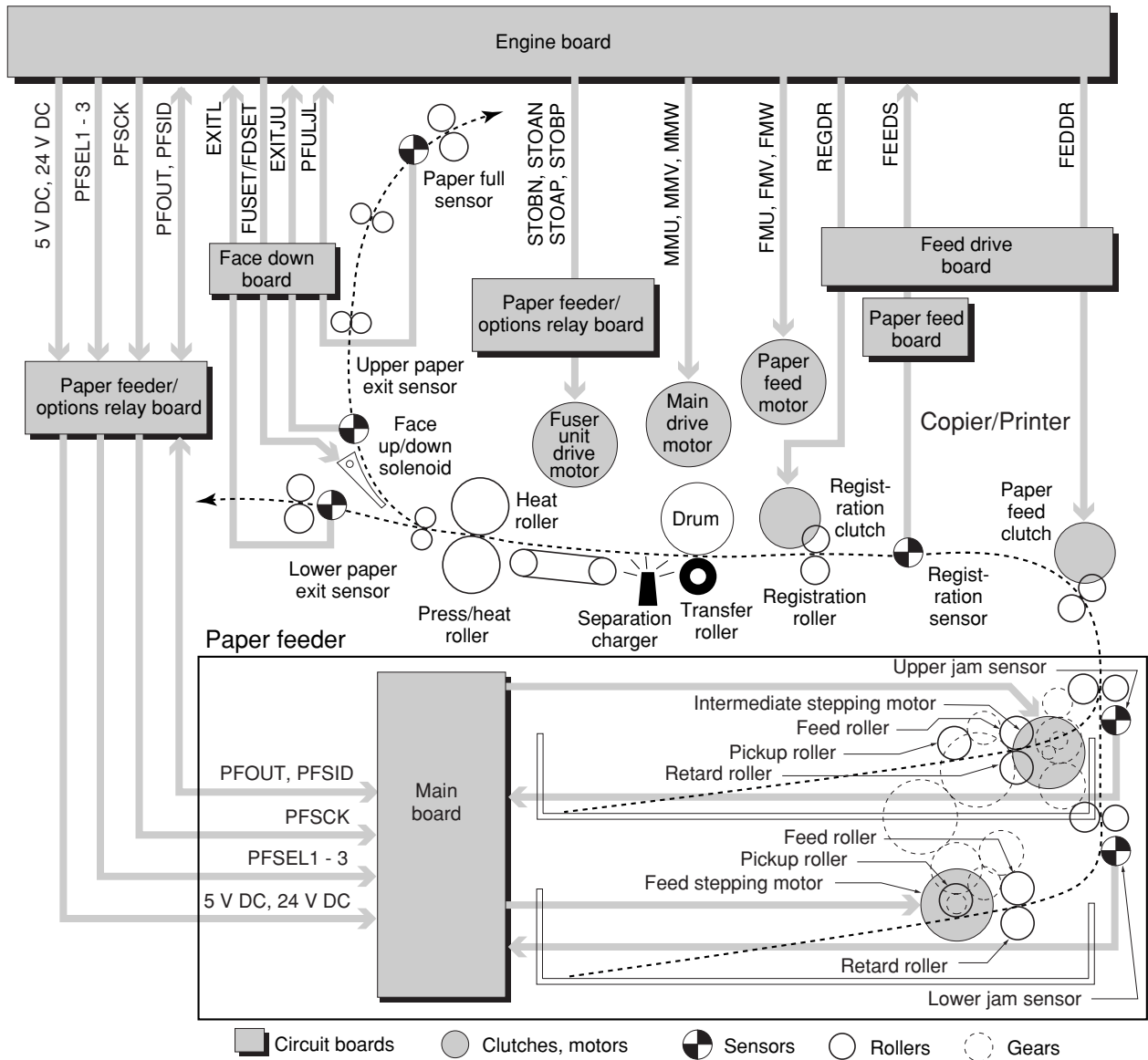
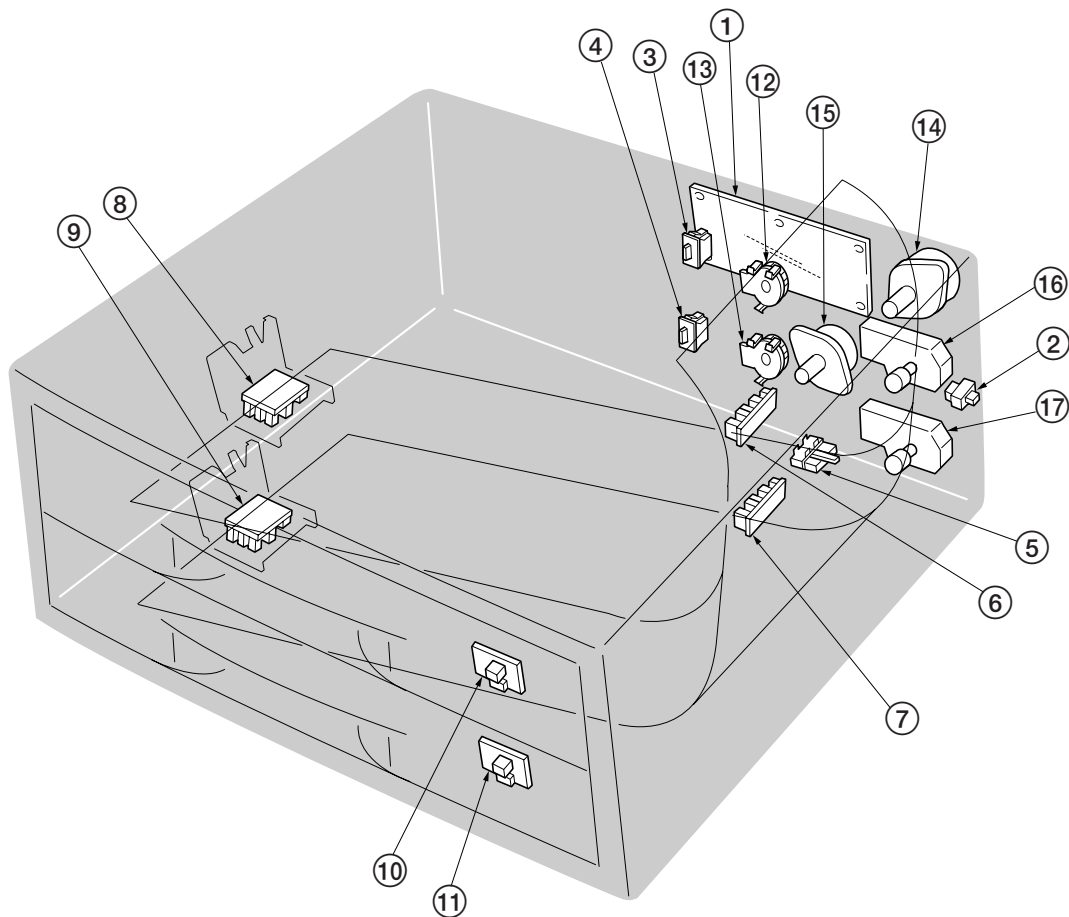

Figure 4-4-2 Paper control signals

4-4-2 Electrical components

The figure below shows the locations of the sensors, switches, motors and LEDs. Each number corresponds to the description in the table on the next page.



**Figure 4-4-3a Electrical components layout
(250-sheet paper feeder)**

Table 4-4-1 Electrical components

Symbol	Title	Locations
①	Main board	
②	Right side cover switch	
③	Upper cassette switch	Drive plate
④	Lower cassette switch	Drive plate
⑤	Upper jam sensor	
⑥	Upper cassette paper sensor/bottom limit sensor (Pickup board)	Upper cassette
⑦	Lower cassette paper sensor/bottom limit sensor (Pickup board)	Lower cassette
⑧	Upper cassette paper size sensors 1/2/3 (Paper size sensor board)	Upper cassette
⑨	Lower cassette paper size sensors 1/2/3 (Paper size sensor board)	Lower cassette
⑩	Upper cassette LED (LED board)	Upper cassette
⑪	Lower cassette LED (LED board)	Lower cassette
⑫	Upper cassette paper level switch	Upper cassette
⑬	Lower cassette paper level switch	Lower cassette
⑭	Intermediate stepping motor	Drive plate
⑮	Feed stepping motor	Drive plate
⑯	Upper cassette base elevation motor	Drive plate
⑰	Lower cassette base elevation motor	Drive plate

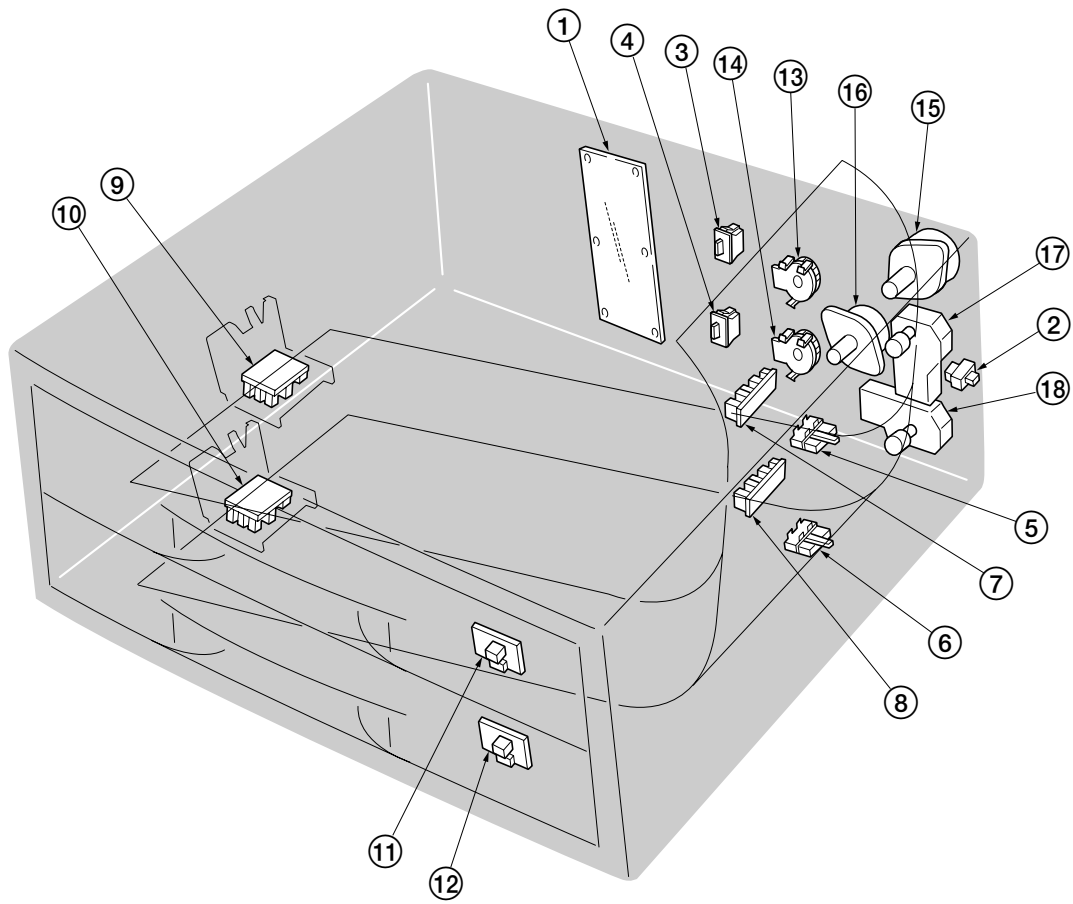

**Figure 4-4-3b Electrical components layout
(500-sheet paper feeder)**

Table 4-4-1 Electrical components

Symbol	Title	Locations
①	Main board	
②	Right side cover switch	
③	Upper cassette switch	Drive plate
④	Lower cassette switch	Drive plate
⑤	Upper jam sensor	
⑥	Lower jam sensor	
⑦	Upper cassette paper sensor/bottom limit sensor (Pickup board)	Upper cassette
⑧	Lower cassette paper sensor/bottom limit sensor (Pickup board)	Lower cassette
⑨	Upper cassette paper size sensors 1/2/3 (Paper size sensor board)	Upper cassette
⑩	Lower cassette paper size sensors 1/2/3 (Paper size sensor board)	Lower cassette
⑪	Upper cassette LED (LED board)	Upper cassette
⑫	Lower cassette LED (LED board)	Lower cassette
⑬	Upper cassette paper level switch	Upper cassette
⑭	Lower cassette paper level switch	Lower cassette
⑮	Intermediate stepping motor	Drive plate
⑯	Feed stepping motor	Drive plate
⑰	Upper cassette base elevation motor	Drive plate
⑱	Lower cassette base elevation motor	Drive plate

4-4-3 Paper cassette feeding

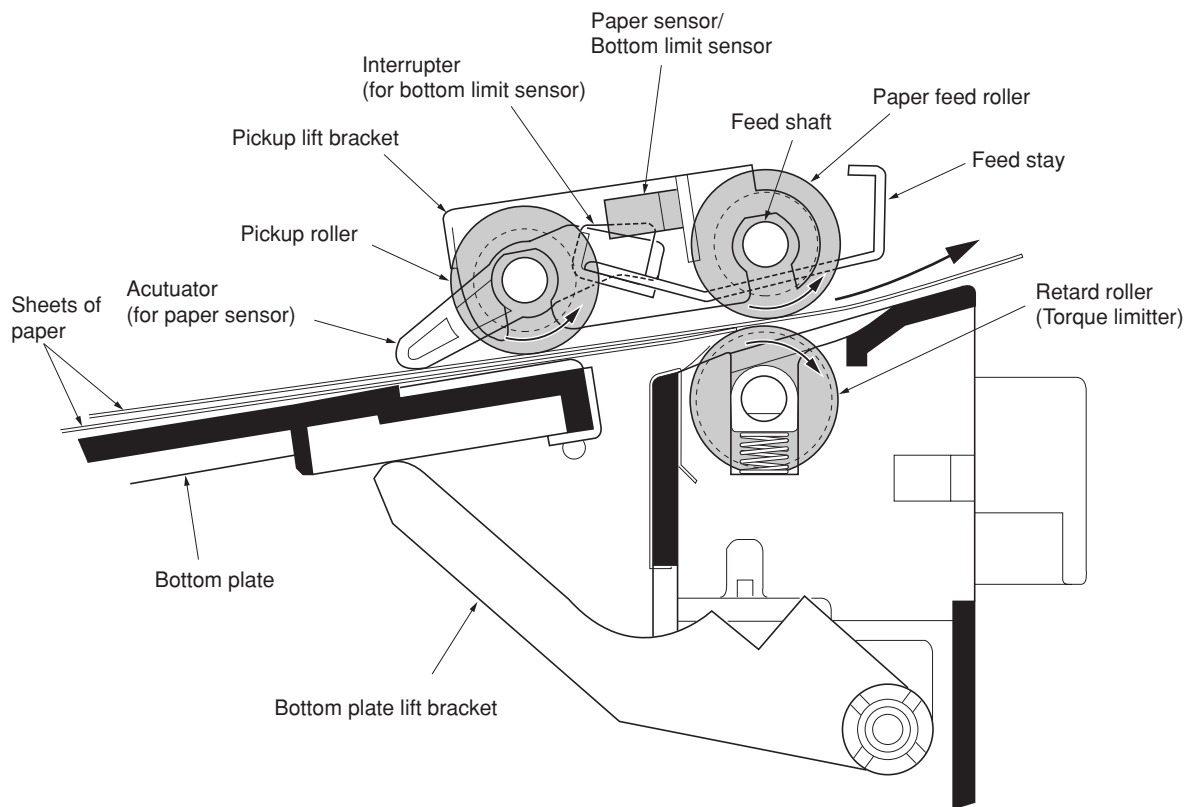

Figure 4-4-4 Paper cassette feeding

Inserting the paper cassette causes the cassette switch to turn on and L level signal is sent to the main board as the cassette detection. The main board then rotates the cassette base elevation motor to activate the bottom plate lift bracket, and subsequently the bottom plate (with paper). The bottom plate pushes the pickup lift bracket up to which the pickup roller is fit. The bottom limit sensor and the paper sensor (both are a photo interrupter) are mounted on the pickup lift bracket, which moves around the feed shaft. Pushing the pickup lift bracket up causes the interrupter mounted on the feed stay to be off of the bottom lift sensor and the bottom limit sensor to turn on to change its level from H to L. The L level signal is used to restrict the lift of the bottom plate at its up most position.

The main board, at receiving this signal, activates the actuator mounted on the pickup lift bracket, subsequently causing the paper sensor output from H to L. If no paper is loaded on the bottom plate, the actuator will not be activated because it is left in the opening on the bottom plate even when the bottom plate is in its topmost position. In this instance, as the paper sensor's output does not change to L despite the bottom limit sensor's output is L, the main board reports the copier/printer that paper is empty.

As the copier/printer requests feeding paper, the main board activates the feed stepping motor, drives the feed shaft on the cassette, thus rotating the feed roller and the pickup roller, according to the paper feed timing. The pickup roller rotates to pull and feed the topmost paper on the stack on the bottom plate. The paper is then sent onto the feed roller, leaving the paper cassette.

In case that more than one sheet of paper is fed together, e.g. the first and second sheets, to the feed roller, the retard roller acts to prevent the second sheet to be fed as a ply. The retard roller is coaxial located with a torque limiter: If a ply of two sheets is fed, since the friction between the torque limiter and the retard roller is greater than that of the ply of paper, the second sheet (the one on the retard roller) is stopped and the first sheet (the one on the feed roller) is fed into the copier/printer.

4-4-4 Paper cassette feeding drive system

Rotation of the feed stepping motor rotates the feed shaft combined by feed gear. The drive of the feed shaft rotates the pickup roller through the feed roller and gear, and feeds paper from the cassette. Rotation of the feed stepping motor is always transmitted to the upper and lower feed shaft with the combination of the gear, and has become as rotate in the opposite direction. The one-way clutch is built in the feed roller and pickup roller which are attached in the feed shaft, only the feed direction transmits the drive of the feed shaft and an opposite direction is made to race the one-way clutch. Therefore, feeding is performed from the lower cassette by which the drive of the feed shaft serves as rotation of the feed direction when rotation of the feed stepping motor is the direction of order, and when rotation of the feed stepping motor is an opposite direction, feeding is performed from the upper cassette by which the drive of the feed shaft serves as rotation of the feed direction.

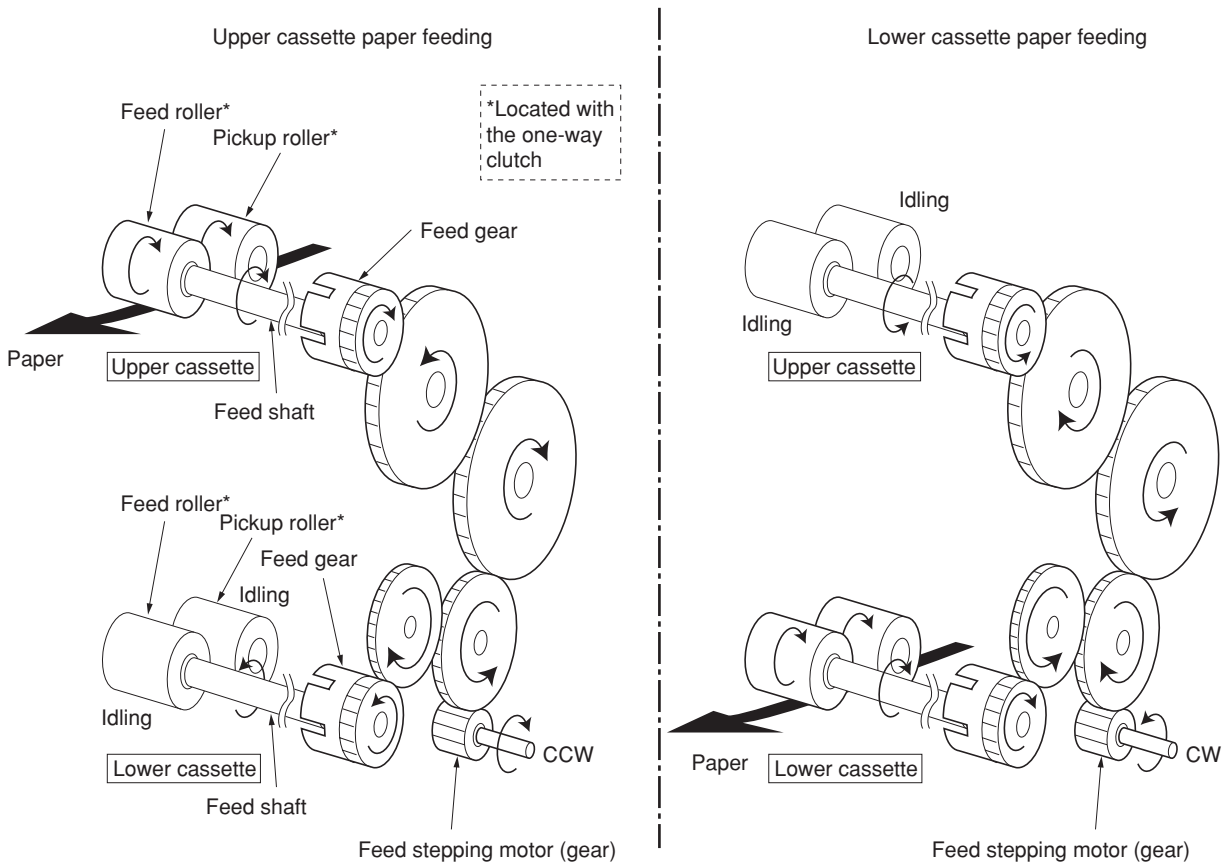

Figure 4-4-5 Paper cassette drive system

4-4-5 Paper size sensing

The size of the paper currently in the selected cassette is acknowledged to the engine board of the copier/printer by means of the on-off status of the paper size sensors PT1, PT2, and PT3 behind the paper stopper of the paper cassette. The table below summarizes the on-off status of these sensors in accordance with the supported paper sizes.

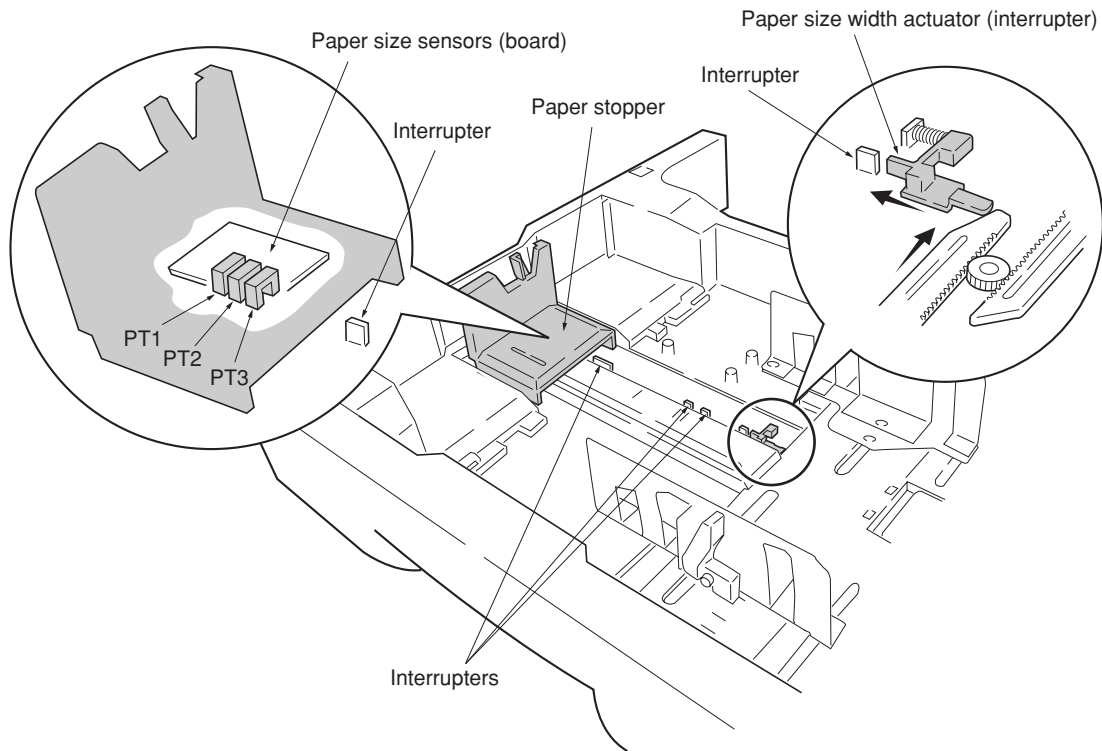

Figure 4-4-6 Paper size sensing

Table 4-4-2 Paper size sensors output levels

Paper size sensors			Paper size
PT1	PT2	PT3	
H	L	L	Ledger (portrait)
L	L	L	A3 (portrait)
H	H	H	B4 (portrait)
H	H	L	Legal (portrait)
H	L	H	B5 (portrait)
L	L	H	Letter (landscape)
L	H	L	A4/A5 (landscape)
L	H	H	-

4-4-6 Paper gauge sensing

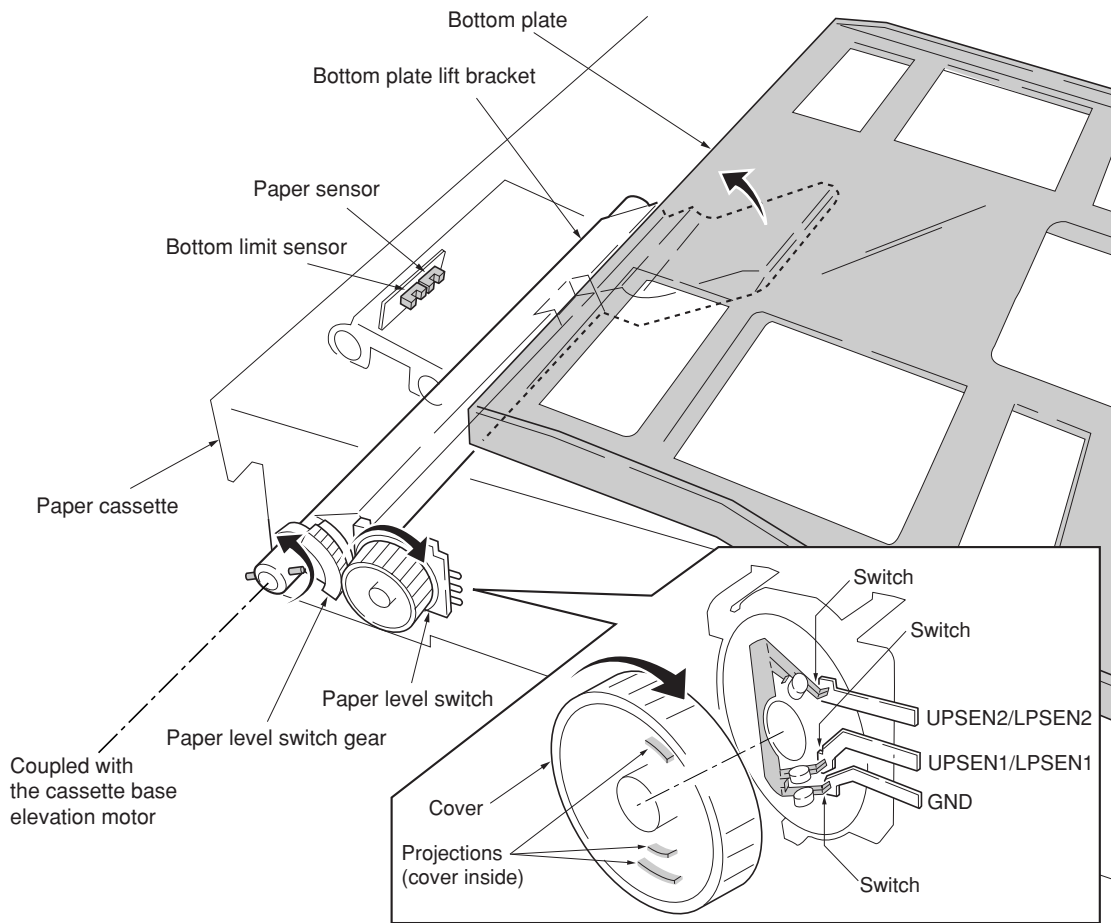

Figure 4-4-7 Paper gauge sensing hardware

When the paper feeder is installed in the copier, graphic image of the amount of remains paper in the paper cassette is given in 4 stages at the operation panel.

When the paper feeder is installed in the printer, it has the facility for allowing the Kyocera Printer Monitor software show the amount of remaining paper in the paper cassettes on the client's display monitor.

The paper gauge on the Kyocera Print Monitor indicates how much paper is remaining in the cassette in the rate of either of 25%, 50%, 75% or 100%, directly. These levels are given by the logic provided by the paper level switches using 2-bit signals of UPSEN1, LPSEN1, UPSEN2, and LPSEN2 in the manner explained below.

See Figure 4-4-7. The paper level switch has three switches on its base, one being the ground. These switches are open unless they are pressed in by the projections on the cover. The paper level switch is driven by the gear which is concentrically located with the bottom plate lift bracket. As the amount of paper remaining in the cassette varies (decreases), the paper level switch revolves and its projections pressing and closing the switches in different combinations depending on the actual position of the bottom plate.

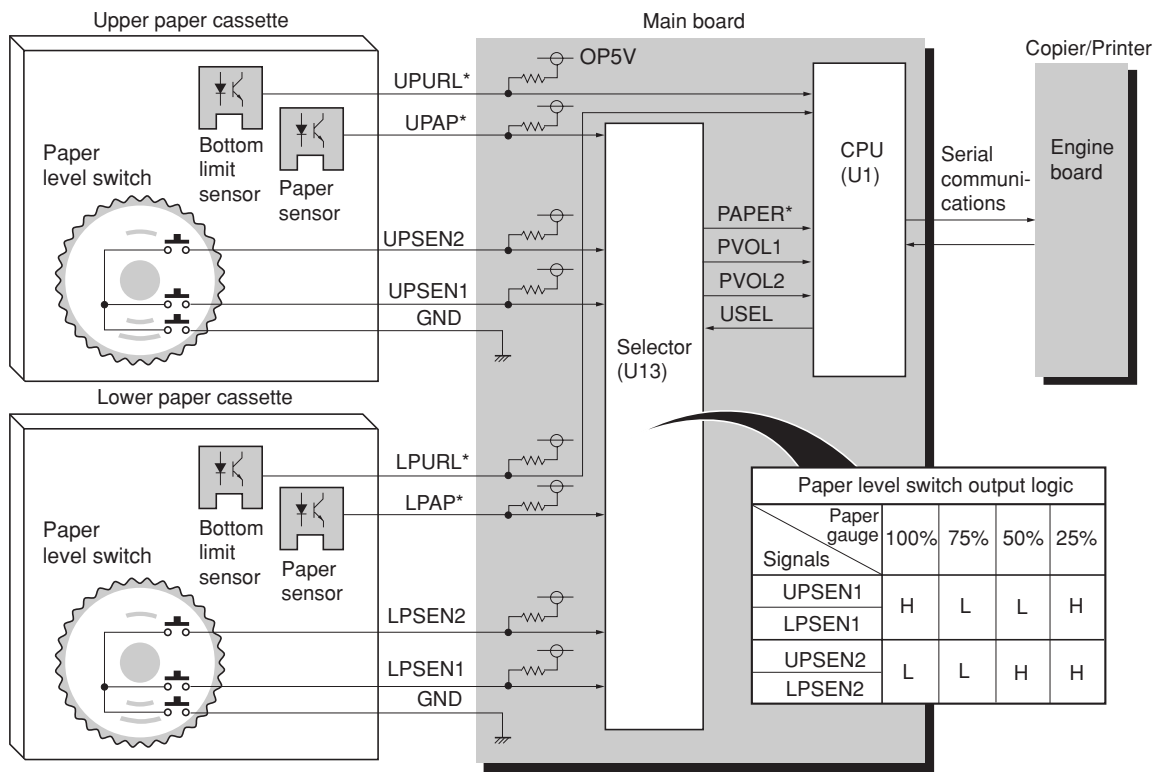

Figure 4-4-8 Paper gauge sensing circuit diagram

The sensing circuit on the main board detects of the amount of the paper remaining and delivers the output information to the engine board of the copier/printer (in serial communication mode) in the following manner:

Detecting either of 25%, 50%, 75%, and 100%

At insertion of the paper cassette into the paper feeder or, as printing proceeds with the paper cassette, dwindling of paper in the cassette, the level of the bottom limit sensor output (UPURL*, LPURL*) becomes H, subsequently the cassette base elevation motor revolves until the output reverts to L, and the bottom plate is elevated as the bottom plate lift bracket revolves. If the paper is present atop the bottom plate, the paper sensor output (UPAP*, LPAP*) becomes L-level, the cassette base elevation motor stops at the moment the bottom limit sensor output (UPURL*, LPURL*) reverts to L.

The rotating angle at which the paper level switch stops revolving depends on the amount of paper remaining, therefore, the more the paper remains in the cassette the greater the angle is. The rotating angle of the gear for the paper level switch varies in proportion with the rotating angle of the cassette base elevation motor in four positions. Then, the 2-bit signals (UPSEN1 or LPSEN1 and UPSEN2 or LPSEN2) are generated according to the four different rotating angles.

Refer to the table in Figure 4-4-8. For example, if UPSEN1=L and UPSEN2=H, the rate of remaining paper is 50%.

Detecting emptiness of paper

When paper is empty in the cassette, the cassette base elevation motor is driven so that the bottom plate lift bracket lifts the bottom plate until the level of the bottom limit sensor output (UPURL*, LPURL*) becomes L. At the moment it becomes L, the cassette base elevation motor stops and the paper sensors output (UPAP*, LPAP*) remains H and the paper empty situation is recognized. This also applies when the last sheet of paper is fed in the cassette and paper becomes empty.

4-4-7 Paper feeder identifying system

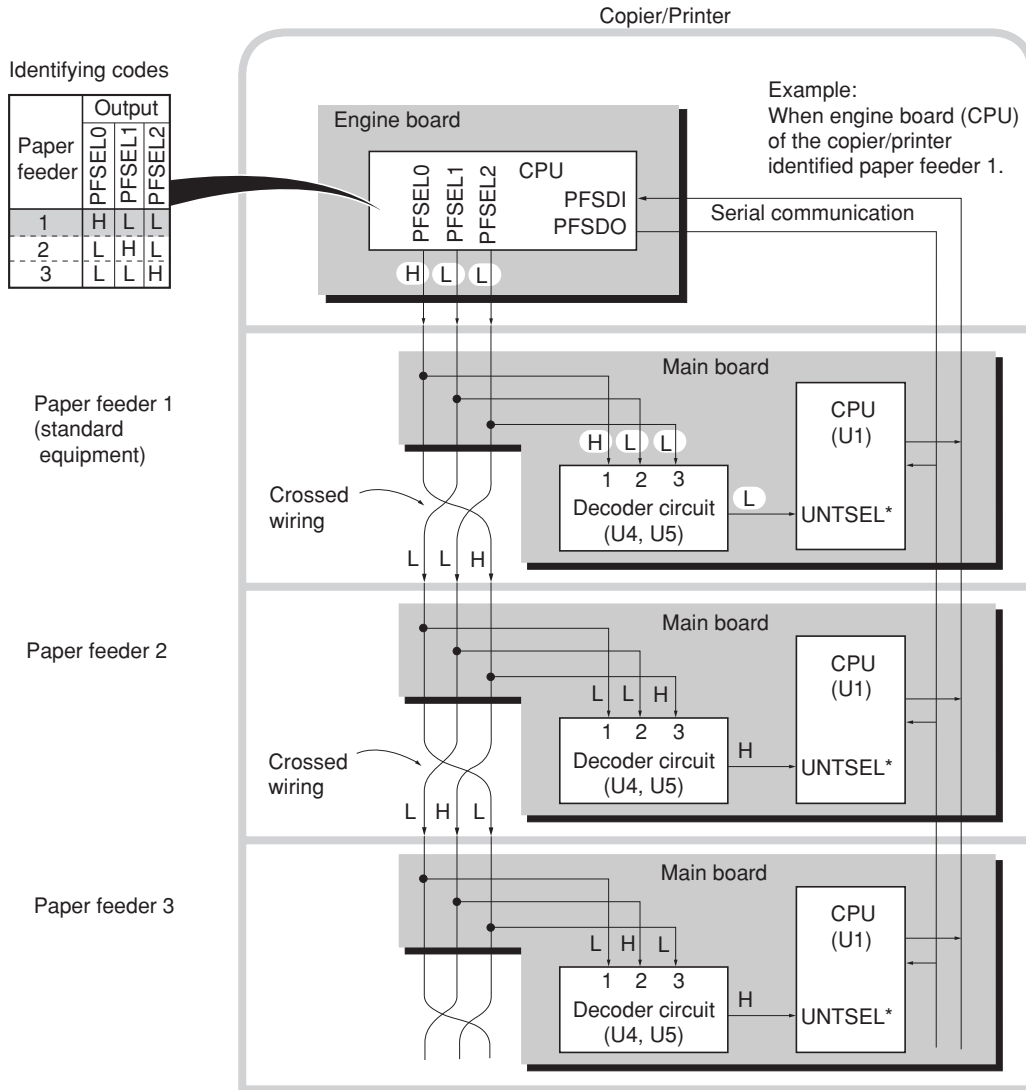

Figure 4-4-9 Paper feeder identifying system

This section explains how the copier/printer automatically designates paper feeder 1, 2 and 3 currently installed. In doing so, the copier/printer requires no hardware manipulations or adjustments. The engine CPU of the copier/printer, when power is turned on, starts to recognize the paper feeders currently installed with the copier/printer. The engine board of the copier/printer and the main boards of the paper feeders are connected to each other via the installation bus incorporating the three signal lines of PFSELO, PFSEL1, and PFSEL2.

Through these lines (PFSELO, PFSEL1, PFSEL2), the engine CPU sends the identifying code signals for designating paper feeder 1, 2 and 3 in the following manner:

1. First, paper feeder 1 is designated. The engine CPU sends the set of the 3-bit identifying code signals of PFSELO= H, PFSEL1= L, and PFSEL2= L. This set is simultaneously received by the decoder circuit (U4 and U5 in the diagram above) in all the installed paper feeders.

2. Since the installation bus lines are electrically "crossed" within the paper feeder as indicated in the diagram below, the decoder circuit of paper feeder 2 and 3 receive the first identifying code signals (PFSEL0= H, PFSEL1= L, and PFSEL2= L) in different ways (L-L-H for paper feeder 2 and L-H-L for paper feeder 3).
3. The decoder circuit is comprised of gate IC's of U4 and U5. See Figure 4-4-9: It decodes the identifying code signals and generates an L-level signal (UNTSEL*) provided that its ports are in the following condition:

$$1= H, 2= L, 3= L$$
4. This condition is only fulfilled by paper feeder 1. Because of the cross-circuit configuration of the installation bus, paper feeder 2 receives the identifying code signals at its ports as 1=L, 2=L, and 3=H; and paper feeder 3 receives as 1=L, 2=H, and 3=L. The either port state does not provides an L-level output (UNTSEL*) required to recognize it as the "paper feeder 1"
5. The feeder's CPU (U1, in Figure 4-4-9) receives the L-level UNTSEL* signal, acknowledging itself to be the paper source as requested by the engine CPU of the copier/printer. Using the serial communication manner, the feeder's CPU then responds to the engine CPU of the copier/printer with several information on the properties of the paper currently loaded in the paper cassettes.

As paper feeder 1 is identified by the engine CPU of the copier/printer as above, paper feeder 2, then paper feeder 3 should be identified.

Using the same steps as above, the engine CPU of the copier/printer subsequently sends the set of the identifying code signals that identifies paper feeder 2, then paper feeder 3. These are PFSEL0=L, PFSEL1= H, and PFSEL2=L; and PFSEL0=L, PFSEL1= L, and PFSEL2= H, respectively (See the table below). If no paper feeder responds to the engine CPU of the copier/printer for the identity code signals, the copier/printer determines that the paper source is not installed with the copier/printer.

Table 4-4-3 Paper feeder identifying code signal output results

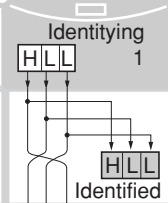
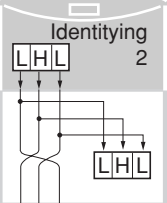
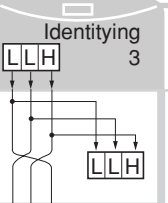
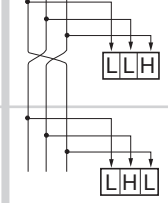
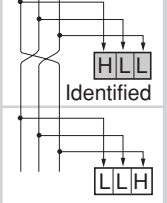
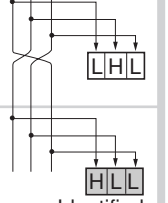
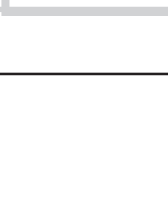
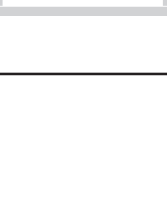
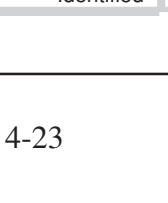
Copier/ Printer Paper feeder	Identifying			Engin board (CPU) of the copier/printer outputs paper feeder identifying code signals (3 bit). Main board (decoder circuit) inputs signals
	1	2	3	
1				
2				
3				

Chapter 5

Troubleshooting

Chapter 5 Contents

5-1 Introduction	5-3
5-2 Self-diagnosis	5-4
5-2-1 Self-diagnostic function	5-4
5-2-2 Error messages	5-6
5-3 Clearing Paper Jams	5-7
5-3-1 Paper misfeed detection (installed to the copier)	5-7
(1) Paper misfeed indication	5-7
(2) Paper misfeed detection conditions	5-7
(3) Paper misfeeds	5-9
5-3-2 Paper misfeed detection (installed to the printer)	5-11
(1) Paper misfeed indication	5-11

5-1 Introduction

This chapter explains procedures for identifying and clearing paper jams.

5-2 Self-diagnosis

5-2-1 Self-diagnostic function

The copier/printer is equipped with a self-diagnostic function. When a problem is detected, copying/printing is disabled. The problem displayed as a code consisting of "C" followed by a number of four digits, indicating the nature of the problem when the paper feeder is installed in the copier. The problem displayed as a code consisting of four digits, indicating the nature of the problem when the paper feeder is installed in the printer.

A message is also displayed requesting the user to call for service.

Table 5-2-1 Self-diagnostic errors

Code	Contents	Remarks	
		Causes	Check procedures/corrective measures
C1030 (1030)	Overcurrent detection of upper cassette base elevation motor (Paper feeder 2) • Excessive current has flowed through the upper cassette base elevation motor which elevates the bottom plate in the cassette when the upper cassette is installed in paper feeder 2 or power is turned on.	Defective upper cassette base elevation motor.	Replace the upper cassette base elevation motor.
		Defective bottom plate elevation mechanism of upper cassette.	Check whether there is an object that prevents the bottom plate of upper cassette from operating normally.
		Defective main board.	Replace the main board.
		Defective engine board of copier/printer.	Replace the engine board. See copier's/printer's service manual.
C1040 (1040)	Overcurrent detection of lower cassette base elevation motor (Paper feeder 2) • Excessive current has flowed through the lower cassette base elevation motor which elevates the bottom plate in the cassette when the lower cassette is installed in paper feeder 2 or power is turned on.	Defective lower cassette base elevation motor.	Replace the lower cassette base elevation motor.
		Defective bottom plate elevation mechanism of lower cassette.	Check whether there is an object that prevents the bottom plate of lower cassette from operating normally.
		Defective main board.	Replace the main board.
		Defective engine board of copier/printer.	Replace the engine board. See copier's/printer's service manual.

Code	Contents	Remarks	
		Causes	Check procedures/corrective measures
1050	Overcurrent detection of upper cassette base elevation motor (Paper feeder 3) • Excessive current has flowed through the upper cassette base elevation motor which elevates the bottom plate in the cassette when the upper cassette is installed in paper feeder 3 or power is turned on.	Defective upper cassette base elevation motor.	Replace the upper cassette base elevation motor.
		Defective bottom plate elevation mechanism of upper cassette.	Check whether there is an object that prevents the bottom plate of upper cassette from operating normally.
		Defective main board.	Replace the main board.
		Defective engine board of copier/printer.	Replace the engine board. See copier's/printer's service manual.
1060	Overcurrent detection of lower cassette base elevation motor (Paper feeder 3) • Excessive current has flowed through the lower cassette base elevation motor which elevates the bottom plate in the cassette when the lower cassette is installed in paper feeder 3 or power is turned on.	Defective lower cassette base elevation motor.	Replace the lower cassette base elevation motor.
		Defective bottom plate elevation mechanism of lower cassette.	Check whether there is an object that prevents the bottom plate of lower cassette from operating normally.
		Defective main board.	Replace the main board.
		Defective engine board of copier/printer.	Replace the engine board. See copier's/printer's service manual.

Note Paper feeder 3 is installed to the printer only as optional.

5-2-2 Error messages

When the following error messages appear on the printer's message display, check the paper feeder.

Table 5-2-2 Error messages

Message	Corrective Action
Add paper (paper source)	The paper has run out in the paper source displayed. Supply paper according to the paper source displayed. This message is displayed alternately with messages indicating the printer status, such as, Ready, Please wait, Processing, Waiting, and Form Feed Time Out. If the number of copies to print is 2 or more, only the Add paper message is displayed.
Cassette # not loaded	The corresponding paper cassette is not installed. Install the cassette. The cassette number can be 1 to 2 (paper feeder 1)/3 to 4 (paper feeder 2)/5 to 6 (paper feeder 3).
Load Cassette # (paper size)/(paper type)	The paper cassette matching the paper size and paper type of the print job is empty. Load paper into the paper cassette. The paper feeder cassettes are indicated by #. Press the GO key to resume printing.
Paper feeder # side cover open	The side cover of paper feeder is open. Close the cover of the paper feeder 1 to 3 as displayed in place of #.

5-3 Clearing Paper Jams

5-3-1 Paper misfeed detection (installed to the copier)

(1) Paper misfeed indication

When a paper misfeed occurs, the copier immediately stops copying and displays the jam location on the operation panel. Paper misfeed counts sorted by the detection condition can be checked in maintenance item U903.

To remove paper jammed in the paper feeder, open the side cover or cassette.

Paper misfeed detection can be reset by opening and closing the respective covers to turn interlock switch off and on.

(2) Paper misfeed detection conditions

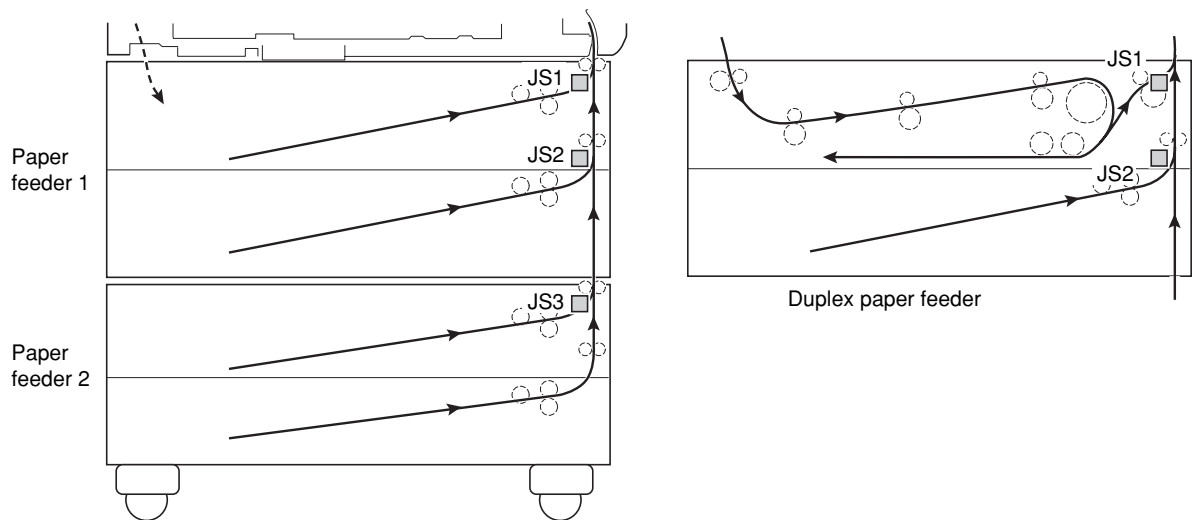
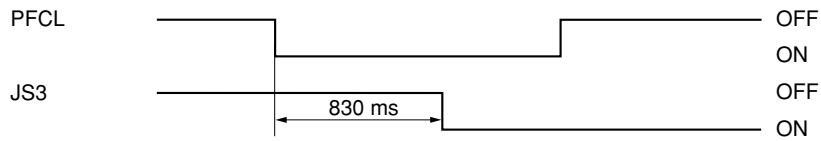

Figure 5-3-1 Paper misfeed detection conditions

- No paper feed from the upper cassette (jam code 12)

Jam sensor 3 (JS3) does not turned on within 830 ms of the paper feed clutch (PFCL) turning on (when paper is fed from the upper cassette of paper feeder 2).



Timing chart 5-3-1

- No paper feed from the lower cassette (jam code 13)

Jam sensor 3 (JS3) does not turned on within 1250 ms of the paper feed clutch (PFCL) turning on (when paper is fed from the lower cassette of paper feeder 2).

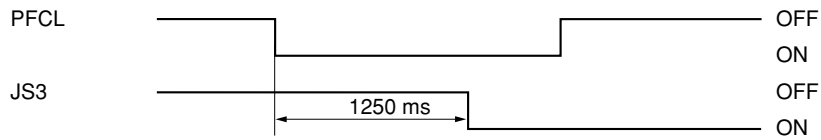

Timing chart 5-3-2

- Misfeed in copier vertical paper conveying section 2 (jam code 22)

Jam sensor 1 (JS1) does not turned on within 970 ms of jam sensor 3 (JS3) turning on (when paper is fed from the upper cassette of paper feeder 2).

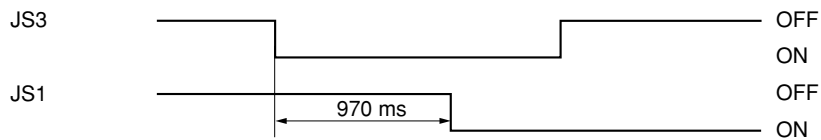

Timing chart 5-3-3

(3) Paper misfeeds

Problem	Causes/check procedures	Corrective measures
(1) A paper jam in the paper feed section is indicated during copying (no paper feed from the upper cassette). Jam code 12	Paper in the upper cassette is extremely curled.	Change the paper.
	Check if the paper feed pulley, separation pulley or forwarding pulley of the upper cassette are deformed.	Check visually and replace any deformed pulleys.
	Broken jam sensor 3 actuator.	Check visually and replace jam sensor 3 if its actuator is broken.
	Defective jam sensor 3.	Run maintenance item U031 and turn jam sensor 3 on and off manually. Replace jam sensor 3 if indication of the corresponding sensor on the operation panel is not displayed in reverse.
	Check if the paper feed clutch malfunctions.	Run maintenance item U032 and select the paper feed clutch on the operation panel to be turned on and off. Check the status and remedy if necessary.
	Electrical problem with the paper feed clutch.	Check (see copier service manual).
(2) A paper jam in the paper feed section is indicated during copying (no paper feed from the lower cassette). Jam code 13	Paper in the lower cassette is extremely curled.	Change the paper.
	Check if the paper feed pulley, separation pulley or forwarding pulley of the lower cassette are deformed.	Check visually and replace any deformed pulleys.
	Broken jam sensor 3 actuator.	Check visually and replace jam sensor 3 if its actuator is broken.
	Defective jam sensor 3.	Run maintenance item U031 and turn jam sensor 3 on and off manually. Replace jam sensor 3 if indication of the corresponding switch on the operation panel is not displayed in reverse.
	Check if the paper feed clutch malfunctions.	Run maintenance item U032 and select the paper feed clutch on the operation panel to be turned on and off. Check the status and remedy if necessary.
	Electrical problem with the paper feed clutch.	Check (see copier service manual).

Problem	Causes/check procedures	Corrective measures
(3) A paper jam in the paper feed section is indicated during copying (jam in copier vertical paper conveying section 2). Jam code 22	Broken jam sensor 1 actuator.	Check visually and replace jam sensor 1 if its actuator is broken.
	Defective jam sensor 1.	Run maintenance item U031 and turn jam sensor 1 on and off manually. Replace jam sensor 1 if indication of the corresponding switch on the operation panel is not displayed in reverse.
	Broken jam sensor 2 actuator.	Check visually and replace am sensor 2 if its actuator is broken.
	Defective jam sensor 2.	Run maintenance item U031 and turn am sensor 2 on and off manually. Replace am sensor 2 if indication of the corresponding switch on the operation panel is not displayed in reverse.
	Broken jam sensor 3 actuator.	Check visually and replace jam sensor 3 if its actuator is broken.
	Defective jam sensor 3.	Run maintenance item U031 and turn jam sensor 3 on and off manually. Replace jam sensor 3 if indication of the corresponding switch on the operation panel is not displayed in reverse.
Check if the feed pulleys and feed roller are deformed.	Check and repair it if necessary.	

5-3-2 Paper misfeed detection (installed to the printer)

(1) Paper misfeed indication

When a paper misfeed occurs, the printer immediately stops printing and displays the jam location on the operation panel.

To remove paper jammed in the paper feeder, open the side cover and paper cassette. Paper misfeed detection can be reset by opening and closing the respective covers.

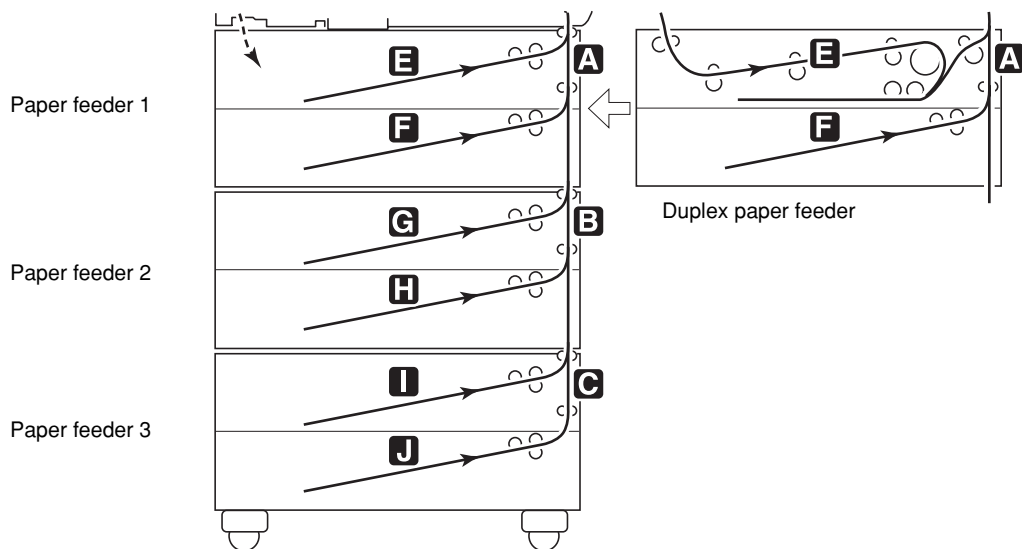

Figure 5-3-1 Paper misfeed indication

Jam location	Contents
A	Misfeed in the side cover of paper feeder 1 Misfeed in the duplex unit side cover
B	Misfeed in the side cover of paper feeder 2
C	Misfeed in the side cover of paper feeder 3
E	No paper feed from cassette 1 (Paper feeder 1) No paper feed from duplexer (Duplex unit)
F	No paper feed from cassette 2 (Paper feeder 1)
G	No paper feed from cassette 3 (Paper feeder 2)
H	No paper feed from cassette 4 (Paper feeder 2)
I	No paper feed from cassette 5 (Paper feeder 3)
J	No paper feed from cassette 6 (Paper feeder 3)

Appendix A

Timing Chart /
Wiring Diagram

Appendix A Contents

Timing chart No. 1 A-3
Timing chart No. 2 A-4
Wiring diagram A-5

Timing chart No. 1

Paper feed from the lower drawer, paper size: A4/11" × 8 1/2", full color

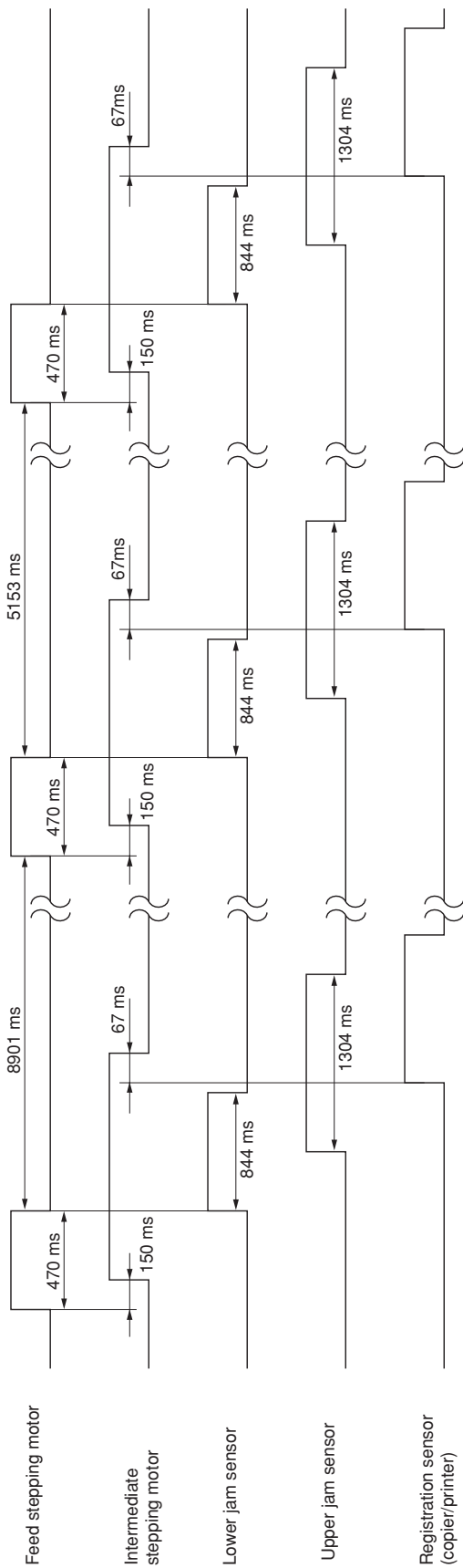

Paper feed from the lower drawer, paper size: A4/11" × 8 1/2", monochrome

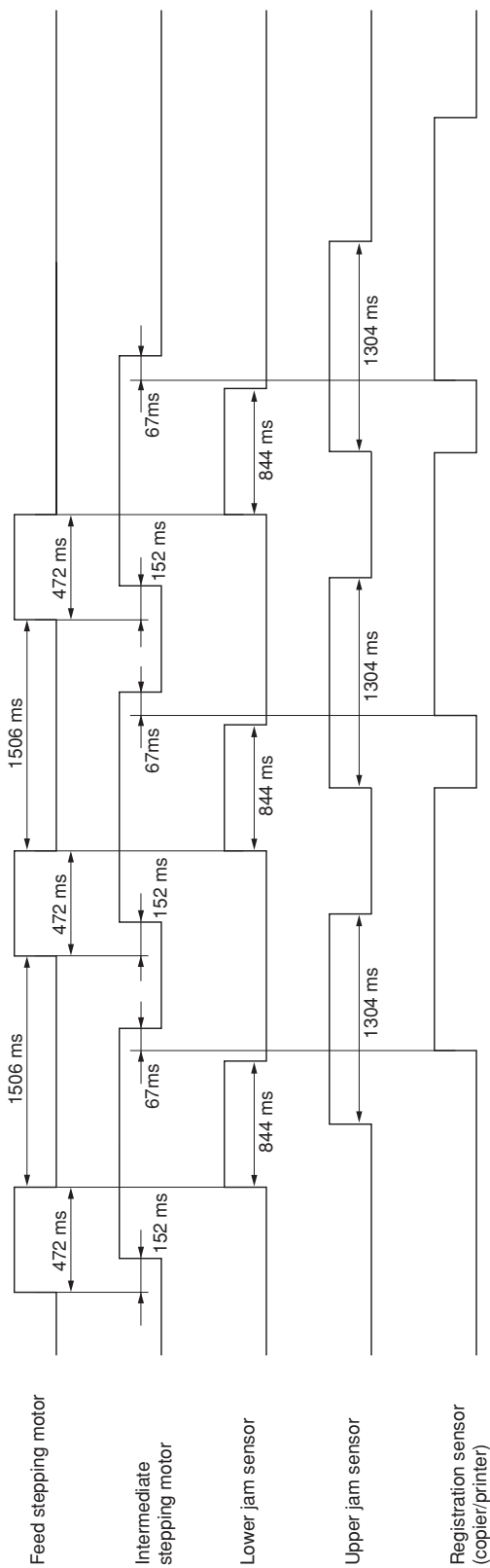

Timing chart No. 2

Paper feed from the lower drawer, paper size: A3/11" × 17", full color

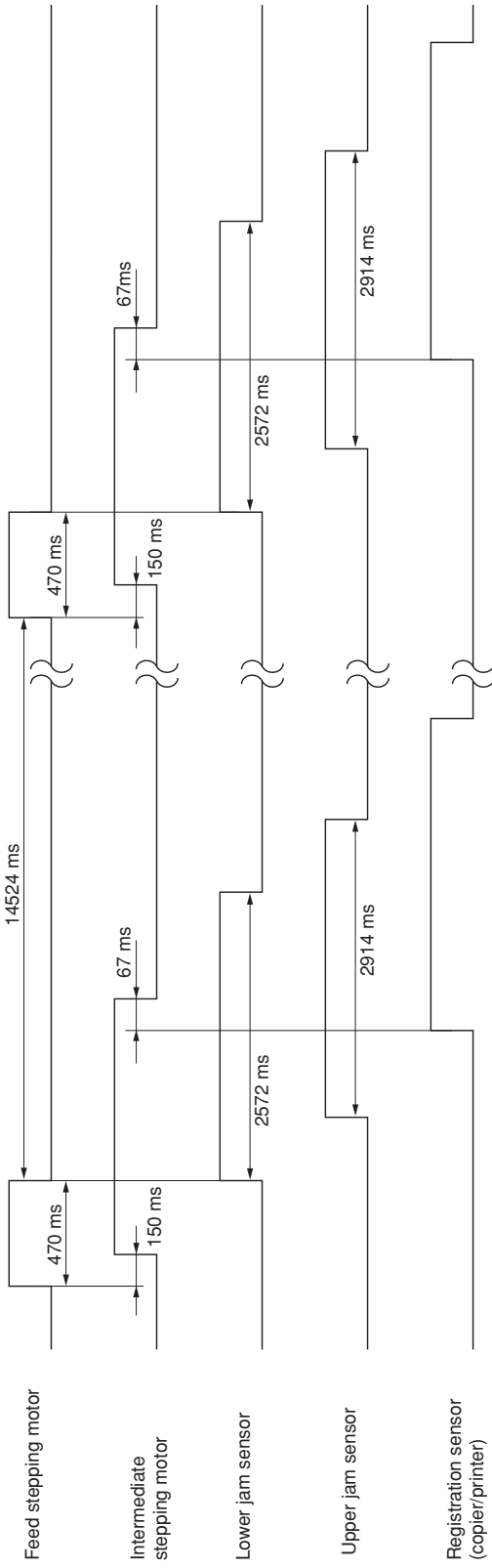

Paper feed from the lower drawer, paper size: A3/11" × 17", full color

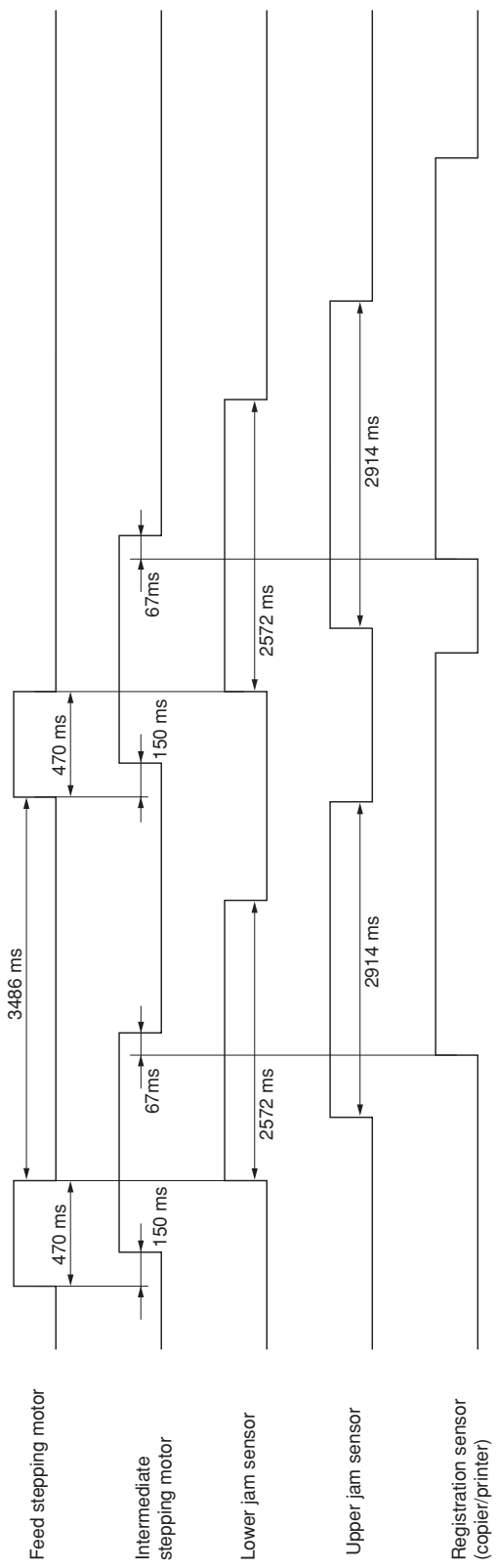

Wiring diagram

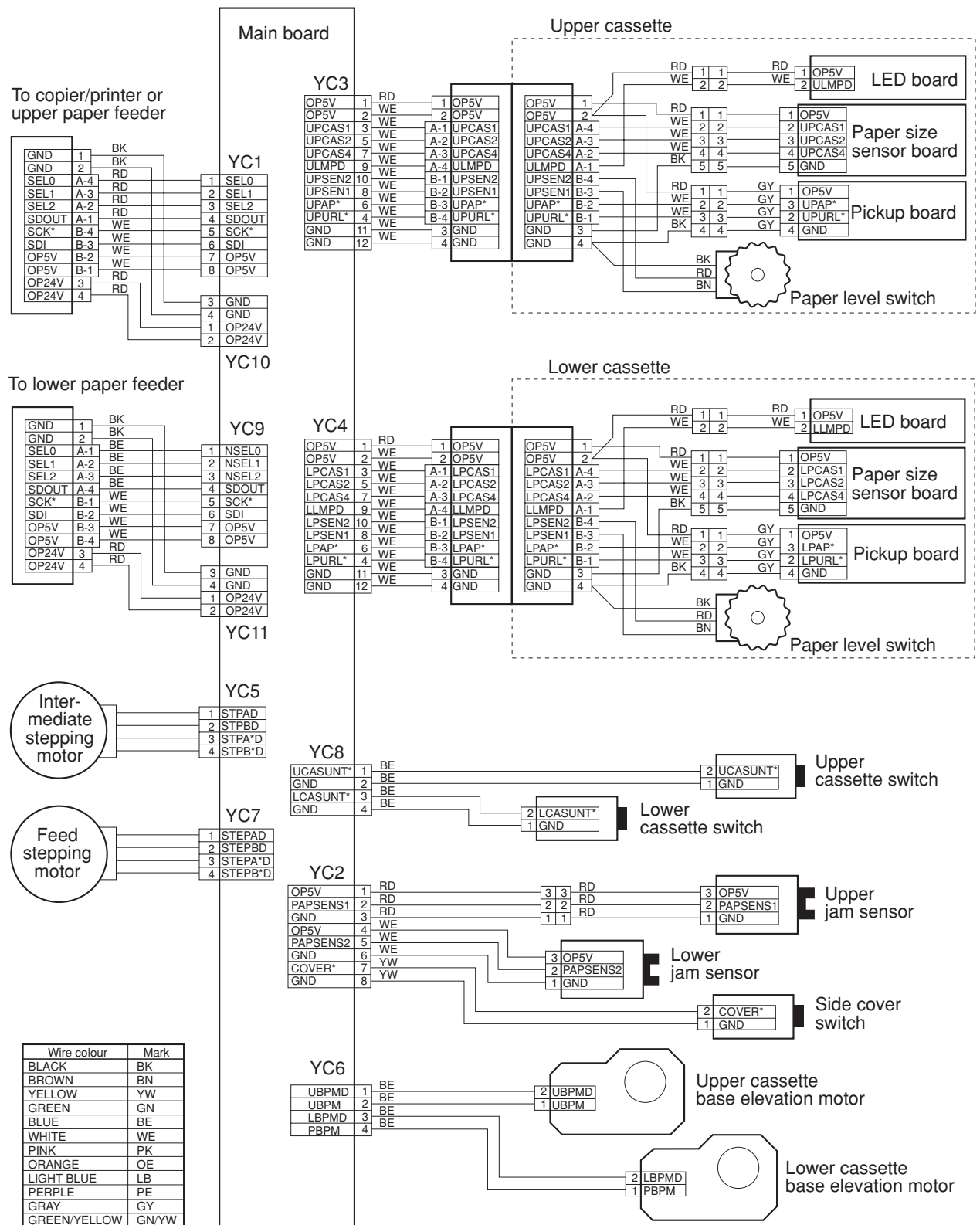

KYOCERA MITA EUROPE B.V.

Hoeksteen 40, 2132 MS Hoofddorp,
The Netherlands
Phone: (020) 6540000
Home page: <http://www.kyoceramita-europe.com>
Email: info@kyoceramita-europe.com

KYOCERA MITA NEDERLAND B.V.

Hoeksteen 40, 2132 MS Hoofddorp,
The Netherlands
Phone: (020) 5877200

KYOCERA MITA (UK) LIMITED

8 Beacontree Plaza
Gillette Way,
Reading RG2 0BS UK
Phone: (0118) 931 1500

KYOCERA MITA ITALIA S.P.A.

Via Verdi 89/91 20063 Cernusco sul Naviglio
(Milano) Italy
Phone: 02-92179 1

S.A. KYOCERA MITA BELGIUM N.V.

Hermesstraat 8A, 1930 Zaventem, Belgium
Phone: (02) 7209270

KYOCERA MITA FRANCE S.A.

Parc les Algorithmes
SAINT AUBIN
91194 GIF-SUR-YVETTE
France
Phone: (01) 69852600

KYOCERA MITA ESPAÑA S.A.

Edificio Kyocera, Avda. De Manacor Nº2,
Urb. Parque Rozas, Apartado de Correos 76,
28230 Las Rozas, Madrid, Spain
Phone: (91) 631-8392

KYOCERA MITA FINLAND OY

Kirvesmiehenkatu 4, 00810 Helsinki,
Finland
Phone: (09) 478-05200

KYOCERA MITA (SCHWEIZ) AG

Industriestrasse 28,
8604 Volketswil, Switzerland
Phone: (01) 908 4949

KYOCERA MITA DEUTSCHLAND GMBH

Mollsfeld 12 40670 Meerbusch,
Germany
Phone: 02159-918120

KYOCERA MITA GMBH AUSTRIA

Eduard-Kittenberger-Gasse 95,
1230, Wien, Austria
Phone: (01) 86338-0

KYOCERA MITA SVENSKA AB

Siktgatan 2,
162 50 Vällingby, Sweden
Phone: (08) 4719999

KYOCERA MITA DANMARK A/S

Industrivej 11, DK-4632 Bjæverskov,
Denmark
Phone: 56871100

KYOCERA MITA PORTUGAL LDA.

CASCAISTOCK-Armazem nº8,
Rua das Figas, Alcoitão,
2765 Estoril, Portugal
Phone: (21) 4602221

KYOCERA MITA SOUTH AFRICA (PTY) LTD.

UNIT 3, "Kyalami Crescent,"
Kyalami Business Park,
1685 Midrand, South Africa
Phone: (11) 466-3290

KYOCERA MITA AMERICA, INC.

Headquarters:

225 Sand Road, P.O. Box 40008,
Fairfield, New Jersey 07004-0008,
U.S.A.
Phone: (973) 808-8444

KYOCERA MITA AUSTRALIA PTY. LTD.

Level 3, 6-10 Talavera Road, North Ryde,
N.S.W. 2113 Australia
Phone: (02) 9888-9999

KYOCERA MITA NEW ZEALAND LTD.

1-3 Parkhead Place,
Albany, Auckland,
New Zealand
Phone: (09) 415-4517

KYOCERA MITA (THAILAND) CORP., LTD.

9/209 Ratchada-Prachachem Road,
Bang Sue, Bangkok 10800, Thailand
Phone: (02) 586-0320

KYOCERA MITA SINGAPORE PTE LTD.

121 Genting Lane, 3rd Level,
Singapore 349572
Phone: (65) 7418733

KYOCERA MITA HONG KONG LIMITED

11/F., Mita Centre,
552-566, Castle Peak Road,
Tsuen Wan, New Territories,
Hong Kong
Phone: (852) 24297422

KYOCERA MITA CORPORATION

2-28, 1-chome, Tamatsukuri, Chuo-ku
Osaka 540-8585, Japan
Phone: (06) 6764-3555

©2002 KYOCERA MITA CORPORATION

 **KYOCERA** is a trademark of Kyocera Corporation

mita is a registered trademark of KYOCERA MITA CORPORATION

Printed in Holland