



---

*Paper Feeder/Duplex Unit  
PF-30A/PD-30/PD-800*

# **PARTS LIST**

3GX70770

## Ordering Information

1. ISP refers to Initially- supplied part; SP refers to Service part.
2. The Ref. No's correspond to those numbers in the exploded diagram.
3. Availability of ISP (Initially- Supplied Parts) varies depending on the destination of the product. For details, refer to the ISP List supplied separately by Kyocera Mita.
4. Those parts bearing numbers in the diagram but not listed in the parts list are not suppliable as a general supply part.

## Guideline

This manual is a combined manual for models PF-30A, PD-30, and PD-800. The following table shows how the manual is organized to ensure easy navigation:

Model	Dominant assembly	See diagram ...	and see parts list on ...
PF-30A	Frame	1 on page 3	Page 7
	Motor block	2 on page 4	Page 7
	Paper cassette	5 on page 10	Page 12
PD-30/PD-800	Frame	3 on page 5	Page 7
	Motor block	4 on page 6	Page 7
	Paper cassette	6 on page 11	Page 12
	Duplex tray unit	7 on page 15	Page 15

1 PF-30A, frame (20-)

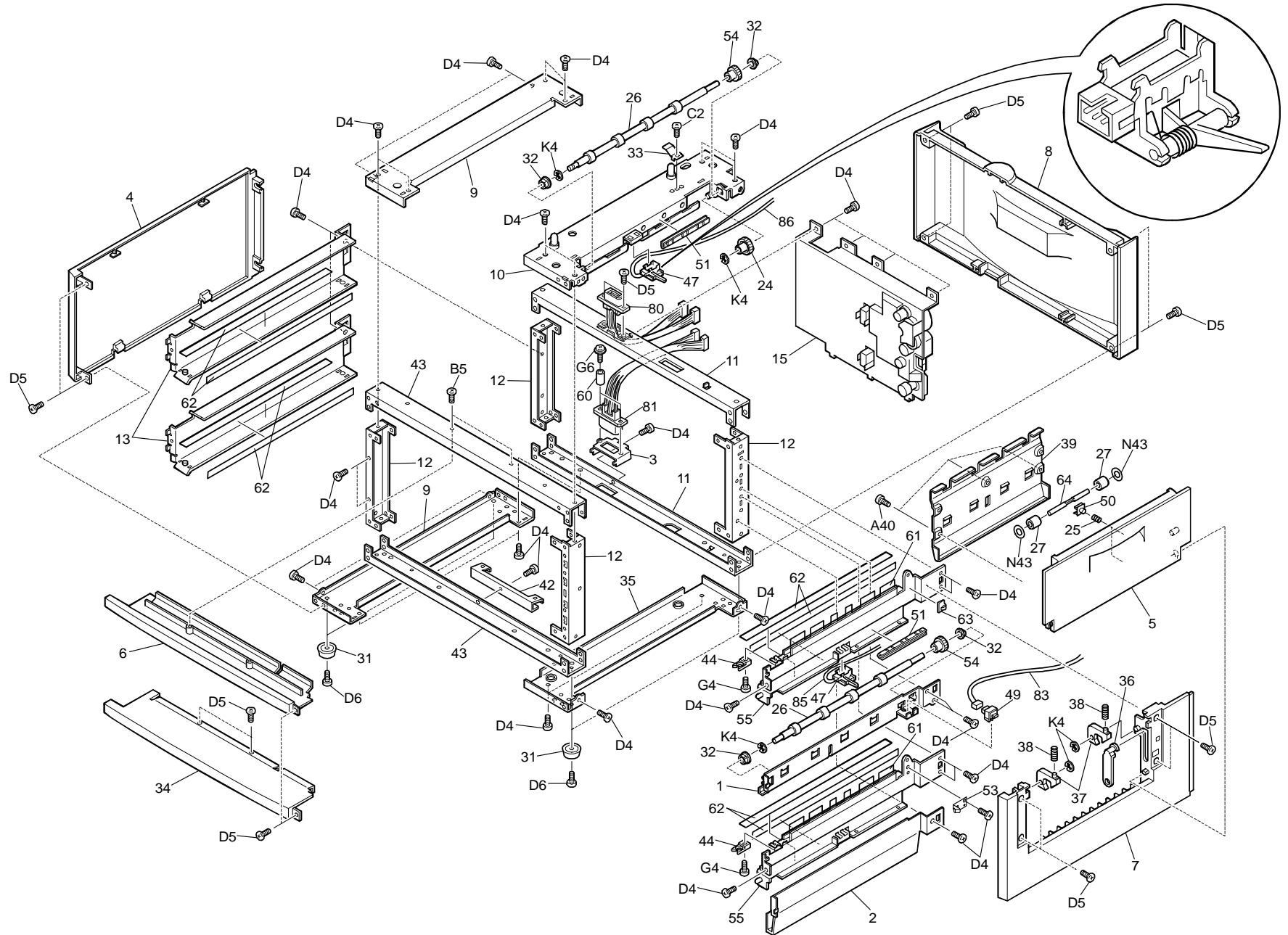

2 PF-30A, motor block (20-)

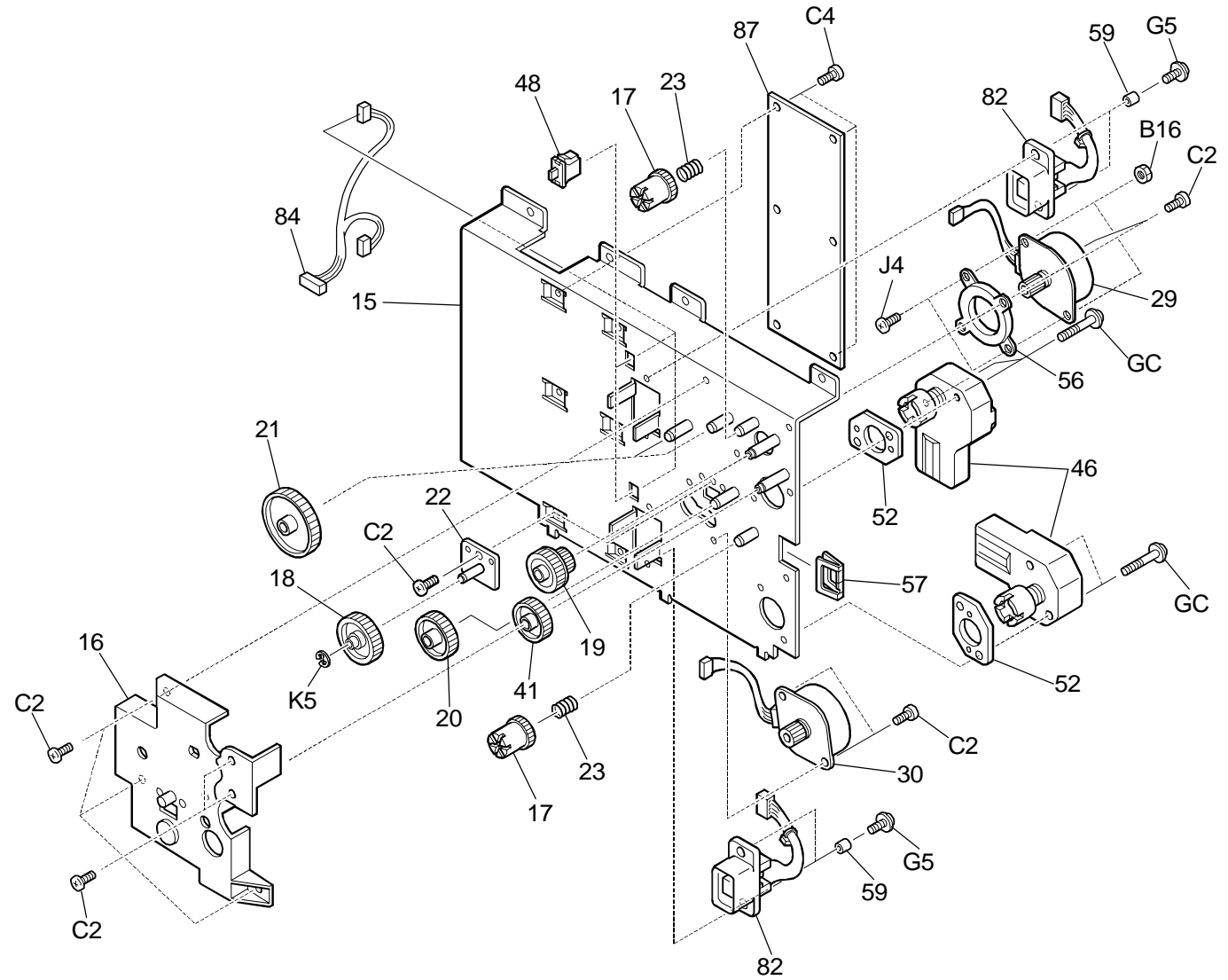

3 PD-30/PD-800, frame (20-)

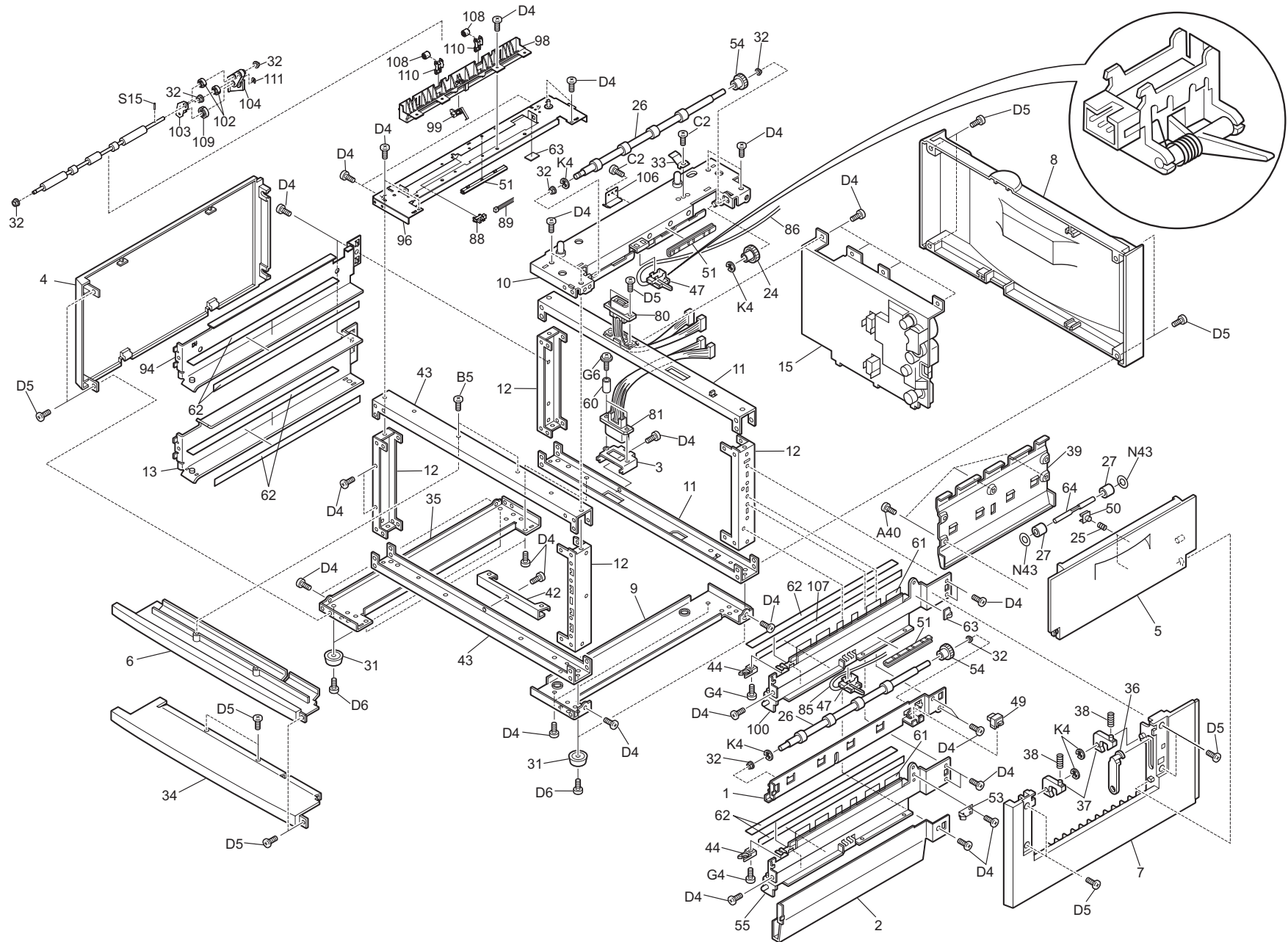

4 PD-30/PD-800, motor block (20-)

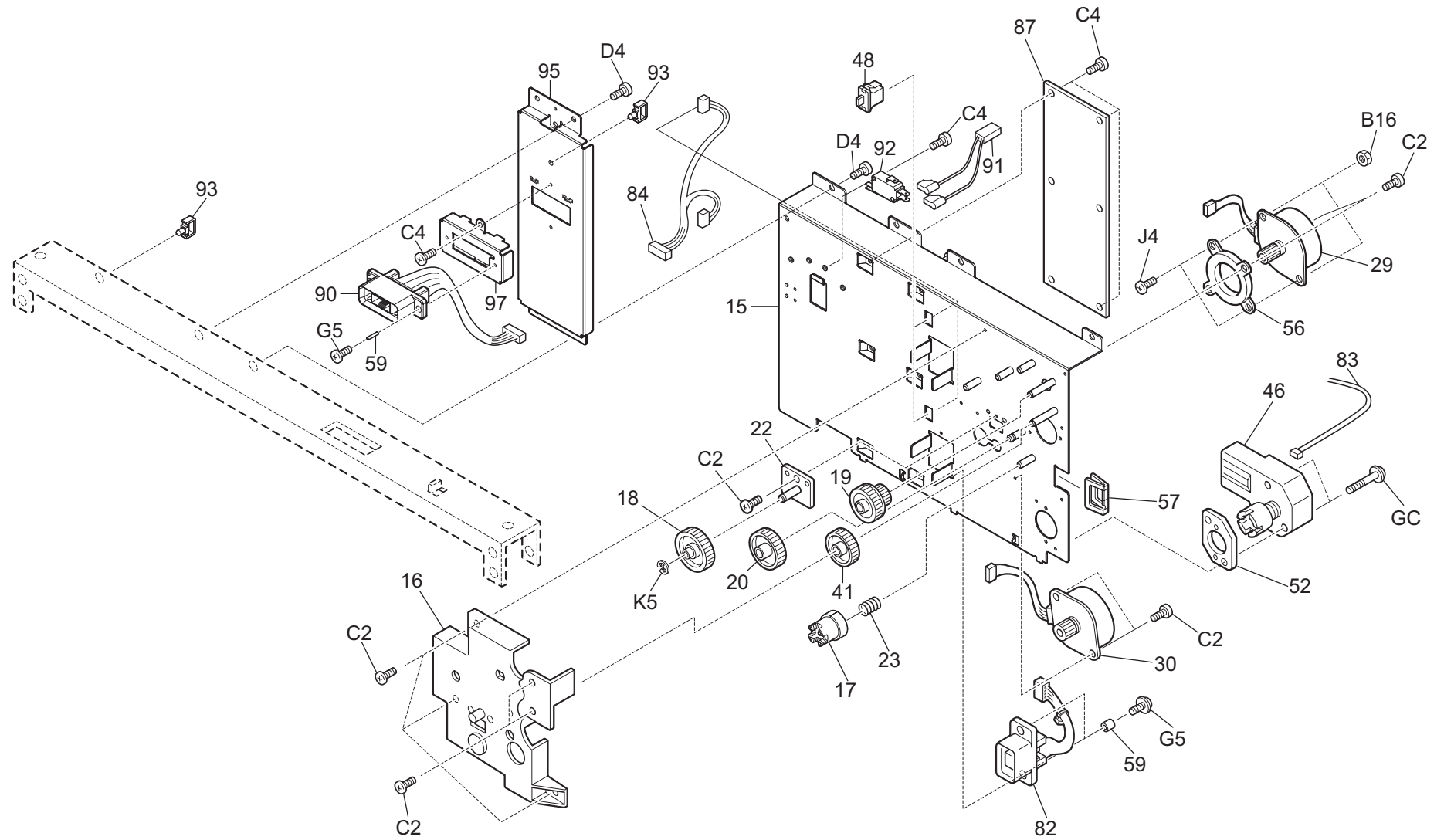

## PF-30A/PD-30A/PF-800 – Frame (20-)

Re. No.	Part code	Description	Applicable Model	SP	Q'ty	Remarks
20-001	84364575	PLATE FEED A		-	1	
20-002	84364570	PLATE FEED B		-	1	
20-003	84364435	PLATE CONNECTOR		-	1	
20-004	84367635	COVER FEED LEFT		X	1	
20-005	84367560	COVER FEED RIGHT		X	1	
20-006	84367620	COVER FEED FRONT A		X	1	
20-007	84367640	COVER FEED		X	1	
20-008	84367650	COVER FEED REAR		X	1	
20-009	84363095	STAY A LEFT		-	2	
20-010	84364585	STAY A-PIN	Excl. PD-30/PD-800	-	1	
20-010	84395305	STAY A PIN PD	PD-30/PD-800	-	1	
20-011	84364550	STAY B		-	2	
20-012	84364510	STAY C		-	4	
20-013	84364565	RAIL CASSETTE L	Excl. PF-30L	-	2	
20-013	84395295	RAIL CASSETTE L	PF-30L	-	2	
20-015	84364595	PLATE FEED DRIVE		-	1	
20-016	84367420	COVER FEED DRIVE		-	1	
20-017	5MVG137DN017	FEED GEAR Z24SJ	PF-30/PF-30L	X	2	
20-017	5MVG137DN073	FEED GEAR C Z24SJ	PF-30A/PD-30/PD-800	X	2	
20-018	5MVG158DN023	GEAR FREE Z41S	PF-30/PF-30L	X	1	
20-018	5MVG148DN089	GEAR Z43S	PF-30A/PD-30/PD-800	X	1	
20-019	5MVG148DN022	GEAR Z36S-Z30S		X	1	
20-020	5MVG148DN023	GEAR Z39S		X	2	
20-021	5MVG169DN022	GEAR Z63S		X	2	
20-022	5MVX331CN001	GEAR HOLDER	PF-30/PF-30L	X	2	
20-022	5MMX432SD005	PLATE GEAR HOLDER	PF-30A/PD-30/PD-800	-	1	
20-023	5MMW261LD021	SPRING JOINT FEED		X	2	
20-024	5MVG132DN002	GEAR FEED Z23S		X	1	
20-025	5MMW261SD003	SPRING NIP FEED		X	2	
20-026	5MMT876SN052	ROLLER NIP FEED		X	2	
20-027	5MVM276DN005	PULLEY MIDDLE		X	4	
20-029	5EZNT2400404*02	STEPPING MOTOR		X	1	
20-030	5EZNT2400404*03	STEPPING MOTOR		X	1	
20-031	5AAMPS6***02	FOOT		X	4	
20-032	5MMM121CX001	BUSH DRUM		X	16	
20-033	5MMX432LD001	SPRING SHAFT FD		X	1	
20-034	5MVX962SH002	COVER FEED FRONT B		-	1	
20-035	5MMX972SD001	STAY A RIGHT		-	1	
20-036	5MVX622DN001	ARM COVER		-	1	

Re. No.	Part code	Description	Applicable Model	SP	Q'ty	Remarks
20-037	5MVX421DN003	LOCK COVER R		-	2	
20-038	5MMW261SD004	SPRING COVER R		-	2	
20-039	5MMX872SD002	PLATE FEED RIGHT		-	1	
20-041	5MVG148DN027	GEAR Z37S		X	1	
20-042	5MMX732SD001	BKT COVER FRONT		-	1	
20-043	5MMX952SD002	STAY B FRONT		-	2	
20-044	5MVX321DN010	LATCH RAIL		X	2	
20-046	5EZND2400001*01	GEARD MOTOR		X	2	
20-047	5ENXGP1A44E1*01	PT.SENSOR GP1A44E1		X	2	
20-048	5ESP01000101*01	PUSH SWITCH 01 SN		X	2	
20-049	5ESP01000100*01	PUSH SWITCH 01 SN		X	1	
20-050	5MVX111DN002	BUSH SP PULLEY		X	2	
20-051	5MVX721SB001	HOLDER CORD		-	2	
20-052	5MVX754SB009	SPACER MOTOR		-	2	
20-053	5MMZ211LD003	PLATE EARTH COVER		-	1	
20-054	5AAVGEAR*028	GEAR NIP ASSY		X	2	
20-055	5AAVPLATE031	RAIL PLATE ASSY		-	2	
20-056	5MMX661SX001	PLATE MOTOR		-	1	
20-057	5MVX531NB004	EDGE CLIP		-	1	
20-059	5MMM140SZ012	COLLAR SPACER A		-	4	
20-060	5MMM140SZ013	COLLAR SPACER B		-	2	
20-061	5MVS431KF013	SHEET PATH		X	2	
20-062	5MVS816EF001	SHEET RAIL CASS		-	8	
20-063	5MMX221SW002	CORD KEEP		-	1	
20-064	5MMT743LD001	SHAFT NIP PULLEY	Excl.PD-30/PD-800	X	2	
20-064	5MMT743LD002	SHAFT NIP PULLEY PD	PD-30/PD-800	X	2	
20-080	5AACCNQD8GGEA	CONN. CORD ASSY	Excl.PD-30/PD-800	X	1	
20-080	5AACCN8A8GGEA	CONN. CORD ASSY	PD-30/PD-800	X	1	
20-081	5AACCNQD9GGEA	CONN. CORD ASSY	Excl.PD-30/PD-800	X	1	
20-081	5AACCN8A7GGEA	CONN. CORD ASSY	PD-30/PD-800	X	1	
20-082	5AACCNQE0GGEA	CONN. CORD ASSY		X	2	
20-083	5AACCNQE1GGEA	CONN. CORD ASSY	Excl.PD-30/PD-800	-	1	
20-083	5AACCN8A6GGEA	CONN. CORD ASSY	PD-30/PD-800	-	1	
20-084	5AACCNQE2GGEA	CONN. CORD ASSY		-	1	
20-084	5AACCN8A5GGEA	CONN. CORD ASSY		-	1	
20-085	5AACCNQE3GGEA	CONN. CORD ASSY		-	1	
20-086	5AACCNQF8GGEA	CONN. CORD ASSY		-	1	
20-087	5AAPRCZR2004BH	P.W.BOARD ASSY	FEED KP-546 Excl.PD-30/PD-800	X	1	
20-087	5AAPRCZG2015AH	P.W.BOARD ASSY	FEED KP-834 PD-30/PD-800	X	1	
20-088	5ENXGP1A73A**01	PT.SENSOR GP1A73AZ	PD-30/PD-800	X	1	
20-089	5MMS997SD001	LID PF-30L	PF-30L	-	1	



Re. No.	Part code	Description	Applicable Model	SP	Q'ty	Remarks
20-089	5AACCNSA4GEA	CONN. CORD ASSY	PD-30/PD-800	-	1	
20-090	5AACCNSA3GEA	CONN. CORD ASSY	PD-30/PD-800	X	1	
20-090	5AACCNSC2GEA	CONN. CORD ASSY	PD-30/PD-800	X	1	
20-091	5AACCNSA0GEA	CONN. CORD ASSY	PD-30/PD-800	-	1	
20-092	5ESM010115++01	MICRO SWITCH	PD-30/PD-800	X	1	
20-093	5MVS627NN001	BAND REUSE CONN.CORD	PD-30/PD-800	-	2	
20-094	5MMX955SD003	RAIL CASSETTE L DU	PD-30/PD-800	-	1	
20-095	5MMU631SD003	STAY CONNECTOR DU	PD-30/PD-800	-	1	
20-096	5MMB972SD002	STAY A LEFT DU	PD-30/PD-800	-	1	
20-097	5MMB652SD003	PLATE BKT CON DU	PD-30/PD-800	-	1	
20-098	5MVX854SB002	GUIDE PD	PD-30/PD-800	X	1	
20-099	5MVX432DB013	ACTUATOR PASS	PD-30/PD-800	X	1	
20-100	5AAVPLATE038	RAIL DU PLATE ASSY	PD-30/PD-800	-	1	
20-102	5MVG127DN109	GEAR PD Z19S	PD-30/PD-800	X	2	
20-103	5MMX531SD003	PLATE DRIVE PD	PD-30/PD-800	-	1	
20-104	5MVX654DN002	JOINT MOVER PD	PD-30/PD-800	-	1	
20-105	5MVT821RX001	ROLLER PD A	PD-30/PD-800	X	1	
20-106	5MMX633SD001	BKT STAY A PD	PD-30/PD-800	-	1	
20-107	5MVS816EF002	SHEET RAIL PD	PD-30/PD-800	-	1	
20-108	5MVM273DB005	PULLEY EXIT	PD-30/PD-800	X	2	
20-109	5MVG137DB025	GEAR M FEED Z25	PD-30/PD-800	X	1	
20-110	5MMX321LD036	PLATE PULLEY PD	PD-30/PD-800	-	2	
20-111	5MVX111DN003	RING STOPPER	PD-30/PD-800	X	1	

5 PF-30A, paper cassette (21-)

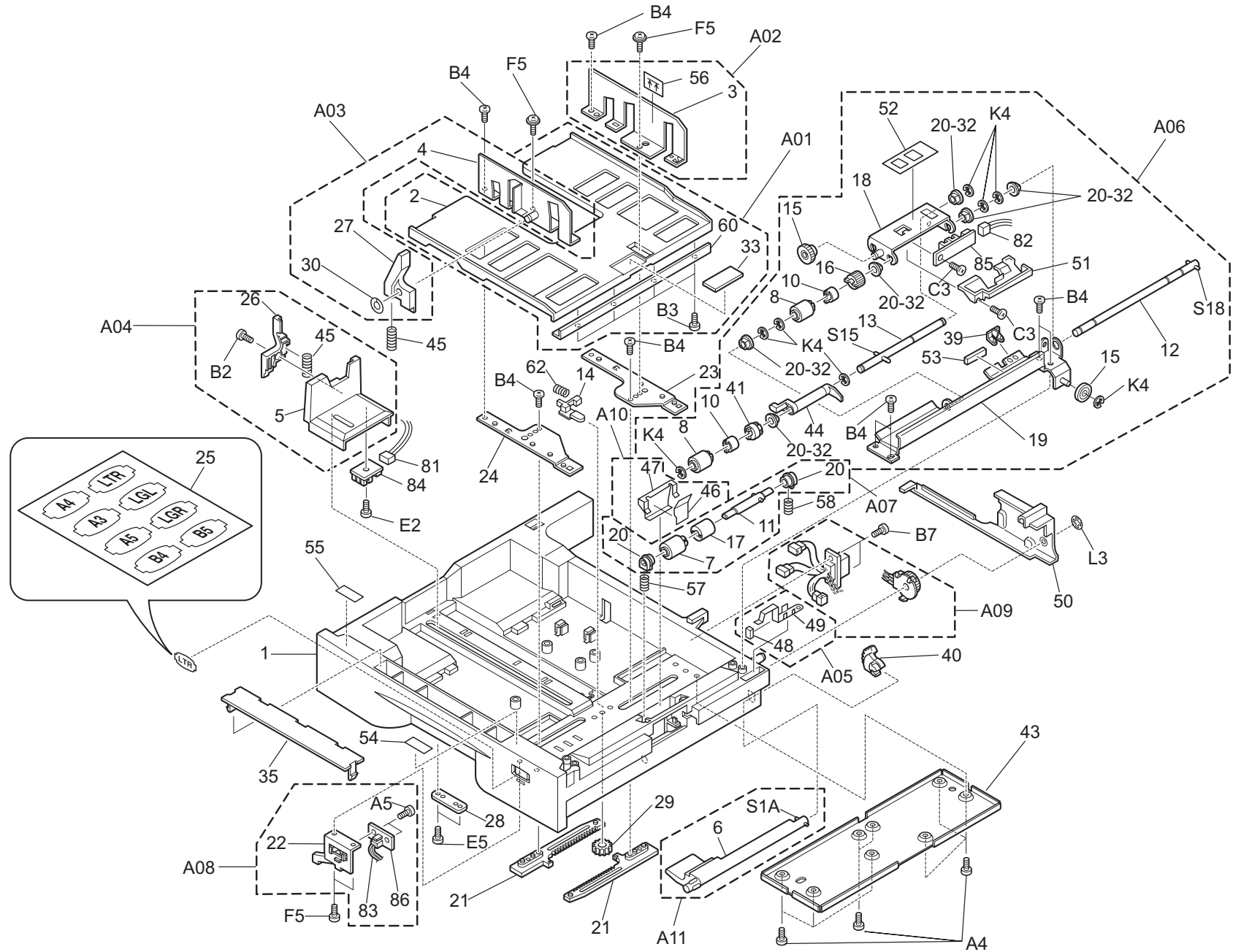

6 PD-30/PD-800, paper cassette (21-)

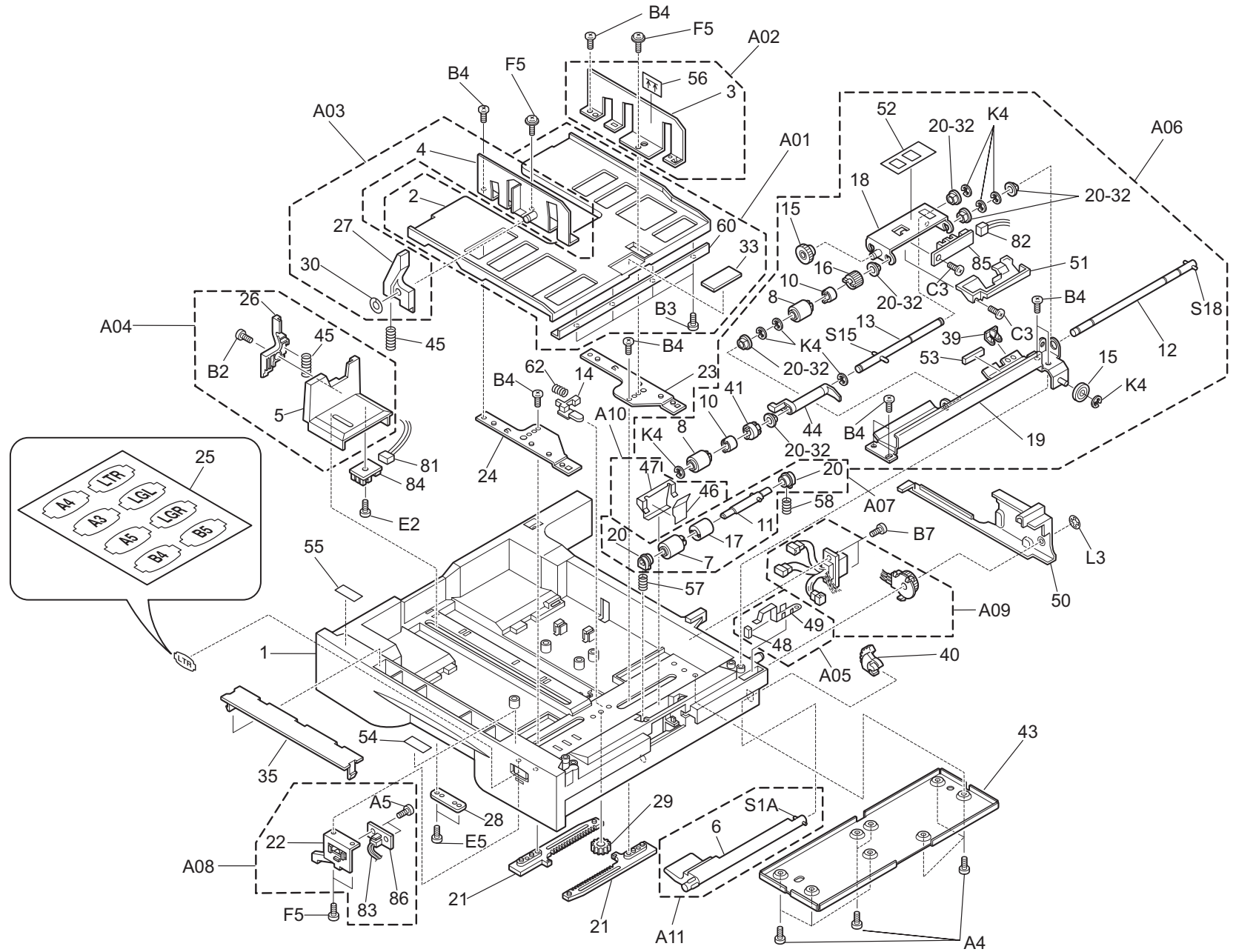

## PF-30A/PD-30/PD-800, paper cassette (21-)

Ref. No.	Part code	Description	Applicable model	SP	Q'ty	Remarks
	5PLPZYLAPKE	PC-30 CASSETTE ASSY	Excl.PF-30L	X	1	
	5PLPXC7APKX	PC-30L CASSETTE ASSY	PF-30L	X	1	
21-A01	5AAVBOT0M008	PLATE BOTTOM ASSY		X	1	
21-A02	5AAVGU1DE016	GUIDE PAPER R ASSY		X	1	
21-A03	5AAVGU1DE015	GUIDE PAPER L ASSY		X	1	
21-A04	5AAVSTOP*003	REAR STOPPER ASSY		X	1	
21-A05	5AAVPLATE033	EARTH PLATE ASSY		X	2	
21-A06	5AAVSTAY*007	STAY FEED ASSY		-	1	
21-A07	5AAVROLL*040	RETARD ROLL SUB ASSY	Excl.ST-1000	-	1	
21-A07	5AAZPF30MT02	RETARD ROLL SUB ASSY	ST-1000	-	1	
21-A08	5AAVHOLDRO24	LED HOLDER ASSY		-	1	
21-A09	5AAVROTER001	MODE ROTARY SW ASSY		X	1	
21-A10	5AAVPLATE035	RETARD PLATE ASSY		X	1	
21-A11	5AAVBRCKT060	BKT LEFT BOTTOM ASSY		X	1	
21-001	5MVB996SH006	BASE CASSETTE		-	2	
21-002	5MVX882SH001	PLATE BOTTOM		-	-	
21-003	5MML763SW002	GUIDE PAPER SIDE R		-	-	
21-004	5MML765SW001	GUIDE PAPER SIDE L		-	-	
21-005	5MVL666SH002	REAR STOPPER		-	-	
21-006	5MVX863SH006	BKT LIFT BOTTOM		-	-	
21-007	5AAVROLL*032	ROLLER RETARD ASSY		X	2	
21-008	5AAVROLL*033	ROLLER FEED		X	4	
21-010	5AAVCLTCH008	CLUTCH ASSY		X	4	
21-011	5MMT665SN001	SHAFT RETARD		-	-	
21-012	5MMT864SN006	SHAFT FEED		X	-	
21-013	5MMT864SN007	SHAFT PICK		X	2	
21-014	5MVX521DB002	ACTUATOR SIZE		X	2	
21-015	5MVG147DN014	GEAR Z35S		X	2	
21-016	5MVG147DN012	GEAR Z30		X	2	
21-017	5AAVROLL*031	TORQUE LIMITTER	Excl.ST-1000	X	2	
21-017	5AAZPF30MT01	TORQUE LIMITTER	ST-1000	X	2	
21-018	5MMU752SD002	BKT LIFT PICK		-	2	
21-019	5MMX863SD006	STAY FEED		-	2	
21-020	5MVM276DN009	BUSH RETARD		X	4	
21-021	5MVX731CN001	RACK		X	4	
21-022	5MVX665AC003	HOLDER LED		-	2	
21-023	5MMS756SD008	HOLDER PAPER SIDE R		-	2	
21-024	5MMS756SD009	HOLDER PAPER SIDE L		-	2	
21-025	5MVS522KX001	LABEL SIZE		X	2	

Ref. No.	Part code	Description	Applicable model	SP	Q'ty	Remarks
21-026	5MVX642CG002	LEVER LOCK REAR		X	2	
21-027	5MVX642CG001	LEVER LOCK SIDE		X	2	
21-028	5MVS628CN001	ACTUATOR REAR		-	2	
21-029	5MVG127DN045	PINION		X	2	
21-030	5MBWL72B05NN	POLY CUT WASER		-	2	
21-031	5MVM176DN001	PULLEY RAIL CASS		X	2	
21-033	5MVS637WK001	PAD FRICTION		-	-	
21-035	5MVX843SH010	LID CASSETTE		X	2	
21-039	5MVX221DN009	SPACER PICK UP		-	2	
21-040	5MVG165DN002	GEAR MODE SW		X	2	
21-041	5MVG147DN013	GEAR Z32		X	2	
21-043	5MMB871SD001	PLATE CASSETTE		-	2	
21-044	5MVX631DB001	ACTUATOR EMPTY		X	2	
21-045	5MMW411LD003	SPRING LEVER		X	4	
21-046	5MVS331KN003	SHEET RETARD		-	2	
21-047	5MMU531LD001	PLATE RETARD		-	2	
21-048	5MVS311RN001	PAD EARTH RAIL		-	-	
21-049	5MMZ331LD002	PLATE EARTH RAIL		-	-	
21-050	5MVX865SX001	COVER CONNECT		-	2	
21-051	5MVX642SX001	COVER PICK UP		-	2	
21-052	5MVVL642WN08	LABEL PICK UP		-	2	
21-053	5MMS411FX001	MAGNET PICK UP		-	2	
21-054	5MVVL632WN04	LABEL CASSETTE A		-	2	
21-055	5MVVL632WN05	LABEL CASSETTE B		-	2	
21-056	5MVVL431WN13	PAPER LIMIT LABEL		-	-	
21-057	5MMW241SD003	SPRING RETARD L		X	2	
21-058	5MMW241SD004	SPRING RETARD R		X	2	
21-060	5MML821SD005	STAY BOTTOM		-	-	
21-062	5MMW264LD003	SPRING ACTUATOR		-	2	
21-081	5AACCNQE5GEA	CONN. CORD ASSY		X	2	
21-082	5AACCNQF5GEA	CONN. CORD ASSY		-	2	
21-083	5AACCNQF6GEA	CONN. CORD ASSY		-	2	
21-084	5AAPRSSC1019AH	P.W.BOARD ASSY	PSIZE KP-581	X	1	
21-085	5AAPRSSC1018AH	P.W.BOARD ASSY	PICKUP KP-583	X	1	
21-086	5AAPRLDC1002AH	P.W.BOARD ASSY	LED KP-585	X	1	
21-087	3FX06080	SPACER PF F		X	1	
21-088	3FX06090	SPACER PF R		X	1	
21-089	3FX06100	SEAL SPACER PF		X	2	
21-090	3FX06040	SEAL CASSETTE A		X	1	
21-091	3FX06050	SEAL CASSETTE B		X	2	
21-092	3FX06060	SEAL CASSETTE C		X	1	

Ref. No.	Part code	Description	Applicable model	SP	Q'ty	Remarks
21-093	3FX06070	SEAL CASSETTE D		X	1	

7 PD-30/PD-800, duplex tray unit (14-)

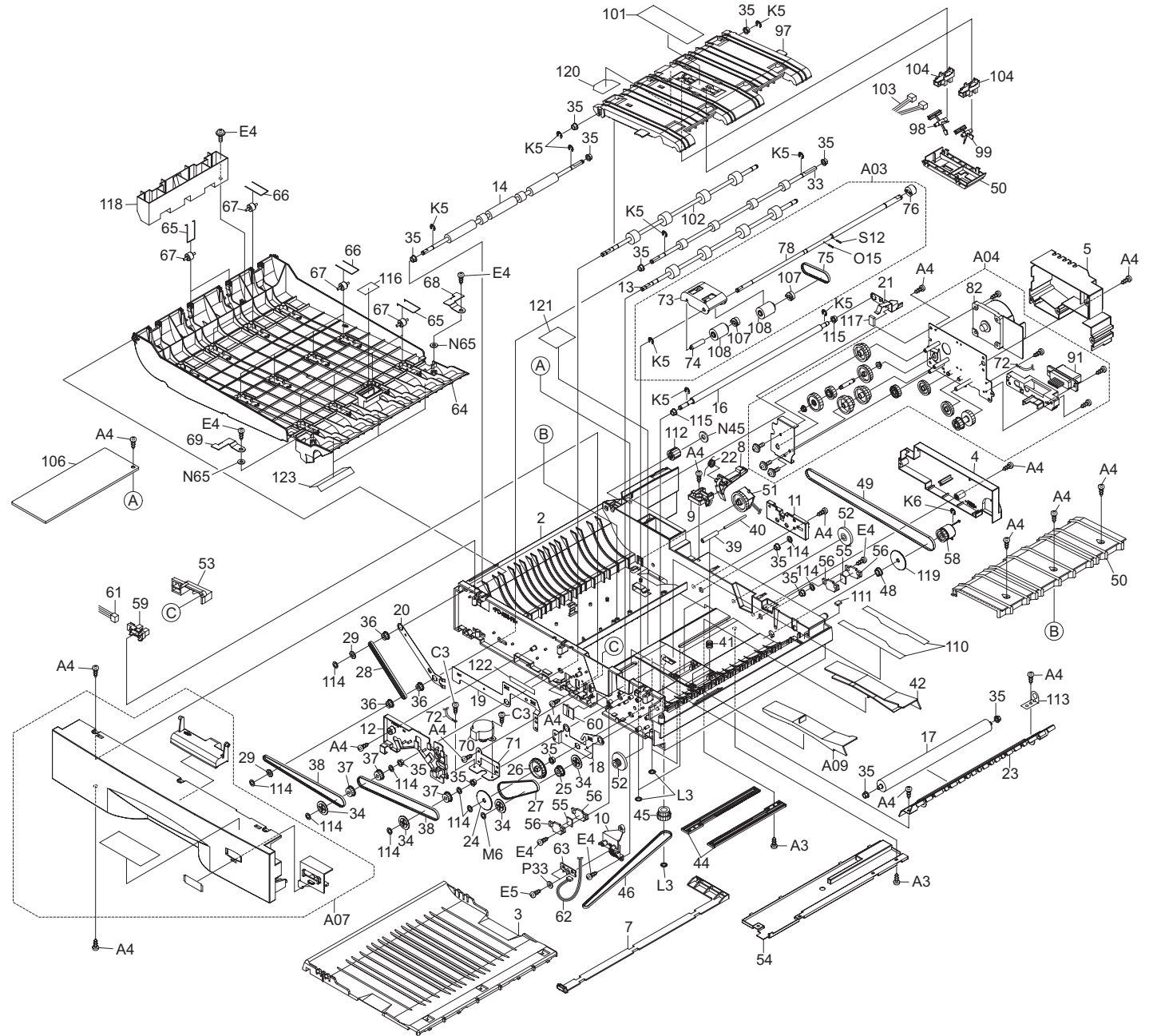

## PD-30, duplex tray unit (14-)

Ref. No.	Part code	Description	Applicable model	SP	Q'ty	Remarks
	5PLPXBGAPKX	DT-800 DUPLEX TRAY UNIT	PD-30/PD-800	X	1	
14-A03	5AAYW52DU+06	PICK UP ROLLER ASSY	PD-30/PD-800	X	1	
14-A04	5AAYW52DU+07	DRIVE UNIT DU	PD-30/PD-800	X	1	
14-A07	5AAYW52DU+11	COVER FRONT DU ASSY	PD-30/PD-800	X	1	
14-002	5MVB996SB001	FRAME MAIN DU	PD-30/PD-800	-	1	
14-003	5MVB883SB015	FRAME BOTTOM DU	PD-30/PD-800	-	1	
14-004	5MVB863SB024	COVER REAR A	PD-30/PD-800	X	1	
14-005	5MVB766SB004	COVER REAR B	PD-30/PD-800	X	1	
14-007	5MVB862DB001	PLATE LEVER	PD-30/PD-800	X	1	
14-008	5MVB652DB001	LOCK LEVER DU	PD-30/PD-800	X	1	
14-009	5MVB542DB001	HOLDER LOCK DU	PD-30/PD-800	X	1	
14-010	5MVB655SB001	BKT LED	PD-30/PD-800	-	1	
14-011	5MVB743SB005	HOLDER HARNESSDU	PD-30/PD-800	-	1	
14-012	5MVX762SB016	HOLDER HARNESS F	PD-30/PD-800	-	1	
14-013	5MMT876SN085	ROLLER FEED DU2	PD-30/PD-800	X	1	
14-014	5MMT876SN083	ROLLER INPUT	PD-30/PD-800	X	1	
14-016	5MMT876SN086	ROLLER DECURL UP	PD-30/PD-800	X	1	
14-017	5MMT876SN087	ROLLER DECURL LOW	PD-30/PD-800	X	1	
14-018	5MMS762LD002	PLATE EARTH A	PD-30/PD-800	-	1	
14-019	5MMS862LD001	PLATE EARTH B	PD-30/PD-800	-	1	
14-020	5MMS662LD001	PLATE EARTH C	PD-30/PD-800	-	1	
14-021	5MMZ653LD001	PLATE EARTH RAIL	PD-30/PD-800	X	1	
14-022	5MMW172LD011	SPRING LOCK	PD-30/PD-800	-	1	
14-023	5MMX843SD001	PLATE DECURL DU	PD-30/PD-800	-	1	
14-024	5MVF177DN006	COVER PULLEY B	PD-30/PD-800	X	1	
14-025	5AAVPULLY023	PULLEY P26 ASSY	PD-30/PD-800	X	1	
14-026	5MVG369DN001	PULLEY P52	PD-30/PD-800	X	1	
14-027	5MVM190RB029	BELT S2M210	PD-30/PD-800	X	1	
14-028	5MVM190RB028	BELT S2M240	PD-30/PD-800	X	1	
14-029	5MVF177DN004	FD FLANGE BELT	PD-30/PD-800	-	2	
14-033	5MMT876SN082	ROLLER FEED DU1	PD-30/PD-800	X	1	
14-034	5MVF182DN001	COVER PULLEY	PD-30/PD-800	X	4	
14-035	5MMM121CX001	BUSH DRUM	PD-30/PD-800	X	13	
14-036	5MVG126DN012	PULLEY P18	PD-30/PD-800	X	3	
14-037	5MVG337DN004	PULLEY P24	PD-30/PD-800	X	3	
14-038	5MVM190RB020	BELT S2M328	PD-30/PD-800	X	2	
14-039	5MVM460DB001	ROLLER IDLE	PD-30/PD-800	X	2	
14-040	5MMT555SN001	SHAFT B	PD-30/PD-800	-	2	
14-041	5MMW155LD001	SPRING BOTTOM	PD-30/PD-800	-	2	



Ref. No.	Part code	Description	Applicable model	SP	Q'ty	Remarks
14-042	5MVB843SB006	GUIDE PAPER R	PD-30/PD-800	-	1	
14-A09	5MVB843SB005	GUIDE PAPER L	PD-30/PD-800	-	1	
14-044	5MVB822DW001	RACK DU	PD-30/PD-800	X	2	
14-045	5MVG147DN010	GEAR Z25-P36	PD-30/PD-800	X	1	
14-046	5MVM190RB024	BELT S2M426	PD-30/PD-800	X	1	
14-048	5MMM176CJ003	METAL BUSH KD	PD-30/PD-800	X	1	
14-049	5MVM190RB021	BELT S2M630	PD-30/PD-800	X	1	
14-050	5MVB873SB048	PLATE PAPER	PD-30/PD-800	-	1	
14-051	5EYYAFAAQ02++02	CLUTCH FEED	PD-30/PD-800	X	1	
14-052	5MVM176DB014	PULLEY BELT DU	PD-30/PD-800	X	2	
14-053	5MVX622SB012	COVER PT	PD-30/PD-800	-	1	
14-054	5MVB861SB008	COVER BOTTOM PD	PD-30/PD-800	-	1	
14-055	5MMK224FJ001	MAGNET	PD-30/PD-800	-	2	
14-056	5MMS426SN003	PLATE MAGNET	PD-30/PD-800	-	4	
14-058	5AAVCLTCH009	CLUTCH ASSY	PD-30/PD-800	X	1	
14-059	5ENXGP1A73A**01	PT.SENSOR GP1A73AZ	PD-30/PD-800	X	1	
14-060	5MVX627NN001	CORD KEEP	PD-30/PD-800	-	1	
14-061	5AACCNQF2GEA	CONN. CORD ASSY	PD-30/PD-800	X	1	
14-062	5AACCNQA2GEA	CONN. CORD ASSY	PD-30/PD-800	-	1	
14-064	5MVB986SC001	PLATE TOP	PD-30/PD-800	-	1	
14-065	5MMW521LX002	SPRING PA L	PD-30/PD-800	X	6	
14-066	5MMW701LX003	SPRING PULLEY DU	PD-30	X	6	
14-066	5MMW701LX003	SPRING PULLEY DU	PD-800	X	8	
14-067	5MVM374DN001	PULLEY PA	PD-30	X	12	
14-067	5MVM374DN001	PULLEY PA	PD-800	X	14	
14-068	5MML211SN002	PLATE CATCH L	PD-30/PD-800	-	1	
14-069	5MML211SN001	PLATE CATCH R	PD-30/PD-800	-	1	
14-070	5AAXMT027GEA	STEPPING MOTOR ASSY	PD-30/PD-800	X	1	
14-071	5MML532SD004	BKT STEP	PD-30/PD-800	-	1	
14-072	5AACCNQJ8GEA	CONN. CORD ASSY	PD-30/PD-800	-	1	
14-073	5MVB662DW001	GUIDE TURN	PD-30/PD-800	-	1	
14-074	5MMT666SN001	SHAFT PU	PD-30/PD-800	-	1	
14-075	5MVM190RB019	BELT S2M124	PD-30/PD-800	X	1	
14-076	5AAVROLL*034	TORUQUE LIMITER	PD-30/PD-800	X	1	
14-078	5MMT866SN036	SHAFT FEED ROLL DU	PD-30/PD-800	-	1	
14-082	5AAXMT052GEA	MAIN MOTOR ASSY	PD-30/PD-800	X	1	
14-091	5AACCNQC2GEA	CONN. CORD ASSY	PD-30/PD-800	X	1	
14-091	5AACCNQA3GEA	CONN. CORD ASSY	PD-30/PD-800	X	1	
14-097	5MVB873CC001	PLATE BOTTOM	PD-30/PD-800	-	1	
14-098	5MVX433DB004	ACTUATOR H	PD-30/PD-800	X	1	
14-099	5MVX433DB003	ACTUATOR S	PD-30/PD-800	X	1	

Ref. No.	Part code	Description	Applicable model	SP	Q'ty	Remarks
14-100	5MVB753SB020	COVER PB	PD-30/PD-800	-	1	
14-101	5MVS522KC003	SHEET BU	PD-30/PD-800	-	1	
14-102	5MMT876SN085	ROLLER FEED DU2	PD-30/PD-800	X	1	
14-103	5AACCNQF1GEA	CONN. CORD ASSY	PD-30/PD-800	X	1	
14-104	5ENXGP1A73A**01	PT.SENSOR GP1A73AZ	PD-30/PD-800	X	2	
14-105	5MVS421VB001	FILM EARTH	PD-30/PD-800	-	1	
14-106	5AAPRCZG2014AH	P.W.BOARD ASSY	DUPLEX KP-836	PD-30/PD-800	X	1
14-107	5MVM576DN001	ROLLER RETURN	PD-30/PD-800	X	2	
14-108	5AAVROLL*036	ROLLER DU ASSY	PD-30/PD-800	X	2	
14-109	5MVS427SF001	SHEET ADJUST DU R	PD-30	-	1	
14-110	5MVS722KF009	SHEET GUIDE DU	PD-30/PD-800	-	2	
14-111	5MVS311RN003	PAD EARTH RAIL DU	PD-30/PD-800	-	1	
14-112	5MVG127DN108	GEAR DU Z19S	PD-30/PD-800	X	1	
14-113	5MMX333SD002	BKT DECUEL UP	PD-30/PD-800	-	1	
14-114	5MVX111DN003	RING STOPPER	PD-30/PD-800	X	9	
14-115	5MBELF106OZZ	BALL BEARING	PD-30/PD-800	X	2	
14-116	5MVS422KE001	SHEET PLATE TOP	PD-30/PD-800	X	1	
14-117	5MVS311RN001	PAD EARTH RAIL	PD-30/PD-800	-	1	
14-118	5MVB743CC001	COVER PULLEY TOP	PD-30/PD-800	-	1	
14-119	5MVS807CX001	COVER PULLEY C	PD-30/PD-800	-	1	
14-120	5MVS422KF007	SHEET GUIDE BOTTOM	PD-30/PD-800	X	1	
14-121	5MVS422KF008	SHEET FRAME BOTTOM	PD-30/PD-800	-	1	
14-122	5MVS522KF009	SHEET HARNESS F	PD-30/PD-800	-	1	
14-123	5MVS632KF012	SHEET GUIDE DECURL	PD-30/PD-800	X	3	
P-001	5AAKPF30**02	PACKING KIT ASSY	PF-30	X	1	
P-001	5AAKPF30MT02	PACKING KIT ASSY	ST-1000	X	1	
P-001	5AAKPF30L+02	PACKING KIT ASSY	PF-30L	X	1	
P-001	5AAKW52PF+02	PACKING KIT ASSY	PF-30A	X	1	
P-001	5AAKW52DU+02	PACKING KIT ASSY	PD-30	X	1	
P-001	3GX77030	PACKING KIT ASSY	PD-800	X	1	
P-002	5KKSPF30**01	OUTER CARTON	PF-30	-	1	
P-002	5KKSPF30MT01	OUTER CARTON	ST-1000	-	1	
P-002	5KKSPF30L+01	OUTER CARTON	PF-30L	-	1	
P-002	5KKSW52PF+01	OUTER CARTON	PF-30A	-	1	
P-002	5KKSW52DU+01	OUTER CARTON	PD-30	-	1	
P-002	3GX78010	OUTER CARTON	PD-800	-	1	
	5KKAPF30**01	TOP PAD	Excl.PD-30/PD-800	-	2	
	5KKAW52DU+01	TOP PAD	PD-30/PD-800	-	2	
	5KKAPF30**02	BOTTOM PAD		-	2	
	5KKF65A060B4	POLY BAG		-	1	

Ref. No.	Part code	Description	Applicable model	SP	Q'ty	Remarks
	5AAVSHEET002	SHEET ADJUST ASSY	Excl.PD-30/PD-800	X	1	
	5AAVSHEET005	SHEET ADJUST PC ASSY	PD-30/PD-800	X	1	
	5AAVKEY++012	KEY PLT	PF-30L	-	1	
	5KKT30**AX	INSTRUCTION MANUAL	PF-30	-	1	
	5KKT30MTAX	INSTRUCTION MANUAL	ST-1000	-	1	
	5KKT30L+AA	INSTRUCTION MANUAL	PF-30L	-	1	
	5KKTW52PF+AX	INSTRUCTION MANUAL	PF-30A	-	1	
	5KKTW52DU+AX	INSTRUCTION MANUAL	PD-30	-	1	
	3FN80052	INSTRUCTION MANUAL	PD-800	-	1	