



PD-30/PD-800

SERVICE MANUAL

Published in Feb. '03
3FN70760



Safety precautions

This booklet provides safety warnings and precautions for our service personnel to ensure the safety of their customers, their machines as well as themselves during maintenance activities. Service personnel are advised to read this booklet carefully to familiarize themselves with the warnings and precautions described here before engaging in maintenance activities.

Safety warnings and precautions

Various symbols are used to protect our service personnel and customers from physical danger and to prevent damage to their property. These symbols are described below:

⚠ DANGER: High risk of serious bodily injury or death may result from insufficient attention to or incorrect compliance with warning messages using this symbol.

⚠ WARNING: Serious bodily injury or death may result from insufficient attention to or incorrect compliance with warning messages using this symbol.

⚠ CAUTION: Bodily injury or damage to property may result from insufficient attention to or incorrect compliance with warning messages using this symbol.

Symbols

The triangle (\triangle) symbol indicates a warning including danger and caution. The specific point of attention is shown inside the symbol.



General warning.



Warning of risk of electric shock.



Warning of high temperature.

⊘ indicates a prohibited action. The specific prohibition is shown inside the symbol.



General prohibited action.



Disassembly prohibited.

● indicates that action is required. The specific action required is shown inside the symbol.



General action required.





Remove the power plug from the wall outlet.











Always ground the copier.

1. Installation Precautions

WARNING











- Do not use a power supply with a voltage other than that specified. Avoid multiple connections to one outlet: they may cause fire or electric shock. When using an extension cable, always check that it is adequate for the rated current. 
- Connect the ground wire to a suitable grounding point. Not grounding the copier may cause fire or electric shock. Connecting the earth wire to an object not approved for the purpose may cause explosion or electric shock. Never connect the ground cable to any of the following: gas pipes, lightning rods, ground cables for telephone lines and water pipes or faucets not approved by the proper authorities. 

CAUTION:





- Do not place the copier on an infirm or angled surface: the copier may tip over, causing injury. 
- Do not install the copier in a humid or dusty place. This may cause fire or electric shock. 
- Do not install the copier near a radiator, heater, other heat source or near flammable material. This may cause fire. 
- Allow sufficient space around the copier to allow the ventilation grills to keep the machine as cool as possible. Insufficient ventilation may cause heat buildup and poor copying performance. 
- Always handle the machine by the correct locations when moving it. 
- Always use anti-toppling and locking devices on copiers so equipped. Failure to do this may cause the copier to move unexpectedly or topple, leading to injury. 
- Avoid inhaling toner or developer excessively. Protect the eyes. If toner or developer is accidentally ingested, drink a lot of water to dilute it in the stomach and obtain medical attention immediately. If it gets into the eyes, rinse immediately with copious amounts of water and obtain medical attention. 
- Advise customers that they must always follow the safety warnings and precautions in the copier's instruction handbook. 











2. Precautions for Maintenance

WARNING

- Always remove the power plug from the wall outlet before starting machine disassembly. 
- Always follow the procedures for maintenance described in the service manual and other related brochures. 
- Under no circumstances attempt to bypass or disable safety features including safety mechanisms and protective circuits. 
- Always use parts having the correct specifications. 
- Always use the thermostat or thermal fuse specified in the service manual or other related brochure when replacing them. Using a piece of wire, for example, could lead to fire or other serious accident. 
- When the service manual or other serious brochure specifies a distance or gap for installation of a part, always use the correct scale and measure carefully. 
- Always check that the copier is correctly connected to an outlet with a ground connection. 
- Check that the power cable covering is free of damage. Check that the power plug is dust-free. If it is dirty, clean it to remove the risk of fire or electric shock. 
- Never attempt to disassemble the optical unit in machines using lasers. Leaking laser light may damage eyesight. 
- Handle the charger sections with care. They are charged to high potentials and may cause electric shock if handled improperly. 

CAUTION

- Wear safe clothing. If wearing loose clothing or accessories such as ties, make sure they are safely secured so they will not be caught in rotating sections. 
- Use utmost caution when working on a powered machine. Keep away from chains and belts. 
- Handle the fixing section with care to avoid burns as it can be extremely hot. 
- Check that the fixing unit thermistor, heat and press rollers are clean. Dirt on them can cause abnormally high temperatures. 
- Do not remove the ozone filter, if any, from the copier except for routine replacement. 

- Do not pull on the AC power cord or connector wires on high-voltage components when removing them; always hold the plug itself. 
- Do not route the power cable where it may be stood on or trapped. If necessary, protect it with a cable cover or other appropriate item. 
- Treat the ends of the wire carefully when installing a new charger wire to avoid electric leaks. 
- Remove toner completely from electronic components. 
- Run wire harnesses carefully so that wires will not be trapped or damaged. 
- After maintenance, always check that all the parts, screws, connectors and wires that were removed, have been refitted correctly. Special attention should be paid to any forgotten connector, trapped wire and missing screws. 
- Check that all the caution labels that should be present on the machine according to the instruction handbook are clean and not peeling. Replace with new ones if necessary. 
- Handle greases and solvents with care by following the instructions below: 
 - Use only a small amount of solvent at a time, being careful not to spill. Wipe spills off completely.
 - Ventilate the room well while using grease or solvents.
 - Allow applied solvents to evaporate completely before refitting the covers or turning the main switch on.
 - Always wash hands afterwards.
- Never dispose of toner or toner bottles in fire. Toner may cause sparks when exposed directly to fire in a furnace, etc. 
- Should smoke be seen coming from the copier, remove the power plug from the wall outlet immediately. 

3. Miscellaneous

 WARNING

- Never attempt to heat the drum or expose it to any organic solvents such as alcohol, other than the specified refiner; it may generate toxic gas. 

CONTENTS

1-1 Specifications	
1-1-1 Specifications	1-1-1
1-1-2 Parts names and their functions	1-1-2
(1) Duplex unit	1-1-2
(2) LED indicator	1-1-3
1-1-3 Cross section view	1-1-4
1-2 Handling Precautions	
1-2-1 Installation environment	1-2-1
1-3 Installation	
1-3-1 Unpacking and installation	1-3-1
(1) Installation procedure	1-3-1
1-4 Troubleshooting	
1-4-1 Paper misfeed detection	1-4-1
(1) Paper misfeed indication	1-4-1
(2) Paper misfeed detection sensors	1-4-1
1-4-2 Self-diagnosis	1-4-2
(1) Self-diagnostic function	1-4-2
1-5 Assembly and Disassembly	
1-5-1 Precautions for assembly and disassembly	1-5-1
(1) Precautions	1-5-1
1-5-2 Duplex unit (frame)	1-5-2
(1) Detaching and refitting the duplex unit PWB	1-5-2
(2) Detaching and refitting the bottom plate elevation motor	1-5-3
1-5-3 Duplexer	1-5-4
(1) Detaching and refitting the upper and lower decurlers	1-5-4
(2) Detaching and refitting the switchback rollers	1-5-6
(3) Detaching and refitting the duplexer drive unit	1-5-8
(4) Detaching and refitting the side registration motor	1-5-10
(5) Detaching and refitting the duplexer feed clutch	1-5-12
(6) Detaching and refitting the duplexer refeed clutch	1-5-13
(7) Detaching and refitting the duplexer PWB	1-5-14
(8) Detaching and refitting the side registration home position sensor	1-5-15
1-5-4 Paper cassette	1-5-16
(1) Detaching and refitting the feed roller and pickup roller	1-5-16
(2) Detaching and refitting the retard roller	1-5-17
2-1 Mechanical construction	
2-1-1 Duplex unit (frame)	2-1-1
(1) Paper entrance section	2-1-1
(2) Paper refeed and vertical paper conveying section	2-1-2
2-1-2 Duplexer	2-1-4
(1) Paper feed section	2-1-4
2-1-3 Paper cassette	2-1-6
(1) Paper feed section	2-1-6
(2) Paper size sensing	2-1-8
(3) Paper gauge sensing	2-1-9
2-2 Electrical Parts Layout	
2-2-1 Electrical parts layout	2-2-1

3FN/3GX

2-3 PWB operation and connector signal assignment

2-3-1 PWB information	2-3-1
(1) Duplex unit PWB [KP-834] block diagram	2-3-1
(2) Duplexer PWB [KP-836] block diagram	2-3-4

2-4 Appendixes

Connection diagram	2-4-1
--------------------------	-------

1-1-1 Specifications

Duplex unit (frame)

Type	Console
Paper feed speed	261.8 mm/s (NIP feed roller [upper]) 255.8 mm/s (NIP feed roller [lower])
Dimensions	560 × 566 × 251 mm (W × D × H) 22 ³ / ₈ " × 22 ¹ / ₄ " × 9 ⁷ / ₈ " (W × D × H)
Weight	21.0 kg/46.3 lbs (Including duplexer and paper cassette)
Floor requirements	891 × 560 mm (W × D) 35 ¹ / ₁₆ " × 22 ¹ / ₁₆ " (W × D)
Power source	24 V DC and 5 V DC supplied from printer/copier
Printer interface	Serial communication (clock synchronization)
Options	Caster, Caster kit

Duplexer

Paper pass method	Center
Paper turn over method	Switchback
Available paper size	ISO A3 (297 × 420 mm) ISO A4 (210 × 297 mm) ISO A5 (148 × 210 mm) JIS B4 (257 × 364 mm) JIS B5 (182 × 257 mm) Letter (8 ¹ / ₂ " × 11") Legal (8 ¹ / ₂ " × 14") Ledger (11" × 17")
Paper feed speed	High speed: 410 mm/s (Refeed roller) Low speed: 134 mm/s (Refeed roller) High speed forward: 410 mm/s (Switchback roller) Low speed forward: 134 mm/s (Switchback roller) High speed reverse: 261.8 mm/s (Switchback roller)
Weight	6.5 Kg/14.33 lbs

Paper cassette

Paper pass method	Center
Paper	Plain paper (64 to 90 g/m ²)
Paper loading capacity	500 sheets (80 g/m ² , 0.11 mm)
Loadable paper size	ISO A3 (297 × 420 mm) ISO A4 (210 × 297 mm) ISO A5 (148 × 210 mm) JIS B4 (257 × 364 mm) JIS B5 (182 × 257 mm) Letter (8 ¹ / ₂ " × 11") Legal (8 ¹ / ₂ " × 14") Ledger (11" × 17")
Weight	3.5 Kg/7.716 lbs

1-1-2 Parts names and their functions

(1) Duplex unit

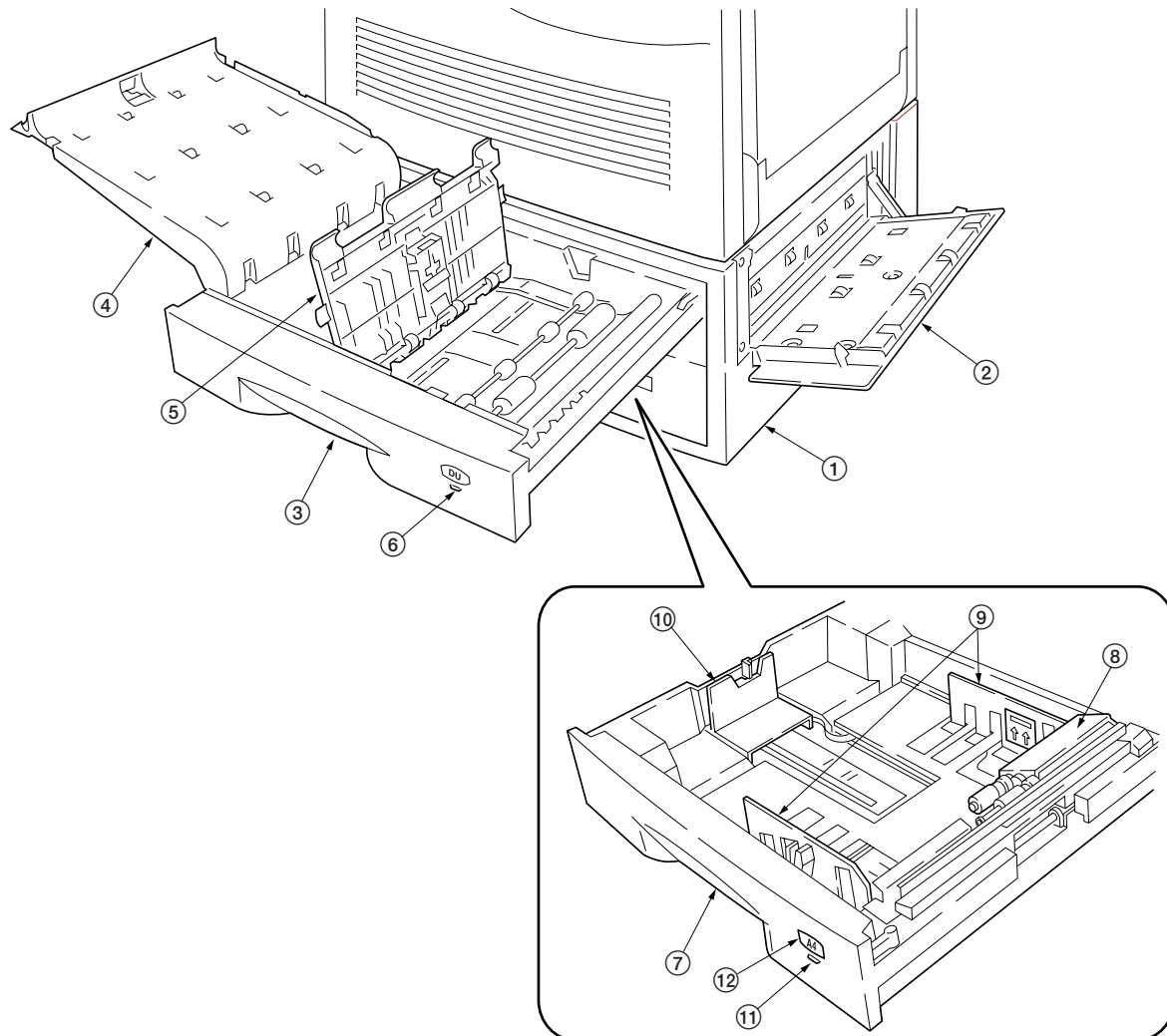

Figure 1-1-1

- | | |
|--------------------------|--------------------------------|
| ① Duplex unit (Frame) | ⑦ Paper cassette |
| ② Duplex unit side cover | ⑧ Paper feed assembly |
| ③ Duplexer | ⑨ Paper guides |
| ④ Duplexer upper cover | ⑩ Paper stopper |
| ⑤ Duplexer lower cover | ⑪ Paper cassette LED indicator |
| ⑥ Duplexer LED indicator | ⑫ Paper size indicator plate |

(2) LED indicator

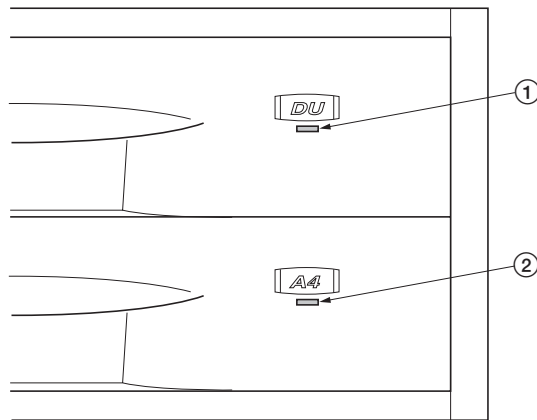

Figure 1-1-2

	LED indicator status			
	Fast flashing	Slow flashing	Lit	Off
① Duplexer LED indicator	Paperjam occurred.	-	Duplex print operating.	-
② Paper cassette LED indicator	Paper jam occurred.	Paper empty.	Selected.	Poor insertion.

1-1-3 Cross section view

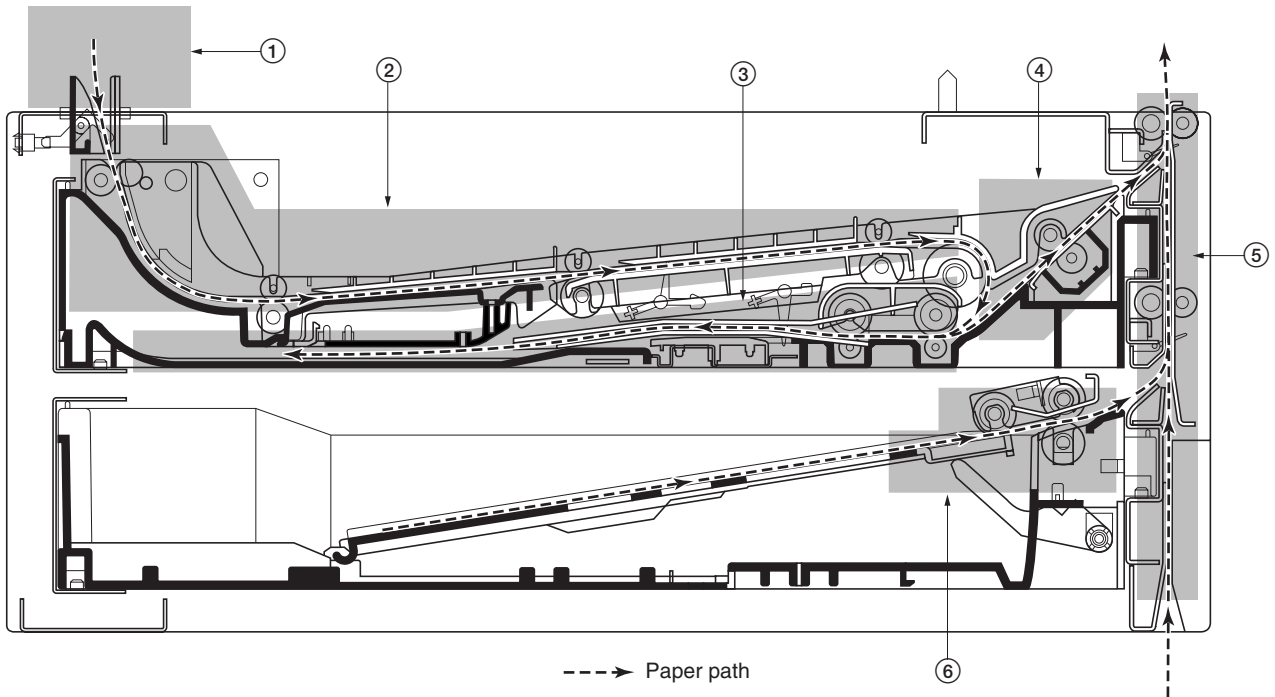

Figure 1-1-3 Cross section view

- ① Paper entrance section
- ② Paper feed section
- ③ Paper switch back section
- ④ Paper refeed section
- ⑤ Paper vertical conveying section
- ⑥ Paper cassette feed section

1-2-1 Installation environment

1. Temperature: 10 - 32.5°C/50 - 90.5°F

2. Humidity: 20 - 80 %RH

3. Installation location

- Avoid direct sunlight or bright lighting.
- Avoid extremes of temperature and humidity, abrupt ambient temperature changes, and hot or cold air directed onto the machine.
- Avoid dust and vibration.
- Choose a surface capable of supporting the weight of the machine.
- Place the machine on a level surface (maximum allowance inclination: 1°).
- Avoid air-borne substances that may adversely affect the machine or degrade the photoconductor, such as mercury, acidic or alkaline vapors, inorganic gasses, NOx, SOx gases, and chlorine-based organic solvents.
- Select a room with good ventilation.

4. Allow sufficient access for proper operation and maintenance of the machine.

Machine front: 600 mm/23⁵/₈" Machine rear: 300 mm/11¹³/₁₆"

Machine right: 500 mm/19¹¹/₁₆" Machine left: 500 mm/19¹¹/₁₆"

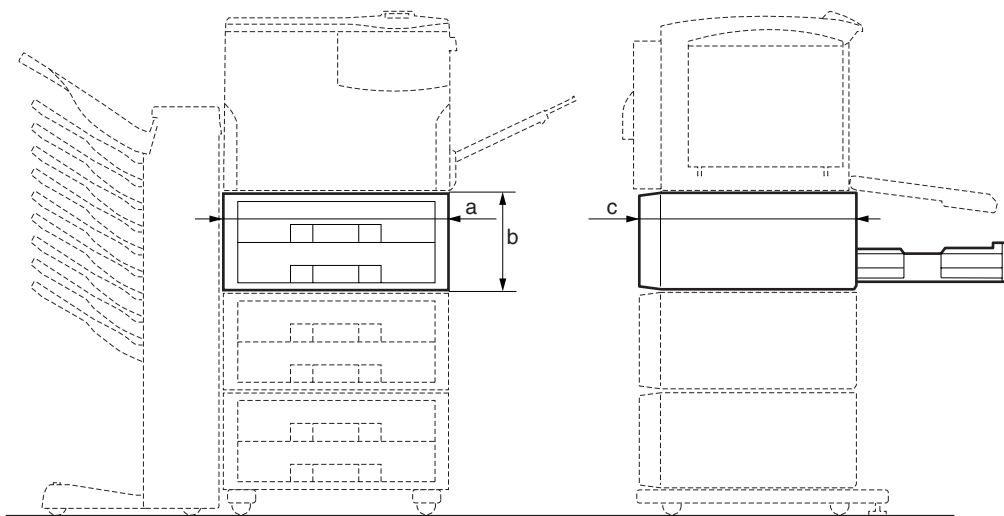

a: 590 mm/23¹/₄"
 b: 585 mm/23⁵/₁₆"
 c: 680 mm/26³/₄"

Figure 1-2-1 Installation dimensions

This page is intentionally left blank.

1-3-1 Unpacking and installation

(1) Installation procedure

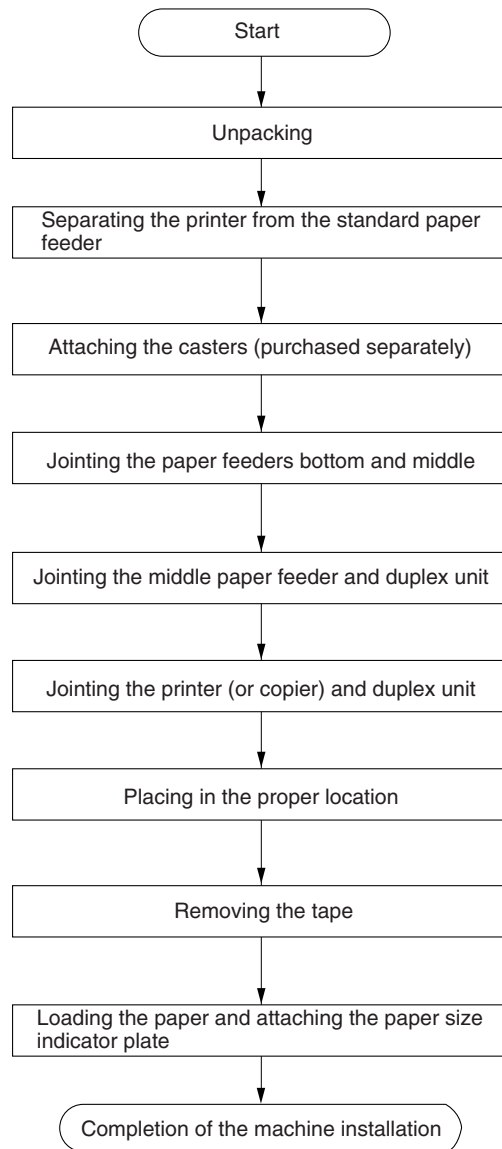

Unpacking

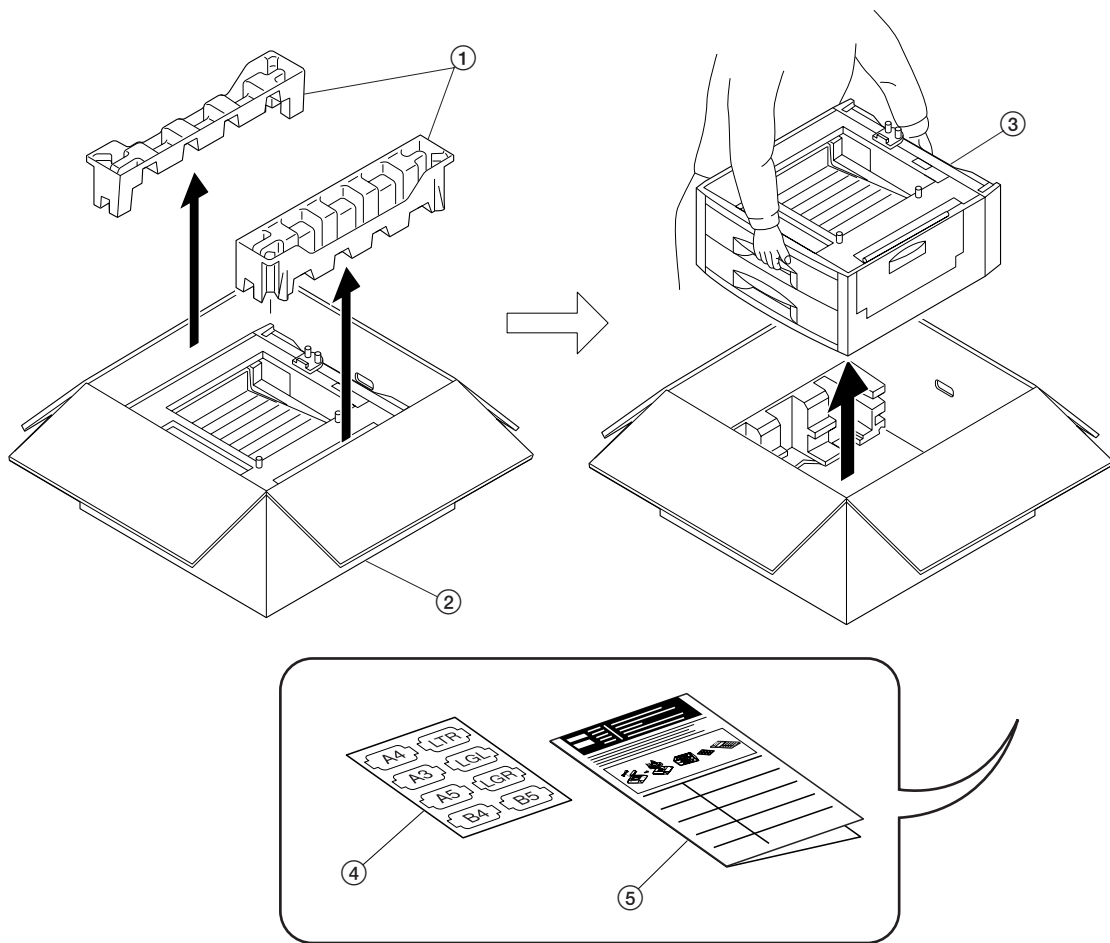

Figure 1-3-1 Unpacking the duplex unit

- ① Pads
- ② Packing case
- ③ Duplex unit
- ④ Paper size indicator plate
- ⑤ Installation guide

Warning:

The duplex unit weighs approximately 21 kg/46.3 lbs.

This procedure is Installation method for the printer to adding optional a duplex unit and a paper feeder.

Separating the printer from the standard paper feeder

1. Remove the screw and then remove the joint jig.

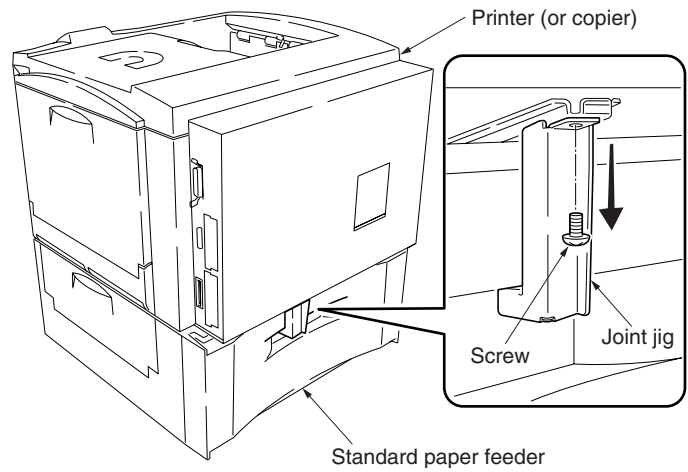

Figure 1-3-2

2. Separate the printer from the paper feeder.

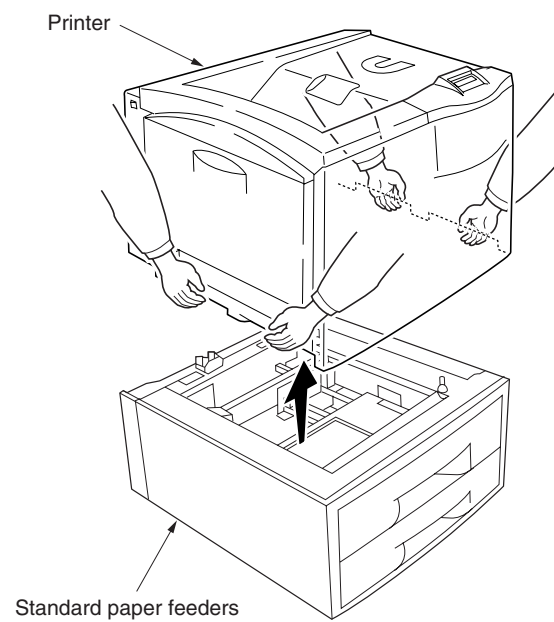

Figure 1-3-3

Attaching the casters (purchased separately)

Caution

To prevent the printer from tipping over because of weight in the printer and the upper paper drawers, the caster kit must be installed at the bottom-most paper feeder, when an optional paper feeder or duplex unit is installed with the printer.

Caution labels have been attached to the paper feeder or duplex unit.

1. Stand the paper feeder with the rear side on the floor.
2. Remove each one screw to remove four feet.
3. Install two optional caster bases onto the bottom of the paper feeder by using four screws for each. Be sure to face the longer end towards the front of the paper feeder.

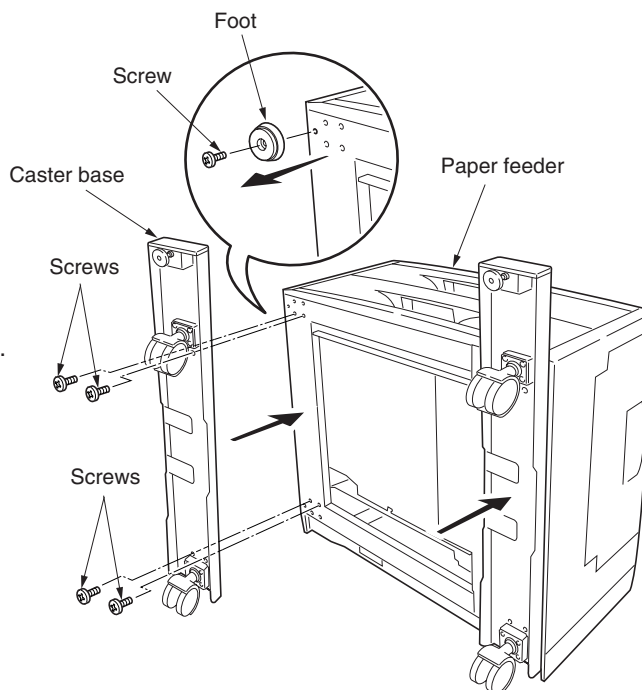

Figure 1-3-4

Joining the paper feeders bottom and middle

1. Stack the middle paper feeder on the bottom paper feeder.
2. Using the topple-resistant bracket (supplied with the caster kit), stack and joint the bottom and middle paper feeder.

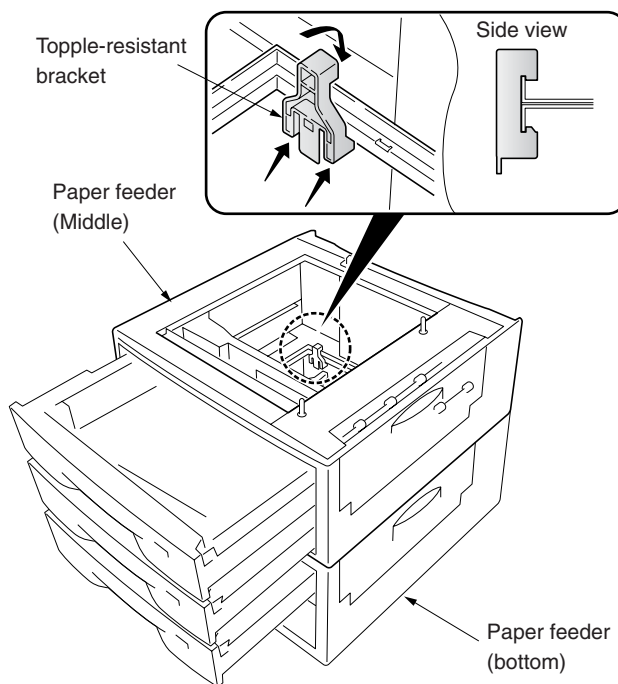

Figure 1-3-5

Joining the middle paper feeder and duplex unit

1. Using the topple-resistant bracket (supplied with the caster kit), stack and joint the middle and duplex unit.

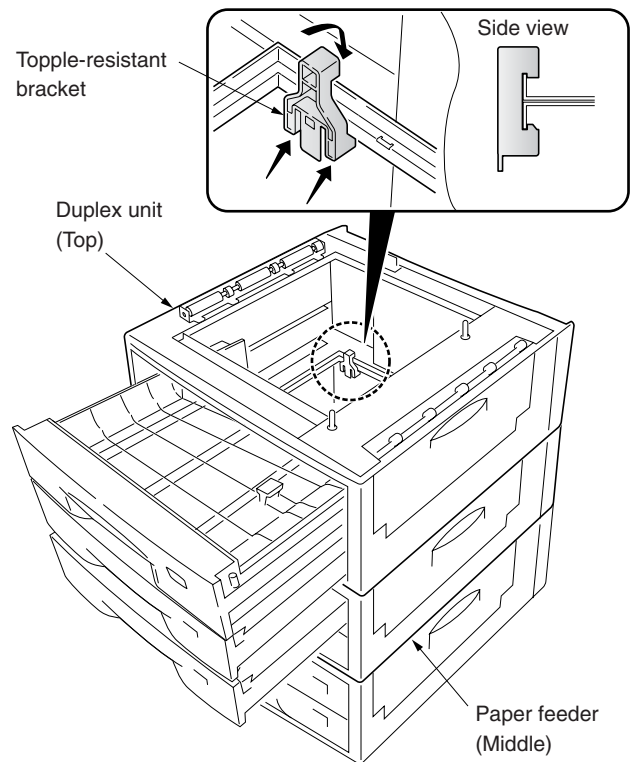

Figure 1-3-6

Joining the printer (or copier) and duplex unit

1. Place the printer (or copier) over the duplex unit (by at more than two persons).
2. Joint the printer (or copier) and duplex unit with the joint jig.

Warning:

Lift the printer (or copier) by at more than two persons. The printer weighs 76 kg/197.96 lbs. (The copier weighs 95.5 kg/211 lbs.)

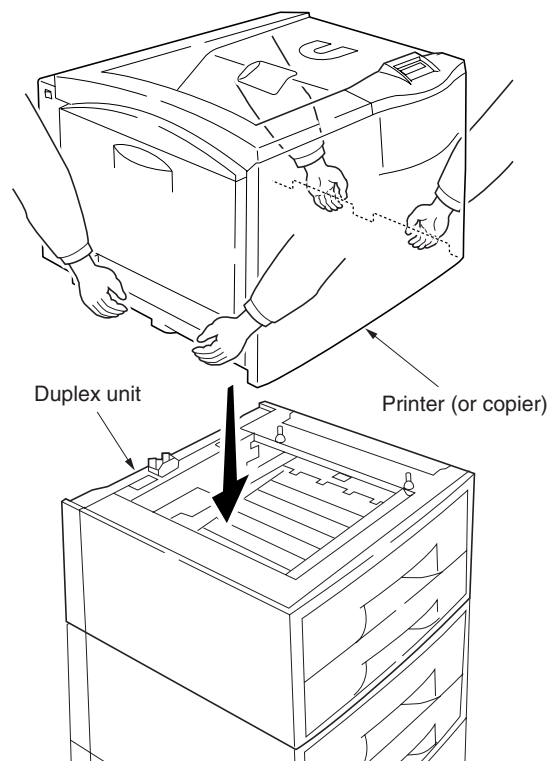

Figure 1-3-7

3. Joint the printer (or copier) and duplex unit with the joint jig.

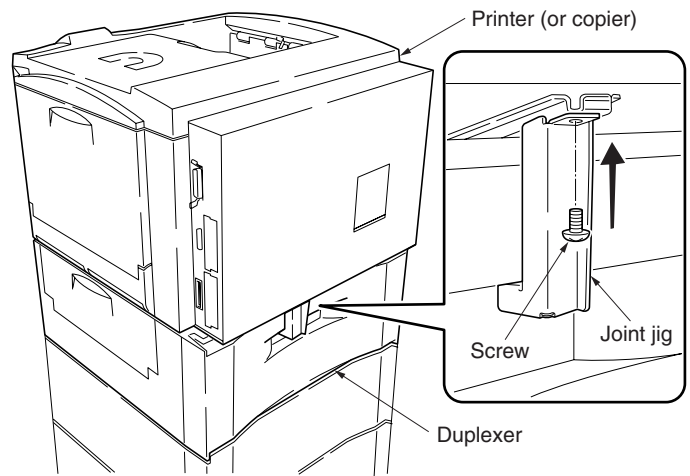

Figure 1-3-8

Placing in the proper location

1. Place the machine in a proper location.
2. Lock the stopper for each caster and turn the height adjusters bolts to fix the printer in place.

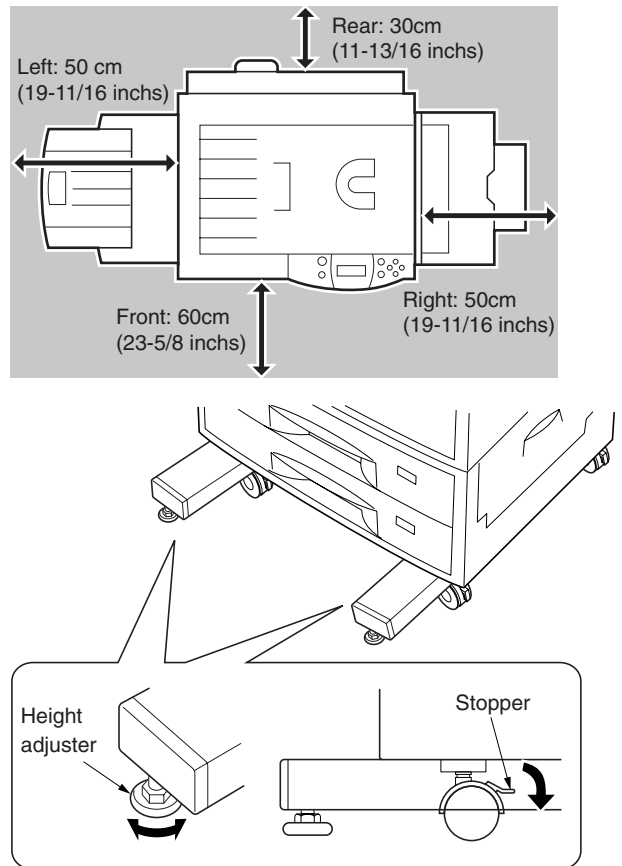

Figure 1-3-9

Removing the tape

1. Draw the paper cassette and then remove the transportation tape.

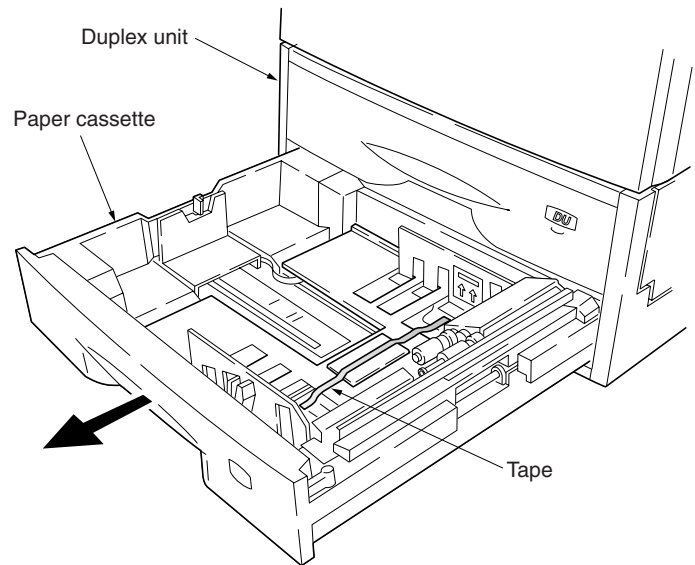

Figure 1-3-10

Loading the paper and attaching the paper size indicator plate

1. Load paper in the paper cassette.
2. Attach the paper size indicator plate.

* When the duplex unit is used with a copier, a paper feeding test and image alignments including center registration, etc., must be performed following the setup procedure. For details on these procedures, refer to the applicable copier service manual.

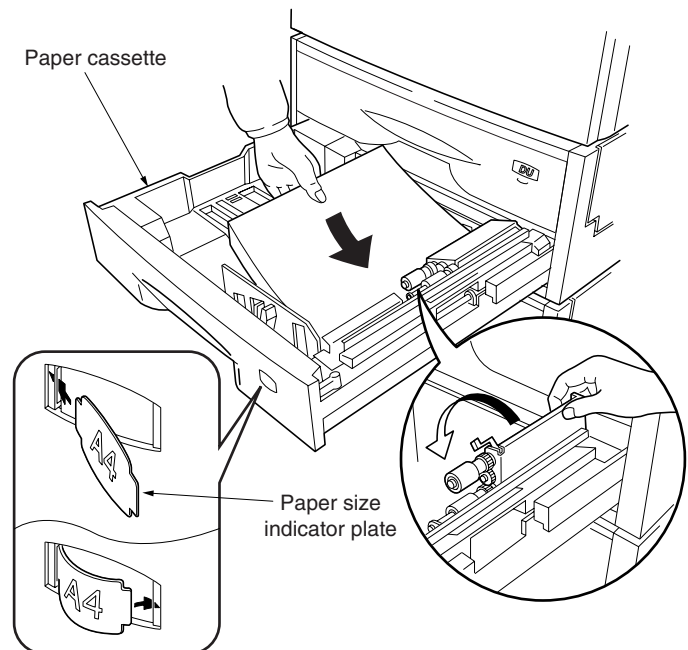

Figure 1-3-11

Completion of the machine installation

This page is intentionally left blank.

1-4-1 Paper misfeed detection

(1) Paper misfeed indication

When a paper misfeed occurs in the duplex unit, the printer/copier displays the jam on the operation panel and duplex unit indicates by fast flashing of the LED indicators. To remove paper jammed in the duplexer, open the duplex unit side cover, paper cassette, duplexer. Paper misfeed detection can be reset by opening and closing the them.

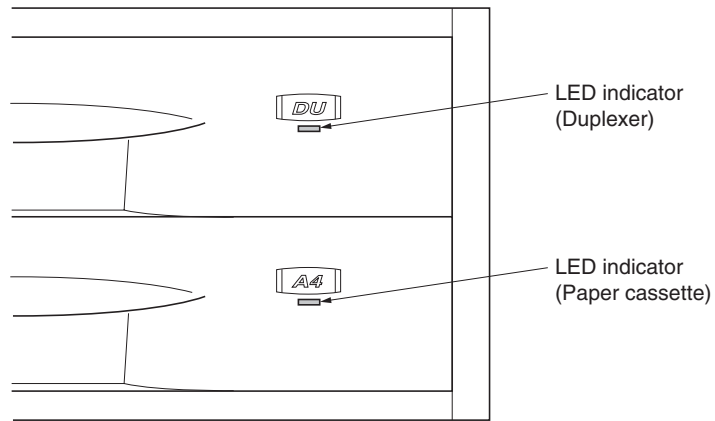

Figure 1-4-1 Paper misfeed indication

(2) Paper misfeed detection sensors

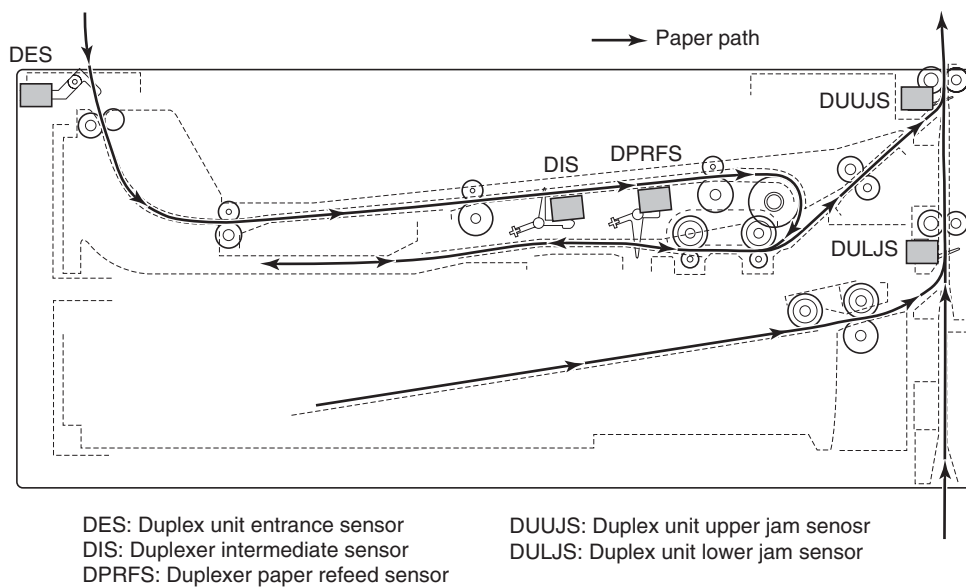

Figure 1-4-2 Paper misfeed detection sensors

1-4-2 Self-diagnosis

(1) Self-diagnostic function

This printer/copier is equipped with a self-diagnostic function. When a problem is detected, printing is disabled. The problem is displayed as a code consisting of digits number followed by a number 0460, 1020 or 1210, indicating the nature of the problem. A message is also displayed requesting the user to call for service.

Self diagnostic codes

Code	Contents	Remarks	
		Causes	Check procedures/corrective measures
0460	Communication error between printer and duplex unit <ul style="list-style-type: none"> Engine controller PWB of the printer/copier does not communicate with the duplex unit normally. 	Defective duplex unit PWB (KP-834).	Replace the duplex unit PWB (KP-834). See page 1-5-2.
		Defective connection printer/copier and duplex unit.	Reinstall duplex unit. See page 1-3-1.
		Defective printer/copier, engine controller PWB, harness, paper feeder/options relay PWB, etc.	See printer's/copier's service manual.
1020	Overcurrent detection of bottom plate elevation motor <ul style="list-style-type: none"> Excessive current has flowed through the cassette base motor which elevates the bottom plate in the cassette when the paper cassette is installed in the duplex unit. 	Defective bottom plate elevation motor.	Replace the bottom plate elevation motor. See page 1-5-3.
		Defective bottom plate elevation mechanism of paper cassette.	Check whether there is an object that prevents the bottom plate of paper cassette from operating normally.
		Defective duplex unit PWB (KP-834).	Replace the duplex unit PWB (KP-834). See page 1-5-2.
		Defective engine controller PWB of the printer/copier.	Replace the engine controller PWB. See printer's/copier's service manual.
1210	Side registration home position sensor detection error <ul style="list-style-type: none"> The side registration home position sensor does not detect home position of paper guides in the switchback section. 	Defective side registration home position sensor.	Replace the side registration home position sensor. See page 1-5-15.
		Defective side registration motor.	Replace the side registration motor. See page 1-5-10.
		Defective duplex unit PWB (KP-834).	Replace the duplex unit PWB (KP-834). See page 1-5-2.
		Defective engine controller PWB of the printer/copier.	Replace the engine controller PWB. See printer's/copier's service manual.

1-5-1 Precautions for assembly and disassembly

(1) Precautions

- Be sure to turn the printer's/copier's power switch off and disconnect the power plug before starting disassembly. The power plug must not be unplugged from power at least 30 minutes since the printer/copier is switched off. In case the power plug must be unplugged just after power off for service purpose, pull out the paper feed unit so that the fuser unit is away from developers to avoid toner lumping due to heat from the fuser unit.
- When handling PWBs (printed wiring boards), do not touch connectors with bare hands. It will damage the PWB.
- Do not touch any PWB containing ICs with bare hands or any object prone to static charge.

1-5-2 Duplex unit (frame)

(1) Detaching and refitting the duplex unit PWB

Follow the procedure below to replace the duplex unit PWB.

Procedure

1. Remove the four screws and then remove the duplex unit rear cover.

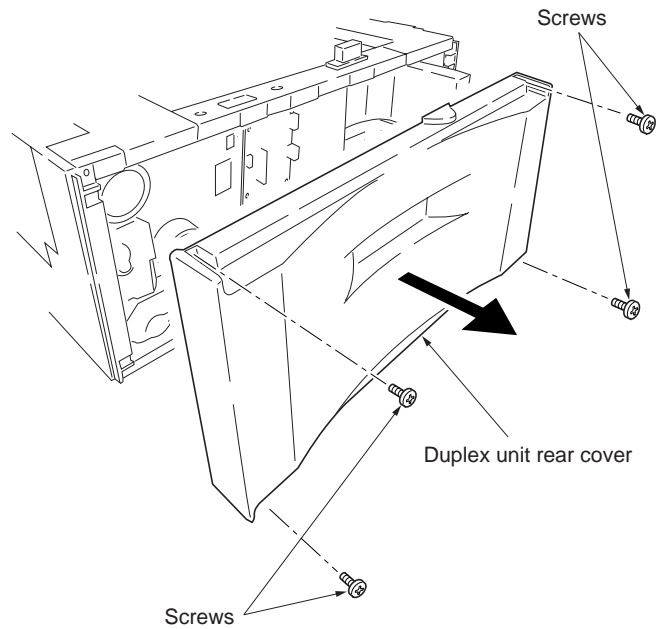

Figure 1-5-1

2. Remove the all (eleven) connectors from the duplex unit PWB.
3. Remove the five screws and then remove the duplex unit PWB.
4. Replace the duplex unit PWB and refit all the removed parts.

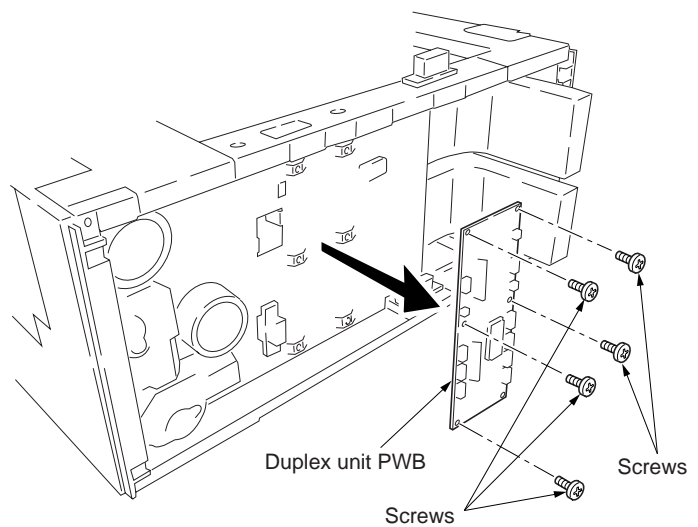

Figure 1-5-2

(2) Detaching and refitting the bottom plate elevation motor

Follow the procedure below to replace the bottom plate elevation motor.

Procedure

1. Remove the duplex unit rear cover (See previous page).
2. Remove the one connector.
3. Remove the two screws and then remove the bottom plate elevation motor and spacer.
4. Replace the bottom plate elevation motor and refit all the removed parts.

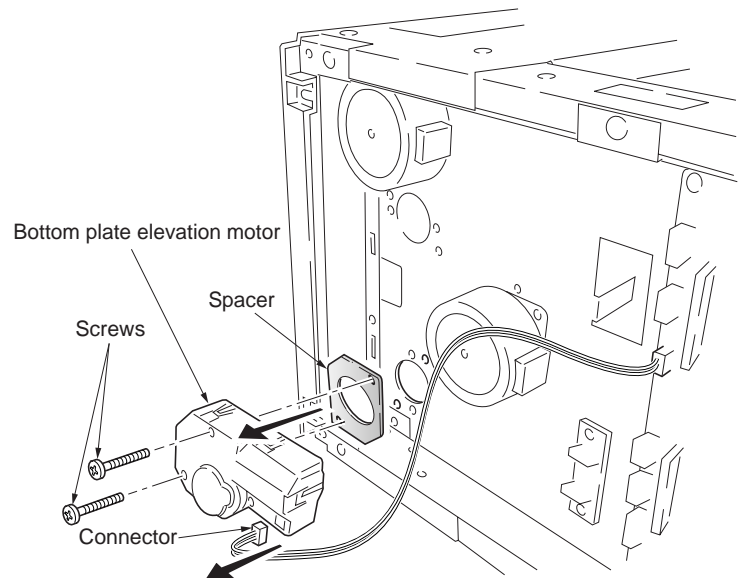

Figure 1-5-3

1-5-3 Duplexer

(1) Detaching and refitting the upper and lower decurlers

Follow the procedure below to replace the upper and lower decurlers.

Procedure

1. Remove the duplexer from the duplex unit.
2. Detach the linkage of tie rod from the lever.
3. Remove the five screws and the remove the duplexer front cover.

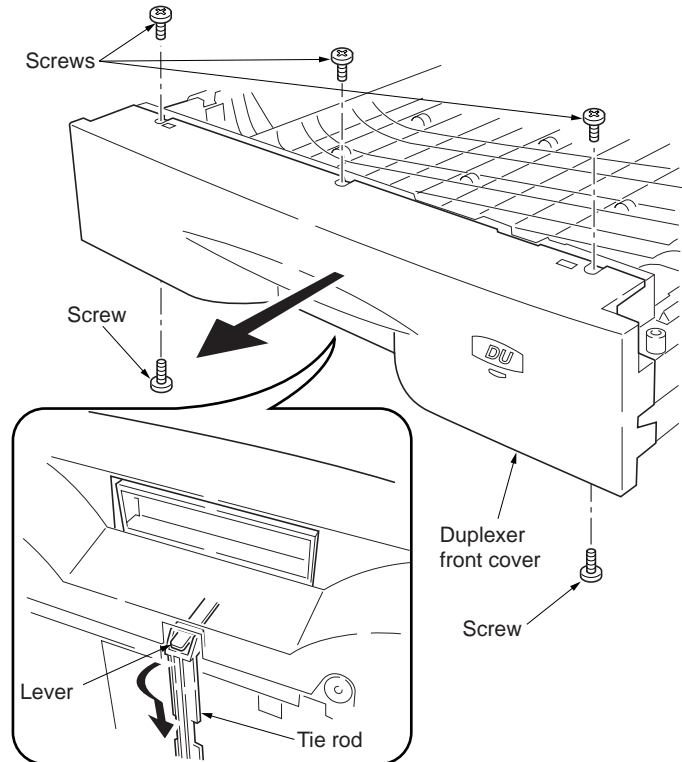

Figure 1-5-4

4. Remove the stopper ring and then remove the pulley B cover and the pulley P26.
5. Remove the two E-rings from the upper decurler.
6. While sliding the upper decurler back and forth and then remove the upper decurler with shim from the duplexer.
7. Remove the shim from the upper decurler.
8. Remove the lower decurler with bushes from the duplexer.
9. Remove the two bushes from the lower decurler.
10. Replace the upper and lower decurlers, and refit all the removed parts.

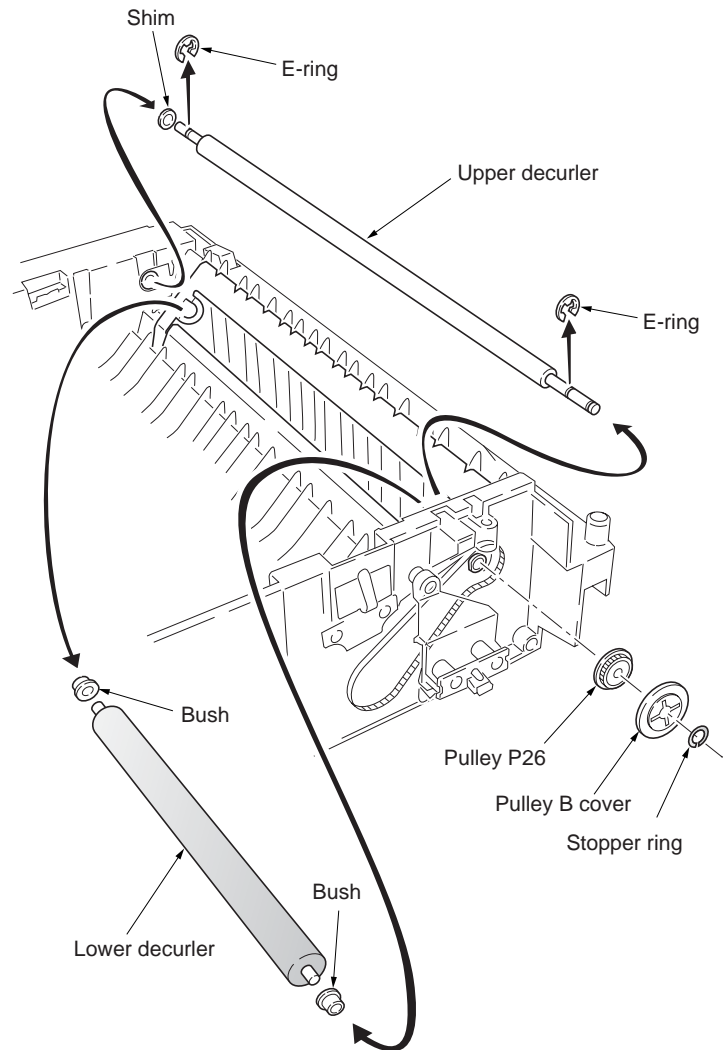

Figure 1-5-5

(2) Detaching and refitting the switchback rollers

Follow the procedure below to replace the switchback rollers.

Procedure

1. Remove the duplexer front cover (See page 1-5-4).
2. Remove the stopper ring and then remove the pulley cover and the pulley P52.

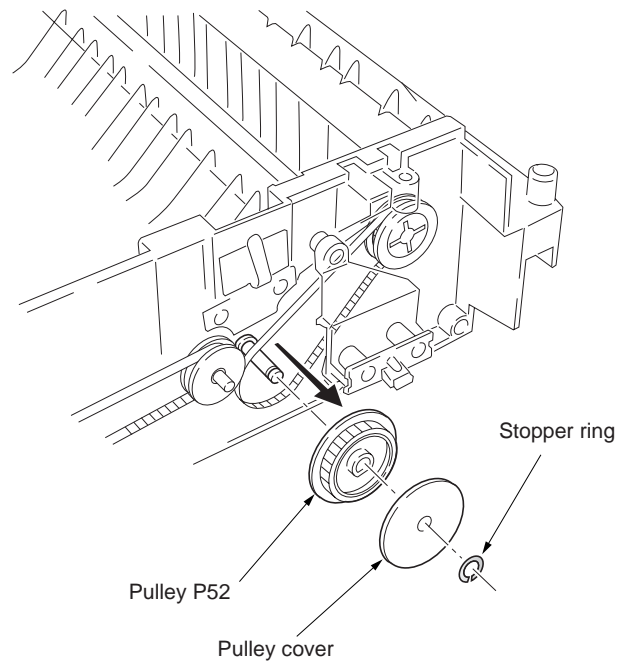

Figure 1-5-6

3. Remove the two screws and then remove the rear A cover.

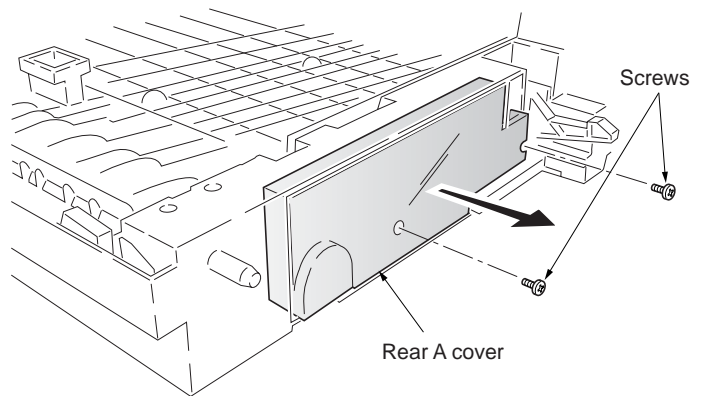

Figure 1-5-7

4. Remove the idle rollers from the duplexer.
5. Remove the E-ring and then remove the duplexer refeed clutch and the bush.
6. While sliding the switchback roller shaft back and forth and then remove the switchback roller assembly.

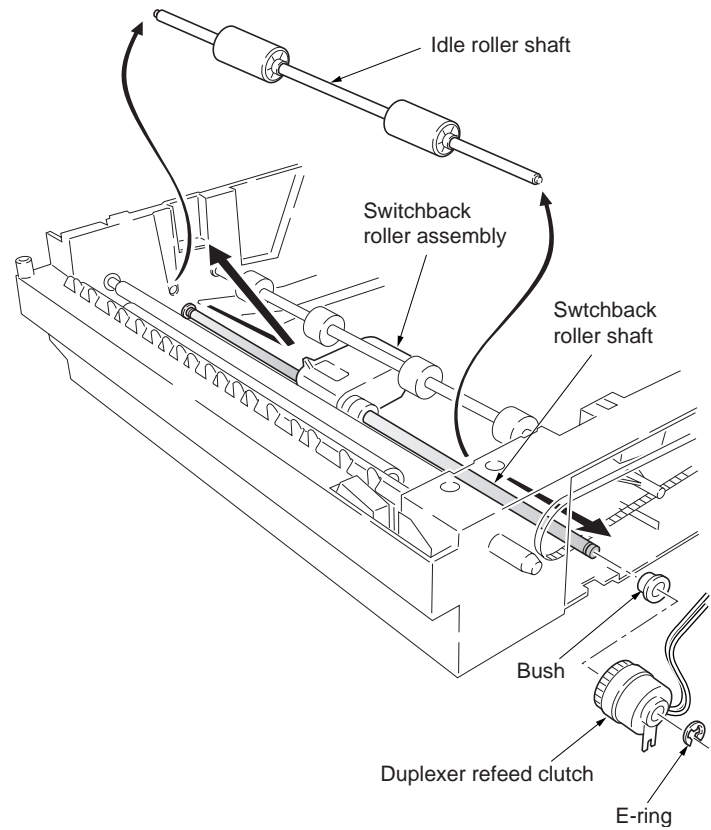

Figure 1-5-8

7. Remove the E-ring and then pull the switchback roller shaft out.
8. Remove the switchback rollers, gears, shaft, and belt from the bracket.
9. Replace the switchback rollers and refit all the removed parts.

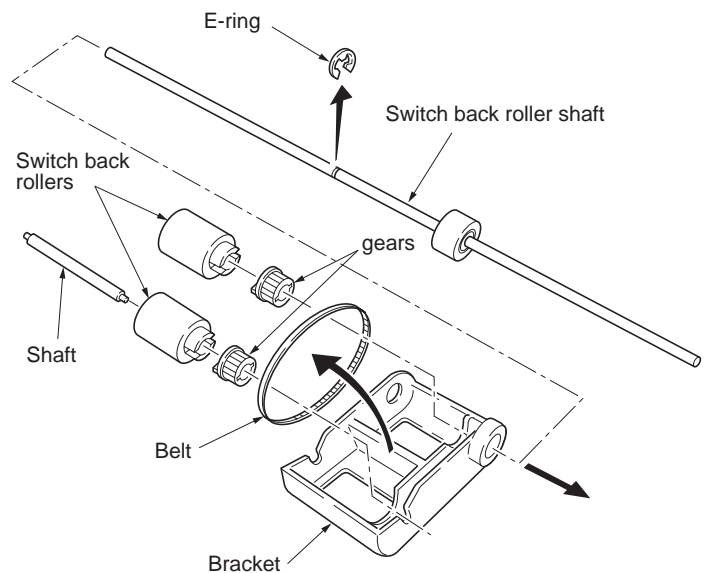

Figure 1-5-9

(3) Detaching and refitting the duplexer drive unit

Follow the procedure below to replace the duplexer drive unit.

Procedure

1. Remove the duplexer from the duplex unit.
2. Remove the three screws and then remove the rear B cover.

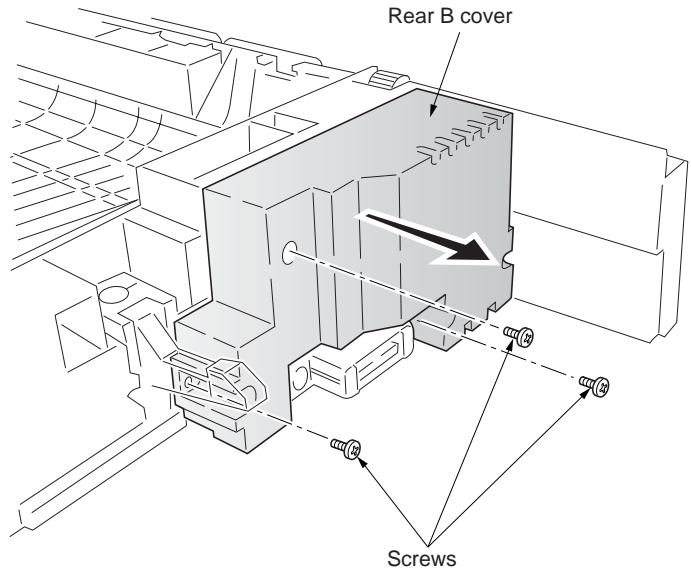

Figure 1-5-10

3. Remove the four screws from the duplexer drive unit.
4. Remove the one screw and the terminal.
5. Remove the two screws and then detach the duplexer drawer connector.

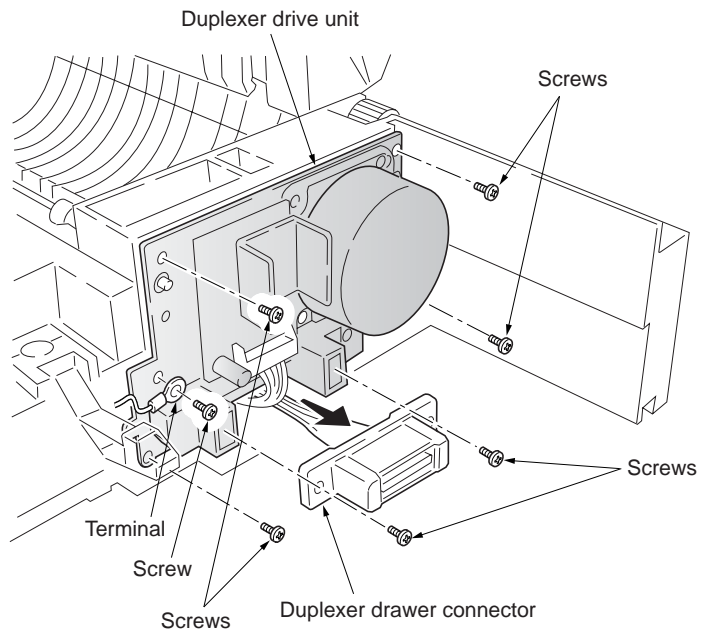

Figure 1-5-11

6. Remove the one connector and then remove the duplexer drive unit.
7. Replace the duplexer drive unit and refit all the removed parts.

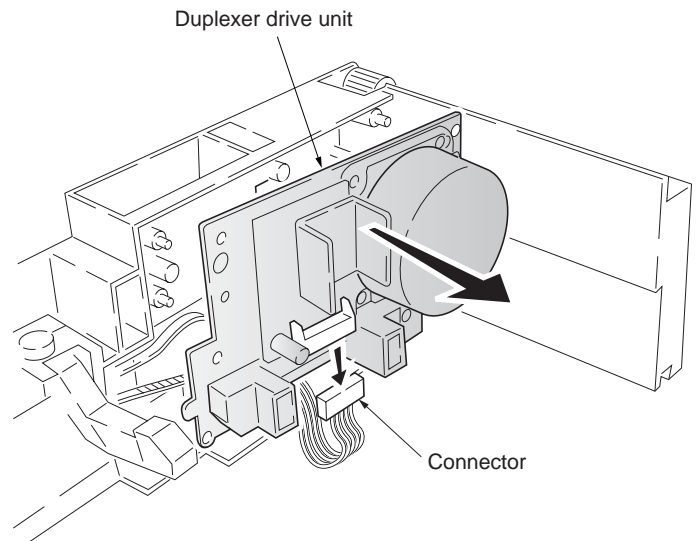

Figure 1-5-12

(4) Detaching and refitting the side registration motor

Follow the procedure below to replace the side registration motor.

Procedure

1. Remove the PWB cover (See page 1-5-14).
2. Remove the one connector (YC6) from the duplexer PWB.

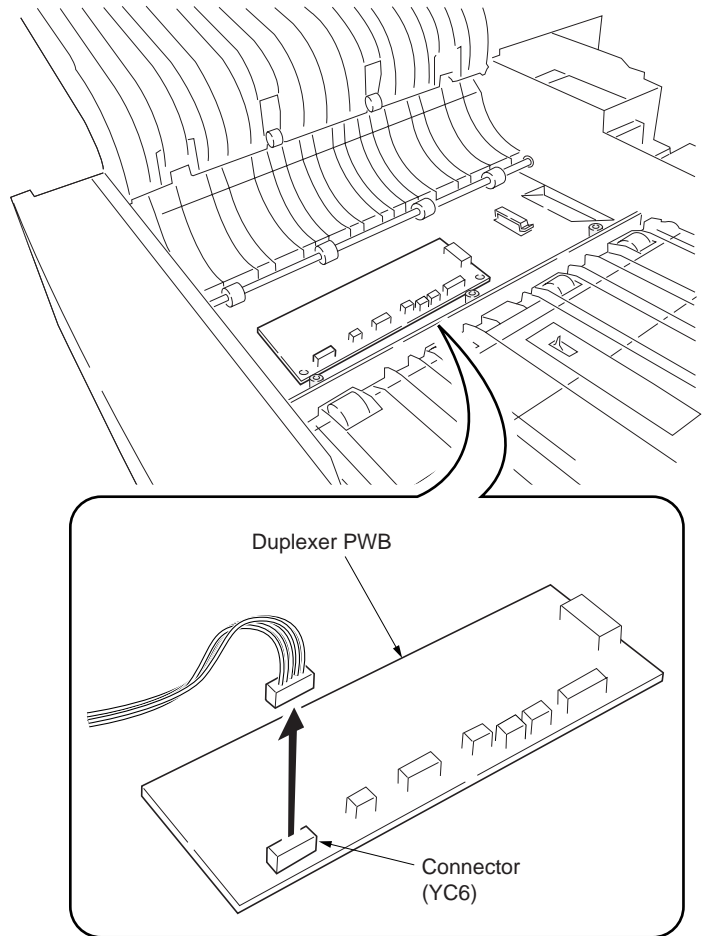

Figure 1-5-13

3. Remove duplexer front cover (See page 1-5-4).
4. Remove the harness from the harness holder.
5. Remove the two screws and then remove the motor bracket.
6. Remove the two screws and then remove the side registration motor.
7. Replace the side registration motor, and refit all the removed parts.

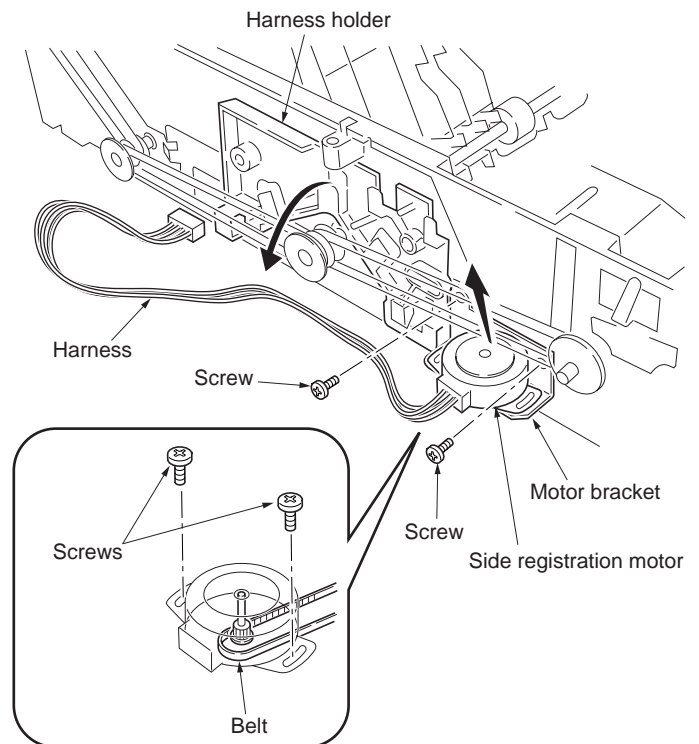

Figure 1-5-14

(5) Detaching and refitting the duplexer feed clutch

Follow the procedure below to replace the duplexer feed clutch.

Procedure

1. Remove the PWB cover (See page 1-5-14).
2. Remove the one connector (YC3) from the duplexer PWB.

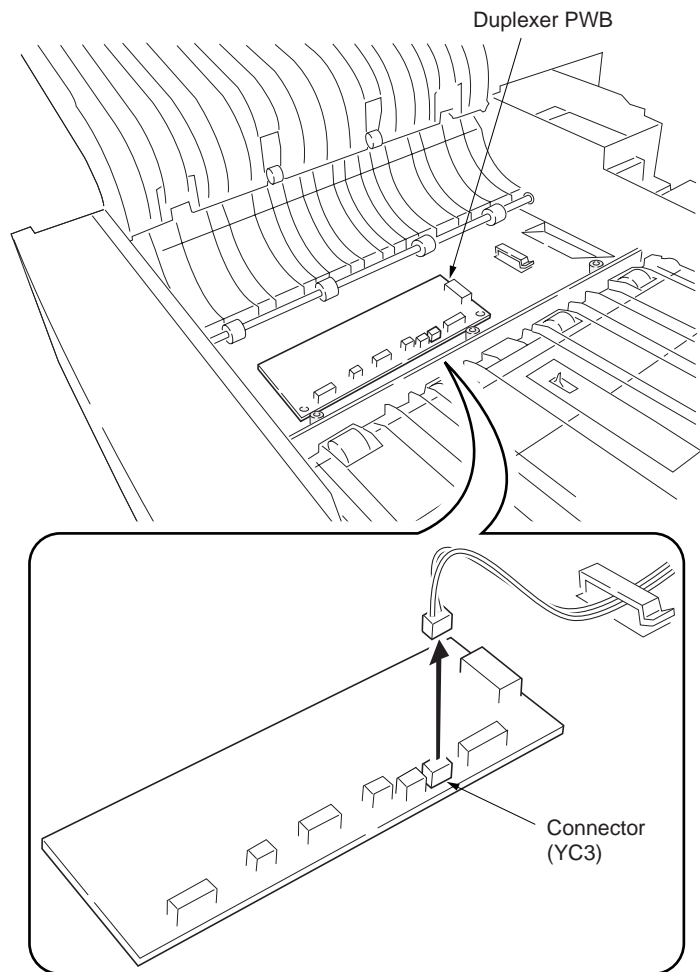

Figure 1-5-15

3. Remove the duplexer drive unit (See page 1-5-8).
4. Remove the duplexer feed clutch.
5. Replace the duplexer feed clutch and refit all the removed parts.

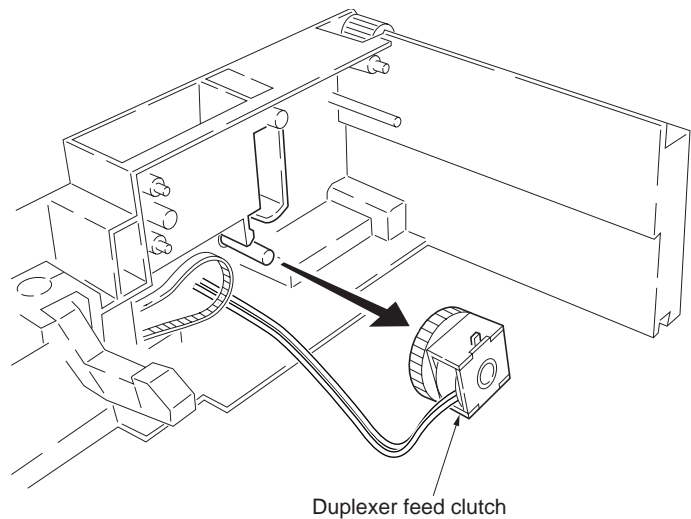

Figure 1-5-16

(6) Detaching and refitting the duplexer refeed clutch

Follow the procedure below to replace the duplexer refeed clutch.

Procedure

1. Remove the PWB cover (See page 1-5-14).
2. Remove the one connector (YC5) from the duplexer PWB.

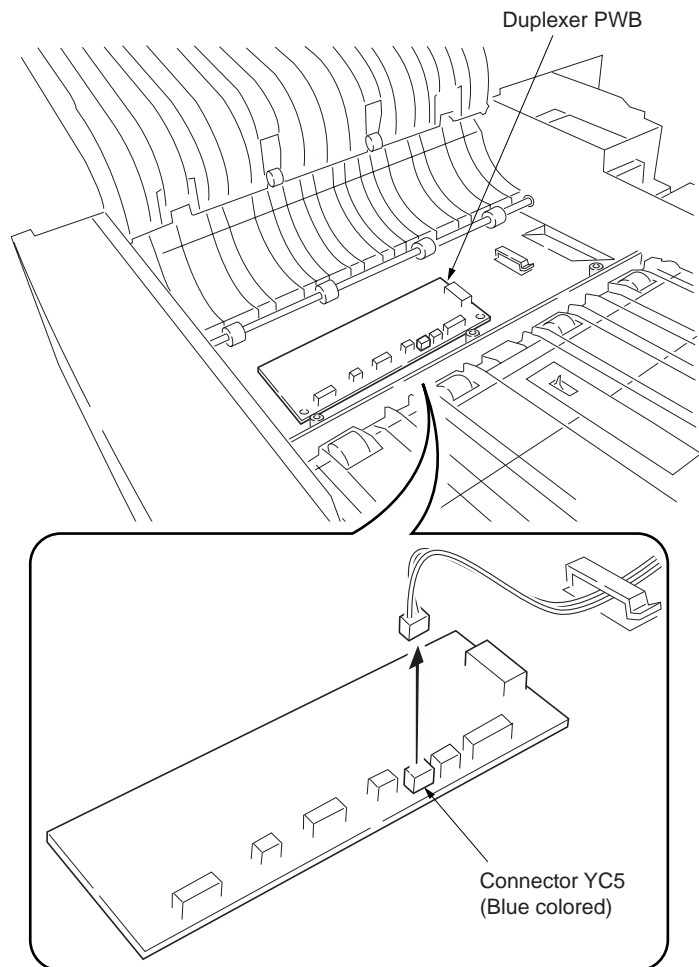

Figure 1-5-17

3. Remove the duplexer drive unit (See page 1-5-8).
4. Remove the rear A cover (See page 1-5-6).
5. Remove the E-ring and then remove the duplexer refeed clutch.
6. Remove the wires from the wire hooks and clamp.
7. Replace the duplexer refeed clutch and refit all the removed parts.

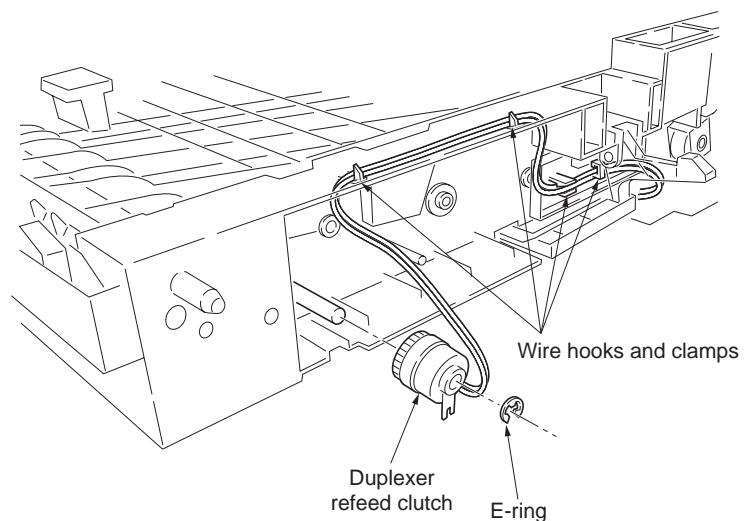

Figure 1-5-18

(7) Detaching and refitting the duplexer PWB

Follow the procedure below to replace the duplexer PWB.

Procedure

1. Remove the duplexer from the duplex unit.
2. Open the duplexer upper cover.
3. Remove the three screws and then remove the PWB cover.

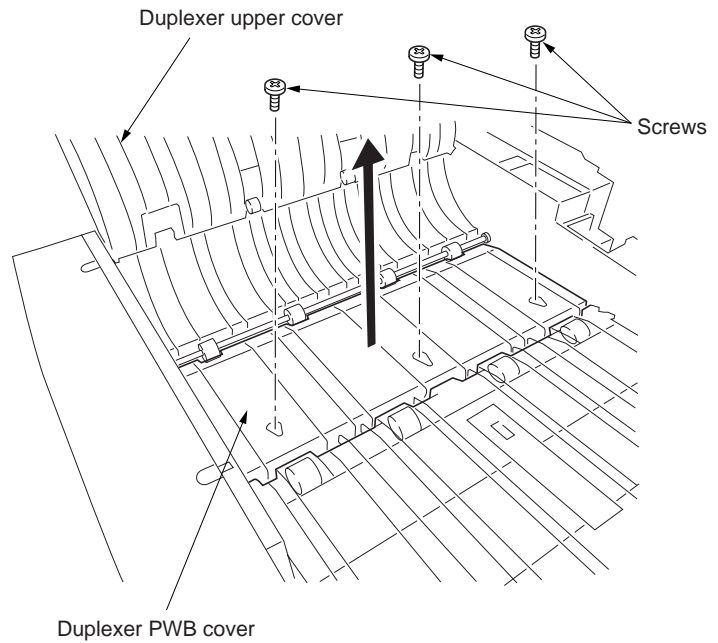

Figure 1-5-19

4. Remove the all (eight) connectors from the duplexer PWB.
5. Remove the two screws and terminals and then remove the duplexer PWB.
6. Replace the duplexer PWB and refit all the removed parts.

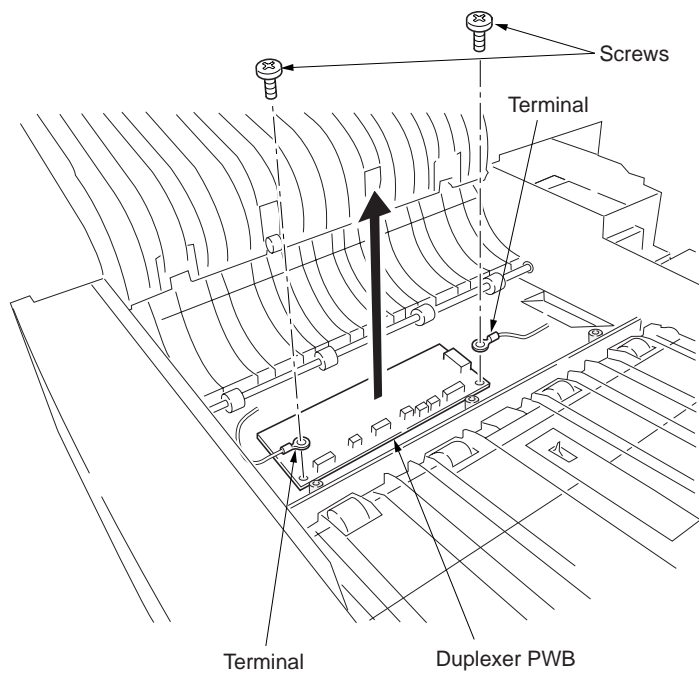

Figure 1-5-20

(8) Detaching and refitting the side registration home position sensor

Follow the procedure below to replace the duplexer side registration home position sensor.

Procedure

1. Remove duplexer front cover (See page 1-5-4).
2. Open the duplexer upper and lower covers.
3. Remove the all harness from the harness holder.
4. Remove the one screw and then remove the harness holder.

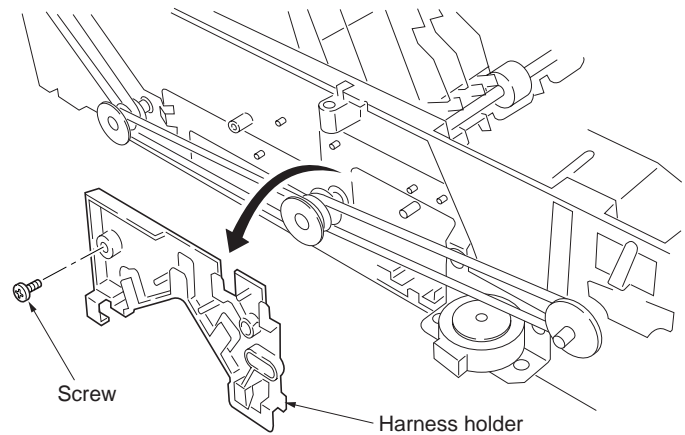
**Figure 1-5-21**

5. Remove the two screws and then remove the sensor cover.
6. Remove the one connector.
7. Remove the side registration home position sensor from the duplexer.
8. Replace the sensor and refit all the removed parts.

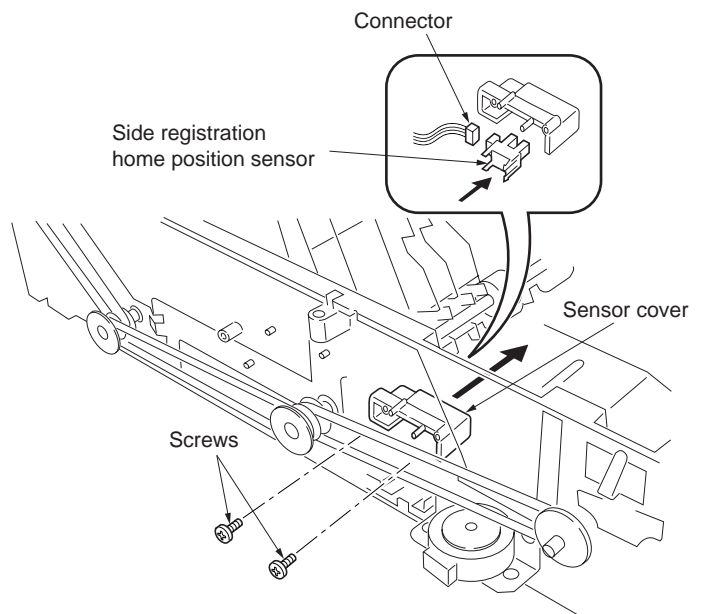
**Figure 1-5-22**

1-5-4 Paper cassette

(1) Detaching and refitting the feed roller and pickup roller

Follow the procedure below to replace the feed roller and pickup roller.

Procedure

1. Remove the paper cassette from the duplex unit.
2. Remove the three E-rings from the feed roller shaft and then detach the feed roller shaft from the bush.
3. Remove the feed roller from the feed roller shaft.
4. Remove the E-ring from the pickup roller shaft and then remove the pickup roller.
5. Replace the feed roller or pickup roller, and refit all the removed parts.

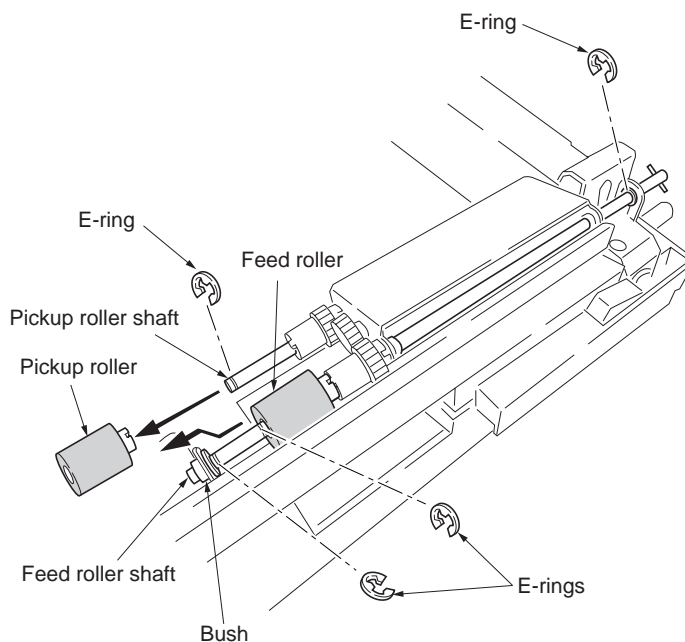

Figure 1-5-23

(2) Detaching and refitting the retard roller

Follow the procedure below to replace the retard roller.

Procedure

1. Remove the paper cassette from the duplex unit.
2. Remove the four screws and then remove the feed stay.
3. Remove the retard plate.
4. Remove the retard roller, shaft, bushes.
5. Replace the retard roller and refit all the removed parts.

Cautions:

- Use care not forget the retard springs lost.
- Be sure to fit the retard R spring (red-colored) on the front side of the retard roller.

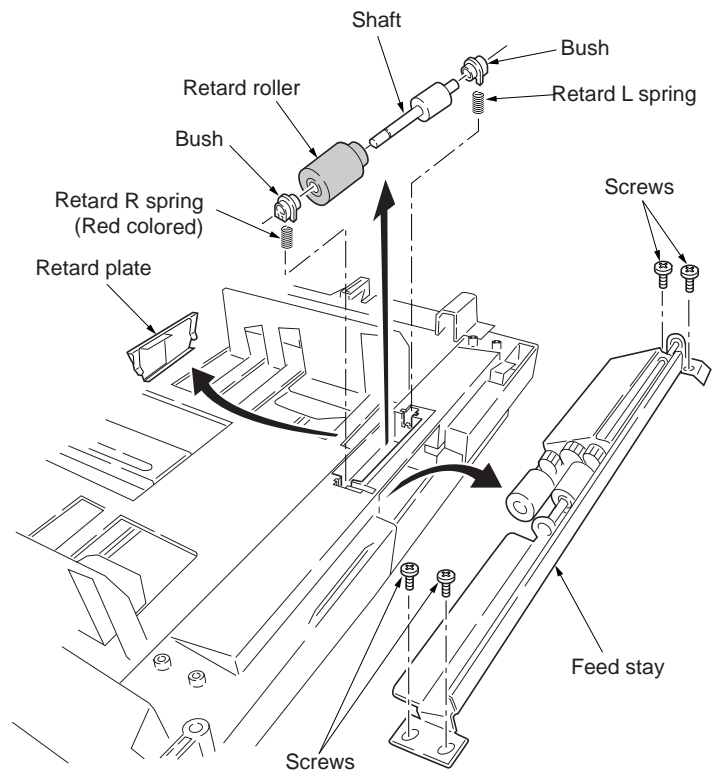

Figure 1-5-24

This page is intentionally left blank.

2-1-1 Duplex unit (frame)

(1) Paper entrance section

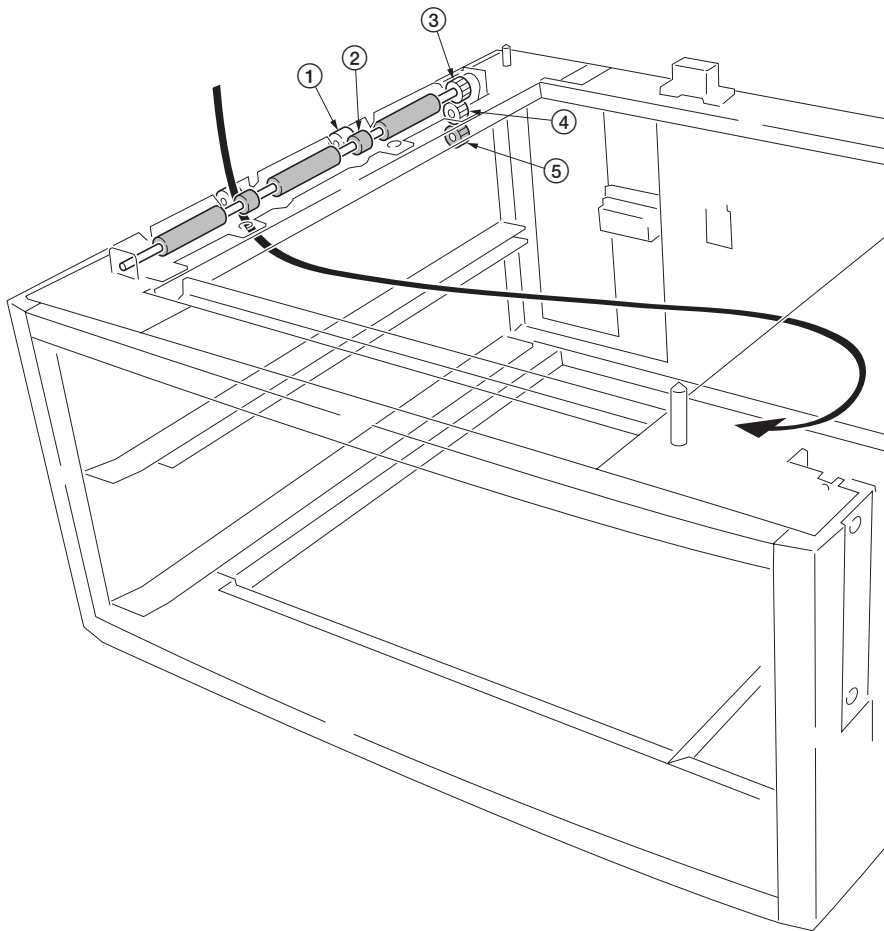

Figure 2-1-1 Paper entrance section

- ① Exit roller
- ② PD roller A
- ③ PD gear Z19S
- ④ PD gear Z19S
- ⑤ Feed gear Z25

(2) Paper refeed and vertical paper conveying section

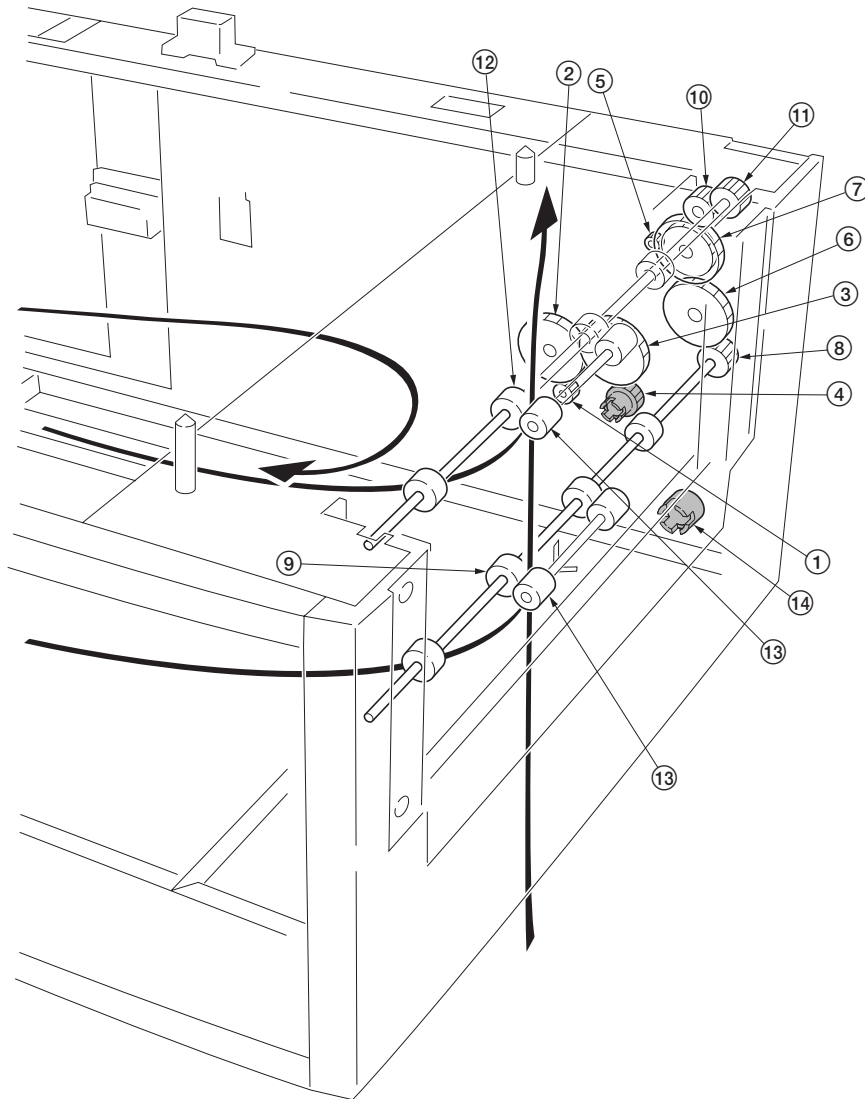
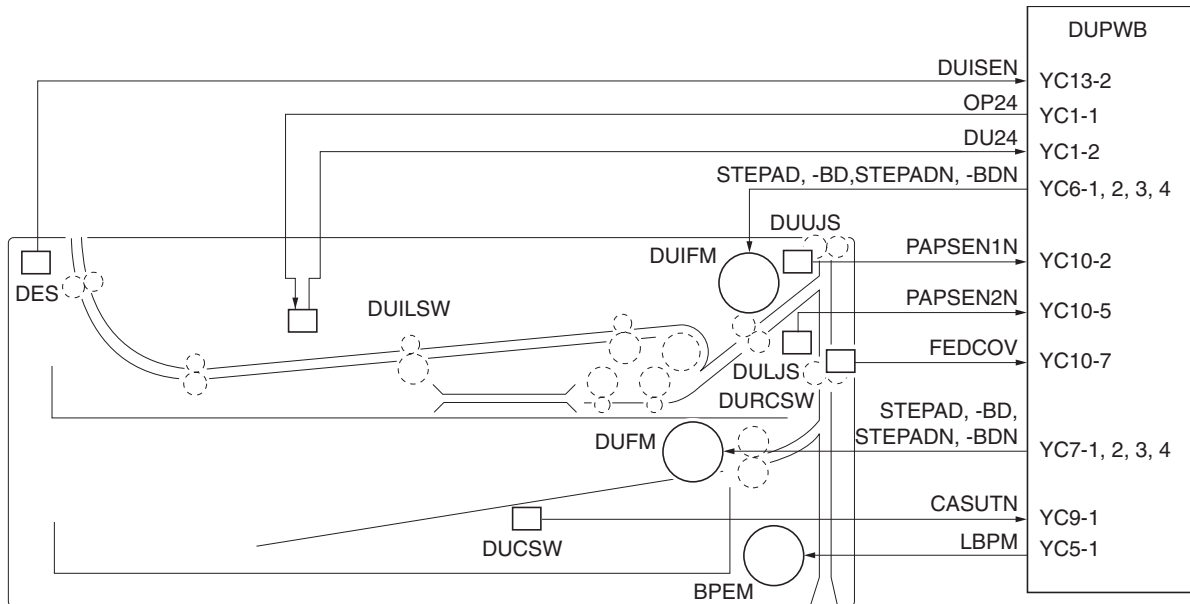

Figure 2-1-2 Paper refeed and vertical paper conveying section

- ① Duplex unit feed motor [gear] (DUFM)
- ② Gear free Z41S
- ③ Gear free Z39S
- ④ Feed gear Z24SJ
- ⑤ Duplex unit intermediate feed motor [gear] (DUIFM)
- ⑥ Gear Z37S
- ⑦ Gear Z36S-Z30S
- ⑧ NIP assembly gear [lower]
- ⑨ NIP feed roller [lower]
- ⑩ Feed gear Z23S
- ⑪ NIP assembly gear [upper]
- ⑫ NIP feed roller [upper]
- ⑬ Middle pulley(s)
- ⑭ Bottom plate elevation motor (BPEM)



DPWB: Duplex unit PWB [KP-834]
 DES: Duplex unit entrance sensor
 DUUJS: Duplex unit upper jam sensor
 DULJS: Duplex unit lower jam sensor
 DUILSW: Duplex unit interlock switch
 DUCSW: Duplex unit cassette switch
 DUIFM: Duplex unit intermediate feed motor
 DUFM: Duplex unit feed motor
 BPEM: Bottom plate elevation motor

Figure 2-1-3 Duplex unit (Frame) block diagram

2-1-2 Duplexer

(1) Paper feed section

The duplexer is upper part of the duplex unit. As duplex printing is commanded in the printer/copier, the page is delivered from the printer/copier to the duplexer at the duplex inlet, then to the paper feed section. The leading edge of the paper reaches under the paper feed section along the upper cover. Afterwards in the switchback section, the switchback roller forwards the paper until it is fully reversed in direction then stops. The paper guides, according to the printer/copier commands, compensates the possible skew of the paper depending on the paper size information signaled by the engine controller PWB in the printer/copier. Now the switchback roller revolves in the opposite direction to start feeding the paper (refeeding). The paper leaving the switchback section proceeds with the bottom guide in the duplexer and pinned by the upper and lower decurlers. This is required to counteract the curling effect caused by the rollers after the paper has cleared the fusing section. The decurlers are consisted of a sponge lower decurler with a large diameter and a metal decurler with a smaller diameter.

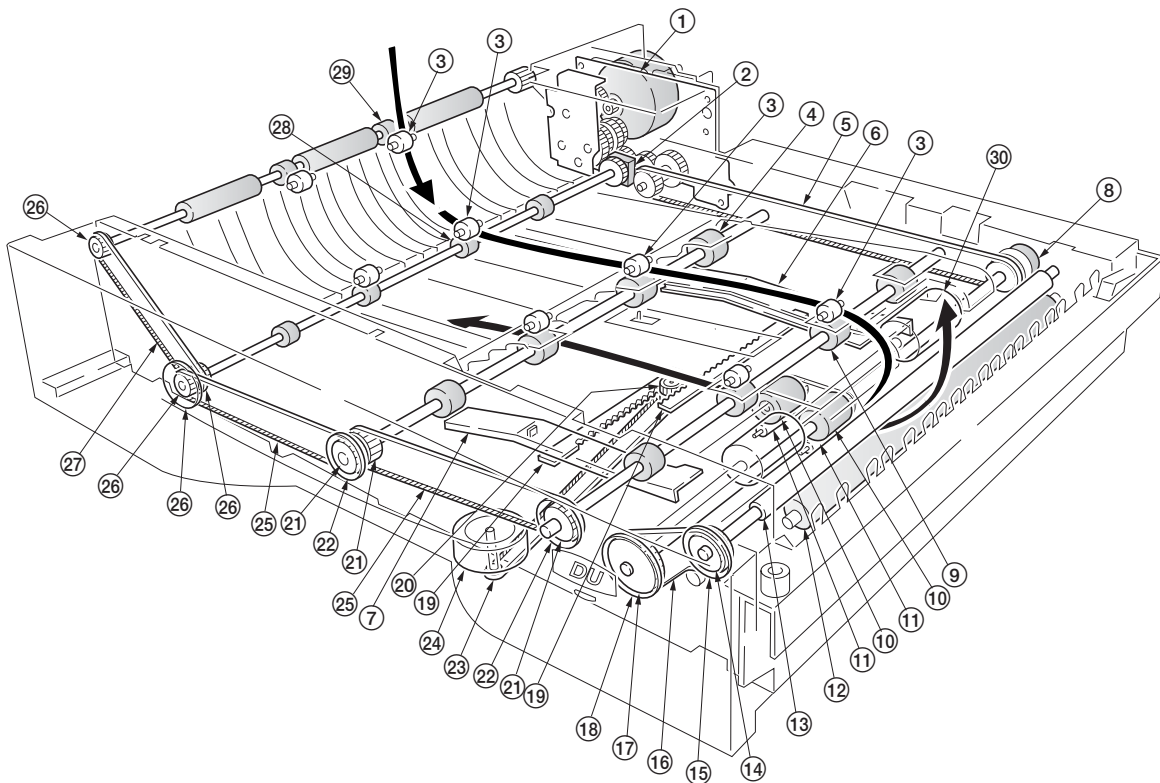
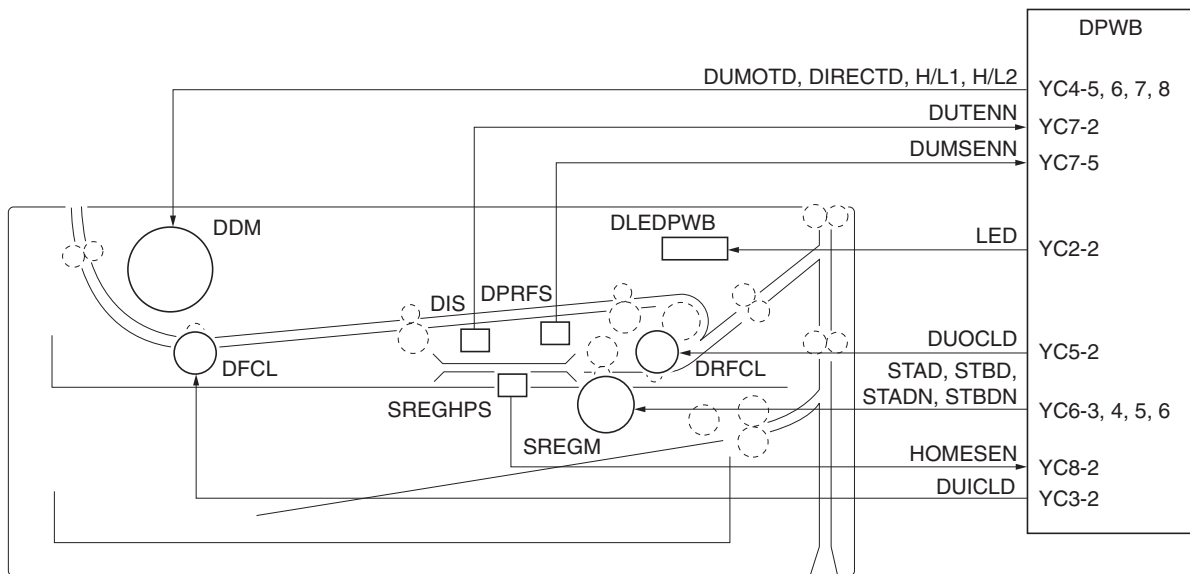

Figure 2-1-4 Duplexer

- | | |
|--|-----------------------------------|
| ① Duplexer drive unit (Duplexer drive motor) | ⑩ Switchback roller |
| ② Duplexer feed clutch | ⑪ Switchback idle roller |
| ③ PA Pulley(s) | ⑫ Lower decurler |
| ④ Middle feed roller (Shaft B) | ⑬ Upper decurler |
| ⑤ Belt S2M630 | ⑭ Pulley P26 |
| ⑥ Paper R guide | ⑮ Pulley B cover |
| ⑦ Paper L guide | ⑯ Belt S2M210 |
| ⑧ Duplexer refeed clutch (DRFCL) | ⑰ Pulley P52 |
| ⑨ Right feed roller (Shaft B) | ⑱ Pulley cover |
| | ⑲ DU rack(s) |
| | ⑳ Gear Z25-P36 |
| | ㉑ Pulley P24(s) |
| | ㉒ Pulley cover(s) |
| | ㉓ Belt S2M426 |
| | ㉔ Side registration motor (SREGM) |
| | ㉕ Belt S2M328 |
| | ㉖ Pulley P18 |
| | ㉗ Belt S2M240 |
| | ㉘ Left feed roller (Shaft guide) |
| | ㉙ PD roller |
| | ㉚ Idle roller(s) |



DLEDPWB: Duplexer LED PWB
 DPWB: Duplexer PWB [KP-836]
 DIS: Duplexer intermediate sensor
 DPRFS: Duplexer paper refeed sensor
 SREGHPS: Side registration home position sensor
 DDM: Duplex unit drive motor
 SREGM: Side registration motor
 DRFCL: Duplexer refeed clutch
 DFCL: Duplexer feed clutch

Figure 2-1-5 Duplexer circuit block diagram

2-1-3 Paper cassette

(1) Paper feed section

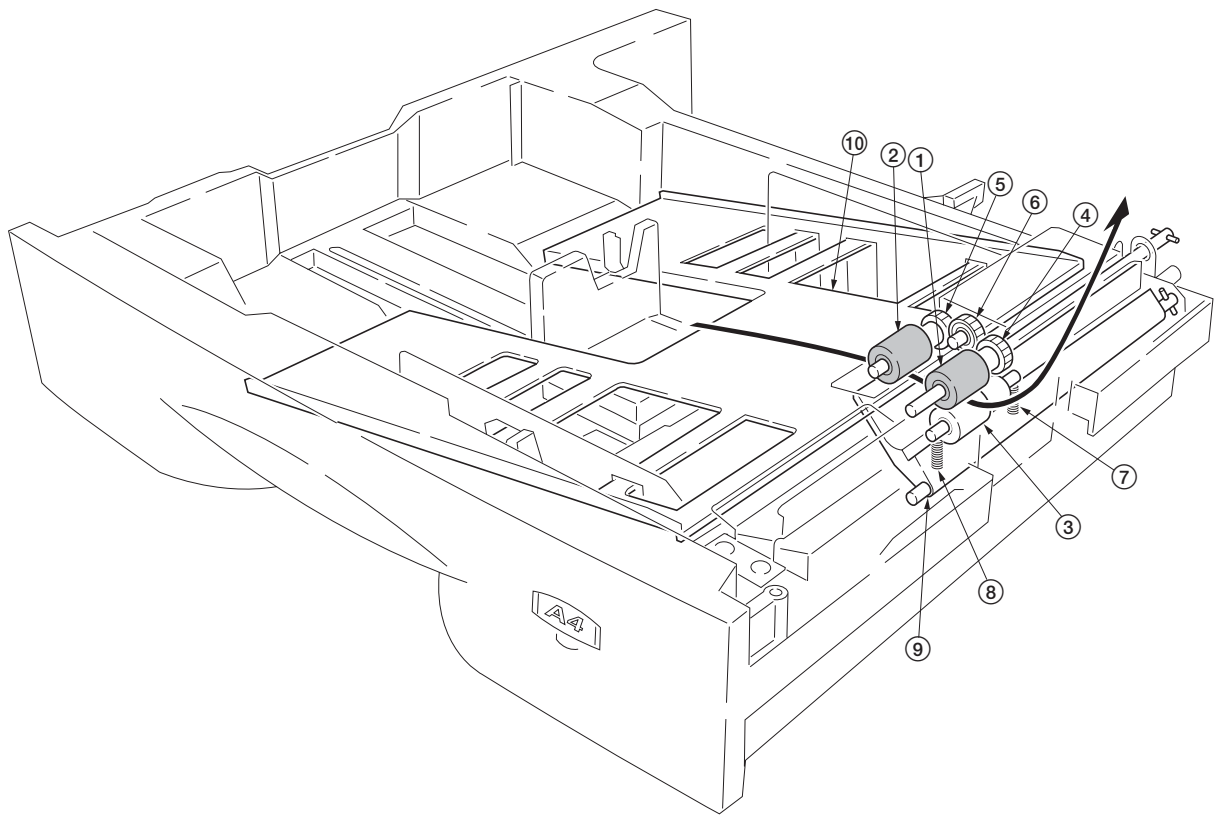
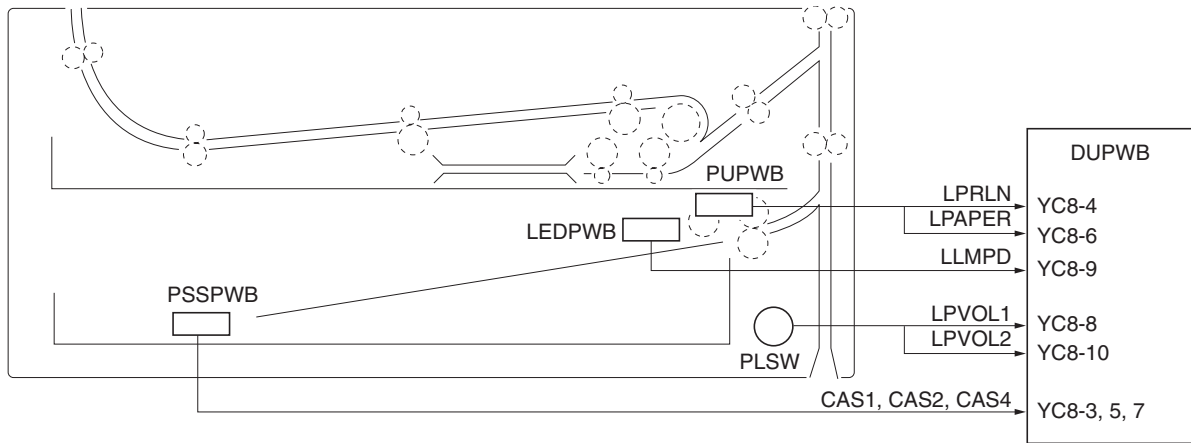

Figure 2-1-6 Paper cassette

- | | |
|-----------------|-----------------------------|
| ① Feed roller | ⑥ Gear Z35S |
| ② Pickup roller | ⑦ Retard R spring |
| ③ Retard roller | ⑧ Retard L spring |
| ④ Gear Z30 | ⑨ Bottom plate lift bracket |
| ⑤ Gear Z32 | ⑩ Bottom plate |



DUPWB: Duplexer unit PWB [KP-834]
 PUPWB: Pickup PWB [KP-583]
 PSSPW: Paper size sensor PWB [KP-581]
 LEDPWB: LED PWB [KP-585]
 PLSW: Paper size switch

Figure 2-1-7 Paper cassette circuit block diagram

(2) Paper size sensing

The size of the paper present in the currently selected cassette is acknowledged to the engine controller by means of the on-off status of sensors PT1, PT2, and PT3 located behind the paper stopper of the paper cassette. The table below summarizes on-off status of these sensors in accordance with the supported paper sizes.

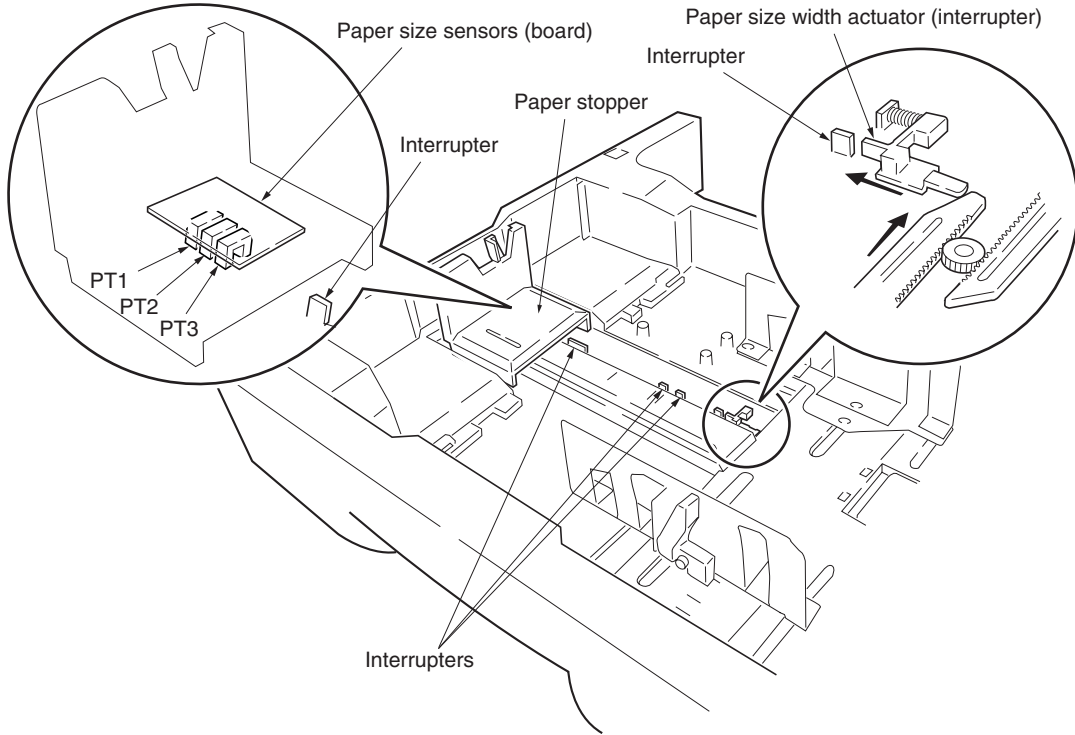

Figure 2-1-8 Paper size sensing

Table 2-1-1 Paper size sensors output levels

Paper size sensors			Paper size
PT1	PT2	PT3	
H	L	L	Ledger (portrait)
L	L	L	A3 (portrait)
H	H	H	B4 (portrait)
H	H	L	Legal (portrait)
H	L	H	B5 (portrait)
L	L	H	Letter (landscape)
L	H	L	A4/A5 (landscape)
L	H	H	-

(3) Paper gauge sensing

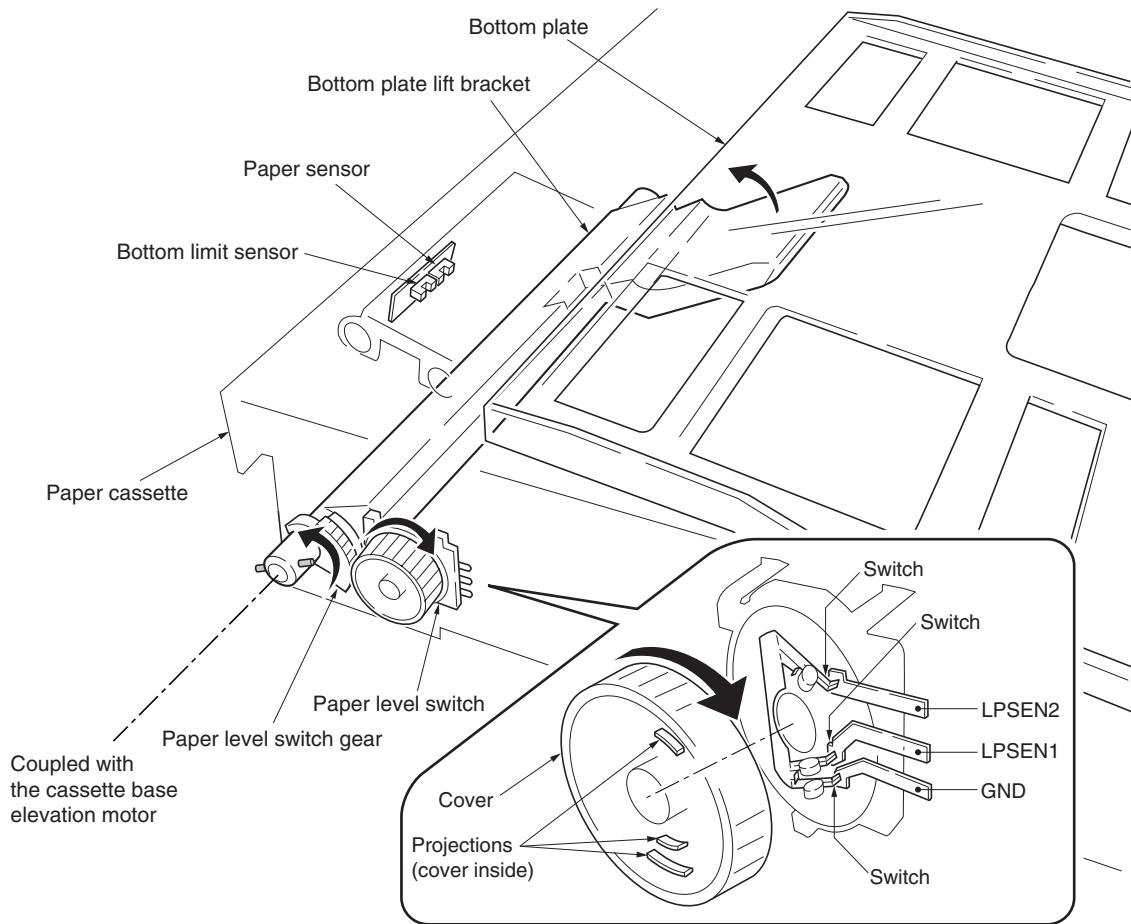

Figure 2-1-9 Paper gauge sensing hardware

The paper feeder has a facility which allows the network printing monitor software to display the amount of remaining paper in the paper cassettes on the client's display monitor.

This page is intentionally left blank.

2-2-1 Electrical parts layout

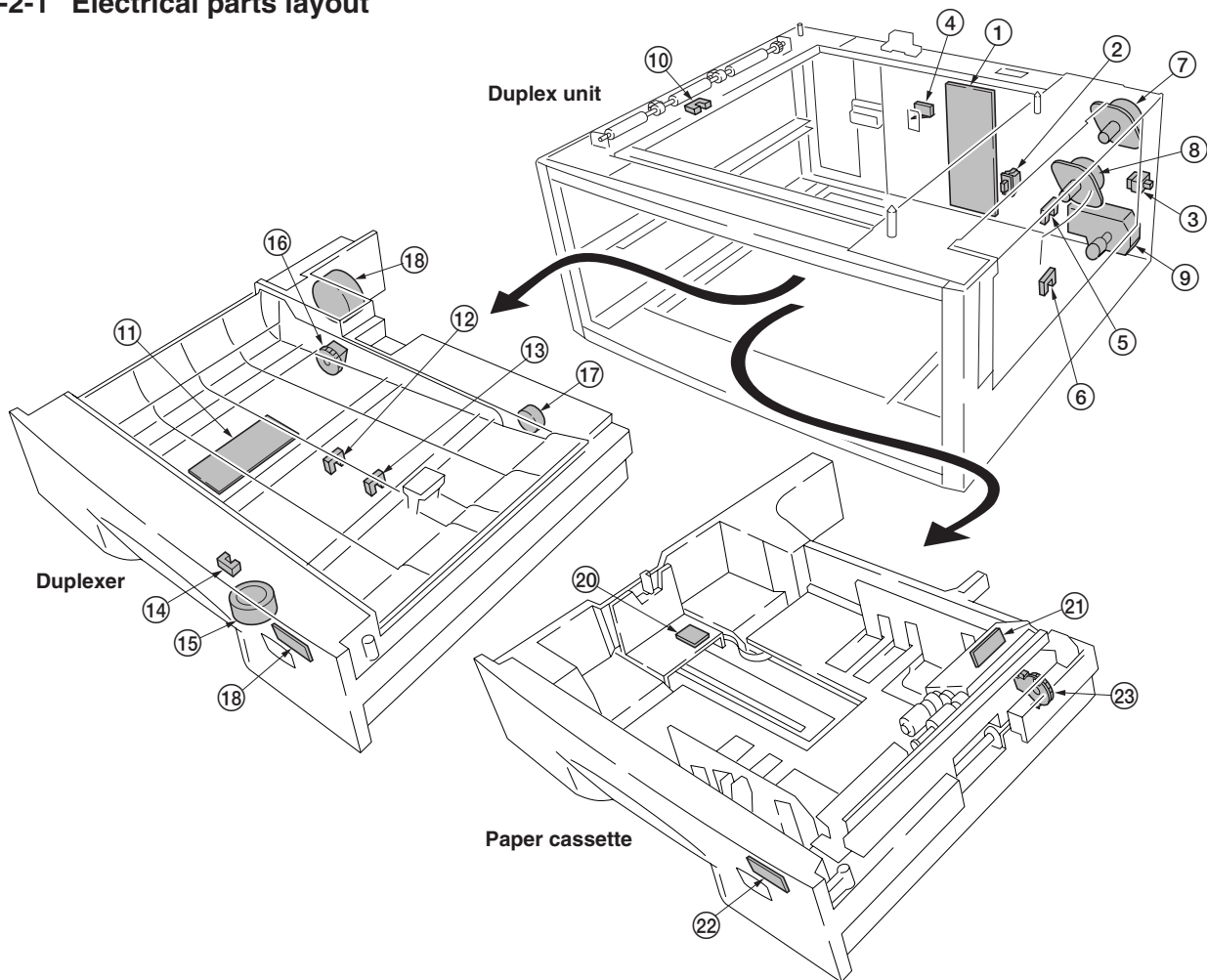

Figure 2-2-1 Duplex unit, duplexer, and cassette

1. Duplex unit PWB (DUF PWB) [KP-834] Establishes communication between the printer/copier and duplex unit; provides overall control over the duplex unit electronics.
2. Duplex unit cassette switch (DUCSW) Detects insertion of the paper cassette.
3. Duplex unit right cover switch (DURCSW) .. Detects the status of the duplex unit right cover.
4. Duplex unit interlock switch (DUILSW) Cuts off the 24 V DC when the duplexer is drawn out.
5. Duplex unit upper jam sensor (DUUJS) Detects paper jam at the paper vertical conveying section.
6. Duplex unit lower jam sensor (DULJS) Detects paper jam at the paper vertical conveying section.
7. Duplex unit Intermediate feed motor (DUIFM) Drives the vertical conveying section.
8. Duplex unit feed motor (DUFM) Drives the paper feed section in the paper cassette.
9. Bottom plate elevation motor (BPEM) Activates the cassette bottom plate.
10. Duplex unit entrance sensor (DES) Detects paper jam in the entrance section of the duplex unit.
11. Duplexer PWB (DPWB) [KP-836] Administers input and output controls in the duplexer.
12. Duplexer intermediate sensor (DIS) Detects paper jam in the duplexer upper cover.
13. Duplexer paper refeed sensor (DPRFS) Detects paper jam in the duplexer lower cover.
14. Side registration home position sensor (SREGHPS) Determines the home position of the paper guides.
15. Side registration motor (SREGM) Provides lateral registration.
16. Duplexer feed clutch (DFCL) Feeds paper to the switchback section.
17. Duplexer refeed clutch (DRFCL) Administer driving of the switchback section.
18. Duplexer drive motor (DDM) Drives the duplexer.
19. Duplexer LED PWB (DLED PWB) Displays the duplexer status such as the occurrence of paper jam and activation of duplex printing.
20. Paper size sensor PWB [KP-581] (PSSPWB) Detects paper size in the paper cassette.
21. Pickup PWB (PUPWB) [KP-583] Mounts the cassette paper sensor (CPS) and the bottom plate limit sensor (BPLS).
22. LED PWB (LED PWB) [KP-585] Displays the status such as the occurrence of paper jam and the active cassette in the paper cassette.
23. Paper level switch (PLSW) Detects the top limit of the cassette bottom plate.

This page is intentionally left blank.

2-3-1 PWB information

(1) Duplex unit PWB [KP-834] block diagram

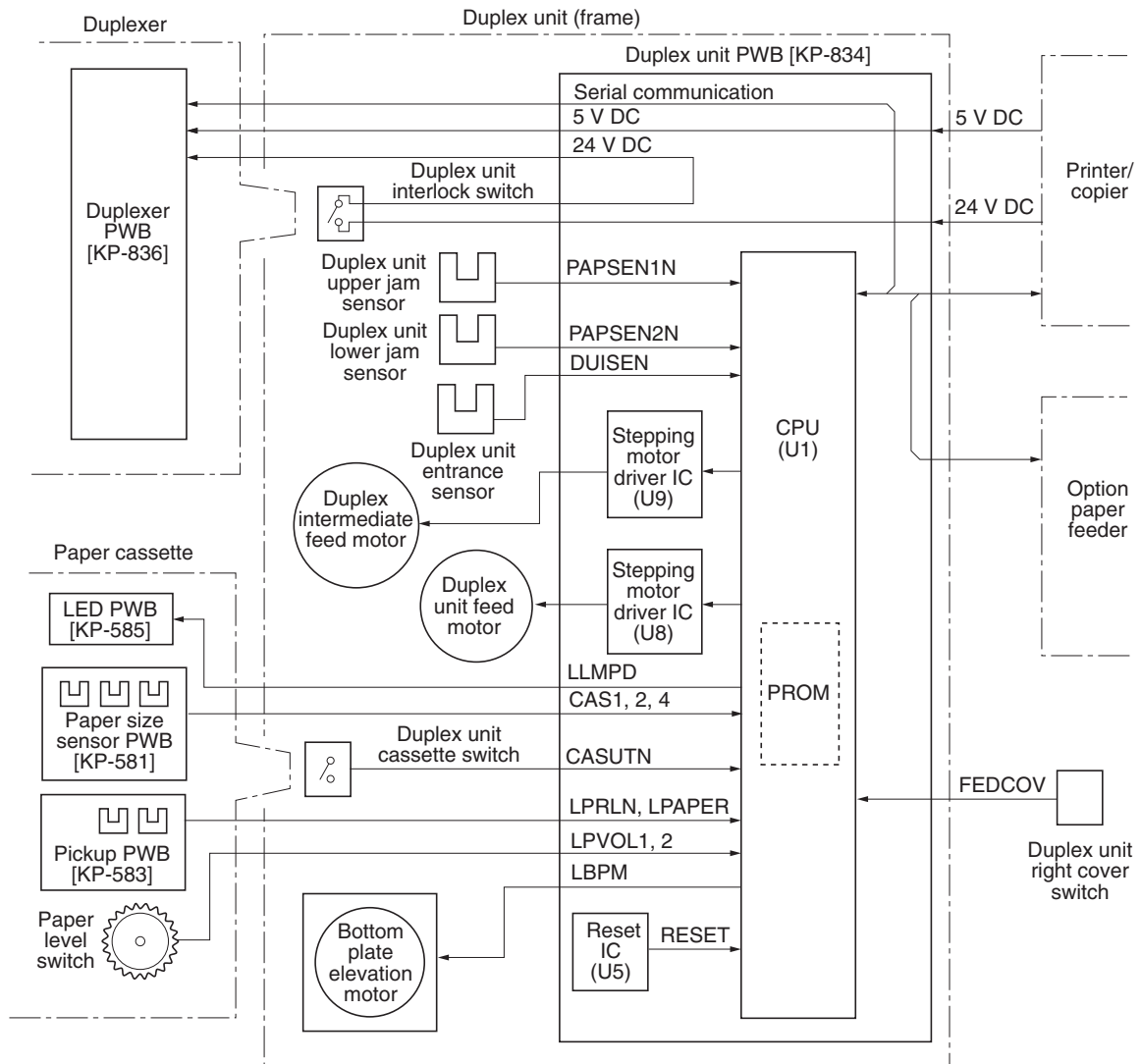

Figure 2-3-1 Duplex unit PWB [KP-834] block diagram

Connector signal assignment

Connector	Pin No.	Signal	I/O	Description
YC1	1	OP24	O	24 V DC
Connected to the duplex unit interlock switch	2	DU24	I	24 V DC via duplex unit interlock switch
YC2	1	GND	-	Ground
Connected to the duplexer PWB [KP-836]	2	SCKN	O	Serial communication clock
	3	GND	-	Ground
	4	GND	-	Ground
	5	SDOUT	O	Serial data output
	6	SDI	I	Serial data input
	7	OP24V	O	24 V DC
	8	OP24V	O	24 V DC
	9	OP5V	O	5 V DC
	10	OP5V	O	5 V DC
	11	GND	-	Ground
	12	SEL0	O	Option paper feeder/duplex unit selection signal 0
	13	SEL1	O	Option paper feeder/duplex unit selection signal 1
	14	SEL2	O	Option paper feeder/duplex unit selection signal 2
YC3	1	SEL0	I	Option paper feeder/duplex unit selection signal 0
Connected to the printer/copier	2	SEL1	I	Option paper feeder/duplex unit selection signal 1
	3	SEL2	I	Option paper feeder/duplex unit selection signal 2
	4	SDOUT	I	Serial data input
	5	SCK	I	Serial clock
	6	SDI	O	Serial data output
	7	OP5V	I	5 V DC
	8	OP5V	I	5 V DC
YC4	1	OP24V	I	24 V DC
Connected to the printer/copier	2	OP24V	I	24 V DC
	3	GND	-	Ground
	4	GND	-	Ground
YC5	1	LBPM	O	Bottom plate elevation motor activation
Connected to the bottom plate elevation motor	2	LBPMD	-	Ground
YC6	1	STEPAD	O	Intermediate feed motor, stepping drive pulse
Connected to the duplex unit intermediate feed motor	2	STEPBD	O	Intermediate feed motor, stepping drive pulse
	3	STEPADN	O	Intermediate feed motor, stepping drive pulse
	4	STEPBDN	O	Intermediate feed motor, stepping drive pulse
YC7	1	STEPAD	O	Duplex unit feed motor, stepping drive pulse
Connected to the duplex unit feed motor	2	STEPBD	O	Duplex unit feed motor, stepping drive pulse
	3	STEPADN	O	Duplex unit feed motor, stepping drive pulse
	4	STEPBDN	O	Duplex unit feed motor, stepping drive pulse

Connector	Pin No.	Signal	I/O	Description
YC8	1	OP5V	O	5 V DC
Connected to the paper cassette	2	OP5V	O	5 V DC
	3	CAS1	I	Paper size sensor, detection 1
	4	LPRLN	I	Bottom plate limit sensor (Pickup PWB), detection
	5	CAS2	I	Paper size sensor, detection 2
	6	LPAPER	I	Cassette paper sensor (Pickup PWB), detection
	7	CAS4	I	Paper size sensor, detection 4
	8	LPVOL1	I	Paper level switch, detection 1
	9	LLMPD	O	LED PWB
	10	LPVOL2	I	Paper level switch, detection 2
	11	GND	-	Ground
	12	GND	-	Ground
YC9	1	CASUTN	I	Paper cassette installation, L: Installed
Connected to the duplex unit cassette switch	2	GND	-	Ground
YC10	1	OP5V	O	5 V DC
Connected to the duplex unit upper jam sensor, duplex unit lower jam sensor, and duplex unit right cover switch	2	PAPSEN1N	I	Duplex unit upper jam sensor, paper detection, L: Detected
	3	GND	-	Ground
	4	OP5V	O	5 V DC
	5	PAPSEN2N	I	Duplex unit lower jam sensor, paper detection, L: Detected
	6	GND	-	Ground
	7	FEDCOV	I	Duplex unit right cover, closure, L: Closed
	8	GND	-	Ground
	YC11	1	SEL0	O
Connected to the option paper feeder	2	SEL1	O	Option paper feeder/duplex unit selection 1
	3	SEL2	O	Option paper feeder/duplex unit selection 2
	4	SDOUT	O	Serial data output
	5	SCK	O	Serial clock
	6	SDI	I	Serial data input
	7	OP5V	O	5 V DC
	8	OP5V	O	5 V DC
YC12	1	OP24V	O	24 V DC
Connected to the option paper feeder	2	OP24V	O	24 V DC
	3	GND	-	Ground
	4	GND	-	Ground
YC13	1	GND	-	Ground
Connected to the duplex unit entrance sensor	2	DUISEN	I	Duplex unit entrance sensor, paper detection, L: Detected
	3	VCC	O	5 V DC

(2) Duplexer PWB [KP-836] block diagram

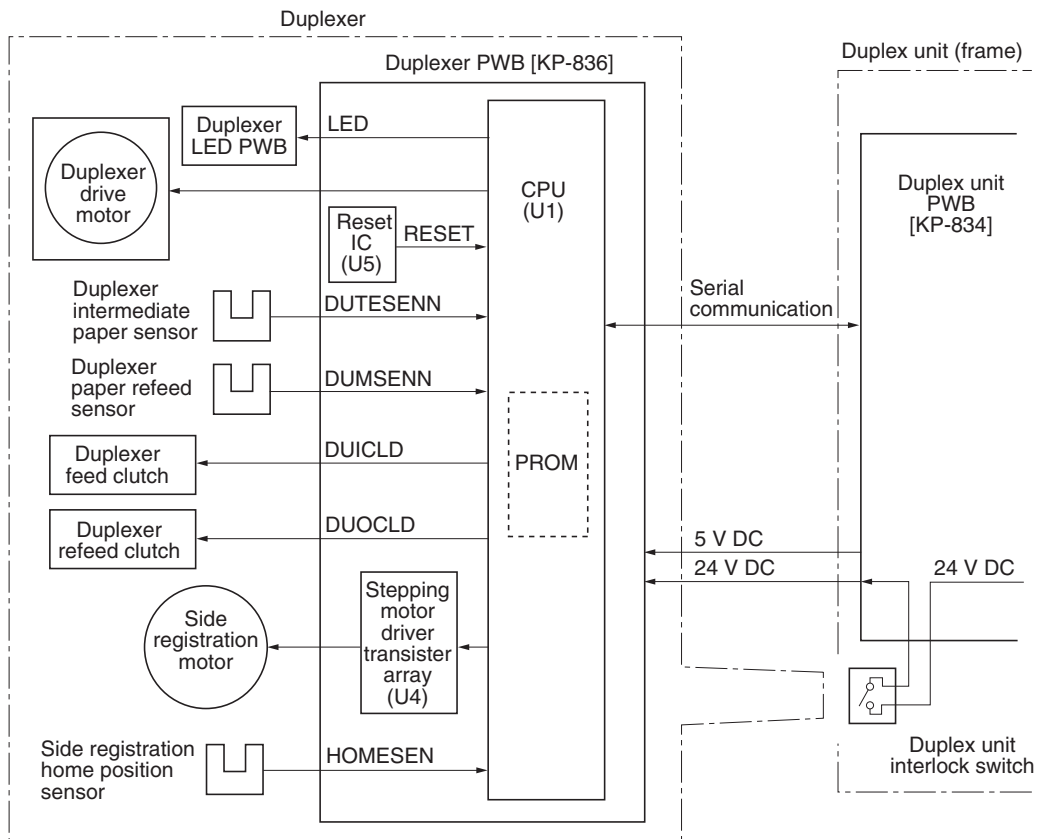

Figure 2-3-2 Duplexer PWB [KP-836] block diagram

Connector signal assignment

Connector	Pin No.	Signal	I/O	Description
YC1	1	GND	-	Ground
Connected to the duplex unit PWB [KP-834]	2	SCLK	I	Serial clock
	3	GND	-	Ground
	4	GND	-	Ground
	5	SDOUT	I	Serial data output
	6	SDI	O	Serial data input
	7	OP24V	I	24 V DC
	8	OP24V	I	24 V DC
	9	OP5V	I	5 V DC
	10	OP5V	I	5 V DC
	11	GND	-	Ground
	12	SEL0	I	Option paper feeder/duplex unit selection 0
	13	SEL1	I	Option paper feeder/duplex unit selection 1
	14	SEL2	I	Option paper feeder/duplex unit selection 2
YC2	1	VCC	O	5 V DC
Connected to the duplexer LED PWB	2	LED	I	Duplexer LED PWB drive, L: Lit
YC3	1	24V	O	24 V DC
Connected to the duplexer feed clutch	2	DUICLD	O	Duplexer feed clutch drive signal, L: On
YC4	1	24V	O	24 V DC
Connected to duplexer drive motor	2	GND	-	Ground
	3	5V	O	5 V DC
	4	FG	I	Duplexer drive motor, pulse generation
	5	DUMOTD	O	Duplexer drive motor, rotation control
	6	DIRECTD	O	Duplexer drive motor, rotation control
	7	H/L1	O	Duplexer drive motor, rotation control
	8	H/L2	O	Duplexer drive motor, rotation control
	9	LD	I	Duplexer drive motor, overload, L: Overloaded
	10	GND	-	Ground
	YC5	1	24V	O
Connected to the duplexer refeed clutch	2	DUOCLD	O	Duplexer refeed clutch, drive, L: On
YC6	1	24V	O	24 V DC
Connected to the side registration motor	2	24V	O	24 V DC
	3	STAD	O	Lateral registration motor, stepping pulse
	4	STND	O	Lateral registration motor, stepping pulse
	5	STADN	O	Lateral registration motor, stepping pulse
	6	TABDN	O	Lateral registration motor, stepping pulse
YC7	1	GND	-	Ground
Connected to the duplexer intermediate paper sensor and duplexer paper refeed sensor	2	DUTENN	I	Intermediate sensor detection, L: Detected
	3	5V	O	5 V DC
	4	GND	-	Ground
	5	DUMSENN	I	Refeed sensor detection, L: Detected
	6	5V	O	5 V DC

Connector	Pin No.	Signal	I/O	Description
YC8	1	GND	O	Ground
Connected to the side registration home position sensor (Lateral registration)	2	HOMESEN	I	Side registration home position sensor signal, H: Home
	3	5V	-	5 V DC

Connection diagram

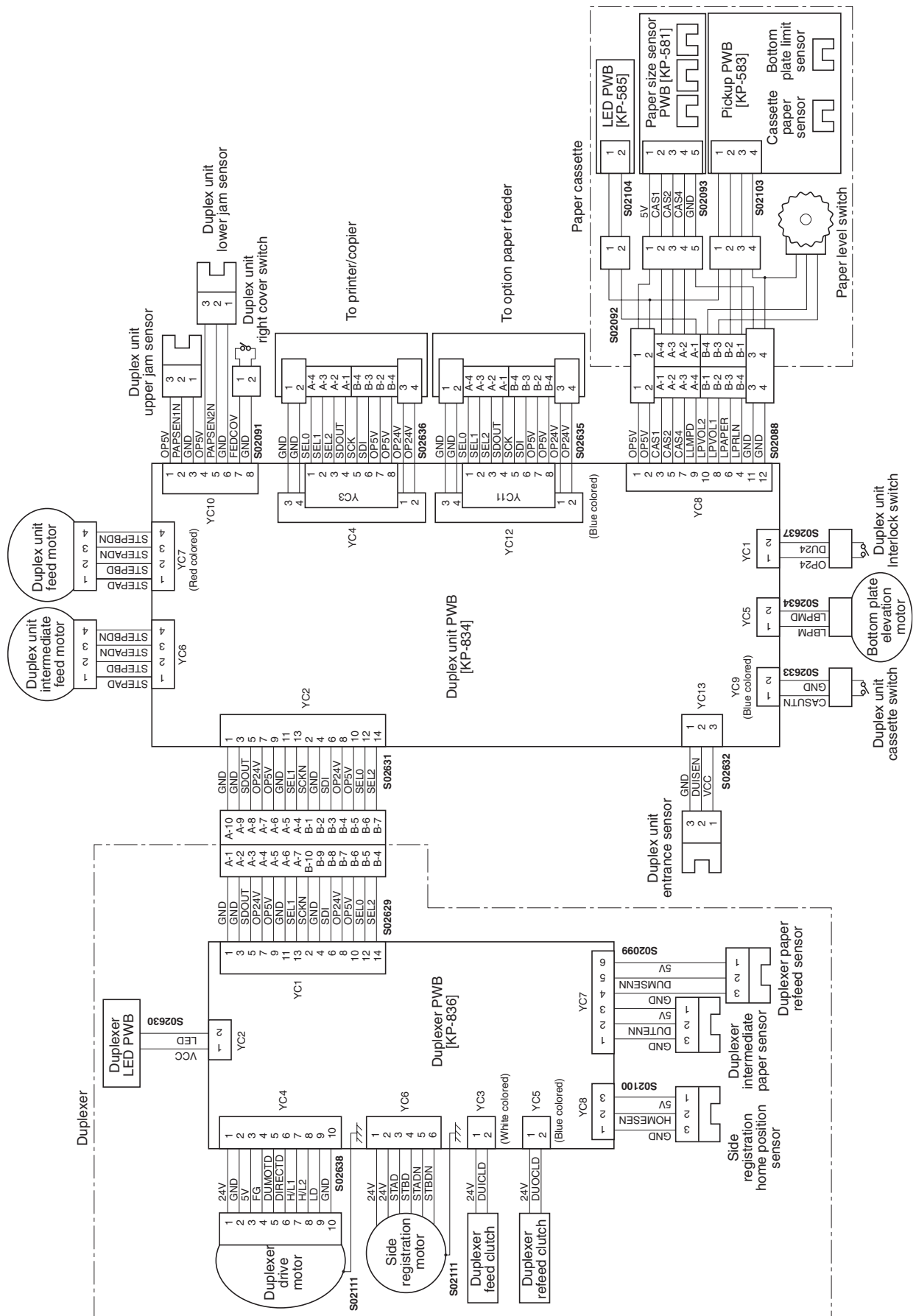

KYOCERA MITA AMERICA, INC.

Headquarters:

225 Sand Road, P.O. Box 40008
Fairfield, New Jersey 07004-0008
TEL : (973) 808-8444
FAX : (973) 882-6000

New York Show Room:

1410 Broadway 23rd floor
New York, NY 10018
TEL : (917) 286-5400
FAX : (917) 286-5402

Northeastern Region:

225 Sand Road, P.O. Box 40008
Fairfield, New Jersey 07004-0008
TEL : (973) 808-8444
FAX : (973) 882-4401

Midwestern Region:

201 Hansen Court Suite 119
Wood Dale, Illinois 60191
TEL : (630) 238-9982
FAX : (630) 238-9487

Western Region:

14101 Alton Parkway,
Irvine, California 92618-7006
TEL : (949) 457-9000
FAX : (949) 457-9119

Southeastern Region:

1500 Oakbrook Drive,
Norcross, Georgia 30093
TEL : (770) 729-9786
FAX : (770) 729-9873

Southwestern Region:

2825 West Story Road,
Irving, Texas 75038-5299
TEL : (972) 550-8987
FAX : (972) 570-4704

Dallas Parts Distribution Center & National Training Center:

2825 West Story Road,
Irving, Texas 75038-5299
TEL : (972) 659-0055
FAX : (972) 570-5816

KYOCERA MITA CANADA, LTD.

6120 Kestrel Road, Mississauga,
Ontario L5T 1S8, Canada
TEL : (905) 670-4425
FAX : (905) 670-8116

KYOCERA MITA MEXICO, S.A. DE C.V.

Av. 16 de Septiembre #407
Col. Santa Inés,
02130 Azcapotzalco
México, D.F. México
TEL : (55) 5383-2741
FAX : (55) 5383-7804

©2003 KYOCERA MITA CORPORATION

 **KYOCERA** is a trademark of Kyocera Corporation

mita is a registered trademark of KYOCERA MITA CORPORATION

Printed in U.S.A.