



---

# **FS-C2526MFP**

# **FS-C2626MFP**

# **SERVICE**

# **MANUAL**

Published in January 2014  
2M9SM067  
Rev.7

## **CAUTION**

RISK OF EXPLOSION IF BATTERY IS REPLACED BY AN INCORRECT TYPE. DISPOSE OF USED BATTERIES ACCORDING TO THE INSTRUCTIONS.

It may be illegal to dispose of this battery into the municipal waste stream. Check with your local solid waste officials for details in your area for proper disposal.

## **ATTENTION**

IL Y A UN RISQUE D'EXPLOSION SI LA BATTERIE EST REMPLACÉE PAR UN MODÈLE DE TYPE INCORRECT. METTRE AU REBUT LES BATTERIES UTILISÉES SELON LES INSTRUCTIONS DONNÉES.

Il peut être illégal de jeter les batteries dans des eaux d'égout municipales. Vérifiez avec les fonctionnaires municipaux de votre région pour les détails concernant des déchets solides et une mise au rebut appropriée.

## Revision history

Revision	Date	Replaced pages	Remarks
1	6 April 2011	CONTENTS, 1-1-2, 1-2-13, 1-2-14, 1-3-2 to 1-3-4, 1-3-65 to 1-3-68, 1-4-5 to 1-4-7, 1-5-11, 1-5-17, 1-5-32, 1-5-33, 1-5-48, 1-5-50, 1-5-52, 1-5-64, 2-2-1, 2-3-16 to 2-3-20, 2-4-9, INSTALLATION GUIDE	-
2	26 September 2011	1-3-2, 1-3-16	-
3	24 April 2012	1-3-27, Address	-
4	18 June 2012	Contents, 1-3-9, 1-3-55, 1-4-25, 1-6-1, 2-4-3, 2-4-9 to 16	-
5	1 December 2012	Contents, 1-6-1, 1-6-2, 2-4-7	-
6	12 February 2013	Contents, 1-3-2 to 5, 1-3-12 to 25, 1-3-29, 1-3-36 to 38, 1-3-41, Address	-
7	26 December 2013	Contents, 1-1-3, 1-3-2 to 5, 1-3-10, 1-3-11, 1-3-14, 1-3-16, 1-3-83, 1-5-29, 1-5-30, 1-5-52 to 77, Address	-

This page is intentionally left blank.





---

# Safety precautions

---

This booklet provides safety warnings and precautions for our service personnel to ensure the safety of their customers, their machines as well as themselves during maintenance activities. Service personnel are advised to read this booklet carefully to familiarize themselves with the warnings and precautions described here before engaging in maintenance activities.

## Safety warnings and precautions

Various symbols are used to protect our service personnel and customers from physical danger and to prevent damage to their property. These symbols are described below:

**⚠ DANGER:** High risk of serious bodily injury or death may result from insufficient attention to or incorrect compliance with warning messages using this symbol.

**⚠ WARNING:** Serious bodily injury or death may result from insufficient attention to or incorrect compliance with warning messages using this symbol.

**⚠ CAUTION:** Bodily injury or damage to property may result from insufficient attention to or incorrect compliance with warning messages using this symbol.

### Symbols

The triangle ( $\triangle$ ) symbol indicates a warning including danger and caution. The specific point of attention is shown inside the symbol.



General warning.



Warning of risk of electric shock.



Warning of high temperature.

⊘ indicates a prohibited action. The specific prohibition is shown inside the symbol.



General prohibited action.



Disassembly prohibited.

● indicates that action is required. The specific action required is shown inside the symbol.



General action required.





Remove the power plug from the wall outlet.











Always ground the copier.

# 1. Installation Precautions

## WARNING











- Do not use a power supply with a voltage other than that specified. Avoid multiple connections to one outlet: they may cause fire or electric shock. When using an extension cable, always check that it is adequate for the rated current. .... 
- Connect the ground wire to a suitable grounding point. Not grounding the copier may cause fire or electric shock. Connecting the earth wire to an object not approved for the purpose may cause explosion or electric shock. Never connect the ground cable to any of the following: gas pipes, lightning rods, ground cables for telephone lines and water pipes or faucets not approved by the proper authorities. .... 

## CAUTION:





- Do not place the copier on an infirm or angled surface: the copier may tip over, causing injury. .... 
- Do not install the copier in a humid or dusty place. This may cause fire or electric shock. .... 
- Do not install the copier near a radiator, heater, other heat source or near flammable material. This may cause fire. .... 
- Allow sufficient space around the copier to allow the ventilation grills to keep the machine as cool as possible. Insufficient ventilation may cause heat buildup and poor copying performance. .... 
- Always handle the machine by the correct locations when moving it. .... 
- Always use anti-toppling and locking devices on copiers so equipped. Failure to do this may cause the copier to move unexpectedly or topple, leading to injury. .... 
- Avoid inhaling toner or developer excessively. Protect the eyes. If toner or developer is accidentally ingested, drink a lot of water to dilute it in the stomach and obtain medical attention immediately. If it gets into the eyes, rinse immediately with copious amounts of water and obtain medical attention. .... 
- Advise customers that they must always follow the safety warnings and precautions in the copier's instruction handbook. .... 












## 2. Precautions for Maintenance

### WARNING

- Always remove the power plug from the wall outlet before starting machine disassembly. .... 
- Always follow the procedures for maintenance described in the service manual and other related brochures. .... 
- Under no circumstances attempt to bypass or disable safety features including safety mechanisms and protective circuits. .... 
- Always use parts having the correct specifications. .... 
- Always use the thermostat or thermal fuse specified in the service manual or other related brochure when replacing them. Using a piece of wire, for example, could lead to fire or other serious accident. .... 
- When the service manual or other serious brochure specifies a distance or gap for installation of a part, always use the correct scale and measure carefully. .... 
- Always check that the copier is correctly connected to an outlet with a ground connection. .... 
- Check that the power cable covering is free of damage. Check that the power plug is dust-free. If it is dirty, clean it to remove the risk of fire or electric shock. .... 
- Never attempt to disassemble the optical unit in machines using lasers. Leaking laser light may damage eyesight. .... 
- Handle the charger sections with care. They are charged to high potentials and may cause electric shock if handled improperly. .... 



### CAUTION

- Wear safe clothing. If wearing loose clothing or accessories such as ties, make sure they are safely secured so they will not be caught in rotating sections. .... 
- Use utmost caution when working on a powered machine. Keep away from chains and belts. .... 
- Handle the fixing section with care to avoid burns as it can be extremely hot. .... 
- Check that the fixing unit thermistor, heat and press rollers are clean. Dirt on them can cause abnormally high temperatures. .... 

- Do not remove the ozone filter, if any, from the copier except for routine replacement. .... 
- Do not pull on the AC power cord or connector wires on high-voltage components when removing them; always hold the plug itself. .... 
- Do not route the power cable where it may be stood on or trapped. If necessary, protect it with a cable cover or other appropriate item. .... 
- Treat the ends of the wire carefully when installing a new charger wire to avoid electric leaks. .... 
- Remove toner completely from electronic components. .... 
- Run wire harnesses carefully so that wires will not be trapped or damaged. .... 
- After maintenance, always check that all the parts, screws, connectors and wires that were removed, have been refitted correctly. Special attention should be paid to any forgotten connector, trapped wire and missing screws. .... 
- Check that all the caution labels that should be present on the machine according to the instruction handbook are clean and not peeling. Replace with new ones if necessary. .... 
- Handle greases and solvents with care by following the instructions below: ..... 
  - Use only a small amount of solvent at a time, being careful not to spill. Wipe spills off completely.
  - Ventilate the room well while using grease or solvents.
  - Allow applied solvents to evaporate completely before refitting the covers or turning the power switch on.
  - Always wash hands afterwards.
- Never dispose of toner or toner bottles in fire. Toner may cause sparks when exposed directly to fire in a furnace, etc. .... 
- Should smoke be seen coming from the copier, remove the power plug from the wall outlet immediately. .... 

### 3. Miscellaneous

#### WARNING

- Never attempt to heat the drum or expose it to any organic solvents such as alcohol, other than the specified refiner; it may generate toxic gas. .... 
- Keep the machine away from flammable liquids, gases, and aerosols. A fire or an electric shock might occur. .... 

This page is intentionally left blank.

# CONTENTS

## 1-1 Specifications

1-1-1 Specifications .....	1-1-1
1-1-2 Parts names .....	1-1-6
(1) Machine (front side).....	1-1-6
(2) Machine (rear side).....	1-1-7
(3) Document processor .....	1-1-8
(4) Operation panel .....	1-1-9
1-1-3 Machine cross section .....	1-1-10

## 1-2 Installation

1-2-1 Installation environment.....	1-2-1
1-2-2 Unpacking.....	1-2-2
1-2-3 Installing the expansion memory (option).....	1-2-12
1-2-4 Installing the memory card (option) .....	1-2-14

## 1-3 Maintenance Mode

1-3-1 Maintenance mode .....	1-3-1
(1) Executing a maintenance item .....	1-3-1
(2) Maintenance modes item list .....	1-3-2
(3) Contents of the maintenance mode items .....	1-3-6
1-3-2 Service mode.....	1-3-77
(1) Executing a service mode .....	1-3-77
(2) Description of service mode .....	1-3-78

## 1-4 Troubleshooting

1-4-1 Paper misfeed detection .....	1-4-1
(1) Paper misfeed indication .....	1-4-1
(2) Paper misfeed detection condition .....	1-4-1
1-4-2 Self-diagnostic function .....	1-4-5
(1) Self-diagnostic function .....	1-4-5
(2) Self diagnostic codes.....	1-4-5
1-4-3 Image formation problems.....	1-4-27
(1) No image appears (entirely white).....	1-4-28
(2) No image appears (entirely black).....	1-4-28
(3) A specific color is printed solid. ....	1-4-29
(4) The back side gets dirty.....	1-4-29
(5) Image is too light. ....	1-4-29
(6) The background is colored. ....	1-4-30
(7) White streaks are printed vertically.....	1-4-30
(8) Black streaks are printed vertically.....	1-4-30
(9) Streaks are printed horizontally.....	1-4-31
(10) Spots are printed. ....	1-4-31
(11) The leading edge of image begins to print too early or too late.....	1-4-31
(12) Paper is wrinkled. ....	1-4-31
(13) Offset occurs. ....	1-4-32
(14) Part of image is missing. ....	1-4-32
(15) Fusing is loose.....	1-4-32
(16) Colors are printed offset to each other. ....	1-4-33
1-4-4 Electric problems .....	1-4-34
1-4-5 Mechanical problems.....	1-4-39

1-4-6 Send error code .....	1-4-41
(1) Scan to SMB error codes .....	1-4-41
(2) Scan to FTP error codes .....	1-4-42
(3) Scan to E-mail error codes .....	1-4-43
1-4-7 Error codes .....	1-4-44
(1) Error code .....	1-4-44
(2) Table of general classification .....	1-4-45
(2-1) U004XX error code table: Interrupted phase B .....	1-4-47
(2-2) U006XX error code table: Problems with the unit .....	1-4-47
(2-3) U008XX error code table: Page transmission error .....	1-4-47
(2-4) U009XX error code table: Page reception error .....	1-4-47
(2-5) U010XX error code table: G3 transmission .....	1-4-48
(2-6) U011XX error code table: G3 reception .....	1-4-49
(2-7) U017XX error code table: V.34 transmission .....	1-4-50
(2-8) U018XX error code table: V.34 reception .....	1-4-50

## 1-5 Assembly and disassembly

1-5-1 Precautions for assembly and disassembly .....	1-5-1
(1) Precautions .....	1-5-1
(2) Drum .....	1-5-1
(3) Toner .....	1-5-1
(4) How to tell a genuine Kyocera Mita toner container .....	1-5-2
1-5-2 Outer covers .....	1-5-3
(1) Detaching and refitting the rear upper cover, right upper cover, left upper cover and front cover .....	1-5-3
(2) Detaching and refitting the right rear cover, right cover and right lower cover .....	1-5-6
(3) Detaching and refitting the left rear cover, left cover and left lower cover .....	1-5-9
(4) Detaching and refitting the inner cover .....	1-5-11
1-5-3 Paper feed section .....	1-5-13
(1) Detaching and refitting the retard roller unit .....	1-5-13
(2) Detaching and refitting the paper feed roller unit .....	1-5-15
(3) Detaching and refitting the MP paper feed roller .....	1-5-17
1-5-4 Developing section .....	1-5-19
(1) Detaching and refitting the developing unit .....	1-5-19
1-5-5 Drum section .....	1-5-21
(1) Detaching and refitting the drum unit .....	1-5-21
1-5-6 Transfer/Separation section .....	1-5-22
(1) Detaching and refitting the intermediate transfer unit .....	1-5-22
(2) Detaching and refitting the transfer roller unit .....	1-5-25
1-5-7 Fuser section .....	1-5-26
(1) Detaching and refitting the fuser unit .....	1-5-26
1-5-8 PWBs .....	1-5-27
(1) Detaching and refitting the engine PWB .....	1-5-27
(2) Detaching and refitting the power source PWB .....	1-5-29
(3) Detaching and refitting the main PWB .....	1-5-30
(4) Detaching and refitting the high voltage PWB .....	1-5-35
(5) Detaching and refitting the FAX control PWB (4 in 1 model (with FAX) only) .....	1-5-36
1-5-9 Drive section .....	1-5-37
(1) Detaching and refitting the MP feed drive unit .....	1-5-37
(2) Detaching and refitting the drum/developing drive unit .....	1-5-38
(3) Detaching and refitting the paper feed drive unit .....	1-5-40
(4) Detaching and refitting the fuser pressure drive unit .....	1-5-41
(5) Detaching and refitting the middle transfer drive unit .....	1-5-43



1-5-10	Optical section .....	1-5-45
	(1) Detaching and refitting the laser scanner unit .....	1-5-45
	(2) Detaching and refitting the scanner unit .....	1-5-48
	(3) Detaching and refitting the image scanner unit .....	1-5-52
1-5-11	Document processor .....	1-5-78
	(1) Detaching and refitting the document processor .....	1-5-78
	(2) Detaching and refitting the DP paper feed pulley unit .....	1-5-82
	(3) Detaching and refitting the DP separation pad .....	1-5-86
	(4) Detaching and refitting the DP drive PWB.....	1-5-87
1-5-12	Others .....	1-5-88
	(1) Detaching and refitting the paper conveying unit .....	1-5-88
	(2) Detaching and refitting the operation panel.....	1-5-90
	(3) Detaching and refitting the power source inlet .....	1-5-91
	(4) Direction of installing the principal fan motors .....	1-5-93
1-6	Requirements on PWB Replacement	
1-6-1	Upgrading the firmware .....	1-6-1
1-6-2	Remarks on engine PWB replacement .....	1-6-3
2-1	Mechanical Construction	
2-1-1	Paper feed/conveying section .....	2-1-1
	(1) Cassette paper feed section.....	2-1-1
	(2) MP tray paper feed section.....	2-1-3
	(3) Paper conveying section .....	2-1-5
2-1-2	Drum section .....	2-1-7
2-1-3	Developing section .....	2-1-9
2-1-4	Optical section .....	2-1-11
	(1) Image scanner section .....	2-1-11
	(2) Laser scanner section .....	2-1-14
2-1-5	Transfer/Separation section .....	2-1-16
	(1) Intermediate transfer unit section .....	2-1-16
	(2) Secondary transfer roller section.....	2-1-18
2-1-6	Fuser section .....	2-1-19
2-1-7	Eject/Feedshift section .....	2-1-21
2-1-8	Duplex conveying section.....	2-1-23
2-1-9	Document processor .....	2-1-25
	(1) Original feed section.....	2-1-25
	(2) Original conveying section.....	2-1-27
	(3) Original switchback/eject sections.....	2-1-29
2-2	Electrical Parts Layout	
2-2-1	Electrical parts layout .....	2-2-1
	(1) PWBs.....	2-2-1
	(2) Switches and sensors.....	2-2-4
	(3) Motors.....	2-2-6
	(4) Others.....	2-2-8
	(5) Document processor .....	2-2-9

## 2-3 Operation of the PWBs

2-3-1 Power source PWB .....	2-3-1
2-3-2 Engine PWB .....	2-3-3
2-3-3 Main PWB.....	2-3-13
2-3-4 Drum relay PWB.....	2-3-21
2-3-5 DP drive PWB.....	2-3-24

## 2-4 Appendixes

2-4-1 Appendixes.....	2-4-1
(1) Maintenance kits.....	2-4-1
(2) Repetitive defects gauge.....	2-4-2
(3) Firmware environment commands .....	2-4-3
(4) Maintenance Commands.....	2-4-9
(5) Wiring diagram .....	2-4-17

## INSTALLATION GUIDE

Card Authentication Kit(D)

## 1-1-1 Specifications

### Machine

Item	Specifications	
	3 in 1 model (without FAX)	4 in 1 model (with FAX)
Type	Desktop	
Printing method	Electrophotography by semiconductor laser, tandem (4) drum system	
Originals	Sheet, Book, 3-dimensional objects (maximum original size: Folio/Legal)	
Original feed system	Fixed	
Paper weight	Cassette	60 to 163 g/m <sup>2</sup> (Duplex: 60 to 163 g/m <sup>2</sup> )
	MP tray	60 to 220 g/m <sup>2</sup> , 230 μm (Cardstock)
Paper type	Cassette	Plain, Recycled, Preprinted, Bond, Color (Colour), Prepunched, Letterhead, Thick, High quality, Custom 1 to 8 (Duplex: Same as simplex)
	MP tray	Plain, Transparency, Vellum, Labels, Recycled, Preprinted, Bond, Cardstock, Color (Colour), Prepunched, Letterhead, Thick, Envelope, Coated, High quality, Custom 1 to 8
Paper size	Cassette	A4, A5, A6, B5, Letter, Legal, Statement, Executive, Oficio II, Folio, 16K, Custom
	MP tray	A4, A5, A6, B5, ISO B5, B6, Letter, Legal, Statement, Executive, Oficio II, Folio, 16K, Envelope #10, Envelope #9, Envelope #6, Envelope Monarch, Envelope DL, Envelope C5, Postcards, Return postcard, Youkei 2, Youkei 4, Custom
Zoom level	Manual mode : 25 to 400%, 1% increments Auto mode : 400%, 200%, 141%, 129%, 115%, 90%, 86%, 78%, 70%, 64%, 50%, 25%	
Copying speed	Simplex	A4R : 26 sheets/min LetterR : 28 sheets/min Legal : 23 sheets/min B5R : 28 sheets/min A5R : 28 sheets/min A6R : 28 sheets/min
	Duplex	A4R : 13 sheets/min LetterR : 13 sheets/min Legal : 12 sheets/min
First copy time (A4, feed from cassette)	B/W	When using the DP : 11.0 s or less When the DP is not used: 10.0 s or less
	Color	When using the DP : 13.0 s or less When the DP is not used: 12.0 s or less
Warm-up time (22 °C/71.6 °F, 60% RH)	Power on : 29 s or less Sleep mode: 20 s or less	
Paper capacity	Cassette	250 sheets (80g/m <sup>2</sup> )
	MP tray	50 sheets (80 g/m <sup>2</sup> , plain paper, A4/Letter or less)
Output tray capacity	150 sheets (80g/m <sup>2</sup> )	
Continuous copying	1 to 999 sheets	

Item	Specifications	
	3 in 1 model (without FAX)	4 in 1 model (with FAX)
<b>Light source</b>	LED	
<b>Scanning system</b>	Flat bed scanning by CCD image sensor	
<b>Photoconductor</b>	OPC drum (diameter 30 mm)	
<b>Image write system</b>	Semiconductor laser	
<b>Charging system</b>	Charger roller	
<b>Developing system</b>	Touch down developing system Developer: 2-component Toner replenishing: Automatic from the toner container	
<b>Transfer system</b>	Primary: Transfer belt Secondary: Transfer roller	
<b>Separation system</b>	Small diameter separation	
<b>Cleaning system</b>	Drum: Counter blade	
<b>Charge erasing system</b>	Exposure by cleaning lamp (LED)	
<b>Fusing system</b>	Heat and pressure fusing with the heat roller and the press roller Heat source: halogen heater Abnormally high temperature protection devices: thermostat	
<b>CPU</b>	PowerPC464 (800MHz)	
<b>Main memory</b>	<b>Standard</b>	1024 MB
	<b>Maximum</b>	2048 MB
<b>Interface</b>	<b>Standard</b>	USB interface connector: 1 (USB Hi-speed) USB host: 2 Network interface: 1 (10BASE-T/100BASE-TX/1000BASE-T)
	<b>Option</b>	eKUIO slot: 1
<b>Resolution</b>	600 × 600 dpi	
<b>Operating environment</b>	<b>Temperature</b>	10 to 32.5 °C/50 to 90.5 °F
	<b>Humidity</b>	15 to 80% RH
	<b>Altitude</b>	2,500 m/8,202 ft or less
	<b>Brightness</b>	1,500 lux or less
<b>Dimensions (W × D × H)</b>	514 × 550 × 603 mm 20 1/4 × 21 5/8 × 23 3/4"	
<b>Weight</b>	38.6 kg / 85.1 lb (with toner container)	38.7 kg / 85.3 lb (with toner container)
<b>Space required (W × D)</b>	514 × 750 mm (using MP tray) 20 1/4 × 29 1/2" (using MP tray)	
<b>Power source</b>	120 V AC, 60 Hz, more than 9.0 A 220 - 240 V AC, 50/60 Hz, more than 5.0 A	
<b>Options</b>	Paper feeder × 2, Expanded memory, Card authentication kit, Card reader holder, Network interface kit, USB keyboard	

**Document processor**

<b>Item</b>	<b>Specifications</b>
<b>Original feed method</b>	Automatic feed
<b>Supported original types</b>	Sheet originals
<b>Original sizes</b>	Maximum: A4/Legal Minimum : A5/Statement
<b>Original weights</b>	Simplex: 50 to 120 g/m <sup>2</sup> Duplex : 50 to 110 g/m <sup>2</sup>
<b>Loading capacity</b>	50 sheets (50 to 80 g/m <sup>2</sup> ) or less
<b>Dimensions (W × D × H)</b>	490 × 338 × 104 mm 19 5/16 × 13 5/16 × 4 1/8"
<b>Weight</b>	3 kg/ 6.6 lb or less

**Printer**

<b>Item</b>	<b>Specifications</b>
<b>Printing speed</b>	Same as copying speed.
<b>First print time (A4, feed from cassette)</b>	B/W : 9.0 s or less Color: 10.5 s or less (Excluding time for system stabilization immediately after turning on the main power.)
<b>Resolution</b>	600 dpi
<b>Operating system</b>	Windows 2000, Windows XP, Windows XP Professional, Windows Server 2003, Windows Server 2003 x64 Edition, Windows Vista x86 Edition, Windows Vista x64 Edition, Windows 7 x86 Edition, Windows 7 x64 Edition, Windows Server 2008, Windows Server 2008 x64 Edition, Apple Macintosh OS 10.x
<b>Interface</b>	USB interface connector: 1 (USB Hi-speed) USB host: 2 Network interface: 1 (10BASE-T/100BASE-TX/1000BASE-T)
<b>Page description language</b>	PRESCRIBE

**Scanner**

<b>Item</b>		<b>Specifications</b>
<b>Operating system</b>		Windows 2000 (Service Pack 4), Windows XP, Windows Vista, Windows 7, Windows Server 2003, Windows Server 2008
<b>System requirements</b>		IBM PC/AT compatible CPU: Celeron 600 MHz or higher RAM: 128 MB or more HDD free space: 20 MB or more Interface: Ethernet
<b>Resolution</b>		600 dpi, 400 dpi, 300 dpi, 200 dpi, 200×400 dpi, 200×100 dpi
<b>File format</b>		JPEG, TIFF, PDF, XPS
<b>Scanning speed</b>	<b>Simplex</b>	B/W : 35 images/min Color: 25 images/min (A4 landscape, 300 dpi, Image quality: Text/Photo original)
	<b>Duplex</b>	B/W : 18 images/min Color: 13 images/min (A4 landscape, 300 dpi, Image quality: Text/Photo original)
<b>Interface</b>		Ethernet (10 BASE-T/100 BASE-TX/1000BASE-T)
<b>Network protocol</b>		TCP/IP
<b>Transmission system</b>		PC transmission SMB Scan to SMB FTP Scan to FTP, FTP over SSL E-mail transmission SNTP Scan to E-mail TWAIN scan*1 WIA scan*2

\*1 Available operating system: Windows 2000 (Service Pack 4), Windows XP, Windows Vista, Windows Server 2008, Windows 7

\*2 Available operating system: Windows Vista, Windows Server 2008, Windows 7

**FAX (4 in 1 model (with FAX) only)**

<b>Item</b>	<b>Specifications</b>
<b>Compatibility</b>	G3
<b>Communication line</b>	Subscriber telephone line
<b>Transmission time</b>	3 s or less (33600 bps, JBIG, ITU-T A4 #1 chart)
<b>Transmission speed</b>	33600/31200/28800/26400/24000/21600/19200/16800/14400/12000/9600/ 7200/4800/2400 bps
<b>Coding scheme</b>	JBIG/MMR/MR/MH
<b>Error correction</b>	ECM
<b>Original size</b>	Max. width: 8 1/2"/216 mm Max. length: 14"/356 mm
<b>Automatic document feed</b>	Max. 50 sheets
<b>Scanner resolution</b>	Horizontal × Vertical 200 × 100 dpi Normal (8 dot/mm × 3.85 line/mm) 200 × 200 dpi Fine (8 dot/mm × 7.7 line/mm) 200 × 400 dpi Super fine (8 dot/mm × 15.4 line/mm) 400 × 400 dpi Ultra fine (16 dot/mm × 15.4 line/mm)
<b>Printing resolution</b>	600 × 600 dpi
<b>Gradations</b>	256 shades (Error diffusion)
<b>One-Touch key</b>	100 keys
<b>Multi-Station transmission</b>	Max. 100 destinations
<b>Substitute memory reception</b>	256 sheets or more (when using ITU-T A4 #1 chart)
<b>Image memory capacity</b>	3.5 MB (standard) (for incoming faxed originals)
<b>Report output</b>	Sent result report, FAX RX result report, Report for job canceled before sending, Activity report, Status page

NOTE: These specifications are subject to change without notice.

## 1-1-2 Parts names

### (1) Machine (front side)

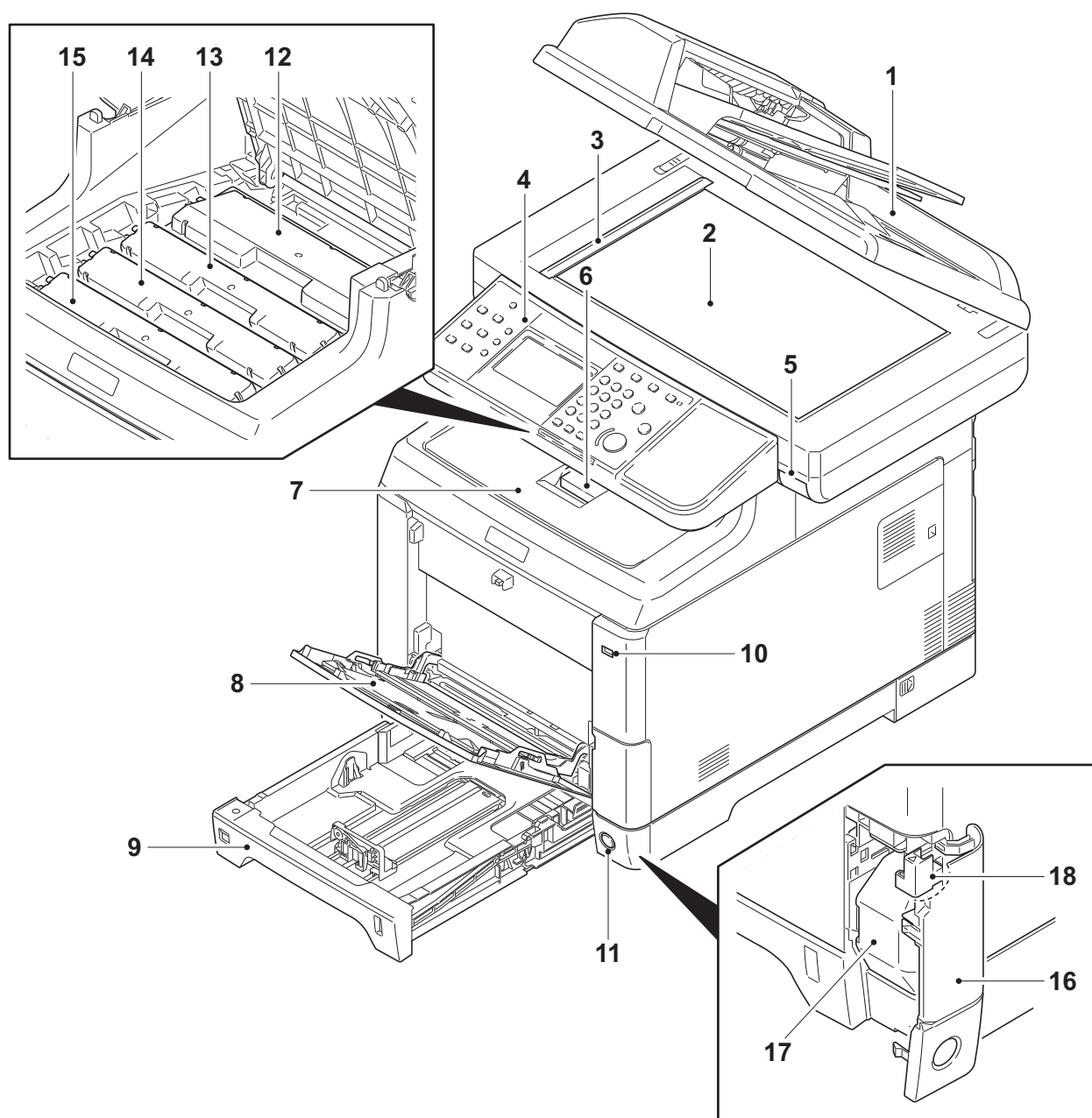
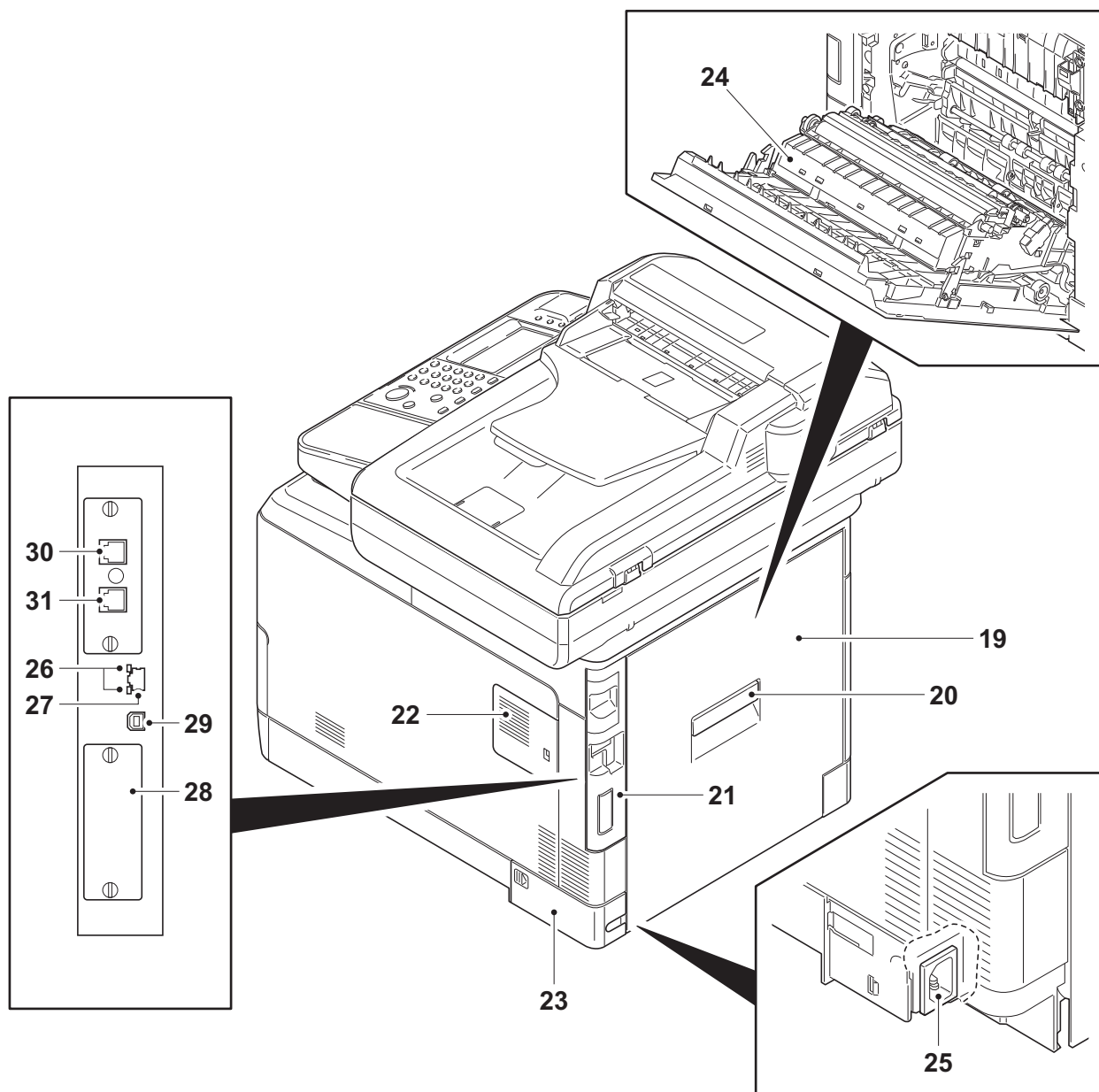


Figure 1-1-1

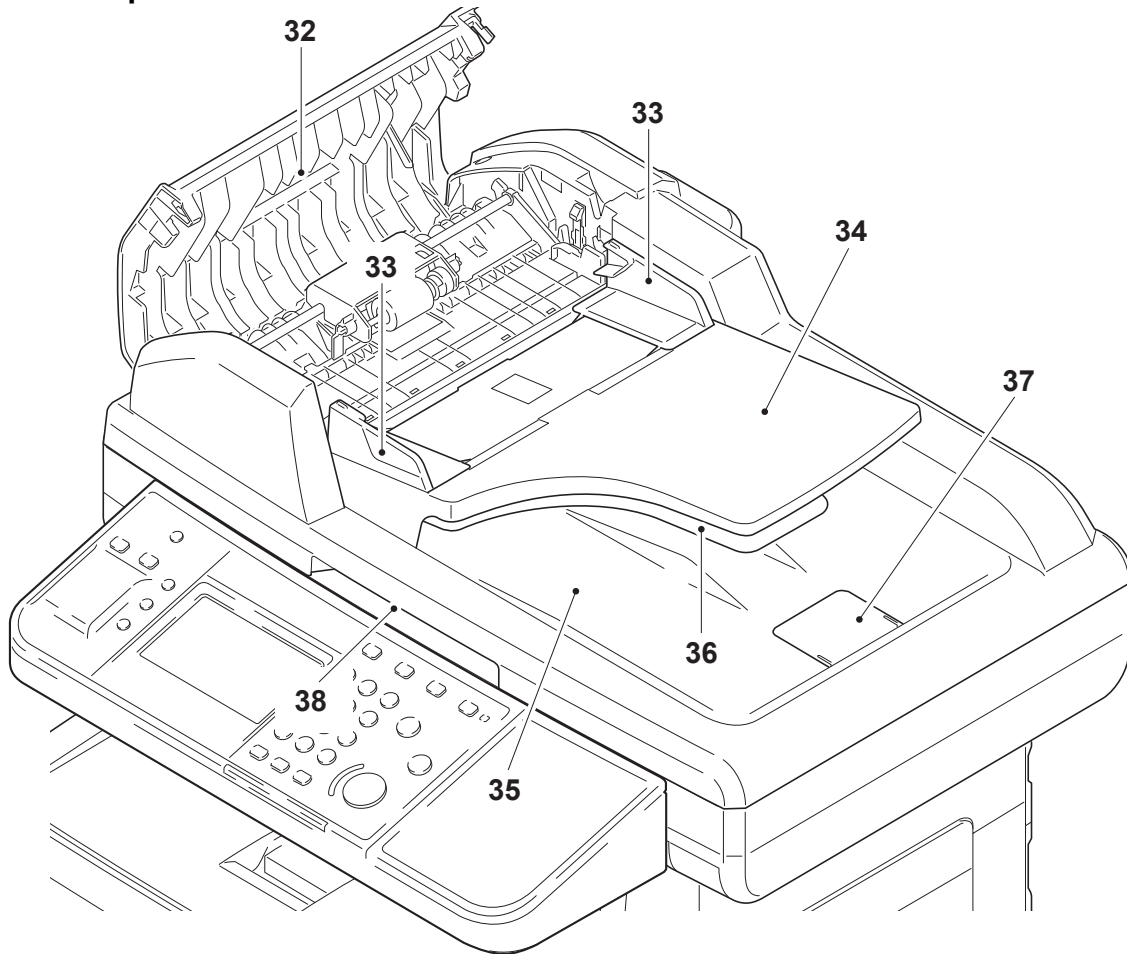
- |                                  |                         |
|----------------------------------|-------------------------|
| 1. Document processor (DP)       | 10. USB memory slot     |
| 2. Contact glass                 | 11. Main power switch   |
| 3. Original size Indicator plate | 12. Toner container K   |
| 4. Operation panel               | 13. Toner container M   |
| 5. Inner tray lever              | 14. Toner container C   |
| 6. Paper stopper                 | 15. Toner container Y   |
| 7. Inner tray                    | 16. Waste toner cover   |
| 8. MP (Multi-Purpose) tray       | 17. Waste toner box     |
| 9. Cassette                      | 18. Lock release button |



**(2) Machine (rear side)****Figure 1-1-2**

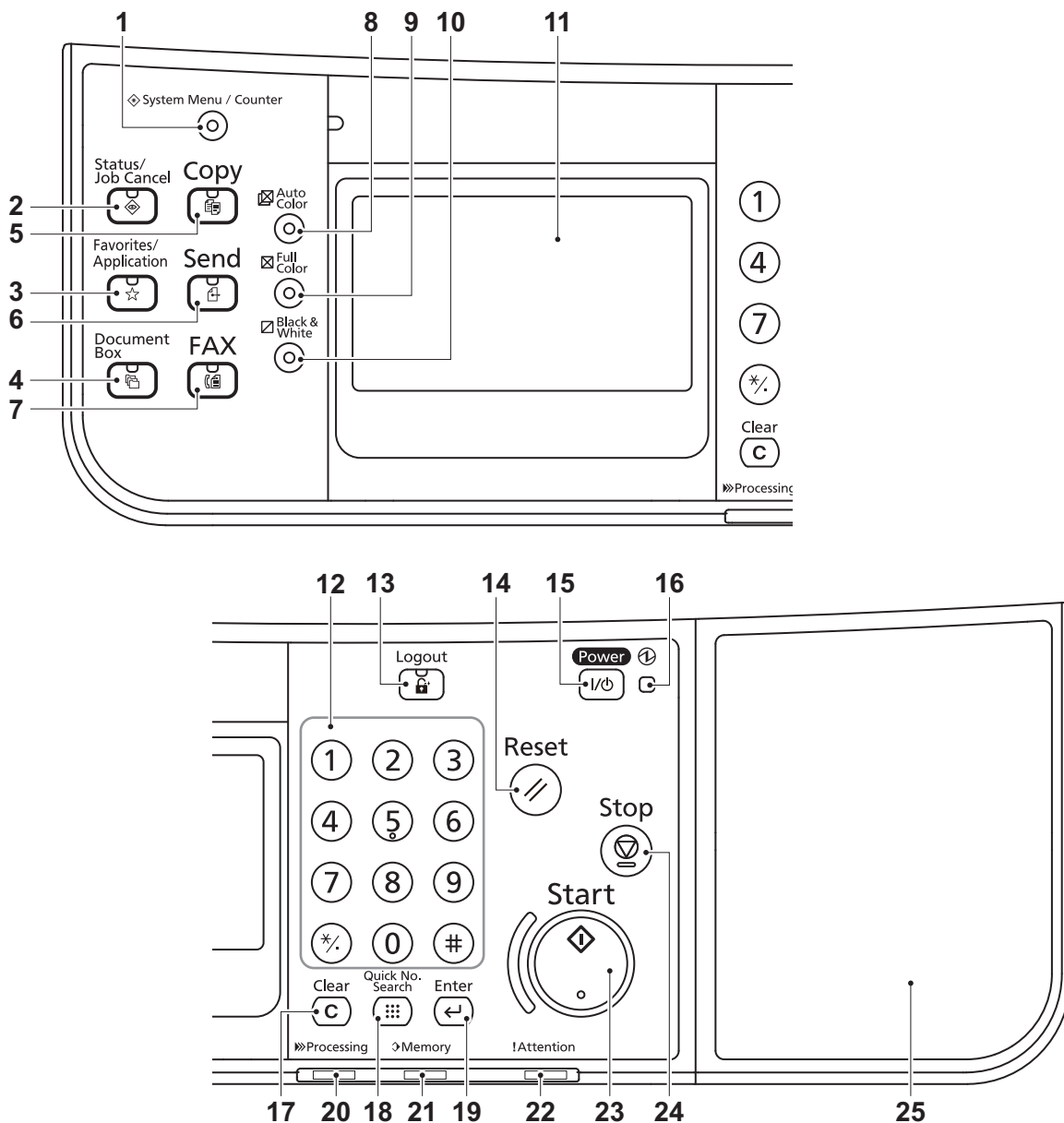
- |                          |                                 |
|--------------------------|---------------------------------|
| 19. Rear cover           | 26. Network indicators          |
| 20. Rear cover lever     | 27. Network interface connector |
| 21. IF cover             | 28. eKUIO connector             |
| 22. Memory cover         | 29. USB interface connector     |
| 23. Power cord cover     | 30. LINE connector*             |
| 24. Paper conveying unit | 31. TEL connector*              |
| 25. Power cord connector |                                 |

\*: 4 in 1 model (with FAX) only

**(3) Document processor****Figure 1-1-3**

- 32. DP top cover
- 33. Original width guides
- 34. Original table
- 35. Original eject table
- 36. Switchback table
- 37. Original stopper
- 38. Opening Handle

**(4) Operation panel**



**Figure 1-1-4**

- |                              |                          |                          |
|------------------------------|--------------------------|--------------------------|
| 1. System menu/Counter key   | 10. Black and White key  | 19. Enter key            |
| 2. Status/Job cancel key     | 11. Message display      | 20. Processing indicator |
| 3. Favorites/application key | 12. Numeric keys         | 21. Memory indicator     |
| 4. Document box key          | 13. Logout key           | 22. Attention indicator  |
| 5. Copy key                  | 14. Reset key            | 23. Start key            |
| 6. Send key                  | 15. Power key            | 24. Stop key             |
| 7. FAX key*                  | 16. Main power LED       | 25. IC Card reader box   |
| 8. Auto color key            | 17. Clear key            |                          |
| 9. Full color key            | 18. Quick No. Search key |                          |
- \*: 4 in 1 model (with FAX) only

### 1-1-3 Machine cross section

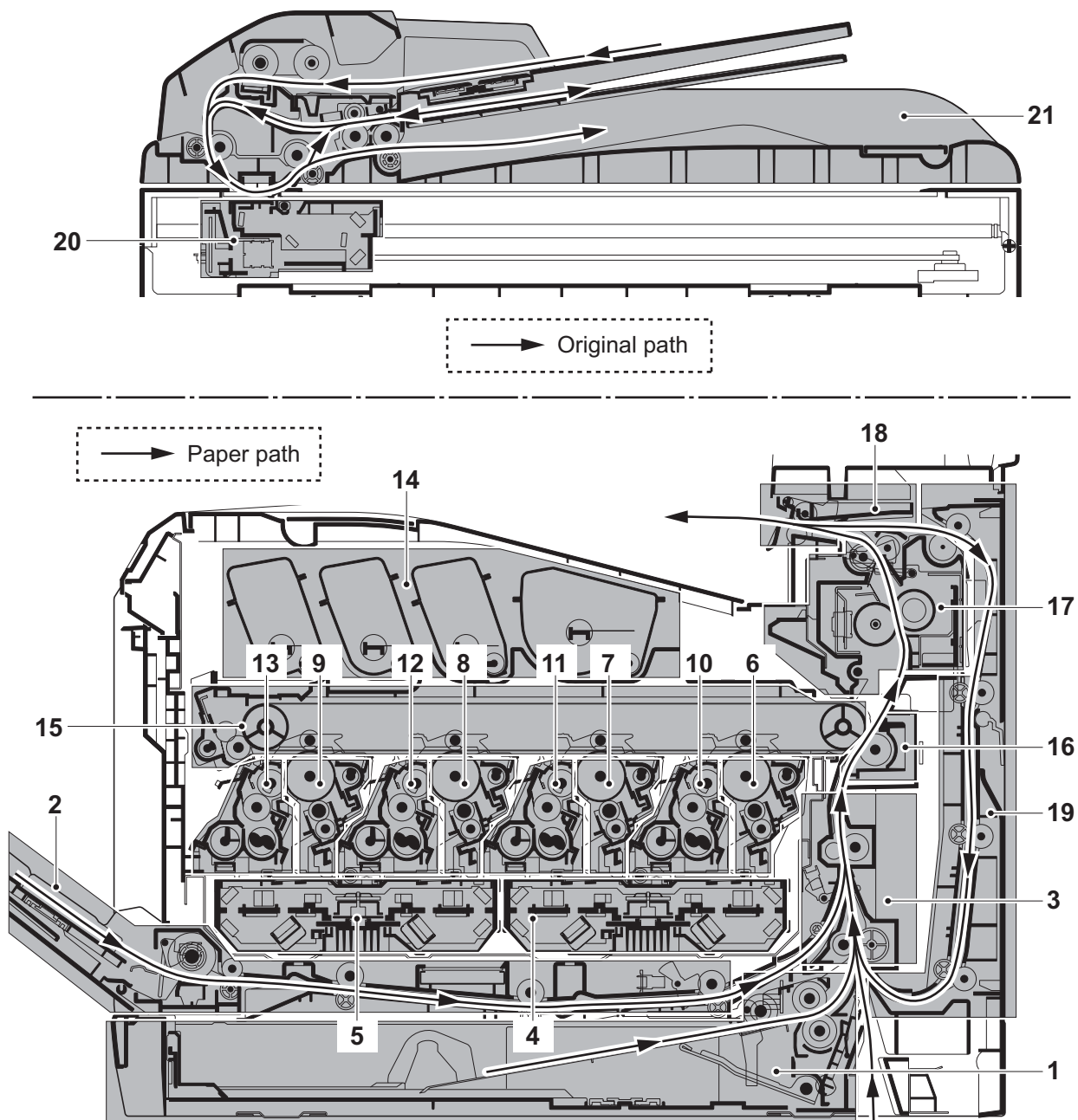


Figure 1-1-5

- |                                |                              |  |
|--------------------------------|------------------------------|--|
| 1. Cassette paper feed section | 9. Drum unit Y               | 16. Secondary transfer/Separation sections |
| 2. MP tray paper feed section  | 10. Developing unit K        | 17. Fuser section                          |
| 3. Paper conveying section     | 11. Developing unit M        | 18. Eject/Feed shift sections              |
| 4. Laser scanner unit KM       | 12. Developing unit C        | 19. Duplex section                         |
| 5. Laser scanner unit CY       | 13. Developing unit Y        | 20. Image scanner unit                     |
| 6. Drum unit K                 | 14. Toner container section  | 21. Document processor                     |
| 7. Drum unit M                 | 15. Primary transfer section |  |
| 8. Drum unit C                 |                              |  |

## 1-2-1 Installation environment

1. Temperature: 10 to 32.5°C/50 to 90.5°F
2. Humidity: 15 to 80% RH
3. Power supply: 120 V AC, 8.9 A  
220 - 240 V AC, 4.7 A
4. Power source frequency: 50 Hz  $\pm$ 2%/60 Hz  $\pm$ 2%
5. Installation location

Avoid direct sunlight or bright lighting. Ensure that the photoconductor will not be exposed to direct sunlight or other strong light when removing paper jams.

Avoid locations subject to high temperature and high humidity or low temperature and low humidity; an abrupt change in the environmental temperature; and cool or hot, direct air.

Avoid places subject to dust and vibrations.

Choose a surface capable of supporting the weight of the machine.

Place the machine on a level surface (maximum allowance inclination: 1°).

Avoid air-borne substances that may adversely affect the machine or degrade the photoconductor, such as mercury, acidic or alkaline vapors, inorganic gasses, NO<sub>x</sub>, SO<sub>x</sub> gases and chlorine-based organic solvents.

Select a well-ventilated location.

6. Allow sufficient access for proper operation and maintenance of the machine.

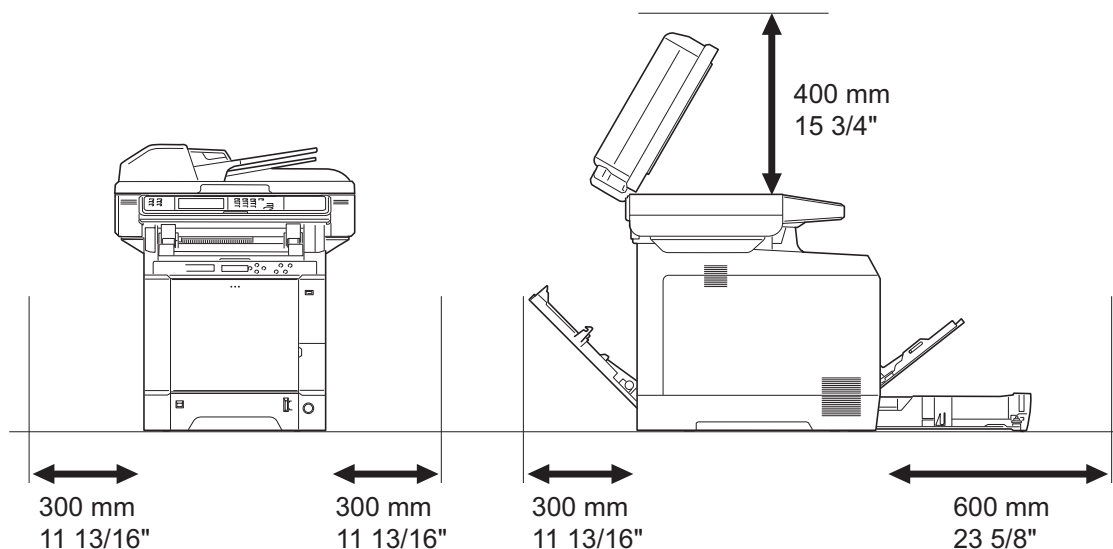


Figure 1-2-1

## 1-2-2 Unpacking

### Unpacking

220-240 V AC model

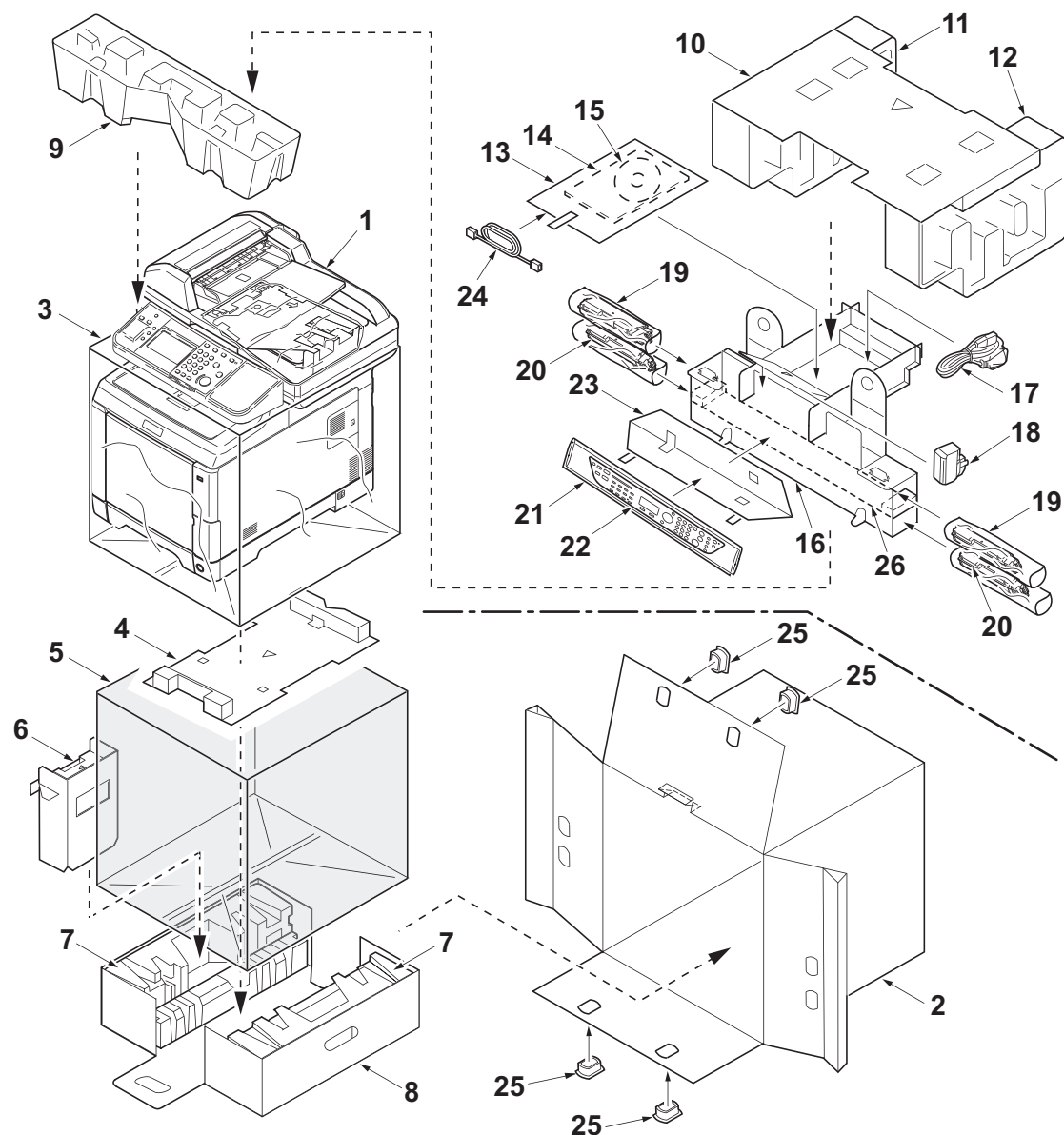


Figure 1-2-2

- |                              |                              |                                   |
|------------------------------|------------------------------|-----------------------------------|
| 1. Machine                   | 11. Top pad L                | 21. Plastic bag (250 × 600)       |
| 2. Outer case                | 12. Top pad R                | 22. Operation labels              |
| 3. Machine cover (620 × 580) | 13. Plastic bag (240 × 350)  | 23. Operation label pad           |
| 4. Bottom spacer             | 14. Installation guide etc.  | 24. Modular cable**               |
| 5. Plastic bag (650 × 650)   | 15. CD-ROM*                  | 25. Hinge joints                  |
| 6. Left spacer               | 16. Middle spacer            | 26. Middle spacer B               |
| 7. Bottom pads               | 17. Power cord               | *: 240 V AC model only.           |
| 8. Bottom case               | 18. Waste toner box          | **: 4 in 1 model (with FAX) only. |
| 9. Front pad                 | 19. Toner containers         |                                   |
| 10. Top spacer               | 20. Plastic bags (200 × 450) |                                   |

120 V AC model

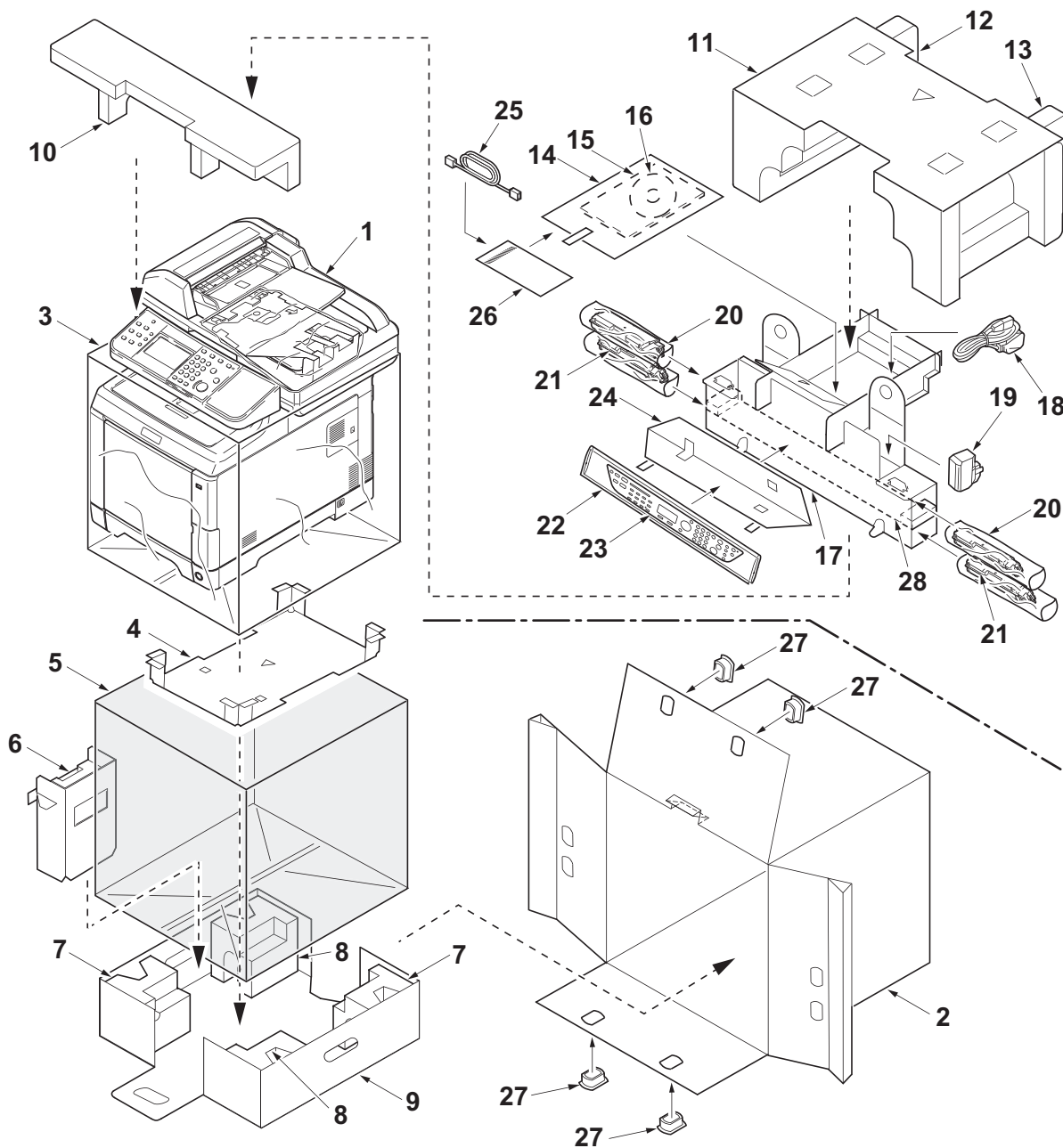


Figure 1-2-3

- |                              |                             |                                  |
|------------------------------|-----------------------------|----------------------------------|
| 1. Machine                   | 11. Top spacer              | 21. Plastic bags (200 × 450)     |
| 2. Outer case                | 12. Top pad L               | 22. Plastic bag (250 × 600)      |
| 3. Machine cover (620 × 580) | 13. Top pad R               | 23. Operation labels             |
| 4. Bottom spacer             | 14. Plastic bag (240 × 350) | 24. Operation label pad          |
| 5. Plastic bag (650 × 650)   | 15. Installation guide etc. | 25. Modular cable*               |
| 6. Left spacer               | 16. CD-ROM                  | 26. Plastic bag*                 |
| 7. Bottom pads A             | 17. Middle spacer           | 27. Hinge joints                 |
| 8. Bottom pads B             | 18. Power cord              | 28. Middle spacer B              |
| 9. Bottom case               | 19. Waste toner box         |                                  |
| 10. Front pad                | 20. Toner containers        | *: 4 in 1 model (with FAX) only. |

Place the machine on a level surface.

Removing the tapes and pads

1. Open the DP.
2. Remove two tapes.
3. Remove the sheet.

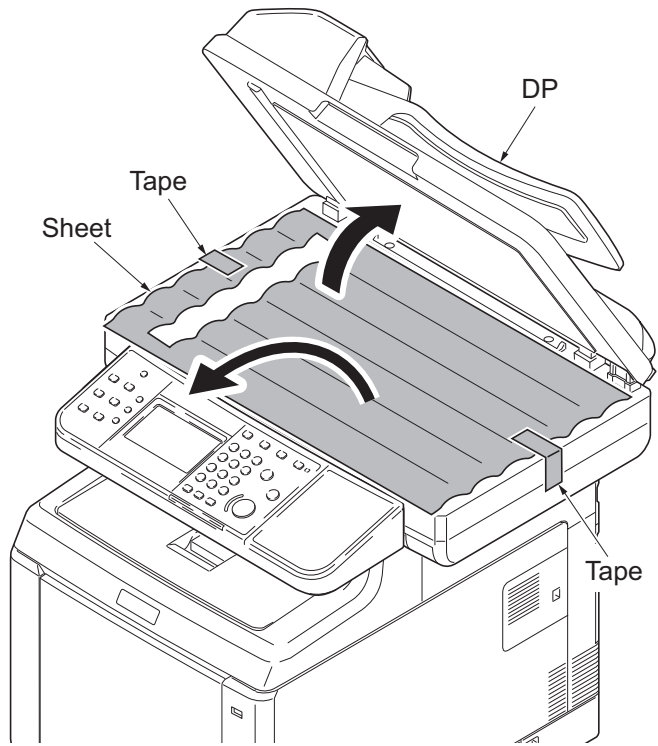


Figure 1-2-4

4. Remove the paper.

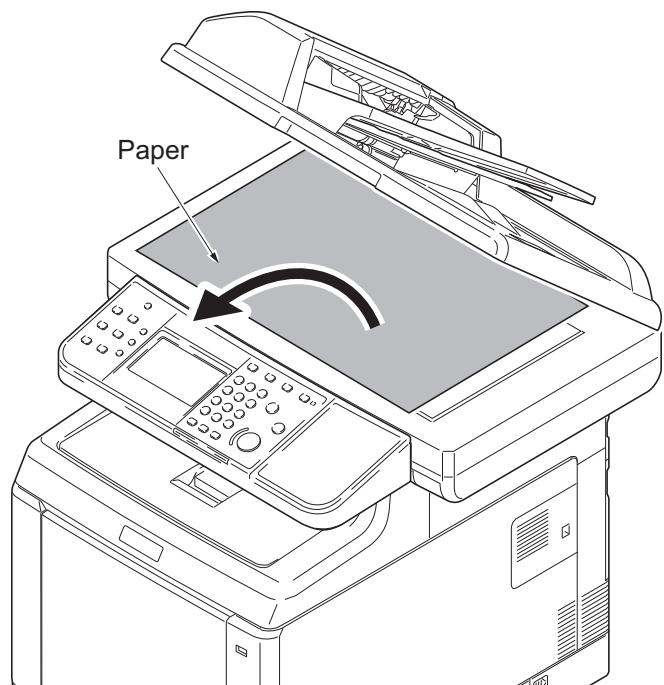


Figure 1-2-5



5. Remove tape A and pad.
6. Move the lock lever to the position of release.
- \* : When turning on power if the lock lever is not released, the error message is displayed.
7. Remove two tapes B.
8. Remove the protection film.
9. Close the DP.

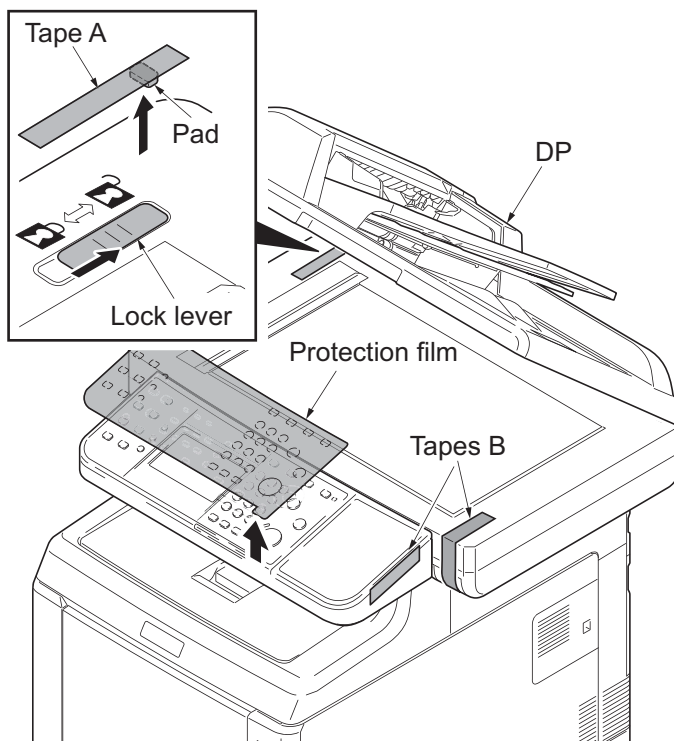


Figure 1-2-6

10. Remove two tapes.

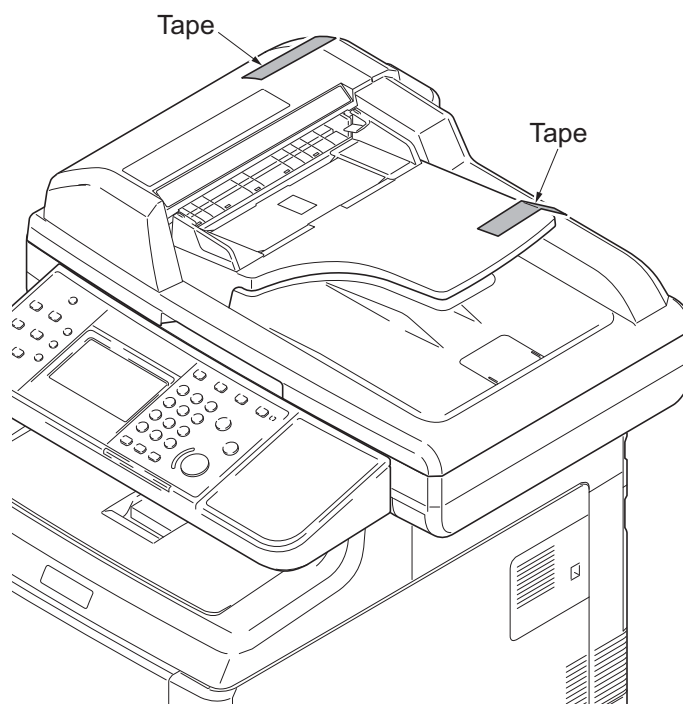
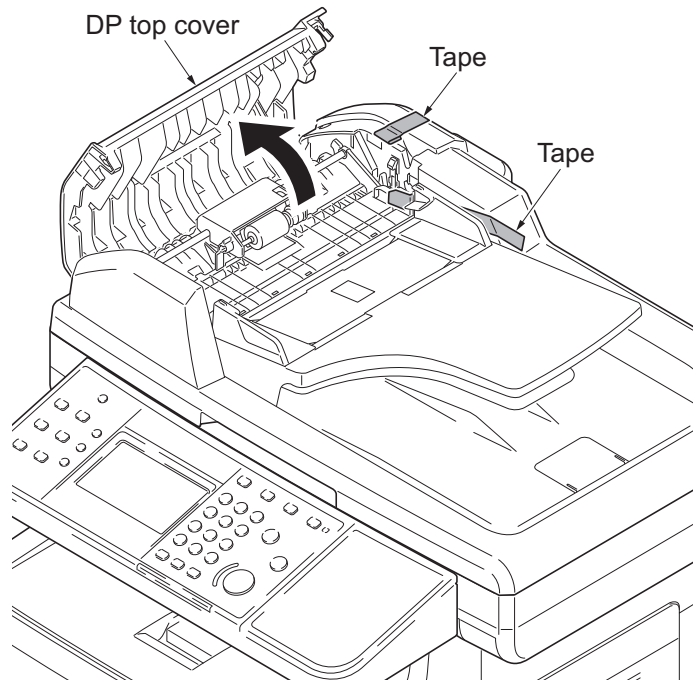


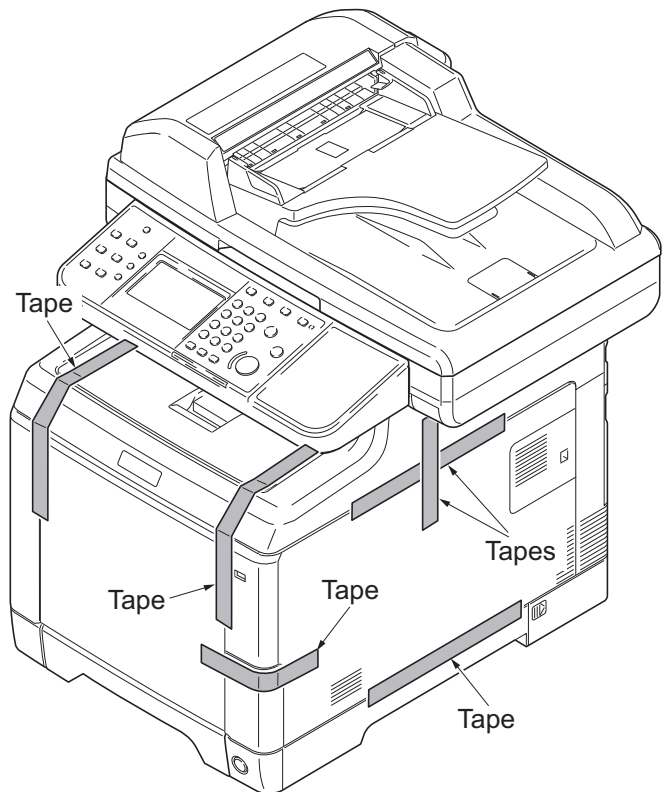
Figure 1-2-7

11. Open the DP top cover.
12. Remove two tapes.
13. Close the DP top cover.



**Figure 1-2-8**

14. Remove six tapes.



**Figure 1-2-9**

15. Remove five tapes.

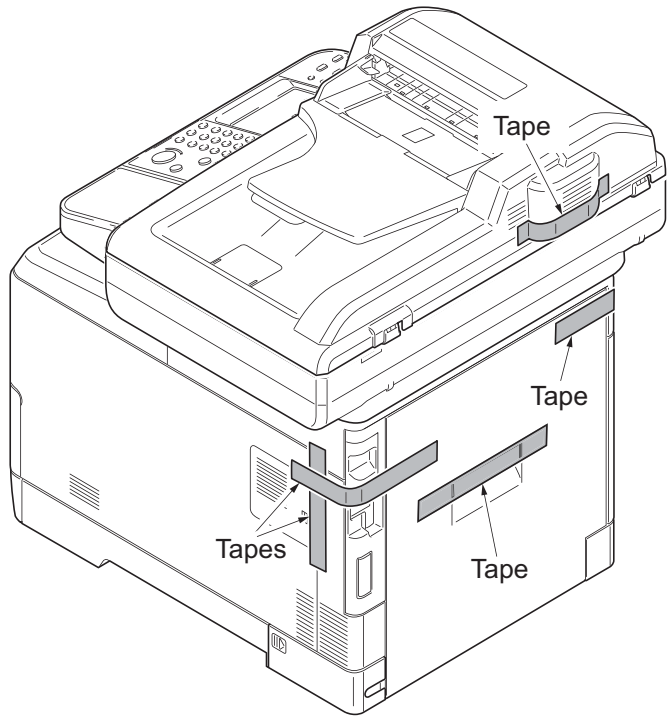


Figure 1-2-10

- 16. Open the inner tray.
- 17. Remove pads A and B.
- 18. Close the inner tray.

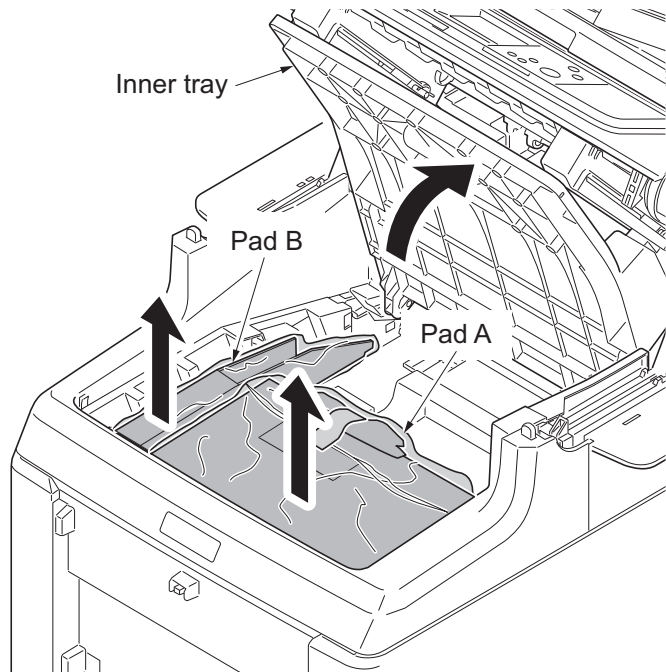


Figure 1-2-11

Installing the toner containers

1. Slide the release lever backward.

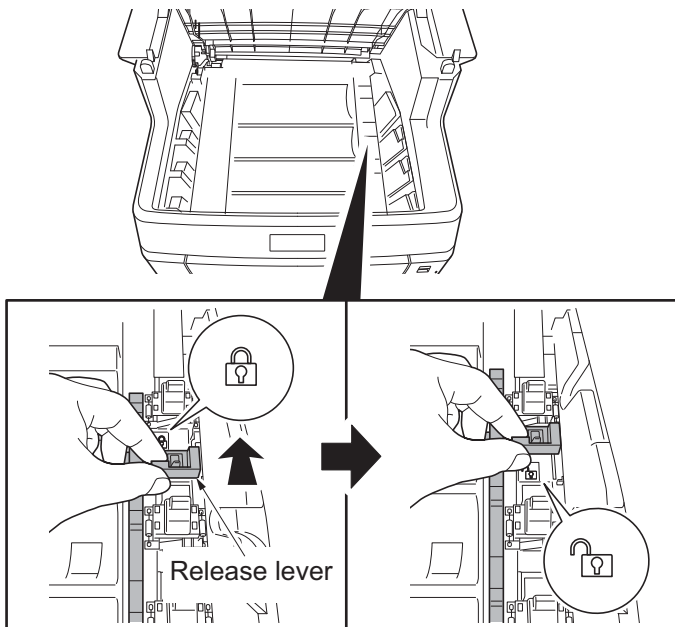


Figure 1-2-12

2. Facing the toner feed slot up and shake the toner container 5 to 6 times.

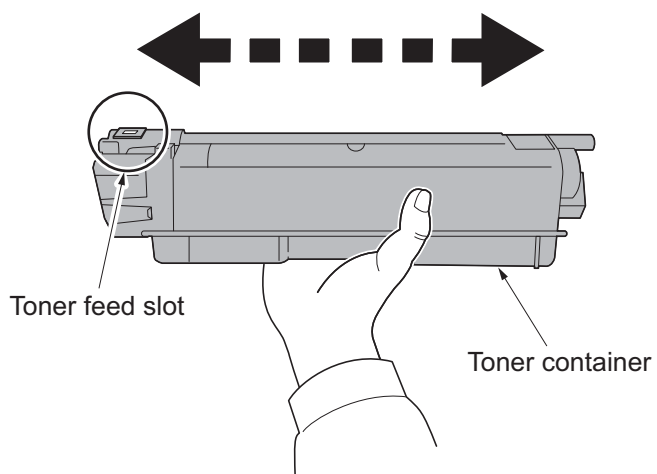
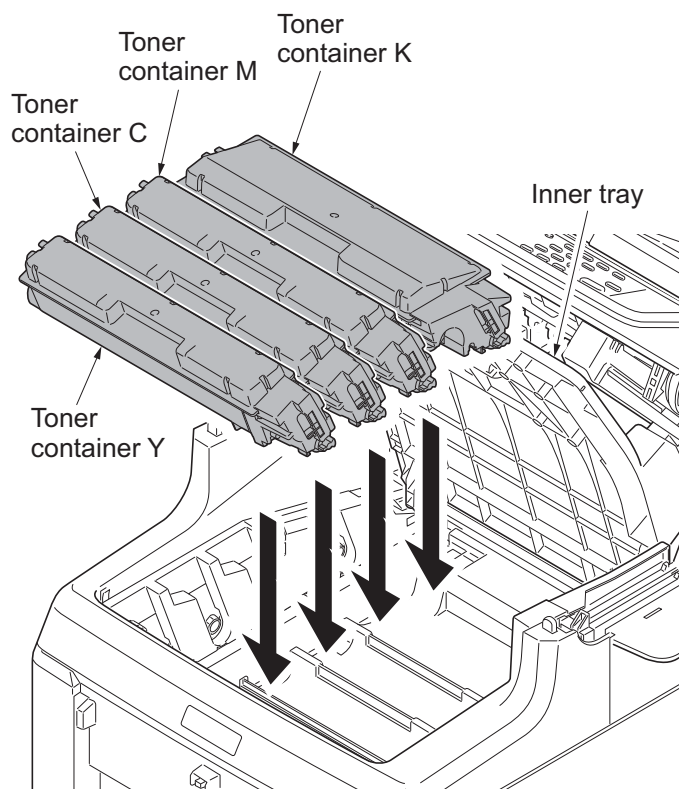


Figure 1-2-13

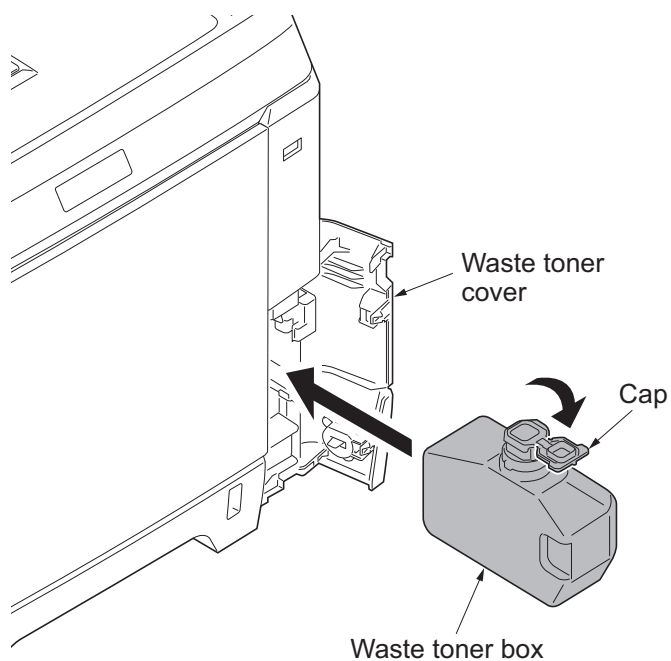
3. Install toner containers (K, M, C, Y).
4. Close the inner tray.



**Figure 1-2-14**

Installing the waste toner box

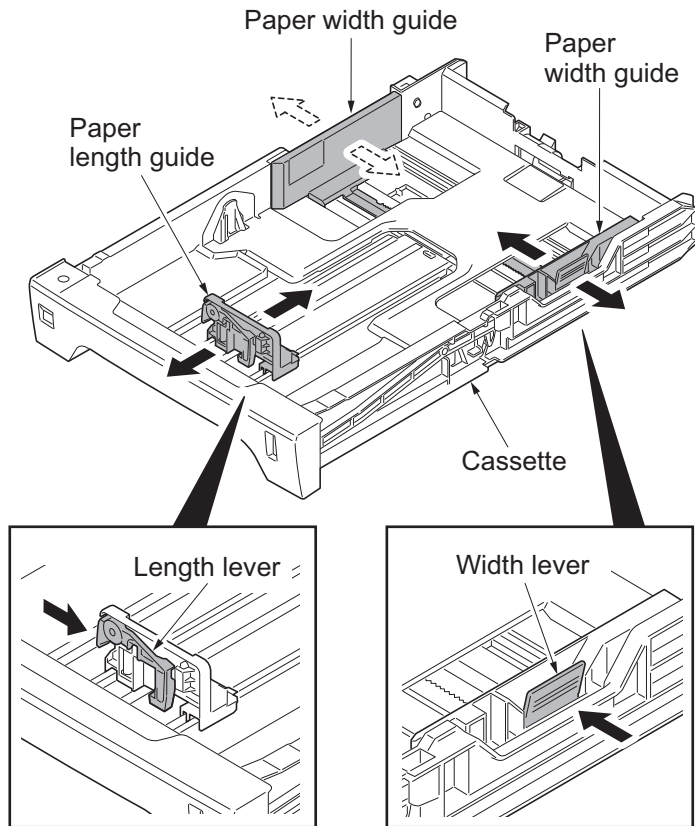
1. Open the waste toner cover.
2. Open the cap of the waste toner box.
3. Install the waste toner box.
4. Close the waste toner cover.



**Figure 1-2-15**

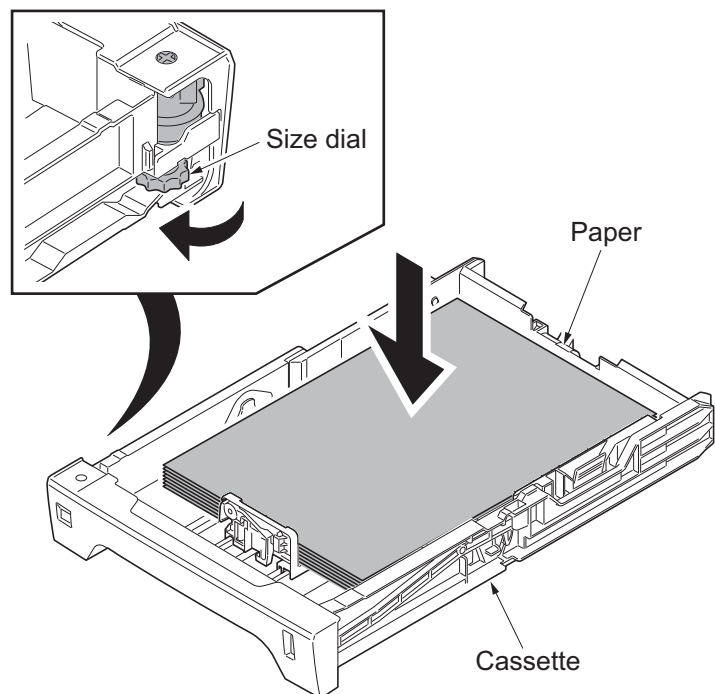
### Loading paper

1. Pull the cassette out.
2. While pressing the width lever, adjust the paper width guides to fit the paper size.
3. While pressing the length lever, adjust the paper length guide to fit the paper size.



**Figure 1-2-16**

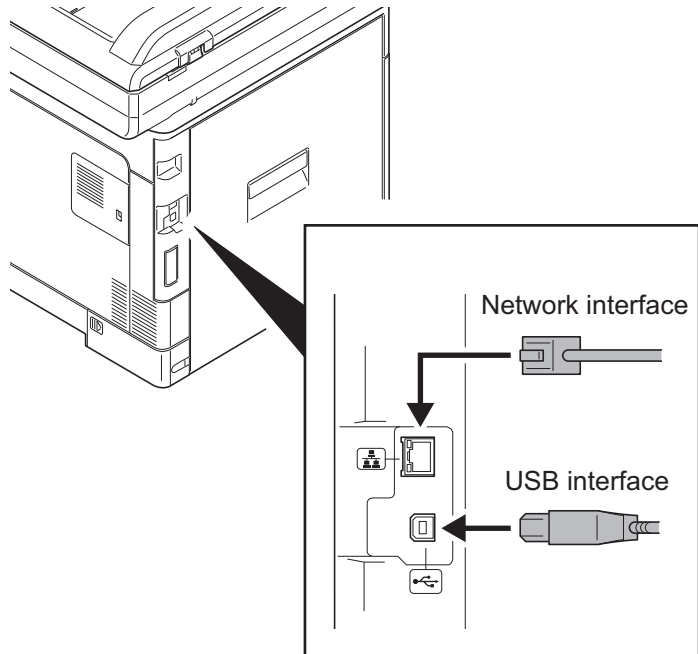
4. Load the paper in the cassette.
5. Turn the paper size dial so that it shows the paper size you are going to use.
6. Insert the cassette.



**Figure 1-2-17**

### Connecting the interface cable

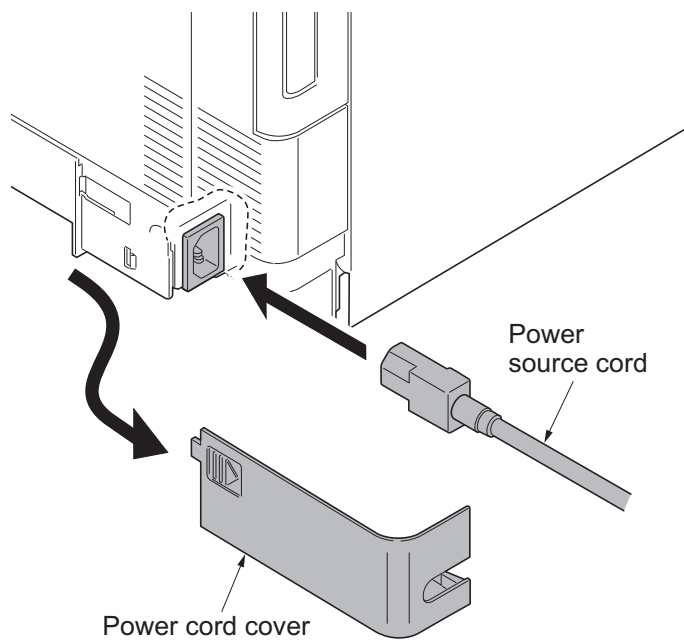
1. Connect the interface cable to the machine and PC or network.



**Figure 1-2-18**

### Connecting the power cord

1. Remove the power cord cover.
2. Connect the power cord to the machine and the wall outlet.
3. Refit the power cord cover.
4. Press the main power switch to turn power on.
5. Installing the printer driver (refer to operation guide).



**Figure 1-2-19**

### Completion of the machine installation

## 1-2-3 Installing the expansion memory (option)

### Procedure

1. Turn off the main power switch.  
**Caution:** Do not insert or remove expansion memory while machine power is on.  
 Doing so may cause damage to the machine and the expansion memory.
2. Remove the memory cover.

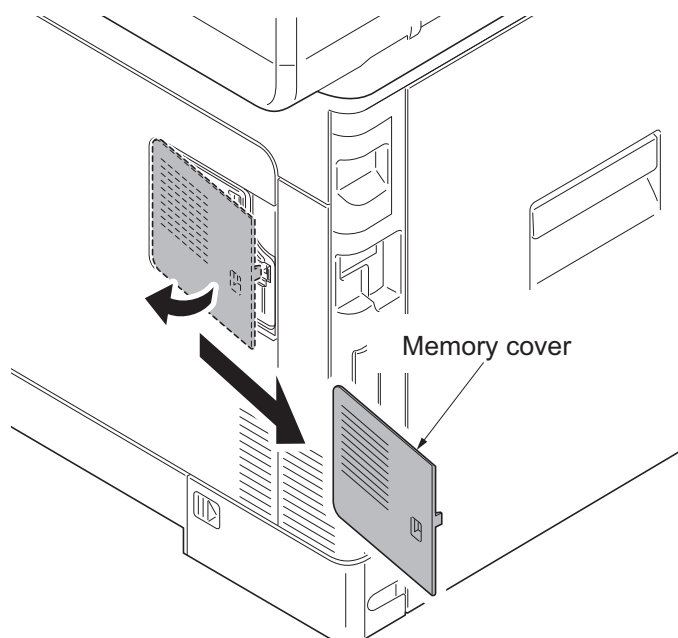


Figure 1-2-20

3. Release the hook and then open the fan bracket.

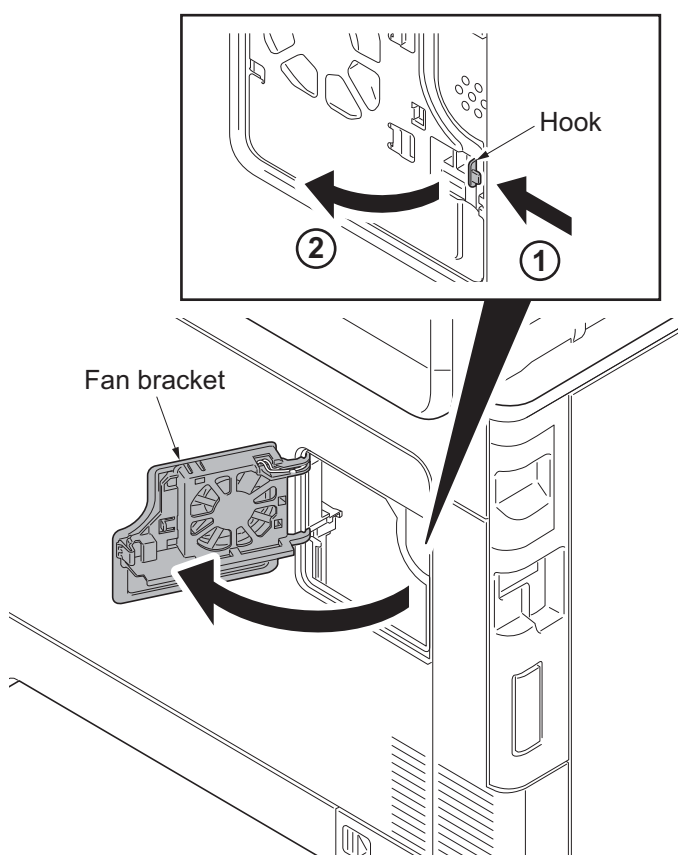
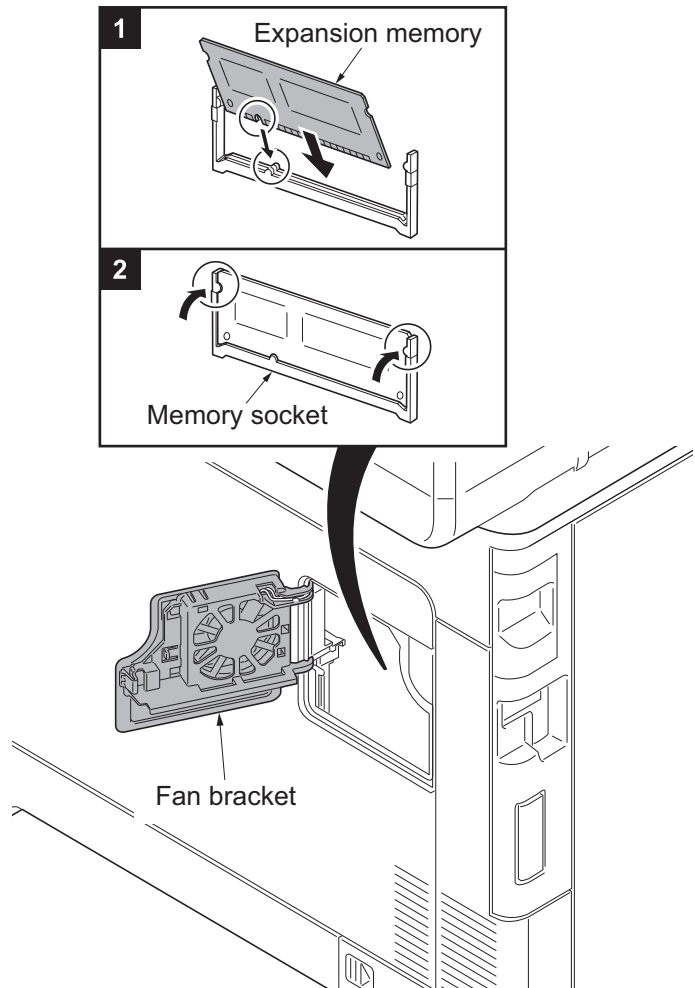


Figure 1-2-21



4. Insert the expansion memory into the memory socket so that the notches on the memory align with the corresponding protrusions in the slot.
  5. Close the fan bracket.
  6. Refit the memory cover.
  7. Print a status page to check the memory expansion (see page 1-3-78).
- If memory expansion has been properly performed, information on the installed memory is printed with the total memory capacity has been increased. Standard memory capacity 1024 MB.

**Figure 1-2-22**

## 1-2-4 Installing the memory card (option)

### <Procedure>

1. Turn off the main power switch.  
Caution: Do not insert or remove memory card while machine power is on.  
Doing so may cause damage to the machine and the memory card.
2. Remove the IF cover.  
(see page 1-5-3)
3. Remove two screws and then remove the option interface slot cover.
4. Install the memory card into the option interface slot.
5. Refit the option interface slot cover by two screws.
6. Refit the IF cover.

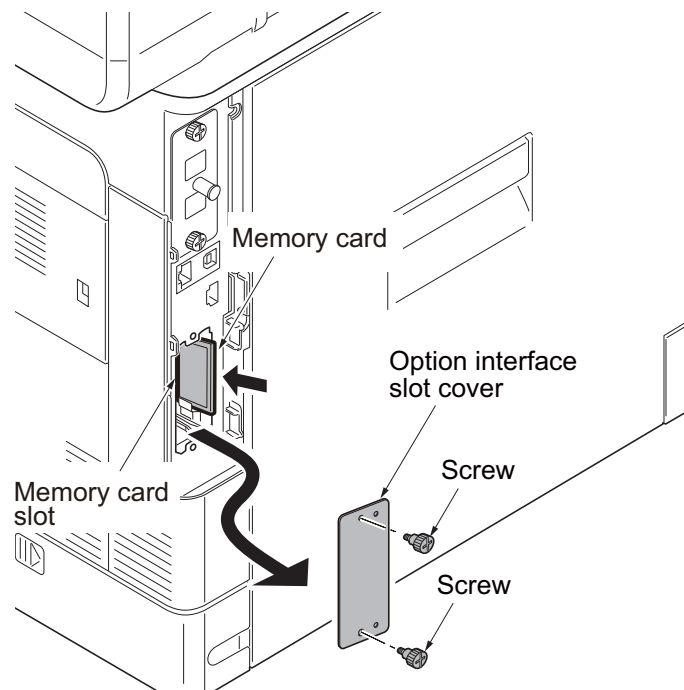
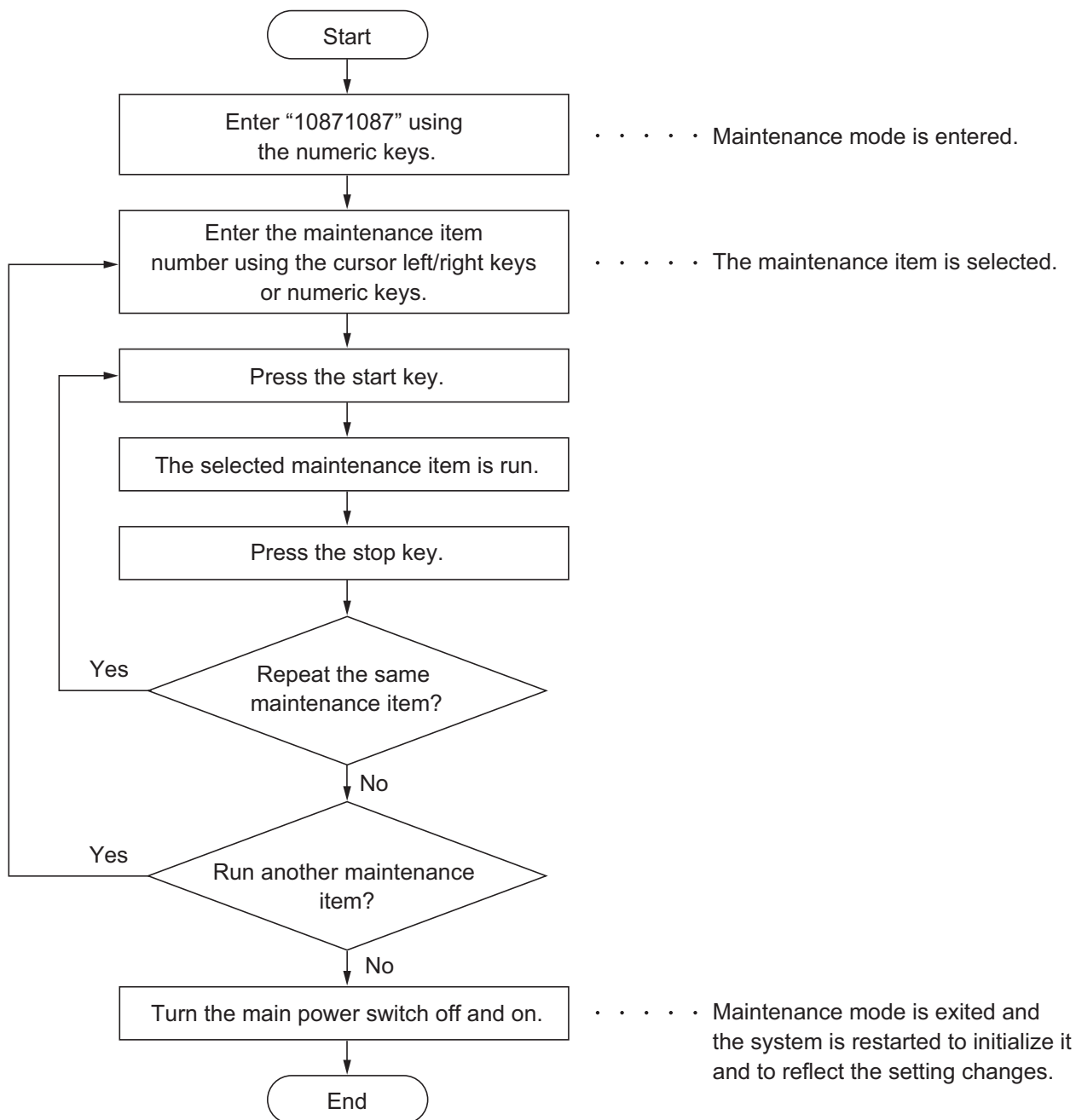


Figure 1-2-23

# 1-3-1 Maintenance mode

The machine is equipped with a maintenance function which can be used to maintain and service the machine.

## (1) Executing a maintenance item



**(2) Maintenance modes item list**

Section	Item No.	Content of maintenance item	Initial setting
General	U000	Outputting an own-status report	-
	U001	Exit Maintenance Mode	-
	U002	Setting the factory default data	-
	U004	Setting the machine number	-
	U010	Set Mainte ID	-
	U019	Firmware Version	-
Initialization	U021	Memory initializing	-
Drive, paper feed and paper conveying system	U034	Adjust Paper Timing Data LSU Out Top LSU Out Left	0/0/0 0/0/0/0/0
Optical	U065	Adjust Scanner Motor Speed	0/0
	U066	Adjust Table Leading Edge Timing	0/0
	U067	Adjust Table Center	0/0
	U068	Adjust DP Scan Position	0/0
	U070	Adjust DP Motor Speed	0
	U071	Adjust DP Leading Edge Timing	0/0/0/0/0
	U072	Adjust DP Original Center	0/12/0
Operation panel and support equipment	U201	Initializing the touch panel	-
	U203	Checking DP operation	-
	U222	Setting the IC card type	Other
	U224	Install Original Panel Display	-
Mode setting	U250	Setting the maintenance cycle	200000
	U251	Checking/clearing the maintenance count	0
	U252	Setting the destination	-
	U253	Switching between double and single counts	Double count
	U260	Selecting the timing for copy counting	Eject
	U285	Setting service status page	On
	U332	Setting the size conversion factor	1.0
	U345	Setting the value for maintenance due indication	0

Section	Item No.	Content of maintenance item	Initial setting
Image processing	U402	Adjust Print Margin	4.0/4.0/4.0/4.0
	U403	Adjust Scanning Margin(Table)	2.0/2.0/2.0/2.0
	U404	Adjust Scanning Margin(DP)	3.0/2.5/3.0/4.0
	U410	Adjusting the halftone automatically	-
	U411	Adjusting the scanner automatically	-
	U425	Setting the target	-
Fax	U600	Initializing all data	-
	U601	Initializing permanent data	-
	U603	Setting user data 1	DTMF
	U604	Setting user data 2	2 (120 V) 1 (220-240 V)
	U605	Clearing data	-
	U610	Setting system 1	3
		Setting the number of lines to be ignored when receiving a fax at 100% magnification	0
		Setting the number of lines to be ignored when receiving a fax in the auto reduction mode	0
	U611	Setting system 2	7
		Setting the number of adjustment lines for automatic reduction	22
		Setting the number of adjustment lines for automatic reduction when A4 paper is set	26
	U612	Setting system 3	On
Selecting if auto reduction in the auxiliary direction is to be performed		Off	
Setting the automatic printing of the protocol list		On	
U620	Setting the remote switching mode	One	
U625	Setting the transmission system 1	3 (120 V)	
	Setting the auto redialing interval	2 (220-240 V)	
U630	Setting the number of times of auto redialing	2 (120 V)	
	Setting communication control 1	3 (220-240 V)	
U630	Setting the communication starting speed	14400bps/V17	
	Setting the reception speed	14400bps	
	Setting the waiting period to prevent echo problems at the sender	300	
	Setting the waiting period to prevent echo problems at the receiver	75	

Section	Item No.	Content of maintenance item	Initial setting
Fax	U631	Setting communication control 2 Setting ECM transmission Setting ECM reception Setting the frequency of the CED signal	On On 2100
	U632	Setting communication control 3 Setting the DIS signal to 4 bytes Setting the CNG detection times in the fax/telephone auto select mode	Off 2Time
	U633	Setting communication control 4 Enabling/disabling V.34 communication Setting the number of times of DIS signal reception Setting the number of times of DIS signal reception Setting the reference for RTN signal output	On On Once 15%
	U634	Setting communication control 5	0
	U640	Setting communication time 1 Setting the one-shot detection time for remote switching Setting the continuous detection time for remote switching	7 80
	U641	Setting communication time 2 Setting the T0 time-out time Setting the T1 time-out time Setting the T2 time-out time Setting the Ta time-out time Setting the Tb1 time-out time Setting the Tb2 time-out time Setting the Tc time-out time Setting the Td time-out time	56 36 69 30 20 80 60 9 (120 V) 6 (220-240 V)
	U650	Setting modem 1 Setting the G3 transmission cable equalizer Setting the G3 reception cable equalizer Setting the modem detection level	0dB 0dB -43dBm
	U651	Setting modem 2 Modem output level  DTMF output level (main value)  DTMF output level (level difference)	9 (120 V) 10 (220-240 V) 5 (120 V) 10.5 (220-240 V) 2 (120 V) 2.5 (220-240 V)
	U660	Setting the NCU Setting the connection to PBX/PSTN Setting PSTN dial tone detection Setting busy tone detection Setting for a PBX Setting the loop current detection before dialing	PSTN On On Loop On
	U670	Outputting lists	-
	U695	FAX function customize	On/Off

Section	Item No.	Content of maintenance item	Initial setting
Fax	U699	Setting the software switches	-
Others	U910	Clearing the print coverage data	-
	U917	Setting backup data reading/writing	-
	U920	Checking the copy counts	-
	U927	Clearing the all copy counts and machine life counts (one time only)	-
	U928	Checking machine life counts	-
	U977	Data capture mode	-
	U995	Memory data Individual setting	-

**(3) Contents of the maintenance mode items**

Item No.	Description																
U000	<p data-bbox="287 293 702 322"><b>Outputting an own-status report</b></p> <p data-bbox="287 360 438 389"><b>Description</b> Outputs lists of the current settings of the maintenance items and paper jam and service call occurrences. Outputs the event log. Also sends output data to the USB memory.</p> <p data-bbox="287 465 399 495"><b>Purpose</b> To check the current setting of the maintenance items, or paper jam or service call occurrences. Before initializing or replacing the backup RAM, output a list of the current settings of the maintenance items to reenter the settings after initialization or replacement.</p> <p data-bbox="287 640 391 669"><b>Method</b></p> <ol data-bbox="303 674 670 739" style="list-style-type: none"> <li>1. Press the start key.</li> <li>2. Select the item to be output.</li> </ol> <table border="1" data-bbox="335 750 1401 943"> <thead> <tr> <th data-bbox="343 757 641 801">Display</th> <th data-bbox="641 757 1393 801">Output list</th> </tr> </thead> <tbody> <tr> <td data-bbox="343 801 641 846">Maintenance</td> <td data-bbox="641 801 1393 846">List of the current settings of the maintenance modes</td> </tr> <tr> <td data-bbox="343 846 641 891">Event</td> <td data-bbox="641 846 1393 891">Outputs the event log</td> </tr> <tr> <td data-bbox="343 891 641 936">All</td> <td data-bbox="641 891 1393 936">Outputs the all reports</td> </tr> </tbody> </table> <ol data-bbox="303 954 742 983" style="list-style-type: none"> <li>3. Press the start key. A list is output.</li> </ol> <p data-bbox="287 1021 726 1050"><b>Method: Send to the USB memory</b></p> <ol data-bbox="303 1055 1428 1328" style="list-style-type: none"> <li>1. Press the power key on the operation panel, and after verifying the main power indicator has gone off, switch off the main power switch.</li> <li>2. Insert USB memory in USB memory slot.</li> <li>3. Turn the main power switch on.</li> <li>4. Enter the maintenance item.</li> <li>5. Press the start key.</li> <li>6. Select the item to be send.</li> <li>7. Select [Text] or [HTML].</li> </ol> <table border="1" data-bbox="335 1339 1401 1532"> <thead> <tr> <th data-bbox="343 1346 641 1391">Display</th> <th data-bbox="641 1346 1393 1391">Output list</th> </tr> </thead> <tbody> <tr> <td data-bbox="343 1391 641 1435">Print</td> <td data-bbox="641 1391 1393 1435">Outputs the report</td> </tr> <tr> <td data-bbox="343 1435 641 1480">USB (Text)</td> <td data-bbox="641 1435 1393 1480">Sends output data to the USB memory (text type)</td> </tr> <tr> <td data-bbox="343 1480 641 1525">USB (HTML)</td> <td data-bbox="641 1480 1393 1525">Sends output data to the USB memory (HTML type)</td> </tr> </tbody> </table> <ol data-bbox="303 1547 805 1612" style="list-style-type: none"> <li>8. Press the start key. Output will be sent to the USB memory.</li> </ol> <p data-bbox="287 1650 438 1680"><b>Completion</b> Press the stop key. The screen for selecting a maintenance item No. is displayed.</p>	Display	Output list	Maintenance	List of the current settings of the maintenance modes	Event	Outputs the event log	All	Outputs the all reports	Display	Output list	Print	Outputs the report	USB (Text)	Sends output data to the USB memory (text type)	USB (HTML)	Sends output data to the USB memory (HTML type)
Display	Output list																
Maintenance	List of the current settings of the maintenance modes																
Event	Outputs the event log																
All	Outputs the all reports																
Display	Output list																
Print	Outputs the report																
USB (Text)	Sends output data to the USB memory (text type)																
USB (HTML)	Sends output data to the USB memory (HTML type)																



Item No.	Description																																																																																																																																																																																																								
U000	<p data-bbox="287 241 414 273"><b>Event log</b></p> <div data-bbox="323 304 1396 1608" style="border: 1px solid black; padding: 10px;"> <h3 data-bbox="355 331 576 376">Event Log</h3> <p data-bbox="355 383 414 409">MFP</p> <p data-bbox="1153 383 1361 409">(2) 06/Apr/2010 08:40</p> <p data-bbox="347 439 831 465">(1) Firmware version 2KX_2000.000.000 2010.04.06</p> <p data-bbox="979 421 1361 465">(3) [XXXXXXXX] (4) [XXXXXXXX] (5) [XXXXXXXX]</p> <hr/> <div style="display: flex; justify-content: space-between;"> <div data-bbox="355 506 790 940"> <p data-bbox="355 506 558 533"><b>(7) Paper Jam Log</b></p> <table border="1"> <thead> <tr> <th>#</th> <th>Count.</th> <th>Event Descriptions</th> </tr> </thead> <tbody> <tr><td>16</td><td>1876543</td><td>0501.01.08.01.01</td></tr> <tr><td>15</td><td>166554</td><td>4020.01.08.01.01</td></tr> <tr><td>14</td><td>4988</td><td>0501.01.08.01.01</td></tr> <tr><td>13</td><td>4988</td><td>4020.01.08.01.01</td></tr> <tr><td>12</td><td>4988</td><td>0501.01.08.01.01</td></tr> <tr><td>11</td><td>4988</td><td>4020.01.08.01.01</td></tr> <tr><td>10</td><td>1103</td><td>0501.01.08.01.01</td></tr> <tr><td>9</td><td>1103</td><td>4020.01.08.01.01</td></tr> <tr><td>8</td><td>1103</td><td>0501.01.08.01.01</td></tr> <tr><td>7</td><td>1103</td><td>4020.01.08.01.01</td></tr> <tr><td>6</td><td>1027</td><td>0501.01.08.01.01</td></tr> <tr><td>5</td><td>1027</td><td>4020.01.08.01.01</td></tr> <tr><td>4</td><td>1027</td><td>0501.01.08.01.01</td></tr> <tr><td>3</td><td>1027</td><td>4020.01.08.01.01</td></tr> <tr><td>2</td><td>406</td><td>0501.01.08.01.01</td></tr> <tr><td>1</td><td>36</td><td>4020.01.08.01.01</td></tr> </tbody> </table> </div> <div data-bbox="893 506 1276 750"> <p data-bbox="893 506 1112 533"><b>(8) Service Call Log</b></p> <table border="1"> <thead> <tr> <th>#</th> <th>Count.</th> <th>Service Code</th> </tr> </thead> <tbody> <tr><td>8</td><td>1881214</td><td>01.6000</td></tr> <tr><td>7</td><td>178944</td><td>01.2100</td></tr> <tr><td>6</td><td>5296</td><td>01.4000</td></tr> <tr><td>5</td><td>5295</td><td>01.6000</td></tr> <tr><td>4</td><td>2099</td><td>01.2100</td></tr> <tr><td>3</td><td>1054</td><td>01.4000</td></tr> <tr><td>2</td><td>809</td><td>01.6000</td></tr> <tr><td>1</td><td>30</td><td>01.2100</td></tr> </tbody> </table> </div> <div data-bbox="893 761 1197 996"> <p data-bbox="893 761 1121 788"><b>(9) Maintenance Log</b></p> <table border="1"> <thead> <tr> <th>#</th> <th>Count.</th> <th>Item</th> </tr> </thead> <tbody> <tr><td>8</td><td>1045571</td><td>01.00</td></tr> <tr><td>7</td><td>104511</td><td>01.00</td></tr> <tr><td>6</td><td>7045</td><td>01.00</td></tr> <tr><td>5</td><td>3454</td><td>01.00</td></tr> <tr><td>4</td><td>3454</td><td>01.01</td></tr> <tr><td>3</td><td>3454</td><td>01.01</td></tr> <tr><td>2</td><td>417</td><td>01.01</td></tr> <tr><td>1</td><td>34</td><td>01.01</td></tr> </tbody> </table> </div> </div> <div style="text-align: center; margin: 10px 0;"> <div data-bbox="483 987 842 1077" style="border: 1px solid black; padding: 5px; display: inline-block;"> <p data-bbox="496 994 829 1032"><b>0501.01.08.01.01</b></p> <p data-bbox="533 1039 825 1066">(a) (b) (c) (d) (e)</p> </div> </div> <div data-bbox="885 1010 1197 1182"> <p data-bbox="885 1010 1150 1037"><b>(10) Unknown toner Log</b></p> <table border="1"> <thead> <tr> <th>#</th> <th>Count.</th> <th>Item</th> </tr> </thead> <tbody> <tr><td>5</td><td>3454</td><td>01.00</td></tr> <tr><td>4</td><td>3454</td><td>01.00</td></tr> <tr><td>3</td><td>3454</td><td>01.00</td></tr> <tr><td>2</td><td>406</td><td>01.00</td></tr> <tr><td>1</td><td>32</td><td>01.00</td></tr> </tbody> </table> </div> <div data-bbox="339 1196 1262 1500"> <p data-bbox="339 1196 526 1223"><b>(11) Counter Log</b></p> <table border="1"> <thead> <tr> <th colspan="3">(f)</th> <th colspan="2">(g)</th> <th colspan="2">(h)</th> </tr> </thead> <tbody> <tr> <td>J0100: 0</td> <td>J0512: 0</td> <td>J4201: 0</td> <td>C0030: 1</td> <td>C2100: 1</td> <td>T00: 1</td> <td></td> </tr> <tr> <td>J0105: 0</td> <td>J0513: 0</td> <td>J4202: 0</td> <td>C0070: 1</td> <td>C2200: 1</td> <td>T01: 1</td> <td></td> </tr> <tr> <td>J0106: 0</td> <td>J0518: 0</td> <td>J4203: 0</td> <td>C0100: 1</td> <td>C2300: 1</td> <td></td> <td></td> </tr> <tr> <td>J0110: 0</td> <td>J0519: 0</td> <td>J4208: 0</td> <td>C0120: 1</td> <td>C2330: 1</td> <td></td> <td></td> </tr> <tr> <td>J0111: 0</td> <td>J1020: 0</td> <td>J4209: 0</td> <td>C0130: 1</td> <td>C2340: 1</td> <td></td> <td></td> </tr> <tr><td>.</td><td>.</td><td>.</td><td>.</td><td>.</td><td></td><td></td></tr> <tr><td>.</td><td>.</td><td>.</td><td>.</td><td>.</td><td></td><td></td></tr> <tr><td>.</td><td>.</td><td>.</td><td>.</td><td>.</td><td></td><td></td></tr> <tr><td>.</td><td>.</td><td>.</td><td>.</td><td>.</td><td></td><td></td></tr> <tr><td>.</td><td>.</td><td>.</td><td>.</td><td>.</td><td></td><td></td></tr> </tbody> </table> </div> <p data-bbox="1082 1554 1353 1581">(6) [XXXXXXXXXXXXXXXXXXXXX]</p> </div>	#	Count.	Event Descriptions	16	1876543	0501.01.08.01.01	15	166554	4020.01.08.01.01	14	4988	0501.01.08.01.01	13	4988	4020.01.08.01.01	12	4988	0501.01.08.01.01	11	4988	4020.01.08.01.01	10	1103	0501.01.08.01.01	9	1103	4020.01.08.01.01	8	1103	0501.01.08.01.01	7	1103	4020.01.08.01.01	6	1027	0501.01.08.01.01	5	1027	4020.01.08.01.01	4	1027	0501.01.08.01.01	3	1027	4020.01.08.01.01	2	406	0501.01.08.01.01	1	36	4020.01.08.01.01	#	Count.	Service Code	8	1881214	01.6000	7	178944	01.2100	6	5296	01.4000	5	5295	01.6000	4	2099	01.2100	3	1054	01.4000	2	809	01.6000	1	30	01.2100	#	Count.	Item	8	1045571	01.00	7	104511	01.00	6	7045	01.00	5	3454	01.00	4	3454	01.01	3	3454	01.01	2	417	01.01	1	34	01.01	#	Count.	Item	5	3454	01.00	4	3454	01.00	3	3454	01.00	2	406	01.00	1	32	01.00	(f)			(g)		(h)		J0100: 0	J0512: 0	J4201: 0	C0030: 1	C2100: 1	T00: 1		J0105: 0	J0513: 0	J4202: 0	C0070: 1	C2200: 1	T01: 1		J0106: 0	J0518: 0	J4203: 0	C0100: 1	C2300: 1			J0110: 0	J0519: 0	J4208: 0	C0120: 1	C2330: 1			J0111: 0	J1020: 0	J4209: 0	C0130: 1	C2340: 1			.	.	.	.	.			.	.	.	.	.			.	.	.	.	.			.	.	.	.	.			.	.	.	.	.		
#	Count.	Event Descriptions																																																																																																																																																																																																							
16	1876543	0501.01.08.01.01																																																																																																																																																																																																							
15	166554	4020.01.08.01.01																																																																																																																																																																																																							
14	4988	0501.01.08.01.01																																																																																																																																																																																																							
13	4988	4020.01.08.01.01																																																																																																																																																																																																							
12	4988	0501.01.08.01.01																																																																																																																																																																																																							
11	4988	4020.01.08.01.01																																																																																																																																																																																																							
10	1103	0501.01.08.01.01																																																																																																																																																																																																							
9	1103	4020.01.08.01.01																																																																																																																																																																																																							
8	1103	0501.01.08.01.01																																																																																																																																																																																																							
7	1103	4020.01.08.01.01																																																																																																																																																																																																							
6	1027	0501.01.08.01.01																																																																																																																																																																																																							
5	1027	4020.01.08.01.01																																																																																																																																																																																																							
4	1027	0501.01.08.01.01																																																																																																																																																																																																							
3	1027	4020.01.08.01.01																																																																																																																																																																																																							
2	406	0501.01.08.01.01																																																																																																																																																																																																							
1	36	4020.01.08.01.01																																																																																																																																																																																																							
#	Count.	Service Code																																																																																																																																																																																																							
8	1881214	01.6000																																																																																																																																																																																																							
7	178944	01.2100																																																																																																																																																																																																							
6	5296	01.4000																																																																																																																																																																																																							
5	5295	01.6000																																																																																																																																																																																																							
4	2099	01.2100																																																																																																																																																																																																							
3	1054	01.4000																																																																																																																																																																																																							
2	809	01.6000																																																																																																																																																																																																							
1	30	01.2100																																																																																																																																																																																																							
#	Count.	Item																																																																																																																																																																																																							
8	1045571	01.00																																																																																																																																																																																																							
7	104511	01.00																																																																																																																																																																																																							
6	7045	01.00																																																																																																																																																																																																							
5	3454	01.00																																																																																																																																																																																																							
4	3454	01.01																																																																																																																																																																																																							
3	3454	01.01																																																																																																																																																																																																							
2	417	01.01																																																																																																																																																																																																							
1	34	01.01																																																																																																																																																																																																							
#	Count.	Item																																																																																																																																																																																																							
5	3454	01.00																																																																																																																																																																																																							
4	3454	01.00																																																																																																																																																																																																							
3	3454	01.00																																																																																																																																																																																																							
2	406	01.00																																																																																																																																																																																																							
1	32	01.00																																																																																																																																																																																																							
(f)			(g)		(h)																																																																																																																																																																																																				
J0100: 0	J0512: 0	J4201: 0	C0030: 1	C2100: 1	T00: 1																																																																																																																																																																																																				
J0105: 0	J0513: 0	J4202: 0	C0070: 1	C2200: 1	T01: 1																																																																																																																																																																																																				
J0106: 0	J0518: 0	J4203: 0	C0100: 1	C2300: 1																																																																																																																																																																																																					
J0110: 0	J0519: 0	J4208: 0	C0120: 1	C2330: 1																																																																																																																																																																																																					
J0111: 0	J1020: 0	J4209: 0	C0130: 1	C2340: 1																																																																																																																																																																																																					
.	.	.	.	.																																																																																																																																																																																																					
.	.	.	.	.																																																																																																																																																																																																					
.	.	.	.	.																																																																																																																																																																																																					
.	.	.	.	.																																																																																																																																																																																																					
.	.	.	.	.																																																																																																																																																																																																					

Figure 1-3-1

Item No.	Description			
U000	<b>Detail of event log</b>			
	<b>No.</b>	<b>Items</b>	<b>Description</b>	
	(1)	System version		
	(2)	System date		
	(3)	Engine soft version		
	(4)	Engine boot version		
	(5)	Operation panel mask version		
	(6)	Machine serial number		
	(7)	Paper Jam Log	<p><b>#</b></p> <p>Remembers 1 to 16 of occurrence. If the occurrence of the previous paper jam is less than 16, all of the paper jams are logged. When the occurrence exceeds 16, the oldest occurrence is removed.</p>	<p><b>Count.</b></p> <p>The total page count at the time of the paper jam.</p> <p><b>Event</b></p> <p>Log code (hexadecimal, 5 categories)</p> <p>(a) Cause of a paper jam</p> <p>(b) Paper source</p> <p>(c) Paper size</p> <p>(d) Paper type</p> <p>(e) Paper eject</p> <p>(a) Cause of paper jam (Hexadecimal)</p> <p>Refer to P.1-4-1 for paper jam location</p> <p>0100: Controller sequence error</p> <p>0105: Registration sensor not detected</p> <p>0106: Controller sequence error</p> <p>0110: Inner tray open</p> <p>0111: Rear cover open</p> <p>0112: Front cover open</p> <p>0113: MP tray open</p> <p>0120: Controller sequence error</p> <p>0121: Controller sequence error</p> <p>0211: Rear cover open (paper feeder 1)</p> <p>0212: Rear cover open (paper feeder 2)</p> <p>0501: No paper feed from cassette 1</p> <p>0502: No paper feed from cassette 2</p> <p>0503: No paper feed from cassette 3</p> <p>0508: No paper feed from duplex section</p> <p>0509: No paper feed from MP tray</p> <p>0511: Multiple sheets in cassette 1</p> <p>0512: Multiple sheets in cassette 2</p> <p>0513: Multiple sheets in cassette 3</p> <p>0518: Multiple sheets in duplex section</p> <p>0519: Multiple sheets in MP tray</p> <p>1020: MP paper conveying sensor is turned ON</p> <p>1403: PF feed sensor 1 does not turn ON</p> <p>1413: PF feed sensor 1 does not turn OFF</p> <p>1420: PF feed sensor 1 is turned ON</p> <p>1620: PF feed sensor 2 is turned ON</p>

Item No.	Description																																											
U000	<b>No.</b>	<b>Items</b>	<b>Description</b>																																									
	(7) cont.	Paper Jam Log	4002: Registration sensor does not turn ON (Paper feeder 1) 4003: Registration sensor does not turn ON (Paper feeder 2) 4009: Registration sensor does not turn ON (MP tray) 4012: Registration sensor does not turn OFF (Paper feeder 1) 4013: Registration sensor does not turn OFF (Paper feeder 2) 4019: Registration sensor does not turn OFF (MP tray) 4020: Registration sensor is turned ON 4201: Eject sensor does not turn ON (Cassette) 4202: Eject sensor does not turn ON (Paper feeder 1) 4203: Eject sensor does not turn ON (Paper feeder 2) 4208: Eject sensor does not turn ON (Duplex) 4209: Eject sensor does not turn ON (MP tray) 4211: Eject sensor does not turn OFF (Cassette) 4212: Eject sensor does not turn OFF (Paper feeder 1) 4213: Eject sensor does not turn OFF (Paper feeder 2) 4218: Eject sensor does not turn OFF (Duplex) 4219: Eject sensor does not turn OFF (MP tray) 4220: Eject sensor is turned ON 9010: DP top cover open 9400: No original feed 9401: An original jam in the original switchback section 2 9410: An original jam in the original conveying section 9411: An original jam in the original switchback section 1																																									
	(b) Detail of paper source (Hexadecimal)																																											
	00: MP tray 01: Cassette 1 02: Cassette 2 (paper feeder 1) 03: Cassette 3 (paper feeder 2) 04 to 09: Reserved																																											
	(c) Detail of paper size (Hexadecimal)																																											
<table border="1"> <tbody> <tr> <td data-bbox="576 1417 855 1462">00: (Not specified)</td> <td data-bbox="855 1417 1134 1462">0B: B4</td> <td data-bbox="1134 1417 1418 1462">22: Special 1</td> </tr> <tr> <td data-bbox="576 1462 855 1507">01: Monarch</td> <td data-bbox="855 1462 1134 1507">0C: Ledger</td> <td data-bbox="1134 1462 1418 1507">23: Special 2</td> </tr> <tr> <td data-bbox="576 1507 855 1552">02: Business</td> <td data-bbox="855 1507 1134 1552">0D: A5R</td> <td data-bbox="1134 1507 1418 1552">24: A3 wide</td> </tr> <tr> <td data-bbox="576 1552 855 1597">03: International DL</td> <td data-bbox="855 1552 1134 1597">0E: A6</td> <td data-bbox="1134 1552 1418 1597">25: Ledger wide</td> </tr> <tr> <td data-bbox="576 1597 855 1641">04: International C5</td> <td data-bbox="855 1597 1134 1641">0F: B6</td> <td data-bbox="1134 1597 1418 1641">26: Full bleed paper (12 x 8)</td> </tr> <tr> <td data-bbox="576 1641 855 1686">05: Executive</td> <td data-bbox="855 1641 1134 1686">10: Commercial #9</td> <td data-bbox="1134 1641 1418 1686">27: 8K</td> </tr> <tr> <td data-bbox="576 1686 855 1731">06: Letter-R</td> <td data-bbox="855 1686 1134 1731">11: Commercial #6</td> <td data-bbox="1134 1686 1418 1731">28: 16K-R</td> </tr> <tr> <td data-bbox="576 1731 855 1776">86: Letter-E</td> <td data-bbox="855 1731 1134 1776">12: ISO B5</td> <td data-bbox="1134 1731 1418 1776">A8: 16K-E</td> </tr> <tr> <td data-bbox="576 1776 855 1821">07: Legal</td> <td data-bbox="855 1776 1134 1821">13: Custom size</td> <td data-bbox="1134 1776 1418 1821">32: Statement-R</td> </tr> <tr> <td data-bbox="576 1821 855 1865">08: A4R</td> <td data-bbox="855 1821 1134 1865">1E: C4</td> <td data-bbox="1134 1821 1418 1865">B2: Statement-E</td> </tr> <tr> <td data-bbox="576 1865 855 1910">88: A4E</td> <td data-bbox="855 1865 1134 1910">1F: Postcard</td> <td data-bbox="1134 1865 1418 1910">33: Folio</td> </tr> <tr> <td data-bbox="576 1910 855 1955">09: B5R</td> <td data-bbox="855 1910 1134 1955">20: Reply-paid post- card</td> <td data-bbox="1134 1910 1418 1955">34: Western type 2</td> </tr> <tr> <td data-bbox="576 1955 855 2000">89: B5E</td> <td data-bbox="855 1955 1134 2000">21: Oficio II</td> <td data-bbox="1134 1955 1418 2000">35: Western type 4</td> </tr> <tr> <td data-bbox="576 2000 855 2045">0A: A3</td> <td></td> <td></td> </tr> </tbody> </table>			00: (Not specified)	0B: B4	22: Special 1	01: Monarch	0C: Ledger	23: Special 2	02: Business	0D: A5R	24: A3 wide	03: International DL	0E: A6	25: Ledger wide	04: International C5	0F: B6	26: Full bleed paper (12 x 8)	05: Executive	10: Commercial #9	27: 8K	06: Letter-R	11: Commercial #6	28: 16K-R	86: Letter-E	12: ISO B5	A8: 16K-E	07: Legal	13: Custom size	32: Statement-R	08: A4R	1E: C4	B2: Statement-E	88: A4E	1F: Postcard	33: Folio	09: B5R	20: Reply-paid post- card	34: Western type 2	89: B5E	21: Oficio II	35: Western type 4	0A: A3		
00: (Not specified)	0B: B4	22: Special 1																																										
01: Monarch	0C: Ledger	23: Special 2																																										
02: Business	0D: A5R	24: A3 wide																																										
03: International DL	0E: A6	25: Ledger wide																																										
04: International C5	0F: B6	26: Full bleed paper (12 x 8)																																										
05: Executive	10: Commercial #9	27: 8K																																										
06: Letter-R	11: Commercial #6	28: 16K-R																																										
86: Letter-E	12: ISO B5	A8: 16K-E																																										
07: Legal	13: Custom size	32: Statement-R																																										
08: A4R	1E: C4	B2: Statement-E																																										
88: A4E	1F: Postcard	33: Folio																																										
09: B5R	20: Reply-paid post- card	34: Western type 2																																										
89: B5E	21: Oficio II	35: Western type 4																																										
0A: A3																																												

Item No.	Description				
<b>U000</b>	<b>Description</b>				
	(7) cont.	Paper Jam Log	(d) Detail of paper type (Hexadecimal)		
			01: Plain 02: Transparency 03: Preprinted 04: Labels 05: Bond 06: Recycled 07: Vellum 08: Rough 09: Letterhead	0A: Color 0B: Prepunched 0C: Envelope 0D: Cardstock 0E: Coated 0F: 2nd side 10: Thick 11: High quality	15: Custom 1 16: Custom 2 17: Custom 3 18: Custom 4 19: Custom 5 1A: Custom 6 1B: Custom 7 1C: Custom 8
			(e) Detail of paper eject location (Hexadecimal)		
			01: Face down (FD)		
	(8)	Service Call Log	#	Count.	Service Code
			Remembers 1 to 8 of occurrence of self diagnostics error. If the occurrence of the previous diagnostics error is less than 8, all of the diagnostics errors are logged.	The total page count at the time of the self diagnostics error.	Self diagnostic error code (See page 1-4-5)  Example: 01.6000  01: Self diagnostic error 6000: Self diagnostic error code number
	(9)	Maintenance Log	#	Count.	Item
			Remembers 1 to 8 of occurrence of replacement. If the occurrence of the previous replacement of toner container is less than 8, all of the occurrences of replacement are logged.	The total page count at the time of the replacement of the toner container.  * :The toner replacement log is triggered by toner empty. This record may contain such a reference as the toner container is inserted twice or a used toner container is inserted.	Code of maintenance replacing item (1 byte, 2 categories)  First byte (Replacing item) 01: Toner container Second byte (Type of replacing item) 00: Black 01: Cyan 02: Magenta 03: Yellow  First byte (Replacing item) 02: Maintenance kit Second byte (Type of replacing item) 01: MK-590/592/594

Item No.	Description				
U000	<b>Description</b>				
	<b>No.</b>	<b>Items</b>	<b>Description</b>		
	(10)	Unknown Toner Log	<p>#</p> <p>Remembers 1 to 5 of occurrence of unknown toner detection. If the occurrence of the previous unknown toner detection is less than 5, all of the unknown toner detection are logged.</p>	<p>Count.</p> <p>The total page count at the time of the toner empty error with using an unknown toner container.</p>	<p>Item</p> <p>Unknown toner log code (1 byte, 2 categories)</p> <p>First byte 01: Toner container (Fixed)</p> <p>Second byte 00: Black 01: Cyan 02: Magenta 03: Yellow</p>
	(11)	<p>Counter Log</p> <p>Comprised of three log counters including paper jams, self diagnostics errors, and replacement of the toner container.</p>	<p>(f) Paper jam</p> <p>Indicates the log counter of paper jams depending on location.</p> <p>Refer to Paper Jam Log.</p> <p>All instances including those are not occurred are displayed.</p>	<p>(g) Self diagnostic error</p> <p>Indicates the log counter of self diagnostics errors depending on cause. (See page 1-4-5)</p> <p>Example: C6000: 4</p> <p>Self diagnostics error 6000 has happened four times.</p>	<p>(h) Maintenance item replacing</p> <p>Indicates the log counter depending on the maintenance item for maintenance.</p> <p>T: Toner container 00: Black 01: Cyan 02: Magenta 03: Yellow</p> <p>M: Maintenance kit 01: MK-590/592/594</p> <p>Example: T00: 1 The toner container has been replaced once.</p> <p>* :The toner replacement log is triggered by toner empty. This record may contain such a reference as the toner container is inserted twice or a used toner container is inserted.</p>

Item No.	Description								
U001	<p><b>Exit Maintenance Mode</b></p> <p><b>Description</b> Exits the maintenance mode and returns to the normal copy mode.</p> <p><b>Purpose</b> To exit the maintenance mode.</p> <p><b>Method</b> 1. Press the start key. The normal copy mode is entered.</p>								
U002	<p><b>Setting the factory default data</b></p> <p><b>Description</b> Restores the machine conditions to the factory default settings.</p> <p><b>Purpose</b> To move the image scanner unit to the home position.</p> <p><b>Method</b> 1. Press the start key. 2. Select [Mode1(All)]. 3. Press the start key. The image scanner unit returns to the home position. 4. Turn the main power switch off and on. * : An error code is displayed in case of an initialization error. When errors occurred, turn main power switch off then on, and execute initialization using maintenance item U002.</p> <p><b>Error codes</b></p> <table border="1" data-bbox="336 1303 1401 1496"> <thead> <tr> <th data-bbox="336 1303 639 1352">Codes</th> <th data-bbox="639 1303 1401 1352">Description</th> </tr> </thead> <tbody> <tr> <td data-bbox="336 1352 639 1402">0001</td> <td data-bbox="639 1352 1401 1402">Controller error</td> </tr> <tr> <td data-bbox="336 1402 639 1451">0020</td> <td data-bbox="639 1402 1401 1451">Engine error</td> </tr> <tr> <td data-bbox="336 1451 639 1496">0040</td> <td data-bbox="639 1451 1401 1496">Scanner error</td> </tr> </tbody> </table>	Codes	Description	0001	Controller error	0020	Engine error	0040	Scanner error
Codes	Description								
0001	Controller error								
0020	Engine error								
0040	Scanner error								

Item No.	Description										
U004	<p data-bbox="292 241 654 275"><b>Setting the machine number</b></p> <p data-bbox="292 313 438 342"><b>Description</b></p> <p data-bbox="292 347 737 376">Sets or displays the machine number.</p> <p data-bbox="292 383 399 412"><b>Purpose</b></p> <p data-bbox="292 416 729 445">To check or set the machine number.</p> <p data-bbox="292 486 387 515"><b>Method</b></p> <p data-bbox="308 519 564 548">1. Press the start key.</p> <p data-bbox="336 553 1240 582">If the machine serial number of engine PWB matches with that of main PWB</p> <table border="1" data-bbox="336 598 1401 694"> <thead> <tr> <th data-bbox="343 604 636 645">Display</th> <th data-bbox="636 604 1394 645">Description</th> </tr> </thead> <tbody> <tr> <td data-bbox="343 651 636 692">Machine No.</td> <td data-bbox="636 651 1394 692">Displays the machine serial number</td> </tr> </tbody> </table> <p data-bbox="336 705 1323 734">If the machine serial number of engine PWB does not match with that of main PWB</p> <table border="1" data-bbox="336 750 1401 896"> <thead> <tr> <th data-bbox="343 757 636 797">Display</th> <th data-bbox="636 757 1394 797">Description</th> </tr> </thead> <tbody> <tr> <td data-bbox="343 804 636 844">Machine No.(Main)</td> <td data-bbox="636 804 1394 844">Displays the machine serial number of main</td> </tr> <tr> <td data-bbox="343 851 636 891">Machine No.(Eng)</td> <td data-bbox="636 851 1394 891">Displays the machine serial number of engine</td> </tr> </tbody> </table> <p data-bbox="292 940 383 969"><b>Setting</b></p> <p data-bbox="292 974 941 1003">Carry out if the machine serial number does not match.</p> <ol data-bbox="308 1008 882 1072" style="list-style-type: none"> <li data-bbox="308 1008 531 1037">1. Press [Execute].</li> <li data-bbox="308 1041 882 1072">2. Press the start key. Writing of serial No. starts.</li> </ol> <p data-bbox="292 1113 438 1142"><b>Completion</b></p> <p data-bbox="292 1146 1254 1176">Press the stop key. The screen for selecting a maintenance item No. is displayed.</p>	Display	Description	Machine No.	Displays the machine serial number	Display	Description	Machine No.(Main)	Displays the machine serial number of main	Machine No.(Eng)	Displays the machine serial number of engine
Display	Description										
Machine No.	Displays the machine serial number										
Display	Description										
Machine No.(Main)	Displays the machine serial number of main										
Machine No.(Eng)	Displays the machine serial number of engine										

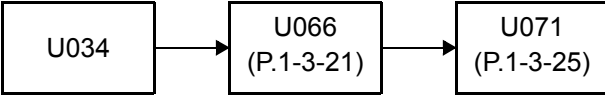
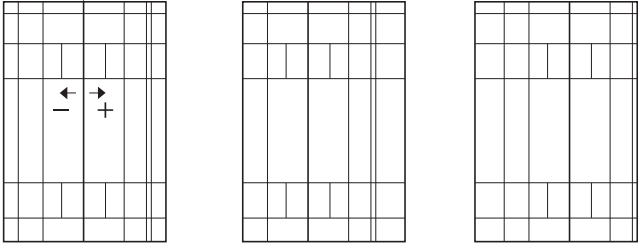
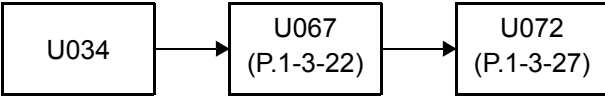
Item No.	Description						
U010	<p><b>Set Mainte ID</b></p> <p><b>Description</b> Maintenance mode ID for markets is changed.</p> <p><b>Purpose</b> The brittleness of a security function is improved by changing maintenance mode ID for markets.</p> <p><b>Method</b></p> <ol style="list-style-type: none"> <li>1. Press the start key.</li> <li>2. Select the item to be set.</li> </ol> <table border="1" data-bbox="336 618 1401 763"> <thead> <tr> <th data-bbox="336 618 639 663">Display</th> <th data-bbox="639 618 1401 663">Description</th> </tr> </thead> <tbody> <tr> <td data-bbox="336 663 639 707">Change</td> <td data-bbox="639 663 1401 707">Maintenance mode ID for markets is changed.</td> </tr> <tr> <td data-bbox="336 707 639 763">Initialize</td> <td data-bbox="639 707 1401 763">Maintenance mode ID for markets is initialized.</td> </tr> </tbody> </table> <p><b>[Setting: Change]</b></p> <ol style="list-style-type: none"> <li>1. Select the [New ID(Reconfirm)].</li> <li>2. New ID is inputted using a ten key. * : New ID of 8 figures is taken as the arbitrary combination of 0 to 9, *, and #. (* or # is certainly included)</li> <li>3. Select the [Excute].</li> <li>4. Press the start key. ID is set.</li> <li>5. Turn the main power switch off and on. Allow more than 5 seconds between Off and On.</li> </ol> <p><b>[Setting: Initialaize]</b></p> <ol style="list-style-type: none"> <li>1. Select the [Excute].</li> <li>2. Press the start key. ID is intialized.</li> <li>3. Turn the main power switch off and on. Allow more than 5 seconds between Off and On.</li> </ol> <p><b>Completion</b> Press the stop key. The screen for selecting a maintenance item No. is displayed.</p>	Display	Description	Change	Maintenance mode ID for markets is changed.	Initialize	Maintenance mode ID for markets is initialized.
Display	Description						
Change	Maintenance mode ID for markets is changed.						
Initialize	Maintenance mode ID for markets is initialized.						





Item No.	Description																																				
U019	<p data-bbox="292 241 515 271"><b>Firmware Version</b></p> <p data-bbox="292 313 440 342"><b>Description</b> Displays the part number of the ROM fitted to each PWB.</p> <p data-bbox="292 383 400 412"><b>Purpose</b> To check the part number or to decide, if the newest version of ROM is installed.</p> <p data-bbox="292 488 387 517"><b>Method</b></p> <ol data-bbox="308 521 954 584" style="list-style-type: none"> <li>1. Press the start key. The ROM version are displayed.</li> <li>2. Change the screen using the cursor up/down keys.</li> </ol> <table border="1" data-bbox="336 598 1401 1460"> <thead> <tr> <th data-bbox="336 598 639 642">Display</th> <th data-bbox="639 598 1401 642">Description</th> </tr> </thead> <tbody> <tr> <td>Main</td> <td>Main ROM</td> </tr> <tr> <td>MMI</td> <td>Operation ROM</td> </tr> <tr> <td>Engine</td> <td>Engine ROM</td> </tr> <tr> <td>Engine Boot</td> <td>Engine booting</td> </tr> <tr> <td>Scanner</td> <td>Scanner ROM</td> </tr> <tr> <td>Scanner Boot</td> <td>Scanner booting</td> </tr> <tr> <td>Browser</td> <td>Browser ROM</td> </tr> <tr> <td>Dictionary</td> <td>-</td> </tr> <tr> <td>Solution Framework</td> <td>Framework ROM</td> </tr> <tr> <td>Cassette2</td> <td>Paper feeder 2</td> </tr> <tr> <td>Cassette3</td> <td>Paper feeder 3</td> </tr> <tr> <td>Option Language</td> <td>Optional language ROM</td> </tr> <tr> <td>Color Table1</td> <td>Color table 1 ROM</td> </tr> <tr> <td>Color Table2</td> <td>Color table 2 ROM</td> </tr> <tr> <td>Fax APL</td> <td>Fax APL</td> </tr> <tr> <td>Fax Boot</td> <td>Fax Boot</td> </tr> <tr> <td>Fax IPL</td> <td>Fax IPL</td> </tr> </tbody> </table> <p data-bbox="292 1525 440 1554"><b>Completion</b> Press the stop key. The screen for selecting a maintenance item No. is displayed.</p>	Display	Description	Main	Main ROM	MMI	Operation ROM	Engine	Engine ROM	Engine Boot	Engine booting	Scanner	Scanner ROM	Scanner Boot	Scanner booting	Browser	Browser ROM	Dictionary	-	Solution Framework	Framework ROM	Cassette2	Paper feeder 2	Cassette3	Paper feeder 3	Option Language	Optional language ROM	Color Table1	Color table 1 ROM	Color Table2	Color table 2 ROM	Fax APL	Fax APL	Fax Boot	Fax Boot	Fax IPL	Fax IPL
Display	Description																																				
Main	Main ROM																																				
MMI	Operation ROM																																				
Engine	Engine ROM																																				
Engine Boot	Engine booting																																				
Scanner	Scanner ROM																																				
Scanner Boot	Scanner booting																																				
Browser	Browser ROM																																				
Dictionary	-																																				
Solution Framework	Framework ROM																																				
Cassette2	Paper feeder 2																																				
Cassette3	Paper feeder 3																																				
Option Language	Optional language ROM																																				
Color Table1	Color table 1 ROM																																				
Color Table2	Color table 2 ROM																																				
Fax APL	Fax APL																																				
Fax Boot	Fax Boot																																				
Fax IPL	Fax IPL																																				

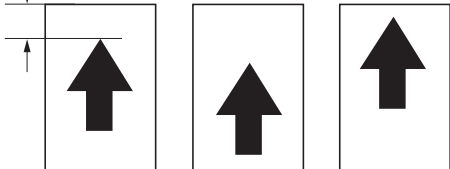
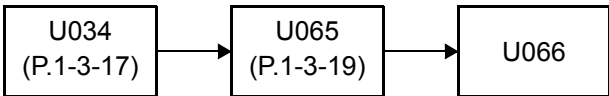
Item No.	Description										
U021	<p data-bbox="292 241 533 275"><b>Memory initializing</b></p> <p data-bbox="292 313 440 342"><b>Description</b></p> <p data-bbox="292 347 1422 448">Initializes all settings, except those pertinent to the type of machine, namely each counter, service call history and mode setting. Also initializes backup RAM according to region specification selected in maintenance item U252 Setting the destination.</p> <p data-bbox="292 452 400 481"><b>Purpose</b></p> <p data-bbox="292 486 922 515">To return the machine settings to their factory default.</p> <p data-bbox="292 555 387 584"><b>Method</b></p> <ol data-bbox="308 589 1342 757" style="list-style-type: none"> <li>1. Press the start key.</li> <li>2. Select [Execute].</li> <li>3. Press the start key. All data other than that for adjustments due to variations between machines is initialized based on the destination setting.</li> <li>4. Turn the main power switch off and on.</li> </ol> <p data-bbox="339 761 1059 790">* : An error code is displayed in case of an initialization error.</p> <p data-bbox="371 795 1426 860">When errors occurred, turn main power switch off then on, and execute initialization using maintenance item U021.</p> <p data-bbox="336 900 488 929"><b>Error codes</b></p> <table border="1" data-bbox="336 943 1401 1182"> <thead> <tr> <th data-bbox="336 943 641 992">Codes</th> <th data-bbox="641 943 1401 992">Description</th> </tr> </thead> <tbody> <tr> <td data-bbox="336 992 641 1041">0001</td> <td data-bbox="641 992 1401 1041">Entity error</td> </tr> <tr> <td data-bbox="336 1041 641 1090">0002</td> <td data-bbox="641 1041 1401 1090">Controller error</td> </tr> <tr> <td data-bbox="336 1090 641 1140">0020</td> <td data-bbox="641 1090 1401 1140">Engine error</td> </tr> <tr> <td data-bbox="336 1140 641 1182">0040</td> <td data-bbox="641 1140 1401 1182">Scanner error</td> </tr> </tbody> </table>	Codes	Description	0001	Entity error	0002	Controller error	0020	Engine error	0040	Scanner error
Codes	Description										
0001	Entity error										
0002	Controller error										
0020	Engine error										
0040	Scanner error										

Item No.	Description																										
<p><b>U034</b></p>	<p><b>Adjust Paper Timing Data</b></p> <p><b>Description</b> Adjusts the leading edge registration or center line.</p> <p><b>Purpose</b> Make the adjustment if there is a regular error between the leading edges of the copy image and original. Make the adjustment if there is a regular error between the center lines of the copy image and original.</p> <p><b>Method</b></p> <ol style="list-style-type: none"> <li>1. Press the start key.</li> <li>2. Select the item to be adjusted.</li> </ol> <table border="1" data-bbox="336 698 1401 846"> <thead> <tr> <th>Display</th> <th>Description</th> </tr> </thead> <tbody> <tr> <td>LSU Out Top</td> <td>Leading edge registration adjustment</td> </tr> <tr> <td>LSU Out Left</td> <td>Center line adjustment</td> </tr> </tbody> </table> <p><b>Adjustment: [LSU Out Top]</b></p> <ol style="list-style-type: none"> <li>1. Press the system menu key.</li> <li>2. Press the start key to output a test pattern.</li> <li>3. Press the system menu key.</li> <li>4. Select the item to be adjusted.</li> </ol> <table border="1" data-bbox="336 1093 1396 1321"> <thead> <tr> <th>Display</th> <th>Description</th> <th>Setting range</th> <th>Initial setting</th> <th>Change in value per step</th> </tr> </thead> <tbody> <tr> <td>MPT</td> <td>Paper feed from MP tray</td> <td>-100 to 600</td> <td>0</td> <td>0.1 mm</td> </tr> <tr> <td>Cassette</td> <td>Paper feed from cassette</td> <td>-100 to 600</td> <td>0</td> <td>0.1 mm</td> </tr> <tr> <td>Duplex</td> <td>Duplex mode (second)</td> <td>-100 to 600</td> <td>0</td> <td>0.1 mm</td> </tr> </tbody> </table> <ol style="list-style-type: none"> <li>5. Change the setting value using the cursor left/right keys or numeric keys. For output example 1, increase the value. For output example 2, decrease the value.</li> </ol> <div data-bbox="367 1473 1193 1796"> </div> <ol style="list-style-type: none"> <li>6. Press the start key. The value is set.</li> </ol>	Display	Description	LSU Out Top	Leading edge registration adjustment	LSU Out Left	Center line adjustment	Display	Description	Setting range	Initial setting	Change in value per step	MPT	Paper feed from MP tray	-100 to 600	0	0.1 mm	Cassette	Paper feed from cassette	-100 to 600	0	0.1 mm	Duplex	Duplex mode (second)	-100 to 600	0	0.1 mm
Display	Description																										
LSU Out Top	Leading edge registration adjustment																										
LSU Out Left	Center line adjustment																										
Display	Description	Setting range	Initial setting	Change in value per step																							
MPT	Paper feed from MP tray	-100 to 600	0	0.1 mm																							
Cassette	Paper feed from cassette	-100 to 600	0	0.1 mm																							
Duplex	Duplex mode (second)	-100 to 600	0	0.1 mm																							

Item No.	Description																														
<p><b>U034</b></p>	<p><b>Caution</b> Check the copy image after the adjustment. If the image is still incorrect, perform the following adjustments in maintenance mode.</p> <div style="text-align: center;">  </div> <p><b>Adjustment: [LSU Out Left]</b></p> <ol style="list-style-type: none"> <li>Press the system menu key.</li> <li>Press the start key to output a test pattern.</li> <li>Press the system menu key.</li> <li>Select the item to be adjusted.</li> </ol> <table border="1" data-bbox="338 716 1391 1041"> <thead> <tr> <th>Display</th> <th>Description</th> <th>Setting range</th> <th>Initial setting</th> <th>Change in value per step</th> </tr> </thead> <tbody> <tr> <td>MPT</td> <td>Paper feed from MP tray</td> <td>-100 to 600</td> <td>0</td> <td>0.1 mm</td> </tr> <tr> <td>Cassette1</td> <td>Paper feed from optional cassette1</td> <td>-100 to 600</td> <td>0</td> <td>0.1 mm</td> </tr> <tr> <td>Cassette2</td> <td>Paper feed from optional cassette2</td> <td>-100 to 600</td> <td>0</td> <td>0.1 mm</td> </tr> <tr> <td>Cassette3</td> <td>Paper feed from optional cassette3</td> <td>-100 to 600</td> <td>0</td> <td>0.1 mm</td> </tr> <tr> <td>Duplex</td> <td>Duplex mode (second)</td> <td>-100 to 600</td> <td>0</td> <td>0.1 mm</td> </tr> </tbody> </table> <ol style="list-style-type: none"> <li>Change the setting value using the cursor left/right keys or numeric keys. For output example 1, increase the value. For output example 2, decrease the value.</li> </ol> <div style="text-align: center;"> <p>Center line of printing (within <math>\pm 2.0</math> mm)</p>  <p>Correct image                      Output example 1                      Output example 2</p> </div> <p><b>Figure 1-3-3</b></p> <ol style="list-style-type: none"> <li>Press the start key. The value is set.</li> </ol> <p><b>Caution</b> Check the copy image after the adjustment. If the image is still incorrect, perform the following adjustments in maintenance mode.</p> <div style="text-align: center;">  </div> <p><b>Completion</b> Press the stop key. The screen for selecting a maintenance item No. is displayed.</p>	Display	Description	Setting range	Initial setting	Change in value per step	MPT	Paper feed from MP tray	-100 to 600	0	0.1 mm	Cassette1	Paper feed from optional cassette1	-100 to 600	0	0.1 mm	Cassette2	Paper feed from optional cassette2	-100 to 600	0	0.1 mm	Cassette3	Paper feed from optional cassette3	-100 to 600	0	0.1 mm	Duplex	Duplex mode (second)	-100 to 600	0	0.1 mm
Display	Description	Setting range	Initial setting	Change in value per step																											
MPT	Paper feed from MP tray	-100 to 600	0	0.1 mm																											
Cassette1	Paper feed from optional cassette1	-100 to 600	0	0.1 mm																											
Cassette2	Paper feed from optional cassette2	-100 to 600	0	0.1 mm																											
Cassette3	Paper feed from optional cassette3	-100 to 600	0	0.1 mm																											
Duplex	Duplex mode (second)	-100 to 600	0	0.1 mm																											

Item No.	Description															
U065	<p data-bbox="288 241 657 273"><b>Adjust Scanner Motor Speed</b></p> <p data-bbox="288 311 440 342"><b>Description</b></p> <p data-bbox="288 344 877 376">Adjusts the magnification of the original scanning.</p> <p data-bbox="288 383 400 414"><b>Purpose</b></p> <p data-bbox="288 416 1276 448">Make the adjustment if the magnification in the main scanning direction is incorrect.</p> <p data-bbox="288 450 1316 481">Make the adjustment if the magnification in the auxiliary scanning direction is incorrect.</p> <p data-bbox="288 519 387 551"><b>Method</b></p> <ol data-bbox="308 555 1058 723" style="list-style-type: none"> <li>1. Press the start key.</li> <li>2. Press the system menu key.</li> <li>3. Place an original and press the start key to make a test copy.</li> <li>4. Press the system menu key.</li> <li>5. Select the item to be adjusted.</li> </ol> <table border="1" data-bbox="336 734 1401 983"> <thead> <tr> <th data-bbox="336 734 528 815">Display</th> <th data-bbox="528 734 922 815">Description</th> <th data-bbox="922 734 1082 815">Setting range</th> <th data-bbox="1082 734 1195 815">Initial setting</th> <th data-bbox="1195 734 1401 815">Change in value per step</th> </tr> </thead> <tbody> <tr> <td data-bbox="336 815 528 898">Main Scan</td> <td data-bbox="528 815 922 898">Scanner magnification in the main scanning direction</td> <td data-bbox="922 815 1082 898">-32 to 127</td> <td data-bbox="1082 815 1195 898">0</td> <td data-bbox="1195 815 1401 898">0.1 %</td> </tr> <tr> <td data-bbox="336 898 528 983">Sub Scan</td> <td data-bbox="528 898 922 983">Scanner magnification in the auxiliary scanning direction</td> <td data-bbox="922 898 1082 983">-25 to 25</td> <td data-bbox="1082 898 1195 983">0</td> <td data-bbox="1195 898 1401 983">0.1 %</td> </tr> </tbody> </table> <p data-bbox="288 1028 606 1059"><b>Adjustment: [Main Scan]</b></p> <ol data-bbox="308 1064 1303 1164" style="list-style-type: none"> <li>1. Change the setting value using the cursor left/right keys or numeric keys. For copy example 1, increase the value. For copy example 2, decrease the value. Increasing the setting enlarges the image and decreasing it narrows the image.</li> </ol> <div data-bbox="667 1189 1058 1413" style="text-align: center;">  <p data-bbox="676 1352 762 1384">Original</p> <p data-bbox="804 1352 916 1413">Copy example 1</p> <p data-bbox="943 1352 1058 1413">Copy example 2</p> </div> <p data-bbox="783 1438 938 1469"><b>Figure 1-3-4</b></p> <ol data-bbox="308 1507 767 1538" style="list-style-type: none"> <li>2. Press the start key. The value is set.</li> </ol>	Display	Description	Setting range	Initial setting	Change in value per step	Main Scan	Scanner magnification in the main scanning direction	-32 to 127	0	0.1 %	Sub Scan	Scanner magnification in the auxiliary scanning direction	-25 to 25	0	0.1 %
Display	Description	Setting range	Initial setting	Change in value per step												
Main Scan	Scanner magnification in the main scanning direction	-32 to 127	0	0.1 %												
Sub Scan	Scanner magnification in the auxiliary scanning direction	-25 to 25	0	0.1 %												


Item No.	Description
U065	<p data-bbox="288 241 596 275"><b>Adjustment: [Sub Scan]</b></p> <p data-bbox="308 277 1414 409">1. Change the setting value using the left/right keys or numeric keys. For copy example 1, increase the value. For copy example 2, decrease the value. Increasing the value makes the image longer, while decreasing the value makes the image shorter.</p> <div data-bbox="667 439 1054 658" style="text-align: center;"><p data-bbox="676 600 1054 658">Original      Copy example 1      Copy example 2</p></div> <p data-bbox="783 689 938 723" style="text-align: center;"><b>Figure 1-3-5</b></p> <p data-bbox="308 759 767 792">2. Press the start key. The value is set.</p> <p data-bbox="288 826 440 860"><b>Completion</b></p> <p data-bbox="288 862 1254 896">Press the stop key. The screen for selecting a maintenance item No. is displayed.</p>

Item No.	Description															
<b>U066</b>	<p data-bbox="288 241 730 275"><b>Adjust Table Leading Edge Timing</b></p> <p data-bbox="288 311 440 340"><b>Description</b></p> <p data-bbox="288 344 1117 376">Adjusts the scanner leading edge registration of the original scanning.</p> <p data-bbox="288 380 400 409"><b>Purpose</b></p> <p data-bbox="288 414 1426 481">Make the adjustment if there is a regular error between the leading edges of the copy image and original.</p> <p data-bbox="288 517 440 546"><b>Adjustment</b></p> <ol data-bbox="304 553 1058 721" style="list-style-type: none"> <li>1. Press the start key.</li> <li>2. Press the system menu key.</li> <li>3. Place an original and press the start key to make a test copy.</li> <li>4. Press the system menu key.</li> <li>5. Select the item to be adjusted.</li> </ol> <table border="1" data-bbox="336 734 1401 983"> <thead> <tr> <th>Display</th> <th>Description</th> <th>Setting range</th> <th>Initial setting</th> <th>Change in value per step</th> </tr> </thead> <tbody> <tr> <td>Front</td> <td>Scanner leading edge registration</td> <td>-45 to 45</td> <td>0</td> <td>0.091 mm</td> </tr> <tr> <td>Rotate</td> <td>Scanner leading edge registration (rotate copying)</td> <td>-45 to 45</td> <td>0</td> <td>0.100 mm</td> </tr> </tbody> </table> <ol data-bbox="304 994 1406 1126" style="list-style-type: none"> <li>6. Change the setting value using the cursor left/right keys or numeric keys. For copy example 1, increase the value. For copy example 2, decrease the value. Increasing the value moves the image forward and decreasing the value moves the image backward.</li> </ol> <div data-bbox="576 1153 1299 1458" data-label="Image"> <p data-bbox="584 1153 1299 1182">Leading edge registration of the copy image (+1.0/-1.5 mm or less)</p>  <p data-bbox="635 1400 715 1429">Original</p> <p data-bbox="767 1400 874 1458">Copy example 1</p> <p data-bbox="911 1400 1018 1458">Copy example 2</p> </div> <p data-bbox="783 1489 938 1518"><b>Figure 1-3-6</b></p> <ol data-bbox="304 1561 767 1590" style="list-style-type: none"> <li>7. Press the start key. The value is set.</li> </ol> <p data-bbox="288 1630 392 1659"><b>Caution</b></p> <p data-bbox="288 1664 1426 1731">If the above adjustment does not optimize the leading edge registration, proceed with the following maintenance modes.</p> <div data-bbox="293 1744 903 1839" data-label="Diagram">  <pre> graph LR     U034["U034 (P.1-3-17)"] --&gt; U065["U065 (P.1-3-19)"]     U065 --&gt; U066["U066"]   </pre> </div> <p data-bbox="288 1888 440 1917"><b>Completion</b></p> <p data-bbox="288 1921 1254 1951">Press the stop key. The screen for selecting a maintenance item No. is displayed.</p>	Display	Description	Setting range	Initial setting	Change in value per step	Front	Scanner leading edge registration	-45 to 45	0	0.091 mm	Rotate	Scanner leading edge registration (rotate copying)	-45 to 45	0	0.100 mm
Display	Description	Setting range	Initial setting	Change in value per step												
Front	Scanner leading edge registration	-45 to 45	0	0.091 mm												
Rotate	Scanner leading edge registration (rotate copying)	-45 to 45	0	0.100 mm												

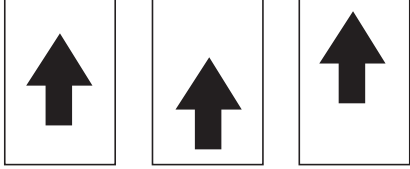
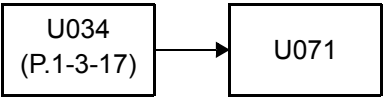
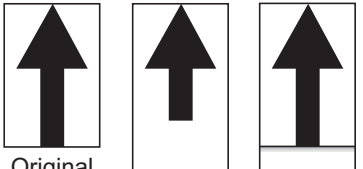
Item No.	Description																				
<b>U067</b>	<p><b>Adjust Table Center</b></p> <p><b>Description</b> Adjusts the scanner center line of the original scanning.</p> <p><b>Purpose</b> Make the adjustment if there is a regular error between the center lines of the copy image and original.</p> <p><b>Adjustment</b></p> <ol style="list-style-type: none"> <li>1. Press the start key.</li> <li>2. Press the system menu key.</li> <li>3. Place an original and press the start key to make a test copy.</li> <li>4. Press the system menu key.</li> <li>5. Select the item to be adjusted.</li> </ol> <table border="1" data-bbox="336 734 1401 949"> <thead> <tr> <th>Display</th> <th>Description</th> <th>Setting range</th> <th>Initial setting</th> <th>Change in value per step</th> </tr> </thead> <tbody> <tr> <td>Front</td> <td>Scanner center line</td> <td>-40 to 40</td> <td>0</td> <td>0.085 mm</td> </tr> <tr> <td>Rotate</td> <td>Scanner center line (rotate copying)</td> <td>-40 to 40</td> <td>0</td> <td>0.100 mm</td> </tr> </tbody> </table> <ol style="list-style-type: none"> <li>6. Change the setting value using the cursor left/right keys or numeric keys. For copy example 1, decrease the value. For copy example 2, increase the value. Increasing the value moves the image leftward and decreasing it moves the image rightward.</li> </ol> <div data-bbox="651 1088 1158 1384" style="text-align: center;"> <p>Center line of the copy image (within <math>\pm 2.0</math> mm)</p> <p>Original      Copy example 1      Copy example 2</p> </div> <p style="text-align: center;"><b>Figure 1-3-7</b></p> <ol style="list-style-type: none"> <li>7. Press the start key. The value is set.</li> </ol> <p><b>Caution</b> If the above adjustment does not optimize the center line, proceed with the following maintenance modes.</p> <div data-bbox="293 1664 903 1756" style="text-align: center;"> <table border="1"> <tr> <td style="padding: 5px;">U034 (P.1-3-17)</td> <td style="padding: 5px; text-align: center;">→</td> <td style="padding: 5px;">U065 (P.1-3-19)</td> <td style="padding: 5px; text-align: center;">→</td> <td style="padding: 5px;">U067</td> </tr> </table> </div> <p><b>Completion</b> Press the stop key. The screen for selecting a maintenance item No. is displayed.</p>	Display	Description	Setting range	Initial setting	Change in value per step	Front	Scanner center line	-40 to 40	0	0.085 mm	Rotate	Scanner center line (rotate copying)	-40 to 40	0	0.100 mm	U034 (P.1-3-17)	→	U065 (P.1-3-19)	→	U067
Display	Description	Setting range	Initial setting	Change in value per step																	
Front	Scanner center line	-40 to 40	0	0.085 mm																	
Rotate	Scanner center line (rotate copying)	-40 to 40	0	0.100 mm																	
U034 (P.1-3-17)	→	U065 (P.1-3-19)	→	U067																	



Item No.	Description															
U068	<p data-bbox="290 241 606 275"><b>Adjust DP Scan Position</b></p> <p data-bbox="290 311 440 340"><b>Description</b></p> <p data-bbox="290 344 1417 412">Adjusts the position for scanning originals from the DP. Performs the test copy at the four scanning positions after adjusting.</p> <p data-bbox="290 416 400 445"><b>Purpose</b></p> <p data-bbox="290 450 1428 517">Used when the image fogging occurs because the scanning position is not proper when the DP is used. Run U071 to adjust the timing of DP leading edge when the scanning position is changed.</p> <p data-bbox="290 553 384 582"><b>Setting</b></p> <p data-bbox="308 586 571 616">1. Press the start key.</p> <table border="1" data-bbox="336 631 1401 880"> <thead> <tr> <th data-bbox="336 631 528 712">Display</th> <th data-bbox="528 631 922 712">Description</th> <th data-bbox="922 631 1082 712">Setting range</th> <th data-bbox="1082 631 1193 712">Initial setting</th> <th data-bbox="1193 631 1401 712">Change in value per step</th> </tr> </thead> <tbody> <tr> <td data-bbox="336 712 528 792">DP Read</td> <td data-bbox="528 712 922 792">Starting position adjustment for scanning originals</td> <td data-bbox="922 712 1082 792">-33 to 33</td> <td data-bbox="1082 712 1193 792">0</td> <td data-bbox="1193 712 1401 792">0.086 mm</td> </tr> <tr> <td data-bbox="336 792 528 880">Black Line</td> <td data-bbox="528 792 922 880">Scanning position for the test copy originals</td> <td data-bbox="922 792 1082 880">0 to 3</td> <td data-bbox="1082 792 1193 880">0</td> <td data-bbox="1193 792 1401 880">0.22 mm</td> </tr> </tbody> </table> <p data-bbox="308 891 549 920">2. Select [DP Read].</p> <p data-bbox="308 925 1126 954">3. Change the setting using the cursor left/right keys or numeric keys.</p> <p data-bbox="336 958 1428 1025">When the setting value is increased, the scanning position moves to the right and it moves to the left when the setting value is decreased.</p> <p data-bbox="308 1030 767 1059">4. Press the start key. The value is set.</p> <p data-bbox="308 1064 564 1093">5. Select [Black Line].</p> <p data-bbox="308 1097 983 1126">6. Change the setting using the +/- keys or numeric keys.</p> <p data-bbox="308 1131 767 1160">7. Press the start key. The value is set.</p> <p data-bbox="308 1164 1417 1193">8. Set the original (the one which density is known) in the DP and press the system menu key.</p> <p data-bbox="308 1198 834 1227">9. Press the start key. Test copy is executed.</p> <p data-bbox="290 1232 1428 1299">10. Perform the test copy at each scanning position with the setting value from 0 to 3 and check that no black line appears and the image is normally scanned.</p> <p data-bbox="290 1335 440 1364"><b>Completion</b></p> <p data-bbox="290 1368 1254 1397">Press the stop key. The screen for selecting a maintenance item No. is displayed.</p>	Display	Description	Setting range	Initial setting	Change in value per step	DP Read	Starting position adjustment for scanning originals	-33 to 33	0	0.086 mm	Black Line	Scanning position for the test copy originals	0 to 3	0	0.22 mm
Display	Description	Setting range	Initial setting	Change in value per step												
DP Read	Starting position adjustment for scanning originals	-33 to 33	0	0.086 mm												
Black Line	Scanning position for the test copy originals	0 to 3	0	0.22 mm												

Item No.	Description										
U070	<p><b>Adjust DP Motor Speed</b></p> <p><b>Description</b> Adjusts the DP original scanning speed.</p> <p><b>Purpose</b> Make the adjustment if the magnification is incorrect in the auxiliary scanning direction when the DP is used.</p> <p><b>Adjustment</b></p> <ol style="list-style-type: none"> <li>1. Press the start key.</li> <li>2. Press the system menu key.</li> <li>3. Place an original on the DP and press the start key to make a test copy.</li> <li>4. Press the system menu key.</li> <li>5. Select [Convey Speed].</li> </ol> <table border="1" data-bbox="336 734 1401 936"> <thead> <tr> <th>Display</th> <th>Description</th> <th>Setting range</th> <th>Initial setting</th> <th>Change in value per step</th> </tr> </thead> <tbody> <tr> <td>Convey Speed</td> <td>Magnification in the auxiliary scanning direction of CCD (first side)</td> <td>-25 to 25</td> <td>0</td> <td>0.1 %</td> </tr> </tbody> </table> <ol style="list-style-type: none"> <li>6. Change the setting value using the cursor left/right keys or numeric keys. For copy example 1, increase the value. For copy example 2, decrease the value. Increasing the value makes the image longer, while decreasing the value makes the image shorter.</li> </ol> <div data-bbox="667 1153 1054 1377" style="text-align: center;">  <p>Original      Copy example 1      Copy example 2</p> </div> <p><b>Figure 1-3-8</b></p> <ol style="list-style-type: none"> <li>7. Press the start key. The value is set.</li> </ol> <p><b>Completion</b> Press the stop key. The screen for selecting a maintenance item No. is displayed.</p>	Display	Description	Setting range	Initial setting	Change in value per step	Convey Speed	Magnification in the auxiliary scanning direction of CCD (first side)	-25 to 25	0	0.1 %
Display	Description	Setting range	Initial setting	Change in value per step							
Convey Speed	Magnification in the auxiliary scanning direction of CCD (first side)	-25 to 25	0	0.1 %							

Item No.	Description																														
U071	<p data-bbox="288 241 699 275"><b>Adjust DP Leading Edge Timing</b></p> <p data-bbox="288 313 440 342"><b>Description</b></p> <p data-bbox="288 347 762 376">Adjusts the DP original scanning timing.</p> <p data-bbox="288 383 400 412"><b>Purpose</b></p> <p data-bbox="288 416 1422 481">Make the adjustment if there is a regular error between the leading or trailing edges of the original and the copy image when the DP is used.</p> <p data-bbox="288 519 387 548"><b>Method</b></p> <ol data-bbox="308 555 1182 723" style="list-style-type: none"> <li>1. Press the start key.</li> <li>2. Press the system menu key.</li> <li>3. Place an original on the DP and press the start key to make a test copy.</li> <li>4. Press the system menu key.</li> <li>5. Select the item to be adjusted.</li> </ol> <table border="1" data-bbox="336 770 1401 1265"> <thead> <tr> <th data-bbox="343 779 525 846">Display</th> <th data-bbox="525 779 922 846">Description</th> <th data-bbox="922 779 1082 846">Setting range</th> <th data-bbox="1082 779 1195 846">Initial setting</th> <th data-bbox="1195 779 1394 846">Change in value per step</th> </tr> </thead> <tbody> <tr> <td data-bbox="343 853 525 882">Front Head</td> <td data-bbox="525 853 922 931">Leading edge registration of CCD (first side)</td> <td data-bbox="922 853 1082 882">-32 to 32</td> <td data-bbox="1082 853 1195 882">0</td> <td data-bbox="1195 853 1394 882">0.196 mm</td> </tr> <tr> <td data-bbox="343 938 525 967">Front Tail</td> <td data-bbox="525 938 922 1016">Trailing edge registration of CCD (first side)</td> <td data-bbox="922 938 1082 967">-32 to 32</td> <td data-bbox="1082 938 1195 967">0</td> <td data-bbox="1195 938 1394 967">0.196 mm</td> </tr> <tr> <td data-bbox="343 1023 525 1052">Back Head</td> <td data-bbox="525 1023 922 1102">Leading edge registration of CCD (second side)</td> <td data-bbox="922 1023 1082 1052">-45 to 45</td> <td data-bbox="1082 1023 1195 1052">0</td> <td data-bbox="1195 1023 1394 1052">0.196 mm</td> </tr> <tr> <td data-bbox="343 1108 525 1137">Back Tail</td> <td data-bbox="525 1108 922 1187">Trailing edge registration of CCD (second side)</td> <td data-bbox="922 1108 1082 1137">-45 to 45</td> <td data-bbox="1082 1108 1195 1137">0</td> <td data-bbox="1195 1108 1394 1137">0.196 mm</td> </tr> <tr> <td data-bbox="343 1193 525 1223">Rotate</td> <td data-bbox="525 1193 922 1272">Leading edge registration (rotate copying)</td> <td data-bbox="922 1193 1082 1223">-128 to 127</td> <td data-bbox="1082 1193 1195 1223">0</td> <td data-bbox="1195 1193 1394 1223">0.196 mm</td> </tr> </tbody> </table>	Display	Description	Setting range	Initial setting	Change in value per step	Front Head	Leading edge registration of CCD (first side)	-32 to 32	0	0.196 mm	Front Tail	Trailing edge registration of CCD (first side)	-32 to 32	0	0.196 mm	Back Head	Leading edge registration of CCD (second side)	-45 to 45	0	0.196 mm	Back Tail	Trailing edge registration of CCD (second side)	-45 to 45	0	0.196 mm	Rotate	Leading edge registration (rotate copying)	-128 to 127	0	0.196 mm
Display	Description	Setting range	Initial setting	Change in value per step																											
Front Head	Leading edge registration of CCD (first side)	-32 to 32	0	0.196 mm																											
Front Tail	Trailing edge registration of CCD (first side)	-32 to 32	0	0.196 mm																											
Back Head	Leading edge registration of CCD (second side)	-45 to 45	0	0.196 mm																											
Back Tail	Trailing edge registration of CCD (second side)	-45 to 45	0	0.196 mm																											
Rotate	Leading edge registration (rotate copying)	-128 to 127	0	0.196 mm																											

Item No.	Description
U071	<p><b>Adjustment: Leading edge registration</b></p> <p>1. Change the setting value using the cursor left/right keys or numeric keys. For copy example 1, increase the value. For copy example 2, decrease the value. Increasing the value moves the image forward and decreasing the value moves the image backward.</p> <div data-bbox="655 439 1066 678" style="text-align: center;">  <p>Original      Copy example 1      Copy example 2</p> </div> <p style="text-align: center;"><b>Figure 1-3-9</b></p> <p>2. Press the start key. The value is set.</p> <p><b>Caution</b> If the first side is adjusted, check the second side and if adjustment is required, carry out the adjustment. If the above adjustment does not optimize the leading edge registration, proceed with the following maintenance modes.</p> <div data-bbox="295 1025 678 1122" style="text-align: center;">  </div> <p><b>Adjustment: Trailing edge registration</b></p> <p>1. Change the setting value using the cursor left/right keys or numeric keys. For copy example 1, increase the value. For copy example 2, decrease the value.</p> <div data-bbox="679 1294 1043 1534" style="text-align: center;">  <p>Original      Copy example 1      Copy example 2</p> </div> <p style="text-align: center;"><b>Figure 1-3-10</b></p> <p>2. Press the start key. The value is set.</p> <p><b>Caution</b> If the first side is adjusted, check the second side and if adjustment is required, carry out the adjustment.</p> <p><b>Completion</b> Press the stop key. The screen for selecting a maintenance item No. is displayed.</p>

Item No.	Description																				
U072	<p><b>Adjust DP Original Center</b></p> <p><b>Description</b> Adjusts the scanning start position for the DP original.</p> <p><b>Purpose</b> Make the adjustment if there is a regular error between the centers of the original and the copy image when the DP is used.</p> <p><b>Adjustment</b></p> <ol style="list-style-type: none"> <li>1. Press the start key.</li> <li>2. Press the system menu key.</li> <li>3. Place an original on the DP and press the start key to make a test copy.</li> <li>4. Press the system menu key.</li> <li>5. Select the item to be adjusted.</li> </ol> <table border="1" data-bbox="336 734 1401 963"> <thead> <tr> <th>Display</th> <th>Description</th> <th>Setting range</th> <th>Initial setting</th> <th>Change in value per step</th> </tr> </thead> <tbody> <tr> <td>Front</td> <td>DP center line (first side)</td> <td>-39 to 39</td> <td>0</td> <td>0.085 mm</td> </tr> <tr> <td>Back</td> <td>DP center line (second side)</td> <td>-39 to 39</td> <td>12</td> <td>0.085 mm</td> </tr> <tr> <td>Rotate</td> <td>DP center line (rotate copying)</td> <td>-39 to 39</td> <td>0</td> <td>0.085 mm</td> </tr> </tbody> </table> <ol style="list-style-type: none"> <li>6. Change the setting value using the cursor left/right keys or numeric keys. For copy example 1, increase the value. For copy example 2, decrease the value. Increasing the value moves the image rightward and decreasing it moves the image leftward.</li> </ol> <div data-bbox="646 1126 1074 1366" style="text-align: center;"> <p>Original      Copy example 1      Copy example 2</p> </div> <p><b>Figure 1-3-11</b></p> <ol style="list-style-type: none"> <li>7. Press the start key. The value is set.</li> </ol> <p><b>Caution</b> If the first side is adjusted, check the second side and if adjustment is required, carry out the adjustment. If the above adjustment does not optimize the center line, proceed with the following maintenance modes.</p> <pre> graph LR     U034["U034 (P.1-3-17)"] --&gt; U065["U065 (P.1-3-19)"]     U065 --&gt; U067["U067 (P.1-3-22)"]     U067 --&gt; U072["U072"]   </pre> <p><b>Completion</b> Press the stop key. The screen for selecting a maintenance item No. is displayed.</p>	Display	Description	Setting range	Initial setting	Change in value per step	Front	DP center line (first side)	-39 to 39	0	0.085 mm	Back	DP center line (second side)	-39 to 39	12	0.085 mm	Rotate	DP center line (rotate copying)	-39 to 39	0	0.085 mm
Display	Description	Setting range	Initial setting	Change in value per step																	
Front	DP center line (first side)	-39 to 39	0	0.085 mm																	
Back	DP center line (second side)	-39 to 39	12	0.085 mm																	
Rotate	DP center line (rotate copying)	-39 to 39	0	0.085 mm																	

Item No.	Description						
U201	<p data-bbox="288 241 628 271"><b>Initializing the touch panel</b></p> <p data-bbox="288 311 440 340"><b>Description</b></p> <p data-bbox="288 344 1174 374">Automatically correct the positions of the X- and Y-axes of the touch panel.</p> <p data-bbox="288 380 400 409"><b>Purpose</b></p> <p data-bbox="288 414 1273 443">To automatically correct the display positions on the touch panel after it is replaced.</p> <p data-bbox="288 483 387 512"><b>Method</b></p> <ol data-bbox="308 517 711 582" style="list-style-type: none"> <li data-bbox="308 517 564 546">1. Press the start key.</li> <li data-bbox="308 551 711 580">2. Select the [Initialize] or [Check].</li> </ol> <table border="1" data-bbox="347 591 1412 719"> <thead> <tr> <th data-bbox="352 598 651 633">Display</th> <th data-bbox="651 598 1407 633">Description</th> </tr> </thead> <tbody> <tr> <td data-bbox="352 638 651 674">Initialize</td> <td data-bbox="651 638 1407 674">Adjusts the display on the panel automatically.</td> </tr> <tr> <td data-bbox="352 678 651 714">Check</td> <td data-bbox="651 678 1407 714">Checks the display on the touch panel.</td> </tr> </tbody> </table> <p data-bbox="288 763 509 792"><b>Method: Initialize</b></p> <ol data-bbox="308 797 1299 969" style="list-style-type: none"> <li data-bbox="308 797 564 826">1. Press the start key.</li> <li data-bbox="308 831 1278 896">2. Press the center of the + keys. Be sure to press three + keys displayed in order. The touch panel is adjusted automatically.</li> <li data-bbox="308 900 1054 929">3. Press the indicated three + keys, and then check the display.</li> <li data-bbox="308 934 1299 963">4. Press the stop key. The screen for selecting a maintenance item No. is displayed.</li> </ol> <p data-bbox="288 1008 485 1037"><b>Method: Check</b></p> <ol data-bbox="308 1041 1372 1178" style="list-style-type: none"> <li data-bbox="308 1041 564 1070">1. Press the start key.</li> <li data-bbox="308 1075 1054 1104">2. Press the indicated three + keys, and then check the display. When adjusting the display, press [INITIALIZE] to execute the adjustment automatically.</li> <li data-bbox="308 1144 1299 1173">3. Press the stop key. The screen for selecting a maintenance item No. is displayed.</li> </ol> <p data-bbox="288 1216 440 1245"><b>Completion</b></p> <p data-bbox="288 1249 1254 1279">Press the stop key. The screen for selecting a maintenance item No. is displayed.</p>	Display	Description	Initialize	Adjusts the display on the panel automatically.	Check	Checks the display on the touch panel.
Display	Description						
Initialize	Adjusts the display on the panel automatically.						
Check	Checks the display on the touch panel.						

Item No.	Description																
U203	<p data-bbox="288 241 587 275"><b>Checking DP operation</b></p> <p data-bbox="288 311 440 340"><b>Description</b></p> <p data-bbox="288 344 1046 376">Simulates the original conveying operation separately in the DP.</p> <p data-bbox="288 383 400 412"><b>Purpose</b></p> <p data-bbox="288 416 612 448">To check the DP operation.</p> <p data-bbox="288 486 387 515"><b>Method</b></p> <ol data-bbox="308 519 1082 618" style="list-style-type: none"> <li>1. Press the start key.</li> <li>2. Place an original in the DP if running this simulation with paper.</li> <li>3. Select the speed to be operated.</li> </ol> <table border="1" data-bbox="336 631 1401 777"> <thead> <tr> <th data-bbox="336 631 639 676">Display</th> <th data-bbox="639 631 1401 676">Description</th> </tr> </thead> <tbody> <tr> <td data-bbox="336 676 639 721">Normal Speed</td> <td data-bbox="639 676 1401 721">Normal reading (600 dpi)</td> </tr> <tr> <td data-bbox="336 721 639 777">High Speed</td> <td data-bbox="639 721 1401 777">High-speed reading</td> </tr> </tbody> </table> <ol data-bbox="308 786 700 851" style="list-style-type: none"> <li>4. Press the start key.</li> <li>5. Select the item to be operated.</li> </ol> <table border="1" data-bbox="336 864 1401 1173"> <thead> <tr> <th data-bbox="336 864 639 909">Display</th> <th data-bbox="639 864 1401 909">Description</th> </tr> </thead> <tbody> <tr> <td data-bbox="336 909 639 994">CCD ADP (Non-P)</td> <td data-bbox="639 909 1401 994">Without paper, single-sided original of CCD (continuous operation)</td> </tr> <tr> <td data-bbox="336 994 639 1039">CCD ADP</td> <td data-bbox="639 994 1401 1039">With paper, single-sided original of CCD</td> </tr> <tr> <td data-bbox="336 1039 639 1124">CCD RADP (Non-P)</td> <td data-bbox="639 1039 1401 1124">Without paper, double-sided original of CCD (continuous operation)</td> </tr> <tr> <td data-bbox="336 1124 639 1173">CCD RADP</td> <td data-bbox="639 1124 1401 1173">With paper, double-sided original of CCD</td> </tr> </tbody> </table> <ol data-bbox="308 1187 916 1252" style="list-style-type: none"> <li>6. Press the start key. The operation starts.</li> <li>7. To stop continuous operation, press the stop key.</li> </ol> <p data-bbox="288 1290 440 1319"><b>Completion</b></p> <p data-bbox="288 1323 1254 1355">Press the stop key. The screen for selecting a maintenance item No. is displayed.</p>	Display	Description	Normal Speed	Normal reading (600 dpi)	High Speed	High-speed reading	Display	Description	CCD ADP (Non-P)	Without paper, single-sided original of CCD (continuous operation)	CCD ADP	With paper, single-sided original of CCD	CCD RADP (Non-P)	Without paper, double-sided original of CCD (continuous operation)	CCD RADP	With paper, double-sided original of CCD
Display	Description																
Normal Speed	Normal reading (600 dpi)																
High Speed	High-speed reading																
Display	Description																
CCD ADP (Non-P)	Without paper, single-sided original of CCD (continuous operation)																
CCD ADP	With paper, single-sided original of CCD																
CCD RADP (Non-P)	Without paper, double-sided original of CCD (continuous operation)																
CCD RADP	With paper, double-sided original of CCD																

Item No.	Description						
U222	<p data-bbox="288 241 592 275"><b>Setting the IC card type</b></p> <p data-bbox="288 311 440 340"><b>Description</b></p> <p data-bbox="288 344 579 374">Sets the type of IC card.</p> <p data-bbox="288 383 400 412"><b>Purpose</b></p> <p data-bbox="288 416 649 445">To change the type of IC card.</p> <p data-bbox="288 486 384 515"><b>Setting</b></p> <ol data-bbox="304 519 564 582" style="list-style-type: none"> <li>1. Press the start key.</li> <li>2. Select the item.</li> </ol> <table border="1" data-bbox="336 598 1399 741"> <thead> <tr> <th data-bbox="336 598 639 642">Display</th> <th data-bbox="639 598 1399 642">Description</th> </tr> </thead> <tbody> <tr> <td data-bbox="336 642 639 687">Other</td> <td data-bbox="639 642 1399 687">The type of IC card is SSFC.</td> </tr> <tr> <td data-bbox="336 687 639 741">SSFC</td> <td data-bbox="639 687 1399 741">The type of IC card is not SSFC.</td> </tr> </tbody> </table> <p data-bbox="336 752 608 781">* : Initial setting: Other</p> <ol data-bbox="304 786 782 815" style="list-style-type: none"> <li>3. Press the start key. The setting is set.</li> </ol> <p data-bbox="288 855 440 884"><b>Completion</b></p> <p data-bbox="288 889 1254 918">Press the stop key. The screen for selecting a maintenance item No. is displayed.</p>	Display	Description	Other	The type of IC card is SSFC.	SSFC	The type of IC card is not SSFC.
Display	Description						
Other	The type of IC card is SSFC.						
SSFC	The type of IC card is not SSFC.						



Item No.	Description														
U224	<p data-bbox="292 241 659 275"><b>Install Original Panel Display</b></p> <p data-bbox="292 313 440 342"><b>Description</b> Changes the image data, the message and telephone number of the service call screen to user specified data.</p> <p data-bbox="292 418 400 448"><b>Purpose</b> Set according to the preference of the user.</p> <p data-bbox="292 521 384 551"><b>Setting</b></p> <ol data-bbox="308 557 1082 757" style="list-style-type: none"> <li>1. Write the image data or the message data to the USB memory.</li> <li>2. Insert USB memory in USB memory slot of the machine.</li> <li>3. Turn the main power switch on.</li> <li>4. Enter the maintenance item.</li> <li>5. Press the start key.</li> <li>6. Select the [Install] or [UnInstall].</li> </ol> <table border="1" data-bbox="338 770 1401 913"> <thead> <tr> <th data-bbox="338 770 641 815">Display</th> <th data-bbox="641 770 1401 815">Description</th> </tr> </thead> <tbody> <tr> <td data-bbox="338 815 641 860">Install</td> <td data-bbox="641 815 1401 860">Installs the image data or the message data</td> </tr> <tr> <td data-bbox="338 860 641 913">UnInstall</td> <td data-bbox="641 860 1401 913">Restores the original image data or message data</td> </tr> </tbody> </table> <ol data-bbox="308 927 523 956" style="list-style-type: none"> <li>7. Select the item.</li> </ol> <table border="1" data-bbox="338 969 1401 1160"> <thead> <tr> <th data-bbox="338 969 641 1014">Display</th> <th data-bbox="641 969 1401 1014">Description</th> </tr> </thead> <tbody> <tr> <td data-bbox="338 1014 641 1059">Call Msg Top</td> <td data-bbox="641 1014 1401 1059">Service call message 1</td> </tr> <tr> <td data-bbox="338 1059 641 1104">Call Msg Detail</td> <td data-bbox="641 1059 1401 1104">Service call message 2</td> </tr> <tr> <td data-bbox="338 1104 641 1160">Call Msg TEL No.</td> <td data-bbox="641 1104 1401 1160">The telephone number for service</td> </tr> </tbody> </table> <ol data-bbox="308 1180 1018 1247" style="list-style-type: none"> <li>8. Press the start key. Installation or uninstallation is started.</li> <li>9. When normally completed, [OK] is displayed.</li> </ol> <p data-bbox="292 1283 440 1312"><b>Completion</b> Press the stop key. The screen for selecting a maintenance item No. is displayed.</p>	Display	Description	Install	Installs the image data or the message data	UnInstall	Restores the original image data or message data	Display	Description	Call Msg Top	Service call message 1	Call Msg Detail	Service call message 2	Call Msg TEL No.	The telephone number for service
Display	Description														
Install	Installs the image data or the message data														
UnInstall	Restores the original image data or message data														
Display	Description														
Call Msg Top	Service call message 1														
Call Msg Detail	Service call message 2														
Call Msg TEL No.	The telephone number for service														

Item No.	Description						
U250	<p data-bbox="287 241 678 275"><b>Setting the maintenance cycle</b></p> <p data-bbox="287 309 438 342"><b>Description</b> Displays, clears and changes the maintenance cycle.</p> <p data-bbox="287 376 399 409"><b>Purpose</b> To check and change the maintenance cycle.</p> <p data-bbox="287 488 391 521"><b>Method</b> 1. Press the start key. The currently set maintenance cycle is displayed.</p> <p data-bbox="287 589 383 622"><b>Setting</b> 1. Select [M.Cnt A]. 2. Change the setting using the cursor left/right keys or numeric keys.</p> <table border="1" data-bbox="335 701 1401 797"> <thead> <tr> <th data-bbox="343 701 869 745">Description</th> <th data-bbox="869 701 1133 745">Setting range</th> <th data-bbox="1133 701 1401 745">Initial setting</th> </tr> </thead> <tbody> <tr> <td data-bbox="343 745 869 797">Maintenance cycle</td> <td data-bbox="869 745 1133 797">0 to 9999999</td> <td data-bbox="1133 745 1401 797">200000</td> </tr> </tbody> </table> <p data-bbox="287 808 766 842">3. Press the start key. The value is set.</p> <p data-bbox="287 875 399 909"><b>Clearing</b> 1. Select [Clear]. 2. Press the start key. The count is cleared.</p> <p data-bbox="287 1010 438 1043"><b>Completion</b> Press the stop key. The screen for selecting a maintenance item No. is displayed.</p>	Description	Setting range	Initial setting	Maintenance cycle	0 to 9999999	200000
Description	Setting range	Initial setting					
Maintenance cycle	0 to 9999999	200000					

Item No.	Description						
U251	<p data-bbox="288 241 823 275"><b>Checking/clearing the maintenance count</b></p> <p data-bbox="288 311 440 340"><b>Description</b> Displays, clears and changes the maintenance count.</p> <p data-bbox="288 380 400 409"><b>Purpose</b> To check the maintenance count. Also to clear the count during maintenance service (replacing the maintenance kit).</p> <p data-bbox="288 517 387 546"><b>Method</b> 1. Press the start key. The maintenance count is displayed.</p> <p data-bbox="288 622 384 651"><b>Setting</b> 1. Select [M.Cnt A]. 2. Change the setting using the cursor left/right keys or numeric keys.</p> <table border="1" data-bbox="336 732 1399 828"> <thead> <tr> <th data-bbox="336 732 868 777">Description</th> <th data-bbox="868 732 1134 777">Setting range</th> <th data-bbox="1134 732 1399 777">Initial setting</th> </tr> </thead> <tbody> <tr> <td data-bbox="336 777 868 828">Maintenance count</td> <td data-bbox="868 777 1134 828">0 to 9999999</td> <td data-bbox="1134 777 1399 828">0</td> </tr> </tbody> </table> <p data-bbox="288 840 767 869">3. Press the start key. The count is set.</p> <p data-bbox="288 907 400 936"><b>Clearing</b> 1. Select [Clear]. 2. Press the start key. The count is cleared.</p> <p data-bbox="288 1046 440 1075"><b>Completion</b> Press the stop key. The screen for selecting a maintenance item No. is displayed.</p>	Description	Setting range	Initial setting	Maintenance count	0 to 9999999	0
Description	Setting range	Initial setting					
Maintenance count	0 to 9999999	0					

Item No.	Description														
U252	<p data-bbox="288 241 580 271"><b>Setting the destination</b></p> <p data-bbox="288 311 440 340"><b>Description</b></p> <p data-bbox="288 344 1254 374">Switches the operations and screens of the machine according to the destination.</p> <p data-bbox="288 380 400 409"><b>Purpose</b></p> <p data-bbox="288 414 1426 479">To be executed after initializing the backup RAM, in order to return the setting to the value before replacement or initialization.</p> <p data-bbox="288 519 384 548"><b>Setting</b></p> <ol data-bbox="304 553 600 618" style="list-style-type: none"> <li>1. Press the start key.</li> <li>2. Select the destination.</li> </ol> <table border="1" data-bbox="347 629 1412 920"> <thead> <tr> <th data-bbox="355 640 651 674">Display</th> <th data-bbox="651 640 1404 674">Description</th> </tr> </thead> <tbody> <tr> <td data-bbox="355 678 651 712">Inch</td> <td data-bbox="651 678 1404 712">Inch (North America) specifications</td> </tr> <tr> <td data-bbox="355 716 651 750">Europe Metric</td> <td data-bbox="651 716 1404 750">Metric (Europe) specifications</td> </tr> <tr> <td data-bbox="355 754 651 788">Asia Pacific</td> <td data-bbox="651 754 1404 788">Metric (Asia Pacific) specifications</td> </tr> <tr> <td data-bbox="355 792 651 826">Australia</td> <td data-bbox="651 792 1404 826">Australia specifications</td> </tr> <tr> <td data-bbox="355 831 651 864">China</td> <td data-bbox="651 831 1404 864">China specifications</td> </tr> <tr> <td data-bbox="355 869 651 902">Korea</td> <td data-bbox="651 869 1404 902">Korea specifications</td> </tr> </tbody> </table> <ol data-bbox="304 929 798 994" style="list-style-type: none"> <li>3. Press the start key.</li> <li>4. Turn the main power switch off and on.</li> </ol> <p data-bbox="288 1034 448 1064"><b>Supplement</b></p> <p data-bbox="288 1068 1426 1167">The specified initial settings are provided according to the destinations in the maintenance items below. To change the initial settings in those items, be sure to run maintenance item U021 after changing the destination.</p>	Display	Description	Inch	Inch (North America) specifications	Europe Metric	Metric (Europe) specifications	Asia Pacific	Metric (Asia Pacific) specifications	Australia	Australia specifications	China	China specifications	Korea	Korea specifications
Display	Description														
Inch	Inch (North America) specifications														
Europe Metric	Metric (Europe) specifications														
Asia Pacific	Metric (Asia Pacific) specifications														
Australia	Australia specifications														
China	China specifications														
Korea	Korea specifications														

Item No.	Description												
U253	<p><b>Switching between double and single counts</b></p> <p><b>Description</b> Switches the count system for the total counter and other counters.</p> <p><b>Purpose</b> Used to select, according to the preference of the user (copy service provider), if folio size paper is to be counted as one sheet (single count) or two sheets (double count).</p> <p><b>Setting</b></p> <ol style="list-style-type: none"> <li>1. Press the start key.</li> <li>2. Select the item to set.</li> </ol> <table border="1" data-bbox="336 631 1401 777"> <thead> <tr> <th>Display</th> <th>Description</th> </tr> </thead> <tbody> <tr> <td>Color</td> <td>Count system of color mode</td> </tr> <tr> <td>B/W</td> <td>Count system of black/white mode</td> </tr> </tbody> </table> <ol style="list-style-type: none"> <li>3. Press the start key.</li> <li>4. Select the count system using the cursor up/down keys.</li> </ol> <table border="1" data-bbox="336 866 1401 1012"> <thead> <tr> <th>Display</th> <th>Description</th> </tr> </thead> <tbody> <tr> <td>SGL (All)</td> <td>Single count for all size paper</td> </tr> <tr> <td>DBL (Folio)</td> <td>Double count for Folio size or larger</td> </tr> </tbody> </table> <p>* : Initial setting: DBL Count(Folio)</p> <ol style="list-style-type: none"> <li>5. Press the start key. The setting is set.</li> </ol> <p><b>Completion</b> Press the stop key. The screen for selecting a maintenance item No. is displayed.</p>	Display	Description	Color	Count system of color mode	B/W	Count system of black/white mode	Display	Description	SGL (All)	Single count for all size paper	DBL (Folio)	Double count for Folio size or larger
Display	Description												
Color	Count system of color mode												
B/W	Count system of black/white mode												
Display	Description												
SGL (All)	Single count for all size paper												
DBL (Folio)	Double count for Folio size or larger												
U260	<p><b>Selecting the timing for copy counting</b></p> <p><b>Description</b> Changes the copy count timing for the total counter and other counters.</p> <p><b>Purpose</b> To be set according to user request.</p> <p><b>Setting</b></p> <ol style="list-style-type: none"> <li>1. Press the start key.</li> <li>2. Select the copy count timing.</li> </ol> <table border="1" data-bbox="336 1563 1401 1709"> <thead> <tr> <th>Display</th> <th>Description</th> </tr> </thead> <tbody> <tr> <td>Feed</td> <td>When secondary paper feed starts</td> </tr> <tr> <td>Eject</td> <td>When the paper is ejected</td> </tr> </tbody> </table> <p>* : Initial setting: Eject</p> <ol style="list-style-type: none"> <li>3. Press the start key. The setting is set.</li> </ol> <p><b>Completion</b> Press the stop key. The screen for selecting a maintenance item No. is displayed.</p>	Display	Description	Feed	When secondary paper feed starts	Eject	When the paper is ejected						
Display	Description												
Feed	When secondary paper feed starts												
Eject	When the paper is ejected												

Item No.	Description								
<b>U285</b>	<p><b>Setting service status page</b></p> <p><b>Description</b> Determines displaying the print coverage report on reporting.</p> <p><b>Purpose</b> According to user request, changes the setting.</p> <p><b>Setting</b></p> <ol style="list-style-type: none"> <li>1. Press the start key.</li> <li>2. Select On or Off.</li> </ol> <table border="1" data-bbox="338 598 1401 741"> <thead> <tr> <th>Display</th> <th>Description</th> </tr> </thead> <tbody> <tr> <td>On</td> <td>Displays the print coverage</td> </tr> <tr> <td>Off</td> <td>Not to display the print coverage</td> </tr> </tbody> </table> <p>* : Initial setting: On</p> <ol style="list-style-type: none"> <li>3. Press the start key. The setting is set.</li> </ol> <p><b>Completion</b> Press the stop key. The screen for selecting a maintenance item No. is displayed.</p>	Display	Description	On	Displays the print coverage	Off	Not to display the print coverage		
Display	Description								
On	Displays the print coverage								
Off	Not to display the print coverage								
<b>U332</b>	<p><b>Setting the size conversion factor</b></p> <p><b>Description</b> Sets the coefficient of nonstandard sizes in relation to the A4/Letter size. The coefficient set here is used to convert the black ratio in relation to the A4/Letter size and to display the result in user simulation.</p> <p><b>Purpose</b> To set the coefficient for converting the black ratio for nonstandard sizes in relation to the A4/Letter size.</p> <p><b>Setting</b></p> <ol style="list-style-type: none"> <li>1. Press the start key.</li> <li>2. Change the setting using the cursor left/right keys or numeric keys.</li> </ol> <table border="1" data-bbox="338 1397 1385 1491"> <thead> <tr> <th>Display</th> <th>Description</th> <th>Setting range</th> <th>Initial setting</th> </tr> </thead> <tbody> <tr> <td>Rate</td> <td>Size parameter</td> <td>0.1 to 3.0</td> <td>1.0</td> </tr> </tbody> </table> <ol style="list-style-type: none"> <li>3. Press the start key. The value is set.</li> </ol> <p><b>Completion</b> Press the stop key. The screen for selecting a maintenance item No. is displayed.</p>	Display	Description	Setting range	Initial setting	Rate	Size parameter	0.1 to 3.0	1.0
Display	Description	Setting range	Initial setting						
Rate	Size parameter	0.1 to 3.0	1.0						

Item No.	Description						
U345	<p data-bbox="288 241 911 275"><b>Setting the value for maintenance due indication</b></p> <p data-bbox="288 311 440 340"><b>Description</b></p> <p data-bbox="288 342 1417 456">Sets when to display a message notifying that the time for maintenance is about to be reached, by setting the number of copies that can be made before the current maintenance cycle ends. When the difference between the number of copies of the maintenance cycle and that of the maintenance count reaches the set value, the message is displayed.</p> <p data-bbox="288 459 400 488"><b>Purpose</b></p> <p data-bbox="288 490 898 519">To change the time for maintenance due indication.</p> <p data-bbox="288 562 384 591"><b>Setting</b></p> <ol data-bbox="304 593 932 696" style="list-style-type: none"> <li>1. Press the start key.</li> <li>2. Select [Cnt].</li> <li>3. Change the setting using the cursor left/right keys.</li> </ol> <table border="1" data-bbox="336 707 1401 875"> <thead> <tr> <th data-bbox="336 707 975 752">Description</th> <th data-bbox="975 707 1187 752">Setting range</th> <th data-bbox="1187 707 1401 752">Initial setting</th> </tr> </thead> <tbody> <tr> <td data-bbox="336 752 975 875">Time for maintenance due indication (Remaining number of copies that can be made before the current maintenance cycle ends)</td> <td data-bbox="975 752 1187 875">0 to 9999</td> <td data-bbox="1187 752 1401 875">0</td> </tr> </tbody> </table> <ol data-bbox="304 887 767 916" style="list-style-type: none"> <li>4. Press the start key. The value is set.</li> </ol> <p data-bbox="288 954 400 983"><b>Clearing</b></p> <ol data-bbox="304 985 820 1050" style="list-style-type: none"> <li>1. Select [Clear].</li> <li>2. Press the start key. The value is cleared.</li> </ol> <p data-bbox="288 1093 440 1122"><b>Completion</b></p> <p data-bbox="288 1124 1254 1153">Press the stop key. The screen for selecting a maintenance item No. is displayed.</p>	Description	Setting range	Initial setting	Time for maintenance due indication (Remaining number of copies that can be made before the current maintenance cycle ends)	0 to 9999	0
Description	Setting range	Initial setting					
Time for maintenance due indication (Remaining number of copies that can be made before the current maintenance cycle ends)	0 to 9999	0					

Item No.	Description																									
<p><b>U402</b></p>	<p><b>Adjust Print Margin</b></p> <p><b>Description</b> Adjusts margins for image printing.</p> <p><b>Purpose</b> Make the adjustment if margins are incorrect.</p> <p><b>Adjustment</b></p> <ol style="list-style-type: none"> <li>1. Press the start key.</li> <li>2. Press the system menu key.</li> <li>3. Press the start key to output a test pattern.</li> <li>4. Press the system menu key.</li> <li>5. Select the item to be adjusted.</li> </ol> <table border="1" data-bbox="336 701 1401 976"> <thead> <tr> <th>Display</th> <th>Description</th> <th>Setting range</th> <th>Initial setting</th> <th>Change in value per step</th> </tr> </thead> <tbody> <tr> <td>Lead</td> <td>Printer leading edge margin</td> <td>0.0 to 10.0</td> <td>4.0</td> <td>-</td> </tr> <tr> <td>A Margin</td> <td>Printer left margin</td> <td>0.0 to 10.0</td> <td>4.0</td> <td>-</td> </tr> <tr> <td>C Margin</td> <td>Printer right margin</td> <td>0.0 to 10.0</td> <td>4.0</td> <td>-</td> </tr> <tr> <td>Trail</td> <td>Printer trailing edge margin</td> <td>0.0 to 10.0</td> <td>4.0</td> <td>-</td> </tr> </tbody> </table> <ol style="list-style-type: none"> <li>6. Change the setting value using the cursor left/right keys or numeric keys. Increasing the value makes the margin wider, and decreasing it makes the margin narrower.</li> </ol> <div data-bbox="528 1081 1193 1496" data-label="Diagram"> </div> <p style="text-align: center;"><b>Figure 1-3-12</b></p> <ol style="list-style-type: none"> <li>7. Press the start key. The value is set.</li> </ol> <p><b>Caution</b> If the above adjustment does not optimize the margins, perform the following maintenance modes.</p> <div data-bbox="293 1778 676 1872" data-label="Diagram"> </div> <p><b>Completion</b> Press the stop key. The screen for selecting a maintenance item No. is displayed.</p>	Display	Description	Setting range	Initial setting	Change in value per step	Lead	Printer leading edge margin	0.0 to 10.0	4.0	-	A Margin	Printer left margin	0.0 to 10.0	4.0	-	C Margin	Printer right margin	0.0 to 10.0	4.0	-	Trail	Printer trailing edge margin	0.0 to 10.0	4.0	-
Display	Description	Setting range	Initial setting	Change in value per step																						
Lead	Printer leading edge margin	0.0 to 10.0	4.0	-																						
A Margin	Printer left margin	0.0 to 10.0	4.0	-																						
C Margin	Printer right margin	0.0 to 10.0	4.0	-																						
Trail	Printer trailing edge margin	0.0 to 10.0	4.0	-																						



Item No.	Description																									
<p><b>U403</b></p>	<p><b>Adjust Scanning Margin(Table)</b></p> <p><b>Description</b> Adjusts margins for scanning the original on the contact glass.</p> <p><b>Purpose</b> Make the adjustment if margins are incorrect.</p> <p><b>Adjustment</b></p> <ol style="list-style-type: none"> <li>1. Press the start key.</li> <li>2. Press the system menu key.</li> <li>3. Place an original and press the start key to make a test copy.</li> <li>4. Press the system menu key.</li> <li>5. Select the item to be adjusted.</li> </ol> <table border="1" data-bbox="336 701 1401 976"> <thead> <tr> <th>Display</th> <th>Description</th> <th>Setting range</th> <th>Initial setting</th> <th>Change in value per step</th> </tr> </thead> <tbody> <tr> <td>A Margin</td> <td>Scanner left margin</td> <td>0.0 to 10.0</td> <td>2.0</td> <td>0.5 mm</td> </tr> <tr> <td>B Margin</td> <td>Scanner leading edge margin</td> <td>0.0 to 10.0</td> <td>2.0</td> <td>0.5 mm</td> </tr> <tr> <td>C Margin</td> <td>Scanner right margin</td> <td>0.0 to 10.0</td> <td>2.0</td> <td>0.5 mm</td> </tr> <tr> <td>D Margin</td> <td>Scanner trailing edge margin</td> <td>0.0 to 10.0</td> <td>2.0</td> <td>0.5 mm</td> </tr> </tbody> </table> <ol style="list-style-type: none"> <li>6. Change the setting value using the cursor left/right keys or numeric keys. Increasing the value makes the margin wider, and decreasing it makes the margin narrower.</li> </ol> <div data-bbox="528 1081 1193 1496" data-label="Diagram"> <p style="text-align: center;">Leading edge margin of the copy image (4.0 +1.5/-1.0 mm)</p> <p style="text-align: center;">Left margin of the copy image (2.5 +1.5/-2.0 mm)</p> <p style="text-align: center;">Right margin of the copy image (2.5 +1.5/-2.0 mm)</p> <p style="text-align: center;">Trailing edge margin of the copy image (4.0 mm or less)</p> </div> <p style="text-align: center;"><b>Figure 1-3-13</b></p> <ol style="list-style-type: none"> <li>7. Press the start key. The value is set.</li> </ol> <p><b>Caution</b> If the above adjustment does not optimize the margins, perform the following maintenance modes.</p> <div data-bbox="293 1778 903 1872" data-label="Diagram"> <pre> graph LR     U034[U034 (P.1-3-17)] --&gt; U402[U402 (P.1-3-38)]     U402 --&gt; U403[U403]     </pre> </div> <p><b>Completion</b> Press the stop key. The indication for selecting a maintenance item No. appears.</p>	Display	Description	Setting range	Initial setting	Change in value per step	A Margin	Scanner left margin	0.0 to 10.0	2.0	0.5 mm	B Margin	Scanner leading edge margin	0.0 to 10.0	2.0	0.5 mm	C Margin	Scanner right margin	0.0 to 10.0	2.0	0.5 mm	D Margin	Scanner trailing edge margin	0.0 to 10.0	2.0	0.5 mm
Display	Description	Setting range	Initial setting	Change in value per step																						
A Margin	Scanner left margin	0.0 to 10.0	2.0	0.5 mm																						
B Margin	Scanner leading edge margin	0.0 to 10.0	2.0	0.5 mm																						
C Margin	Scanner right margin	0.0 to 10.0	2.0	0.5 mm																						
D Margin	Scanner trailing edge margin	0.0 to 10.0	2.0	0.5 mm																						

Item No.	Description																																
<b>U404</b>	<p data-bbox="288 241 655 275"><b>Adjust Scanning Margin(DP)</b></p> <p data-bbox="288 311 440 340"><b>Description</b></p> <p data-bbox="288 344 927 376">Adjusts margins for scanning the original from the DP.</p> <p data-bbox="288 383 400 412"><b>Purpose</b></p> <p data-bbox="288 416 826 448">Make the adjustment if margins are incorrect.</p> <p data-bbox="288 486 440 515"><b>Adjustment</b></p> <ol data-bbox="304 519 1182 687" style="list-style-type: none"> <li>1. Press the start key.</li> <li>2. Press the system menu key.</li> <li>3. Place an original on the DP and press the start key to make a test copy.</li> <li>4. Press the system menu key.</li> <li>5. Select the item to be adjusted.</li> </ol> <table border="1" data-bbox="336 701 1401 976"> <thead> <tr> <th>Display</th> <th>Description</th> <th>Setting range</th> <th>Initial setting</th> <th>Change in value per step</th> </tr> </thead> <tbody> <tr> <td>A Margin</td> <td>DP left margin</td> <td>0.0 to 10.0</td> <td>3.0</td> <td>0.5 mm</td> </tr> <tr> <td>B Margin</td> <td>DP leading edge margin</td> <td>0.0 to 10.0</td> <td>2.5</td> <td>0.5 mm</td> </tr> <tr> <td>C Margin</td> <td>DP right margin</td> <td>0.0 to 10.0</td> <td>3.0</td> <td>0.5 mm</td> </tr> <tr> <td>D Margin</td> <td>DP trailing edge margin</td> <td>0.0 to 10.0</td> <td>4.0</td> <td>0.5 mm</td> </tr> </tbody> </table> <ol data-bbox="304 987 1425 1055" style="list-style-type: none"> <li>6. Change the setting value using the cursor left/right keys or numeric keys. Increasing the value makes the margin wider, and decreasing it makes the margin narrower.</li> </ol> <div data-bbox="564 1081 1230 1496" style="text-align: center;"> <p>DP leading edge margin (4.0 +1.5/-1.0 mm)</p> <p>DP left margin (2.5 +1.5/-2.0 mm)</p> <p>DP right margin (2.5 +1.5/-2.0 mm)</p> <p>DP trailing edge margin (4.0 mm or less)</p> </div> <p data-bbox="775 1525 946 1554"><b>Figure 1-3-14</b></p> <ol data-bbox="304 1592 767 1624" style="list-style-type: none"> <li>7. Press the start key. The value is set.</li> </ol> <p data-bbox="288 1662 392 1691"><b>Caution</b></p> <p data-bbox="288 1695 1361 1762">If the above adjustment does not optimize the margins, perform the following maintenance modes.</p> <div data-bbox="293 1778 1129 1872" style="text-align: center;"> <table border="1"> <tr> <td style="padding: 5px;">U034 (P.1-3-17)</td> <td style="padding: 5px; text-align: center;">→</td> <td style="padding: 5px;">U402 (P.1-3-38)</td> <td style="padding: 5px; text-align: center;">→</td> <td style="padding: 5px;">U403 (P.1-3-39)</td> <td style="padding: 5px; text-align: center;">→</td> <td style="padding: 5px;">U404</td> </tr> </table> </div> <p data-bbox="288 1919 440 1948"><b>Completion</b></p> <p data-bbox="288 1953 1254 1984">Press the stop key. The screen for selecting a maintenance item No. is displayed.</p>	Display	Description	Setting range	Initial setting	Change in value per step	A Margin	DP left margin	0.0 to 10.0	3.0	0.5 mm	B Margin	DP leading edge margin	0.0 to 10.0	2.5	0.5 mm	C Margin	DP right margin	0.0 to 10.0	3.0	0.5 mm	D Margin	DP trailing edge margin	0.0 to 10.0	4.0	0.5 mm	U034 (P.1-3-17)	→	U402 (P.1-3-38)	→	U403 (P.1-3-39)	→	U404
Display	Description	Setting range	Initial setting	Change in value per step																													
A Margin	DP left margin	0.0 to 10.0	3.0	0.5 mm																													
B Margin	DP leading edge margin	0.0 to 10.0	2.5	0.5 mm																													
C Margin	DP right margin	0.0 to 10.0	3.0	0.5 mm																													
D Margin	DP trailing edge margin	0.0 to 10.0	4.0	0.5 mm																													
U034 (P.1-3-17)	→	U402 (P.1-3-38)	→	U403 (P.1-3-39)	→	U404																											

Item No.	Description																																
<b>U410</b>	<p data-bbox="288 241 753 275"><b>Adjusting the halftone automatically</b></p> <p data-bbox="288 311 440 340"><b>Description</b></p> <p data-bbox="288 344 1390 409">Carries out processing for the data acquisition that is required in order to perform either automatic adjustment of the halftone or the ID correction operation.</p> <p data-bbox="288 414 400 443"><b>Purpose</b></p> <p data-bbox="288 448 1069 479">Performed when the quality of reproduced halftones has dropped.</p> <p data-bbox="288 517 387 546"><b>Method</b></p> <ol data-bbox="304 553 1292 965" style="list-style-type: none"> <li>1. Select [Normal Mode].</li> <li>2. Press the start key. A test patterns 1 and 2 are outputted.</li> <li>3. Place the output test pattern 1 as the original. Place approximately 20 sheets of white paper on the test pattern 1 and set them.</li> <li>4. Press the start key. Adjustment is made (first time).</li> <li>5. Place the output test pattern 2 as the original. Place approximately 20 sheets of white paper on the test pattern 2 and set them.</li> <li>6. Press the start key. Adjustment is made (second time).</li> <li>7. When normally completed, [Finish] is displayed. If a problem occurs during auto adjustment, error code is displayed.</li> </ol> <p data-bbox="288 1003 443 1032"><b>Error codes</b></p> <table border="1" data-bbox="336 1048 1399 1480"> <thead> <tr> <th data-bbox="336 1048 491 1093">Codes</th> <th data-bbox="491 1048 869 1093">Description</th> <th data-bbox="869 1048 1019 1093">Codes</th> <th data-bbox="1019 1048 1399 1093">Description</th> </tr> </thead> <tbody> <tr> <td data-bbox="336 1093 491 1137">S001</td> <td data-bbox="491 1093 869 1137">Patch not detected</td> <td data-bbox="869 1093 1019 1137">E001</td> <td data-bbox="1019 1093 1399 1137">Engine status error</td> </tr> <tr> <td data-bbox="336 1137 491 1227">S002</td> <td data-bbox="491 1137 869 1227">Original deviation in the main scanning direction</td> <td data-bbox="869 1137 1019 1227">E002</td> <td data-bbox="1019 1137 1399 1227">Engine sensor error</td> </tr> <tr> <td data-bbox="336 1227 491 1317">S003</td> <td data-bbox="491 1227 869 1317">Original deviation in the auxiliary scanning direction</td> <td data-bbox="869 1227 1019 1317">EFFF</td> <td data-bbox="1019 1227 1399 1317">Engine other error</td> </tr> <tr> <td data-bbox="336 1317 491 1361">S004</td> <td data-bbox="491 1317 869 1361">Original inclination error</td> <td data-bbox="869 1317 1019 1361">C001</td> <td data-bbox="1019 1317 1399 1361">Controller error</td> </tr> <tr> <td data-bbox="336 1361 491 1406">S005</td> <td data-bbox="491 1361 869 1406">Original type error</td> <td data-bbox="869 1361 1019 1406">C100</td> <td data-bbox="1019 1361 1399 1406">Adjustment value error</td> </tr> <tr> <td data-bbox="336 1406 491 1451">SFFF</td> <td data-bbox="491 1406 869 1451">Scanner other error</td> <td data-bbox="869 1406 1019 1451">C200</td> <td data-bbox="1019 1406 1399 1451">Adjustment value error</td> </tr> <tr> <td data-bbox="336 1451 491 1480"></td> <td data-bbox="491 1451 869 1480"></td> <td data-bbox="869 1451 1019 1480">CFFF</td> <td data-bbox="1019 1451 1399 1480">Controller other error</td> </tr> </tbody> </table> <p data-bbox="288 1525 440 1554"><b>Completion</b></p> <p data-bbox="288 1559 1206 1590">Press the stop key. The screen for selecting a maintenance item is displayed.</p>	Codes	Description	Codes	Description	S001	Patch not detected	E001	Engine status error	S002	Original deviation in the main scanning direction	E002	Engine sensor error	S003	Original deviation in the auxiliary scanning direction	EFFF	Engine other error	S004	Original inclination error	C001	Controller error	S005	Original type error	C100	Adjustment value error	SFFF	Scanner other error	C200	Adjustment value error			CFFF	Controller other error
Codes	Description	Codes	Description																														
S001	Patch not detected	E001	Engine status error																														
S002	Original deviation in the main scanning direction	E002	Engine sensor error																														
S003	Original deviation in the auxiliary scanning direction	EFFF	Engine other error																														
S004	Original inclination error	C001	Controller error																														
S005	Original type error	C100	Adjustment value error																														
SFFF	Scanner other error	C200	Adjustment value error																														
		CFFF	Controller other error																														

Item No.	Description												
U411	<p data-bbox="287 241 751 275"><b>Adjusting the scanner automatically</b></p> <p data-bbox="287 311 440 340"><b>Description</b></p> <p data-bbox="287 344 1423 409">Uses a specified original and automatically adjusts the following items in the scanner and the DP scanning sections.</p> <p data-bbox="287 414 1423 479">Scanner section: Original size magnification, leading edge timing, center line, input gamma, input gamma in monochrome mode and matrix</p> <p data-bbox="287 483 1246 515">DP scanning section: Original size magnification, leading edge timing, center line</p> <p data-bbox="287 519 400 548"><b>Purpose</b></p> <p data-bbox="287 553 1418 584">To perform automatic adjustment of various items in the scanner and the DP scanning sections.</p> <p data-bbox="287 620 387 649"><b>Method</b></p> <ol data-bbox="304 654 564 719" style="list-style-type: none"> <li>1. Press the start key.</li> <li>2. Select the item.</li> </ol> <table border="1" data-bbox="336 734 1399 1099"> <thead> <tr> <th data-bbox="336 734 564 815">Display</th> <th data-bbox="564 734 1096 815">Description</th> <th data-bbox="1096 734 1399 815">Original to be used for adjustment (P/N)</th> </tr> </thead> <tbody> <tr> <td data-bbox="336 815 564 936">All</td> <td data-bbox="564 815 1096 936">Performs automatic adjustment in the DP scanning section following automatic adjustment in the scanner section</td> <td data-bbox="1096 815 1399 936">302FZ56990/ 303LJ57010</td> </tr> <tr> <td data-bbox="336 936 564 1016">Table</td> <td data-bbox="564 936 1096 1016">Automatic adjustment in the scanner section</td> <td data-bbox="1096 936 1399 1016">302FZ56990</td> </tr> <tr> <td data-bbox="336 1016 564 1099">DP</td> <td data-bbox="564 1016 1096 1099">Automatic adjustment in the DP scanning section:</td> <td data-bbox="1096 1016 1399 1099">303LJ57010</td> </tr> </tbody> </table> <p data-bbox="287 1144 472 1173"><b>Method: Table</b></p> <ol data-bbox="304 1178 1431 1556" style="list-style-type: none"> <li>1. Enter the target values which are shown on the specified original (P/N: 302FZ56990) executing maintenance item U425.</li> <li>2. Set a specified original (P/N: 302FZ56990) on the platen.</li> <li>3. Enter maintenance item U411.</li> <li>4. Select [Table].</li> <li>5. Press the start key. Auto adjustment starts.</li> <li>6. When automatic adjustment has normally completed, [OK] is displayed. If a problem occurs during auto adjustment, [NG XX] (XX is replaced by an error code) is displayed and operation stops. Should this happen, determine the details of the problem and repeat the procedure from the beginning.</li> <li>7. To return to the screen for selecting an item, press the stop key.</li> </ol> <p data-bbox="287 1597 440 1626"><b>Method: DP</b></p> <ol data-bbox="304 1630 1423 1904" style="list-style-type: none"> <li>1. Select [DP].</li> <li>2. Set a specified original (P/N: 303LJ57010) in the DP.</li> <li>3. Press the start key. Auto adjustment starts.</li> <li>4. When automatic adjustment has normally completed, [OK] is displayed. If a problem occurs during auto adjustment, [NG XX] (XX is replaced by an error code) is displayed and operation stops. Should this happen, determine the details of the problem and repeat the procedure from the beginning.</li> <li>5. To return to the screen for selecting an item, press the stop key.</li> </ol>	Display	Description	Original to be used for adjustment (P/N)	All	Performs automatic adjustment in the DP scanning section following automatic adjustment in the scanner section	302FZ56990/ 303LJ57010	Table	Automatic adjustment in the scanner section	302FZ56990	DP	Automatic adjustment in the DP scanning section:	303LJ57010
Display	Description	Original to be used for adjustment (P/N)											
All	Performs automatic adjustment in the DP scanning section following automatic adjustment in the scanner section	302FZ56990/ 303LJ57010											
Table	Automatic adjustment in the scanner section	302FZ56990											
DP	Automatic adjustment in the DP scanning section:	303LJ57010											

Item No.	Description																																																										
U411	<p data-bbox="288 241 448 271"><b>Error Codes</b></p> <table border="1" data-bbox="336 286 1401 1850"> <thead> <tr> <th data-bbox="336 286 491 331">Codes</th> <th data-bbox="491 286 1401 331">Description</th> </tr> </thead> <tbody> <tr><td data-bbox="336 331 491 376">01</td><td data-bbox="491 331 1401 376">Black band detection error (scanner leading edge registration)</td></tr> <tr><td data-bbox="336 376 491 421">02</td><td data-bbox="491 376 1401 421">Black band detection error (scanner center line)</td></tr> <tr><td data-bbox="336 421 491 465">03</td><td data-bbox="491 421 1401 465">Black band detection error (scanner main scanning direction magnification)</td></tr> <tr><td data-bbox="336 465 491 510">04</td><td data-bbox="491 465 1401 510">Black band is not detected (scanner leading edge registration)</td></tr> <tr><td data-bbox="336 510 491 555">05</td><td data-bbox="491 510 1401 555">Black band is not detected (scanner center line)</td></tr> <tr><td data-bbox="336 555 491 600">06</td><td data-bbox="491 555 1401 600">Black band is not detected (scanner main scanning direction magnification)</td></tr> <tr><td data-bbox="336 600 491 645">07</td><td data-bbox="491 600 1401 645">Black band is not detected (scanner auxiliary scanning direction magnification)</td></tr> <tr><td data-bbox="336 645 491 689">08</td><td data-bbox="491 645 1401 689">Black band is not detected (DP main scanning direction magnification far end)</td></tr> <tr><td data-bbox="336 689 491 734">09</td><td data-bbox="491 689 1401 734">Black band is not detected (DP main scanning direction magnification near end)</td></tr> <tr><td data-bbox="336 734 491 779">0a</td><td data-bbox="491 734 1401 779">Black band is not detected (DP auxiliary scanning direction magnification leading edge)</td></tr> <tr><td data-bbox="336 779 491 824">0b</td><td data-bbox="491 779 1401 824">Black band is not detected (DP auxiliary scanning direction magnification leading edge original check)</td></tr> <tr><td data-bbox="336 824 491 869">0c</td><td data-bbox="491 824 1401 869">Black band is not detected (DP auxiliary scanning direction trailing edge)</td></tr> <tr><td data-bbox="336 869 491 913">0d</td><td data-bbox="491 869 1401 913">Black band is not detected (DP auxiliary scanning direction trailing edge 2)</td></tr> <tr><td data-bbox="336 913 491 958">0e</td><td data-bbox="491 913 1401 958">DMA time out</td></tr> <tr><td data-bbox="336 958 491 1003">0f</td><td data-bbox="491 958 1401 1003">Auxiliary scanning direction magnification error</td></tr> <tr><td data-bbox="336 1003 491 1048">10</td><td data-bbox="491 1003 1401 1048">Auxiliary scanning direction leading edge detection error</td></tr> <tr><td data-bbox="336 1048 491 1093">11</td><td data-bbox="491 1048 1401 1093">Auxiliary scanning direction trailing edge detection error</td></tr> <tr><td data-bbox="336 1093 491 1137">12</td><td data-bbox="491 1093 1401 1137">Auxiliary scanning direction skew 1.5 error</td></tr> <tr><td data-bbox="336 1137 491 1182">13</td><td data-bbox="491 1137 1401 1182">Maintenance request error</td></tr> <tr><td data-bbox="336 1182 491 1227">14</td><td data-bbox="491 1182 1401 1227">Main scanning direction center line error</td></tr> <tr><td data-bbox="336 1227 491 1272">15</td><td data-bbox="491 1227 1401 1272">Main scanning direction skew 1.5 error</td></tr> <tr><td data-bbox="336 1272 491 1317">16</td><td data-bbox="491 1272 1401 1317">Main scanning direction magnification error</td></tr> <tr><td data-bbox="336 1317 491 1361">17</td><td data-bbox="491 1317 1401 1361">Service call error</td></tr> <tr><td data-bbox="336 1361 491 1406">18</td><td data-bbox="491 1361 1401 1406">DP paper misfeed error</td></tr> <tr><td data-bbox="336 1406 491 1451">19</td><td data-bbox="491 1406 1401 1451">PWB replacement error</td></tr> <tr><td data-bbox="336 1451 491 1496">1a</td><td data-bbox="491 1451 1401 1496">Original error</td></tr> <tr><td data-bbox="336 1496 491 1541">1b</td><td data-bbox="491 1496 1401 1541">Original error (scanner input gamma adjustment)</td></tr> <tr><td data-bbox="336 1541 491 1585">1c</td><td data-bbox="491 1541 1401 1585">Original error (scanner matrix adjustment)</td></tr> </tbody> </table> <p data-bbox="288 1906 440 1935"><b>Completion</b></p> <p data-bbox="288 1939 1206 1968">Press the stop key. The screen for selecting a maintenance item is displayed.</p>	Codes	Description	01	Black band detection error (scanner leading edge registration)	02	Black band detection error (scanner center line)	03	Black band detection error (scanner main scanning direction magnification)	04	Black band is not detected (scanner leading edge registration)	05	Black band is not detected (scanner center line)	06	Black band is not detected (scanner main scanning direction magnification)	07	Black band is not detected (scanner auxiliary scanning direction magnification)	08	Black band is not detected (DP main scanning direction magnification far end)	09	Black band is not detected (DP main scanning direction magnification near end)	0a	Black band is not detected (DP auxiliary scanning direction magnification leading edge)	0b	Black band is not detected (DP auxiliary scanning direction magnification leading edge original check)	0c	Black band is not detected (DP auxiliary scanning direction trailing edge)	0d	Black band is not detected (DP auxiliary scanning direction trailing edge 2)	0e	DMA time out	0f	Auxiliary scanning direction magnification error	10	Auxiliary scanning direction leading edge detection error	11	Auxiliary scanning direction trailing edge detection error	12	Auxiliary scanning direction skew 1.5 error	13	Maintenance request error	14	Main scanning direction center line error	15	Main scanning direction skew 1.5 error	16	Main scanning direction magnification error	17	Service call error	18	DP paper misfeed error	19	PWB replacement error	1a	Original error	1b	Original error (scanner input gamma adjustment)	1c	Original error (scanner matrix adjustment)
Codes	Description																																																										
01	Black band detection error (scanner leading edge registration)																																																										
02	Black band detection error (scanner center line)																																																										
03	Black band detection error (scanner main scanning direction magnification)																																																										
04	Black band is not detected (scanner leading edge registration)																																																										
05	Black band is not detected (scanner center line)																																																										
06	Black band is not detected (scanner main scanning direction magnification)																																																										
07	Black band is not detected (scanner auxiliary scanning direction magnification)																																																										
08	Black band is not detected (DP main scanning direction magnification far end)																																																										
09	Black band is not detected (DP main scanning direction magnification near end)																																																										
0a	Black band is not detected (DP auxiliary scanning direction magnification leading edge)																																																										
0b	Black band is not detected (DP auxiliary scanning direction magnification leading edge original check)																																																										
0c	Black band is not detected (DP auxiliary scanning direction trailing edge)																																																										
0d	Black band is not detected (DP auxiliary scanning direction trailing edge 2)																																																										
0e	DMA time out																																																										
0f	Auxiliary scanning direction magnification error																																																										
10	Auxiliary scanning direction leading edge detection error																																																										
11	Auxiliary scanning direction trailing edge detection error																																																										
12	Auxiliary scanning direction skew 1.5 error																																																										
13	Maintenance request error																																																										
14	Main scanning direction center line error																																																										
15	Main scanning direction skew 1.5 error																																																										
16	Main scanning direction magnification error																																																										
17	Service call error																																																										
18	DP paper misfeed error																																																										
19	PWB replacement error																																																										
1a	Original error																																																										
1b	Original error (scanner input gamma adjustment)																																																										
1c	Original error (scanner matrix adjustment)																																																										

Item No.	Description																																		
U425	<p data-bbox="288 241 512 275"><b>Setting the target</b></p> <p data-bbox="288 311 440 340"><b>Description</b></p> <p data-bbox="288 344 1366 409">Enters the lab values that is indicated on the back of the chart (P/N: 302FZ56990) used for adjustment.</p> <p data-bbox="288 414 400 443"><b>Purpose</b></p> <p data-bbox="288 448 1406 479">Performs data input in order to correct for differences in originals during automatic adjustment.</p> <p data-bbox="288 515 387 544"><b>Method</b></p> <ol data-bbox="304 548 632 613" style="list-style-type: none"> <li>1. Press the start key.</li> <li>2. Select the item to be set.</li> </ol> <table border="1" data-bbox="336 629 1399 1158"> <thead> <tr> <th data-bbox="336 629 639 674">Display</th> <th data-bbox="639 629 1399 674">Description</th> </tr> </thead> <tbody> <tr> <td data-bbox="336 674 639 719">N875</td> <td data-bbox="639 674 1399 719">Setting the N875 patch for the original for adjustment</td> </tr> <tr> <td data-bbox="336 719 639 763">N475</td> <td data-bbox="639 719 1399 763">Setting the N475 patch for the original for adjustment</td> </tr> <tr> <td data-bbox="336 763 639 808">N125</td> <td data-bbox="639 763 1399 808">Setting the N125 patch for the original for adjustment</td> </tr> <tr> <td data-bbox="336 808 639 853">C</td> <td data-bbox="639 808 1399 853">Setting the cyan patch for the original for adjustment</td> </tr> <tr> <td data-bbox="336 853 639 898">M</td> <td data-bbox="639 853 1399 898">Setting the magenta patch for the original for adjustment</td> </tr> <tr> <td data-bbox="336 898 639 943">Y</td> <td data-bbox="639 898 1399 943">Setting the yellow patch for the original for adjustment</td> </tr> <tr> <td data-bbox="336 943 639 987">R</td> <td data-bbox="639 943 1399 987">Setting the red patch for the original for adjustment</td> </tr> <tr> <td data-bbox="336 987 639 1032">G</td> <td data-bbox="639 987 1399 1032">Setting the green patch for the original for adjustment</td> </tr> <tr> <td data-bbox="336 1032 639 1077">B</td> <td data-bbox="639 1032 1399 1077">Setting the blue patch for the original for adjustment</td> </tr> <tr> <td data-bbox="336 1077 639 1158">Adjust Original</td> <td data-bbox="639 1077 1399 1158">Setting the main and auxiliary scanning directions</td> </tr> </tbody> </table> <ol data-bbox="304 1167 632 1198" style="list-style-type: none"> <li>3. Select the item to be set.</li> </ol> <table border="1" data-bbox="336 1211 1399 1404"> <thead> <tr> <th data-bbox="336 1211 639 1256">Display</th> <th data-bbox="639 1211 1018 1256">Description</th> <th data-bbox="1018 1211 1399 1256">Setting range</th> </tr> </thead> <tbody> <tr> <td data-bbox="336 1256 639 1301">L</td> <td data-bbox="639 1256 1018 1301">Setting the L value</td> <td data-bbox="1018 1256 1399 1301">0.0 to 100.0</td> </tr> <tr> <td data-bbox="336 1301 639 1346">a</td> <td data-bbox="639 1301 1018 1346">Setting the a value</td> <td data-bbox="1018 1301 1399 1346">-200.0 to 200.0</td> </tr> <tr> <td data-bbox="336 1346 639 1404">b</td> <td data-bbox="639 1346 1018 1404">Setting the b value</td> <td data-bbox="1018 1346 1399 1404">-200.0 to 200.0</td> </tr> </tbody> </table> <ol data-bbox="304 1413 1406 1514" style="list-style-type: none"> <li>4. Enters the value that is indicated on the back of the chart using the cursor left/right keys or numeric keys.</li> <li>5. Press the start key. The value is set.</li> </ol>	Display	Description	N875	Setting the N875 patch for the original for adjustment	N475	Setting the N475 patch for the original for adjustment	N125	Setting the N125 patch for the original for adjustment	C	Setting the cyan patch for the original for adjustment	M	Setting the magenta patch for the original for adjustment	Y	Setting the yellow patch for the original for adjustment	R	Setting the red patch for the original for adjustment	G	Setting the green patch for the original for adjustment	B	Setting the blue patch for the original for adjustment	Adjust Original	Setting the main and auxiliary scanning directions	Display	Description	Setting range	L	Setting the L value	0.0 to 100.0	a	Setting the a value	-200.0 to 200.0	b	Setting the b value	-200.0 to 200.0
Display	Description																																		
N875	Setting the N875 patch for the original for adjustment																																		
N475	Setting the N475 patch for the original for adjustment																																		
N125	Setting the N125 patch for the original for adjustment																																		
C	Setting the cyan patch for the original for adjustment																																		
M	Setting the magenta patch for the original for adjustment																																		
Y	Setting the yellow patch for the original for adjustment																																		
R	Setting the red patch for the original for adjustment																																		
G	Setting the green patch for the original for adjustment																																		
B	Setting the blue patch for the original for adjustment																																		
Adjust Original	Setting the main and auxiliary scanning directions																																		
Display	Description	Setting range																																	
L	Setting the L value	0.0 to 100.0																																	
a	Setting the a value	-200.0 to 200.0																																	
b	Setting the b value	-200.0 to 200.0																																	

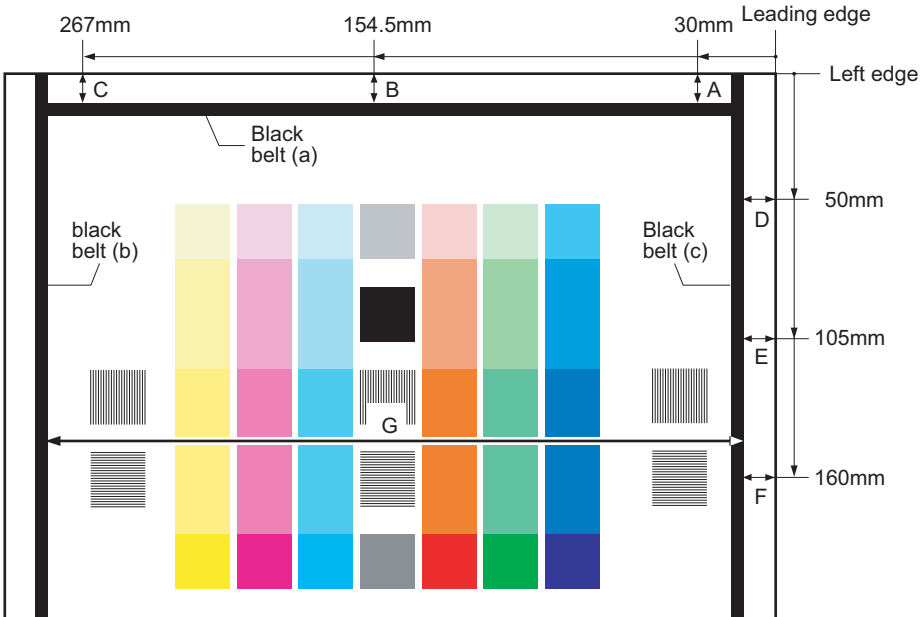
Item No.	Description
U425	<p><b>Setting: [Adjust Original]</b></p> <ol style="list-style-type: none"> <li>Measure the distance from the left edge to the black belt (a) of the original at A, B and C. Measurement procedure               <ol style="list-style-type: none"> <li>1) Measure the distance from the edge to the black belt (a) of the original at A (30 mm from the leading edge), B (154.5 mm from the leading edge) and C (267 mm from the leading edge), respectively.</li> <li>2) Apply the following formula for the values obtained: <math>((A + C) / 2 + B) / 2</math></li> </ol> </li> <li>Enter the values solved using the cursor left/right keys or numeric keys in [MAIN].</li> <li>Press the start key. The value is set.</li> <li>Measure the distance from the leading edge to the black belt (c) of the original at D, E and F. Measurement procedure               <ol style="list-style-type: none"> <li>1) Measure the distance from the edge to the black belt (c) of the original at D (50 mm from the left edge), E (105 mm from the left edge) and F (160 mm from the left edge), respectively.</li> <li>2) Apply the following formula for the values obtained: <math>((D + F) / 2 + E) / 2</math></li> </ol> </li> <li>Enter the values solved using the cursor left/right keys or numeric keys in [SUB LEAD].</li> <li>Press the start key. The value is set.</li> <li>Measure the length (G) from the edge of the black belt (b) to edge of the black belt (c) of the original.</li> <li>Enter the measured value using the cursor left/right keys or numeric keys in [SUB TAIL].</li> <li>Press the start key. The value is set.</li> </ol> <div style="text-align: center; margin-top: 20px;">  <p>Original for adjustment (P/N: 302FZ56990)</p> </div> <div style="border: 1px solid black; padding: 5px; width: fit-content; margin-top: 20px;"> <p>[ Main ] = <math>((A+C)/2+B)/2</math></p> <p>[ Sub Lead ] = <math>((D+F)/2+E)/2</math></p> <p>[ SubTail ] = G</p> </div>

Figure 1-3-15

**Completion**

Press the stop key. The screen for selecting a maintenance item No. is displayed.

Item No.	Description																																																																												
<b>U600</b>	<p data-bbox="287 241 523 273"><b>Initializing all data</b></p> <p data-bbox="287 309 440 340"><b>Description</b></p> <p data-bbox="287 344 1423 407">Initializes software switches and all data in the backup data on the FAX control PWB, according to the destination and OEM.</p> <p data-bbox="287 412 1423 474">Executes the check of the file system, when abnormality of the file system is detected, initializes the file system, communication past record and register setting contents.</p> <p data-bbox="287 479 399 510"><b>Purpose</b></p> <p data-bbox="287 515 689 546">To initialize the FAX control PWB.</p> <p data-bbox="287 582 386 613"><b>Method</b></p> <ol data-bbox="303 618 1423 963" style="list-style-type: none"> <li>1. Press the start key.</li> <li>2. Select [Execute]. The screen for entering the destination code and OEM code is displayed.</li> <li>3. Select [Country Code] and enter a destination code using the numeric keys (refer to the destination code list on following for the destination code).</li> <li>4. Press the start key.  There is no operation necessary on this screen.  The destination code and the OEM code are displayed with the values currently set.</li> <li>5. Press the start key. Data initialization starts. To cancel data initialization, press the stop key.</li> <li>6. After data initialization, the entered destination, OEM codes and ROM version are displayed.  A ROM version displays three kinds, application, boot, and IPL.</li> </ol> <p data-bbox="287 999 555 1030"><b>Destination code list</b></p> <table border="1" data-bbox="335 1043 1401 1957"> <thead> <tr> <th>Code</th> <th>Destination</th> <th>Code</th> <th>Destination</th> </tr> </thead> <tbody> <tr> <td>000</td> <td>Japan</td> <td>253</td> <td>CTR21 (European nations)</td> </tr> <tr> <td>009</td> <td>Australia</td> <td></td> <td>Italy</td> </tr> <tr> <td>038</td> <td>China</td> <td></td> <td>Germany</td> </tr> <tr> <td>080</td> <td>Hong Kong</td> <td></td> <td>Spain</td> </tr> <tr> <td>084</td> <td>Indonesia</td> <td></td> <td>U.K.</td> </tr> <tr> <td>088</td> <td>Israel</td> <td></td> <td>Netherlands</td> </tr> <tr> <td>097</td> <td>Korea</td> <td></td> <td>Sweden</td> </tr> <tr> <td>108</td> <td>Malaysia</td> <td></td> <td>France</td> </tr> <tr> <td>126</td> <td>New Zealand</td> <td></td> <td>Austria</td> </tr> <tr> <td>136</td> <td>Peru</td> <td></td> <td>Switzerland</td> </tr> <tr> <td>137</td> <td>Philippines</td> <td></td> <td>Belgium</td> </tr> <tr> <td>152</td> <td>Middle East</td> <td></td> <td>Denmark</td> </tr> <tr> <td>156</td> <td>Singapore</td> <td></td> <td>Finland</td> </tr> <tr> <td>159</td> <td>South Africa</td> <td></td> <td>Portugal</td> </tr> <tr> <td>169</td> <td>Thailand</td> <td></td> <td>Ireland</td> </tr> <tr> <td>181</td> <td>U.S.A.</td> <td></td> <td>Norway</td> </tr> <tr> <td>242</td> <td>South America</td> <td>254</td> <td>Taiwan</td> </tr> <tr> <td>243</td> <td>Saudi Arabia</td> <td></td> <td></td> </tr> </tbody> </table>	Code	Destination	Code	Destination	000	Japan	253	CTR21 (European nations)	009	Australia		Italy	038	China		Germany	080	Hong Kong		Spain	084	Indonesia		U.K.	088	Israel		Netherlands	097	Korea		Sweden	108	Malaysia		France	126	New Zealand		Austria	136	Peru		Switzerland	137	Philippines		Belgium	152	Middle East		Denmark	156	Singapore		Finland	159	South Africa		Portugal	169	Thailand		Ireland	181	U.S.A.		Norway	242	South America	254	Taiwan	243	Saudi Arabia		
Code	Destination	Code	Destination																																																																										
000	Japan	253	CTR21 (European nations)																																																																										
009	Australia		Italy																																																																										
038	China		Germany																																																																										
080	Hong Kong		Spain																																																																										
084	Indonesia		U.K.																																																																										
088	Israel		Netherlands																																																																										
097	Korea		Sweden																																																																										
108	Malaysia		France																																																																										
126	New Zealand		Austria																																																																										
136	Peru		Switzerland																																																																										
137	Philippines		Belgium																																																																										
152	Middle East		Denmark																																																																										
156	Singapore		Finland																																																																										
159	South Africa		Portugal																																																																										
169	Thailand		Ireland																																																																										
181	U.S.A.		Norway																																																																										
242	South America	254	Taiwan																																																																										
243	Saudi Arabia																																																																												



Item No.	Description								
<b>U601</b>	<p><b>Initializing permanent data</b></p> <p><b>Description</b> Initializes software switches on the FAX control PWB according to the destination and OEM.</p> <p><b>Purpose</b> To initialize the FAX control PWB without changing user registration data.</p> <p><b>Method</b></p> <ol style="list-style-type: none"> <li>1. Press the start key.</li> <li>2. Select [Execute]. The screen for entering the destination code and OEM code is displayed.</li> <li>3. Select [Country Code] and enter a destination code using the numeric keys (refer to the destination code list on page 1-3-46 for the destination code).</li> <li>4. Press the start key. There is no operation necessary on this screen. The destination code and the OEM code are displayed with the values currently set.</li> <li>5. Press the start key. Data initialization starts. To cancel data initialization, press the back key.</li> <li>6. After data initialization, the entered destination, OEM codes and ROM version are displayed. A ROM version displays three kinds, application, boot, and IPL.</li> </ol>								
<b>U603</b>	<p><b>Setting user data 1</b></p> <p><b>Description</b> Makes user settings to enable the use of the machine as a fax.</p> <p><b>Purpose</b> To be executed as required.</p> <p><b>Method</b></p> <ol style="list-style-type: none"> <li>1. Press the start key.</li> <li>2. Select [Line Type] and press the start key.</li> <li>3. Select the setting.</li> </ol> <table border="1" data-bbox="336 1301 1401 1496"> <thead> <tr> <th data-bbox="336 1301 639 1350">Display</th> <th data-bbox="639 1301 1401 1350">Description</th> </tr> </thead> <tbody> <tr> <td data-bbox="336 1350 639 1400">DTMF</td> <td data-bbox="639 1350 1401 1400">DTMF</td> </tr> <tr> <td data-bbox="336 1400 639 1449">10PPS</td> <td data-bbox="639 1400 1401 1449">10 PPS</td> </tr> <tr> <td data-bbox="336 1449 639 1496">20PPS</td> <td data-bbox="639 1449 1401 1496">20 PPS</td> </tr> </tbody> </table> <p>* : Initial setting: DTMF</p> <ol style="list-style-type: none"> <li>4. Press the start key. The setting is set.</li> </ol> <p><b>Completion</b> Press the stop key. The screen for selecting a maintenance item No. is displayed.</p>	Display	Description	DTMF	DTMF	10PPS	10 PPS	20PPS	20 PPS
Display	Description								
DTMF	DTMF								
10PPS	10 PPS								
20PPS	20 PPS								

Item No.	Description						
<b>U604</b>	<p><b>Setting user data 2</b></p> <p><b>Description</b> Makes user settings to enable the use of the machine as a fax.</p> <p><b>Purpose</b> Use this if the user wishes to adjust the number of rings that occur before the unit switches into fax receiving mode when fax/telephone auto-select is enabled.</p> <p><b>Method</b></p> <ol style="list-style-type: none"> <li>1. Press the start key.</li> <li>2. Change the setting using the cursor left/right keys or numeric keys.</li> </ol> <table border="1" data-bbox="338 633 1401 728"> <thead> <tr> <th data-bbox="338 633 866 678">Description</th> <th data-bbox="866 633 1098 678">Setting range</th> <th data-bbox="1098 633 1401 678">Initial setting</th> </tr> </thead> <tbody> <tr> <td data-bbox="338 678 866 728">Number of fax/telephone rings</td> <td data-bbox="866 678 1098 728">0 to 15</td> <td data-bbox="1098 678 1401 728">2 (120 V)/1 (220-240 V)</td> </tr> </tbody> </table> <p>* : If you set this to 0, the unit will start fax reception without any ringing.</p> <ol style="list-style-type: none"> <li>3. Press the start key. The value is set.</li> </ol> <p><b>Completion</b> Press the stop key. The screen for selecting a maintenance item No. is displayed.</p>	Description	Setting range	Initial setting	Number of fax/telephone rings	0 to 15	2 (120 V)/1 (220-240 V)
Description	Setting range	Initial setting					
Number of fax/telephone rings	0 to 15	2 (120 V)/1 (220-240 V)					
<b>U605</b>	<p><b>Clearing data</b></p> <p><b>Description</b> Initializes data related to the fax transmission such as transmission history.</p> <p><b>Purpose</b> To clear the transmission history.</p> <p><b>Method</b></p> <ol style="list-style-type: none"> <li>1. Press the start key.</li> <li>2. Select [Comm REC].</li> <li>3. Press the start key. Initialization processing starts. When processing is finished, [Completed] is displayed.</li> </ol> <p><b>Completion</b> Press the stop key. The screen for selecting a maintenance item No. is displayed.</p>						

Item No.	Description																								
U610	<p data-bbox="288 241 504 275"><b>Setting system 1</b></p> <p data-bbox="288 311 440 340"><b>Description</b></p> <p data-bbox="288 344 1404 412">Makes settings for fax reception regarding the sizes of the fax paper and received images and automatic printing of the protocol list.</p> <p data-bbox="288 450 387 479"><b>Method</b></p> <ol data-bbox="304 486 632 546" style="list-style-type: none"> <li>1. Press the start key.</li> <li>2. Select the item to be set.</li> </ol> <table border="1" data-bbox="336 562 1401 860"> <thead> <tr> <th data-bbox="336 562 639 607">Display</th> <th data-bbox="639 562 1401 607">Description</th> </tr> </thead> <tbody> <tr> <td data-bbox="336 607 639 689">Cut Line:100%</td> <td data-bbox="639 607 1401 689">Sets the number of lines to be ignored when receiving a fax at 100% magnification.</td> </tr> <tr> <td data-bbox="336 689 639 772">Cut Line:Auto</td> <td data-bbox="639 689 1401 772">Sets the number of lines to be ignored when receiving a fax in the auto reduction mode.</td> </tr> <tr> <td data-bbox="336 772 639 860">Cut Line:A4</td> <td data-bbox="639 772 1401 860">Sets the number of lines to be ignored when receiving a fax (A4R/LetterR) in the auto reduction mode.</td> </tr> </tbody> </table> <p data-bbox="288 904 1372 936"><b>Setting the number of lines to be ignored when receiving a fax at 100% magnification</b></p> <p data-bbox="288 940 1431 1039">Sets the maximum number of lines to be ignored if the received data volume exceeds the recording capacity when recording the data at 100% magnification. If the number of excess lines is below the setting, those lines are ignored. If over the setting, they are recorded on the next page.</p> <ol data-bbox="304 1043 1126 1075" style="list-style-type: none"> <li>1. Change the setting using the cursor left/right keys or numeric keys.</li> </ol> <table border="1" data-bbox="336 1088 1401 1252"> <thead> <tr> <th data-bbox="336 1088 823 1171">Description</th> <th data-bbox="823 1088 1003 1171">Setting range</th> <th data-bbox="1003 1088 1187 1171">Initial setting</th> <th data-bbox="1187 1088 1401 1171">Change in value per step</th> </tr> </thead> <tbody> <tr> <td data-bbox="336 1171 823 1252">Number of lines to be ignored when receiving at 100%</td> <td data-bbox="823 1171 1003 1252">0 to 22</td> <td data-bbox="1003 1171 1187 1252">3</td> <td data-bbox="1187 1171 1401 1252">16 lines</td> </tr> </tbody> </table> <p data-bbox="336 1261 1366 1323">* : Increase the setting if a blank second page is output, and decrease it if the received image does not include the entire transmitted data.</p> <ol data-bbox="304 1330 767 1361" style="list-style-type: none"> <li>2. Press the start key. The value is set.</li> </ol> <p data-bbox="288 1397 1431 1429"><b>Setting the number of lines to be ignored when receiving a fax in the auto reduction mode</b></p> <p data-bbox="288 1433 1431 1568">Sets the maximum number of lines to be ignored if the received data volume exceeds the recording capacity when the data is recorded in the auto reduction mode. If the number of excess lines is below the setting, those lines are ignored. If over the setting, the entire data on a page is further reduced so that it can be recorded on the same page.</p> <ol data-bbox="304 1572 1126 1603" style="list-style-type: none"> <li>1. Change the setting using the cursor left/right keys or numeric keys.</li> </ol> <table border="1" data-bbox="336 1617 1401 1780"> <thead> <tr> <th data-bbox="336 1617 823 1700">Description</th> <th data-bbox="823 1617 1003 1700">Setting range</th> <th data-bbox="1003 1617 1187 1700">Initial setting</th> <th data-bbox="1187 1617 1401 1700">Change in value per step</th> </tr> </thead> <tbody> <tr> <td data-bbox="336 1700 823 1780">Number of lines to be ignored when receiving in the auto reduction mode</td> <td data-bbox="823 1700 1003 1780">0 to 22</td> <td data-bbox="1003 1700 1187 1780">0</td> <td data-bbox="1187 1700 1401 1780">16 lines</td> </tr> </tbody> </table> <p data-bbox="336 1789 1394 1888">* : Increase the setting if a page received in the reduction mode is over-reduced and too much trailing edge margin is left. Decrease it if the received image does not include all transmitted data.</p> <ol data-bbox="304 1895 767 1926" style="list-style-type: none"> <li>2. Press the start key. The value is set.</li> </ol>	Display	Description	Cut Line:100%	Sets the number of lines to be ignored when receiving a fax at 100% magnification.	Cut Line:Auto	Sets the number of lines to be ignored when receiving a fax in the auto reduction mode.	Cut Line:A4	Sets the number of lines to be ignored when receiving a fax (A4R/LetterR) in the auto reduction mode.	Description	Setting range	Initial setting	Change in value per step	Number of lines to be ignored when receiving at 100%	0 to 22	3	16 lines	Description	Setting range	Initial setting	Change in value per step	Number of lines to be ignored when receiving in the auto reduction mode	0 to 22	0	16 lines
Display	Description																								
Cut Line:100%	Sets the number of lines to be ignored when receiving a fax at 100% magnification.																								
Cut Line:Auto	Sets the number of lines to be ignored when receiving a fax in the auto reduction mode.																								
Cut Line:A4	Sets the number of lines to be ignored when receiving a fax (A4R/LetterR) in the auto reduction mode.																								
Description	Setting range	Initial setting	Change in value per step																						
Number of lines to be ignored when receiving at 100%	0 to 22	3	16 lines																						
Description	Setting range	Initial setting	Change in value per step																						
Number of lines to be ignored when receiving in the auto reduction mode	0 to 22	0	16 lines																						

Item No.	Description								
U610	<p data-bbox="288 241 1409 304"><b>Setting the number of lines to be ignored when receiving a fax (A4R/LetterR) in the auto reduction mode</b></p> <p data-bbox="288 311 1433 409">Sets the maximum number of lines to be ignored if the received data volume exceeds the recording capacity when the data is recorded in the auto reduction mode onto A4R or LetterR paper under the conditions below.</p> <p data-bbox="288 416 1425 479">If the number of excess lines is below the setting, those lines are ignored. If over the setting, the entire data on a page is further reduced so that it can be recorded on the same page.</p> <p data-bbox="308 486 1126 517">1. Change the setting using the cursor left/right keys or numeric keys.</p> <table border="1" data-bbox="336 526 1401 728"> <thead> <tr> <th data-bbox="341 533 823 607">Description</th> <th data-bbox="823 533 1003 607">Setting range</th> <th data-bbox="1003 533 1187 607">Initial setting</th> <th data-bbox="1187 533 1396 607">Change in value per step</th> </tr> </thead> <tbody> <tr> <td data-bbox="341 613 823 721">Number of lines to be ignored when receiving a fax (A4R, letter) in the auto reduction mode</td> <td data-bbox="823 613 1003 721">0 to 22</td> <td data-bbox="1003 613 1187 721">0</td> <td data-bbox="1187 613 1396 721">16 lines</td> </tr> </tbody> </table> <p data-bbox="336 739 1396 837">* : Increase the setting if a page received in the reduction mode is over-reduced and too much trailing edge margin is left. Decrease it if the received image does not include all transmitted data.</p> <p data-bbox="308 844 767 875">2. Press the start key. The value is set.</p> <p data-bbox="288 913 440 945"><b>Completion</b></p> <p data-bbox="288 952 1254 983">Press the stop key. The screen for selecting a maintenance item No. is displayed.</p>	Description	Setting range	Initial setting	Change in value per step	Number of lines to be ignored when receiving a fax (A4R, letter) in the auto reduction mode	0 to 22	0	16 lines
Description	Setting range	Initial setting	Change in value per step						
Number of lines to be ignored when receiving a fax (A4R, letter) in the auto reduction mode	0 to 22	0	16 lines						

Item No.	Description																										
U611	<p data-bbox="290 241 507 273"><b>Setting system 2</b></p> <p data-bbox="290 309 440 340"><b>Description</b> Sets the number of adjustment lines for automatic reduction.</p> <p data-bbox="290 416 386 448"><b>Method</b></p> <ol data-bbox="306 452 632 515" style="list-style-type: none"> <li>1. Press the start key.</li> <li>2. Select the item to be set.</li> </ol> <table border="1" data-bbox="336 526 1401 790"> <thead> <tr> <th data-bbox="336 526 639 571">Display</th> <th data-bbox="639 526 1401 571">Description</th> </tr> </thead> <tbody> <tr> <td data-bbox="336 571 639 616">Adj Lines</td> <td data-bbox="639 571 1401 616">Sets the number of adjustment lines for automatic reduction.</td> </tr> <tr> <td data-bbox="336 616 639 705">Adj Lines(A4)</td> <td data-bbox="639 616 1401 705">Sets the number of adjustment lines for automatic reduction when A4 paper is set.</td> </tr> <tr> <td data-bbox="336 705 639 790">Adj Lines(LT)</td> <td data-bbox="639 705 1401 790">Sets the number of adjustment lines for automatic reduction when letter size paper is set.</td> </tr> </tbody> </table> <p data-bbox="290 831 1094 862"><b>Setting the number of adjustment lines for automatic reduction</b> Sets the number of adjustment lines for automatic reduction.</p> <ol data-bbox="306 898 1126 929" style="list-style-type: none"> <li>1. Change the setting using the cursor left/right keys or numeric keys.</li> </ol> <table border="1" data-bbox="336 943 1401 1039"> <thead> <tr> <th data-bbox="336 943 975 987">Description</th> <th data-bbox="975 943 1187 987">Setting range</th> <th data-bbox="1187 943 1401 987">Initial setting</th> </tr> </thead> <tbody> <tr> <td data-bbox="336 987 975 1039">Number of adjustment lines for automatic reduction</td> <td data-bbox="975 987 1187 1039">0 to 22</td> <td data-bbox="1187 987 1401 1039">7</td> </tr> </tbody> </table> <ol data-bbox="306 1050 766 1081" style="list-style-type: none"> <li>2. Press the start key. The value is set.</li> </ol> <p data-bbox="290 1122 1369 1153"><b>Setting the number of adjustment lines for automatic reduction when A4 paper is set</b> Sets the number of adjustment lines for automatic reduction when A4 paper is set.</p> <ol data-bbox="306 1189 1126 1220" style="list-style-type: none"> <li>1. Change the setting using the cursor left/right keys or numeric keys.</li> </ol> <table border="1" data-bbox="336 1234 1401 1364"> <thead> <tr> <th data-bbox="336 1234 975 1279">Description</th> <th data-bbox="975 1234 1187 1279">Setting range</th> <th data-bbox="1187 1234 1401 1279">Initial setting</th> </tr> </thead> <tbody> <tr> <td data-bbox="336 1279 975 1364">Number of adjustment lines for automatic reduction when A4 paper is set</td> <td data-bbox="975 1279 1187 1364">0 to 22</td> <td data-bbox="1187 1279 1401 1364">22</td> </tr> </tbody> </table> <ol data-bbox="306 1375 766 1406" style="list-style-type: none"> <li>2. Press the start key. The value is set.</li> </ol> <p data-bbox="290 1447 1410 1509"><b>Setting the number of adjustment lines for automatic reduction when letter size paper is set</b> Sets the number of adjustment lines for automatic reduction when letter size paper is set.</p> <ol data-bbox="306 1545 1126 1576" style="list-style-type: none"> <li>1. Change the setting using the cursor left/right keys or numeric keys.</li> </ol> <table border="1" data-bbox="336 1590 1401 1720"> <thead> <tr> <th data-bbox="336 1590 975 1635">Description</th> <th data-bbox="975 1590 1187 1635">Setting range</th> <th data-bbox="1187 1590 1401 1635">Initial setting</th> </tr> </thead> <tbody> <tr> <td data-bbox="336 1635 975 1720">Number of adjustment lines for automatic reduction when letter size paper is set</td> <td data-bbox="975 1635 1187 1720">0 to 26</td> <td data-bbox="1187 1635 1401 1720">26</td> </tr> </tbody> </table> <ol data-bbox="306 1731 766 1762" style="list-style-type: none"> <li>2. Press the start key. The value is set.</li> </ol> <p data-bbox="290 1803 440 1834"><b>Completion</b> Press the stop key. The screen for selecting a maintenance item No. is displayed.</p>	Display	Description	Adj Lines	Sets the number of adjustment lines for automatic reduction.	Adj Lines(A4)	Sets the number of adjustment lines for automatic reduction when A4 paper is set.	Adj Lines(LT)	Sets the number of adjustment lines for automatic reduction when letter size paper is set.	Description	Setting range	Initial setting	Number of adjustment lines for automatic reduction	0 to 22	7	Description	Setting range	Initial setting	Number of adjustment lines for automatic reduction when A4 paper is set	0 to 22	22	Description	Setting range	Initial setting	Number of adjustment lines for automatic reduction when letter size paper is set	0 to 26	26
Display	Description																										
Adj Lines	Sets the number of adjustment lines for automatic reduction.																										
Adj Lines(A4)	Sets the number of adjustment lines for automatic reduction when A4 paper is set.																										
Adj Lines(LT)	Sets the number of adjustment lines for automatic reduction when letter size paper is set.																										
Description	Setting range	Initial setting																									
Number of adjustment lines for automatic reduction	0 to 22	7																									
Description	Setting range	Initial setting																									
Number of adjustment lines for automatic reduction when A4 paper is set	0 to 22	22																									
Description	Setting range	Initial setting																									
Number of adjustment lines for automatic reduction when letter size paper is set	0 to 26	26																									

Item No.	Description																						
U612	<p data-bbox="287 241 507 275"><b>Setting system 3</b></p> <p data-bbox="287 309 440 342"><b>Description</b></p> <p data-bbox="287 344 1431 448">Makes settings for fax transmission regarding operation and automatic printing of the protocol list. This determines how trailing edge margin is detected (to prevent image from being mutilated) while printing a received Fax.</p> <p data-bbox="287 481 387 515"><b>Method</b></p> <ol data-bbox="303 517 632 584" style="list-style-type: none"> <li>1. Press the start key.</li> <li>2. Select the item to be set.</li> </ol> <table border="1" data-bbox="336 595 1399 824"> <thead> <tr> <th data-bbox="336 595 639 640">Display</th> <th data-bbox="639 595 1399 640">Description</th> </tr> </thead> <tbody> <tr> <td data-bbox="336 640 639 730">Auto Reduction</td> <td data-bbox="639 640 1399 730">Selects if auto reduction in the auxiliary direction is to be performed.</td> </tr> <tr> <td data-bbox="336 730 639 775">Protocol List</td> <td data-bbox="639 730 1399 775">Sets the automatic printing of the protocol list.</td> </tr> <tr> <td data-bbox="336 775 639 819">Detect Trail</td> <td data-bbox="639 775 1399 819">Sets how trailing edge margins are detected</td> </tr> </tbody> </table> <p data-bbox="287 869 1185 902"><b>Selecting if auto reduction in the auxiliary direction is to be performed</b></p> <p data-bbox="287 904 1431 972">Sets whether to receive a long document by automatically reducing it in the auxiliary direction or at 100% magnification.</p> <ol data-bbox="303 974 911 1008" style="list-style-type: none"> <li>1. Select the setting using the cursor left/right keys.</li> </ol> <table border="1" data-bbox="336 1019 1399 1196"> <thead> <tr> <th data-bbox="336 1019 639 1064">Display</th> <th data-bbox="639 1019 1399 1064">Description</th> </tr> </thead> <tbody> <tr> <td data-bbox="336 1064 639 1153">On</td> <td data-bbox="639 1064 1399 1153">Auto reduction is performed if the received document is longer than the fax paper.</td> </tr> <tr> <td data-bbox="336 1153 639 1196">Off</td> <td data-bbox="639 1153 1399 1196">Auto reduction is not performed.</td> </tr> </tbody> </table> <p data-bbox="336 1207 576 1240">* : Initial setting: On</p> <ol data-bbox="303 1243 783 1276" style="list-style-type: none"> <li>2. Press the start key. The setting is set.</li> </ol> <p data-bbox="287 1310 916 1344"><b>Setting the automatic printing of the protocol list</b></p> <p data-bbox="287 1346 884 1379">Sets if the protocol list is automatically printed out.</p> <ol data-bbox="303 1382 911 1415" style="list-style-type: none"> <li>1. Select the setting using the cursor left/right keys.</li> </ol> <table border="1" data-bbox="336 1426 1399 1682"> <thead> <tr> <th data-bbox="336 1426 639 1471">Display</th> <th data-bbox="639 1426 1399 1471">Description</th> </tr> </thead> <tbody> <tr> <td data-bbox="336 1471 639 1561">On</td> <td data-bbox="639 1471 1399 1561">The protocol list is automatically printed out after communication.</td> </tr> <tr> <td data-bbox="336 1561 639 1650">Err</td> <td data-bbox="639 1561 1399 1650">The protocol list is automatically printed out after communication only if a communication error occurs.</td> </tr> <tr> <td data-bbox="336 1650 639 1682">Off</td> <td data-bbox="639 1650 1399 1682">The protocol list is not printed out automatically.</td> </tr> </tbody> </table> <p data-bbox="336 1693 576 1727">* : Initial setting: Off</p> <ol data-bbox="303 1729 783 1762" style="list-style-type: none"> <li>2. Press the start key. The setting is set.</li> </ol>	Display	Description	Auto Reduction	Selects if auto reduction in the auxiliary direction is to be performed.	Protocol List	Sets the automatic printing of the protocol list.	Detect Trail	Sets how trailing edge margins are detected	Display	Description	On	Auto reduction is performed if the received document is longer than the fax paper.	Off	Auto reduction is not performed.	Display	Description	On	The protocol list is automatically printed out after communication.	Err	The protocol list is automatically printed out after communication only if a communication error occurs.	Off	The protocol list is not printed out automatically.
Display	Description																						
Auto Reduction	Selects if auto reduction in the auxiliary direction is to be performed.																						
Protocol List	Sets the automatic printing of the protocol list.																						
Detect Trail	Sets how trailing edge margins are detected																						
Display	Description																						
On	Auto reduction is performed if the received document is longer than the fax paper.																						
Off	Auto reduction is not performed.																						
Display	Description																						
On	The protocol list is automatically printed out after communication.																						
Err	The protocol list is automatically printed out after communication only if a communication error occurs.																						
Off	The protocol list is not printed out automatically.																						

Item No.	Description						
<b>U612</b>	<p><b>Setting how trailing edge margins are detected</b></p> <p>This determines whether trailing edge margin is detected (to prevent image from being mutilated) while printing a received Fax.</p> <ol style="list-style-type: none"> <li>1. Select On or Off using the cursor left/right keys.</li> </ol> <table border="1" data-bbox="336 389 1401 533"> <thead> <tr> <th data-bbox="336 389 639 434">Display</th> <th data-bbox="639 389 1401 434">Description</th> </tr> </thead> <tbody> <tr> <td data-bbox="336 434 639 479">On</td> <td data-bbox="639 434 1401 479">Detects trailing edge margin</td> </tr> <tr> <td data-bbox="336 479 639 533">Off</td> <td data-bbox="639 479 1401 533">Does not detect trailing edge margin</td> </tr> </tbody> </table> <p>* : Initial setting: On</p> <ol style="list-style-type: none"> <li>2. Press the start key. The setting is set.</li> </ol> <p><b>Completion</b></p> <p>Press the stop key. The screen for selecting a maintenance item No. is displayed.</p>	Display	Description	On	Detects trailing edge margin	Off	Does not detect trailing edge margin
Display	Description						
On	Detects trailing edge margin						
Off	Does not detect trailing edge margin						
<b>U620</b>	<p><b>Setting the remote switching mode</b></p> <p><b>Description</b></p> <p>Sets the signal detection method for remote switching. Be sure to change the setting according to the type of telephone connected to the machine.</p> <p><b>Setting</b></p> <ol style="list-style-type: none"> <li>1. Press the start key.</li> <li>2. Select [Remort Mode] and press the start key.</li> <li>3. Select the mode.</li> </ol> <table border="1" data-bbox="336 1084 1401 1227"> <thead> <tr> <th data-bbox="336 1084 639 1128">Display</th> <th data-bbox="639 1084 1401 1128">Description</th> </tr> </thead> <tbody> <tr> <td data-bbox="336 1128 639 1173">One</td> <td data-bbox="639 1128 1401 1173">One-shot detection</td> </tr> <tr> <td data-bbox="336 1173 639 1227">Cont</td> <td data-bbox="639 1173 1401 1227">Continuous detection</td> </tr> </tbody> </table> <p>* : Initial setting: One</p> <ol style="list-style-type: none"> <li>4. Press the start key. The setting is set.</li> </ol> <p><b>Completion</b></p> <p>Press the stop key. The screen for selecting a maintenance item No. is displayed.</p>	Display	Description	One	One-shot detection	Cont	Continuous detection
Display	Description						
One	One-shot detection						
Cont	Continuous detection						

Item No.	Description																		
U625	<p data-bbox="288 241 724 275"><b>Setting the transmission system 1</b></p> <p data-bbox="288 311 440 340"><b>Description</b></p> <p data-bbox="288 344 1315 376">Makes settings for the auto redialing interval and the number of times of auto redialing.</p> <p data-bbox="288 380 400 409"><b>Purpose</b></p> <p data-bbox="288 414 1426 515">Change the setting to prevent the following problems: fax transmission is not possible due to too short redial interval, or fax transmission takes too much time to complete due to too long redial interval.</p> <p data-bbox="288 553 387 582"><b>Method</b></p> <ol data-bbox="304 589 632 651" style="list-style-type: none"> <li>1. Press the start key.</li> <li>2. Select the item to be set.</li> </ol> <table border="1" data-bbox="336 665 1399 808"> <thead> <tr> <th data-bbox="336 665 639 712">Display</th> <th data-bbox="639 665 1399 712">Description</th> </tr> </thead> <tbody> <tr> <td data-bbox="336 712 639 759">Interval</td> <td data-bbox="639 712 1399 759">Setting the auto redialing interval</td> </tr> <tr> <td data-bbox="336 759 639 808">Times</td> <td data-bbox="639 759 1399 808">Setting the number of times of auto redialing</td> </tr> </tbody> </table> <p data-bbox="288 853 716 882"><b>Setting the auto redialing interval</b></p> <ol data-bbox="304 887 932 918" style="list-style-type: none"> <li>1. Change the setting using the cursor left/right keys.</li> </ol> <table border="1" data-bbox="336 929 1399 1025"> <thead> <tr> <th data-bbox="336 929 868 976">Description</th> <th data-bbox="868 929 1096 976">Setting range</th> <th data-bbox="1096 929 1399 976">Initial setting</th> </tr> </thead> <tbody> <tr> <td data-bbox="336 976 868 1025">Redialing interval</td> <td data-bbox="868 976 1096 1025">1 to 9 (min.)</td> <td data-bbox="1096 976 1399 1025">3 (120 V)/2 (220-240 V)</td> </tr> </tbody> </table> <ol data-bbox="304 1034 767 1066" style="list-style-type: none"> <li>2. Press the start key. The value is set.</li> </ol> <p data-bbox="288 1104 861 1133"><b>Setting the number of times of auto redialing</b></p> <ol data-bbox="304 1137 1126 1169" style="list-style-type: none"> <li>1. Change the setting using the cursor left/right keys or numeric keys.</li> </ol> <table border="1" data-bbox="336 1180 1399 1276"> <thead> <tr> <th data-bbox="336 1180 868 1227">Description</th> <th data-bbox="868 1180 1096 1227">Setting range</th> <th data-bbox="1096 1180 1399 1227">Initial setting</th> </tr> </thead> <tbody> <tr> <td data-bbox="336 1227 868 1276">Number of redialing</td> <td data-bbox="868 1227 1096 1276">0 to 15</td> <td data-bbox="1096 1227 1399 1276">2 (120 V)/3 (220-240 V)</td> </tr> </tbody> </table> <ol data-bbox="304 1285 767 1317" style="list-style-type: none"> <li>2. Press the start key. The value is set.</li> </ol> <p data-bbox="288 1355 440 1384"><b>Completion</b></p> <p data-bbox="288 1388 1254 1420">Press the stop key. The screen for selecting a maintenance item No. is displayed.</p>	Display	Description	Interval	Setting the auto redialing interval	Times	Setting the number of times of auto redialing	Description	Setting range	Initial setting	Redialing interval	1 to 9 (min.)	3 (120 V)/2 (220-240 V)	Description	Setting range	Initial setting	Number of redialing	0 to 15	2 (120 V)/3 (220-240 V)
Display	Description																		
Interval	Setting the auto redialing interval																		
Times	Setting the number of times of auto redialing																		
Description	Setting range	Initial setting																	
Redialing interval	1 to 9 (min.)	3 (120 V)/2 (220-240 V)																	
Description	Setting range	Initial setting																	
Number of redialing	0 to 15	2 (120 V)/3 (220-240 V)																	



Item No.	Description																														
U630	<p data-bbox="290 241 707 271"><b>Setting communication control 1</b></p> <p data-bbox="290 311 440 340"><b>Description</b></p> <p data-bbox="290 344 1069 374">Makes settings for fax transmission regarding the communication.</p> <p data-bbox="290 414 387 443"><b>Method</b></p> <ol data-bbox="306 448 632 515" style="list-style-type: none"> <li>1. Press the start key.</li> <li>2. Select the item to be set.</li> </ol> <table border="1" data-bbox="336 526 1401 837"> <thead> <tr> <th data-bbox="336 526 639 571">Display</th> <th data-bbox="639 526 1401 571">Description</th> </tr> </thead> <tbody> <tr> <td data-bbox="336 571 639 616">TX Speed</td> <td data-bbox="639 571 1401 616">Sets the communication starting speed.</td> </tr> <tr> <td data-bbox="336 616 639 660">RX Speed</td> <td data-bbox="639 616 1401 660">Sets the reception speed.</td> </tr> <tr> <td data-bbox="336 660 639 750">TX Echo</td> <td data-bbox="639 660 1401 750">Sets the waiting period to prevent echo problems at the sender.</td> </tr> <tr> <td data-bbox="336 750 639 837">RX Echo</td> <td data-bbox="639 750 1401 837">Sets the waiting period to prevent echo problems at the receiver.</td> </tr> </tbody> </table> <p data-bbox="290 882 826 911"><b>Setting the communication starting speed</b></p> <p data-bbox="290 916 1418 983">Sets the initial communication speed when starting transmission. When the destination unit has V.34 capability, V.34 is selected for transmission, regardless of this setting.</p> <ol data-bbox="306 987 549 1016" style="list-style-type: none"> <li>1. Select the setting.</li> </ol> <table border="1" data-bbox="336 1028 1401 1267"> <thead> <tr> <th data-bbox="336 1028 639 1072">Display</th> <th data-bbox="639 1028 1401 1072">Description</th> </tr> </thead> <tbody> <tr> <td data-bbox="336 1072 639 1117">14400bps/V17</td> <td data-bbox="639 1072 1401 1117">V.17, 14400 bps</td> </tr> <tr> <td data-bbox="336 1117 639 1162">9600bps/V29</td> <td data-bbox="639 1117 1401 1162">V.17, 9600 bps</td> </tr> <tr> <td data-bbox="336 1162 639 1207">4800bps/V27ter</td> <td data-bbox="639 1162 1401 1207">V.27ter, 4800 bps</td> </tr> <tr> <td data-bbox="336 1207 639 1267">2400bps/V27ter</td> <td data-bbox="639 1207 1401 1267">V.27ter, 2400 bps</td> </tr> </tbody> </table> <p data-bbox="336 1279 711 1308">* : Initial setting: 14400bps/V17</p> <ol data-bbox="306 1312 780 1341" style="list-style-type: none"> <li>2. Press the start key. The setting is set.</li> </ol> <p data-bbox="290 1382 643 1411"><b>Setting the reception speed</b></p> <p data-bbox="290 1415 1410 1482">Sets the reception speed that the sender is informed of using the DIS or NSF signal. When the destination unit has V.34 capability, V.34 is selected, regardless of the setting.</p> <ol data-bbox="306 1487 549 1516" style="list-style-type: none"> <li>1. Select the setting.</li> </ol> <table border="1" data-bbox="336 1527 1401 1769"> <thead> <tr> <th data-bbox="336 1527 639 1572">Display</th> <th data-bbox="639 1527 1401 1572">Description</th> </tr> </thead> <tbody> <tr> <td data-bbox="336 1572 639 1617">14400bps</td> <td data-bbox="639 1572 1401 1617">V.17, V.33, V.29, V.27ter</td> </tr> <tr> <td data-bbox="336 1617 639 1662">9600bps</td> <td data-bbox="639 1617 1401 1662">V.29, V.27ter</td> </tr> <tr> <td data-bbox="336 1662 639 1706">4800bps</td> <td data-bbox="639 1662 1401 1706">V.27ter</td> </tr> <tr> <td data-bbox="336 1706 639 1769">2400bps</td> <td data-bbox="639 1706 1401 1769">V.27ter (fallback only)</td> </tr> </tbody> </table> <p data-bbox="336 1780 657 1809">* : Initial setting: 14400bps</p> <ol data-bbox="306 1814 780 1843" style="list-style-type: none"> <li>2. Press the start key. The setting is set.</li> </ol>	Display	Description	TX Speed	Sets the communication starting speed.	RX Speed	Sets the reception speed.	TX Echo	Sets the waiting period to prevent echo problems at the sender.	RX Echo	Sets the waiting period to prevent echo problems at the receiver.	Display	Description	14400bps/V17	V.17, 14400 bps	9600bps/V29	V.17, 9600 bps	4800bps/V27ter	V.27ter, 4800 bps	2400bps/V27ter	V.27ter, 2400 bps	Display	Description	14400bps	V.17, V.33, V.29, V.27ter	9600bps	V.29, V.27ter	4800bps	V.27ter	2400bps	V.27ter (fallback only)
Display	Description																														
TX Speed	Sets the communication starting speed.																														
RX Speed	Sets the reception speed.																														
TX Echo	Sets the waiting period to prevent echo problems at the sender.																														
RX Echo	Sets the waiting period to prevent echo problems at the receiver.																														
Display	Description																														
14400bps/V17	V.17, 14400 bps																														
9600bps/V29	V.17, 9600 bps																														
4800bps/V27ter	V.27ter, 4800 bps																														
2400bps/V27ter	V.27ter, 2400 bps																														
Display	Description																														
14400bps	V.17, V.33, V.29, V.27ter																														
9600bps	V.29, V.27ter																														
4800bps	V.27ter																														
2400bps	V.27ter (fallback only)																														

Item No.	Description												
U630	<p data-bbox="288 241 1129 275"><b>Setting the waiting period to prevent echo problems at the sender</b></p> <p data-bbox="288 277 1422 338">Sets the period before a DCS signal is sent after a DIS signal is received. Used when problems occur due to echoes at the sender.</p> <p data-bbox="304 344 549 378">1. Select the setting.</p> <table border="1" data-bbox="336 389 1401 533"> <thead> <tr> <th data-bbox="336 389 639 434">Display</th> <th data-bbox="639 389 1401 434">Description</th> </tr> </thead> <tbody> <tr> <td data-bbox="336 434 639 479">500</td> <td data-bbox="639 434 1401 479">Sends a DCS 500 ms after receiving a DIS.</td> </tr> <tr> <td data-bbox="336 479 639 533">300</td> <td data-bbox="639 479 1401 533">Sends a DCS 300 ms after receiving a DIS.</td> </tr> </tbody> </table> <p data-bbox="336 539 584 573">* : Initial setting: 300</p> <p data-bbox="304 575 783 609">2. Press the start key. The setting is set.</p> <p data-bbox="288 645 1145 678"><b>Setting the waiting period to prevent echo problems at the receiver</b></p> <p data-bbox="288 680 1394 741">Sets the period before an NSF, CSI or DIS signal is sent after a CED signal is received. Used when problems occur due to echoes at the receiver.</p> <p data-bbox="304 748 549 781">1. Select the setting.</p> <table border="1" data-bbox="336 792 1401 936"> <thead> <tr> <th data-bbox="336 792 639 837">Display</th> <th data-bbox="639 792 1401 837">Description</th> </tr> </thead> <tbody> <tr> <td data-bbox="336 837 639 882">500</td> <td data-bbox="639 837 1401 882">Sends an NSF, CSI or DIS 500 ms after receiving a CED.</td> </tr> <tr> <td data-bbox="336 882 639 936">75</td> <td data-bbox="639 882 1401 936">Sends an NSF, CSI or DIS 75 ms after receiving a CED.</td> </tr> </tbody> </table> <p data-bbox="336 943 571 976">* : Initial setting: 75</p> <p data-bbox="304 978 783 1012">2. Press the start key. The setting is set.</p> <p data-bbox="288 1048 440 1081"><b>Completion</b></p> <p data-bbox="288 1084 1257 1117">Press the stop key. The screen for selecting a maintenance item No. is displayed.</p>	Display	Description	500	Sends a DCS 500 ms after receiving a DIS.	300	Sends a DCS 300 ms after receiving a DIS.	Display	Description	500	Sends an NSF, CSI or DIS 500 ms after receiving a CED.	75	Sends an NSF, CSI or DIS 75 ms after receiving a CED.
Display	Description												
500	Sends a DCS 500 ms after receiving a DIS.												
300	Sends a DCS 300 ms after receiving a DIS.												
Display	Description												
500	Sends an NSF, CSI or DIS 500 ms after receiving a CED.												
75	Sends an NSF, CSI or DIS 75 ms after receiving a CED.												

Item No.	Description																										
U631	<p data-bbox="288 241 710 271"><b>Setting communication control 2</b></p> <p data-bbox="288 311 440 340"><b>Description</b></p> <p data-bbox="288 344 799 374">Makes settings regarding fax transmission.</p> <p data-bbox="288 414 387 443"><b>Method</b></p> <ol data-bbox="304 450 632 515" style="list-style-type: none"> <li>1. Press the start key.</li> <li>2. Select the item to be set.</li> </ol> <table border="1" data-bbox="336 526 1401 719"> <thead> <tr> <th data-bbox="336 526 639 571">Display</th> <th data-bbox="639 526 1401 571">Description</th> </tr> </thead> <tbody> <tr> <td data-bbox="336 571 639 616">ECM TX</td> <td data-bbox="639 571 1401 616">Sets ECM transmission.</td> </tr> <tr> <td data-bbox="336 616 639 660">ECM RX</td> <td data-bbox="639 616 1401 660">Sets ECM reception.</td> </tr> <tr> <td data-bbox="336 660 639 719">CED Freq</td> <td data-bbox="639 660 1401 719">Sets the frequency of the CED signal.</td> </tr> </tbody> </table> <p data-bbox="288 761 624 790"><b>Setting ECM transmission</b></p> <p data-bbox="288 795 1374 860">To be set to Off when reduction of transmission costs is of higher priority than image quality. This should not be set to Off when connecting to the IP (Internet Protocol) telephone line.</p> <ol data-bbox="304 866 549 896" style="list-style-type: none"> <li>1. Select the setting.</li> </ol> <table border="1" data-bbox="336 907 1401 1055"> <thead> <tr> <th data-bbox="336 907 639 952">Display</th> <th data-bbox="639 907 1401 952">Description</th> </tr> </thead> <tbody> <tr> <td data-bbox="336 952 639 996">On</td> <td data-bbox="639 952 1401 996">ECM transmission is enabled.</td> </tr> <tr> <td data-bbox="336 996 639 1055">Off</td> <td data-bbox="639 996 1401 1055">ECM transmission is disabled.</td> </tr> </tbody> </table> <p data-bbox="336 1061 576 1090">* : Initial setting: On</p> <ol data-bbox="304 1097 780 1126" style="list-style-type: none"> <li>2. Press the start key. The setting is set.</li> </ol> <p data-bbox="288 1167 576 1196"><b>Setting ECM reception</b></p> <p data-bbox="288 1200 1374 1265">To be set to Off when reduction of transmission costs is of higher priority than image quality. This should not be set to Off when connecting to the IP (Internet Protocol) telephone line.</p> <ol data-bbox="304 1272 549 1301" style="list-style-type: none"> <li>1. Select the setting.</li> </ol> <table border="1" data-bbox="336 1312 1401 1460"> <thead> <tr> <th data-bbox="336 1312 639 1357">Display</th> <th data-bbox="639 1312 1401 1357">Description</th> </tr> </thead> <tbody> <tr> <td data-bbox="336 1357 639 1402">On</td> <td data-bbox="639 1357 1401 1402">ECM reception is enabled.</td> </tr> <tr> <td data-bbox="336 1402 639 1460">Off</td> <td data-bbox="639 1402 1401 1460">ECM reception is disabled.</td> </tr> </tbody> </table> <p data-bbox="336 1467 576 1496">* : Initial setting: On</p> <ol data-bbox="304 1503 780 1532" style="list-style-type: none"> <li>2. Press the start key. The setting is set.</li> </ol> <p data-bbox="288 1572 796 1601"><b>Setting the frequency of the CED signal</b></p> <p data-bbox="288 1606 1433 1671">Sets the frequency of the CED signal. Used as one of the measures to improve transmission performance for international communications.</p> <ol data-bbox="304 1677 549 1706" style="list-style-type: none"> <li>1. Select the setting.</li> </ol> <table border="1" data-bbox="336 1718 1401 1865"> <thead> <tr> <th data-bbox="336 1718 639 1762">Display</th> <th data-bbox="639 1718 1401 1762">Description</th> </tr> </thead> <tbody> <tr> <td data-bbox="336 1762 639 1807">2100</td> <td data-bbox="639 1762 1401 1807">2100 Hz</td> </tr> <tr> <td data-bbox="336 1807 639 1865">1100</td> <td data-bbox="639 1807 1401 1865">1100 Hz</td> </tr> </tbody> </table> <p data-bbox="336 1872 600 1901">* : Initial setting: 2100</p> <ol data-bbox="304 1908 780 1937" style="list-style-type: none"> <li>2. Press the start key. The setting is set.</li> </ol> <p data-bbox="288 1977 440 2007"><b>Completion</b></p> <p data-bbox="288 2011 1254 2040">Press the stop key. The screen for selecting a maintenance item No. is displayed.</p>	Display	Description	ECM TX	Sets ECM transmission.	ECM RX	Sets ECM reception.	CED Freq	Sets the frequency of the CED signal.	Display	Description	On	ECM transmission is enabled.	Off	ECM transmission is disabled.	Display	Description	On	ECM reception is enabled.	Off	ECM reception is disabled.	Display	Description	2100	2100 Hz	1100	1100 Hz
Display	Description																										
ECM TX	Sets ECM transmission.																										
ECM RX	Sets ECM reception.																										
CED Freq	Sets the frequency of the CED signal.																										
Display	Description																										
On	ECM transmission is enabled.																										
Off	ECM transmission is disabled.																										
Display	Description																										
On	ECM reception is enabled.																										
Off	ECM reception is disabled.																										
Display	Description																										
2100	2100 Hz																										
1100	1100 Hz																										

Item No.	Description																		
U632	<p data-bbox="288 241 708 271"><b>Setting communication control 3</b></p> <p data-bbox="288 311 440 340"><b>Description</b></p> <p data-bbox="288 344 1070 374">Makes settings for fax transmission regarding the communication.</p> <p data-bbox="288 414 387 443"><b>Method</b></p> <ol data-bbox="304 450 632 515" style="list-style-type: none"> <li>1. Press the start key.</li> <li>2. Select the item to be set.</li> </ol> <table border="1" data-bbox="336 526 1401 705"> <thead> <tr> <th data-bbox="336 526 639 571">Display</th> <th data-bbox="639 526 1401 571">Description</th> </tr> </thead> <tbody> <tr> <td data-bbox="336 571 639 616">DIS 4Byte</td> <td data-bbox="639 571 1401 616">Sets the DIS signal to 4 bytes.</td> </tr> <tr> <td data-bbox="336 616 639 705">Num OF CNG(F/T)</td> <td data-bbox="639 616 1401 705">Sets the CNG detection times in the fax/telephone auto select mode.</td> </tr> </tbody> </table> <p data-bbox="288 748 699 777"><b>Setting the DIS signal to 4 bytes</b></p> <p data-bbox="288 781 976 810">Sets if bit 33 and later bits of the DIS/DTC signal are sent.</p> <ol data-bbox="304 817 549 846" style="list-style-type: none"> <li>1. Select the setting.</li> </ol> <table border="1" data-bbox="336 862 1401 1005"> <thead> <tr> <th data-bbox="336 862 639 907">Display</th> <th data-bbox="639 862 1401 907">Description</th> </tr> </thead> <tbody> <tr> <td data-bbox="336 907 639 952">On</td> <td data-bbox="639 907 1401 952">Bit 33 and later bits of the DIS/DTC signal are not sent.</td> </tr> <tr> <td data-bbox="336 952 639 1005">Off</td> <td data-bbox="639 952 1401 1005">Bit 33 and later bits of the DIS/DTC signal are sent.</td> </tr> </tbody> </table> <p data-bbox="336 1012 576 1041">* : Initial setting: Off</p> <ol data-bbox="304 1048 782 1077" style="list-style-type: none"> <li>2. Press the start key. The setting is set.</li> </ol> <p data-bbox="288 1120 1185 1149"><b>Setting the CNG detection times in the fax/telephone auto select mode</b></p> <p data-bbox="288 1153 1102 1182">Sets the CNG detection times in the fax/telephone auto select mode.</p> <ol data-bbox="304 1189 549 1218" style="list-style-type: none"> <li>1. Select the setting.</li> </ol> <table border="1" data-bbox="336 1229 1401 1373"> <thead> <tr> <th data-bbox="336 1229 639 1274">Display</th> <th data-bbox="639 1229 1401 1274">Description</th> </tr> </thead> <tbody> <tr> <td data-bbox="336 1274 639 1319">1Time</td> <td data-bbox="639 1274 1401 1319">Detects CNG once.</td> </tr> <tr> <td data-bbox="336 1319 639 1373">2Time</td> <td data-bbox="639 1319 1401 1373">Detects CNG twice.</td> </tr> </tbody> </table> <p data-bbox="336 1379 612 1408">* : Initial setting: 2Time</p> <ol data-bbox="304 1415 782 1444" style="list-style-type: none"> <li>2. Press the start key. The setting is set.</li> </ol> <p data-bbox="288 1487 440 1516"><b>Completion</b></p> <p data-bbox="288 1520 1256 1550">Press the stop key. The screen for selecting a maintenance item No. is displayed.</p>	Display	Description	DIS 4Byte	Sets the DIS signal to 4 bytes.	Num OF CNG(F/T)	Sets the CNG detection times in the fax/telephone auto select mode.	Display	Description	On	Bit 33 and later bits of the DIS/DTC signal are not sent.	Off	Bit 33 and later bits of the DIS/DTC signal are sent.	Display	Description	1Time	Detects CNG once.	2Time	Detects CNG twice.
Display	Description																		
DIS 4Byte	Sets the DIS signal to 4 bytes.																		
Num OF CNG(F/T)	Sets the CNG detection times in the fax/telephone auto select mode.																		
Display	Description																		
On	Bit 33 and later bits of the DIS/DTC signal are not sent.																		
Off	Bit 33 and later bits of the DIS/DTC signal are sent.																		
Display	Description																		
1Time	Detects CNG once.																		
2Time	Detects CNG twice.																		

Item No.	Description																										
U633	<p data-bbox="287 241 710 275"><b>Setting communication control 4</b></p> <p data-bbox="287 309 438 342"><b>Description</b></p> <p data-bbox="287 344 1069 378">Makes settings for fax transmission regarding the communication.</p> <p data-bbox="287 380 399 414"><b>Purpose</b></p> <p data-bbox="287 416 1021 450">To reduce transmission errors when a low quality line is used.</p> <p data-bbox="287 483 391 517"><b>Method</b></p> <ol data-bbox="303 519 630 586" style="list-style-type: none"> <li>1. Press the start key.</li> <li>2. Select the item to be set.</li> </ol> <table border="1" data-bbox="335 598 1399 837"> <thead> <tr> <th data-bbox="343 609 635 642">Display</th> <th data-bbox="635 609 1391 642">Description</th> </tr> </thead> <tbody> <tr> <td data-bbox="343 642 635 676">V.34</td> <td data-bbox="635 642 1391 676">Enables or disables V.34 communication.</td> </tr> <tr> <td data-bbox="343 676 635 710">V.34-3429Hz</td> <td data-bbox="635 676 1391 710">Sets the V.34 symbol speed (3429 Hz).</td> </tr> <tr> <td data-bbox="343 710 635 743">DIS 2Res</td> <td data-bbox="635 710 1391 743">Sets the number of times of DIS signal reception.</td> </tr> <tr> <td data-bbox="343 743 635 777">RTN Check</td> <td data-bbox="635 743 1391 777">Sets the reference for RTN signal output.</td> </tr> </tbody> </table> <p data-bbox="287 882 798 916"><b>Enabling/disabling V.34 communication</b></p> <p data-bbox="287 918 1300 952">Sets whether V.34 communication is enabled/disabled for transmission and reception.</p> <ol data-bbox="303 954 542 987" style="list-style-type: none"> <li>1. Select the setting</li> </ol> <table border="1" data-bbox="335 999 1399 1238"> <thead> <tr> <th data-bbox="343 1010 563 1043">Display</th> <th data-bbox="563 1010 1391 1043">Description</th> </tr> </thead> <tbody> <tr> <td data-bbox="343 1043 563 1077">On</td> <td data-bbox="563 1043 1391 1077">V.34 communication is enabled for both transmission and reception.</td> </tr> <tr> <td data-bbox="343 1077 563 1111">TX</td> <td data-bbox="563 1077 1391 1111">V.34 communication is enabled for transmission only.</td> </tr> <tr> <td data-bbox="343 1111 563 1144">RX</td> <td data-bbox="563 1111 1391 1144">V.34 communication is enabled for reception only.</td> </tr> <tr> <td data-bbox="343 1144 563 1178">Off</td> <td data-bbox="563 1144 1391 1178">V.34 communication is disabled for both transmission and reception.</td> </tr> </tbody> </table> <p data-bbox="335 1249 574 1283">* : Initial setting: On</p> <ol data-bbox="303 1285 782 1319" style="list-style-type: none"> <li>2. Press the start key. The setting is set.</li> </ol> <p data-bbox="287 1352 805 1386"><b>Setting the V.34 symbol speed (3429 Hz)</b></p> <p data-bbox="287 1388 853 1422">Sets if the V.34 symbol speed 3429 Hz is used.</p> <ol data-bbox="303 1424 542 1458" style="list-style-type: none"> <li>1. Select the setting</li> </ol> <table border="1" data-bbox="335 1469 1399 1608"> <thead> <tr> <th data-bbox="343 1480 635 1514">Display</th> <th data-bbox="635 1480 1391 1514">Description</th> </tr> </thead> <tbody> <tr> <td data-bbox="343 1514 635 1547">On</td> <td data-bbox="635 1514 1391 1547">V.34 symbol speed 3429 Hz is used.</td> </tr> <tr> <td data-bbox="343 1547 635 1581">Off</td> <td data-bbox="635 1547 1391 1581">V.34 symbol speed 3429 Hz is not used.</td> </tr> </tbody> </table> <p data-bbox="335 1619 574 1653">* : Initial setting: On</p> <ol data-bbox="303 1655 782 1688" style="list-style-type: none"> <li>2. Press the start key. The setting is set.</li> </ol>	Display	Description	V.34	Enables or disables V.34 communication.	V.34-3429Hz	Sets the V.34 symbol speed (3429 Hz).	DIS 2Res	Sets the number of times of DIS signal reception.	RTN Check	Sets the reference for RTN signal output.	Display	Description	On	V.34 communication is enabled for both transmission and reception.	TX	V.34 communication is enabled for transmission only.	RX	V.34 communication is enabled for reception only.	Off	V.34 communication is disabled for both transmission and reception.	Display	Description	On	V.34 symbol speed 3429 Hz is used.	Off	V.34 symbol speed 3429 Hz is not used.
Display	Description																										
V.34	Enables or disables V.34 communication.																										
V.34-3429Hz	Sets the V.34 symbol speed (3429 Hz).																										
DIS 2Res	Sets the number of times of DIS signal reception.																										
RTN Check	Sets the reference for RTN signal output.																										
Display	Description																										
On	V.34 communication is enabled for both transmission and reception.																										
TX	V.34 communication is enabled for transmission only.																										
RX	V.34 communication is enabled for reception only.																										
Off	V.34 communication is disabled for both transmission and reception.																										
Display	Description																										
On	V.34 symbol speed 3429 Hz is used.																										
Off	V.34 symbol speed 3429 Hz is not used.																										

Item No.	Description																
<b>U633</b>	<p><b>Setting the number of times of DIS signal reception</b> Sets the number of times to receive the DIS signal to once or twice. Used as one of the correction measures for transmission errors and other problems.</p> <ol style="list-style-type: none"> <li>Select the setting.</li> </ol> <table border="1" data-bbox="336 389 1399 533"> <thead> <tr> <th>Display</th> <th>Description</th> </tr> </thead> <tbody> <tr> <td>Once</td> <td>Responds to the first signal.</td> </tr> <tr> <td>Twice</td> <td>Responds to the second signal.</td> </tr> </tbody> </table> <p>* : Initial setting: Once</p> <ol style="list-style-type: none"> <li>Press the start key. The setting is set.</li> </ol> <p><b>Setting the reference for RTN signal output</b> Sets the error line rate as the reference for RTN signal output. If transmission errors occur frequently due to the quality of the line, they can be reduced by lowering this setting.</p> <ol style="list-style-type: none"> <li>Select the setting.</li> </ol> <table border="1" data-bbox="336 795 1399 1032"> <thead> <tr> <th>Display</th> <th>Description</th> </tr> </thead> <tbody> <tr> <td>5%</td> <td>Error line rate of 5%</td> </tr> <tr> <td>10%</td> <td>Error line rate of 10%</td> </tr> <tr> <td>15%</td> <td>Error line rate of 15%</td> </tr> <tr> <td>20%</td> <td>Error line rate of 20%</td> </tr> </tbody> </table> <p>* : Initial setting: 15%</p> <ol style="list-style-type: none"> <li>Press the start key. The setting is set.</li> </ol> <p><b>Completion</b> Press the stop key. The screen for selecting a maintenance item No. is displayed.</p>	Display	Description	Once	Responds to the first signal.	Twice	Responds to the second signal.	Display	Description	5%	Error line rate of 5%	10%	Error line rate of 10%	15%	Error line rate of 15%	20%	Error line rate of 20%
Display	Description																
Once	Responds to the first signal.																
Twice	Responds to the second signal.																
Display	Description																
5%	Error line rate of 5%																
10%	Error line rate of 10%																
15%	Error line rate of 15%																
20%	Error line rate of 20%																
<b>U634</b>	<p><b>Setting communication control 5</b></p> <p><b>Description</b> Sets the maximum number of error bytes judged acceptable when receiving a TCF signal. Used as a measure to ease transmission conditions if transmission errors occur.</p> <p><b>Setting</b></p> <ol style="list-style-type: none"> <li>Press the start key.</li> <li>Change the setting using the cursor left/right keys or numeric keys.</li> </ol> <table border="1" data-bbox="336 1552 1399 1646"> <thead> <tr> <th>Description</th> <th>Setting range</th> <th>Initial setting</th> </tr> </thead> <tbody> <tr> <td>Number of allowed error bytes when detecting TCF</td> <td>0 to 255</td> <td>0</td> </tr> </tbody> </table> <ol style="list-style-type: none"> <li>Press the start key. The value is set.</li> </ol> <p><b>Completion</b> Press the stop key. The screen for selecting a maintenance item No. is displayed.</p>	Description	Setting range	Initial setting	Number of allowed error bytes when detecting TCF	0 to 255	0										
Description	Setting range	Initial setting															
Number of allowed error bytes when detecting TCF	0 to 255	0															

Item No.	Description																		
U640	<p data-bbox="287 241 670 275"><b>Setting communication time 1</b></p> <p data-bbox="287 309 438 342"><b>Description</b></p> <p data-bbox="287 344 1404 412">Sets the detection time when one-shot detection is selected for remote switching. (This setting item will be displayed, but the setting made is ineffective.)</p> <p data-bbox="287 414 1428 481">Sets the detection time when continuous detection is selected for remote switching. (This setting item will be displayed, but the setting made is ineffective.)</p> <p data-bbox="287 515 391 548"><b>Method</b></p> <ol data-bbox="303 551 630 618" style="list-style-type: none"> <li>1. Press the start key.</li> <li>2. Select the item to be set.</li> </ol> <table border="1" data-bbox="335 629 1401 775"> <thead> <tr> <th data-bbox="343 640 639 674">Display</th> <th data-bbox="639 640 1393 674">Description</th> </tr> </thead> <tbody> <tr> <td data-bbox="343 685 639 719">Time (One)</td> <td data-bbox="639 685 1393 719">Sets the one-shot detection time for remote switching.</td> </tr> <tr> <td data-bbox="343 730 639 763">Time (Cont)</td> <td data-bbox="639 730 1393 763">Sets the continuous detection time for remote switching.</td> </tr> </tbody> </table> <p data-bbox="287 813 1013 846"><b>Setting the one-shot detection time for remote switching</b></p> <ol data-bbox="303 848 933 882" style="list-style-type: none"> <li>1. Change the setting using the cursor left/right keys.</li> </ol> <table border="1" data-bbox="335 893 1401 987"> <thead> <tr> <th data-bbox="343 904 975 938">Description</th> <th data-bbox="975 904 1190 938">Setting range</th> <th data-bbox="1190 904 1393 938">Initial setting</th> </tr> </thead> <tbody> <tr> <td data-bbox="343 949 975 983">One-shot detection time for remote switching</td> <td data-bbox="975 949 1190 983">0 to 255</td> <td data-bbox="1190 949 1393 983">7</td> </tr> </tbody> </table> <ol data-bbox="303 999 766 1032" style="list-style-type: none"> <li>2. Press the start key. The value is set.</li> </ol> <p data-bbox="287 1066 1045 1099"><b>Setting the continuous detection time for remote switching</b></p> <ol data-bbox="303 1102 933 1135" style="list-style-type: none"> <li>1. Change the setting using the cursor left/right keys.</li> </ol> <table border="1" data-bbox="335 1146 1401 1240"> <thead> <tr> <th data-bbox="343 1158 975 1191">Description</th> <th data-bbox="975 1158 1190 1191">Setting range</th> <th data-bbox="1190 1158 1393 1191">Initial setting</th> </tr> </thead> <tbody> <tr> <td data-bbox="343 1202 975 1236">Continuous detection time for remote switching</td> <td data-bbox="975 1202 1190 1236">0 to 255</td> <td data-bbox="1190 1202 1393 1236">80</td> </tr> </tbody> </table> <ol data-bbox="303 1252 766 1285" style="list-style-type: none"> <li>2. Press the start key. The value is set.</li> </ol> <p data-bbox="287 1319 438 1352"><b>Completion</b></p> <p data-bbox="287 1355 1252 1388">Press the stop key. The screen for selecting a maintenance item No. is displayed.</p>	Display	Description	Time (One)	Sets the one-shot detection time for remote switching.	Time (Cont)	Sets the continuous detection time for remote switching.	Description	Setting range	Initial setting	One-shot detection time for remote switching	0 to 255	7	Description	Setting range	Initial setting	Continuous detection time for remote switching	0 to 255	80
Display	Description																		
Time (One)	Sets the one-shot detection time for remote switching.																		
Time (Cont)	Sets the continuous detection time for remote switching.																		
Description	Setting range	Initial setting																	
One-shot detection time for remote switching	0 to 255	7																	
Description	Setting range	Initial setting																	
Continuous detection time for remote switching	0 to 255	80																	

Item No.	Description																														
U641	<p data-bbox="290 241 673 273"><b>Setting communication time 2</b></p> <p data-bbox="290 309 440 340"><b>Description</b></p> <p data-bbox="290 344 798 376">Sets the time-out time for fax transmission.</p> <p data-bbox="290 380 399 412"><b>Purpose</b></p> <p data-bbox="290 416 1222 448">To improve transmission performance for international communications mainly.</p> <p data-bbox="290 483 386 515"><b>Method</b></p> <ol data-bbox="306 519 632 582" style="list-style-type: none"> <li>1. Press the start key.</li> <li>2. Select the item to be set.</li> </ol> <table border="1" data-bbox="336 595 1399 1028"> <thead> <tr> <th data-bbox="344 600 641 645">Display</th> <th data-bbox="641 600 1391 645">Description</th> </tr> </thead> <tbody> <tr> <td data-bbox="344 645 641 689">T0 Time Out</td> <td data-bbox="641 645 1391 689">Sets the T0 time-out time.</td> </tr> <tr> <td data-bbox="344 689 641 734">T1 Time Out</td> <td data-bbox="641 689 1391 734">Sets the T1 time-out time.</td> </tr> <tr> <td data-bbox="344 734 641 779">T2 Time Out</td> <td data-bbox="641 734 1391 779">Sets the T2 time-out time.</td> </tr> <tr> <td data-bbox="344 779 641 824">Ta Time Out</td> <td data-bbox="641 779 1391 824">Sets the Ta time-out time.</td> </tr> <tr> <td data-bbox="344 824 641 869">Tb1 Time Out</td> <td data-bbox="641 824 1391 869">Sets the Tb1 time-out time.</td> </tr> <tr> <td data-bbox="344 869 641 913">Tb2 Time Out</td> <td data-bbox="641 869 1391 913">Sets the Tb2 time-out time.</td> </tr> <tr> <td data-bbox="344 913 641 958">Tc Time Out</td> <td data-bbox="641 913 1391 958">Sets the Tc time-out time.</td> </tr> <tr> <td data-bbox="344 958 641 1003">Td Time Out</td> <td data-bbox="641 958 1391 1003">Sets the Td time-out time.</td> </tr> </tbody> </table> <p data-bbox="290 1070 644 1102"><b>Setting the T0 time-out time</b></p> <p data-bbox="290 1106 1232 1137">Sets the time before detecting a CED or DIS signal after a dialing signal is sent.</p> <p data-bbox="290 1142 1388 1205">Depending on the quality of the exchange, or when the auto select function is selected at the destination unit, a line can be disconnected. Change the setting to prevent this problem.</p> <ol data-bbox="306 1209 932 1240" style="list-style-type: none"> <li>1. Change the setting using the cursor left/right keys.</li> </ol> <table border="1" data-bbox="336 1249 1399 1348"> <thead> <tr> <th data-bbox="344 1254 975 1299">Description</th> <th data-bbox="975 1254 1187 1299">Setting range</th> <th data-bbox="1187 1254 1391 1299">Initial setting</th> </tr> </thead> <tbody> <tr> <td data-bbox="344 1299 975 1344">T0 time-out time</td> <td data-bbox="975 1299 1187 1344">30 to 90 s</td> <td data-bbox="1187 1299 1391 1344">56</td> </tr> </tbody> </table> <ol data-bbox="306 1357 766 1388" style="list-style-type: none"> <li>2. Press the start key. The value is set.</li> </ol> <p data-bbox="290 1424 644 1456"><b>Setting the T1 time-out time</b></p> <p data-bbox="290 1460 1423 1523">Sets the time before receiving the correct signal after call reception. No change is necessary for this maintenance item.</p> <ol data-bbox="306 1527 932 1559" style="list-style-type: none"> <li>1. Change the setting using the cursor left/right keys.</li> </ol> <table border="1" data-bbox="336 1568 1399 1666"> <thead> <tr> <th data-bbox="344 1572 975 1617">Description</th> <th data-bbox="975 1572 1187 1617">Setting range</th> <th data-bbox="1187 1572 1391 1617">Initial setting</th> </tr> </thead> <tbody> <tr> <td data-bbox="344 1617 975 1662">T1 time-out time</td> <td data-bbox="975 1617 1187 1662">30 to 90 s</td> <td data-bbox="1187 1617 1391 1662">36</td> </tr> </tbody> </table> <ol data-bbox="306 1675 766 1706" style="list-style-type: none"> <li>2. Press the start key. The value is set.</li> </ol>	Display	Description	T0 Time Out	Sets the T0 time-out time.	T1 Time Out	Sets the T1 time-out time.	T2 Time Out	Sets the T2 time-out time.	Ta Time Out	Sets the Ta time-out time.	Tb1 Time Out	Sets the Tb1 time-out time.	Tb2 Time Out	Sets the Tb2 time-out time.	Tc Time Out	Sets the Tc time-out time.	Td Time Out	Sets the Td time-out time.	Description	Setting range	Initial setting	T0 time-out time	30 to 90 s	56	Description	Setting range	Initial setting	T1 time-out time	30 to 90 s	36
Display	Description																														
T0 Time Out	Sets the T0 time-out time.																														
T1 Time Out	Sets the T1 time-out time.																														
T2 Time Out	Sets the T2 time-out time.																														
Ta Time Out	Sets the Ta time-out time.																														
Tb1 Time Out	Sets the Tb1 time-out time.																														
Tb2 Time Out	Sets the Tb2 time-out time.																														
Tc Time Out	Sets the Tc time-out time.																														
Td Time Out	Sets the Td time-out time.																														
Description	Setting range	Initial setting																													
T0 time-out time	30 to 90 s	56																													
Description	Setting range	Initial setting																													
T1 time-out time	30 to 90 s	36																													



Item No.	Description																						
<b>U641</b>	<p data-bbox="290 241 646 273"><b>Setting the T2 time-out time</b></p> <p data-bbox="290 277 801 309">The T2 time-out time decides the following.</p> <p data-bbox="290 313 863 344">From CFR signal output to image data reception</p> <p data-bbox="290 349 940 380">From image data reception to the next signal reception</p> <p data-bbox="290 385 1035 416">In ECM, from RNR signal detection to the next signal reception</p> <ol data-bbox="308 421 932 452" style="list-style-type: none"> <li>1. Change the setting using the cursor left/right keys.</li> </ol> <table border="1" data-bbox="336 459 1399 589"> <thead> <tr> <th data-bbox="336 459 807 539">Description</th> <th data-bbox="807 459 991 539">Setting range</th> <th data-bbox="991 459 1171 539">Initial setting</th> <th data-bbox="1171 459 1399 539">Change in value per step</th> </tr> </thead> <tbody> <tr> <td data-bbox="336 539 807 589">T2 time-out time</td> <td data-bbox="807 539 991 589">1 to 255</td> <td data-bbox="991 539 1171 589">69</td> <td data-bbox="1171 539 1399 589">100 ms</td> </tr> </tbody> </table> <ol data-bbox="308 600 767 631" style="list-style-type: none"> <li>2. Press the start key. The value is set.</li> </ol> <p data-bbox="290 667 643 698"><b>Setting the Ta time-out time</b></p> <p data-bbox="290 703 1423 801">In the fax/telephone auto select mode, sets the time to continue ringing an operator through the connected telephone after receiving a call as a fax machine (see figure 1-3-16). A fax signal is received within the Ta set time, or the fax mode is selected automatically when the time elapses.</p> <p data-bbox="290 806 1402 869">In fax/telephone auto select mode, change the setting when fax reception is unsuccessful or a telephone fails to receive a call.</p> <ol data-bbox="308 873 932 904" style="list-style-type: none"> <li>1. Change the setting using the cursor left/right keys.</li> </ol> <table border="1" data-bbox="336 916 1399 1014"> <thead> <tr> <th data-bbox="336 916 975 965">Description</th> <th data-bbox="975 916 1187 965">Setting range</th> <th data-bbox="1187 916 1399 965">Initial setting</th> </tr> </thead> <tbody> <tr> <td data-bbox="336 965 975 1014">Ta time-out time</td> <td data-bbox="975 965 1187 1014">1 to 255</td> <td data-bbox="1187 965 1399 1014">30</td> </tr> </tbody> </table> <ol data-bbox="308 1025 767 1057" style="list-style-type: none"> <li>2. Press the start key. The value is set.</li> </ol> <div data-bbox="518 1084 1220 1458" style="text-align: center;"> </div> <p data-bbox="612 1491 1110 1523"><b>Figure 1-3-16 Ta/Tb1/Tb2 time-out time</b></p> <p data-bbox="290 1561 662 1592"><b>Setting the Tb1 time-out time</b></p> <p data-bbox="290 1597 1423 1695">In the fax/telephone auto select mode, sets the time to start sending the ring back tone after receiving a call as a fax machine (see figure 1-3-16). In fax/telephone auto select mode, change the setting when fax reception is unsuccessful or a telephone fails to receive a call.</p> <ol data-bbox="308 1700 932 1731" style="list-style-type: none"> <li>1. Change the setting using the cursor left/right keys.</li> </ol> <table border="1" data-bbox="336 1742 1399 1872"> <thead> <tr> <th data-bbox="336 1742 807 1823">Description</th> <th data-bbox="807 1742 991 1823">Setting range</th> <th data-bbox="991 1742 1171 1823">Initial setting</th> <th data-bbox="1171 1742 1399 1823">Change in value per step</th> </tr> </thead> <tbody> <tr> <td data-bbox="336 1823 807 1872">Tb1 time-out time</td> <td data-bbox="807 1823 991 1872">1 to 255</td> <td data-bbox="991 1823 1171 1872">20</td> <td data-bbox="1171 1823 1399 1872">100 ms</td> </tr> </tbody> </table> <ol data-bbox="308 1883 767 1915" style="list-style-type: none"> <li>2. Press the start key. The value is set.</li> </ol>	Description	Setting range	Initial setting	Change in value per step	T2 time-out time	1 to 255	69	100 ms	Description	Setting range	Initial setting	Ta time-out time	1 to 255	30	Description	Setting range	Initial setting	Change in value per step	Tb1 time-out time	1 to 255	20	100 ms
Description	Setting range	Initial setting	Change in value per step																				
T2 time-out time	1 to 255	69	100 ms																				
Description	Setting range	Initial setting																					
Ta time-out time	1 to 255	30																					
Description	Setting range	Initial setting	Change in value per step																				
Tb1 time-out time	1 to 255	20	100 ms																				

Item No.	Description																				
U641	<p data-bbox="288 241 662 271"><b>Setting the Tb2 time-out time</b></p> <p data-bbox="288 277 1430 409">In the fax/telephone auto select mode, sets the time to start ringing an operator through the connected telephone after receiving a call as a fax machine (see figure 1-3-16). In the fax/telephone auto select mode, change the setting when fax reception is unsuccessful or a telephone fails to receive a call.</p> <ol data-bbox="308 416 930 445" style="list-style-type: none"> <li>1. Change the setting using the cursor left/right keys.</li> </ol> <table border="1" data-bbox="336 459 1401 589"> <thead> <tr> <th data-bbox="336 459 807 539">Description</th> <th data-bbox="807 459 991 539">Setting range</th> <th data-bbox="991 459 1171 539">Initial setting</th> <th data-bbox="1171 459 1401 539">Change in value per step</th> </tr> </thead> <tbody> <tr> <td data-bbox="336 539 807 589">Tb2 time-out time</td> <td data-bbox="807 539 991 589">1 to 255</td> <td data-bbox="991 539 1171 589">80</td> <td data-bbox="1171 539 1401 589">100 ms</td> </tr> </tbody> </table> <ol data-bbox="308 600 766 629" style="list-style-type: none"> <li>2. Press the start key. The value is set.</li> </ol> <p data-bbox="288 667 643 696"><b>Setting the Tc time-out time</b></p> <p data-bbox="288 703 1425 799">In the TAD mode, set the time to check if there are any triggers for shifting to fax reception after a connected telephone receives a call. Only the telephone function is available if shifting is not made within the set Tc time.</p> <p data-bbox="288 806 1410 869">In the TAD mode, change the setting when fax reception is unsuccessful or a telephone fails to receive a call.</p> <ol data-bbox="308 875 930 904" style="list-style-type: none"> <li>1. Change the setting using the cursor left/right keys.</li> </ol> <table border="1" data-bbox="336 918 1401 1014"> <thead> <tr> <th data-bbox="336 918 975 965">Description</th> <th data-bbox="975 918 1187 965">Setting range</th> <th data-bbox="1187 918 1401 965">Initial setting</th> </tr> </thead> <tbody> <tr> <td data-bbox="336 965 975 1014">Tc time-out time</td> <td data-bbox="975 965 1187 1014">1 to 255</td> <td data-bbox="1187 965 1401 1014">60</td> </tr> </tbody> </table> <ol data-bbox="308 1025 766 1055" style="list-style-type: none"> <li>2. Press the start key. The value is set.</li> </ol> <p data-bbox="288 1093 647 1122"><b>Setting the Td time-out time</b></p> <p data-bbox="288 1128 1425 1261">Sets the length of the time required to determine silent status (fax), one of the triggers for Tc time check. In the TAD mode, change the setting when fax reception is unsuccessful or a telephone fails to receive a call. Be sure not to set it too short; otherwise, the mode may be shifted to fax while the unit is being used as a telephone.</p> <ol data-bbox="308 1267 930 1296" style="list-style-type: none"> <li>1. Change the setting using the cursor left/right keys.</li> </ol> <table border="1" data-bbox="336 1310 1401 1406"> <thead> <tr> <th data-bbox="336 1310 868 1357">Description</th> <th data-bbox="868 1310 1096 1357">Setting range</th> <th data-bbox="1096 1310 1401 1357">Initial setting</th> </tr> </thead> <tbody> <tr> <td data-bbox="336 1357 868 1406">Td time-out time</td> <td data-bbox="868 1357 1096 1406">1 to 255</td> <td data-bbox="1096 1357 1401 1406">9 (120 V)/6 (220-240 V)</td> </tr> </tbody> </table> <ol data-bbox="308 1417 766 1447" style="list-style-type: none"> <li>2. Press the start key. The value is set.</li> </ol> <p data-bbox="288 1485 440 1514"><b>Completion</b></p> <p data-bbox="288 1520 1254 1550">Press the stop key. The screen for selecting a maintenance item No. is displayed.</p>	Description	Setting range	Initial setting	Change in value per step	Tb2 time-out time	1 to 255	80	100 ms	Description	Setting range	Initial setting	Tc time-out time	1 to 255	60	Description	Setting range	Initial setting	Td time-out time	1 to 255	9 (120 V)/6 (220-240 V)
Description	Setting range	Initial setting	Change in value per step																		
Tb2 time-out time	1 to 255	80	100 ms																		
Description	Setting range	Initial setting																			
Tc time-out time	1 to 255	60																			
Description	Setting range	Initial setting																			
Td time-out time	1 to 255	9 (120 V)/6 (220-240 V)																			

Item No.	Description								
U650	<p data-bbox="288 241 507 271"><b>Setting modem 1</b></p> <p data-bbox="288 311 440 340"><b>Description</b></p> <p data-bbox="288 344 1015 374">Sets the G3 cable equalizer. Sets the modem detection level.</p> <p data-bbox="288 380 400 409"><b>Purpose</b></p> <p data-bbox="288 414 1417 479">Perform the following adjustment to make the equalizer compatible with the line characteristics. To improve the transmission performance when a low quality line is used.</p> <p data-bbox="288 519 387 548"><b>Method</b></p> <ol data-bbox="304 553 632 618" style="list-style-type: none"> <li>1. Press the start key.</li> <li>2. Select the item to be set.</li> </ol> <table border="1" data-bbox="336 631 1401 824"> <thead> <tr> <th data-bbox="336 631 639 676">Display</th> <th data-bbox="639 631 1401 676">Description</th> </tr> </thead> <tbody> <tr> <td data-bbox="336 676 639 721">Reg G3 TX Eqr</td> <td data-bbox="639 676 1401 721">Sets the G3 transmission cable equalizer.</td> </tr> <tr> <td data-bbox="336 721 639 766">Reg G3 RX Eqr</td> <td data-bbox="639 721 1401 766">Sets the G3 reception cable equalizer.</td> </tr> <tr> <td data-bbox="336 766 639 810">RX Mdm Level</td> <td data-bbox="639 766 1401 810">Sets the modem detection level.</td> </tr> </tbody> </table> <p data-bbox="288 869 847 898"><b>Setting the G3 transmission cable equalizer</b></p> <ol data-bbox="304 902 783 1003" style="list-style-type: none"> <li>1. Select [0dB], [4dB], [8dB] or [12dB]. * : Initial setting: 0dB</li> <li>2. Press the start key. The setting is set.</li> </ol> <p data-bbox="288 1043 802 1072"><b>Setting the G3 reception cable equalizer</b></p> <ol data-bbox="304 1077 783 1178" style="list-style-type: none"> <li>1. Select [0dB], [4dB], [8dB] or [12dB]. * : Initial setting: 0dB</li> <li>2. Press the start key. The setting is set.</li> </ol> <p data-bbox="288 1218 727 1247"><b>Setting the modem detection level</b></p> <ol data-bbox="304 1252 927 1352" style="list-style-type: none"> <li>1. Select [-33dBm], [-38dBm], [-43dBm] or [-48dBm]. * : Initial setting: -43dBm</li> <li>2. Press the start key. The setting is set.</li> </ol> <p data-bbox="288 1393 440 1422"><b>Completion</b></p> <p data-bbox="288 1426 1254 1456">Press the stop key. The screen for selecting a maintenance item No. is displayed.</p>	Display	Description	Reg G3 TX Eqr	Sets the G3 transmission cable equalizer.	Reg G3 RX Eqr	Sets the G3 reception cable equalizer.	RX Mdm Level	Sets the modem detection level.
Display	Description								
Reg G3 TX Eqr	Sets the G3 transmission cable equalizer.								
Reg G3 RX Eqr	Sets the G3 reception cable equalizer.								
RX Mdm Level	Sets the modem detection level.								

Item No.	Description																
U651	<p data-bbox="288 241 507 271"><b>Setting modem 2</b></p> <p data-bbox="288 311 440 340"><b>Description</b></p> <p data-bbox="288 344 638 374">Sets the modem output level.</p> <p data-bbox="288 378 997 407">Sets the DTMF output level of a push-button dial telephone.</p> <p data-bbox="288 412 400 441"><b>Purpose</b></p> <p data-bbox="288 445 1246 474">Used if problems occur when sending a signal with a push-button dial telephone.</p> <p data-bbox="288 515 384 544"><b>Setting</b></p> <ol data-bbox="304 548 1129 651" style="list-style-type: none"> <li>1. Press the start key.</li> <li>2. Select the item to be set.</li> <li>3. Change the setting using the cursor left/right keys or numeric keys.</li> </ol> <table border="1" data-bbox="336 665 1385 960"> <thead> <tr> <th data-bbox="336 665 564 710">Display</th> <th data-bbox="564 665 959 710">Description</th> <th data-bbox="959 665 1158 710">Setting range</th> <th data-bbox="1158 665 1385 710">Initial setting</th> </tr> </thead> <tbody> <tr> <td data-bbox="336 710 564 792">Sgl LV Mdm</td> <td data-bbox="564 710 959 792">Modem output level</td> <td data-bbox="959 710 1158 792">1 to 15</td> <td data-bbox="1158 710 1385 792">9 (120 V) 10 (220-240 V)</td> </tr> <tr> <td data-bbox="336 792 564 875">DTMF LV(C)</td> <td data-bbox="564 792 959 875">DTMF output level (main value)</td> <td data-bbox="959 792 1158 875">0 to 15.0</td> <td data-bbox="1158 792 1385 875">5 (120 V) 10.5 (220-240 V)</td> </tr> <tr> <td data-bbox="336 875 564 960">DTMF LV(D)</td> <td data-bbox="564 875 959 960">DTMF output level (level difference)</td> <td data-bbox="959 875 1158 960">0 to 5.5</td> <td data-bbox="1158 875 1385 960">2 (120 V) 2.5 (220-240 V)</td> </tr> </tbody> </table> <ol data-bbox="304 972 783 1001" style="list-style-type: none"> <li>4. Press the start key. The setting is set.</li> </ol> <p data-bbox="288 1041 440 1070"><b>Completion</b></p> <p data-bbox="288 1075 1254 1104">Press the stop key. The screen for selecting a maintenance item No. is displayed.</p>	Display	Description	Setting range	Initial setting	Sgl LV Mdm	Modem output level	1 to 15	9 (120 V) 10 (220-240 V)	DTMF LV(C)	DTMF output level (main value)	0 to 15.0	5 (120 V) 10.5 (220-240 V)	DTMF LV(D)	DTMF output level (level difference)	0 to 5.5	2 (120 V) 2.5 (220-240 V)
Display	Description	Setting range	Initial setting														
Sgl LV Mdm	Modem output level	1 to 15	9 (120 V) 10 (220-240 V)														
DTMF LV(C)	DTMF output level (main value)	0 to 15.0	5 (120 V) 10.5 (220-240 V)														
DTMF LV(D)	DTMF output level (level difference)	0 to 5.5	2 (120 V) 2.5 (220-240 V)														

Item No.	Description																								
U660	<p data-bbox="288 241 496 271"><b>Setting the NCU</b></p> <p data-bbox="288 311 440 340"><b>Description</b> Makes setting regarding the network control unit (NCU).</p> <p data-bbox="288 380 400 409"><b>Purpose</b> To be executed as required.</p> <p data-bbox="288 486 387 515"><b>Method</b></p> <ol data-bbox="304 519 632 582" style="list-style-type: none"> <li>1. Press the start key.</li> <li>2. Select the item to be set.</li> </ol> <table border="1" data-bbox="336 595 1401 887"> <thead> <tr> <th data-bbox="336 595 639 640">Display</th> <th data-bbox="639 595 1401 640">Description</th> </tr> </thead> <tbody> <tr> <td data-bbox="336 640 639 685">Exchange</td> <td data-bbox="639 640 1401 685">Sets the connection to PBX/PSTN.</td> </tr> <tr> <td data-bbox="336 685 639 730">Dial Tone</td> <td data-bbox="639 685 1401 730">Sets PSTN dial tone detection.</td> </tr> <tr> <td data-bbox="336 730 639 775">Busy Tone</td> <td data-bbox="639 730 1401 775">Sets busy tone detection.</td> </tr> <tr> <td data-bbox="336 775 639 819">PBX Setting</td> <td data-bbox="639 775 1401 819">Setting for a PBX.</td> </tr> <tr> <td data-bbox="336 819 639 887">DC Loop</td> <td data-bbox="639 819 1401 887">Sets the loop current detection before dialing.</td> </tr> </tbody> </table> <p data-bbox="288 929 754 958"><b>Setting the connection to PBX/PSTN</b></p> <p data-bbox="288 963 1331 992">Selects if a fax is to be connected to either a PBX or public switched telephone network.</p> <ol data-bbox="304 996 549 1025" style="list-style-type: none"> <li>1. Select the setting.</li> </ol> <table border="1" data-bbox="336 1039 1401 1187"> <thead> <tr> <th data-bbox="336 1039 639 1084">Display</th> <th data-bbox="639 1039 1401 1084">Description</th> </tr> </thead> <tbody> <tr> <td data-bbox="336 1084 639 1128">PSTN</td> <td data-bbox="639 1084 1401 1128">Connected to the public switched telephone network.</td> </tr> <tr> <td data-bbox="336 1128 639 1187">PBX</td> <td data-bbox="639 1128 1401 1187">Connected to a PBX.</td> </tr> </tbody> </table> <p data-bbox="336 1196 611 1225">* : Initial setting: PSTN</p> <ol data-bbox="304 1229 782 1258" style="list-style-type: none"> <li>2. Press the start key. The setting is set.</li> </ol> <p data-bbox="288 1299 705 1328"><b>Setting PSTN dial tone detection</b></p> <p data-bbox="288 1332 1426 1395">Selects if the dial tone is detected to check the telephone is off the hook when a fax is connected to a public switched telephone network.</p> <ol data-bbox="304 1400 549 1429" style="list-style-type: none"> <li>1. Select the setting.</li> </ol> <table border="1" data-bbox="336 1442 1401 1590"> <thead> <tr> <th data-bbox="336 1442 639 1487">Display</th> <th data-bbox="639 1442 1401 1487">Description</th> </tr> </thead> <tbody> <tr> <td data-bbox="336 1487 639 1532">On</td> <td data-bbox="639 1487 1401 1532">Detects the dial tone.</td> </tr> <tr> <td data-bbox="336 1532 639 1590">Off</td> <td data-bbox="639 1532 1401 1590">Does not detect the dial tone.</td> </tr> </tbody> </table> <p data-bbox="336 1599 576 1628">* : Initial setting: On</p> <ol data-bbox="304 1632 782 1662" style="list-style-type: none"> <li>2. Press the start key. The setting is set.</li> </ol>	Display	Description	Exchange	Sets the connection to PBX/PSTN.	Dial Tone	Sets PSTN dial tone detection.	Busy Tone	Sets busy tone detection.	PBX Setting	Setting for a PBX.	DC Loop	Sets the loop current detection before dialing.	Display	Description	PSTN	Connected to the public switched telephone network.	PBX	Connected to a PBX.	Display	Description	On	Detects the dial tone.	Off	Does not detect the dial tone.
Display	Description																								
Exchange	Sets the connection to PBX/PSTN.																								
Dial Tone	Sets PSTN dial tone detection.																								
Busy Tone	Sets busy tone detection.																								
PBX Setting	Setting for a PBX.																								
DC Loop	Sets the loop current detection before dialing.																								
Display	Description																								
PSTN	Connected to the public switched telephone network.																								
PBX	Connected to a PBX.																								
Display	Description																								
On	Detects the dial tone.																								
Off	Does not detect the dial tone.																								

Item No.	Description																		
<b>U660</b>	<p data-bbox="288 241 644 271"><b>Setting busy tone detection</b></p> <p data-bbox="288 277 1431 443">When a fax signal is sent, sets whether the line is disconnected immediately after a busy tone is detected, or the busy tone is not detected and the line remains connected until T0 time-out time. Fax transmission may fail due to incorrect busy tone detection. When set to 2, this problem may be prevented. However, the line is not disconnected within the T0 time-out time even if the destination line is busy.</p> <p data-bbox="304 450 549 479">1. Select the setting.</p> <table border="1" data-bbox="336 495 1401 636"> <thead> <tr> <th data-bbox="336 495 639 539">Display</th> <th data-bbox="639 495 1401 539">Description</th> </tr> </thead> <tbody> <tr> <td data-bbox="336 539 639 584">On</td> <td data-bbox="639 539 1401 584">Detects busy tone.</td> </tr> <tr> <td data-bbox="336 584 639 636">Off</td> <td data-bbox="639 584 1401 636">Does not detect busy tone.</td> </tr> </tbody> </table> <p data-bbox="336 647 576 676">* : Initial setting: On</p> <p data-bbox="304 683 783 712">2. Press the start key. The setting is set.</p> <p data-bbox="288 750 512 779"><b>Setting for a PBX</b></p> <p data-bbox="288 786 1129 815">Selects the mode to connect an outside call when connected to a PBX.</p> <p data-bbox="288 822 1329 851">According to the type of the PBX connected, select the mode to connect an outside call.</p> <p data-bbox="304 857 549 887">1. Select the setting.</p> <table border="1" data-bbox="336 902 1401 1043"> <thead> <tr> <th data-bbox="336 902 639 947">Display</th> <th data-bbox="639 902 1401 947">Description</th> </tr> </thead> <tbody> <tr> <td data-bbox="336 947 639 992">Flash</td> <td data-bbox="639 947 1401 992">Flashing mode</td> </tr> <tr> <td data-bbox="336 992 639 1043">Loop</td> <td data-bbox="639 992 1401 1043">Code number mode</td> </tr> </tbody> </table> <p data-bbox="336 1055 600 1084">* : Initial setting: Loop</p> <p data-bbox="304 1090 783 1120">2. Press the start key. The setting is set.</p> <p data-bbox="288 1158 903 1187"><b>Setting the loop current detection before dialing</b></p> <p data-bbox="288 1193 1005 1223">Sets if the loop current detection is performed before dialing.</p> <p data-bbox="304 1229 549 1258">1. Select the setting.</p> <table border="1" data-bbox="336 1274 1401 1415"> <thead> <tr> <th data-bbox="336 1274 639 1319">Display</th> <th data-bbox="639 1274 1401 1319">Description</th> </tr> </thead> <tbody> <tr> <td data-bbox="336 1319 639 1364">On</td> <td data-bbox="639 1319 1401 1364">Performs loop current detection before dialing.</td> </tr> <tr> <td data-bbox="336 1364 639 1415">Off</td> <td data-bbox="639 1364 1401 1415">Does not perform loop current detection before dialing.</td> </tr> </tbody> </table> <p data-bbox="336 1426 576 1456">* : Initial setting: On</p> <p data-bbox="304 1462 783 1491">2. Press the start key. The setting is set.</p> <p data-bbox="288 1529 440 1559"><b>Completion</b></p> <p data-bbox="288 1565 1254 1594">Press the stop key. The screen for selecting a maintenance item No. is displayed.</p>	Display	Description	On	Detects busy tone.	Off	Does not detect busy tone.	Display	Description	Flash	Flashing mode	Loop	Code number mode	Display	Description	On	Performs loop current detection before dialing.	Off	Does not perform loop current detection before dialing.
Display	Description																		
On	Detects busy tone.																		
Off	Does not detect busy tone.																		
Display	Description																		
Flash	Flashing mode																		
Loop	Code number mode																		
Display	Description																		
On	Performs loop current detection before dialing.																		
Off	Does not perform loop current detection before dialing.																		

Item No.	Description																				
U670	<p data-bbox="290 241 491 273"><b>Outputting lists</b></p> <p data-bbox="290 309 440 340"><b>Description</b></p> <p data-bbox="290 344 1385 443">Outputs a list of data regarding fax transmissions. Printing a list is disabled either when a job is remaining in the buffer or when [Pause All Print Jobs] is pressed to halt printing.</p> <p data-bbox="290 452 399 483"><b>Purpose</b></p> <p data-bbox="290 488 1187 519">To check conditions of use, settings and transmission procedures of the fax.</p> <p data-bbox="290 555 386 586"><b>Method</b></p> <ol data-bbox="306 591 880 689" style="list-style-type: none"> <li>1. Press the start key.</li> <li>2. Select the item to be output.</li> <li>3. Press the start key. The selected list is output.</li> </ol> <table border="1" data-bbox="338 698 1401 1285"> <thead> <tr> <th data-bbox="346 710 641 754">Display</th> <th data-bbox="641 710 1393 754">Description</th> </tr> </thead> <tbody> <tr> <td data-bbox="346 754 641 831">Sys Conf Report</td> <td data-bbox="641 754 1393 831">Outputs a list of software switches, self telephone number, confidential boxes, ROM versions and other information.</td> </tr> <tr> <td data-bbox="346 831 641 907">Action List</td> <td data-bbox="641 831 1393 907">Outputs a list of error history, transmission line details and other information.</td> </tr> <tr> <td data-bbox="346 907 641 983">Self Sts Report</td> <td data-bbox="641 907 1393 983">Outputs a list of settings in maintenance mode (own-status report) regarding fax transmission only.</td> </tr> <tr> <td data-bbox="346 983 641 1037">Protocol List</td> <td data-bbox="641 983 1393 1037">Outputs a list of transmission procedures.</td> </tr> <tr> <td data-bbox="346 1037 641 1090">Error List</td> <td data-bbox="641 1037 1393 1090">Outputs a list of error.</td> </tr> <tr> <td data-bbox="346 1090 641 1144">Addr List(No.)</td> <td data-bbox="641 1090 1393 1144">Outputs address book in order IDs were added</td> </tr> <tr> <td data-bbox="346 1144 641 1198">Addr List(Idx)</td> <td data-bbox="641 1144 1393 1198">Outputs address book in order of names</td> </tr> <tr> <td data-bbox="346 1198 641 1252">One-touch List</td> <td data-bbox="641 1198 1393 1252">Outputs a list of one-touch.</td> </tr> <tr> <td data-bbox="346 1252 641 1283">Group List</td> <td data-bbox="641 1252 1393 1283">Outputs a list of group.</td> </tr> </tbody> </table> <p data-bbox="290 1330 440 1361"><b>Completion</b></p> <p data-bbox="290 1366 1254 1397">Press the stop key. The screen for selecting a maintenance item No. is displayed.</p>	Display	Description	Sys Conf Report	Outputs a list of software switches, self telephone number, confidential boxes, ROM versions and other information.	Action List	Outputs a list of error history, transmission line details and other information.	Self Sts Report	Outputs a list of settings in maintenance mode (own-status report) regarding fax transmission only.	Protocol List	Outputs a list of transmission procedures.	Error List	Outputs a list of error.	Addr List(No.)	Outputs address book in order IDs were added	Addr List(Idx)	Outputs address book in order of names	One-touch List	Outputs a list of one-touch.	Group List	Outputs a list of group.
Display	Description																				
Sys Conf Report	Outputs a list of software switches, self telephone number, confidential boxes, ROM versions and other information.																				
Action List	Outputs a list of error history, transmission line details and other information.																				
Self Sts Report	Outputs a list of settings in maintenance mode (own-status report) regarding fax transmission only.																				
Protocol List	Outputs a list of transmission procedures.																				
Error List	Outputs a list of error.																				
Addr List(No.)	Outputs address book in order IDs were added																				
Addr List(Idx)	Outputs address book in order of names																				
One-touch List	Outputs a list of one-touch.																				
Group List	Outputs a list of group.																				

Item No.	Description																		
U695	<p data-bbox="288 241 596 271"><b>FAX function customize</b></p> <p data-bbox="288 311 440 340"><b>Description</b></p> <p data-bbox="288 344 1426 409">Sets fax batch transmission ON/OFF. Also changes the print size priority at the time of small size reception.</p> <p data-bbox="288 414 400 443"><b>Purpose</b></p> <p data-bbox="288 448 624 477">To be executed as required.</p> <p data-bbox="288 517 384 546"><b>Setting</b></p> <p data-bbox="304 551 549 580">1. Select the setting.</p> <table border="1" data-bbox="336 595 1399 741"> <thead> <tr> <th data-bbox="336 595 639 640">Display</th> <th data-bbox="639 595 1399 640">Description</th> </tr> </thead> <tbody> <tr> <td data-bbox="336 640 639 685">FAX Bulk TX</td> <td data-bbox="639 640 1399 685">fax batch transmission On/Off</td> </tr> <tr> <td data-bbox="336 685 639 741">A5 Pt Pri Chg</td> <td data-bbox="639 685 1399 741">Change of print size priority at the time of small size reception</td> </tr> </tbody> </table> <p data-bbox="288 786 576 815"><b>Setting: [FAX Bulk TX]</b></p> <p data-bbox="304 819 564 848">1. Select [On] or [Off].</p> <table border="1" data-bbox="336 864 1399 1010"> <thead> <tr> <th data-bbox="336 864 639 909">Display</th> <th data-bbox="639 864 1399 909">Description</th> </tr> </thead> <tbody> <tr> <td data-bbox="336 909 639 954">On</td> <td data-bbox="639 909 1399 954">Fax batch transmission is enabled.</td> </tr> <tr> <td data-bbox="336 954 639 1010">Off</td> <td data-bbox="639 954 1399 1010">Fax batch transmission is disabled.</td> </tr> </tbody> </table> <p data-bbox="336 1016 576 1046">* : Initial setting: On</p> <p data-bbox="304 1050 783 1079">2. Press the start key. The setting is set.</p> <p data-bbox="288 1124 587 1153"><b>Setting: [A5 Pt Pri Chg]</b></p> <p data-bbox="304 1158 587 1187">1. Select [ON] or [OFF].</p> <table border="1" data-bbox="336 1202 1399 1348"> <thead> <tr> <th data-bbox="336 1202 639 1247">Display</th> <th data-bbox="639 1202 1399 1247">Description</th> </tr> </thead> <tbody> <tr> <td data-bbox="336 1247 639 1292">On</td> <td data-bbox="639 1247 1399 1292">At the time of A5 size reception: A5→B5→A4</td> </tr> <tr> <td data-bbox="336 1292 639 1348">Off</td> <td data-bbox="639 1292 1399 1348">At the time of A5 size reception: A5→A4→B5</td> </tr> </tbody> </table> <p data-bbox="336 1355 576 1384">* : Initial setting: Off</p> <p data-bbox="304 1388 783 1417">2. Press the start key. The setting is set.</p> <p data-bbox="288 1462 440 1491"><b>Completion</b></p> <p data-bbox="288 1496 1254 1525">Press the stop key. The screen for selecting a maintenance item No. is displayed.</p>	Display	Description	FAX Bulk TX	fax batch transmission On/Off	A5 Pt Pri Chg	Change of print size priority at the time of small size reception	Display	Description	On	Fax batch transmission is enabled.	Off	Fax batch transmission is disabled.	Display	Description	On	At the time of A5 size reception: A5→B5→A4	Off	At the time of A5 size reception: A5→A4→B5
Display	Description																		
FAX Bulk TX	fax batch transmission On/Off																		
A5 Pt Pri Chg	Change of print size priority at the time of small size reception																		
Display	Description																		
On	Fax batch transmission is enabled.																		
Off	Fax batch transmission is disabled.																		
Display	Description																		
On	At the time of A5 size reception: A5→B5→A4																		
Off	At the time of A5 size reception: A5→A4→B5																		



Item No.	Description																																														
U699	<p data-bbox="288 241 667 271"><b>Setting the software switches</b></p> <p data-bbox="288 311 440 340"><b>Description</b></p> <p data-bbox="288 344 1046 374">Sets the software switches on the FAX control PWB individually.</p> <p data-bbox="288 380 400 409"><b>Purpose</b></p> <p data-bbox="288 414 1366 515">To change the setting when a problem such as split output of received originals occurs. Since the communication performance is largely affected, normally this setting need not be changed.</p> <p data-bbox="288 555 387 584"><b>Method</b></p> <ol data-bbox="304 589 1390 790" style="list-style-type: none"> <li>1. Press the start key.</li> <li>2. Press [SW No.].</li> <li>3. Enter the desired software switch number (3 digits) using the numeric keys and press the enter key.</li> <li>4. Use numeric keys 7 to 0 to switch each bit between 0 and 1.</li> <li>5. Press the start key to set the value.</li> </ol> <p data-bbox="288 831 440 860"><b>Completion</b></p> <p data-bbox="288 864 1254 893">Press the stop key. The screen for selecting a maintenance item No. is displayed.</p> <p data-bbox="288 934 1102 963"><b>List of Software Switches of Which the Setting Can Be Changed</b></p> <p data-bbox="288 1003 762 1032">&lt;Communication control procedure&gt;</p> <table border="1" data-bbox="336 1046 1399 2004"> <thead> <tr> <th data-bbox="336 1046 427 1090">No.</th> <th data-bbox="427 1046 596 1090">Bit</th> <th data-bbox="596 1046 1399 1090">Item</th> </tr> </thead> <tbody> <tr> <td data-bbox="336 1090 427 1189" rowspan="2">36</td> <td data-bbox="427 1090 596 1144">7654</td> <td data-bbox="596 1090 1399 1144">Coding format in transmission</td> </tr> <tr> <td data-bbox="427 1144 596 1189">3210</td> <td data-bbox="596 1144 1399 1189">Coding format in reception</td> </tr> <tr> <td data-bbox="336 1189 427 1478" rowspan="6">37</td> <td data-bbox="427 1189 596 1243">5</td> <td data-bbox="596 1189 1399 1243">33600 bps/V34</td> </tr> <tr> <td data-bbox="427 1243 596 1296">4</td> <td data-bbox="596 1243 1399 1296">31200 bps/V34</td> </tr> <tr> <td data-bbox="427 1296 596 1350">3</td> <td data-bbox="596 1296 1399 1350">28800 bps/V34</td> </tr> <tr> <td data-bbox="427 1350 596 1404">2</td> <td data-bbox="596 1350 1399 1404">26400 bps/V34</td> </tr> <tr> <td data-bbox="427 1404 596 1458">1</td> <td data-bbox="596 1404 1399 1458">24000 bps/V34</td> </tr> <tr> <td data-bbox="427 1458 596 1478">0</td> <td data-bbox="596 1458 1399 1478">21600 bps/V34</td> </tr> <tr> <td data-bbox="336 1478 427 1861" rowspan="8">38</td> <td data-bbox="427 1478 596 1532">7</td> <td data-bbox="596 1478 1399 1532">19200 bps/V34</td> </tr> <tr> <td data-bbox="427 1532 596 1585">6</td> <td data-bbox="596 1532 1399 1585">16800 bps/V34</td> </tr> <tr> <td data-bbox="427 1585 596 1639">5</td> <td data-bbox="596 1585 1399 1639">14400 bps/V34</td> </tr> <tr> <td data-bbox="427 1639 596 1693">4</td> <td data-bbox="596 1639 1399 1693">12000 bps/V34</td> </tr> <tr> <td data-bbox="427 1693 596 1747">3</td> <td data-bbox="596 1693 1399 1747">9600 bps/V34</td> </tr> <tr> <td data-bbox="427 1747 596 1800">2</td> <td data-bbox="596 1747 1399 1800">7200 bps/V34</td> </tr> <tr> <td data-bbox="427 1800 596 1854">1</td> <td data-bbox="596 1800 1399 1854">4800 bps/V34</td> </tr> <tr> <td data-bbox="427 1854 596 1861">0</td> <td data-bbox="596 1854 1399 1861">2400 bps/V34</td> </tr> <tr> <td data-bbox="336 1861 427 1915">41</td> <td data-bbox="427 1861 596 1915">3</td> <td data-bbox="596 1861 1399 1915">FSK detection in V.8</td> </tr> <tr> <td data-bbox="336 1915 427 2004" rowspan="2">42</td> <td data-bbox="427 1915 596 1968">4</td> <td data-bbox="596 1915 1399 1968">4800 bps when low-speed setting is active</td> </tr> <tr> <td data-bbox="427 1968 596 2004">2</td> <td data-bbox="596 1968 1399 2004">FIF length in transmission of more than 4 times of DIS/DTC signal</td> </tr> </tbody> </table>	No.	Bit	Item	36	7654	Coding format in transmission	3210	Coding format in reception	37	5	33600 bps/V34	4	31200 bps/V34	3	28800 bps/V34	2	26400 bps/V34	1	24000 bps/V34	0	21600 bps/V34	38	7	19200 bps/V34	6	16800 bps/V34	5	14400 bps/V34	4	12000 bps/V34	3	9600 bps/V34	2	7200 bps/V34	1	4800 bps/V34	0	2400 bps/V34	41	3	FSK detection in V.8	42	4	4800 bps when low-speed setting is active	2	FIF length in transmission of more than 4 times of DIS/DTC signal
No.	Bit	Item																																													
36	7654	Coding format in transmission																																													
	3210	Coding format in reception																																													
37	5	33600 bps/V34																																													
	4	31200 bps/V34																																													
	3	28800 bps/V34																																													
	2	26400 bps/V34																																													
	1	24000 bps/V34																																													
	0	21600 bps/V34																																													
38	7	19200 bps/V34																																													
	6	16800 bps/V34																																													
	5	14400 bps/V34																																													
	4	12000 bps/V34																																													
	3	9600 bps/V34																																													
	2	7200 bps/V34																																													
	1	4800 bps/V34																																													
	0	2400 bps/V34																																													
41	3	FSK detection in V.8																																													
42	4	4800 bps when low-speed setting is active																																													
	2	FIF length in transmission of more than 4 times of DIS/DTC signal																																													

Item No.	Description		
<b>U699</b>	<b>&lt;Communication time setting&gt;</b>		
	<b>No.</b>	<b>Bit</b>	<b>Item</b>
	53	76543210	T3 timeout setting
	54	76543210	T4 timeout setting (automatic equipment)
	55	76543210	T5 timeout setting
	60	76543210	Time before transmission of CNG (1100 Hz) signal
	63	76543210	T0 timeout setting (manual equipment)
	64	7	Phase C timeout in ECM reception
	66	76543210	Timeout 1 in countermeasures against echo
	68	76543210	Timeout for FSK detection start in V.8
	<b>&lt;Modem setting&gt;</b>		
	<b>No.</b>	<b>Bit</b>	<b>Item</b>
	89	76543	RX gain adjust
	<b>&lt;NCU setting&gt;</b>		
	<b>No.</b>	<b>Bit</b>	<b>Item</b>
	121	7654	Dial tone/busy tone detection pattern
	122	7654	Busy tone detection pattern
		1	Busy tone detection in automatic FAX/TEL switching
	125	76543210	Access code registration for connection to PSTN
	126	7654	FAX/TEL automatic switching ringback tone ON/OFF cycle
	<b>&lt;Calling time setting&gt;</b>		
	<b>No.</b>	<b>Bit</b>	<b>Item</b>
	133	76543210	DTMF signal transmission time
	134	76543210	DTMF signal pause time
	141	76543210	Ringer detection cycle (minimum)
	142	76543210	Ringer detection cycle (maximum)
	143	76543210	Ringer ON time detection
	144	76543210	Ringer OFF time detection
	145	76543210	Ringer OFF non-detection time
	147	76543210	Dial tone detection time (continuous tone)
148	76543210	Allowable dial tone interruption time	
149	76543210	Time for transmitting selection signal after closing the DC circuit	
151	76543210	Ringer frequency detection invalid time	

Item No.	Description
U910	<p data-bbox="292 241 703 275"><b>Clearing the print coverage data</b></p> <p data-bbox="292 315 440 342"><b>Description</b></p> <p data-bbox="292 353 1414 414">Clears the accumulated data for the print coverage per A4 size paper and its period of time (as shown on the service status report).</p> <p data-bbox="292 421 400 448"><b>Purpose</b></p> <p data-bbox="292 454 1129 481">To clear data as required at times such as during maintenance service.</p> <p data-bbox="292 521 389 548"><b>Method</b></p> <ol data-bbox="308 555 983 656" style="list-style-type: none"><li>1. Press the start key.</li><li>2. Select [Execute].</li><li>3. Press the start key. The print coverage data is cleared.</li></ol> <p data-bbox="292 696 440 723"><b>Completion</b></p> <p data-bbox="292 730 1254 757">Press the stop key. The screen for selecting a maintenance item No. is displayed.</p>

Item No.	Description																														
U917	<p data-bbox="287 241 746 275"><b>Setting backup data reading/writing</b></p> <p data-bbox="287 309 440 342"><b>Description</b></p> <p data-bbox="287 344 1423 412">Retrieves the backup data to a USB memory from the machine; or writes the data from the USB memory to the machine.</p> <p data-bbox="287 414 400 448"><b>Purpose</b></p> <p data-bbox="287 450 866 483">To store and write data when replacing the HDD.</p> <p data-bbox="287 517 387 551"><b>Method</b></p> <ol data-bbox="304 553 1423 831" style="list-style-type: none"> <li>1. Press the power key on the operation panel, and after verifying the power indicator has gone off, switch off the main power switch.</li> <li>2. Insert USB memory in USB memory slot.</li> <li>3. Turn the main power switch on. Wait for 10 seconds to allow the machine to recognize the USB memory.</li> <li>4. Enter the maintenance item.</li> <li>5. Press the start key.</li> <li>6. Select [Export] or [Import] and press the start key.</li> </ol> <table border="1" data-bbox="336 837 1399 983"> <thead> <tr> <th data-bbox="336 837 639 882">Display</th> <th data-bbox="639 837 1399 882">Description</th> </tr> </thead> <tbody> <tr> <td data-bbox="336 882 639 927">Import</td> <td data-bbox="639 882 1399 927">Writing data from the USB memory to the machine</td> </tr> <tr> <td data-bbox="336 927 639 983">Export</td> <td data-bbox="639 927 1399 983">Retrieving from the machine to a USB memory</td> </tr> </tbody> </table> <ol data-bbox="304 992 520 1025" style="list-style-type: none"> <li>7. Select the item.</li> </ol> <table border="1" data-bbox="336 1032 1399 1525"> <thead> <tr> <th data-bbox="336 1032 549 1077">Display</th> <th data-bbox="549 1032 927 1077">Description</th> <th data-bbox="927 1032 1399 1077">Depending data</th> </tr> </thead> <tbody> <tr> <td data-bbox="336 1077 549 1122">Address Book</td> <td data-bbox="549 1077 927 1122">Address book</td> <td data-bbox="927 1077 1399 1122">-</td> </tr> <tr> <td data-bbox="336 1122 549 1167">Job Account</td> <td data-bbox="549 1122 927 1167">Job accounting</td> <td data-bbox="927 1122 1399 1167">-</td> </tr> <tr> <td data-bbox="336 1167 549 1211">One Touch</td> <td data-bbox="549 1167 927 1211">Information on one-touch key</td> <td data-bbox="927 1167 1399 1211">Address book</td> </tr> <tr> <td data-bbox="336 1211 549 1256">User</td> <td data-bbox="549 1211 927 1256">User managements</td> <td data-bbox="927 1211 1399 1256">Job accounting</td> </tr> <tr> <td data-bbox="336 1256 549 1301">Program</td> <td data-bbox="549 1256 927 1301">Program information</td> <td data-bbox="927 1256 1399 1301">Job accountings and user managements</td> </tr> <tr> <td data-bbox="336 1301 549 1346">Document Box</td> <td data-bbox="549 1301 927 1346">Document box information</td> <td data-bbox="927 1301 1399 1346">Job accountings and user managements</td> </tr> <tr> <td data-bbox="336 1346 549 1525">Fax Forward</td> <td data-bbox="549 1346 927 1525">FAX transfer information</td> <td data-bbox="927 1346 1399 1525">Job accountings, user managements and document box information</td> </tr> </tbody> </table> <p data-bbox="336 1534 1355 1601">* : Since data are dependent with each other, data other than those assigned are also retrieved or written in.</p> <ol data-bbox="304 1603 1361 1809" style="list-style-type: none"> <li>8. Select [On].</li> <li>9. Press the start key. Starts reading or writing. The progress of selected item is displayed in %. When an error occurs, the operation is canceled and an error code is displayed.</li> <li>10. When normally completed, [Fin] is displayed.</li> <li>11. Turn the main power switch off and on after completing writing when selecting [Import].</li> </ol>	Display	Description	Import	Writing data from the USB memory to the machine	Export	Retrieving from the machine to a USB memory	Display	Description	Depending data	Address Book	Address book	-	Job Account	Job accounting	-	One Touch	Information on one-touch key	Address book	User	User managements	Job accounting	Program	Program information	Job accountings and user managements	Document Box	Document box information	Job accountings and user managements	Fax Forward	FAX transfer information	Job accountings, user managements and document box information
Display	Description																														
Import	Writing data from the USB memory to the machine																														
Export	Retrieving from the machine to a USB memory																														
Display	Description	Depending data																													
Address Book	Address book	-																													
Job Account	Job accounting	-																													
One Touch	Information on one-touch key	Address book																													
User	User managements	Job accounting																													
Program	Program information	Job accountings and user managements																													
Document Box	Document box information	Job accountings and user managements																													
Fax Forward	FAX transfer information	Job accountings, user managements and document box information																													

Item No.	Description			
<b>U917</b>	<b>Error Codes</b>			
	<b>Codes</b>	<b>Description</b>	<b>Codes</b>	<b>Description</b>
	e002	Parameter error	e31e	User managements error
	e003	File write error	e31f	User managements open error
	e004	File initialization error	e320	User managements error
	e005	File error	e410	Box file open error
	e006	Processing error	e411	Box error in writing
	e010	Address book clear error (contact)	e412	Box error in reading
	e011	Address book open error (contact)	e413	Box list error
	e012	Address book list error (contact)	e414	Box list error
	e013	Address book list error (contact)	e415	Box error
	e014	Address book clear error (group)	e416	Box error
	e015	Address book open error (group)	e417	Box open error
	e016	Address book list error (group)	e418	Box close error
	e017	Address book list error (group)	e419	Box creation error
	e110	Job accounting clear error	e41a	Box creation error
	e111	Job accounting open error	e41b	Box deletion error
	e112	Job accounting open error	e41c	Box movement error
	e113	Job accounting error in writing	e510	Program error in writing
	e114	Job accounting list error	e511	Program error in reading
	e115	Job accounting list error	e710	Fax memory open error
	e210	One-touch open error	e711	Fax memory initialization error
	e211	One-touch list error	e712	Fax memory list error
	e212	One-touch list error	e713	Fax memory error
	e310	User managements backup error	e714	Fax memory error
	e311	User managements clear error	e715	Fax memory mode error
	e312	User managements open error	e716	Fax memory error
	e313	User managements open error	e717	Fax memory error
	e314	User managements open error	e718	Fax memory mode error
	e315	User managements error in writing	e910	File reading error
	e316	User managements list error	e911	File writing error
	e317	User managements list error	e912	Data mismatch
	e318	User managements list error	e913	Log file open error
	e319	User managements list error	e914	Log file error in writing
	e31a	User managements open error	e915	Directory open error
	e31b	User managements error	e916	Directory error in reading
	e31c	User managements error	e917	Synchronization error
	e31d	User managements open error	e918	Synchronization error

Item No.	Description			
<b>U917</b>	<b>Error Codes</b>			
	<b>Codes</b>	<b>Description</b>	<b>Codes</b>	<b>Description</b>
	d000	Unspecified error	d00b	File reading error
	d001	HDD unavailable	d00c	File writing error
	d002	USB memory is not inserted	d00d	File copy error
	d003	File for writing is not found in the USB	d00e	File compressed error
	d004	File for reading is not found in the HDD	d00f	File decompressed error
	d005	USB error in writing	d010	Directory open error
	d006	USB error in reading	d011	Directory creation error
	d007	USB unmount error	d012	File writing error
	d008	File rename error	d013	File reading error
	d009	File open error	d014	File deletion error
	d00a	File close error	d015	File copy error to the USB
	<b>Supplement</b>			
	The following restrictions apply to the data which were imported from 4 in 1 models (with FAX) to 3 in 1 models (without FAX).			
Personal address book: FAX-related data are not imported.				
Group address book: Group addresses including FAX addresses are not imported.				
Job accounting data: Initial values are added for FAX-related data.				
One-touch data: Groups assigned with FAX addresses or those including FAX are not imported.				
User management data: Initial values are added for out-going FAXes of authentication.				
Program data: Not imported. (The same applies when data are imported from 3 in 1 to 4 in 1 models.)				
<b>Completion</b>				
Press the stop key. The screen for selecting a maintenance item No. is displayed.				

Item No.	Description												
<b>U920</b>	<p><b>Checking the copy counts</b></p> <p><b>Description</b> Checks the copy counts.</p> <p><b>Purpose</b> To check the copy counts.</p> <p><b>Method</b> 1. Press the start key. The current counts are displayed.</p> <table border="1" data-bbox="336 562 1401 851"> <thead> <tr> <th data-bbox="336 562 639 607">Display</th> <th data-bbox="639 562 1401 607">Description</th> </tr> </thead> <tbody> <tr> <td data-bbox="336 607 639 651">Color Copy</td> <td data-bbox="639 607 1401 651">Count value of color copy</td> </tr> <tr> <td data-bbox="336 651 639 696">B/W Copy</td> <td data-bbox="639 651 1401 696">Count value of black/white copy</td> </tr> <tr> <td data-bbox="336 696 639 741">Color Prn</td> <td data-bbox="639 696 1401 741">Count value of color print</td> </tr> <tr> <td data-bbox="336 741 639 786">B/W Prn</td> <td data-bbox="639 741 1401 786">Count value of black/white print</td> </tr> <tr> <td data-bbox="336 786 639 831">B/W Fax</td> <td data-bbox="639 786 1401 831">Count value of black/white FAX</td> </tr> </tbody> </table> <p><b>Completion</b> Press the stop key. The screen for selecting a maintenance item No. is displayed.</p>	Display	Description	Color Copy	Count value of color copy	B/W Copy	Count value of black/white copy	Color Prn	Count value of color print	B/W Prn	Count value of black/white print	B/W Fax	Count value of black/white FAX
Display	Description												
Color Copy	Count value of color copy												
B/W Copy	Count value of black/white copy												
Color Prn	Count value of color print												
B/W Prn	Count value of black/white print												
B/W Fax	Count value of black/white FAX												
<b>U927</b>	<p><b>Clearing the all copy counts and machine life counts (one time only)</b></p> <p><b>Description</b> Resets all of the counts back to zero.</p> <p><b>Supplement</b> The total account counter and the machine life counter can be cleared only once if all count values are 1000 or less.</p> <p><b>Method</b> 1. Press the start key. 2. Select [Execute]. 3. Press the start key. All copy counts and machine life counts are cleared.</p> <p><b>Completion</b> Press the stop key. The screen for selecting a maintenance item No. is displayed.</p>												

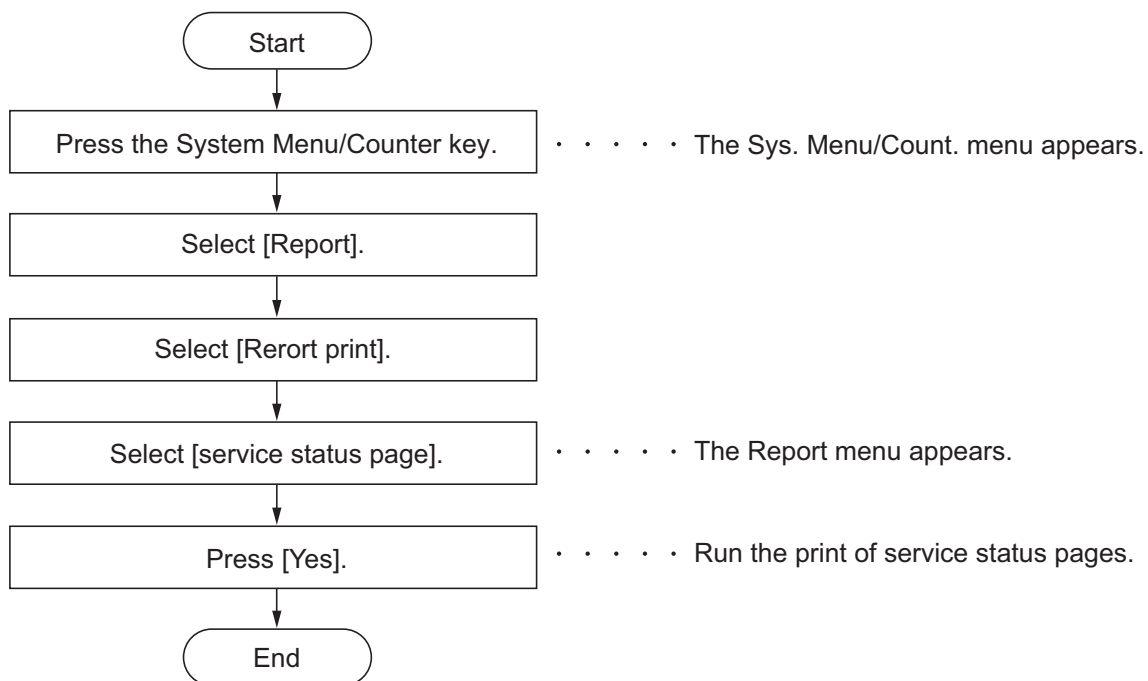
Item No.	Description				
<b>U928</b>	<p><b>Checking machine life counts</b></p> <p><b>Description</b> Displays the machine life counts.</p> <p><b>Purpose</b> To check the machine life counts.</p> <p><b>Method</b></p> <ol style="list-style-type: none"> <li>1. Press the start key. The current machine life counts is displayed.</li> </ol> <table border="1" data-bbox="336 562 1401 658"> <thead> <tr> <th data-bbox="336 562 639 607">Display</th> <th data-bbox="639 562 1401 607">Description</th> </tr> </thead> <tbody> <tr> <td data-bbox="336 607 639 658">Life Cont</td> <td data-bbox="639 607 1401 658">Machine life counts</td> </tr> </tbody> </table> <p><b>Completion</b> Press the stop key. The screen for selecting a maintenance item No. is displayed.</p>	Display	Description	Life Cont	Machine life counts
Display	Description				
Life Cont	Machine life counts				
<b>U977</b>	<p><b>Data capture mode</b></p> <p><b>Description</b> Store the print data sent to the machine into USB memory.</p> <p><b>Purpose</b> In case to occur the error at printing, check the print data sent to the machine.</p> <p><b>Method</b></p> <ol style="list-style-type: none"> <li>1. Insert USB memory in USB memory slot.</li> <li>2. Turn the main power switch on.</li> <li>3. Enter the maintenance item.</li> <li>4. Press the start key.</li> <li>5. Select [Execute].</li> <li>6. Press the start key.</li> <li>7. Send the print data to the machine.</li> </ol> <p>Once the print data is stored into USB memory, [OK] will be displayed.</p> <p><b>Completion</b> Press the stop key. The screen for selecting a maintenance item No. is displayed.</p>				
<b>U995</b>	<p><b>Memory data Individual setting</b></p> <p><b>Description</b> Displays the memory data.</p> <p><b>Purpose</b> This mode need not be executed. When the status report is output, the setting is displayed.</p> <p><b>Completion</b> Press the stop key. The screen for selecting a maintenance item No. is displayed.</p>				



## 1-3-2 Service mode

The machine is equipped with a maintenance function which can be used to maintain and service the machine.

### (1) Executing a service mode



**(2) Description of service mode**

<b>Service items</b>	<b>Description</b>
<b>Service Status</b>	<p><b>Printing a status page for service purpose</b></p> <p><b>Description</b> Prints a status page for service purpose. The status page includes various settings and service cumulative.</p> <p><b>Purpose</b> To acquire the current printing environmental parameters and cumulative information.</p> <p><b>Method</b></p> <ol style="list-style-type: none"><li>1. Select [Service status].</li><li>2. Select [YES]. Two pages will be printed.</li></ol> <p><b>Completion</b> Press the System Menu/Counter key.</p>

Service items	Description																																																										
	<p data-bbox="386 241 683 273"><b>Service status page (1)</b></p> <div data-bbox="338 304 1398 1760" style="border: 1px solid black; padding: 10px;"> <p data-bbox="363 327 801 376"><b>Service Status Page</b></p> <p data-bbox="363 376 421 403">MFP</p> <p data-bbox="1152 371 1343 398">(2) 06/04/2010 12:00</p> <p data-bbox="354 430 829 456">(1) Firmware version 2M9_2000.000.000 2010.04.06</p> <p data-bbox="979 407 1353 456">(3) [XXXXXXXX] (4) [XXXXXXXX] (5) [XXXXXXXX]</p> <hr/> <p data-bbox="370 506 654 533"><b>Controller Information</b></p> <p data-bbox="402 537 545 564"><b>Memory status</b></p> <table data-bbox="363 564 734 645"> <tr> <td>(7) Standard Size</td> <td>128.0 KB</td> </tr> <tr> <td>(8) Option Slot</td> <td>128.0 KB</td> </tr> <tr> <td>(9) Total Size</td> <td>256.0 KB</td> </tr> </table> <p data-bbox="874 564 1050 591">(27) FRPO Status</p> <table data-bbox="925 591 1353 645"> <tr> <td>User Top Margin</td> <td>A1+A2/100</td> <td>0.00</td> </tr> <tr> <td>User Left Margin</td> <td>A3+A4/100</td> <td>0.00</td> </tr> </table> <p data-bbox="402 672 450 698"><b>Time</b></p> <table data-bbox="354 698 804 779"> <tr> <td>(10) Local Time Zone</td> <td>+01:00 Tokio</td> </tr> <tr> <td>(11) Date and Time</td> <td>06/04/2010 12:00</td> </tr> <tr> <td>(12) Time Server</td> <td>10.183.53.13</td> </tr> </table> <p data-bbox="402 801 564 828"><b>Installed Options</b></p> <table data-bbox="354 828 746 936"> <tr> <td>(13) Paper Feeder</td> <td>Cassette</td> </tr> <tr> <td>(14) Card Authentication Kit (B)</td> <td>Installed</td> </tr> <tr> <td>(15) USB Keyboard</td> <td>Connected</td> </tr> <tr> <td>(16) USB Keyboard Type</td> <td>US-English</td> </tr> </table> <p data-bbox="402 949 545 976"><b>Print Coverage</b></p> <p data-bbox="354 976 890 1003">(17) Average(%) / Usage Page(A4/Letter Conversion)</p> <p data-bbox="354 1003 686 1133">(18) Total</p> <table data-bbox="411 1025 686 1133"> <tr> <td>K: 1.10</td> <td>/ 1111111.11</td> </tr> <tr> <td>C: 2.20</td> <td>/ 2222222.22</td> </tr> <tr> <td>M: 3.30</td> <td>/ 3333333.33</td> </tr> <tr> <td>Y: 4.40</td> <td>/ 4444444.44</td> </tr> </table> <p data-bbox="354 1133 686 1263">(19) Copy</p> <table data-bbox="411 1155 686 1263"> <tr> <td>K: 1.10</td> <td>/ 1111111.11</td> </tr> <tr> <td>C: 2.20</td> <td>/ 2222222.22</td> </tr> <tr> <td>M: 3.30</td> <td>/ 3333333.33</td> </tr> <tr> <td>Y: 4.40</td> <td>/ 4444444.44</td> </tr> </table> <p data-bbox="354 1263 1334 1290">(20) Printer PDF mode Y5 00</p> <table data-bbox="411 1290 686 1397"> <tr> <td>K: 1.10</td> <td>/ 1111111.11</td> </tr> <tr> <td>C: 2.20</td> <td>/ 2222222.22</td> </tr> <tr> <td>M: 3.30</td> <td>/ 3333333.33</td> </tr> <tr> <td>Y: 4.40</td> <td>/ 4444444.44</td> </tr> </table> <p data-bbox="354 1397 673 1424">(21) FAX</p> <table data-bbox="411 1424 673 1451"> <tr> <td>K: 1.10</td> <td>/ 1111111.11</td> </tr> </table> <p data-bbox="354 1451 865 1478">(22) Period (27/10/2009 - 03/11/2009 08:40)</p> <p data-bbox="354 1478 823 1505">(23) Last Page K/C/M/Y(%) 1.00 / 2.22 / 3.33 / 4.44</p> <p data-bbox="402 1527 561 1554"><b>FAX Information</b></p> <table data-bbox="354 1554 628 1635"> <tr> <td>(24) Rings (Normal)</td> <td>3</td> </tr> <tr> <td>(25) Rings (FAX/TEL)</td> <td>3</td> </tr> <tr> <td>(26) Rings (TAD)</td> <td>3</td> </tr> </table> <hr/> <p data-bbox="858 1697 1362 1724">1 (6) [XXXXXXXXXXXXXXXXXXXX]</p> </div>	(7) Standard Size	128.0 KB	(8) Option Slot	128.0 KB	(9) Total Size	256.0 KB	User Top Margin	A1+A2/100	0.00	User Left Margin	A3+A4/100	0.00	(10) Local Time Zone	+01:00 Tokio	(11) Date and Time	06/04/2010 12:00	(12) Time Server	10.183.53.13	(13) Paper Feeder	Cassette	(14) Card Authentication Kit (B)	Installed	(15) USB Keyboard	Connected	(16) USB Keyboard Type	US-English	K: 1.10	/ 1111111.11	C: 2.20	/ 2222222.22	M: 3.30	/ 3333333.33	Y: 4.40	/ 4444444.44	K: 1.10	/ 1111111.11	C: 2.20	/ 2222222.22	M: 3.30	/ 3333333.33	Y: 4.40	/ 4444444.44	K: 1.10	/ 1111111.11	C: 2.20	/ 2222222.22	M: 3.30	/ 3333333.33	Y: 4.40	/ 4444444.44	K: 1.10	/ 1111111.11	(24) Rings (Normal)	3	(25) Rings (FAX/TEL)	3	(26) Rings (TAD)	3
(7) Standard Size	128.0 KB																																																										
(8) Option Slot	128.0 KB																																																										
(9) Total Size	256.0 KB																																																										
User Top Margin	A1+A2/100	0.00																																																									
User Left Margin	A3+A4/100	0.00																																																									
(10) Local Time Zone	+01:00 Tokio																																																										
(11) Date and Time	06/04/2010 12:00																																																										
(12) Time Server	10.183.53.13																																																										
(13) Paper Feeder	Cassette																																																										
(14) Card Authentication Kit (B)	Installed																																																										
(15) USB Keyboard	Connected																																																										
(16) USB Keyboard Type	US-English																																																										
K: 1.10	/ 1111111.11																																																										
C: 2.20	/ 2222222.22																																																										
M: 3.30	/ 3333333.33																																																										
Y: 4.40	/ 4444444.44																																																										
K: 1.10	/ 1111111.11																																																										
C: 2.20	/ 2222222.22																																																										
M: 3.30	/ 3333333.33																																																										
Y: 4.40	/ 4444444.44																																																										
K: 1.10	/ 1111111.11																																																										
C: 2.20	/ 2222222.22																																																										
M: 3.30	/ 3333333.33																																																										
Y: 4.40	/ 4444444.44																																																										
K: 1.10	/ 1111111.11																																																										
(24) Rings (Normal)	3																																																										
(25) Rings (FAX/TEL)	3																																																										
(26) Rings (TAD)	3																																																										

Figure 1-3-17



Service items	Description	
	<b>Detail of service status page</b>	
	<b>No.</b>	<b>Description</b>
		<b>Supplement</b>
(1)	Firmware version	-
(2)	System date	-
(3)	Engine soft version	-
(4)	Engine boot version	-
(5)	Operation panel mask version	-
(6)	Machine serial number	-
(7)	Standard memory size	-
(8)	Optional memory size	-
(9)	Total memory size	-
(10)	Local time zone	-
(11)	Report output date	Day/Month/Year hour:minute
(12)	NTP server name	-
(13)	Presence or absence of the optional paper feeder	Paper feeder 2/Paper feeder 3/Not Installed
(14)	Presence or absence of the optional IC card authentication kit	Installed/Not Installed/Trial
(15)	Presence or absence of the USB Keyboard	Connected/Not Connected
(16)	Type of the USB Keyboard	US-English/US-English with Euro
(17)	Page of relation to the A4/Letter	* :Print Coverage provides a close-matching reference of toner consumption and will not match with the actual toner consumption.
(18)	Average coverage for total	Black/Cyan/Magenta/Yellow
(19)	Average coverage for copy	Black/Cyan/Magenta/Yellow
(20)	Average coverage for printer	Black/Cyan/Magenta/Yellow
(21)	Average coverage for fax	Black
(22)	Cleared date and output date	-
(23)	Coverage on the final output page	-
(24)	Number of rings	0 to 15
(25)	Number of rings before automatic switching	0 to 15
(26)	Number of rings before connecting to answering machine	0 to 15
(27)	FRPO setting	-

Service items	Description																																																
	<table border="1"> <thead> <tr> <th data-bbox="295 286 386 331">No.</th> <th data-bbox="386 286 798 331">Description</th> <th data-bbox="798 286 1423 331">Supplement</th> </tr> </thead> <tbody> <tr> <td data-bbox="295 331 386 972">(28)</td> <td data-bbox="386 331 798 972">NV RAM version</td> <td data-bbox="798 331 1423 972"> <p>_ 1F3 1225 _ 1F3 1225 (a) (b) (c) (d) (e) (f)</p> <p>(a) Consistency of the present software version and the database _ (underscore): OK * (Asterisk): NG</p> <p>(b) Database version</p> <p>(c) The oldest time stamp of database version</p> <p>(d) Consistency of the present software version and the ME firmware version _ (underscore): OK * (Asterisk): NG</p> <p>(e) ME firmware version</p> <p>(f) The oldest time stamp of the ME database version</p> <p>Normal if (a) and (d) are underscored, and (b) and (e) are identical with (c) and (f).</p> </td> </tr> <tr> <td data-bbox="295 972 386 1016">(29)</td> <td data-bbox="386 972 798 1016">Scanner firmware version</td> <td data-bbox="798 972 1423 1016">-</td> </tr> <tr> <td data-bbox="295 1016 386 1061">(30)</td> <td data-bbox="386 1016 798 1061">Fax firmware version</td> <td data-bbox="798 1016 1423 1061">-</td> </tr> <tr> <td data-bbox="295 1061 386 1106">(31)</td> <td data-bbox="386 1061 798 1106">Mac address</td> <td data-bbox="798 1061 1423 1106">-</td> </tr> <tr> <td data-bbox="295 1106 386 1151">(32)</td> <td data-bbox="386 1106 798 1151">Number of original feed from DP</td> <td data-bbox="798 1106 1423 1151">-</td> </tr> <tr> <td data-bbox="295 1151 386 1196">(33)</td> <td data-bbox="386 1151 798 1196">The last sent date and time</td> <td data-bbox="798 1151 1423 1196">-</td> </tr> <tr> <td data-bbox="295 1196 386 1240">(34)</td> <td data-bbox="386 1196 798 1240">Transmission address</td> <td data-bbox="798 1196 1423 1240">-</td> </tr> <tr> <td data-bbox="295 1240 386 1285">(35)</td> <td data-bbox="386 1240 798 1285">Destination information</td> <td data-bbox="798 1240 1423 1285">-</td> </tr> <tr> <td data-bbox="295 1285 386 1330">(36)</td> <td data-bbox="386 1285 798 1330">Area information</td> <td data-bbox="798 1285 1423 1330">-</td> </tr> <tr> <td data-bbox="295 1330 386 1375">(37)</td> <td data-bbox="386 1330 798 1375">Margin settings</td> <td data-bbox="798 1330 1423 1375">Top margin/Left margin</td> </tr> <tr> <td data-bbox="295 1375 386 1420">(38)</td> <td data-bbox="386 1375 798 1420">Top offset for each paper source</td> <td data-bbox="798 1375 1423 1420">MP tray/Paper feeder 2/Paper feeder 3/Duplex/ Page rotation</td> </tr> <tr> <td data-bbox="295 1420 386 1464">(39)</td> <td data-bbox="386 1420 798 1464">Left offset for each paper source</td> <td data-bbox="798 1420 1423 1464">MP tray/Paper feeder 2/Paper feeder 3/Duplex/ Page rotation</td> </tr> <tr> <td data-bbox="295 1464 386 1720" rowspan="2">(40)</td> <td data-bbox="386 1464 798 1720">Margin/Page length/Page width settings</td> <td data-bbox="798 1464 1423 1720">Top margin integer part/Top margin decimal part/ Left margin integer part/Left margin decimal part/ Page length integer part/Page length decimal part/ Page width integer part/Page width decimal part</td> </tr> <tr> <td data-bbox="386 1720 798 1800">Life counter (The first line)</td> <td data-bbox="798 1720 1423 1800">Machine life/MP tray/Cassette/Paper feeder 1/ Paper feeder 2 /Duplex</td> </tr> <tr> <td data-bbox="295 1800 386 1953">(41)</td> <td data-bbox="386 1800 798 1953">Life counter (The second line)</td> <td data-bbox="798 1800 1423 1953">Drum unit K/Drum unit C/Drum unit M/Drum unit Y/ Intermediate transfer unit/Developing unit K/ Developing unit C/Developing unit M/ Developing unit Y/Maintenance kit</td> </tr> </tbody> </table>	No.	Description	Supplement	(28)	NV RAM version	<p>_ 1F3 1225 _ 1F3 1225 (a) (b) (c) (d) (e) (f)</p> <p>(a) Consistency of the present software version and the database _ (underscore): OK * (Asterisk): NG</p> <p>(b) Database version</p> <p>(c) The oldest time stamp of database version</p> <p>(d) Consistency of the present software version and the ME firmware version _ (underscore): OK * (Asterisk): NG</p> <p>(e) ME firmware version</p> <p>(f) The oldest time stamp of the ME database version</p> <p>Normal if (a) and (d) are underscored, and (b) and (e) are identical with (c) and (f).</p>	(29)	Scanner firmware version	-	(30)	Fax firmware version	-	(31)	Mac address	-	(32)	Number of original feed from DP	-	(33)	The last sent date and time	-	(34)	Transmission address	-	(35)	Destination information	-	(36)	Area information	-	(37)	Margin settings	Top margin/Left margin	(38)	Top offset for each paper source	MP tray/Paper feeder 2/Paper feeder 3/Duplex/ Page rotation	(39)	Left offset for each paper source	MP tray/Paper feeder 2/Paper feeder 3/Duplex/ Page rotation	(40)	Margin/Page length/Page width settings	Top margin integer part/Top margin decimal part/ Left margin integer part/Left margin decimal part/ Page length integer part/Page length decimal part/ Page width integer part/Page width decimal part	Life counter (The first line)	Machine life/MP tray/Cassette/Paper feeder 1/ Paper feeder 2 /Duplex	(41)	Life counter (The second line)	Drum unit K/Drum unit C/Drum unit M/Drum unit Y/ Intermediate transfer unit/Developing unit K/ Developing unit C/Developing unit M/ Developing unit Y/Maintenance kit	
No.	Description	Supplement																																															
(28)	NV RAM version	<p>_ 1F3 1225 _ 1F3 1225 (a) (b) (c) (d) (e) (f)</p> <p>(a) Consistency of the present software version and the database _ (underscore): OK * (Asterisk): NG</p> <p>(b) Database version</p> <p>(c) The oldest time stamp of database version</p> <p>(d) Consistency of the present software version and the ME firmware version _ (underscore): OK * (Asterisk): NG</p> <p>(e) ME firmware version</p> <p>(f) The oldest time stamp of the ME database version</p> <p>Normal if (a) and (d) are underscored, and (b) and (e) are identical with (c) and (f).</p>																																															
(29)	Scanner firmware version	-																																															
(30)	Fax firmware version	-																																															
(31)	Mac address	-																																															
(32)	Number of original feed from DP	-																																															
(33)	The last sent date and time	-																																															
(34)	Transmission address	-																																															
(35)	Destination information	-																																															
(36)	Area information	-																																															
(37)	Margin settings	Top margin/Left margin																																															
(38)	Top offset for each paper source	MP tray/Paper feeder 2/Paper feeder 3/Duplex/ Page rotation																																															
(39)	Left offset for each paper source	MP tray/Paper feeder 2/Paper feeder 3/Duplex/ Page rotation																																															
(40)	Margin/Page length/Page width settings	Top margin integer part/Top margin decimal part/ Left margin integer part/Left margin decimal part/ Page length integer part/Page length decimal part/ Page width integer part/Page width decimal part																																															
	Life counter (The first line)	Machine life/MP tray/Cassette/Paper feeder 1/ Paper feeder 2 /Duplex																																															
(41)	Life counter (The second line)	Drum unit K/Drum unit C/Drum unit M/Drum unit Y/ Intermediate transfer unit/Developing unit K/ Developing unit C/Developing unit M/ Developing unit Y/Maintenance kit																																															

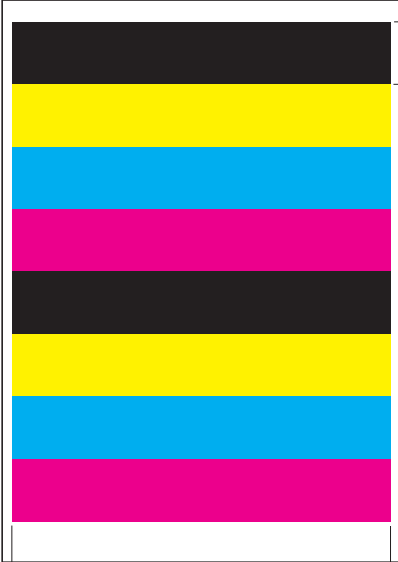
Service items	Description																			
	<b>No.</b>	<b>Description</b>																		
		<b>Supplement</b>																		
(42)	Panel lock information	0: OFF/1: Partial lock/2: Full lock																		
(43)	USB information	U00: Not installed/U01: Full speed/U02: Hi speed																		
(44)	Paper handling information	0: Paper source unit select/1: Paper source unit																		
(45)	Color printing double count mode	0: All single counts 3: Folio, Single count, Less than 330 mm (length)																		
(46)	Black and white printing double count mode	0: All single counts 3: Folio, Single count, Less than 330 mm (length)																		
(47)	Billing counting timing	-																		
(48)	Temperature (machine inside)	-																		
(49)	Temperature (machine outside)	-																		
(50)	Relative temperature (machine outside)	-																		
(51)	Absolute temperature (machine outside)	-																		
(52)	Fixed assets number	-																		
(53)	Job end judgment time-out time	-																		
(54)	Job end detection mode	-																		
(55)	Media type attributes 1 to 28 (Not used: 18, 19, 20)	<table border="0"> <tr> <td>Weight settings</td> <td>Fuser settings</td> </tr> <tr> <td>0: Light</td> <td>0: High</td> </tr> <tr> <td>1: Normal 1</td> <td>1: Middle</td> </tr> <tr> <td>2: Normal 2</td> <td>2: Low</td> </tr> <tr> <td>3: Normal 3</td> <td>3: Vellum</td> </tr> <tr> <td>4: Heavy 1</td> <td>Duplex settings</td> </tr> <tr> <td>5: Heavy 2</td> <td>0: Disable</td> </tr> <tr> <td>6: Heavy 3</td> <td>1: Enable</td> </tr> <tr> <td>7: Extra Heavy</td> <td></td> </tr> </table>	Weight settings	Fuser settings	0: Light	0: High	1: Normal 1	1: Middle	2: Normal 2	2: Low	3: Normal 3	3: Vellum	4: Heavy 1	Duplex settings	5: Heavy 2	0: Disable	6: Heavy 3	1: Enable	7: Extra Heavy	
Weight settings	Fuser settings																			
0: Light	0: High																			
1: Normal 1	1: Middle																			
2: Normal 2	2: Low																			
3: Normal 3	3: Vellum																			
4: Heavy 1	Duplex settings																			
5: Heavy 2	0: Disable																			
6: Heavy 3	1: Enable																			
7: Extra Heavy																				
(56)	Calibration information	Black/Cyan/Magenta/Yellow																		
(57)	RFID information	-																		
(58)	RFID reader/writer version information	-																		
(59)	Toner install mode information	0: Off t: On																		
(60)	Soft version of the optional paper feeder	Paper feeder 2/Paper feeder 3																		
(61)	Version of the optional message	-																		
(62)	Color table version for printer	-																		
(63)	Second's color table version for printer	-																		
(64)	Maintenance information	-																		

Service items	Description																																																																															
	<table border="1" data-bbox="295 286 1422 792"> <thead> <tr> <th data-bbox="300 293 384 331">No.</th> <th data-bbox="389 293 798 331">Description</th> <th colspan="8" data-bbox="802 293 1417 331">Supplement</th> </tr> </thead> <tbody> <tr> <td data-bbox="300 338 384 454">(65)</td> <td data-bbox="389 338 798 454">Altitude</td> <td colspan="8" data-bbox="802 338 1417 454">0: Standard 1: High altitude 1 2: High altitude 2</td> </tr> <tr> <td data-bbox="300 461 384 499">(66)</td> <td data-bbox="389 461 798 499">Charger roller correction</td> <td colspan="8" data-bbox="802 461 1417 499">1 to 5</td> </tr> <tr> <td data-bbox="300 506 384 544">(67)</td> <td data-bbox="389 506 798 544">Drum serial number</td> <td colspan="8" data-bbox="802 506 1417 544">Black/Cyan/Magenta/Yellow</td> </tr> <tr> <td colspan="2" data-bbox="300 551 798 786" style="text-align: center;">Code conversion</td> <td colspan="8" data-bbox="802 551 1417 786"> <table border="1" data-bbox="537 633 1222 730"> <tbody> <tr> <td>A</td><td>B</td><td>C</td><td>D</td><td>E</td><td>F</td><td>G</td><td>H</td><td>I</td><td>J</td> </tr> <tr> <td>0</td><td>1</td><td>2</td><td>3</td><td>4</td><td>5</td><td>6</td><td>7</td><td>8</td><td>9</td> </tr> </tbody> </table> </td> </tr> </tbody> </table>										No.	Description	Supplement								(65)	Altitude	0: Standard 1: High altitude 1 2: High altitude 2								(66)	Charger roller correction	1 to 5								(67)	Drum serial number	Black/Cyan/Magenta/Yellow								Code conversion		<table border="1" data-bbox="537 633 1222 730"> <tbody> <tr> <td>A</td><td>B</td><td>C</td><td>D</td><td>E</td><td>F</td><td>G</td><td>H</td><td>I</td><td>J</td> </tr> <tr> <td>0</td><td>1</td><td>2</td><td>3</td><td>4</td><td>5</td><td>6</td><td>7</td><td>8</td><td>9</td> </tr> </tbody> </table>								A	B	C	D	E	F	G	H	I	J	0	1	2	3	4	5	6	7	8	9
No.	Description	Supplement																																																																														
(65)	Altitude	0: Standard 1: High altitude 1 2: High altitude 2																																																																														
(66)	Charger roller correction	1 to 5																																																																														
(67)	Drum serial number	Black/Cyan/Magenta/Yellow																																																																														
Code conversion		<table border="1" data-bbox="537 633 1222 730"> <tbody> <tr> <td>A</td><td>B</td><td>C</td><td>D</td><td>E</td><td>F</td><td>G</td><td>H</td><td>I</td><td>J</td> </tr> <tr> <td>0</td><td>1</td><td>2</td><td>3</td><td>4</td><td>5</td><td>6</td><td>7</td><td>8</td><td>9</td> </tr> </tbody> </table>								A	B	C	D	E	F	G	H	I	J	0	1	2	3	4	5	6	7	8	9																																																			
A	B	C	D	E	F	G	H	I	J																																																																							
0	1	2	3	4	5	6	7	8	9																																																																							
<b>Network Status</b>	<p data-bbox="389 855 823 884"><b>Printing a status page for network</b></p> <p data-bbox="389 920 539 949"><b>Description</b></p> <p data-bbox="389 956 772 985">Prints a status page for network.</p> <p data-bbox="389 992 497 1021"><b>Purpose</b></p> <p data-bbox="389 1028 992 1057">To acquire the detailed network setting information.</p> <p data-bbox="389 1093 485 1122"><b>Method</b></p> <ol data-bbox="405 1128 1251 1263" style="list-style-type: none"> <li>1. Enter the Service Setting menu.</li> <li>2. Select [Network Status].</li> <li>3. Press the start key.</li> <li>4. Press [Yes] (the Left Select key). Network status page will be printed.</li> </ol> <p data-bbox="389 1299 539 1328"><b>Completion</b></p> <p data-bbox="389 1335 616 1364">Press the stop key.</p>																																																																															



Service items	Description
<p><b>Test Page</b></p>	<p><b>Printing a test page</b></p> <p><b>Description</b> Four colors are printed respectively with halftones of three different levels.</p> <p><b>Purpose</b> To check the activation of the developer and drum units of four colors.</p> <p><b>Method</b></p> <ol style="list-style-type: none"> <li>1. Enter the Service Setting menu.</li> <li>2. Select [Test Page].</li> <li>3. Press the start key.</li> <li>4. Press [Yes] (the Left Select key). Test page will be printed.</li> </ol> <div data-bbox="507 712 1316 1276" style="text-align: center;"> </div> <p>*1: Since focusing in yellow is hardly readable, yellow is mixed with cyan for more readability, resulting in green.</p> <p>*2: Each portion of colors has three different magnitude of halftones (bands). If focus is excessively lost, dots are not recognizable with the 16/256 band, resulting in uneven density. It also results in vertical streaks in the 24/256 and/or 32/256 bands.</p> <p style="text-align: center;"><b>Figure 1-3-19</b></p> <p><b>Completion</b> Press the stop key.</p>

Service items	Description
<b>Developer Setting</b>	<p><b>Entering initial value for replacing the developing unit</b></p> <p><b>Description</b> After replacing the developing unit, enter the initial value (6-digit data) assigned on a label attached to the package or developing unit.</p> <p><b>Purpose</b> To set the initial value after replacing the developing unit.</p> <p><b>Method</b></p> <ol style="list-style-type: none"> <li>1. Enter the Service Setting menu.</li> <li>2. Select [DeveloperSetting].</li> <li>3. Press the start key. Enter the initial value (6-digit data) using the numeric keys.</li> <li>4. Press the start key. The initial value is set.</li> </ol> <div data-bbox="534 784 1289 1288" style="text-align: center;"> <p>The diagram illustrates the location of the initial value label. A label with two QR codes and the alphanumeric string '128F1E' above 'DV560Y' is shown. Two callout lines point from the label to a 'Developing unit' (a long, thin mechanical component) and its 'Package' (a rectangular box). Dashed circles highlight the label on the developing unit and the label on the package.</p> </div> <p><b>Figure 1-3-20</b></p> <p><b>Completion</b> Press the stop key.</p>

Service items	Description
<b>Developer Refresh</b>	<p><b>Performing developer refresh</b></p> <p><b>Description</b> The laser output of the image data for developer refreshing is carried out, and operation to exposure, developing, and primary transfer is performed by 10 pages (paper is not fed).</p> <p><b>Purpose</b> To perform cleaning when faulty images occur and a line appears longitudinally.</p> <p><b>Method</b></p> <ol style="list-style-type: none"> <li>1. Enter the Service Setting menu.</li> <li>2. Select [Developer Refresh].</li> <li>3. Press the start key.</li> <li>4. Press [Yes] (the Left Select key). Developer refresh is performed.</li> </ol> <div data-bbox="651 792 1173 1478" style="text-align: center;"> <p>A4 paper size</p>  <p>33 mm</p> <p>200 mm</p> <p>Toner image on the transfer belt</p> </div> <p><b>Figure 1-3-21</b></p> <p><b>Completion</b> Press the stop key.</p>

Service items	Description
<b>Laser Scanner Cleaning</b>	<p><b>Performing LSU cleaning</b></p> <p><b>Description</b> The LSU cleaning motor drives the cleaning pad which in turn wipes clean the LSU dust shield glass.</p> <p><b>Purpose</b> To perform cleaning when the printed image is bad and stripes are seen in the vertical direction.</p> <p><b>Method</b></p> <ol style="list-style-type: none"> <li>1. Enter the Service Setting menu.</li> <li>2. Select [Laser Scanner Cln].</li> <li>3. Press the start key.</li> <li>4. Press [Yes] (the Left Select key). LSU cleaning is performed.</li> </ol> <p><b>Completion</b> Press the stop key.</p>
<b>Drum surface refreshing</b>	<p><b>Performing drum surface refreshing</b></p> <p><b>Description</b> Rotates the drum approximately 2 minutes with toner lightly on the overall drum. The cleaning blade in the drum unit scrapes toner off the drum surface to clean it.</p> <p><b>Purpose</b> To clean the drum surface when image failure occurs due to the drum. This mode is effective when dew condensation on the drum occurs.</p> <p><b>Method</b></p> <ol style="list-style-type: none"> <li>1. Enter the Service Setting menu.</li> <li>2. Select [Drum Refresh].</li> <li>3. Press the start key.</li> <li>4. Press [Yes] (the Left Select key). Drum surface refreshing is performed.</li> </ol> <p><b>Completion</b> Press the stop key.</p>

Service items	Description
<b>Altitude adjustment</b>	<p><b>Setting altitude adjustment</b></p> <p><b>Description</b> Sets the altitude adjustment mode.</p> <p><b>Purpose</b> Used when print quality deteriorates in an installation at the altitude of 1,500 meters or higher.</p> <p><b>Method</b></p> <ol style="list-style-type: none"> <li>1. Enter the Service Setting menu.</li> <li>2. Select [Altitude Adj].</li> <li>3. Press the start key.</li> <li>4. Select [Normal], [High 1] or [High 2]].</li> <li>5. Press the start key. The setting is set.</li> </ol> <p><b>Completion</b> Press the stop key.</p>
<b>Main charger adjustment</b>	<p><b>Setting main charger output</b></p> <p><b>Description</b> Sets the main charger output. This is executable only when the altitude adjustment mode is set to [Normal].</p> <p><b>Purpose</b> Execute when the image density declines or an offset has occurred.</p> <p><b>Method</b></p> <ol style="list-style-type: none"> <li>1. Enter the Service Setting menu.</li> <li>2. Select [MC].</li> <li>3. Press the start key.</li> <li>4. Select [1], [2] or [3].</li> <li>5. Press the start key. The setting is set.</li> </ol> <p><b>Completion</b> Press the stop key.</p>

Service items	Description																																																																												
<b>FAX country code</b>	<p data-bbox="387 244 628 271"><b>FAX Country Code</b></p> <p data-bbox="387 315 539 342"><b>Description</b> Initializes software switches and all data in the backup data on the FAX control PWB, according to the destination.</p> <p data-bbox="387 421 499 448"><b>Purpose</b> To initialize the FAX control PWB.</p> <p data-bbox="387 526 485 553"><b>Method</b></p> <ol data-bbox="403 560 1011 757" style="list-style-type: none"> <li>1. Enter the Service Setting menu.</li> <li>2. Select [FAX Country Code].</li> <li>3. Press the start key.</li> <li>4. Enter a destination code using the numeric keys.</li> <li>5. Press the start key. The setting is set.</li> <li>6. Press the start key. Data initialization starts.</li> </ol> <p data-bbox="387 801 655 828"><b>Destination code list</b></p> <table border="1" data-bbox="435 840 1385 1749"> <thead> <tr> <th>Code</th> <th>Destination</th> <th>Code</th> <th>Destination</th> </tr> </thead> <tbody> <tr> <td>000</td> <td>Japan</td> <td>253</td> <td>CTR21 (European nations)</td> </tr> <tr> <td>009</td> <td>Australia</td> <td></td> <td>Italy</td> </tr> <tr> <td>038</td> <td>China</td> <td></td> <td>Germany</td> </tr> <tr> <td>080</td> <td>Hong Kong</td> <td></td> <td>Spain</td> </tr> <tr> <td>084</td> <td>Indonesia</td> <td></td> <td>U.K.</td> </tr> <tr> <td>088</td> <td>Israel</td> <td></td> <td>Netherlands</td> </tr> <tr> <td>097</td> <td>Korea</td> <td></td> <td>Sweden</td> </tr> <tr> <td>108</td> <td>Malaysia</td> <td></td> <td>France</td> </tr> <tr> <td>126</td> <td>New Zealand</td> <td></td> <td>Austria</td> </tr> <tr> <td>136</td> <td>Peru</td> <td></td> <td>Switzerland</td> </tr> <tr> <td>137</td> <td>Philippines</td> <td></td> <td>Belgium</td> </tr> <tr> <td>152</td> <td>Middle East</td> <td></td> <td>Denmark</td> </tr> <tr> <td>156</td> <td>Singapore</td> <td></td> <td>Finland</td> </tr> <tr> <td>159</td> <td>South Africa</td> <td></td> <td>Portugal</td> </tr> <tr> <td>169</td> <td>Thailand</td> <td></td> <td>Ireland</td> </tr> <tr> <td>181</td> <td>U.S.A.</td> <td></td> <td>Norway</td> </tr> <tr> <td>242</td> <td>South America</td> <td>254</td> <td>Taiwan</td> </tr> <tr> <td>243</td> <td>Saudi Arabia</td> <td></td> <td></td> </tr> </tbody> </table> <p data-bbox="387 1800 539 1827"><b>Completion</b> Press the stop key.</p>	Code	Destination	Code	Destination	000	Japan	253	CTR21 (European nations)	009	Australia		Italy	038	China		Germany	080	Hong Kong		Spain	084	Indonesia		U.K.	088	Israel		Netherlands	097	Korea		Sweden	108	Malaysia		France	126	New Zealand		Austria	136	Peru		Switzerland	137	Philippines		Belgium	152	Middle East		Denmark	156	Singapore		Finland	159	South Africa		Portugal	169	Thailand		Ireland	181	U.S.A.		Norway	242	South America	254	Taiwan	243	Saudi Arabia		
Code	Destination	Code	Destination																																																																										
000	Japan	253	CTR21 (European nations)																																																																										
009	Australia		Italy																																																																										
038	China		Germany																																																																										
080	Hong Kong		Spain																																																																										
084	Indonesia		U.K.																																																																										
088	Israel		Netherlands																																																																										
097	Korea		Sweden																																																																										
108	Malaysia		France																																																																										
126	New Zealand		Austria																																																																										
136	Peru		Switzerland																																																																										
137	Philippines		Belgium																																																																										
152	Middle East		Denmark																																																																										
156	Singapore		Finland																																																																										
159	South Africa		Portugal																																																																										
169	Thailand		Ireland																																																																										
181	U.S.A.		Norway																																																																										
242	South America	254	Taiwan																																																																										
243	Saudi Arabia																																																																												

Service items	Description								
<b>FAX call Setting</b>	<p><b>FAX call setting</b></p> <p><b>Description</b>  Selects if a fax is to be connected to either a PBX or public switched telephone network.  Selects the mode to connect an outside call when connected to a PBX.  Access code registration for connection to PSTN.</p> <p><b>Purpose</b>  To be executed as required.</p> <p><b>Method</b></p> <ol style="list-style-type: none"> <li>1. Enter the Service Setting menu.</li> <li>2. Select [FAX Call Set.].</li> <li>3. Press the start key.</li> </ol> <table border="1" data-bbox="437 701 1385 893"> <thead> <tr> <th data-bbox="437 701 703 745">Display</th> <th data-bbox="703 701 1385 745">Description</th> </tr> </thead> <tbody> <tr> <td data-bbox="437 745 703 790">Exchange Select.</td> <td data-bbox="703 745 1385 790">Setting the connection to PBX/PSTN</td> </tr> <tr> <td data-bbox="437 790 703 835">PBX Setting</td> <td data-bbox="703 790 1385 835">Setting for a PBX</td> </tr> <tr> <td data-bbox="437 835 703 880">Dial No. to PSTN</td> <td data-bbox="703 835 1385 880">Setting access code to PSTN</td> </tr> </tbody> </table> <p><b>Setting the connection to PBX/PSTN</b></p> <ol style="list-style-type: none"> <li>1. Select [Exchange Select.].</li> <li>2. Press the start key.</li> <li>3. Select [PBX] or [PSTN].</li> <li>4. Press the start key. The setting is set.</li> </ol> <p><b>Setting for PBX</b></p> <ol style="list-style-type: none"> <li>1. Select [PBX Setting].</li> <li>2. Press the start key.</li> <li>3. Select [Loop], [Flash] or [Earth].</li> <li>4. Press the start key. The setting is set.</li> </ol> <p><b>Setting access code to PSTN</b></p> <ol style="list-style-type: none"> <li>1. Select [Dial No. to PSTN].</li> <li>2. Press the start key.</li> <li>3. Enter access code using the numeric keys. (0 to 9, 00 to 99)</li> <li>4. Press the start key. The setting is set.</li> </ol> <p><b>Completion</b>  Press the stop key.</p>	Display	Description	Exchange Select.	Setting the connection to PBX/PSTN	PBX Setting	Setting for a PBX	Dial No. to PSTN	Setting access code to PSTN
Display	Description								
Exchange Select.	Setting the connection to PBX/PSTN								
PBX Setting	Setting for a PBX								
Dial No. to PSTN	Setting access code to PSTN								

Service items	Description
<b>Remote diagnostics</b>	<p data-bbox="389 241 735 275"><b>Setting remote diagnostics</b></p> <p data-bbox="389 311 539 340"><b>Description</b></p> <p data-bbox="389 344 727 374">Sets the remote diagnostics.</p> <p data-bbox="389 383 499 412"><b>Purpose</b></p> <p data-bbox="389 416 1409 479">Used to establish communication between the machine and the service facility when a problem is encountered.</p> <p data-bbox="389 517 488 546"><b>Method</b></p> <ol data-bbox="405 555 1358 898" style="list-style-type: none"><li>1. Enter the Service Setting menu.</li><li>2. Select [Remote Diag.Set.].</li><li>3. Press the start key.</li><li>4. Select [On].</li><li>5. Press the start key. The setting is set.</li><li>6. Select [Remote Diag. ID].</li><li>7. Press the start key.</li><li>8. Enter the prespecified remote diagnostics ID number (0000 to 9999) using the numeric keys.</li><li>9. Press the start key. The setting is set.</li></ol> <p data-bbox="389 936 539 965"><b>Completion</b></p> <p data-bbox="389 969 616 999">Press the stop key.</p>

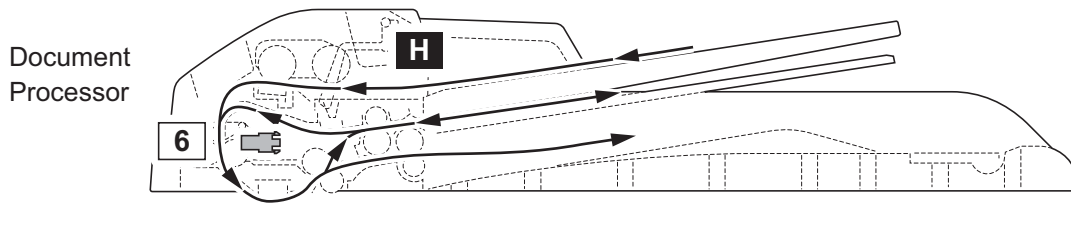


# 1-4-1 Paper misfeed detection

## (1) Paper misfeed indication

When a paper misfeed occurs, the machine immediately stops printing and displays the paper misfeed message on the operation panel. To remove paper misfed in the machine, pull out the cassette, open the rear cover or paper conveying unit.

## (2) Paper misfeed detection condition



Paper jam location	
<b>A</b>	Cassette 1
<b>B</b>	MP tray
<b>C</b>	Machine inside
<b>D</b>	Fuser/Eject sections
<b>E</b>	Duplex section
<b>F</b>	Cassette 2
<b>G</b>	Cassette 3
<b>H</b>	Document processor

Sensors	
<b>1</b>	Registration sensor
<b>2</b>	MP paper conveying sensor
<b>3</b>	Eject sensor
<b>4</b>	PF feed sensor 1
<b>5</b>	PF feed sensor 2
<b>6</b>	DP timing sensor

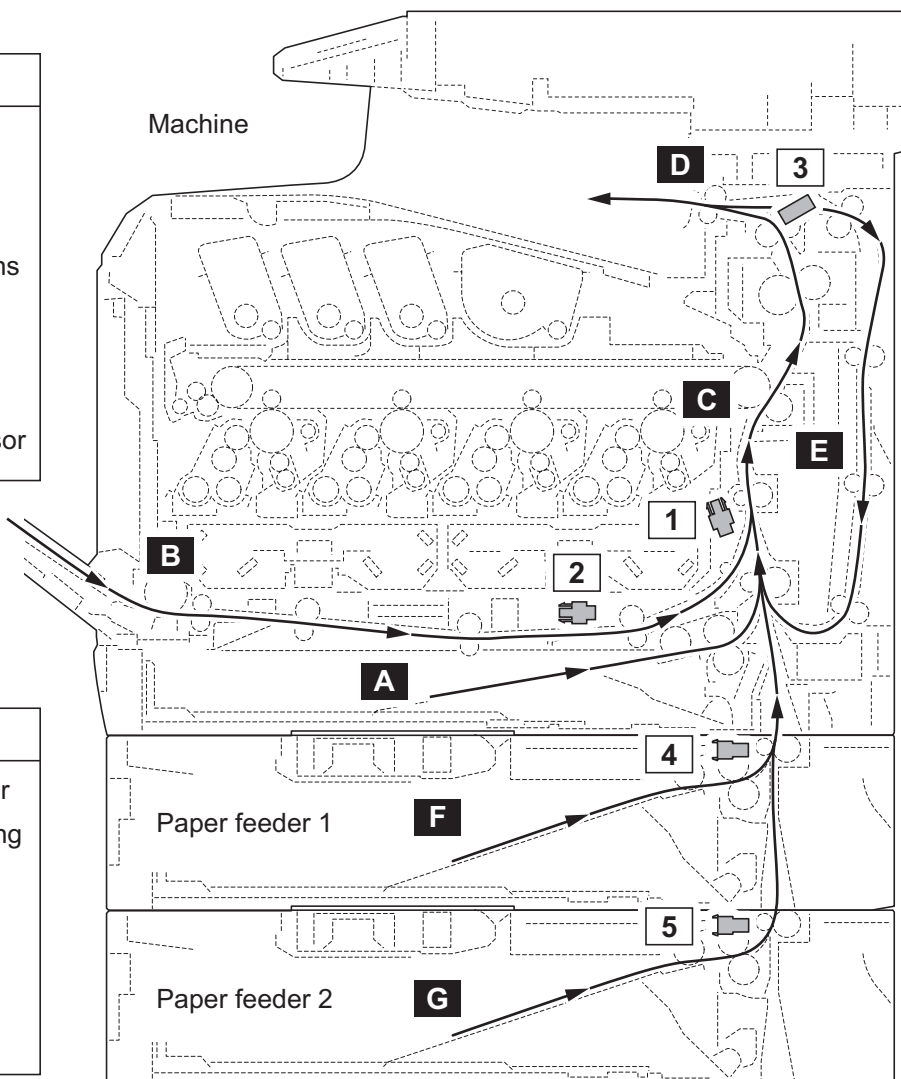


Figure 1-4-1 Paper jam location

Code	Contents	Conditions	Jam location*
0100	Controller sequence error	Secondary paper feed request given by the controller is unreachable.	C
0105	Registration sensor not detected	Activation of the registration sensor (on/off) is undetected for 90 s during printing.	-
0106	Controller sequence error	Paper feeding request for duplex printing given by the controller is unreachable.	E
0110	Inner tray open	The inner tray is opened during printing.	-
0111	Rear cover open	The rear cover is opened during printing.	-
0112	Front cover open	The waste toner cover is opened during printing.	-
0120	Controller sequence error	Paper feed request was received from the duplex section despite the absence of paper in the duplex section.	E
0121	Controller sequence error	The controller issued the duplex section a request for more pages than the duplex print cycle contains.	E
0211	Rear cover open (paper feeder 1)	The rear cover of paper feeder 1 is opened during printing.	-
0212	Rear cover open (paper feeder 2)	The rear cover of paper feeder 2 is opened during printing.	-
0501	No paper feed from cassette 1	The registration sensor (RS) does not turn on during paper feed from cassette.	A
0502	No paper feed from cassette 2	PF feed sensor 1 (PFFS1) does not turn on during paper feed from paper feeder 1.	F
0503	No paper feed from cassette 3	PF feed sensor 2 (PFFS2) does not turn on during paper feed from paper feeder 2.	G
0508	No paper feed from duplex section	The registration sensor (RS) does not turn on during paper feed from duplex section.	E
0509	No paper feed from MP tray	MP paper conveying sensor (MPPCS) does not turn on during paper feed from MP tray.	B
0511	Multiple sheets in cassette 1	The registration sensor (RS) does not turn off during paper feed from cassette.	A
0512	Multiple sheets in cassette 2	PF feed sensor 1 (PFFS1) does not turn off during paper feed from paper feeder 1.	F
0513	Multiple sheets in cassette 3	PF feed sensor 2 (PFFS2) does not turn off during paper feed from paper feeder 2.	G
0518	Multiple sheets in duplex section	The registration sensor (RS) does not turn off during paper feed from duplex section.	E
0519	Multiple sheets in MP tray	MP paper conveying sensor (MPPCS) does not turn off during paper feed from MP tray.	B

\*: Refer to figure 1-4-2 for paper jam location (see page 1-4-1).

Code	Contents	Conditions	Jam location*
1020	MP feed sensor remaining jam	MP feed sensor (MPFS) is turned on when the power is turned on.	B
1403	PF feed sensor 1 non arrival jam	PF feed sensor 1 (PFFS1) does not turn on during paper feed from paper feeder 2.	F
1413	PF feed sensor 1 stay jam	PF feed sensor 1 (PFFS1) does not turn off during paper feed from paper feeder 2.	F
1420	PF feed sensor 1 remaining jam	PF feed sensor 1 (PFFS1) is turned on when the power is turned on.	F
1620	PF feed sensor 2 remaining jam	PF feed sensor 2 (PFFS2) is turned on when the power is turned on.	G
4002	Registration sensor non arrival jam	The registration sensor (RS) does not turn on during paper feed from paper feeder 1.	A
4003		The registration sensor (RS) does not turn on during paper feed from paper feeder 2.	A
4009		The registration sensor (RS) does not turn on during paper feed from MP tray.	A
4012	Registration sensor stay jam	The registration sensor (RS) does not turn off during paper feed from paper feeder 1.	C
4013		The registration sensor (RS) does not turn off during paper feed from paper feeder 2.	C
4019		The registration sensor (RS) does not turn off during paper feed from MP tray.	C
4020	Registration sensor remaining jam	The registration sensor (RS) is turned on when the power is turned on.	C
4201	Eject sensor non arrival jam	The eject sensor (ES) does not turn on during paper feed from cassette.	C
4202		The eject sensor (ES) does not turn on during paper feed from paper feeder 1.	C
4203		The eject sensor (ES) does not turn on during paper feed from paper feeder 2.	C
4208		The eject sensor (ES) does not turn on during paper feed from duplex section.	C
4209		The eject sensor (ES) does not turn on during paper feed from MP tray.	C

\*: Refer to figure 1-4-2 for paper jam location (see page 1-4-1).

Code	Contents	Conditions	Jam location*
4211	Eject sensor stay jam	The eject sensor (ES) does not turn off during paper feed from cassette.	D
4212		The eject sensor (ES) does not turn off during paper feed from paper feeder 1.	D
4213		The eject sensor (ES) does not turn off during paper feed from paper feeder 2.	D
4218		The eject sensor (ES) does not turn off during paper feed from duplex section.	D
4219		The eject sensor (ES) does not turn off during paper feed from MP tray.	D
4220	Eject sensor remaining jam	The eject sensor (ES) is turned on when the power is turned on.	D
9000	No original feed	The DP timing sensor (DPTS) does not turn on within specified time during the first sheet feeding (Retry 5 times).	H
9001	An original jam in the original conveying section	DP timing sensor (DPTS) turns off within the specified time since the sensor turns on.	H
9003	An original jam in the original switchback section 1	During duplex switchback scanning, the DP timing sensor (DPTS) does not turn off within specified time.	H
9004	An original jam in the original switchback section 2	During duplex switchback scanning, the DP timing sensor (DPTS) does not turn on within specified time since original switchback operation starts.	H
9011	DP top cover open	The DP or DP top cover is opened during original feeding.	H
9401	An original jam in the original conveying section	The DP timing sensor (DPTS) does not turn off within specified time of the DP timing sensor (DPTS) turning on.	H

\*: Refer to figure 1-4-2 for paper jam location (see page 1-4-1).

## 1-4-2 Self-diagnostic function

### (1) Self-diagnostic function

This machine is equipped with self-diagnostic function. When a problem is detected, the machine stops printing and display an error message on the operation panel. An error message consists of a message prompting a contact to service personnel and a four-digit error code indicating the type of the error.

### (2) Self diagnostic codes

If the part causing the problem was not supplied, use the unit including the part for replacement.

Code	Contents	Causes	Check procedures/ corrective measures
0030	<b>FAX control PWB system error</b> Processing with the fax software was disabled due to a hardware problem.	Defective FAX control PWB.	Replace the fax control PWB and check for correct operation. (see page 1-5-36).
0070	<b>FAX control PWB incompatible detection error</b> Abnormal detection of FAX control PWB incompatibility In the initial communication with the FAX control PWB, any normal communication command is not transmitted.	Defective FAX software.	Install the fax software.
		Defective FAX control PWB.	Replace the fax control PWB and check for correct operation. (see page 1-5-36).
0100	<b>Backup memory device error</b>	Defective flash memory.	Replace the main PWB and check for correct operation (see page 1-5-30).
		Defective main PWB.	Replace the main PWB and check for correct operation (see page 1-5-30).
0120	<b>MAC address data error</b> For data in which the MAC address is invalid.	Defective flash memory.	Replace the main PWB and check for correct operation (see page 1-5-30).
		Defective engine PWB.	Replace the engine PWB and check for correct operation (see page 1-5-27).
0130	<b>Backup memory read/write error (main PWB)</b>	Defective flash memory.	Replace the main PWB and check for correct operation (see page 1-5-30).
		Defective main PWB.	Replace the main PWB and check for correct operation (see page 1-5-30).

Code	Contents	Causes	Check procedures/ corrective measures
0140	<b>Backup memory data error (main PWB)</b>	Defective flash memory.	Replace the main PWB and check for correct operation (see page 1-5-30).
		Defective main PWB.	Replace the main PWB and check for correct operation (see page 1-5-30).
0150	<b>Engine PWB EEPROM error</b> Detecting engine PWB EEPROM communication error.	Improper installation engine PWB EEPROM.	Check the installation of the EEPROM and remedy if necessary.
		Defective engine PWB.	Replace the engine PWB and check for correct operation (see page 1-5-27).
		Device damage of EEPROM.	Contact the Service Administrative Division.
0170	<b>Billing counting error</b> A checksum error is detected in the main and engine backup memories for the billing counters.	Data damage of EEPROM.	Contact the Service Administrative Division.
		Defective PWB.	Replace the main PWB or the engine PWB and check for correct operation (see page 1-5-30, 1-5-27).
0180	<b>Machine number mismatch</b> Machine number of main and engine does not match.	Data damage of EEPROM.	Contact the Service Administrative Division.
0600	<b>Expanded memory (DIMM) installing error</b> The expansion memory modules (DIMM) are not correctly mounted.	Improper installation expanded memory (DIMM).	Check the installation of the expanded memory (DIMM).

Code	Contents	Causes	Check procedures/ corrective measures
0610	<b>Expanded memory (DIMM) error</b> The expansion memory modules (DIMM) mounted on the main PWB does not operate correctly.	Defective expanded memory (DIMM).	Replace the expanded memory (DIMM) and check for correct operation (see page 1-2-12).
		Defective main PWB.	Replace the main PWB and check for correct operation (see page 1-5-30).
0830	<b>FAX control PWB flash program area checksum error</b> A checksum error occurred with the program of the FAX control PWB.	Defective FAX software.	Install the fax software.
		Defective FAX control PWB.	Replace the FAX control PWB (see page 1-5-36).
0840	<b>Faults of RTC</b> The time is judged to go back based on the comparison of the RTC time and the current time or five years or more have passed.	The battery is disconnected from the main PWB.	Check visually and remedy if necessary
		Defective main PWB.	Replace the main PWB and check for correct operation (see page 1-5-30).
0870	<b>FAX control PWB to main PWB high capacity data transfer error</b> High-capacity data transfer between the FAX control PWB and the main PWB of the machine was not normally performed even if the data transfer was retried the specified times.	Improper installation FAX control PWB.	Reinstall the FAX control PWB (see page 1-5-36).
		Defective FAX control PWB or main PWB.	Replace the FAX control PWB or main PWB and check for correct operation (see page 1-5-36 or 1-5-30).
0920	<b>Fax file system error</b> The backup data is not retained for file system abnormality of flash memory of the FAX control PWB.	Defective FAX control PWB.	Replace the FAX control PWB and check for correct operation (see page 1-5-36).

Code	Contents	Causes	Check procedures/ corrective measures
<b>0930</b>	<b>EEPROM bus error</b>	Defective drum PWB (EEPROM).	Replace the drum unit (see page 1-5-21).
		Defective engine PWB (EEPROM).	Replace the engine PWB and check for correct operation (see page 1-5-27).
		Defective engine PWB.	Replace the engine PWB and check for correct operation (see page 1-5-27).
		Defective main PWB.	Replace the main PWB and check for correct operation (see page 1-5-30).
<b>1010</b>	<b>Lift motor error</b> When the lift motor is driven, the motor over-current detection signal is detected continuously for 50 times (5 s) at 100 ms intervals. After the lift motor is driven, the ON status of lift sensor cannot be detected for 8 s. The cassette installed confirmation message is displayed on the operation panel, and even if the cassette is opened and closed, the cassette installed confirmation message is displayed 5 times successively.	Defective bottom plate elevation mechanism in the cassette.	Check to see if the bottom plate can move smoothly and repair it if any problem is found.
		Defective connector cable or poor contact in the connector.	Reinsert the connector. Also check for continuity within the connector cable. If none, replace the cable.  Lift motor and engine PWB (YC27)
		Defective drive transmission system of the lift motor.	Check if the gears rotate smoothly. If not, grease the bushes and gears. Check for broken gears and replace if any.
		Defective lift motor.	Replace the lift motor
		Defective engine PWB.	Replace the engine PWB and check for correct operation (see page 1-5-27).
		<b>1020</b>	<b>PF lift motor error (paper feeder 1)</b> When the lift motor is driven, the motor over-current detection signal is detected continuously for 50 times (5 s) at 100 ms intervals. After the lift motor is driven, the ON status of lift sensor cannot be detected for 8 s. The cassette installed confirmation message is displayed on the operation panel, and even if the cassette is opened and closed, the cassette installed confirmation message is displayed 5 times successively.
Defective connector cable or poor contact in the connector.	Reinsert the connector. Also check for continuity within the connector cable. If none, replace the cable.  PF lift motor and PF main PWB (YC7)		
Defective drive transmission system of the PF lift motor.	Check if the gears rotate smoothly. If not, grease the bushes and gears. Check for broken gears and replace if any.		
Defective PF lift motor.	Replace the PF lift motor		
Defective PF main PWB.	Replace the PF main PWB (Refer to the service manual for the paper feeder).		



Code	Contents	Causes	Check procedures/ corrective measures
1030	<p><b>PF lift motor error (paper feeder 2)</b> When the lift motor is driven, the motor over-current detection signal is detected continuously for 50 times (5 s) at 100 ms intervals. After the lift motor is driven, the ON status of lift sensor cannot be detected for 8 s. The cassette installed confirmation message is displayed on the operation panel, and even if the cassette is opened and closed, the cassette installed confirmation message is displayed 5 times successively.</p>	Defective bottom plate elevation mechanism in the cassette.	Check to see if the bottom plate can move smoothly and repair it if any problem is found.
		Defective connector cable or poor contact in the connector.	Reinsert the connector. Also check for continuity within the connector cable. If none, replace the cable. PF lift motor and PF main PWB (YC7)
		Defective drive transmission system of the PF lift motor.	Check if the gears rotate smoothly. If not, grease the bushes and gears. Check for broken gears and replace if any.
		Defective PF lift motor.	Replace the PF lift motor
		Defective PF main PWB.	Replace the PF main PWB (Refer to the service manual for the paper feeder).
1500	<p><b>PF heater 1 high temperature error (paper feeder 1)</b> A temperature higher than 75°C/167°F is detected.</p>	Defective connector cable or poor contact in the connector.	Reinsert the connector. Also check for continuity within the connector cable. If none, replace the cable. PF fan motor 1 and PF main PWB (YC111)
		Shorted PF thermistor 1.	Replace the top heater unit (Refer to the service manual for the paper feeder).
		Defective PF fan motor 1.	Replace the top heater unit (Refer to the service manual for the paper feeder).
		Defective PF main PWB.	Replace the PF main PWB (Refer to the service manual for the paper feeder).
1510	<p><b>PF heater 2 high temperature error (paper feeder 1)</b> A temperature higher than 75°C/167°F is detected.</p>	Defective connector cable or poor contact in the connector.	Reinsert the connector. Also check for continuity within the connector cable. If none, replace the cable. PF fan motor 2 and PF main PWB (YC111)
		Shorted PF thermistor 2.	Replace the side heater unit (Refer to the service manual for the paper feeder).
		Defective PF fan motor 2.	Replace the side heater unit (Refer to the service manual for the paper feeder).
		Defective PF main PWB.	Replace the PF main PWB (Refer to the service manual for the paper feeder).

Code	Contents	Causes	Check procedures/ corrective measures
1520	<b>PF heater 1 high temperature error (paper feeder 2)</b> A temperature higher than 75°C/167°F is detected.	Defective connector cable or poor contact in the connector.	Reinsert the connector. Also check for continuity within the connector cable. If none, replace the cable. PF fan motor 1 and PF main PWB (YC111)
		Shorted PF thermistor 1.	Replace the top heater unit (Refer to the service manual for the paper feeder).
		Defective PF fan motor 1.	Replace the top heater unit (Refer to the service manual for the paper feeder).
		Defective PF main PWB.	Replace the PF main PWB (Refer to the service manual for the paper feeder).
1530	<b>PF heater 2 high temperature error (paper feeder 2)</b> A temperature higher than 75°C/167°F is detected.	Defective connector cable or poor contact in the connector.	Reinsert the connector. Also check for continuity within the connector cable. If none, replace the cable. PF fan motor 2 and PF main PWB (YC111)
		Shorted PF thermistor 2.	Replace the side heater unit (Refer to the service manual for the paper feeder).
		Defective PF fan motor 2.	Replace the side heater unit (Refer to the service manual for the paper feeder).
		Defective PF main PWB.	Replace the PF main PWB (Refer to the service manual for the paper feeder).
1600	<b>PF heater 1 low temperature error (paper feeder 1)</b> An external temperature higher than + 5°C/+ 9°F is not detected when one minute elapses after PF heater 1 is turned on.	Defective connector cable or poor contact in the connector.	Reinsert the connector. Also check for continuity within the connector cable. If none, replace the cable. PF heater 1 and PF heater PWB (YC1) PF heater PWB (YC3) and PF main PWB (YC113) PF thermistor 1 and PF main PWB (YC114)
		PF thermistor 1 installed incorrectly.	Check the installation of the PF thermistor 1.
		Defective PF thermistor 1.	Replace the top heater unit (Refer to the service manual for the paper feeder).
		Broken PF heater 1.	Replace the top heater unit (Refer to the service manual for the paper feeder).
		Defective PF heater PWB or PF main PWB.	Replace the PF heater PWB or PF main PWB (Refer to the service manual for the paper feeder).

Code	Contents	Causes	Check procedures/ corrective measures
<b>1610</b>	<b>PF heater 2 low temperature error (paper feeder 1)</b> An external temperature higher than + 5°C/+ 9°F is not detected when one minute elapses after PF heater 2 is turned on.	Defective connector cable or poor contact in the connector.	Reinsert the connector. Also check for continuity within the connector cable. If none, replace the cable. PF heater 2 and PF heater PWB (YC2) PF heater PWB (YC3) and PF main PWB (YC113) PF thermistor 2 and PF main PWB (YC115)
		PF thermistor 2 installed incorrectly.	Check the installation of the PF thermistor 2.
		Defective PF thermistor 2.	Replace the side heater unit (Refer to the service manual for the paper feeder).
		Broken PF heater 2.	Replace the side heater unit (Refer to the service manual for the paper feeder).
		Defective PF heater PWB or PF main PWB.	Replace the PF heater PWB or PF main PWB (Refer to the service manual for the paper feeder).
<b>1620</b>	<b>PF heater 1 low temperature error (paper feeder 2)</b> An external temperature higher than + 5°C/+ 9°F is not detected when one minute elapses after PF heater 1 is turned on.	Defective connector cable or poor contact in the connector.	Reinsert the connector. Also check for continuity within the connector cable. If none, replace the cable. PF heater 1 and PF heater PWB (YC1) PF heater PWB (YC3) and PF main PWB (YC113) PF thermistor 1 and PF main PWB (YC114)
		PF thermistor 1 installed incorrectly.	Check the installation of the PF thermistor 1.
		Defective PF thermistor 1.	Replace the top heater unit (Refer to the service manual for the paper feeder).
		Broken PF heater 1.	Replace the top heater unit (Refer to the service manual for the paper feeder).
		Defective PF heater PWB or PF main PWB.	Replace the PF heater PWB or PF main PWB (Refer to the service manual for the paper feeder).

Code	Contents	Causes	Check procedures/ corrective measures
<b>1630</b> <b>PF heater 2 low temperature error (paper feeder 2)</b> An external temperature higher than + 5°C/+ 9°F is not detected when one minute elapses after PF heater 2 is turned on.		Defective connector cable or poor contact in the connector.	Reinsert the connector. Also check for continuity within the connector cable. If none, replace the cable. PF heater 2 and PF heater PWB (YC2) PF heater PWB (YC3) and PF main PWB (YC113) PF thermistor 2 and PF main PWB (YC115)
		PF thermistor 2 installed incorrectly.	Check the installation of the PF thermistor 2.
		Defective PF thermistor 2.	Replace the side heater unit (Refer to the service manual for the paper feeder).
		Broken PF heater 2.	Replace the side heater unit (Refer to the service manual for the paper feeder).
		Defective PF heater PWB or PF main PWB.	Replace the PF heater PWB or PF main PWB (Refer to the service manual for the paper feeder).
<b>1800</b> <b>Paper feeder communication error</b> Communication error between engine PWB and optional paper feeder.		Improper installation paper feeder.	Follow installation instruction carefully again.
		Defective connector cable or poor contact in the connector.	Reinsert the connector. Also check for continuity within the connector cable. If none, replace the cable. PF main PWB (YC3) and engine PWB (YC33)
		Defective engine PWB.	Replace the engine PWB and check for correct operation (see page 1-5-27).
		Defective PF main PWB.	Replace the PF main PWB (Refer to the service manual for the paper feeder).
<b>2100</b> <b>Developing motor error</b> The developing motor ready input is not given for 5 s during the main motor is ON.		Defective connector cable or poor contact in the connector.	Reinsert the connector. Also check for continuity within the connector cable. If none, replace the cable. Developing motor and engine PWB (YC14)
		Defective drive transmission system of the developing motor.	Check if the rollers and gears rotate smoothly. If not, grease the bushes and gears. Check for broken gears and replace if any.
		Defective developing motor.	Replace the developing motor.
		Defective engine PWB.	Replace the engine PWB and check for correct operation (see page 1-5-27).

Code	Contents	Causes	Check procedures/ corrective measures
<b>2200</b>	<b>Drum motor error</b> The drum motor ready input is not given for 5 s during the drum motor is ON.	Defective connector cable or poor contact in the connector.	Reinsert the connector. Also check for continuity within the connector cable. If none, replace the cable. Drum motor and engine PWB (YC13)
		Defective drive transmission system of the drum motor.	Check if the rollers and gears rotate smoothly. If not, grease the bushes and gears. Check for broken gears and replace if any.
		Defective drum motor.	Replace the drum motor.
		Defective engine PWB.	Replace the engine PWB and check for correct operation (see page 1-5-27).
<b>2330</b>	<b>Fuser pressure release motor error</b> When the fuser pressure release motor is driven, the motor over-current detection signal is detected continuously for 8 times (800 ms) at 100 ms intervals.	Defective connector cable or poor contact in the connector.	Reinsert the connector. Also check for continuity within the connector cable. If none, replace the cable. Fuser pressure release motor and engine PWB (YC38)
		Defective drive transmission system of the fuser pressure release motor.	Check if the rollers and gears rotate smoothly. If not, grease the bushes and gears. Check for broken gears and replace if any.
		Defective fuser pressure release motor.	Replace the fuser pressure release motor.
		Defective engine PWB.	Replace the engine PWB and check for correct operation (see page 1-5-27).
<b>2340</b>	<b>Fuser pressure release motor time-out error</b> When the fuser pressure release motor is driven, the envelope switch (EVS) is not detectable for 6 s.	Defective connector cable or poor contact in the connector.	Reinsert the connector. Also check for continuity within the connector cable. If none, replace the cable. Fuser pressure release motor and engine PWB (YC38)
		Defective drive transmission system of the fuser pressure release motor.	Check if the rollers and gears rotate smoothly. If not, grease the bushes and gears. Check for broken gears and replace if any.
		Defective fuser pressure release motor.	Replace the fuser pressure release motor.
		Defective engine PWB.	Replace the engine PWB and check for correct operation (see page 1-5-27).

Code	Contents	Causes	Check procedures/ corrective measures
2500	<b>Paper feed motor error</b> The drum motor ready input is not given for 5 s during the paper feed motor is ON.	Defective connector cable or poor contact in the connector.	Reinsert the connector. Also check for continuity within the connector cable. If none, replace the cable. Paper feed motor and engine PWB (YC3)
		Defective drive transmission system of the paper feed motor.	Check if the rollers and gears rotate smoothly. If not, grease the bushes and gears. Check for broken gears and replace if any.
		Defective paper feed motor.	Replace the paper feed motor.
		Defective engine PWB.	Replace the engine PWB and check for correct operation (see page 1-5-27).
2600	<b>PF paper feed motor error (paper feeder 1)</b> The drum motor ready input is not given for 2 s during the PF paper feed motor is ON.	Defective connector cable or poor contact in the connector.	Reinsert the connector. Also check for continuity within the connector cable. If none, replace the cable. PF paper feed motor and PF main PWB (YC6)
		Defective drive transmission system of the PF paper feed motor.	Check if the rollers and gears rotate smoothly. If not, grease the bushes and gears. Check for broken gears and replace if any.
		Defective PF paper feed motor.	Replace the PF paper feed motor.
		Defective PF main PWB.	Replace the PF main PWB (Refer to the service manual for the paper feeder).
2610	<b>PF paper feed motor error (paper feeder 2)</b> The drum motor ready input is not given for 2 s during the PF paper feed motor is ON.	Defective connector cable or poor contact in the connector.	Reinsert the connector. Also check for continuity within the connector cable. If none, replace the cable. PF paper feed motor and PF main PWB (YC6)
		Defective drive transmission system of the PF paper feed motor.	Check if the rollers and gears rotate smoothly. If not, grease the bushes and gears. Check for broken gears and replace if any.
		Defective PF paper feed motor.	Replace the PF paper feed motor.
		Defective PF main PWB.	Replace the PF main PWB (Refer to the service manual for the paper feeder).

Code	Contents	Causes	Check procedures/ corrective measures
2730	<b>Developing release motor error</b> When the developing release motor is driven, the motor over-current detection signal is detected continuously for 8 times (800 ms) at 100 ms intervals.	Defective connector cable or poor contact in the connector.	Reinsert the connector. Also check for continuity within the connector cable. If none, replace the cable. Developing release motor and engine PWB (YC35)
		Defective drive transmission system of the developing release motor.	Check if the rollers and gears rotate smoothly. If not, grease the bushes and gears. Check for broken gears and replace if any.
		Defective developing release motor.	Replace the developing release motor.
		Defective engine PWB.	Replace the engine PWB and check for correct operation (see page 1-5-27).
2740	<b>Developing release motor time-out error</b> When the developing release motor is driven, the developing release switch (DEVRSW) is not detectable for 1 s.	Defective connector cable or poor contact in the connector.	Reinsert the connector. Also check for continuity within the connector cable. If none, replace the cable. Developing release motor and engine PWB (YC35)
		Defective drive transmission system of the developing release motor.	Check if the rollers and gears rotate smoothly. If not, grease the bushes and gears. Check for broken gears and replace if any.
		Defective developing release motor.	Replace the developing release motor.
		Defective engine PWB.	Replace the engine PWB and check for correct operation (see page 1-5-27).
2820	<b>Fuser motor error</b> The fuser motor ready input is not given for 5 s during the fuser motor is ON.	Defective connector cable or poor contact in the connector.	Reinsert the connector. Also check for continuity within the connector cable. If none, replace the cable. Fuser motor and engine PWB (YC15)
		Defective drive transmission system of the fuser motor.	Check if the rollers and gears rotate smoothly. If not, grease the bushes and gears. Check for broken gears and replace if any.
		Defective fuser motor.	Replace the fuser motor.
		Defective engine PWB.	Replace the engine PWB and check for correct operation (see page 1-5-27).

Code	Contents	Causes	Check procedures/ corrective measures
3100	<b>ISU home position error</b> The home position is not correct when the power is turned on or at the start of copying using the table.	Defective connector cable or poor contact in the connector.	Reinsert the connector. Also check for continuity within the connector cable. If none, replace the cable. Home position sensor and CCD PWB (YC3) CCD PWB (YC1) and main PWB (YC8) ISU motor and main PWB (YC36)
		Defective home position sensor.	Replace the home position sensor.
		Defective ISU motor.	Replace the ISU motor.
		Defective CCD PWB.	Replace the scanner unit (see page 1-5-48).
		Defective main PWB.	Replace the main PWB and check for correct operation (see page 1-5-30).
3200	<b>Exposure lamp error</b> The exposure lamp does not turn on when power is on. The lamp's lumosity does not stabilize in one minute after power is on.	Defective connector cable or poor contact in the connector.	Reinsert the connector. Also check for continuity within the connector cable. If none, replace the cable. LED PWB and LED driving PWB (YC2) LED driving PWB (YC1) and CCD PWB (YC3) CCD PWB (YC1) and main PWB (YC8)
		Defective LED PWB.	Replace the scanner unit (see page 1-5-48).
		Defective LED driving PWB or CCD PWB.	Replace the scanner unit (see page 1-5-48).
		Defective main PWB.	Replace the main PWB and check for correct operation (see page 1-5-30).

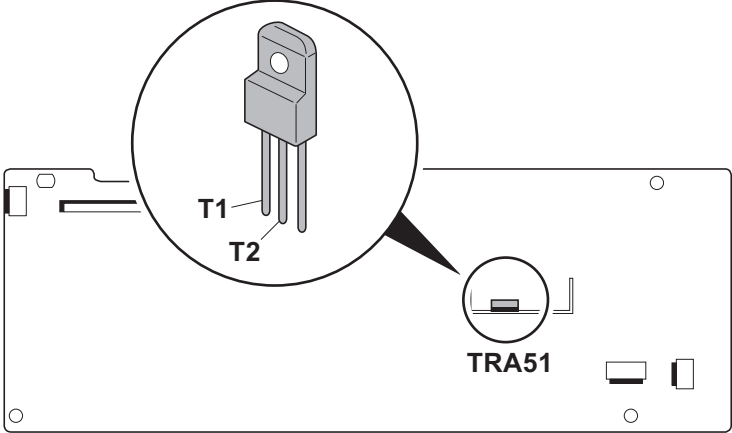


Code	Contents	Causes	Check procedures/ corrective measures
3500	<b>Communication error between scanner and ASIC</b> An error code is detected.	Defective connector cable or poor contact in the connector.	Reinsert the connector. Also check for continuity within the connector cable. If none, replace the cable. CCD PWB (YC1) and main PWB (YC8)
		Defective CCD PWB.	Replace the scanner unit (see page 1-5-48).
		Defective main PWB.	Replace the main PWB and check for correct operation (see page 1-5-30).
4001	<b>Polygon motor KM error</b> The polygon motor KM ready input is not given for 10 s during the polygon motor is ON.	Defective connector cable or poor contact in the connector.	Reinsert the connector. Also check for continuity within the connector cable. If none, replace the cable. Laser scanner unit KM and engine PWB (YC31)
		Defective polygon motor KM.	Replace the laser scanner unit KM (see page 1-5-45).
		Defective engine PWB.	Replace the engine PWB and check for correct operation (see page 1-5-27).
4002	<b>Polygon motor CY error</b> The polygon motor CY ready input is not given for 10 s during the polygon motor is ON.	Defective connector cable or poor contact in the connector.	Reinsert the connector. Also check for continuity within the connector cable. If none, replace the cable. Laser scanner unit CY and engine PWB (YC31)
		Defective polygon motor CY.	Replace the laser scanner unit CY (see page 1-5-45).
		Defective engine PWB.	Replace the engine PWB and check for correct operation (see page 1-5-27).
4201	<b>Laser output error (black)</b> The pin photo signal is not output from PD PWB K for one second while laser is emitted.	Defective connector cable or poor contact in the connector.	Reinsert the connector. Also check for continuity within the connector cable. If none, replace the cable. APC PWB K and engine PWB (YC31)
		Defective APC PWB K.	Replace the laser scanner unit KM (see page 1-5-45).
		Defective PD PWB K.	Replace the laser scanner unit KM (see page 1-5-45).
		Defective engine PWB.	Replace the engine PWB and check for correct operation (see page 1-5-27).

Code	Contents	Causes	Check procedures/ corrective measures
4202	<b>Laser output error (cyan)</b> The pin photo signal is not output from PD PWB C for one second while laser is emitted.	Defective connector cable or poor contact in the connector.	Reinsert the connector. Also check for continuity within the connector cable. If none, replace the cable. APC PWB C and engine PWB (YC32)
		Defective APC PWB C.	Replace the laser scanner unit CY (see page 1-5-45).
		Defective PD PWB C.	Replace the laser scanner unit CY (see page 1-5-45).
		Defective engine PWB.	Replace the engine PWB (see page 1-5-27).
4203	<b>Laser output error (magenta)</b> The pin photo signal is not output from PD PWB M for one second while laser is emitted.	Defective connector cable or poor contact in the connector.	Reinsert the connector. Also check for continuity within the connector cable. If none, replace the cable. APC PWB M and engine PWB (YC31)
		Defective APC PWB M.	Replace the laser scanner unit KM (see page 1-5-45).
		Defective PD PWB M.	Replace the laser scanner unit KM (see page 1-5-45).
		Defective engine PWB.	Replace the engine PWB (see page 1-5-27).
4204	<b>Laser output error (yellow)</b> The pin photo signal is not output from PD PWB Y for one second while laser is emitted.	Defective connector cable or poor contact in the connector.	Reinsert the connector. Also check for continuity within the connector cable. If none, replace the cable. APC PWB Y and engine PWB (YC32)
		Defective APC PWB Y.	Replace the laser scanner unit CY (see page 1-5-45).
		Defective PD PWB Y.	Replace the laser scanner unit CY (see page 1-5-45).
		Defective engine PWB.	Replace the engine PWB (see page 1-5-27).
4600	<b>LSU cleaning motor error</b> When the LSU cleaning motor is driven, the motor over-current detection signal is detected continuously for 50 times (5 s) at 100 ms intervals.	Defective connector cable or poor contact in the connector.	Reinsert the connector. Also check for continuity within the connector cable. If none, replace the cable. LSU cleaning motor and engine PWB (YC36)
		Defective drive transmission system of the LSU cleaning motor.	Check if the rollers and gears rotate smoothly. If not, grease the bushes and gears. Check for broken gears and replace if any.
		Defective LSU cleaning motor.	Replace the LSU cleaning motor.
		Defective engine PWB.	Replace the engine PWB and check for correct operation (see page 1-5-27).

Code	Contents	Causes	Check procedures/ corrective measures
4700	<b>VIDEO ASIC device error</b>	Defective connector cable or poor contact in the connector.	Reinsert the connector. Also check for continuity within the connector cable. If none, replace the cable. Main PWB (YC39) and relay PWB (YC3) Relay PWB (YC2, 4) and engine PWB (YC8, 9)
		Defective main PWB or engine PWB.	Replace the main PWB or the engine PWB and check for correct operation (see page 1-5-30, 1-5-27).
5301	<b>Broken cleaning lamp K wire</b> When the cleaning lamp K is driven, the lamp over-current detection signal is detected continuously for 10 times (1 s) at 100 ms intervals.	Defective connector cable or poor contact in the connector.	Reinsert the connector. Also check for continuity within the connector cable. If none, replace the cable. Drum unit K and Drum relay PWB (YC2) Drum relay PWB (YC1) and engine PWB (YC34)
		Defective cleaning lamp K.	Replace the drum unit K. (see page 1-5-21).
		Defective engine PWB.	Replace the engine PWB and check for correct operation (see page 1-5-27).
5302	<b>Broken cleaning lamp C wire</b> When the cleaning lamp C is driven, the lamp over-current detection signal is detected continuously for 10 times (1 s) at 100 ms intervals.	Defective connector cable or poor contact in the connector.	Reinsert the connector. Also check for continuity within the connector cable. If none, replace the cable. Drum unit C and Drum relay PWB (YC4) Drum relay PWB (YC1) and engine PWB (YC34)
		Defective cleaning lamp C.	Replace the drum unit C. (see page 1-5-21).
		Defective engine PWB.	Replace the engine PWB and check for correct operation (see page 1-5-27).
5303	<b>Broken cleaning lamp M wire</b> When the cleaning lamp M is driven, the lamp over-current detection signal is detected continuously for 10 times (1 s) at 100 ms intervals.	Defective connector cable or poor contact in the connector.	Reinsert the connector. Also check for continuity within the connector cable. If none, replace the cable. Drum unit M and Drum relay PWB (YC3) Drum relay PWB (YC1) and engine PWB (YC34)
		Defective cleaning lamp M.	Replace the drum unit M. (see page 1-5-21).
		Defective engine PWB.	Replace the engine PWB and check for correct operation (see page 1-5-27).

Code	Contents	Causes	Check procedures/ corrective measures
5304	<b>Broken cleaning lamp Y wire</b> When the cleaning lamp Y is driven, the lamp over-current detection signal is detected continuously for 10 times (1 s) at 100 ms intervals.	Defective connector cable or poor contact in the connector.	Reinsert the connector. Also check for continuity within the connector cable. If none, replace the cable. Drum unit Y and Drum relay PWB (YC5) Drum relay PWB (YC1) and engine PWB (YC34)
		Defective cleaning lamp Y.	Replace the drum unit Y. (see page 1-5-21).
		Defective engine PWB.	Replace the engine PWB and check for correct operation (see page 1-5-27).
6000	<b>Broken fuser heater wire</b> The detected temperature of fuser thermistor does not rise 1°C/1.8°F after the fuser heater has been turned on continuously for 10 s in warming up. The fuser temperature does not reach 100°C/212°F after the fuser heater has been turned on continuously for 30 s in warming up. The detected temperature of fuser thermistor does not reach the specified temperature (ready indication temperature) after the fuser heater has been turned on continuously for 60 s in warming up. The detected temperature of fuser thermistor does not rise 1°C/1.8°F after the fuser heater has been turned on continuously for 10 s during printing.	Defective connector cable or poor contact in the connector.	Reinsert the connector. Also check for continuity within the connector cable. If none, replace the cable. Fuser heater and power source PWB (YC102) Fuser unit and eject PWB (YC3) Eject PWB (YC1) and engine PWB (YC19)
		Deformed connector pin.	See page 1-4-21.
		Defective triac.	See page 1-4-21.
		Fuser thermostat triggered.	Reinsert the fuser unit (see page 1-5-26).
		Broken fuser heater wire.	Replace the fuser unit (see page 1-5-26).
		Defective engine PWB.	Replace the engine PWB and check for correct operation (see page 1-5-27).
6020	<b>Abnormally high fuser thermistor temperature</b> The fuser thermistor detects a temperature higher than 240°C/464°F. By the activation of the high temperature error detection circuit (230°C/446°F or more) of fuser thermistor, the illumination of fuser heater was forcibly turned off and 10 s has elapsed.	Deformed connector pin.	See page 1-4-21.
		Defective triac.	See page 1-4-21.
		Shorted fuser thermistor.	Replace the fuser unit (see page 1-5-26).
		Defective engine PWB.	Replace the engine PWB and check for correct operation (see page 1-5-27).

Code	Contents	Causes	Check procedures/ corrective measures
6030	<b>Broken fuser thermistor wire</b> Input from fuser thermistor is 3 or less (A/D value) continuously for 1 s.	Defective connector cable or poor contact in the connector.	Reinsert the connector. Also check for continuity within the connector cable. If none, replace the cable. Fuser unit and eject PWB (YC3) Eject PWB (YC1) and engine PWB (YC19)
		Deformed connector pin.	See page 1-4-21.
		Defective triac.	See page 1-4-21.
		Broken fuser thermistor wire.	Replace the fuser unit (see page 1-5-26).
		Fuser thermostat triggered.	Reinsert the fuser unit (see page 1-5-26).
		Broken fuser heater wire.	Replace the fuser unit (see page 1-5-26).
		Defective engine PWB.	Replace the engine PWB and check for correct operation (see page 1-5-27).
6000/ 6020/ 6030 Combined	<b>Broken fuser heater wire</b> <b>Abnormally high fuser thermistor temperature</b> <b>Broken fuser thermistor wire</b>	Deformed connector pin.	If the I/F connector pins of the fuser unit and the main unit are deformed owing to foreign matters, such as paper dusts, replace the connectors or the units including the connectors.
		Defective triac.	Remove the power cord and check that the resistance between terminals T1 and T2 of the triac TRA51 is of several Mega-Ohms and not shorted (see figure 1-4-4). If failed, replace the power source PWB (see page 1-5-29).
 <p data-bbox="943 1827 1182 1854">Power source PWB</p> <p data-bbox="967 1872 1123 1899"><b>Figure 1-4-2</b></p>			

Code	Contents	Causes	Check procedures/ corrective measures
6400	<b>Zero-cross signal error</b> The zero-cross signal does not reach the engine PWB for more than 1 s.	Defective connector cable or poor contact in the connector.	Reinsert the connector. Also check for continuity within the connector cable. If none, replace the cable. Power source PWB (YC103) and relay PWB (YC1) Relay PWB (YC4) and engine PWB (YC9)
		Defective power source PWB or engine PWB.	Replace the power source PWB or the engine PWB and check for correct operation (see page 1-5-29, 1-5-27).
7001	<b>Toner motor K error</b> When the toner motor K is driven, the motor over-current detection signal is detected continuously for 50 times (5 s) at 100 ms intervals.	Defective connector cable or poor contact in the connector.	Reinsert the connector. Also check for continuity within the connector cable. If none, replace the cable. Toner motor K and engine PWB (YC23)
		Defective drive transmission system of the toner motor K.	Check if the rollers and gears rotate smoothly. If not, grease the bushes and gears. Check for broken gears and replace if any.
		Defective toner motor K.	Replace the toner motor K.
		Defective engine PWB.	Replace the engine PWB and check for correct operation (see page 1-5-27).
7002	<b>Toner motor C error</b> When the toner motor C is driven, the motor over-current detection signal is detected continuously for 50 times (5 s) at 100 ms intervals.	Defective connector cable or poor contact in the connector.	Reinsert the connector. Also check for continuity within the connector cable. If none, replace the cable. Toner motor C and engine PWB (YC25)
		Defective drive transmission system of the toner motor C.	Check if the rollers and gears rotate smoothly. If not, grease the bushes and gears. Check for broken gears and replace if any.
		Defective toner motor C.	Replace the toner motor C.
		Defective engine PWB.	Replace the engine PWB and check for correct operation (see page 1-5-27).
7003	<b>Toner motor M error</b> When the toner motor M is driven, the motor over-current detection signal is detected continuously for 50 times (5 s) at 100 ms intervals.	Defective connector cable or poor contact in the connector.	Reinsert the connector. Also check for continuity within the connector cable. If none, replace the cable. Toner motor M and engine PWB (YC24)
		Defective drive transmission system of the toner motor M.	Check if the rollers and gears rotate smoothly. If not, grease the bushes and gears. Check for broken gears and replace if any.
		Defective toner motor M.	Replace the toner motor M.
		Defective engine PWB.	Replace the engine PWB and check for correct operation (see page 1-5-27).

Code	Contents	Causes	Check procedures/ corrective measures
7004	<b>Toner motor Y error</b> When the toner motor Y is driven, the motor over-current detection signal is detected continuously for 50 times (5 s) at 100 ms intervals.	Defective connector cable or poor contact in the connector.	Reinsert the connector. Also check for continuity within the connector cable. If none, replace the cable. Toner motor Y and engine PWB (YC26)
		Defective drive transmission system of the toner motor Y.	Check if the rollers and gears rotate smoothly. If not, grease the bushes and gears. Check for broken gears and replace if any.
		Defective toner motor Y.	Replace the toner motor Y.
		Defective engine PWB.	Replace the engine PWB and check for correct operation (see page 1-5-27).
7401	<b>Developing unit K non-installing error</b> No density detection signal is output from toner sensor K in developing unit K.	Defective connector cable or poor contact in the connector.	Reinsert the connector. Also check for continuity within the connector cable. If none, replace the cable. Developing unit K and Drum relay PWB (YC6) Drum relay PWB (YC1) and engine PWB (YC34)
		Defective toner sensor K.	Replace the developing unit K (see page 1-5-19).
		Defective engine PWB.	Replace the engine PWB and check for correct operation (see page 1-5-27).
7402	<b>Developing unit C non-installing error</b> No density detection signal is output from toner sensor C in developing unit C.	Defective connector cable or poor contact in the connector.	Reinsert the connector. Also check for continuity within the connector cable. If none, replace the cable. Developing unit C and Drum relay PWB (YC10) Drum relay PWB (YC1) and engine PWB (YC34)
		Defective toner sensor C.	Replace the developing unit C (see page 1-5-19).
		Defective engine PWB.	Replace the engine PWB and check for correct operation (see page 1-5-27).
7403	<b>Developing unit M non-installing error</b> No density detection signal is output from toner sensor M in developing unit M.	Defective connector cable or poor contact in the connector.	Reinsert the connector. Also check for continuity within the connector cable. If none, replace the cable. Developing unit M and Drum relay PWB (YC7) Drum relay PWB (YC1) and engine PWB (YC34)
		Defective toner sensor M.	Replace the developing unit M (see page 1-5-19).
		Defective engine PWB.	Replace the engine PWB and check for correct operation (see page 1-5-27).

Code	Contents	Causes	Check procedures/ corrective measures
7404	<b>Developing unit Y non-installing error</b> No density detection signal is output from toner sensor Y in developing unit Y.	Defective connector cable or poor contact in the connector.	Reinsert the connector. Also check for continuity within the connector cable. If none, replace the cable. Developing unit Y and Drum relay PWB (YC13) Drum relay PWB (YC1) and engine PWB (YC34)
		Defective toner sensor Y.	Replace the developing unit Y (see page 1-5-19).
		Defective engine PWB.	Replace the engine PWB and check for correct operation (see page 1-5-27).
7411	<b>Drum unit K non-installing error</b> The EEPROM of drum PWB K does not communicate normally.	Installation of incompatible drum unit K.	Install drum unit K compatible with the specifications to the machine.
		Defective connector cable or poor contact in the connector.	Reinsert the connector. Also check for continuity within the connector cable. If none, replace the cable. Drum unit K and Drum relay PWB (YC2) Drum relay PWB (YC1) and engine PWB (YC34)
		Defective drum PWB K.	Replace the drum unit K (see page 1-5-21).
		Defective engine PWB.	Replace the engine PWB and check for correct operation (see page 1-5-27).
7412	<b>Drum unit C non-installing error</b> The EEPROM of drum PWB C does not communicate normally.	Installation of incompatible drum unit C.	Install drum unit C compatible with the specifications to the machine.
		Defective connector cable or poor contact in the connector.	Reinsert the connector. Also check for continuity within the connector cable. If none, replace the cable. Drum unit C and Drum relay PWB (YC4) Drum relay PWB (YC1) and engine PWB (YC34)
		Defective drum PWB C.	Replace the drum unit C (see page 1-5-21).
		Defective engine PWB.	Replace the engine PWB and check for correct operation (see page 1-5-27).



Code	Contents	Causes	Check procedures/ corrective measures
7413	<b>Drum unit M non- installing error</b> The EEPROM of drum PWB M does not communicate normally.	Installation of incompatible drum unit M.	Install drum unit M compatible with the specifications to the machine.
		Defective connector cable or poor contact in the connector.	Reinsert the connector. Also check for continuity within the connector cable. If none, replace the cable. Drum unit M and Drum relay PWB (YC3) Drum relay PWB (YC1) and engine PWB (YC34)
		Defective drum PWB M.	Replace the drum unit M (see page 1-5-21).
		Defective engine PWB.	Replace the engine PWB and check for correct operation (see page 1-5-27).
7414	<b>Drum unit Y non- installing error</b> The EEPROM of drum PWB Y does not communicate normally.	Installation of incompatible drum unit Y.	Install drum unit Y compatible with the specifications to the machine.
		Defective connector cable or poor contact in the connector.	Reinsert the connector. Also check for continuity within the connector cable. If none, replace the cable. Drum unit Y and Drum relay PWB (YC5) Drum relay PWB (YC1) and engine PWB (YC34)
		Defective drum PWB Y.	Replace the drum unit Y (see page 1-5-21).
		Defective engine PWB.	Replace the engine PWB and check for correct operation (see page 1-5-27).
9500			Contact the Service Administrative Division.
9510			
9520			
9530	<b>Backup data error</b> The serial number of the machine written on the EEPROM of the engine PWB differs with that is written on both the flash memory of the engine PWB and the EEPROM of the drum PWB as a backup.	Replacing both the engine PWB and the drum unit at the same time.	Check that the machine operates properly by reverting the engine controller and the drum unit to the old ones. To replace the engine PWB and the drum unit at the same time, turn on the machine after replacing either one. Check that the machine operates properly and then turn off the machine. Replace the other and turn on the machine to check that the machine operates properly. Be sure to replace one by one.

<b>Code</b>	<b>Contents</b>	<b>Causes</b>	<b>Check procedures/ corrective measures</b>
<b>F000</b>	<b>Main PWB - operation panel PWB communication error</b>	Defective main PWB.	Turn the main power switch off/on to restart the machine. If the error is not resolved, replace main PWB (see page 1-5-30).
		Defective operation panel PWB.	Replace the operation panel PWB and check for correct operation.
<b>F010</b>	<b>Main PWB checksum error</b>	Defective main PWB.	Turn the main power switch off/on to restart the machine. If the error is not resolved, replace main PWB (see page 1-5-30).
<b>F020</b>	<b>Main PWB RAM checksum error</b>	Defective main memory (RAM) on the main PWB.	Turn the main power switch off/on to restart the machine. If the error is not resolved, replace main PWB (see page 1-5-30).
		Defective expanded memory (DIMM).	Replace the expanded memory (DIMM) (see page 1-2-12).
<b>F040</b>	<b>Main PWB - print engine communication error</b>	Defective main PWB.	Turn the main power switch off/on to restart the machine. If the error is not resolved, replace main PWB (see page 1-5-30).
			Replace the engine PWB and check for correct operation (see page 1-5-27).
<b>F041</b>	<b>Main PWB - scanner engine communication error</b>	Defective main PWB.	Turn the main power switch off/on to restart the machine. If the error is not resolved, replace main PWB (see page 1-5-30).
<b>F050</b>	<b>Print engine ROM checksum error</b>	Defective engine PWB.	Turn the main power switch off/on to restart the machine. If the error is not resolved, replace engine PWB (see page 1-5-27).
<b>F051</b>	<b>Scanner engine ROM checksum error</b>	Defective engine PWB.	Turn the main power switch off/on to restart the machine. If the error is not resolved, replace engine PWB (see page 1-5-27).
<b>F278</b>	<b>Power supply in drive system error</b>	Main power switch was turned off without using the power key, or a power failure has occurred.	Turn on power. (To switch off power, first press the power key until the main power indicator goes off, then turn the main power switch off.)

## 1-4-3 Image formation problems

If the part causing the problem was not supplied, use the unit including the part for replacement.

(1) No image appears (entirely white).



See page 1-4-28

(2) No image appears (entirely black).



See page 1-4-28

(3) A specific color is printed solid.



See page 1-4-29

(4) The back side gets dirty.



See page 1-4-29

(5) Image is too light.



See page 1-4-29

(6) The background is colored.



See page 1-4-30

(7) White streaks are printed vertically.



See page 1-4-30

(8) Black streaks are printed vertically.



See page 1-4-30

(9) Streaks are printed horizontally.



See page 1-4-31

(10) Spots are printed.



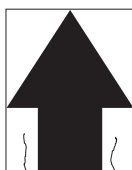
See page 1-4-31

(11) The leading edge of image begins to print too early or too late.



See page 1-4-31

(12) Paper is wrinkled.



See page 1-4-31

(13) Offset occurs.



See page 1-4-32

(14) Part of image is missing.



See page 1-4-32

(15) Fusing is loose.



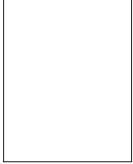
See page 1-4-32

(16) Colors are printed offset to each other.




See page 1-4-33


**(1) No image appears (entirely white).**

Print example	Causes		Check procedures/corrective measures
	Defective transfer bias output.	Defective connector cable or poor contact in the connector.	Reinsert the connector. Also check for continuity within the connector cable. If none, replace the cable. High voltage PWB and engine PWB (YC11)
		Defective high voltage PWB.	Replace the high voltage PWB (see page 1-5-35).
		Defective engine PWB.	Replace the engine PWB (see page 1-5-27).
	Defective developing bias output.	Defective connector cable or poor contact in the connector.	Reinsert the connector. Also check for continuity within the connector cable. If none, replace the cable. High voltage PWB and engine PWB (YC11)
		Defective high voltage PWB.	Replace the high voltage PWB (see page 1-5-35).
		Defective engine PWB.	Replace the engine PWB (see page 1-5-27).
	No LSU laser is output.	Defective laser scanner unit.	Replace the laser scanner unit KM/CY (see page 1-5-45).
		Defective engine PWB.	Replace the engine PWB (see page 1-5-27).

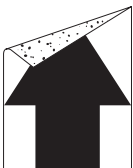
**(2) No image appears (entirely black).**

Print example	Causes		Check procedures/corrective measures
	No main charging.	Defective connector cable or poor contact in the connector.	Reinsert the connector. Also check for continuity within the connector cable. If none, replace the cable. High voltage PWB and engine PWB (YC11)
		Defective charger roller unit.	Replace the drum unit (see page 1-5-21).
		Defective high voltage PWB.	Replace the high voltage PWB (see page 1-5-35).
		Defective engine PWB.	Replace the engine PWB (see page 1-5-27).
	Exposure lamp fails to light.	Defective connector cable or poor contact in the connector.	Reinsert the connector. Also check for continuity within the connector cable. If none, replace the cable. Exposure lamp and inverter PWB (CN2) Inverter PWB (CN1) and CCD PWB (YC3) CCD PWB (YC1) and main PWB (YC8)
		Defective inverter PWB or CCD PWB.	Replace the scanner unit (see page 1-5-48).
		Defective main PWB.	Replace the main PWB (see page 1-5-30).
	The laser is activated simultaneously for all colors.	Defective laser scanner unit.	Replace the laser scanner unit KM/CY (see page 1-5-45).

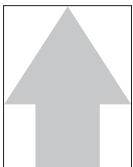
**(3) A specific color is printed solid.**

Print example	Causes	Check procedures/corrective measures
	Defective charger roller unit which corresponds to the color causing the problem.	Replace the drum unit for the color that causes an error (see page 1-5-21).
	Laser of laser scanner unit for solid color printing is ON. Defective laser scanner unit.	Replace the laser scanner unit KM/CY (see page 1-5-45).

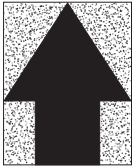
**(4) The back side gets dirty.**

Print example	Causes	Check procedures/corrective measures
	Dirty secondary transfer roller.	Clean the secondary transfer roller.
	Dirty paper conveying path.	Clean the paper conveying path.
	Dirty heat roller and press roller.	Clean the heat roller and press roller.


**(5) Image is too light.**

Print example	Causes		Check procedures/corrective measures
	Defective developing bias output.	Defective developing unit.	Replace the developing unit for the color that causes an error (see page 1-5-19).
		Defective high voltage PWB.	Replace the high voltage PWB (see page 1-5-35).
		Defective engine PWB.	Replace the engine PWB (see page 1-5-27).
	Defective drum unit.		Decrease the surface potential by performing the main charger adjustment (see page 1-3-89). When the problem is not cleared, replace the drum unit (see page 1-5-21).
	Defective transfer bias output.	Defective high voltage PWB.	Replace the high voltage PWB (see page 1-5-35).
		Defective engine PWB.	Replace the engine (see page 1-5-27).
	Defective color calibration.		Perform the color calibration (Refer to operation guide).
	Insufficient toner.		If the display shows the message requesting toner replenishment, replace the container.
	Insufficient agitation of toner container.		Shake the toner container vertically approximately 10 times.
Paper damp.		Check the paper storage conditions, replace the paper.	

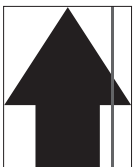
**(6) The background is colored.**

Print example	Causes		Check procedures/corrective measures
	Defective color calibration.		Perform the color calibration (Refer to operation guide).
	Defective developing bias output.	Defective developing unit.	Replace the developing unit for the color that causes an error (see page 1-5-19).
		Defective high voltage PWB.	Replace the high voltage PWB (see page 1-5-35).
		Defective engine PWB.	Replace the engine PWB (see page 1-5-27).
	Defective drum surface charging.	Defective drum unit.	Replace the drum unit (see page 1-5-21).
		Defective high voltage PWB.	Replace the high voltage PWB (see page 1-5-35).
		Defective engine PWB.	Replace the engine PWB (see page 1-5-27).

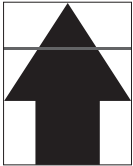
**(7) White streaks are printed vertically.**

Print example	Causes	Check procedures/corrective measures
	Foreign object in one of the developing units.	Replace the developing unit for the color that causes an error (see page 1-5-19).
	Adhesion of soiling to transfer belt.	Clean the transfer belt. Replace the intermediate transfer unit if it is extremely dirty (see page 1-5-22).
	Adhesion of soiling to transfer roller.	Clean the transfer roller. Replace the transfer roller if it is extremely dirty (see page 1-5-25).
	Dirty LSU dust shield glass.	Perform the LSU dust shield glass cleaning.


**(8) Black streaks are printed vertically.**

Print example	Causes	Check procedures/corrective measures
	Dirty contact glass.	Clean the contact glass.
	Dirty slit glass.	Clean the slit glass.
	Dirty or flawed drum.	Perform the drum surface refreshing (see page 1-3-88). Flawed drum. Replace the drum unit (see page 1-5-21).
	Deformed or worn cleaning blade in the drum unit.	Replace the drum unit (see page 1-5-21).
	Worn primary transfer belt.	Replace the intermediate transfer unit (see page 1-5-22).
	Defective transfer roller.	Replace the transfer roller (see page 1-5-25).

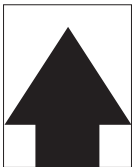
**(9) Streaks are printed horizontally.**

Print example	Causes	Check procedures/corrective measures
	Dirty or flawed drum.	Perform the drum surface refreshing (see page 1-3-88). Flawed drum. Replace the drum unit (see page 1-5-21).
	Dirty developing section.	Clean any part contaminated with toner in the developing section.
	Poor contact of grounding terminal of drum unit.	Check the installation of the drum unit. If it operates incorrectly, replace it (see page 1-5-21).

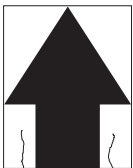
**(10) Spots are printed.**

Print example	Causes	Check procedures/corrective measures
	Dirty contact glass.	Clean the contact glass.
	Dirty or flawed drum.	Perform the drum surface refreshing (see page 1-3-88). Flawed drum. Replace the drum unit (see page 1-5-21).
	Deformed or worn cleaning blade in the drum unit.	Replace the drum unit (see page 1-5-21).
	Flawed developing roller.	Replace the developing unit (see page 1-5-19).
	Dirty heat roller and press roller.	Clean the heat roller and press roller.

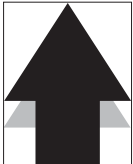
**(11) The leading edge of image begins to print too early or too late.**

Print example	Causes	Check procedures/corrective measures
	Paper feed clutch or registration clutch operating incorrectly.	Check the installation of the clutch. If it operates incorrectly, replace it.


**(12) Paper is wrinkled.**

Print example	Causes	Check procedures/corrective measures
	Paper curled.	Check the paper storage conditions.
	Paper damp.	Check the paper storage conditions.

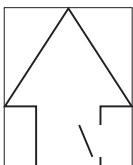
**(13) Offset occurs.**

Print example	Causes	Check procedures/corrective measures
	Defective drum surface charging.	Perform the drum surface refreshing (see page 1-3-88). When the problem is not cleared, increase the surface potential by performing the main charger adjustment (see page 1-3-89).
	Deformed or worn cleaning blade in the drum unit.	Replace the drum unit (see page 1-5-21).
	Defective transfer belt cleaning.	Replace the intermediate transfer unit (see page 1-5-22).
	Defective fuser unit.	Replace the fuser unit (see page 1-5-26).
	Wrong types of paper.	Check if the paper meets specifications. Replace paper.

**(14) Part of image is missing.**

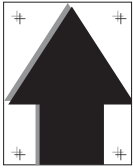
Print example	Causes	Check procedures/corrective measures
	Paper damp.	Check the paper storage conditions.
	Paper creased.	Replace the paper.
	Drum condensation.	Perform the drum surface refreshing (see page 1-3-88).
	Dirty or flawed drum.	Perform the drum surface refreshing (see page 1-3-88). Flawed drum. Replace the drum unit (see page 1-5-21).
	Dirty transfer belt.	Clean the transfer belt. Replace the intermediate transfer unit if it is extremely dirty (see page 1-5-22).
	Dirty transfer roller.	Clean the transfer roller. Replace the transfer roller if it is extremely dirty (see page 1-5-25).

**(15) Fusing is loose.**

Print example	Causes	Check procedures/corrective measures
	Wrong types of paper.	Check if the paper meets specifications, replace paper.
	Flawed heat roller or press roller.	Replace the fuser unit (see page 1-5-26).



**(16) Colors are printed offset to each other.**

<b>Print example</b>	<b>Causes</b>	<b>Check procedures/corrective measures</b>
	Defective color calibration.	Perform the color calibration (refer to operation guide).
	Slip the mirror position of laser scanner unit.	Perform the normal color registration. When the problem is not cleared, perform the detail color registration adjustment (refer to operation guide).

## 1-4-4 Electric problems

If the part causing the problem was not supplied, use the unit including the part for replacement. Troubleshooting to each failure must be in the order of the numbered symptoms.

Problem	Causes	Check procedures/corrective measures
(1) The machine does not operate when the main power switch is turned on.	1. No electricity at the power outlet.	Measure the input voltage.
	2. The power cord is not plugged in properly.	Check the contact between the power plug and the outlet.
	3. The inner tray is not closed completely.	Check the inner tray.
	4. Broken power cord.	Check for continuity. If none, replace the cord.
	5. Defective main power switch.	Check for continuity across the contacts. If none, replace the power source PWB (see page 1-5-29).
	6. Defective interlock switch.	Check for continuity across the contacts of interlock switch. If none, replace the power source PWB (see page 1-5-29).
	7. Defective power source PWB.	Replace the power source PWB (see page 1-5-29).
(2) Duplex motor does not operate.	1. Defective connector cable or poor contact in the connector.	Reinsert the connector. Also check for continuity within the connector cable. If none, replace the cable. Duplex motor and engine PWB (YC37)
	2. Defective drive transmission system.	Check if the rollers and gears rotate smoothly. If not, grease the bushes and gears. Check for broken gears and replace if any.
	3. Defective motor.	Replace the duplex motor.
	4. Defective PWB.	Replace the engine PWB and check for correct operation (see page 1-5-27).
(3) Right fan motor does not operate.	1. Defective connector cable or poor contact in the connector.	Reinsert the connector. Also check for continuity within the connector cable. If none, replace the cable. Right fan motor and main PWB (YC42)
	2. Defective motor.	Replace the right fan motor.
	3. Defective PWB.	Replace the main PWB and check for correct operation (see page 1-5-30).
(4) Left fan motor does not operate.	1. Defective connector cable or poor contact in the connector.	Reinsert the connector. Also check for continuity within the connector cable. If none, replace the cable. Left fan motor and engine PWB (YC29)
	2. Defective motor.	Replace the left fan motor.
	3. Defective PWB.	Replace the engine PWB and check for correct operation (see page 1-5-27).

<b>Problem</b>	<b>Causes</b>	<b>Check procedures/corrective measures</b>
(5) Controller fan motor does not operate.	1. Defective connector cable or poor contact in the connector.	Reinsert the connector. Also check for continuity within the connector cable. If none, replace the cable. Controller fan motor and main PWB (YC41)
	2. Defective motor.	Replace the controller fan motor.
	3. Defective PWB.	Replace the main PWB and check for correct operation (see page 1-5-30).
(6) Fuser fan motor does not operate.	1. Defective connector cable or poor contact in the connector.	Reinsert the connector. Also check for continuity within the connector cable. If none, replace the cable. Fuser fan motor and engine PWB (YC40)
	2. Defective motor.	Replace the fuser fan motor.
	3. Defective PWB.	Replace the engine PWB and check for correct operation (see page 1-5-27).
(7) Container fan motor does not operate.	1. Defective connector cable or poor contact in the connector.	Reinsert the connector. Also check for continuity within the connector cable. If none, replace the cable. Container fan motor and engine PWB (YC28)
	2. Defective motor.	Replace the container fan motor.
	3. Defective PWB.	Replace the engine PWB and check for correct operation (see page 1-5-27).
(8) ISU motor does not operate.	1. Defective connector cable or poor contact in the connector.	Reinsert the connector. Also check for continuity within the connector cable. If none, replace the cable. ISU motor and main PWB (YC36)
	2. Defective drive transmission system.	Check if the rollers and gears rotate smoothly. If not, grease the bushes and gears. Check for broken gears and replace if any.
	3. Defective motor.	Replace the ISU motor.
	4. Defective PWB.	Replace the main PWB and check for correct operation (see page 1-5-30).
(9) Paper feed clutch does not operate.	1. Defective connector cable or poor contact in the connector.	Reinsert the connector. Also check for continuity within the connector cable. If none, replace the cable. Paper feed clutch and engine PWB (YC3)
	2. Defective clutch.	Replace the paper feed clutch.
	3. Defective PWB.	Replace the engine PWB and check for correct operation (see page 1-5-27).
(10) MP feed clutch does not operate.	1. Defective connector cable or poor contact in the connector.	Reinsert the connector. Also check for continuity within the connector cable. If none, replace the cable. MP feed clutch and engine PWB (YC3)
	2. Defective clutch.	Replace the MP feed clutch.
	3. Defective PWB.	Replace the engine PWB and check for correct operation (see page 1-5-27).

<b>Problem</b>	<b>Causes</b>	<b>Check procedures/corrective measures</b>
(11) Registration clutch does not operate.	1. Defective connector cable or poor contact in the connector.	Reinsert the connector. Also check for continuity within the connector cable. If none, replace the cable. Registration clutch and engine PWB (YC3)
	2. Defective clutch.	Replace the registration clutch.
	3. Defective PWB.	Replace the engine PWB and check for correct operation (see page 1-5-27).
(12) Middle clutch does not operate.	1. Defective connector cable or poor contact in the connector.	Reinsert the connector. Also check for continuity within the connector cable. If none, replace the cable. Middle clutch and engine PWB (YC3)
	2. Defective clutch.	Replace the middle clutch.
	3. Defective PWB.	Replace the engine PWB and check for correct operation (see page 1-5-27).
(13) MP solenoid does not operate.	1. Defective connector cable or poor contact in the connector.	Reinsert the connector. Also check for continuity within the connector cable. If none, replace the cable. MP solenoid and engine PWB (YC4)
	2. Defective solenoid.	Replace the MP solenoid.
	3. Defective PWB.	Replace the engine PWB and check for correct operation (see page 1-5-27).
(14) The message requesting paper to be loaded is shown when paper is present on the cassette.	1. Defective connector cable or poor contact in the connector.	Reinsert the connector. Also check for continuity within the connector cable. If none, replace the cable. Cassette PWB (YC1) and engine PWB (YC21)
	2. Deformed actuator of the paper sensor.	Check visually and replace if necessary.
	3. Defective paper sensor.	Replace the cassette PWB.
	4. Defective PWB.	Replace the engine PWB and check for correct operation (see page 1-5-27).
(15) The message requesting paper to be loaded is shown when paper is present on the MP tray.	1. Defective connector cable or poor contact in the connector.	Reinsert the connector. Also check for continuity within the connector cable. If none, replace the cable. MP paper sensor and engine PWB (YC16)
	2. Deformed actuator of the MP paper sensor.	Check visually and replace if necessary.
	3. Defective MP paper sensor.	Replace the MP paper sensor.
	4. Defective PWB.	Replace the engine PWB and check for correct operation (see page 1-5-27).
(16) The size of paper on the cassette is not displayed correctly.	1. Defective connector cable or poor contact in the connector.	Reinsert the connector. Also check for continuity within the connector cable. If none, replace the cable. Cassette size switch and engine PWB (YC17)
	2. Defective cassette size switch.	Replace the cassette size switch.
	3. Defective PWB.	Replace the engine PWB and check for correct operation (see page 1-5-27).

<b>Problem</b>	<b>Causes</b>	<b>Check procedures/corrective measures</b>
(17) A paper jam in the paper feed, paper conveying or eject section is indicated when the main power switch is turned on.	1. A piece of paper torn from paper is caught around registration sensor, MP paper conveying sensor or eject sensor.	Check visually and remove it, if any.
	2. Defective registration sensor.	Replace the registration sensor.
	3. Defective MP paper conveying sensor.	Replace the MP paper conveying sensor.
	4. Defective eject sensor.	Replace the eject PWB.
(18) A message indicating cover open is displayed when the inner tray or rear cover is closed.	1. Deformed actuator of the interlock switch.	Check visually and replace if necessary.
	2. Defective interlock switch.	Replace the interlock switch.
(19) DP paper feed motor does not operate.	1. Defective connector cable or poor contact in the connector.	Reinsert the connector. Also check for continuity within the connector cable. If none, replace the cable. DP paper feed motor and DP drive PWB (YC3) DP drive PWB (YC1) and main PWB (YC32)
	2. Defective drive transmission system.	Check if the rollers and gears rotate smoothly. If not, grease the bushes and gears. Check for broken gears and replace if any.
	3. Defective motor.	Replace the DP paper feed motor.
	4. Defective PWB.	Replace the DP drive PWB or main PWB and check for correct operation (see page 1-5-87, 1-5-30).
(20) DP paper feed clutch does not operate.	1. Defective connector cable or poor contact in the connector.	Reinsert the connector. Also check for continuity within the connector cable. If none, replace the cable. DP paper feed clutch and DP drive PWB (YC6) DP drive PWB (YC8) and main PWB (YC32)
	2. Defective clutch.	Replace the DP paper feed clutch.
	3. Defective PWB.	Replace the DP drive PWB or main PWB and check for correct operation (see page 1-5-87, 1-5-30).
(21) DP pressure solenoid does not operate.	1. Defective connector cable or poor contact in the connector.	Reinsert the connector. Also check for continuity within the connector cable. If none, replace the cable. DP pressure solenoid and DP drive PWB (YC4) DP drive PWB (YC8) and main PWB (YC32)
	2. Defective solenoid.	Replace the DP pressure solenoid.
	3. Defective PWB.	Replace the DP drive PWB or main PWB and check for correct operation (see page 1-5-87, 1-5-30).

<b>Problem</b>	<b>Causes</b>	<b>Check procedures/corrective measures</b>
(22) DP switchback solenoid does not operate.	1. Defective connector cable or poor contact in the connector.	Reinsert the connector. Also check for continuity within the connector cable. If none, replace the cable. DP switchback solenoid and DP drive PWB (YC5) DP drive PWB (YC8) and main PWB (YC32)
	2. Defective solenoid.	Replace the DP switchback solenoid.
	3. Defective PWB.	Replace the DP drive PWB or main PWB and check for correct operation (see page 1-5-87, 1-5-30).
(23) An original jams when the main power switch is turned on.	1. A piece of paper torn from an original is caught around the DP timing sensor.	Check visually and remove it, if any.
	2. Defective DP timing sensor.	Replace the DP timing sensor.
(24) A message indicating cover open is displayed when the DP top cover is closed.	1. Defective connector cable or poor contact in the connector.	Reinsert the connector. Also check for continuity within the connector cable. If none, replace the cable. DP open/close sensor and DP drive PWB (YC2) DP drive PWB (YC8) and main PWB (YC32)
	2. Defective DP open/close sensor.	Replace the DP open/close sensor.

## 1-4-5 Mechanical problems

If the part causing the problem was not supplied, use the unit including the part for replacement.

Problem	Causes/check procedures	Corrective measures
(1) No primary paper feed.	Check if the surfaces of the following rollers are dirty with paper powder. Pickup roller Paper feed roller MP paper feed roller	Clean with isopropyl alcohol.
	Check if the following rollers is deformed. Pickup roller Paper feed roller MP paper feed roller	Check visually and replace any deformed (see page 1-5-15, 1-5-17).
	Defective paper feed clutch installation.	Check visually and remedy if necessary.
(2) No secondary paper feed.	Check if the surfaces of the following rollers are dirty with paper powder. Front registration roller Rear registration roller	Clean with isopropyl alcohol.
	Defective registration clutch installation.	Check visually and remedy if necessary.
(3) Skewed paper feed.	Paper width guide in a cassette installed incorrectly.	Check the paper width guide visually and remedy or replace if necessary.
(4) Multiple sheets of paper are fed.	Check if the paper is excessively curled.	Change the paper.
	Paper is loaded incorrectly.	Load the paper correctly.
	Check if the retard roller is worn.	Replace the retard roller if it is worn (see page 1-5-13).
(5) Paper jams.	Check if the paper is excessively curled.	Change the paper.
	Check if the contact between the front and rear registration rollers is correct.	Check visually and remedy if necessary.
	Check if the heat roller or press roller is extremely dirty or deformed.	Check visually and replace the fuser unit (see page 1-5-26).
(6) Abnormal noise is heard.	Check if the rollers, pulleys and gears operate smoothly.	Grease the bushes and gears.
	Check if the following clutches are installed correctly. Paper feed clutch MP feed clutch Registration clutch Middle clutch	Check visually and remedy if necessary.
	Check if the following fan motors are installed correctly. Left fan motor Right fan motor Controller fan motor Fuser fan motor Container fan motor	Check visually and remedy if necessary.

Problem	Causes/check procedures	Corrective measures
(7) No primary original feed.	Check if the surfaces of the following pulleys are dirty with paper powder. DP forwarding pulley DP feed pulley	Clean with isopropyl alcohol.
	Check if the following pulleys is deformed. DP forwarding pulley DP feed pulley	Check visually and replace any deformed (see page 1-5-82).
(8) Multiple sheets of original are fed.	Original is not correctly set.	Set the original correctly.
	Check if the DP separation pad is worn.	Replace the DP separation pad if it is worn (see page 1-5-86).
(9) Originals jam.	Originals outside the specifications are used.	Use only originals conforming to the specifications.
	Check if the surfaces of the following pulleys are dirty with paper powder. DP forwarding pulley DP feed pulley	Clean with isopropyl alcohol.
	Check if the contact between the conveying roller and conveying pulley is correct.	Check visually and remedy if necessary.
	Check if the contact between the eject roller and eject pulley is correct.	Check visually and remedy if necessary.
	Check if the contact between the switchback roller and switchback pulley is correct.	Check visually and remedy if necessary.



## 1-4-6 Send error code

This section describes the scanning errors and descriptions, preventive actions, as well as corrective actions. Error codes not described here could fall within software errors.

If such an error is encountered, turn power off then on, and advise the service representative.

### (1) Scan to SMB error codes

Code	Contents	Check procedures/corrective measures
1101	Host destined does not exist on the network.	<ol style="list-style-type: none"> <li>1. Confirm destined host.</li> <li>2. Confirm device's network parameters.</li> <li>3. Confirm the network parameters the device is connected.</li> </ol>
1102	Login to the host has failed.	<ol style="list-style-type: none"> <li>1. Confirm user name and password.</li> <li>2. Confirm the network parameters the device is connected.</li> <li>3. Check the host if the folder is properly shared.</li> </ol>
1103	Destined host, folder, and/or file names are invalid.	<ol style="list-style-type: none"> <li>1. Check illegal characters are not contained within these names.</li> <li>2. Check the name of the folder and files conform with the naming syntax.</li> <li>3. Confirm destined host and folder.</li> </ol>
1105	SMB protocol is not enabled.	<ol style="list-style-type: none"> <li>1. Confirm device's SMB protocols.</li> </ol>
2101	Login to the host has failed.	<ol style="list-style-type: none"> <li>1. Confirm destined host.</li> <li>2. Confirm that the LAN cable is properly connected to the device.</li> <li>3. Check the SMB port number.</li> <li>4. Confirm device's network parameters.</li> <li>5. Confirm the network parameters the device is connected.</li> </ol>
2201	Writing scanned data has failed.	<ol style="list-style-type: none"> <li>1. Check the scanning file name.</li> <li>2. Confirm device's network parameters.</li> <li>3. Confirm the network parameters the device is connected.</li> </ol>

**(2) Scan to FTP error codes**

<b>Code</b>	<b>Contents</b>	<b>Check procedures/corrective measures</b>
<b>1101</b>	FTP server does not exist on the network.	<ol style="list-style-type: none"> <li>1. Check the FTP server name.</li> <li>2. Confirm device's network parameters.</li> <li>3. Confirm the network parameters the device is connected.</li> </ol>
<b>1102</b>	Login to the FTP server has failed.	<ol style="list-style-type: none"> <li>1. Confirm user name and password.</li> <li>2. Check the FTP server name.</li> </ol>
<b>1103</b>	Destined folder is invalid.	<ol style="list-style-type: none"> <li>1. Check illegal characters are not contained within these names.</li> <li>2. Check the FTP server name.</li> </ol>
<b>1105</b>	FTP protocol is not enabled.	<ol style="list-style-type: none"> <li>1. Confirm device's FTP protocols.</li> </ol>
<b>1131</b>	Initializing TLS has failed.	<ol style="list-style-type: none"> <li>1. Confirm device's security parameters.</li> </ol>
<b>1132</b>	TLS negotiation has failed.	<ol style="list-style-type: none"> <li>1. Confirm device's security parameters.</li> <li>2. Check the FTP server name.</li> </ol>
<b>2101</b>	Access to the FTP server has failed.	<ol style="list-style-type: none"> <li>1. Check the FTP server name.</li> <li>2. Confirm that the LAN cable is properly connected to the device.</li> <li>3. Check the FTP port number.</li> <li>4. Confirm device's network parameters.</li> <li>5. Confirm the network parameters the device is connected.</li> <li>6. Check the FTP server name.</li> </ol>
<b>2102</b>	Access to the FTP server has failed. (Connection timeout)	<ol style="list-style-type: none"> <li>1. Check the FTP server name.</li> <li>2. Check the FTP port number.</li> <li>3. Confirm device's network parameters.</li> <li>4. Confirm the network parameters the device is connected.</li> <li>5. Check the FTP server name.</li> </ol>
<b>2201</b>	Connection with the FTP server has failed.	<ol style="list-style-type: none"> <li>1. Confirm device's network parameters.</li> <li>2. Confirm the network parameters the device is connected.</li> <li>3. Confirm destined folder.</li> <li>4. Check the FTP server name.</li> </ol>
<b>2202</b>	Connection with the FTP server has failed. (Timeout)	<ol style="list-style-type: none"> <li>1. Confirm device's network parameters.</li> <li>2. Confirm the network parameters the device is connected.</li> </ol>
<b>2231</b>	Connection with the FTP server has failed. (FTPS communication)	<ol style="list-style-type: none"> <li>1. Confirm device's network parameters.</li> <li>2. Confirm the network parameters the device is connected.</li> </ol>
<b>3101</b>	FTP server responded with an error.	<ol style="list-style-type: none"> <li>1. Confirm device's network parameters.</li> <li>2. Confirm the network parameters the device is connected.</li> <li>3. Check the FTP server.</li> </ol>

**(3) Scan to E-mail error codes**

<b>Code</b>	<b>Contents</b>	<b>Check procedures/corrective measures</b>
<b>1101</b>	SMTP/POP3 server does not exist on the network.	<ol style="list-style-type: none"> <li>1. Check the SMTP/POP3 server name.</li> <li>2. Confirm device's network parameters.</li> <li>3. Confirm the network parameters the device is connected.</li> </ol>
<b>1102</b>	Login to the SMTP/POP3 server has failed.	<ol style="list-style-type: none"> <li>1. Confirm user name and password.</li> <li>2. Check the SMTP/POP3 server.</li> </ol>
<b>1104</b>	The domain the destinated address belongs is prohibited by scanning restriction.	<ol style="list-style-type: none"> <li>1. Confirm device's SMTP parameters.</li> </ol>
<b>1105</b>	SMTP protocol is not enabled.	<ol style="list-style-type: none"> <li>1. Confirm device's SMTP protocols.</li> </ol>
<b>1106</b>	Sender's address is not specified.	<ol style="list-style-type: none"> <li>1. Confirm device's SMTP protocols.</li> </ol>
<b>2101</b>	Connection to the SMTP/POP3 server has failed.	<ol style="list-style-type: none"> <li>1. Check the SMTP/POP3 server name.</li> <li>2. Confirm that the LAN cable is properly connected to the device.</li> <li>3. Check the SMTP/POP3 port number.</li> <li>4. Confirm device's network parameters.</li> <li>5. Confirm the network parameters the device is connected.</li> <li>6. Check the SMTP/POP3 server.</li> </ol>
<b>2102</b>	Connection to the SMTP/POP3 server has failed. (Connection timeout)	<ol style="list-style-type: none"> <li>1. Check the SMTP/POP3 server name.</li> <li>2. Check the SMTP/POP3 port number.</li> <li>3. Confirm device's network parameters.</li> <li>4. Confirm the network parameters the device is connected.</li> <li>5. Check the SMTP/POP3 server.</li> </ol>
<b>2201</b>	Connection to the SMTP/POP3 server has failed.	<ol style="list-style-type: none"> <li>1. Confirm device's network parameters.</li> <li>2. Confirm the network parameters the device is connected.</li> </ol>
<b>2202</b>	Connection to the SMTP/POP3 server has failed. (Timeout)	<ol style="list-style-type: none"> <li>1. Confirm device's network parameters.</li> <li>2. Confirm the network parameters the device is connected.</li> </ol>
<b>2204</b>	The size of scanning exceeded its limit.	<ol style="list-style-type: none"> <li>1. Confirm device's network parameters.</li> </ol>
<b>3101</b>	SMTP/POP3 server responded with an error.	<ol style="list-style-type: none"> <li>1. Confirm device's network parameters.</li> <li>2. Confirm the network parameters the device is connected.</li> <li>3. Check the SMTP/POP3 server.</li> </ol>
<b>3201</b>	No SMTP authentication is found.	<ol style="list-style-type: none"> <li>1. Check the SMTP server. The device supports SMTP authentication services including CRAM-MD5, DIGEST-MD5, PLAIN and LOGIN.</li> </ol>

## 1-4-7 Error codes

### (1) Error code

Error codes are listed on the communication reports, activity report, etc. The codes consist of an error code indication U followed by a 5-digit number. (Error codes for V34 communication errors start with an E indication, followed by five digits.)

The upper three of the five digits indicate general classification of the error and its cause, while the lower two indicate the detailed classification. Items for which detailed classification is not necessary have 00 as the last two digits.

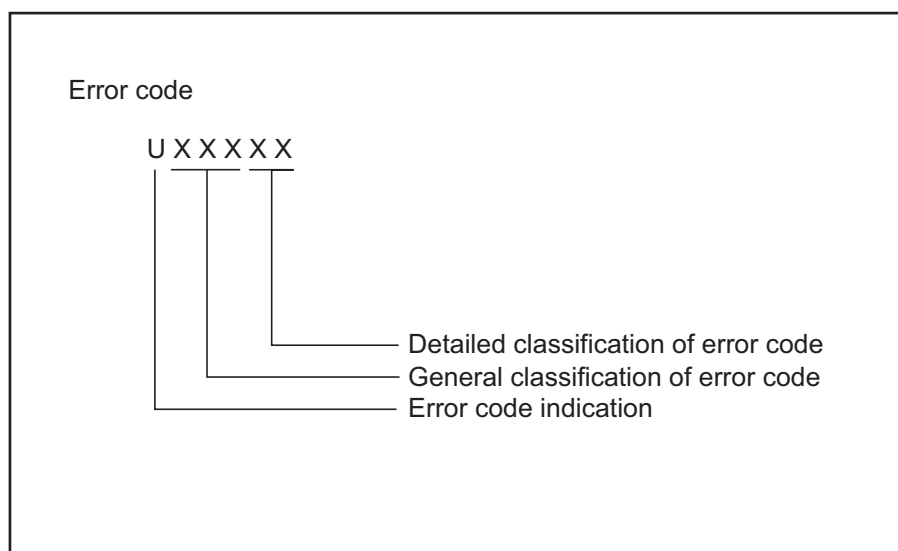


Figure 1-4-3

**(2) Table of general classification**

<b>Error code</b>	<b>Description</b>
U00000	No response or busy after the set number of redials.
U00100	Transmission was interrupted by a press of the stop/clear key.
U00200	Reception was interrupted by a press of the stop/clear key.
U00300	Recording paper on the destination unit has run out during transmission.
U004XX	A connection was made but interrupted during handshake with the receiver unit (refer to 1-4-47 U004XX error code table).
U006XX	Communication was interrupted because of a machine problem (refer to 1-4-47 U006XX error code table).
U00700	Communication was interrupted because of a problem in the destination unit.
U008XX	A page transmission error occurred in G3 mode (refer to 1-4-47 U008XX error code table).
U009XX	A page reception error occurred in G3 mode (refer to 1-4-47 U009XX error code table).
U010XX	Transmission in G3 mode was interrupted by a signal error (refer to 1-4-48 U010XX error code table).
U011XX	Reception in G3 mode was interrupted by a signal error (refer to 1-4-49 U011XX error code table).
U01400	An invalid one-touch key was specified during communication.
U01500	A communication error occurred when calling in V.8 mode.
U01600	A communication error occurred when called in V.8 mode.
U017XX	A communication error occurred before starting T.30 protocol during transmission in V.34 mode (refer to 1-4-50 U017XX error code table).
U018XX	A communication error occurred before starting T.30 protocol during reception in V.34 mode (refer to 1-4-50 U018XX error code table).
U03000	No document was present in the destination unit when polling reception started.
U03200	In interoffice subaddress-based bulletin board reception, data was not stored in the box specified by the destination unit.
U03300	In polling reception from a unit of our make, operation was interrupted due to a mismatch in permit ID or telephone number. Or, in interoffice subaddress-based bulletin board reception, operation was interrupted due to a mismatch in permit ID or telephone number.
U03400	Polling reception was interrupted because of a mismatch in individual numbers (destination unit is either of our make or by another manufacturer).
U03500	In interoffice subaddress-based bulletin board reception, the specified Subaddress confidential box number was not registered in the destination unit.
U03600	An interoffice subaddress-based bulletin board reception was interrupted because of a mismatch in the specified subaddress confidential box number.
U03700	Interoffice subaddress-based bulletin board reception failed because the destination unit had no subaddress-based bulletin board transmission capability, or data was not stored in any subaddress confidential box in the destination unit.
U04000	In interoffice subaddress-based transmission mode, the specified subaddress box number was not registered in the destination unit.

Error code	Description
U04100	Subaddress-based transmission failed because the destination unit had no subaddress-based reception capability.
U04200	In encrypted transmission, the specified encryption box was not registered in the destination unit.
U04300	Encrypted transmission failed because the destination unit had no encrypted communication capability.
U04400	Encrypted transmission was interrupted because encryption keys did not agree.
U04500	Encrypted reception was interrupted because of a mismatch in encryption keys.
U05100	Password check transmission or restricted transmission was interrupted because the permit ID's did not agree with.
U05200	Password check reception or restricted reception was interrupted because the permit ID's did not match, the rejected FAX number's did match, or the destination receiver did not return its phone number.
U05300	The password check reception or the restricted reception was interrupted because the permitted numbers did not match, the rejected numbers did match, or the machine in question did not acknowledge its phone number.
U14000	Memory overflowed during confidential reception. Or, in subaddress-based confidential reception, memory overflowed.
U14100	In interoffice subaddress-based transmission, memory overflowed in the destination unit.
U19000	Memory overflowed during memory reception.
U19100	Memory overflowed in the destination unit during transmission.
U19300	Transmission failed because an error occurred during JBIG encoding.

**(2-1) U004XX error code table: Interrupted phase B**

<b>Error code</b>	<b>Description</b>
U00430	Polling request was received but interrupted because of a mismatch in permit number. Or, subaddress-based bulletin board transmission request was received but interrupted because of a mismatch in permit ID in the transmitting unit.
U00431	An subaddress-based bulletin board transmission was interrupted because the specified subaddress confidential box was not registered.
U00432	An subaddress-based bulletin board transmission was interrupted because of a mismatch in Subaddress confidential box numbers.
U00433	Subaddress-based bulletin board transmission request was received but data was not present in the subaddress confidential box.
U00440	Subaddress-based confidential reception was interrupted because the specified subaddress box was not registered.
U00450	The destination transmitter disconnected because the permit ID's did not agree with while the destination transmitter is in password-check transmission or restricted transmission.
U00460	Encrypted reception was interrupted because the specified encryption box number was not registered.
U00462	Encrypted reception was interrupted because the encryption key for the specified encryption box was not registered.

**(2-2) U006XX error code table: Problems with the unit**

<b>Error code</b>	<b>Description</b>
U00601	Document jam or the document length exceeds the maximum.
U00613	Image writing section problem
U00656	Data was not transmitted to a modem error.
U00690	System error.

**(2-3) U008XX error code table: Page transmission error**

<b>Error code</b>	<b>Description</b>
U00800	A page transmission error occurred because of reception of a RTN or PIN signal.
U00811	A page transmission error reoccurred after retry of transmission in the ECM mode.

**(2-4) U009XX error code table: Page reception error**

<b>Error code</b>	<b>Description</b>
U00900	An RTN or PIN signal was transmitted because of a page reception error.
U00910	A page reception error remained after retry of transmission in the ECM mode.

**(2-5) U010XX error code table: G3 transmission**

<b>Error code</b>	<b>Description</b>
U01000	An FTT signal was received for a set number of times after TCF signal transmission at 2400 bps. Or, an RTN signal was received in response to a Q signal (excluding EOP) after transmission at 2400 bps.
U01001	Function of the unit differs from that indicated by a DIS signal.
U01016	An MCF signal was received but no DIS signal was received after transmission of an EOM signal, and T1 timeout was detected.
U01019	No relevant signal was received after transmission of a CNC signal, and the preset number of command retransfers was exceeded (between units of our make).
U01020	No relevant signal was received after transmission of a CTC signal, and the preset number of command retransfers was exceeded (ECM).
U01021	No relevant signal was received after transmission of an EOR.Q signal, and the preset number of command retransfers was exceeded (ECM).
U01022	No relevant signal was received after transmission of an RR signal, and the preset number of command retransfers was exceeded (ECM).
U01028	T5 time-out was detected during ECM transmission (ECM).
U01052	A DCN signal was received after transmission of an RR signal (ECM).
U01080	A PIP signal was received after transmission of a PPS.NULL signal.
U01092	During transmission in V.34 mode, communication was interrupted because of an impossible combination of the symbol speed and communication speed.
U01093	A DCN or other inappropriate signal was received during phase B of transmission.
U01094	The preset number of command retransfers for DCS/NSS signals was exceeded during phase B of transmission.
U01095	No relevant signal was received after transmission of a PPS (Q) signal during phase D of transmission, and the preset number of command transfers was exceeded.
U01096	A DCN signal or invalid command was received during phase D of transmission.
U01097	The preset number of command retransfers was exceeded after transmission of an RR signal or no response.



**(2-6) U011XX error code table: G3 reception**

<b>Error code</b>	<b>Description</b>
U01100	Function of the unit differs from that indicated by a DCS signal.
U01101	Function of the unit (excl. communication mode select) differs from that indicated by an NSS signal.
U01102	A DTC (NSC) signal was received when no transmission data was in the unit.
U01110	No response after transmission of a DIS signal.
U01111	No response after transmission of a DTC (NSC) signal.
U01113	No response after transmission of an FTT signal.
U01125	No response after transmission of a CNS signal (between units of our make).
U01129	No response after transmission of an SPA signal (short protocol).
U01141	A DCN signal was received after transmission of a DTC signal.
U01143	A DCN signal was received after transmission of an FTT signal.
U01155	A DCN signal was received after transmission of an SPA signal (short protocol).
U01160	During message reception, transmission time exceeded the maximum transmission time per line.
U01162	Reception was aborted due to a modem malfunction during message reception.
U01191	Communication was interrupted because an error occurred during an image data reception sequence in the V.34 mode.
U01193	There was no response, or a DCN signal or invalid command was received, during phase C/D of reception.
U01194	A DCN signal was received during phase B of reception.
U01195	No message was received during phase C of reception.
U01196	Error line control was exceeded and a decoding error occurred for the message being received.

**(2-7) U017XX error code table: V.34 transmission**

<b>Error code</b>	<b>Description</b>
U01700	A communication error occurred in phase 2 (line probing).
U01720	A communication error occurred in phase 4 (modem parameter exchange).
U01721	Operation was interrupted due to the absence of a common communication speed between units.

U01700: A communication error that occurs at the transmitting unit in the period after transmission of INFO0 before entering phase 3 (primary channel equivalent device training). For example, INFO0/A/Abar (B/Bbar, for polling transmission)/INFOh was not detected.

U01720: A communication error that occurs at the transmitting unit in the period after initiating the control channel before entering the T.30 process. For example, PPh/ALT/MPh/E was not detected.

U01721: In the absence of a common communication speed between units (including when an impossible combination of communication speed and symbol speed occurs) after MPh exchange; 1) a DCN signal was received from the destination unit, and the line was cut; or 2) a DIS (NSF, CSI) signal was received from the destination unit and, in response to the signal, the unit transmitted a DCN signal, and the line was cut.

**(2-8) U018XX error code table: V.34 reception**

<b>Error code</b>	<b>Description</b>
U01800	A communication error occurred in phase 2 (line probing).
U01810	A communication error occurred in phase 3 (primary channel equivalent device training).
U01820	A communication error occurred in phase 4 (modem parameter exchange).
U01821	Operation was interrupted due to the absence of a common communication speed between units.

U01800: A communication error that occurs at the receiver unit in the period after transmission of INFO0 before entering phase 3 (primary channel equivalent device training). For example, INFO0/B/Bbar (A/Abar, for polling reception)/probing tone was not detected.

U01810: A communication error that occurs at the receiver unit in phase 3 (primary channel equivalent device training). For example, S/Sbar/PP/TRN was not detected.

U01820: A communication error that occurs at the receiver unit in the period after initiating the control channel before entering the T.30 process. For example, PPh/ALT/MPh/E was not detected.

U01821: In the absence of a common communication speed between units (including when an impossible combination of communication speed and symbol speed occurs) after MPh exchange, a DCN signal was transmitted to the destination unit and the line was cut.

## 1-5-1 Precautions for assembly and disassembly

### (1) Precautions

Before starting disassembly, press the Power key on the operation panel to off. Make sure that the Power lamp is off before turning off the main power switch. And then unplug the power cable from the wall outlet.

When the fax kit is installed, be sure to disconnect the modular code before starting disassembly.

When handling PWBs (printed wiring boards), do not touch parts with bare hands.

The PWBs are susceptible to static charge.

Do not touch any PWB containing ICs with bare hands or any object prone to static charge.

When removing the hook of the connector, be sure to release the hook.

Take care not to get the cables caught.

To reassemble the parts, use the original screws. If the types and the sizes of screws are not known, refer to the PARTS LIST.

### (2) Drum

Note the following when handling or storing the drum.

When removing the drum unit, never expose the drum surface to strong direct light.

Keep the drum at an ambient temperature between -20°C/-4°F and 40°C/104°F and at a relative humidity not higher than 85% RH. Avoid abrupt changes in temperature and humidity.

Avoid exposure to any substance which is harmful to or may affect the quality of the drum.

Do not touch the drum surface with any object. Should it be touched by hands or stained with oil, clean it.

### (3) Toner

Store the toner container in a cool, dark place.

Avoid direct light and high humidity.

### (4) How to tell a genuine Kyocera Mita toner container

As a means of brand protection, the Kyocera Mita toner container utilizes an optical security technology to enable visual validation. A validation viewer is required to accomplish this.

Hold the validation viewer over the left side part of the brand protection seal on the toner container. Through each window of the validation viewer, the left side part of the seal should be seen as follows:

A black-colored band when seen through the left side window ( ● )

A shiny or gold-colored band when seen through the right side window ( ☀ )

The above will reveal that the toner container is a genuine Kyocera Mita branded toner container, otherwise, it is a counterfeit.

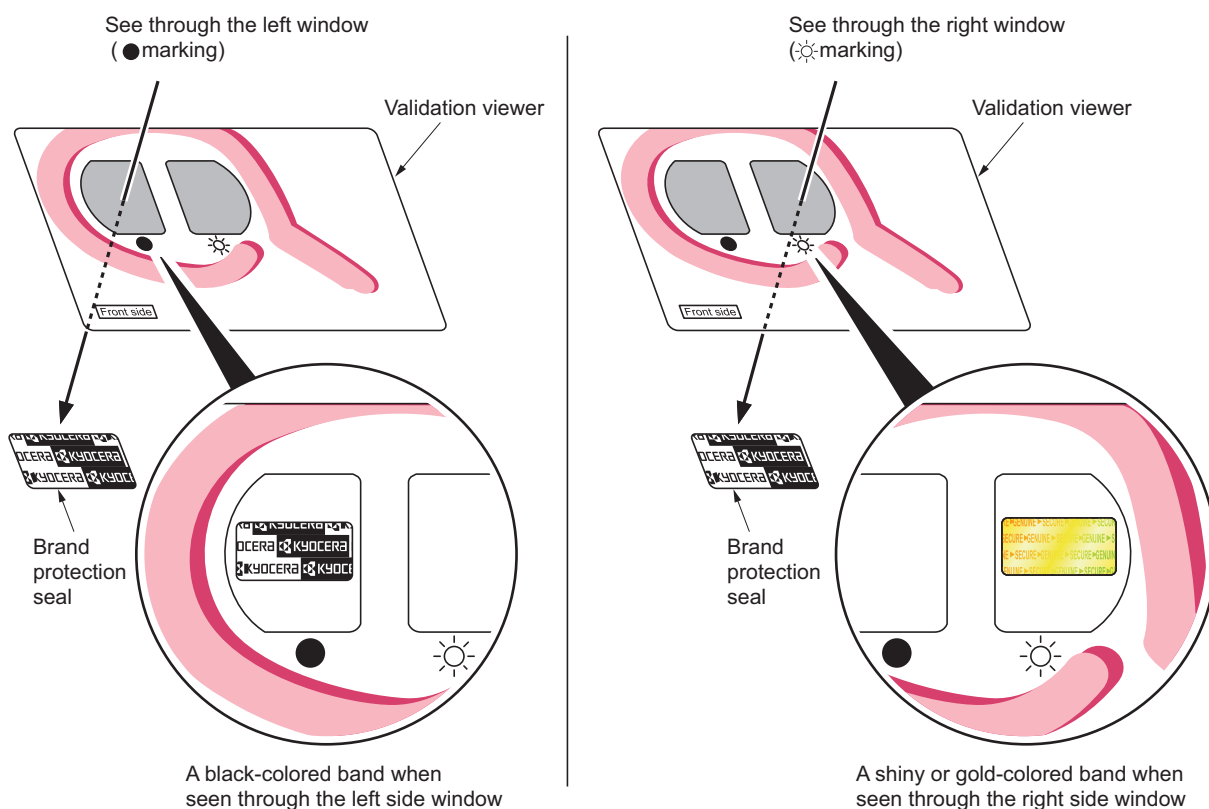


Figure 1-5-1

The brand protection seal has an incision as shown below to prohibit reuse.

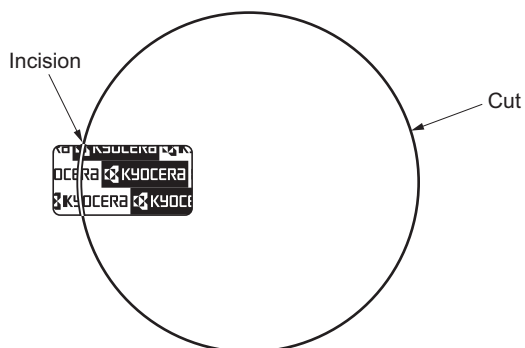


Figure 1-5-2

## 1-5-2 Outer covers

### (1) Detaching and refitting the rear upper cover, right upper cover, left upper cover and front cover

#### Procedure

1. Open the paper conveying unit.
2. Release the hook and then remove the IF cover.

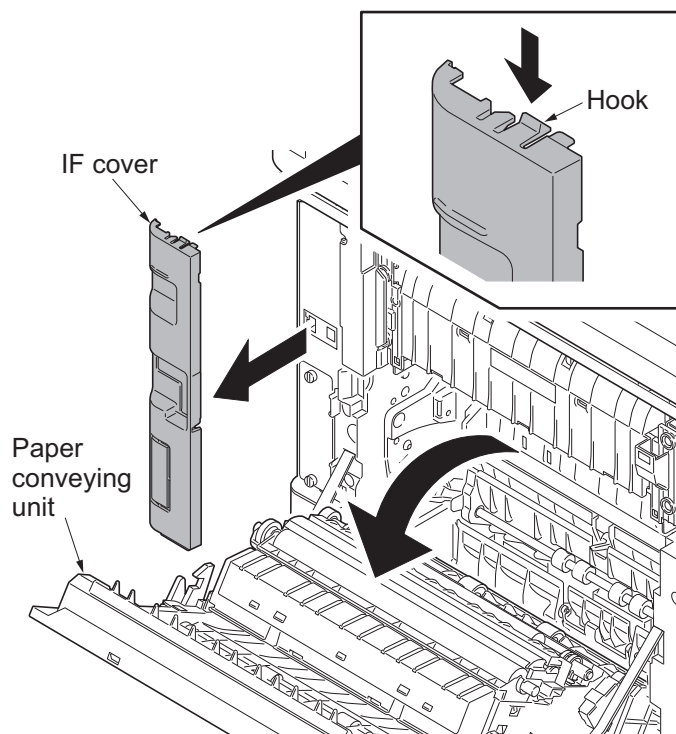


Figure 1-5-3

3. Remove two screws and then remove the rear upper cover.

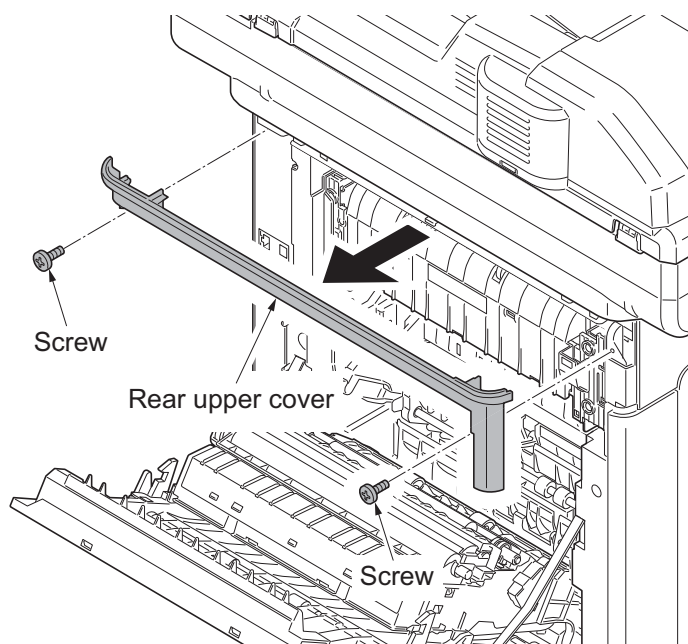


Figure 1-5-4

4. Pull the inner tray lever and open the inner tray.
5. Release two hooks. Slide the right upper cover backward and then remove it.

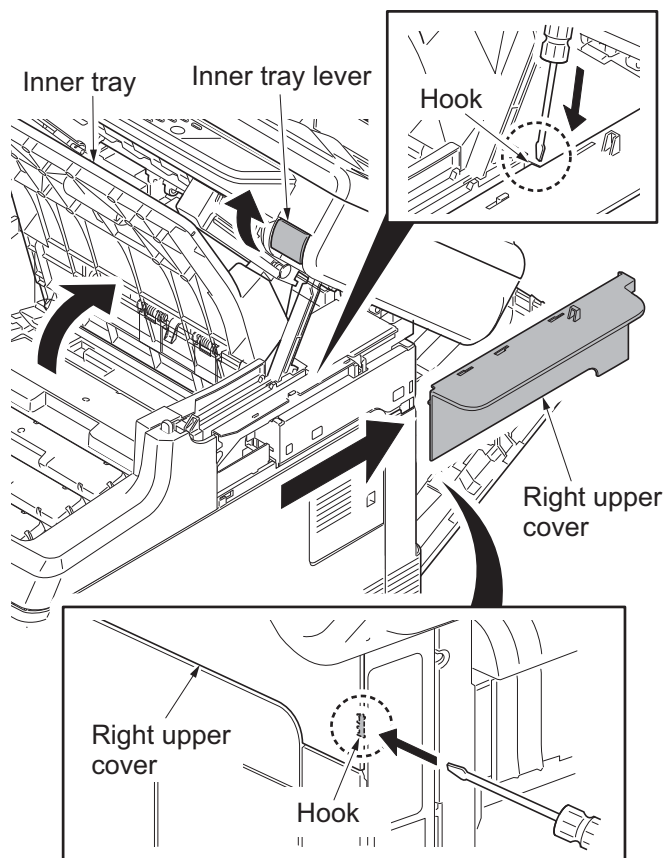


Figure 1-5-5

6. Release the hook. Slide the left upper cover backward and then remove it.

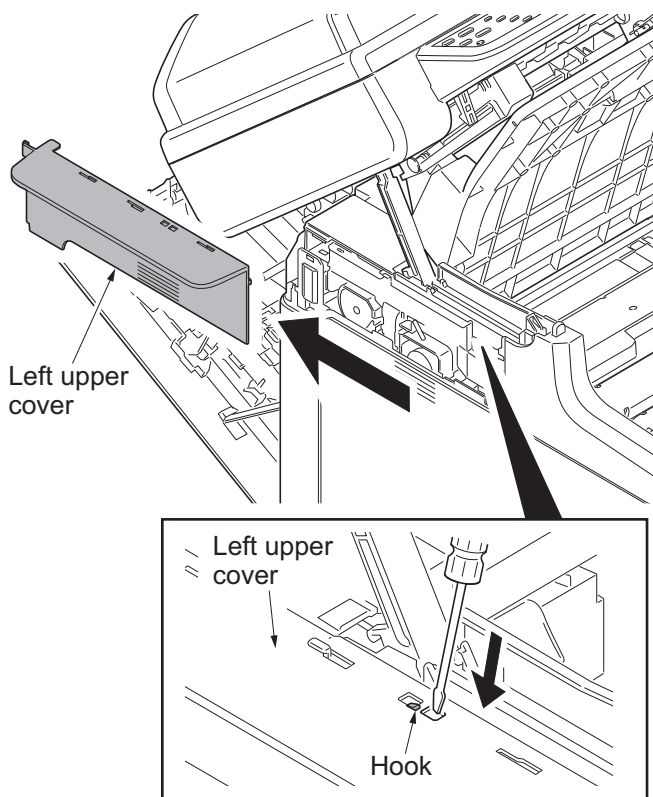


Figure 1-5-6

7. Release five hooks (hook A → B) and then remove the front cover.

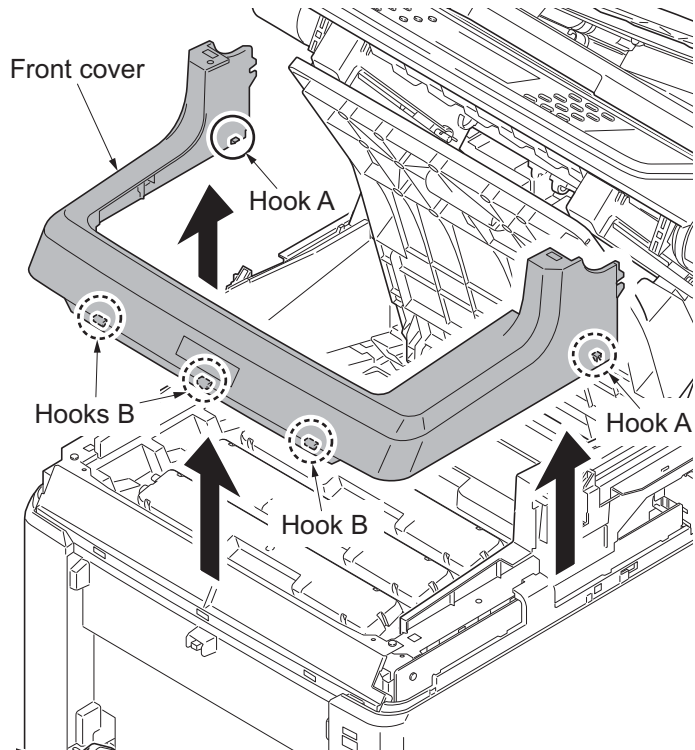


Figure 1-5-7

## (2) Detaching and refitting the right rear cover, right cover and right lower cover

### Procedure

1. Remove the rear upper cover, right upper cover, left upper cover and front cover (see page 1-5-3).
2. Slide the power source cover backward and then remove it.

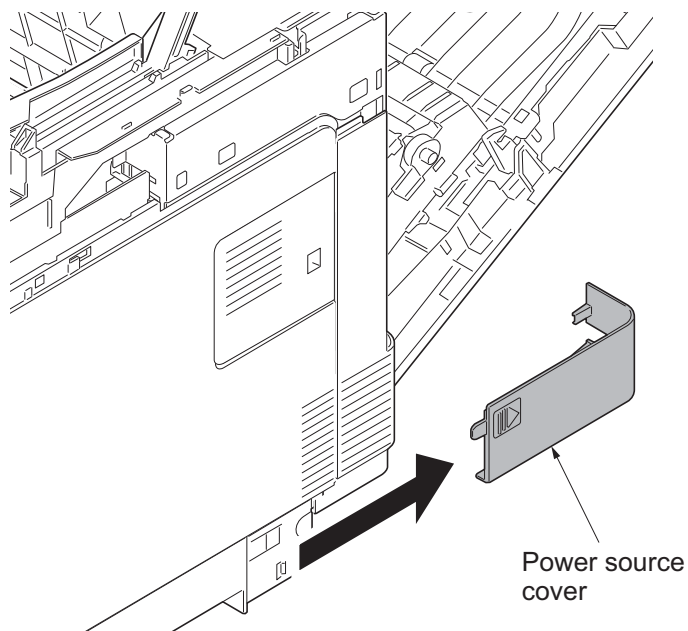


Figure 1-5-8

3. Remove the screw.
4. Release four hooks. Slide the right rear cover backward and then remove it.

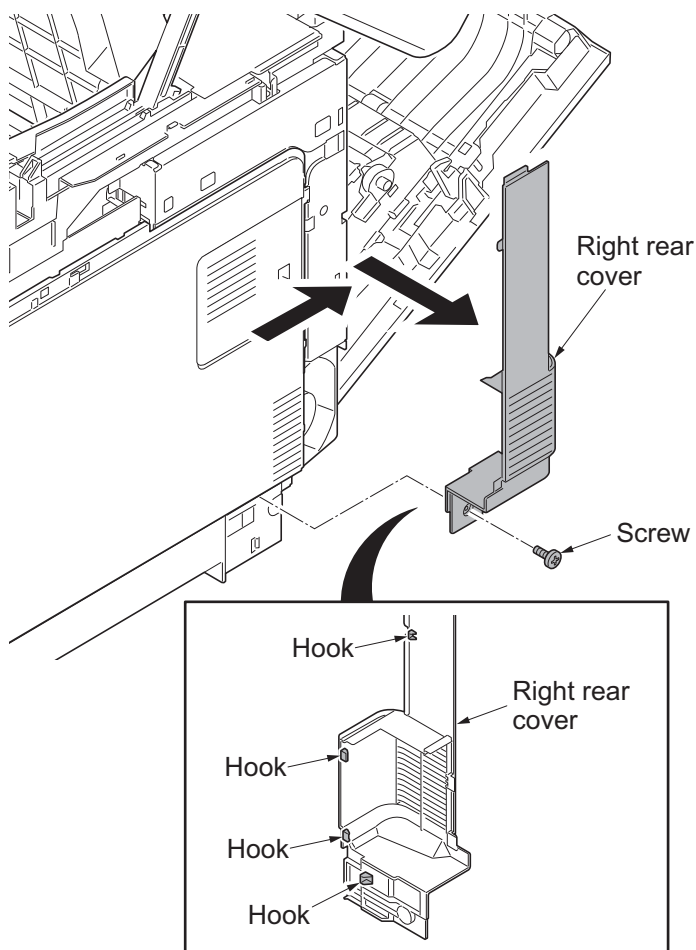
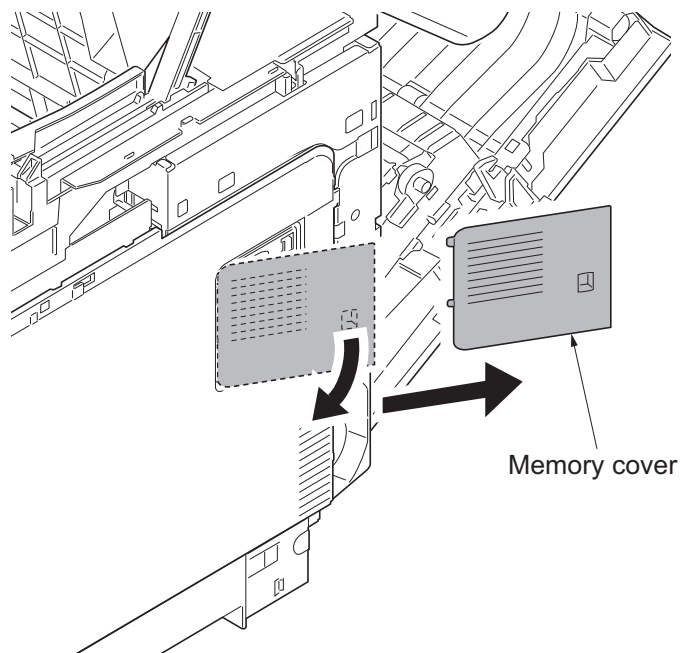


Figure 1-5-9

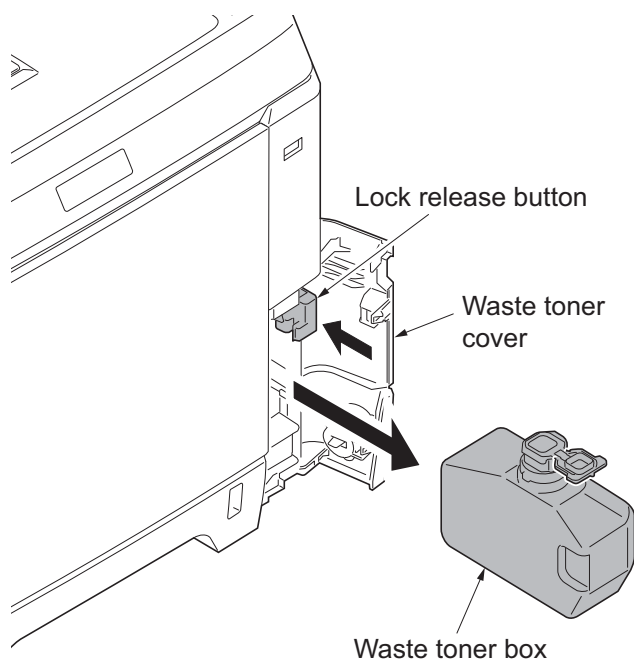


5. Open the memory cover and then remove it.



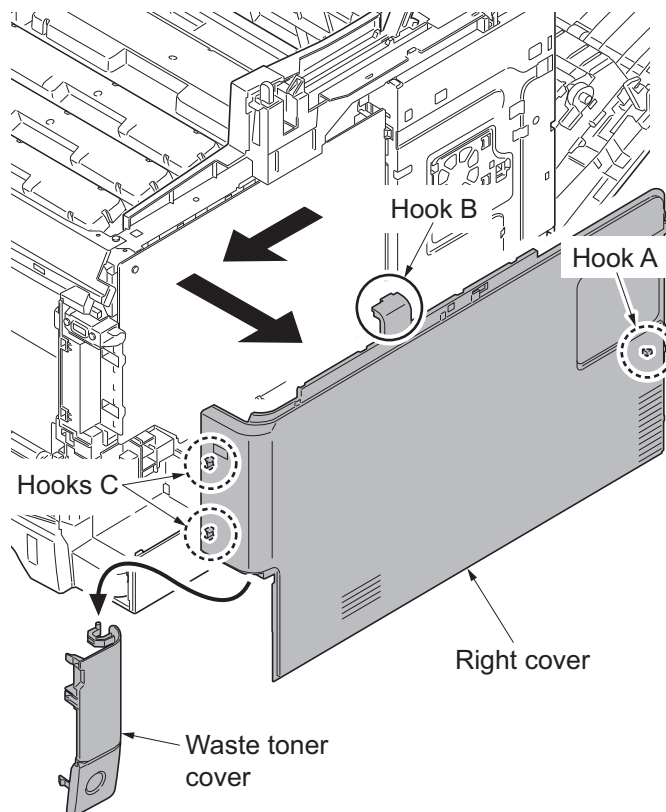
**Figure 1-5-10**

6. Open the waste toner cover.
7. Push the lock release button and then remove the waste toner box.

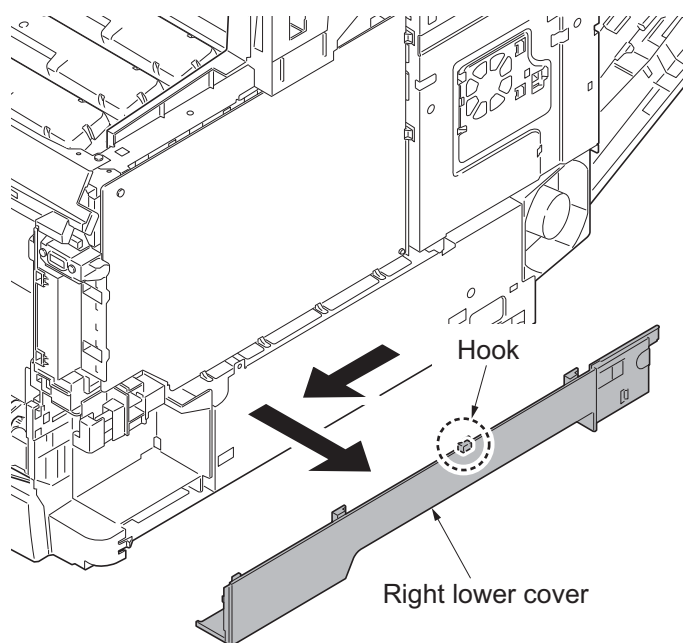


**Figure 1-5-11**

8. Release four hooks (hook A → B → C). Slide the right cover forward and then remove it.
9. Remove the waste toner cover.

**Figure 1-5-12**

10. Release the hook. Slide the right lower cover forward and then remove it.

**Figure 1-5-13**

### (3) Detaching and refitting the left rear cover, left cover and left lower cover

#### Procedure

1. Remove the rear upper cover, right upper cover, left upper cover and front cover (see page 1-5-3).
2. Release the hook. Slide the left rear cover upward and then remove it.

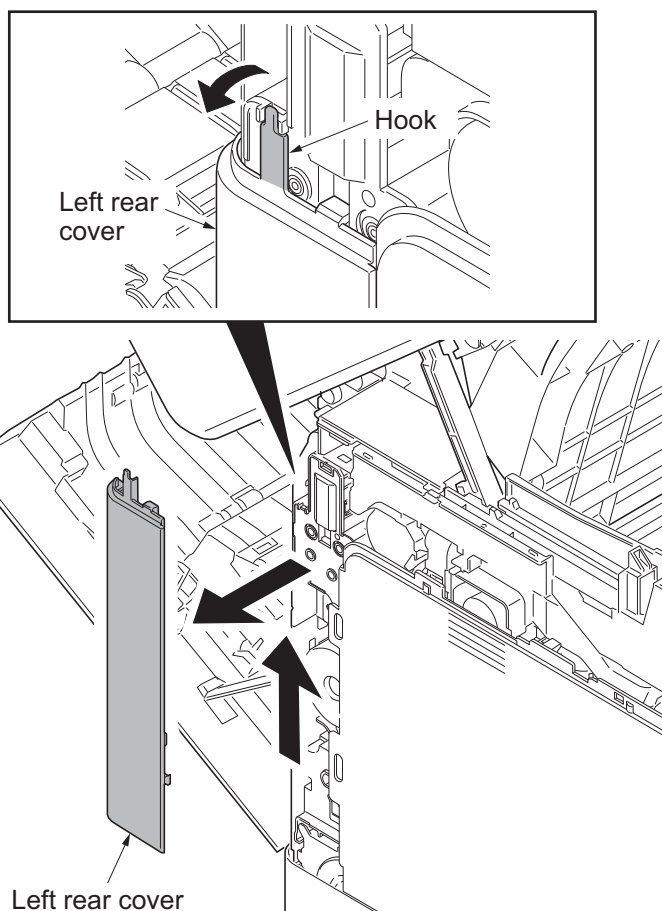


Figure 1-5-14

3. Release four hooks (hook A → B) and then remove the left cover.

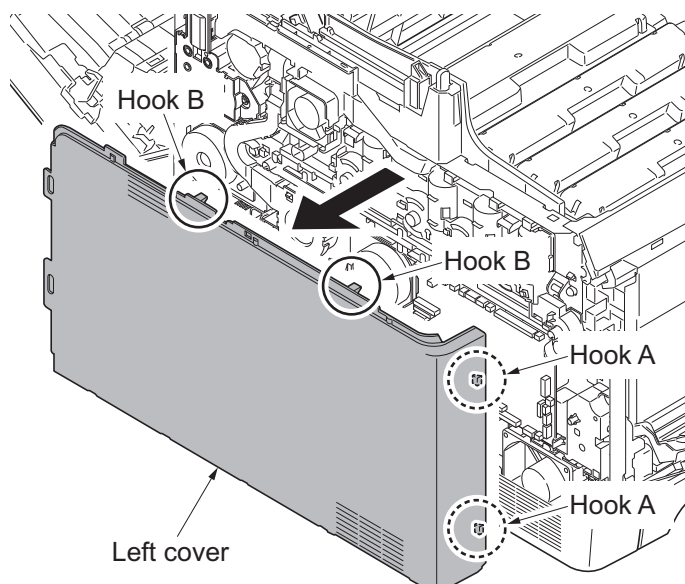
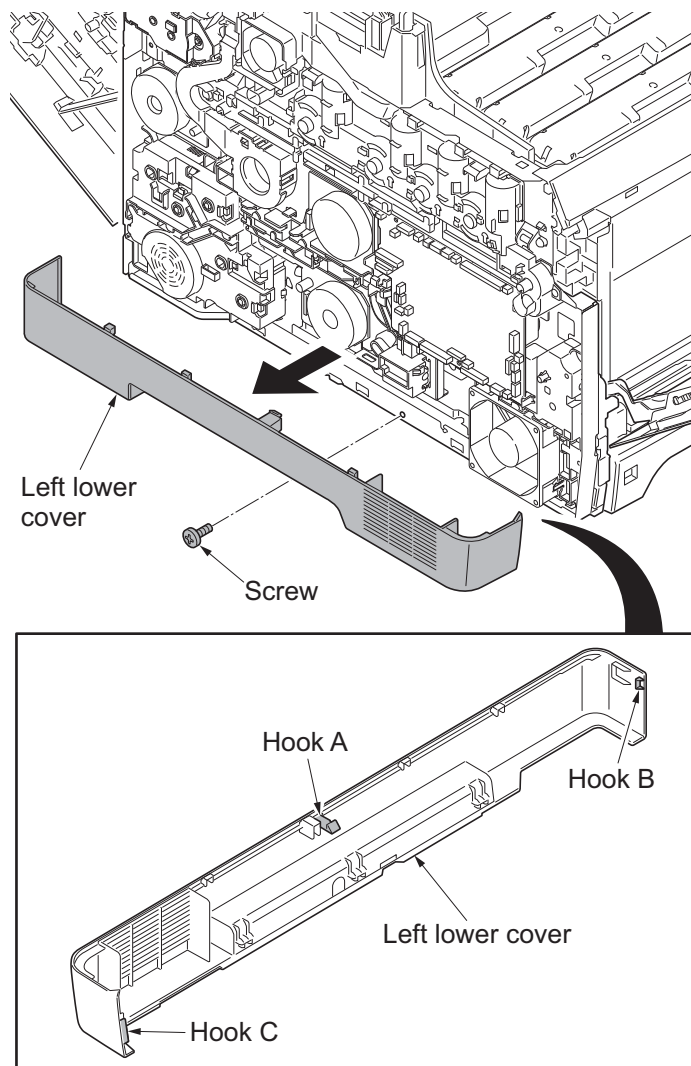


Figure 1-5-15

4. Remove the screw.
5. Release three hooks (hook A → B → C) and then remove the left lower cover.



**Figure 1-5-16**

#### (4) Detaching and refitting the inner cover

##### Procedure

1. Remove the cassette.

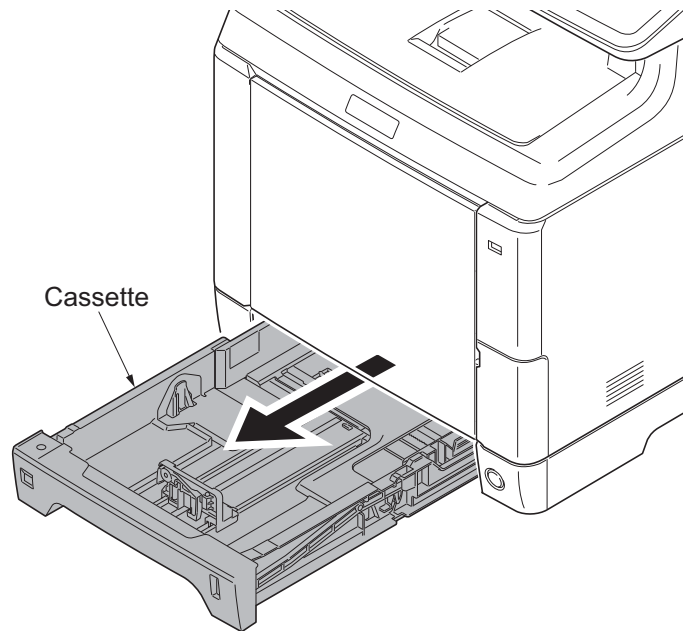


Figure 1-5-17

2. Remove the MP tray cover.  
(see page 1-5-17)
3. Remove the MP tray.

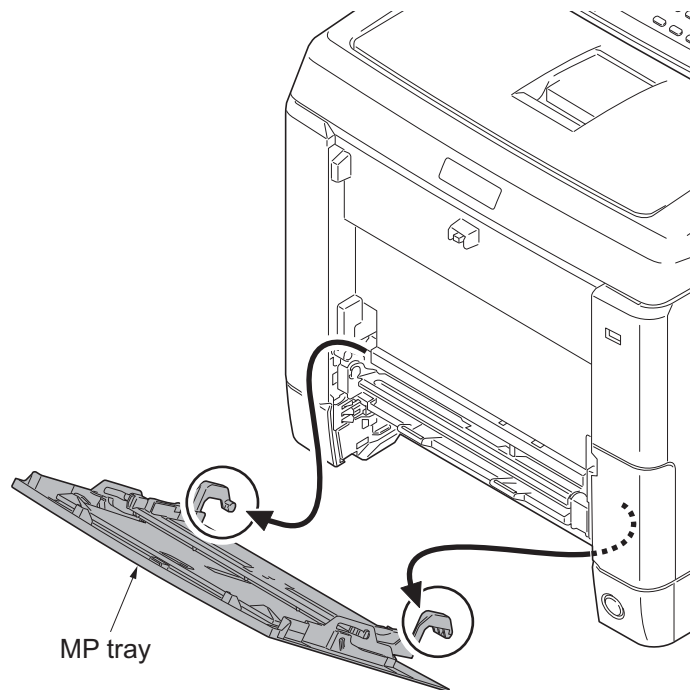
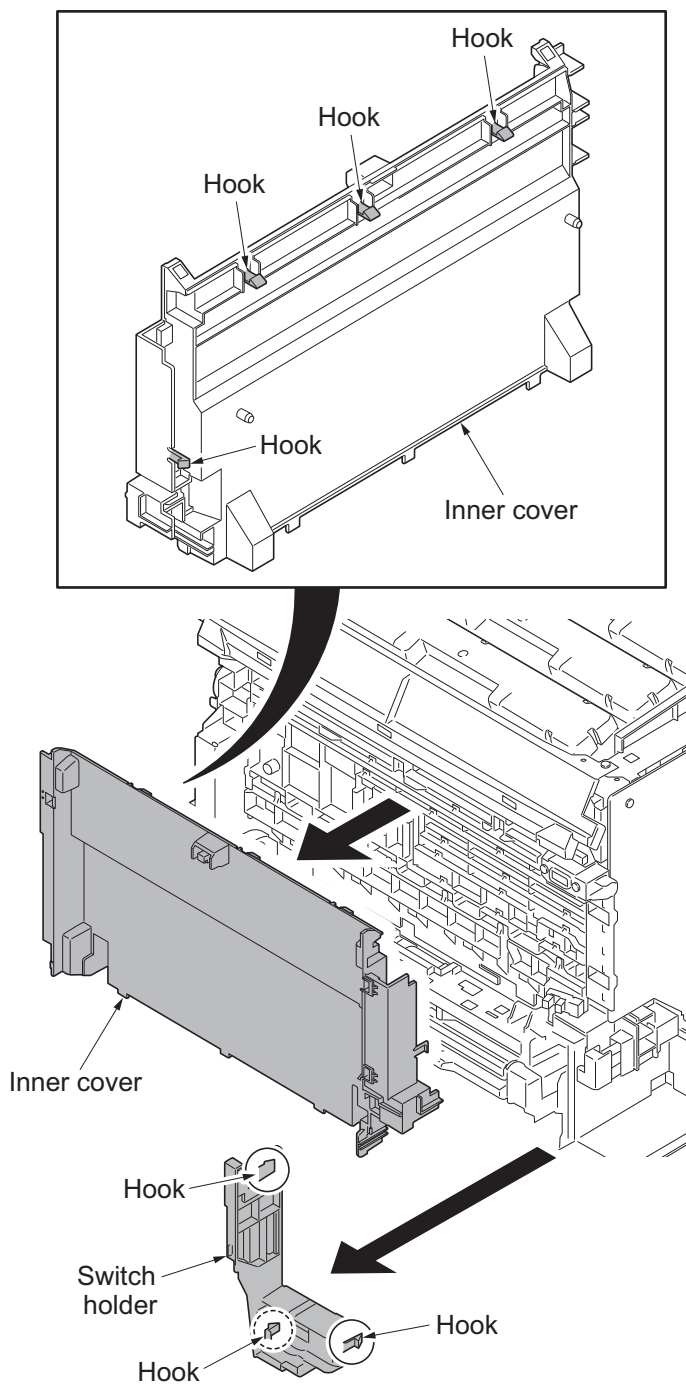


Figure 1-5-18

4. Remove the rear upper cover, right upper cover, left upper cover and front cover (see page 1-5-3).
5. Remove the right rear cover and right cover (see page 1-5-6).
6. Remove the left rear cover and left cover (see page 1-5-9).
7. Release three hooks and then remove the switch holder.
8. Release four hooks and then remove the inner cover.

**Figure 1-5-19**

## 1-5-3 Paper feed section

### (1) Detaching and refitting the retard roller unit

#### Procedure

1. Open the paper conveying unit.
2. Pull the middle roller unit forward to the hook.
3. While pressing the right and left hooks outwards, unlatch the shaft from the rail and remove the middle roller unit.

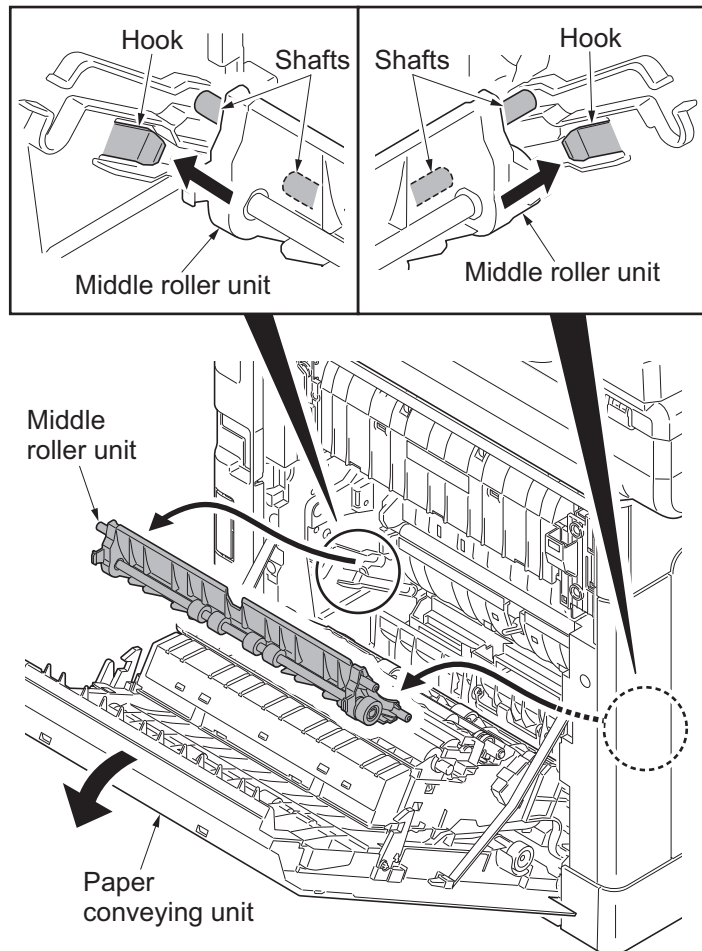


Figure 1-5-20

4. Pull the retard cover down and remove.
5. Release two hooks and then remove the retard roller unit.
6. Check or replace the retard roller unit and refit all the removed parts.

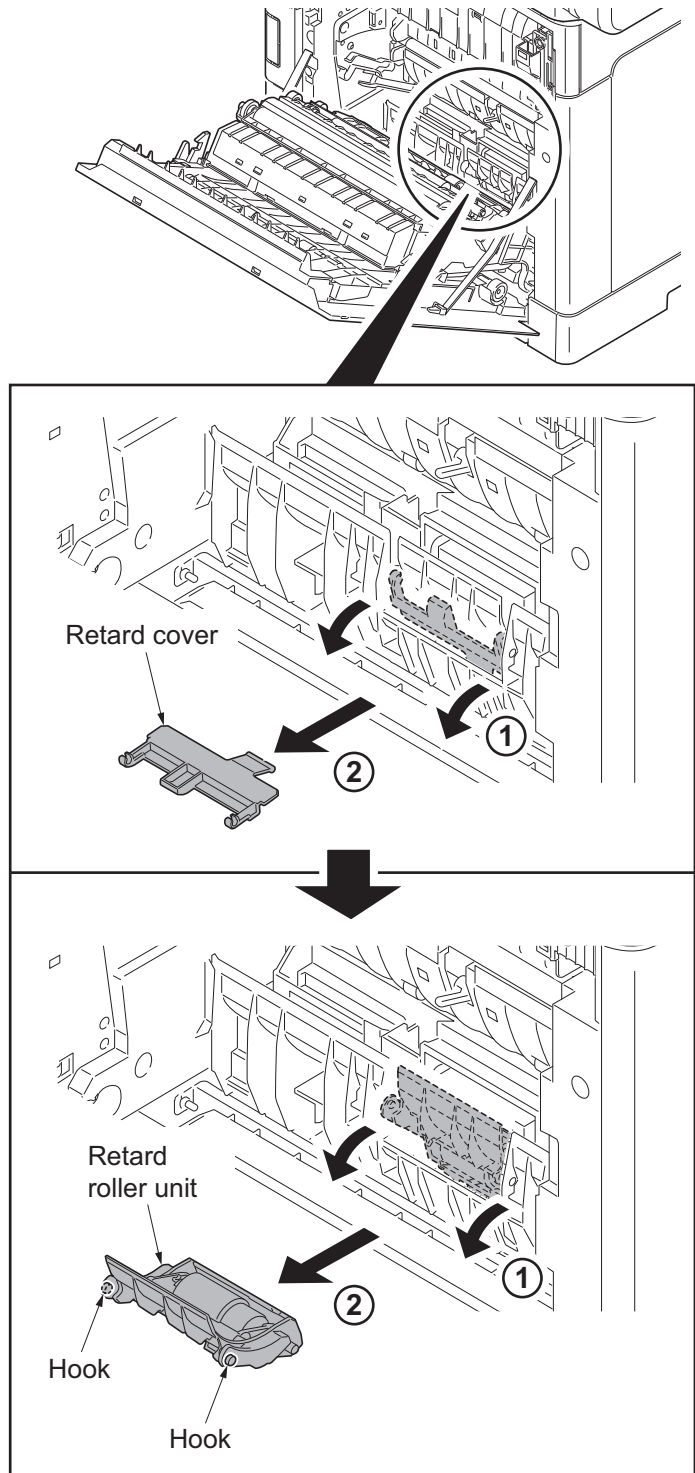


Figure 1-5-21



## (2) Detaching and refitting the paper feed roller unit

### Procedure

1. Remove the retard roller unit (see page 1-5-13).
2. Turn forward the lever of the feed pin to release the lock.
3. Slide the feed pin.

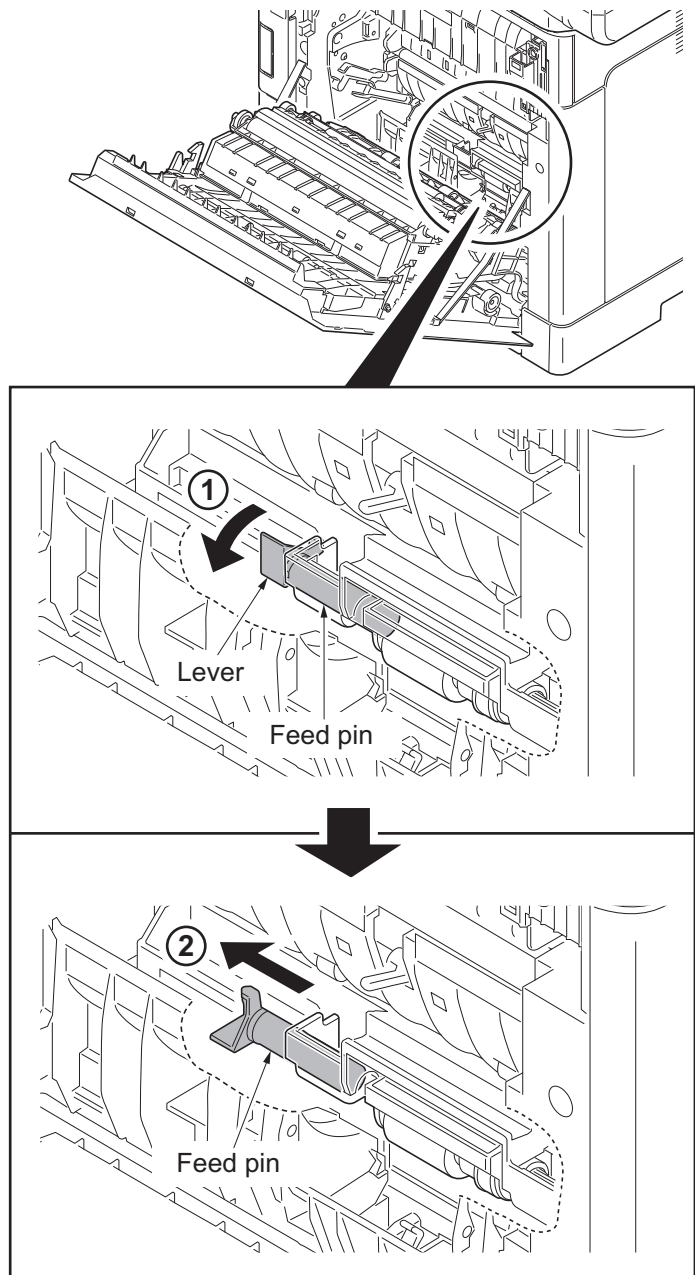
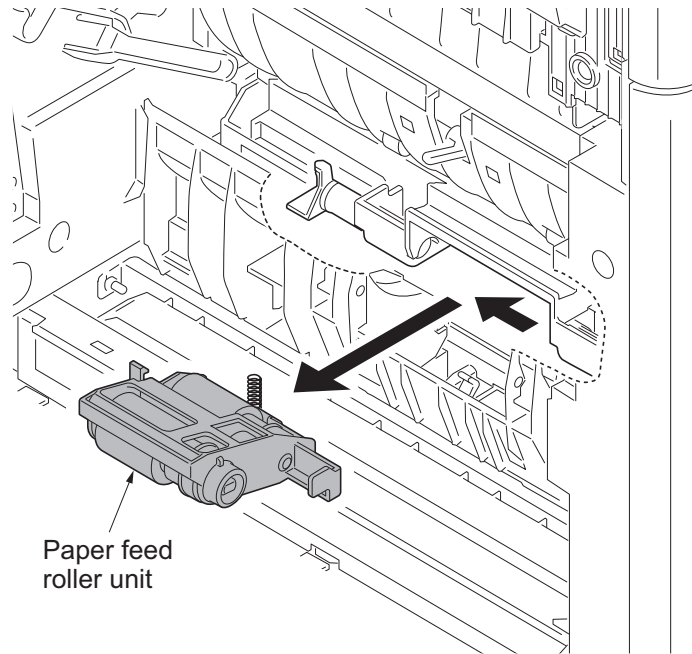


Figure 1-5-22

4. Remove the paper feed roller unit.
5. Check or replace the paper feed roller unit and refit all the removed parts.



**Figure 1-5-23**

### (3) Detaching and refitting the MP paper feed roller

#### Procedure

1. Remove the cassette.
2. Remove the guide sections of the MP tray cover from the MP tray.
3. Raise the MP tray cover upward. Release two hooks and then remove the MP tray cover.

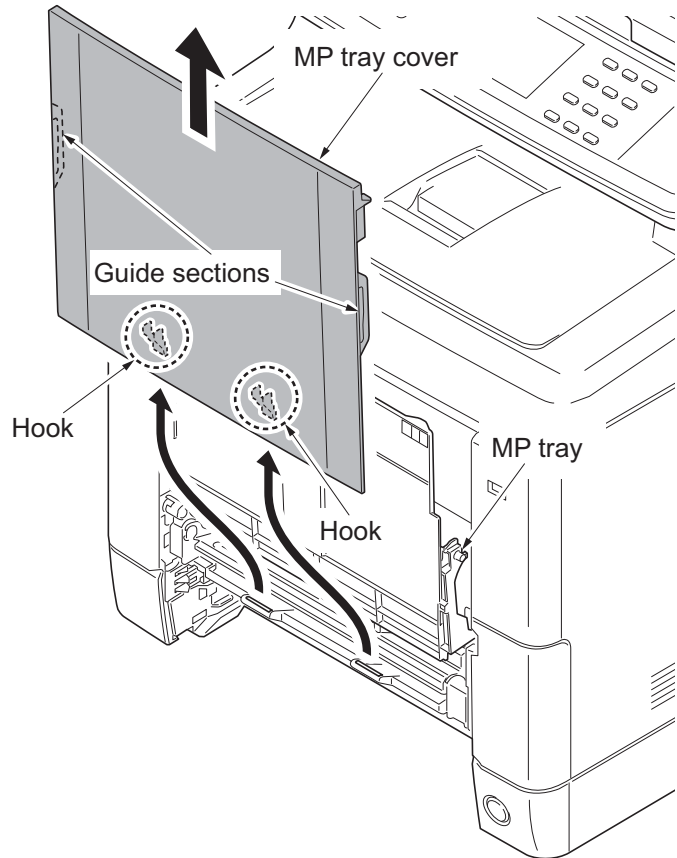


Figure 1-5-24

4. Open the conveying lower cover.

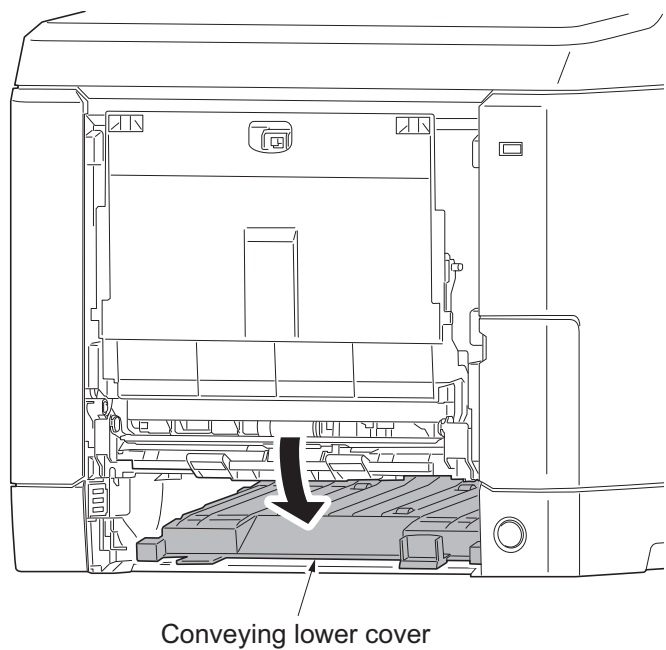
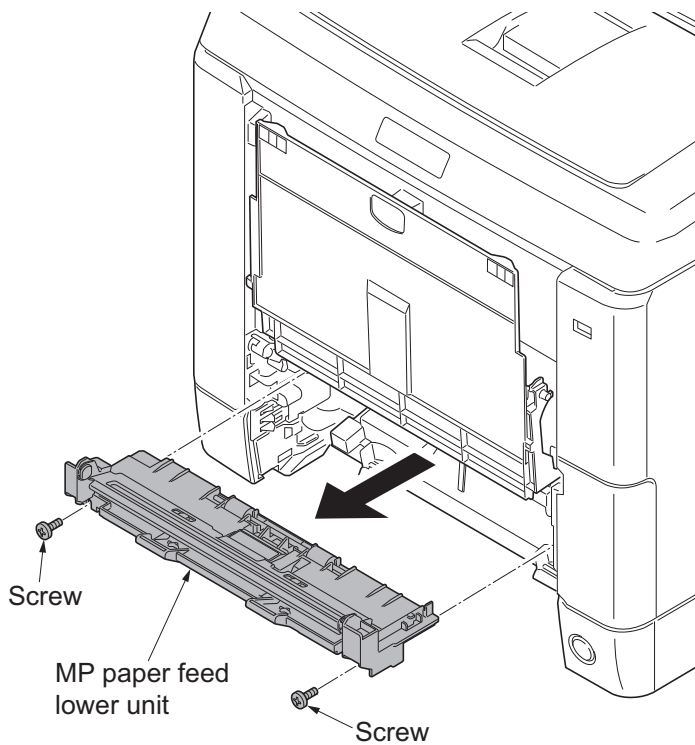


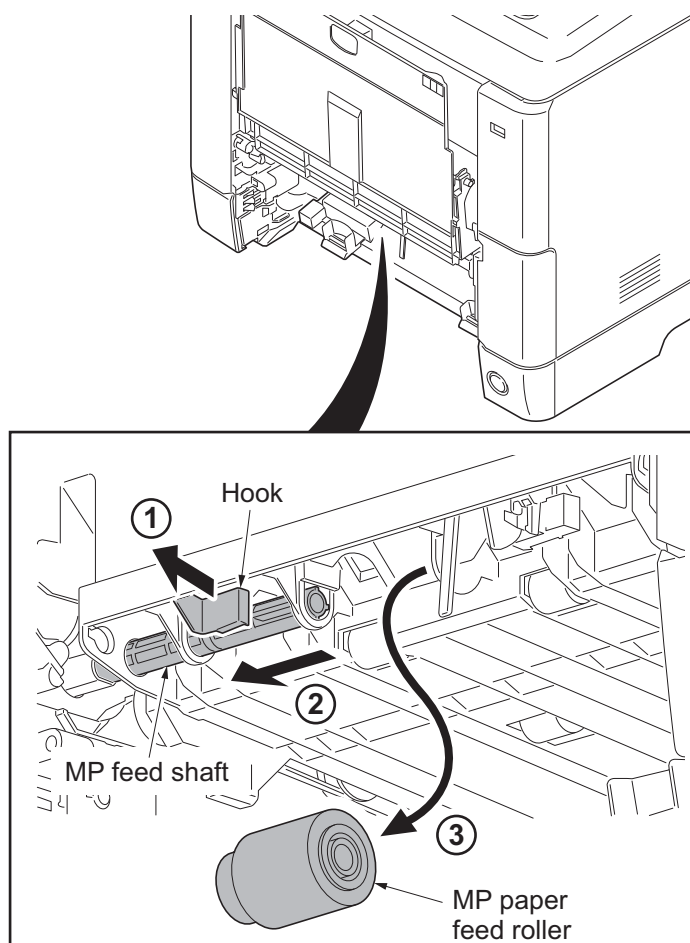
Figure 1-5-25

- Remove two screws and then remove the MP paper feed lower unit.



**Figure 1-5-26**

- Pull the hook forward and then slide the MP feed shaft.
- Remove the MP paper feed roller.
- Check or replace the MP paper feed roller and refit all the removed parts.



**Figure 1-5-27**

## 1-5-4 Developing section

### (1) Detaching and refitting the developing unit

#### Procedure

1. Remove the intermediate transfer unit (see page 1-5-22).
2. Remove drum units (K, M, C, Y).
3. Pinch the lever of developing unit.
4. Remove developing units (K, M, C, Y).

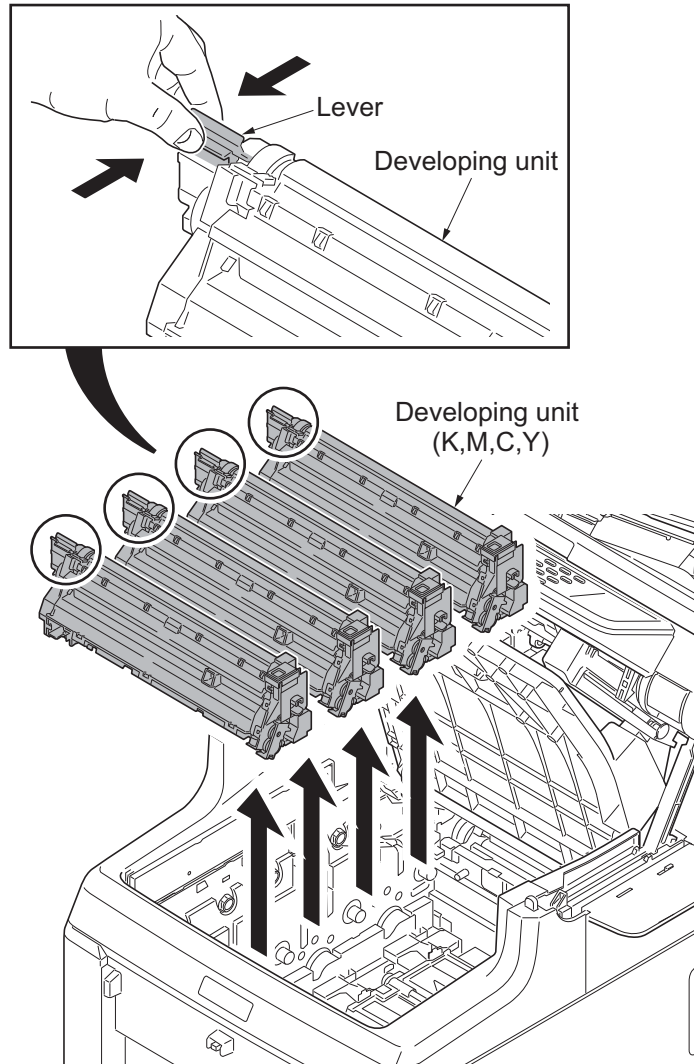
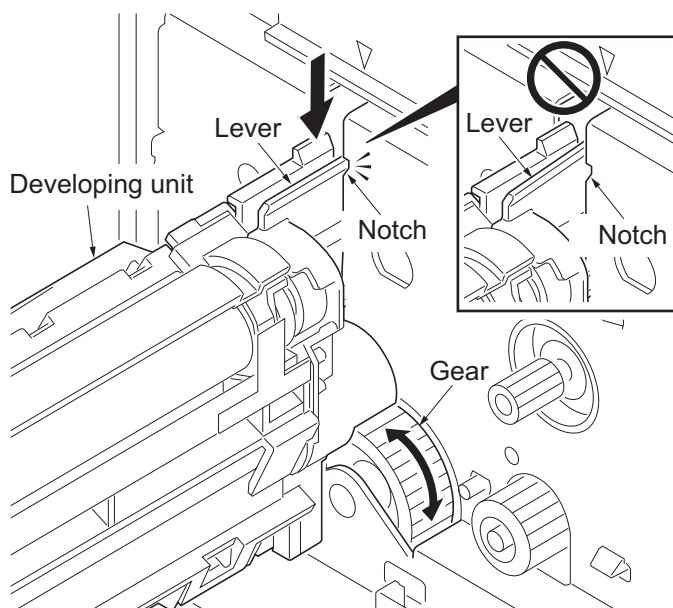
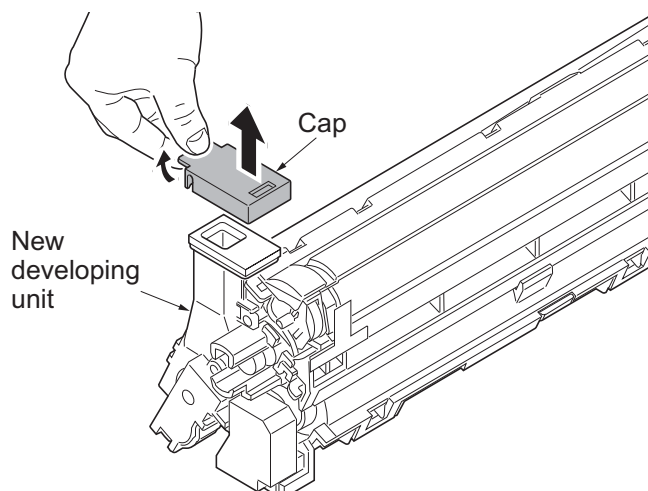


Figure 1-5-28

5. Check or replace the developing unit and refit all the removed parts.

**NOTE:**

- \*: Remove the cap before installing the new developing unit.
- \*: When reinstalling the developing unit, press it down until the lever of developing unit is engaged with the notch.
- \*: If it is difficult to engage the lever, press the unit down while rotating the gear to engage it.



**Figure 1-5-29**

## 1-5-5 Drum section

### (1) Detaching and refitting the drum unit

#### Procedure

1. Remove the intermediate transfer unit (see page 1-5-22).
2. Remove drum units (K, M, C, Y).
3. Check or replace the drum unit and refit all the removed parts.

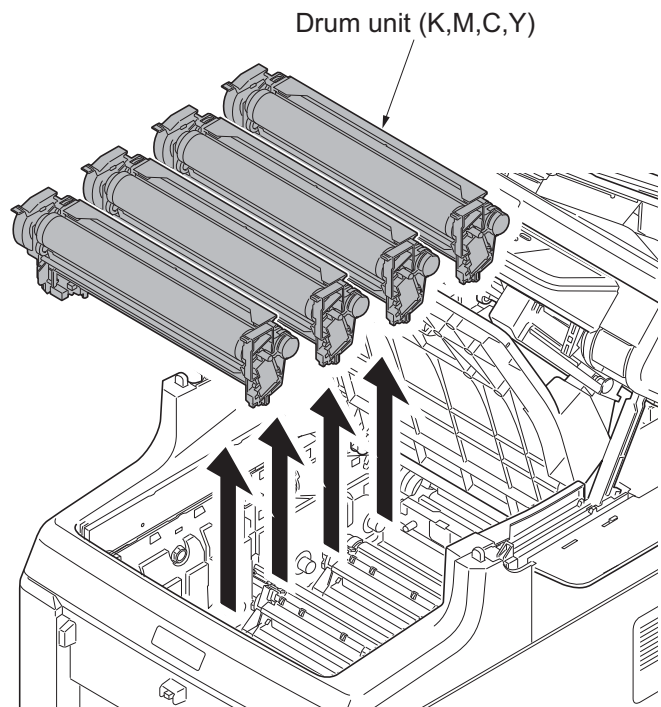


Figure 1-5-30

## 1-5-6 Transfer/Separation section

### (1) Detaching and refitting the intermediate transfer unit

#### Procedure

1. Open the inner tray and the paper conveying unit.
2. Remove toner containers (K, M, C, Y).

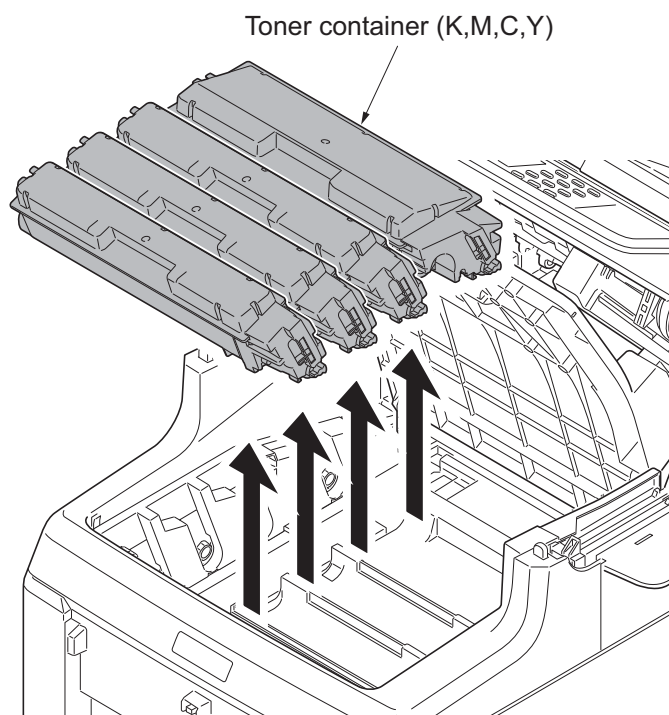


Figure 1-5-31

3. Slide the container guide forward and then remove it.

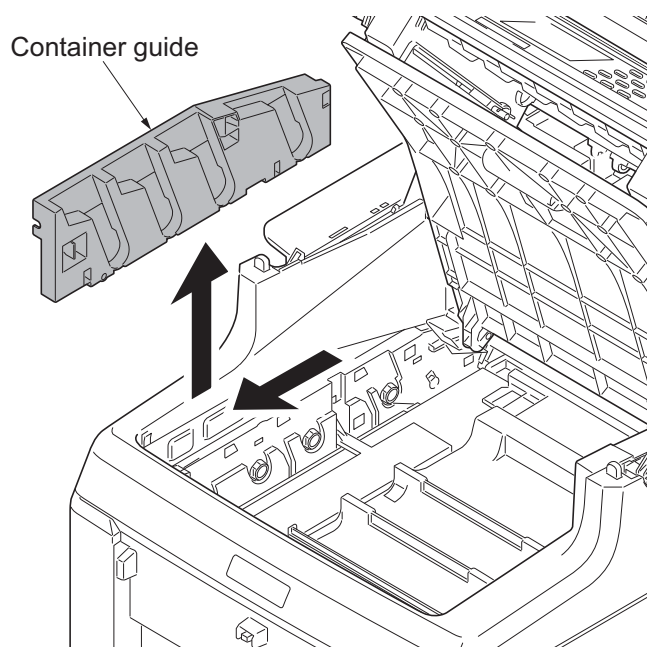


Figure 1-5-32



4. Open the RFID holder.

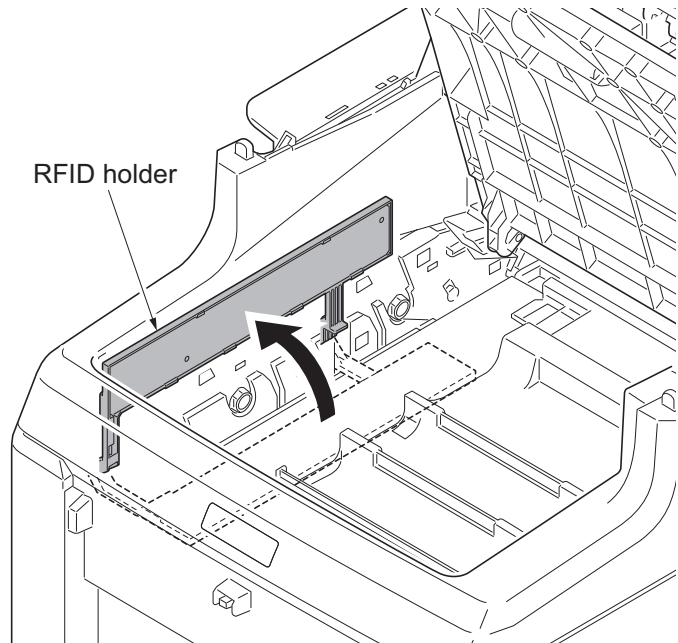


Figure 1-5-33

- 5. Slide the shutter forward and seal the toner inlet.
- 6. Remove the screw.

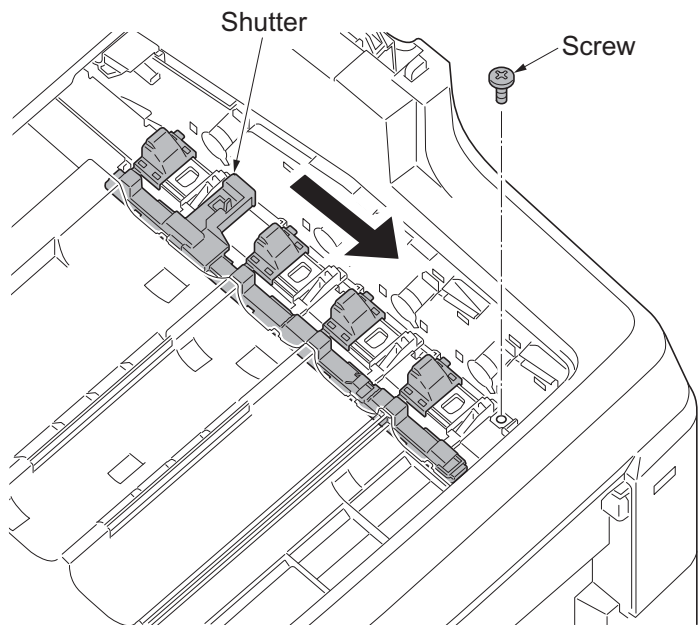
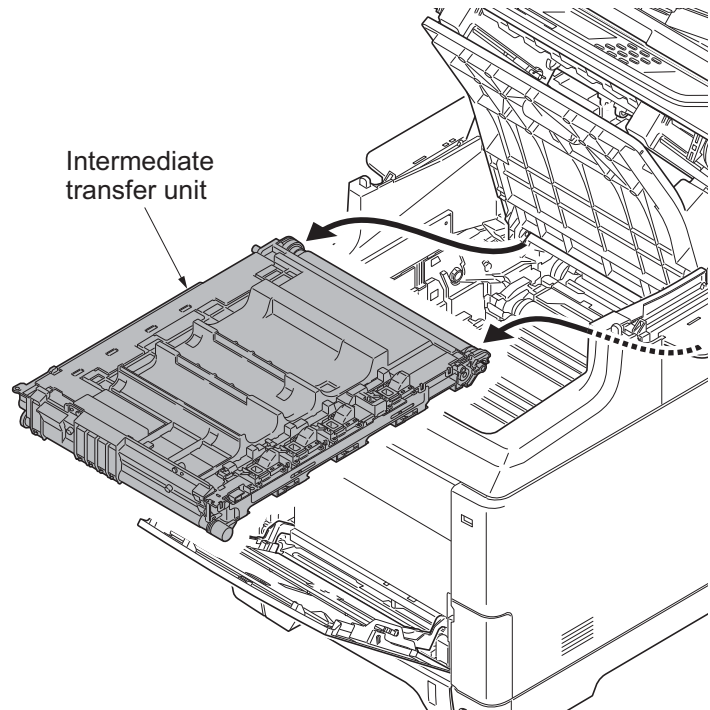


Figure 1-5-34

7. Remove the intermediate transfer unit.
8. Check or replace the intermediate transfer unit and refit all the removed parts.



**Figure 1-5-35**

## (2) Detaching and refitting the transfer roller unit

### Procedure

1. Open the paper conveying unit.
2. Release two hooks and then remove the transfer roller unit.
3. Check or replace the transfer roller unit and refit all the removed parts.

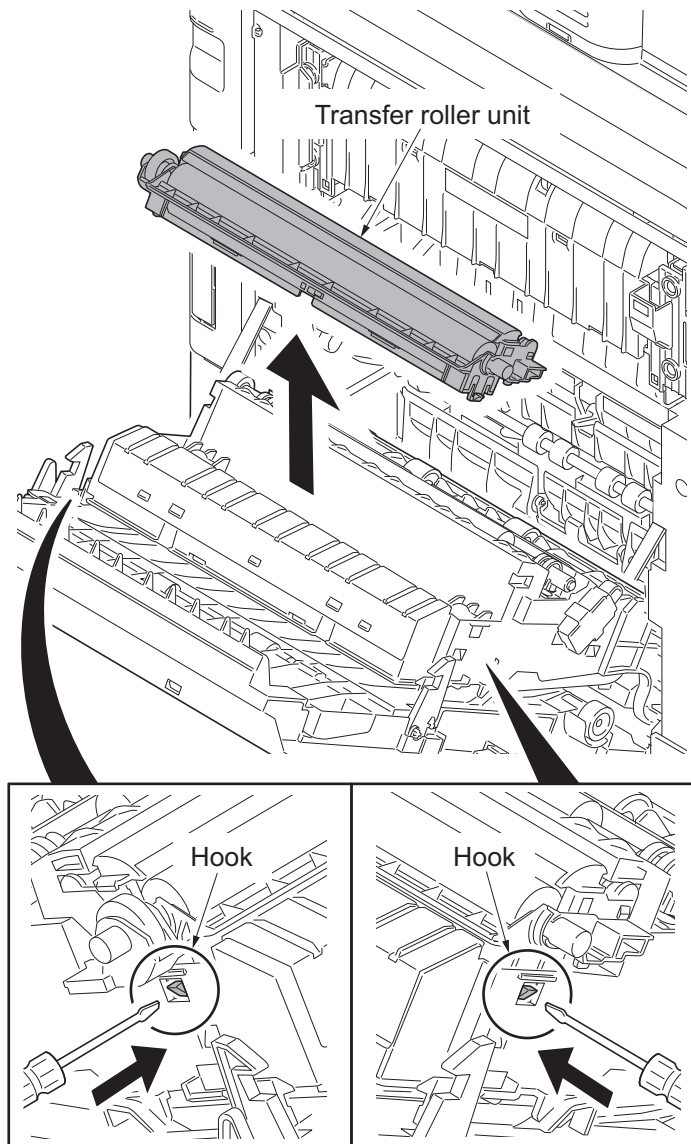


Figure 1-5-36

## 1-5-7 Fuser section

### (1) Detaching and refitting the fuser unit

#### Procedure

1. Open the paper conveying unit.
2. Remove the IF cover (see page 1-5-3).
3. Remove the screw and then fuser wire cover.

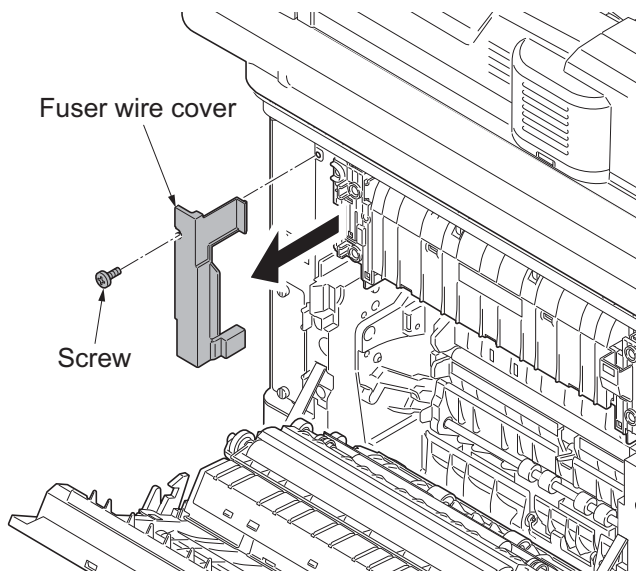


Figure 1-5-37

4. Remove three connectors.
  5. Remove two screws and then remove the fuser unit.
  6. Check or replace the fuser unit and refit all the removed parts.
- \*: Take care not to get the cables caught.

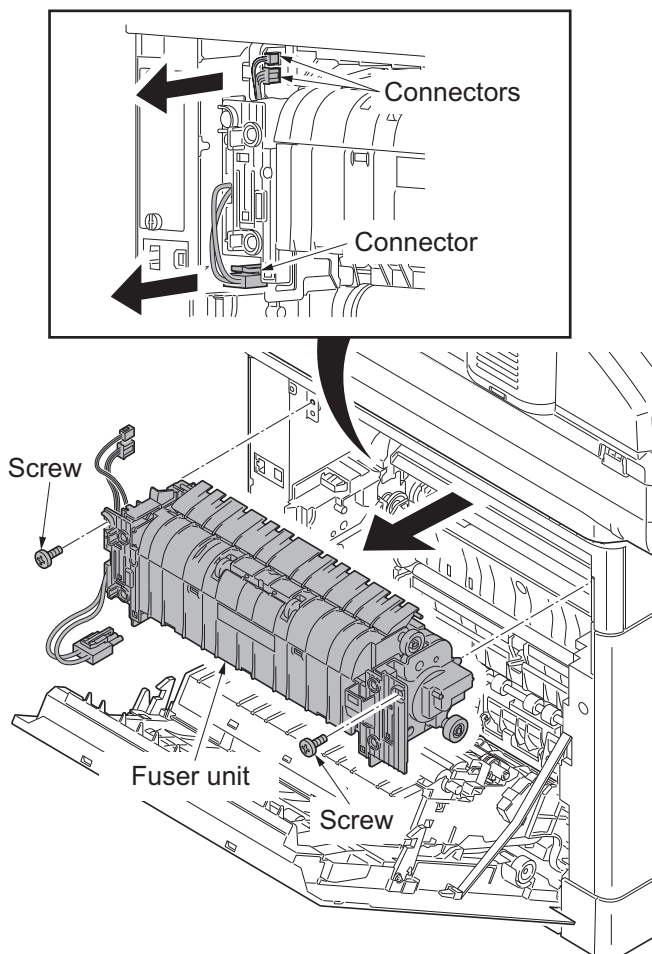


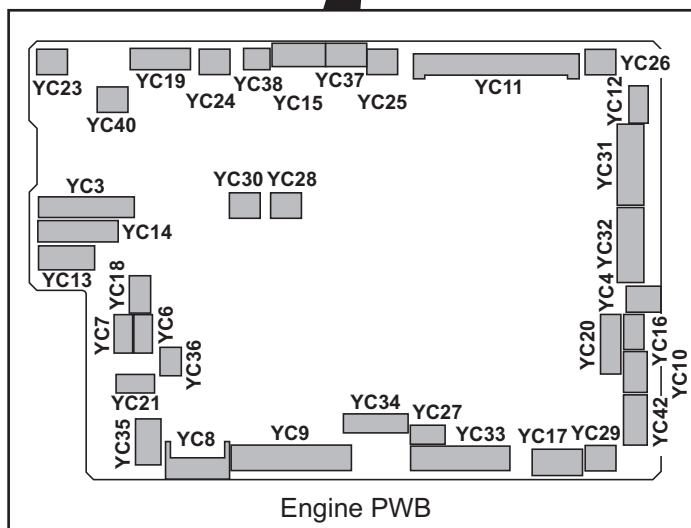
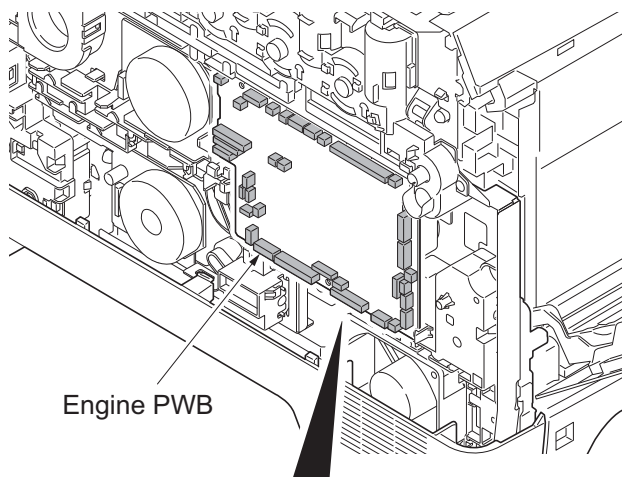
Figure 1-5-38

## 1-5-8 PWBs

### (1) Detaching and refitting the engine PWB

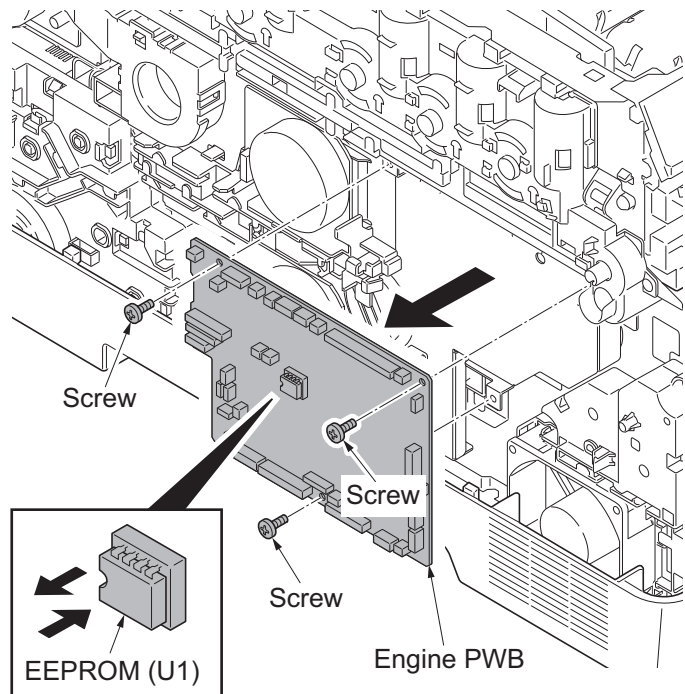
**Procedure**

1. Remove the left cover (see page 1-5-9).
2. Remove all connectors from the engine PWB.



**Figure 1-5-39**

3. Remove three screws and then remove the engine PWB.
  4. Check or replace the engine PWB and refit all the removed parts.
- \*: To replace the engine PWB, remove the EEPROM (U1) from the old engine PWB and mount it to the new engine PWB.



**Figure 1-5-40**

## (2) Detaching and refitting the power source PWB

### Procedure

1. Remove the right rear cover, right cover and right lower cover (see page 1-5-6).
2. Remove four screws and then remove the power source shield.  
Screws A and B are unidentical, therefore, do not mix up.

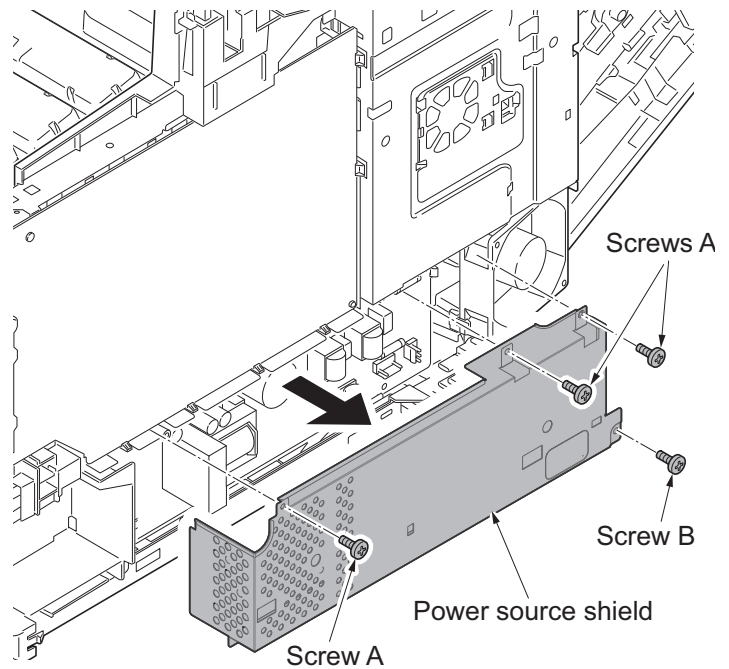


Figure 1-5-41

3. Remove all connectors from power source PWB.
4. Remove two screws.
5. Release three hooks and then remove the power source PWB.
6. Check or replace the power source PWB and refit all the removed parts.

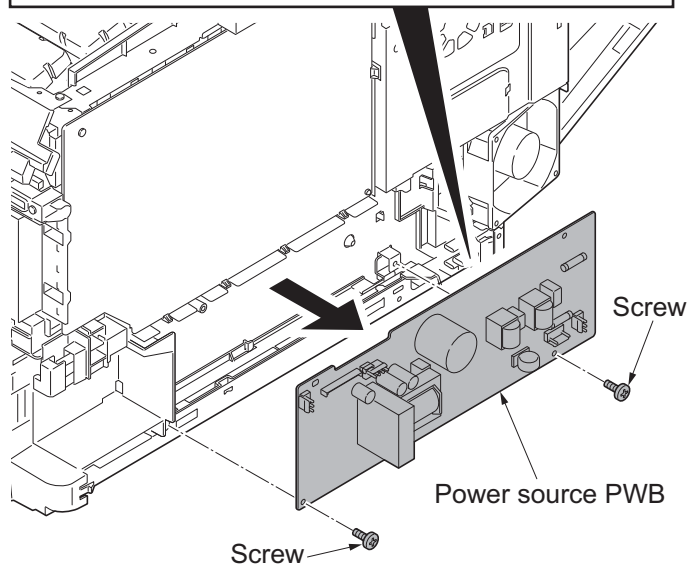
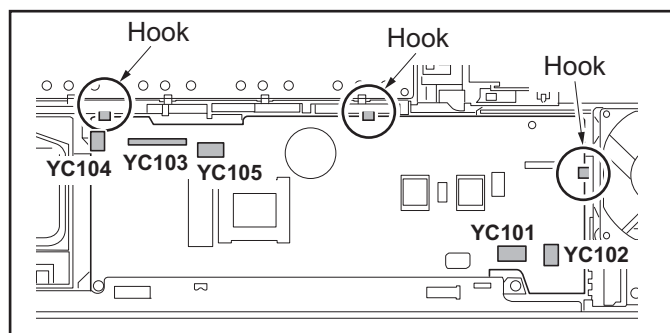


Figure 1-5-42

### (3) Detaching and refitting the main PWB

#### Procedure

1. Remove the FAX control PWB, if installed (see page 1-5-36).
2. Remove the right rear cover, right cover and right lower cover (see page 1-5-6).
3. Remove four screws and then remove the power source shield.  
Screws A and B are unidentical, therefore, do not mix up.

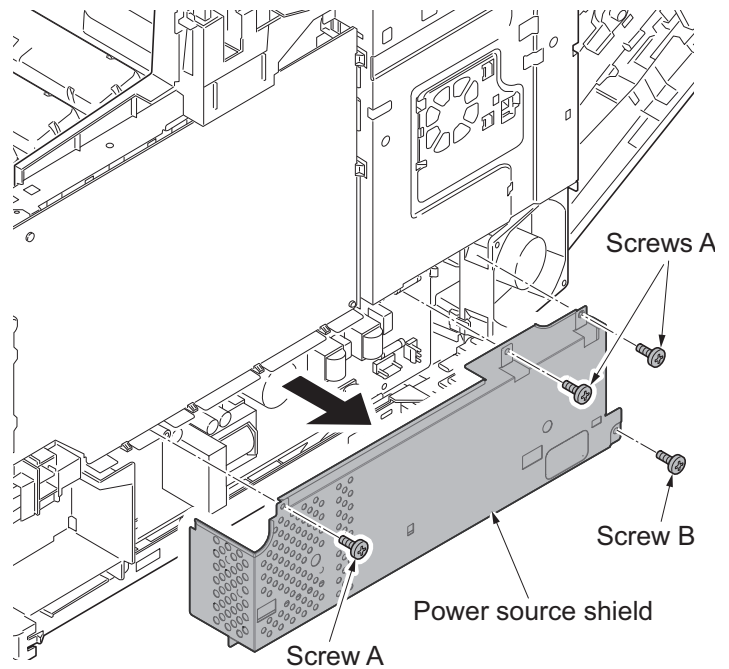


Figure 1-5-43

4. Open the fan bracket.
5. Slide the fan plate. Release four hooks and then remove the fan plate.

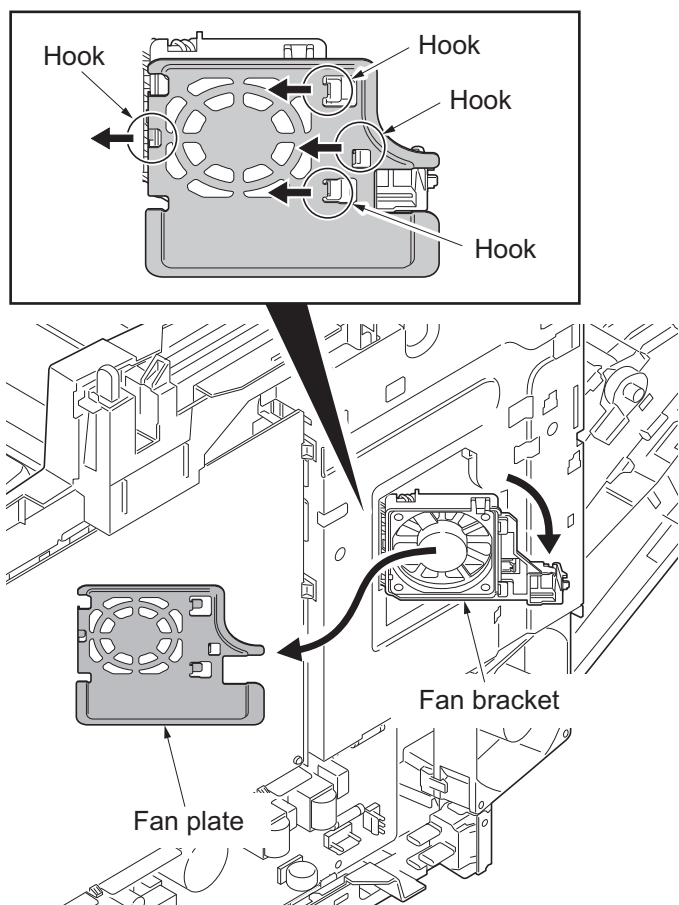


Figure 1-5-44



6. Remove the screw and then remove the fuser wire cover.

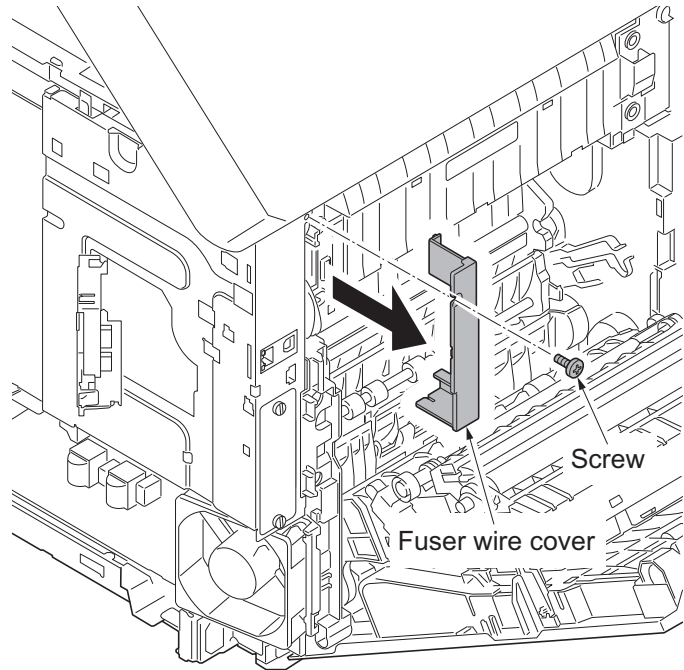


Figure 1-5-45

7. Remove five screws and then remove the controller shield.

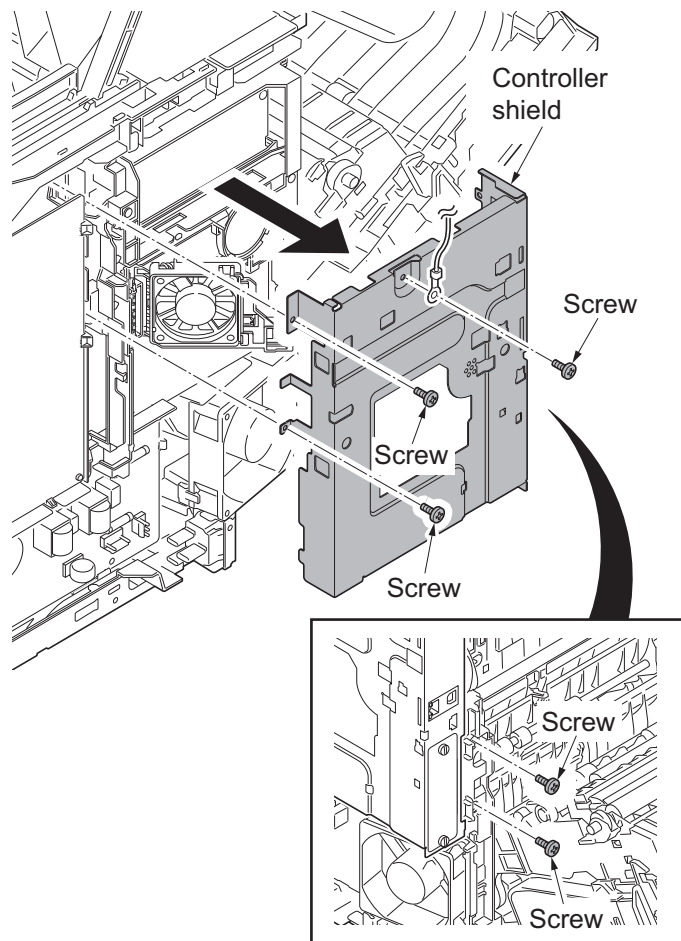


Figure 1-5-46

8. Remove the connector (YC41) of the controller fan motor.
9. Open the fan bracket and then remove it.

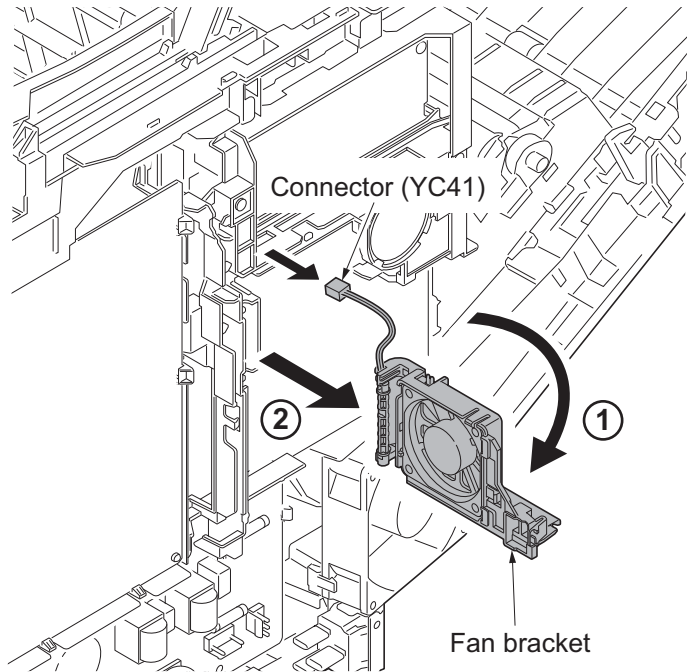


Figure 1-5-47

10. Remove seven connectors (YC37, YC41, YC40, YC100, YC38, YC39 and YC42) from the main PWB.

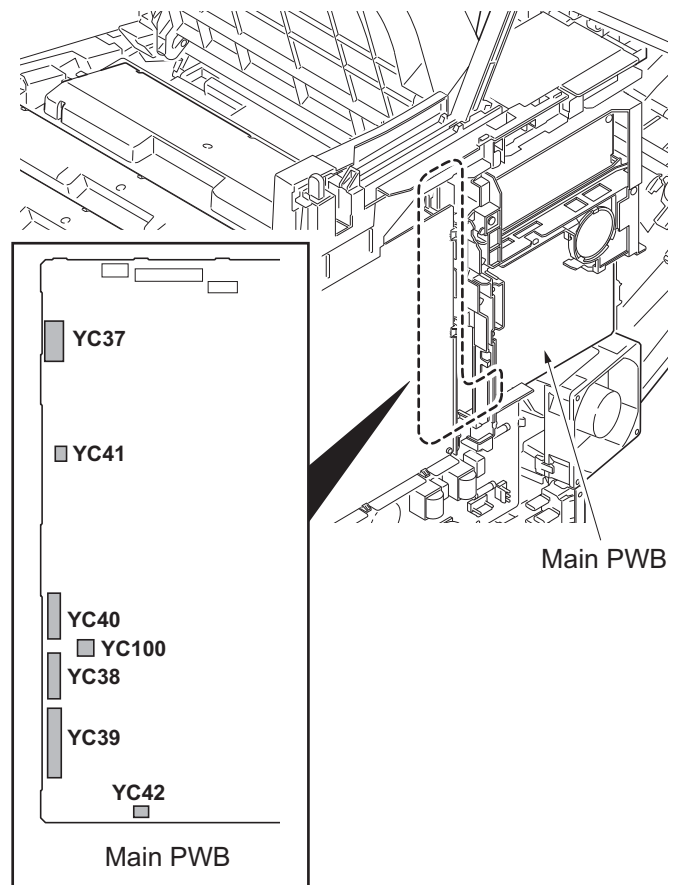
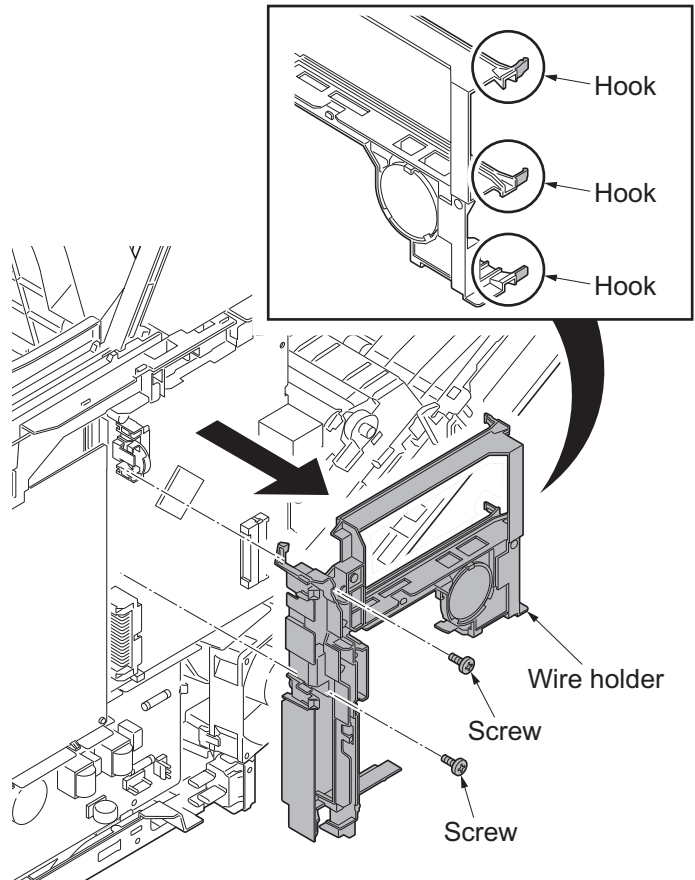


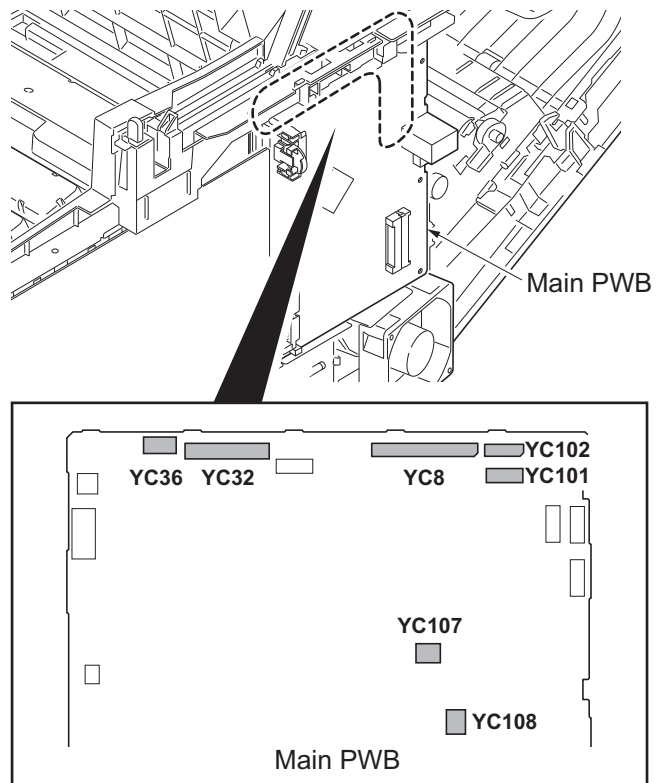
Figure 1-5-48

11. Remove two screws.
12. Release three hooks and then remove the wire holder.



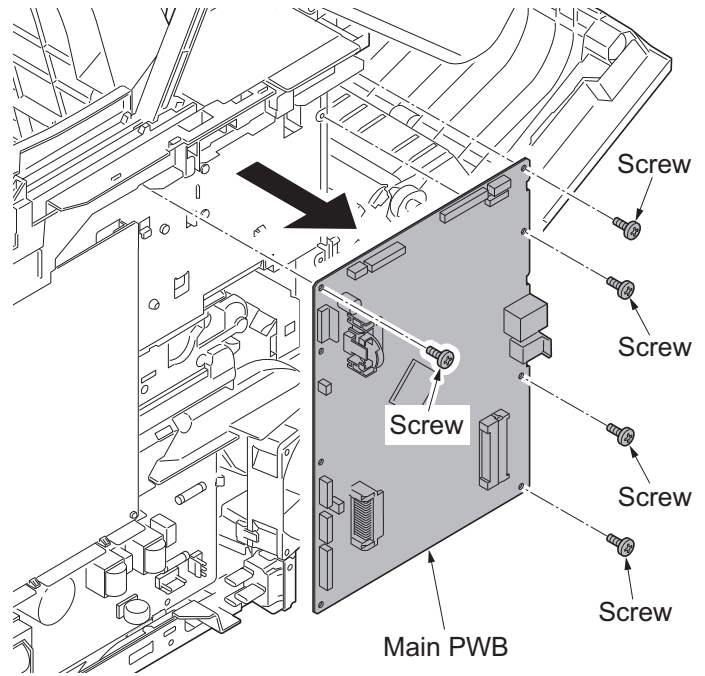
**Figure 1-5-49**

13. Remove six connectors (YC36, YC32, YC102, YC101, YC107, YC108) and FFC (YC8) from the main PWB.



**Figure 1-5-50**

14. Remove five screws and then remove the main PWB.
15. Check or replace the main PWB and refit all the removed parts.



**Figure 1-5-51**

#### (4) Detaching and refitting the high voltage PWB

##### Procedure

1. Remove the right rear cover and right cover (see page 1-5-6).
2. Remove the FFC from the high voltage PWB.

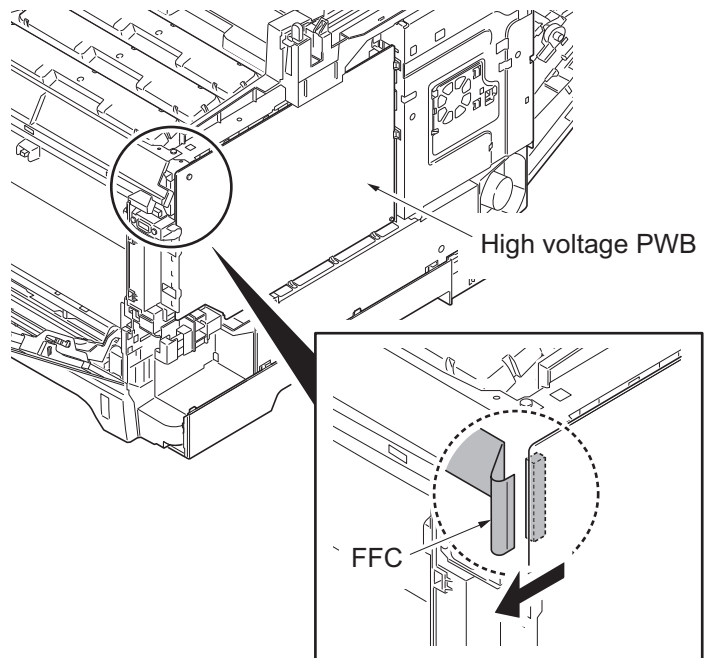


Figure 1-5-52

3. Remove the screw.
4. Release eight hooks and then remove the high voltage PWB.
5. Check or replace the high voltage PWB and refit all the removed parts.

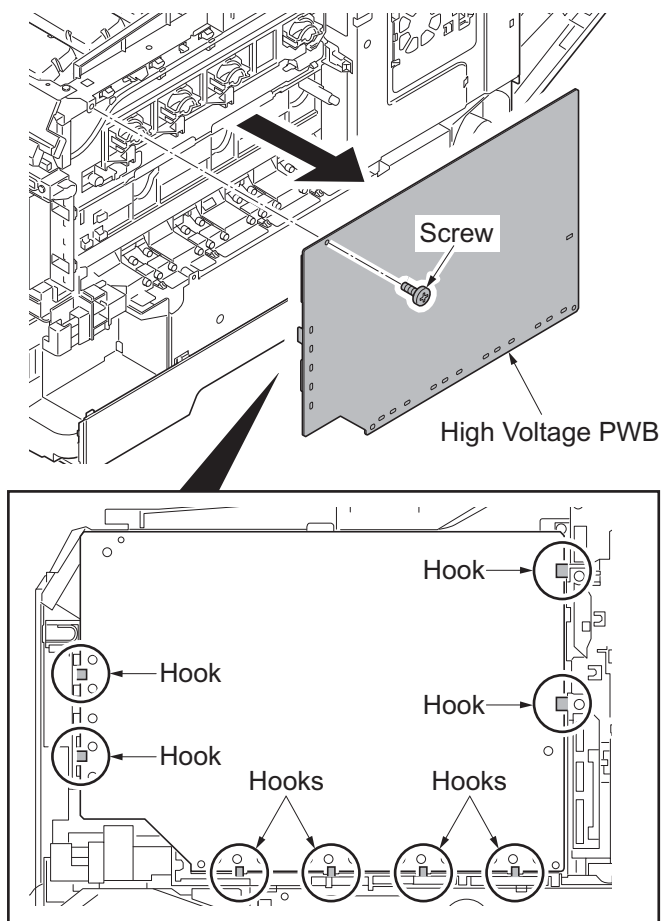
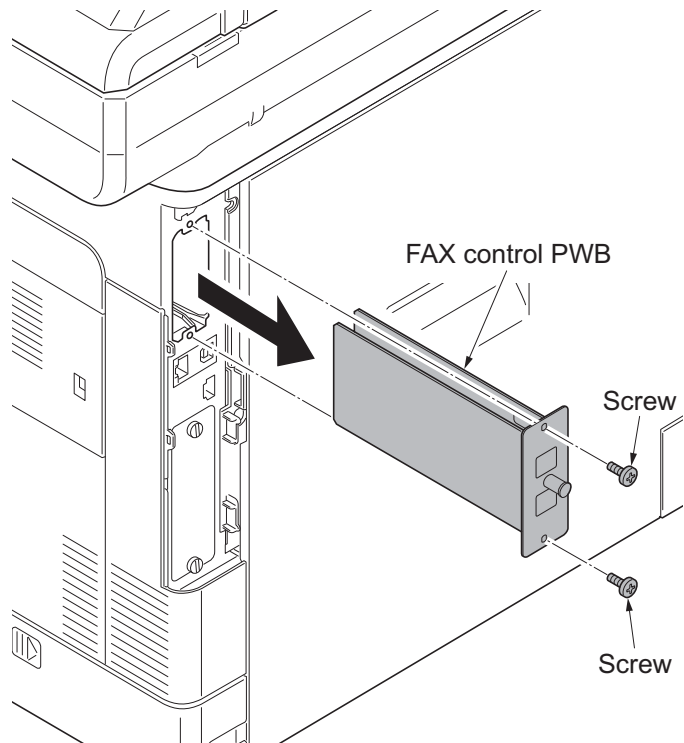


Figure 1-5-53

**(5) Detaching and refitting the FAX control PWB (4 in 1 model (with FAX) only)****Procedure**

1. Remove the IF cover (see page 1-5-3).
2. Remove two screws and then remove the FAX control PWB.
3. Check or replace the FAX control PWB and refit all the removed parts.

**Figure 1-5-54**

## 1-5-9 Drive section

### (1) Detaching and refitting the MP feed drive unit

#### Procedure

1. Remove the rear upper cover, right upper cover, left upper cover and front cover (see page 1-5-3).
2. Remove the right rear cover and right cover (see page 1-5-6).
3. Remove the left rear cover, left cover and left lower cover (see page 1-5-9).
4. Remove the inner cover (see page 1-5-11).
5. Remove the engine PWB (see page 1-5-27).
6. Release three hooks and then remove the left fan motor.

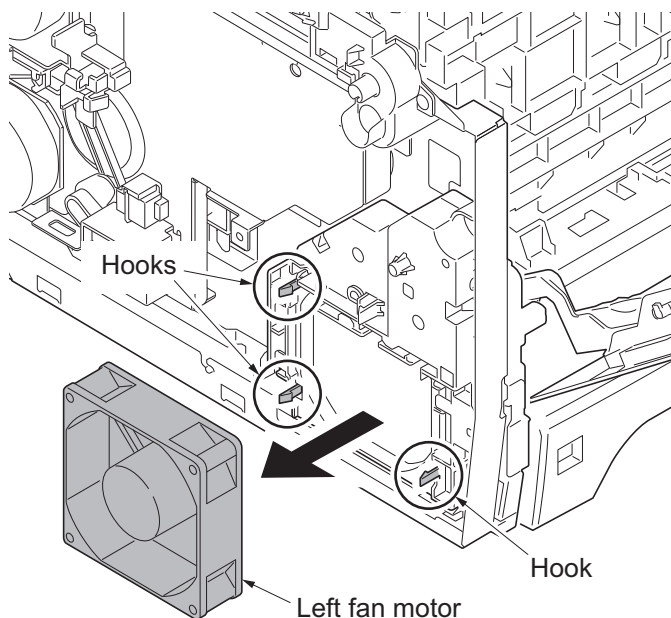


Figure 1-5-55

7. Turn the cam inside the device to the position indicated.
8. Remove three screws and then remove MP feed drive unit.
9. Check or replace the MP feed drive unit and refit all the removed parts.

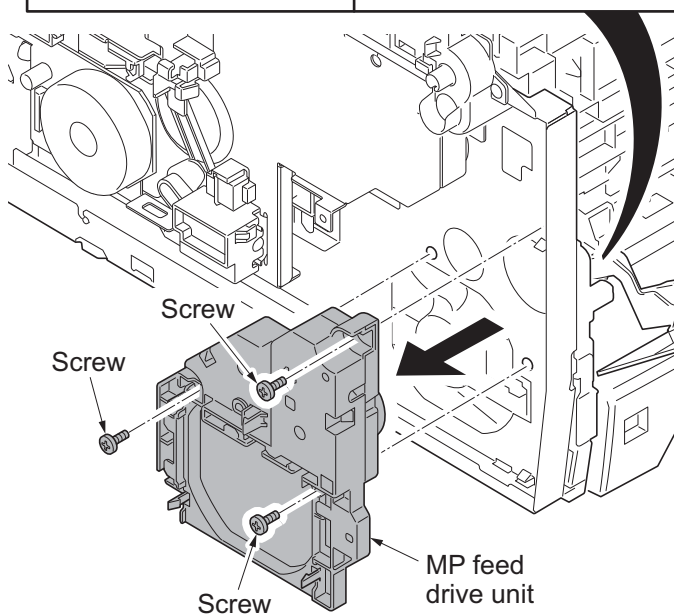
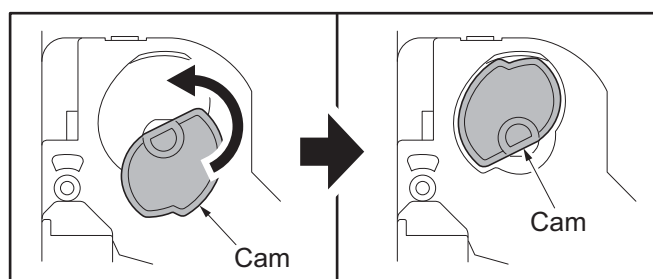


Figure 1-5-56

## (2) Detaching and refitting the drum/developing drive unit

### Procedure

1. Remove drum units (K, M, C, Y) and developing units (K, M, C, Y) (see page 1-5-21, 19).
2. Remove the rear upper cover, right upper cover, left upper cover and front cover (see page 1-5-3).
3. Remove the left rear cover, left cover and left lower cover (see page 1-5-9).
4. Remove the engine PWB (see page 1-5-27).
5. Remove the screw and release the hook, and then remove the container fan unit.

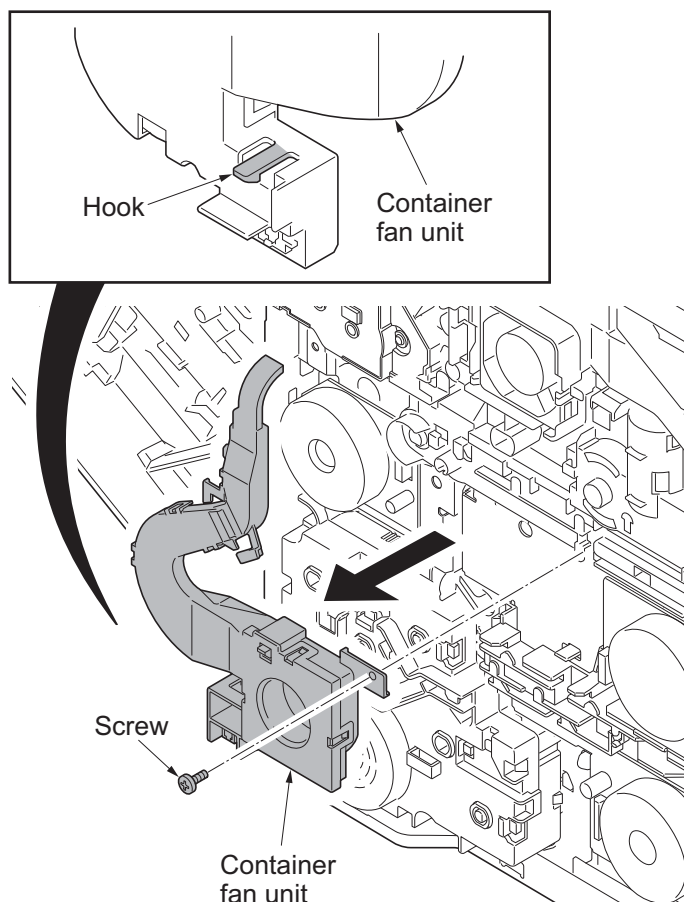


Figure 1-5-57

6. Remove the screw and then remove the ID guide.

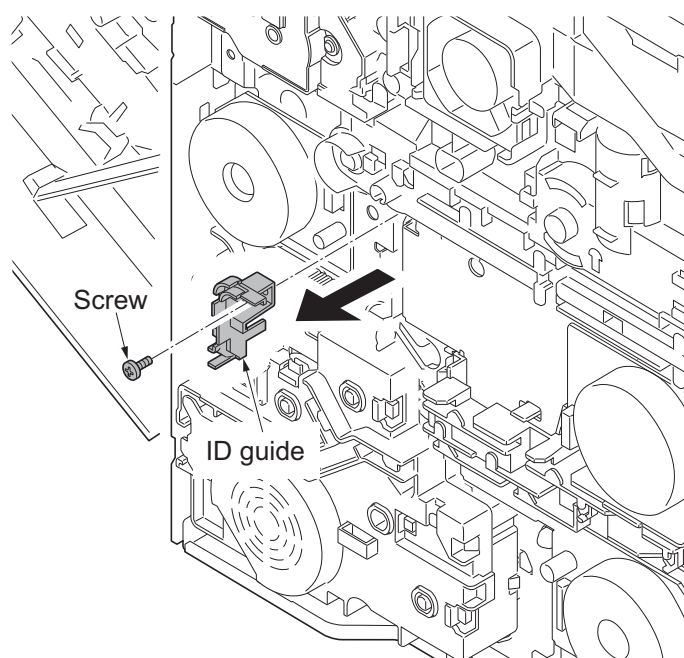
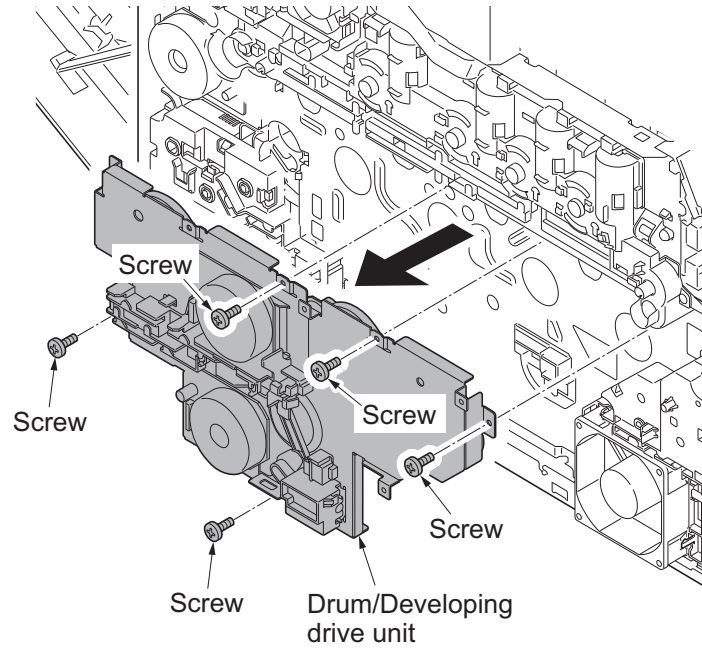


Figure 1-5-58



7. Remove five screws and then remove drum/developing drive unit.
8. Check or replace the drum/developing drive unit and refit all the removed parts.

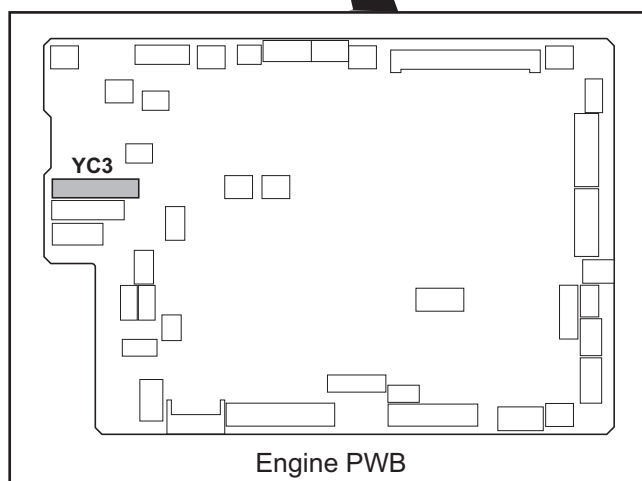
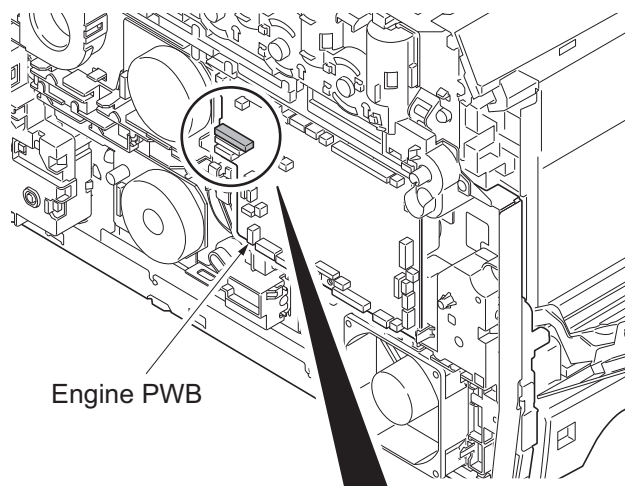


**Figure 1-5-59**

### (3) Detaching and refitting the paper feed drive unit

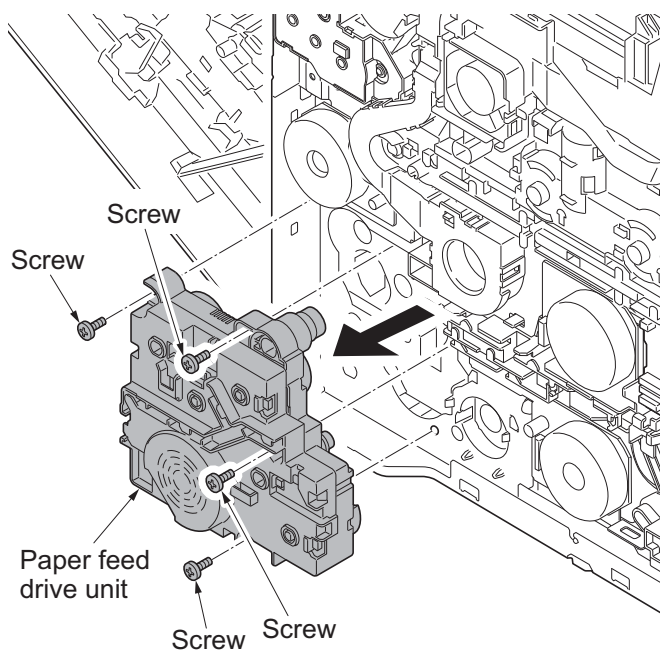
#### Procedure

1. Remove the rear upper cover, right upper cover, left upper cover and front cover (see page 1-5-3).
2. Remove the left rear cover, left cover and left lower cover (see page 1-5-9).
3. Remove connector (YC3) from engine PWB.



**Figure 1-5-60**

4. Remove four screws and then remove the paper feed drive unit.
5. Check or replace the paper feed drive unit and refit all the removed parts.



**Figure 1-5-61**

#### (4) Detaching and refitting the fuser pressure drive unit

##### Procedure

1. Remove the fuser unit (see page 1-5-26).
2. Remove the rear upper cover, right upper cover, left upper cover and front cover (see page 1-5-3).
3. Remove the left rear cover and left cover (see page 1-5-9).
4. Remove connector (YC38) from engine PWB.

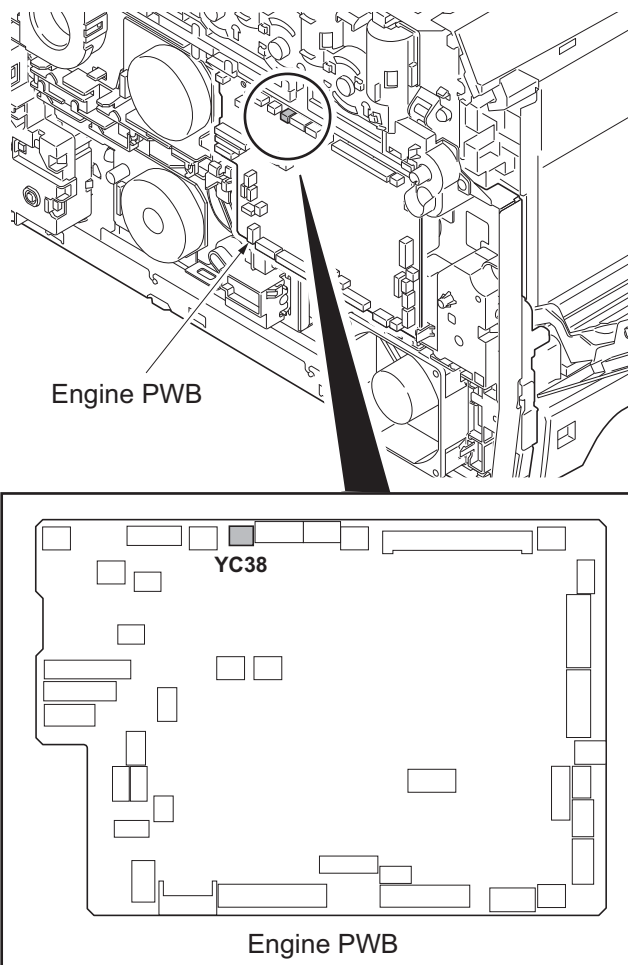
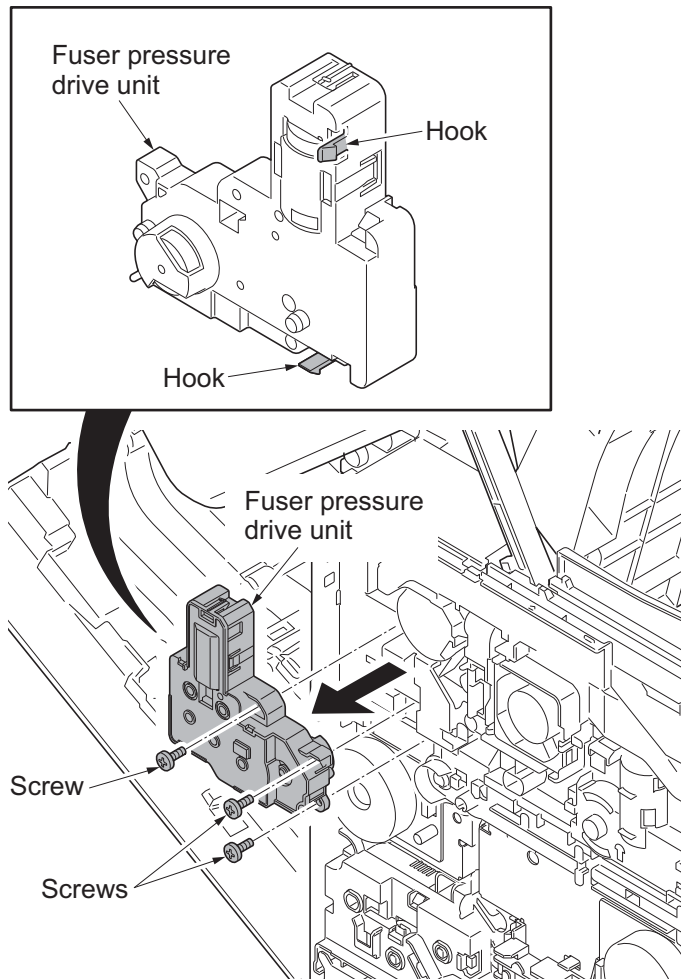


Figure 1-5-62

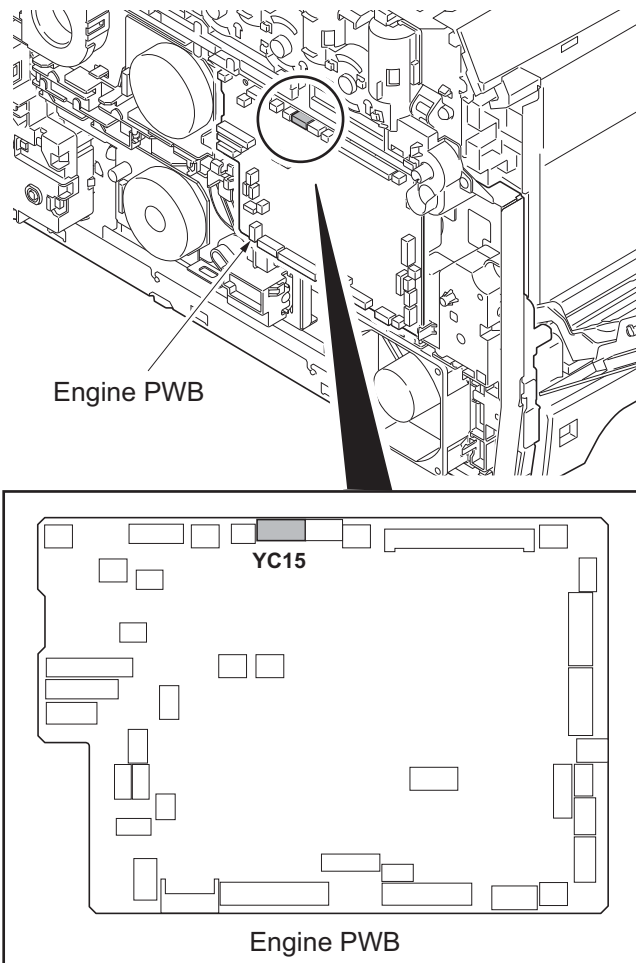
5. Remove the developing fan unit (see page 1-5-38).
6. Remove three screws.
7. Release two hooks remove the fuser pressure drive unit.
8. Check or replace the fuser pressure drive unit and refit all the removed parts.

**Figure 1-5-63**

## (5) Detaching and refitting the middle transfer drive unit

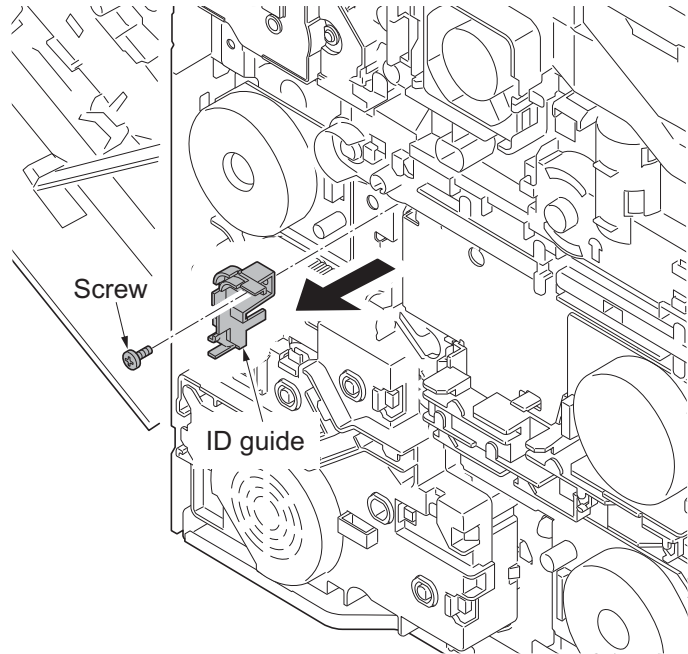
### Procedure

1. Remove the intermediate transfer unit (see page 1-5-22).
2. Remove the rear upper cover, right upper cover, left upper cover and front cover (see page 1-5-3).
3. Remove the left rear cover and left cover (see page 1-5-9).
4. Remove the fuser pressure drive unit (see page 1-5-41).
5. Remove connector (YC15) from engine PWB.



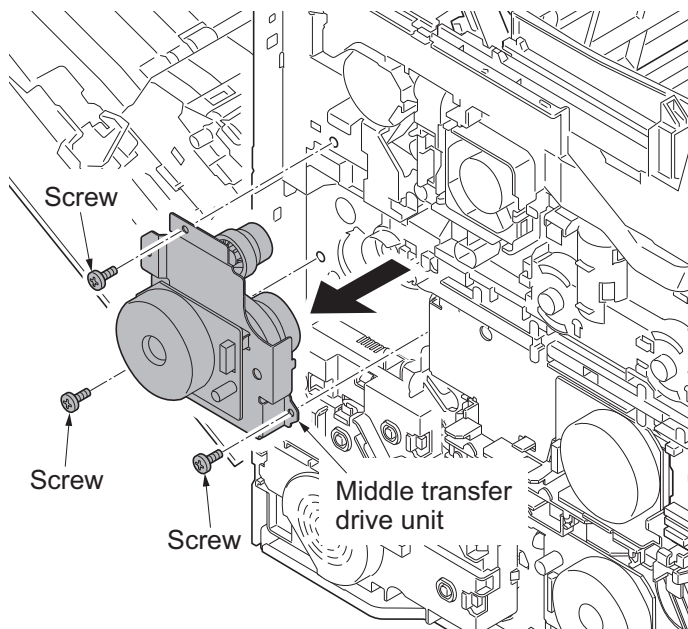
**Figure 1-5-64**

6. Remove the screw and then remove the ID guide.



**Figure 1-5-65**

7. Remove three screws and then remove the middle transfer drive unit.
8. Check or replace the middle transfer drive unit and refit all the removed parts.



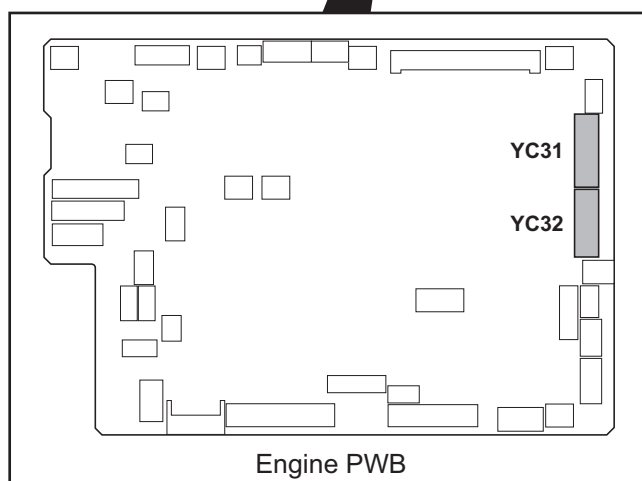
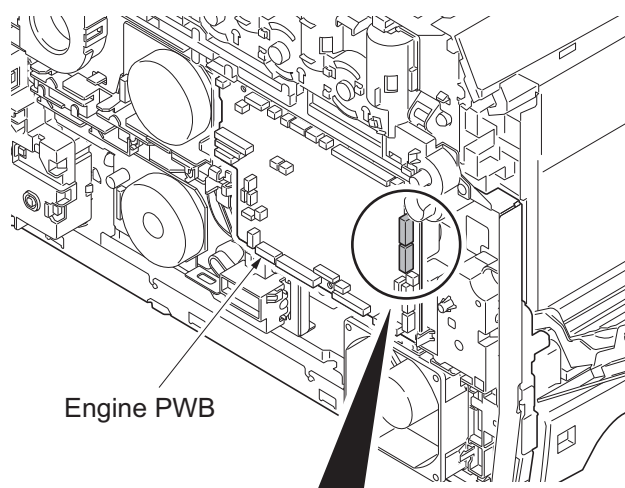
**Figure 1-5-66**

## 1-5-10 Optical section

### (1) Detaching and refitting the laser scanner unit

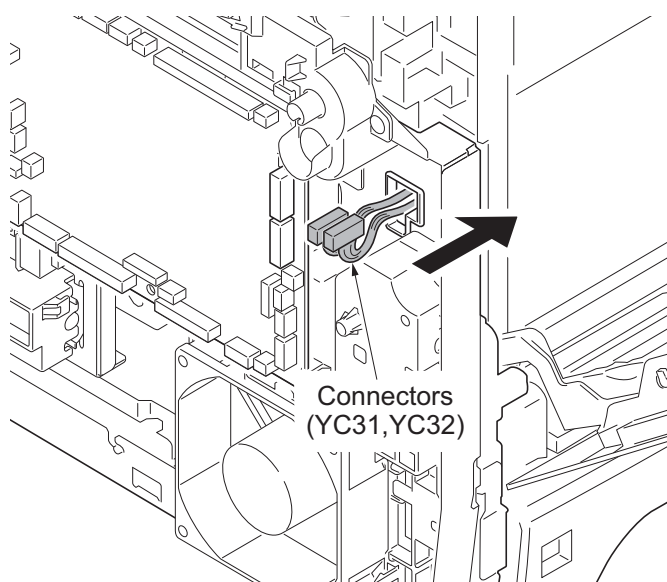
#### Procedure

1. Remove the intermediate transfer unit (see page 1-5-22).
2. Remove drum units (K, M, C, Y) and developing units (K, M, C, Y) (see page 1-5-21, 19).
3. Remove the rear upper cover, right upper cover, left upper cover and front cover (see page 1-5-3).
4. Remove the left rear cover and left cover (see page 1-5-9).
5. Remove two connectors (YC32, YC32) from engine PWB.



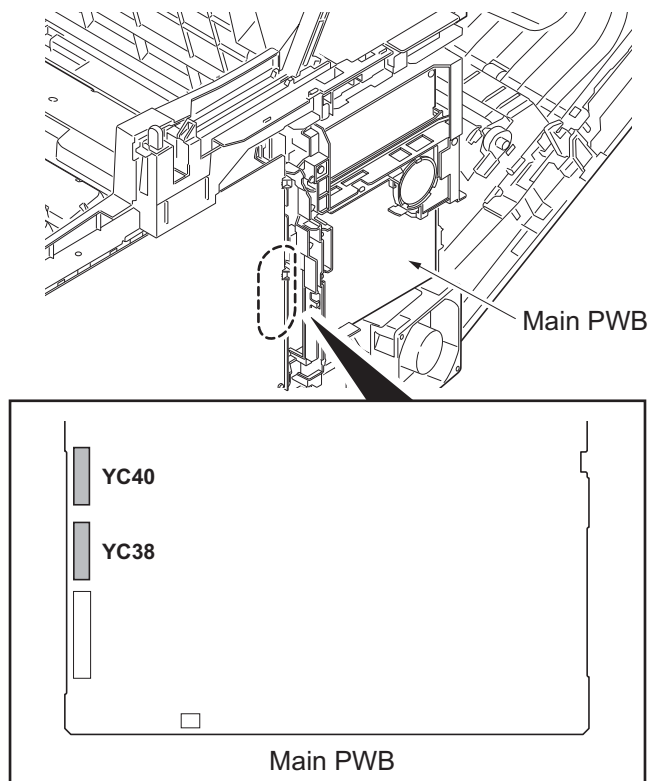
**Figure 1-5-67**

6. Draw two connectors (YC31, YC32) into the machine inside.



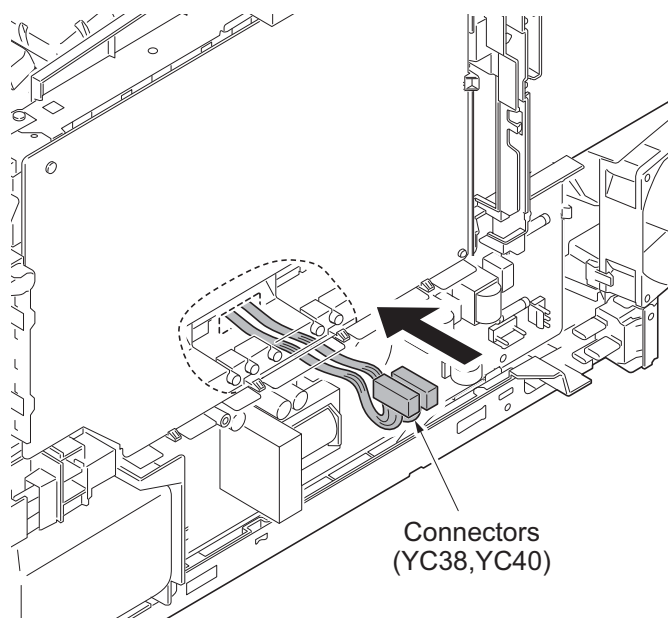
**Figure 1-5-68**

7. Remove the right rear cover, right cover and right lower cover (see page 1-5-6).
8. Remove the controller shield (see page 1-5-30).
9. Remove two connectors (YC38, YC40) from main PWB.



**Figure 1-5-69**

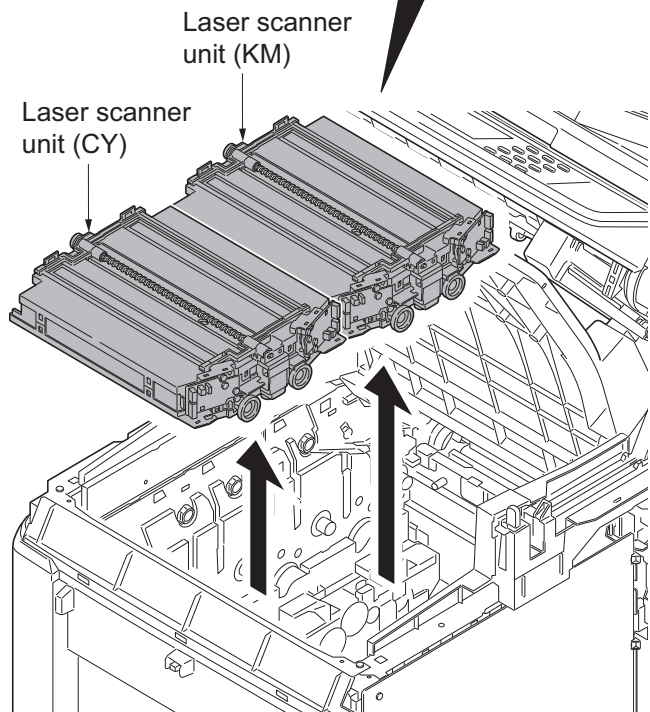
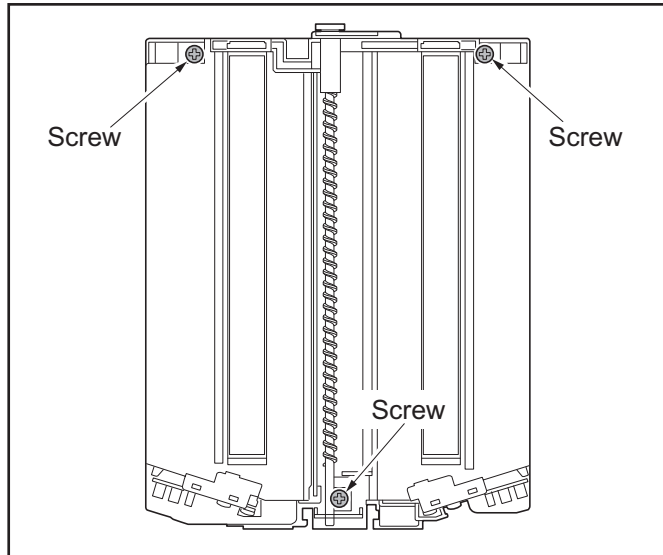
10. Draw two connectors (YC38, YC40) into the machine inside.



**Figure 1-5-70**



11. Remove each three screws and then remove laser scanner unit (KM, CY).
12. Check or replace the laser scanner unit and refit all the removed parts.



**Figure 1-5-71**

## (2) Detaching and refitting the scanner unit

### Procedure

1. Remove the document processor (see page 1-5-78).
2. Remove five connectors and the FFC from main PWB.
3. Open the scanner unit.

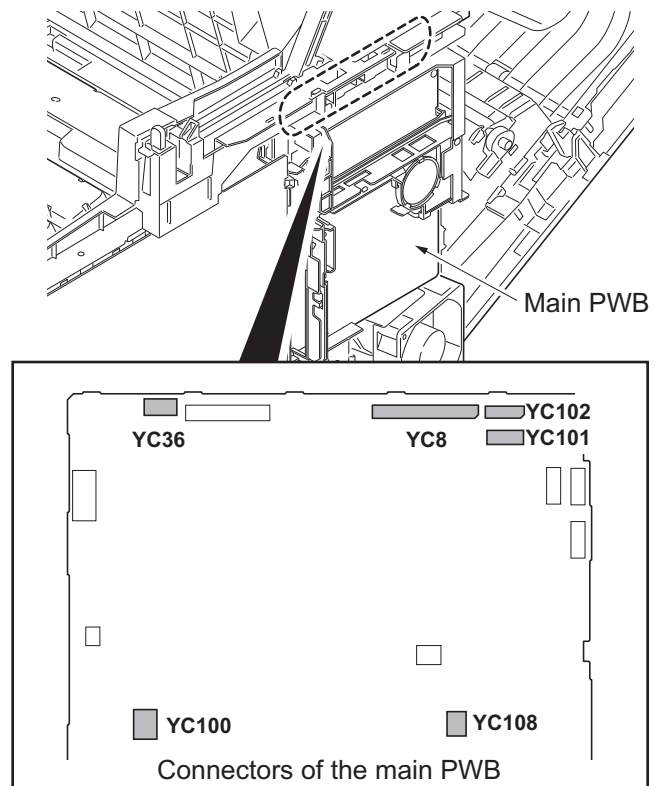


Figure 1-5-72

4. Remove the motor wire, CCD wire and operation panel wires from the wire holder.

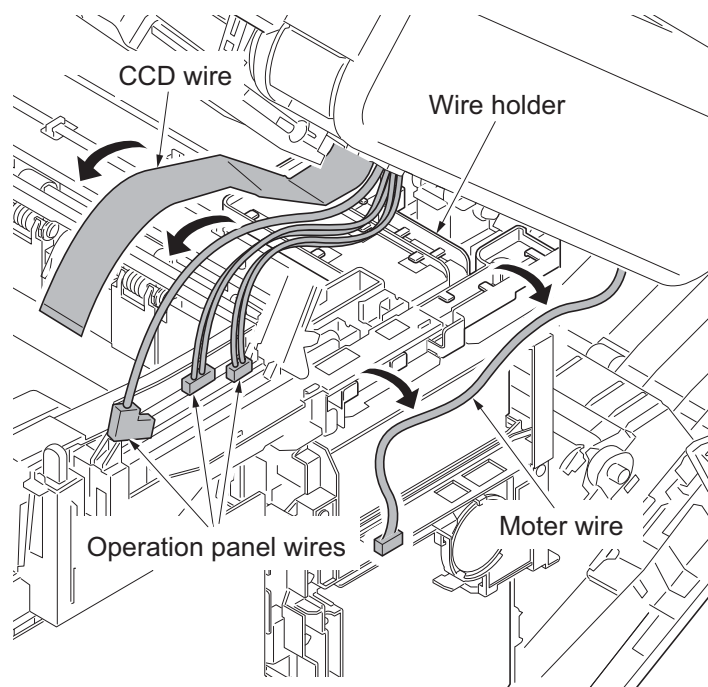


Figure 1-5-73

5. Release each four hooks and then remove left and right rails.

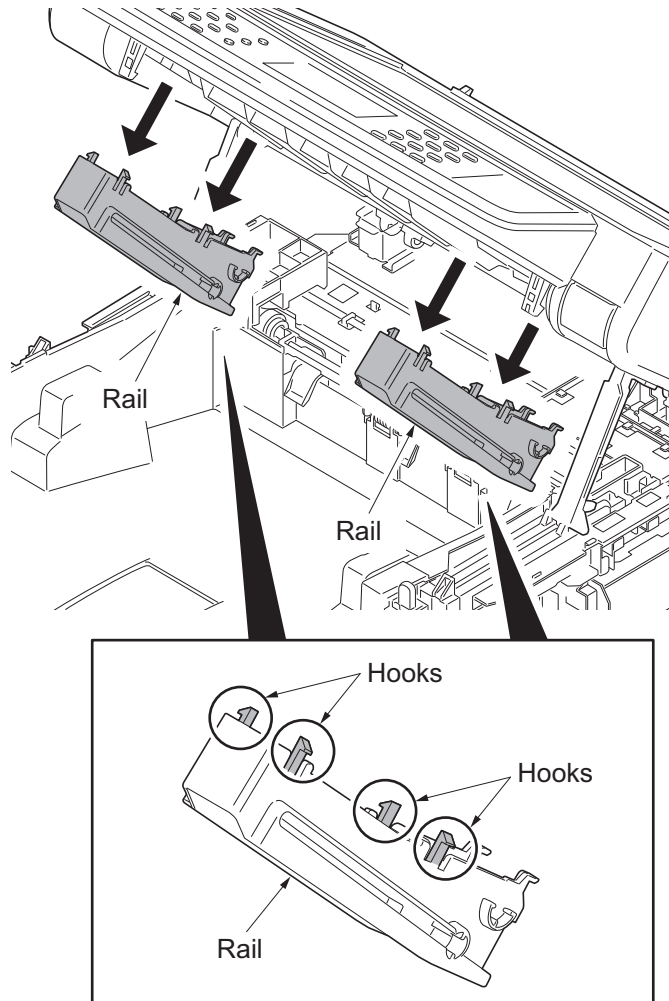


Figure 1-5-74

6. Remove two springs from left and right rails.

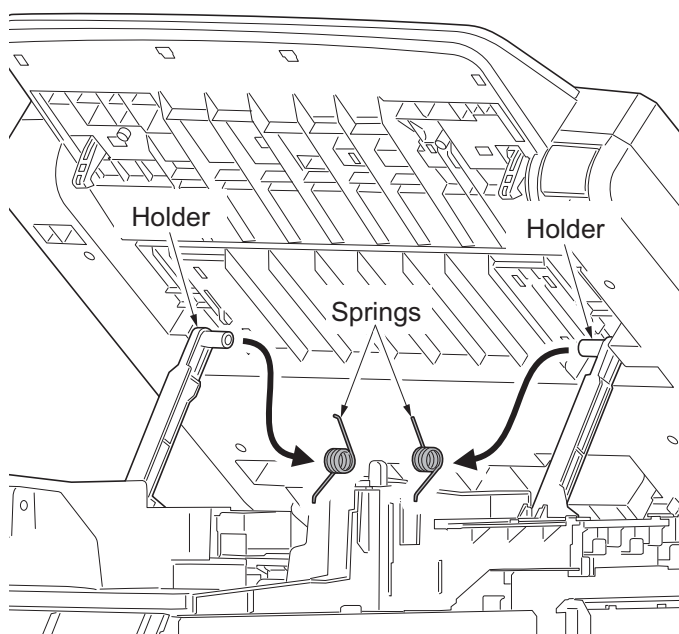


Figure 1-5-75

7. Remove left and right rails from the scanner unit.

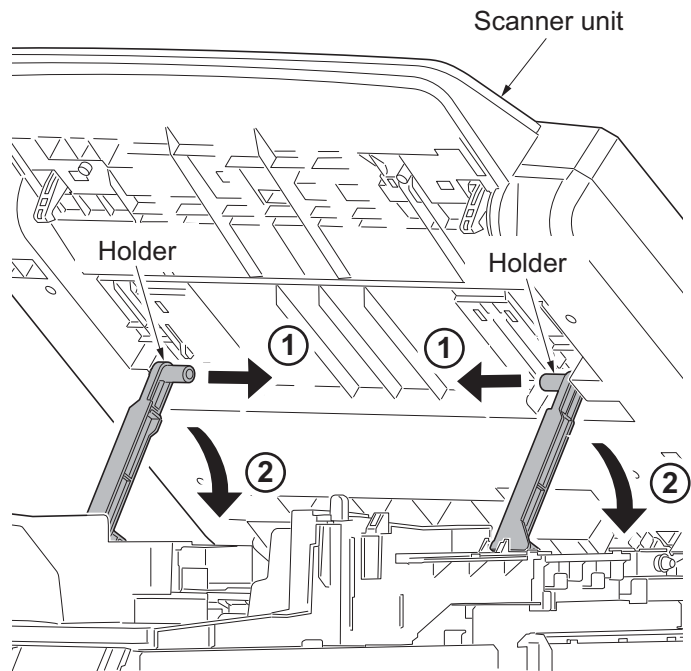


Figure 1-5-76

8. Remove the spring and then pull right and left pin out.

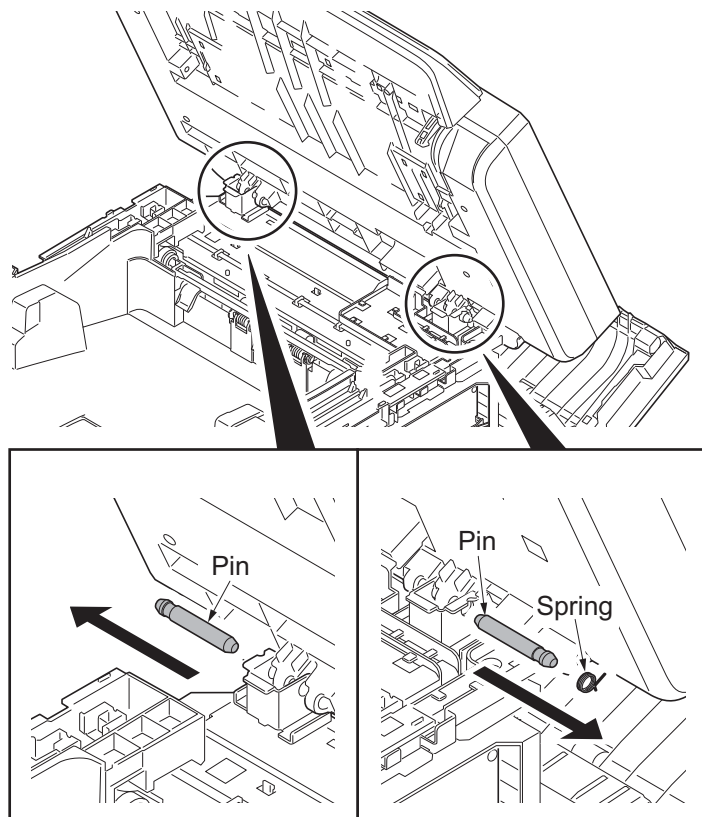
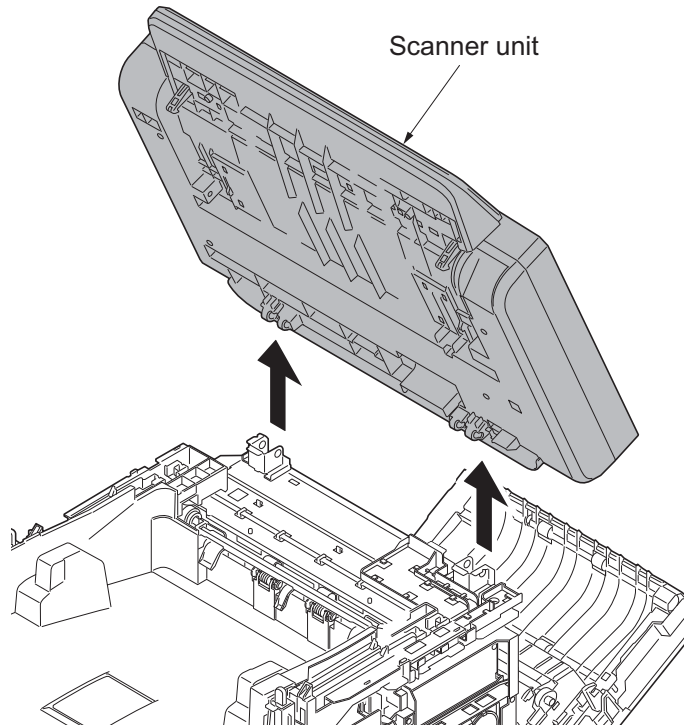


Figure 1-5-77

9. Remove the scanner unit.



**Figure 1-5-78**

### (3) Detaching and refitting the image scanner unit

#### Procedure

(Detach the covers)

1. Open the paper conveying unit.
2. Release the hook and then remove the IF cover.

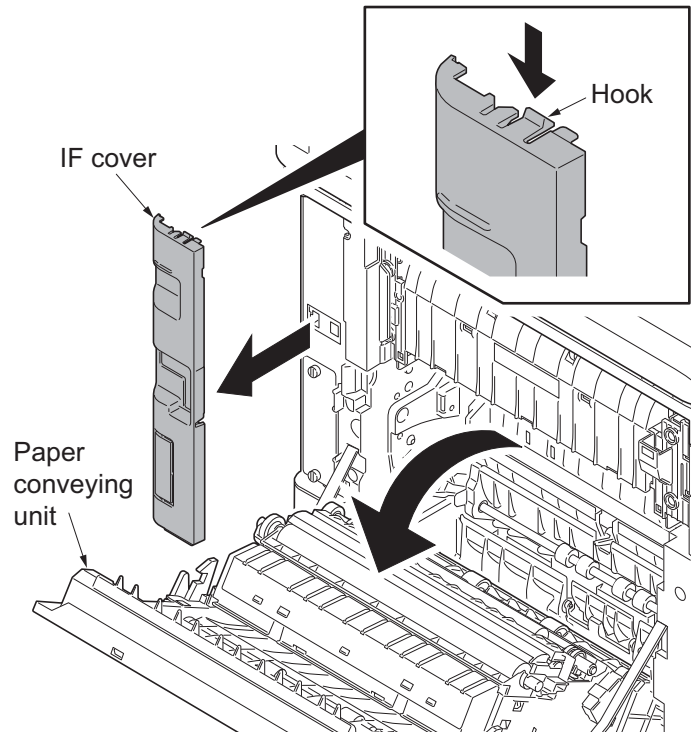


Figure 1-5-79

3. Remove two screws and then remove the rear uppercover.

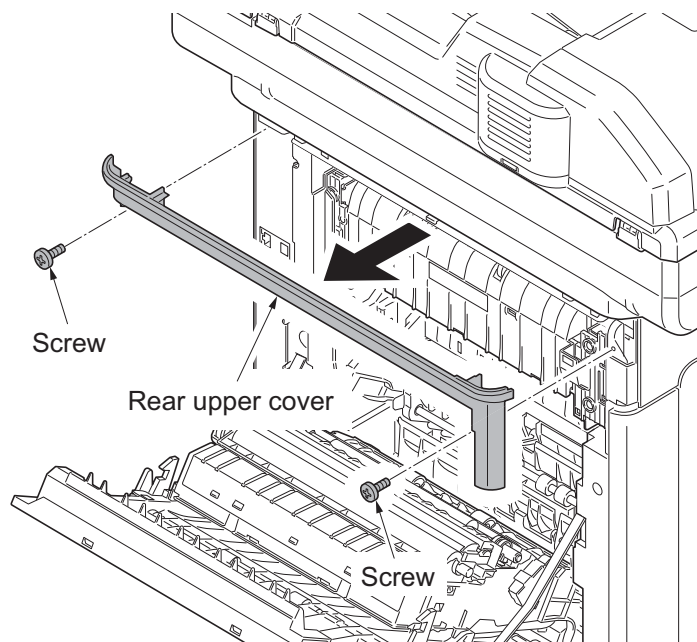


Figure 1-5-80

4. Pull the inner tray lever and open the inner tray.
5. Release two hooks. Slide the right upper cover backward and then remove it.

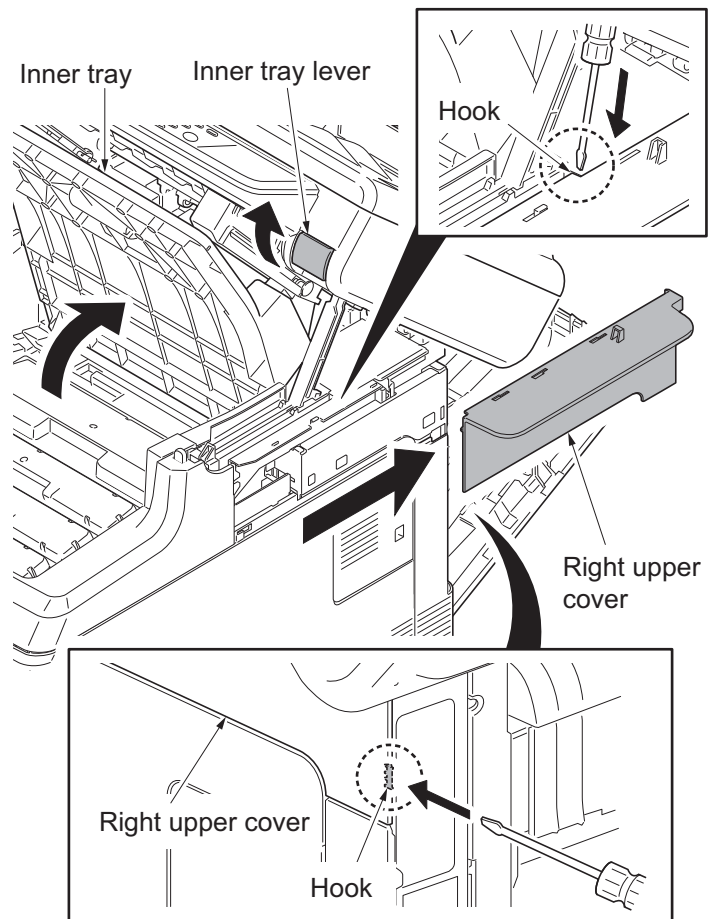


Figure 1-5-81

6. Release the hook. Slide the left upper cover backward and then remove it.

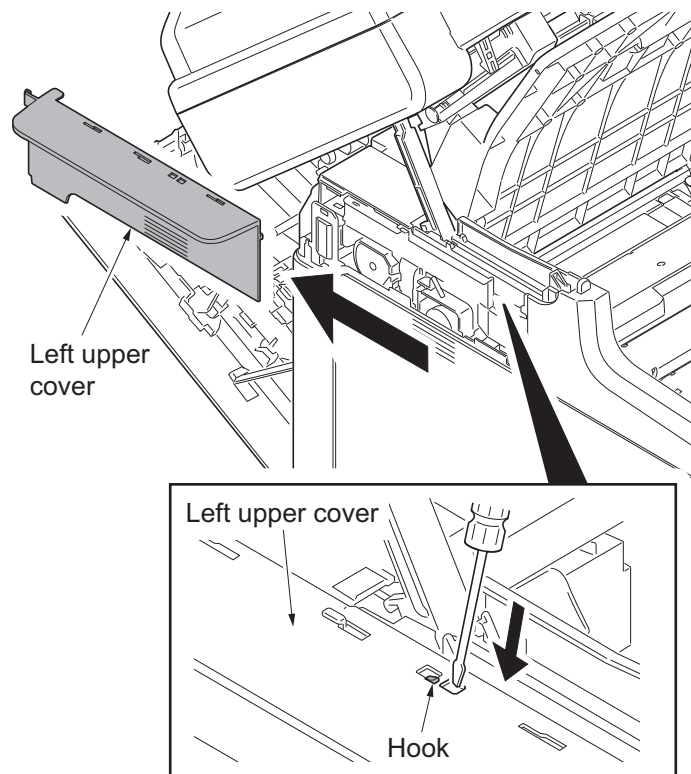


Figure 1-5-82

7. Release five hooks (hook A → B) and then remove the front cover.

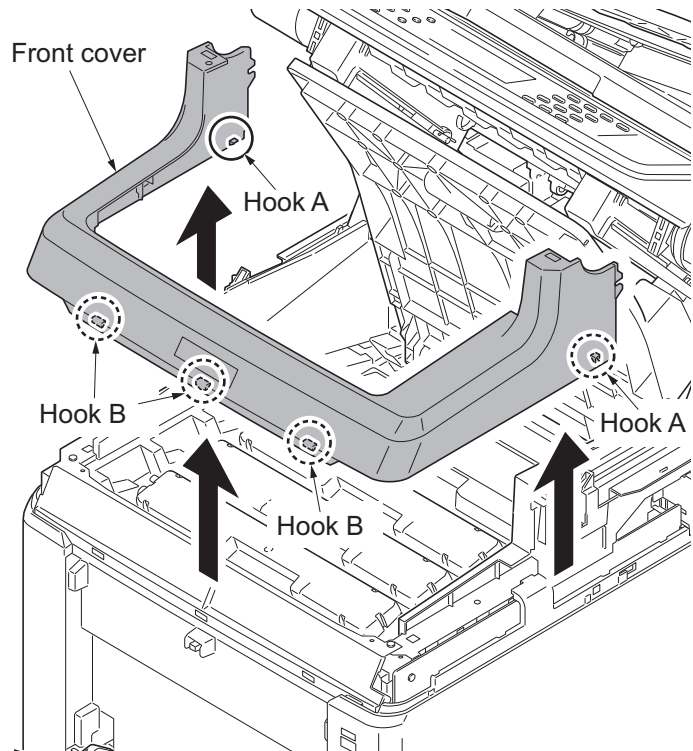


Figure 1-5-83

8. Slide the power source cover backward and then remove it.

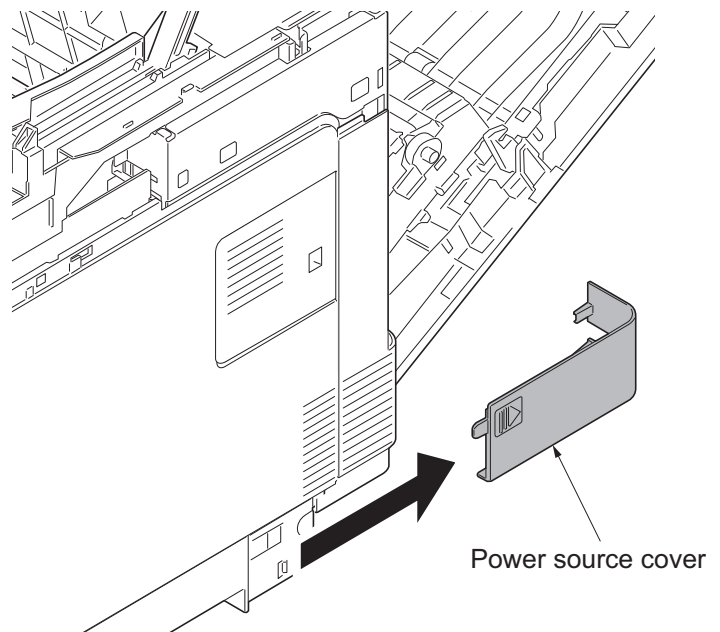


Figure 1-5-84



9. Remove the screw.
10. Release four hooks. Slide the right rear cover backward and then remove it.

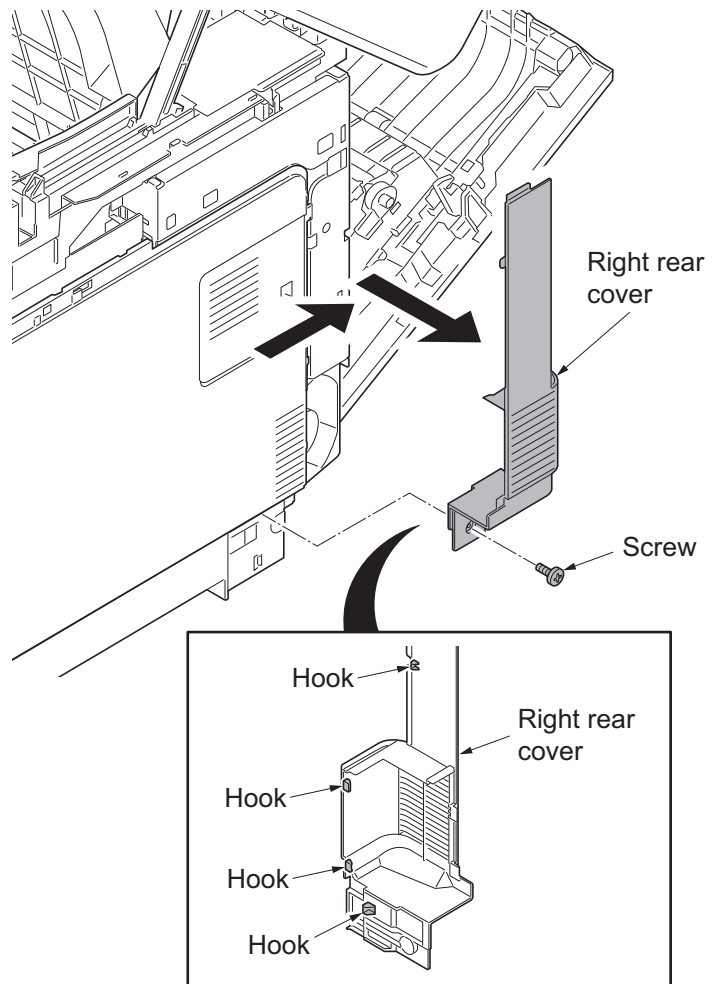


Figure 1-5-85

11. Open the memory cover and then remove it.

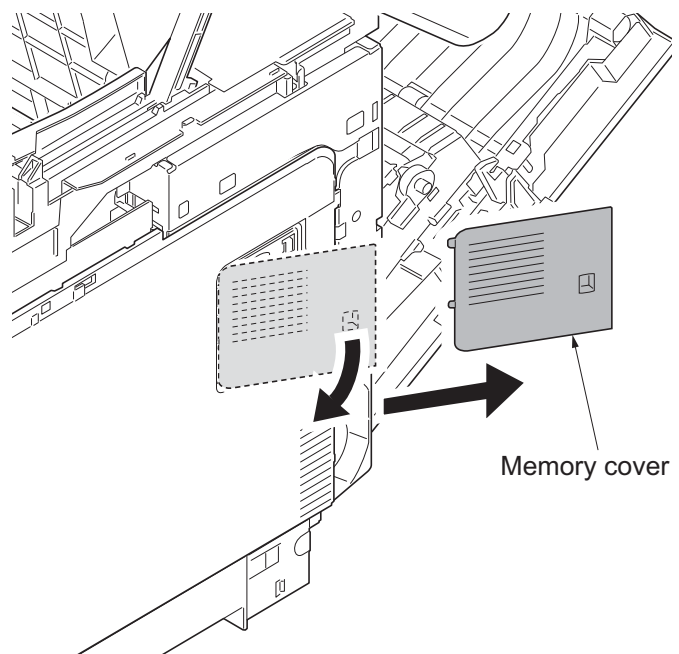


Figure 1-5-86

12. Open the waste toner cover.
13. Push the lock release button and then remove the waste toner box.  
(Close the cap of the waste toner box.)

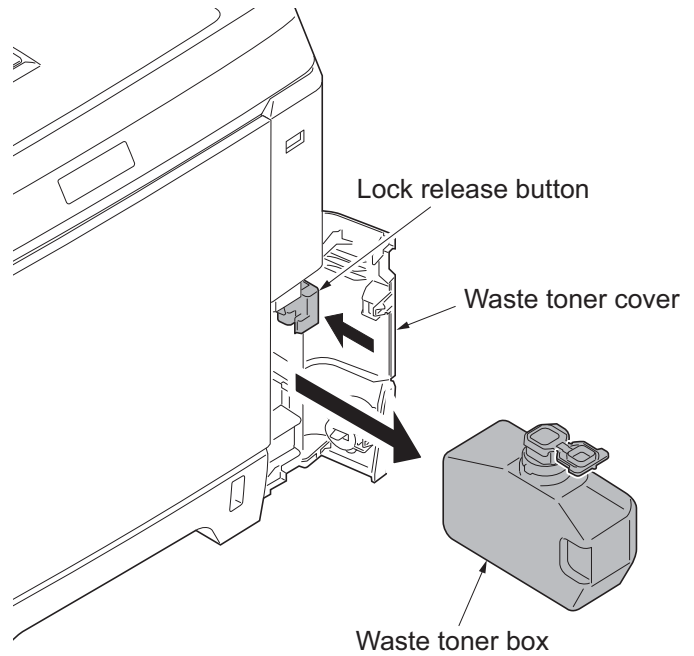


Figure 1-5-87

14. Open the MP tray.
15. Release four hooks (hook A → B → C).  
Slide the right cover forward and then remove it.
16. Remove the waste toner cover.

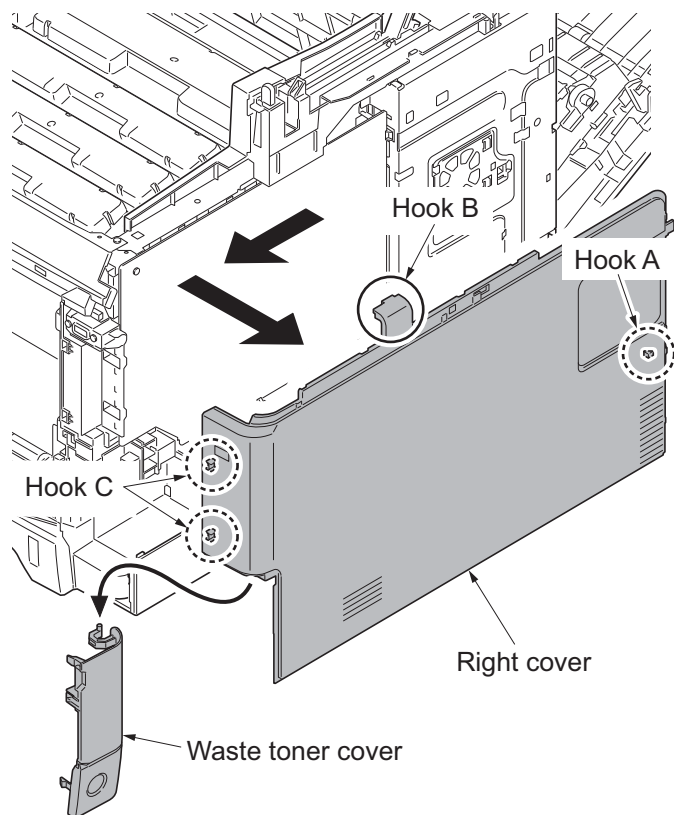


Figure 1-5-88

17. Release the hook. Slide the right lower cover forward and then remove it.

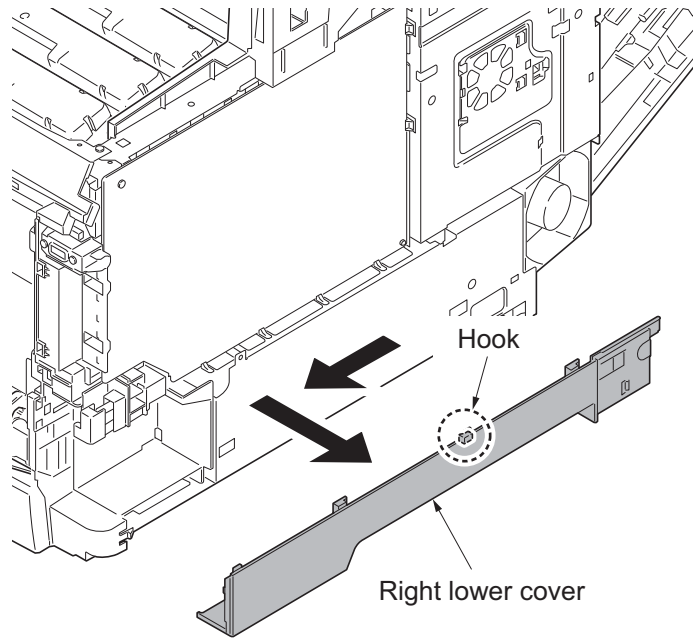


Figure 1-5-89

(Fully open the Document Processor and the scanner unit.)

18. Remove the left and right pins by pushing the pins out from inside while opening the top tray till the half way of the opening angle. (After this procedure, the top tray goes down and only the scanner unit opens.)

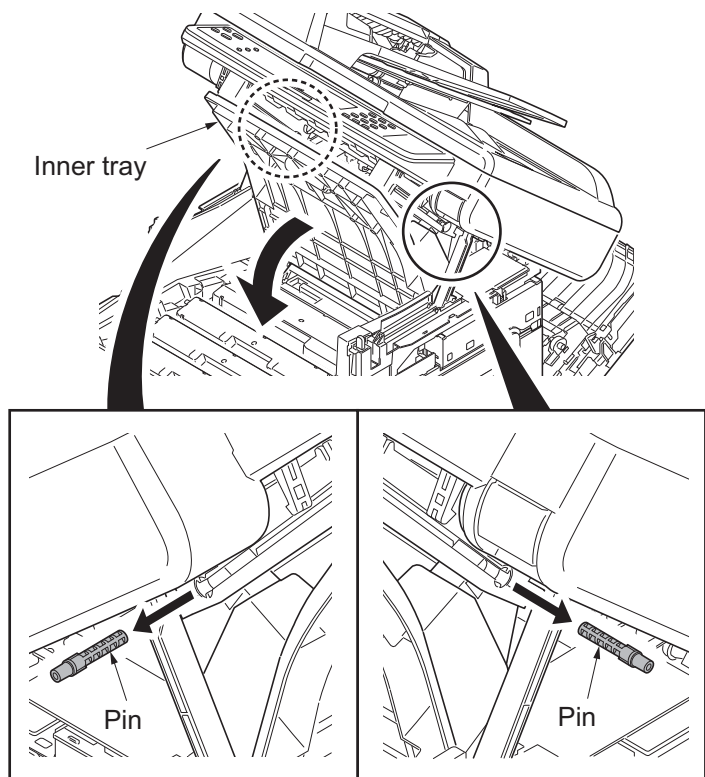


Figure 1-5-90

19. Release each four hooks and remove the left and right rails.

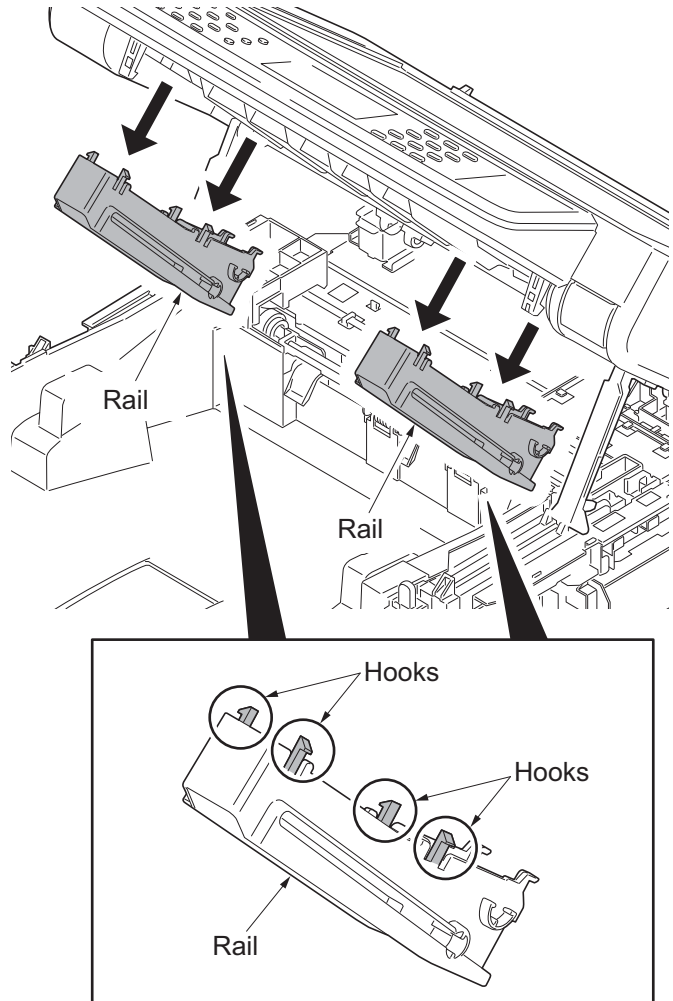


Figure 1-5-91

20. Remove two springs from the left and right holders.

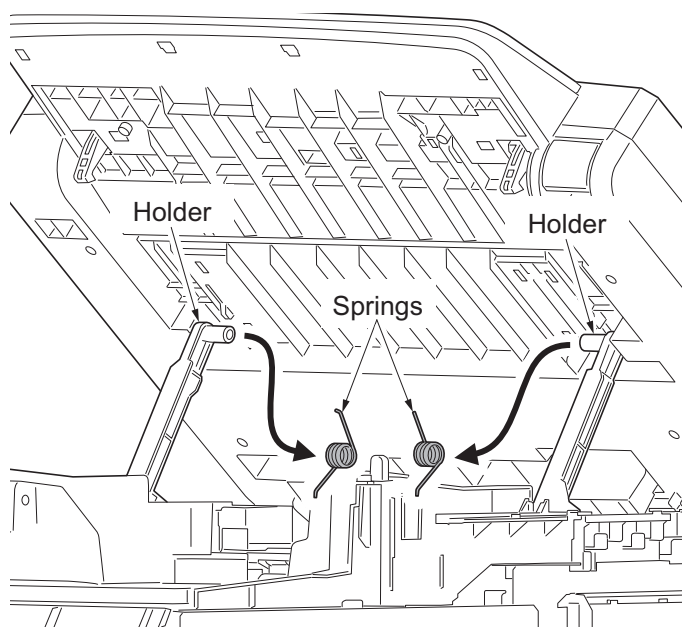
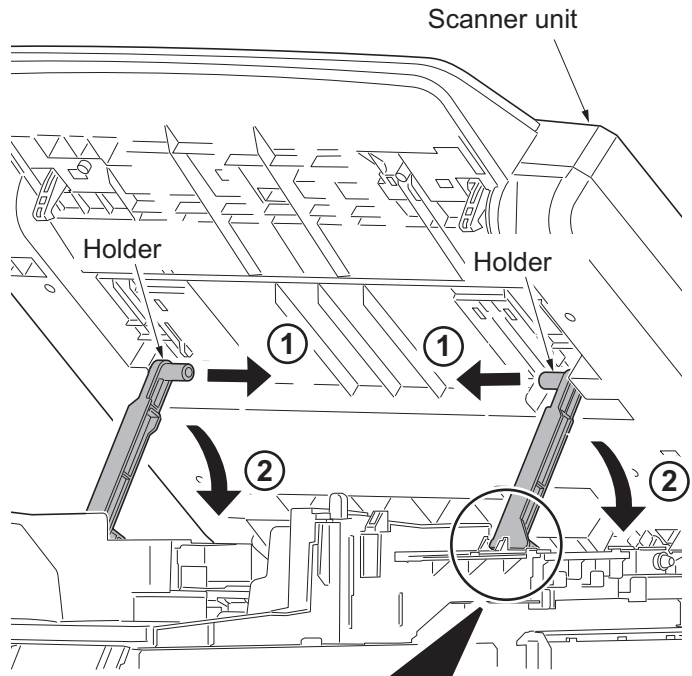


Figure 1-5-92

21. Remove left and right holders from the scanner unit.



\*: When reattaching the holders in the scanner unit, assemble the parts so that the holders are in front of the triangle ribs of the ISU frame.  
(If the holders are behind the triangle ribs, the scanner unit cannot be closed.)

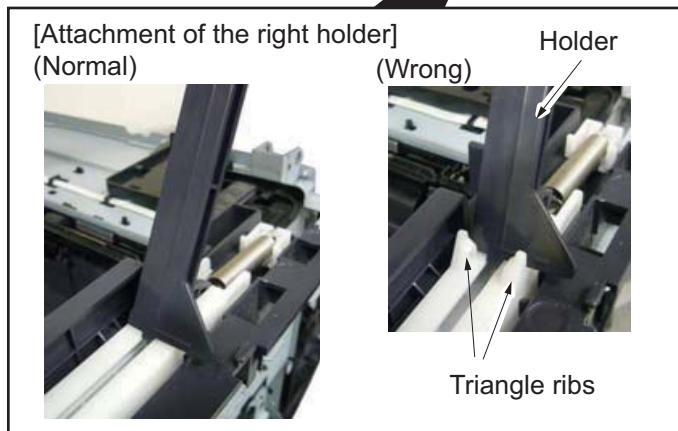


Figure 1-5-93

22. Release four hooks and remove the upper middle cover.

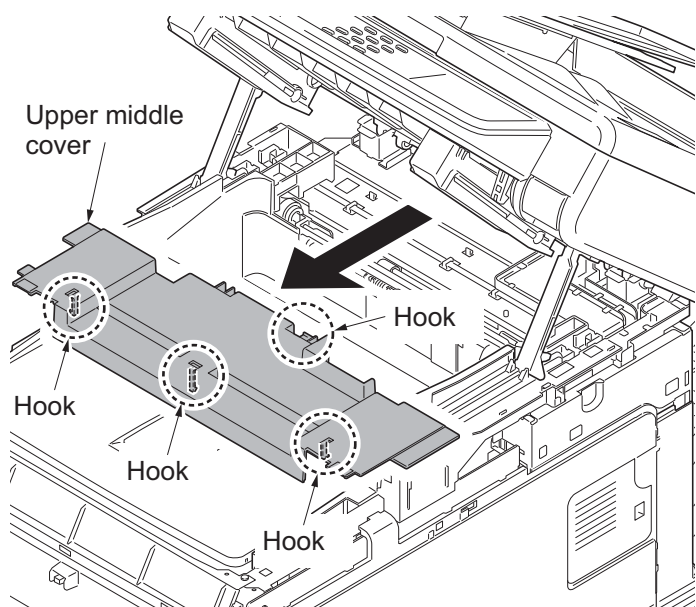
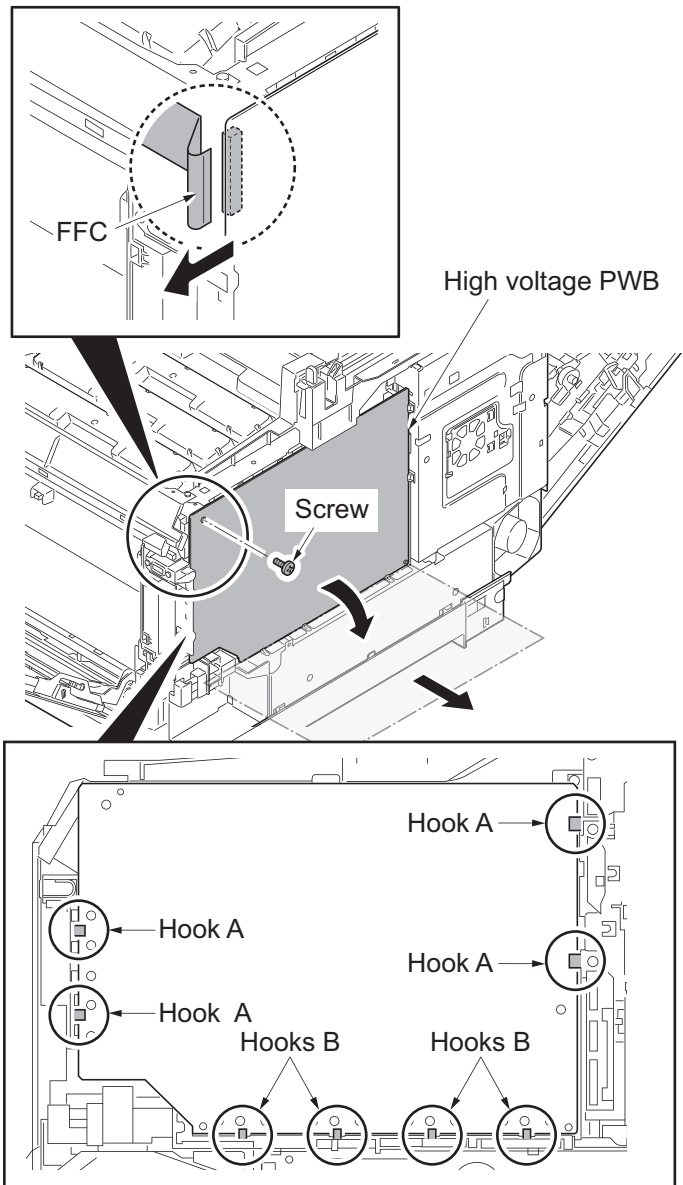


Figure 1-5-94

(Detach the high voltage PWB (HVU PWB).)

23. Remove the screw.
24. Release four hooks of the upside of the PWB circled in the figure and slant the upside of the high voltage PWB like opening it, and then remove the FFC.
25. After surely slanting the high voltage PWB till ninety degree, pull it out toward the machine right side.

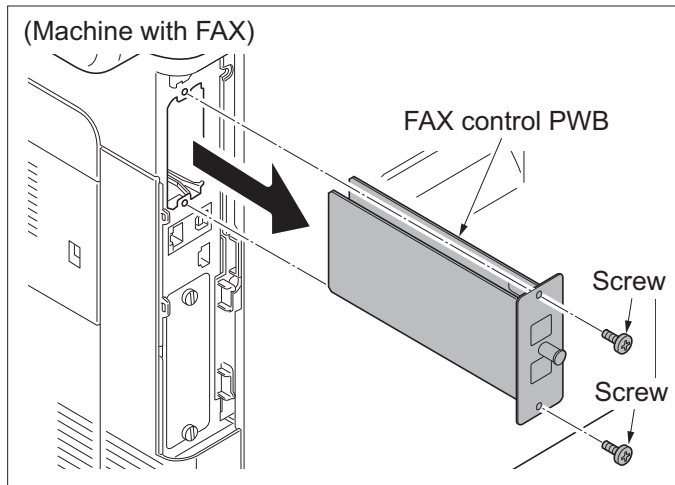
\*: If trying to pull out the PWB on the way of slanting till ninety degree, the hooks securing the PWB's low side may damage. (The hooks are circled at the figure.)



(Disconnect the connectors on the main PWB.)

[For the machine with FAX]

26. Remove two screws and then remove the FAX control PWB.



[For the machine with the hard disk or the network interface card]

27. Remove two pins and then pull out the hard disk or the network interface card.

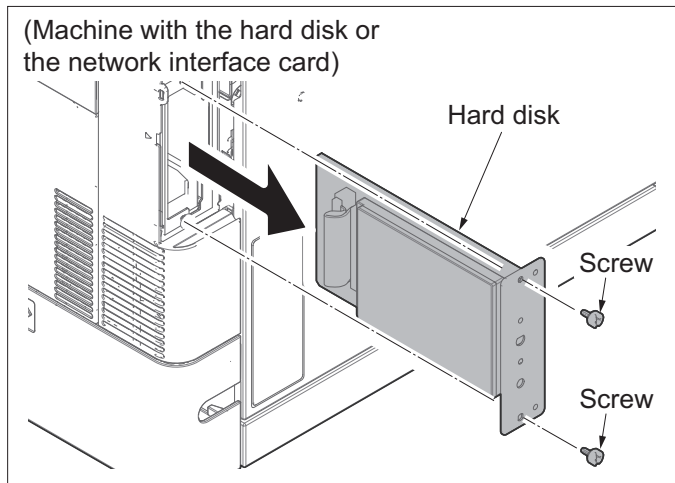


Figure 1-5-96

28. Remove four screws and then remove the power source shield.

\*: Screws A and B are unidentical, Thus, do not mix up.

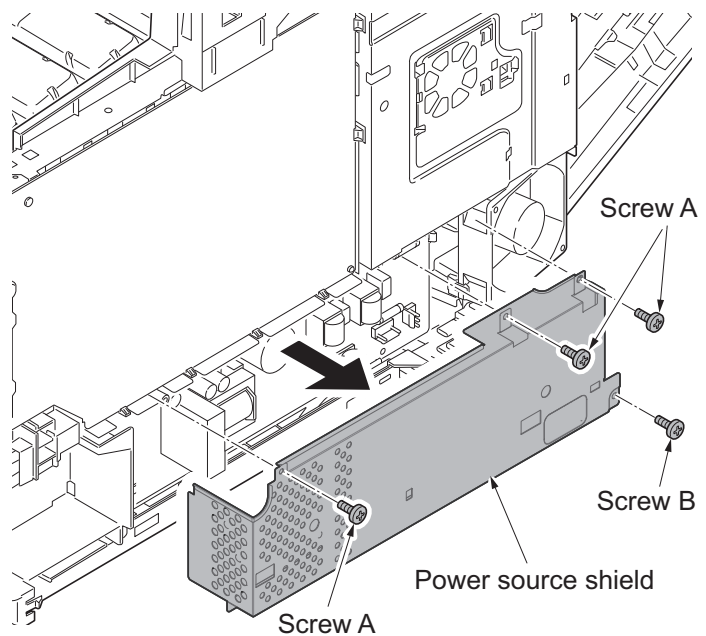


Figure 1-5-97



29. Pick up the hook A and then open the fan bracket.
30. Release the hook B and slide the fan plate to release the remaining three hooks, and then remove it.

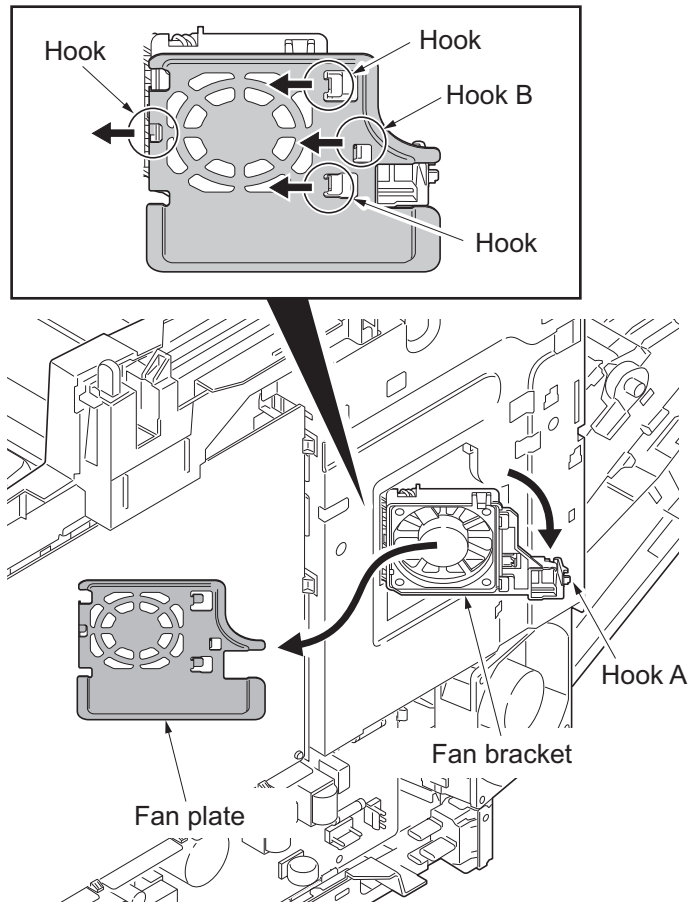


Figure 1-5-98

31. Remove the screw and remove the fuser wire cover.
32. Remove the cap.

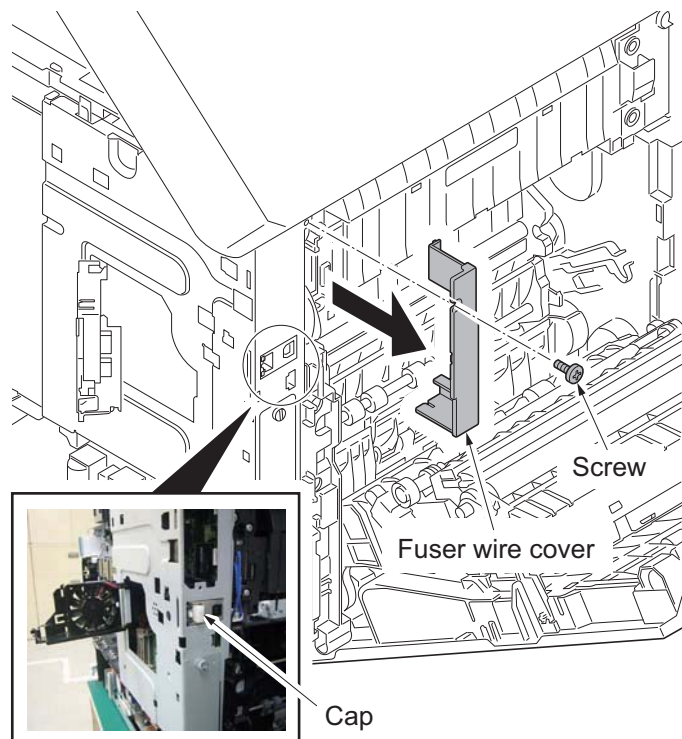


Figure 1-5-99



- 33. Remove five screws and the controller shield.

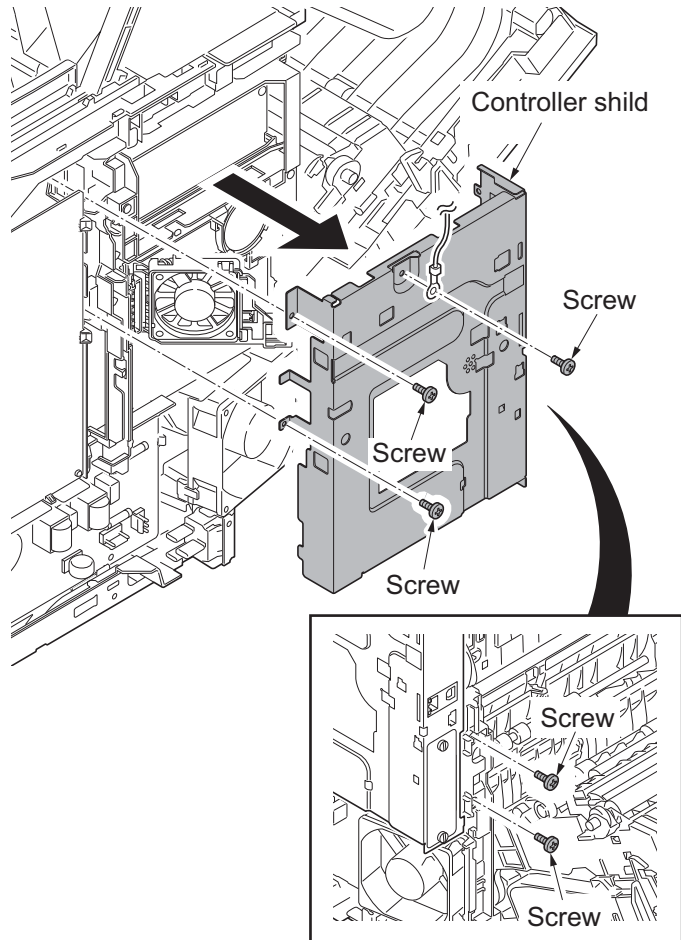


Figure 1-5-100

- 34. Disconnect the connector (YC41) of the controller fan motor.
- 35. Open the fan bracket and remove it.

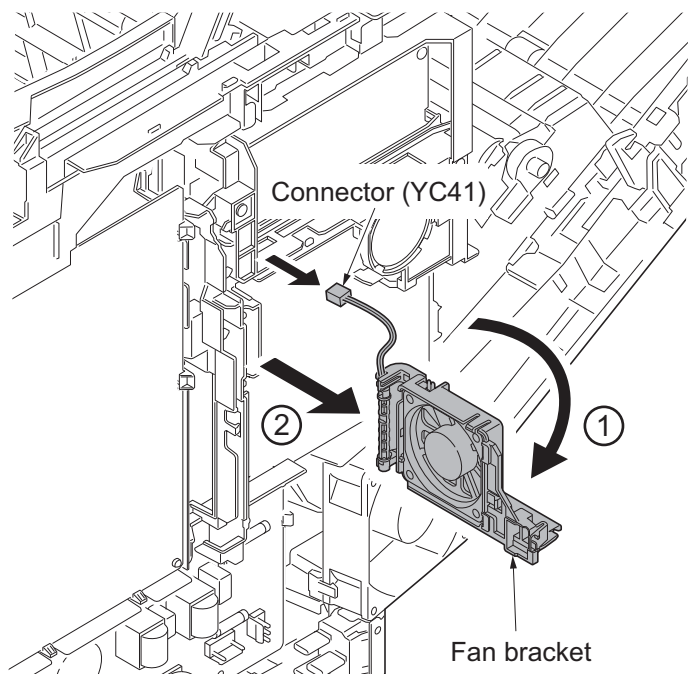


Figure 1-5-101

36. Disconnect the connectors (YC15, YC37, YC40, YC38, YC39, YC42) from the main PWB.
  37. Loosen four screws fixing the machine rear side of the main PWB.
- \*: Be sure to retighten the screws after reattaching the wire holder.

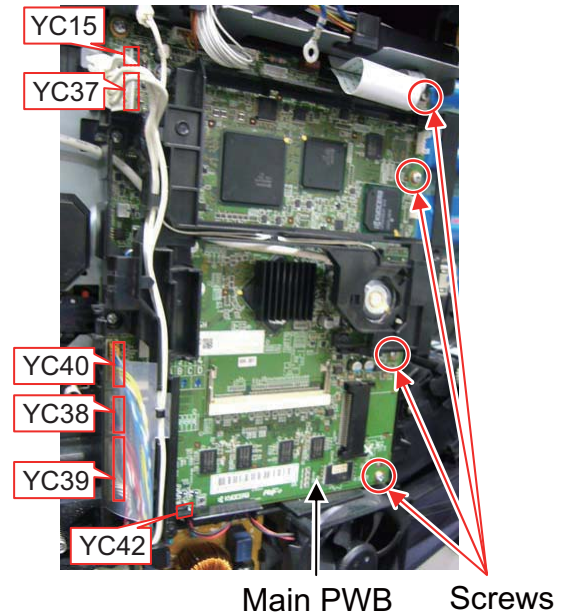


Figure 1-5-102

38. Remove the wires from the wire holder.
39. Remove two screws.
40. Release three hooks and then remove the wire holder.

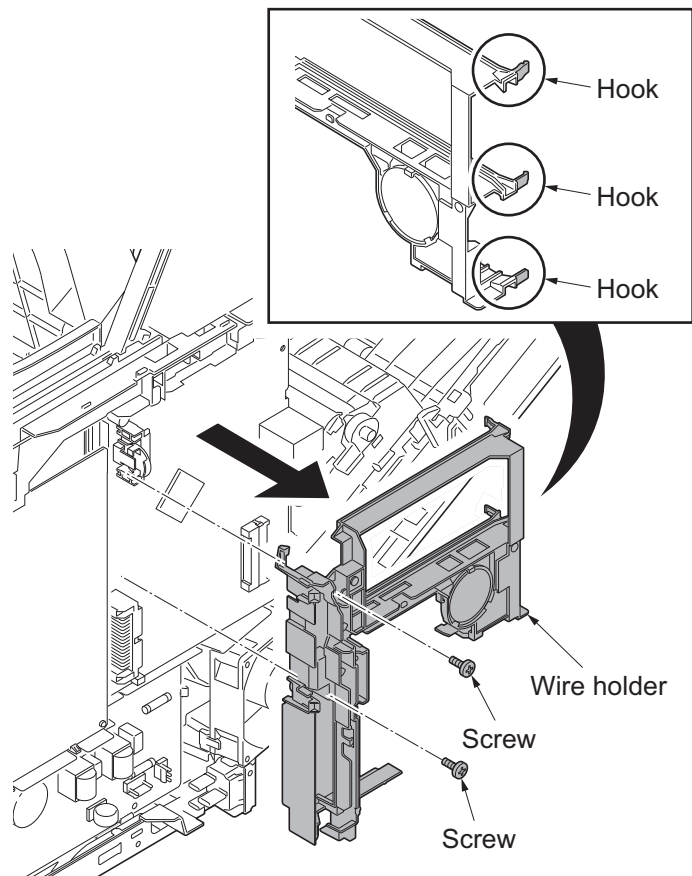


Figure 1-5-103

41. Disconnect the FFC wire at the connector YC8 on the main PWB.

\*: Reconnect the connectors on the main PWB before reattaching the wire holder detached at Step 40.

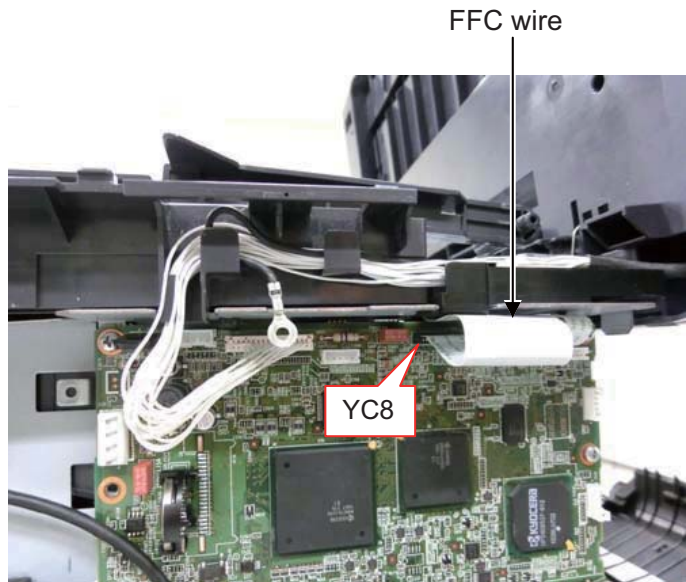


Figure 1-5-104

42. Remove the wire holder and the ferrite core.

(Upper side of the main PWB)

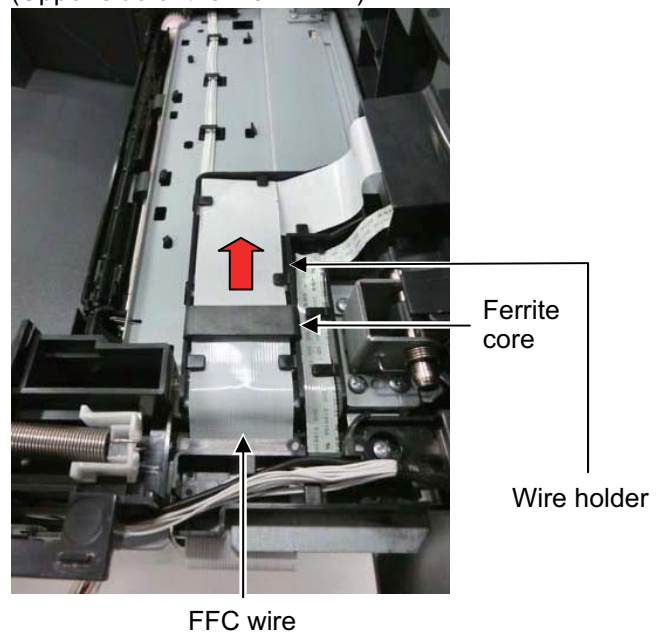


Figure 1-5-105

43. Reattach the left and right holders in a reverse manner of removal at Step 20, 21.  
Close the Document Processor and the scanner unit.

(Remove the ISU cover.)

- 44. Open the DP top cover and remove the screw fixing the DP rear cover.

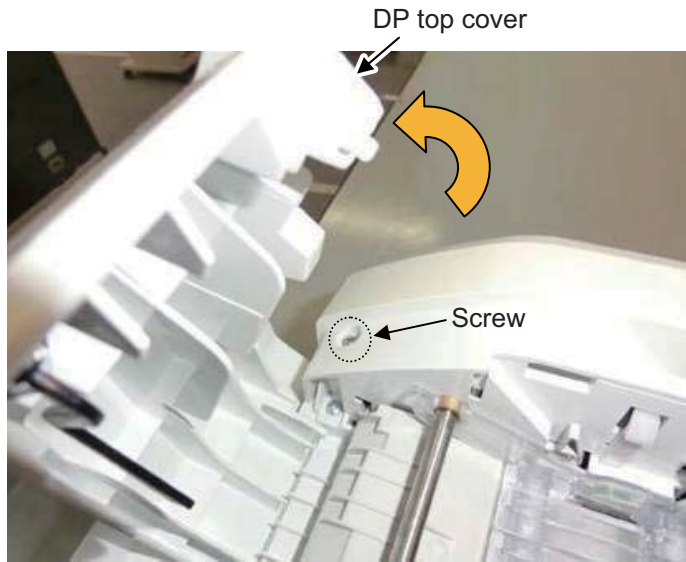


Figure 1-5-106

- 45. Open the Document Processor and release two hooks fixing the original tray. And close the Document Processor.

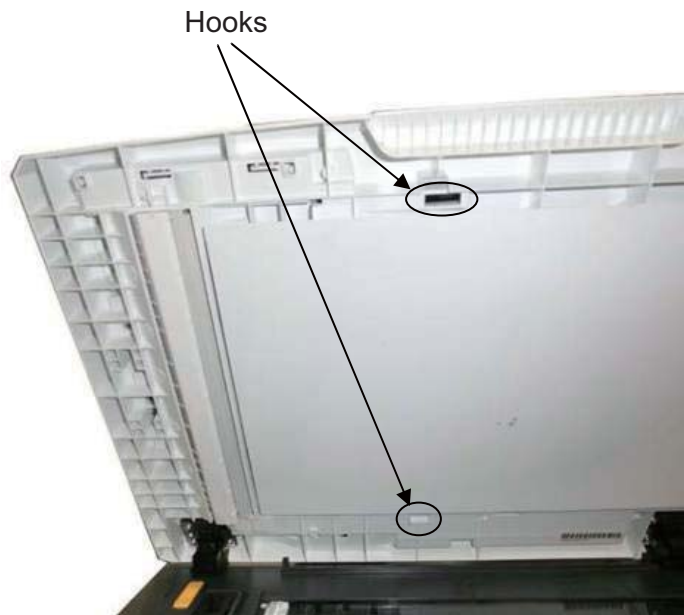


Figure 1-5-107

46. Slide the cursors to the center of the original tray and lift up the original tray.

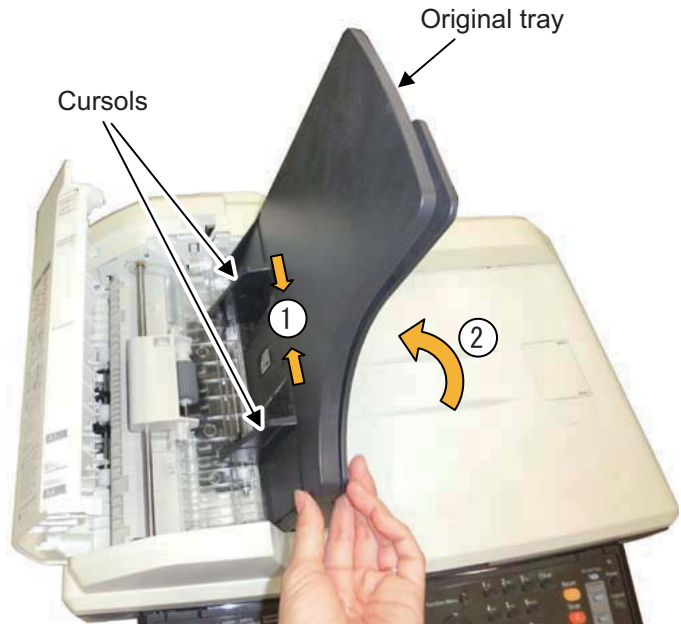


Figure 1-5-108

47. Release three hooks in the machine rear side of the DP rear cover. (in the order of hook A → B → C)  
Release the hook D and E at the machine front side while rotating the DP rear cover in the arrow's direction and then remove it.

\*: Release the hook A, B and C while pressing the upper part of the hook to prevent the hook from breaking.

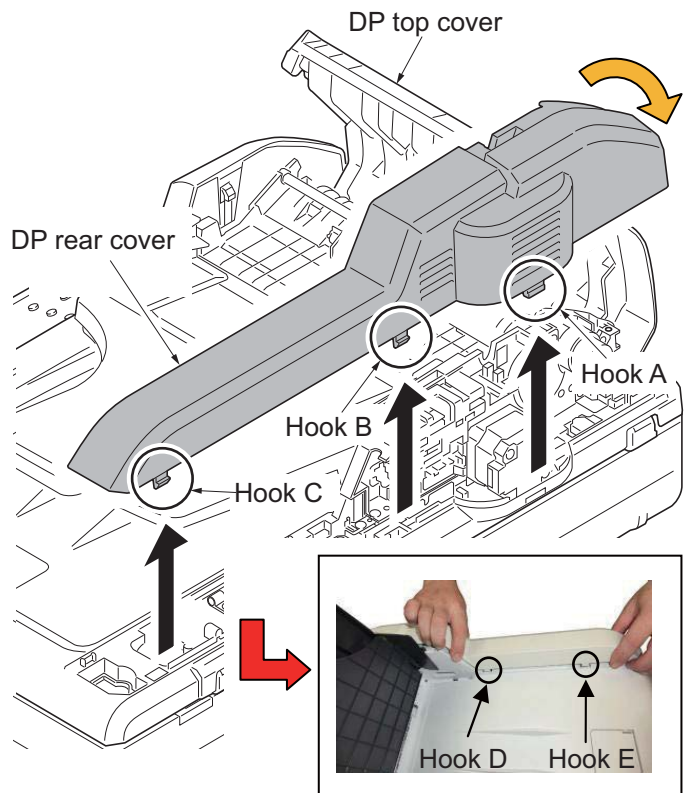


Figure 1-5-109

48. Remove two screws and disconnect two connectors from the DP drive PWB.

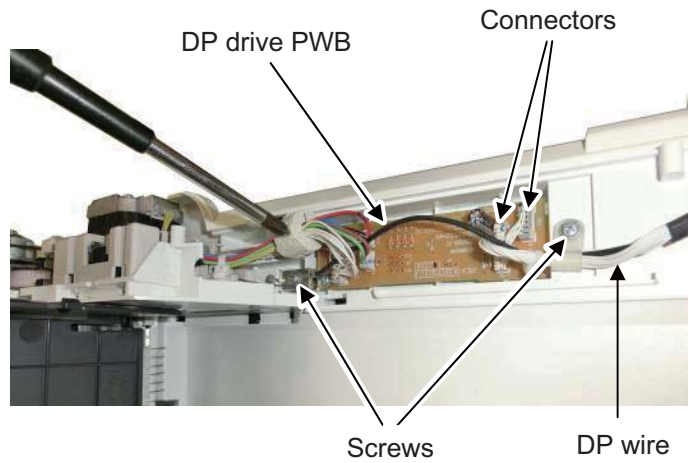


Figure 1-5-110

49. Press the DP lock lever through the hole at the bottom right side of the scanner unit by inserting a screwdriver, etc., and open the Document Processor.

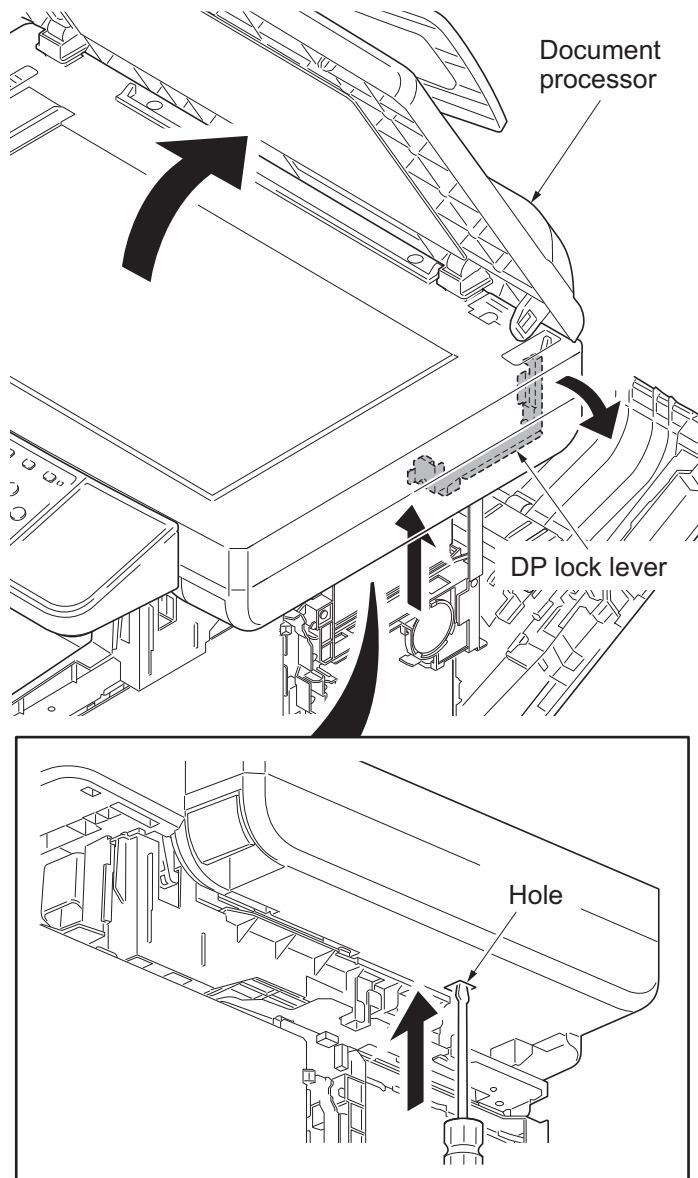


Figure 1-5-111



50. Remove the wire cover.



Figure 1-5-112

51. Detach the Document Processor.

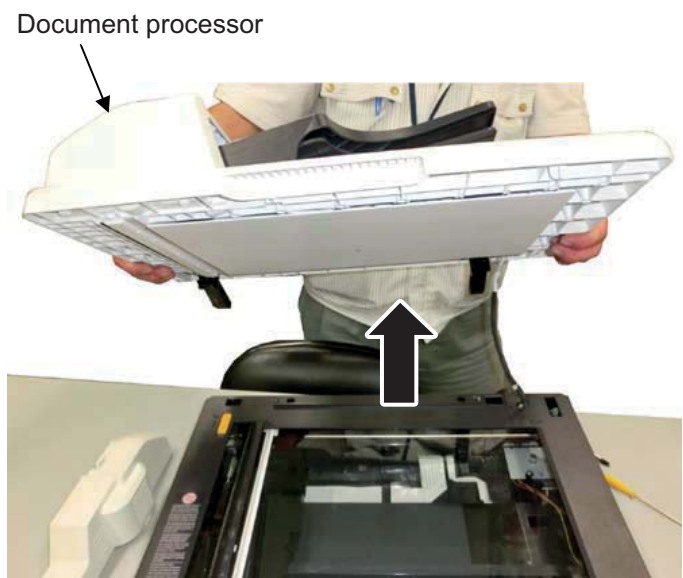


Figure 1-5-113

52. Remove the cover and panel and sheet on the operation unit in the order of A, B, C, D, E.

Remove two screws and release three hooks and then forward slide the operation cover.

\*: Note not to break each of two hooks when detaching the panel C, D.

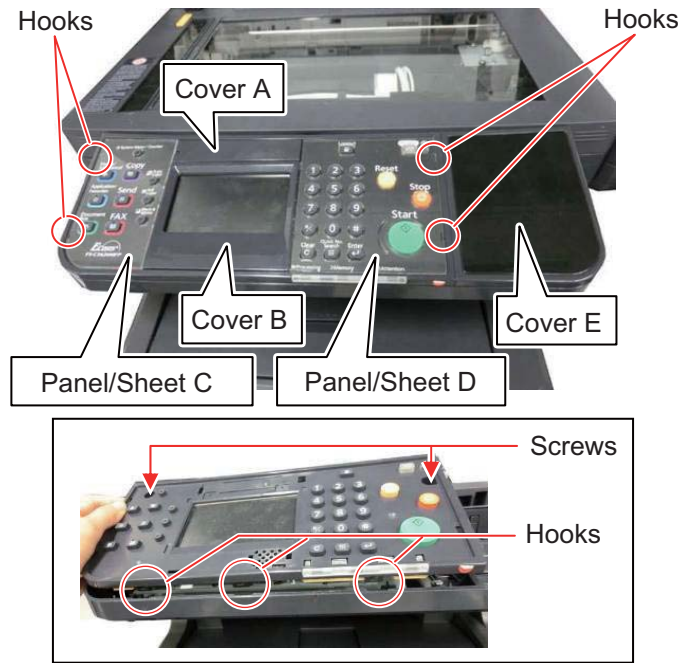


Figure 1-5-114



53. Remove two screws at the machine rear side and release three hooks under the operation cover.

Remove the ISU cover while pushing the DP lock lever to the right using a flat-blade screw driver.

\*: Do not touch the inner side of the contact glass removed with the ISU cover. (Dirt adhered triggers the abnormal image.)

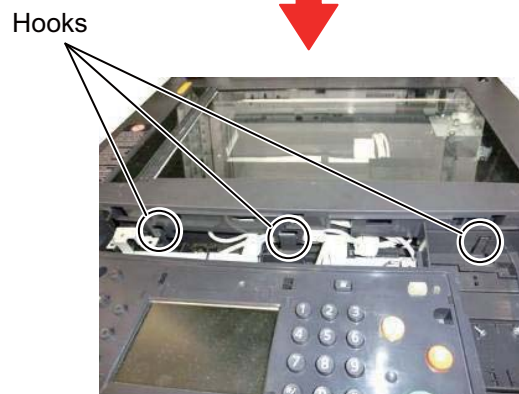
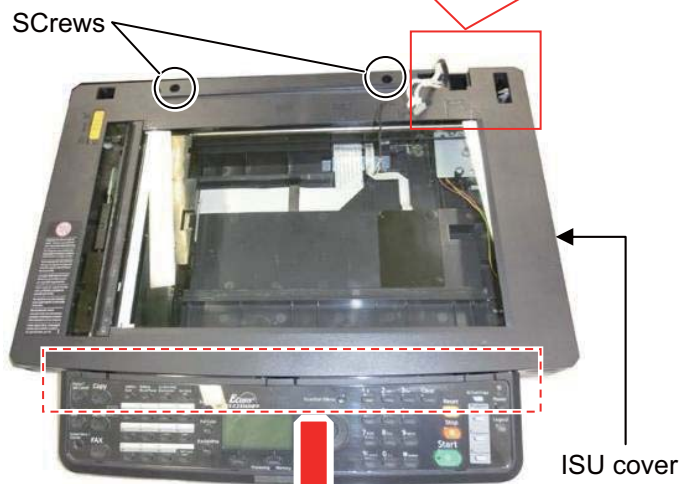
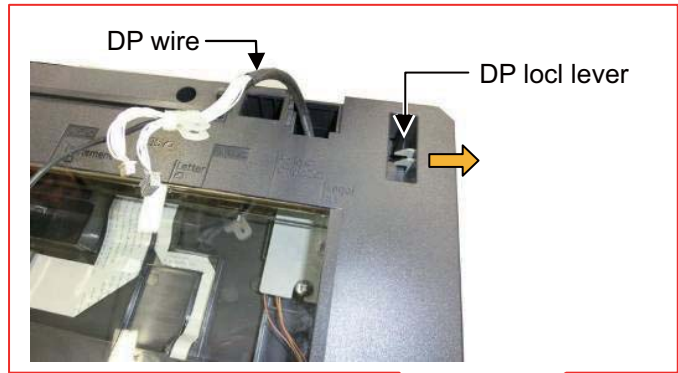


Figure 1-5-115

(Detaching the ISU)

54. Lift up the machine right end of the shaft to come off from the locking hole of the scanner frame, and then pull out the shaft in the machine right direction.
- \*: Confirm the end of the ground spring surely fits the groove F of the shaft when reattaching.

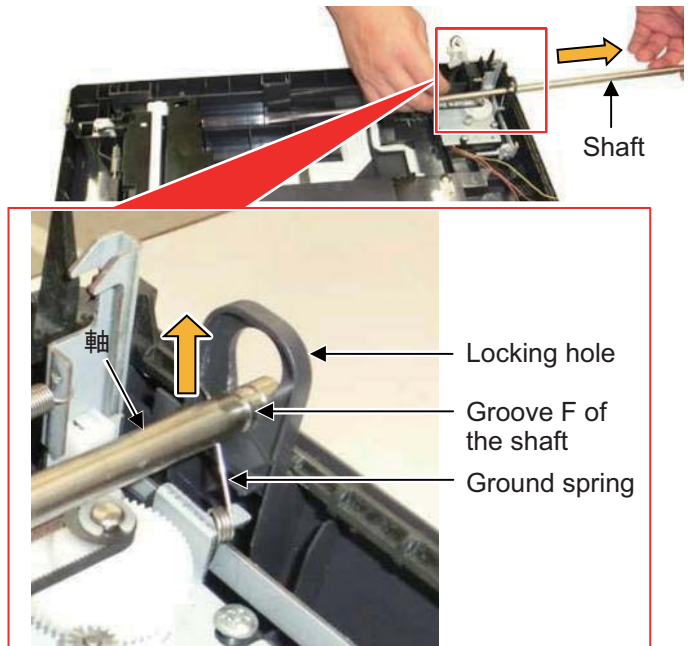


Figure 1-5-116

55. Slightly lift up the ISU and remove the ISU drive belt from the groove locking the ISU drive belt.

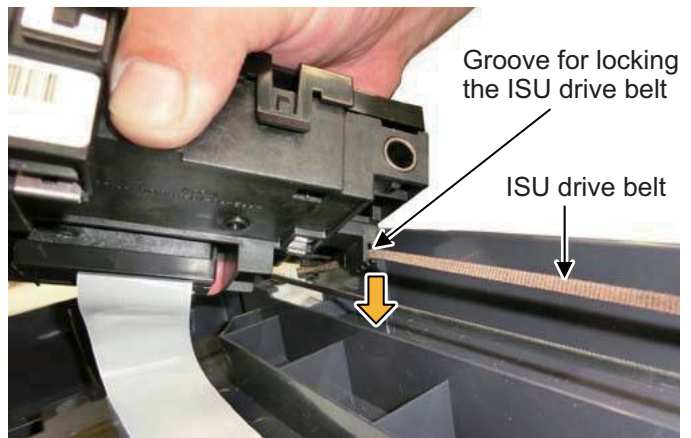


Figure 1-5-117

56. Remove the FFC wire connecting to the ISU from the wire alignment part in the scanner unit.  
Take off the bending part of the FFC wire from the two double-sided tapes on the wire alignment part.  
Detach the ISU.  
Then, peel off the double-sided tapes and clean the affixing part to remove the adhesive.

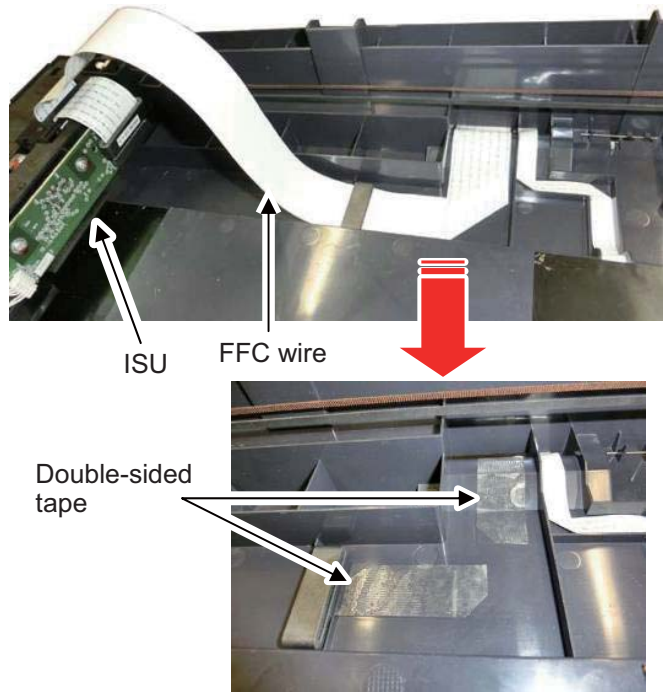


Figure 1-5-118

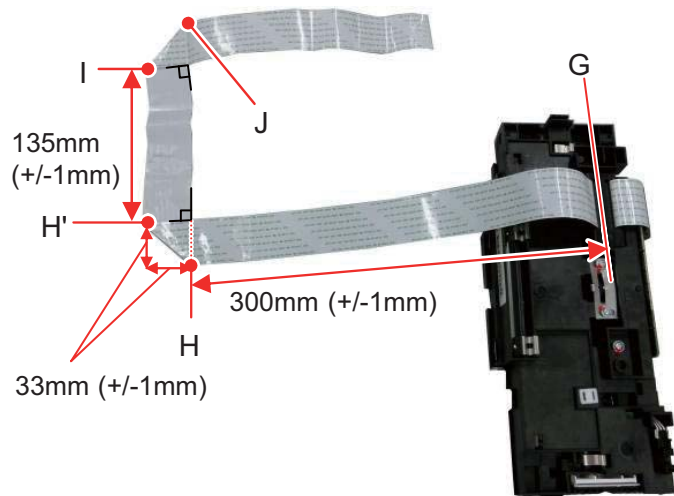
(Attaching the new ISU)

57. Fold the FFC wire of the new ISU with the alignment to the right.

(1) Fold the FFC wire in 90 degrees at 300mm from Alignment **G** at the edge of the holder passing the FFC wire to make Alignment **H**.

(Or, fold it in 90 degrees on the line connecting the Alignment **H** and Alignment **H'** at 33mm from **H**.)

(2) Fold it in 90 degrees at Alignment **I** at 135mm from the Alignment **H'** to make Alignment **J**.



(3) Fold the FFC wire in 180 degrees at the Alignment **J**.

(The reference length from the Alignment **J** to the wire's edge is about 195mm.)

(4) Unfold the FFC wire to easily pass the FFC wire through the ferrite core at the next step.

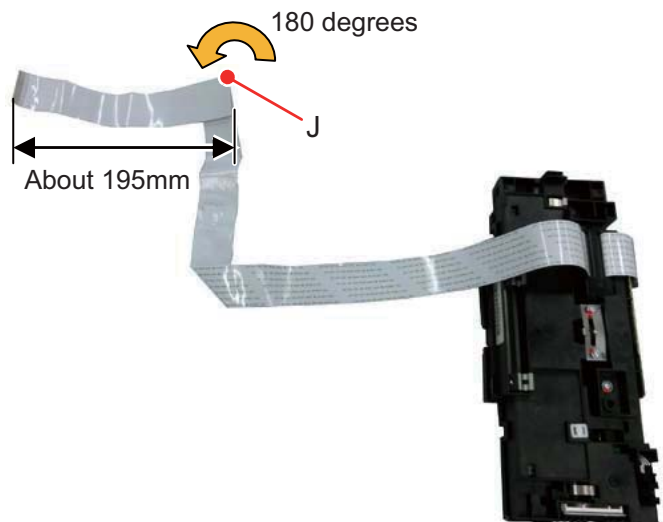


Figure 1-5-119

58. Pass the ISU's FFC wire through the ferrite core affixed on the scanner frame and then pass its edge through the aperture in the center of the scanner frame.

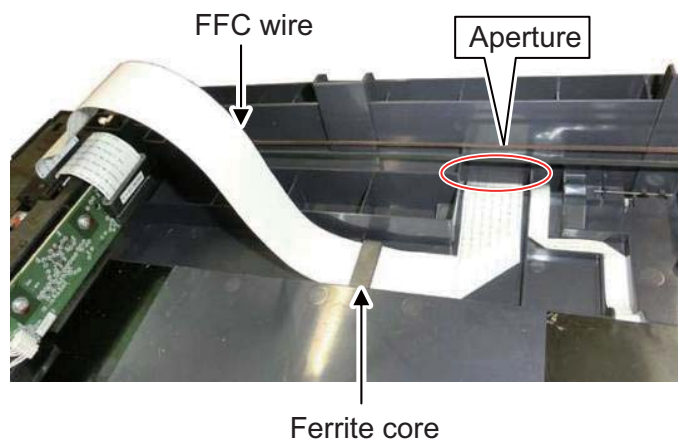


Figure 1-5-120



59. Fit the ISU drive belt to the groove at the ISU bottom side.  
 Confirm the teeth of the ISU drive belt face the machine front side before fitting as above.  
 After fitting, confirm the ISU drive belt and the ISU are connected by horizontally shifting the ISU (in the red arrow's direction in the figure).

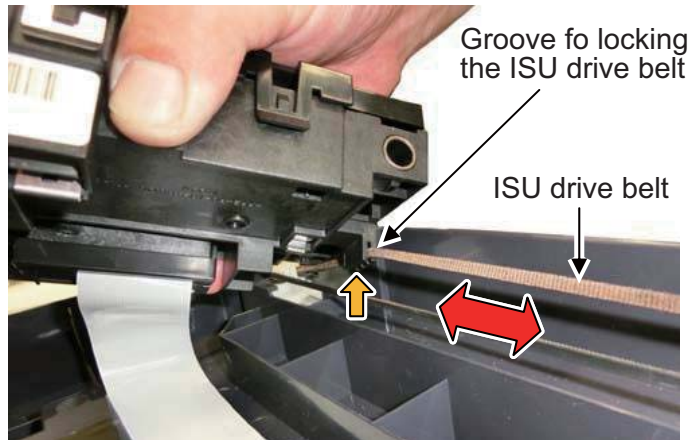
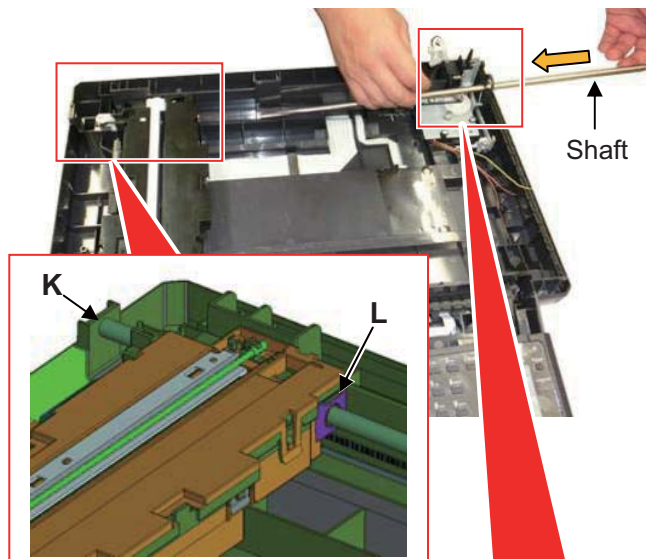


Figure 1-5-121

60. Pass the shaft removed at Step 54 through the holes (K, L) of the scanner frame's machine left side and the ISU's machine rear side, and then fit the groove of the shaft to the locking hole of the scanner frame's machine right side.



\*: After that, confirm the edge of the ground spring is fitted to the groove (F) of the shaft.

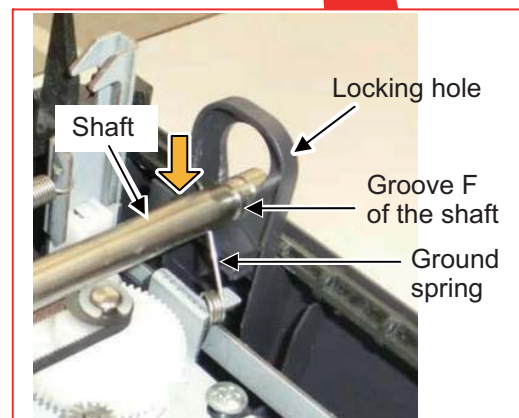
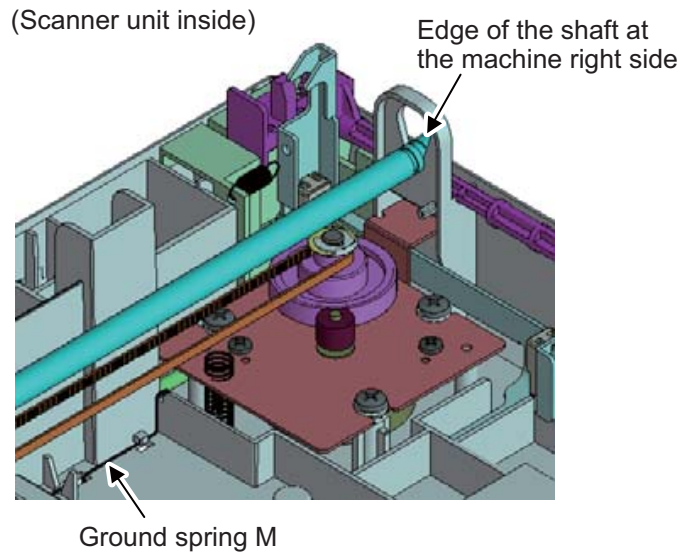
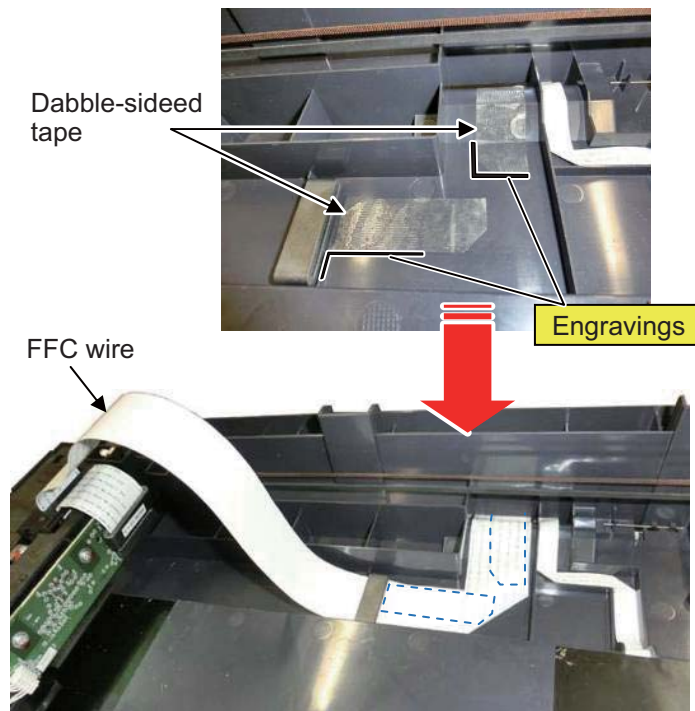


Figure 1-5-122

61. Confirm the conductivity between the ground spring M and the machine right side's edge of the shaft.  
(Electric resistance:  $10\Omega$  or less)



62. Affix two double-sided tapes bundled in the ISU for service while aligning their edges to the engravings on the scanner frame.
63. Affix the ISU side's folding part of the FFC wire to the double-sided tapes.



64. Refit the ISU cover and the operation cover in the reverse procedures of removal.

Figure 1-5-123

(Align the FFC wire at the main PWB side.)

- 65. Remove the left and right holders of the scanner unit at Step 20, 21 and fully open the scanner unit.

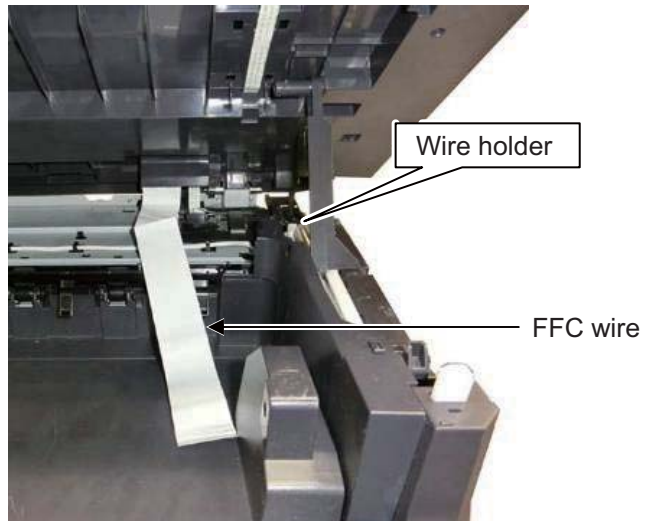


Figure 1-5-124

- 66. Align the FFC wire like the figure to the right.  
(Seven alignment ribs and one ferrite core)

(Wire holder viewed from the machine right side)

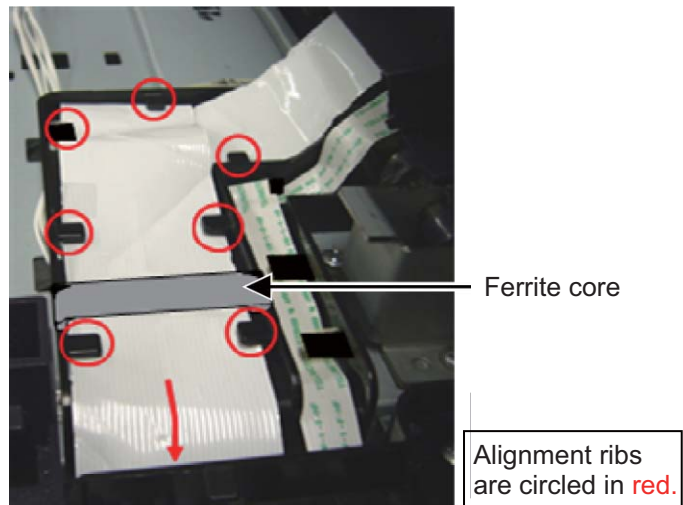


Figure 1-5-125

- 67. Insert the end of the FFC wire into the connector YC8 on the main PWB.

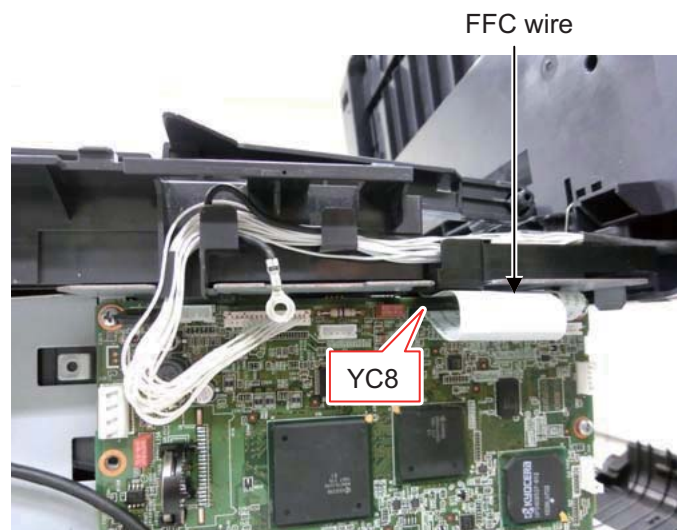


Figure 1-5-126

- 68. Refit all the parts and the unit detached in the reverse manner of the above procedures.

## 1-5-11 Document processor

### (1) Detaching and refitting the document processor

#### Procedure

1. Remove the rear upper cover, right upper cover, left upper cover and front cover (see page 1-5-3).
2. Remove left and right pins and then close the inner tray.

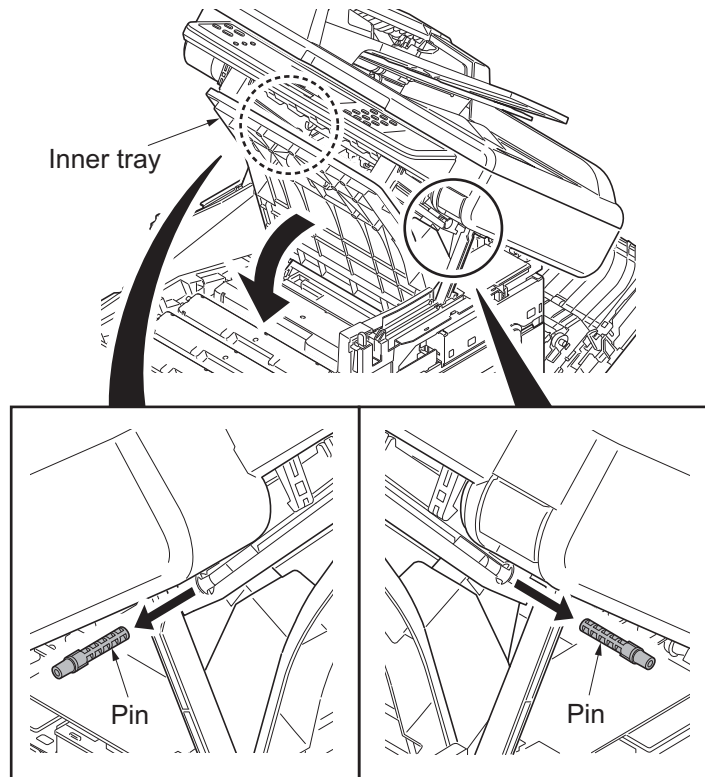


Figure 1-5-127

3. Release three hooks and then remove the upper middle cover.

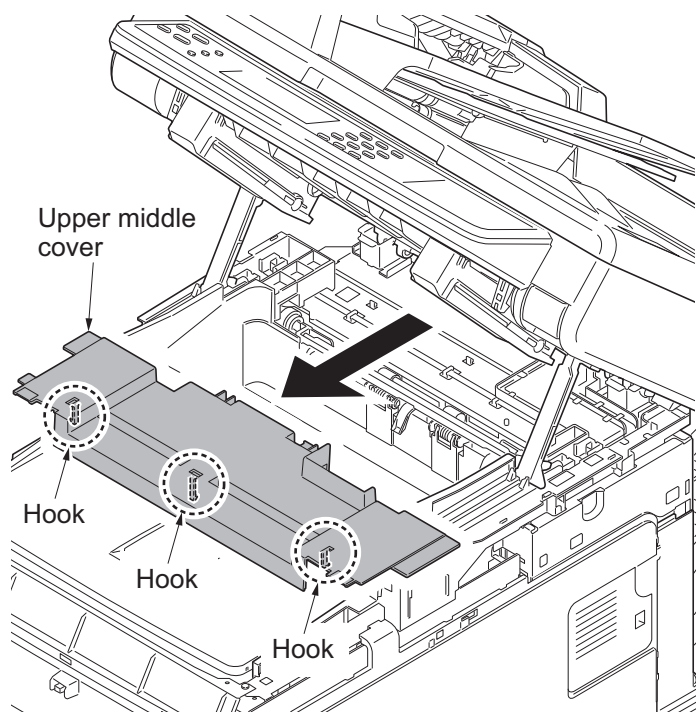
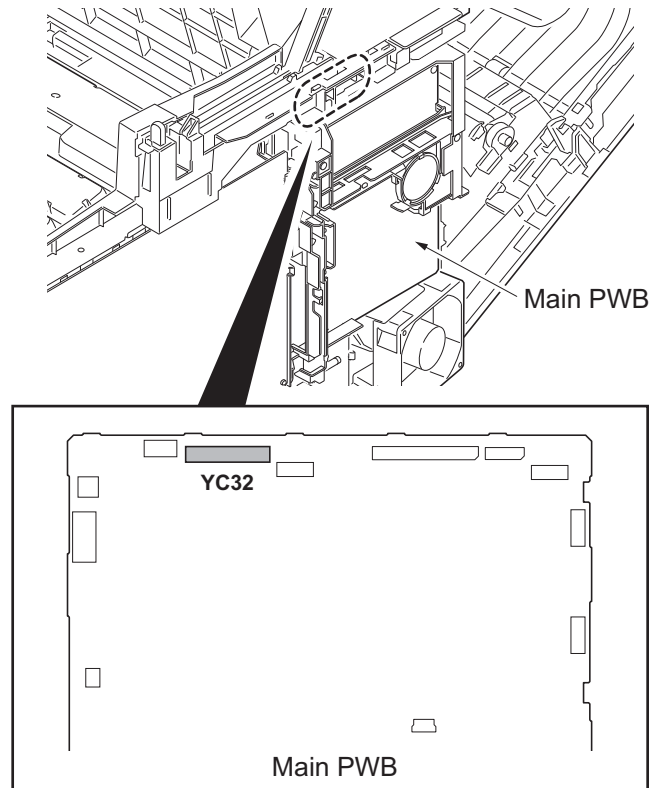


Figure 1-5-128

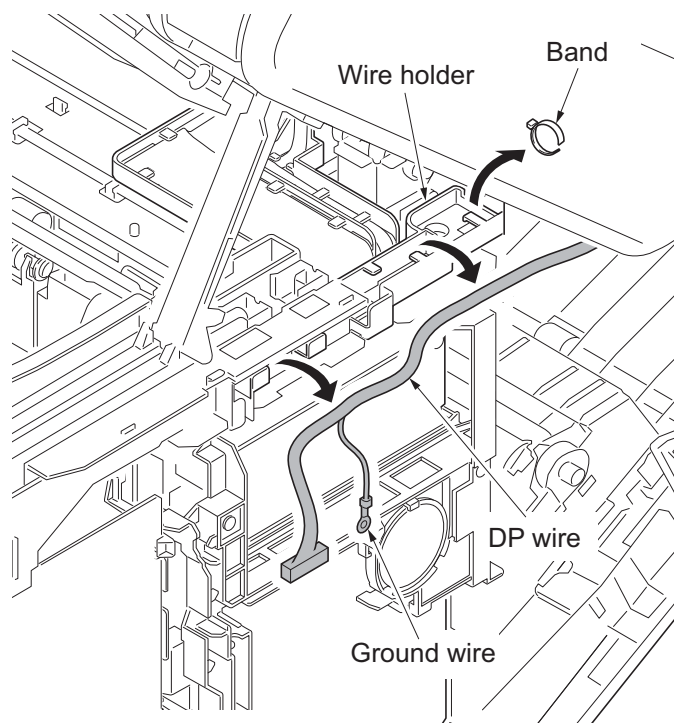


4. Remove the right rear cover, right cover and right lower cover (see page 1-5-6).
5. Remove the controller shield (see page 1-5-30).
6. Remove connector (YC32) from main PWB.



**Figure 1-5-129**

7. Cut the band and then remove the it.
8. Remove the DP wire and ground wire from wire holder.
9. Close the scanner unit.



**Figure 1-5-130**

10. Press the DP lock lever through the hole at the bottom right side of the scanner unit, and open the document processor.

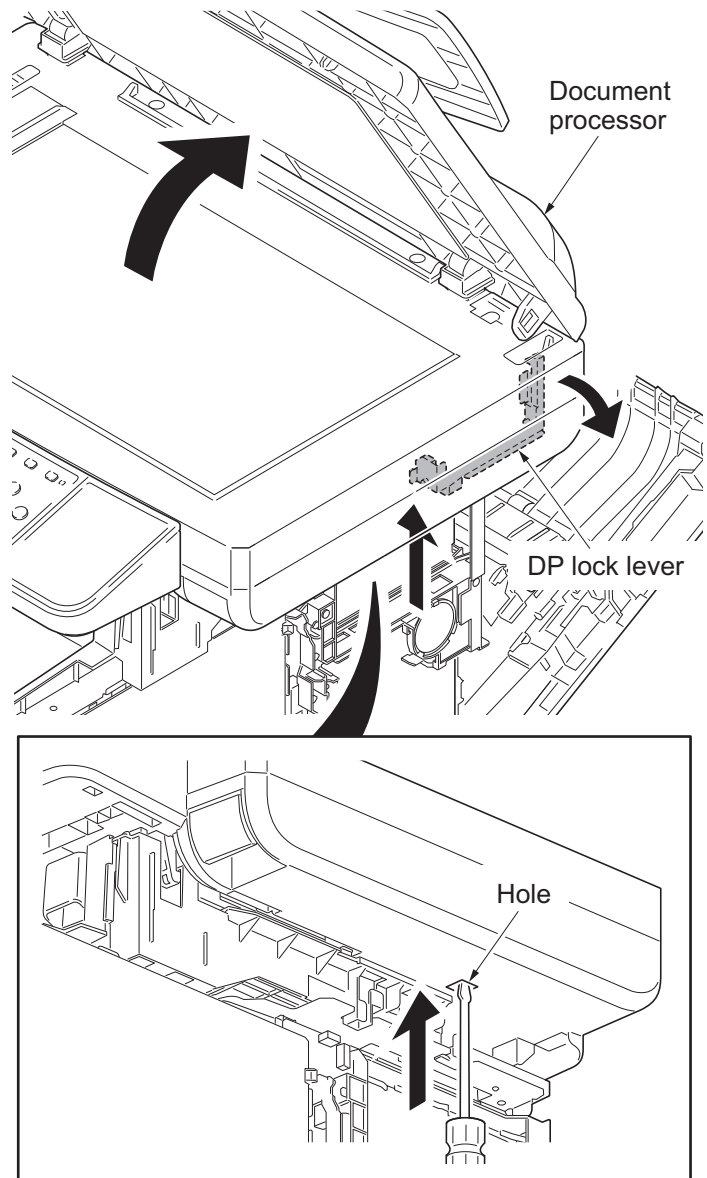


Figure 1-5-131

11. Remove the wire cover.

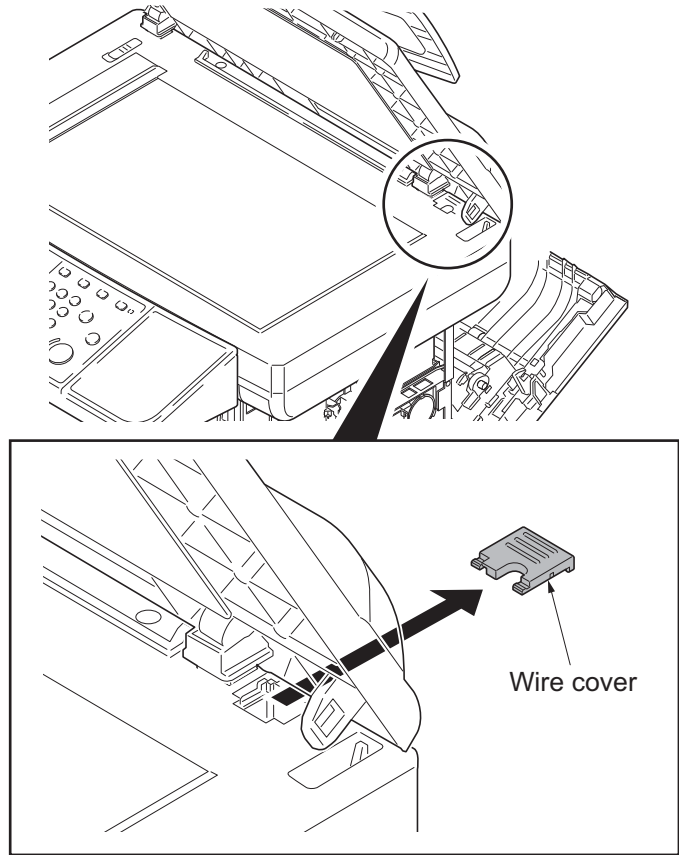


Figure 1-5-132

12. Remove the document processor.

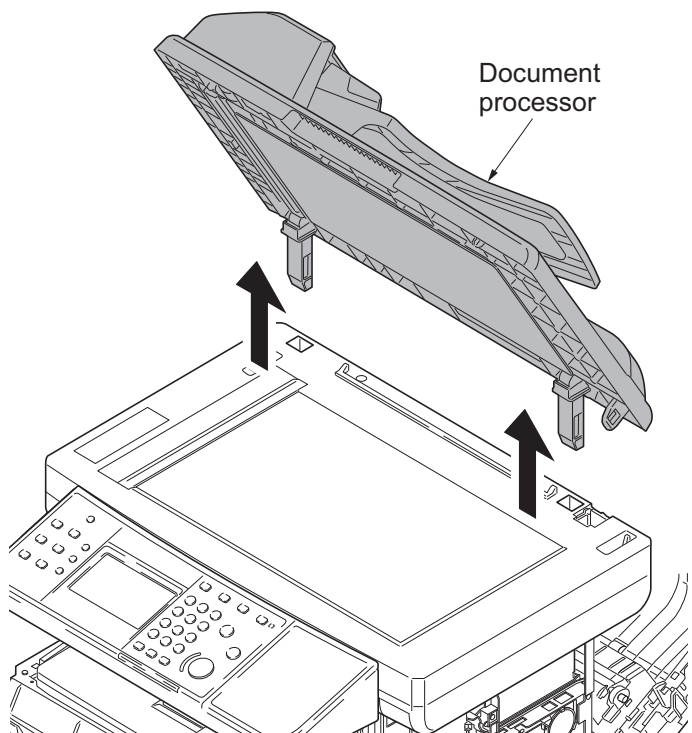


Figure 1-5-133

## (2) Detaching and refitting the DP paper feed pulley unit

### Procedure

1. Open the DP top cover.
2. Remove the screw.
3. Release three hooks and then remove the DP rear cover.

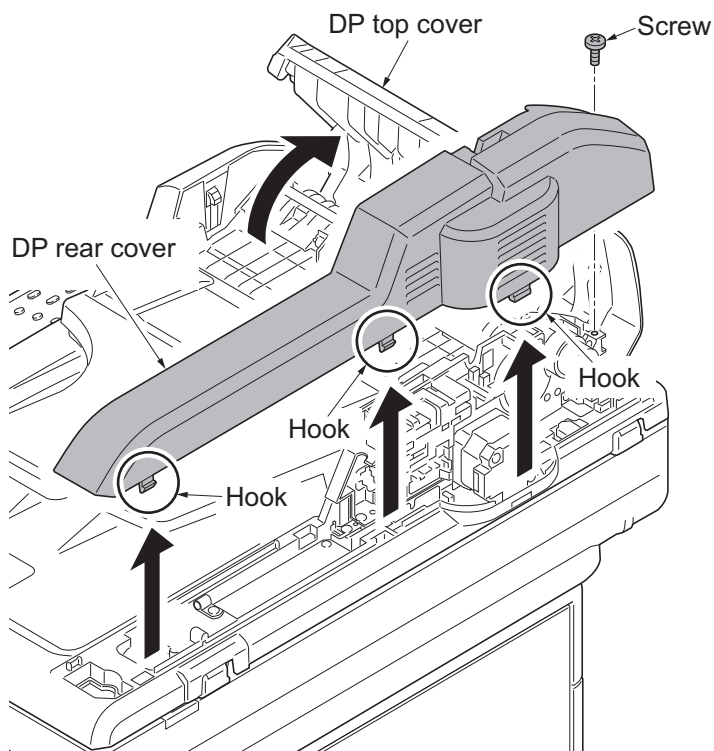


Figure 1-5-134

4. Release two hooks and then remove the DP front cover.

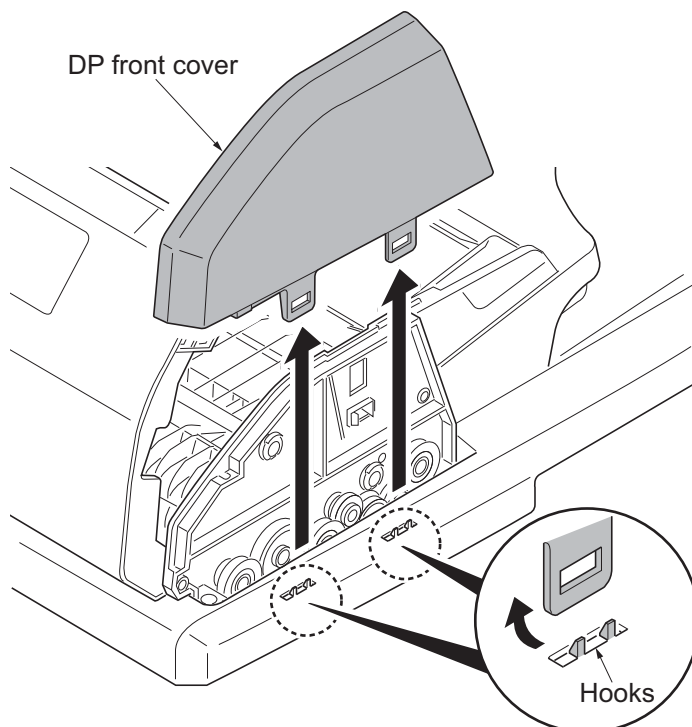


Figure 1-5-135

5. Remove the stop ring and bush.

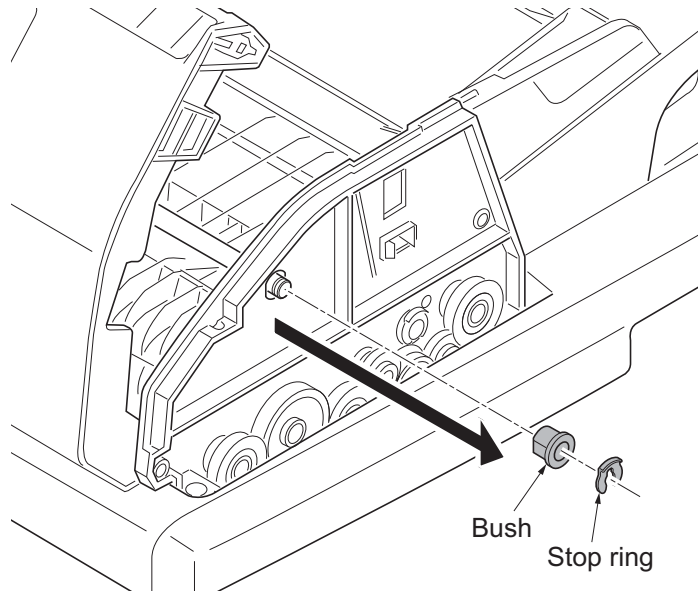


Figure 1-5-136

6. Remove the stop ring A and then remove the DP paper feed clutch from the PF shaft.
7. Remove the stop ring B and then remove the PF collar, spring, spring collar, pin and bush from the PF shaft.

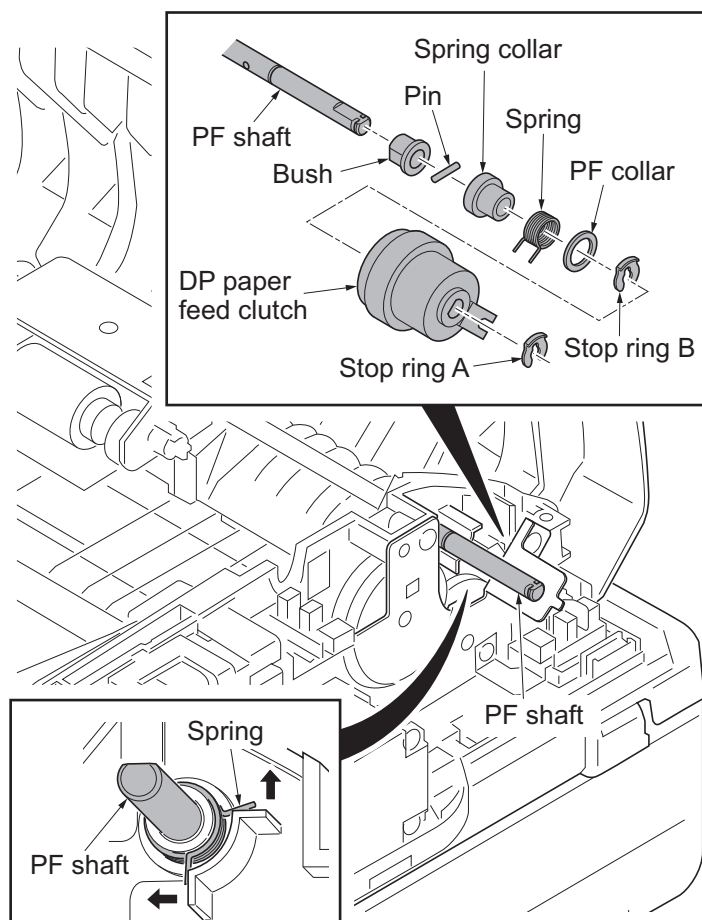


Figure 1-5-137

8. Remove the DP forwarding pulley unit.

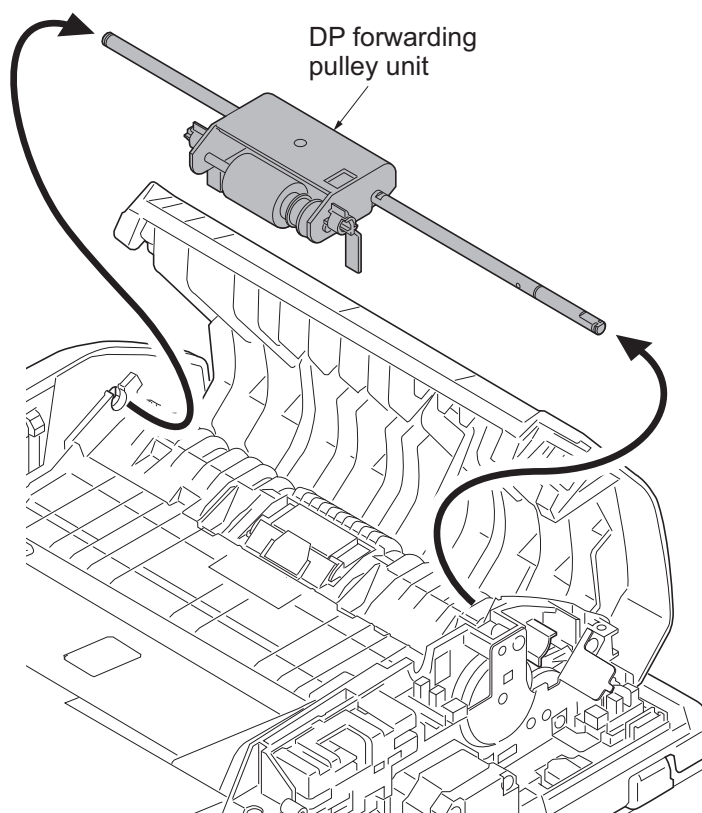


Figure 1-5-138

9. Remove the stop ring A.
10. Remove the DP feed pulley unit from the LF holder.
11. Remove the stop ring B.
12. Remove the PF collar, spring, spring collar and pin from the PF shaft.
13. Remove the DP feed pulley, one-way clutch, PF pulley gear and pin from the PF shaft.

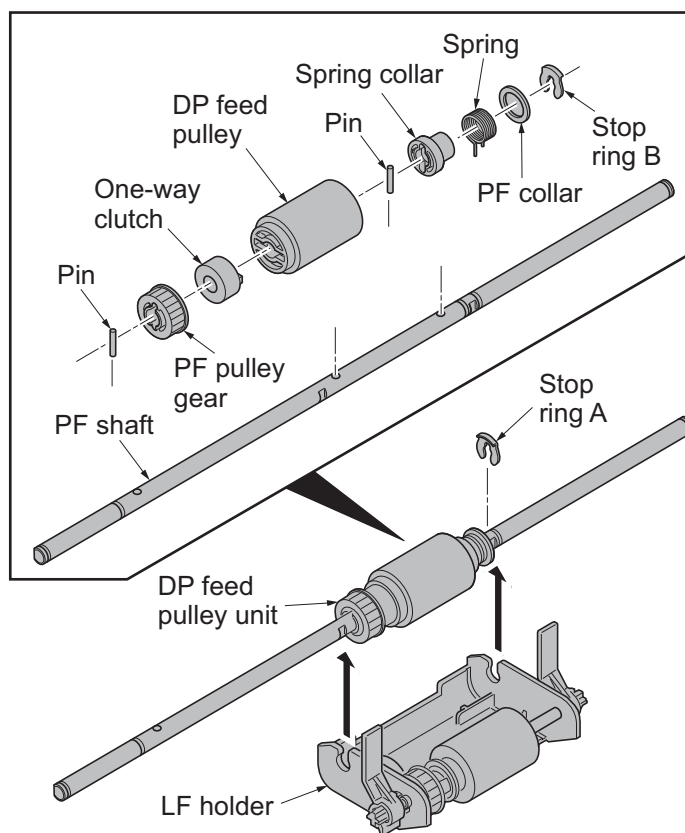
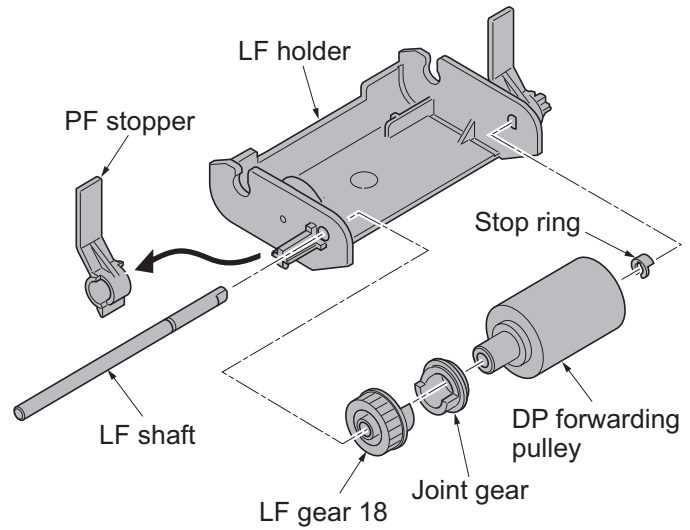


Figure 1-5-139

14. Remove the PF stopper from the LF holder.
15. Remove the stop ring.
16. Pull out the LF shaft and then remove the LF gear 18, joint gear and DP forwarding pulley.
17. Check or replace the DP feed pulley and DP forwarding pulley, and refit all the removed parts.



**Figure 1-5-140**

### (3) Detaching and refitting the DP separation pad

#### Procedure

1. Remove the DP paper feed pulley unit (see page 1-5-82).
2. Remove the DP separation pad.
3. Check or replace the DP separation pad and refit all the removed parts.

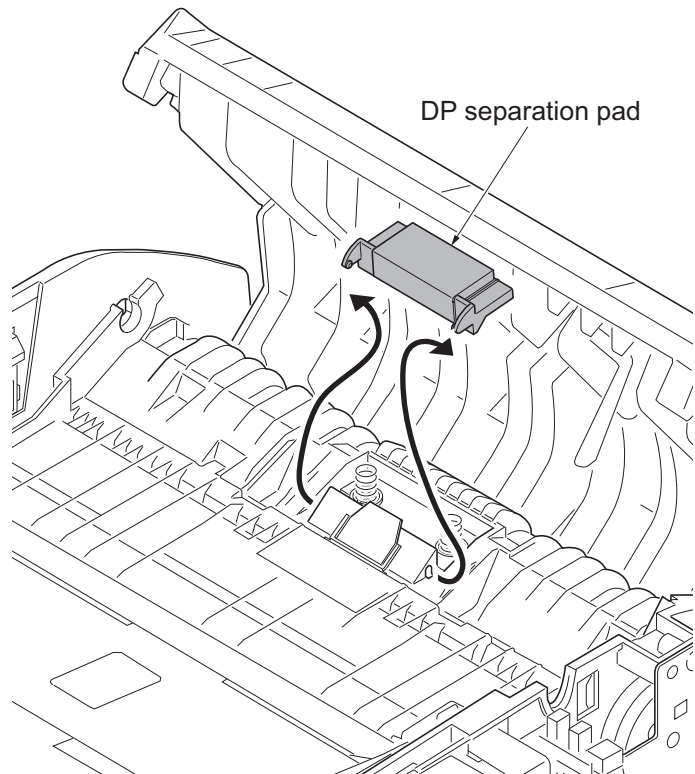


Figure 1-5-141



#### (4) Detaching and refitting the DP drive PWB

##### Procedure

1. Remove the DP rear cover (see page 1-5-82).
2. Remove all connectors from DP drive PWB.
3. Remove the screw and then remove the DP drive PWB.
4. Check or replace the DP drive PWB and refit all the removed parts.

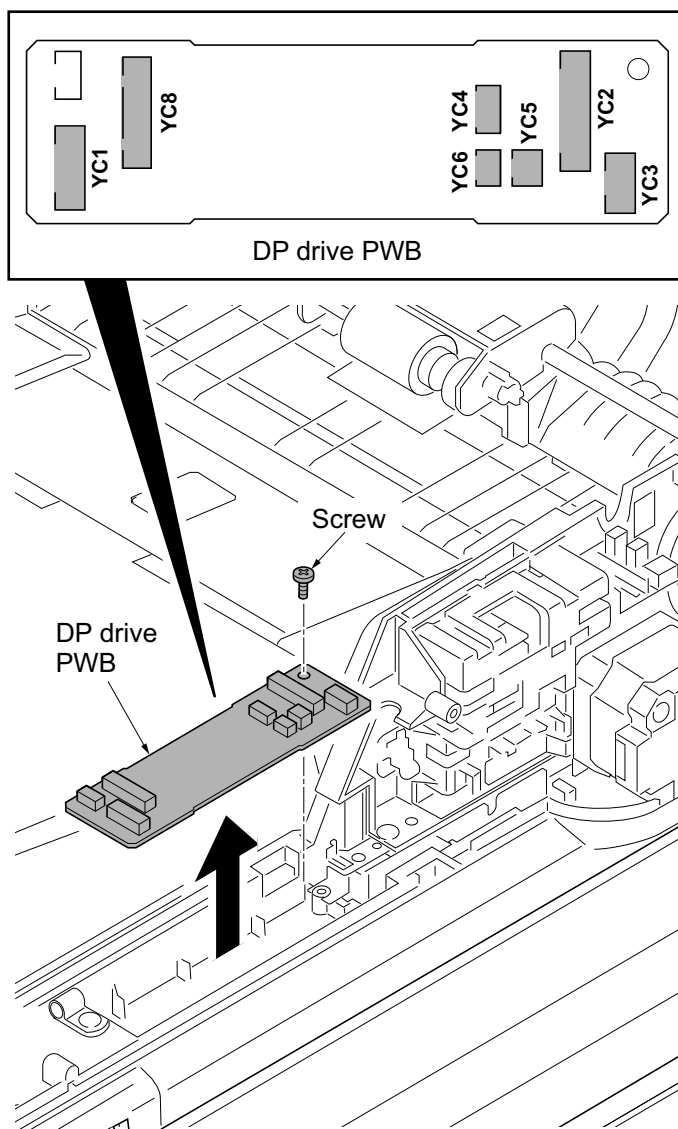


Figure 1-5-142

## 1-5-12 Others

### (1) Detaching and refitting the paper conveying unit

#### Procedure

1. Open the rear cover.
2. Remove left and right straps.

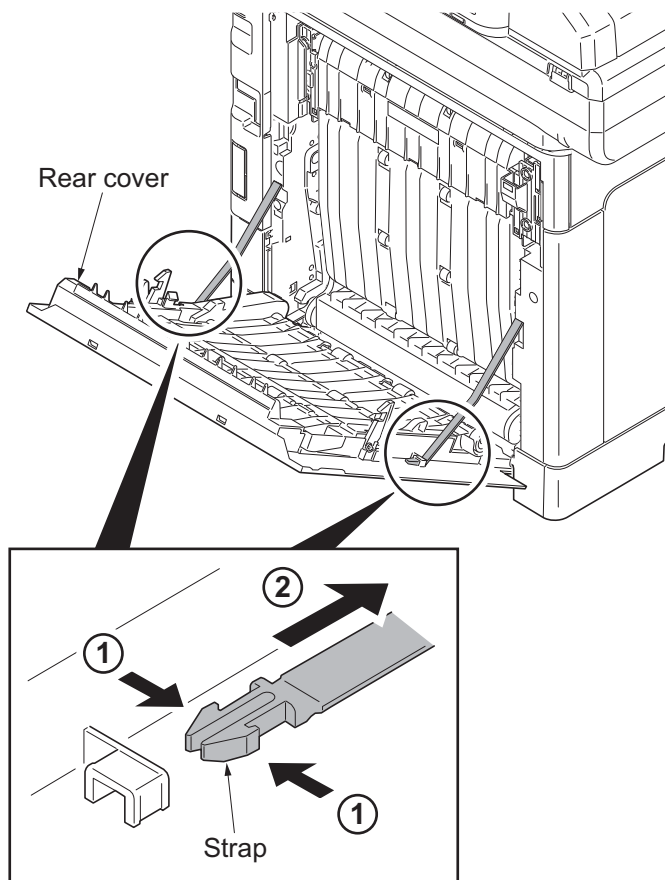


Figure 1-5-143

3. Remove the rear cover unit.

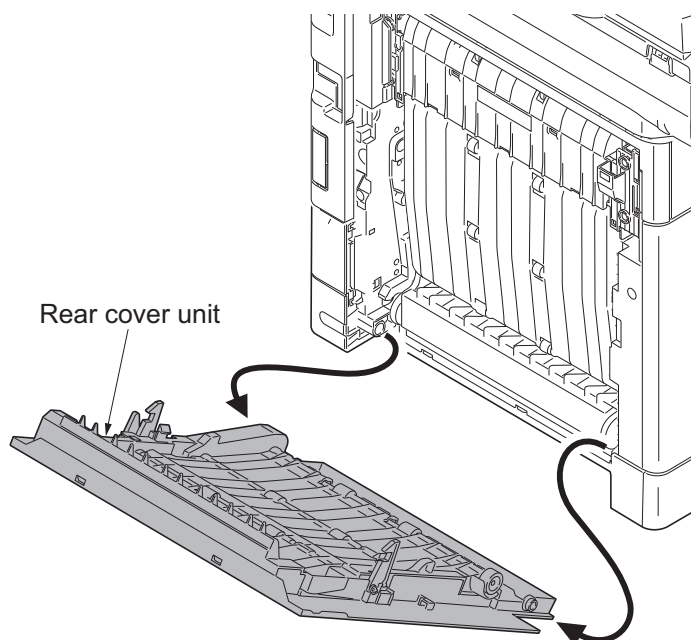


Figure 1-5-144

4. Remove the paper conveying unit.

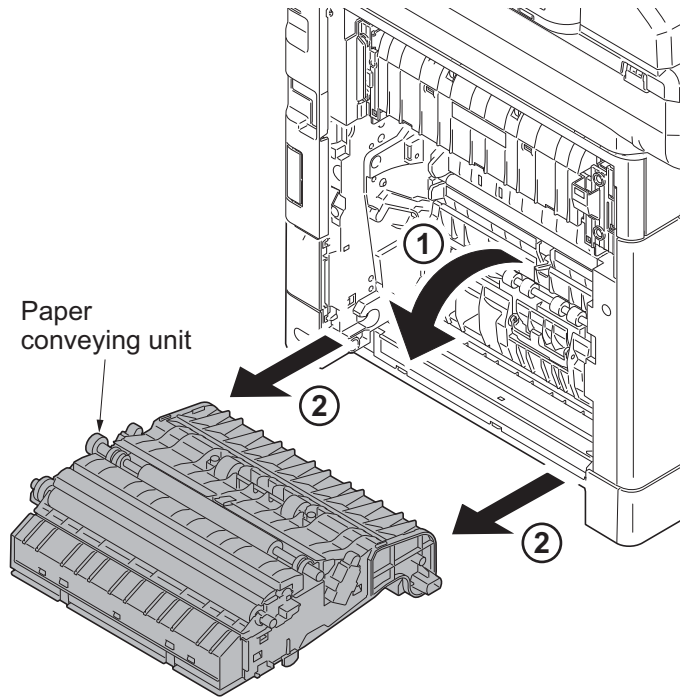


Figure 1-5-145

## (2) Detaching and refitting the operation panel

### Procedure

1. Remove the operation panel right cover by sliding forward.

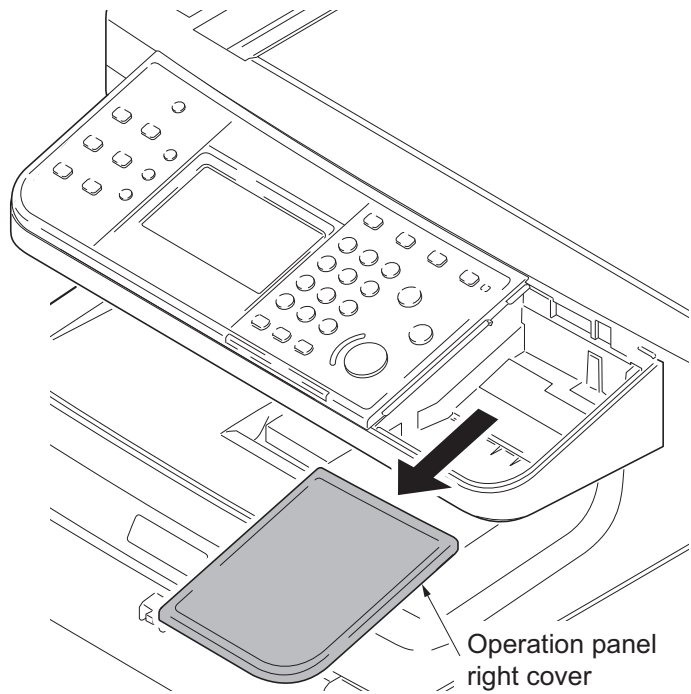


Figure 1-5-146

2. Release three hooks and then remove the operation panel.
3. Remove three connectors.
4. Check or replace the operation panel and refit all the removed parts.

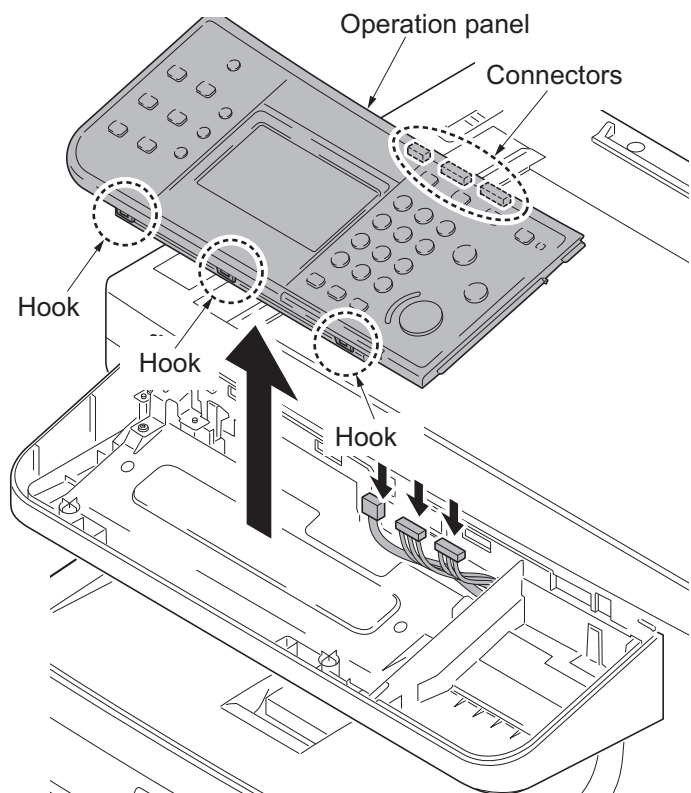


Figure 1-5-147

### (3) Detaching and refitting the power source inlet

#### Procedure

1. Remove the power source PWB (see page 1-5-29).
2. Remove the connector and release the hook and then remove the right fan motor.

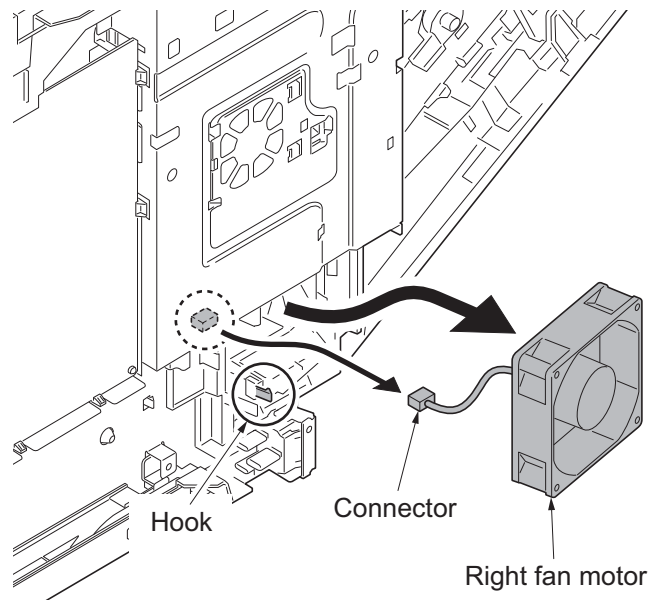


Figure 1-5-148

3. Remove the screw of the grounding wire.

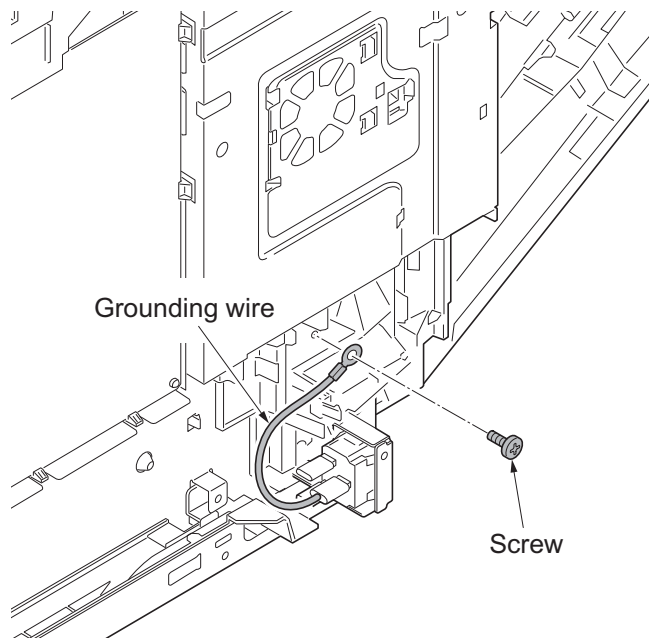
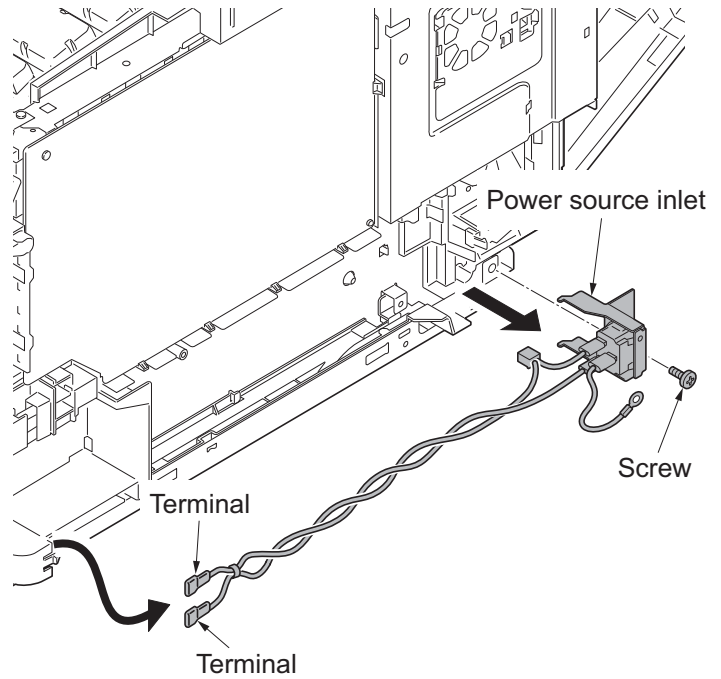


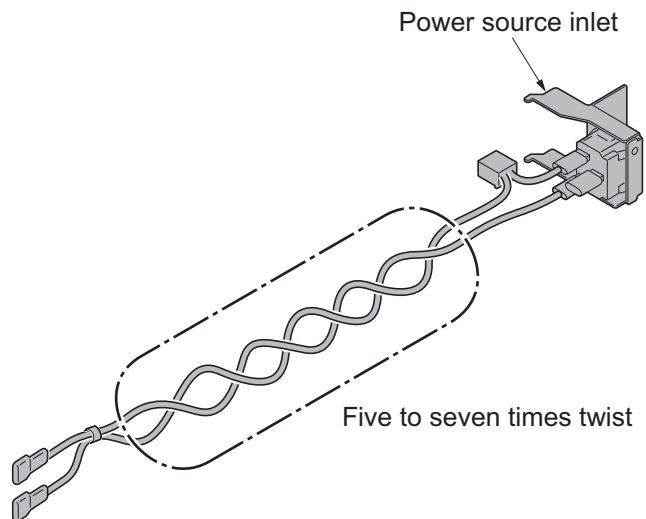
Figure 1-5-149

4. Remove the screw and two terminals and then remove the power source inlet.



**Figure 1-5-150**

5. Check or replace the power source inlet and refit all the removed parts.  
 \*: Before mounting the AC inlet on the main unit, twist the wires 5 to 7 turns.



**Figure 1-5-151**

### (4) Direction of installing the principal fan motors

When detaching or refitting the fan motors, be careful of the airflow direction (intake or exhaust).

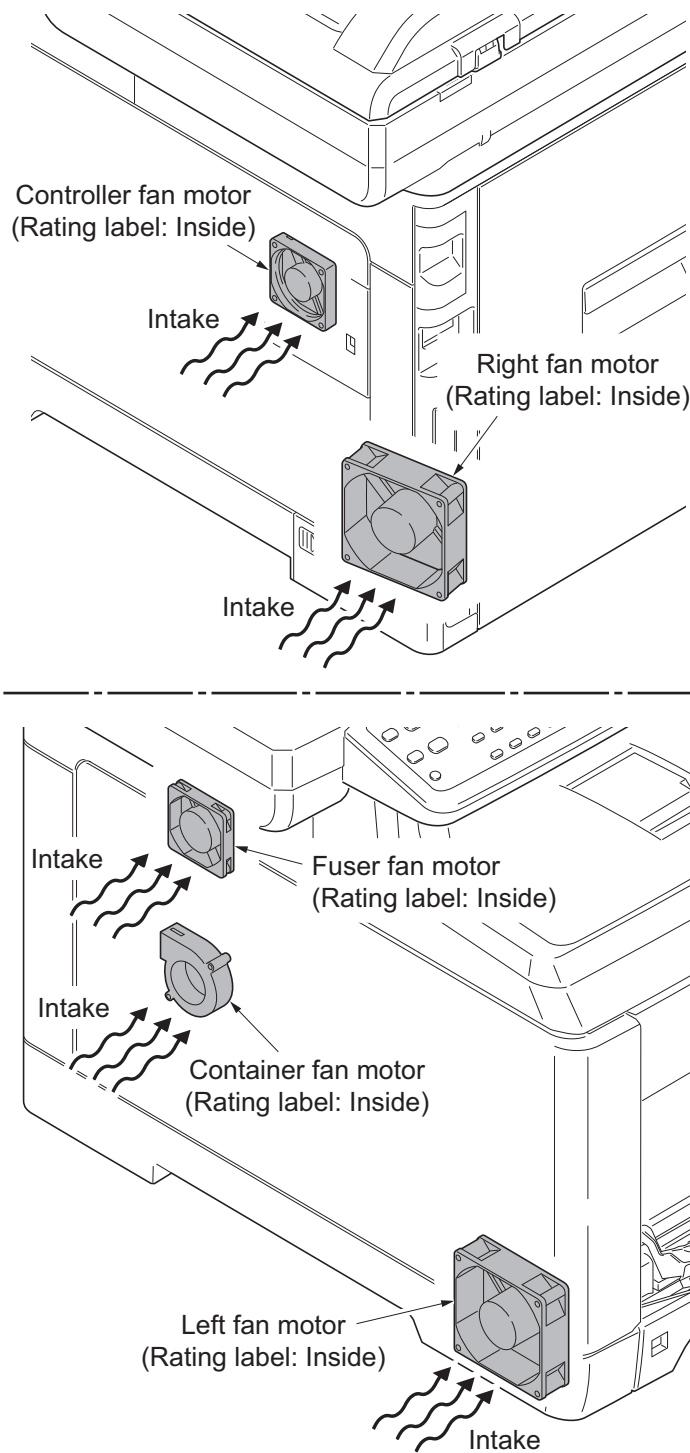


Figure 1-5-152

This page is intentionally left blank.



## 1-6-1 Upgrading the firmware

Follow the procedure below to upgrade the firmware of main PWB (main controller and scanner), engine PWB, FAX control PWB\*, optional language, optional paper feeder and color table.

### Preparation

Extract the file that has the download firmware and put them in the USB Memory.

### Procedure

1. Turn ON the main power switch and confirm if the screen shows "Ready to copy" then, turn OFF the main power switch.
2. Insert USB memory that has the firmware in the USB memory slot.
3. Turn ON the main power switch.
4. About 40 seconds later, "FW-Update" will be displayed and blinking the memory indicator (this shows to start the download).
5. Display the software that now upgrading.

"FW-Update [CTRL]"  
 "FW-Update [ENGN]"  
 "FW-Update [PF1]"  
 "FW-Update [PF2]"  
 "FW-Update [SCAN]"  
 "FW-Update [FAX]" \*  
 "FW-Update [OPT]"  
 "FW-Update [CLT]"

### Caution:

Never turn off the power switch or remove the USB flash device during upgrading.

6. Display the completion of the upgrade (Memory indicator is ON condition).
7. ROM version is confirmed by the content of the display.
8. Turn OFF the main power switch and remove the USB memory.

\*: 4 in 1 model (with FAX) only.

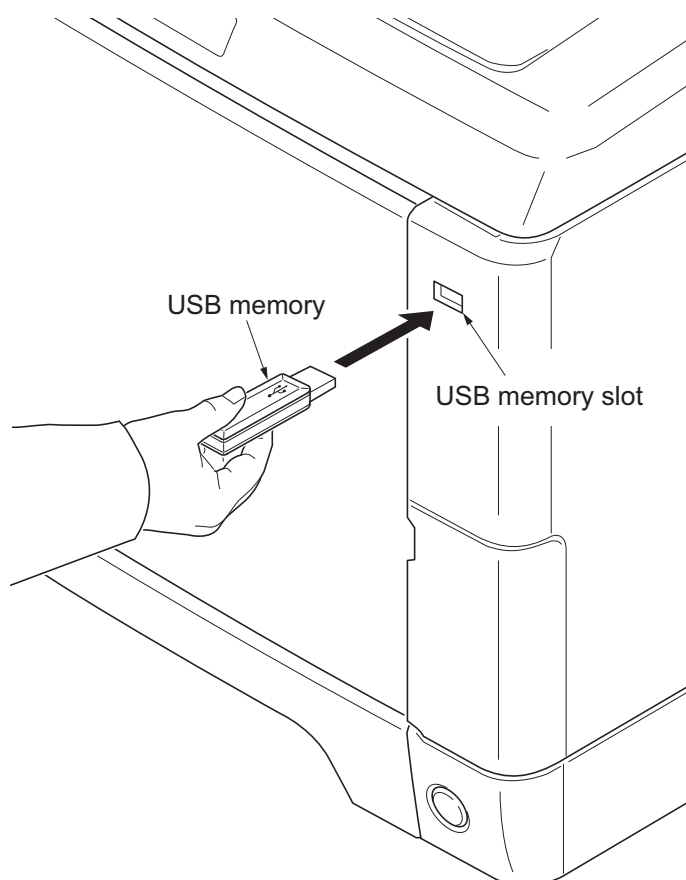


Figure 1-6-1

## Emergency-UPDATE

If the device is accidentally switched off and upgrading was incomplete, upgrade becomes impossible. In that case, retry upgrading after recovering the software by following the procedure below.

### Preparation

The USB memory must be formatted in FAT or FAT32 in advance.

Extract the main firmware to download from the file.

Rename the file which was extracted from the archive. [DL\_CTRL.2M9] to [KM\_EMRG.2M9]

Copy the all extracted files to the root of the USB memory.

1. **Procedur** Turn the main power switch off.
2. Insert the USB memory which contains the firmware into the USB memory slot.
3. Turn the main power switch on.
4. Rewriting of the PWB software will start for restoration.  
The memory and attention indicators will be blinking.
5. Only the Memory indicator will be blinking when rewriting is successful.  
\* : Only the Attention indicator will be blinking when rewriting is failed.
6. Turn the main power switch off.
7. Wait for several seconds and then remove the USB memory from the USB memory slot.
8. Extract the firmware to download from the archive and copy to the root of the formatted USB memory.  
**NOTE:** Deletes the "ES\_SKIP.on" file When it is contained directly under the USB memory.

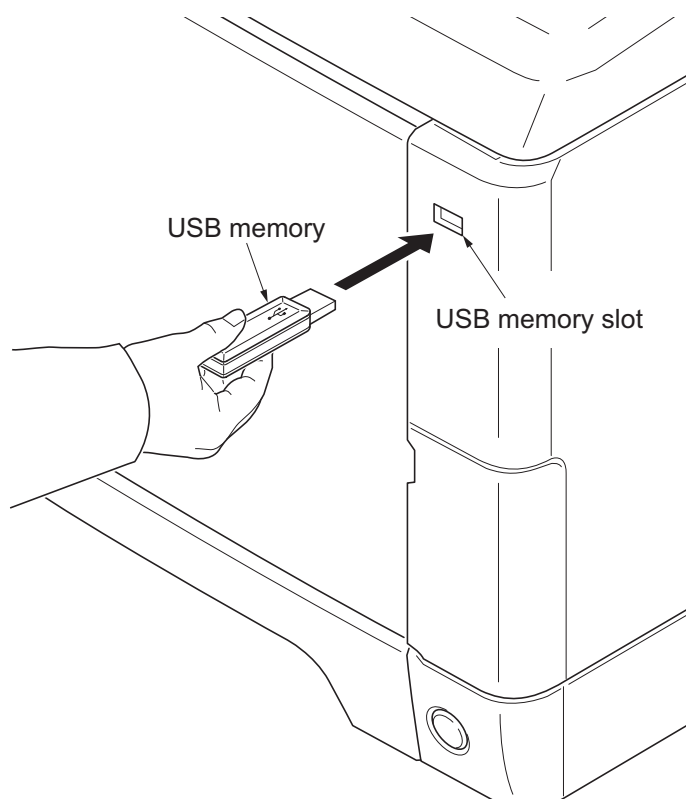


Figure 1-6-2

9. Insert the USB memory in which the firmware was copied in the USB memory slot.
10. Perform steps 3 to 8 on the previous page.
11. Turn the main power switch on.
12. Perform maintenance item U000 (Print a maintenance report) to check that the version of ROM U019 has been upgraded.

## 1-6-2 Remarks on engine PWB replacement

When replacing the engine PWB, remove the EEPROM (U1) from the engine PWB that has been removed and then reattach it to the new engine PWB.

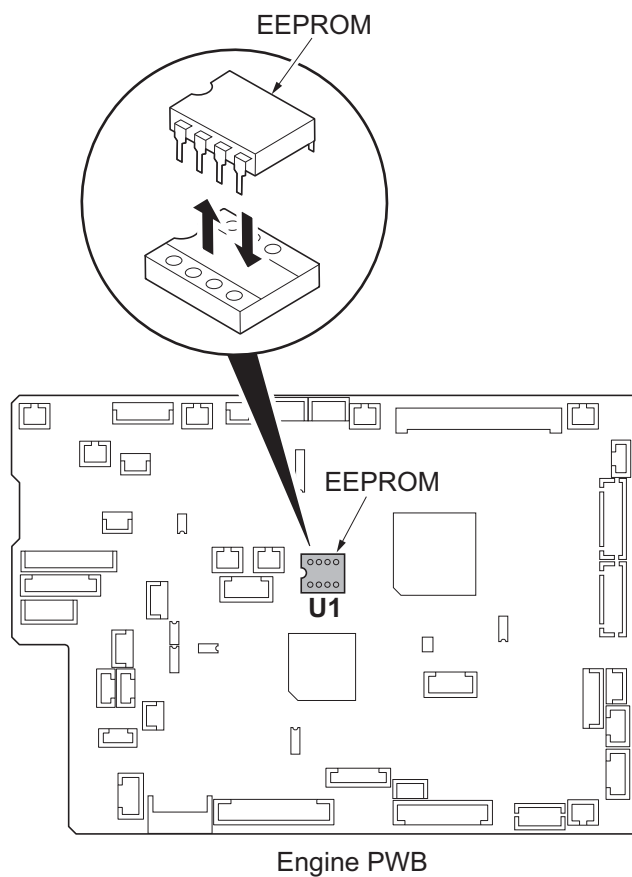


Figure 1-6-3

## 2-1-1 Paper feed/conveying section

Paper feed/conveying section consists of the paper feed unit that feeds paper from the cassette and the MP tray paper feed unit that feeds paper from the MP tray, and the paper conveying section that conveys the fed paper to the transfer/separation section.

### (1) Cassette paper feed section

The cassette can contain 250 sheets. The sheet from the cassette is pulled out by rotation of the pickup roller and sent to the paper conveying section by rotation of the paper feed roller. Also the retard roller prevents multiple feeding of paper.

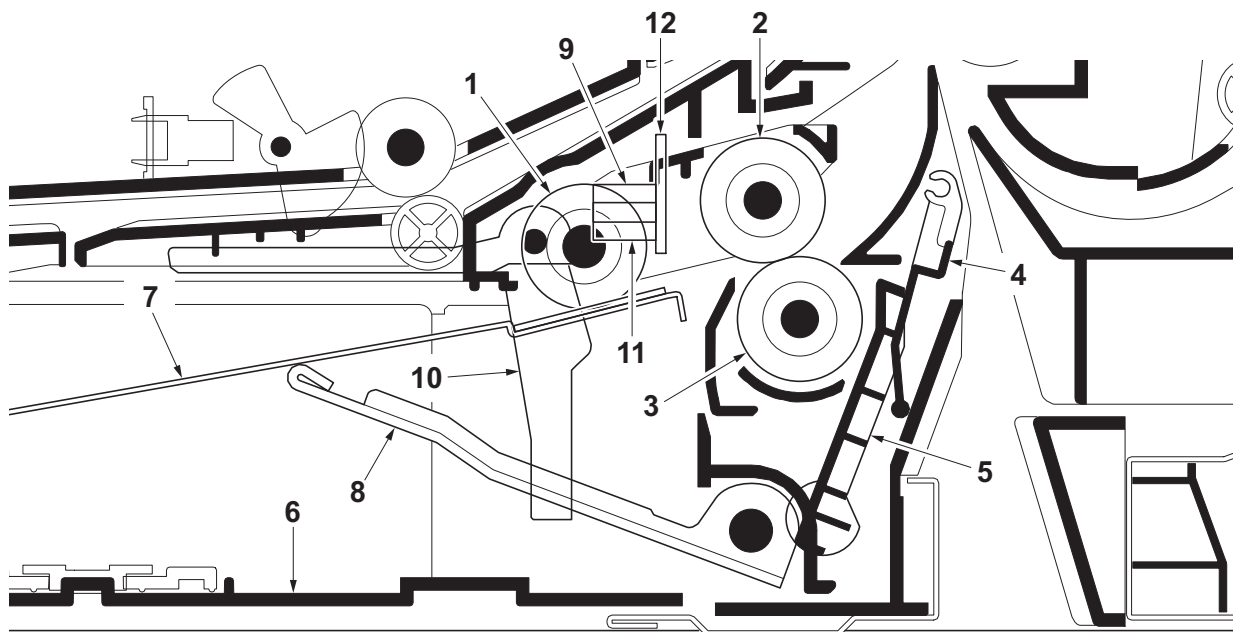


Figure 2-1-1 Cassette paper feed section

- |                      |                             |
|----------------------|-----------------------------|
| 1. Pickup roller     | 7. Bottom plate             |
| 2. Paper feed roller | 8. Lift work plate          |
| 3. Retard roller     | 9. Paper sensor (PS)        |
| 4. Retard cover      | 10. Actuator (paper sensor) |
| 5. Retard lever      | 11. Lift sensor (LS)        |
| 6. Cassette base     | 12. Cassette PWB (CPWB)     |

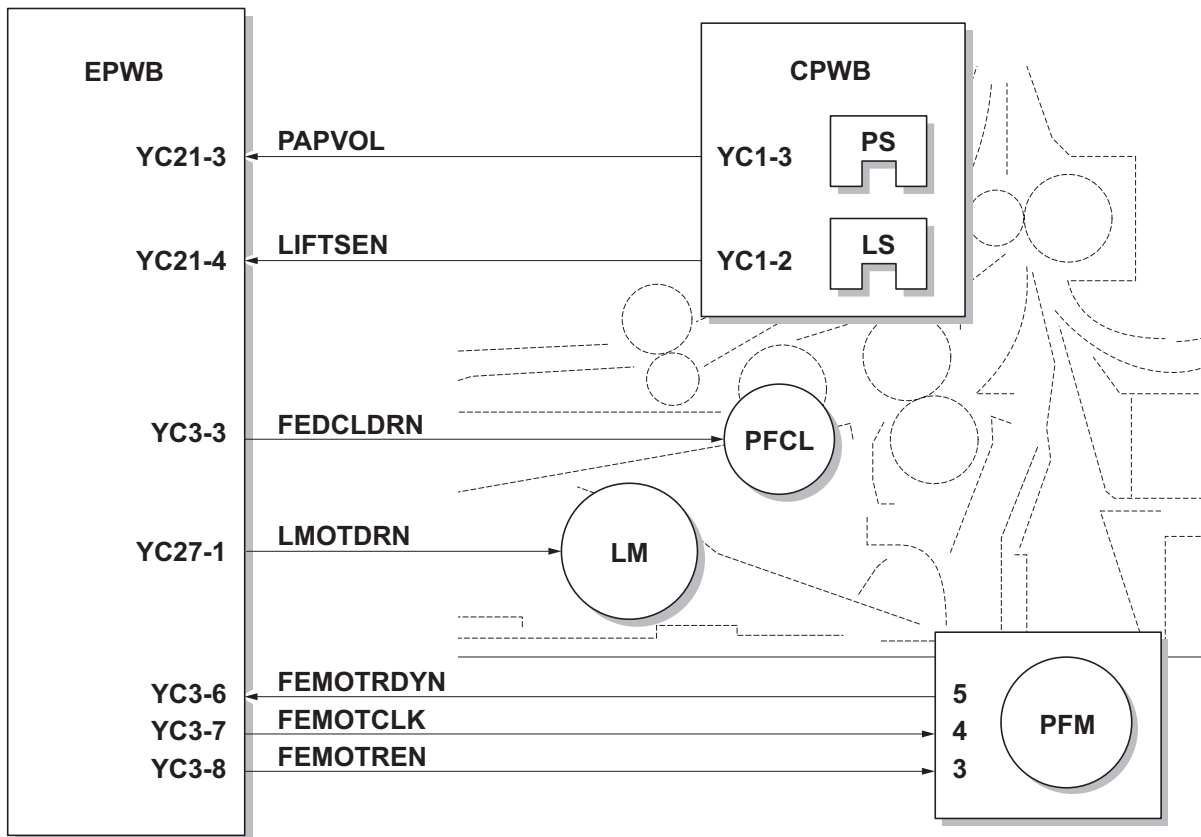


Figure 2-1-2 Cassette paper feed section block diagram

## (2) MP tray paper feed section

The MP tray can contain 50 sheets. Feeding from the MP tray is performed by the rotation of the MP paper feed roller. Also, function of the MPF separation pad prevents paper from multiple feeding.

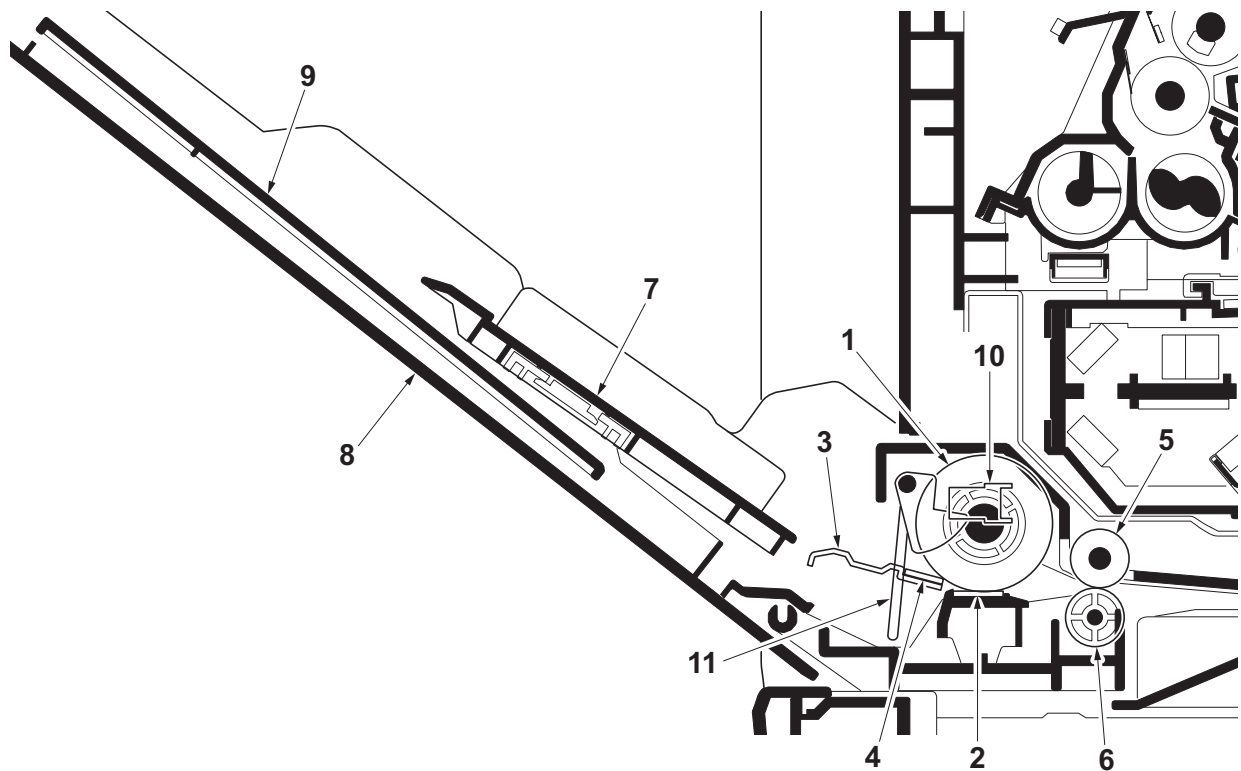


Figure 2-1-3 MP tray paper feed section

- |                         |                                |
|-------------------------|--------------------------------|
| 1. MP paper feed roller | 7. MPF base                    |
| 2. MPF separation pad   | 8. MPF cover                   |
| 3. MPF bottom plate     | 9. MPF tray                    |
| 4. Friction pad         | 10. MP paper sensor (MPPS)     |
| 5. MPF feed roller      | 11. Actuator (MP paper sensor) |
| 6. Feed pulley          |                                |

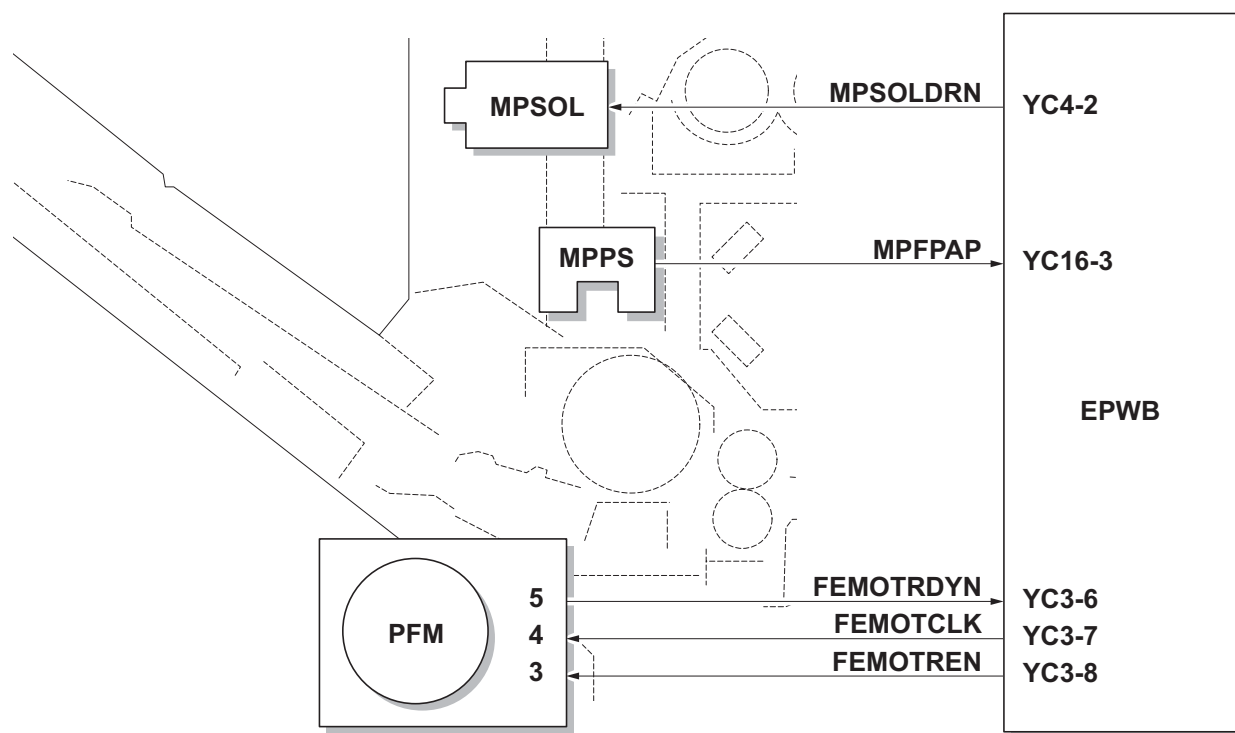


Figure 2-1-4 MP tray paper feed section block diagram

### (3) Paper conveying section

The paper conveying section conveys paper to the transfer/separation section as paper feeding from the cassette or MP tray, or as paper refeeding for duplex printing. Paper by feeding is conveyed by the middle roller to the position where the registration sensor (RS) is turned on, and then sent to the transfer/separation section by the front registration roller and rear registration roller.

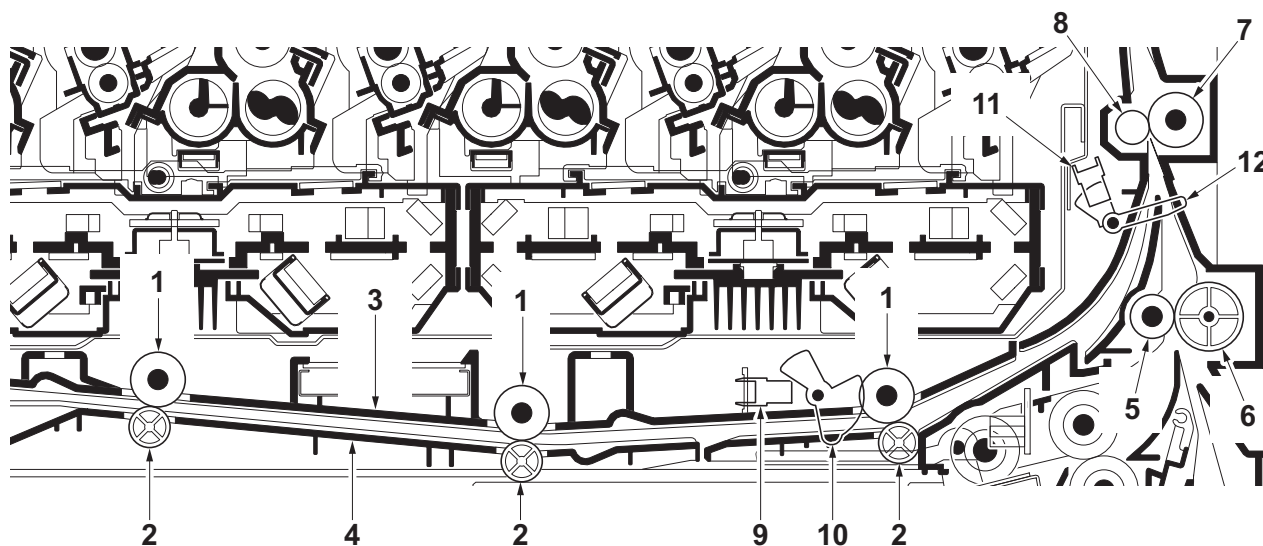


Figure 2-1-5 Paper conveying section

- |                              |  |
|------------------------------|--|
| 1. MPF feed rollers          | 8. Rear registration roller              |
| 2. Feed pulleys              | 9. MP paper conveying sensor (MPPCS)     |
| 3. MPF feed upper guide      | 10. Actuator (MP paper conveying sensor) |
| 4. MPF feed lower guide      | 11. Registration sensor (RS)             |
| 5. Middle roller             | 12. Actuator (registration sensor)       |
| 6. Middle pulley             |  |
| 7. Front registration roller |  |



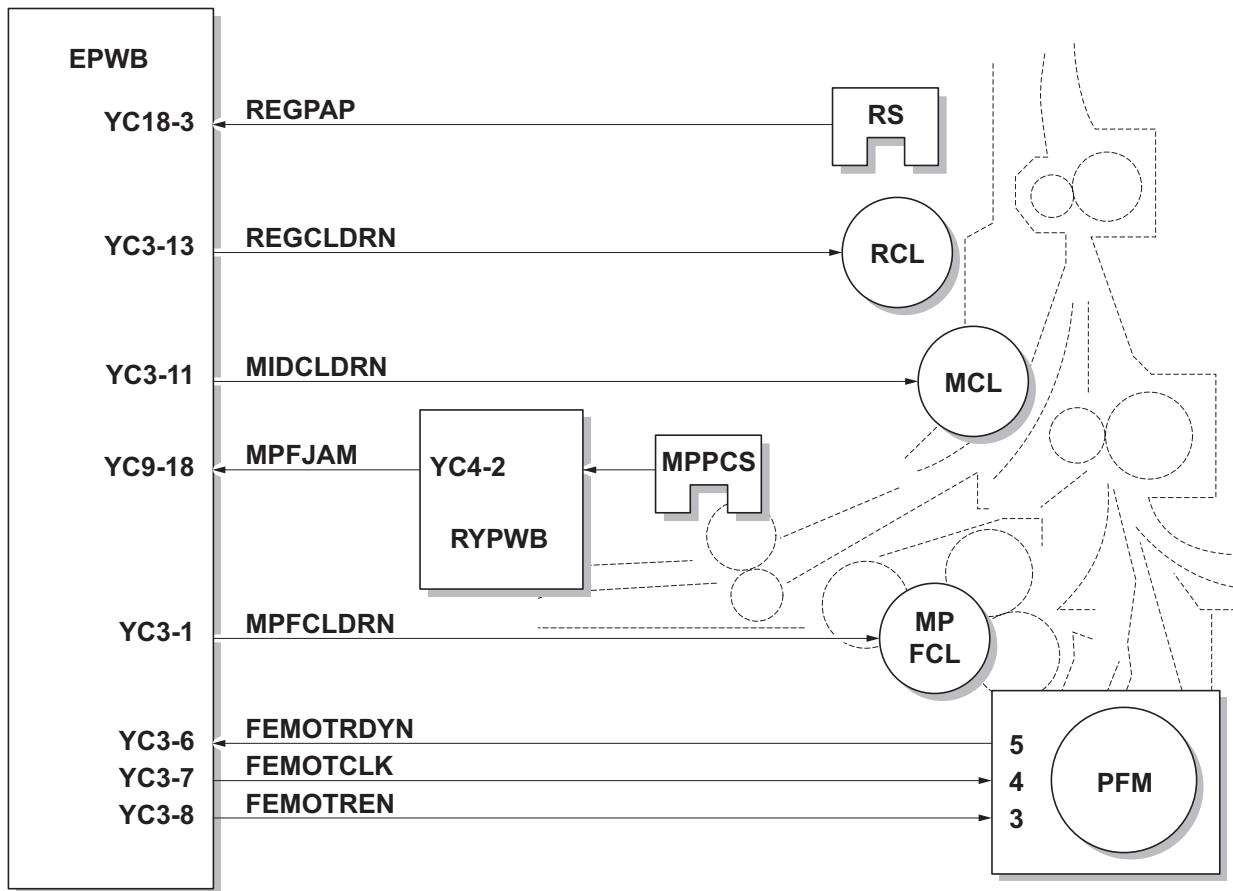


Figure 2-1-6 Paper conveying section block diagram

## 2-1-2 Drum section

The drum section consists of the drum, the charger roller unit, and the cleaning unit, and the drum surface is uniformly charged in preparation for formation of residual image by laser beam.

After transfer is complete, toner remaining on the drum surface is chipped off with the cleaning blade and is collected to the waste toner box with the drum screw. The cleaning lamp (CL) consists of LEDs and removes residual charge on the drum before main charging.

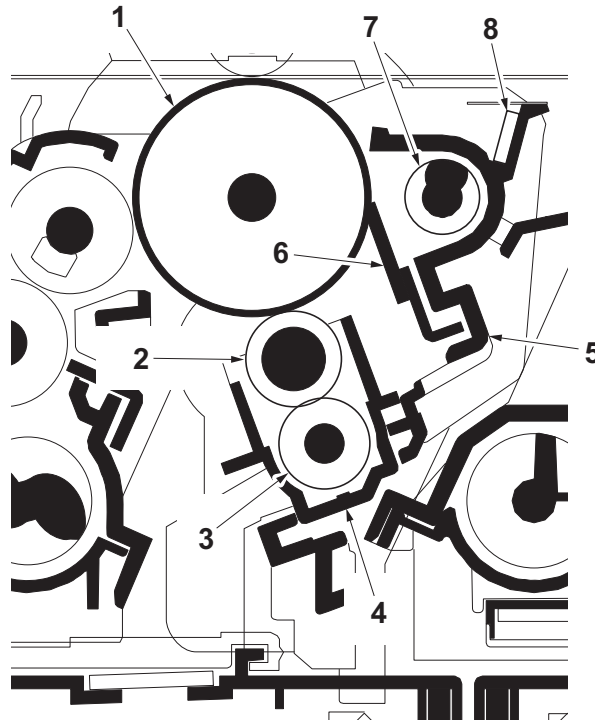


Figure 2-1-7 Drum section

- |                            |                       |
|----------------------------|-----------------------|
| 1. Drum                    | 5. Drum frame         |
| 2. Charger roller          | 6. Cleaning blade     |
| 3. Charger cleaning roller | 7. Drum screw         |
| 4. Charger case            | 8. Cleaning lamp (CL) |

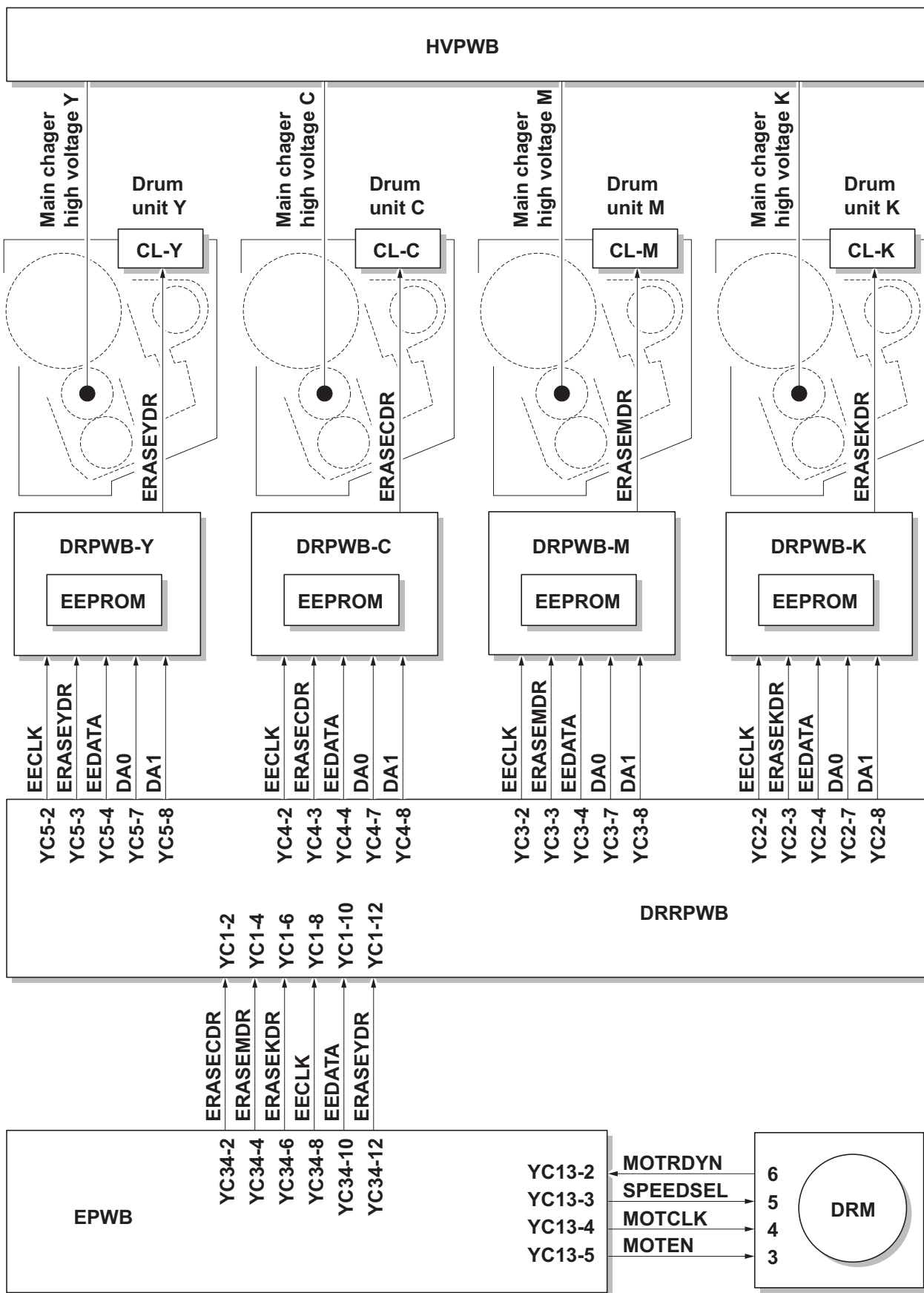


Figure 2-1-8 Drum section block diagram

## 2-1-3 Developing section

The developing unit consists of the sleeve roller that forms the magnetic brush, the magnet roller, the developing blade and the developing screws that agitate the toner. Also, the toner sensor (TS) checks whether or not toner remains in the developing unit.

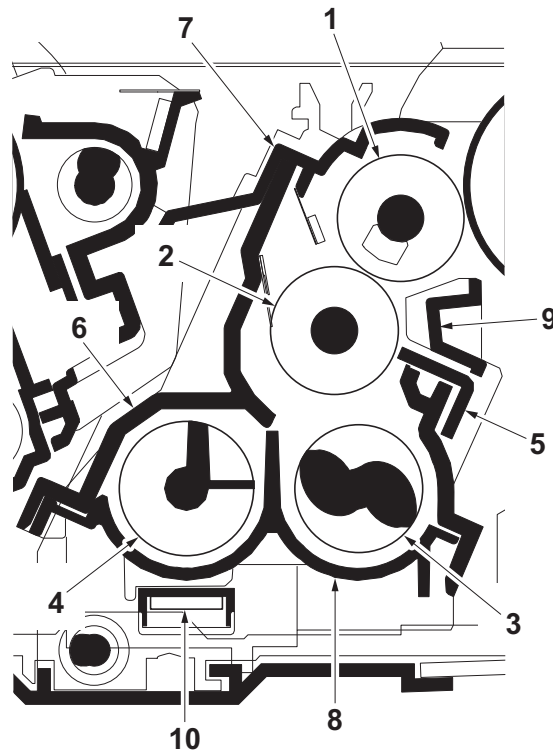


Figure 2-1-9 Developing section

- |                       |                          |
|-----------------------|--------------------------|
| 1. Sleeve roller      | 6. Developer case        |
| 2. Magnet roller      | 7. Upper developer cover |
| 3. Developing screw A | 8. Developer base        |
| 4. Developing screw B | 9. Sleeve cover          |
| 5. Developing blade   | 10. Toner sensor (TS)    |

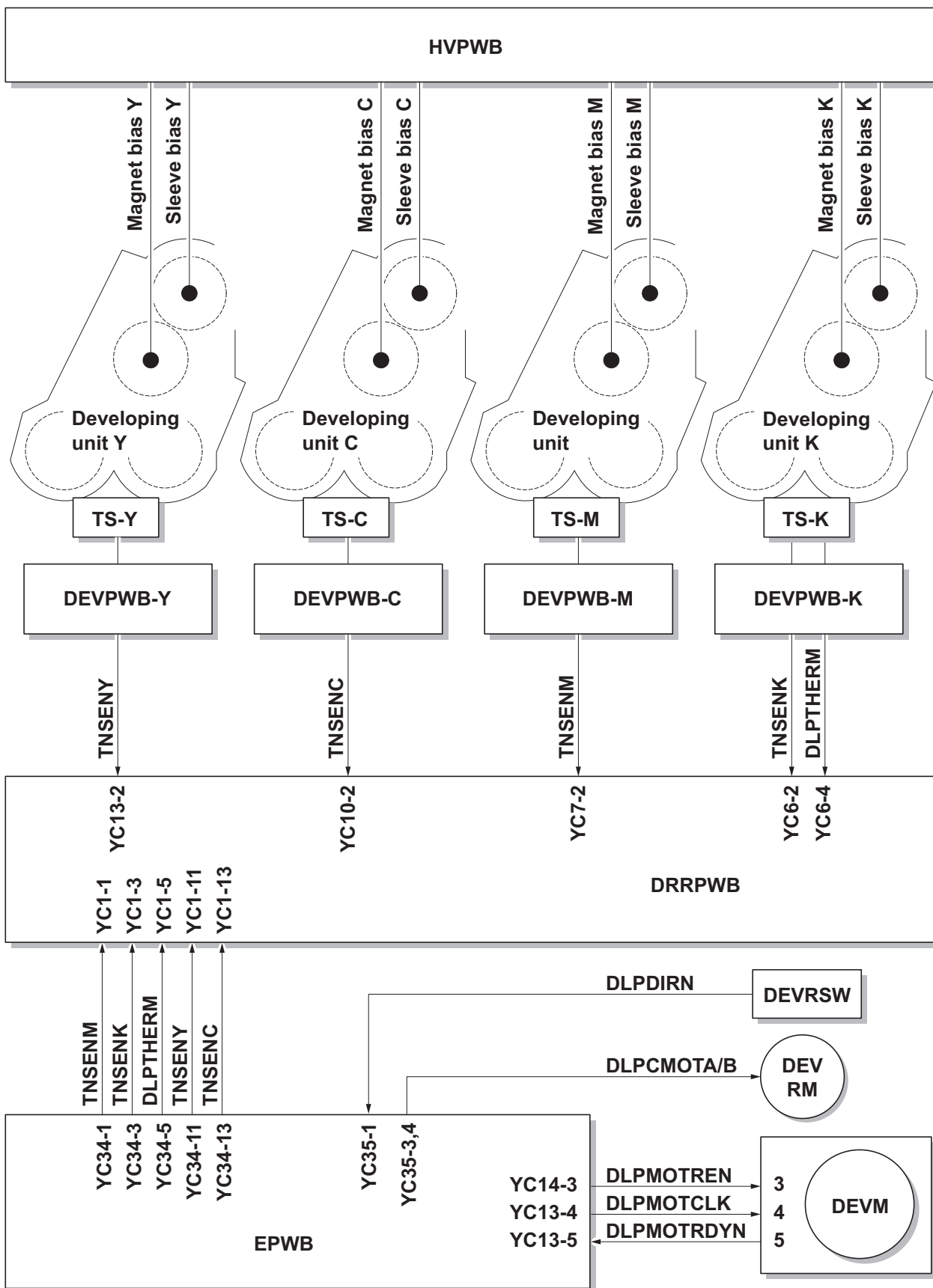


Figure 2-1-10 Developing section block diagram

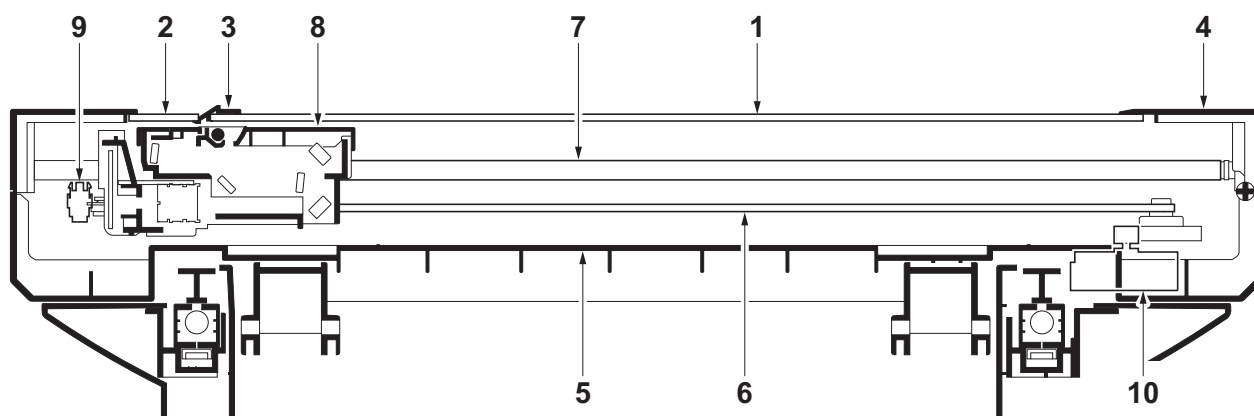
## 2-1-4 Optical section

The optical section consists of the image scanner section for scanning and the laser scanner section for printing.

### (1) Image scanner section

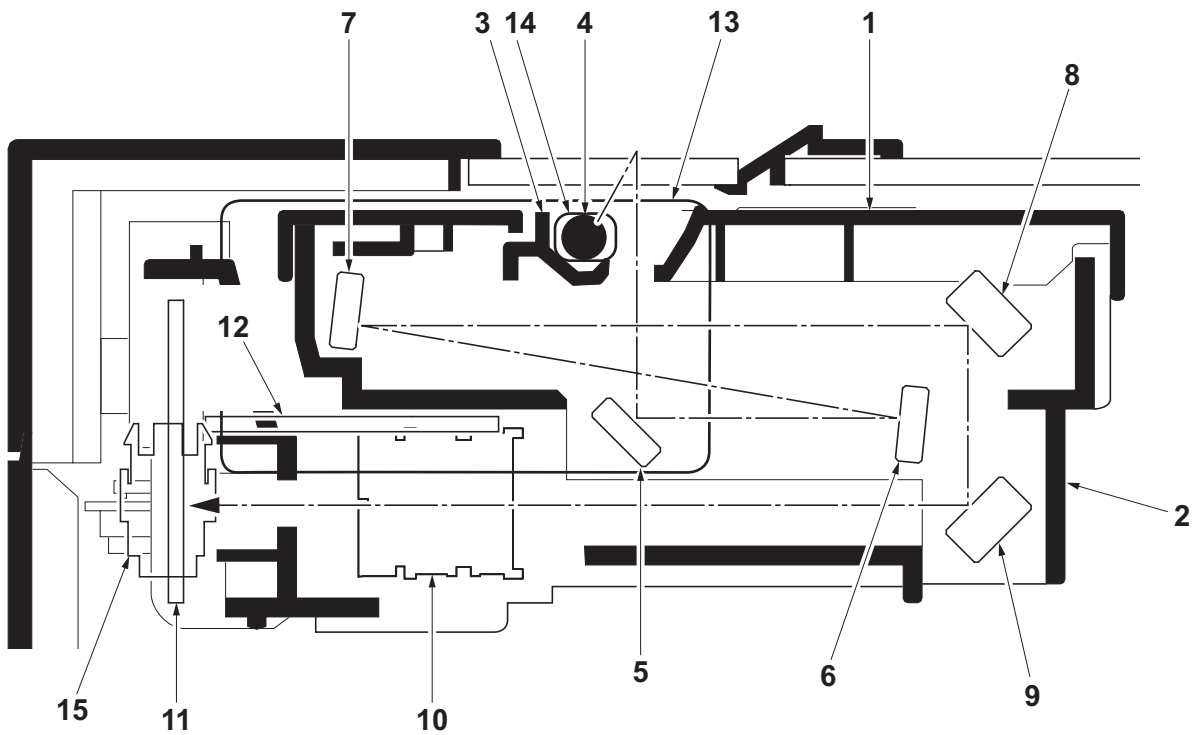
The original image is illuminated by the LED and scanned by the CCD image sensor in the CCD PWB (CCD-PWB) via the five mirrors and ISU lens, the reflected light being converted to an electrical signal.

If a document processor is used, the image scanner unit stops at the position of the DP contact glass and scans sequentially one row of the image on the original in synchronization with the moving timing of the original in the sub scan direction by driving the DP.



**Figure 2-1-11 Scanner unit**

- |                                  |                               |
|----------------------------------|-------------------------------|
| 1. Contact glass                 | 6. ISU belt                   |
| 2. DP contact glass              | 7. ISU shaft                  |
| 3. Original size indicator plate | 8. Image scanner unit (ISU)   |
| 4. ISU top frame                 | 9. Home position sensor (HPS) |
| 5. ISU bottom frame              | 10. ISU motor (ISUM)          |



**Figure 2-1-12 Image scanner unit (ISU)**

- |                         |                                |
|-------------------------|--------------------------------|
| 1. Unit cover           | 9. Mirror E                    |
| 2. ISU housing          | 10. ISU lens                   |
| 3. Reflector            | 11. CCD PWB (CCDPWB)           |
| 4. Transparent material | 12. DriverPWB (DRPWB)          |
| 5. Mirror A             | 13. LED PWB (LEDPWB)           |
| 6. Mirror B             | 14. LED                        |
| 7. Mirror C             | 15. Home position sensor (HPS) |
| 8. Mirror D             |                                |

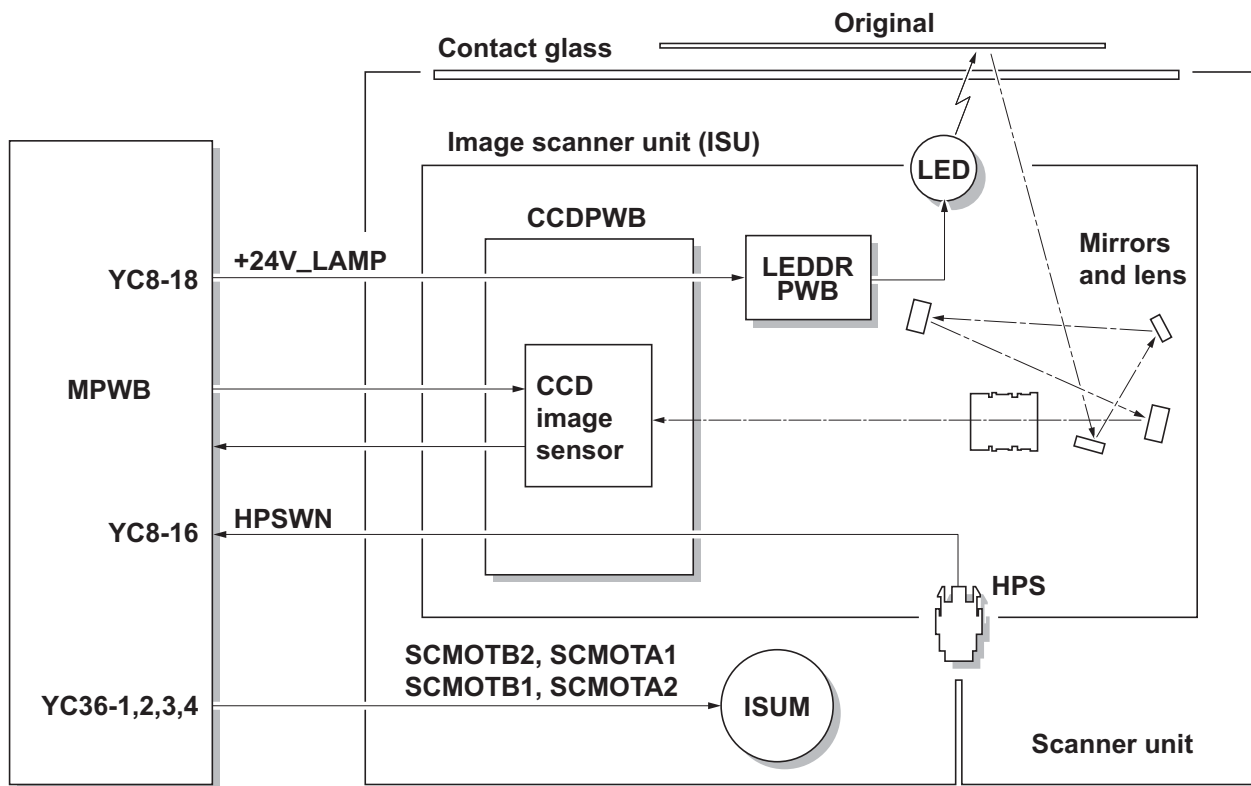


Figure 2-1-13 Scanner unit block diagram



## (2) Laser scanner section

The charged surface of the drum is then scanned by the laser beam from the laser scanner unit. The laser beam is dispersed as the polygon motor (PM) revolves to reflect the laser beam over the drum. Various lenses and mirror are housed in the laser scanner unit, adjust the diameter of the laser beam, and focalize it at the drum surface. Also the LSU cleaning motor (LSUCM) is activated to conduct automatically cleaning of the LSU dust shield glass.

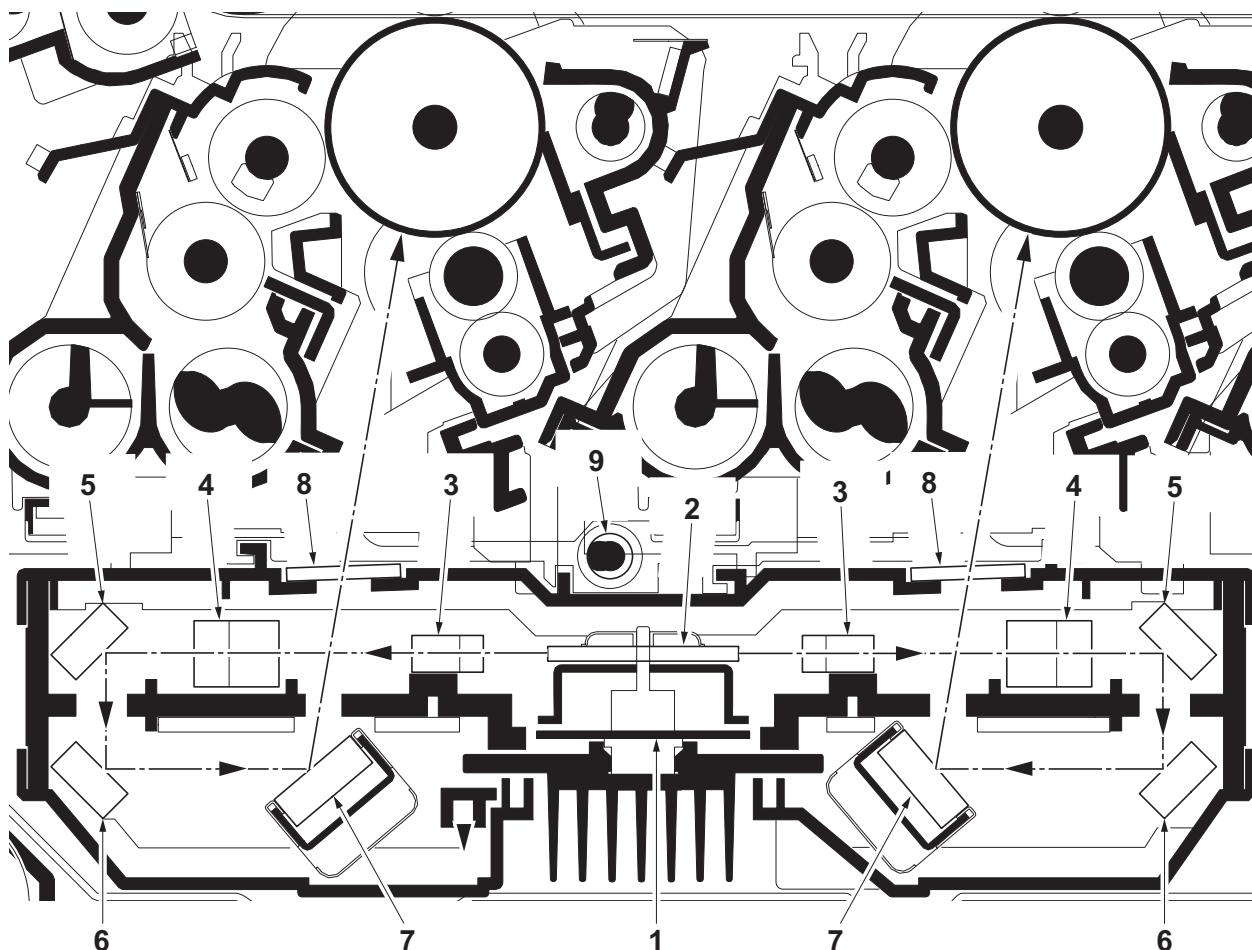


Figure 2-1-14 Laser scanner unit (LSU)

- |                       |                          |
|-----------------------|--------------------------|
| 1. Polygon motor (PM) | 6. Mirror B              |
| 2. Polygon mirror     | 7. Mirror C              |
| 3. f-θ lens A         | 8. LSU dust shield glass |
| 4. f-θ lens B         | 9. LSU spiral            |
| 5. Mirror A           |                          |

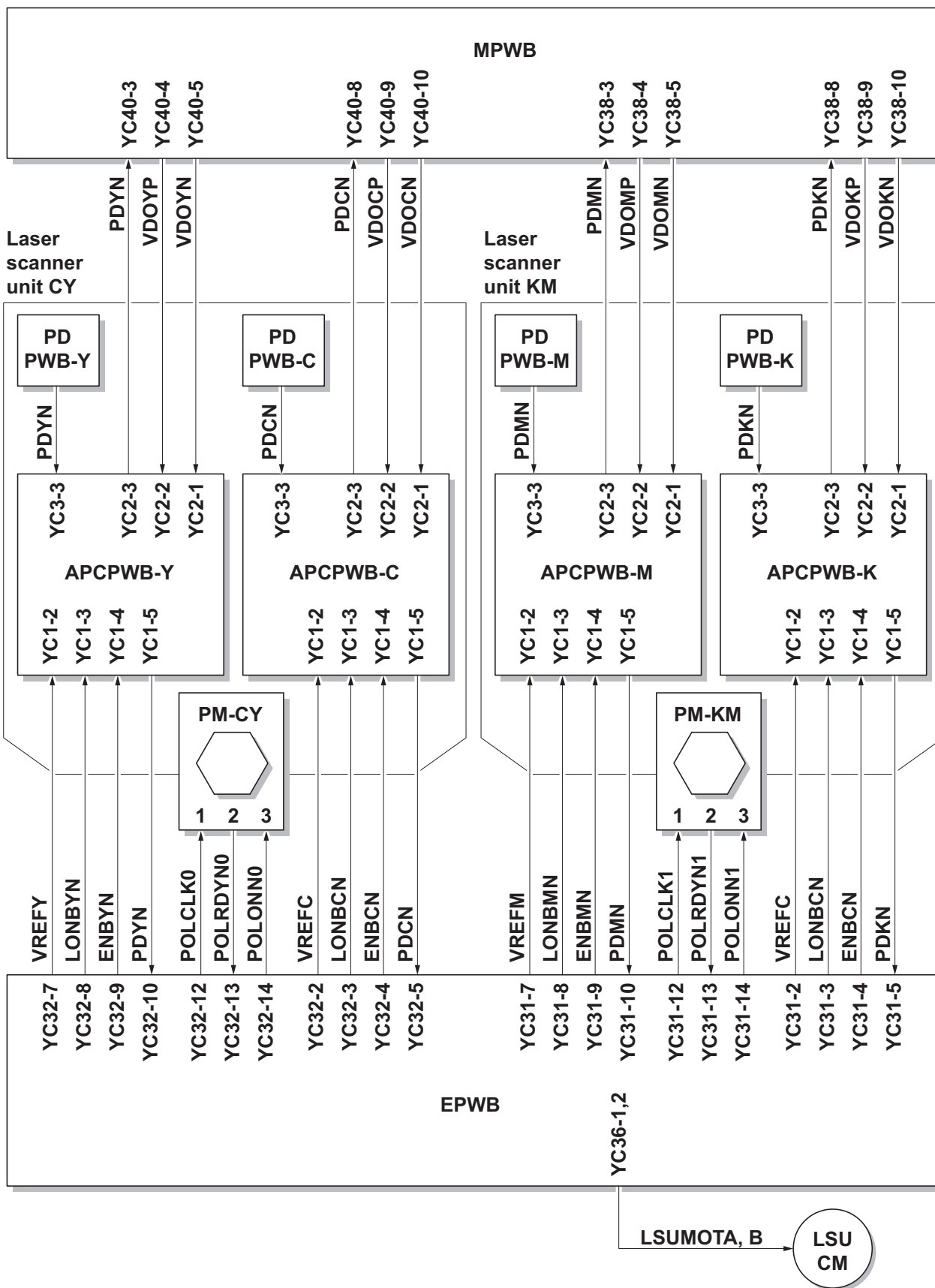


Figure 2-1-15 Laser scanner unit block diagram

## 2-1-5 Transfer/Separation section

The transfer/separation section consists of the intermediate transfer unit section and the secondary transfer roller section.

### (1) Intermediate transfer unit section

The intermediate transfer unit section consists of the transfer cleaning unit, the transfer belt, and the four primary transfer rollers for respective color drums, and forms a full-color toner image by superimposing and transferring single-color toner images formed on each drum onto the transfer belt. Also with the ID sensors (IDS) mounted on the machine frame, the toner density on the transfer belt is measured.

The transfer cleaning unit collects toner remaining on the transfer belt after secondary transfer and forwards it as waste toner to the waste toner box.

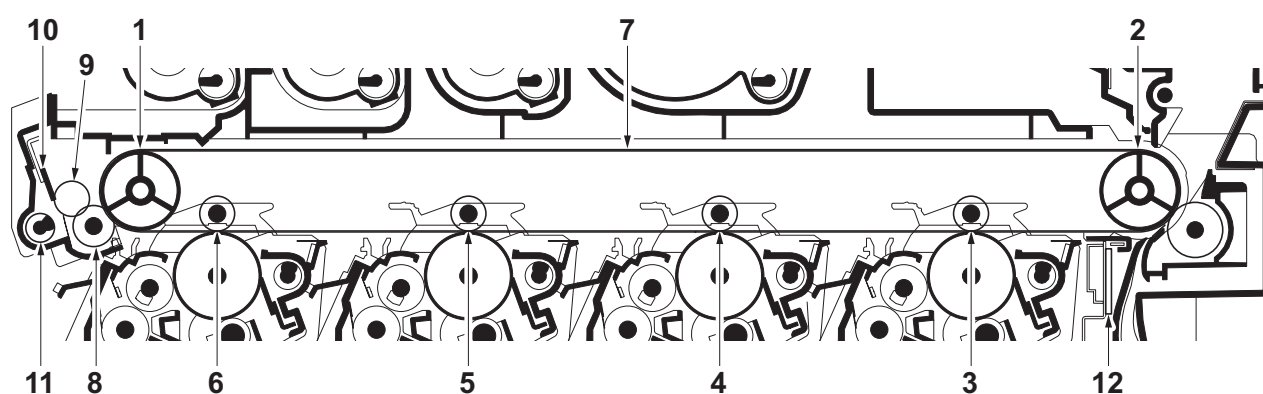


Figure 2-1-16 Intermediate transfer unit section

- |                              |                       |
|------------------------------|-----------------------|
| 1. Tension roller            | 7. Transfer belt      |
| 2. Drive roller              | 8. Cleaning fur brush |
| 3. Primary transfer roller K | 9. Cleaning roller    |
| 4. Primary transfer roller M | 10. Cleaning blade    |
| 5. Primary transfer roller C | 11. Cleaning screw    |
| 6. Primary transfer roller Y | 12. ID sensors (IDS)  |

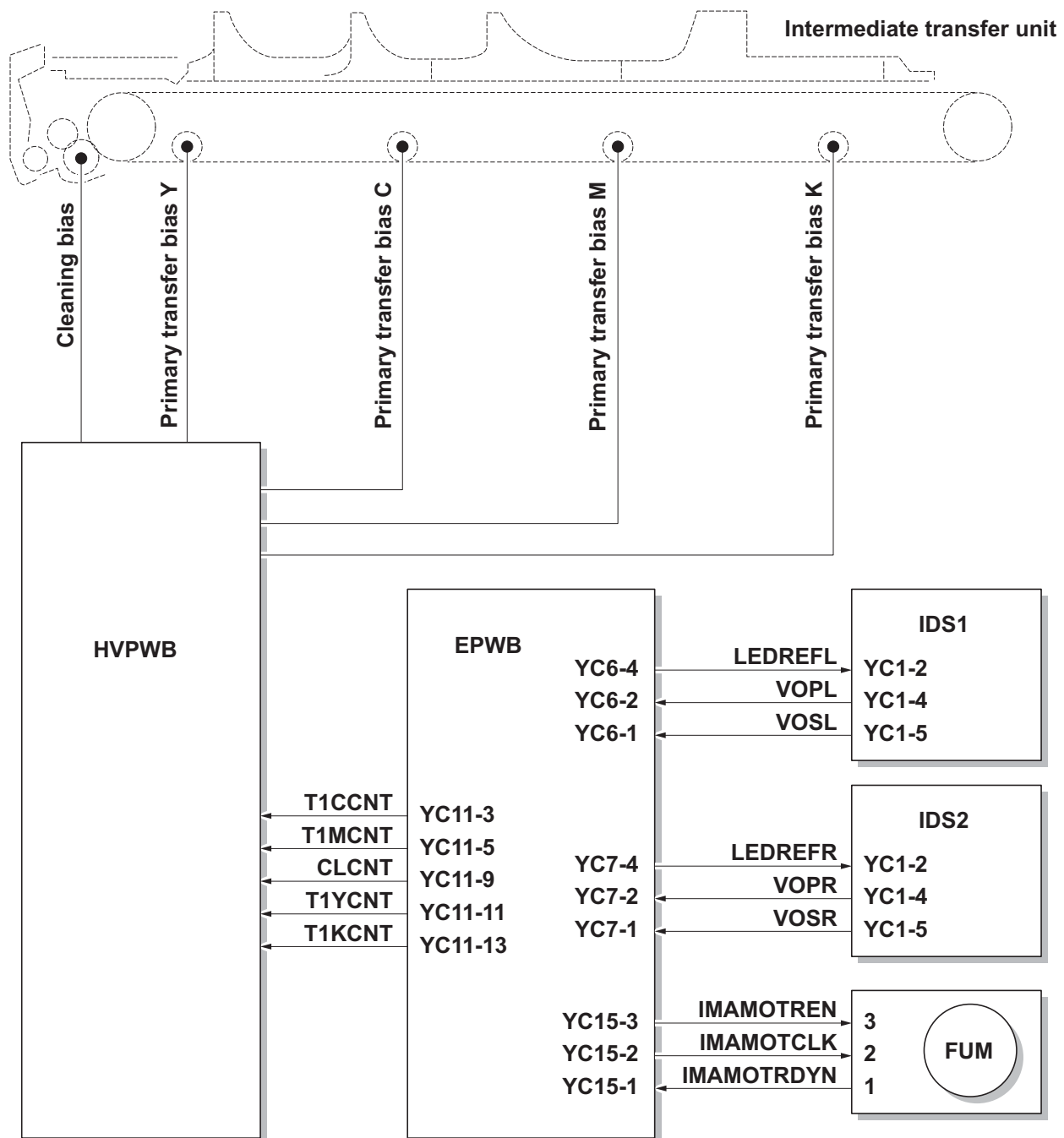
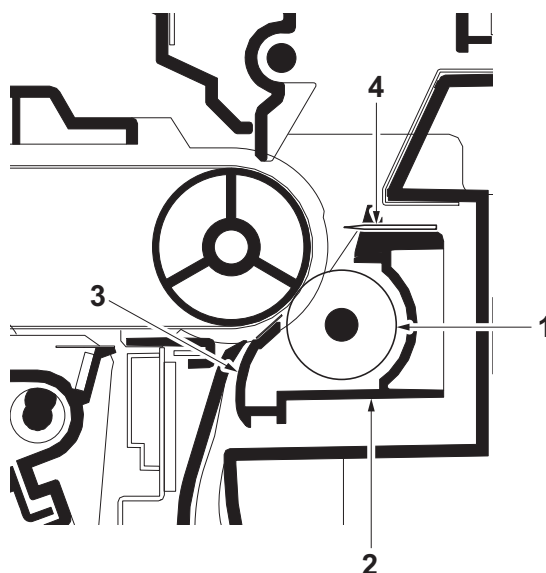


Figure 2-1-17 Intermediate transfer unit section block diagram

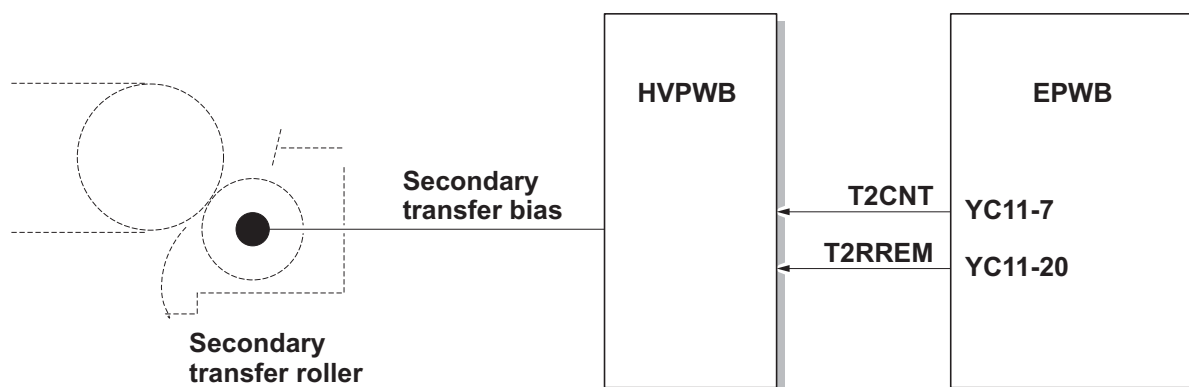
**(2) Secondary transfer roller section**

The secondary transfer roller section consists of the secondary transfer roller mounted to the paper conveying unit and the separation brush. To the secondary transfer roller, DC bias is applied from the high voltage PWB (HVPWB). The toner image formed on the transfer belt is transferred to the paper by the potential difference and the paper is separated by curvature separation.



**Figure 2-1-18 Secondary transfer roller section**

- 1. Secondary transfer roller
- 2. Brush holder
- 3. Paper chute guide
- 4. Separation brush



**Figure 2-1-19 Secondary transfer roller section block diagram**

## 2-1-6 Fuser section

The paper sent from the transfer/separation section is interleaved between the heat roller and the press roller. The heat roller is heated by the fuser heater (FH), and the toner is fused by heat and pressure and fixed onto the paper because the press roller is pressed by the fuser press spring. The surface temperature of heat roller is detected by the fuser thermistor (FTH) and controlled by the engine PWB (EPWB). If the fuser section shows extremely high temperature, the power line will be shut off and the fuser heater (FH) is forced to turn off.

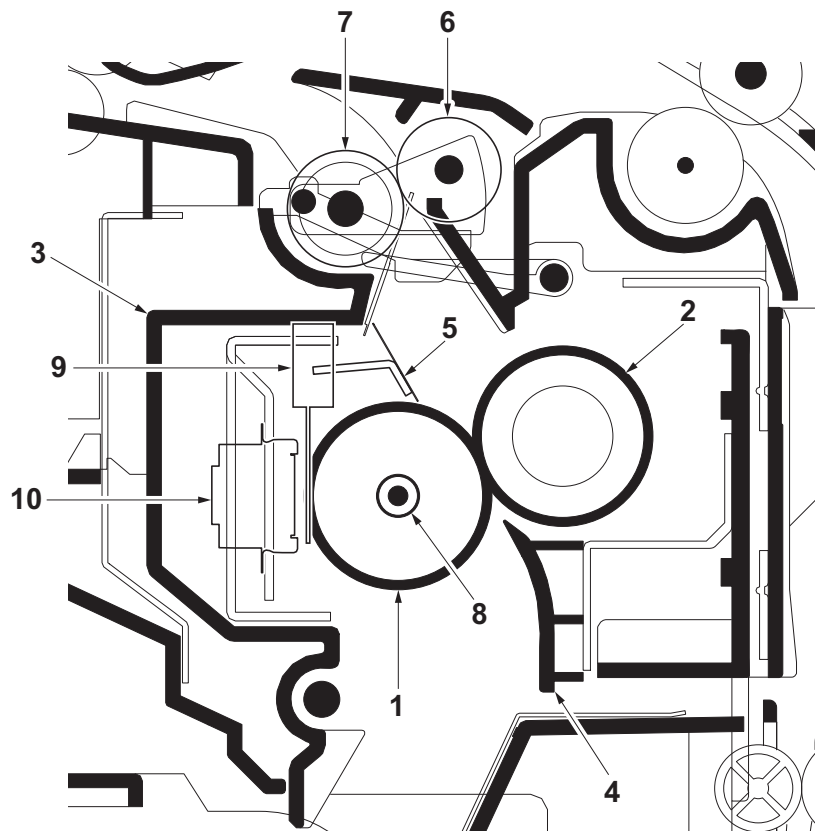


Figure 2-1-20 Fuser section

- |                      |                            |
|----------------------|----------------------------|
| 1. Heat roller       | 6. Eject roller            |
| 2. Press roller      | 7. Eject pulley            |
| 3. Upper fuser frame | 8. Fuser heater (FH)       |
| 4. Fuser paper guide | 9. Fuser thermistor (FTH)  |
| 5. Separators        | 10. Fuser thermostat (FTS) |

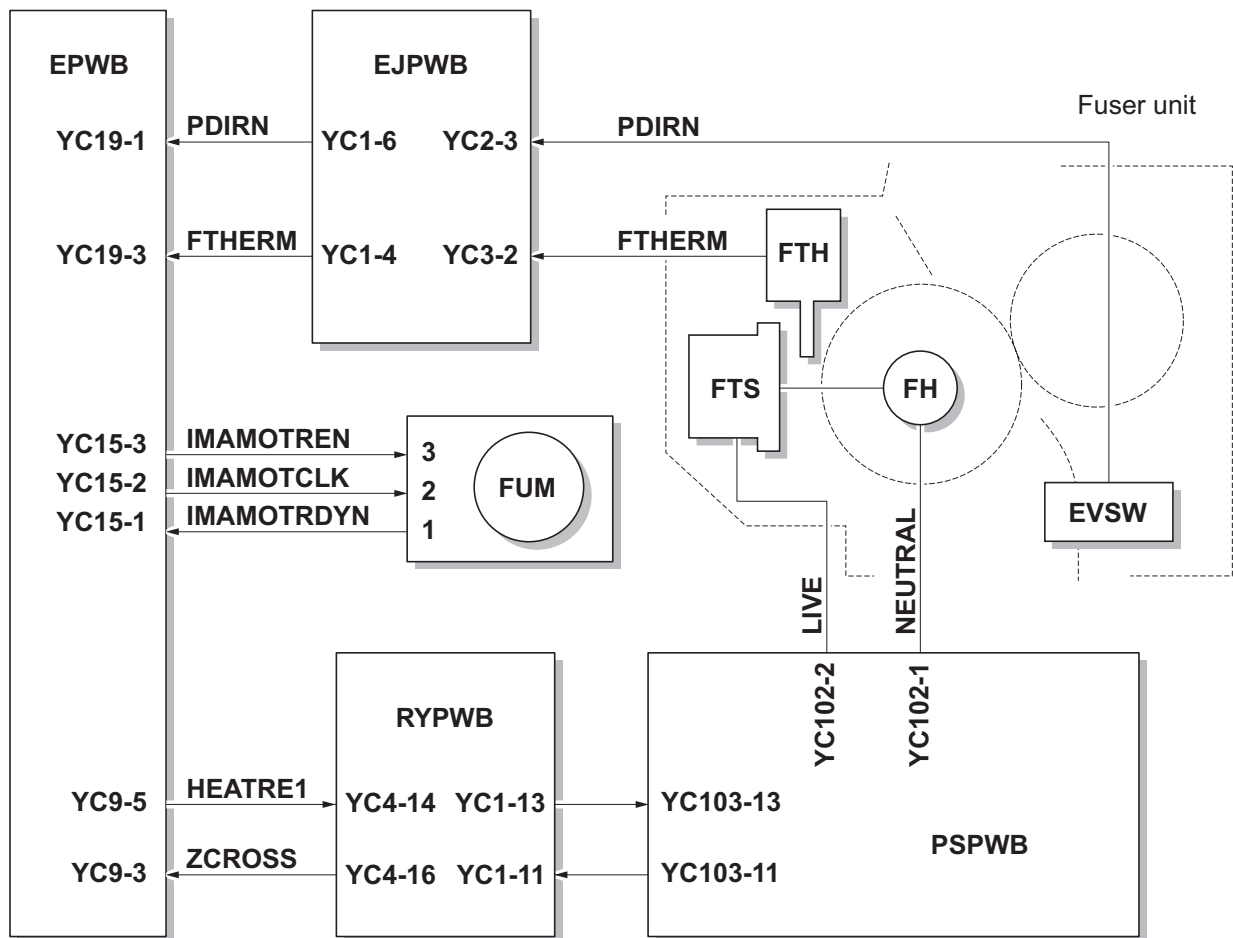
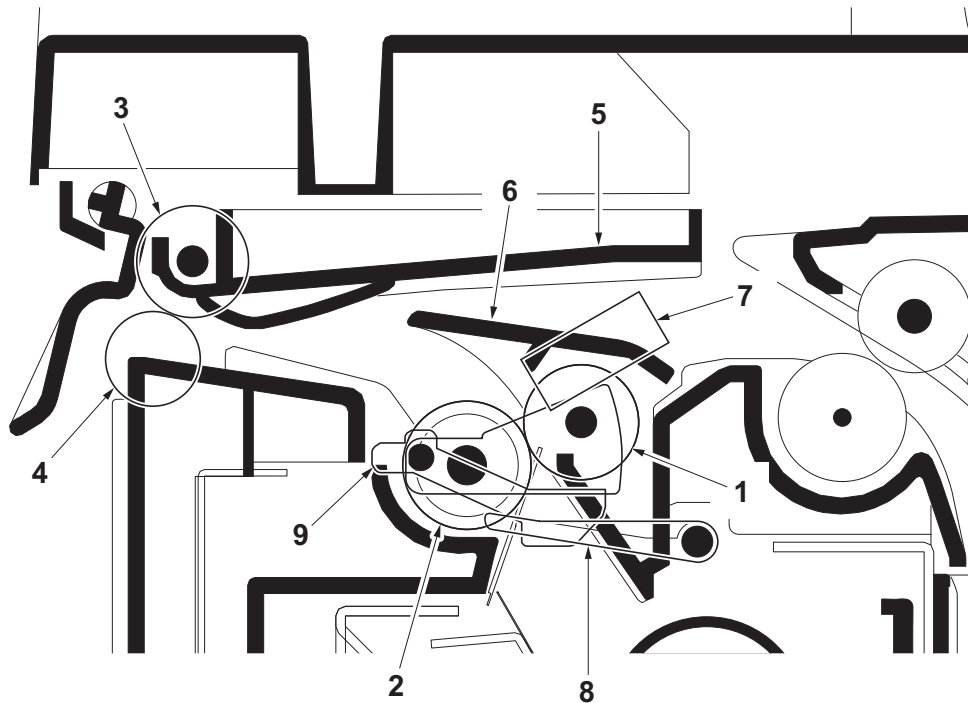


Figure 2-1-21 Fuser section block diagram

## 2-1-7 Eject/Feedshift section

The paper eject/feedshift section consists of the conveying path which sends the paper that has passed the fuser section to the inner tray or the duplex conveying section.



**Figure 2-1-22 Eject/Feed shift section**

- |                      |                            |
|----------------------|----------------------------|
| 1. Eject roller      | 6. Change guide            |
| 2. Eject pulley      | 7. Eject sensor (ES)       |
| 3. Eject roller      | 8. Actuator (eject sensor) |
| 4. Eject pulley      | 9. Actuator (eject sensor) |
| 5. Upper eject guide |                            |



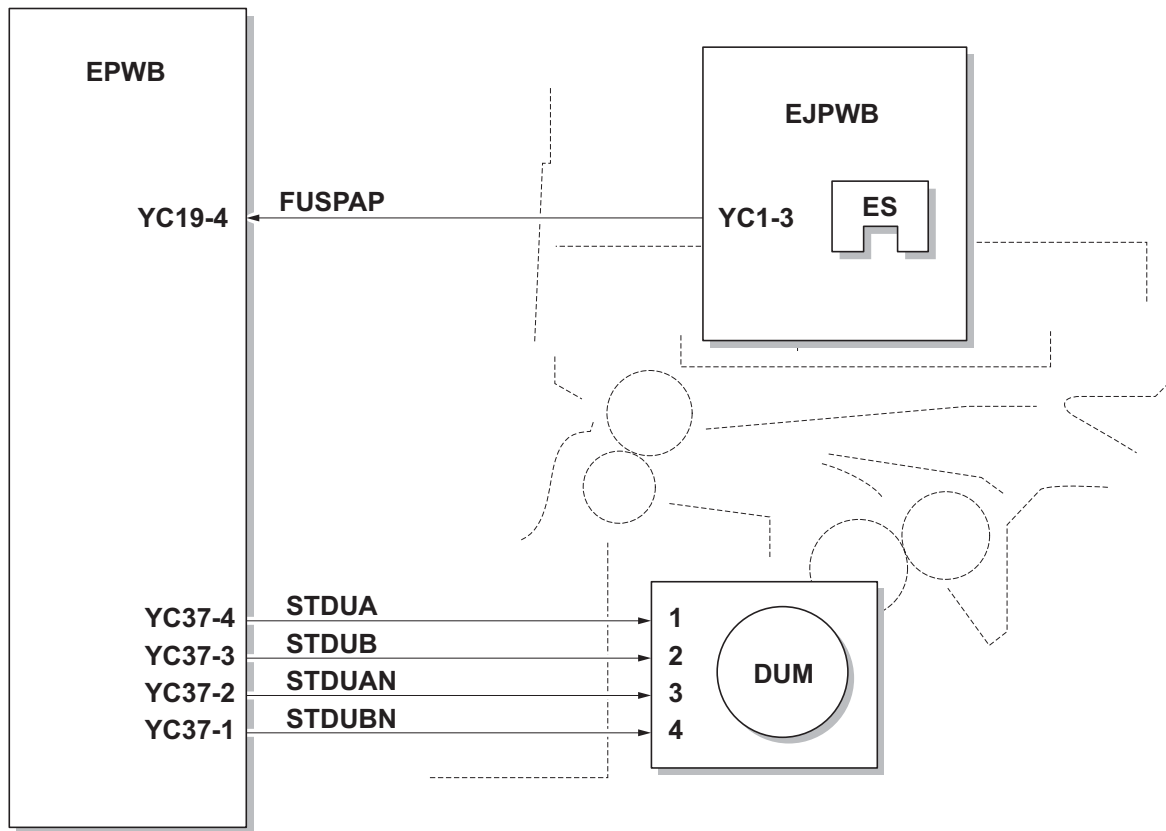


Figure 2-1-23 Eject/Feed shift section block diagram

## 2-1-8 Duplex conveying section

The duplex conveying section consists of conveying path which sends the paper sent from the eject/feedshift section to the paper feed/conveying section when duplex printing.

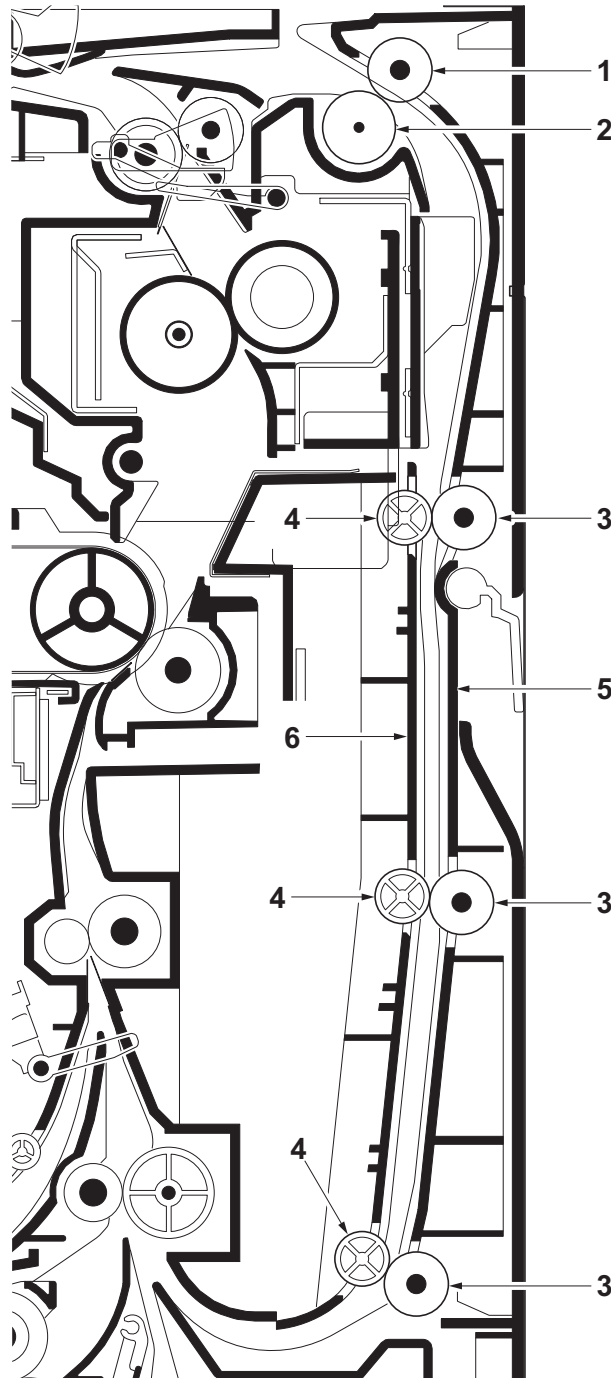


Figure 2-1-24 Duplex conveying section

- |                     |                      |
|---------------------|----------------------|
| 1. Duplex roller L  | 4. Duplex pulleys    |
| 2. Eject pulley     | 5. Duplex frame      |
| 3. Duplex rollers S | 6. Duplex feed guide |

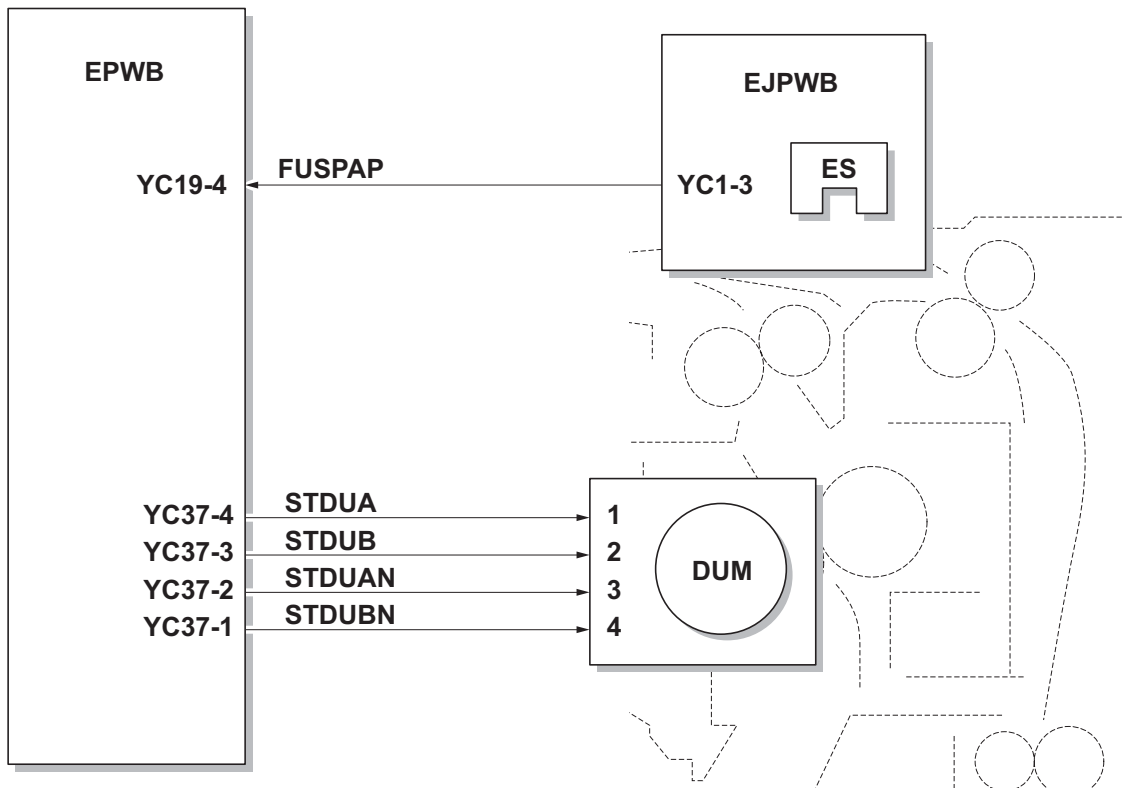


Figure 2-1-25 Duplex conveying section block diagram

## 2-1-9 Document processor

### (1) Original feed section

The original feed section consists of the parts shown in figure. An original placed on the original table is conveyed to the original conveying section. Original is fed by the rotation of the DP forwarding pulley and DP feed pulley.

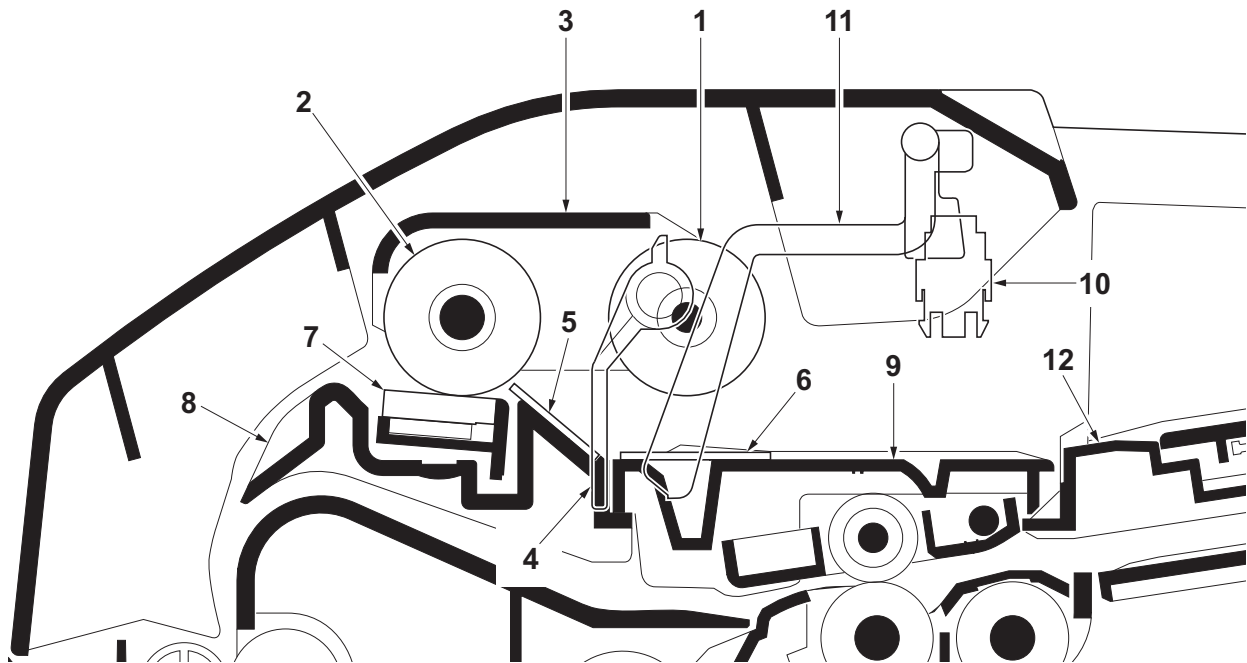


Figure 2-1-26 Original feed section

- |                         |                                   |
|-------------------------|-----------------------------------|
| 1. DP forwarding pulley | 7. DP separation pad              |
| 2. DP feed pulley       | 8. Upper guide                    |
| 3. LF holder            | 9. Switchback guide               |
| 4. PF stopper           | 10. DP original sensor (DPOS)     |
| 5. Front separation pad | 11. Actuator (DP original sensor) |
| 6. LF friction plate    | 12. Original table                |

1

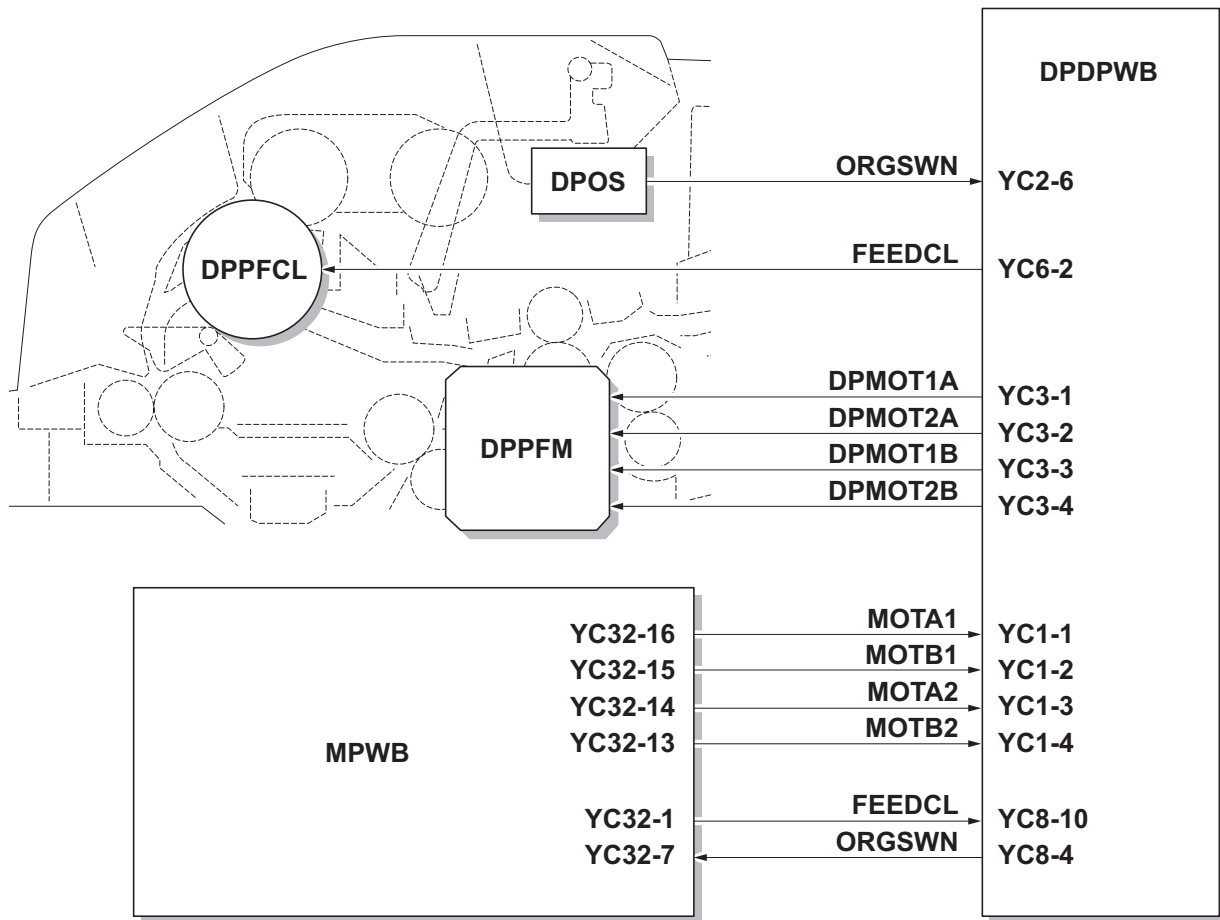


Figure 2-1-27 Original feed section block diagram

## (2) Original conveying section

The original conveying section consists of the parts shown in figure. A conveyed original is scanned by the optical section (CCD) of main machine when it passes through the DP contact glass of main machine.

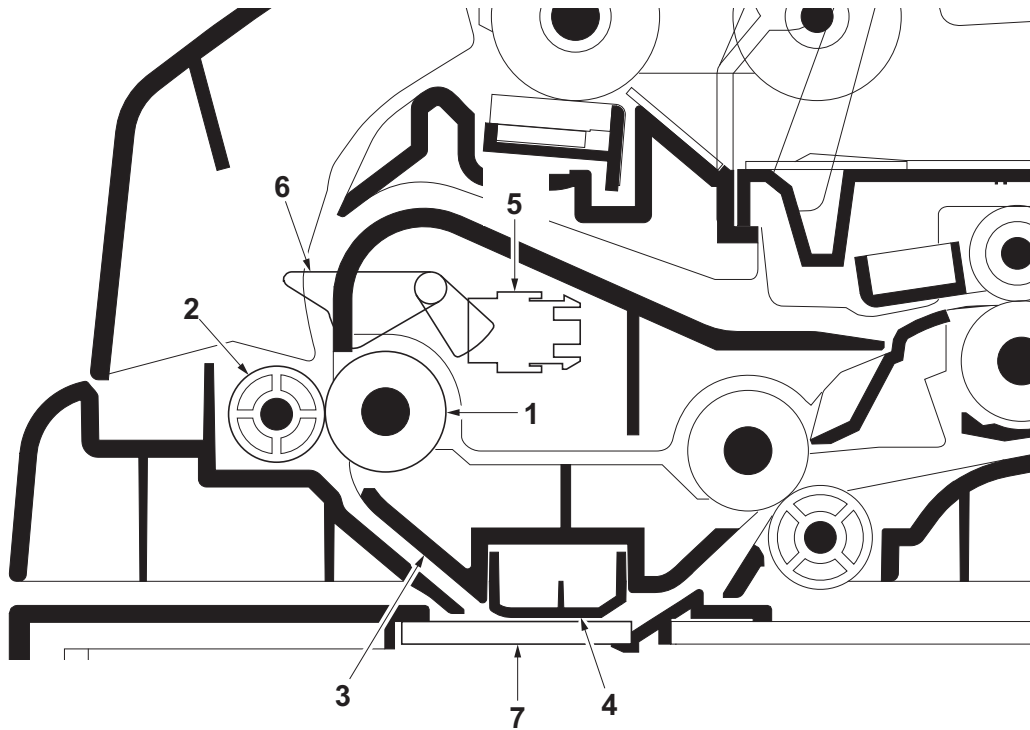


Figure 2-1-28 Original conveying section

- |                       |                                |
|-----------------------|--------------------------------|
| 1. Conveying roller A | 5. DP timing sensor (DPTS)     |
| 2. Conveying pulley   | 6. Actuator (DP timing sensor) |
| 3. Conveying bottom   | 7. DP contact glass            |
| 4. Reading guide      |                                |

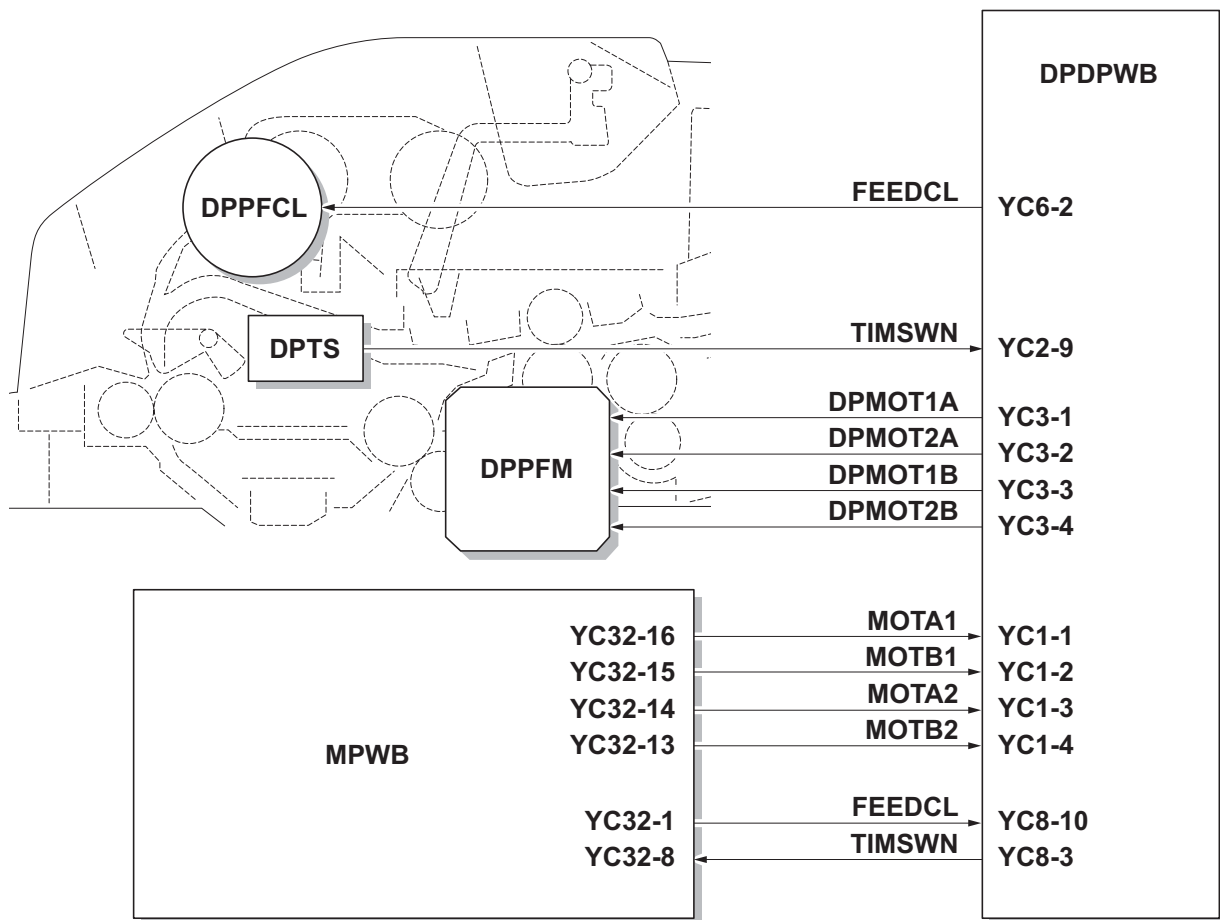


Figure 2-1-29 Original conveying section block diagram

### (3) Original switchback/eject sections

The original switchback/eject sections consists of the parts shown in figure. An original of which scanning is complete is ejected to the original eject table by the eject roller. In the case of duplex switchback scanning, an original is conveyed temporarily to the switchback tray and conveyed again to the original conveying section by the switchback roller.

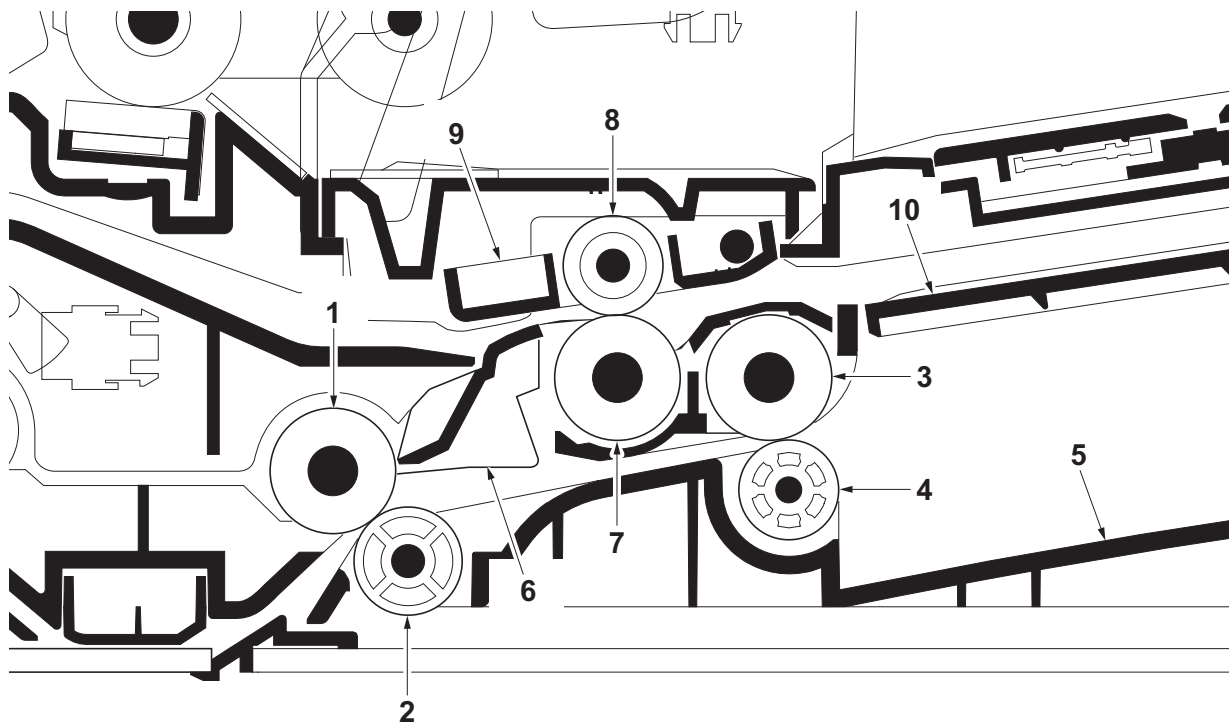


Figure 2-1-30 Original switchback/eject sections

- |                         |                            |
|-------------------------|----------------------------|
| 1. Conveying roller B   | 6. Switchback guide        |
| 2. Conveying pulley     | 7. Switchback roller       |
| 3. Eject roller         | 8. Switchback pulley       |
| 4. Eject pulley         | 9. Switchback pulley mount |
| 5. Original eject table | 10. Switchback tray        |



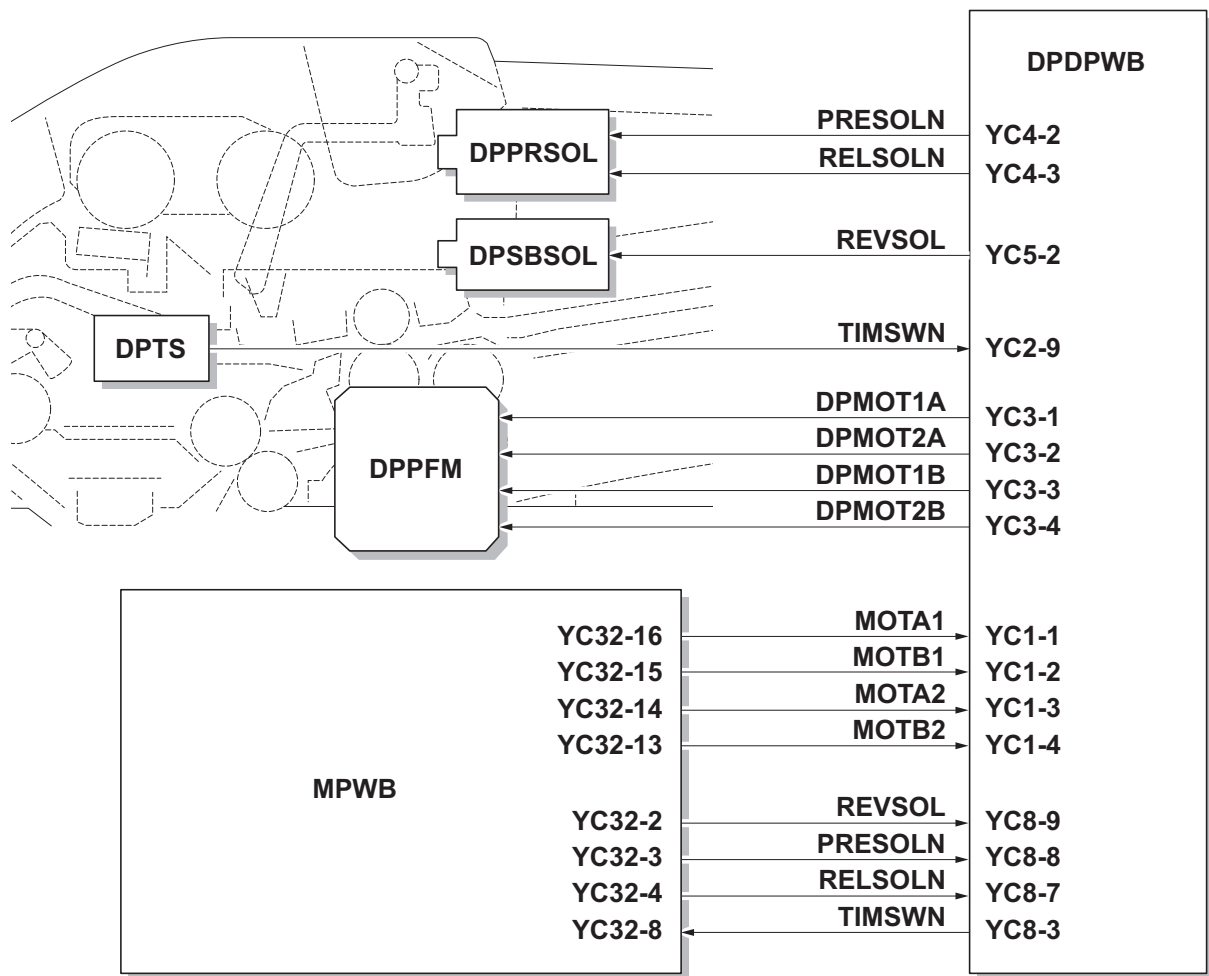
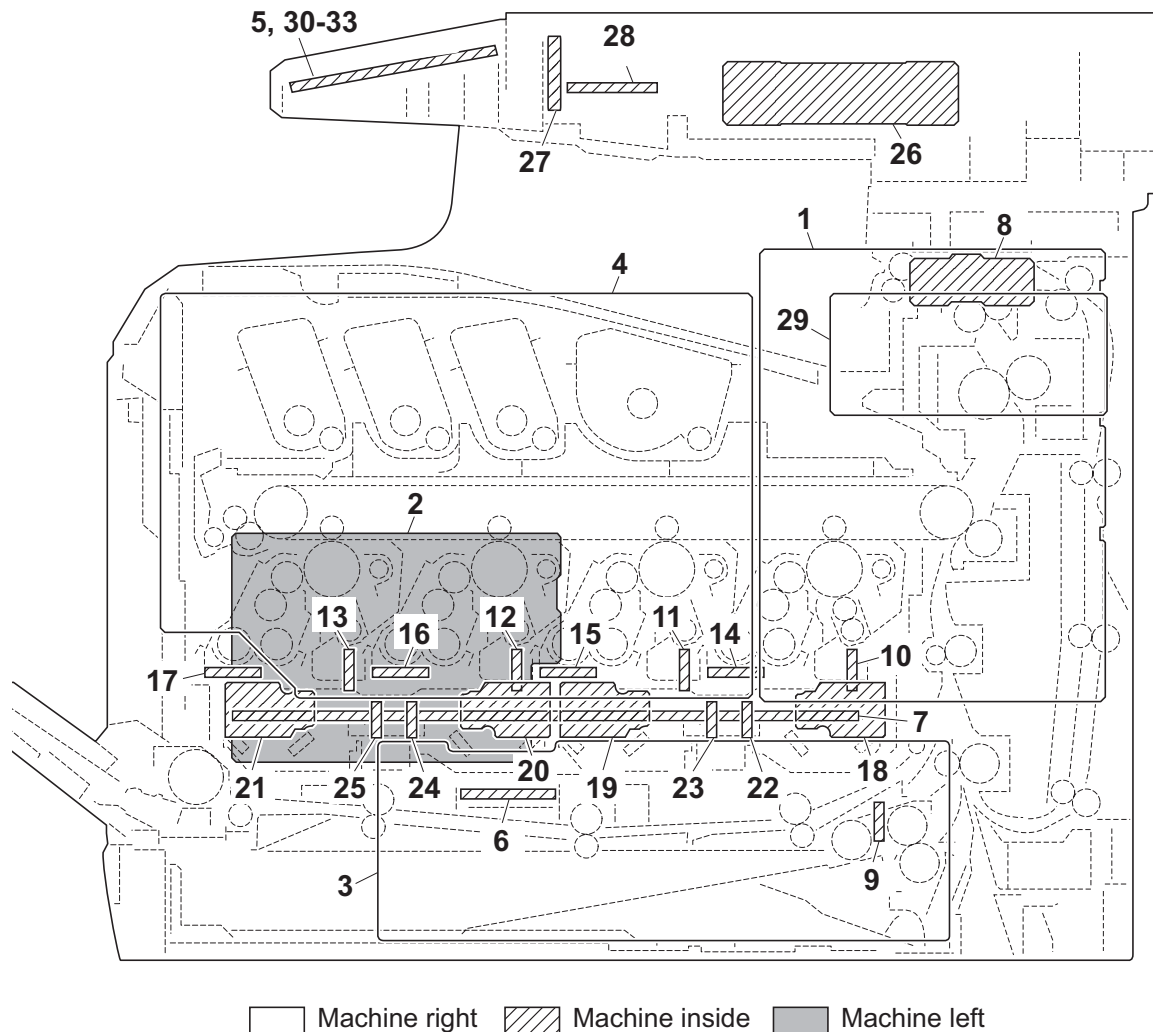


Figure 2-1-31 Original switchback/eject sections block diagram

## 2-2-1 Electrical parts layout

### (1) PWBs



**Figure 2-2-1 PWBs**

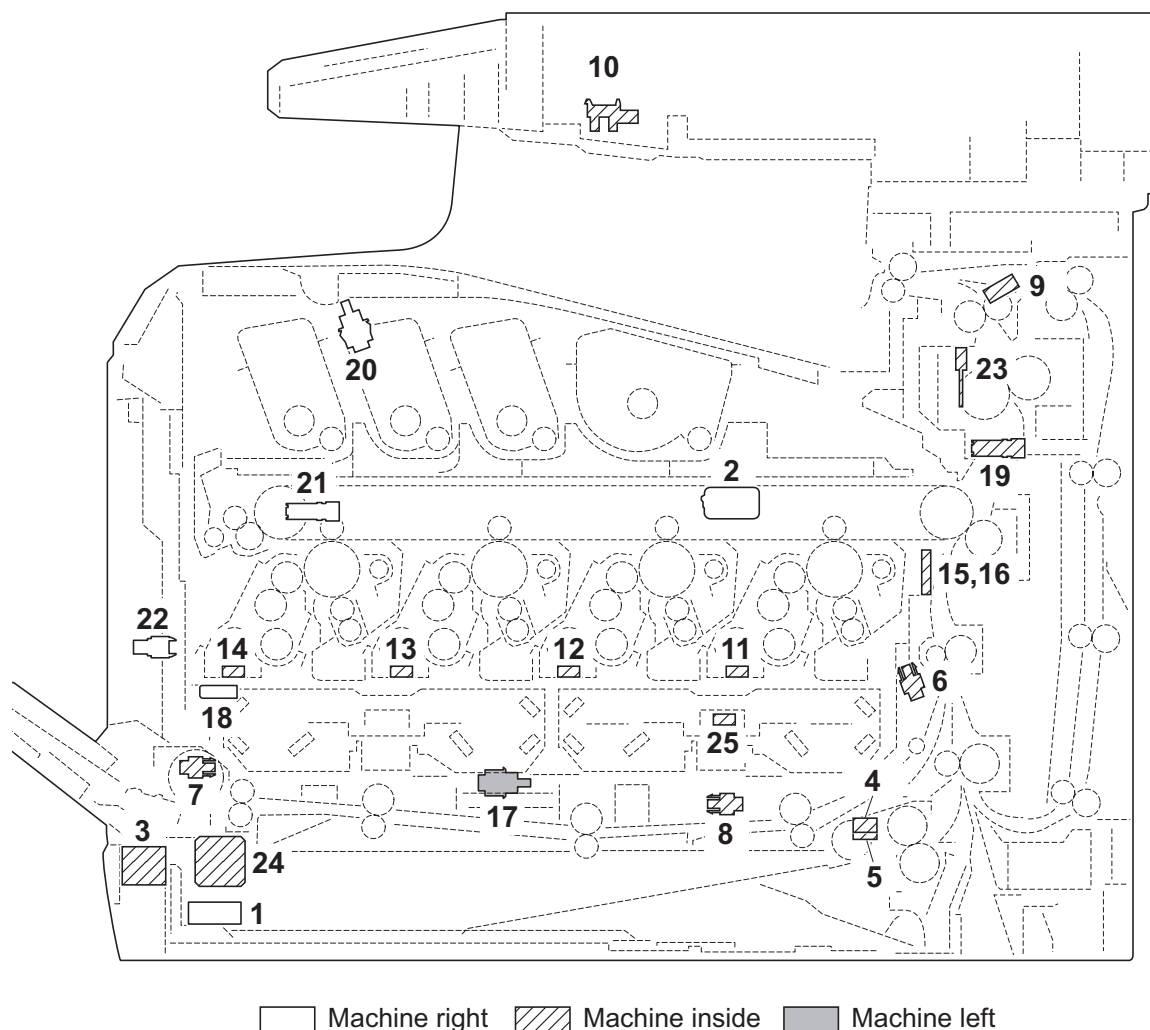
- |                                      |  |
|--------------------------------------|--|
| 1. Main PWB (MPWB) .....             | Controls the software such as the print data processing and provides the interface with computers.   |
| 2. Engine PWB (EPWB).....            | Controls printer hardware such as high voltage/bias output control, paper conveying system control, and fuser temperature control, etc.      |
| 3. Power source PWB (PSPWB) .....    | After full-wave rectification of AC power source input, switching for converting to 24 V DC and 5V DC for output. Controls the fuser heater. |
| 4. High voltage PWB (HVPWB) .....    | Generates main charging, developing bias, transfer bias and cleaning bias.   |
| 5. Operation panel PWB (OPPWB) ..... | Controls the touch panel. Consists the touch panel, LED indicators and key switches.   |
| 6. Relay PWB (RPWB) .....            | Consists of wiring relay circuit between main PWB and engine PWB and power source PWB.   |
| 7. Drum relay PWB (DRRPWB).....      | Consists of wiring relay circuit between engine PWB and the drum units and developing units.   |

- 8. Eject PWB (EJPWB) ..... Consists of wiring relay circuit between engine PWB and each electrical component (eject section).
- 9. Cassette PWB (CPWB) ..... Interconnects the engine PWB and each electrical component (cassette section).
- 10. Drum PWB K (DRPWB-K) ..... Relays wirings from electrical components on the drum unit K. Drum individual information in EEPROM storage.
- 11. Drum PWB M (DRPWB-M) ..... Relays wirings from electrical components on the drum unit M. Drum individual information in EEPROM storage.
- 12. Drum PWB C (DRPWB-C) ..... Relays wirings from electrical components on the drum unit C. Drum individual information in EEPROM storage.
- 13. Drum PWB Y (DRPWB-Y) ..... Relays wirings from electrical components on the drum unit Y. Drum individual information in EEPROM storage.
- 14. Developing PWB K (DEVPWB-K) ..... Relays wirings from electrical components on the developing unit K.
- 15. Developing PWB M (DEVPWB-M) ..... Relays wirings from electrical components on the developing unit M.
- 16. Developing PWB C (DEVPWB-C) ..... Relays wirings from electrical components on the developing unit C.
- 17. Developing PWB Y (DEVPWB-Y) ..... Relays wirings from electrical components on the developing unit Y.
- 18. APC PWB K (APCPWB-K) ..... Generates and controls the laser beam (black).
- 19. APC PWB M (APCPWB-M) ..... Generates and controls the laser beam (magenta).
- 20. APC PWB C (APCPWB-C) ..... Generates and controls the laser beam (cyan).
- 21. APC PWB Y (APCPWB-Y) ..... Generates and controls the laser beam (yellow).
- 22. PD PWB K (PDPWB-K) ..... Controls horizontal synchronizing timing of laser beam (black).
- 23. PD PWB M (PDPWB-M) ..... Controls horizontal synchronizing timing of laser beam (magenta).
- 24. PD PWB C (PDPWB-C) ..... Controls horizontal synchronizing timing of laser beam (cyan).
- 25. PD PWB Y (PDPWB-Y) ..... Controls horizontal synchronizing timing of laser beam (yellow).
- 26. CCD PWB (CCDPWB) ..... Reads the image of originals.
- 27. LED PWB (LEDPWB) ..... Controls the LED.
- 28. LED Driver PWB (LEDDRPWB) ..... Controls the LED.
- 29. Fax control PWB (FCPWB)\* ..... Modulates, demodulates, compresses, decompresses and smoothes out image data, and converts resolution of image data.
- 30. Operation panel PWB L (OPPWB-L) .... Controls the key switches and LED.
- 31. Operation panel PWB R (OPPWB-R) ... Controls the key switches and LED.
- 32. LCD relay PWB (LCDRPWB) ..... Consists of wiring relay circuit between operation panel PWB and the LED.
- 33. LCD PDB (LCDPWB) ..... Controls the LCD.

\*: 4 in 1 model (with FAX) only.

**List of correspondences of PWB names**

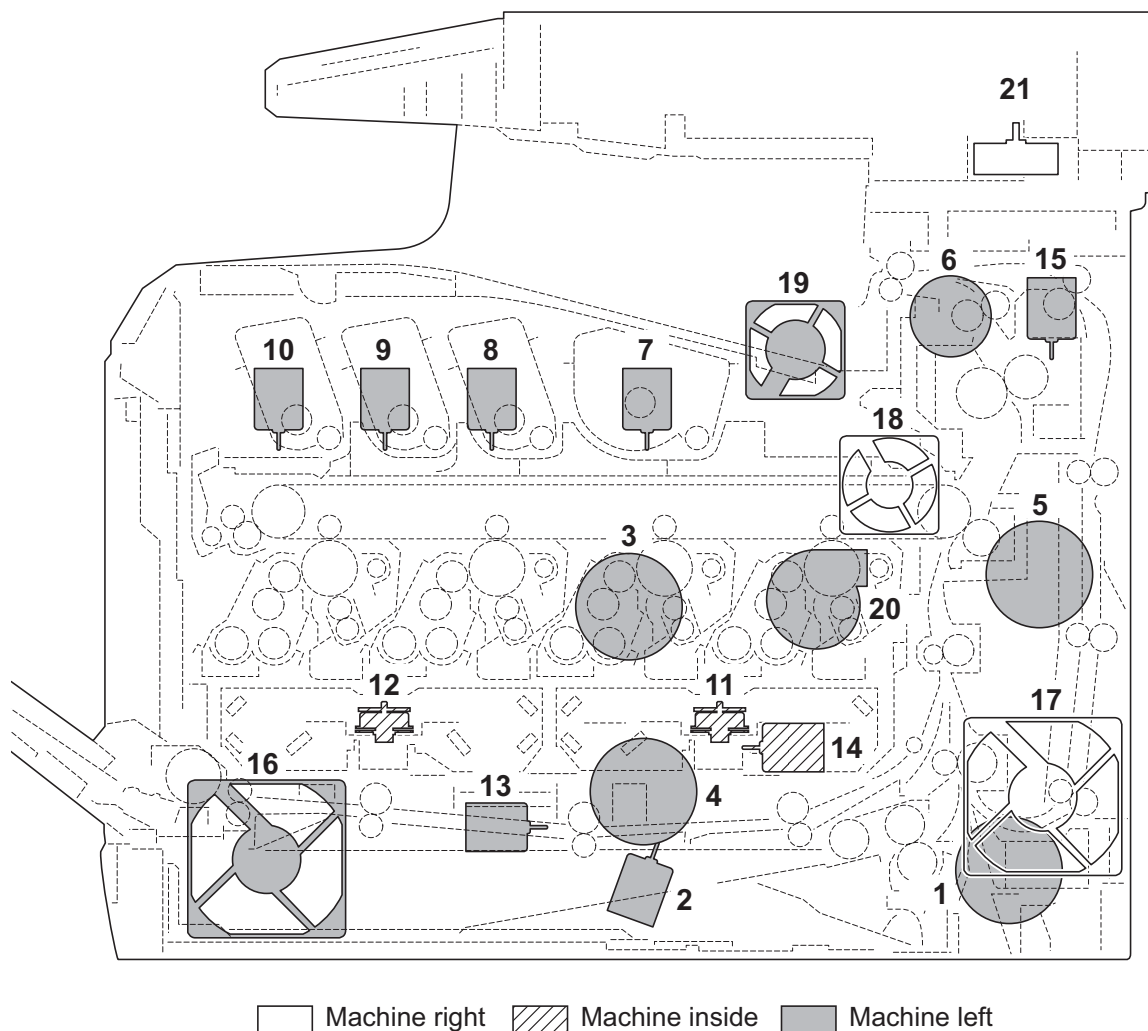
<b>No.</b>	<b>Name used in service manual</b>	<b>Name used in parts list</b>
1	Main PWB (MPWB)	PARTS PWB MAIN ASSY SP
2	Engine PWB (EPWB)	PARTS PWB ENGINE ASSY SP
3	Power source PWB (PSPWB)	PARTS SWITCHING REGULATOR SP
4	High voltage PWB (HVPWB)	PARTS HIGH VOLTAGE UNIT SP
5	Operation panel PWB (OPPWB)	-
6	Relay PWB (RPWB)	-
7	Drum relay PWB (DRRPWB)	-
8	Eject PWB (EJPWB)	PARTS PWB ASSY EXIT SP
9	Cassette PWB (CPWB)	PARTS PWB ASSY CASSETTE SP
10	Drum PWB K (DRPWB-K)	-
11	Drum PWB M (DRPWB-M)	-
12	Drum PWB C (DRPWB-C)	-
13	Drum PWB Y (DRPWB-Y)	-
14	Developing PWB K (DEVPWB-K)	-
15	Developing PWB M (DEVPWB-M)	-
16	Developing PWB C (DEVPWB-C)	-
17	Developing PWB Y (DEVPWB-Y)	-
18	APC PWB K (APCPWB-K)	-
19	APC PWB M (APCPWB-M)	-
20	APC PWB C (APCPWB-C)	-
21	APC PWB Y (APCPWB-Y)	-
22	PD PWB K (PDPWB-K)	-
23	PD PWB M (PDPWB-M)	-
24	PD PWB C (PDPWB-C)	-
25	PD PWB Y (PDPWB-Y)	-
26	CCD PWB (CCDPWB)	-
27	LED PWB (LEDPWB)	-
28	LED driver PWB (LEDDRPWB)	-
29	Fax control PWB (FCPWB)	PARTS FAX UNIT J SP
30	Operation panel PWB L (OPPWB-L)	-
31	Operation panel PWB R (OPPWB-R)	-
32	LCD relay PWB (LCDRPWB)	-
33	LCD PDB (LCDPWB)	-

**(2) Switches and sensors****Figure 2-2-2 Switches and sensors**

- |   |   |
|---|---|
| 1. Main power switch (MSW) .....        | Turns ON/OFF the AC power source.   |
| 2. Interlock switch (ILSW) .....        | Shuts off 24 V DC power line when the inner tray and rear cover are opened. |
| 3. Cassette size switch (CSSW) .....    | Detects the paper size dial setting of the paper setting dial.              |
| 4. Paper sensor (PS) .....              | Detects the presence of paper in the cassette.                              |
| 5. Lift sensor (LS).....                | Detects activation of upper limit of the bottom plate.                      |
| 6. Registration sensor (RS).....        | Controls the secondary paper feed start timing.                             |
| 7. MP paper sensor (MPPS) .....         | Detects the presence of paper on the MP tray.                               |
| 8. MP paper conveying sensor (MPFS).... | Detects a paper misfeed in the MP paper conveying section.                  |
| 9. Eject sensor (ES).....               | Detects a paper misfeed in the fuser or eject section.                      |
| 10. Home position sensor (HPS) .....    | Detects the ISU in the home position.                                       |
| 11. Toner sensor K (TS-K) .....         | Detects the toner density in the developing unit K.                         |
| 12. Toner sensor K (TS-M).....          | Detects the toner density in the developing unit M.                         |
| 13. Toner sensor K (TS-C).....          | Detects the toner density in the developing unit C.                         |
| 14. Toner sensor K (TS-Y) .....         | Detects the toner density in the developing unit Y.                         |
| 15. ID sensor 1 (IDS1) .....            | Measures image density for color calibration.                               |
| 16. ID sensor 2 (IDS2) .....            | Measures image density for color calibration.                               |

17. Developing release switch (DEVRSW)..... Detects separation of developing units M, C and Y.
18. Waste toner sensor (WTS)..... Detects when the waste toner box is full.
19. Envelope switch (EVSW)..... Detects the envelope mode setting.
20. Inner tray switch (ITSW) ..... Detects the opening and closing of the inner tray.
21. Toner container sensor (TCS)..... Detects the presence of the toner container.
22. Waste toner cover sensor (WTCS) ..... Detects the opening and closing of the waste toner cover.
23. Fuser thermistor (FTH) ..... Detects the heat roller temperature.
24. Outer temperature sensor (OTEMS)..... Detects the outside temperature and humidity.
25. Inner temperature sensor (ITEMS) ..... Detects the inside temperature.

**(3) Motors**



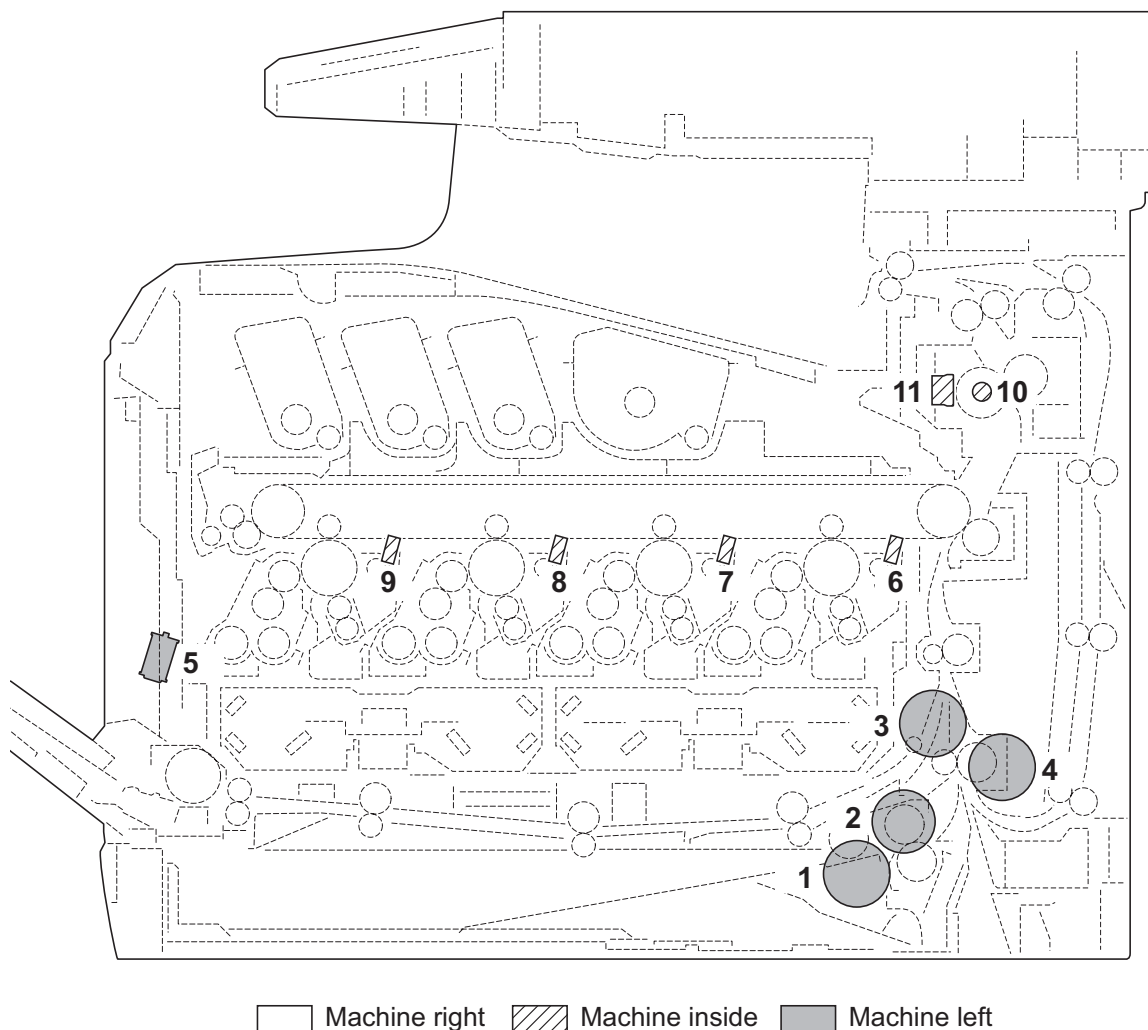
**Figure 2-2-3 Motors**

- 1. Paper feed motor (PFM) ..... Drives the paper feed section.
- 2. Lift motor (LM)..... Operates the bottom plate.
- 3. Drum motor (DRM) ..... Drives the drum unit.
- 4. Developing motor (DEVM)..... Drives the developing unit.
- 5. Fuser motor (FUM) ..... Drives the transfer section and the fuser section.
- 6. Duplex motor (DUM)..... Drives the duplex section.
- 7. Toner motor K (TM-K)..... Replenishes toner to the developing unit K
- 8. Toner motor M (TM-M)..... Replenishes toner to the developing unit M
- 9. Toner motor C (TM-C)..... Replenishes toner to the developing unit C
- 10. Toner motor Y (TM-Y) ..... Replenishes toner to the developing unit Y
- 11. Polygon motor KM (PM-KM)..... Drives the polygon mirror KM.
- 12. Polygon motor CY (PM-CY)..... Drives the polygon mirror CY.
- 13. Developing release motor (DEVRM)..... Drives separation of developing units M, C and Y.
- 14. LSU cleaning motor (LSUCM) ..... Drives LSU dust shield glass cleaning system.
- 15. Fuser pressure release motor (FPRM) ..... Drives fuser pressure release.
- 16. Left fan motor (LFM) ..... Cools the interior of machine.
- 17. Right fan motor (RFM) ..... Cools the interior of machine.

- 18. Controller fan motor (CONFM)..... Cools the controller section.
- 19. Fuser fan motor (FUFM) ..... Cools the toner container section.
- 20. Container fan motor (CFM) ..... Cools the toner container section.
- 21. ISU motor (ISUM) ..... Drives the ISU.

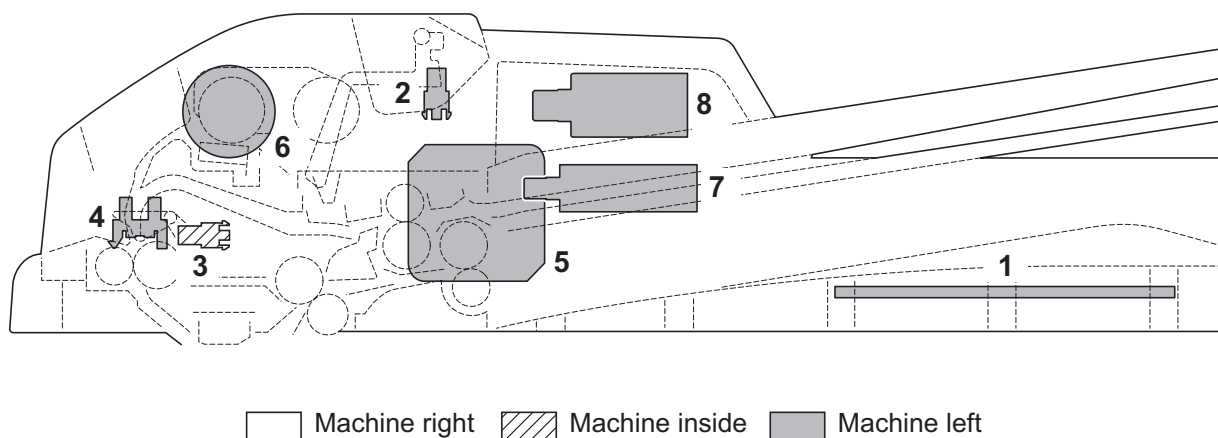


**(4) Others**



**Figure 2-2-4 Others**

- |  |  |
|--|--|
| <p>1. Paper feed clutch (PFCL) .....</p> <p>2. MP feed clutch (MPFCL).....</p> <p>3. Registration clutch (RCL).....</p> <p>4. Middle clutch (MCL).....</p> <p>5. MP solenoid (MPSOL) .....</p> <p>6. Cleaning lamp K (CL-K).....</p> <p>7. Cleaning lamp M (CL-M).....</p> <p>8. Cleaning lamp C (CL-C).....</p> <p>9. Cleaning lamp Y (CL-Y).....</p> <p>10. Fuser heater (FH) .....</p> <p>11. Fuser thermal cutout.....</p> | <p>Primary paper feed from cassette.</p> <p>Controls the drive of MP conveying section.</p> <p>Controls the secondary paper feed.</p> <p>Controls the drive of conveying section.</p> <p>Controls the MP bottom plate.</p> <p>Eliminates the residual electrostatic charge on the drum (black).</p> <p>Eliminates the residual electrostatic charge on the drum (magenta).</p> <p>Eliminates the residual electrostatic charge on the drum (cyan).</p> <p>Eliminates the residual electrostatic charge on the drum (yellow).</p> <p>Heats the heat roller.</p> <p>Prevents overheating of the heat roller.</p> |
|--|--|

**(5) Document processor****Figure 2-2-5 Document processor**

1. DP drive PWB (DPDPWB)..... Consists the solenoids and clutch driver circuit and wiring relay circuit.
2. DP original sensor (DPOS)..... Detects the presence of an original.
3. DP timing sensor (DPTS)..... Detects the original scanning timing.
4. DP open/close sensor (DPOCS)..... Detects the opening/closing of the DP.
5. DP paper feed motor (DPPFM)..... Drives the original feed section.
6. DP paper feed clutch (DPPFCL)..... Controls the drive of the DP forwarding pulley and DP feed pulley.
7. DP switchback solenoid (DPSBSOL).... Operates the switchback guide.
8. DP pressure solenoid (DPPRSOL)..... Operates the switchback pulley.

This page is intentionally left blank.

## 2-3-1 Power source PWB

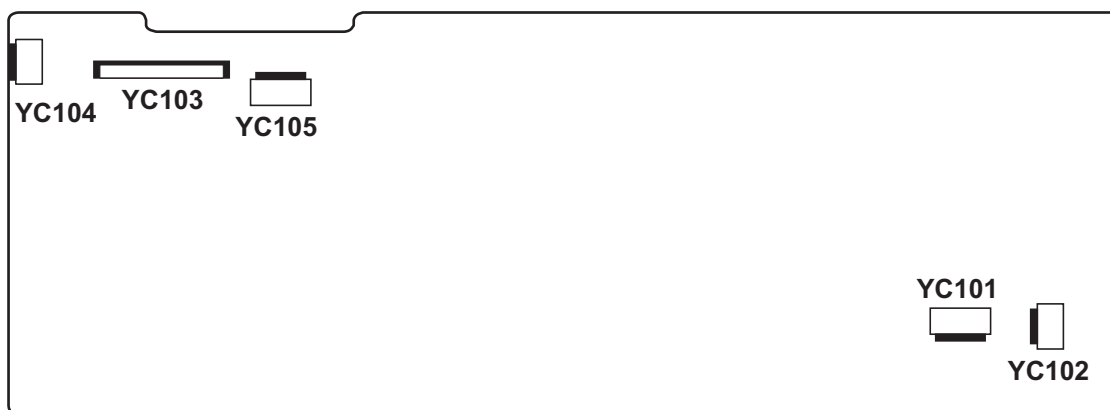


Figure 2-3-1 Power source PWB silk-screen diagram

Connector	Pin	Signal	I/O	Voltage	Description	
<b>YC101</b>	1	LIVE	I	120 V AC 220-240 V AC	AC power input	
	Connected to AC inlet and main power switch	2	NEUTRAL	I	120 V AC 220-240 V AC	AC power input
<b>YC102</b>	1	NEUTRAL	O	120 V AC/0 V 220-240 V AC/0 V	FH: On/Off	
	Connected to fuser heater	2	LIVE	O	120 V AC 220-240 V AC	AC power to FH
<b>YC103</b>	1	+24V1	O	24 V DC	24 V DC power to RYPWB	
	Connected to relay PWB	2	GND	-	-	Ground
		3	GND	-	-	Ground
		4	GND	-	-	Ground
		5	GND	-	-	Ground
		6	+24V2	O	24 V DC	24 V DC power to RYPWB (via ILSW)
	7	+24V2	O	24 V DC	24 V DC power to RYPWB (via ILSW)	
	8	+24V2	O	24 V DC	24 V DC power to RYPWB (via ILSW)	
	9	+24V2	O	24 V DC	24 V DC power to RYPWB (via ILSW)	
	10	PSSLEEPN	I	0/3.3 V DC	Sleep mode signal: On/Off	
	11	ZCROSS	O	0/3.3 V DC (pulse)	Zero-cross signal	
	12	RELAY	I	0/3.3 V DC	Power relay signal: On/Off	
	13	HEATRE1	I	0/3.3 V DC	FH: On/Off	
<b>YC104</b>	1	+24V1	O	24 V DC	24 V DC power to ILSW	
	Connected to interlock switch	2	N.C	-	-	Not used
		3	+24V2	I	24 V DC	24 V DC power from ILSW
<b>YC105</b>	1	+24V1	O	24 V DC	24 V DC power to MPWB	
	Connected to main PWB	2	GND	-	-	Ground
		3	GND	-	-	Ground
		4	+5V1	O	5 V DC	5 V DC power to MPWB

### 2-3-2 Engine PWB

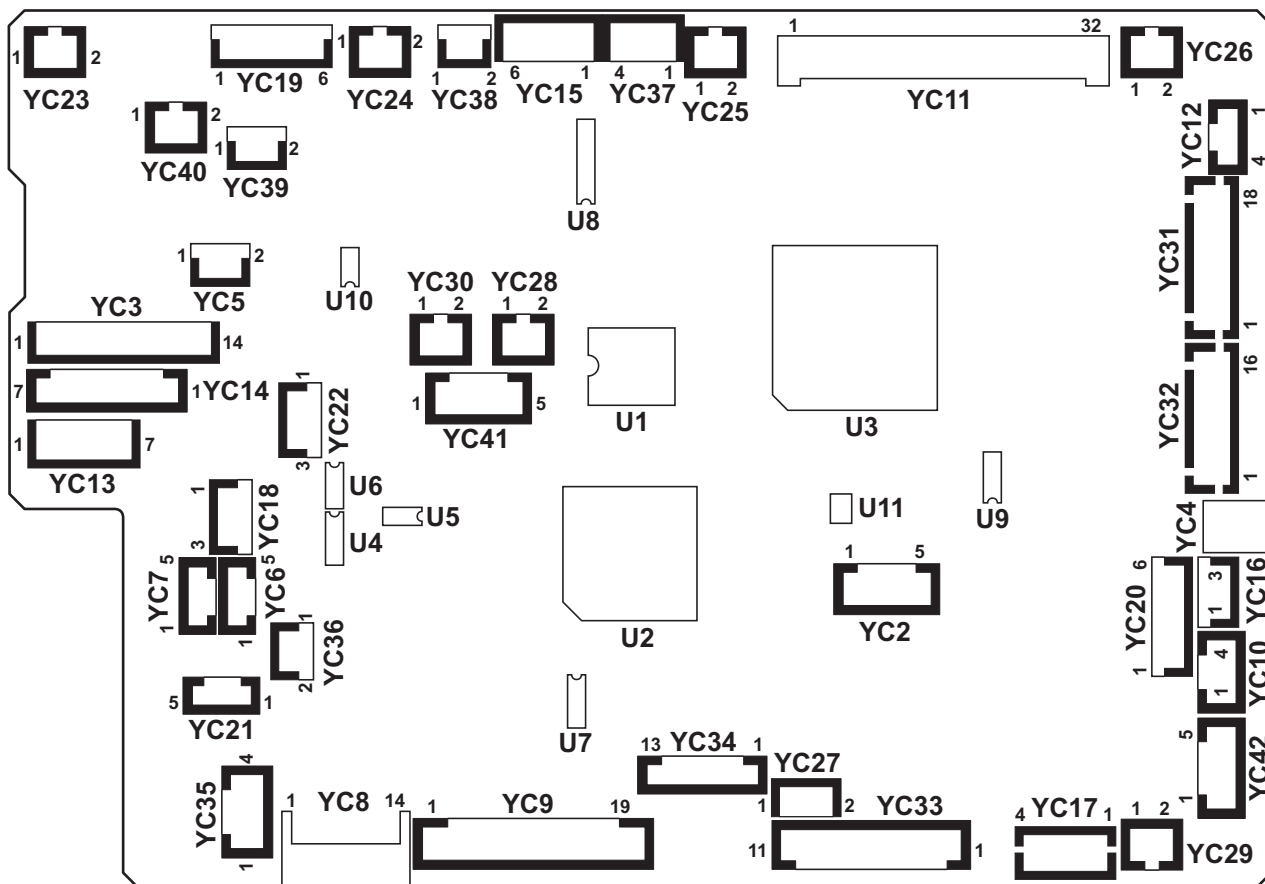


Figure 2-3-2 Engine PWB silk-screen diagram

Connector	Pin	Signal	I/O	Voltage	Description
<b>YC3</b>	1	MPFCLDRN	O	0/24 V DC	MPFCL: On/Off
Connected to MP feed clutch, paper feed clutch, paper feed motor, middle clutch and registration clutch	2	+24V3	O	24 V DC	24 V DC power to MPFCL
	3	FEDCLDRN	O	0/24 V DC	PFCL: On/Off
	4	+24V3	O	24 V DC	24 V DC power to PFCL
	5	N.C.	-	-	Not used
	6	FEMOTRDYN	I	0/3.3 V DC	PFM ready signal
	7	FEMOTCLK	O	0/3.3 V DC (pulse)	PFM clock signal
	8	FEMOTREN	O	0/3.3 V DC	PFM: On/Off
	9	GND	-	-	Ground
	10	+24V3	O	24 V DC	24 V DC power to PFM
	11	MIDCLDRN	O	0/24 V DC	MCL: On/Off
	12	+24V3	O	24 V DC	24 V DC power to MCL
	13	REGCLDRN	O	0/24 V DC	RCL: On/Off
	14	+24V3	O	24 V DC	24 V DC power to RCL
	<b>YC4</b>	1	+24V3	O	24 V DC
Connected to MP solenoid	2	MPSOLDRN	I	0/24 V DC	MPSOL: On/Off
<b>YC6</b>	1	VOSL	I	Analog	IDS1 detection signal
Connected to ID sensor 1	2	VOPL	I	Analog	IDS1 detection signal
	3	GND	-	-	Ground
	4	LEDREFL	O	Analog	IDS1 control signal
	5	+3.3V2	O	3.3 V DC	3.3 V DC power to IDS1
<b>YC7</b>	1	VOSR	I	Analog	IDS2 detection signal
Connected to ID sensor 2	2	VOPR	I	Analog	IDS2 detection signal
	3	GND	-	-	Ground
	4	LEDREFR	O	Analog	IDS2 control signal
	5	+3.3V2	O	3.3 V DC	3.3 V DC power to IDS2

Connector	Pin	Signal	I/O	Voltage	Description
<b>YC8</b>	1	+24V1	I	24 V DC	24 V DC power from RYPWB
Connected to relay PWB	2	GND	-	-	Ground
	3	GND	-	-	Ground
	4	GND	-	-	Ground
	5	GND	-	-	Ground
	6	+24V3	O	24 V DC	24 V DC power from RYPWB
	7	+24V3	O	24 V DC	24 V DC power from RYPWB
	8	+24V3	O	24 V DC	24 V DC power from RYPWB
	9	+24V3	O	24 V DC	24 V DC power from RYPWB
	10	GND	-	-	Ground
	11	SLEEPN	O	0/3.3 V DC	Sleep mode signal: On/Off
	12	HYPINT	O	0/3.3 V DC	Sleep return signal: On/Off
	13	I2CINT	-	-	Not used
	14	+3.3V2	I	3.3 V DC	3.3 V DC power from RYPWB
	<b>YC9</b>	1	TCOVOPN	O	0/3.3 V DC
Connected to relay PWB	2	EGHOLD	I	0/3.3 V DC	Engine hold signal
	3	ZCROSS	I	0/3.3 V DC (pulse)	Zero-cross signal
	4	RELAY	O	0/3.3 V DC	Power relay signal
	5	HEATRE1	O	0/3.3 V DC	FH: On/Off
	6	(HEATRE2)	-	-	Not used
	7	VSYNC	O	0/3.3 V DC	Vertical synchronizing signal
	8	EGIRN	O	0/3.3 V DC	Engine interruption signal
	9	SBSY	O	0/3.3 V DC	Serial busy signal
	10	SDIR	O	0/3.3 V DC	Serial communication direction change signal
	11	SI	I	0/3.3 V DC (pulse)	Serial communication data signal input
	12	SO	O	0/3.3 V DC (pulse)	Serial communication data signal output
	13	SCKN	I	0/3.3 V DC (pulse)	Serial communication clock signal
	14	N.C.	-	-	Not used
	15	I2CSCL	I	0/3.3 V DC (pulse)	EEPROM clock signal
	16	GND	-	-	Ground
	17	I2CSDA	I/O	0/3.3 V DC (pulse)	EEPROM data signal
	18	MPFJAM	I	0/3.3 V DC	MPPCS: On/Off
	19	+3.3V1_MFP	O	3.3 V DC	3.3 V DC power to RYPWB



Connector	Pin	Signal	I/O	Voltage	Description
<b>YC10</b> Connected to waste toner sensor	1	LEDA	O	3.3 V DC	3.3 V DC power to WTS
	2	LEDK	O	0/3.3 V DC (pulse)	WTS LED emitter signal
	3	PTRE	I	Analog	WTS detection signal
	4	PTRC	O	3.3 V DC	3.3 V DC power to WTS
<b>YC11</b> Connected to high voltage PWB	1	+24V3	O	24 V DC	24 V DC power to HVPWB
	2	+24V3	O	24 V DC	24 V DC power to HVPWB
	3	T1CCNT	O	PWM	Primary transfer bias control voltage (Cyan)
	4	HVCLKY	O	0/3.3 V DC (pulse)	Developing bias clock signal (Yellow)
	5	T1MCNT	O	PWM	Primary transfer bias control voltage (Magenta)
	6	HVCLKC	O	0/3.3 V DC (pulse)	Developing bias clock signal (Cyan)
	7	T2CNT	O	PWM	Secondary transfer bias control voltage
	8	BCMCNT	O	PWM	Developing magnet roller bias control voltage (Cyan)
	9	CLCNT	O	PWM	Cleaning bias control voltage
	10	BKMCNT	O	PWM	Developing magnet roller bias control voltage (Black)
	11	T1YCNT	O	PWM	Primary transfer bias control voltage (Yellow)
	12	BKSCNT	O	PWM	Developing sleeve roller bias control voltage (Black)
	13	T1KCNT	O	PWM	Primary transfer bias control voltage (Black)
	14	BYSCNT	O	PWM	Developing sleeve roller bias control voltage (Yellow)
	15	MYCNT	O	PWM	Charger roller control voltage (Yellow)
	16	BMMCNT	O	PWM	Developing magnet roller bias control voltage (Magenta)
	17	MKCNT	O	PWM	Charger roller control voltage (Black)
	18	BYMCNT	O	PWM	Developing magnet roller bias control voltage (Yellow)
	19	MCCNT	O	PWM	Charger roller control voltage (Cyan)
	20	T2RREM	O	0/3.3 V DC (pulse)	Secondary transfer bias reverse signal
	21	MMCNT	O	PWM	Charger roller control voltage (Magenta)
	22	BMSCNT	O	PWM	Developing sleeve roller bias control voltage (Magenta)
	23	MISENS	I	Analog	Charger roller AC current signal
	24	BKACNT	O	PWM	Developing AC bias control voltage (Black)

Connector	Pin	Signal	I/O	Voltage	Description
YC11 Connected to high voltage PWB	25	BCACNT	O	PWM	Developing AC bias control voltage (Cyan)
	26	BMACNT	O	PWM	Developing AC bias control voltage (Magenta)
	27	BYACNT	O	PWM	Developing AC bias control voltage (Yellow)
	28	HVCLKK	O	0/3.3 V DC (pulse)	Developing bias clock signal (Black)
	29	BCSCNT	O	PWM	Developing sleeve roller bias control voltage (Cyan)
	30	HVCLKM	O	0/3.3 V DC (pulse)	Developing bias clock signal (Magenta)
	31	GND	-	-	Ground
	32	GND	-	-	Ground
YC12 Connected to RFID PWB.	1	+3.3V2		3.3 V DC	3.3 V DC power to RFPWB
	2	RFCLK	O	0/3.3 V DC (pulse)	RFPWB EEPROM clock signal
	3	GND	-	-	Ground
	4	RFDATA	I/O	0/3.3 V DC (pulse)	RFPWB EEPROM data signal
	5	GND	-	-	Ground
YC13 Connected to drum motor	1	MOTREV (GND)	-	-	Ground
	2	MOTRDYN	I	0/3.3 V DC	DRM ready signal
	3	SPEEDSEL	O	0/3.3 V DC	DRM speed selection signal
	4	MOTCLK	O	0/3.3 V DC (pulse)	DRM clock signal
	5	MOTEN	O	0/3.3 V DC	DRM: On/Off
	6	GND	-	-	Ground
	7	+24V3	O	24 V DC	24 V DC power to DRM
YC14 Connected to developing motor	1	+24V3	O	24 V DC	24 V DC power to DEVM
	2	GND	-	-	Ground
	3	DLPMOTREN	O	0/3.3 V DC	DEVM: On/Off
	4	DLPMOTCLK	O	0/3.3 V DC (pulse)	DEVM clock signal
	5	DLPMOT RDYN	I	0/3.3 V DC	DEVM ready signal
	6	MOTREV	O	0/3.3 V DC	DEVM drive switch signal
YC15 Connected to fuser motor	1	IMAMOT RDYN	I	0/3.3 V DC	FUM ready signal
	2	IMAMOTCLK	O	0/3.3 V DC (pulse)	FUM clock signal
	3	IMAMOTREN	O	0/3.3 V DC	FUM: On/Off
	4	GND	-	-	Ground
	5	+24V3	O	24 V DC	24 V DC power to FUM

Connector	Pin	Signal	I/O	Voltage	Description
<b>YC16</b> Connected to MP paper sensor	1	+3.3V2_LED1	O	3.3 V DC	3.3 V DC power to MPPS
	2	GND	-	-	Ground
	3	MPFPAP	I	0/3.3 V DC	MPPS: On/Off
<b>YC17</b> Connected to cassette size switch	1	CAS2	I	0/3.3 V DC	CSSW (SW2): On/Off
	2	CAS1	I	0/3.3 V DC	CSSW (SW1): On/Off
	3	COM	-	-	Ground
	4	CAS0	I	0/3.3 V DC	CSSW (SW0): On/Off
<b>YC18</b> Connected to registration sensor	1	+3.3V2_LED2	O	3.3 V DC	3.3 V DC power to RS
	2	GND	-	-	Ground
	3	REGPAP	I	0/3.3 V DC	RS: On/Off
<b>YC19</b> Connected to eject PWB	1	PDIRN	I	0/3.3 V DC	EVSW: On/Off
	2	+3.3V2	O	3.3 V DC	3.3 V DC power to EJPWB
	3	F THERM	I	Analog	FTH detection voltage
	4	FUSPAP	I	0/3.3 V DC	ES: On/Off
	5	NC	-	-	Not used
	6	GND	-	-	Ground
<b>YC20</b> Connected to toner container sensor and waste toner cover sensor	1	+3.3V2_LED3	O	3.3 V DC	3.3 V DC power to TCS
	2	GND	-	-	Ground
	3	TCONTN	I	0/3.3 V DC	TCS: On/Off
	4	+3.3V2_LED7	O	3.3 V DC	3.3 V DC power to WTCS
	5	GND	-	-	Ground
	6	WSTOPN	I	0/3.3 V DC	WTCS: On/Off
<b>YC21</b> Connected to cassette PWB	1	GND	-	-	Ground
	2	PAPVOL2	-	-	Not used
	3	PAPVOL1	I	0/3.3 V DC	PS: On/Off
	4	LIFTSEN	I	0/3.3 V DC	LS: On/Off
	5	+3.3V2	O	3.3 V DC	3.3 V DC power to CPWB
<b>YC23</b> Connected to toner motor K	1	+24V3	O	24 V DC	24 V DC power to TM-K
	2	TNMKDRN	O	0/24 V DC	TM-K: On/Off
<b>YC24</b> Connected to toner motor M	1	+24V3	O	24 V DC	24 V DC power to TM-M
	2	TNMMDRN	O	0/24 V DC	TM-M: On/Off

Connector	Pin	Signal	I/O	Voltage	Description
<b>YC25</b> Connected to toner motor C	1	+24V3	O	24 V DC	24 V DC power to TM-C
	2	TNMCDRN	O	0/24 V DC	TM-C: On/Off
<b>YC26</b> Connected to toner motor Y	1	+24V3	O	24 V DC	24 V DC power to TM-Y
	2	TNMYDRN	O	0/24 V DC	TM-Y: On/Off
<b>YC27</b> Connected to lift motor	1	LMOTDRN	O	0/24 V DC	LM: On/Off
	2	GND	-	-	Ground
<b>YC28</b> Connected to container fan motor	1	+24V1	O	24 V DC	24 V DC power to CFM
	2	TCONTFAN DRN	O	0/12/24 V DC	CFM: Full speed/Half speed/Off
<b>YC29</b> Connected to left fan motor	1	+24V1	O	24 V DC	24 V DC power to LFM
	2	LFANDRN	O	0/12/24 V DC	LFM: Full speed/Half speed/Off
<b>YC30</b> Connected to inner tray switch	1	TOPOPON	O	0/3.3 V DC	ITSW: On/Off
	2	GND	-	-	Ground
<b>YC31</b> Connected to laser scanner unit KM	1	GND	-	-	Ground
	2	VREFK	O	Analog	APCPWB-K laser power standard voltage
	3	LONBKN	O	0/3.3 V DC	APCPWB-K sample/hold signal
	4	ENBKN	O	0/3.3 V DC	APCPWB-K laser enable signal
	5	PDKN	I	0/3.3 V DC (pulse)	Horizontal synchronizing signal
	6	GND	-	-	Ground
	7	VREFM	O	Analog	APCPWB-M laser power standard voltage
	8	LONBMN	O	0/3.3 V DC	APCPWB-M sample/hold signal
	9	ENBMN	O	0/3.3 V DC	APCPWB-M laser enable signal
	10	PDMN	I	0/3.3 V DC (pulse)	Horizontal synchronizing signal
	11	LSUTHERMM	I	Analog	ITEMS detection voltage
	12	POLCLK1	O	0/3.3 V DC (pulse)	PM-KM clock signal
	13	POLRDYN1	I	0/3.3 V DC	PM-KM ready signal
	14	POLONN1	O	0/3.3 V DC	PM-KM: On/Off
	15	GND	-	-	Ground
	16	+24V3	O	24 V DC	24 V DC power to PM-KM
	17	N.C.	-	-	Not used
	18	N.C.	-	-	Not used

Connector	Pin	Signal	I/O	Voltage	Description
<b>YC32</b>	1	GND	-	-	Ground
Connected to laser scanner unit CY	2	VREFC	O	Analog	APCPWB-C laser power standard voltage
	3	LONBCN	O	0/3.3 V DC	APCPWB-C sample/hold signal
	4	ENBCN	O	0/3.3 V DC	APCPWB-C laser enable signal
	5	PDCN	I	0/3.3 V DC (pulse)	Horizontal synchronizing signal
	6	GND	-	-	Ground
	7	VREFY	O	Analog	APCPWB-Y laser power standard voltage
	8	LONBYN	O	0/3.3 V DC	APCPWB-Y sample/hold signal
	9	ENBYN	O	0/3.3 V DC	APCPWB-Y laser enable signal
	10	PDYN	I	0/3.3 V DC (pulse)	Horizontal synchronizing signal
	11	LSUTHERMY	-	-	Not used
	12	POLCLK0	O	0/3.3 V DC (pulse)	PM-CY clock signal
	13	POLRDYN0	I	0/3.3 V DC	PM-CY ready signal
	14	POLONN0	O	0/3.3 V DC	PM-CY: On/Off
	15	GND	-	-	Ground
	16	+24V3	O	24 V DC	24 V DC power to PM-CY
<b>YC33</b>	1	GND	-	-	Ground
Connected to paper feeder	2	OPCLK	O	0/3.3 V DC (pulse)	Paper feeder clock signal
	3	OPRDYN	I	0/3.3 V DC	Paper feeder ready signal
	4	OPSDI	I	0/3.3 V DC (pulse)	Paper feeder serial communication data signal input
	5	OPSDO	O	0/3.3 V DC (pulse)	Paper feeder serial communication data signal output
	6	+3.3V1	O	3.3 V DC	3.3 V DC power to paper feeder
	7	GND	-	-	Ground
	8	OPSEL0	O	0/3.3 V DC	Paper feeder selection signal
	9	OPSEL1	O	0/3.3 V DC	Paper feeder selection signal
	10	OPSEL2	O	0/3.3 V DC	Paper feeder selection signal
	11	+24V3	O	24 V DC	24 V DC power to paper feeder

Connector	Pin	Signal	I/O	Voltage	Description
<b>YC34</b>	1	TNSENK	I	Analog	TS-M detection voltage
Connected to drum relay PWB	2	ERASECDR	O	0/24 V DC	CL-C: On/Off
	3	TNSENK	I	Analog	TS-K detection voltage
	4	ERASEMDR	O	0/24 V DC	CL-M: On/Off
	5	DLPTHERM	I	Analog	DEVTH detection voltage
	6	ERASEKDR	O	0/24 V DC	CL-K: On/Off
	7	+3.3V2	O	3.3 V DC	3.3 V DC power to DRRPWB
	8	EECLK	O	0/3.3 V DC (pulse)	EEPROM clock signal
	9	GND	-	-	Ground
	10	EEDATA	I/O	0/3.3 V DC (pulse)	EEPROM data signal
	11	TNSENK	I	Analog	TS-Y detection voltage
	12	ERASEYDR	O	0/24 V DC	CL-Y: On/Off
	13	TNSENK	I	Analog	TS-C detection voltage
<b>YC35</b>	1	DLDIRN	I	0/3.3 V DC	DEVRSW: On/Off
Connected to developing release switch and developing release motor	2	GND	-	-	Ground
	3	DLPCMOTA	O	24/0 V DC	DEVCM: Forward/Stop (Reverse)
	4	DLPCMOTB	O	24/0 V DC	DEVCM: Reverse/Stop (Forward)
<b>YC36</b>	1	LSUMOTA	O	24/0 V DC	LSUCM: Forward/Stop (Reverse)
Connected to LSU cleaning motor	2	LSUMOTB	O	24/0 V DC	LSUCM: Reverse/Stop (Forward)
<b>YC37</b>	1	STDUBN	O	0/24 V DC (pulse)	DUM drive control signal
Connected to duplex motor	2	STDUAN	O	0/24 V DC (pulse)	DUM drive control signal
	3	STDUB	O	0/24 V DC (pulse)	DUM drive control signal
	4	STDUA	O	0/24 V DC (pulse)	DUM drive control signal
<b>YC38</b>	1	PREMOTDRN	O	0/24 V DC	FPRM: On/Off
Connected to fuser pressure release motor	2	GND	-	-	Ground
<b>YC40</b>	1	+24V1	O	24 V DC	24 V DC power to FUFM
Connected to fuser fan motor	2	FUFANDRN	O	0/12/24 V DC	FUFM: Full speed/Half speed/Off

Connector	Pin	Signal	I/O	Voltage	Description
YC42	1	GND	-	-	Ground
Connected to outer temper- ature sensor	2	AIRTEMP	I	Analog	OITEMS detection voltage (temperature)
	3	WETCLK0	O	0/3.3 V DC (pulse)	OITEMS clock signal
	4	WETCLK1	O	0/3.3 V DC (pulse)	OITEMS clock signal
	5	AIRWETOUT	I	Analog	OITEMS detection voltage (humidity)

### 2-3-3 Main PWB

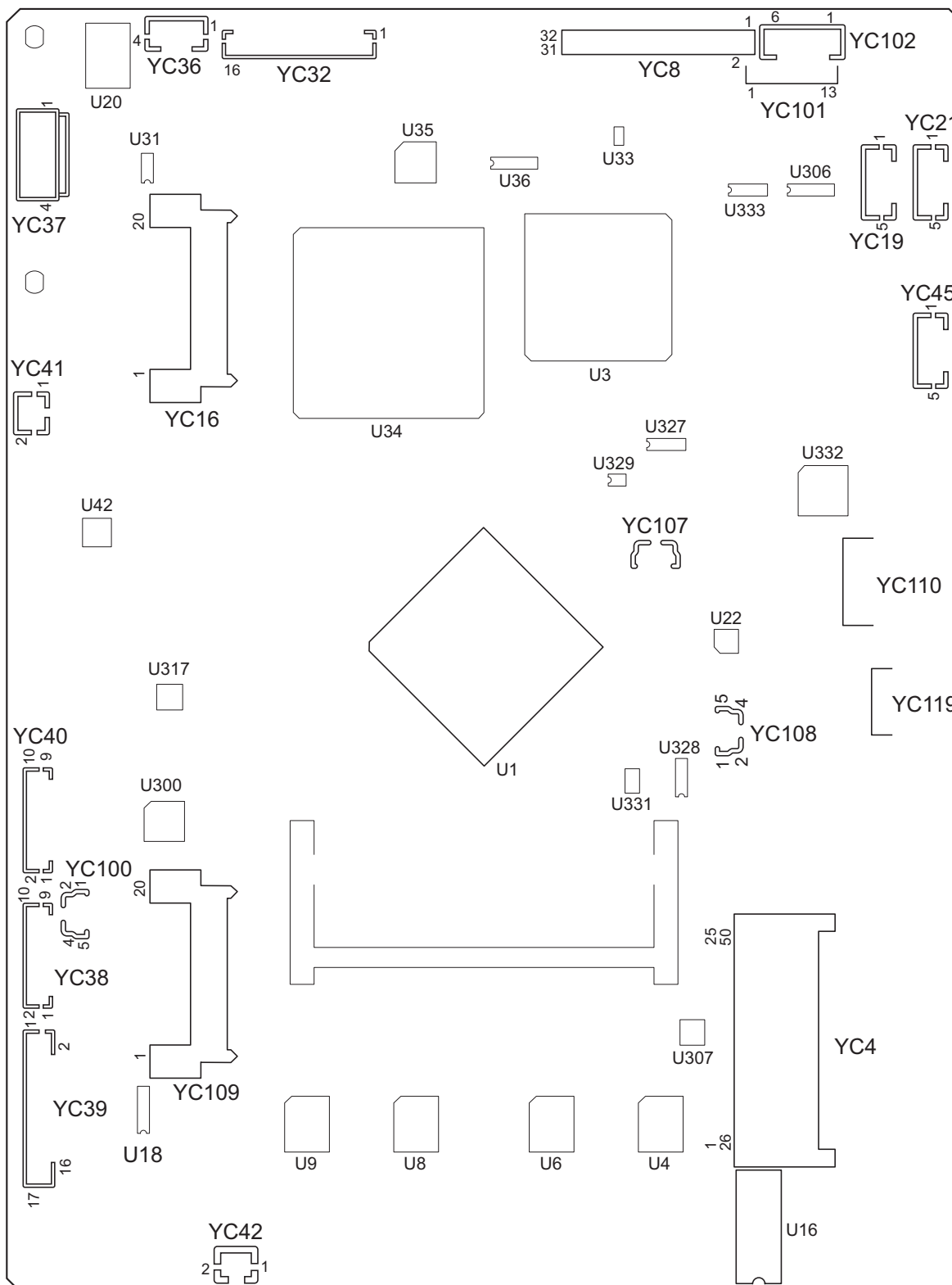


Figure 2-3-3 Main PWB silk-screen diagram



Connector	Pin	Signal	I/O	Voltage	Description
<b>YC8</b>	1	CCDSW	O	0/3.3 V DC	CCD color/BW change signal
Connected to CCD PWB	2	CCDSH	O	0/3.3 V DC	CCD shift gate signal
	3	CCDCLPN	O	LVDS	CCD clamp signal
	4	CCDCLPP	O	LVDS	CCD clamp signal
	5	GND	-	-	Ground
	6	CCDRSP	O	LVDS	CCD reset signal
	7	CCDRSN	O	LVDS	CCD reset signal
	8	GND	-	-	Ground
	9	CCDPH1N	O	LVDS	CCD shift register clock signal
	10	CCDPH1P	O	LVDS	CCD shift register clock signal
	11	GND	-	-	Ground
	12	CCDPH2P	O	LVDS	CCD shift register clock signal
	13	CCDPH2N	O	LVDS	CCD shift register clock signal
	14	NC	-	-	Not used
	15	+3.3VS	O	3.3 V DC	3.3 V DC power to CCDPWB
	16	HPSWN	I	0/3.3 V DC	HPS: On/Off
	17	NC	-	-	Not used
	18	+24V_LAMP	O	24 V DC	24 V DC power to CCDPWB
	19	LAMPTH	O	0/3.3 V DC	EL drive signal
	20	GND_LAMP	-	-	Ground
	21	GND	-	-	Ground
	22	GND	-	-	Ground
	23	CCDDATAB	I	Analog	CCD image output signal (B)
	24	GND	-	-	Ground
	25	CCDDATAG	I	Analog	CCD image output signal (G)
	26	GND	-	-	Ground
	27	CCDDATAR	I	Analog	CCD image output signal (R)
	28	GND	-	-	Ground
	29	GND	-	-	Ground
	30	+5V1	O	5 V DC	5 V DC power to CCDPWB
	31	NC	-	-	Not used
	32	+12VS	O	DC12V	12 V DC power to CCDPWB

Connector	Pin	Signal	I/O	Voltage	Description
YC16 Connected to Fax control PWB	1	VDD5	O	3.3 V DC	3.3 V DC power to FCPWB
	2	GND	-	-	Ground
	3	RESETN	I	0/3.3 V DC	Reset signal
	4	VDD5_CUT	O	3.3 V DC	3.3 V DC power to FCPWB
	5	GND	-	-	Ground
	6	WAKEUP	O	0/3.3 V DC	Control signal
	7	AUDIO	I	Analog	Audio signal
	8	RESERVE	-	-	-
	9	RESERVE	-	-	-
	10	RESERVE	-	-	-
	11	GND	-	-	Ground
	12	RESERVE	-	-	-
	13	RESERVE	-	-	-
	14	GND	-	-	Ground
	15	RESERVE	-	-	-
	16	RESERVE	-	-	-
	17	GND	-	-	Ground
	18	USB_DP	I/O	-	USB data signal
	19	USB_DN	I/O	-	USB data signal
	20	VBUS	O	3.3 V DC	3.3 V DC power to FCPWB
YC32 Connected to DP drive PWB	1	FEEDCL	O	0/24 V DC	DPPFCL: On/Off
	2	REVSOL	O	0/24 V DC	DPSBSOL: On/Off
	3	PRESOLN	O	0/24 V DC	DPPRSOL: On (Press)/Off
	4	RELSOLN	O	0/24 V DC	DPPRSOL: On (Release)/Off
	5	DPDETN	I	0/3.3 V DC	DP set signal
	6	OPSWN	I	0/3.3 V DC	DPOCS: On/Off
	7	ORGSWN	I	0/3.3 V DC	DPOS: On/Off
	8	TIMSWN	I	0/3.3 V DC	DPTS: On/Off
	9	GND	-	-	Ground
	10	+3.3V2	O	3.3 V DC	3.3 V DC power to DPDPWB
	11	GND	-	-	Ground
	12	+24V2	O	24 V DC	24 V DC power to PDPWB
	13	MOTB2	O	0/24 V DC (pulse)	DPPFM drive control signal
	14	MOTA2	O	0/24 V DC (pulse)	DPPFM drive control signal
	15	MOTB1	O	0/24 V DC (pulse)	DPPFM drive control signal
	16	MOTA1	O	0/24 V DC (pulse)	DPPFM drive control signal

Connector	Pin	Signal	I/O	Voltage	Description
<b>YC36</b> Connected to ISU motor	1	SCMOTB2	O	0/24 V DC (pulse)	ISUM drive control signal
	2	SCMOTA1	O	0/24 V DC (pulse)	ISUM drive control signal
	3	SCMOTB1	O	0/24 V DC (pulse)	ISUM drive control signal
	4	SCMOTA2	O	0/24 V DC (pulse)	ISUM drive control signal
<b>YC37</b> Connected to power source PWB	1	+24V1	I	24 V DC	24 V DC power from PSPWB
	2	GND	-	-	Ground
	3	GND	-	-	Ground
	4	+5V1	I	5 V DC	5 V DC power from PSPWB
<b>YC38</b> Connected to laser scanner unit KM	1	GND	-	-	Ground
	2	+3.3V3	O	3.3 V DC	3.3 V DC power to APCPWB-K
	3	PDMN	I	0/3.3 V DC (pulse)	Horizontal synchronizing signal
	4	VDOMP	O	LVDS	APCPWB-K video data signal (+)
	5	VDOMN	O	LVDS	APCPWB-K video data signal (-)
	6	GND	-	-	Ground
	7	+3.3V3	O	3.3 V DC	3.3 V DC power to APCPWB-M
	8	PDKN	I	0/3.3 V DC (pulse)	Horizontal synchronizing signal
	9	VDOKP	O	LVDS	APCPWB-M video data signal (+)
	10	VDOKN	O	LVDS	APCPWB-M video data signal (-)
<b>YC39</b> Connected to relay PWB	1	+3.3V1_MFP	O	3.3 V DC	3.3 V DC power to RYPWB
	2	I2CSDA	I/O	0/3.3 V DC (pulse)	EEPROM data signal
	3	GND	-	-	Ground
	4	I2CSCL	O	0/3.3 V DC (pulse)	EEPROM clock signal
	5	SCKN	O	0/3.3 V DC (pulse)	Serial communication clock signal
	6	SO	I	0/3.3 V DC (pulse)	Serial communication data signal input
	7	SI	O	0/3.3 V DC (pulse)	Serial communication data signal output
	8	SDIR	I	0/3.3 V DC	Serial communication direction change signal
	9	SBSY	I	0/3.3 V DC	Serial busy signal
	10	EGIRN	I	0/3.3 V DC	Engine interruption signal
	11	VSYNC	I	0/3.3 V DC (pulse)	Vertical synchronizing signal
	12	+3.3V2	O	3.3 V DC	3.3 V DC power to RYPWB
	13	GND	-	-	Ground
	14	EGHOLD	O	0/3.3 V DC	Engine hold signal
	15	I2CINT	-	-	Not used
	16	HYPINT	I	0/3.3 V DC	Sleep return signal: On/Off
	17	PSSLEEPN	O	0/3.3 V DC	Sleep mode signal: On/Off

Connector	Pin	Signal	I/O	Voltage	Description
<b>YC40</b>	1	GND	-	-	Ground
Connected to laser scanner unit CY	2	+3.3V3	O	3.3 V DC	3.3 V DC power to APCPWB-C
	3	PDCN	I	0/3.3 V DC (pulse)	Horizontal synchronizing signal
	4	VDOCP	O	LVDS	APCPWB-C video data signal (+)
	5	VDOCN	O	LVDS	APCPWB-C video data signal (-)
	6	GND	-	-	Ground
	7	+3.3V3	O	3.3 V DC	3.3 V DC power to APCPWB-Y
	8	PDYN	I	0/3.3 V DC (pulse)	Horizontal synchronizing signal
	9	VDOYP	O	LVDS	APCPWB-Y video data signal (+)
	10	VDOYN	O	LVDS	APCPWB-Y video data signal (-)
	<b>YC41</b>	1	+24V1	O	24 V DC
Connected to controller fan motor	2	CONTFAN DRN	O	0/12/24 V DC	CONFM: Full speed/Half speed/Off
<b>YC42</b>	1	+24V1	O	24 V DC	24 V DC power to RFM
Connected to right fan motor	2	RFANDRN	O	0/12/24 V DC	RFM: Full speed/Half speed/Off
<b>YC100</b>	1	VBUS	O	5 V DC	5 V DC power to OPPWB
Connected to operation panel PWB.	2	DATA+	I/O	-	USB data signal
	3	DATA-	I/O	-	USB data signal
	4	NC(ID)	-	-	Not used
	5	GND	-	-	Ground

Connector	Pin	Signal	I/O	Voltage	Description
<b>YC101</b>	1	GND	-	-	Ground
Connected to operation panel PWB.	2	PANEL_STAT US	I	0/3.3 V DC	Operation panel status signal
	3	INT_POWER KEY_N	I	0/3.3 V DC	Power key: On/Off
	4	PANEL_RESE T	O	0/3.3 V DC	Reset signal
	5	AUDIO	O	Analog	Audio output signal
	6	LIGHTOFF_P OWERON	O	0/3.3 V DC	Sleep return signal
	7	SHUTDOWN	O	0/3.3 V DC	24 V down signal
	8	LED_PROCE SSING_N	O	0/3.3 V DC	Processing LED control signal
	9	LED_ATTENS ION_N	O	0/3.3 V DC	Attention LED control signal
	10	LED_MEMOR Y_N	O	0/3.3 V DC	Memory LED control signal
	11	SUSPEND_P OWER	O	3.3 V DC	3.3 V DC power to OPWB1
	12	ENERGY_SA VE	O	0/3.3 V DC	Energy save signal
	13	BEEP_POWE RON	O	0/3.3 V DC	Sleep return signal
	<b>YC102</b>	1	+5V2	O	5 V DC
Connected to operation panel PWB.	2	+5V2	O	5 V DC	5 V DC power to OPPWB
	3	+5V2	O	5 V DC	5 V DC power to OPPWB
	4	GND	-	-	Ground
	5	GND	-	-	Ground
	6	GND	-	-	Ground
<b>YC107</b>	1	VBUS	O	5 V DC	5 V DC power output
Connected to USB	2	DATA-	I/O	-	USB data signal
	3	DATA+	I/O	-	USB data signal
	4	NC	-	-	Not used
	5	GND	-	-	Ground

Connector	Pin	Signal	I/O	Voltage	Description
<b>YC108</b> Connected to IC card reader.	1	VBUS	O	5 V DC	5 V DC power to ICCR
	2	DATA-	I/O	-	USB data signal
	3	DATA+	I/O	-	USB data signal
	4	NC(ID)	-	-	Not used
	5	GND	-	-	Ground
<b>YC109</b> Connected to e-KUIO slot	1	VDD5	O	3.3 V DC	3.3 V DC power
	2	GND	-	-	Ground
	3	RESETN	I	0/3.3 V DC	Reset signal
	4	VDD5_CUT	O	3.3 V DC	3.3 V DC power
	5	GND	-	-	Ground
	6	WAKEUP	O	0/3.3 V DC	Control signal
	7	AUDIO	I	Analog	Audio signal
	8	RESERVE	-	-	-
	9	RESERVE	-	-	-
	10	RESERVE	-	-	-
	11	GND	-	-	Ground
	12	RESERVE	-	-	-
	13	RESERVE	-	-	-
	14	GND	-	-	Ground
	15	RESERVE	-	-	-
	16	RESERVE	-	-	-
	17	GND	-	-	Ground
	18	USB_DP	I/O	-	USB data signal
	19	USB_DN	I/O	-	USB data signal
	20	VBUS	O	3.3 V DC	3.3 V DC power

Connector	Pin	Signal	I/O	Voltage	Description
<b>YC110</b>	1	TC1+	O	0/3.3 V DC (pulse)	Transmission data
Connected to ethernet	2	TD1-	O	0/3.3 V DC (pulse)	Transmission data
	3	TD2+	O	0/3.3 V DC (pulse)	Transmission data
	4	RD2-	O	0/3.3 V DC (pulse)	Transmission data
	5	CT1	O	3.3 V DC	3.3 V DC power output
	6	CT2	O	3.3 V DC	3.3 V DC power output
	7	TD3+	O	0/3.3 V DC (pulse)	Transmission data
	8	TD3-	O	0/3.3 V DC (pulse)	Transmission data
	9	TD4+	O	0/3.3 V DC (pulse)	Transmission data
	10	TD4-	O	0/3.3 V DC (pulse)	Transmission data
	11	GRLED-A	O	0/3.3 V DC	LED emitter signal
	12	GRLED-K	O	0/3.3 V DC	LED emitter signal
	13	YWLED-A	O	0/3.3 V DC	LED emitter signal
	14	YWLED-K	O	0/3.3 V DC	LED emitter signal

### 2-3-4 Drum relay PWB



Figure 2-3-4 Drum relay PWB silk-screen diagram



Connector	Pin	Signal	I/O	Voltage	Description
YC1 Connected to engine PWB	1	TNSENK	O	Analog	TS-M detection voltage
	2	ERASECDR	I	0/24 V DC	CL-C: On/Off
	3	TNSENK	O	Analog	TS-K detection voltage
	4	ERASEMDR	I	0/24 V DC	CL-M: On/Off
	5	DLP THERM	O	Analog	DEVTH detection voltage
	6	ERASEKDR	I	0/24 V DC	CL-K: On/Off
	7	+3.3V2	I	3.3 V DC	3.3 V DC power from EPWB
	8	EECLK	I	0/3.3 V DC (pulse)	EEPROM clock signal
	9	GND	-	-	Ground
	10	EEDATA	I/O	0/3.3 V DC (pulse)	EEPROM data signal
	11	TNSENK	O	Analog	TS-Y detection voltage
	12	ERASEYDR	I	0/24 V DC	CL-Y: On/Off
	13	TNSENK	O	Analog	TS-C detection voltage
YC2 Connected to drum PWB K	1	GND	-	-	Ground
	2	EECLK	O	0/3.3 V DC (pulse)	EEPROM clock signal
	3	ERASEKDR	O	0/24 V DC	CL-K: On/Off
	4	EEDATA	I/O	0/3.3 V DC (pulse)	EEPROM data signal
	5	N.C.	-	-	Not used
	6	+3.3V2	O	3.3 V DC	3.3 V DC power to DRPWB-K
	7	DA0	-	-	Not used
	8	DA1	-	-	Not used
YC3 Connected to drum PWB M	1	GND	-	-	Ground
	2	EECLK	O	0/3.3 V DC (pulse)	EEPROM clock signal
	3	ERASEMDR	O	0/24 V DC	CL-M: On/Off
	4	EEDATA	I/O	0/3.3 V DC (pulse)	EEPROM data signal
	5	N.C.	-	-	Not used
	6	+3.3V2	O	3.3 V DC	3.3 V DC power to DRPWB-M
	7	DA0	-	-	Ground
	8	DA1	-	-	Not used
YC4 Connected to drum PWB C	1	GND	-	-	Ground
	2	EECLK	O	0/3.3 V DC (pulse)	EEPROM clock signal
	3	ERASECDR	O	0/24 V DC	CL-C: On/Off
	4	EEDATA	I/O	0/3.3 V DC (pulse)	EEPROM data signal
	5	N.C.	-	-	Not used
	6	+3.3V2	O	3.3 V DC	3.3 V DC power to DRPWB-C
	7	DA0	-	-	Not used
	8	DA1	-	-	Ground

Connector	Pin	Signal	I/O	Voltage	Description
<b>YC5</b> Connected to drum PWB Y	1	GND	-	-	Ground
	2	EECLK	O	0/3.3 V DC (pulse)	EEPROM clock signal
	3	ERASEYDR	O	0/24 V DC	CL-Y: On/Off
	4	EEDATA	I/O	0/3.3 V DC (pulse)	EEPROM data signal
	5	N.C.	-	-	Not used
	6	+3.3V2	O	3.3 V DC	3.3 V DC power to DRPWB-Y
	7	DA0	-	-	Ground
	8	DA1	-	-	Ground
<b>YC6</b> Connected to developing PWB K	1	GND	-	-	Ground
	2	TNSENK	I	Analog	TS-K detection voltage
	3	+3.3V2	O	3.3 V DC	3.3 V DC power to DEVPWB-K
	4	DLP THERM	I	Analog	DEVTH detection voltage
<b>YC7</b> Connected to developing PWB M	1	GND	-	-	Ground
	2	TNSEN M	I	Analog	TS-M detection voltage
	3	+3.3V2	O	3.3 V DC	3.3 V DC power to DEVPWB-M
	4	N.C.	-	-	Not used
<b>YC10</b> Connected to developing PWB C	1	GND	-	-	Ground
	2	TNSEN C	I	Analog	TS-C detection voltage
	3	+3.3V2	O	3.3 V DC	3.3 V DC power to DEVPWB-C
	4	N.C.	-	-	Not used
<b>YC13</b> Connected to developing PWB Y	1	GND	-	-	Ground
	2	TNSEN Y	I	Analog	TS-Y detection voltage
	3	+3.3V2	O	3.3 V DC	3.3 V DC power to DEVPWB-Y
	4	N.C.	-	-	Not used

### 2-3-5 DP drive PWB

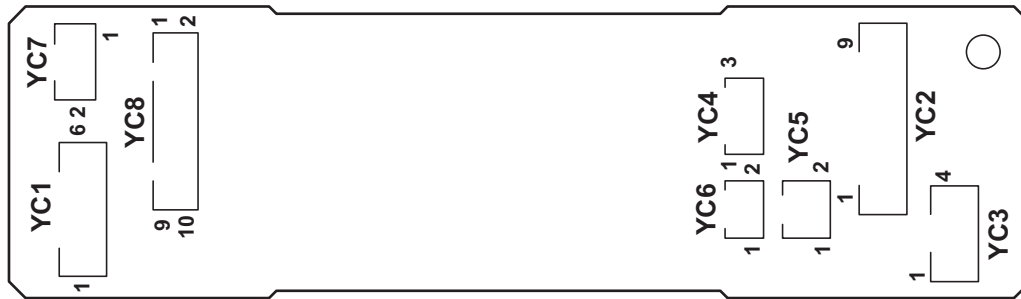


Figure 2-3-5 DP drive PWB silk-screen diagram

Connector	Pin	Signal	I/O	Voltage	Description
<b>YC1</b> Connected to main PWB	1	MOTA1	I	0/24 V DC (pulse)	DPPFM drive control signal
	2	MOTB1	I	0/24 V DC (pulse)	DPPFM drive control signal
	3	MOTA2	I	0/24 V DC (pulse)	DPPFM drive control signal
	4	MOTB2	I	0/24 V DC (pulse)	DPPFM drive control signal
	5	+24V2	I	24 V DC	24 V DC power from MPWB
	6	GND	-	-	Ground
<b>YC2</b> Connected to DP open/close sensor, DP original sensor and DP timing sensor	1	+3.3V2	O	3.3 V DC	3.3 V DC power to DPOCS
	2	GND	-	-	Ground
	3	OPSWN	I	0/3.3 V DC	DPOCS: On/Off
	4	+3.3V2	O	3.3 V DC	3.3 V DC power to DPOS
	5	GND	-	-	Ground
	6	ORGSWN	I	0/3.3 V DC	DPOS: On/Off
	7	+3.3V2	O	3.3 V DC	3.3 V DC power to DPTS
	8	GND	-	-	Ground
	9	TIMSWN	I	0/3.3 V DC	DPTS: On/Off
<b>YC3</b> Connected to DP paper feed motor	1	DPMOT1A	O	0/24 V DC (pulse)	DPPFM drive control signal
	2	DPMOT2A	O	0/24 V DC (pulse)	DPPFM drive control signal
	3	DPMOT1B	O	0/24 V DC (pulse)	DPPFM drive control signal
	4	DPMOT2B	O	0/24 V DC (pulse)	DPPFM drive control signal
<b>YC4</b> Connected to DP pressure solenoid	1	+24V2	O	24 V DC	24 V DC power to DPPRSOL
	2	PRESOLN	O	0/24 V DC	DPPRSOL: On (Press)/Off
	3	RELSOLN	O	0/24 V DC	DPPRSOL: On (Release)/Off
<b>YC5</b> Connected to DP switch-back solenoid	1	+24V2	O	24 V DC	24 V DC power to DPSBSOL
	2	REVSOL	O	0/24 V DC	DPSBSOL: On/Off
<b>YC6</b> Connected to DP paper feed clutch	1	+24V2	O	24 V DC	24 V DC power to DPPFCL
	2	FEEDCL	O	0/24 V DC	DPPFCL: On/Off

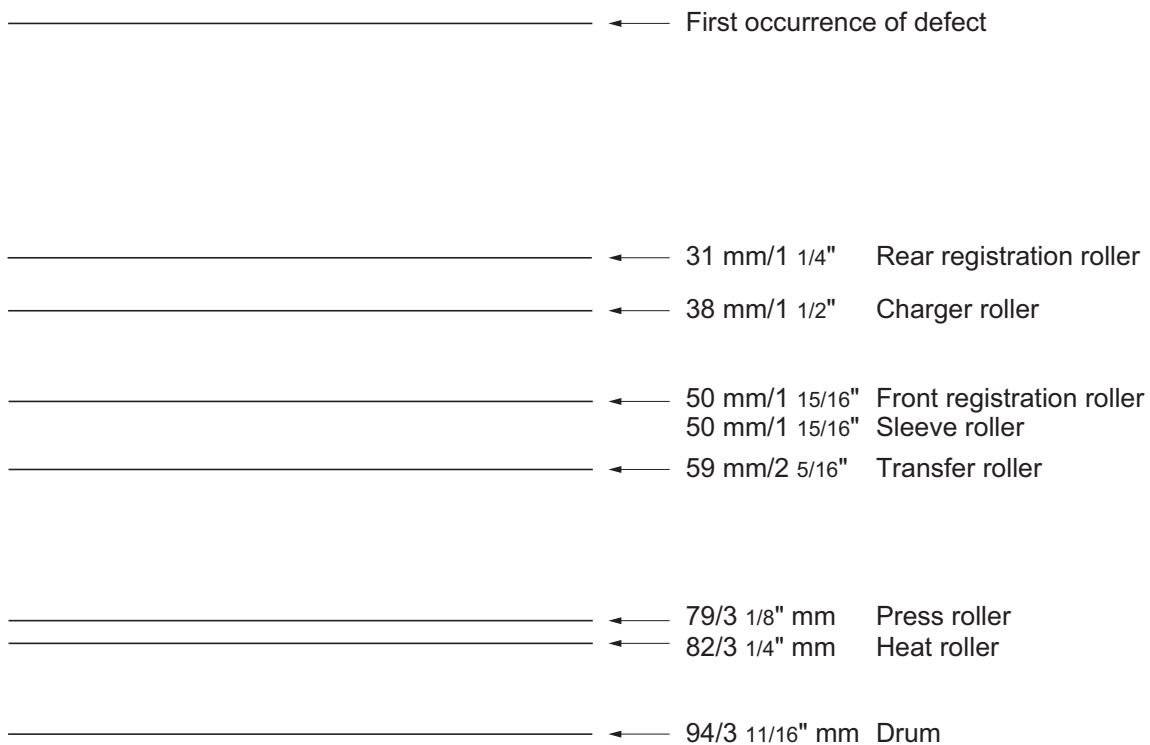
Connector	Pin	Signal	I/O	Voltage	Description
<b>YC8</b>	1	+3.3V2	I	3.3 V DC	3.3 V DC power from MPWB
Connected to main PWB	2	GND	-	-	Ground
	3	TIMSWN	O	0/3.3 V DC	DPTS: On/Off
	4	ORGSWN	O	0/3.3 V DC	DPOS: On/Off
	5	OPSWN	O	0/3.3 V DC	DPOCS: On/Off
	6	DPDETN	O	0/3.3 V DC	DP set signal
	7	RELSOLN	I	0/24 V DC	DPPRSOL: On (Release)/Off
	8	PRESOLN	I	0/24 V DC	DPPRSOL: On (Press)/Off
	9	REVSOL	I	0/24 V DC	DPSBSOL: On/Off
	10	FEEDCL	I	0/24 V DC	DPPFCL: On/Off

## 2-4-1 Appendixes

### (1) Maintenance kits

Maintenance part name		Parts No.	Alternative part No.
Name used in service	Name used in parts list		
MK-592/Maintenance kit	MK-592/MAINTENANCE KIT	1702KV7US0	072KV7US
Developing unit K	DV-560 US (K)	-	-
Developing unit M	DV-560 US (M)	-	-
Developing unit C	DV-560 US (C)	-	-
Developing unit Y	DV-560 US (Y)	-	-
Drum unit	DK-590	-	-
Intermediate transfer unit	TR-590	-	-
Fuser unit	FK-590(U)	-	-
Retard roller unit	PARTS HOLDER RETARD ASSY SP	-	-
Paper feed roller unit	PARTS HOLDER FEED ASSY SP	-	-
MP paper feed roller	ROLLER M/P ASSY	-	-
MK-590/Maintenance kit	MK-590/MAINTENANCE KIT	1702KV8NLO	072KV8NL
Developing unit K	DV-560(K)	-	-
Developing unit M	DV-560(M)	-	-
Developing unit C	DV-560(C)	-	-
Developing unit Y	DV-560(Y)	-	-
Drum unit	DK-590	-	-
Intermediate transfer unit	TR-590	-	-
Fuser unit	FK-590(E)	-	-
Retard roller unit	PARTS HOLDER RETARD ASSY SP	-	-
Paper feed roller unit	PARTS HOLDER FEED ASSY SP	-	-
MP paper feed roller	ROLLER M/P ASSY	-	-

**(2) Repetitive defects gauge**



### (3) Firmware environment commands

The printer maintains a number of printing parameters in its memory. These parameters may be changed permanently with the FRPO (Firmware RePrOgram) commands.

This section provides information on how to use the FRPO command and its parameters using examples.

#### Using FRPO commands for reprogramming firmware

The current settings of the FRPO parameters are listed as optional values on the service status page.

Note: Before changing any FRPO parameter, print out a service status page, so you will know the parameter values before the changes are made. To return FRPO parameters to their factory default values, send the FRPO INIT (FRPO-INITialize) command.(!R! FRPO INIT; EXIT;)

The FRPO command is sent to the printer in the following sequence:

!R! FRPO parameter, value; EXIT;

Example: Changing emulation mode to PCL6

!R! FRPO P1, 6; EXIT;

#### FRPO parameters

Item	FRPO	Setting values	Factory setting
Default pattern resolution	B8	0: 300 dpi 1: 600 dpi	0
Page orientation	C1	0: Portrait 1: Landscape	0
Default font No. *	C2 C3 C5	Middle two digits of power-up font Last two digits of power-up font First two digits of power-up font	0 0 0
PCL font switch	C8	0: HP compatibility mode 32: Conventional compatibility mode	0
Total host buffer size	H8	0 to 99 in units of the size defined by FRPO S5	5
Form feed time-out value	H9	Value in units of 5 seconds (1 to 99)	6
Duplex mode	N4	0: Off 1: Long edge binding 2: Short edge binding	0
Sleep timer time-out time	N5	Value in units of 1 minute (1 to 240)	1
Ecoprint level	N6	0: Off 2: On	0



Item	FRPO	Setting values	Factory setting
Default emulation mode	P1	6: PCL 6 9: KPDL	120V: 9 220-240V: 6
Carriage-return action	P2	0: Ignores 1: Carriage-return 2: Carriage-return + linefeed	1
Linefeed action	P3	0: Ignores 1: Linefeed 2: Linefeed + carriage-return	1
Automatic emulation switching	P4	0: AES disabled 1: AES enabled	120V: 1 220-240V: 0
Automatic emulation switching trigger	P7	0: Page eject commands 1: None 2: Page eject and prescribe EXIT commands 3: Prescribe EXIT commands 4: Formfeed (^L) commands 6: Prescribe EXIT and formfeed commands 10: Page eject commands; if AES fails, resolves to KPDL	120V: 11 220-240V: 10
Command recognition character	P9	ASCII code of 33 to 126	82 (R)
Default paper size	R2	0: Size of the default paper cassette (See R4.) 1: Envelope Monarch 2: Envelope #10 3: Envelope DL 4: Envelope C5 5: Executive 6: Letter 7: Legal 8: ISO A4 9: JIS B5 13: ISO A5 14: ISO A6 15: JIS B6 16: Envelope #9 17: Envelope #6-3/4 18: ISO B5 19: Custom 31: Postcard 32: Reply-paid postcard 33: Oficio II 40: 16K 50: Statement 51: Folio 52: Youkei 2 53: Youkei 4	0
Default cassette	R4	0: MP tray 1: Cassette 1 2: Cassette 2 3: Cassette 3	1

Item	FRPO	Setting values	Factory setting
MP tray paper size	R7	0: Maximum paper size Same as the R2 values except: 0	120V: 6 220-240V: 8
A4/letter equation	S4	0: Off 1: On	1
Host buffer size	S5	0: 10 KB 1: 100 KB 2: 1024 KB	1
RAM disk capacity	S6	0 to 1024 MB	400
RAM disk	S7	0: Disabled 1: Enabled	0
Wide A4	T6	0: Off 1: On	0
Line spacing *	U0	Lines per inch (integer value)	6
	U1	Lines per inch (decimal value)	0
Character spacing *	U2	Characters per inch (integer value)	10
	U3	Characters per inch (decimal value)	0
Country code	U6	0: US-ASCII 1: France 2: Germany 3: UK 4: Denmark 5: Sweden 6: Italy 7: Spain 8: Japan 9: US Legal 10: IBM PC-850 (Multilingual) 11: IBM PC-860 (Portuguese) 12: IBM PC-863 (Canadian French) 13: IBM PC-865 (Norwegian) 14: Norway 15: Denmark 2 16: Spain 2 17: Latin America 50 - 99: HP PCL symbol set coding	41
Code set at power up in daisywheel emulation	U7	0: Same as the default emulation mode (P1) 1: IBM 6: IBM PC-8 7 - 99: HP PCL symbol set coding	53
Font pitch for fixedpitch scalable font *	U8	Default font pitch (integer value)	10
	U9	Default font pitch (decimal value)	0
Font height for the default scalable font *	V0	Integer value in 100 points: 0 to 9	0
	V1	Integer value in points: 0 to 99	12
	V2	decimal value in 1/100 points: 0, 25, 50, 75	0

<b>Item</b>	<b>FRPO</b>	<b>Setting values</b>	<b>Factory setting</b>
Default scalable font *	V3	Name of typeface of up to 32 characters, enclosed with single or double quotation marks	Courier
Default weight (courier and letter Gothic)	V9	0: Courier = darkness Letter Gothic = darkness 1: Courier = regular Letter Gothic = darkness 4: Courier = darkness Letter Gothic = regular 5: Courier = regular Letter Gothic = regular	5
Color mode	W1	0: Black & white 1: Color	1
Gloss mode	W6	0: Low (normal) 1: High	0
Paper type for the MP tray	X0	1: Plain 2: Transparency 3: Preprinted 4: Label 5: Bond 6: Recycle 7: Vellum 9: Letterhead 10: Color 11: Prepunched 12: Envelope 13: Cardstock 14: Coated 16: Thick 17: High quality 21 to 28: Custom1 to 8	1
Paper type for cassettes 1	X1	1: Plain 3: Preprinted 5: Bond 6: Recycled 7: Vellum 9: Letterhead 10: Color 11: Prepunched 16: Thick 17: High quality 21 to 28: Custom1 to 8	1

Item	FRPO	Setting values	Factory setting
Paper type for cassettes 2 and 3	X2 X3	Paper feeder (Normal) 1: Plain 3: Preprinted 5: Bond 6: Recycled 9: Letterhead 10: Color 11: Prepunched 17: High quality 21 to 28: Custom1 to 8  Multi purpose feeder 1: Plain 3: Preprinted 4: Label 5: Bond 6: Recycle 7: Vellum 9: Letterhead 10: Color 11: Prepunched 12: Envelope 13: Cardstock 14: Coated 16: Thick 17: High quality 21 to 28: Custom1 to 8	1
PCL paper source	X9	0: Paper selection depending on an escape sequence compatible with HP-LJ5Si. 2: Paper selection depending on an escape sequence compatible with HP-LJ8000.	0
Automatic continue for 'Press GO'	Y0	0: Off 1: On	0
Automatic continue timer	Y1	Value in units of 5 seconds (1 to 99)	6 (30 s)
Error message for device error	Y3	0: Not detect 127: Detect	127
Duplex operation for specified paper type (Prepunched, Preprinted and Letterhead)	Y4	0: Off 1: On	0

Item	FRPO	Setting values	Factory setting
Default operation for PDF direct printing	Y5	0: Enlarges or reduces the image to fit in the current paper size. Loads paper from the current paper cassette. 1: Through the image. Loads paper which is the same size as the image. 2: Enlarges or reduces the image to fit in the current paper size. Loads Letter, A4 size paper depending on the image size. 3: Through the image. Loads Letter, A4 size paper depending on the image size. 8: Through the image. Loads paper from the current paper cassette. 9: Through the image. Loads Letter, A4 size paper depending on the image size. 10: Enlarges or reduces the image to fit in the current paper size. Loads Letter, A4 size paper depending on the imagesize.	0
e-MPS error	Y6	0: Does not print the error report and display the error message. 1: Prints the error report. 2: Displays the error message. 3: Prints the error report and displays the error message.	3

\*: Ignored in some emulation modes.

#### (4) Maintenance Commands

This section provides information on how to use the maintenance command and its parameters using examples.

##### Adjusting the print start timing (alternative command for the maintenance mode U034)

###### Description

Adjusts the leading edge registration or left edge.

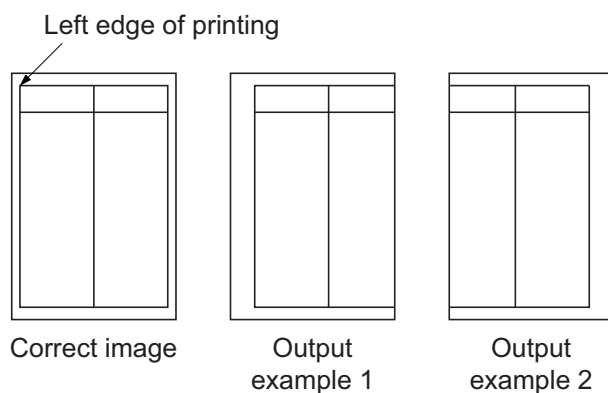
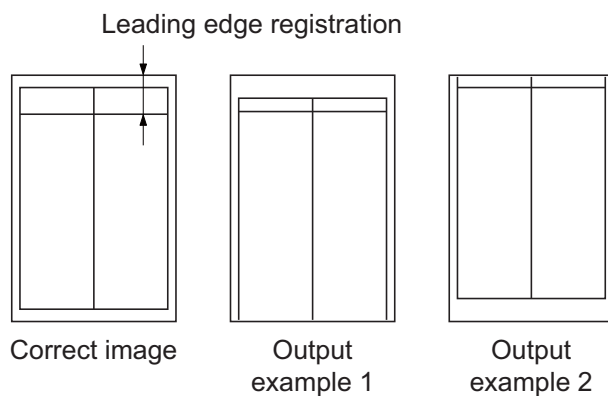
###### Purpose

Make the adjustment if there is a regular error between the leading edges of the copy image and original.  
Make the adjustment if there is a regular error between the left edges of the copy image and original.

Format	!R! KCFG"PFRC",#1 ,#2 ,#3;	
Parameter	#1	Paper source number 0: MP tray 2-6 : Cassette2-6 100: Duplex (e.g. landscape images short-edge bind) 200: Rotated duplex (e.g. portrait images long-edge bind)
	#2	Edge to adjust 1: Leading edge 2: Left edge
	#3	Adjustable range (-128 to +127) number of dot in 600dpi

##### Example: Set the leading edge of MP tray to +30 dots

!R! KCFG "PFRC",0,1,30;EXIT;



## Adjusting the scanner magnification (alternative command for the maintenance mode U065)

### Description

Adjusts the magnification of the original scanning.

### Purpose

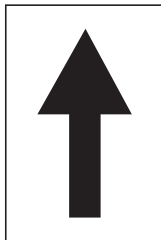
Make the adjustment if the magnification in the main scanning direction is incorrect.

Make the adjustment if the magnification in the auxiliary scanning direction is incorrect.

<b>Format</b>	!R! KCFG "SCAN",8, #1,#2;EXIT;	
<b>Parameter</b>	#1	1: Y SCAN ZOOM Scanner magnification in the main scanning direction 2: X SCAN ZOOM Scanner magnification in the auxiliary scanning direction
	#2	#1=1: Adjustable range: -32 to 127 (in 0.1% increment) (0: default) #2=2 : Adjustable range: -25 to 25 (in 0.1% increment) (0: default)

### Example: Y SCAN ZOOM set to 55, X SCAN ZOOM set to 10

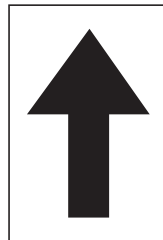
!R! KCFG "SCAN",8,1,55; KCFG "SCAN",8,2,10;EXIT;



Original

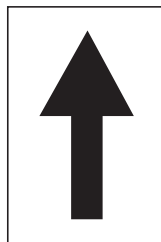


Copy  
example 1

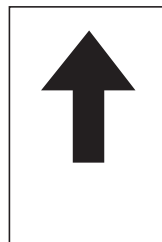


Copy  
example 2

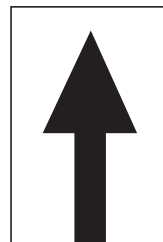
Magnified in the main  
scanning direction



Original



Copy  
example 1



Copy  
example 2

Magnified in the auxiliary  
scanning direction

## Adjusting the scanner leading edge registration (alternative command for the maintenance U066)

### Description

Adjusts the scanner leading edge registration of the original scanning.

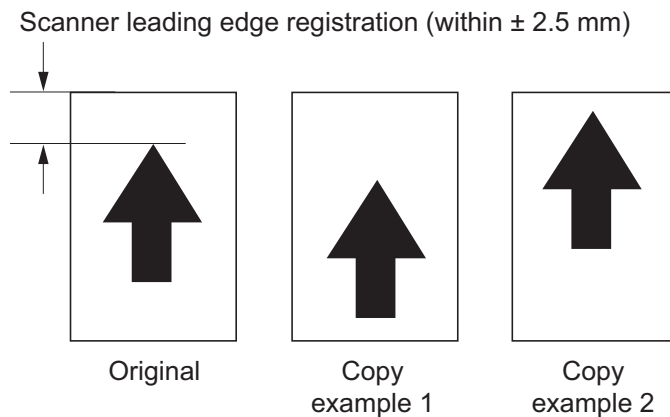
### Purpose

Make the adjustment if there is a regular error between the leading edges of the copy image and original.

<b>Format</b>	!R! KCFG "SCAN",5,#1,#2;;EXIT;	
<b>Parameter</b>	#1	1: Scanner leading edge registration 2: Scanner leading edge registration of rotated scan
	#2	Adjustable range: -45 to 45 (in 0.086mm increment) (0: default)

### Example: Scanner leading edge registration set to 10 to increase 0.86mm

!R! KCFG "SCAN",5,1,"10";EXIT;





## Adjusting the scanner center line (alternative command for the maintenance mode U067)

### Description

Adjusts the scanner center line of the original scanning.

### Purpose

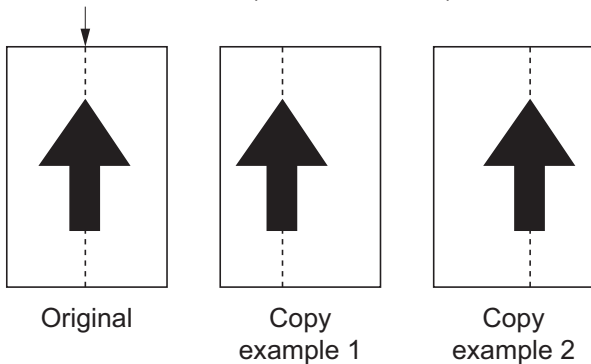
Make the adjustment if there is a regular error between the center lines of the copy image and original.

<b>Format</b>	!R! KCFG "SCAN",6, #1;#2;EXIT;	
<b>Parameter</b>	#1	1: Scanner center line 2: Scanner center line of rotated scan
	#2	#1=1: Adjustable range: -70 to 70 (in 0.086mm increment) (0: default) #1=2: Adjustable range: -40 to 40 (in 0.086mm increment) (0: default)

### Example: Scanner leading edge registration set to 20 to increase 1.72mm

!R! KCFG "SCAN",6,1,20;EXIT;

Scanner center line (within  $\pm 2.0$  mm)



## Adjusting the scanning position for originals from the DP (alternative command for the maintenance mode U068)

### Description

Adjusts the position for scanning originals from the DP. Performs the test copy at the four scanning positions after adjusting.

### Purpose

Used when the image fogging occurs because the scanning position is not proper when the DP is used. Execute KCFG "EESS",4, 107, 1, "#1"; command to adjust the timing of DP leading edge when the scanning position is changed.

<b>Format</b>	!R! KCFG "SCAN",9, #1,#2;EXIT;	
<b>Parameter</b>	#1	1: DP READ Starting position adjustment for scanning originals 2: BLACK LINE Scanning position for the test copy originals
	#2	#1=1: Adjustable range: -33 to 33 (in 0.086mm increment) (0: default) #1=2: Adjustable range: 0 to 3 (in 0.22mm increment) (0: default)

### Example: DP READ set to 15, BLACK LINE set to 3

!R! KCFG "SCAN",9,1,15; KCFG "SCAN",9,2,3;EXIT;

## Adjusting the DP magnification (alternative command for the maintenance mode U070)

### Description

Adjusts the DP original scanning speed.

### Purpose

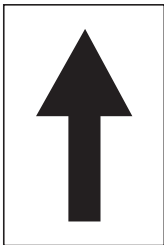
Make the adjustment if the magnification is incorrect in the auxiliary scanning direction when the DP is used.

<b>Format</b>	!R! KCFG "SCAN",4, #1;#2;EXIT;	
<b>Parameter</b>	#1	2: CONVEYING SPEED Magnification in the auxiliary scanning direction
	#2	Adjustable range: --25 to 25 (in 0.1% increment) (0: default)

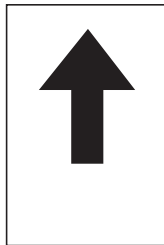
### Example: DP scanning magnification set to 20 to increase 2%

!R! KCFG "SCAN",4,2,20;EXIT;

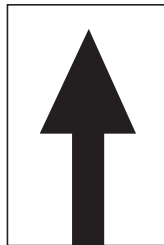
### Leading edge registration



Original



Copy  
example 1



Copy  
example 2

## Adjusting the DP scanning timing (alternative command for the maintenance mode U071)

### Description

Adjusts the DP original scanning timing.

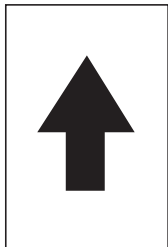
### Purpose

Make the adjustment if there is a regular error between the leading or trailing edges of the original and the copy image when the DP is used.

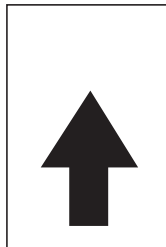
<b>Format</b>	!R! KCFG "SCAN",2,#1,#2;EXIT;	
<b>Parameter</b>	#1	1: FRONT HEAD Leading edge registration (first page) 2: FRONT TAIL Trailing edge registration (first page) 3: BACK HEAD Leading edge registration (second page) 4: BACK TAIL Trailing edge registration (second page) 5: ROTATE Leading edge registration (rotate scan)
	#2	#1=1: Adjustable range: -32 to 32 (in 0.196mm increment) (0: default) #1=2: Adjustable range: -32 to 32 (in 0.196mm increment) (0: default) #1=3: Adjustable range: -45 to 45 (in 0.196mm increment) (0: default) #1=4: Adjustable range: -45 to 45 (in 0.196mm increment) (0: default) #1=5: Adjustable range: -128 to 128 (in 0.196mm increment) (0: default)

**Example: FRONT HEAD set to 10, FRONT TAIL set to 15, BACK HEAD set to 10, BACK TAIL 15**  
!R! KCFG "SCAN",2,1,10; KCFG "SCAN",2,2,15; KCFG "SCAN",2,3,10; KCFG "SCAN",2,4,15;EXIT;

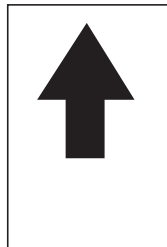
### Leading edge registration



Original

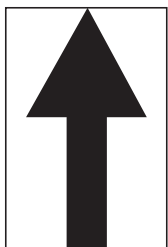


Copy example 1

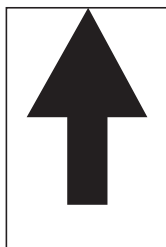


Copy example 2

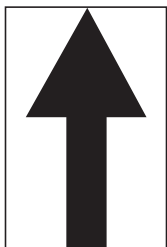
### Trailing edge registration



Original



Copy example 1



Copy example 2

## Adjusting the DP center line (alternative command for the maintenance mode U072)

### Description

Adjusts the scanning center line for the DP original.

### Purpose

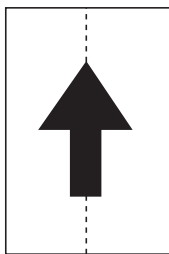
Make the adjustment if there is a regular error between the centers of the original and the copy image when the DP is used.

<b>Format</b>	!R! KCFG "SCAN",3, #1,#2;EXIT;	
<b>Parameter</b>	#1	1: FRONT Center line (first page) 2: BACK Center line (second page) 3: ROTATE Center line (rotated scan)
	#2	Setting range: -39 to 39 (in 0.086mm increment) (initial: 0)

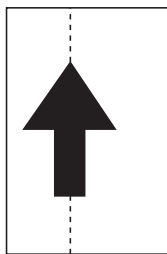
### Example: FRONT set to 15, BACK set to 3

!R! KCFG "SCAN",3,1,15; KCFG "SCAN",3,2,3;EXIT;

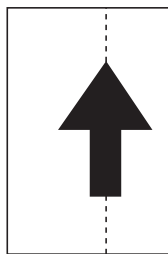
### DP center line



Original

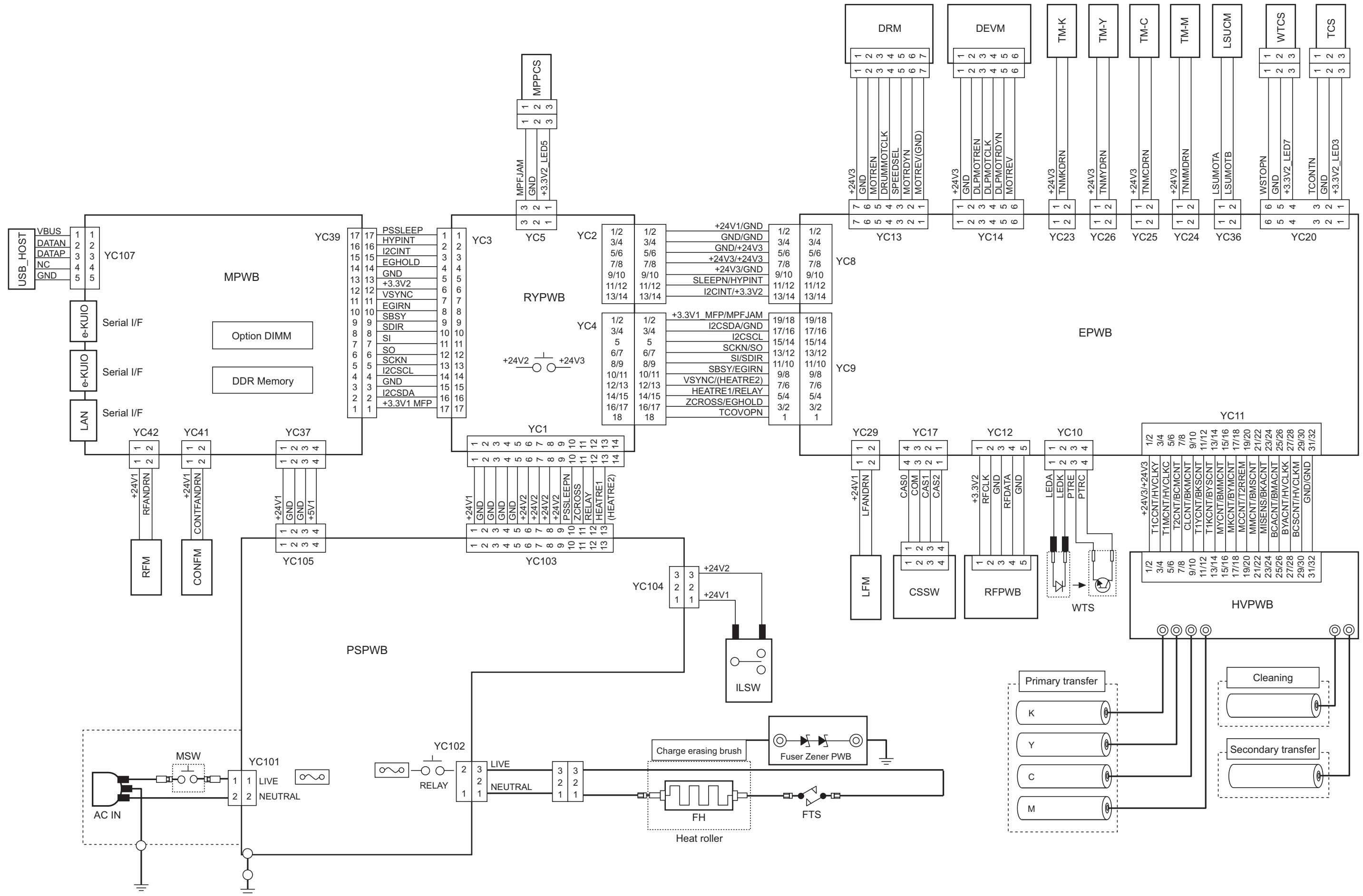


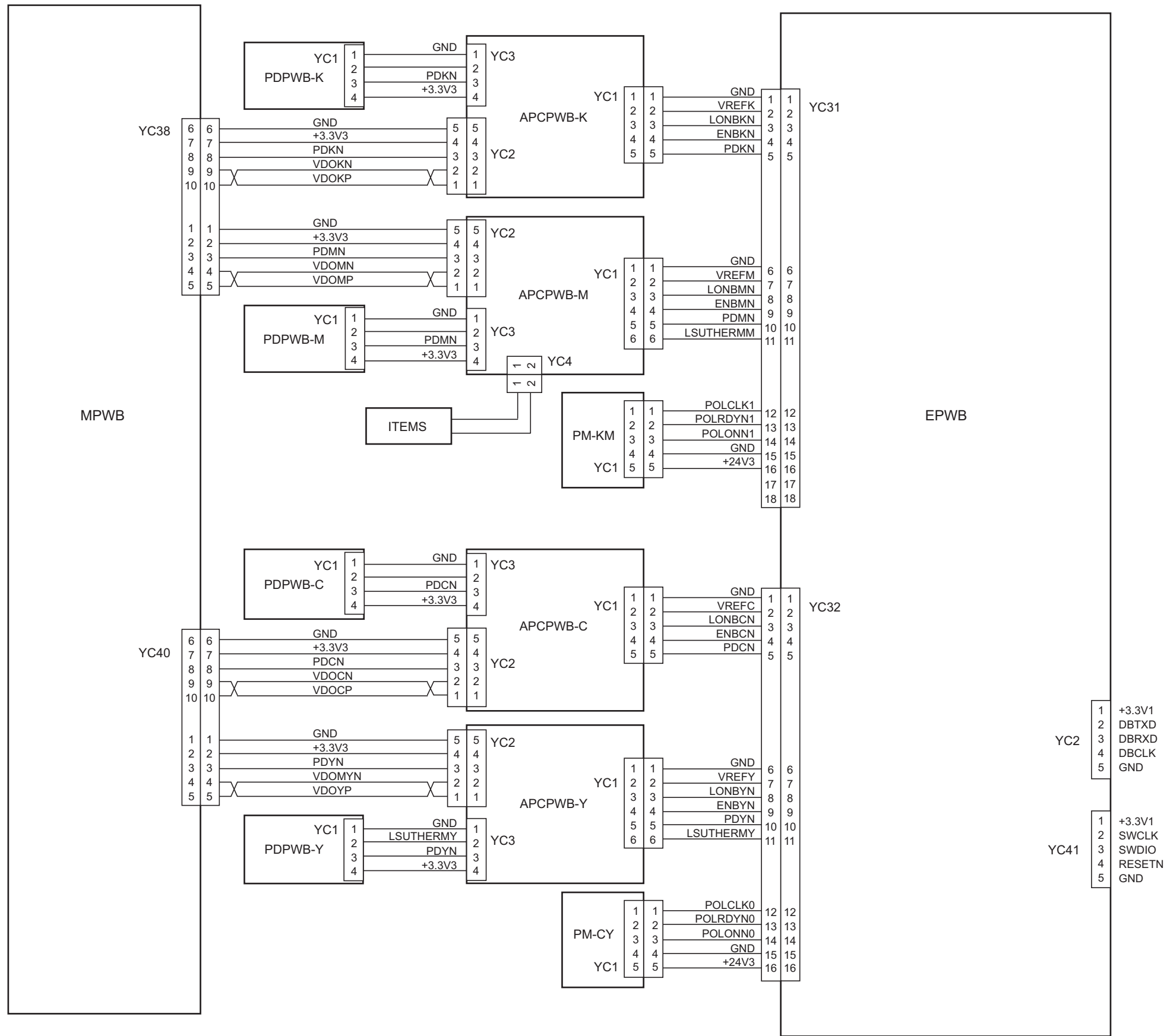
Copy  
example 1

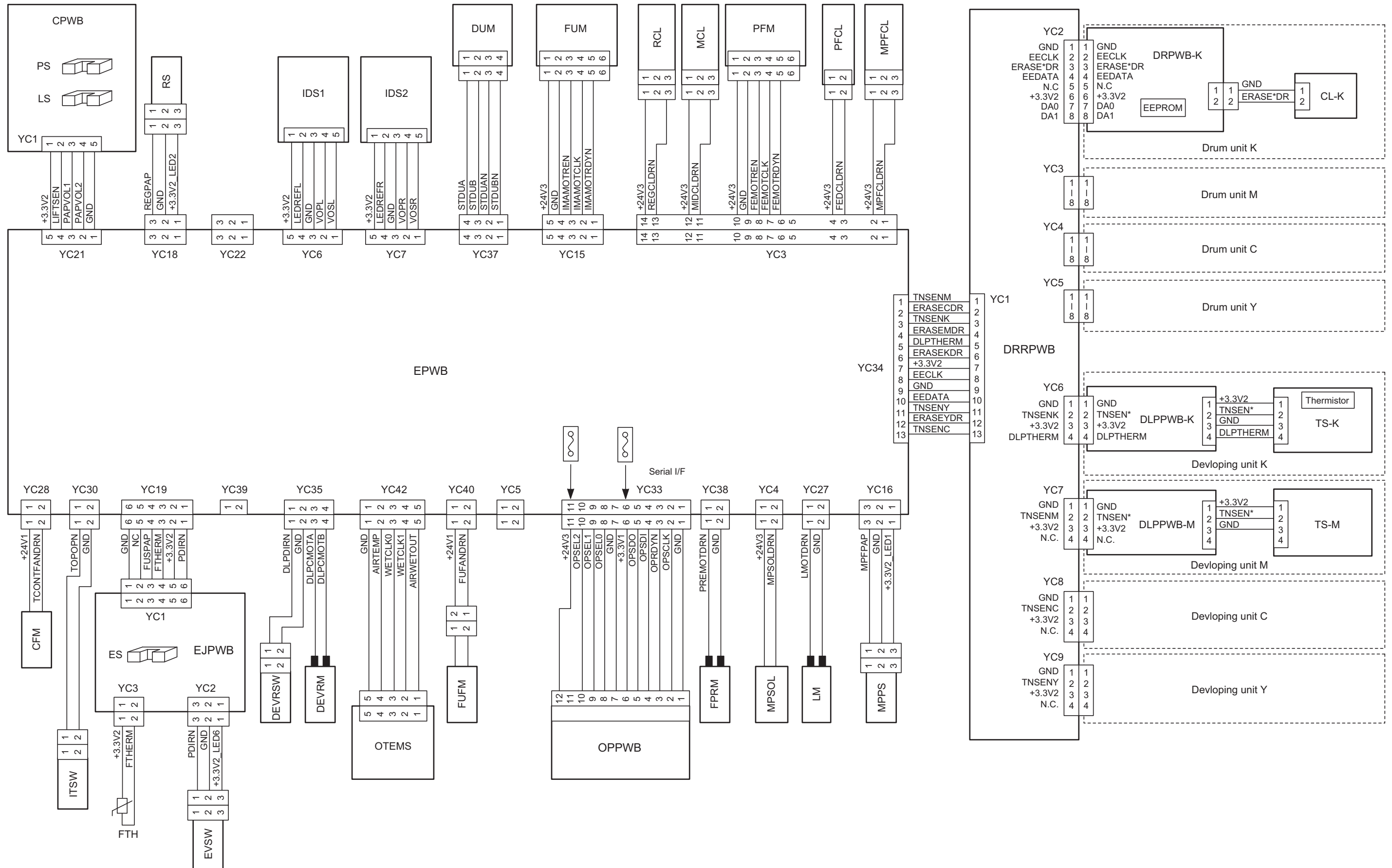


Copy  
example 2

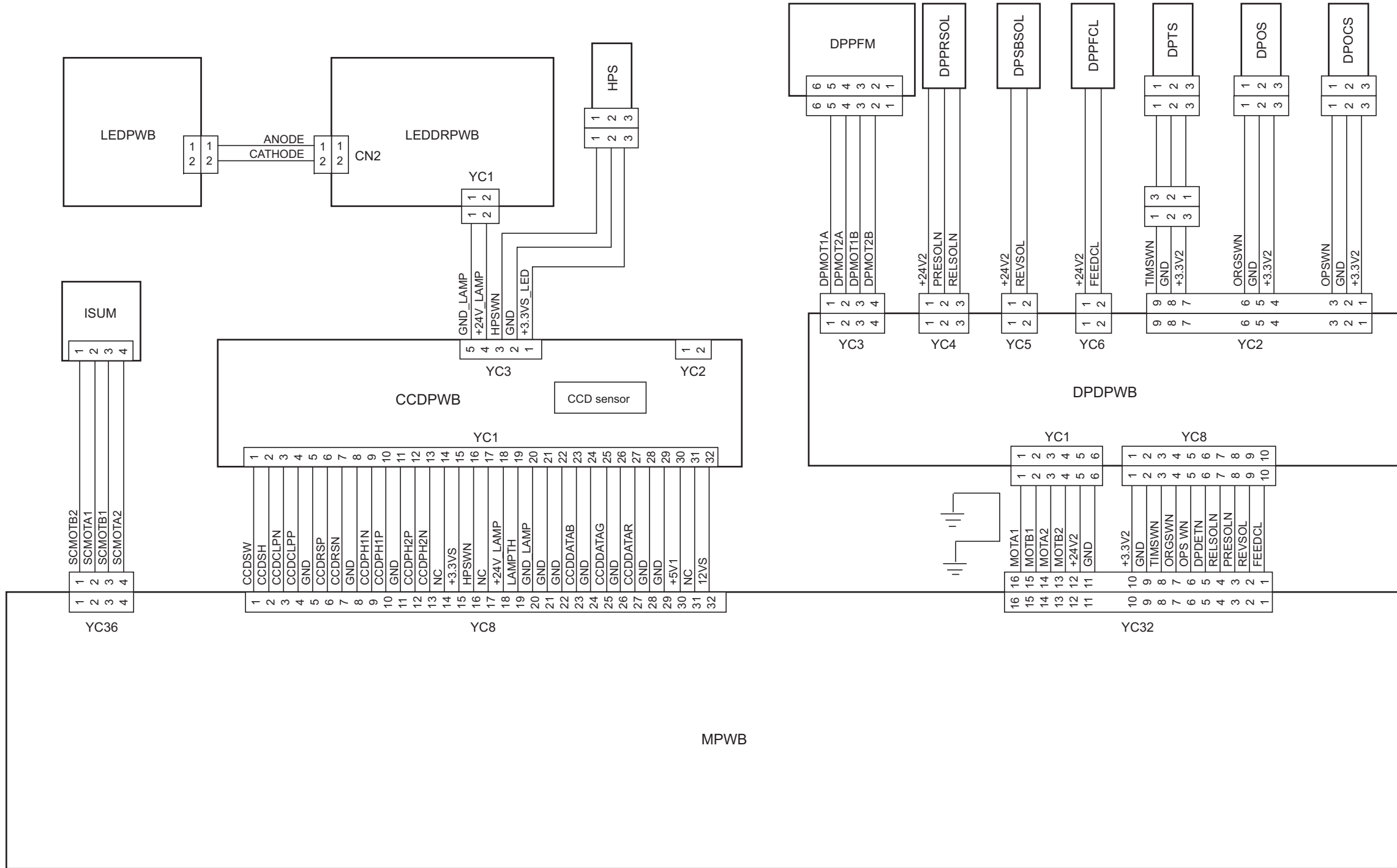
(5) Wiring diagram

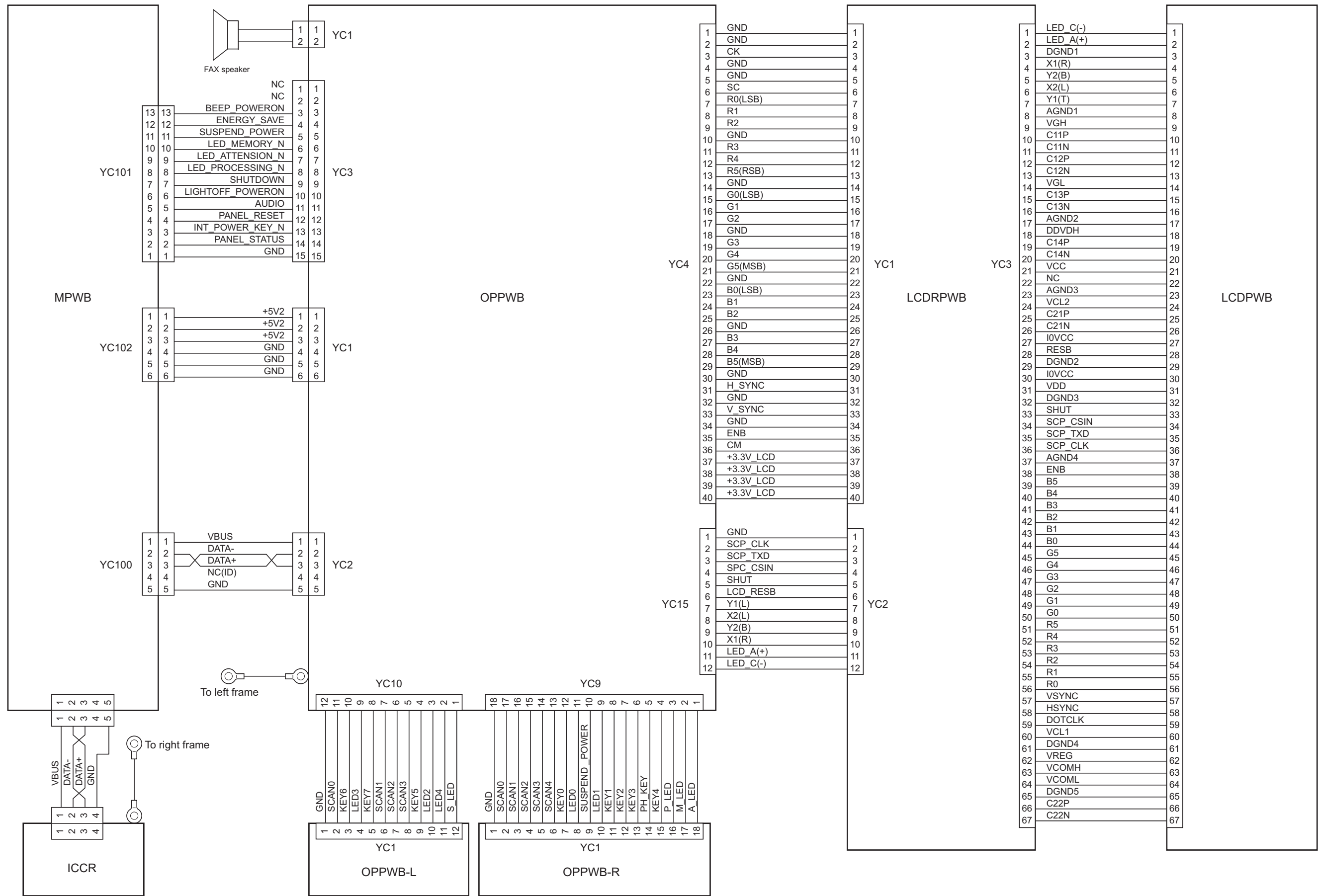






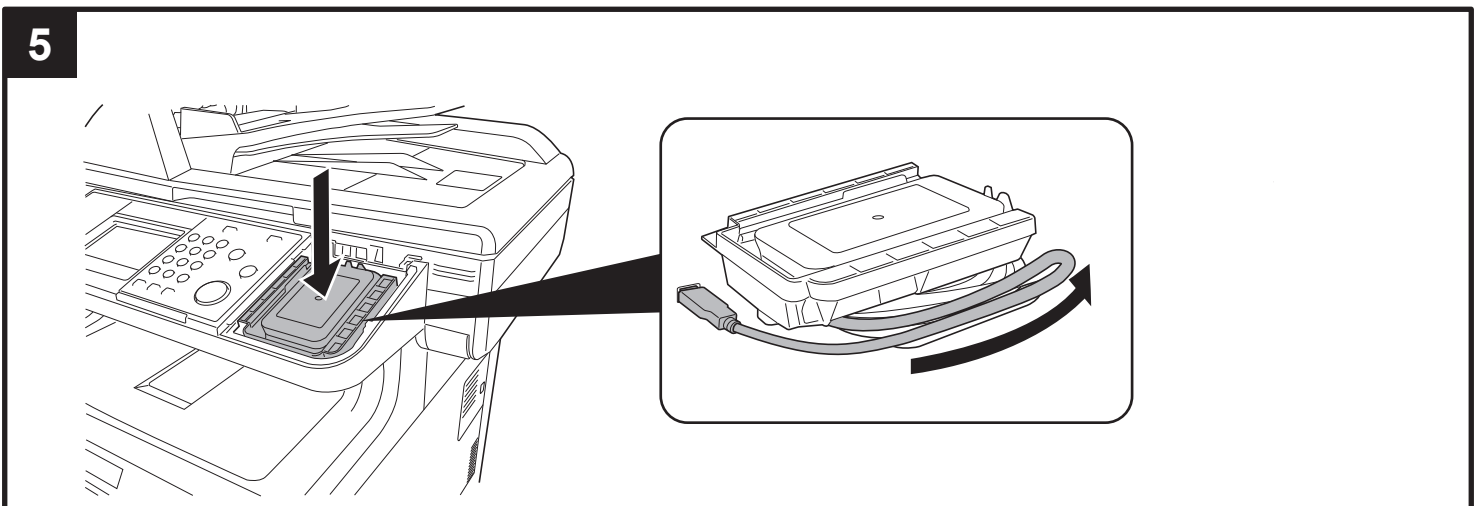
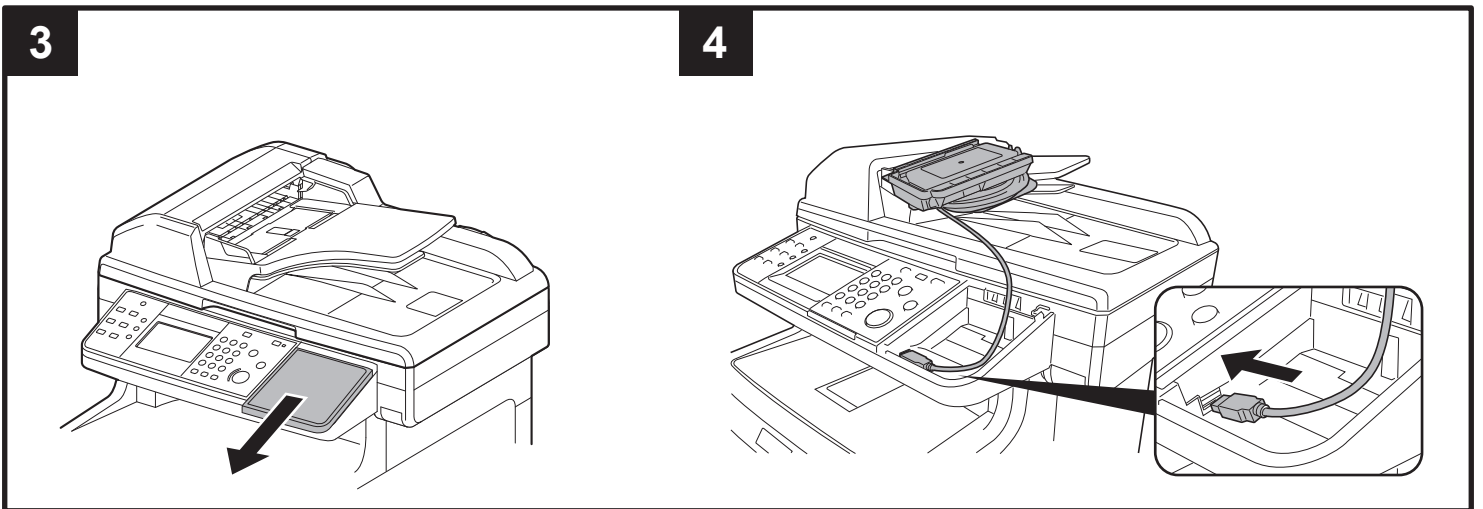
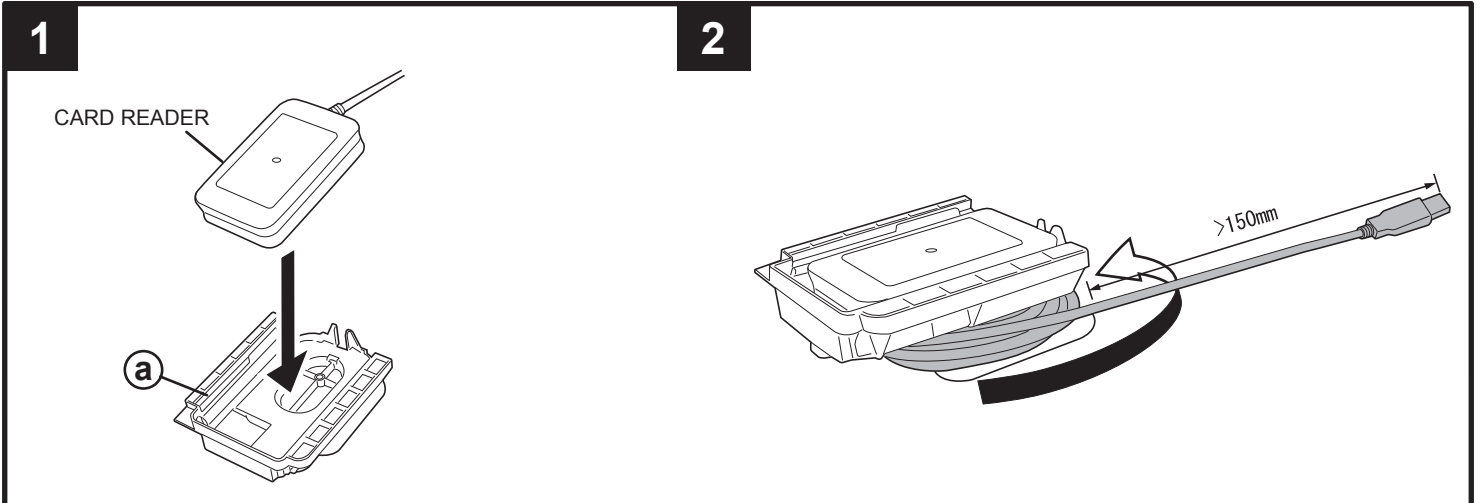
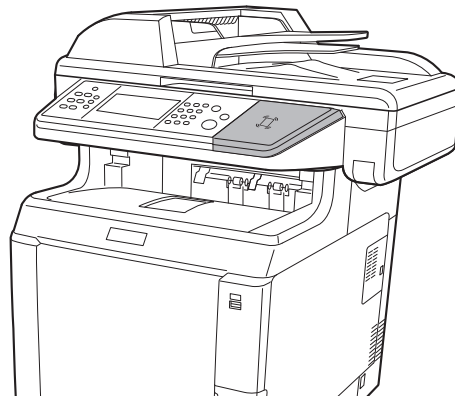
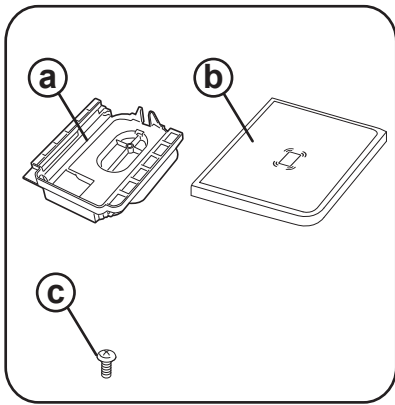




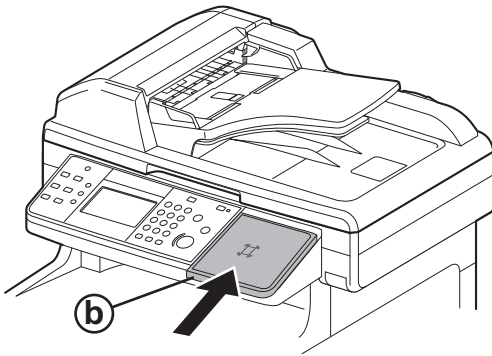


# **INSTALLATION GUIDE FOR Card Authentication Kit(D)**

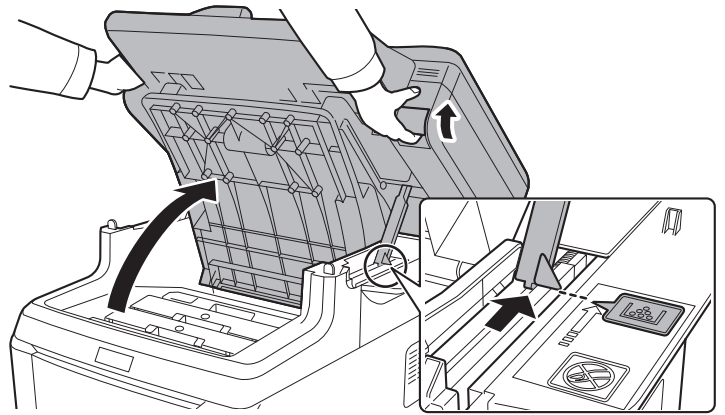
# CARD READER HOLDER (D)



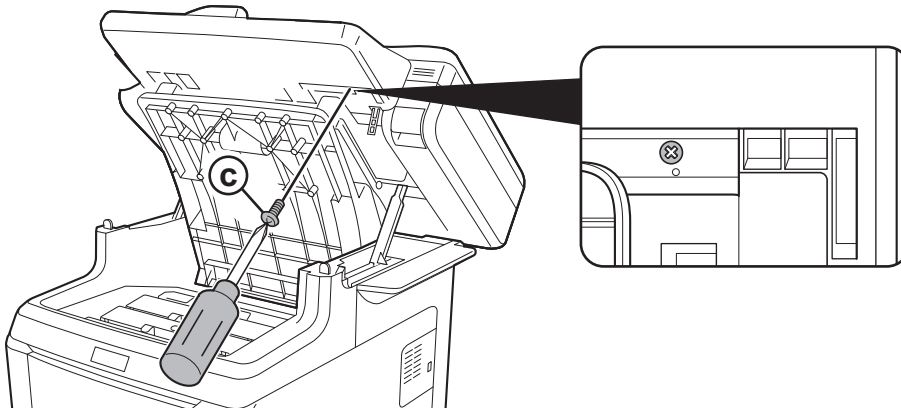
6



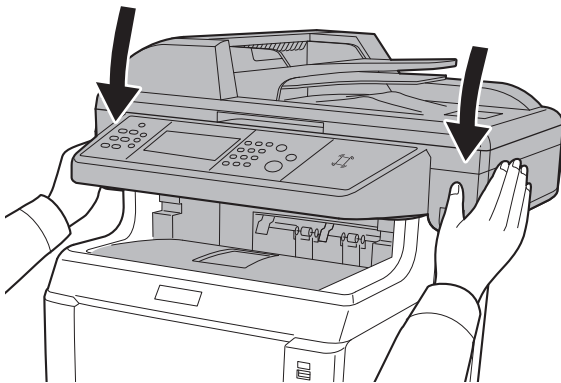
7



8



9



10

- (ENG) Refer to the Card Authentication Kit (B) Operation Guide on the bundled Product Library DVD for descriptions of the Card Authentication Kit options and the procedures for using them.
- (ES) Consulte la Card Authentication Kit (B) Operation Guide, disponible en el Product Library DVD suministrado, para obtener descripciones de las opciones de Card Authentication Kit y los procedimientos de uso.
- (FR) Se reporter au Card Authentication Kit (B) Operation Guide sur le Product Library DVD fourni pour les descriptions des options de Card Authentication Kit et leurs procédures d'utilisation.
- (DE) Siehe auch in Card Authentication Kit (B) Operation Guide auf der Product Library DVD für Erklärungen der Card Authentication Kit Optionen und den Gebrauch.
- (IT) Vedere Card Authentication Kit (B) Operation Guide sul Product Library DVD fornito per la descrizione delle opzioni Card Authentication Kit e le procedure di utilizzo del kit.
- (CN) 有关 Card Authentication Kit 选项的说明以及使用该选项的步骤, 请参阅附带的 Product Library DVD 上的 Card Authentication Kit (B) 操作手册。
- (TW) 有關 Card Authentication Kit 選項和使用它們的步驟的說明, 請參閱附帶的 Product Library DVD 上的 Card Authentication Kit (B) 操作手冊。
- (KO) Card Authentication Kit 옵션과 사용 과정에 관한 설명은 함께 제공된 Product Library DVD 에 있는 Card Authentication Kit (B) 조작 설 명서를 참조하시기 바랍니다 .
- (JP) ICカード認証キットで設定できる内容や操作方法については、付属のProduct Library DVD に収録されているICカード認証キット (B) 使用説明書を参照してください。

**KYOCERA Document Solutions America, Inc.****Headquarters**

225 Sand Road,  
Fairfield, New Jersey 07004-0008, USA  
Phone: +1-973-808-8444  
Fax: +1-973-882-6000

**Latin America**

8240 NW 52nd Terrace Dawson Building, Suite 100  
Miami, Florida 33166, USA  
Phone: +1-305-421-6640  
Fax: +1-305-421-6666

**KYOCERA Document Solutions Canada, Ltd.**

6120 Kestrel Rd., Mississauga, ON L5T 1S8,  
Canada  
Phone: +1-905-670-4425  
Fax: +1-905-670-8116

**KYOCERA Document Solutions  
Mexico, S.A. de C.V.**

Calle Arquimedes No. 130, 4 Piso, Colonia Polanco  
Chapultepec, Delegacion Miguel Hidalgo,  
Distrito Federal, C.P. 11560, México  
Phone: +52-555-383-2741  
Fax: +52-555-383-7804

**KYOCERA Document Solutions Brazil, Ltda.**

Alameda África, 545, Pólo Empresarial Consbrás,  
Tamboré, Santana de Parnaíba-SP, CEP 06543-306,  
Brazil  
Phone: +55-11-4195-8496  
Fax: +55-11-4195-6167

**KYOCERA Document Solutions  
Australia Pty. Ltd.**

Level 3, 6-10 Talavera Road North Ryde N.S.W, 2113,  
Australia  
Phone: +61-2-9888-9999  
Fax: +61-2-9888-9588

**KYOCERA Document Solutions  
New Zealand Ltd.**

Ground Floor, 19 Byron Avenue, Takapuna, Auckland,  
New Zealand  
Phone: +64-9-415-4517  
Fax: +64-9-415-4597

**KYOCERA Document Solutions Asia Limited**

16/F., Mita Centre, 552-566, Castle Peak Road  
Tsuenwan, NT, Hong Kong  
Phone: +852-2610-2181  
Fax: +852-2610-2063

**KYOCERA Document Solutions  
(China) Corporation**

8F, No. 288 Nanjing Road West, Huangpu District,  
Shanghai, 200003, China  
Phone: +86-21-5301-1777  
Fax: +86-21-5302-8300

**KYOCERA Document Solutions  
(Thailand) Corp., Ltd.**

335 Ratchadapisek Road, Bangsue, Bangkok 10800,  
Thailand  
Phone: +66-2-586-0333  
Fax: +66-2-586-0278

**KYOCERA Document Solutions  
Singapore Pte. Ltd.**

12 Tai Seng Street #04-01A,  
Luxasia Building, Singapore 534118  
Phone: +65-6741-8733  
Fax: +65-6748-3788

**KYOCERA Document Solutions  
Hong Kong Limited**

16/F., Mita Centre, 552-566, Castle Peak Road  
Tsuenwan, NT, Hong Kong  
Phone: +852-3582-4000  
Fax: +852-3185-1399

**KYOCERA Document Solutions  
Taiwan Corporation**

6F., No.37, Sec. 3, Minquan E. Rd.,  
Zhongshan Dist., Taipei 104, Taiwan R.O.C.  
Phone: +886-2-2507-6709  
Fax: +886-2-2507-8432

**KYOCERA Document Solutions Korea Co., Ltd.**

18F, Kangnam bldg, 1321-1,  
Seocho-Dong, Seocho-Gu, Seoul, Korea  
Phone: +822-6933-4050  
Fax: +822-747-0084

**KYOCERA Document Solutions  
India Private Limited**

First Floor, ORCHID CENTRE  
Sector-53, Golf Course Road, Gurgaon 122 002,  
India  
Phone: +91-0124-4671000  
Fax: +91-0124-4671001

**KYOCERA Document Solutions Europe B.V.**

Bloemlaan 4, 2132 NP Hoofddorp,  
The Netherlands  
Phone: +31-20-654-0000  
Fax: +31-20-653-1256

**KYOCERA Document Solutions Nederland B.V.**

Beechavenue 25, 1119 RA Schiphol-Rijk,  
The Netherlands  
Phone: +31-20-5877200  
Fax: +31-20-5877260

**KYOCERA Document Solutions (U.K.) Limited**

Eldon Court, 75-77 London Road,  
Reading, Berkshire RG1 5BS,  
United Kingdom  
Phone: +44-118-931-1500  
Fax: +44-118-931-1108

**KYOCERA Document Solutions Italia S.p.A.**

Via Verdi, 89/91 20063 Cernusco s/N.(MI),  
Italy  
Phone: +39-02-921791  
Fax: +39-02-92179-600

**KYOCERA Document Solutions Belgium N.V.**

Sint-Martinusweg 199-201 1930 Zaventem,  
Belgium  
Phone: +32-2-7209270  
Fax: +32-2-7208748

**KYOCERA Document Solutions France S.A.S.**

Espace Technologique de St Aubin  
Route de l'Orme 91195 Gif-sur-Yvette CEDEX,  
France  
Phone: +33-1-69852600  
Fax: +33-1-69853409

**KYOCERA Document Solutions Espana, S.A.**

Edificio Kyocera, Avda. de Manacor No.2,  
28290 Las Matas (Madrid), Spain  
Phone: +34-91-6318392  
Fax: +34-91-6318219

**KYOCERA Document Solutions Finland Oy**

Atomitie 5C, 00370 Helsinki,  
Finland  
Phone: +358-9-47805200  
Fax: +358-9-47805390

**KYOCERA Document Solutions****Europe B.V., Amsterdam (NL) Zürich Branch**

Hohlstrasse 614, 8048 Zürich,  
Switzerland  
Phone: +41-44-9084949  
Fax: +41-44-9084950

**KYOCERA Document Solutions****Deutschland GmbH**

Otto-Hahn-Strasse 12, 40670 Meerbusch,  
Germany  
Phone: +49-2159-9180  
Fax: +49-2159-918100

**KYOCERA Document Solutions Austria GmbH**

Eduard-Kittenberger-Gasse 95, 1230 Vienna,  
Austria  
Phone: +43-1-863380  
Fax: +43-1-86338-400

**KYOCERA Document Solutions Nordic AB**

Esbogatan 16B 164 75 Kista, Sweden  
Phone: +46-8-546-550-00  
Fax: +46-8-546-550-10

**KYOCERA Document Solutions Norge Nuf**

Postboks 150 Oppsal, 0619 Oslo,  
Norway  
Phone: +47-22-62-73-00  
Fax: +47-22-62-72-00

**KYOCERA Document Solutions Danmark A/S**

Ejby Industrivej 60, DK-2600 Glostrup,  
Denmark  
Phone: +45-70223880  
Fax: +45-45765850

**KYOCERA Document Solutions Portugal Lda.**

Rua do Centro Cultural, 41 (Alvalade) 1700-106 Lisboa,  
Portugal  
Phone: +351-21-843-6780  
Fax: +351-21-849-3312

**KYOCERA Document Solutions****South Africa (Pty) Ltd.**

KYOCERA House, Hertford Office Park,  
90 Bekker Road (Cnr. Allandale), Midrand, South Africa.  
Phone: +27-11-540-2600  
Fax: +27-11-466-3050

**KYOCERA Document Solutions Russia LLC**

Botanichesky pereulok 5, Moscow, 129090,  
Russia  
Phone: +7(495)741-0004  
Fax: +7(495)741-0018

**KYOCERA Document Solutions Middle East**

Dubai Internet City, Bldg. 17,  
Office 157 P.O. Box 500817, Dubai,  
United Arab Emirates  
Phone: +971-04-433-0412

**KYOCERA Document Solutions Inc.**

2-28, 1-chome, Tamatsukuri, Chuo-ku  
Osaka 540-8585, Japan  
Phone: +81-6-6764-3555  
<http://www.kyoceradocumentsolutions.com>