

FS-C2026MFP / C2126MFP

FS-C5150 / C5250

▶ print ▶ copy ▶ scan ▶ fax

# TRAINING MANUAL

TRAINER VERSION

ENGLISH



**Module name:** TWP-C5250 / TPP-C8500 (partial) / TWM-C2126 (previous)  
**Certification:** -

©KYOCERA ACADEMY

**Author:** R. Blume

**Creation:** 02/11

**Version:** 01.00

**Note:**

All the contents of this document have been carefully researched. However, we cannot assume liability for the information provided being accurate, complete and up to date.

Please bear in mind that this document is meant to accompany a training and is in no way supposed to be a replacement for your Service Manual.



## Note for students

This training manual contains information, topics for discussion, exercises concerning your course, and is organized into individual “lessons”. The aim of organizing it in this way is to gain practical knowledge by following specific, carefully structured (learning) steps as presented in our Learning Units (LU).

In order to make the training material simpler and clearer, we have marked the most important learning points with symbols.



This symbol indicates **Learning Objectives**.  
Learning objectives help you keep your focus on the subject matter and enable you to check your success at the end of the training.



This symbol indicates **Exercises**.  
These exercises give you the opportunity to apply your knowledge hands-on.



This symbol indicates a **KyoQuizZ**.  
Quizzes enable students to test their knowledge by answering review questions.



This symbol indicates a **Summary**.  
The contents of the preceding chapter are presented in an overview.

We hope this manual is a valuable tool for you to find your own personal way of learning.

We wish you success and hope you enjoy reading, studying and “using” this documentation!

Your KYOCERA ACADEMY



|  |           |
|--|-----------|
| <b>LU 01. Overview</b>   | <b>7</b>  |
| Product Features 26ppm MFP .....                                 | 8         |
| Product Features 21ppm Printer.....                              | 10        |
| Product Features 26ppm Printer.....                              | 12        |
| Operation panel, MFP .....                                       | 14        |
| Operation panel, printer.....                                    | 16        |
| <b>LU 02. Installation</b>                                       | <b>19</b> |
| Who should undertake installation? .....                         | 20        |
| Fitting optional paper feeder .....                              | 22        |
| More Options, MFP.....   | 23        |
| More Options, Printer .....                                      | 24        |
| Hints for installation (MFP).....                                | 25        |
| Tips for installation (Printer) .....                            | 27        |
| The DeviceAdmin account (MFP) .....                              | 28        |
| <b>LU 03. Design</b>   | <b>33</b> |
| Overview, function groups and paper path .....                   | 34        |
| Overview, left side .....  | 35        |
| Overview, right side.....  | 36        |
| Paper feeder .....   | 37        |
| Multi purpose paper feeder.....                                  | 38        |
| Paper transport.....   | 40        |
| Imaging drums.....   | 42        |
| Developer .....  | 43        |
| Laser units .....  | 44        |
| Transfer unit .....  | 45        |
| Secondary transfer.....  | 47        |
| Fusing unit.....   | 48        |
| Paper output and re-feeding (duplex).....                        | 49        |
| Automatic color calibration.....                                 | 50        |
| <b>LU 04. Maintenance</b>  | <b>51</b> |
| Maintenance Kit MK-590 (only 26 ppm models) .....                | 52        |
| Replacement of separation roller (retard roller) .....           | 53        |
| Replacement of feed roller (paper feed roller unit) .....        | 56        |
| Replacement of the feed roller, multi purpose paper feeder ..... | 57        |
| Dismantling the side casings.....                                | 58        |
| Maintenance Mode (MFP).....                                      | 66        |
| U-parameters (MFP) .....   | 67        |
| U-410, Automatic half tone calibration (MFP) .....               | 71        |
| U-425, automatic color calibration of the scanner (MFP) .....    | 72        |
| U-411, automatic scanner adjustment (MFP) .....                  | 74        |
| Setting up color registration .....                              | 75        |
| Service settings (MFP) .....                                     | 77        |
| Service Settings (Printer).....                                  | 78        |

# Contents

|   |           |
|---|-----------|
| <b>Hints</b>  | <b>83</b> |
| Detaching the transfer unit .....                           | 84        |
| Handling the drums.....                                     | 85        |
| Handling developer units.....                               | 86        |
| Handling laser units.....                                   | 87        |
| Replacing toner motors .....                                | 88        |
| Detaching the scanner unit (MFP) .....                      | 89        |
| Replacing main board.....                                   | 90        |
| Replacing engine board .....                                | 90        |
| <br>  |           |
| <b>LU 05. Command Center</b>                                | <b>91</b> |
| Access to the Command Center .....                          | 92        |
| Design of the Command Center .....                          | 93        |
| Style of presentation in this manual .....                  | 94        |
| Helpful hints .....   | 95        |
| Safety Concept .....  | 96        |
| Device safety.....  | 97        |
| Change password.....  | 98        |
| Blocking the operation panel .....                          | 99        |
| Blocking the interfaces.....                                | 100       |
| Network safety .....  | 101       |
| IP-Filter (v4 and v6) .....                                 | 102       |
| Authentication models (MFP) .....                           | 103       |
| User login, MFP (user authentication) .....                 | 106       |
| Authentication, MFP .....                                   | 107       |
| Authentication, administrator status (MFP) .....            | 108       |
| Authentication, user status (MFP).....                      | 109       |
| Group authorization, MFP (for network authentication) ..... | 110       |
| Scan via network, preparations (MFP) .....                  | 111       |
| Scanning, Scan-to-Email (MFP) .....                         | 112       |
| Scanning, Scan-to-FTP (MFP) .....                           | 114       |
| Scanning, Scan-to-SMB (MFP).....                            | 115       |
| Address book, local (MFP).....                              | 116       |
| Sending service lists .....                                 | 117       |
| Reset / restart .....                                       | 118       |

**Contents:**

- Introducing the device series

**At the end of the chapter you will be able to...**

- assign individual product variants
- make specific statements about features
- set device options as needed
- provide customer-oriented advice

## Product Features 26ppm MFP

### FS-C2026MFP/FS-C2126MFP

COLOUR MULTIFUNCTIONALS FOR A4 FORMAT

► print ► copy ► scan ► fax

## HIGH COLOUR PRODUCTIVITY IN COMPACT SIZE.

Speed and reliability in colour and b/w: an unbeatable combination. These highly productive multifunctional devices offer a short first copy time and a fast print speed so that they can quickly deal with your office workload. Even heavy digital workloads are taken care of just as quickly thanks to the impressive scanning speed. The exceptional reliability of KYOCERA's long-life components makes them ideal for your finances. And their full duplex support, reduced emissions and waste make them good for the environment and perfect for your office.

- Up to 26 copies/prints per minute in A4 in colour and b/w
- Up to 35 scans per minute via 50-sheet document processor
- Up to 9,600 dpi printing quality with multibit technology
- Time to first copy 10(12) seconds in b/w (colour)
- Double-sided print, copy, scan and fax\* functionality as standard
- Active Directory support combines ease of use and security
- High security through SSL, IPsec and Private Print functionality
- Compact design with ease of use and low-noise printing
- Exceptionally low printing costs in its class

\*Only FS-C2126MFP

The Private Print functionality requires identification before the printing job starts – ensuring accountability and top-level security.



Toner is easily and economically replenished with access through the top.



## Product Features (continued)

# FS-C2026MFP/FS-C2126MFP

COLOUR MULTIFUNCTIONALS FOR A4 FORMAT

**ECOSYS** stands for ECOlogy,  
ECONomy and SYStem-printing.

With their long-life components, ECOSYS devices are designed to maximise durability and minimise the total cost of ownership with regard to maintenance, administration and consumables. The cartridge-free system means that only the toner has to be replaced regularly. The modular design concept allows you to add workflow-enhancing functions as required. Integrated system software provides long-term cross-network compatibility. KYOCERA's long-life components cost you and the environment less.

### General

**Technology:** KYOCERA ECOSYS, Colour Laser  
**Engine speed:** Up to 26 pages A4 per minute in colour and b/w  
**Resolution:** 600 x 600 dpi multibit for 9,600 x 600 dpi (print), 600 x 600 dpi, 256 greyscales per colour (scan/copy)  
**Duty cycle:** Max. 65,000 pages per month  
**Recommended monthly printing volume:** up to 10,000 pages\*\*  
**Warm-up time:** Approx. 29 seconds or less  
**Time to first print:** Approx. 9/10.5 seconds or less in b/w / colour  
**Time to first copy:** Approx. 10/12 seconds or less in b/w / colour  
**CPU:** PowerPC 464 / 667 MHz  
**Memory:** Standard 768 MB, max. 1,792 MB  
**Integrated accounting:** 20 department codes  
**Dimensions (W x D x H):** 514 x 550 x 580 mm  
**Weight:** Approx. 36.5 kg including toner container  
**Power source:** AC 220 ~ 240 V, 50/60 Hz  
**Power consumption:**  
 Printing: FS-C2026MFP – 466 W / FS-C2126MFP – 477 W  
 Copying: FS-C2026MFP – 470 W / FS-C2126MFP – 479 W  
 Stand-by: FS-C2026MFP – 79 W / FS-C2126MFP – 79 W  
 Sleep-mode: FS-C2026MFP – 16 W / FS-C2126MFP – 17 W  
**Noise level (sound pressure level ISO 7779/ISO 9296):**  
 Copying/Printing: 50 dB(A)  
 Stand-by: 30 dB(A)  
**Safety standards:** TÜV/GS, CE  
 This unit is manufactured according to ISO 9001 quality standard and ISO 14001 environmental standard.

### Paper handling

All paper capacities quoted are based on a paper thickness of max. 0.11 mm. Please use paper recommended by KYOCERA under normal environmental conditions.  
**Input capacity:** Max. 50-sheet multi-purpose tray, 60–220 g/m<sup>2</sup>, A4, A5, A6, B5, letter, legal, folio, envelopes, custom (70 x 138 to 216 x 356 mm), max. 250-sheet universal paper cassette, 60–163 g/m<sup>2</sup>, A4, A5, A6, B5, letter, legal, folio, custom (105 x 148 to 216 x 356 mm), max. input capacity with options: 1,300 sheets  
**Duplex unit:** Duplex as standard supports 60–163 g/m<sup>2</sup>  
**Reversing document processor:** 50-sheet, Simplex scan 50–120 g/m<sup>2</sup>, Duplex scan 50–110 g/m<sup>2</sup>, A4, A5, B5, letter, legal, custom (140 x 210 to 216 x 356 mm)  
**Output capacity:** Max. 150 sheets face-down

### Print functions

**Controller language:** PRESCRIBE IIc  
**Emulations:** PCL 6 (5c/XL), KPDL 3 (PostScript 3 compatible), PDF Direct Print, XPS Direct Print

### Your KYOCERA Business Partner:

KYOCERA MITA Europe B.V. – Branch Office Germany – Otto-Hahn-Straße 12 – 40670 Meerbusch – Germany  
 Tel +49 (0) 2159 928-500 – Fax +49 (0) 2159 918-100  
 www.kyoceramita-europe.com – info@kyoceramita-europe.com  
 KYOCERA MITA Corporation – 2-28, 1-Chome – Tamatsukuri – Chuo-Ku  
 Osaka 540-8585 – Japan – www.kyoceramita.com

\* KYOCERA does not warrant that any specifications mentioned will be error-free. Specifications are subject to change without notice. Information is correct at time of going to press. All other brand and product names may be registered trademarks or trademarks of their respective holders and are hereby acknowledged.

### PRESCRIBE IIc

With the KYOCERA page design and control language PRESCRIBE IIc, even complex graphics, logos and forms (multipart forms) can be created independently on the system and saved and updated in the printer. Consequently, integration into print files no longer applies. They are only accessed as required and therefore relieve the load on the network.

### The KM NetViewer

The KM NetViewer enables complete monitoring and control of all ECOSYS printers and digital KYOCERA multifunction units from any Windows® PC and thus provides ideal network administration. It also supports the standardised SNMP protocol.

### Status Monitor and Command Center

The Status Monitor shows the current printer's condition and gives direct access to the Command Center for the modification of settings that are not contained in the drivers (e.g. network settings, adjustment of sleep mode or blocking of the control panel).

### USB Host Interface for USB Flash Memory

Documents can be printed directly from and scanned to a USB Flash Memory (e.g. USB stick) via the USB host interface. The documents stored as PDF, XPS, TIFF or JPEG are selected directly via the printer's control panel. No computer is required.

**Interface:** USB 2.0 (Hi-Speed), USB Host 2.0, Fast Ethernet 10/100Base-TX, slot for optional print server, slot for optional CompactFlash®-Card

**Operating systems:** All current Windows operating systems, MAC OS X Version 10.2 or higher, Unix, Linux as well as other operating systems on request

**Fonts/barcodes:** 93 outline fonts (PCL 6, KPDL3) + 8 (Windows Vista), 1 bitmap font, 45 types of one-dimensional barcodes, 1 type of two-dimensional barcode (PDF417)

**Features:** encrypted PDF Direct Print, IPP printing, e-mail printing, WSD print, secure printing via SSL, IPsec, SNMPv3 and Private print (requires memory expansion)

### Copy functions

**Max. original size:** A4/legal  
**Continuous copying:** 1–999  
**Zoom range:** 25–400% in 1% steps  
**Preset magnification ratios:** 7 Reductions / 5 Enlargements  
**Features:** Scan-once-copy-many, electronic sort, 2in1, 4in1, ID-card copy, job reserve, priority print, program, auto duplex copy, split copy, continuous scan, auto cassette change, copy density control  
**Exposure mode:** Auto, manual: 7 steps  
**Image adjustments:** Text, Photo, Mix, Map, Printed photo mode

### Scan functions

**Functionality:** Scan-to-Email, Scan-to-FTP, Scan-to-SMB, Scan to USB Host, Network TWAIN, WSD scan  
**Interface:** Fast Ethernet 10/100Base-TX, USB Host 2.0  
**Scan speed:** 35 ipm (300 dpi, A4, b/w), 25ipm (600 dpi, A4 b/w, 300 dpi, A4, colour)  
**Scan resolution:** 600, 400, 300, 200 dpi (256 grey scales per colour)  
**Max. scan size:** A4, legal  
**Original recognition:** Text, photo, text + photo, OCR  
**File types:** TIFF, PDF, JPEG, XPS  
**Compression method:** MMR/JPEG  
**Features:** Integrated address book, Active Directory support, encrypted data transfer, multi send (e-mail, fax, SMB/FTP folder, print) at once

### Fax functions (FS-C2126MFP only)

**Compatibility:** ITU-T Super G3  
**Modem speed:** Max. 33.6 kbps  
**Transmission speed:** Less than 3 sec  
**Scanning speed:** 2.5 seconds  
**One touch dial:** 22 numbers

**Address book:** 100 entries

**Interface:** Fast Ethernet 10/100Base-TX

### Scanning density:

Normal: 8 dot/mm x 3.85 line/mm  
 Fine: 8 dot/mm x 7.7 line/mm  
 Superfine: 8 dot/mm x 15.4 line/mm  
 Ultrafine: 16 dot/mm x 15.4 line/mm  
 Halftone: 256 grey scales

**Maximum original size:** A4, legal

**Compression method:** JBIG, MMR, MR, MH

**Memory reception:** 256 sheets or more

**Features:** Network fax, duplex transmission and reception, encrypted transmission and reception, polling transmission and reception, broadcast

### Options

#### Paper handling

**PF-520 Paper feeder:** Max. 500 sheets; 60–163 g/m<sup>2</sup>; A4, A5, B5, letter, legal, custom (148 x 210 mm – 216 x 356 mm)  
**PF-530 Paper feeder:** Max. 500 sheets; 60–220 g/m<sup>2</sup>; A4, A5, B5, letter, legal, custom (148 x 210 mm – 216 x 356 mm)

**Memory upgrade:** MDDR2-256: 256 MB; MDDR2-512: 512 MB, MDDR2-1024: 1,024 MB

**CompactFlash®-Card:** CF-4 (4 GB) for printing forms, fonts, logos, macro storage

#### Others

**USB Flash Memory:** Supports direct printing and scanning of PDF, XPS, TIFF, JPEG files via USB Host interface

**UG-33:** ThinPrint support

#### Optional interfaces:

**PS159:** Wireless LAN (802.11b/g)  
**PS1109 Gigabit Ethernet:** 10BaseT/100BaseTX/1000BaseT (RJ-45)  
**PS129 Fibre Optic:** 100BaseSX (SC)  
**PS1129 Gigabit Fibre Optic:** 1000BaseSX (SC)

**CB-520 Cabinet:** Wooden desk with storage capacity, including castors (wheels)

### Consumables

**TK-590K Toner-Kit:** Microfine toner black for 7,000 pages A4 in accordance with ISO/IEC 19798

**TK-590C, TK-590M, TK-590Y Toner-Kits:** Microfine toner cyan, magenta, yellow for 5,000 pages A4 each in accordance with ISO/IEC 19798

Capacity of starter toner is black 3,500 pages, cyan, magenta, yellow 2,500 pages in accordance with ISO/IEC 19798

### Warranty

2-year warranty as standard. KYOCERA guarantees the drum and developer for 3 years or 200,000 pages (whichever occurs sooner), provided each device is used and cleaned in accordance with the service instructions.

**KYO LIFE** Up to 5-year on-site warranty extensions available for product and options.



Product depicted includes optional extras.

**KYOCERA**

## Product Features 21ppm Printer

### FS-C5150DN

COLOUR PRINTER FOR A4 FORMAT

► print ► copy ► scan ► fax

ENVIRONMENTALLY RESPONSIBLE –  
COLOUR PRINTING FOR YOUR OFFICE.

Professional office colour is provided by the FS-C5150DN for demanding users and small office teams. This compact colour printer saves your office space and fits perfectly in any office environment due to its low noise emissions. It convinces with reduced power consumption, lower emissions and less waste as well as with its integrated duplex unit for double-sided printing. The FS-C5150DN is not only an excellent business decision, it's an excellent choice for the environment, too.

- ▶ Up to 21 pages per minute in A4 in colour and b/w
- ▶ Up to 9,600 dpi printing quality with multibit technology
- ▶ Standard duplex unit for double-sided printing
- ▶ 250-sheet universal cassette, also for A6 format
- ▶ Up to 4 paper feeders for flexible media support
- ▶ Direct Printing from USB flash memory
- ▶ Low noise printing, no noise in sleep mode
- ▶ Exceptionally low printing costs in its class

Innovative design makes this device easy to operate. Simplified top access ensures fast worry-free toner replacement.



The user-friendly USB host interface is placed at the front of the device. It gives you extra hospitality and easy accessibility for fast and easy document output.





## Product Features (continued)

# FS-C5150DN

COLOUR PRINTER FOR A4 FORMAT



ECOSYS stands for ECOlogy,  
Economy and SYStem-printing.

With their long-life components, ECOSYS devices are designed to maximise durability and minimise the total cost of ownership with regard to maintenance, administration and consumables. The cartridge-free system means that only the toner has to be replaced regularly. The modular design concept allows you to add workflow-enhancing functions as required. Integrated system software provides long-term cross-network compatibility. KYOCERA's long-life components cost you and the environment less.

#### PRESCRIBE IIc

With the KYOCERA page design and control language PRESCRIBE IIc, even complex graphics, logos and forms (multipart forms) can be created independently on the system and saved and updated in the printer. Consequently, integration into print files no longer applies. They are only accessed as required and therefore relieve the load on the network.

#### The KM NetViewer

The KM NetViewer enables complete monitoring and control of all ECOSYS printers and digital KYOCERA multifunction units from any Windows® PC and thus provides ideal network administration. It also supports the standardised SNMP protocol.

#### Status Monitor and Command Center

The Status Monitor shows the current printer's condition and gives direct access to the Command Center for the modification of settings that are not contained in the drivers (e.g. network settings, adjustment of sleep mode or blocking of the control panel).

#### USB Host Interface for USB Flash Memory

Documents can be printed directly from and scanned to a USB Flash Memory (e.g. USB stick) via the USB host interface. The documents stored as PDF, XPS, TIFF or JPEG are selected directly via the printer's control panel. No computer is required.

#### Application based profiles

The KX printer driver can create a direct link between dedicated applications and predefined or customized printing profiles. All documents can be printed, for example from MS Outlook, always in monochrome with activated duplex mode resulting in reduced toner and paper consumption.

#### General

**Technology:** KYOCERA ECOSYS, Colour Laser  
**Engine speed:** Up to 21 pages per minute in A4 in colour and b/w  
**Resolution:** 600 x 600 dpi  
 Multibit technology for print quality of up to 9,600 x 600 dpi  
**Duty cycle:** Max. 50,000 pages per month  
**Recommended monthly printing volume:** Up to 2,800 pages\*\*  
**Warm-up time:** Approx. 32 seconds or less from power on  
**Time to first page:** Approx. 10.5 seconds or less in b/w  
 Approx. 12 seconds or less in colour  
**Dimensions (W x D x H):** Main unit: 390 mm x 523 mm x 370 mm  
**Weight:** Main unit: approx. 29.3 kg  
**Power source:** AC 220 ~ 240 V, 50/60 Hz  
**Power consumption**  
 Printing: 360 W  
 Stand-by: 57 W  
 Sleep-mode: 6 W  
**Noise level (sound pressure level ISO 7779/ISO 9296)**  
 Printing: 50 dB(A)  
 Stand-by: 30 dB(A)  
 Sleep mode: Immeasurably low  
**Safety standards:** GS, TÜV, CE  
 This unit is manufactured according to ISO 9001 quality standard and ISO 14001 environmental standard.

#### Paper handling

All paper capacities quoted are based on a paper thickness of max. 0.11 mm. Please use paper recommended by KYOCERA under normal environmental conditions.  
**Input capacity:** 50-sheet multi-purpose tray; 60-220 g/m<sup>2</sup>; A4, A5, A6, B5, B6, Letter, Legal, Custom (70 x 148 mm - 216 x 356 mm)  
 250-sheet universal cassette; 60-163 g/m<sup>2</sup>; A4, A5, A6, B5, B6, Letter, Legal, Custom (105 x 148 - 216 x 356 mm)  
 Max. paper capacity incl. options: 1,300 sheets  
**Duplex functionality as standard**  
 Double-sided printing: 60-163 g/m<sup>2</sup>; A4, A5, B5, Letter, Legal, Custom (140 x 210 mm - 216 x 356 mm)  
**Output capacity:** 250 sheets face-down

#### Controller

**CPU:** PowerPC 464/667 MHz  
**Memory**  
 Standard: 256 MB RAM, max. 1,280 MB RAM  
**Standard interfaces:** USB 2.0 (Hi-Speed), USB Host Interface dedicated for USB Flash Memory device, FastEthernet (10/100BaseTX)  
 Slot for optional internal print server  
 Slot for optional CompactFlash\*-Card  
**Controller language:** PRESCRIBE IIc  
**Emulations:** PCL 6 (5c, XL), KPDL 3 (PostScript\* 3 compatible), XPS Direct Print, PDF Direct Print, with automatic emulation sensing  
**Operating systems:** All current Windows operating systems, Mac OS X Version 10.2 or higher, UNIX, LINUX as well as other operating systems on request  
**Fonts/barcodes:** 93 scalable fonts for PCL/PostScript\*, 8 fonts for Windows Vista\*, 1 bitmap font, 45 barcodes (e.g. EAN8, EAN13, EAN128) with automatic generation of checksums as well as support of two-dimensional barcodes PDF-417 under PRESCRIBE (PCL and other barcodes available as an option)  
**Integrated accounting:** 100 department codes

#### Consumables

**Toner-Kit TK-580C, TK-580M, TK-580Y:** Average continuous cyan, magenta, yellow toner yield 2,800 pages in accordance with ISO/IEC 19798  
 Starter toner: Average continuous cyan, magenta, yellow toner yield 1,200 pages in accordance with ISO/IEC 19798  
**Toner-Kit TK-580K:** Average continuous black toner yield 3,500 pages in accordance with ISO/IEC 19798  
 Starter toner: Average continuous black toner yield 1,200 pages in accordance with ISO/IEC 19798

#### Options

**PF-520 Paper feeder:** 500 sheets; 60-163 g/m<sup>2</sup>; A4, A5, B5, Letter, Legal, Custom (148 x 210 mm - 216 x 356 mm)  
**PF-530 Paper feeder:** 500 sheets; 60-220 g/m<sup>2</sup>; A4, A5, B5, Letter, Legal, Custom (148 x 210 mm - 216 x 356 mm)  
**CB-520 Cabinet:** Wooden desk with storage capacity. Approx. 38.5 cm x 50 cm x 58 cm (WxHxD)

**Memory upgrade:** MDDR2-256: 256 MB; MDDR2-512: 512 MB, MDDR2-1024: 1.024 MB  
**CompactFlash\*-Card:** CF-4: 4 GB (for printing forms, fonts, logos, macro)  
**USB Flash Memory:** Supports direct printing of PDF, XPS, TIFF, JPEG files via USB Host Interface  
**UG-33:** ThinPrint support  
**Optional interfaces:**  
**PS159:** Wireless LAN (802.11b/g)  
**PS1109 Gigabit Ethernet:** 10BaseT/100BaseTX/1000BaseT (RJ-45)  
**PS129 Fibre Optic:** 100BaseSX (SC)  
**PS1129 Gigabit Fibre Optic:** 1000BaseSX (SC)

#### Model variations

**FS-C5150DN/KL3**  
 FS-C5150DN incl. warranty extension KYOLife 3 years

#### Warranty

1-year warranty as standard.\*\*\* KYOCERA guarantees the drums and developers for 3 years or maximum 100,000 pages (whichever occurs sooner), provided the printer is used and cleaned in accordance with the service instructions.

**KYO LIFE** The up to 3-year on-site warranty extension for printer and options.



Your KYOCERA Business Partner:

10100SECS150DN\_ENC  
 KYOCERA MITA Europe B.V. - Branch Office Germany - Otto-Hahn-Straße 12 - 40670 Meerbusch - Germany  
 Tel +49 (0) 2159 928-500 - Fax +49 (0) 2159 918-100  
 www.kyoceramita-europe.com - info@kyoceramita-europe.com

KYOCERA MITA Corporation - 2-28, 1-Chome - Tamatsukuri - Chuo-Ku  
 Osaka 540-8585 - Japan - www.kyoceramita.com

\* KYOCERA does not warrant that any specifications mentioned will be error-free. Specifications are subject to change without notice. Information is correct at time of going to press. All other brand and product names may be registered trademarks or trademarks of their respective holders and are hereby acknowledged.

\*\* Based on 36 months' usage.



Product depicted includes optional extras.

**KYOCERA**

## Product Features 26ppm Printer

### FS-C5250DN

COLOUR PRINTER FOR A4 FORMAT

► print ► copy ► scan ► fax

REDUCED ENVIRONMENTAL IMPACT,  
INCREASED COLOUR PRINTING EFFICIENCY.

The FS-C5250DN persuades workgroups, which demand professional, office colour printing solutions. Built with KYOCERA's exceptionally reliable long-life components, this compact printer not only saves downtime, it saves office space as well. This high-quality colour device impresses with reduced power consumption, low noise emissions, fast print speed and is a welcome member of your team. KYOCERA's excellent colour printer is good for the environment and also for your budget.

- ▶ Up to 26 pages per minute in A4 in colour and b/w
- ▶ Up to 9,600 dpi printing quality with multibit technology
- ▶ Standard duplex unit for double-sided printing
- ▶ 500-sheet universal cassette, also for A6 format
- ▶ Up to 5 paper feeders for very flexible media support
- ▶ Network connectivity with integrated security functions
- ▶ Low noise printing, no noise in sleep mode
- ▶ Exceptionally low printing costs in its class

High flexibility – with up to 5 paper trays this device can be configured to suit your exact needs to handle multiple paper types and sizes for different document types.



The cost reduction initiatives are supported by the integrated 100 department codes for sophisticated access control and access restrictions.



## Product Features (continued)

# FS-C5250DN

COLOUR PRINTER FOR A4 FORMAT

**ECOSYS** stands for **ECO**logy, **ECON**omy and **SYStem**-printing. With their long-life components, ECOSYS devices are designed to maximise durability and minimise the total cost of ownership with regard to maintenance, administration and consumables. The cartridge-free system means that only the toner has to be replaced regularly. The modular design concept allows you to add workflow-enhancing functions as required. Integrated system software provides long-term cross-network compatibility. KYOCERA's long-life components cost you and the environment less.

#### PRESCRIBE IIc

With the KYOCERA page design and control language PRESCRIBE IIc, even complex graphics, logos and forms (multipart forms) can be created independently on the system and saved and updated in the printer. Consequently, integration into print files no longer applies. They are only accessed as required and therefore relieve the load on the network.

#### The KM NetViewer

The KM NetViewer enables complete monitoring and control of all ECOSYS printers and digital KYOCERA multifunction units from any Windows® PC and thus provides ideal network administration. It also supports the standardised SNMP protocol.

#### Status Monitor and Command Center

The Status Monitor shows the current printer's condition and gives direct access to the Command Center for the modification of settings that are not contained in the drivers (e.g. network settings, adjustment of sleep mode or blocking of the control panel).

#### USB Host Interface for USB Flash Memory

Documents can be printed directly from and scanned to a USB Flash Memory (e.g. USB stick) via the USB host interface. The documents stored as PDF, XPS, TIFF or JPEG are selected directly via the printer's control panel. No computer is required.

#### Application based profiles

The KX printer driver can create a direct link between dedicated applications and predefined or customized printing profiles. All documents can be printed, for example from MS Outlook, always in monochrome with activated duplex mode resulting in reduced toner and paper consumption.

#### General

**Technology:** KYOCERA ECOSYS, Colour Laser  
**Engine speed:** Up to 26 pages per minute in A4 in colour and b/w  
**Resolution:** 600 x 600 dpi  
 Multibit technology for print quality of up to 9,600 x 600 dpi  
**Duty cycle:** Max. 65,000 pages per month  
**Recommended monthly printing volume:** Up to 10,000 pages\*\*  
**Warm-up time:** Approx. 29 seconds or less from power on  
**Time to first page:** Approx. 9 seconds or less in b/w  
 Approx. 10.5 seconds or less in colour  
**Dimensions (W x D x H):** Main unit: 390 mm x 523 mm x 397 mm  
**Weight:** Main unit: approx. 30.2 kg  
**Power source:** AC 220 ~ 240 V, 50/60 Hz  
**Power consumption**  
 Printing: 428 W  
 Stand-by: 58 W  
 Sleep-mode: 7 W  
**Noise level (sound pressure level ISO 7779/ISO 9296)**  
 Printing: 50 dB(A)  
 Stand-by: 30 dB(A)  
 Sleep mode: Immeasurably low  
**Safety standards:** GS, TÜV, CE  
 This unit is manufactured according to ISO 9001 quality standard and ISO 14001 environmental standard.

#### Paper handling

All paper capacities quoted are based on a paper thickness of max. 0.11 mm. Please use paper recommended by KYOCERA under normal environmental conditions.  
**Input capacity:** 50-sheet multi-purpose tray; 60–220 g/m<sup>2</sup>; A4, A5, A6, B5, B6, Letter, Legal, Custom (70 x 148 mm – 216 x 356 mm)  
 500-sheet universal cassette; 60–163 g/m<sup>2</sup>; A4, A5, A6, B5, B6, Letter, Legal, Custom (105 x 148 – 216 x 356 mm)  
 Max. paper capacity incl. options: 2,050 sheets  
**Duplex functionality as standard**  
 Double-sided printing: 60–163 g/m<sup>2</sup>; A4, A5, B5, Letter, Legal, Custom (140 x 210 mm – 216 x 356 mm)  
**Output capacity:** 250 sheets face-down with paper full sensor

#### Controller

**CPU:** PowerPC 464/667 MHz  
**Memory**  
 Standard: 256 MB RAM, max. 1,280 MB RAM  
**Standard interfaces:** USB 2.0 (Hi-Speed), 2 x USB Host Interface, FastEthernet (10/100BaseTX)  
 Slot for optional internal print server or hard disc  
 Slot for optional CompactFlash\*-Card  
**Controller language:** PRESCRIBE IIc  
**Emulations:** PCL 6 (Sc, XL), KPDL 3 (PostScript\* 3 compatible), XPS Direct Print, PDF Direct Print, with automatic emulation sensing  
**Operating systems:** All current Windows operating systems, Mac OS X Version 10.2 or higher, UNIX, LINUX as well as other operating systems on request  
**Fonts/barcodes:** 93 scalable fonts for PCL/PostScript\*, 8 fonts for Windows Vista\*, 1 bitmap font, 45 barcodes (e.g. EAN8, EAN13, EAN128) with automatic generation of checksums as well as support of two-dimensional barcodes PDF-417 under PRESCRIBE (PCL and other barcodes available as an option)  
**Integrated accounting:** 100 department codes

#### Consumables

**Toner-Kit TK-590C, TK-590M, TK-590Y:** Average continuous cyan, magenta, yellow toner yield 5,000 pages in accordance with ISO/IEC 19798  
 Starter toner: Average continuous cyan, magenta, yellow toner yield 2,500 pages in accordance with ISO/IEC 19798  
**Toner-Kit TK-590K:** Average continuous black toner yield 7,000 pages in accordance with ISO/IEC 19798  
 Starter toner: Average continuous black toner yield 3,500 pages in accordance with ISO/IEC 19798

#### Options

**PF-520 Paper feeder:** 500 sheets; 60–163 g/m<sup>2</sup>; A4, A5, B5, Letter, Legal, Custom (148 x 210 mm – 216 x 356 mm)  
**PF-530 Paper feeder:** 500 sheets; 60–220 g/m<sup>2</sup>; A4, A5, B5, Letter, Legal, Custom (148 x 210 mm – 216 x 356 mm)  
**CB-520 Cabinet:** Wooden desk with storage capacity. Approx. 38.5 cm x 50 cm x 58 cm (WxHxD)

**Memory upgrade:** MDDR2-256: 256 MB; MDDR2-512: 512 MB, MDDR2-1024: 1.024 MB  
**CompactFlash\*-Card:** CF-4: 4 GB (for printing forms, fonts, logos, macro)  
**USB Flash Memory:** Supports direct printing of PDF, XPS, TIFF, JPEG files via USB Host Interface  
**HD-5a Hard disc:** HD-5a Hard disc  
**UG-33:** ThinPrint support  
**Optional interfaces:**  
**PS159:** Wireless LAN (802.11b/g)  
**PS1109 Gigabit Ethernet:** 10BaseT/100BaseTX/1000BaseT (RJ-45)  
**PS129 Fibre Optic:** 100BaseSX (SC)  
**PS1129 Gigabit Fibre Optic:** 1000BaseSX (SC)

#### Model variations

**FS-C5250DN/KL3**  
 FS-C5250DN incl. warranty extension KYOLife 3 years

#### Warranty

1-year warranty as standard.\*\*\* KYOCERA guarantees the drums and developers for 3 years or maximum 200,000 pages (whichever occurs sooner), provided the printer is used and cleaned in accordance with the service instructions..

**KYOLIFE** The up to 5-year on-site warranty extension for printer and options.



Your KYOCERA Business Partner:

KYOCERA MITA Europe B.V. – Branch Office Germany – Otto-Hahn-Straße 12 – 40670 Meerbusch – Germany  
 Tel +49 (0) 2159 928-500 – Fax +49 (0) 2159 918-100  
 www.kyoceramita-europe.com – info@kyoceramita-europe.com

KYOCERA MITA Corporation – 2-28, 1-Chome – Tamatsukuri – Chuo-Ku  
 Osaka 540-8585 – Japan – www.kyoceramita.com

\* KYOCERA does not warrant that any specifications mentioned will be error-free. Specifications are subject to change without notice. Information is correct at time of going to press. All other brand and product names may be registered trademarks or trademarks of their respective holders and are hereby acknowledged.

\*\* Based on 36 months' usage.



Product depicted includes optional extras.

**KYOCERA**

## Operation panel, MFP



### Function keys

Select between:

- Copy mode
- Scan mode
- Fax (only for FS-C2126MFP)

### Status key

- Current job status
- Change job priority
- Delete jobs
- Journals

### Document box

- Fax box
- USB stick storage management
- Scan to USB

### System menu key

- System settings
- Lists (including menu list)
- Counter status query
- Cost center management
- Service settings

### One touch keys

- Addresses for scan and fax destinations

### Communication keys

- Open address book
- Redial
- Temporary group
- Manual fax transmission





## Operation panel, MFP (continued)

### Color modes

- Automatic color recognition
- Color copy
- Black & white copy



The color recognition level in mode "Automatic color recognition" can be changed in the system settings.  
(System menu/ Adjust/Maint. / AutoColorCorrect)



### Display

#### Softkeys

Fully configurable, e.g. for frequently used functions. The corresponding function is shown above the key in the display.

#### Four-way key

For the navigation menu.

#### Function menu key

Opens the function menu depending on the operation mode that has been set.



### Numeric keypad

#### Copier control keys



## Operation panel, MFP (continued)

### Program keys

Any 4 function profiles can be selected as needed.  
Programs can be used in all device modes.

### Logout key

For specific logout in the cost centre or authentication mode.

### Power key

Corresponds to the function "Energy Saving mode"  
When the device is in Energy Saving Mode, it can only be operated with this key.



## Operation panel, printer



- 1 Display
- 2 Status displays
  - Ready (online) status
  - Receiving data, preparing data
  - Notification
- 3 Menu control keys ? Help key: in case of errors an online help appears in the display
- 4 Function keys
  - Menu: Start / exit printer menu
  - STOP: Cancel print job
  - OK: Confirmation (e.g. in the menu)
  - GO: Wake up from sleep mode, more functions



## Apply your knowledge!

### Practice 1

Install the device:

- Change the operation panel language.
- Print out the menu list.
- Make a few test copies to check for correct functioning.

### Practice 2

Work out the differences (in groups of two, as the case may be) between the individual model variants.

### Practice 3

Discussion about first impressions and experiences.

| Features         | FS-C5150 | FS-C5250 | FS-C2026MFP | FS-C2126MFP |
|------------------|----------|----------|-------------|-------------|
| 21 ppm           |          |          |             |             |
| 26 ppm           |          |          |             |             |
| Maintenance Kit  |          |          |             |             |
| TK-590           |          |          |             |             |
| TK-580           |          |          |             |             |
| 250 sheet feeder |          |          |             |             |
| 500 sheet feeder |          |          |             |             |
| USB print        |          |          |             |             |
| Job Accounting   |          |          |             |             |

|                  |   |   |   |   |
|------------------|---|---|---|---|
| 21 ppm           | x | / | / | / |
| 26 ppm           | / | x | x | x |
| Maintenance Kit  | / | x | x | x |
| TK-590           | / | x | x | x |
| TK-580           | x | / | / | / |
| 250 sheet feeder | x | / | x | x |
| 500 sheet feeder | / | x | / | / |
| USB print        | x | x | x | x |
| Job Accounting   | x | x | x | x |



- 1.) Can the printer memory be extended?  
 Yes  
 No
- 2.) Can the FS-C2026MFP be upgraded with a fax system?  
 Yes  
 No
- 3.) A6 paper can only be fed via the multi purpose tray.  
 correct  
 incorrect
- 4.) The recommended monthly print/copy volume is (MFP):  
 10,000 pages  
 20,000 pages  
 65,000 pages
- 5.) The maximum paper volume (including options) is (FS-C5250):  
 1,000 pages  
 1,300 pages  
 2,050 pages
- 6.) The first filling requires special toner:  
 correct  
 incorrect  
 yes, for FS-C5150 only
- 7.) The printer interface is a ...  
 GDI printer  
 Postscript printer
- 8.) Due to the RFID technology, only original toner can be used.  
 correct  
 incorrect
- 9.) FS-C2026MFP can only be upgraded to FS-C2126MFP  
 correct  
 incorrect



**Contents:**

- Transport lock lever
- Preparation for initial filling
- Optional paper cassettes
- Further options
- Installation hints
- Device Admin account

**At the end of the chapter you will be able to...**

- install the device professionally.
- adjust the device configuration according to customer needs.
- give the customer useful information and tips about how to operate the device.

## Who should undertake installation?

The initial installation should be carried out by technical staff. The following reasons support this advice:

- Although initial installation is documented ("Quick Installation Guide"), instructions are seldom read.
- Transport safety devices are sometimes not recognized or removed.
- Damage from transportation can be identified beforehand.
- Brief introduction according to customer needs (e.g. tips about toner replacement).
- Adjustment of basic settings as per customer requirements.
- Connection to the network or PC.
- Effective customer support.

## Notes

### MFP:

The scanner lock lever secures the scanner's carriage during transportation.

If it is not released, an error message appears (C3100). In this case, switch the machine off, release the transport lock lever and switch the machine on again.

The transportation lock lever should be activated every time the device is transported.

### MFP:

To insert toner container, the top cover must be opened completely. The blue indicator on the right side of the device must be in the position shown.

### All:

Before the toner container is inserted, the release lever on the transfer belt must be put in the rear position.

### All:

The toner containers may now be inserted.

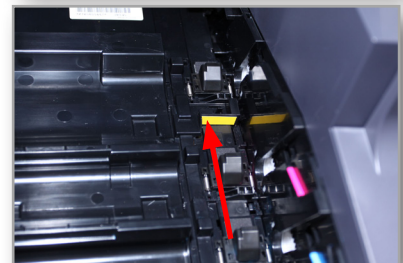
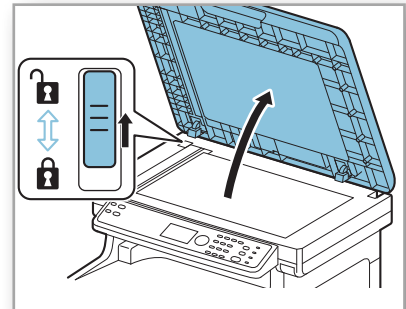

- The yield of the toner included in the delivery is reduced!
- Please notice the details on the next page!

## Further Information

When inserting the toner container, take care that the container's shutter is in the correct position. otherwise the following error message may be displayed when the device is switched on:

Check the Toner container

Correct position of the shutter (example).

The actuator should point in the direction of the green marking.

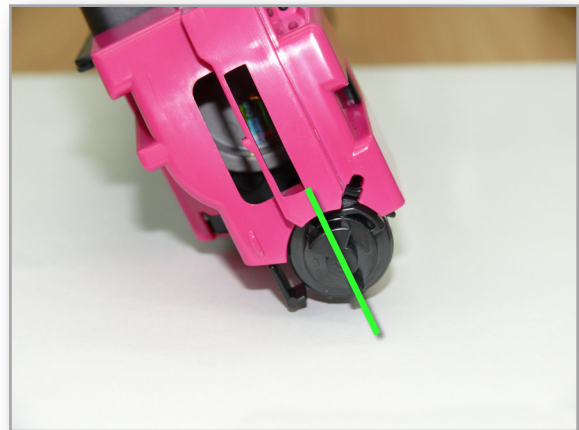

Correct position of the shutter (example).

In this case, the shutter should be put manually into the correct position. If necessary, turn the lock bar in the direction of the arrow.



Take care to set the paper format correctly for each paper feeder. Otherwise a paper jam might occur.



The picture at the back shows the sensor unit that checks the indicator's position.

## Fitting optional paper feeder

### PF-520

Paper feeder up to a max. 500 sheets (60 - 163 g/cm<sup>2</sup>).

Power supply via the basic device.

### PF-530

Paper feeder up to a max. 500 sheets (60 - 220 g/cm<sup>2</sup>).

Dedicated power supply with integrated mains connection for basic device.

All feeders are stacked and automatically connected to the basic device via the internal plug. At most 2 optional paper feeders can be used.



For example, if PF-530 is used, then it must be fitted as the **first** cassette under the device.



### View of feeder combination PF-520 and PF-530 (with the cover removed):

The lowest paper feeder (PF-520) is supplied internally via PF-530 which is situated above it.



### Comparison of optional paper feeder PF-520 (left) and PF-530 (right):

PF-530 has its own power connection (1), which feeds the feeder heater.

The ventilators (2 & 3) facilitate better separation for certain media by blowing preheated air into the feeder.

When using this feeder, the ventilation and separation performance depends on the preset media type.

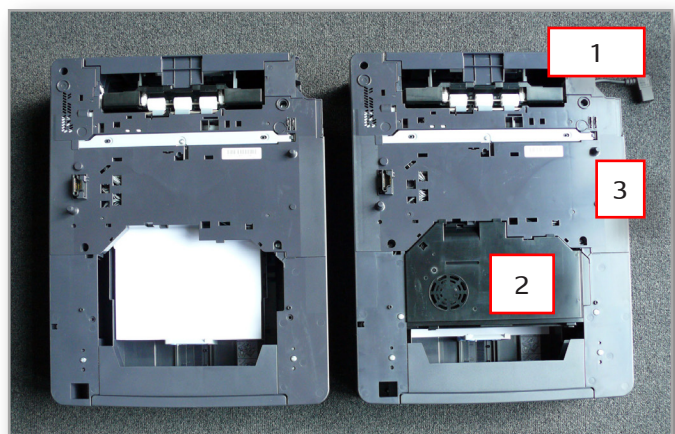

## More Options, MFP

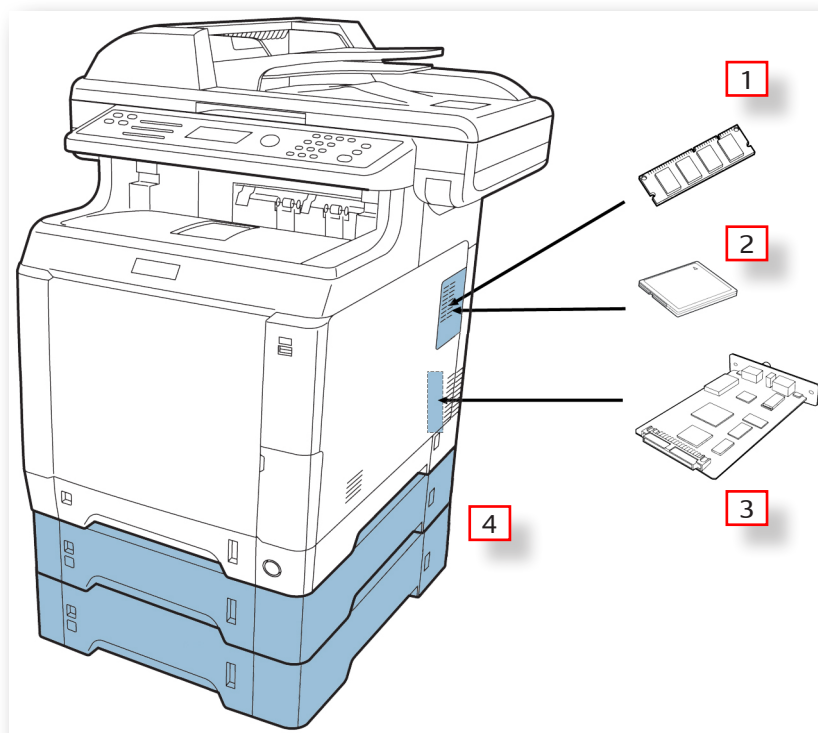

The following options are available:

|   |                |                             |  |
|---|----------------|-----------------------------|--|
| 1 | MDDR2          | Extension memory            | 256, 512 and 1024 MByte.<br>Required for e-MPS functions (e.g. private printing and RAM disk) as well as copier job storage (print priority).  |
| 2 | CF-4GB         | CF card (type 1), max. 4 GB | For forms, logos etc.<br><b>PCL barcode flash module B/C:</b> (CF-card) extends the printer for additional one- and two-dimensional barcodes. In addition, other resident and machine-readable fonts (OCR-A, OCR-B) are available.<br><b>KYomulticode B/C:</b> (CF-card) contains all functionalities of the PCLBarcode Flash Module plus unicode script "Other Mono World Type" for printing Asian characters (Japanese, Korean, simple and traditional Chinese).<br><b>ThinPrint Kit UG-33:</b> enables printing with ThinPrint. |
| 3 | PS1xxx         | Optional interfaces         | PS159: Wireless LAN card (802.11b/g)<br>PS1109: Gigabit print server 10BaseT/100BaseTX/1000BaseT<br>PS129: Optical fiber card 100BaseSX (SC)<br>PS1129: Optical fiber card 1000Base (SC)   |
| 4 | PF-520, PF-530 | Paper feeder                | <b>PF-520:</b> max. 500 sheets, 60-163 g/m <sup>2</sup> ; A4, A5, B5, Letter, Legal, user defined (148 x 210 mm bis 216 x 356 mm).<br><b>PF-530:</b> max. 500 sheets; 60-220 g/m <sup>2</sup> ; A4, A5, B5, Letter, Legal, user defined (148 x 210 mm to 216 x 356 mm); supports labels, envelopes, special paper.<br>Up to 2 x PF-520 or PF-530 possible.<br>(can be combined with each other)  |



## More Options, Printer

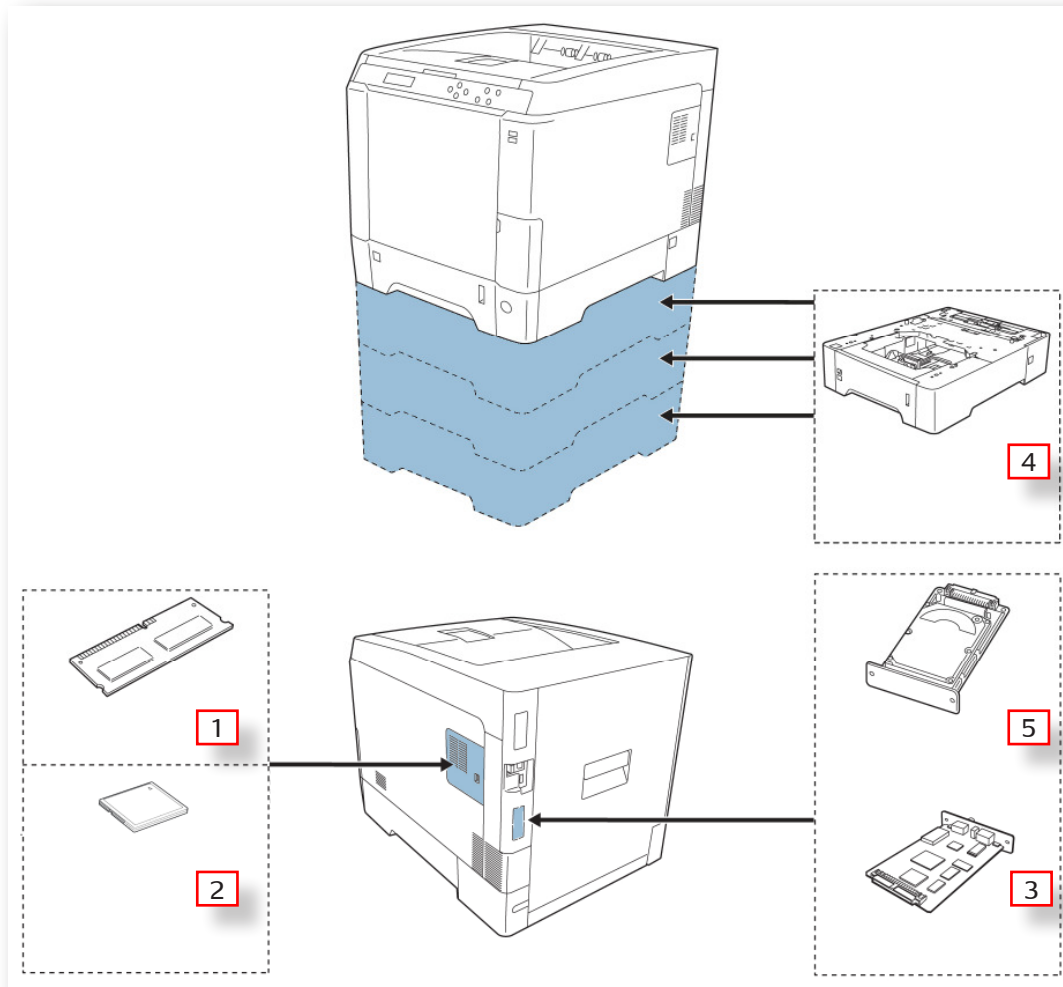

|   |                  |                                      |   |
|---|------------------|--------------------------------------|---|
| 1 | MDDR2<br>144-pin | Extension memory                     | 256, 512 and 1024 MByte.<br>A RAM disk can be inserted even without memory expansion.   |
| 2 | CF-4GB           | CF card (type 1), max. 4 GB          | For forms, logos etc.<br><b>PCL Barcode Flash Modul B/C:</b> see MFP.<br><b>KYomulticode B/C:</b> see MFP<br><b>ThinPrint Kit UG-33:</b> see MFP  |
| 3 | PS1xxx           | Optional interfaces                  | <b>PS159:</b> Wireless LAN card (802.11b/g)<br><b>PS1109:</b> Gigabit Printserver 10BaseT/100BaseTX/1000BaseT<br><b>PS129:</b> Optical fiber card 100BaseSX (SC)<br><b>PS1129:</b> Optical fiber card 1000Base (SC)<br><br><b>Note:</b><br>Only ONE option can be set for for each KUIO port! |
| 4 | PF-520, PF-530   | Paper feeder                         | <b>PF-520:</b> see MFP options<br><b>PF-530:</b> see MFP options<br><br>FS-C5150: maximum of 2 feeders<br>FS-C5250: maximum of 3 feeders  |
| 5 | HD-5A            | Hard disk (40 GB)<br>(only FS-C5250) | For document storage (document box) and extended print functions (e-MPS).<br><br><b>Note:</b><br>Only ONE option can be set for for each KUIO port!   |

## Hints for installation (MFP)

Print out the menu list:

Sys. Menu/Report/Report Print/Menu Map

This list provides a quick overview of all available setup options.

Set date / time:

Sys. Menu/Common Settings/Date Setting/Date Time

For some system settings, entries are protected by an account (Device Admin).

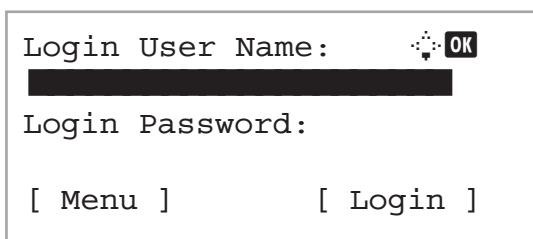

Standard entries are:

**User Name: 2600**

**Password: 2600**

When entering these data with the numeric pad, the input mode has to be changed with the right softkey, so that numeric inputs are enabled.



If this input procedure is too complicated, a new account can be defined with a simple input (e.g. „a“/„a“).

For instructions, see page 28 .

- The inputs for date and time refer to the current local time.
- After that, the time zone is specified in the same menu list.
- Then a decision is taken in the same menu list, if the automatic summer/ winter time switch is to be activated.

Set different timers.

Sys. Menu/Common Settings/Timer Setting

|  |  |
|--|--|
| Sleep timer  | “Deep Sleep Mode“.<br>Scanner lamp, fixing unit, display lights and ventilator are switched off.<br>Reactivating the device with the „Power“ button.   |
| PanelReset Timer                                       | After this time period, preset functions (preset to: 90 sec.) are automatically reset.<br>Can be switched off (Panel Reset Timer), so that reset does not occur anymore.   |
| Unusable Time<br>(only for devices<br>with fax system) | In a preset time frame, printouts are not made. Fax and print jobs are stored and printed automatically after the time expires.<br>For example, this mode can be set if the device is situated in rooms with temporary active motion sensors, so that unsupervised machine activity sets off an alarm. |

## Hints for installation, MFP (continued)

**Streaky copies when using the document processor.**

There could be several reasons for this:

- Dirty slit glass
- Worn slit glass
- Certain basic settings (brightness, scan mode)
- Color of original (e.g. old, yellowed paper)

The following function can compensate for streaks occurring:

`Sys. Menu/Common Settings/Adjust Maint./Correct. Bk Line`

The following settings are possible:

- Low (low compensation)
- High (high compensation)



If black line correction is activated, fine structures in the copy can be lost.

### **Automatic color recognition**

If the copier is set to "Auto Color" mode (see page 15), the recognition level for b & w to color change can be set under the following setting:

`Sys. Menu/Common Settings/Adjust Maint./AutoColorCorrect`

The lower the preset value, the more sensitive the color recognition.



## Tips for installation (Printer)

### Print out the menu list.

Menu Key / Report Print / Print Menu Map

This list provides a quick overview of all available setup options.

### Device Admin account

Certain settings can only be carried out with an authentication at the device:

|                           |   |
|---------------------------|---|
| Security                  | When the security level is lowered, certain Prescribe commands that may pose a security risk, can be carried out again. |
| Job Accounting management | Setup and management of Job accounting up to 100.   |
| Administrator             | Name (ID) and password of the DeviceAdmin account can be changed here.  |

Standard entries are:

|                 | FS-C5150 (21 ppm) | FS-C5150 (26 ppm) |
|-----------------|-------------------|-------------------|
| <b>ID</b>       | <b>2100</b>       | <b>2600</b>       |
| <b>Password</b> | <b>2100</b>       | <b>2600</b>       |

Numerical entries are carried out by using the vertical menu control keys.



The device has to be reset if the password is lost. In this case, contact KYOCERA Software Support.

### Set diverse timers.

Menu Key / Device Common / Timer /...

|                                       |  |
|---------------------------------------|--|
| Sleep Timer                           | "Deep Sleep Mode". Fixing unit, display lights and ventilators are switched off.<br>Reactivation of the device with the "GO" button or a print job.<br>Menu settings can still be carried out. |
| Panel Reset Timer<br>Auto Panel Reset | After this time period, preset functions (preset to: 90 sec.) are automatically reset.<br>Can be switched off (Auto Panel Reset), so that reset does not occur anymore.                        |





### After successful installation:

- Carry out a test print (Menu key /Settings Maintenance / Service / Print Test Page).
- Check color registration, correct if necessary (see page 75 ).

## The DeviceAdmin account (MFP)

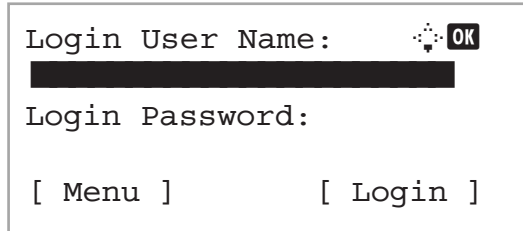
Certain inputs in the device (e.g. system settings, cost centre definitions etc.), require authentication:



Login User Name:   
 [redacted]  
 Login Password:  
 [ Menu ]                      [ Login ]

The standard inputs (depending on device) are:

**User Name: 2600**

**Password: 2600**

The data are part of the DeviceAdmin account, which is set up in the device as a standard.  
 The DeviceAdmin account cannot be deleted, because system settings cannot be accessed anymore.

However, the standard input (2600 / 2600) can be changed as desired:

Sys. Menu/User Job Account/Login/User Login Set./Local User List

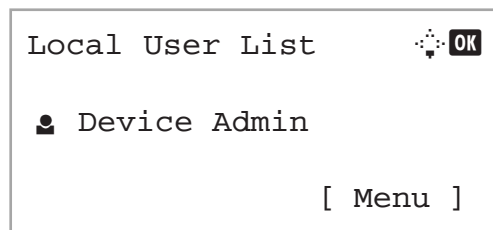

Local User List   
 👤 Device Admin  
 [ Menu ]

After selecting DeviceAdmin, go to:

Menu/Detail-Edit

...to select the relevant entry and modify it by using the "Edit" key.

Please note that the "OK" button has to be pressed several times until a security question appears. Only after this has been confirmed is the entry saved.



Modifying the access data of the DeviceAdmin is part of a security concept.  
 If the password is lost, access to the system settings of the device is no longer possible.  
 In this case, the device has to be reset to factory settings.

**The DeviceAdmin account can only be edited from the operation panel**



- It is recommended that installation is carried out by a qualified person.
- The introduction should be conducted in line with the customer's expectations and requirements.
- When inserting the toner container, take care that the container's shutter is in the correct position.
- If possible, access to system settings should be simplified (MFP).
- Demonstrate the processes that are required in order to replace the toner correctly.
- Take care to set the paper format correctly for each paper feeder.



**Test your knowledge!**

- 1.) The toner supplied with the delivery has a reduced filling quantity.  
 correct  
 incorrect
- 2.) For a RAM disk an extension memory is required.  
 for MFP only  
 for printer only
- 3.) The e-MPS function "Private Print" is only possible with a hard disk.  
 correct  
 incorrect
- 4.) After unpacking, the fixing pressure has to be adjusted.  
 correct  
 incorrect
- 5.) Device Admin has the following access data (FS-C5150):  
 2600 / 2600  
 2100 / 2100  
 5150 / 5150
- 6.) The password of the Device Admin CANNOT be changed.  
 correct  
 incorrect
- 7.) A special toner is required for the initial installation.  
 correct  
 incorrect
- 8.) If the scanner transport lock lever is not unlocked, the scanner rope comes off (MFP).  
 correct  
 incorrect
- 9.) Only one PF-530 can be fitted.  
 correct  
 incorrect



**Contents:**

- Cross sections
- Functional principles
- Localization and identification of components

**This chapter provides information about...**

- the functionality of individual modules
- the general relationship between the components

## Overview, function groups and paper path

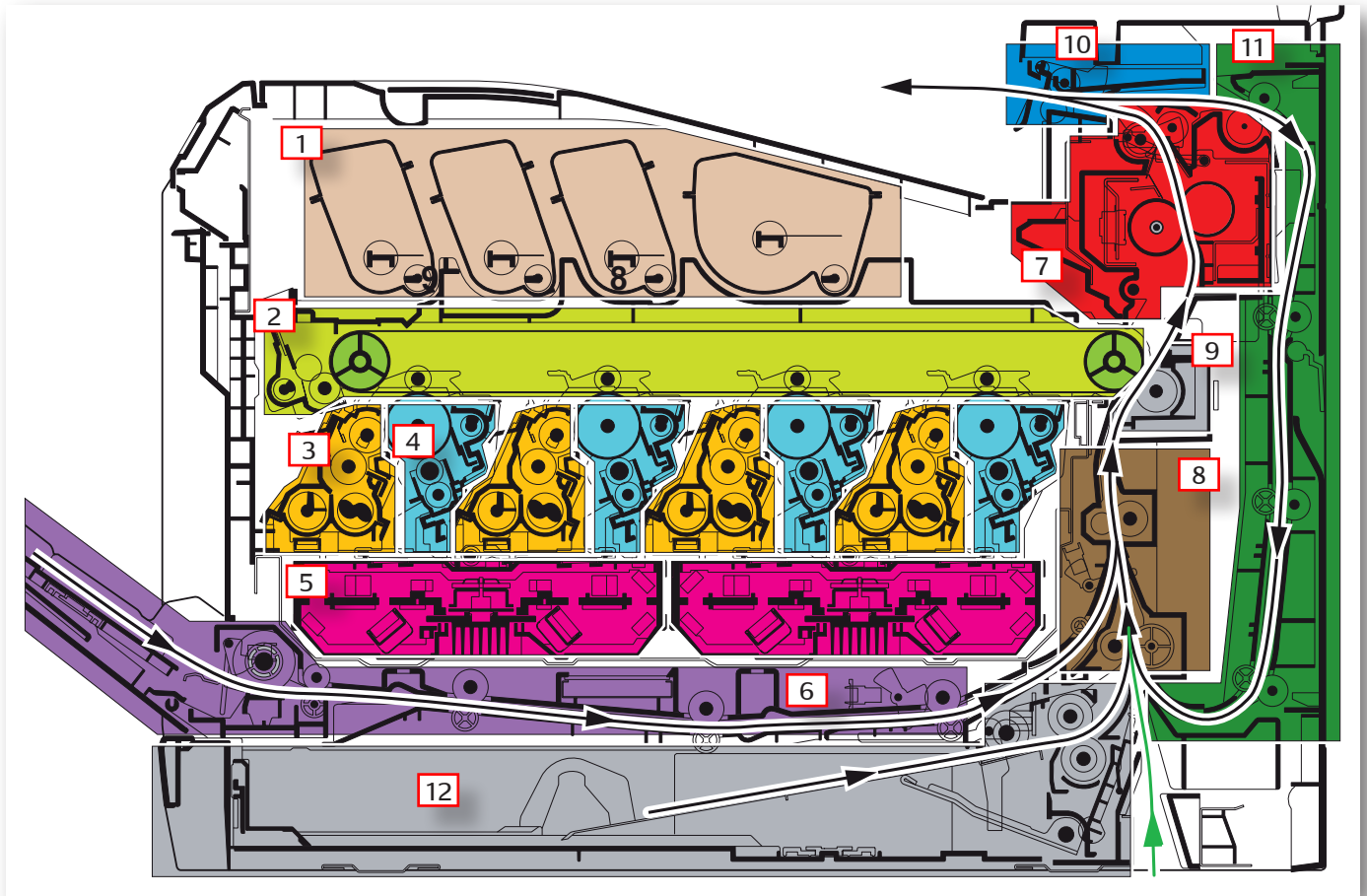

### Function groups

|    |  |  |  |
|----|--|--|--|
| 1  | Toner Container Section                  |  | Toner container (YCMK), RFID checked.  |
| 2  | Primary Transfer Section (Transfer belt) |  |  |
| 3  | Developing Unit                          |  | Sequence (from the front): Y C M K   |
| 4  | Drum Unit                                |  | Sequence (from the front): Y C M K   |
| 5  | Laser Scanner Unit                       |  | Sequence (from the front): Y C , M K   |
| 6  | MP Tray Paper Feed Section               |  | Feeder and transport.  |
| 7  | Fuser Section                            |  | Fixing pressure can be reduced by means of the driver setting (for "envelope" medium). |
| 8  | Paper Conveying Section                  |  |  |
| 9  | Secondary Transfer / Separation Section  |  |  |
| 10 | Eject / Feed Shift Section               |  | Re-feeding for duplex  |
| 11 | Duplex Section                           |  |  |
| 12 | Paper Feed Section                       |  |  |



## Overview, left side

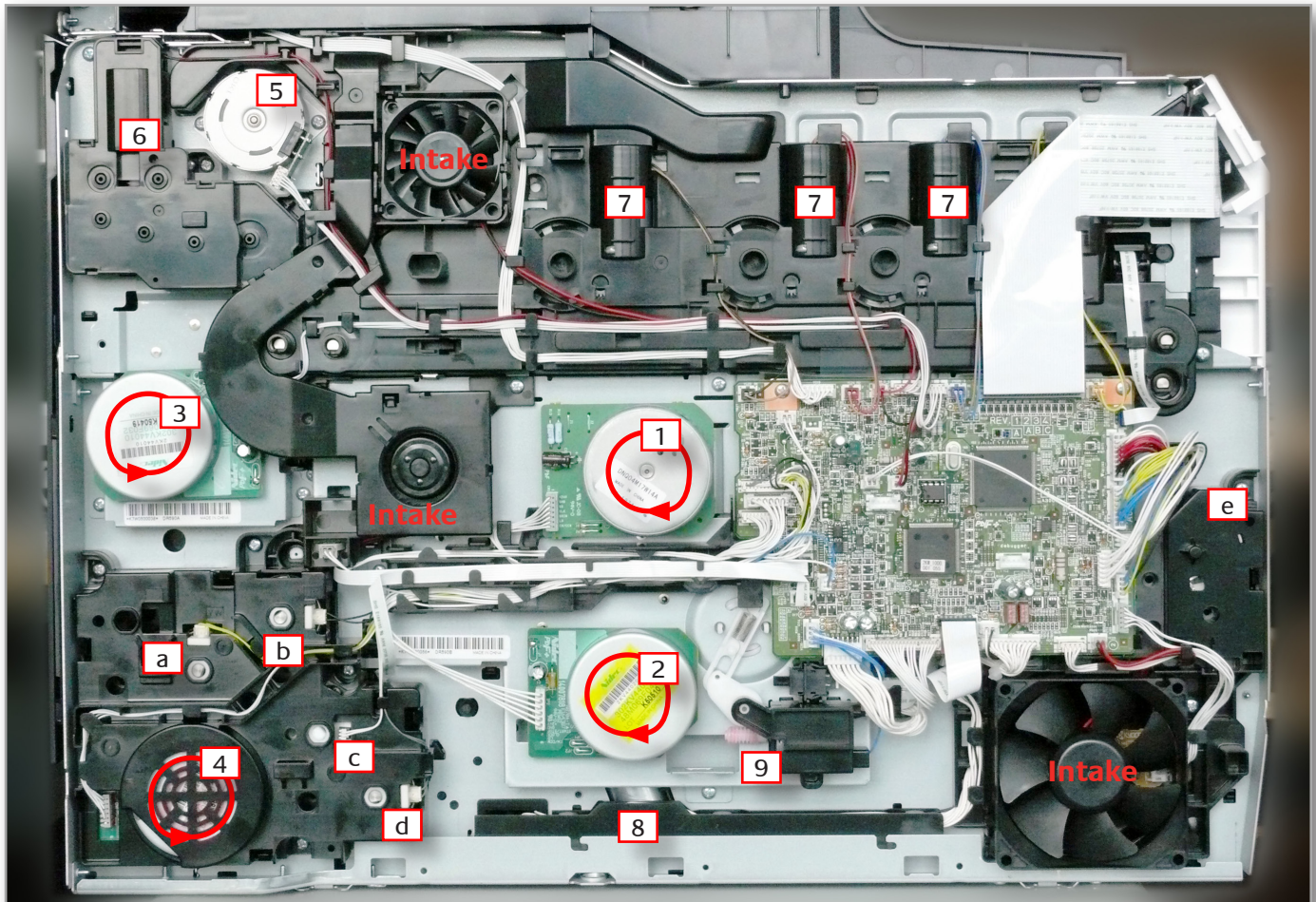

## Motors and drives

|   |                                     |  |   |
|---|-------------------------------------|--|---|
| 1 | Drum Motor (DRM)                    |  | Drives all drums (CMYK)   |
| 2 | Developing Motor (DEVM)             |  | Drives the developer units (K: Permanent - CMY: Dependent on position 9).   |
| 3 | Fuser Motor (FUM)                   |  | Drives fuser unit, transfer belt and transfer cleaning.   |
| 4 | Paper feed Motor (PFM)              |  | Drives: paper feeder, multi-purpose feeder, registration roller, paper transport.                                   |
| 5 | Duplex Motor (DUM)                  |  | Drives paper output and re-feeding.   |
| 6 | Fuser Pressure Release Motor (FPRM) |  | Servomotor for fixing pressure (can be selected via media type selection in the printer driver). Standard: Normal). |
| 7 | Toner Motor (TM-x)                  |  | Drives toner transport in toner containers (CMYK).  |
| 8 | Lift Motor (LM)                     |  | Drives the paper ramps in the paper cassette.   |
| 9 | Developing Release Motor (DEVRM)    |  | Drives color switch gear unit (Position in illustration: b/w mode).   |

## Clutches

|   |                           |  |   |
|---|---------------------------|--|---|
| a | Middle Clutch (MCL)       |  | Controls internal paper transport.  |
| b | Registration Clutch (RCL) |  | Controls the registration roller.   |
| c | Paper Feed Clutch (PFCL)  |  | Controls the paper feed from the cassette.                                |
| d | MP Feed Clutch (MPFCL)    |  | Controls the multi-purpose paper feeder's paper feed and paper transport. |
| e | MP Solenoid (MPSOL)       |  | Controls the multi-purpose paper feeder's paper ramp.                     |



## Overview, right side

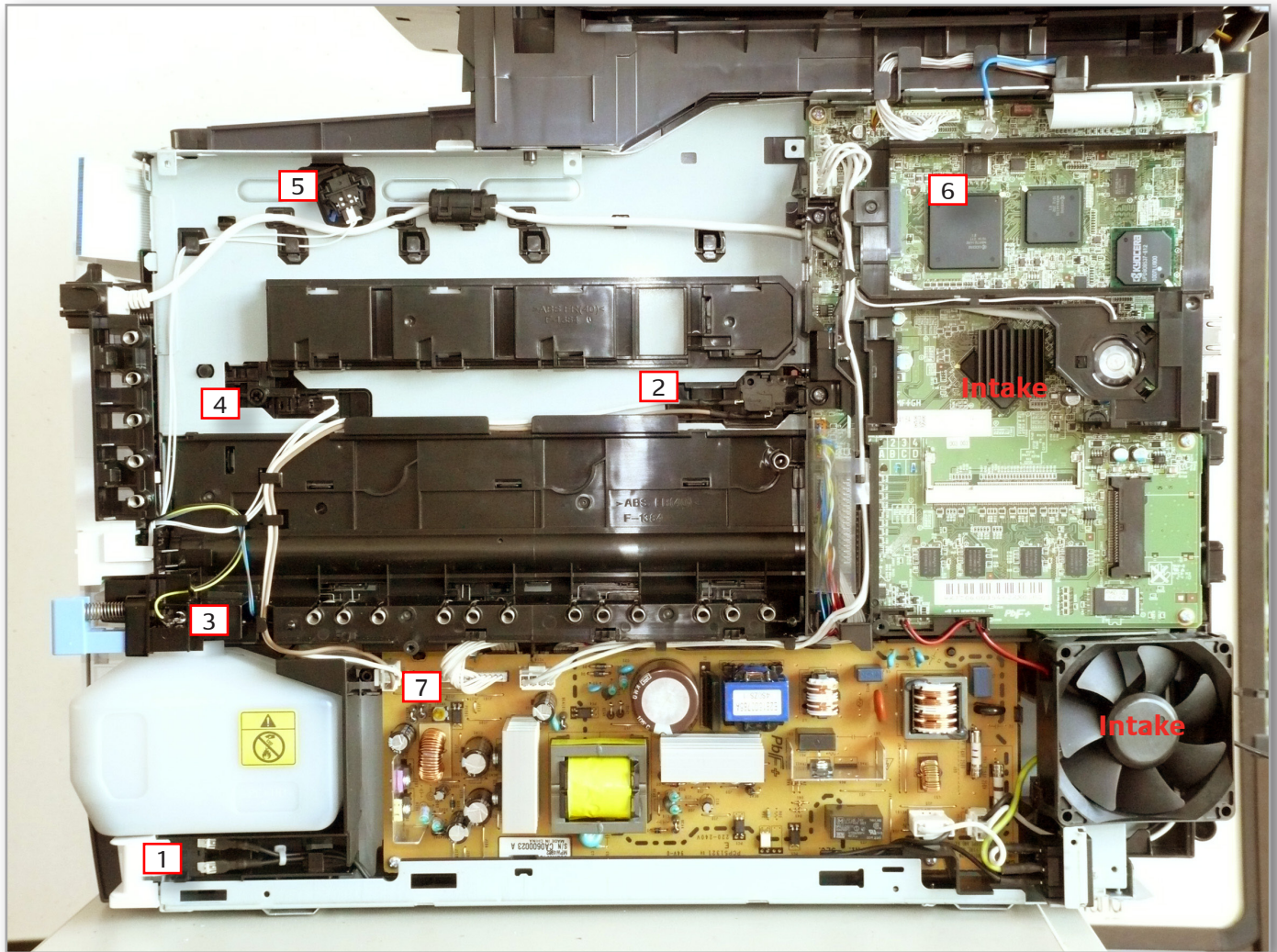

### Components

|   |                               |  |  |
|---|-------------------------------|--|--|
| 1 | Main Power Switch (MSW)       |  |  |
| 2 | Interlock Switch (ILSW)       |  | Interrupts the 24 Volt power supply when the upper and/ or rear cover is/are opened. |
| 3 | Waste Toner Sensor (WTS)      |  | Signals full waste toner box.  |
| 4 | Toner Container Switch (TCSW) |  | Monitors deployment of the toner container.  |
| 5 | Top Tray Switch (TTSW)        |  | Interrupts the security switch if upper cover is open.                               |
| 6 | Main PWB (MPWB)               |  | View when shielding plate is removed.  |
| 7 | Power Source PWB (PSPWB)      |  | View when shielding plate is removed.  |

### Notes:

- In the above illustration, the High Voltage PWB (HVPWB) is removed.
- The removal of the shielding plate from the main board is possible after removing the HVPWB.
- The printer models does not have a PCB fan.

**Paper feeder**

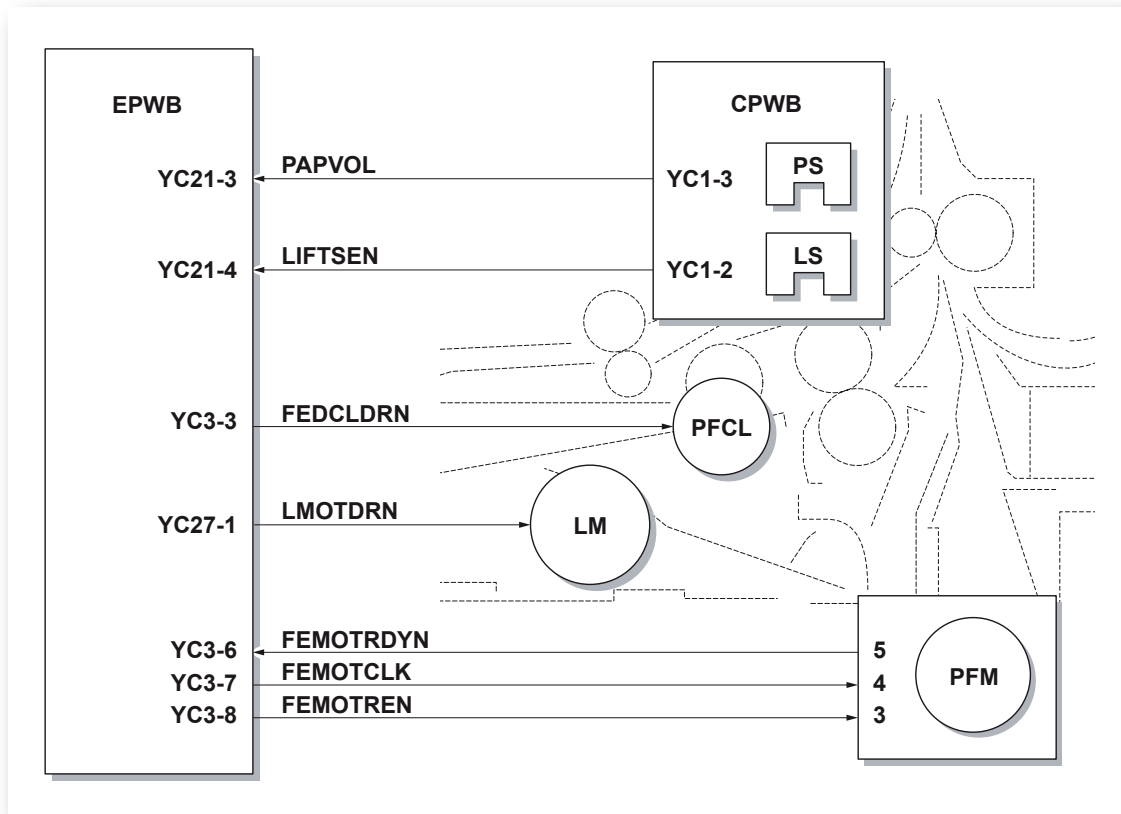

**Underside of the device when paper cassette is pulled out:**

The red frame marks the illustrated section.

1. Driving toothed wheel for paper ramp
2. Sensor flag paper sensor (PAPVOL)
3. Sensor for lift position (LIFTSEN)
4. Cover for sensor board
5. Feeder rollers

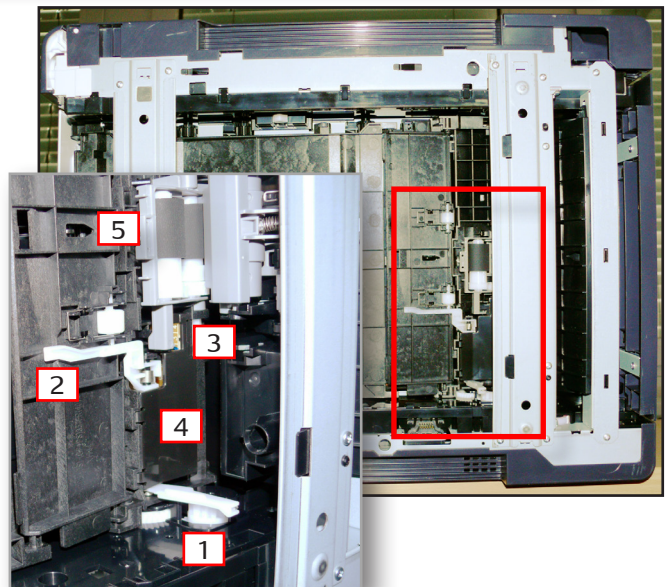

**Detail of feeder sensors when cover of sensor boards is removed:**

1. Sensor for lift position (LIFTSEN)
2. Sensor flag for paper sensor
3. Paper sensor (PAPVOL)

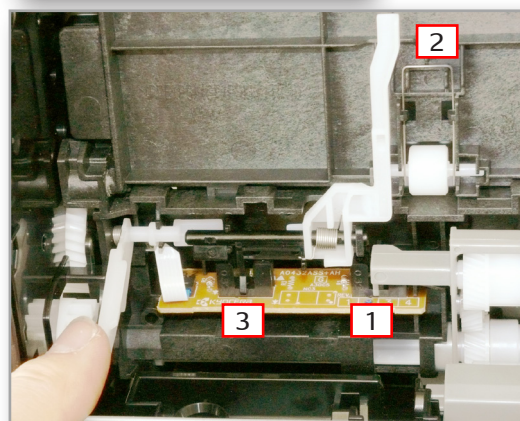



## Multi purpose paper feeder

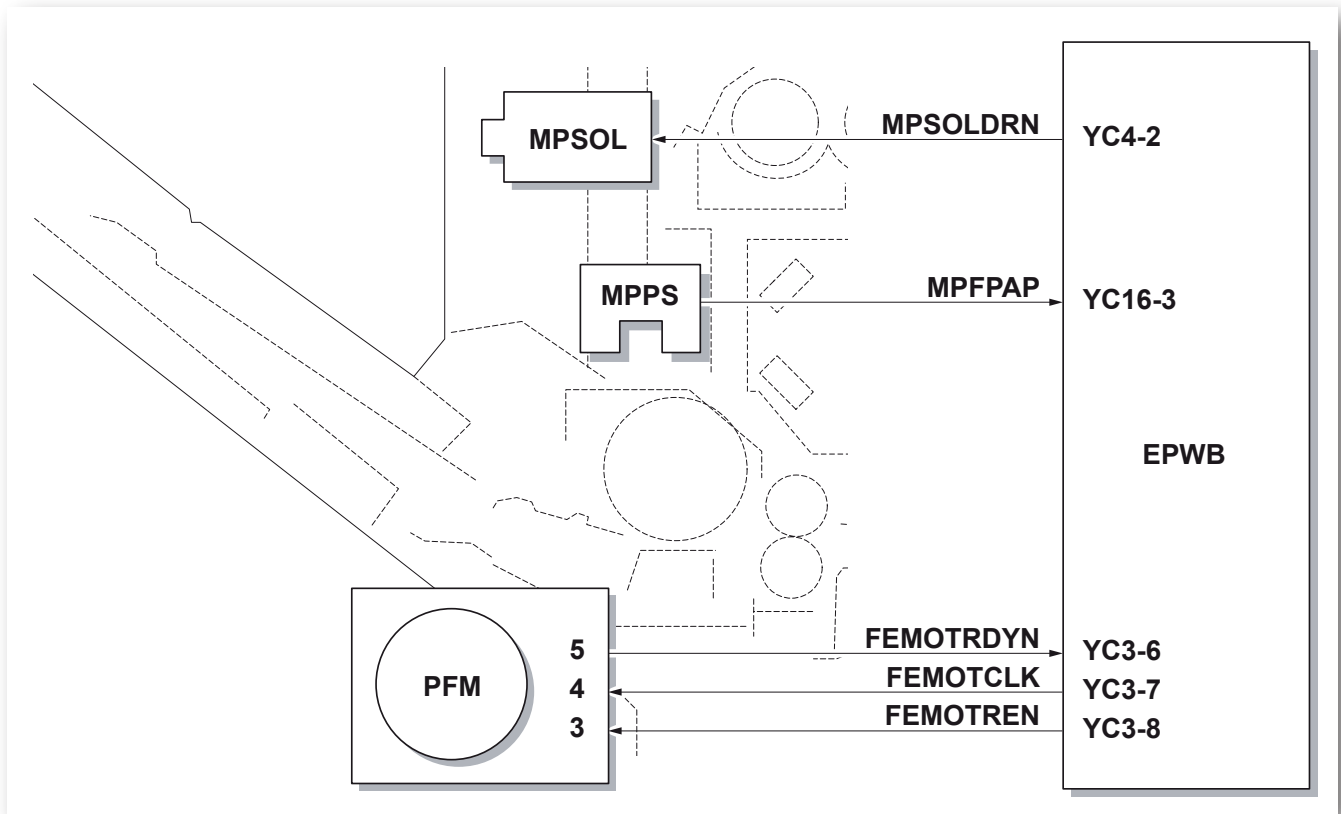

**Multi purpose paper feeder (view when casing and paper feeder is removed):**

1. Sensor flag (MPPS)
2. Sensor component (MPPS)
3. Feed roller (partially removed)

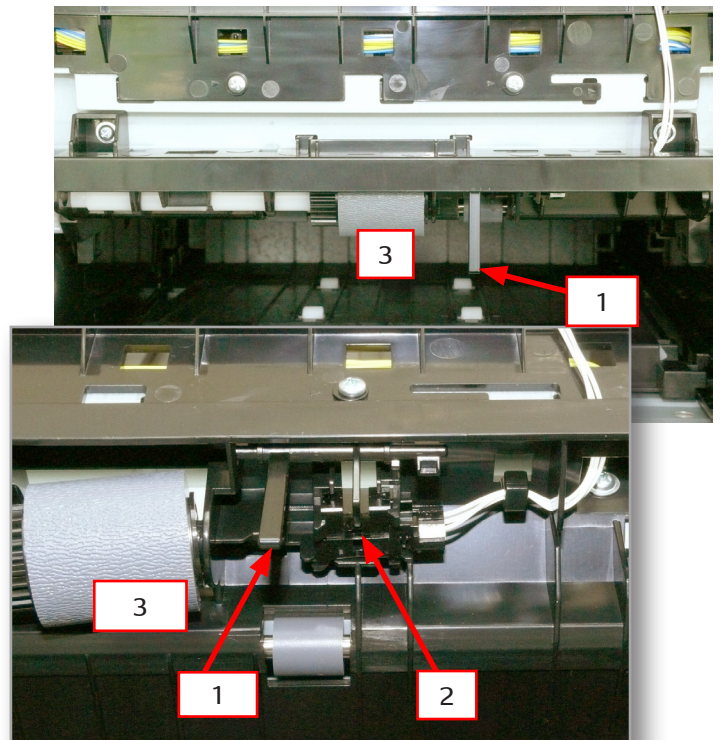

## Multi purpose paper feeder (continued)

**Universal paper feeder (view when casing is removed and paper cassette is pulled out):**

1. Paper ramp
2. Paper ramp lift

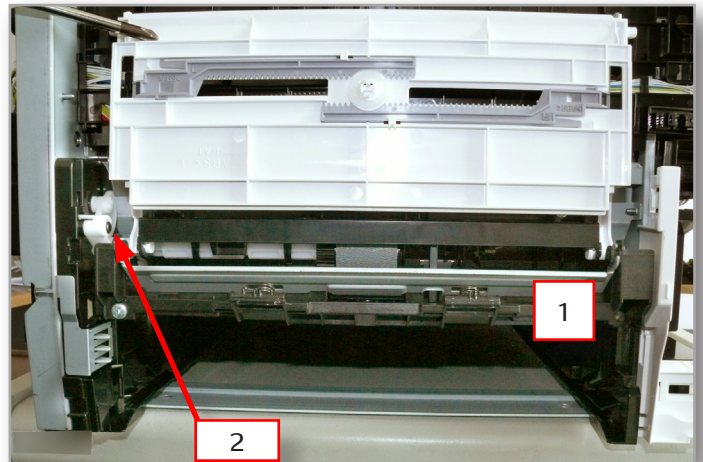

### Paper ramp lift, eccentric disc (1):

Illustration shows the position for removal of the eccentric disc.

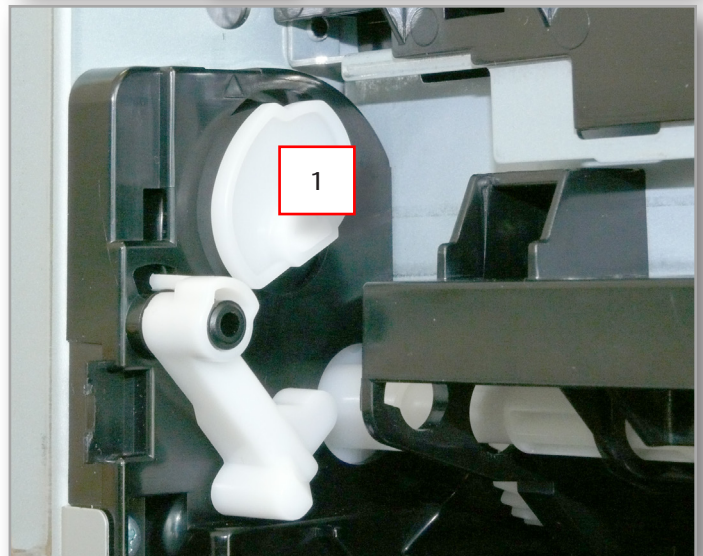

### Dismantled paper ramp lift:

1. Eccentric disc
2. Rotor magnet (MPSOL)
3. Gear wheel

A unit is driven by the paper feeder motor (PFM + MP Feed Clutch, MPFCL).  
(Localization see page 35 )

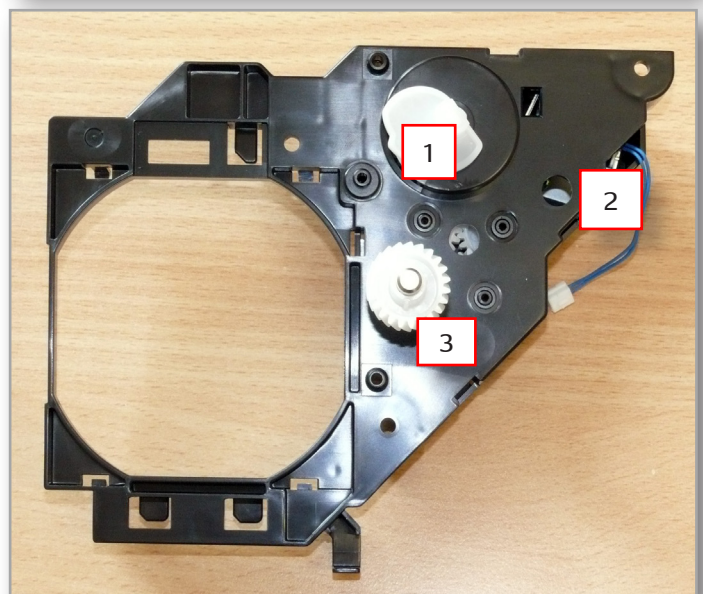

## Paper transport

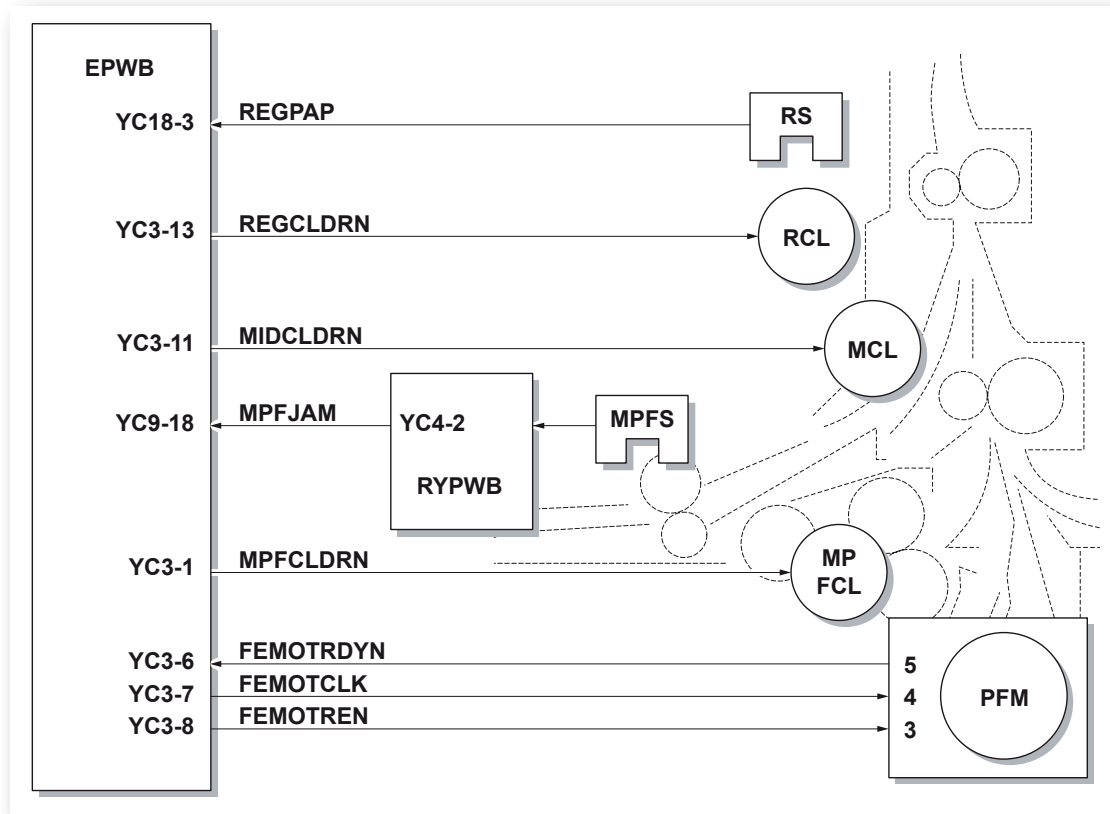

### Position of components:

- Registration clutch (RCL)
- Paper Feed Motor (PFM)
- Middle Feed Clutch (MCL)
- MP Feed Clutch (MPFCL)

See page 35.

### Registration sensor (RS):

View when rear cover is open.

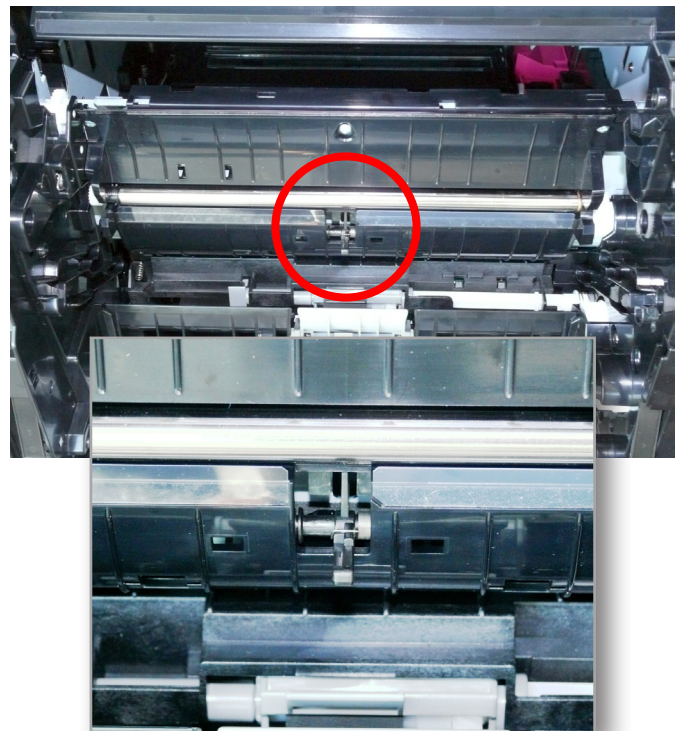



## Paper transport (continued)

### Position of the MPFS sensor (view of the underside of the device):

The sensor monitors the paper transport of media from the multi purpose paper feeder.

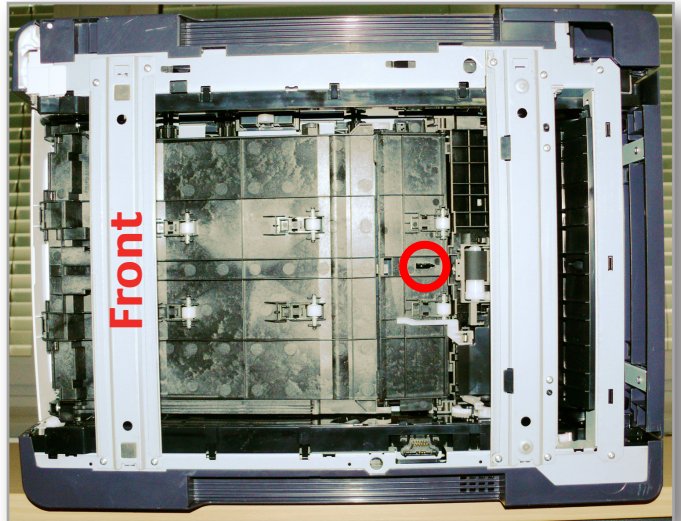

### View of the dismantled paper guide of the multi purpose paper feeder:

The red circle marks the MPFS sensor.  
The connection is made via a relay board (RYPWB) (2).

The transport rollers are driven by the toothed wheel (1) and the three timing belts (arrows).  
This unit is controlled by the combination of PFM and MPFCL (see page 35).

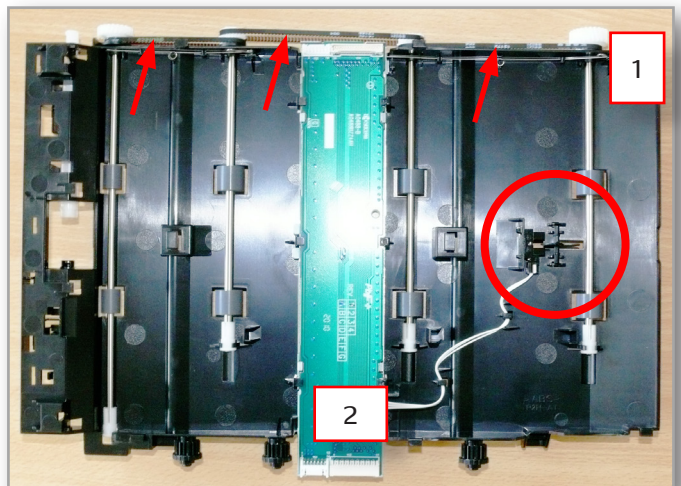

## Imaging drums

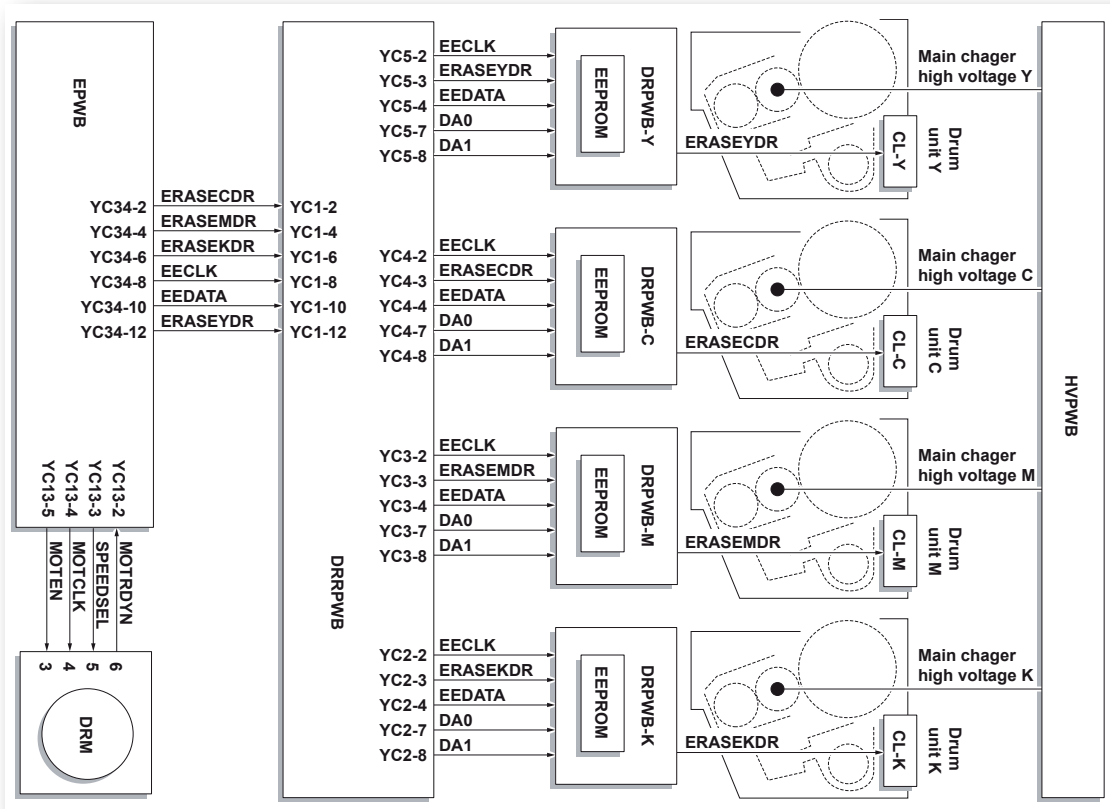

### Disassembled drum unit:

1. Drum (OPC material)
2. EEPROM plug (with connected discharge lamp)
3. Charge roller, handle to release the charge rollers
4. Contact spring for charging voltage



View of contact springs for charging voltage in the device.

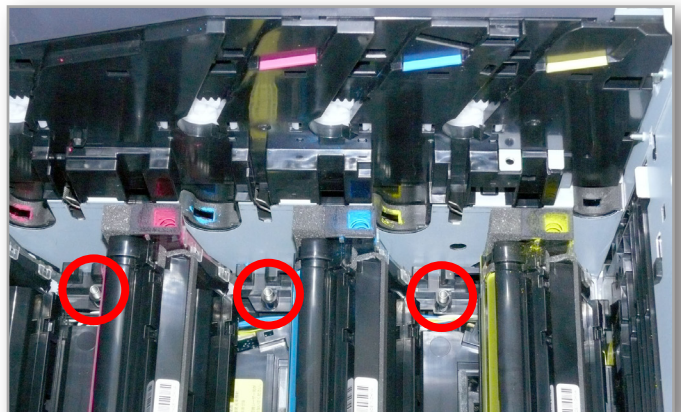



Developer

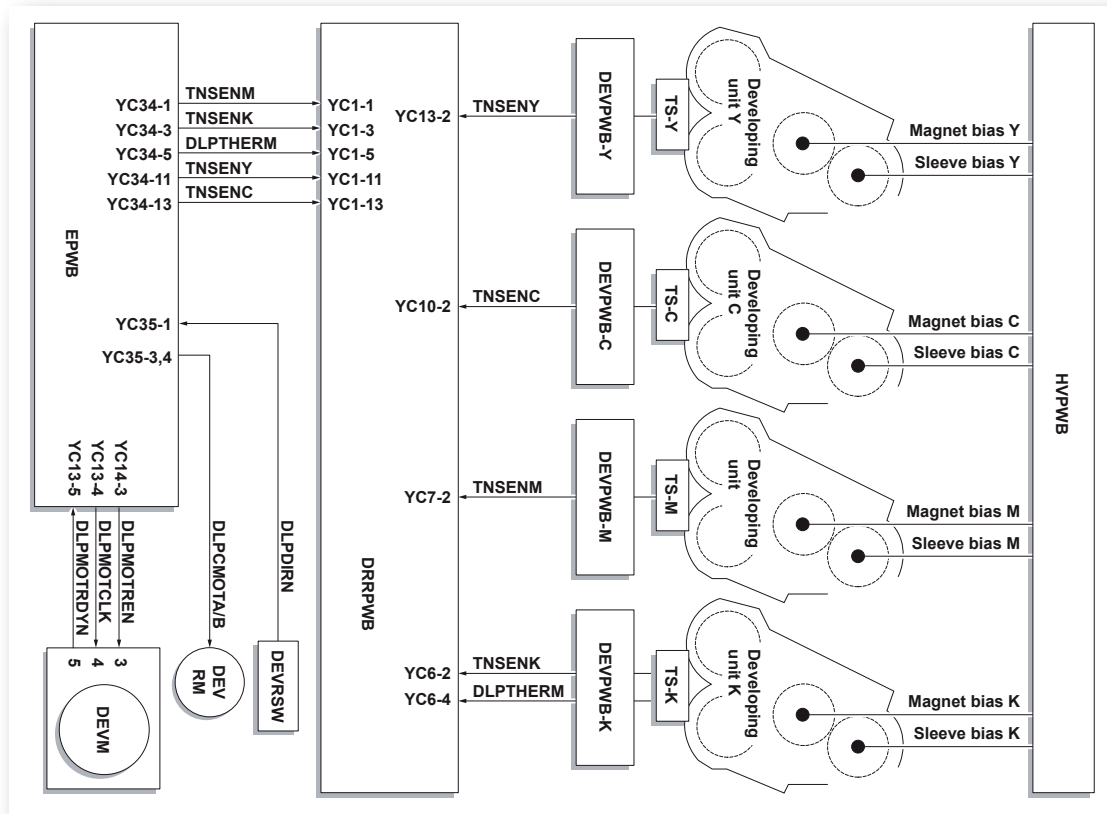

Developer units (CMYK) are filled - ex factory - with toner and ferromagnetic developer material. During running operation, a toner density sensor measures the ratio of developer material and toner. Toner is added via the corresponding toner motors (see page 35) when needed.

Developer unit with disassembled underside:

1. Plug for toner density sensor.
2. Toner density sensor (TS-x).
3. Contact spring, Sleeve Bias.
4. Contact spring, Magnet Bias.

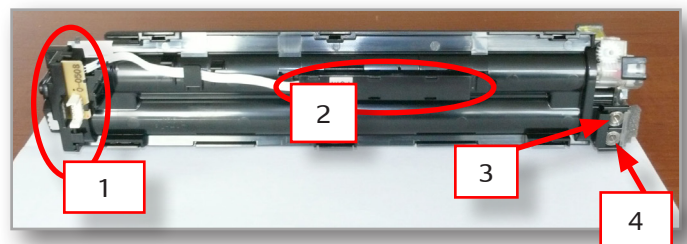

Developer unit, right side:

1. Filler pipe for toner.
2. Transport mechanism.

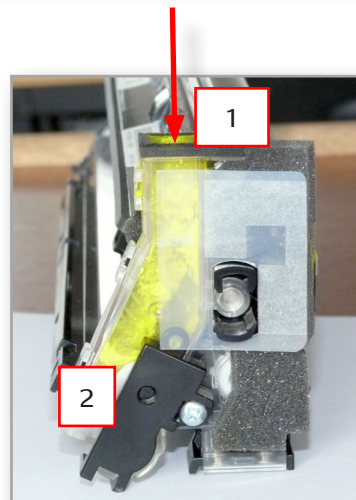

Please take care that the developer units are not interchanged when they are inserted!

## Laser units

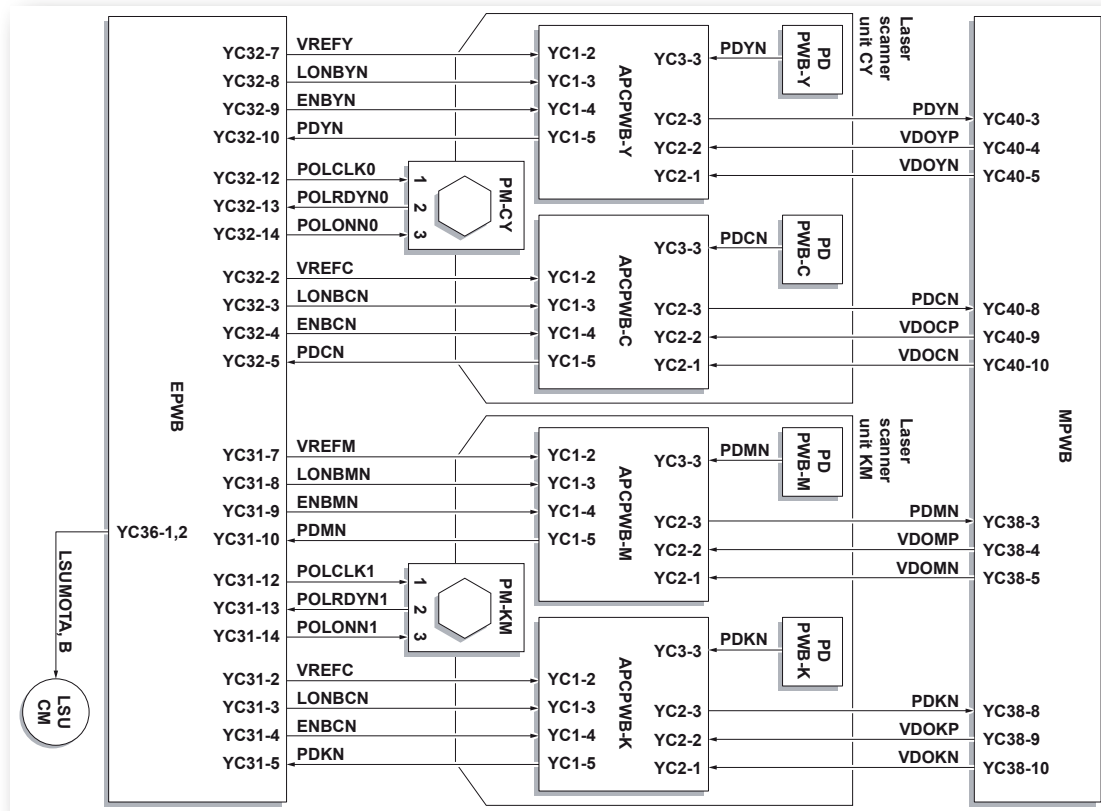

Two laser units (LSU) illuminate 4 drums (LSU-1: CY, LSU-2: KM).

The exposure window is cleaned automatically, or via a menu command (see page 68).

When a new LSU is inserted, a mirror correction without dismantling may be possible depending on the circumstances (see page 67).

### View of laser unit (second unit is removed):

1. Exposure window.
2. Cleaner for exposure window.
3. Drive unit for exposure window cleaner.

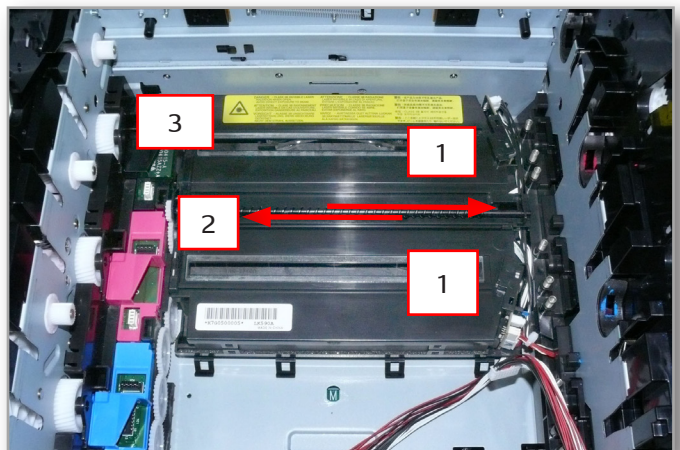

### Drive unit for cleaner (view from below):

Driving motor (LSUCM).

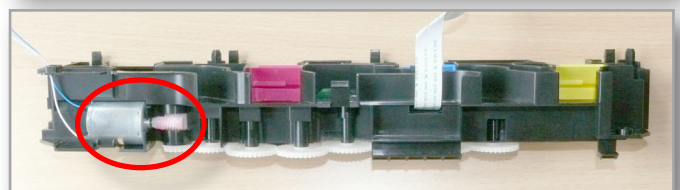

## Transfer unit

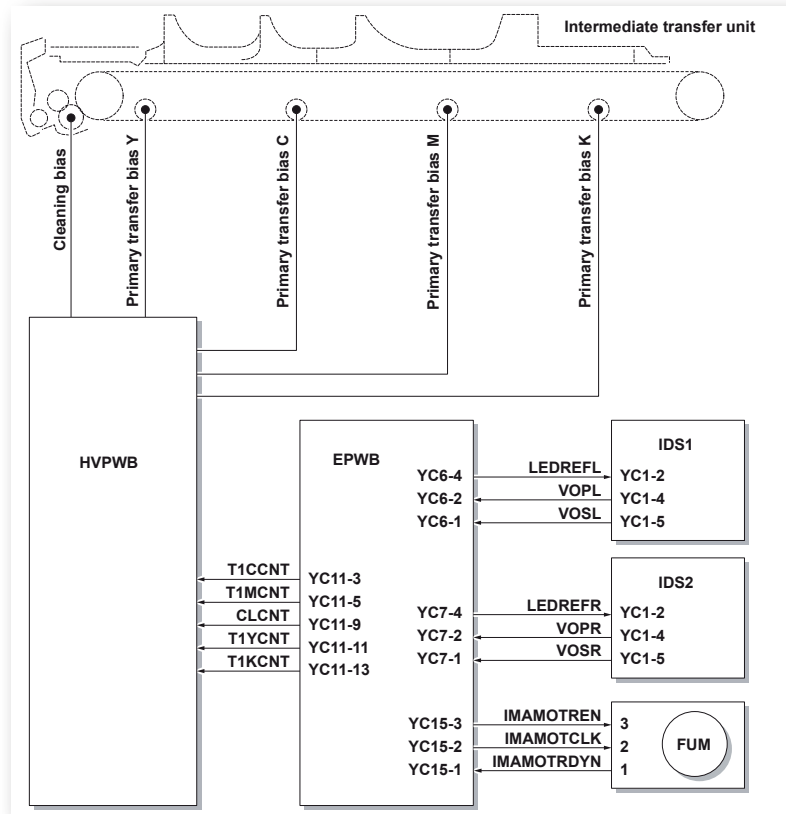

The transfer unit (Intermediate Transfer Unit) consists of a flexible belt which facilitates toner transfer to individual imaging drums.

The fixing motor (FUM) (see page 35) drives the transfer belt directly. A timing belt (inside the machine) transfers the drive to the transfer belt's cleaning roller.

An ID sensor (toner density), which is fixed at the rear side of the transfer unit, monitors the adjustment patterns that are applied to the transfer belt at certain times (see page 50).

The ID sensor is cleaned automatically when the upper cover is opened.

Due to the movement of the transfer belt, the toner material from the toner container is actively transported to the developer units situated below it.

### Transfer unit, top side:

The circle marks the individual toner containers' filler pipes.

The arrow marks the slide that seals the toner outlets from the developer units situated below it (transport position).

### Notes:

- The transfer unit can only be removed when the slide is closed.
- When the slide is closed, the toner containers cannot be inserted.

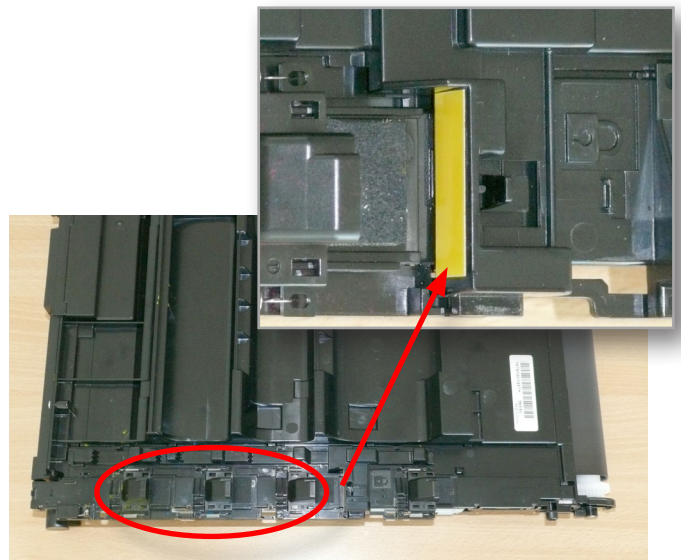



## Transfer unit (continued)

### Connections (front view, underside):

1. Prim. Trans. Bias - Yellow
2. Prim. Trans. Bias - Cyan
3. Prim. Trans. Bias - Magenta
4. Prim. Trans. Bias - Black
5. Cleaning Bias

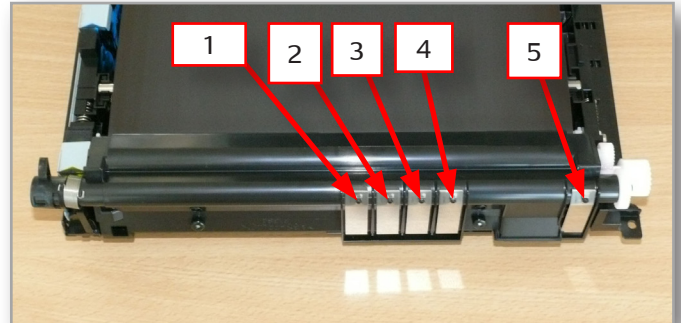

### Transfer unit, front left side:

Details about transfer belt cleaning.

The fixing motor's (FUM) drive is transferred to the cleaning roller via the timing belt. It takes up the waste toner material of the transfer belt in the opposite running direction.

To prevent the toner material from sticking, high voltage is applied to this roller (Cleaning Bias).

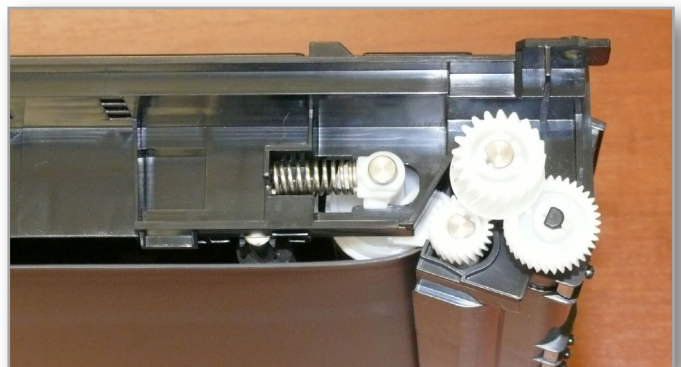

### Transfer unit, front view, underside:

Detail of a toner outlet (1) for the developer unit. The slide (2) normally closes this opening in case of a removed transfer unit.

The transfer unit's waste toner material is transported directly into the waste toner box via the outlet (3).

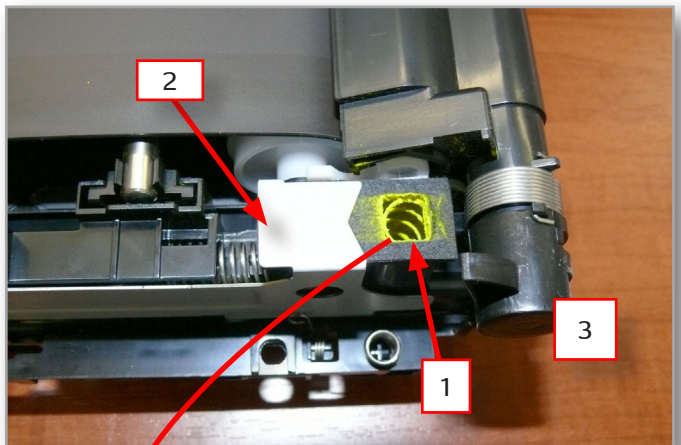

### View inside the device when the transfer unit is removed:

Through opening (1), the waste toner material is transported from the transfer unit to the waste toner box.

Opening (2) shows the toner inlet to the developer unit.

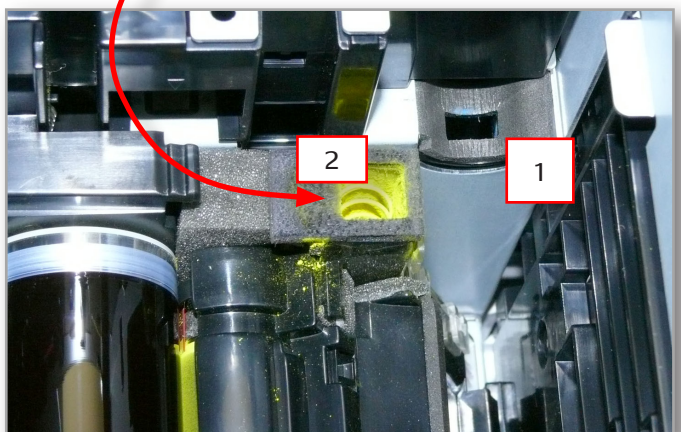

**Secondary transfer**

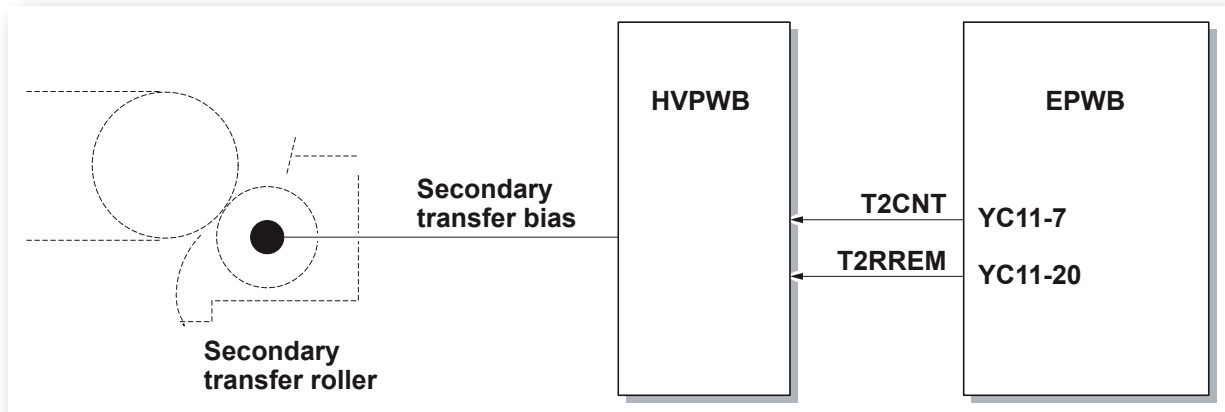

**Vertical transport (Paper Conveying Unit):**

1. Transfer Roller
2. Separation electrode
3. Registration pressure roller

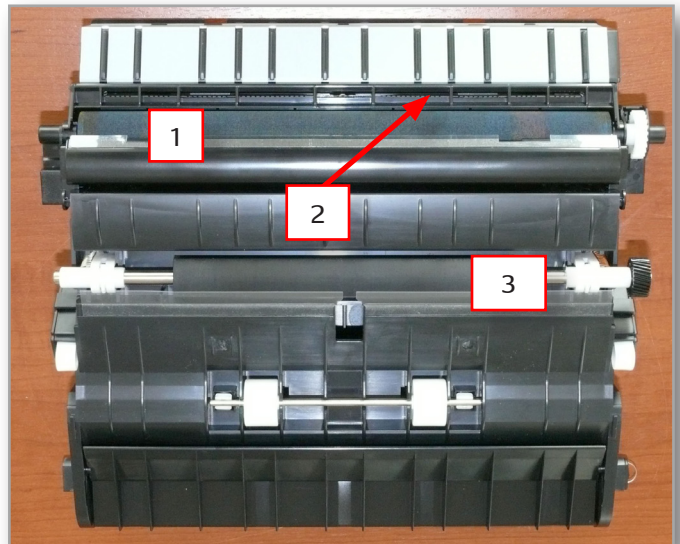

**Transfer roller, drive end:**

The transfer voltage is applied to a conducting plastic bush via the contact spring (see next illustration).

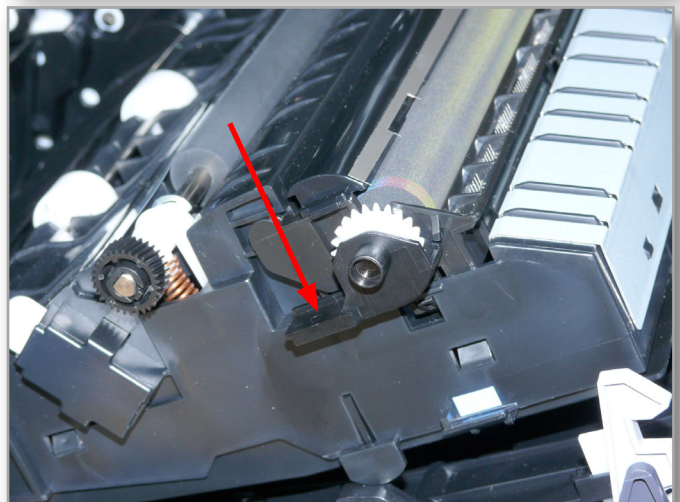

**Vertical transport, inside the device:**

View of the contact spring of the transfer voltage.  
(1) Registration roller.

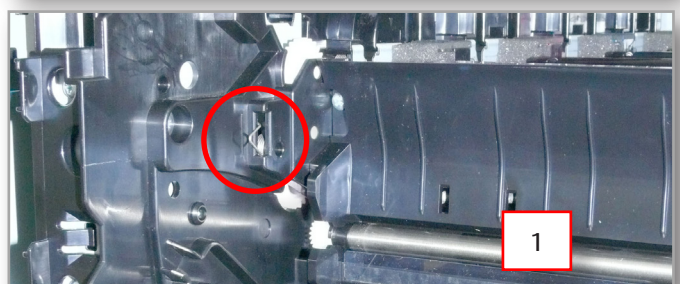

## Fusing unit

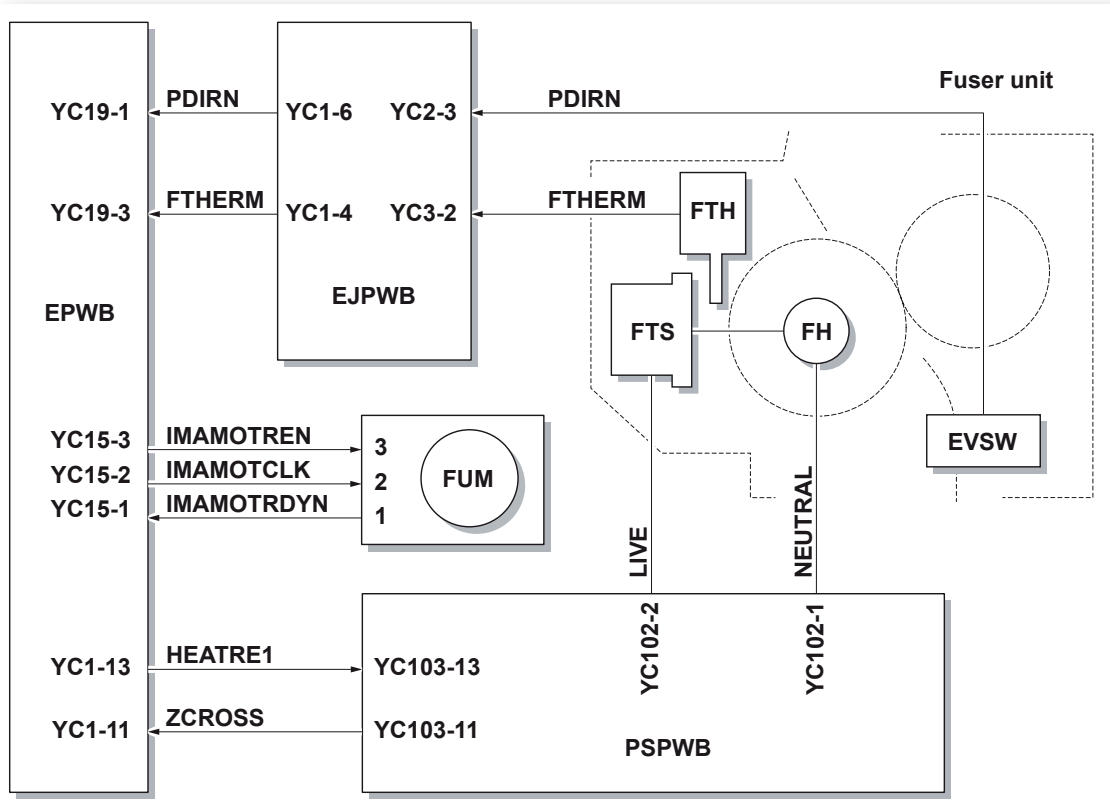

The fusing unit has an optional position for reduced fixing pressure. The selection can be made in the printer driver under media type "Envelope". A servomotor (FPRM) in the device activates an eccentric disc in the fixing unit via a gear unit which changes the pressure. The sensor EVSW (Envelope Switch) monitors the position.

### Fusing unit, view from below:

1. Driving wheel for changing the pressure.
2. Eccentric disc
3. Sensor EVSW

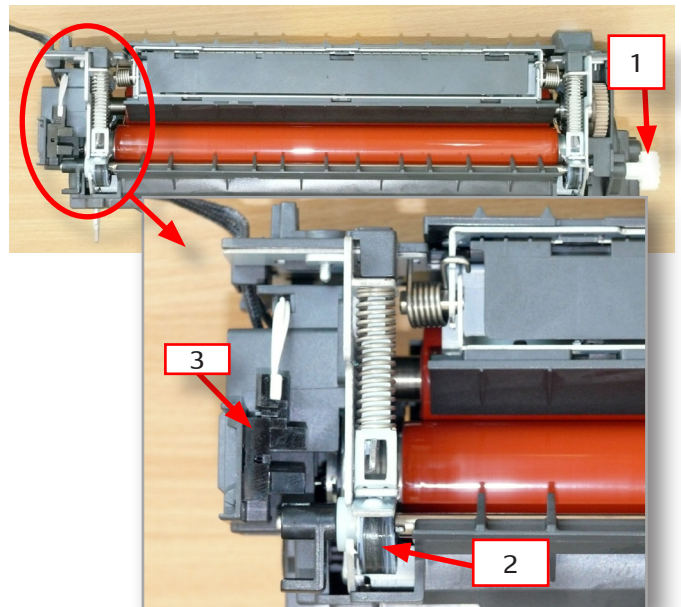



**Paper output and re-feeding (duplex)**

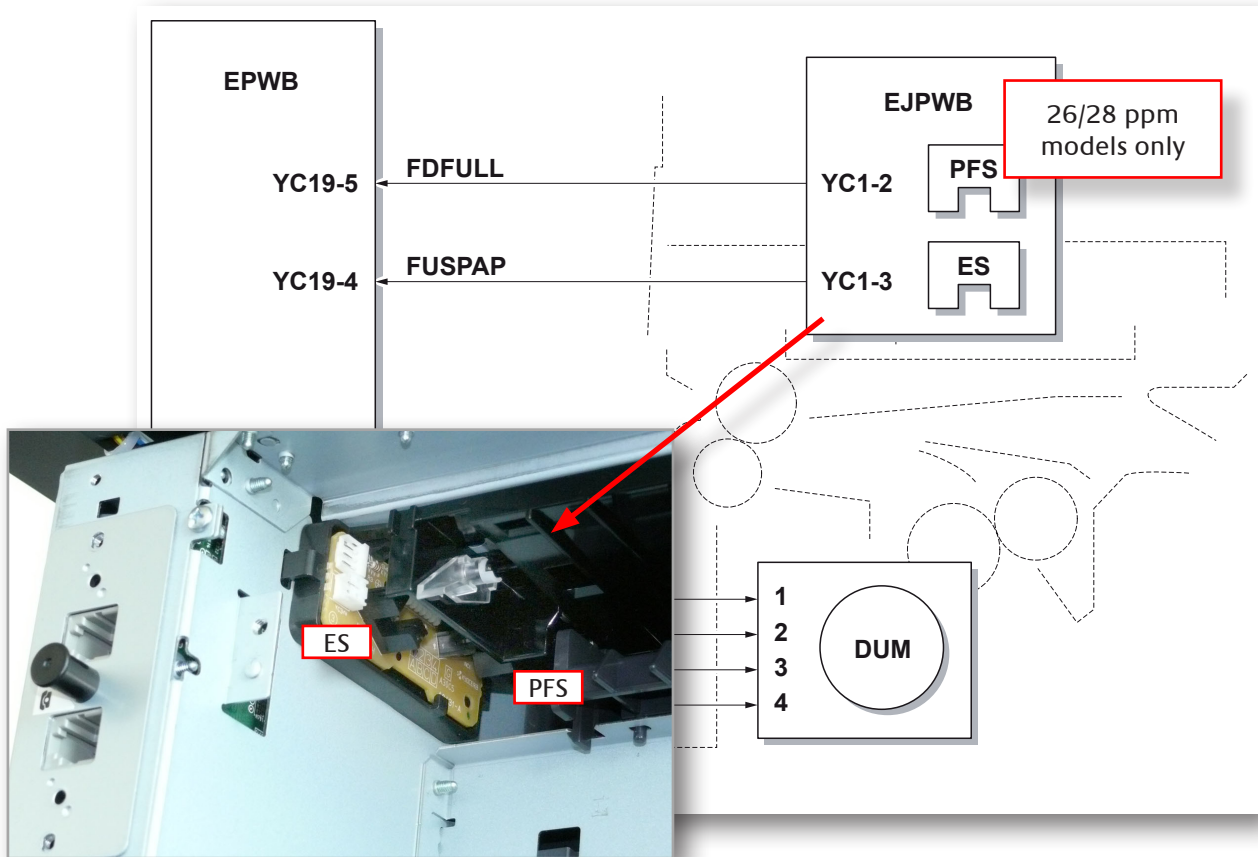

Paper output is handled by a separate motor (DUM). In case of duplex operation, re-feeding occurs by changing the direction of rotation.  
 In addition to paper output (ES), the level in the output is monitored (PFS).

**Picture at top:**  
 Dismantled fixing unit, view of EJPWB.

**Paper output:**  
 Sensor flags Paper Full Sensor (PFS).

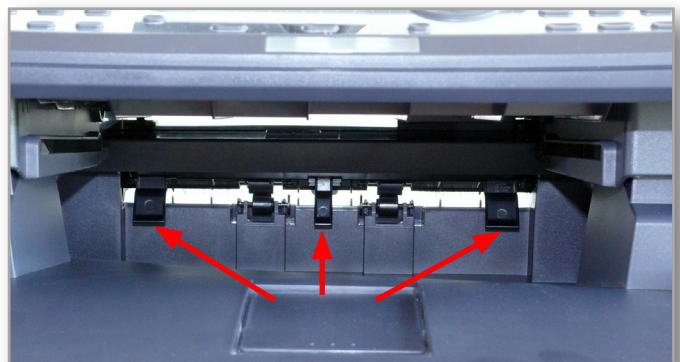

**Fixing unit - view from above:**

1. Sensor flag Paper output (ES).
2. Sensor flag (ES), sensor side.

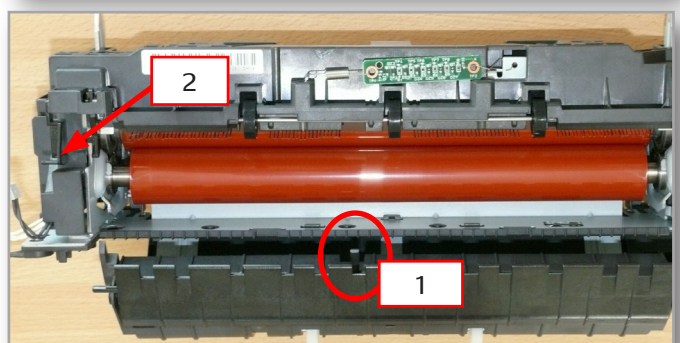

## Automatic color calibration

Automatic color calibration ensures the required long-term stability of the color output.

The following factors trigger a color calibration:

- After power-up (at a fixing temperature under 50 ° C).
- After 18 hours in Energy Saving Mode.
- During continuous printing, after 500 pages (without adjustment of color registration).
- Manually triggered (System Menu / Adjust/Maint. / ColorCalibration).

Color calibration is done in 3 phases and takes a total of ca. 25 seconds.

- BIAS calibration
- I/O calibration
- Registration adjustment

### Phase 1, Bias Calibration:

The Bias Calibration is used for half tone density monitoring. The parameters for Dev Bias, T/C voltage and toner feed quantity are set. For this, test patterns with 3 different bias voltages (33.3% - 100%) and all 4 colors are applied to the transfer belt.

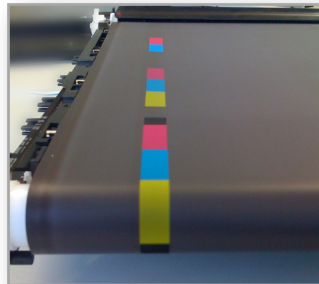

### Phase 2, I/O calibration:

Also known as half tone levelling table or gradation curve. The half tone table is created by evaluating 8 test fields to which 15% to 99,6% toner is applied. These are created in the FM grid (1) and the AM grid (2).

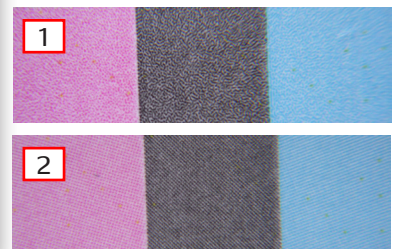

### Phase 3, adjustment of color registration:

To adjust the color registration, 8 diagonal and 8 horizontal color bars are applied to the transfer belt on both sides. This checks whether the color application on both sides takes place synchronously.



An additional calibration (calibration in between pages) takes place during printing. Between consecutive pages, small test fields are created (AM line grids), in which the toner density is monitored.



**Contents:**

- Maintenance kit
- Change of wear components: Feed rollers, separation (cassette and multi purpose paper feeder).
- Suggested sequence for dismantling casings.
- Maintenance Mode
- Service Mode
- Calibration and adjustment of scanner
- Color registration
- Half tone calibration

**At the end of the chapter you will be able to....**

- change service parameters
- perform maintenance
- make adjustments
- monitor operating parameters (e.g. counter status)

## Maintenance Kit MK-590 (only 26 ppm models)

|                 |  |
|-----------------|--|
| Action          | Installing components of the maintenance kit MK-590 (Art. No.: 1702KV8NL0).  |
| Recommendations | To be carried out when maintenance message appears (after 200,000 copies/prints).  |
| Pre-conditions  | <ul style="list-style-type: none"> <li>• Knowledge concerning access to maintenance mode</li> <li>• Maintenance Kit MK-590</li> </ul>  |
| Notes           | <p>After installing the components, please take the following actions:</p> <p><b>MFP:</b></p> <ul style="list-style-type: none"> <li>• U-251 (resets maintenance counter and deletes maintenance message)</li> <li>• Enter adjustment parameters of developer unit (see page 86)</li> </ul> <p><b>FS-C5250:</b></p> <ul style="list-style-type: none"> <li>• Call Maintenance within the Service Mode, confirm with OK (resets maintenance counter and deletes maintenance message).</li> <li>• Enter identification parameters of the developer units (see page 86)</li> </ul> <p> For printer FS-C5150, the MK-Kit maintenance kit CANNOT be used. Any attempts to install components of the MK kit will result in an error message.</p> |

### Maintenance kit MK-590 consists of the following components:

- TR-590 (transfer belt)
- DK-590 (drum) 4x
- FK-590 (fixing unit)
- DV-560 (developer) K, Y, C, M
- Feed roller, multi purpose paper feeder
- Feed roller, paper cassette
- Separation roller, 250 sheet feeder
- Separation roller, 500 sheet feeder

#### Note:

All article and serial numbers of the enclosed components can be found on the packaging. The adjustment parameter of the developer units can also be found there.



## Replacement of separation roller (retard roller)

|                 |   |
|-----------------|---|
| Action          | Replace the separation roller.  |
| Recommendations | Recommended for maintenance or in case of paper feed problems related to wear and tear.   |
| Pre-conditions  | <ul style="list-style-type: none"> <li>The “middle roller unit” must be removed (see service manual).</li> <li>The paper cassette should <b>NOT</b> be pulled out.</li> </ul> |
| Notes           | <ul style="list-style-type: none"> <li>Maintenance kit component.</li> <li>Mind the two types of the retard roller (see page 55).</li> </ul>                                  |

For easy replacement of the separation roller **additional** removal is recommended for:

- Rear Cover Unit
- Paper Conveying Unit

Remove the rear cover (rear cover unit):

- Release both braces.

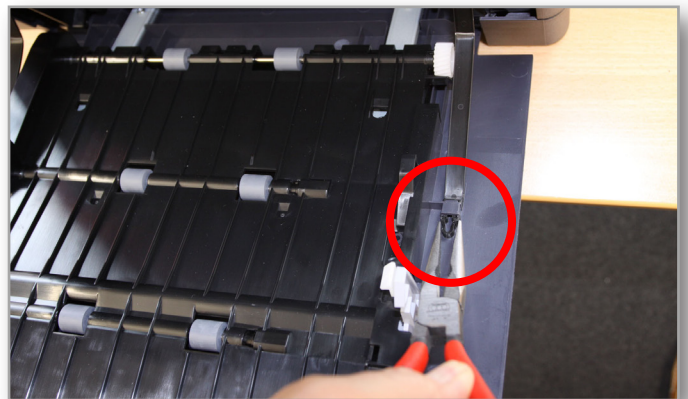

- Pry out the hinge pins.

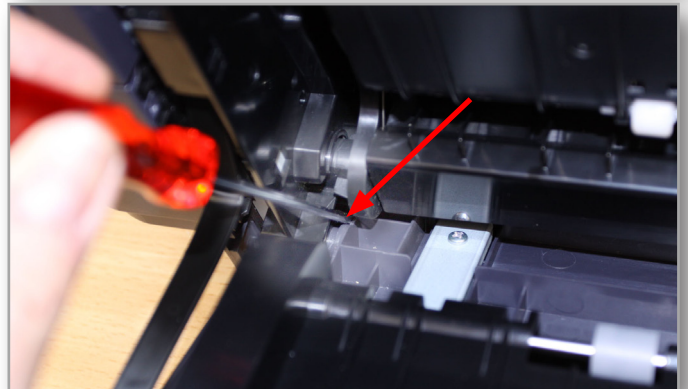

View of “retard roller unit”.

At the front:

The detached “middle roller unit”.

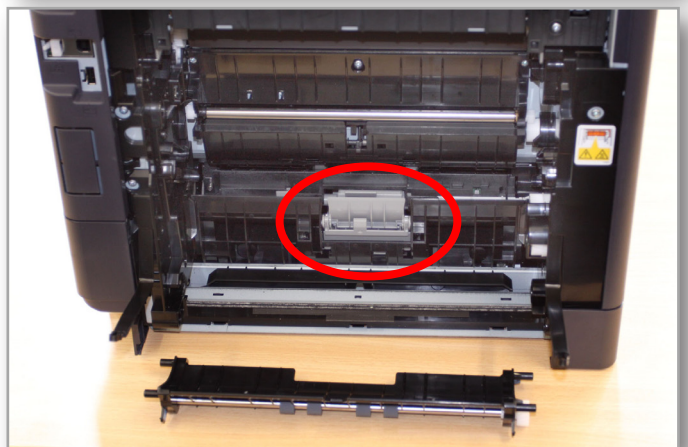

## Replacement of the separation roller (continued)

Lift and pry the “retard cover” over the pins (left and right).

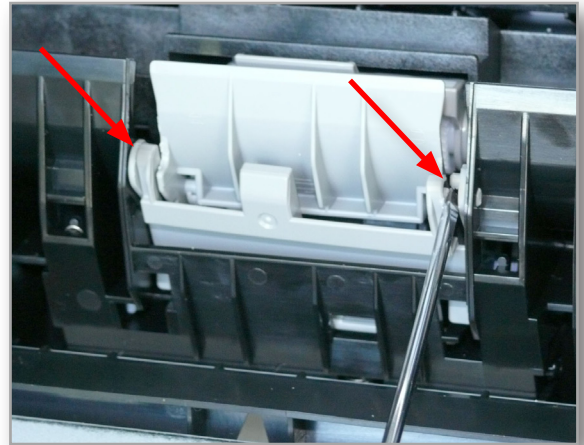

Lift and pry the “retard roller” unit out of the frame.

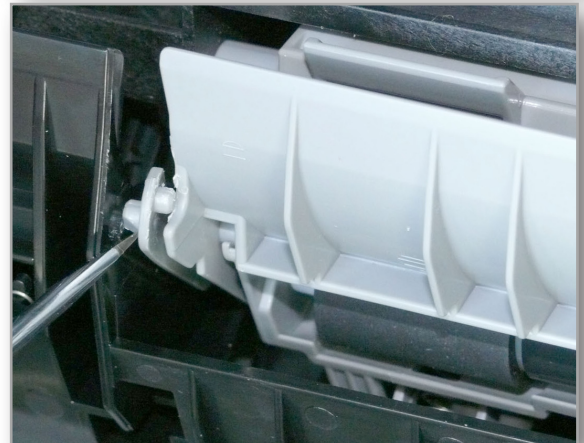

When replacing the separation roller, please note the following points:

- Paper cassette should be completely closed. Otherwise it might be fitted incorrectly!
- The “retard cover” should be inserted correctly.

Incorrect fitting of the “retard cover”.

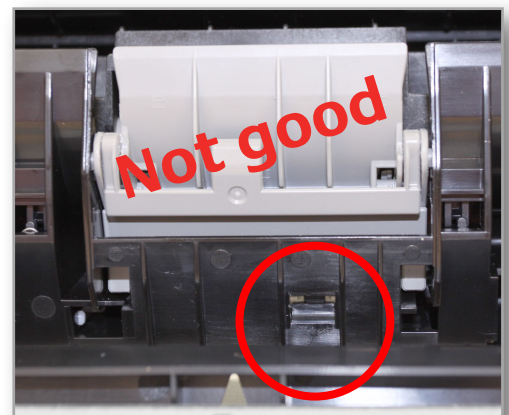

Correct position of the “retard cover”.

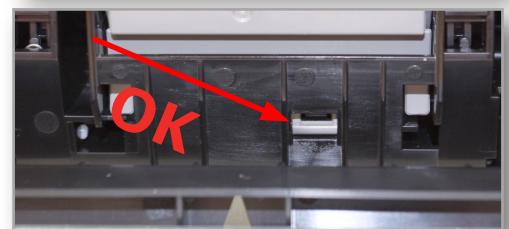

## Classification of Separation Rollers

Separation rollers for 250 page feeders:

- FS-C2126MFP
- FS-C5150

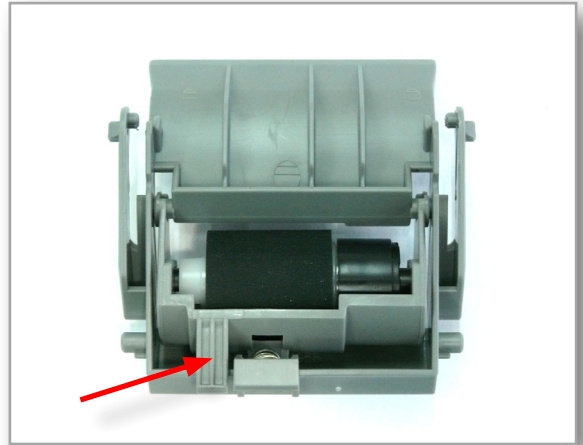

Separation rollers for 500 page feeders:

- FS-C5250
- all optional feeders

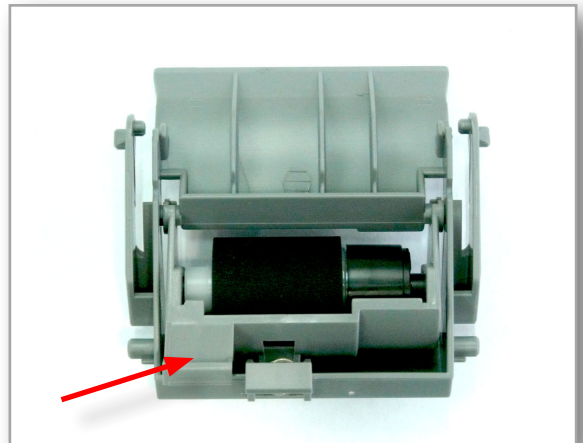



## Replacement of feed roller (paper feed roller unit)

|                 |   |
|-----------------|---|
| Action          | Replace feed roller (paper cassette).   |
| Recommendations | Recommended for maintenance or in case of wear and tear related paper feed problems.      |
| Pre-conditions  | Removing the separation roller (see page 53).<br>The paper cassette should be pulled out. |
| Notes           | Please take care to put components in the correct position when re-fitting.               |

Press the lock bar (1) down until it is released.  
After that, it can be slid to the left to release the feeder unit (2). This can then be removed.

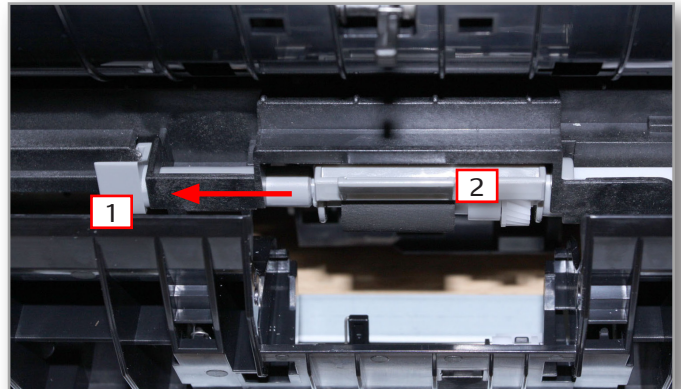

After refitting, check that the unit moves smoothly.

Correct position of the “paper feed unit”.

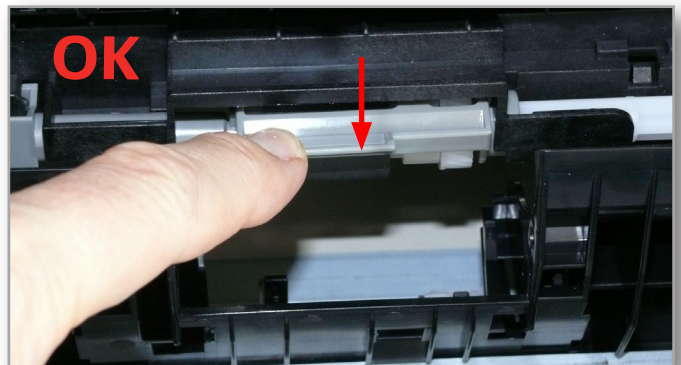

Incorrect fitting of the “paper feed unit”.

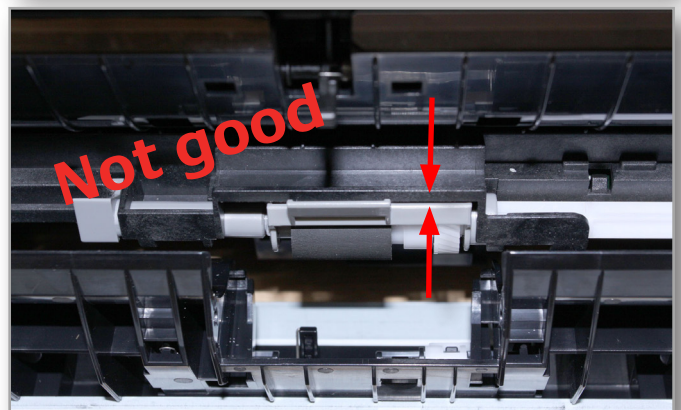

## Replacement of the feed roller, multi purpose paper feeder

|                 |  |
|-----------------|--|
| Action          | Replace feed roller (multi purpose feeder).  |
| Recommendations | Recommended for maintenance or in case of wear and tear related paper feed problems.   |
| Pre-conditions  | Detaching the paper conveying unit (see service manual).<br>Detaching the "MP Paper Feed Lower Unit" (see service manual).<br>The paper cassette should be pulled out. |
| Notes           | Please note the following:   |

After removing the required components, the "MP Paper Feed Lower Unit" is easily accessible.

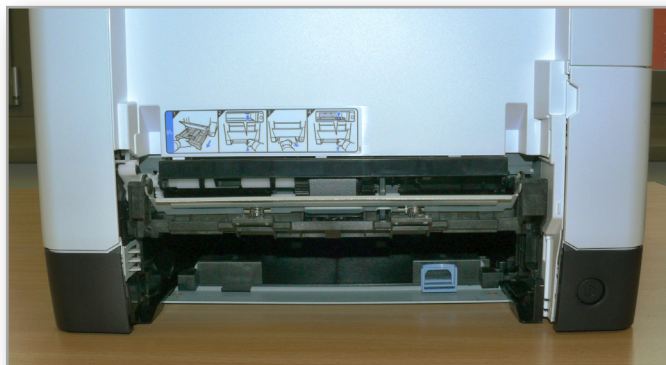

When removing the unit, please take care that it is not tilted.

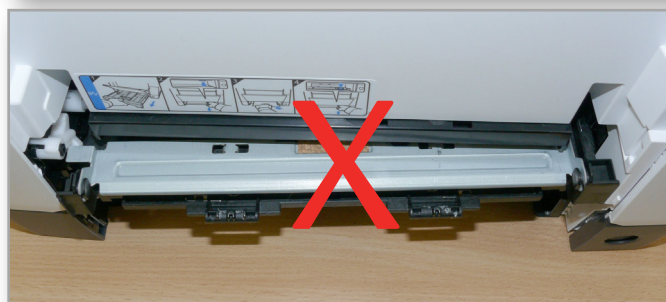

Please take care that the sensor flag is not damaged when fitting and removing the unit.

When fitting the unit, press the paper ramp down.

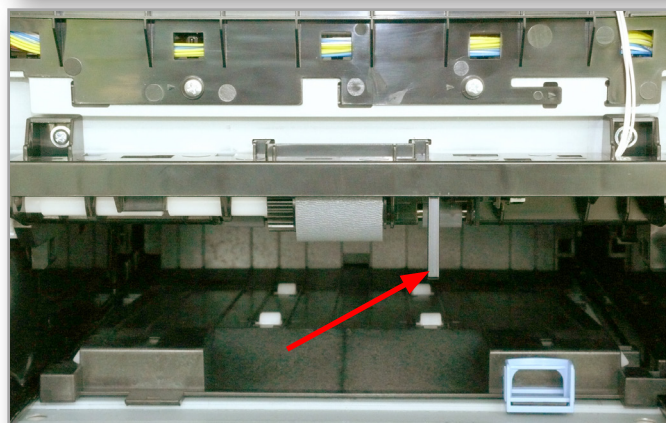

Remove the feed roller by releasing and sliding the drive shaft.

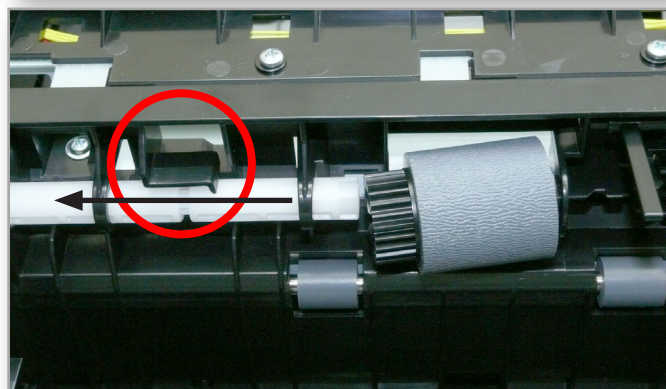

## Dismantling the side casings

|                 |   |
|-----------------|---|
| Action          | Dismantling the side casings.   |
| Recommendations | Required for repair or intensive maintenance.   |
| Pre-conditions  | The large number of casing parts follow a logical sequence.   |
| Notes           | <ul style="list-style-type: none"> <li>When dismantling all the components shown here, the device remains operational.<br/><b>CAUTION: FOLLOW SAFETY INSTRUCTIONS!</b></li> <li>All procedures are described in the service manual.</li> <li>Pay attention to the relevant marked shafts and hooks, then dismantling is carried out easily.</li> <li>Also applies to printer models from step 5 onwards.</li> </ul> |

### Step 1

IF Cover.

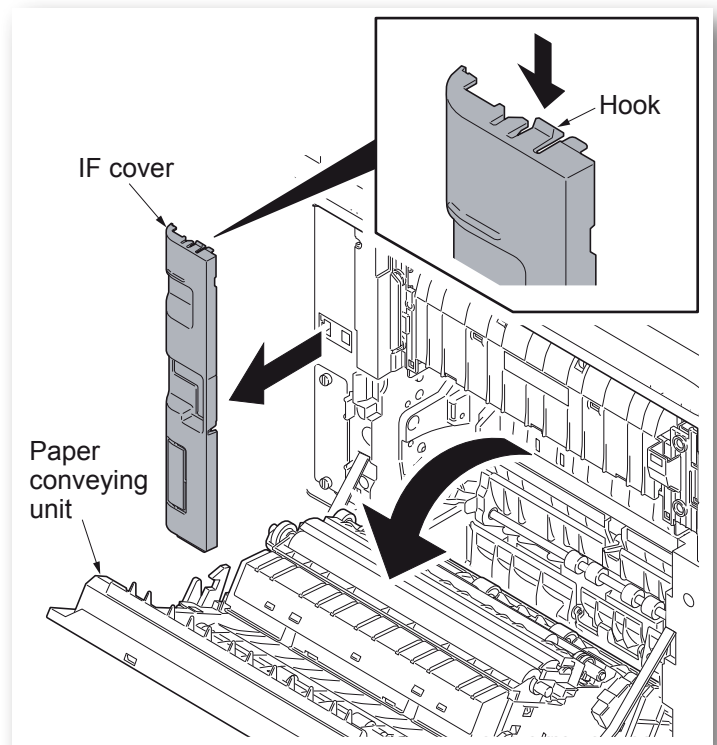

### Step 2

Rear Upper Cover.

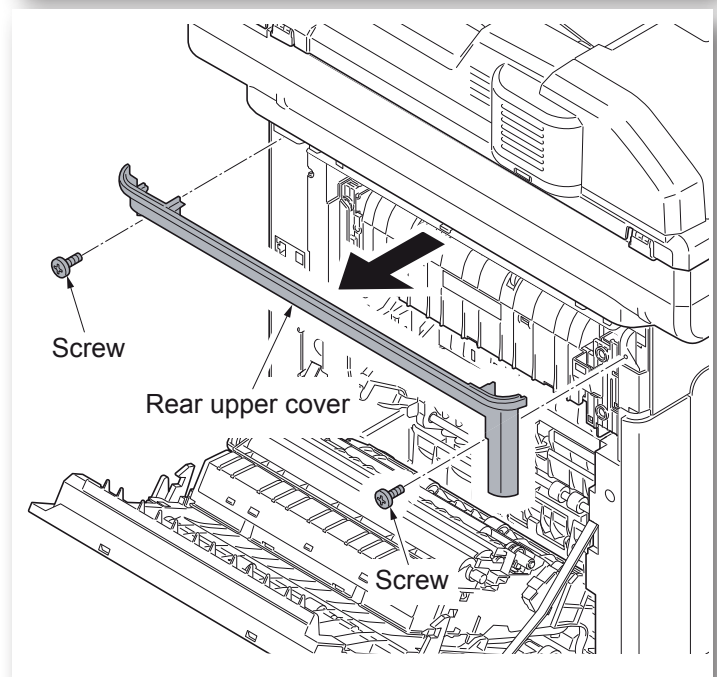



**Dismantling the side casings (continued)**

**Step 3**

Right Upper Cover.

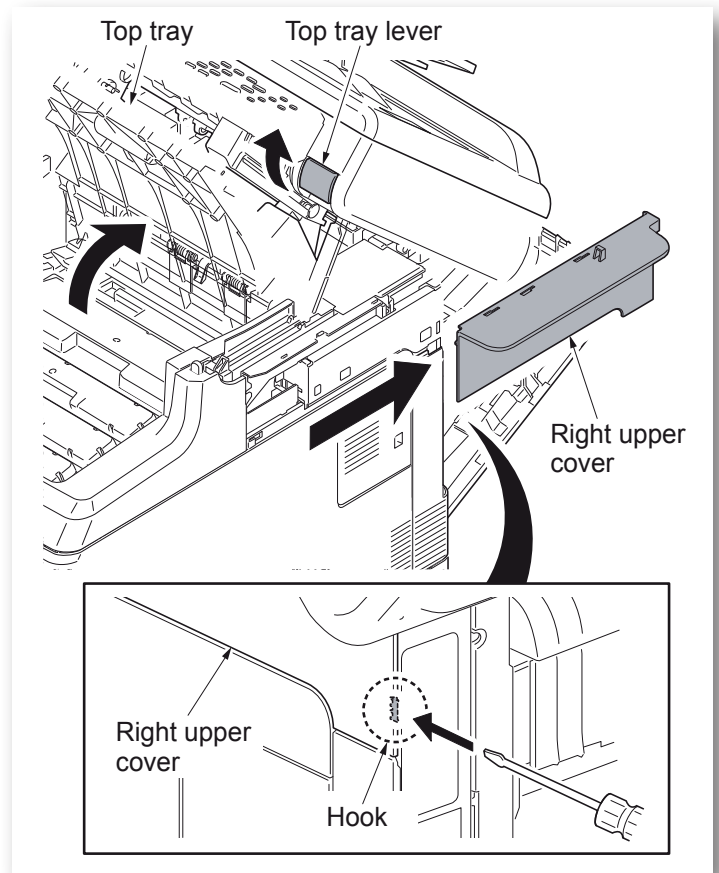

**Step 4**

Left Upper Cover

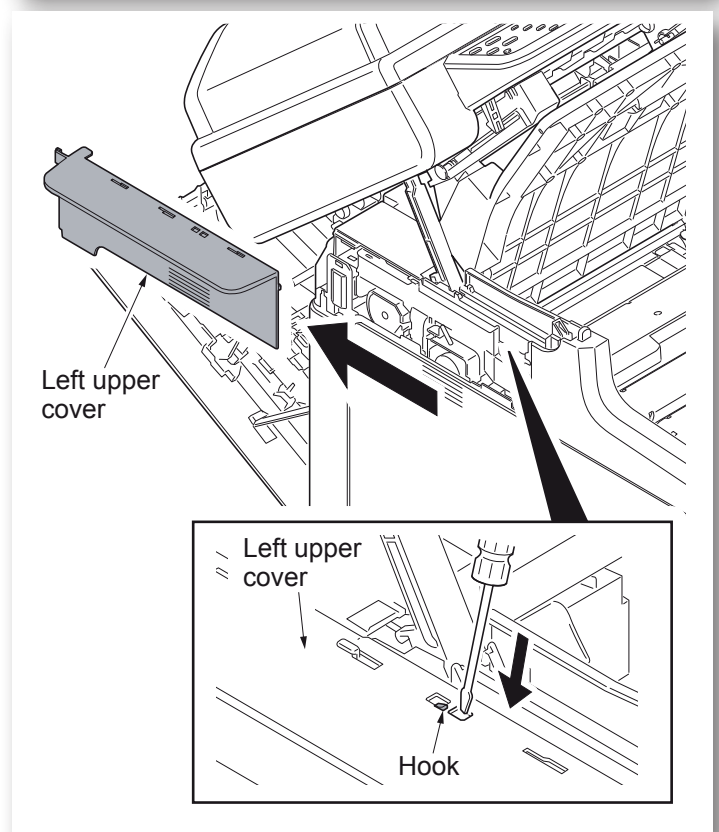

## Dismantling the side casings (continued)

### Step 5

Front Cover.

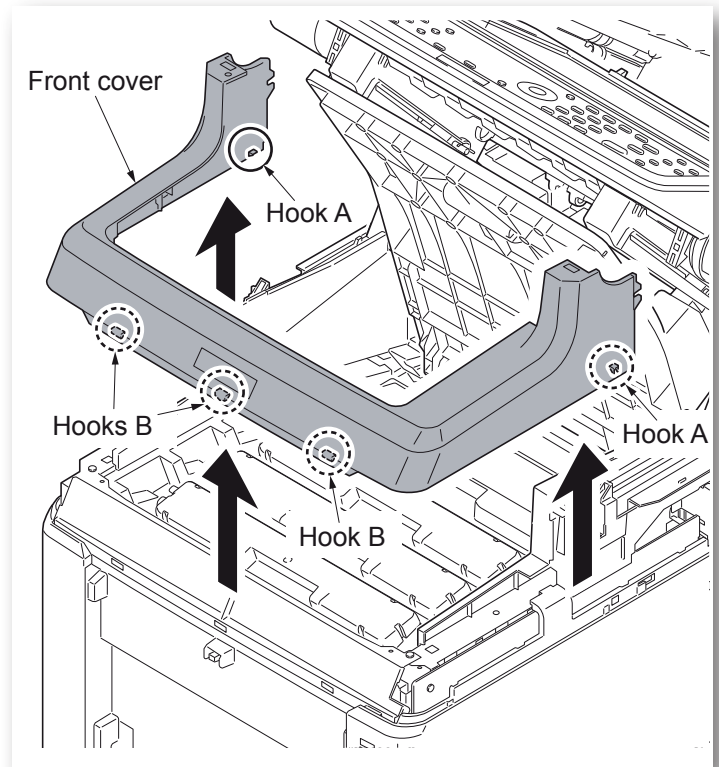

**Note:**

The following steps are also applicable to printer models.

### Step 6

Power Source Cover.

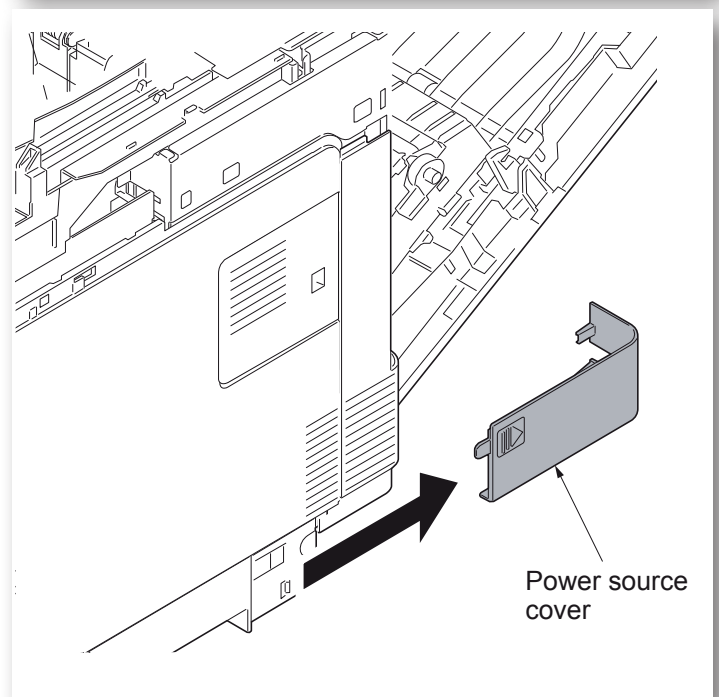

## Dismantling the side casings (continued)

### Step 7

Right Rear Cover.

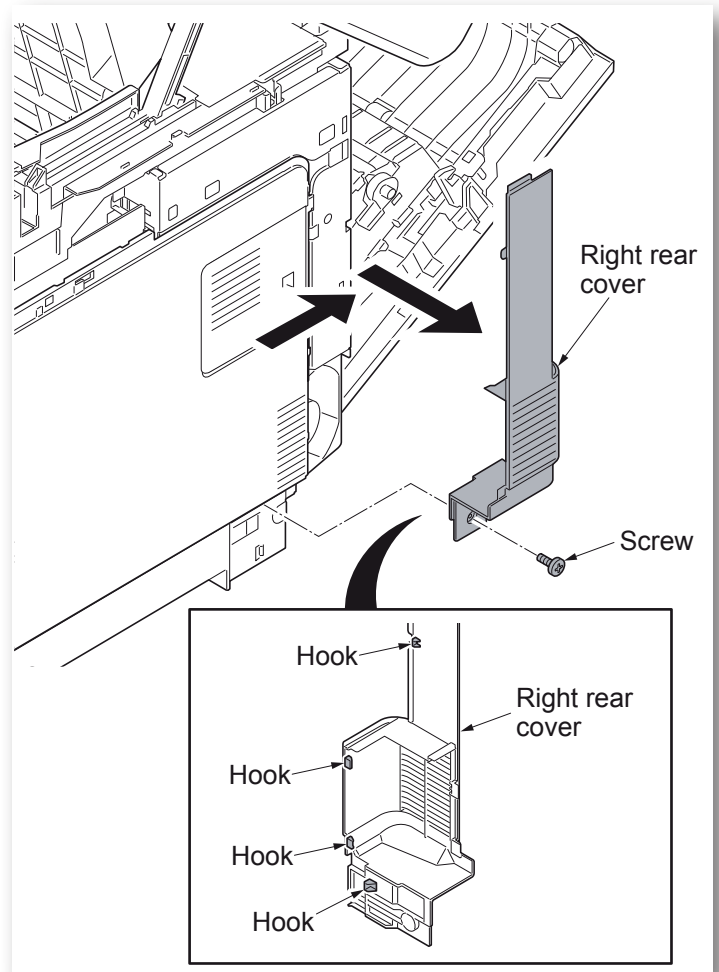

### Step 8

Memory Cover.

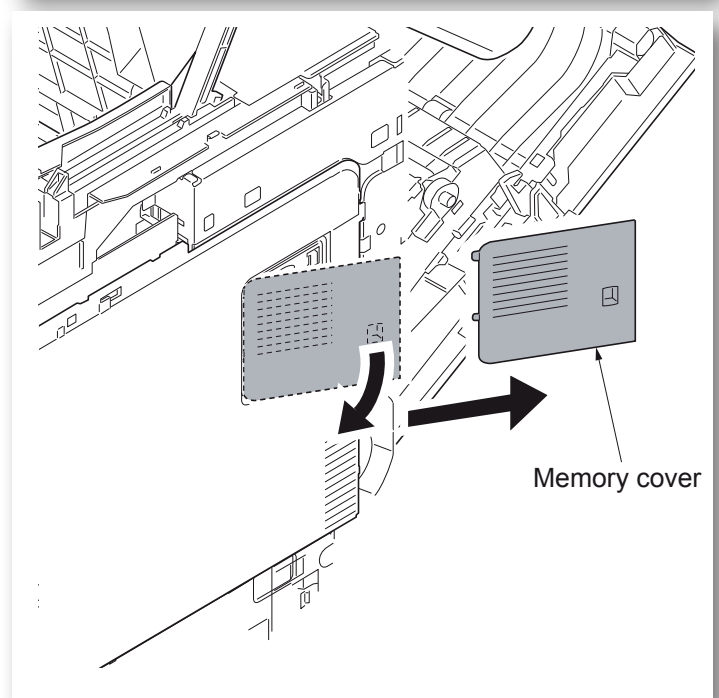

## Dismantling the side casings (continued)

### Step 9

Right Cover, Waste Toner Cover.

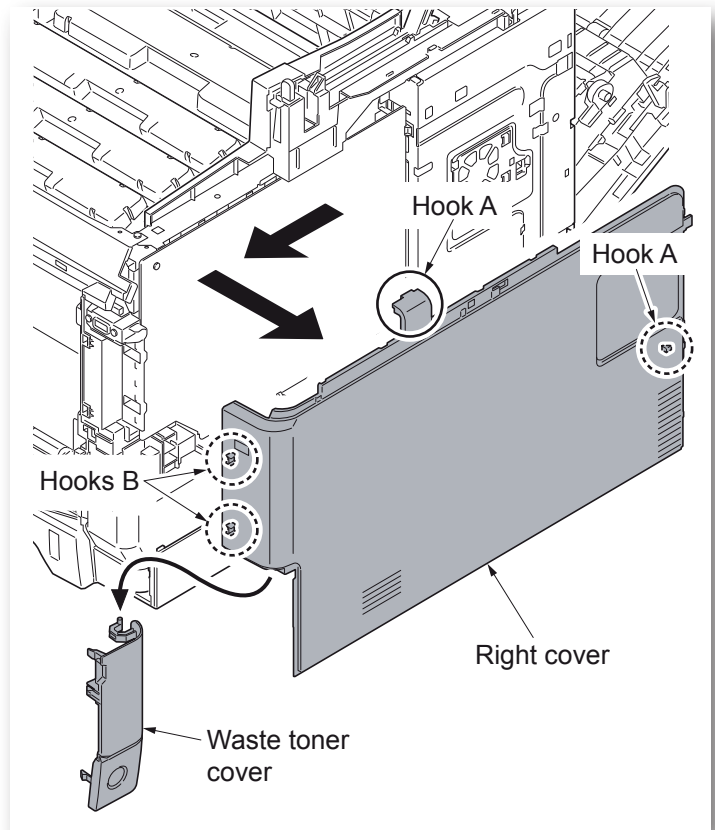

### Step 10

Right Lower Cover.

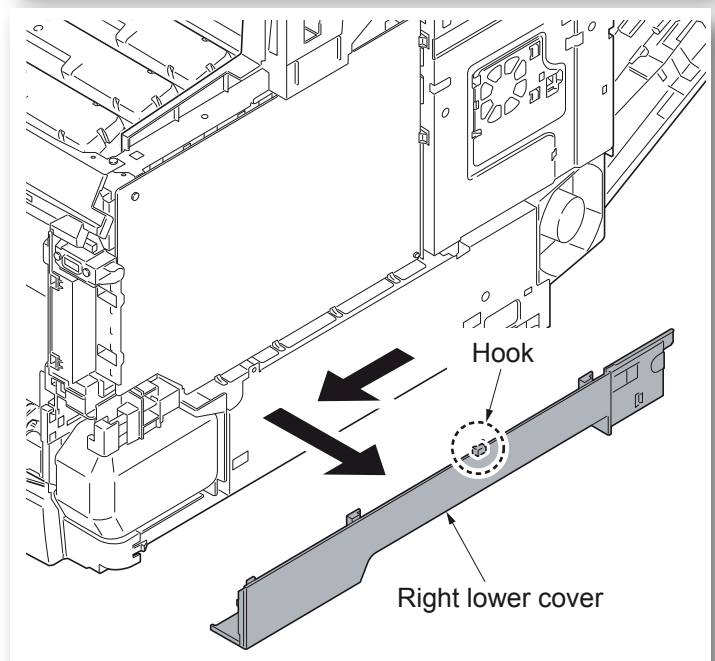

**Dismantling the side casings (continued)**

**Step 11**

Left Rear Cover.

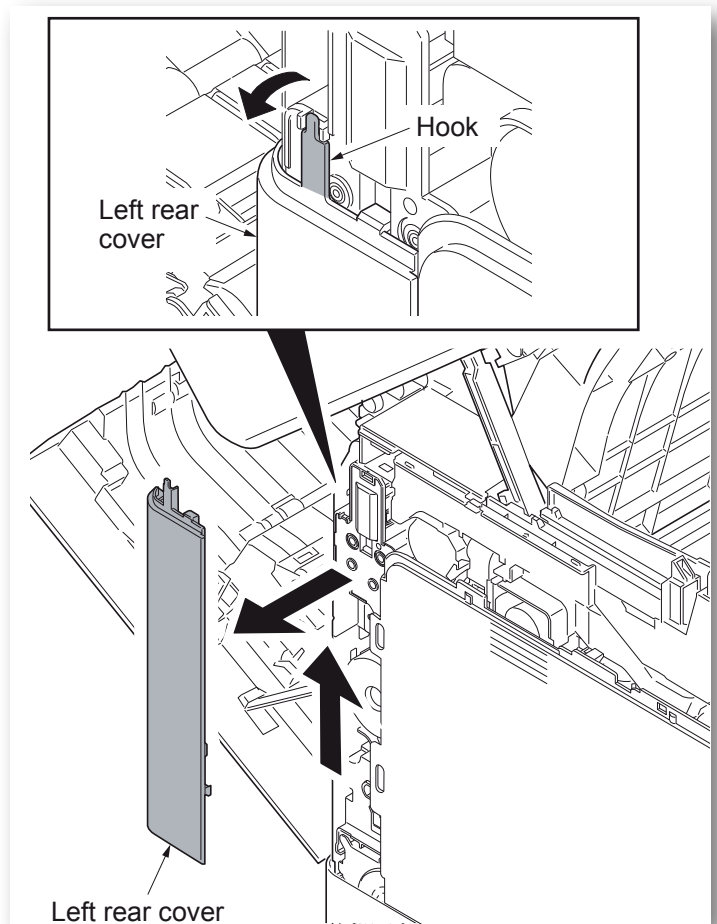

**Step 12**

Left Cover.

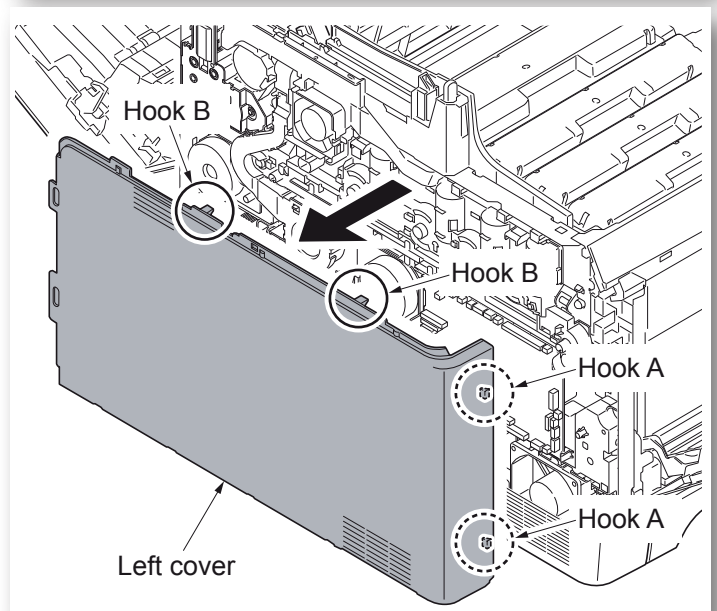

## Dismantling the side casings (continued)

### Step 13

Left Lower Cover.

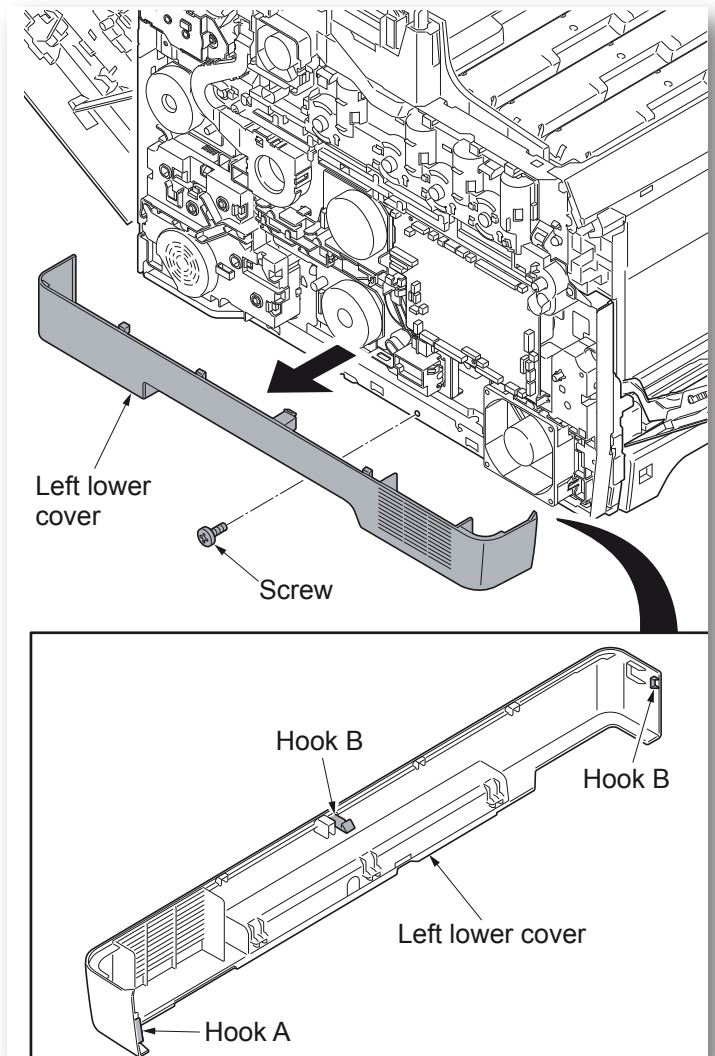

## Dismantling the side casings (continued)

### Step 14

Inner Cover.

**Note:**

FIRST remove cover 1, THEN the “inner cover” can be removed.

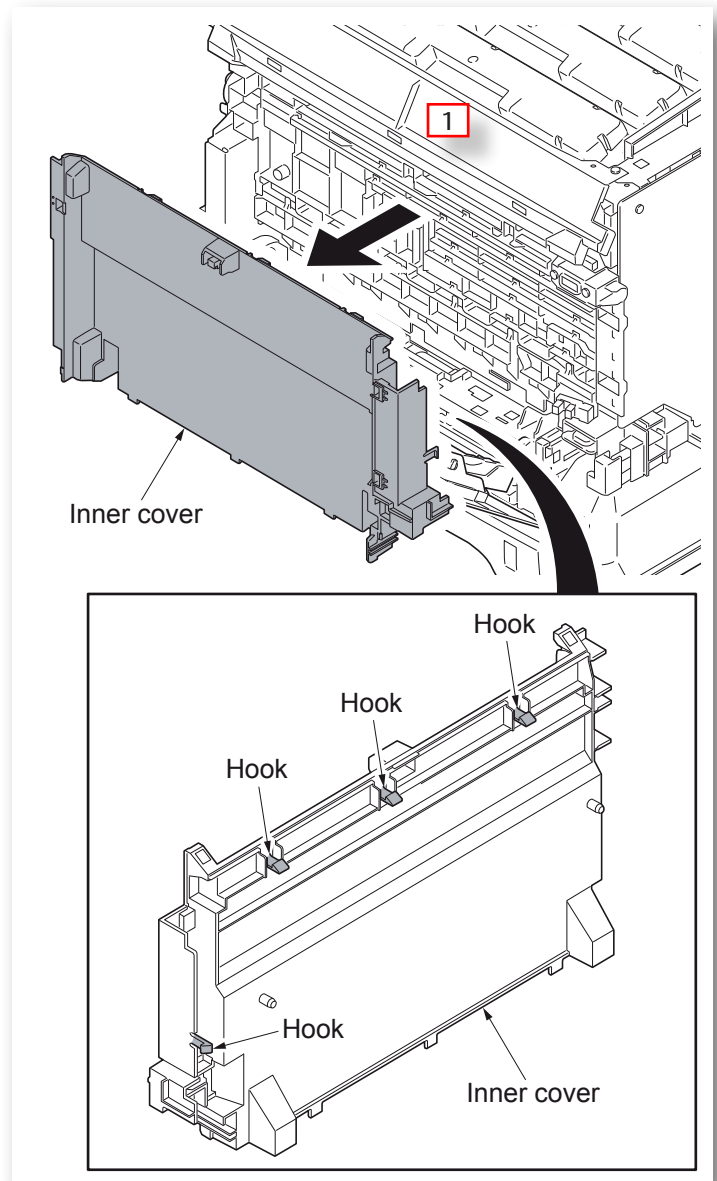

## Maintenance Mode (MFP)

|                 |   |
|-----------------|---|
| Action          | Enter maintenance mode.   |
| Recommendations | <ul style="list-style-type: none"> <li>• When specific device parameters (U-parameters) are to be adjusted or changed.</li> <li>• When special service prints (e.g. error protocol) are to be printed out.</li> <li>• When test prints (e.g. for device adjustments) are to be generated.</li> <li>• When adjustments and calibrations are to be made to the machine.</li> </ul>  |
| Pre-conditions  | <ul style="list-style-type: none"> <li>• Knowledge about access to maintenance mode.</li> <li>• Detailed knowledge about the functioning of U-parameters.</li> </ul>  |
| Hinweise        | <ul style="list-style-type: none"> <li>• The maintenance mode allows access to the device's technical parameters so that the machine's behavior can be influenced in a number of areas of operation.</li> <li>• Dealing with parameters requires a certain level of knowledge. Therefore you should ensure that users cannot access them.</li> <li>• A detailed description of all U-parameters can be found in the service manual.</li> </ul> <div style="display: flex; align-items: center; margin-top: 10px;">  <div> <p style="color: red; margin: 0;"><b>Maintenance mode should not be operated by customers!</b></p> <p style="margin: 0;">Do not leave the maintenance mode permanently switched on, because the Energy Saving function is deactivated while in this mode. Thus it results in higher heat emission and higher power consumption.</p> </div> </div> |

### Entering maintenance mode:

|            |                   |           |
|------------|-------------------|-----------|
| Variant 1: | Copy mode         | 1087 1087 |
| Variant 2: | Status/Job Cancel | 1087 1087 |

Choose variant 2 if variant 1 does not give the desired result. For example, it has to be selected when the device is in job accounting mode.

**In specific cases, the front lid has to be opened briefly after 10871087 is entered.**

### Navigation in maintenance mode:

|          |                              |
|----------|------------------------------|
| Inputs:  | Numeric keys, oder < > key   |
| Confirm: | START- or OK button          |
| Back:    | Back or reset or stop button |

### Exit maintenance mode:

Turn device off



## U-parameters (MFP)

### Important hints and tips:

- Before changing the U-parameters, a list of current settings has to be printed out via U-000. As the U-parameter settings are not saved, this list provides the only way to restore the original status.
- If in doubt about the function of a U-parameter, you can refer to the service manual for a detailed description of all U-parameters (in English). A brief description in English can be found on the following pages.
- Some U-parameters allow the generation of test prints or adjustments. Service mode can be temporarily exited for a test copy or test print by pushing the “System Menu/Counter” key. The temporary copy or printer mode lasts until this key is pressed once again.
- Only when the newly set values are confirmed with OK or START are they saved.
- Some counters (certain U-parameters) count the test prints while others do not. In the course of time, there may be differences between the counters.
- U-parameters for faxes are not included in the U-000 list. The fax U-parameters can be printed by using U-670 / “Self Status Report”.
- Make sure that the maintenance mode is switched off when you leave the customer.

## U-parameters (continued)

| Area   | Param. | Meaning   | Standard setting* |
|--|--------|---|-------------------|
| General  | U000   | <b>Lists:</b><br>U-parameter list<br>EventLOG Report                                | -                 |
|  | U002   | Optical parameters are partially reset<br>Movable mirror unit in transport position | -                 |
|  | U004   | Displays of serial number<br>Deletes C-0180 error when mainboard is replaced        |                   |
| Operation panel<br>and additional<br>equipment | U203   | Tests all functions of the document processor                                       | -                 |
|  | U222   | IC card type (for future use)   | -                 |
| Basic settings                                 | U250   | Sets maintenance interval   | 200000*1          |
|  | U251   | Counter for next maintenance message (can be reset)                                 | -                 |
|  | U253   | One-click / doubleclick for FOLIO formats   | Double count      |
|  | U260   | Click trigger (for feed or output)  | EJECT*1           |
|  | U285   | Displays toner coverage on service status page                                      | ON                |
|  | U332   | Conversion factor for toner coverage (not for A4 formats)                           | 1.0*1             |
|  | U345   | Maintenance message advance notice (0 = no advance notice)                          | 0*1               |
| Image processing                               | U410   | Automatic half tone calibration   | -                 |
|  | U411   | Automatic scanner adjustment  | -                 |
|  | U425   | Color value on adjustment chart (P/N: 302FZ56990)                                   | -                 |

## U-parameters (continued)

|      |  |  |  |
|------|--|--|--|
| Fax  | U600   | Initialization (country code for EMEA: 253)  | -  |
|      | U601   | Initialization of specific country settings  | -  |
|      | U603   | Selection procedure  | DTMF*2   |
|      | U604   | Call counter for incoming fax  | 2 (120 V)*2 1 (220-240 V)*2  |
|      | U605   | Delete all fax protocols (for data protection)   | -  |
|      | U610   | Reduction factor for marginally excessive length (Is used when extra sheets are printed frequently)  | 3 0 0  |
|      | U611   | Reduction parameter for automatic reduction when receiving   | 7 22 26  |
|      | U612   | Dynamic reduction for very long faxes<br>Conditions for output of the transmission report<br>Automatic page recognition                                  | ON OFF ON  |
|      | U620   | Remote switching to fax (one: one-time recognition)  | ONE*2  |
|      | U625   | Number of redialling attempts if connection not made<br>Interval between redialling  | 3 (120 V)*2 2 (220-240 V)*2 2 (120 V)*2<br>3 (220-240 V)*2           |
|      | U630   | Initial transmission speed (send and/or receive)<br>Echo compensation (send and receive)<br><br>Note:<br>Super G3 transmissions are not affected by this | 14400bps/V17*2<br>14400bps*2 300*2<br>75*2                           |
|      | U631   | Activate ECM (error correction) (send and/or receive)<br>CED frequency   | ON*2 ON*2 2100*2   |
|      | U632   | Configuration of DIS<br>Short protocol TX<br>Short protocol RX<br>Number of CNG signals until switchover to fax (tel/fax mode)                           | OFF*2 ON*2 ON*2<br>2TIME*2   |
|      | U633   | V.34 protocol (Super G3) active (send and/or receive)<br>V.34 symbol speed<br>DIS signal recognition<br>Failure rate for sending from RTN                | ON*2 ON*2 ONCE*2<br>15%*2  |
|      | U634   | Permitted errors during training (TCF)   | 0*2  |
|      | U640   | Time frame for recognition of remote switching   | 7*2 80*2   |
|      | U641   | Timing for:<br>T0 Time-out<br>T1 Time-out<br>T2 Time-out<br>Ta Time-out<br>Tb1 Time-out<br>Tb2 Time-out<br>Tc Time-out<br>Td Time-out                    | 56*2 36*2 69*2 30*2<br>20*2 80*2 60*2 9<br>(120 V)*2 6 (220-240 V)*2 |
| U650 | Send G3 equalizer<br>Receive G3 equalizer<br>Reception sensitivity | 0dB*2 0dB*2<br>43dBm*2   |  |

## U-parameters (continued)

|      |       |   |   |
|------|-------|---|---|
| Fax  | U651  | Modem transmission level<br>Tone dial transmission level  | 9 (120 V)*2 10 (220-240 V)*2 5 (120 V)*2 10.5 (220-240 V)*2 2 (120 V)*2 2.5 (220-240 V)*2 |
|      | U660  | Connection type (main connection – PSTN, extension – PBX)<br>Dial tone detection<br>Busy tone detection<br>Procedure for public line access<br>Loop current check after public line access  | PSTN*2 ON*2 ON*2 LOOP*2 ON*2  |
|      | U670  | <b>Lists:</b><br>Setting- Software switches<br>Action- error report<br>Self Status Report – Fax U-parameter list<br>Protocol- communication protocol of last transmission<br>Error- error report<br>Addr Book No.- fax address book IDs<br>Addr Book (Name)- fax addressbook name list<br>One Touch List- speed dialling keys assignment<br>Group list- group call list | -   |
|      | U695  | Fax stapling reception (start printing only after all pages have been received)<br>Page formatting prioritization (in subroom)  | ON/OFF  |
|      | U699  | Software switch (see service manual)  | -   |
|      | Other | U910  | Remove toner coverage detection   |
| U917 |       | Export or import of the following data on USB stick:<br>- Address book<br>- Cost centers<br>- Speed dialling keys<br>- User accounts<br>- Programs<br>- Document boxes<br>- Fax transmission  | -   |
| U920 |       | Number of copies per function (copy, print, fax)  | -   |
| U927 |       | Deletion of all counters (only 1x and <1000)  | -   |
| U928 |       | Totals counter (including test sheets)  | -   |
| U977 |       | Print data are stored as CAPT files on the USB stick  | -   |
| U995 |       | Memory dump   | -   |

## U-410, Automatic half tone calibration (MFP)

|                 |   |
|-----------------|---|
| Action          | Automatic half tone calibration.  |
| Recommendations | Recommended when the following components are to be replaced/repared: <ul style="list-style-type: none"> <li>• Drum units</li> <li>• Developer units</li> <li>• Transfer unit</li> <li>• Transfer roller</li> </ul> |
| Conditions      | Use of color copy paper is necessary, otherwise optimal results cannot be expected.   |
| Notes           | Carry out the following procedure completely.   |

- Call U-410, confirm with „OK“

Two pages of a color test sample are printed out.

- First put sheet 1 of the test sample that was just printed on the glass platen, so that the marked corner of the sheet lies precisely along the contact edge of the glass platen.
- Carry out the first scan by pressing “START”.
- Then repeat the same procedure with sheet 2.

The result should be “OK”.



### Note:

The two test sample prints look superficially identical. They are printed with two different grids. This is necessary to ensure that that output for different print objects (text, photos, graphics etc.) is optimal.

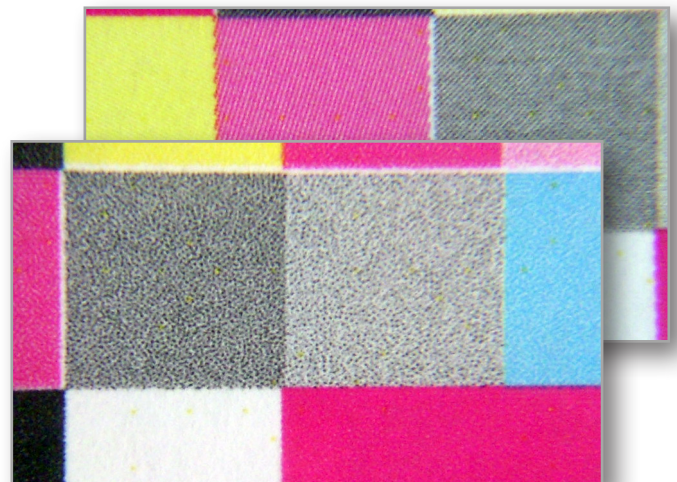



## U-425, automatic color calibration of the scanner (MFP)

|                 |   |
|-----------------|---|
| Action          | Automatic color calibration of the scanner - <b>Step 1</b>  |
| Recommendations | After repair or replacement of the CCD module, the scanner or the main board (control PWB).   |
| Pre-conditions  | Adjustment chart (Art. No.: 302FZ56990 01).   |
| Notes           | <p>Color calibration starts by entering LAB values. These Lab values are individually printed on the backside of each chart. Calibration <b>MUST</b> be carried out with the corresponding chart after these values have been entered.</p> <p><b>Attention:</b></p> <ul style="list-style-type: none"> <li>The adjustment chart is light sensitive and should be stored in the enclosed light-proof foil.</li> <li>NEVER pull in the adjustment chart with the document processor!</li> </ul> |

### Procedure:

1. Activate service mode.
2. Call U-425.
3. Enter ALL Lab values from the chart table (beginning with N8.75) (confirm with OK).
4. At the end of the table (pos.10), enter the measurements of the boundary frame (see below).\*
5. Continue with step 2 (on next page).

### \*) Determine measurements of pos. 10 (adjust original)

For geometric adjustments, which are also carried out during the calibration process, the exact position of the graphics on the adjustment chart is required.

In order to do this, the current measurements of the adjustment chart may have to be corrected.

- Main: Enter the distance between the “leading edge” and the bar (pos “B”).
- Sub Lead: Enter the distance between the “left edge” and the bar (pos “E”).
- Sub Tail: Enter the distance “G”.

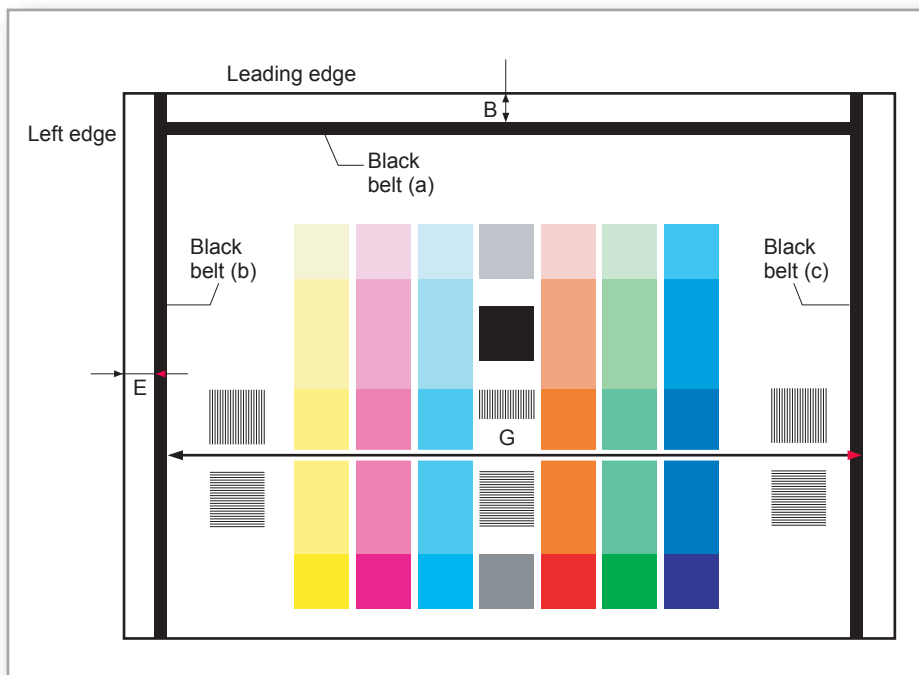

## U-425, automatic color calibration of the scanner (continued)

|                 |  |
|-----------------|--|
| Action          | Automatic color calibration of the scanner - <b>Step 2</b>   |
| Recommendations | After repairing or replacing the CCD module of the scanner or main board (control PWB).  |
| Pre-conditions  | <ul style="list-style-type: none"> <li>Adjustment chart (Art. No.: 302FZ56990 01).</li> <li>LAB values of the relevant charts have already been entered under U-425.</li> </ul>  |
| Notes           | <p>In addition, the following parameters are automatically adjusted:</p> <ul style="list-style-type: none"> <li>Scale</li> <li>Front edge position of the flat bed scanner</li> <li>Central adjustment of the flat bed scanner</li> <li>Contrast setting</li> </ul> <p><b>Attention:</b></p> <ul style="list-style-type: none"> <li>The adjustment chart is light sensitive and should be stored in the enclosed light-proof foil.</li> <li>NEVER pull in the adjustment chart with the document processor!</li> </ul> |

### Procedure:

- Place adjustment chart on the glass platen (the correct placement is shown in the picture on the back of the chart). Cover original with several white A4 sheets.
- Close document processor carefully so that the chart does not slip out of place.
- Activate service mode.
- Call U-411, select "Adjust table".
- Confirm with "OK".

The scanner now carries out several scanning procedures.

After ca. 1 minute, "OK" should appear.

If the calibration was not successful, the result "NG" appears in the display.

Check if the position of the adjustment original is correct and repeat the procedure.



## U-411, automatic scanner adjustment (MFP)

|                 |  |
|-----------------|--|
| Action          | Automatic adjustment of the scanner and document processor   |
| Recommendations | After repairing or replacing scanner components  |
| Pre-conditions  | <ul style="list-style-type: none"> <li>Adjustment chart for the document processor (Art. No.: 303LJ57010)</li> <li>Adjustment chart for glass platen (Art. No.: 302FZ56990)</li> </ul>   |
| Notes           | <p>The test includes optional adjustment of:</p> <ul style="list-style-type: none"> <li>Glass platen</li> <li>Document processor</li> <li>Both components</li> </ul> <p>The following parameters are automatically adjusted:</p> <ul style="list-style-type: none"> <li>Scale</li> <li>Position of front edge</li> <li>Central adjustment</li> </ul> |

### Preparation:

If the adjustment is to be made via the **glass platen**, the correct dimensions of the original under U-425, position 10 (Adjust Original), must be entered (see page 72).

### Procedure (for complete adjustment):

1. Apply the adjustment chart for the glass platen (Art. No.: 302FZ56990).
2. Insert the adjustment chart for the document processor (Art. No.: 303LJ57010).
3. Call U-411, select "All".
4. Confirm with "OK".

Adjustments are being carried out...

If the calibration was not successful, the result "NG" appears in the display.  
Check if the position of adjustment original(s) is correct and repeat the procedure.

### Notes:

The adjustments can be carried out separately.



## Setting up color registration

|                 |  |
|-----------------|--|
| Action          | Correction of color registration if required.  |
| Recommendations | <ul style="list-style-type: none"> <li>• After installation</li> <li>• After repair or replacement of LSU</li> <li>• After repair or replacement of transfer belt</li> </ul> <p>Also useful after lengthy transportation.</p>  |
| Pre-conditions  | -  |
| Notes           | <p>The adjustment of color registration comprises 3 processes:</p> <ol style="list-style-type: none"> <li>1. Manual LSU mirror correction (optional, only if LSU is being replaced)</li> <li>2. Simple color registration</li> <li>3. Detailed color registration</li> </ol> |

Color registration is made with 2 different test prints.

**MFP:**  
System / Adjust/Maint. / Color Registr.

**Printer:**  
Menu / Adjust/Maintenance / Registration

- Normal (1)
- Detail (2)

The corresponding test print depicts the current status of color registration for all colors. In case of discrepancies, the relevant color correction value can be entered in the menu.

Under “Detail”, color registration is checked not only in one position, but in several positions. Thus the adjustment is more precise.

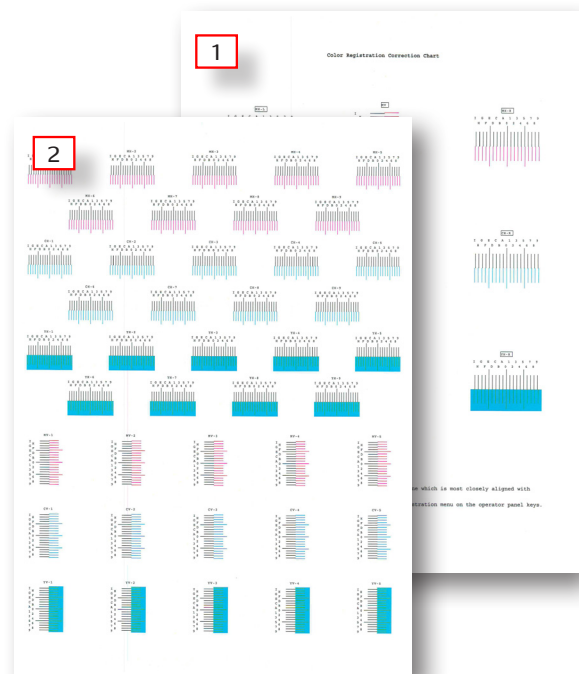

### Example of a correction:

Faulty registration: Magenta (1).  
After entering the correction value (MH-1: = 3)...  
...correct registration (2).

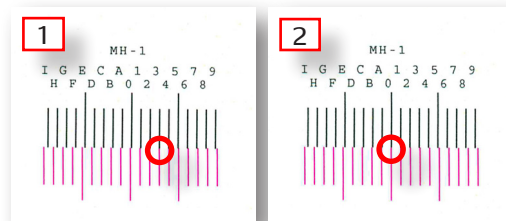

A correction is only required if there is a discrepancy of two lines on the scale.

### Useful hints:

- Assessment of yellow is easier under blue (LED) light.
- Looking through a smart phone camera has the same effect.

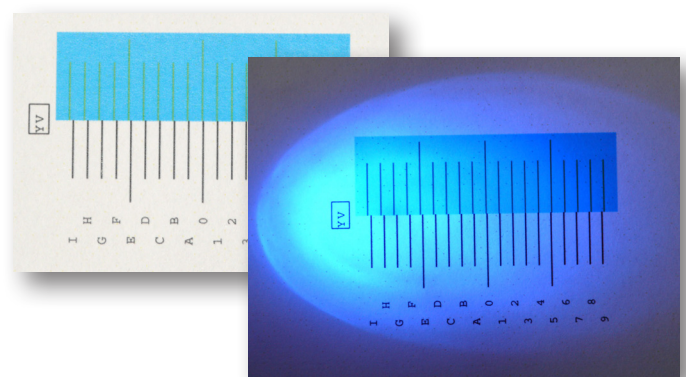

## Setting up color registration (continued)

### Manual mirror correction:

The LSUs have a contrivance which influences the position of the deflection mirror.

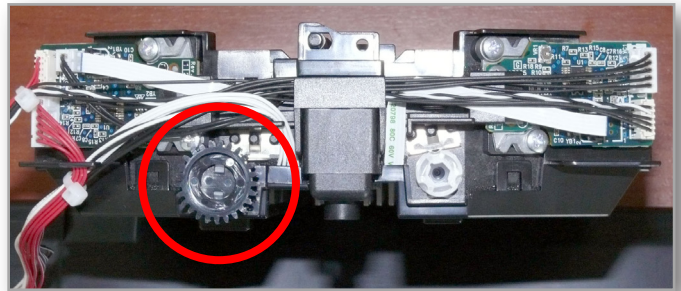

For each color there is an adjustment wheel that can be accessed inside the empty cassette holder. The position of the colors corresponds to the arrangement of the toner containers: Y C M (from front to back).

The picture shows the cassette holder with the lowered "conveying lower cover".

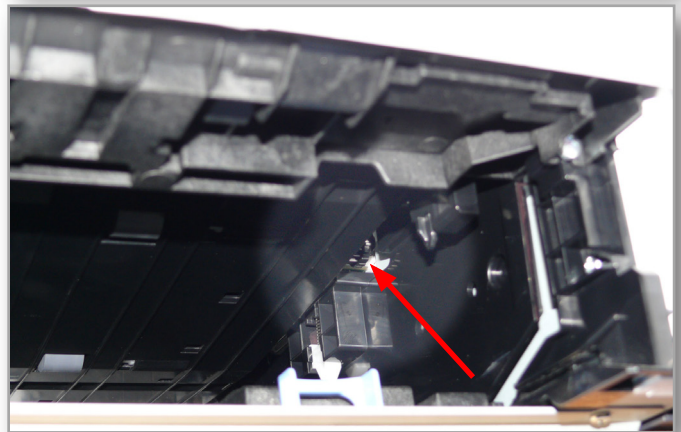

**Manual** mirror correction should **ONLY** be carried out after replacing the corresponding LSU.

To carry out a mirror correction, the test print for **detailed** color registration has to be selected.

### MFP:

**System / Adjust/Maint. / Color Registr. / detail**

### Printer:

**Menu / Adjust/Maintenance / Registration Details**

A correction is only required if individual indicators of the vertical registration show **different discrepancies**:

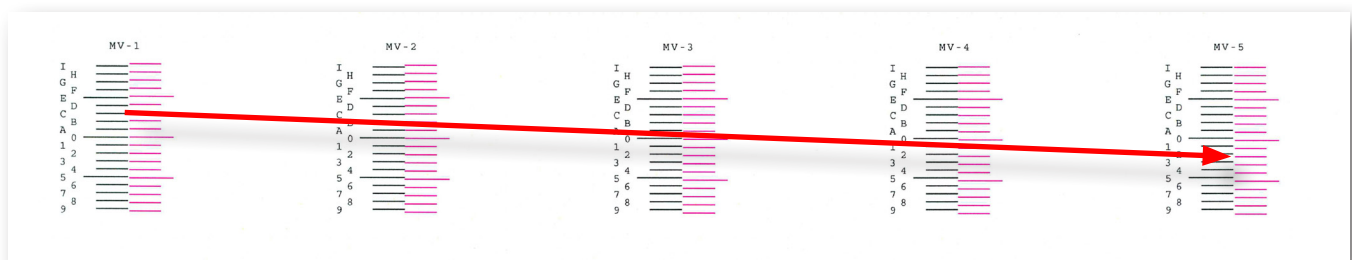

### The correction is carried out in 2 steps:

1. Mechanical adjustment of the corresponding LSU, so that the **discrepancy** of all indicators is finally **identical**.
2. Input of the correction value XV-3, so that the vertical registration over the entire breadth is correct (i.e. that the indicator displays 0).

### Tip:

The discrepancy shown above can be compensated by moving the correction wheel (magenta) **backwards**.



## Service settings (MFP)

|                 |  |
|-----------------|--|
| Action          | Enter service settings.  |
| Recommendations | <ul style="list-style-type: none"> <li>• When copy or print quality is poor.</li> <li>• When a detailed summary of technical settings is required (e.g. during customer-technician communications).</li> <li>• When fax connection parameters have to be set (e.g. connection to a private branch exchange).</li> <li>• When certain adjustments are required (e.g. relocation or replacement of components).</li> </ul> |
| Pre-conditions  | -  |
| Notes           | <ul style="list-style-type: none"> <li>• Access to service settings does not require any special actions.</li> <li>• Detailed information can be found in the service manual (service mode).</li> </ul>  |

### Entry:

**System Menu / Adjust/Maint. / Service Setting.**

### Overview:

|                      |   |  |
|----------------------|---|--|
| Service status       | Print "Service Status Page" (2 pages).<br>Overview of device settings and consumption information.  |  |
| Network status       | Detailed printout of network settings.  |  |
| Test page            | Printout of color separations (YC-Green, M, C, K) each in 3 different density levels.   |  |
| Developer settings   | When replacing a developer unit, an alphanumeric value has to be entered. This measure leads to the adjustment of electrical parameters on the new developer unit.  |  |
| Refresh developer    | By removing the existing toner material from the developer roller, fresh toner is applied. To be used if printouts are stained.   |  |
| Laser scan. Cleaning | Cleaning of the laser exit window. To be used if printouts are streaky (in print direction).  |  |
| Refresh drum         | Polishing the drum surface by an idle run lasting 2 minutes. Here the toner is used as a "polish" for the drum in question. To be used if printouts are stained.  |  |
| Altitude Adj.        | If the location of the device is 1,500 m. above sea level, or higher, a correction has to be carried out.   |  |
| MC                   | A change in the drum load, to be used if printouts are pale.<br>1 (darker)...5 (brighter).<br>Adjustment is not allowed if "Altitude Adj." is set to High 1 or High 2.  |  |
| Fax country code     | Specific country code for fax parameter.<br>Standard settings for Europe: <b>253</b>  |  |
| Fax Call Settings    | The following settings can be made: <ul style="list-style-type: none"> <li>• Connection to telephone network (PSTN) or private branches (PBX)</li> <li>• Procedure for public line access</li> <li>• Code number(s) for public line access</li> </ul> |  |
| Remote diag. Sett.   | Not applicable for Europe.  |  |
| Remote diagnosis ID  | Not applicable for Europe.  |  |

## Service Settings (Printer)

|                 |   |
|-----------------|---|
| Action          | Enter service settings.   |
| Recommendations | <ul style="list-style-type: none"> <li>• When the print quality is poor.</li> <li>• When a detailed summary of technical settings is required (e.g. during customer-technician communications).</li> <li>• When certain adjustments are required (e.g. relocation or replacement of components).</li> </ul> |
| Pre-conditions  | -   |
| Notes           | <ul style="list-style-type: none"> <li>• Access to service settings does not require any special actions.</li> <li>• Detailed information can be found in the service manual (service mode).</li> </ul>   |

### Entry:

**Menu key / Adjust/Maintenance / Service**

### Overview:

|                           |  |  |
|---------------------------|--|--|
| Print status page         | Print "Service Status Page" (2 pages).<br>Overview of device settings and consumption information.   |  |
| Print network status page | Detailed printout of network settings.   |  |
| Print test page           | Printout of color separations (YC-Green, M, C, K) each in 3 different density levels.  |  |
| DEV-SET                   | When replacing a developer unit, an alphanumeric value has to be entered. This action leads to the adjustment of electrical parameters on the new developer unit.      |  |
| DEV-CLN                   | By removing the existing toner material from the developer roller, fresh toner is applied. To be used if printouts are stained.  |  |
| LSU                       | Cleaning of the laser exit window. To be used if printouts are streaky (in print direction).   |  |
| Drum                      | Polishing the drum surface by an idle run lasting 2 minutes. Here the toner is used as a "polish" for the drum in question. To be used if printouts are stained.       |  |
| Altitude Adj.             | If the location of the device is more than 1,500 m above sea level a correction has to be carried out.   |  |
| MC                        | A change in the drum load, to be used if printouts are pale.<br>1 (darker)...5 (brighter).<br>Adjustment is not allowed if "Altitude Adj." is set to High 1 or High 2. |  |



- Replacement of wearout components (separation, feed rollers) is quick and does not require any special tools.
- Removing the side casings can be done easily if the relevant information in the documentation is used.
- The maintenance mode (10871087) allows differentiated access to the device settings. A detailed description of all U-parameters can be found in the Service Manual.
- When replacing certain components, adjustments are required.

**Apply your knowledge!**

Please refer to “Hints“.

**Practice 1**

Clean the laser window.

**Practice 2**

Refresh the developer.

**Practice 3**

Clean the drum.

**Practice 4**

Make a correction to the color registration.

**Practice 5**

Carry out a half tone calibration.

**Practice 6**

Carry out a scanner calibration.

**Practice 7**

Adjust the document processor.

**Practice 8**

Remove all casings as described in the manual.

**Practice 9**

Make a replacement (detaching and refitting):

- Separation unit (paper cassette)
- Feed roller (paper cassette)

**Practice 10**

Locate the components:

- Motors
- Sensors
- Clutches
- Boards

**Practice 11**

Remove the components:

- Toner
- Transfer belt
- Drums
- Developer units

**Practice, continued.**

Please refer to “Hints“.

**Practice 12**

Remove the high voltage circuit board.

**Practice 13**

Remove the protective hood of the mainboard and the power supply.

**Practice 14**

Detach the front LSU (Caution: do not remove cable from LSU).

**Practice 15**

Detach the fixing unit.

**Practice 16**

Detach the transfer unit.

**Practice 17 (MFP)**

Remove the connection between the top cover and the scanner.

**Practice 18 (MFP)**

Remove the document processor.

**Intention:**

FIRST go through all exercises that do not require any dismantling of the machine.

THEN remove all side casings to get a global overview.

The last step involves studying the individual components in depth by dismantling them.





- 1.) Replacement of wear components (feed roller, separation) is only possible if special tools are used.
  - True
  - False
- 2.) (MFP) Color calibration of the scanner takes place automatically between individual scanning procedures (for white balance).
  - True
  - False
- 3.) (MFP) The adjustment of the scanner and the document processor is carried out with the same adjustment original.
  - Correct
  - Incorrect
- 4.) Correction of color registration is required when:
  - Replacing the LSU
  - Replacing the Transfer Roller
  - Replacing the mainboard
  - Replacing the ISU (Image Scanner Unit)
  - Replacing the fixing unit
  - After moving the device
  - Not required, as it is an automatic process

**Contents:**

- Detaching the transfer unit
- Handling drums
- Handling developer units
- Handling laser units
- Replacing toner motors
- Detaching the scanner unit
- Replacing main board
- Replacing engine board

## Detaching the transfer unit

### Tip 1: Detaching the "Container Guide":

A component can only be released by pressing the safety latch.



### Tip 2: RFID Holder:

The RFID holder can be locked in the swung out position.



**Attention: If the RFID holder is swung out, the top cover CANNOT be closed.**



### Tip 3: Checklist for detaching transfer unit:

- Has the fastening screw been removed?
- Has the slide been closed?
- Is the RFID holder in a swung out position?

Lift the transfer unit carefully and remove it.



## Handling the drums



**Attention:** The drums must be protected from light after the transfer units have been removed.

**CAUTION** when closing the top casing cover (position of the RFID holder?)!

### Tip 1: Detaching the drum unit:

Use the handles provided for this purpose.

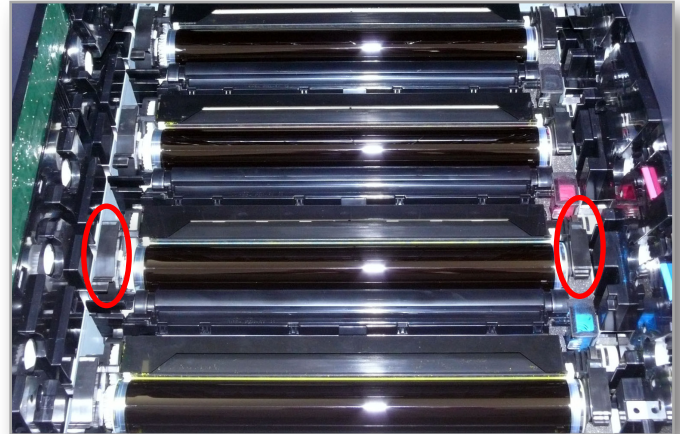

### Tip 2: Cleaning the charge roller:

The charge roller can be removed from the unit for cleaning.

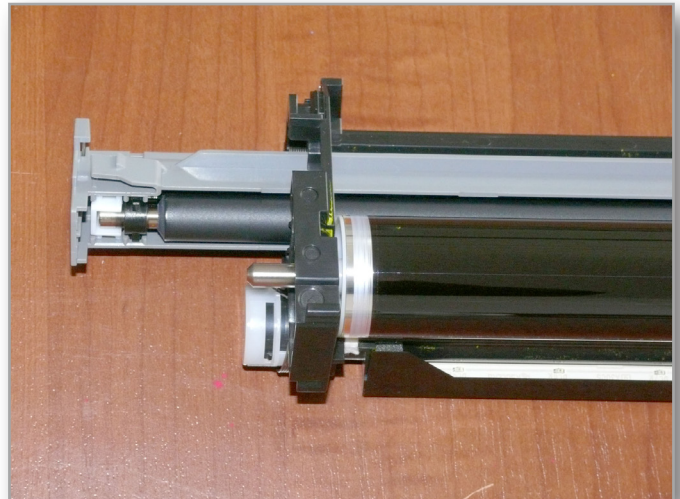

### Tip 3: Inserting the drum unit:

When all components have been inserted, the correct position can be checked with a ruler. All handles must be oriented parallel to the ruler.



**The rearmost drum (black) must be inserted with special care.**

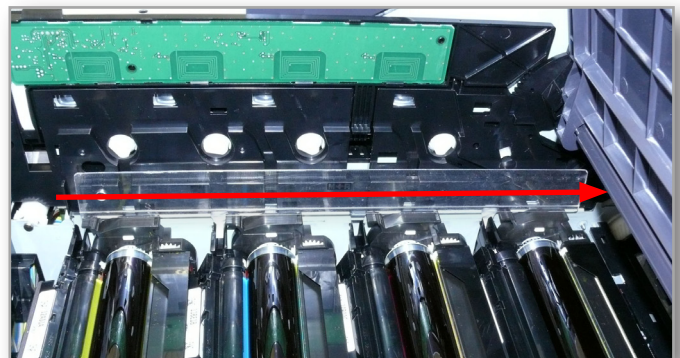



## Handling developer units

### Tip 1: Detaching developer units:

The components are held tight on the left side by two latch noses. To release, please press these.



When refitting, take care to completely lock the components in place.

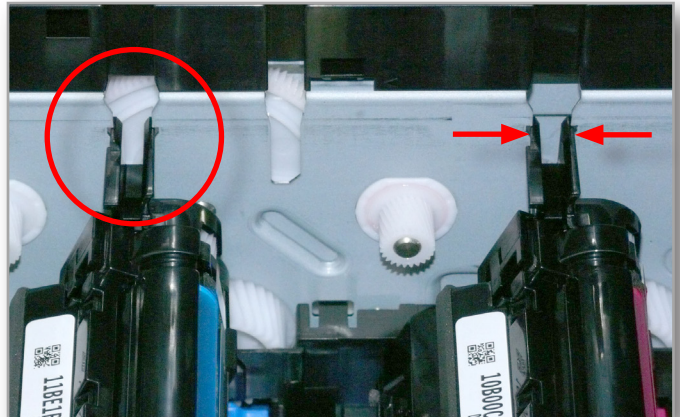

### Tip 2: Transporting developer units:

- Do not touch the surface of the developer roller.
- Always hold the developer unit in such a way that the filler pipe points upwards. **Otherwise, the toner may leak out.**
- If the developer unit is to be transported, the toner pipe must be sealed.
- If you have received a new developer unit, you can use the transport cap for this purpose.

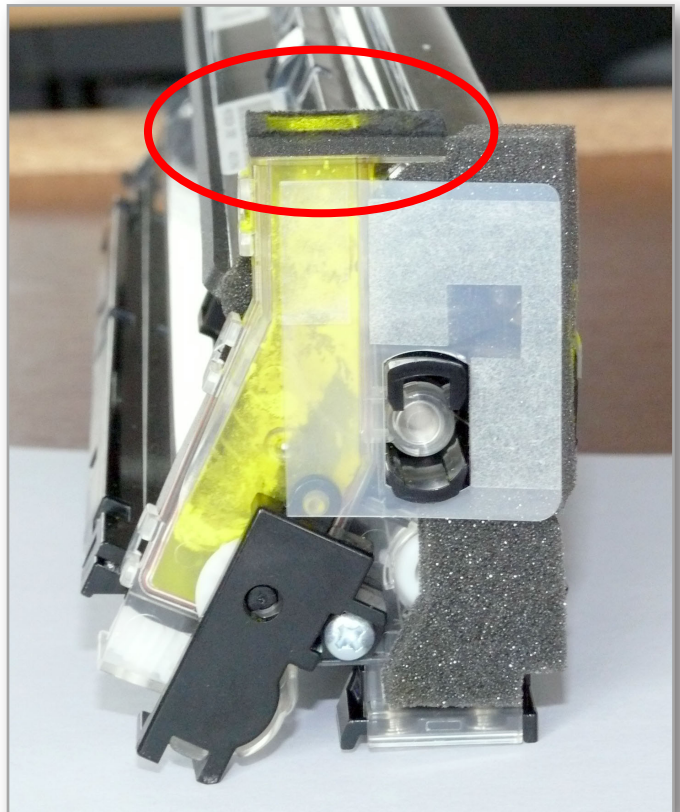

### Tip 3: Register the new developer unit:

After fitting a NEW developer unit, enter the code printed on it (see page 77).





## Handling laser units

### Tip 1: Remove cable:

**NEVER** pull out the control board plug of the laser unit; it is very sensitive and can easily break off.



Only remove the cables to the laser unit on the engine board and main board!

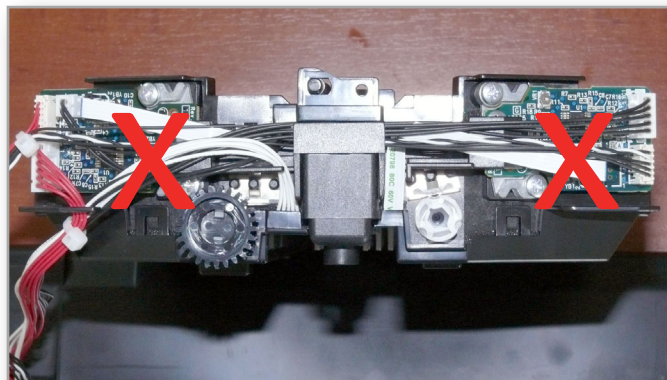

### Tip 2: Cable routing:

When refitting the laser unit, take care to route the cable correctly.

The units should not tilt on the base plate.

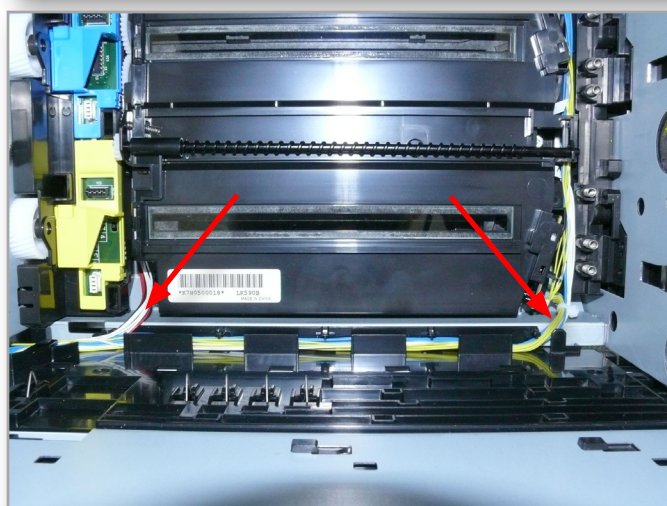
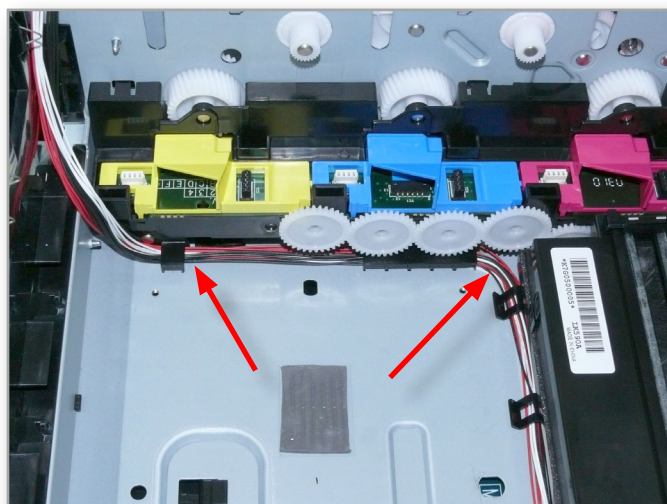

## Replacing toner motors

### Tip 1: Releasing the strap of the ID sensor cleaner:

Before the motor carrier plate (2) can be removed, the belt has to be pulled from the carrier. Therefore remove the clamp (see arrow) and then carefully pull the belt from the positioning pins. The belt is additionally secured with a flexible glue.

The strap can only be accessed by detaching the ventilation unit (1).

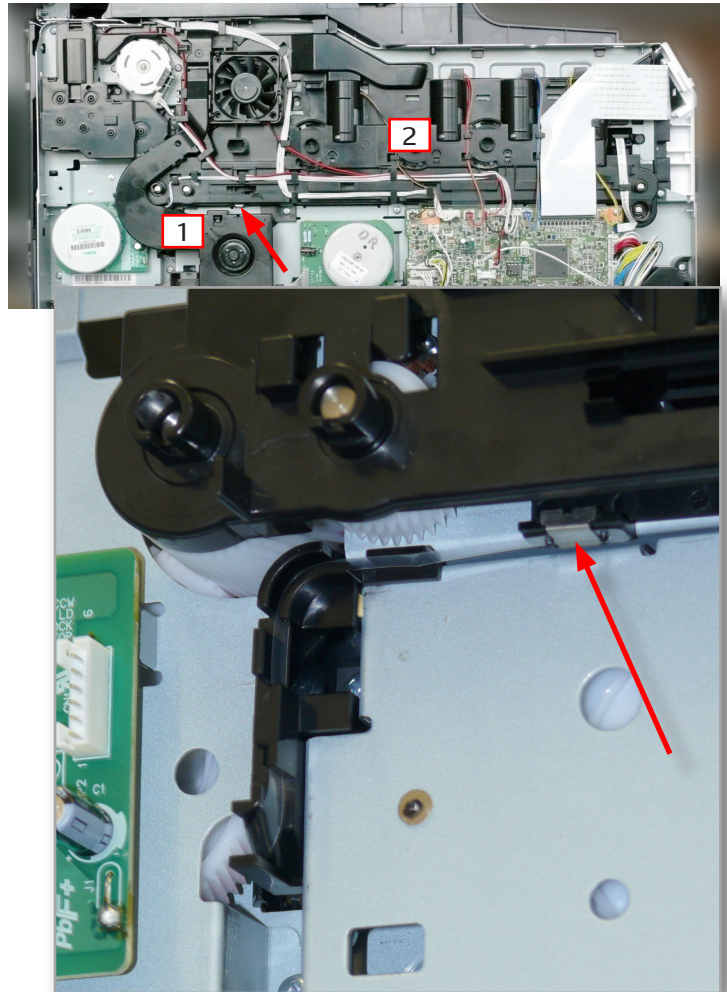

### Tip 2: Detaching the motor carrier plate:

- Close the cover so that there is no mechanical tension on the locking mechanism.
- Carefully remove the carrier plate.

**Note:** The illustration shows the locking mechanism in released position.

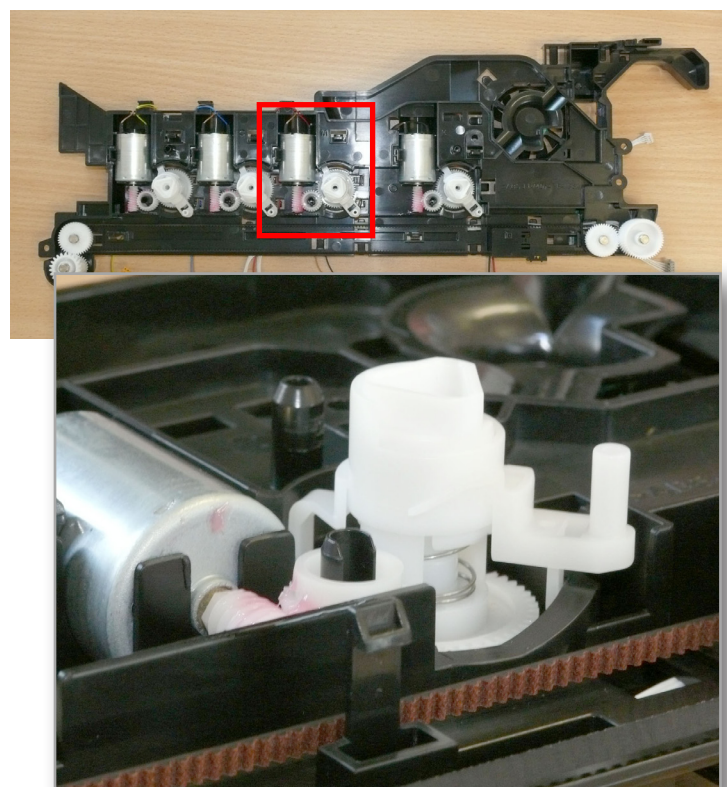

The timing belt driving the transfer belt cleaning process can be seen in the foreground.



## Detaching the scanner unit (MFP)

### Tip 1: Pull out the bolts from the top housing cover:

The transit bolts can easily be removed as follows:

1. Grip the bolt head from the outside with a pair of pliers.
2. Turn the pliers 90° so that the guiding groove is pushed apart by the pliers' shanks (see picture).
3. Pull the bolt out in this position.

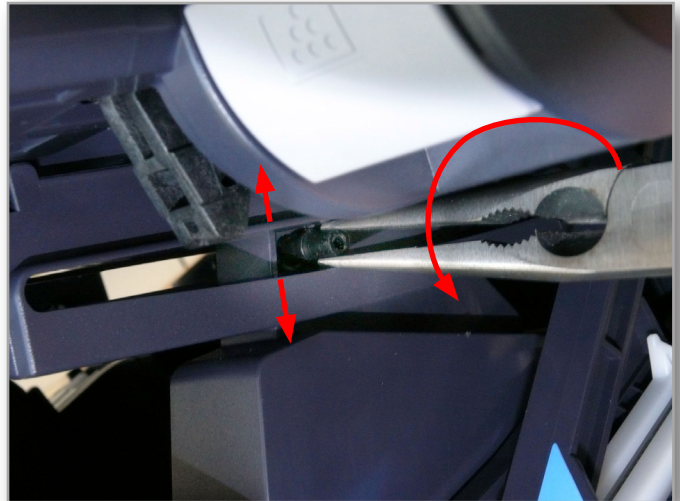

### Tip 2: Attaching leg springs:

When refitting, take care to attach both leg springs correctly:

1. Left side (2x crimped shanks)
2. Right side (one crimped shank)

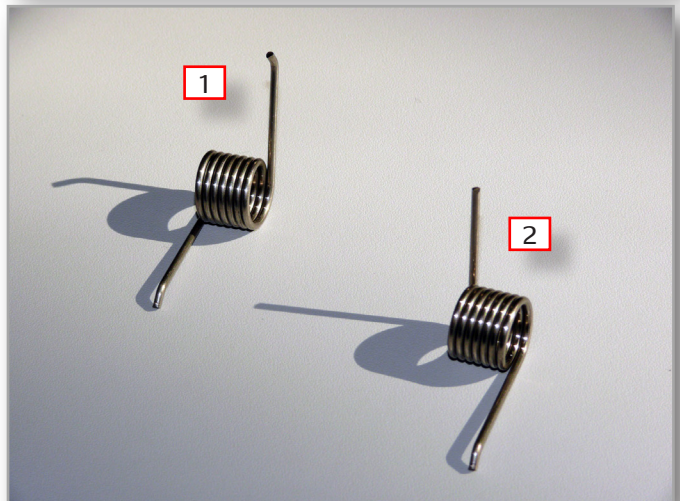

### Tip 3: Safety mechanism of document processor:

As soon as the "Right Upper Cover" is removed, the document processor cannot be opened or removed from the scanner housing. To release the mechanism a suitable object can be put in the opening.

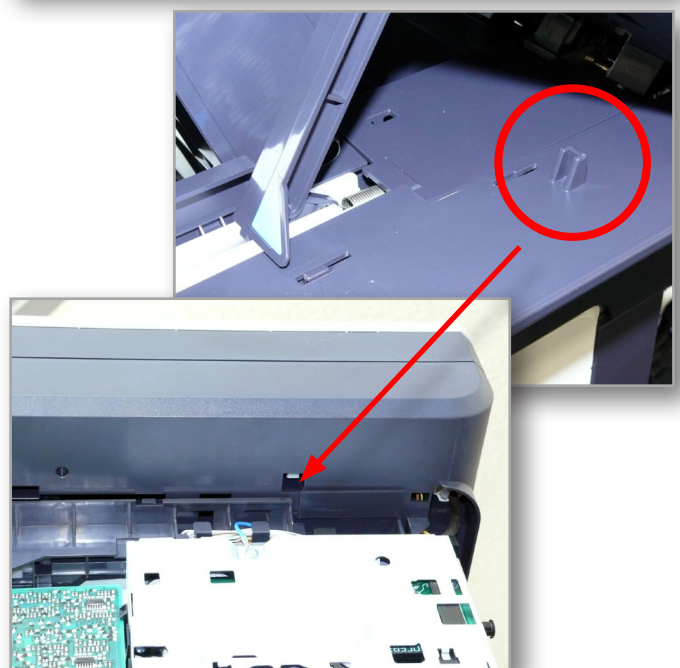

## Replacing main board

The following points should be noted for replacement:

- (MFP) BEFORE replacing, save all relevant data on a USB stick using U-917.
- (MFP) The ventilator must be removed before the protective hood can be taken out.



After refitting the main board, error C-0180 sometimes appears. In this case, execute U-004 (MFP).

After successful replacement:

- Perform a F/W upgrade.
- (MFP) Restore data from USB stick (U-917).
- (MFP) Carry out scanner adjustment (U-411, see page 74).
- (MFP) Carry out scanner calibration (U-425, see page 72).
- (MFP) Carry out adjustment of the document processor (DP) (U-411, see page 74).
- (MFP) Carry out a halftone calibration (see page 71).
- Carry out color registration (see page 75).

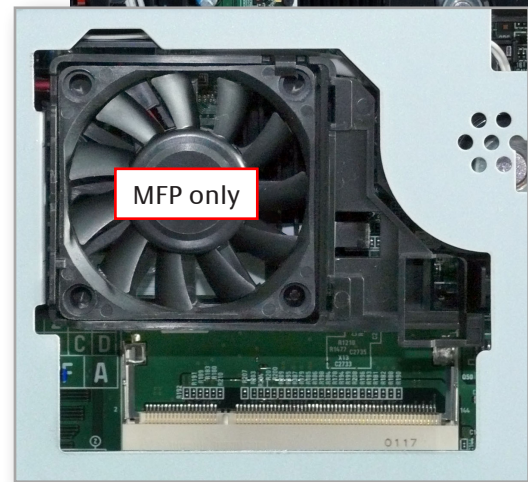
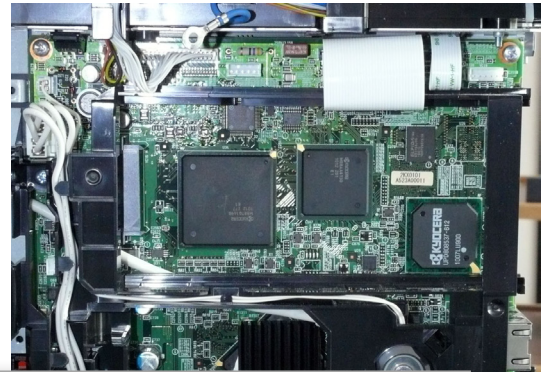

## Replacing engine board

The following points should be noted for replacement:

- Do not mix up the two ribbon cables (ID sensors)! See picture.
- Retain the EEPROM (1) of the old engine board! This MUST be inserted in the new engine board.
- Take care that all plugs are inserted securely.
- In case of an EEPROM error (C-0170), please contact hardware support.
- Perform a F/W upgrade.

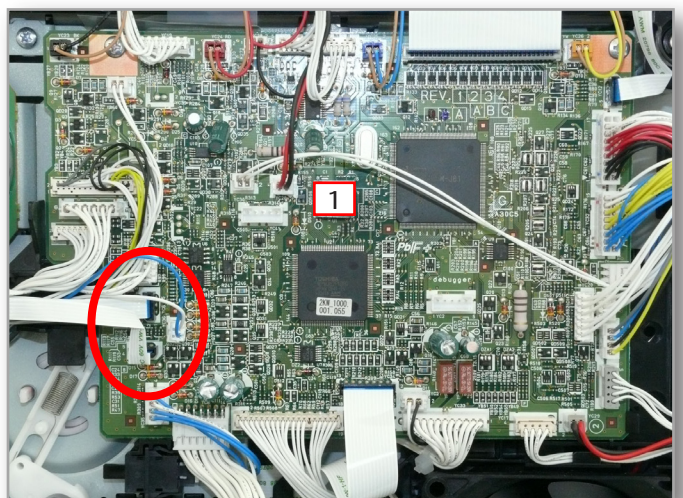

**Contents:**

- Access
- Design
- Helpful hints
- Safety concept
- Passwords
- Blocking the Operation Panel
- Blocking interfaces
- IP filter
- Local authentication
- Network authentication

**At the end of the chapter you will be able to...**

- integrate the device in the network.
- have an informed dialog with the administrator.
- protect the device from unauthorized network access (flexible security concept).
- set up different network scan modes.
- establish administrative security functions.

## Access to the Command Center

Access to the Command Center is available via a web browser (e.g. internet Explorer, Mozilla Firefox etc.).

Enter the IP address or the host name of the printer or multifunction device in the browser's address bar.

Example:

<http://192.168.100.25>

or

<http://KM4C3174>

**KYOCERA COMMAND CENTER** FS-C2126MFP Status: Warning

**Start**

**FS-C2126MFP**

**Operation Panel**

Ruhemodus

Refresh

**Toner Level**

|         |     |
|---------|-----|
| Black   | 65% |
| Cyan    | 99% |
| Magenta | 99% |
| Yellow  | 99% |

**Network IP Information**

|                                  |              |
|----------------------------------|--------------|
| IP Address:                      | 10.177.6.115 |
| IP Address (IPv6) (Manual):      |              |
| IP Address (IPv6) (Link Local):  |              |
| IP Address 1 (IPv6) (Stateless): |              |
| IP Address 2 (IPv6) (Stateless): |              |
| IP Address 3 (IPv6) (Stateless): |              |
| IP Address 4 (IPv6) (Stateless): |              |
| IP Address 5 (IPv6) (Stateless): |              |
| IP Address (IPv6) (Stateful):    |              |
| Host Name:                       | KM794154     |

**System Identification**

|                  |                   |
|------------------|-------------------|
| MAC Address:     | 00:C0:EE:79:41:54 |
| System Firmware: | 2KX_2F00.001.129  |

If the Command Center is called up, access is limited for security reasons.

Apart from setting the Command Center's language, no other settings can be made. The contents of the various registers are limited exclusively to the display of status information.

If full access is wanted, a password has to be entered.

A click on the "Login" button calls up the registration window.

**Login**

Password:

OK Cancel

The login takes place by entering the standard password

**admin00**



## Design of the Command Center

The screenshot shows the Kyocera Command Center interface for device FS-C2126MFP. The interface is divided into three main areas:

- 1 Main Menu:** Located at the top, featuring a 'Start' button.
- 2 Submenu:** Located on the left side, containing a 'Login' button, 'Select Language' (set to English), and various status pages like Network, Security, Device / Printer, Scanner, FAX, Jobs, Counters, Information, Address Book, User Login, About, Links, Download Drivers, and Kyocera Online.
- 3 Information/setup area:** The main content area, displaying:
  - Operation Panel:** A cyan box labeled 'Ruhemodus' with a 'Refresh' button.
  - Toner Level:** A bar chart showing toner levels: Black (65%), Cyan (99%), Magenta (99%), and Yellow (99%).
  - Network IP Information:** A table listing IP addresses:
 

|                                  |              |
|----------------------------------|--------------|
| IP Address:                      | 10.177.6.115 |
| IP Address (IPv6) (Manual):      |              |
| IP Address (IPv6) (Link Local):  |              |
| IP Address 1 (IPv6) (Stateless): |              |
| IP Address 2 (IPv6) (Stateless): |              |
| IP Address 3 (IPv6) (Stateless): |              |
| IP Address 4 (IPv6) (Stateless): |              |
| IP Address 5 (IPv6) (Stateless): |              |
| IP Address (IPv6) (Stateful):    |              |
| Host Name:                       | KM794154     |
  - System Identification:** A table listing system details:
 

|                  |                   |
|------------------|-------------------|
| MAC Address:     | 00:C0:EE:79:41:54 |
| System Firmware: | 2KX_2F00.001.129  |

The Command Center is divided into the following areas:

- 1 Main Menu**  
Access to the main functions of the Command Center.  
If no login for the Command Center takes place, the "Start" menu appears.
- 2 Submenu**  
The contents depend on which item was chosen in the main menu.  
If there is a ► after the menu item, more submenus are located there. By moving the mouse over it, these become visible.  
Each submenu is colored differently for better differentiation.  
A different color is used for each submenu for better differentiation.
- 3 Information/setup area**  
The contents can be scrolled over with the right scroll bar if the setup areas are particularly extensive.

### Important Note:

- If the Command Center has not been accessed for a long time, a new password has to be entered.
- It is advisable to change the access password after the first use (see page 98).
- If the password has been forgotten, there is NO way to access the Command Center. When this happens, the device has to be reset to the factory settings by taking the relevant measures. In this case, all individual settings are lost.  
(Also see Command Center, "Helpful hints")

## Style of presentation in this manual

Each function of the Command Center is described in the following pages.

The presentation of nested menu structures and the corresponding screenshots have been modified here due to space restrictions.

Example:

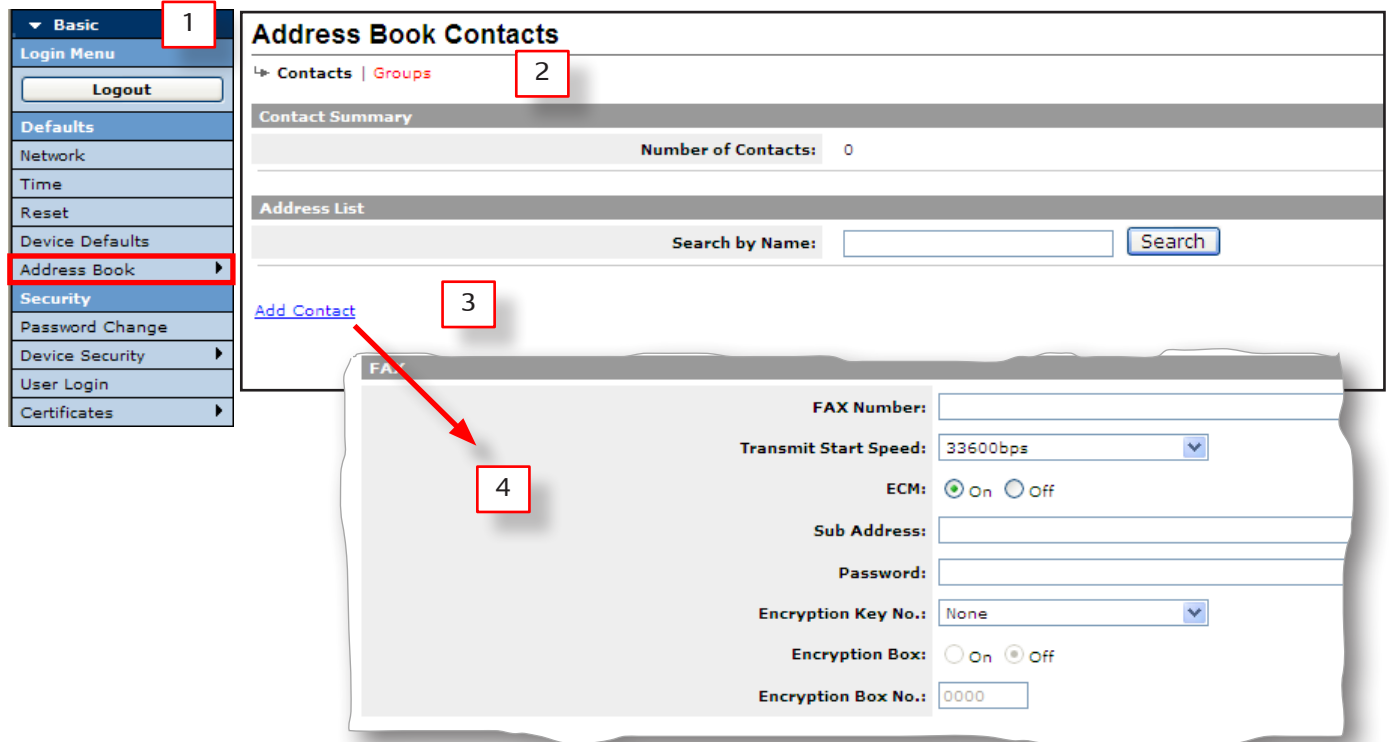

The presentation of the Command Center is structured as follows:

### 1 Submenu

The submenu is subordinate to the main menu. However, the presentation of the main menu can be dispensed with, because the first text entry of the submenu always mirrors the main menu item.

Furthermore, all submenus are differentiated by their ground color so that each submenu can be identified easily.

Within the submenu, the menu item—the contents of which are to be presented—is indicated by a red frame.

### 2 Site map

The site map not only depicts the selected information or setup area, but also has a kind of position indicator that shows the page where the user is (black entry).

If there are additional parallel pages to the selected page, then these are represented by red terms that can be clicked on.

### 3 Link

If further settings are required for the selected page (function), then these are represented by blue underlined terms.

### 4 More settings

The additional settings that have been clicked on in (3) are marked with an arrow. Several cascading displays are also possible.

The rough image indicates that the illustration is incomplete and only the relevant area is shown in the view. In practical terms this could mean that the area can only be accessed by scrolling.

## Helpful hints

|                                |  |
|--------------------------------|--|
| Entries                        | <p>All entries in the Command Center have to be confirmed using the “Send” button, only then are the data sent to the device.<br/>Some entries take a little time so be sure to keep an eye on the progress bar.</p>   |
| Password                       | <ul style="list-style-type: none"> <li>• The access password (admin00) should be changed as soon as possible so that there is optimal protection (see page 98).</li> <li>• In principle, it is possible NOT to define ANY password. Access to the Command Center would then be unprotected (not recommended).</li> </ul>   |
| Password forgotten/<br>unknown | <p>The password can <b>only</b> be changed in the relevant Command Center menu. If the password is not known, the Command Center can neither be accessed nor can a new password be defined.</p> <p>The following strategy is helpful if the access password is not known:</p> <ul style="list-style-type: none"> <li>• While installing the device, a separate administrator account is set up (see page 106). Important: The account must have administrator rights!</li> <li>• This administrator account can be used to access system settings via operation panel.</li> <li>• <i>Local authentication</i> can be activated via the system settings.</li> <li>• After that the administrator account can be used to access the Command Center.</li> <li>• Though the password has not been changed, all settings in the Command Center are available.</li> <li>• After making the required settings, local authentication (in the Command Center) can be switched off again.</li> </ul> <p>A password change, when the old password is not known, can only be carried out by resetting the device:</p> <ul style="list-style-type: none"> <li>• Reset via the Command Center (see page 118)</li> </ul> <p> "Reset to factory settings" results in the loss of certain data. Make sure that these data are saved before the reset is carried out.</p> |

## Safety Concept

| Requirements  | Measure  |
|---|--|
| <b>MFP:</b><br>The device's system settings have to be protected.   | The system settings are protected by a standard account (DeviceAdmin) (2600 / 2600).<br>This standard account should be changed as required to ensure long-term security.<br>It is also practical to set up an additional account to ensure access if the "official" password is lost or unknown (should be arranged with the customer). |
| <b>MFP:</b><br>In addition to system settings, any unauthorized device configuration should generally be prevented. | Activation of the authentication mode.<br>See page 107.  |
| System settings must be protected from access via the Command Center.   | Access to the Command Center is protected by a standard password (admin00). This standard password should be changed as required to ensure long-term security (see page 98).<br><br><b>MFP:</b><br>It is also practical to set up an additional account (see page 106) to ensure access if the "official" password is lost or unknown.   |
| Only selected communication protocols must be used.   | See page 101.  |
| Only certain interfaces must be used.   | See page 100.  |
| Only certain PCs must be allowed to access the device.  | See page 102.  |
| <b>MFP:</b><br>Access to the device / Command Center must only be granted to certain persons.                       | Local authentication (see page 107).   |
| <b>MFP:</b><br>Specific use of the device is granted to certain persons.  | Local authentication linked to a job accounting.   |

## Device safety

|                 |   |
|-----------------|---|
| Measure         | The start page is the starting point for various settings to increase the network's operational dependability.  |
| Recommendations | Part of a security concept.   |
| Pre-conditions  | Administrative access to the Command Center.  |
| Notes           | On this start page, the relevant areas are briefly explained. By clicking on the underlined terms the desired setup area can be reached.<br><br>Some settings require, where necessary, a network administrator's presence. |

**Device Security**

↳ **General** | **Interface Block** | **Network Security**

Settings

**Lock Operation Panel:**  Lock  Partial Lock  Unlock

**Network Access**

- Filtering/ Firewall:** Network access to the device can be restricted to allow only specific network addresses. See [IP Filters\(IPv4\)](#), [IP Filters\(IPv6\)](#).
- SNMPv1/v2:** The SNMP Read and Write Community settings function as passwords to control read and write access to the device via SNMP. See [SNMP](#).
- SNMPv3:** The SNMPv3 communication settings are used to control the authentication and the encryption communication that occur via SNMP. See [SNMPv3](#).
- SSL:** To use SSL communication, Secure Protocols must be set. See [Secure Protocols](#).
- IEEE802.1x:** To use IEEE802.1x communication, IEEE802.1 communication must be set. See [IEEE802.1x](#).
- IPSec:** To use the IPSec communication, IPSec must be set. See [IPSec](#).

## Change password

|                 |  |
|-----------------|--|
| Action          | Password change for accessing the Command Center.  |
| Recommendations | <ul style="list-style-type: none"> <li>• Access to the Command Center should generally be protected.</li> <li>• The password should be changed at regular intervals.</li> <li>• Part of a security concept.</li> </ul> |
| Pre-conditions  | Administrative access to the Command Center.   |
| Notes           | If the password has been forgotten, the only option is to reset to the factory settings. All network and authentication settings are thereby lost.   |

- ▼ Basic
- Login Menu
  - Logout
- Defaults
- Network
- Time
- Reset
- Device Defaults
- Address Book ▶
- Security
  - Password Change**
  - Device Security ▶
  - User Login
  - Certificates ▶

Basic > Security: Password Change

### Password Change

**Administrator Account**

Old Password:

New Password:

Confirm New Password:

**Note:**  
The Administrator password controls access to the configuration.



## Blocking the operation panel

|                 |   |
|-----------------|---|
| Action          | Blocking the system menu of the device.   |
| Recommendations | <ul style="list-style-type: none"> <li>• If arbitrary system settings and system changes are to be prevented.</li> <li>• If specifically qualified personnel is responsible for maintaining the device.</li> <li>• Part of a security concept.</li> </ul> |
| Pre-conditions  | Administrative access to the Command Center.  |
| Notes           | <ul style="list-style-type: none"> <li>• In the locked status, access to system settings is possible from the operation panel with the help of the administrator account.</li> </ul>  |

The screenshot shows the 'Device Security' configuration page. On the left, a navigation menu lists various settings, with 'Device Security' highlighted in red. The main content area is titled 'Device Security' and includes sub-sections for 'General', 'Interface Block', and 'Network Security'. Under the 'Settings' section, the 'Lock Operation Panel' is configured with three radio buttons: 'Lock', 'Partial Lock', and 'Unlock'. The 'Unlock' option is selected, indicated by a green dot.

### Partial lock:

In case of partial locking, access to the device's system menu is only possible with the DeviceAdmin account:

21 ppm printer: 2100 / 2100  
 26 ppm rinter, MFP: 2600 / 2600

### Lock:

Like partial locking.

In addition, the STOP button does not have any function anymore. Running processes can no longer be interrupted/cancelled.

### MFP:

In addition, deleting jobs in the queue is no longer possible.

## Blocking the interfaces

|                 |  |
|-----------------|--|
| Action          | Targeted blocking of the device's interfaces.  |
| Recommendations | <ul style="list-style-type: none"> <li>• If unauthorized use of the device is to be prevented (e.g. to print holiday photos).</li> <li>• If arbitrary firmware updates are to be prevented (e.g. USB host).</li> <li>• Part of a security concept.</li> </ul>  |
| Pre-conditions  | Administrative access to the Command Center.   |
| Notes           | <ul style="list-style-type: none"> <li>• After setup, the device has to be switched off briefly so that the status can be activated. Alternatively, a restart can be carried out via the Command Center (see page 118).</li> </ul> <p> If a fax system is integrated in the system, this is done by blocking the "Opt. interface 1" causes it to be switched off. As the interface status is changed only after the device is switched on again, the causal link might be lost.</p> |

- ▼ Basic
- Login Menu
- Logout
- Defaults
- Network
- Time
- Reset
- Device Defaults
- Address Book ▶
- Security
- Password Change
- Device Security ▶
- User Login
- Certificates ▶

### Interface Block

↳ General | **Interface Block** | Network Security

**Note:**  
You need to restart the device when you have changed the setting with \*.  
Restart the device in the [Reset](#) section.

**Settings**

|  |                 |  |
|--|-----------------|--|
|  | <b>Network:</b> | Unblock  |
|  | * USB Device:   | <input type="radio"/> Block <input checked="" type="radio"/> Unblock |
|  | * USB Host:     | <input type="radio"/> Block <input checked="" type="radio"/> Unblock |
|  | * Option I/F 1: | <input type="radio"/> Block <input checked="" type="radio"/> Unblock |
|  | * Option I/F 2: | <input type="radio"/> Block <input checked="" type="radio"/> Unblock |

## Network safety

|                 |  |
|-----------------|--|
| Action          | Targeted activation of transfer protocols.   |
| Recommendations | <ul style="list-style-type: none"> <li>Only those protocols should be activated that are required for communicating with the device.</li> <li>Part of a security concept.</li> </ul> |
| Pre-conditions  | Administrative access to the Command Center.   |
| Notes           | After the settings are made, the network interfaces have to be re-initialized (see page 118).  |

- ▼ Basic
- Login Menu
- Logout
- Defaults
- Network
- Time
- Reset
- Device Defaults
- Address Book ▶
- Security
- Password Change
- Device Security ▶
- User Login
- Certificates ▶

### Network Security

↳ General | Interface Block | Network Security

**Note:**  
You need to restart the device or network when you have changed the setting with \*.  
Restart the device or network in the [Reset](#) section.

Settings

|                     |  |
|---------------------|--|
| * SNMPv3:           | <input checked="" type="radio"/> Block <input type="radio"/> Unblock |
| * NetWare:          | <input type="radio"/> Block <input checked="" type="radio"/> Unblock |
| * AppleTalk:        | <input type="radio"/> Block <input checked="" type="radio"/> Unblock |
| * NetBEUI:          | <input type="radio"/> Block <input checked="" type="radio"/> Unblock |
| * Raw:              | <input type="radio"/> Block <input checked="" type="radio"/> Unblock |
| * IPP:              | <input checked="" type="radio"/> Block <input type="radio"/> Unblock |
| * IPP over SSL:     | <input checked="" type="radio"/> Block <input type="radio"/> Unblock |
| * HTTP:             | <input type="radio"/> Block <input checked="" type="radio"/> Unblock |
| * HTTPS:            | <input type="radio"/> Block <input checked="" type="radio"/> Unblock |
| FTP (Transmission): | <input type="radio"/> Block <input checked="" type="radio"/> Unblock |
| * FTP (Reception):  | <input type="radio"/> Block <input checked="" type="radio"/> Unblock |
| * SMB:              | <input type="radio"/> Block <input checked="" type="radio"/> Unblock |
| * SNMP:             | <input type="radio"/> Block <input checked="" type="radio"/> Unblock |
| SMTP:               | <input type="radio"/> Block <input checked="" type="radio"/> Unblock |
| POP3:               | <input checked="" type="radio"/> Block <input type="radio"/> Unblock |
| * LPD:              | <input type="radio"/> Block <input checked="" type="radio"/> Unblock |
| LDAP:               | <input checked="" type="radio"/> Block <input type="radio"/> Unblock |
| * WSD Scan:         | <input type="radio"/> Block <input checked="" type="radio"/> Unblock |
| * WSD Print:        | <input type="radio"/> Block <input checked="" type="radio"/> Unblock |

## IP-Filter (v4 and v6)

|                 |  |
|-----------------|--|
| Action          | Setup of exclusive communication addresses   |
| Recommendations | <ul style="list-style-type: none"> <li>Only very specific computers may connect to the device.</li> <li>Only a very specific address range may communicate with the device within the network.</li> <li>When communicating, the device may only use specific protocols.</li> </ul>                           |
| Pre-conditions  | Administrative access to the Command Center.   |
| Notes           | <ul style="list-style-type: none"> <li>This page is linked to the menu "Basic/device security".</li> <li>A total of ten filters is available, that can be set independently of each other.</li> <li>After the settings are made, the network interfaces have to be re-initialized (see page 118).</li> </ul> |

**IP Filters(IPv4)**

General | IP Filters(IPv4) | IP Filters(IPv6) | Logical Printers

**Note:**  
When there are no entries, access is allowed to all.  
To allow access to a network, enter the network IP address (IPv4) and subnet mask.  
To allow access to a single IP address, enter the IP address and 255.255.255.255 as the subnet mask.  
You need to restart the device or network when you have changed the setting with \*.  
Restart the device or network in the [Reset](#) section.

**Filter 1**

\* IP Address (IPv4):  1

\* Subnet Mask:  2

\* Protocols: 3

LPD  FTP  IPP  HTTP  RAW Port  
 SNMP  IPP over SSL  HTTPS

**Filter 2**

### 1 IP address

IP address of the computer with which the device is to communicate.

Depending on the definition of the subnet mask, the segment address that is entered determines the kind of communication that is allowed with the device.

### 2 Subnet mask

Depending on the entry of the IP address, the subnet mask defines the area (segment) within which communication with the device is possible.

### 3 Protocols

The above settings are only applicable for the protocols that have been marked. Protocols that have not been marked are excluded from the communication!

### Configuration example (IPv4):

IP address: 192.168.100.xxx (x=any)

Subnet mask: 255.255.255.0

All computers within the address area of the IP: 192.168.100.1 to IP: 192.168.100.255 may communicate with the device (provided that at least one protocol has been marked).

All other computers are excluded from communicating.

## Authentication models (MFP)

No authentication:

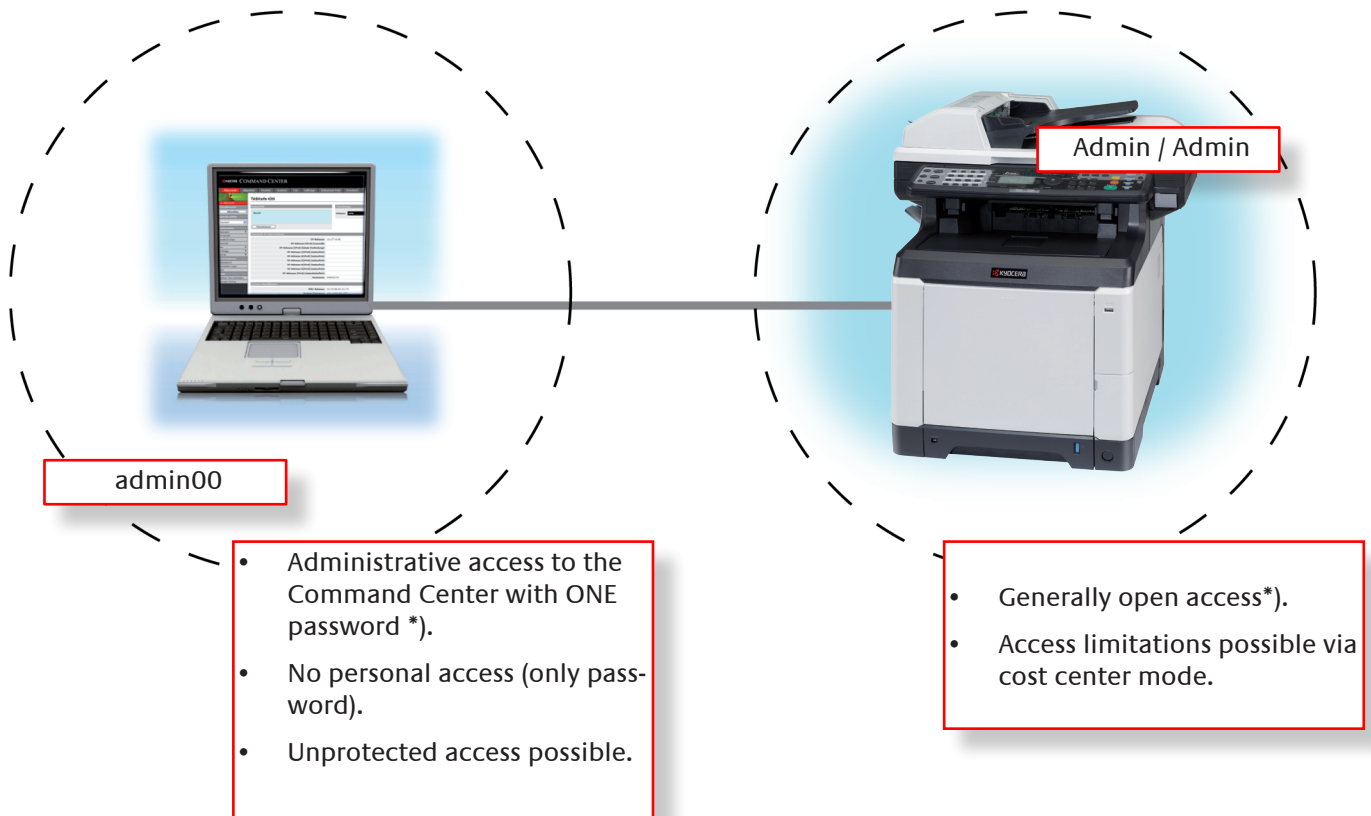

\* For security reasons, administrative access to the Command Center in the factory default settings is protected (see page 92).

For security reasons, access to vital system settings via the operation panel is also protected:

System menu:

- System
- User/ Job Accounting

Factory default settings allow access to these areas via the following (standard) accounts:  
(<Name> / <Password>)

**2600 / 2600**

-or-

**Admin / Admin**



## Authentication models (continued)

Local authentication:

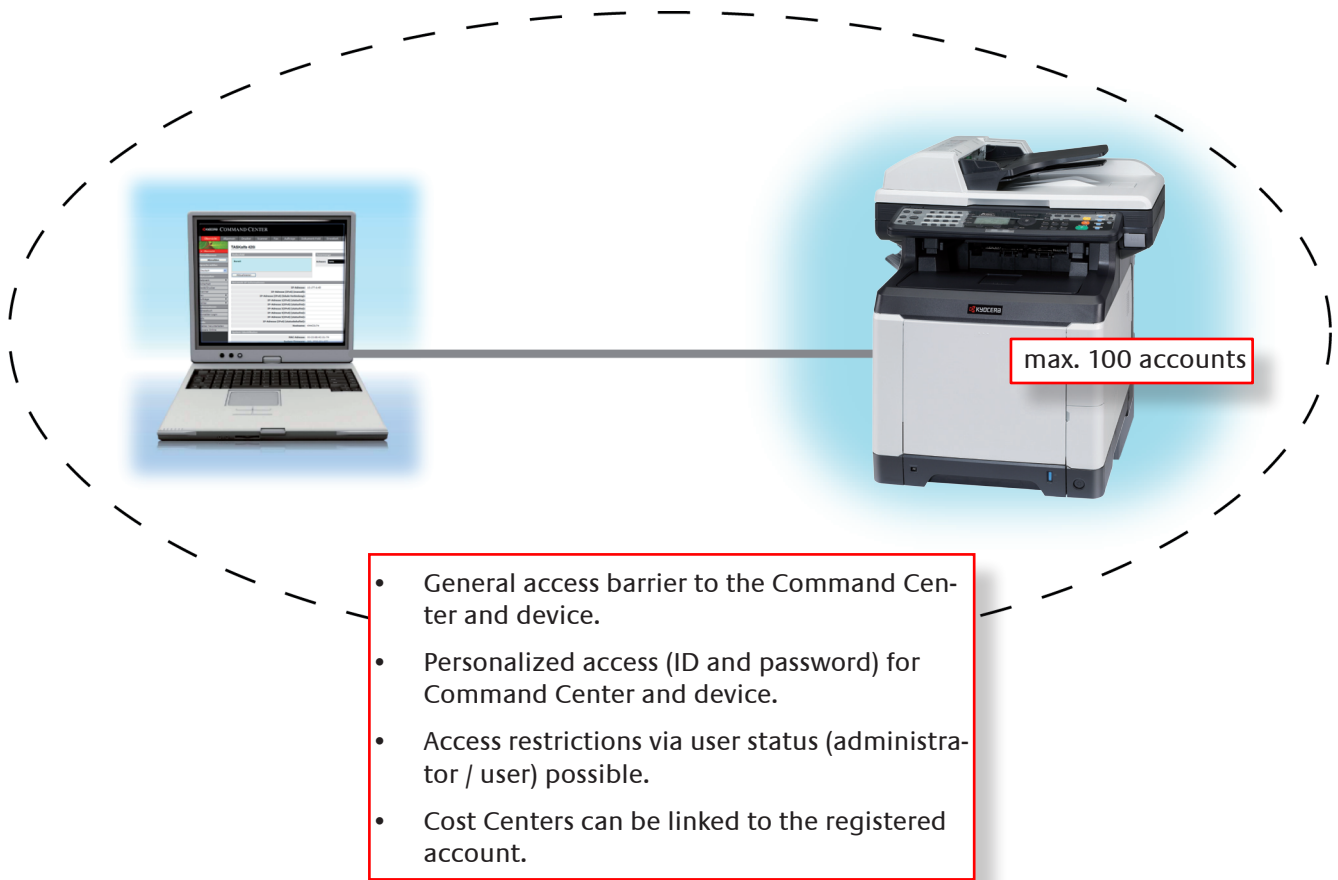

Up to 100 user accounts can be set up via the Command Center and via the operation panel.

2 different user statuses (administrator or user) determine the account holder's access rights.

While the administrator has full access to the Command Center and the device's system settings, access for user status is severely restricted.

The restrictions are noticeably greater than with systems that are not subject to authentication.

### **Important:**

If the device is operated as a printer, the authentication (login-username and login password) has to be entered in the device settings of the printer driver, otherwise printing is denied.

## Authentication models (continued)

Network Authentication:

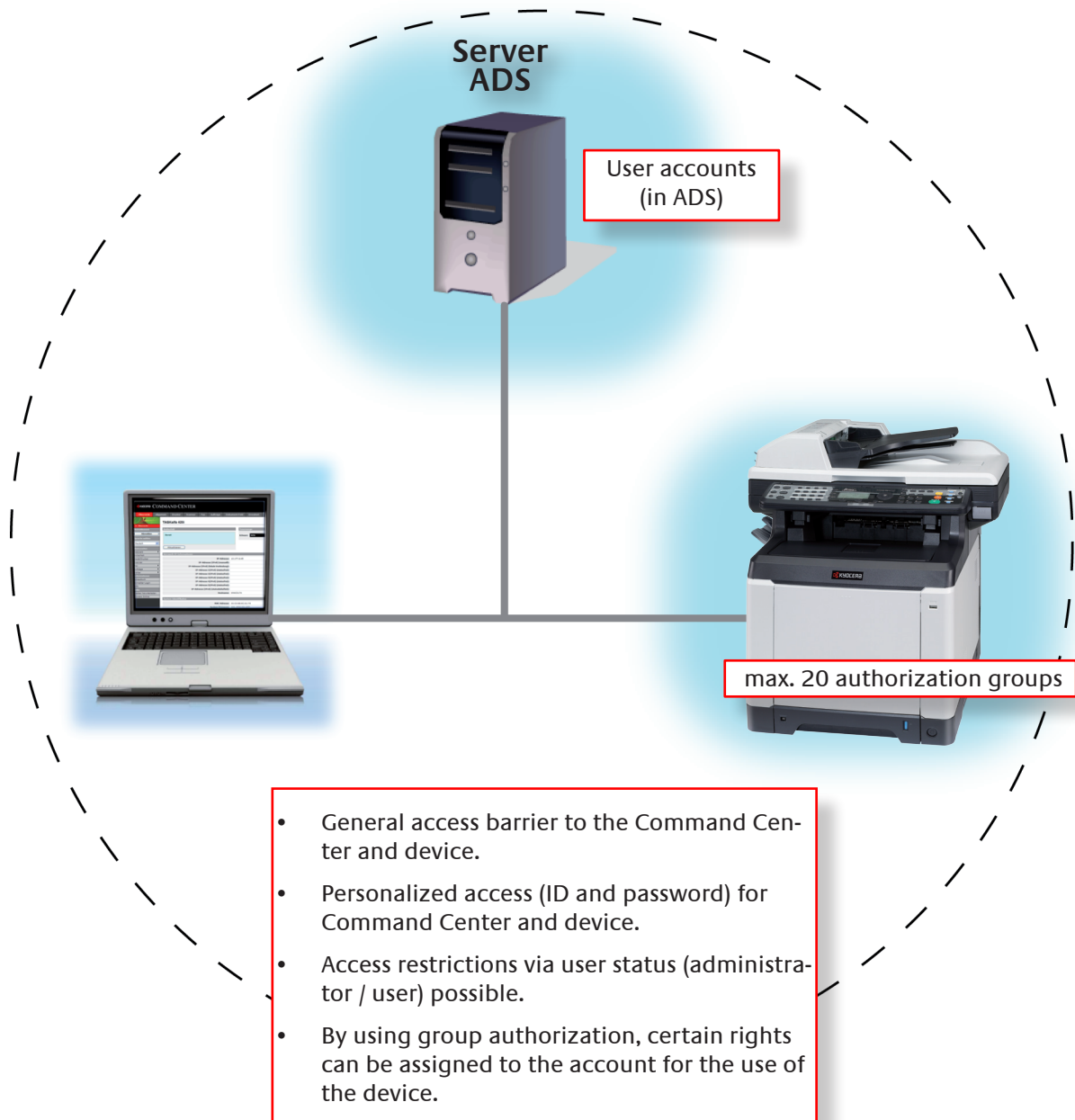

ADS (Active Directory Services) has to be available.

The user accounts are centrally provided on the server in the ADS (Active Directory Service).

The authorization group is assigned to the user account via the group ID.  
The configuration of the group profile results in the access profile of the account.

## User login, MFP (user authentication)

|                 |   |
|-----------------|---|
| Action          | Creating personalized accounts (local).   |
| Recommendations | <ul style="list-style-type: none"> <li>• Only certain persons may administer the cost centers.</li> <li>• Only certain persons may apply administrative settings to the device.</li> <li>• Only certain persons are allowed to have administrative access to the Command Center.</li> <li>• Only certain persons may use the device.</li> <li>• Certain persons are subject to limitations (copy, scan, print etc.)</li> </ul>  |
| Pre-conditions  | Administrative access to the Command Center or administrative access to system settings of the device.  |
| Notes           | <ul style="list-style-type: none"> <li>• The standard account (Admin/Admin) is set up and cannot be deleted. After installing the device, the password of this account should be changed for security reasons.</li> <li>• The user accounts for login can also be used for the device's system settings (only in the case of administrator status).</li> <li>• A max. of 100 local accounts is possible.</li> <li>• For further information, see paragraph "Authentication" on page 103.</li> </ul> |

- 1 Full name of account holder.
- 2 Login name that is to be entered in the computer or the device's operation panel.
- 3 Password, enter twice for security control.
- 4 E-mail address of the account holder is used in certain cases for notification and identification purposes.
- 5 A cost center can be assigned to the account holder so that for local authentication (see page 104) the criteria of this cost center (counting, limitations, allocations etc.) are automatically linked to this user.
- 6 Status of the account holder:
  - User:**  
No administration and system configuration is possible at the device and Command Center.
  - Administrator:**  
Full administrative access to the device and Command Center is possible.

## Authentication, MFP

|                 |   |
|-----------------|---|
| Action          | Specifying the authentication   |
| Recommendations | When generally a person-specific authentication is wanted for the device.   |
| Pre-conditions  | <ul style="list-style-type: none"> <li>Administrative access to the Command Center.</li> <li>Local user accounts (see page 104) or network accounts via ADS (Active Directory Services) must be available.</li> </ul> |
| Notes           | As very detailed knowledge of networks is required for this, it is recommended that the network administrator is present for the setup.<br>(See "Authentication models", page 103)                                    |

### 1 Authentication mode:

#### Off:

No authentication via accounts.

#### Local authentication:

If local user accounts are to be used (see page 104), then this setting requires login on the device's operation panel as well as within the Command Center.

#### Network authentication:

If user account administration is organized via a server (ADS, Active Directory Services).

By using definitions of up to 20 group guidelines (see page 110), specific rights for use of the device can be granted to these accounts.

After setup, this setting requires login on the device's operation panel and also inside the Command Center.

#### Important:

The internal clock has to run synchronously with the server, otherwise the authentication process fails. Hence a time server has to be registered.

- 2 Entry of network domains (for network authentication).
- 3 Entry of the ADS host name (for network authentication).
- 4 Entry of server type (for network authentication).

## Authentication, administrator status (MFP)

- Full access to the Command Center and to the device's system menu.

### User Login - Add

**User Settings**

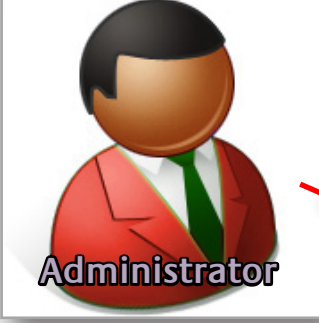

**User Name:**

**Login User Name:**

**Password:**

**Confirm Password:**

**E-mail Address:**

**Account Name:**

**Access Level:**  User  Administrator

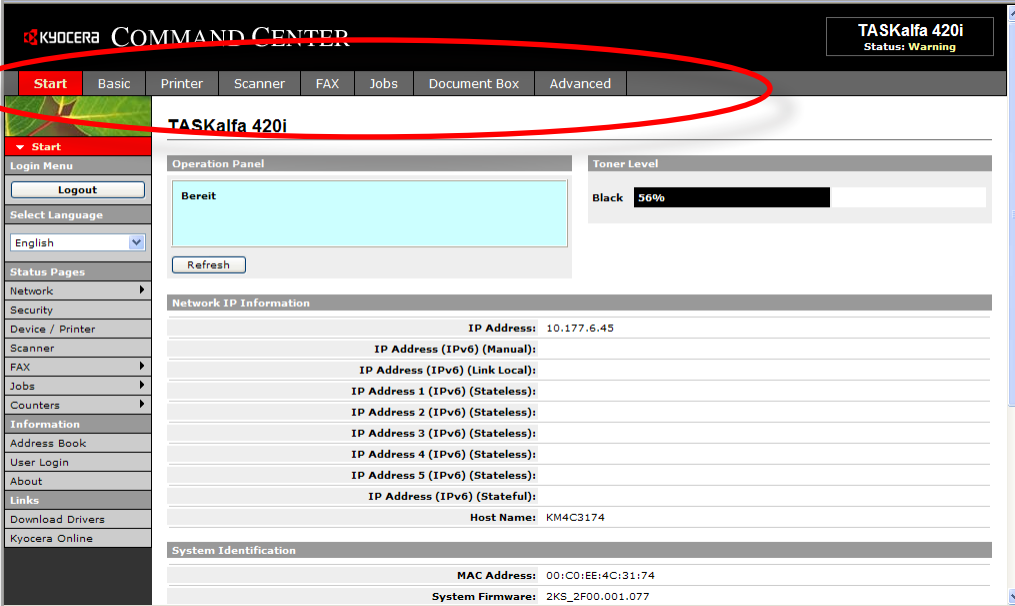

**KYOCERA COMMAND CENTER** TASKalfa 420i Status: Warning

Start Basic Printer Scanner FAX Jobs Document Box Advanced

**Start**

Logout

Select Language: English

Status Pages: Network, Security, Device / Printer, Scanner, FAX, Jobs, Counters, Information, Address Book, User Login, About, Links, Download Drivers, Kyocera Online

**Operation Panel**

Bereit

Refresh

**Toner Level**

Black 56%

**Network IP Information**

|                                  |             |
|----------------------------------|-------------|
| IP Address:                      | 10.177.6.45 |
| IP Address (IPv6) (Manual):      |             |
| IP Address (IPv6) (Link Local):  |             |
| IP Address 1 (IPv6) (Stateless): |             |
| IP Address 2 (IPv6) (Stateless): |             |
| IP Address 3 (IPv6) (Stateless): |             |
| IP Address 4 (IPv6) (Stateless): |             |
| IP Address 5 (IPv6) (Stateless): |             |
| IP Address (IPv6) (Stateful):    |             |
| Host Name:                       | KM4C3174    |

**System Identification**

|                  |                   |
|------------------|-------------------|
| MAC Address:     | 00:C0:EE:4C:31:74 |
| System Firmware: | 2KS_2F00.001.077  |



### Authentication, user status (MFP)

- Limited access to the Command Center. No access to the device's system menu.

#### User Login - Add

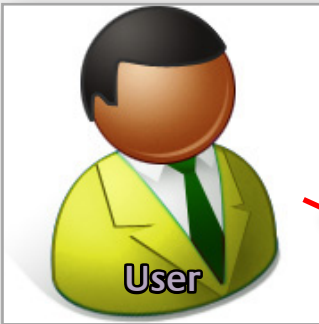

**User Name:**

**Login User Name:**

**Password:**

**Confirm Password:**

**E-mail Address:**

**Account Name:**

**Access Level:**  User  Administrator

KYOCERA COMMAND CENTER
FS-C2126MFP  
Status: OK

**Start** Basic Document Box

▼ Start

Login Menu

Logout

Select Language

English

Status Pages

Network

Security

Device / Printer

Scanner

FAX

Jobs

Counters

Information

Address Book

User Login

About

Links

Download Drivers

Kyocera Online

FS-C2126MFP

Generation Panel

Sleeping

Refresh

Network IP

System Ide

Toner Level

Black 99%

Cyan 99%

#### User Login

**User Name:**

**Login User Name:**

**Password:**

**E-mail Address:**

**Account Name:** Other

**Access Level:**  User  Administrator





## Group authorization, MFP (for network authentication)

|                 |   |
|-----------------|---|
| Action          | Mapping a user profile for network authentication.  |
| Recommendations | When different personalized access rights to the device are desired.  |
| Pre-conditions  | <ul style="list-style-type: none"> <li>Administrative access to the Command Center.</li> <li>Network access via ADS (Active Directory Services) has to be available.</li> </ul> |
| Notes           | As very detailed knowledge of networks is required for this, it is recommended that the network administrator is present for the setup.   |

**Group Authorization Set.**

General | Network User Property | Group Authorization Set.

**General Settings**

Group Authorization:  On  Off **1**

Number of Registered Groups: 0

**Group List**

[Add](#) | [Delete](#)

Group ID **2**

**3**

Group Name:

Access Level:  User  Administrator

**Profile Settings**

Print Restriction:  Off  Reject Usage **4**

Copy Restriction:  Off  Reject Usage

Send Restriction:  Off  Reject Usage

FAX TX Restriction:  Off  Reject Usage

Storing Restr. in Box:  Off  Reject Usage

Storing Restr. in Memory:  Off  Reject Usage

- Group authorization switch on/off.
- Group ID (numerical entry).  
An account is assigned to this ID in the ADS (Active Directory Service).
- Group name.  
Serves for identification of the group by name.
- Profile settings.

## Scan via network, preparations (MFP)

The following scan modes are available via the network:

- Scan to email
- Scan to SMB
- Scan to FTP

For these scan modes, basic settings can be specified.

Scanner > Defaults

### Defaults

Settings

Color Selection(Copy): Full Color

Color Sel.(Send/Store): Full Color

Density:  Auto  Manual

Scan Resolution: 300x300 dpi

Original Image: Text+Photo

File Format: PDF

PDF/A: Off

Image Quality PDF/TIFF/JPEG: 1(Low)

Zoom:  Auto  100%

Original Orientation:  Top Edge Top  Top Edge Left

Submit Cancel

## Scanning, Scan-to-Email (MFP)

|                 |   |
|-----------------|---|
| Action          | Scan to e-mail accounts.  |
| Recommendations | If there is a requirement for sending scanned objects via e-mail.   |
| Pre-conditions  | <ul style="list-style-type: none"> <li>Administrative access to the Command Center.</li> <li>E-mail server (SMTP server) is accessible via the network.</li> <li>Large attachments (graphics) may be deposited in the e-mail server.</li> </ul> |
| Notes           | Though address entries can be made via the operation panel, it is recommended that target addresses are stored for this device. This can be done via the address books (see page 116) or by using the one touch keys.                           |

The image shows two screenshots from the Command Center interface. The top screenshot displays the 'E-mail' configuration page, which includes a 'Subject' field, a 'Body' field, and a 'Subject Conversion Strings' section. The bottom screenshot displays the 'SMTP Protocol Settings' dialog box, which includes fields for SMTP Protocol status, SMTP Port Number, SMTP Server Name, SMTP Server Timeout, Authentication Protocol, Authenticate as, Login User Name, Login Password, and POP before SMTP Timeout. Red boxes and arrows highlight specific settings in both screenshots.

**Scanner > E-mail**

**E-mail**

**E-mail Template**

**Subject:** [ ]

**Subject Conversion Strings**

%printer = Model  
 %serial = Serial Number  
 %etheraddr = MAC Address  
 %host = Host Name  
 %ip = IP Address

**Body:** [ ]

**Note:**  
 Click [here](#) to set up SMTP server.

**Advanced > SMTP Protocol Settings**

**SMTP Protocol:**  On  Off

**SMTP Port Number:** 25

**SMTP Server Name:** [ ]

**SMTP Server Timeout:** 10 seconds

**Authentication Protocol:**  On  POP before SMTP  Off

**Authenticate as:**

POP3 Account 1  
 POP3 Account 2  
 POP3 Account 3  
 Other

**Login User Name:** [ ]

**Login Password:** [ ]

**POP before SMTP Timeout:** 0 seconds

**Test**

1. E-mail Basic Settings (Re and Body Text)
2. SMTP protocol status. **For Scan-to-Email, the protocol must be activated!**
3. Mail server connection parameter (IP address or host name)
4. Mail-Server Authentication (optional)
5. E-mail account for mail server authentication (only if authentication is required)
6. Test connection to mail server (should be confirmed by the system with "OK")

## Scanning, Scan-to-email (continued)

The screenshot shows the configuration interface for Scan-to-email. On the left is a navigation menu with 'SMTP' highlighted. The main configuration area has the following fields:

- E-mail Size Limit:** A text input field containing '0' followed by 'KB'. A red box labeled '1' is around the '0'.
- Sender Address:** A text input field. A red box labeled '2' is around the field.
- Signature:** A text area containing '%printer' and ' [%etheraddr]'. A red box labeled '3' is around the text.
- Domain Restriction:** A section with three radio buttons: 'Off' (selected), 'Reject', and 'Permit'. A red box labeled '4' is around the 'Off' radio button.
- Domain Name:** A list of five empty text input fields numbered 1 to 5.

1. If the preset size limit is exceeded, the scan aborts with an error message and the file is not transferred.
2. **Entering the sender's address is mandatory (!)**, otherwise Scan-to-Email cannot be carried out. For practical purposes, the sender's address should be an active address so that, for example, there is a reply to the scan email.
3. The signature can be a text or a so-called object string (variables, they provide certain information).
4. Domains, that are entered in the list (e.g. "kyoceramita.de") serve as a control for free address entry for Scan-to-Email. For example, some domains may be explicitly prohibited ("reject") or may be used exclusively ("accept").

### Summary

- Activate SMPT protocol (!)
- The mail server must be accessible via the network. For gateway connections timeouts have to be taken into account (extended, if necessary).
- Keep potential server authentication in mind.
- Carry out test connection.
- Enter sender's address (!)
- Set mail limit, if necessary (consult administrator).
- Make meaningful entries for "Re:", "Body Text" and "Signature".
- In case of manual input of mail addresses (at the device operation panel), specify domain limitations, where necessary.

## Scanning, Scan-to-FTP (MFP)

|                 |   |
|-----------------|---|
| Action          | Scan to FTP resources.  |
| Recommendations | If there is a requirement for sending scanned objects via FTP transfer.   |
| Pre-conditions  | <ul style="list-style-type: none"> <li>Administrative access to the Command Center.</li> <li>FTP resource (FTP server) can be accessed via the network.</li> </ul>  |
| Notes           | Though address entries can be made via the operation panel, it is recommended for this device that the FTP target addresses are stored. This can be done via the address books (see page 116) or by using the one touch keys. |

Scanner > FTP

### FTP

**FTP Settings**

FTP:  On  Off

FTP Port Number:

FTP Encrypted TX:  On  Off

### Summary

- The FTP protocol must be switched on.
- The port addresses can be edited as needed.
- FTP encryption (FTP over SSL) is supported optionally, if the FTP resource allows it.

## Scanning, Scan-to-SMB (MFP)

|                 |   |
|-----------------|---|
| Action          | Scan to Windows Services (e.g. in folder).  |
| Recommendations | If there is a requirement for sending scanned objects to Windows Services.  |
| Pre-conditions  | <ul style="list-style-type: none"> <li>Administrative access to the Command Center.</li> <li>Services can be accessed via the network.</li> </ul>   |
| Notes           | Though SMB address entries can be made via the operation panel, it is recommended that target addresses for this device are stored. This can be done via the address books (see page 116) or by using the one touch keys. |

The screenshot shows the Command Center interface for configuring SMB settings. On the left, a sidebar menu includes 'Scanner', 'Login Menu', 'Logout', 'Defaults', 'FTP', 'SMB' (highlighted with a red border), and 'E-mail'. The main content area is titled 'Scanner > SMB' and 'SMB'. Below this, the 'SMB Protocol Settings' section is visible, featuring a radio button for 'SMB Protocol' set to 'On' and a text input field for 'SMB Port Number' containing '139'. At the bottom of the settings area are 'Submit' and 'Cancel' buttons.

### Summary

- The SMB protocol must be switched on.
- The port addresses can be edited as needed.
- Check by means of a PC that the relevant rights have been assigned to the services that will receive the scans. Transfer the required information (account, password etc.) to the address book (see page 116).
- If the computer receiving the scan is part of a domain, then the user entry for the scanner has to be the corresponding **domain name**. The login user name is (for example): **<domain user name>@domain.local**.
- The firewall settings may have to be modified, if this is required ("file and printer sharing").



## Address book, local (MFP)

|                 |  |
|-----------------|--|
| Action          | Setting up a local address book for selection of scan and fax destinations.  |
| Recommendations | If scanning and faxing are always to be used for the same destinations.  |
| Pre-conditions  | Administrative access to the Command Center.   |
| Notes           | <ul style="list-style-type: none"> <li>Address entries are stored in the device in question.</li> <li>Via U-917 these entries can be stored on a CF card and transferred to another device (only for WiseCore from Level II onwards).</li> <li>Via the KM NetViewer (5.x), these entries can also be stored on a PC and transferred to other devices.</li> </ul> |

**Address Book Contacts**

↳ Contacts | Groups

Contact Summary

Number of Contacts: 0

Address List

Search by Name:

[Add Contact](#) 1

**Address Book Contacts - Add**

↳ Contacts | Groups

Contact Information

Number:

Name:

E-mail

E-mail Address:

SMB

Host Name:

Port Number:

Path:

Login User Name:

Login Password:

FTP

Host Name:

Port Number:

Path:

Login User Name:

Login Password:

1. Link for adding address book entries.
2. Position and name entry of the record.
3. E-mail based address data (for Scan-to-Email).
4. SMB based address data (for Scan-to-SMB).
5. FTP based address data (for Scan-to-FTP).

## Sending service lists

By means of the following entry in the browser's address bar:

**http://<IPAddress>/svcmntrpt**

an HTML page is called up that can be used to send specific service reports via e-mail.

- 1 Mail address to which the desired reports can be sent ( as attachment).
- 2 Automated terms (strings) that appear in the subject line.
- 3 Option for the relevant list(s).
- 4 File format of the list (HTML or TXT).
- 5 Activation of the body text.
- 6 Time interval for the regular transmission of lists (optional).
- 7 Send button for one-time and immediate transmission of the lists.

### Important Note:

For the above function the STMP settings (mail server settings) have to be complete.

## Reset / restart

|                 |   |
|-----------------|---|
| Action          | Reset / restart   |
| Recommendations | <ul style="list-style-type: none"> <li>• With network settings via the Command Center</li> <li>• Where there are changes to the status of interfaces via the Command Center</li> <li>• When a reset to the factory settings is desired</li> </ul> |
| Pre-conditions  | Administrative access to the Command Center   |
| Notes           | When selecting, different functionalities have to be taken into account   |

The screenshot shows the 'Reset' page in the Command Center. The left sidebar has a menu with 'Reset' highlighted in red. The main content area is titled 'Reset' and contains three sections:

- Restart Options:**
  - Restart entire device:** A button labeled 'Restart' with a red box containing the number 1 next to it.
  - Restart Network:** A button labeled 'Restart' with a red box containing the number 2 next to it.
- Initialize Options:**
  - Reset entire device to factory default:** A button labeled 'Reset' with a red box containing the number 3 next to it.

### 1 Restart

Is identical to switching the device off and on.

### 2 Initializing the network connection

All changes to the network settings in the Command Center require these measures. While the reset takes place, the copier can be used without restrictions.

### 3 Reset to factory settings

All settings relating to networks are reset to factory settings or deleted. The passwords are also reset to the standard ones.

Display language is reset to English.

#### Note:

Address entries and user accounts (for local authentication) are preserved.



- Access to the CommandCenter is password protected for security reasons.
- It is recommended that the access password for the CommandCenter is changed if needed.
- For secure administration via the CommandCenter as well as the device operation panel, it is recommended that a special user account is set up.



## Apply your knowledge!

### Practice 1

Change the access password for the Command Center.

### Practice 2 (MFP)

Define two new accounts. One with user status and one with administrator status. Choose simple account data ("a" / "a") for this.

### Practice 3 (MFP)

Log into both accounts alternately via the operation panel.

- Are there any differences in the behavior of the device?

### Practice 4 (MFP)

Set the device to "local user authentication" mode.

- Consequences for the device?
- Consequences for the Command Center?

### Practice 5 (MFP)

Switch off the local user authentication in the Command Center.

### Practice 6 (MFP)

Set up the different scan modes in the Command Center (Scan to E-Mail, Scan to SMB, Scan to FTP) and test them.

Use the local address book for this.

### Practice 7

Request for service lists via the Command Center.

#3

Administrator: Full access to all menus.

User: Limited access to Command Center, system settings at console not allowed (authentication required).

#4

Device: Authentication required at device.

CommandCenter: Authentication (account + password) required for access.

#### Extra practice:

- Discuss the logical printer.
- Access the CommandCenter via the FTP protocol.
- Discuss options to transfer print data directly to the printer (FTP transfer). Set up a Scan-to-FTP environment (scan directly to printer with FTP protocol).

**Test your knowledge!**

- 1.) What is the standard password for administrative access to the CommandCenter?  
**admin00**
- 2.) Can password protection for the CommandCenter be removed?  
 Yes  
 No
- 3.) What are the (standard) login data for local authentication?  
 2600 / 2600  
 admin00 / admin00  
 admin / admin  
 Admin / Admin
- 4.) Can accounts for local authentication be used for configuring system settings via the operation panel?  
 No  
 Yes, all  
 Yes, but only those with administrator status
- 5.) Can the Device Admin account be changed in the Command Center?  
 No  
 Yes, but only by the Device Admin himself.
- 6.) How can the forgotten access password for the Command Center be recreated?  
 Cannot be done  
 By resetting to factory settings  
 By entering the general password .....







# IF YOU HAVE ANY QUESTIONS... CONTACT US!

Do you require information about the training or one of our detailed information brochures about individual training programs?

Contact us at:

[kyocera\\_academy@kyoceramita-europe.com](mailto:kyocera_academy@kyoceramita-europe.com)

Or visit our website:

<http://www.kyocera-academy.com>

Kyocera Academy  
Otto-Hahn-Str. 12  
D-40 670 Meerbusch

▶print ▶copy ▶scan ▶fax