



FS-C5400DN ECOSYS P7035cdn

PARTS LIST

Published in February 2014
2HGPL073
842HG123
Rev.3

— CONTENTS —

FIG. 1	Covers 1	2
FIG. 2	Covers 2	4
FIG. 3	Frames 1	6
FIG. 4	Frames 2	8
FIG. 5	Paper Cassettes	10
FIG. 6	Paper Feed Section 1	12
FIG. 7	Paper Feed Section 2	14
FIG. 8	Paper Conveying Section	16
FIG. 9	Image Formation Section	18
FIG. 10	Developing Section	20
FIG. 11	Fuser Section	22
FIG. 12	Drive Section	24
FIG. 13	Exit Section	26
FIG. 14	Electrical Components	28
FIG. 15	Maintenance Kits	30
	• INDEX	31

<Notation of products>

For the purpose of this parts list, products are identified as following.

FS-C5400DN : (A)

ECOSYS P7035cdn : (B)

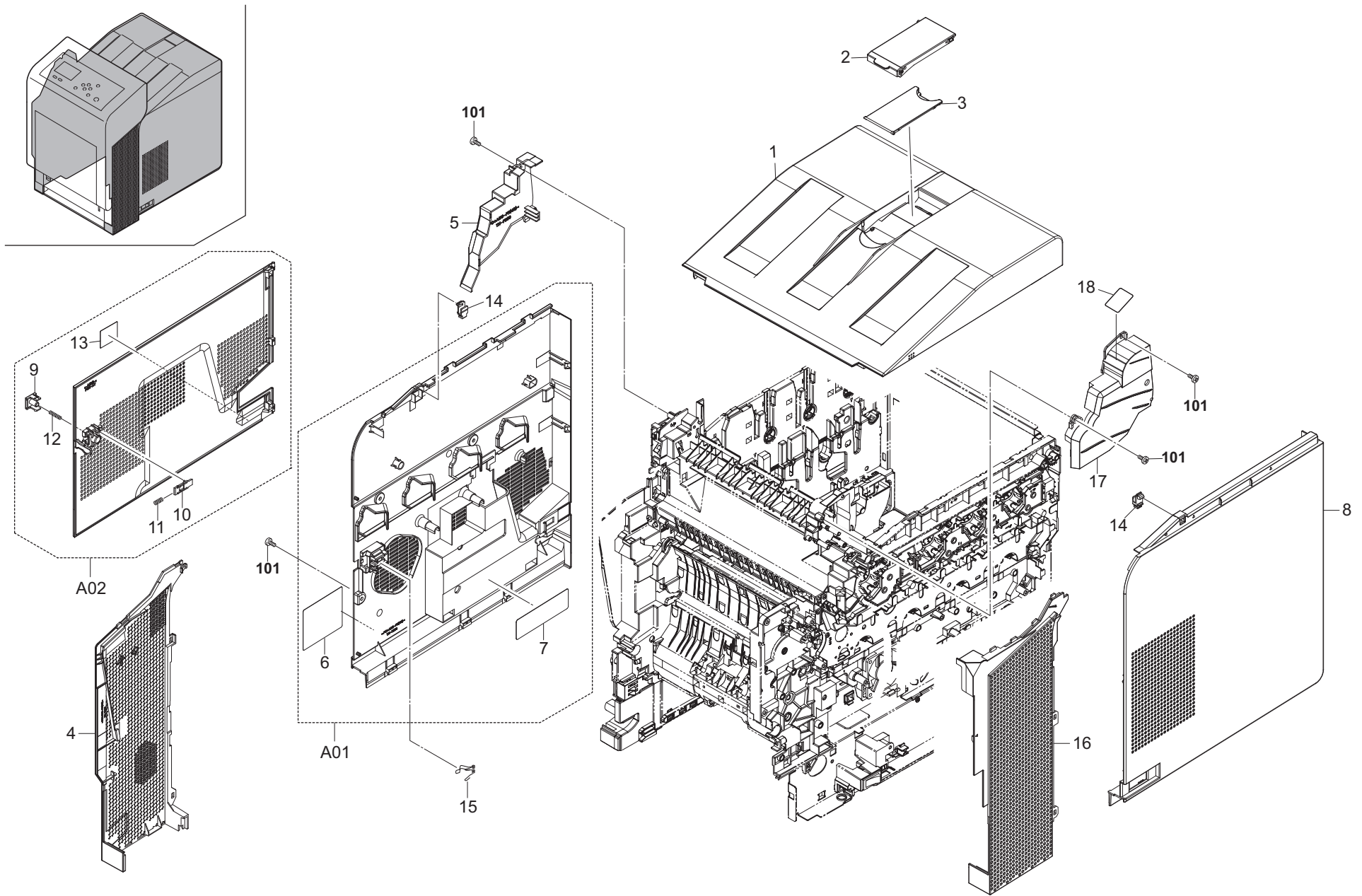

FIG. 1 Covers 1

2HG/2PR-1

	Ref. No.	Part.No.	Alternative.	Description	Notes	Quantity		
						120	230	240
	1	302HG04090	2HG04090	COVER TOP		1	1	1
	2	302HG04120	2HG04120	STOPPER EXIT A		1	1	1
	3	302HG04130	2HG04130	STOPPER EXIT B		1	1	1
⊙	4	302HG04110	2HG04110	COVER LEFT FRONT		1	1	1
⊙	5	302HG04030	2HG04030	COVER UPPER LEFT		1	1	1
⊙	A01	302HG94080	2HG94080	COVER LEFT REAR ASSY		1	1	1
	6	*302HG04140	2HG04140	LABEL WASTE BOTTLE		1	1	1
	7	*302HG04160	2HG04160	SEAL WASTE BOTTLE		1	1	1
⊙	8	302HG04061	2HG04061	COVER RIGHT REAR		1	1	1
⊙	A02	302HG94140	2HG94140	COVER SIDE ASSY SP		1	1	1
	9	*302HN04200	2HN04200	LEVER SIDE COVER		1	1	1
	10	*302HN04210	2HN04210	HOOK SIDE COVER		1	1	1
	11	*302HN04250	2HN04250	SPRING SIDE COVER		1	1	1
	12	*302HN04260	2HN04260	SPRING SIDE LEVER		1	1	1
	13	*302HN04320	2HN04320	LABEL USB		1	1	1
	14	302HN04230	2HN04230	HOOK TOP COVER		2	2	2
	15	302HN04240	2HN04240	SPRING LEFT COVER		1	1	1
⊙	16	302HG04100	2HG04100	COVER RIGHT FRONT		1	1	1
⊙	17	302HG04020	2HG04020	COVER UPPER RIGHT		1	1	1
	18	302HG04150	2HG04150	LABEL FUSER CAUTION R		1	1	1

	Ref. No.	Part.No.	Alternative.	Description	Notes	Quantity		
						120	230	240
	101	7BB200410H	BB105700	+BIND T.T P SCREW 4X10				

- Parts with "⊙" indicate regular maintenance parts.
- Parts with Ref.No. indicate maintenance parts and the ones without it indicate out of the above.

- Parts with "*" are component parts or sub-assemblies of the assembly appearing immediately above them.
- Parts with "*•" are component parts or sub-assembly with "*" appearing immediately above them.

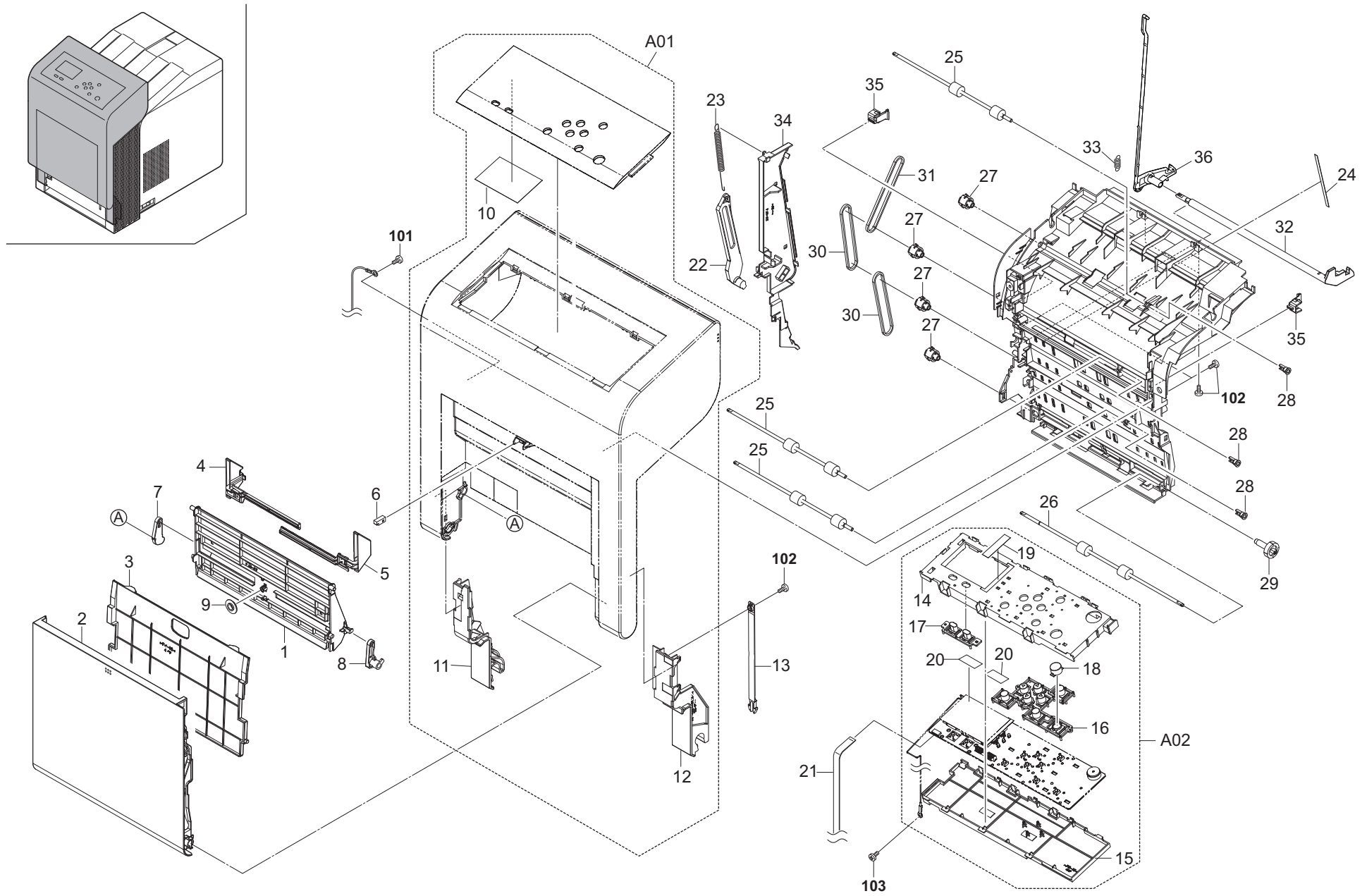

FIG. 2 Covers 2

2HG/2PR-3

Ref. No.	Part.No.	Alternative.	Description	Notes	Quantity			
					120	230	240	
	1	302HN08010	2HN08010	BASE MPF		1	1	1
	2	302HN08020	2HN08020	COVER MPF		1	1	1
	3	302HN08030	2HN08030	TRAY MPF TOP		1	1	1
	4	302HN08050	2HN08050	GUIDE MPF L		1	1	1
	5	302HN08060	2HN08060	GUIDE MPF R		1	1	1
	6	302HN08140	2HN08140	LUTCH		1	1	1
	7	302HN08150	2HN08150	LINK LEVER MPF L		1	1	1
	8	302HN08160	2HN08160	LINK LEVER MPF R		1	1	1
	9	302B700780	2B700780	GEAR MANUAL		1	1	1
⊙	A01	302HG94110	2HG94110	COVER FRONT ASSY SP	(A)	1	1	1
⊙	A01	302PR94010	2PR94010	PPARTS COVER FRONT ASSY SP	(B)	1	1	1
	10	*302HG05070	2HG05070	SHEET STATIC ELIMINATOR		1	1	1
⊙	11	*302HG04190	2HG04190	COVER LOWER LEFT		1	1	1
⊙	12	*302HG04200	2HG04200	COVER LOWER RIGHT		1	1	1
	13	302HN04170	2HN04170	STOPPER FRONT COVER RIGHT		1	1	1
⊙	A02	302HG94100	2HG94100	KEY BOARD ASSY SP	(A)	1	1	1
⊙	A02	302PR94040	2PR94040	PARTS KEY BOARD ASSY SP	(B)	1	1	1
	14	*302HG05020	2HG05020	MOUNT UPPER OPERATION		1	1	1
	15	*302HG05030	2HG05030	MOUNT LOWER OPERATION		1	1	1
	16	*302HG05040	2HG05040	BUTTON A		1	1	1
	17	*302HG05051	2HG05051	BUTTON B		1	1	1
	18	*302HG05060	2HG05060	BUTTON C		1	1	1
	19	*302HG05100	2HG05100	SHEET LCD		1	1	1
	20	*7ZGSTGR55010H01	ZG110970	SHIELD GASKET		2	2	2
	21	302HG46120	2HG46120	CONN.CORD ASSY S03331		1	1	1
⊙	22	302HN04181	2HN04181	STOPPER FRONT COVER LEFT		1	1	1
	23	302HN04270	2HN04270	SPRING FRONT COVER		1	1	1
	24	302HN29190	2HN29190	SHEET BASE DU		1	1	1
⊙	25	302HN29010	2HN29010	ROLLER DU		3	3	3
⊙	26	302HN29020	2HN29020	ROLLER DU FEED		1	1	1
⊙	27	302HN29040	2HN29040	PULLEY P24 S2M DU		4	4	4
	28	302HN29050	2HN29050	BUSH DU		3	3	3
⊙	29	302HN29060	2HN29060	GEAR Z23L DU FEED		1	1	1
⊙	30	302HN29150	2HN29150	BELT DU		2	2	2
	31	302HG29060	2HG29060	BELT DU B		1	1	1
	32	302HN29080	2HN29080	HOOK DU RELEASE RIGHT		1	1	1
	33	302F908300	2F908300	SPRING LOCK MPF		1	1	1
	34	302HN29101	2HN29101	COVER INNER DU		1	1	1
	35	302HG29120	2HG29120	HOOK CONVEYING		2	2	2
	36	302HG29070	2HG29070	HOOK DU RELEASE LEFT		1	1	1

Ref. No.	Part.No.	Alternative.	Description	Notes	Quantity		
					120	230	240
101	7BB700408H	BB105640	+BIND T.T S SCREW 4X8 SR				
102	7BB302308H	BB018120	+TP-FLAT T.T B SCREW 3X8				
103	B1A54080	B1A54080	+BIND TAP-TITE S SCREW M4X08				

- Parts with "⊙" indicate regular maintenance parts.
- Parts with Ref.No. indicate maintenance parts and the ones without it indicate out of the above.

- Parts with "*" are component parts or sub-assemblies of the assembly appearing immediately above them.
- Parts with "• •" are component parts or sub-assembly with "•" appearing immediately above them.

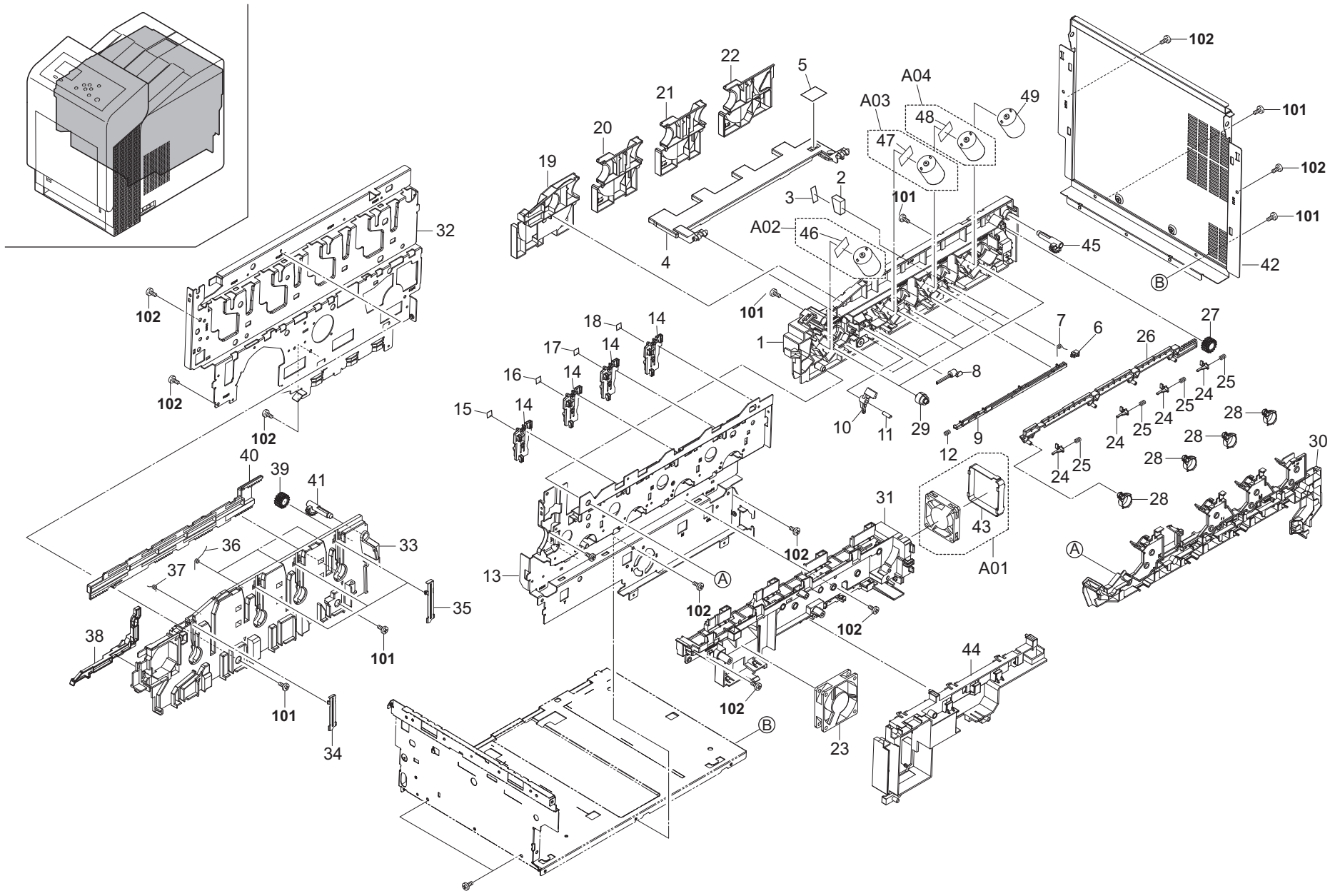

FIG. 3 Frames 1

2HG/2PR

Ref. No.	Part.No.	Alternative.	Description	Notes	Quantity		
					120	230	240
1	302HN02120	2HN02120	HOUSING RIGHT		1	1	1
2	302HG02520	2HG02520	SPACER HOUSING RIGHT		1	1	1
3	302HG02530	2HG02530	TAPE SPACER HOUSING RIGHT		1	1	1
4	302HN02210	2HN02210	HOLDER RFID		1	1	1
5	302HN02720	2HN02720	SEAL SQUARE 25-20		1	1	1
6	302HG02170	2HG02170	GUIDE SPRING THRUST		4	4	4
7	302HG02320	2HG02320	SPRING CONTACT HV PT		4	4	4
8	302HG02140	2HG02140	ACTUATOR LEVER LINK		1	1	1
9	302HG02160	2HG02160	RACK SPRING THRUST		1	1	1
10	302HG02150	2HG02150	LEVER LINK		1	1	1
11	302HG02510	2HG02510	PIN HOUSING RIGHT		1	1	1
12	302HG02360	2HG02360	SPRING RACK THRUST		1	1	1
13	302HG02020	2HG02020	FRAME RIGHT		1	1	1
14	302HG02180	2HG02180	GUIDE DLP		4	4	4
15	302HG02580	2HG02580	LABEL GUIDE DLP K		1	1	1
16	302HG02550	2HG02550	LABEL GUIDE DLP Y		1	1	1
17	302HG02560	2HG02560	LABEL GUIDE DLP C		1	1	1
18	302HG02570	2HG02570	LABEL GUIDE DLP M		1	1	1
19	302HN15070	2HN15070	GUIDE CONTAINER K		1	1	1
20	302HN15080	2HN15080	GUIDE CONTAINER Y		1	1	1
21	302HN15090	2HN15090	GUIDE CONTAINER C		1	1	1
22	302HN15110	2HN15110	GUIDE CONTAINER M		1	1	1
23	302HG44080	2HG44080	FAN MOTOR 70		1	1	1
24	302HN02701	2HN02701	ACTUATOR CONTAINER		4	4	4
25	302HN02710	2HN02710	SPRING ACT CONT		4	4	4
26	302HN02170	2HN02170	RACK TONER SUPPLY R		1	1	1
27	302HN02150	2HN02150	GEAR Z16S HINGE		1	1	1
28	302HN02190	2HN02190	CAM TONER SUPPLY		4	4	4
29	302HN15030	2HN15030	GEAR Z20S-Z26L		4	4	4
30	302HN02200	2HN02200	HOLDER HARNESS		1	1	1
31	302HG02120	2HG02120	DUCT RIGHT A		1	1	1
32	302HG02010	2HG02010	FRAME LEFT		1	1	1
33	302HN02110	2HN02110	HOUSING LEFT		1	1	1
34	302HN02670	2HN02670	PLATE CONTAINER K		1	1	1
35	302HN02680	2HN02680	PLATE CONTAINER C		3	3	3
36	302HN15160	2HN15160	SPRING P CONT C		3	3	3
37	302HN15170	2HN15170	SPRING P CONT K		1	1	1
38	302HN02300	2HN02300	ROD INTERLOCK		1	1	1
39	302HN02150	2HN02150	GEAR Z16S HINGE		1	1	1
40	302HN02160	2HN02160	RACK TONER SUPPLY L		1	1	1
41	302HN02130	2HN02130	HINGE LEFT		1	1	1
42	302HG02030	2HG02030	FRAME REAR		1	1	1
43	302HG94150	2HG94150	FAN DLP ASSY SP		1	1	1
44	*302HG02490	2HG02490	SEAL FAN DLP		1	1	1
45	302HG02130	2HG02130	DUCT RIGHT B		1	1	1
46	302HN02140	2HN02140	HINGE RIGHT		1	1	1
47	302HN94060	2HN94060	DC MOTOR ASSY K SP		1	1	1
48	*302HN02750	2HN02750	SEAL DC MOTOR		1	1	1

Ref. No.	Part.No.	Alternative.	Description	Notes	Quantity		
					120	230	240
49	302HG94040	2HG94040	DC MOTOR ASSY Y SP		1	1	1
47	*302HN02750	2HN02750	SEAL DC MOTOR		1	1	1
48	302HG94050	2HG94050	DC MOTOR ASSY C SP		1	1	1
49	*302HN02750	2HN02750	SEAL DC MOTOR		1	1	1
49	302HG94060	2HG94060	DC MOTOR ASSY M SP		1	1	1
101	7BB700308H	BB105600	+BIND T.T S SCREW 3X8 SR				
102	7BB100306H1	BB105820	+BIND T.T S SCREW 3X6				

- Parts with "⊙" indicate regular maintenance parts.
- Parts with Ref.No. indicate maintenance parts and the ones without it indicate out of the above.

- Parts with "." are component parts or sub-assemblies of the assembly appearing immediately above them.
- Parts with ". ." are component parts or sub-assembly with ". ." appearing immediately above them.

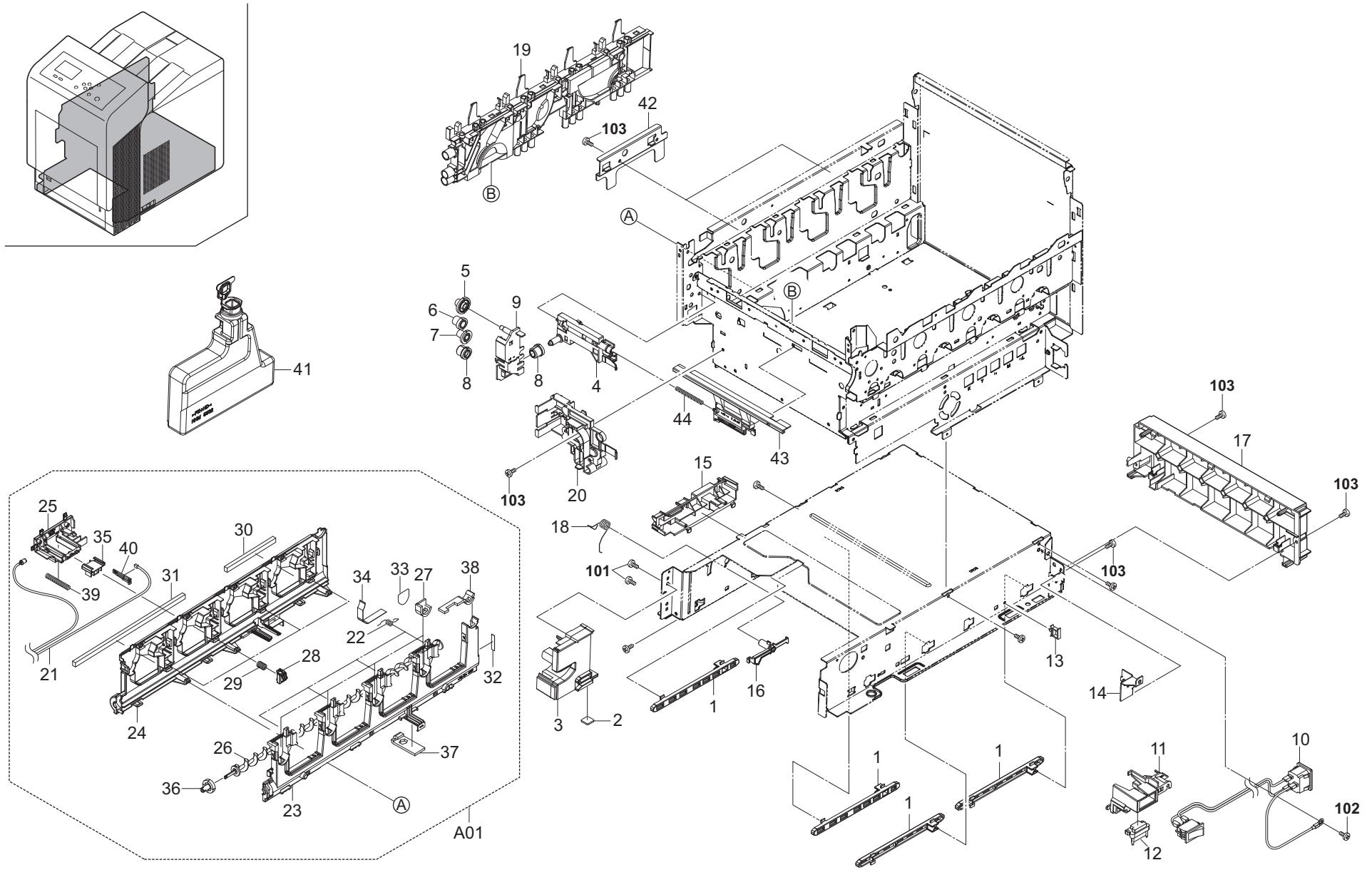

FIG. 4 Frames 2

2HG/2PR-1

Ref. No.	Part.No.	Alternative.	Description	Notes	Quantity		
					120	230	240
1	302HN02740	2HN02740	RAIL CASSETTE		4	4	4
2	302HN02611	2HN02611	FOOT		1	1	1
3	302HN02080	2HN02080	HINGE FEED LEFT		1	1	1
4	302HN02250	2HN02250	BRACKET FRONT		1	1	1
⊙	5	302HN02320	GEAR Z25S WASTE		1	1	1
⊙	6	302HN02330	GEAR Z17S WASTE		1	1	1
⊙	7	302HN02340	GEAR Z20S WASTE		1	1	1
⊙	8	302HN02350	GEAR Z14L-Z17S WASTE		2	2	2
	9	302HN02590	BRACKET GEAR		1	1	1
⊙	10	302HG00610	INLET ASSY		1	1	1
	11	302HG02090	BRACKET SWITCH		1	1	1
	12	302HN46350	CONN.CORD ASSY S03290		1	1	1
	13	7YZM610007++H01	ACCESS.SADDLE		1	1	1
	14	302HG02060	BRACKET BASE		1	1	1
	15	302HG02380	BRACKET HARNESS L		1	1	1
	16	302HN02780	LOCK CASSETTE		1	1	1
⊙	17	302HN02070	COVER REAR		1	1	1
	18	302HN02770	SPRING LOCK CASSETTE		1	1	1
⊙	19	302HG94030	DUCT LEFT A ASSY SP		1	1	1
⊙	20	302HG94010	CASE CONTACT HV K ASSY SP		1	1	1
⊙	A01	302HG93170	PARTS WASTE TONER		1	1	1
	21	*302HG00180	TONER FULL DETECT ASSY		1	1	1
	22	*302HG02500	SPRING LOCK DRUM		4	4	4
	23	*302HG03010	CASE WASTE A		1	1	1
	24	*302HG03020	CASE WASTE B		1	1	1
	25	*302HG03030	CASE SENSOR		1	1	1
	26	*302HG03040	SCREW WASTE		1	1	1
	27	*302HG03070	SEAL CASE WASTE A		4	4	4
	28	*302HG03090	LOCK DLP		4	4	4
	29	*302HG03100	SPRING LOCK DLP		4	4	4
	30	*302HG03110	SEAL WASTE LONG A		1	1	1
	31	*302HG03120	SEAL WASTE LONG B		1	1	1
	32	*302HG03130	SEAL CASE WASTE REAR		1	1	1
	33	*302HG03140	SEAL CASE WASTE C		4	4	4
	34	*302HG03150	SEAL CASE WASTE D		4	4	4
	35	*302HN03050	SHUTTER WASTE		1	1	1
	36	*302HN03060	GEAR Z20S WASTE		1	1	1
	37	*302HN03080	SEAL SHUTTER WASTE		1	1	1
	38	*302HN03090	SEAL CASE WASTE CLN		1	1	1
	39	*302KV03360	SPRING SHUTTER WASTE		1	1	1
	40	*302KV02C60	SPACER LED		1	1	1
⊙	41	302HG93140	WT-570		1	1	1
	42	302HG02540	STAY FRAME LEFT		2	2	2
⊙	43	302HN94051	BAR CLEANERED ID ASSY SP		1	1	1
	44	302HN02490	SPRING CLEANER ID		1	1	1

Ref. No.	Part.No.	Alternative.	Description	Notes	Quantity		
					120	230	240
101	7BB200308H	BB105660	+BIND T.T P SCREW 3X8				
102	7BB700408H	BB105640	+BIND T.T S SCREW 4X8 SR				
103	7BB700308H	BB105600	+BIND T.T S SCREW 3X8 SR				

- Parts with "⊙" indicate regular maintenance parts.
- Parts with Ref.No. indicate maintenance parts and the ones without it indicate out of the above.

- Parts with "." are component parts or sub-assemblies of the assembly appearing immediately above them.
- Parts with ". ." are component parts or sub-assembly with ". ." appearing immediately above them.

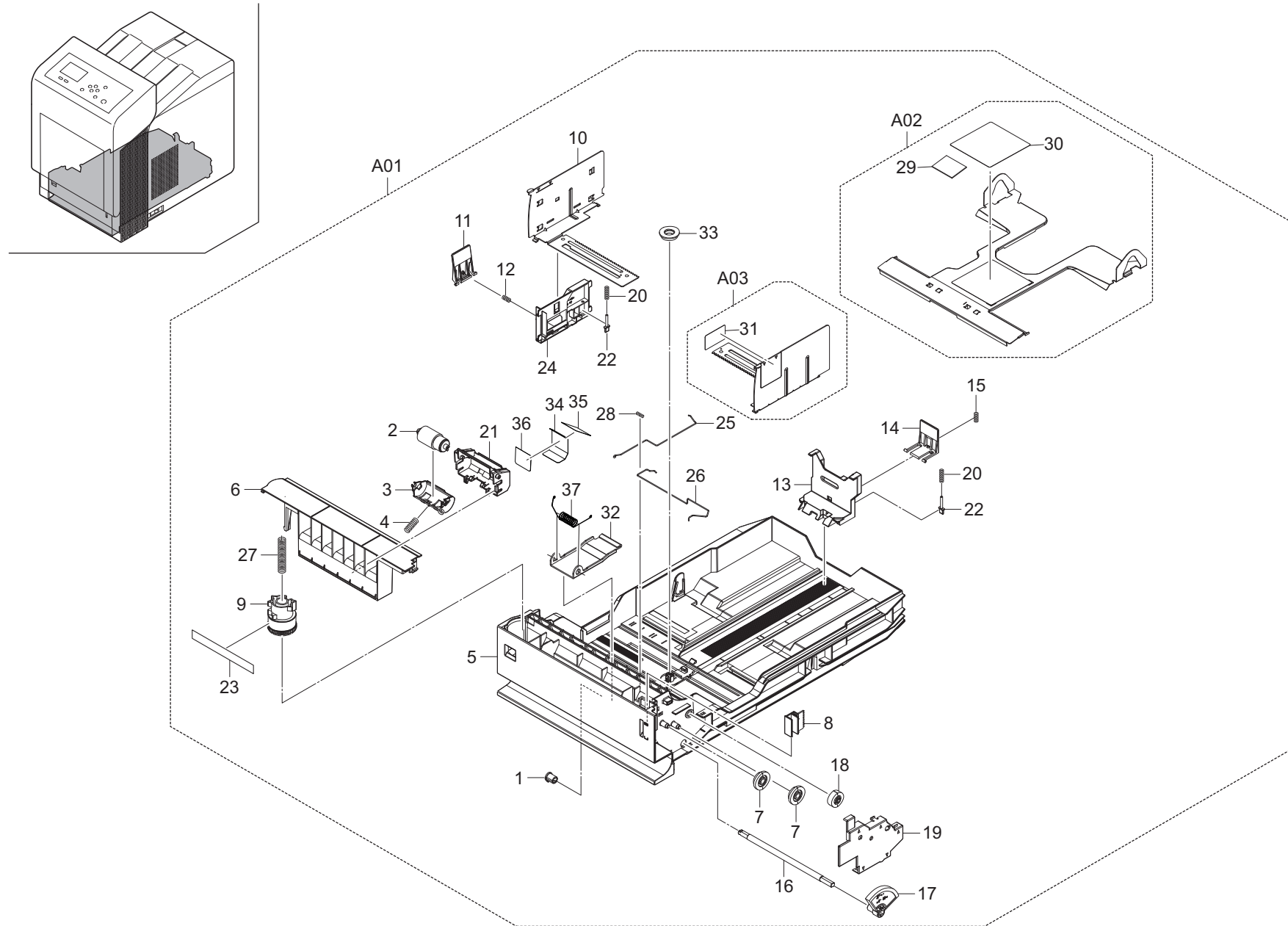

FIG. 5 Paper Cassette

2HG/2PR-1

Ref. No.	Part.No.	Alternative.	Description	Notes	Quantity		
					120	230	240
⊙ A01	302HG93220	2HG93220	CT-504		1	1	1
1	*302F909160	2F909160	BUSH LIFT 6		1	1	1
⊙ 2	*302F909171	2F909171	RETARD ROLLER ASSY		1	1	1
3	*302F909180	2F909180	HOLDER RETARD		1	1	1
4	*302HN09430	2HN09430	SPRING RETARD		1	1	1
5	*302HN09012	2HN09012	BASE CASSETTE		1	1	1
6	*302HN09020	2HN09020	COVER CASSETTE TOP		1	1	1
7	*302HN09030	2HN09030	GEAR Z20S-Z17S INDICATOR		2	2	2
8	*302HN09041	2HN09041	MARKER INDICATOR		1	1	1
9	*302HN09050	2HN09050	DIAL CASSETTE		1	1	1
10	*302HN09070	2HN09070	CURSOR LEFT		1	1	1
11	*302HN09090	2HN09090	LEVER GUIDE SIDE		1	1	1
12	*302HN09100	2HN09100	SPRING GUIDE SIDE		1	1	1
13	*302HN09110	2HN09110	CURSOR END		1	1	1
14	*302HN09120	2HN09120	LEVER STOPPER		1	1	1
15	*302HN09130	2HN09130	SPRING STOPPER		1	1	1
16	*302HN09150	2HN09150	SHAFT WORKPLATE		1	1	1
17	*302HN09160	2HN09160	GEAR Z50S LIFT		1	1	1
18	*302HN09170	2HN09170	GEAR Z13S JOINT		1	1	1
19	*302HN09180	2HN09180	COVER LIFT GEAR		1	1	1
20	*302HN09190	2HN09190	SPRING FIX		2	2	2
21	*302HN09230	2HN09230	GUIDE RETARD		1	1	1
22	*302HN09240	2HN09240	SIZE FIX		2	2	2
23	*302HN09250	2HN09250	LABEL DIAL		1	1	1
24	*302HN09350	2HN09350	CURSOR LEFT B		1	1	1
25	*302HN09371	2HN09371	SPRING EARTH		1	1	1
26	*302HN09391	2HN09391	SPRING EARTH SIDE		1	1	1
27	*302HN09400	2HN09400	SPRING DIAL		1	1	1
28	*302HN09410	2HN09410	SPRING EARTH C		1	1	1
⊙ A02	*302HN94190	2HN94190	PLATE BOTTOM ASSY SP		1	1	1
29	**302F909210	2F909210	PAD BOTTOM		1	1	1
30	**302HN09210	2HN09210	LABEL OPERATION		1	1	1
⊙ A03	*302HN94300	2HN94300	CURSOR RIGHT PF ASSY 2HN SP		1	1	1
31	**302HN09420	2HN09420	LABEL CURSOR		1	1	1
32	*303K809490	3K809490	WORKPLATE LIFT PF		1	1	1
33	*302B700770	2B700770	GEAR CASSETTE		1	1	1
34	*302HG09011	2HG09011	PLATE RETARD		1	1	1
35	*302HG09020	2HG09020	SHEET RETARD		1	1	1
36	*302HG09030	2HG09030	TAPE RETARD		1	1	1
37	*302HG09052	2HG09052	SPRING EARTH RETARD		1	1	1

Ref. No.	Part.No.	Alternative.	Description	Notes	Quantity		
					120	230	240

- Parts with "⊙" indicate regular maintenance parts.
- Parts with Ref.No. indicate maintenance parts and the ones without it indicate out of the above.

- Parts with "*" are component parts or sub-assemblies of the assembly appearing immediately above them.
- Parts with "*•" are component parts or sub-assembly with "*" appearing immediately above them.

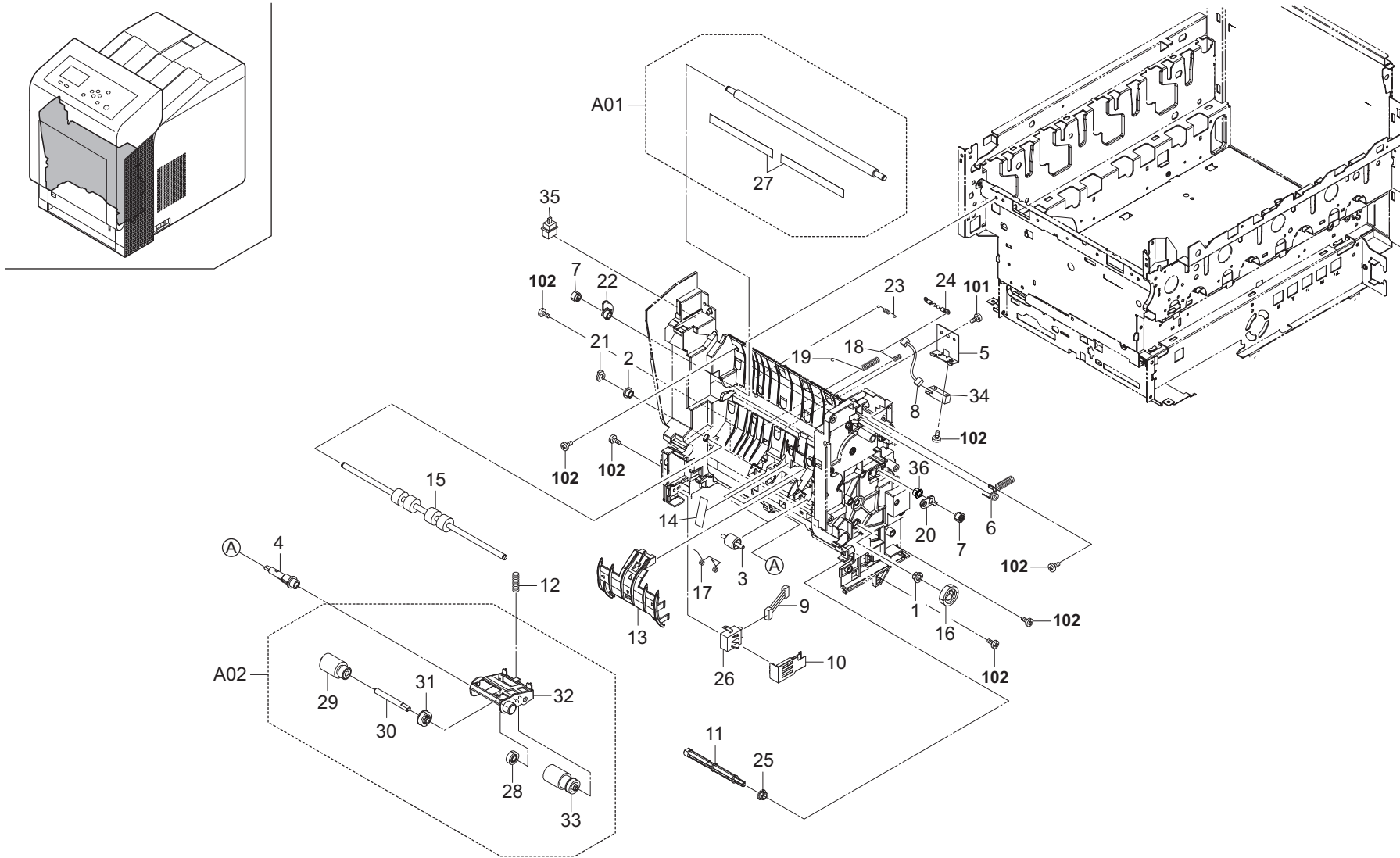

FIG. 6 Paper Feed Section 1

2HG/2PR-1

Ref. No.	Part.No.	Alternative.	Description	Notes	Quantity		
					120	230	240
1	302H702590	2H702590	BUSH SCREW		1	1	1
2	302H024370	2H024370	BUSH 6 EW		1	1	1
3	302C921041	2C921041	PULLEY FEED SHIFT		2	2	2
4	302F906110	2F906110	PIN FEED ROLL		1	1	1
5	302HG02310	2HG02310	HOLDER SENSOR		1	1	1
6	302HG24010	2HG24010	SPRING CONTACT HV SEPA		1	1	1
7	302HG24160	2HG24160	GEAR Z19L REG REAR		2	2	2
8	302HG46090	2HG46090	CONN.CORD ASSY S03326		1	1	1
9	302HG46400	2HG46400	CONN.CORD ASSY S03415		1	1	1
10	302HN02470	2HN02470	PLATE EARTH SIZE		1	1	1
11	302HN06030	2HN06030	SHAFT FEED R		1	1	1
12	302HG06010	2HG06010	SPRING PICKUP		1	1	1
13	302HN06160	2HN06160	GUIDE HOUSING		1	1	1
14	302HN06180	2HN06180	SHEET HOUSING		2	2	2
15	302HN24030	2HN24030	ROLLER MIDDLE		1	1	1
16	302HN24080	2HN24080	GEAR Z27R MIDDLE		1	1	1
17	302HN24230	2HN24230	SPRING MIDDLE		2	2	2
18	302HN24260	2HN24260	SPRING REG EARTH A		1	1	1
19	302HN24320	2HN24320	SPRING MID EARTH		1	1	1
20	302HG24190	2HG24190	BUSH REGIST CL		1	1	1
21	5MVX111DN003	2A806250	RING STOPPER /A-49 FEED A4		1	1	1
22	302HN24410	2HN24410	BUSH REGIST EW		1	1	1
23	302HN24420	2HN24420	SPRING REG EARTH B		1	1	1
24	302HN24430	2HN24430	HIGH MEG R ASSY		1	1	1
25	302HN31590	2HN31590	BUSH DRIVE		1	1	1
26	302HN44180	2HN44180	SWITCH SIZE		1	1	1
A01	302HG94230	2HG94230	PARTS ROLLER REG REAR SP		1	1	1
27	*302HG24170	2HG24170	SHEET REGIST FRONT		2	2	2
A02	302HN94201	2HN94201	HOLDER FEED ASSY SP		1	1	1
28	*302F906030	2F906030	GEAR FEED Z26H		1	1	1
29	*302F906230	2F906230	PULLEY FEED ASSY		1	1	1
30	*302F906272	2F906272	SHAFT FEED L		1	1	1
31	*302F906280	2F906280	GEAR FEED Z30H		1	1	1
32	*302HN06010	2HN06010	HOLDER FEED		1	1	1
33	*302HN06080	2HN06080	PULLEY PICKUP ASSY		1	1	1
34	3H327410	3H327410	SENSOR,CONVEYING		1	1	1
35	7SP01000001+H01	SP044290	SW.PUSH		1	1	1
36	302HG24200	2HG24200	BUSH METAL REGIST		1	1	1

Ref. No.	Part.No.	Alternative.	Description	Notes	Quantity		
					120	230	240
101	7BB200308H	BB105660	+BIND T.T P SCREW 3X8				
102	7BB100306H1	BB105820	+BIND T.T S SCREW 3X6				

- Parts with "⊙" indicate regular maintenance parts.
- Parts with Ref.No. indicate maintenance parts and the ones without it indicate out of the above.

- Parts with "." are component parts or sub-assemblies of the assembly appearing immediately above them.
- Parts with ". ." are component parts or sub-assembly with ". ." appearing immediately above them.

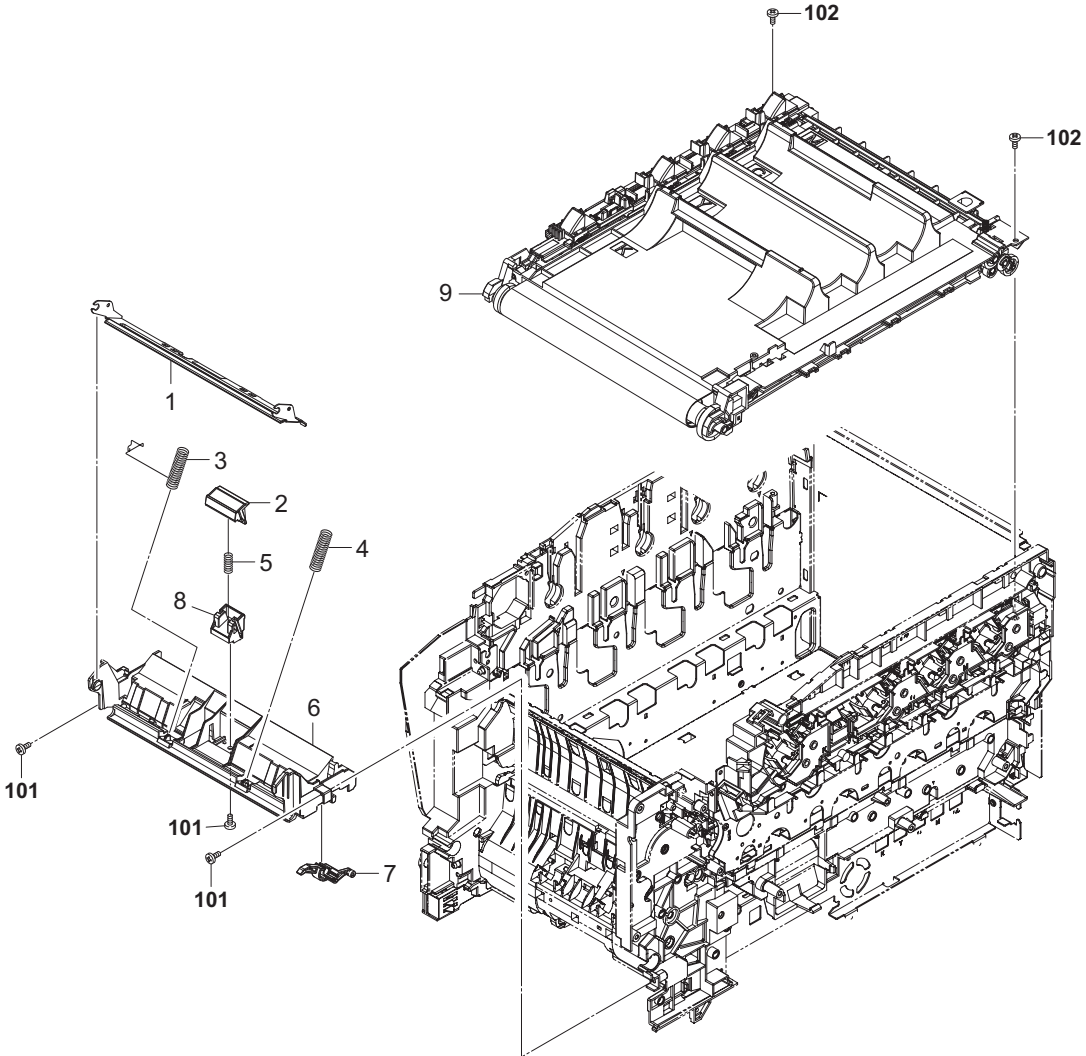
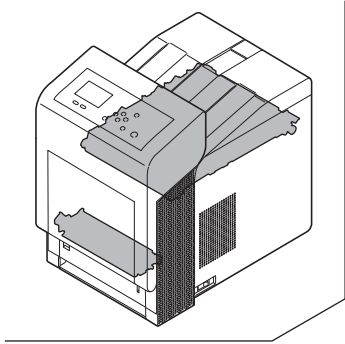

FIG. 7 Paper Feed Section 2

2HG/2PR-1

	Ref. No.	Part.No.	Alternative.	Description	Notes	Quantity		
						120	230	240
⊙	1	302HN94150	2HN94150	PLATE BOTTOM MPF ASSY SP		1	1	1
⊙	2	302HN94160	2HN94160	SEPARATOR MPF ASSY SP		1	1	1
	3	302HN08080	2HN08080	SP BOTTOM MPF L		1	1	1
	4	302HN08090	2HN08090	SP BOTTOM MPF R		1	1	1
	5	302HN08100	2HN08100	SPRING SEPARATOR		1	1	1
	6	302HN08111	2HN08111	FRAME MPF LOW		1	1	1
	7	302HN08181	2HN08181	LEVER CAM MPF		1	1	1
	8	302HN08210	2HN08210	HOLDER SEPARATOR MPF		1	1	1
⊙	9	302HG93092	2HG93092	TR-570		1	1	1

	Ref. No.	Part.No.	Alternative.	Description	Notes	Quantity		
						120	230	240
	101	7BB200410H	BB105700	+BIND T.T P SCREW 4X10				
	102	7BB200416H	BB040720	+BIND T.T P SCREW 4X16				

- Parts with "⊙" indicate regular maintenance parts.
- Parts with Ref.No. indicate maintenance parts and the ones without it indicate out of the above.

- Parts with "." are component parts or sub-assemblies of the assembly appearing immediately above them.
- Parts with ". ." are component parts or sub-assembly with ". ." appearing immediately above them.

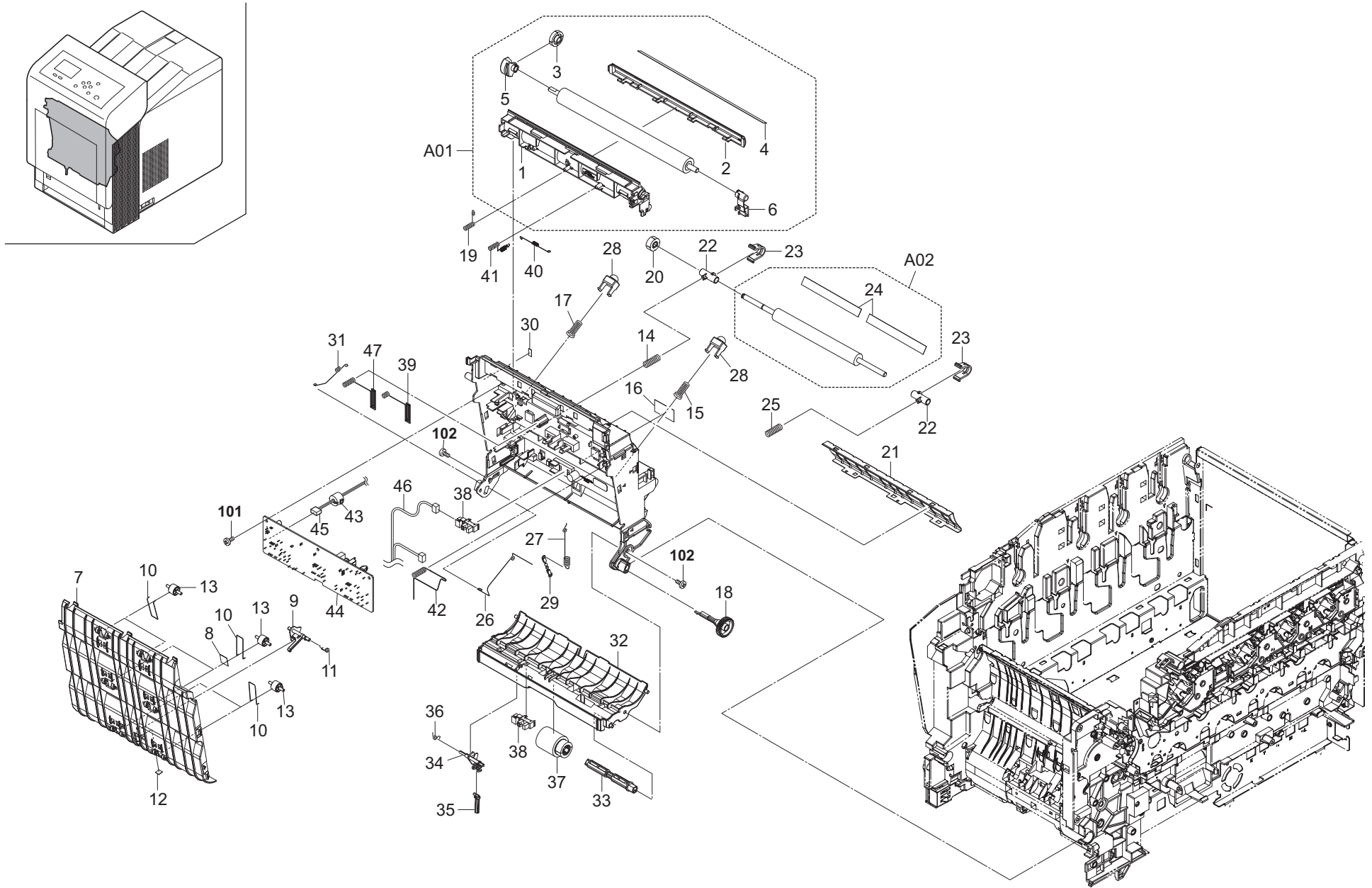

FIG. 8 Paper Conveying Section

2HG/2PR-1

Ref. No.	Part.No.	Alternative.	Description	Notes	Quantity		
					120	230	240
⊙ A01	302HG93150	2HG93150	PARTS TRANSFER ASSY		1	1	1
1	*302HG22020	2HG22020	HOLDER BRUSH		1	1	1
2	*302HG22030	2HG22030	PAPER CHUTE		1	1	1
3	*302HG22040	2HG22040	GEAR Z24L TC ROLL		1	1	1
4	*302HG22050	2HG22050	SHEET PAPER CHUTE		1	1	1
5	*302HN22050	2HN22050	BUSH TRANS L		1	1	1
6	*302HN22060	2HN22060	BUSH TRANS R		1	1	1
7	302HG24110	2HG24110	GUIDE FEED DU		1	1	1
8	302HG24120	2HG24120	SHEET HIGH VOLTAGE SUB		2	2	2
9	302HN24140	2HN24140	ACTUATOR DU		1	1	1
10	302HN24290	2HN24290	SPRING DU		6	6	6
11	302HN24300	2HN24300	SPRING ACT DU		1	1	1
12	302HN24360	2HN24360	SPONGE A		1	1	1
13	302HN24400	2HN24400	PULLEY PA		6	6	6
14	302HG24080	2HG24080	SPRING REG L		1	1	1
15	302HG24100	2HG24100	SPRING TC R		1	1	1
16	302HG24130	2HG24130	SHEET DU SENSOR		1	1	1
17	302HG24150	2HG24150	SPRING TC L		1	1	1
⊙ 18	302HN06150	2HN06150	GEAR Z30S MPF		1	1	1
19	302HN22080	2HN22080	SPRING SEP EARTH B		1	1	1
⊙ 20	302HN24070	2HN24070	GEAR Z31R REG FRONT		1	1	1
21	302HN24090	2HN24090	PLATE EARTH GUIDE		1	1	1
22	302HN24110	2HN24110	BUSH REG R		2	2	2
23	302HN24150	2HN24150	STOPPER BUSH REG		2	2	2
⊙ A02	302HG94240	2HG94240	PARTS ROLLER REG FRONT SP		1	1	1
24	*302HG24170	2HG24170	SHEET REGIST FRONT		2	2	2
25	302HN24190	2HN24190	SPRING REG R		1	1	1
26	302HN24250	2HN24250	SPRING EARTH FEED		1	1	1
27	302HN24280	2HN24280	SPRING GUIDE EARTH		1	1	1
28	302HN24370	2HN24370	STOPPER TC SPRING		2	2	2
29	302HN24430	2HN24430	HIGH MEG R ASSY		1	1	1
30	302HG24180	2HG24180	LABEL EXIT B		1	1	1
31	302HN24390	2HN24390	SPRING EARTH B		1	1	1
32	302HN06100	2HN06100	FRAME MPF UP		1	1	1
33	302HN06110	2HN06110	SHAFT FEED MPF		1	1	1
34	302HN06121	2HN06121	ACTUATOR MPF		1	1	1
35	302HN06131	2HN06131	ACTUATOR MPF B		1	1	1
36	302HN06170	2HN06170	SPRING MPF B		1	1	1
⊙ 37	5AAVR0LL+051	2CL16130	ROLLER M/P ASSY /43487B0027 A4		1	1	1
⊙ 38	7NXSG2481+++H01	NX052600	SENSOR OPT.		2	2	2
39	302HG24020	2HG24020	SPRING CONTACT HV		1	1	1
40	302HG24030	2HG24030	SPRING CONTACT HV TC A		1	1	1
41	302HG24040	2HG24040	SPRING CONTACT HV TC B		1	1	1
42	302HG24050	2HG24050	SPRING HV TC BK		1	1	1
43	2A627940	2A627940	CORE 10-20X10		1	1	1
⊙ 44	302HG45020	2HG45020	HIGH VOLTAGE UNIT 2		1	1	1
45	302HG46030	2HG46030	CONN.CORD ASSY S03320		1	1	1
46	302HG46390	2HG46390	CONN.CORD ASSY S03437		1	1	1
47	302HG24070	2HG24070	SPRING CONTACT HV DISCHARGER		1	1	1

Ref. No.	Part.No.	Alternative.	Description	Notes	Quantity		
					120	230	240
101	7BB200308H	BB105660	+BIND T.T P SCREW 3X8				
102	7BB200410H	BB105700	+BIND T.T P SCREW 4X10				

- Parts with "⊙" indicate regular maintenance parts.
- Parts with Ref.No. indicate maintenance parts and the ones without it indicate out of the above.

- Parts with "." are component parts or sub-assemblies of the assembly appearing immediately above them.
- Parts with ".•" are component parts or sub-assembly with ".•" appearing immediately above them.

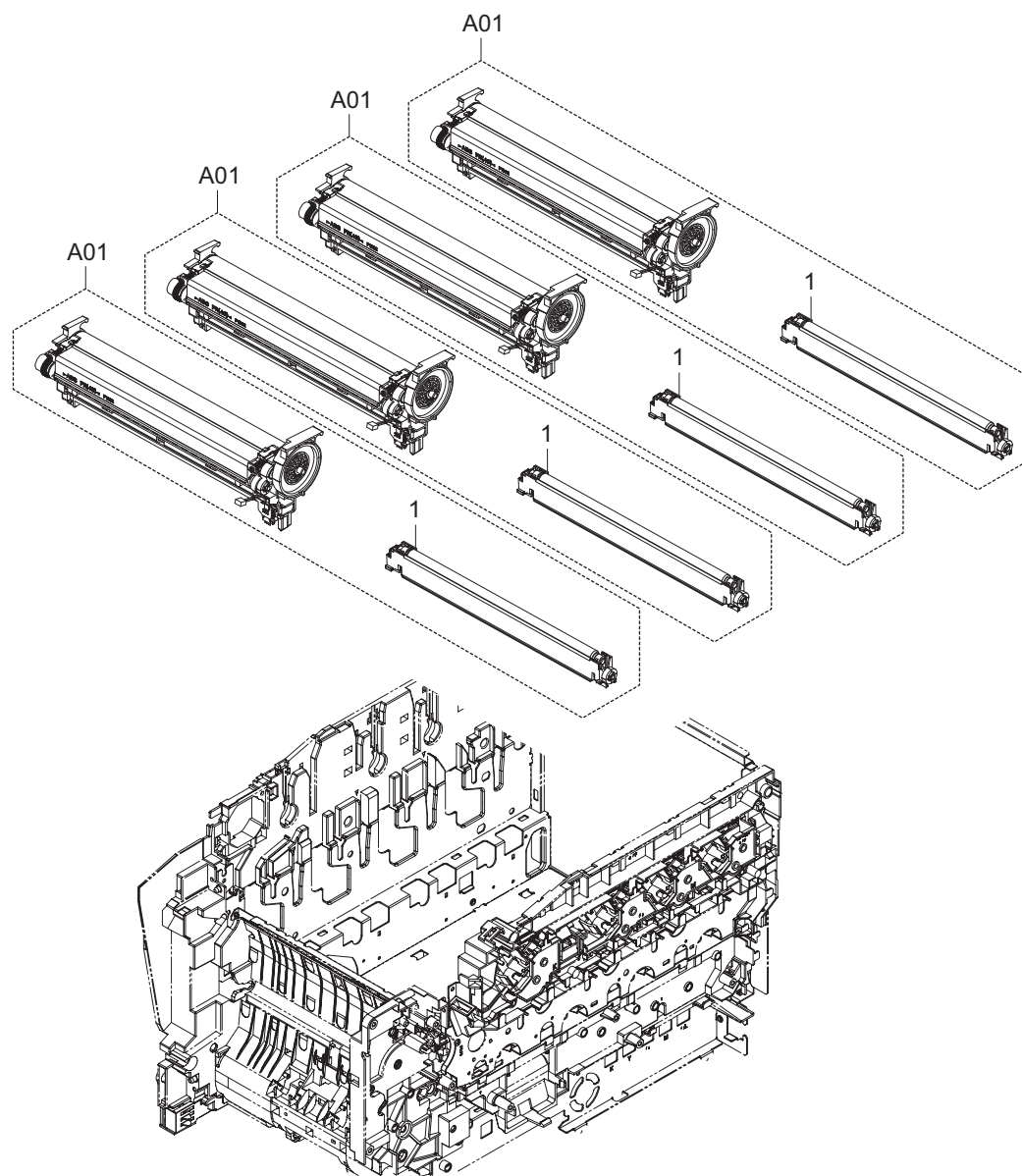
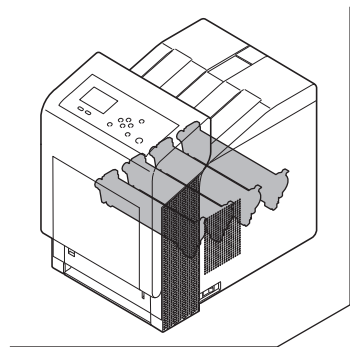

FIG. 9 Image Formation Section

2HG/2PR-1

	Ref. No.	Part.No.	Alternative.	Description	Notes	Quantity		
						120	230	240
⊙	A01	302HG93011	2HG93011	DK-570		4	4	4
⊙	1	*302HG93131	2HG93131	MC-570		4	4	4

	Ref. No.	Part.No.	Alternative.	Description	Notes	Quantity		
						120	230	240

- Parts with "⊙" indicate regular maintenance parts.
- Parts with Ref.No. indicate maintenance parts and the ones without it indicate out of the above.

- Parts with "." are component parts or sub-assemblies of the assembly appearing immediately above them.
- Parts with ".•" are component parts or sub-assembly with ".•" appearing immediately above them.

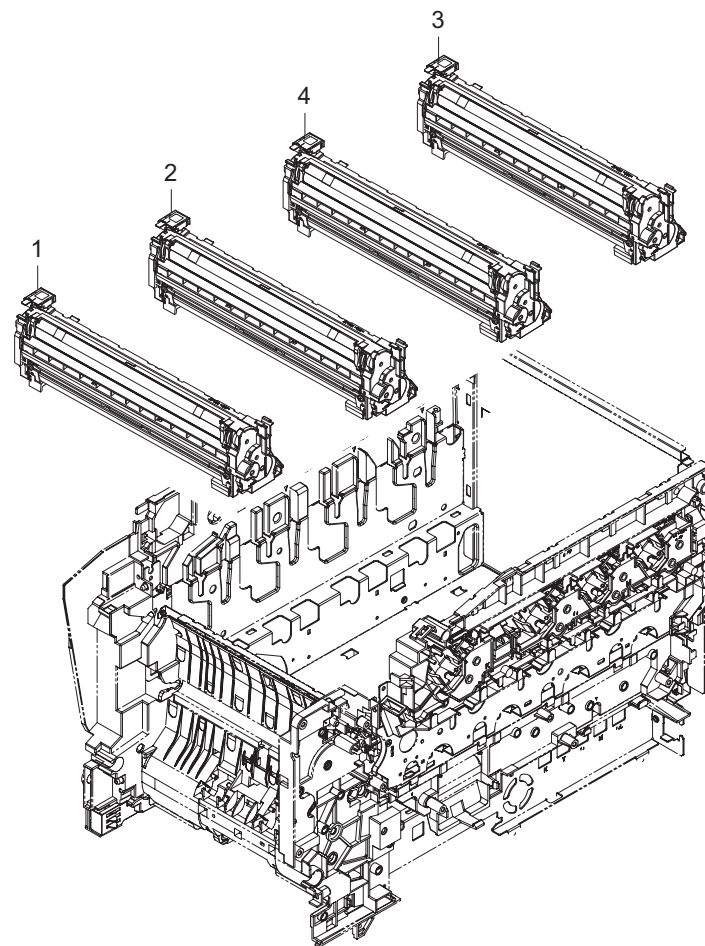
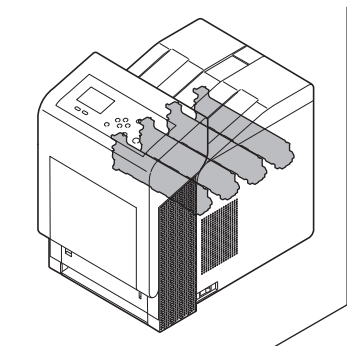

FIG. 10 Developing Section

2HG/2PR-1

	Ref. No.	Part.No.	Alternative.	Description	Notes	Quantity		
						120	230	240
⊙	1	302HG93025	2HG93025	DV-570(K)			1	1
⊙	1	302HG93185	2HG93185	DV-570 US(K)		1		
⊙	2	302HG93035	2HG93035	DV-570(Y)			1	1
⊙	2	302HG93195	2HG93195	DV-570 US(Y)		1		
⊙	3	302HG93045	2HG93045	DV-570(M)			1	1
⊙	3	302HG93205	2HG93205	DV-570 US(M)		1		
⊙	4	302HG93055	2HG93055	DV-570(C)			1	1
⊙	4	302HG93215	2HG93215	DV-570 US(C)		1		

	Ref. No.	Part.No.	Alternative.	Description	Notes	Quantity		
						120	230	240

- Parts with "⊙" indicate regular maintenance parts.
- Parts with Ref.No. indicate maintenance parts and the ones without it indicate out of the above.

- Parts with "•" are component parts or sub-assemblies of the assembly appearing immediately above them.
- Parts with "••" are component parts or sub-assembly with "•" appearing immediately above them.

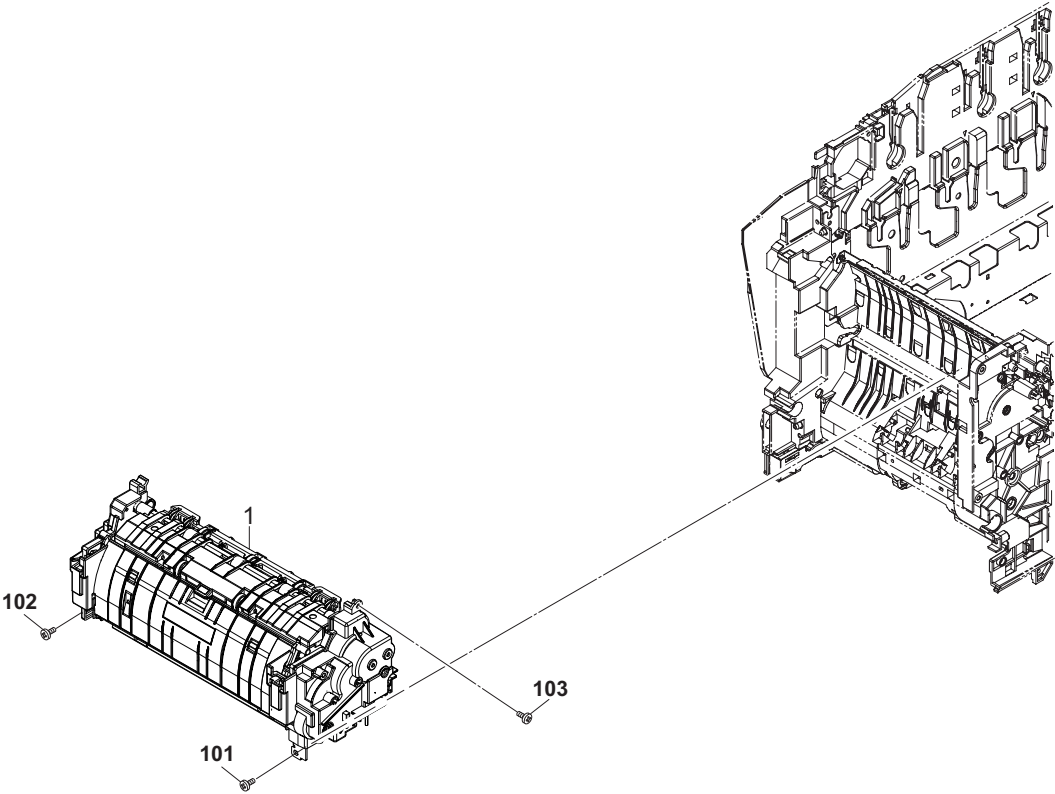
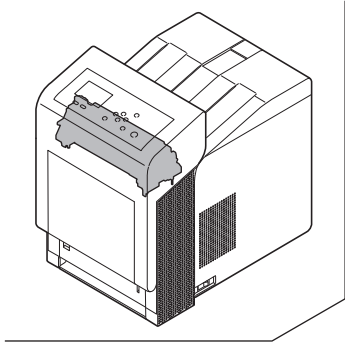

FIG. 11 Fuser Section

2HG/2PR-2

	Ref. No.	Part.No.	Alternative.	Description	Notes	Quantity		
						120	230	240
⊙	1	302HG93060	2HG93060	FK-570(E)	(A)		1	1
⊙	1	302PR93010	2PR93010	FK-571(E)	(B)		1	1
⊙	1	302HG93070	2HG93070	FK-570(U)		1		

	Ref. No.	Part.No.	Alternative.	Description	Notes	Quantity		
						120	230	240
	101	7BB200410H	BB105700	+BIND T.T P SCREW 4X10				
	102	7BB700408H	BB105640	+BIND T.T S SCREW 4X8 SR				
	103	7BB200308H	BB105660	+BIND T.T P SCREW 3X8				

- Parts with "⊙" indicate regular maintenance parts.
- Parts with Ref.No. indicate maintenance parts and the ones without it indicate out of the above.

- Parts with "*" are component parts or sub-assemblies of the assembly appearing immediately above them.
- Parts with "••" are component parts or sub-assembly with "•" appearing immediately above them.

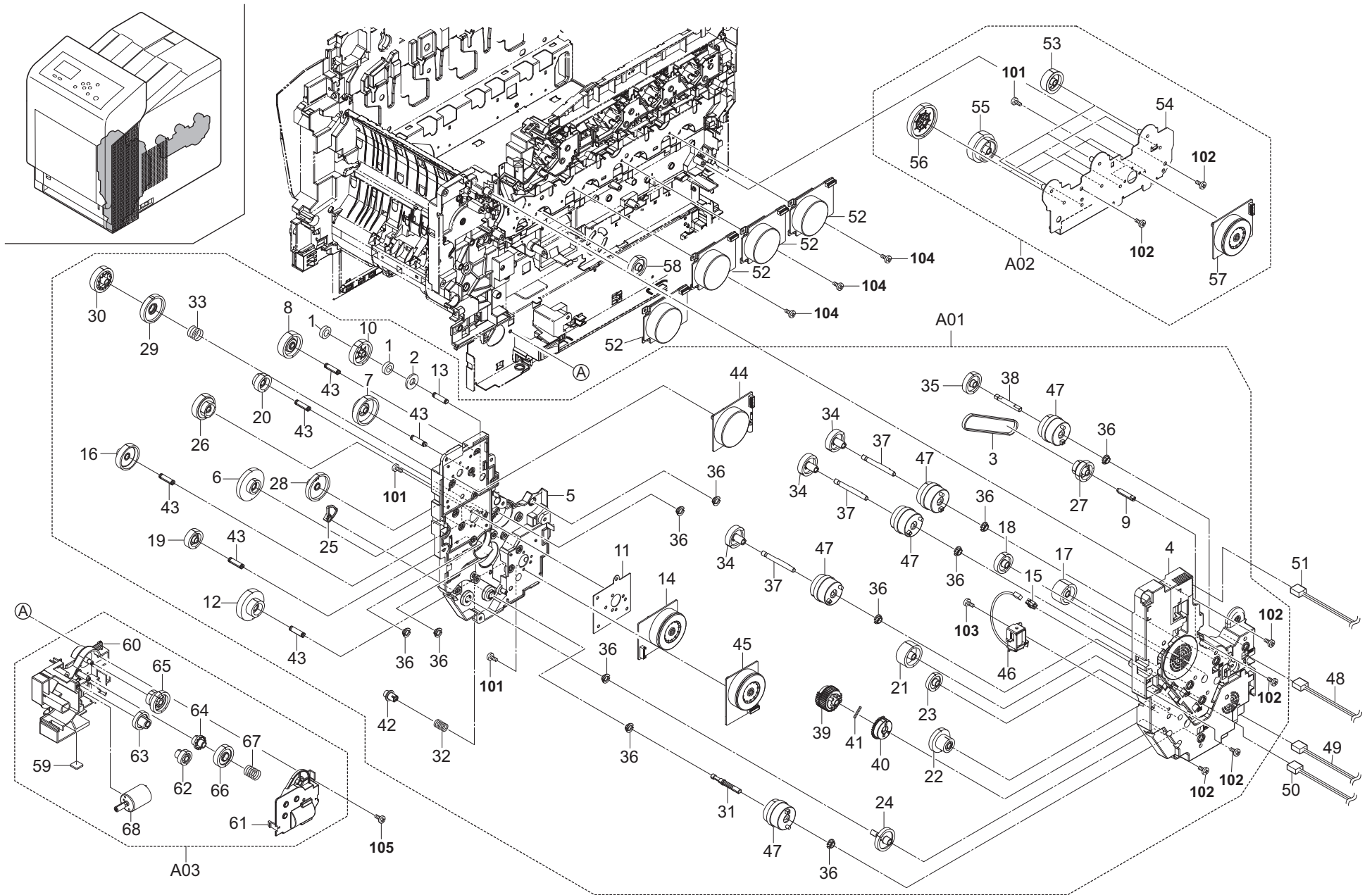

FIG. 12 Drive Section

2HG/2PR-2

Ref. No.	Part.No.	Alternative.	Description	Notes	Quantity		
					120	230	240
⊙ A01	302HG93110	2HG93110	DR-570A		1	1	1
⊙ 1	*19514250	19514250	BEARING,DEVELOPING		2	2	2
⊙ 2	*2C904550	2C904550	CUT WASHER 5		1	1	1
⊙ 3	*2FB17260	2FB17260	BELT FEED HANDLE		1	1	1
⊙ 4	*302HG31010	2HG31010	HOLDER FEED DRIVE A		1	1	1
⊙ 5	*302HG31020	2HG31020	HOLDER FEED DRIVE B		1	1	1
⊙ 6	*302HG31050	2HG31050	GEAR Z63R-Z35L		1	1	1
⊙ 7	*302HG31060	2HG31060	GEAR Z74R-Z26S		1	1	1
⊙ 8	*302HG31070	2HG31070	GEAR Z40S INPUT FUSER		1	1	1
⊙ 9	*302HG31110	2HG31110	PIN DRIVE B		1	1	1
⊙ 10	*302HG31120	2HG31120	GEAR Z38R INPUT MT		1	1	1
⊙ 11	*302HG31130	2HG31130	PLATE DRIVE MT		1	1	1
⊙ 12	*302HG31140	2HG31140	GEAR Z74R-Z25R		1	1	1
⊙ 13	*302HG31150	2HG31150	PIN DRIVE MT2		1	1	1
⊙ 14	*302HG44140	2HG44140	MOTOR DRIVE M2		1	1	1
⊙ 15	*7YCC02B1003+H01	YC013860	CONNECTOR 292254-2		1	1	1
⊙ 16	*302HN31141	2HN31141	GEAR Z39L		1	1	1
⊙ 17	*302HN31150	2HN31150	GEAR Z32R IDLE		1	1	1
⊙ 18	*302HN31160	2HN31160	GEAR Z30L		1	1	1
⊙ 19	*302HN31180	2HN31180	GEAR Z28R INPUT DU		1	1	1
⊙ 20	*302HN31190	2HN31190	GEAR Z31R-Z26R INPUT REGIST		1	1	1
⊙ 21	*302HN31200	2HN31200	GEAR Z35L		1	1	1
⊙ 22	*302HN31210	2HN31210	GEAR Z36R-Z22S		1	1	1
⊙ 23	*302HN31220	2HN31220	GEAR Z28S		1	1	1
⊙ 24	*302HN31240	2HN31240	GEAR Z36S MPF CAM		1	1	1
⊙ 25	*302HN31250	2HN31250	CAM MPF		1	1	1
⊙ 26	*302HN31260	2HN31260	GEAR Z62R-P32		1	1	1
⊙ 27	*302HN31270	2HN31270	GEAR Z30L-P30		1	1	1
⊙ 28	*302HN31311	2HN31311	GEAR Z70R		1	1	1
⊙ 29	*302HN31320	2HN31320	GEAR Z70L		1	1	1
⊙ 30	*302HN31330	2HN31330	GEAR Z38L		1	1	1
⊙ 31	*302HN31370	2HN31370	SHAFT CLUTCH FEED		1	1	1
⊙ 32	*302HN31410	2HN31410	SPRING FEED		1	1	1
⊙ 33	*302HN31430	2HN31430	SPRING MID TRANSFER		1	1	1
⊙ 34	*302HN31570	2HN31570	GEAR Z32L CL		3	3	3
⊙ 35	*302HN31580	2HN31580	GEAR Z32R CL		1	1	1
⊙ 36	*302HN31590	2HN31590	BUSH DRIVE		11	11	11
⊙ 37	*302HN31600	2HN31600	SHAFT CL FEED		3	3	3
⊙ 38	*302HN31610	2HN31610	SHAFT CL DLP		1	1	1
⊙ 39	*302HN31620	2HN31620	GEAR Z36S INPUT MPF A		1	1	1
⊙ 40	*302HN31630	2HN31630	GEAR Z36S INPUT MPF B		1	1	1
⊙ 41	*302HN31650	2HN31650	SPRING INPUT MPF		1	1	1
⊙ 42	*302HN31660	2HN31660	JOINT SHAFT CASSETTE		1	1	1
⊙ 43	*302HN31670	2HN31670	PIN DRIVE A		6	6	6
⊙ 44	*302HN44060	2HN44060	MOTOR DRIVE L		1	1	1
⊙ 45	*302HN44070	2HN44070	MOTOR DRIVE M		1	1	1
⊙ 46	*302HN44160	2HN44160	SOLENOID MPF		1	1	1
⊙ 47	*302HN44200	2HN44200	CLUTCH FEED L		5	5	5
⊙ 48	302HN46020	2HN46020	CONN.CORD ASSY S03254		1	1	1

Ref. No.	Part.No.	Alternative.	Description	Notes	Quantity		
					120	230	240
⊙ 49	302HN46380	2HN46380	CONN.CORD ASSY S03293		1	1	1
⊙ 50	302HN46490	2HN46490	CONN.CORD ASSY S03387		1	1	1
⊙ 51	302HG46270	2HG46270	CONN.CORD ASSY S03398		1	1	1
⊙ 52	302HG44011	2HG44011	MOTOR DRUM		4	4	4
⊙ A02	302HG93120	2HG93120	DR-570B		1	1	1
⊙ 53	*302HG31090	2HG31090	GEAR Z33L		3	3	3
⊙ 54	*302HN31070	2HN31070	PLATE DRIVE		1	1	1
⊙ 55	*302HN31080	2HN31080	GEAR Z74R-Z35L		3	3	3
⊙ 56	*302HN31090	2HN31090	GEAR Z54R		3	3	3
⊙ 57	*302HN44070	2HN44070	MOTOR DRIVE M		1	1	1
⊙ 58	302HG31040	2HG31040	GEAR Z33L INPUT DLP		1	1	1
⊙ A03	302HN94182	2HN94182	DRIVE LIFT ASSY SP		1	1	1
⊙ 59	*302HN02611	2HN02611	FOOT		1	1	1
⊙ 60	*302HN31010	2HN31010	BRACKET DRIVE LIFT		1	1	1
⊙ 61	*302HN31020	2HN31020	COVER GEAR LIFT		1	1	1
⊙ 62	*302HN31030	2HN31030	GEAR Z36L-Z20S		1	1	1
⊙ 63	*302HN31040	2HN31040	GEAR Z46S-Z13S		1	1	1
⊙ 64	*302HN31050	2HN31050	GEAR Z13S		1	1	1
⊙ 65	*302HN31060	2HN31060	GEAR Z35S-Z13S		1	1	1
⊙ 66	*302HN31540	2HN31540	GEAR Z34S		1	1	1
⊙ 67	*302HN31550	2HN31550	SPRING DRIVE LIFT		1	1	1
⊙ 68	*302HN94261	2HN94261	DC MOTOR ASSY LIFT SP		1	1	1
101	7BB000304H	BB105720	+BIND M SCREW 3X4				
102	7BB200410H	BB105700	+BIND T.T P SCREW 4X10				
103	7BB200308H	BB105660	+BIND T.T P SCREW 3X8				
104	7BB100306H1	BB105820	+BIND T.T S SCREW 3X6				
105	7BB700408H	BB105640	+BIND T.T S SCREW 4X8 SR				

- Parts with "⊙" indicate regular maintenance parts.
- Parts with Ref.No. indicate maintenance parts and the ones without it indicate out of the above.

- Parts with "*" are component parts or sub-assemblies of the assembly appearing immediately above them.
- Parts with "•" are component parts or sub-assembly with "•" appearing immediately above them.

FIG. 13 Exit Section

2HG/2PR-1

Ref. No.	Part.No.	Alternative.	Description	Notes	Quantity		
					120	230	240
⊙ A01	302HG93161	2HG93161	PARTS EXIT ASSY		1	1	1
1	*2BG22990	2BG22990	CUT WASHER 4		1	1	1
2	*2FM02210	5MVM274DN002	PULLEY MID /B-11 FRAME A4		4	4	4
3	*302F325010	2F325010	STUD SCREW M3		2	2	2
4	*302F925060	2F925060	ACTUATOR SOL		1	1	1
5	*302HG04040	2HG04040	LEVER FRONT COVER LEFT		1	1	1
6	*302HG04050	2HG04050	LEVER FRONT COVER RIGHT		1	1	1
⊙ 7	*302HG28020	2HG28020	GUIDE CHANGE		1	1	1
⊙ 8	*302HG28030	2HG28030	GEAR Z38R-Z17R		1	1	1
⊙ 9	*302HG28040	2HG28040	GEAR FD Z20S		1	1	1
⊙ 10	*302HG28050	2HG28050	GEAR IDLE Z34S		1	1	1
⊙ 11	*302HG28060	2HG28060	GEAR IDLE Z28S		1	1	1
12	*302HG28070	2HG28070	PLATE MOTOR B		1	1	1
13	*302HG28080	2HG28080	GUIDE EXIT UP		1	1	1
14	*302HG28090	2HG28090	SPRING EARTH EXIT E		1	1	1
15	*302HG28100	2HG28100	SPRING EARTH EXIT F		1	1	1
16	*302HG28110	2HG28110	SPRING LEVER		2	2	2
17	*302HG28120	2HG28120	GUIDE CORRUGATION		1	1	1
⊙ 18	*302HG28130	2HG28130	GEAR Z36L-Z14S		1	1	1
19	*302HG28140	2HG28140	DISCHARGER FD		2	2	2
20	*302HG28150	2HG28150	ACTUATOR FULL		1	1	1
⊙ 21	*302HG28160	2HG28160	ROLLER FD		1	1	1
22	*302HG28170	2HG28170	SHEET PLATE MOTOR		1	1	1
23	*302HG28200	2HG28200	SPRING EARTH EXIT G		1	1	1
24	*302HG28230	2HG28230	SPRING PULLEY B		2	2	2
⊙ 25	*302HG28241	2HG28241	ROLLER REVERSE		1	1	1
26	*302HG28250	2HG28250	PIN EXIT		1	1	1
27	*302HG28260	2HG28260	SEAL FAN FUSER SUB		1	1	1
28	*302HG28270	2HG28270	SPRING REVERSE		2	2	2
⊙ 29	*302HG44020	2HG44020	MOTOR REVERSE		1	1	1
30	*302HG46250	2HG46250	CONN.CORD ASSY S03377		1	1	1
⊙ 31	*302HG94070	2HG94070	DC MOTOR ASSY EXIT SP		1	1	1
⊙ 32	*302HN28071	2HN28071	GEAR Z20L REVERSE		1	1	1
33	*302HN28110	2HN28110	SPRING SOLENOID		1	1	1
34	*302HN28120	2HN28120	SPRING PULLEY A		2	2	2
35	*302HN28150	2HN28150	SPRING EARTH EXIT A		1	1	1
36	*302HN28180	2HN28180	STAY FRONT		1	1	1
37	*302HN28220	2HN28220	SEAL ACTUATOR		1	1	1
38	*302HN29050	2HN29050	BUSH DU		2	2	2
⊙ 39	*302HN44210	2HN44210	FAN MOTOR		1	1	1
⊙ 40	*302HN94140	2HN94140	SOLENOID FD ASSY SP		1	1	1
41	*5MVM273DB005	2A820100	PULLEY EXIT /A-49 FUSER A3		2	2	2
⊙ 42	302HG44110	2HG44110	FAN MOTOR 50		1	1	1
⊙ 43	302HG01100	2HG01100	P.W.BOARD ASSY EXIT		1	1	1
44	302HG46020	2HG46020	CONN.CORD ASSY S03318		1	1	1
45	302HG46260	2HG46260	CONN.CORD ASSY S03391		1	1	1
46	302HG02590	2HG02590	SHEET EXIT LEFT		1	1	1

Ref. No.	Part.No.	Alternative.	Description	Notes	Quantity		
					120	230	240
101	7BB200308H	BB105660	+BIND T.T P SCREW 3X8				
102	7BB202308H	BB105690	+TP-FLAT T.T P SCREW 3X8				
103	7BB000303H	BB107000	+BIND M SCREW 3X3				
104	7BB300323H	BB105800	+BIND T.T B SCREW 3X23				

- Parts with "⊙" indicate regular maintenance parts.
- Parts with Ref.No. indicate maintenance parts and the ones without it indicate out of the above.

- Parts with "." are component parts or sub-assemblies of the assembly appearing immediately above them.
- Parts with ". ." are component parts or sub-assembly with ". ." appearing immediately above them.

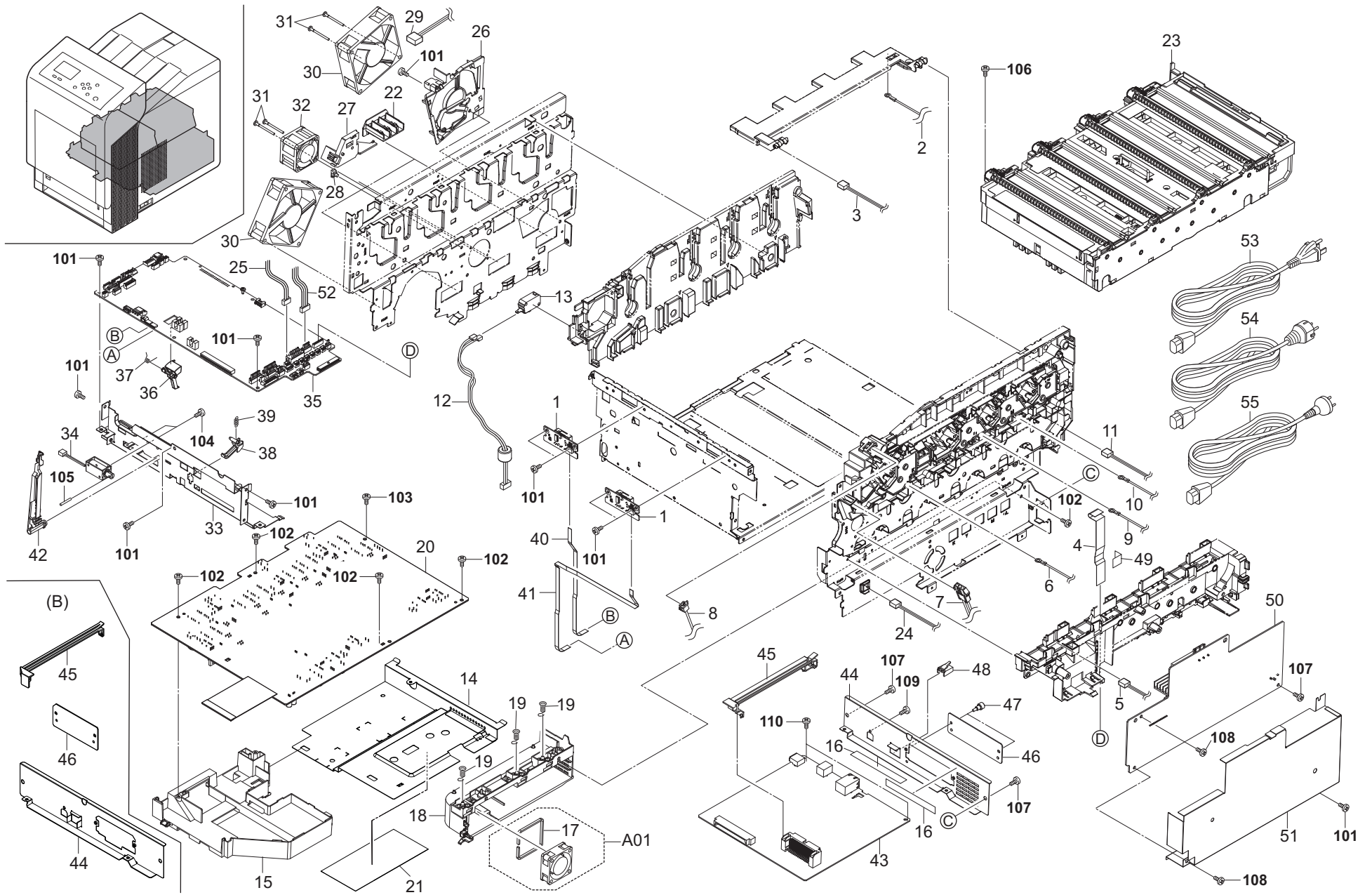

FIG. 14 Electrical Components

2HG/2PR-2

Ref. No.	Part.No.	Alternative.	Description	Notes	Quantity		
					120	230	240
⊙ 1	302HN94320	2HN94320	ID SENSOR ASSY SP		2	2	2
2	302HG46190	2HG46190	CONN.CORD ASSY S03339		1	1	1
3	302HG46410	2HG46410	CONN.CORD ASSY S03421		1	1	1
4	302HG46420	2HG46420	CONN.CORD ASSY S03424		1	1	1
5	302HG46470	2HG46470	CONN.CORD ASSY S03513		1	1	1
6	302HG46150	2HG46150	CONN.CORD ASSY S03335		1	1	1
7	302HG46040	2HG46040	CONN.CORD ASSY S03321		1	1	1
8	302HN46580	2HN46580	CONN.CORD ASSY S03436		1	1	1
9	302HG46170	2HG46170	CONN.CORD ASSY S03337		1	1	1
10	302HG46180	2HG46180	CONN.CORD ASSY S03338		1	1	1
11	302HG46240	2HG46240	CONN.CORD ASSY S03376		1	1	1
12	302HN46150	2HN46150	CONN.CORD ASSY S03268		1	1	1
⊙ 13	7SM010104+++H01	SM055200	SW.MICRO		1	1	1
14	302HG39021	2HG39021	SHIELD HV		1	1	1
15	302HG39010	2HG39010	DUCT CONTROLLER		1	1	1
16	7ZGSTG110075H01	ZG111050	SHIELD GASKET		2	2	2
⊙ A01	302HN94230	2HN94230	FAN PS ASSY SP		1	1	1
17	*302HN39100	2HN39100	SEAL PS FAN		1	1	1
18	302HG39060	2HG39060	BRACKET HV PWB		1	1	1
19	302HN39090	2HN39090	SPRING HV PT		3	3	3
⊙ 20	302HG94161	2HG94161	HIGH VOLTAGE UNIT SP		1	1	1
21	302PP39030	2PP39030	SHEET SHIELD		1	1	1
⊙ 22	302HG94020	2HG94020	CASE CONTACT HV C ASSY SP		3	3	3
⊙ 23	302HG93100	2HG93100	LK-570		1	1	1
⊙ 24	302HN94010	2HN94010	BRACKET HV TC ASSY SP		1	1	1
25	302HG46460	2HG46460	CONN.CORD ASSY S03507		1	1	1
26	302HG02110	2HG02110	DUCT LEFT B		1	1	1
27	302HG02480	2HG02480	HOLDER FAN LEFT		1	1	1
28	7YZM610007+++H01	YZ023340	ACCESS.SADDLE		1	1	1
29	302HG46340	2HG46340	CONN.CORD ASSY S03434		1	1	1
⊙ 30	302HN44010	2HN44010	FAN MOTOR		2	2	2
31	302HG02350	2HG02350	BIND TAP-TITE S		4	4	4
⊙ 32	302HG44090	2HG44090	FAN MOTOR 40		1	1	1
33	302HG39050	2HG39050	PLATE ENGINE		1	1	1
⊙ 34	302HN94220	2HN94220	SOLENOID FD ASSY CLN SP		1	1	1
⊙ 35	302HG80060	2HG80060	P.W.BOARD ASSY ENGINE WITH SOFTWARE(SP)	(A)	1	1	1
⊙ 35	302PR94060	2PR94060	PARTS PWB ASSY ENGINE SP	(B)	1	1	1
⊙ 36	302HN39070	2HN39070	ACTUATOR CASSETTE		1	1	1
37	302HN39110	2HN39110	SPRING ACTUATOR		1	1	1
⊙ 38	302HN06050	2HN06050	ACTUATOR PICKUP		1	1	1
39	302HN06060	2HN06060	SPRING PICK ACT		1	1	1
⊙ 40	302HN46290	2HN46290	CONN.CORD ASSY S03282		1	1	1
41	302HN46300	2HN46300	CONN.CORD ASSY S03283		1	1	1
42	302HN02660	2HN02660	LINK LEVER		1	1	1
⊙ 43	302HG01110	2HG01110	P.W.BOARD ASSY MAIN WITH SOFTWARE(E)	(A)	1	1	1
⊙ 43	302PR94070	2PR94070	PARTS PWB ASSY MAIN SP	(B)	1	1	1
⊙ 43	302PR94080	2PR94080	PARTS PWB ASSY MAIN EU SP	(B)	1	1	1

Ref. No.	Part.No.	Alternative.	Description	Notes	Quantity		
					120	230	240
44	302HG39040	2HG39040	PLATE CONTROLLER	(A)	1	1	1
44	302PR39010	2PR39010	PLATE CONTROLLER	(B)	1	1	1
45	302HN39060	2HN39060	RAIL OPTION	(A)	1	1	1
45	302PP39020	2PP39020	RAIL OPTION	(B)	1	1	1
46	303BH26021	3BH26021	PLATE,OPTION	(A)	1	1	1
46	302K339050	2K339050	PLATE OPTION	(B)	1	1	1
⊙ 47	5MMT263SN012++R	2D903100	SCREW OP / M3 X 8 CRFREE A4		2	2	2
48	302F939090	2F939090	CAP NETWORK		1	1	1
49	302HG02600	2HG02600	SEAL HARNESS R		1	1	1
⊙ 50	302HG45041	2HG45041	SWITCHING REGULATOR 120V		1	1	1
⊙ 50	302HG45031	2HG45031	SWITCHING REGULATOR 230V	(A)	1	1	1
⊙ 50	302PR94050	2PR94050	PARTS SWITCHING REGULATOR 230V SP	(B)	1	1	1
51	302HG39030	2HG39030	SHIELD POWER		1	1	1
52	302HG46380	2HG46380	CONN.CORD ASSY S03411		1	1	1
53	3019527401	19527401	POWER CORD(120)		1	1	1
54	302FV94010	2FV94010	PARTS AC CORD EU SP		1	1	1
55	302FV45040	2FV45040	AC CORD ASSY		1	1	1
101	7BB700308H	BB105600	+BIND T.T S SCREW 3X8 SR				
102	7BB200308H	BB105660	+BIND T.T P SCREW 3X8				
103	7BB702306H	BB105630	+TP-FLAT T.T S SCREW 3X6 SR				
104	7BB007303H	BB105750	+TP-CUP M SCREW 3X3				
105	5MBP2518WXSP	E0025180	SPRING PIN /M2.5 X 18 S-BLK				
106	7BB000306H	BB106880	+BIND M SCREW 3X6				
107	7BB700408H	BB105640	+BIND T.T S SCREW 4X8 SR				
108	7BB200410H	BB105700	+BIND T.T P SCREW 4X10				
109	7BB601306H	BB105790	+PAN M SCREW 3X6 R				
110	7BB100306H1	BB105820	+BIND T.T S SCREW 3X6				

- Parts with "⊙" indicate regular maintenance parts.
- Parts with Ref.No. indicate maintenance parts and the ones without it indicate out of the above.

- Parts with "*" are component parts or sub-assemblies of the assembly appearing immediately above them.
- Parts with "••" are component parts or sub-assembly with "•" appearing immediately above them.

FIG. 15 Maintenance Kits

2HG/2PR-2

Ref. No.	Part.No.	Alternative.	Description	Notes	Quantity		
					120	230	240
	1702HG7US0	072HG7US	MK-570/MAINTENANCE KIT RETARD ROLLER ASSY DV-570 US(K) DV-570 US(Y) DV-570 US(M) DV-570 US(C) DK-570 FK-570(U) TR-570 HOLDER FEED ASSY SP ROLLER M/P ASSY /43487B0027 A4	OPTION	1		
	1702HG8EU0	072HG8EU	MK-570/MAINTENANCE KIT RETARD ROLLER ASSY DV-570(K) DV-570(Y) DV-570(M) DV-570(C) DK-570 FK-570(E) TR-570 HOLDER FEED ASSY SP ROLLER M/P ASSY /43487B0027 A4	OPTION (A)	1	1	
	1702PR8NL0	072PR8NL	MK-575/MAINTENANCE KIT RETARD ROLLER ASSY DV-570(K) DV-570(Y) DV-570(M) DV-570(C) DK-570 FK-571(E) TR-570 HOLDER FEED ASSY SP ROLLER M/P ASSY /43487B0027 A4	OPTION (B)	1	1	

Ref. No.	Part.No.	Alternative.	Description	Notes	Quantity		
					120	230	240

- Parts with "⊙" indicate regular maintenance parts.
- Parts with Ref.No. indicate maintenance parts and the ones without it indicate out of the above.

- Parts with "*" are component parts or sub-assemblies of the assembly appearing immediately above them.
- Parts with "••" are component parts or sub-assembly with "•" appearing immediately above them.

	Part.No.	Alternative.	Description	Fig.No.
	1702HG7US0	072HG7US	MK-570/MAINTENANCE KIT	15
	1702HG8EU0	072HG8EU	MK-570/MAINTENANCE KIT	15
	1702PR8NLO	072PR8NL	MK-575/MAINTENANCE KIT	15
⊙	19514250	19514250	BEARING,DEVELOPING	12
	2A627940	2A627940	CORE 10-20X10	8
	2BG22990	2BG22990	CUT WASHER 4	13
	2C904550	2C904550	CUT WASHER 5	12
⊙	2FB17260	2FB17260	BELT FEED HANDLE	12
	2FM02210	5MVM274DN002	PULLEY MID /B-11 FRAME A4	13
	3019527401	19527401	POWER CORD(120)	14
	302B700770	2B700770	GEAR CASSETTE	5
	302B700780	2B700780	GEAR MANUAL	2
	302C921041	2C921041	PULLEY FEED SHIFT	6
	302F325010	2F325010	STUD SCREW M3	13
⊙	302F906030	2F906030	GEAR FEED Z26H	6
	302F906110	2F906110	PIN FEED ROLL	6
	302F906230	2F906230	PULLEY FEED ASSY	6
	302F906272	2F906272	SHAFT FEED L	6
⊙	302F906280	2F906280	GEAR FEED Z30H	6
	302F908300	2F908300	SPRING LOCK MPF	2
	302F909160	2F909160	BUSH LIFT 6	5
⊙	302F909171	2F909171	RETARD ROLLER ASSY	5
	302F909180	2F909180	HOLDER RETARD	5
	302F909210	2F909210	PAD BOTTOM	5
	302F925060	2F925060	ACTUATOR SOL	13
	302F939090	2F939090	CAP NETWORK	14
	302FV45040	2FV45040	AC CORD ASSY	14
	302FV94010	2FV94010	PARTS AC CORD EU SP	14
	302H024370	2H024370	BUSH 6 EW	6
	302H702590	2H702590	BUSH SCREW	6
⊙	302HG00180	2HG00180	TONER FULL DETECT ASSY	4
⊙	302HG00610	2HG00610	INLET ASSY	4
⊙	302HG01100	2HG01100	P.W.BOARD ASSY EXIT	13
⊙	302HG01110	2HG01110	P.W.BOARD ASSY MAIN WITH SOFTWARE(E)	14
	302HG02010	2HG02010	FRAME LEFT	3
	302HG02020	2HG02020	FRAME RIGHT	3
	302HG02030	2HG02030	FRAME REAR	3
	302HG02060	2HG02060	BRACKET BASE	4
	302HG02090	2HG02090	BRACKET SWITCH	4
	302HG02110	2HG02110	DUCT LEFT B	14
	302HG02120	2HG02120	DUCT RIGHT A	3
	302HG02130	2HG02130	DUCT RIGHT B	3
	302HG02140	2HG02140	ACTUATOR LEVER LINK	3
	302HG02150	2HG02150	LEVER LINK	3
	302HG02160	2HG02160	RACK SPRING THRUST	3
	302HG02170	2HG02170	GUIDE SPRING THRUST	3
	302HG02180	2HG02180	GUIDE DLP	3
	302HG02310	2HG02310	HOLDER SENSOR	6
	302HG02320	2HG02320	SPRING CONTACT HV PT	3
	302HG02350	2HG02350	BIND TAP-TITE S	14

	Part.No.	Alternative.	Description	Fig.No.
	302HG02360	2HG02360	SPRING RACK THRUST	3
	302HG02380	2HG02380	BRACKET HARNESS L	4
	302HG02480	2HG02480	HOLDER FAN LEFT	14
	302HG02490	2HG02490	SEAL FAN DLP	3
	302HG02500	2HG02500	SPRING LOCK DRUM	4
	302HG02510	2HG02510	PIN HOUSING RIGHT	3
	302HG02520	2HG02520	SPACER HOUSING RIGHT	3
	302HG02530	2HG02530	TAPE SPACER HOUSING RIGHT	3
	302HG02540	2HG02540	STAY FRAME LEFT	4
	302HG02550	2HG02550	LABEL GUIDE DLP Y	3
	302HG02560	2HG02560	LABEL GUIDE DLP C	3
	302HG02570	2HG02570	LABEL GUIDE DLP M	3
	302HG02580	2HG02580	LABEL GUIDE DLP K	3
	302HG02590	2HG02590	SHEET EXIT LEFT	13
	302HG02600	2HG02600	SEAL HARNESS R	14
	302HG03010	2HG03010	CASE WASTE A	4
	302HG03020	2HG03020	CASE WASTE B	4
	302HG03030	2HG03030	CASE SENSOR	4
	302HG03040	2HG03040	SCREW WASTE	4
	302HG03070	2HG03070	SEAL CASE WASTE A	4
	302HG03090	2HG03090	LOCK DLP	4
	302HG03100	2HG03100	SPRING LOCK DLP	4
	302HG03110	2HG03110	SEAL WASTE LONG A	4
	302HG03120	2HG03120	SEAL WASTE LONG B	4
	302HG03130	2HG03130	SEAL CASE WASTE REAR	4
	302HG03140	2HG03140	SEAL CASE WASTE C	4
	302HG03150	2HG03150	SEAL CASE WASTE D	4
⊙	302HG04020	2HG04020	COVER UPPER RIGHT	1
⊙	302HG04030	2HG04030	COVER UPPER LEFT	1
	302HG04040	2HG04040	LEVER FRONT COVER LEFT	13
	302HG04050	2HG04050	LEVER FRONT COVER RIGHT	13
⊙	302HG04061	2HG04061	COVER RIGHT REAR	1
	302HG04090	2HG04090	COVER TOP	1
⊙	302HG04100	2HG04100	COVER RIGHT FRONT	1
⊙	302HG04110	2HG04110	COVER LEFT FRONT	1
	302HG04120	2HG04120	STOPPER EXIT A	1
	302HG04130	2HG04130	STOPPER EXIT B	1
	302HG04140	2HG04140	LABEL WASTE BOTTLE	1
	302HG04150	2HG04150	LABEL FUSER CAUTION R	1
	302HG04160	2HG04160	SEAL WASTE BOTTLE	1
⊙	302HG04190	2HG04190	COVER LOWER LEFT	2
⊙	302HG04200	2HG04200	COVER LOWER RIGHT	2
	302HG05020	2HG05020	MOUNT UPPER OPERATION	2
	302HG05030	2HG05030	MOUNT LOWER OPERATION	2
	302HG05040	2HG05040	BUTTON A	2
	302HG05051	2HG05051	BUTTON B	2
	302HG05060	2HG05060	BUTTON C	2
	302HG05070	2HG05070	SHEET STATIC ELIMINATOR	2
	302HG05100	2HG05100	SHEET LCD	2
	302HG06010	2HG06010	SPRING PICKUP	6

• Parts with "⊙" indicate regular maintenance parts.

Part.No.	Alternative.	Description	Fig.No.	Part.No.	Alternative.	Description	Fig.No.
302HG09011	2HG09011	PLATE RETARD	5	302HG31010	2HG31010	HOLDER FEED DRIVE A	12
302HG09020	2HG09020	SHEET RETARD	5	302HG31020	2HG31020	HOLDER FEED DRIVE B	12
302HG09030	2HG09030	TAPE RETARD	5	⊙ 302HG31040	2HG31040	GEAR Z33L INPUT DLP	12
302HG09052	2HG09052	SPRING EARTH RETARD	5	⊙ 302HG31050	2HG31050	GEAR Z63R-Z35L	12
302HG22020	2HG22020	HOLDER BRUSH	8	⊙ 302HG31060	2HG31060	GEAR Z74R-Z26S	12
302HG22030	2HG22030	PAPER CHUTE	8	⊙ 302HG31070	2HG31070	GEAR Z40S INPUT FUSER	12
302HG22040	2HG22040	GEAR Z24L TC ROLL	8	⊙ 302HG31090	2HG31090	GEAR Z33L	12
302HG22050	2HG22050	SHEET PAPER CHUTE	8	⊙ 302HG31110	2HG31110	PIN DRIVE B	12
302HG24010	2HG24010	SPRING CONTACT HV SEPA	6	⊙ 302HG31120	2HG31120	GEAR Z38R INPUT MT	12
302HG24020	2HG24020	SPRING CONTACT HV	8	302HG31130	2HG31130	PLATE DRIVE MT	12
302HG24030	2HG24030	SPRING CONTACT HV TC A	8	⊙ 302HG31140	2HG31140	GEAR Z74R-Z25R	12
302HG24040	2HG24040	SPRING CONTACT HV TC B	8	⊙ 302HG31150	2HG31150	PIN DRIVE MT2	12
302HG24050	2HG24050	SPRING HV TC BK	8	302HG39010	2HG39010	DUCT CONTROLLER	14
302HG24070	2HG24070	SPRING CONTACT HV DISCHARGER	8	302HG39021	2HG39021	SHIELD HV	14
302HG24080	2HG24080	SPRING REG L	8	302HG39030	2HG39030	SHIELD POWER	14
302HG24100	2HG24100	SPRING TC R	8	302HG39040	2HG39040	PLATE CONTROLLER	14
302HG24110	2HG24110	GUIDE FEED DU	8	302HG39050	2HG39050	PLATE ENGINE	14
302HG24120	2HG24120	SHEET HIGH VOLTAGE SUB	8	302HG39060	2HG39060	BRACKET HV PWB	14
302HG24130	2HG24130	SHEET DU SENSOR	8	⊙ 302HG44011	2HG44011	MOTOR DRUM	12
302HG24150	2HG24150	SPRING TC L	8	⊙ 302HG44020	2HG44020	MOTOR REVERSE	13
⊙ 302HG24160	2HG24160	GEAR Z19L REG REAR	6	⊙ 302HG44080	2HG44080	FAN MOTOR 70	3
302HG24170	2HG24170	SHEET REGIST FRONT	6,8	⊙ 302HG44090	2HG44090	FAN MOTOR 40	14
302HG24180	2HG24180	LABEL EXIT B	8	⊙ 302HG44110	2HG44110	FAN MOTOR 50	13
302HG24190	2HG24190	BUSH REGIST CL	6	⊙ 302HG44140	2HG44140	MOTOR DRIVE M2	12
302HG24200	2HG24200	BUSH METAL REGIST	6	⊙ 302HG45020	2HG45020	HIGH VOLTAGE UNIT 2	8
⊙ 302HG28020	2HG28020	GUIDE CHANGE	13	⊙ 302HG45031	2HG45031	SWITCHING REGULATOR 230V	14
⊙ 302HG28030	2HG28030	GEAR Z38R-Z17R	13	⊙ 302HG45041	2HG45041	SWITCHING REGULATOR 120V	14
⊙ 302HG28040	2HG28040	GEAR FD Z20S	13	302HG46020	2HG46020	CONN.CORD ASSY S03318	13
⊙ 302HG28050	2HG28050	GEAR IDLE Z34S	13	302HG46030	2HG46030	CONN.CORD ASSY S03320	8
⊙ 302HG28060	2HG28060	GEAR IDLE Z28S	13	302HG46040	2HG46040	CONN.CORD ASSY S03321	14
302HG28070	2HG28070	PLATE MOTOR B	13	302HG46090	2HG46090	CONN.CORD ASSY S03326	6
302HG28080	2HG28080	GUIDE EXIT UP	13	302HG46120	2HG46120	CONN.CORD ASSY S03331	2
302HG28090	2HG28090	SPRING EARTH EXIT E	13	302HG46150	2HG46150	CONN.CORD ASSY S03335	14
302HG28100	2HG28100	SPRING EARTH EXIT F	13	302HG46170	2HG46170	CONN.CORD ASSY S03337	14
302HG28110	2HG28110	SPRING LEVER	13	302HG46180	2HG46180	CONN.CORD ASSY S03338	14
302HG28120	2HG28120	GUIDE CORRUGATION	13	302HG46190	2HG46190	CONN.CORD ASSY S03339	14
⊙ 302HG28130	2HG28130	GEAR Z36L-Z14S	13	302HG46240	2HG46240	CONN.CORD ASSY S03376	14
302HG28140	2HG28140	DISCHARGER FD	13	302HG46250	2HG46250	CONN.CORD ASSY S03377	13
302HG28150	2HG28150	ACTUATOR FULL	13	302HG46260	2HG46260	CONN.CORD ASSY S03391	13
⊙ 302HG28160	2HG28160	ROLLER FD	13	302HG46270	2HG46270	CONN.CORD ASSY S03398	12
302HG28170	2HG28170	SHEET PLATE MOTOR	13	302HG46340	2HG46340	CONN.CORD ASSY S03434	14
302HG28200	2HG28200	SPRING EARTH EXIT G	13	302HG46380	2HG46380	CONN.CORD ASSY S03411	14
302HG28230	2HG28230	SPRING PULLEY B	13	302HG46390	2HG46390	CONN.CORD ASSY S03437	8
⊙ 302HG28241	2HG28241	ROLLER REVERSE	13	302HG46400	2HG46400	CONN.CORD ASSY S03415	6
302HG28250	2HG28250	PIN EXIT	13	302HG46410	2HG46410	CONN.CORD ASSY S03421	14
302HG28260	2HG28260	SEAL FAN FUSER SUB	13	302HG46420	2HG46420	CONN.CORD ASSY S03424	14
302HG28270	2HG28270	SPRING REVERSE	13	302HG46460	2HG46460	CONN.CORD ASSY S03507	14
302HG29060	2HG29060	BELT DU B	2	302HG46470	2HG46470	CONN.CORD ASSY S03513	14
302HG29070	2HG29070	HOOK DU RELEASE LEFT	2	⊙ 302HG80060	2HG80060	P.W.BOARD ASSY ENGINE WITH SOFTWARE(SP)	14
302HG29120	2HG29120	HOOK CONVEYING	2	⊙ 302HG93011	2HG93011	DK-570	9

• Parts with "⊙" indicate regular maintenance parts.

	Part.No.	Alternative.	Description	Fig.No.		Part.No.	Alternative.	Description	Fig.No.
⊙	302HG93025	2HG93025	DV-570(K)	10	⊙	302HN02330	2HN02330	GEAR Z17S WASTE	4
⊙	302HG93035	2HG93035	DV-570(Y)	10	⊙	302HN02340	2HN02340	GEAR Z20S WASTE	4
⊙	302HG93045	2HG93045	DV-570(M)	10	⊙	302HN02350	2HN02350	GEAR Z14L-Z17S WASTE	4
⊙	302HG93055	2HG93055	DV-570(C)	10		302HN02470	2HN02470	PLATE EARTH SIZE	6
⊙	302HG93060	2HG93060	FK-570(E)	11		302HN02490	2HN02490	SPRING CLEANER ID	4
⊙	302HG93070	2HG93070	FK-570(U)	11		302HN02590	2HN02590	BRACKET GEAR	4
⊙	302HG93092	2HG93092	TR-570	7		302HN02611	2HN02611	FOOT	4,12
⊙	302HG93100	2HG93100	LK-570	14		302HN02660	2HN02660	LINK LEVER	14
⊙	302HG93110	2HG93110	DR-570A	12		302HN02670	2HN02670	PLATE CONTAINER K	3
⊙	302HG93120	2HG93120	DR-570B	12		302HN02680	2HN02680	PLATE CONTAINER C	3
⊙	302HG93131	2HG93131	MC-570	9		302HN02701	2HN02701	ACTUATOR CONTAINER	3
⊙	302HG93140	2HG93140	WT-570	4		302HN02710	2HN02710	SPRING ACT CONT	3
⊙	302HG93150	2HG93150	PARTS TRANSFER ASSY	8		302HN02720	2HN02720	SEAL SQUARE 25-20	3
⊙	302HG93161	2HG93161	PARTS EXIT ASSY	13		302HN02740	2HN02740	RAIL CASSETTE	4
⊙	302HG93170	2HG93170	PARTS WASTE TONER	4		302HN02750	2HN02750	SEAL DC MOTOR	3
⊙	302HG93185	2HG93185	DV-570 US(K)	10		302HN02770	2HN02770	SPRING LOCK CASSETTE	4
⊙	302HG93195	2HG93195	DV-570 US(Y)	10		302HN02780	2HN02780	LOCK CASSETTE	4
⊙	302HG93205	2HG93205	DV-570 US(M)	10		302HN03050	2HN03050	SHUTTER WASTE	4
⊙	302HG93215	2HG93215	DV-570 US(C)	10		302HN03060	2HN03060	GEAR Z20S WASTE	4
⊙	302HG93220	2HG93220	CT-504	5		302HN03080	2HN03080	SEAL SHUTTER WASTE	4
⊙	302HG94010	2HG94010	CASE CONTACT HV K ASSY SP	4		302HN03090	2HN03090	SEAL CASE WASTE CLN	4
⊙	302HG94020	2HG94020	CASE CONTACT HV C ASSY SP	14		302HN04170	2HN04170	STOPPER FRONT COVER RIGHT	2
⊙	302HG94030	2HG94030	DUCT LEFT A ASSY SP	4	⊙	302HN04181	2HN04181	STOPPER FRONT COVER LEFT	2
⊙	302HG94040	2HG94040	DC MOTOR ASSY Y SP	3		302HN04200	2HN04200	LEVER SIDE COVER	1
⊙	302HG94050	2HG94050	DC MOTOR ASSY C SP	3		302HN04210	2HN04210	HOOK SIDE COVER	1
⊙	302HG94060	2HG94060	DC MOTOR ASSY M SP	3		302HN04230	2HN04230	HOOK TOP COVER	1
⊙	302HG94070	2HG94070	DC MOTOR ASSY EXIT SP	13		302HN04240	2HN04240	SPRING LEFT COVER	1
⊙	302HG94080	2HG94080	COVER LEFT REAR ASSY	1		302HN04250	2HN04250	SPRING SIDE COVER	1
⊙	302HG94100	2HG94100	KEY BOARD ASSY SP	2		302HN04260	2HN04260	SPRING SIDE LEVER	1
⊙	302HG94110	2HG94110	COVER FRONT ASSY SP	2		302HN04270	2HN04270	SPRING FRONT COVER	2
⊙	302HG94140	2HG94140	COVER SIDE ASSY SP	1		302HN04320	2HN04320	LABEL USB	1
⊙	302HG94150	2HG94150	FAN DLP ASSY SP	3		302HN06010	2HN06010	HOLDER FEED	6
⊙	302HG94161	2HG94161	HIGH VOLTAGE UNIT SP	14		302HN06030	2HN06030	SHAFT FEED R	6
⊙	302HG94230	2HG94230	PARTS ROLLER REG REAR SP	6	⊙	302HN06050	2HN06050	ACTUATOR PICKUP	14
⊙	302HG94240	2HG94240	PARTS ROLLER REG FRONT SP	8		302HN06060	2HN06060	SPRING PICK ACT	14
⊙	302HN02070	2HN02070	COVER REAR	4		302HN06080	2HN06080	PULLEY PICKUP ASSY	6
	302HN02080	2HN02080	HINGE FEED LEFT	4		302HN06100	2HN06100	FRAME MPF UP	8
	302HN02110	2HN02110	HOUSING LEFT	3		302HN06110	2HN06110	SHAFT FEED MPF	8
	302HN02120	2HN02120	HOUSING RIGHT	3		302HN06121	2HN06121	ACTUATOR MPF	8
	302HN02130	2HN02130	HINGE LEFT	3		302HN06131	2HN06131	ACTUATOR MPF B	8
	302HN02140	2HN02140	HINGE RIGHT	3	⊙	302HN06150	2HN06150	GEAR Z30S MPF	8
	302HN02150	2HN02150	GEAR Z16S HINGE	3		302HN06160	2HN06160	GUIDE HOUSING	6
	302HN02160	2HN02160	RACK TONER SUPPLY L	3		302HN06170	2HN06170	SPRING MPF B	8
	302HN02170	2HN02170	RACK TONER SUPPLY R	3		302HN06180	2HN06180	SHEET HOUSING	6
	302HN02190	2HN02190	CAM TONER SUPPLY	3		302HN08010	2HN08010	BASE MPF	2
	302HN02200	2HN02200	HOLDER HARNESS	3		302HN08020	2HN08020	COVER MPF	2
	302HN02210	2HN02210	HOLDER RFID	3		302HN08030	2HN08030	TRAY MPF TOP	2
	302HN02250	2HN02250	BRACKET FRONT	4		302HN08050	2HN08050	GUIDE MPF L	2
	302HN02300	2HN02300	ROD INTERLOCK	3		302HN08060	2HN08060	GUIDE MPF R	2
⊙	302HN02320	2HN02320	GEAR Z25S WASTE	4		302HN08080	2HN08080	SP BOTTOM MPF L	7

• Parts with "⊙" indicate regular maintenance parts.

Part.No.	Alternative.	Description	Fig.No.	Part.No.	Alternative.	Description	Fig.No.
302HN08090	2HN08090	SP BOTTOM MPF R	7	302HN24140	2HN24140	ACTUATOR DU	8
302HN08100	2HN08100	SPRING SEPARATOR	7	302HN24150	2HN24150	STOPPER BUSH REG	8
302HN08111	2HN08111	FRAME MPF LOW	7	302HN24190	2HN24190	SPRING REG R	8
302HN08140	2HN08140	LUTCH	2	302HN24230	2HN24230	SPRING MIDDLE	6
302HN08150	2HN08150	LINK LEVER MPF L	2	302HN24250	2HN24250	SPRING EARTH FEED	8
302HN08160	2HN08160	LINK LEVER MPF R	2	302HN24260	2HN24260	SPRING REG EARTH A	6
302HN08181	2HN08181	LEVER CAM MPF	7	302HN24280	2HN24280	SPRING GUIDE EARTH	8
302HN08210	2HN08210	HOLDER SEPARATOR MPF	7	302HN24290	2HN24290	SPRING DU	8
302HN09012	2HN09012	BASE CASSETTE	5	302HN24300	2HN24300	SPRING ACT DU	8
302HN09020	2HN09020	COVER CASSETTE TOP	5	302HN24320	2HN24320	SPRING MID EARTH	6
302HN09030	2HN09030	GEAR Z20S-Z17S INDICATOR	5	302HN24360	2HN24360	SPONGE A	8
302HN09041	2HN09041	MARKER INDICATOR	5	302HN24370	2HN24370	STOPPER TC SPRING	8
302HN09050	2HN09050	DIAL CASSETTE	5	302HN24390	2HN24390	SPRING EARTH B	8
302HN09070	2HN09070	CURSOR LEFT	5	302HN24400	2HN24400	PULLEY PA	8
302HN09090	2HN09090	LEVER GUIDE SIDE	5	302HN24410	2HN24410	BUSH REGIST EW	6
302HN09100	2HN09100	SPRING GUIDE SIDE	5	302HN24420	2HN24420	SPRING REG EARTH B	6
302HN09110	2HN09110	CURSOR END	5	302HN24430	2HN24430	HIGH MEG R ASSY	6,8
302HN09120	2HN09120	LEVER STOPPER	5	302HN28071	2HN28071	GEAR Z20L REVERSE	13
302HN09130	2HN09130	SPRING STOPPER	5	302HN28110	2HN28110	SPRING SOLENOID	13
302HN09150	2HN09150	SHAFT WORKPLATE	5	302HN28120	2HN28120	SPRING PULLEY A	13
302HN09160	2HN09160	GEAR Z50S LIFT	5	302HN28150	2HN28150	SPRING EARTH EXIT A	13
302HN09170	2HN09170	GEAR Z13S JOINT	5	302HN28180	2HN28180	STAY FRONT	13
302HN09180	2HN09180	COVER LIFT GEAR	5	302HN28220	2HN28220	SEAL ACTUATOR	13
302HN09190	2HN09190	SPRING FIX	5	302HN29010	2HN29010	ROLLER DU	2
302HN09210	2HN09210	LABEL OPERATION	5	302HN29020	2HN29020	ROLLER DU FEED	2
302HN09230	2HN09230	GUIDE RETARD	5	302HN29040	2HN29040	PULLEY P24 S2M DU	2
302HN09240	2HN09240	SIZE FIX	5	302HN29050	2HN29050	BUSH DU	2,13
302HN09250	2HN09250	LABEL DIAL	5	302HN29060	2HN29060	GEAR Z23L DU FEED	2
302HN09350	2HN09350	CURSOR LEFT B	5	302HN29080	2HN29080	HOOK DU RELEASE RIGHT	2
302HN09371	2HN09371	SPRING EARTH	5	302HN29101	2HN29101	COVER INNER DU	2
302HN09391	2HN09391	SPRING EARTH SIDE	5	302HN29150	2HN29150	BELT DU	2
302HN09400	2HN09400	SPRING DIAL	5	302HN29190	2HN29190	SHEET BASE DU	2
302HN09410	2HN09410	SPRING EARTH C	5	302HN31010	2HN31010	BRACKET DRIVE LIFT	12
302HN09420	2HN09420	LABEL CURSOR	5	302HN31020	2HN31020	COVER GEAR LIFT	12
302HN09430	2HN09430	SPRING RETARD	5	302HN31030	2HN31030	GEAR Z36L-Z20S	12
302HN15030	2HN15030	GEAR Z20S-Z26L	3	302HN31040	2HN31040	GEAR Z46S-Z13S	12
302HN15070	2HN15070	GUIDE CONTAINER K	3	302HN31050	2HN31050	GEAR Z13S	12
302HN15080	2HN15080	GUIDE CONTAINER Y	3	302HN31060	2HN31060	GEAR Z35S-Z13S	12
302HN15090	2HN15090	GUIDE CONTAINER C	3	302HN31070	2HN31070	PLATE DRIVE	12
302HN15110	2HN15110	GUIDE CONTAINER M	3	302HN31080	2HN31080	GEAR Z74R-Z35L	12
302HN15160	2HN15160	SPRING P CONT C	3	302HN31090	2HN31090	GEAR Z54R	12
302HN15170	2HN15170	SPRING P CONT K	3	302HN31141	2HN31141	GEAR Z39L	12
302HN22050	2HN22050	BUSH TRANS L	8	302HN31150	2HN31150	GEAR Z32R IDLE	12
302HN22060	2HN22060	BUSH TRANS R	8	302HN31160	2HN31160	GEAR Z30L	12
302HN22080	2HN22080	SPRING SEP EARTH B	8	302HN31180	2HN31180	GEAR Z28R INPUT DU	12
302HN24030	2HN24030	ROLLER MIDDLE	6	302HN31190	2HN31190	GEAR Z31R-Z26R INPUT REGIST	12
302HN24070	2HN24070	GEAR Z31R REG FRONT	8	302HN31200	2HN31200	GEAR Z35L	12
302HN24080	2HN24080	GEAR Z27R MIDDLE	6	302HN31210	2HN31210	GEAR Z36R-Z22S	12
302HN24090	2HN24090	PLATE EARTH GUIDE	8	302HN31220	2HN31220	GEAR Z28S	12
302HN24110	2HN24110	BUSH REG R	8	302HN31240	2HN31240	GEAR Z36S MPF CAM	12

• Parts with "⊙" indicate regular maintenance parts.

	Part.No.	Alternative.	Description	Fig.No.		Part.No.	Alternative.	Description	Fig.No.
⊙	302HN31250	2HN31250	CAM MPF	12	⊙	302HN94220	2HN94220	SOLENOID FD ASSY CLN SP	14
⊙	302HN31260	2HN31260	GEAR Z62R-P32	12	⊙	302HN94230	2HN94230	FAN PS ASSY SP	14
⊙	302HN31270	2HN31270	GEAR Z30L-P30	12	⊙	302HN94261	2HN94261	DC MOTOR ASSY LIFT SP	12
⊙	302HN31311	2HN31311	GEAR Z70R	12	⊙	302HN94300	2HN94300	CURSOR RIGHT PF ASSY 2HN SP	5
⊙	302HN31320	2HN31320	GEAR Z70L	12	⊙	302HN94320	2HN94320	ID SENSOR ASSY SP	14
⊙	302HN31330	2HN31330	GEAR Z38L	12	⊙	302K339050	2K339050	PLATE OPTION	14
⊙	302HN31370	2HN31370	SHAFT CLUTCH FEED	12	⊙	302KV02C60	2KV02C60	SPACER LED	4
	302HN31410	2HN31410	SPRING FEED	12	⊙	302KV03360	2KV03360	SPRING SHUTTER WASTE	4
	302HN31430	2HN31430	SPRING MID TRANSFER	12	⊙	302PP39020	2PP39020	RAIL OPTION	14
⊙	302HN31540	2HN31540	GEAR Z34S	12	⊙	302PP39030	2PP39030	SHEET SHIELD	14
	302HN31550	2HN31550	SPRING DRIVE LIFT	12	⊙	302PR39010	2PR39010	PLATE CONTROLLER	14
⊙	302HN31570	2HN31570	GEAR Z32L CL	12	⊙	302PR93010	2PR93010	FK-571(E)	11
⊙	302HN31580	2HN31580	GEAR Z32R CL	12	⊙	302PR94010	2PR94010	PPARTS COVER FRONT ASSY SP	2
⊙	302HN31590	2HN31590	BUSH DRIVE	6,12	⊙	302PR94040	2PR94040	PARTS KEY BOARD ASSY SP	2
⊙	302HN31600	2HN31600	SHAFT CL FEED	12	⊙	302PR94050	2PR94050	PARTS SWITCHING REGULATOR 230V SP	14
⊙	302HN31610	2HN31610	SHAFT CL DLP	12	⊙	302PR94060	2PR94060	PARTS PWB ASSY ENGINE SP	14
⊙	302HN31620	2HN31620	GEAR Z36S INPUT MPF A	12	⊙	302PR94070	2PR94070	PARTS PWB ASSY MAIN SP	14
⊙	302HN31630	2HN31630	GEAR Z36S INPUT MPF B	12	⊙	302PR94080	2PR94080	PARTS PWB ASSY MAIN EU SP	14
	302HN31650	2HN31650	SPRING INPUT MPF	12	⊙	303BH26021	3BH26021	PLATE,OPTION	14
⊙	302HN31660	2HN31660	JOINT SHAFT CASSETTE	12	⊙	303K809490	3K809490	WORKPLATE LIFT PF	5
⊙	302HN31670	2HN31670	PIN DRIVE A	12	⊙	3H327410	3H327410	SENSOR,CONVEYING	6
	302HN39060	2HN39060	RAIL OPTION	14	⊙	5AAVR0LL+051	2CL16130	ROLLER M/P ASSY /43487B0027 A4	8
⊙	302HN39070	2HN39070	ACTUATOR CASSETTE	14	⊙	5MMT263SN012+++R	2D903100	SCREW OP / M3 X 8 CRFREE A4	14
	302HN39090	2HN39090	SPRING HV PT	14		5MVM273DB005	2A820100	PULLEY EXIT /A-49 FUSER A3	13
	302HN39100	2HN39100	SEAL PS FAN	14		5MVX111DN003	2A806250	RING STOPPER /A-49 FEED A4	6
	302HN39110	2HN39110	SPRING ACTUATOR	14	⊙	7NXSG2481+++H01	NX052600	SENSOR OPT.	8,11
⊙	302HN44010	2HN44010	FAN MOTOR	14	⊙	7SM010104+++H01	SM055200	SW.MICRO	14
⊙	302HN44060	2HN44060	MOTOR DRIVE L	12	⊙	7SP01000001+H01	SP044290	SW.PUSH	6
⊙	302HN44070	2HN44070	MOTOR DRIVE M	12	⊙	7YCC02B1003+H01	YC013860	CONNECTOR 292254-2	12
⊙	302HN44160	2HN44160	SOLENOID MPF	12		7YZM610007++H01	YZ023340	ACCESS.SADDLE	4,14
⊙	302HN44180	2HN44180	SWITCH SIZE	6		7ZGSTG110075H01	ZG111050	SHIELD GASKET	14
⊙	302HN44200	2HN44200	CLUTCH FEED L	12		7ZGSTGR55010H01	ZG110970	SHIELD GASKET	2
⊙	302HN44210	2HN44210	FAN MOTOR	13					
	302HN46020	2HN46020	CONN.CORD ASSY S03254	12					
	302HN46150	2HN46150	CONN.CORD ASSY S03268	14					
⊙	302HN46290	2HN46290	CONN.CORD ASSY S03282	14					
	302HN46300	2HN46300	CONN.CORD ASSY S03283	14					
	302HN46350	2HN46350	CONN.CORD ASSY S03290	4					
	302HN46380	2HN46380	CONN.CORD ASSY S03293	12					
	302HN46490	2HN46490	CONN.CORD ASSY S03387	12					
	302HN46580	2HN46580	CONN.CORD ASSY S03436	14					
⊙	302HN94010	2HN94010	BRACKET HV TC ASSY SP	14					
⊙	302HN94051	2HN94051	BAR CLEANERED ID ASSY SP	4					
⊙	302HN94060	2HN94060	DC MOTOR ASSY K SP	3					
⊙	302HN94140	2HN94140	SOLENOID FD ASSY SP	13					
⊙	302HN94150	2HN94150	PLATE BOTTOM MPF ASSY SP	7					
⊙	302HN94160	2HN94160	SEPARATOR MPF ASSY SP	7					
⊙	302HN94182	2HN94182	DRIVE LIFT ASSY SP	12					
⊙	302HN94190	2HN94190	PLATE BOTTOM ASSY SP	5					
⊙	302HN94201	2HN94201	HOLDER FEED ASSY SP	6					

• Parts with "⊙" indicate regular maintenance parts.

KYOCERA Document Solutions America, Inc.

Headquarters

225 Sand Road,
Fairfield, New Jersey 07004-0008, USA
Phone: +1-973-808-8444
Fax: +1-973-882-6000

Latin America

8240 NW 52nd Terrace Dawson Building, Suite 100
Miami, Florida 33166, USA
Phone: +1-305-421-6640
Fax: +1-305-421-6666

KYOCERA Document Solutions Canada, Ltd.

6120 Kestrel Rd., Mississauga, ON L5T 1S8,
Canada
Phone: +1-905-670-4425
Fax: +1-905-670-8116

KYOCERA Document Solutions

Mexico, S.A. de C.V.

Calle Arquimedes No. 130, 4 Piso, Colonia Polanco
Chapultepec, Delegacion Miguel Hidalgo,
Distrito Federal, C.P. 11560, México
Phone: +52-555-383-2741
Fax: +52-555-383-7804

KYOCERA Document Solutions Brazil, Ltda.

Alameda África, 545, Pólo Empresarial Consbrás,
Tamboré, Santana de Parnaíba-SP, CEP 06543-306,
Brazil
Phone: +55-11-4195-8496
Fax: +55-11-4195-6167

**KYOCERA Document Solutions
Australia Pty. Ltd.**

Level 3, 6-10 Talavera Road North Ryde N.S.W, 2113,
Australia
Phone: +61-2-9888-9999
Fax: +61-2-9888-9588

**KYOCERA Document Solutions
New Zealand Ltd.**

Ground Floor, 19 Byron Avenue, Takapuna, Auckland,
New Zealand
Phone: +64-9-415-4517
Fax: +64-9-415-4597

KYOCERA Document Solutions Asia Limited

16/F.,Mita Centre, 552-566, Castle Peak Road
Tsuenwan, NT, Hong Kong
Phone: +852-2610-2181
Fax: +852-2610-2063

**KYOCERA Document Solutions
(China) Corporation**

8F, No. 288 Nanjing Road West, Huangpu District,
Shanghai,200003, China
Phone: +86-21-5301-1777
Fax: +86-21-5302-8300

**KYOCERA Document Solutions
(Thailand) Corp., Ltd.**

335 Ratchadapisek Road, Bangsue, Bangkok 10800,
Thailand
Phone: +66-2-586-0333
Fax: +66-2-586-0278

**KYOCERA Document Solutions
Singapore Pte. Ltd.**

12 Tai Seng Street #04-01A,
Luxasia Building, Singapore 534118
Phone: +65-6741-8733
Fax: +65-6748-3788

**KYOCERA Document Solutions
Hong Kong Limited**

16/F.,Mita Centre, 552-566, Castle Peak Road
Tsuenwan, NT, Hong Kong
Phone: +852-3582-4000
Fax: +852-3185-1399

**KYOCERA Document Solutions
Taiwan Corporation**

6F., No.37, Sec. 3, Minquan E. Rd.,
Zhongshan Dist., Taipei 104, Taiwan R.O.C.
Phone: +886-2-2507-6709
Fax: +886-2-2507-8432

KYOCERA Document Solutions Korea Co., Ltd.

18F, Kangnam bldg, 1321-1,
Seocho-Dong, Seocho-Gu, Seoul, Korea
Phone: +822-6933-4050
Fax: +822-747-0084

**KYOCERA Document Solutions
India Private Limited**

First Floor, ORCHID CENTRE
Sector-53, Golf Course Road, Gurgaon 122 002,
India
Phone: +91-0124-4671000
Fax: +91-0124-4671001

KYOCERA Document Solutions Europe B.V.

Bloemlaan 4, 2132 NP Hoofddorp,
The Netherlands
Phone: +31-20-654-0000
Fax: +31-20-653-1256

KYOCERA Document Solutions Nederland B.V.

Beechavenue 25, 1119 RA Schiphol-Rijk,
The Netherlands
Phone: +31-20-5877200
Fax: +31-20-5877260

KYOCERA Document Solutions (U.K.) Limited

Eldon Court, 75-77 London Road,
Reading, Berkshire RG1 5BS,
United Kingdom
Phone: +44-118-931-1500
Fax: +44-118-931-1108

KYOCERA Document Solutions Italia S.p.A.

Via Verdi, 89/91 20063 Cernusco s/N.(MI),
Italy
Phone: +39-02-921791
Fax: +39-02-92179-600

KYOCERA Document Solutions Belgium N.V.

Sint-Martinusweg 199-201 1930 Zaventem,
Belgium
Phone: +32-2-7209270
Fax: +32-2-7208748

KYOCERA Document Solutions France S.A.S.

Espace Technologique de St Aubin
Route de l'Orme 91195 Gif-sur-Yvette CEDEX,
France
Phone: +33-1-69852600
Fax: +33-1-69853409

KYOCERA Document Solutions Espana, S.A.

Edificio Kyocera, Avda. de Manacor No.2,
28290 Las Matas (Madrid), Spain
Phone: +34-91-6318392
Fax: +34-91-6318219

KYOCERA Document Solutions Finland Oy

Atomitie 5C, 00370 Helsinki,
Finland
Phone: +358-9-47805200
Fax: +358-9-47805390

**KYOCERA Document Solutions
Europe B.V., Amsterdam (NL) Zürich Branch**

Hohlstrasse 614, 8048 Zürich,
Switzerland
Phone: +41-44-9084949
Fax: +41-44-9084950

**KYOCERA Document Solutions
Deutschland GmbH**

Otto-Hahn-Strasse 12, 40670 Meerbusch,
Germany
Phone: +49-2159-9180
Fax: +49-2159-918100

KYOCERA Document Solutions Austria GmbH

Eduard-Kittenberger-Gasse 95, 1230 Vienna,
Austria
Phone: +43-1-863380
Fax: +43-1-86338-400

KYOCERA Document Solutions Nordic AB

Esbogatan 16B 164 75 Kista, Sweden
Phone: +46-8-546-550-00
Fax: +46-8-546-550-10

KYOCERA Document Solutions Norge Nuf

Postboks 150 Oppsal, 0619 Oslo,
Norway
Phone: +47-22-62-73-00
Fax: +47-22-62-72-00

KYOCERA Document Solutions Danmark A/S

Ejby Industrivej 60, DK-2600 Glostrup,
Denmark
Phone: +45-70223880
Fax: +45-45765850

KYOCERA Document Solutions Portugal Lda.

Rua do Centro Cultural, 41 (Alvalade) 1700-106 Lisboa,
Portugal
Phone: +351-21-843-6780
Fax: +351-21-849-3312

**KYOCERA Document Solutions
South Africa (Pty) Ltd.**

KYOCERA House, Hertford Office Park,
90 Bekker Road (Cnr. Allandale), Midrand, South Africa.
Phone: +27-11-540-2600
Fax: +27-11-466-3050

KYOCERA Document Solutions Russia LLC

Botanicheskoy pereulok 5, Moscow, 129090,
Russia
Phone: +7(495)741-0004
Fax: +7(495)741-0018

KYOCERA Document Solutions Middle East

Dubai Internet City, Bldg. 17,
Office 157 P.O. Box 500817, Dubai,
United Arab Emirates
Phone: +971-04-433-0412

KYOCERA Document Solutions Inc.

2-28, 1-chome, Tamatsukuri, Chuo-ku
Osaka 540-8585, Japan
Phone: +81-6-6764-3555
<http://www.kyoceradocumentsolutions.com>

© 2014 KYOCERA Document Solutions Inc.

 is a trademark of KYOCERA Corporation