



ECOSYS P7035cdn

SERVICE MANUAL

Published in October 2013
842PR110
2PRSM060
First Edition

CAUTION

RISK OF EXPLOSION IF BATTERY IS REPLACED BY AN INCORRECT TYPE. DISPOSE OF USED BATTERIES ACCORDING TO THE INSTRUCTIONS.

It may be illegal to dispose of this battery into the municipal waste stream. Check with your local solid waste officials for details in your area for proper disposal.

ATTENTION

IL Y A UN RISQUE D'EXPLOSION SI LA BATTERIE EST REMPLACÉE PAR UN MODÈLE DE TYPE INCORRECT. METTRE AU REBUT LES BATTERIES UTILISÉES SELON LES INSTRUCTIONS DONNÉES.

Il peut être illégal de jeter les batteries dans des eaux d'égout municipales. Vérifiez avec les fonctionnaires municipaux de votre région pour les détails concernant des déchets solides et une mise au rebut appropriée.

Revision history

Revision	Date	Replaced pages	Remarks

This page is intentionally left blank.





Safety precautions

This booklet provides safety warnings and precautions for our service personnel to ensure the safety of their customers, their machines as well as themselves during maintenance activities. Service personnel are advised to read this booklet carefully to familiarize themselves with the warnings and precautions described here before engaging in maintenance activities.

Safety warnings and precautions

Various symbols are used to protect our service personnel and customers from physical danger and to prevent damage to their property. These symbols are described below:

 **DANGER:** High risk of serious bodily injury or death may result from insufficient attention to or incorrect compliance with warning messages using this symbol.

 **WARNING:** Serious bodily injury or death may result from insufficient attention to or incorrect compliance with warning messages using this symbol.

 **CAUTION:** Bodily injury or damage to property may result from insufficient attention to or incorrect compliance with warning messages using this symbol.

Symbols

The triangle () symbol indicates a warning including danger and caution. The specific point of attention is shown inside the symbol.



General warning.



Warning of risk of electric shock.



Warning of high temperature.

 indicates a prohibited action. The specific prohibition is shown inside the symbol.



General prohibited action.



Disassembly prohibited.

 indicates that action is required. The specific action required is shown inside the symbol.



General action required.





Remove the power plug from the wall outlet.











Always ground the copier.

1. Installation Precautions

WARNING











- Do not use a power supply with a voltage other than that specified. Avoid multiple connections to one outlet: they may cause fire or electric shock. When using an extension cable, always check that it is adequate for the rated current. 
- Connect the ground wire to a suitable grounding point. Not grounding the copier may cause fire or electric shock. Connecting the earth wire to an object not approved for the purpose may cause explosion or electric shock. Never connect the ground cable to any of the following: gas pipes, lightning rods, ground cables for telephone lines and water pipes or faucets not approved by the proper authorities. 

CAUTION:





- Do not place the copier on an infirm or angled surface: the copier may tip over, causing injury. 
- Do not install the copier in a humid or dusty place. This may cause fire or electric shock. 
- Do not install the copier near a radiator, heater, other heat source or near flammable material. This may cause fire. 
- Allow sufficient space around the copier to allow the ventilation grills to keep the machine as cool as possible. Insufficient ventilation may cause heat buildup and poor copying performance. 
- Always handle the machine by the correct locations when moving it. 
- Always use anti-toppling and locking devices on copiers so equipped. Failure to do this may cause the copier to move unexpectedly or topple, leading to injury. 
- Avoid inhaling toner or developer excessively. Protect the eyes. If toner or developer is accidentally ingested, drink a lot of water to dilute it in the stomach and obtain medical attention immediately. If it gets into the eyes, rinse immediately with copious amounts of water and obtain medical attention. 
- Advise customers that they must always follow the safety warnings and precautions in the copier's instruction handbook. 











2. Precautions for Maintenance

WARNING

- Always remove the power plug from the wall outlet before starting machine disassembly. 
- Always follow the procedures for maintenance described in the service manual and other related brochures. 
- Under no circumstances attempt to bypass or disable safety features including safety mechanisms and protective circuits. 
- Always use parts having the correct specifications. 
- Always use the thermostat or thermal fuse specified in the service manual or other related brochure when replacing them. Using a piece of wire, for example, could lead to fire or other serious accident. 
- When the service manual or other serious brochure specifies a distance or gap for installation of a part, always use the correct scale and measure carefully. 
- Always check that the copier is correctly connected to an outlet with a ground connection. 
- Check that the power cable covering is free of damage. Check that the power plug is dust-free. If it is dirty, clean it to remove the risk of fire or electric shock. 
- Never attempt to disassemble the optical unit in machines using lasers. Leaking laser light may damage eyesight. 
- Handle the charger sections with care. They are charged to high potentials and may cause electric shock if handled improperly. 



CAUTION

- Wear safe clothing. If wearing loose clothing or accessories such as ties, make sure they are safely secured so they will not be caught in rotating sections. 
- Use utmost caution when working on a powered machine. Keep away from chains and belts. 
- Handle the fixing section with care to avoid burns as it can be extremely hot. 
- Check that the fixing unit thermistor, heat and press rollers are clean. Dirt on them can cause abnormally high temperatures. 

- Do not remove the ozone filter, if any, from the copier except for routine replacement. 
- Do not pull on the AC power cord or connector wires on high-voltage components when removing them; always hold the plug itself. 
- Do not route the power cable where it may be stood on or trapped. If necessary, protect it with a cable cover or other appropriate item. 
- Treat the ends of the wire carefully when installing a new charger wire to avoid electric leaks. 
- Remove toner completely from electronic components. 
- Run wire harnesses carefully so that wires will not be trapped or damaged. 
- After maintenance, always check that all the parts, screws, connectors and wires that were removed, have been refitted correctly. Special attention should be paid to any forgotten connector, trapped wire and missing screws. 
- Check that all the caution labels that should be present on the machine according to the instruction handbook are clean and not peeling. Replace with new ones if necessary. 
- Handle greases and solvents with care by following the instructions below: 
 - Use only a small amount of solvent at a time, being careful not to spill. Wipe spills off completely.
 - Ventilate the room well while using grease or solvents.
 - Allow applied solvents to evaporate completely before refitting the covers or turning the power switch on.
 - Always wash hands afterwards.
- Never dispose of toner or toner bottles in fire. Toner may cause sparks when exposed directly to fire in a furnace, etc. 
- Should smoke be seen coming from the copier, remove the power plug from the wall outlet immediately. 

3. Miscellaneous

WARNING

- Never attempt to heat the drum or expose it to any organic solvents such as alcohol, other than the specified refiner; it may generate toxic gas. 
- Keep the machine away from flammable liquids, gases, and aerosols. A fire or an electric shock might occur. 

This page is intentionally left blank.

CONTENTS

1-1 Specifications

1-1-1 Specifications	1-1-1
1-1-2 Parts names	1-1-3
(1) Overall	1-1-3
(2) Operation panel	1-1-4
1-1-3 Machine cross section	1-1-5

1-2 Installation

1-2-1 Installation environment	1-2-1
1-2-2 Unpacking	1-2-2
(1) Unpacking	1-2-2
(2) Removing the tape, installation guide, stoppers, panel sheet and upper inner pad assembly	1-2-4
1-2-3 Installing the expansion memory modules (option)	1-2-5
1-2-4 Installing the SD card (option)	1-2-6
1-2-5 Installing the SSD disk	1-2-7

1-3 Maintenance Mode

1-3-1 Maintenance mode	1-3-1
(1) Executing a maintenance item	1-3-1
(2) Service mode	1-3-2
(3) Printing a event log (EVENT LOG)	1-3-12

1-4 Troubleshooting

1-4-1 Paper misfeed detection	1-4-1
(1) Paper misfeed indication	1-4-1
(2) Paper misfeed detection condition	1-4-2
1-4-2 Self-diagnostic function	1-4-3
(1) Self-diagnostic function	1-4-3
(2) Self diagnostic codes	1-4-4
1-4-3 Image formation problems	1-4-28
(1) No image appears (entirely white)	1-4-29
(2) No image appears (entirely black)	1-4-30
(3) A specific color is printed solid	1-4-30
(4) The back side gets dirty	1-4-30
(5) Image is too light	1-4-31
(6) The background is colored	1-4-31
(7) White streaks are printed vertically	1-4-32
(8) Black streaks are printed vertically	1-4-32
(9) Streaks are printed horizontally	1-4-32
(10) Spots are printed	1-4-32
(11) The leading edge of image begins to print too early or too late	1-4-33
(12) Paper is wrinkled	1-4-33
(13) Offset occurs	1-4-33
(14) Part of image is missing	1-4-33
(15) Fusing is loose	1-4-34
(16) Colors are printed offset to each other	1-4-34
1-4-4 Electric problems	1-4-35
1-4-5 Mechanical problems	1-4-38

1-5 Assembly and Disassembly

1-5-1	Precautions for assembly and disassembly	1-5-1
	(1) Precautions	1-5-1
	(2) Drum.....	1-5-1
	(3) Toner container	1-5-1
	(4) How to tell a genuine Kyocera toner container.....	1-5-2
1-5-2	Outer covers	1-5-3
	(1) Detaching and refitting the left rear cover, left upper cover and left front cover.....	1-5-3
	(2) Detaching and refitting the right rear cover, right upper cover and right front cover	1-5-6
1-5-3	Paper feed section	1-5-8
	(1) Detaching and refitting the paper feed roller assembly (paper feed roller and pickup roller)	1-5-8
	(2) Detaching and refitting the retard roller	1-5-10
	(3) Detaching and refitting the MP paper feed roller.....	1-5-11
1-5-4	Developing section.....	1-5-12
	(1) Detaching and refitting the developing unit	1-5-12
1-5-5	Drum section.....	1-5-14
	(1) Detaching and refitting the drum unit	1-5-14
	(2) Detaching and refitting the main charger unit.....	1-5-15
1-5-6	Transfer/separation section	1-5-16
	(1) Detaching and refitting the intermediate transfer unit.....	1-5-16
	(2) Detaching and refitting the transfer roller unit	1-5-18
	(3) Detaching and refitting the duplex unit B.....	1-5-19
1-5-7	Fuser section	1-5-24
	(1) Detaching and refitting the fuser unit.....	1-5-24
1-5-8	PWBs	1-5-25
	(1) Detaching and refitting the power source PWB.....	1-5-25
	(2) Detaching and refitting the main PWB	1-5-27
	(3) Detaching and refitting the engine PWB	1-5-28
	(4) Detaching and refitting the high voltage PWB 1	1-5-34
	(5) Detaching and refitting the high voltage PWB 2.....	1-5-41
1-5-9	Others	1-5-42
	(1) Detaching and refitting the laser scanner unit.....	1-5-42
	(2) Direction of installing the principal fan motors.....	1-5-44

1-6 Firmware

1-6-1	Downloading firmware	1-6-1
	(1) Firmware file.....	1-6-1
	(2) Downloading the firmware from the USB memory	1-6-2
	(3) Downloading the firmware from the SD card.....	1-6-4

2-1 Mechanical Construction

2-1-1	Paper feed/conveying section.....	2-1-1
	(1) Cassette paper feed section.....	2-1-1
	(2) MP tray paper feed section	2-1-2
	(3) Paper conveying section	2-1-3
2-1-2	Drum section.....	2-1-4
	(1) Drum section	2-1-4
	(2) Main charger unit.....	2-1-6
2-1-3	Expose section.....	2-1-8
	(1) Laser scanner unit.....	2-1-8
2-1-4	Developing section.....	2-1-10
2-1-5	Transfer/separation section	2-1-12
2-1-6	Fuser section	2-1-14
2-1-7	Paper exit/feed shift section	2-1-16
2-1-8	Duplex/conveying section	2-1-18

2-2 Electrical Parts Layout

2-2-1 Electrical parts layout.....	2-2-1
(1) PWBs	2-2-1
(2) Switches and sensors	2-2-3
(3) Motors	2-2-5
(4) Other electrical components.....	2-2-6

2-3 Operation of the PWBs

2-3-1 Power source PWB.....	2-3-1
2-3-2 Engine PWB.....	2-3-2
2-3-3 Paper exit PWB.....	2-3-11

2-4 Appendixes

2-4-1 Appendixes	2-4-1
(1) Wiring diagram	2-4-1
(2) Repetitive defects gauge.....	2-4-3
(3) Maintenance Kitt.....	2-4-4

This page is intentionally left blank.

1-1-1 Specifications

Item		Specifications
Type		Desktop
Printing method		Electrophotographic four color (CMYK) printing using tandem (4) drum system
Paper weight	Cassette	60 to 120 g/m ²
	MP tray	60 to 220 g/m ² , 220 g/m ² (Hagaki)
Paper type	Cassette	Plain, Preprinted, Bond, Recycled, Rough, Letterhead, Color, Prepunched, High quality, and custom 1 to 8
	MP tray	Plain, Transparency, Preprinted, Labels, Bond, Recycled, Vellum, Rough, Letterhead, Color, Prepunched, Envelope, Cardstock, Coated, Thick, High quality, Coated and Custom 1 to 8
Paper size	Cassette	A4, B5, A5, Folio, 8 1/2" × 14" (Legal), 8 1/2" × 11" (Letter), Oficio II, Statement, Executive, ISO B5, A6, Envelope C5, 16K, Custom and 216 x 340 mm
	MP tray	A4, B5, A5, Folio, 8 1/2" × 14" (Legal), 8 1/2" × 11" (Letter), Oficio II, Statement, Executive, A6, B6, ISO B5, Env. Monarch, Envelope #10, Envelope #9, Envelope #6, Envelope DL, Envelope C5, 16K, Hagaki, Custom and 216 x 340 mm
Copying speed	Simplex	A4 : 35 sheets/min Letter : 37 sheets/min Legal : 30 sheets/min B5 : 37 sheets/min A5 : 37 sheets/min
	Duplex	A4 : 35 sheets/min Letter : 37 sheets/min Legal : 28 sheets/min
First print time (A4, feed from cassette)		B/W : 8 s or less Color: 9 s or less (Excluding time for system stabilization immediately after turning on the main power.)
Warm-up time (22 °C/71.6 °F, 60% RH)		Power on : 45 s or less Sleep mode : 38 s or less
Paper capacity	Cassette	500 sheets (80g/m ²)
	MP tray	150 sheets (80 g/m ²)
Output tray capacity		500 sheets (80g/m ²)
Photoconductor		a-Si drum (diameter 30 mm)
Image write system		Semiconductor laser (1 beam)
Charging system		Roller plus charging
Developing system		Dual component interactive touch down developing system Toner replenishing: Automatic from the toner container
Transfer system		Primary transfer: Elasticity intermediate transfer belt (DC bias) Secondary transfer: Transfer roller (DC bias)
Separation system		Small diameter separation, discharger needles
Cleaning system		Drum: Counter blade
Charge erasing system		Exposure by eraser lamp (LED)
Fusing system		Heat fusing with a heat roller and a pressure roller
CPU		PPC465S 667MHz

Item		Specifications
Main memory	Standard	512 MB
	Maximum	1536 MB
Operating system		Windows XP, Windows XP Professional Windows Server 2003, Windows Server 2003 x64 Edition Windows Vista x86 Edition, Windows Vista x64 Edition Windows 7 x86 Edition, Windows 7 x64 Edition, Windows 8 x86 Edition, Windows 8 x64 Edition, Windows Server 2008, Windows Server 2008 x64 Edition, Windows Server 2012 R2 Apple Macintosh OS 10.x (ver.10.5 or more)
Interface	Standard	USB: 1 (Hi-Speed USB) Network: 1 (10BASE-T/100BASE-TX/1000BASE-T) USB memory slot: 1 (Hi-speed USB)
	Option	e-KUIO slot: 1
Resolution		600 dpi
Operating environment	Temperature	10 to 32.5 °C/50 to 90.5 °F
	Humidity	15 to 80% RH
	Altitude	2,000 m/6,562 ft or less
	Brightness	1,500 lux or less
Dimensions (W × D × H)		345 ´ 518 ´ 512 mm 13 5/8 ´ 18 1/2 ´ 20 3/16"
Weight		Approx. 35 kg (77 lbs)
Space required (W × D)		345 × 720 mm (using MP tray) 13 9/16 × 28 3/8" (using MP tray)
Power source		120 V, 60 Hz, max. 9.4 A (U.S.A./Canada) 220-240 V, 50 Hz/60 Hz, max. 4.8 A (European countries) Allowable voltage fluctuation: ±10% Max. Allowable frequency fluctuation: ±2%
Options		Paper feeder, Expanded memory, SSD(HD-6/7), Network interface card, Wireless LAN interface card

NOTE: These specifications are subject to change without notice.

1-1-2 Parts names

(1) Overall

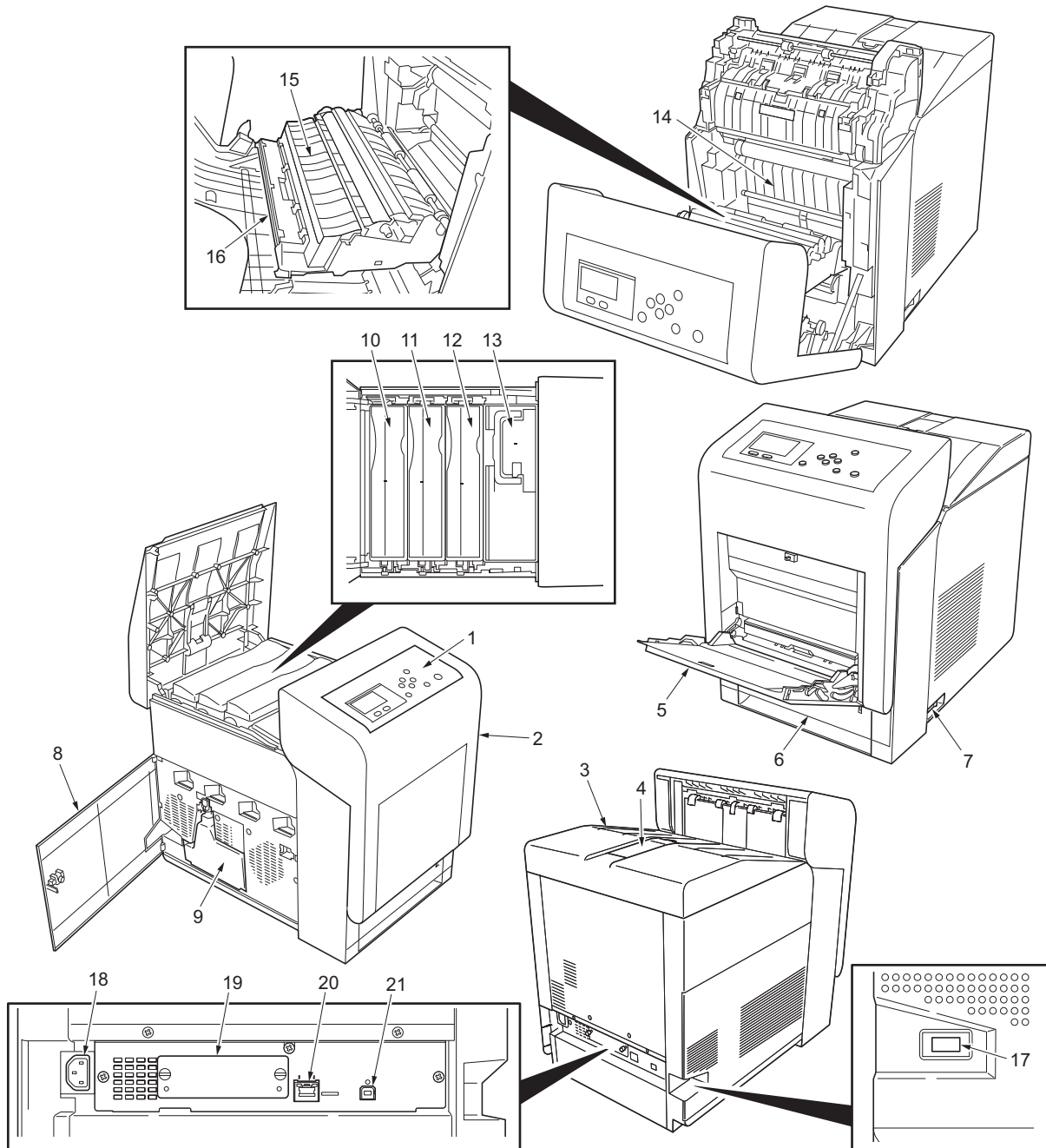
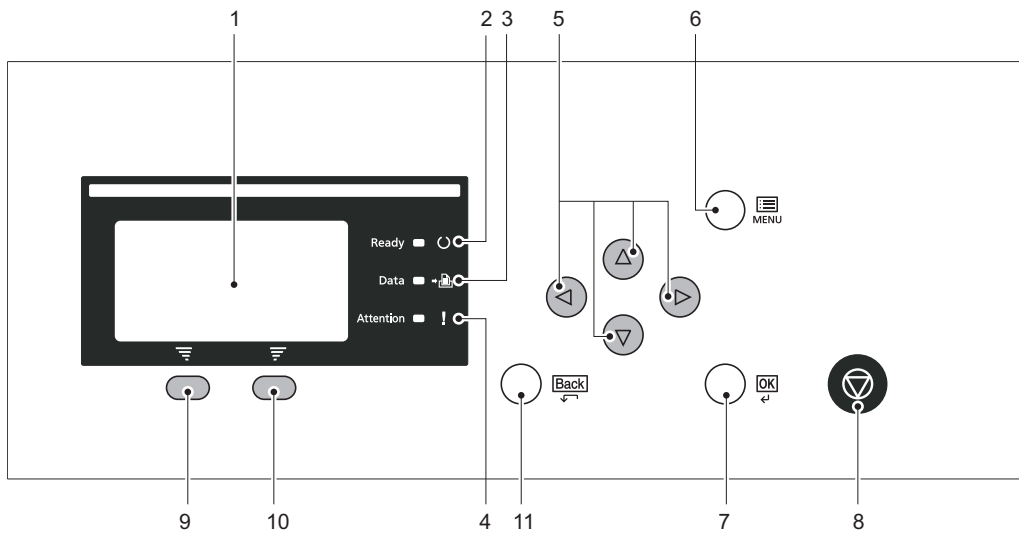

Figure 1-1-1

- | | | |
|----------------------------|-------------------------|---------------------------------|
| 1. Operation panel | 8. Left side cover | 15. Paper ramp |
| 2. Front cover | 9. Waste toner box | 16. Duplex unit B |
| 3. Paper stopper | 10. Toner Container M | 17. USB memory slot |
| 4. Top cover (Top tray) | 11. Toner Container C | 18. AC inlet |
| 5. MP (Multi-Purpose) tray | 12. Toner Container Y | 19. Option interface slot |
| 6. Paper cassette | 13. Toner Container K | 20. Network interface connector |
| 7. Power switch | 14. Paper transfer unit | 21. USB interface connector |

(2) Operation panel

**Figure 1-1-2**

1. Message display
2. Ready indicator
3. Data indicator
4. Attention indicator
5. Arrow keys
6. MENU key
7. OK key
8. Stop key
9. Left select key
10. Right select key
11. Back key

1-1-3 Machine cross section

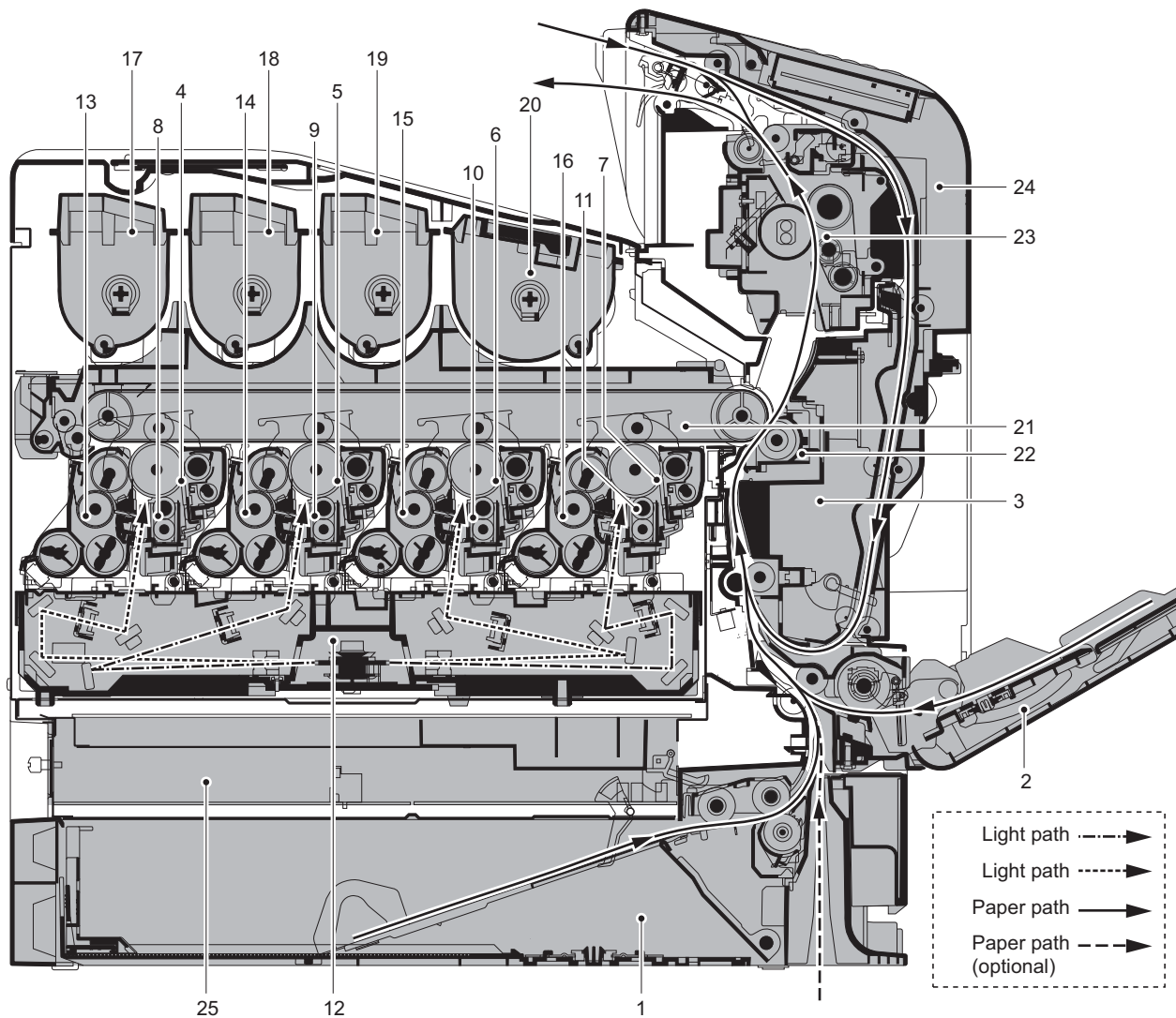

Figure 1-1-3

- | | |
|-------------------------|--------------------------------|
| 1. Cassette | 14. Developing unit C |
| 2. MP tray | 15. Developing unit Y |
| 3. Duplex unit B | 16. Developing unit K |
| 4. Drum unit M | 17. Toner container M |
| 5. Drum unit C | 18. Toner container C |
| 6. Drum unit Y | 19. Toner container Y |
| 7. Drum unit K | 20. Toner container K |
| 8. Main charger unit M | 21. Intermediate transfer unit |
| 9. Main charger unit C | 22. Transfer roller unit |
| 10. Main charger unit Y | 23. Fuser unit |
| 11. Main charger unit K | 24. Front cover |
| 12. Laser scanner unit | 25. Controller box |
| 13. Developing unit M | |

This page is intentionally left blank.

1-2-1 Installation environment

1. Temperature: 10 to 32.5°C/50 to 90.5°F
2. Humidity: 15 to 80%RH
3. Power supply: 120 V AC, 220 - 240 V AC
4. Power source frequency: 50 Hz \pm 0.3%/60 Hz \pm 0.3%
5. Installation location

Avoid direct sunlight or bright lighting. Ensure that the photoconductor will not be exposed to direct sunlight or other strong light when removing paper jams.

Avoid locations subject to high temperature and high humidity or low temperature and low humidity; an abrupt change in the environmental temperature; and cool or hot, direct air.

Avoid places subject to dust and vibrations.

Choose a surface capable of supporting the weight of the machine.

Place the machine on a level surface (maximum allowance inclination: 1°).

Avoid air-borne substances that may adversely affect the machine or degrade the photoconductor, such as mercury, acidic or alkaline vapors, inorganic gasses, NOx, SOx gases and chlorine-based organic solvents.

Select a well-ventilated location.

6. Allow sufficient access for proper operation and maintenance of the machine.

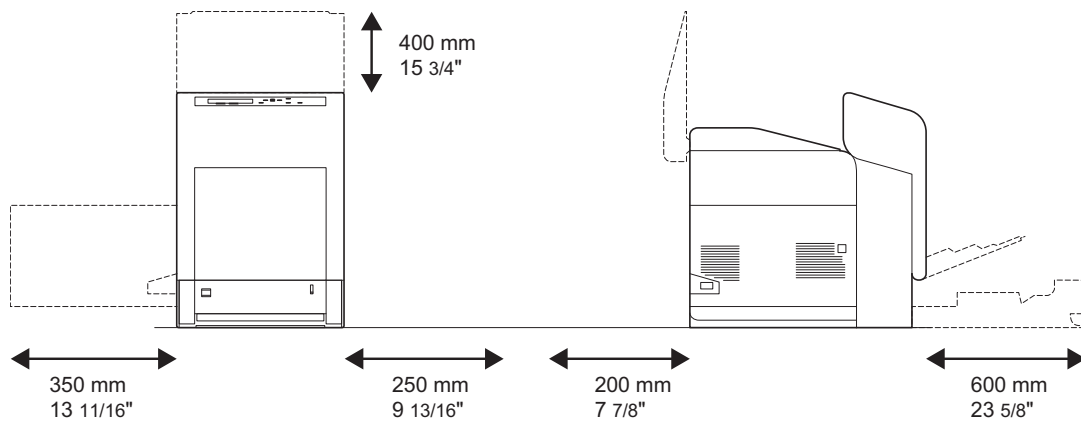

Figure 1-2-1

1-2-2 Unpacking

(1) Unpacking

220-240 V AC model

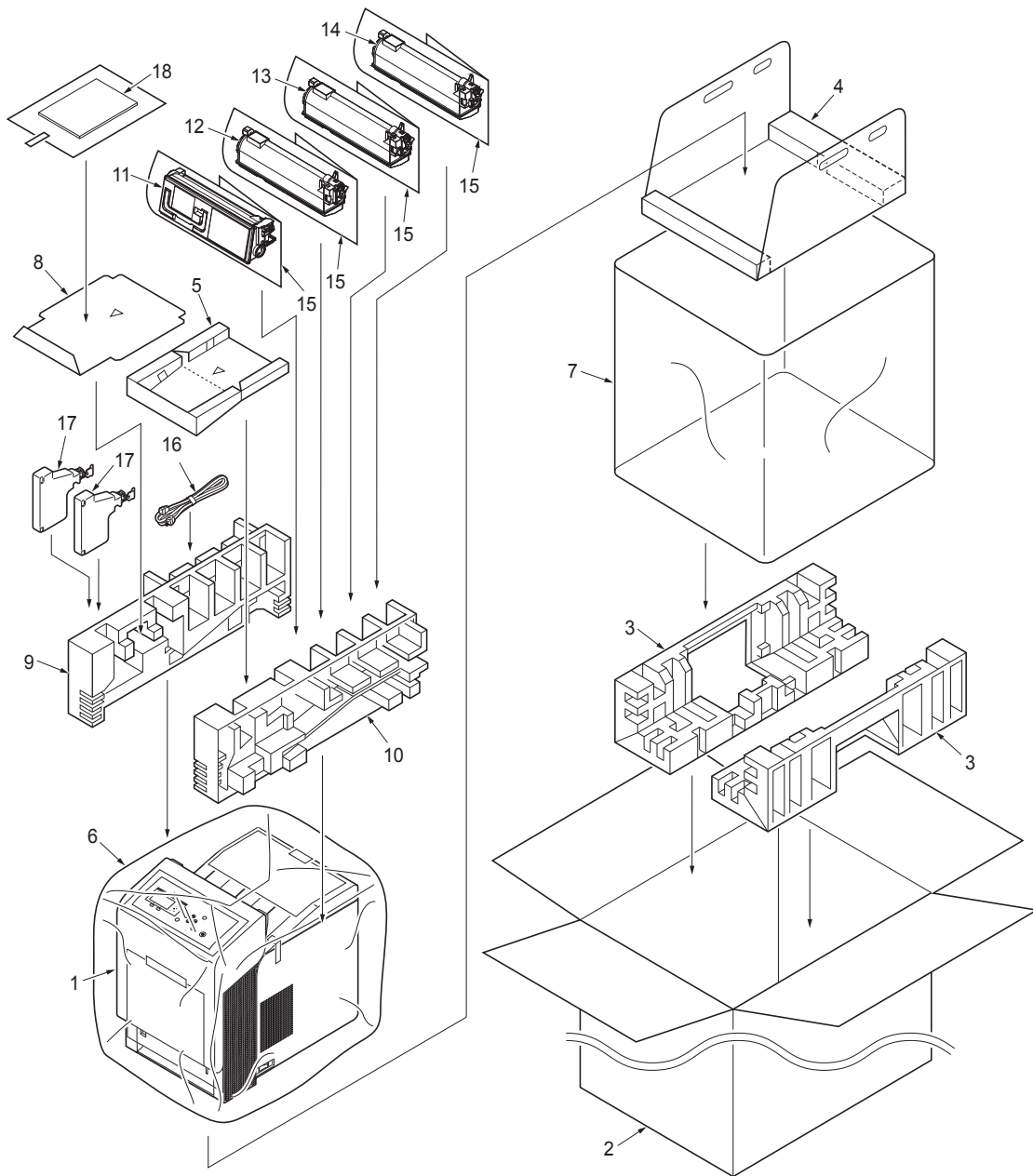

Figure 1-2-2 220-240 V AC model

- | | |
|----------------------------------|-------------------------------|
| 1. Printer | 10. Right upper pad |
| 2. Outer case | 11. Toner container (Black) |
| 3. Bottom pad | 12. Toner container (Yellow) |
| 4. Main pad | 13. Toner container (Cyan) |
| 5. Upper pad | 14. Toner container (Magenta) |
| 6. Machine cover 600 × 600 × 900 | 15. Plastic bags 200 × 700 |
| 7. Machine cover | 16. Power cord |
| 8. Upper tray | 17. Waste toner boxes |
| 9. Left upper pad | 18. Documents etc. |

120 V AC model

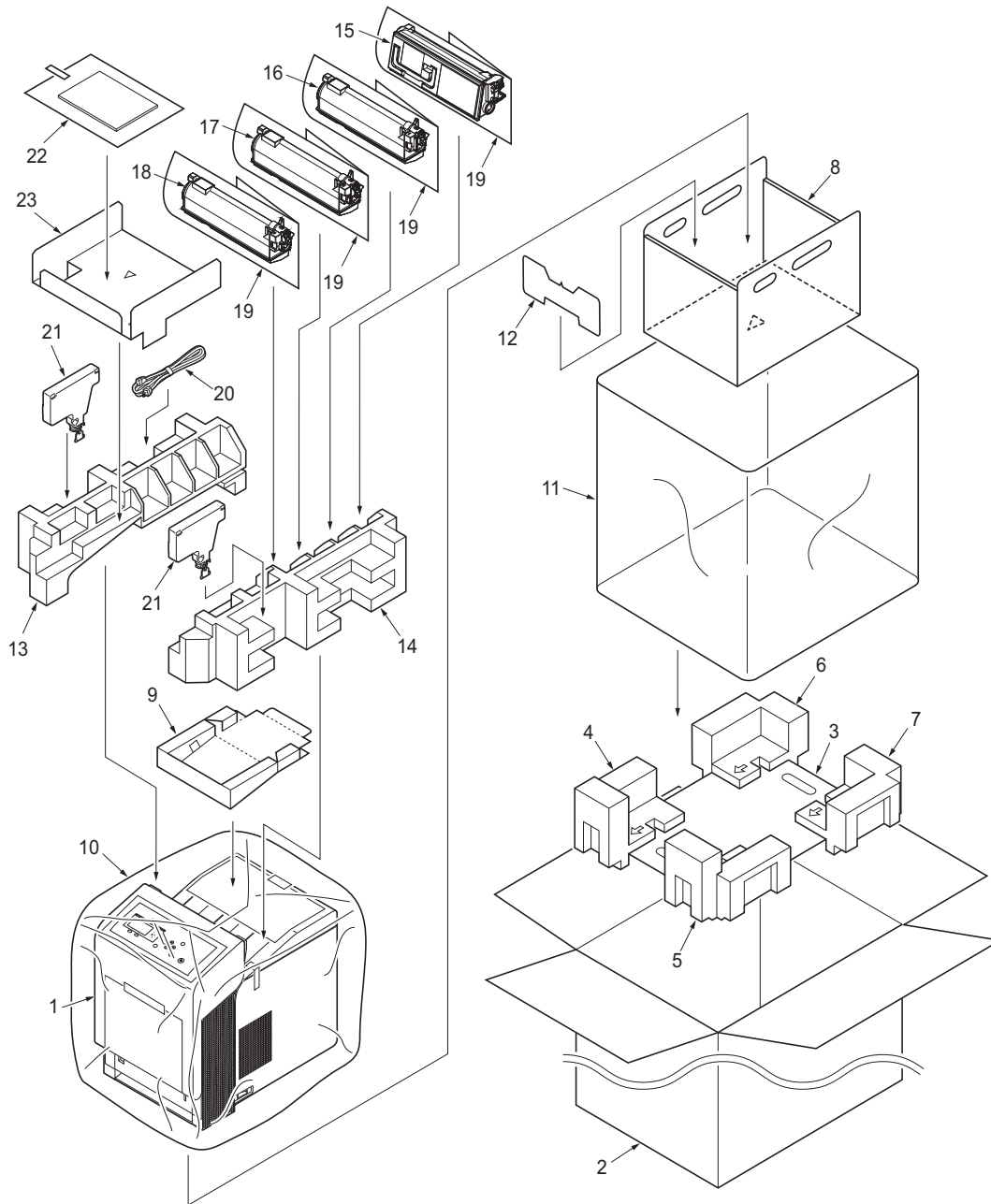

Figure 1-2-3 120 V AC model

- | | |
|-----------------------------------|-------------------------------|
| 1. Printer | 12. Cassette cushion US |
| 2. Outer case | 13. Left upper pad |
| 3. Bottom sheet | 14. Right upper pad |
| 4. Bottom pad FL | 15. Toner container (Black) |
| 5. Bottom pad FR | 16. Toner container (Yellow) |
| 6. Bottom pad BL | 17. Toner container (Cyan) |
| 7. Bottom pad BR | 18. Toner container (Magenta) |
| 8. Main pad | 19. Plastic bags 200 × 700 |
| 9. Upper tray US | 20. Power cord |
| 10. Machine cover 600 × 600 × 900 | 21. Waste toner boxes |
| 11. Machine cover | 22. Documents etc. |

(2) Removing the tape, installation guide, stoppers, panel sheet and upper inner pad assembly

<Procedure>

1. Remove the tape-A and then remove the installation guide.
2. Remove two tapes-B and then remove two stoppers.
3. Remove three tapes-C.
4. Remove the panel sheet.

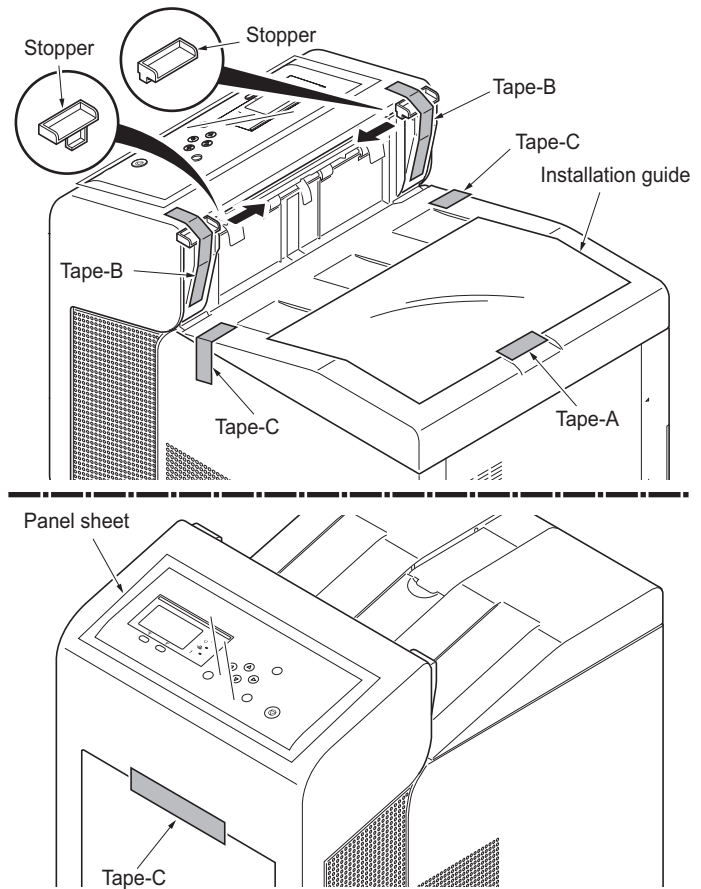

Figure 1-2-4

5. Open the top cover.
6. Remove the upper inner pad assembly.
7. Remove the tape.

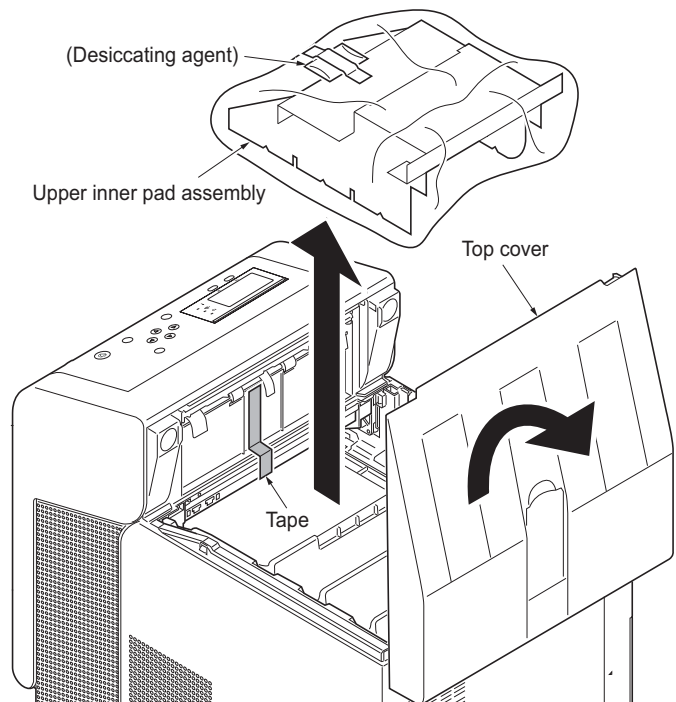

Figure 1-2-5

1-2-3 Installing the expansion memory modules (option)

<Procedure>

1. Turn off printer power switch.
 Caution:
 Do not insert or remove expansion memory modules while printer power is on.
 Doing so may cause damage to the printer and the expansion memory modules.
2. Remove two screws and then remove the main PWB.

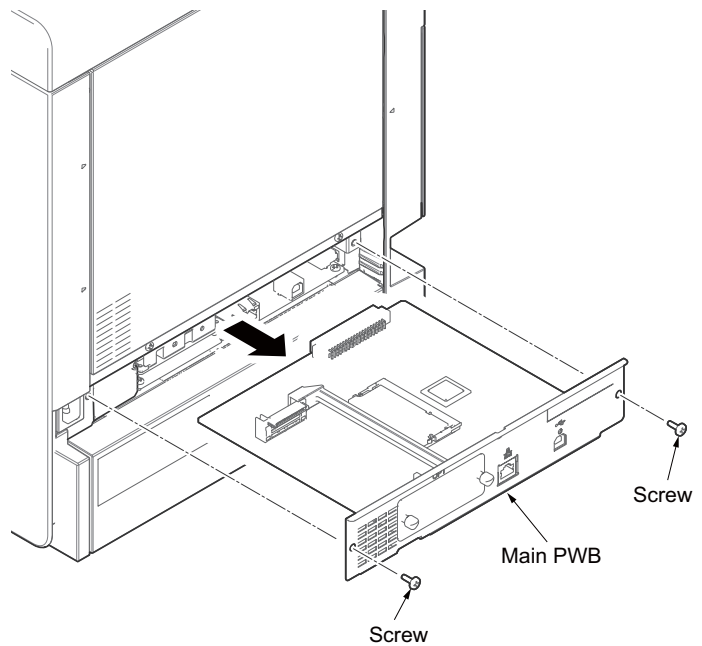

Figure 1-2-6

3. Insert the expansion memory modules into the expansion memory socket so that the notches on the memory align with the corresponding protrusions in the slot.
4. Refit the main PWB.
5. Print a status page to check the memory expansion (See page P.1-3-2).
 If memory expansion has been properly performed, information on the installed memory is printed with the total memory capacity has been increased.
 Standard memory capacity: 512 MB

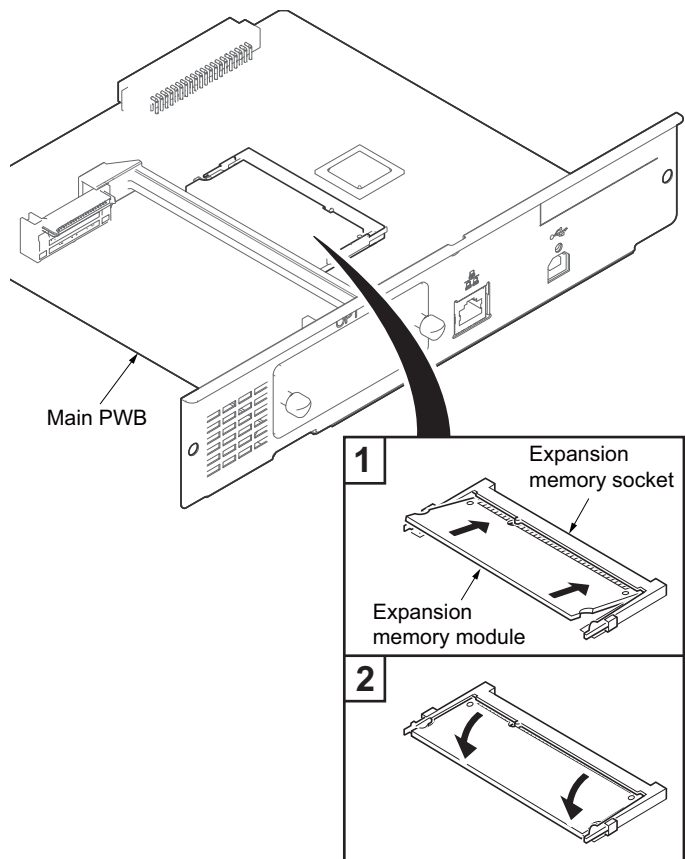

Figure 1-2-7

1-2-4 Installing the SD card (option)

<Procedure>

1. Turn off printer power switch.
 Caution:
 Do not insert or remove SD card while printer power is on.
 Doing so may cause damage to the printer and the SD card.
2. Remove the two screws and the option interface slot cover.

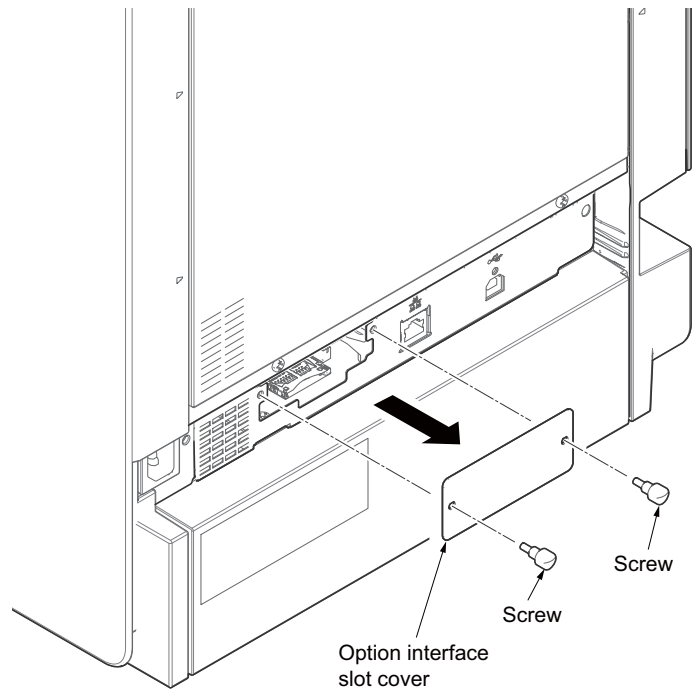

Figure 1-2-8

3. Insert the SD card into the SD card slot.
 Push it in all the way.
4. Refit the option interface slot cover.

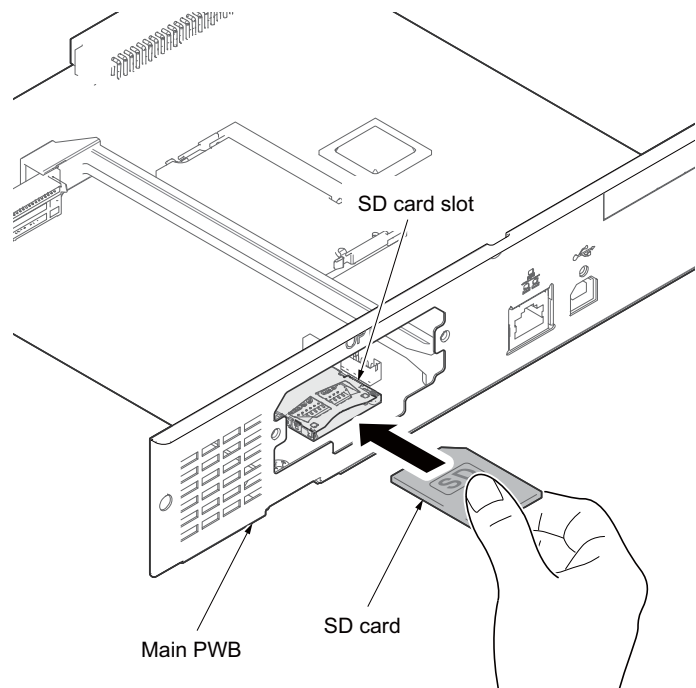

Figure 1-2-9

1-2-5 Installing the SSD disk

<Procedure>

1. Turn off printer power switch.
Caution: Do not insert or remove SSD unit while printer power is on.
Doing so may cause damage to the printer and the SSD.
2. Remove two screws and then remove the option interface slot cover.
3. Insert the SSD into the option interface slot.
Push it in all the way.
4. Secure the SSD by using two screws.

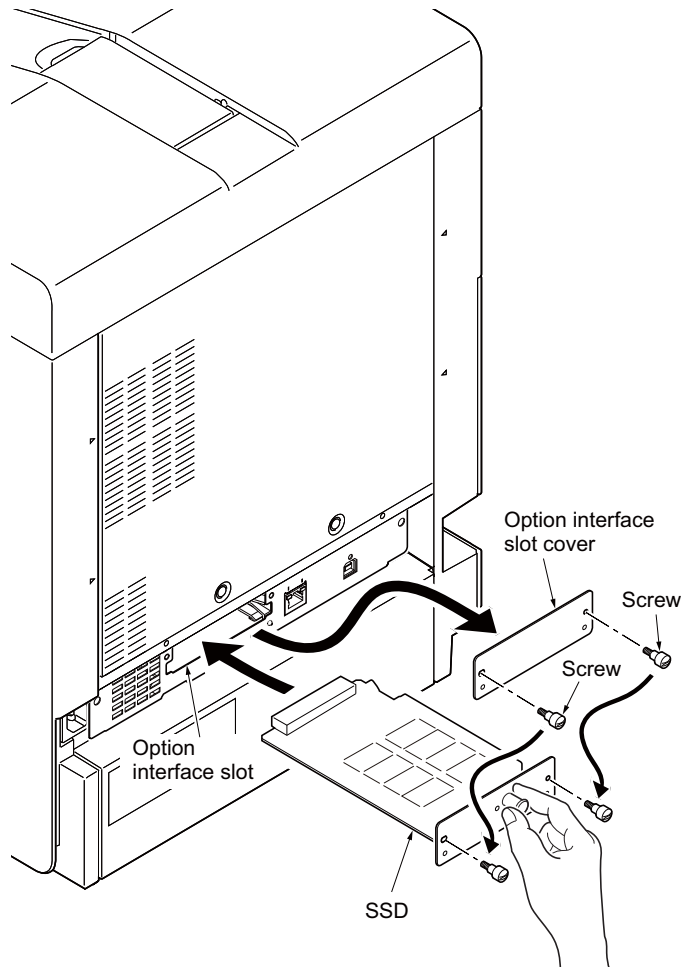

Figure 1-2-10

This page is intentionally left blank.

1-3-1 Maintenance mode

The printer is equipped with a maintenance function which can be used to maintain and service the machine.

(1) Executing a maintenance item

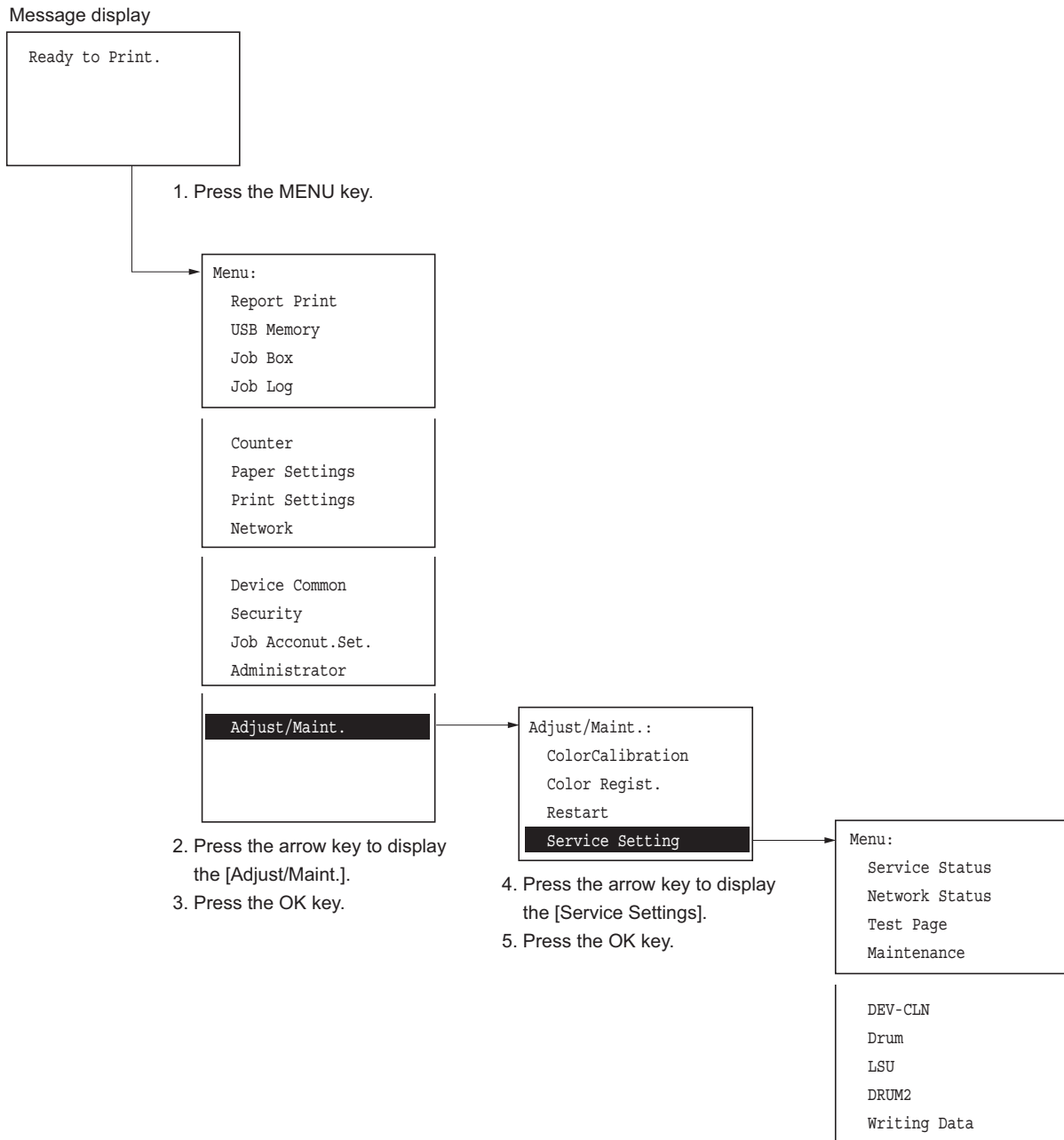

Service Settings

Service Status	To print a status page for service purpose (See page 1-3-2).
Network Status	To print a network status page (See page 1-3-8).
Test Page	To print a test page (See page 1-3-8).
Maintenance	To reset the counter after replacing the maintenance kit (See page 1-3-9).
DEV-CLN	To perform developing unit refreshing (See page 1-3-10).
Drum	To perform drum surface refreshing (See page 1-3-10).
LSU	To perform LSU dust shield glass cleaning (See page 1-3-11).
DRUM2	To setting fuser heater control in a sleep mode (See page 1-3-11).
Writing Data	To write data into a USB memory (See page 1-3-11).

(2) Service mode

Service items	Description
Service Status	<p>Printing a status page for service purpose</p> <p>Description Prints a status page for service purpose. The status page includes various printing settings and service cumulative.</p> <p>Purpose To acquire the current printing environmental parameters and cumulative information.</p> <p>Procedure</p> <ol style="list-style-type: none"> 1. In the [Service Setting] menu, press the arrow key to select [Service Status]. 2. Press the OK key. A confirmation screen appears. 3. Press [Yes] (Left select key). [Accepted.] appears and printing begins. <p>Completion</p> <p>Service status page (1)</p>

Service Status Page

Printer (2) 2013/06/07 15:15

(1) Firmware version 2PR_2000.000.000 2013.06.07 (3) [XXXXXXXX] (4) [XXXXXXXX] (5) [XXXXXXXX]

Controller Information

Memory status

(7) Standard Size	128.0 KB	.
(8) Option Slot	128.0 KB	.
(9) Total Size	2.0 GB	.

Time

(10) Local Time Zone	+01:00 Tokio	.
(11) Date and Time	28/07/2010 16:39	.
(12) Time Server	10.183.53.13	.

Installed Options

(13) Paper feeder2	Installed	.
(14) Paper feeder3	Installed	.
(15) Paper feeder4	Not Installed	.
(16) Memory card	Installed	.
(17) SSD	Installed	.
(18) UG-33	Installed	.

(19) P tint Coverage

(20) Average(%) / Usage Page(A4/Letter Conversion)

K: 1.10	/ 1111111.11	.
C: 2.20	/ 2222222.22	.
M: 3.30	/ 3333333.33	.
Y: 4.40	/ 4444444.44	.

Period (07/11/2005 - 07/12/2005 08:05)

(21) Last Page K/C/M/Y(%) 1.00 / 2.22 / 3.33 / 4.44

(22) FRPO Status

User Top Margin	A1+A2/100	0.00	PDF mode	Y5	00
User Left Margin	A3+A4/100	0.00			

1 (6) [XXXXXXXXXXXXXXXXXXXX]

Figure 1-3-1 Service status page (1)

Service items	Description						
	<p data-bbox="443 271 711 302">Service status page (2)</p> <div data-bbox="300 353 1358 1809" style="border: 1px solid black; padding: 10px;"> <p data-bbox="320 376 759 421">Service Status Page</p> <p data-bbox="320 425 405 450">Printer</p> <p data-bbox="1145 425 1302 450">2013/06/07 15:15</p> <p data-bbox="341 479 788 504">Firmware version 2PR_2000.000.000 2013.06.07</p> <p data-bbox="938 479 1310 504">[XXXXXXXX] [XXXXXXXX] [XXXXXXXX]</p> <hr/> <table border="0" data-bbox="320 548 1278 638"> <tr> <td data-bbox="320 548 571 577">Engine Information</td> <td data-bbox="922 548 1145 577">Send Information</td> </tr> <tr> <td data-bbox="309 586 799 611">(23) NVRAM Version _F1F31225_1F31225</td> <td data-bbox="906 586 1278 611">(25) Date and Time 10/07/28 16:39</td> </tr> <tr> <td data-bbox="309 613 799 638">(24) MAC Address 00:C0:EE:D0:01:0D</td> <td data-bbox="906 613 1023 638">(26) Address</td> </tr> </table> <p data-bbox="357 748 485 772">1/2 (27) (28)</p> <p data-bbox="309 775 427 799">(29) 100/100</p> <p data-bbox="309 801 453 826">(30) 0/0/0/0/0/0/</p> <p data-bbox="309 828 453 853">(31) 0/0/0/0/0/0/</p> <p data-bbox="309 855 416 880">(32) 0/0/0/0</p> <p data-bbox="309 882 906 907">(33) 000000/000000/000000/000000/000000/000000/000000/</p> <p data-bbox="357 909 1142 934">000000/000000/000000/000000/000000/000000/000000/000000/000000/000000/</p> <p data-bbox="357 936 1369 960">F00/U00/0/0/0/0/30/35/70/65/abcde/1/0/1/ (34)(35)(36)(37)(38)(39)(40)(41)(42)(43)(44)(45)(46)(47)(48)</p> <p data-bbox="309 963 1059 987">(49) 0000/0000/0000/0000/0000/0000/0000/0000/0000/0000/0000/0000/0000/0000/0000/0000/</p> <p data-bbox="357 990 828 1014">0000/0000/0000/0000/0000/0000/0000/0000/0000/0000/</p> <p data-bbox="309 1016 1107 1041">(50) 0000/0000/0000/0000/0000/0000/0000/0000/0000/0000/0000/0000/0000/0000/0000/0000/</p> <p data-bbox="357 1043 1107 1068">0000/0000/0000/0000/0000/0000/0000/0000/0000/0000/0000/0000/0000/0000/0000/0000/</p> <p data-bbox="309 1070 1305 1095">(51) 12345678/11223344/00001234abcd567800001234abcd5678/01234567890123456789012345678901/0008/00/07</p> <p data-bbox="197 1097 1305 1122">12345678/11223344/00001234abcd567800001234abcd5678/01234567890123456789012345678901/0008/00/07</p> <p data-bbox="197 1124 1305 1149">12345678/11223344/00001234abcd567800001234abcd5678/01234567890123456789012345678901/0008/00/07</p> <p data-bbox="197 1151 1305 1176">12345678/11223344/00001234abcd567800001234abcd5678/01234567890123456789012345678901/0008/00/07</p> <p data-bbox="309 1178 523 1202">(52) 2PR_D100.001.005</p> <p data-bbox="309 1205 1331 1229">(53) 00000000000000/00000000000000/00000000000000/00000000000000/00000000000000/00000000000000/</p> <p data-bbox="357 1232 1331 1256">00000000000000/00000000000000/00000000000000/00000000000000/00000000000000/00000000000000/</p> <p data-bbox="357 1258 1331 1283">00000000000000/00000000000000/00000000000000/00000000000000/00000000000000/00000000000000/</p> <p data-bbox="357 1285 1331 1310">00000000000000/00000000000000/00000000000000/00000000000000/00000000000000/00000000000000/</p> <p data-bbox="357 1312 1331 1337">00000000000000/00000000000000/00000000000000/00000000000000/00000000000000/00000000000000/</p> <p data-bbox="357 1339 1331 1364">00000000000000/00000000000000/00000000000000/00000000000000/00000000000000/00000000000000/</p> <p data-bbox="357 1366 1331 1391">00000000000000/00000000000000/00000000000000/00000000000000/00000000000000/00000000000000/</p> <p data-bbox="309 1415 416 1440">(54) [[]][[]]</p> <p data-bbox="357 1442 954 1467">[2PR_81BR.001.010] [ABCDEFGHJIJ] [ABCDEFGHJIJ] (55) (56) (57)</p> <p data-bbox="309 1469 373 1494">(58) 0/</p> <p data-bbox="357 1496 619 1520">0/12. 3/56. 7/ (59) (60) (61)</p> <p data-bbox="357 1523 485 1547">1/5 (62) (63)</p> <p data-bbox="309 1550 373 1574">(64) 1/</p> <p data-bbox="357 1576 523 1601">0/15:47 (65) (66)</p> <p data-bbox="309 1603 373 1628">(67) 1/</p> <p data-bbox="309 1630 852 1655">(68) ABCDEFGHIJ/ABCDEFGHIJ/ABCDEFGHIJ/ABCDEFGHIJ/</p> <hr/> <p data-bbox="815 1760 831 1785">2</p> <p data-bbox="1098 1760 1315 1785">[XXXXXXXXXXXXXXXXXXXX]</p> </div>	Engine Information	Send Information	(23) NVRAM Version _F1F31225_1F31225	(25) Date and Time 10/07/28 16:39	(24) MAC Address 00:C0:EE:D0:01:0D	(26) Address
Engine Information	Send Information						
(23) NVRAM Version _F1F31225_1F31225	(25) Date and Time 10/07/28 16:39						
(24) MAC Address 00:C0:EE:D0:01:0D	(26) Address						

Figure 1-3-2Service status page (2)

Service items	Description	
Detail of service status page		
No.	Description	Supplement
(1)	Firmware version	-
(2)	System date	-
(3)	Engine soft version	-
(4)	Engine boot version	-
(5)	Operation panel mask version	-
(6)	Machine serial number	-
(7)	Standard memory size	-
(8)	Optional memory size	-
(9)	Total memory size	-
(10)	Local time zone	-
(11)	Report output date	Day/Month/Year hour:minute
(12)	NTP server name	-
(13)	Presence or absence of the optional paper feeder 1	Installed/Not Installed
(14)	Presence or absence of the optional paper feeder 2	Installed/Not Installed
(15)	Presence or absence of the optional paper feeder 3	Installed/Not Installed
(16)	Presence or absence of the optional memory card	Installed/Not Installed
(17)	Presence or absence of the optional SSD	Installed/Not Installed
(18)	Presence or absence of the optional UG-33	Installed/Not Installed
(19)	Page of relation to the A4/Letter	* :Print Coverage provides a close-matching reference of toner consumption and will not match with the actual toner consumption.
(20)	Average coverage for printer	Black/Cyan/Magenta/Yellow
(21)	Coverage on the final output page	-
(22)	FRPO setting	-

Service items	Description	
	No.	Description
(23)	NV RAM version	_ 1F3 1225 _ 1F3 1225 (a) (b) (c) (d) (e) (f) (a) Consistency of the present software version and the database _ (underscore): OK * (Asterisk): NG (b) Database version (c) The oldest time stamp of database version (d) Consistency of the present software version and the ME firmware version _ (underscore): OK * (Asterisk): NG (e) ME firmware version (f) The oldest time stamp of the ME database version Normal if (a) and (d) are underscored, and (b) and (e) are identical with (c) and (f).
(24)	Mac address	-
(25)	The last sent date and time	-
(26)	Transmission address	-
(27)	Destination information	-
(28)	Area information	-
(29)	Margin settings	Top margin/Left margin
(30)	Top offset for each paper source	MP tray/Paper feeder 1/Paper feeder 2/ Paper feeder 3/Duplex/Page rotation
(31)	Left offset for each paper source	MP tray/Paper feeder 1/Paper feeder 2/ Paper feeder 3/Duplex/Page rotation
(32)	Margin/Page length/Page width settings	Top margin integer part/Top margin decimal part/ Left margin integer part/Left margin decimal part
(33)	Life counter (The first line)	Machine life/MP tray/Cassette/Paper feeder 1/ Paper feeder 2/Paper feeder 3/Duplex
	Life counter (The second line)	Drum unit K/Drum unit C/Drum unit M/Drum unit Y/ Intermediate transfer unit/Developing unit K/ Developing unit C/Developing unit M/ Developing unit Y/Maintenance kit
(34)	Panel lock information	F00: OFF F01 to F03: Partial lock F04: Full lock
(35)	USB information	U00: Not installed/U01: Full speed/U02: Hi speed
(36)	Paper handling information	0: Paper source unit select/1: Paper source unit
(37)	Auto cassette change mode	0: Prohibition of the Auto cassette change 1: Permission of the Auto cassette change

Service items	Description		
	No.	Description	Supplement
(38)	Color printing double count mode	0: All single counts 3: Folio, Single count, Less than 330 mm (length)	
(39)	Black and white printing double count mode	0: All single counts 3: Folio, Single count, Less than 330 mm (length)	
(40)	Billing counting timing	-	
(41)	Temperature (machine inside)	-	
(42)	Temperature (machine outside)	-	
(43)	Relative temperature (machine outside)	-	
(44)	Absolute temperature (machine outside)	-	
(45)	Fixed assets number	-	
(46)	Job end judgment time-out time	-	
(47)	Job end detection mode	-	
(48)	Reset the prescribe environmental	0: OFF 1: ON	
(49)	Media type attributes 1 to 28 (Not used: 18, 19, 20)	Weight settings 0: Light 1: Normal 1 2: Normal 2 3: Normal 3 4: Heavy 1 5: Heavy 2 6: Heavy 3 7: Extra Heavy	Fuser settings 0: High 1: Middle 2: Low 3: Vellum Duplex settings 0: Disable 1: Enable
(50)	Calibration information	Black/Cyan/Magenta/Yellow	
(51)	RFID information	-	
(52)	RFID reader/writer version information	-	
(53)	Engine parameter information	-	
(54)	Soft version of the optional paper feeder	Paper feeder 1/Paper feeder 2/Paper feeder 3	
(55)	Version of the optional message	-	
(56)	Color table version	-	
(57)	2th color table version	-	
(58)	Altitude	0: Standard 1: High altitude 1 2: High altitude 2	

Service items	Description																					
No.	Description	Supplement																				
(59)	The counter according to toner coverage	0: Full color counter 1: Color coverage counter																				
(60)	Low coverage setting	0.1 to 100.0																				
(61)	Middle coverage setting	0.1 to 100.0																				
(62)	Toner low setting	0: Invalidation 1: Effective																				
(63)	Toner low detection level	0 to 100(%)																				
(64)	Full page printing Mode	0: Normal Mode 1: Full Page Mode																				
(65)	Wake Up Mode	0: OFF, 1: ON																				
(66)	Wake Up timer	Wake Up Time																				
(67)	BAM conformity Mode setting	0: Un-suited Mode 1: Conformity Mode																				
(68)	Drum serial number	Black/Cyan/Magenta/Yellow																				
<p style="text-align: center;">Code conversion</p> <table border="1" style="margin-left: auto; margin-right: auto;"> <tr> <td>A</td><td>B</td><td>C</td><td>D</td><td>E</td><td>F</td><td>G</td><td>H</td><td>I</td><td>J</td> </tr> <tr> <td>0</td><td>1</td><td>2</td><td>3</td><td>4</td><td>5</td><td>6</td><td>7</td><td>8</td><td>9</td> </tr> </table>			A	B	C	D	E	F	G	H	I	J	0	1	2	3	4	5	6	7	8	9
A	B	C	D	E	F	G	H	I	J													
0	1	2	3	4	5	6	7	8	9													

Service items	Description
<p>Network Status</p>	<p>Printing a status page for network Description On the status page for network, detailed network setting information is printed.</p> <p>Procedure</p> <ol style="list-style-type: none"> 1. In the [Service Setting] menu, press the arrow key to select [Network Status]. 2. Press the OK key. A confirmation screen appears. 3. Press [Yes] (Left select key). [Accepted.] appears and printing begins. <p>Completion</p>
<p>Test Page</p>	<p>Printing a test page Description Four colors are printed respectively with halftones of three different levels.</p> <p>Purpose To check the activation of the developing and drum units of four colors.</p> <p>Procedure</p> <ol style="list-style-type: none"> 1. In the [Service Setting] menu, press the arrow key to select [Test Page]. 2. Press the OK key. A confirmation screen appears. 3. Press [Yes] (Left select key). [Accepted.] appears and printing begins. <p>Completion</p> <div data-bbox="534 943 1284 1503" data-label="Figure"> </div> <p>*1: Since focusing in yellow is hardly readable, yellow is mixed with cyan for more readability, resulting in green.</p> <p>*2: Each portion of colors has three different magnitude of halftones (bands). If focus is excessively lost, dots are not recognizable with the 16/256 band, resulting in uneven density. It also results in vertical streaks in the 24/256 and/or 32/256 bands.</p> <p style="text-align: center;">Figure 1-3-3 Test page</p>

Service items	Description
Maintenance	<p>Counter reset for the maintenance kit</p> <p>Description The "Install MK" message means that maintenance kit should be replaced at 300,000 sheets (images) of printing. The interval counter must be manually reset using this service item.</p> <p>Maintenance kit includes the following units: Drum unit × 4 Developing unit M, C, Y and K Fuser unit Intermediate transfer roller Paper feed roller assembly Retard roller assembly MP paper feed roller</p> <p>Purpose To reset the life counter for the drum units, developing units, intermediate transfer unit, and fuser unit included in maintenance kit.</p> <p>Procedure for replacing the maintenance kit Drum unit × 4 (See page 1-5-15) Developing unit M, C, Y and K (See page 1-5-12) Fuser unit (See page 1-5-24) Intermediate transfer unit (See page 1-5-16) Paper feed roller assembly (See page 1-5-8) Retard roller assembly (See page 1-5-10) MP paper feed roller (See page 1-5-11)</p> <p>Procedure</p> <ol style="list-style-type: none"> 1. In the [Service Setting] menu, press the arrow key to select [Maintenance]. 2. Press the OK key. A confirmation screen appears. 3. Press [Yes] (Left select key). <p>[Completed] appears and maintenance counter is reset.</p> <p>Completion</p> <p>Note: Occurrences of resetting the maintenance kits are recorded on the service status page in number of pages at which the maintenance kit was replaced (See page 1-3-2). This may be used to determine the possibility that the counter was erroneously or unintentionally reset.</p>

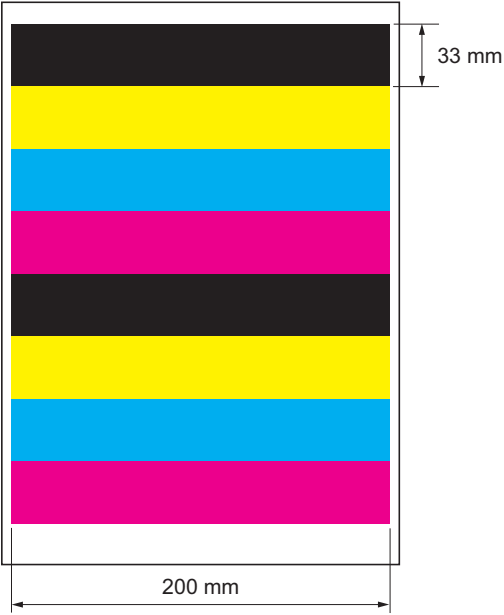
Service items	Description
DEV-CLN	<p>Developer refreshing</p> <p>Description The laser output of the image data for developer refreshing is carried out, and operation to exposure, developing, and primary transfer is performed by 10 pages. (Paper is not fed)</p> <p>Purpose To perform cleaning when faulty images occur and a line appears longitudinally.</p> <p>Procedure</p> <ol style="list-style-type: none"> 1. In the [Service Setting] menu, press the arrow key to select [DEV-CLN]. 2. Press the OK key. A confirmation screen appears. 3. Press [Yes] (Left select key). The developer unit is refreshed. <p>Completion</p> <div data-bbox="683 638 1189 1317" style="text-align: center;"> <p>A4 paper size</p>  <p>Toner image on the transfer belt</p> </div> <p>Figure 1-3-4 Developer refreshing Image data</p>
Drum	<p>Drum surface refreshing</p> <p>Description Rotates the drum approximately 2 minutes with toner lightly on the overall drum using the high-voltage output control of the engine PWB. The cleaning blade in the drum unit scrapes toner off the drum surface to clean it.</p> <p>Purpose To clean the drum surface when image failure occurs due to the drum. This mode is effective when dew condensation on the drum occurs.</p> <p>Procedure</p> <ol style="list-style-type: none"> 1. In the [Service Setting] menu, press the arrow key to select [Drum]. 2. Press the OK key. A confirmation screen appears. 3. Press [Yes] (Left select key). Carry out drum refresh. <p>Completion</p>

Service items	Description
LSU	<p>LSU dust shield glass cleaning</p> <p>Description The LSU cleaning motor drives the cleaning pad which in turn wipes clean the LSU dust shield glass.</p> <p>Purpose To perform cleaning when the printed image is bad and stripes are seen in the vertical direction.</p> <p>Procedure</p> <ol style="list-style-type: none"> 1. In the [Service Setting] menu, press the arrow key to select [LSU]. 2. Press the OK key. A confirmation screen appears. 3. Press [Yes] (Left select key). Carry out the LSU cleaning. <p>Completion</p>
DRUM2	<p>Setting of fuser heater control</p> <p>Description To setting fuser heater control in a sleep mode.</p> <p>Purpose Under high-temperature and high-humidity environment, drum refresh mode can take longer to start. Turning DRUM2 mode to On will allow drum refresh mode to start without delay even under such environment. However, power consumption of the machine during sleeping mode will increase.</p> <p>Procedure</p> <ol style="list-style-type: none"> 1. In the [Service Setting] menu, press the arrow key to select [DRUM2]. 2. Press the arrow key to select a setting and then press the OK key. <p>Completion</p>
Write Data	<p>Write data (USB memory data write)</p> <p>Description To write data into a USB memory.</p> <p>Procedure Install the USB memory before attempting to write data.</p> <ol style="list-style-type: none"> 1. In the [Service Setting] menu, press the arrow key to select [Write Data]. 2. Press the OK key. A confirmation screen appears. 3. Press [Yes] (Left select key). The printer waits for data to be written. 4. When the data is sent, [Processing] appears and the data is written to USB memory. When data writing ends, the display returns to [Ready to print.]. <p>Completion</p>

(3) Printing a event log (EVENT LOG)

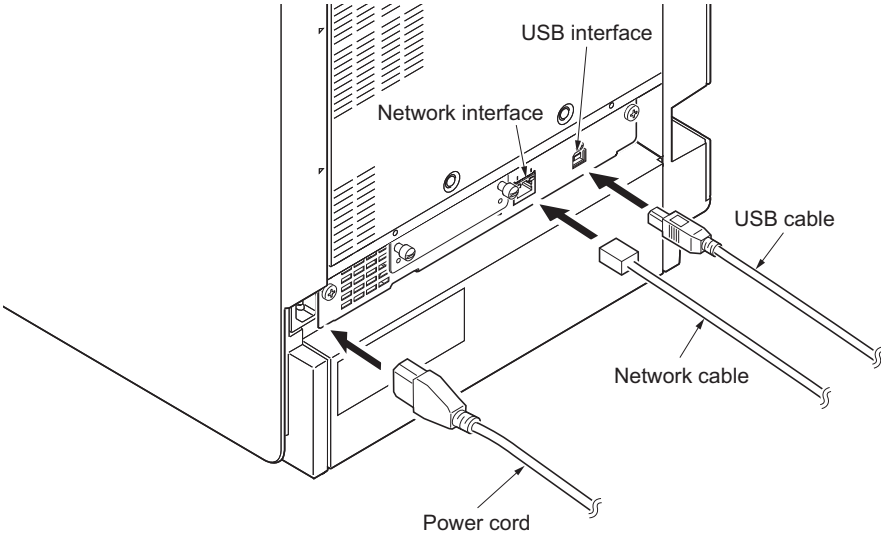
Service items	Description
Printing an event log (EVENT LOG)	<p>Printing an event log (EVENT LOG)</p> <p>Description Prints a history list of occurrences of paper jam, self-diagnostics, toner replacements, etc.</p> <p>Purpose To allow machine malfunction analysis based on the frequency of paper misfeeds, self diagnostic errors and replacements.</p> <p>Procedure</p> <ol style="list-style-type: none"> 1. Connect the USB or network cable between printer and PC (network). 2. Connect the power cord.  <p style="text-align: center;">Figure 1-3-5</p> <ol style="list-style-type: none"> 3. Turn printer power on. Make sure the printer is ready. 4. Send the following PRESCRIBE command sequence from the PC to the printer. <pre>!R!KCFG"ELOG";EXIT;</pre> <p>A sheet of event log will be printed.</p> <p>Completion</p> <p>Remarks: Details of configurations (See above 4.)</p> <p>Notes on Connecting to USB</p> <ol style="list-style-type: none"> (1) Save the Prescribe commands above as a text file in the PC. (2) Select the Sharing tab of the printer properties and share the printer. (3) Select a USB port in the Port tab. (Specify the printer name for sharing.) (4) From the DOS Prompt, execute the following command line: copy file-name\\computer-name\shared-printe File-name should be the name of the file that was saved in step 1. <p>Notes on connecting via network (using FTP protocol)</p> <ol style="list-style-type: none"> (1) Save the Prescribe commands above as a text file in the PC. (2) From the DOS Prompt, execute the following command line: ftp printer-IP-address Do not specify user name and password. (3) From the DOS Prompt, execute the following command: put file-name File-name should be the name of the file that was saved in step 1.

Service items	Description																																																																																																																																																																												
	<p>Detail of event log</p> <h2 style="margin: 0;">Event Log</h2> <p>Printer (2) 2013/05/31 15:15</p> <p>(1) Firmware version 2PR_2000.000.000 2013.05.31 (3) [XXXXXXXX] (4) [XXXXXXXX] (5) [XXXXXXXX]</p> <hr/> <div style="display: flex; justify-content: space-between;"> <div style="width: 60%;"> <p>(7) Paper Jam Log</p> <table border="1" style="width:100%; border-collapse: collapse; font-size: small;"> <thead> <tr> <th>#</th> <th>Count.</th> <th>Event Descriptions</th> <th>Data and Time</th> </tr> </thead> <tbody> <tr><td>12</td><td>1876543</td><td>0501.01.08.01.01</td><td>2013/03/02 11:11</td></tr> <tr><td>11</td><td>166554</td><td>4020.01.08.01.01</td><td>2013/03/02 10:57</td></tr> <tr><td>10</td><td>4988</td><td>0501.01.08.01.01</td><td>2013/03/02 10:44</td></tr> <tr><td>9</td><td>4988</td><td>4020.01.08.01.01</td><td>2013/03/02 10:00</td></tr> <tr><td>8</td><td>1103</td><td>0501.01.08.01.01</td><td>2013/03/02 09:27</td></tr> <tr><td>7</td><td>1103</td><td>4020.01.08.01.01</td><td>2013/03/01 17:30</td></tr> <tr><td>6</td><td>1027</td><td>0501.01.08.01.01</td><td>2013/03/01 10:02</td></tr> <tr><td>5</td><td>1027</td><td>4020.01.08.01.01</td><td>2013/03/01 08:57</td></tr> <tr><td>4</td><td>1027</td><td>0501.01.08.01.01</td><td>2013/02/29 17:00</td></tr> <tr><td>3</td><td>1027</td><td>4020.01.08.01.01</td><td>2013/02/29 15:38</td></tr> <tr><td>2</td><td>406</td><td>0501.01.08.01.01</td><td>2013/02/28 09:00</td></tr> <tr><td>1</td><td>36</td><td>4020.01.08.01.01</td><td>2013/02/28 08:12</td></tr> </tbody> </table> <div style="border: 1px solid black; padding: 5px; margin: 10px auto; width: fit-content;"> <p style="text-align: center; font-size: large; margin: 0;">0501.01.08.01.01</p> <p style="text-align: center; font-size: small; margin: 0;">(a) (b) (c) (d) (e)</p> </div> </div> <div style="width: 35%;"> <p>(11) Counter Log</p> <table border="1" style="width:100%; border-collapse: collapse; font-size: small;"> <thead> <tr> <th>(f)</th> <th>(g)</th> <th>(h)</th> </tr> </thead> <tbody> <tr><td>J0100: 0</td><td>C0000: 0</td><td>T00: 10</td></tr> <tr><td>J0105: 0</td><td>C0001: 1</td><td>T01: 20</td></tr> <tr><td>J0106: 0</td><td>C0002: 2</td><td>T02: 30</td></tr> <tr><td>J0110: 0</td><td>C0003: 3</td><td>T03: 40</td></tr> <tr><td>J0111: 0</td><td>C0004: 4</td><td>T04: 50</td></tr> <tr><td>J0512: 0</td><td>C0005: 5</td><td>T05: 999</td></tr> <tr><td>J0513: 0</td><td>C0006: 6</td><td></td></tr> <tr><td>J0518: 0</td><td>C0007: 7</td><td></td></tr> <tr><td>J0519: 0</td><td>C0008: 8</td><td></td></tr> <tr><td>J1020: 0</td><td>C0009: 9</td><td></td></tr> <tr><td>J4201: 0</td><td>C0010: 10</td><td></td></tr> <tr><td>J4202: 0</td><td>C0011: 11</td><td></td></tr> <tr><td>J4203: 0</td><td></td><td></td></tr> <tr><td>J4208: 0</td><td></td><td></td></tr> <tr><td>J4209: 0</td><td></td><td></td></tr> </tbody> </table> </div> </div> <div style="margin-top: 20px;"> <p>(8) Service Call Log</p> <table border="1" style="width:100%; border-collapse: collapse; font-size: small;"> <thead> <tr> <th>#</th> <th>Count.</th> <th>Service Code</th> <th>Data and Time</th> </tr> </thead> <tbody> <tr><td>8</td><td>1881214</td><td>01.6000</td><td>2013/03/02 11:11</td></tr> <tr><td>7</td><td>178944</td><td>01.2100</td><td>2013/03/02 10:57</td></tr> <tr><td>6</td><td>5296</td><td>01.4000</td><td>2013/03/02 10:44</td></tr> <tr><td>5</td><td>5295</td><td>01.6000</td><td>2013/03/02 10:00</td></tr> <tr><td>4</td><td>2099</td><td>01.2100</td><td>2013/03/02 09:27</td></tr> <tr><td>3</td><td>1054</td><td>01.4000</td><td>2013/03/01 17:30</td></tr> <tr><td>2</td><td>809</td><td>01.6000</td><td>2013/03/01 10:02</td></tr> <tr><td>1</td><td>30</td><td>01.2100</td><td>2013/03/01 08:57</td></tr> </tbody> </table> <p>(9) Maintenance Log</p> <table border="1" style="width:100%; border-collapse: collapse; font-size: small;"> <thead> <tr> <th>#</th> <th>Count.</th> <th>Item</th> <th>Data and Time</th> </tr> </thead> <tbody> <tr><td>3</td><td>104511</td><td>01.00</td><td>2013/03/02 11:11</td></tr> <tr><td>2</td><td>3454</td><td>01.01</td><td>2013/03/02 10:57</td></tr> <tr><td>1</td><td>34</td><td>01.01</td><td>2013/03/02 10:44</td></tr> </tbody> </table> <p>(10) Unknown toner Log</p> <table border="1" style="width:100%; border-collapse: collapse; font-size: small;"> <thead> <tr> <th>#</th> <th>Count.</th> <th>Item</th> <th>Data and Time</th> </tr> </thead> <tbody> <tr><td>4</td><td>3454</td><td>01.00</td><td>2013/03/02 11:11</td></tr> <tr><td>3</td><td>3454</td><td>01.00</td><td>2013/03/02 10:57</td></tr> <tr><td>2</td><td>406</td><td>01.00</td><td>2013/03/02 10:44</td></tr> <tr><td>1</td><td>32</td><td>01.00</td><td>2013/03/02 10:00</td></tr> </tbody> </table> <p style="text-align: right; margin-top: 20px;">(6) [XXXXXXXXXXXXXXXXXXXX]</p> </div>	#	Count.	Event Descriptions	Data and Time	12	1876543	0501.01.08.01.01	2013/03/02 11:11	11	166554	4020.01.08.01.01	2013/03/02 10:57	10	4988	0501.01.08.01.01	2013/03/02 10:44	9	4988	4020.01.08.01.01	2013/03/02 10:00	8	1103	0501.01.08.01.01	2013/03/02 09:27	7	1103	4020.01.08.01.01	2013/03/01 17:30	6	1027	0501.01.08.01.01	2013/03/01 10:02	5	1027	4020.01.08.01.01	2013/03/01 08:57	4	1027	0501.01.08.01.01	2013/02/29 17:00	3	1027	4020.01.08.01.01	2013/02/29 15:38	2	406	0501.01.08.01.01	2013/02/28 09:00	1	36	4020.01.08.01.01	2013/02/28 08:12	(f)	(g)	(h)	J0100: 0	C0000: 0	T00: 10	J0105: 0	C0001: 1	T01: 20	J0106: 0	C0002: 2	T02: 30	J0110: 0	C0003: 3	T03: 40	J0111: 0	C0004: 4	T04: 50	J0512: 0	C0005: 5	T05: 999	J0513: 0	C0006: 6		J0518: 0	C0007: 7		J0519: 0	C0008: 8		J1020: 0	C0009: 9		J4201: 0	C0010: 10		J4202: 0	C0011: 11		J4203: 0			J4208: 0			J4209: 0			#	Count.	Service Code	Data and Time	8	1881214	01.6000	2013/03/02 11:11	7	178944	01.2100	2013/03/02 10:57	6	5296	01.4000	2013/03/02 10:44	5	5295	01.6000	2013/03/02 10:00	4	2099	01.2100	2013/03/02 09:27	3	1054	01.4000	2013/03/01 17:30	2	809	01.6000	2013/03/01 10:02	1	30	01.2100	2013/03/01 08:57	#	Count.	Item	Data and Time	3	104511	01.00	2013/03/02 11:11	2	3454	01.01	2013/03/02 10:57	1	34	01.01	2013/03/02 10:44	#	Count.	Item	Data and Time	4	3454	01.00	2013/03/02 11:11	3	3454	01.00	2013/03/02 10:57	2	406	01.00	2013/03/02 10:44	1	32	01.00	2013/03/02 10:00
#	Count.	Event Descriptions	Data and Time																																																																																																																																																																										
12	1876543	0501.01.08.01.01	2013/03/02 11:11																																																																																																																																																																										
11	166554	4020.01.08.01.01	2013/03/02 10:57																																																																																																																																																																										
10	4988	0501.01.08.01.01	2013/03/02 10:44																																																																																																																																																																										
9	4988	4020.01.08.01.01	2013/03/02 10:00																																																																																																																																																																										
8	1103	0501.01.08.01.01	2013/03/02 09:27																																																																																																																																																																										
7	1103	4020.01.08.01.01	2013/03/01 17:30																																																																																																																																																																										
6	1027	0501.01.08.01.01	2013/03/01 10:02																																																																																																																																																																										
5	1027	4020.01.08.01.01	2013/03/01 08:57																																																																																																																																																																										
4	1027	0501.01.08.01.01	2013/02/29 17:00																																																																																																																																																																										
3	1027	4020.01.08.01.01	2013/02/29 15:38																																																																																																																																																																										
2	406	0501.01.08.01.01	2013/02/28 09:00																																																																																																																																																																										
1	36	4020.01.08.01.01	2013/02/28 08:12																																																																																																																																																																										
(f)	(g)	(h)																																																																																																																																																																											
J0100: 0	C0000: 0	T00: 10																																																																																																																																																																											
J0105: 0	C0001: 1	T01: 20																																																																																																																																																																											
J0106: 0	C0002: 2	T02: 30																																																																																																																																																																											
J0110: 0	C0003: 3	T03: 40																																																																																																																																																																											
J0111: 0	C0004: 4	T04: 50																																																																																																																																																																											
J0512: 0	C0005: 5	T05: 999																																																																																																																																																																											
J0513: 0	C0006: 6																																																																																																																																																																												
J0518: 0	C0007: 7																																																																																																																																																																												
J0519: 0	C0008: 8																																																																																																																																																																												
J1020: 0	C0009: 9																																																																																																																																																																												
J4201: 0	C0010: 10																																																																																																																																																																												
J4202: 0	C0011: 11																																																																																																																																																																												
J4203: 0																																																																																																																																																																													
J4208: 0																																																																																																																																																																													
J4209: 0																																																																																																																																																																													
#	Count.	Service Code	Data and Time																																																																																																																																																																										
8	1881214	01.6000	2013/03/02 11:11																																																																																																																																																																										
7	178944	01.2100	2013/03/02 10:57																																																																																																																																																																										
6	5296	01.4000	2013/03/02 10:44																																																																																																																																																																										
5	5295	01.6000	2013/03/02 10:00																																																																																																																																																																										
4	2099	01.2100	2013/03/02 09:27																																																																																																																																																																										
3	1054	01.4000	2013/03/01 17:30																																																																																																																																																																										
2	809	01.6000	2013/03/01 10:02																																																																																																																																																																										
1	30	01.2100	2013/03/01 08:57																																																																																																																																																																										
#	Count.	Item	Data and Time																																																																																																																																																																										
3	104511	01.00	2013/03/02 11:11																																																																																																																																																																										
2	3454	01.01	2013/03/02 10:57																																																																																																																																																																										
1	34	01.01	2013/03/02 10:44																																																																																																																																																																										
#	Count.	Item	Data and Time																																																																																																																																																																										
4	3454	01.00	2013/03/02 11:11																																																																																																																																																																										
3	3454	01.00	2013/03/02 10:57																																																																																																																																																																										
2	406	01.00	2013/03/02 10:44																																																																																																																																																																										
1	32	01.00	2013/03/02 10:00																																																																																																																																																																										
	<p>Figure 1-3-6Event log</p>																																																																																																																																																																												
	<table border="1" style="width:100%; border-collapse: collapse;"> <thead> <tr> <th style="width:10%;">No.</th> <th>Description</th> </tr> </thead> <tbody> <tr><td>(1)</td><td>System version</td></tr> <tr><td>(2)</td><td>System date</td></tr> <tr><td>(3)</td><td>Engine soft version</td></tr> <tr><td>(4)</td><td>Engine boot version</td></tr> <tr><td>(5)</td><td>Operation panel mask version</td></tr> <tr><td>(6)</td><td>Machine serial number</td></tr> </tbody> </table>	No.	Description	(1)	System version	(2)	System date	(3)	Engine soft version	(4)	Engine boot version	(5)	Operation panel mask version	(6)	Machine serial number																																																																																																																																																														
No.	Description																																																																																																																																																																												
(1)	System version																																																																																																																																																																												
(2)	System date																																																																																																																																																																												
(3)	Engine soft version																																																																																																																																																																												
(4)	Engine boot version																																																																																																																																																																												
(5)	Operation panel mask version																																																																																																																																																																												
(6)	Machine serial number																																																																																																																																																																												

Service items		Description		
(7) cont.	Paper Jam Log	Description		
		#	Count.	Event
		Remembers 1 to 16 of occurrence. If the occurrence of the previous paper jam is less than 16, all of the paper jams are logged. When the occurrence exceeded 16, the oldest occurrence is removed.	The total page count at the time of the paper jam.	Log code (2 digit, hexadecimal, 5 categories) (a) Cause of a paper jam (b) Paper source (c) Paper size (d) Paper type (e) Paper exit
		(a) Cause of paper jam		
		0105: Registration sensor not detected [-] 0110: Top tray open [-] 0111: Rear cover open [-] 0112: Front cover open [-] 0501: No paper feed from cassette 1 [1] 0502: No paper feed from cassette 2 [2] 0503: No paper feed from cassette 3 [3] 0504: No paper feed from cassette 4 [4] 0505: No paper feed from cassette 5 [5] 0508: No paper feed from duplex section [I] 0511: Multiple sheets in cassette 1 [1] 0518: Multiple sheets in duplex section [I] 1403: PF feed sensor 1 does not turn ON (Paper feeder 2) [2] 1404: PF feed sensor 1 does not turn ON (Paper feeder 3) [2] 1405: PF feed sensor 1 does not turn ON (Paper feeder 4) [2] 1420: PF feed sensor 1 is turned ON [2] 1604: PF feed sensor 2 does not turn ON (Paper feeder 3) [3] 1605: PF feed sensor 2 does not turn ON (Paper feeder 4) [3] 1620: PF feed sensor 2 is turned ON [3] 1805: PF feed sensor 3 does not turn ON (Paper feeder 4) [4] 1820: PF feed sensor 3 is turned ON [4] 2020: PF feed sensor 4 is turned ON [5] 4002: Registration sensor does not turn ON (Paper feeder 1) [1] 4003: Registration sensor does not turn ON (Paper feeder 2) [1] 4004: Registration sensor does not turn ON (Paper feeder 3) [1] 4005: Registration sensor does not turn ON (Paper feeder 4) [1] 4009: Registration sensor does not turn ON (MP tray) [1] 4012: Registration sensor does not turn OFF (Paper feeder 1) [H] 4013: Registration sensor does not turn OFF (Paper feeder 2) [H] 4014: Registration sensor does not turn OFF (Paper feeder 3) [H] 4015: Registration sensor does not turn OFF (Paper feeder 4) [H] 4019: Registration sensor does not turn OFF (MP tray) [H] 4020: Registration sensor is turned ON [H]		

Service items		Description
(7) cont.	Paper Jam Log	<p>4201: Eject sensor does not turn ON (Cassette) [H] 4202: Eject sensor does not turn ON (Paper feeder 1) [H] 4203: Eject sensor does not turn ON (Paper feeder 2) [H] 4204: Eject sensor does not turn ON (Paper feeder 3) [H] 4205: Eject sensor does not turn ON (Paper feeder 4) [H] 4208: Eject sensor does not turn ON (Duplex) [H] 4209: Eject sensor does not turn ON (MP tray) [H] 4211: Eject sensor does not turn OFF (Cassette) [G] 4212: Eject sensor does not turn OFF (Paper feeder 1) [G] 4213: Eject sensor does not turn OFF (Paper feeder 2) [G] 4214: Eject sensor does not turn OFF (Paper feeder 3) [G] 4215: Eject sensor does not turn OFF (Paper feeder 4) [G] 4218: Eject sensor does not turn OFF (Duplex) [G] 4219: Eject sensor does not turn OFF (MP tray) [G] 4220: Eject sensor is turned ON [G] 4301: Duplex sensor does not turn OFF (Cassette) [I] 4302: Duplex sensor does not turn OFF (Paper feeder 1) [I] 4303: Duplex sensor does not turn OFF (Paper feeder 2) [I] 4304: Duplex sensor does not turn OFF (Paper feeder 3) [I] 4305: Duplex sensor does not turn OFF (Paper feeder 4) [I] 4309: Duplex sensor does not turn OFF (MP tray) [I] 4320: Duplex sensor is turned ON [I]</p> <p>Note: Values (hexadecimal) within [] indicate paper misfeed locations.</p>

Service items		Description
(7) cont.	Paper Jam Log	<p>Jam location</p> <p>Sensors</p> <ul style="list-style-type: none"> ① Registration sensor ② Paper exit sensor ③ Duplex conveying sensor ④ Paper full sensor ⑤ PF paper feed sensor <p>Paper jam location</p> <ul style="list-style-type: none"> [B] MP tray [1] Cassette 1 (printer) [2] Paper feeder 1 [3] Paper feeder 2 [4] Paper feeder 3 [5] Paper feeder 4 [H] Printer inside [G] Paper exit section [I] Duplex section <p style="text-align: center;">Figure 1-3-7Jam location</p>

Service items		Description		
(7) cont.	Paper Jam Log	(b) Detail of paper source (Hexadecimal)		
		00: MP tray 01: Paper cassette 1 (printer) 02: Paper cassette 2 (paper feeder 1) 03: Paper cassette 3 (paper feeder 2) 04: Paper cassette 4 (paper feeder 3) 05: Paper cassette 5 (paper feeder 4) 06: - 07: Duplex unit 08: Bulk paper feeder 09: Envelope feeder		
(7) cont.	Paper Jam Log	(c) Detail of paper size (Hexadecimal)		
		01: Monarch 02: Business 03: International DL 04: International C5 05: Executive 06: Letter-R 07: Legal 08: A4R 08: A4E 09: B5R 09: B5E 0A: A3 0B: B4 0C: Ledger 0D: A5R 8D: A5E 0E: A6 0F: B6 10: Commercial #9 11: Commercial #6 12: ISO B5 13: Custom size 1E: C4 1F: Postcard 20: Reply-paid postcard 21: Oficio II 22: Special 1 23: Special 2 24: A3 wide 25: Ledger wide 26: Full bleed paper (12 ´ 8) 27: 8K 28: 16K-R A8: 16K-E 32: Statement-R B2: Statement-E 33: Folio 34: Western type 2 35: Western type 4		
(7) cont.	Paper Jam Log	(d) Detail of paper type (Hexadecimal)		
		01: Plain 02: Transparency 03: Preprint 04: Labels 05: Bond 06: Recycle 07: Vellum 08: Rough 09: Letter head 0A: Color 0B: Prepunched 0C: Envelope 0D: Cardstock 0E: Coated 0F: 2nd side 10: Media 16 11: High quality 15: Custom 1 16: Custom 2 17: Custom 3 18: Custom 4 19: Custom 5 1A: Custom 6 1B: Custom 7 1C: Custom 8		
(7) cont.	Paper Jam Log	(e) Detail of paper exit location (Hexadecimal)		
		01: Face down tray (FD) 02: Face up tray (FU) 03 to 48: Reserved		
(8)	Service Call (Self diagnostic error) Log	#	Count.	Service Code
		Remembers 1 to 8 of occurrence of self diagnostics error. If the occurrence of the previous diagnostics error is less than 8, all of the diagnostics errors are logged.	The total page count at the time of the self diagnostics error.	Self diagnostic error code (See page 1-4-4) Example 01.6000 01 means a self-diagnostic error; 6000 means a self diagnostic error code.

Service items		Description		
No.	Items	Description		
(9)	<p>Maintenance Log</p> <p>NOTE: It is not logged if 100 or more counts are not added to the count at the last occurrence of replacement.</p>	<p>#</p> <p>Remembers 1 to 8 of occurrence of replacement. If the occurrence of the previous replacement of toner container is less than 8, all of the occurrences of replacement are logged.</p>	<p>Count.</p> <p>The total page count at the time of the replacement of the toner container.</p> <p>This is virtually logged as the occurrence of the "Toner Empty" or "Install MK" condition since the replacement of the toner container is not precisely detectable.</p> <p>* :The toner replacement log is triggered by toner empty. This record may contain such a reference as the toner container is inserted twice or a used toner container is inserted.</p>	<p>Item</p> <p>Code of maintenance replacing item (1 byte, 2 categories)</p> <p>First byte (Replacing item) 01: Toner container</p> <p>Second byte (Type of replacing item) 00: Black 01: Cyan 02: Magenta 03: Yellow</p> <p>First byte (Replacing item) 02: Maintenance kit</p> <p>Second byte (Type of replacing item) 01: Fixed (MK-570)</p>
(10)	<p>Unknown Toner Log</p> <p>NOTE: It is not logged if 100 or more counts are not added to the count at the last error.</p>	<p>#</p> <p>Remembers 1 to 5 of occurrence of unknown toner detection.</p> <p>If the occurrence of the previous unknown toner detection is less than 5, all of the unknown toner detection are logged.</p>	<p>Count.</p> <p>The total page count at the time of the "Toner Empty" error with using an unknown toner container.</p>	<p>Item</p> <p>Unknown toner log code (1 byte, 2 categories)</p> <p>First byte 01: Fixed (Toner container)</p> <p>Second byte 00: Black 00: Cyan 00: Magenta 00: Yellow</p>

Service items		Description		
No.	Items	Description		
(11)	<p>Counter Log</p> <p>Comprised of three log counters including paper jams, self diagnostics errors, and replacement of the toner container.</p> <p>NOTE: It is not logged if 100 or more counts are not added to the count at the last error.</p>	<p>(f) Jam</p> <p>Indicates the log counter of paper jams depending on location.</p> <p>Refer to Paper Jam Log.</p> <p>All instances including those are not occurred are displayed.</p>	<p>(g) Self diagnostic error</p> <p>Indicates the log counter of self diagnostics errors depending on cause. (See page 1-4-4)</p> <p>Example C6000: 4</p> <p>Self diagnostics error 6000 has happened four times.</p>	<p>(h) Maintenance item replacing</p> <p>Indicates the log counter depending on the maintenance item for maintenance.</p> <p>T: Toner container 00: Black 00: Cyan 00: Magenta 00: Yellow</p> <p>M: Maintenance kit 00:Fixed (MK-570)</p> <p>Example T00: 1</p> <p>The (black) toner container has been replaced once. This is virtually logged as the occurrence of the "Toner Empty" or "Install MK" condition.</p> <p>* :The toner replacement log is triggered by toner empty. This record may contain such a reference as the toner container is inserted twice or a used toner container is inserted.</p>

This page is intentionally left blank.

1-4-1 Paper misfeed detection

(1) Paper misfeed indication

If the paper jammed in the paper transport system, or no paper sheets were fed at all, the “Paper jam” message appears and the location of the paper jam (the component where the paper jam has occurred) is also indicated. The printer automatically goes off-line when this message is displayed. Remove jammed paper. After removing jammed paper, the printer will re-start printing.

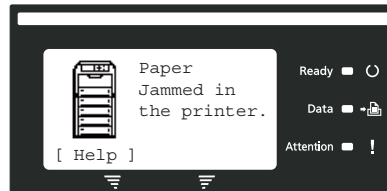

Figure 1-4-1 Paper misfeed indication

(2) Paper misfeed detection condition

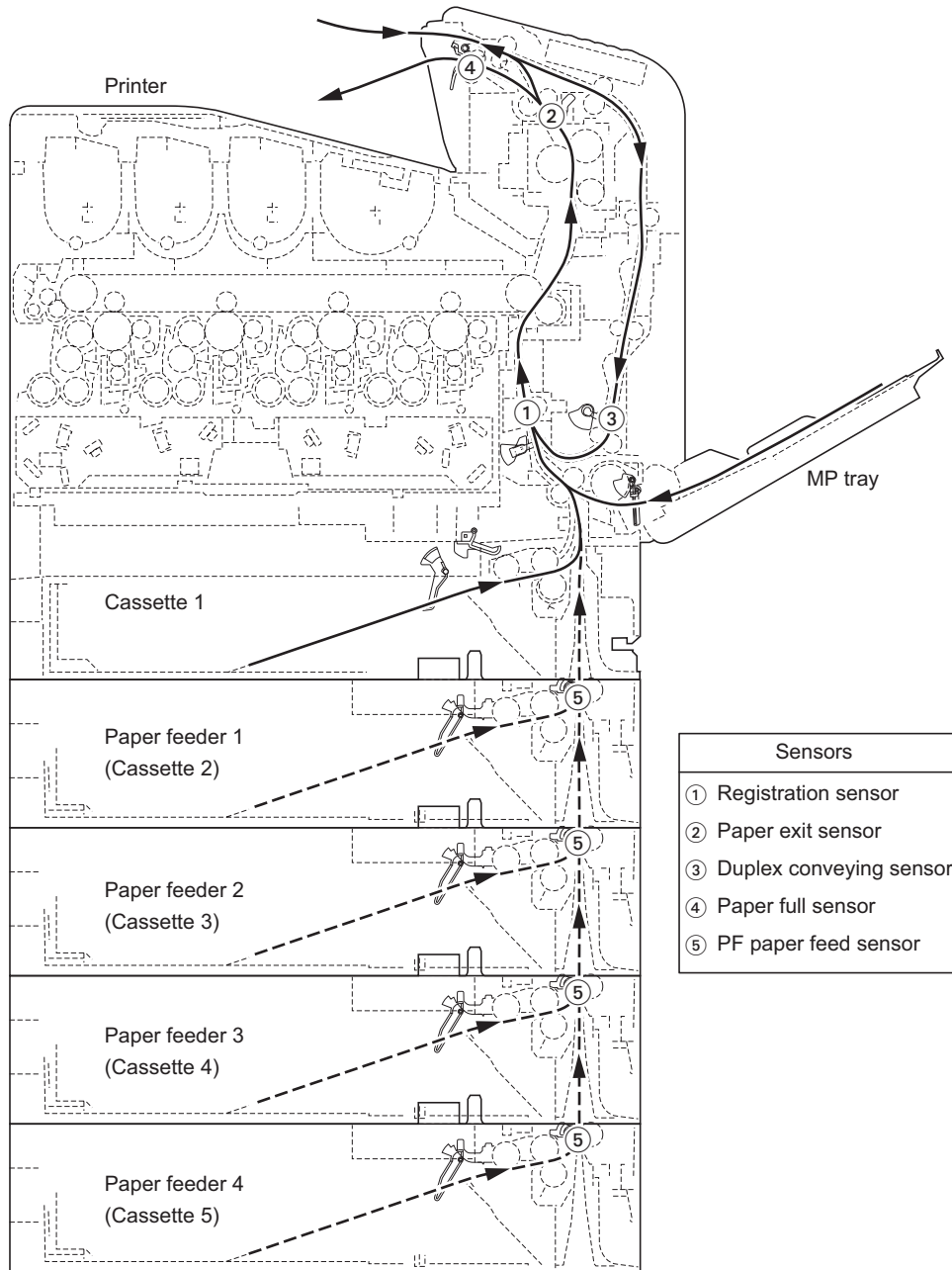

Figure 1-4-2

1-4-2 Self-diagnostic function

(1) Self-diagnostic function

This printer is equipped with self-diagnostic function. When a problem is detected, the printer stops printing and display an error message on the operation panel. An error message consists of a message prompting a contact to service personnel, total print count, and a four-digit error code indicating the type of the error. (The display varies depending on the type of the error.)

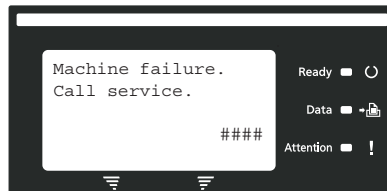

Figure 1-4-3 Self-diagnostic error message

(2) Self diagnostic codes

Code	Contents	Remarks	
		Causes	Check procedures/corrective measures
0100	Backup memory read/write error	Defective main PWB.	Replace the main PWB (See page 1-5-27).
0110	Backup memory data error	Defective main PWB.	Replace the main PWB (See page 1-5-27).
0120	MAC address data error For data in which the MAC address is invalid.	Defective main PWB.	Replace the main PWB (See page 1-5-27).
0150	Engine PWB (EEPROM) error Data read from EEPROM is judged abnormal.	Defective EEPROM.	Replace the engine PWB (See page 1-5-28).
		Defective engine PWB.	Replace the engine PWB (See page 1-5-28).
0170	Billing counting error	Defective main PWB.	Replace the main PWB (See page 1-5-27).
0420	Paper feeder communication error Communication error between engine PWB and optional paper feeder.	Improper installation paper feeder.	Follow installation instruction carefully again.
		Defective harness between PF main PWB (YC3, YC5) and paper feeder interface connector, or improper connector insertion.	Reinsert the connector. Also check for continuity within the connector harness. If none, remedy or replace the harness. (Refer to the service manual for the paper feeder).
		Defective PF main PWB.	Replace the PF main PWB (Refer to the service manual for the paper feeder).
		Defective harness between engine PWB (YC33) and paper feeder interface connector, or improper connector insertion.	Reinsert the connector. Also check for continuity within the connector harness. If none, remedy or replace the harness.
		Defective engine PWB.	Replace the engine PWB (See page 1-5-28).
0600	Expanded memory (DIMM) installing error The expansion memory modules (DIMM) are not correctly mounted.	Improper installation expanded memory (DIMM).	Check the installation of the expanded memory (DIMM) and remedy if necessary (See page 1-2-5).
0610	Expanded memory (DIMM) error The expansion memory modules (DIMM) mounted on the main PWB does not operate correctly.	Defective expanded memory (DIMM).	Replace the expanded memory (DIMM) (See page 1-2-5).
		Defective main PWB.	Replace the main PWB (See page 1-5-27).

Code	Contents	Remarks	
		Causes	Check procedures/corrective measures
0640	Hard disk error	Defective hard disk.	Replace the hard disk (See page 1-2-7).
		Defective main PWB.	Replace the main PWB (See page 1-5-27).
0930	I2C bus error	Defective RFID.	Replace the RFID.
		Defective drum PWB (EEPROM).	Replace the drum unit (See page 1-5-14).
		Defective engine PWB (EEPROM).	Replace the engine PWB (EEPROM) (See page 1-5-28).
		Defective main PWB.	Replace the main PWB (See page 1-5-27).
		Defective engine PWB.	Replace the engine PWB (See page 1-5-28).
1010	<p>Lift motor error</p> <p>When the lift motor is driven, the lift motor over-current detection signal is detected continuously for 50 times (5 s) at 100 ms intervals.</p> <p>After the lift motor is driven, the ON status of lift limit sensor cannot be detected for 8 seconds.</p> <p>The cassette installed confirmation message is displayed on the printer operation panel, and even if the cassette is opened and closed, the cassette installed confirmation message is displayed 5 times successively.</p>	Defective bottom plate elevation mechanism in the cassette.	Check to see if the bottom plate can move smoothly and repair it if any problem is found.
		Defective drive transmission system of the lift motor.	Check if the rollers and gears rotate smoothly. If not, grease the bushings and gears. Check for broken gears and replace if any.
		Defective lift motor.	Replace the lift motor.
		Defective engine PWB.	Replace the engine PWB (See page 1-5-28).
1020 1030 1040 1050	<p>PF lift motor error (Option paper feeder)</p> <p>When the PF lift motor is driven, the PF lift motor over-current detection signal is detected continuously for 50 times (5 s) at 100 ms intervals.</p> <p>After the PF lift motor is driven, the ON status of PF lift limit sensor cannot be detected for 8 seconds.</p> <p>The cassette installed confirmation message is displayed on the printer operation panel, and even if the cassette is opened and closed, the cassette installed confirmation message is displayed 5 times successively.</p> <p>1020: Paper feeder 1 1030: Paper feeder 2 1040: Paper feeder 3 1050: Paper feeder 4</p>	Defective harness between PF lift motor and PF main PWB (YC7), or improper connector insertion.	Reinsert the connector. Also check for continuity within the connector harness. If none, remedy or replace the harness. (Refer to the service manual for the paper feeder).
Defective bottom plate elevation mechanism in the cassette.		Check to see if the bottom plate can move smoothly and repair it if any problem is found.(Refer to the service manual for the paper feeder).	
Defective drive transmission system of the PF lift motor.		Check if the gears rotate smoothly. If not, grease the bushings and gears. Check for broken gears and replace if any.(Refer to the service manual for the paper feeder).	
Defective PF lift motor.		Replace the PF lift motor. (Refer to the service manual for the paper feeder).	
Defective PF lift limit sensor.		Replace the PF main PWB (Refer to the service manual for the paper feeder).	
Defective PF cassette size switch.		Replace the PF cassette size switch.(Refer to the service manual for the paper feeder).	
Defective PF main PWB.		Replace the PF main PWB (Refer to the service manual for the paper feeder).	
Defective engine PWB.		Replace the engine PWB (See page 1-5-28).	

Code	Contents	Remarks	
		Causes	Check procedures/corrective measures
1500 1520 1540 1560	PF warm air heater (upper blower) high temperature error* (Option paper feeder) A temperature higher than 85°C/185°F is detected. *: Multi purpose feeder only 1500: Paper feeder 1 1520: Paper feeder 2 1540: Paper feeder 3 1560: Paper feeder 4	The inlet of upper blower assembly is blocked by paper pieces or the like.	Check visually and remove it, if any (Refer to the service manual for the paper feeder).
		Defective harness between PF warm air fan motor 2 and PF main PWB (YC11), or improper connector insertion.	Reinsert the connector. Also check for continuity within the connector harness. If none, remedy or replace the harness. (Refer to the service manual for the paper feeder).
		Shorted PF thermistor 2.	Replace the PF thermistor 2 (Refer to the service manual for the paper feeder).
		Defective PF warm air fan motor 2.	Replace the PF warm air fan motor 2 (Refer to the service manual for the paper feeder).
		Defective PF main PWB.	Replace the PF main PWB (Refer to the service manual for the paper feeder).
		Defective engine PWB.	Replace the engine PWB (See page 1-5-28).
1510 1530 1550 1570	PF warm air heater (side blower) high temperature error* (Option paper feeder) A temperature higher than 85°C/185°F is detected. *: Multi purpose feeder only 1510: Paper feeder 1 1530: Paper feeder 2 1550: Paper feeder 3 1570: Paper feeder 4	The inlet of side blower assembly is blocked by paper pieces or the like.	Check visually and remove it, if any (Refer to the service manual for the paper feeder).
		Defective harness between PF warm air fan motor 1 and PF main PWB (YC11), or improper connector insertion.	Reinsert the connector. Also check for continuity within the connector harness. If none, remedy or replace the harness. (Refer to the service manual for the paper feeder).
		Shorted PF thermistor 1.	Replace the PF thermistor 1. (Refer to the service manual for the paper feeder).
		Defective PF warm air fan motor 1.	Replace the PF warm air fan motor 1 (Refer to the service manual for the paper feeder).
		Defective PF main PWB.	Replace the PF main PWB (Refer to the service manual for the paper feeder).
		Defective engine PWB.	Replace the engine PWB (See page 1-5-28).

Code	Contents	Remarks	
		Causes	Check procedures/corrective measures
1600 1620 1640 1660	PF warm air heater (upper blower) low temperature error* (Option paper feeder) An external temperature higher than +5°C/+41°F is not detected when one minute elapses after PF warm air heater 2 is turned on. *: Multi purpose feeder only 1600: Paper feeder 1 1620: Paper feeder 2 1640: Paper feeder 3 1660: Paper feeder 4	Defective harness between PF warm air heater 2 and PF warm air heater driver PWB (YC2), or improper connector insertion.	Reinsert the connector. Also check for continuity within the connector harness. If none, remedy or replace the harness. (Refer to the service manual for the paper feeder).
		Defective harness between PF warm air heater driver PWB (YC3) and PF main PWB (YC13), or improper connector insertion.	Reinsert the connector. Also check for continuity within the connector harness. If none, remedy or replace the harness. (Refer to the service manual for the paper feeder).
		Defective harness between PF thermistor 2 and PF main PWB (YC12), or improper connector insertion.	Reinsert the connector. Also check for continuity within the connector harness. If none, remedy or replace the harness. (Refer to the service manual for the paper feeder).
		PF thermistor 2 installed incorrectly.	Check the installation of the PF thermistor 2 and remedy if necessary (Refer to the service manual for the paper feeder).
		Defective PF thermistor 2.	Replace the PF thermistor 2 (Refer to the service manual for the paper feeder).
		PF thermal cutout 2 triggered.	Replace the PF thermal cutout 2 (Refer to the service manual for the paper feeder).
		Broken PF warm air heater 2.	Replace the PF warm air heater 2 (Refer to the service manual for the paper feeder).
		Defective PF warm air heater driver PWB.	Replace the PF warm air driver PWB (Refer to the service manual for the paper feeder).
		Defective PF main PWB.	Replace the PF main PWB (Refer to the service manual for the paper feeder).
		Defective engine PWB.	Replace the engine PWB (See page 1-5-28).

Code	Contents	Remarks	
		Causes	Check procedures/corrective measures
1610 1630 1650 1670	PF warm air heater (side blower) error* (Option paper feeder) An external temperature higher than +5°C/+41°F is not detected when one minute elapses after PF warm air heater 2 is turned on. *: Multi purpose feeder only 1610: Paper feeder 1 1630: Paper feeder 2 1650: Paper feeder 3 1670: Paper feeder 4	Defective harness between PF warm air heater 1 and PF warm air heater driver PWB (YC1), or improper connector insertion.	Reinsert the connector. Also check for continuity within the connector harness. If none, remedy or replace the harness. (Refer to the service manual for the paper feeder).
		Defective harness between PF warm air heater driver PWB (YC3) and PF main PWB (YC13), or improper connector insertion.	Reinsert the connector. Also check for continuity within the connector harness. If none, remedy or replace the harness. (Refer to the service manual for the paper feeder).
		Defective harness between PF thermistor 2 and PF main PWB (YC12), or improper connector insertion.	Reinsert the connector. Also check for continuity within the connector harness. If none, remedy or replace the harness. (Refer to the service manual for the paper feeder).
		PF thermistor 1 installed incorrectly.	Check the installation of the PF thermistor 1 and remedy if necessary (Refer to the service manual for the paper feeder).
		Defective PF thermistor 1.	Replace the PF thermistor 1 (Refer to the service manual for the paper feeder).
		PF thermostat 1 triggered.	Replace the PF thermostat 1 (Refer to the service manual for the paper feeder).
		Broken PF warm air heater 1.	Replace the PF warm air heater 1 (Refer to the service manual for the paper feeder).
		Defective PF warm air heater driver PWB.	Replace the PF warm air driver PWB (Refer to the service manual for the paper feeder).
		Defective PF main PWB.	Replace the PF main PWB (Refer to the service manual for the paper feeder).
		Defective engine PWB.	Replace the engine PWB (See page 1-5-28).

Code	Contents	Remarks	
		Causes	Check procedures/corrective measures
2102	Developing motor MCY error The ready signal cannot be detected within 5 seconds after the developing motor MCY turns on.	Defective harness between developing motor MCY and engine PWB (YC27), or improper connector insertion.	Reinsert the connector. Also check for continuity within the connector harness. If none, remedy or replace the harness.
		Defective drive transmission system of the developing motor MCY.	Check if the gears rotate smoothly. If not, grease the bushings and gears. Check for broken gears and replace if any.
		Defective developing motor MCY.	Replace the developing motor MCY.
		Defective engine PWB.	Replace the engine PWB (See page 1-5-28).
2201	Drum motor K error The ready signal cannot be detected within 5 seconds after the drum motor K turns on.	Defective harness between drum motor K and engine PWB (YC608), or improper connector insertion.	Reinsert the connector. Also check for continuity within the connector harness. If none, remedy or replace the harness.
		Defective drive transmission system of the drum motor K.	Check if the gears rotate smoothly. If not, grease the bushings and gears. Check for broken gears and replace if any.
		Defective drum motor K.	Replace the drum motor K.
		Defective engine PWB.	Replace the engine PWB (See page 1-5-28).
2202	Drum motor C error The ready signal cannot be detected within 5 seconds after the drum motor C turns on.	Defective harness between drum motor C and engine PWB (YC608), or improper connector insertion.	Reinsert the connector. Also check for continuity within the connector harness. If none, remedy or replace the harness.
		Defective drive transmission system of the drum motor C.	Check if the gears rotate smoothly. If not, grease the bushings and gears. Check for broken gears and replace if any.
		Defective drum motor C.	Replace the drum motor C.
		Defective engine PWB.	Replace the engine PWB (See page 1-5-28).

Code	Contents	Remarks	
		Causes	Check procedures/corrective measures
2203	Drum motor M error The ready signal cannot be detected within 5 seconds after the drum motor M turns on.	Defective harness between drum motor M and engine PWB (YC608), or improper connector insertion.	Reinsert the connector. Also check for continuity within the connector harness. If none, remedy or replace the harness.
		Defective drive transmission system of the drum motor M.	Check if the gears rotate smoothly. If not, grease the bushings and gears. Check for broken gears and replace if any.
		Defective drum motor M.	Replace the drum motor M.
		Defective engine PWB.	Replace the engine PWB (See page 1-5-28).
2204	Drum motor Y error The ready signal cannot be detected within 5 seconds after the drum motor Y turns on.	Defective harness between drum motor Y and engine PWB (YC608), or improper connector insertion.	Reinsert the connector. Also check for continuity within the connector harness. If none, remedy or replace the harness.
		Defective drive transmission system of the drum motor Y.	Check if the gears rotate smoothly. If not, grease the bushings and gears. Check for broken gears and replace if any.
		Defective drum motor Y.	Replace the drum motor Y.
		Defective engine PWB.	Replace the engine PWB (See page 1-5-28).
2300	Fuser motor error The ready signal cannot be detected within 5 seconds after the fuser motor turns on.	Defective harness between fuser motor and engine PWB (YC605), or improper connector insertion.	Reinsert the connector. Also check for continuity within the connector harness. If none, remedy or replace the harness.
		Defective drive transmission system of the fuser motor.	Check if the gears rotate smoothly. If not, grease the bushings and gears. Check for broken gears and replace if any.
		Defective fuser motor.	Replace the fuser motor.
		Defective engine PWB.	Replace the engine PWB (See page 1-5-28).

Code	Contents	Remarks	
		Causes	Check procedures/corrective measures
2330	Fuser pressure change motor (over-current) error When the fuser pressure change motor is driven, the fuser pressure change motor over-current detection signal is detected continuously for 8 times (800 ms) at 100 ms intervals.	Defective harness between fuser pressure change motor and engine PWB (YC615), or improper connector insertion.	Reinsert the connector. Also check for continuity within the connector harness. If none, remedy or replace the harness.
		Defective drive transmission system of the fuser pressure change motor.	Check if the gears rotate smoothly. If not, grease the bushings and gears. Check for broken gears and replace if any.
		Defective fuser pressure change motor.	Replace the fuser pressure change motor.
		Defective engine PWB.	Replace the engine PWB (See page 1-5-28).
2340	Fuser pressure change motor (time-out) error After the fuser pressure change motor is driven, the ON status of the fuser pressure change sensor cannot be detected for 6 seconds.	Defective harness between fuser pressure change motor and paper exit PWB (YC8), or improper connector insertion.	Reinsert the connector. Also check for continuity within the connector harness. If none, remedy or replace the harness.
		Defective fuser pressure change sensor.	Replace the fuser pressure change sensor.
		Defective engine PWB.	Replace the engine PWB (See page 1-5-28).
		Defective paper exit PWB.	Replace the paper exit PWB.
2500	Paper feed motor error The main motor ready input is not given for 5 seconds during the main motor is ON.	Defective harness between paper feed motor and engine PWB (YC3), or improper connector insertion.	Reinsert the connector. Also check for continuity within the connector harness. If none, remedy or replace the harness.
		Defective drive transmission system of the paper feed motor.	Check if the rollers and gears rotate smoothly. If not, grease the bushings and gears. Check for broken gears and replace if any.
		Defective paper feed motor.	Replace the paper feed motor.
		Defective engine PWB.	Replace the engine PWB (See page 1-5-28).

Code	Contents	Remarks	
		Causes	Check procedures/corrective measures
2610 2620 2630 2640	PF paper feed motor error (Option paper feeder) The PF paper feed motor of paper feeder 1 ready input is not given for 2 seconds during the PF paper feed motor is ON. 2610: Paper feeder 1 2620: Paper feeder 2 2630: Paper feeder 3 2640: Paper feeder 4	Defective harness between PF paper feed motor and PF main PWB (YC6), or improper connector insertion.	Reinsert the connector. Also check for continuity within the connector harness. If none, remedy or replace the harness (Refer to the service manual for the paper feeder).
		Defective PF paper feed motor drive transmission system.	Check if the gears rotate smoothly. If not, grease the bushings and gears. Check for broken gears and replace if any (Refer to the service manual for the paper feeder).
		Defective PF main motor.	Replace the PF main motor.
		Defective PF main PWB.	Replace the PF main PWB (Refer to the service manual for the paper feeder).
		Defective printer's engine PWB.	Replace the printer's engine PWB (Refer to the service manual for the printer).
2830	Developing motor K error The developing motor K ready input is not given for 5 seconds during the developing motor K is ON.	Defective harness between developing motor K and engine PWB (YC26), or improper connector insertion.	Reinsert the connector. Also check for continuity within the connector harness. If none, remedy or replace the harness.
		Defective drive transmission system of the developing motor K.	Check if the gears rotate smoothly. If not, grease the bushings and gears. Check for broken gears and replace if any.
		Improper installation intermediate transfer unit.	Check the installation of the intermediate transfer unit and reinstall them if necessary (See page 1-5-16).
		Defective developing motor K.	Replace the developing motor K.
		Defective engine PWB.	Replace the engine PWB (See page 1-5-28).
4000	Polygon motor error The polygon motor ready input is not given for 10 seconds during the polygon motor is ON.	Defective harness between polygon motor and engine PWB (YC604), or improper connector insertion.	Reinsert the connector. Also check for continuity within the connector harness. If none, remedy or replace the harness.
		Defective laser scanner unit.	Replace the laser scanner unit (See page 1-5-42).
		Defective engine PWB.	Replace the engine PWB (See page 1-5-28).

Code	Contents	Remarks	
		Causes	Check procedures/corrective measures
4201	Laser output error (Black) The pin photo signal (PDN) is not output from PD PWB Y for one second while laser is emitted.	Defective engine PWB.	Replace the engine PWB (See page 1-5-28).
4202	Laser output error (Cyan) The pin photo signal (PDN) is not output from PD PWB M for one second while laser is emitted.	Defective engine PWB.	Replace the engine PWB (See page 1-5-28).
4203	Laser output error (Magenta) The pin photo signal (PDN) is not output from PD PWB M for one second while laser is emitted.	Defective harness between APC PWB M and engine PWB (YC607), or improper connector insertion.	Reinsert the connector. Also check for continuity within the connector harness. If none, remedy or replace the harness.
		Defective APC PWB M.	Replace the laser scanner unit (See page 1-5-42).
		Defective PD PWB M.	Replace the laser scanner unit (See page 1-5-42).
		Defective engine PWB.	Replace the engine PWB (See page 1-5-28).
4204	Laser output error (Yellow) The pin photo signal (PDN) is not output from PD PWB Y for one second while laser is emitted.	Defective harness between APC PWB Y and engine PWB (YC607), or improper connector insertion.	Reinsert the connector. Also check for continuity within the connector harness. If none, remedy or replace the harness.
		Defective APC PWB Y.	Replace the laser scanner unit (See page 1-5-42).
		Defective PD PWB Y.	Replace the laser scanner unit (See page 1-5-42).
		Defective engine PWB.	Replace the engine PWB (See page 1-5-28).
4600	LSU cleaning motor error When the LSU cleaning motor is driven, the LSU cleaning motor over-current detection signal is detected continuously for 50 times (5 s) at 100 ms intervals.	Defective harness between LSU cleaning motor and engine PWB (YC37), or improper connector insertion.	Reinsert the connector. Also check for continuity within the connector harness. If none, remedy or replace the harness.
		Defective drive transmission system of the LSU cleaning motor.	Check if the rollers and gears rotate smoothly. If not, grease the bushings and gears. Check for broken gears and replace if any.
		Defective LSU cleaning motor.	Replace the LSU cleaning motor.
		Defective engine PWB.	Replace the engine PWB (See page 1-5-28).

Code	Contents	Remarks	
		Causes	Check procedures/corrective measures
4700	VIDEO ASIC device error	Faulty connection of the connector between the main PWB and engine PWB.	Check the installation of the main PWB and engine PWB and reinstall them if necessary (See page 1-5-27 and 1-5-28).
		Defective main PWB.	Replace the main PWB (See page 1-5-27).
		Defective engine PWB.	Replace the engine PWB (See page 1-5-28).
5301	Broken eraser lamp K wire When the eraser lamp K is driven, the eraser lamp K over-current detection signal is detected continuously for 10 times (1 s) at 100 ms intervals.	Defective harness between drum unit K and drum relay PWB (YC3), or improper connector insertion.	Reinsert the connector. Also check for continuity within the connector harness. If none, remedy or replace the harness.
		Defective harness between drum relay PWB (YC1) and engine PWB (YC34), or improper connector insertion.	Reinsert the connector. Also check for continuity within the connector harness. If none, remedy or replace the harness.
		Defective eraser lamp K.	Replace the drum unit K. (See page 1-5-14).
		Defective engine PWB.	Replace the engine PWB (See page 1-5-28).
5302	Broken eraser lamp C wire When the eraser lamp C is driven, the eraser lamp C over-current detection signal is detected continuously for 10 times (1 s) at 100 ms intervals.	Defective harness between drum unit C and drum relay PWB (YC7), or improper connector insertion.	Reinsert the connector. Also check for continuity within the connector harness. If none, remedy or replace the harness.
		Defective harness between drum relay PWB (YC1) and engine PWB (YC34), or improper connector insertion.	Reinsert the connector. Also check for continuity within the connector harness. If none, remedy or replace the harness.
		Defective eraser lamp C.	Replace the drum unit C (See page 1-5-14).
		Defective engine PWB.	Replace the engine PWB (See page 1-5-28).

Code	Contents	Remarks	
		Causes	Check procedures/corrective measures
5303	Broken eraser lamp M wire When the eraser lamp M is driven, the eraser lamp M over-current detection signal is detected continuously for 10 times (1 s) at 100 ms intervals.	Defective harness between drum unit M and drum relay PWB (YC9), or improper connector insertion.	Reinsert the connector. Also check for continuity within the connector harness. If none, remedy or replace the harness.
		Defective harness between drum relay PWB (YC1) and engine PWB (YC34), or improper connector insertion.	Reinsert the connector. Also check for continuity within the connector harness. If none, remedy or replace the harness.
		Defective eraser lamp M.	Replace the drum unit M (See page 1-5-14).
		Defective engine PWB.	Replace the engine PWB (See page 1-5-28).
5304	Broken eraser lamp Y wire When the eraser lamp Y is driven, the eraser lamp Y over-current detection signal is detected continuously for 10 times (1 s) at 100 ms intervals.	Defective harness between drum unit Y and drum relay PWB (YC5), or improper connector insertion.	Reinsert the connector. Also check for continuity within the connector harness. If none, remedy or replace the harness.
		Defective harness between drum relay PWB (YC1) and engine PWB (YC34), or improper connector insertion.	Reinsert the connector. Also check for continuity within the connector harness. If none, remedy or replace the harness.
		Defective eraser lamp Y.	Replace the drum unit Y (See page 1-5-14).
		Defective engine PWB.	Replace the engine PWB (See page 1-5-28).

Code	Contents	Remarks	
		Causes	Check procedures/corrective measures
6000	<p>Broken fuser heater lamp 1 wire</p> <p>The detected fuser thermistor 1 temperature does not rise 1°C/1.8°F after the fuser heater lamp 1 has been turned on continuously for 10 seconds in warming up.</p> <p>The fuser temperature does not reach 100°C/212°F after the fuser heater lamp 1 has been turned on continuously for 40 seconds in warming up.</p> <p>The detected temperature of fuser thermistor 2 does not reach the specified temperature (ready indication temperature) after fuser heater lamp 1 has been turned on continuously for 90 seconds in warming up.</p> <p>The detected temperature of fuser thermistor 2 does not rise 1°C/1.8°F after fuser heater lamp 1 has been turned on continuously for 10 seconds during printing.</p> <p>The detected temperature of fuser thermistor 2 is 120°C/248°F or less continuously for 3 seconds during printing.</p> <p>The detected temperature of fuser thermistor 2 is 100°C/180°F lower than the detected temperature of fuser thermistor 1 continuously for 3 seconds.</p>	Defective harness between fuser thermistor 2 and paper exit PWB (YC5), or improper connector insertion.	Reinsert the connector. Also check for continuity within the connector harness. If none, remedy or replace the harness.
		Defective harness between paper exit PWB (YC1) and engine PWB (YC602), or improper connector insertion.	Reinsert the connector. Also check for continuity within the connector harness. If none, remedy or replace the harness.
		Fuser thermistor 2 installed incorrectly.	Replace the fuser unit (See page 1-5-24).
		Fuser thermal cut-out triggered.	Replace the fuser unit (See page 1-5-24).
		Fuser heater lamp 1 installed incorrectly.	Replace the fuser unit (See page 1-5-24).
		Broken fuser heater lamp 1 wire.	Replace the fuser unit (See page 1-5-24).
		Defective engine PWB.	Replace the engine PWB (See page 1-5-28).

Code	Contents	Remarks	
		Causes	Check procedures/corrective measures
6020	<p>Abnormally high temperature fuser heater lamp 1</p> <p>The fuser thermistor 2 detects a temperature higher than 240°C/464°F.</p> <p>By the activation of the high temperature error detection circuit (230°C/446°F or more) of fuser thermistor 1, the illumination of fuser heater lamp 1 was forcibly turned off and 10 seconds has elapsed.</p>	Shorted fuser thermistor 2.	Replace the fuser unit (See page 1-5-24).
		Defective engine PWB.	Replace the engine PWB (See page 1-5-28).

Code	Contents	Remarks	
		Causes	Check procedures/corrective measures
6030	Broken fuser thermistor 1 wire The detected temperature of fuser thermistor 1 is 60 °C/140°F or more and input from fuser thermistor 2 is 3 or less (A/D value) continuously for 1 second (5.5 ms × 182 times).	Defective harness between fuser thermistor 2 and paper exit PWB (YC5), or improper connector insertion.	Reinsert the connector. Also check for continuity within the connector harness. If none, remedy or replace the harness.
		Defective harness between paper exit PWB (YC1) and engine PWB (YC602), or improper connector insertion.	Reinsert the connector. Also check for continuity within the connector harness. If none, remedy or replace the harness.
		Broken fuser thermistor 2 wire.	Replace the fuser unit (See page 1-5-24).
		Fuser thermistor 2 installed incorrectly.	Replace the fuser unit (See page 1-5-24).
		Fuser thermal cut-out triggered.	Replace the fuser unit (See page 1-5-24).
		Fuser heater lamp 1 installed incorrectly.	Replace the fuser unit (See page 1-5-24).
		Broken fuser heater lamp 1 wire.	Replace the fuser unit (See page 1-5-24).
		Defective engine PWB.	Replace the engine PWB (See page 1-5-28).

Code	Contents	Remarks	
		Causes	Check procedures/corrective measures
6100	<p>Broken fuser heater lamp 2 wire The detected fuser thermistor 2 temperature does not rise 1°C/1.8°F after the fuser heater lamp 2 has been turned on continuously for 5 seconds in warming up. The detected temperature of fuser thermistor 1 does not reach 80°C/176°F after fuser heater lamp 2 has been turned on continuously for 40 seconds in warming up. The detected temperature of fuser thermistor 1 does not rise 1°C/1.8°F after fuser heater lamp 2 has been turned on continuously for 5 seconds during printing. The detected temperature of fuser thermistor 1 is 100°C/180°F lower than the detected temperature of fuser thermistor 2 continuously for 3 seconds.</p>	Defective harness between fuser thermistor 1 and paper exit PWB (YC4), or improper connector insertion.	Reinsert the connector. Also check for continuity within the connector harness. If none, remedy or replace the harness.
		Defective harness between paper exit PWB (YC1) and engine PWB (YC602), or improper connector insertion.	Reinsert the connector. Also check for continuity within the connector harness. If none, remedy or replace the harness.
		Fuser thermistor 1 installed incorrectly.	Replace the fuser unit (See page 1-5-24).
		Fuser thermal cut-out triggered.	Replace the fuser unit (See page 1-5-24).
		Fuser heater lamp 2 installed incorrectly.	Replace the fuser unit (See page 1-5-24).
		Broken fuser heater lamp 2 wire.	Replace the fuser unit (See page 1-5-24).
		Defective engine PWB.	Replace the engine PWB (See page 1-5-28).
6120	<p>Abnormally high temperature fuser heater lamp 2 The fuser thermistor 1 detects a temperature higher than 240°C/464°F. By the activation of the high temperature error detection circuit (230°C/446°F or more) of fuser thermistor 2, the illumination of fuser heater lamp 2 was forcibly turned off and 10 seconds has elapsed.</p>	Shorted fuser thermistor 1.	Replace the fuser unit (See page 1-5-24).
		Defective engine PWB.	Replace the engine PWB (See page 1-5-28).

Code	Contents	Remarks	
		Causes	Check procedures/corrective measures
6130	Broken fuser thermistor 2 wire Input from fuser thermistor 1 is 3 or less (A/D value) continuously for 1 second (5.5 ms × 182 times).	Defective harness between fuser thermistor 1 and paper exit PWB (YC5), or improper connector insertion.	Reinsert the connector. Also check for continuity within the connector harness. If none, remedy or replace the harness.
		Defective harness between paper exit PWB (YC1) and engine PWB (YC602), or improper connector insertion.	Reinsert the connector. Also check for continuity within the connector harness. If none, remedy or replace the harness.
		Broken fuser thermistor 1 wire.	Replace the fuser unit (See page 1-5-24).
		Fuser thermistor 1 installed incorrectly.	Replace the fuser unit (See page 1-5-24).
		Defective engine PWB.	Replace the engine PWB (See page 1-5-28).
6400	Zero cross signal error The zero cross signal (ZCROSS) does not reach the engine PWB for specified time.	Defective harness between power source PWB (YC103) and engine PWB (YC19), or improper connector insertion.	Reinsert the connector. Also check for continuity within the connector harness. If none, remedy or replace the harness.
		Defective power source PWB.	Replace the power source PWB (See page 1-5-25).
		Defective engine PWB.	Replace the engine PWB (See page 1-5-28).

Code	Contents	Remarks	
		Causes	Check procedures/corrective measures
7001	Toner motor K error When the toner motor K is driven, the toner motor K over-current detection signal is detected continuously for 50 times (5 s) at 100 ms intervals.	Defective harness between toner motor K and engine PWB (YC22), or improper connector insertion.	Reinsert the connector. Also check for continuity within the connector harness. If none, remedy or replace the harness.
		Defective drive transmission system of the toner motor K.	Check if the gears rotate smoothly. If not, grease the bushings and gears. Check for broken gears and replace if any.
		Defective toner motor K.	Replace the toner motor K.
		Defective engine PWB.	Replace the engine PWB (See page 1-5-28).
7002	Toner motor C error When the toner motor C is driven, the toner motor C over-current detection signal is detected continuously for 50 times (5 s) at 100 ms intervals.	Defective harness between toner motor C and engine PWB (YC24), or improper connector insertion.	Reinsert the connector. Also check for continuity within the connector harness. If none, remedy or replace the harness.
		Defective drive transmission system of the toner motor C.	Check if the gears rotate smoothly. If not, grease the bushings and gears. Check for broken gears and replace if any.
		Defective toner motor C.	Replace the toner motor C.
		Defective engine PWB.	Replace the engine PWB (See page 1-5-28).
7003	Toner motor M error When the toner motor M is driven, the toner motor M over-current detection signal is detected continuously for 50 times (5 s) at 100 ms intervals.	Defective harness between toner motor M and engine PWB (YC25), or improper connector insertion.	Reinsert the connector. Also check for continuity within the connector harness. If none, remedy or replace the harness.
		Defective drive transmission system of the toner motor M.	Check if the gears rotate smoothly. If not, grease the bushings and gears. Check for broken gears and replace if any.
		Defective toner motor M.	Replace the toner motor M.
		Defective engine PWB.	Replace the engine PWB (See page 1-5-28).

Code	Contents	Remarks	
		Causes	Check procedures/corrective measures
7004	Toner motor Y error When the toner motor Y is driven, the toner motor Y over-current detection signal is detected continuously for 50 times (5 s) at 100 ms intervals.	Defective harness between toner motor Y and engine PWB (YC23), or improper connector insertion.	Reinsert the connector. Also check for continuity within the connector harness. If none, remedy or replace the harness.
		Defective drive transmission system of the toner motor Y.	Check if the gears rotate smoothly. If not, grease the bushings and gears. Check for broken gears and replace if any.
		Defective toner motor Y.	Replace the toner motor Y.
		Defective engine PWB.	Replace the engine PWB (See page 1-5-28).
7401	Developing unit K non-installing error The EEPROM of the developing PWB K does not communicate normally. Incompatible developing unit K is installed.	Faulty connection of the connector between the developing PWB K and drum relay PWB.	Check the installation of the developing unit K and drum relay PWB and reinstall them if necessary (See page 1-5-12).
		Defective harness between drum relay PWB (YC2) and engine PWB (YC619), or improper connector insertion.	Reinsert the connector. Also check for continuity within the connector harness. If none, remedy or replace the harness.
		Installation of incompatible developing unit K.	Install developing unit K compatible with the specifications to the printer.
		Defective toner sensor K.	Replace the developing unit K (See page 1-5-12).
		Defective engine PWB.	Replace the engine PWB (See page 1-5-28).

Code	Contents	Remarks	
		Causes	Check procedures/corrective measures
7402	Developing unit C non-installing error The EEPROM of the developing PWB C does not communicate normally. Incompatible developing unit C is installed.	Faulty connection of the connector between the developing PWB C and drum relay PWB.	Check the installation of the developing unit C and drum relay PWB and reinstall them if necessary (See page 1-5-12).
		Defective harness between drum relay PWB (YC2) and engine PWB (YC619), or improper connector insertion.	Reinsert the connector. Also check for continuity within the connector harness. If none, remedy or replace the harness.
		Installation of incompatible developing unit C.	Install developing unit C compatible with the specifications to the printer.
		Defective toner sensor C.	Replace the developing unit C (See page 1-5-12).
		Defective engine PWB.	Replace the engine PWB (See page 1-5-28).
7403	Developing unit M non-installing error The EEPROM of the developing PWB M does not communicate normally. Incompatible developing unit M is installed.	Faulty connection of the connector between the developing PWB M and drum relay PWB.	Check the installation of the developing unit M and drum relay PWB and reinstall them if necessary (See page 1-5-12).
		Defective harness between drum relay PWB (YC2) and engine PWB (YC619), or improper connector insertion.	Reinsert the connector. Also check for continuity within the connector harness. If none, remedy or replace the harness.
		Installation of incompatible developing unit M.	Install developing unit M compatible with the specifications to the printer.
		Defective toner sensor M.	Replace the developing unit M (See page 1-5-12).
		Defective engine PWB.	Replace the engine PWB (See page 1-5-28).

Code	Contents	Remarks	
		Causes	Check procedures/corrective measures
7404	Developing unit Y non-installing error The EEPROM of the developing PWB Y does not communicate normally. Incompatible developing unit Y is installed.	Faulty connection of the connector between the developing PWB Y and drum relay PWB.	Check the installation of the developing unit Y and drum relay PWB and reinstall them if necessary (See page 1-5-12).
		Defective harness between drum relay PWB (YC2) and engine PWB (YC619), or improper connector insertion.	Reinsert the connector. Also check for continuity within the connector harness. If none, remedy or replace the harness.
		Installation of incompatible developing unit Y.	Install developing unit Y compatible with the specifications to the printer.
		Defective toner sensor Y.	Replace the developing unit Y (See page 1-5-12).
		Defective engine PWB.	Replace the engine PWB (See page 1-5-28).
7411	Drum unit K non-installing error The EEPROM of drum PWB K does not communicate normally. Incompatible drum unit K is installed.	Faulty connection of the connector between the drum PWB K and drum relay PWB.	Check the installation of the developing unit K and drum relay PWB and reinstall them if necessary (See page 1-5-14).
		Defective harness between drum relay PWB (YC1) and engine PWB (YC34), or improper connector insertion.	Reinsert the connector. Also check for continuity within the connector harness. If none, remedy or replace the harness.
		Installation of incompatible drum unit K.	Install drum unit K compatible with the specifications to the printer.
		Defective drum PWB K.	Replace the drum unit Y (See page 1-5-14).
		Defective engine PWB.	Replace the engine PWB (See page 1-5-28).

Code	Contents	Remarks	
		Causes	Check procedures/corrective measures
7412	Drum unit C non-installing error The EEPROM of drum PWB C does not communicate normally. Incompatible drum unit C is installed.	Faulty connection of the connector between the drum PWB C and drum relay PWB.	Check the installation of the developing unit C and drum relay PWB and reinstall them if necessary (See page 1-5-14).
		Defective harness between drum relay PWB (YC1) and engine PWB (YC34), or improper connector insertion.	Reinsert the connector. Also check for continuity within the connector harness. If none, remedy or replace the harness.
		Installation of incompatible drum unit C.	Install drum unit C compatible with the specifications to the printer.
		Defective drum PWB C.	Replace the drum unit C (See page 1-5-14).
		Defective engine PWB.	Replace the engine PWB (See page 1-5-28).
7413	Drum unit M non-installing error The EEPROM of drum PWB M does not communicate normally. Incompatible drum unit M is installed.	Faulty connection of the connector between the drum PWB M and drum relay PWB.	Check the installation of the developing unit M and drum relay PWB and reinstall them if necessary (See page 1-5-14).
		Defective harness between drum relay PWB (YC1) and engine PWB (YC34), or improper connector insertion.	Reinsert the connector. Also check for continuity within the connector harness. If none, remedy or replace the harness.
		Installation of incompatible drum unit M.	Install drum unit M compatible with the specifications to the printer.
		Defective drum PWB M.	Replace the drum unit M (See page 1-5-14).
		Defective engine PWB.	Replace the engine PWB (See page 1-5-28).

Code	Contents	Remarks	
		Causes	Check procedures/corrective measures
7414	Drum unit Y non-installing error The EEPROM of drum PWB Y does not communicate normally. Incompatible drum unit Y is installed.	Faulty connection of the connector between the drum PWB Y and drum relay PWB.	Check the installation of the developing unit Y and drum relay PWB and reinstall them if necessary (See page 1-5-14).
		Defective harness between drum relay PWB (YC1) and engine PWB (YC34), or improper connector insertion.	Reinsert the connector. Also check for continuity within the connector harness. If none, remedy or replace the harness.
		Installation of incompatible drum unit Y.	Install drum unit Y compatible with the specifications to the printer.
		Defective drum PWB Y.	Replace the drum unit Y (See page 1-5-14).
		Defective engine PWB.	Replace the engine PWB (See page 1-5-28).
9530	Backup data error The serial number of the machine written on the EEPROM of the engine PWB differs with that is written on both the flash memory of the engine PWB and the EEPROM of the drum PWB as a backup.	Replacing both the engine PWB and the drum unit at the same time.	Check that the machine operates properly by reverting the engine controller and the drum unit to the old ones. To replace the engine PWB and the drum unit at the same time, turn on the printer after replacing either one. Check that the printer operates properly and then turn off the printer. Replace the other and turn on the printer to check that the printer operates properly. Be sure to replace one by one.
F0 F000	Main PWB - Operation panel PWB communication error	Defective main PWB.	Turn the power switch off/on to restart the printer. If the error is not resolved, replace main PWB (See page 1-5-27).
		Defective operation panel PWB.	Replace the operation panel PWB.
F010	Main PWB checksum error	Defective main PWB.	Turn the power switch off/on to restart the printer.
			In recovery mode, download the controller firmware using a CompactFlash card. In recovery mode, only a CompactFlash card is usable, not a USB memory.
			Replace main PWB (See page 1-5-27).
F020	Main memory or expanded memory checksum error	Defective main memory (RAM) on the main PWB.	Turn the power switch off/on to restart the printer. If the error is not resolved, replace main PWB (See page 1-5-27).
		Defective expansion memory module.	Replace the expansion memory module (See page 1-2-5).
F030	Main PWB general failure	Defective main PWB.	Turn the power switch off/on to restart the printer. If the error is not resolved, replace main PWB (See page 1-5-27).

Code	Contents	Remarks	
		Causes	Check procedures/corrective measures
F040	Main PWB - Engine PWB communication error	Faulty connection of the connector between the main PWB and engine PWB.	Check the installation of the main PWB and engine PWB and reinstall them if necessary (See page 1-5-27 and 1-5-28).
		Defective main PWB.	Turn the power switch off/on to restart the printer. If the error is not resolved, replace main PWB (See page 1-5-27).
		Defective engine PWB.	Replace engine PWB (See page 1-5-28).
F050	Engine PWB ROM checksum error	Some error may have occurred when downloading the firmware of the engine PWB.	Download the firmware of the engine PWB again using the memory card (See page 1-6-4).
		Defective engine PWB.	Turn the power switch off/on to restart the printer. If the error is not resolved, replace engine PWB (See page 1-5-28).
F186	Main PWB video data control error	Defective main PWB.	Turn the power switch off/on to restart the printer. If the error is not resolved, replace main PWB (See page 1-5-27).

1-4-3 Image formation problems

(1) No image appears (entirely white).

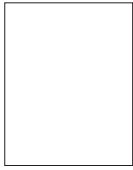

See page 1-4-29

(2) No image appears (entirely black).



See page 1-4-30

(3) A specific color is printed solid.



See page 1-4-30

(4) The back side gets dirty.

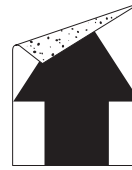

See page 1-4-30

(5) Image is too light.



See page 1-4-31

(6) The background is colored.

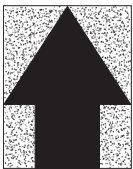

See page 1-4-31

(7) White streaks are printed vertically.



See page 1-4-32

(8) Black streaks are printed vertically.



See page 1-4-32

(9) Streaks are printed horizontally.



See page 1-4-32

(10) Spots are printed.



See page 1-4-32

(11) The leading edge of image begins to print too early or too late.

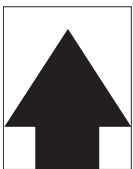

See page 1-4-33

(12) Paper is wrinkled.

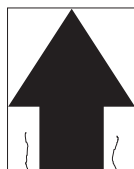

See page 1-4-33

(13) Offset occurs.



See page 1-4-33

(14) Part of image is missing.



See page 1-4-33

(15) Fusing is loose.

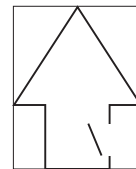

See page 1-4-34

(16) Colors are printed offset to each other.

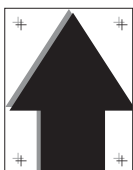

See page 1-4-34

(1) No image appears (entirely white).

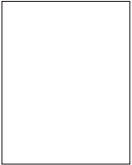
Print example	Causes		Check procedures/corrective measures
	No secondary transfer charging.	Defective harness between high voltage PWB 2 and engine PWB (YC610), or improper connector insertion.	Reinsert the connector. Also check for continuity within the connector harness. If none, remedy or replace the harness.
		Defective high voltage PWB 2.	Replace the high voltage PWB 2 (See page 1-5-41).
		Defective engine PWB.	Replace the engine PWB (See page 1-5-28).
	No primary transfer charging.	Defective harness between high voltage PWB 1 and engine PWB (YC600), or improper connector insertion.	Reinsert the connector. Also check for continuity within the connector harness. If none, remedy or replace the harness.
		Defective high voltage PWB 1.	Replace the high voltage PWB 1 (See page 1-5-34).
		Defective engine PWB.	Replace the engine PWB (See page 1-5-28).
	No laser beam output.	Defective laser scanner unit.	Replace the laser scanner unit (See page 1-5-42).
		Defective engine PWB.	Replace the engine PWB (See page 1-5-28).
	No developing bias output.	Defective harness between high voltage PWB and engine PWB (YC600), or improper connector insertion.	Reinsert the connector. Also check for continuity within the connector harness. If none, remedy or replace the harness.
		Defective high voltage PWB 1.	Replace the high voltage PWB 1 (See page 1-5-34).
		Defective engine PWB.	Replace the engine PWB (See page 1-5-28).
	Defective driving system of developing unit.		Replace the developing unit (See page 1-5-12).
	Image synchronization signal failure.	Defective harness between engine PWB (YC31) and main PWB (YC6), or improper connector insertion.	Reinsert the connector. Also check for continuity within the connector harness. If none, remedy or replace the harness.

(2) No image appears (entirely black).

Print example	Causes		Check procedures/corrective measures
	No main charging.	Defective harness between high voltage PWB and engine PWB (YC600), or improper connector insertion.	Reinsert the connector. Also check for continuity within the connector harness. If none, remedy or replace the harness.
		Defective main charger unit.	Replace the main charger unit or drum unit (See page 1-5-15, 1-5-14).
		Defective high voltage PWB 1.	Replace the high voltage PWB 1 (See page 1-5-34).
		Defective engine PWB.	Replace the engine PWB (See page 1-5-28).
	The laser is activated simultaneously for all colors.	Defective laser scanner unit.	Replace the laser scanner unit (See page 1-5-42).

(3) A specific color is printed solid.

Print example	Causes	Check procedures/corrective measures
	Defective main charger unit which corresponds to the color causing the problem.	Check if the main charger unit is properly seated. If necessary, reseal it properly (See page 1-5-15).
	Disconnected main charger wire.	Replace the main charger unit (See page 1-5-15).
	Laser of laser scanner unit for solid color printing is ON. Defective laser scanner unit.	Replace the laser scanner unit (See page 1-5-42).

(4) The back side gets dirty.

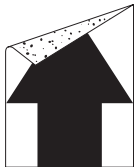
Print example	Causes	Check procedures/corrective measures
	Dirty secondary transfer roller.	Clean the secondary transfer roller.
	Dirty paper conveying path.	Clean the paper conveying path.
	Dirty heat roller and fuser belt.	Clean the heat roller and fuser belt.

(5) Image is too light.

Print example	Causes		Check procedures/corrective measures
	Defective developing bias output.	Defective developing unit.	Replace the developing unit for the color that causes an error (See page 1-5-12).
		Defective high voltage PWB 1.	Replace the high voltage PWB 1 (See page 1-5-34).
		Defective engine PWB.	Replace the engine PWB (See page 1-5-28).
	Dirty drum.		Perform the drum surface refreshing (See page 1-3-10).
	No secondary transfer charging.	Defective harness between high voltage PWB 2 and engine PWB (YC610), or improper connector insertion.	Reinsert the connector. Also check for continuity within the connector harness. If none, remedy or replace the harness.
		Defective high voltage PWB 2.	Replace the high voltage PWB 2 (See page 1-5-41).
		Defective engine PWB.	Replace the engine PWB (See page 1-5-28).
	Defective color calibration.		Perform the color calibration (Refer to operation guide).
	Insufficient toner.		If the display shows the message requesting toner replenishment, replace the container.
	Insufficient agitation of toner container.		Shake the toner container vertically approximately 10 times.
Paper damp.		Check the paper storage conditions, replace the paper.	

(6) The background is colored.

Print example	Causes		Check procedures/corrective measures
	Defective color calibration.		Perform the color calibration (Refer to operation guide).
	Defective developing bias output.	Defective developing unit.	Check the four colors of image by using the test page of service mode. If the defect appears on a particular color, replace the developing unit for that color (See page 1-5-12).
		Defective high voltage PWB 1.	Replace the high voltage PWB 1 (See page 1-5-34).
		Defective engine PWB.	Replace the engine PWB (See page 1-5-28).
	Defective drum surface charging.	Defective drum unit.	Replace the drum unit (See page 1-5-14).
		Defective high voltage PWB 1.	Replace the high voltage PWB 1 (See page 1-5-34).
		Defective engine PWB.	Replace the engine PWB (See page 1-5-28).

(7) White streaks are printed vertically.

Print example	Causes	Check procedures/corrective measures
	Foreign object in one of the developing units.	Check the image by using the test print of service mode. If the white line appears on a particular page, replace the developing unit for that color (See page 1-5-12).
	Adhesion of soiling to transfer belt.	Clean the transfer belt. Replace the intermediate transfer unit (See page 1-5-16).
	Dirty LSU protective glass.	Perform the LSU dust shield glass cleaning (See page 1-3-11).

(8) Black streaks are printed vertically.

Print example	Causes	Check procedures/corrective measures
	Dirty or flawed drum.	Perform the drum surface refreshing (See page 1-3-10). Flawed drum. Replace the drum unit (See page 1-5-14).
	Deformed or worn cleaning blade in the drum unit.	Replace the drum unit (See page 1-5-14).
	Worn transfer belt.	Replace the intermediate transfer unit (See page 1-5-16).
	Dirty MC roller of main charger unit.	Replace the main charger unit (See page 1-5-15).

(9) Streaks are printed horizontally.

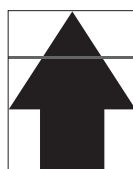
Print example	Causes	Check procedures/corrective measures
	Flawed drum.	Replace the drum unit (See page 1-5-14).
	Dirty developing section.	Clean any part contaminated with toner in the developing section.
	Poor contact of grounding terminal of drum unit.	Check the installation of the drum unit. If it operates incorrectly, replace it (See page 1-5-14).

(10) Spots are printed.

Print example	Causes	Check procedures/corrective measures
	Dirty or flawed drum.	Perform the drum surface refreshing (See page 1-3-10). Flawed drum. Replace the drum unit (See page 1-5-14).
	Deformed or worn cleaning blade in the drum unit.	Replace the drum unit (See page 1-5-14).
	Flawed developing roller.	Replace the developing unit (See page 1-5-12).
	Dirty heat roller and fuser belt.	Clean the heat roller and fuser belt.

(11) The leading edge of image begins to print too early or too late.

Print example	Causes	Check procedures/corrective measures
	Paper feed clutch or registration clutch operating incorrectly.	Check the installation of the clutch. If it operates incorrectly, replace it.

(12) Paper is wrinkled.

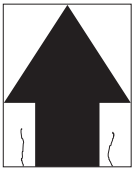
Print example	Causes	Check procedures/corrective measures
	Paper curled.	Check the paper storage conditions, replace the paper.
	Paper damp.	Check the paper storage conditions, replace the paper.

(13) Offset occurs.

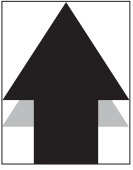
Print example	Causes	Check procedures/corrective measures
	Deformed or worn cleaning blade in the drum unit.	Replace the drum unit (See page 1-5-14).
	Defective transfer belt cleaning.	Replace the intermediate transfer unit (See page 1-5-16).
	Defective fuser unit.	Replace the fuser unit (See page 1-5-24).
	Wrong types of paper.	Check if the paper meets specifications. Replace paper.

(14) Part of image is missing.

Print example	Causes	Check procedures/corrective measures
	Paper damp.	Check the paper storage conditions, replace the paper.
	Paper creased.	Replace the paper.
	Drum condensation.	Perform the drum surface refreshing (See page 1-3-10).
	Dirty or flawed drum.	Perform the drum surface refreshing (See page 1-3-10). Flawed drum. Replace the drum unit (See page 1-5-14).
	Dirty transfer belt.	Clean the transfer belt. Replace the intermediate transfer unit (See page 1-5-16).
	Dirty transfer roller.	Clean the transfer roller. Replace the transfer roller unit (See page 1-5-18).

(15) Fusing is loose.

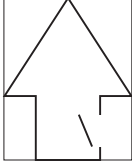
Print example	Causes	Check procedures/corrective measures
	Wrong types of paper.	Check if the paper meets specifications, replace paper.
	Flawed heat roller or fuser belt.	Replace the fuser unit (See page 1-5-24).

(16) Colors are printed offset to each other.

Print example	Causes	Check procedures/corrective measures
	Defective calibration.	Perform the color calibration (Refer to operation guide).
	Slip the mirror position of laser scanner unit.	Perform the color registration. When the problem is not cleared, perform the manual color registration adjustment (Refer to operation guide).

1-4-4 Electric problems

Problem	Causes	Check procedures/corrective measures
(1)The machine does not operate when the power switch is turned on.	The power cord is not plugged in properly.	Check the contact between the power plug and the outlet.
	No electricity at the power outlet.	Measure the input voltage.
	Broken power cord.	Check for continuity. If none, replace the cord.
	Defective power switch.	Check for continuity across the contacts. If none, replace the power switch.
	Defective power source PWB.	Replace the power source PWB (See page 1-5-25).
(2)Drum motor M/C/Y/K, duplex motor, fuser motor and fuser pressure change motor do not operate.	Defective harness or improper connector insertion.	Reinsert the connector. Also check for continuity within the connector harness. If none, remedy or replace the harness. Drum motor M/C/Y/K - Engine PWB (YC18) Duplex motor - Engine PWB (YC17) Fuser motor - Engine PWB (YC39) Fuser pressure change motor - Engine PWB (YC615)
	Broken the gear.	Check visually and replace the gear if necessary.
	Defective motor.	Replace the motor.
	Defective engine PWB.	Replace the engine PWB (See page 1-5-28).
(3)Power source fan motor, ozone fan motor, developing fan motor 1/2, fuser fan motor 1/2, left side fan motor and LSU fan motor do not operate.	Broken the fan motor coil.	Check for continuity across the coil. If none, replace the fan motor.
	Defective harness or improper connector insertion.	Reinsert the connector. Also check for continuity within the connector harness. If none, remedy or replace the harness. Power source fan motor - Engine PWB (YC614) Ozone fan motor - Engine PWB (YC11) Developing fan motor 1 - Engine PWB (YC10) Developing fan motor 2 - Engine PWB (YC618) Fuser fan motor 1 - Paper exit PWB (YC2) Fuser fan motor 2 - Engine PWB (YC612) Left side fan motor - Engine PWB (YC609) LSU fan motor - Engine PWB (YC613)
	Defective engine PWB.	Replace the engine PWB (See page 1-5-28).
(4)Paper feed clutch, registration clutch, developing clutch K, duplex clutch and intermediate clutch do not operate.	Broken clutch coil.	Check for continuity across the coil. If none, replace the clutch.
	Defective harness or improper connector insertion.	Reinsert the connector. Also check for continuity within the connector harness. If none, remedy or replace the harness. Paper feed clutch - Engine PWB (YC26) Registration clutch - Engine PWB (YC26) Developing clutch K - Engine PWB (YC26) Duplex clutch - Engine PWB (YC3) Intermediate clutch - Engine PWB (YC3)
	Defective engine PWB.	Replace the engine PWB (See page 1-5-28).

Problem	Causes	Check procedures/corrective measures
(5)MP paper feed solenoid, ID solenoid, duplex solenoid do not operate.	Broken solenoid coil.	Check for continuity across the coil. If none, replace the solenoid.
	Defective harness or improper connector insertion.	Reinsert the connector. Also check for continuity within the connector harness. If none, remedy or replace the harness. MP paper feed solenoid - Engine PWB (YC40) ID solenoid - Engine PWB (YC617) Duplex solenoid - Engine PWB (YC3)
	Defective engine PWB.	Replace the engine PWB (See page 1-5-28).
(6)Main charging is not performed.	Defective harness or improper connector insertion.	Reinsert the connector. Also check for continuity within the connector harness. If none, remedy or replace the high voltage PWB 1 (See page 1-5-34). High voltage PWB 1 - Engine PWB (YC600)
	Defective main charger unit	Replace the main charger unit (See page 1-5-15).
	Defective high voltage PWB 1.	Replace the high voltage PWB 1 (See page 1-5-34).
	Defective engine PWB.	Replace the engine PWB (See page 1-5-28).
(7)No developing bias is output.	Defective harness or improper connector insertion.	Reinsert the connector. Also check for continuity within the connector harness. If none, remedy or replace the high voltage PWB 1 (See page 1-5-34). High voltage PWB 1 - Engine PWB (YC600)
	Defective high voltage PWB 1.	Replace the high voltage PWB 1 (See page 1-5-34).
	Defective engine PWB.	Replace the engine PWB (See page 1-5-28).
(8)Transfer charging is not performed.	Defective harness or improper connector insertion.	Reinsert the connector. Also check for continuity within the connector harness. If none, remedy or replace the high voltage PWB 2 (See page 1-5-41). High voltage PWB 2 - Engine PWB (YC610)
	Defective high voltage PWB 2.	Replace the high voltage PWB 2 (See page 1-5-41).
	Defective engine PWB.	Replace the engine PWB (See page 1-5-28).
(9)The message requesting paper to be loaded is shown when paper is present in the cassette.	Defective paper sensor 1/2.	Replace the engine PWB (See page 1-5-28).
	Broken paper sensor 1/2 actuator.	Check the bending of the actuator lever of the paper sensor 1/2 if there is trouble, remedy or replace.
	Defective engine PWB.	Replace the engine PWB (See page 1-5-28).
(10)The message requesting paper to be loaded is shown when paper is present in the MP tray.	Defective harness or improper connector insertion.	Reinsert the connector. Also check for continuity within the connector harness. If none, remedy or replace the harness. MP tray sensor - Engine PWB (YC21)
	Defective MP tray sensor.	Replace the MP tray sensor.
	Defective engine PWB.	Replace the engine PWB (See page 1-5-28).
(11)The size of paper in the cassette is not displayed correctly.	Defective harness or improper connector insertion.	Reinsert the connector. Also check for continuity within the connector harness. If none, remedy or replace the harness. Cassette size switch - Engine PWB (YC9)
	Defective cassette size switch.	Replace the cassette size switch.
	Defective engine PWB.	Replace the engine PWB (See page 1-5-28).

Problem	Causes	Check procedures/corrective measures
(12)A paper jam in the paper feed section, paper conveying section, fuser section or duplex section is indicated when the power switch is turned on.	A piece of paper torn from copy paper is caught around registration switch, duplex conveying sensor or paper exit sensor.	Check and remove if any.
	Defective registration sensor or duplex conveying sensor.	Replace the registration sensor or duplex conveying sensor.
	Defective paper exit sensor.	Replace the paper exit PWB.
	Defective engine PWB.	Replace the engine PWB (See page 1-5-28).
(13)The message requesting front cover to be closed is displayed when the front cover is closed.	Defective harness or improper connector insertion.	Reinsert the connector. Also check for continuity within the connector harness. If none, remedy or replace the harness. Front cover open/close switch - Paper exit PWB (YC6) Paper exit PWB (YC1) - Engine PWB (YC602)
	Defective front cover open/close switch.	Replace the front cover open/close switch.
	Defective paper exit PWB.	Replace the paper exit PWB.
	Defective engine PWB.	Replace the engine PWB (See page 1-5-28).
(14)The message requesting cover to be closed is displayed when the top cover is closed.	Defective harness or improper connector insertion.	Reinsert the connector. Also check for continuity within the connector harness. If none, remedy or replace the harness. Interlock switch - Engine PWB (YC13)
	Defective interlock switch.	Replace the interlock switch.
	Defective engine PWB.	Replace the engine PWB (See page 1-5-28).
(15)The message requesting left cover to be closed is displayed when the left cover is closed.	Defective harness or improper connector insertion.	Reinsert the connector. Also check for continuity within the connector harness. If none, remedy or replace the harness. Left cover switch - Engine PWB (YC14)
	Defective left cover switch.	Replace the left cover switch.
	Defective engine PWB.	Replace the engine PWB (See page 1-5-28).
(16)Defective waste toner box detecting.	Defective harness or improper connector insertion.	Reinsert the connector. Also check for continuity within the connector harness. If none, remedy or replace the harness. Waste toner full sensor - Engine PWB (YC12)
	Defective waste toner full sensor.	Replace the waste toner full sensor.
	Defective engine PWB.	Replace the engine PWB (See page 1-5-28).
(17)Others.	Wiring is broken, shorted or makes poor contact.	Check for continuity. If none, repair.

1-4-5 Mechanical problems

Problem	Causes/check procedures	Corrective measures
(1)No primary paper feed.	Check if the surfaces of the paper feed roller, MP paper feed roller are dirty with paper powder.	Clean with isopropyl alcohol.
	Check if the paper feed roller, MP paper feed roller are deformed.	Check visually and replace any deformed rollers (See page 1-5-8 and 1-5-11).
	Defective paper feed clutch installation.	Check visually and remedy if necessary.
(2)No secondary paper feed.	Check if the surfaces of the upper and lower registration rollers are dirty with paper powder.	Clean with isopropyl alcohol.
	Defective registration clutch installation.	Check visually and remedy if necessary.
(3)Skewed paper feed.	Width guide in a cassette installed incorrectly.	Check the width guide visually and correct or replace if necessary.
	Deformed width guide in a cassette.	Repair or replace if necessary.
	Defective MP tray slider installation.	Check the slider visually and correct or replace if necessary.
	Deformed MP tray slider.	Check visually and replace any deformed slider.
(4)Multiple sheets of paper are fed at one time.	Check if the paper is curled.	Replace the paper.
	Paper is not placed correctly in the cassette.	Set the paper correctly.
	Check if the retard roller is worn.	Replace the retard roller pulley if it is worn.
	Check if the separator pad or MPF separation pad (duplex model only) is worn.	Replace the separator pad if it is worn (See page 1-5-11).
(5)Paper jams.	Check if the paper is excessively curled.	Replace the paper.
	Check if the contact between the front and rear registration rollers is correct.	Check visually and remedy if necessary.
	Check if the heat roller or press roller is extremely dirty or deformed.	Replace the fuser unit (See page 1-5-24).
(6)Toner drops on the paper conveying path.	Check if the drum unit or developing unit is extremely dirty.	Clean the drum unit or developing unit.
(7)Abnormal noise is heard.	Check if the pulleys, rollers and gears operate smoothly.	Grease the bearings and gears.
	Check if the following electromagnetic clutches are installed correctly:	Check visually and remedy if necessary.

1-5-1 Precautions for assembly and disassembly

(1) Precautions

Be sure to turn the power switch off and disconnect the power plug before starting disassembly.

When handling PWBs, do not touch connectors with bare hands or damage the PWB.

Use only the specified parts to replace the fuser unit thermostat. Never substitute electric wires, as the machine may be seriously damaged.

Do not touch any PWB containing ICs with bare hands or any object prone to static charge.

When removing the hook of the connector, be sure to release the hook.

Take care not to get the wire caught.

(2) Drum

Note the following when handling or storing the drum.

When removing the drum unit, never expose the drum surface to strong direct light.

Keep the drum at an ambient temperature between 0 °C/32 °F and 40 °C/104 °F and at a relative humidity not higher than 90% RH. Avoid abrupt changes in temperature and humidity.

Avoid exposure to any substance which is harmful to or may affect the quality of the drum.

Do not touch the drum surface with any object. Should it be touched by hands or stained with oil, clean it.

(3) Toner container

Store the toner container(s) in a cool, dark place.

Avoid direct light and high humidity.

(4) How to tell a genuine Kyocera toner container

As a means of brand protection, the Kyocera toner container utilizes an optical security technology to enable visual validation. A validation viewer is required to accomplish this.

Hold the validation viewer over the left side part of the brand protection seal on the toner container. Through each window of the validation viewer, the left side part of the seal should be seen as follows:

A black-colored band when seen through the left side window (●)

A shiny or gold-colored band when seen through the right side window (☀)

The above will reveal that the toner container is a genuine Kyocera branded toner container, otherwise, it is a counterfeit.

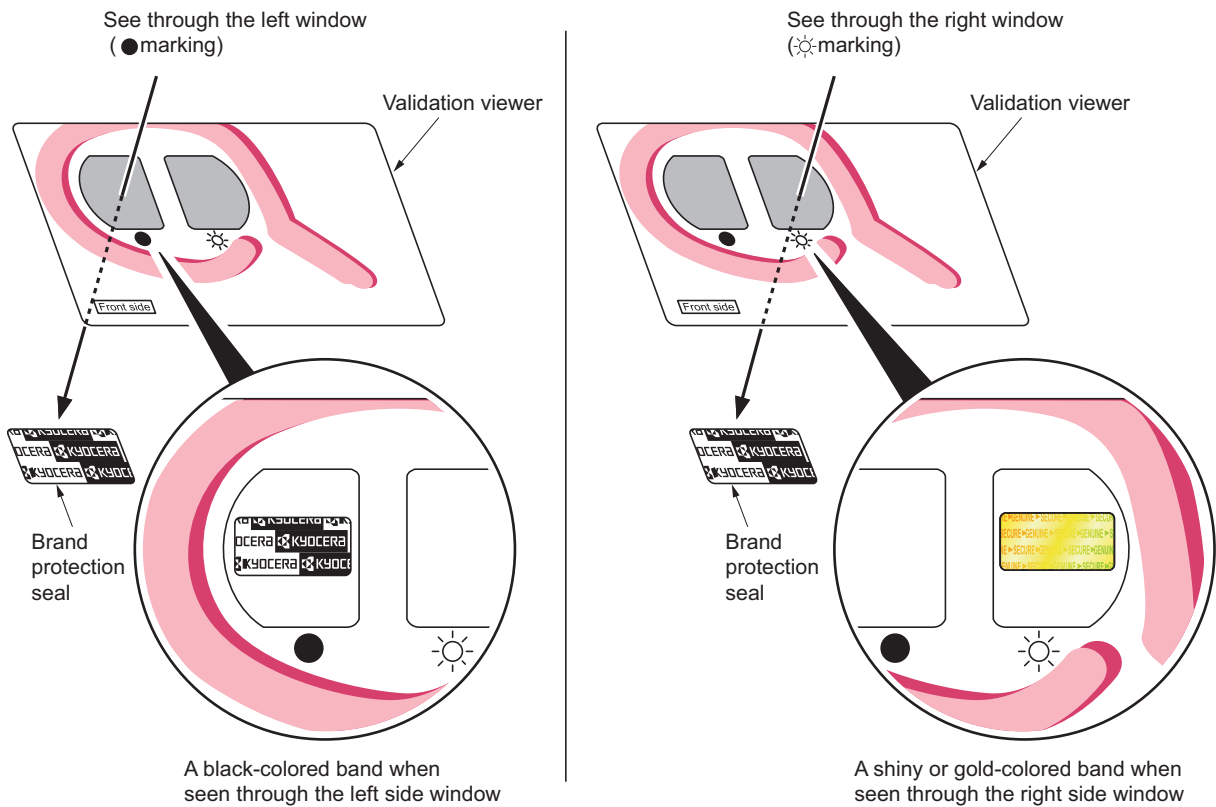

Figure 1-5-1

The brand protection seal has an incision as shown below to prohibit reuse.

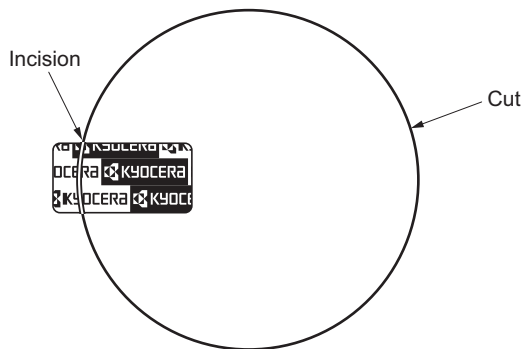

Figure 1-5-2

1-5-2 Outer covers

(1) Detaching and refitting the left rear cover, left upper cover and left front cover

Procedure

1. Open the left cover.
2. Remove the waste toner box.
3. Remove three screws.

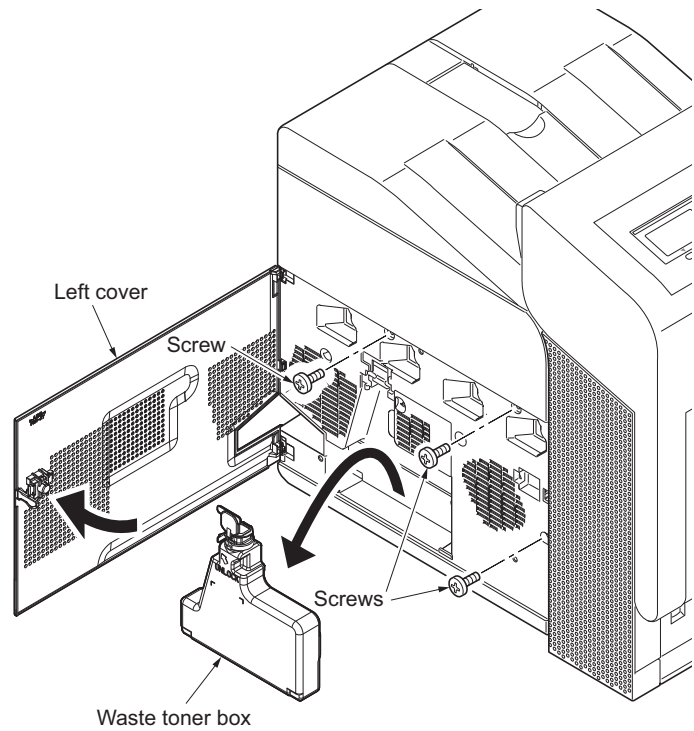

Figure 1-5-3

- 4. Open the top cover.
- 5. Release eight hooks and then remove the left rear cover.

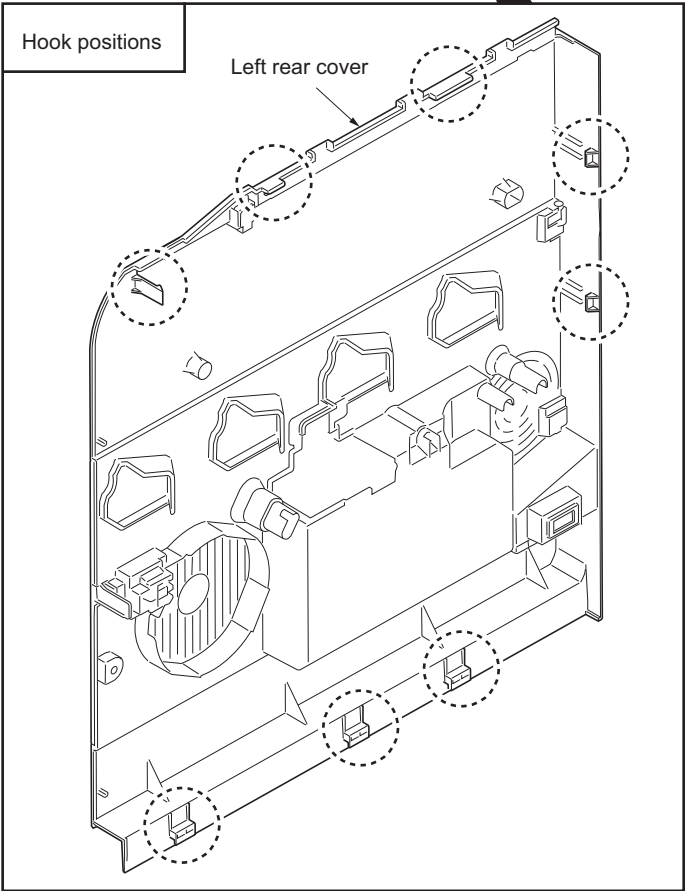
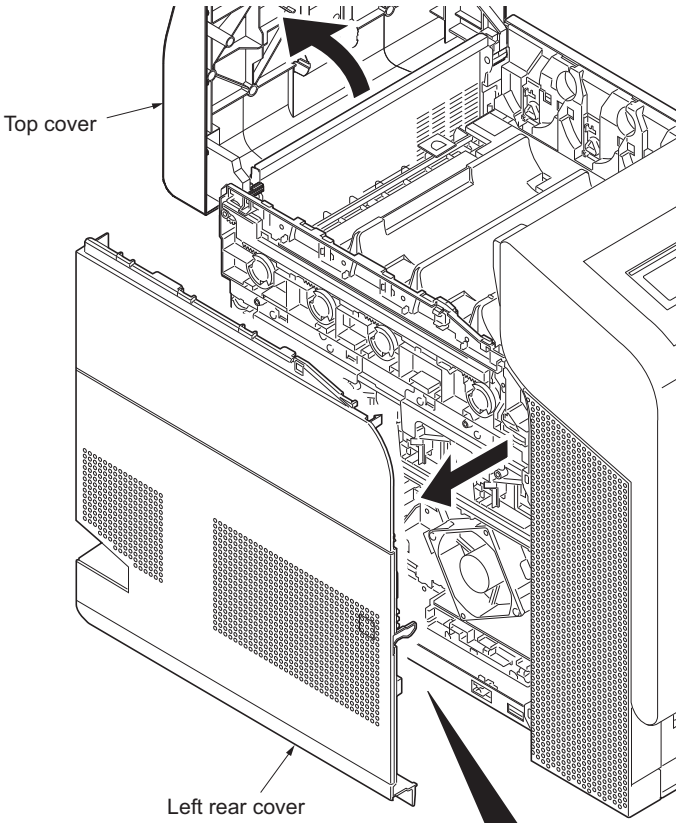

Figure 1-5-4

6. Open the front cover.
7. Remove the screw and then remove the left upper cover.
8. Slide the left front cover upward and then remove it.

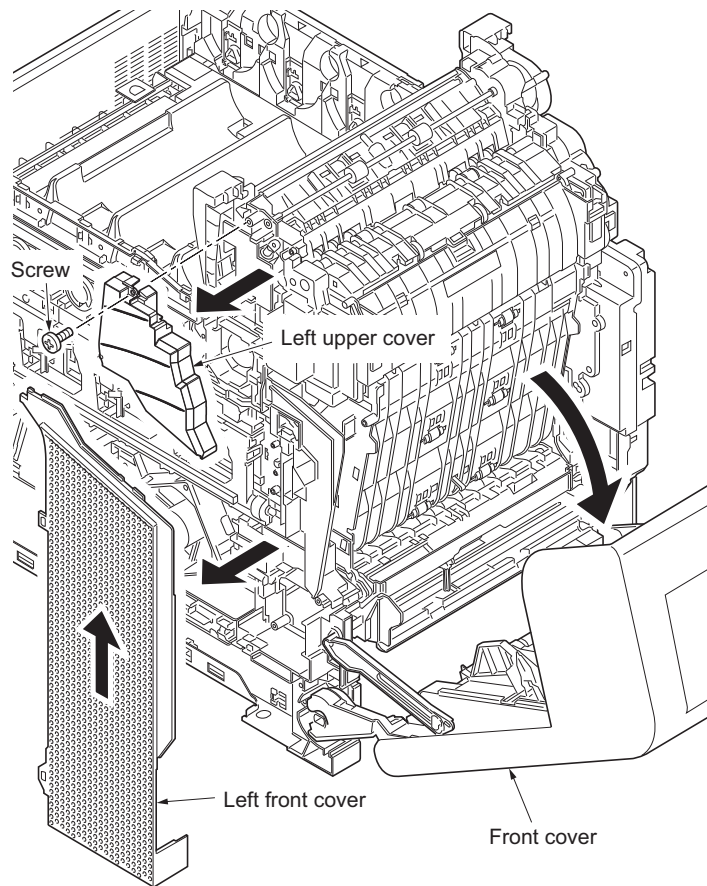
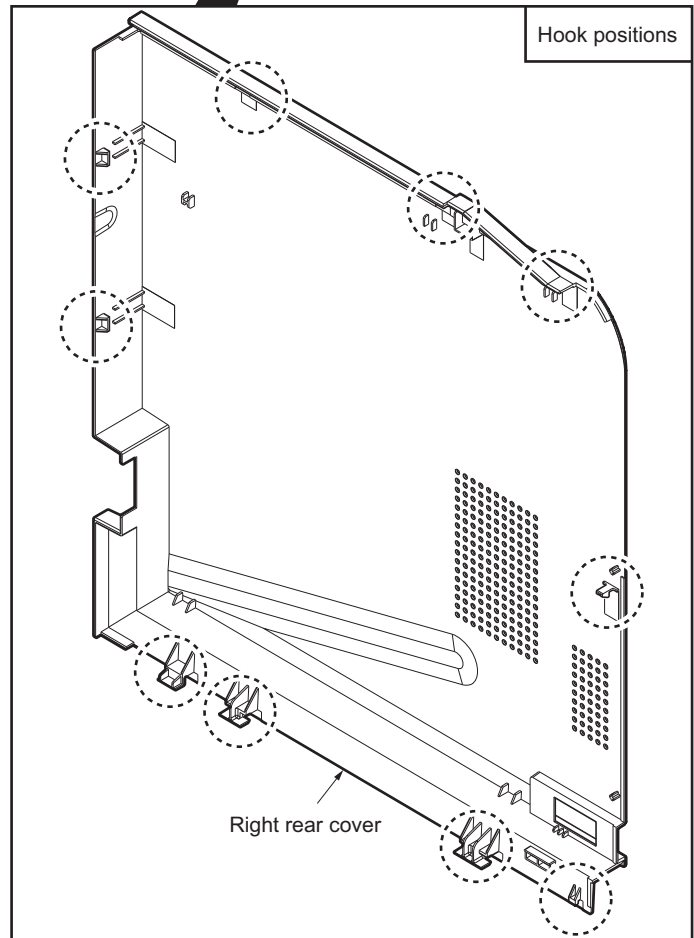
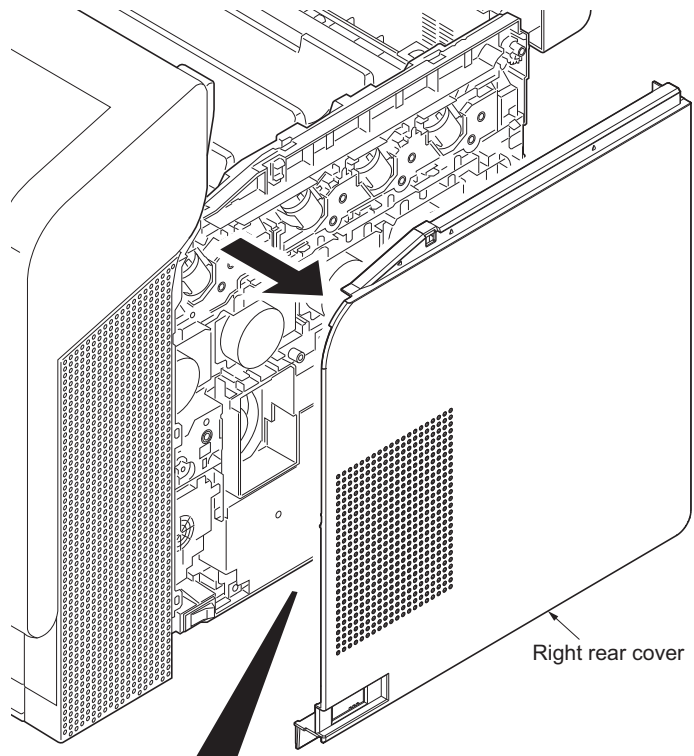

Figure 1-5-5

(2) Detaching and refitting the right rear cover, right upper cover and right front cover**Procedure**

1. Open the top cover.
2. Release ten hooks and then remove the right rear cover.

**Figure 1-5-6**

3. Open the front cover.
4. Remove two screws and then remove the right upper cover.
5. Slide the right front cover and then remove it.

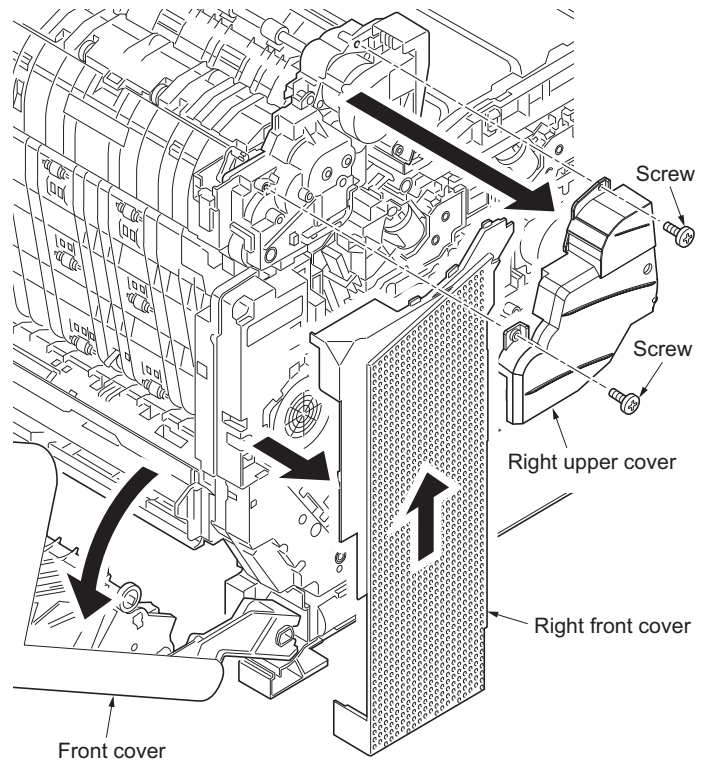

Figure 1-5-7

1-5-3 Paper feed section

(1) Detaching and refitting the paper feed roller assembly (paper feed roller and pickup roller)

Procedure

1. Remove the cassette.

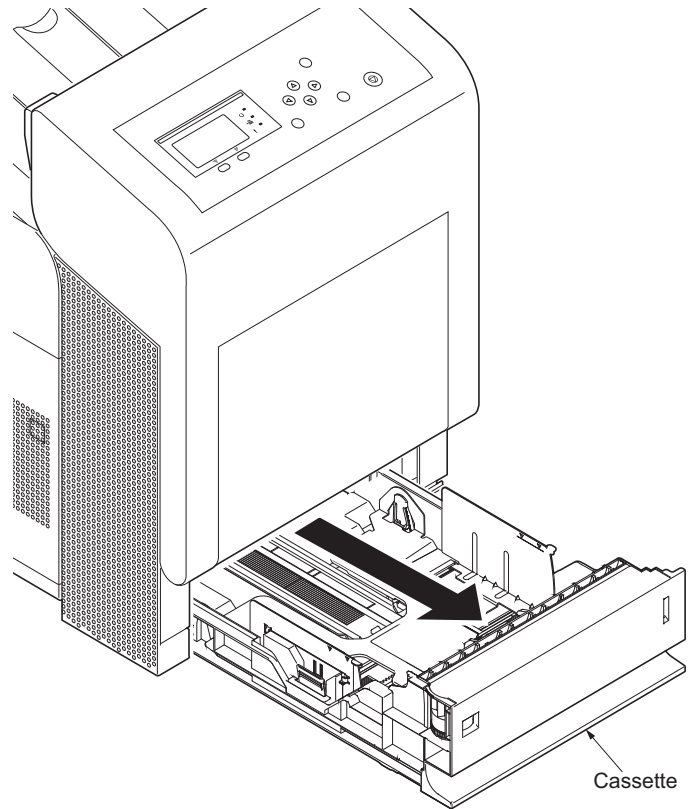

Figure 1-5-8

2. While pressing lever A and then slide the feed roller pin.
3. While pressing the lever B and then remove the paper feed roller assembly.

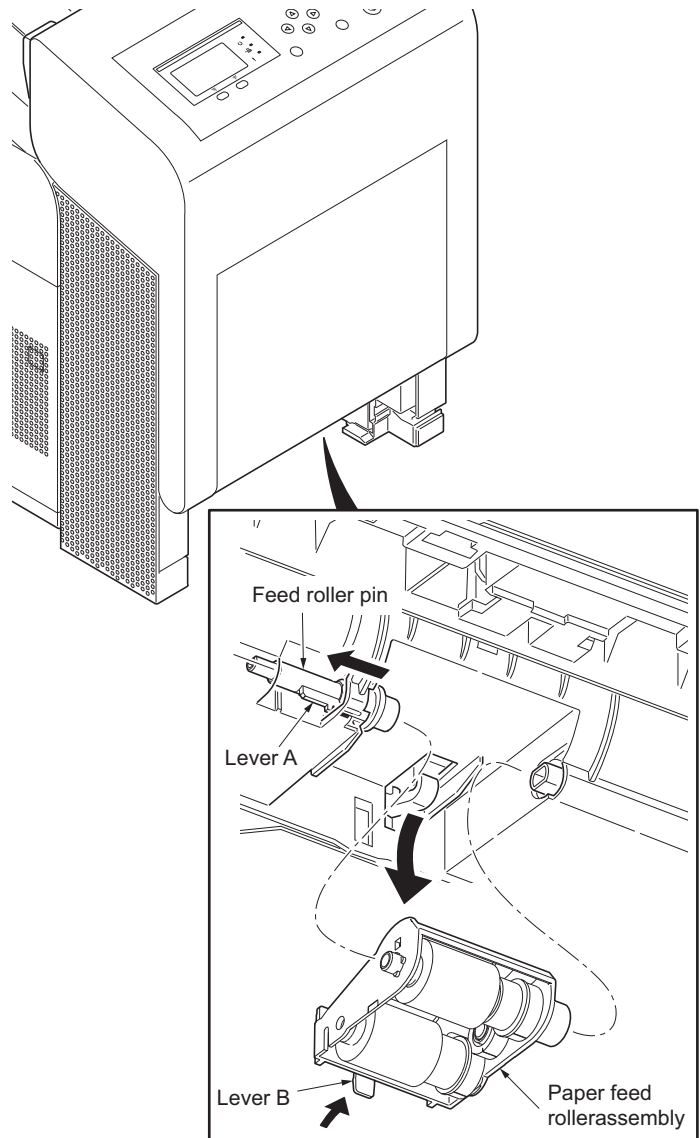

Figure 1-5-9

4. Check or replace the paper feed roller assembly and refit all the removed parts.

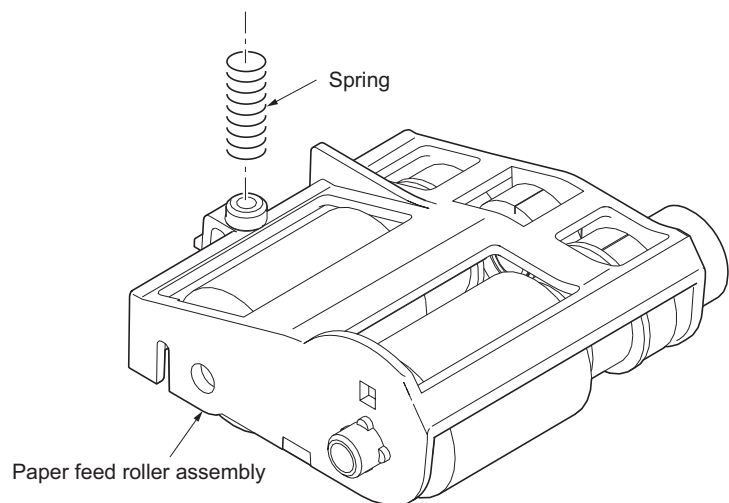
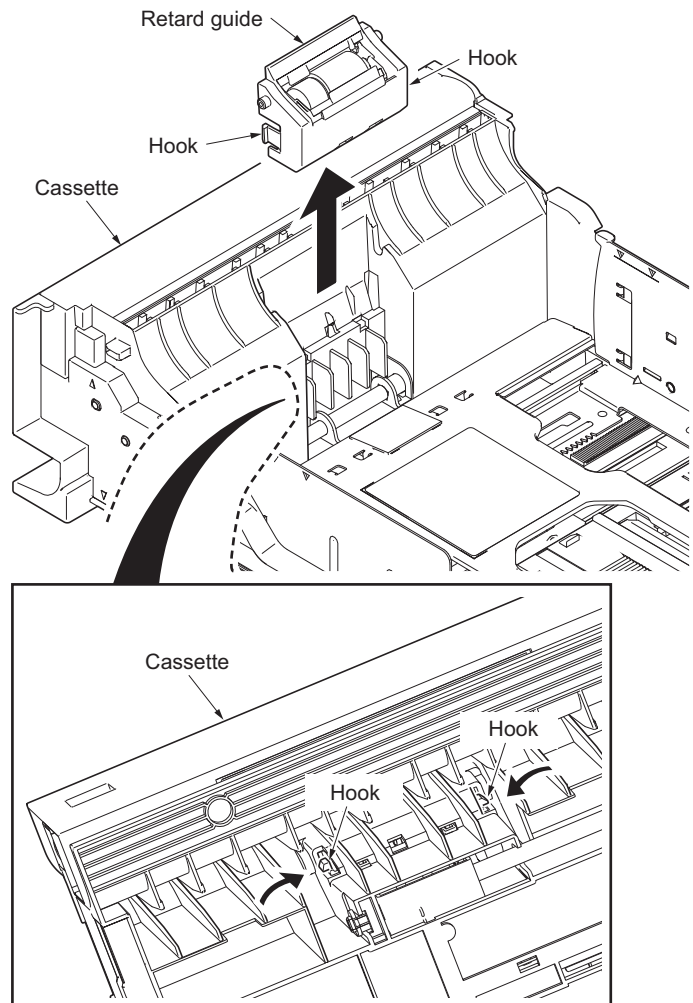

Figure 1-5-10

(2) Detaching and refitting the retard roller**Procedure**

1. Remove the cassette (See page 1-5-8).
2. Push the bottom plate down until it locks.
3. Release two hooks and then remove the retard guide (retard roller assembly).

**Figure 1-5-11**

4. Remove the retard roller assembly.
5. Check or replace the retard roller assembly and refit all the removed parts.

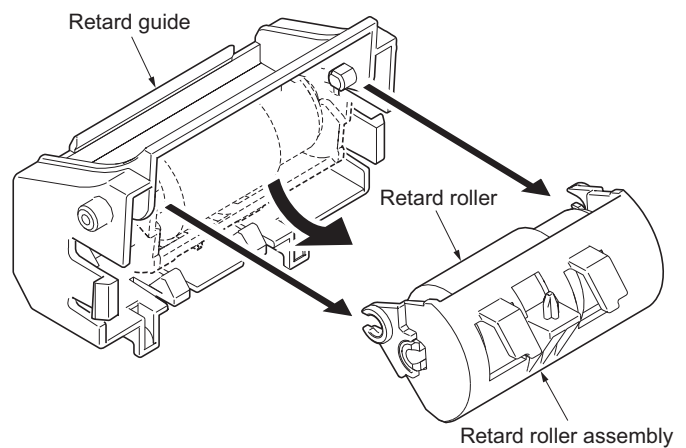
**Figure 1-5-12**

(3) Detaching and refitting the MP paper feed roller**Procedure**

1. Open the front cover.
2. While releasing the hook and the slide the MPF shaft.
3. Remove the MP paper feed roller.
4. Check or replace the MP paper feed roller and refit all the removed parts.

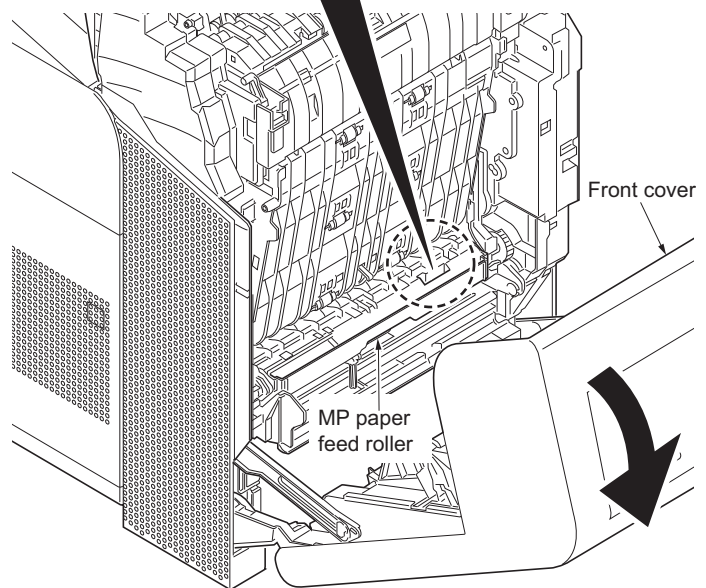
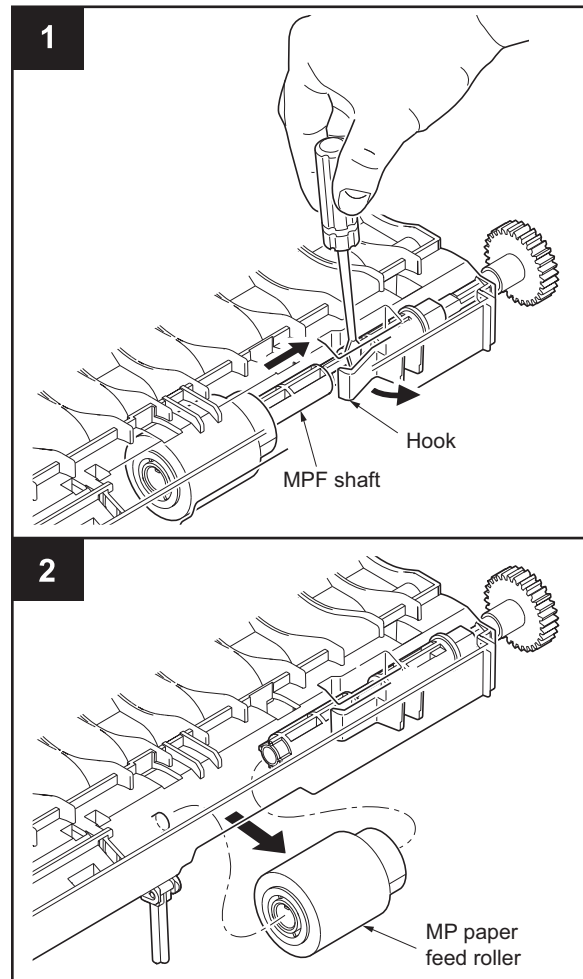
**Figure 1-5-13**

1-5-4 Developing section

(1) Detaching and refitting the developing unit

Procedure

1. Remove the intermediate transfer unit (See page 1-5-16).
2. Remove the drum unit (M,C,Y and K) (See page 1-5-14).
3. Pinch the lever of developing unit to release the lock.
4. Hold the grips and then remove the developing unit (M,C,Y and K).

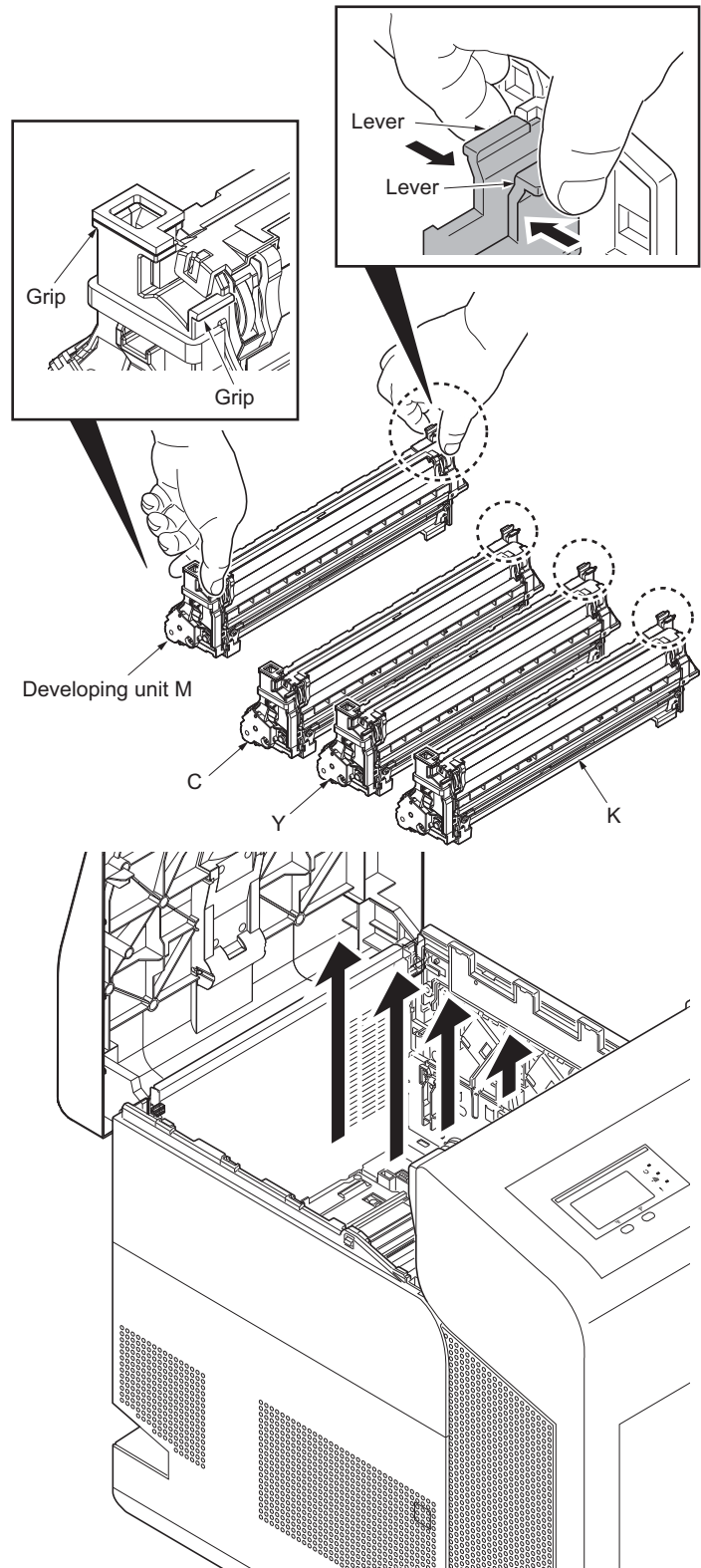
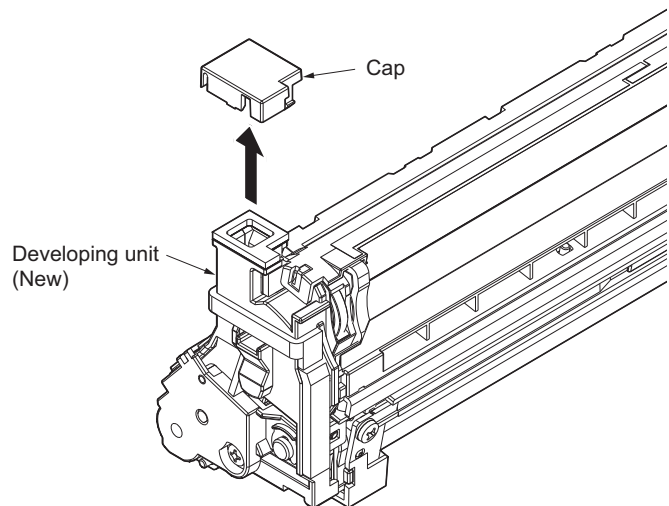

Figure 1-5-14

5. Check or replace the developing unit and refit all the removed parts.

NOTE:

Remove the cap before installing the new developing unit.



When reinstalling the developing unit, press it down until the lever of developing unit is engaged with the notch.

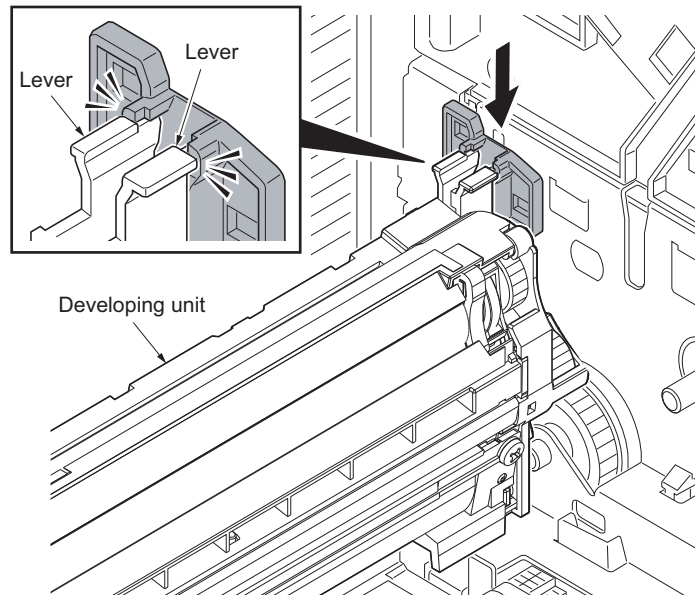

Figure 1-5-15

1-5-5 Drum section

(1) Detaching and refitting the drum unit

Procedure

1. Remove the intermediate transfer unit (See page 1-5-16).
2. Hold the grips and then remove the drum unit (M,C,Y and K).
3. Check or replace the drum unit and refit all the removed parts.

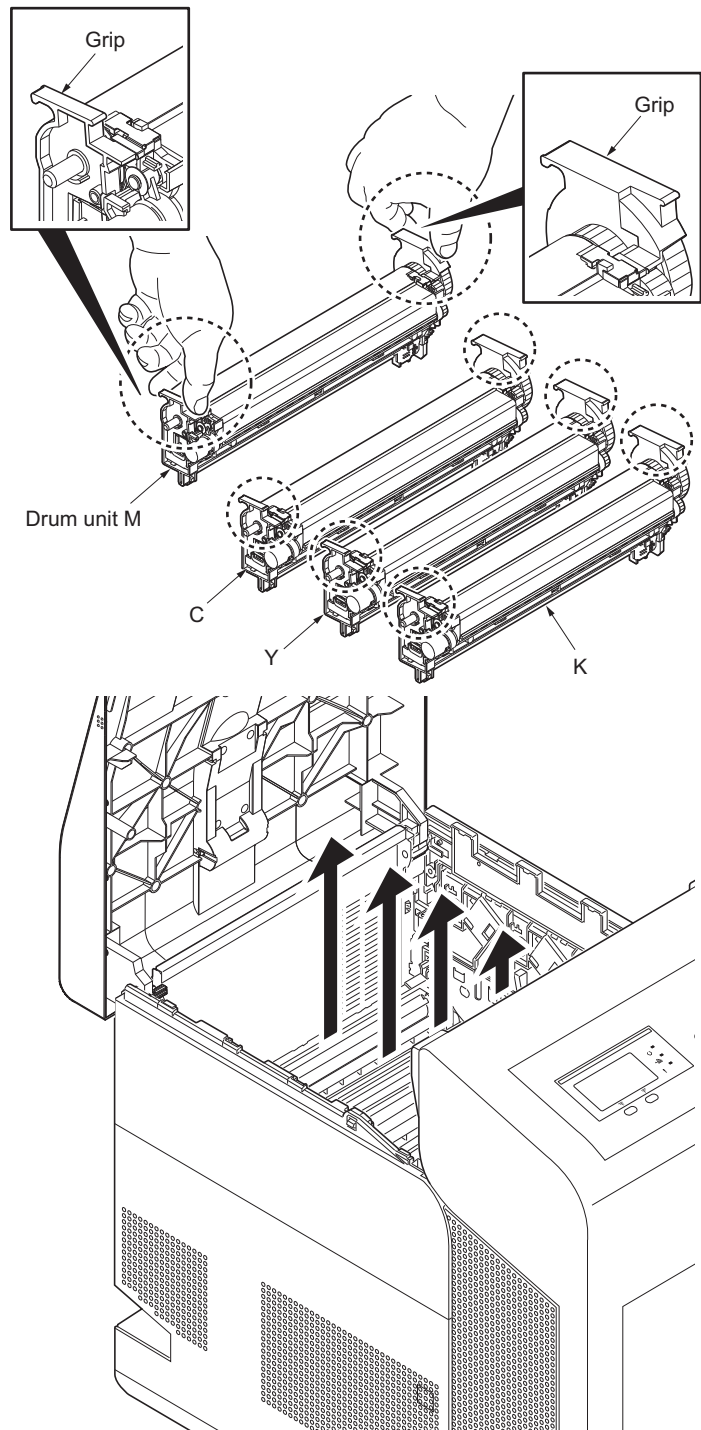

Figure 1-5-16

(2) Detaching and refitting the main charger unit

Procedure

1. Open the left cover.
2. Remove the screw and then remove the main charger unit (M,C,Y and K).
3. Check or replace the main charger unit and refit all the removed parts.

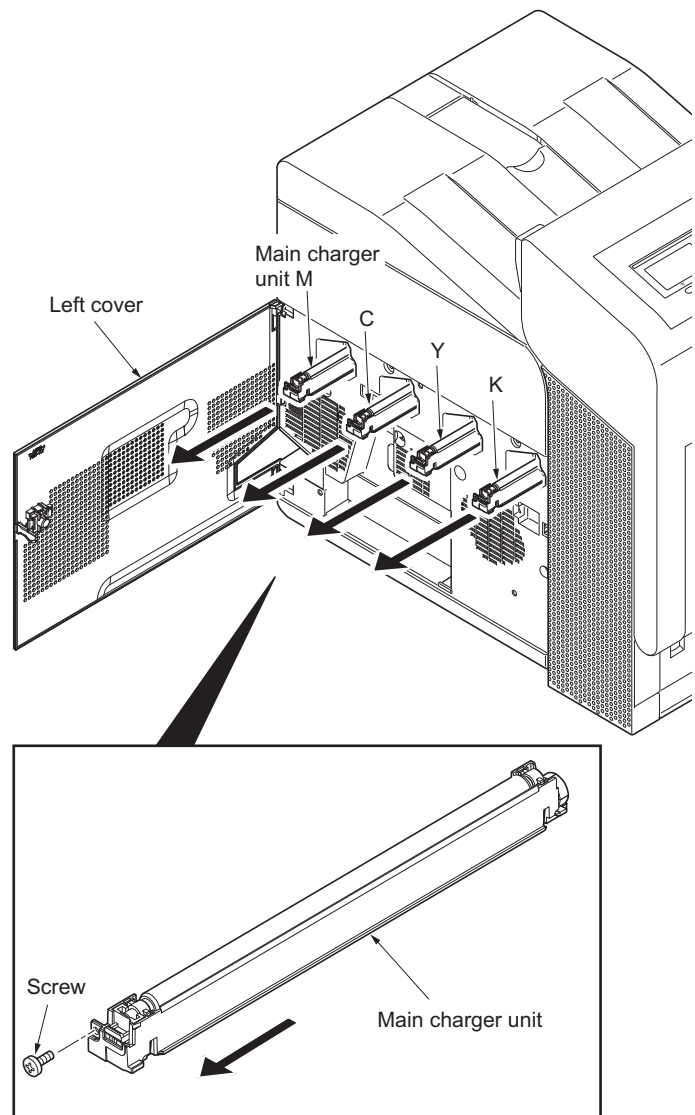

Figure 1-5-17

1-5-6 Transfer/separation section

(1) Detaching and refitting the intermediate transfer unit

Procedure

1. Open the top cover.
2. Remove the all toner containers (M,C,Y and K).

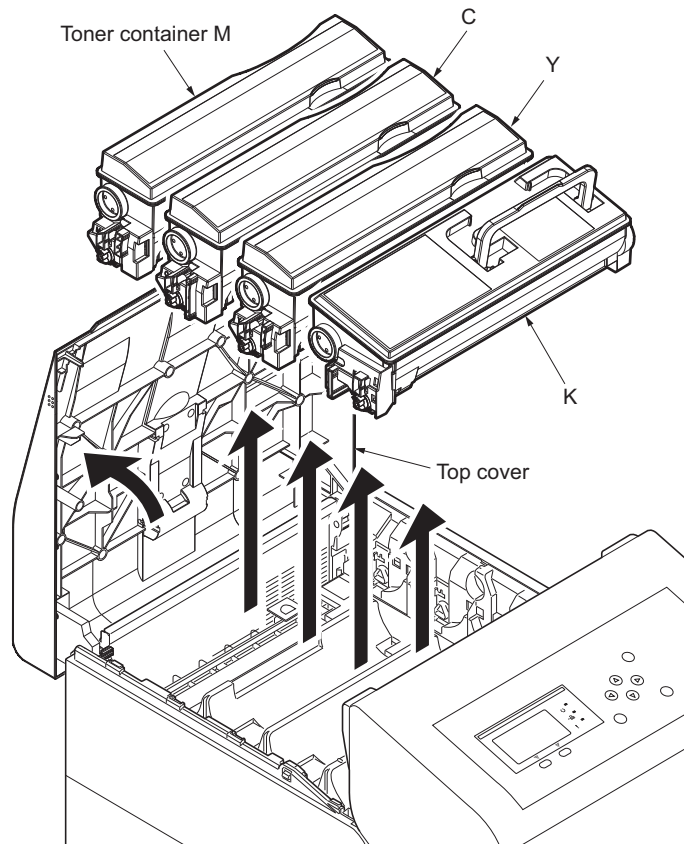

Figure 1-5-18

3. Remove the all container guides (M,C,Y and K).

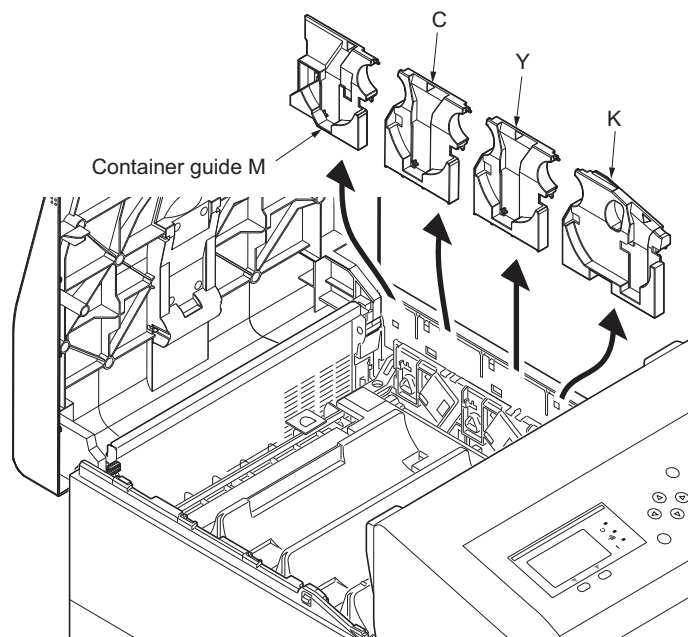

Figure 1-5-19

4. Remove two screws.
5. Open the RFID holder.

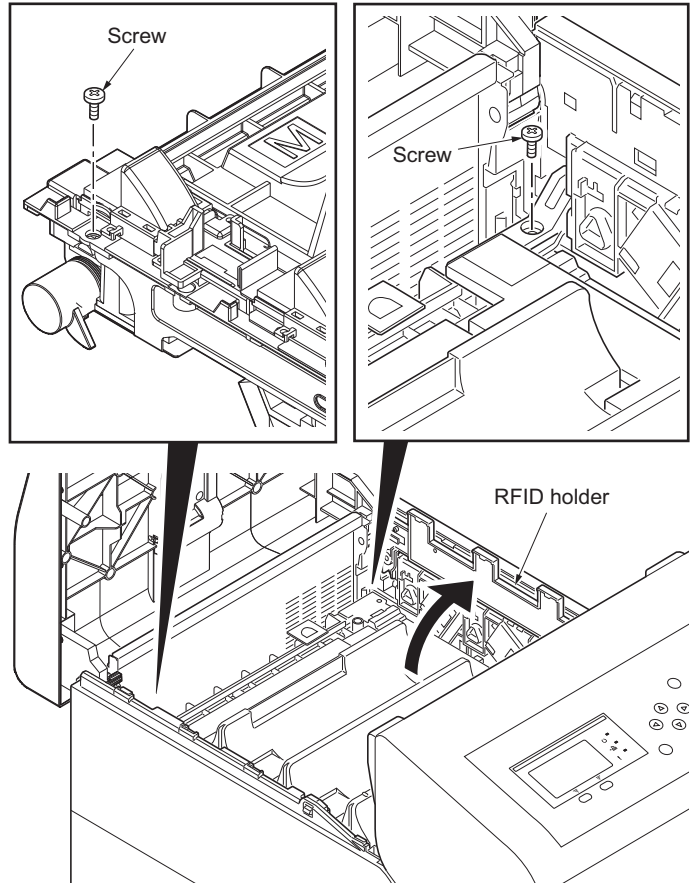

Figure 1-5-20

6. Hold the grips and then remove the intermediate transfer unit.
7. Check or replace the intermediate transfer unit and refit all the removed parts.

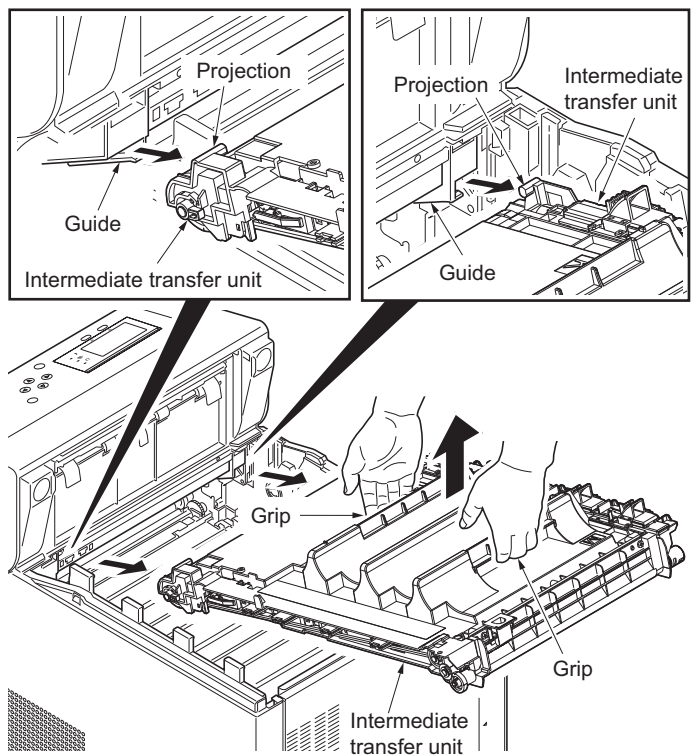
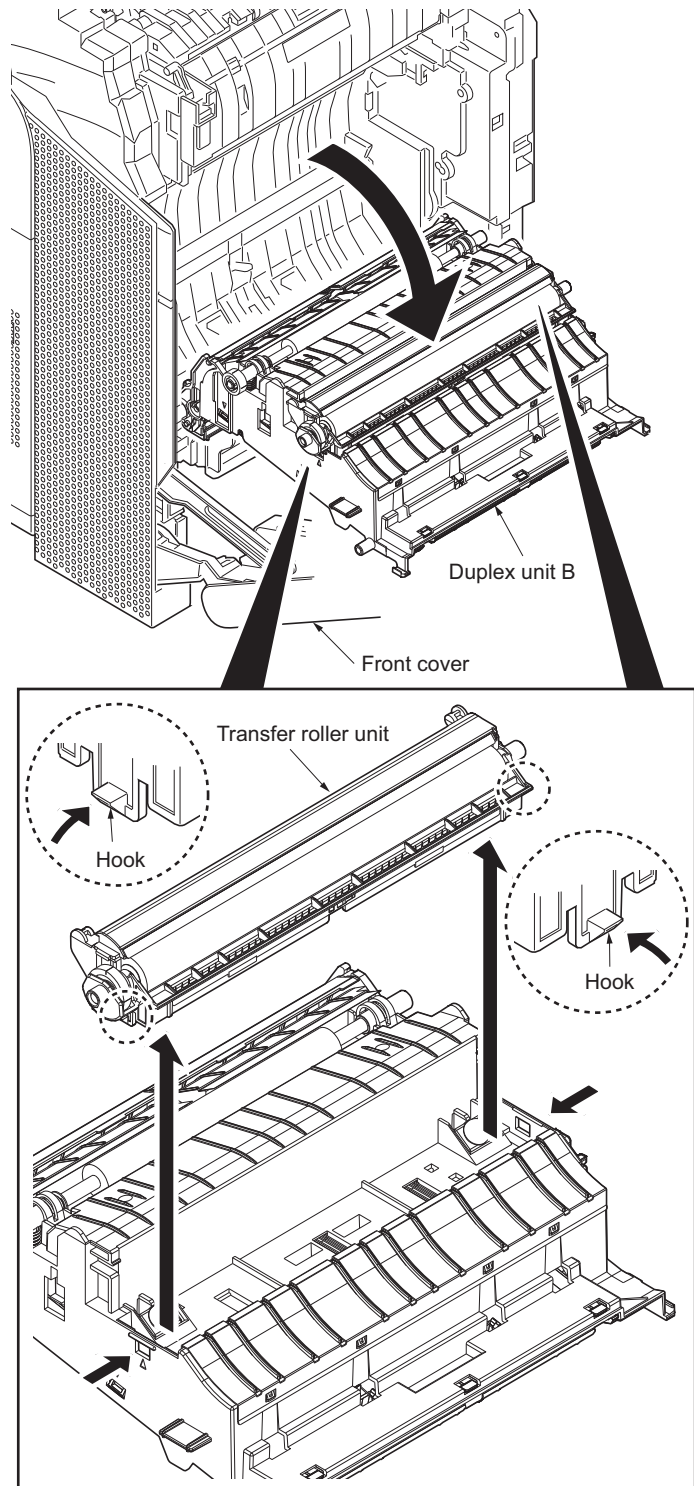

Figure 1-5-21

(2) Detaching and refitting the transfer roller unit**Procedure**

1. Open the front cover.
2. Open the duplex unit B.
3. Release two hooks and then remove the transfer roller unit.
4. Check or replace the transfer roller unit and refit all the removed parts.

**Figure 1-5-22**

(3) Detaching and refitting the duplex unit B**Procedure**

1. Remove the outer covers (See page 1-5-3).
2. Remove the power source PWB (See page 1-5-25).
3. Open the front cover.
4. Remove the screw and then remove the front cover right stopper.

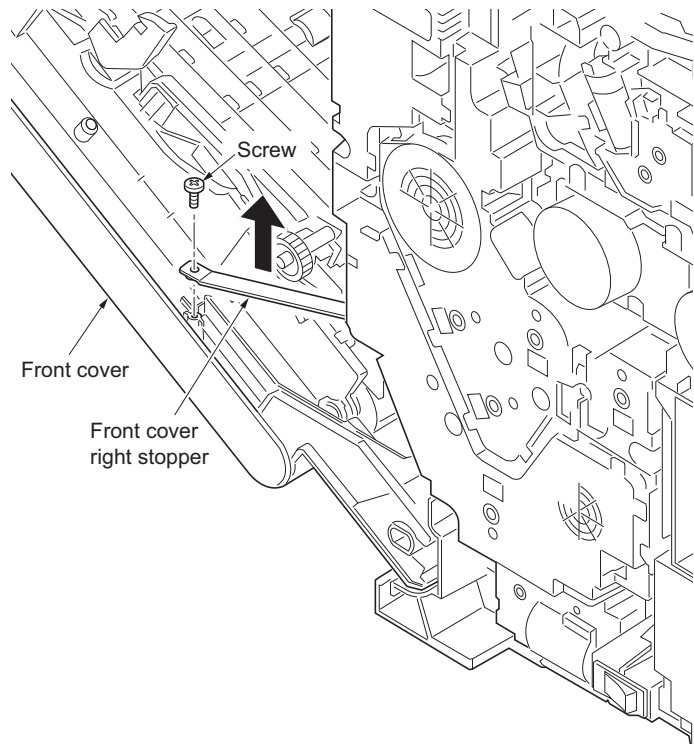
**Figure 1-5-23**

5. Remove the FFC from the engine PWB.
6. Remove the screw and then remove two grounding terminals.

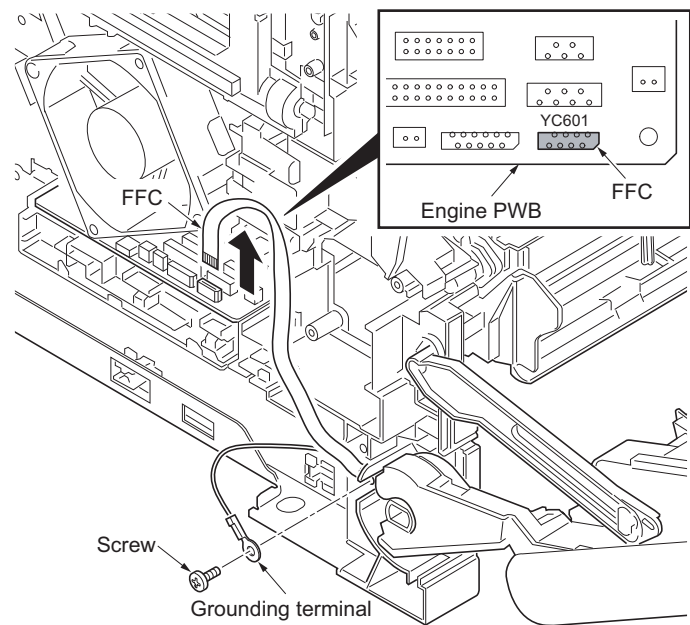
**Figure 1-5-24**

7. Remove the axis of the front cover left stopper from the hole.
8. Remove the front cover.

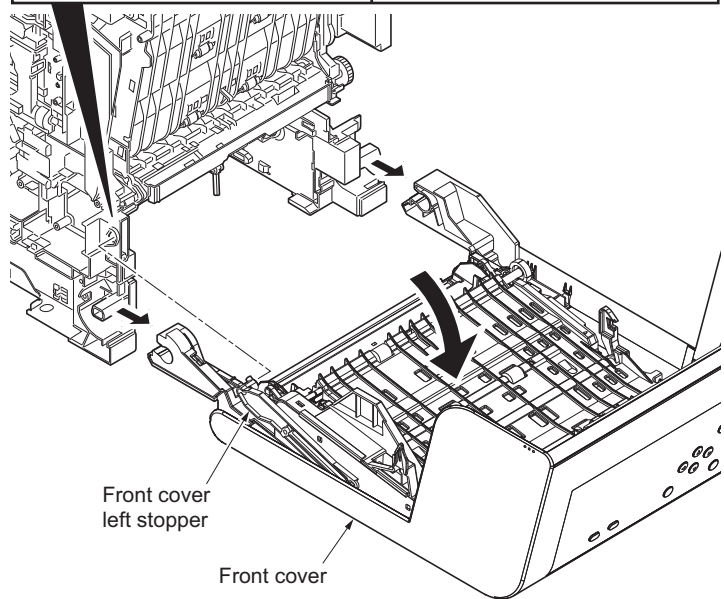
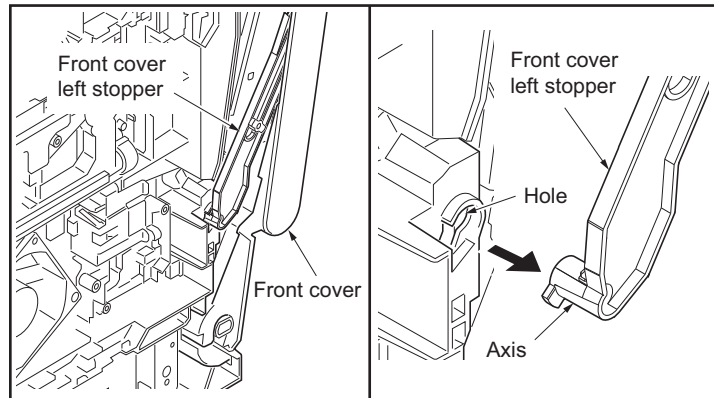

Figure 1-5-25

9. Remove the connector.
10. Remove three screws and then remove the drum motor K.

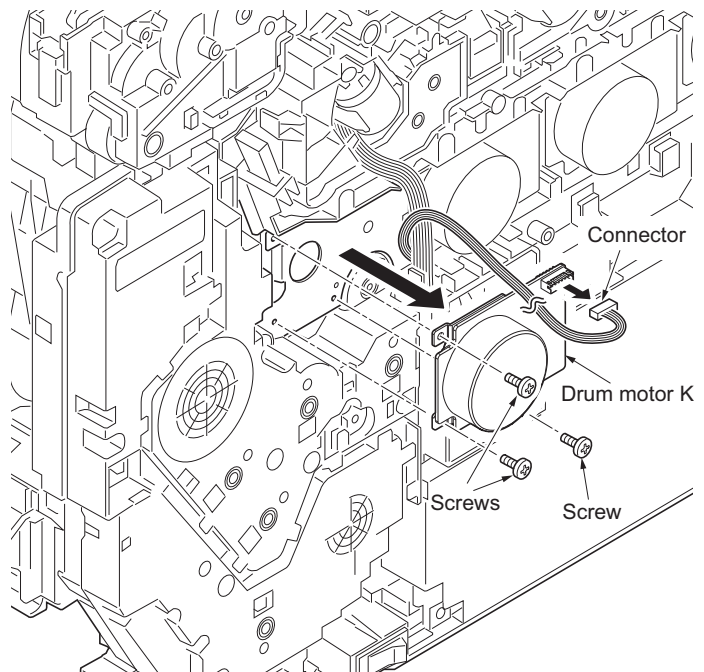

Figure 1-5-26

- 11. Remove six screws and then remove the feed drive unit.
- 12. Remove four connectors from the engine PWB.

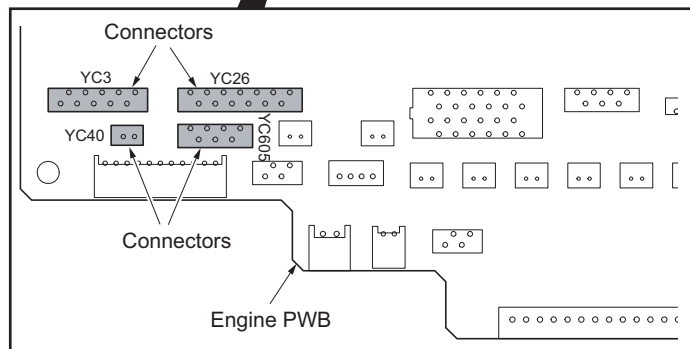
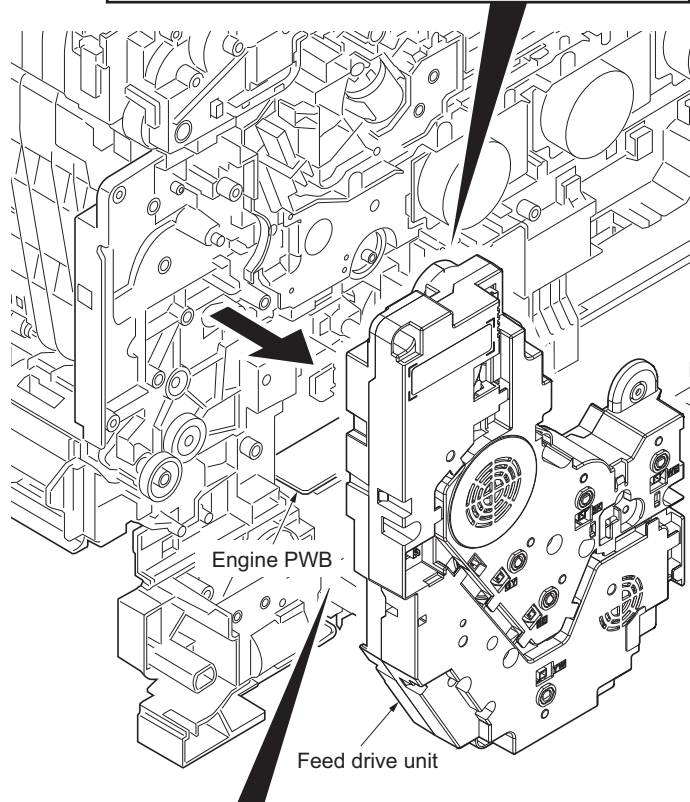
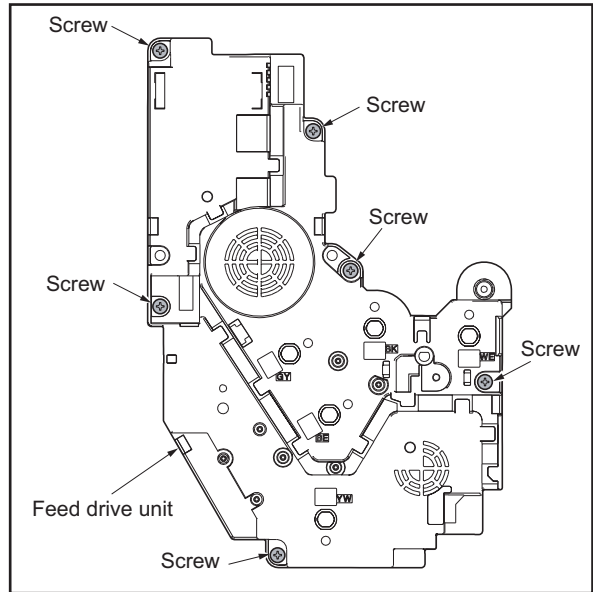

Figure 1-5-27

- 13. Remove two screws and then remove the MP paper feed lower unit.

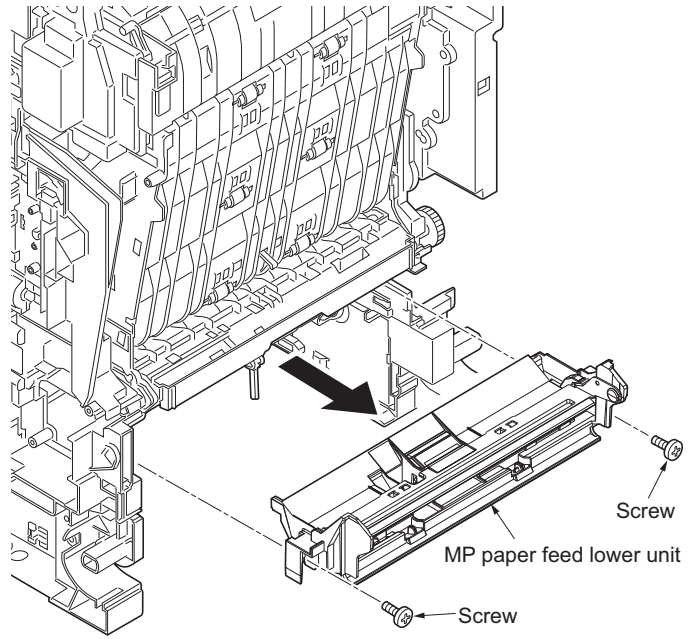

Figure 1-5-28

- 14. Remove two screws and then remove the developing fan motor 1.
- 15. Remove three connectors from the engine PWB.

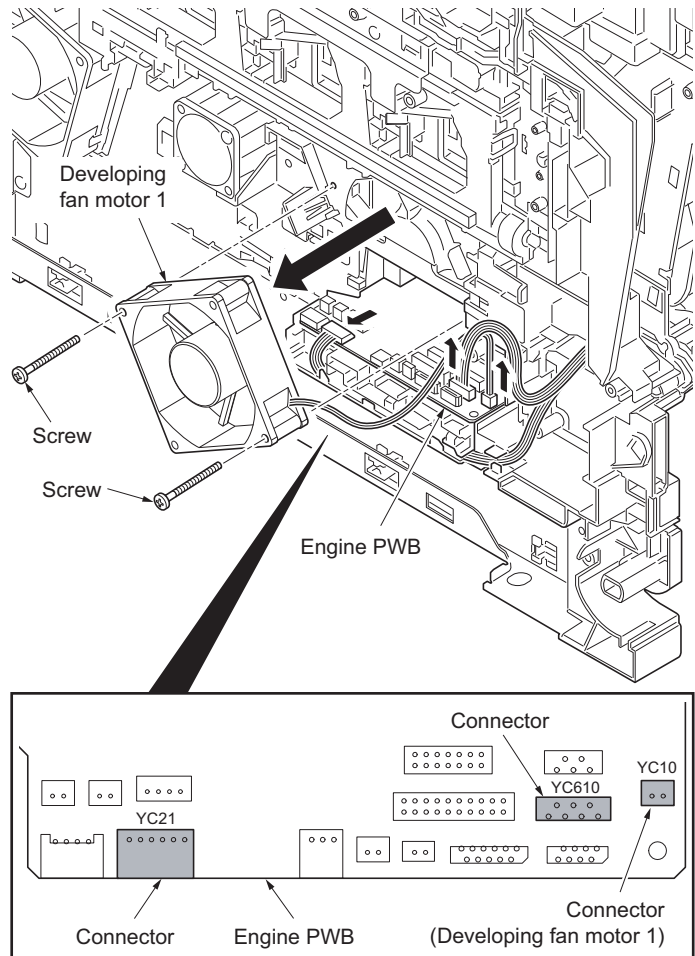

Figure 1-5-29

16. Remove the spring.
17. Open the duplex unit B.
18. Remove the duplex unit B.
19. Check or replace the duplex unit B and refit all the removed parts.

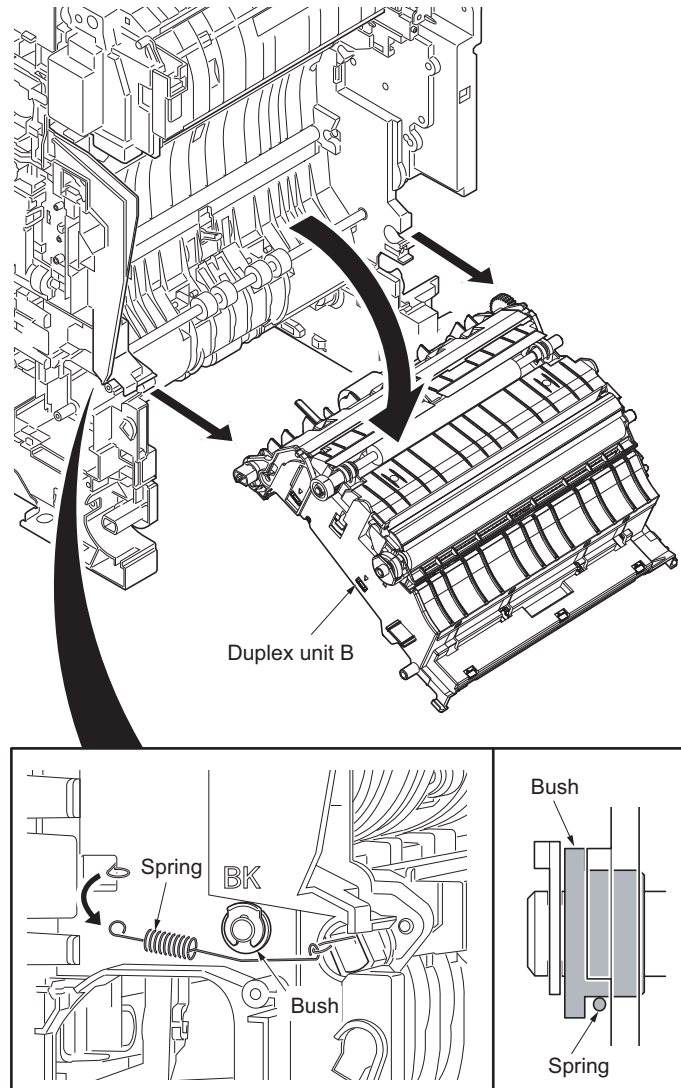

Figure 1-5-30

1-5-7 Fuser section

(1) Detaching and refitting the fuser unit

Procedure

1. Remove the outer covers (See page 1-5-3).
2. Remove five connectors.

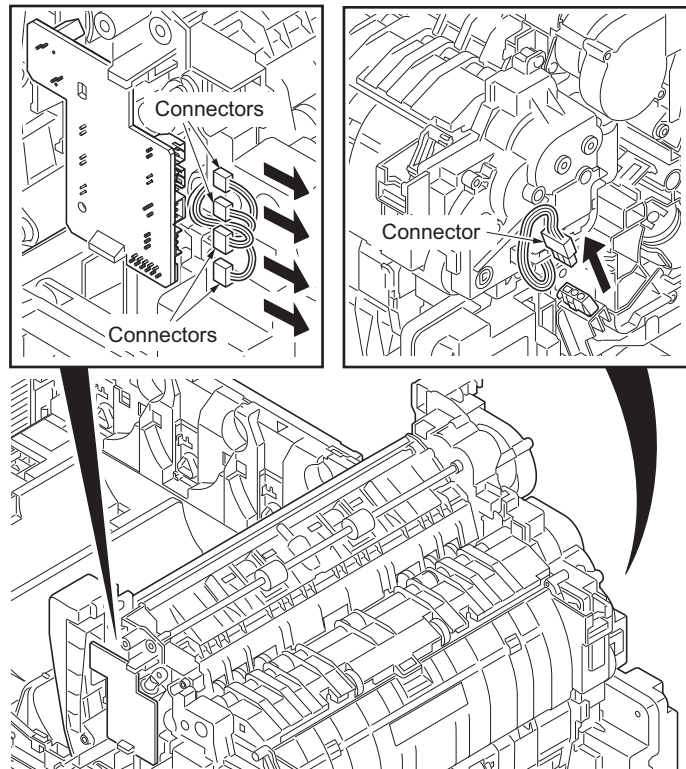

Figure 1-5-31

3. Open the duplex unit B.
4. Remove two screws.
5. Remove the fuser unit.
6. Check or replace the fuser unit and refit all the removed parts.

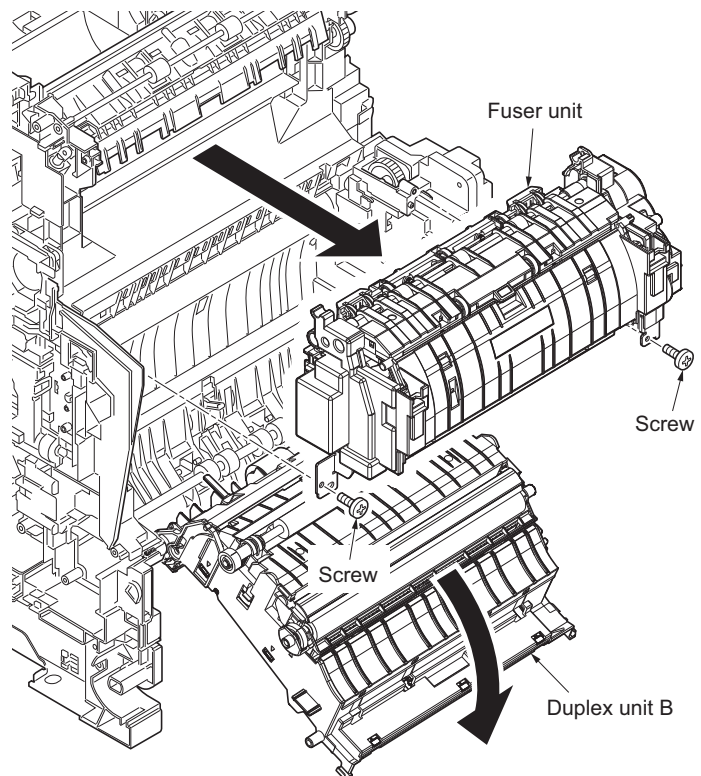

Figure 1-5-32

1-5-8 PWBs

(1) Detaching and refitting the power source PWB

Procedure

1. Remove the right rear cover (See page 1-5-6).
2. Remove three screws and then remove the power source shield.

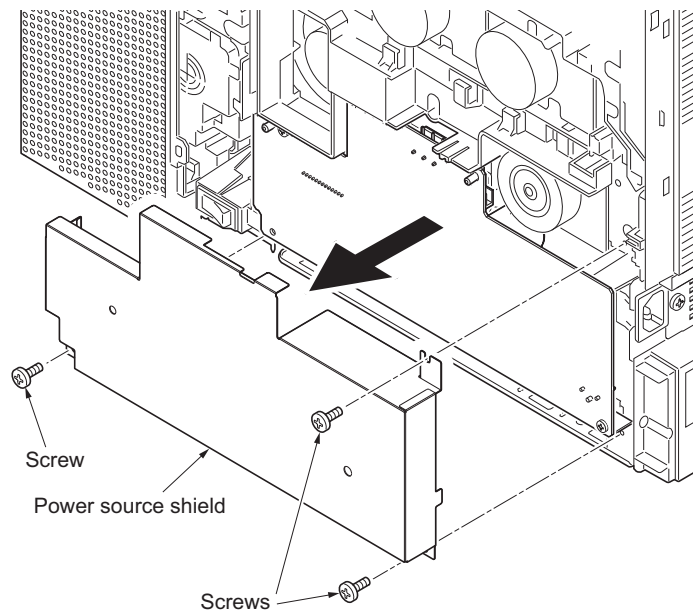

Figure 1-5-33

3. Remove two screws.

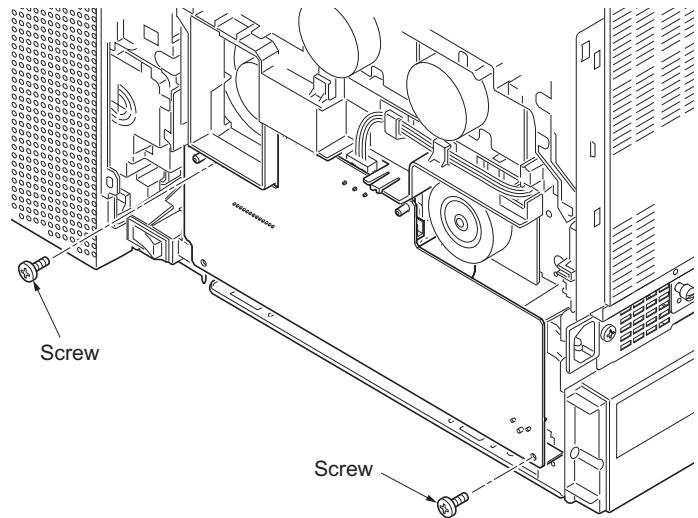

Figure 1-5-34

4. Release the hook and then remove the power source PWB.
5. Remove three connectors and then remove the power source PWB.
6. Check or replace the power source PWB and refit all the removed parts.

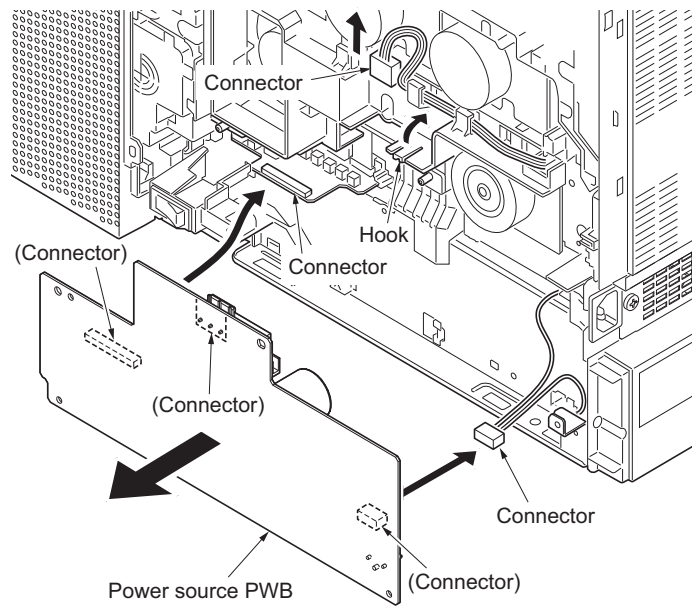
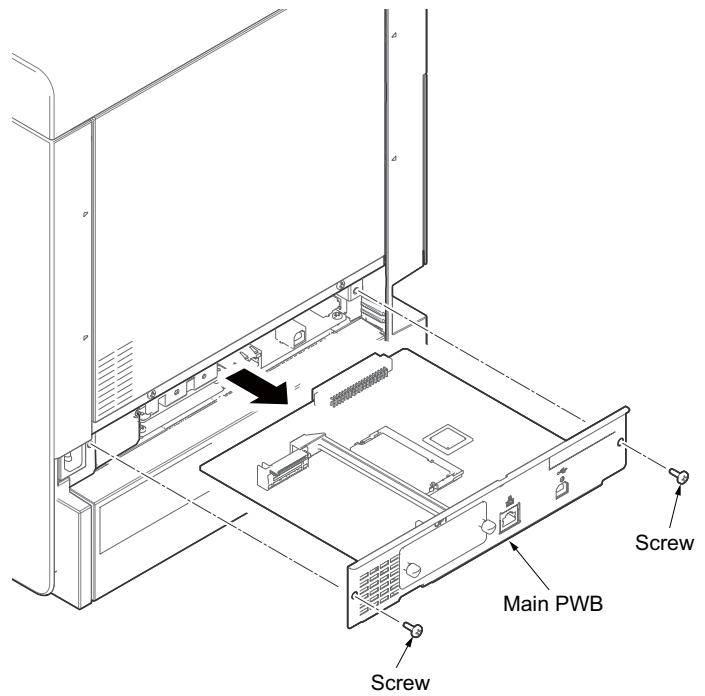

Figure 1-5-35

(2) Detaching and refitting the main PWB**Procedure**

1. Remove two screws.
2. Remove the main PWB.
3. Check or replace the main PWB and refit all the removed parts.

**Figure 1-5-36**

(3) Detaching and refitting the engine PWB

Procedure

1. Remove the fuser unit (See page 1-5-24).
2. Remove the duplex unit B (See page 1-5-19).
3. Remove the front cover open/close switch.
4. Remove nine connectors and one FFC from the engine PWB.

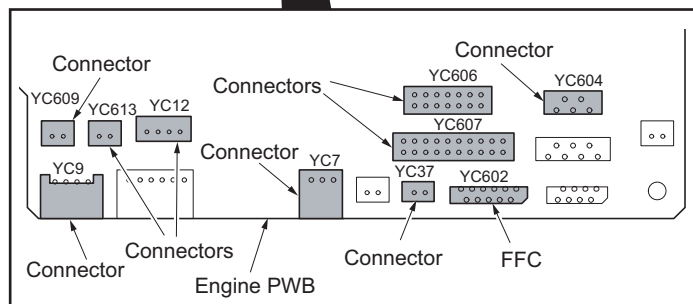
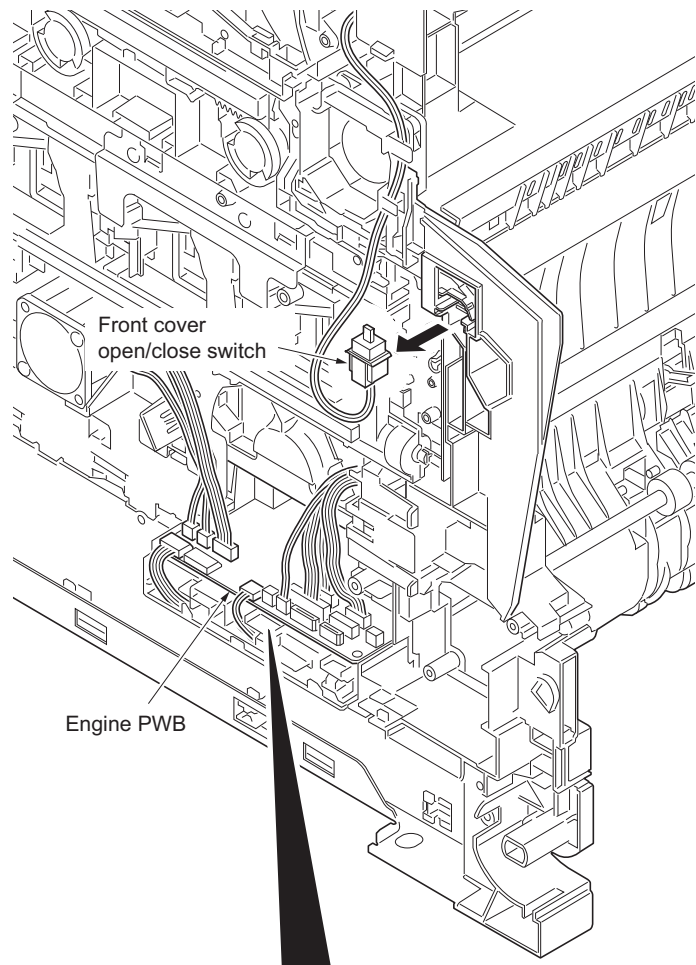

Figure 1-5-37

- 5. Remove seven screws and then remove the feed housing.

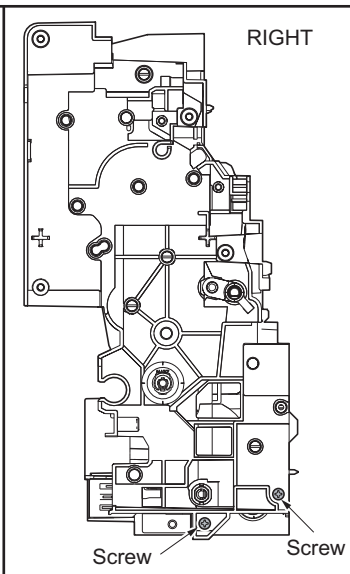
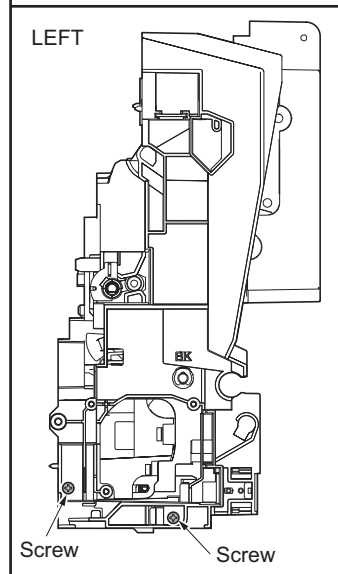
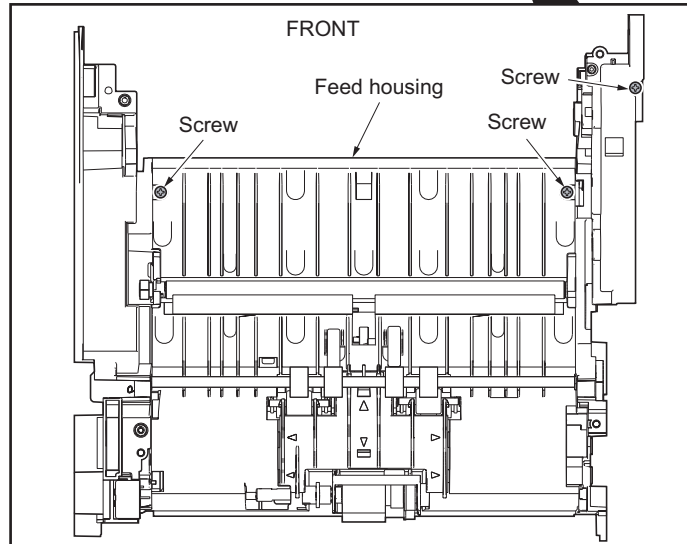
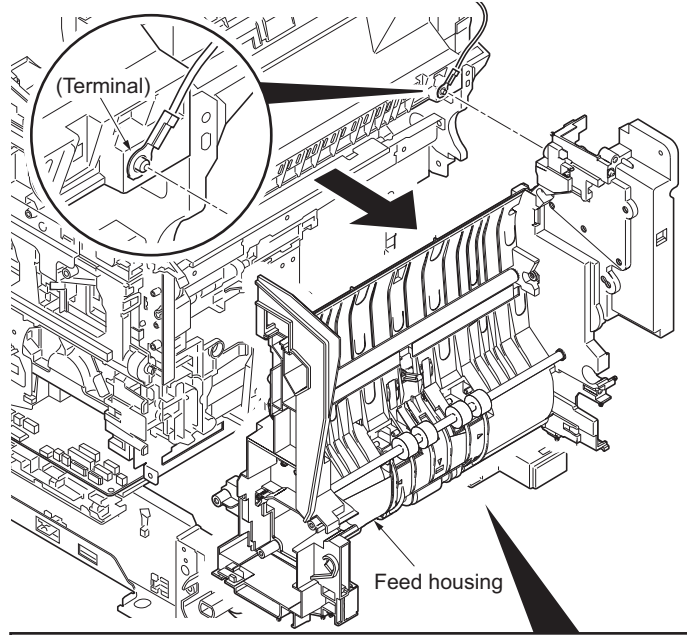

Figure 1-5-38

6. Release the lock lever and then remove the link lever.
7. Remove three connectors and three FFCs from the engine PWB.

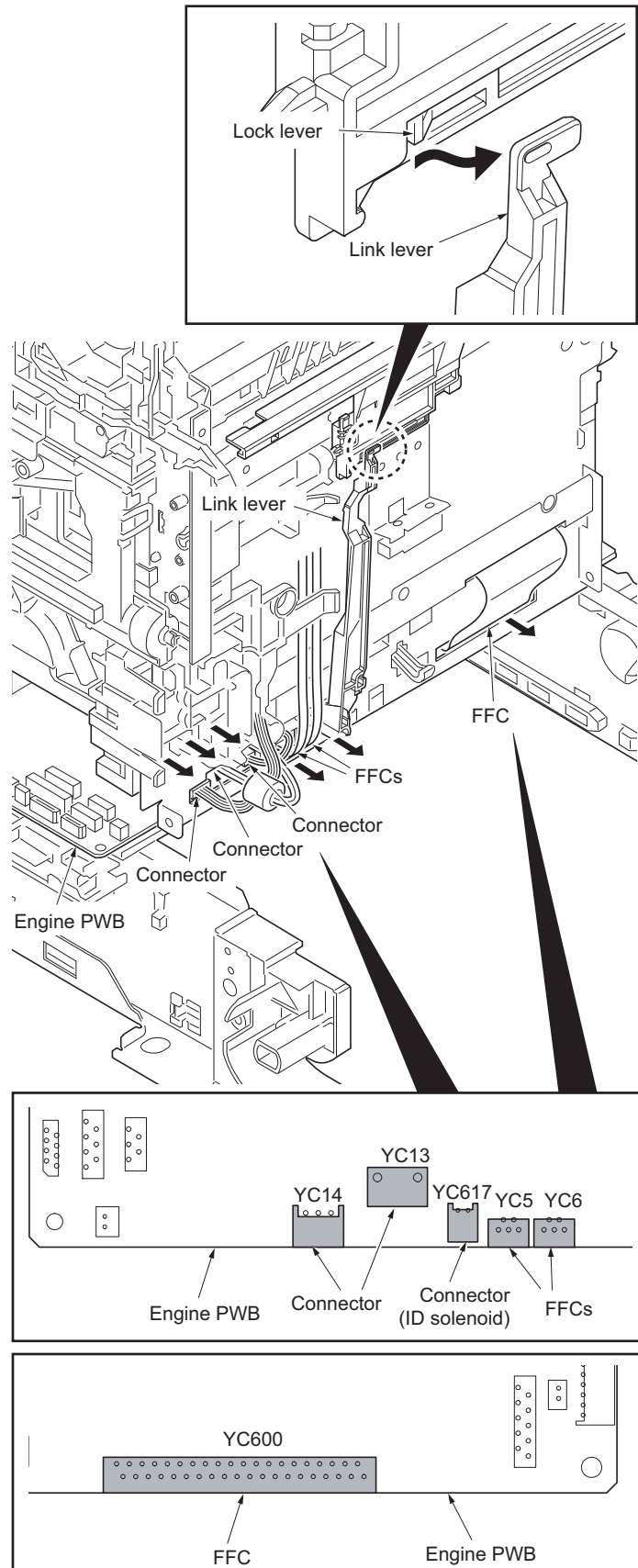

Figure 1-5-39

8. Remove five connectors and one FFC from the engine PWB.
9. Remove three screws.

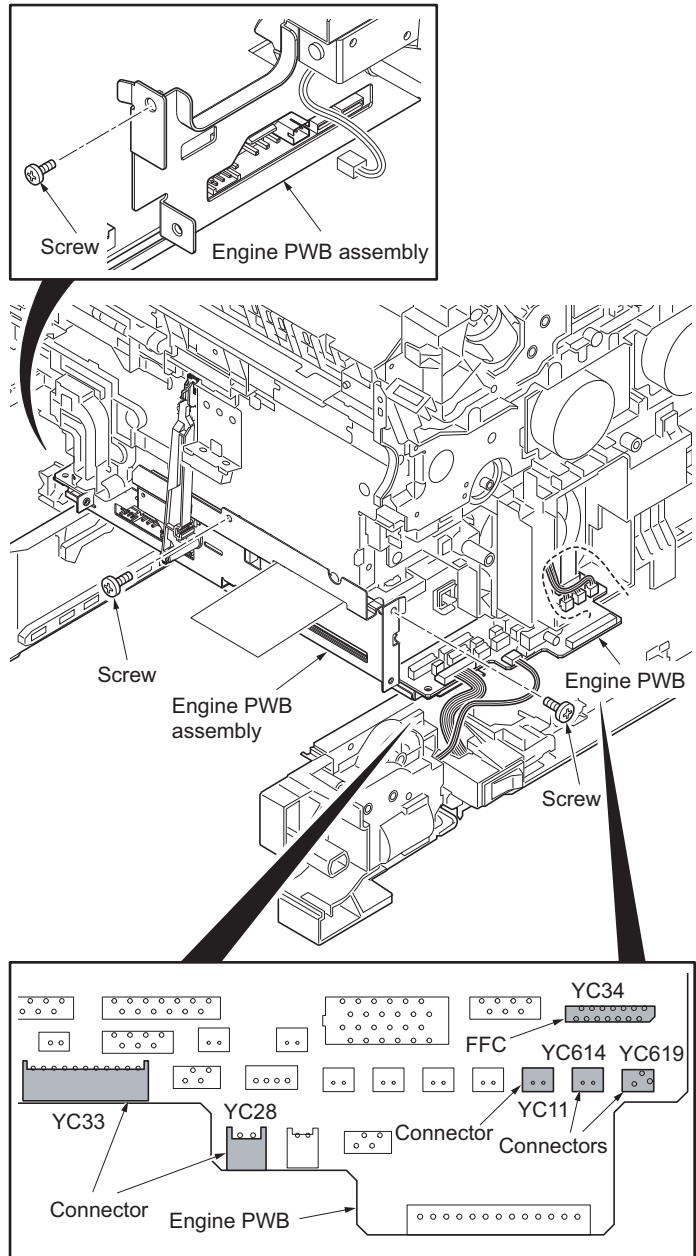

Figure 1-5-40

- 10. Draw the engine PWB assembly slightly.
- 11. Remove eleven connectors from the engine PWB.

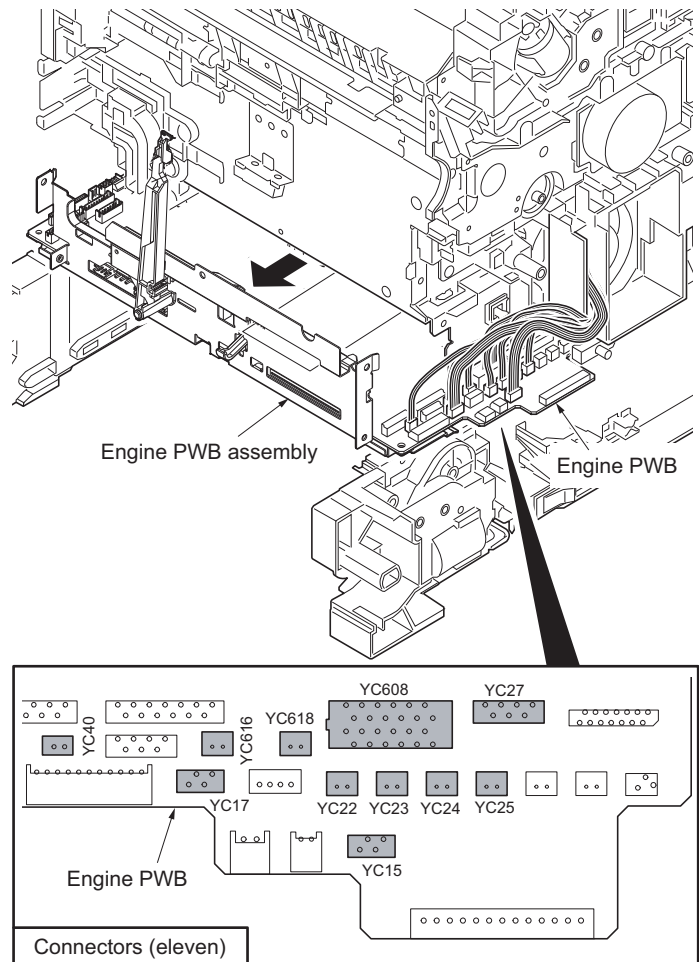

Figure 1-5-41

- 12. Remove the engine PWB assembly.

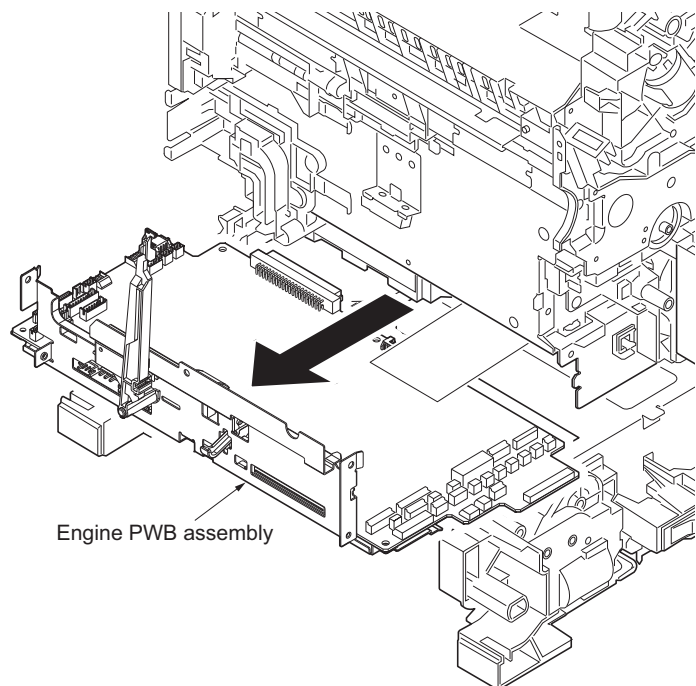

Figure 1-5-42

13. Remove two screws and then remove the engine PWB.
14. Check or replace the engine PWB and refit all the removed parts.
To replace the engine PWB, remove the EEPROM (U4) from the old engine PWB and mount it to the new engine PWB.

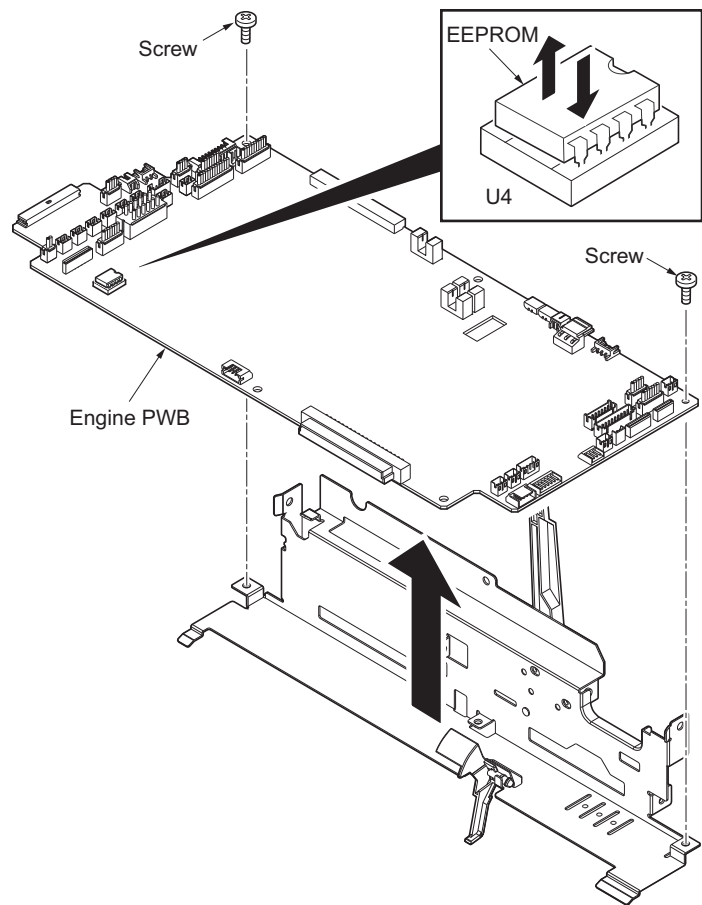
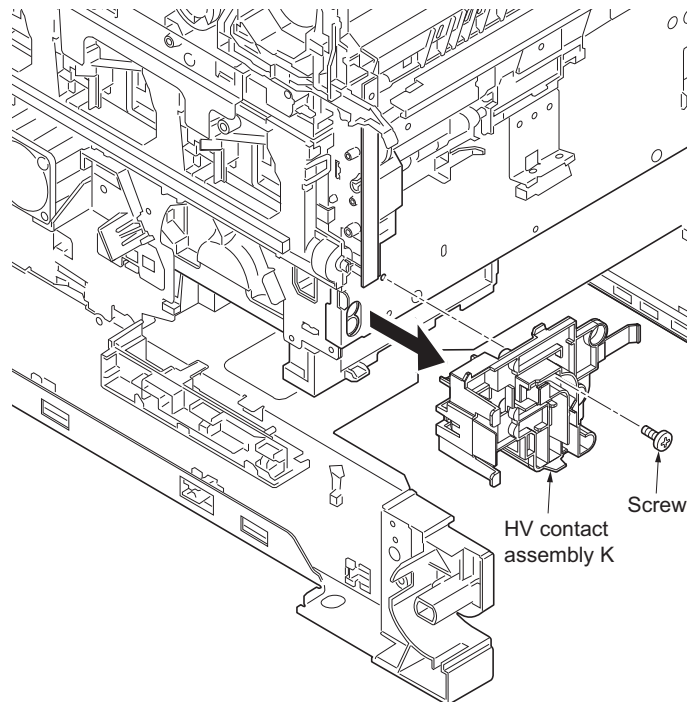

Figure 1-5-43

(4) Detaching and refitting the high voltage PWB 1**Procedure**

1. Remove the cassette.
2. Remove the main PWB (See page 1-5-27).
3. Remove the left rear cover and left front cover (See page 1-5-3).
4. Remove the right rear cover and right front cover (See page 1-5-6).
5. Remove the laser scanner unit (See page 1-5-42).
6. Remove the engine PWB (See page 1-5-28).
7. Remove the screw and then remove the HV contact assembly K.

**Figure 1-5-44**

8. Remove two screws and then remove the LSU fan motor.
9. Remove the screw and then remove the left fan holder.

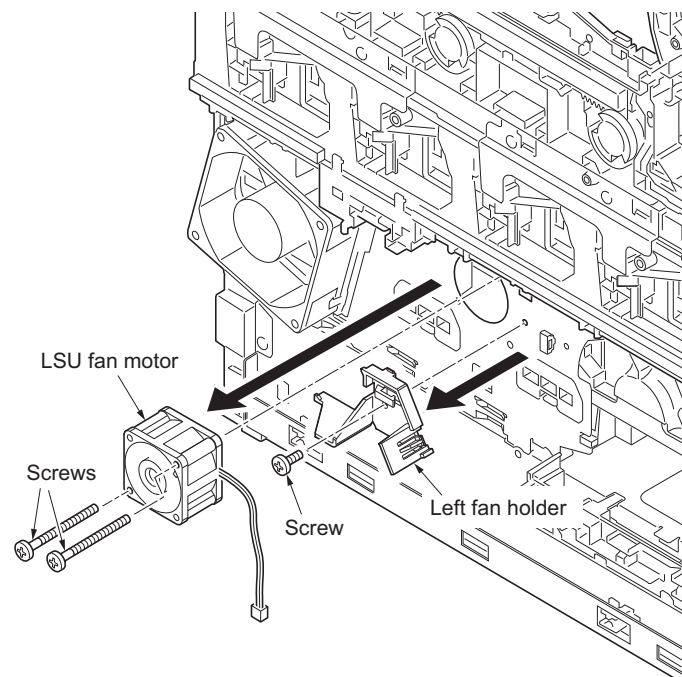
**Figure 1-5-45**

10. Release the wire clamp and then remove the wires.
11. Remove the connector.
12. Release four hooks and then remove the left side fan motor.

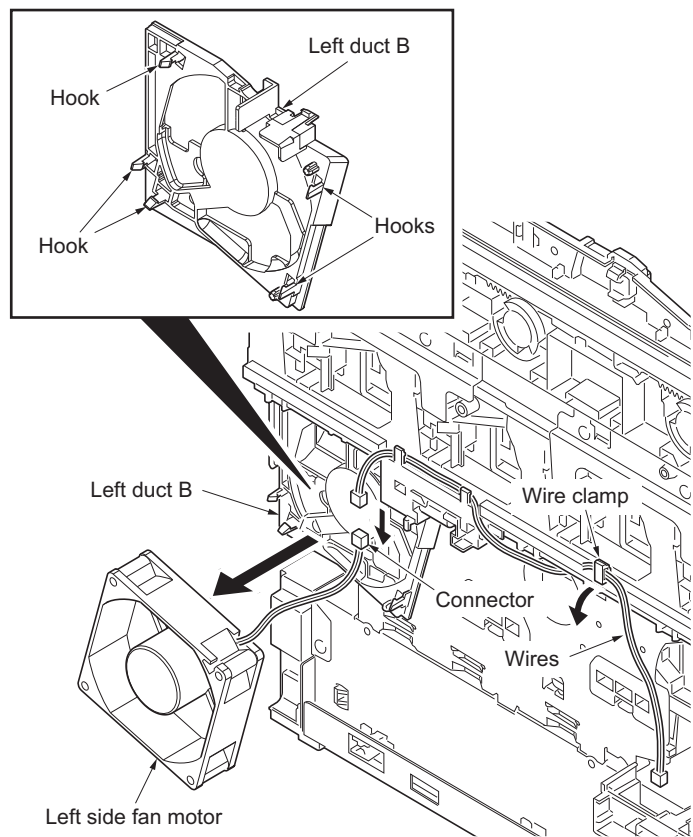

Figure 1-5-46

13. Remove the screw.
14. Release the hook and then remove the left duct B.

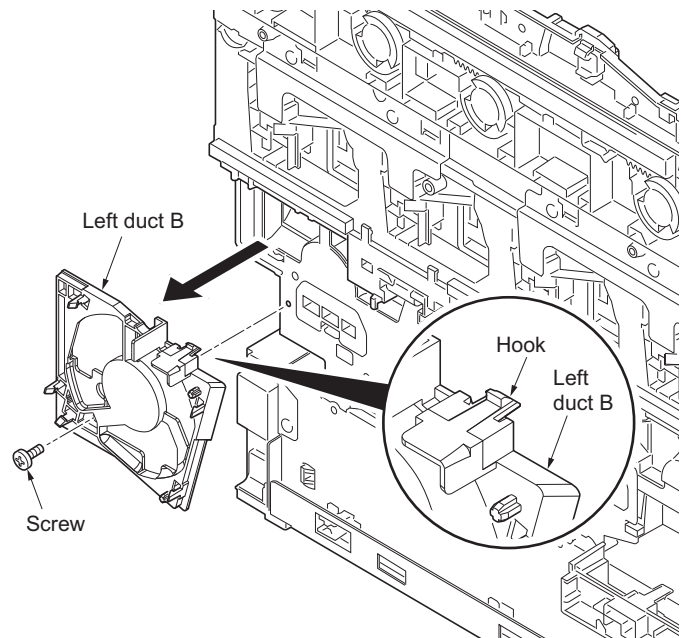

Figure 1-5-47

15. Remove each two screws and then remove two left frame stays.

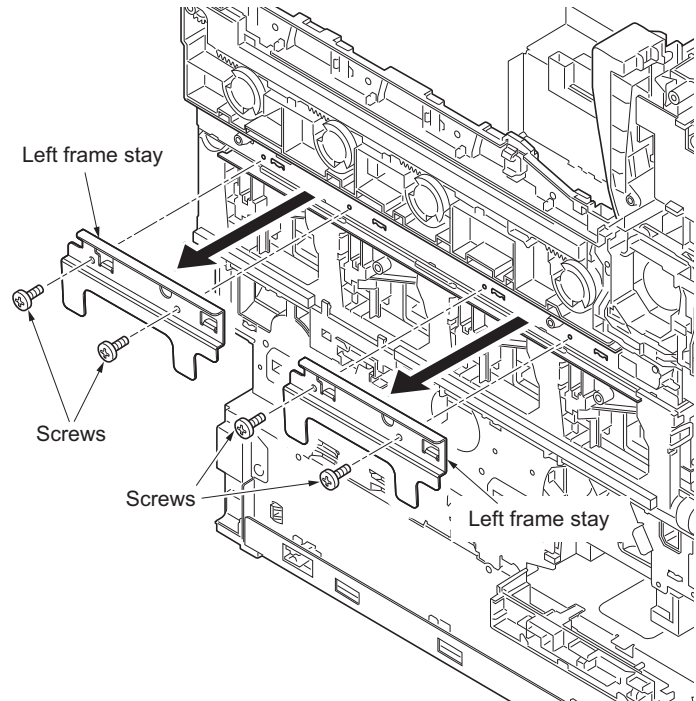

Figure 1-5-48

16. Release three hooks.
17. Pull down three bosses and then remove the waste toner assembly.

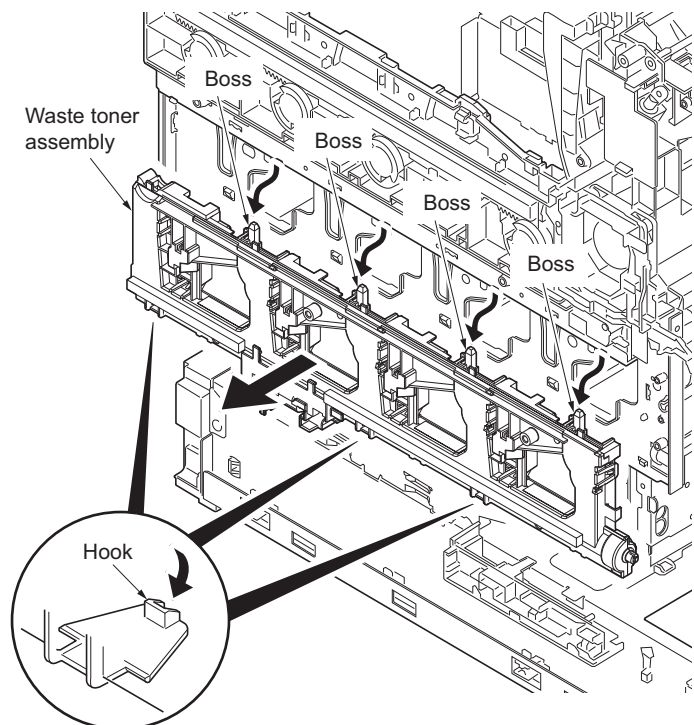

Figure 1-5-49

18. Release four hooks and then remove the HV bracket assembly.

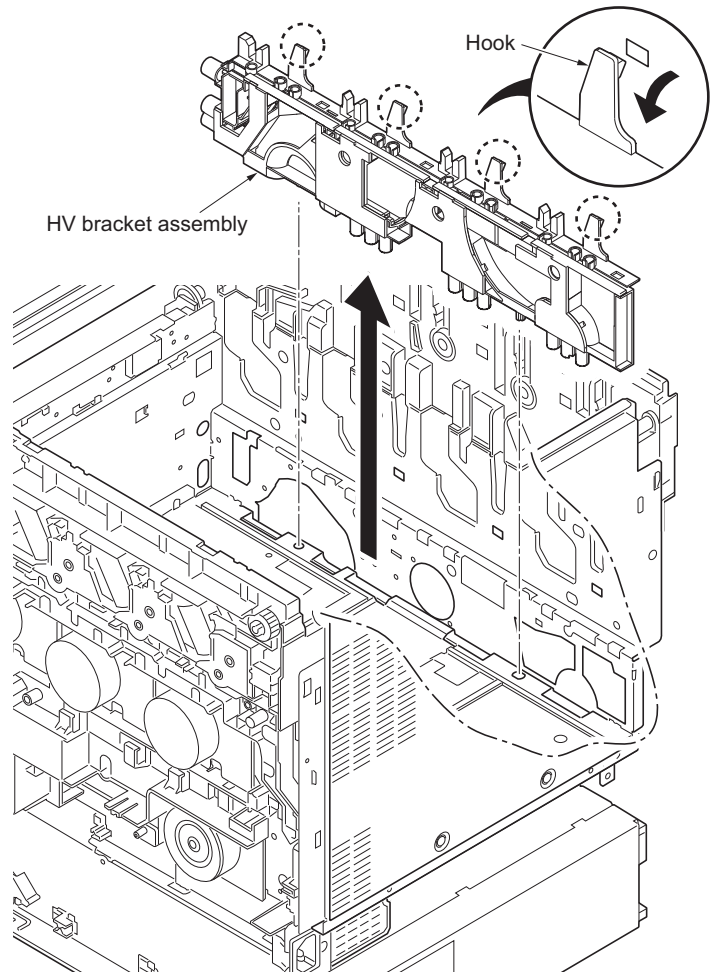

Figure 1-5-50

19. Release each one hook and then remove three HV contact assemblies C.

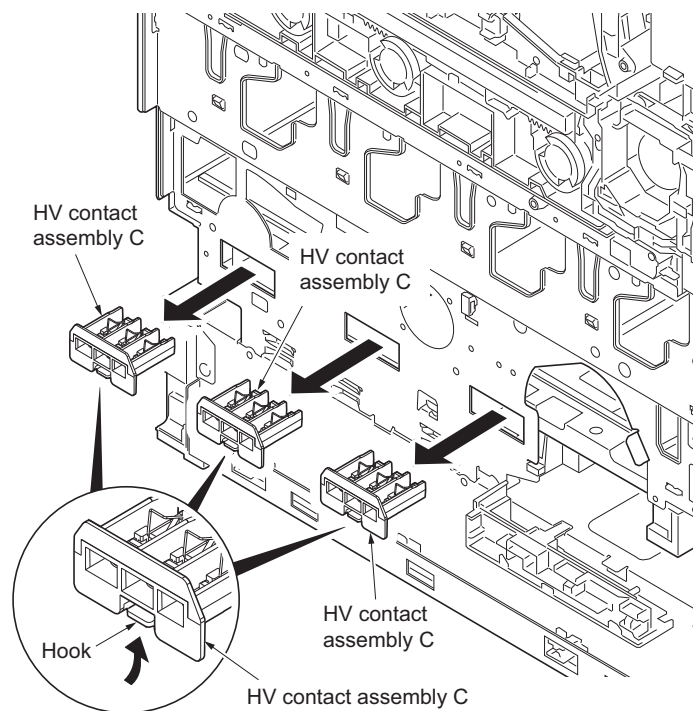

Figure 1-5-51

- 20. Release the hook and then remove the TC high voltage bracket.
- 21. Remove three terminals.

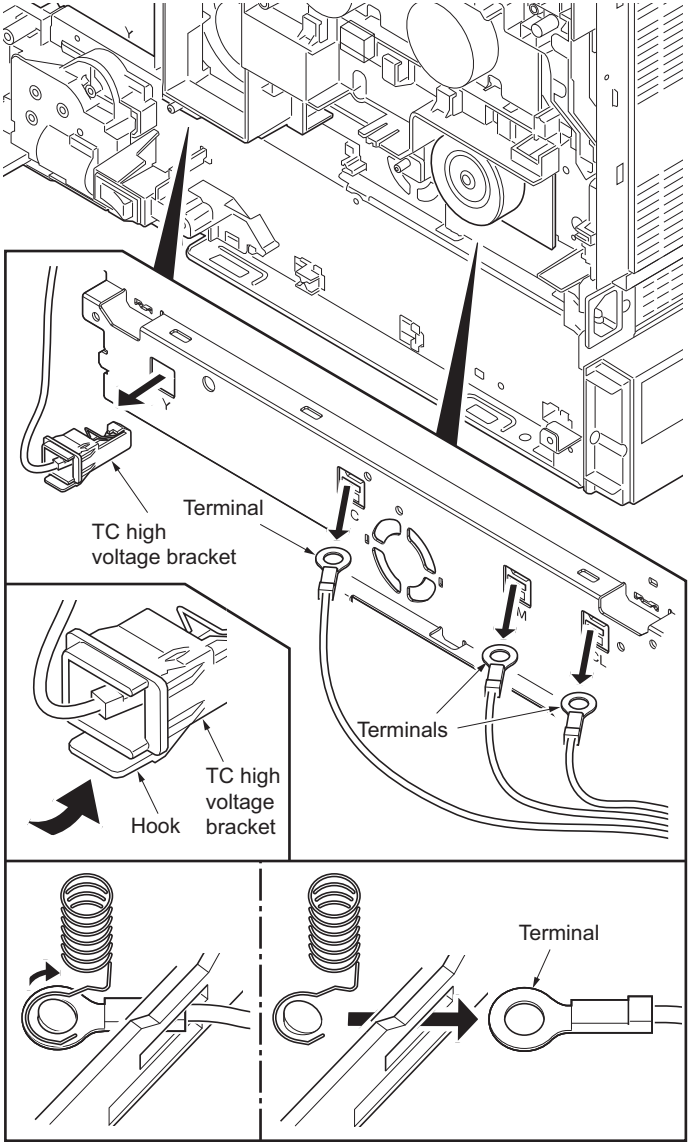

Figure 1-5-52

- 22. Remove two screws.

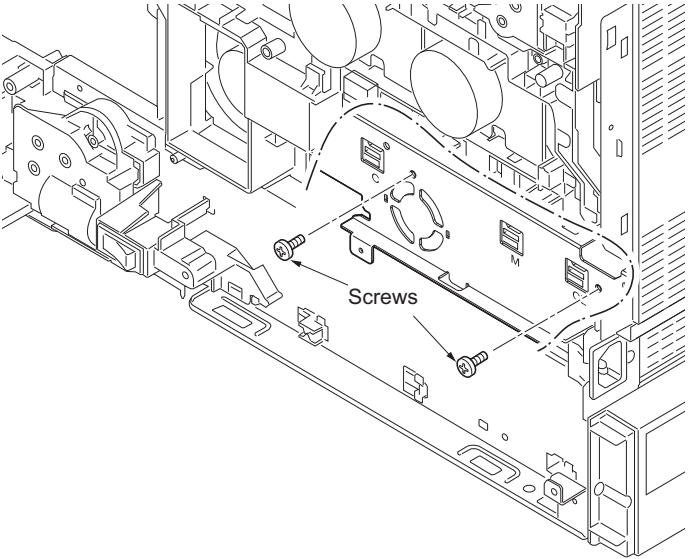

Figure 1-5-53

23. Remove the screw.

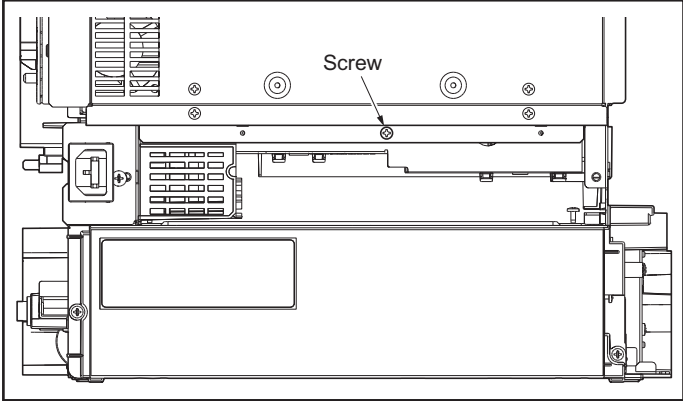
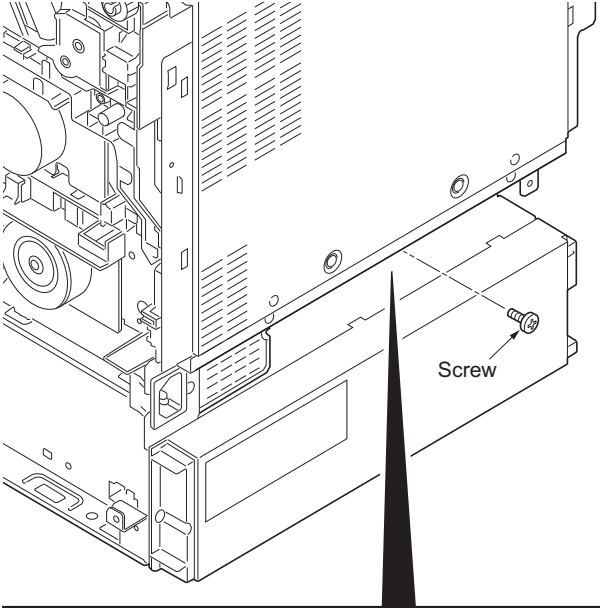

Figure 1-5-54

24. Remove the high voltage PWB assembly.

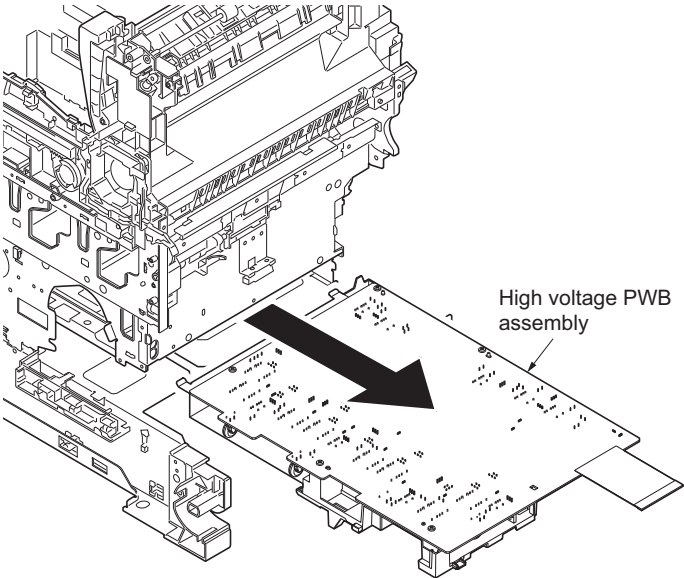

Figure 1-5-55

25. Remove five screws and then remove the high voltage PWB 1.
26. Check or replace the high voltage PWB 1 and refit all the removed parts.

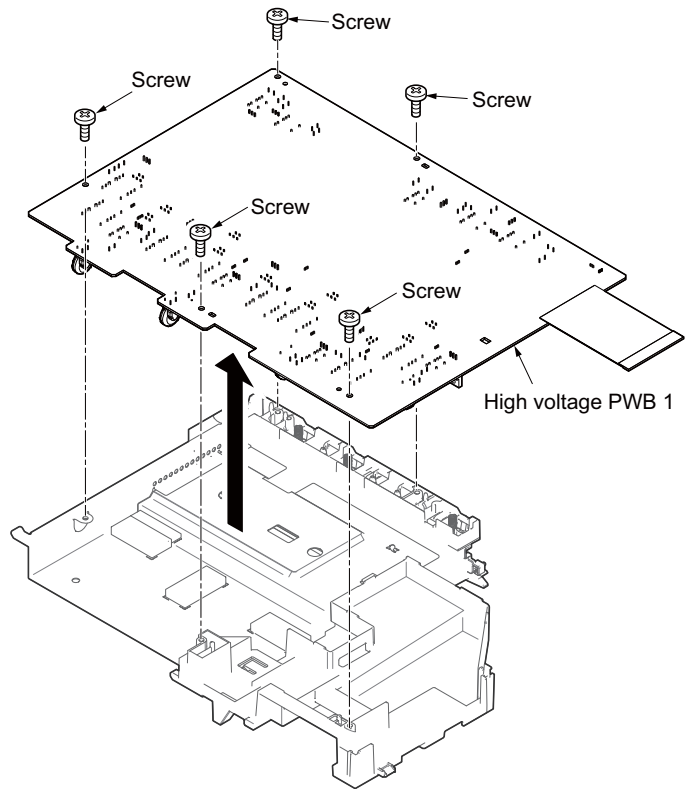
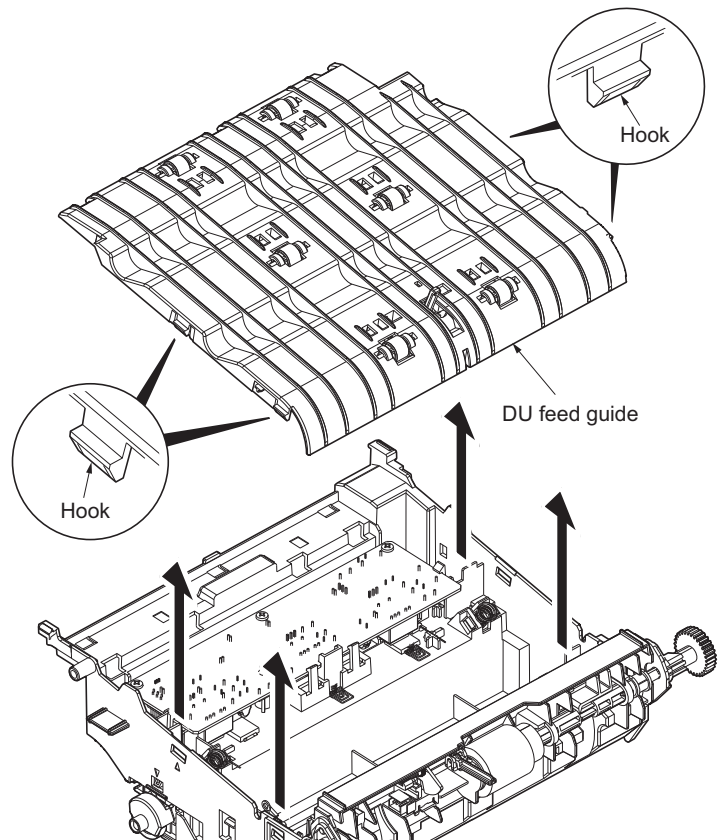

Figure 1-5-56

(5) Detaching and refitting the high voltage PWB 2**Procedure**

1. Remove the duplex unit B (See page 1-5-19).
2. Release four hooks and then remove the DU feed guide.

**Figure 1-5-57**

3. Remove three screws.
4. Release three hooks and then remove the high voltage PWB 2.
5. Remove the connector.
6. Check or replace the high voltage PWB 2 and refit all the removed parts.

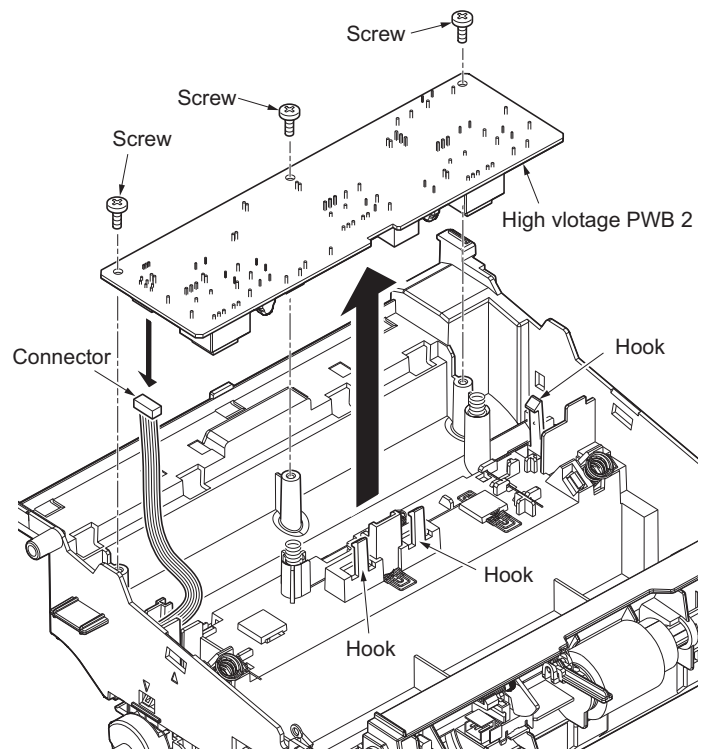
**Figure 1-5-58**

1-5-9 Others

(1) Detaching and refitting the laser scanner unit

Procedure

1. Remove the left rear cover (See page 1-5-12).
2. Remove the all developing units (See page 1-5-12).
3. Remove two screws and then remove the developing fan motor 1.
4. Remove five connectors.

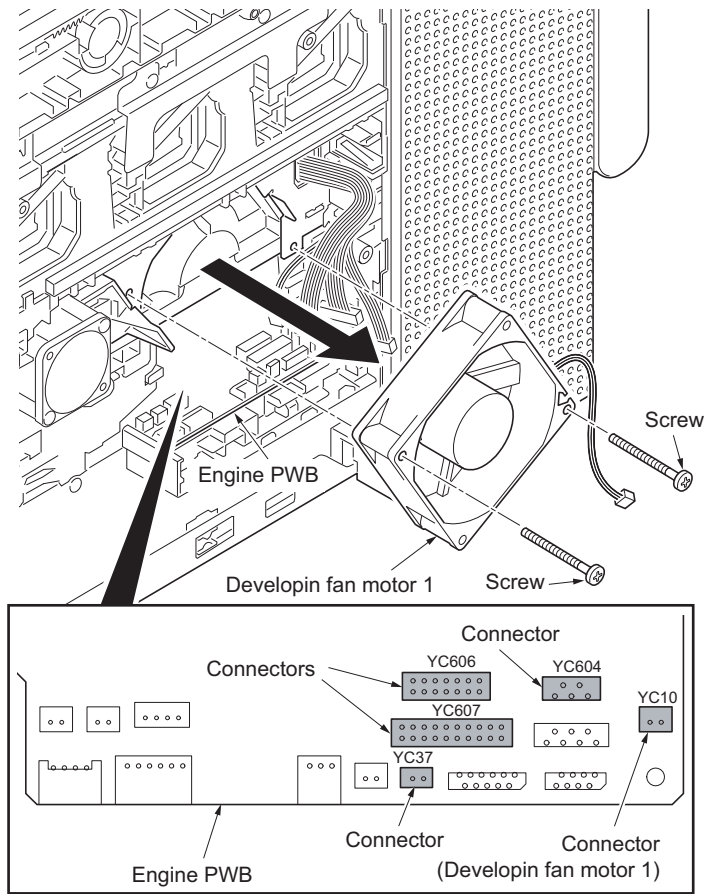

Figure 1-5-59

5. Remove two screws.

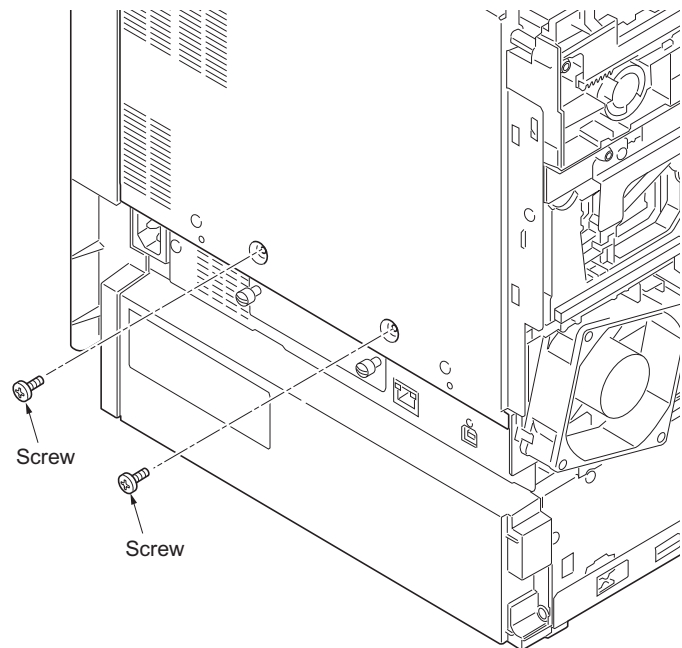
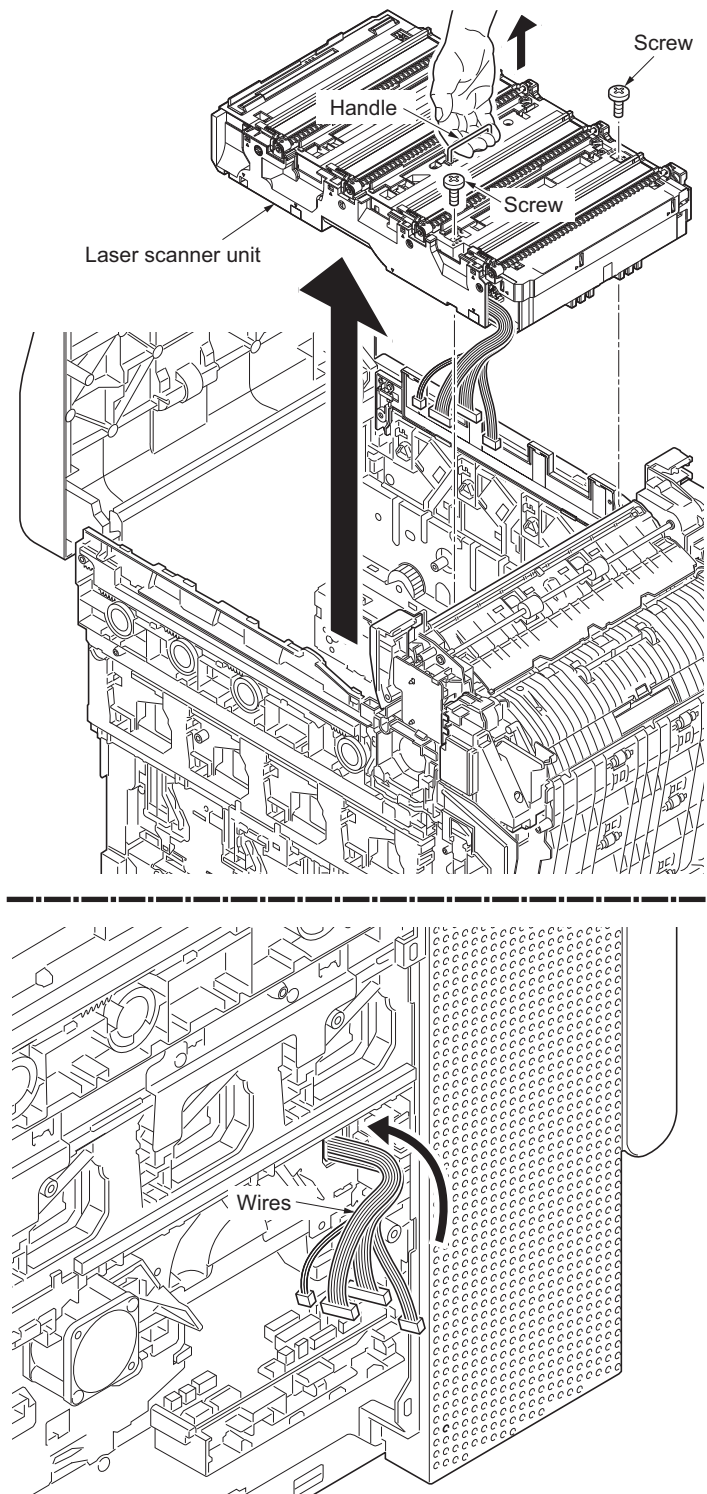

Figure 1-5-60

6. Remove two screws.
7. Draw the wires into the printer inside.
8. Hold the handle and then remove the laser scanner unit.
9. Check or replace the laser scanner unit and refit all the removed parts.

**Figure 1-5-61**

(2) Direction of installing the principal fan motors

When detaching or refitting the ozone fan motor, developing fan motor 1, developing fan motor 2, left side fan motor or LSU fan motor, be careful of the airflow direction (intake or exhaust).

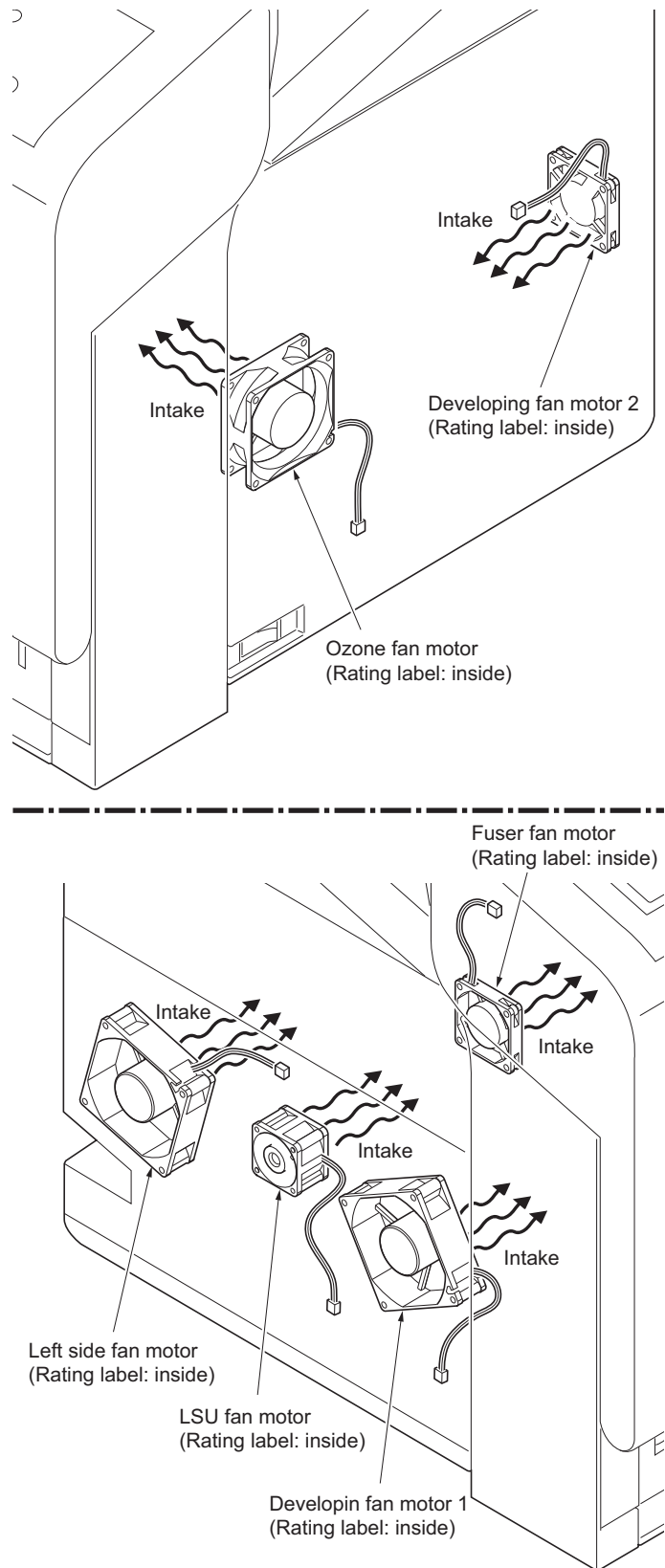

Figure 1-5-62

1-6-1 Downloading firmware

(1) Firmware file

Firmware files are named after the following codes:

Firmware file name example

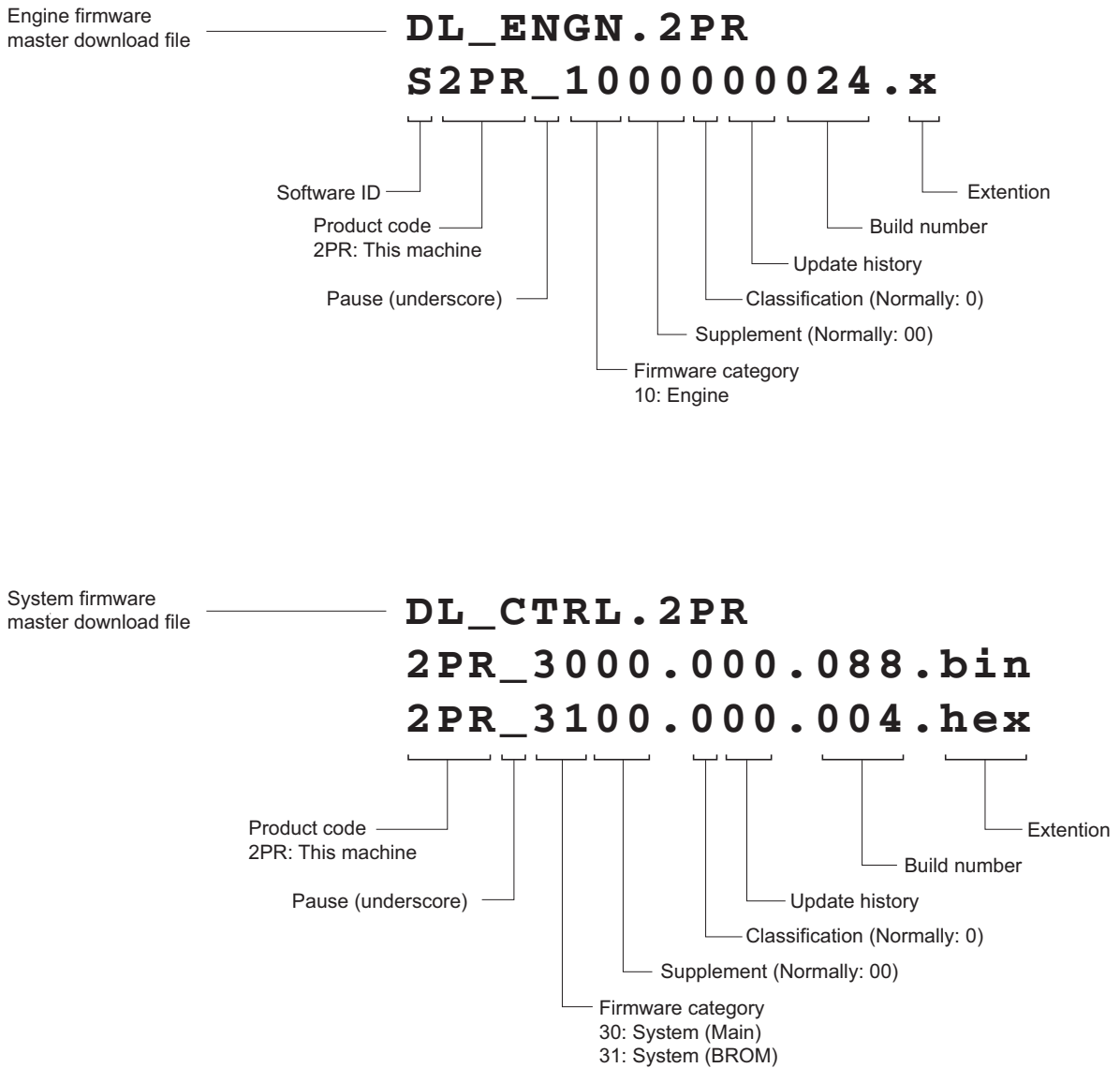

Figure 1-6-1

(2) Downloading the firmware from the USB memory

To download data written in a USB memory to the printer, proceed as explained in this section.

CAUTION

Downloading firmware takes several minutes. Do not turn power off during downloading.

Procedure

1. Turn printer power off.
2. Insert the USB memory to the PC's USB slot.
3. Copy the firmware file to download to the root directory of the USB memory.
4. Remove the USB memory from the PC's USB slot.
5. Insert the USB memory into the printer's USB memory slot.

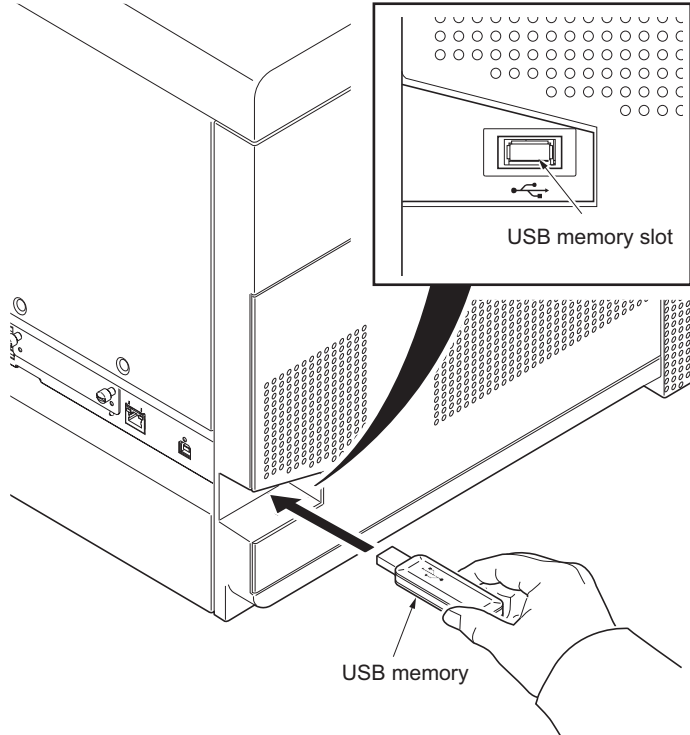
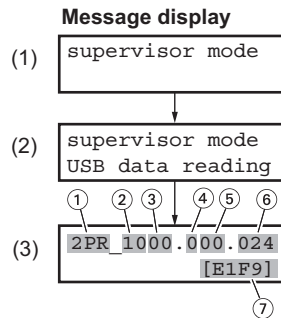

Figure 1-6-2

6. Turn printer power on.
7. When message display (1) is displayed to detect firmware in the USB memory.
8. Message display (2) is displayed during downloading.
9. When message display (3) is displayed to indicate downloading is finished.



- 1 Product code
2PR: This machine
- 2 Firmware category
10: Engine
30: System
31: System (BROM)
- 3 Supplement (Normally: 00)
- 4 Classification (Normally: 0)
- 5 Update history
- 6 Build number
- 7 Checksum

Figure 1-6-3

10. Turn printer power off.
11. Remove the USB memory from USB memory slot.
12. Turn printer power on.
13. Print the status page to check that the firmware version has been updated (See page P.1-3-2).

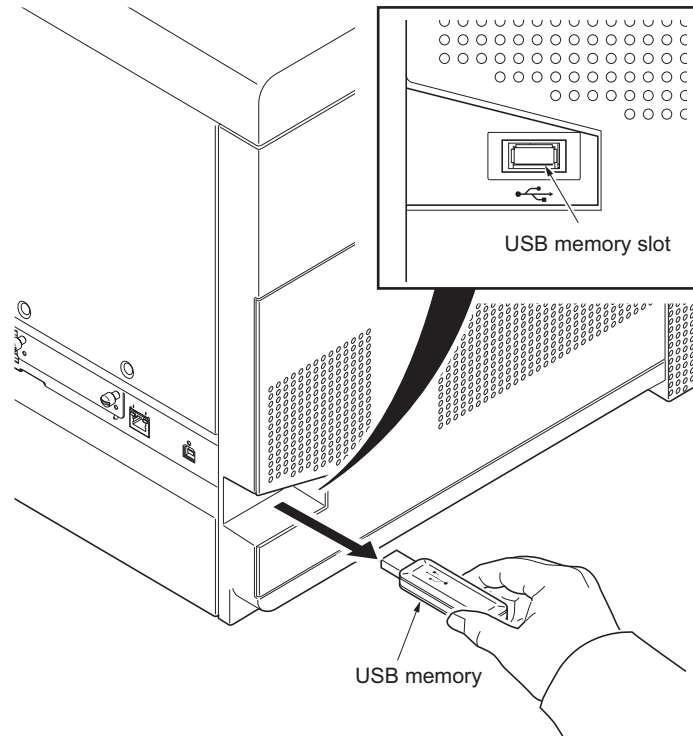

Figure 1-6-4

(3) Downloading the firmware from the SD card

To download data written in a SD card to the printer, proceed as explained in this section.

CAUTION

Downloading firmware takes several minutes. Do not turn power off during downloading. If downloading is interrupted by an accidental power failure, etc., the main PWB may have to be replaced.

Procedure

1. Turn printer power off.
2. Remove two screws and then remove the option interface slot cover.
3. Insert the SD card into the SD card socket.
4. Refit the option interface slot cover.

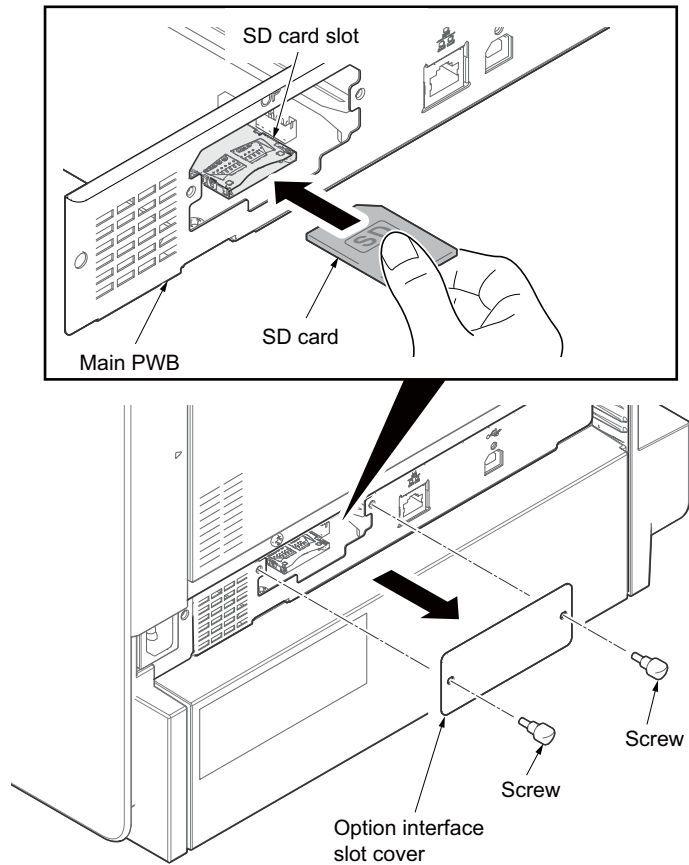

Figure 1-6-5

5. Turn printer power on.
6. Press MENU key on the printer's operation panel and carry out the SD card formatting procedure.
7. When formatting is complete, turn printer power off.

Message display

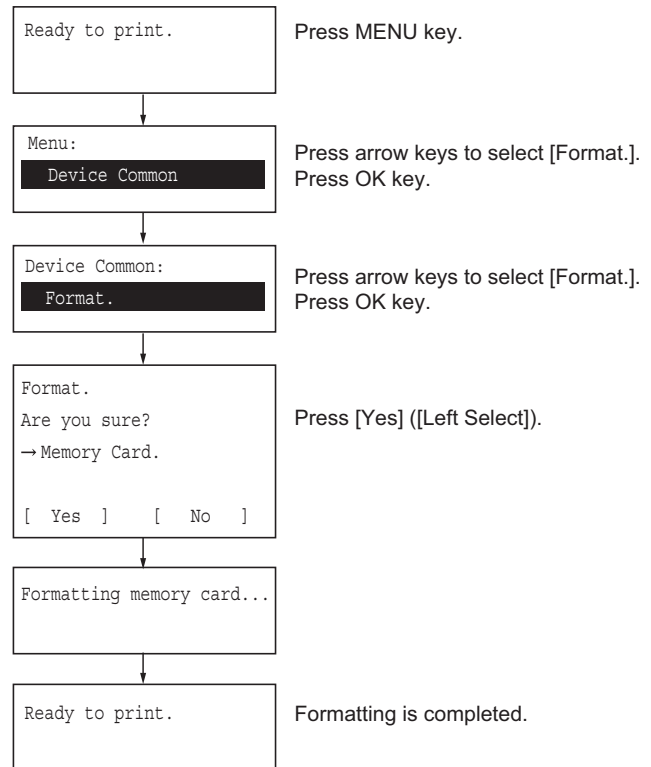

Figure 1-6-6Memory card formatting procedure

8. Remove two screws and then remove the option interface slot cover.
9. Remove the formatted SD card from the SD card slot.

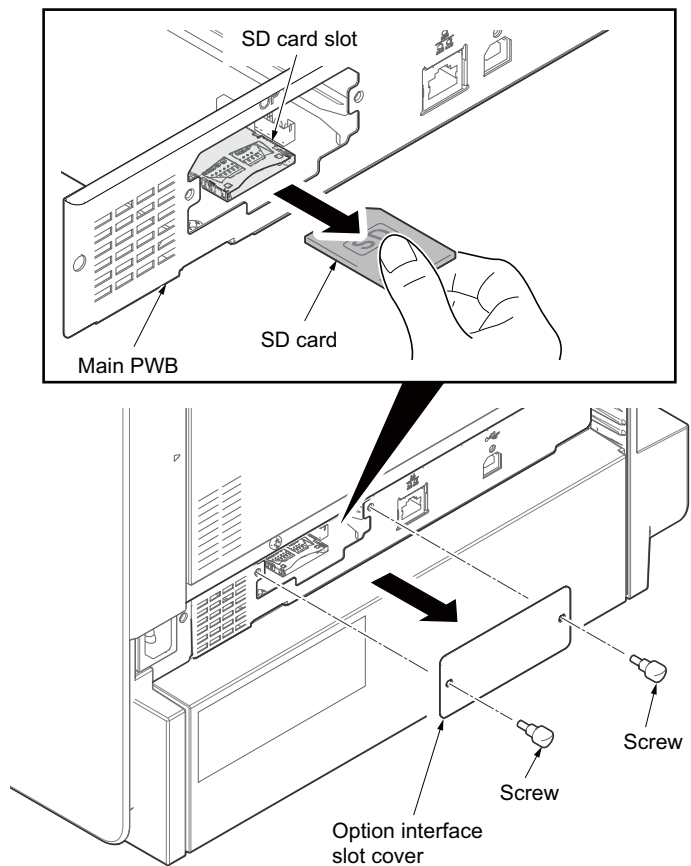

Figure 1-6-7

10. Insert the SD card to the PC's slot or to the adaptor.
11. Copy the firmware file to download to the root directory of the SD card.
12. Remove the SD card from the PC's slot or the adaptor.

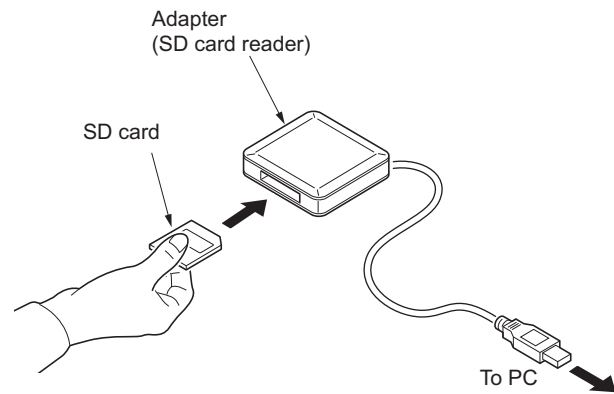

Figure 1-6-8

13. Insert the SD card into the SD card slot.
14. Refit the option interface slot cover.

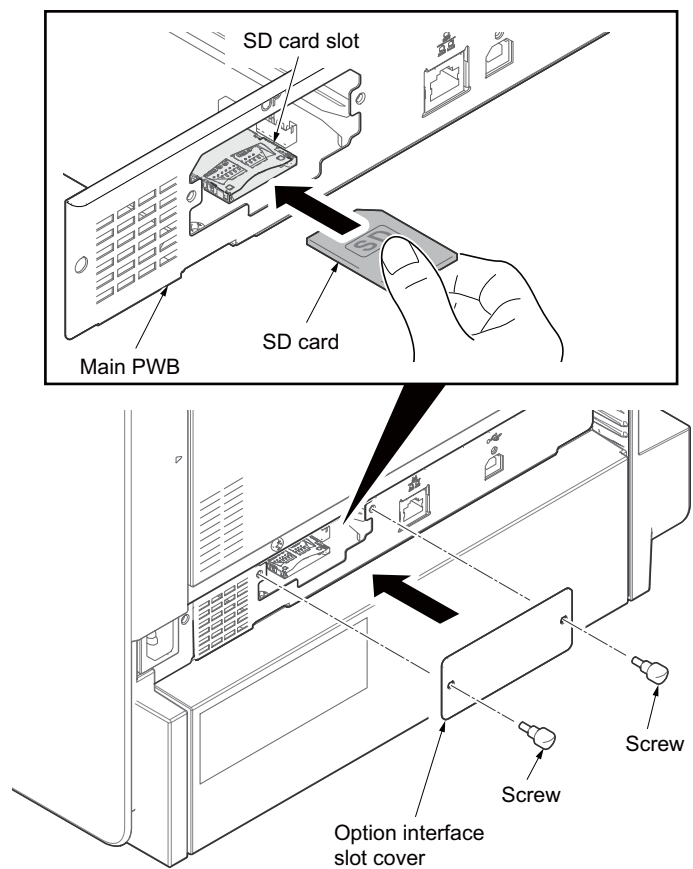

Figure 1-6-9

- 15. Turn printer power on.
- 16. When message display (1) is displayed to detect firmware in the SD card.
- 17. Message display (2) is displayed during downloading.
- 18. When message display (3) is displayed to indicate downloading is finished.

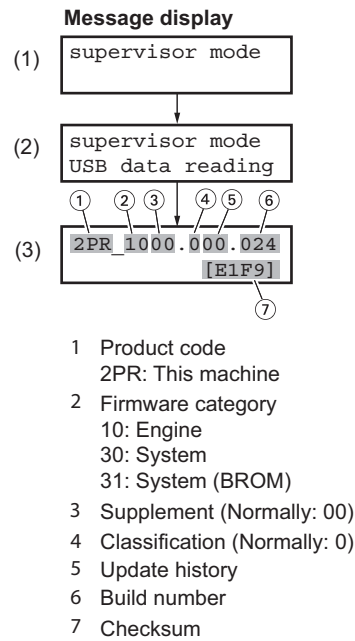

Figure 1-6-10

- 19. Turn printer power off.
- 20. Remove the two screws and then remove the option interface slot cover.
- 21. Remove the SD card from SD card slot.
- 22. Refit the option interface slot cover.
- 23. Turn printer power on.
- 24. Print the status page to check that the firmware version has been updated (See page P.1-3-2).

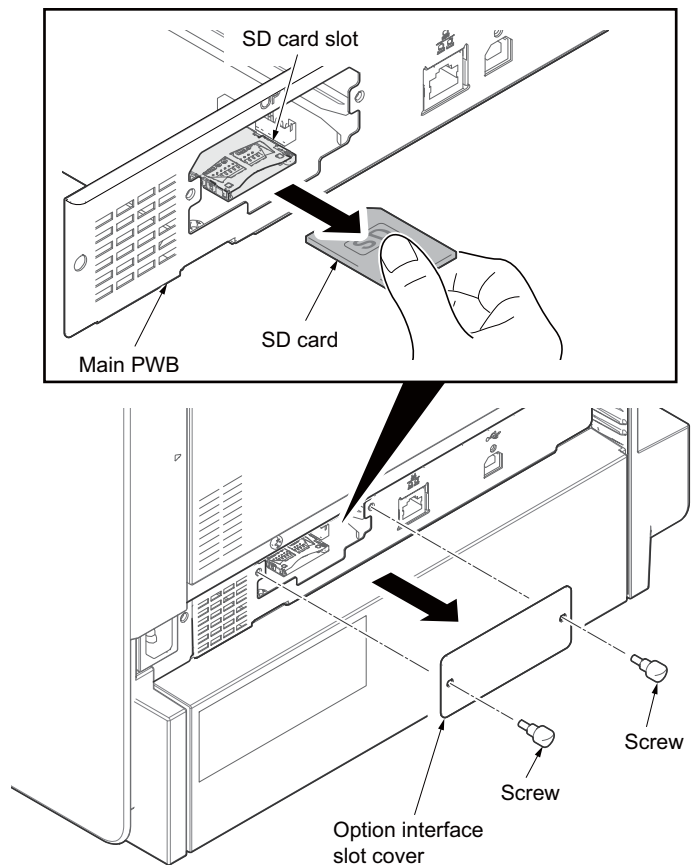

Figure 1-6-11

This page is intentionally left blank.

2-1-1 Paper feed/conveying section

Paper feed/conveying section consists of the paper feed unit that feeds paper from the cassette and the MP tray paper feed unit that feeds paper from the MP tray, and the paper conveying section that conveys the fed paper to the transfer/separation section.

(1) Cassette paper feed section

The cassette can contain 500 sheets. The sheet from the cassette is pulled out by rotation of the pickup roller and sent to the paper conveying section by rotation of the paper feed roller. Also the retard roller prevents multiple feeding of paper.

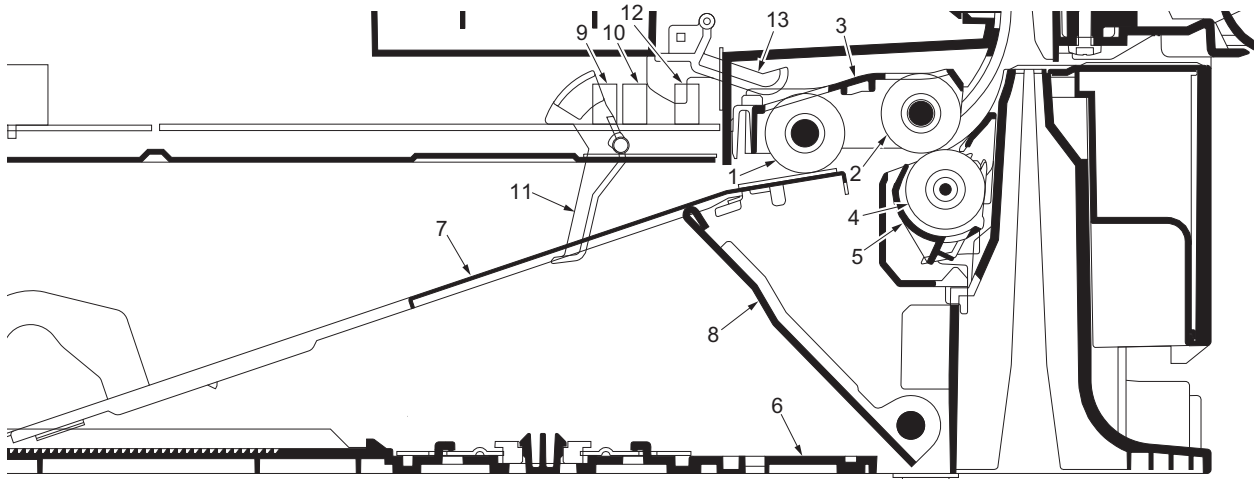

Figure 2-1-1 Cassette paper feed section

- | | |
|-----------------------|-----------------------------------|
| (1) Pickup roller | (8) Lift work plate |
| (2) Paper feed roller | (9) Paper sensor 1 |
| (3) Paper feed holder | (10) Paper sensor 2 |
| (4) Retard roller | (11) Actuator (paper sensor 1/2) |
| (5) Retard holder | (12) Lift limit sensor |
| (6) Cassette base | (13) Actuator (lift limit sensor) |
| (7) Bottom plate | |

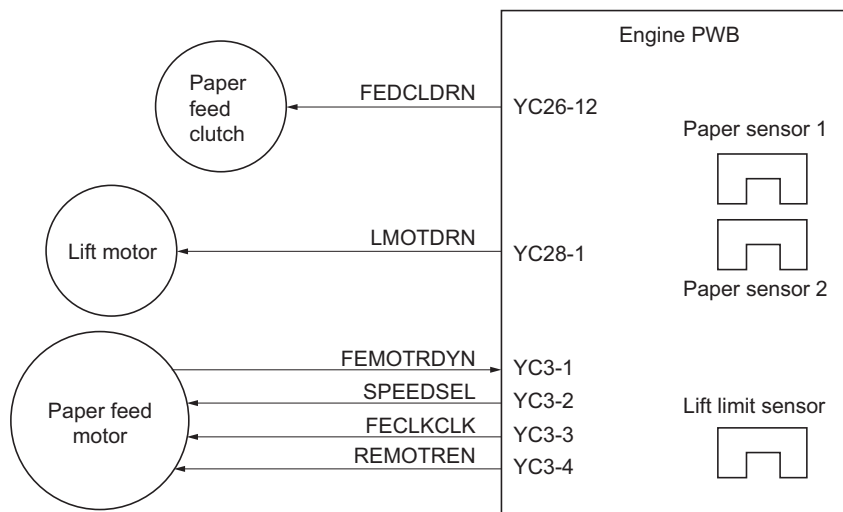

Figure 2-1-2Cassette paper feed section block diagram

(2) MP tray paper feed section

The MP tray can contain about 150 sheets. Feeding from the MP tray is performed by the rotation of the MP paper feed roller. Also, function of the MPF separation pad prevents paper from multiple feeding.

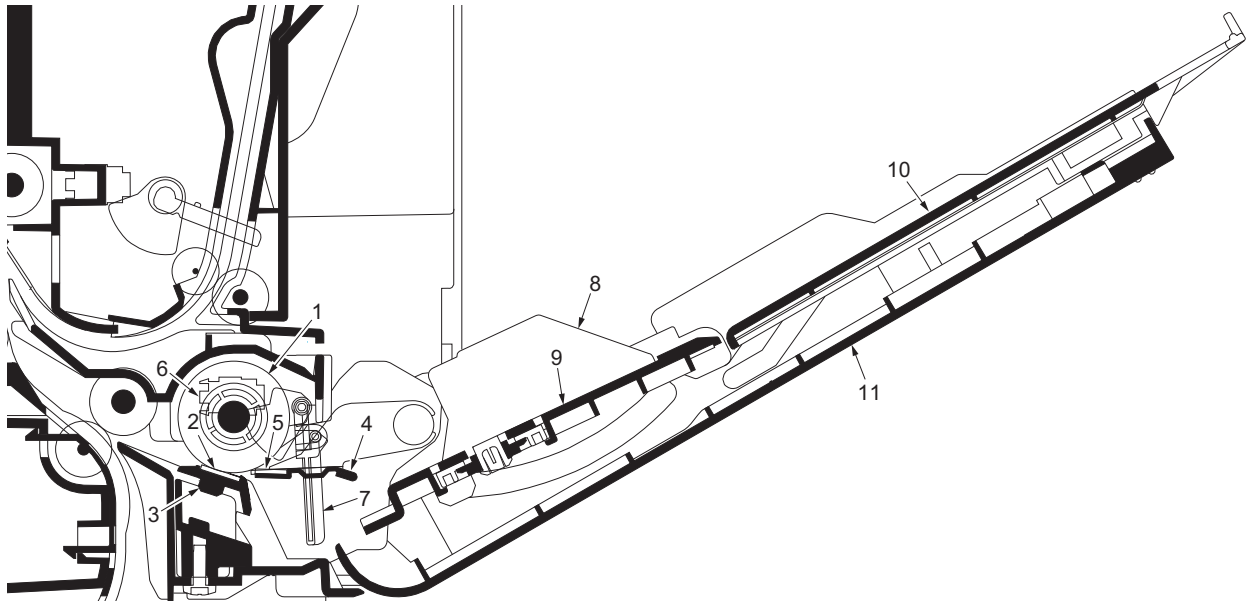

Figure 2-1-3 MP tray paper feed section

- | | | |
|--------------------------|-------------------------------|---------------------|
| (1) MP paper feed roller | (5) MPF friction pad | (9) MPF base |
| (2) MPF separation pad | (6) MP tray sensor | (10) MPF upper tray |
| (3) MPF separator | (7) Actuator (MP tray sensor) | (11) MPF cover |
| (4) MPF bottom plate | (8) MPF guide R/L | |

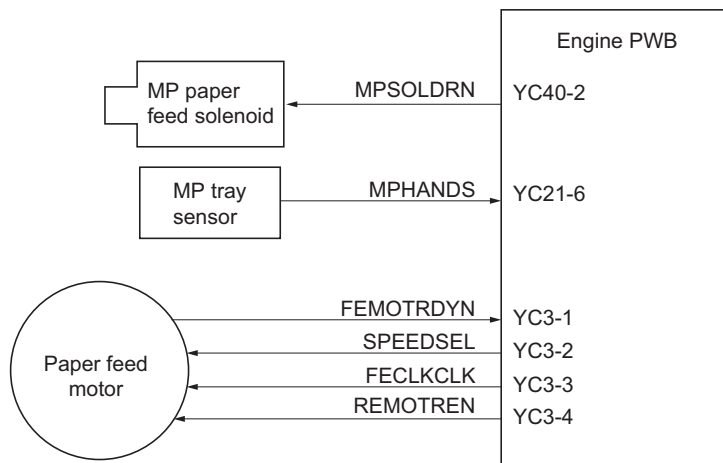

Figure 2-1-4 MP tray paper feed section block diagram

(3) Paper conveying section

The paper conveying section conveys paper to the transfer/separation section as paper feeding from the cassette or MP tray, or as paper refeeding for duplex printing. Paper by feeding is conveyed by the middle roller to the position where the registration sensor is turned on, and then sent to the transfer/separation section by the front registration roller and rear registration roller.

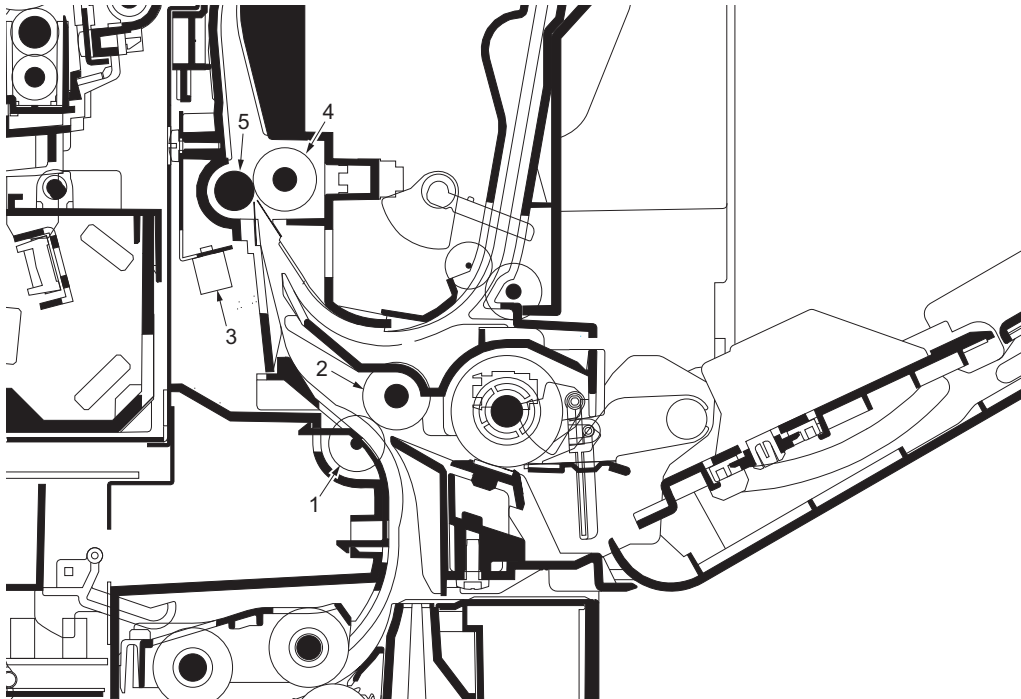

Figure 2-1-5 Paper conveying section

- (1) Feed pulley
- (2) Middle roller
- (3) Registration sensor
- (4) Front registration roller
- (5) Rear registration roller

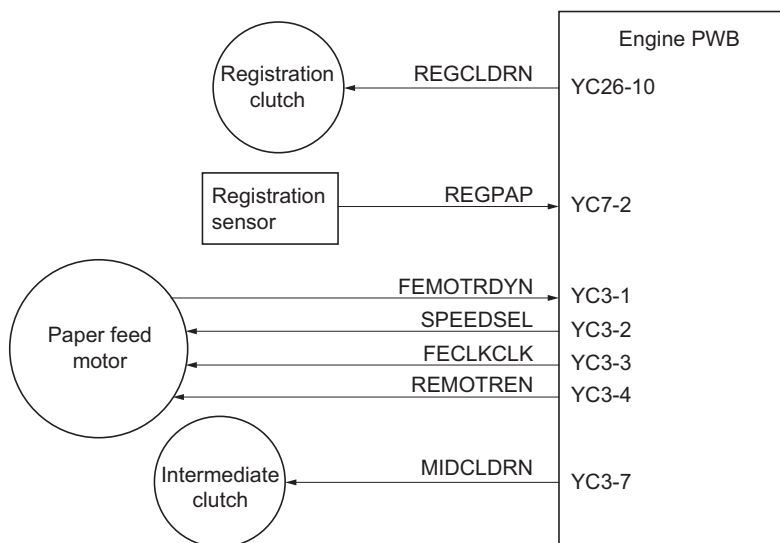

Figure 2-1-6 Paper conveying section block diagram

2-1-2 Drum section

(1) Drum section

The drum section consists of the drum, the main charger unit, and the cleaning unit, and the drum surface is uniformly charged in preparation for formation of residual image by laser beam. After transfer is complete, toner remaining on the drum surface is chipped off with the cleaning blade and is collected to the waste toner box with the drum screw. Also electric charge remaining on the drum surface is eliminated by irradiating the eraser lamp for preparing for next charge of the main charger.

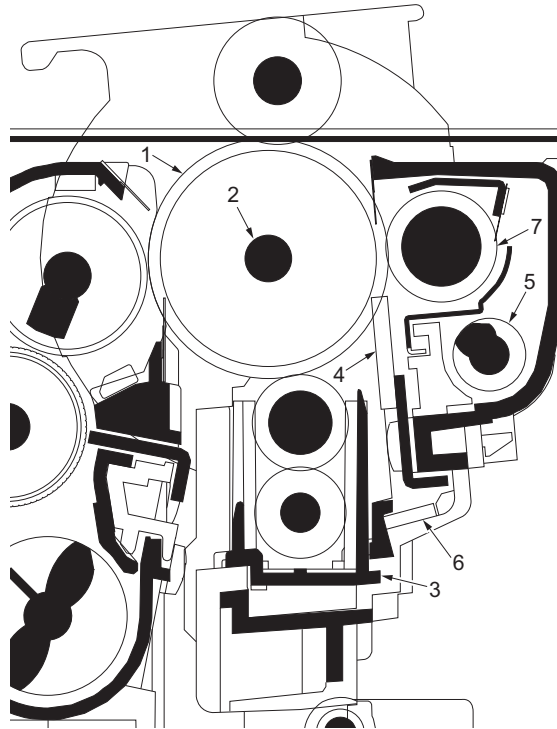

Figure 2-1-7 Drum section

- (1) Drum
- (2) Drum shaft
- (3) Main charger unit
- (4) Cleaning blade
- (5) Drum screw
- (6) Eraser lamp
- (7) Cleaning roller

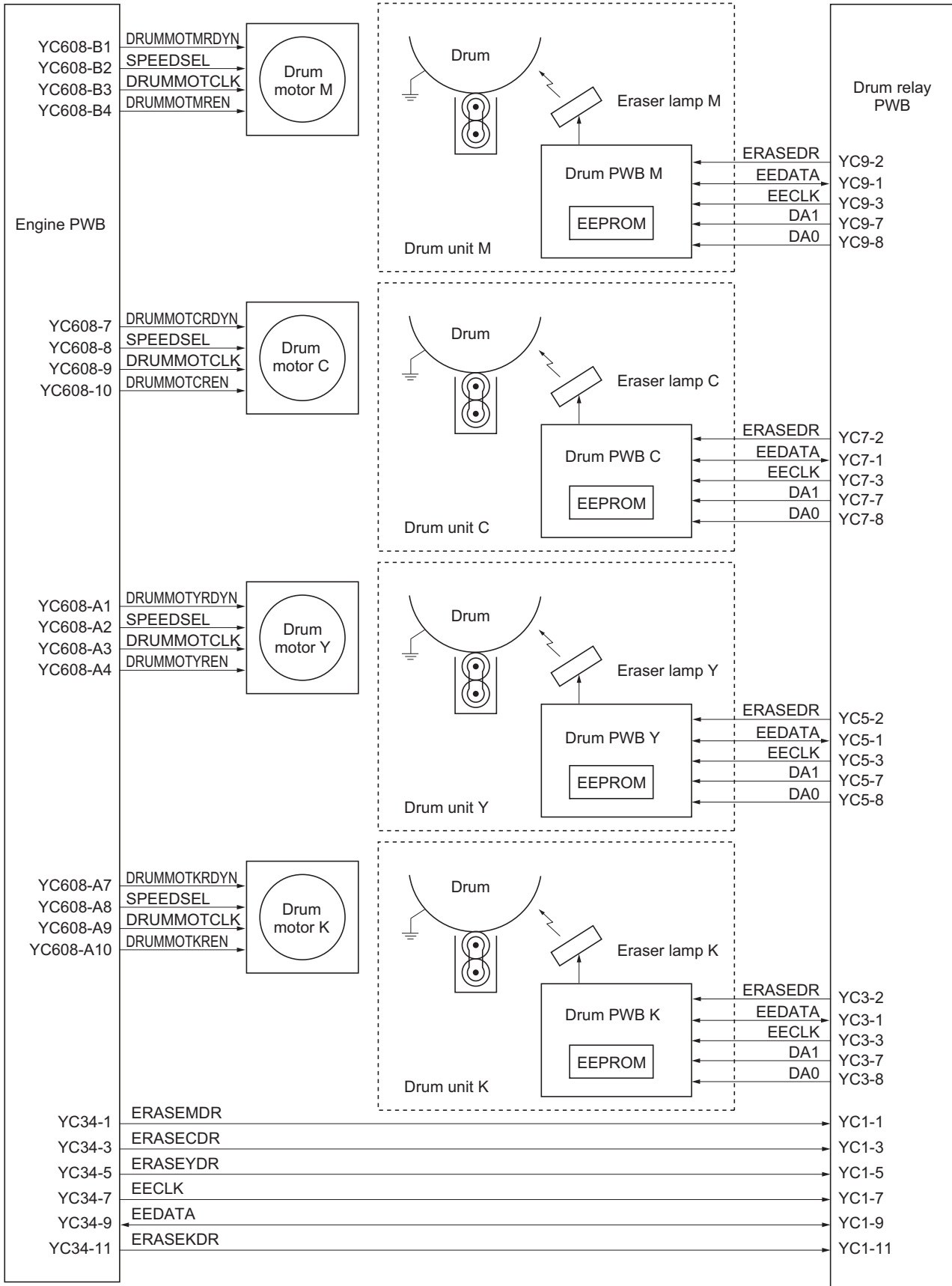

Figure 2-1-8 Drum section block diagram

(2) Main charger unit

The main charger unit consists of the MC case, the MC roller, and the MC CLN roller, and charges the drum for image forming.

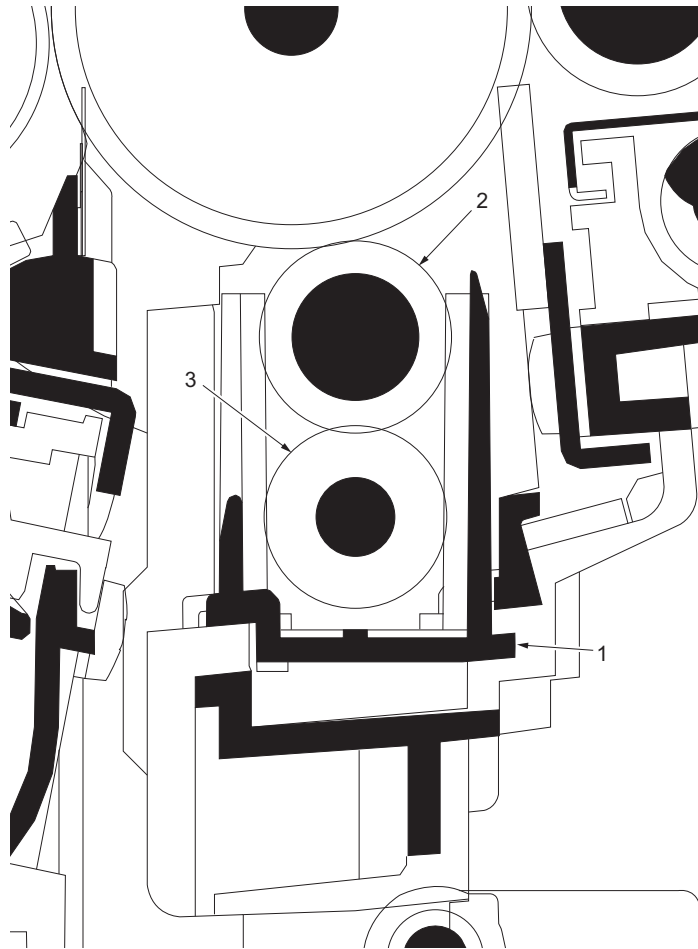

Figure 2-1-9 Main charger unit

- (1) MC case
- (2) MC roller
- (3) MC CLN roller

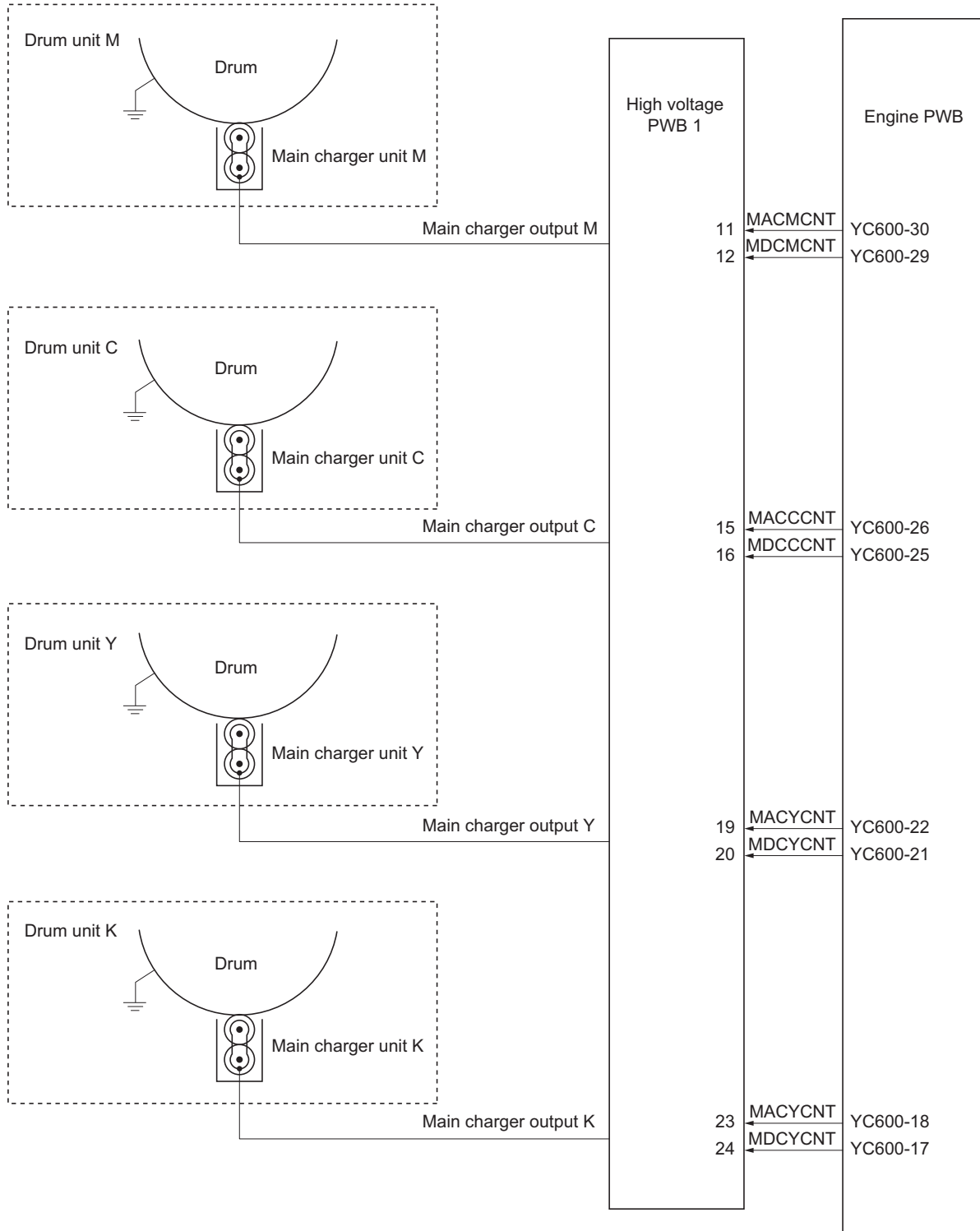

Figure 2-1-10 Main charger section block diagram

2-1-3 Expose section

(1) Laser scanner unit

The charged surface of the drum is then scanned by the laser beam from the laser scanner unit. The laser beam is dispersed as the polygon motor revolves to reflect the laser beam over the drum. Various lenses and mirror are housed in the laser scanner unit, adjust the diameter of the laser beam, and focalize it at the drum surface. Also the LSU cleaning motor is activated to conduct automatically cleaning of the LSU dust shield glass.

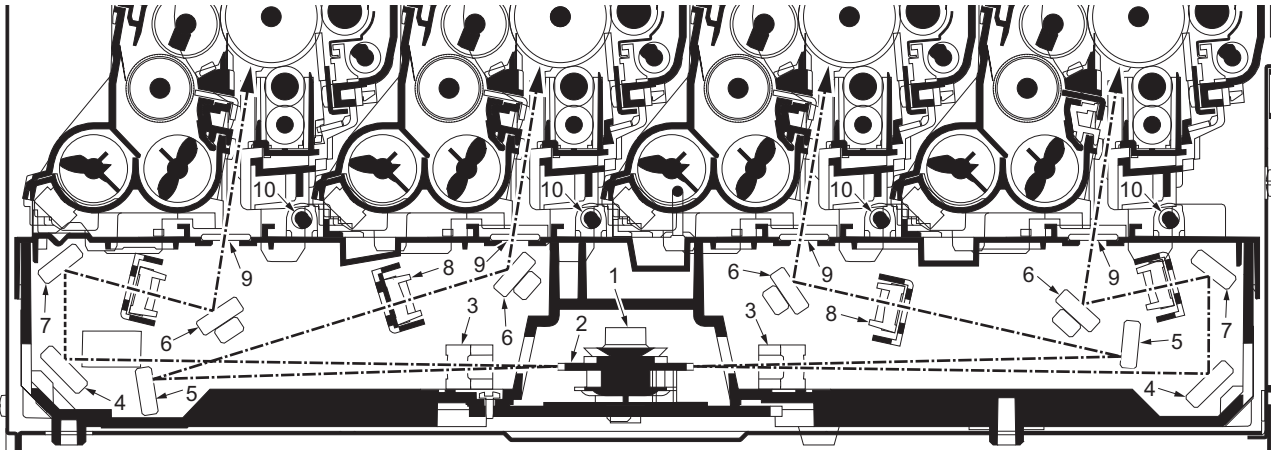

Figure 2-1-11 Laser scanner unit

- | | |
|--------------------|---------------------------|
| (1) Polygon motor | (6) Mirror C |
| (2) Polygon mirror | (7) Mirror B |
| (3) F lens A | (8) F lens B |
| (4) Mirror A | (9) LSU dust shield glass |
| (5) Mirror D | (10) LSU spiral |

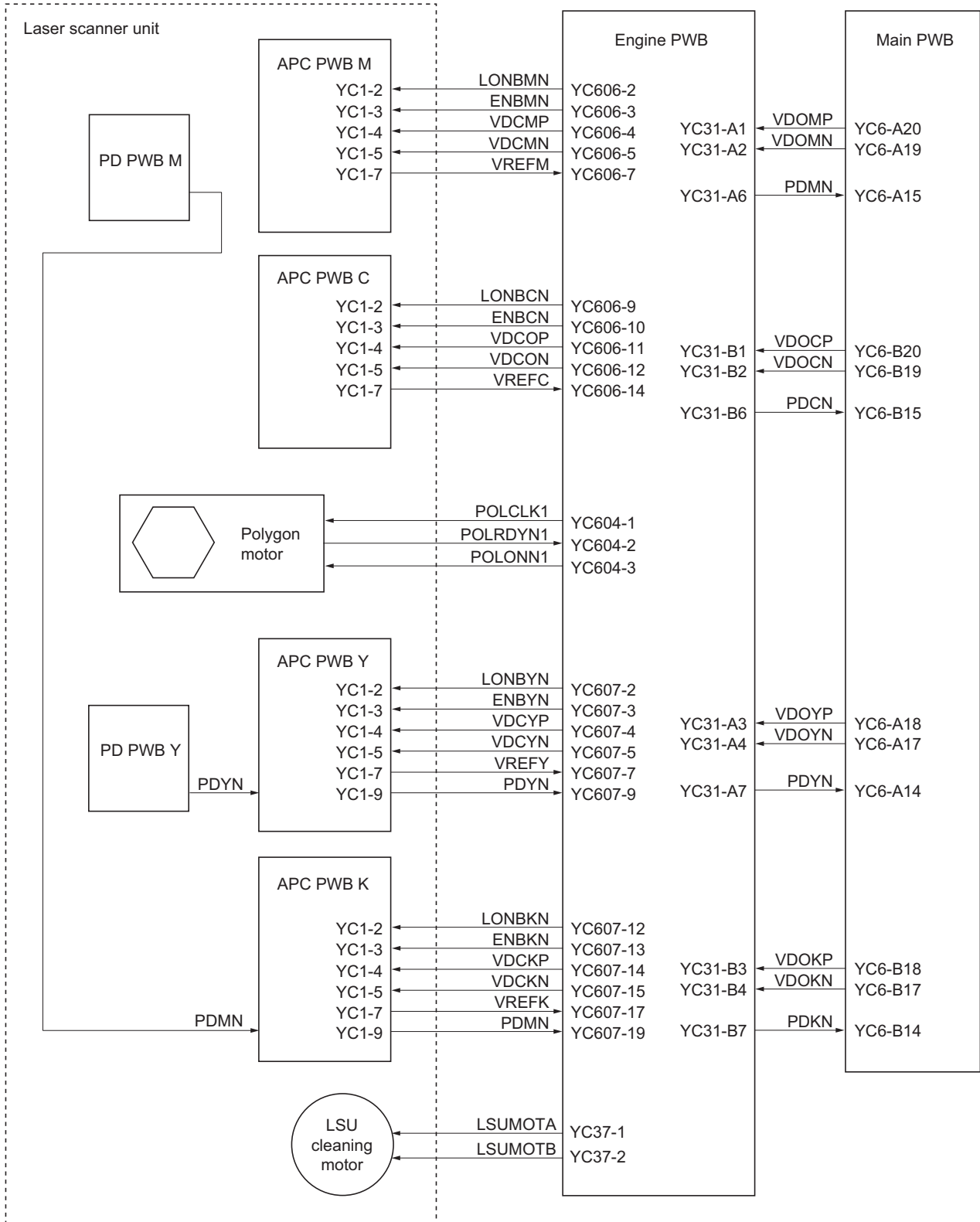

Figure 2-1-12Expose section block diagram

2-1-4 Developing section

The developing unit consists of the sleeve roller that forms the magnetic brush, the magnet roller, the developing blade and the developing screws that agitate the toner. Also, the toner sensor checks whether or not toner remains in the developing unit.

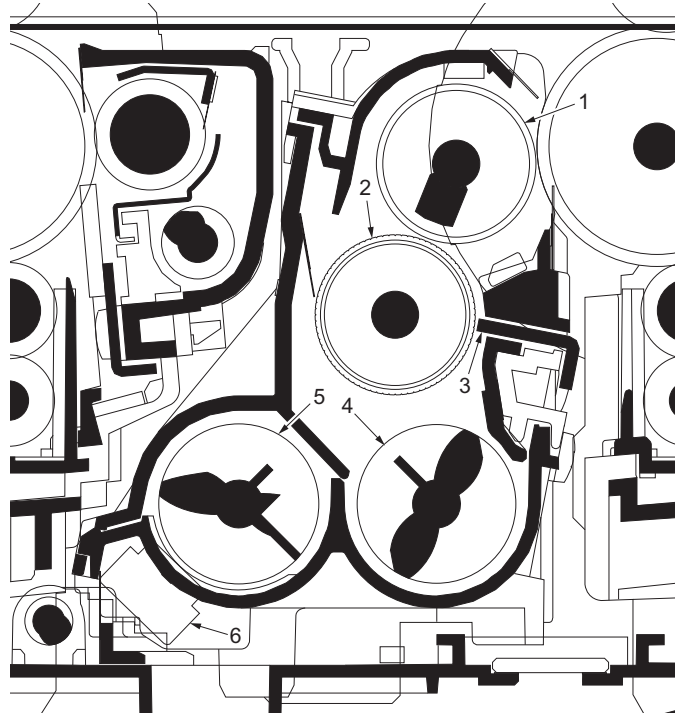

Figure 2-1-13 Developing unit and toner container

- (1) Sleeve roller
- (2) Magnet roller
- (3) Developing blade
- (4) Developing screw A
- (5) Developing screw B
- (6) Sleeve cover
- (7) Toner sensor

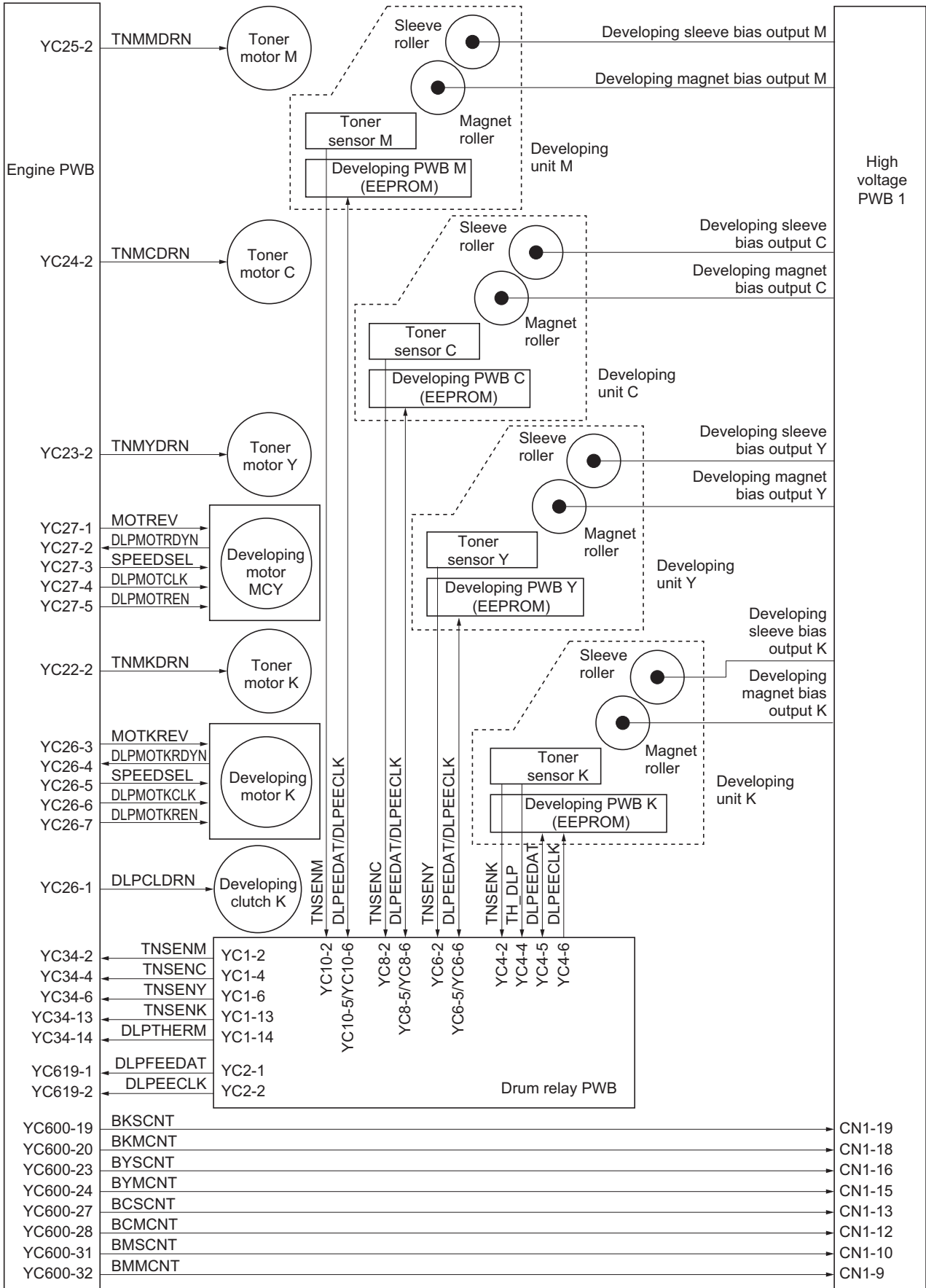

Figure 2-1-14 Developing section block diagram

2-1-5 Transfer/separation section

The transfer/separation section consists of the intermediate transfer unit and the transfer roller unit. The intermediate transfer unit consists of the transfer cleaning unit, the transfer belt, and the four primary transfer rollers for respective color drums, and forms a full-color toner image by superimposing and transferring single-color toner images formed on each drum onto the transfer belt. Also with the left and right ID sensors mounted on the machine frame, the toner density on the transfer belt is measured. The transfer cleaning unit collects toner remaining on the transfer belt after secondary transfer and forwards it as waste toner to the waste toner box. The transfer roller unit consists of the secondary transfer roller mounted to the paper conveying unit and the separation brush. To the secondary transfer roller, DC bias is applied from the high voltage PWB. The toner image formed on the transfer belt is transferred to the paper by the potential difference and the paper is separated by curvature separation and separation needle (DC bias).

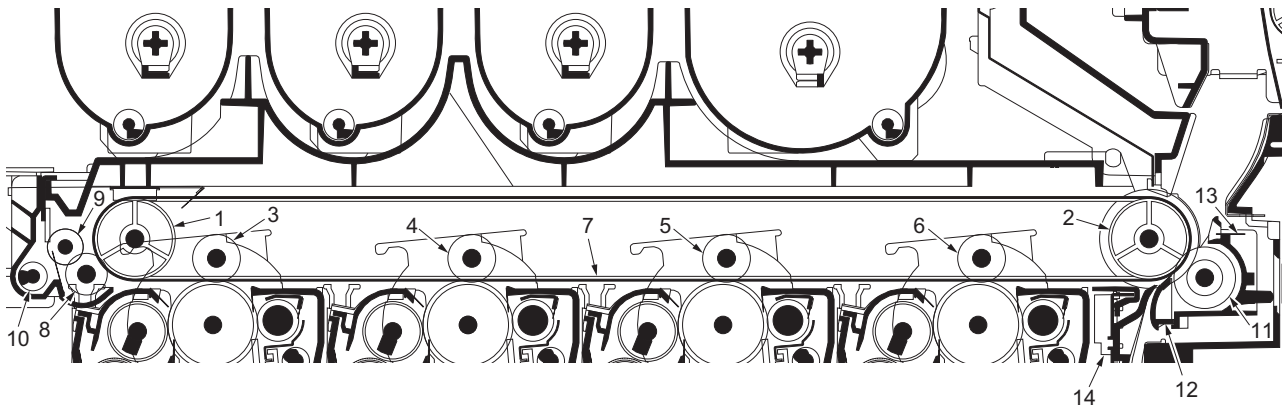

Figure 2-1-15 Transfer/separation section

- | | |
|-------------------------------|-------------------------------------|
| (1) Tension roller | (8) Cleaning fur brush |
| (2) Drive roller | (9) Cleaning roller |
| (3) Primary transfer roller M | (10) Cleaning screw |
| (4) Primary transfer roller C | (11) Secondary transfer roller |
| (5) Primary transfer roller Y | (12) Paper chute |
| (6) Primary transfer roller K | (13) Separation needle |
| (7) Transfer belt | (14) Left ID sensor/Right ID sensor |

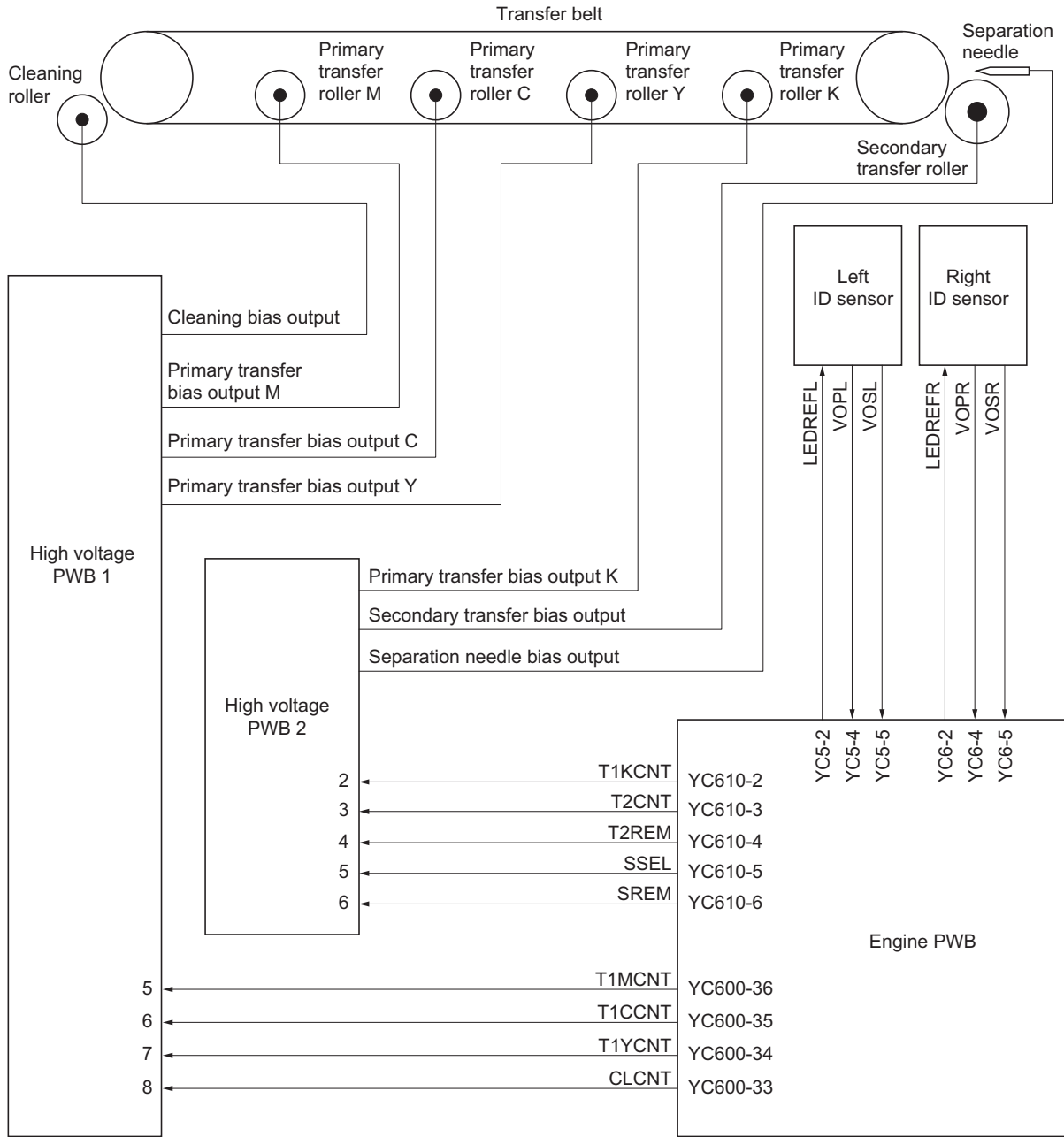

Figure 2-1-16 Transfer/separation section block diagram

2-1-6 Fuser section

The paper sent from the transfer/separation section is interleaved between the heat roller and the fuser belt (press roller). The heat roller is heated by the fuser heater lamp, and the toner is fused by heat and pressure and fixed onto the paper because the press roller is pressed by the fuser press spring. The surface temperature of heat roller is detected by the fuser thermistor 1/2 and controlled by the engine PWB. If the fuser section shows extremely high temperature, the power line will be shut off and the fuser heater lamp is forced to turn off.

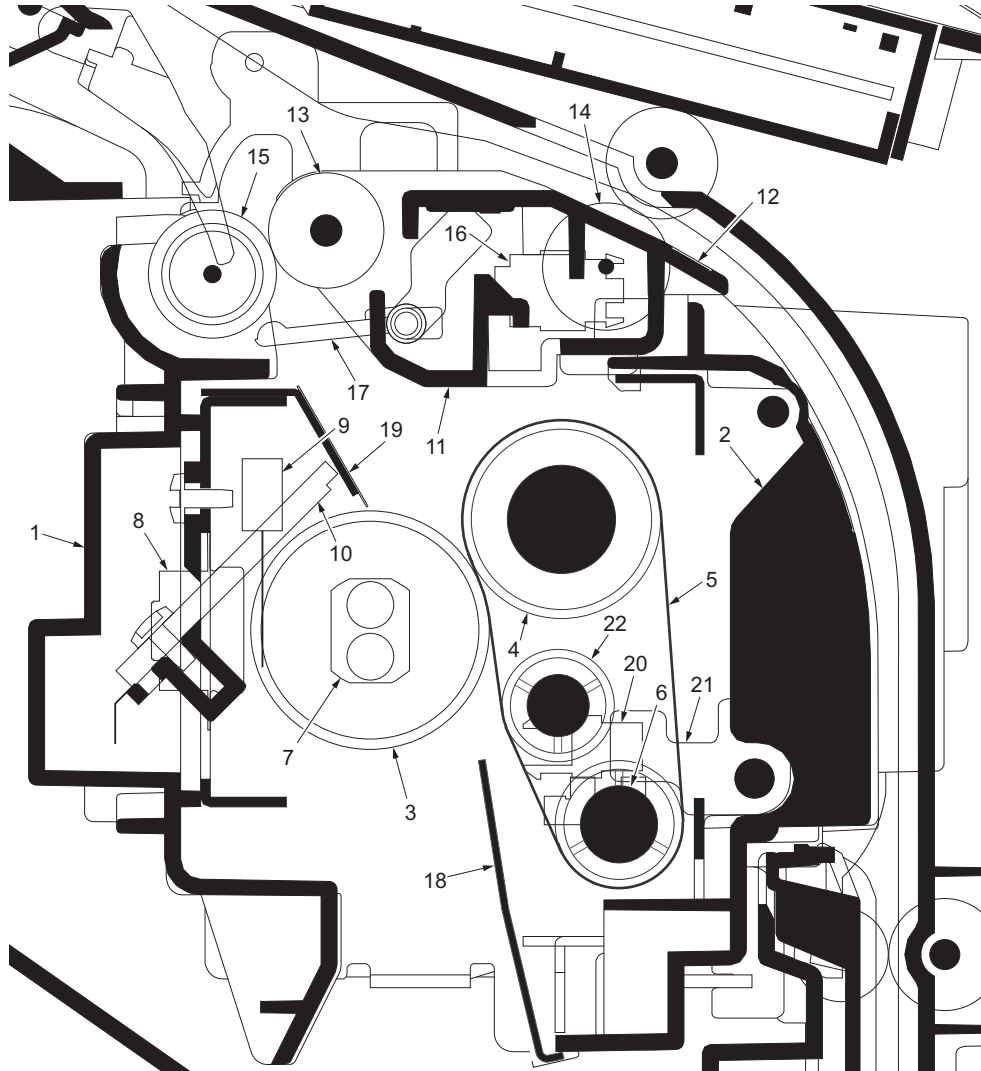

Figure 2-1-17 Fuser section

- | | |
|--------------------------|--|
| (1) Upper fuser frame | (13) Paper exit roller |
| (2) Lower fuser cover | (14) Paper exit pulley |
| (3) Heat roller | (15) Paper exit pulley/
Paper exit pulley PFA |
| (4) Press roller | (16) Paper exit sensor |
| (5) Fuser belt | (17) Actuator (paper exit sensor) |
| (6) Belt roller | (18) Fuser paper chute |
| (7) Fuser heater lamp | (19) Separator |
| (8) Fuser thermal cutout | (20) Fuser pressure change sensor |
| (9) Fuser thermistor 1 | (21) Actuator
(Fuser pressure change sensor) |
| (10) Fuser thermistor 2 | (22) Belt guide roller |
| (11) Paper exit guide | |
| (12) DU guide | |

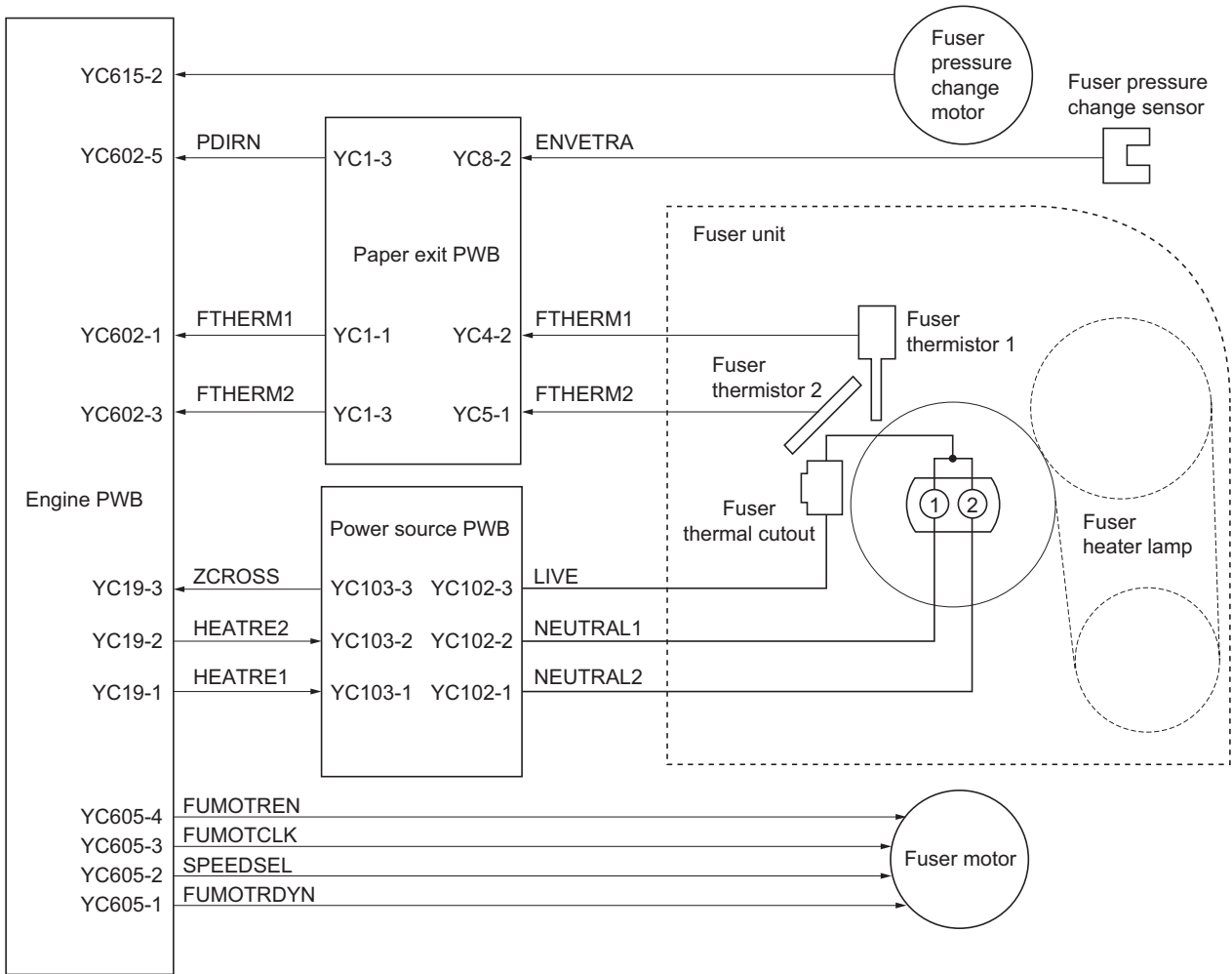

Figure 2-1-18 Fuser section block diagram

2-1-7 Paper exit/feed shift section

The paper exit/feedshift section consists of the conveying path which sends the paper that has passed the fuser section to the top tray or the duplex section. The conveying path is switched by the change guide activated by the duplex solenoid.

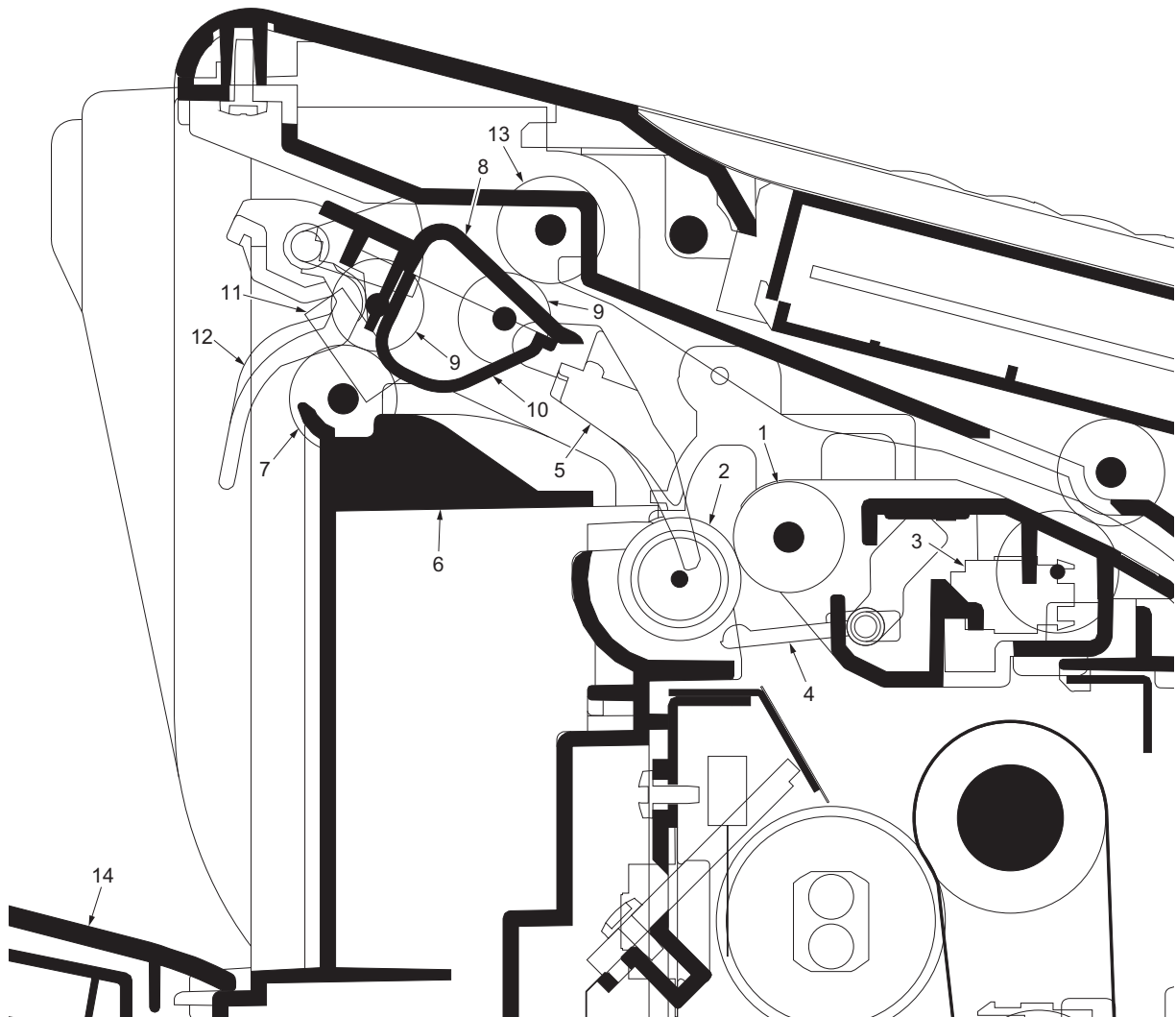

Figure 2-1-19 Paper exit/feed shift section

- | | |
|---|-----------------------------------|
| (1) Paper exit roller | (8) Paper exit upper guide |
| (2) Paper exit pulley/
Paper exit pulley PFA | (9) Middle pulley |
| (3) Paper exit sensor | (10) corrugation guide |
| (4) Actuator (paper exit sensor) | (11) Paper full sensor |
| (5) Change guide | (12) Actuator (paper full sensor) |
| (6) Paper exit housing | (13) DU roller |
| (7) FD roller | (14) Top tray |

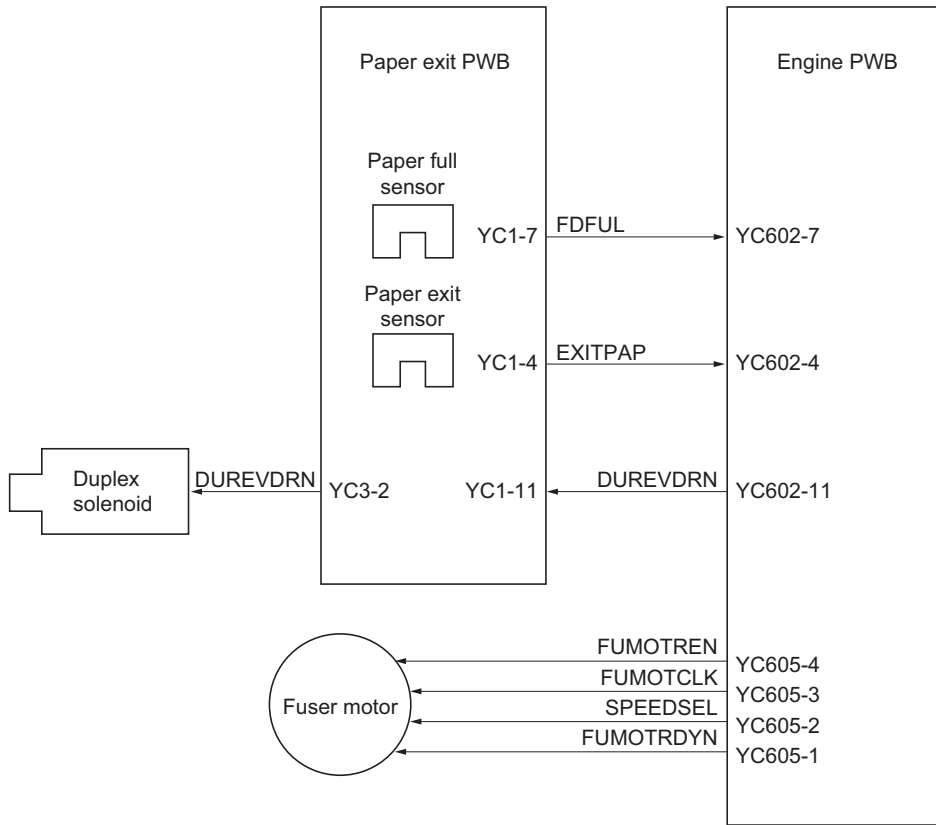

Figure 2-1-20 Paper exit section block diagram

2-1-8 Duplex/conveying section

The duplex/conveying section consists of conveying path which sends the paper sent from the eject section to the paper feed/conveying section when duplex printing.

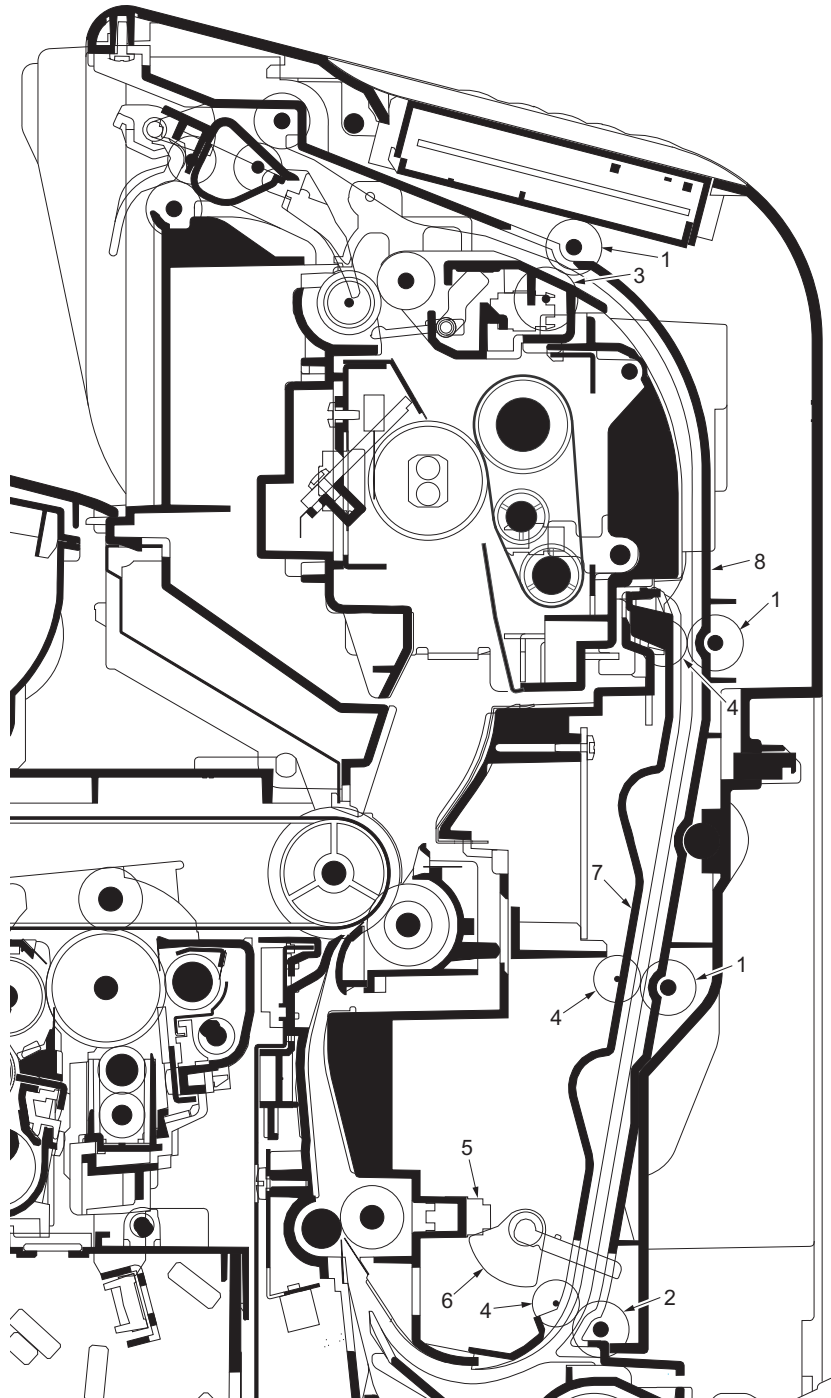

Figure 2-1-21 Duplex/conveying section

- | | |
|-----------------------------|---------------------------|
| (1) DU roller | (6) Actuator |
| (2) DU feed roller | (duplex conveying sensor) |
| (3) Paper exit pulley | (7) DU feed guide |
| (4) PA pulley | (8) DU base |
| (5) Duplex conveying sensor | |

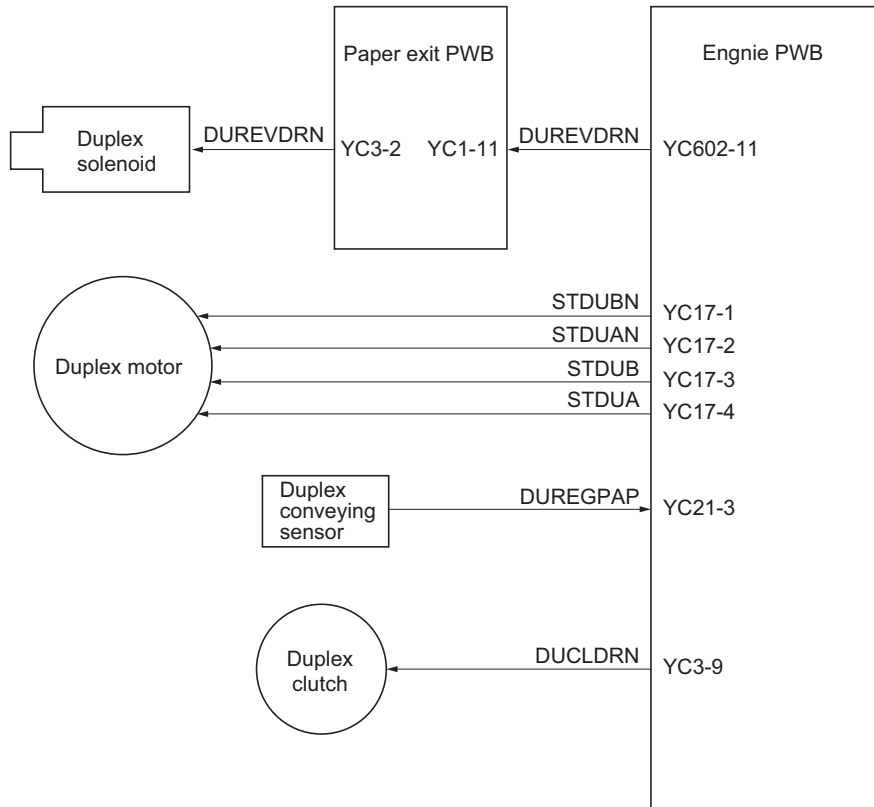

Figure 2-1-22 Duplex/paper conveying section block diagram

This page is intentionally left blank.

2-2-1 Electrical parts layout

(1) PWBs

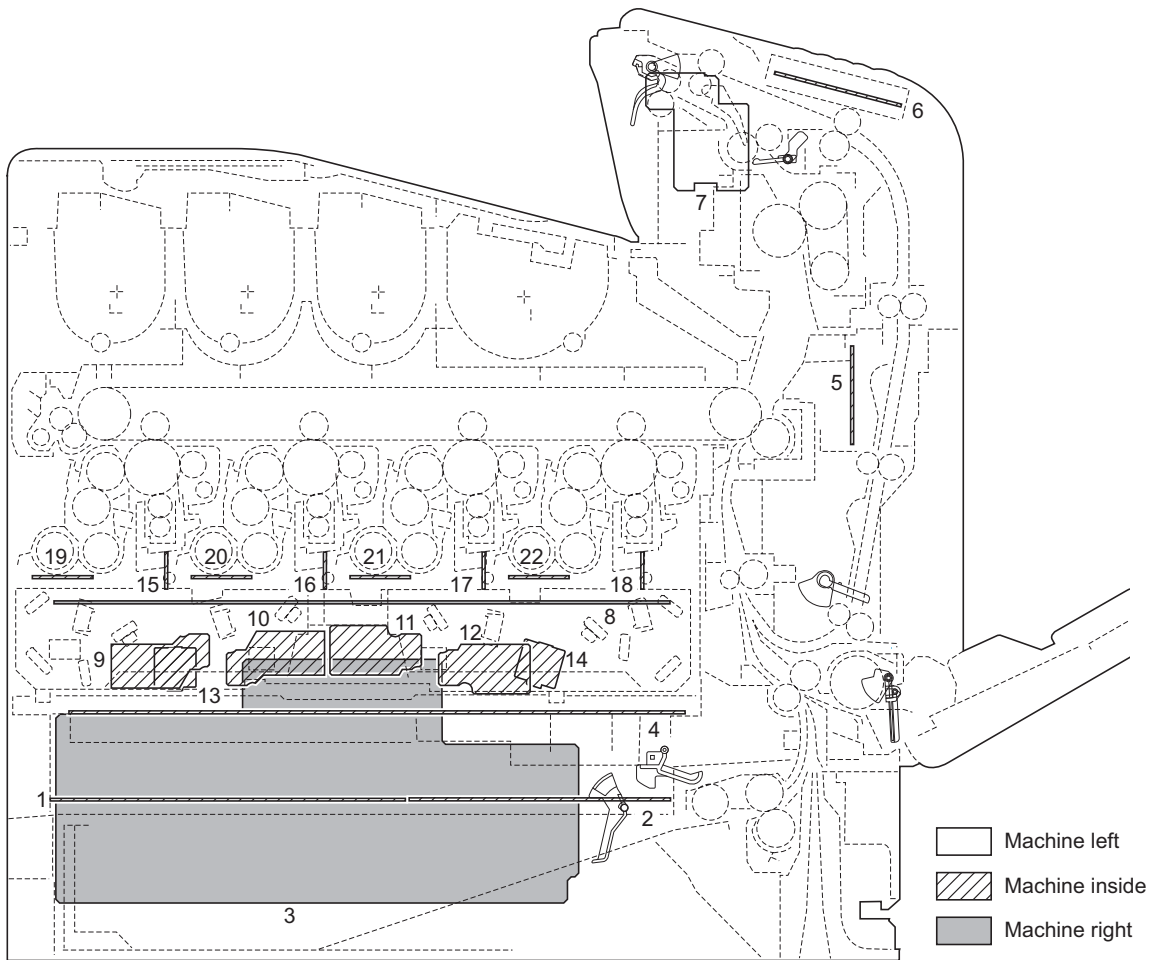

Figure 2-2-1 PWBs

- | | | |
|-----|---------------------------|---|
| 1. | Main PWB | Controls the software such as the print data processing and provides the interface with computers. |
| 2. | Engine PWB | Controls printer hardware such as high voltage/bias output control, paper conveying system control, and fuser temperature control, etc. |
| 3. | Power source PWB | After full-wave rectification of AC power source input, switching for converting to 24 V DC for output. Controls the fuser heater lamp 1/2. |
| 4. | High voltage PWB 1 | Generates main charging, developing bias, primary transfer bias (yellow, cyan and magenta) and cleaning bias. |
| 5. | High voltage PWB 2 | Generates primary transfer bias (black), secondary transfer bias and separation needle charging. |
| 6. | Operation panel PWB | Controls the LCD display. Consists the LCD display, LED indicators and key switches. |
| 7. | Paper exit PWB | Interconnects the engine PWB and the electrical parts (paper exit section). |
| 8. | Drum relay PWB | Interconnects the engine PWB and the drum units/developing units. |
| 9. | APC PWB C | Generates and controls the laser beam. (cyan) |
| 10. | APC PWB M | Generates and controls the laser beam. (magenta) |
| 11. | APC PWB K | Generates and controls the laser beam. (black) |
| 12. | APC PWB Y | Generates and controls the laser beam. (yellow) |
| 13. | PD PWB M | Controls horizontal synchronizing timing of laser beam. (yellow, black) |
| 14. | PD PWB Y | Controls horizontal synchronizing timing of laser beam. (magenta, cyan) |

15. Drum PWB M..... Relays wirings from electrical components on the drum unit M. Drum individual information in EEPROM storage.
16. Drum PWB C Relays wirings from electrical components on the drum unit C. Drum individual information in EEPROM storage.
17. Drum PWB Y..... Relays wirings from electrical components on the drum unit Y. Drum individual information in EEPROM storage.
18. Drum PWB K..... Relays wirings from electrical components on the drum unit K. Drum individual information in EEPROM storage.
19. Developing PWB M..... Relays wirings from electrical components on the developing unit M.
20. Developing PWB C Relays wirings from electrical components on the developing unit C.
21. Developing PWB Y Relays wirings from electrical components on the developing unit Y.
22. Developing PWB K Relays wirings from electrical components on the developing unit K.

(2) Switches and sensors

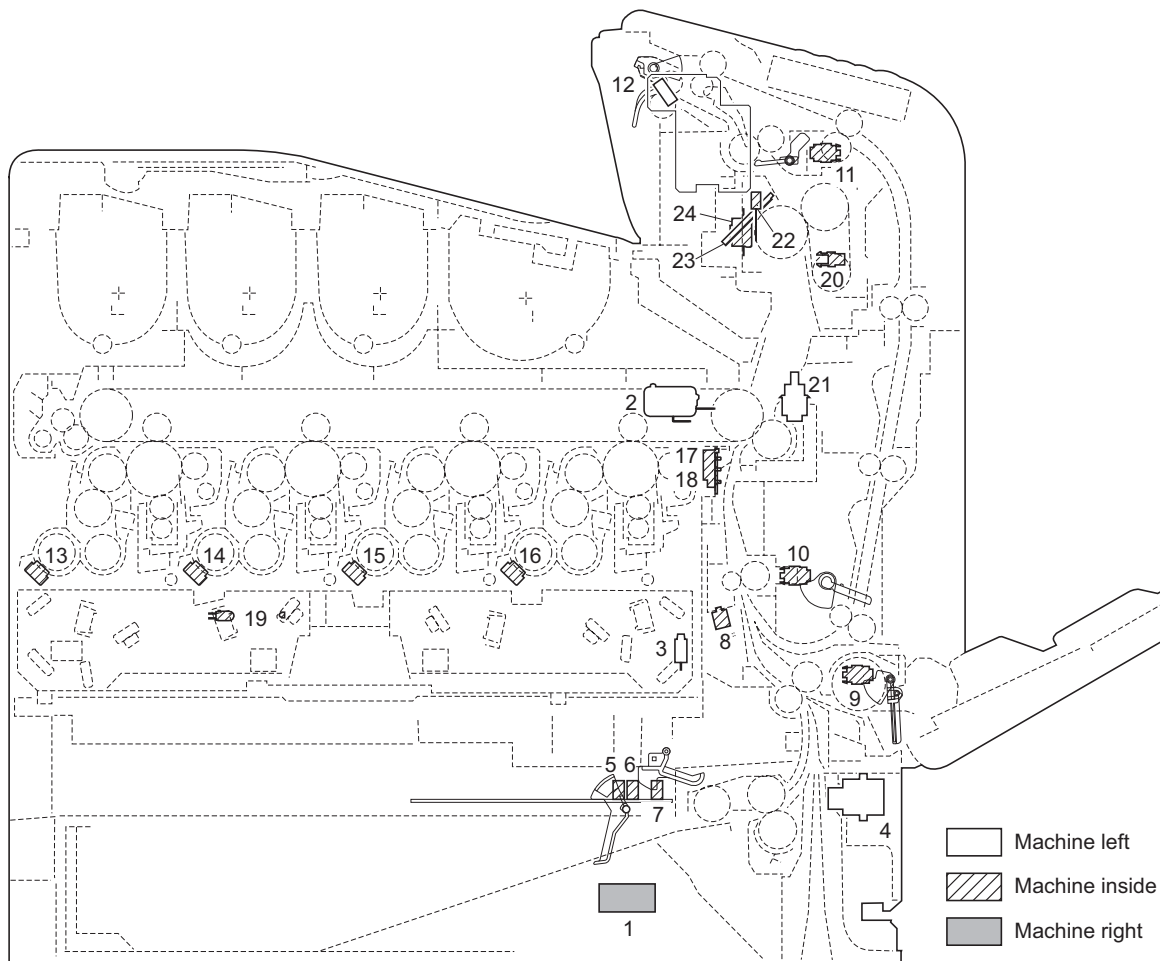

Figure 2-2-2 Switches and sensors

- | | |
|-----------------------------------|---|
| 1. Power switch | Turns ON/OFF the AC power source. |
| 2. Interlock switch | Shuts off 24 V DC power line when the top cover and front cover are opened. |
| 3. Left cover switch | Shuts off 24 V DC power line when the left cover is opened. |
| 4. Cassette size switch | Detects the paper size dial setting of the paper setting dial. |
| 5. Paper sensor 1 | Detects the presence of paper in the cassette. (Engine PWB) |
| 6. Paper sensor 2 | Detects the presence of paper in the cassette. (Engine PWB) |
| 7. Lift limit sensor | Detects activation of upper limit of the bottom plate in the cassette. |
| 8. Registration sensor | Detects the timing of primary paper feed. |
| 9. MP tray sensor | Detects the presence of paper on the MP tray. |
| 10. Duplex conveying sensor | Detects paper jam in the duplex section. |
| 11. Paper exit sensor | Detects paper jam in the fuser/paper exit section. (Paper exit PWB) |
| 12. Paper full sensor | Detects the paper full in the top tray. |
| 13. Toner sensor M | Detects the toner density in the developing unit M. |
| 14. Toner sensor C | Detects the toner density in the developing unit C. |
| 15. Toner sensor Y | Detects the toner density in the developing unit Y. |
| 16. Toner sensor K | Detects the toner density in the developing unit K. |
| 17. Right ID sensor | Measures image density for color calibration. |
| 18. Left ID sensor | Measures image density for color calibration. |
| 19. Waste toner full sensor | Detects the waste toner box being full. |
| 20. Fuser pressure change sensor | Detects the switching status of the fuser pressure. |
| 21. Front cover open/close switch | Detects open/close front cover. |
| 22. Fuser thermistor 1 | Measures the heat roller temperature (left). |

- 23. Fuser thermistor 2..... Measures the heat roller temperature (center).
- 24. Fuser thermal cutout..... Shuts off the power source to the fuser heater lamp 1/2 when the heat roller reaches extremely high temperature.

(3) Motors

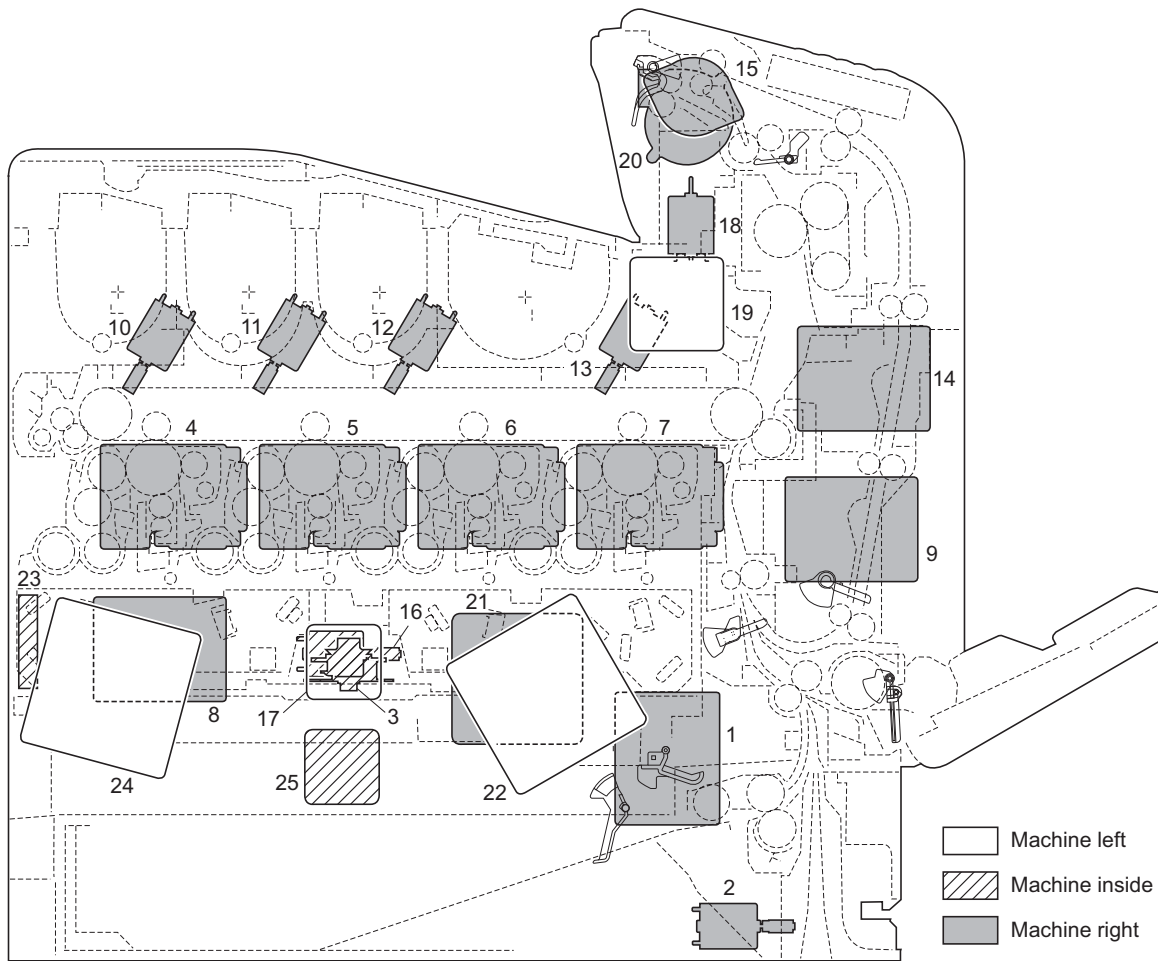

Figure 2-2-3 Motors

- | | |
|---------------------------------------|--|
| 1. Paper feed motor | Drives the paper feed section. |
| 2. Lift motor | Operates the bottom plate in the cassette. |
| 3. Polygon motor | Drives the polygon mirror. |
| 4. Drum motor M | Drives drum unit M. |
| 5. Drum motor C | Drives drum unit C. |
| 6. Drum motor Y | Drives drum unit Y. |
| 7. Drum motor K | Drives drum unit K. |
| 8. Developing motor MCY | Drives developing unit M, C and Y. |
| 9. Developing motor K | Drives developing unit K and intermediate transfer unit. |
| 10. Toner motor M | Replenishes the developing unit M with toner. |
| 11. Toner motor C | Replenishes the developing unit C with toner. |
| 12. Toner motor Y | Replenishes the developing unit Y with toner. |
| 13. Toner motor K | Replenishes the developing unit K with toner. |
| 14. Duplex motor | Drives duplex section. |
| 15. Fuser motor | Drives fuser section and paper exit section. |
| 16. LSU cleaning motor | Drives LSU dust shield glass cleaning system. |
| 17. LSU fan motor | Cools the LSU. |
| 18. Fuser pressure change motor | Switch drive of the fuser (press roller) pressure. |
| 19. Fuser fan motor 1 | Cools the duplex solenoid and fuser section. |
| 20. Fuser fan motor 2 | Disperses steam. |
| 21. Ozone fan motor | Cools the image formation section. The exhaust gas of ozone. |
| 22. Developing fan motor 1 | Cools the image formation section. |
| 23. Developing fan motor 2 | Cools the image formation section. |
| 24. Left side fan motor | Cools the image formation section. |
| 25. Power source fan motor | Cools the power source PWB. |

(4) Other electrical components

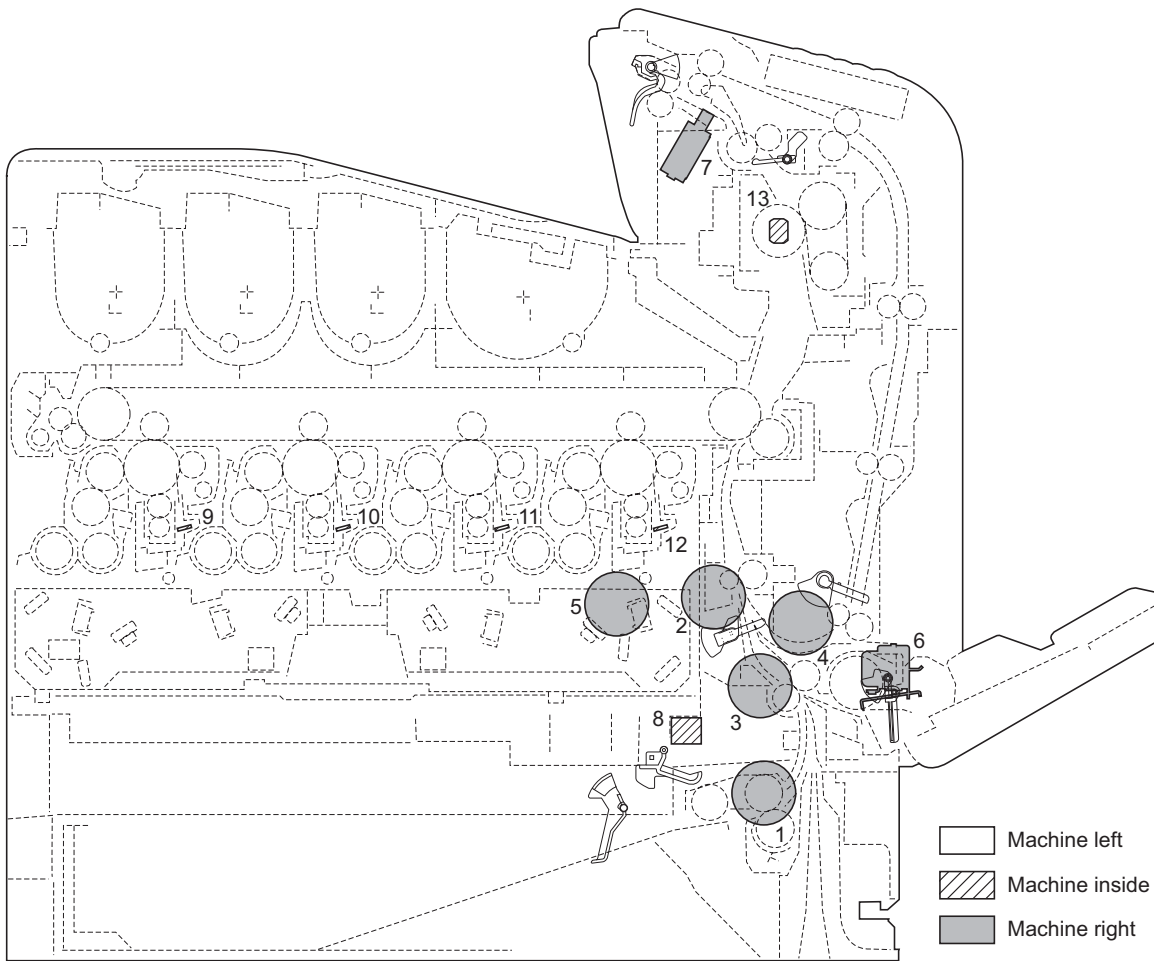

Figure 2-2-4 Other electrical components

- | | |
|---------------------------------|---|
| 1. Paper feed clutch | Controls the paper cassette paper feed. |
| 2. Registration clutch | Controls the secondary paper feed. |
| 3. Intermediate clutch | Controls the paper conveying at the conveying section. |
| 4. Duplex clutch | Controls the paper conveying at the duplex section. |
| 5. Developing clutch K | Detaches the drive transmission of developing units other than developing unit K at the time of B/W printing. |
| 6. MP paper feed solenoid | Controls the MPF bottom plate of the MP tray. |
| 7. Duplex solenoid | Operates the change guide. |
| 8. ID solenoid | Operates the ID sensors cleaning system. |
| 9. Eraser lamp M | Eliminates the residual electrostatic charge on the drum. (magenta) |
| 10. Eraser lamp C | Eliminates the residual electrostatic charge on the drum. (cyan) |
| 11. Eraser lamp Y | Eliminates the residual electrostatic charge on the drum. (yellow) |
| 12. Eraser lamp K | Eliminates the residual electrostatic charge on the drum. (black) |
| 13. Fuser heater lamp1/2 | Heats the heat roller. |

2-3-1 Power source PWB

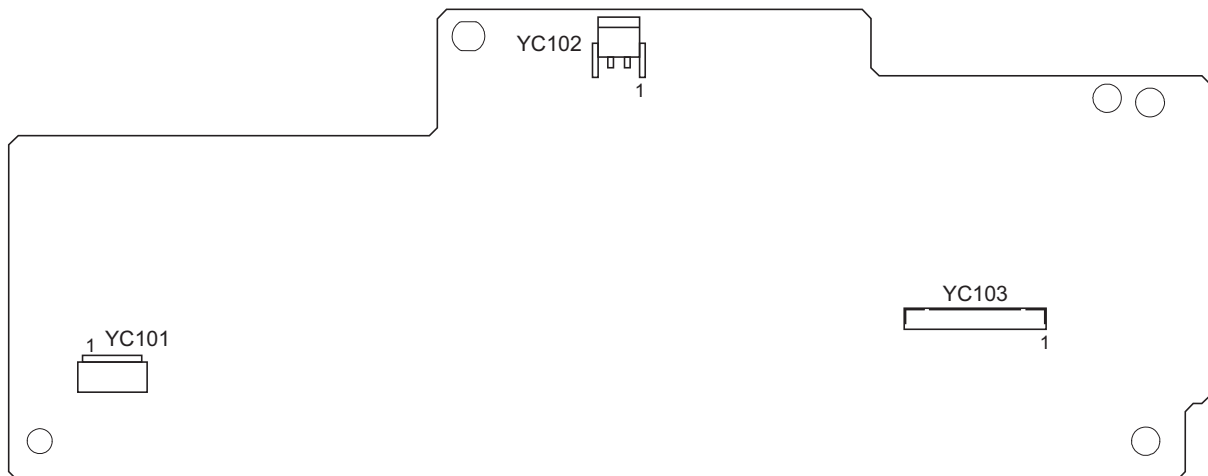

Figure 2-3-1 Power source PWB silk-screen diagram

Connector	Pin	Signal	I/O	Voltage	Description
YC101	1	LIVE	I	120 V AC 220 - 240 V AC	AC power input
Connected to the AC inlet and power switch.	2	NEUTRAL	I	120 V AC 220 - 240 V AC	AC power input
YC102	1	NEUTRAL2	O	120/0 V AC 220 - 240/0 V AC	Fuser heater lamp 2: On/Off
Connected to the fuser heater lamp 1/2.	2	NEUTRAL1	-	120/0 V AC 220 - 240/0 V AC	Fuser heater lamp 1: On/Off
	3	LIVE	O	120 V AC 220 - 240 V AC	AC power output
YC103	1	HEATREN1	I	0/24 V DC	Fuser heater lamp 1: On/Off
Connected to the engine PWB.	2	HEATREN2	I	0/24 V DC	Fuser heater lamp 2: On/Off
	3	ZCROSS	O	0/3.3 V DC (pulse)	Zero-cross signal
	4	SLEEPN	I	0/24 V DC	Sleep mode signal: On/Off
	5	+24V3	I	24 V DC	24 V DC power source
	6	GND	-	-	Ground
	7	GND	-	-	Ground
	8	GND	-	-	Ground
	9	GND	-	-	Ground
	10	+24V1	O	24 V DC	24 V DC power source
	11	+24V1	O	24 V DC	24 V DC power source
	12	+24V1	O	24 V DC	24 V DC power source
	13	+24V1	O	24 V DC	24 V DC power source

2-3-2 Engine PWB

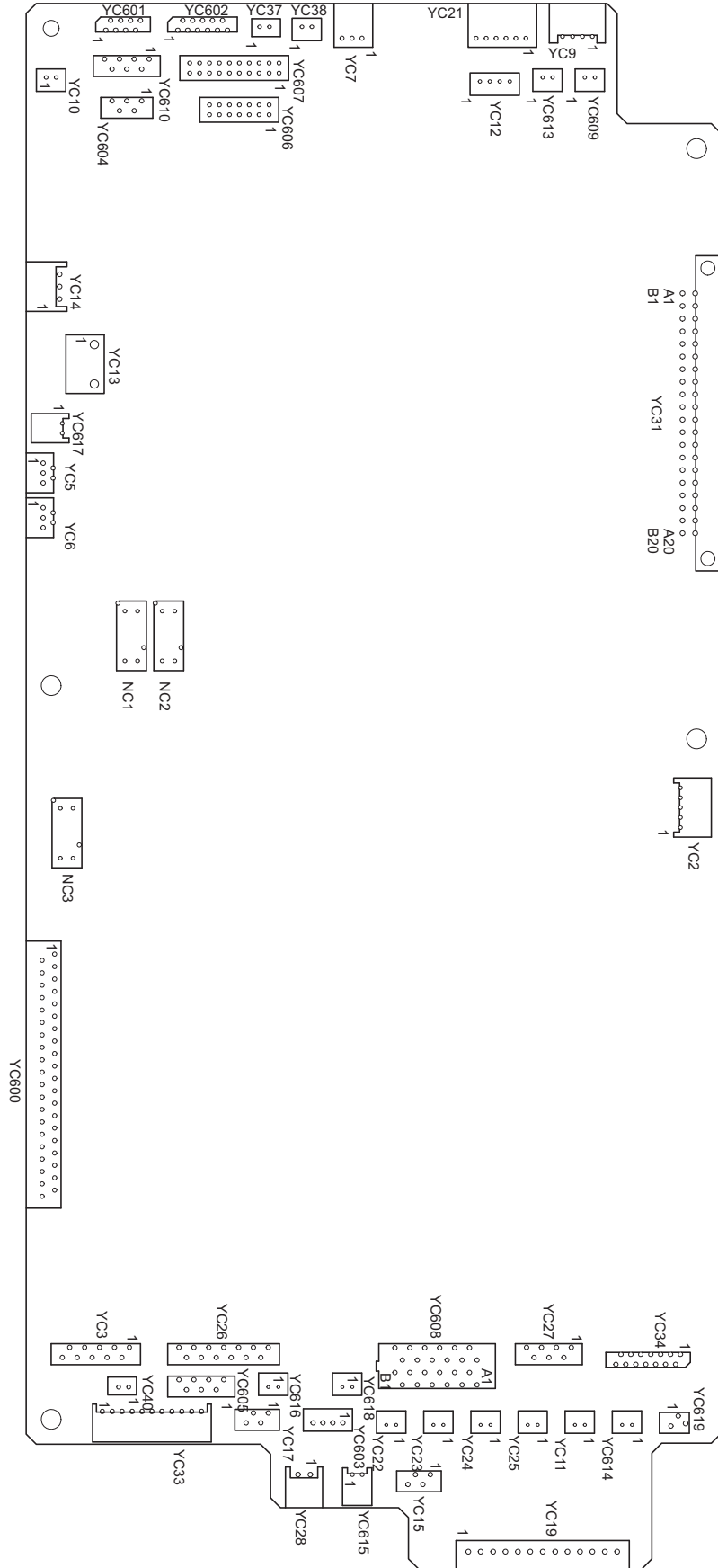

Figure 2-3-2 Engine PWB silk-screen diagram

Connector	Pin	Signal	I/O	Voltage	Description
YC3	1	FEMOTRDYN	I	0/3.3 V DC	Paper feed motor ready signal
Connected to the paper feed motor, intermediate clutch and duplex clutch	2	SPEEDSEL	O	0/3.3 V DC	Paper feed motor speed switch signal
	3	FEMOTCLK	O	0/3.3 V DC (pulse)	Paper feed motor clock signal
	4	FEMOTREN	O	0/3.3 V DC	Paper feed motor: On/Off
	5	GND	-	-	Ground
	6	+24V3	O	24 V DC	24 V DC power source
	7	MIDCLDRN	O	0/24 V DC	Intermediate clutch: On/Off
	8	+24V3	O	24 V DC	24 V DC power source
	9	DUCLDRN	O	0/24 V DC	Duplex clutch: On/Off
	10	+24V3	O	24 V DC	24 V DC power source
YC5	1	+5V1	O	5 V DC	5 V DC power source
Connected to the left ID sensor	2	LEDREFL	O	Analog	Left ID sensor control signal
	3	GND	-	-	Ground
	4	VOPL	I	Analog	Left ID sensor detection signal
	5	VOSL	I	Analog	Left ID sensor detection signal
YC6	1	+5V1	O	5 V DC	5 V DC power source
Connected to the right ID sensor	2	LEDREFR	O	Analog	Right ID sensor control signal
	3	GND	-	-	Ground
	4	VOPR	I	Analog	Right ID sensor detection signal
	5	VOSR	I	Analog	Right ID sensor detection signal
YC7	1	GND	-	-	Ground
Connected to the registration sensor	2	REGPAP	I	0/3.3 V DC	Registration sensor: On/Off
	3	+5V2	O	5 V DC	5 V DC power source
YC9	1	CAS2	I	0/3.3 V DC	Cassette size switch (SW2): On/Off
Connected to the cassette size switch	2	CAS1	I	0/3.3 V DC	Cassette size switch (SW1): On/Off
	3	COM	-	-	Ground
	4	CAS0	I	0/3.3 V DC	Cassette size switch (SW0): On/Off
YC10	1	+24V1	O	24 V DC	24 V DC power source
Connected to the developing fan motor 1	2	DLPFANDRN	O	0/12/24 V DC	Developing fan motor 1: Full speed/Half speed/Off
YC11	1	+24V1	O	24 V DC	24 V DC power source
Connected to the ozone fan motor	2	OZFANDRN	O	0/12/24 V DC	Ozone fan motor: Full speed/Half speed/Off
YC12	1	LEDA	O	5 V DC	5 V DC power source
Connected to the waste toner full sensor	2	LEDK	O	0/5 V DC (pulse)	Waste toner full sensor (emitter)
	3	PTRE	I	Analog	Waste toner full sensor (receiver)
	4	PTRC	O	5 V DC	5 V DC power source
YC13	1	+24V1	O	24 V DC	24 V DC power source
Connected to the interlock switch	2	N.C.	-	-	Not used
	3	+24V2	I	24/0 V DC	24 V DC power source Interlock switch: On/Off

Connector	Pin	Signal	I/O	Voltage	Description
YC14 Connected to the left cover switch	1	+24V3	O	24 V DC	24 V DC power source
	2	N.C.	-	-	Not used
	3	+24V4	I	24/0 V DC	24 V DC power source Left cover switch: On/Off
YC17 Connected to the duplex motor	1	STDUBN	O	0/24 V DC (pulse)	Duplex motor drive control signal (_B)
	2	STDUAN	O	0/24 V DC (pulse)	Duplex motor drive control signal (_A)
	3	STDUB	O	0/24 V DC (pulse)	Duplex motor drive control signal (B)
	4	STDUA	O	0/24 V DC (pulse)	Duplex motor drive control signal (A)
YC19 Connected to the power source PWB	1	HEATER1	O	0/24 V DC	Fuser heater lamp 1: On/Off
	2	HEATER2	-	0/24 V DC	Fuser heater lamp 2: On/Off
	3	ZCROSS	I	0/3.3 V DC (pulse)	Zero-cross signal
	4	SLEEPN	O	0/24 V DC	Sleep mode signal: On/Off
	5	+24V3	O	24 V DC	24 V DC power source
	6	GND	-	-	Ground
	7	GND	-	-	Ground
	8	GND	-	-	Ground
	9	GND	-	-	Ground
	10	+24V1	I	24 V DC	24 V DC power source
	11	+24V1	i	24 V DC	24 V DC power source
	12	+24V1	I	24 V DC	24 V DC power source
	13	+24V1	I	24 V DC	24 V DC power source
YC21 Connected to the duplex con- veying sen- sor and MP tray sensor	1	+3.3V2	O	3.3 V DC	3.3 V DC power source
	2	GND	-	-	Ground
	3	DUREGPAP	I	0/3.3 V DC	Duplex conveying sensor: On/Off
	4	+3.3V2	O	3.3 V DC	3.3 V DC power source
	5	GND	-	-	Ground
	6	MPHANDS	I	0/3.3 V DC	MP tray sensor: On/Off
YC22 Connected to the toner motor K	1	+24V3	O	24 V DC	24 V DC power source
	2	TNMKDRN	O	0/24 V DC	Toner motor K: On/Off
YC23 Connected to the toner motor Y	1	+24V3	O	24 V DC	24 V DC power source
	2	TNMYDRN	O	0/24 V DC	Toner motor Y: On/Off
YC24 Connected to the toner motor C	1	+24V3	O	24 V DC	24 V DC power source
	2	TNMCDRN	O	0/24 V DC	Toner motor C: On/Off
YC25 Connected to the toner motor M	1	+24V3	O	24 V DC	24 V DC power source
	2	TNMMDRN	O	0/24 V DC	Toner motor M: On/Off

Connector	Pin	Signal	I/O	Voltage	Description
YC26	1	DLPCLDNRN	O	0/24 V DC	Developing clutch K: On/Off
Connected to the developing clutch K, developing motor K, Registration clutch and paper feed clutch	2	+24V3	O	24 V DC	24 V DC power source
	3	MOTKREV	O	0/3.3 V DC	Developing motor K drive switch signal
	4	DLPMOTKRDRN	I	0/3.3 V DC	Developing motor K ready signal
	5	SPEEDSEL	O	0/3.3 V DC	Developing motor K speed selection signal
	6	DLPMOTKCLK	O	0/3.3 V DC (pulse)	Developing motor K clock signal
	7	DLPMOTKREN	O	0/3.3 V DC	Developing motor K: On/Off
	8	GND	-	-	Ground
	9	+24V3	O	24 V DC	24 V DC power source
	10	REGCLDRN	O	0/24 V DC	Registration clutch: On/Off
	11	+24V3	O	24 V DC	24 V DC power source
	12	FEDCLDRN	O	0/24 V DC	Paper feed clutch: On/Off
	13	+24V3	O	24 V DC	24 V DC power source
YC27	1	MOTREV	O	0/3.3 V DC	Developing motor MCY drive switch signal
Connected to the developing motor MCY	2	DLPMOTRDYN	I	0/3.3 V DC	Developing motor MCY ready signal
	3	SPEEDSEL	O	0/3.3 V DC	Developing motor MCY speed switch signal
	4	DLPMOTCLK	O	0/3.3 V DC (pulse)	Developing motor MCY clock signal
	5	DLPMOTREN	O	0/3.3 V DC	Developing motor MCY: On/Off
	6	GND	-	-	Ground
	7	+24V3	O	24 V DC	24 V DC power source
YC28	1	LMOTDRN	O	0/24 V DC	Lift motor: On/Off
Connected to the lift motor	2	GND	-	-	Ground
YC31	A1	VDOMP	I	LVDS	APC PWB M video data signal (+)
Connected to the main PWB	A2	VDOMN	I	LVDS	APC PWB M video data signal (-)
	A3	VDOYP	I	LVDS	APC PWB Y video data signal (+)
	A4	VDOYN	I	LVDS	APC PWB Y video data signal (-)
	A5	GND	-	-	Ground
	A6	PDMN	O	0/3.3 V DC (pulse)	Horizontal synchronization signal
	A7	PDYN	O	0/3.3 V DC (pulse)	Horizontal synchronization signal
	A8	GND	-	-	Ground
	A9	FPRXD	I	0/3.3 V DC	Operation panel PWB communication receive exchange data signal
	A10	FPTXD	I	0/3.3 V DC	Operation panel PWB communication transmit exchange data signal
	A11	FPRSTN	I	0/3.3 V DC	Operation panel PWB reset signal
	A12	+3.3V1	O	3.3 V DC	3.3 V DC power source
	A13	SO	O	0/3.3 V DC (pulse)	Main PWB serial communication data signal
	A14	SDIR	O	0/3.3 V DC	Main PWB communication direction signal
	A15	EGIRN	O	0/3.3 V DC	Engine interrupt signal
	A16	+5V1	O	5 V DC	5 V DC power source
	A17	+5V1	O	5 V DC	5 V DC power source
	A18	GND	-	-	Ground
	A19	GND	-	-	Ground
	A20	+24V1	O	24 V DC	24 V DC power source

Connector	Pin	Signal	I/O	Voltage	Description
YC31	B1	VDOCP	I	LVDS	APC PWB C video data signal (+)
Connected to the main PWB	B2	VDOCN	I	LVDS	APC PWB C video data signal (-)
	B3	VDOCP	I	LVDS	APC PWB K video data signal (+)
	B4	VDOCN	I	LVDS	APC PWB K video data signal (-)
	B5	GND	-	-	Ground
	B6	PDMN	O	0/3.3 V DC (pulse)	Horizontal synchronization signal
	B7	PDYN	O	0/3.3 V DC (pulse)	Horizontal synchronization signal
	B8	GND	-	-	Ground
	B9	WAKEUP_PNL KEY	O	0/3.3 V DC	Pannel wakeup signal
	B10	FPRTS	I	0/3.3 V DC (pulse)	Operation panel comunication recive signal
	B11	ST_WUP	I	0/3.3 V DC	Warmup signal
	B12	+3.3V1	O	3.3 V DC	3.3 V DC power source
	B13	SI	O	0/3.3 V DC (pulse)	Main PWB serial communication data signal
	B14	SCLN	O	0/3.3 V DC (pulse)	Main PWB clock signal
	B15	SBSY	O	0/3.3 V DC	Main PWB busy signal
	B16	VSYNC	O	0/3.3 V DC	PD mask control signal
	B17	EEDAT	I/O	0/3.3 V DC (pulse)	EEPROM data signal
	B18	EECLK	O	0/3.3 V DC (pulse)	EEPROM clock signal
	B19	GND	-	-	Ground
	B20	GND	-	-	Ground
YC33	1	GND	-	-	Ground
Connected to the option paper feeder	2	OPSCCLK	O	0/5 V DC (pulse)	Paper feeder clock signal
	3	OPRDYN	I	0/5 V DC	Paper feeder ready signal
	4	OPSDI	I	0/5 V DC (pulse)	Paper feeder serial communication data signal
	5	OPSDO	O	0/5 V DC (pulse)	Paper feeder serial communication data signal
	6	OP5V	O	5 V DC	5 V DC power source
	7	GND	-	-	Ground
	8	OPSEL0	O	0/5 V DC	Paper feeder selection signal
	9	OPSEL1	O	0/5 V DC	Paper feeder selection signal
	10	OPSEL2	O	0/5 V DC	Paper feeder selection signal
	11	OP24	O	24 V DC	24 V DC power source
YC34	1	ERASEMDR	O	0/24 V DC	Eraser lamp M: On/Off
Connected to the drum relay PWB	2	TNSEN M	I	Analog	Toner sensor M detection voltage
	3	ERASECDR	O	0/24 V DC	Eraser lamp C: On/Off
	4	TNSEN C	I	Analog	Toner sensor C detection voltage
	5	ERASEYDR	O	0/24 V DC	Eraser lamp Y: On/Off
	6	TNSEN Y	I	Analog	Toner sensor Y detection voltage
	7	EECLK	O	0/3.3 V DC (pulse)	EEPROM clock signal
	8	GND	-	-	Ground
	9	EEDATA	I/O	0/3.3 V DC (pulse)	EEPROM data signal
	10	+3.3V1	O	3.3 V DC	3.3 V DC power source
	11	ERASEKDR	O	0/24 V DC	Eraser lamp K: On/Off
	12	+3.3V2	O	3.3 V DC	3.3 V DC power source
	13	TNSEN K	I	Analog	Toner sensor K detection voltage
	14	DLPTHERM	I	Analog	Developing thermistor detection voltage

Connector	Pin	Signal	I/O	Voltage	Description
YC37 Connected to the LSU cleaning motor	1	LSUMOTA	O	24/0 V DC	LSU cleaning motor: Fwd/Stop/(Rev)
	2	LSUMOTB	O	24/0 V DC	LSU cleaning motor: Rev/Stop/(Fwd)
YC38 Connected to the power source fan motor	1	+24V1	O	24 V DC	24 V DC power source
	2	PSFANDRN	O	0/12/24 V DC	Power source fan motor: Full speed/Half speed/Off
YC40 Connected to the MP paper feed solenoid	1	+24V3	O	24 V DC	24 V DC power source
	2	MPSOLDRN	O	0/24 V DC	MP paper feed solenoid: On/Off
YC600 Connected to the high voltage PWB 1	1	GND	-	-	Ground
	2	GND	-	-	Ground
	3	GND	-	-	Ground
	4	GND	-	-	Ground
	5	MKISENS	I	Analog	Main charger AC current detection signal (Black)
	6	MYISENS	I	Analog	Main charger AC current detection signal (Yellow)
	7	MCISENS	I	Analog	Main charger AC current detection signal (Cyan)
	8	MMISENS	I	Analog	Main charger AC current detection signal (Magenta)
	9	MHVCLKK	O	0/3.3 V DC (pulse)	Main charger clock signal (Black)
	10	MHVCLKY	O	0/3.3 V DC (pulse)	Main charger clock signal (Yellow)
	11	MHVCLKC	O	0/3.3 V DC (pulse)	Main charger clock signal (Cyan)
	12	MHVCLKM	O	0/3.3 V DC (pulse)	Main charger clock signal (Magenta)
	13	HVCLKK	O	PWM	Developing clock signal (Black)
	14	HVCLKY	O	PWM	Developing clock signal (Yellow)
	15	HVCLKC	O	PWM	Developing clock signal (Cyan)
	16	HVCLKM	O	PWM	Developing clock signal (Magenta)
	17	MDCKCNT	O	PWM	Main charger DC control signal (Black)
	18	MACKCNT	O	PWM	Main charger AC control signal (Black)
	19	BKSCNT	O	PWM	Developing sleeve DC control signal (Black)
	20	BKMCNT	O	PWM	Developing magnet AC control signal (Black)
	21	MDCYCNT	O	PWM	Main charger DC control signal (Yellow)
	22	MACYCNT	O	PWM	Main charger AC control signal (Yellow)
	23	BYSCNT	O	PWM	Developing sleeve DC control signal (Yellow)
	24	BYMCNT	O	PWM	Developing magnet AC control signal (Yellow)
	25	MDCCCNT	O	PWM	Main charger DC control signal (Cyan)
	26	MACCCNT	O	PWM	Main charger AC control signal (Cyan)
	27	BCSCNT	O	PWM	Developing sleeve DC control signal (Cyan)
	28	BCMCNT	O	PWM	Developing magnet AC control signal (Cyan)
	29	MDCMCNT	O	PWM	Main charger DC control signal (Magenta)
	30	MACMCNT	O	PWM	Main charger AC control signal (Magenta)

Connector	Pin	Signal	I/O	Voltage	Description
YC600 Connected to the high voltage PWB 1	31	BMSCNT	O	PWM	Developing sleeve DC Control signal (Magenta)
	32	BMMCNT	O	PWM	Developing magnet AC Control signal (Magenta)
	33	CLCNT	O	PWM	Cleaning bias control signal
	34	T1YCNT	O	PWM	Primary transfer bias control signal (Yellow)
	35	T1CCNT	O	PWM	Primary transfer bias control signal (Cyan)
	36	T1MCNT	O	PWM	Primary transfer bias control signal (Magenta)
	37	T1RREM	O	0/3.3 V DC	Primary transfer bias (reverse) signal
	38	+24V4	O	24 V DC	24 V DC power source
	39	+24V4	O	24 V DC	24 V DC power source
	40	+24V4	O	24 V DC	24 V DC power source
YC601 Connected to the operation panel PWB	1	+5V1	O	5 V DC	5 V DC power source
	2	FPRTS	O	0/3.3 V DC	Operation panel PWB communication control signal
	3	WAKEUP_PNL KEY	O	0/3.3 V DC	Operation panel wakeup signal
	4	+3.3V1	O	3.3 V DC	3.3 V DC power source
	5	FPRSTN	O	3.3 V DC	Operation panel reset signal
	6	FPTXD	O	0/3.3 V DC (pulse)	Operation panel PWB communication direct signal
	7	GND	-	-	Ground
	8	FPRXD	O	0/3.3 V DC (pulse)	
YC602 Connected to the paper exit PWB	1	FTHERM1	I	Analog	Fuser thermistor 1 detection voltage
	2	+3.3V2	O	3.3 V DC	3.3 V DC power source
	3	FTHERM2	I	Analog	Fuser thermistor 2 detection voltage
	4	EXITPAP	I	0/3.3 V DC	Paper exit sensor: On/Off
	5	ENVETEA	I	0/3.3 V DC	Fuser pressure change sensor: On/Off
	6	GND	-	-	Ground
	7	FDFUL	I	0/3.3 V DC	Paper full sensor: On/Off
	8	FEEDOPN	I	0/3.3 V DC	Front cover open/close switch: On/Off
	9	FUFANDRN	O	0/12/24 V DC	Fuser fan motor 1: Full speed/Half speed/Off
	10	+24V1	O	24 V DC	24 V DC power source
	11	DUREVDRN	O	0/24 V DC	Duplex solenoid: On/Off
YC604 Connected to the polygon motor	1	POLCLK1	O	0/3.3 V DC (pulse)	Polygon motor clock signal
	2	POLRDYN1	I	0/3.3 V DC	Polygon motor ready signal
	3	POLONN01	O	0/3.3 V DC	Polygon motor: On/Off
	4	GND	-	-	Ground
	5	+24V3	O	24 V DC	24 V DC power source
YC605 Connected to the fuser motor	1	+24V3	O	24 V DC	24 V DC power source
	2	GND	-	-	Ground
	3	FUMOTREN	O	0/3.3 V DC	Fuser motor: On/Off
	4	FUMOTCLK	O	0/3.3 V DC (pulse)	Fuser motor clock signal
	5	SPEEDSEL	O	0/3.3 V DC	Fuser motor speed change signal
	6	FUMOTRDYN	I	0/3.3 V DC	Fuser motor ready signal

Connector	Pin	Signal	I/O	Voltage	Description
YC606	1	+5V3	O	5 V DC	5 V DC power source
Connected to the APC PWB M/C	2	LONBMN	O	0/3.3 V DC	APC PWB M sample/hold signal
	3	ENBMN	O	0/3.3 V DC	APC PWB M laser enable signal
	4	VDOMP	O	LVDS	APC PWB M video data signal (+)
	5	VDOMN	O	LVDS	APC PWB M video data signal (-)
	6	GND	-	-	Ground
	7	VREFM	O	Analog	APC PWB M control signal
	8	+5V3	O	5 V DC	5 V DC power source
	9	LONBCN	I	0/3.3 V DC (pulse)	APC PWB C sample/hold signal
	10	ENBCN	O	3.3 V DC	APC PWB C laser enable signal
	11	VDOCP	O	0/3.3 V DC	APC PWB C video data signal (+)
	12	VDOCN	O	0/3.3 V DC	APC PWB C video data signal (-)
	13	GND	-	-	Ground
	14	VREFC	O	Analog	APC PWB C laser power reference voltage
	YC607	1	+5V3	O	5 V DC
Connected to the APC PWB Y/K	2	LONBYN	O	0/3.3 V DC	APC PWB Y sample/hold signal
	3	ENBYN	O	0/3.3 V DC	APC PWB Y laser enable signal
	4	VDOYP	O	LVDS	APC PWB Y video data signal (+)
	5	VDOYN	O	LVDS	APC PWB Y video data signal (-)
	6	GND	-	-	Ground
	7	VREFY	O	Analog	APC PWB Y laser power reference voltage
	8	-	-	-	-
	9	PDYN	I	0/3.3 V DC (pulse)	Horizontal synchronization signal
	10	+3.3V3	O	3.3 V DC	3.3 V DC power source
	11	+5V3	O	5 V DC	5 V DC power source
	12	LONBKN	O	0/3.3 V DC	APC PWB K sample/hold signal
	13	ENBKN	O	0/3.3 V DC	APC PWB K laser enable signal
	14	VDOKP	O	LVDS	APC PWB K video data signal (+)
	15	VDOKN	O	LVDS	APC PWB K video data signal (-)
	16	GND	-	-	Ground
	17	VREFK	O	Analog	APC PWB K laser power reference voltage
	18	THERM2	-	-	Not used
	19	PDMN	I	0/3.3 V DC (pulse)	Horizontal synchronization signal
	20	+3.3V3	O	3.3 V DC	3.3 V DC power source
	YC608	A1	DRUMMOTYRDYN	I	0/3.3 V DC
Connected to the drum motor Y/K/M/C	A2	SPEEDSEL	O	0/3.3 V DC	Drum motor Y speed change signal
	A3	DRUMMOTCLK	O	0/3.3 V DC (pulse)	Drum motor Y clock signal
	A4	DRUMMOTYREN	O	0/3.3 V DC	Drum motor Y: On/Off
	A5	GND	-	-	Ground
	A6	+24V3	O	24 V DC	24 V DC power source
	A7	DRUMMOTKRDYN	I	0/3.3 V DC	Drum motor K ready signal
	A8	SPEEDSEL	O	0/3.3 V DC	Drum motor K speed change signal
	A9	DRUMMOTCLK	O	0/3.3 V DC (pulse)	Drum motor K clock signal
	A10	DRUMMOTKREN	O	0/3.3 V DC	Drum motor K: On/Off
	A11	GND	-	-	Ground
	A12	+24V3	O	24 V DC	24 V DC power source

Connector	Pin	Signal	I/O	Voltage	Description
YC608	B1	DRUMMOTMRDYN	I	0/3.3 V DC	Drum motor M ready signal
Connected to the drum motor Y/K/M/C	B2	SPEEDSEL	O	0/3.3 V DC	Drum motor M speed change signal
	B3	DRUMMOTCLK	O	0/3.3 V DC (pulse)	Drum motor M clock signal
	B4	DRUMMOTMREN	O	0/3.3 V DC	Drum motor M: On/Off
	B5	GND	-	-	Ground
	B6	+24V3	O	24 V DC	24 V DC power source
	B7	DRUMMOTCRDYN	I	0/3.3 V DC	Drum motor C ready signal
	B8	SPEEDSEL	O	0/3.3 V DC	Drum motor C speed change signal
	B9	DRUMMOTCLK	O	0/3.3 V DC (pulse)	Drum motor C clock signal
	B10	DRUMMOTCREN	O	0/3.3 V DC	Drum motor C: On/Off
	B11	GND	-	-	Ground
	B12	+24V3	O	24 V DC	24 V DC power source
	YC609	1	+24V1	O	24 V DC
Connected to the left side fan motor	2	LSIDEDRN	O	0/12/24 V DC	Left side fan motor: Full speed/Half speed/Off
YC610	1	GND	-	-	Ground
Connected to the high voltage PWB 2	2	T1KCNT	O	0/24 V DC	Primary transfer bias control signal (Black)
	3	T2CNT	O	0/24 V DC	Secondary transfer bias control signal
	4	T2RREM	O	0/24 V DC	Secondary transfer bias (reverse) control signal
	5	SSEL	O	0/24 V DC	Separation needle bias output change signal
	6	SREM	O	0/24 V DC	Separation needle bias: On/Off
	7	+24V4	O	24 V DC	24 V DC power source
YC613	1	+24V1	O	24 V DC	24 V DC power source
Connected to the LSU fan motor	2	LSUFANDRN	O	0/12/24 V DC	LSU fan motor: Full speed/Half speed/Off
YC615	1	ENVEMOTA	O	24/0 V DC	Fuser pressure change motor: Fwd/Stop/(Rev)
Connected to the fuser pressure change motor	2	ENVEMOTB	O	24/0 V DC	Fuser pressure change motor: Rev/Stop/(Fwd)
YC616	1	+24V3	O	24 V DC	24 V DC power source
Connected to the fuser fan motor 2	2	SUBFANDRN	O	0/12/24 V DC	Fuser fan motor 2: Full speed/Half speed/Off
YC617	1	+24V3	O	24 V DC	24 V DC power source
Connected to the ID solenoid	2	IDSOLDRN	O	0/24 V DC	ID solenoid: On/Off
YC618	1	+24V1	O	24 V DC	24 V DC power source
Connected to the developing fan motor 2	2	DLPFANDRN	O	0/12/24 V DC	Developing fan motor 2: Full speed/Half speed/Off
YC619	1	DLPEEDAT	I/O	0/3.3 V DC	Developing PWB EEPROM data signal
Connected to the drum relay PWB	2	DLPEECLK	O	0/3.3 V DC (pulse)	Developing PWB EEPROM clock signal

2-3-3 Paper exit PWB

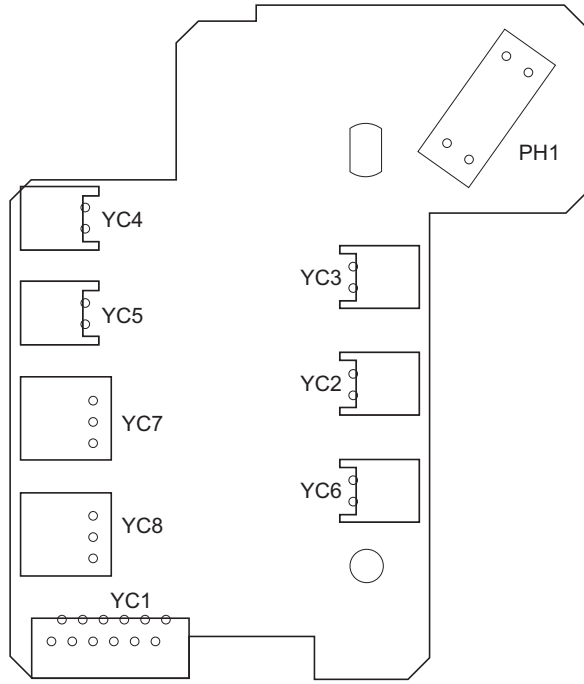
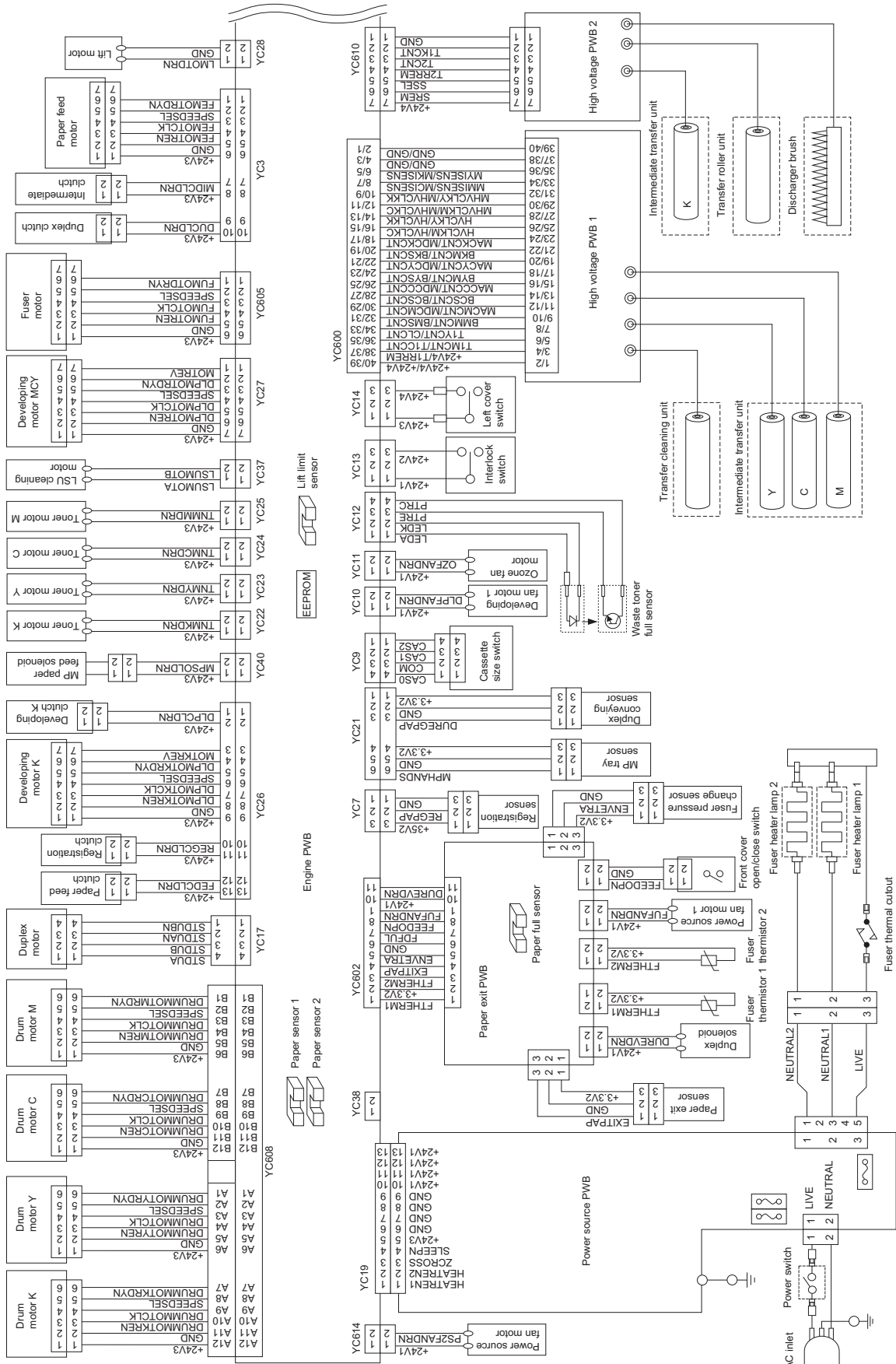

Figure 2-3-3 Paper exit PWB silk-screen diagram

Connector	Pin	Signal	I/O	Voltage	Description
YC1	1	F THERM1	O	Analog	Fuser thermistor 1 detection voltage
Connected to the engine PWB.	2	+3.3V2	I	3.3 V DC	3.3 V DC power source
	3	F THERM2	O	Analog	Fuser thermistor 2 detection voltage
	4	EXITPAP	O	0/3.3 V DC	Paper exit sensor: On/Off
	5	ENVETRA	O	0/3.3 V DC	Fuser pressure change sensor: On/Off
	6	GND	-	-	Ground
	7	FD FUL	O	0/3.3 V DC	Paper full sensor: On/Off
	8	FEEDOPN	O	0/3.3 V DC	Front cover open/close switch: On/Off
	9	FUFANDRN	I	0/12/24 V DC	Fuser fan motor 1: Full speed/Half speed/Off
	10	+24V1	I	24 V DC	24 V DC power source
	11	DUREVDRN	I	0/24 V DC	Duplex solenoid: On/Off
YC2	1	+24V1	O	24 V DC	24 V DC power source
Connected to the fuser fan motor 1	2	FUFANDRN	O	0/12/24 V DC	Fuser fan motor 1: Full speed/Half speed/Off
YC3	1	+24V1	O	24 V DC	24 V DC power source
Connected to the duplex solenoid	2	DUREVDRN	O	0/24 V DC	Duplex solenoid: On/Off
YC4	1	+3.3V1	O	3.3 V DC	3.3 V DC power source
Connected to the fuser thermistor 1	2	F THERM1	I	Analog	Fuser thermistor 1 detection voltage
YC5	1	+3.3V1	O	3.3 V DC	3.3 V DC power source
Connected to the fuser thermistor 2	2	F THERM2	I	Analog	Fuser thermistor 2 detection voltage
YC6	1	FEEDOPN	I	0/3.3 V DC	Front cover open/close switch: On/Off
Connected to the front cover open/close switch	2	GND	-	-	Ground
YC7	1	+3.3V2	O	3.3 V DC	3.3 V DC power source
Connected to the paper exit sensor	2	GND	-	-	Ground
	3	EXITPAP	O	0/3.3 V DC	Paper exit sensor: On/Off
YC8	1	GND	-	-	Ground
Connected to the fuser pressure change sensor	2	ENVETRA	I	0/3.3 V DC	Fuser pressure change sensor: On/Off
	3	+3.3V2	O	3.3 V DC	3.3 V DC power source

2-4-1 Appendixes

(1) Wiring diagram



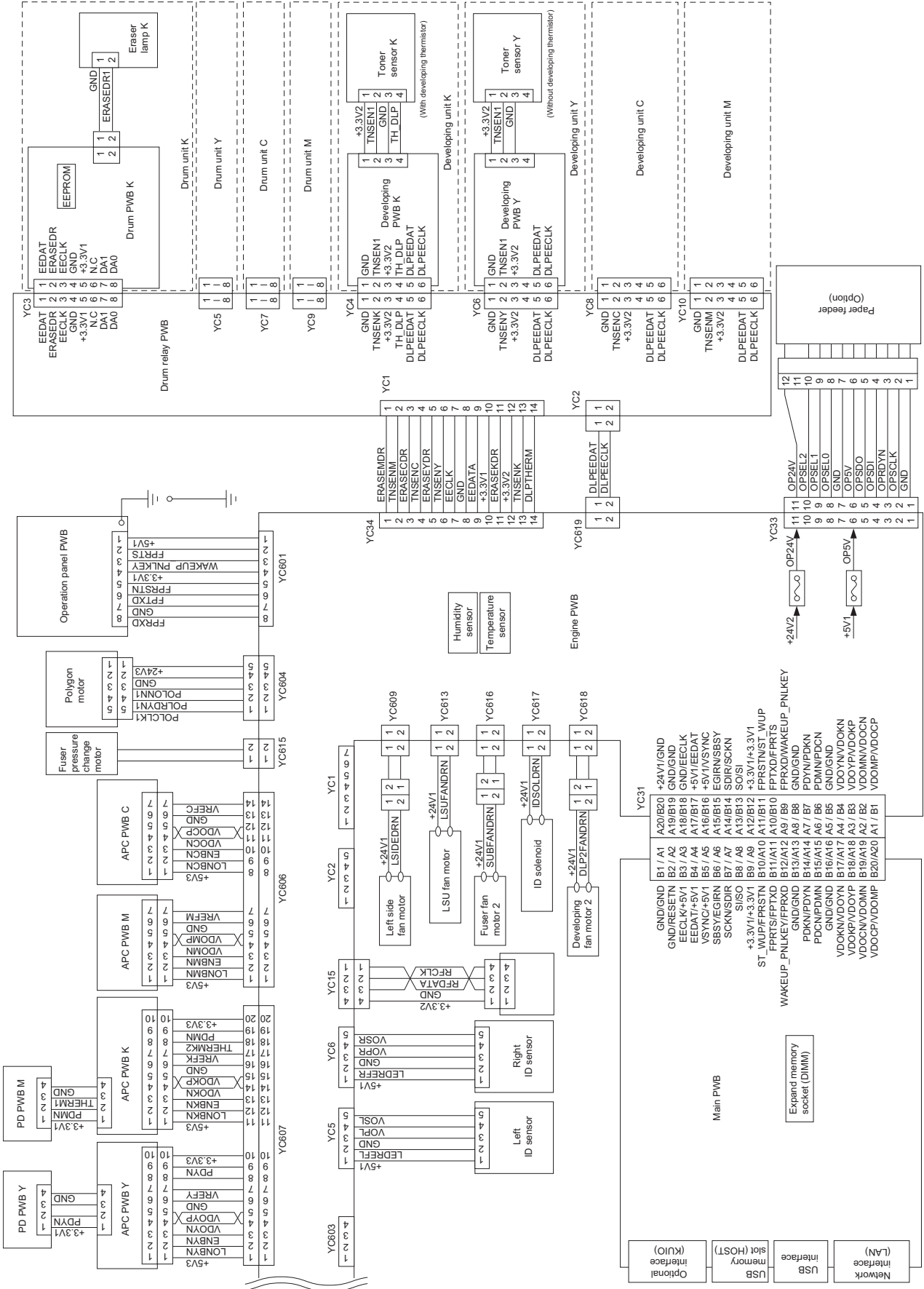

(2) Repetitive defects gauge

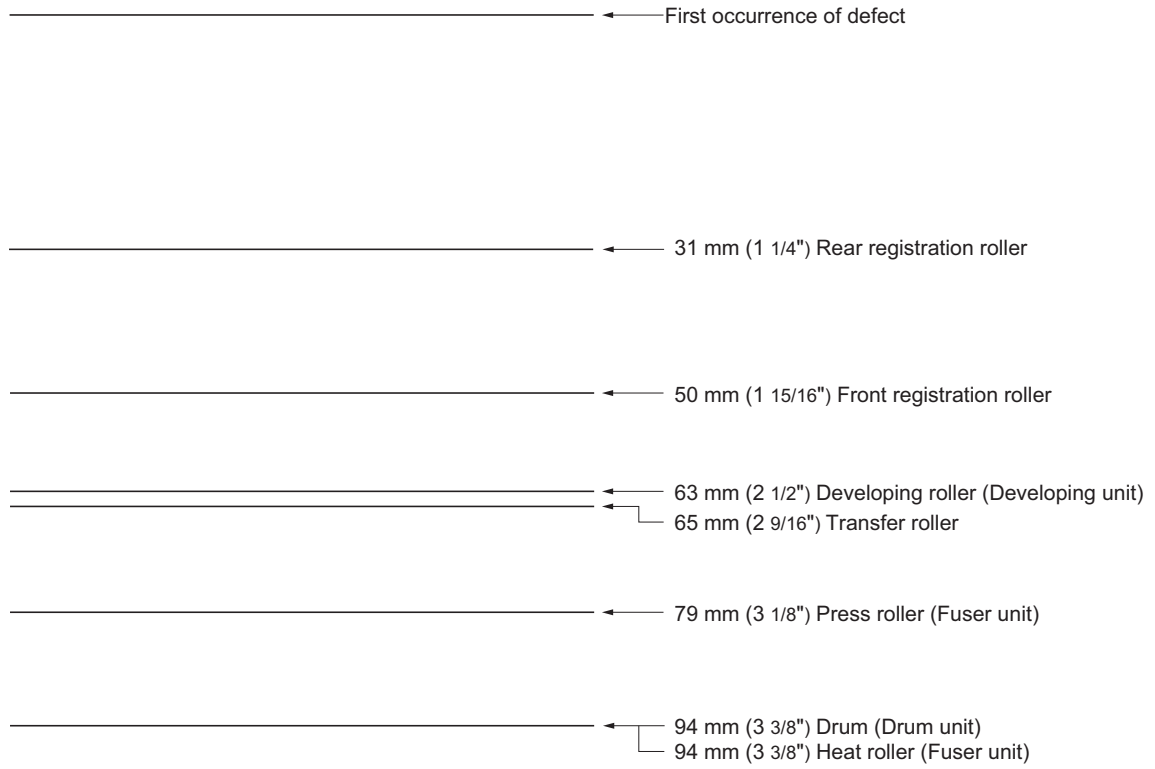

(3) Maintenance Kitt

Maintenance part name		Part No.	Alternative part No.
Name used in service manual	Name used in parts list		
Maintenance kit MK-570 (300,000 images)	MK-570/MAINTENANCE KIT (OPTION)	1702HG7US0	072HG7US
Retard roller assembly	RETARD ROLLER ASSY	-	-
Developing unit K	DV-570 US(K)	-	-
Developing unit Y	DV-570 US(Y)	-	-
Developing unit M	DV-570 US(M)	-	-
Developing unit C	DV-570 US(C)	-	-
Drum unit	DK-570	-	-
Fuser unit	FK-570(U)	-	-
Intermediate transfer unit	TR-570	-	-
Paper feed roller assembly	HOLDER FEED ASSY SP	-	-
MP paper feed roller	ROLLER M/P ASSY /43487B0027 A4	-	-
Maintenance kit MK-575 (300,000 images)	MK-575/MAINTENANCE KIT (OPTION)	1702PR8NL0	072PR8NL
Retard roller assembly	RETARD ROLLER ASSY	-	-
Developing unit K	DV-570(K)	-	-
Developing unit Y	DV-570(Y)	-	-
Developing unit M	DV-570(M)	-	-
Developing unit C	DV-570(C)	-	-
Drum unit	DK-570	-	-
Fuser unit	FK-571(E)	-	-
Intermediate transfer unit	TR-570	-	-
Paper feed roller assembly	HOLDER FEED ASSY SP	-	-
MP paper feed roller	ROLLER M/P ASSY /43487B0027 A4	-	-

KYOCERA Document Solutions America, Inc.**Headquarters**

225 Sand Road,
Fairfield, New Jersey 07004-0008, USA
Phone: +1-973-808-8444
Fax: +1-973-882-6000

Latin America

8240 NW 52nd Terrace Dawson Building, Suite 100
Miami, Florida 33166, USA
Phone: +1-305-421-6640
Fax: +1-305-421-6666

KYOCERA Document Solutions Canada, Ltd.

6120 Kestrel Rd., Mississauga, ON L5T 1S8,
Canada
Phone: +1-905-670-4425
Fax: +1-905-670-8116

**KYOCERA Document Solutions
Mexico, S.A. de C.V.**

Calle Arquimedes No. 130, 4 Piso, Colonia Polanco
Chapultepec, Delegacion Miguel Hidalgo,
Distrito Federal, C.P. 11560, México
Phone: +52-555-383-2741
Fax: +52-555-383-7804

KYOCERA Document Solutions Brazil, Ltda.

Av. Tambore, 1180 Mod.B-09 CEP 06460-000
Tambore-Barueri-SP, Brazil
Phone: +55-11-4195-8496
Fax: +55-11-4195-6167

**KYOCERA Document Solutions
Australia Pty. Ltd.**

Level 3, 6-10 Talavera Road North Ryde N.S.W, 2113,
Australia
Phone: +61-2-9888-9999
Fax: +61-2-9888-9588

**KYOCERA Document Solutions
New Zealand Ltd.**

1-3 Parkhead Place, Albany, Auckland 1330,
New Zealand
Phone: +64-9-415-4517
Fax: +64-9-415-4597

KYOCERA Document Solutions Asia Limited

16/F., Mita Centre, 552-566, Castle Peak Road
Tsuenwan, NT, Hong Kong
Phone: +852-2610-2181
Fax: +852-2610-2063

**KYOCERA Document Solutions
(China) Corporation**

8F, No. 288 Nanjing Road West, Huangpu District,
Shanghai, 200003, China
Phone: +86-21-5301-1777
Fax: +86-21-5302-8300

**KYOCERA Document Solutions
(Thailand) Corp., Ltd.**

335 Ratchadapisek Road, Bangsue, Bangkok 10800,
Thailand
Phone: +66-2-586-0333
Fax: +66-2-586-0278

**KYOCERA Document Solutions
Singapore Pte. Ltd.**

12 Tai Seng Street #04-01A,
Luxasia Building, Singapore 534118
Phone: +65-6741-8733
Fax: +65-6748-3788

**KYOCERA Document Solutions
Hong Kong Limited**

16/F., Mita Centre, 552-566, Castle Peak Road
Tsuenwan, NT, Hong Kong
Phone: +852-3582-4000
Fax: +852-3185-1399

**KYOCERA Document Solutions
Taiwan Corporation**

6F., No.37, Sec. 3, Minquan E. Rd.,
Zhongshan Dist., Taipei 104, Taiwan R.O.C.
Phone: +886-2-2507-6709
Fax: +886-2-2507-8432

KYOCERA Document Solutions Korea Co., Ltd.

18F, Kangnam bldg, 1321-1,
Seocho-Dong, Seocho-Gu, Seoul, Korea
Phone: +822-6933-4050
Fax: +822-747-0084

**KYOCERA Document Solutions
India Private Limited**

First Floor, ORCHID CENTRE
Sector-53, Golf Course Road, Gurgaon 122 002,
India
Phone: +91-0124-4671000
Fax: +91-0124-4671001

KYOCERA Document Solutions Europe B.V.

Bloemlaan 4, 2132 NP Hoofddorp,
The Netherlands
Phone: +31-20-654-0000
Fax: +31-20-653-1256

KYOCERA Document Solutions Nederland B.V.

Beechavenue 25, 1119 RA Schiphol-Rijk,
The Netherlands
Phone: +31-20-5877200
Fax: +31-20-5877260

KYOCERA Document Solutions (U.K.) Limited

Eldon Court, 75-77 London Road,
Reading, Berkshire RG1 5BS,
United Kingdom
Phone: +44-118-931-1500
Fax: +44-118-931-1108

KYOCERA Document Solutions Italia S.p.A.

Via Verdi, 89/91 20063 Cernusco s/N.(MI),
Italy
Phone: +39-02-921791
Fax: +39-02-92179-600

KYOCERA Document Solutions Belgium N.V.

Sint-Martinusweg 199-201 1930 Zaventem,
Belgium
Phone: +32-2-7209270
Fax: +32-2-7208748

KYOCERA Document Solutions France S.A.S.

Espace Technologique de St Aubin
Route de l'Orme 91195 Gif-sur-Yvette CEDEX,
France
Phone: +33-1-69852600
Fax: +33-1-69853409

KYOCERA Document Solutions Espana, S.A.

Edificio Kyocera, Avda. de Manacor No.2,
28290 Las Matas (Madrid), Spain
Phone: +34-91-6318392
Fax: +34-91-6318219

KYOCERA Document Solutions Finland Oy

Atomitie 5C, 00370 Helsinki,
Finland
Phone: +358-9-47805200
Fax: +358-9-47805390

KYOCERA Document Solutions**Europe B.V., Amsterdam (NL) Zürich Branch**

Hohlstrasse 614, 8048 Zürich,
Switzerland
Phone: +41-44-9084949
Fax: +41-44-9084950

KYOCERA Document Solutions**Deutschland GmbH**

Otto-Hahn-Strasse 12, 40670 Meerbusch,
Germany
Phone: +49-2159-9180
Fax: +49-2159-918100

KYOCERA Document Solutions Austria GmbH

Eduard-Kittenberger-Gasse 95, 1230 Vienna,
Austria
Phone: +43-1-863380
Fax: +43-1-86338-400

KYOCERA Document Solutions Nordic AB

Esbogatan 16B 164 75 Kista, Sweden
Phone: +46-8-546-550-00
Fax: +46-8-546-550-10

KYOCERA Document Solutions Norge Nuf

Postboks 150 Oppsal, 0619 Oslo,
Norway
Phone: +47-22-62-73-00
Fax: +47-22-62-72-00

KYOCERA Document Solutions Danmark A/S

Ejby Industrivej 60, DK-2600 Glostrup,
Denmark
Phone: +45-70223880
Fax: +45-45765850

KYOCERA Document Solutions Portugal Lda.

Rua do Centro Cultural, 41 (Alvalade) 1700-106 Lisboa,
Portugal
Phone: +351-21-843-6780
Fax: +351-21-849-3312

KYOCERA Document Solutions**South Africa (Pty) Ltd.**

KYOCERA House, Hertford Office Park,
90 Bekker Road (Cnr. Allandale), Midrand, South Africa.
Phone: +27-11-540-2600
Fax: +27-11-466-3050

KYOCERA Document Solutions Russia LLC

Botanichesky pereulok 5, Moscow, 129090,
Russia
Phone: +7(495)741-0004
Fax: +7(495)741-0018

KYOCERA Document Solutions Middle East

Dubai Internet City, Bldg. 17,
Office 157 P.O. Box 500817, Dubai,
United Arab Emirates
Phone: +971-04-433-0412

KYOCERA Document Solutions Inc.

2-28, 1-chome, Tamatsukuri, Chuo-ku
Osaka 540-8585, Japan
Phone: +81-6-6764-3555
<http://www.kyoceradocumentsolutions.com>