



ECOSYS P6030cdn

SERVICE MANUAL

Published in March 2014
2PPSM061
Rev.1

CAUTION

RISK OF EXPLOSION IF BATTERY IS REPLACED BY AN INCORRECT TYPE. DISPOSE OF USED BATTERIES ACCORDING TO THE INSTRUCTIONS.

It may be illegal to dispose of this battery into the municipal waste stream. Check with your local solid waste officials for details in your area for proper disposal.

ATTENTION

IL Y A UN RISQUE D'EXPLOSION SI LA BATTERIE EST REMPLACÉE PAR UN MODÈLE DE TYPE INCORRECT. METTRE AU REBUT LES BATTERIES UTILISÉES SELON LES INSTRUCTIONS DONNÉES.

Il peut être illégal de jeter les batteries dans des eaux d'égout municipales. Vérifiez avec les fonctionnaires municipaux de votre région pour les détails concernant des déchets solides et une mise au rebut appropriée.

Revision history

Revision	Date	Replaced pages	Remarks
1	20 February 2014	Contents, 1-1-2, 1-3-6, 1-6-2, 1-6-3, 2-4-3, 2-4-5, Address	-

This page is intentionally left blank.

Safety precautions

This booklet provides safety warnings and precautions for our service personnel to ensure the safety of their customers, their machines as well as themselves during maintenance activities. Service personnel are advised to read this booklet carefully to familiarize themselves with the warnings and precautions described here before engaging in maintenance activities.

Safety warnings and precautions

Various symbols are used to protect our service personnel and customers from physical danger and to prevent damage to their property. These symbols are described below:

⚠ DANGER: High risk of serious bodily injury or death may result from insufficient attention to or incorrect compliance with warning messages using this symbol.

⚠ WARNING: Serious bodily injury or death may result from insufficient attention to or incorrect compliance with warning messages using this symbol.

⚠ CAUTION: Bodily injury or damage to property may result from insufficient attention to or incorrect compliance with warning messages using this symbol.

Symbols

The triangle () symbol indicates a warning including danger and caution. The specific point of attention is shown inside the symbol.



General warning.



Warning of risk of electric shock.



Warning of high temperature.

 indicates a prohibited action. The specific prohibition is shown inside the symbol.



General prohibited action.



Disassembly prohibited.

 indicates that action is required. The specific action required is shown inside the symbol.



General action required.





Remove the power plug from the wall outlet.











Always ground the copier.

1. Installation Precautions

WARNING











- Do not use a power supply with a voltage other than that specified. Avoid multiple connections to one outlet: they may cause fire or electric shock. When using an extension cable, always check that it is adequate for the rated current. 
- Connect the ground wire to a suitable grounding point. Not grounding the copier may cause fire or electric shock. Connecting the earth wire to an object not approved for the purpose may cause explosion or electric shock. Never connect the ground cable to any of the following: gas pipes, lightning rods, ground cables for telephone lines and water pipes or faucets not approved by the proper authorities. 

CAUTION:





- Do not place the copier on an infirm or angled surface: the copier may tip over, causing injury. 
- Do not install the copier in a humid or dusty place. This may cause fire or electric shock. 
- Do not install the copier near a radiator, heater, other heat source or near flammable material. This may cause fire. 
- Allow sufficient space around the copier to allow the ventilation grills to keep the machine as cool as possible. Insufficient ventilation may cause heat buildup and poor copying performance. 
- Always handle the machine by the correct locations when moving it. 
- Always use anti-toppling and locking devices on copiers so equipped. Failure to do this may cause the copier to move unexpectedly or topple, leading to injury. 
- Avoid inhaling toner or developer excessively. Protect the eyes. If toner or developer is accidentally ingested, drink a lot of water to dilute it in the stomach and obtain medical attention immediately. If it gets into the eyes, rinse immediately with copious amounts of water and obtain medical attention. 
- Advise customers that they must always follow the safety warnings and precautions in the copier's instruction handbook. 











2. Precautions for Maintenance

WARNING

- Always remove the power plug from the wall outlet before starting machine disassembly. 
- Always follow the procedures for maintenance described in the service manual and other related brochures. 
- Under no circumstances attempt to bypass or disable safety features including safety mechanisms and protective circuits. 
- Always use parts having the correct specifications. 
- Always use the thermostat or thermal fuse specified in the service manual or other related brochure when replacing them. Using a piece of wire, for example, could lead to fire or other serious accident. 
- When the service manual or other serious brochure specifies a distance or gap for installation of a part, always use the correct scale and measure carefully. 
- Always check that the copier is correctly connected to an outlet with a ground connection. 
- Check that the power cable covering is free of damage. Check that the power plug is dust-free. If it is dirty, clean it to remove the risk of fire or electric shock. 
- Never attempt to disassemble the optical unit in machines using lasers. Leaking laser light may damage eyesight. 
- Handle the charger sections with care. They are charged to high potentials and may cause electric shock if handled improperly. 



CAUTION

- Wear safe clothing. If wearing loose clothing or accessories such as ties, make sure they are safely secured so they will not be caught in rotating sections. 
- Use utmost caution when working on a powered machine. Keep away from chains and belts. 
- Handle the fixing section with care to avoid burns as it can be extremely hot. 
- Check that the fixing unit thermistor, heat and press rollers are clean. Dirt on them can cause abnormally high temperatures. 

- Do not remove the ozone filter, if any, from the copier except for routine replacement. 
- Do not pull on the AC power cord or connector wires on high-voltage components when removing them; always hold the plug itself. 
- Do not route the power cable where it may be stood on or trapped. If necessary, protect it with a cable cover or other appropriate item. 
- Treat the ends of the wire carefully when installing a new charger wire to avoid electric leaks. 
- Remove toner completely from electronic components. 
- Run wire harnesses carefully so that wires will not be trapped or damaged. 
- After maintenance, always check that all the parts, screws, connectors and wires that were removed, have been refitted correctly. Special attention should be paid to any forgotten connector, trapped wire and missing screws. 
- Check that all the caution labels that should be present on the machine according to the instruction handbook are clean and not peeling. Replace with new ones if necessary. 
- Handle greases and solvents with care by following the instructions below: 
 - Use only a small amount of solvent at a time, being careful not to spill. Wipe spills off completely.
 - Ventilate the room well while using grease or solvents.
 - Allow applied solvents to evaporate completely before refitting the covers or turning the power switch on.
 - Always wash hands afterwards.
- Never dispose of toner or toner bottles in fire. Toner may cause sparks when exposed directly to fire in a furnace, etc. 
- Should smoke be seen coming from the copier, remove the power plug from the wall outlet immediately. 

3. Miscellaneous

WARNING

- Never attempt to heat the drum or expose it to any organic solvents such as alcohol, other than the specified refiner; it may generate toxic gas. 
- Keep the machine away from flammable liquids, gases, and aerosols. A fire or an electric shock might occur. 

This page is intentionally left blank.

CONTENTS

1-1 Specifications

1-1-1 Specifications	1-1-1
1-1-2 Parts names	1-1-3
(1) Overall	1-1-3
(2) Operation panel	1-1-4
1-1-3 Machine cross section	1-1-5

1-2 Installation

1-2-1 Installation environment	1-2-1
1-2-2 Unpacking	1-2-2
(1) Unpacking	1-2-2
(2) Removing the tape	1-2-4
1-2-3 Installing the expansion memory module (option)	1-2-5
1-2-4 Installing the SD card (option)	1-2-6
1-2-5 Installing the SSD disk (option)	1-2-7

1-3 Maintenance Mode

1-3-1 Maintenance mode	1-3-1
(1) Executing a maintenance item	1-3-1
(2) Service mode	1-3-2
(3) Printing a event log (EVENT LOG)	1-3-12

1-4 Troubleshooting

1-4-1 Paper misfeed detection	1-4-1
(1) Paper misfeed indication	1-4-1
(2) Paper misfeed detection condition	1-4-1
1-4-2 Self-diagnostic function	1-4-2
(1) Self-diagnostic function	1-4-2
(2) Self diagnostic codes	1-4-3
1-4-3 Image formation problems	1-4-22
(1) No image appears (entirely white)	1-4-23
(2) No image appears (entirely black)	1-4-24
(3) A specific color is printed solid.	1-4-24
(4) The back side gets dirty.	1-4-24
(5) Image is too light.	1-4-25
(6) The background is colored.	1-4-25
(7) White streaks are printed vertically.	1-4-26
(8) Black streaks are printed vertically.	1-4-26
(9) Streaks are printed horizontally.	1-4-26
(10) Spots are printed.	1-4-26
(11) The leading edge of image begins to print too early or too late.	1-4-27
(12) Paper is wrinkled.	1-4-27
(13) Offset occurs.	1-4-27
(14) Part of image is missing.	1-4-27
(15) Fusing is loose.	1-4-28
(16) Colors are printed offset to each other.	1-4-28
1-4-4 Electric problems	1-4-29
1-4-5 Mechanical problems	1-4-32

1-5 Assembly and Disassembly

1-5-1 Precautions for assembly and disassembly	1-5-1
(1) Precautions	1-5-1
(2) Drum	1-5-1
(3) Toner container	1-5-1
(4) How to tell a genuine Kyocera toner container.	1-5-2
1-5-2 Outer covers	1-5-3
(1) Detaching and refitting the left rear cover, left upper cover and left front cover.	1-5-3
(2) Detaching and refitting the right rear cover, right upper cover and right front cover	1-5-6

1-5-3	Paper feed section	1-5-8
	(1) Detaching and refitting the paper feed roller assembly (paper feed roller and pickup roller)	1-5-8
	(2) Detaching and refitting the retard roller	1-5-10
	(3) Detaching and refitting the MP paper feed roller	1-5-11
1-5-4	Developing section	1-5-12
	(1) Detaching and refitting the developing unit	1-5-12
1-5-5	Drum section	1-5-14
	(1) Detaching and refitting the drum unit	1-5-14
	(2) Detaching and refitting the main charger unit	1-5-15
1-5-6	Transfer/separation section	1-5-16
	(1) Detaching and refitting the intermediate transfer unit	1-5-16
	(2) Detaching and refitting the transfer roller unit	1-5-19
	(3) Detaching and refitting the duplex unit B	1-5-20
1-5-7	Fuser section	1-5-25
	(1) Detaching and refitting the fuser unit	1-5-25
1-5-8	PWBs	1-5-26
	(1) Detaching and refitting the power source PWB	1-5-26
	(2) Detaching and refitting the main PWB	1-5-28
	(3) Detaching and refitting the engine PWB	1-5-29
	(4) Detaching and refitting the high voltage PWB	1-5-34
1-5-9	Others	1-5-37
	(1) Detaching and refitting the laser scanner unit	1-5-37
	(2) Detaching and refitting the ozone filter	1-5-39
	(3) Direction of installing the principal fan motors	1-5-40
1-6 Firmware		
1-6-1	Upgrading the firmware	1-6-1
	(1) Firmware file	1-6-1
	(2) Upgrading the firmware from the USB memory	1-6-2
2-1 Mechanical Construction		
2-1-1	Paper feed/conveying section	2-1-1
	(1) Cassette paper feed section	2-1-1
	(2) MP tray paper feed section	2-1-3
	(3) Paper conveying section	2-1-4
2-1-2	Drum section	2-1-6
	(1) Drum section	2-1-6
	(2) Main charger unit	2-1-8
2-1-3	Expose section	2-1-10
	(1) Laser scanner unit	2-1-10
2-1-4	Developing section	2-1-13
2-1-5	Transfer/separation section	2-1-15
2-1-6	Fuser section	2-1-17
2-1-7	Paper exit/feed shift section	2-1-19
2-1-8	Duplex/conveying section	2-1-21
2-2 Electrical Parts Layout		
2-2-1	Electrical parts layout	2-2-1
	(1) PWBs	2-2-1
	(2) Switches and sensors	2-2-4
	(3) Motors	2-2-6
	(4) Other electrical components	2-2-8
2-3 Operation of the PWBs		
2-3-1	Power source PWB	2-3-1
2-3-2	Engine PWB	2-3-2
2-3-3	Drum relay PWB	2-3-11
2-3-4	Paper exit PWB	2-3-14

2-4 Appendixes

2-4-1 Appendixes	2-4-1
(1) Wiring diagram	2-4-1
(2) Repetitive defects gauge.....	2-4-3
(3) Maintenance parts list	2-4-4
(4) Maintenance Commands	2-4-5

This page is intentionally left blank.

1-1-1 Specifications

Item	Description	
Type	Desktop	
Printing method	Electrophotographic four color (CMYK) printing using tandem (4) drum system	
Paper weight	Cassette: 60 to 120 g/m ² , MP tray: 60 to 220 g/m ²	
Paper types*1	Cassette	Plain, preprinted, bond, recycled, rough, letterhead, color, prepunched, high quality, and custom
	MP tray	Plain, transparency, preprinted, labels, bond, recycled, vellum, rough, letterhead, color, prepunched, envelope, cardstock, coated, thick, high quality, and custom
Paper sizes	Cassette	A4, B5, A5, Folio, 8 1/2" ´ 14" (Legal), 8 1/2" ´ 11" (Letter), Oficio II, Statement, Executive, ISO B5, A6, Envelope C5, 16K, and Custom, 216x340 mm
	MP tray	A4, B5, A5, Folio, 8 1/2" ´ 14" (Legal), 8 1/2" ´ 11" (Letter), Oficio II, Statement, Executive, A6, B6, ISO B5, Env. Monarch, Envelope #10, Envelope #9, Envelope #6, Envelope DL, Envelope C5, 16K, Hagaki, Oufuku Hagaki, Youkei 2, Youkei 4, and Custom, 216x340 mm
Printing speeds	Cassette	A4: 30 ppm B5, A5, A6: 27 ppm (After 16 pages the printing speed becomes 14 ppm) Letter: 32 ppm Legal: 26 ppm
	MP tray	A4: 27 ppm B5, A5, A6: 27 ppm (After 16 pages the printing speed becomes 14 ppm) Letter: 28 ppm Legal: 23 ppm
Duplex printing speed	A4: 30 ppm B5, A5: 27 ppm (After 16 pages the printing speed becomes 14 ppm) Letter: 32 ppm Legal: 14 ppm	
First print out time (22°C, 60%RH)	B/W : 8.5 seconds or less Color: 10.0 seconds or less (Excluding time for system stabilization immediately after turning on the main power.)	
Warm-up time (22°C, 60%RH)	Power on: 36 seconds or less Sleep mode: 24 seconds or less Low power mode: 17 seconds or less	
Paper feed source capacity	Cassette: 500 sheets (80 g/m ²) MP tray: 150 sheets (80 g/m ²)	
Output tray capacity	Top tray: 250 sheets (80 g/m ²)	
Photoconductor	OPC drum (diameter 30 mm)	
Printing method	Semiconductor laser (1 beam)	
Charging system	Scorotron plus charging	
Developing system	Dual component interactive touch down developing system Toner replenishing: Automatic from the toner container	
Transfer system	Primary transfer: Elasticity intermediate transfer belt (DC bias) Secondary transfer: Transfer roller (DC bias)	
Separation system	Small diameter separation, discharger brush	
Fusing system	Heat fusing with a heat roller and a press roller	
Charge erasing system	Exposure by eraser lamp (LED)	
Cleaning system	Drum: Counter blade	

Item		Description
Controller		PowerPC465S-667 MHz
Memory		Standard: 512 MB Maximum: 1536 MB
Resolution		600 dpi
Operating systems		Windows 2000, Windows XP, Windows XP Professional Windows Server 2003, Windows Server 2003 x64 Edition Windows Vista x86 Edition, Windows Vista x64 Edition Windows 7 x86 Edition, Windows 7 x64 Edition, Windows Server 2008 Windows Server 2008 x64 Edition, Windows Server 2012 x64 Edition Apple Macintosh OS 10.x
Interface		USB: Hi-Speed USB Network: 10 BASE-T/100 BASE-TX/1000BASE-T eKUIO slot Option: SSD (HD-6/7)
Memory card slot		1 (SD card, 32 GB or less)
Margin		4 mm (left, right, top and bottom)
Operation environment		Temperature: 10 to 32.5°C/50 to 90.5°F Relative humidity: 15 to 80% Altitude 2,500 m (8,202 feet) maximum Illumination 1,500 lux maximum
Dimensions (W ´ D ´ H)		345 ´ 518 ´ 480 mm 13 5/8 ´ 20 2/5 ´ 18 9/10"
Weight		Approx. 29.5 kg (65 lbs)
Rated input		120 V, 60 Hz, max. 9.2 A (U.S.A./Canada) 220-240 V, 50 Hz/60 Hz, max. 4.7 A (European countries) Max. Allowable voltage fluctuation: ±10% Max. Allowable frequency fluctuation: ±2%
Power consumption	120 V AC model	Maximum 1,103 W or less During printing: 554 W During standby: 79 W During sleep mode: 4 W Power off: 0 W
	220-240 V AC model	Maximum 1,103 W or less During printing: 529 W During standby: 76 W During sleep mode: 4 W Power off: 0 W
Operating noise*2		During printing: LpA = 55 dB (A) During standby: LpA = 36 dB (A) During sleep mode: Immeasurably low

*1: When using CUSTOM 1 (to 8), use the MP tray for paper sizes smaller than 105 × 148 mm (4 1/8 × 5 13/16").
The MP tray can be used with paper sizes over 70 × 138 mm (2 3/4 × 5 7/16").

*2: Sound pressure level at bystander position [front] in accordance with EN ISO 7779.

NOTE: These specifications are subject to change without notice.

1-1-2 Parts names

(1) Overall

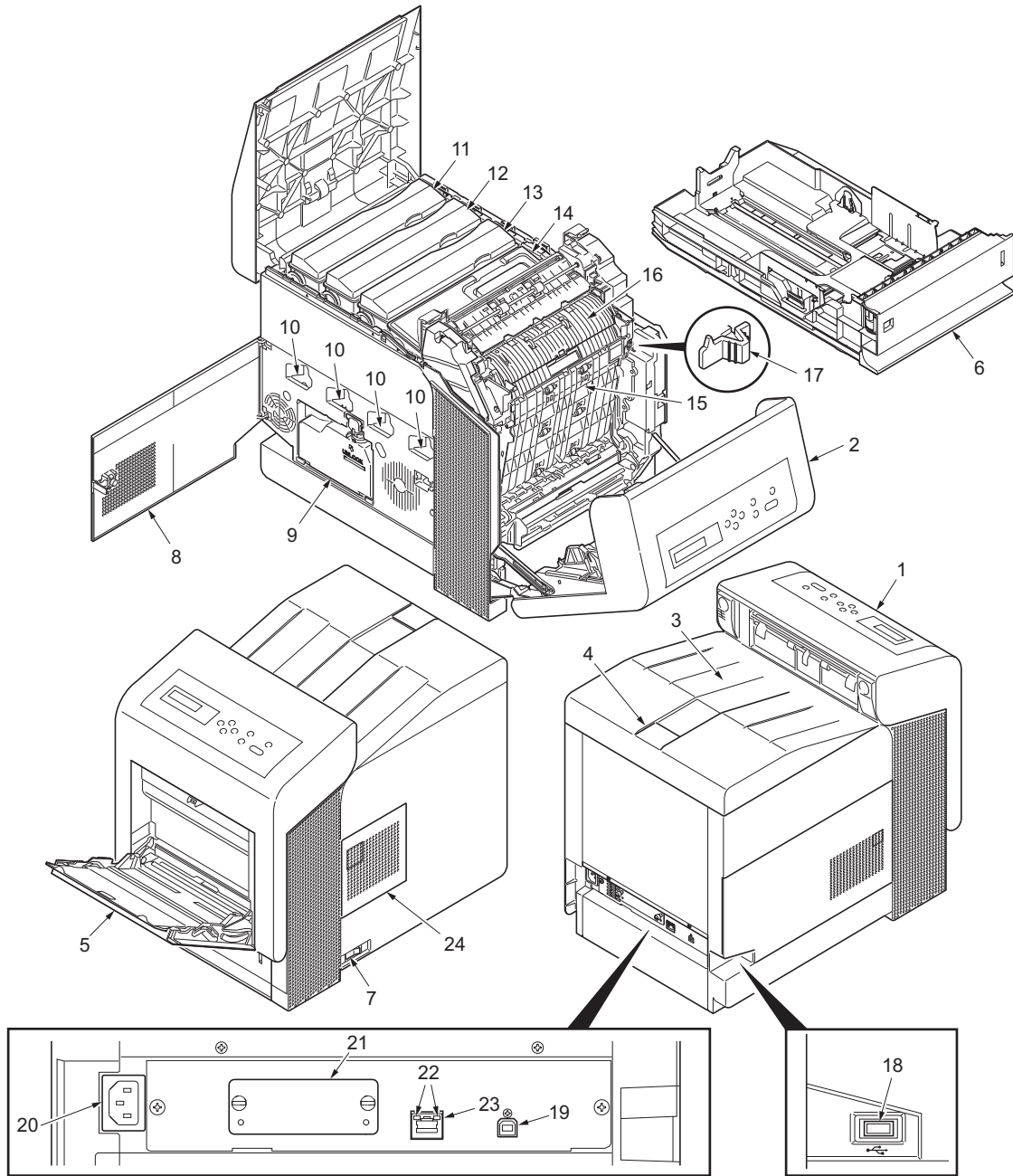

Figure 1-1-1

- | | | |
|-------------------------|------------------------|-----------------------------|
| 1. Operation panel | 9. Waste toner box | 17. Envelope switch |
| 2. Front cover | 10. Main charger units | 18. USB memory slot |
| 3. Top cover (Top tray) | 11. Toner container M | 19. USB interface |
| 4. Paper stopper | 12. Toner container C | 20. AC inlet |
| 5. MP tray | 13. Toner container Y | 21. Optional interface slot |
| 6. Cassette | 14. Toner container K | 22. Network indicators |
| 7. Power switch | 15. Duplex unit B | 23. Network interface |
| 8. Left cover | 16. Fuser cover A | 24. Right cover |

(2) Operation panel

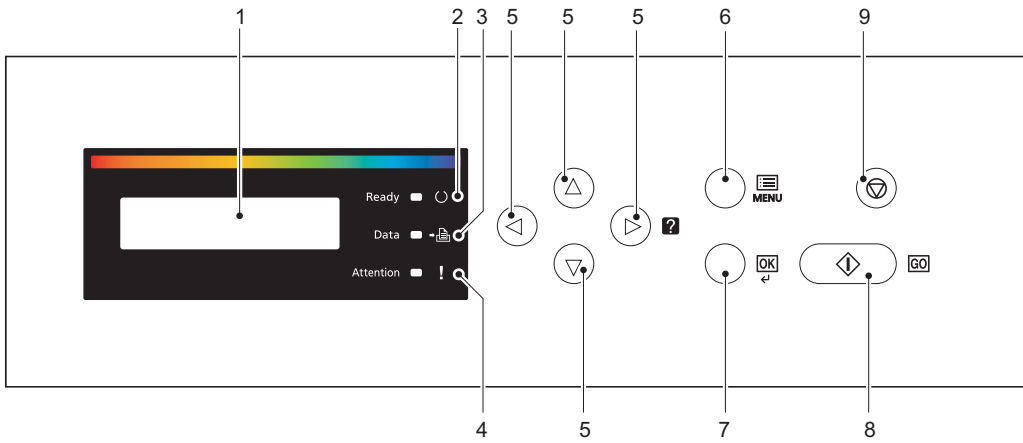

Figure 1-1-2

- 1. Message display
- 2. Ready indicator
- 3. Data indicator
- 4. Attention indicator
- 5. Arrow keys
- 6. MENU key
- 7. OK key
- 8. GO key
- 9. CANCEL key

1-1-3 Machine cross section

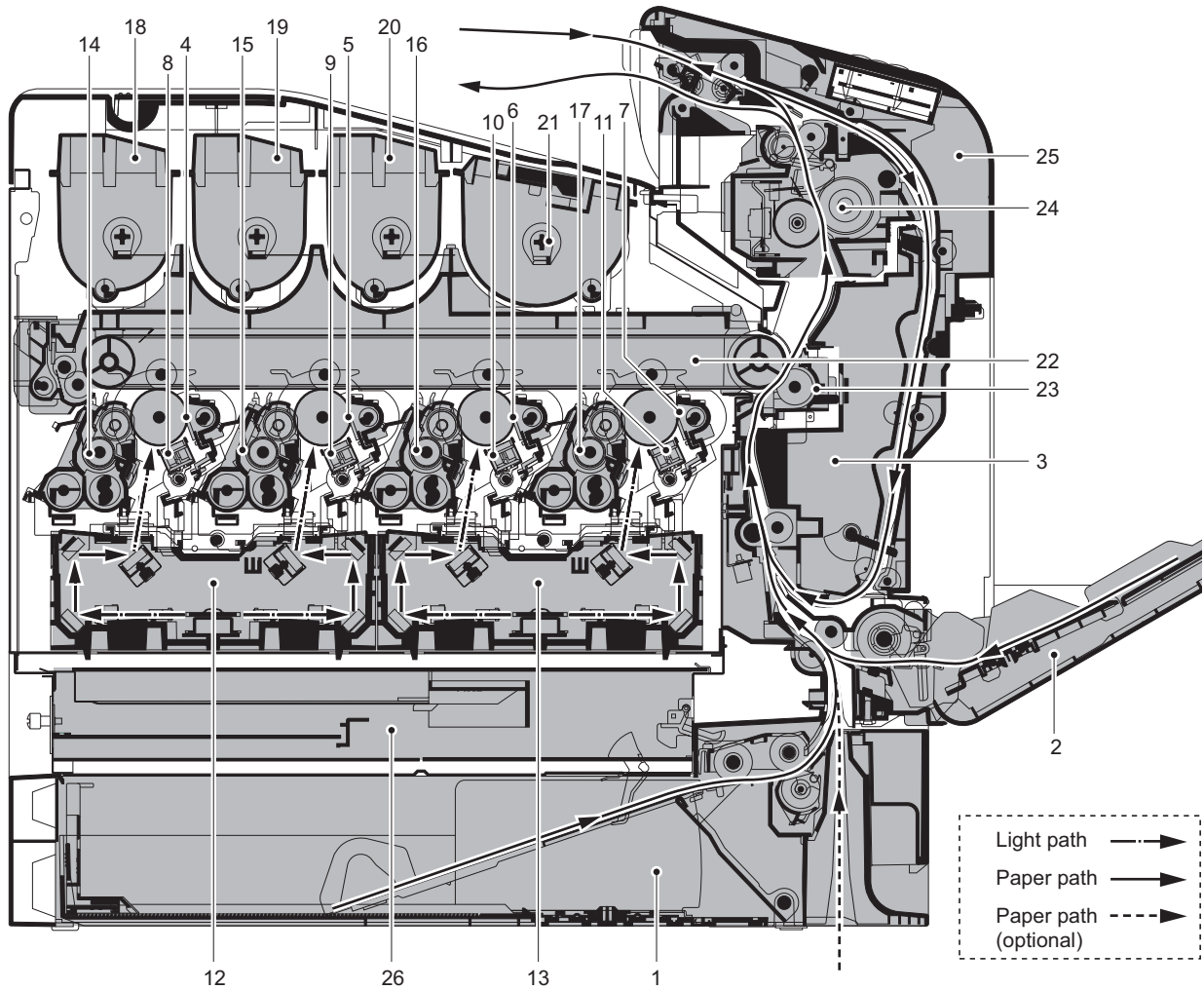

Figure 1-1-3

- | | |
|---------------------------|--------------------------------|
| 1. Cassette | 14. Developing unit M |
| 2. MP tray | 15. Developing unit C |
| 3. Duplex unit B | 16. Developing unit Y |
| 4. Drum unit M | 17. Developing unit K |
| 5. Drum unit C | 18. Toner container M |
| 6. Drum unit Y | 19. Toner container C |
| 7. Drum unit K | 20. Toner container Y |
| 8. Main charger unit M | 21. Toner container K |
| 9. Main charger unit C | 22. Intermediate transfer unit |
| 10. Main charger unit Y | 23. Transfer roller unit |
| 11. Main charger unit K | 24. Fuser unit |
| 12. Laser scanner unit MC | 25. Front cover |
| 13. Laser scanner unit YK | 26. Controller box |

This page is intentionally left blank.

1-2-1 Installation environment

1. Temperature: 10 to 32.5°C/50 to 90.5°F
2. Humidity: 15 to 80%RH
3. Power supply: 120 V AC, 220 - 240 V AC
4. Power source frequency: 50 Hz ±0.3%/60 Hz ±0.3%
5. Installation location

Avoid direct sunlight or bright lighting. Ensure that the photoconductor will not be exposed to direct sunlight or other strong light when removing paper jams.

Avoid locations subject to high temperature and high humidity or low temperature and low humidity; an abrupt change in the environmental temperature; and cool or hot, direct air.

Avoid places subject to dust and vibrations.

Choose a surface capable of supporting the weight of the machine.

Place the machine on a level surface (maximum allowance inclination: 1°).

Avoid air-borne substances that may adversely affect the machine or degrade the photoconductor, such as mercury, acidic or alkaline vapors, inorganic gasses, NOx, SOx gases and chlorine-based organic solvents.

Select a well-ventilated location.

6. Allow sufficient access for proper operation and maintenance of the machine.

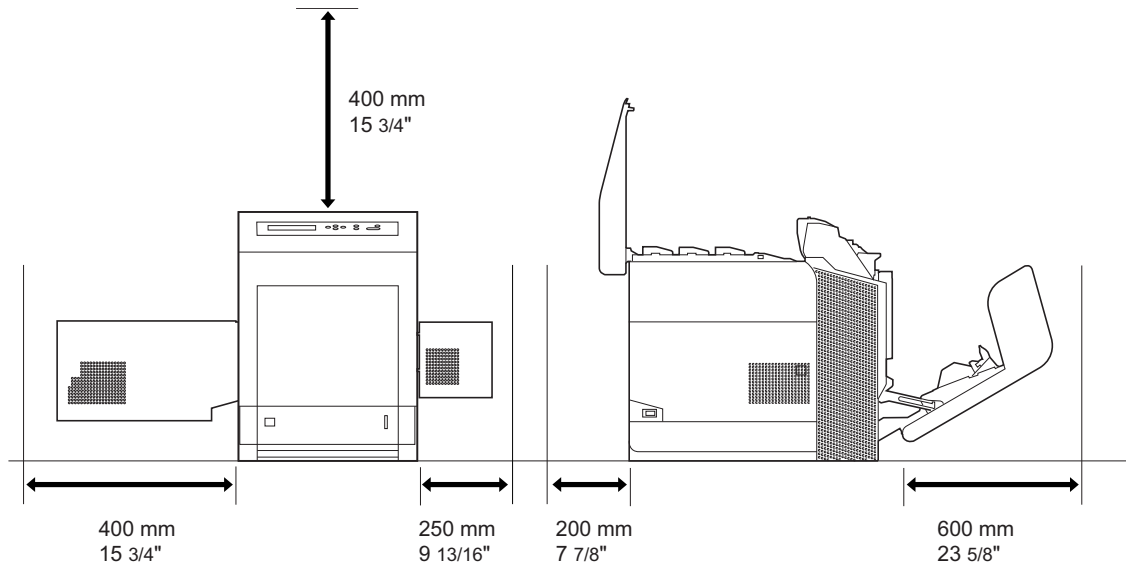

Figure 1-2-1

1-2-2 Unpacking

(1) Unpacking

220-240 V AC model

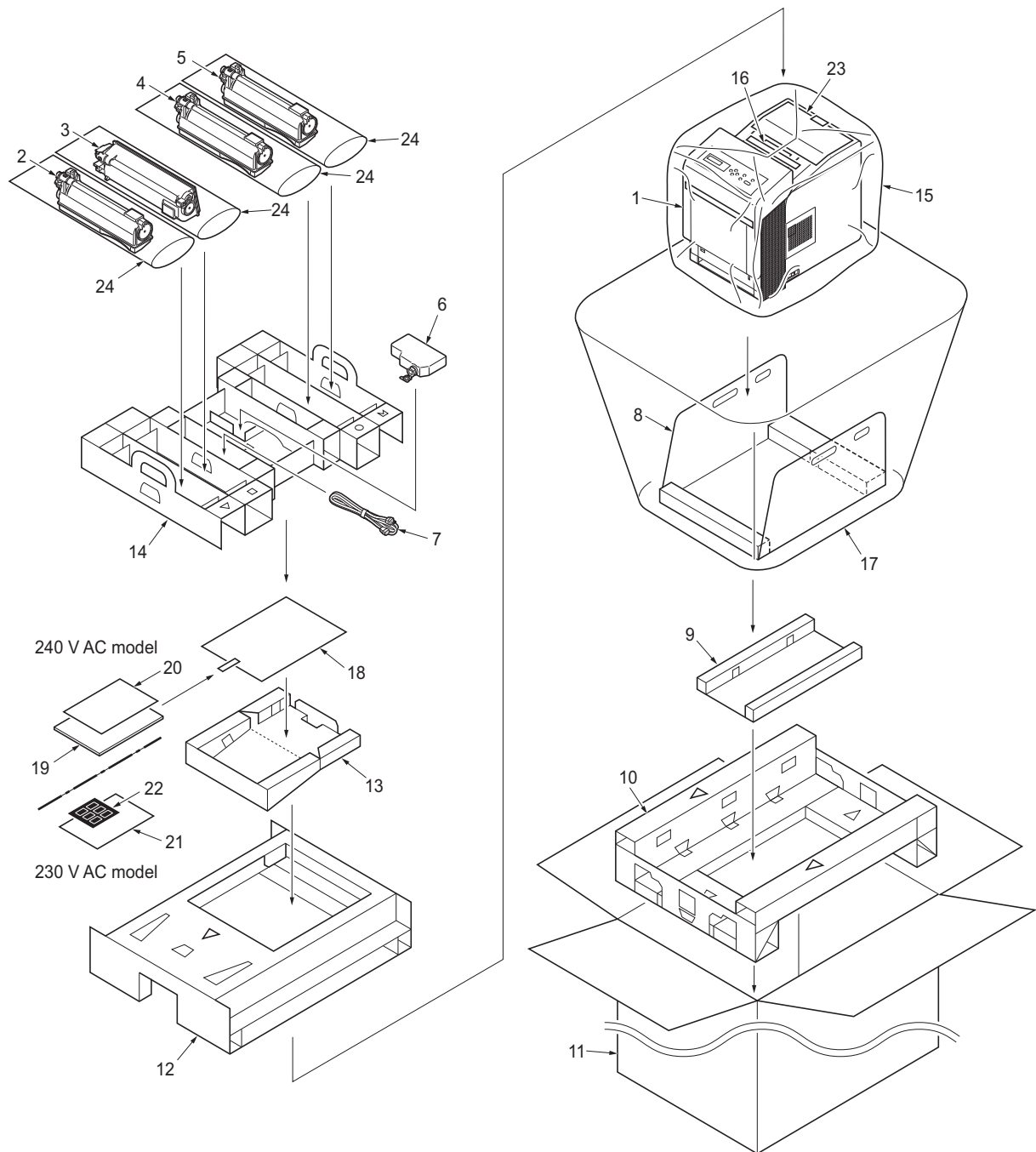

Figure 1-2-2 220-240 V AC model

- | | | |
|------------------------------|---------------------------|-----------------------------|
| 1. Printer | 10. Bottom front/side pad | 17. Machine cover |
| 2. Toner container (Yellow) | 11. Outer case | 650 × 650 × 1200 |
| 3. Toner container (Black) | 12. Top pad | 18. Plastic bag 240 × 350 |
| 4. Toner container (Cyan) | 13. Top tray | 19. Operation guide |
| 5. Toner container (Magenta) | 14. Top spacer | 20. Warranty card |
| 6. Waste toner box | 15. Machine cover | 21. Leaflet EEA information |
| 7. Power cord | 600 × 600 × 900 | 22. 6 nations label |
| 8. Main pad | 16. Desiccating agent | 23. Installation guide |
| 9. Bottom pad | | 24. Plastic bags 200 × 700 |

120 V AC model

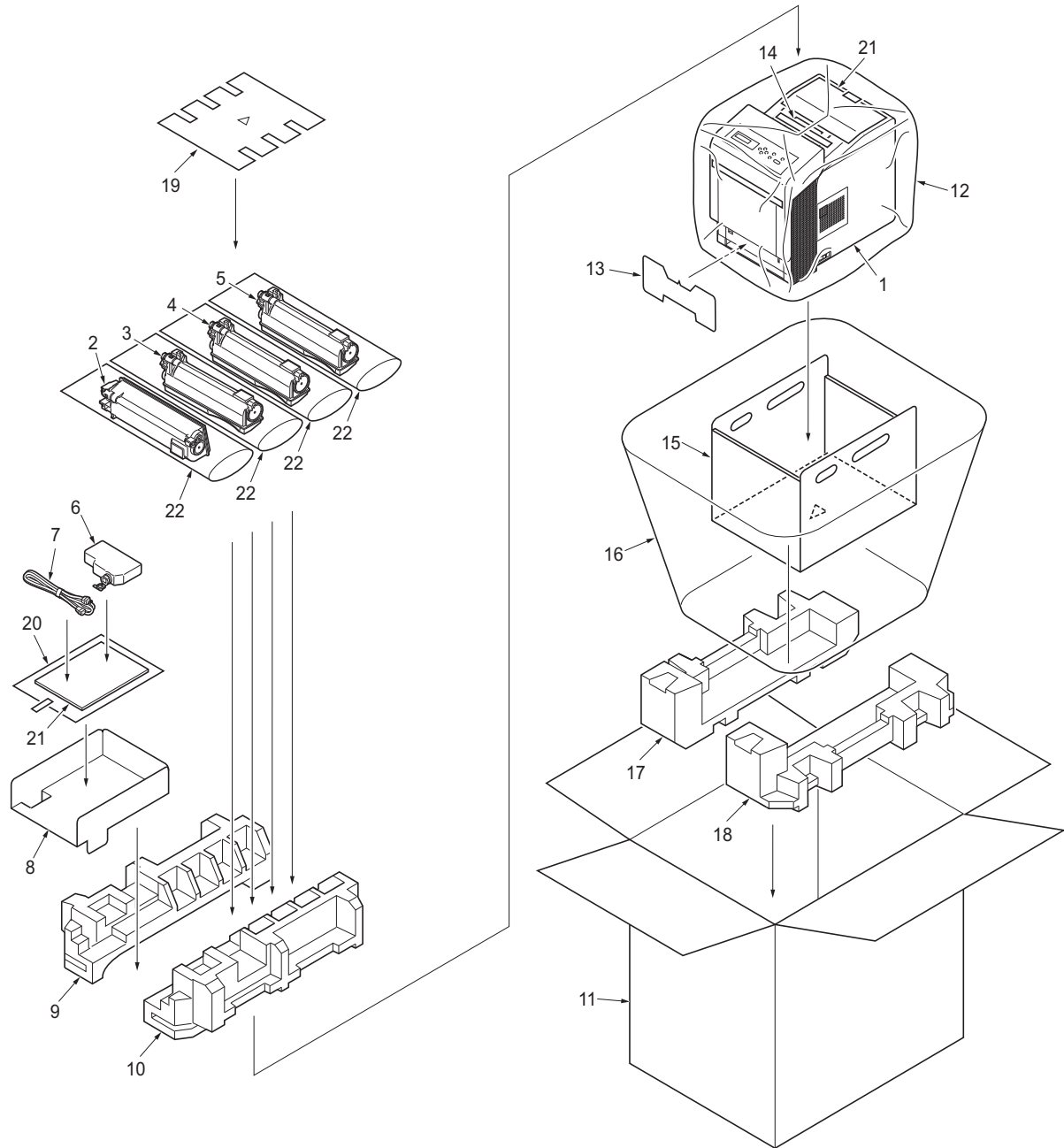

Figure 1-2-3 120 V AC model

- | | |
|------------------------------|------------------------------------|
| 1. Printer | 12. Machine cover 600 × 600 × 900 |
| 2. Toner container (Yellow) | 13. Cassette cushion |
| 3. Toner container (Black) | 14. Desiccating agent |
| 4. Toner container (Cyan) | 15. Main pad |
| 5. Toner container (Magenta) | 16. Machine cover 650 × 650 × 1200 |
| 6. Waste toner box | 17. Bottom left cushion |
| 7. Power cord | 18. Bottom right cushion |
| 8. Document tray | 19. Toner pad US |
| 9. Upper left cushion | 20. Plastic bag 240 × 350 |
| 10. Upper right cushion | 21. Operation guide |
| 11. Outer case | 22. Plastic bags 200 × 700 |

(2) Removing the tape

<Procedure>

1. Remove the tape-A.
2. Remove two tapes-B and then remove the installation guide and desiccating agent.

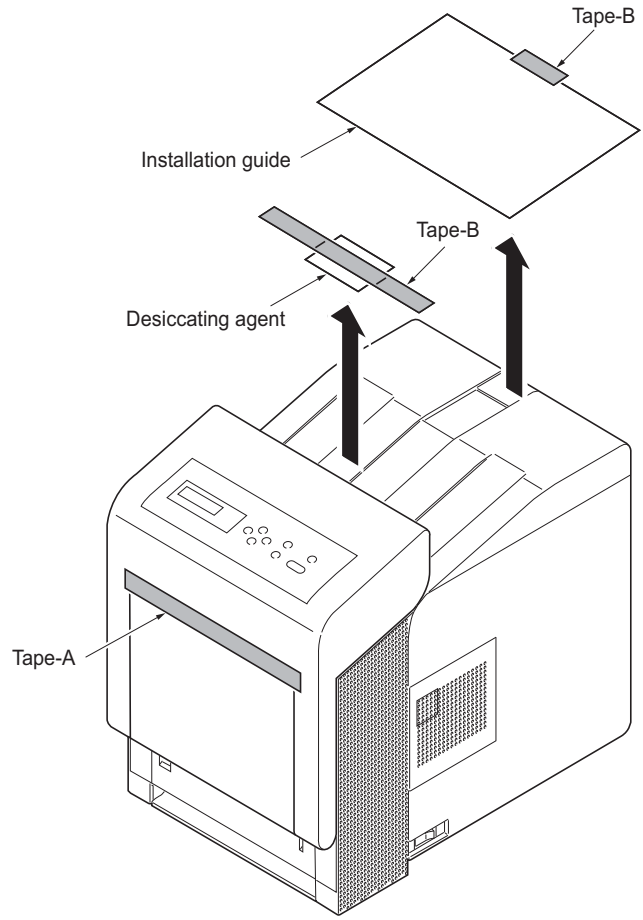

Figure 1-2-4

1-2-3 Installing the expansion memory module (option)

<Procedure>

1. Turn off printer power switch.
Caution:
Do not insert or remove expansion memory modules while printer power is on.
Doing so may cause damage to the printer and the expansion memory modules.
2. Remove the two screws and then remove the main PWB.

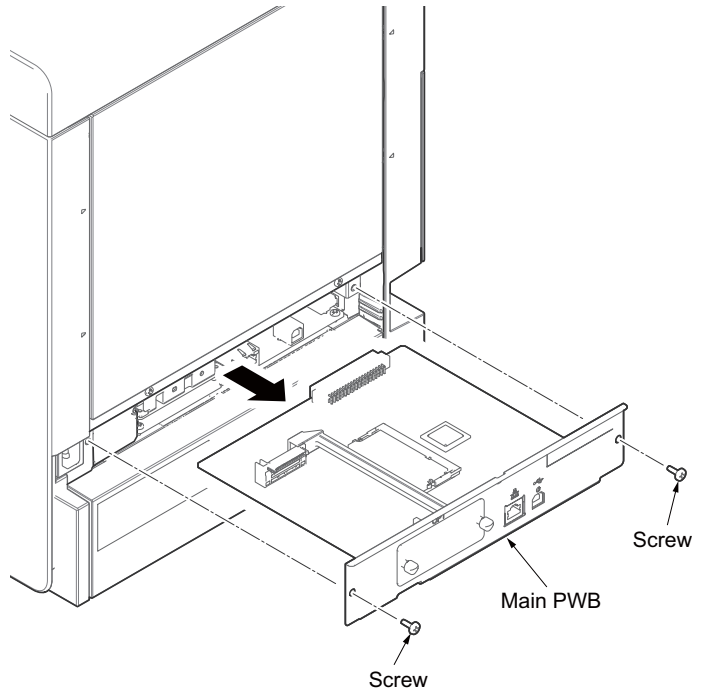

Figure 1-2-5

3. Insert the expansion memory modules into the expansion memory socket so that the notches on the memory align with the corresponding protrusions in the slot.
4. Refit the main PWB.
5. Print a status page to check the memory expansion (See page P.1-3-2).
If memory expansion has been properly performed, information on the installed memory is printed with the total memory capacity has been increased.
Standard memory capacity: 512 MB

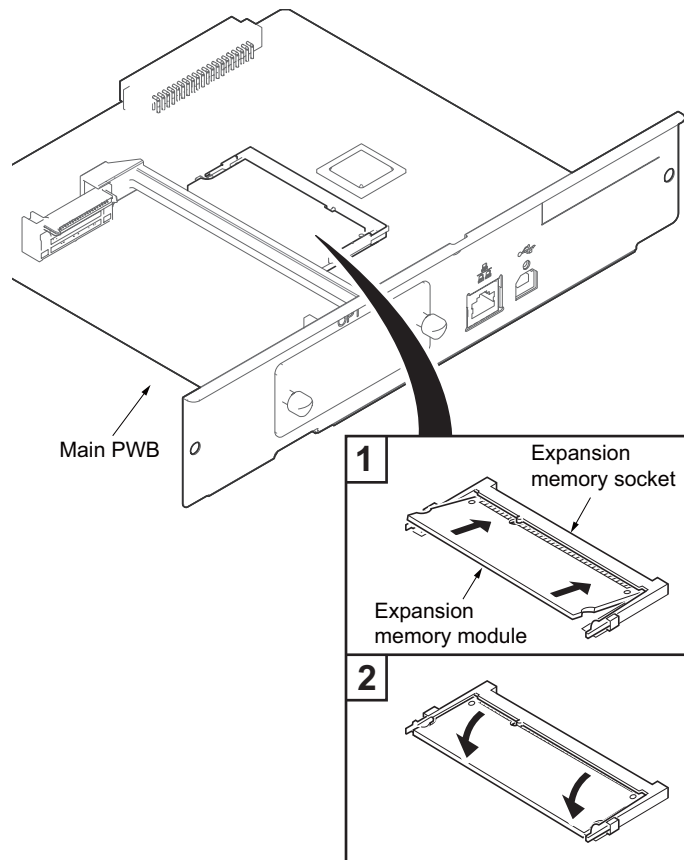

Figure 1-2-6

1-2-4 Installing the SD card (option)

<Procedure>

1. Turn off printer power switch.
 Caution:
 Do not insert or remove SD card while printer power is on.
 Doing so may cause damage to the printer and the SD card.
2. Remove the two screws and the option interface slot cover.

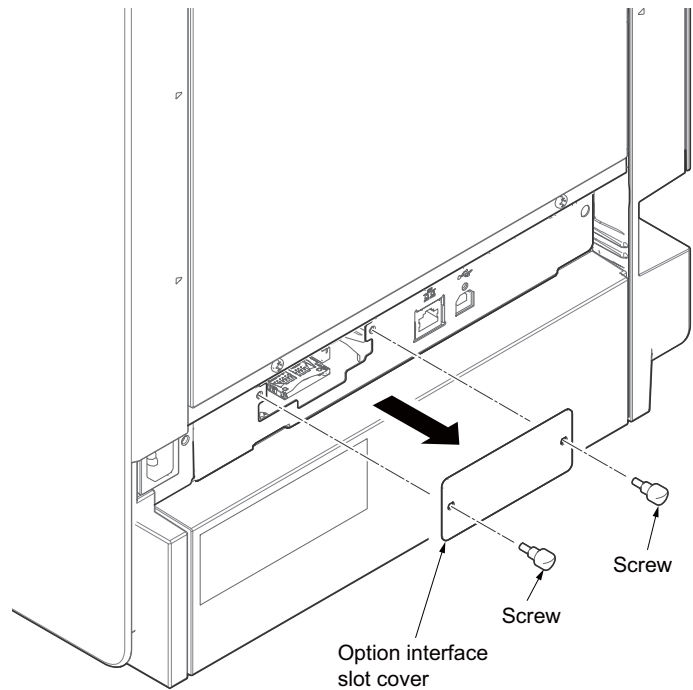

Figure 1-2-7

3. Insert the SD card into the SD card slot.
 Push it in all the way.
4. Refit the option interface slot cover.

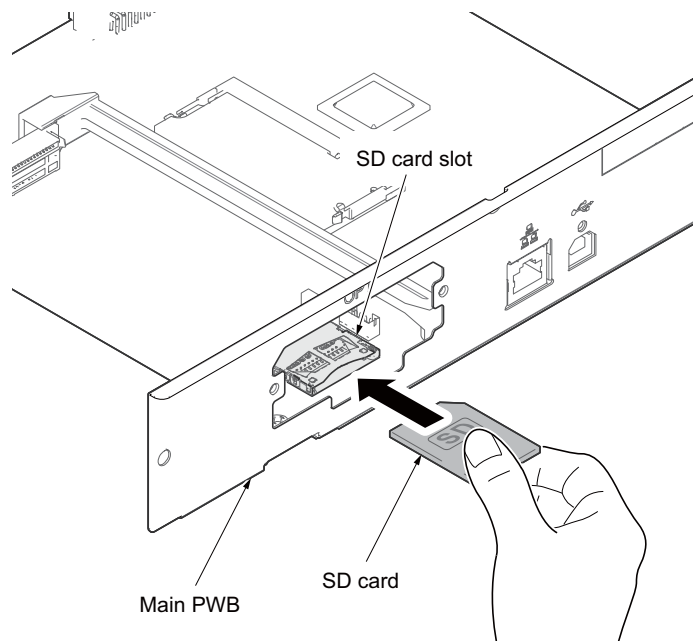

Figure 1-2-8

1-2-5 Installing the SSD disk (option)

<Procedure>

1. Turn off printer power switch.
Caution: Do not insert or remove SSD unit while printer power is on.
Doing so may cause damage to the printer and the SSD.
2. Remove two screws and then remove the option interface slot cover.
3. Insert the SSD into the option interface slot.
Push it in all the way.
4. Secure the SSD by using two screws.

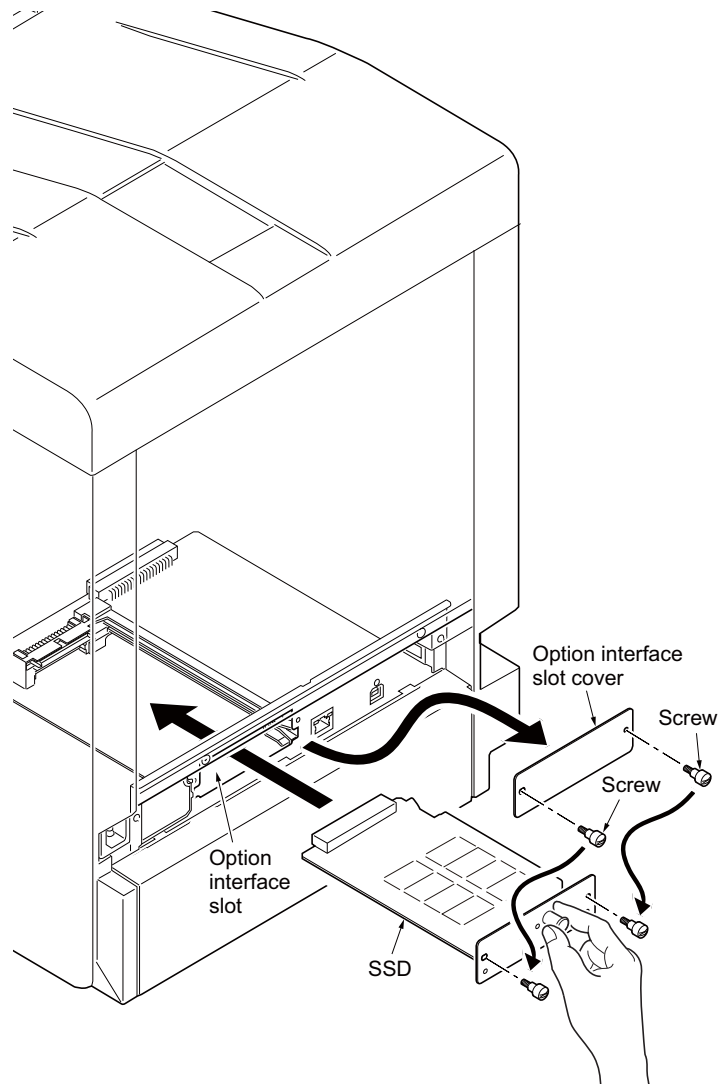

Figure 1-2-9

This page is intentionally left blank.

1-3-1 Maintenance mode

The printer is equipped with a maintenance function which can be used to maintain and service the machine.

(1) Executing a maintenance item

Message display

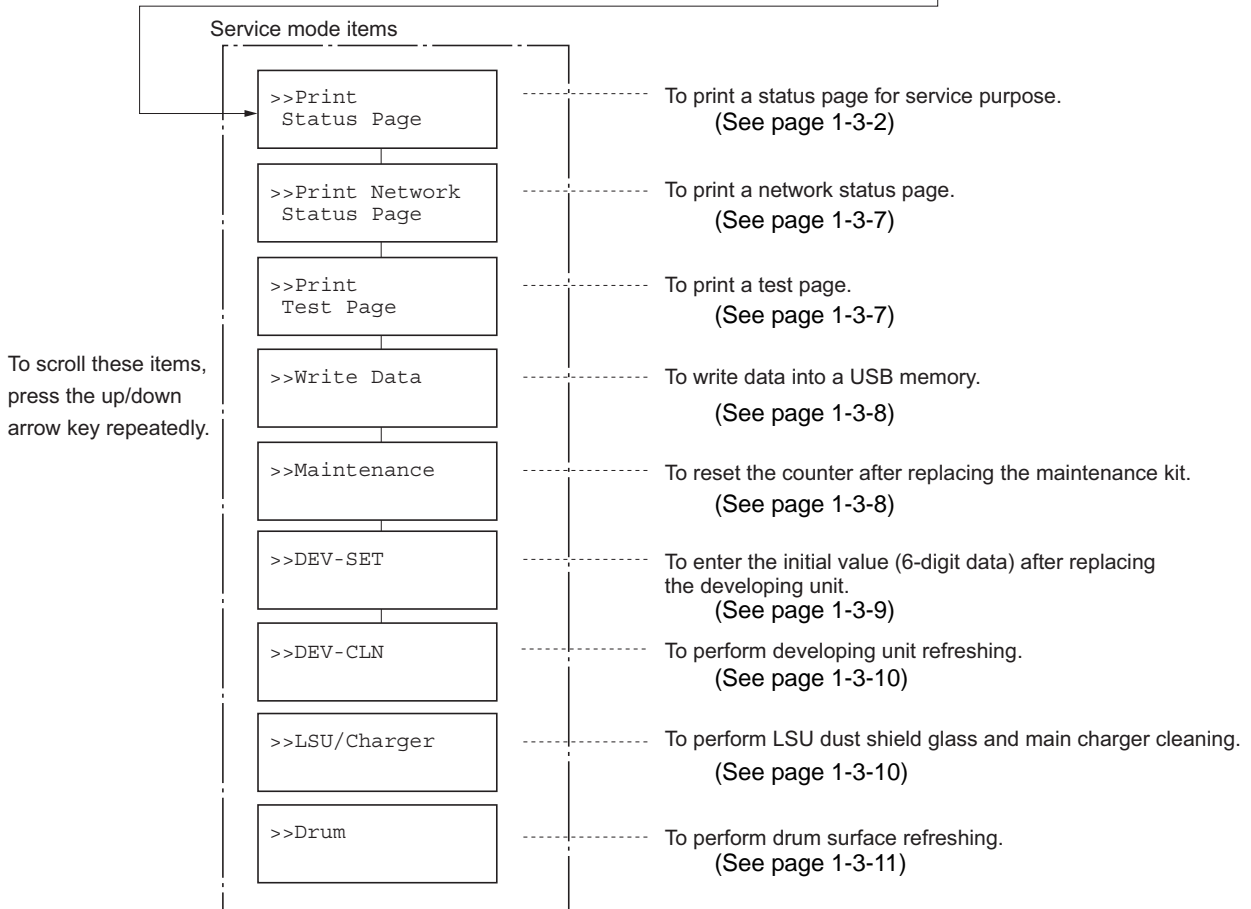
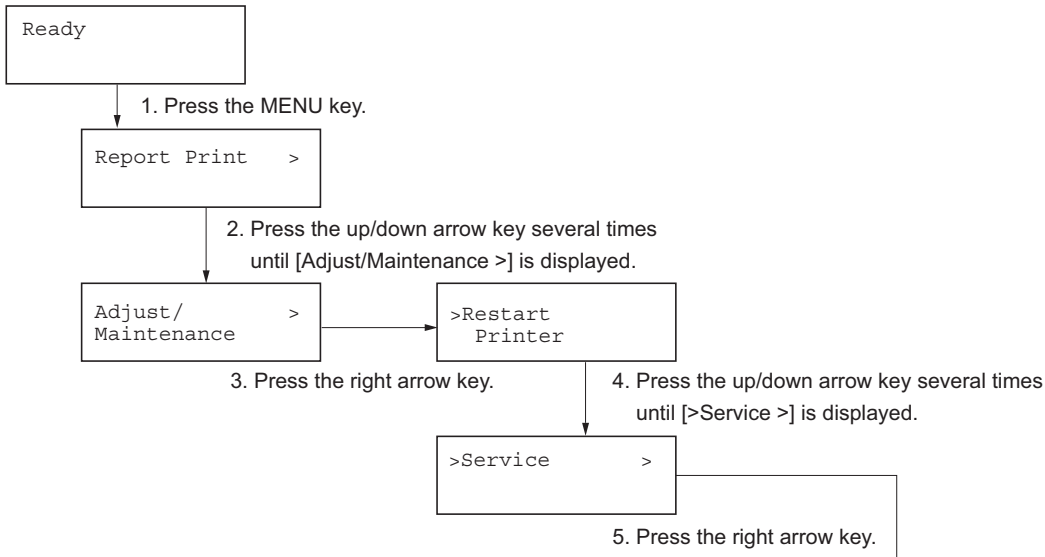

(2) Service mode

Service items	Description																																																												
<div style="border: 1px solid black; padding: 5px; width: fit-content;"> >>Print Status Page </div>	<p>Printing a status page for service purpose</p> <p>Description Prints a status page for service purpose. The status page includes various printing settings and service cumulative.</p> <p>Purpose To acquire the current printing environmental parameters and cumulative information.</p> <p>Procedure</p> <ol style="list-style-type: none"> 1. Enter the service mode [>>Print Status Page]. 2. Press the OK key. [Print Status Page?] will be displayed. 3. Press the OK key. Two pages will be printed. <p>Completion</p> <p>Service status page (1)</p>																																																												
<div style="border: 1px solid black; padding: 10px;"> <h2 style="margin: 0;">Service Status Page</h2> <p>Printer (2) 2013/0607 15:15</p> <p>(1) Firmware version 2PP_2000.000.000 2013.06.07 (3) [XXXXXXXX] (4) [XXXXXXXX] (5) [XXXXXXXX]</p> <hr/> <p>Controller Information</p> <p>Memory status</p> <table style="width: 100%; border-collapse: collapse;"> <tr> <td style="width: 15%;">(7) Standard Size</td> <td style="width: 40%;">128.0 KB</td> <td style="width: 45%;">.</td> </tr> <tr> <td>(8) Option Slot</td> <td>128.0 KB</td> <td>.</td> </tr> <tr> <td>(9) Total Size</td> <td>2.0 GB</td> <td>.</td> </tr> </table> <p>Time</p> <table style="width: 100%; border-collapse: collapse;"> <tr> <td style="width: 15%;">(10) Local Time Zone</td> <td style="width: 40%;">+01:00 Tokio</td> <td style="width: 45%;">.</td> </tr> <tr> <td>(11) Date and Time</td> <td>28/07/2010 16:39</td> <td>.</td> </tr> <tr> <td>(12) Time Server</td> <td>10.183.53.13</td> <td>.</td> </tr> </table> <p>Installed Options</p> <table style="width: 100%; border-collapse: collapse;"> <tr> <td style="width: 15%;">(13) Paper feeder2</td> <td style="width: 40%;">Installed</td> <td style="width: 45%;">.</td> </tr> <tr> <td>(14) Paper feeder3</td> <td>Installed</td> <td>.</td> </tr> <tr> <td>(15) Paper feeder4</td> <td>Not Installed</td> <td>.</td> </tr> <tr> <td>(16) Memory card</td> <td>Installed</td> <td>.</td> </tr> <tr> <td>(17) SSD</td> <td>Installed</td> <td>.</td> </tr> <tr> <td>(18) UG-33</td> <td>Installed</td> <td>PDF mode Y5 00</td> </tr> </table> <p>(19) P tint Coverage</p> <table style="width: 100%; border-collapse: collapse;"> <tr> <td style="width: 15%;">(20) Average(%) / Usage Page(A4/Letter Conversion)</td> <td style="width: 40%;"></td> <td style="width: 45%;">RP Code</td> </tr> <tr> <td>K: 1.10 / 1111111.11</td> <td></td> <td>(23) 1234 5678 9012</td> </tr> <tr> <td>C: 2.20 / 2222222.22</td> <td></td> <td>(24) 5678 9012 3456</td> </tr> <tr> <td>M: 3.30 / 3333333.33</td> <td></td> <td>(25) 9012 3456 7890</td> </tr> <tr> <td>Y: 4.40 / 4444444.44</td> <td></td> <td>(26) 3456 7890 1234</td> </tr> <tr> <td>Period (07/11/2005 - 07/12/2005 08:05)</td> <td></td> <td></td> </tr> </table> <p>(21) Last Page K/C/M/Y(%) 1.00 / 2.22 / 3.33 / 4.44</p> <p>(22) FRPO Status</p> <table style="width: 100%; border-collapse: collapse;"> <tr> <td style="width: 30%;">User Top Margin</td> <td style="width: 30%;">A1+A2/100</td> <td style="width: 40%;">0.00</td> </tr> <tr> <td>User Left Margin</td> <td>A3+A4/100</td> <td>0.00</td> </tr> </table> <hr style="width: 80%; margin: 10px auto;"/> <p style="text-align: center;">1 (6) [XXXXXXXXXXXXXXXXXX]</p> </div>		(7) Standard Size	128.0 KB	.	(8) Option Slot	128.0 KB	.	(9) Total Size	2.0 GB	.	(10) Local Time Zone	+01:00 Tokio	.	(11) Date and Time	28/07/2010 16:39	.	(12) Time Server	10.183.53.13	.	(13) Paper feeder2	Installed	.	(14) Paper feeder3	Installed	.	(15) Paper feeder4	Not Installed	.	(16) Memory card	Installed	.	(17) SSD	Installed	.	(18) UG-33	Installed	PDF mode Y5 00	(20) Average(%) / Usage Page(A4/Letter Conversion)		RP Code	K: 1.10 / 1111111.11		(23) 1234 5678 9012	C: 2.20 / 2222222.22		(24) 5678 9012 3456	M: 3.30 / 3333333.33		(25) 9012 3456 7890	Y: 4.40 / 4444444.44		(26) 3456 7890 1234	Period (07/11/2005 - 07/12/2005 08:05)			User Top Margin	A1+A2/100	0.00	User Left Margin	A3+A4/100	0.00
(7) Standard Size	128.0 KB	.																																																											
(8) Option Slot	128.0 KB	.																																																											
(9) Total Size	2.0 GB	.																																																											
(10) Local Time Zone	+01:00 Tokio	.																																																											
(11) Date and Time	28/07/2010 16:39	.																																																											
(12) Time Server	10.183.53.13	.																																																											
(13) Paper feeder2	Installed	.																																																											
(14) Paper feeder3	Installed	.																																																											
(15) Paper feeder4	Not Installed	.																																																											
(16) Memory card	Installed	.																																																											
(17) SSD	Installed	.																																																											
(18) UG-33	Installed	PDF mode Y5 00																																																											
(20) Average(%) / Usage Page(A4/Letter Conversion)		RP Code																																																											
K: 1.10 / 1111111.11		(23) 1234 5678 9012																																																											
C: 2.20 / 2222222.22		(24) 5678 9012 3456																																																											
M: 3.30 / 3333333.33		(25) 9012 3456 7890																																																											
Y: 4.40 / 4444444.44		(26) 3456 7890 1234																																																											
Period (07/11/2005 - 07/12/2005 08:05)																																																													
User Top Margin	A1+A2/100	0.00																																																											
User Left Margin	A3+A4/100	0.00																																																											
<p>Figure 1-3-1</p>																																																													

Service items	Description		
	<p align="center">Service status page (2)</p>		
	<div style="border: 1px solid black; padding: 10px;"> <h2 align="center">Service Status Page</h2> <p>Printer 2013/06/07 15:15</p> <p>Firmware version 2PP_2000.000.000 2013.06.07 [XXXXXXXX] [XXXXXXXX] [XXXXXXXX]</p> <hr/> <table border="0" style="width: 100%;"> <tr> <td style="width: 50%; vertical-align: top;"> <h3>Engine Information</h3> <p>(27) NVRAM Version _1F31225_1F31225 (28) MAC Address 00:C0:EE:D0:01:0D</p> </td> <td style="width: 50%; vertical-align: top;"> <h3>Send Information</h3> <p>(29) Date and Time 10/07/28 16:39 (30) Address mail@bjd.ne.jp</p> </td> </tr> </table> <p>1/2 (31) (32)</p> <p>(33) 100/100 (34) 0/0/0/0/0/0/ (35) 0/0/0/0/0/0/ (36) 0/0/0/0 (37) 0000000/0000000/0000000/0000000/0000000/0000000/0000000/ 0000000/0000000/0000000/0000000/0000000/0000000/0000000/0000000/0000000/0000000/ F00/U00/0/0/0/0/0/30/35/70/65/abcde/1/0/1/ (38)(39)(40)(41)(42)(43)(44)(45)(46)(47)(48)(49)(50)(51)(52) (53) 0000/0000/0000/0000/0000/0000/0000/0000/0000/0000/0000/0000/0000/0000/0000/0000/ 0000/0000/0000/0000/0000/0000/0000/0000/0000/0000/0000/0000/0000/0000/0000/ (54) 0000/0000/0000/0000/0000/0000/0000/0000/0000/0000/0000/0000/0000/0000/0000/0000/ 0000/0000/0000/0000/0000/0000/0000/0000/0000/0000/0000/0000/0000/0000/0000/0000/ (55) 12345678/11223344/00001234abcd567800001234abcd5678/01234567890123456789012345678901/0008/00/07 12345678/11223344/00001234abcd567800001234abcd5678/01234567890123456789012345678901/0008/00/07 12345678/11223344/00001234abcd567800001234abcd5678/01234567890123456789012345678901/0008/00/07 12345678/11223344/00001234abcd567800001234abcd5678/01234567890123456789012345678901/0008/00/07 (56) 2PP_D100.001.005 (57) 00000000000000/00000000000000/00000000000000/00000000000000/00000000000000/00000000000000/00000000000000/ 00000000000000/00000000000000/00000000000000/00000000000000/00000000000000/00000000000000/00000000000000/ 00000000000000/00000000000000/00000000000000/00000000000000/00000000000000/00000000000000/00000000000000/ 00000000000000/00000000000000/00000000000000/00000000000000/00000000000000/00000000000000/00000000000000/ 00000000000000/00000000000000/00000000000000/00000000000000/00000000000000/00000000000000/00000000000000/ 00000000000000/00000000000000/00000000000000/00000000000000/00000000000000/00000000000000/00000000000000/ 00000000000000/00000000000000/00000000000000/00000000000000/00000000000000/00000000000000/00000000000000/ 00000000000000/00000000000000/00000000000000/00000000000000/00000000000000/00000000000000/00000000000000/ (58) [[]][[]] [2PP_81BR.001.010] [ABCDEFGHJIJ] [ABCDEFGHJIJ] (59) (60) (61) (62) 0/ 0/12. 3/56. 7/ (63) (64) (65) 1/5 (66) (67) (68) 1/ 0/15:47 (69) (70) (71) 1/ (72) ABCDEFGHIJ/ABCDEFGHJIJ/ABCDEFGHJIJ/ABCDEFGHJIJ/</p></div> <hr style="width: 80%; margin: 10px auto;"/> <p align="center">2 [XXXXXXXXXXXXXXXXXXXX]</p>	<h3>Engine Information</h3> <p>(27) NVRAM Version _1F31225_1F31225 (28) MAC Address 00:C0:EE:D0:01:0D</p>	<h3>Send Information</h3> <p>(29) Date and Time 10/07/28 16:39 (30) Address mail@bjd.ne.jp</p>
<h3>Engine Information</h3> <p>(27) NVRAM Version _1F31225_1F31225 (28) MAC Address 00:C0:EE:D0:01:0D</p>	<h3>Send Information</h3> <p>(29) Date and Time 10/07/28 16:39 (30) Address mail@bjd.ne.jp</p>		

Figure 1-3-2

Service items	Description	
	Detail of service status page	
	No.	Description
		Supplement
	(1)	Firmware version -
	(2)	System date -
	(3)	Engine soft version -
	(4)	Engine boot version -
	(5)	Operation panel mask version -
	(6)	Machine serial number -
	(7)	Standard memory size -
	(8)	Optional memory size -
	(9)	Total memory size -
	(10)	Local time zone -
	(11)	Report output date Day/Month/Year hour:minute
	(12)	NTP server name -
	(13)	Presence or absence of the optional paper feeder 1 Installed/Not Installed
	(14)	Presence or absence of the optional paper feeder 2 Installed/Not Installed
	(15)	Presence or absence of the optional paper feeder 3 Installed/Not Installed
	(16)	Presence or absence of the optional memory card Installed/Not Installed
	(17)	Presence or absence of the optional SSD Installed/Not Installed
	(18)	Presence or absence of the optional UG-33 Installed/Not Installed
	(19)	Page of relation to the A4/Letter * :Print Coverage provides a close-matching reference of toner consumption and will not match with the actual toner consumption.
	(20)	Average coverage for printer Black/Cyan/Magenta/Yellow
	(21)	Coverage on the final output page -
	(22)	FRPO setting -
	(23)	RP code Code the engine software version and the date of update.
	(24)	RP code Code the main software version and the date of update.
	(25)	RP code Code the engine software version and the date of the previous update.
	(26)	RP code Code the main software version and the date of the previous update.

Service items	Description		
	No.	Description	Supplement
(27)	NV RAM version	_ 1F3 1225 _ 1F3 1225 (a) (b) (c) (d) (e) (f) (a) Consistency of the present software version and the database _ (underscore): OK * (Asterisk): NG (b) Database version (c) The oldest time stamp of database version (d) Consistency of the present software version and the ME firmware version _ (underscore): OK * (Asterisk): NG (e) ME firmware version (f) The oldest time stamp of the ME database version Normal if (a) and (d) are underscored, and (b) and (e) are identical with (c) and (f).	
(28)	Mac address	-	
(29)	The last sent date and time	-	
(30)	Transmission address	-	
(31)	Destination information	-	
(32)	Area information	-	
(33)	Margin settings	Top margin/Left margin	
	Top offset for each paper source	MP tray/Paper feeder 1/Paper feeder 2/ Paper feeder 3/Duplex/Page rotation	
(34)	Left offset for each paper source	MP tray/Paper feeder 1/Paper feeder 2/ Paper feeder 3/Duplex/Page rotation	
(35)	Margin/Page length/Page width settings	Top margin integer part/Top margin decimal part/ Left margin integer part/Left margin decimal part	
(36)	Life counter (The first line)	Machine life/MP tray/Cassette/Paper feeder 1/ Paper feeder 2/Paper feeder 3/Duplex	
(37)	Life counter (The second line)	Drum unit K/Drum unit C/Drum unit M/Drum unit Y/ Intermediate transfer unit/Developing unit K/ Developing unit C/Developing unit M/ Developing unit Y/Maintenance kit	
(38)	Panel lock information	F00: OFF F01 to F03: Partial lock F04: Full lock	
(39)	USB information	U00: Not installed/U01: Full speed/U02: Hi speed	
(40)	Paper handling information	0: Paper source unit select/1: Paper source unit	
(41)	Auto cassette change mode	0: Prohibition of the Auto cassette change 1: Permission of the Auto cassette change	
(42)	Color printing double count mode	0: All single counts 3: Folio, Single count, Less than 330 mm (length)	
(43)	Black and white printing double count mode	0: All single counts 3: Folio, Single count, Less than 330 mm (length)	
(44)	Billing counting timing	-	
(45)	Temperature (machine inside)	-	
(46)	Temperature (machine outside)	-	
(47)	Relative temperature (machine outside)	-	

Service items	Description																					
No.	Description	Supplement																				
(48)	Absolute temperature (machine outside)	-																				
(49)	Fixed assets number	-																				
(50)	Job end judgment time-out time	-																				
(51)	Job end detection mode	-																				
(52)	Reset the prescribe environmental	0: OFF, 1: ON																				
(53)	Media type attributes 1 to 28 (Not used: 18, 19, 20) * : For details on settings, refer to "Prescribe Commands Reference Manual.	<table border="0"> <tr> <td>Weight settings</td> <td>Fuser settings</td> </tr> <tr> <td>0: Light</td> <td>0: High</td> </tr> <tr> <td>1: Normal 1</td> <td>1: Middle</td> </tr> <tr> <td>2: Normal 2</td> <td>2: Low</td> </tr> <tr> <td>3: Normal 3</td> <td>3: Vellum</td> </tr> <tr> <td>4: Heavy 1</td> <td>Duplex settings</td> </tr> <tr> <td>5: Heavy 2</td> <td>0: Disable</td> </tr> <tr> <td>6: Heavy 3</td> <td>1: Enable</td> </tr> <tr> <td>7: Extra Heavy</td> <td></td> </tr> </table>	Weight settings	Fuser settings	0: Light	0: High	1: Normal 1	1: Middle	2: Normal 2	2: Low	3: Normal 3	3: Vellum	4: Heavy 1	Duplex settings	5: Heavy 2	0: Disable	6: Heavy 3	1: Enable	7: Extra Heavy			
Weight settings	Fuser settings																					
0: Light	0: High																					
1: Normal 1	1: Middle																					
2: Normal 2	2: Low																					
3: Normal 3	3: Vellum																					
4: Heavy 1	Duplex settings																					
5: Heavy 2	0: Disable																					
6: Heavy 3	1: Enable																					
7: Extra Heavy																						
(54)	Calibration information	Black/Cyan/Magenta/Yellow																				
(55)	RFID information	-																				
(56)	RFID reader/writer version information	-																				
(57)	Engine parameter information	-																				
(58)	Soft version of the optional paper feeder	Paper feeder 1/Paper feeder 2/Paper feeder 3																				
(59)	Version of the optional message	-																				
(60)	Color table version	-																				
(61)	2th color table version	-																				
(62)	Altitude	0: Standard 1: High altitude 1 2: High altitude 2																				
(63)	The counter according to toner coverage	0: Full color counter 1: Color coverage counter																				
(64)	Low coverage setting	0.1 to 100.0																				
(65)	Middle coverage setting	0.1 to 100.0																				
(66)	Toner low setting	0: Invalidity , 1: Effective																				
(67)	Toner low detection level	0 to 100(%)																				
(68)	Full page printing Mode	0: Normal Mode 1: Full Page Mode																				
(69)	Wake Up Mode	0: OFF, 1: ON																				
(70)	Wake Up timer	Wake Up Time																				
(71)	BAM conformity Mode setting	0: Un-suiting Mode 1: Conformity Mode																				
(72)	Drum serial number	Black/Cyan/Magenta/Yellow																				
	<p style="text-align: center;">Code conversion</p> <table border="1" style="margin-left: auto; margin-right: auto;"> <tr> <td>A</td><td>B</td><td>C</td><td>D</td><td>E</td><td>F</td><td>G</td><td>H</td><td>I</td><td>J</td> </tr> <tr> <td>0</td><td>1</td><td>2</td><td>3</td><td>4</td><td>5</td><td>6</td><td>7</td><td>8</td><td>9</td> </tr> </table>		A	B	C	D	E	F	G	H	I	J	0	1	2	3	4	5	6	7	8	9
A	B	C	D	E	F	G	H	I	J													
0	1	2	3	4	5	6	7	8	9													

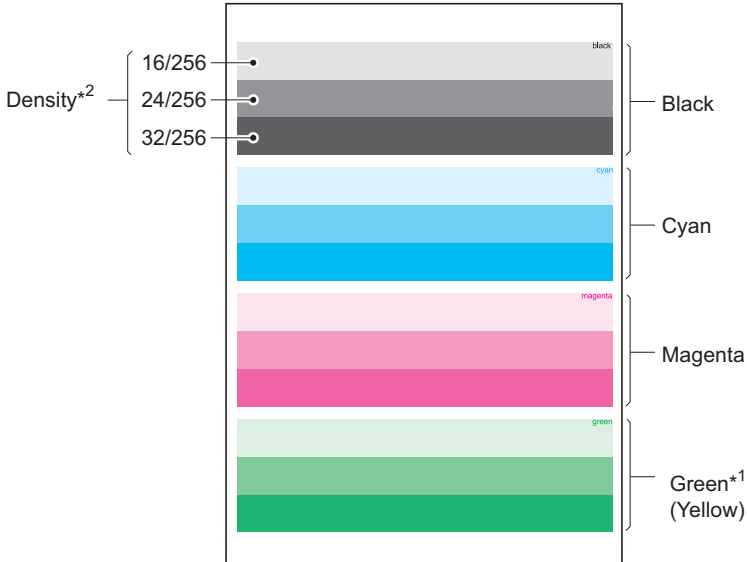
Service items	Description
<div style="border: 1px solid black; padding: 5px; width: fit-content;"> >>Print Network Status Page </div>	<p>Printing a status page for network</p> <p>Description On the status page for network, detailed network setting information is printed.</p> <p>Procedure</p> <ol style="list-style-type: none"> 1. Enter the service mode [>>Print Network Status Page]. 2. Press the OK key. [>>Print Network Status Page?] will be displayed. 3. Press the OK key. Three sheets of network status page will be printed. <p>Completion</p>
<div style="border: 1px solid black; padding: 5px; width: fit-content;"> >>Print Test Page </div>	<p>Printing a test page</p> <p>Description Four colors are printed respectively with halftones of three different levels.</p> <p>Purpose To check the activation of the developer and drum units of four colors.</p> <p>Procedure</p> <ol style="list-style-type: none"> 1. Enter the service mode [>>Print Test Page]. 2. Press the OK key. [>>Print Test Page?] will be displayed. 3. Press the OK key. A sheet of test page will be printed. <p>Completion</p> <div style="text-align: center;">  </div> <p>*1: Since focusing in yellow is hardly readable, yellow is mixed with cyan for more readability, resulting in green.</p> <p>*2: Each portion of colors has three different magnitude of halftones (bands). If focus is excessively lost, dots are not recognizable with the 16/256 band, resulting in uneven density. It also results in vertical streaks in the 24/256 and/or 32/256 bands.</p> <p style="text-align: center;">Figure 1-3-3 Test page</p>

Service items	Description
<div style="border: 1px solid black; padding: 5px; width: fit-content;">>>Write Data</div>	<p>Write data (USB memory data write)</p> <p>Description To write data into a USB memory.</p> <p>Procedure Install the USB memory before attempting to write data.</p> <ol style="list-style-type: none"> 1. Enter the service mode [>>Write Data]. 2. Press the OK key. [>>Write Data?] will be displayed. 3. Press the OK key. [Data waiting] is displayed and the printer waits for data to be written. 4. When the data is sent, [Processing] appears and the data is written to USB memory. When data writing ends, the display returns to [Ready]. <p>Completion</p>
<div style="border: 1px solid black; padding: 5px; width: fit-content;">>>Maintenance</div>	<p>Counter reset for the maintenance kit</p> <p>Description The "Install MK" message means that maintenance kit should be replaced at 200,000 pages of printing. The interval counter must be manually reset using this service item.</p> <p>Maintenance kit includes the following units: Drum unit × 4 Developing unit M, C, Y and K Fuser unit Intermediate transfer unit Paper feed roller assembly Retard roller assembly Ozone filter</p> <p>Purpose To reset the life counter for the drum units, developing units, intermediate transfer unit, and fuser unit included in maintenance kit.</p> <p>Procedure for replacing the maintenance kit Drum unit × 4 (See page 1-5-14) Developing unit M, C, Y and K (See page 1-5-12) Fuser unit (See page 1-5-25) Intermediate transfer unit (See page 1-5-16) Paper feed roller assembly (See page 1-5-8) Retard roller assembly (See page 1-5-10) Ozone filter (See page 1-5-39)</p> <p>Procedure</p> <ol style="list-style-type: none"> 1. Enter the service mode [>>Maintenance]. 2. Press the OK key. [>>Maintenance?] will be displayed. 3. Press the OK key twice. The counter for each component is reset immediately. <p>Completion</p> <p>Note: Occurrences of resetting the maintenance kits are recorded on the service status page in number of pages at which the maintenance kit was replaced (See page 1-3-2). This may be used to determine the possibility that the counter was erroneously or unintentionally reset.</p>

Service items	Description								
<div data-bbox="167 286 414 369" style="border: 1px solid black; padding: 5px; margin-bottom: 10px;"> >>DEV-SET . </div>	<p data-bbox="448 241 1219 273">Entering initial value (6-digit data) for replacing the developing unit</p> <p data-bbox="448 275 580 302">Description</p> <p data-bbox="448 304 1406 360">After replacing the developing unit, enter the initial value (6-digit data) assigned on a label attached to the package or developing unit.</p> <p data-bbox="448 392 568 418">Procedure</p> <ol data-bbox="472 421 1342 566" style="list-style-type: none"> 1. Enter the service mode [>>DEV-SET]. 2. Press the OK key. [>>DEV-SET 000000] will be displayed. 3. Enter the initial value (6-digit data) with cursor keys. 6-digit data is assigned on a label attached to the package or developing unit. <div data-bbox="571 622 1305 1104" style="text-align: center;"> </div> <div data-bbox="587 1126 1305 1608" style="text-align: center;"> </div> <p data-bbox="727 1653 791 1675">Notes</p> <table data-bbox="826 1680 1289 1803"> <tr> <td>0: 21/23 ppm (250-sheet) model</td> <td>0: Magenta</td> </tr> <tr> <td>1: 21/23 ppm (250-sheet) model</td> <td>1: Cyan</td> </tr> <tr> <td>1: 26/28 ppm (500-sheet) model</td> <td>2: Yellow</td> </tr> <tr> <td>30/32 ppm (500-sheet) model*</td> <td>3: Black</td> </tr> </table> <p data-bbox="847 1783 986 1805">*This machine</p> <ol data-bbox="472 1825 1209 1939" style="list-style-type: none"> 4. Press the OK key. [>>OK? 128F1E] will be displayed. 5. Press the OK key. [DEV-SET] will be displayed. The initial value (6-digit data) is set. <p data-bbox="448 1942 580 1968">Completion</p>	0: 21/23 ppm (250-sheet) model	0: Magenta	1: 21/23 ppm (250-sheet) model	1: Cyan	1: 26/28 ppm (500-sheet) model	2: Yellow	30/32 ppm (500-sheet) model*	3: Black
0: 21/23 ppm (250-sheet) model	0: Magenta								
1: 21/23 ppm (250-sheet) model	1: Cyan								
1: 26/28 ppm (500-sheet) model	2: Yellow								
30/32 ppm (500-sheet) model*	3: Black								

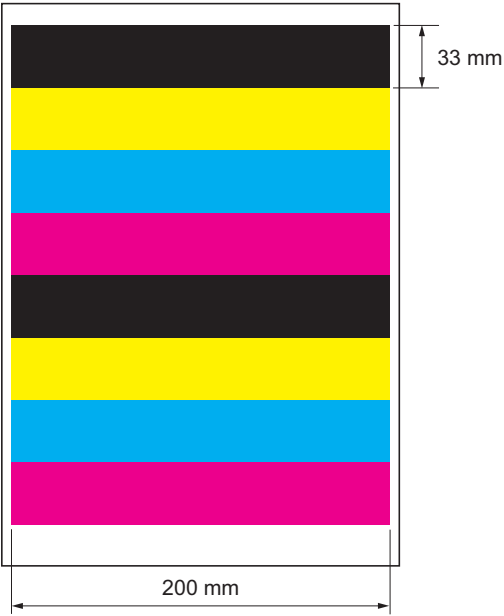
Service items	Description
<div style="border: 1px solid black; padding: 5px; width: fit-content;">>>DEV-CLN</div>	<p>Developer refreshing</p> <p>Description The laser output of the image data for developer refreshing is carried out, and operation to exposure, developing, and primary transfer is performed by 10 pages. (Paper is not fed)</p> <p>Purpose To perform cleaning when faulty images occur and a line appears longitudinally.</p> <p>Procedure</p> <ol style="list-style-type: none"> 1. Enter the service mode [>>DEV-CLN]. 2. Press the OK key. [>>DEV-CLN?] will be displayed. 3. Press the OK key. Developer refreshing will be started. <p>Completion</p> <div style="text-align: center;"> <p>A4 paper size</p>  <p>33 mm</p> <p>200 mm</p> <p>Toner image on the transfer belt</p> </div> <p>Figure 1-3-4Developer refreshing Image data</p>
<div style="border: 1px solid black; padding: 5px; width: fit-content;">>>LSU/Charger</div>	<p>LSU dust shield glass and main charger cleaning</p> <p>Description The LSU cleaning motor drives the cleaning pad which in turn wipes clean the LSU dust shield glass. The main charger cleaning motor drives the cleaning pad which in turn wipes clean the main charger wire and the main charger grid.</p> <p>Purpose To perform cleaning when the printed image is bad and stripes are seen in the vertical direction.</p> <p>Procedure</p> <ol style="list-style-type: none"> 1. Enter the service mode [>>LSU/Charger]. 2. Press the OK key. [>>LSU/Charger?] will be displayed. 3. Press the OK key. LSU dust shield glass and main charger cleaning will be started. <p>Completion</p>

Service items	Description
<div data-bbox="167 286 416 371" style="border: 1px solid black; padding: 5px; width: fit-content;"> >>Drum </div>	<p>Drum surface refreshing</p> <p>Description Rotates the drum approximately 2 minutes with toner lightly on the overall drum using the high-voltage output control of the engine PWB. The cleaning blade in the drum unit scrapes toner off the drum surface to clean it.</p> <p>Purpose To clean the drum surface when image failure occurs due to the drum. This mode is effective when dew condensation on the drum occurs.</p> <p>Method</p> <ol style="list-style-type: none"> 1. Enter the service mode [>>Drum]. 2. Press the OK key. [>>Drum?] will be displayed. 3. Press the OK key. Drum surface refreshing will start and finish after approximately 2 minutes. <p>Completion</p>

(3) Printing a event log (EVENT LOG)

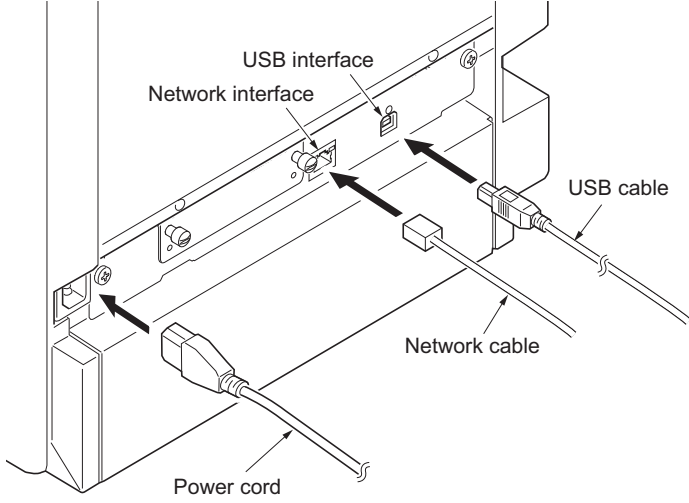
Service items	Description
<p>Printing an event log (EVENT LOG)</p>	<p>Printing an event log (EVENT LOG) Description Prints a history list of occurrences of paper jam, self-diagnostics, toner replacements, etc. Purpose To allow machine malfunction analysis based on the frequency of paper misfeeds, self diagnostic errors and replacements. Procedure</p> <ol style="list-style-type: none"> 1. Connect the USB or network cable between printer and PC (network). 2. Connect the power cord.  <p>The diagram shows the back panel of a printer with several connection points. From left to right, there is a power cord plug, a network interface (RJ45), a USB interface (Type-B), and a power cord outlet. A network cable is plugged into the network interface, a USB cable is plugged into the USB interface, and a power cord is plugged into the power cord outlet. Arrows point from the labels to the respective ports.</p> <p style="text-align: center;">Figure 1-3-5</p> <ol style="list-style-type: none"> 3. Turn printer power on. Make sure the printer is ready. 4. Send the following PRESCRIBE command sequence from the PC to the printer. <pre>!R!KCFG"ELOG";EXIT;</pre> <p>A sheet of event log will be printed.</p> <p>Completion</p> <p>Remarks: Details of configurations (See above 4.)</p> <p>Notes on Connecting to USB</p> <ol style="list-style-type: none"> (1) Save the Prescribe commands above as a text file in the PC. (2) Select the Sharing tab of the printer properties and share the printer. (3) Select a USB port in the Port tab. (Specify the printer name for sharing.) (4) From the DOS Prompt, execute the following command line: copy file-name\computer-name\shared-printe File-name should be the name of the file that was saved in step 1. <p>Notes on connecting via network (using FTP protocol)</p> <ol style="list-style-type: none"> (1) Save the Prescribe commands above as a text file in the PC. (2) From the DOS Prompt, execute the following command line: ftp printer-IP-address Do not specify user name and password. (3) From the DOS Prompt, execute the following command: put file-name File-name should be the name of the file that was saved in step 1.

Service items	Description																																																																																																																																																																									
	Detail of event log																																																																																																																																																																									
	<div style="border: 1px solid black; padding: 10px;"> <h2 style="margin:0;">Event Log</h2> <p>Printer (2) 2013/05/31 15:15</p> <p>(1) Firmware version 2PP_2000.000.000 2013.05.31 (3) [XXXXXXXX] (4) [XXXXXXXX] (5) [XXXXXXXX]</p> <hr/> <div style="display: flex; justify-content: space-between;"> <div style="width: 48%;"> <p>(7) Paper Jam Log</p> <table border="1" style="width:100%; border-collapse: collapse; font-size: small;"> <thead> <tr> <th>#</th> <th>Count.</th> <th>Event Descriptions</th> <th>Data and Time</th> </tr> </thead> <tbody> <tr><td>12</td><td>1876543</td><td>0501.01.08.01.01</td><td>2013/03/02 11:11</td></tr> <tr><td>11</td><td>166554</td><td>4020.01.08.01.01</td><td>2013/03/02 10:57</td></tr> <tr><td>10</td><td>4988</td><td>0501.01.08.01.01</td><td>2013/03/02 10:44</td></tr> <tr><td>9</td><td>4988</td><td>4020.01.08.01.01</td><td>2013/03/02 10:00</td></tr> <tr><td>8</td><td>1103</td><td>0501.01.08.01.01</td><td>2013/03/02 09:27</td></tr> <tr><td>7</td><td>1103</td><td>4020.01.08.01.01</td><td>2013/03/01 17:30</td></tr> <tr><td>6</td><td>1027</td><td>0501.01.08.01.01</td><td>2013/03/01 10:02</td></tr> <tr><td>5</td><td>1027</td><td>4020.01.08.01.01</td><td>2013/03/01 08:57</td></tr> <tr><td>4</td><td>1027</td><td>0501.01.08.01.01</td><td>2013/02/29 17:00</td></tr> <tr><td>3</td><td>1027</td><td>4020.01.08.01.01</td><td>2013/02/29 15:38</td></tr> <tr><td>2</td><td>406</td><td>0501.01.08.01.01</td><td>2013/02/28 09:00</td></tr> <tr><td>1</td><td>36</td><td>4020.01.08.01.01</td><td>2013/02/28 08:12</td></tr> </tbody> </table> </div> <div style="width: 48%;"> <p>(11) Counter Log</p> <table border="1" style="width:100%; border-collapse: collapse; font-size: small;"> <thead> <tr> <th>(f) J0100: 0</th> <th>(g) C0000: 0</th> <th>(h) T00: 10</th> </tr> </thead> <tbody> <tr><td>J0105: 0</td><td>C0001: 1</td><td>T01: 20</td></tr> <tr><td>J0106: 0</td><td>C0002: 2</td><td>T02: 30</td></tr> <tr><td>J0110: 0</td><td>C0003: 3</td><td>T03: 40</td></tr> <tr><td>J0111: 0</td><td>C0004: 4</td><td>T04: 50</td></tr> <tr><td>J0512: 0</td><td>C0005: 5</td><td>T05: 999</td></tr> <tr><td>J0513: 0</td><td>C0006: 6</td><td></td></tr> <tr><td>J0518: 0</td><td>C0007: 7</td><td></td></tr> <tr><td>J0519: 0</td><td>C0008: 8</td><td></td></tr> <tr><td>J1020: 0</td><td>C0009: 9</td><td></td></tr> <tr><td>J4201: 0</td><td>C0010: 10</td><td></td></tr> <tr><td>J4202: 0</td><td>C0011: 11</td><td></td></tr> <tr><td>J4203: 0</td><td></td><td></td></tr> <tr><td>J4208: 0</td><td></td><td></td></tr> <tr><td>J4209: 0</td><td></td><td></td></tr> </tbody> </table> </div> </div> <div style="text-align: center; margin: 10px 0;"> <div style="border: 1px solid black; padding: 5px; display: inline-block;"> 0501.01.08.01.01 (a) (b) (c) (d) (e) </div> </div> <p>(8) Service Call Log</p> <table border="1" style="width:100%; border-collapse: collapse; font-size: small;"> <thead> <tr> <th>#</th> <th>Count.</th> <th>Service Code</th> <th>Data and Time</th> </tr> </thead> <tbody> <tr><td>8</td><td>1881214</td><td>01.6000</td><td>2013/03/02 11:11</td></tr> <tr><td>7</td><td>178944</td><td>01.2100</td><td>2013/03/02 10:57</td></tr> <tr><td>6</td><td>5296</td><td>01.4000</td><td>2013/03/02 10:44</td></tr> <tr><td>5</td><td>5295</td><td>01.6000</td><td>2013/03/02 10:00</td></tr> <tr><td>4</td><td>2099</td><td>01.2100</td><td>2013/03/02 09:27</td></tr> <tr><td>3</td><td>1054</td><td>01.4000</td><td>2013/03/01 17:30</td></tr> <tr><td>2</td><td>809</td><td>01.6000</td><td>2013/03/01 10:02</td></tr> <tr><td>1</td><td>30</td><td>01.2100</td><td>2013/03/01 08:57</td></tr> </tbody> </table> <p>(9) Maintenance Log</p> <table border="1" style="width:100%; border-collapse: collapse; font-size: small;"> <thead> <tr> <th>#</th> <th>Count.</th> <th>Item</th> <th>Data and Time</th> </tr> </thead> <tbody> <tr><td>3</td><td>104511</td><td>01.00</td><td>2013/03/02 11:11</td></tr> <tr><td>2</td><td>3454</td><td>01.01</td><td>2013/03/02 10:57</td></tr> <tr><td>1</td><td>34</td><td>01.01</td><td>2013/03/02 10:44</td></tr> </tbody> </table> <p>(10) Unknown toner Log</p> <table border="1" style="width:100%; border-collapse: collapse; font-size: small;"> <thead> <tr> <th>#</th> <th>Count.</th> <th>Item</th> <th>Data and Time</th> </tr> </thead> <tbody> <tr><td>4</td><td>3454</td><td>01.00</td><td>2013/03/02 11:11</td></tr> <tr><td>3</td><td>3454</td><td>01.00</td><td>2013/03/02 10:57</td></tr> <tr><td>2</td><td>406</td><td>01.00</td><td>2013/03/02 10:44</td></tr> <tr><td>1</td><td>32</td><td>01.00</td><td>2013/03/02 10:00</td></tr> </tbody> </table> <p style="text-align: right;">(6) [XXXXXXXXXXXXXXXXXXXX]</p> </div>	#	Count.	Event Descriptions	Data and Time	12	1876543	0501.01.08.01.01	2013/03/02 11:11	11	166554	4020.01.08.01.01	2013/03/02 10:57	10	4988	0501.01.08.01.01	2013/03/02 10:44	9	4988	4020.01.08.01.01	2013/03/02 10:00	8	1103	0501.01.08.01.01	2013/03/02 09:27	7	1103	4020.01.08.01.01	2013/03/01 17:30	6	1027	0501.01.08.01.01	2013/03/01 10:02	5	1027	4020.01.08.01.01	2013/03/01 08:57	4	1027	0501.01.08.01.01	2013/02/29 17:00	3	1027	4020.01.08.01.01	2013/02/29 15:38	2	406	0501.01.08.01.01	2013/02/28 09:00	1	36	4020.01.08.01.01	2013/02/28 08:12	(f) J0100: 0	(g) C0000: 0	(h) T00: 10	J0105: 0	C0001: 1	T01: 20	J0106: 0	C0002: 2	T02: 30	J0110: 0	C0003: 3	T03: 40	J0111: 0	C0004: 4	T04: 50	J0512: 0	C0005: 5	T05: 999	J0513: 0	C0006: 6		J0518: 0	C0007: 7		J0519: 0	C0008: 8		J1020: 0	C0009: 9		J4201: 0	C0010: 10		J4202: 0	C0011: 11		J4203: 0			J4208: 0			J4209: 0			#	Count.	Service Code	Data and Time	8	1881214	01.6000	2013/03/02 11:11	7	178944	01.2100	2013/03/02 10:57	6	5296	01.4000	2013/03/02 10:44	5	5295	01.6000	2013/03/02 10:00	4	2099	01.2100	2013/03/02 09:27	3	1054	01.4000	2013/03/01 17:30	2	809	01.6000	2013/03/01 10:02	1	30	01.2100	2013/03/01 08:57	#	Count.	Item	Data and Time	3	104511	01.00	2013/03/02 11:11	2	3454	01.01	2013/03/02 10:57	1	34	01.01	2013/03/02 10:44	#	Count.	Item	Data and Time	4	3454	01.00	2013/03/02 11:11	3	3454	01.00	2013/03/02 10:57	2	406	01.00	2013/03/02 10:44	1	32	01.00	2013/03/02 10:00
#	Count.	Event Descriptions	Data and Time																																																																																																																																																																							
12	1876543	0501.01.08.01.01	2013/03/02 11:11																																																																																																																																																																							
11	166554	4020.01.08.01.01	2013/03/02 10:57																																																																																																																																																																							
10	4988	0501.01.08.01.01	2013/03/02 10:44																																																																																																																																																																							
9	4988	4020.01.08.01.01	2013/03/02 10:00																																																																																																																																																																							
8	1103	0501.01.08.01.01	2013/03/02 09:27																																																																																																																																																																							
7	1103	4020.01.08.01.01	2013/03/01 17:30																																																																																																																																																																							
6	1027	0501.01.08.01.01	2013/03/01 10:02																																																																																																																																																																							
5	1027	4020.01.08.01.01	2013/03/01 08:57																																																																																																																																																																							
4	1027	0501.01.08.01.01	2013/02/29 17:00																																																																																																																																																																							
3	1027	4020.01.08.01.01	2013/02/29 15:38																																																																																																																																																																							
2	406	0501.01.08.01.01	2013/02/28 09:00																																																																																																																																																																							
1	36	4020.01.08.01.01	2013/02/28 08:12																																																																																																																																																																							
(f) J0100: 0	(g) C0000: 0	(h) T00: 10																																																																																																																																																																								
J0105: 0	C0001: 1	T01: 20																																																																																																																																																																								
J0106: 0	C0002: 2	T02: 30																																																																																																																																																																								
J0110: 0	C0003: 3	T03: 40																																																																																																																																																																								
J0111: 0	C0004: 4	T04: 50																																																																																																																																																																								
J0512: 0	C0005: 5	T05: 999																																																																																																																																																																								
J0513: 0	C0006: 6																																																																																																																																																																									
J0518: 0	C0007: 7																																																																																																																																																																									
J0519: 0	C0008: 8																																																																																																																																																																									
J1020: 0	C0009: 9																																																																																																																																																																									
J4201: 0	C0010: 10																																																																																																																																																																									
J4202: 0	C0011: 11																																																																																																																																																																									
J4203: 0																																																																																																																																																																										
J4208: 0																																																																																																																																																																										
J4209: 0																																																																																																																																																																										
#	Count.	Service Code	Data and Time																																																																																																																																																																							
8	1881214	01.6000	2013/03/02 11:11																																																																																																																																																																							
7	178944	01.2100	2013/03/02 10:57																																																																																																																																																																							
6	5296	01.4000	2013/03/02 10:44																																																																																																																																																																							
5	5295	01.6000	2013/03/02 10:00																																																																																																																																																																							
4	2099	01.2100	2013/03/02 09:27																																																																																																																																																																							
3	1054	01.4000	2013/03/01 17:30																																																																																																																																																																							
2	809	01.6000	2013/03/01 10:02																																																																																																																																																																							
1	30	01.2100	2013/03/01 08:57																																																																																																																																																																							
#	Count.	Item	Data and Time																																																																																																																																																																							
3	104511	01.00	2013/03/02 11:11																																																																																																																																																																							
2	3454	01.01	2013/03/02 10:57																																																																																																																																																																							
1	34	01.01	2013/03/02 10:44																																																																																																																																																																							
#	Count.	Item	Data and Time																																																																																																																																																																							
4	3454	01.00	2013/03/02 11:11																																																																																																																																																																							
3	3454	01.00	2013/03/02 10:57																																																																																																																																																																							
2	406	01.00	2013/03/02 10:44																																																																																																																																																																							
1	32	01.00	2013/03/02 10:00																																																																																																																																																																							
	Figure 1-3-6																																																																																																																																																																									
	<table border="1" style="width:100%; border-collapse: collapse;"> <thead> <tr> <th style="width:5%;">No.</th> <th style="width:25%;">Items</th> <th>Description</th> </tr> </thead> <tbody> <tr> <td>(1)</td> <td>System version</td> <td></td> </tr> <tr> <td>(2)</td> <td>System date</td> <td></td> </tr> <tr> <td>(3)</td> <td>Engine soft version</td> <td></td> </tr> <tr> <td>(4)</td> <td>Engine boot version</td> <td></td> </tr> <tr> <td>(5)</td> <td>Operation panel mask version</td> <td></td> </tr> <tr> <td>(6)</td> <td>Machine serial number</td> <td></td> </tr> </tbody> </table>	No.	Items	Description	(1)	System version		(2)	System date		(3)	Engine soft version		(4)	Engine boot version		(5)	Operation panel mask version		(6)	Machine serial number																																																																																																																																																					
No.	Items	Description																																																																																																																																																																								
(1)	System version																																																																																																																																																																									
(2)	System date																																																																																																																																																																									
(3)	Engine soft version																																																																																																																																																																									
(4)	Engine boot version																																																																																																																																																																									
(5)	Operation panel mask version																																																																																																																																																																									
(6)	Machine serial number																																																																																																																																																																									

Service items		Description		
No.	Items	Description		
		#	Count.	Event
(7)	Paper Jam Log	Remembers 1 to 16 of occurrence. If the occurrence of the previous paper jam is less than 16, all of the paper jams are logged. When the occurrence exceeds 16, the oldest occurrence is removed.	The total page count at the time of the paper jam.	Log code (hexadecimal, 5 categories) (a) Cause of a paper jam (b) Paper source (c) Paper size (d) Paper type (e) Paper eject
		(a) Cause of paper jam (Hexadecimal)		
		0105: Registration sensor not detected [-] 0110: Top tray open [-] 0111: Rear cover open [-] 0112: Front cover open [-] 0501: No paper feed from cassette 1 [1] 0502: No paper feed from cassette 2 [2] 0503: No paper feed from cassette 3 [3] 0504: No paper feed from cassette 4 [4] 0508: No paper feed from duplex section [I] 0511: Multiple sheets in cassette 1 [1] 0518: Multiple sheets in duplex section [I] 1403: PF feed sensor 1 does not turn ON (Paper feeder 2) [2] 1404: PF feed sensor 1 does not turn ON (Paper feeder 3) [2] 1420: PF feed sensor 1 is turned ON [2] 1604: PF feed sensor 2 does not turn ON (Paper feeder 3) [3] 1620: PF feed sensor 2 is turned ON [3] 1820: PF feed sensor 3 is turned ON [4] 2020: PF feed sensor 4 is turned ON [5] 4002: Registration sensor does not turn ON (Paper feeder 1) [1] 4003: Registration sensor does not turn ON (Paper feeder 2) [1] 4004: Registration sensor does not turn ON (Paper feeder 3) [1] 4009: Registration sensor does not turn ON (MP tray) [1] 4012: Registration sensor does not turn OFF (Paper feeder 1) [H] 4013: Registration sensor does not turn OFF (Paper feeder 2) [H] 4014: Registration sensor does not turn OFF (Paper feeder 3) [H] 4019: Registration sensor does not turn OFF (MP tray) [H] 4020: Registration sensor is turned ON [H] 4201: Eject sensor does not turn ON (Cassette) [H] 4202: Eject sensor does not turn ON (Paper feeder 1) [H] 4203: Eject sensor does not turn ON (Paper feeder 2) [H] 4204: Eject sensor does not turn ON (Paper feeder 3) [H] 4208: Eject sensor does not turn ON (Duplex) [H] 4209: Eject sensor does not turn ON (MP tray) [H] 4211: Eject sensor does not turn OFF (Cassette) [G] 4212: Eject sensor does not turn OFF (Paper feeder 1) [G] 4213: Eject sensor does not turn OFF (Paper feeder 2) [G] 4214: Eject sensor does not turn OFF (Paper feeder 3) [G] 4215: Eject sensor does not turn OFF (Paper feeder 4) [G] 4218: Eject sensor does not turn OFF (Duplex) [G]		

Service items		Description																																				
No.	Items	Description																																				
(7) cont.	Paper Jam Log	<p>4219: Eject sensor does not turn OFF (MP tray) [G] 4220: Eject sensor is turned ON [G] 4301: Duplex sensor does not turn OFF (Cassette) [I] 4302: Duplex sensor does not turn OFF (Paper feeder 1) [I] 4303: Duplex sensor does not turn OFF (Paper feeder 2) [I] 4304: Duplex sensor does not turn OFF (Paper feeder 3) [I] 4309: Duplex sensor does not turn OFF (MP tray) [I] 4320: Duplex sensor is turned ON [I]</p> <p>Note: Values (hexadecimal) within [] indicate paper misfeed locations.</p> <p>Jam location</p>  <table border="1" style="margin-left: auto; margin-right: auto;"> <thead> <tr> <th colspan="2">Sensors</th> <th colspan="2">Paper jam location</th> </tr> </thead> <tbody> <tr> <td style="text-align: center;">①</td> <td>Registration sensor</td> <td style="text-align: center;">[B]</td> <td>MP tray</td> </tr> <tr> <td style="text-align: center;">②</td> <td>Paper exit sensor</td> <td style="text-align: center;">[1]</td> <td>Cassette 1 (printer)</td> </tr> <tr> <td style="text-align: center;">③</td> <td>Duplex conveying sensor</td> <td style="text-align: center;">[2]</td> <td>Paper feeder 1</td> </tr> <tr> <td style="text-align: center;">④</td> <td>Paper full sensor</td> <td style="text-align: center;">[3]</td> <td>Paper feeder 2</td> </tr> <tr> <td style="text-align: center;">⑤</td> <td>PF paper feed sensor</td> <td style="text-align: center;">[4]</td> <td>Paper feeder 3</td> </tr> <tr> <td></td> <td></td> <td style="text-align: center;">[H]</td> <td>Printer inside</td> </tr> <tr> <td></td> <td></td> <td style="text-align: center;">[G]</td> <td>Paper exit section</td> </tr> <tr> <td></td> <td></td> <td style="text-align: center;">[I]</td> <td>Duplex section</td> </tr> </tbody> </table>	Sensors		Paper jam location		①	Registration sensor	[B]	MP tray	②	Paper exit sensor	[1]	Cassette 1 (printer)	③	Duplex conveying sensor	[2]	Paper feeder 1	④	Paper full sensor	[3]	Paper feeder 2	⑤	PF paper feed sensor	[4]	Paper feeder 3			[H]	Printer inside			[G]	Paper exit section			[I]	Duplex section
Sensors		Paper jam location																																				
①	Registration sensor	[B]	MP tray																																			
②	Paper exit sensor	[1]	Cassette 1 (printer)																																			
③	Duplex conveying sensor	[2]	Paper feeder 1																																			
④	Paper full sensor	[3]	Paper feeder 2																																			
⑤	PF paper feed sensor	[4]	Paper feeder 3																																			
		[H]	Printer inside																																			
		[G]	Paper exit section																																			
		[I]	Duplex section																																			

Figure 1-3-7

Service items		Description		
(7) cont.	Paper Jam Log	(b) Detail of paper source (Hexadecimal)		
		00: MP tray 01: Paper cassette 1 (printer) 02: Paper cassette 2 (paper feeder 1) 03: Paper cassette 3 (paper feeder 2) 04: Paper cassette 4 (paper feeder 3) 05: - 06: - 07: Duplex unit 08: Bulk paper feeder 09: Envelope feeder		
		(c) Detail of paper size (Hexadecimal)		
		01: Monarch 02: Business 03: International DL 04: International C5 05: Executive 06: Letter-R 86: Letter-E 07: Legal 08: A4R 88: A4E 09: B5R 89: B5E 0A: A3 0B: B4 0C: Ledger 0D: A5R 8D: A5E 0E: A6 0F: B6 10: Commercial #9 11: Commercial #6 12: ISO B5 13: Custom size 1E: C4 1F: Postcard 20: Reply-paid postcard 21: Oficio II 22: Special 1 23: Special 2 24: A3 wide 25: Ledger wide 26: Full bleed paper (12 ´ 8) 27: 8K 28: 16K-R A8: 16K-E 32: Statement-R B2: Statement-E 33: Folio 34: Western type 2 35: Western type 4		
		(d) Detail of paper type (Hexadecimal)		
		01: Plain 02: Transparency 03: Preprint 04: Labels 05: Bond 06: Recycle 07: Vellum 08: Rough 09: Letter head 0A: Color 0B: Prepunched 0C: Envelope 0D: Cardstock 0E: Coated 0F: 2nd side 10: Media 16 11: High quality 15: Custom 1 16: Custom 2 17: Custom 3 18: Custom 4 19: Custom 5 1A: Custom 6 1B: Custom 7 1C: Custom 8		
		(e) Detail of paper exit location (Hexadecimal)		
		01: Face down tray (FD) 02: Face up tray (FU) 03 to 48: Reserved		
(8)	Service Call (Self diagnostic error) Log	#	Count.	Service Code
		Remembers 1 to 8 of occurrence of self diagnostics error. If the occurrence of the previous diagnostics error is less than 8, all of the diagnostics errors are logged.	The total page count at the time of the self diagnostics error.	Self diagnostic error code (See page 1-4-3) Example 01.6000 01 means a self-diagnostic error; 6000 means a self diagnostic error code.

Service items		Description		
No.	Items	Description		
(9)	<p>Maintenance Log</p> <p>NOTE: It is not logged if 100 or more counts are not added to the count at the last occurrence of replacement.</p>	<p>#</p> <p>Remembers 1 to 8 of occurrence of replacement. If the occurrence of the previous replacement of toner container is less than 8, all of the occurrences of replacement are logged.</p>	<p><u>Count.</u></p> <p>The total page count at the time of the replacement of the toner container.</p> <p>This is virtually logged as the occurrence of the "Toner Empty" or "Install MK" condition since the replacement of the toner container is not precisely detectable.</p> <p>* :The toner replacement log is triggered by toner empty. This record may contain such a reference as the toner container is inserted twice or a used toner container is inserted.</p>	<p><u>Item</u></p> <p>Code of maintenance replacing item (1 byte, 2 categories)</p> <p>First byte (Replacing item) 01: Toner container</p> <p>Second byte (Type of replacing item) 00: Black 01: Cyan 02: Magenta 03: Yellow</p> <p>First byte (Replacing item) 02: Maintenance kit</p> <p>Second byte (Type of replacing item) 01: Fixed (MK-580)</p>
(10)	<p>Unknown Toner Log</p> <p>NOTE: It is not logged if 100 or more counts are not added to the count at the last error.</p>	<p>#</p> <p>Remembers 1 to 5 of occurrence of unknown toner detection.</p> <p>If the occurrence of the previous unknown toner detection is less than 5, all of the unknown toner detection are logged.</p>	<p><u>Count.</u></p> <p>The total page count at the time of the "Toner Empty" error with using an unknown toner container.</p>	<p><u>Item</u></p> <p>Unknown toner log code (1 byte, 2 categories)</p> <p>First byte 01: Fixed (Toner container)</p> <p>Second byte 00: Black 00: Cyan 00: Magenta 00: Yellow</p>

Service items		Description		
No.	Items	Description		
(11)	<p>Counter Log</p> <p>Comprised of three log counters including paper jams, self diagnostics errors, and replacement of the toner container.</p> <p>NOTE: It is not logged if 100 or more counts are not added to the count at the last error.</p>	<p>(f) Jam</p> <p>Indicates the log counter of paper jams depending on location.</p> <p>Refer to Paper Jam Log.</p> <p>All instances including those are not occurred are displayed.</p>	<p>(g) Self diagnostic error</p> <p>Indicates the log counter of self diagnostics errors depending on cause. (See page 1-4-3)</p> <p>Example C6000: 4</p> <p>Self diagnostics error 6000 has happened four times.</p>	<p>(h) Maintenance item replacing</p> <p>Indicates the log counter depending on the maintenance item for maintenance.</p> <p>T: Toner container 00: Black 00: Cyan 00: Magenta 00: Yellow</p> <p>M: Maintenance kit 00: Fixed (MK-580)</p> <p>Example T00: 1</p> <p>The (black) toner container has been replaced once. This is virtually logged as the occurrence of the "Toner Empty" or "Install MK" condition.</p> <p>* :The toner replacement log is triggered by toner empty. This record may contain such a reference as the toner container is inserted twice or a used toner container is inserted.</p>

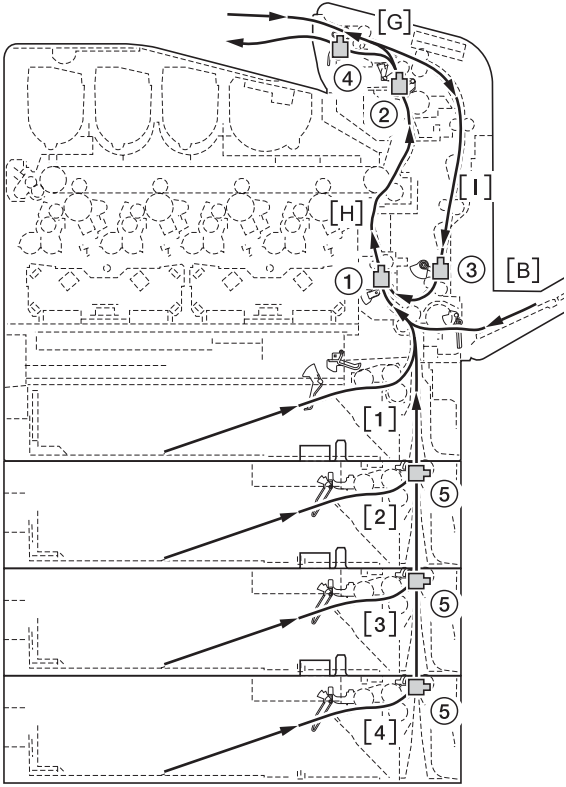
1-4-1 Paper misfeed detection

(1) Paper misfeed indication

If the paper jammed in the paper transport system, or no paper sheets were fed at all, the “Paper jam” message appears and the location of the paper jam (the component where the paper jam has occurred) is also indicated. The printer automatically goes off-line when this message is displayed. Remove jammed paper. After removing jammed paper, the printer will re-start printing.

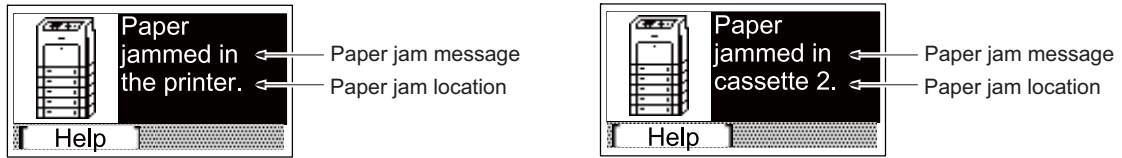
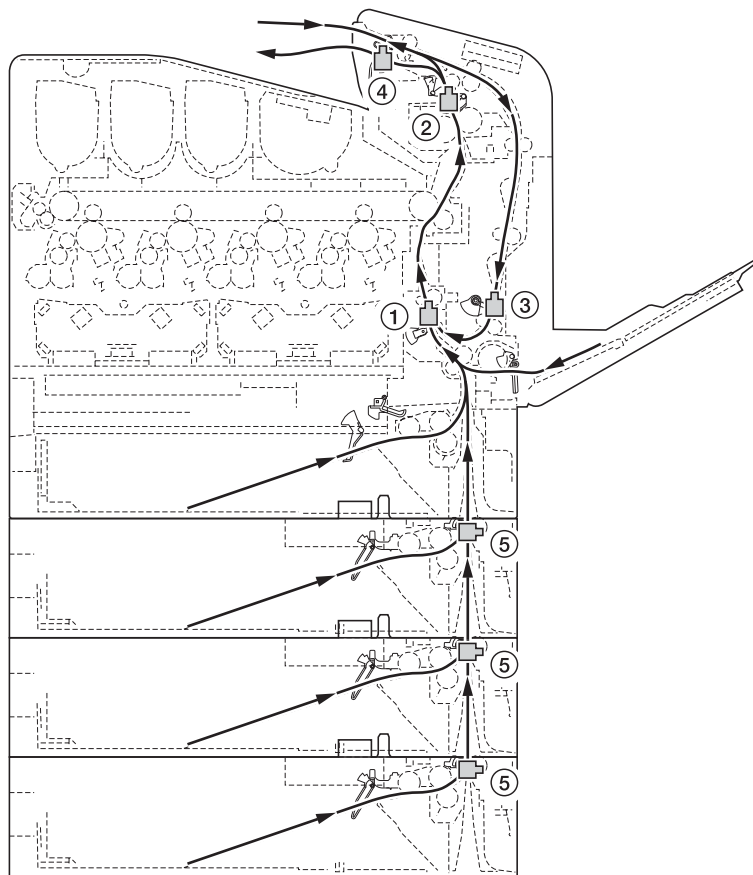

Figure 1-4-1

(2) Paper misfeed detection condition



- ① Registration sensor
- ② Paper exit sensor
- ③ Duplex conveying sensor
- ④ Paper full sensor
- ⑤ PF paper feed sensor

Figure 1-4-2

1-4-2 Self-diagnostic function

(1) Self-diagnostic function

This printer is equipped with self-diagnostic function. When a problem is detected, the printer stops printing and display an error message on the operation panel. An error message consists of a message prompting a contact to service personnel, total print count, and a four-digit error code indicating the type of the error. (The display varies depending on the type of the error.)

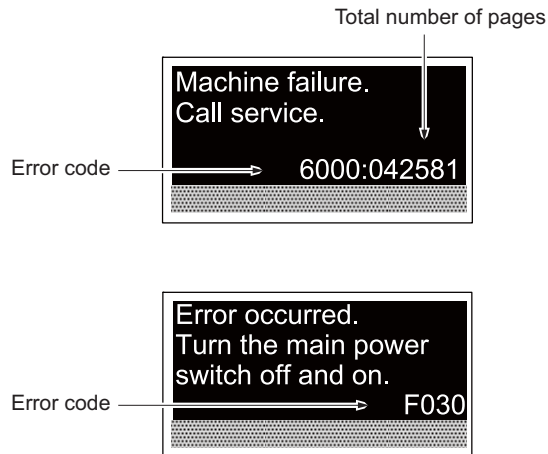

Figure 1-4-3

(2) Self diagnostic codes

Code	Contents	Remarks	
		Causes	Check procedures/corrective measures
0100	Backup memory read/write error	Defective main PWB.	Replace the main PWB (See page 1-5-28).
0110	Backup memory data error	Defective main PWB.	Replace the main PWB (See page 1-5-28).
0120	MAC address data error For data in which the MAC address is invalid.	Defective main PWB.	Replace the main PWB (See page 1-5-28).
0150	Engine PWB (EEPROM) error Data read from EEPROM is judged abnormal.	Improper installation EEPROM.	Replace the engine PWB (See page 1-5-29).
		Defective engine PWB.	Replace the engine PWB (See page 1-5-29).
0170	Billing counting error	Defective main PWB.	Replace the main PWB (See page 1-5-28).
0420	Paper feeder communication error Communication error between engine PWB and optional paper feeder.	Improper installation paper feeder.	Follow installation instruction carefully again.
		Defective harness between PF main PWB (YC3, YC5) and paper feeder interface connector, or improper connector insertion.	Reinsert the connector. Also check for continuity within the connector harness. If none, remedy or replace the harness. (Refer to the service manual for the paper feeder).
		Defective PF main PWB.	Replace the PF main PWB (Refer to the service manual for the paper feeder).
		Defective harness between engine PWB (YC33) and paper feeder interface connector, or improper connector insertion.	Reinsert the connector. Also check for continuity within the connector harness. If none, remedy or replace the harness.
		Defective engine PWB.	Replace the engine PWB (See page 1-5-29).
0600	Expanded memory (DIMM) installing error The expansion memory modules (DIMM) are not correctly mounted.	Improper installation expanded memory (DIMM).	Check the installation of the expanded memory (DIMM) and remedy if necessary.
0610	Expanded memory (DIMM) error The expansion memory modules (DIMM) mounted on the main PWB does not operate correctly.	Defective expanded memory (DIMM).	Replace the expanded memory (DIMM) (See page 1-2-5).
		Defective main PWB.	Replace the main PWB (See page 1-5-28).

Code	Contents	Remarks	
		Causes	Check procedures/corrective measures
0640	SSD error	Defective SSD.	Replace the SSD (See page 1-2-7).
		Defective main PWB.	Replace the main PWB (See page 1-5-28).
0930	I2C bus error	Defective RFID.	Replace the RFID.
		Defective drum PWB (EEPROM).	Replace the drum unit (See page 1-5-14).
		Defective engine PWB (EEPROM).	Replace the engine PWB (EEPROM) (See page 1-5-29).
		Defective main PWB.	Replace the main PWB (See page 1-5-28).
		Defective engine PWB.	Replace the engine PWB (See page 1-5-29).
1010	<p>Lift motor error</p> <p>When the lift motor is driven, the lift motor over-current detection signal is detected continuously for 50 times (5 s) at 100 ms intervals.</p> <p>After the lift motor is driven, the ON status of lift limit sensor cannot be detected for 8 seconds.</p> <p>The cassette installed confirmation message is displayed on the printer operation panel, and even if the cassette is opened and closed, the cassette installed confirmation message is displayed 5 times successively.</p>	Defective bottom plate elevation mechanism in the cassette.	Check to see if the bottom plate can move smoothly and repair it if any problem is found.
		Defective drive transmission system of the lift motor.	Check if the rollers and gears rotate smoothly. If not, grease the bushings and gears. Check for broken gears and replace if any.
		Defective lift motor.	Replace the lift motor.
		Defective engine PWB.	Replace the engine PWB (See page 1-5-29).
1020 1030 1040	<p>PF lift motor error (Option paper feeder)</p> <p>When the PF lift motor is driven, the PF lift motor over-current detection signal is detected continuously for 50 times (5 s) at 100 ms intervals.</p> <p>After the PF lift motor is driven, the ON status of PF lift limit sensor cannot be detected for 8 seconds.</p> <p>The cassette installed confirmation message is displayed on the printer operation panel, and even if the cassette is opened and closed, the cassette installed confirmation message is displayed 5 times successively.</p> <p>1020: Paper feeder 1 1030: Paper feeder 2 1040: Paper feeder 3</p>	Defective harness between PF lift motor and PF main PWB (YC7), or improper connector insertion.	Reinsert the connector. Also check for continuity within the connector harness. If none, remedy or replace the harness. (Refer to the service manual for the paper feeder).
	Defective bottom plate elevation mechanism in the cassette.	Check to see if the bottom plate can move smoothly and repair it if any problem is found.(Refer to the service manual for the paper feeder).	
	Defective drive transmission system of the PF lift motor.	Check if the gears rotate smoothly. If not, grease the bushings and gears. Check for broken gears and replace if any.(Refer to the service manual for the paper feeder).	
	Defective PF lift motor.	Replace the PF lift motor. (Refer to the service manual for the paper feeder).	
	Defective PF lift limit sensor.	Replace the PF main PWB (Refer to the service manual for the paper feeder).	
	Defective PF cassette size switch.	Replace the PF cassette size switch.(Refer to the service manual for the paper feeder).	
	Defective PF main PWB.	Replace the PF main PWB (Refer to the service manual for the paper feeder).	
	Defective engine PWB.	Replace the engine PWB (See page 1-5-29).	

Code	Contents	Remarks	
		Causes	Check procedures/corrective measures
1500 1520 1540 PF warm air heater (upper blower) high temperature error* (Option paper feeder) A temperature higher than 85°C/185°F is detected. *: Multi purpose feeder only 1500: Paper feeder 1 1520: Paper feeder 2 1540: Paper feeder 3		The inlet of upper blower assembly is blocked by paper pieces or the like.	Check visually and remove it, if any (Refer to the service manual for the paper feeder).
		Defective harness between PF warm air fan motor 2 and PF main PWB (YC11), or improper connector insertion.	Reinsert the connector. Also check for continuity within the connector harness. If none, remedy or replace the harness. (Refer to the service manual for the paper feeder).
		Shorted PF thermistor 2.	Replace the PF thermistor 2 (Refer to the service manual for the paper feeder).
		Defective PF warm air fan motor 2.	Replace the PF warm air fan motor 2 (Refer to the service manual for the paper feeder).
		Defective PF main PWB.	Replace the PF main PWB (Refer to the service manual for the paper feeder).
		Defective engine PWB.	Replace the engine PWB (See page 1-5-29).
1510 1530 1550 PF warm air heater (side blower) high temperature error* (Option paper feeder) A temperature higher than 85°C/185°F is detected. *: Multi purpose feeder only 1510: Paper feeder 1 1530: Paper feeder 2 1550: Paper feeder 3		The inlet of side blower assembly is blocked by paper pieces or the like.	Check visually and remove it, if any (Refer to the service manual for the paper feeder).
		Defective harness between PF warm air fan motor 1 and PF main PWB (YC11), or improper connector insertion.	Reinsert the connector. Also check for continuity within the connector harness. If none, remedy or replace the harness. (Refer to the service manual for the paper feeder).
		Shorted PF thermistor 1.	Replace the PF thermistor 1. (Refer to the service manual for the paper feeder).
		Defective PF warm air fan motor 1.	Replace the PF warm air fan motor 1 (Refer to the service manual for the paper feeder).
		Defective PF main PWB.	Replace the PF main PWB (Refer to the service manual for the paper feeder).
		Defective engine PWB.	Replace the engine PWB (See page 1-5-29).

Code	Contents	Remarks	
		Causes	Check procedures/corrective measures
1600 1620 1640 PF warm air heater (upper blower) low temperature error* (Option paper feeder) An external temperature higher than +5°C/+41°F is not detected when one minute elapses after PF warm air heater 2 is turned on. *: Multi purpose feeder only 1600: Paper feeder 1 1620: Paper feeder 2 1640: Paper feeder 3	Defective harness between PF warm air heater 2 and PF warm air heater driver PWB (YC2), or improper connector insertion.	Reinsert the connector. Also check for continuity within the connector harness. If none, remedy or replace the harness. (Refer to the service manual for the paper feeder).	
	Defective harness between PF warm air heater driver PWB (YC3) and PF main PWB (YC13), or improper connector insertion.	Reinsert the connector. Also check for continuity within the connector harness. If none, remedy or replace the harness. (Refer to the service manual for the paper feeder).	
	Defective harness between PF thermistor 2 and PF main PWB (YC12), or improper connector insertion.	Reinsert the connector. Also check for continuity within the connector harness. If none, remedy or replace the harness. (Refer to the service manual for the paper feeder).	
	PF thermistor 2 installed incorrectly.	Check the installation of the PF thermistor 2 and remedy if necessary (Refer to the service manual for the paper feeder).	
	Defective PF thermistor 2.	Replace the PF thermistor 2 (Refer to the service manual for the paper feeder).	
	PF thermal cutout 2 triggered.	Replace the PF thermal cutout 2 (Refer to the service manual for the paper feeder).	
	Broken PF warm air heater 2.	Replace the PF warm air heater 2 (Refer to the service manual for the paper feeder).	
	Defective PF warm air heater driver PWB.	Replace the PF warm air driver PWB (Refer to the service manual for the paper feeder).	
	Defective PF main PWB.	Replace the PF main PWB (Refer to the service manual for the paper feeder).	
	Defective engine PWB.	Replace the engine PWB (See page 1-5-29).	

Code	Contents	Remarks	
		Causes	Check procedures/corrective measures
1610 1630 1650	PF warm air heater (side blower) error* (Option paper feeder) An external temperature higher than +5°C/+41°F is not detected when one minute elapses after PF warm air heater 2 is turned on. *: Multi purpose feeder only 1610: Paper feeder 1 1630: Paper feeder 2 1650: Paper feeder 3	Defective harness between PF warm air heater 1 and PF warm air heater driver PWB (YC1), or improper connector insertion.	Reinsert the connector. Also check for continuity within the connector harness. If none, remedy or replace the harness. (Refer to the service manual for the paper feeder).
		Defective harness between PF warm air heater driver PWB (YC3) and PF main PWB (YC13), or improper connector insertion.	Reinsert the connector. Also check for continuity within the connector harness. If none, remedy or replace the harness. (Refer to the service manual for the paper feeder).
		Defective harness between PF thermistor 2 and PF main PWB (YC12), or improper connector insertion.	Reinsert the connector. Also check for continuity within the connector harness. If none, remedy or replace the harness. (Refer to the service manual for the paper feeder).
		PF thermistor 1 installed incorrectly.	Check the installation of the PF thermistor 1 and remedy if necessary (Refer to the service manual for the paper feeder).
		Defective PF thermistor 1.	Replace the PF thermistor 1 (Refer to the service manual for the paper feeder).
		PF thermostat 1 triggered.	Replace the PF thermostat 1 (Refer to the service manual for the paper feeder).
		Broken PF warm air heater 1.	Replace the PF warm air heater 1 (Refer to the service manual for the paper feeder).
		Defective PF warm air heater driver PWB.	Replace the PF warm air driver PWB (Refer to the service manual for the paper feeder).
		Defective PF main PWB.	Replace the PF main PWB (Refer to the service manual for the paper feeder).
		Defective engine PWB.	Replace the engine PWB (See page 1-5-29).

Code	Contents	Remarks	
		Causes	Check procedures/corrective measures
2102	Developing motor MCY error The ready signal cannot be detected within 5 seconds after the developing motor MCY turns on.	Defective harness between developing motor MCY and engine PWB (YC27), or improper connector insertion.	Reinsert the connector. Also check for continuity within the connector harness. If none, remedy or replace the harness.
		Defective drive transmission system of the developing motor MCY.	Check if the gears rotate smoothly. If not, grease the bushings and gears. Check for broken gears and replace if any.
		Defective developing motor MCY.	Replace the developing motor MCY.
		Defective engine PWB.	Replace the engine PWB (See page 1-5-29).
2250	Main charger cleaning motor error When the main charger cleaning motor is driven, the main charger cleaning motor over-current detection signal is detected continuously for 50 times (5 s) at 100 ms intervals.	Defective harness between main charger cleaning motor and engine PWB (YC36), or improper connector insertion.	Reinsert the connector. Also check for continuity within the connector harness. If none, remedy or replace the harness.
		Defective drive transmission system of the main charger cleaning motor.	Check if the rollers and gears rotate smoothly. If not, grease the bushings and gears. Check for broken gears and replace if any.
		Defective main charger cleaning motor.	Replace the main charger cleaning motor.
		Defective engine PWB.	Replace the engine PWB (See page 1-5-29).
2500	Paper feed motor error The paper feed motor ready input is not given for 5 seconds during the main motor is ON.	Defective harness between paper feed motor and engine PWB (YC3), or improper connector insertion.	Reinsert the connector. Also check for continuity within the connector harness. If none, remedy or replace the harness.
		Defective drive transmission system of the paper feed motor.	Check if the rollers and gears rotate smoothly. If not, grease the bushings and gears. Check for broken gears and replace if any.
		Defective paper feed motor.	Replace the paper feed motor.
		Defective engine PWB.	Replace the engine PWB (See page 1-5-29).

Code	Contents	Remarks	
		Causes	Check procedures/corrective measures
2610 2620 2630	PF paper feed motor error (Option paper feeder) The PF paper feed motor of paper feeder 1 ready input is not given for 2 seconds during the PF paper feed motor is ON. 2610: Paper feeder 1 2620: Paper feeder 2 2630: Paper feeder 3	Defective harness between PF paper feed motor and PF main PWB (YC6), or improper connector insertion.	Reinsert the connector. Also check for continuity within the connector harness. If none, remedy or replace the harness. (Refer to the service manual for the paper feeder).
		Defective PF paper feed motor drive transmission system.	Check if the gears rotate smoothly. If not, grease the bushings and gears. Check for broken gears and replace if any. (Refer to the service manual for the paper feeder).
		Defective PF main motor.	Replace the PF main motor.
		Defective PF main PWB.	Replace the PF main PWB (Refer to the service manual for the paper feeder).
		Defective printer's engine PWB.	Replace the printer's engine PWB (Refer to the service manual for the printer).
2830	Developing motor K error The ready signal cannot be detected within 5 seconds after the developing motor K turns on.	Defective harness between developing motor K and engine PWB (YC26), or improper connector insertion.	Reinsert the connector. Also check for continuity within the connector harness. If none, remedy or replace the harness (Refer to the service manual for the paper feeder).
		Defective drive transmission system of the developing motor K.	Check if the gears rotate smoothly. If not, grease the bushings and gears. Check for broken gears and replace if any.
		Improper installation intermediate transfer unit.	Check the installation of the intermediate transfer unit and reinstall them if necessary (See page 1-5-16).
		Defective developing motor K.	Replace the developing motor K.
		Defective engine PWB.	Replace the engine PWB (See page 1-5-29).
4001	Polygon motor YK error The polygon motor YK ready input is not given for 10 seconds during the polygon motor YK is ON.	Defective harness between polygon motor YK and engine PWB (YC29), or improper connector insertion.	Reinsert the connector. Also check for continuity within the connector harness. If none, remedy or replace the harness.
		Defective laser scanner unit YK.	Replace the laser scanner unit YK (See page 1-5-37).
		Defective engine PWB.	Replace the engine PWB (See page 1-5-29).

Code	Contents	Remarks	
		Causes	Check procedures/corrective measures
4002	Polygon motor MC error The polygon motor MC ready input is not given for 10 seconds during the polygon motor MC is ON.	Defective harness between polygon motor MC and engine PWB (YC30), or improper connector insertion.	Reinsert the connector. Also check for continuity within the connector harness. If none, remedy or replace the harness.
		Defective laser scanner unit MC.	Replace the laser scanner unit MC (See page 1-5-37).
		Defective engine PWB.	Replace the engine PWB (See page 1-5-29).
4201	Laser output error (Black) The pin photo signal (PDN) is not output from PD PWB K for one second while laser is emitted.	Defective harness between APC PWB K and engine PWB (YC29), or improper connector insertion.	Reinsert the connector. Also check for continuity within the connector harness. If none, remedy or replace the harness.
		Defective APC PWB K.	Replace the laser scanner unit YK (See page 1-5-37).
		Defective PD PWB K.	Replace the laser scanner unit YK (See page 1-5-37).
		Defective engine PWB.	Replace the engine PWB (See page 1-5-29).
4202	Laser output error (Cyan) The pin photo signal (PDN) is not output from PD PWB C for one second while laser is emitted.	Defective harness between APC PWB C and engine PWB (YC30), or improper connector insertion.	Reinsert the connector. Also check for continuity within the connector harness. If none, remedy or replace the harness.
		Defective APC PWB C.	Replace the laser scanner unit MC (See page 1-5-37).
		Defective PD PWB C.	Replace the laser scanner unit MC (See page 1-5-37).
		Defective engine PWB.	Replace the engine PWB (See page 1-5-29).
4203	Laser output error (Magenta) The pin photo signal (PDN) is not output from PD PWB M for one second while laser is emitted.	Defective harness between APC PWB M and engine PWB (YC30), or improper connector insertion.	Reinsert the connector. Also check for continuity within the connector harness. If none, remedy or replace the harness.
		Defective APC PWB M.	Replace the laser scanner unit MC (See page 1-5-37).
		Defective PD PWB M.	Replace the laser scanner unit MC (See page 1-5-37).
		Defective engine PWB.	Replace the engine PWB (See page 1-5-29).

Code	Contents	Remarks	
		Causes	Check procedures/corrective measures
4204	Laser output error (Yellow) The pin photo signal (PDN) is not output from PD PWB Y for one second while laser is emitted.	Defective harness between APC PWB Y and engine PWB (YC29), or improper connector insertion.	Reinsert the connector. Also check for continuity within the connector harness. If none, remedy or replace the harness.
		Defective APC PWB Y.	Replace the laser scanner unit YK (See page 1-5-37).
		Defective PD PWB Y.	Replace the laser scanner unit YK (See page 1-5-37).
		Defective engine PWB.	Replace the engine PWB (See page 1-5-29).
4600	LSU cleaning motor error When the LSU cleaning motor is driven, the LSU cleaning motor over-current detection signal is detected continuously for 50 times (5 s) at 100 ms intervals.	Defective harness between LSU cleaning motor and engine PWB (YC37), or improper connector insertion.	Reinsert the connector. Also check for continuity within the connector harness. If none, remedy or replace the harness.
		Defective drive transmission system of the LSU cleaning motor.	Check if the rollers and gears rotate smoothly. If not, grease the bushings and gears. Check for broken gears and replace if any.
		Defective LSU cleaning motor.	Replace the LSU cleaning motor.
		Defective engine PWB.	Replace the engine PWB (See page 1-5-29).
4700	VIDEO ASIC device error	Faulty connection of the connector between the main PWB and engine PWB.	Check the installation of the main PWB and engine PWB and reinstall them if necessary (See page 1-5-28 and 1-5-29).
		Defective main PWB.	Replace the main PWB (See page 1-5-28).
		Defective engine PWB.	Replace the engine PWB (See page 1-5-29).

Code	Contents	Remarks	
		Causes	Check procedures/corrective measures
5301	Broken eraser lamp K wire When the eraser lamp K is driven, the eraser lamp K over-current detection signal is detected continuously for 10 times (1 s) at 100 ms intervals.	Defective harness between drum unit K and drum relay PWB (YC2/YC3), or improper connector insertion.	Reinsert the connector. Also check for continuity within the connector harness. If none, remedy or replace the harness.
		Defective harness between drum relay PWB (YC1) and engine PWB (YC34), or improper connector insertion.	Reinsert the connector. Also check for continuity within the connector harness. If none, remedy or replace the harness.
		Defective eraser lamp K.	Replace the drum unit K. (See page 1-5-14).
		Defective engine PWB.	Replace the engine PWB (See page 1-5-29).
5302	Broken eraser lamp C wire When the eraser lamp C is driven, the eraser lamp C over-current detection signal is detected continuously for 10 times (1 s) at 100 ms intervals.	Defective harness between drum unit C and drum relay PWB (YC8/YC9), or improper connector insertion.	Reinsert the connector. Also check for continuity within the connector harness. If none, remedy or replace the harness.
		Defective harness between drum relay PWB (YC1) and engine PWB (YC34), or improper connector insertion.	Reinsert the connector. Also check for continuity within the connector harness. If none, remedy or replace the harness.
		Defective eraser lamp C.	Replace the drum unit C (See page 1-5-14).
		Defective engine PWB.	Replace the engine PWB (See page 1-5-29).
5303	Broken eraser lamp M wire When the eraser lamp M is driven, the eraser lamp M over-current detection signal is detected continuously for 10 times (1 s) at 100 ms intervals.	Defective harness between drum unit M and drum relay PWB (YC11/YC12), or improper connector insertion.	Reinsert the connector. Also check for continuity within the connector harness. If none, remedy or replace the harness.
		Defective harness between drum relay PWB (YC1) and engine PWB (YC34), or improper connector insertion.	Reinsert the connector. Also check for continuity within the connector harness. If none, remedy or replace the harness.
		Defective eraser lamp M.	Replace the drum unit M (See page 1-5-14).
		Defective engine PWB.	Replace the engine PWB (See page 1-5-29).

Code	Contents	Remarks	
		Causes	Check procedures/corrective measures
5304	Broken eraser lamp Y wire When the eraser lamp Y is driven, the eraser lamp Y over-current detection signal is detected continuously for 10 times (1 s) at 100 ms intervals.	Defective harness between drum unit Y and drum relay PWB (YC5/YC6), or improper connector insertion.	Reinsert the connector. Also check for continuity within the connector harness. If none, remedy or replace the harness.
		Defective harness between drum relay PWB (YC1) and engine PWB (YC34), or improper connector insertion.	Reinsert the connector. Also check for continuity within the connector harness. If none, remedy or replace the harness.
		Defective eraser lamp Y.	Replace the drum unit Y (See page 1-5-14).
		Defective engine PWB.	Replace the engine PWB (See page 1-5-29).

Code	Contents	Remarks	
		Causes	Check procedures/corrective measures
6000	<p>Broken fuser heater lamp wire The detected fuser thermistor temperature does not rise 1°C/1.8°F after the fuser heater lamp has been turned on continuously for 10 seconds in warming up. The fuser temperature does not reach 100°C/212°F after the fuser heater lamp has been turned on continuously for 40 seconds in warming up. The detected temperature of fuser thermistor does not reach the specified temperature (ready indication temperature) after fuser heater lamp has been turned on continuously for 90 seconds in warming up. The detected temperature of fuser thermistor 2 does not rise 1°C/1.8°F after fuser heater lamp has been turned on continuously for 10 seconds during printing.</p>	Defective harness between fuser thermistor and paper exit PWB (YC4), or improper connector insertion.	Reinsert the connector. Also check for continuity within the connector harness. If none, remedy or replace the harness.
		Defective harness between paper exit PWB (YC1) and engine PWB (YC20), or improper connector insertion.	Reinsert the connector. Also check for continuity within the connector harness. If none, remedy or replace the harness.
		Fuser thermistor installed incorrectly.	Replace the fuser unit (See page 1-5-25).
		Fuser thermal cut-out triggered.	Replace the fuser unit (See page 1-5-25).
		Fuser heater lamp installed incorrectly.	Replace the fuser unit (See page 1-5-25).
		Broken fuser heater lamp wire.	Replace the fuser unit (See page 1-5-25).
		Defective engine PWB.	Replace the engine PWB (See page 1-5-29).
6020	<p>Abnormally high temperature fuser heater lamp The fuser thermistor detects a temperature higher than 240°C/464°F. By the activation of the high temperature error detection circuit (230°C/446°F or more) of fuser thermistor, the illumination of fuser heater lamp was forcibly turned off and 10 seconds has elapsed.</p>	Shorted fuser thermistor.	Replace the fuser unit (See page 1-5-25).
		Defective engine PWB.	Replace the engine PWB (See page 1-5-29).

Code	Contents	Remarks	
		Causes	Check procedures/corrective measures
6030	Broken fuser thermistor wire Input from fuser thermistor is 3 or less (A/D value) continuously for 1.1 second (11 ms × 100 times).	Defective harness between fuser thermistor and paper exit PWB (YC4), or improper connector insertion.	Reinsert the connector. Also check for continuity within the connector harness. If none, remedy or replace the harness.
		Defective harness between paper exit PWB (YC1) and engine PWB (YC20), or improper connector insertion.	Reinsert the connector. Also check for continuity within the connector harness. If none, remedy or replace the harness.
		Broken fuser thermistor wire.	Replace the fuser unit (See page 1-5-25).
		Fuser thermistor installed incorrectly.	Replace the fuser unit (See page 1-5-25).
		Fuser thermal cut-out triggered.	Replace the fuser unit (See page 1-5-25).
		Fuser heater lamp installed incorrectly.	Replace the fuser unit (See page 1-5-25).
		Broken fuser heater lamp wire.	Replace the fuser unit (See page 1-5-25).
		Defective engine PWB.	Replace the engine PWB (See page 1-5-29).
6400	Zero cross signal error The zero cross signal does not reach the engine PWB for specified time.	Defective harness between power source PWB (YC103) and engine PWB (YC19), or improper connector insertion.	Reinsert the connector. Also check for continuity within the connector harness. If none, remedy or replace the harness.
		Defective power source PWB.	Replace the power source PWB (See page 1-5-26).
		Defective engine PWB.	Replace the engine PWB (See page 1-5-29).

Code	Contents	Remarks	
		Causes	Check procedures/corrective measures
7001	Toner motor K error When the toner motor K is driven, the toner motor K over-current detection signal is detected continuously for 50 times (5 s) at 100 ms intervals.	Defective harness between toner motor K and engine PWB (YC22), or improper connector insertion.	Reinsert the connector. Also check for continuity within the connector harness. If none, remedy or replace the harness.
		Defective drive transmission system of the toner motor K.	Check if the gears rotate smoothly. If not, grease the bushings and gears. Check for broken gears and replace if any.
		Defective toner motor K.	Replace the toner motor K.
		Defective engine PWB.	Replace the engine PWB (See page 1-5-29).
7002	Toner motor C error When the toner motor C is driven, the toner motor C over-current detection signal is detected continuously for 50 times (5 s) at 100 ms intervals.	Defective harness between toner motor C and engine PWB (YC24), or improper connector insertion.	Reinsert the connector. Also check for continuity within the connector harness. If none, remedy or replace the harness.
		Defective drive transmission system of the toner motor C.	Check if the gears rotate smoothly. If not, grease the bushings and gears. Check for broken gears and replace if any.
		Defective toner motor C.	Replace the toner motor C.
		Defective engine PWB.	Replace the engine PWB (See page 1-5-29).
7003	Toner motor M error When the toner motor M is driven, the toner motor M over-current detection signal is detected continuously for 50 times (5 s) at 100 ms intervals.	Defective harness between toner motor M and engine PWB (YC25), or improper connector insertion.	Reinsert the connector. Also check for continuity within the connector harness. If none, remedy or replace the harness.
		Defective drive transmission system of the toner motor M.	Check if the gears rotate smoothly. If not, grease the bushings and gears. Check for broken gears and replace if any.
		Defective toner motor M.	Replace the toner motor M.
		Defective engine PWB.	Replace the engine PWB (See page 1-5-29).

Code	Contents	Remarks	
		Causes	Check procedures/corrective measures
7004	Toner motor Y error When the toner motor Y is driven, the toner motor Y over-current detection signal is detected continuously for 50 times (5 s) at 100 ms intervals.	Defective harness between toner motor Y and engine PWB (YC23), or improper connector insertion.	Reinsert the connector. Also check for continuity within the connector harness. If none, remedy or replace the harness.
		Defective drive transmission system of the toner motor Y.	Check if the gears rotate smoothly. If not, grease the bushings and gears. Check for broken gears and replace if any.
		Defective toner motor Y.	Replace the toner motor Y.
		Defective engine PWB.	Replace the engine PWB (See page 1-5-29).
7401	Developing unit K non-installing error No density detection signal is output from toner sensor K in developing unit K.	Faulty connection of the connector between the developing PWB K and drum relay PWB.	Check the installation of the developing unit K and drum relay PWB and reinstall them if necessary (See page 1-5-12).
		Defective harness between drum relay PWB (YC1) and engine PWB (YC34), or improper connector insertion.	Reinsert the connector. Also check for continuity within the connector harness. If none, remedy or replace the harness.
		Defective toner sensor K.	Replace the developing unit K (See page 1-5-12).
		Defective engine PWB.	Replace the engine PWB (See page 1-5-29).
7402	Developing unit C non-installing error No density detection signal is output from toner sensor C in developing unit C.	Faulty connection of the connector between the developing PWB C and drum relay PWB.	Check the installation of the developing unit C and drum relay PWB and reinstall them if necessary (See page 1-5-12).
		Defective harness between drum relay PWB (YC1) and engine PWB (YC34), or improper connector insertion.	Reinsert the connector. Also check for continuity within the connector harness. If none, remedy or replace the harness.
		Defective toner sensor C.	Replace the developing unit C (See page 1-5-12).
		Defective engine PWB.	Replace the engine PWB (See page 1-5-29).

Code	Contents	Remarks	
		Causes	Check procedures/corrective measures
7403	Developing unit M non-installing error No density detection signal is output from toner sensor M in developing unit M.	Faulty connection of the connector between the developing PWB M and drum relay PWB.	Check the installation of the developing unit M and drum relay PWB and reinstall them if necessary (See page 1-5-12).
		Defective harness between drum relay PWB (YC1) and engine PWB (YC34), or improper connector insertion.	Reinsert the connector. Also check for continuity within the connector harness. If none, remedy or replace the harness.
		Defective toner sensor M.	Replace the developing unit M (See page 1-5-12).
		Defective engine PWB.	Replace the engine PWB (See page 1-5-29).
7404	Developing unit Y non-installing error No density detection signal is output from toner sensor Y in developing unit Y.	Faulty connection of the connector between the developing PWB Y and drum relay PWB.	Check the installation of the developing unit Y and drum relay PWB and reinstall them if necessary (See page 1-5-12).
		Defective harness between drum relay PWB (YC1) and engine PWB (YC34), or improper connector insertion.	Reinsert the connector. Also check for continuity within the connector harness. If none, remedy or replace the harness.
		Defective toner sensor Y.	Replace the developing unit Y (See page 1-5-12).
		Defective engine PWB.	Replace the engine PWB (See page 1-5-29).
7411	Drum unit K non-installing error The EEPROM of drum PWB K does not communicate normally.	Faulty connection of the connector between the drum PWB K and drum relay PWB.	Check the installation of the drum unit K and drum relay PWB and reinstall them if necessary (See page 1-5-14).
		Defective harness between drum relay PWB (YC1) and engine PWB (YC34), or improper connector insertion.	Reinsert the connector. Also check for continuity within the connector harness. If none, remedy or replace the harness.
		Installation of incompatible drum unit K.	Install drum unit K compatible with the specifications to the printer.
		Defective drum PWB K.	Replace the drum unit Y (See page 1-5-14).
		Defective engine PWB.	Replace the engine PWB (See page 1-5-29).

Code	Contents	Remarks	
		Causes	Check procedures/corrective measures
7412	Drum unit C non-installing error The EEPROM of drum PWB C does not communicate normally. Incompatible drum unit C is installed.	Faulty connection of the connector between the drum PWB C and drum relay PWB.	Check the installation of the drum unit C and drum relay PWB and reinstall them if necessary (See page 1-5-14).
		Defective harness between drum relay PWB (YC1) and engine PWB (YC34), or improper connector insertion.	Reinsert the connector. Also check for continuity within the connector harness. If none, remedy or replace the harness.
		Installation of incompatible drum unit C.	Install drum unit C compatible with the specifications to the printer.
		Defective drum PWB C.	Replace the drum unit C (See page 1-5-14).
		Defective engine PWB.	Replace the engine PWB (See page 1-5-29).
7413	Drum unit M non-installing error The EEPROM of drum PWB M does not communicate normally. Incompatible drum unit M is installed.	Faulty connection of the connector between the drum PWB M and drum relay PWB.	Check the installation of the drum unit M and drum relay PWB and reinstall them if necessary (See page 1-5-14).
		Defective harness between drum relay PWB (YC1) and engine PWB (YC34), or improper connector insertion.	Reinsert the connector. Also check for continuity within the connector harness. If none, remedy or replace the harness.
		Installation of incompatible drum unit M.	Install drum unit M compatible with the specifications to the printer.
		Defective drum PWB M.	Replace the drum unit M (See page 1-5-14).
		Defective engine PWB.	Replace the engine PWB (See page 1-5-29).

Code	Contents	Remarks	
		Causes	Check procedures/corrective measures
7414	Drum unit Y non-installing error The EEPROM of drum PWB Y does not communicate normally. Incompatible drum unit Y is installed.	Faulty connection of the connector between the drum PWB Y and drum relay PWB.	Check the installation of the drum unit Y and drum relay PWB and reinstall them if necessary (See page 1-5-14).
		Defective harness between drum relay PWB (YC1) and engine PWB (YC34), or improper connector insertion.	Reinsert the connector. Also check for continuity within the connector harness. If none, remedy or replace the harness.
		Installation of incompatible drum unit Y.	Install drum unit Y compatible with the specifications to the printer.
		Defective drum PWB Y.	Replace the drum unit Y (See page 1-5-14).
		Defective engine PWB.	Replace the engine PWB (See page 1-5-29).
9530	Backup data error The serial number of the machine written on the EEPROM of the engine PWB differs with that is written on both the flash memory of the engine PWB and the EEPROM of the drum PWB as a backup.	Replacing both the engine PWB and the drum unit at the same time.	Check that the machine operates properly by reverting the engine controller and the drum unit to the old ones. To replace the engine PWB and the drum unit at the same time, turn on the printer after replacing either one. Check that the printer operates properly and then turn off the printer. Replace the other and turn on the printer to check that the printer operates properly. Be sure to replace one by one.
F0 F000	Main PWB - Operation panel PWB communication error	Defective main PWB.	Turn the power switch off/on to restart the printer. If the error is not resolved, replace main PWB (See page 1-5-28).
		Defective operation panel PWB.	Replace the operation panel PWB.
F010	Main PWB checksum error	Defective main PWB.	Turn the power switch off/on to restart the printer.
			In recovery mode, download the controller firmware using a SD card. In recovery mode, only a SD card is usable, not a USB memory.
			Replace main PWB (See page 1-5-28).
F020	Main memory or expanded memory checksum error	Defective main memory (RAM) on the main PWB.	Turn the power switch off/on to restart the printer. If the error is not resolved, replace main PWB (See page 1-5-28).
		Defective expansion memory module.	Replace the expansion memory module (See page 1-2-5).

Code	Contents	Remarks	
		Causes	Check procedures/corrective measures
F030	Main PWB general failure	Defective main PWB.	Turn the power switch off/on to restart the printer. If the error is not resolved, replace main PWB (See page 1-5-28).
F040	Main PWB - Engine PWB communication error	Faulty connection of the connector between the main PWB and engine PWB.	Check the installation of the main PWB and engine PWB and reinstall them if necessary (See page 1-5-28 and 1-5-29).
		Defective main PWB.	Turn the power switch off/on to restart the printer. If the error is not resolved, replace main PWB (See page 1-5-28).
		Defective engine PWB.	Replace engine PWB (See page 1-5-29).
F050	Engine PWB ROM checksum error	Some error may have occurred when downloading the firmware of the engine PWB.	Download the firmware of the engine PWB again using the memory card (See page 1-5-29).
		Defective engine PWB.	Turn the power switch off/on to restart the printer. If the error is not resolved, replace engine PWB (See page 1-5-29).
F186	Main PWB video data control error	Defective main PWB.	Turn the power switch off/on to restart the printer. If the error is not resolved, replace main PWB (See page 1-5-28).

1-4-3 Image formation problems

(1) No image appears (entirely white).

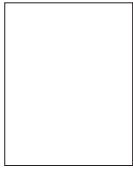

See page 1-4-23

(2) No image appears (entirely black).



See page 1-4-24

(3) A specific color is printed solid.



See page 1-4-24

(4) The back side gets dirty.

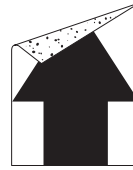

See page 1-4-24

(5) Image is too light.



See page 1-4-25

(6) The background is colored.

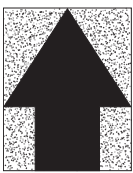

See page 1-4-25

(7) White streaks are printed vertically.



See page 1-4-26

(8) Black streaks are printed vertically.



See page 1-4-26

(9) Streaks are printed horizontally.



See page 1-4-26

(10) Spots are printed.



See page 1-4-26

(11) The leading edge of image begins to print too early or too late.



See page 1-4-27

(12) Paper is wrinkled.

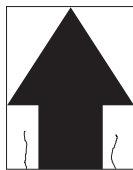

See page 1-4-27

(13) Offset occurs.



See page 1-4-27

(14) Part of image is missing.



See page 1-4-27

(15) Fusing is loose.



See page 1-4-28

(16) Colors are printed offset to each other.

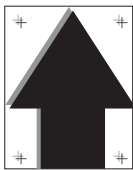

See page 1-4-28

(1) No image appears (entirely white).

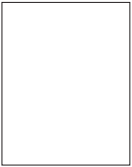
Print example	Causes		Check procedures/corrective measures
	No transfer charging.	Defective harness between high voltage PWB and engine PWB (YC16), or improper connector insertion.	Reinsert the connector. Also check for continuity within the connector harness. If none, remedy or replace the harness.
		Defective high voltage PWB.	Replace the high voltage PWB (See page 1-5-34).
		Defective engine PWB.	Replace the engine PWB (See page 1-5-29).
	No laser beam output.	Defective laser scanner unit.	Replace the laser scanner unit YK and laser scanner unit MC (See page 1-5-37).
		Defective engine PWB.	Replace the engine PWB (See page 1-5-29).
	No developing bias output.	Defective harness between high voltage PWB and engine PWB (YC16), or improper connector insertion.	Reinsert the connector. Also check for continuity within the connector harness. If none, remedy or replace the harness.
		Defective high voltage PWB.	Replace the high voltage PWB (See page 1-5-34).
		Defective engine PWB.	Replace the engine PWB (See page 1-5-29).
	Defective driving system of developing unit.		Replace the developing unit (See page 1-5-12).
	Image synchronization signal failure.	Defective harness between engine PWB (YC31) and main PWB (YC6), or improper connector insertion.	Reinsert the connector. Also check for continuity within the connector harness. If none, remedy or replace the harness.

(2) No image appears (entirely black).

Print example	Causes		Check procedures/corrective measures
	No main charging.	Defective harness between high voltage PWB and engine PWB (YC16), or improper connector insertion.	Reinsert the connector. Also check for continuity within the connector harness. If none, remedy or replace the harness.
		Defective main charger unit.	Replace the drum unit (See page 1-5-14).
		Defective high voltage PWB.	Replace the high voltage PWB (See page 1-5-34).
		Defective engine PWB.	Replace the engine PWB (See page 1-5-29).
	The laser is activated simultaneously for all colors.	Defective laser scanner unit.	Replace the laser scanner unit YK and laser scanner unit MC (See page 1-5-37).

(3) A specific color is printed solid.

Print example	Causes	Check procedures/corrective measures
	Defective main charger unit which corresponds to the color causing the problem.	Check if the main charger unit is properly seated. If necessary, reseal it properly.
	Disconnected main charger wire.	Replace the main charger unit (See page 1-5-15).
	Laser of laser scanner unit for solid color printing is ON. Defective laser scanner unit.	Replace the laser scanner unit YK and laser scanner unit MC (See page, 1-5-37).

(4) The back side gets dirty.

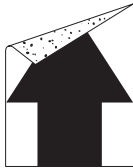
Print example	Causes	Check procedures/corrective measures
	Dirty secondary transfer roller.	Clean the secondary transfer roller.
	Dirty paper conveying path.	Clean the paper conveying path.
	Dirty heat roller and press roller.	Clean the heat roller and press roller.

(5) Image is too light.

Print example	Causes		Check procedures/corrective measures
	Defective developing bias output.	Defective developing unit.	Replace the developing unit for the color that causes an error.
		Defective high voltage PWB.	Replace the high voltage PWB (See page 1-5-34).
		Defective engine PWB.	Replace the engine (See page 1-5-29).
	Dirty drum.		Perform the drum surface refreshing (See page 1-3-11).
	Defective developing bias output.	Defective high voltage PWB.	Replace the high voltage PWB (See page 1-5-34).
		Defective engine PWB.	Replace the engine (See page 1-5-29).
	Defective color calibration.		Perform the color calibration (Refer to operation guide).
	Insufficient toner.		If the display shows the message requesting toner replenishment, replace the container.
Insufficient agitation of toner container.		Shake the toner container vertically approximately 10 times.	
Paper damp.		Check the paper storage conditions, replace the paper.	

(6) The background is colored.

Print example	Causes		Check procedures/corrective measures
	Defective color calibration.		Perform the color calibration (Refer to operation guide).
	Defective developing bias output.	Defective developing unit.	Check the four colors of image by using the test page of service mode. If the defect appears on a particular color, replace the developer for that color (See page 1-5-12).
		Defective high voltage PWB.	Replace the high voltage PWB (See page 1-5-34).
		Defective engine PWB.	Replace the engine (See page 1-5-29).
	Defective drum surface charging.	Defective drum unit.	Replace the drum unit (See page 1-5-14).
		Defective high voltage PWB.	Replace the high voltage PWB (See page 1-5-34).
		Defective engine PWB.	Replace the engine (See page 1-5-29).

(7) White streaks are printed vertically.

Print example	Causes	Check procedures/corrective measures
	Foreign object in one of the developing units.	Check the image by using the test print of service mode. If the white line appears on a particular page, replace the developer for that color (See page 1-5-12).
	Adhesion of soiling to primary transfer belt.	Replace the intermediate transfer unit (See page 1-5-16).
	Dirty LSU protective glass.	Perform the LSU dust shield glass cleaning (See page 1-3-10).

(8) Black streaks are printed vertically.

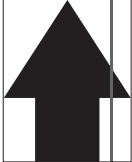
Print example	Causes	Check procedures/corrective measures
	Dirty or flawed drum.	Perform the drum surface refreshing (See page 1-3-11). Flawed drum. Replace the drum unit (See page 1-5-14).
	Deformed or worn cleaning blade in the drum unit.	Replace the drum unit (See page 1-5-14).
	Worn primary transfer belt.	Replace the intermediate transfer unit (See page 1-5-16).
	Dirty main charger wire.	Perform the main charger cleaning (See page 1-3-10).

(9) Streaks are printed horizontally.

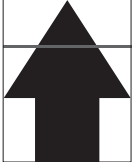
Print example	Causes	Check procedures/corrective measures
	Flawed drum.	Replace the drum unit (See page 1-5-14).
	Dirty developing section.	Clean any part contaminated with toner in the developing section.
	Poor contact of grounding terminal of drum unit.	Check the installation of the drum unit. If it operates incorrectly, replace it (See page 1-5-14).

(10) Spots are printed.

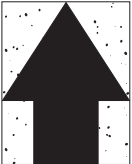
Print example	Causes	Check procedures/corrective measures
	Dirty or flawed drum.	Perform the drum surface refreshing (See page 1-3-11). Flawed drum. Replace the drum unit (See page 1-5-14).
	Deformed or worn cleaning blade in the drum unit.	Replace the drum unit (See page 1-5-14).
	Flawed developing roller.	Replace the developing unit (See page 1-5-12).
	Dirty heat roller and press roller.	Clean the heat roller and press roller.

(11) The leading edge of image begins to print too early or too late.

Print example	Causes	Check procedures/corrective measures
	Paper feed clutch or registration clutch operating incorrectly.	Check the installation of the clutch. If it operates incorrectly, replace it.

(12) Paper is wrinkled.

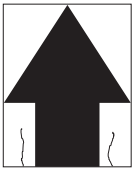
Print example	Causes	Check procedures/corrective measures
	Paper curled.	Check the paper storage conditions, replace the paper.
	Paper damp.	Check the paper storage conditions, replace the paper.

(13) Offset occurs.

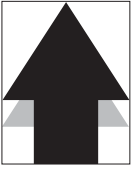
Print example	Causes	Check procedures/corrective measures
	Deformed or worn cleaning blade in the drum unit.	Replace the drum unit.
	Defective intermediate transfer belt cleaning.	Replace the intermediate transfer unit (See page 1-5-16).
	Defective fuser unit.	Replace the fuser unit (See page 1-5-25).
	Wrong types of paper.	Check if the paper meets specifications. Replace paper.

(14) Part of image is missing.

Print example	Causes	Check procedures/corrective measures
	Paper damp.	Check the paper storage conditions, replace the paper.
	Paper creased.	Replace the paper.
	Drum condensation.	Perform the drum surface refreshing (See page 1-3-11).
	Dirty or flawed drum.	Perform the drum surface refreshing (See page 1-3-11). Flawed drum. Replace the drum unit (See page 1-5-14).
	Dirty transfer belt.	Clean the transfer belt. Replace the intermediate transfer unit (See page 1-5-16).
	Dirty transfer roller.	Clean the transfer roller. Replace the transfer roller unit (See page 1-5-19).

(15) Fusing is loose.

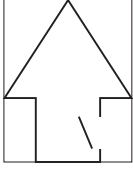
Print example	Causes	Check procedures/corrective measures
	Wrong types of paper.	Check if the paper meets specifications, replace paper.
	Flawed heat roller or press roller.	Replace the fuser unit (See page 1-5-25).

(16) Colors are printed offset to each other.

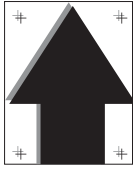
Print example	Causes	Check procedures/corrective measures
	Defective calibration.	Perform the color calibration (Refer to operation guide).
	Slip the mirror position of laser scanner unit.	Perform the color registration. When the problem is not cleared, perform the manual color registration adjustment (Refer to operation guide).

1-4-4 Electric problems

Problem	Causes	Check procedures/corrective measures
(1)The machine does not operate when the power switch is turned on.	The power cord is not plugged in properly.	Check the contact between the power plug and the outlet.
	No electricity at the power outlet.	Measure the input voltage.
	Broken power cord.	Check for continuity. If none, replace the cord.
	Defective power switch.	Check for continuity across the contacts. If none, replace the power switch.
	Defective power source PWB.	Replace the power source PWB (See page 1-5-26).
(2)Drum motor M/C/Y/K, duplex motor and fuser motor do not operate.	Defective harness or improper connector insertion.	Reinsert the connector. Also check for continuity within the connector harness. If none, remedy or replace the harness. Drum motor M/C/Y/K - Engine PWB (YC18) Duplex motor - Engine PWB (YC17) Fuser motor - Engine PWB (YC39)
	Broken the gear.	Check visually and replace the gear if necessary.
	Defective motor.	Replace the motor.
	Defective engine PWB.	Replace the engine PWB (See page 1-5-29).
(3)Power source fan motor, ozone fan motor, developing fan motor 1/2 and fuser fan motor 1/2 do not operate.	Broken the fan motor coil.	Check for continuity across the coil. If none, replace the fan motor.
	Defective harness or improper connector insertion.	Reinsert the connector. Also check for continuity within the connector harness. If none, remedy or replace the harness. Power source fan motor - Engine PWB (YC8) Ozone fan motor - Engine PWB (YC11) Developing fan motor 1 - Engine PWB (YC10) Developing fan motor 2 - Engine PWB (YC41) Fuser fan motor 1 - Paper exit PWB (YC2) Fuser fan motor 2 - Engine PWB (YC44)
	Defective engine PWB.	Replace the engine PWB (See page 1-5-29).
(4)Paper feed clutch, registration clutch, developing clutch K, duplex clutch and intermediate clutch do not operate.	Broken clutch coil.	Check for continuity across the coil. If none, replace the clutch.
	Defective harness or improper connector insertion.	Reinsert the connector. Also check for continuity within the connector harness. If none, remedy or replace the harness. Paper feed clutch - Engine PWB (YC26) Registration clutch - Engine PWB (YC26) Developing clutch K - Engine PWB (YC26) Duplex clutch - Engine PWB (YC3) Intermediate clutch - Engine PWB (YC3)
	Defective engine PWB.	Replace the engine PWB (See page 1-5-29).
(5)MP paper feed solenoid, ID solenoid, duplex solenoid do not operate.	Broken solenoid coil.	Check for continuity across the coil. If none, replace the solenoid.
	Defective harness or improper connector insertion.	Reinsert the connector. Also check for continuity within the connector harness. If none, remedy or replace the harness. MP paper feed solenoid - Engine PWB (YC40) ID solenoid - Engine PWB (YC43) Duplex solenoid - paper exit PWB (YC3)
	Defective engine PWB.	Replace the engine PWB (See page 1-5-29).
	Defective paper exit PWB.	Replace the paper exit PWB.

Problem	Causes	Check procedures/corrective measures
(6)Main charging is not performed.	Defective harness or improper connector insertion.	Reinsert the connector. Also check for continuity within the connector harness. If none, remedy or replace the high voltage PWB (See page 1-5-34). High voltage PWB - Engine PWB (YC16)
	Defective main charger unit	Replace the main charger unit (See page 1-5-15).
	Defective high voltage PWB.	Replace the high voltage PWB (See page 1-5-34).
	Defective engine PWB.	Replace the engine PWB (See page 1-5-29).
(7)No developing bias is output.	Defective harness or improper connector insertion.	Reinsert the connector. Also check for continuity within the connector harness. If none, remedy or replace the high voltage PWB (See page 1-5-34). High voltage PWB - Engine PWB (YC16)
	Defective high voltage PWB.	Replace the high voltage PWB (See page 1-5-34).
	Defective engine PWB.	Replace the engine PWB (See page 1-5-29).
(8)Transfer charging is not performed.	Defective harness or improper connector insertion.	Reinsert the connector. Also check for continuity within the connector harness. If none, remedy or replace the high voltage PWB (See page 1-5-34). High voltage PWB - Engine PWB (YC16)
	Defective high voltage PWB.	Replace the high voltage PWB (See page 1-5-34).
	Defective engine PWB.	Replace the engine PWB (See page 1-5-29).
(9)The message requesting paper to be loaded is shown when paper is present in the cassette.	Defective paper sensor 1/2.	Replace the engine PWB (See page 1-5-29).
	Broken paper sensor 1/2 actuator.	Check the bending of the actuator lever of the paper sensor 1/2 if there is trouble, remedy or replace.
	Defective engine PWB.	Replace the engine PWB (See page 1-5-29).
(10)The message requesting paper to be loaded is shown when paper is present in the MP tray.	Defective harness or improper connector insertion.	Reinsert the connector. Also check for continuity within the connector harness. If none, remedy or replace the harness. MP tray sensor - Engine PWB (YC21)
	Defective MP tray sensor.	Replace the MP tray sensor.
	Defective engine PWB.	Replace the engine PWB (See page 1-5-29).
(11)The size of paper in the cassette is not displayed correctly.	Defective harness or improper connector insertion.	Reinsert the connector. Also check for continuity within the connector harness. If none, remedy or replace the harness. Cassette size switch - Engine PWB (YC9)
	Defective cassette size switch.	Replace the cassette size switch.
	Defective engine PWB.	Replace the engine PWB (See page 1-5-29).
(12)A paper jam in the paper feed section, paper conveying section, fuser section or duplex section is indicated when the power switch is turned on.	A piece of paper torn from copy paper is caught around registration switch, duplex conveying sensor or paper exit sensor.	Check and remove if any.
	Defective registration sensor or duplex conveying sensor.	Replace the registration sensor or duplex conveying sensor.
	Defective paper exit sensor.	Replace the paper exit PWB.
	Defective engine PWB.	Replace the engine PWB (See page 1-5-29).

Problem	Causes	Check procedures/corrective measures
(13)The message requesting front cover to be closed is displayed when the front cover is closed.	Defective harness or improper connector insertion.	Reinsert the connector. Also check for continuity within the connector harness. If none, remedy or replace the harness. Front cover open/close switch - Paper exit PWB (YC5) Paper exit PWB (YC1) - Engine PWB (YC20)
	Defective front cover open/close switch.	Replace the front cover open/close switch.
	Defective paper exit PWB.	Replace the paper exit PWB.
	Defective engine PWB.	Replace the engine PWB (See page 1-5-29).
(14)The message requesting cover to be closed is displayed when the top cover is closed.	Defective harness or improper connector insertion.	Reinsert the connector. Also check for continuity within the connector harness. If none, remedy or replace the harness. Interlock switch - Engine PWB (YC13)
	Defective interlock switch.	Replace the interlock switch.
	Defective engine PWB.	Replace the engine PWB (See page 1-5-29).
(15)The message requesting left cover to be closed is displayed when the left cover is closed.	Defective harness or improper connector insertion.	Reinsert the connector. Also check for continuity within the connector harness. If none, remedy or replace the harness. Left cover switch - Engine PWB (YC14)
	Defective left cover switch.	Replace the left cover switch.
	Defective engine PWB.	Replace the engine PWB (See page 1-5-29).
(16)Defective waste toner box detecting.	Defective harness or improper connector insertion.	Reinsert the connector. Also check for continuity within the connector harness. If none, remedy or replace the harness. Waste toner full sensor - Engine PWB (YC12)
	Defective waste toner full sensor.	Replace the waste toner full sensor.
	Defective engine PWB.	Replace the engine PWB (See page 1-5-29).
(17)Others.	Wiring is broken, shorted or makes poor contact.	Check for continuity. If none, repair.

1-4-5 Mechanical problems

Problem	Causes/check procedures	Corrective measures
(1)No primary paper feed.	Check if the surfaces of the paper feed roller, MP paper feed roller are dirty with paper powder.	Clean with isopropyl alcohol.
	Check if the paper feed roller, MP paper feed roller are deformed.	Check visually and replace any deformed rollers (See page 1-5-8 and 1-5-11).
	Defective paper feed clutch installation.	Check visually and remedy if necessary.
(2)No secondary paper feed.	Check if the surfaces of the upper and lower registration rollers are dirty with paper powder.	Clean with isopropyl alcohol.
	Defective registration clutch installation.	Check visually and remedy if necessary.
(3)Skewed paper feed.	Width guide in a cassette installed incorrectly.	Check the width guide visually and correct or replace if necessary.
	Deformed width guide in a cassette.	Repair or replace if necessary.
	Defective MP tray slider installation.	Check the slider visually and correct or replace if necessary.
	Deformed MP tray slider.	Check visually and replace any deformed slider.
(4)Multiple sheets of paper are fed at one time.	Check if the paper is curled.	Replace the paper.
	Paper is not placed correctly in the cassette.	Set the paper correctly.
	Check if the retard roller is worn.	Replace the retard roller pulley if it is worn.
	Check if the separator pad or MPF separation pad is worn.	Replace the separator pad if it is worn.
(5)Paper jams.	Check if the paper is excessively curled.	Replace the paper.
	Check if the contact between the front and rear registration rollers is correct.	Check visually and remedy if necessary.
	Check if the heat roller or press roller is extremely dirty or deformed.	Replace the fuser unit (See page 1-5-25).
(6)Toner drops on the paper conveying path.	Check if the drum unit or developing unit is extremely dirty.	Clean the drum unit or developing unit.
(7)Abnormal noise is heard.	Check if the pulleys, rollers and gears operate smoothly.	Grease the bearings and gears.
	Check if the following electromagnetic clutches are installed correctly:	Check visually and remedy if necessary.

1-5-1 Precautions for assembly and disassembly

(1) Precautions

Be sure to turn the power switch off and disconnect the power plug before starting disassembly.

When handling PWBs, do not touch connectors with bare hands or damage the PWB.

Use only the specified parts to replace the fuser thermal cutout. Never substitute electric wires, as the machine may be seriously damaged.

Do not touch any PWB containing ICs with bare hands or any object prone to static charge.

When removing the hook of the connector, be sure to release the hook.

Take care not to get the wire caught.

To reassemble the parts, use the original screws. If the types and the sizes of screws are not known, refer to the PARTS LIST.

(2) Drum

Note the following when handling or storing the drum.

When removing the drum unit, never expose the drum surface to strong direct light.

Keep the drum at an ambient temperature between 0 °C/32 °F and 40 °C/104 °F and at a relative humidity not higher than 90% RH. Avoid abrupt changes in temperature and humidity.

Avoid exposure to any substance which is harmful to or may affect the quality of the drum.

Do not touch the drum surface with any object. Should it be touched by hands or stained with oil, clean it.

(3) Toner container

Store the toner container(s) in a cool, dark place.

Avoid direct light and high humidity.

(4) How to tell a genuine Kyocera toner container

As a means of brand protection, the Kyocera toner container utilizes an optical security technology to enable visual validation. A validation viewer is required to accomplish this.

Hold the validation viewer over the left side part of the brand protection seal on the toner container. Through each window of the validation viewer, the left side part of the seal should be seen as follows:

A black-colored band when seen through the left side window

A shiny or gold-colored band when seen through the right side window

The above will reveal that the toner container is a genuine Kyocera branded toner container, otherwise, it is a counterfeit.

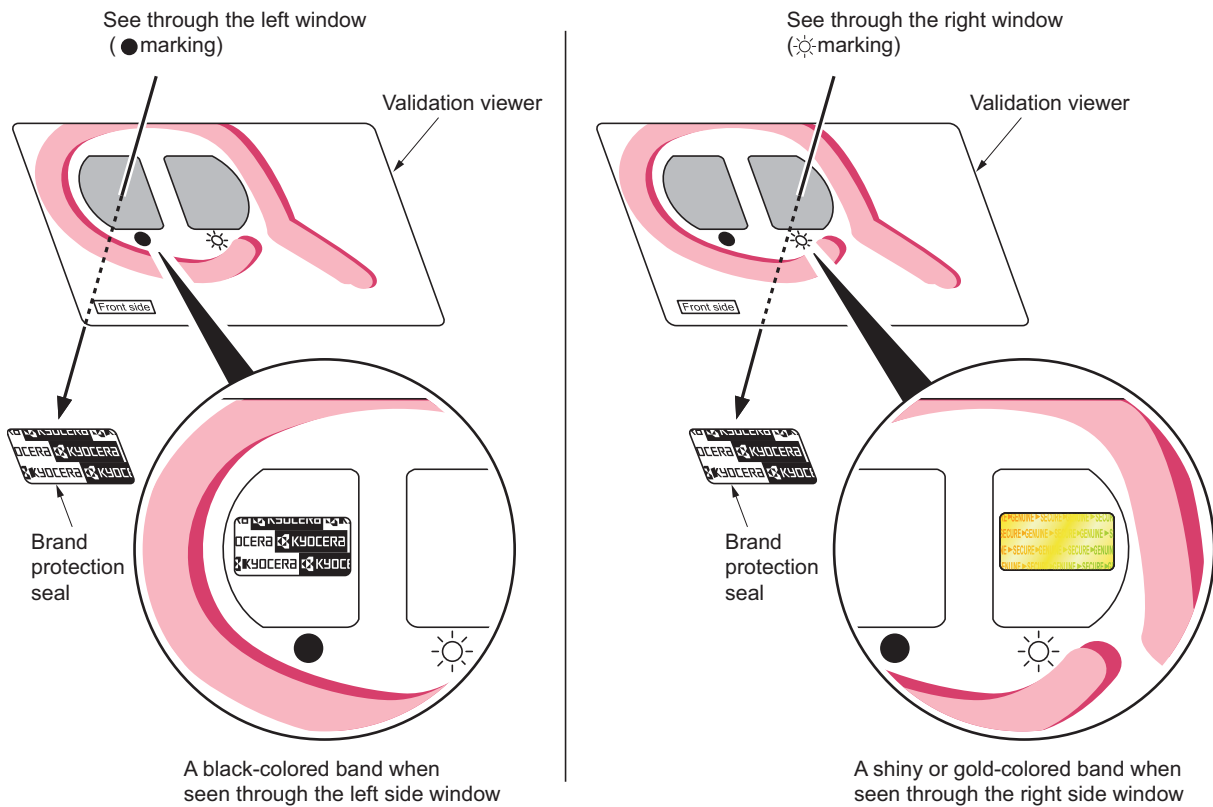

Figure 1-5-1

The brand protection seal has an incision as shown below to prohibit reuse.

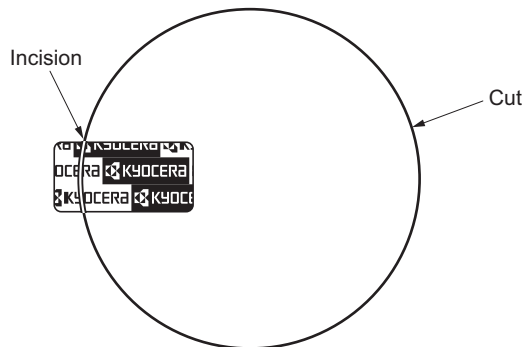

Figure 1-5-2

1-5-2 Outer covers

(1) Detaching and refitting the left rear cover, left upper cover and left front cover

Procedure

1. Open the left cover.
2. Remove the waste toner box.
3. Remove two screws.

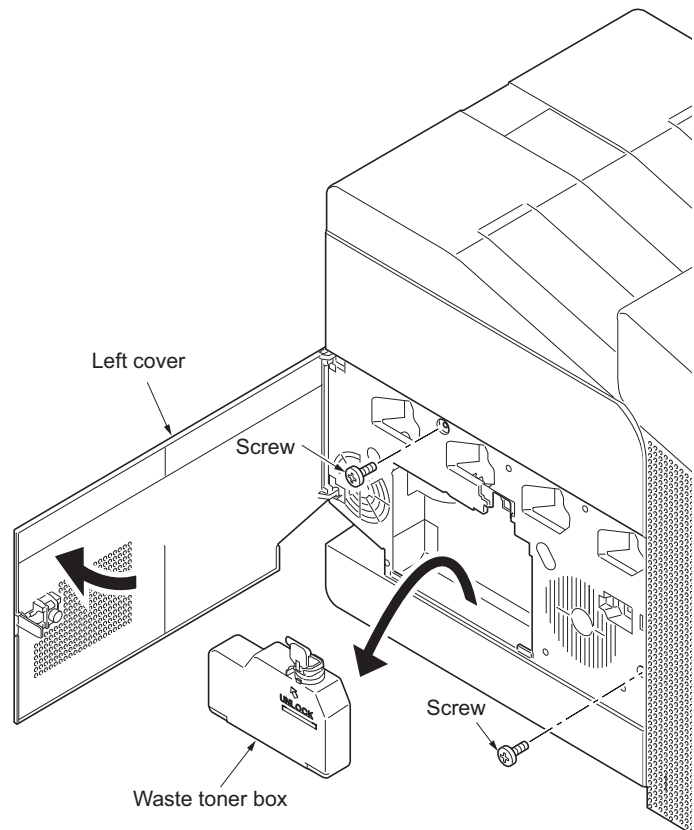

Figure 1-5-3

- 4. Open the top cover.
- 5. Release the five hooks and then remove the left rear cover.

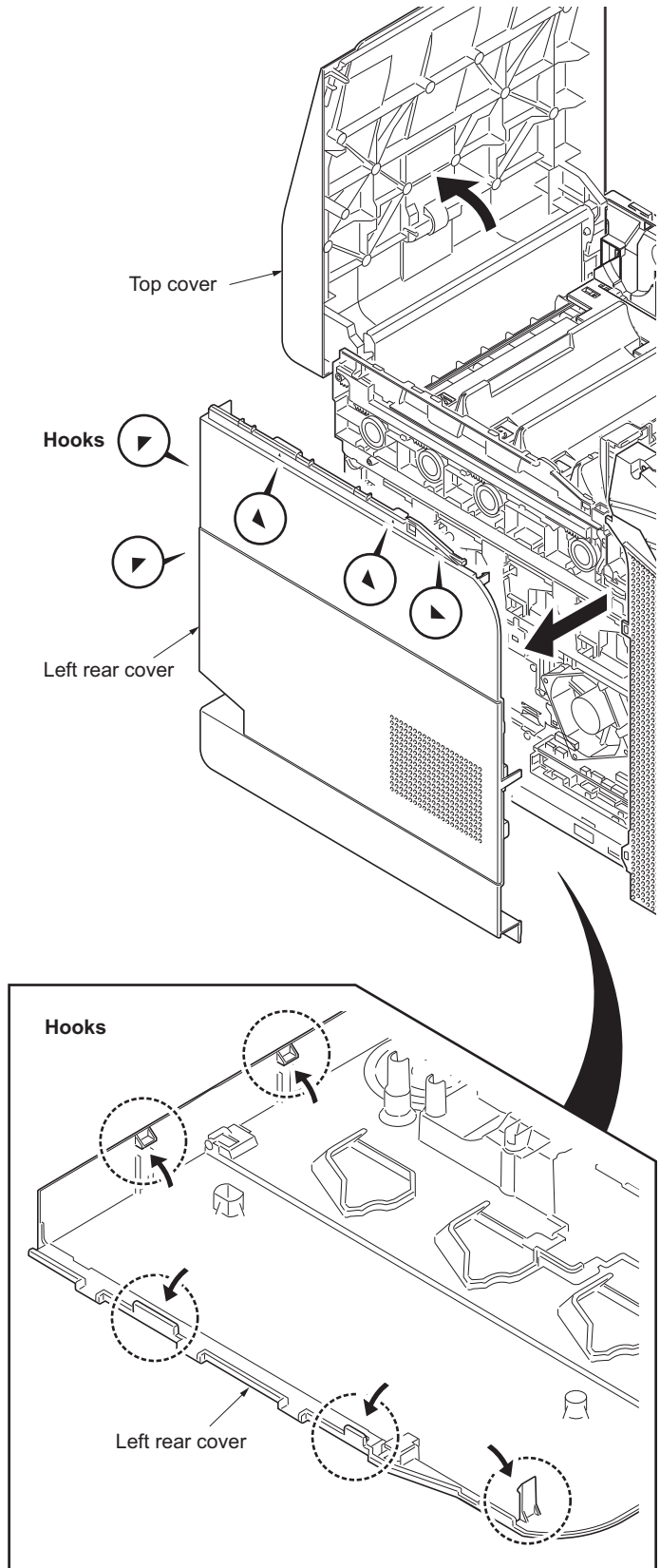

Figure 1-5-4

6. Open the front cover.
7. Remove the screw and then remove the left upper cover.
8. Slide the left front cover upward and then remove it.

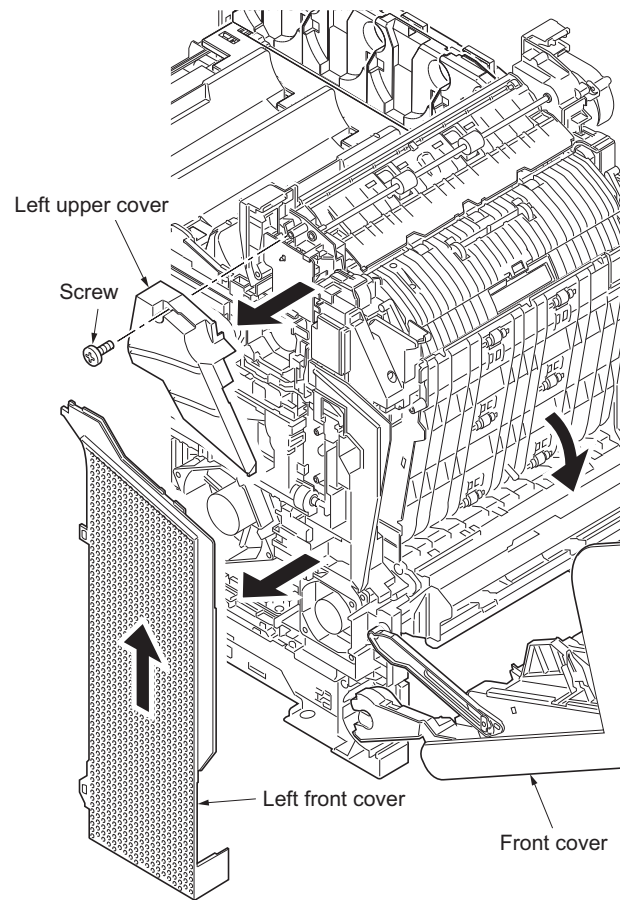

Figure 1-5-5

(2) Detaching and refitting the right rear cover, right upper cover and right front cover

Procedure

1. Open the top cover.
2. Open the right cover.
3. Remove the two screws.
4. Release the five hooks and then remove the right rear cover.

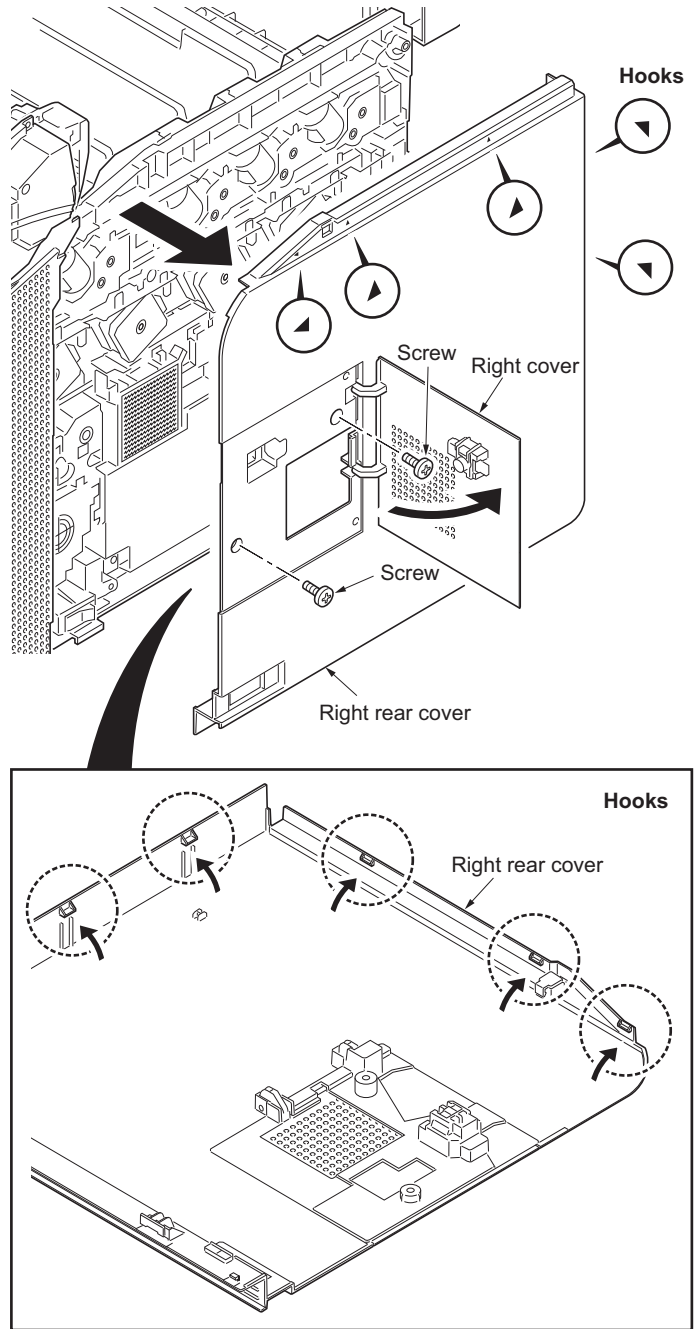

Figure 1-5-6

5. Open the front cover.
6. Remove the two screws and then remove the right upper cover.
7. Slide the right front cover and then remove it.

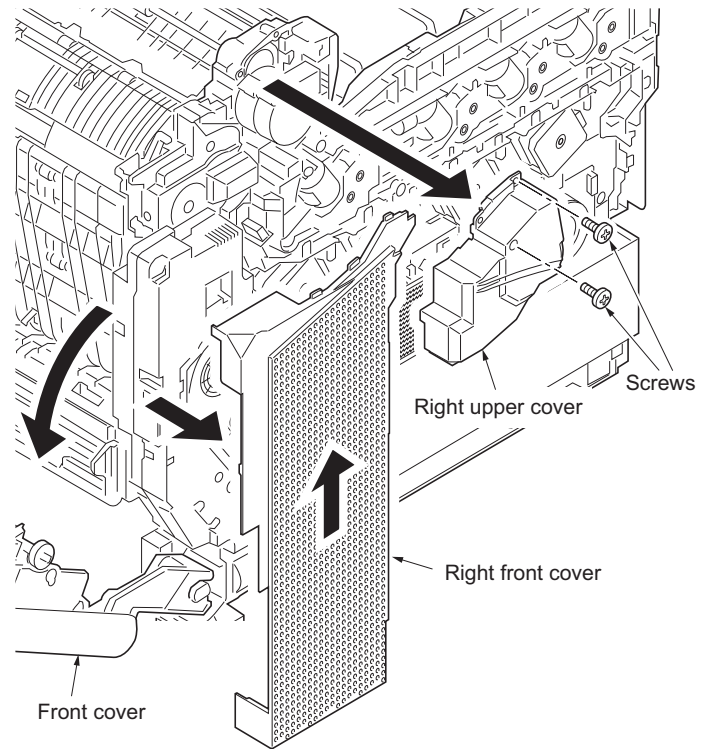

Figure 1-5-7

1-5-3 Paper feed section

(1) Detaching and refitting the paper feed roller assembly (paper feed roller and pickup roller)

Procedure

1. Remove the cassette.

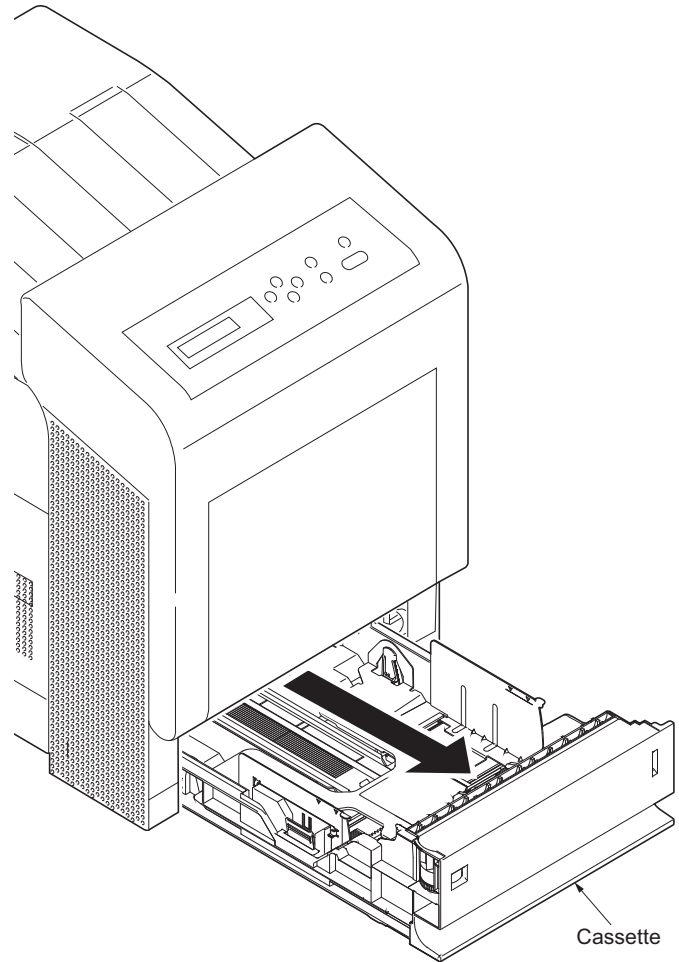

Figure 1-5-8

2. While pressing lever A and then slide the feed roller pin.
3. While pressing the lever B and then remove the paper feed roller assembly.

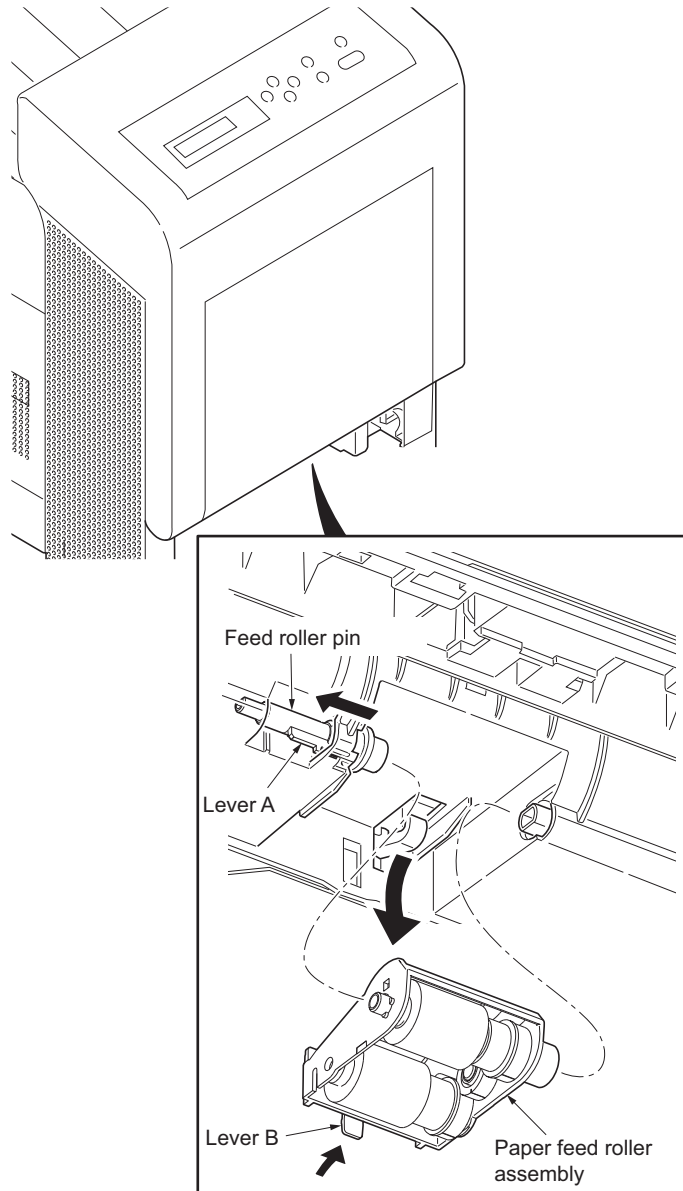

Figure 1-5-9

4. Check or replace the paper feed roller assembly and refit all the removed parts.

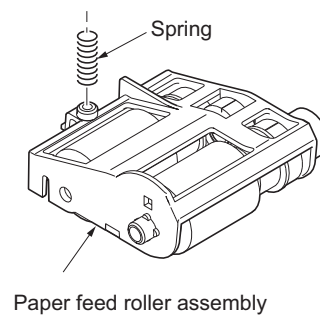
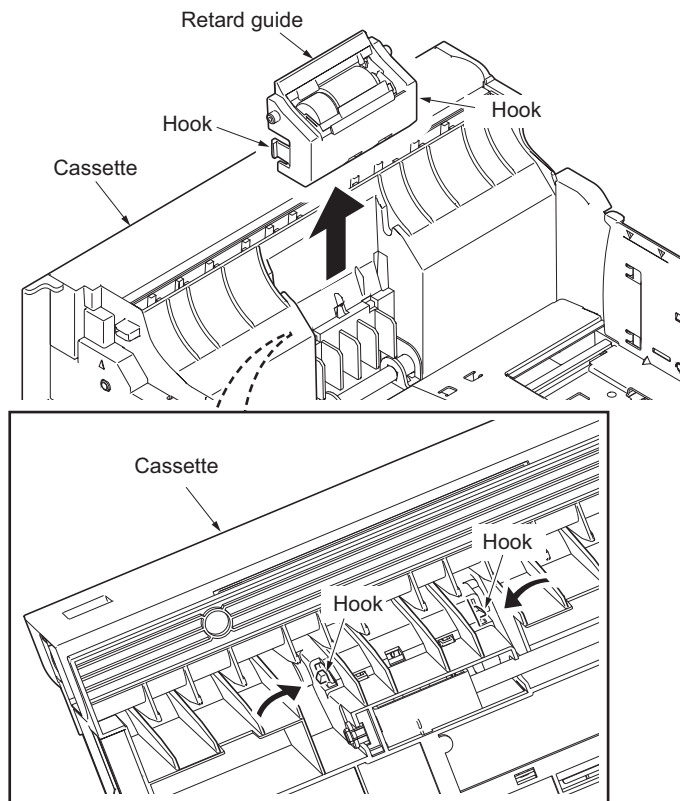

Figure 1-5-10

(2) Detaching and refitting the retard roller**Procedure**

1. Remove the cassette (See page 1-5-8).
2. Release the two hooks and then remove the retard guide (retard roller assembly).

**Figure 1-5-11**

3. Remove the retard roller assembly.
4. Check or replace the retard roller assembly and refit all the removed parts.

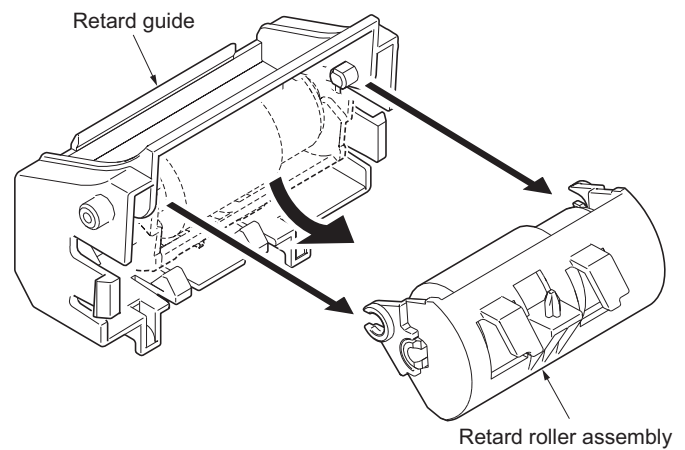
**Figure 1-5-12**

(3) Detaching and refitting the MP paper feed roller

Procedure

1. Open the front cover.
2. While releasing the hook and the slide the MPF shaft.
3. Remove the MP paper feed roller.
4. Check or replace the MP paper feed roller and refit all the removed parts.

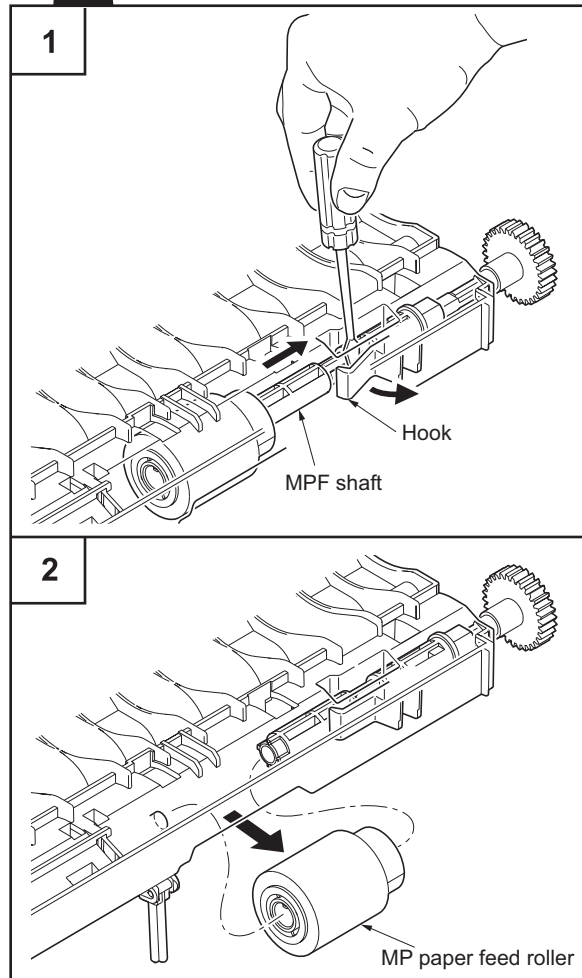
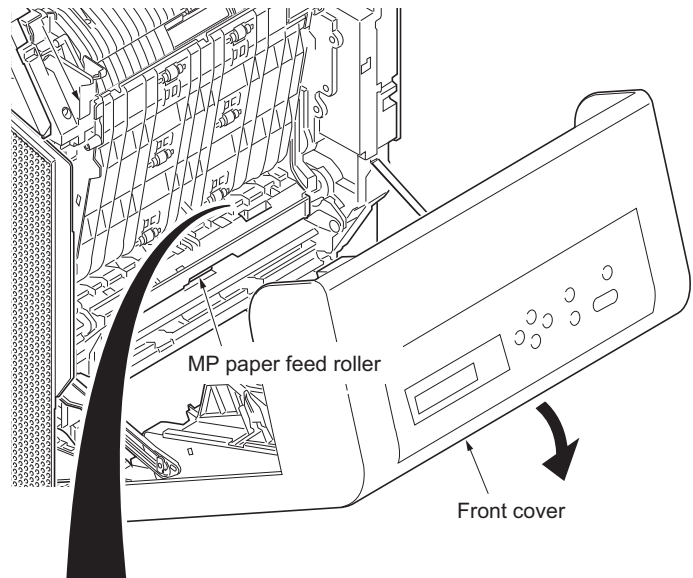

Figure 1-5-13

1-5-4 Developing section

(1) Detaching and refitting the developing unit

Procedure

1. Remove the intermediate transfer unit (See page 1-5-16).
2. Remove the drum units (M,C,Y and K) (See page 1-5-14).
3. Pinch the lever of developing unit to release the lock.
4. Hold the grips and then remove the developing units (M,C,Y and K).

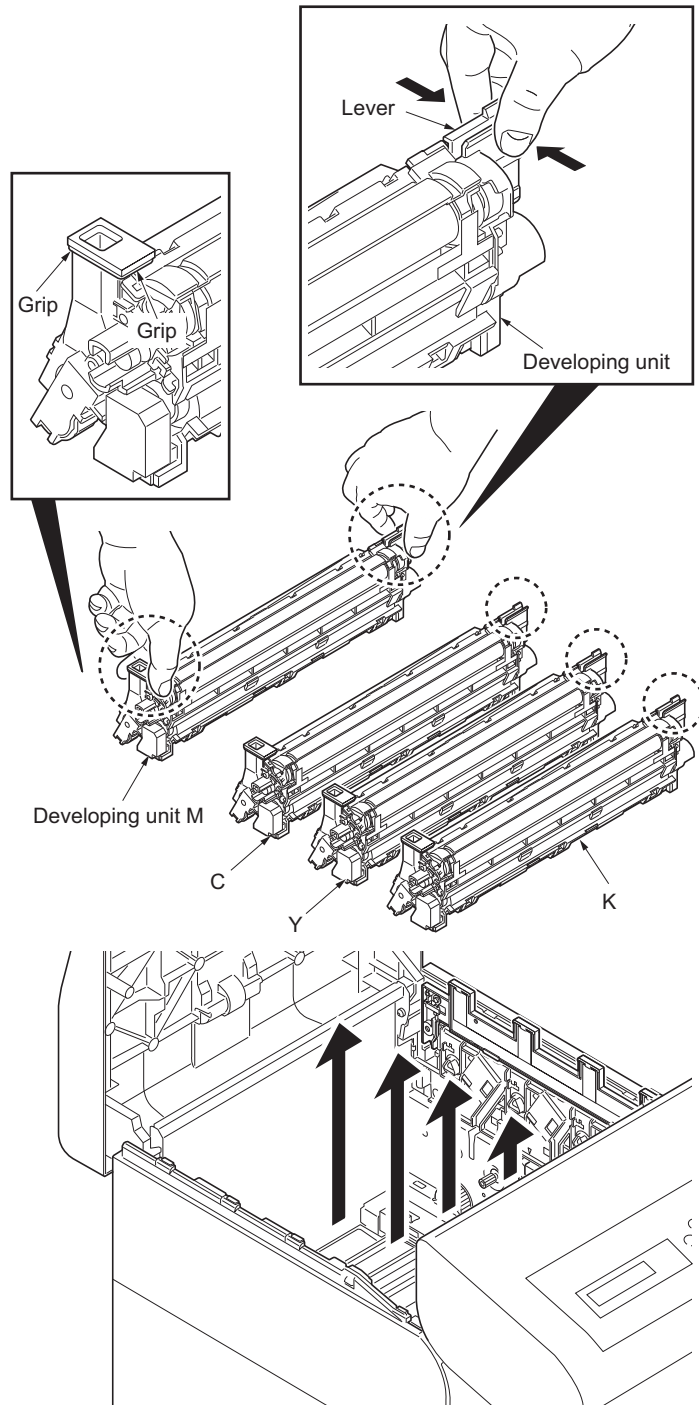

Figure 1-5-14

- 5. Check or replace the developing unit and refit all the removed parts.

NOTE:

Remove the cap before installing the new developing unit.

When reinstalling the developing unit, press it down until the lever of developing unit is engaged with the notch.

If it is difficult to engage the lever, press the unit down while rotating the gear to engage it.

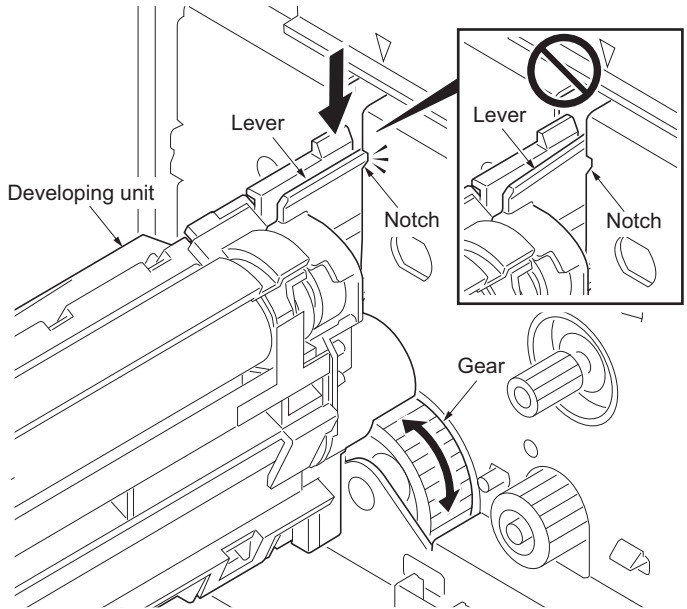
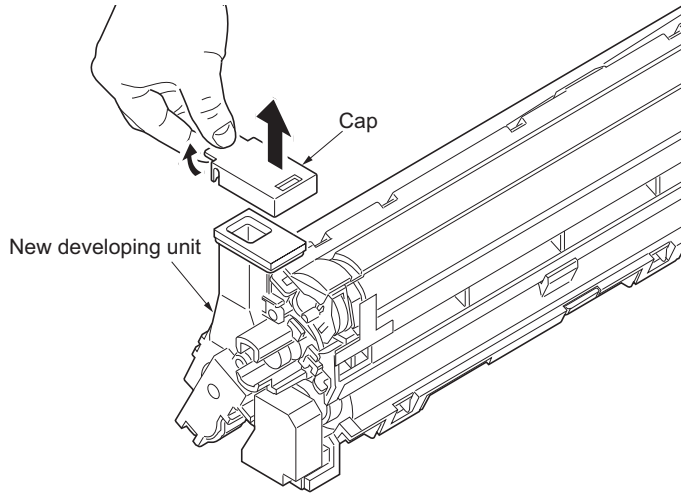

Figure 1-5-15

1-5-5 Drum section

(1) Detaching and refitting the drum unit

Procedure

1. Remove the intermediate transfer unit (See page 1-5-16).
2. Hold the grips and then remove the drum units (M,C,Y and K).
3. Check or replace the drum unit and refit all the removed parts.

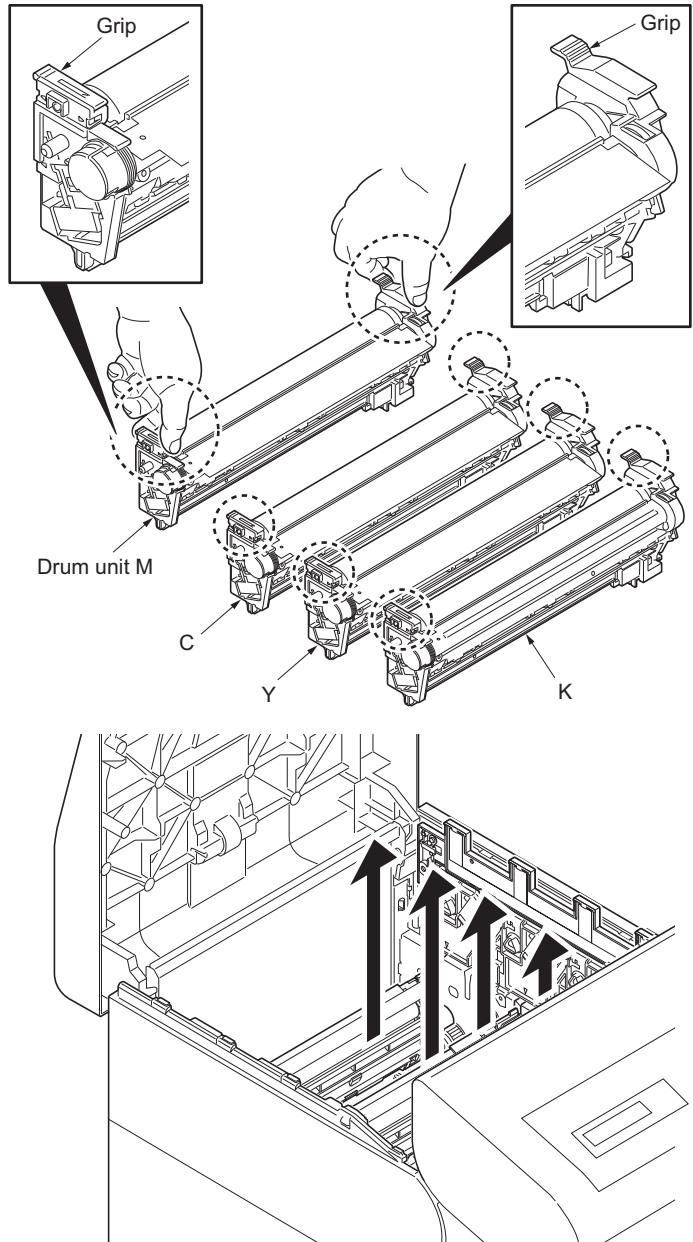

Figure 1-5-16

(2) Detaching and refitting the main charger unit

Procedure

1. Open the left cover.
2. Remove the main charger units (M,C,Y and K).
3. Check or replace the main charger units and refit all the removed parts.

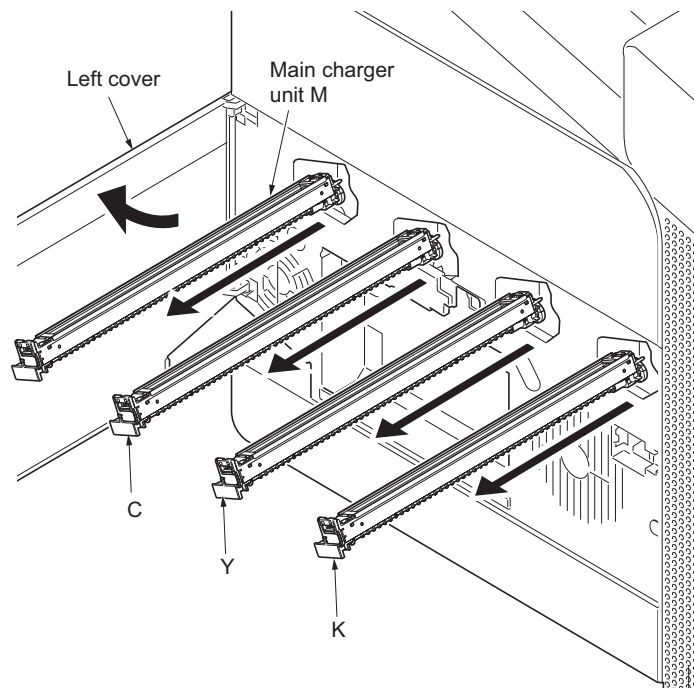

Figure 1-5-17

1-5-6 Transfer/separation section

(1) Detaching and refitting the intermediate transfer unit

Procedure

1. Open the top cover.
2. Remove the all toner containers (M,C,Y and K).

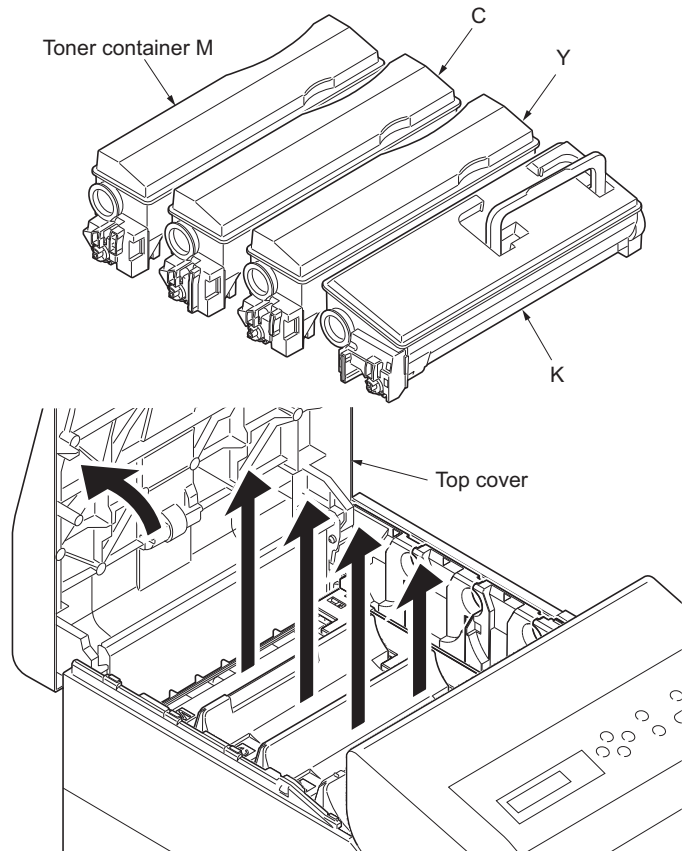

Figure 1-5-18

3. Remove the all container guides (M,C,Y and K).

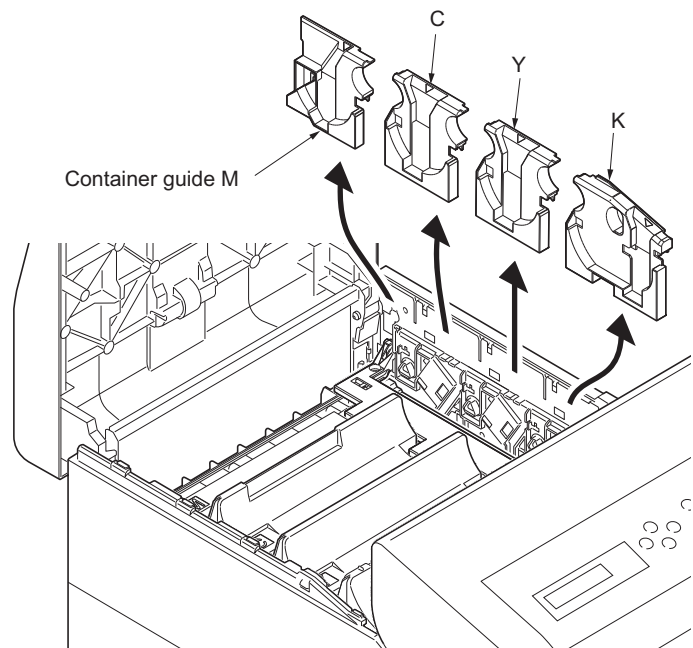

Figure 1-5-19

- 4. Remove the two screws.
- 5. Open the RFID holder.

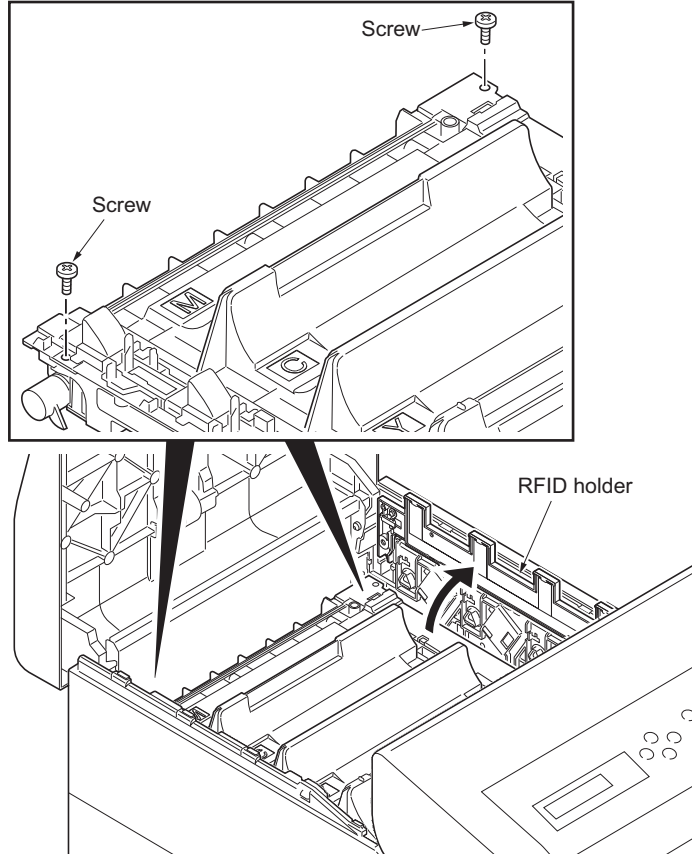

Figure 1-5-20

- 6. Slide the lever in order to close the toner feed shutter.

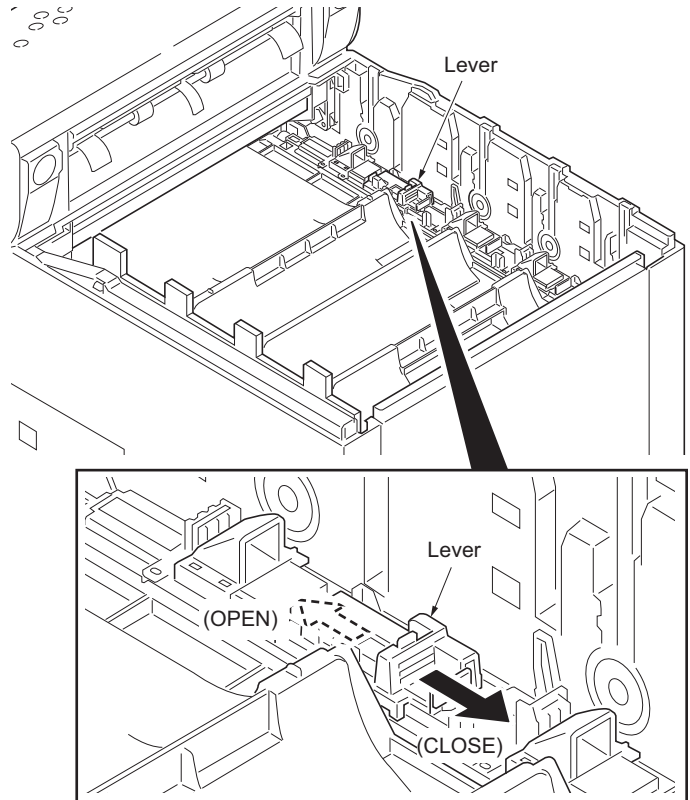

Figure 1-5-21

7. Hold the grips and then remove the intermediate transfer unit.
8. Check or replace the intermediate transfer unit and refit all the removed parts.

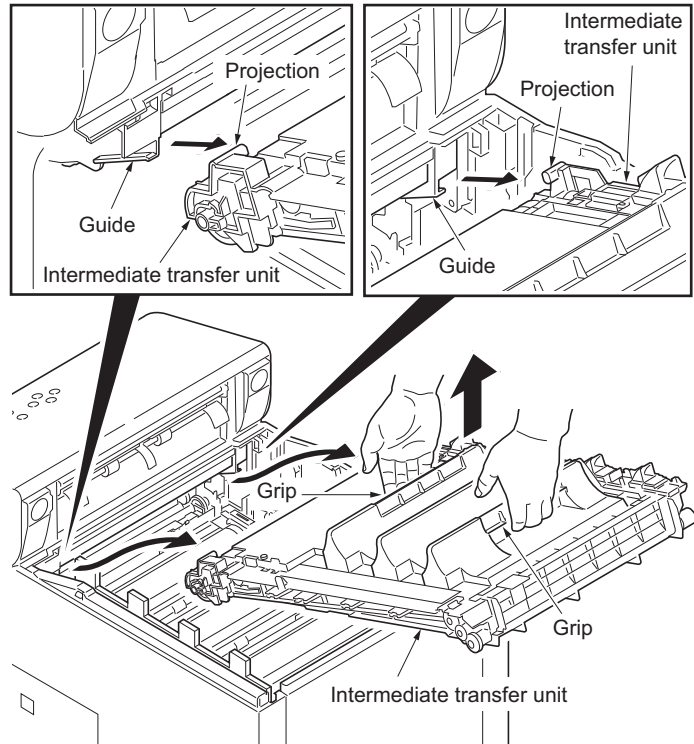

Figure 1-5-22

(2) Detaching and refitting the transfer roller unit

Procedure

1. Open the front cover.
2. Open the duplex unit B.
3. Release the two hooks and then remove the transfer roller unit.
4. Check or replace the transfer roller unit and refit all the removed parts.

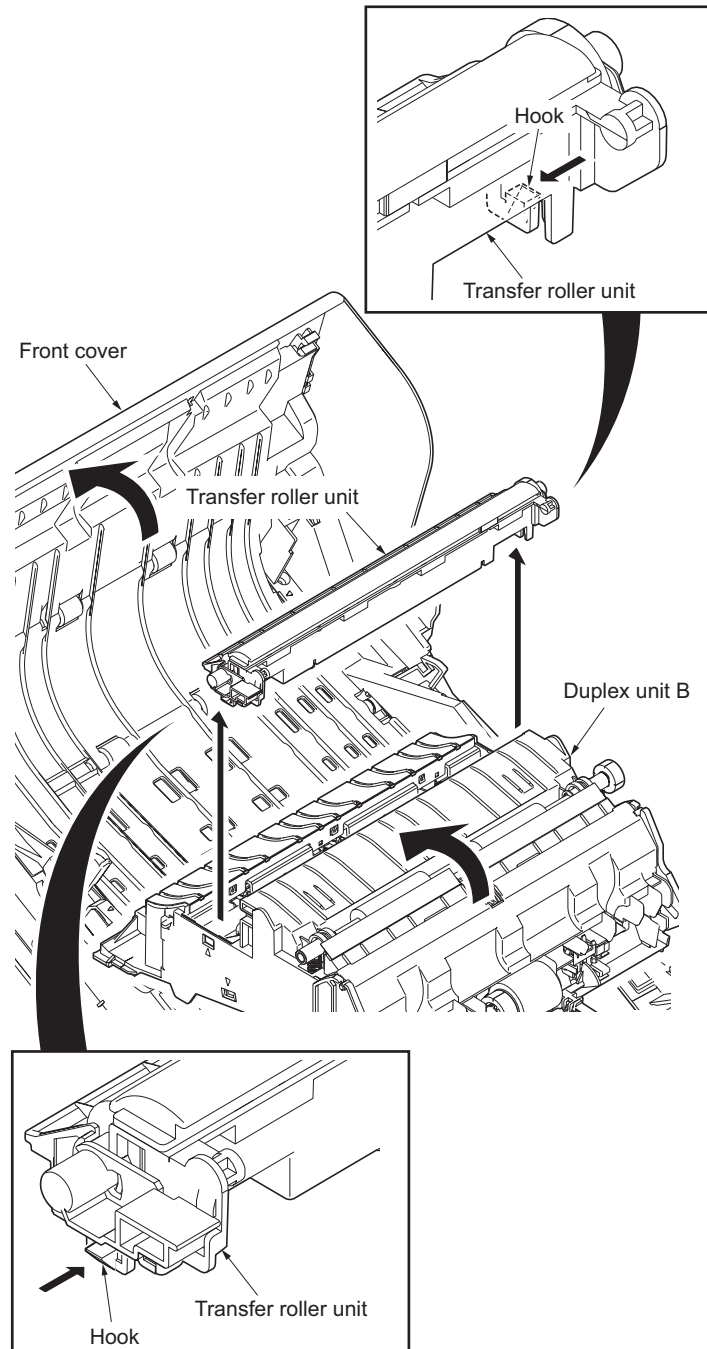

Figure 1-5-23

(3) Detaching and refitting the duplex unit B

Procedure

1. Remove the outer covers (See page 1-5-3).
2. Remove the power source PWB (See page 1-5-26).
3. While releasing the hook and then pull the MCH cleaning shaft.

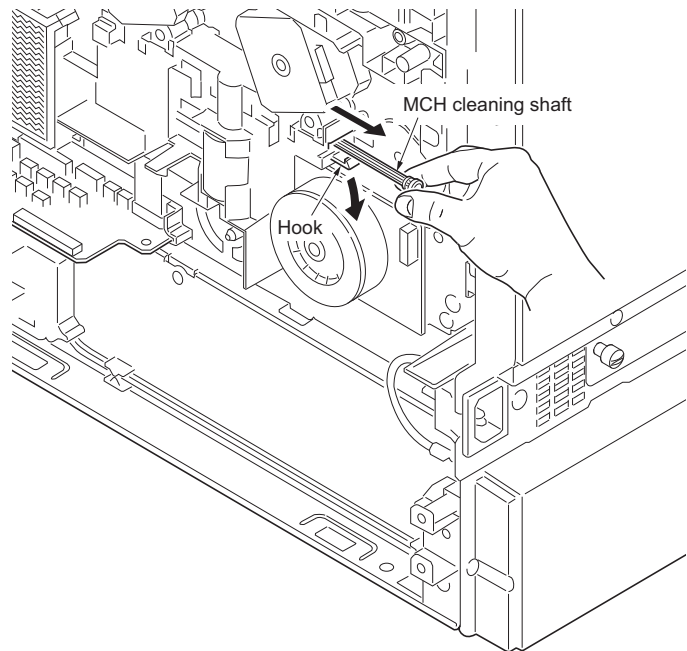

Figure 1-5-24

4. Open the front cover.
5. Remove the screw and then remove the front cover right stopper.

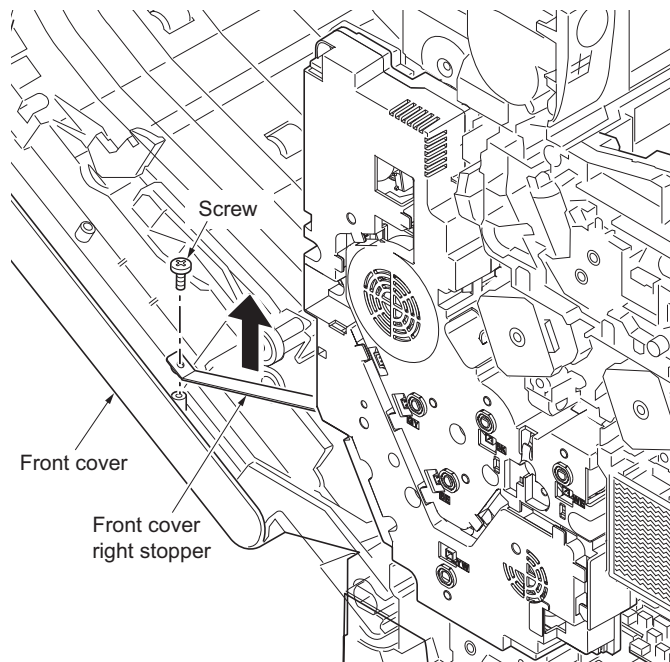

Figure 1-5-25

- 6. Remove the six screws and then remove the feed drive unit.

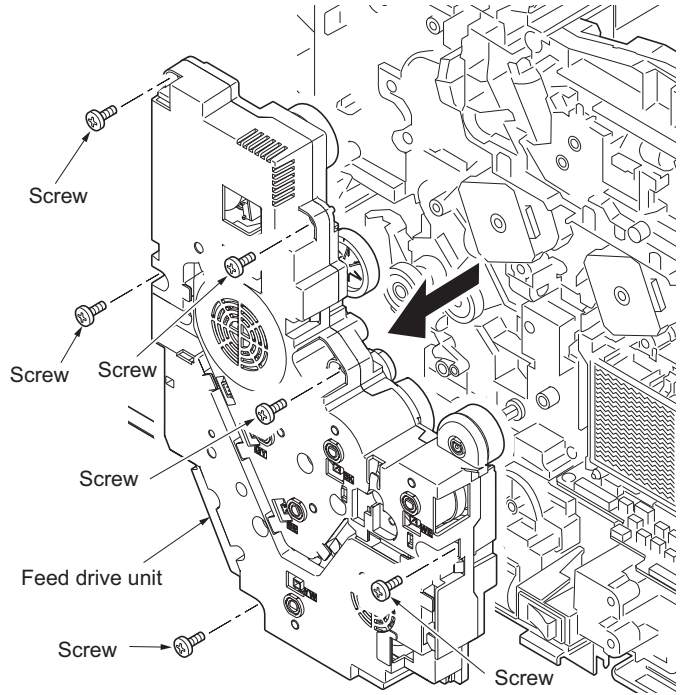

Figure 1-5-26

- 7. Remove the four connectors.

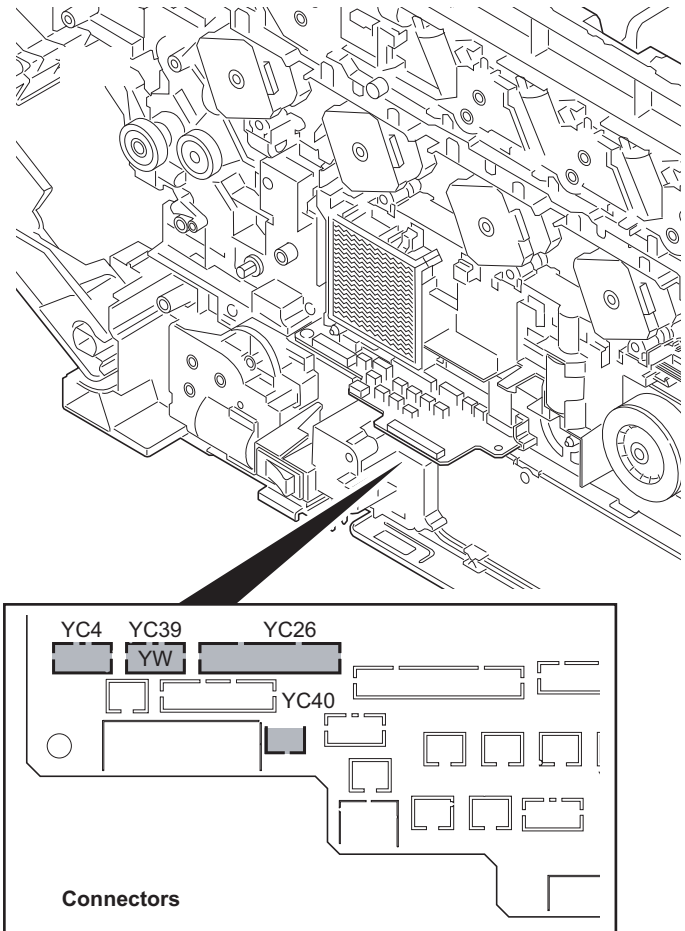

Figure 1-5-27

- 8. Remove the FFC.
- 9. Remove the screw and then remove the grounding terminal.

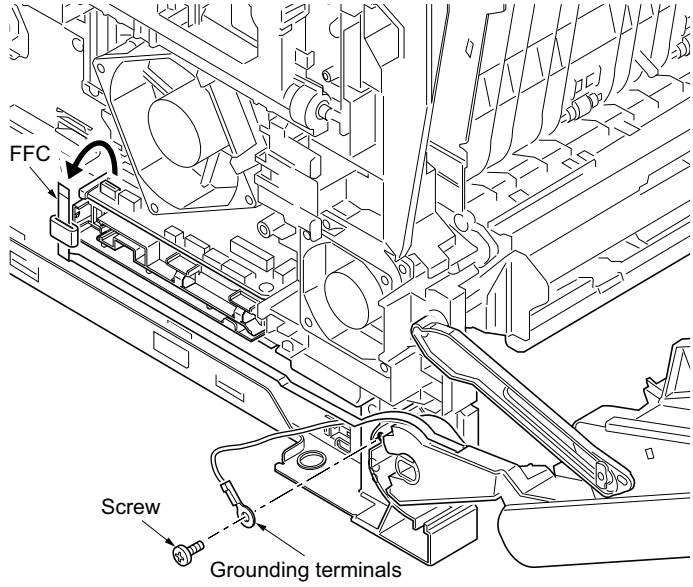

Figure 1-5-28

- 10. Remove the axis of the front cover left stopper from the hole.
- 11. Remove the front cover.

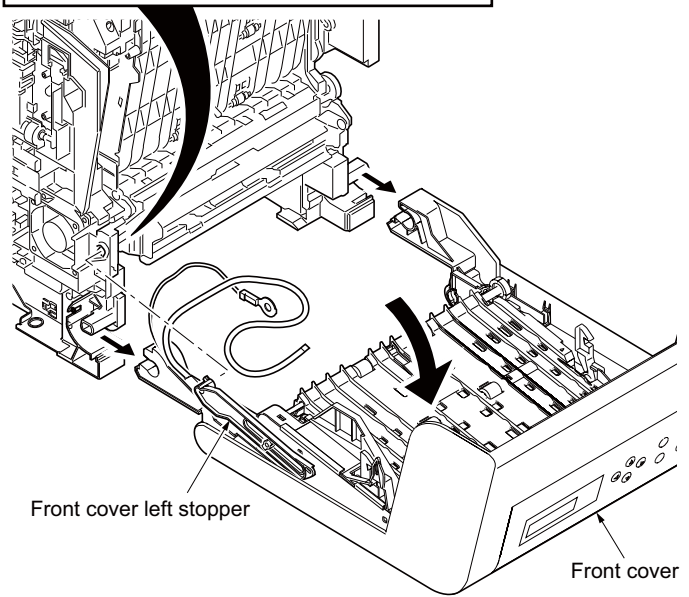
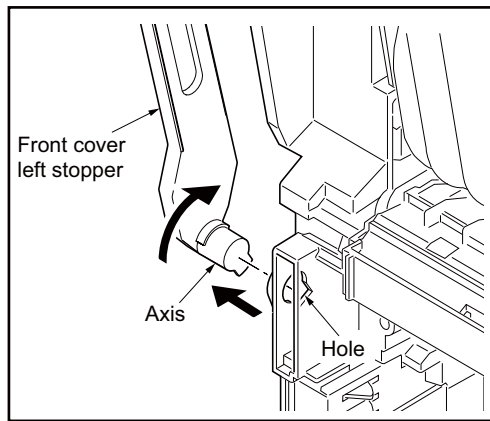

Figure 1-5-29

12. Remove the two screws and then remove the MP paper feed lower unit.

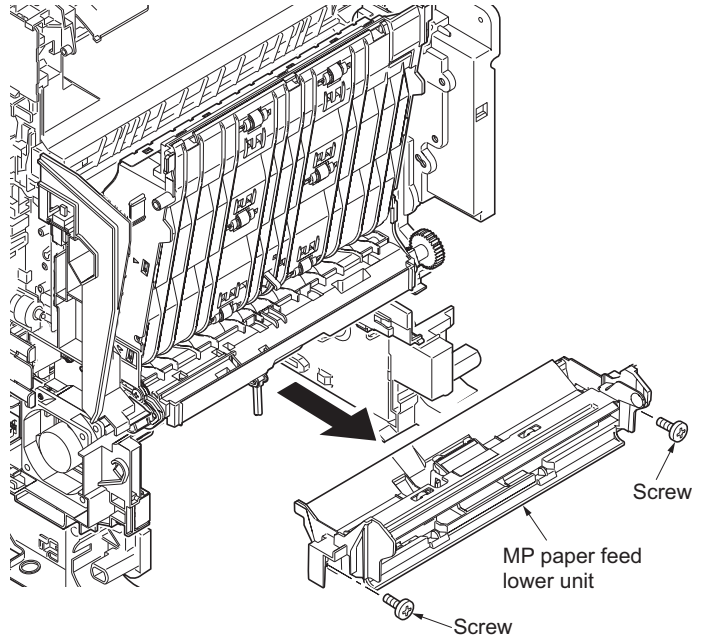

Figure 1-5-30

13. Remove the three connectors.

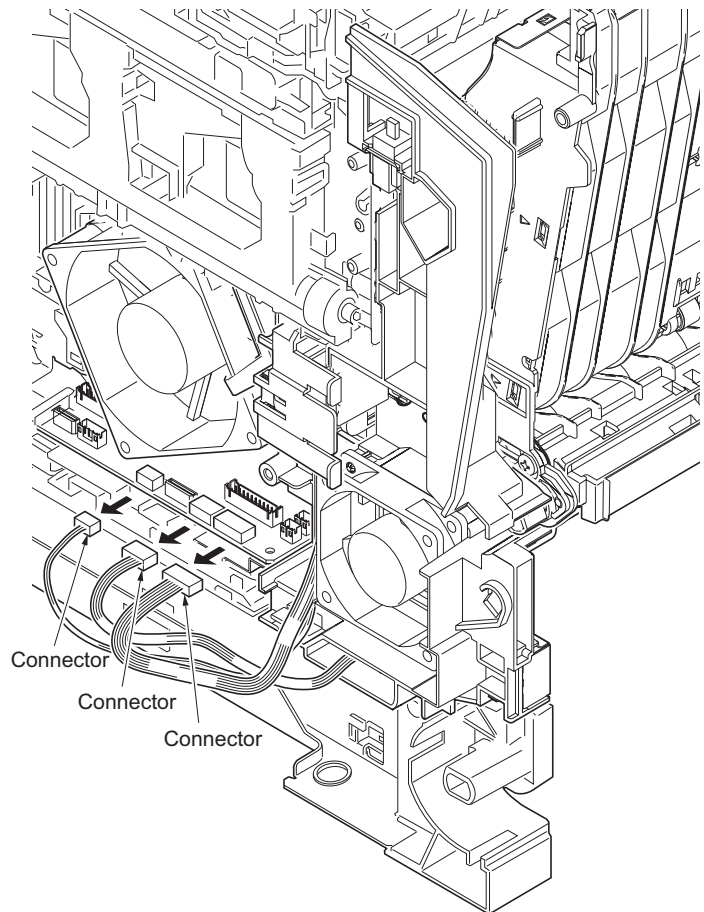

Figure 1-5-31

- 14. Open the duplex unit B.
- 15. Remove the duplex unit B.
- 16. Check or replace the duplex unit B and refit all the removed parts.

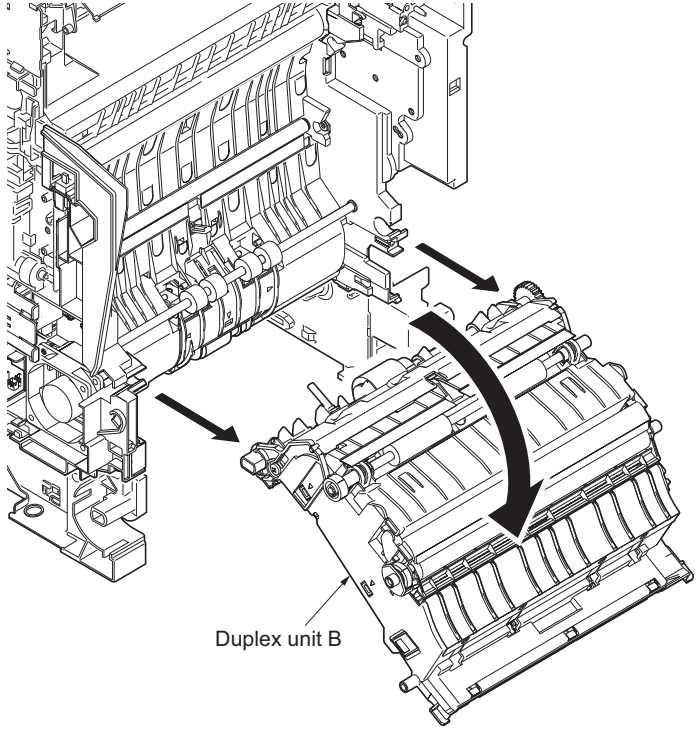

Figure 1-5-32

1-5-7 Fuser section

(1) Detaching and refitting the fuser unit

Procedure

1. Remove the outer covers (See page 1-5-3).
2. Remove three connectors.

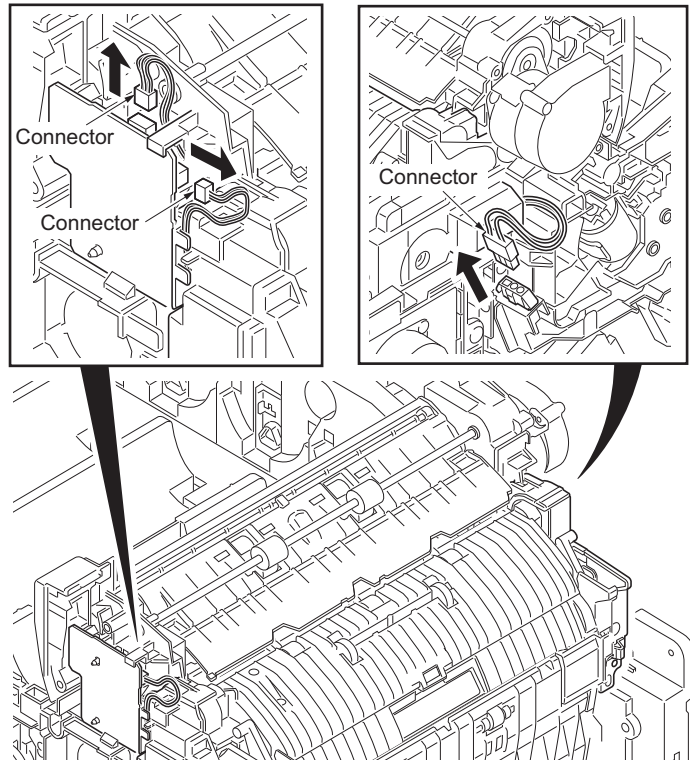

Figure 1-5-33

3. Remove two screws (P tight and S tight).
4. Unhook the hook and then remove the fuser unit.
5. Check or replace the fuser unit and refit all the removed parts.

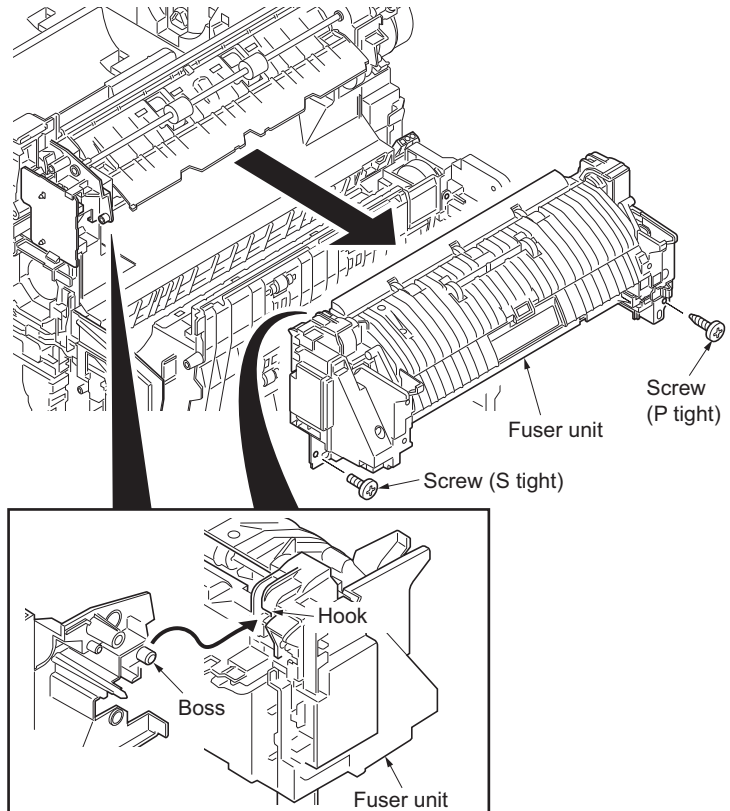

Figure 1-5-34

1-5-8 PWBs

(1) Detaching and refitting the power source PWB

Procedure

1. Remove the right rear cover (See page 1-5-6).
2. Remove the three screws and then remove the power source shield.

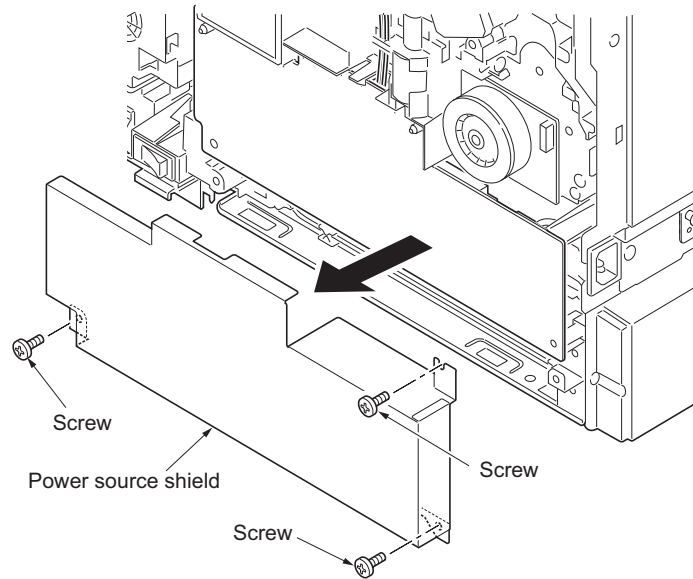

Figure 1-5-35

3. Remove the connector.
4. Remove the two screws.

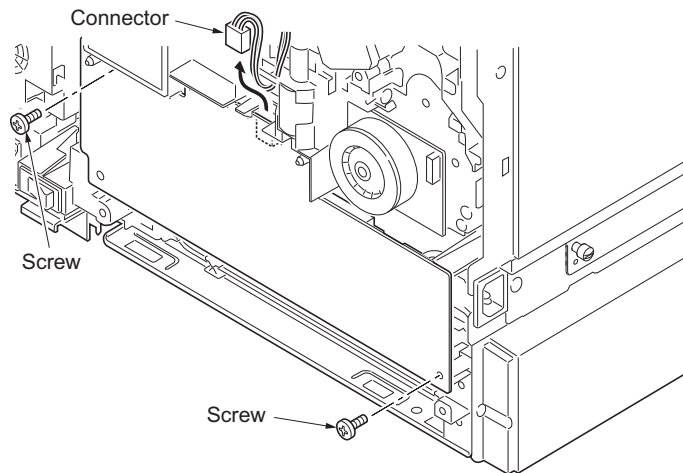

Figure 1-5-36

- 5. Remove the two connectors and then remove the power source PWB.
- 6. Check or replace the power source PWB and refit all the removed parts.

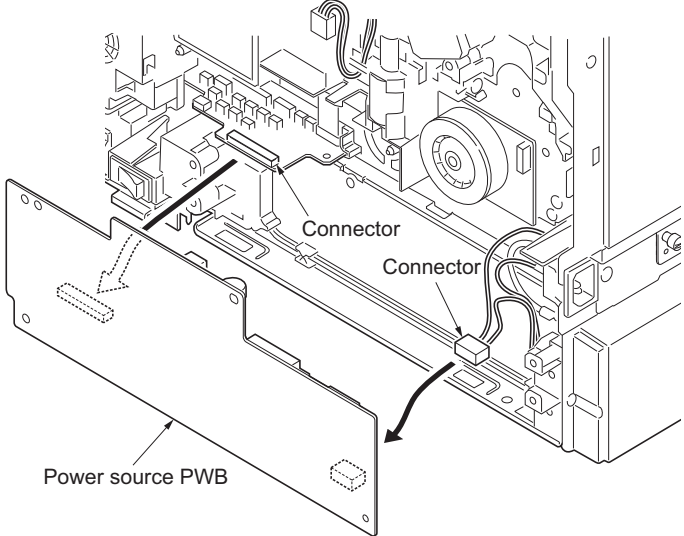

Figure 1-5-37

(2) Detaching and refitting the main PWB

Procedure

1. Remove the two screws.
2. Remove the main PWB.
3. Check or replace the main PWB and refit all the removed parts.

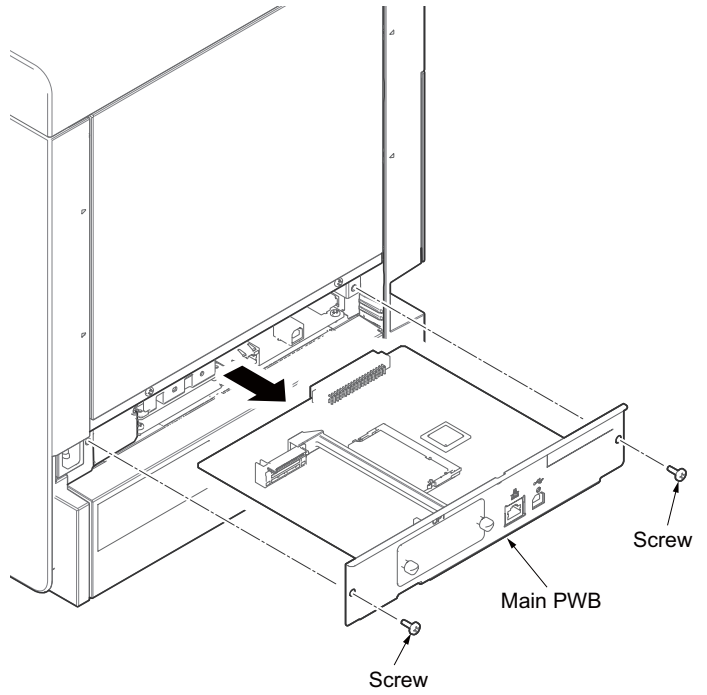

Figure 1-5-38

(3) Detaching and refitting the engine PWB

Procedure

1. Remove the duplex unit B (See page 1-5-20)
2. Remove the connector.

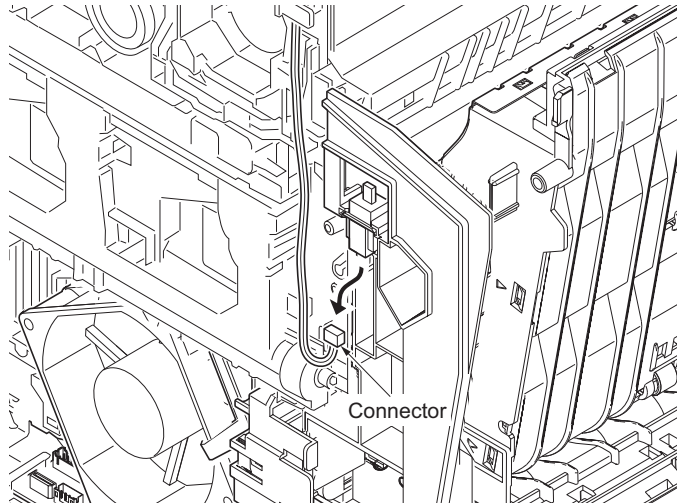

Figure 1-5-39

3. Remove the seven screws and then remove the feed housing.

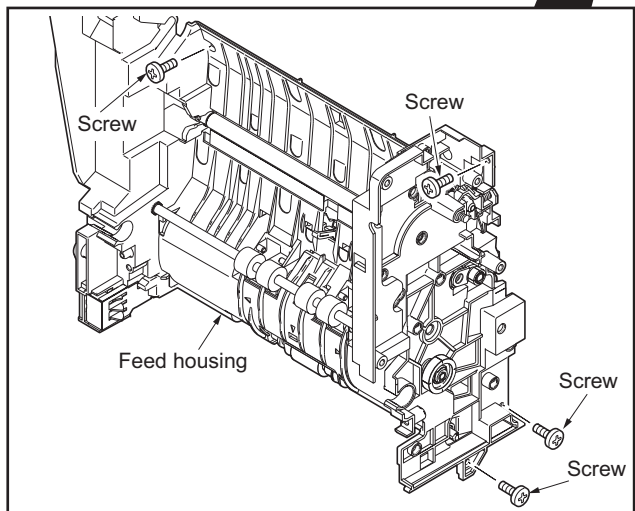
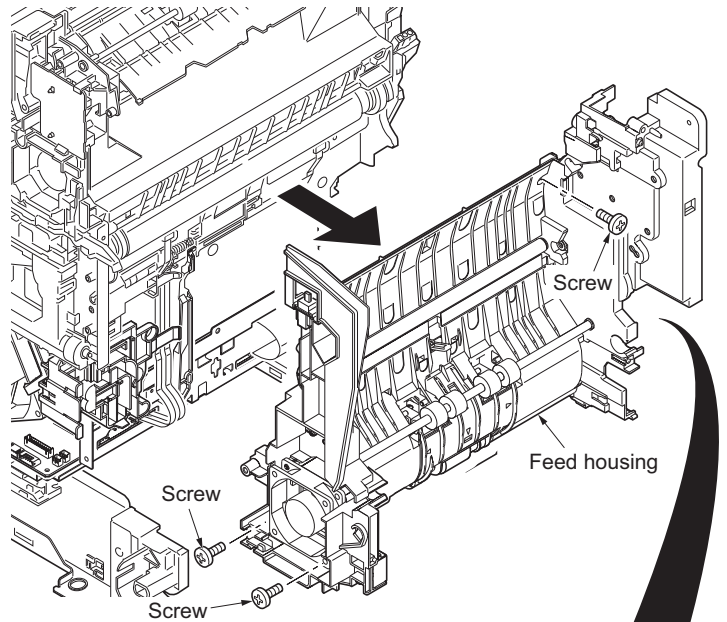

Figure 1-5-40

- 4. Remove the connector A.
- 5. Remove the developing fan motor 1.
- 6. Remove the two connectors B.
- 7. Remove the FFC.

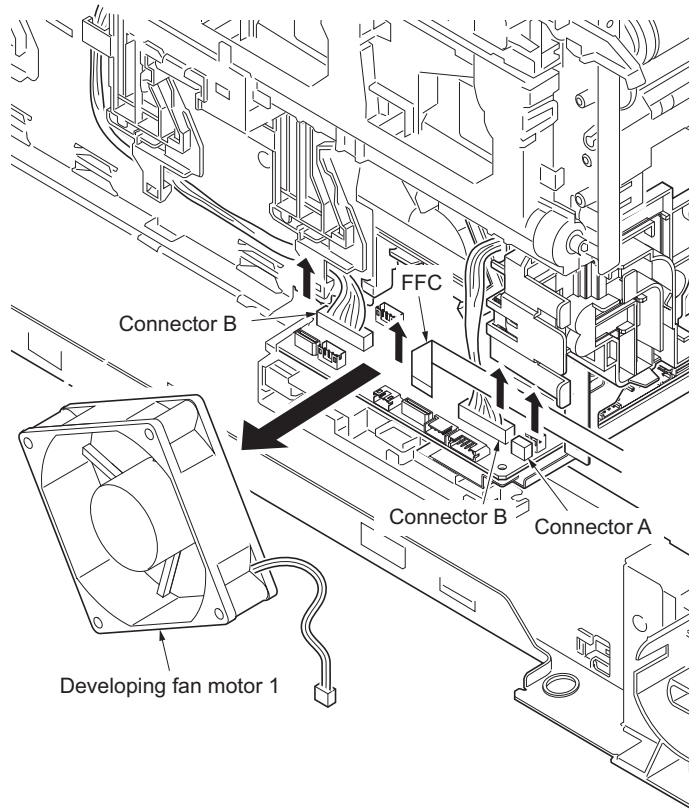

Figure 1-5-41

- 8. Remove the three FFCs.
- 9. Remove the two connectors.

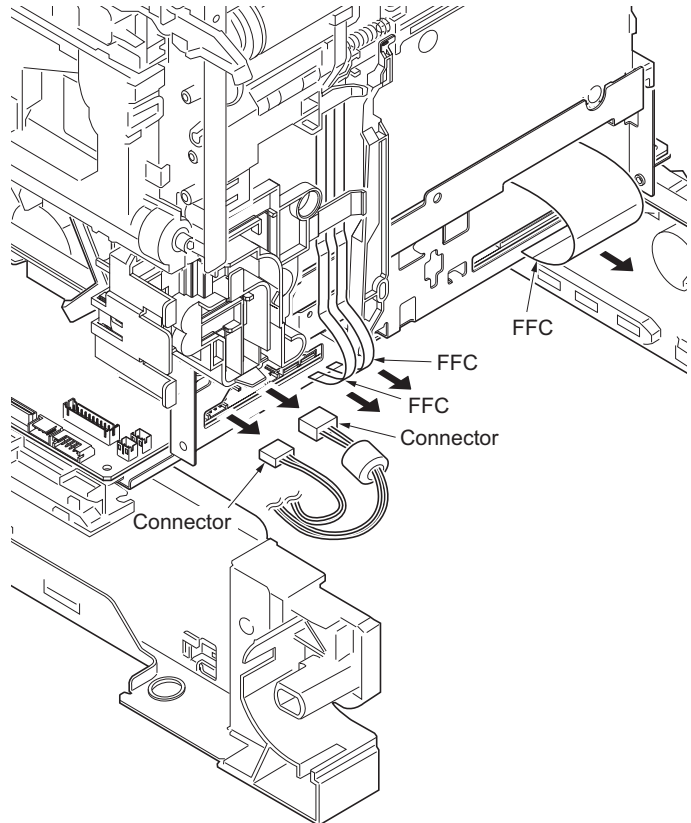

Figure 1-5-42

10. While unlatching the latch and then remove the lever link.

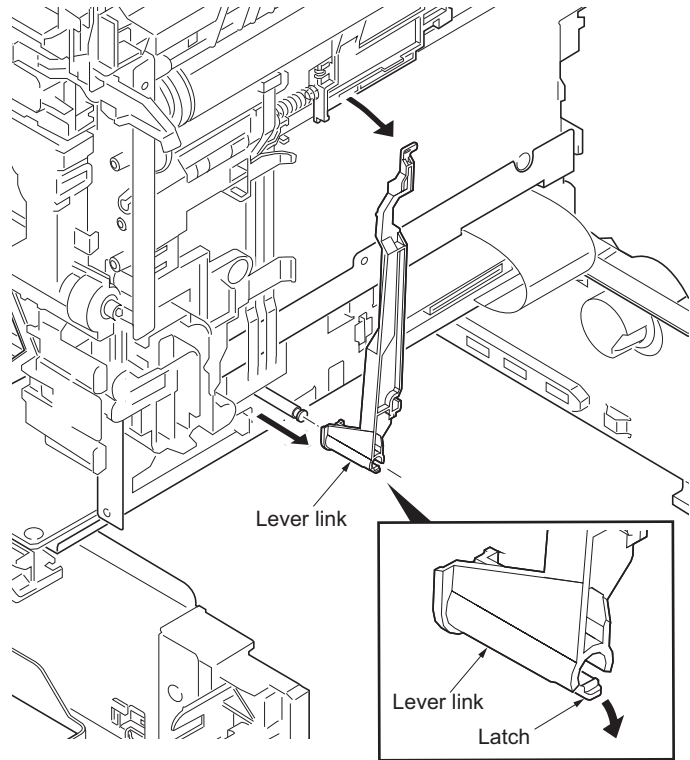

Figure 1-5-43

11. Remove the twenty connectors.

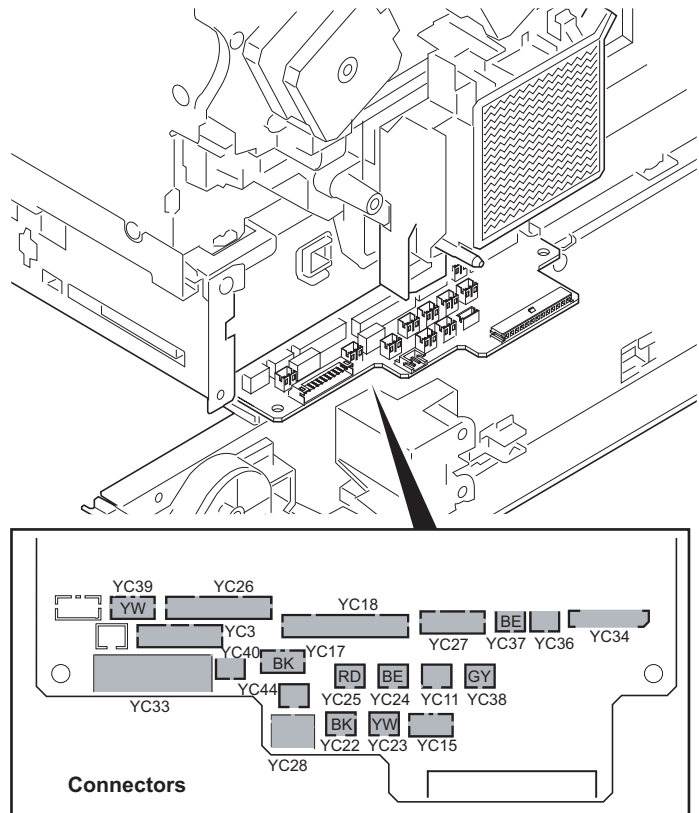

Figure 1-5-44

12. Remove the three screws and then remove the engine PWB assembly.

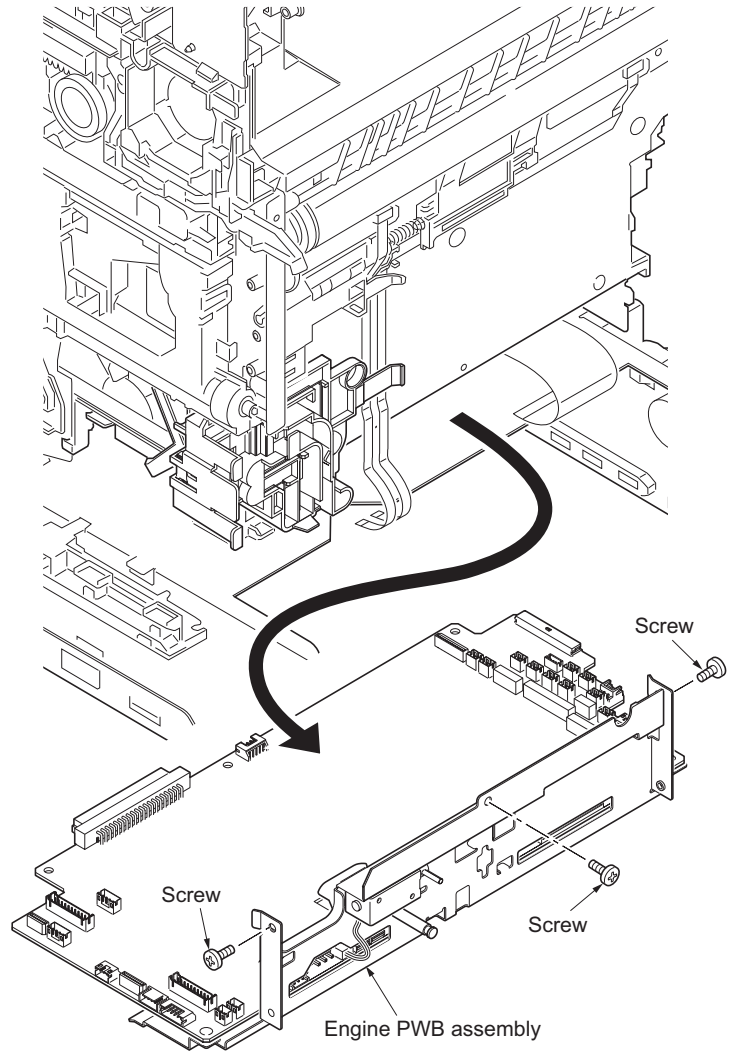

Figure 1-5-45

13. Remove the connector from the engine PWB.

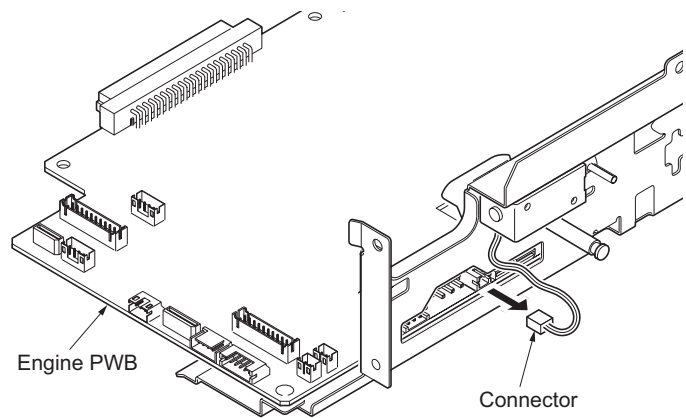
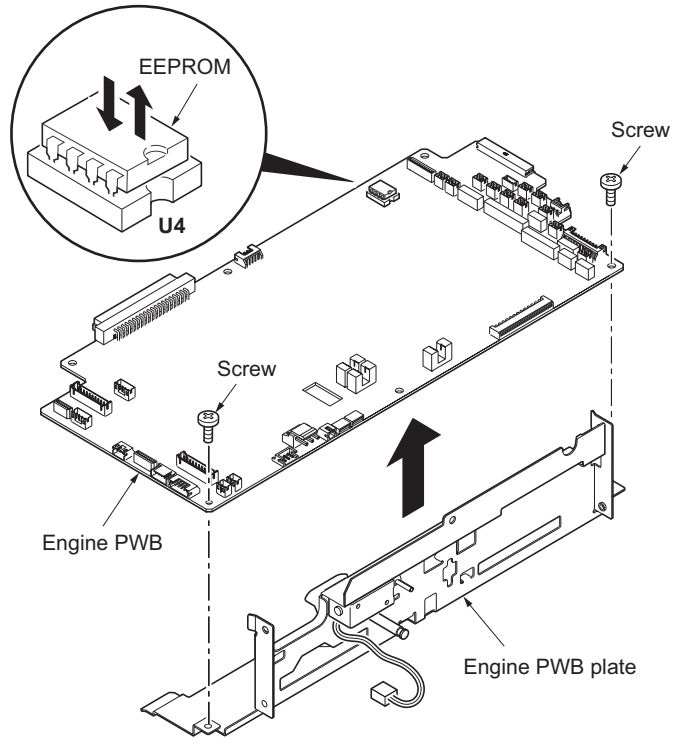

Figure 1-5-46

- 14. Remove the two screws and then remove the engine PWB.
- 15. Check or replace the engine PWB and refit all the removed parts.
To replace the engine PWB, remove the EEPROM (U4) from the old engine PWB and mount it to the new engine PWB.



Caution on re-installing the engine board assembly

Insert the engine PWB assembly in the printer so that both the engine PWB and the harness bracket are flush at each end. Do not insert the engine PWB assembly the way beyond the above, otherwise, the engine PWB plate will be deformed, causing malfunctioning of the ID sensor cleaning system.

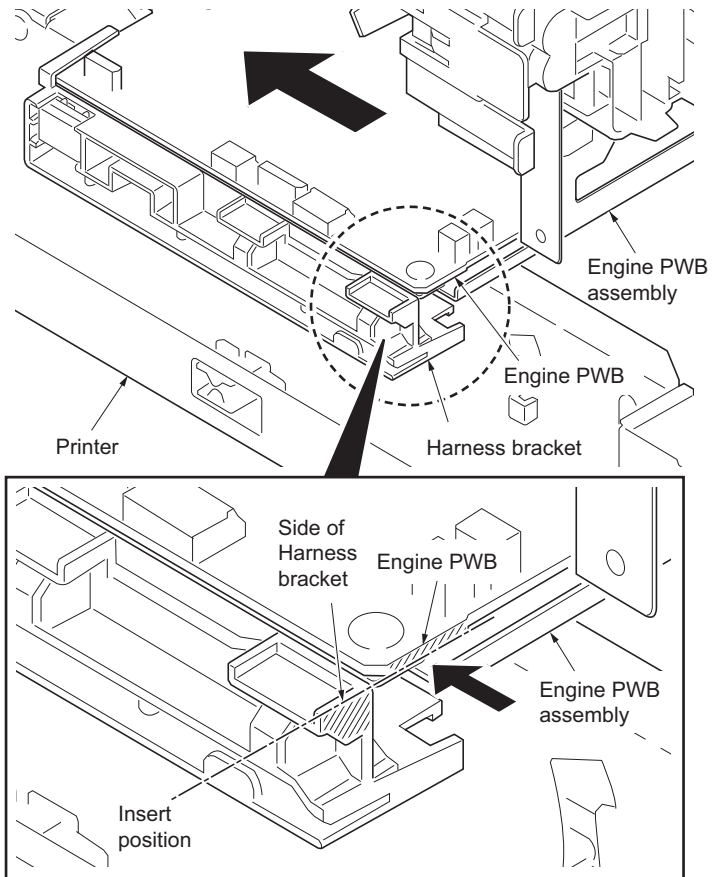

Figure 1-5-47

(4) Detaching and refitting the high voltage PWB

Procedure

1. Remove the all drum units (See page 1-5-14).
2. Remove the all developing units (See page 1-5-12).
3. Remove the engine PWB (See page 1-5-29).
4. Remove the screw and then remove the HV terminal assembly K.

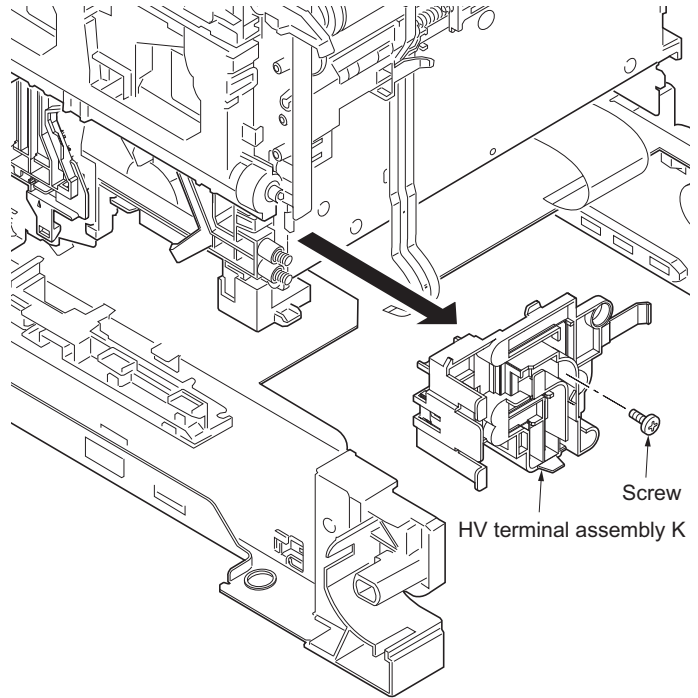

Figure 1-5-48

5. Remove the screw and then remove the inner cover.
6. Remove the three HV bracket C assemblies.

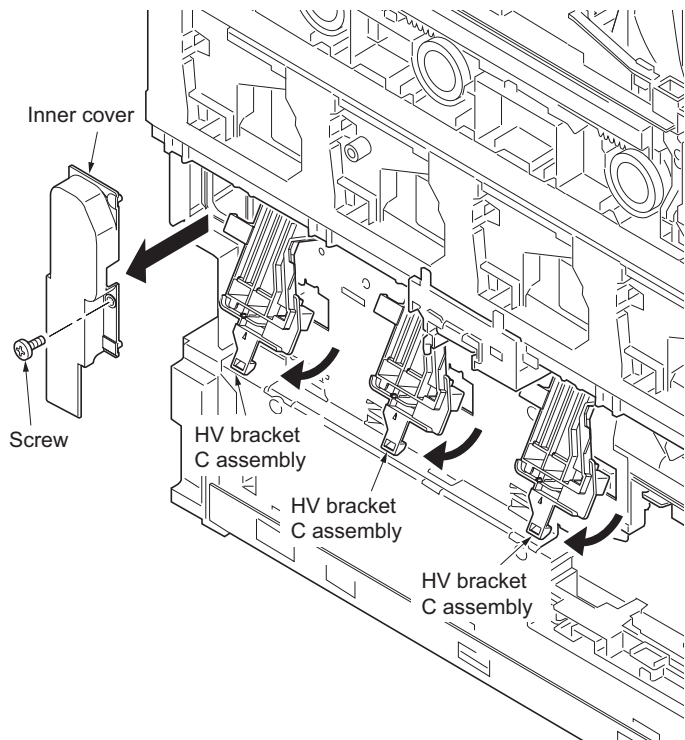

Figure 1-5-49

- 7. Remove five terminals.
- 8. Remove the TC high voltage bracket.
- 9. Remove the two screws.

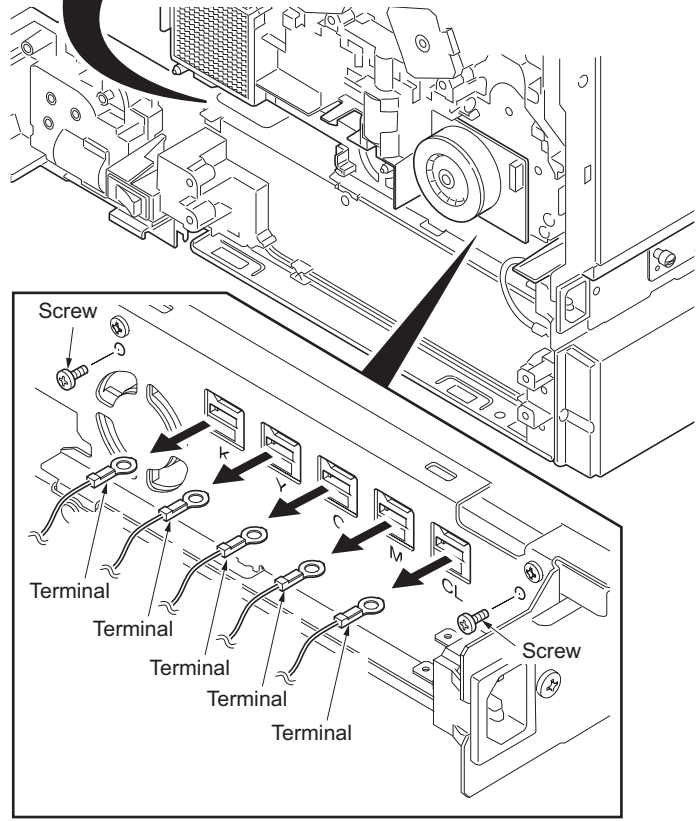
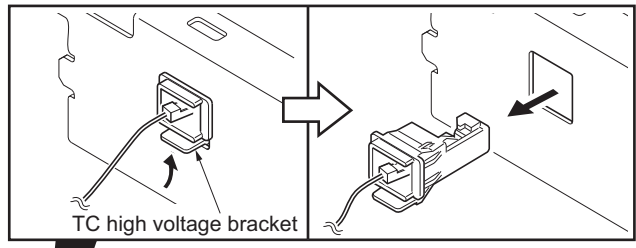

Figure 1-5-50

- 10. Remove the screw.

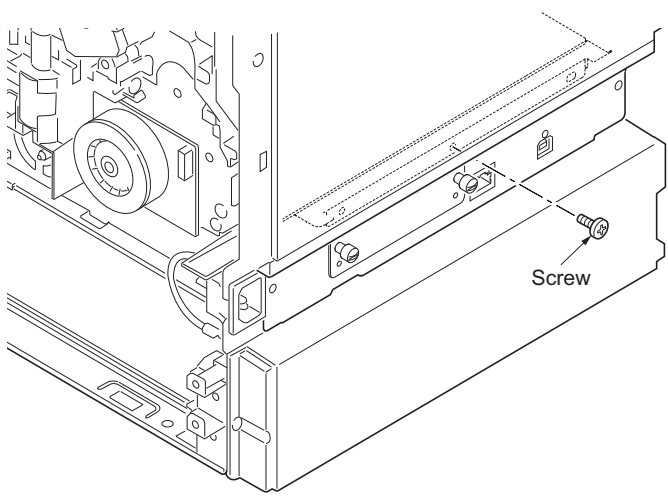

Figure 1-5-51

11. Remove the high voltage PWB assembly.

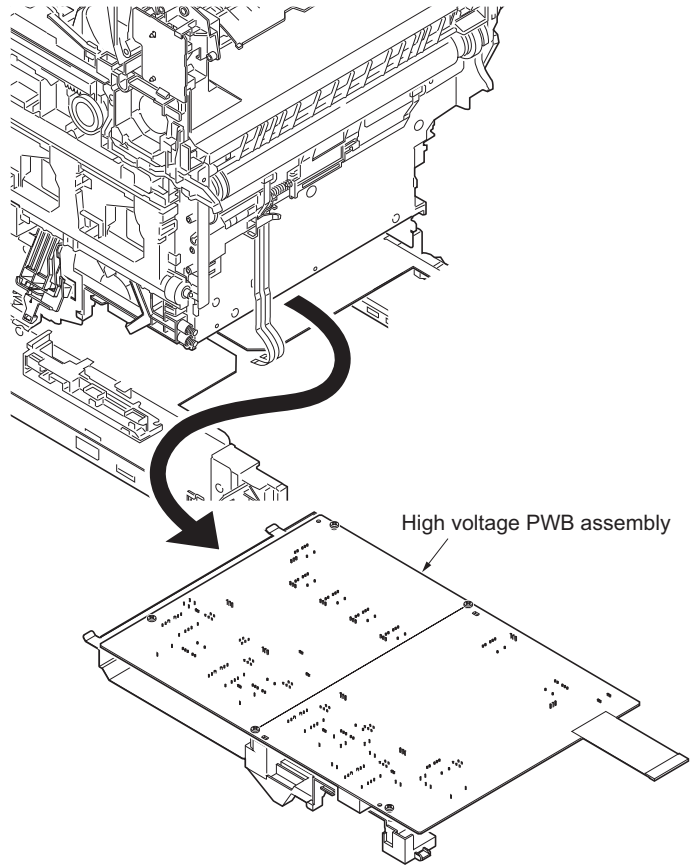

Figure 1-5-52

- 12. Remove five screws and then remove the high voltage PWB.
- 13. Check or replace the high voltage PWB and refit all the removed parts.

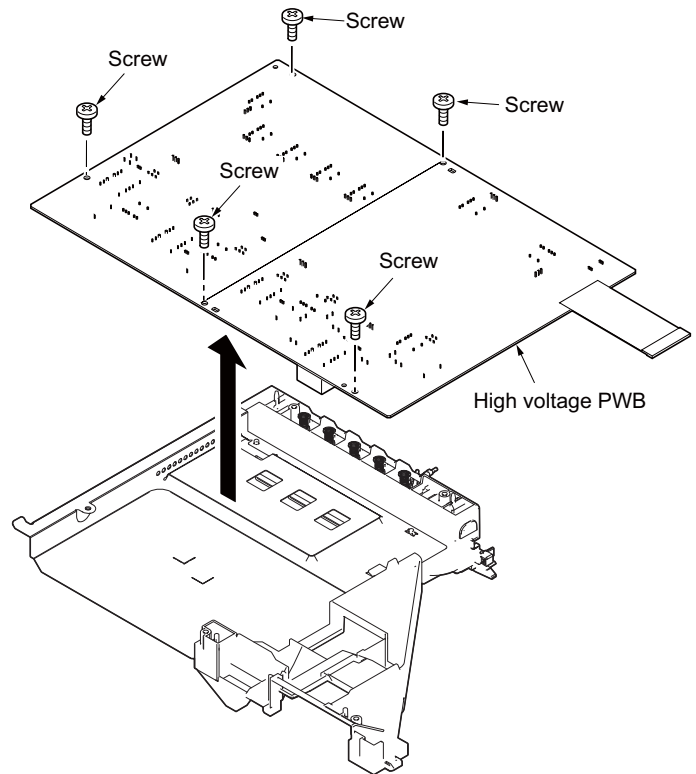

Figure 1-5-53

1-5-9 Others

(1) Detaching and refitting the laser scanner unit

Procedure

1. Remove the all drum units (See page 1-5-14).
2. Remove the all developing units (See page 1-5-12).
3. Remove the two connectors.
4. Remove the wires form the three clamps.

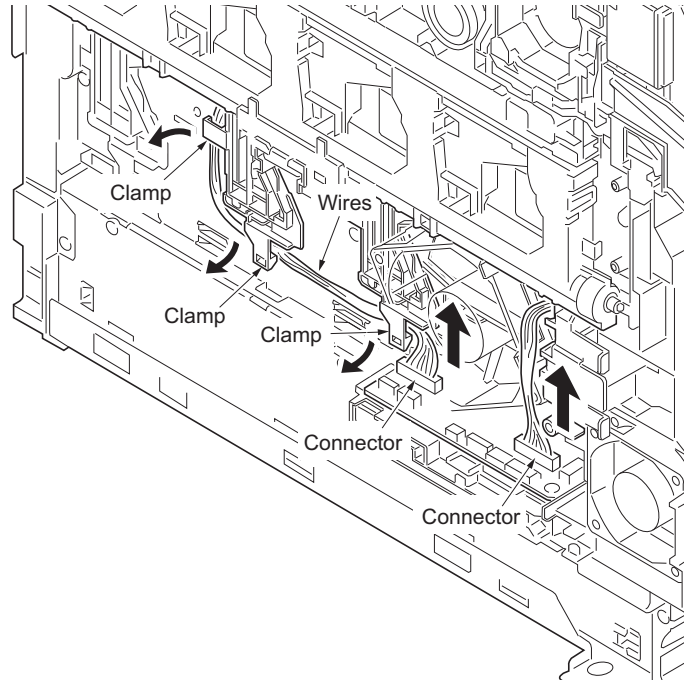

Figure 1-5-54

5. Draw the two connectors into the printer inside.

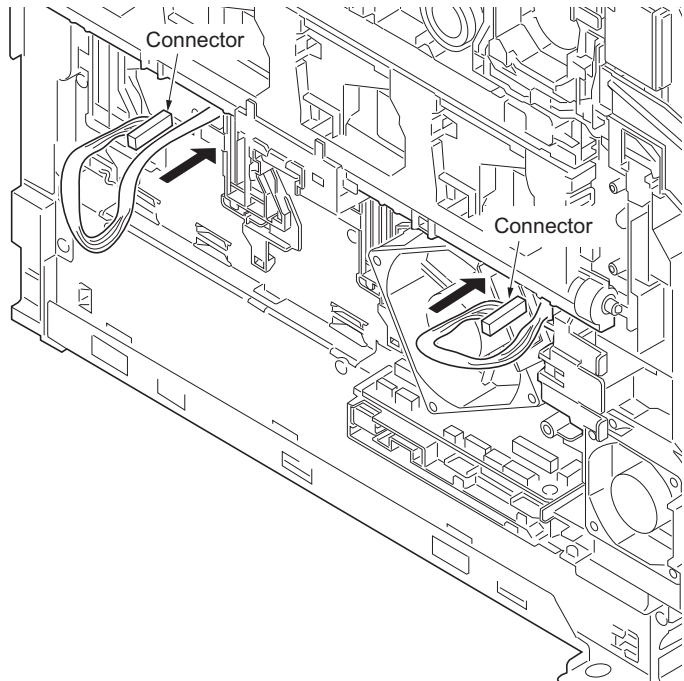

Figure 1-5-55

- 6. Remove the each three screws and then remove the laser scanner units (MC, YK).
- 7. Check or replace the laser scanner units and refit all the removed parts.

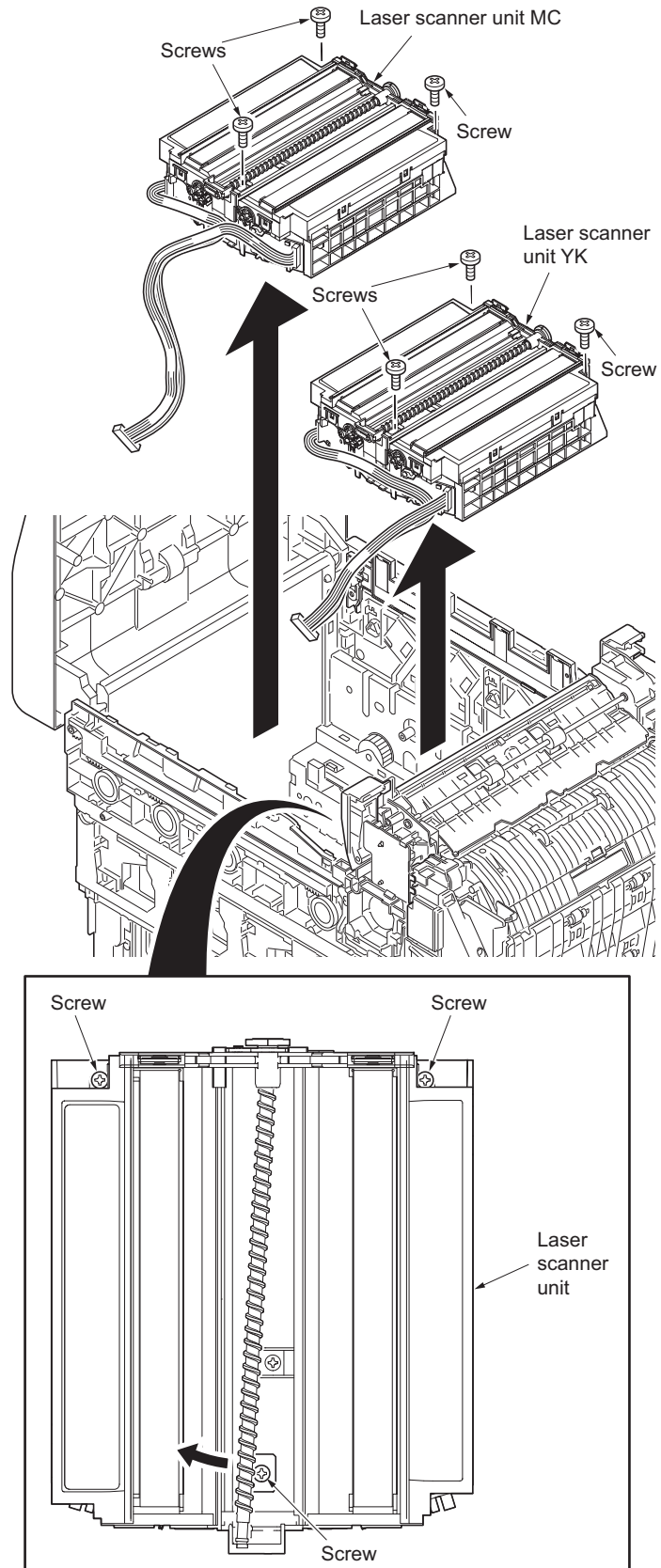
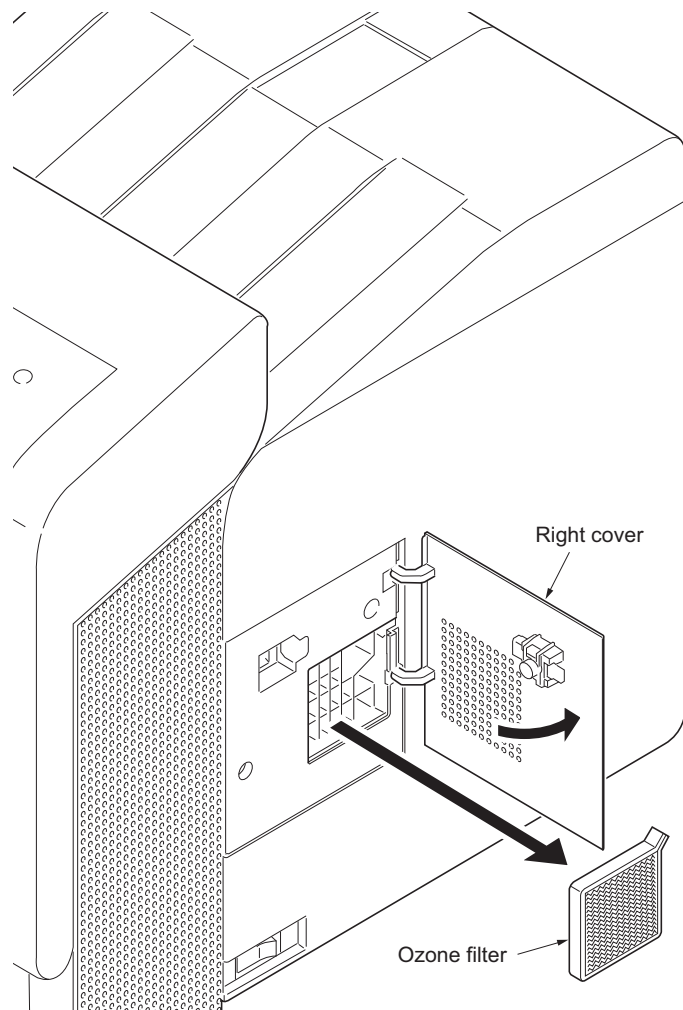

Figure 1-5-56

(2) Detaching and refitting the ozone filter**Procedure**

1. Open the right cover.
2. Remove the ozone filter.
3. Check or replace the ozone filter and refit all the removed parts.

**Figure 1-5-57**

(3) Direction of installing the principal fan motors

When detaching or refitting the developing fan motor 1, developing fan motor 2, fuser fan motor 1 or ozone fan motor, be careful of the airflow direction (intake or exhaust).

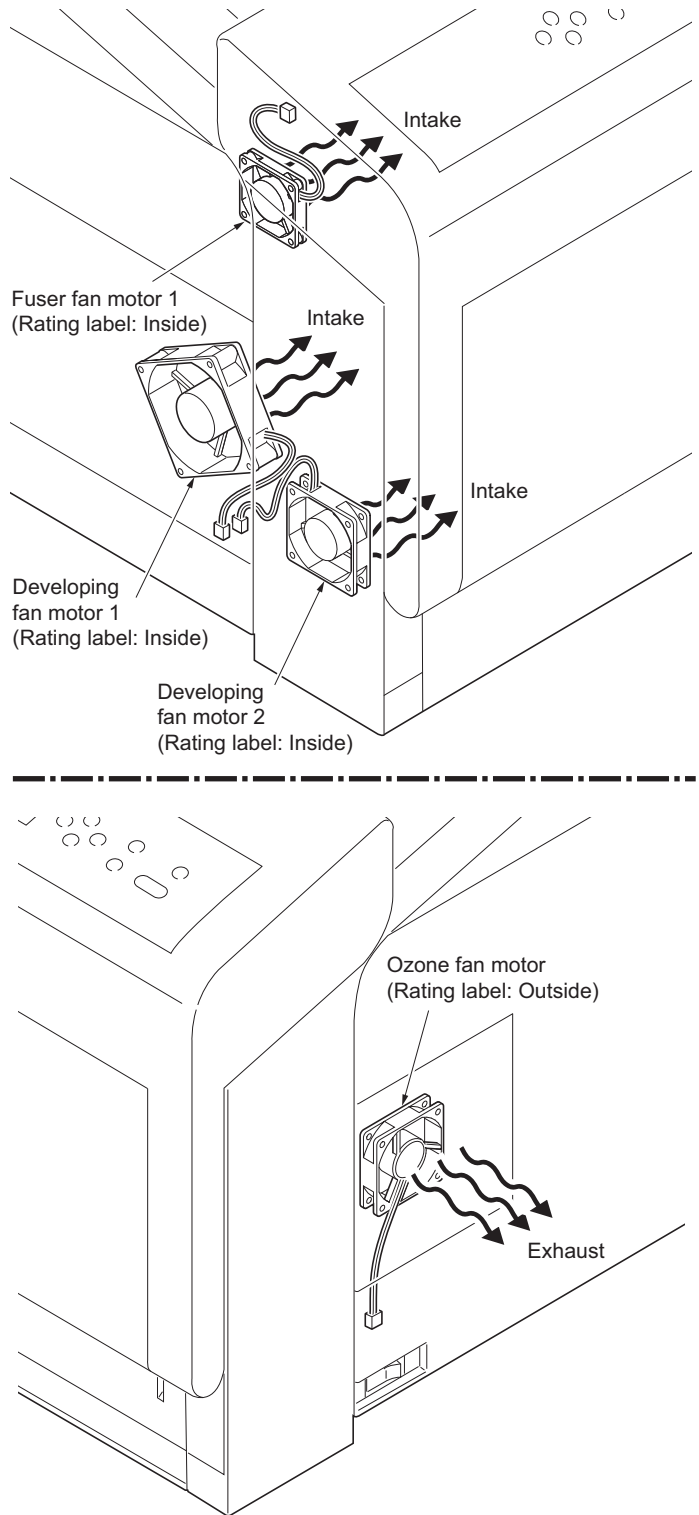

Figure 1-5-58

1-6-1 Upgrading the firmware

(1) Firmware file

Firmware files are named after the following codes:

Firmware file name example

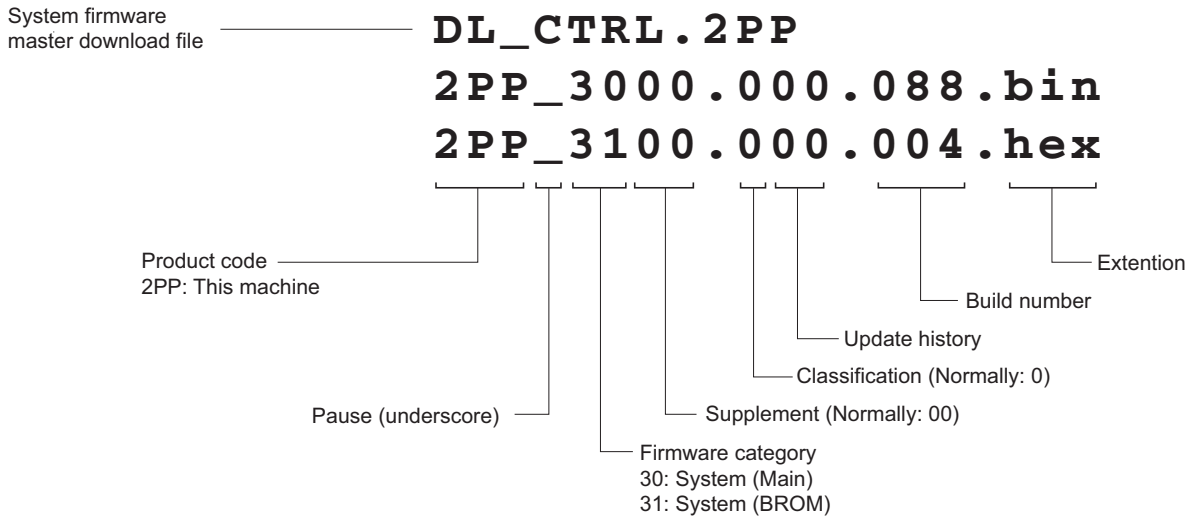
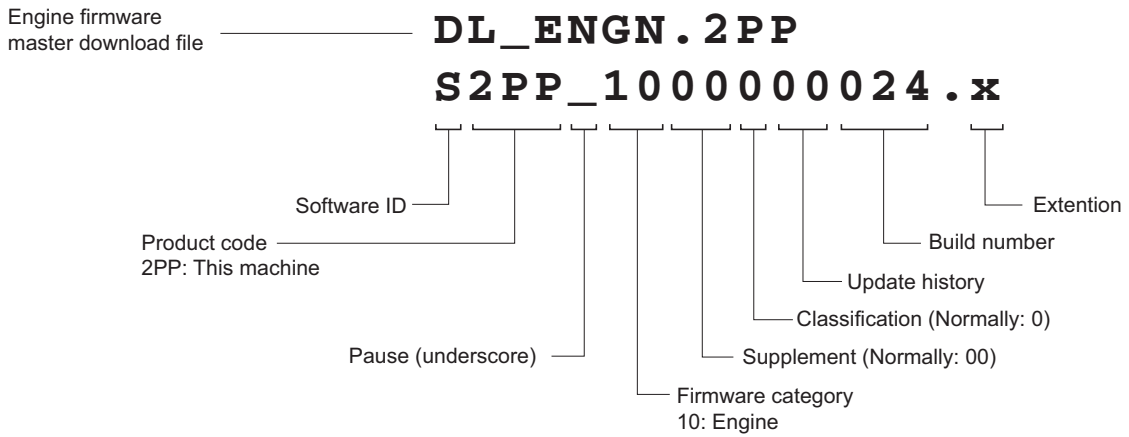

Figure 1-6-1

(2) Upgrading the firmware from the USB memory

Follow the procedure to upgrade the firmware below.

- * Controller data (CTRL)
- * Engine PWB (ENGN)
- * Language data (OPT)
- * 1th color table (PCLT1)
- * 2th color table (PCLT2)

Preparation

Extract the file that has the download firmware and put them in the USB Memory.

NOTE: To improve Firmware Upgrade speed, a separate SKIP file can be added to the USB Memory Stick with the Firmware Upgrade package. The Skip file will allow ONLY the Firmware that has been Upgraded to a New Version to load, skipping duplicate Firmware Levels.

Procedure

1. Turn ON the power switch and confirm if the screen shows "Ready to print" then, turn OFF the power switch.
2. Insert USB memory that has the firmware in the USB host interface slot.
3. Turn ON the power switch.
4. After tens of seconds, "FW-Update" will be displayed (this shows to start the download).
5. Display the software that now upgrading.

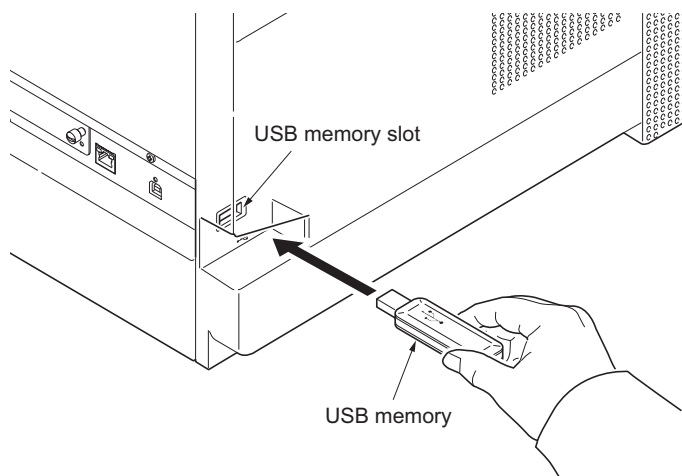

Figure 1-6-3

CTRL ENGN OPT PCLT1 PCLT2

SAMPLE:

```
=====
FW-Update [CTRL]
=====
```

The first line: Display that shows update object
 The second line: The progress bar that shows update advance degree

Caution:

Never turn off the power switch or remove the USB flash device during upgrading.

6. Display the completion of the upgrade.

(The 1st page)

```
=====
FW-Update 1/5
Completed
=====
```

(2 page or subsequent ones)

```
=====
[ENGN] 2/5
2PP_2000.001.005
=====
```

7. ROM version is confirmed by the content of the display.
8. Unplug the power cable and remove the USB memory.

Safe-UPDATE

If the device is accidentally switched off or the USB memory is disconnected and upgrading was incomplete, upgrading is retried when turning the main power switch on next time. Insert USB memory and turn the main power switch on to perform steps 3 to 8 as the above.

Emergency-UPDATE

If Safe-UPDATE is not successful in upgrading, the message below appears.

In that case, retry upgrading after recovering the software by following the procedure below.

FW-Update
Error FFFF

Preparation

The USB memory must be formatted in FAT or FAT32 in advance.

Extract the main firmware to download from the file.

Rename the file which was extracted from the archive.

[DL_CTRL.2PP] to [KM_EMRG.2PP]

Copy the all extracted files to the root of the USB memory.

Procedure

1. Turn the main power switch off.
2. Insert the USB memory which contains the firmware into the USB memory slot.
3. Turn the main power switch on.
4. Rewriting of the PWB software will start for restoration.
"Emergency Update" is displayed on the LCD of the operation panel.
5. "Completed" will be displayed when rewriting is successful.
* : "Failed" will be displayed when rewriting is failed.
6. Turn the main power switch off.
7. Wait for several seconds and then remove the USB memory from the USB memory slot.
8. Extract the firmware to download from the archive and copy to the root of the formatted USB memory.

NOTE: Deletes the "ES_SKIP.on" file
When it is contained directly under the USB memory.

9. Insert the USB memory in which the firmware was copied in the USB memory slot.
10. Perform steps 3 to 8 on the previous page.
11. Turn the main power switch on.
12. Perform maintenance item U000 (Print a maintenance report) to check that the version of ROM U019 has been upgraded.

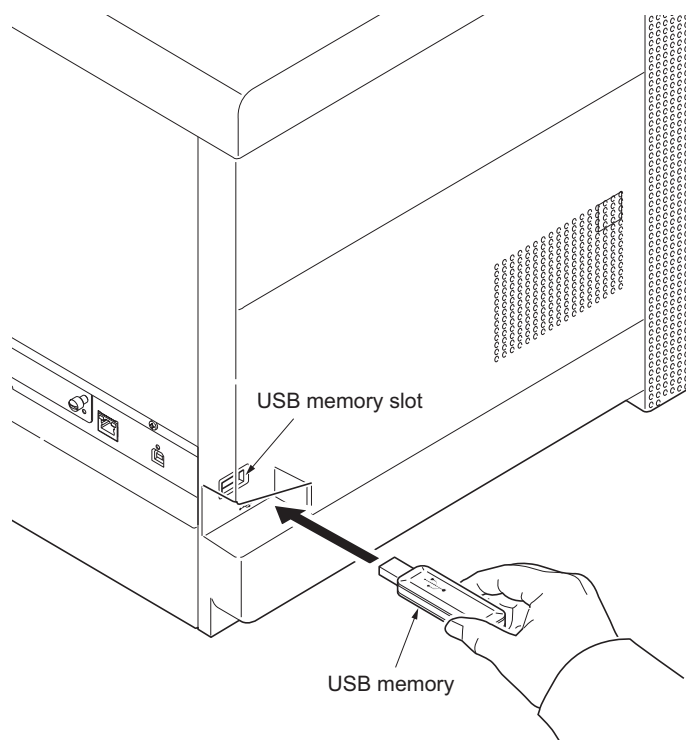

Figure 1-6-4

This page is intentionally left blank.

2-1-1 Paper feed/conveying section

Paper feed/conveying section consists of the paper feed unit that feeds paper from the cassette and the MP tray paper feed unit that feeds paper from the MP tray, and the paper conveying section that conveys the fed paper to the transfer/separation section.

(1) Cassette paper feed section

The cassette can contain 500 sheets. The sheet from the cassette is pulled out by rotation of the pickup roller and sent to the paper conveying section by rotation of the paper feed roller. Also the retard roller prevents multiple feeding of paper.

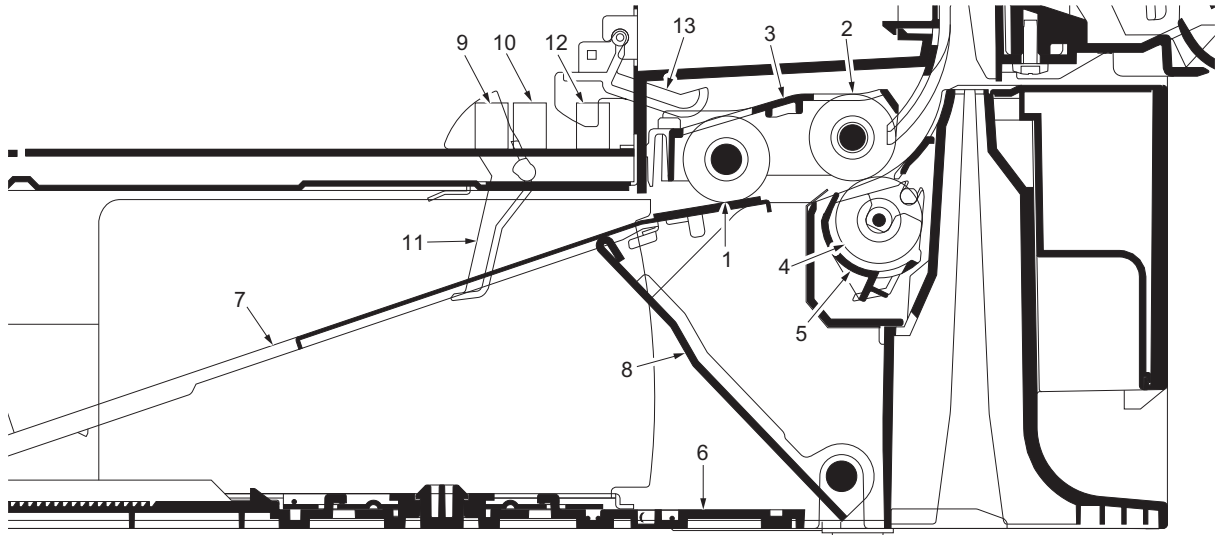

Figure 2-1-1 Cassette paper feed section

- | | |
|-----------------------|-----------------------------------|
| (1) Pickup roller | (8) Lift work plate |
| (2) Paper feed roller | (9) Paper sensor 1 |
| (3) Paper feed holder | (10) Paper sensor 2 |
| (4) Retard roller | (11) Actuator (paper sensor 1, 2) |
| (5) Retard holder | (12) Lift limit sensor |
| (6) Cassette base | (13) Actuator (lift limit sensor) |
| (7) Bottom plate | |

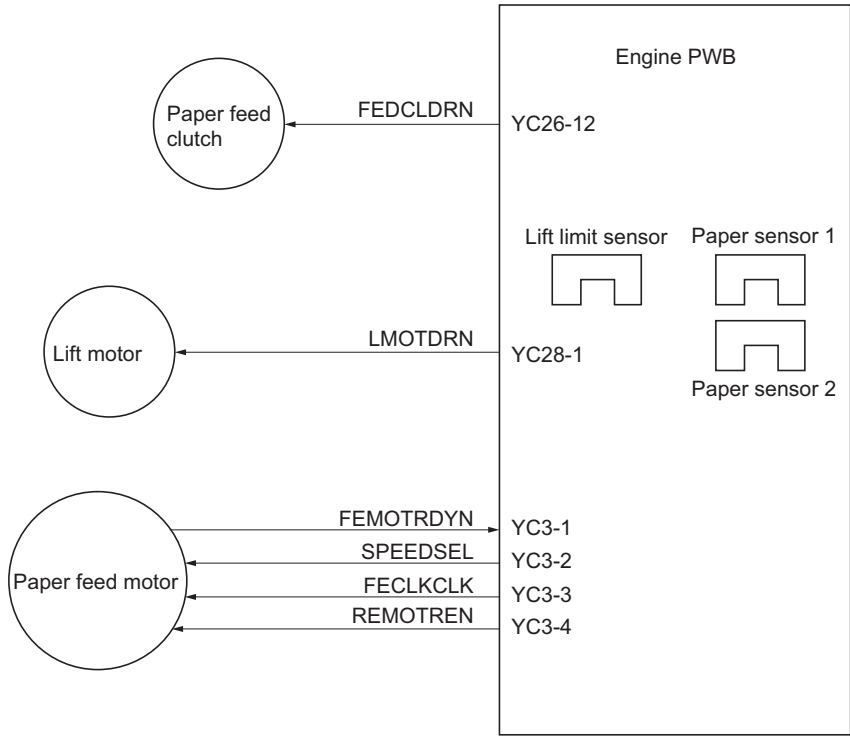

Figure 2-1-2Cassette paper feed section block diagram

(2) MP tray paper feed section

The MP tray can contain about 150 sheets. Feeding from the MP tray is performed by the rotation of the MP paper feed roller. Also, function of the MPF separation pad prevents paper from multiple feeding.

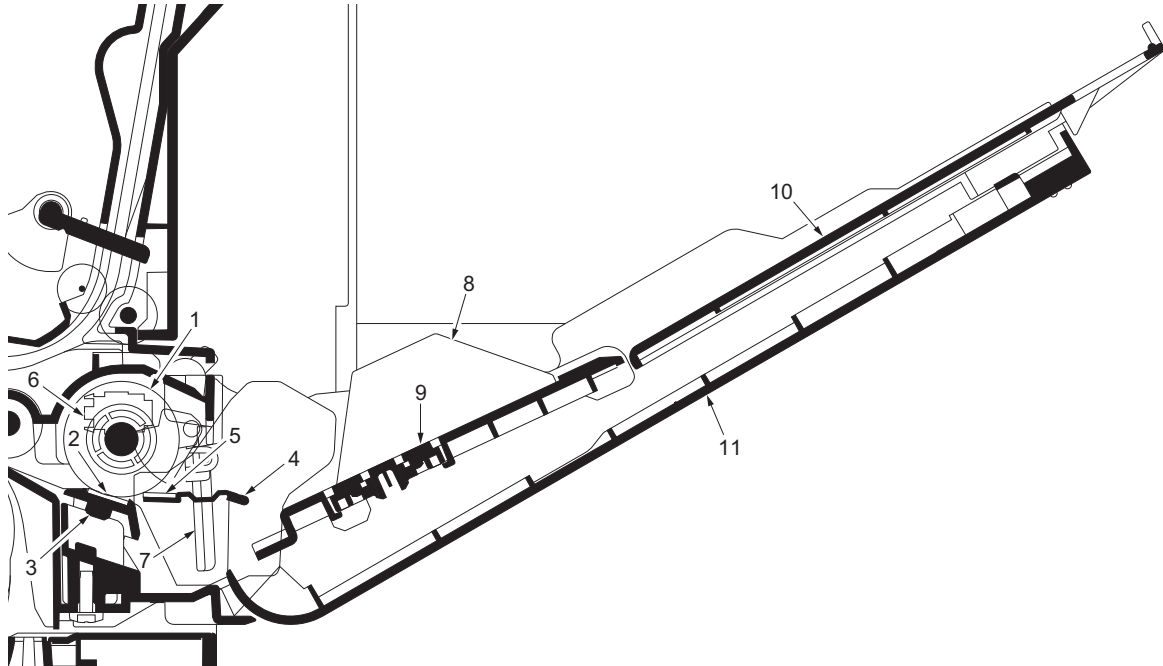

Figure 2-1-3 MP tray paper feed section

- | | | |
|--------------------------|-------------------------------|---------------------|
| (1) MP paper feed roller | (5) MPF friction pad | (9) MPF base |
| (2) MPF separation pad | (6) MP tray sensor | (10) MPF upper tray |
| (3) MPF separator | (7) Actuator (MP tray sensor) | (11) MPF cover |
| (4) MPF bottom plate | (8) MPF guide R/L | |

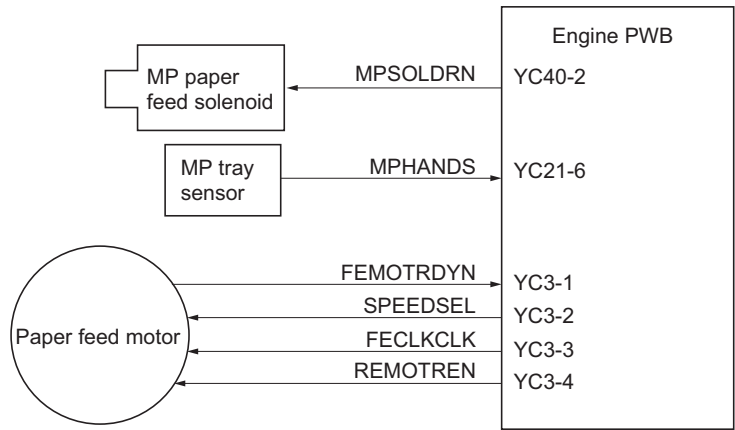

Figure 2-1-4 MP tray paper feed section block diagram

(3) Paper conveying section

The paper conveying section conveys paper to the transfer/separation section as paper feeding from the cassette or MP tray, or as paper refeeding for duplex printing. Paper by feeding is conveyed by the middle roller to the position where the registration sensor is turned on, and then sent to the transfer/separation section by the front registration roller and rear registration roller.

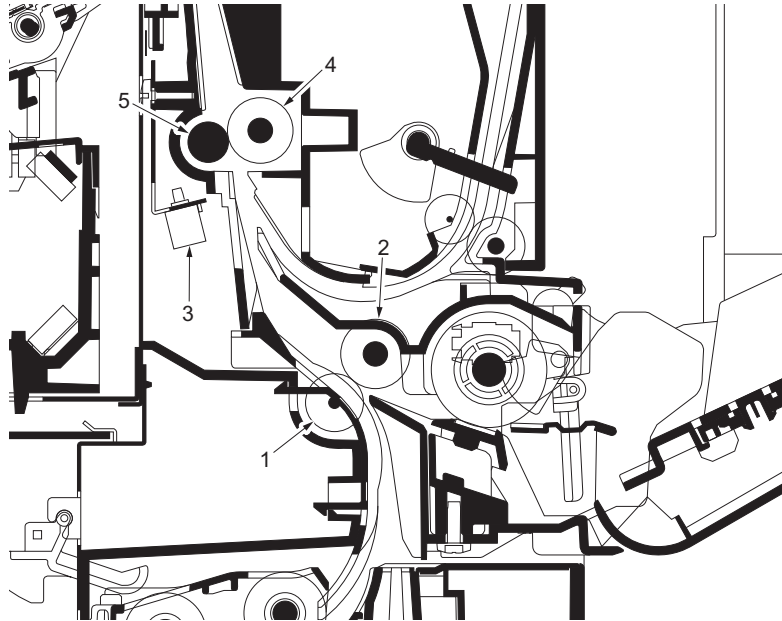

Figure 2-1-5 Paper conveying section

- (1) Feed pulley
- (2) Middle roller
- (3) Registration sensor
- (4) Front registration roller
- (5) Rear registration roller

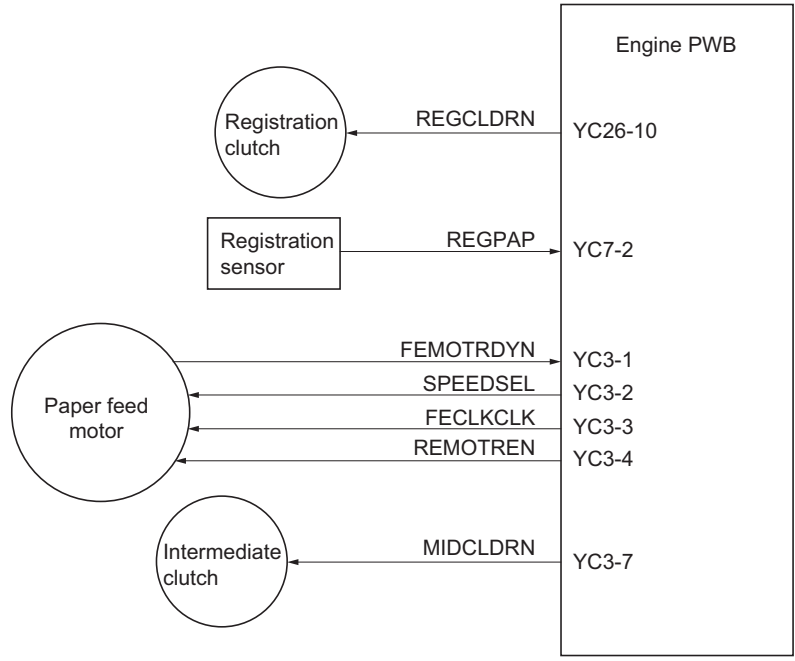

Figure 2-1-6 Paper conveying section block diagram

2-1-2 Drum section

(1) Drum section

The drum section consists of the drum, the main charger unit, and the cleaning unit, and the drum surface is uniformly charged in preparation for formation of residual image by laser beam. After transfer is complete, toner remaining on the drum surface is chipped off with the cleaning blade and is collected to the waste toner box with the drum screw. Also electric charge remaining on the drum surface is eliminated by irradiating the eraser lamp for preparing for next charge of the main charger.

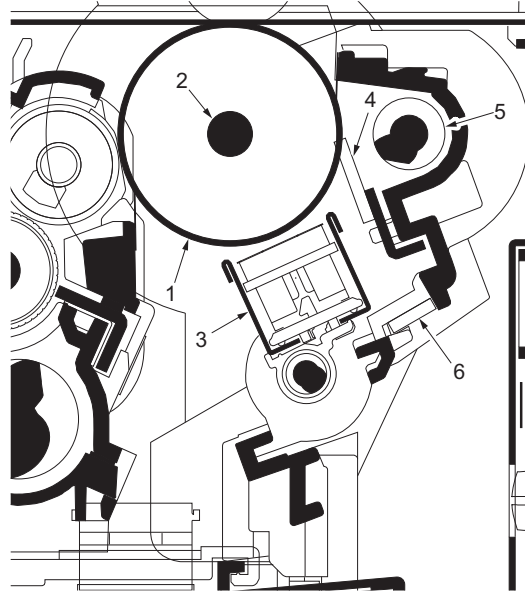

Figure 2-1-7 Drum section

- (1) Drum
- (2) Drum shaft
- (3) Main charger unit
- (4) Cleaning blade
- (5) Drum screw
- (6) Eraser lamp

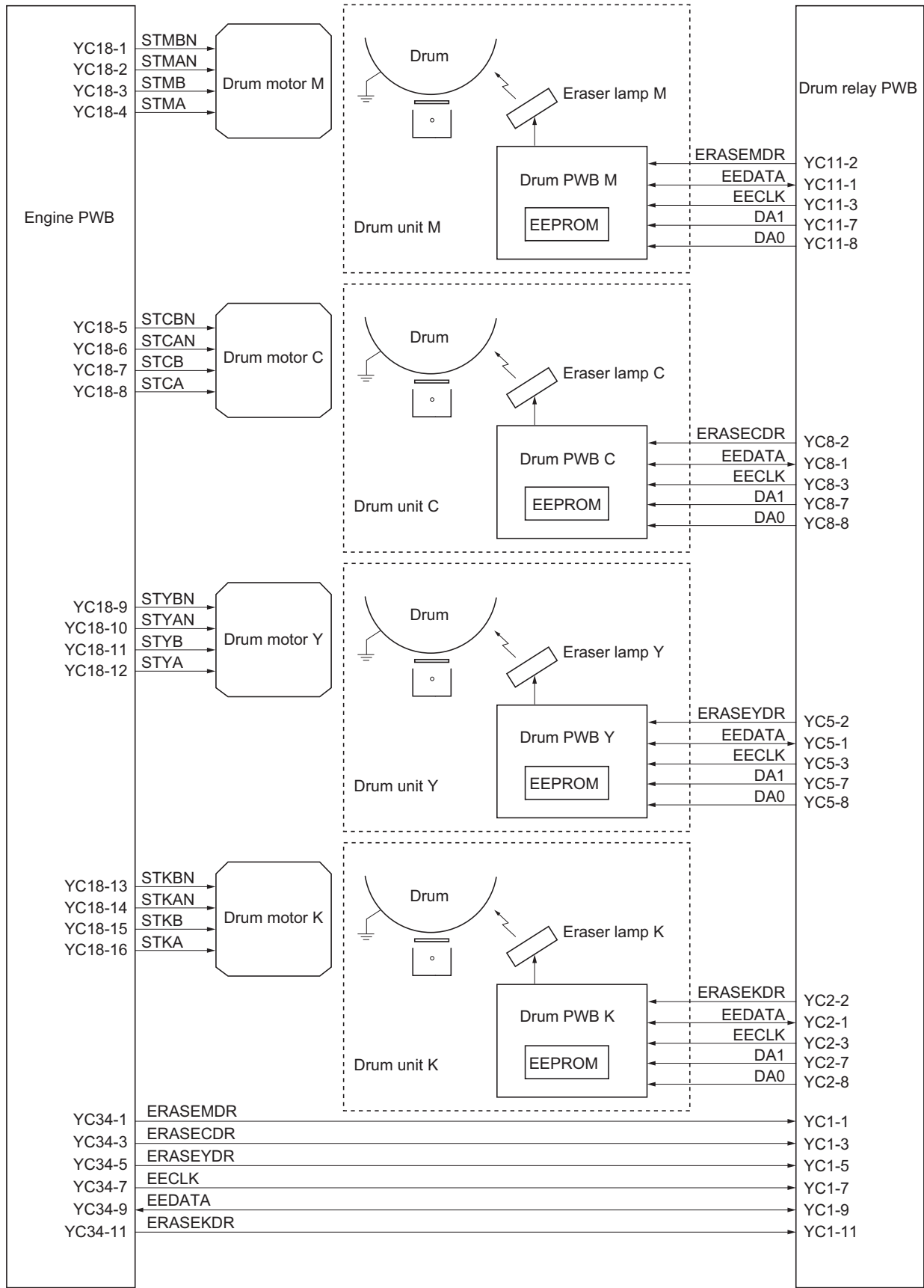

Figure 2-1-8 Drum section block diagram

(2) Main charger unit

The main charger unit consists of the main charger wire, the main charger grid, and the main charger shield, and charges the drum for image forming. Also the main charger unit is equipped with a main charger cleaning motor to conduct cleaning automatically.

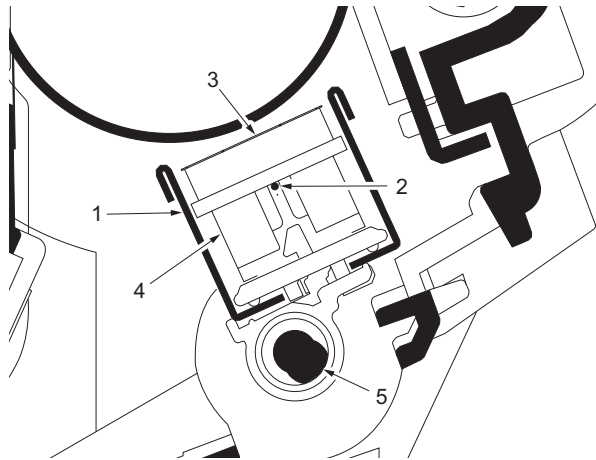

Figure 2-1-9 Main charger unit

- (1) Main charger shield
- (2) Main charger wire
- (3) Main charger grid
- (4) Main charger cleaner unit
- (5) Main charger spiral

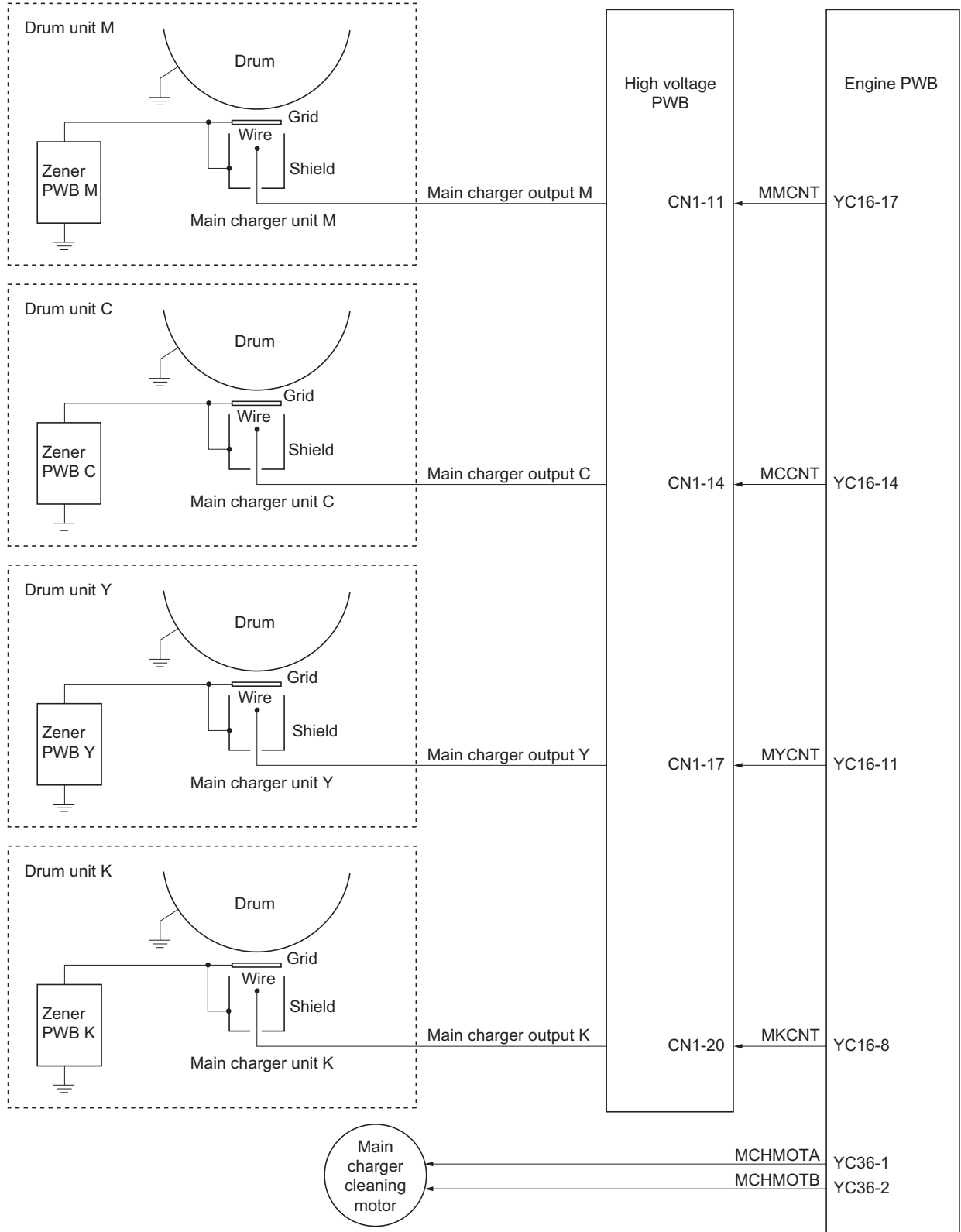

Figure 2-1-10 Main charger unit block diagram

2-1-3 Expose section

(1) Laser scanner unit

The charged surface of the drum is then scanned by the laser beam from the laser scanner unit. The laser beam is dispersed as the polygon motor revolves to reflect the laser beam over the drum. Various lenses and mirror are housed in the laser scanner unit, adjust the diameter of the laser beam, and focalize it at the drum surface. Also the LSU cleaning motor is activated to conduct automatically cleaning of the LSU dust shield glass.

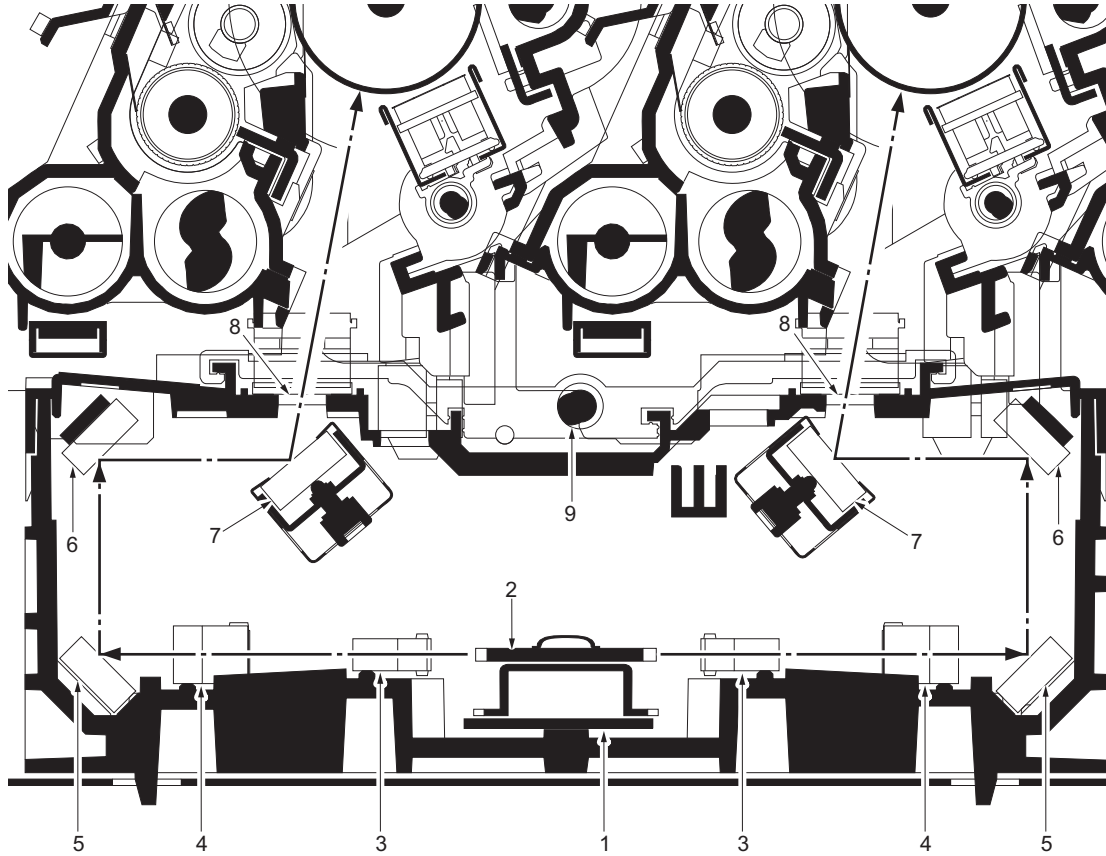

Figure 2-1-11 Laser scanner unit

- | | |
|------------------------|---------------------------|
| (1) Polygon motor | (6) Mirror B |
| (2) Polygon mirror | (7) Mirror C |
| (3) F- θ lens A | (8) LSU dust shield glass |
| (4) F- θ lens B | (9) LSU spiral |
| (5) Mirror A | |

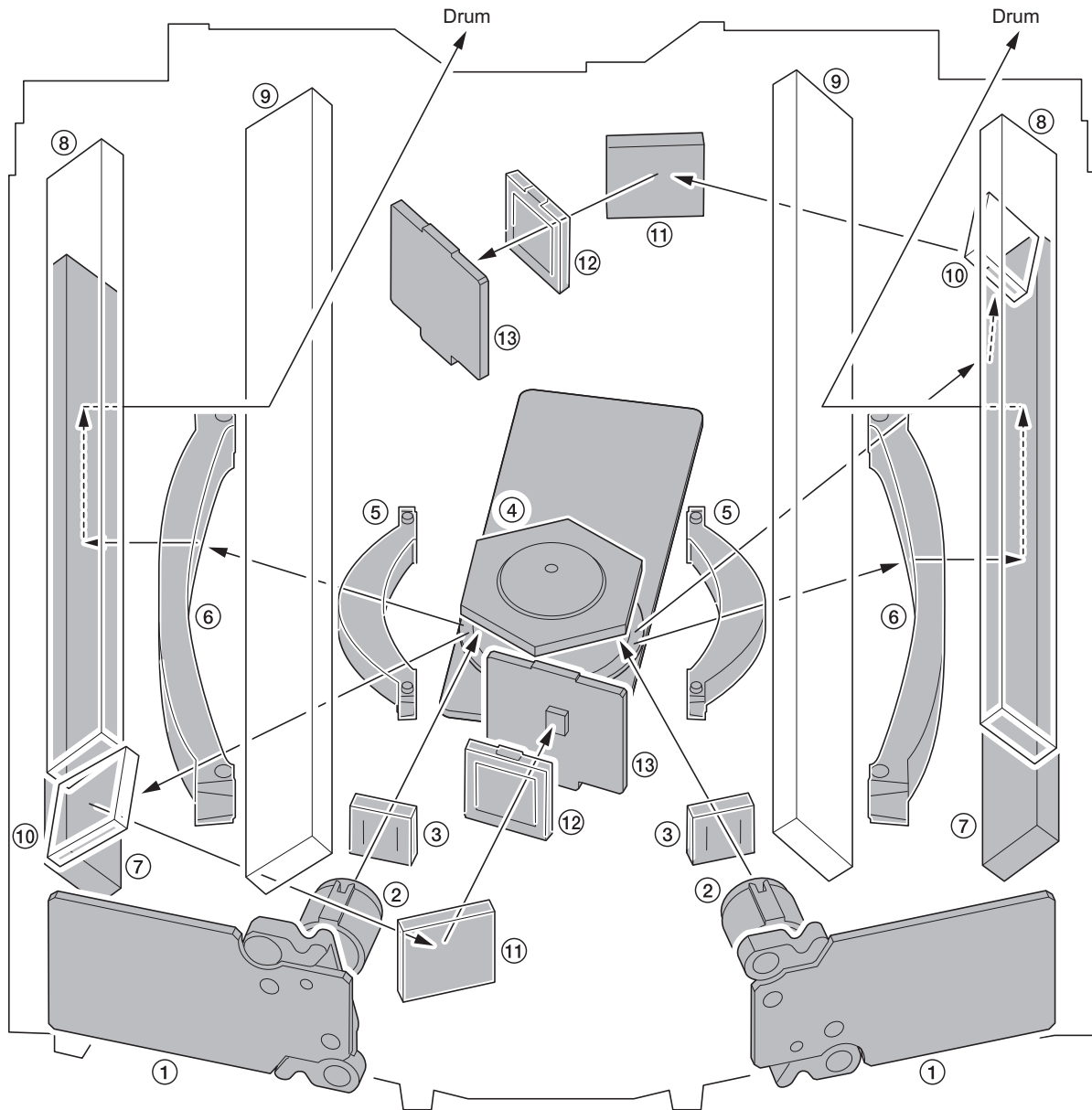

Figure 2-1-12 Laser scanner unit

- | | |
|----------------------------|--------------------------------------|
| (1) APC PWB (Laser diode) | (8) Mirror B |
| (2) Collimator lens | (9) Mirror C |
| (3) Cylindrical lens | (10) PD mirror |
| (4) Polygon motor (mirror) | (11) PD mirror |
| (5) F-θ lens A | (12) SOS lens |
| (6) F-θ lens B | (13) PD PWB (Pin photo diode sensor) |
| (7) Mirror A | |

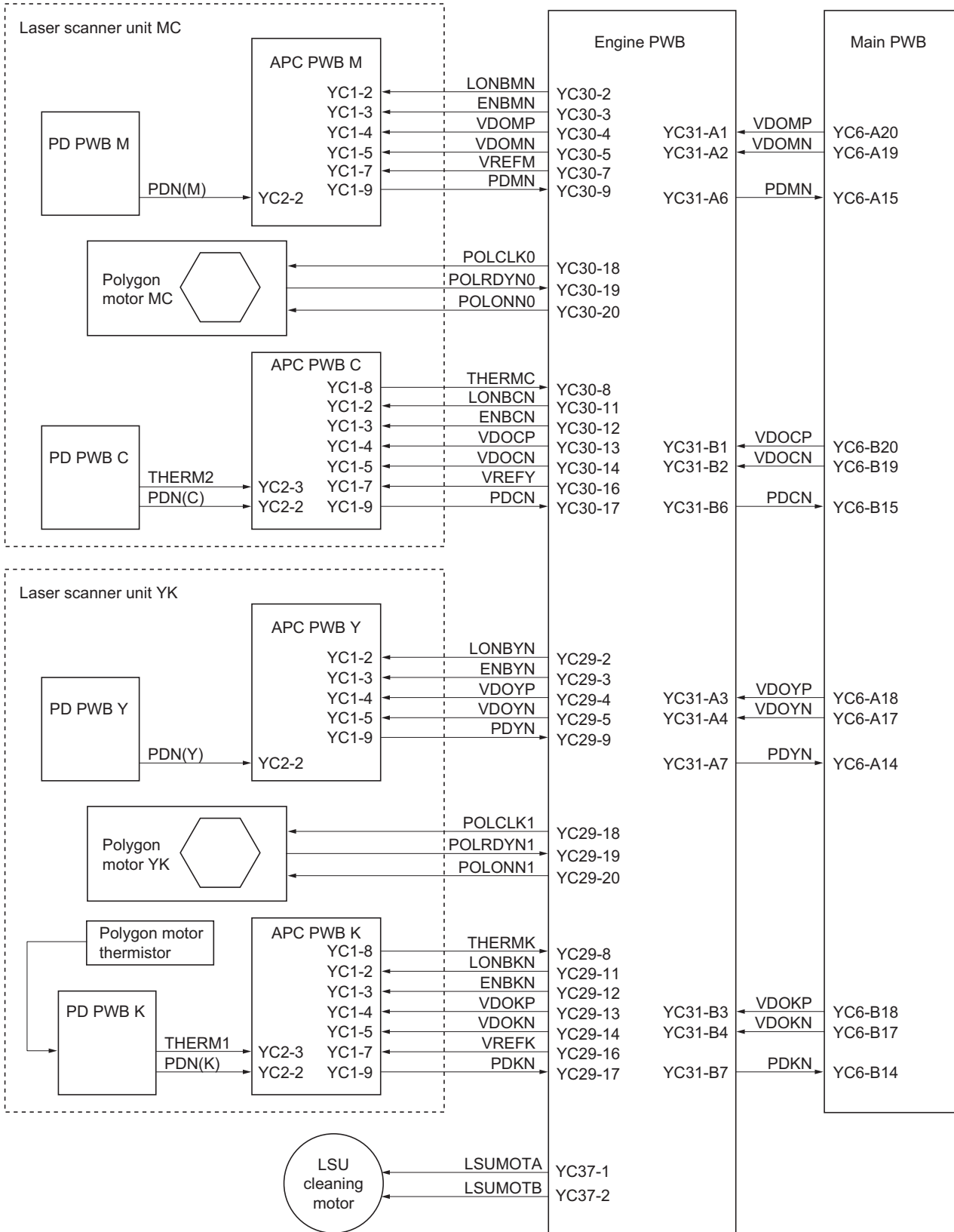

Figure 2-1-13Expose section block diagram

2-1-4 Developing section

The developing unit consists of the sleeve roller that forms the magnetic brush, the magnet roller, the developing blade and the developing screws that agitate the toner. Also, the toner sensor checks whether or not toner remains in the developing unit.

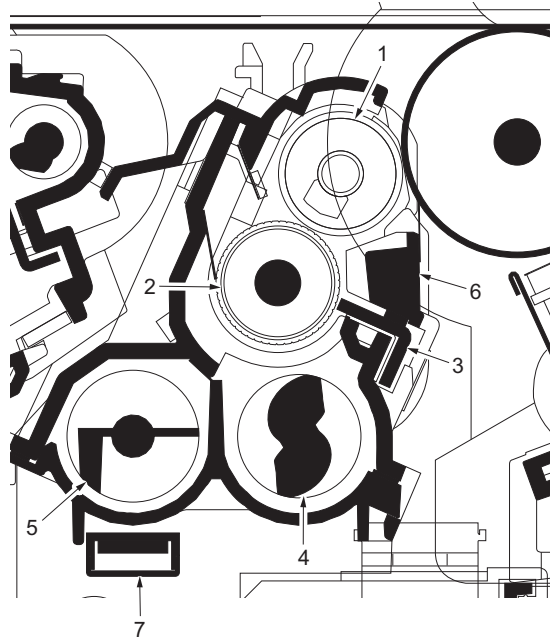

Figure 2-1-14 Developing unit and toner container

- | | |
|------------------------|------------------------|
| (1) Sleeve roller | (5) Developing screw B |
| (2) Magnet roller | (6) Sleeve cover |
| (3) Developing blade | (7) Toner sensor |
| (4) Developing screw A | |

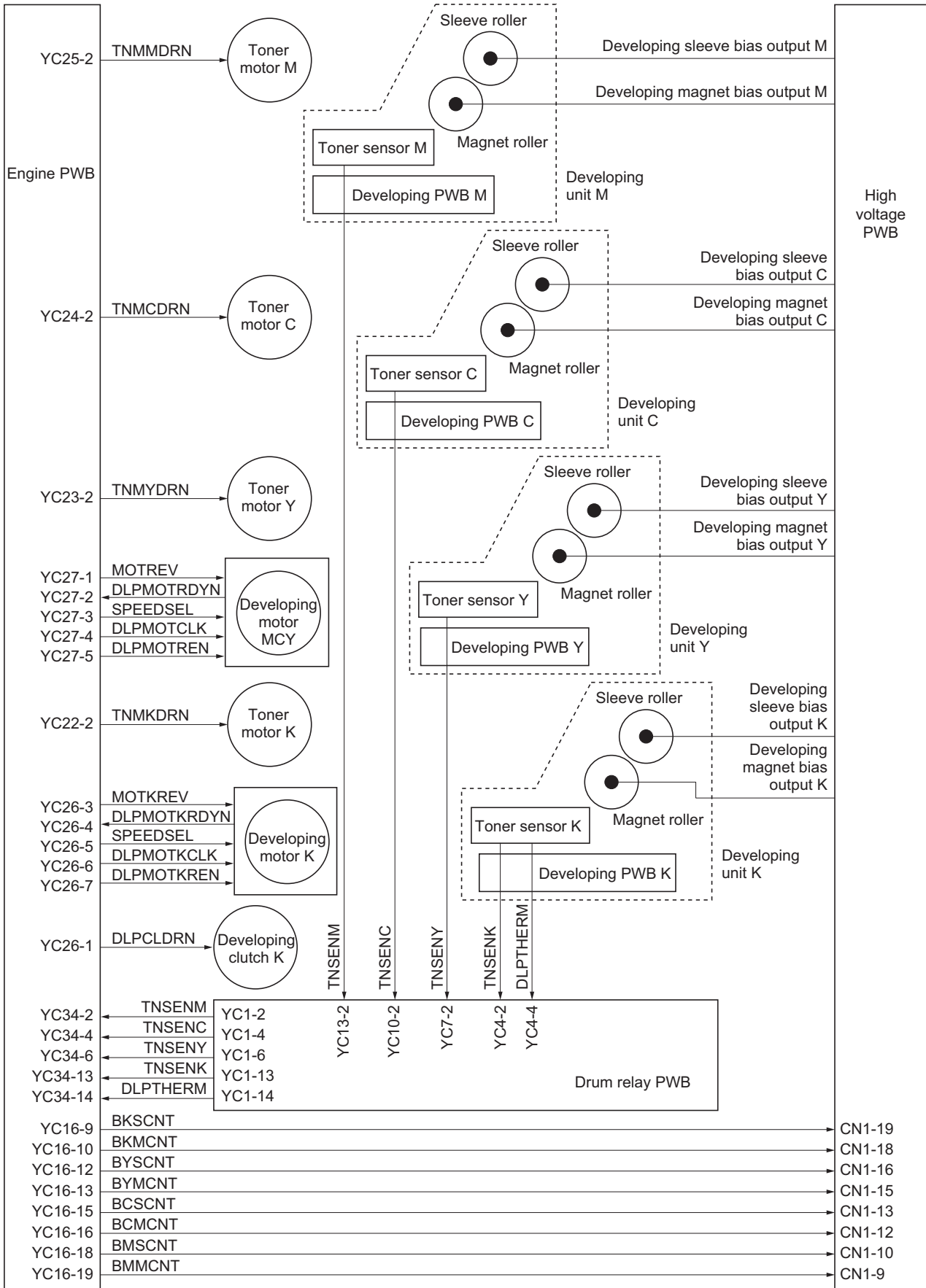

Figure 2-1-15 Developing section block diagram

2-1-5 Transfer/separation section

The transfer/separation section consists of the intermediate transfer unit and the transfer roller unit. The intermediate transfer unit consists of the transfer cleaning unit, the transfer belt, and the four primary transfer rollers for respective color drums, and forms a full-color toner image by superimposing and transferring single-color toner images formed on each drum onto the transfer belt. Also with the left and right ID sensors mounted on the machine frame, the toner density on the transfer belt is measured. The transfer cleaning unit collects toner remaining on the transfer belt after secondary transfer and forwards it as waste toner to the waste toner box. The transfer roller unit consists of the secondary transfer roller mounted to the paper conveying unit and the separation brush. To the secondary transfer roller, DC bias is applied from the high voltage PWB. The toner image formed on the transfer belt is transferred to the paper by the potential difference and the paper is separated by curvature separation.

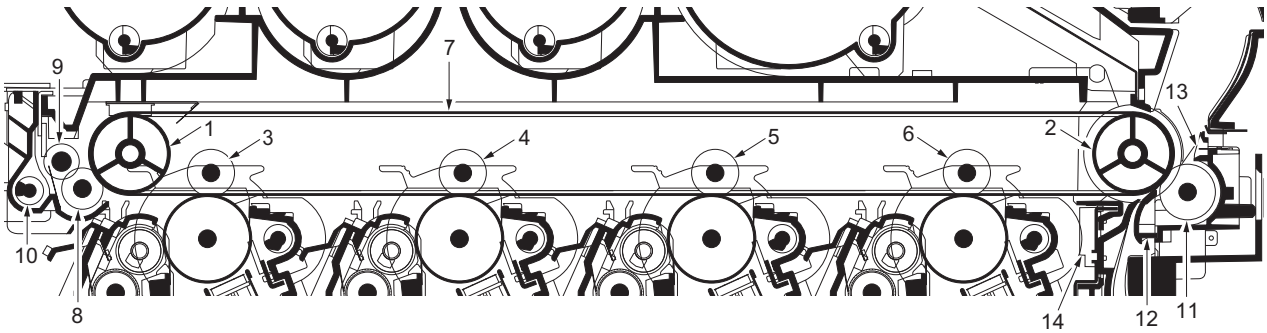

Figure 2-1-16 Transfer/separation section

- | | |
|-------------------------------|-------------------------------------|
| (1) Tension roller | (8) Cleaning fur brush |
| (2) Drive roller | (9) Cleaning roller |
| (3) Primary transfer roller M | (10) Cleaning screw |
| (4) Primary transfer roller C | (11) Secondary transfer roller |
| (5) Primary transfer roller Y | (12) Paper chute |
| (6) Primary transfer roller K | (13) Separation needle |
| (7) Transfer belt | (14) Left ID sensor/Right ID sensor |

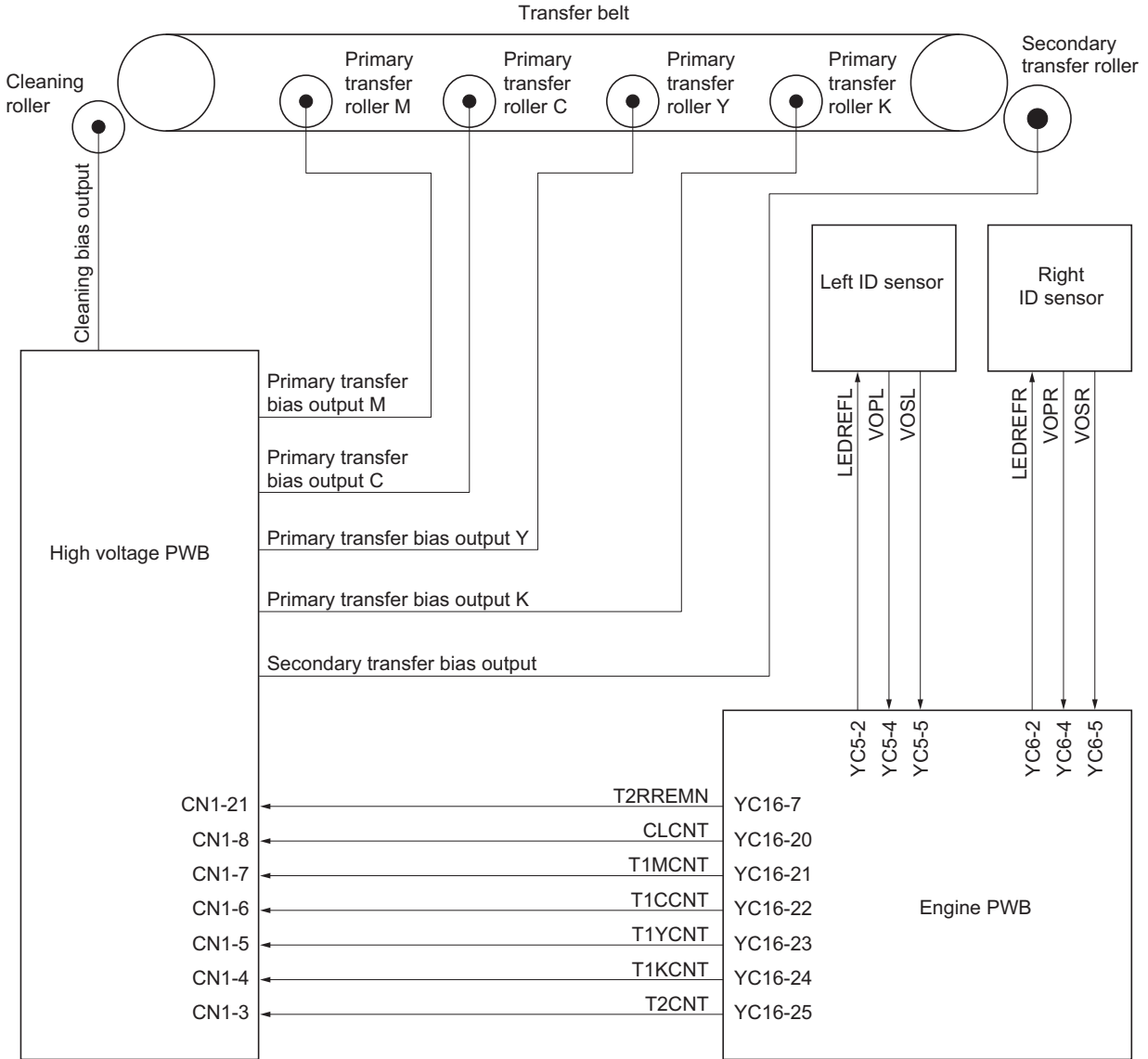

Figure 2-1-17 Transfer/separation section block diagram

2-1-6 Fuser section

The paper sent from the transfer/separation section is interleaved between the heat roller and the press roller. The heat roller is heated by the fuser heater lamp, and the toner is fused by heat and pressure and fixed onto the paper because the press roller is pressed by the fuser press spring. The surface temperature of heat roller is detected by the fuser thermistor and controlled by the engine PWB. If the fuser section shows extremely high temperature, the power line will be shut off and the fuser heater lamp is forced to turn off.

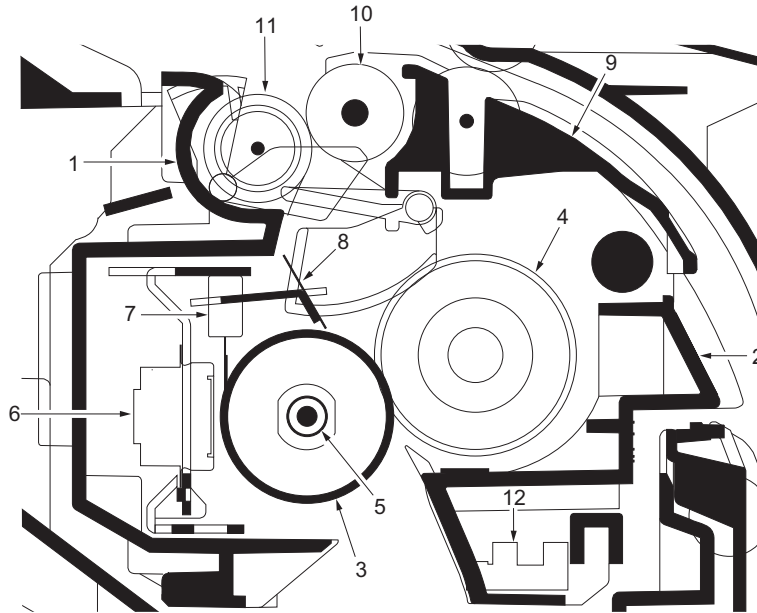

Figure 2-1-18 Fuser section

- | | |
|--------------------------|------------------------|
| (1) Upper fuser frame | (7) Fuser thermistor |
| (2) Lower fuser frame | (8) Separators |
| (3) Heat roller | (9) Paper exit guide |
| (4) Press roller | (10) Paper exit roller |
| (5) Fuser heater lamp | (11) Paper exit pulley |
| (6) Fuser thermal cutout | (12) Envelope switch |

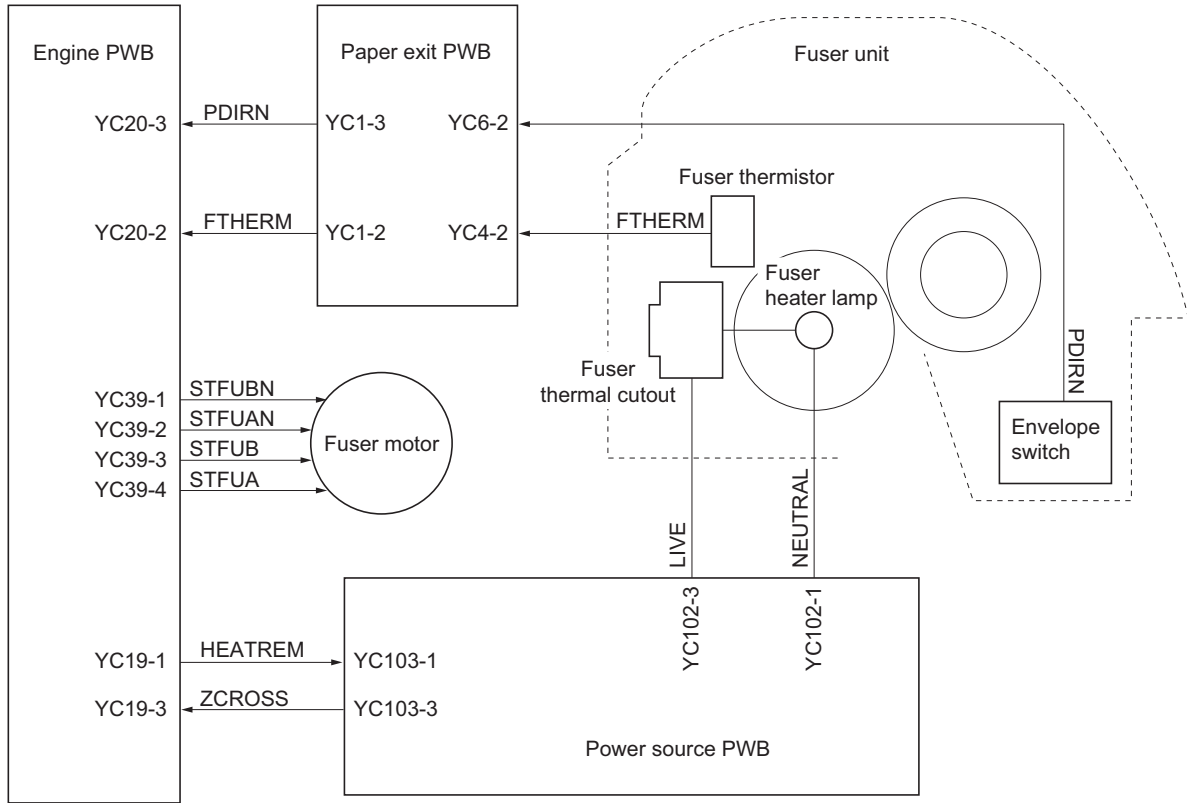

Figure 2-1-19 Fuser section block diagram

2-1-7 Paper exit/feed shift section

The paper exit/feedshift section consists of the conveying path which sends the paper that has passed the fuser section to the top tray or the duplex section. The conveying path is switched by the change guide activated by the duplex solenoid.

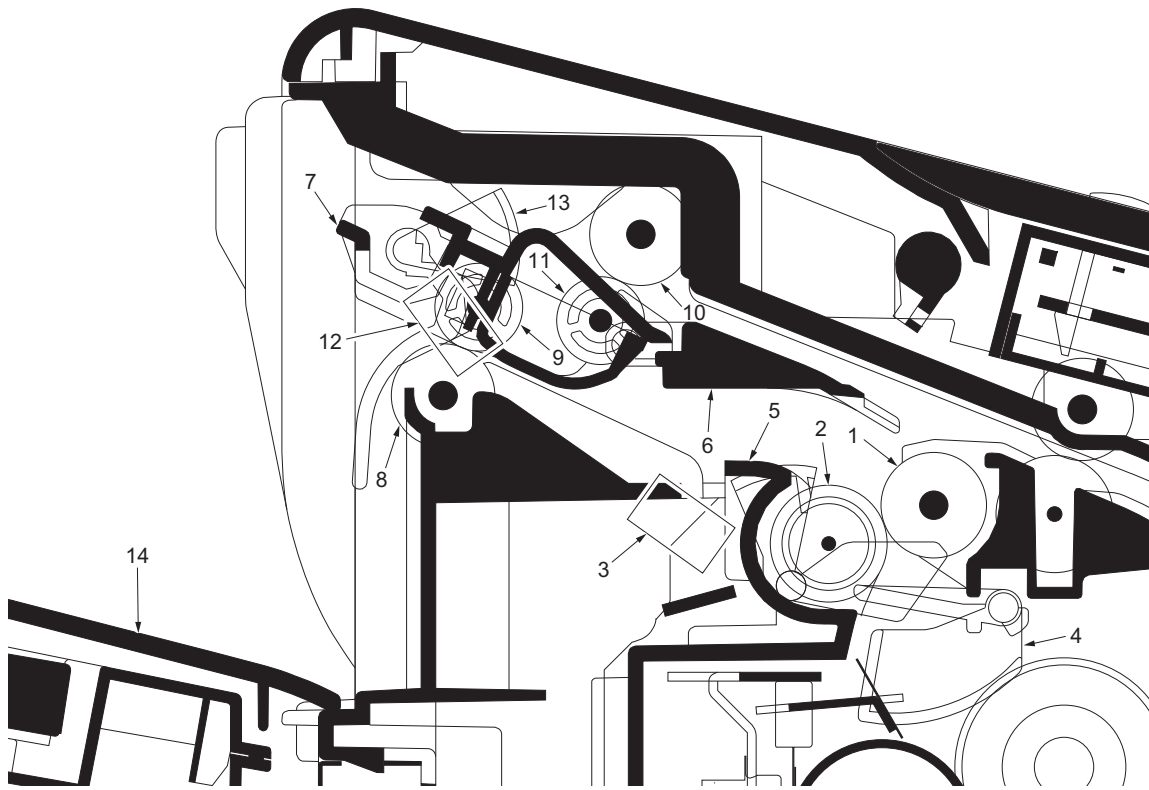

Figure 2-1-20 Paper exit/feed shift section

- | | |
|----------------------------------|-----------------------------------|
| (1) Paper exit roller | (8) FD roller |
| (2) Paper exit pulley | (9) Middle pulley |
| (3) Paper exit sensor | (10) Switchback roller |
| (4) Actuator (paper exit sensor) | (11) Middle pulley |
| (5) Actuator (paper exit sensor) | (12) Paper full sensor |
| (6) Change guide | (13) Actuator (paper full sensor) |
| (7) Paper exit upper guide | (14) Top tray |

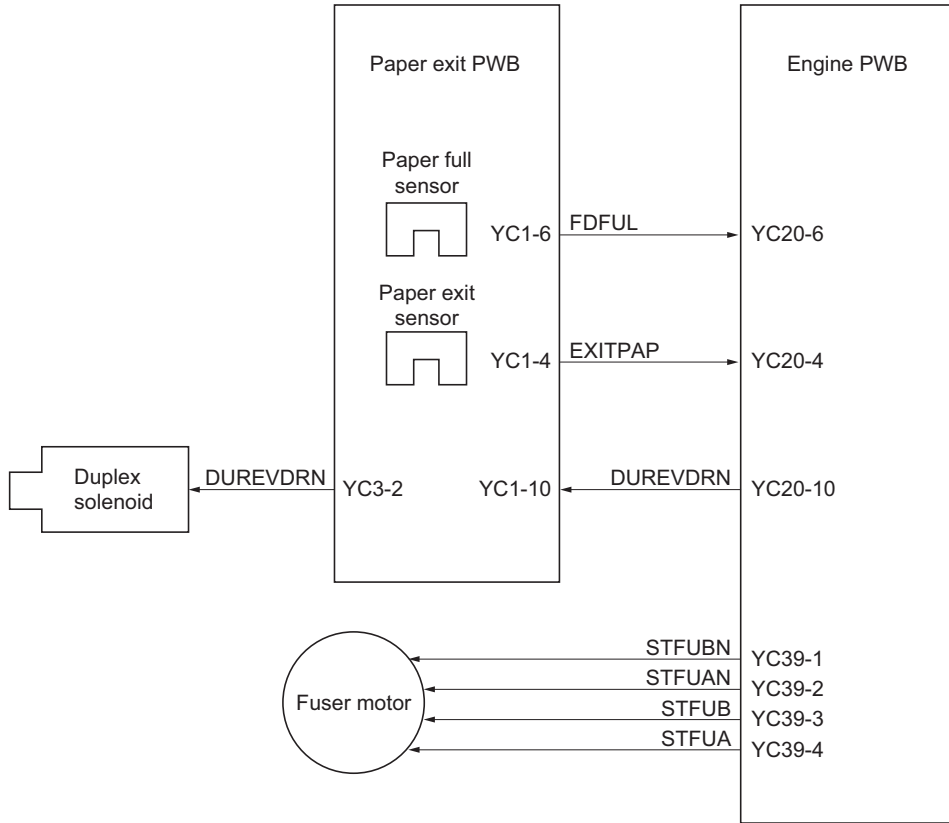

Figure 2-1-21 Paper exit section block diagram

2-1-8 Duplex/conveying section

The duplex/conveying section consists of conveying path which sends the paper sent from the eject section to the paper feed/conveying section when duplex printing.

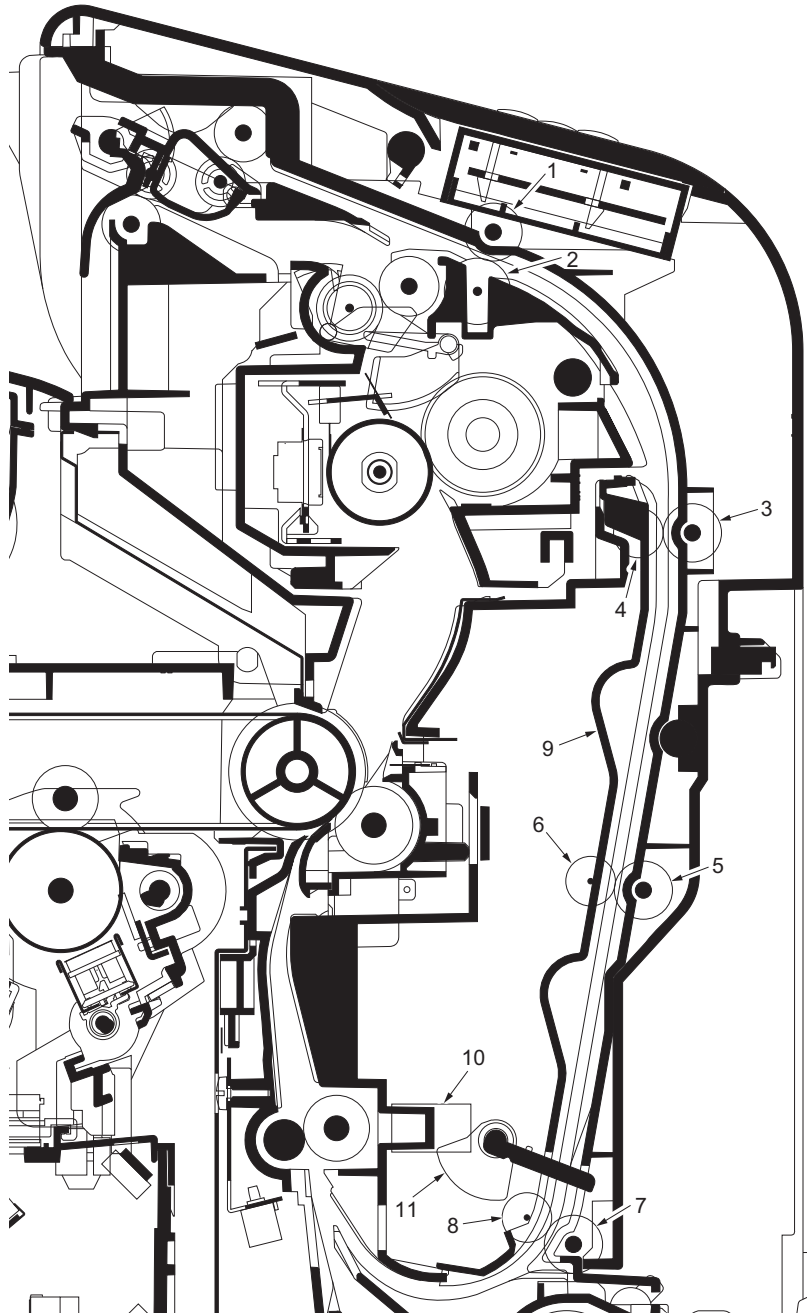

Figure 2-1-22 Duplex/conveying section

- | | |
|-----------------------|------------------------------|
| (1) Duplex roller 1 | (7) Duplex feed roller |
| (2) Paper exit pulley | (8) Duplex pulley |
| (3) Duplex roller 2 | (9) Duplex feed guide |
| (4) Duplex roller 3 | (10) Duplex conveying sensor |
| (5) Duplex pulley | (11) Actuator |
| (6) Duplex pulley | (duplex conveying sensor) |

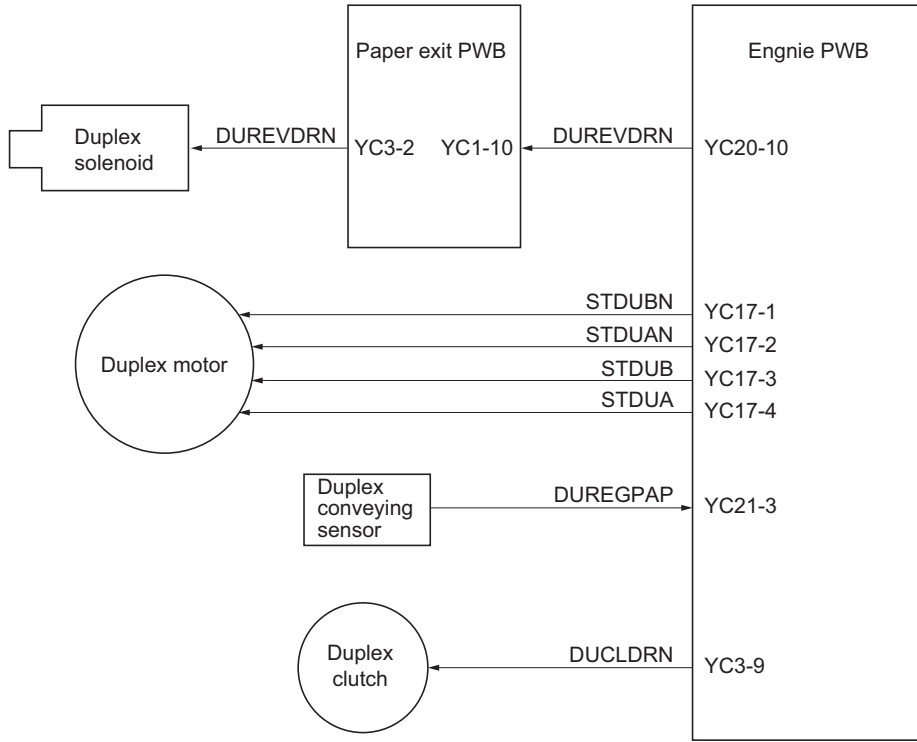

Figure 2-1-23 Duplex/paper conveying section block diagram

2-2-1 Electrical parts layout

(1) PWBs

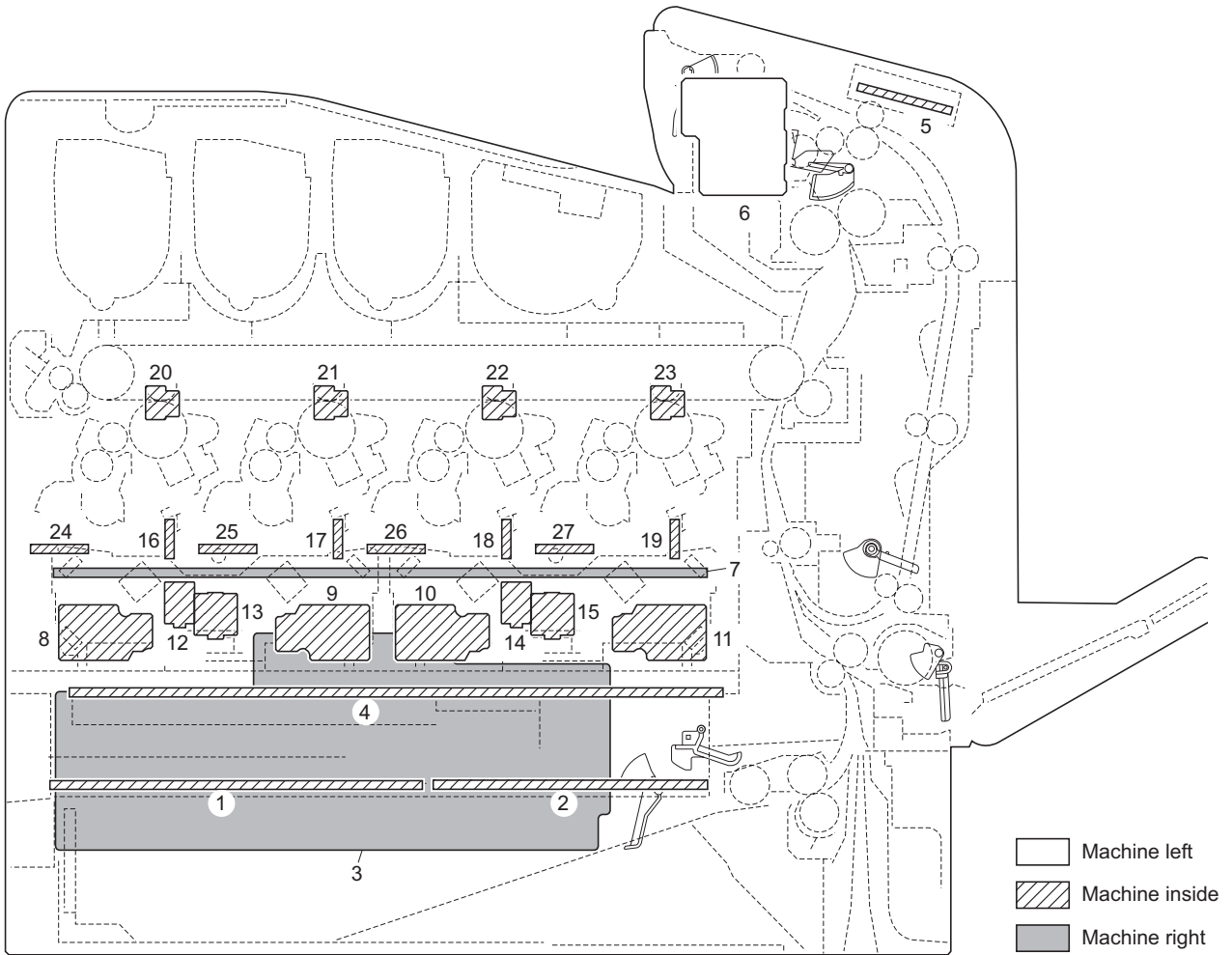

Figure 2-2-1 PWBs

- 1. Main PWB Controls the software such as the print data processing and provides the interface with computers.
- 2. Engine PWB Controls printer hardware such as high voltage/bias output control, paper conveying system control, and fuser temperature control, etc.
- 3. Power source PWB After full-wave rectification of AC power source input, switching for converting to 24 V DC for output. Controls the fuser heater lamp.
- 4. High voltage PWB Generates main charging, developing bias, transfer bias and cleaning bias.
- 5. Operation panel PWB Controls the LCD display. Consists the LCD display, LED indicators and key switches.
- 6. Paper exit PWB Interconnects the engine PWB and the electrical parts (paper exit section).
- 7. Drum relay PWB Interconnects the engine PWB and the drum units/developing units.
- 8. APC PWB M Generates and controls the laser beam. (magenta)
- 9. APC PWB C Generates and controls the laser beam. (cyan)
- 10. APC PWB Y Generates and controls the laser beam. (yellow)
- 11. APC PWB K Generates and controls the laser beam. (black)
- 12. PD PWB M Controls horizontal synchronizing timing of laser beam. (magenta)
- 13. PD PWB C Controls horizontal synchronizing timing of laser beam. (cyan)
- 14. PD PWB Y Controls horizontal synchronizing timing of laser beam. (yellow)

15. PD PWB K Controls horizontal synchronizing timing of laser beam. (black)
16. Drum PWB M Relays wirings from electrical components on the drum unit M. Drum individual information in EEPROM storage.
17. Drum PWB C Relays wirings from electrical components on the drum unit C. Drum individual information in EEPROM storage.
18. Drum PWB Y..... Relays wirings from electrical components on the drum unit Y. Drum individual information in EEPROM storage.
19. Drum PWB K..... Relays wirings from electrical components on the drum unit K. Drum individual information in EEPROM storage.
20. Zener PWB M Adjusts the drum surface potential. (Magenta)
21. Zener PWB C Adjusts the drum surface potential. (Cyan)
22. Zener PWB Y Adjusts the drum surface potential. (Yellow)
23. Zener PWB K Adjusts the drum surface potential. (Black)
24. Developing PWB M..... Relays wirings from electrical components on the developing unit M.
25. Developing PWB C Relays wirings from electrical components on the developing unit C.
26. Developing PWB Y Relays wirings from electrical components on the developing unit Y.
27. Developing PWB K Relays wirings from electrical components on the developing unit K.

List of correspondences of PWB names

No.	Name used in service manual	Name used in parts list
1	Main PWB	PARTS PWB MAIN SP
2	Engine PWB	PARTS PWB ENGINE SP
3	Power source PWB	PARTS SWITCHING REGULATOR 120V SP
3	Power source PWB	SWITCHING REGULATOR 230V
4	High voltage PWB	HIGH VOLTAGE UNIT SP
5	Operation panel PWB	P.W.BOARD ASSY LCD CONT
6	Paper exit PWB	P.W.BOARD ASSY EXIT
7	Drum relay PWB	-
8	APC PWB M	-
9	APC PWB C	-
10	APC PWB Y	-
11	APC PWB K	-
12	PD PWB M	-
13	PD PWB C	-
14	PD PWB Y	-
15	PD PWB K	-
16	Drum PWB M	-
17	Drum PWB C	-
18	Drum PWB Y	-
19	Drum PWB K	-
20	Zener PWB M	-
21	Zener PWB C	-
22	Zener PWB Y	-
23	Zener PWB K	-
24	Developing PWB M	-
25	Developing PWB C	-
26	Developing PWB Y	-
27	Developing PWB K	-

(2) Switches and sensors

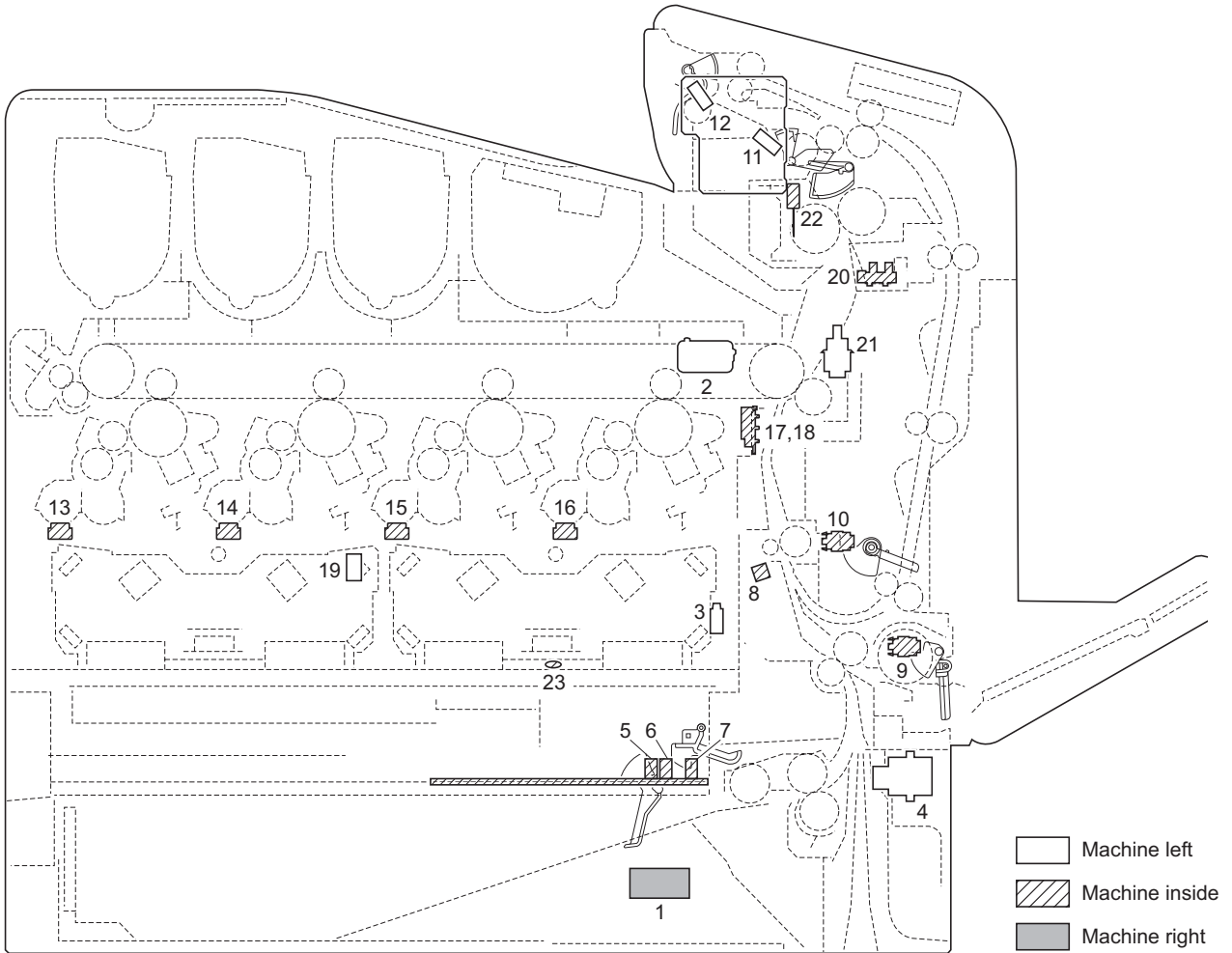

Figure 2-2-2 Switches and sensors

- 1. Power switch Turns ON/OFF the AC power source.
- 2. Interlock switch Shuts off 24 V DC power line when the top cover and front cover are opened.
- 3. Left cover switch Shuts off 24 V DC power line when the left cover is opened.
- 4. Cassette size switch Detects the paper size dial setting of the paper setting dial.
- 5. Paper sensor 1..... Detects the presence of paper in the cassette.
- 6. Paper sensor 2..... Detects the presence of paper in the cassette.
- 7. Lift limit sensor Detects activation of upper limit of the bottom plate in the cassette.
- 8. Registration sensor Detects the timing of primary paper feed.
- 9. MP tray sensor..... Detects the presence of paper on the MP tray.
- 10. Duplex conveying sensor..... Detects paper jam in the duplex section.
- 11. Paper exit sensor Detects paper jam in the fuser/paper exit section.
- 12. Paper full sensor Detects the paper full in the top tray.
- 13. Toner sensor M Detects the toner density in the developing unit M.
- 14. Toner sensor C..... Detects the toner density in the developing unit C.
- 15. Toner sensor Y..... Detects the toner density in the developing unit Y.
- 16. Toner sensor K..... Detects the toner density in the developing unit K.
- 17. Right ID sensor Measures image density for color calibration.
- 18. Left ID sensor..... Measures image density for color calibration.
- 19. Waste toner full sensor Detects the waste toner box being full.
- 20. Envelope switch Detects the envelope mode setting.

- 21. Front cover open/close switch Detects open/close front cover.
- 22. Fuser thermistor Measures the heat roller temperature.
- 23. Polygon motor thermistor Measures the polygon motor YK temperature.

(3) Motors

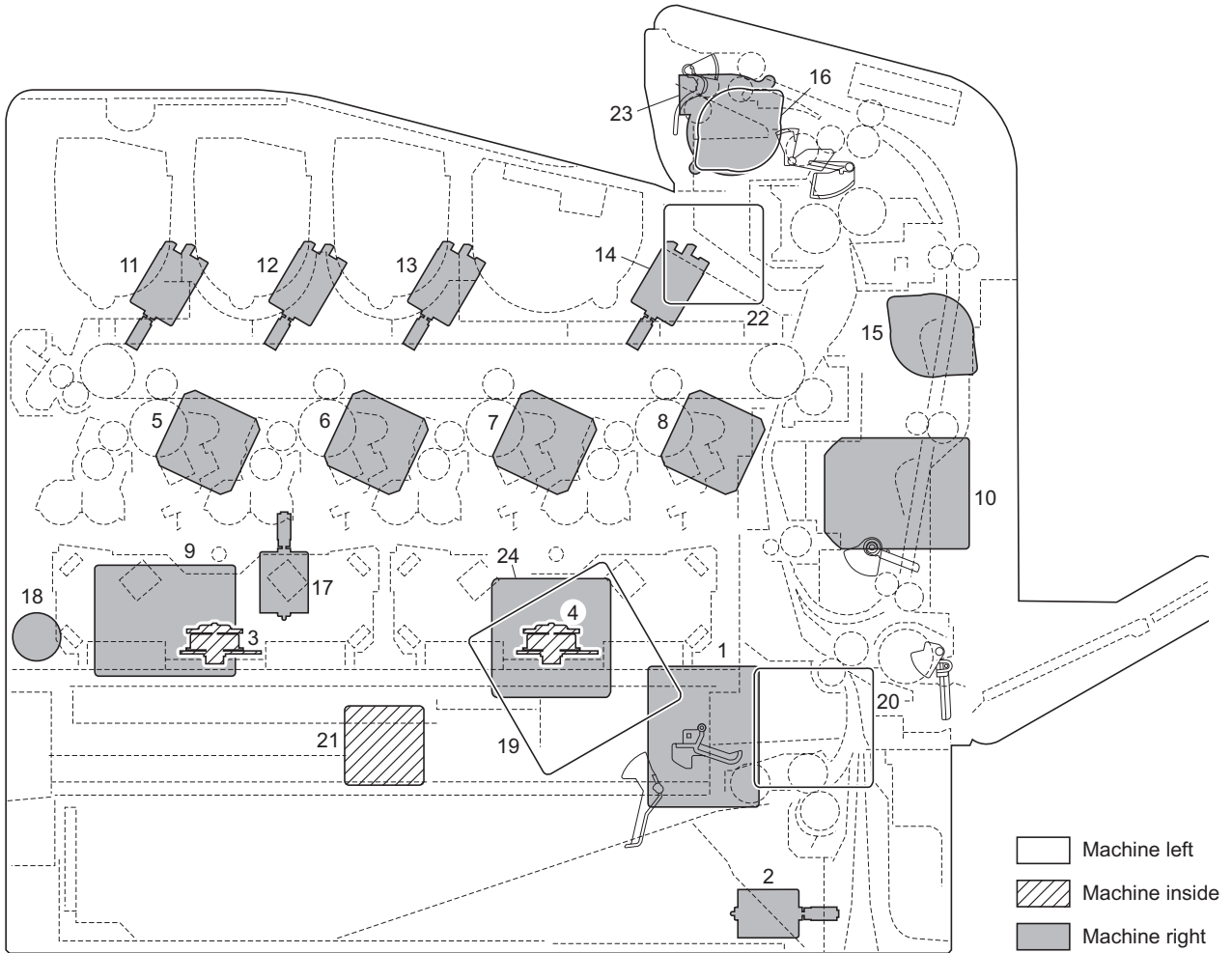

Figure 2-2-3 Motors

- | | |
|---------------------------------------|---|
| 1. Paper feed motor | Drives the paper feed section. |
| 2. Lift motor | Operates the bottom plate in the cassette. |
| 3. Polygon motor MC | Drives the polygon mirror. |
| 4. Polygon motor YK | Drives the polygon mirror. |
| 5. Drum motor M | Drives drum unit M. |
| 6. Drum motor C | Drives drum unit C. |
| 7. Drum motor Y | Drives drum unit Y. |
| 8. Drum motor K | Drives drum unit K. |
| 9. Developing motor MCY | Drives developing unit M, C and Y. |
| 10. Developing motor K | Drives developing unit K and intermediate transfer unit. |
| 11. Toner motor M | Replenishes the developing unit M with toner. |
| 12. Toner motor C | Replenishes the developing unit C with toner. |
| 13. Toner motor Y | Replenishes the developing unit Y with toner. |
| 14. Toner motor K | Replenishes the developing unit K with toner. |
| 15. Fuser motor | Drives fuser section and paper exit section. |
| 16. Duplex motor | Drives duplex section. |
| 17. Main charger cleaning motor | Drives main charger wire cleaning system. |
| 18. LSU cleaning motor | Drives LSU dust shield glass cleaning system. |
| 19. Developing fan motor 1 | Cools the image formation section, engine PWB, main PWB and high voltage PWB. |
| 20. Developing fan motor 2 | Cools the image formation section, engine PWB, main PWB and high voltage PWB. |

- 21. Power source fan motor..... Cools the power source PWB.
- 22. Fuser fan motor 1..... Cools the fuser section.
- 23. Fuser fan motor 2..... Cools the fuser section.
- 24. Ozone fan motor The exhaust gas of ozone.

(4) Other electrical components

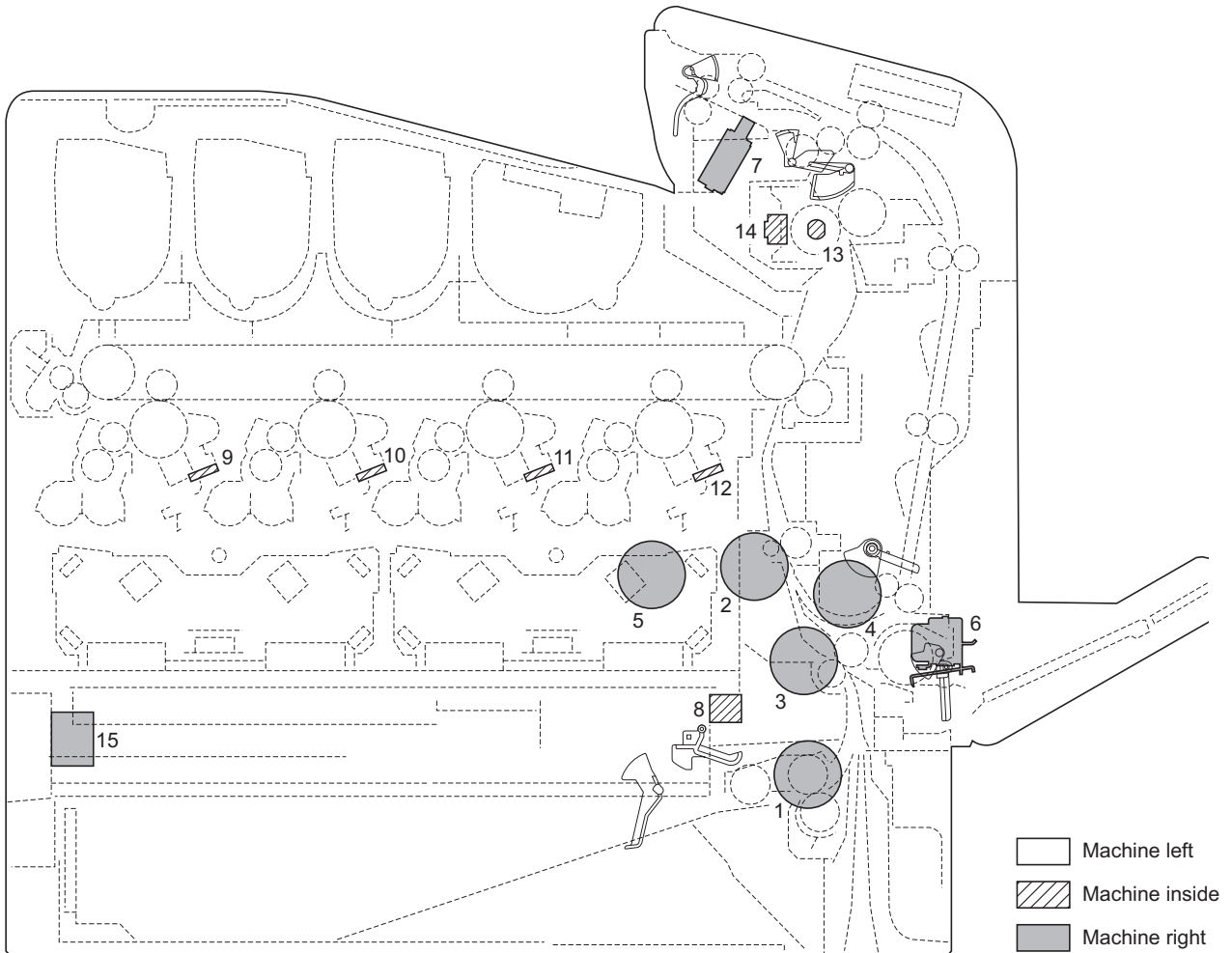

Figure 2-2-4 Other electrical components

- | | |
|--------------------------------|---|
| 1. Paper feed clutch | Controls the paper cassette paper feed. |
| 2. Registration clutch | Controls the secondary paper feed. |
| 3. Intermediate clutch..... | Controls the paper conveying at the conveying section. |
| 4. Duplex clutch | Controls the paper conveying at the duplex section. |
| 5. Developing clutch..... | Detaches the drive transmission of developing units other than developing unit K at the time of B/W printing. |
| 6. MP paper feed solenoid..... | Controls the MPF bottom plate of the MP tray. |
| 7. Duplex solenoid | Operates the change guide. |
| 8. ID solenoid..... | Operates the ID sensors cleaning system. |
| 9. Eraser lamp M..... | Eliminates the residual electrostatic charge on the drum. (Magenta) |
| 10. Eraser lamp C..... | Eliminates the residual electrostatic charge on the drum. (Cyan) |
| 11. Eraser lamp Y..... | Eliminates the residual electrostatic charge on the drum. (Yellow) |
| 12. Eraser lamp K..... | Eliminates the residual electrostatic charge on the drum. (Black) |
| 13. Fuser heater lamp..... | Heats the heat roller. |
| 14. Fuser thermal cutout..... | Shuts off the power source to the fuser heater lamp when the heat roller reaches extremely high temperature. |
| 15. AC inlet | Connects the AC power source. |

2-3-1 Power source PWB

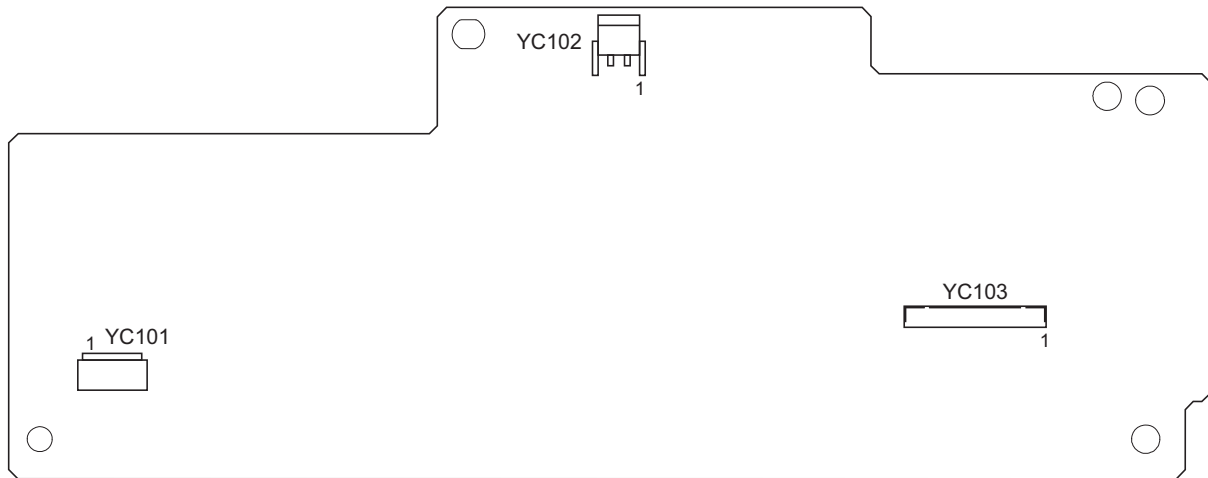

Figure 2-3-1 Power source PWB silk-screen diagram

Connector	Pin	Signal	I/O	Voltage	Description
YC101	1	LIVE	I	120 V AC 220 - 240 V AC	AC power input
Connected to the AC inlet and power switch.	2	NEUTRAL	I	120 V AC 220 - 240 V AC	AC power input
YC102	1	NEUTRAL	O	120/0 V AC 220 - 240/0 V AC	Fuser heater lamp: On/Off
Connected to the fuser heater lamp.	2	N.C.	-	-	Not used
	3	LIVE	O	120 V AC 220 - 240 V AC	AC power output
YC103	1	HEATREM	I	24 V DC	Fuser heater lamp: On/Off
Connected to the engine PWB.	2	N.C.	-	-	Not used
	3	ZCROSS	O	0/3.3 V DC (pulse)	Zero-cross signal
	4	SLEEPN	I	0/24 V DC	Sleep mode signal: On/Off
	5	+24V3	I	24 V DC	24 V DC power source
	6	GND	-	-	Ground
	7	GND	-	-	Ground
	8	GND	-	-	Ground
	9	GND	-	-	Ground
	10	+24V1	O	24 V DC	24 V DC power source
	11	+24V1	O	24 V DC	24 V DC power source
	12	+24V1	O	24 V DC	24 V DC power source
	13	+24V1	O	24 V DC	24 V DC power source

2-3-2 Engine PWB

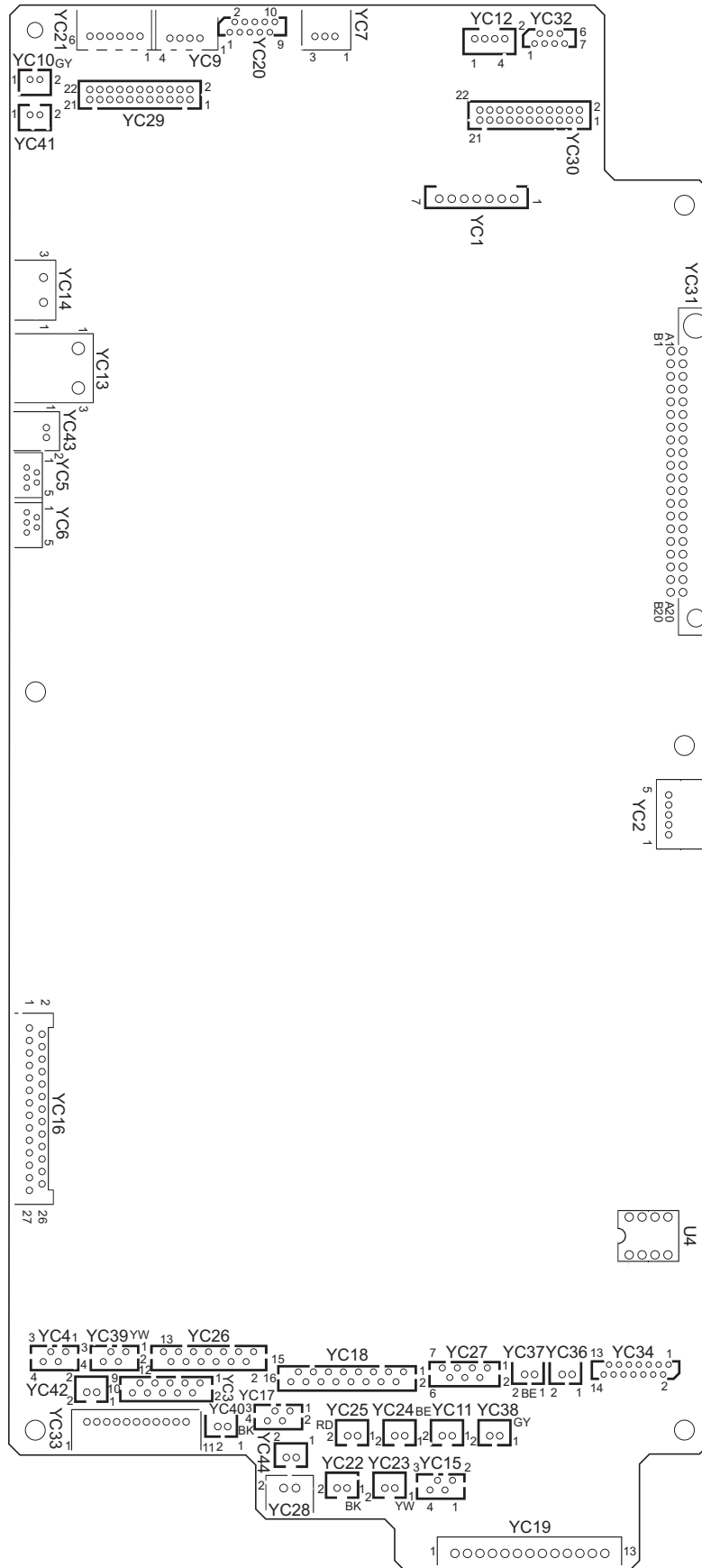

Figure 2-3-2 Engine PWB silk-screen diagram

Connector	Pin	Signal	I/O	Voltage	Description
YC3	1	FEMOTRDYN	I	0/3.3 V DC	Paper feed motor ready signal
Connected to the paper feed motor, intermediate clutch and duplex clutch	2	SPEEDSEL	O	0/3.3 V DC	Paper feed motor speed switch signal
	3	FEMOTCLK	O	0/3.3 V DC (pulse)	Paper feed motor clock signal
	4	FEMOTREN	O	0/3.3 V DC	Paper feed motor: On/Off
	5	GND	-	-	Ground
	6	+24V3	O	24 V DC	24 V DC power source
	7	MIDCLDRN	O	0/24 V DC	Intermediate clutch: On/Off
	8	+24V3	O	24 V DC	24 V DC power source
	9	DUCLDRN	O	0/24 V DC	Duplex clutch: On/Off
	10	+24V3	O	24 V DC	24 V DC power source
YC5	1	+5V1	O	5 V DC	5 V DC power source
Connected to the left ID sensor	2	LEDREFL	O	Analog	Left ID sensor control signal
	3	GND	-	-	Ground
	4	VOPL	I	Analog	Left ID sensor detection signal
	5	VOSL	I	Analog	Left ID sensor detection signal
YC6	1	+5V1	O	5 V DC	5 V DC power source
Connected to the right ID sensor	2	LEDREFR	O	Analog	Right ID sensor control signal
	3	GND	I	-	Ground
	4	VOPR	I	Analog	Right ID sensor detection signal
	5	VOSR	I	Analog	Right ID sensor detection signal
YC7	1	GND	-	-	Ground
Connected to the registration sensor	2	REGPAP	I	0/5 V DC	Registration sensor: On/Off
	3	+5V2	O	5 V DC	5 V DC power source
YC9	1	CAS2	I	0/3.3 V DC	Cassette size switch (SW2): On/Off
Connected to the cassette size switch	2	CAS1	I	0/3.3 V DC	Cassette size switch (SW1): On/Off
	3	COM	-	-	Ground
	4	CAS0	I	0/3.3 V DC	Cassette size switch (SW0): On/Off
YC10	1	+24V1	O	24 V DC	24 V DC power source
Connected to the developing fan motor 1	2	DLPFANDRN	O	0/12/24 V DC	Developing fan motor 1: Full speed/Half speed/Off
YC11	1	+24V1	O	24 V DC	24 V DC power source
Connected to the ozone fan motor	2	OZFANDRN	O	0/12/24 V DC	Ozone fan motor: Full speed/Half speed/Off
YC12	1	LEDA	O	5 V DC	5 V DC power source
Connected to the waste toner full sensor	2	LEDK	O	0/5 V DC (pulse)	Waste toner full sensor (emitter)
	3	PTRE	I	Analog	Waste toner full sensor (receiver)
	4	PTRC	O	5 V DC	5 V DC power source

Connector	Pin	Signal	I/O	Voltage	Description
YC13 Connected to the inter- lock switch	1	+24V1	O	24 V DC	24 V DC power source
	2	N.C.	-	-	Not used
	3	+24V2	I	24/0 V DC	24 V DC power source Interlock switch: On/Off
YC14 Connected to the left cover switch	1	+24V3	O	24 V DC	24 V DC power source
	2	N.C.	-	-	Not used
	3	+24V4	I	24/0 V DC	24 V DC power source Left cover switch: On/Off
YC16 Connected to the high voltage PWB	1	GND	-	-	Ground
	2	GND	-	-	Ground
	3	HVCLKK	O	0/3.3 V DC (pulse)	Developing bias clock signal (Black)
	4	HVCLKY	O	0/3.3 V DC (pulse)	Developing bias clock signal (Yellow)
	5	HVCLKC	O	0/3.3 V DC (pulse)	Developing bias clock signal (Cyan)
	6	HVCLKM	O	0/3.3 V DC (pulse)	Developing bias clock signal (Magenta)
	7	T2RREMN	O	0/3.3 V DC (pulse)	Secondary transfer bias reverse signal
	8	MKCNT	O	PWM	Main charger high voltage control voltage (Black)
	9	BKSCNT	O	PWM	Developing sleeve bias control voltage (Black)
	10	BKMCNT	O	PWM	Developing magnet bias control voltage (Black)
	11	MYCNT	O	PWM	Main charger high voltage control voltage (Yellow)
	12	BYSCNT	O	PWM	Developing sleeve bias control voltage (Yellow)
	13	BYMCNT	O	PWM	Developing magnet bias control voltage (Yellow)
	14	MCCNT	O	PWM	Main charger high voltage control voltage (Cyan)
	15	BCSCNT	O	PWM	Developing sleeve bias control voltage (Cyan)
	16	BCMCNT	O	PWM	Developing magnet bias control voltage (Cyan)
	17	MMCNT	O	PWM	Main charger high voltage control voltage (Magenta)
	18	BMSCNT	O	PWM	Developing sleeve bias control voltage (Magenta)
	19	BMMCNT	O	PWM	Developing magnet bias control voltage (Magenta)
	20	CLCNT	O	PWM	Cleaning bias control voltage
	21	T1MCNT	O	PWM	Primary transfer bias control voltage (Magenta)
	22	T1CCNT	O	PWM	Primary transfer bias control voltage (Cyan)
	23	T1YCNT	O	PWM	Primary transfer bias control voltage (Yellow)
	24	T1KCNT	O	PWM	Primary transfer bias control voltage (Black)
	25	T2CNT	O	PWM	Secondary transfer bias control voltage
	26	+24V4	O	24 V DC	24 V DC power source
	27	+24V4	O	24 V DC	24 V DC power source
YC17 Connected to the duplex motor	1	STDUBN	O	0/24 V DC (pulse)	Duplex motor drive control signal (_B)
	2	STDUAN	O	0/24 V DC (pulse)	Duplex motor drive control signal (_A)
	3	STDUB	O	0/24 V DC (pulse)	Duplex motor drive control signal (B)
	4	STDUA	O	0/24 V DC (pulse)	Duplex motor drive control signal (A)

Connector	Pin	Signal	I/O	Voltage	Description
YC18 Connected to the drum motor M/C/ Y/K	1	STMBN	O	0/24 V DC (pulse)	Drum motor M drive control signal (_B)
	2	STMAN	O	0/24 V DC (pulse)	Drum motor M drive control signal (_A)
	3	STMB	O	0/24 V DC (pulse)	Drum motor M drive control signal (B)
	4	STMA	O	0/24 V DC (pulse)	Drum motor M drive control signal (A)
	5	STCBN	O	0/24 V DC (pulse)	Drum motor C drive control signal (_B)
	6	STCAN	O	0/24 V DC (pulse)	Drum motor C drive control signal (_A)
	7	STCB	O	0/24 V DC (pulse)	Drum motor C drive control signal (B)
	8	STCA	O	0/24 V DC (pulse)	Drum motor C drive control signal (A)
	9	STYBN	O	0/24 V DC (pulse)	Drum motor Y drive control signal (_B)
	10	STYAN	O	0/24 V DC (pulse)	Drum motor Y drive control signal (_A)
	11	STYB	O	0/24 V DC (pulse)	Drum motor Y drive control signal (B)
	12	STYA	O	0/24 V DC (pulse)	Drum motor Y drive control signal (A)
	13	STKBN	O	0/24 V DC (pulse)	Drum motor K drive control signal (_B)
	14	STKAN	O	0/24 V DC (pulse)	Drum motor K drive control signal (_A)
	15	STKB	O	0/24 V DC (pulse)	Drum motor K drive control signal (B)
	16	STKA	O	0/24 V DC (pulse)	Drum motor K drive control signal (A)
YC19 Connected to the power source PWB	1	HEATREM	O	24 V DC	Fuser heater lamp: On/Off
	2	N.C.	-	-	Not used
	3	ZCROSS	I	0/3.3 V DC (pulse)	Zero-cross signal
	4	SLEEPN	O	0/24 V DC	Sleep mode signal: On/Off
	5	+24V3	O	24 V DC	24 V DC power source
	6	GND	-	-	Ground
	7	GND	-	-	Ground
	8	GND	-	-	Ground
	9	GND	-	-	Ground
	10	+24V1	I	24 V DC	24 V DC power source
	11	+24V1	i	24 V DC	24 V DC power source
	12	+24V1	I	24 V DC	24 V DC power source
	13	+24V1	I	24 V DC	24 V DC power source
YC20 Connected to the paper exit PWB	1	+3.3V2	O	3.3 V DC	3.3 V DC power source
	2	F THERM	I	Analog	Fuser thermistor detection voltage
	3	PDIRN	I	0/3.3 V DC	Envelope switch: On/Off
	4	EXITPAP	I	0/3.3 V DC	Paper exit sensor: On/Off
	5	GND	-	-	Ground
	6	FD FUL	I	0/3.3 V DC	Paper full sensor: On/Off
	7	FEEDOPN	I	0/3.3 V DC	Front cover open/close switch: On/Off
	8	FUFANDRN	O	0/12/24 V DC	Fuser fan motor 1: Full speed/Half speed/Off
	9	+24V1	O	24 V DC	24 V DC power source
	10	DUREVDRN	O	0/24 V DC	Duplex solenoid: On/Off
YC21 Connected to the duplex con- veying sen- sor and MP tray sensor	1	+3.3V2	O	3.3 V DC	3.3 V DC power source
	2	GND	-	-	Ground
	3	DUREGPAP	I	0/3.3 V DC	Duplex conveying sensor: On/Off
	4	+3.3V2	O	3.3 V DC	3.3 V DC power source
	5	GND	-	-	Ground
	6	MPHANDS	I	0/3.3 V DC	MP tray sensor: On/Off
YC22 Connected to the toner motor K	1	+24V3	O	24 V DC	24 V DC power source
	2	TNMKDRN	O	0/24 V DC	Toner motor K: On/Off

Connector	Pin	Signal	I/O	Voltage	Description
YC23	1	+24V3	O	24 V DC	24 V DC power source
Connected to the toner motor Y	2	TNMYDRN	O	0/24 V DC	Toner motor Y: On/Off
YC24	1	+24V3	O	24 V DC	24 V DC power source
Connected to the toner motor C	2	TNMCDRN	O	0/24 V DC	Toner motor C: On/Off
YC25	1	+24V3	O	24 V DC	24 V DC power source
Connected to the toner motor M	2	TNMMDRN	O	0/24 V DC	Toner motor M: On/Off
YC26	1	DLPCLDNRN	O	0/24 V DC	Developing clutch K: On/Off
Connected to the developing clutch K, developing motor K, Registration clutch and paper feed clutch	2	+24V3	O	24 V DC	24 V DC power source
	3	MOTKREV	O	0/3.3 V DC	Developing motor K drive switch signal
	4	DLPMOTKRDRN	I	0/3.3 V DC	Developing motor K ready signal
	5	SPEEDSEL	O	0/3.3 V DC	Developing motor K speed selection signal
	6	DLPMOTKCLK	O	0/3.3 V DC (pulse)	Developing motor K clock signal
	7	DLPMOTKREN	O	0/3.3 V DC	Developing motor K: On/Off
	8	GND	-	-	Ground
	9	+24V3	O	24 V DC	24 V DC power source
	10	REGCLDRN	O	0/24 V DC	Registration clutch: On/Off
	11	+24V3	O	24 V DC	24 V DC power source
	12	FEDCLDRN	O	0/24 V DC	Paper feed clutch: On/Off
	13	+24V3	O	24 V DC	24 V DC power source
	YC27	1	MOTREV	O	0/3.3 V DC
Connected to the developing motor MCY	2	DLPMOTRDRN	I	0/3.3 V DC	Developing motor MCY ready signal
	3	SPEEDSEL	O	0/3.3 V DC	Developing motor MCY speed switch signal
	4	DLPMOTCLK	O	0/3.3 V DC (pulse)	Developing motor MCY clock signal
	5	DLPMOTREN	O	0/3.3 V DC	Developing motor MCY: On/Off
	6	GND	-	-	Ground
	7	+24V3	O	24 V DC	24 V DC power source
	YC28	1	LMOTDRN	O	0/24 V DC
Connected to the lift motor	2	GND	-	-	Ground

Connector	Pin	Signal	I/O	Voltage	Description
YC29 Connected to the APC PWB Y, APC PWB K and poly- gon motor YK	1	+3.3V3	O	3.3 V DC	3.3 V DC power source
	2	LONBYN	O	0/3.3 V DC	APC PWB Y sample/hold signal
	3	ENBYN	O	0/3.3 V DC	APC PWB Y laser enable signal
	4	VDOYP	O	LVDS	APC PWB Y video data signal (+)
	5	VDOYN	O	LVDS	APC PWB Y video data signal (-)
	6	GND	-	-	Ground
	7	VREFY	O	Analog	APC PWB Y control signal
	8	THERMK	I	Analog	LSU thermistor detection voltage
	9	PDYN	I	0/3.3 V DC (pulse)	Horizontal synchronization signal
	10	+3.3V3	O	3.3 V DC	3.3 V DC power source
	11	LONBKN	O	0/3.3 V DC	APC PWB K sample/hold signal
	12	ENBKN	O	0/3.3 V DC	APC PWB K laser enable signal
	13	VDOKP	O	LVDS	APC PWB K video data signal (+)
	14	VDOKN	O	LVDS	APC PWB K video data signal (-)
	15	GND	-	-	Ground
	16	VREFK	O	Analog	APC PWB K control signal
	17	PDKN	I	0/3.3 V DC (pulse)	Horizontal synchronization signal
	18	POLCLK1	O	0/3.3 V DC (pulse)	Polygon motor YK clock signal
	19	POLRDYN1	I	0/3.3 V DC	Polygon motor YK ready signal
	20	POLONN1	O	0/3.3 V DC	Polygon motor YK: On/Off
	21	GND	-	-	Ground
	22	+24V3	O	24 V DC	24 V DC power source
YC30 Connected to the APC PWB M, APC PWB C and poly- gon motor MC	1	+3.3V3	O	3.3 V DC	3.3 V DC power source
	2	LONBMN	O	0/3.3 V DC	APC PWB M sample/hold signal
	3	ENBMN	O	0/3.3 V DC	APC PWB M laser enable signal
	4	VDOMP	O	LVDS	APC PWB M video data signal (+)
	5	VDOMN	O	LVDS	APC PWB M video data signal (-)
	6	GND	-	-	Ground
	7	VREFM	O	Analog	APC PWB M control signal
	8	THERMC	I	Analog	LSU thermistor detection voltage
	9	PDMN	I	0/3.3 V DC (pulse)	Horizontal synchronization signal
	10	+3.3V3	O	3.3 V DC	3.3 V DC power source
	11	LONBCN	O	0/3.3 V DC	APC PWB C sample/hold signal
	12	ENBCN	O	0/3.3 V DC	APC PWB C laser enable signal
	13	VDOCP	O	LVDS	APC PWB C video data signal (+)
	14	VDOCN	O	LVDS	APC PWB C video data signal (-)
	15	GND	-	-	Ground
	16	VREFC	O	Analog	APC PWB C control signal
	17	PDCN	I	0/3.3 V DC (pulse)	Horizontal synchronization signal
	18	POLCLK0	O	0/3.3 V DC (pulse)	Polygon motor MC clock signal
	19	POLRDYN0	I	0/3.3 V DC	Polygon motor MC ready signal
	20	POLONN0	O	0/3.3 V DC	Polygon motor MC: On/Off
	21	GND	-	-	Ground
	22	+24V3	O	24 V DC	24 V DC power source

Connector	Pin	Signal	I/O	Voltage	Description
YC31	A1	VDOMP	I	LVDS	APC PWB M video data signal (+)
Connected to the main PWB	A2	VDOMN	I	LVDS	APC PWB M video data signal (-)
	A3	VDOYP	I	LVDS	APC PWB Y video data signal (+)
	A4	VDOYN	I	LVDS	APC PWB Y video data signal (-)
	A5	GND	-	-	Ground
	A6	PDMN	O	0/3.3 V DC (pulse)	Horizontal synchronization signal
	A7	PDYN	O	0/3.3 V DC (pulse)	Horizontal synchronization signal
	A8	GND	-	-	Ground
	A9	FPRXD	I	0/3.3 V DC (pulse)	Operation panel PWB communication data signal
	A10	FPTXD	I	0/3.3 V DC	Operation panel PWB communication direct signal
	A11	FPRSTN	I	0/3.3 V DC	Panel reset signal
	A12	+3.3V1	O	3.3 V DC	3.3 V DC power source
	A13	SO	O	0/3.3 V DC (pulse)	Main PWB serial communication data signal
	A14	SDIR	O	0/3.3 V DC	Main PWB communication direction signal
	A15	EGIRN	O	0/3.3 V DC	Engine interrupt signal
	A16	+5V1	O	5 V DC	5 V DC power source
	A17	+5V1	O	5 V DC	5 V DC power source
	A18	GND	-	-	Ground
	A19	GND	-	-	Ground
	A20	+24V1	-	24 V DC	24 V DC power source
	Connected to the operation panel PWB	B1	VDOCP	I	LVDS
B2		VDOCN	I	LVDS	APC PWB C video data signal (-)
B3		VDOCP	I	LVDS	APC PWB K video data signal (+)
B4		VDOCN	I	LVDS	APC PWB K video data signal (-)
B5		GND	-	-	Ground
B6		PDCN	O	0/3.3 V DC (pulse)	Horizontal synchronization signal
B7		PDKN	O	0/3.3 V DC (pulse)	Horizontal synchronization signal
B8		GND	-	-	Ground
B9		WAKEUP_PNL KEY	O	0/3.3 V DC	Panel reset signal
B10		NC	-	-	Not used
B11		ST_WUP	I	0/3.3 V DC	Sleep reset signal
B12		+3.3V1	O	3.3 V DC	3.3 V DC power source
B13		SI	O	0/3.3 V DC (pulse)	Main PWB serial communication data signal
B14		SCKN	I	0/3.3 V DC (pulse)	Main PWB serial communication clock signal
B15		SBSY	O	0/3.3 V DC	Main PWB busy signal
B16		VSYNC	O	0/3.3 V DC	PD mask control signal
B17		EEDAT	I/O	0/3.3 V DC (pulse)	EEPROM data signal
B18		EECLK	O	0/3.3 V DC (pulse)	EEPROM clock signal
B19		GND	-	-	Ground
B20		GND	-	-	Ground
YC32	1	GND	-	-	Ground
Connected to the operation panel PWB	2	FPCLK	O	0/3.3 V DC (pulse)	Operation panel PWB clock signal
	3	FPDIR	O	0/3.3 V DC	Operation panel PWB communication direct signal
	4	FPDATA	I/O	0/3.3 V DC	Operation panel PWB data signal
	5	+3.3V1	O	3.3 V DC	3.3 V DC power source
	6	FPRSTN	O	0/3.3 V DC	Operation panel reset signal
	7	+5V	O	5 V DC	5 V DC power source

Connector	Pin	Signal	I/O	Voltage	Description
YC33	1	GND	-	-	Ground
Connected to the option paper feeder	2	OPSCCLK	O	0/5 V DC (pulse)	Paper feeder clock signal
	3	OPRDYN	I	0/5 V DC	Paper feeder ready signal
	4	OPSDI	I	0/5 V DC (pulse)	Paper feeder serial communication data signal
	5	OPSDO	O	0/5 V DC (pulse)	Paper feeder serial communication data signal
	6	OP5V	O	5 V DC	5 V DC power source
	7	GND	-	-	Ground
	8	OPSEL0	O	0/5 V DC	Paper feeder selection signal
	9	OPSEL1	O	0/5 V DC	Paper feeder selection signal
	10	OPSEL2	O	0/5 V DC	Paper feeder selection signal
	11	OP24	O	24 V DC	24 V DC power source
YC34	1	ERASEMDR	O	0/24 V DC	Eraser lamp M: On/Off
Connected to the drum relay signal	2	TNSEN M	I	Analog	Toner sensor M detection voltage
	3	ERASEC DR	O	0/24 V DC	Eraser lamp C: On/Off
	4	TNSEN C	I	Analog	Toner sensor C detection voltage
	5	ERASEY DR	O	0/24 V DC	Eraser lamp Y: On/Off
	6	TNSEN Y	I	Analog	Toner sensor Y detection voltage
	7	EECLK	O	0/3.3 V DC (pulse)	EEPROM clock signal
	8	GND	-	-	Ground
	9	EEDATA	I/O	0/3.3 V DC (pulse)	EEPROM data signal
	10	+3.3V1	O	3.3 V DC	3.3 V DC power source
	11	ERASEK DR	O	0/24 V DC	Eraser lamp K: On/Off
	12	+3.3V2	O	3.3 V DC	3.3 V DC power source
	13	TNSEN K	I	Analog	Toner sensor K detection voltage
	14	DLPTHERM	I	Analog	Developing thermistor detection voltage
YC36	1	MCHMOTA	O	24/0 V DC	Main charger cleaning motor: Fwd/Stop/(Rev)
Connected to the main charger cleaning motor	2	MCHMOTB	O	24/0 V DC	Main charger cleaning motor: Rev/Stop/(Fwd)
YC37	1	LSUMOTA	O	24/0 V DC	LSU cleaning motor: Fwd/Stop/(Rev)
Connected to the LSU cleaning motor	2	LSUMOTB	O	24/0 V DC	LSU cleaning motor: Rev/Stop/(Fwd)
YC38	1	+24V1	O	24 V DC	24 V DC power source
Connected to the power source fan motor	2	PSFANDRN	O	0/12/24 V DC	Power source fan motor: Full speed/Half speed/Off
YC39	1	STFUBN	O	0/24 V DC (pulse)	Fuser motor drive control signal (_B)
Connected to the fuser motor	2	STFUAN	O	0/24 V DC (pulse)	Fuser motor drive control signal (_A)
	3	STFUB	O	0/24 V DC (pulse)	Fuser motor drive control signal (B)
	4	STFUA	O	0/24 V DC (pulse)	Fuser motor drive control signal (A)
YC40	1	+24V3	O	24 V DC	24 V DC power source
Connected to the MP paper feed solenoid	2	MPSOLDRN	O	0/24 V DC	MP paper feed solenoid: On/Off

Connector	Pin	Signal	I/O	Voltage	Description
YC41	1	+24V1	O	24 V DC	24 V DC power source
Connected to the developing fan motor 2	2	DLPFANDRN	O	0/12/24 V DC	Developing fan motor 2: Full speed/Half speed/Off
YC43	1	+24V3	O	24 V DC	24 V DC power source
Connected to the ID solenoid	2	IDSOLDRN	O	0/24 V DC	ID solenoid: On/Off
YC44	1	+24V3	O	24 V DC	24 V DC power source
Connected to the fuser fan motor 2	2	SUBFANDRN	O	0/12/24 V DC	Fuser fan motor 2: Full speed/Half speed/Off

2-3-3 Drum relay PWB

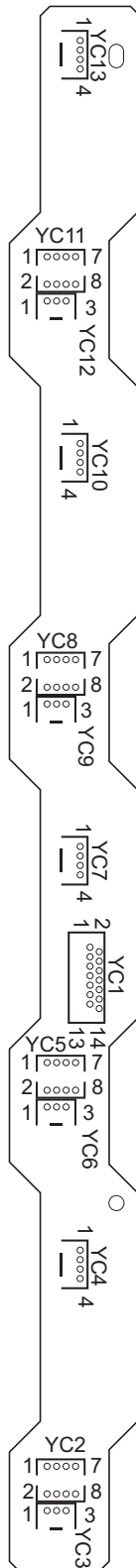

Figure 2-3-3 Drum relay PWB silk-screen diagram

Connector	Pin	Signal	I/O	Voltage	Description
YC1 Connected to the engine PWB.	1	ERASEMDR	I	0/24 V DC	Eraser lamp M: On/Off
	2	TNSEN M	O	Analog	Toner sensor M detection voltage
	3	ERASEC DR	I	0/24 V DC	Eraser lamp C: On/Off
	4	TNSEN C	O	Analog	Toner sensor C detection voltage
	5	ERASEY DR	I	0/24 V DC	Eraser lamp Y: On/Off
	6	TNSEN Y	O	Analog	Toner sensor Y detection voltage
	7	EECLK	I	0/3.3 V DC (pulse)	EEPROM clock signal
	8	GND	-	-	Ground
	9	EEDATA	I/O	0/3.3 V DC (pulse)	EEPROM data signal
	10	+3.3V1	I	3.3 V DC	3.3 V DC power source
	11	ERASEK DR	I	0/24 V DC	Eraser lamp K: On/Off
	12	+3.3V2	I	3.3 V DC	3.3 V DC power source
	13	TNSEN K	O	Analog	Toner sensor K detection voltage
	14	DLPTHERM	O	Analog	Developing thermistor detection voltage
YC2 Connected to the drum PWB K	1	EEDATA	I/O	0/3.3 V DC (pulse)	EEPROM data signal
	2	ERASEDR	O	0/24 V DC	Eraser lamp K: On/Off
	3	EECLK	O	0/3.3 V DC (pulse)	EEPROM clock signal
	4	GND	-	-	Ground
	5	+3.3V1	O	3.3 V DC	3.3 V DC power source
	6	N.C.	-	-	Not used
	7	DA1	O	0/3.3 V DC	Data address signal
	8	DA0	O	0/3.3 V DC	Data address signal
YC3 Connected to the drum PWB K	1	GND	-	-	Ground
	2	ERASEK DR	O	0/24 V DC	Eraser lamp K: On/Off
	3	N.C.	-	-	Not used
YC4 Connected to the devel- oping PWB K	1	GND	-	-	Ground
	2	TNSEN K	I	Analog	Toner sensor K detection voltage
	3	+3.3V2	O	3.3 V DC	3.3 V DC power source
	4	TH_DLP	I	Analog	Developing thermistor detection voltage
YC5 Connected to the drum PWB Y	1	EEDATA	I/O	0/3.3 V DC (pulse)	EEPROM data signal
	2	ERASEDR	O	0/24 V DC	Eraser lamp Y: On/Off
	3	EECLK	O	0/3.3 V DC (pulse)	EEPROM clock signal
	4	GND	-	-	Ground
	5	+3.3V1	O	3.3 V DC	3.3 V DC power source
	6	N.C.	-	-	Not used
	7	DA1	O	0/3.3 V DC	Data address signal
	8	DA0	O	0/3.3 V DC	Data address signal
YC6 Connected to the drum PWB Y	1	GND	-	-	Ground
	2	ERASEY DR	O	0/24 V DC	Eraser lamp Y: On/Off
	3	N.C.	-	-	Not used
YC7 Connected to the drum PWB C	1	GND	-	-	Ground
	2	TNSEN Y	I	Analog	Toner sensor Y detection voltage
	3	+3.3V2	O	3.3 V DC	3.3 V DC power source
	4	N.C.	-	-	Not used

Connector	Pin	Signal	I/O	Voltage	Description
YC8 Connected to the drum PWB C	1	EEDATA	I/O	0/3.3 V DC (pulse)	EEPROM data signal
	2	ERASEDR	O	0/24 V DC	Eraser lamp C: On/Off
	3	EECLK	O	0/3.3 V DC (pulse)	EEPROM clock signal
	4	GND	-	-	Ground
	5	+3.3V1	O	3.3 V DC	3.3 V DC power source
	6	N.C.	-	-	Not used
	7	DA1	O	0/3.3 V DC	Data address signal
	8	DA0	O	0/3.3 V DC	Data address signal
YC9 Connected to the drum PWB C	1	GND	-	-	Ground
	2	ERASECDR	O	0/24 V DC	Eraser lamp C: On/Off
	3	N.C.	-	-	Not used
YC10 Connected to the devel- oping PWB C	1	GND	-	-	Ground
	2	TNSEN C	I	Analog	Toner sensor C detection voltage
	3	+3.3V2	O	3.3 V DC	3.3 V DC power source
	4	N.C.	-	-	Not used
YC11 Connected to the drum PWB M	1	EEDATA	I/O	0/3.3 V DC (pulse)	EEPROM data signal
	2	ERASEDR	O	0/24 V DC	Eraser lamp M: On/Off
	3	EECLK	O	0/3.3 V DC (pulse)	EEPROM clock signal
	4	GND	-	-	Ground
	5	+3.3V1	O	3.3 V DC	3.3 V DC power source
	6	N.C.	-	-	Not used
	7	DA1	O	0/3.3 V DC	Data address signal
	8	DA0	O	0/3.3 V DC	Data address signal
YC12 Connected to the drum PWB M	1	GND	-	-	Ground
	2	ERASMCDR	O	0/24 V DC	Eraser lamp M: On/Off
	3	N.C.	-	-	Not used
YC13 Connected to the devel- oping PWB M	1	GND	-	-	Ground
	2	TNSEN M	I	Analog	Toner sensor M detection voltage
	3	+3.3V2	O	3.3 V DC	3.3 V DC power source
	4	N.C.	-	-	Not used

2-3-4 Paper exit PWB

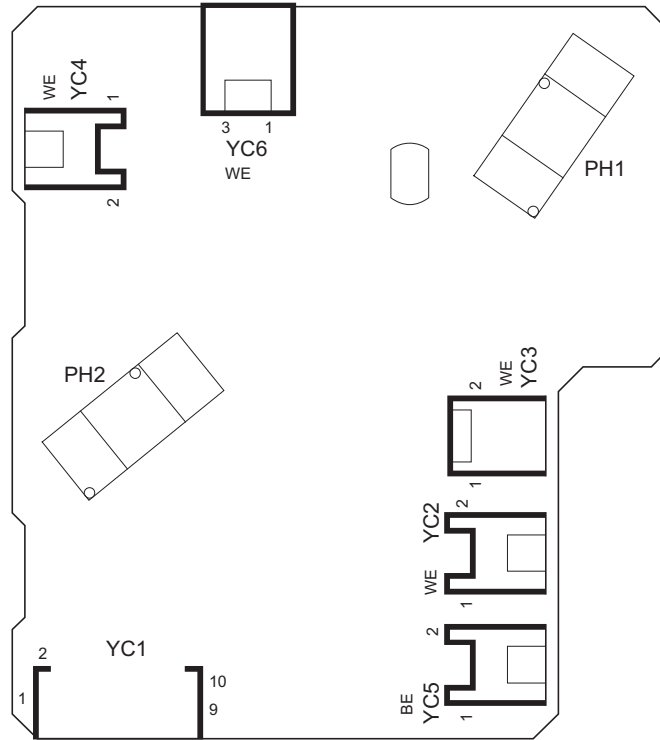

Figure 2-3-4 Paper exit PWB silk-screen diagram

Connector	Pin	Signal	I/O	Voltage	Description
YC1	1	+3.3V2	I	3.3 V DC	3.3 V DC power source
Connected to the engine PWB.	2	F THERM	O	Analog	Fuser thermistor detection voltage
	3	PDIRN	O	0/3.3 V DC	Envelope switch: On/Off
	4	EXITPAP	O	0/3.3 V DC	Paper exit sensor: On/Off
	5	GND	-	-	Ground
	6	FD FUL	O	0/3.3 V DC	Paper full sensor: On/Off
	7	FEEDOPN	O	0/3.3 V DC	Front cover open/close switch: On/Off
	8	FUFANDRN	I	0/12/24 V DC	Fuser fan motor 1: Full speed/Half speed/Off
	9	+24V1	I	24 V DC	24 V DC power source
	10	DUREVDRN	I	0/24 V DC	Duplex solenoid: On/Off
	YC2	1	+24V1	O	24 V DC
Connected to the fuser fan motor 1	2	FUFANDRN	O	0/12/24 V DC	Fuser fan motor 1: Full speed/Half speed/Off
YC3	1	+24V1	O	24 V DC	24 V DC power source
Connected to the duplex solenoid	2	DUREVDRN	O	0/24 V DC	Duplex solenoid: On/Off

Connector	Pin	Signal	I/O	Voltage	Description
YC4	1	+3.3V1	O	3.3 V DC	3.3 V DC power source
Connected to the fuser thermistor	2	FTHERM	I	Analog	Fuser thermistor detection voltage
YC5	1	FEEDOPN	I	0/3.3 V DC	Front cover open/close switch: On/Off
Connected to the front cover open/close switch	2	GND	-	-	Ground
YC6	1	GND	-	-	Ground
Connected to the envelope switch	2	PDIRN	I	0/3.3 V DC	Envelope switch: On/Off
	3	+3.3V2	O	3.3 V DC	3.3 V DC power source

This page is intentionally left blank.

2-4-1 Appendixes

(1) Wiring diagram

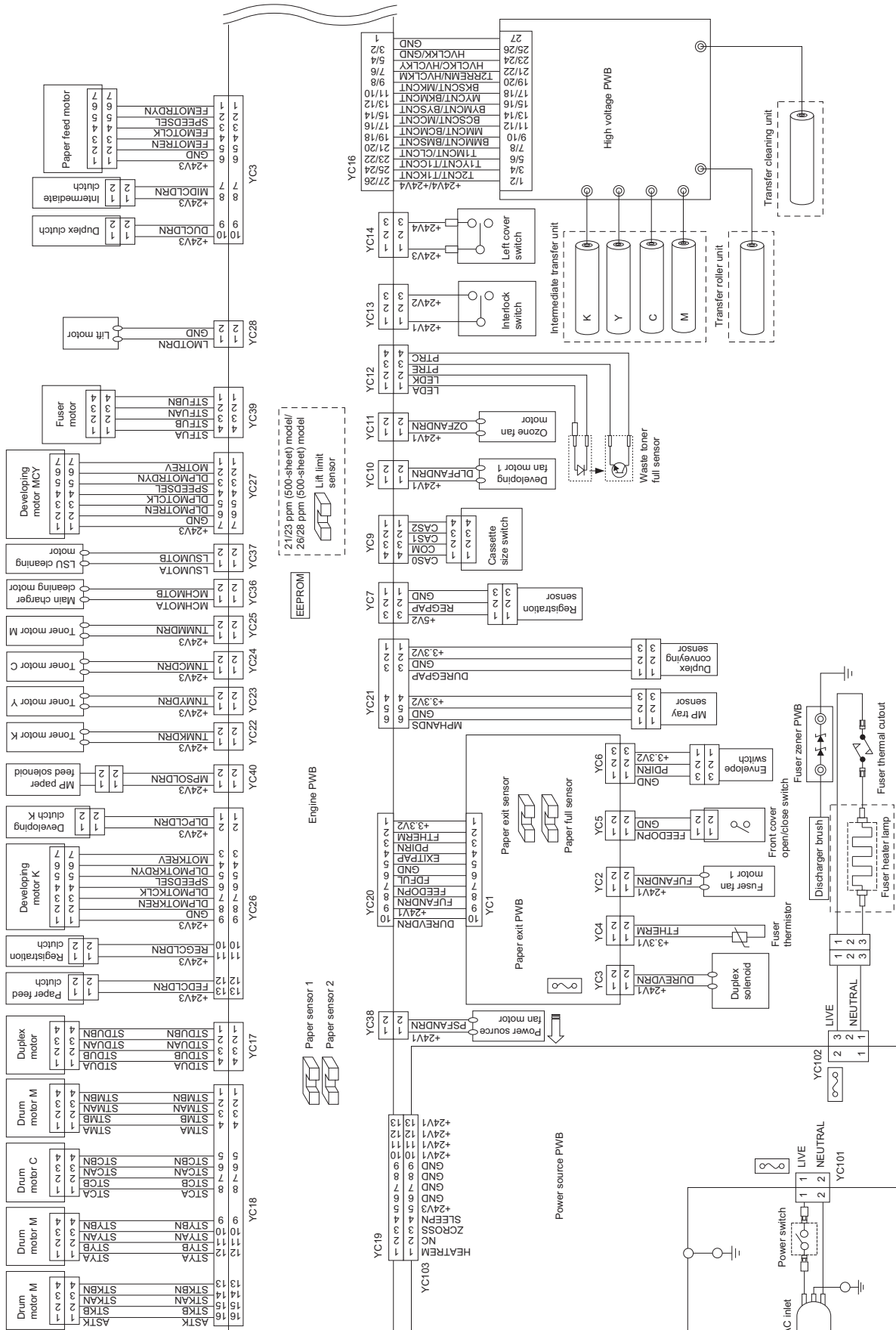

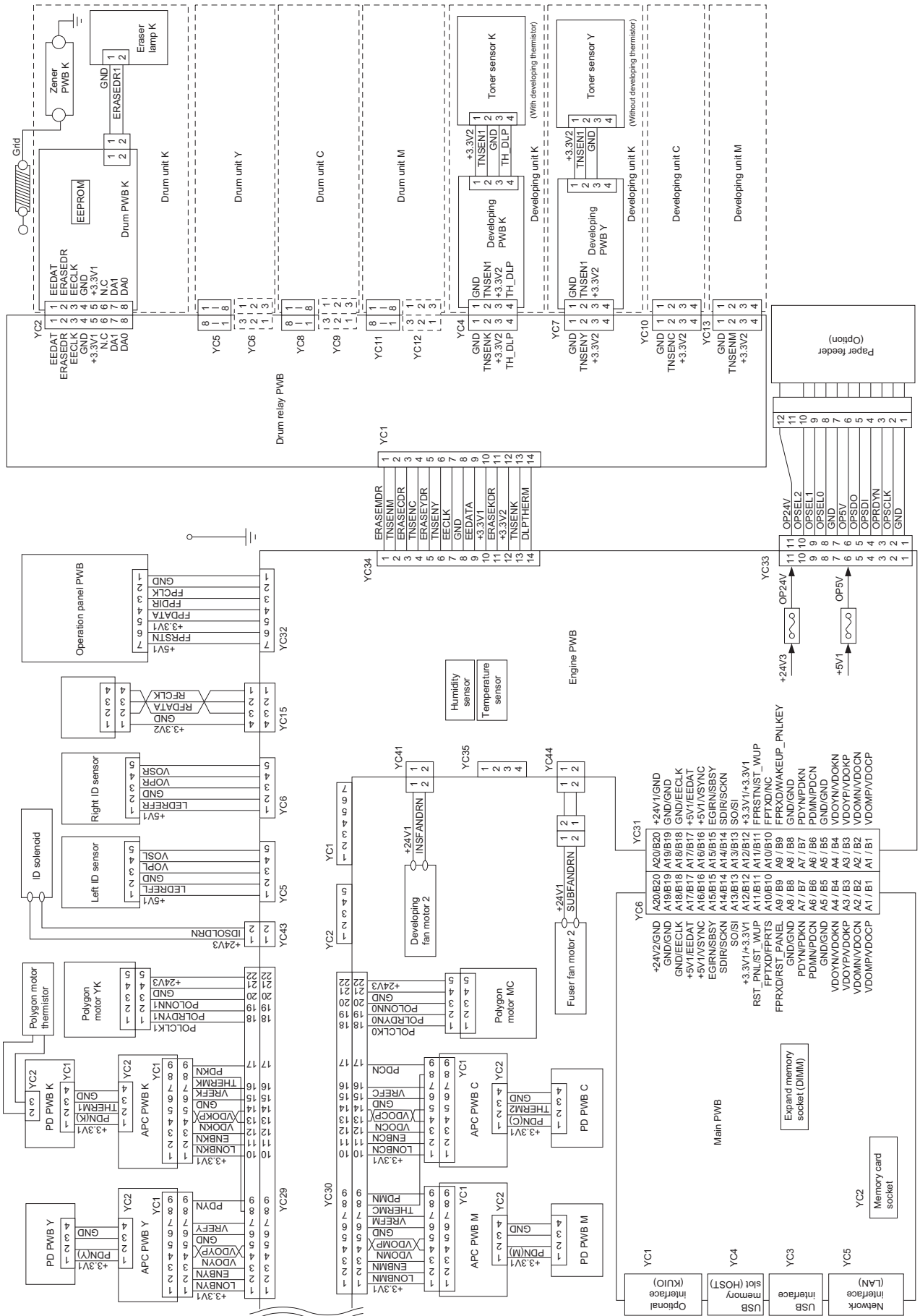

(2) Repetitive defects gauge

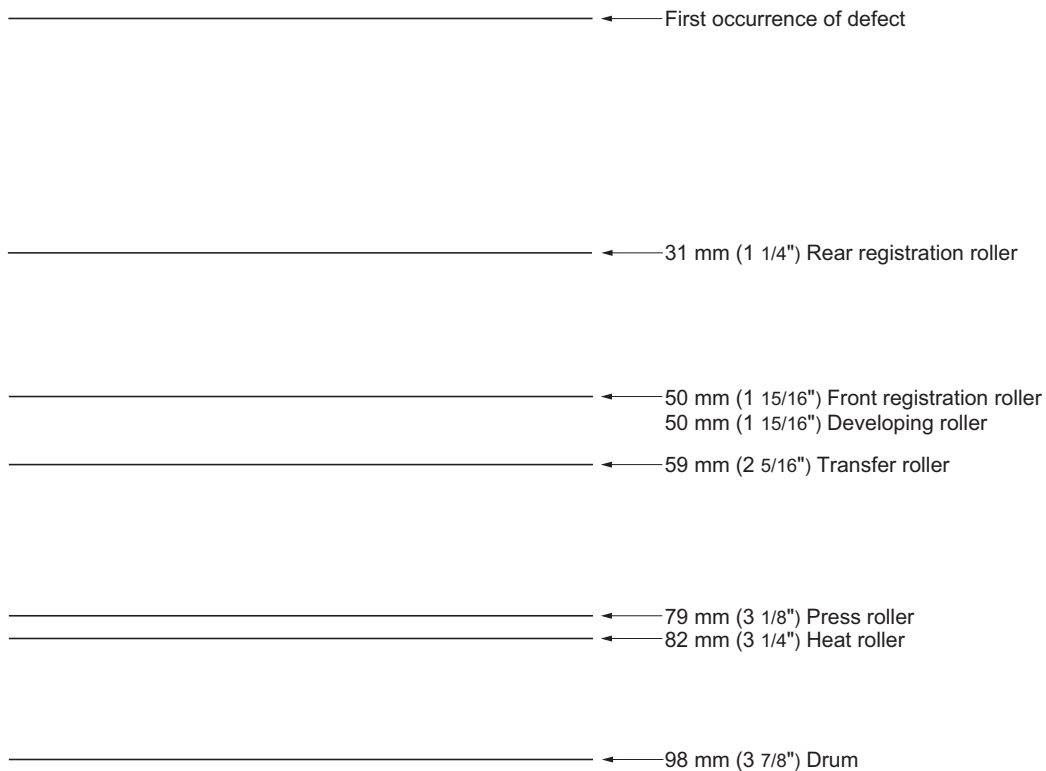

*: The repetitive marks interval may vary depending on operating conditions.

(3) Maintenance parts list**120 V AC model**

Maintenance part name		Part No.	Alternative part	Fig. No.	Ref. No.
Name used in service manual	Name used in parts list				
Maintenance kit MK-580	MK-580/MAINTENANCE KIT (OPTION)	1702K87US0	072K87US	15	-
Retard roller	RETARD ROLLER ASSY			-	-
Paper feed roller assembly	HOLDER FEED ASSY SP			-	-
Developing unit Y	DV-560 US (Y)			-	-
Developing unit K	DV-560 US (K)			-	-
Developing unit C	DV-560 US (C)			-	-
Developing unit M	DV-560 US (M)			-	-
Fuser unit	FK-580(U)			-	-
Drum unit	DK-580			-	-
Intermediate transfer unit	TR-580			-	-
MP paper feed roller	ROLLER M/P ASSY /43487B0027 A4			-	-

220 - 240 V AC model

Maintenance part name		Part No.	Alternative part	Fig. No.	Ref. No.
Name used in service manual	Name used in parts list				
Maintenance kit MK-580	MK-580/MAINTENANCE KIT (OPTION)	1702K88NL0	072K88NL	15	-
Retard roller	RETARD ROLLER ASSY			-	-
Paper feed roller assembly	HOLDER FEED ASSY SP			-	-
Developing unit Y	DV-560(Y)			-	-
Developing unit K	DV-560(K)			-	-
Developing unit C	DV-560(C)			-	-
Developing unit M	DV-560(M)			-	-
Drum unit	DK-580			-	-
Fuser unit	FK-580(E)			-	-
Intermediate transfer unit	TR-580			-	-
MP paper feed roller	ROLLER M/P ASSY /43487B0027 A4			-	-

(4) Maintenance Commands

This section provides information on how to use the maintenance command and its parameters using examples.

Coverage setting

Description

Make settings on the color print coverage counter displays, as well as the coverage threshold.

Purpose

Make settings on the color print coverage counter displays.

Format	!R! KCFG "TCCM",#,EXIT;
Parameter	The counter of full color printing is divided into three steps by the average coverage of the toner of "Y. M.C." 0 = (Only One Step) Full Color Counter : Initial Value 1 = Color Coverage Counter

Example 1: Set the coverage counter.

```
!R! KCFG "TCCM",1;EXIT;
```

Purpose

Setting the coverage thresholds to segment the color count depending on the density level of 1, 2, and 3, for the counters of color printing.

Format	!R! KCFG "STCT",##, EXIT;	
Parameter	Level 1 (Low Coverage)	!R! KCFG "STCT",1,##; EXIT; (The Level 1 value # can be set from 1 to 999, in 0.1% increments) All prints with Level 1 set percentage of coverage or less will be counted as Low Coverage.
	Level 2 (Middle Coverage)	!R! KCFG "STCT",2,##; EXIT; (The Level 2 value # can be set from 2 to 999, in 0.1% increments) All prints above the Level1 percentage and Level 2 set percentage or less will be counted as Middle Coverage.

Example 1: Set the low coverage to 2%.

```
!R! KCFG "STCT",1,20; EXIT;
```

Example 2: Set the middle coverage to 5%.

```
!R! KCFG "STCT",2,50; EXIT;
```

* : All prints at or above the Level 2 set percentage will be counted as Level 3, High Coverage.

This page is intentionally left blank.

KYOCERA Document Solutions America, Inc.**Headquarters**

225 Sand Road,
Fairfield, New Jersey 07004-0008, USA
Phone: +1-973-808-8444
Fax: +1-973-882-6000

Latin America

8240 NW 52nd Terrace Dawson Building, Suite 100
Miami, Florida 33166, USA
Phone: +1-305-421-6640
Fax: +1-305-421-6666

KYOCERA Document Solutions Canada, Ltd.

6120 Kestrel Rd., Mississauga, ON L5T 1S8,
Canada
Phone: +1-905-670-4425
Fax: +1-905-670-8116

**KYOCERA Document Solutions
Mexico, S.A. de C.V.**

Calle Arquimedes No. 130, 4 Piso, Colonia Polanco
Chapultepec, Delegacion Miguel Hidalgo,
Distrito Federal, C.P. 11560, México
Phone: +52-555-383-2741
Fax: +52-555-383-7804

KYOCERA Document Solutions Brazil, Ltda.

Alameda África, 545, Pólo Empresarial Consbrás,
Tamboré, Santana de Parnaíba-SP, CEP 06543-306,
Brazil
Phone: +55-11-4195-8496
Fax: +55-11-4195-6167

**KYOCERA Document Solutions
Australia Pty. Ltd.**

Level 3, 6-10 Talavera Road North Ryde N.S.W, 2113,
Australia
Phone: +61-2-9888-9999
Fax: +61-2-9888-9588

**KYOCERA Document Solutions
New Zealand Ltd.**

Ground Floor, 19 Byron Avenue, Takapuna, Auckland,
New Zealand
Phone: +64-9-415-4517
Fax: +64-9-415-4597

KYOCERA Document Solutions Asia Limited

16/F., Mita Centre, 552-566, Castle Peak Road
Tsuenwan, NT, Hong Kong
Phone: +852-2610-2181
Fax: +852-2610-2063

**KYOCERA Document Solutions
(China) Corporation**

8F, No. 288 Nanjing Road West, Huangpu District,
Shanghai, 200003, China
Phone: +86-21-5301-1777
Fax: +86-21-5302-8300

**KYOCERA Document Solutions
(Thailand) Corp., Ltd.**

335 Ratchadapisek Road, Bangsue, Bangkok 10800,
Thailand
Phone: +66-2-586-0333
Fax: +66-2-586-0278

**KYOCERA Document Solutions
Singapore Pte. Ltd.**

12 Tai Seng Street #04-01A,
Luxasia Building, Singapore 534118
Phone: +65-6741-8733
Fax: +65-6748-3788

**KYOCERA Document Solutions
Hong Kong Limited**

16/F., Mita Centre, 552-566, Castle Peak Road
Tsuenwan, NT, Hong Kong
Phone: +852-3582-4000
Fax: +852-3185-1399

**KYOCERA Document Solutions
Taiwan Corporation**

6F., No.37, Sec. 3, Minquan E. Rd.,
Zhongshan Dist., Taipei 104, Taiwan R.O.C.
Phone: +886-2-2507-6709
Fax: +886-2-2507-8432

KYOCERA Document Solutions Korea Co., Ltd.

18F, Kangnam bldg, 1321-1,
Seocho-Dong, Seocho-Gu, Seoul, Korea
Phone: +822-6933-4050
Fax: +822-747-0084

**KYOCERA Document Solutions
India Private Limited**

First Floor, ORCHID CENTRE
Sector-53, Golf Course Road, Gurgaon 122 002,
India
Phone: +91-0124-4671000
Fax: +91-0124-4671001

KYOCERA Document Solutions Europe B.V.

Bloemlaan 4, 2132 NP Hoofddorp,
The Netherlands
Phone: +31-20-654-0000
Fax: +31-20-653-1256

KYOCERA Document Solutions Nederland B.V.

Beechavenue 25, 1119 RA Schiphol-Rijk,
The Netherlands
Phone: +31-20-5877200
Fax: +31-20-5877260

KYOCERA Document Solutions (U.K.) Limited

Eldon Court, 75-77 London Road,
Reading, Berkshire RG1 5BS,
United Kingdom
Phone: +44-118-931-1500
Fax: +44-118-931-1108

KYOCERA Document Solutions Italia S.p.A.

Via Verdi, 89/91 20063 Cernusco s/N.(MI),
Italy
Phone: +39-02-921791
Fax: +39-02-92179-600

KYOCERA Document Solutions Belgium N.V.

Sint-Martinusweg 199-201 1930 Zaventem,
Belgium
Phone: +32-2-7209270
Fax: +32-2-7208748

KYOCERA Document Solutions France S.A.S.

Espace Technologique de St Aubin
Route de l'Orme 91195 Gif-sur-Yvette CEDEX,
France
Phone: +33-1-69852600
Fax: +33-1-69853409

KYOCERA Document Solutions Espana, S.A.

Edificio Kyocera, Avda. de Manacor No.2,
28290 Las Matas (Madrid), Spain
Phone: +34-91-6318392
Fax: +34-91-6318219

KYOCERA Document Solutions Finland Oy

Atomitie 5C, 00370 Helsinki,
Finland
Phone: +358-9-47805200
Fax: +358-9-47805390

**KYOCERA Document Solutions
Europe B.V., Amsterdam (NL) Zürich Branch**

Hohlstrasse 614, 8048 Zürich,
Switzerland
Phone: +41-44-9084949
Fax: +41-44-9084950

**KYOCERA Document Solutions
Deutschland GmbH**

Otto-Hahn-Strasse 12, 40670 Meerbusch,
Germany
Phone: +49-2159-9180
Fax: +49-2159-918100

KYOCERA Document Solutions Austria GmbH

Eduard-Kittenberger-Gasse 95, 1230 Vienna,
Austria
Phone: +43-1-863380
Fax: +43-1-86338-400

KYOCERA Document Solutions Nordic AB

Esbogatan 16B 164 75 Kista, Sweden
Phone: +46-8-546-550-00
Fax: +46-8-546-550-10

KYOCERA Document Solutions Norge Nuf

Postboks 150 Oppsal, 0619 Oslo,
Norway
Phone: +47-22-62-73-00
Fax: +47-22-62-72-00

KYOCERA Document Solutions Danmark A/S

Ejby Industrivej 60, DK-2600 Glostrup,
Denmark
Phone: +45-70223880
Fax: +45-45765850

KYOCERA Document Solutions Portugal Lda.

Rua do Centro Cultural, 41 (Alvalade) 1700-106 Lisboa,
Portugal
Phone: +351-21-843-6780
Fax: +351-21-849-3312

**KYOCERA Document Solutions
South Africa (Pty) Ltd.**

KYOCERA House, Hertford Office Park,
90 Bekker Road (Cnr. Allandale), Midrand, South Africa.
Phone: +27-11-540-2600
Fax: +27-11-466-3050

KYOCERA Document Solutions Russia LLC

Botanichesky pereulok 5, Moscow, 129090,
Russia
Phone: +7(495)741-0004
Fax: +7(495)741-0018

KYOCERA Document Solutions Middle East

Dubai Internet City, Bldg. 17,
Office 157 P.O. Box 500817, Dubai,
United Arab Emirates
Phone: +971-04-433-0412

KYOCERA Document Solutions Inc.

2-28, 1-chome, Tamatsukuri, Chuo-ku
Osaka 540-8585, Japan
Phone: +81-6-6764-3555
<http://www.kyoceradocumentsolutions.com>