



FS-C5350DN ECOSYS-P6030cdn

PARTS LIST

Published in January 2014
2K8PL072
Rev.2

CONTENTS

FIG. 1	Covers 1	2
FIG. 2	Covers 2	4
FIG. 3	Frames 1	6
FIG. 4	Frames 2	8
FIG. 5	Paper Cassette	10
FIG. 6	Paper Feed Section 1	12
FIG. 7	Paper Feed Section 2	14
FIG. 8	Paper Conveying Section	16
FIG. 9	Image Formation Section	18
FIG. 10	Developing Section	20
FIG. 11	Fuser Section	22
FIG. 12	Drive Section	24
FIG. 13	Exit Section	26
FIG. 14	Electrical Components	28
FIG. 15	Maintenance Kits	30
	• INDEX	31

<Notation of products>

For the purpose of this parts list, products are identified as following.

FS-C5350DN : (A)

ECOSYS-P6030cdn : (B)

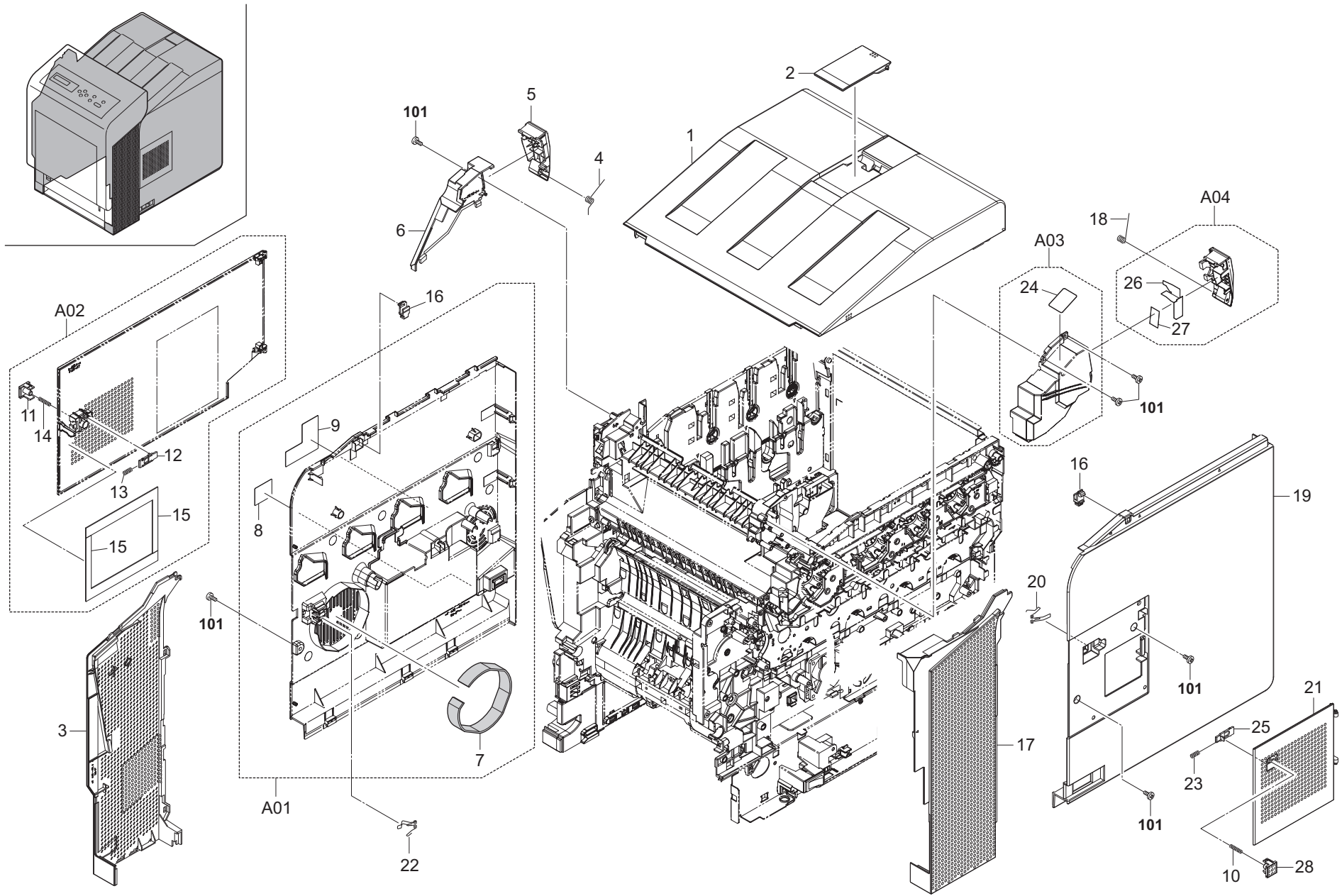

FIG. 1 Covers 1

2K8/2PP

Ref. No.	Part.No.	Alternative.	Description	Notes	Quantity		
					120	230	240
⊙ 1	302HN04010	2HN04010	COVER TOP		1	1	1
⊙ 2	302HN04190	2HN04190	STOPPER EXIT		1	1	1
⊙ 3	302HN04070	2HN04070	COVER LEFT FRONT		1	1	1
4	302HN04300	2HN04300	SPRING LEFT LEVER		1	1	1
⊙ 5	302HN04130	2HN04130	LEVER FRONT COVER LEFT		1	1	1
⊙ 6	302HN04090	2HN04090	COVER UPPER LEFT		1	1	1
⊙ A01	302HN94210	2HN94210	COVER LEFT REAR ASSY SP		1	1	1
7	*302HN04310	2HN04310	SPONGE LEFT COVER		1	1	1
8	*302HN04320	2HN04320	LABEL USB		1	1	1
9	*302HN04340	2HN04340	LABEL WASTE BOTTLE		1	1	1
10	302HN04260	2HN04260	SPRING SIDE LEVER		1	1	1
⊙ A02	302HN94340	2HN94340	COVER SIDE ASSY SP		1	1	1
⊙ 11	*302HN04200	2HN04200	LEVER SIDE COVER		1	1	1
⊙ 12	*302HN04210	2HN04210	HOOK SIDE COVER		1	1	1
13	*302HN04250	2HN04250	SPRING SIDE COVER		1	1	1
14	*302HN04260	2HN04260	SPRING SIDE LEVER		1	1	1
15	*302HN04391	2HN04391	SEAL COVER SIDE		2	2	2
⊙ 16	302HN04230	2HN04230	HOOK TOP COVER		2	2	2
⊙ 17	302HN04080	2HN04080	COVER RIGHT FRONT		1	1	1
18	302HN04290	2HN04290	SPRING RIGHT LEVER		1	1	1
⊙ 19	302HN04041	2HN04041	COVER RIGHT REAR		1	1	1
20	302HN04280	2HN04280	SPRING RIGHT LID		1	1	1
⊙ 21	302HN04050	2HN04050	LID RIGHT COVER		1	1	1
22	302HN04240	2HN04240	SPRING LEFT COVER		1	1	1
23	302HN04250	2HN04250	SPRING SIDE COVER		1	1	1
⊙ A03	302HN94280	2HN94280	COVER UPPER RIGHT ASSY SP		1	1	1
24	*302HN04330	2HN04330	LABEL FUSER CAUTION		1	1	1
⊙ 25	302HN04210	2HN04210	HOOK SIDE COVER		1	1	1
⊙ A04	302HN94270	2HN94270	LEVER FRONT COVER RIGHT ASSY SP		1	1	1
26	*302HN04350	2HN04350	SHEET LEVER RIGHT A		1	1	1
27	*302HN04360	2HN04360	SHEET LEVER RIGHT B		1	1	1
⊙ 28	302HN04200	2HN04200	LEVER SIDE COVER		1	1	1

Ref. No.	Part.No.	Alternative.	Description	Notes	Quantity		
					120	230	240
101	5MBTPB4010PW++R	B1A64100	BIND T.T SCREW(+)/ M4 X 10 CRFREE P-T				

- Parts with "⊙" indicate regular maintenance parts.
- Parts with Ref.No. indicate maintenance parts and the ones without it indicate out of the above.

- Parts with "*" are component parts or sub-assemblies of the assembly appearing immediately above them.
- Parts with "*•" are component parts or sub-assembly with "*" appearing immediately above them.

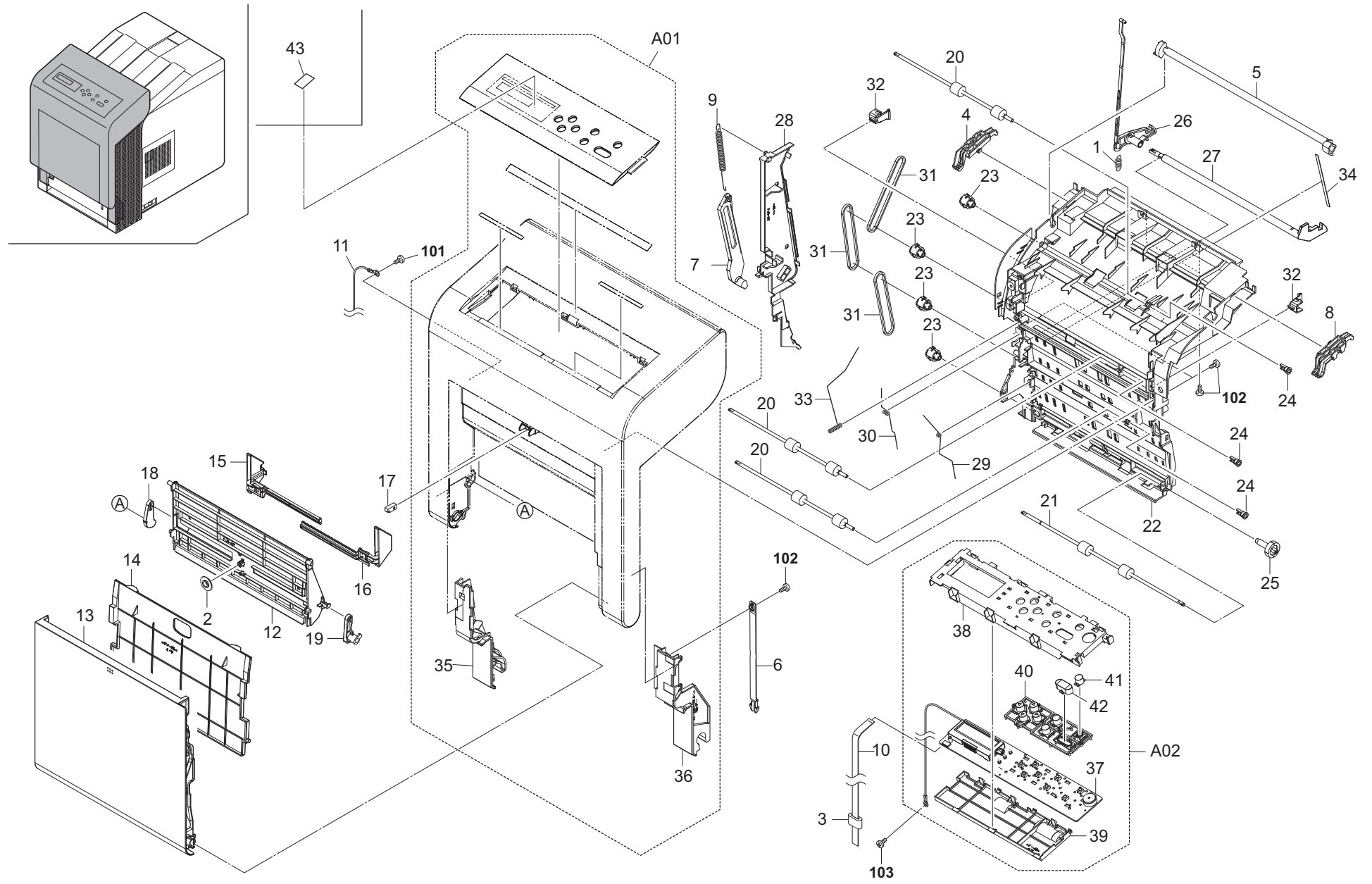

FIG. 2 Covers 2

2K8/2PP-2

Ref. No.	Part.No.	Alternative.	Description	Notes	Quantity		
					120	230	240
1	302F908300	2F908300	SPRING LOCK MPF		1	1	1
2	302B700780	2B700780	GEAR MANUAL		1	1	1
3	7YBFG0509001H01	YB055270	FERRITE CORE		1	1	1
4	302HN04151	2HN04151	GUIDE FRONT COVER RELEASE LEFT		1	1	1
⊙	5	302HN04160	SHAFT FRONT COVER RELEASE		1	1	1
⊙	6	302HN04170	STOPPER FRONT COVER RIGHT		1	1	1
⊙	7	302HN04181	STOPPER FRONT COVER LEFT		1	1	1
8	302HN04221	2HN04221	GUIDE FRONT COVER RELEASE RIGHT		1	1	1
9	302HN04270	2HN04270	SPRING FRONT COVER		1	1	1
⊙	10	302HN46320	CONN.CORD ASSY S03285		1	1	1
⊙	11	302HN46480	CONN.CORD ASSY S03386		1	1	1
12	302HN08010	2HN08010	BASE MPF		1	1	1
13	302HN08020	2HN08020	COVER MPF		1	1	1
14	302HN08030	2HN08030	TRAY MPF TOP		1	1	1
15	302HN08050	2HN08050	GUIDE MPF L		1	1	1
16	302HN08060	2HN08060	GUIDE MPF R		1	1	1
17	302HN08140	2HN08140	LUTCH		1	1	1
18	302HN08150	2HN08150	LINK LEVER MPF L		1	1	1
19	302HN08160	2HN08160	LINK LEVER MPF R		1	1	1
⊙	20	302HN29010	ROLLER DU		3	3	3
⊙	21	302HN29020	ROLLER DU FEED		1	1	1
22	302HN29031	2HN29031	BASE DU		1	1	1
⊙	23	302HN29040	PULLEY P24 S2M DU		4	4	4
24	302HN29050	2HN29050	BUSH DU		3	3	3
⊙	25	302HN29060	GEAR Z23L DU FEED		1	1	1
26	302HN29070	2HN29070	HOOK DU RELEASE LEFT		1	1	1
27	302HN29080	2HN29080	HOOK DU RELEASE RIGHT		1	1	1
28	302HN29101	2HN29101	COVER INNER DU		1	1	1
29	302HN29130	2HN29130	SPRING DU EARTH A		1	1	1
30	302HN29140	2HN29140	SPRING DU EARTH B		1	1	1
⊙	31	302HN29150	BELT DU		3	3	3
32	302HN29160	2HN29160	HOOK CONVEYING		2	2	2
33	302HN29170	2HN29170	SPRING DU EARTH C		1	1	1
34	302HN29190	2HN29190	SHEET BASE DU		1	1	1
⊙	A01	302K894010	COVER FRONT SUB ASSY	(A)	1	1	1
⊙	A01	302PP94030	PARTS COVER FRONT SUB ASSY SP	(B)	1	1	1
⊙	35	*302HN04111	COVER LOWER LEFT		1	1	1
⊙	36	*302HN04120	COVER LOWER RIGHT		1	1	1
⊙	A02	302HN94241	KEY BORAD ASSY SP	(A)	1	1	1
⊙	A02	302PP94050	PARTS KEY BOARD ASSY SP	(B)	1	1	1
⊙	37	*302HN01030	P.W.BOARD ASSY LCD CONT	(A)	1	1	1
⊙	37	*302PP94100	PARTS PWB ASSY LCDCONT SP	(B)	1	1	1
38	*302HN05022	2HN05022	MOUNT LCD UPPER		1	1	1
39	*302HN05030	2HN05030	MOUNT LCD LOWER		1	1	1
40	*302HN05041	2HN05041	BUTTON A		1	1	1
41	*302HN05050	2HN05050	BUTTON B		1	1	1
42	*302HN05060	2HN05060	BUTTON C	(A)	1	1	1
42	*302PP05020	2PP05020	BUTTON C	(B)	1	1	1
43	302HN05180	2HN05180	LABEL 6 NATIONS		1		

Ref. No.	Part.No.	Alternative.	Description	Notes	Quantity		
					120	230	240
101	BAA63080	BAA63080	+TP TAP-TITE P SCREW M3X08				
102	5MBTPB3008PW++R	B1A63080	BIND T.T SCREW(+)/ M3 X 8 CRFREE P-T				
103	B1A54080	B1A54080	+BIND TAP-TITE S SCREW M4X08				

- Parts with "⊙" indicate regular maintenance parts.
- Parts with Ref.No. indicate maintenance parts and the ones without it indicate out of the above.

- Parts with "*" are component parts or sub-assemblies of the assembly appearing immediately above them.
- Parts with "••" are component parts or sub-assembly with "•" appearing immediately above them.

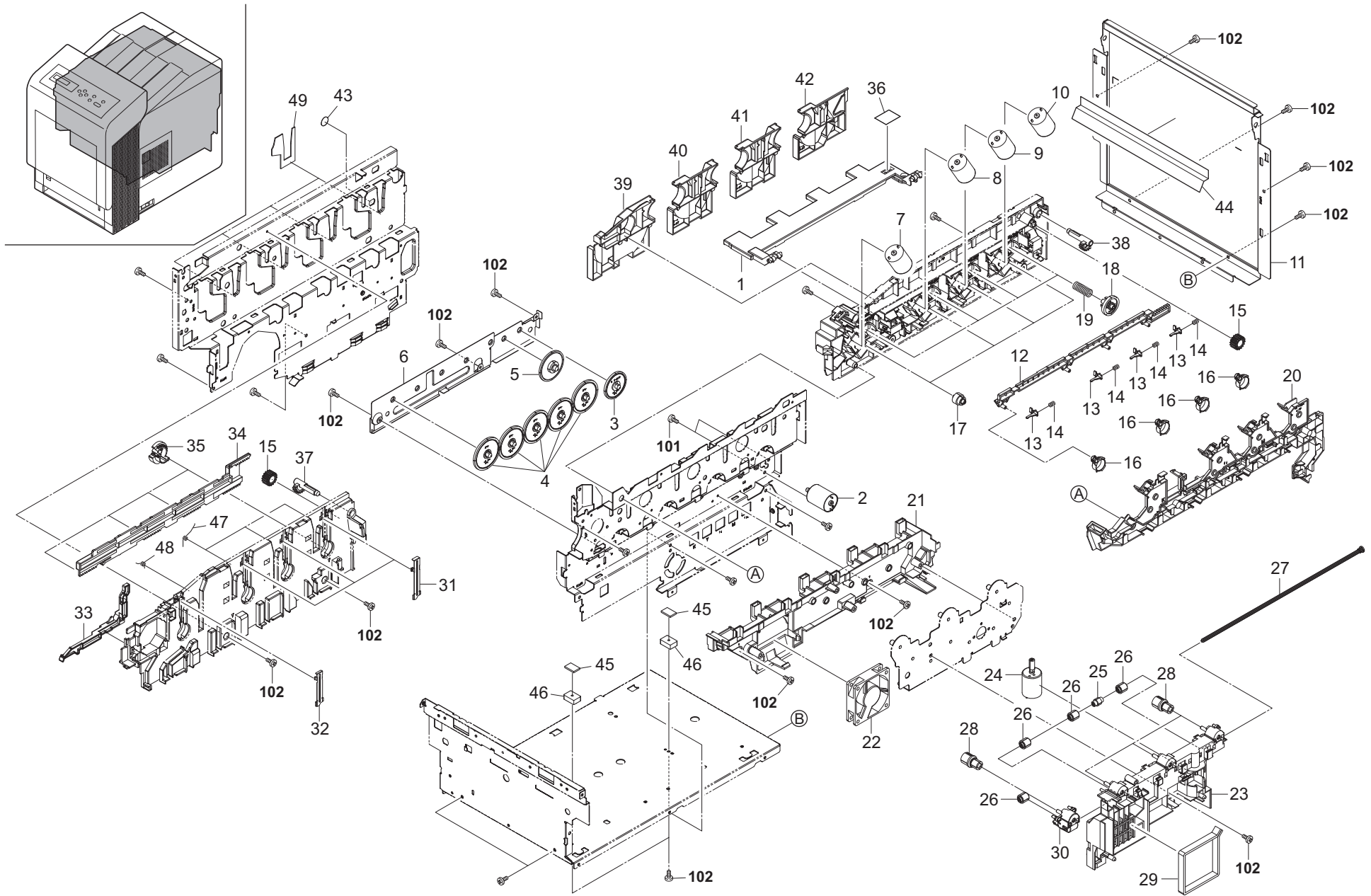

FIG. 3 Frames 1

2K8/2PP

Ref. No.	Part.No.	Alternative.	Description	Notes	Quantity		
					120	230	240
1	302HN02210	2HN02210	HOLDER RFID		1	1	1
2	302HN94110	2HN94110	DC MOTOR ASSY LSU SP		1	1	1
3	302HN03430	2HN03430	GEAR Z63R-Z25R		1	1	1
4	302HN03450	2HN03450	GEAR Z54S		5	5	5
5	302HN03440	2HN03440	GEAR Z70L-Z17S		1	1	1
6	302HN03410	2HN03410	MOUNT GLASS CLN DRIVE		1	1	1
7	302HN94060	2HN94060	DC MOTOR ASSY K SP		1	1	1
8	302HN94070	2HN94070	DC MOTOR ASSY Y SP		1	1	1
9	302HN94080	2HN94080	DC MOTOR ASSY C SP		1	1	1
10	302HN94090	2HN94090	DC MOTOR ASSY M SP		1	1	1
11	302HN02050	2HN02050	FRAME REAR		1	1	1
12	302HN02170	2HN02170	RACK TONER SUPPLY R		1	1	1
13	302HN02701	2HN02701	ACTUATOR CONTAINER		4	4	4
14	302HN02710	2HN02710	SPRING ACT CONT		4	4	4
15	302HN02150	2HN02150	GEAR Z16S HINGE		2	2	2
16	302HN02190	2HN02190	CAM TONER SUPPLY		4	4	4
17	302HN15030	2HN15030	GEAR Z20S-Z26L		4	4	4
18	302HN15020	2HN15020	GEAR Z50S		4	4	4
19	302HN15040	2HN15040	SPRING JOINT		4	4	4
20	302HN02200	2HN02200	HOLDER HARNESS		1	1	1
21	302HN02230	2HN02230	DUCT RIGHT		1	1	1
22	302HN44020	2HN44020	FAN MOTOR		1	1	1
23	302HN03340	2HN03340	HOLDER MCH CLN MOTOR		1	1	1
24	302HN94100	2HN94100	DC MOTOR ASSY MCH SP		1	1	1
25	302HN03310	2HN03310	GEAR Z16L		1	1	1
26	302HN03320	2HN03320	GEAR Z14R		4	4	4
27	302HN03360	2HN03360	SHAFT MCH CLN		1	1	1
28	302HN03330	2HN03330	GEAR Z16S-Z14R		4	4	4
29	302HN02990	2HN02990	OZONE FILTER VOC700		1	1	1
30	302HN03350	2HN03350	HOLDER MCH CLN DRIVE GEAR		1	1	1
31	302HN02680	2HN02680	PLATE CONTAINER C		3	3	3
32	302HN02670	2HN02670	PLATE CONTAINER K		1	1	1
33	302HN02300	2HN02300	ROD INTERLOCK		1	1	1
34	302HN02160	2HN02160	RACK TONER SUPPLY L		1	1	1
35	302HN02180	2HN02180	RATCHET CONTAINER		4	4	4
36	302HN02720	2HN02720	SEAL SQUARE 25-20		1	1	1
37	302HN02130	2HN02130	HINGE LEFT		1	1	1
38	302HN02140	2HN02140	HINGE RIGHT		1	1	1
39	302HN15070	2HN15070	GUIDE CONTAINER K		1	1	1
40	302HN15080	2HN15080	GUIDE CONTAINER Y		1	1	1
41	302HN15090	2HN15090	GUIDE CONTAINER C		1	1	1
42	302HN15110	2HN15110	GUIDE CONTAINER M		1	1	1
43	302HN02730	2HN02730	SEAL CIRCLE 12		1	1	1
44	302HN02850	2HN02850	SHEET FRAME REAR		1	1	1
45	302HN02870	2HN02870	SHEET SARCON		2	2	2
46	302HN02860	2HN02860	BLOCK HEAT CONDUCT		2	2	2
47	302HN15160	2HN15160	SPRING P CONT C		3	3	3
48	302HN15170	2HN15170	SPRING P CONT K		1	1	1
49	302HN02880	2HN02880	SEAL TN WASTE		4	4	4

Ref. No.	Part.No.	Alternative.	Description	Notes	Quantity		
					120	230	240
101	7BB001303H	BB063500	PAN HEAD SCREW M3X3				
102	5MBTPB3006TW++R	B1A53060	BIND T.T SCREW(+)/M3 X6 CRFREE S-T				

- Parts with "⊙" indicate regular maintenance parts.
- Parts with Ref.No. indicate maintenance parts and the ones without it indicate out of the above.

- Parts with "•" are component parts or sub-assemblies of the assembly appearing immediately above them.
- Parts with "••" are component parts or sub-assembly with "•" appearing immediately above them.

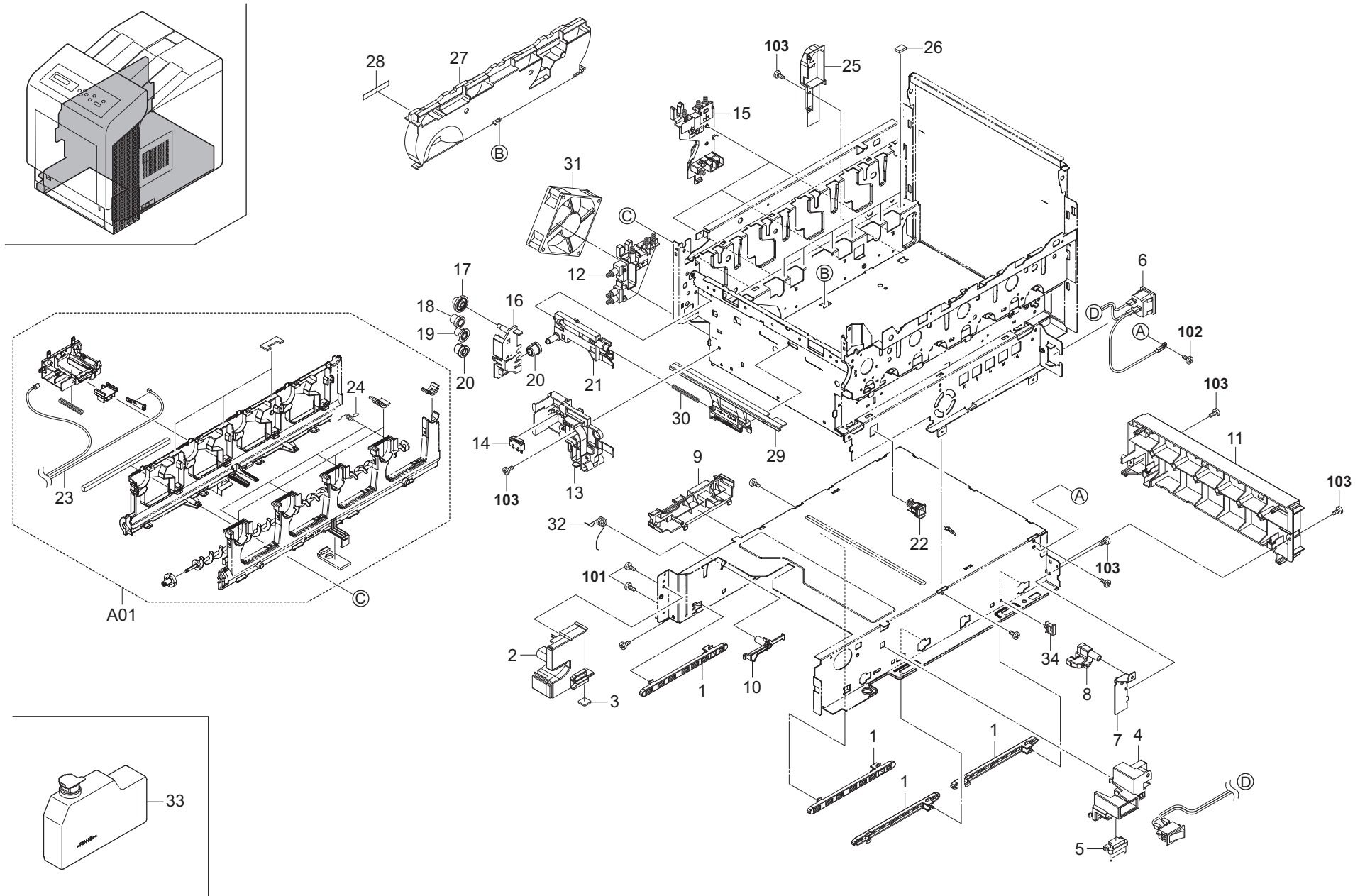

FIG. 4 Frames 2

2K8/2PP-1

	Ref. No.	Part.No.	Alternative.	Description	Notes	Quantity		
						120	230	240
	1	302HN02740	2HN02740	RAIL CASSETTE		4	4	4
	2	302HN02080	2HN02080	HINGE FEED LEFT		1	1	1
	3	302HN02611	2HN02611	FOOT		1	1	1
	4	302HN02541	2HN02541	BRACKET SWITCH		1	1	1
	5	302HN46350	2HN46350	CONN.CORD ASSY S03290		1	1	1
⊙	6	302HN00050	2HN00050	INLET ASSY		1	1	1
	7	302HN02550	2HN02550	BRACKET BASE		1	1	1
	8	302HN02620	2HN02620	BRACKET HARNESS		1	1	1
	9	302HN02630	2HN02630	BRACKET HARNESS L		1	1	1
	10	302HN02780	2HN02780	LOCK CASSETTE		1	1	1
⊙	11	302HN02070	2HN02070	COVER REAR		1	1	1
⊙	12	302HN94030	2HN94030	BRACKET HV K ASSY		1	1	1
⊙	13	302HN94040	2HN94040	CASE CONTACT HV K ASSY SP		1	1	1
⊙	14	302HN00060	2HN00060	SIDE SW ASSY		1	1	1
⊙	15	302HN94020	2HN94020	BRACKET HV C ASSY SP		3	3	3
	16	302HN02590	2HN02590	BRACKET GEAR		1	1	1
⊙	17	302HN02320	2HN02320	GEAR Z25S WASTE		1	1	1
⊙	18	302HN02330	2HN02330	GEAR Z17S WASTE		1	1	1
⊙	19	302HN02340	2HN02340	GEAR Z20S WASTE		1	1	1
⊙	20	302HN02350	2HN02350	GEAR Z14L-Z17S WASTE		2	2	2
	21	302HN02250	2HN02250	BRACKET FRONT		1	1	1
⊙	22	302HN94010	2HN94010	BRACKET HV TC ASSY SP		1	1	1
⊙	A01	302HN93171	2HN93171	PARTS WASTE TONER		1	1	1
	23	*302HN00130	2HN00130	TONER FULL DETECT ASSY		1	1	1
	24	*302HN02500	2HN02500	SPRING LOCK DRUM		4	4	4
	25	302HN02580	2HN02580	INNER COVER		1	1	1
	26	302HN02810	2HN02810	SEAL DUCT A		6	6	6
	27	302HN02220	2HN02220	DUCT LEFT		1	1	1
	28	302HN02840	2HN02840	SEAL DUCT D		1	1	1
⊙	29	302HN94051	2HN94051	BAR CLEANER ID ASSY SP		1	1	1
	30	302HN02490	2HN02490	SPRING CLEANER ID		1	1	1
⊙	31	302HN44010	2HN44010	FAN MOTOR		1	1	1
	32	302HN02770	2HN02770	SPRING LOCK CASSETTE		1	1	1
⊙	33	302HN93180	2HN93180	WT-560		1	1	1
	34	7YZM610007++H01	YZ023340	ACCESS.SADDLE		1	1	1

	Ref. No.	Part.No.	Alternative.	Description	Notes	Quantity		
						120	230	240
	101	5MBTPB3008PW++R	B1A63080	BIND T.T SCREW(+)/ M3 X 8 CRFREE P-T				
	102	B1A54080	B1A54080	+BIND TAP-TITE S SCREW M4X08				
	103	5MBTPB3006TW++R	B1A53060	BIND T.T SCREW(+)/M3 X6 CRFREE S-T				

- Parts with "⊙" indicate regular maintenance parts.
- Parts with Ref.No. indicate maintenance parts and the ones without it indicate out of the above.

- Parts with "*" are component parts or sub-assemblies of the assembly appearing immediately above them.
- Parts with "*•" are component parts or sub-assembly with "*" appearing immediately above them.

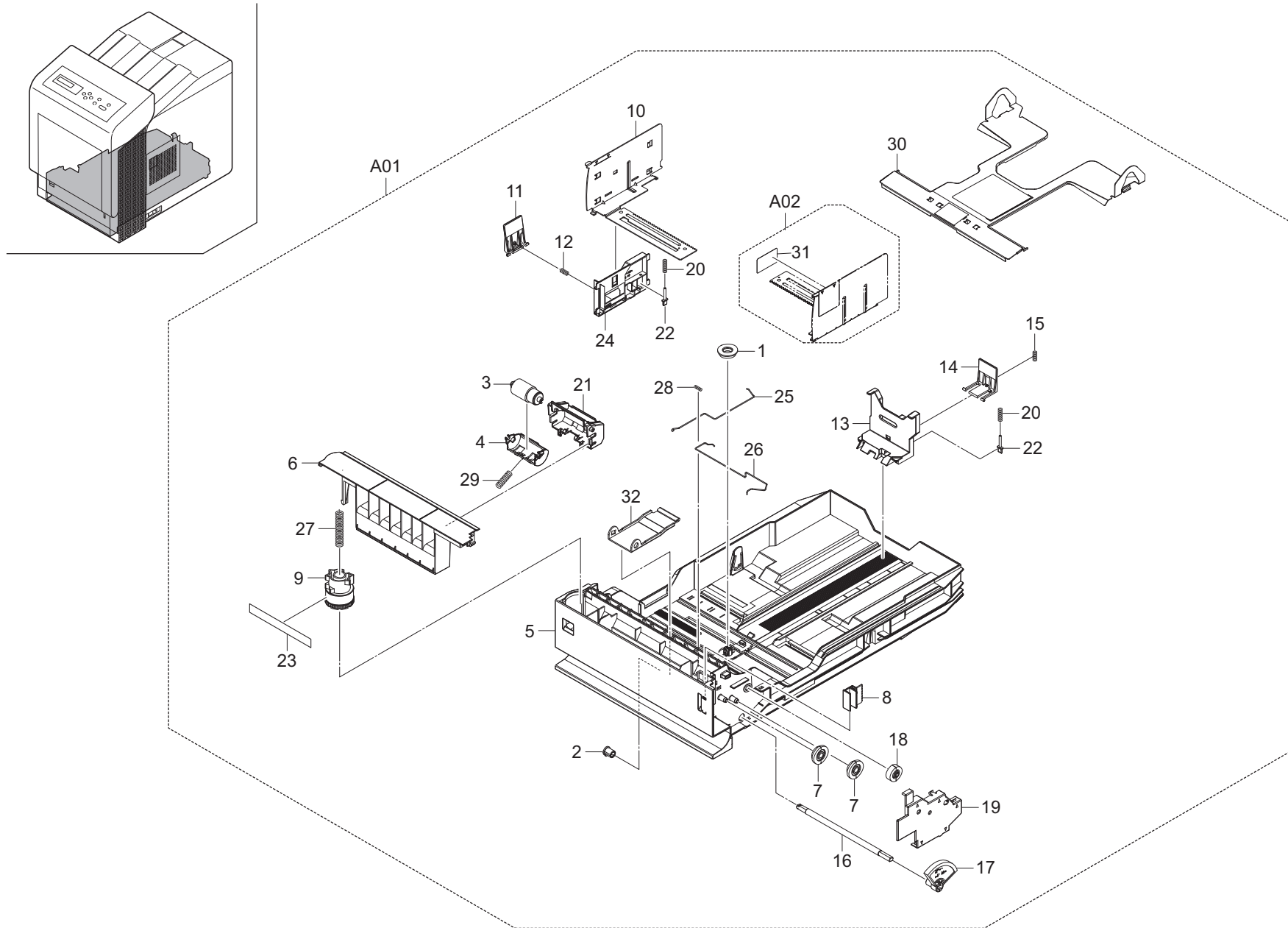

FIG. 5 Paper Cassette

2K8/2PP-1

	Ref. No.	Part.No.	Alternative.	Description	Notes	Quantity		
						120	230	240
⊙	A01	302HN93162	2HN93162	CT-501		1	1	1
	1	*302B700770	2B700770	GEAR CASSETTE		1	1	1
	2	*302F909160	2F909160	BUSH LIFT 6		1	1	1
⊙	3	*302F909171	2F909171	RETARD ROLLER ASSY		1	1	1
	4	*302F909180	2F909180	HOLDER RETARD		1	1	1
	5	*302HN09012	2HN09012	BASE CASSETTE		1	1	1
	6	*302HN09020	2HN09020	COVER CASSETTE TOP		1	1	1
	7	*302HN09030	2HN09030	GEAR Z20S-Z17S INDICATOR		2	2	2
	8	*302HN09041	2HN09041	MARKER INDICATOR		1	1	1
	9	*302HN09050	2HN09050	DIAL CASSETTE		1	1	1
	10	*302HN09070	2HN09070	CURSOR LEFT		1	1	1
	11	*302HN09090	2HN09090	LEVER GUIDE SIDE		1	1	1
	12	*302HN09100	2HN09100	SPRING GUIDE SIDE		1	1	1
	13	*302HN09110	2HN09110	CURSOR END		1	1	1
	14	*302HN09120	2HN09120	LEVER STOPPER		1	1	1
	15	*302HN09130	2HN09130	SPRING STOPPER		1	1	1
	16	*302HN09150	2HN09150	SHAFT WORKPLATE		1	1	1
	17	*302HN09160	2HN09160	GEAR Z50S LIFT		1	1	1
	18	*302HN09170	2HN09170	GEAR Z13S JOINT		1	1	1
	19	*302HN09180	2HN09180	COVER LIFT GEAR		1	1	1
	20	*302HN09190	2HN09190	SPRING FIX		2	2	2
	21	*302HN09230	2HN09230	GUIDE RETARD		1	1	1
	22	*302HN09240	2HN09240	SIZE FIX		2	2	2
	23	*302HN09250	2HN09250	LABEL DIAL		1	1	1
	24	*302HN09350	2HN09350	CURSOR LEFT B		1	1	1
	25	*302HN09371	2HN09371	SPRING EARTH		1	1	1
	26	*302HN09391	2HN09391	SPRING EARTH SIDE		1	1	1
	27	*302HN09400	2HN09400	SPRING DIAL		1	1	1
	28	*302HN09410	2HN09410	SPRING EARTH C		1	1	1
	29	*302HN09430	2HN09430	SPRING RETARD		1	1	1
⊙	30	*302HN94190	2HN94190	PLATE BOTTOM ASSY SP		1	1	1
⊙	A02	*302HN94300	2HN94300	CURSOR RIGHT PF ASSY 2HN SP		1	1	1
	31	**302HN09420	2HN09420	LABEL CURSOR		1	1	1
	32	*303K809490	3K809490	WORKPLATE LIFT PF		1	1	1

	Ref. No.	Part.No.	Alternative.	Description	Notes	Quantity		
						120	230	240

- Parts with "⊙" indicate regular maintenance parts.
- Parts with Ref.No. indicate maintenance parts and the ones without it indicate out of the above.

- Parts with "*" are component parts or sub-assemblies of the assembly appearing immediately above them.
- Parts with "*•" are component parts or sub-assembly with "*" appearing immediately above them.

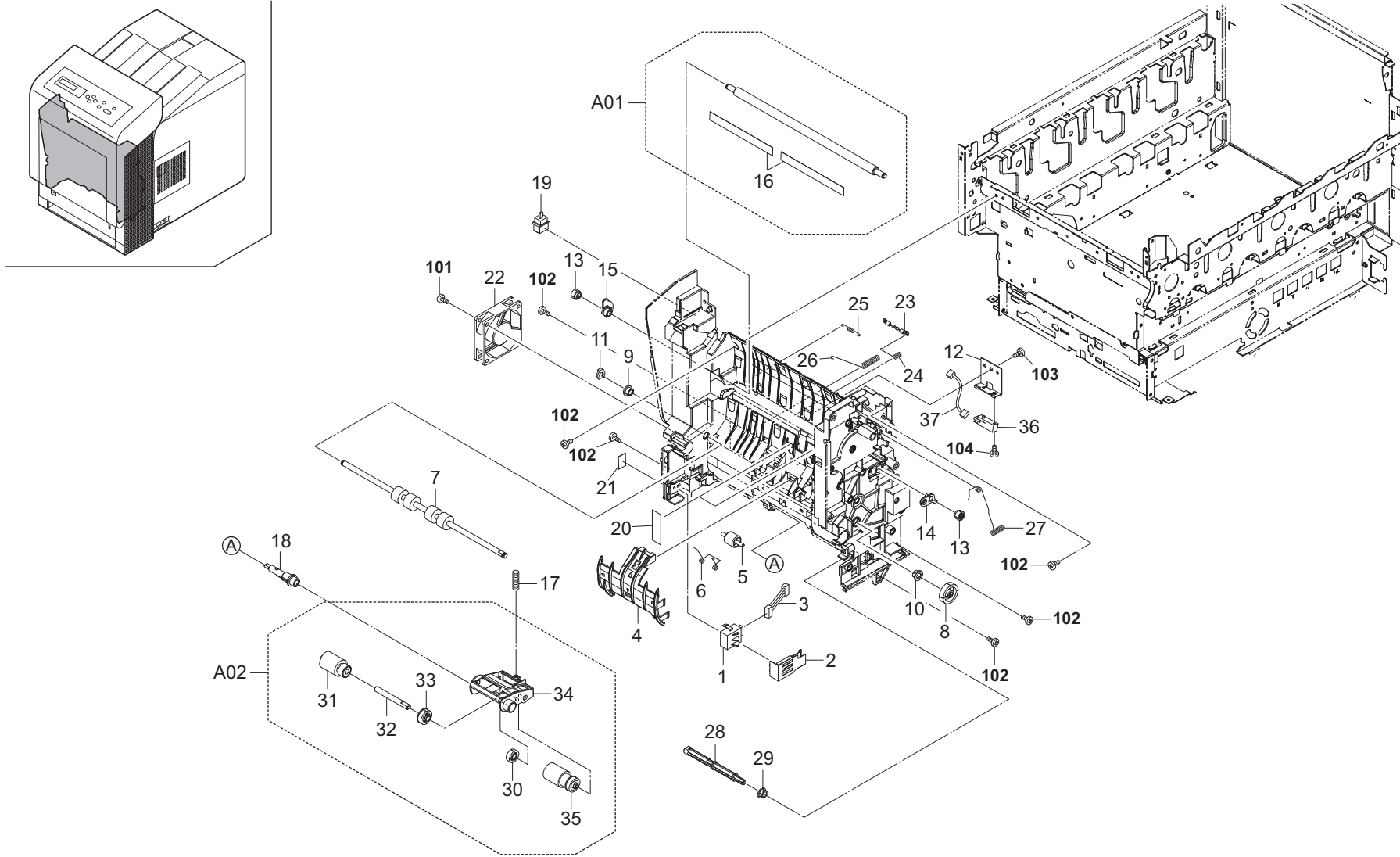

FIG. 6 Paper Feed Section 1

2K8/2PP-1

Ref. No.	Part.No.	Alternative.	Description	Notes	Quantity		
					120	230	240
⊙ 1	302HN44180	2HN44180	SWITCH SIZE		1	1	1
2	302HN02470	2HN02470	PLATE EARTH SIZE		1	1	1
3	302HN46130	2HN46130	CONN.CORD ASSY S03266		1	1	1
4	302HN06160	2HN06160	GUIDE HOUSING		1	1	1
5	302C921041	2C921041	PULLEY FEED SHIFT		2	2	2
6	302HN24230	2HN24230	SPRING MIDDLE		2	2	2
⊙ 7	302HN24030	2HN24030	ROLLER MIDDLE		1	1	1
⊙ 8	302HN24080	2HN24080	GEAR Z27R MIDDLE		1	1	1
9	302H024370	2H024370	BUSH 6 EW		1	1	1
10	302H702590	2H702590	BUSH SCREW		1	1	1
11	5MVX111DN003	2A806250	RING STOPPER /A-49 FEED A4		1	1	1
12	302HG02310	2HG02310	HOLDER SENSOR		1	1	1
⊙ 13	302HN24060	2HN24060	GEAR Z19L REG REAR		2	2	2
14	302HN24350	2HN24350	BUSH REGIST CL		1	1	1
15	302HN24410	2HN24410	BUSH REGIST EW		1	1	1
⊙ A01	302HN94130	2HN94130	ROLLER REG REAR SP		1	1	1
16	*302HN24160	2HN24160	SHEET REGIST FRONT		2	2	2
17	302HG06010	2HG06010	SPRING PICKUP		1	1	1
18	302F906110	2F906110	PIN FEED ROLL		1	1	1
⊙ 19	7SP01000001+H01	SP044290	SW.PUSH		1	1	1
20	302HN06180	2HN06180	SHEET HOUSING		2	2	2
21	302HN28220	2HN28220	SEAL ACTUATOR		1	1	1
⊙ 22	302HN44020	2HN44020	FAN MOTOR		1	1	1
23	302HN24430	2HN24430	HIGH MEG R ASSY		1	1	1
24	302HN24260	2HN24260	SPRING REG EARTH A		1	1	1
25	302HN24420	2HN24420	SPRING REG EARTH B		1	1	1
26	302HN24320	2HN24320	SPRING MID EARTH		1	1	1
27	302HN02450	2HN02450	SPRING CONTACT HV TC		1	1	1
28	302HN06030	2HN06030	SHAFT FEED R		1	1	1
29	302HN31590	2HN31590	BUSH DRIVE		1	1	1
⊙ A02	302HN94201	2HN94201	HOLDER FEED ASSY SP		1	1	1
30	*302F906030	2F906030	GEAR FEED Z26H		1	1	1
31	*302F906230	2F906230	PULLEY FEED ASSY		1	1	1
32	*302F906272	2F906272	SHAFT FEED L		1	1	1
⊙ 33	*302F906280	2F906280	GEAR FEED Z30H		1	1	1
34	*302HN06010	2HN06010	HOLDER FEED		1	1	1
35	*302HN06080	2HN06080	PULLEY PICKUP ASSY		1	1	1
⊙ 36	3H327410	3H327410	SENSOR,CONVEYING		1	1	1
37	302HG46090	2HG46090	CONN.CORD ASSY S03326		1	1	1

Ref. No.	Part.No.	Alternative.	Description	Notes	Quantity		
					120	230	240
101	5MBTPB3023WW++R	B1B73230	BIND T.T SCREW(+)/ M3 X 23 CRFREE B-T				
102	5MBTPB3006TW++R	B1A53060	BIND T.T SCREW(+)/M3 X6 CRFREE S-T				
103	7BB200308H	BB105660	+BIND T.T P SCREW 3X8				
104	7BB700314H	BB105610	+BIND T.T S SCREW 3X14 SR				

- Parts with "⊙" indicate regular maintenance parts.
- Parts with Ref.No. indicate maintenance parts and the ones without it indicate out of the above.

- Parts with "*" are component parts or sub-assemblies of the assembly appearing immediately above them.
- Parts with "*•" are component parts or sub-assembly with "*" appearing immediately above them.

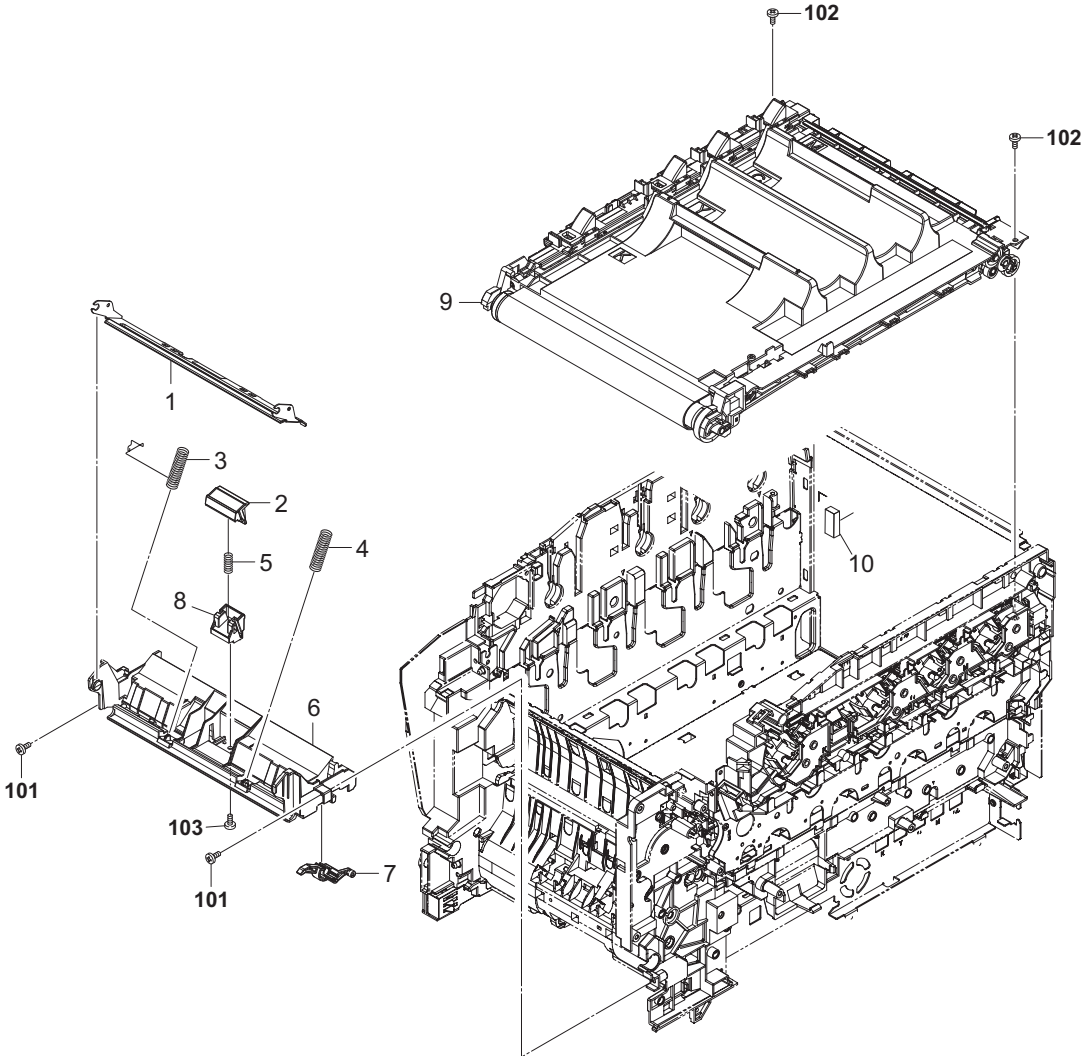
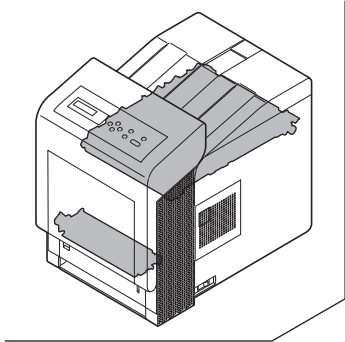

FIG. 7 Paper Feed Section 2

2K8/2PP-1

Ref. No.	Part.No.	Alternative.	Description	Notes	Quantity		
					120	230	240
⊙ 1	302HN94150	2HN94150	PLATE BOTTOM MPF ASSY SP		1	1	1
⊙ 2	302HN94160	2HN94160	SEPARATOR MPF ASSY SP		1	1	1
3	302HN08080	2HN08080	SP BOTTOM MPF L		1	1	1
4	302HN08090	2HN08090	SP BOTTOM MPF R		1	1	1
5	302HN08100	2HN08100	SPRING SEPARATOR		1	1	1
6	302HN08111	2HN08111	FRAME MPF LOW		1	1	1
7	302HN08181	2HN08181	LEVER CAM MPF		1	1	1
8	302HN08210	2HN08210	HOLDER SEPARATOR MPF		1	1	1
⊙ 9	302K893101	2K893101	TR-580		1	1	1
10	302HN02900	2HN02900	SEAL IMAGE REAR		1	1	1

Ref. No.	Part.No.	Alternative.	Description	Notes	Quantity		
					120	230	240
101	5MBTPB4010TW++R	B1A54100	BIND T.T SCREW(+)/ M4 X 10 CRFREE S-T				
102	5MBTPB4016PW++R	B1B64160	BIND T.T SCREW(+)/ M4 X 16 CRFREE P-T				
103	5MBTPB4010PW++R	B1A64100	BIND T.T SCREW(+)/ M4 X 10 CRFREE P-T				

- Parts with "⊙" indicate regular maintenance parts.
- Parts with Ref.No. indicate maintenance parts and the ones without it indicate out of the above.

- Parts with "." are component parts or sub-assemblies of the assembly appearing immediately above them.
- Parts with ". ." are component parts or sub-assembly with "." appearing immediately above them.

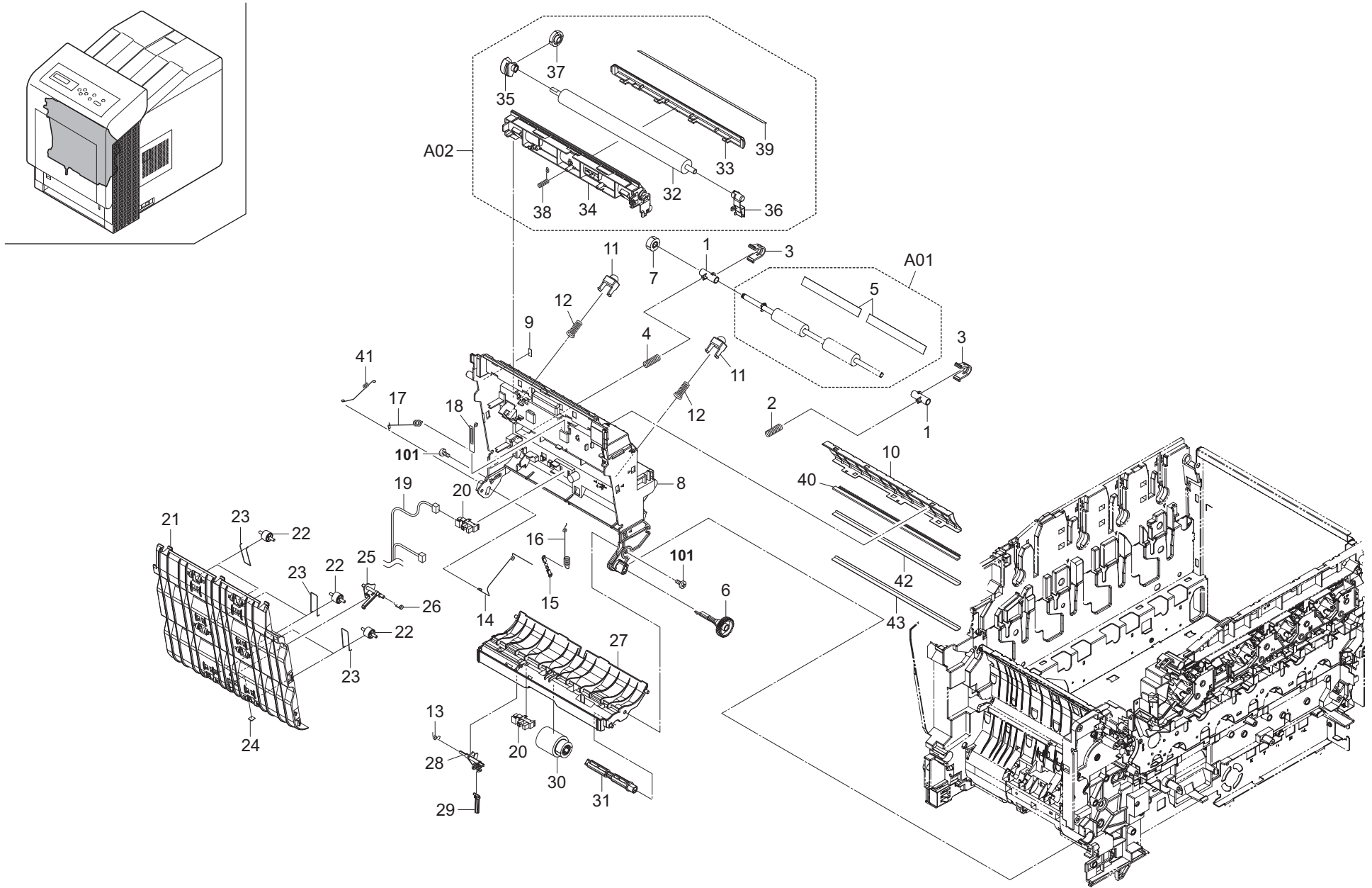

FIG. 8 Paper Conveying Section

2K8/2PP-1

Ref. No.	Part.No.	Alternative.	Description	Notes	Quantity		
					120	230	240
1	302HN24110	2HN24110	BUSH REG R		2	2	2
2	302HN24190	2HN24190	SPRING REG R		1	1	1
3	302HN24150	2HN24150	STOPPER BUSH REG		2	2	2
4	302HN24180	2HN24180	SPRING REG L		1	1	1
⊙ A01	302HN94170	2HN94170	ROLLER REG FRONT SP		1	1	1
5	*302HN24160	2HN24160	SHEET REGIST FRONT		2	2	2
⊙ 6	302HN06150	2HN06150	GEAR Z30S MPF		1	1	1
⊙ 7	302HN24070	2HN24070	GEAR Z31R REG FRONT		1	1	1
8	302HN24042	2HN24042	FRAME CONVEYING		1	1	1
9	302HG24180	2HG24180	LABEL EXIT B		1	1	1
10	302HN24090	2HN24090	PLATE EARTH GUIDE		1	1	1
11	302HN24370	2HN24370	STOPPER TC SPRING		2	2	2
12	302HG24150	2HG24150	SPRING TC L		2	2	2
13	302HN06170	2HN06170	SPRING MPF B		1	1	1
14	302HN24250	2HN24250	SPRING EARTH FEED		1	1	1
15	302HN24430	2HN24430	HIGH MEG R ASSY		1	1	1
16	302HN24280	2HN24280	SPRING GUIDE EARTH		1	1	1
17	302HN24380	2HN24380	SPRING GUIDE EARTH B		1	1	1
18	302HN24270	2HN24270	SPRING SEP EARTH A		1	1	1
19	302HN46110	2HN46110	CONN.CORD ASSY S03264		1	1	1
⊙ 20	7NXSG2481+++H01	NX052600	SENSOR OPT.		2	2	2
21	302HN24050	2HN24050	GUIDE FEED DU		1	1	1
22	302HN24400	2HN24400	PULLEY PA		6	6	6
23	302HN24290	2HN24290	SPRING DU		6	6	6
24	302HN24360	2HN24360	SPONGE A		1	1	1
25	302HN24140	2HN24140	ACTUATOR DU		1	1	1
26	302HN24300	2HN24300	SPRING ACT DU		1	1	1
27	302HN06100	2HN06100	FRAME MPF UP		1	1	1
28	302HN06121	2HN06121	ACTUATOR MPF		1	1	1
29	302HN06131	2HN06131	ACTUATOR MPF B		1	1	1
⊙ 30	5AAVROLL+051	2CL16130	ROLLER M/P ASSY /43487B0027 A4		1	1	1
31	302HN06110	2HN06110	SHAFT FEED MPF		1	1	1
⊙ A02	302HN93240	2HN93240	PARTS TRANSFER ASSY		1	1	1
⊙ 32	*302HN22010	2HN22010	ROLLER TRANSFER		1	1	1
33	*302HN22020	2HN22020	PAPER CHUTE		1	1	1
34	*302HN22030	2HN22030	HOLDER BRUSH		1	1	1
35	*302HN22050	2HN22050	BUSH TRANS L		1	1	1
36	*302HN22060	2HN22060	BUSH TRANS R		1	1	1
37	*302HN22070	2HN22070	GEAR Z22L TC ROLL		1	1	1
38	*302HN22080	2HN22080	SPRING SEP EARTH B		1	1	1
39	*302HN22110	2HN22110	SHEET PAPER CHUTE		1	1	1
⊙ 40	302HN24460	2HN24460	DISCHARGER TRANS		1	1	1
41	302HN24390	2HN24390	SPRING EARTH B		1	1	1
42	302HN24471	2HN24471	PLATE DISCHARGER		1	1	1
43	302HN24481	2HN24481	SHEET SEP PLATE		1	1	1

Ref. No.	Part.No.	Alternative.	Description	Notes	Quantity		
					120	230	240
101	5MBTPB4010PW++R	B1A64100	BIND T.T SCREW(+)/ M4 X 10 CRFREE P-T				

- Parts with "⊙" indicate regular maintenance parts.
- Parts with Ref.No. indicate maintenance parts and the ones without it indicate out of the above.

- Parts with "." are component parts or sub-assemblies of the assembly appearing immediately above them.
- Parts with ".•" are component parts or sub-assembly with ".•" appearing immediately above them.

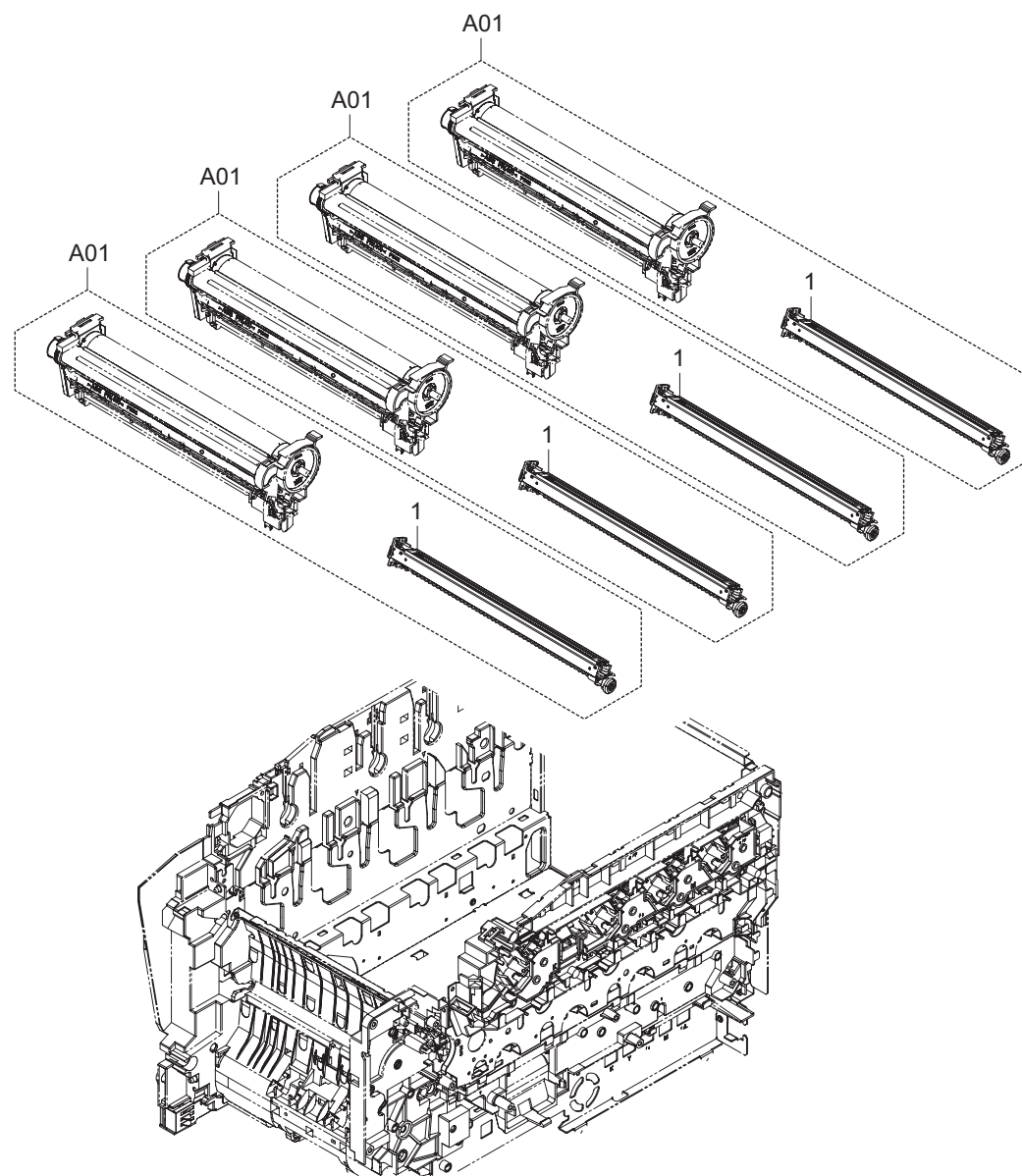
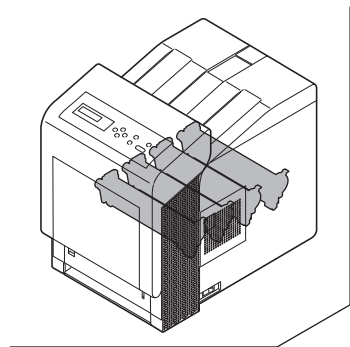

FIG. 9 Image Formation Section

2K8/2PP

	Ref. No.	Part.No.	Alternative.	Description	Notes	Quantity		
						120	230	240
⊙	A01	302K893010	2K893010	DK-580		4	4	4
⊙	1	*302HL93200	2HL93200	MC-560		4	4	4

	Ref. No.	Part.No.	Alternative.	Description	Notes	Quantity		
						120	230	240

- Parts with "⊙" indicate regular maintenance parts.
- Parts with Ref.No. indicate maintenance parts and the ones without it indicate out of the above.

- Parts with "." are component parts or sub-assemblies of the assembly appearing immediately above them.
- Parts with ".•" are component parts or sub-assembly with ".•" appearing immediately above them.

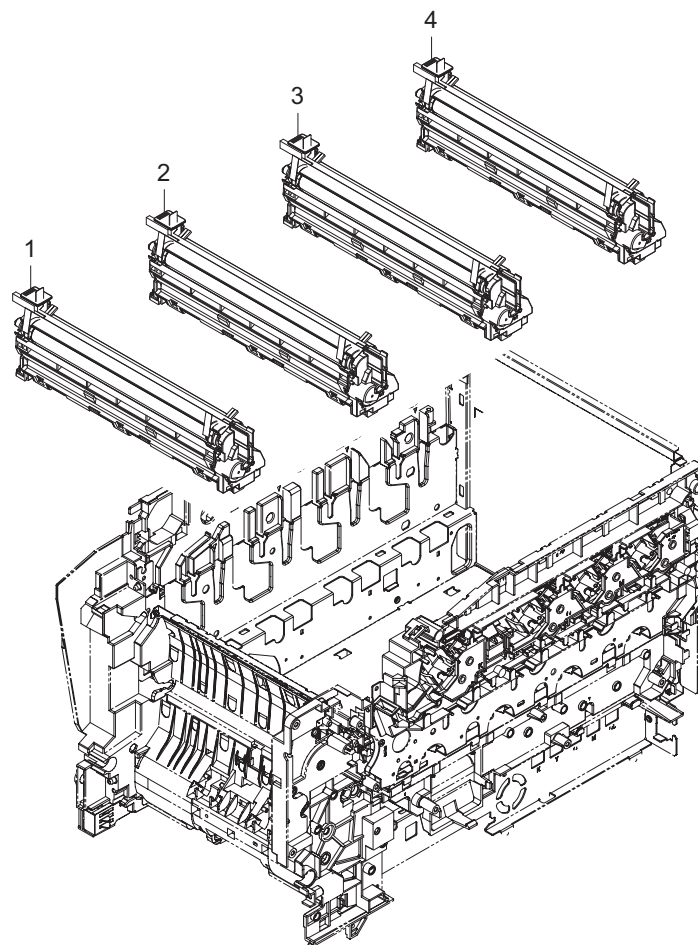
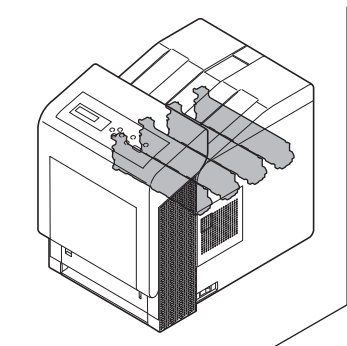

FIG. 10 Developing Section

2K8/2PP-1

	Ref. No.	Part.No.	Alternative.	Description	Notes	Quantity		
						120	230	240
⊙	1	302HN93013	2HN93013	DV-560(K)			1	1
⊙	1	302HN93253	2HN93253	DV-560 US (K)		1		
⊙	2	302HN93023	2HN93023	DV-560(Y)			1	1
⊙	2	302HN93263	2HN93263	DV-560 US (Y)		1		
⊙	3	302HN93033	2HN93033	DV-560(C)			1	1
⊙	3	302HN93273	2HN93273	DV-560 US (C)		1		
⊙	4	302HN93043	2HN93043	DV-560(M)			1	1
⊙	4	302HN93283	2HN93283	DV-560 US (M)		1		

	Ref. No.	Part.No.	Alternative.	Description	Notes	Quantity		
						120	230	240

- Parts with "⊙" indicate regular maintenance parts.
- Parts with Ref.No. indicate maintenance parts and the ones without it indicate out of the above.

- Parts with "•" are component parts or sub-assemblies of the assembly appearing immediately above them.
- Parts with "••" are component parts or sub-assembly with "•" appearing immediately above them.

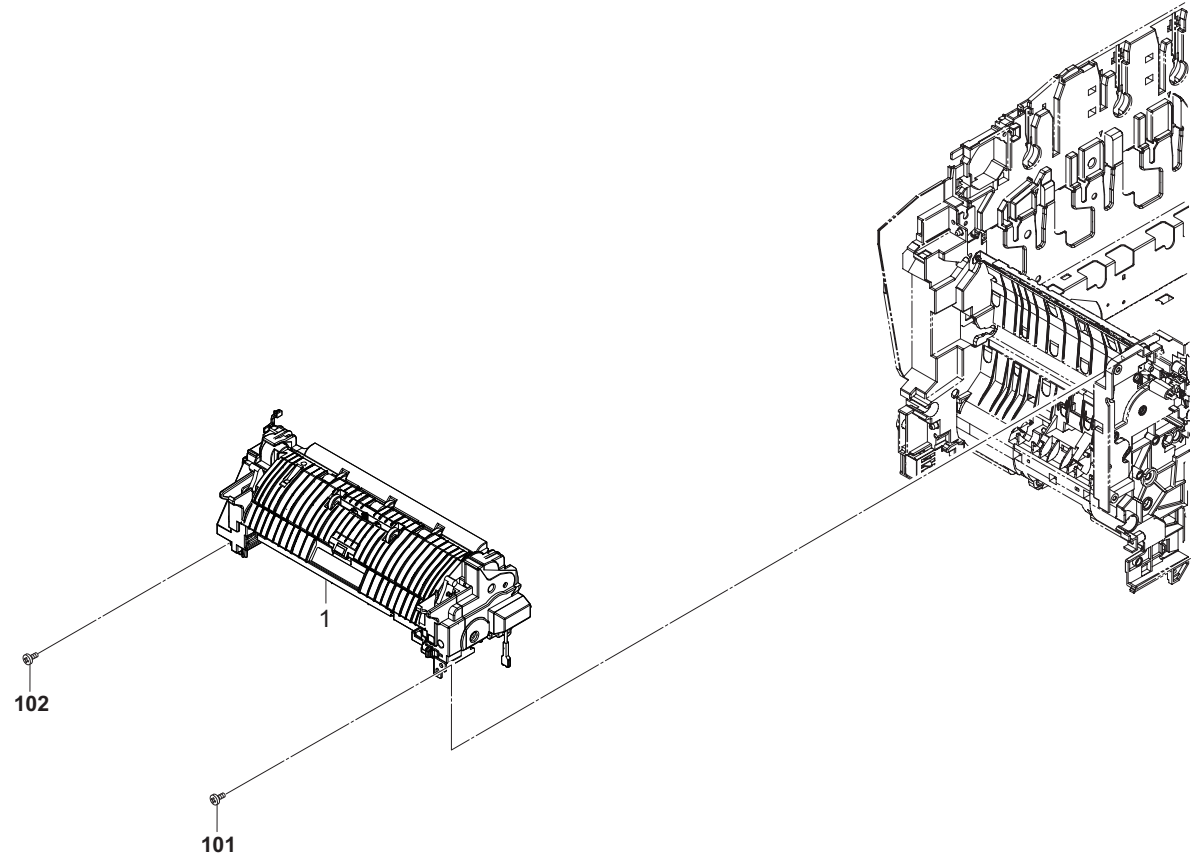
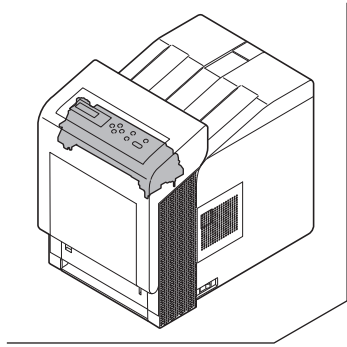

FIG. 11 Fuser Section

2K8/2PP-1

	Ref. No.	Part.No.	Alternative.	Description	Notes	Quantity		
						120	230	240
⊙	1	302K893031	2K893031	FK-580(U)		1		
⊙	1	302K893021	2K893021	FK-580(E)			1	1
	101	5MBTPB4010PW++R	B1A64100	BIND T.T SCREW(+) / M4 X 10 CRFREE P-T				
	102	B1A54080	B1A54080	+BIND TAP-TITE S SCREW M4X08				

	Ref. No.	Part.No.	Alternative.	Description	Notes	Quantity		
						120	230	240

- Parts with "⊙" indicate regular maintenance parts.
- Parts with Ref.No. indicate maintenance parts and the ones without it indicate out of the above.

- Parts with "." are component parts or sub-assemblies of the assembly appearing immediately above them.
- Parts with ". ." are component parts or sub-assembly with "." appearing immediately above them.

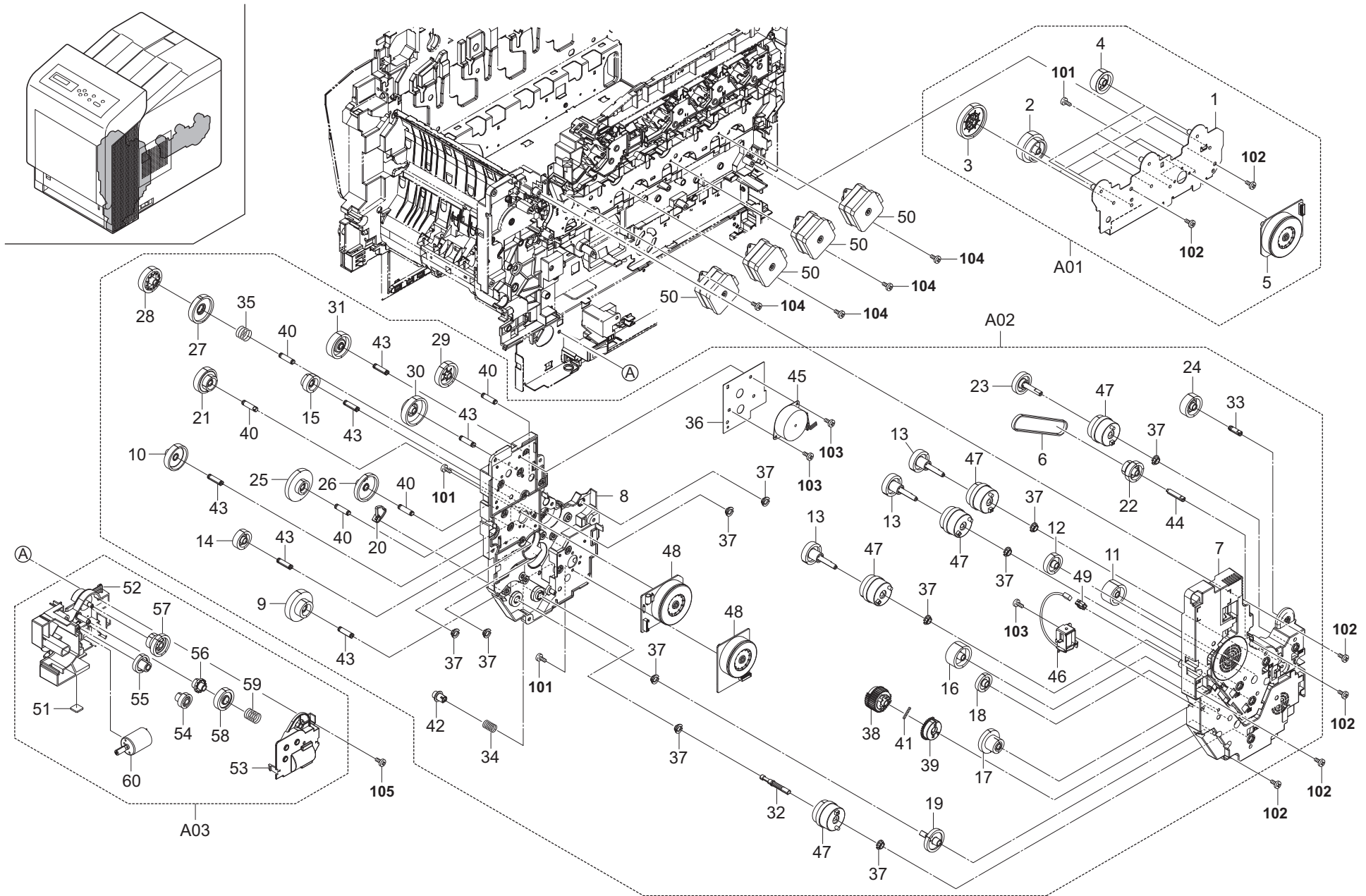

FIG. 12 Drive Section

2K8/2PP

	Ref. No.	Part.No.	Alternative.	Description	Notes	Quantity		
						120	230	240
⊙	A01	302K893080	2K893080	DR-580B		1	1	1
	1	*302HN31070	2HN31070	PLATE DRIVE		1	1	1
⊙	2	*302HN31080	2HN31080	GEAR Z74R-Z35L		3	3	3
⊙	3	*302HN31090	2HN31090	GEAR Z54R		3	3	3
⊙	4	*302HN31100	2HN31100	GEAR Z33L		3	3	3
⊙	5	*302KK94540	2KK94540	PARTS MOTOR BL W25 SP		1	1	1
⊙	A02	302K893070	2K893070	DR-580A		1	1	1
⊙	6	*2FB17260	2FB17260	BELT FEED HANDLE		1	1	1
	7	*302HN31111	2HN31111	HOLDER FEED DRIVE A		1	1	1
	8	*302HN31120	2HN31120	HOLDER FEED DRIVE B		1	1	1
⊙	9	*302HN31130	2HN31130	GEAR Z77R-Z25R		1	1	1
⊙	10	*302HN31141	2HN31141	GEAR Z39L		1	1	1
⊙	11	*302HN31150	2HN31150	GEAR Z32R IDLE		1	1	1
⊙	12	*302HN31160	2HN31160	GEAR Z30L		1	1	1
⊙	13	*302HN31170	2HN31170	GEAR Z32L CL FEED		3	3	3
⊙	14	*302HN31180	2HN31180	GEAR Z28R INPUT DU		1	1	1
⊙	15	*302HN31190	2HN31190	GEAR Z31R-Z26R INPUT REGIST		1	1	1
⊙	16	*302HN31200	2HN31200	GEAR Z35L		1	1	1
⊙	17	*302HN31210	2HN31210	GEAR Z36R-Z22S		1	1	1
⊙	18	*302HN31220	2HN31220	GEAR Z28S		1	1	1
⊙	19	*302HN31240	2HN31240	GEAR Z36S MPF CAM		1	1	1
⊙	20	*302HN31250	2HN31250	CAM MPF		1	1	1
⊙	21	*302HN31260	2HN31260	GEAR Z62R-P32		1	1	1
⊙	22	*302HN31270	2HN31270	GEAR Z30L-P30		1	1	1
⊙	23	*302HN31280	2HN31280	GEAR Z32R CL DLP		1	1	1
⊙	24	*302HN31290	2HN31290	GEAR Z33L INPUT DLP		1	1	1
⊙	25	*302HN31300	2HN31300	GEAR Z81R-Z35L		1	1	1
⊙	26	*302HN31311	2HN31311	GEAR Z70R		1	1	1
⊙	27	*302HN31320	2HN31320	GEAR Z70L		1	1	1
⊙	28	*302HN31330	2HN31330	GEAR Z38L		1	1	1
⊙	29	*302HN31340	2HN31340	GEAR Z38R INPUT MT		1	1	1
⊙	30	*302HN31350	2HN31350	GEAR Z72L-Z26S		1	1	1
⊙	31	*302HN31360	2HN31360	GEAR Z40S INPUT FUSER		1	1	1
	32	*302HN31370	2HN31370	SHAFT CLUTCH FEED		1	1	1
	33	*302HN31390	2HN31390	PIN DRIVE DLP		1	1	1
	34	*302HN31410	2HN31410	SPRING FEED		1	1	1
	35	*302HN31430	2HN31430	SPRING MID TRANSFER		1	1	1
	36	*302HN31560	2HN31560	PLATE MOTOR FUSER		1	1	1
	37	*302HN31590	2HN31590	BUSH DRIVE		11	11	11
⊙	38	*302HN31620	2HN31620	GEAR Z36S INPUT MPF A		1	1	1
⊙	39	*302HN31630	2HN31630	GEAR Z36S INPUT MPF B		1	1	1
	40	*302HN31640	2HN31640	PIN DRIVE MT		5	5	5
	41	*302HN31650	2HN31650	SPRING INPUT MPF		1	1	1
⊙	42	*302HN31660	2HN31660	JOINT SHAFT CASSETTE		1	1	1
	43	*302HN31670	2HN31670	PIN DRIVE A		6	6	6
	44	*302HN31680	2HN31680	PIN DRIVE B		1	1	1
⊙	45	*302HN44090	2HN44090	MOTOR FUSER		1	1	1
⊙	46	*302HN44160	2HN44160	SOLENOID MPF		1	1	1
⊙	47	*302HN44200	2HN44200	CLUTCH FEED L		5	5	5

	Ref. No.	Part.No.	Alternative.	Description	Notes	Quantity		
						120	230	240
⊙	48	*302KK94540	2KK94540	PARTS MOTOR BL W25 SP		2	2	2
	49	*7YCC02B1003+H01	YC013860	CONNECTOR 292254-2		1	1	1
⊙	50	302HN44050	2HN44050	MOTOR DRUM		4	4	4
⊙	A03	302HN94182	2HN94182	DRIVE LIFT ASSY SP		1	1	1
	51	*302HN02611	2HN02611	FOOT		1	1	1
	52	*302HN31010	2HN31010	BRACKET DRIVE LIFT		1	1	1
	53	*302HN31020	2HN31020	COVER GEAR LIFT		1	1	1
⊙	54	*302HN31030	2HN31030	GEAR Z36L-Z20S		1	1	1
⊙	55	*302HN31040	2HN31040	GEAR Z46S-Z13S		1	1	1
⊙	56	*302HN31050	2HN31050	GEAR Z13S		1	1	1
⊙	57	*302HN31060	2HN31060	GEAR Z35S-Z13S		1	1	1
⊙	58	*302HN31540	2HN31540	GEAR Z34S		1	1	1
	59	*302HN31550	2HN31550	SPRING DRIVE LIFT		1	1	1
⊙	60	*302HN94261	2HN94261	DC MOTOR ASSY LIFT SP		1	1	1
	101	B1B03040	B1B03040	+BIND SCREW M3X04 (TRIVALENT CHROMATING)				
	102	5MBTPB4010PW++R	B1A64100	BIND T.T SCREW(+)/ M4 X 10 CRFREE P-T				
	103	5MBTPB3008PW++R	B1A63080	BIND T.T SCREW(+)/ M3 X 8 CRFREE P-T				
	104	5MBTPB3006TW++R	B1A53060	BIND T.T SCREW(+)/M3 X6 CRFREE S-T				
	105	B1A54080	B1A54080	+BIND TAP-TITE S SCREW M4X08				

- Parts with "⊙" indicate regular maintenance parts.
- Parts with Ref.No. indicate maintenance parts and the ones without it indicate out of the above.

- Parts with "." are component parts or sub-assemblies of the assembly appearing immediately above them.
- Parts with ". ." are component parts or sub-assembly with ". ." appearing immediately above them.

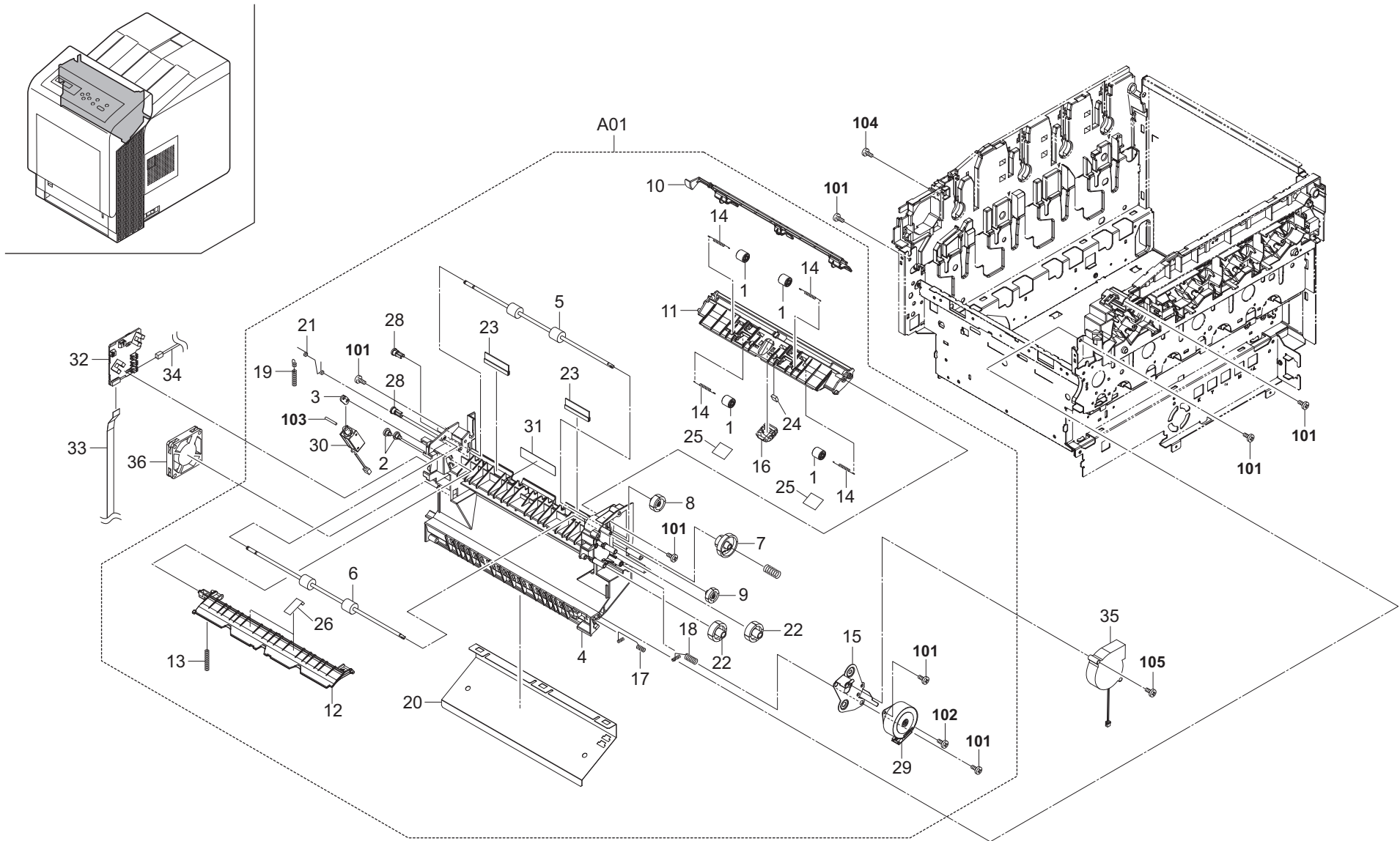

FIG. 13 Exit Section

2K8/2PP-1

	Ref. No.	Part.No.	Alternative.	Description	Notes	Quantity		
						120	230	240
⊙	A01	302HN93141	2HN93141	PARTS EXIT ASSY(25)		1	1	1
	1	*2FM02210	5MVM274DN002	PULLEY MID /B-11 FRAME A4		4	4	4
	2	*302F325010	2F325010	STUD SCREW M3		2	2	2
	3	*302F925060	2F925060	ACTUATOR SOL		1	1	1
	4	*302HN28010	2HN28010	HOUSING EXIT		1	1	1
⊙	5	*302HN28021	2HN28021	ROLLER FD		1	1	1
⊙	6	*302HN28030	2HN28030	ROLLER REVERSE		1	1	1
⊙	7	*302HN28050	2HN28050	GEAR Z55R-Z17R		1	1	1
⊙	8	*302HN28060	2HN28060	GEAR Z23S FD		1	1	1
⊙	9	*302HN28071	2HN28071	GEAR Z20L REVERSE		1	1	1
⊙	10	*302HN28080	2HN28080	ACTUATOR FULL		1	1	1
	11	*302HN28090	2HN28090	GUIDE EXIT UP		1	1	1
	12	*302HN28100	2HN28100	GUIDE CHANGE		1	1	1
	13	*302HN28110	2HN28110	SPRING SOLENOID		1	1	1
	14	*302HN28120	2HN28120	SPRING PULLEY A		4	4	4
	15	*302HN28130	2HN28130	PLATE MOTOR A		1	1	1
	16	*302HN28140	2HN28140	GUIDE CORRUGATION		1	1	1
	17	*302HN28150	2HN28150	SPRING EARTH EXIT A		1	1	1
	18	*302HN28160	2HN28160	SPRING EARTH EXIT B		1	1	1
	19	*302HN28170	2HN28170	SPRING EARTH EXIT C		1	1	1
	20	*302HN28180	2HN28180	STAY FRONT		1	1	1
	21	*302HN28190	2HN28190	SPRING EARTH EXIT D		1	1	1
⊙	22	*302HN28200	2HN28200	GEAR Z28S IDLE		2	2	2
	23	*302HN28210	2HN28210	DISCHARGER FD		2	2	2
	24	*302HN28220	2HN28220	SEAL ACTUATOR		1	1	1
	25	*302HN28230	2HN28230	SHEET PULLEY		2	2	2
	26	*302HN28240	2HN28240	SHEET CHANGE		2	2	2
	27	*302HN28250	2HN28250	SPRING GEAR		1	1	1
	28	*302HN29050	2HN29050	BUSH DU		2	2	2
⊙	29	*302HN44100	2HN44100	MOTOR REVERSE		1	1	1
⊙	30	*302HN94140	2HN94140	SOLENOID FD ASSY SP		1	1	1
	31	*5MVVL611WN06	2FV20100	LABEL FUSER CAUTION		1	1	1
⊙	32	302HN01150	2HN01150	P.W.BOARD ASSY EXIT		1	1	1
⊙	33	302HN46570	2HN46570	CONN.CORD ASSY S03400		1	1	1
	34	302HN46180	2HN46180	CONN.CORD ASSY S03271		1	1	1
⊙	35	302HN44210	2HN44210	FAN MOTOR		1	1	1
⊙	36	302HG44110	2HG44110	FAN MOTOR 50		1	1	1

	Ref. No.	Part.No.	Alternative.	Description	Notes	Quantity		
						120	230	240
	101	5MBTPB3008PW++R	B1A63080	BIND T.T SCREW(+)/ M3 X 8 CRFREE P-T				
	102	5MBTPB3006TW++R	B1A53060	BIND T.T SCREW(+)/M3 X6 CRFREE S-T				
	103	E0025140	E0025140	SPRING PIN 2.5X14				
	104	5MBTPB3023WW++R	B1B73230	BIND T.T SCREW(+)/ M3 X 23 CRFREE B-T				
	105	5MBTPB3020TW++R	B1A53200	BIND T.T SCREW(+)/ M3 X 20 CRFREE S-T				

- Parts with "⊙" indicate regular maintenance parts.
- Parts with Ref.No. indicate maintenance parts and the ones without it indicate out of the above.

- Parts with "." are component parts or sub-assemblies of the assembly appearing immediately above them.
- Parts with ". ." are component parts or sub-assembly with "." appearing immediately above them.

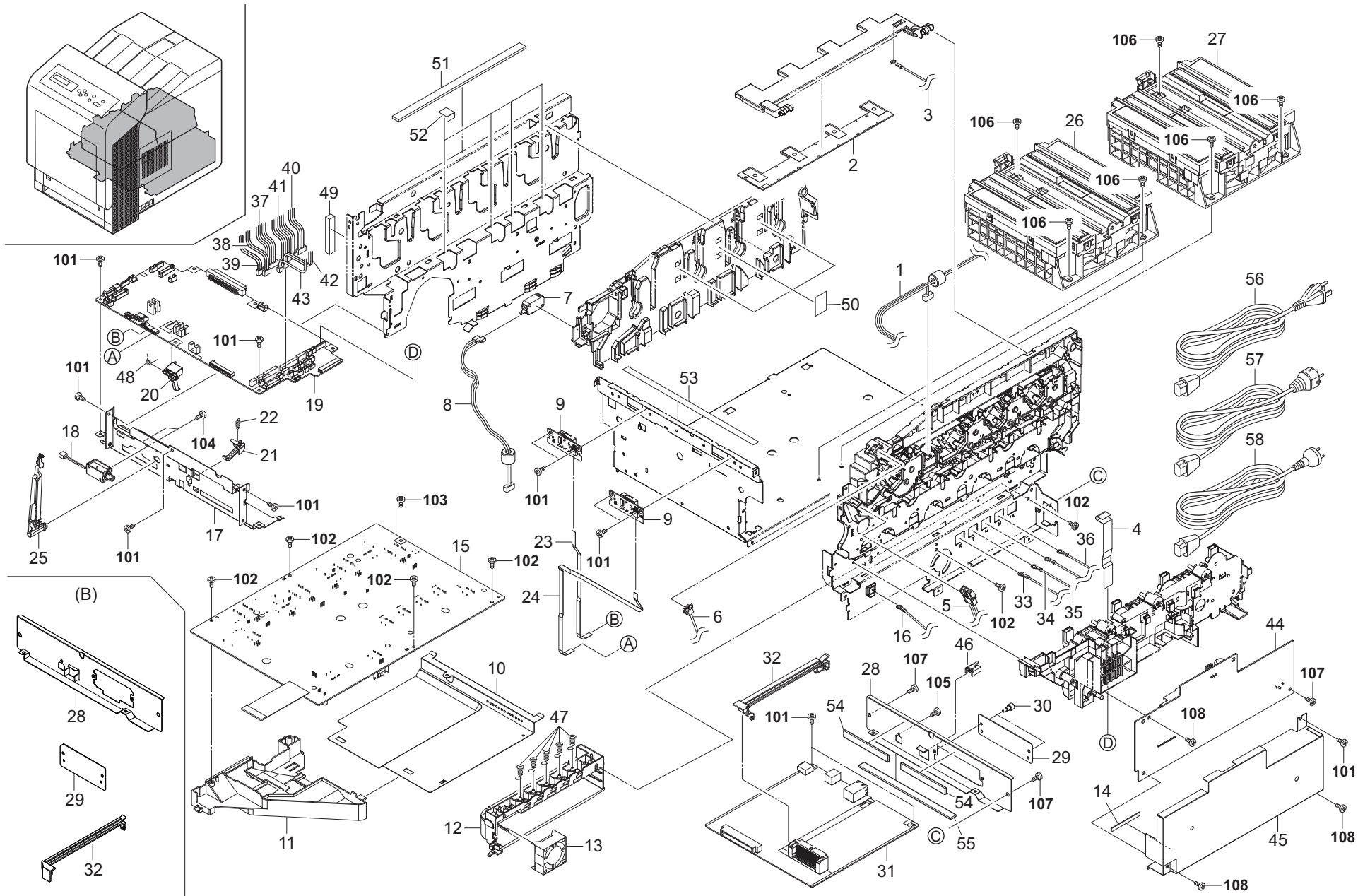

FIG. 14 Electrical Components

2K8/2PP-2

Ref. No.	Part.No.	Alternative.	Description	Notes	Quantity		
					120	230	240
1	302HN46310	2HN46310	CONN.CORD ASSY S03284		1	1	1
2	302HG01240	2HG01240	P.W.BOARD ASSY RFID WITH SOFTWARE		1	1	1
3	302HN46440	2HN46440	CONN.CORD ASSY S03300		1	1	1
4	302HN46340	2HN46340	CONN.CORD ASSY S03287		1	1	1
5	302HN46210	2HN46210	CONN.CORD ASSY S03274		1	1	1
6	302HN46580	2HN46580	CONN.CORD ASSY S03436		1	1	1
7	7SM010104+++H01	SM055200	SW.MICRO		1	1	1
8	302HN46150	2HN46150	CONN.CORD ASSY S03268		1	1	1
9	302HN94320	2HN94320	ID SENSOR ASSY SP		2	2	2
10	302HN39042	2HN39042	SHIELD HV		1	1	1
11	302HN39050	2HN39050	DUCT CONTROLLER		1	1	1
12	302HN39082	2HN39082	BRACKET HV PWB		1	1	1
13	302HN94230	2HN94230	FAN PS ASSY SP		1	1	1
14	7ZGSTG15C050H01	ZG000470	SHIELD GASKET		1	1	1
15	302K894030	2K894030	HIGH VOLTAGE UNIT SP		1	1	1
16	302HN46450	2HN46450	CONN.CORD ASSY S03301		1	1	1
17	302HN39011	2HN39011	PLATE ENGINE		1	1	1
18	302HN94220	2HN94220	SOLENOID FD ASSY CLN SP		1	1	1
19	302K894050	2K894050	PARTS PWB ENGINE SP	(A)	1	1	1
19	302PP94090	2PP94090	PARTS PWB ASSY ENGINE SP	(B)	1	1	1
20	302HN39070	2HN39070	ACTUATOR CASSETTE		1	1	1
21	302HN06050	2HN06050	ACTUATOR PICKUP		1	1	1
22	302HN06060	2HN06060	SPRING PICK ACT		1	1	1
23	302HN46290	2HN46290	CONN.CORD ASSY S03282		1	1	1
24	302HN46300	2HN46300	CONN.CORD ASSY S03283		1	1	1
25	302HN02660	2HN02660	LINK LEVER		1	1	1
26	302K893040	2K893040	LK-580 A		1	1	1
27	302K893050	2K893050	LK-580 B		1	1	1
28	302HN39021	2HN39021	PLATE CONTROLLER	(A)	1	1	1
28	302PP39010	2PP39010	PLATE CONTROLLER	(B)	1	1	1
29	303BH26021	3BH26021	PLATE,OPTION	(A)	1	1	1
29	302K339050	2K339050	PLATE OPTION	(B)	1	1	1
30	5MMT263SN012++R	2D903100	SCREW OP / M3 X 8 CRFREE A4		2	2	2
31	302K894040	2K894040	PARTS PWB MAIN SP	(A)	1	1	1
31	302PP94070	2PP94070	PARTS PWB ASSY MAIN SP	(B)	1	1	1
31	302PP94080	2PP94080	PARTS PWB ASSY MAIN EU SP	(B)	1	1	1
32	302HN39060	2HN39060	RAIL OPTION	(A)	1	1	1
32	302PP39020	2PP39020	RAIL OPTION	(B)	1	1	1
33	302HN46400	2HN46400	CONN.CORD ASSY S03296		1	1	1
34	302HN46410	2HN46410	CONN.CORD ASSY S03297		1	1	1
35	302HN46420	2HN46420	CONN.CORD ASSY S03298		1	1	1
36	302HN46430	2HN46430	CONN.CORD ASSY S03299		1	1	1
37	302HN46020	2HN46020	CONN.CORD ASSY S03254		1	1	1
38	302HN46380	2HN46380	CONN.CORD ASSY S03293		1	1	1
39	302HN46500	2HN46500	CONN.CORD ASSY S03388		1	1	1
40	302HN46090	2HN46090	CONN.CORD ASSY S03261		1	1	1
41	302HN46010	2HN46010	CONN.CORD ASSY S03253		1	1	1
42	302HN46560	2HN46560	CONN.CORD ASSY S03431		1	1	1
43	302HN46490	2HN46490	CONN.CORD ASSY S03387		1	1	1

- Parts with "⊙" indicate regular maintenance parts.
- Parts with Ref.No. indicate maintenance parts and the ones without it indicate out of the above.

Ref. No.	Part.No.	Alternative.	Description	Notes	Quantity		
					120	230	240
⊙ 44	302K894060	2K894060	PARTS SWITCHING REGULATOR 120V SP		1		
⊙ 44	302HN45031	2HN45031	SWITCHING REGULATOR 230V	(A)		1	1
⊙ 44	302PP94060	2PP94060	PARTS SWITCHING REGULATOR 230V SP	(B)		1	1
45	302HN39030	2HN39030	SHIELD POWER		1	1	1
46	302F939090	2F939090	CAP NETWORK		1	1	1
47	302HN39090	2HN39090	SPRING HV PT		5	5	5
48	302HN39110	2HN39110	SPRING ACTUATOR		1	1	1
49	302HN02890	2HN02890	SEAL LEFT WASTE A		1	1	1
50	302HN02930	2HN02930	SHEET HOUSING LEFT		3	3	3
51	302HN02940	2HN02940	SEAL DUCT TOP		1	1	1
52	302HN02950	2HN02950	SEAL DUCT HALF		4	4	4
53	302HN02980	2HN02980	SHEET FRONT		1	1	1
54	7ZGSTG110075H01	ZG111050	SHIELD GASKET		2	2	2
55	7ZGSTG110155H01	ZG106390	SHIELD GASKET		1	1	1
56	3019527401	19527401	POWER CORD(120)		1		
57	302FV45020	2FV45020	AC CORD ASSY			1	
58	302FV45040	2FV45040	AC CORD ASSY				1
101	5MBTPB3006TW++R	B1A53060	BIND T.T SCREW(+)/M3 X6 CRFREE S-T				
102	5MBTPB3008PW++R	B1A63080	BIND T.T SCREW(+)/ M3 X 8 CRFREE P-T				
103	BAB53060	BAB53060	+TP TAP-TITE S SCREW M3X06				
104	B4A03030	B4A03030	+TP-A SCREW M3X03(TRIVALENT CHRO MATING)				
105	5MBSPP3006NW++R	B0B03060	PAN HEAD SCREW(+)/ M3 X 6 CRFREE				
106	B1B03080	B1B03080	+BIND SCREW M3X08				
107	B1A54080	B1A54080	+BIND TAP-TITE S SCREW M4X08				
108	5MBTPB4010PW++R	B1A64100	BIND T.T SCREW(+)/ M4 X 10 CRFREE P-T				

- Parts with "*" are component parts or sub-assemblies of the assembly appearing immediately above them.
- Parts with "••" are component parts or sub-assembly with "•" appearing immediately above them.

FIG. 15 Maintenance Kits

2K8/2PP

Ref. No.	Part.No.	Alternative.	Description	Notes	Quantity		
					120	230	240
	1702K87US0	072K87US	MK-580/MAINTENANCE KIT (OPTION) •RETARD ROLLER ASSY •HOLDER FEED ASSY SP •DV-560 US (Y) •DV-560 US (K) •DV-560 US (C) •DV-560 US (M) •FK-580(U) •DK-580 •TR-580 •ROLLER M/P ASSY /43487B0027 A4		1 1 1 1 1 1 1 1 4 1 1		
	1702K88NL0	072K88NL	MK-580/MAINTENANCE KIT (OPTION) •RETARD ROLLER ASSY •HOLDER FEED ASSY SP •DV-560(Y) •DV-560(K) •DV-560(C) •DV-560(M) •DK-580 •FK-580(E) •TR-580 •ROLLER M/P ASSY /43487B0027 A4			1 1 1 1 1 1 1 4 1 1 1	1 1 1 1 1 1 1 4 1 1 1

Ref. No.	Part.No.	Alternative.	Description	Notes	Quantity		
					120	230	240

- Parts with "⊙" indicate regular maintenance parts.
- Parts with Ref.No. indicate maintenance parts and the ones without it indicate out of the above.

- Parts with "•" are component parts or sub-assemblies of the assembly appearing immediately above them.
- Parts with "••" are component parts or sub-assembly with "•" appearing immediately above them.

	Part.No.	Alternative.	Description	Fig.No.
	3019527401	19527401	POWER CORD(120)	14
	1702K87US0	072K87US	MK-580/MAINTENANCE KIT (OPTION)	15
	1702K88NL0	072K88NL	MK-580/MAINTENANCE KIT (OPTION)	15
⊙	2FB17260	2FB17260	BELT FEED HANDLE	12
	2FM02210	5MVM274DN002	PULLEY MID /B-11 FRAME A4	13
	302B700770	2B700770	GEAR CASSETTE	5
	302B700780	2B700780	GEAR MANUAL	2
	302C921041	2C921041	PULLEY FEED SHIFT	6
	302F325010	2F325010	STUD SCREW M3	13
	302F906030	2F906030	GEAR FEED Z26H	6
	302F906110	2F906110	PIN FEED ROLL	6
	302F906230	2F906230	PULLEY FEED ASSY	6
	302F906272	2F906272	SHAFT FEED L	6
⊙	302F906280	2F906280	GEAR FEED Z30H	6
	302F908300	2F908300	SPRING LOCK MPF	2
	302F909160	2F909160	BUSH LIFT 6	5
⊙	302F909171	2F909171	RETARD ROLLER ASSY	5
	302F909180	2F909180	HOLDER RETARD	5
	302F925060	2F925060	ACTUATOR SOL	13
	302F939090	2F939090	CAP NETWORK	14
	302FV45020	2FV45020	AC CORD ASSY	14
	302FV45040	2FV45040	AC CORD ASSY	14
	302H024370	2H024370	BUSH 6 EW	6
	302H702590	2H702590	BUSH SCREW	6
⊙	302HG01240	2HG01240	P.W.BOARD ASSY RFID WITH SOFTWARE	14
	302HG02310	2HG02310	HOLDER SENSOR	6
	302HG06010	2HG06010	SPRING PICKUP	6
	302HG24150	2HG24150	SPRING TC L	8
	302HG24180	2HG24180	LABEL EXIT B	8
⊙	302HG44110	2HG44110	FAN MOTOR 50	13
	302HG46090	2HG46090	CONN.CORD ASSY S03326	6
⊙	302HL93200	2HL93200	MC-560	9
⊙	302HN00050	2HN00050	INLET ASSY	4
⊙	302HN00060	2HN00060	SIDE SW ASSY	4
	302HN00130	2HN00130	TONER FULL DETECT ASSY	4
⊙	302HN01030	2HN01030	P.W.BOARD ASSY LCD CONT	2
⊙	302HN01150	2HN01150	P.W.BOARD ASSY EXIT	13
	302HN02050	2HN02050	FRAME REAR	3
⊙	302HN02070	2HN02070	COVER REAR	4
	302HN02080	2HN02080	HINGE FEED LEFT	4
	302HN02130	2HN02130	HINGE LEFT	3
	302HN02140	2HN02140	HINGE RIGHT	3
⊙	302HN02150	2HN02150	GEAR Z16S HINGE	3
	302HN02160	2HN02160	RACK TONER SUPPLY L	3
	302HN02170	2HN02170	RACK TONER SUPPLY R	3
	302HN02180	2HN02180	RATCHET CONTAINER	3
	302HN02190	2HN02190	CAM TONER SUPPLY	3
	302HN02200	2HN02200	HOLDER HARNESS	3
	302HN02210	2HN02210	HOLDER RFID	3
	302HN02220	2HN02220	DUCT LEFT	4

	Part.No.	Alternative.	Description	Fig.No.
	302HN02230	2HN02230	DUCT RIGHT	3
	302HN02250	2HN02250	BRACKET FRONT	4
⊙	302HN02300	2HN02300	ROD INTERLOCK	3
⊙	302HN02320	2HN02320	GEAR Z25S WASTE	4
⊙	302HN02330	2HN02330	GEAR Z17S WASTE	4
⊙	302HN02340	2HN02340	GEAR Z20S WASTE	4
⊙	302HN02350	2HN02350	GEAR Z14L-Z17S WASTE	4
	302HN02450	2HN02450	SPRING CONTACT HV TC	6
	302HN02470	2HN02470	PLATE EARTH SIZE	6
	302HN02490	2HN02490	SPRING CLEANER ID	4
	302HN02500	2HN02500	SPRING LOCK DRUM	4
	302HN02541	2HN02541	BRACKET SWITCH	4
	302HN02550	2HN02550	BRACKET BASE	4
	302HN02580	2HN02580	INNER COVER	4
	302HN02590	2HN02590	BRACKET GEAR	4
	302HN02611	2HN02611	FOOT	4,12
	302HN02620	2HN02620	BRACKET HARNESS	4
	302HN02630	2HN02630	BRACKET HARNESS L	4
	302HN02660	2HN02660	LINK LEVER	14
	302HN02670	2HN02670	PLATE CONTAINER K	3
	302HN02680	2HN02680	PLATE CONTAINER C	3
	302HN02701	2HN02701	ACTUATOR CONTAINER	3
	302HN02710	2HN02710	SPRING ACT CONT	3
	302HN02720	2HN02720	SEAL SQUARE 25-20	3
	302HN02730	2HN02730	SEAL CIRCLE 12	3
	302HN02740	2HN02740	RAIL CASSETTE	4
	302HN02770	2HN02770	SPRING LOCK CASSETTE	4
	302HN02780	2HN02780	LOCK CASSETTE	4
	302HN02810	2HN02810	SEAL DUCT A	4
	302HN02840	2HN02840	SEAL DUCT D	4
	302HN02850	2HN02850	SHEET FRAME REAR	3
	302HN02860	2HN02860	BLOCK HEAT CONDUCT	3
	302HN02870	2HN02870	SHEET SARCON	3
	302HN02880	2HN02880	SEAL TN WASTE	3
	302HN02890	2HN02890	SEAL LEFT WASTE A	14
	302HN02900	2HN02900	SEAL IMAGE REAR	7
	302HN02930	2HN02930	SHEET HOUSING LEFT	14
	302HN02940	2HN02940	SEAL DUCT TOP	14
	302HN02950	2HN02950	SEAL DUCT HALF	14
	302HN02980	2HN02980	SHEET FRONT	14
⊙	302HN02990	2HN02990	OZONE FILTER VOC700	3
⊙	302HN03310	2HN03310	GEAR Z16L	3
⊙	302HN03320	2HN03320	GEAR Z14R	3
⊙	302HN03330	2HN03330	GEAR Z16S-Z14R	3
	302HN03340	2HN03340	HOLDER MCH CLN MOTOR	3
	302HN03350	2HN03350	HOLDER MCH CLN DRIVE GEAR	3
	302HN03360	2HN03360	SHAFT MCH CLN	3
	302HN03410	2HN03410	MOUNT GLASS CLN DRIVE	3
⊙	302HN03430	2HN03430	GEAR Z63R-Z25R	3
⊙	302HN03440	2HN03440	GEAR Z70L-Z17S	3

• Parts with "⊙" indicate regular maintenance parts.

	Part.No.	Alternative.	Description	Fig.No.		Part.No.	Alternative.	Description	Fig.No.
⊙	302HN03450	2HN03450	GEAR Z54S	3		302HN06170	2HN06170	SPRING MPF B	8
⊙	302HN04010	2HN04010	COVER TOP	1		302HN06180	2HN06180	SHEET HOUSING	6
⊙	302HN04041	2HN04041	COVER RIGHT REAR	1		302HN08010	2HN08010	BASE MPF	2
⊙	302HN04050	2HN04050	LID RIGHT COVER	1		302HN08020	2HN08020	COVER MPF	2
⊙	302HN04070	2HN04070	COVER LEFT FRONT	1		302HN08030	2HN08030	TRAY MPF TOP	2
⊙	302HN04080	2HN04080	COVER RIGHT FRONT	1		302HN08050	2HN08050	GUIDE MPF L	2
⊙	302HN04090	2HN04090	COVER UPPER LEFT	1		302HN08060	2HN08060	GUIDE MPF R	2
⊙	302HN04111	2HN04111	COVER LOWER LEFT	2		302HN08080	2HN08080	SP BOTTOM MPF L	7
⊙	302HN04120	2HN04120	COVER LOWER RIGHT	2		302HN08090	2HN08090	SP BOTTOM MPF R	7
⊙	302HN04130	2HN04130	LEVER FRONT COVER LEFT	1		302HN08100	2HN08100	SPRING SEPARATOR	7
	302HN04151	2HN04151	GUIDE FRONT COVER RELEASE LEFT	2		302HN08111	2HN08111	FRAME MPF LOW	7
⊙	302HN04160	2HN04160	SHAFT FRONT COVER RELEASE	2		302HN08140	2HN08140	LUTCH	2
⊙	302HN04170	2HN04170	STOPPER FRONT COVER RIGHT	2		302HN08150	2HN08150	LINK LEVER MPF L	2
⊙	302HN04181	2HN04181	STOPPER FRONT COVER LEFT	2		302HN08160	2HN08160	LINK LEVER MPF R	2
⊙	302HN04190	2HN04190	STOPPER EXIT	1		302HN08181	2HN08181	LEVER CAM MPF	7
⊙	302HN04200	2HN04200	LEVER SIDE COVER	1		302HN08210	2HN08210	HOLDER SEPARATOR MPF	7
⊙	302HN04210	2HN04210	HOOK SIDE COVER	1		302HN09012	2HN09012	BASE CASSETTE	5
	302HN04221	2HN04221	GUIDE FRONT COVER RELEASE RIGHT	2		302HN09020	2HN09020	COVER CASSETTE TOP	5
⊙	302HN04230	2HN04230	HOOK TOP COVER	1		302HN09030	2HN09030	GEAR Z20S-Z17S INDICATOR	5
	302HN04240	2HN04240	SPRING LEFT COVER	1		302HN09041	2HN09041	MARKER INDICATOR	5
	302HN04250	2HN04250	SPRING SIDE COVER	1		302HN09050	2HN09050	DIAL CASSETTE	5
	302HN04260	2HN04260	SPRING SIDE LEVER	1		302HN09070	2HN09070	CURSOR LEFT	5
	302HN04270	2HN04270	SPRING FRONT COVER	2		302HN09090	2HN09090	LEVER GUIDE SIDE	5
	302HN04280	2HN04280	SPRING RIGHT LID	1		302HN09100	2HN09100	SPRING GUIDE SIDE	5
	302HN04290	2HN04290	SPRING RIGHT LEVER	1		302HN09110	2HN09110	CURSOR END	5
	302HN04300	2HN04300	SPRING LEFT LEVER	1		302HN09120	2HN09120	LEVER STOPPER	5
	302HN04310	2HN04310	SPONGE LEFT COVER	1		302HN09130	2HN09130	SPRING STOPPER	5
	302HN04320	2HN04320	LABEL USB	1		302HN09150	2HN09150	SHAFT WORKPLATE	5
	302HN04330	2HN04330	LABEL FUSER CAUTION	1		302HN09160	2HN09160	GEAR Z50S LIFT	5
	302HN04340	2HN04340	LABEL WASTE BOTTLE	1		302HN09170	2HN09170	GEAR Z13S JOINT	5
	302HN04350	2HN04350	SHEET LEVER RIGHT A	1		302HN09180	2HN09180	COVER LIFT GEAR	5
	302HN04360	2HN04360	SHEET LEVER RIGHT B	1		302HN09190	2HN09190	SPRING FIX	5
	302HN04391	2HN04391	SEAL COVER SIDE	1		302HN09230	2HN09230	GUIDE RETARD	5
	302HN05022	2HN05022	MOUNT LCD UPPER	2		302HN09240	2HN09240	SIZE FIX	5
	302HN05030	2HN05030	MOUNT LCD LOWER	2		302HN09250	2HN09250	LABEL DIAL	5
	302HN05041	2HN05041	BUTTON A	2		302HN09350	2HN09350	CURSOR LEFT B	5
	302HN05050	2HN05050	BUTTON B	2		302HN09371	2HN09371	SPRING EARTH	5
	302HN05060	2HN05060	BUTTON C	2		302HN09391	2HN09391	SPRING EARTH SIDE	5
	302HN05180	2HN05180	LABEL 6 NATIONS	2		302HN09400	2HN09400	SPRING DIAL	5
	302HN06010	2HN06010	HOLDER FEED	6		302HN09410	2HN09410	SPRING EARTH C	5
	302HN06030	2HN06030	SHAFT FEED R	6		302HN09420	2HN09420	LABEL CURSOR	5
⊙	302HN06050	2HN06050	ACTUATOR PICKUP	14		302HN09430	2HN09430	SPRING RETARD	5
	302HN06060	2HN06060	SPRING PICK ACT	14	⊙	302HN15020	2HN15020	GEAR Z50S	3
	302HN06080	2HN06080	PULLEY PICKUP ASSY	6	⊙	302HN15030	2HN15030	GEAR Z20S-Z26L	3
	302HN06100	2HN06100	FRAME MPF UP	8		302HN15040	2HN15040	SPRING JOINT	3
	302HN06110	2HN06110	SHAFT FEED MPF	8	⊙	302HN15070	2HN15070	GUIDE CONTAINER K	3
	302HN06121	2HN06121	ACTUATOR MPF	8	⊙	302HN15080	2HN15080	GUIDE CONTAINER Y	3
	302HN06131	2HN06131	ACTUATOR MPF B	8	⊙	302HN15090	2HN15090	GUIDE CONTAINER C	3
⊙	302HN06150	2HN06150	GEAR Z30S MPF	8	⊙	302HN15110	2HN15110	GUIDE CONTAINER M	3
	302HN06160	2HN06160	GUIDE HOUSING	6	⊙	302HN15160	2HN15160	SPRING P CONT C	3

• Parts with "⊙" indicate regular maintenance parts.

	Part.No.	Alternative.	Description	Fig.No.
	302HN15170	2HN15170	SPRING P CONT K	3
⊙	302HN22010	2HN22010	ROLLER TRANSFER	8
	302HN22020	2HN22020	PAPER CHUTE	8
	302HN22030	2HN22030	HOLDER BRUSH	8
	302HN22050	2HN22050	BUSH TRANS L	8
	302HN22060	2HN22060	BUSH TRANS R	8
	302HN22070	2HN22070	GEAR Z22L TC ROLL	8
	302HN22080	2HN22080	SPRING SEP EARTH B	8
	302HN22110	2HN22110	SHEET PAPER CHUTE	8
⊙	302HN24030	2HN24030	ROLLER MIDDLE	6
	302HN24042	2HN24042	FRAME CONVEYING	8
	302HN24050	2HN24050	GUIDE FEED DU	8
⊙	302HN24060	2HN24060	GEAR Z19L REG REAR	6
⊙	302HN24070	2HN24070	GEAR Z31R REG FRONT	8
⊙	302HN24080	2HN24080	GEAR Z27R MIDDLE	6
	302HN24090	2HN24090	PLATE EARTH GUIDE	8
	302HN24110	2HN24110	BUSH REG R	8
	302HN24140	2HN24140	ACTUATOR DU	8
	302HN24150	2HN24150	STOPPER BUSH REG	8
	302HN24160	2HN24160	SHEET REGIST FRONT	6,8
	302HN24180	2HN24180	SPRING REG L	8
	302HN24190	2HN24190	SPRING REG R	8
	302HN24230	2HN24230	SPRING MIDDLE	6
	302HN24250	2HN24250	SPRING EARTH FEED	8
	302HN24260	2HN24260	SPRING REG EARTH A	6
	302HN24270	2HN24270	SPRING SEP EARTH A	8
	302HN24280	2HN24280	SPRING GUIDE EARTH	8
	302HN24290	2HN24290	SPRING DU	8
	302HN24300	2HN24300	SPRING ACT DU	8
	302HN24320	2HN24320	SPRING MID EARTH	6
	302HN24350	2HN24350	BUSH REGIST CL	6
	302HN24360	2HN24360	SPONGE A	8
	302HN24370	2HN24370	STOPPER TC SPRING	8
	302HN24380	2HN24380	SPRING GUIDE EARTH B	8
	302HN24390	2HN24390	SPRING EARTH B	8
	302HN24400	2HN24400	PULLEY PA	8
	302HN24410	2HN24410	BUSH REGIST EW	6
	302HN24420	2HN24420	SPRING REG EARTH B	6
	302HN24430	2HN24430	HIGH MEG R ASSY	6,8
⊙	302HN24460	2HN24460	DISCHARGER TRANS	8
	302HN24471	2HN24471	PLATE DISCHARGER	8
	302HN24481	2HN24481	SHEET SEP PLATE	8
	302HN28010	2HN28010	HOUSING EXIT	13
⊙	302HN28021	2HN28021	ROLLER FD	13
⊙	302HN28030	2HN28030	ROLLER REVERSE	13
⊙	302HN28050	2HN28050	GEAR Z55R-Z17R	13
⊙	302HN28060	2HN28060	GEAR Z23S FD	13
⊙	302HN28071	2HN28071	GEAR Z20L REVERSE	13
⊙	302HN28080	2HN28080	ACTUATOR FULL	13
	302HN28090	2HN28090	GUIDE EXIT UP	13

• Parts with "⊙" indicate regular maintenance parts.

	Part.No.	Alternative.	Description	Fig.No.
	302HN28100	2HN28100	GUIDE CHANGE	13
	302HN28110	2HN28110	SPRING SOLENOID	13
	302HN28120	2HN28120	SPRING PULLEY A	13
	302HN28130	2HN28130	PLATE MOTOR A	13
	302HN28140	2HN28140	GUIDE CORRUGATION	13
	302HN28150	2HN28150	SPRING EARTH EXIT A	13
	302HN28160	2HN28160	SPRING EARTH EXIT B	13
	302HN28170	2HN28170	SPRING EARTH EXIT C	13
	302HN28180	2HN28180	STAY FRONT	13
	302HN28190	2HN28190	SPRING EARTH EXIT D	13
⊙	302HN28200	2HN28200	GEAR Z28S IDLE	13
	302HN28210	2HN28210	DISCHARGER FD	13
	302HN28220	2HN28220	SEAL ACTUATOR	6,13
	302HN28230	2HN28230	SHEET PULLEY	13
	302HN28240	2HN28240	SHEET CHANGE	13
	302HN28250	2HN28250	SPRING GEAR	13
⊙	302HN29010	2HN29010	ROLLER DU	2
⊙	302HN29020	2HN29020	ROLLER DU FEED	2
	302HN29031	2HN29031	BASE DU	2
⊙	302HN29040	2HN29040	PULLEY P24 S2M DU	2
	302HN29050	2HN29050	BUSH DU	2,13
⊙	302HN29060	2HN29060	GEAR Z23L DU FEED	2
	302HN29070	2HN29070	HOOK DU RELEASE LEFT	2
	302HN29080	2HN29080	HOOK DU RELEASE RIGHT	2
	302HN29101	2HN29101	COVER INNER DU	2
	302HN29130	2HN29130	SPRING DU EARTH A	2
	302HN29140	2HN29140	SPRING DU EARTH B	2
⊙	302HN29150	2HN29150	BELT DU	2
	302HN29160	2HN29160	HOOK CONVEYING	2
	302HN29170	2HN29170	SPRING DU EARTH C	2
	302HN29190	2HN29190	SHEET BASE DU	2
	302HN31010	2HN31010	BRACKET DRIVE LIFT	12
	302HN31020	2HN31020	COVER GEAR LIFT	12
⊙	302HN31030	2HN31030	GEAR Z36L-Z20S	12
⊙	302HN31040	2HN31040	GEAR Z46S-Z13S	12
⊙	302HN31050	2HN31050	GEAR Z13S	12
⊙	302HN31060	2HN31060	GEAR Z35S-Z13S	12
	302HN31070	2HN31070	PLATE DRIVE	12
⊙	302HN31080	2HN31080	GEAR Z74R-Z35L	12
⊙	302HN31090	2HN31090	GEAR Z54R	12
⊙	302HN31100	2HN31100	GEAR Z33L	12
	302HN31111	2HN31111	HOLDER FEED DRIVE A	12
	302HN31120	2HN31120	HOLDER FEED DRIVE B	12
⊙	302HN31130	2HN31130	GEAR Z77R-Z25R	12
⊙	302HN31141	2HN31141	GEAR Z39L	12
⊙	302HN31150	2HN31150	GEAR Z32R IDLE	12
⊙	302HN31160	2HN31160	GEAR Z30L	12
⊙	302HN31170	2HN31170	GEAR Z32L CL FEED	12
⊙	302HN31180	2HN31180	GEAR Z28R INPUT DU	12
⊙	302HN31190	2HN31190	GEAR Z31R-Z26R INPUT REGIST	12

	Part.No.	Alternative.	Description	Fig.No.
⊙	302HN31200	2HN31200	GEAR Z35L	12
⊙	302HN31210	2HN31210	GEAR Z36R-Z22S	12
⊙	302HN31220	2HN31220	GEAR Z28S	12
⊙	302HN31240	2HN31240	GEAR Z36S MPF CAM	12
⊙	302HN31250	2HN31250	CAM MPF	12
⊙	302HN31260	2HN31260	GEAR Z62R-P32	12
⊙	302HN31270	2HN31270	GEAR Z30L-P30	12
⊙	302HN31280	2HN31280	GEAR Z32R CL DLP	12
⊙	302HN31290	2HN31290	GEAR Z33L INPUT DLP	12
⊙	302HN31300	2HN31300	GEAR Z81R-Z35L	12
⊙	302HN31311	2HN31311	GEAR Z70R	12
⊙	302HN31320	2HN31320	GEAR Z70L	12
⊙	302HN31330	2HN31330	GEAR Z38L	12
⊙	302HN31340	2HN31340	GEAR Z38R INPUT MT	12
⊙	302HN31350	2HN31350	GEAR Z72L-Z26S	12
⊙	302HN31360	2HN31360	GEAR Z40S INPUT FUSER	12
	302HN31370	2HN31370	SHAFT CLUTCH FEED	12
	302HN31390	2HN31390	PIN DRIVE DLP	12
	302HN31410	2HN31410	SPRING FEED	12
	302HN31430	2HN31430	SPRING MID TRANSFER	12
⊙	302HN31540	2HN31540	GEAR Z34S	12
	302HN31550	2HN31550	SPRING DRIVE LIFT	12
	302HN31560	2HN31560	PLATE MOTOR FUSER	12
	302HN31590	2HN31590	BUSH DRIVE	6,12
⊙	302HN31620	2HN31620	GEAR Z36S INPUT MPF A	12
⊙	302HN31630	2HN31630	GEAR Z36S INPUT MPF B	12
	302HN31640	2HN31640	PIN DRIVE MT	12
	302HN31650	2HN31650	SPRING INPUT MPF	12
⊙	302HN31660	2HN31660	JOINT SHAFT CASSETTE	12
	302HN31670	2HN31670	PIN DRIVE A	12
	302HN31680	2HN31680	PIN DRIVE B	12
	302HN39011	2HN39011	PLATE ENGINE	14
	302HN39021	2HN39021	PLATE CONTROLLER	14
	302HN39030	2HN39030	SHIELD POWER	14
	302HN39042	2HN39042	SHIELD HV	14
	302HN39050	2HN39050	DUCT CONTROLLER	14
	302HN39060	2HN39060	RAIL OPTION	14
⊙	302HN39070	2HN39070	ACTUATOR CASSETTE	14
	302HN39082	2HN39082	BRACKET HV PWB	14
	302HN39090	2HN39090	SPRING HV PT	14
	302HN39110	2HN39110	SPRING ACTUATOR	14
⊙	302HN44010	2HN44010	FAN MOTOR	4
⊙	302HN44020	2HN44020	FAN MOTOR	3,6
⊙	302HN44050	2HN44050	MOTOR DRUM	12
⊙	302HN44090	2HN44090	MOTOR FUSER	12
⊙	302HN44100	2HN44100	MOTOR REVERSE	13
⊙	302HN44160	2HN44160	SOLENOID MPF	12
⊙	302HN44180	2HN44180	SWITCH SIZE	6
⊙	302HN44200	2HN44200	CLUTCH FEED L	12
⊙	302HN44210	2HN44210	FAN MOTOR	13

	Part.No.	Alternative.	Description	Fig.No.
⊙	302HN45031	2HN45031	SWITCHING REGULATOR 230V	14
	302HN46010	2HN46010	CONN.CORD ASSY S03253	14
	302HN46020	2HN46020	CONN.CORD ASSY S03254	14
	302HN46090	2HN46090	CONN.CORD ASSY S03261	14
	302HN46110	2HN46110	CONN.CORD ASSY S03264	8
	302HN46130	2HN46130	CONN.CORD ASSY S03266	6
	302HN46150	2HN46150	CONN.CORD ASSY S03268	14
	302HN46180	2HN46180	CONN.CORD ASSY S03271	13
	302HN46210	2HN46210	CONN.CORD ASSY S03274	14
⊙	302HN46290	2HN46290	CONN.CORD ASSY S03282	14
⊙	302HN46300	2HN46300	CONN.CORD ASSY S03283	14
	302HN46310	2HN46310	CONN.CORD ASSY S03284	14
⊙	302HN46320	2HN46320	CONN.CORD ASSY S03285	2
⊙	302HN46340	2HN46340	CONN.CORD ASSY S03287	14
	302HN46350	2HN46350	CONN.CORD ASSY S03290	4
	302HN46380	2HN46380	CONN.CORD ASSY S03293	14
	302HN46400	2HN46400	CONN.CORD ASSY S03296	14
	302HN46410	2HN46410	CONN.CORD ASSY S03297	14
	302HN46420	2HN46420	CONN.CORD ASSY S03298	14
	302HN46430	2HN46430	CONN.CORD ASSY S03299	14
	302HN46440	2HN46440	CONN.CORD ASSY S03300	14
	302HN46450	2HN46450	CONN.CORD ASSY S03301	14
⊙	302HN46480	2HN46480	CONN.CORD ASSY S03386	2
	302HN46490	2HN46490	CONN.CORD ASSY S03387	14
	302HN46500	2HN46500	CONN.CORD ASSY S03388	14
	302HN46560	2HN46560	CONN.CORD ASSY S03431	14
⊙	302HN46570	2HN46570	CONN.CORD ASSY S03400	13
	302HN46580	2HN46580	CONN.CORD ASSY S03436	14
⊙	302HN93013	2HN93013	DV-560(K)	10
⊙	302HN93023	2HN93023	DV-560(Y)	10
⊙	302HN93033	2HN93033	DV-560(C)	10
⊙	302HN93043	2HN93043	DV-560(M)	10
⊙	302HN93141	2HN93141	PARTS EXIT ASSY(25)	13
⊙	302HN93162	2HN93162	CT-501	5
⊙	302HN93171	2HN93171	PARTS WASTE TONER	4
⊙	302HN93180	2HN93180	WT-560	4
⊙	302HN93240	2HN93240	PARTS TRANSFER ASSY	8
⊙	302HN93253	2HN93253	DV-560 US (K)	10
⊙	302HN93263	2HN93263	DV-560 US (Y)	10
⊙	302HN93273	2HN93273	DV-560 US (C)	10
⊙	302HN93283	2HN93283	DV-560 US (M)	10
⊙	302HN94010	2HN94010	BRACKET HV TC ASSY SP	4
⊙	302HN94020	2HN94020	BRACKET HV C ASSY SP	4
⊙	302HN94030	2HN94030	BRACKET HV K ASSY	4
⊙	302HN94040	2HN94040	CASE CONTACT HV K ASSY SP	4
⊙	302HN94051	2HN94051	BAR CLEANER ID ASSY SP	4
⊙	302HN94060	2HN94060	DC MOTOR ASSY K SP	3
⊙	302HN94070	2HN94070	DC MOTOR ASSY Y SP	3
⊙	302HN94080	2HN94080	DC MOTOR ASSY C SP	3
⊙	302HN94090	2HN94090	DC MOTOR ASSY M SP	3

• Parts with "⊙" indicate regular maintenance parts.

	Part.No.	Alternative.	Description	Fig.No.
⊙	302HN94100	2HN94100	DC MOTOR ASSY MCH SP	3
⊙	302HN94110	2HN94110	DC MOTOR ASSY LSU SP	3
⊙	302HN94130	2HN94130	ROLLER REG REAR SP	6
⊙	302HN94140	2HN94140	SOLENOID FD ASSY SP	13
⊙	302HN94150	2HN94150	PLATE BOTTOM MPF ASSY SP	7
⊙	302HN94160	2HN94160	SEPARATOR MPF ASSY SP	7
⊙	302HN94170	2HN94170	ROLLER REG FRONT SP	8
⊙	302HN94182	2HN94182	DRIVE LIFT ASSY SP	12
⊙	302HN94190	2HN94190	PLATE BOTTOM ASSY SP	5
⊙	302HN94201	2HN94201	HOLDER FEED ASSY SP	6
⊙	302HN94210	2HN94210	COVER LEFT REAR ASSY SP	1
⊙	302HN94220	2HN94220	SOLENOID FD ASSY CLN SP	14
⊙	302HN94230	2HN94230	FAN PS ASSY SP	14
⊙	302HN94241	2HN94241	KEY BORAD ASSY SP	2
⊙	302HN94261	2HN94261	DC MOTOR ASSY LIFT SP	12
⊙	302HN94270	2HN94270	LEVER FRONT COVER RIGHT ASSY SP	1
⊙	302HN94280	2HN94280	COVER UPPER RIGHT ASSY SP	1
⊙	302HN94300	2HN94300	CURSOR RIGHT PF ASSY 2HN SP	5
⊙	302HN94320	2HN94320	ID SENSOR ASSY SP	14
⊙	302HN94340	2HN94340	COVER SIDE ASSY SP	1
⊙	302K339050	2K339050	PLATE OPTION	14
⊙	302K893010	2K893010	DK-580	9
⊙	302K893021	2K893021	FK-580(E)	11
⊙	302K893031	2K893031	FK-580(U)	11
⊙	302K893040	2K893040	LK-580 A	14
⊙	302K893050	2K893050	LK-580 B	14
⊙	302K893070	2K893070	DR-580A	12
⊙	302K893080	2K893080	DR-580B	12
⊙	302K893101	2K893101	TR-580	7
⊙	302K894010	2K894010	COVER FRONT SUB ASSY	2
⊙	302K894030	2K894030	HIGH VOLTAGE UNIT SP	14
⊙	302K894040	2K894040	PARTS PWB MAIN SP	14
⊙	302K894050	2K894050	PARTS PWB ENGINE SP	14
⊙	302K894060	2K894060	PARTS SWITCHING REGULATOR 120V SP	14
⊙	302K894540	2K894540	PARTS MOTOR BL W25 SP	12
⊙	302PP05020	2PP05020	BUTTON C	2
⊙	302PP39010	2PP39010	PLATE CONTROLLER	14
⊙	302PP39020	2PP39020	RAIL OPTION	14
⊙	302PP94030	2PP94030	PARTS COVER FRONT SUB ASSY SP	2
⊙	302PP94050	2PP94050	PARTS KEY BOARD ASSY SP	2
⊙	302PP94060	2PP94060	PARTS SWITCHING REGULATOR 230V SP	14
⊙	302PP94070	2PP94070	PARTS PWB ASSY MAIN SP	14
⊙	302PP94080	2PP94080	PARTS PWB ASSY MAIN EU SP	14
⊙	302PP94090	2PP94090	PARTS PWB ASSY ENGINE SP	14
⊙	302PP94100	2PP94100	PARTS PWB ASSY LCDCONT SP	2
⊙	303BH26021	3BH26021	PLATE,OPTION	14
⊙	303K809490	3K809490	WORKPLATE LIFT PF	5
⊙	3H327410	3H327410	SENSOR,CONVEYING	6
⊙	5AAVR0LL+051	2CL16130	ROLLER M/P ASSY /43487B0027 A4	8
⊙	5MMT263SN012++R	2D903100	SCREW OP / M3 X 8 CRFREE A4	14

	Part.No.	Alternative.	Description	Fig.No.
	5MVVL611WN06	2FV20100	LABEL FUSER CAUTION	13
	5MVX111DN003	2A806250	RING STOPPER /A-49 FEED A4	6
⊙	7NXSG2481+++H01	NX052600	SENSOR OPT.	8
	7SM010104+++H01	SM055200	SW.MICRO	14
⊙	7SP01000001+H01	SP044290	SW.PUSH	6
	7YBF0509001H01	YB055270	FERRITE CORE	2
	7YCC02B1003+H01	YC013860	CONNECTOR 292254-2	12
	7YZM610007++H01	YZ023340	ACCESS.SADDLE	4
	7ZGSGT110075H01	ZG111050	SHIELD GASKET	14
	7ZGSGT110155H01	ZG106390	SHIELD GASKET	14
	7ZGSGT15C050H01	ZG000470	SHIELD GASKET	14

• Parts with "⊙" indicate regular maintenance parts.

KYOCERA Document Solutions America, Inc.**Headquarters**

225 Sand Road,
Fairfield, New Jersey 07004-0008, USA
Phone: +1-973-808-8444
Fax: +1-973-882-6000

Latin America

8240 NW 52nd Terrace Dawson Building, Suite 100
Miami, Florida 33166, USA
Phone: +1-305-421-6640
Fax: +1-305-421-6666

KYOCERA Document Solutions Canada, Ltd.

6120 Kestrel Rd., Mississauga, ON L5T 1S8,
Canada
Phone: +1-905-670-4425
Fax: +1-905-670-8116

KYOCERA Document Solutions**Mexico, S.A. de C.V.**

Calle Arquimedes No. 130, 4 Piso, Colonia Polanco
Chapultepec, Delegacion Miguel Hidalgo,
Distrito Federal, C.P. 11560, México
Phone: +52-555-383-2741
Fax: +52-555-383-7804

KYOCERA Document Solutions Brazil, Ltda.

Alameda África, 545, Pólo Empresarial Consbrás,
Tamboré, Santana de Parnaíba-SP, CEP 06543-306,
Brazil
Phone: +55-11-4195-8496
Fax: +55-11-4195-6167

KYOCERA Document Solutions**Australia Pty. Ltd.**

Level 3, 6-10 Talavera Road North Ryde N.S.W, 2113,
Australia
Phone: +61-2-9888-9999
Fax: +61-2-9888-9588

KYOCERA Document Solutions**New Zealand Ltd.**

Ground Floor, 19 Byron Avenue, Takapuna, Auckland,
New Zealand
Phone: +64-9-415-4517
Fax: +64-9-415-4597

KYOCERA Document Solutions Asia Limited

16/F., Mita Centre, 552-566, Castle Peak Road
Tsuenwan, NT, Hong Kong
Phone: +852-2610-2181
Fax: +852-2610-2063

KYOCERA Document Solutions**(China) Corporation**

8F, No. 288 Nanjing Road West, Huangpu District,
Shanghai, 200003, China
Phone: +86-21-5301-1777
Fax: +86-21-5302-8300

KYOCERA Document Solutions**(Thailand) Corp., Ltd.**

335 Ratchadapisek Road, Bangsue, Bangkok 10800,
Thailand
Phone: +66-2-586-0333
Fax: +66-2-586-0278

KYOCERA Document Solutions**Singapore Pte. Ltd.**

12 Tai Seng Street #04-01A,
Luxasia Building, Singapore 534118
Phone: +65-6741-8733
Fax: +65-6748-3788

KYOCERA Document Solutions**Hong Kong Limited**

16/F., Mita Centre, 552-566, Castle Peak Road
Tsuenwan, NT, Hong Kong
Phone: +852-3582-4000
Fax: +852-3185-1399

KYOCERA Document Solutions**Taiwan Corporation**

6F., No.37, Sec. 3, Minquan E. Rd.,
Zhongshan Dist., Taipei 104, Taiwan R.O.C.
Phone: +886-2-2507-6709
Fax: +886-2-2507-8432

KYOCERA Document Solutions Korea Co., Ltd.

18F, Kangnam bldg, 1321-1,
Seocho-Dong, Seocho-Gu, Seoul, Korea
Phone: +822-6933-4050
Fax: +822-747-0084

KYOCERA Document Solutions**India Private Limited**

First Floor, ORCHID CENTRE
Sector-53, Golf Course Road, Gurgaon 122 002,
India
Phone: +91-0124-4671000
Fax: +91-0124-4671001

KYOCERA Document Solutions Europe B.V.

Bloemlaan 4, 2132 NP Hoofddorp,
The Netherlands
Phone: +31-20-654-0000
Fax: +31-20-653-1256

KYOCERA Document Solutions Nederland B.V.

Beechavenue 25, 1119 RA Schiphol-Rijk,
The Netherlands
Phone: +31-20-5877200
Fax: +31-20-5877260

KYOCERA Document Solutions (U.K.) Limited

Eldon Court, 75-77 London Road,
Reading, Berkshire RG1 5BS,
United Kingdom
Phone: +44-118-931-1500
Fax: +44-118-931-1108

KYOCERA Document Solutions Italia S.p.A.

Via Verdi, 89/91 20063 Cernusco s/N.(MI),
Italy
Phone: +39-02-921791
Fax: +39-02-92179-600

KYOCERA Document Solutions Belgium N.V.

Sint-Martinusweg 199-201 1930 Zaventem,
Belgium
Phone: +32-2-7209270
Fax: +32-2-7208748

KYOCERA Document Solutions France S.A.S.

Espace Technologique de St Aubin
Route de l'Orme 91195 Gif-sur-Yvette CEDEX,
France
Phone: +33-1-69852600
Fax: +33-1-69853409

KYOCERA Document Solutions Espana, S.A.

Edificio Kyocera, Avda. de Manacor No.2,
28290 Las Matas (Madrid), Spain
Phone: +34-91-6318392
Fax: +34-91-6318219

KYOCERA Document Solutions Finland Oy

Atomitie 5C, 00370 Helsinki,
Finland
Phone: +358-9-47805200
Fax: +358-9-47805390

**KYOCERA Document Solutions
Europe B.V., Amsterdam (NL) Zürich Branch**

Hohlstrasse 614, 8048 Zürich,
Switzerland
Phone: +41-44-9084949
Fax: +41-44-9084950

**KYOCERA Document Solutions
Deutschland GmbH**

Otto-Hahn-Strasse 12, 40670 Meerbusch,
Germany
Phone: +49-2159-9180
Fax: +49-2159-918100

KYOCERA Document Solutions Austria GmbH

Eduard-Kittenberger-Gasse 95, 1230 Vienna,
Austria
Phone: +43-1-863380
Fax: +43-1-86338-400

KYOCERA Document Solutions Nordic AB

Esbogatan 16B 164 75 Kista, Sweden
Phone: +46-8-546-550-00
Fax: +46-8-546-550-10

KYOCERA Document Solutions Norge Nuf

Postboks 150 Oppsal, 0619 Oslo,
Norway
Phone: +47-22-62-73-00
Fax: +47-22-62-72-00

KYOCERA Document Solutions Danmark A/S

Ejby Industrivej 60, DK-2600 Glostrup,
Denmark
Phone: +45-70223880
Fax: +45-45765850

KYOCERA Document Solutions Portugal Lda.

Rua do Centro Cultural, 41 (Alvalade) 1700-106 Lisboa,
Portugal
Phone: +351-21-843-6780
Fax: +351-21-849-3312

**KYOCERA Document Solutions
South Africa (Pty) Ltd.**

KYOCERA House, Hertford Office Park,
90 Bekker Road (Cnr. Allandale), Midrand, South Africa.
Phone: +27-11-540-2600
Fax: +27-11-466-3050

KYOCERA Document Solutions Russia LLC

Botanichesky pereulok 5, Moscow, 129090,
Russia
Phone: +7(495)741-0004
Fax: +7(495)741-0018

KYOCERA Document Solutions Middle East

Dubai Internet City, Bldg. 17,
Office 157 P.O. Box 500817, Dubai,
United Arab Emirates
Phone: +971-04-433-0412

KYOCERA Document Solutions Inc.

2-28, 1-chome, Tamatsukuri, Chuo-ku
Osaka 540-8585, Japan
Phone: +81-6-6764-3555
<http://www.kyoceradocumentsolutions.com>

© 2014 KYOCERA Document Solutions Inc.

 is a trademark of KYOCERA Corporation