



ECOSYS P5021cdn
ECOSYS P5021cdw
ECOSYS P5026cdn
ECOSYS P5026cdw
ECOSYS M5521cdn
ECOSYS M5521cdw
ECOSYS M5526cdn
ECOSYS M5526cdw
PF-5110

PARTS LIST

Published in May 2016
2R7PL070
842R7120
First Edition

ECOSYS P5026cdw
ECOSYS M5526cdw
PF-5110

パーツリスト

2016年5月初版
2R7PL010

ECOSYS P5021cdn/ECOSYS P5021cdw
ECOSYS P5026cdn/ECOSYS P5026cdw
ECOSYS M5521cdn/ECOSYS M5521cdw
ECOSYS M5526cdn/ECOSYS M5526cdw

CONTENTS / 目次

<p>FIG. 1 Covers (21ppm(A4),22ppm(Letter)(A)/ 21ppm(A4),22ppm(Letter)(B)/26ppm(A4),27ppm(Let- ter)(A)/26ppm(A4),27ppm(Letter)(B)) 2</p> <p>FIG. 2 Covers (21ppm(A4),22ppm(Letter)(AF)/ 21ppm(A4),22ppm(Letter)(BF)/26ppm(A4),27ppm(Let- ter)(AF)/26ppm(A4),27ppm(Letter)(BF)) 4</p> <p>FIG. 3 Covers Label 6</p> <p>FIG. 4 Frame 8</p> <p>FIG. 5 Paper Cassette 10</p> <p>FIG. 6 Paper Feed Section 1 12</p> <p>FIG. 7 Paper Feed Section 2 14</p> <p>FIG. 8 Paper Feed Section 3 16</p> <p>FIG. 9 Paper Conveying Section 18</p> <p>FIG. 10 Laser Scanner Section 20</p> <p>FIG. 11 Scanner Section 22</p> <p>FIG. 12 Image Formation Section 24</p> <p>FIG. 13 Fuser Section 26</p> <p>FIG. 14 Drive Section 1 28</p> <p>FIG. 15 Drive Section 2 30</p> <p>FIG. 16 Exit Section 32</p> <p>FIG. 17 Electrical Components 34</p> <p>FIG. 18 Operation Section (26ppm(A4),27ppm(Letter)(AF)/ 26ppm(A4),27ppm(Letter)(BF)) 37</p> <p>FIG. 19 Operation Section (21ppm(A4),22ppm(Letter)(AF)/ 21ppm(A4),22ppm(Letter)(BF)) 39</p> <p>FIG. 20 DP ASSY SP 41</p> <p>FIG. 21 DP covers 43</p> <p>FIG. 22 DP frame 45</p> <p>FIG. 23 DP Paper Feed Section 47</p> <p>FIG. 24 DP Conveying Section (26ppm(A4),27ppm(Letter)(A)/ 26ppm(A4),27ppm(Letter)(B)) 49</p>	<p>FIG. 25 DP Conveying Section (21ppm(A4),22ppm(Letter)(AF)/ 21ppm(A4),22ppm(Letter)(BF)) 51</p> <p>FIG. 26 DP Drive Section 53</p> <p>FIG. 27 Wire Sections 1 (21ppm(A4),22ppm(Letter)(A)/ 21ppm(A4),22ppm(Letter)(B)/26ppm(A4),27ppm(Let- ter)(A)/26ppm(A4),27ppm(Letter)(B)) 55</p> <p>FIG. 28 Wire Sections 2 (21ppm(A4),22ppm(Letter)(A)/ 21ppm(A4),22ppm(Letter)(B)/26ppm(A4),27ppm(Let- ter)(A)/26ppm(A4),27ppm(Letter)(B)/PF-5110) 57</p> <p>FIG. 29 Wire Sections 1 (21ppm(A4),22ppm(Letter)(AF)/ 21ppm(A4),22ppm(Letter)(BF)/26ppm(A4),27ppm(Let- ter)(AF)/26ppm(A4),27ppm(Letter)(BF)) 59</p> <p>FIG. 30 Wire Sections 2 (21ppm(A4),22ppm(Letter)(AF)/ 21ppm(A4),22ppm(Letter)(BF)/26ppm(A4),27ppm(Let- ter)(AF)/26ppm(A4),27ppm(Letter)(BF)/PF-5110) 61</p> <p>FIG. 31 Accessory 63</p> <p style="text-align: right;">• INDEX / 索引 65</p>
--	--

FIG. 1 Covers (21ppm(A4),22ppm(Letter)(A)/21ppm(A4),22ppm(Letter)(B)/
26ppm(A4),27ppm(Letter)(A)/26ppm(A4),27ppm(Letter)(B))

2RB/2RC/2RD/2RF/2R7/2R8/2R9/2RA

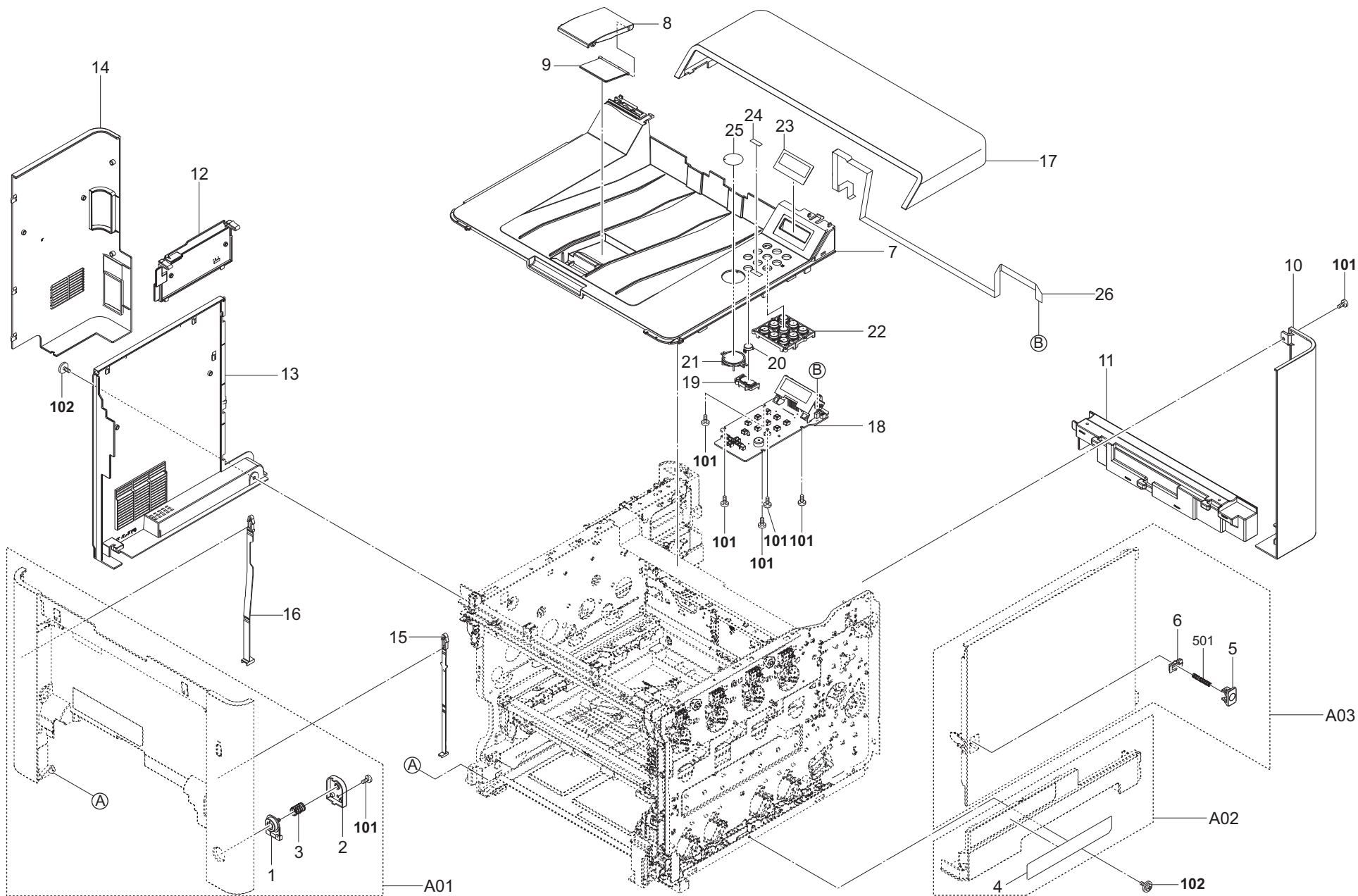

FIG. 2 Covers (21ppm(A4),22ppm(Letter)(AF)/21ppm(A4),22ppm(Letter)(BF)/
26ppm(A4),27ppm(Letter)(AF)/26ppm(A4),27ppm(Letter)(BF))

2RB/2RC/2RD/2RF/2R7/2R8/2R9/2RA

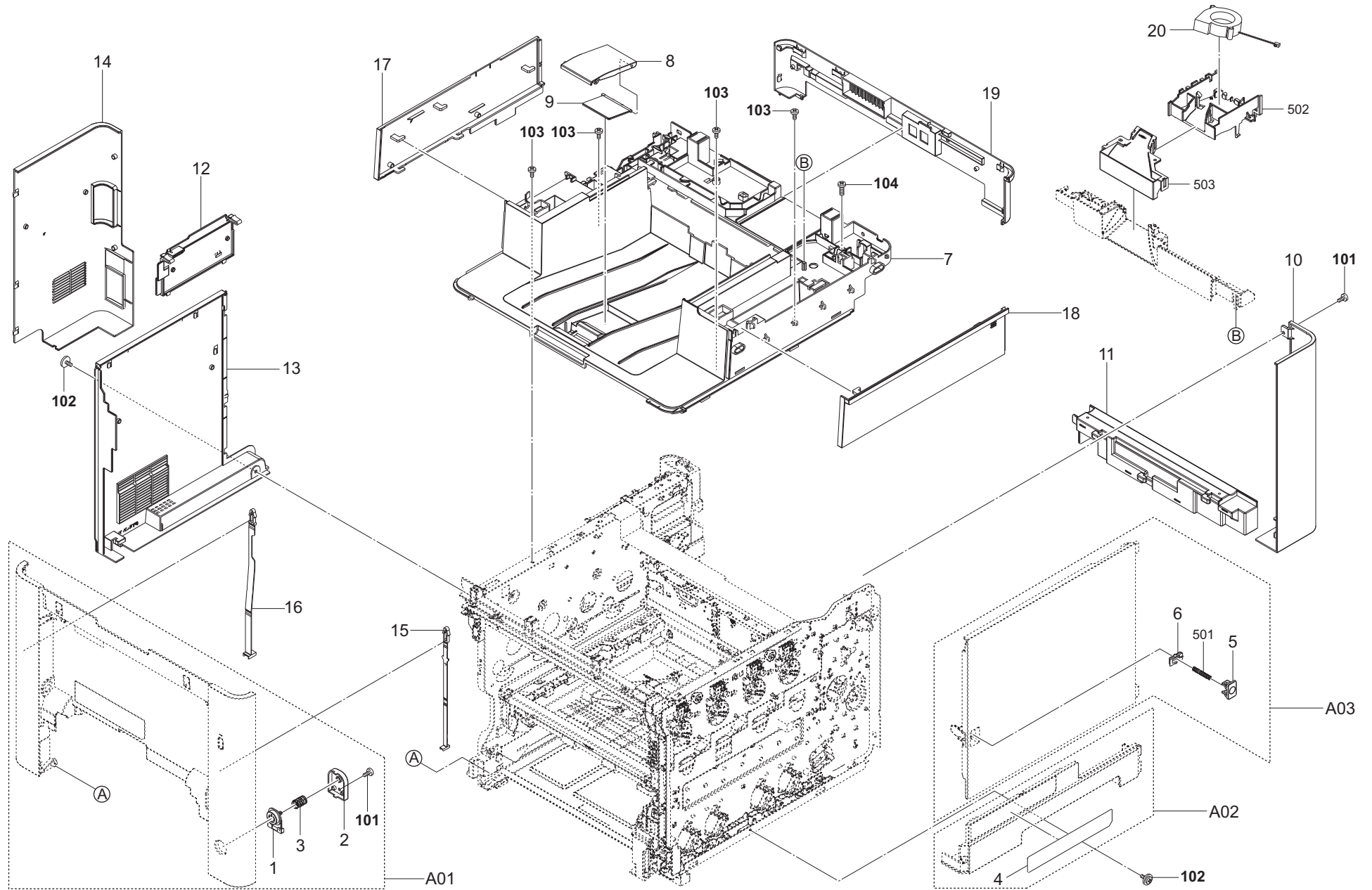

FIG. 2 Covers (21ppm(A4),22ppm(Letter)(AF)/21ppm(A4),22ppm(Letter)(BF)/
26ppm(A4),27ppm(Letter)(AF)/26ppm(A4),27ppm(Letter)(BF))

2RB/2RC/2RD/2RF/2R7/2R8/2R9/2RA

Ref. No. 番号	Part.No. 部品番号	Alternative. 代替部品番号	Description 部品名称	Notes 備考	Revision 改訂	Quantity 個数			
						100(日本)	120	230	240
A01	302R794020	2R794020	PARTS COVER FRONT ASSY SP			1	1	1	1
1	+302R704110	2R704110	KEY POWER SW			1	1	1	1
2	+302R704160	2R704160	HOLDER MAIN SW			1	1	1	1
3	+302F931270	2F931270	SPRING FUSER			1	1	1	1
A02	302R794030	2R794030	PARTS RIGHT BOTTOM ASSY SP			1	1	1	1
4	+302R734050	2R734050	LABEL CONTAINER OPERATION			1	1	1	1
A03	302R794040	2R794040	PARTS COVER CONTAINER ASSY SP			1	1	1	1
5	+302R704130	2R704130	PUSH BUTTON			1	1	1	1
6	+302R704140	2R704140	LOCK CROW			1	1	1	1
7	302R704060	2R704060	COVER TOP M			1	1	1	1
8	302R704090	2R704090	STOPPER PAPER			1	1	1	1
9	302R704290	2R704290	STOPPER PAPER B			1	1	1	1
10	302R704040	2R704040	COVER RIGHT REAR			1	1	1	1
11	302R704240	2R704240	COVER REAR BOTTOM			1	1	1	1
12	302R704170	2R704170	COVER LEFT REAR HARNESS			1	1	1	1
13	302R704020	2R704020	COVER LEFT			1	1	1	1
14	302R704050	2R704050	COVER LEFT REAR			1	1	1	1
15	302R704270	2R704270	STRAP COVER FRONT R			1	1	1	1
16	302R704280	2R704280	STRAP COVER FRONT L			1	1	1	1
17	302R704070	2R704070	COVER ISU LEFT			1	1	1	1
18	302R704220	2R704220	COVER ISU RIGHT			1	1	1	1
19	302R704180	2R704180	COVER ISU REAR			1	1	1	1
20	302HN44210	2HN44210	FAN MOTOR			1	1	1	1
101	7BB200308H	BB105660	+BIND T.T P SCREW 3X8						
102	7BB702308H	BB107060	+TP-FLAT T.T S SCREW 3X8 SR						
103	7BB700308H	BB105600	+BIND T.T S SCREW 3X8 SR						
104	7BB200412H	BB105710	+BIND T.T P SCREW 4X12						

• Parts with a Ref.No. of 500 and above in the illustration indicate they are not selected for service parts.

• イラスト中で 500 番台の Ref 番号が付いている部品はサービスパーツに選定されていません。

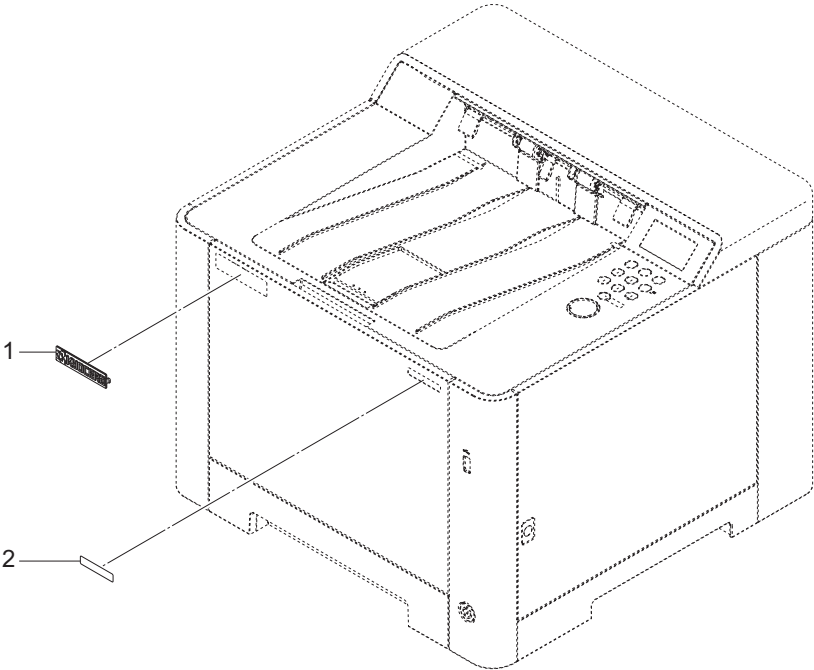
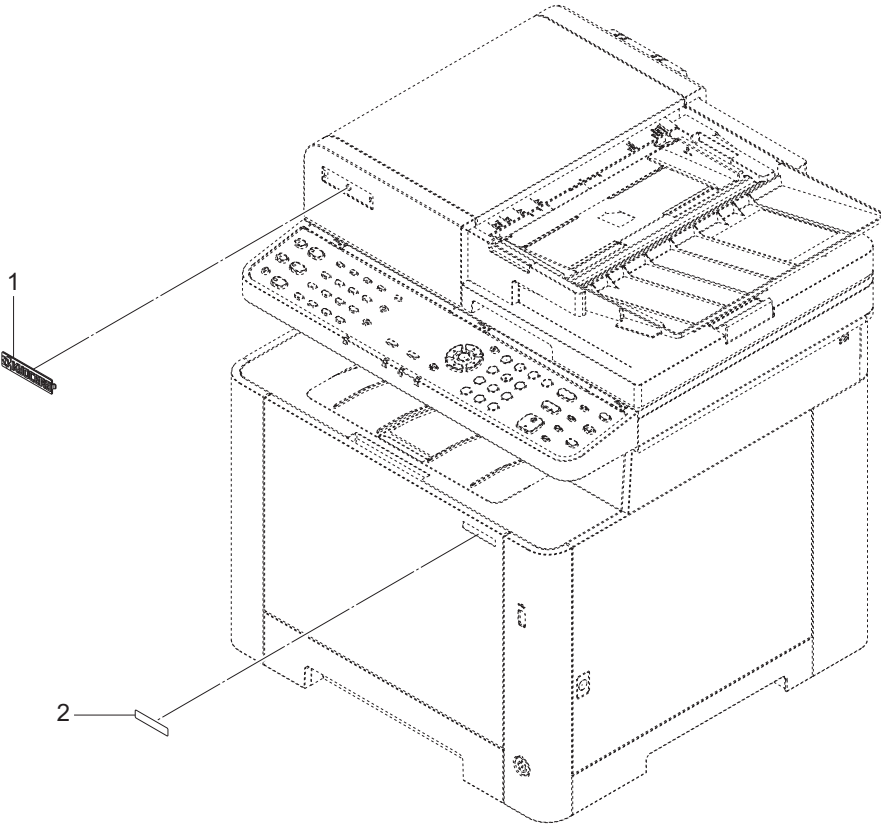

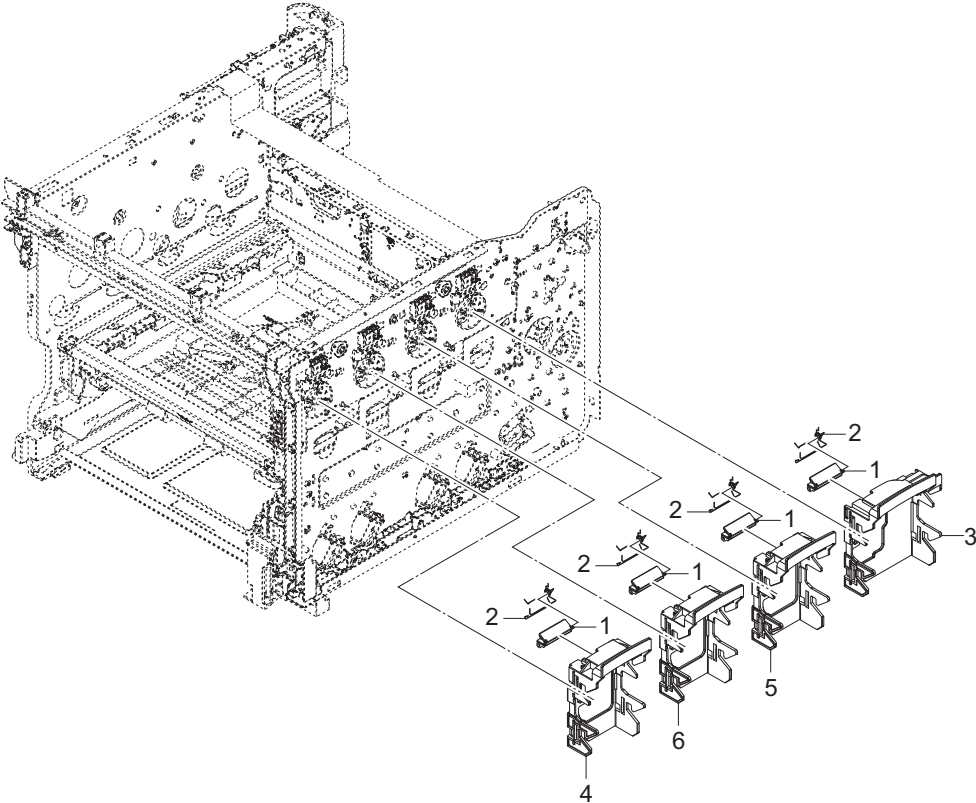

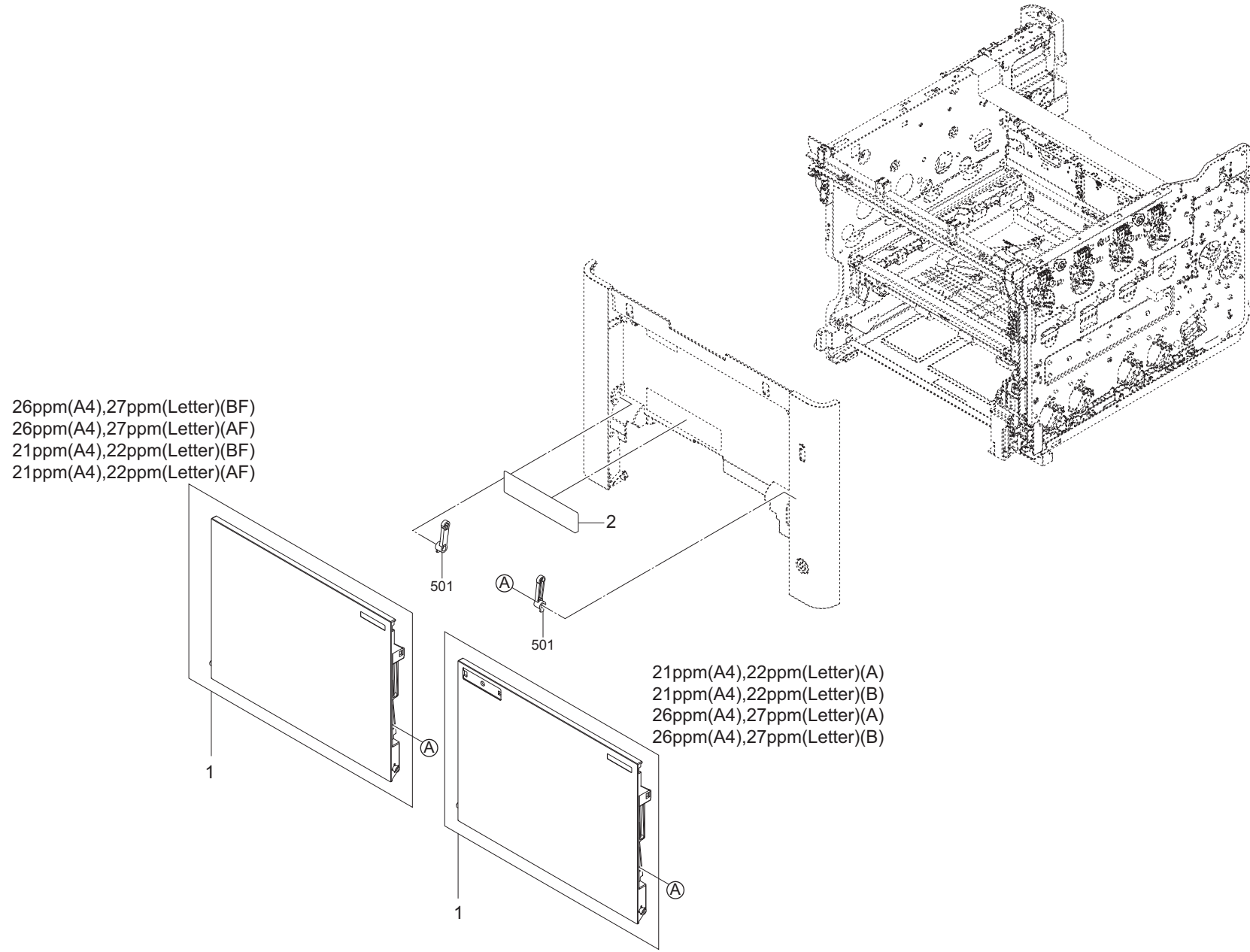

FIG. 7 Paper Feed Section 2

2RB/2RC/2RD/2RF/2R7/2R8/2R9/2RA

Ref. No. 番号	Part.No. 部品番号	Alternative. 代替部品番号	Description 部品名称	Notes 備考	Revision 改訂	Quantity 個数			
						100(日本)	120	230	240
A01	302R794080	2R794080	PARTS FRAME MPF ASSY SP			1	1	1	1
1	*302HS08260	2HS08260	ROLLER M/P ASSY			1	1	1	1
2	*302P794010	2P794010	PARTS SENSOR OPT. SP			1	1	1	1
3	*302GR44150	2GR44150	SOLENOID TONER			1	1	1	1
4	*302R746100	2R746100	CONN.CORD ASSY MPF PE			1	1	1	1
A02	302R794090	2R794090	PARTS GUIDE MPF FEED LOW ASSY SP			1	1	1	1
101	7BB700308H	BB105600	+BIND T.T S SCREW 3X8 SR						

• Parts with a Ref.No. of 500 and above in the illustration indicate they are not selected for service parts.

・イラスト中で 500 番台の Ref 番号が付いている部品はサービスパーツに選定されていません。

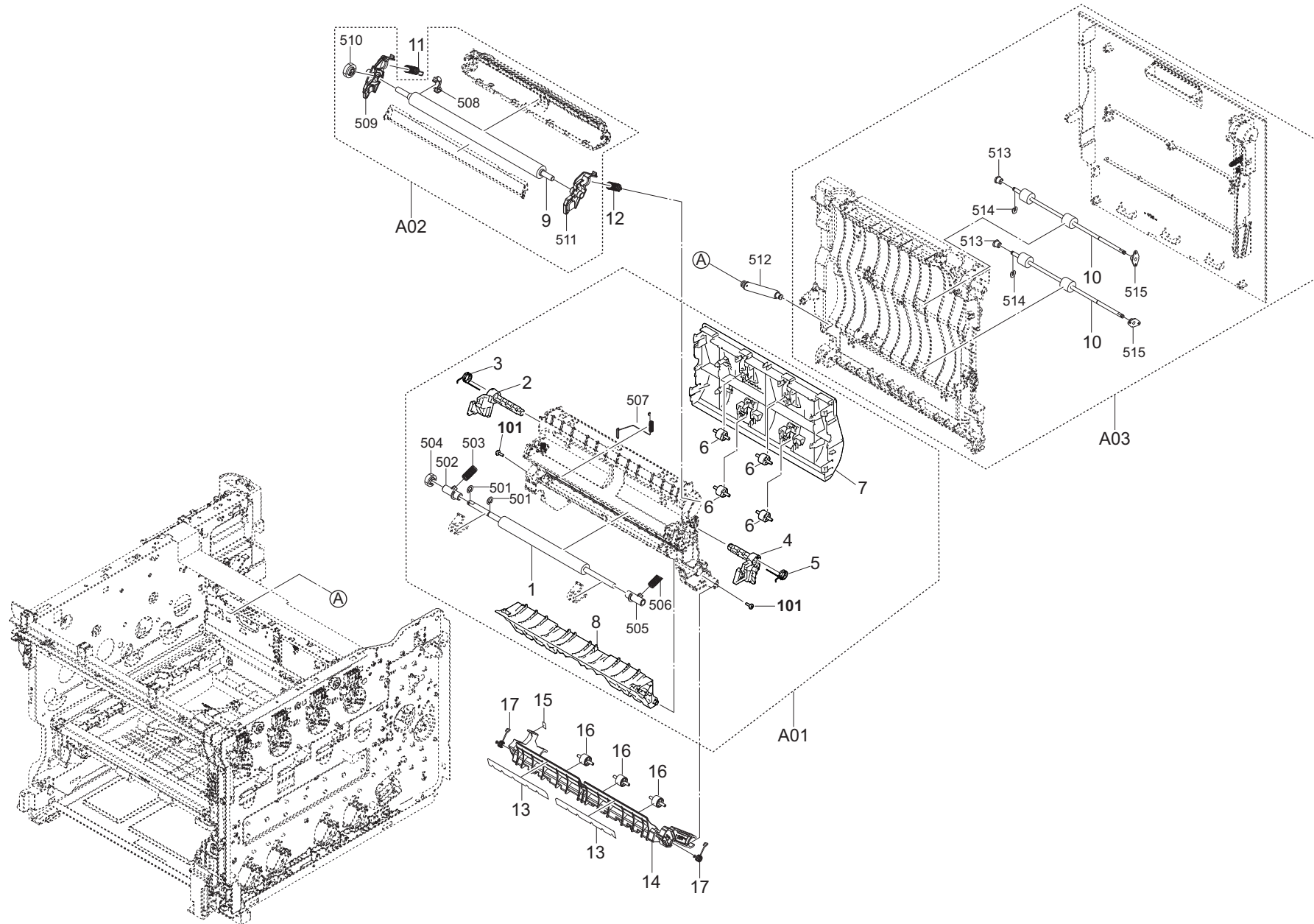

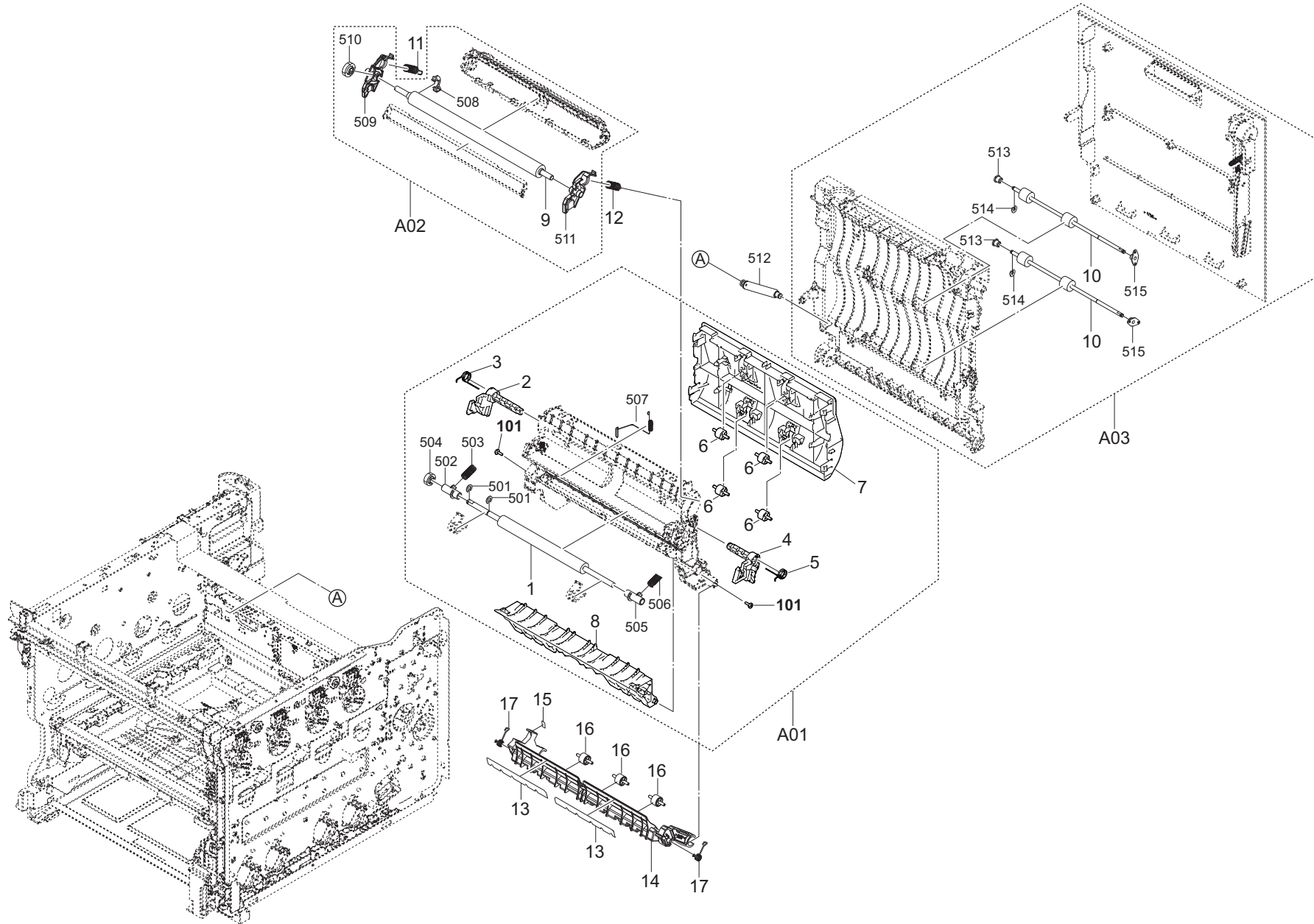

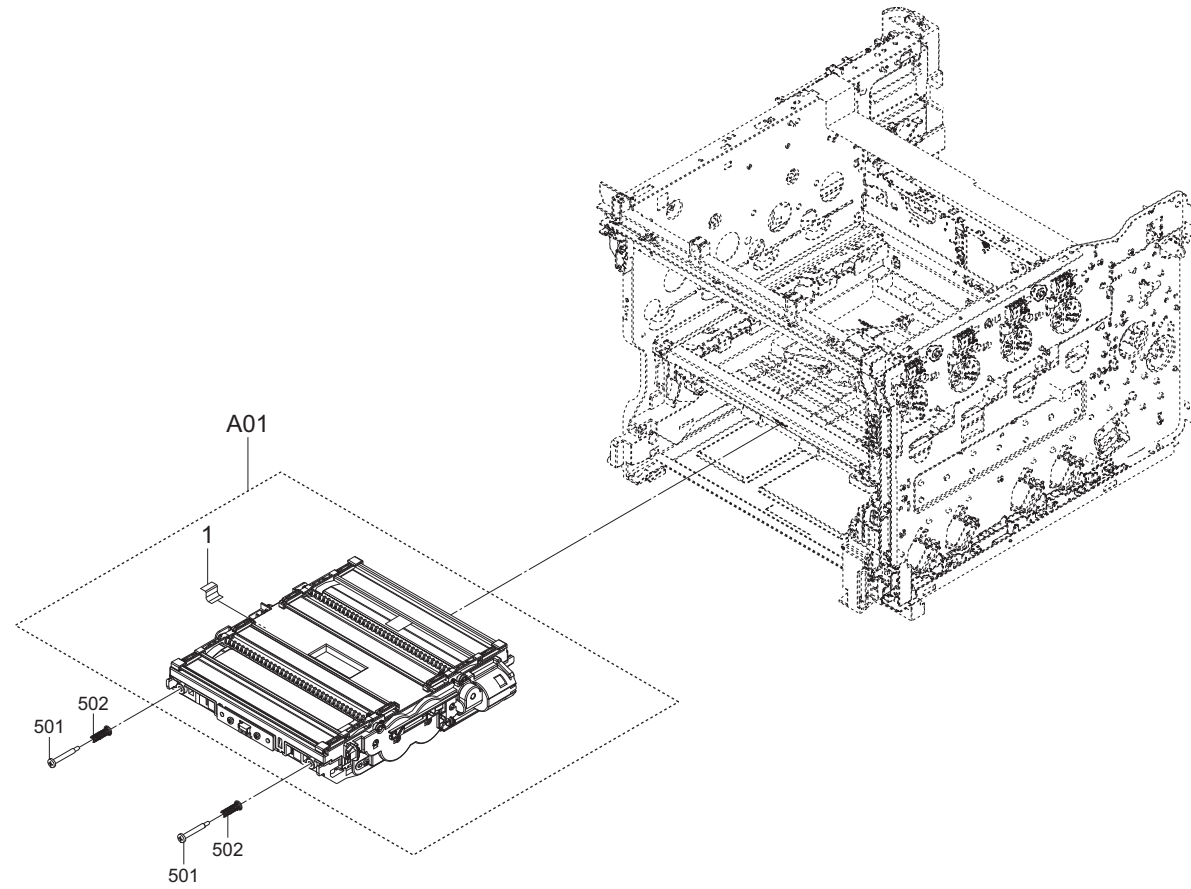

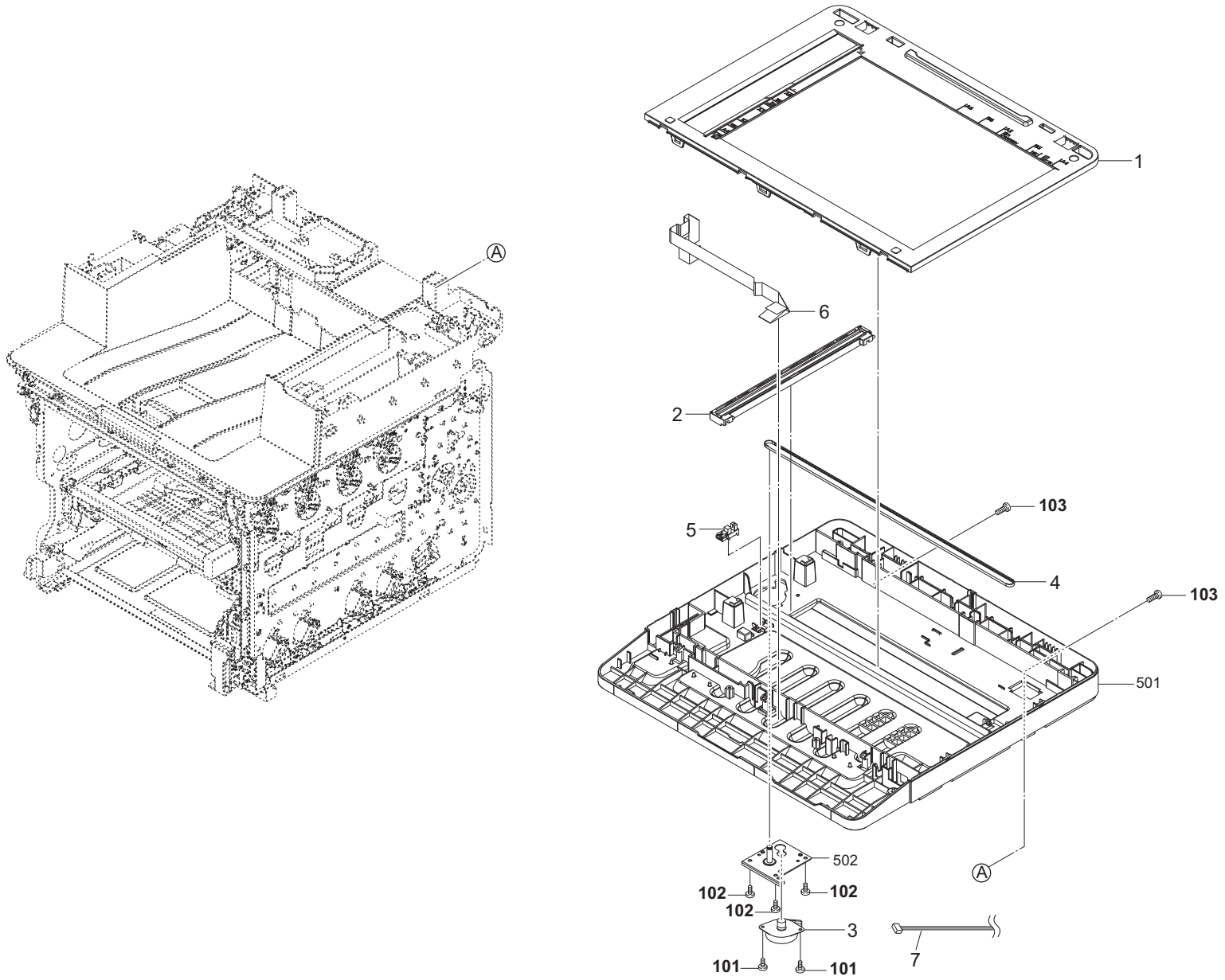

FIG. 11 Scanner Section

2RB/2RC/2RD/2RF/2R7/2R8/2R9/2RA

Ref. No. 番号	Part.No. 部品番号	Alternative. 代替部品番号	Description 部品名称	Notes 備考	Revision 改訂	Quantity 個数			
						100(日本)	120	230	240
1	302R794110	2R794110	PARTS FRAME ISU TOP A ASSY SP			1	1	1	1
2	302R794320	2R794320	PARTS SENSOR A4 CIS SP			1	1	1	1
3	302R794380	2R794380	PARTS MOTOR ISU SP			1	1	1	1
4	302S017340	2S017340	BELT ISU A			1	1	1	1
5	302P794010	2P794010	PARTS SENSOR OPT. SP			1	1	1	1
6	302R746170	2R746170	CONN.CORD ASSY FFC PANEL	26ppm(A4),27ppm(Letter)(AF)/26ppm(A4),27ppm(Letter)(BF)		1	1	1	1
6	302R946010	2R946010	CONN.CORD ASSY FFC PANEL	21ppm(A4),22ppm(Letter)(AF)/21ppm(A4),22ppm(Letter)(BF)			1	1	1
7	302R746310	2R746310	CONN.CORD ASSY TABLE MOT			1	1	1	1
101	7BB700308H	BB105600	+BIND T.T S SCREW 3X8 SR						
102	7BB200308H	BB105660	+BIND T.T P SCREW 3X8						
103	7BB200412H	BB105710	+BIND T.T P SCREW 4X12						

• Parts with a Ref.No. of 500 and above in the illustration indicate they are not selected for service parts.

• イラスト中で 500 番台の Ref 番号が付いている部品はサービスパーツに選定されていません。

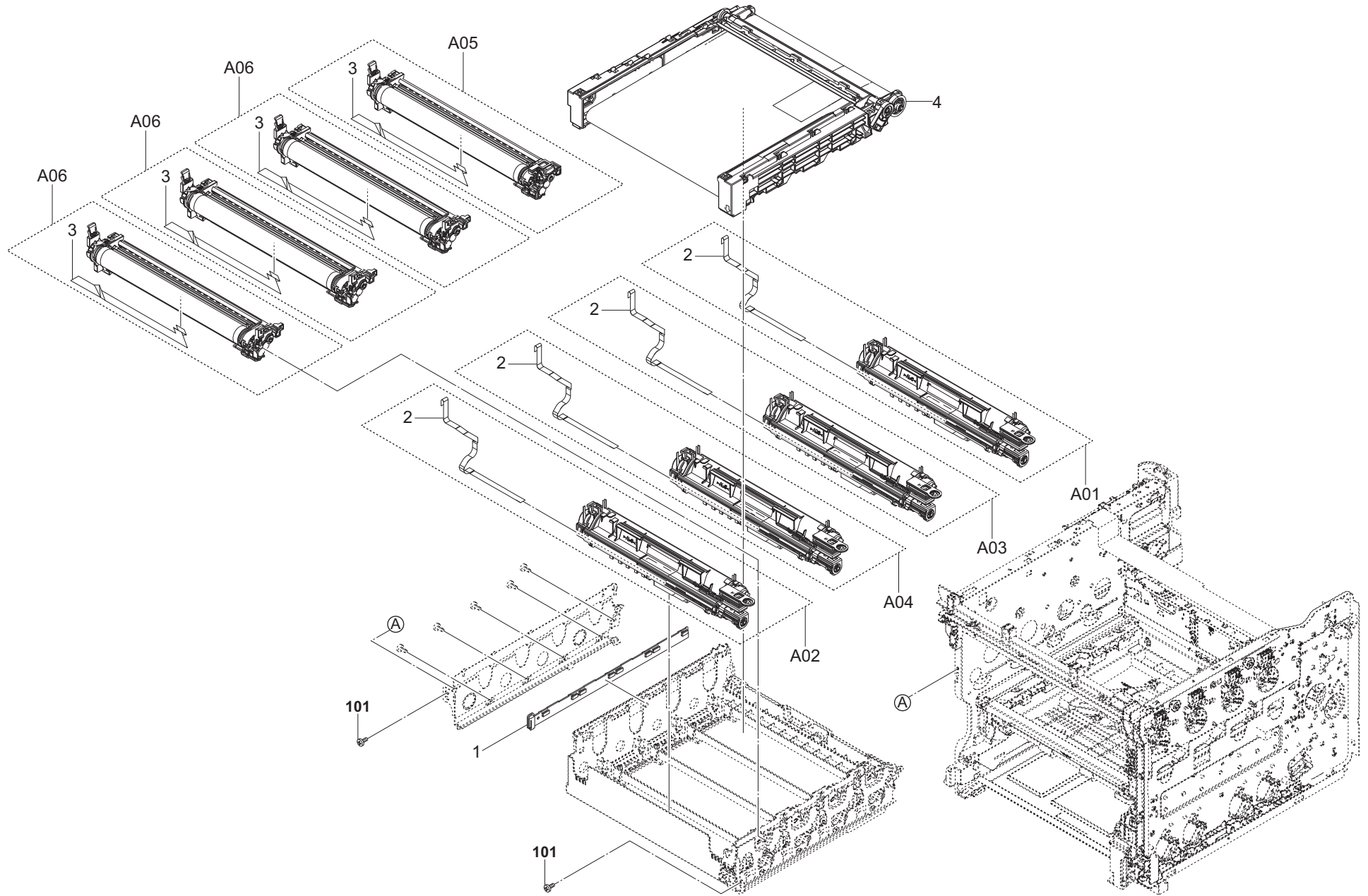

FIG. 12 Image Formation Section

2RB/2RC/2RD/2RF/2R7/2R8/2R9/2RA

Ref. No. 番号	Part.No. 部品番号	Alternative. 代替部品番号	Description 部品名称	Notes 備考	Revision 改訂	Quantity 個数			
						100(日本)	120	230	240
1	302R794240	2R794240	PARTS PWB UNIT CONNECT ASSY SP			1	1	1	1
A01	302R793030	2R793030	DV-5230(K)			1	1	1	1
2	*302R746070	2R746070	CONN.CORD ASSY FFC SENSOR TONER			1	1	1	1
A02	302R793040	2R793040	DV-5230(Y)			1	1	1	1
2	*302R746070	2R746070	CONN.CORD ASSY FFC SENSOR TONER			1	1	1	1
A03	302R793050	2R793050	DV-5230(M)			1	1	1	1
2	*302R746070	2R746070	CONN.CORD ASSY FFC SENSOR TONER			1	1	1	1
A04	302R793060	2R793060	DV-5230(C)			1	1	1	1
2	*302R746070	2R746070	CONN.CORD ASSY FFC SENSOR TONER			1	1	1	1
A05	302R793010	2R793010	DK-5230			1	1	1	1
3	*302R746200	2R746200	CONN.CORD ASSY FFC DRUM			1	1	1	1
A06	302R793020	2R793020	DK-5231			3	3	3	3
3	*302R746200	2R746200	CONN.CORD ASSY FFC DRUM			3	3	3	3
4	302R793070	2R793070	TR-5230			1	1	1	1

• Parts with a Ref.No. of 500 and above in the illustration indicate they are not selected for service parts.

・イラスト中で 500 番台の Ref 番号が付いている部品はサービスパーツに選定されていません。

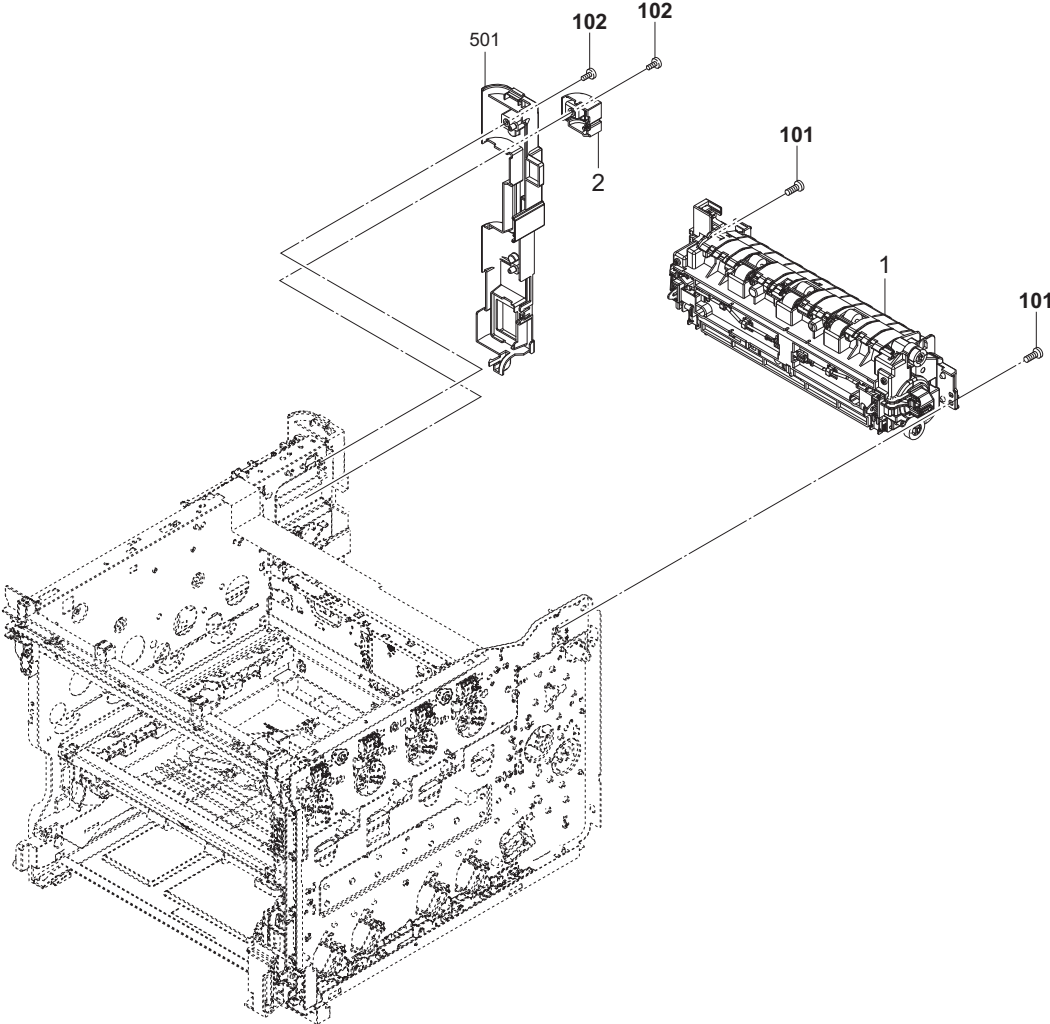

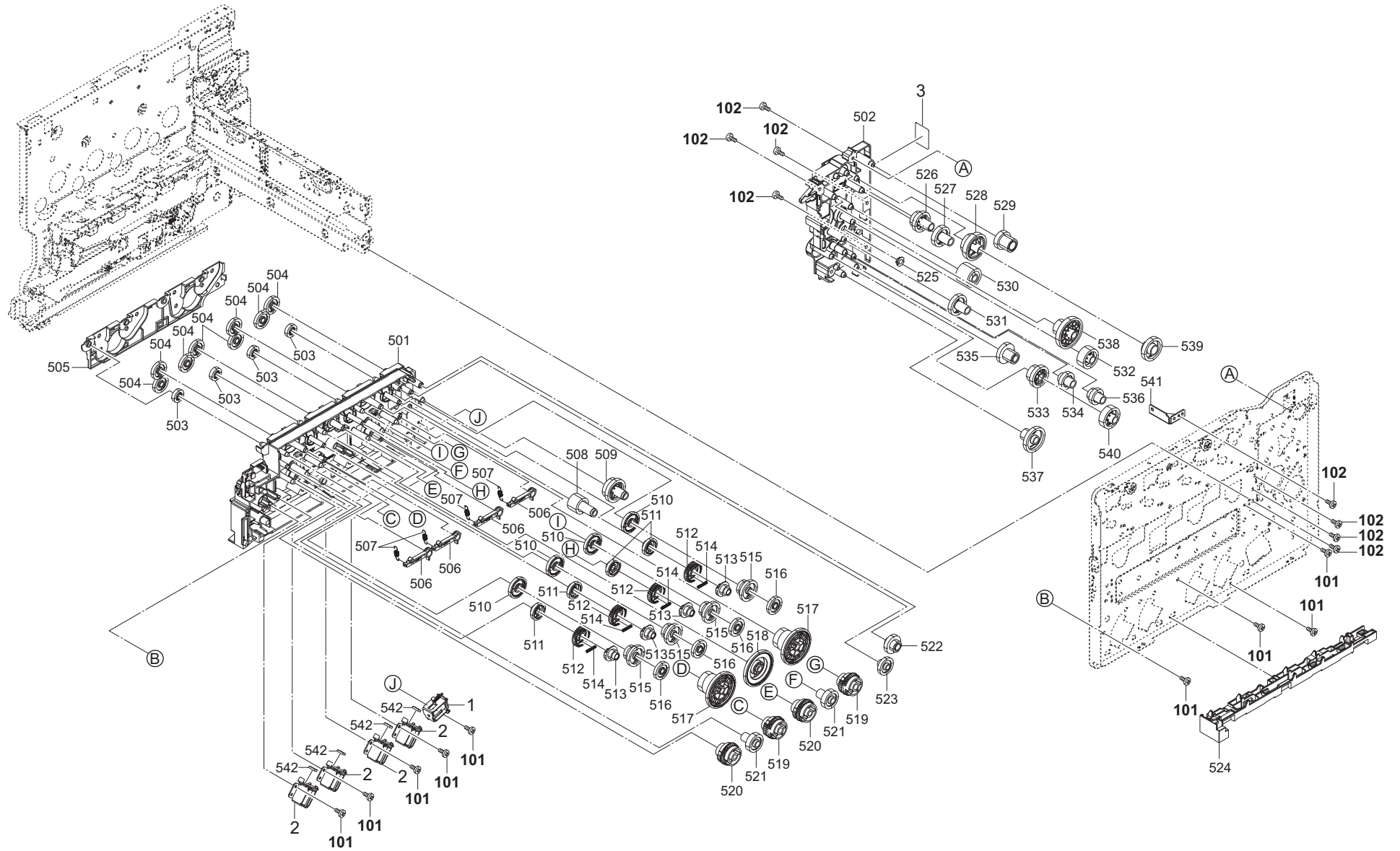

FIG. 16 Exit Section

2RB/2RC/2RD/2RF/2R7/2R8/2R9/2RA

21ppm(A4),22ppm(Letter)(A)/
 21ppm(A4),22ppm(Letter)(B)/
 26ppm(A4),27ppm(Letter)(A)/
 26ppm(A4),27ppm(Letter)(B)

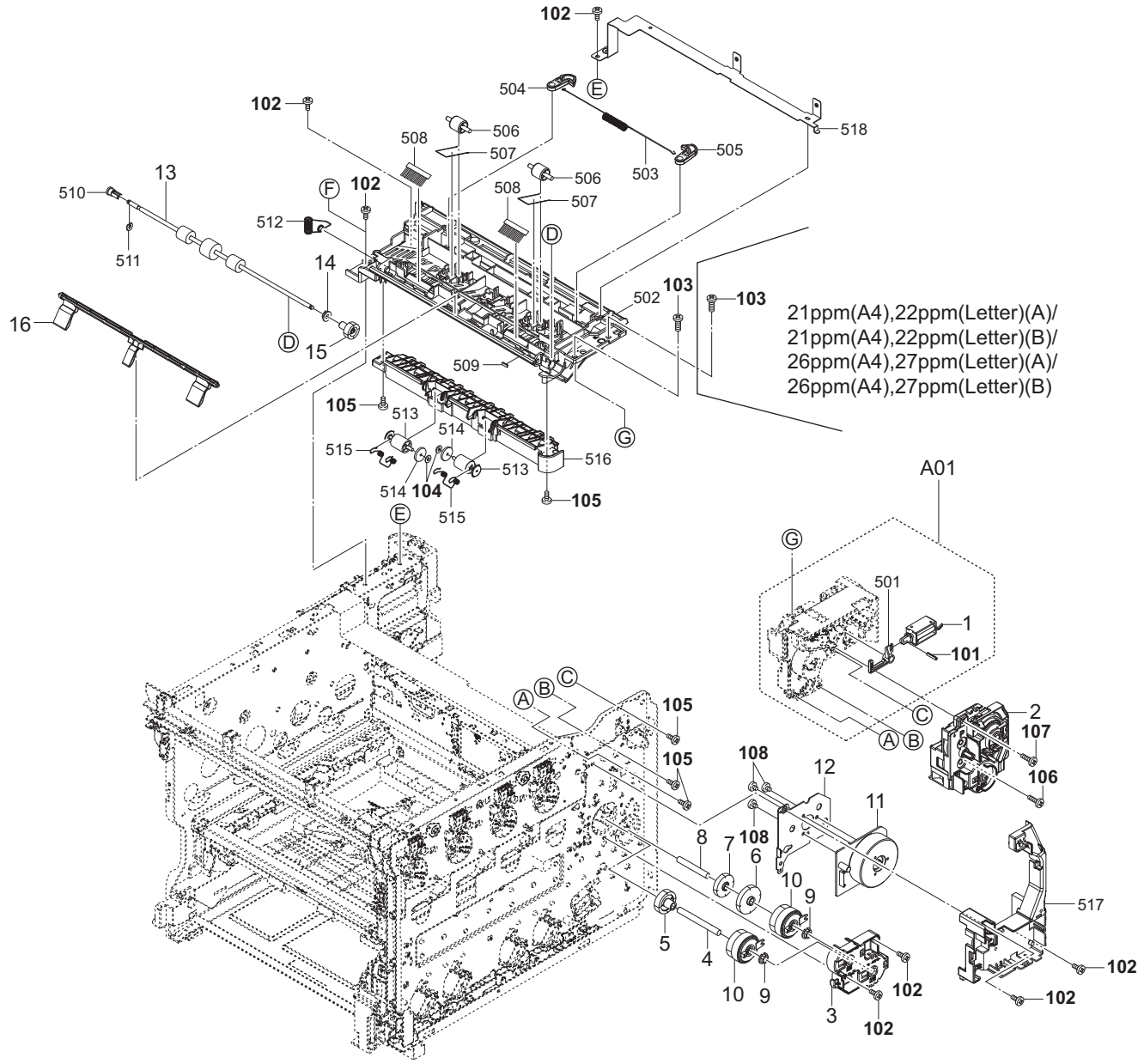
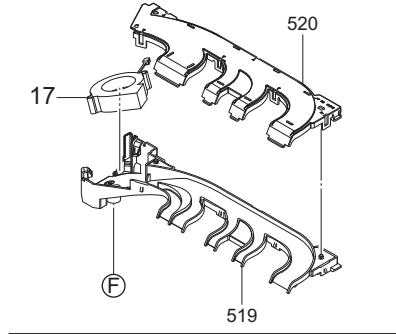

FIG. 16 Exit Section

2RB/2RC/2RD/2RF/2R7/2R8/2R9/2RA

Ref. No. 番号	Part.No. 部品番号	Alternative. 代替部品番号	Description 部品名称	Notes 備考	Revision 改訂	Quantity 個数			
						100(日本)	120	230	240
A01	302R794160	2R794160	PARTS GUIDE EXIT R ASSY SP			1	1	1	1
1	*302HN94140	2HN94140	SOLENOID FD ASSY SP			1	1	1	1
2	302R794180	2R794180	PARTS DRIVE EXIT PRESS ASSY SP			1	1	1	1
3	302R731630	2R731630	COVER CLUTCH			1	1	1	1
4	302R731520	2R731520	SHAFT CLUTCH REGIST			1	1	1	1
5	302R731510	2R731510	GEAR Z28L			1	1	1	1
6	302R731570	2R731570	GEAR Z35R			1	1	1	1
7	302R731530	2R731530	GEAR Z28R			1	1	1	1
8	302R731540	2R731540	SHAFT CLUTCH FEED			1	1	1	1
9	302LV31480	2LV31480	BUSH DRIVE POM			2	2	2	2
10	302NR94010	2NR94010	PARTS CLUTCH 35 Z35R SP			2	2	2	2
11	302LC94283	2LC94283	PARTS MOTOR-BL W40 SP			1	1	1	1
12	302R731660	2R731660	PLATE MOTOR FEED			1	1	1	1
13	302R794370	2R794370	PARTS ROLLER EXIT SP			1	1	1	1
14	302HS25220	2HS25220	BUSH FUSER			1	1	1	1
15	302R728110	2R728110	GEAR Z19S			1	1	1	1
16	302R728180	2R728180	ACTUATOR FD			1	1	1	1
17	302HN44210	2HN44210	FAN MOTOR	21ppm(A4),22ppm(Letter)(A)/21ppm(A4),22ppm(Letter)(B)/26ppm(A4),27ppm(Letter)(A)/26ppm(A4),27ppm(Letter)(B)		1	1	1	1
101	E0025140	E0025140	SPRING PIN 2.5X14						
102	7BB700308H	BB105600	+BIND T.T S SCREW 3X8 SR						
103	7BB200412H	BB105710	+BIND T.T P SCREW 4X12						
104	5MBWK32808NN	C2803080	POLY SLIDER /M3.2X 8 X0.8T XX						
105	7BB200308H	BB105660	+BIND T.T P SCREW 3X8						
106	7BB700312H	BB106820	+BIND T.T S SCREW 3X12 SR						
107	7BB200312H	BB105680	+BIND T.T P SCREW 3X12						
108	7BB000304H	BB105720	+BIND M SCREW 3X4						

• Parts with a Ref.No. of 500 and above in the illustration indicate they are not selected for service parts.

• イラスト中で 500 番台の Ref 番号が付いている部品はサービスパーツに選定されていません。

FIG. 17 Electrical Components

2RB/2RC/2RD/2RF/2R7/2R8/2R9/2RA

Ref. No. 番号	Part.No. 部品番号	Alternative. 代替部品番号	Description 部品名称	Notes 備考	Revision 改訂	Quantity 個数			
						100 (日本)	120	230	240
1	302R794200	2R794200	PARTS PWB ID SENSOR ASSY SP			2	2	2	2
2	302P794010	2P794010	PARTS SENSOR OPT. SP			2	2	2	2
3	302M294130	2M294130	PARTS PWB ASSY THERMISTOR SP			1	1	1	1
4	2FB27160	2FB27160	INTER LOCK SWITCH						
5	302R794230	2R794230	PARTS PWB ERASER ASSY SP			1	1	1	1
6	302R794210	2R794210	PARTS PWB CONTAINER CONNECT ASSY SP			1	1	1	1
7	7SP01000004+H01	SP136500	SW.PUSH			1	1	1	1
8	302R794260	2R794260	PARTS PWB SWITCH ASSY SP			1	1	1	1
9	302NG94220	2NG94220	PARTS FAN MOTOR SP			1	1	1	1
10	302R794290	2R794290	PARTS UNIT LOW VOLTAGE 120V SP			1	1		
10	302R794300	2R794300	PARTS UNIT LOW VOLTAGE 230V SP					1	1
11	302R794270	2R794270	PARTS PWB MAIN ASSY SP	21ppm(A4),22ppm(Letter)(AF)/21ppm(A4),22ppm(Letter)(BF)/26ppm(A4),27ppm(Letter)(AF)/26ppm(A4),27ppm(Letter)(BF)		1	1		1
11	302R794280	2R794280	PARTS PWB MAIN ASSY EU SP	21ppm(A4),22ppm(Letter)(AF)/21ppm(A4),22ppm(Letter)(BF)/26ppm(A4),27ppm(Letter)(AF)/26ppm(A4),27ppm(Letter)(BF)				1	
11	302R894010	2R894010	PARTS PWB MAIN ASSY SP	21ppm(A4),22ppm(Letter)(AF)/21ppm(A4),22ppm(Letter)(BF)/26ppm(A4),27ppm(Letter)(AF)/26ppm(A4),27ppm(Letter)(BF)					1
11	302R894020	2R894020	PARTS PWB MAIN ASSY EU SP	21ppm(A4),22ppm(Letter)(AF)/21ppm(A4),22ppm(Letter)(BF)/26ppm(A4),27ppm(Letter)(AF)/26ppm(A4),27ppm(Letter)(BF)				1	
11	302R994030	2R994030	PARTS PWB MAIN ASSY SP	21ppm(A4),22ppm(Letter)(AF)/21ppm(A4),22ppm(Letter)(BF)/26ppm(A4),27ppm(Letter)(AF)/26ppm(A4),27ppm(Letter)(BF)			1		1
11	302R994040	2R994040	PARTS PWB MAIN ASSY EU SP	21ppm(A4),22ppm(Letter)(AF)/21ppm(A4),22ppm(Letter)(BF)/26ppm(A4),27ppm(Letter)(AF)/26ppm(A4),27ppm(Letter)(BF)				1	
11	302RA94020	2RA94020	PARTS PWB MAIN ASSY SP	21ppm(A4),22ppm(Letter)(AF)/21ppm(A4),22ppm(Letter)(BF)/26ppm(A4),27ppm(Letter)(AF)/26ppm(A4),27ppm(Letter)(BF)			1		1
11	302RA94030	2RA94030	PARTS PWB MAIN ASSY EU SP	21ppm(A4),22ppm(Letter)(AF)/21ppm(A4),22ppm(Letter)(BF)/26ppm(A4),27ppm(Letter)(AF)/26ppm(A4),27ppm(Letter)(BF)				1	
12	302RB94030	2RB94030	PARTS PWB MAIN ASSY SP	21ppm(A4),22ppm(Letter)(A)/21ppm(A4),22ppm(Letter)(B)/26ppm(A4),27ppm(Letter)(A)/26ppm(A4),27ppm(Letter)(B)		1	1		1
12	302RB94040	2RB94040	PARTS PWB MAIN ASSY EU SP	21ppm(A4),22ppm(Letter)(A)/21ppm(A4),22ppm(Letter)(B)/26ppm(A4),27ppm(Letter)(A)/26ppm(A4),27ppm(Letter)(B)				1	
12	302RC94010	2RC94010	PARTS PWB MAIN ASSY SP	21ppm(A4),22ppm(Letter)(A)/21ppm(A4),22ppm(Letter)(B)/26ppm(A4),27ppm(Letter)(A)/26ppm(A4),27ppm(Letter)(B)			1		1
12	302RC94020	2RC94020	PARTS PWB MAIN ASSY EU SP	21ppm(A4),22ppm(Letter)(A)/21ppm(A4),22ppm(Letter)(B)/26ppm(A4),27ppm(Letter)(A)/26ppm(A4),27ppm(Letter)(B)				1	
12	302RD94010	2RD94010	PARTS PWB MAIN ASSY SP	21ppm(A4),22ppm(Letter)(A)/21ppm(A4),22ppm(Letter)(B)/26ppm(A4),27ppm(Letter)(A)/26ppm(A4),27ppm(Letter)(B)			1		1
12	302RD94020	2RD94020	PARTS PWB MAIN ASSY EU SP	21ppm(A4),22ppm(Letter)(A)/21ppm(A4),22ppm(Letter)(B)/26ppm(A4),27ppm(Letter)(A)/26ppm(A4),27ppm(Letter)(B)				1	

• Parts with a Ref.No. of 500 and above in the illustration indicate they are not selected for service parts.

• イラスト中で 500 番台の Ref 番号が付いている部品はサービスパーツに選定されていません。

FIG. 17 Electrical Components

2RB/2RC/2RD/2RF/2R7/2R8/2R9/2RA

Ref. No. 番号	Part.No. 部品番号	Alternative. 代替部品番号	Description 部品名称	Notes 備考	Revision 改訂	Quantity 個数			
						100 (日本)	120	230	240
12	302RF94010	2RF94010	PARTS PWB MAIN ASSY SP	21ppm(A4),22ppm(Letter)(A)/21ppm(A4),22ppm(Letter)(B)/26ppm(A4),27ppm(Letter)(A)/26ppm(A4),27ppm(Letter)(B)			1		1
12	302RF94020	2RF94020	PARTS PWB MAIN ASSY EU SP	21ppm(A4),22ppm(Letter)(A)/21ppm(A4),22ppm(Letter)(B)/26ppm(A4),27ppm(Letter)(A)/26ppm(A4),27ppm(Letter)(B)				1	
13	302R794310	2R794310	PARTS UNIT HIGH VOLTAGE SP			1	1	1	1
14	302R794330	2R794330	PARTS FAX UNIT J SP	21ppm(A4),22ppm(Letter)(AF)/21ppm(A4),22ppm(Letter)(BF)/26ppm(A4),27ppm(Letter)(BF)		1			
14	302R794340	2R794340	PARTS FAX UNIT U SP	21ppm(A4),22ppm(Letter)(AF)/21ppm(A4),22ppm(Letter)(BF)/26ppm(A4),27ppm(Letter)(AF)/26ppm(A4),27ppm(Letter)(BF)			1		
14	303PA94011	3PA94011	PARTS FAX UNIT E SP	21ppm(A4),22ppm(Letter)(AF)/21ppm(A4),22ppm(Letter)(BF)/26ppm(A4),27ppm(Letter)(AF)/26ppm(A4),27ppm(Letter)(BF)				1	1
15	302R794390	2R794390	PARTS SPEAKER SP	21ppm(A4),22ppm(Letter)(AF)/21ppm(A4),22ppm(Letter)(BF)/26ppm(A4),27ppm(Letter)(AF)/26ppm(A4),27ppm(Letter)(BF)		1	1	1	1
16	302R794010	2R794010	PARTS WIFI UNIT SP	21ppm(A4),22ppm(Letter)(AF)/21ppm(A4),22ppm(Letter)(BF)/26ppm(A4),27ppm(Letter)(AF)/26ppm(A4),27ppm(Letter)(BF)		1	1	1	1
	7BB700308H 7BB200308H	BB105600 BB105660	+BIND T.T S SCREW 3X8 SR +BIND T.T P SCREW 3X8						

• Parts with a Ref.No. of 500 and above in the illustration indicate they are not selected for service parts.

• イラスト中で 500 番の Ref 番号が付いている部品はサービスパーツに選定されていません。

FIG. 18 Operation Section (26ppm(A4),27ppm(Letter)(AF)/26ppm(A4),27ppm(Letter)(BF))

2RB/2RC/2RD/2RF/2R7/2R8/2R9/2RA

Ref. No. 番号	Part.No. 部品番号	Alternative. 代替部品番号	Description 部品名称	Notes 備考	Revision 改訂	Quantity 個数			
						100(日本)	120	230	240
A01	302R794050	2R794050	PARTS OPERATION ASSY SP	26ppm(A4),27ppm(Letter)(AF)/26ppm(A4),27ppm(Letter)(BF)		1	1	1	1
1	*302K394171	2K394171	PARTS LCD COLOR SP			1	1	1	1
2	*302R794190	2R794190	PARTS PWB PANEL ASSY SP			1	1	1	1
3	*302R794220	2R794220	PARTS PWB KEY RIGHT ASSY SP			1	1	1	1
4	*302R746340	2R746340	CONN.CORD ASSY FFC KEY RIGHT			1	1	1	1
5	*302R794250	2R794250	PARTS PWB KEY LEFT ASSY SP			1	1	1	1
6	*302S505040	2S505040	LID SHEET COVER T			2	2	2	2
7	302R705710	2R705710	LABEL OPERATION T LEFT EN			1	1	1	1
7	302R705720	2R705720	LABEL OPERATION T LEFT JP			1	1	1	1
8	302S505030	2S505030	SHEET COVER T LEFT			1	1	1	1
9	302R705510	2R705510	LABEL OPERATION T RIGHT EN			1	1	1	1
9	302R705520	2R705520	LABEL OPERATION T RIGHT JP			1	1	1	1
10	302S505020	2S505020	SHEET COVER T RIGHT			1	1	1	1
101	7BB700308H	BB105600	+BIND T.T S SCREW 3X8 SR						
102	7BB200308H	BB105660	+BIND T.T P SCREW 3X8						

• Parts with a Ref.No. of 500 and above in the illustration indicate they are not selected for service parts.

• イラスト中で 500 番台の Ref 番号が付いている部品はサービスパーツに選定されていません。

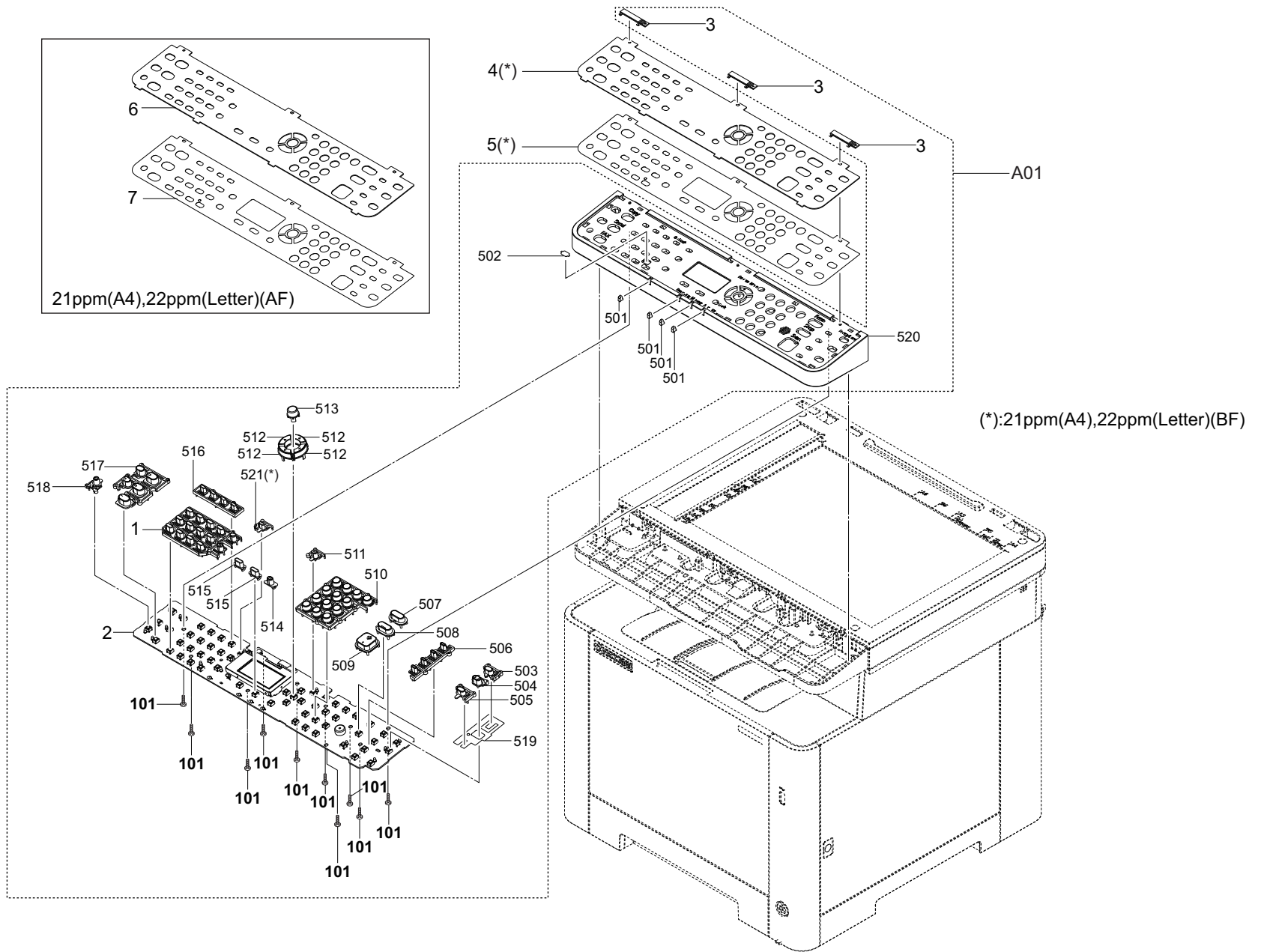

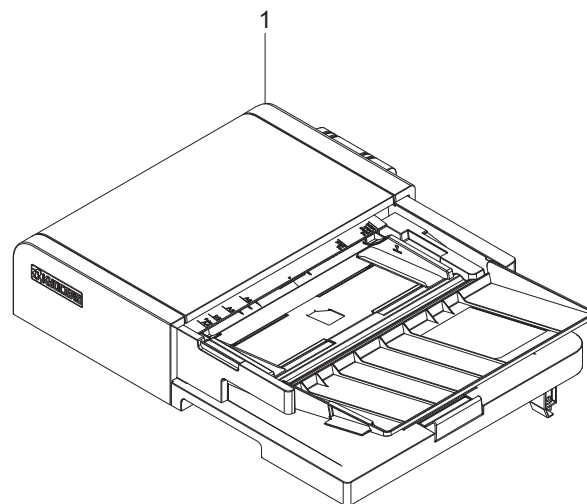

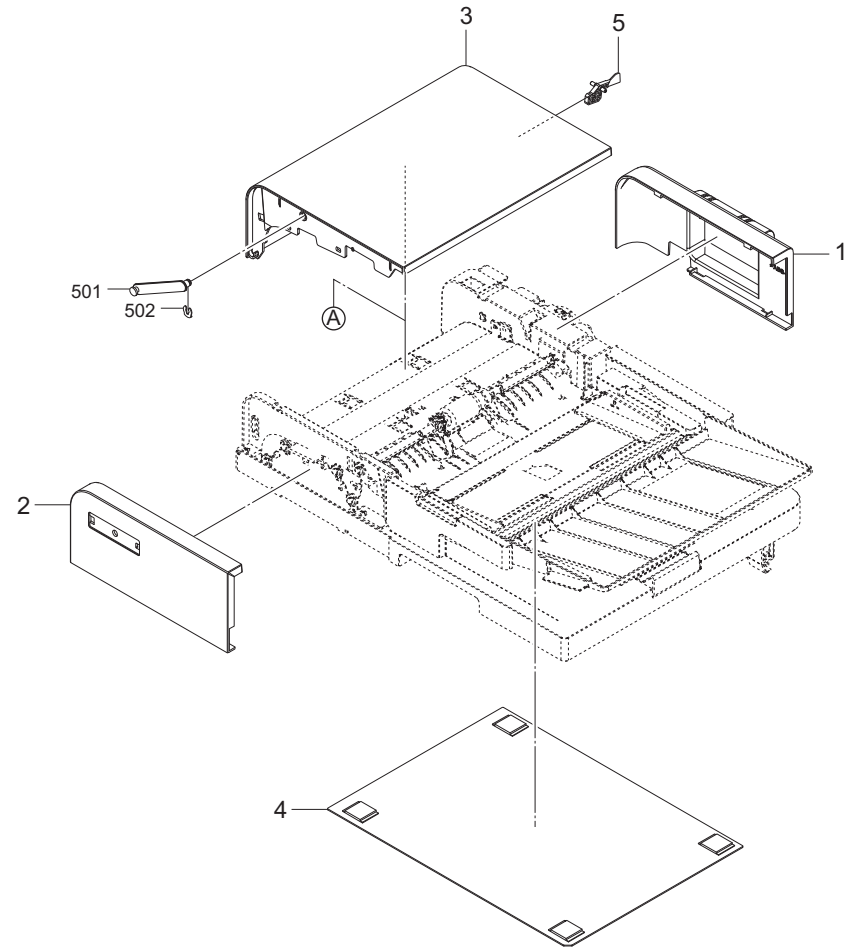
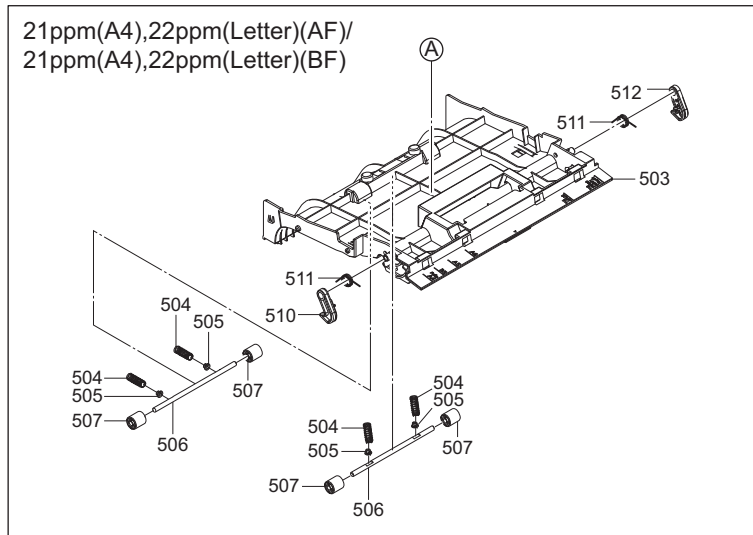
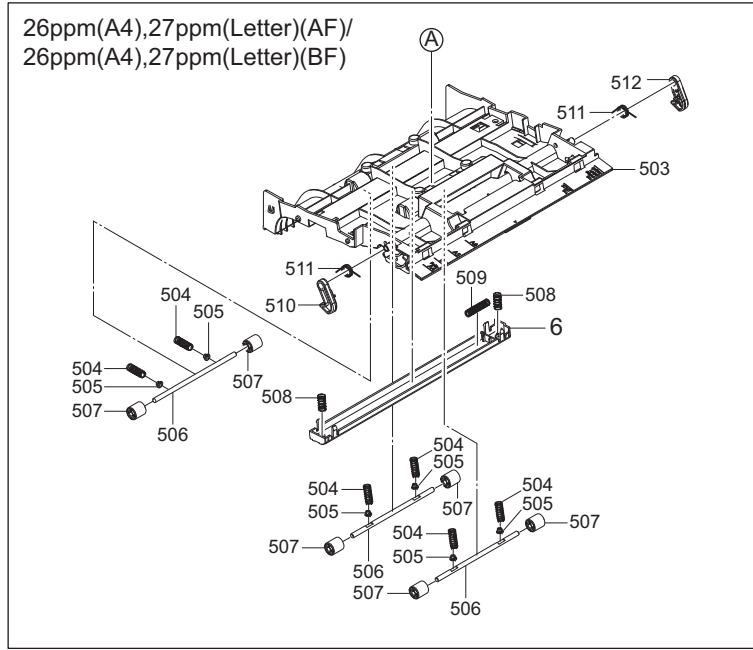

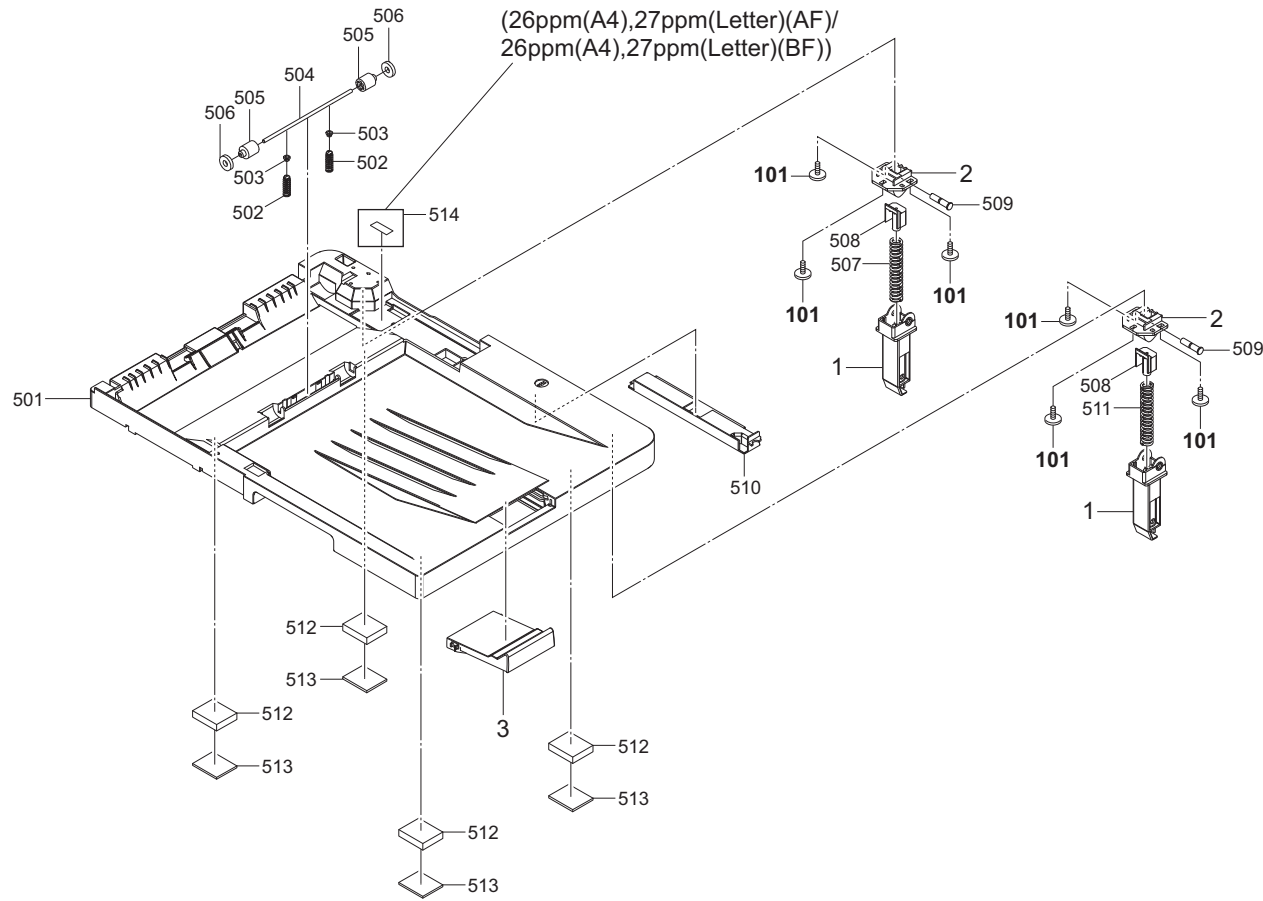

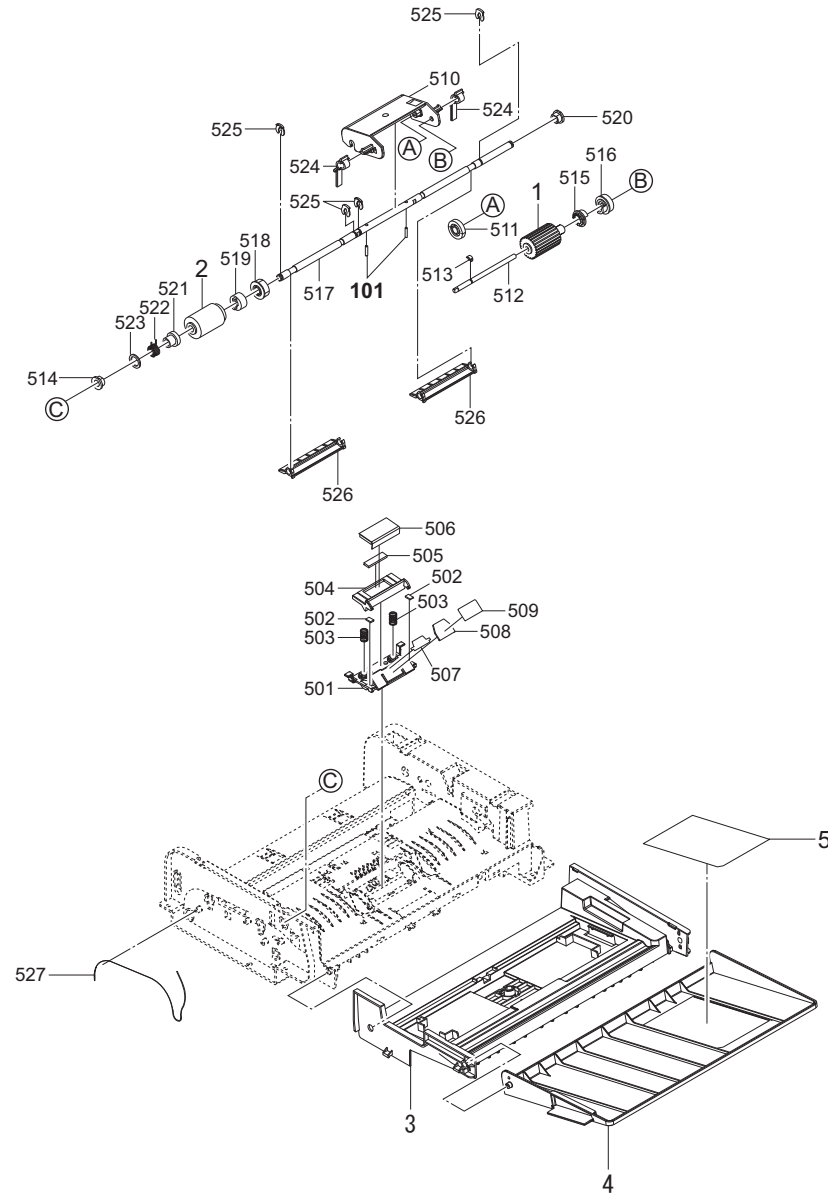

FIG. 23 DP Paper Feed Section

2RB/2RC/2RD/2RF/2R7/2R8/2R9/2RA

Ref. No. 番号	Part.No. 部品番号	Alternative. 代替部品番号	Description 部品名称	Notes 備考	Revision 改訂	Quantity 個数			
						100(日本)	120	230	240
1	36211110	36211110	PULLEY,LEADING FEED ADF			1	1	1	1
2	3BR07040	3BR07040	PULLEY,PAPER FEED			1	1	1	1
3	302R794120	2R794120	PARTS TABLE MAIN ASSY SP			1	1	1	1
4	302S018440	2S018440	COVER TABLE			1	1	1	1
5	302R734090	2R734090	LABEL DP TABLE	26ppm(A4),27ppm(Letter)(AF)/26ppm(A4),27ppm(Letter)(BF)		1	1	1	1
5	302R934090	2R934090	LABEL DP TABLE	26ppm(A4),27ppm(Letter)(AF)/26ppm(A4),27ppm(Letter)(BF)			1	1	1
101	7BP512010B0CH01	BP126160	PARALLEL PIN 2.0X10						

• Parts with a Ref.No. of 500 and above in the illustration indicate they are not selected for service parts.

• イラスト中で 500 番の Ref 番号が付いている部品はサービスパーツに選定されていません。

FIG. 24 DP Conveying Section (26ppm(A4),27ppm(Letter)(AF)/26ppm(A4),27ppm(Letter)(BF))

2RB/2RC/2RD/2RF/2R7/2R8/2R9/2RA

Ref. No. 番号	Part.No. 部品番号	Alternative. 代替部品番号	Description 部品名称	Notes 備考	Revision 改訂	Quantity 個数			
						100(日本)	120	230	240
1	302S018260	2S018260	ACTUATOR TIMING C			1	1	1	1
2	302S018370	2S018370	GEAR Z30R			3	3	3	3
3	302S018170	2S018170	GEAR Z25L			3	3	3	3
4	302S018150	2S018150	ACTUATOR TIMING A			1	1	1	1
5	302P794010	2P794010	PARTS SENSOR OPT. SP			4	4	4	4
6	302S018120	2S018120	GUIDE READING			1	1	1	1
7	302S018180	2S018180	ACTUATOR SET			1	1	1	1
8	302S018690	2S018690	COVER PI			1	1	1	1
9	302R794320	2R794320	PARTS SENSOR A4 CIS SP			1	1	1	1
10	302S318030	2S318030	ACTUATOR TIMING B			1	1	1	1
11	303LL31430	3LL31430	GEAR Z25L			1	1	1	1
101	7BB200308H	BB105660	+BIND T.T P SCREW 3X8						

• Parts with a Ref.No. of 500 and above in the illustration indicate they are not selected for service parts.

・イラスト中で 500 番台の Ref 番号が付いている部品はサービスパーツに選定されていません。

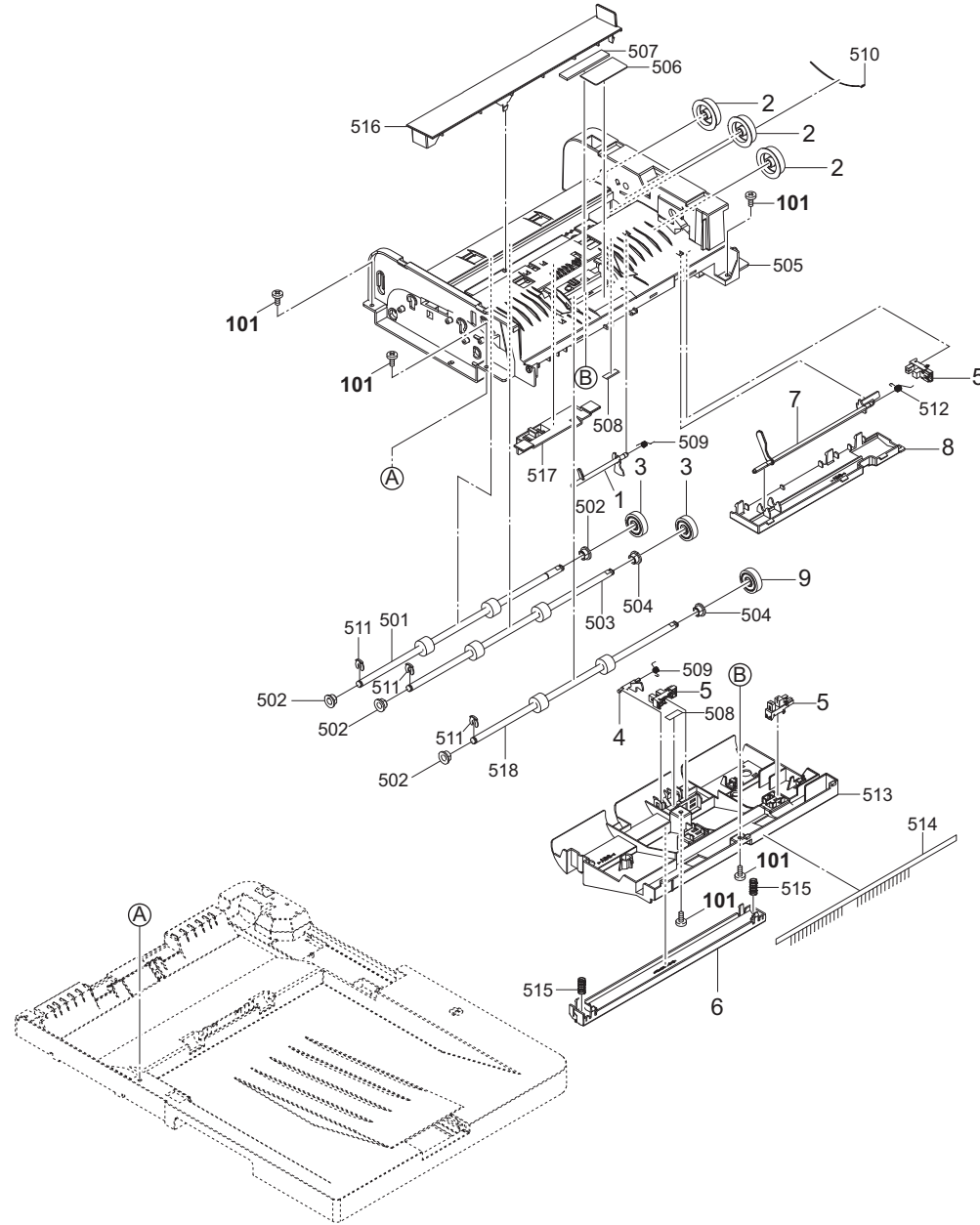

FIG. 25 DP Conveying Section (21ppm(A4),22ppm(Letter)(AF)/21ppm(A4),22ppm(Letter)(BF))

2RB/2RC/2RD/2RF/2R7/2R8/2R9/2RA

Ref. No. 番号	Part.No. 部品番号	Alternative. 代替部品番号	Description 部品名称	Notes 備考	Revision 改訂	Quantity 個数			
						100(日本)	120	230	240
1	302S018260	2S018260	ACTUATOR TIMING C				1	1	1
2	302S018370	2S018370	GEAR Z30R				3	3	3
3	302S018170	2S018170	GEAR Z25L				2	2	2
4	302S018150	2S018150	ACTUATOR TIMING A				1	1	1
5	302P794010	2P794010	PARTS SENSOR OPT. SP				3	3	3
6	302S018120	2S018120	GUIDE READING				1	1	1
7	302S018180	2S018180	ACTUATOR SET				1	1	1
8	302S018690	2S018690	COVER PI				1	1	1
9	303LL31430	3LL31430	GEAR Z25L				1	1	1
101	7BB200308H	BB105660	+BIND T.T P SCREW 3X8						

• Parts with a Ref.No. of 500 and above in the illustration indicate they are not selected for service parts.

・イラスト中で 500 番台の Ref 番号が付いている部品はサービスパーツに選定されていません。

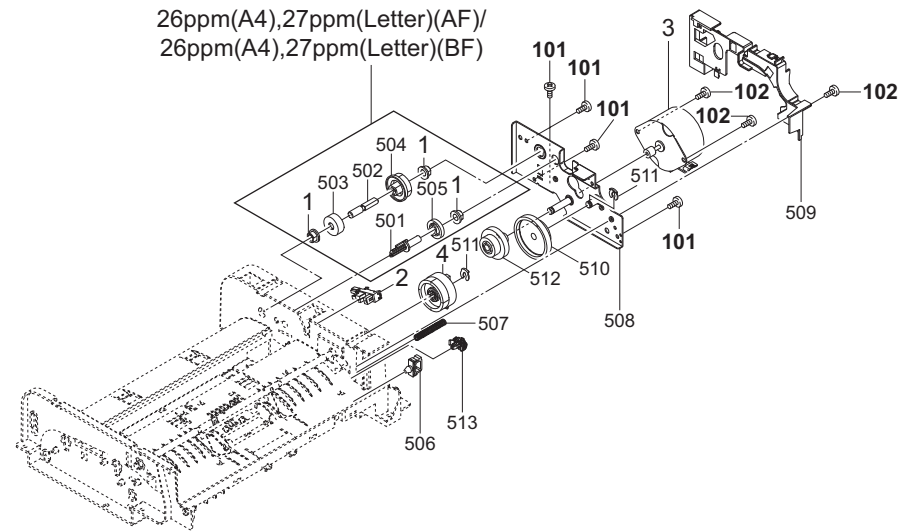

FIG. 26 DP Drive Section

2RB/2RC/2RD/2RF/2R7/2R8/2R9/2RA

Ref. No. 番号	Part.No. 部品番号	Alternative. 代替部品番号	Description 部品名称	Notes 備考	Revision 改訂	Quantity 個数			
						100(日本)	120	230	240
1	302H702590	2H702590	BUSH SCREW	26ppm(A4),27ppm(Letter)(AF)/26ppm(A4),27ppm(Letter)(BF)		3	3	3	3
2	302P794010	2P794010	PARTS SENSOR OPT. SP			1	1	1	1
3	302S094010	2S094010	PARTS MOTOR-PM DP SP			1	1	1	1
4	302NR94010	2NR94010	PARTS CLUTCH 35 Z35R SP			1	1	1	1
101	7BB200308H	BB105660	+BIND T.T P SCREW 3X8						
102	7BB700308H	BB105600	+BIND T.T S SCREW 3X8 SR						

• Parts with a Ref.No. of 500 and above in the illustration indicate they are not selected for service parts.

・イラスト中で 500 番台の Ref 番号が付いている部品はサービスパーツに選定されていません。

FIG. 27 Wire Sections 1 (21ppm(A4),22ppm(Letter)(A)/21ppm(A4),22ppm(Letter)(B)
/26ppm(A4),27ppm(Letter)(A)/26ppm(A4),27ppm(Letter)(B))

2RB/2RC/2RD/2RF/2R7/2R8/2R9/2RA

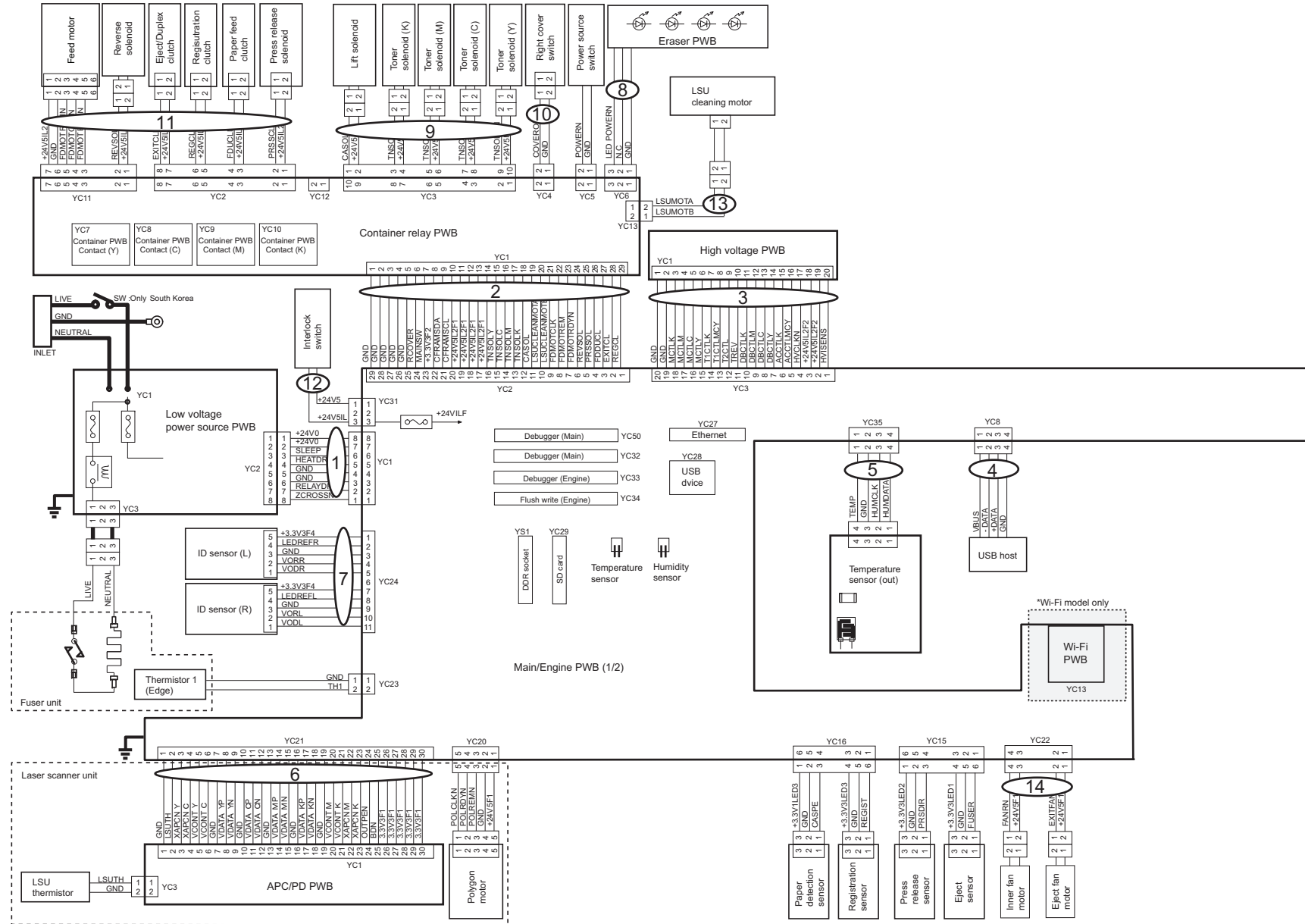

FIG. 27 Wire Sections 1 (21ppm(A4),22ppm(Letter)(A)/21ppm(A4),22ppm(Letter)(B)/
26ppm(A4),27ppm(Letter)(A)/26ppm(A4),27ppm(Letter)(B))

2RB/2RC/2RD/2RF/2R7/2R8/2R9/2RA

Ref. No. 番号	Part.No. 部品番号	Alternative. 代替部品番号	Description 部品名称	Notes 備考	Revision 改訂	Quantity 個数			
						100(日本)	120	230	240
1	302R746010	2R746010	CONN.CORD ASSY LVU			1	1	1	1
2	302R746020	2R746020	CONN.CORD ASSY FFC CONTAINER			1	1	1	1
3	302R746030	2R746030	CONN.CORD ASSY FFC HVU			1	1	1	1
4	302R746050	2R746050	CONN.CORD ASSY USB HOST			1	1	1	1
5	302R746330	2R746330	CONN.CORD ASSY THERMISTOR			1	1	1	1
6	302R746140	2R746140	CONN.CORD ASSY FFC APC			1	1	1	1
7	302R746160	2R746160	CONN.CORD ASSY FFC ID SENSOR			1	1	1	1
8	302R746180	2R746180	CONN.CORD ASSY FFC ERASER			1	1	1	1
9	302R746220	2R746220	CONN.CORD ASSY TONER SOL			1	1	1	1
10	302R746230	2R746230	CONN.CORD ASSY RIGHT COVER SW			1	1	1	1
11	302R746240	2R746240	CONN.CORD ASSY FEED MOTOR			1	1	1	1
12	302R746250	2R746250	CONN.CORD ASSY INTER LOCK SW			1	1	1	1
13	302R746380	2R746380	CONN.CORD ASSY CLEANER JUNCTION			1	1	1	1
14	302RB46040	2RB46040	CONN.CORD ASSY COOLING FAN						

• Parts with a Ref.No. of 500 and above in the illustration indicate they are not selected for service parts.

• イラスト中で 500 番台の Ref 番号が付いている部品はサービスパーツに選定されていません。

FIG. 28 Wire Sections 2 (21ppm(A4),22ppm(Letter)(A)/21ppm(A4),22ppm(Letter)(B)/
26ppm(A4),27ppm(Letter)(A)/26ppm(A4),27ppm(Letter)(B)/PF-5110)

2RB/2RC/2RD/2RF/2R7/2R8/2R9/2RA

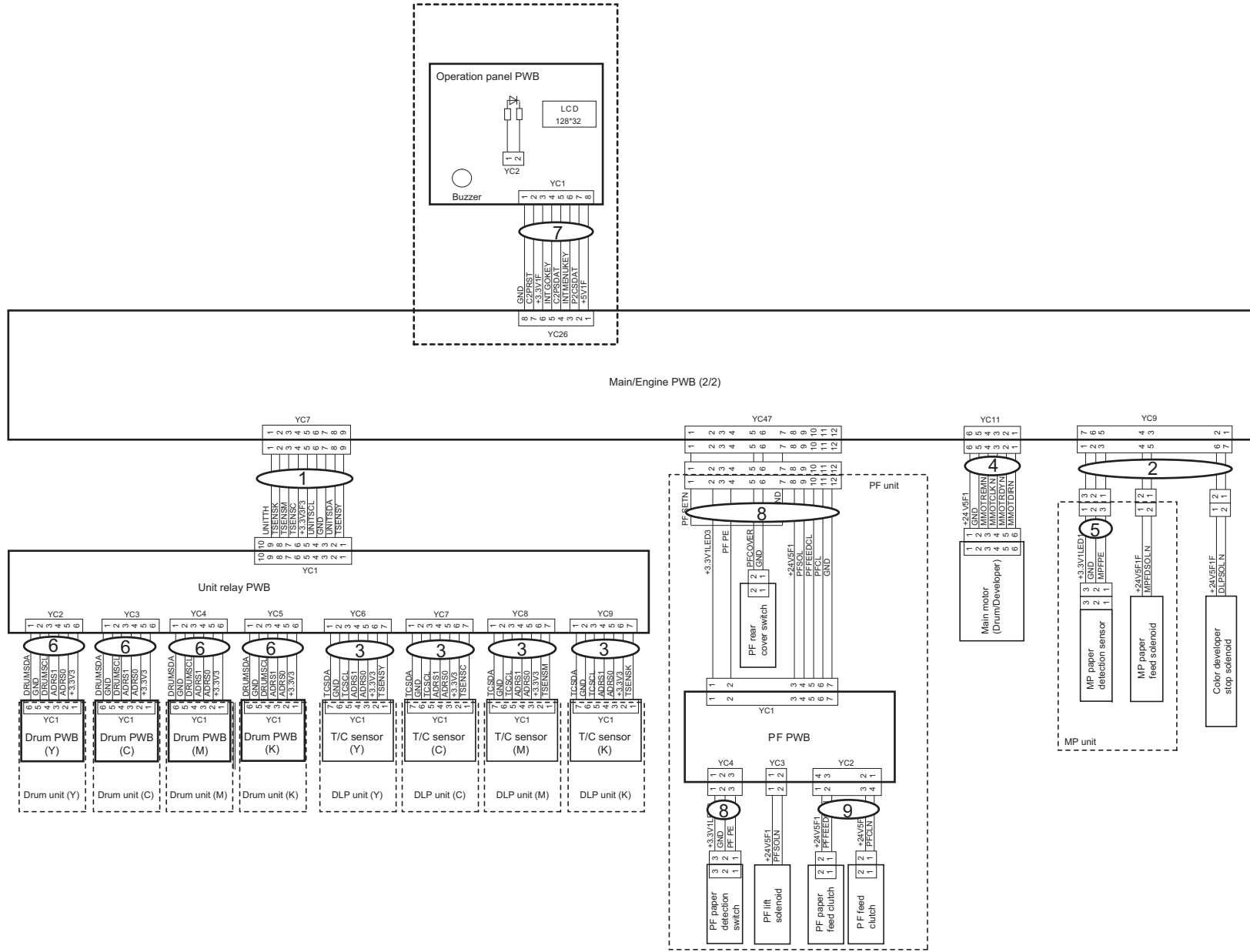

FIG. 29 Wire Sections 1 (21ppm(A4),22ppm(Letter)(AF)/21ppm(A4),22ppm(Letter)(BF)/
26ppm(A4),27ppm(Letter)(AF)/26ppm(A4),27ppm(Letter)(BF))

2RB/2RC/2RD/2RF/2R7/2R8/2R9/2RA

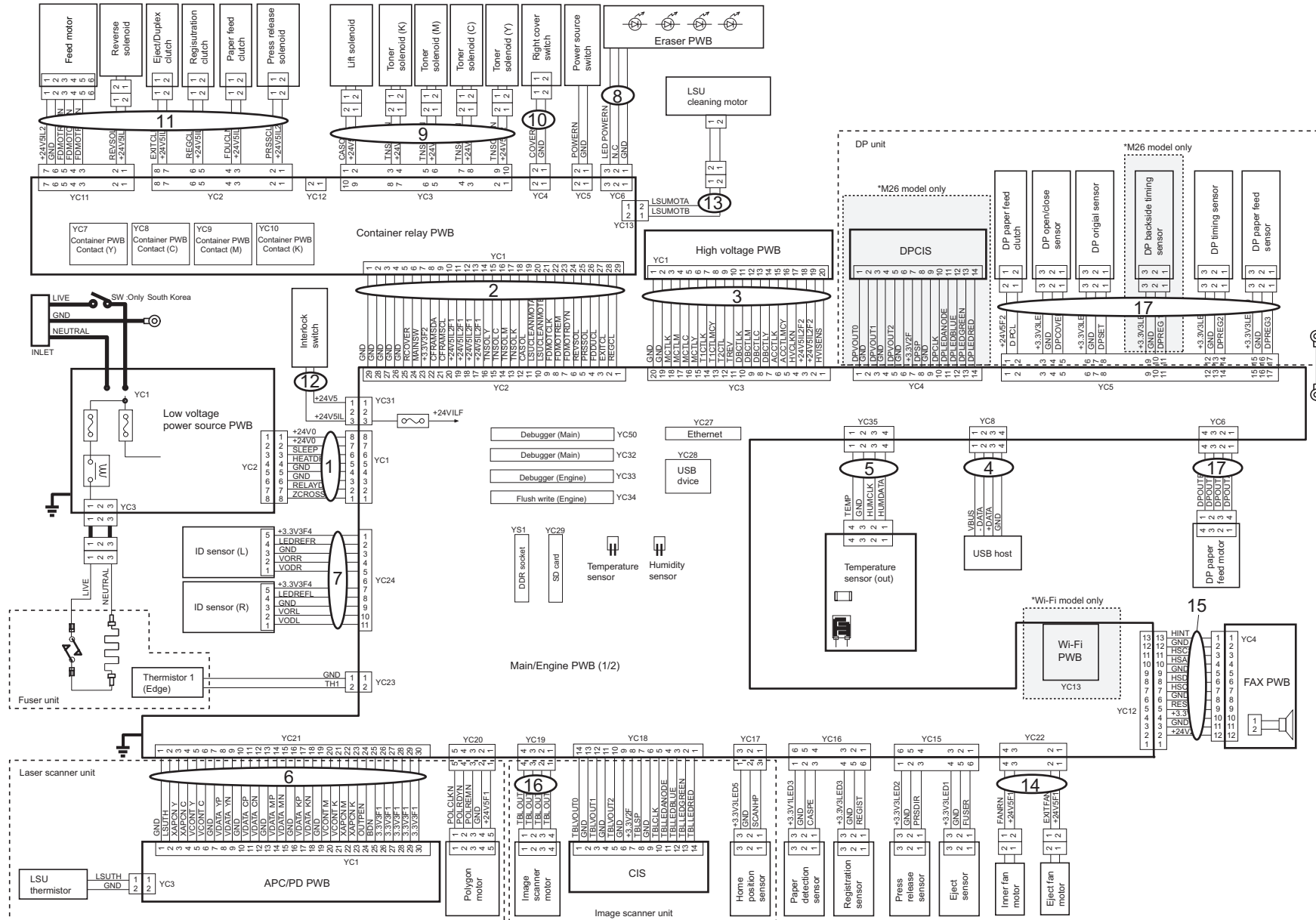

FIG. 29 Wire Sections 1 (21ppm(A4),22ppm(Letter)(AF)/21ppm(A4),22ppm(Letter)(BF)/
26ppm(A4),27ppm(Letter)(AF)/26ppm(A4),27ppm(Letter)(BF))

2RB/2RC/2RD/2RF/2R7/2R8/2R9/2RA

Ref. No. 番号	Part.No. 部品番号	Alternative. 代替部品番号	Description 部 品 名 称	Notes 備 考	Revision 改 訂	Quantity 個数			
						100 (日本)	120	230	240
1	302R746010	2R746010	CONN.CORD ASSY LVU			1	1	1	1
2	302R746020	2R746020	CONN.CORD ASSY FFC CONTAINER			1	1	1	1
3	302R746030	2R746030	CONN.CORD ASSY FFC HVU			1	1	1	1
4	302R746050	2R746050	CONN.CORD ASSY USB HOST			1	1	1	1
5	302R746330	2R746330	CONN.CORD ASSY THERMISTOR			1	1	1	1
6	302R746140	2R746140	CONN.CORD ASSY FFC APC			1	1	1	1
7	302R746160	2R746160	CONN.CORD ASSY FFC ID SENSOR			1	1	1	1
8	302R746180	2R746180	CONN.CORD ASSY FFC ERASER			1	1	1	1
9	302R746220	2R746220	CONN.CORD ASSY TONER SOL			1	1	1	1
10	302R746230	2R746230	CONN.CORD ASSY RIGHT COVER SW			1	1	1	1
11	302R746240	2R746240	CONN.CORD ASSY FEED MOTOR			1	1	1	1
12	302R746250	2R746250	CONN.CORD ASSY INTER LOCK SW			1	1	1	1
13	302R746380	2R746380	CONN.CORD ASSY CLEANER JUNCTION			1	1	1	1
14	302R746320	2R746320	CONN.CORD ASSY COOLING FAN			1	1	1	1
15	302R746090	2R746090	CONN.CORD ASSY FAX			1	1	1	1
16	302R746310	2R746310	CONN.CORD ASSY TABLE MOT			1	1	1	1
17	302R746400	2R746400	CONN.CORD ASSY DP	26ppm(A4),27ppm(Letter)(AF)/26ppm(A4),27ppm(Letter)(BF)		1	1	1	1
17	302R946030	2R946030	CONN.CORD ASSY DP	21ppm(A4),22ppm(Letter)(AF)/21ppm(A4),22ppm(Letter)(BF)			1	1	1

• Parts with a Ref.No. of 500 and above in the illustration indicate they are not selected for service parts.

• イラスト中で 500 番台の Ref 番号が付いている部品はサービスパーツに選定されていません。

FIG. 30 Wire Sections 2 (21ppm(A4),22ppm(Letter)(AF)/21ppm(A4),22ppm(Letter)(BF)/
26ppm(A4),27ppm(Letter)(AF)/26ppm(A4),27ppm(Letter)(BF)/PF-5110)

2RB/2RC/2RD/2RF/2R7/2R8/2R9/2RA

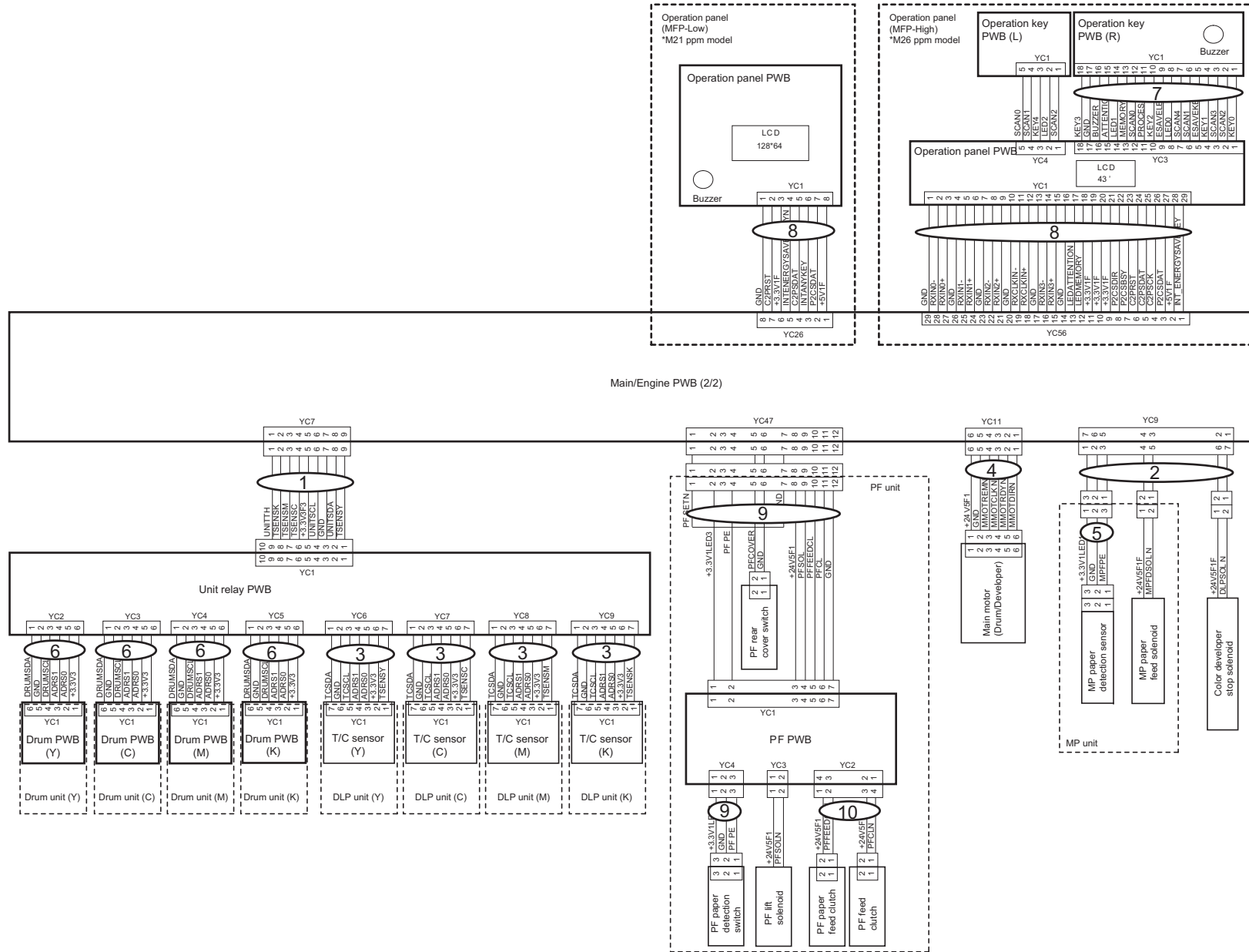

FIG. 30 Wire Sections 2 (21ppm(A4),22ppm(Letter)(AF)/21ppm(A4),22ppm(Letter)(BF)/
26ppm(A4),27ppm(Letter)(AF)/26ppm(A4),27ppm(Letter)(BF)/PF-5110)

2RB/2RC/2RD/2RF/2R7/2R8/2R9/2RA

Ref. No. 番号	Part.No. 部品番号	Alternative. 代替部品番号	Description 部品名称	Notes 備考	Revision 改訂	Quantity 個数			
						100(日本)	120	230	240
1	302R746040	2R746040	CONN.CORD ASSY UNIT CONNECT			1	1	1	1
2	302R746060	2R746060	CONN.CORD ASSY MPF DLP SOL			1	1	1	1
3	302R746070	2R746070	CONN.CORD ASSY FFC SENSOR TONER			1	1	1	1
4	302R746080	2R746080	CONN.CORD ASSY MAIN MOTOR			1	1	1	1
5	302R746100	2R746100	CONN.CORD ASSY MPF PE			1	1	1	1
6	302R746200	2R746200	CONN.CORD ASSY FFC DRUM			1	1	1	1
7	302R746340	2R746340	CONN.CORD ASSY FFC KEY RIGHT			1	1	1	1
8	302R746170	2R746170	CONN.CORD ASSY FFC PANEL	26ppm(A4),27ppm(Letter)(AF)/26ppm(A4),27ppm(Letter)(BF)		1	1	1	1
8	302R946010	2R946010	CONN.CORD ASSY FFC PANEL	21ppm(A4),22ppm(Letter)(AF)/21ppm(A4),22ppm(Letter)(BF)			1	1	1
9	303R646010	3R646010	CONN.CORD ASSY PF	PF-5110		1	1	1	1
10	303R646020	3R646020	CONN.CORD ASSY PF CL	PF-5110		1	1	1	1

• Parts with a Ref.No. of 500 and above in the illustration indicate they are not selected for service parts.

• イラスト中で 500 番台の Ref 番号が付いている部品はサービスパーツに選定されていません。

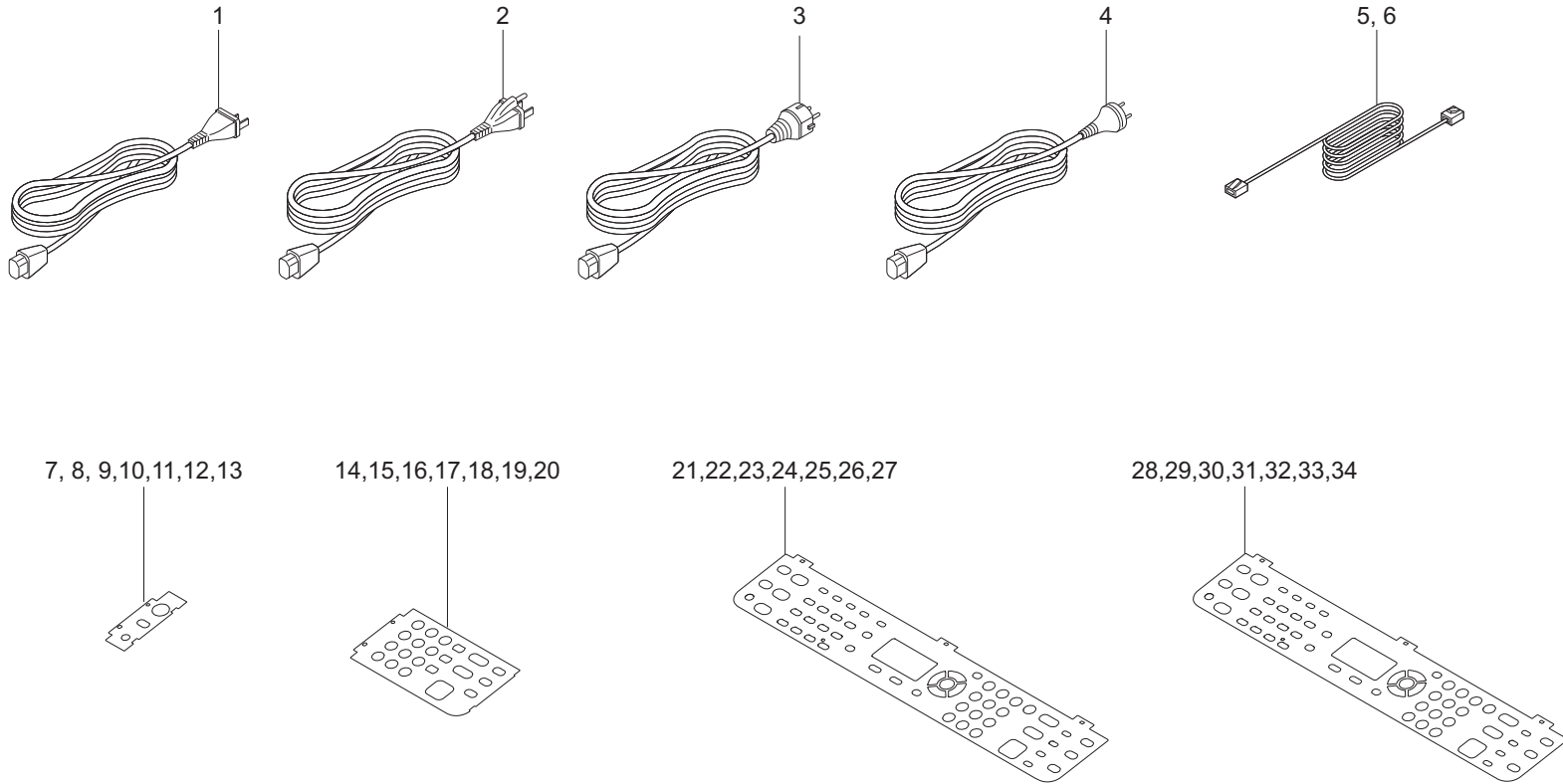

FIG. 31 Accessory

2RB/2RC/2RD/2RF/2R7/2R8/2R9/2RA

Ref. No. 番号	Part.No. 部品番号	Alternative. 代替部品番号	Description 部 品 名 称	Notes 備 考	Revision 改 訂	Quantity 個数			
						100(日本)	120	230	240
1	7AAACCJP+15H007	AA150200	AC CORD ASSY JP			1			
2	3019527401	19527401	POWER CORD(120)				1		
3	302FV94010	2FV94010	PARTS AC CORD EU SP					1	
4	302FV45040	2FV45040	AC CORD ASSY						1
5	303HZ45010	3HZ45010	MODULAR CORD			1	1		
6	3063527482	63527482	MODULAR CORD AUSTRALIA						1
7	302R705730	2R705730	LABEL OPERATION T LEFT GER					1	
8	302R705740	2R705740	LABEL OPERATION T LEFT FRA				1	1	
9	302R705750	2R705750	LABEL OPERATION T LEFT ITA					1	
10	302R705760	2R705760	LABEL OPERATION T LEFT SPA				1	1	
11	302R705770	2R705770	LABEL OPERATION T LEFT DUT					1	
12	302R705780	2R705780	LABEL OPERATION T LEFT RUS					1	
13	302R705790	2R705790	LABEL OPERATION T LEFT PTB				1	1	
14	302R705530	2R705530	LABEL OPERATION T RIGHT GER					1	
15	302R705540	2R705540	LABEL OPERATION T RIGHT FRA				1	1	
16	302R705550	2R705550	LABEL OPERATION T RIGHT ITA					1	
17	302R705560	2R705560	LABEL OPERATION T RIGHT SPA				1	1	
18	302R705570	2R705570	LABEL OPERATION T RIGHT DUT					1	
19	302R705580	2R705580	LABEL OPERATION T RIGHT RUS					1	
20	302R705590	2R705590	LABEL OPERATION T RIGHT PTB				1	1	
21	302R905530	2R905530	LABEL OPERATION LCD W GER					1	
22	302R905540	2R905540	LABEL OPERATION LCD W FRA				1	1	
23	302R905550	2R905550	LABEL OPERATION LCD W ITA					1	
24	302R905560	2R905560	LABEL OPERATION LCD W SPA				1	1	
25	302R905570	2R905570	LABEL OPERATION LCD W DUT					1	
26	302R905580	2R905580	LABEL OPERATION LCD W RUS					1	
27	302R905590	2R905590	LABEL OPERATION LCD W PTB				1	1	
28	302RA05530	2RA05530	LABEL OPERATION LCD GER					1	
29	302RA05540	2RA05540	LABEL OPERATION LCD FRA				1	1	
30	302RA05550	2RA05550	LABEL OPERATION LCD ITA					1	
31	302RA05560	2RA05560	LABEL OPERATION LCD SPA				1	1	
32	302RA05570	2RA05570	LABEL OPERATION LCD DUT					1	
33	302RA05580	2RA05580	LABEL OPERATION LCD RUS					1	
34	302RA05590	2RA05590	LABEL OPERATION LCD PTB				1	1	

• Parts with a Ref.No. of 500 and above in the illustration indicate they are not selected for service parts.

• イラスト中で 500 番台の Ref 番号が付いている部品はサービスパーツに選定されていません。

INDEX / 索引

2RB/2RC/2RD/2RF/2R7/2R8/2R9/2RA

Part.No. 部品番号	Alternative. 代替部品番号	Description 部品名称	Fig.No.
2FB27160	2FB27160	INTER LOCK SWITCH	17
3019527401	19527401	POWER CORD(120)	31
302F909171	2F909171	RETARD ROLLER ASSY	8
302F931270	2F931270	SPRING FUSER	1,2
302FV45040	2FV45040	AC CORD ASSY	31
302FV94010	2FV94010	PARTS AC CORD EU SP	31
302GR44150	2GR44150	SOLENOID TONER	7,15
302H702590	2H702590	BUSH SCREW	26
302HN24010	2HN24010	ROLLER REG REAR	8
302HN24400	2HN24400	PULLEY PA	9
302HN44160	2HN44160	SOLENOID MPF	14,15
302HN44210	2HN44210	FAN MOTOR	2,16
302HN94140	2HN94140	SOLENOID FD ASSY SP	16
302HS08260	2HS08260	ROLLER M/P ASSY	7
302HS25220	2HS25220	BUSH FUSER	16
302K394171	2K394171	PARTS LCD COLOR SP	18
302LC94283	2LC94283	PARTS MOTOR-BL W40 SP	14,16
302LV31480	2LV31480	BUSH DRIVE POM	16
302M294130	2M294130	PARTS PWB ASSY THERMISTOR SP	17
302NG94220	2NG94220	PARTS FAN MOTOR SP	17
302NR94010	2NR94010	PARTS CLUTCH 35 Z35R SP	16,26
302P794010	2P794010	PARTS SENSOR OPT. SP	7,11,17,24,25,26
302R494410	2R494410	PARTS ROLLER DU SP	9
302R702180	2R702180	COVER SD CARD	13
302R702310	2R702310	GUIDE CONTAINER Y	4
302R702320	2R702320	GUIDE CONTAINER M	4
302R702330	2R702330	GUIDE CONTAINER C	4
302R702340	2R702340	GUIDE CONTAINER K	4
302R702390	2R702390	SHUTTER SECURITY	4
302R702420	2R702420	SPRING SHUTTER SECURITY	4
302R704020	2R704020	COVER LEFT	1,2
302R704040	2R704040	COVER RIGHT REAR	1,2
302R704050	2R704050	COVER LEFT REAR	1,2
302R704060	2R704060	COVER TOP M	2
302R704070	2R704070	COVER ISU LEFT	2
302R704090	2R704090	STOPPER PAPER	1,2
302R704110	2R704110	KEY POWER SW	1,2
302R704130	2R704130	PUSH BUTTON	1,2
302R704140	2R704140	LOCK CROW	1,2
302R704160	2R704160	HOLDER MAIN SW	1,2
302R704170	2R704170	COVER LEFT REAR HARNESS	1,2
302R704180	2R704180	COVER ISU REAR	2
302R704220	2R704220	COVER ISU RIGHT	2
302R704240	2R704240	COVER REAR BOTTOM	1,2
302R704270	2R704270	STRAP COVER FRONT R	1,2
302R704280	2R704280	STRAP COVER FRONT L	1,2
302R704290	2R704290	STOPPER PAPER B	1,2
302R705110	2R705110	KEY ONE-TOUCH COLOR	19
302R705510	2R705510	LABEL OPERATION T RIGHT EN	18
302R705520	2R705520	LABEL OPERATION T RIGHT JP	18
302R705530	2R705530	LABEL OPERATION T RIGHT GER	31

Part.No. 部品番号	Alternative. 代替部品番号	Description 部品名称	Fig.No.
302R705540	2R705540	LABEL OPERATION T RIGHT FRA	31
302R705550	2R705550	LABEL OPERATION T RIGHT ITA	31
302R705560	2R705560	LABEL OPERATION T RIGHT SPA	31
302R705570	2R705570	LABEL OPERATION T RIGHT DUT	31
302R705580	2R705580	LABEL OPERATION T RIGHT RUS	31
302R705590	2R705590	LABEL OPERATION T RIGHT PTB	31
302R705710	2R705710	LABEL OPERATION T LEFT EN	18
302R705720	2R705720	LABEL OPERATION T LEFT JP	18
302R705730	2R705730	LABEL OPERATION T LEFT GER	31
302R705740	2R705740	LABEL OPERATION T LEFT FRA	31
302R705750	2R705750	LABEL OPERATION T LEFT ITA	31
302R705760	2R705760	LABEL OPERATION T LEFT SPA	31
302R705770	2R705770	LABEL OPERATION T LEFT DUT	31
302R705780	2R705780	LABEL OPERATION T LEFT RUS	31
302R705790	2R705790	LABEL OPERATION T LEFT PTB	31
302R706010	2R706010	FRAME FEED	8
302R706020	2R706020	ACTUATOR REGIST	8
302R706100	2R706100	GUIDE PICK HOLDER	8
302R706170	2R706170	GEAR SHAFT Z26R	8
302R706180	2R706180	GUIDE CASSETTE REAR	8
302R706200	2R706200	COVER GUIDE RETARD	8
302R709050	2R709050	CURSOR LEFT	5
302R709060	2R709060	CURSOR RIGHT	5
302R709070	2R709070	CURSOR END	5
302R709100	2R709100	ACTUATOR CASSETTE 1	5
302R709110	2R709110	ACTUATOR CASSETTE 2	5
302R709140	2R709140	SPRING BOTTOM	5
302R709150	2R709150	COVER CASSETTE	5
302R718040	2R718040	COVER DP FEED	21
302R722010	2R722010	ROLLER TRANSFER	9
302R722080	2R722080	SPRING PRESS TC L	9
302R722090	2R722090	SPRING PRESS TC R	9
302R724030	2R724030	FRAME CONVEYING B	9
302R724040	2R724040	FRAME CONVEYING C	9
302R724070	2R724070	HOOK CONVEYING L	9
302R724080	2R724080	HOOK CONVEYING R	9
302R724090	2R724090	SPRING HOOK CONVEYING L	9
302R724100	2R724100	SPRING HOOK CONVEYING R	9
302R724170	2R724170	GUIDE MIDDLE	9
302R724180	2R724180	SPRING PRESS GUIDE MIDDLE	9
302R724200	2R724200	SHEET GUIDE MIDDLE L	9
302R728110	2R728110	GEAR Z19S	16
302R728180	2R728180	ACTUATOR FD	16
302R731410	2R731410	PLATE MOTOR MAIN	14
302R731510	2R731510	GEAR Z28L	16
302R731520	2R731520	SHAFT CLUTCH REGIST	16
302R731530	2R731530	GEAR Z28R	16
302R731540	2R731540	SHAFT CLUTCH FEED	16
302R731570	2R731570	GEAR Z35R	16
302R731630	2R731630	COVER CLUTCH	16
302R731660	2R731660	PLATE MOTOR FEED	16

Part.No. 部品番号	Alternative. 代替部品番号	Description 部品名称	Fig.No.
302R734030	2R734030	LABEL B	9
302R734050	2R734050	LABEL CONTAINER OPERATION	1,2
302R734060	2R734060	LABEL MPF	6
302R734070	2R734070	LABEL FUSER CAUTION	15
302R734090	2R734090	LABEL DP TABLE	23
302R734100	2R734100	EMBLEM MACHINE NUMBER	3
302R746010	2R746010	CONN.CORD ASSY LVU	27,29
302R746020	2R746020	CONN.CORD ASSY FFC CONTAINER	27,29
302R746030	2R746030	CONN.CORD ASSY FFC HVU	27,29
302R746040	2R746040	CONN.CORD ASSY UNIT CONNECT	28,30
302R746050	2R746050	CONN.CORD ASSY USB HOST	27,29
302R746060	2R746060	CONN.CORD ASSY MPF DLP SOL	28,30
302R746070	2R746070	CONN.CORD ASSY FFC SENSOR TONER	12,28,30
302R746080	2R746080	CONN.CORD ASSY MAIN MOTOR	28,30
302R746090	2R746090	CONN.CORD ASSY FAX	29
302R746100	2R746100	CONN.CORD ASSY MPF PE	7,28,30
302R746140	2R746140	CONN.CORD ASSY FFC APC	10,27,29
302R746160	2R746160	CONN.CORD ASSY FFC ID SENSOR	27,29
302R746170	2R746170	CONN.CORD ASSY FFC PANEL	11,28,30
302R746180	2R746180	CONN.CORD ASSY FFC ERASER	27,29
302R746200	2R746200	CONN.CORD ASSY FFC DRUM	12,30
302R746220	2R746220	CONN.CORD ASSY TONER SOL	27,29
302R746230	2R746230	CONN.CORD ASSY RIGHT COVER SW	27,29
302R746240	2R746240	CONN.CORD ASSY FEED MOTOR	27,29
302R746250	2R746250	CONN.CORD ASSY INTER LOCK SW	27,29
302R746310	2R746310	CONN.CORD ASSY TABLE MOT	11,29
302R746320	2R746320	CONN.CORD ASSY COOLING FAN	29
302R746330	2R746330	CONN.CORD ASSY THERMISTOR	27,29
302R746340	2R746340	CONN.CORD ASSY FFC KEY RIGHT	18,30
302R746380	2R746380	CONN.CORD ASSY CLEANER JUNCTION	27,29
302R746400	2R746400	CONN.CORD ASSY DP	29
302R793010	2R793010	DK-5230	12
302R793020	2R793020	DK-5231	12
302R793030	2R793030	DV-5230(K)	12
302R793040	2R793040	DV-5230(Y)	12
302R793050	2R793050	DV-5230(M)	12
302R793060	2R793060	DV-5230(C)	12
302R793070	2R793070	TR-5230	12
302R793080	2R793080	FK-5230	13
302R793090	2R793090	FK-5232	13
302R793100	2R793100	FK-5231	13
302R793110	2R793110	LK-5230	10
302R793130	2R793130	PARTS DP UNIT SP	20
302R793140	2R793140	CT-5230	5
302R793150	2R793150	DR-5230	14
302R794010	2R794010	PARTS WIFI UNIT SP	17
302R794020	2R794020	PARTS COVER FRONT ASSY SP	1,2
302R794030	2R794030	PARTS RIGHT BOTTOM ASSY SP	1,2
302R794040	2R794040	PARTS COVER CONTAINER ASSY SP	1,2
302R794050	2R794050	PARTS OPERATION ASSY SP	18
302R794060	2R794060	PARTS HOLDER RETARD ASSY SP	8

Part.No. 部品番号	Alternative. 代替部品番号	Description 部品名称	Fig.No.
302R794070	2R794070	PARTS HOLDER FEED ASSY SP	8
302R794080	2R794080	PARTS FRAME MPF ASSY SP	6
302R794090	2R794090	PARTS GUIDE MPF FEED LOW ASSY SP	7
302R794100	2R794100	PARTS TRAY MPF UNIT M SP	6
302R794110	2R794110	PARTS FRAME ISU TOP A ASSY SP	11
302R794120	2R794120	PARTS TABLE MAIN ASSY SP	23
302R794130	2R794130	PARTS PLATE ORIGINAL SP	21
302R794140	2R794140	PARTS ROLLER TRANSFER ASSY SP	9
302R794150	2R794150	PARTS FRAME CONVEYING A ASSY SP	9
302R794160	2R794160	PARTS GUIDE EXIT R ASSY SP	16
302R794170	2R794170	PARTS COVER REAR ASSY SP	9
302R794180	2R794180	PARTS DRIVE EXIT PRESS ASSY SP	16
302R794190	2R794190	PARTS PWB PANEL ASSY SP	18
302R794200	2R794200	PARTS PWB ID SENSOR ASSY SP	17
302R794210	2R794210	PARTS PWB CONTAINER CONNECT ASSY SP	17
302R794220	2R794220	PARTS PWB KEY RIGHT ASSY SP	18
302R794230	2R794230	PARTS PWB ERASER ASSY SP	17
302R794240	2R794240	PARTS PWB UNIT CONNECT ASSY SP	12
302R794250	2R794250	PARTS PWB KEY LEFT ASSY SP	18
302R794260	2R794260	PARTS PWB SWITCH ASSY SP	17
302R794270	2R794270	PARTS PWB MAIN ASSY SP	17
302R794280	2R794280	PARTS PWB MAIN ASSY EU SP	17
302R794290	2R794290	PARTS UNIT LOW VOLTAGE 120V SP	17
302R794300	2R794300	PARTS UNIT LOW VOLTAGE 230V SP	17
302R794310	2R794310	PARTS UNIT HIGH VOLTAGE SP	17
302R794320	2R794320	PARTS SENSOR A4 CIS SP	11,24
302R794330	2R794330	PARTS FAX UNIT J SP	17
302R794340	2R794340	PARTS FAX UNIT U SP	17
302R794350	2R794350	PARTS PULLEY FEED ASSY SP	8
302R794360	2R794360	PARTS ROLLER REGIST RUBBER SP	9
302R794370	2R794370	PARTS ROLLER EXIT SP	16
302R794380	2R794380	PARTS MOTOR ISU SP	11
302R794390	2R794390	PARTS SPEAKER SP	17
302R834100	2R834100	EMBLEM MACHINE NUMBER	3
302R894010	2R894010	PARTS PWB MAIN ASSY SP	17
302R894020	2R894020	PARTS PWB MAIN ASSY EU SP	17
302R905020	2R905020	SHEET COVER LCD W	19
302R905510	2R905510	LABEL OPERATION LCD W EN	19
302R905530	2R905530	LABEL OPERATION LCD W GER	31
302R905540	2R905540	LABEL OPERATION LCD W FRA	31
302R905550	2R905550	LABEL OPERATION LCD W ITA	31
302R905560	2R905560	LABEL OPERATION LCD W SPA	31
302R905570	2R905570	LABEL OPERATION LCD W DUT	31
302R905580	2R905580	LABEL OPERATION LCD W RUS	31
302R905590	2R905590	LABEL OPERATION LCD W PTB	31
302R934090	2R934090	LABEL DP TABLE	23
302R934100	2R934100	EMBLEM MACHINE NUMBER	3
302R946010	2R946010	CONN.CORD ASSY FFC PANEL	11,30
302R946030	2R946030	CONN.CORD ASSY DP	29
302R993130	2R993130	PARTS DP UNIT SP	20
302R994010	2R994010	PARTS OPERATION ASSY SP	19

Part.No. 部品番号	Alternative. 代替部品番号	Description 部品名称	Fig.No.
302R994020	2R994020	PARTS PWB M PANEL ASSY SP	19
302R994030	2R994030	PARTS PWB MAIN ASSY SP	17
302R994040	2R994040	PARTS PWB MAIN ASSY EU SP	17
302RA05020	2RA05020	SHEET COVER LCD	19
302RA05510	2RA05510	LABEL OPERATION LCD EN	19
302RA05530	2RA05530	LABEL OPERATION LCD GER	31
302RA05540	2RA05540	LABEL OPERATION LCD FRA	31
302RA05550	2RA05550	LABEL OPERATION LCD ITA	31
302RA05560	2RA05560	LABEL OPERATION LCD SPA	31
302RA05570	2RA05570	LABEL OPERATION LCD DUT	31
302RA05580	2RA05580	LABEL OPERATION LCD RUS	31
302RA05590	2RA05590	LABEL OPERATION LCD PTB	31
302RA34100	2RA34100	EMBLEM MACHINE NUMBER	3
302RA94010	2RA94010	PARTS OPERATION ASSY SP	19
302RA94020	2RA94020	PARTS PWB MAIN ASSY SP	17
302RA94030	2RA94030	PARTS PWB MAIN ASSY EU SP	17
302RB04010	2RB04010	COVER TOP FRONT	1
302RB04020	2RB04020	COVER TOP REAR	1
302RB05020	2RB05020	KEY OPERATION	1
302RB05030	2RB05030	KEY QUIET A	1
302RB05040	2RB05040	INDICATOR	1
302RB05100	2RB05100	KEY QUIET B	1
302RB05130	2RB05130	PANEL LCD W	1
302RB05140	2RB05140	KEY OPERATION JP	1
302RB34010	2RB34010	LABEL INDICATOR W	1
302RB34020	2RB34020	LABEL QUIET MODE EN	1
302RB34030	2RB34030	LABEL QUIET MODE JP	1
302RB34100	2RB34100	EMBLEM MACHINE NUMBER	3
302RB46010	2RB46010	CONN.CORD ASSY FFC PANEL	1,28
302RB46040	2RB46040	CONN.CORD ASSY COOLING FAN	27
302RB94010	2RB94010	PARTS TRAY MPF UNIT P SP	5
302RB94020	2RB94020	PARTS PWB P PANEL ASSY SP	1
302RB94030	2RB94030	PARTS PWB MAIN ASSY SP	17
302RB94040	2RB94040	PARTS PWB MAIN ASSY EU SP	17
302RC05010	2RC05010	PANEL LCD	1
302RC34010	2RC34010	LABEL INDICATOR	1
302RC34100	2RC34100	EMBLEM MACHINE NUMBER	3
302RC94010	2RC94010	PARTS PWB MAIN ASSY SP	17
302RC94020	2RC94020	PARTS PWB MAIN ASSY EU SP	17
302RD34100	2RD34100	EMBLEM MACHINE NUMBER	3
302RD94010	2RD94010	PARTS PWB MAIN ASSY SP	17
302RD94020	2RD94020	PARTS PWB MAIN ASSY EU SP	17
302RF34100	2RF34100	EMBLEM MACHINE NUMBER	3
302RF94010	2RF94010	PARTS PWB MAIN ASSY SP	17
302RF94020	2RF94020	PARTS PWB MAIN ASSY EU SP	17
302S005030	2S005030	LID SHEET COVER LCD	19
302S017340	2S017340	BELT ISU A	11
302S018050	2S018050	COVER FRONT	21
302S018060	2S018060	COVER REAR	21
302S018120	2S018120	GUIDE READING	21,24,25
302S018150	2S018150	ACTUATOR TIMING A	24,25

Part.No. 部品番号	Alternative. 代替部品番号	Description 部品名称	Fig.No.
302S018170	2S018170	GEAR Z25L	24,25
302S018180	2S018180	ACTUATOR SET	24,25
302S018250	2S018250	STOPPER ORIGINAL	22
302S018260	2S018260	ACTUATOR TIMING C	24,25
302S018370	2S018370	GEAR Z30R	24,25
302S018440	2S018440	COVER TABLE	23
302S018490	2S018490	EMBLEM	3
302S018560	2S018560	ACTUATOR BASE	21
302S018610	2S018610	HINGE LOW	22
302S018620	2S018620	HINGE UP	22
302S018690	2S018690	COVER PI	24,25
302S094010	2S094010	PARTS MOTOR-PM DP SP	26
302S318030	2S318030	ACTUATOR TIMING B	24
302S505020	2S505020	SHEET COVER T RIGHT	18
302S505030	2S505030	SHEET COVER T LEFT	18
302S505040	2S505040	LID SHEET COVER T	18
303HZ45010	3HZ45010	MODULAR CORD	31
303LL31430	3LL31430	GEAR Z25L	24,25
303PA94011	3PA94011	PARTS FAX UNIT E SP	17
303R646010	3R646010	CONN.CORD ASSY PF	28,30
303R646020	3R646020	CONN.CORD ASSY PF CL	28,30
3063527482	63527482	MODULAR CORD AUSTRALIA	31
36211110	36211110	PULLEY,LEADING FEED ADF	23
3BR07040	3BR07040	PULLEY,PAPER FEED	23
5MVG127DN071	2A807050	GEAR CASSETTE/A-49 CASSETTE A4	5
7AAACCJP+15H007	AA150200	AC CORD ASSY JP	31
7BB200308H	BB105660	+BIND T.T P SCREW 3X8	18,19
7BB700308H	BB105600	+BIND T.T S SCREW 3X8 SR	18
7SP01000004+H01	SP136500	SW.PUSH	17

PF-5110

—— CONTENTS / 目次 ——

FIG. 1	Paper Cassettes.....	2
FIG. 2	Paper Feed Section	4
	• INDEX / 索引	6

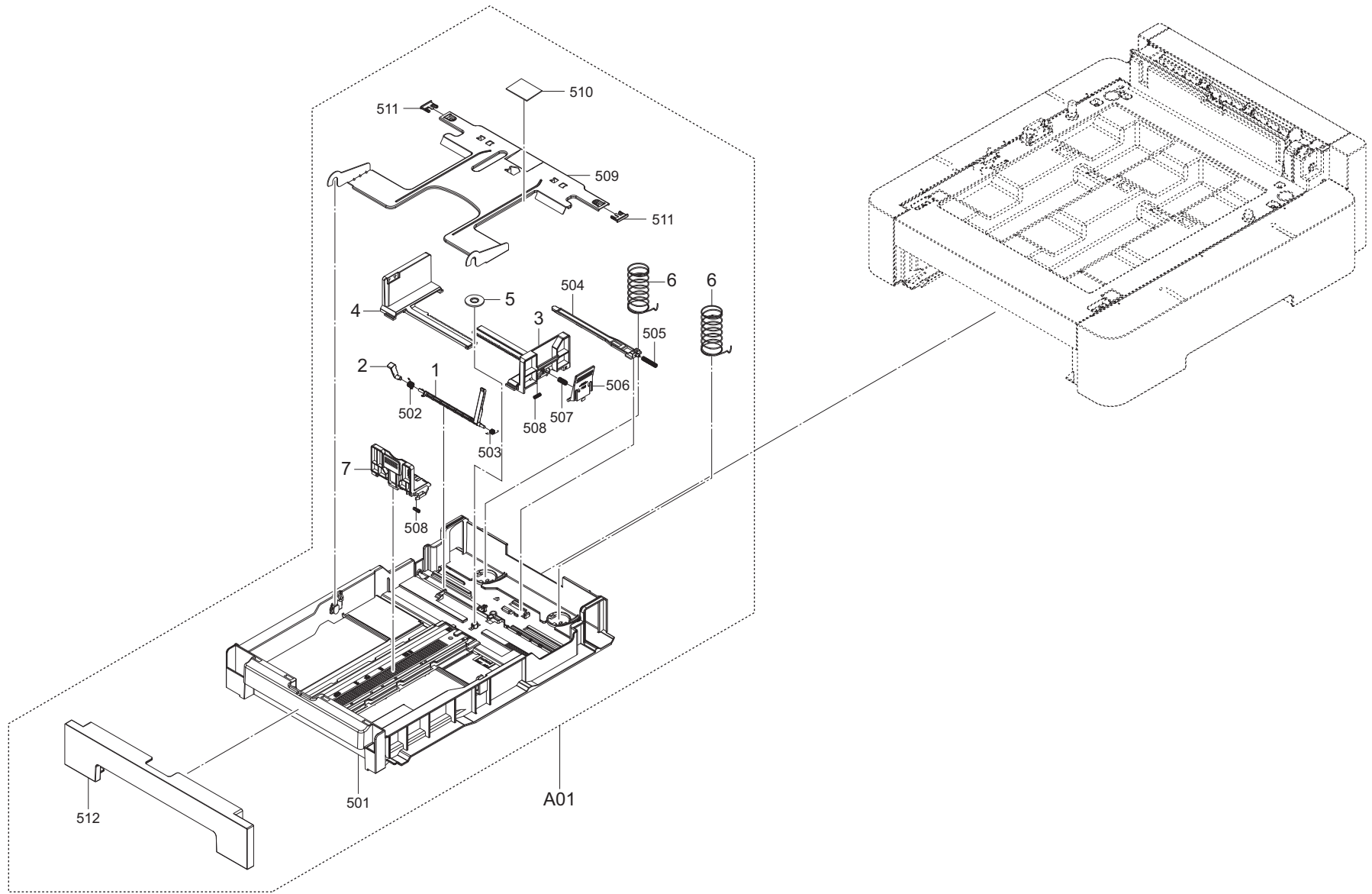

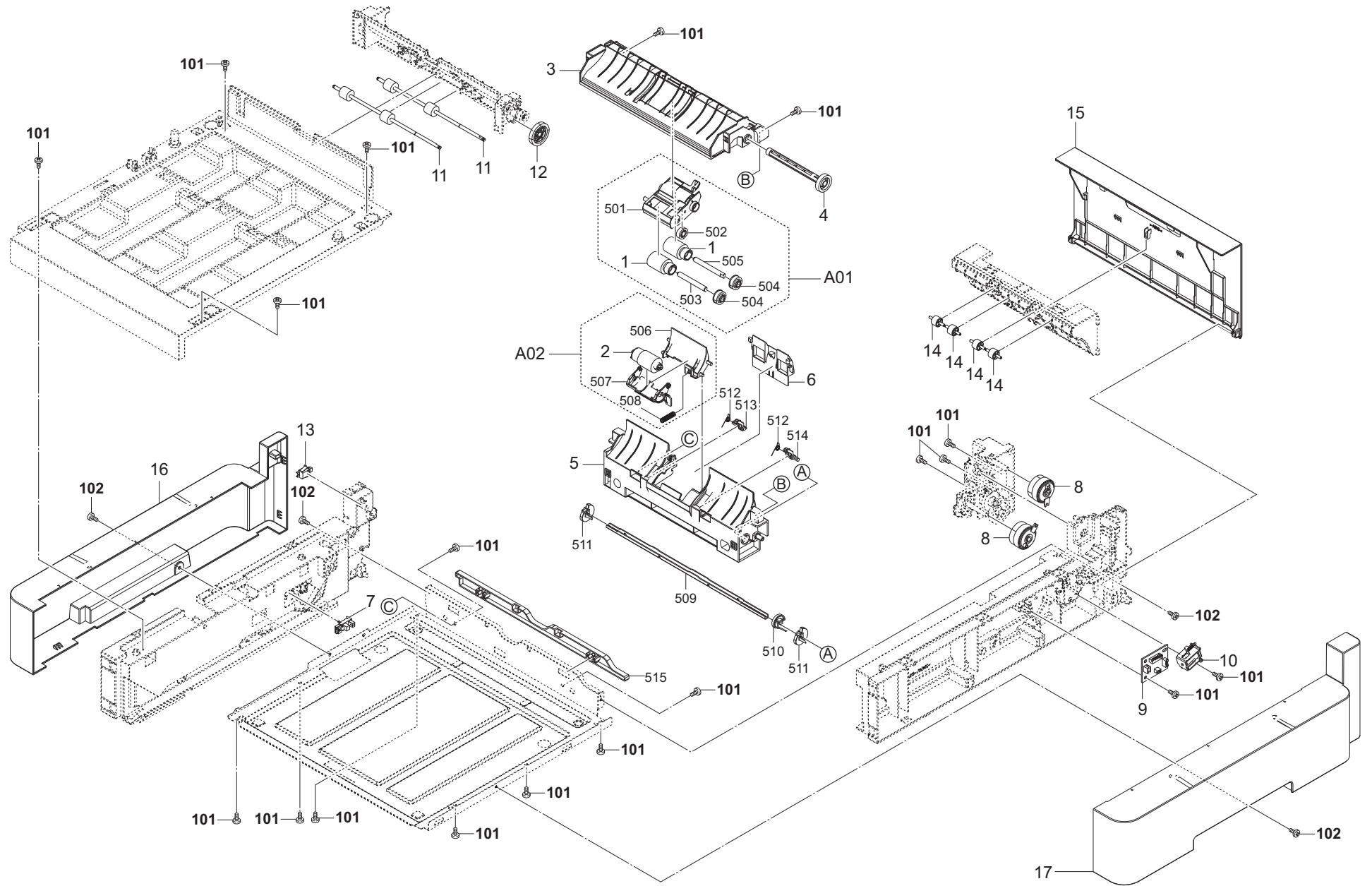

KYOCERA Document Solutions Europe B.V.

Bloemlaan 4, 2132 NP Hoofddorp,
The Netherlands
Phone: +31-20-654-0000
Fax: +31-20-653-1256

KYOCERA Document Solutions Nederland B.V.

Beechavenue 25, 1119 RA Schiphol-Rijk,
The Netherlands
Phone: +31-20-5877200
Fax: +31-20-5877260

KYOCERA Document Solutions (U.K.) Limited

Eldon Court, 75-77 London Road,
Reading, Berkshire RG1 5BS,
United Kingdom
Phone: +44-118-931-1500
Fax: +44-118-931-1108

KYOCERA Document Solutions Italia S.p.A.

Via Monfalcone 15, 20132, Milano, Italy,
Phone: +39-02-921791
Fax: +39-02-92179-600

KYOCERA Document Solutions Belgium N.V.

Sint-Martinusweg 199-201 1930 Zaventem,
Belgium
Phone: +32-2-7209270
Fax: +32-2-7208748

KYOCERA Document Solutions France S.A.S.

Espace Technologique de St Aubin
Route de l'Orme 91195 Gif-sur-Yvette CEDEX,
France
Phone: +33-1-69852600
Fax: +33-1-69853409

KYOCERA Document Solutions Espana, S.A.

Edificio Kyocera, Avda. de Manacor No.2,
28290 Las Matas (Madrid), Spain
Phone: +34-91-6318392
Fax: +34-91-6318219

© 2016 KYOCERA Document Solutions Inc.

 is a trademark of KYOCERA Corporation

KYOCERA Document Solutions Finland Oy

Atomitie 5C, 00370 Helsinki,
Finland
Phone: +358-9-47805200
Fax: +358-9-47805390

KYOCERA Document Solutions Europe B.V., Amsterdam (NL) Zürich Branch

Hohlstrasse 614, 8048 Zürich,
Switzerland
Phone: +41-44-9084949
Fax: +41-44-9084950

KYOCERA Bilgitas Document Solutions Turkey A.S.

Gülbahar Mahallesi Otello Kamil Sk. No:6 Mecidiyeköy
34394 Şişli İstanbul, Turkey
Phone: +90-212-356-7000
Fax: +90-212-356-6725

KYOCERA Document Solutions Deutschland GmbH

Otto-Hahn-Strasse 12, 40670 Meerbusch,
Germany
Phone: +49-2159-9180
Fax: +49-2159-918100

KYOCERA Document Solutions Austria GmbH

Altmannsdorferstraße 91, Stiege 1, 2. OG, Top 1, 1120,
Wien, Austria
Phone: +43-1-863380
Fax: +43-1-86338-400

KYOCERA Document Solutions Nordic AB

Esbogatan 16B 164 75 Kista, Sweden
Phone: +46-8-546-550-00
Fax: +46-8-546-550-10

京セラドキュメントソリューションズ株式会社
京セラドキュメントソリューションズジャパン株式会社

 は京セラ株式会社の登録商標です。

KYOCERA Document Solutions Norge Nuf

Olaf Helsetsv. 6, 0619 Oslo, Norway
Phone: +47-22-62-73-00
Fax: +47-22-62-72-00

KYOCERA Document Solutions Danmark A/S

Ejby Industrivej 60, DK-2600 Glostrup,
Denmark
Phone: +45-70223880
Fax: +45-45765850

KYOCERA Document Solutions Portugal Lda.

Rua do Centro Cultural, 41 (Alvalade) 1700-106 Lisboa,
Portugal
Phone: +351-21-843-6780
Fax: +351-21-849-3312

KYOCERA Document Solutions South Africa (Pty) Ltd.

KYOCERA House, Hertford Office Park,
90 Bekker Road (Cnr. Allandale), Midrand, South Africa
Phone: +27-11-540-2600
Fax: +27-11-466-3050

KYOCERA Document Solutions Russia LLC.

Building 2, 51/4, Schepkina St., 129110, Moscow,
Russia
Phone: +7(495)741-0004
Fax: +7(495)741-0018

KYOCERA Document Solutions Middle East

Dubai Internet City, Bldg. 17,
Office 157 P.O. Box 500817, Dubai,
United Arab Emirates
Phone: +971-04-433-0412

KYOCERA Document Solutions Inc.

2-28, 1-chome, Tamatsukuri, Chuo-ku
Osaka 540-8585, Japan
Phone: +81-6-6764-3555
<http://www.kyoceradocumentsolutions.com>