



ECOSYS M3040dn

ECOSYS M3540dn

ECOSYS M3040idn

ECOSYS M3540idn

ECOSYS M3550idn

ECOSYS M3560idn

SERVICE MANUAL

Published in May 2015
842NM11A
2NMSM06A
Rev.A

CAUTION

RISK OF EXPLOSION IF BATTERY IS REPLACED BY AN INCORRECT TYPE. DISPOSE OF USED BATTERIES ACCORDING TO THE INSTRUCTIONS.

It may be illegal to dispose of this battery into the municipal waste stream. Check with your local solid waste officials for details in your area for proper disposal.

ATTENTION

IL Y A UN RISQUE D'EXPLOSION SI LA BATTERIE EST REMPLACÉE PAR UN MODÈLE DE TYPE INCORRECT. METTRE AU REBUT LES BATTERIES UTILISÉES SELON LES INSTRUCTIONS DONNÉES.

Il peut être illégal de jeter les batteries dans des eaux d'égout municipales. Vérifiez avec les fonctionnaires municipaux de votre région pour les détails concernant des déchets solides et une mise au rebut appropriée.

Notation of products in the manual

For the purpose of this service manual, products are identified to the following type.

ECOSYS M3040dn	(40 ppm / LED / without FAX)	: 40L model
ECOSYS M3540dn	(40 ppm / LED / with FAX)	: 40LF model
ECOSYS M3040idn	(40 ppm / HyPAS / without FAX)	: 40H model
ECOSYS M3540idn	(40 ppm / HyPAS / with FAX)	: 40HF model
ECOSYS M3550idn	(50 ppm / HyPAS / with FAX)	: 50HF model
ECOSYS M3560idn	(60 ppm / HyPAS / with FAX)	: 60HF model

Revision history

Revision	Date	Pages	Revised contents
1	14 February 2014	1-1-2	Correction: Power source → Rated input
		1-1-3, 1-1-4	Correction: sheets/min → ppm, images/min → ipm
		1-1-5	Correction: 18.Left cover → controller cover
		1-1-12	Correction: (2)ECOSYS ... → 50/60 ppm model ...
		1-2-1	Correction: 120V60Hz 10.0A →12.0A
		1-2-3	Correction: The parts of No.15 and No.16
		1-2-4	Added: Cautions sentence for carrying the machine
		1-2-8	Correction: Left cover → controller cover
		1-2-11	Changed: Procedures and Figure for the loading paper
		1-2-15	Added: Setting the country code
		1-3-16	Added: into the description of (60) Media type attributes
		1-3-16, 17	Added: Contents addition in (62),(75), (78) to (81), (84) to (87)
		1-3-32	Changed: Figure 1-3-9 in U070
		1-3-38	Changed: Procedure in U201
		1-3-40	Changed: Procedure in U207
		1-3-44	Added: Error codes
		1-3-54, 1-3-55 1-3-58 to 60	Changed: Item number of original
		1-3-55 to 57	Correction: List of the Error Codes
		1-3-62	Added: a display of TDRS connection state
		1-3-63, 1-3-65	Correction: The position of "Excute" Correction: Kind of error
		1-3-98	Correction: Procedure in U917
		1-3-106, 1-3-109, 1-3-110	Added: Completion
		1-3-107	Added: 254 Taiwan to Destination code list
		1-4-83	Correction: right cover → rear cover
		1-4-108	Added: Error code 3102
		1-5-11	Added: Procedure 8 "Remove..."
		1-5-16	Deleted: Procedure 5 "Refit..."
		1-5-20, 1-5-52	Added: Procedure 4 "Open the ..."
		1-5-20, 1-5-21, 1-5-52, 1-5-53, 1-5-59, 1-5-64, 1-5-65, 1-5-67, 1-5-86, 1-5-87, 1-5-94, 1-5-95	Correction: Names of cover (upper right cover → right upper cover) (right upper cover → right middle cover) (upper left cover → left upper cover) (left upper cover → left middle cover) (right upper cover → front right cover)
		1-5-71	Correction: Duplex assembly → Duplex conveying unit
		1-5-82	Deleted: Procedure 3

Revision	Date	Pages	Revised contents
1	14 February 2014	1-5-40	Correction: Main/engine → control
		1-5-71	Added: (37) "Check ..."
		1-5-81	Deleted: (8) "Check..."
		1-5-90 to 93	Deleted: The procedure linked to the procedure of other pages
		1-5-99	Correction: Names of fan motor Deleted: Center and rear fan motor (Japan only)
		2-1-1	Changed: Item number (6 to 3 , 3 to 7)
		2-1-3, 2-1-4 2-1-6, 2-1-7 2-1-9, 2-1-10 2-1-12	Correction: Parts number
		2-2-1, 2-2-2	Correction: Change of the contents of explanation
		2-2-12, 2-2-20, 2-2-21, 2-2-31, 2-2-32, 2-2-36, 2-2-37, 2-2-39, 2-2-41, 2-2-48, 2-2-49	Correction: Names of cover (upper right cover → right upper cover) (right upper cover → right middle cover) (upper left cover → left upper cover) (left upper cover → left middle cover)
		2-2-16	Deleted: U326/U341/U343/U407/U429/U432/U470
		2-3-1, 2-3-2	Correction: parts number in maintenance parts
		2-3-3	Added: cautions sentence
		2-3-15	Correction: main/engine board → controlboard
		2-3-22	Deleted: Center and rear fan motor (Japan only)
2	31 April 2014	1-3-10, 1-3-11	Correction: Name of MK
3	23 May 2014	Contents	Correction: number of pages
		1-3-6, 1-3-102, 1-3-103	Added: U977
		1-3-48	Added: Initial setting: Off This function is available only Asia area.
		1-3-54	Correction: Description of table
		2-2-1, 2-2-2	Correction: Correction of an explanatory note
4	20 June 2014	Contents, 1-2-20	Correction: (HyPAS model only)
		2-2-2	Correction: Procedure 10 (8 → 7)
5	22 July 2014	Contents	Correction: number of pages
		1-4-42, 1-4-43	Added: F code
		1-4-74, 1-4-97	Added: (24) Carrier leaking occurs.
		2-3-12 to 15	Added: F code
6	18 August 2014	1-3-12 to 17	Correction: Description of Service Status Page
		2-2-28	Correction: Description of pin 7, 8 and 9 in YC1
		2-3-20, 2-3-23	Correction: Signal names of pin 7, 8 and 9 in YC29

Revision	Date	Pages	Revised contents
7	8 September 2014	1-2-20	Correction: Part.No. (1702P60UN1)
		1-3-13	Correction: Description of Service Status Page
		2-2-1 to 2-2-2	Correction: Procedure
8	6 November 2014	Contents	Correction: Added the content and changed the number of pages
		1-3-45	Added: Description of the counter value
		1-5-17, 1-5-18	Correction: Description of procedure
		1-5-23 to 25	Added: (1-3) Detaching and refitting the LCD
		1-5-82, 1-5-83	Change: Description of Procedure (Added the flat screw driver)
9	29 January 2015	Contents	Correction: Added the content and changed the number of pages
		1-3-17	Correction: 5 to 100 (%)
		1-3-45	Correction: Initial setting of U253 [DBL(Folio)]
		1-41 to 44	Added: C9180
		1-5-12, 1-5-13 1-5-65, 1-5-66	Correction: Clerical error of actuator
A	9 May 2015	1-4-2 to 8	Correction: Symbols of JAM position

This page is intentionally left blank.

Safety precautions

This booklet provides safety warnings and precautions for our service personnel to ensure the safety of their customers, their machines as well as themselves during maintenance activities. Service personnel are advised to read this booklet carefully to familiarize themselves with the warnings and precautions described here before engaging in maintenance activities.

Safety warnings and precautions

Various symbols are used to protect our service personnel and customers from physical danger and to prevent damage to their property. These symbols are described below:

 **DANGER:** High risk of serious bodily injury or death may result from insufficient attention to or incorrect compliance with warning messages using this symbol.

 **WARNING:** Serious bodily injury or death may result from insufficient attention to or incorrect compliance with warning messages using this symbol.

 **CAUTION:** Bodily injury or damage to property may result from insufficient attention to or incorrect compliance with warning messages using this symbol.

Symbols

The triangle (\triangle) symbol indicates a warning including danger and caution. The specific point of attention is shown inside the symbol.



General warning.



Warning of risk of electric shock.



Warning of high temperature.

 indicates a prohibited action. The specific prohibition is shown inside the symbol.



General prohibited action.



Disassembly prohibited.

 indicates that action is required. The specific action required is shown inside the symbol.



General action required.





Remove the power plug from the wall outlet.











Always ground the copier.

1. Installation Precautions

WARNING











- Do not use a power supply with a voltage other than that specified. Avoid multiple connections to one outlet: they may cause fire or electric shock. When using an extension cable, always check that it is adequate for the rated current. 
- Connect the ground wire to a suitable grounding point. Not grounding the copier may cause fire or electric shock. Connecting the earth wire to an object not approved for the purpose may cause explosion or electric shock. Never connect the ground cable to any of the following: gas pipes, lightning rods, ground cables for telephone lines and water pipes or faucets not approved by the proper authorities. 

CAUTION:





- Do not place the copier on an infirm or angled surface: the copier may tip over, causing injury. 
- Do not install the copier in a humid or dusty place. This may cause fire or electric shock. 
- Do not install the copier near a radiator, heater, other heat source or near flammable material. This may cause fire. 
- Allow sufficient space around the copier to allow the ventilation grills to keep the machine as cool as possible. Insufficient ventilation may cause heat buildup and poor copying performance. 
- Always handle the machine by the correct locations when moving it. 
- Always use anti-toppling and locking devices on copiers so equipped. Failure to do this may cause the copier to move unexpectedly or topple, leading to injury. 
- Avoid inhaling toner or developer excessively. Protect the eyes. If toner or developer is accidentally ingested, drink a lot of water to dilute it in the stomach and obtain medical attention immediately. If it gets into the eyes, rinse immediately with copious amounts of water and obtain medical attention. 
- Advise customers that they must always follow the safety warnings and precautions in the copier's instruction handbook. 











2. Precautions for Maintenance

WARNING

- Always remove the power plug from the wall outlet before starting machine disassembly. 
- Always follow the procedures for maintenance described in the service manual and other related brochures. 
- Under no circumstances attempt to bypass or disable safety features including safety mechanisms and protective circuits. 
- Always use parts having the correct specifications. 
- Always use the thermostat or thermal fuse specified in the service manual or other related brochure when replacing them. Using a piece of wire, for example, could lead to fire or other serious accident. 
- When the service manual or other serious brochure specifies a distance or gap for installation of a part, always use the correct scale and measure carefully. 
- Always check that the copier is correctly connected to an outlet with a ground connection. 
- Check that the power cable covering is free of damage. Check that the power plug is dust-free. If it is dirty, clean it to remove the risk of fire or electric shock. 
- Never attempt to disassemble the optical unit in machines using lasers. Leaking laser light may damage eyesight. 
- Handle the charger sections with care. They are charged to high potentials and may cause electric shock if handled improperly. 



CAUTION

- Wear safe clothing. If wearing loose clothing or accessories such as ties, make sure they are safely secured so they will not be caught in rotating sections. 
- Use utmost caution when working on a powered machine. Keep away from chains and belts. 
- Handle the fixing section with care to avoid burns as it can be extremely hot. 
- Check that the fixing unit thermistor, heat and press rollers are clean. Dirt on them can cause abnormally high temperatures. 

- Do not remove the ozone filter, if any, from the copier except for routine replacement. 
- Do not pull on the AC power cord or connector wires on high-voltage components when removing them; always hold the plug itself. 
- Do not route the power cable where it may be stood on or trapped. If necessary, protect it with a cable cover or other appropriate item. 
- Treat the ends of the wire carefully when installing a new charger wire to avoid electric leaks. 
- Remove toner completely from electronic components. 
- Run wire harnesses carefully so that wires will not be trapped or damaged. 
- After maintenance, always check that all the parts, screws, connectors and wires that were removed, have been refitted correctly. Special attention should be paid to any forgotten connector, trapped wire and missing screws. 
- Check that all the caution labels that should be present on the machine according to the instruction handbook are clean and not peeling. Replace with new ones if necessary. 
- Handle greases and solvents with care by following the instructions below: 
 - Use only a small amount of solvent at a time, being careful not to spill. Wipe spills off completely.
 - Ventilate the room well while using grease or solvents.
 - Allow applied solvents to evaporate completely before refitting the covers or turning the power switch on.
 - Always wash hands afterwards.
- Never dispose of toner or toner bottles in fire. Toner may cause sparks when exposed directly to fire in a furnace, etc. 
- Should smoke be seen coming from the copier, remove the power plug from the wall outlet immediately. 

3. Miscellaneous

WARNING

- Never attempt to heat the drum or expose it to any organic solvents such as alcohol, other than the specified refiner; it may generate toxic gas. 
- Keep the machine away from flammable liquids, gases, and aerosols. A fire or an electric shock might occur. 

This page is intentionally left blank.

CONTENTS

1-1 Specifications

1-1-1 Specifications	1-1-1
(1) Common function	1-1-1
(2) Copy function.....	1-1-3
(3) Printer function	1-1-3
(4) Scanner function.....	1-1-4
(5) Document processor	1-1-4
1-1-2 Parts names	1-1-5
(1) Main part appearance.....	1-1-5
(2) A connector and an inside	1-1-6
(3) Option	1-1-8
(4) Operation panel	1-1-9
(4-1) Basic model.....	1-1-9
(4-2) HyPAS model	1-1-10
1-1-3 Machine cross section	1-1-11
1-1-4 Option composition	1-1-12

1-2 Installation

1-2-1 Installation environment.....	1-2-1
1-2-2 Unpacking and installation.....	1-2-2
(1) Installation procedure	1-2-2
1-2-3 Installing an accessories option.....	1-2-16
(1) Installing the SD card.	1-2-16
(2) Installing the expansion memory	1-2-17
(3) Installing the HD-6/HD-7(SSD).....	1-2-18
(4) Installing the IC card reader holder (HyPAS model only)	1-2-20

1-3 Maintenance Mode

1-3-1 Maintenance Mode	1-3-1
(1) Executing a maintenance item	1-3-1
(2) Maintenance modes item list	1-3-2
(3) Contents of the maintenance mode items	1-3-7
1-3-2 Service mode	1-3-104
(1) Executing a service mode	1-3-104
(2) Description of service mode	1-3-105

1-4 Troubleshooting

1-4-1 Paper misfeed detection	1-4-1
(1) Paper misfeed indication	1-4-1
(2) Paper misfeed detection condition	1-4-2
1-4-2 Troubleshooting	1-4-9
(1) First check items.....	1-4-9
(2) Items and corrective actions relating to the device that will cause paper jam	1-4-12
(3) Paper jam at feeding from cassette 1	1-4-15
(4) Paper jam at feeding from cassette 2 (paper feeder).....	1-4-16
(5) Paper jam at feeding from multi paper feed	1-4-17
(6) Paper jam at the duplex re-feeding part	1-4-18
(7) Electrical parts that could cause paper jam at the transfer , the fuser and the eject parts	1-4-19

1-4-3 Self-diagnostic function	1-4-20
(1) Self-diagnostic function	1-4-20
(2) Self diagnostic codes.....	1-4-20
1-4-4 Image formation problems.....	1-4-45
1-4-5 Poor image (due to DP and scanner reading).....	1-4-46
(1) No image appears (entirely white).....	1-4-47
(2) No image appears (entirely black).....	1-4-49
(3) Image is too light.	1-4-50
(4) The background is colored.	1-4-52
(5) White streaks are printed vertically.....	1-4-54
(6) Black streaks appear longitudinally.	1-4-56
(7) Streaks are printed horizontally.	1-4-58
(8) One side of the print image is darker or brighter than the other.	1-4-60
(9) Black dots appear on the image.....	1-4-62
(10) Image is blurred.....	1-4-63
(11) The leading edge of the image is consistently misaligned with the original.	1-4-65
(12) Part of image is missing.	1-4-66
(13) Image is out of focus.	1-4-68
(14) Image center does not align with the original center.	1-4-70
(15) Moires.....	1-4-71
(16) Skewed image.....	1-4-72
(17) Abnormal image	1-4-73
1-4-6 Poor image (Image rendering problems: printer engine).....	1-4-74
(1) No image appears (entirely white).....	1-4-76
(2) No image appears (entirely black).....	1-4-77
(3) Image is too light.	1-4-78
(4) The background is colored.	1-4-80
(5) White streaks are printed vertically.....	1-4-81
(6) Black streaks appear longitudinally.	1-4-82
(7) Black or white streaks appear horizontally.	1-4-84
(8) Uneven density longitudinally.	1-4-85
(9) Uneven density horizontally.....	1-4-86
(10) Black dots appear on the image.	1-4-87
(11) Offset occurs.	1-4-88
(12) Image is partly missing.	1-4-89
(13) Image is out of focus.	1-4-90
(14) Poor grayscale reproducibility.	1-4-90
(15) Unevenly repeating horizontal streaks in the printed objects. Spots in the printed objects.	1-4-91
(16) Image is blurred (Shifted transferring).....	1-4-92
(17) The leading edge of the image is consistently misaligned with the original.	1-4-93
(18) The leading edge of the image is sporadically misaligned with the original.	1-4-94
(19) Paper is wrinkled.	1-4-94
(20) Fusing is loose.....	1-4-95
(21) Image center does not align with the original center.	1-4-96
(22) Dirty paper edges with toner.....	1-4-96
(23) Dirty reverse side of paper.	1-4-97
(24) Carrier leaking occurs.....	1-4-98
1-4-7 Electric problems	1-4-99
1-4-8 Mechanical problems.....	1-4-106
1-4-9 Send error code.....	1-4-108
(1) Scan to SMB error codes	1-4-108
(2) Scan to FTP error codes	1-4-109
(3) Scan to E-mail error codes.....	1-4-111

1-4-10 Error codes	1-4-113
(1) Error code	1-4-113
(2) Table of general classification	1-4-114
(2-1) U004XX error code table: Interrupted phase B	1-4-117
(2-2) U006XX error code table: Problems with the unit	1-4-118
(2-3) U008XX error code table: Page transmission error.....	1-4-118
(2-4) U009XX error code table: Page reception error	1-4-118
(2-5) U010XX error code table: G3 transmission.....	1-4-119
(2-6) U011XX error code table: G3 reception	1-4-121
(2-7) U017XX error code table: V.34 transmission	1-4-122
(2-8) U018XX error code table: V.34 reception.....	1-4-123
(2-9) U023XX error code table: Relay command abnormal reception	1-4-123
(2-10) U044XX error code table: Encrypted transmission	1-4-123

1-5 Sectional Construction

1-5-1 Precautions for assembly and disassembly.....	1-5-1
(1) Precautions.....	1-5-1
(2) Drum unit.....	1-5-1
(3) Toner	1-5-1
(4) How to tell a genuine Kyocera toner container.....	1-5-2
1-5-2 Paper feed / conveying section	1-5-3
(1) Cassette paper feed section.....	1-5-3
(1-1) Detaching and refitting the primary paper feed unit and the pickup roller	1-5-5
(1-2) Detaching and refitting the retard roller	1-5-5
(2) MP tray paper feed section.....	1-5-7
(2-1) Detaching and refitting the MP paper feed pulley	1-5-9
(3) Conveying section	1-5-12
1-5-3 Optical section	1-5-14
(1) Image scanner section	1-5-14
(1-1) Detaching and refitting the exposure lamp.....	1-5-16
(1-2) Detaching and refitting the image scanner unit.....	1-5-20
(1-3) Detaching and refitting the LCD	1-5-23
(2) Laser scanner section	1-5-26
(2-1) Detaching and refitting the laser scanner unit.....	1-5-28
1-5-4 Developer section.....	1-5-31
(1) Developer unit.....	1-5-31
(1-1) Detaching and refitting the developer unit.....	1-5-33
1-5-5 Drum section	1-5-35
(1) Chager roller unit.....	1-5-35
(1-1) Detaching and refitting the drum unit	1-5-37
(1-2) Detaching and refitting the chager unit.....	1-5-37
(2) Cleaning unit.....	1-5-38
1-5-6 [Transfer/Separation section	1-5-39
(1) Transfer/Separation.....	1-5-39
(1-1) Detaching and refitting the transfer roller	1-5-41
(1-2) Detaching and refitting the separation needle holder.....	1-5-42
1-5-7 Fuser and eject/feedshift section	1-5-43
(1) 50/60 ppm model.....	1-5-43
(2) 40 ppm model.....	1-5-45
(2-1) Detaching and refitting the fuser unit.....	1-5-47

1-5-8 Eject section	1-5-51
(1) 50/60 ppm model.....	1-5-51
(2) 40 ppm model.....	1-5-53
(2-1) Detaching and refitting the eject unit.....	1-5-55
1-5-9 Duplex conveying section.....	1-5-65
(1) Duplex conveying unit.....	1-5-65
(1-1) Detaching and refitting the duplex conveying unit.....	1-5-67
1-5-10 Document processor	1-5-75
(1) Original feed section.....	1-5-75
(1-1) Detaching and refitting DP paper feed roller or DP pickup pulley	1-5-77
(1-2) Detaching and refitting the DP separation pad.....	1-5-79
(2) Original conveying section and switchback/eject section	1-5-80
(2-1) Detaching and refitting the DP switchback motor.....	1-5-82
(2-2) Detaching and refitting the DP paper feed motor and the DP conveying motor....	1-5-83
(2-3) Detaching and refitting the DP unit.....	1-5-85
1-5-11 Covers	1-5-86
(1) Detaching and refitting the MP paper feed pulley.....	1-5-86
(2) Detaching and refitting the inlet cover and the interface slot cover	1-5-88
(3) Detaching and refitting the right stay cover	1-5-88
(4) Detaching and refitting the right upper cover.....	1-5-89
(5) Detaching and refitting the left upper cover.....	1-5-89
(6) Detaching and refitting the center stay cover	1-5-90
(7) Detaching and refitting the front right cover.....	1-5-90
(8) Detaching and refitting the top tray cover.....	1-5-91
(9) Detaching and refitting the right middle cover	1-5-93
(10) Detaching and refitting the right lower cover	1-5-94
(11) Detaching and refitting the rear left cover.....	1-5-94
(12) Detaching and refitting the left middle cover and the waste toner box cover	1-5-95
(13) Detaching and refitting the left lower cover	1-5-95
(14) Detaching and refitting the rear cover	1-5-96
1-5-12 Othes	1-5-97
(1) Detaching and refitting the main driving motor unit	1-5-97
(2) Detaching and refitting the paper feed driving motor unit.....	1-5-98
(3) Detaching and refitting the language sheets	1-5-99
(3-1) HyPAS model	1-5-99
(3-2) Basic model.....	1-5-100
(4) Detaching and refitting the FAX control PWB (FAX model only).....	1-5-101
(5) Direction of installing the principal fan motors	1-5-102

2-1 Electrical Parts Layout

2-1-1 PWBs.....	2-1-1
2-1-2 Switches and sensors.....	2-1-5
2-1-3 Motors.....	2-1-8
2-1-4 Others.....	2-1-11

2-2 Operation of the PWBs

2-2-1 Upgrading the firmware	2-2-1
2-2-2 Control PWB (CONPWB)	2-2-3
(1) Connector position.....	2-2-3
(2) PWB photograph	2-2-3
(3) Connector lists.....	2-2-4
(4) Detaching and refitting the PWB. (CONPWB).....	2-2-12

(5) Remarks on Control PWB replacement.....	2-2-15
2-2-3 Connect Left PWB (CLPWB).....	2-2-17
(1) Connector position.....	2-2-17
(2) PWB photograph.....	2-2-17
(3) Connector lists.....	2-2-18
(4) Detaching and refitting the PWB. (C-LPWB).....	2-2-20
2-2-4 Connect Right PWB (CRPWB).....	2-2-27
(1) Connector position.....	2-2-27
(2) PWB photograph.....	2-2-27
(3) Connector lists.....	2-2-28
(4) Detaching and refitting the PWB. (CRPWB).....	2-2-31
2-2-5 High Voltage PWB (HVPWB).....	2-2-34
(1) Connector position.....	2-2-34
(2) PWB photograph.....	2-2-34
(3) Connector lists.....	2-2-35
(4) Detaching and refitting the PWB. (HVPWB).....	2-2-36
2-2-6 Power source PWB (PSPWB).....	2-2-46
(1) Connector position.....	2-2-46
(2) PWB photograph.....	2-2-46
(3) Connector lists.....	2-2-47
(4) Detaching and refitting the PWB. (PSPWB).....	2-2-48
2-2-7 Operation panel PWB (OPPWB) for HyPAS model.....	2-2-52
(1) Connector position.....	2-2-52
(2) PWB photograph.....	2-2-52
(3) Connector lists.....	2-2-53
(4) Detaching and refitting the PWB. (OPPWB).....	2-2-56
2-2-8 Operation panel PWB (OPPWB) for Basic model.....	2-2-58
(1) Connector position.....	2-2-58
(2) PWB photograph.....	2-2-58
(3) Connector lists.....	2-2-59
(4) Detaching and refitting the PWB. (OPPWB).....	2-2-60

2-3 Appendixes

2-3-1 Appendixes.....	2-3-1
(1) List of maintenance parts.....	2-3-1
(2) Maintenance kits.....	2-3-2
(2-1) 40 ppm model.....	2-3-2
(2-2) 50/60 ppm model.....	2-3-2
(2-3) For DP.....	2-3-2
(3) Repetitive defects gauge.....	2-3-3
(4) Firmware environment commands.....	2-3-4
(5) System Error (Fxxxx) Outline.....	2-3-12
(6) Chart of image adjustment procedures.....	2-3-16
(7) Wiring diagram (40 ppm (LED model)).....	2-3-19
(8) Wiring diagram (40 ppm (HyPAS model)).....	2-3-22
(9) Wiring diagram (50/60 ppm (HyPAS model)).....	2-3-25

Installation Guide

PF-320 (Paper Feeder)

This page is intentionally left blank.

1-1-1 Specifications

(1) Common function

Item		Description		
		40 ppm	50 ppm	60 ppm
Type		Desktop		
Printing Method		Electrophotography by semiconductor laser, single drum system		
Paper Weight	Cassette	60 to 120 g/m ²		
	Multi Purpose Tray	60 to 220 g/m ² , 230 g/m ² (Cardstock)		
Paper Type	Cassette	Plain, Rough, Recycled, Preprinted, Bond, Color (Colour), Prepunched, Letterhead, High Quality, Custom 1 to 8 (Duplex: Same as Simplex)		
	Multi Purpose Tray	Plain, Transparency (OHP film), Rough, Vellum, Labels, Recycled, Preprinted, Bond, Cardstock, Color (Colour), Prepunched, Letterhead, Envelope, Thick, High Quality, Custom 1 to 8		
Paper Size	Cassette	A4, A5, A6 *1, B5, Letter, Legal, B6 *1, Statement, Executive, Oficio II, Folio, 216 × 340 mm, 16K, ISO B5, Envelope DL *1, Envelope C5, Oufuku Hagaki *1, Custom *1 : 50/60 ppm model only		
	Multi Purpose Tray	A4, A5, A6, B5, B6, Folio, 216 × 340 mm, Letter, Legal, Statement, Executive, Oficio II, 16K, ISO B5, Envelope #10, Envelope #9, Envelope #6, Envelope Monarch, Envelope DL, Envelope C5, Hagaki, Oufuku Hagaki, Youkei 4, Youkei 2, Custom		
Warm-up Time (22°C/ 71.6°F, 60%)	Power on	21 s or less		25 s or less
	Low power mode	10 s or less		
	Sleep	15 s or less	20 s or less	25 s or less
Paper Capacity	Cassette	500 sheets (80 g/m ²)		
	Multi Purpose Tray	100 sheets (80 g/m ²)		
Output Tray Capacity	Inner tray (Face down)	250 sheets (80 g/m ²)	500 sheets (80 g/m ²)	
	Rear tray (Face up)	-	250 sheets (80 g/m ²)	
Photoconductor		a-Si drum (diameter 30 mm)		
Image Write System		Semiconductor laser and electrophotography		
Charging system		Contact charger roller method		
Developer system		Mono component dry developing method Toner replenishing: Automatic from the toner container		
Transfer system		Transfer roller method		
Separation system		Small diameter separation, separation needle		
Cleaning system		Counter blade cleaning + cleaning roller		

Item		Description		
		40 ppm	50 ppm	60 ppm
Charge erasing system		Exposure by cleaning lamp (LED)		
Fusing system		Heat and pressure fusing with the heat roller and the press roller Heat source: halogen heater Abnormally high temperature protection devices: thermostat		
Operating Environment	Temperature	10 to 32.5°C/50 to 90.5°F		
	Humidity	15 to 80 %		
	Altitude	2,500 m/8,202 ft maximum		
	Brightness	1,500 lux maximum		
CPU		PPC465S 667MHz + ARM926 400MHz		
Interface		USB Interface Connector: 1 (USB Hi-Speed) SD card interface: 1 Network interface (10BASE-T/100BASE-TX/1000BASE-T): 1 *2 Fax interface: 1 *2 *2: FAX model only		
Main Memory	Standard	512 MB (LED model) 1024 MB (HyPAS model)		
	Max	1536 MB (LED model) 2048 MB (HyPAS model)		
Dimension (W × D × H)		18 11/16 × 17 15/16 × 22 5/8" 475 × 455 × 575 mm	18 11/16 × 17 15/16 × 23 1/4" 475 × 455 × 590 mm	
Weight (Not include toner container)		(Basic model) 47.4 lbs or less/ 21.5 kg or less (HyPAS model) 48.5 lbs or less/ 22.0 kg or less	51.4 lbs or less/ 23.3 kg or less	
Space Required (W × D) (Using multi purpose tray)		18 11/16 × 24 7/8" 475 × 632 mm		
Rated input		120 V 60 Hz 8.4 A 220-240 V 50/60 Hz 4.4 A	120 V 60 Hz 10.4 A 220-240 V 50/60 Hz 5.5 A	
Option		Papre Feeder PF-320 Expansion Memory SD/SDHC memory card Expansion HDD HD-6/7 Network Interface Kit IB-50 Wireless LAN Interface Kit IB-51 IC Card Authentication kit (B) IC Card Reader USB Keyboard Thin Print UG-33	Papre Feeder PF-320 Faceup Tray PT-320 Expansion Memory SD/SDHC memory card Expansion HDD HD-6/7 Network Interface Kit IB-50 Wireless LAN Interface Kit IB-51 IC Card Authentication kit (B) IC Card Reader USB Keyboard Thin Print UG-33	

(2) Copy function

Item		Description		
		40 ppm	50 ppm	60 ppm
Copy Speed (from Cassette) (with DP)	A4-R	40 ppm	50 ppm	60 ppm
	Letter-R	42 ppm	52 ppm	62 ppm
	Legal	33 ppm	42 ppm	50 ppm
	B5-R	33 ppm	40 ppm	48 ppm
	A5-R	22 ppm	27 ppm	32 ppm
First Copy Time (A4, feed from Cassette)		9.0 seconds or less	8.0 seconds or less	
Zoom Level		Manual mode: 25 to 400%, 1% increments Auto mode: 400%, 200%, 141%, 129%, 115%, 90%, 86%, 78%, 70%, 64%, 50%, 25%		
Continuous Copying		1 to 999 sheets		
Resolution		600 × 600 dpi		
Supported Original Types		Sheet, Book, 3-dimensional objects (maximum original size: Folio/Legal)		
Original Feed System		Fixed		

(3) Printer function

Item		Description		
		40 ppm	50 ppm	60 ppm
Printing Speed		Same as Copy Speed.		
First Print Time (A4, feed from Cassette)		9.0 seconds or less	8.0 seconds or less	
		(Excluding time for system stabilization immediately after turning on the main power.)		
Resolution		Fast 1200, 600 dpi, 300 dpi		
Operating System		Windows XP, Windows Server 2003, Windows Vista, Windows 7, Windows 8, Windows Server 2008/R2 *6, Windows Server 2012, Mac OS 10.x *6: HyPAS model only		
Interface		USB Interface Connector: 1 (USB Hi-Speed) Network interface: 1(10 BASE-T/100 BASE-TX/1000 BASE-T) Optional Interface (Option): 1(For IB50/IB-51 mounting)		
Page Description Language		PRESCRIBE		
Emulation		PCL6(PCL5e, PCL-XL, PCL5c), KPDL3 (PostScript3), XPS Line Printer, IBM Proprinter, EPSON LQ-850		

(4) Scanner function

Item	Description		
	40 ppm	50 ppm	60 ppm
Resolution	600 dpi, 400 dpi, 300 dpi, 200 dpi, 200×400 dpi, 200×100 dpi		
File Format	TIFF (MMR/JPEG compression), JPEG, PDF (MMR/JPEG compression), XPS, PDF/A, PDF(high compression)		
Scanning Speed *3	(A4 landscape,300 dpi, Image quality: Text/Photo original)		
	Simplex	40 ipm (B/W) 30 ipm (Color)	60 ipm (B/W) 40 ipm (Color)
	Duplex	17 ipm (B/W) 13 ipm (Color)	26 ipm (B/W) 17 ipm (Color)
Interface	Ethernet (10BASE-T/100BASE-TX/1000BASE-T), USB		
Network protocol	TCP/IP		
Transmission system	SMB, SMTP, FTP, FTP over SSL, USB, TWAIN *4, WIA *5, WSD		

*3: When using the document processor (except TWAIN and WIA scanning)

*4: Available operating system:Windows XP, Windows Vista, Windows 7, Windows 8, Windows Server 2003, Windows Server 2008, Windows Server 2008 R2, Windows Server 2012

*5: Available operating system:Windows Vista, Windows 7, Windows 8, Windows Server 2008, Windows Server 2008 R2, Windows Server 2012

(5) Document processor

Item	Description
Original Feed Method	Automatic feed
Supported Original Types	Sheet originals
Paper Size	Maximum: Legal/A4 Minimum: Statement-R/A5-R
Paper Weight	50 to 120 g/m ² (Simplex) 50 to 120 g/m ² (Duplex)
Loading Capacity	75 sheets or less (50 to 80 g/m ²)

NOTE: These specifications are subject to change without notice.

1-1-2 Parts names

(1) Main part appearance

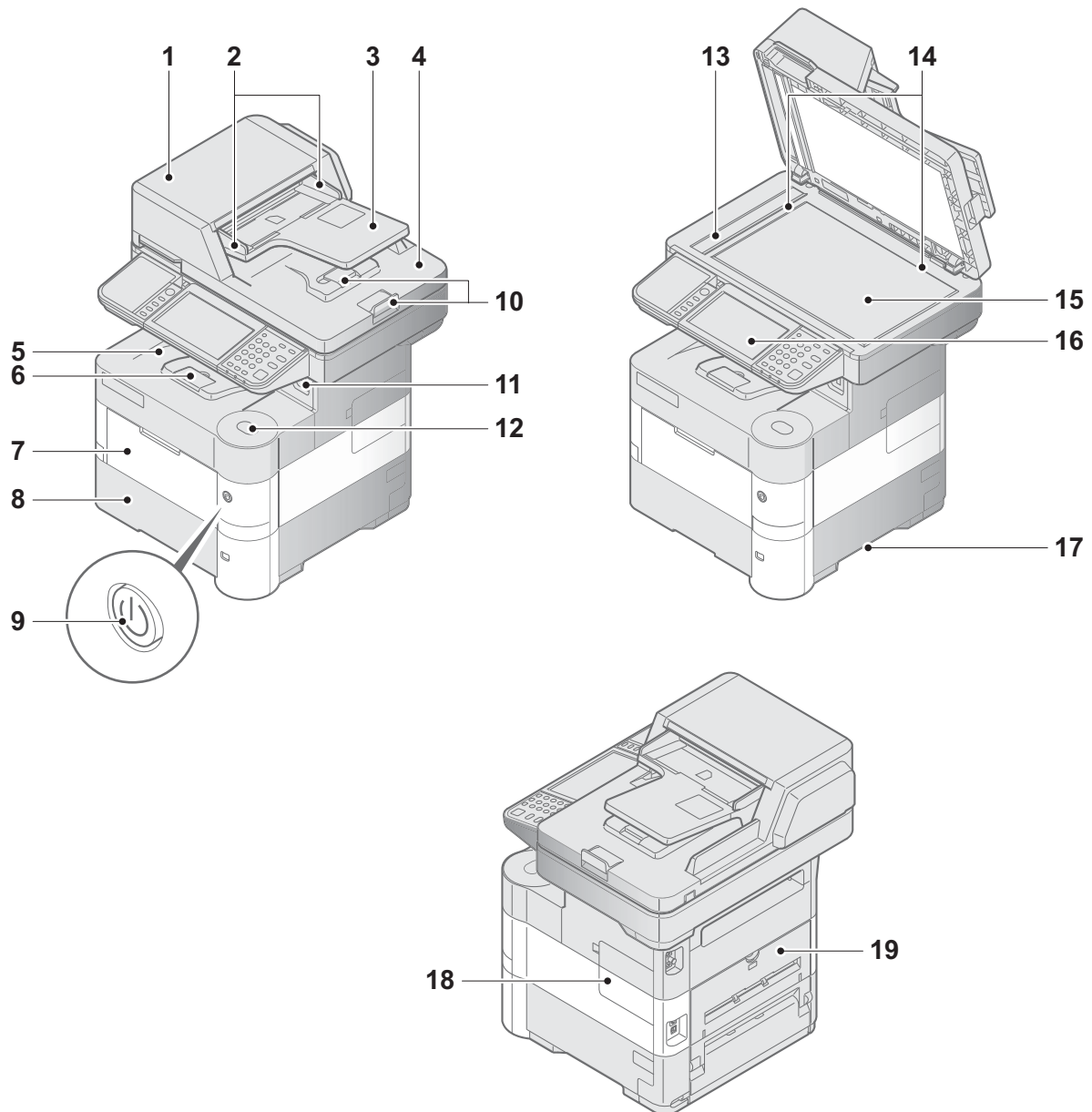

Figure 1-1-1

- | | |
|-----------------------------------|------------------------------------|
| 1. Document Processor | 11. USB Memory Slot |
| 2. Original Width Guides | 12. Front Cover Open Button |
| 3. Original Tray | 13. Slit Glass |
| 4. Original Eject Table | 14. Original Size Indicator Plates |
| 5. Inner Tray | 15. Contact Glass |
| 6. Eject Paper stopper | 16. Operation Panel |
| 7. Front Cover | 17. Handles |
| 8. Cassette1 | 18. controller Cover |
| 9. Power Switch | 19. Rear Cover |
| 10. Original Stopper Compartments | |

(2) A connector and an inside

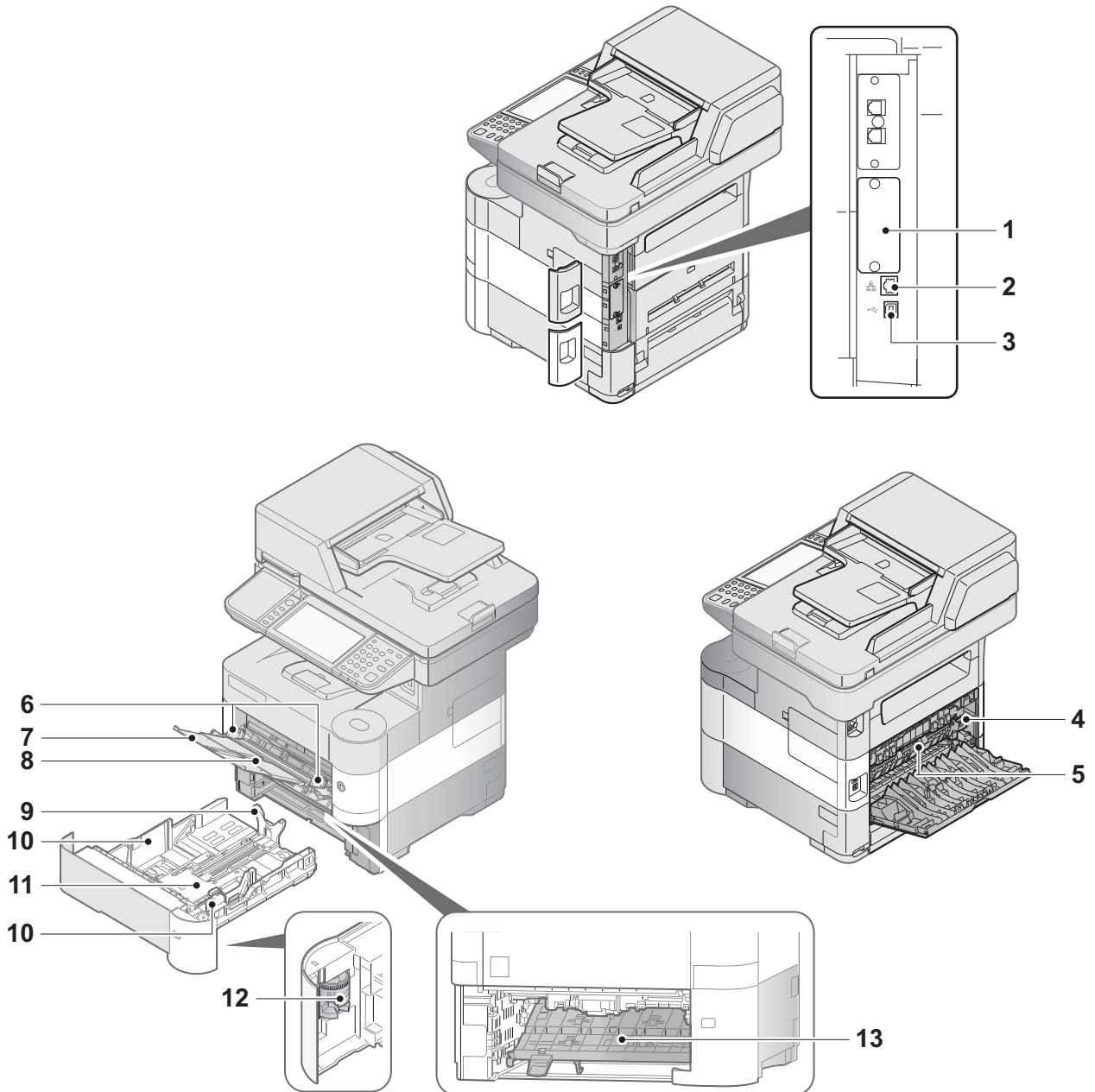

Figure 1-1-2

- 1. Option Interface Slot
- 2. Network Interface Connector
- 3. USB Interface Connector
- 4. Envelope Lever
- 5. Fuser Cover
- 6. MP Paper Guides
- 7. MP Sub Tray

- 8. MP Tray
- 9. Paper Length Guide
- 10. Paper Width Guide
- 11. Bottom Plate
- 12. Cassette Size Dial
- 13. Duplex Cover

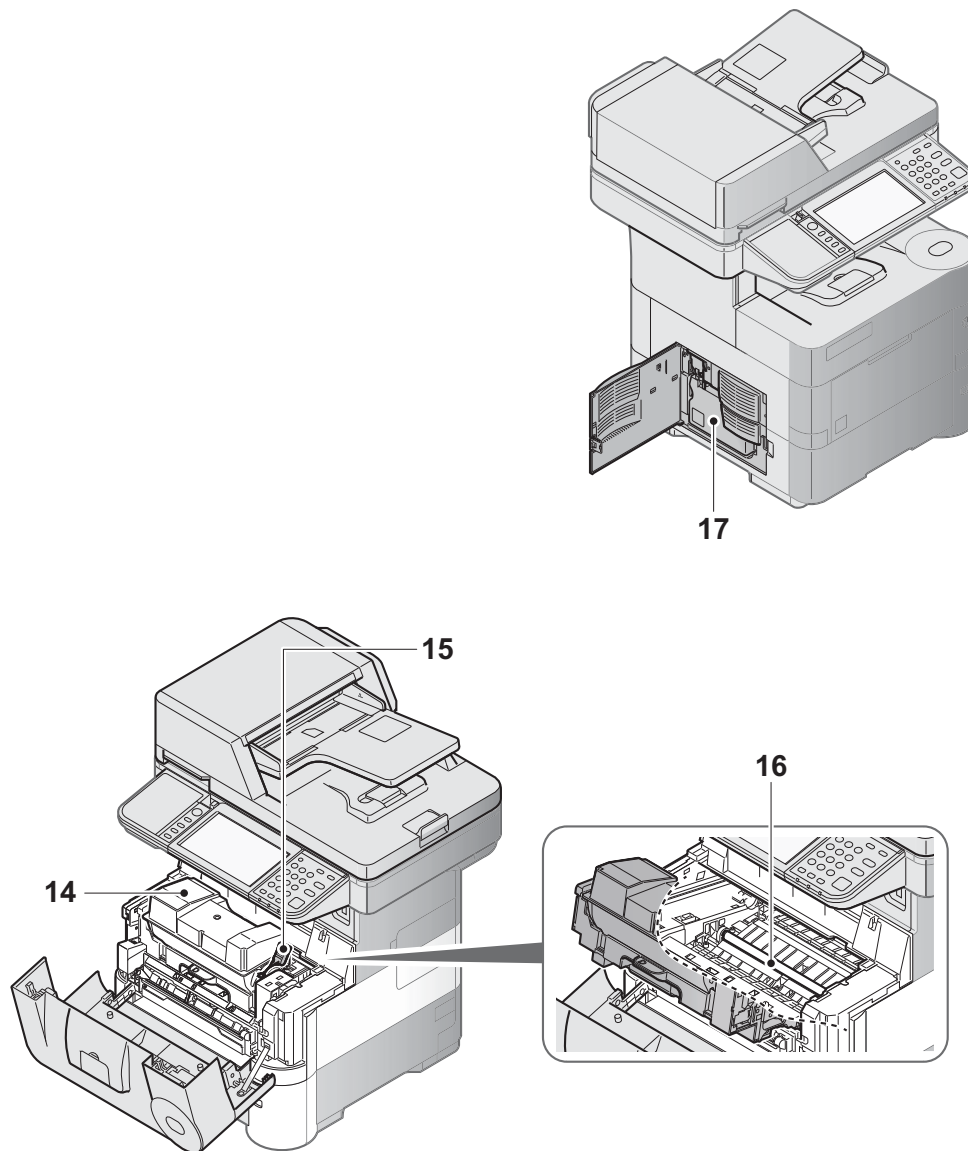

Figure 1-1-3

- 14. Toner Container
- 15. Toner Container Lock Lever
- 16. Registration roller
- 17. Waste Toner Box

(3) Option

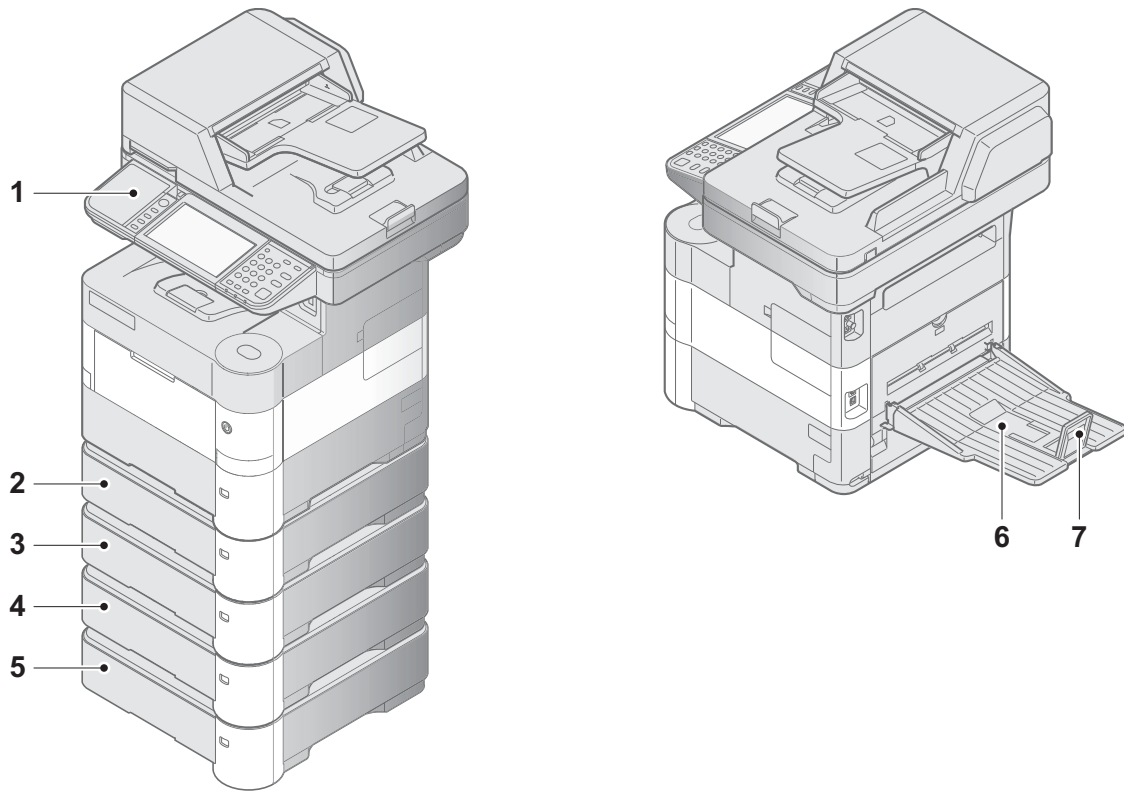
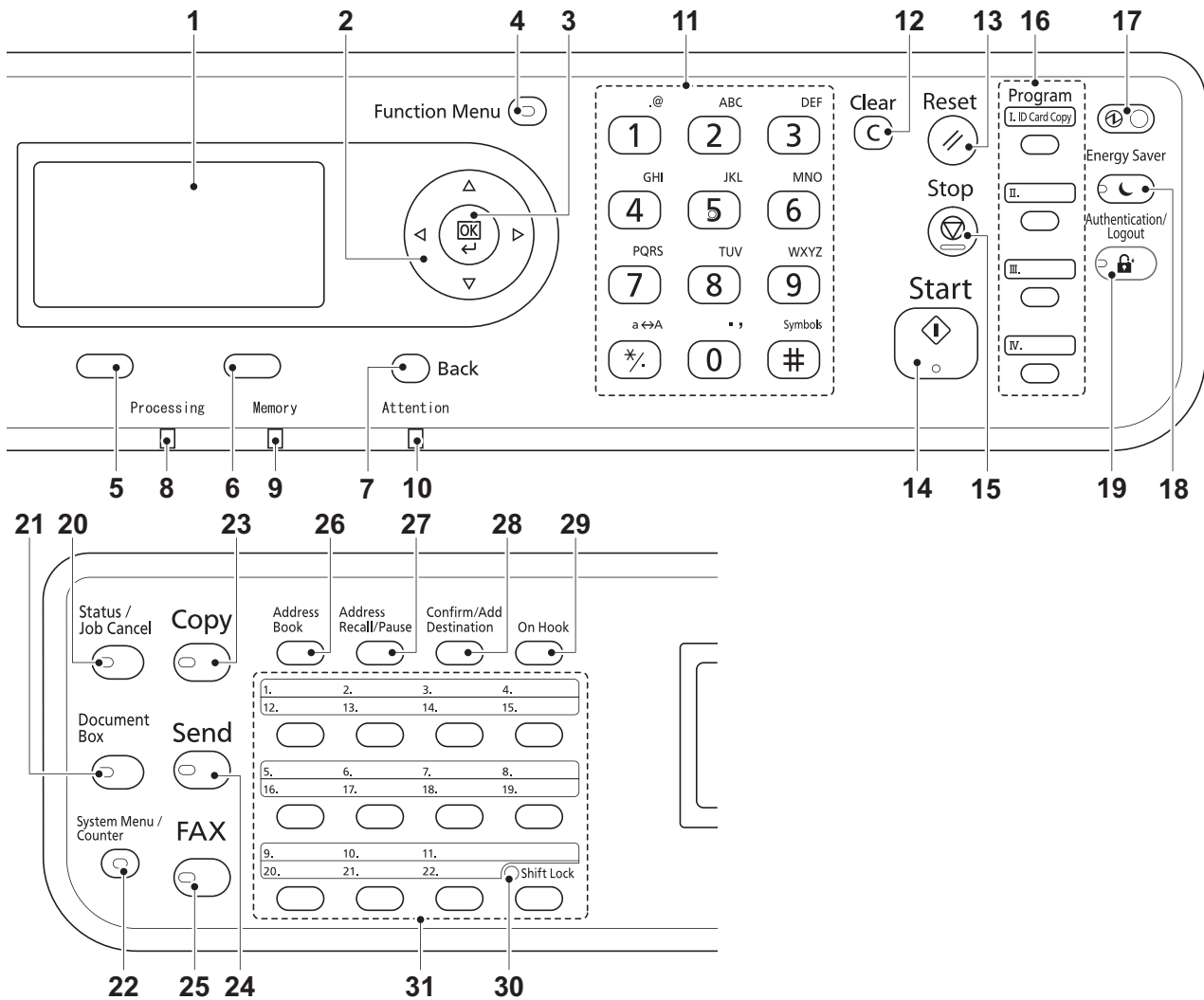

Figure 1-1-4

- 1. Card Reader
- 2. Cassette 2
- 3. Cassette 3
- 4. Cassette 4

- 5. Cassette 5
- 6. Rear Tray
- 7. Eject Paper Stopper

(4) Operation panel**(4-1) Basic model****Figure 1-1-5**

- | | |
|-------------------------|---------------------------------|
| 1. LCD | 17. Power Indication |
| 2. Arrow key | 18. Energy Saver key |
| 3. OK key | 19. Authentication/Logout key |
| 4. Function Menu key | 20. Status/Job Cancel key |
| 5. Select key(Left) | 21. Document Box key |
| 6. Select key(Right) | 22. System Menu/Counter key |
| 7. Back key | 23. Copy key |
| 8. Processing Indicator | 24. Send key |
| 9. Memory Indicator | 25. FAX key |
| 10. Attention Indicator | 26. Address Book key |
| 11. Numeric keys | 27. Address Recall/Pause key |
| 12. Clear key | 28. Confirm/Add Destination key |
| 13. Reset key | 29. On Hook key |
| 14. Start key | 30. Sift Lock Indicator |
| 15. Stop key | 31. One Touch key |
| 16. Program key | |

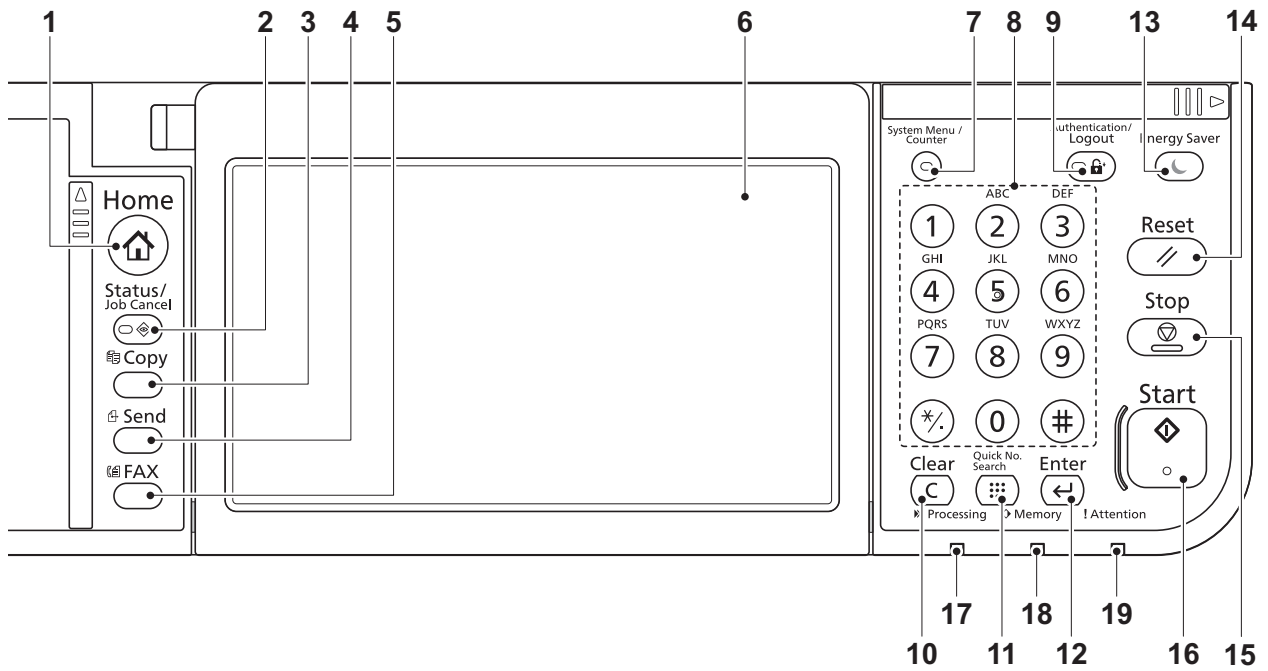
(4-2) HyPAS model**Figure 1-1-6**

- | | |
|-------------------------------|--------------------------|
| 1. Home Key | 11. Quick No. Search key |
| 2. Status/Job Cancel key | 12. Enter key |
| 3. Copy key | 13. Energy Saver key |
| 4. Send key | 14. Reset key |
| 5. FAX key | 15. Stop key |
| 6. LCD | 16. Start key |
| 7. System Menu/Counter key | 17. Processing Indicator |
| 8. Numeric keys | 18. Memory Indicator |
| 9. Authentication /Logout key | 19. Attention Indicator |
| 10. Clear key | |

1-1-3 Machine cross section

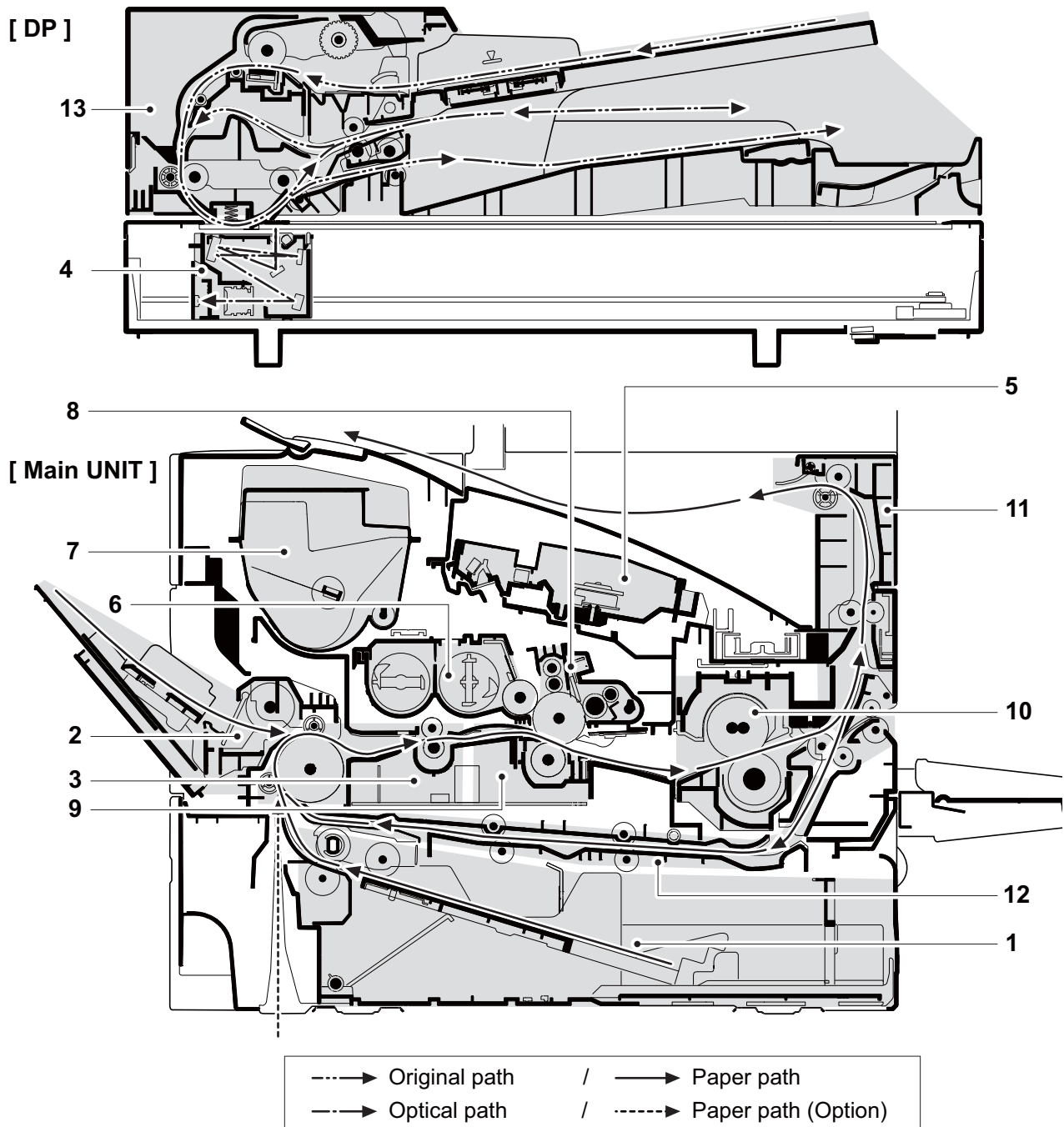
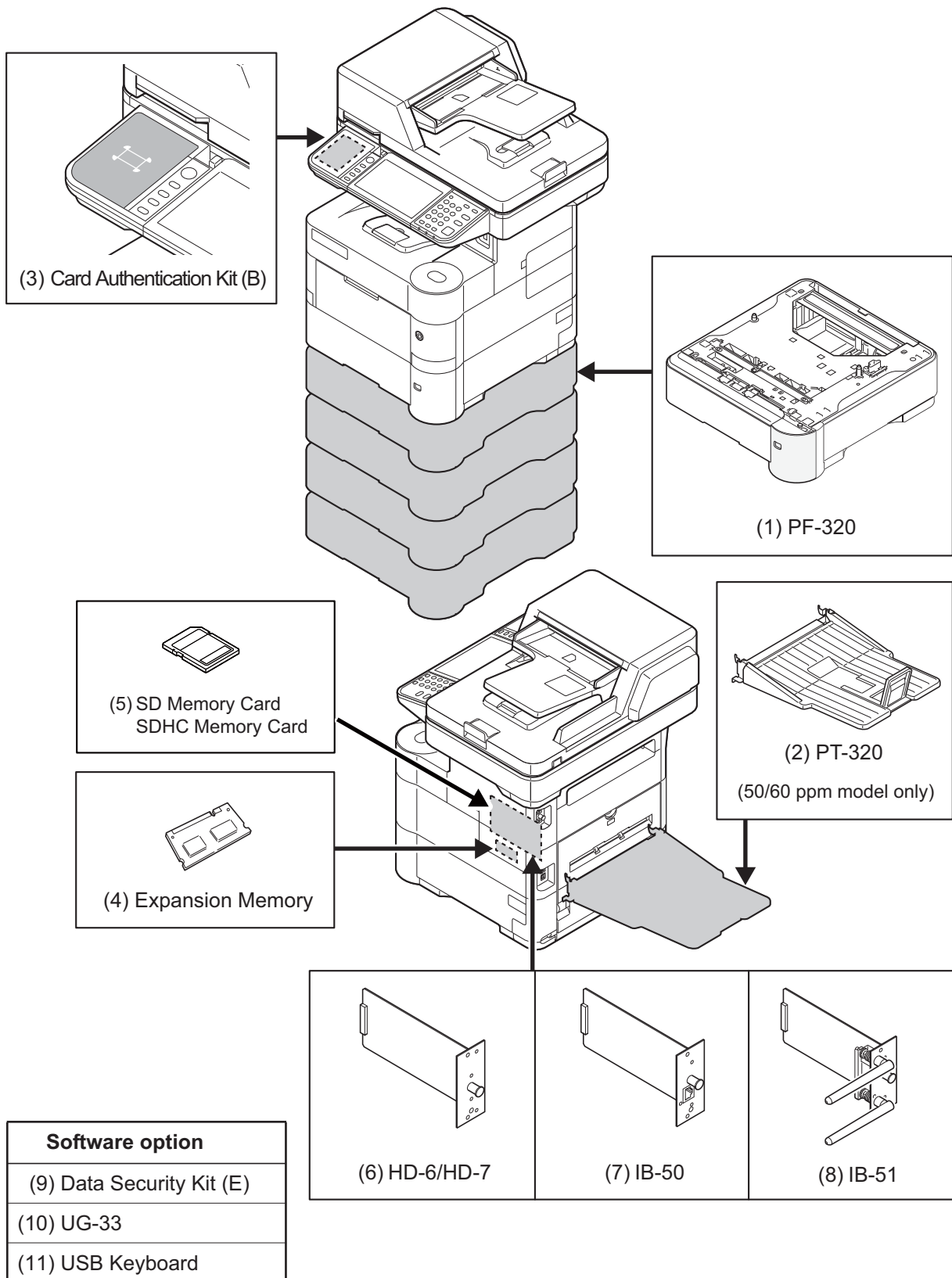

Figure 1-1-7

- | | |
|--------------------------------|--|
| 1. Cassette paper feed section | 9. Transfer/Separation section |
| 2. MP tray paper feed section | 10. Fuser and eject/feed shift section |
| 3. Conveying section | 11. Eject section |
| 4. Image scanner section | 12. Duplex conveying section |
| 5. Laser scanner section | 13. DP section |
| 6. Developer section | |
| 7. Toner container section | |
| 8. Drum section | |

1-1-4 Option composition

The following optional equipment is available for the machine.



1-2-1 Installation environment

1. Temperature: 10 to 32.5°C/50 to 90.5°F
2. Humidity: 15 to 80% RH
3. Power supply: 120 V AC, 12.0 A
220 - 240 V AC, 6.0 A
4. Power supply frequency: 50 Hz \pm 2%/60 Hz \pm 2%
5. Installation location

Avoid direct sunlight or bright lighting. Ensure that the photoconductor will not be exposed to direct sunlight or other strong light when removing paper jams.

Avoid locations subject to high temperature and high humidity or low temperature and low humidity; an abrupt change in the environmental temperature; and cool or hot, direct air.

Avoid places subject to dust and vibrations.

Choose a surface capable of supporting the weight of the machine.

Place the machine on a level surface (maximum allowance inclination: 1°).

Avoid air-borne substances that may adversely affect the machine or degrade the photoconductor, such as mercury, acidic or alkaline vapors, inorganic gasses, NO_x, SO_x gases and chlorine-based organic solvents.

Select a well-ventilated location.

6. Allow sufficient access for proper operation and maintenance of the machine.

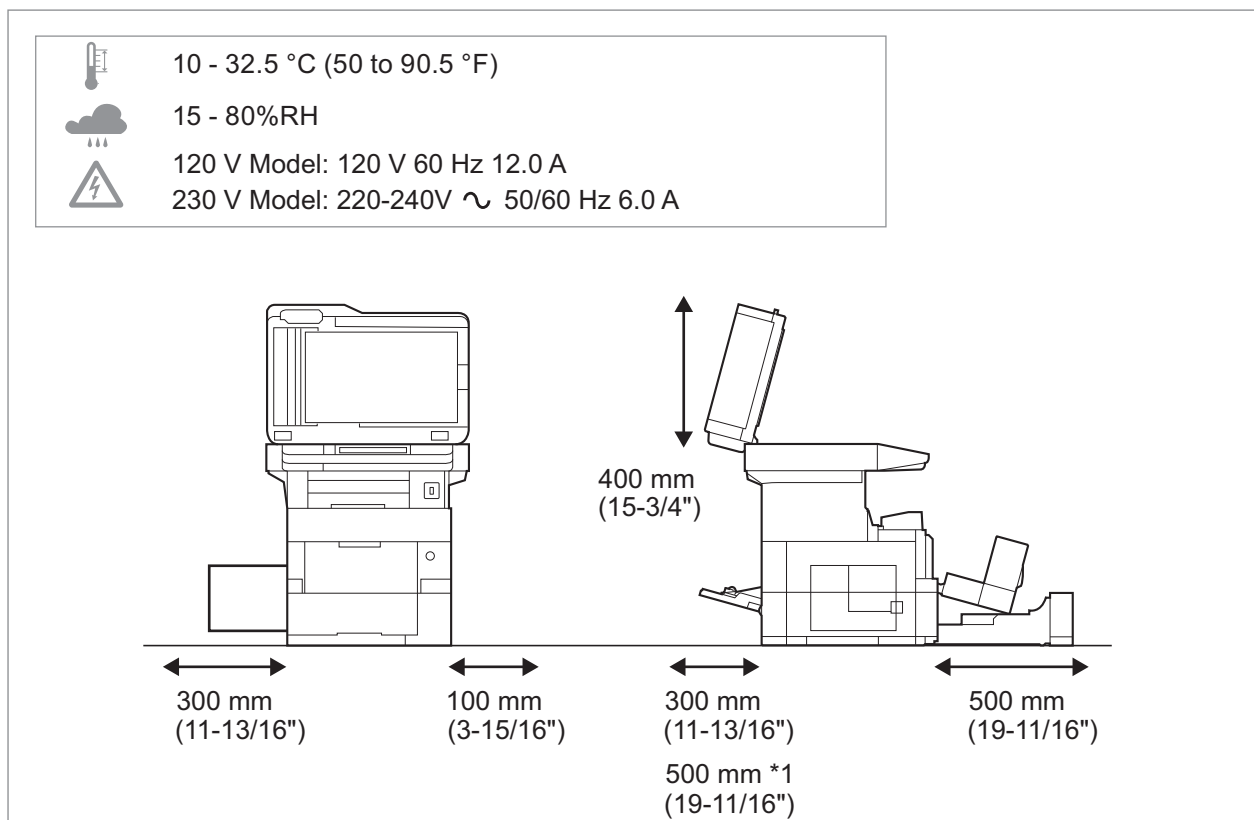

*1: With PT-320 (50/60 ppm model only)

Figure 1-2-1

1-2-2 Unpacking and installation

(1) Installation procedure

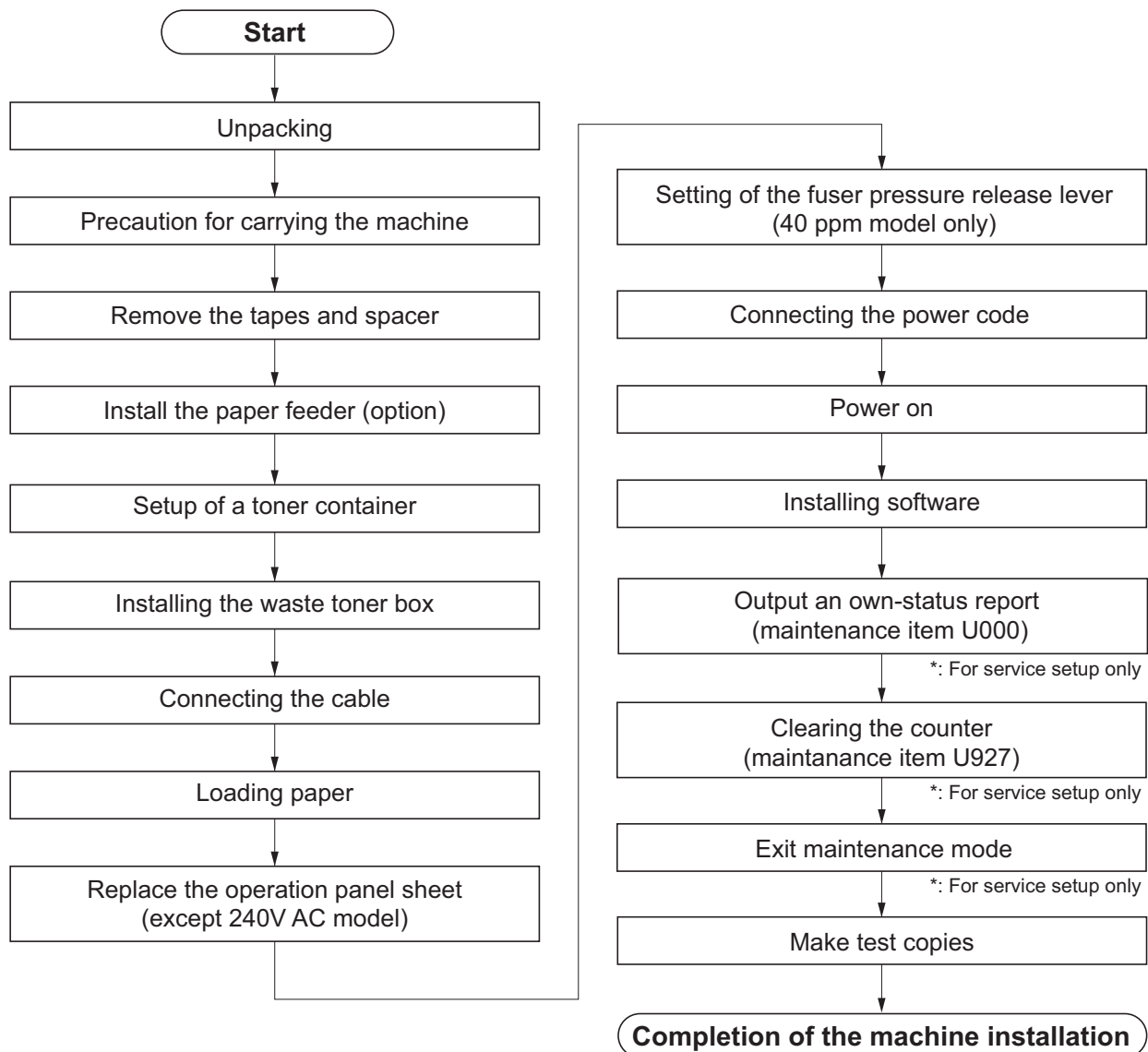

Unpacking

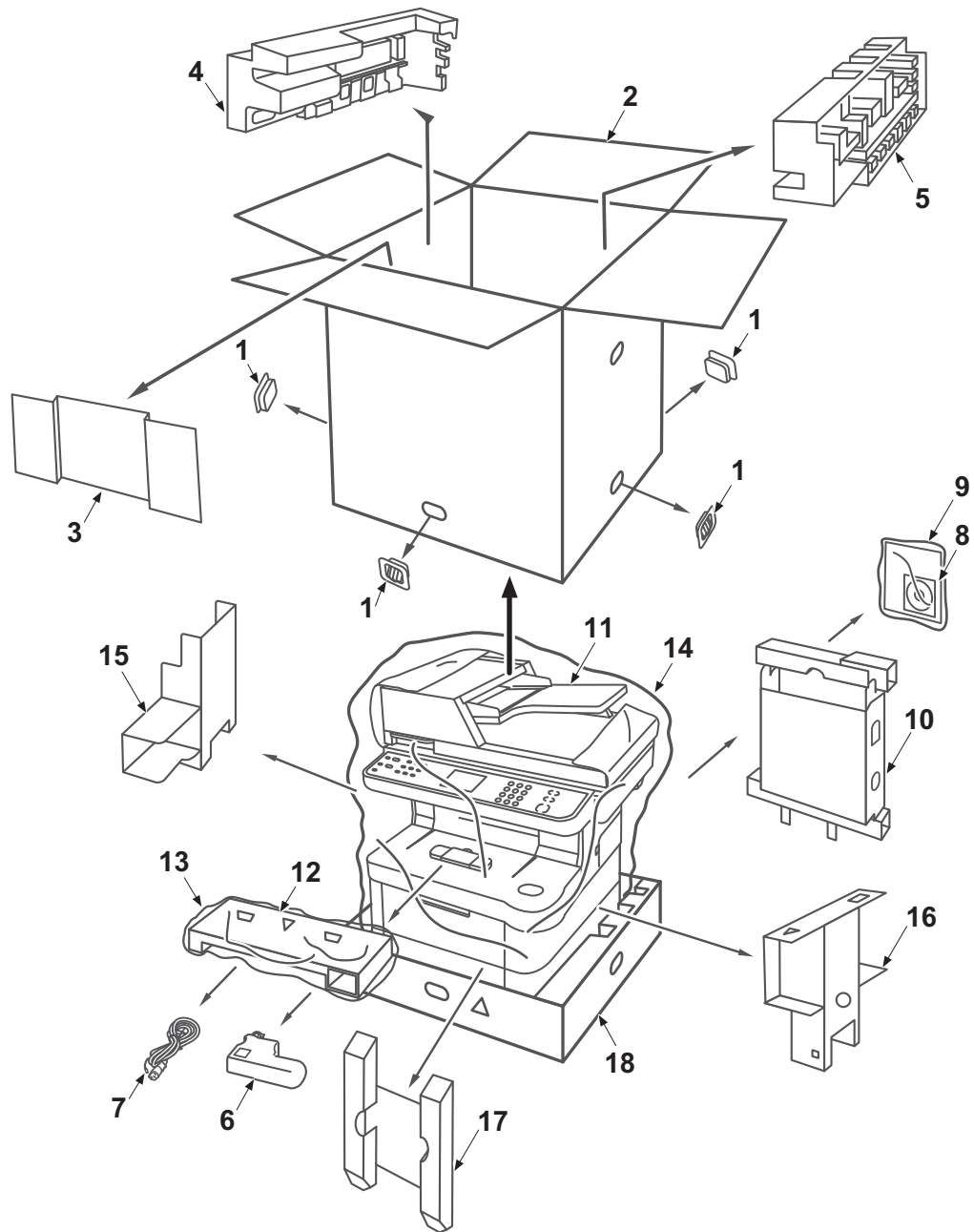

Figure 1-2-2

- | | | |
|--------------------|-------------------------|---------------------|
| 1. Hinge joints | 7. Power code | 13. Plastic bag |
| 2. Outer case | 8. Operation guide etc. | 14. Plastic bag |
| 3. Upper front pad | 9. Plastic bag | 15. Lower left pad |
| 4. Upper left pad | 10. Document tray | 16. Lower right pad |
| 5. Upper right pad | 11. Main unit | 17. Lower front pad |
| 6. Waste toner box | 12. Inner pad | 18. Bottom case |

*: Place the machine on a level surface.

Precaution for carrying the machine

- *: Be sure to hold the both side of the lower part of the machine by two persons when carrying it, as shown in the figure.
- *: Don't have the operation panel part, because there is fear of breakage.

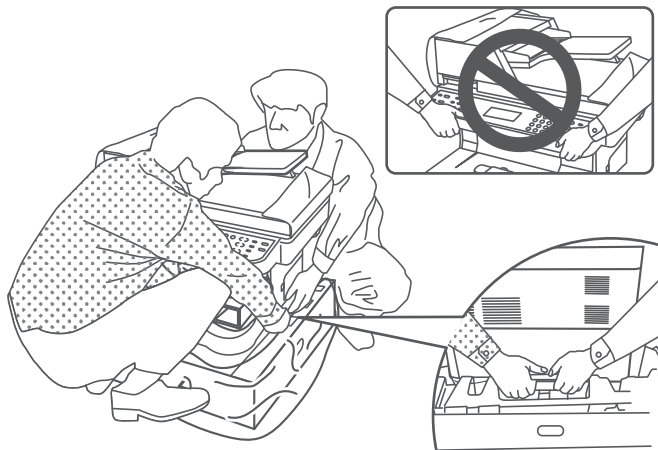

Figure 1-2-3

Remove the tapes and spacer

- *: Removed the packing components that a fixed tape and shock absorbing material etc. are.

Install the paper feeder (option)

1. A main unit is carried on a paper feeder.

- *: Refer to the installation guide for the details of attachment.

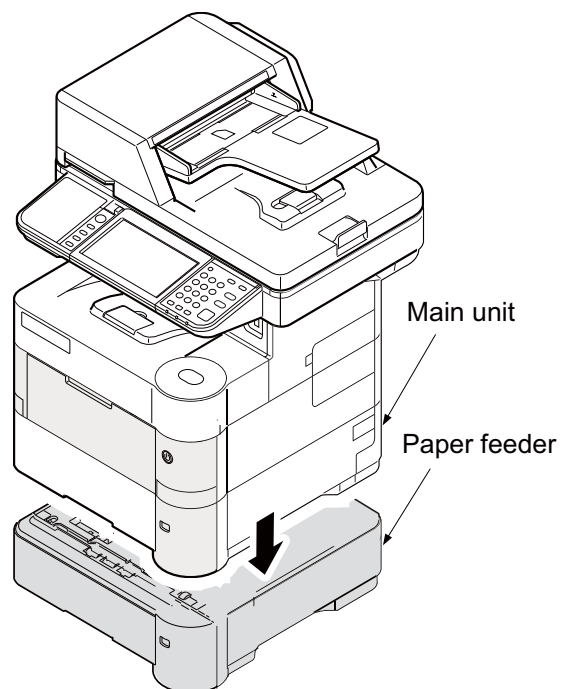

Figure 1-2-4

Setup of a toner container

1. Push the release button down and open the front cover.

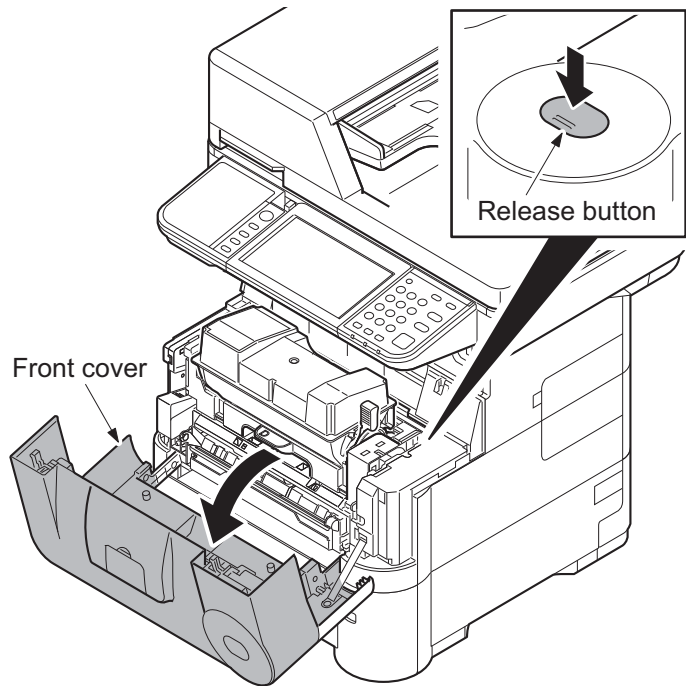

Figure 1-2-5

2. Rotate the toner container lock lever to the lock position and then the unlock position.

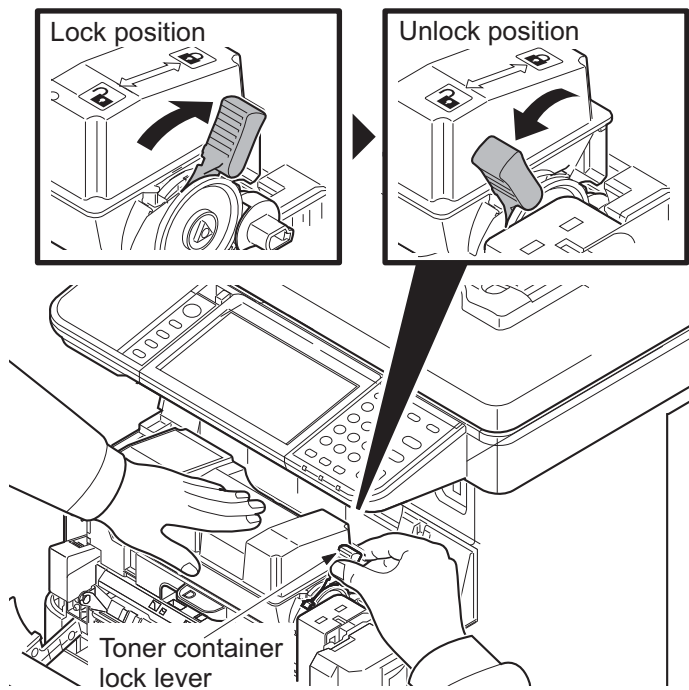

Figure 1-2-6

3. Remove the toner container from the main unit.

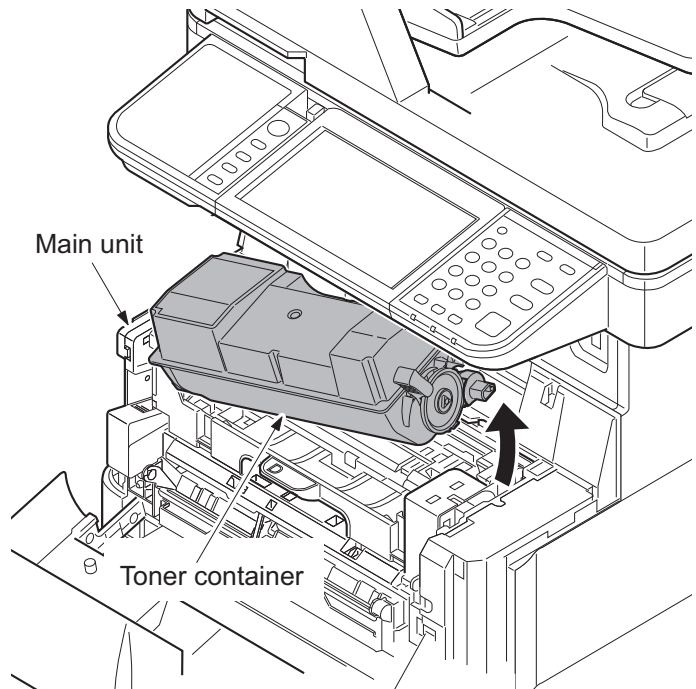

Figure 1-2-7

*: Caution: Do not press too firmly on the center of the toner container or touch the toner feed slot or the terminal parts.

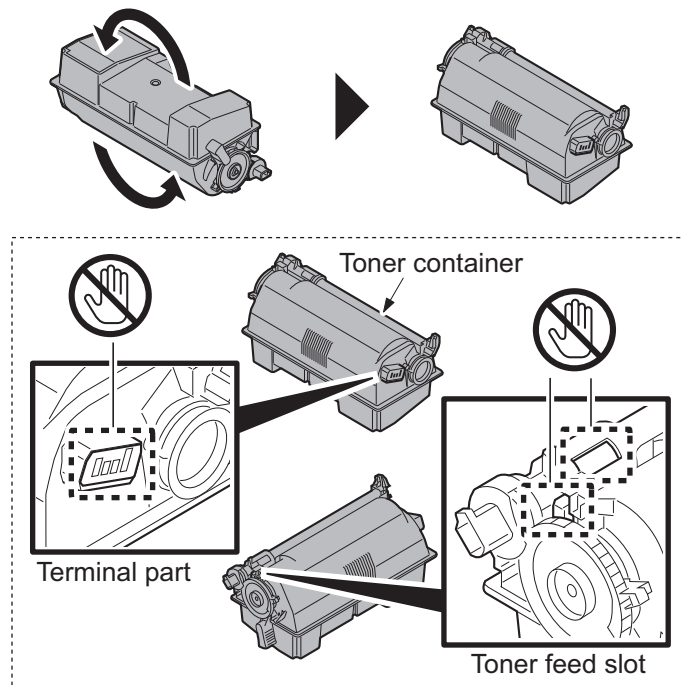

Figure 1-2-8

4. Shake the turned toner container 10 times or more as shown in the figure in order to distribute the toner evenly inside the container.

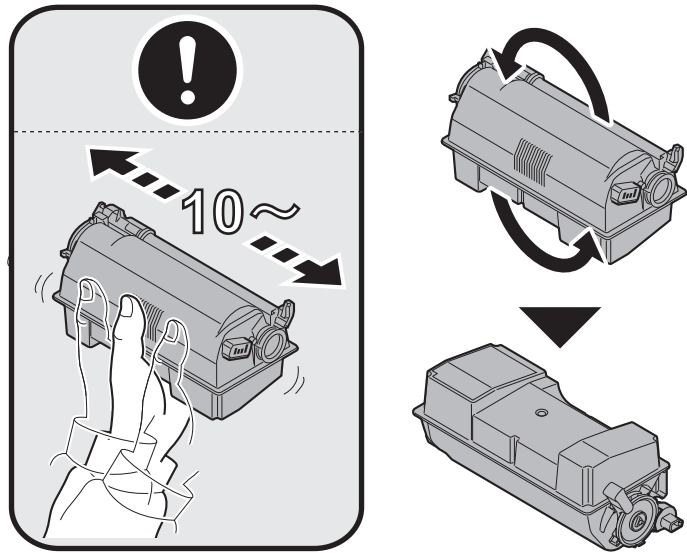

Figure 1-2-9

5. Set the toner container to the main unit and then turn the toner container lock lever to the lock position.
6. Close the front cover.

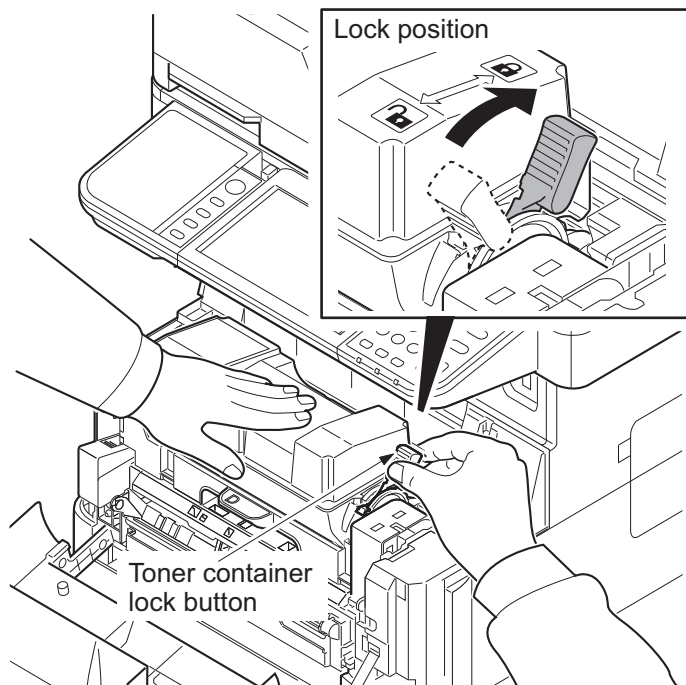

Figure 1-2-10

Installing the waste toner box

1. Open the controller cover.
2. Open the cap of the waste toner box.
3. Install the waste toner box.
4. Close the controller cover.

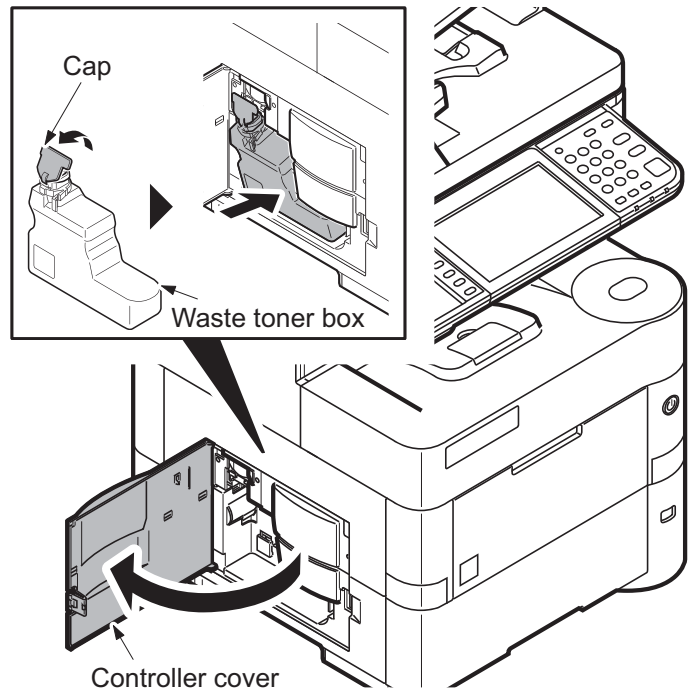
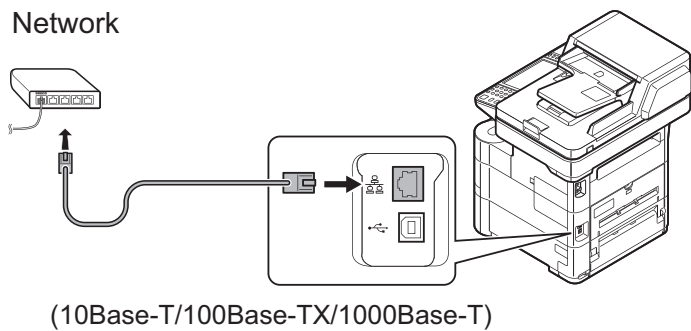

Figure 1-2-11

Connecting the cable

[Connecting at Network]

1. Connect the network cable to the network interface connector located on the back side of the main unit.
2. Connect the other end of the cable to the network router.



[Connecting at USB]

1. Connect the USB cable to the USB interface connector located on the back side of the main unit.
2. Connect the other end of the cable to the PC.

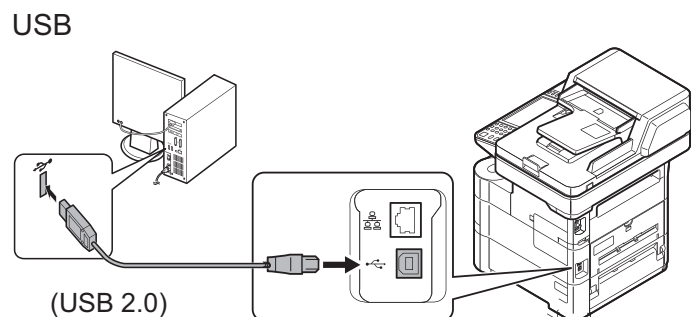

Loading paper

1. Pull the cassette from the main unit out.

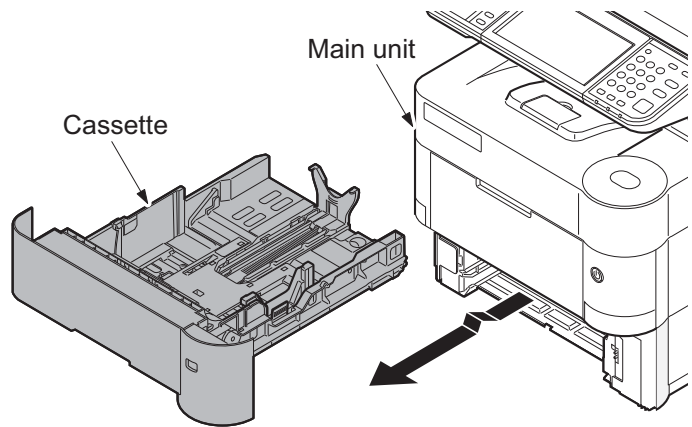

Figure 1-2-13

- *: Push the bottom plate down.
(40 ppm model only)

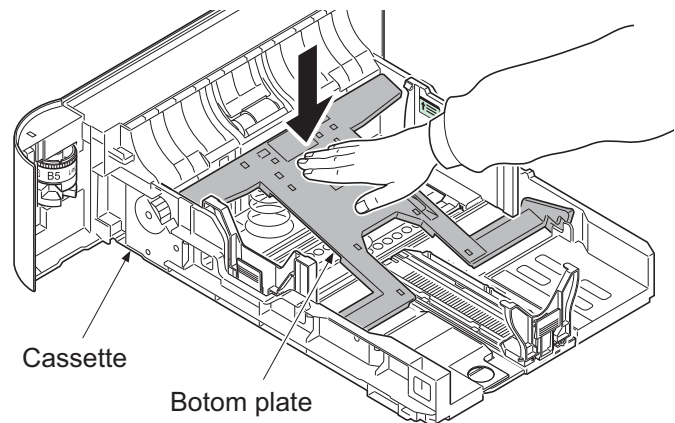

Figure 1-2-14

2. Push the lock lever on the right side guide and slide to the desired paper size.

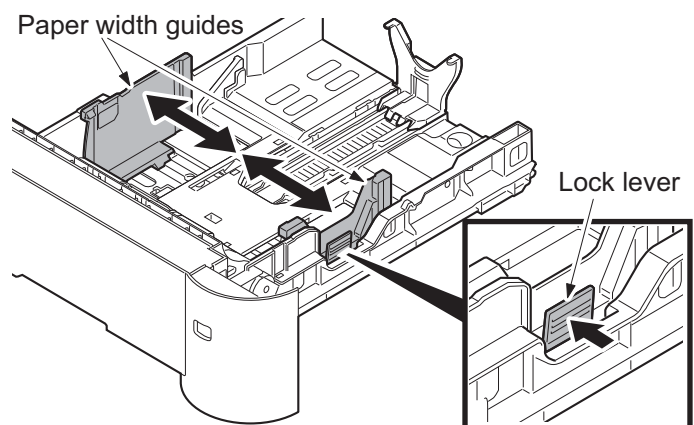

Figure 1-2-15

3. Push the lock lever and slide the paper length guide to the desired paper size.
4. Turn the cassette size dial so that the size of the paper you are going to use appears in the cassette size window.

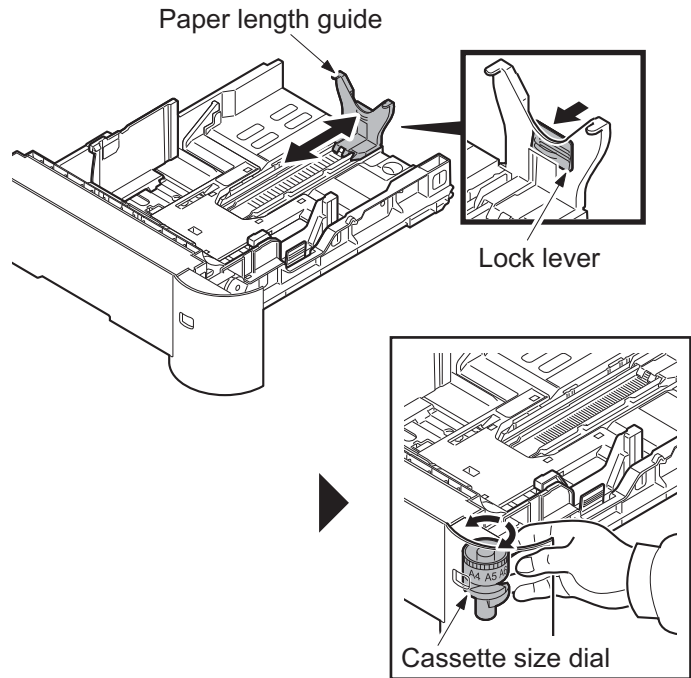
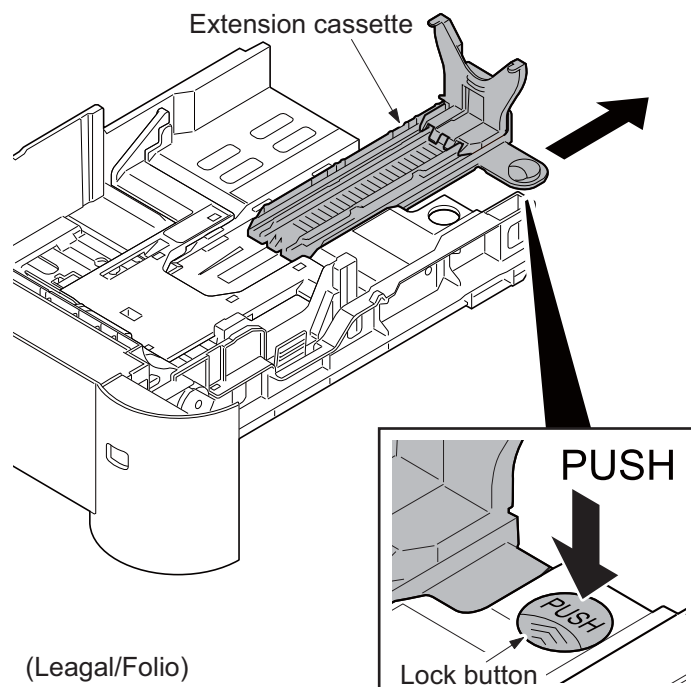

Figure 1-2-16

5. If you are going to set paper that is longer than A4, pull out the extension cassettes pushing the lock button one by one and adjust them to the desired paper size.



(Legal/Folio)

Figure 1-2-17

Before loading paper

When you open a new package of paper, fan the sheets to separate them slightly prior to loading in the following steps.

- (1) Bend the whole set of sheets to swell them in the middle.
- (2) Hold the stack at both ends and stretch it while keeping the entire stack swelled.
- (3) Raise the right and left hands alternately to create a gap and feed air between the papers.
- (4) Finally, align the papers on a level, flat table.

*: If the paper is curled or folded, straighten it before loading. Paper that is curled or folded may cause a jam.

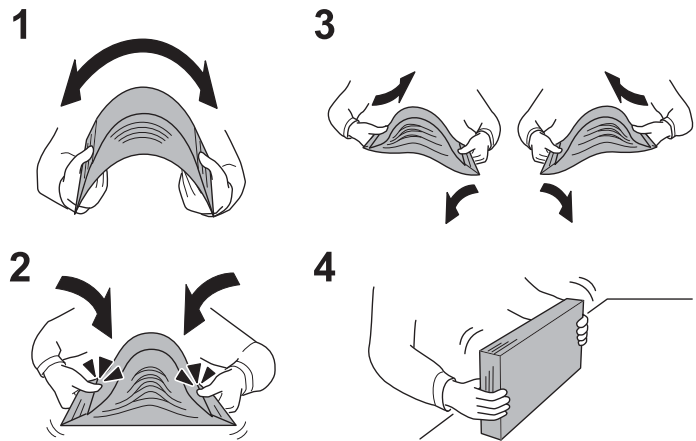

Figure 1-2-18

6. Fan the media (paper/transparencies), then tap it on a level surface to avoid media jams or skewed printing.
7. Slide the paper into the paper cassette.
8. Insert the cassette into the slot in the main unit. Push it straight in as far as it will go.

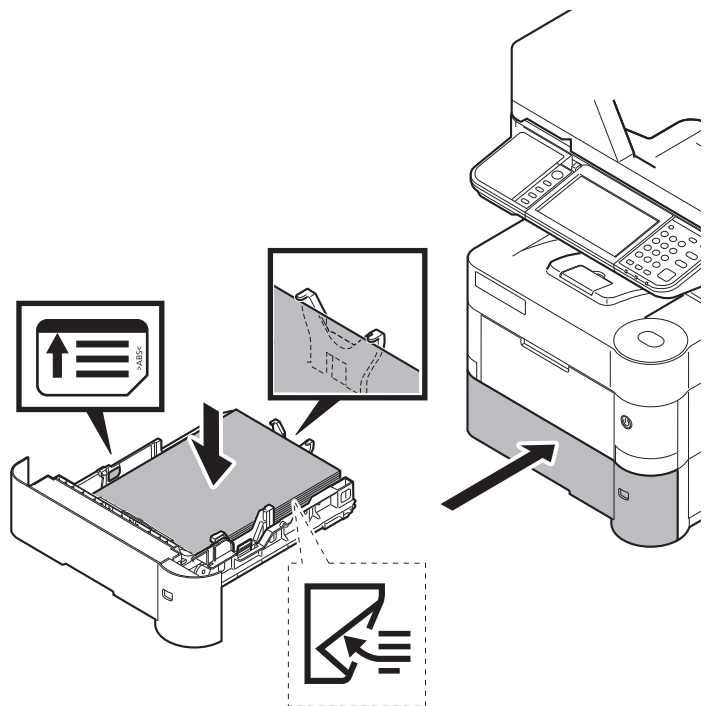

Figure 1-2-19

Replace the operation panel sheet (except 240V AC model)

1. Slide the right operation lid and the left operation lid.
2. Remove the their lids.

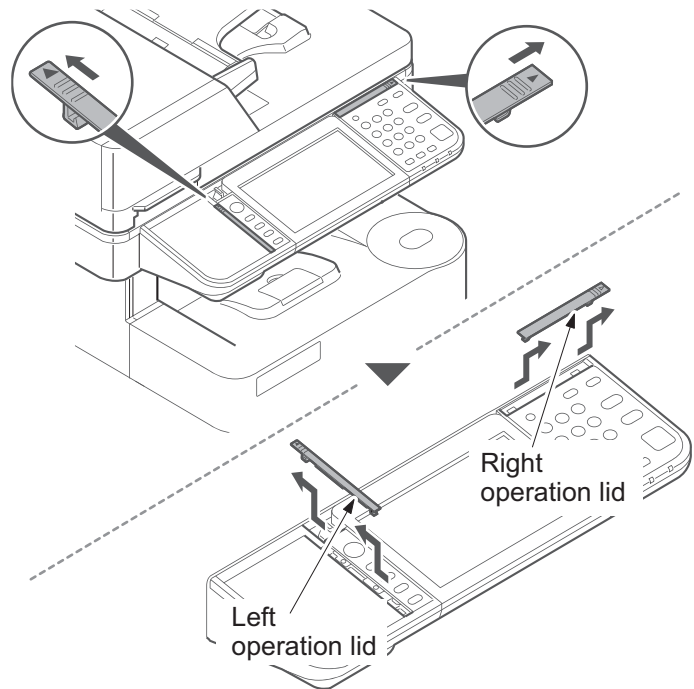

Figure 1-2-20

3. Remove the operation panel cover.
4. Replace it to the operation panel sheet of the corresponding language.
5. Refit all the removed parts.

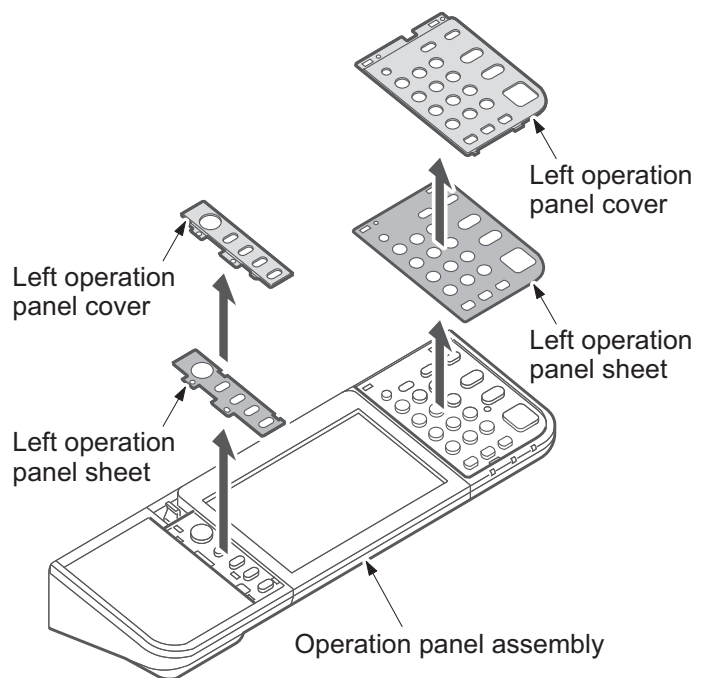

Figure 1-2-21

Setting of the fuser pressure release lever (40 ppm model only)

1. Open the rear cover.
2. Push the release lever down for changing the lever position to a normal position from a shipment position.
3. Close the rear cover.

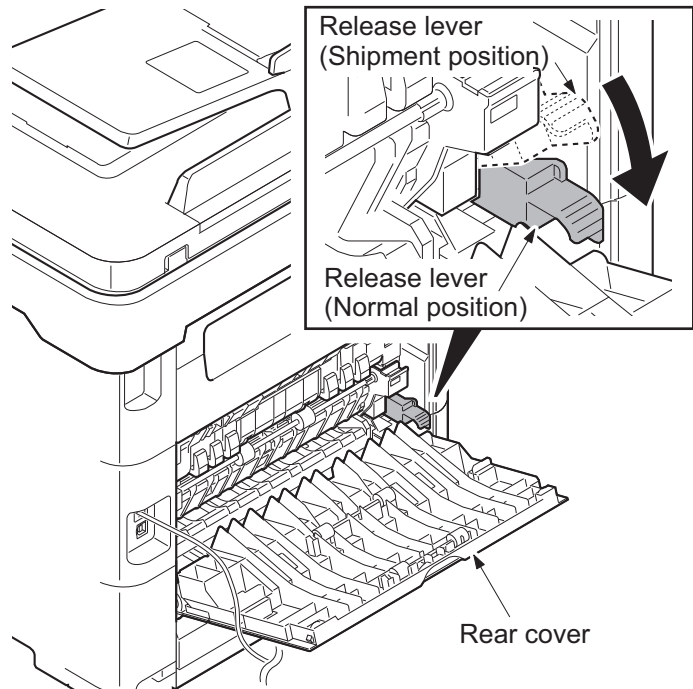

Figure 1-2-22

Connecting the power cord

1. Open the rear cover.
2. Remove the inlet cover.
3. Connect the power cord to the main unit and the wall outlet.
4. Refit the inlet cover.
5. Close the rear cover.

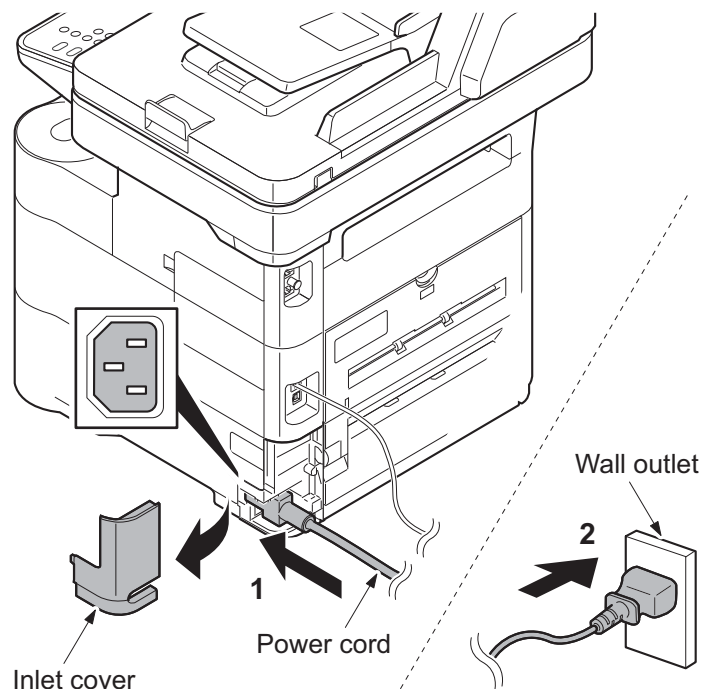

Figure 1-2-23

Power on

1. Turn the power switch on.

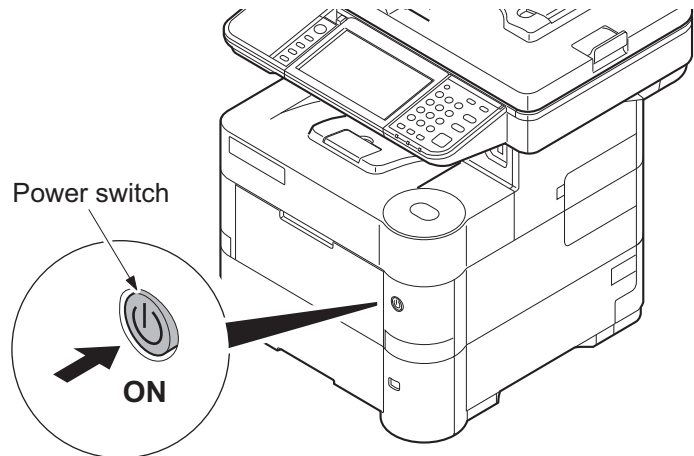

Figure 1-2-24

- *: At the first time when turning on the power switch, the machine runs Startup Wizard to set the following:
1. Language 2. Date and Time 3. Network
- Follow the instructions on the operation panel.

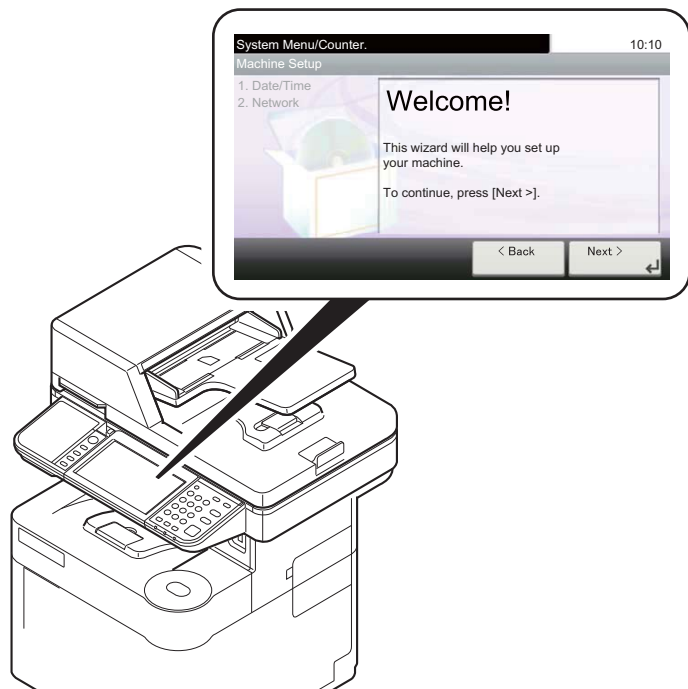

Figure 1-2-25

Installing software

1. Install appropriate software on your PC from the included Product Library disc if you want to use the printer function of this machine or perform TWAIN / WIA transmission from your PC. (Reference of an operation guide)

* : Perform the high altitude settings when a leakage is developed on images in a high altitude installation such as in Mexico City (see page P.1-3-109).

Output an own-status report (maintenance item U000)

*: For service setup only

1. Enter the maintenance mode by entering 10871087 using the numeric keys.
2. Enter 000 using the numeric keys and press the start key.
3. Select Maintenance and press the start key to output a list of the current settings of the maintenance items.
4. Press the stop key to exit.

Clearing the counter (maintenance item U927)

*: For service setup only

1. Enter 927 using the numeric keys and press the start key.
2. Select [Excute].
3. Press the start key. The counter is cleared.
4. Press the stop key to exit.

Setting the country code (maintenance item U600) (with Fax model only)

*: For service setup only

1. Enter 600 using the numeric keys and press the start key.
2. Select [Country Code] and enter a destination code using the numeric keys.
(refer to the destination code list :P.1-3-63)
3. Press the start key. Data initialization starts.
4. Press the stop key to exit.

Exit maintenance mode

*: For service setup only

1. Enter 001 using the numeric keys and press the start key. The machine exits the maintenance mode.

Make test copies

1. Place an original and make test copies.

Completion of machine installation

1-2-3 Installing an accessories option

(1) Installing the SD card.

Procedure

1. Open the rear cover.
2. Remove the upper interface cover and the lower interface cover.

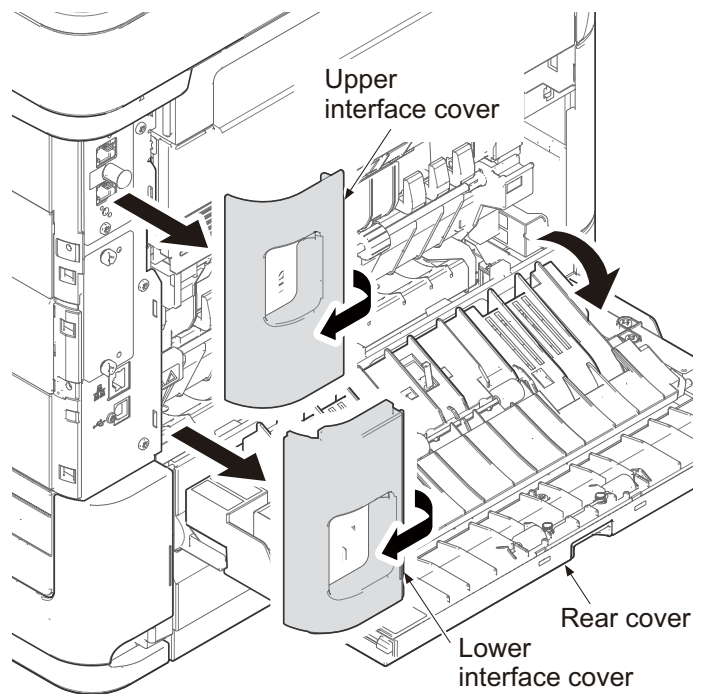

Figure 1-2-26

3. Remove two screws and the Slot cover.
4. Insert the SD card in the SD card slot.
5. Refit all the removed parts.

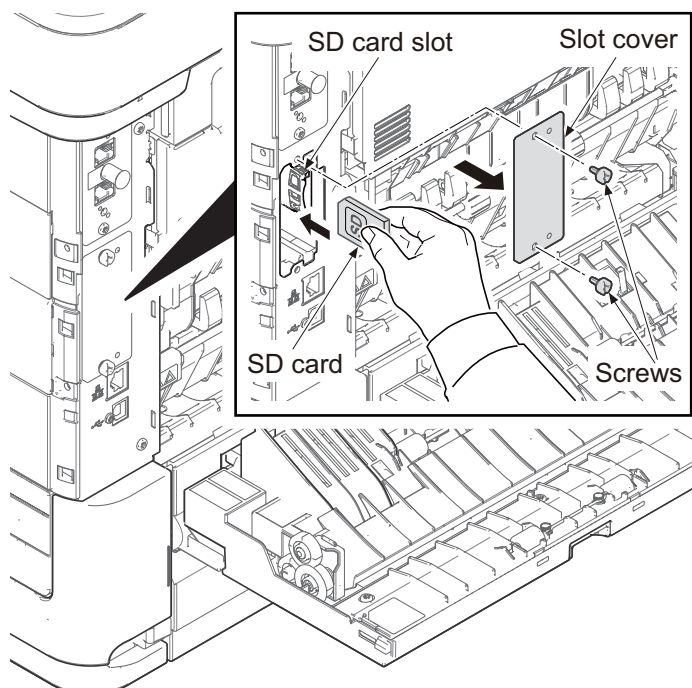

Figure 1-2-27

(2) Installing the expansion memory

Procedure

1. Remove the controller cover.

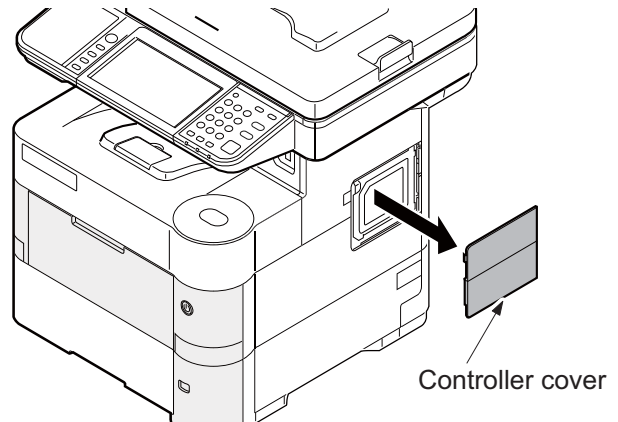

Figure 1-2-28

2. Open the shield plate by rotating.

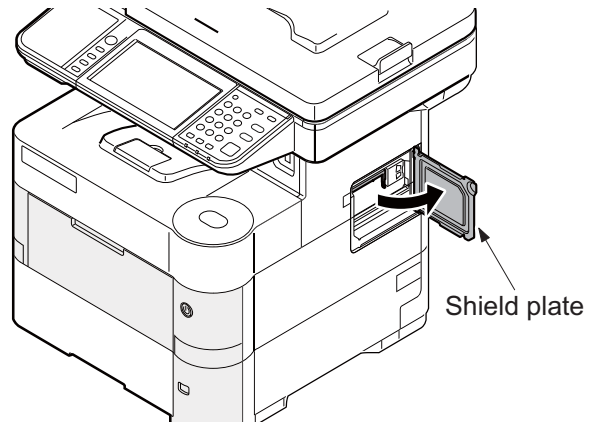

Figure 1-2-29

3. Insert the expansion memory into the memory socket so that the notches on the memory align with the corresponding protrusions in the slot.
4. Close the shield plate.
5. Refit the controller cover.

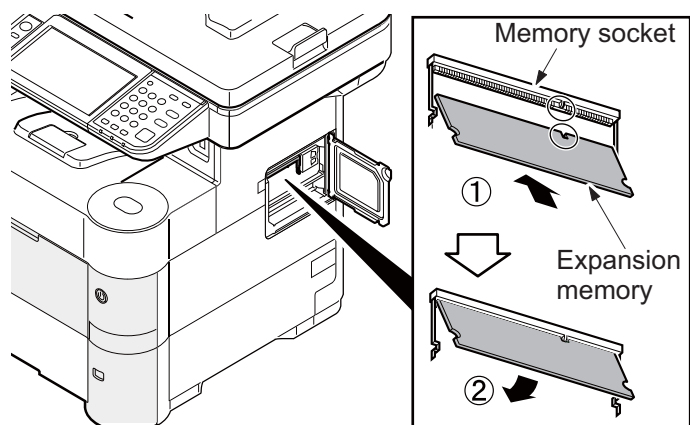

Figure 1-2-30

(3) Installing the HD-6/HD-7(SSD)

Procedure

1. It checks that the indicator has disappeared.
2. Turn the power switch off.
3. Unplug the power cord from the wall outlet.

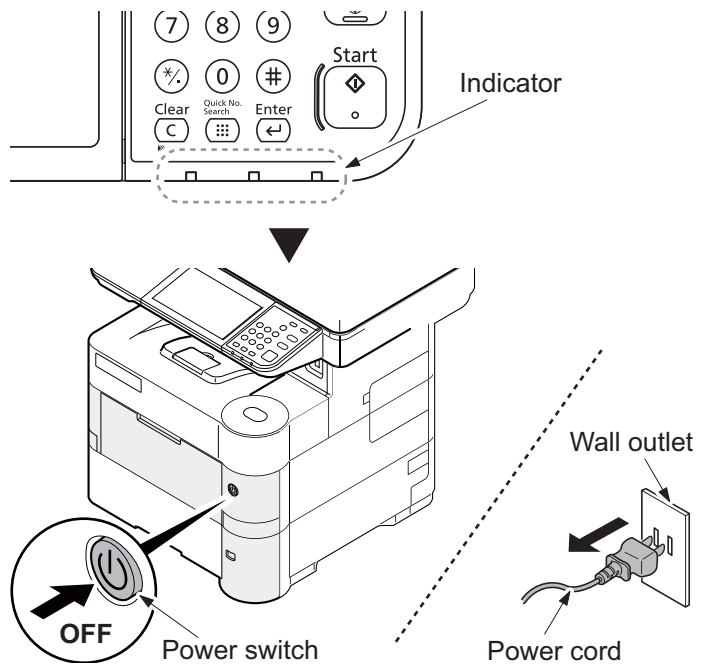

Figure 1-2-31

4. Open the rear cover.
5. Remove two interface covers from the main unit.

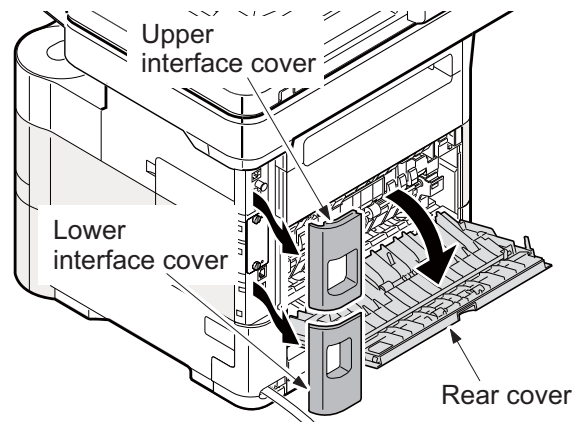

Figure 1-2-32

6. Remove two screws and the option slot cover.

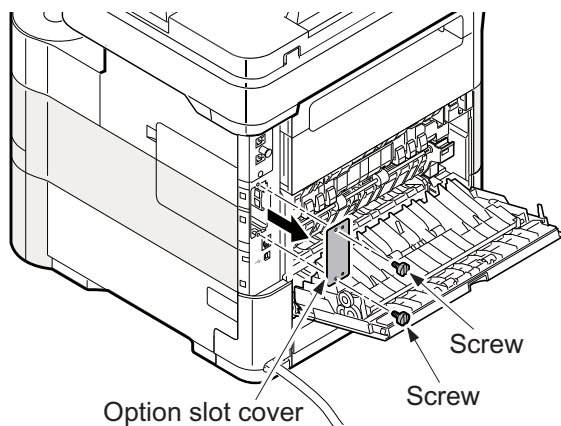

Figure 1-2-33

7. Insert the SSD in an option slot.
8. Fix the SSD with using two screws to main unit.

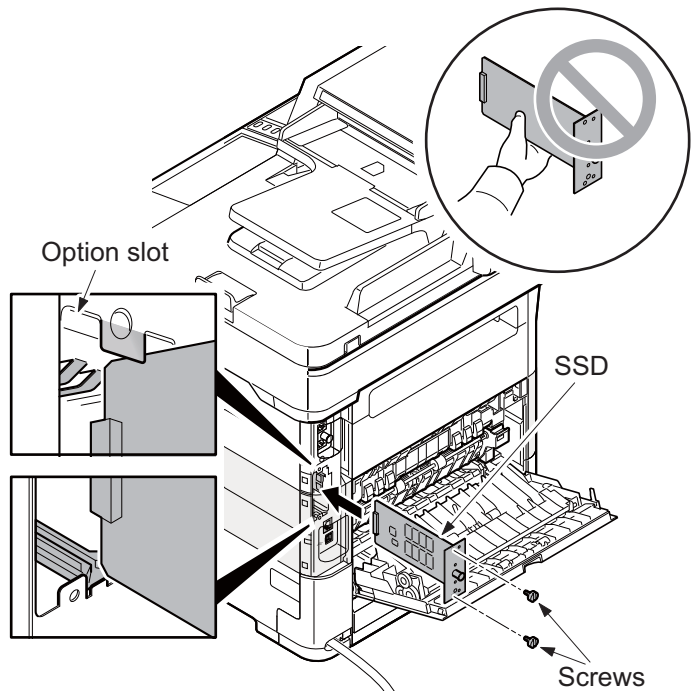

Figure 1-2-34

9. Refit two interface covers.
10. Close the rear cover.

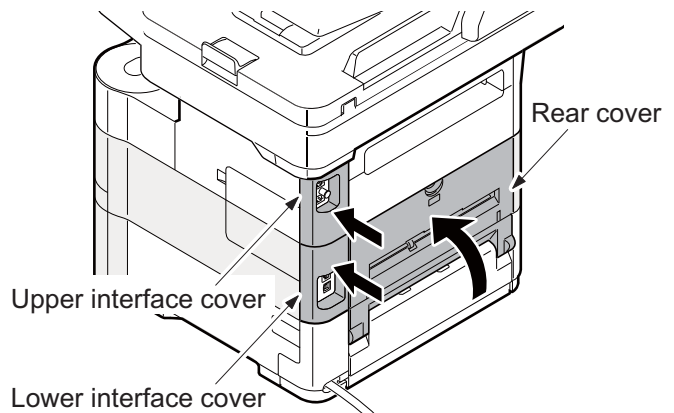

Figure 1-2-35

11. Connect the plug of the power cord to a wall outlet.
12. Turn the power switch on.

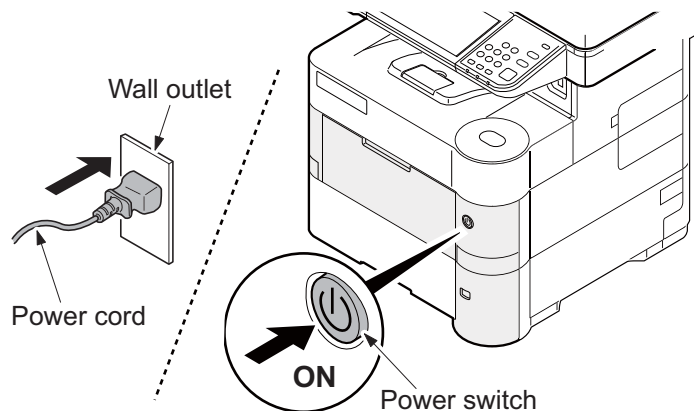

Figure 1-2-36

(4) Installing the IC card reader holder (HyPAS model only)

IC card reader holder installation requires the following parts):

Parts	Quantity	Part.No.
IC card reader holder 10	1	1702P60UN1

Supplied parts of IC card reader holder 10 (1702P60UN1):

Parts	Quantity	Part.No.
IC card reader holder	1	-
Label	1	-
M3 ×8 bind screw	1	-

Procedure

1. Mount the IC card reader to the IC card reader holder.

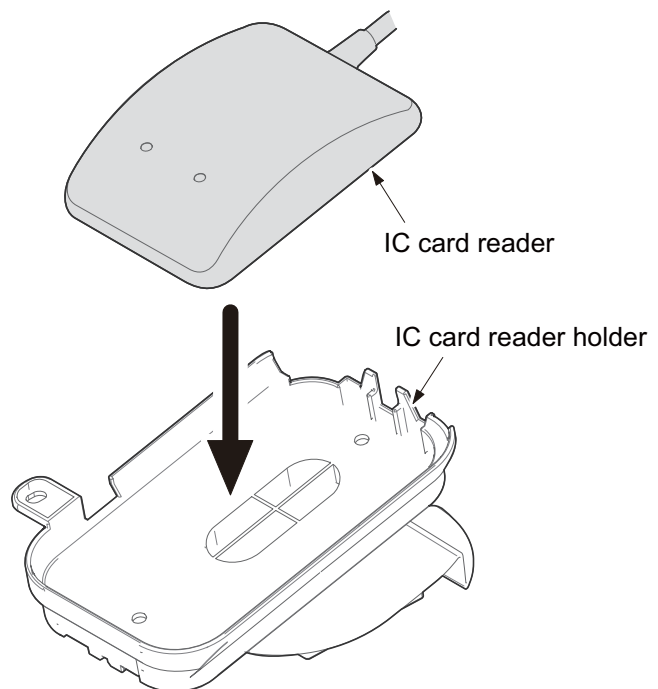

Figure 1-2-37

- Route the USB cable from the IC card reader through the IC card reader holder ribs, wind around its back and route through another rib.

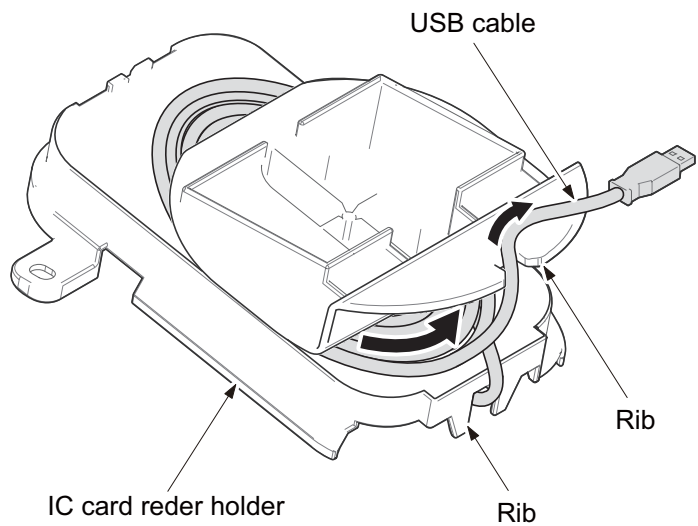

Figure 1-2-38

- Slide the left operation lid and then remove it.
- Remove the left operation panel cover and the left operation panel sheet.
- Remove the IC card reader cover.

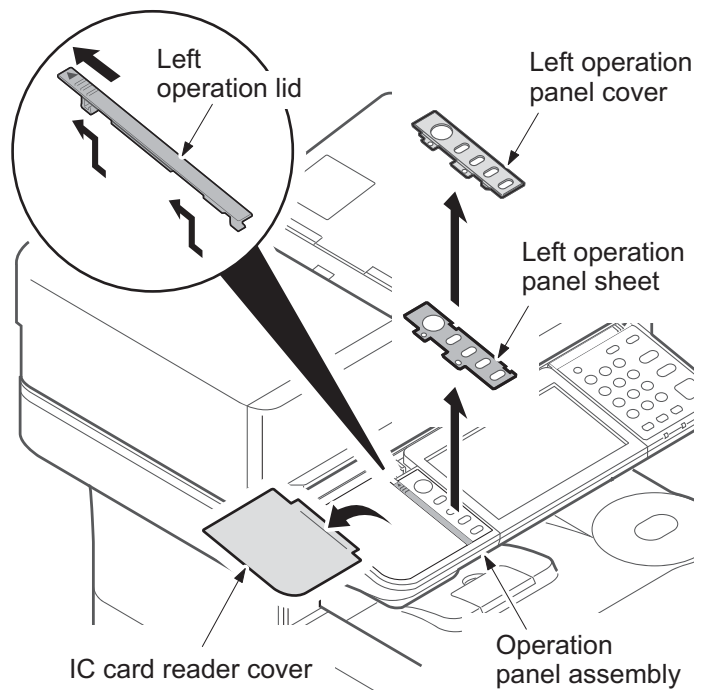

Figure 1-2-39

6. Connect the USB connector to the USB interface slot.
7. Fix the IC card reader holder using a screw.
8. Refit all the removed parts.

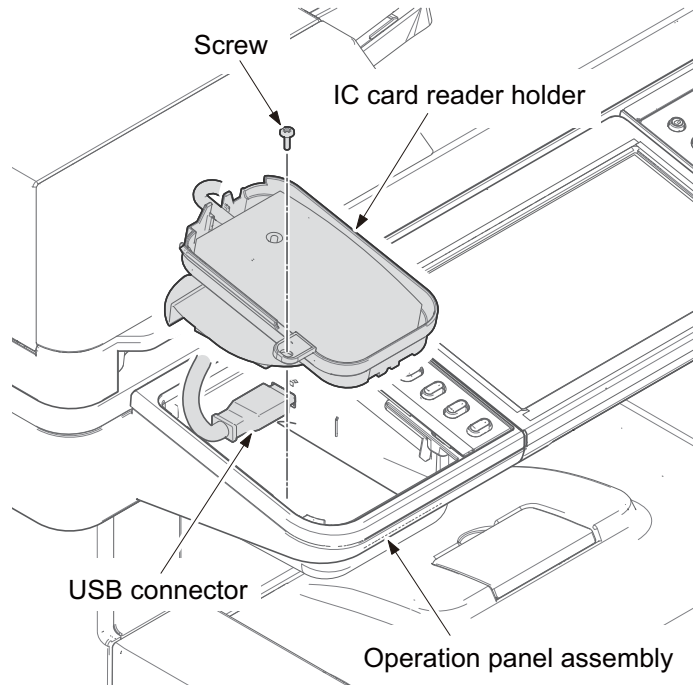

Figure 1-2-40

9. Affix a label on the IC card reader cover aligning it with the positioning mark.

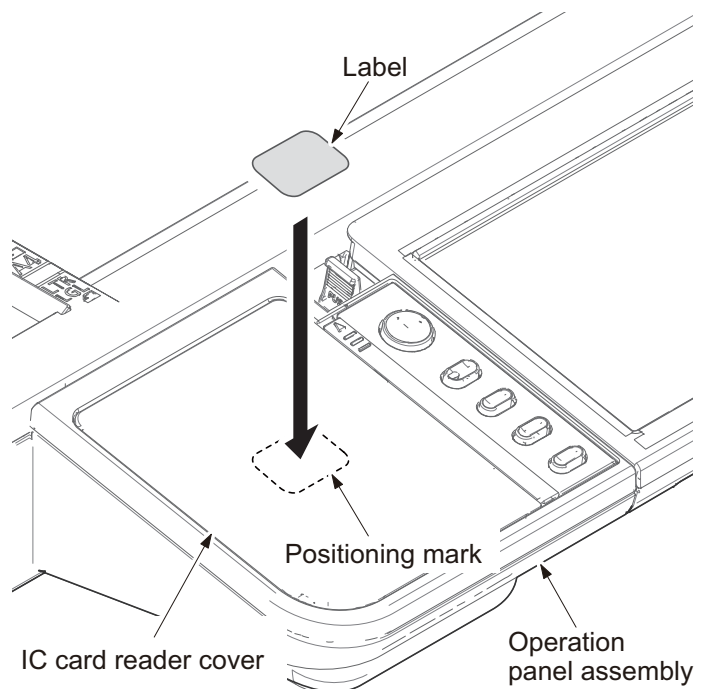

Figure 1-2-41

Enabling IC Card Authentication

Precautions

To install the optional function, you need the License Key. Please access the designated website of your dealer or service representative, and register "Machine No." indicated on your machine and "Product ID" indicated on the License Certificate supplied with the product to issue the License Key.

1. Turn the main power switch on.
2. Press the System Menu key and then press [System/Network].
If user login administration is disabled, the user authentication screen appears.
Enter your login user name and password and then press [Login]. For this, you need to log in with administrator privileges.
3. Press [Next] of Optional Function.
4. Select CARD AUTHENTICATION KIT(B) and press [Activate].
5. The License Key entry screen is displayed.
Enter the License Key using the numeric keys and press [Official].
6. Confirm the product name CARD AUTHENTICATION KIT(B) and press [Yes].
7. To use a SSFC card, run maintenance mode U222 and set SSFC.

*: When the machine has entered sleep mode with Energy Saver ON, IC cards can not be recognized by the Card reader, since it does not wake from sleep mode. To enable the IC Card Reader in Sleep Mode, refer to the Operation Guide to change the Sleep level to OFF in the Sleep Rules at the Date/Timer/Energy Saver section of the System Menu.

This setting is not necessary when the optional network interface kit is installed.

This page is intentionally left blank.

1-3-1 Maintenance Mode

The machine is equipped with a maintenance function which can be used to maintain and service the machine.

(1) Executing a maintenance item

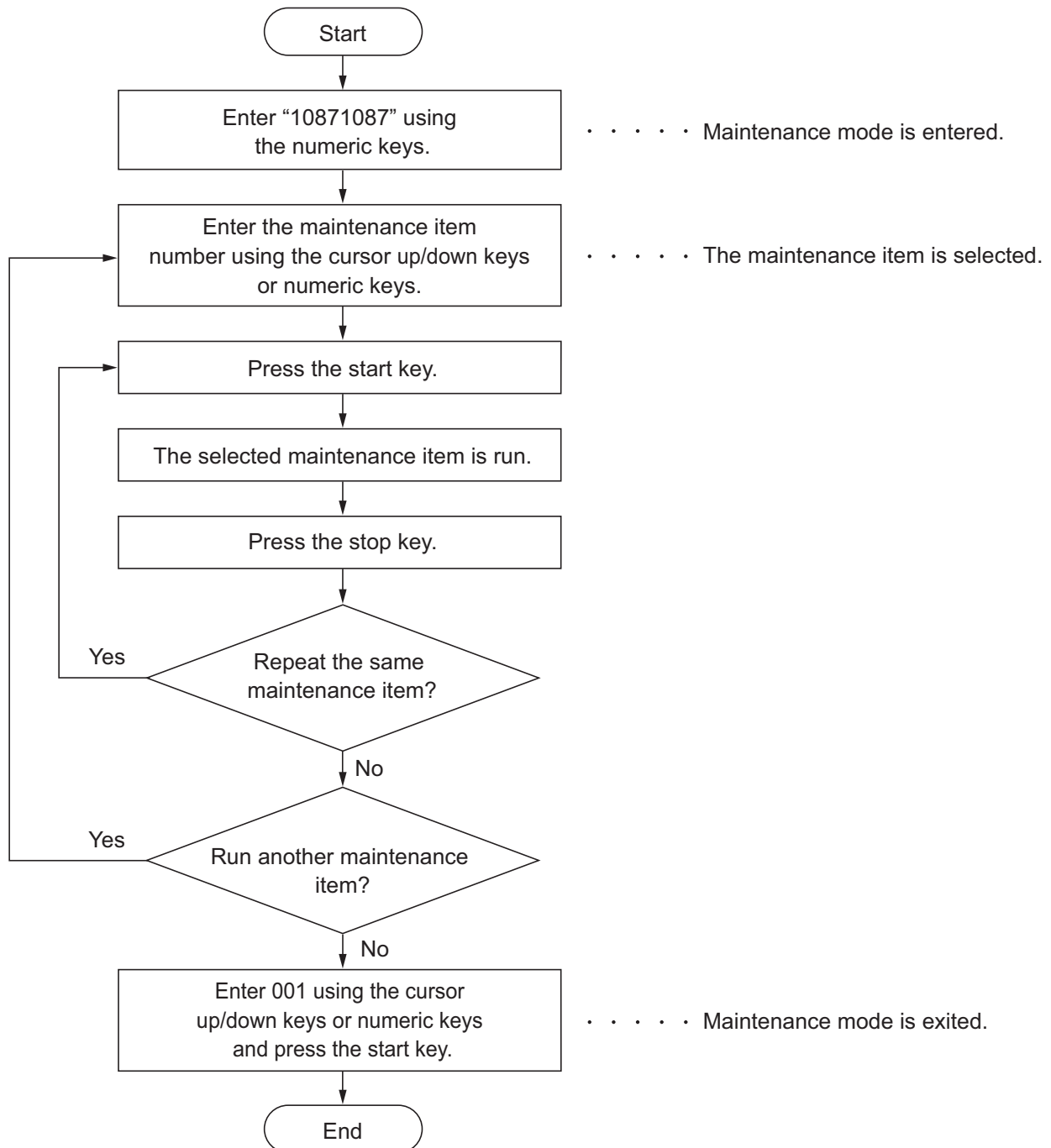

(2) Maintenance modes item list

Section	Item No.	Content of maintenance item	Summary
General	U000	Mainte Report	It outputs to printing of each report, and USB.
	U001	Exit Mainte	Maintenance mode is canceled.
	U002	Set Factory Def	A factory-shipments setup (initialization) and packing mode are set up.
	U004	Machine No.	The display of machine serial No. and serial No. acquired from the engine at the time of substrate exchange are copied to MAIN backup.
	U010	Set Mainte ID	The brittleness of a security function is prevented by changing ID.
	U019	Firm Version	Each soft version is displayed.
Initializa- tion	U021	Init memory	The backup data except an adjustment value is initialized.
	U025	Firm Update(S)	Only an administrator can be made to do FW-UPDATE.
Drive, paper feed and paper conveying system	U034	Adj Paper Timing	The timing data of leading edge and the center line adjustment data in a paper standard are set up.
Optical	U065	Adj Scn	The degrees of the main and auxiliary scanning direction at the time of table reading are adjusted.
	U066	Table Timing	The timing of leading edge and trailing edge at the time of table reading are adjusted.
	U067	Table Center	The position of main scanning direction at the time of table reading are adjusted.
	U068	DP Scn Start Pos	The timing of starting position at the time of DP reading are adjusted.
	U070	Adj DP Motor	The degree of auxiliary scanning direction are adjusted by adjusting the speed of time of DP reading.
	U071	DP Timing	The timing of DP reading are adjusted.
	U072	DP Center	The center line of DP reading image are adjusted.
Developer	U130	Set Toner Install	Installation of a toner is performed.
	U147	Set Toner Apply	Same as the above

Section	Item No.	Content of maintenance item	Summary
Operation panel and support equipment	U201	Init Touch Panel (HyPAS only)	It adjusts, when the detection position of the touch panel has shifted.
	U203	Chk DP Ope	Each simulation is operated with DP simple substance.
	U207	Chk Panel Key	An operation key is checked.
	U222	Set IC Card Type	Sets the type of IC card.
Mode setting	U250	Mnt Cnt Pre-set	The preset value (number of sheets) of a maintenance cycle is set up.
	U251	Clr Mnt Cnt	A maintenance counter are displayed and the data are changed.
	U252	Set Dest	The destination is set up.
	U253	Sel D/S Count	The copy count methods (double count), such as a total counter, are set up.
	U260	Set Count Mode	The timing (feeding or ejection) which a total count etc. count is changed.
	U265	Set Model Dest	The consecutive numbers of the OEM are set up.
	U285	Set Svc Sts Page	A coverage report output (permission or failure) is changed.
	U332	Adj Calc Rate	The coefficient of the fixed form external application paper to A4 (or 11x8.5) paper is set up.
	U339	Chk Drum Heater	The display existence of a drum heater setup of a system menu is changed.
	U345	Set Mnt Time Disp	The number of sheets of a check close display is set up.
	U346	Slct Sleep Mode	A BAM conformity country is set up.
Image processing	U402	Adjust Margin	The space of a leading edge, AC side, and a trailing edge is adjusted.
	U403	Scan Margin Tbl	The margin of reading data is adjusted by picture reading by a scanner.
	U404	Scan Margin DP	The margin of reading data is adjusted by picture reading by DP
	U411	Auto Adj Scn	A scanner and DP are adjusted automatically.
	U425	Set Target	The target value of an adjustment original is set up.
Network	U520	Set TDRS	Perform TDRS settings and information views.

Section	Item No.	Content of maintenance item	Summary
FAX	U600	Init All Data	According to the country code and the OEM code which were inputted, all the softswitches, backup data, and an image memory are initialized.
	U601	Init Keep Data	Softswitches other than machine data are initialized according to the country code and the OEM code which were inputted.
	U603	User Data 1	A circuit class is set up.
	U604	User Data 2	The number of times of a bell at the time of a FAX/TEL automatic change is set up.
	U605	Clr Data	All the data of a communication history and a protocol list is cleared.
	U610	System Setting 1	The number of waste lines at the time of degree, the number of waste lines at the time of automatic reduction, and the number of waste lines at the time of automatic reduction (A4, LETTER) are set up.
	U611	System Setting 2	The number of adjustment lines at the time of automatic reduction and the number of adjustment lines at the time of automatic reduction (A4, LETTER) are set up.
	U612	System Setting 3	An automatic reduction setup at the time of receiving a long manuscript is carried out. The automatic output of a protocol list is set up.
	U620	FAX System	Remote change mode (a continued type / one shot type) is set up.
	U625	Set Comm	The interval of a redial and the number of times are set up.
	U630	Comm Ctrl 1	Transmitting start speed and receiving ability speed are set up. The measure against an echo at the time of transmission/reception is set up.
	U631	Comm Ctrl 2	It is set up whether transmission and reception can be performed in ECM. The frequency of CED is set up.
	U632	Comm Ctrl 3	It is set up whether sending out after bit33 of a DIS/DTC signal is performed. The number of times of CNG detection at the time of a FAX/TEL automatic change is set up.

Section	Item No.	Content of maintenance item	Summary
FAX	U633	Comm Ctrl 4	<p>It is whether communication by V.34 is permitted, and transmission and reception -- it sets up individually.</p> <p>It is set up whether 3429 Hz in V.34 symbol speed is used.</p> <p>The number of times of reception of a DIS signal is set up.</p> <p>A RTN signal sending-out judging standard (rate of an error line) is set up.</p>
	U634	Comm Ctrl 5	The judging standard of TCF is set up.
	U640	Comm Time 1	<p>The detection time at the time of one shot selection of a remote change is set up.</p> <p>The detection time at the time of the continuous selection of a remote change is set up.</p>
	U641	Comm Time 2	The timeout time at the time of FAX communication is set up.
	U650	Modem 1	<p>G3 cable equalizer is set up.</p> <p>A modem disregard level is set up.</p>
	U651	Modem 2	A modem outgoing level is set up.
	U660	Set Calls	A setup relevant to NCU (network control unit) is carried out.
	U670	Output List	The list of the data relevant to facsimile communication is outputted.
	U695	Custom FAX Func	<p>FAX package transmission is set up.</p> <p>The output priority at the time of receiving A5 size is set up.</p>
	U699	Set Soft SW	A setup of the softswitch on a FAX control circuit board is set up individually.

Section	Item No.	Content of maintenance item	Summary
Others	U901	Clr Paper FD Cnt	The feed number of sheets count according to feed stage are displayed and cleared.
	U905	Option Cnt	The each counter of DP and a sorter are displayed and cleared.
	U910	Clr Coverage Dat	All the data of a black ratio data value is cleared.
	U917	R/W Bkup Data	Reading/writing of backup data
	U920	Chg Cnt	Displaying and clearing of copy counts.
	U927	Clr Chg/Life Cnt	The count for fee collection and a life count are cleared.
	U928	Life Cnt	A machine life counter are displayed and cleared.
	U969	Toner Area Code	The area code for toner container discernment set up for every machine is referred to.
	U977	Data capture mode	Store the print data sent to the machine into USB memory.
	U995	Mem Data Indi	Displays the memory data.

(3) Contents of the maintenance mode items

U000	Mainte Report
-------------	----------------------

Description

Outputs lists of the current settings of the maintenance items and paper jam and service call occurrences. Outputs the event log. Also sends output data to the SD card.

Purpose

To check the current setting of the maintenance items, or paper jam or service call occurrences. Before initializing or replacing the backup RAM, output a list of the current settings of the maintenance items to reenter the settings after initialization or replacement.

Method

1. Press the start key.
2. Select the item to be output.

Display	Output list
Maintenance	Output the maintenance report.
User Status	Output the user status report.
Service Status	Output the service status report.
Event	Output the event report.
NW Status	Out put the network status report
All	Output the All report.

3. Press the start key. A list is output.

* : When A4/Letter paper is available, a report of this size is output. If not, specify the paper feed location.

Method: Send to the USB memory

1. Press the start key.
2. Insert USB memory in UBS memory slot.
3. Select the item to be send.
4. Select [USB(Text)] or [USB(HTML)].

Display	Output list
Print	A report is printed.
USB(Text)	It outputs to USB memory in Text form.
USB(HTML)	It outputs to USB memory in HTML form.

5. Press the start key.
Output will be sent to the USB memory.

Completion

Press the stop key. The screen for selecting a maintenance item No. is displayed.

[Event log]

Event Log

MFP (2) 2013/02/19 15:15

ECOSYS M3550idn

(1) Firmware version 2NM_2000.000.000 2013.02.19 (3) [XXXXXXXX] (4) [XXXXXXXX] (5) [XXXXXXXX]

(7) Paper Jam Log

#	Count.	Event Descriptions	Date and Time
12	5555555	0501.01.08.01.00	2013/02/12 17:30
11	4444444	4002.01.08.01.00	2013/02/12 17:30
10	3333333	0501.01.08.01.00	2013/02/12 17:30
9	2222222	4002.01.08.01.00	2013/02/12 17:30
8	1111111	0501.01.08.01.00	2013/02/12 17:30
7	9999999	4002.01.08.01.00	2013/02/12 17:30
6	8888888	0501.01.08.01.00	2013/02/12 17:30
5	7777777	4002.01.08.01.00	2013/02/12 17:30
4	6666666	0501.01.08.01.00	2013/02/12 17:30
3	5555555	4002.01.08.01.00	2013/02/12 17:30
2	4444444	0501.01.08.01.00	2013/02/12 17:30
1	1	4002.01.08.01.00	2013/02/12 17:30

(11) Counter Log

(f) J0000:	0	J4209:	0
J0100:	1	J4211:	1
J0101:	11	J4212:	11
J0104:	222	J4213:	222
J0105:	1	(g) C0000:	0
J0106:	1	C0001:	1
J0107:	1	C0002:	2
J0110:	1	C0003:	3
J0111:	1	C0004:	4
J0211:	1	C0005:	5
J0212:	1	C0006:	6
J0213:	999	C0007:	7
J0501:	1	C0008:	8
J0502:	1	C0009:	9
J0503:	1	C0010:	10
J0504:	1	C0011:	11
J0508:	1	C0012:	12
J0509:	1	C0013:	13
J0512:	1	C0014:	14
J0513:	1	C0015:	15
J0514:	1	C0016:	16
J0518:	1	C0017:	17
J0519:	1	C0018:	18
J1403:	1	C0019:	19
J1404:	1	C0020:	20
J1413:	1	C0021:	21
J1414:	1	C0022:	22
J1604:	1	C0023:	23
J1614:	1	(h) T00:	10
J4002:	1	M00:	20
J4003:	1	M02:	30
J4012:	1		
J4013:	1		
J4014:	1		
J4201:	1		
J4202:	1		
J4203:	1		
J4204:	1		
J4208:	1		

(8) Service Call Log

#	Count.	Service Code	Data and Time
8	1111111	01.6000	2013/02/12 17:30
7	9999999	01.2100	2013/02/12 17:30
6	8888888	01.4000	2013/02/12 17:30
5	7777777	01.6000	2013/02/12 17:30
4	6666666	01.2100	2013/02/12 17:30
3	5555555	01.4000	2013/02/12 17:30
2	4444444	01.6000	2013/02/12 17:30
1	1	01.2100	2013/02/12 17:30

(9) Maintenance Log

#	Count.	Item.	Data and Time
7	9999999	01.21	2013/02/12 17:30
6	8888888	01.40	2013/02/12 17:30
5	7777777	01.60	2013/02/12 17:30
4	6666666	01.21	2013/02/12 17:30
3	5555555	01.40	2013/02/12 17:30
2	4444444	01.60	2013/02/12 17:30
1	1	01.21	2013/02/12 17:30

(10) Unknown toner Log

#	Count.	Item.	Data and Time
5	1111111	01.00	2013/02/12 17:30
4	9999999	01.00	2013/02/12 17:30
3	8888888	01.00	2013/02/12 17:30
2	7777777	01.00	2013/02/12 17:30
1	6666666	01.00	2013/02/12 17:30

(6) [XXXXXXXXXXXXXXXXXXXX]

Figure 1-3-1

[Detail of event log]

No.	Items	Description		
(1)	System version			
(2)	System date			
(3)	Engine software version			
(4)	Engine boot software version			
(5)	Operation panel software version			
(6)	Machine serial number			
(7)	Paper Jam Log	#	Count.	Event
		Remembers 1 to 16 of occurrence. If the occurrence of the previous paper jam is less than 16, all of the paper jams are logged. When the occurrence exceeds 16, the oldest occurrence is removed.	The total page count at the time of the paper jam.	Log code (hexadecimal, 5 categories) (a) Cause of a paper jam (b) Paper source (c) Paper size (d) Paper type (e) Paper eject
		(a) Cause of paper jam (Hexadecimal)		
		For details on the case of paper jam, refer to Paper Misfeed Detection. (See P.1-4-2)		
		(b) Detail of paper source (Hexadecimal)		
		00: MP tray 01: Cassette 1 02: Cassette 2 (paper feeder) 03: Cassette 3 (paper feeder) 04: Cassette 4 (paper feeder) 05 to 09: Reserved		
		(c) Detail of paper size (Hexadecimal)		
00: (Not specified) 01: Monarch 02: Business 03: International DL 04: International C5 05: Executive 06: Letter-R 08: Letter-E 07: Legal 08: A4R 88: A4E 09: B5R 89: B5E 0A: A3	0B: B4 0C: Ledger 0D: A5R 0E: A6 0F: B6 10: Commercial #9 11: Commercial #6 12: ISO B5 13: Custom size 1E: C4 1F: Postcard 20: Reply-paid postcard 21: Oficio II	22: Special 1 23: Special 2 24: A3 wide 25: Ledger wide 26: Full bleed paper (12 x 8) 27: 8K 28: 16K-R A8: 16K-E 32: Statement-R B2: Statement-E 33: Folio 34: Western type 2 35: Western type 4		

No.	Items	Description		
(7) cont.	Paper Jam Log	(d) Detail of paper type (Hexadecimal)		
		01: Plain 02: Transparency 03: Preprinted 04: Labels 05: Bond 06: Recycled 07: Vellum 08: Rough 09: Letterhead	0A: Color 0B: Prepunched 0C: Envelope 0D: Cardstock 0E: Coated 0F: 2nd side 10: Media 16 11: High quality	15: Custom 1 16: Custom 2 17: Custom 3 18: Custom 4 19: Custom 5 1A: Custom 6 1B: Custom 7 1C: Custom 8
(8)	Service Call Log	#	Count.	Service Code
		Remembers 1 to 8 of occurrence of self diagnostics error. If the occurrence of the previous diagnostics error is less than 8, all of the diagnostics errors are logged.	The total page count at the time of the self diagnostics error.	Self diagnostic error code (See P.1-4-20) Example: 01.6000 01: Self diagnostic error 6000: Self diagnostic error code number
(9)	Maintenance Log	#	Count.	item
		Remembers 1 to 8 of occurrence of replacement. If the occurrence of the previous replacement of toner container is less than 8, all of the occurrences of replacement are logged.	The total page count at the time of the replacement of the toner container. * :The toner replacement log is triggered by toner empty. This record may contain such a reference as the toner container is inserted twice or a used toner container is inserted.	Code of maintenance replacing item (1 byte, 2 categories) First byte (Replacing item) 01: Toner container Second byte (Type of replacing item) 00: Black First byte (Replacing item) 02: Maintenance kit Second byte (Type of replacing item) 01: MK-3100/MK-3102/ MK-3104 (40ppm model only) MK-3130/MK-3132/ MK-3134 (50/60ppm model only)

No.	Items	Description		
(10)	Unknown Toner Log	#	Count.	item
		Remembers 1 to 5 of occurrence of unknown toner detection. If the occurrence of the previous unknown toner detection is less than 5, all of the unknown toner detection are logged.	The total page count at the time of the toner empty error with using an unknown toner container.	Unknown toner log code (1 byte, 2 categories) First byte 01: Toner container (Fixed) Second byte 00: Black
(11)	Counter Log Comprised of three log counters including paper jams, self diagnostics errors, and replacement of the toner container.	(f) Paper jam	(g) Self diagnostic error	(h) Maintenance item replacing
		Indicates the log counter of paper jams depending on location. Refer to Paper Jam Log. All instances including those are not occurred are displayed.	Indicates the log counter of self diagnostics errors depending on cause. Example: C6000: 4 Self diagnostics error 6000 has happened four times.	Indicates the log counter depending on the maintenance item for maintenance. T: Toner container 00: Black M: Maintenance kit 01: MK-3100/MK-3102/ MK-3104 (40ppm model only) MK-3130/MK-3132/ MK-3134 (50/60ppm model only) Example: T00: 1 The toner container has been replaced once. * :The toner replacement log is triggered by toner empty. This record may contain such a reference as the toner container is inserted twice or a used toner container is inserted.

[Service status page]

Service Status Page

MFP (2) 2013/02/19 15:15

(1) Firmware version 2NM_2000.000.000 2013.02.19 (3) [XXXXXXXX] (4) [XXXXXXXX] (5) [XXXXXXXX]

Controller Information

Memory status		FAX Information	
(7) Standard Size	1.0 GB	(32) Rings (Normal)	3
(8) Option Slot	1.0 GB	(33) Rings (FAX/TEL)	3
(9) Total Size	2.0 GB	(34) Rings (TAD)	3
Time		(35) FRPO Status	
(10) Local Time Zone	+01:00 Amsterdam	User Top Margin	A1+A2/100 0.00
(11) Date and Time	06/04/2010 12:00	User Left Margin	A3+A4/100 0.00
(12) Time Server	10.183.53.13		
Installed Options			
(13) Paper Feeder2:	Not Installed		
(14) Paper Feeder3:	Installed		
(15) Paper Feeder4:	Not Installed		
(16) Paper Feeder5:	Not Installed		
(17) Memory Card	Installed		
(18) SSD	Installed		
(19) Card Authentication Kit (B)	Installed		
(20) Security Kit (E)	Installed	PDF mode	Y5 00
(21) UG-33	Installed		
(22) USB Keyboard	Connected		
(23) USB Keyboard Type	US-English		
Print Settings		RP Code	
(24) MP Tray Priority	Auto Feed	(36) 1234 5678 9012	
Print Coverage		(37) 5678 9012 3456	
(25) Average(%) / Usage Page(A4/Letter Conversion)		(38) 9012 3456 7890	
(26) Total		(39) 3456 7890 1234	
K: 1.10 / 1111111.11			
(27) Copy			
K: 1.10 / 1111111.11			
(28) Printer			
K: 1.10 / 1111111.11			
(29) FAX			
K: 1.10 / 1111111.11			
(30) Period (27/10/2009 - 03/11/2009 08:40)			
(31) Last Page (%) 1.00			

1 (6) [XXXXXXXXXXXXXXXXXXXX]

Figure 1-3-2

Service Status Page

MFP 2013/02/19 15:15

Firmware version 2NM_2000.000.000 2013.02.19 [XXXXXXXX] [XXXXXXXX] [XXXXXXXX]

Engine Information

(40) NVRAM Version _F1F31225_1F31225

(41) FAX Slot1

FAX BOOT Version 2NM_5000.001.001

FAX APL Version 2NM_5100.001.001

FAX IPL Version 2NM_5200.001.001

(42) MAC Address 00:C0:EE:D0:01:0D

(43) DP Counters

Total 1234

Send Information

(44) Date and Time 2013/02/19 15:30

(45) Address mail@bjd.ne.jp

1/2 **(46) (47)**

(48) 100/100

(49) 0/0/0/0/0/0/

(50) 0/0/0/0/0/0/

(51) 0/0/0/0/

(52) 0000000/0000000/0000000/0000000/0000000/0000000/0000000/0000000/

0000000/0000000/0000000/

F00/U00/0/0/0/0/27/10/abcde/1/0/1 **(53) (54) (55) (56) (57) (58) (59) (60) (61) (62) (63) (64)**

(65) 0000/0000/0000/0000/0000/0000/0000/0000/0000/0000/0000/0000/0000/0000/0000/

0000/0000/0000/0000/0000/0000/0000/0000/0000/

(66) 12345678/11223344/00001234abcd567800001234abcd5678/01234567890123456789012345678901/0008/00/07

(67) [[]][[]]

(68) [2NM_81BR.001.006]

(69) 0070107FE/0700FE00FE/00FE000100/00000000/

0/3/ **(70) (71)**

(72) 1/0/1/1/ 2010/12/15 12:34:56

1/5/ **(73) (74)**

(75) 1/

0/15:47 **(76) (77)**

(78) 1/

(79) ABCDEFGHIJKL/

2 [XXXXXXXXXXXXXXXXXXXX]

Figure 1-3-3

[Detail of service status page]

No.	Description	Supplement
(1)	Firmware version	-
(2)	System date	-
(3)	Engine soft version	-
(4)	Engine boot version	-
(5)	Operation panel mask version	-
(6)	Machine serial number	-
(7)	Standard memory size	-
(8)	Option Memory size	-
(9)	Total Memory Size	-
(10)	Local time zone	-
(11)	Report output date	Day/Month/Year hour:minute
(12)	NTP server name	-
(13)	Presence or absence of the optional paper feeder 2	Installed/Not Installed
(14)	Presence or absence of the optional paper feeder 3	Installed/Not Installed
(15)	Presence or absence of the optional paper feeder 4	Installed/Not Installed
(16)	Presence or absence of the optional paper feeder 5	Installed/Not Installed
(17)	Presence or absence of the optional memory card	Installed/Not Installed
(18)	Presence or absence of the SSD	Installed/Not Installed
(19)	Presence or absence of the optional card authentication kit	Installed/Not Installed/Trial
(20)	Presence or absence of the data security kit	Installed/Not Installed
(21)	Presence or absence of the UG-33	Installed/Not Installed/Trial
(22)	Presence or absence of the USB Keyboard	Connected/Not Connected
(23)	Type of the USB Keyboard	US-English/US-English with Euro
(24)	Setting of MP Tray Priority	Off (Paper handling basic motion) Auto feed (A priority setup with paper) Always (Fixed setup with paper)
(25)	Page of relation to the A4/Letter	* :Print Coverage provides a close-matching reference of toner consumption and will not match with the actual toner consumption.
(26)	Average coverage for total	Black
(27)	Average coverage for copy	Black

No.	Description	Supplement
(28)	Average coverage for printer	Black
(29)	Average coverage for fax	Black
(30)	Cleared date and output date	-
(31)	Coverage on the final output page	-
(32)	Number of rings	0 to 15
(33)	Number of rings before automatic switching	0 to 15
(34)	Number of rings before connecting to answering machine	0 to 15
(35)	FRPO setting	-
(36)	RP code	Code the engine software version and the date of update.
(37)	RP code	Code the main software version and the date of update.
(38)	RP code	Code the engine software version and the date of the previous update.
(39)	RP code	Code the main software version and the date of the previous update.
(40)	NV RAM version	<p>_ 1F3 1225 _ 1F3 1225 (a) (b) (c) (d) (e) (f)</p> <p>(a) Consistency of the present software version and the database _ (underscore): OK * (Asterisk): NG</p> <p>(b) Database version (c) The oldest time stamp of database version (d) Consistency of the present software version and the ME firmware version _ (underscore): OK * (Asterisk): NG</p> <p>(e) ME firmware version (f) The oldest time stamp of the ME database version Normal if (a) and (d) are underscored, and (b) and (e) are identical with (c) and (f).</p>
(41)	Fax firmware version	-
(42)	Mac address	-
(43)	DP Counter	-
(44)	The last sent date and time	-
(45)	Transmission address	-
(46)	Destination information	-
(47)	Area information	-
(48)	Margin settings	Top margin/Left margin
(49)	Top offset for each paper source	MP tray/Paper feeder 1/Paper feeder 2/ Paper feeder 3/Paper feeder 4/Duplex/Page rotation

No.	Description	Supplement	
(50)	Left offset for each paper source	MP tray/Paper feeder 1/Paper feeder 2/ Paper feeder 3/Paper feeder 4/Duplex/Page rotation	
(51)	L value settings	Top margin integer part / Top margin decimal part/ Left margin integer part / Left margin decimal part/	
(52)	Life counter (The first line)	Machine life/MP tray/Cassette/Paper feeder 1/ Paper feeder 2 /Paper feeder 3/Paper feeder 4/Duplex	
	Life counter (The second line)	Drum unit K/Developing unit K/ Maintenance kit	
(53)	Panel lock information	0: OFF/1: Partial lock/2: Full lock	
(54)	USB information	U00: Not installed/U01: Full speed/U02: Hi speed	
(55)	Paper handling information	0: Paper source unit select/1: Paper source unit	
(56)	Auto cassette change	0: OFF/ 1: ON	
(57)	Black and white printing double count mode	0: All single counts 3: Folio, Single count, Less than 330 mm (length)	
(58)	Billing counting timing	-	
(59)	Temperature (machine outside)	-	
(60)	Relative humidity (machine outside)	-	
(61)	Fixed assets number	-	
(62)	Job end judgment time-out time	-	
(63)	Job end detection mode	-	
(64)	Prescribe environment reset	0: Off 1: On	
(65)	Media type attributes 1 to 28 (Not used: 18, 19, 20) * : For details on settings, refer to "Prescribe Commands Reference Manual.	Weight settings 0: Light 1: Normal 1 2: Normal 2 3: Normal 3 4: Heavy 1 5: Heavy 2 6: Heavy 3 7: Extra Heavy	Fuser settings 0: High 1: Middle 2: Low 3: Vellum Duplex settings 0: Disable 1: Enable
(66)	RFID information	-	
(67)	Soft version of the optional paper feeder	Paper feeder 1/Paper feeder 2/Paper feeder 3 Paper feeder 4	
(68)	Version of the optional message	-	
(69)	Maintenance information	-	
(70)	Altitude	0: Standard 1: High altitude 1 2: High altitude 2	
(71)	Charger roller correction	1 to 5	

No.	Description	Supplement																			
(72)	Data Sanitization information	FAX Board (Port1)/FAX Board (Port2)/FAX Memory/ Main Memory/Panel Memory/Performed time 1: Success 0: Failure - : Not performed or Not installed																			
(73)	Toner low setting	0: Enabled 1: Disabled																			
(74)	Toner low detection level	5 to 100 (%)																			
(75)	Full-page print mode	0: Normal mode (Factory setting) 1: Full-page mode																			
(76)	Wake UP mode	0: OFF (Don't wake up) 1: ON (Do wake up)																			
(77)	Wake Up Timer	Displays the wake-up time																			
(78)	BAM conformity Mode setting	0: Un-suited Mode 1: Conformity Mode																			
(79)	Drum serial number	Black																			
	<p style="text-align: center;">Code conversion</p> <table border="1" style="margin-left: auto; margin-right: auto;"> <tbody> <tr> <td style="text-align: center;">A</td> <td style="text-align: center;">B</td> <td style="text-align: center;">C</td> <td style="text-align: center;">D</td> <td style="text-align: center;">E</td> <td style="text-align: center;">F</td> <td style="text-align: center;">G</td> <td style="text-align: center;">H</td> <td style="text-align: center;">I</td> <td style="text-align: center;">J</td> </tr> <tr> <td style="text-align: center;">0</td> <td style="text-align: center;">1</td> <td style="text-align: center;">2</td> <td style="text-align: center;">3</td> <td style="text-align: center;">4</td> <td style="text-align: center;">5</td> <td style="text-align: center;">6</td> <td style="text-align: center;">7</td> <td style="text-align: center;">8</td> <td style="text-align: center;">9</td> </tr> </tbody> </table>		A	B	C	D	E	F	G	H	I	J	0	1	2	3	4	5	6	7	8
A	B	C	D	E	F	G	H	I	J												
0	1	2	3	4	5	6	7	8	9												

U001	Exit Mainte
-------------	--------------------

Description

Exits the maintenance mode and returns to the normal copy mode.

Purpose

To exit the maintenance mode.

Method

1. Press the start key. The normal copy mode is entered.

U002	Set Factory Def
-------------	------------------------

Description

Restores the machine conditions to the factory default settings.

Purpose

To move the mirror frame of the scanner to the position for transport.

Method

1. Press the start key.
2. Select [Mode1(All)].
3. Press the start key.

It brings near by a left end so that the carriage of Scanner can be fixed.

Display	Description
Mode1(All)	A factory-default setup is performed.

4. Turn the main power switch off and on. Allow more than 5 seconds between Off and On.

* : An error code is displayed in case of an initialization error.

When errors occurred, turn main power switch off then on, and execute initialization using maintenance item U002.

Error codes

Codes	Description
0001	Controller (Entity error)
0002	Controller (Counter error)
0003	Controller (OS error)
0020	Engine

U004	Machine No.
-------------	--------------------

Description

Sets or displays the machine number.

Purpose

To check or set the machine number.

Method

Press the start key.

If the machine serial number of engine PWB matches with that of main PWB.

Display	Description
Machine No.	Displays the machine serial number.

If the machine serial number of engine PWB does not match with that of main PWB.

Display	Description
Machine No.(Main)	Displays the machine serial number of main.
Machine No.(Eng)	Displays the machine serial number of engine.

If the machine serial number of engine PWB does not match with serial number of engine sub PWB.

Display	Description
Machine No.(Eng)	Displays the machine serial number of engine.

Setting

Carry out if the machine serial number does not match.

1. Select [Execute].
2. Press the start key. Writing of serial No. starts.
3. Turn the main power switch off and on. Allow more than 5 seconds between Off and On.

Completion

Press the stop key. The screen for selecting a maintenance item No. is displayed.

U010	Set Mainte ID
-------------	----------------------

Description

Sets the maintenance mode ID.

Purpose

Modify maintenance mode ID for more security.

Method

1. Press the start key.
2. Select [Change] or [Initialize].

Display	Description
Change	Changes the maintenance mode ID at the market.
Initialize	Initializes the maintenance mode ID at the market.

Setting: Change

1. Select [New ID].
2. Enter a new 8-digit ID on ten keys (0 – 9, *, #). * and # are mandatory to contain.
3. Select [New ID(Reconfirm)].
4. Enter a new 8-digit ID on ten keys (0 – 9, *, #).
5. Select [Execute].
6. Press the start key. The setting is set.

Display	Description
New ID	Enter a new 8-digit ID
New ID(Reconfirm)	Enter a new 8-digit ID (to confirm)
Execute	Changes the maintenance mode ID

Method: Initialize

1. Select [Initialize].
2. Press the start key. ID is initialized.

Completion

Press the stop key. The screen for selecting a maintenance item No. is displayed.

U019	Firm Version
-------------	---------------------

Description

Displays the part number of the ROM fitted to each board.

Purpose

To check the part number or to decide, if the newest version of ROM is installed.

Method

1. Press the start key. The ROM version are displayed.
2. Change the screen using the cursor up/down keys.

Display	Description
Main	Main ROM
MMI	Operation ROM
Browser *1	Browser ROM
Engine	Engine ROM
Engine Boot	Engine booting
Dictionary *1	Dictionary ROM
Option Language	Optional language ROM
Cass2	Cassette2 ROM
Cass2 Boot	Cassette2 booting
Cass3	Cassette3 ROM
Cass3 Boot	Cassette3 booting
Cass4	Cassette4ROM
Cass4 Boot	Cassette4 booting
Cass5	Cassette5 ROM
Cass5 Boot	Cassette5 booting
Fax APL *2	Fax APL
Fax Boot *2	Fax booting
Fax IPL *2	Fax IPL
Application Name1 *1	Application1 ROM
Application Name2 *1	Application2 ROM
Application Name3 *1	Application3 ROM
Application Name4 *1	Application4 ROM
Application Name5 *1	Application5 ROM

*1: HyPAS model only

*2: FAX model only

Completion

Press the stop key. The screen for selecting a maintenance item No. is displayed.

U021	Init memory
-------------	--------------------

Description

Initializes all settings, except those pertinent to the type of machine, namely each counter, service call history and mode setting. Also initializes backup RAM according to region specification selected in maintenance item U252 Setting the destination.

Purpose

To return the machine settings to their factory default.

Method

1. Press the start key.
2. Select [Execute].

Display	Description
(No. Action) *1	The item for malfunction prevention
Execute	Data is initialized according to destination information.

*1: Basic model only

3. Press the start key.

* : All data other than that for adjustments due to variations between machines is initialized based on the destination setting.

4. Turn the main power switch off and on. Allow more than 5 seconds between Off and On.

* : An error code is displayed in case of an initialization error.

When errors occurred, turn main power switch off then on, and execute initialization using maintenance item U021.

Error codes

Display	Description
0001	Controller (Entity Error)
0002	Controller (Counter Error)
0020	Engine
0040	Scanner

Completion

Press the stop key. The screen for selecting a maintenance item No. is displayed.

U025	Firm Update(S)
-------------	-----------------------

Description

Used to execute FW-Update from the USB flash device while Very High is selected in the Security Level settings under the System Menu.

Purpose

Firmware upgrading is initiated by a service person to conduct U025 while a USB flash device is inserted.

Method

1. Press the start key.
2. Press [Execute].

Display	Description
(No. Action) *1	The item for malfunction prevention
Execute	Executes the firmware-update.

*1: Basic model only

3. Press the start key.
 - * : This is not executable when a USB has not been installed.
4. After normal completion of operation, turn the main power switch off and on. Allow more than 5 seconds between Off and On.

Completion

Press the stop key. The screen for selecting a maintenance item No. is displayed.

U034	Adj Paper Timing
-------------	-------------------------

Description

Adjusts the leading edge registration or center line.

Purpose

Make the adjustment if there is a regular error between the leading edges of the copy image and original.

Make the adjustment if there is a regular error between the center lines of the copy image and original.

Method

1. Press the start key.
2. Select the item to be adjusted.

Display	Description
LSU Out Top	Leading edge registration adjustment
LSU Out Left	Center line adjustment

Adjustment: LSU Out Top

1. Press the system menu key.
2. Press the start key to output a test pattern.
3. Press the system menu key.
4. Select the item to be adjusted.

[LSU Out Top]

Display	Description	Setting range	Initial setting	Change in value per step
Top	The standard value of leading edge	0 to 1180	590	1 dot
MPT	Paper feed from MP tray.	-70 to 70	-3	1 dot
Cass	Paper feed from cassette.	-70 to 70	0	1 dot
Dup	Duplex mode. (second)	-70 to 70	2	1 dot

5. Change the setting value using the cursor right/left keys or numeric keys.

For output example 1, increase the value. For output example 2, decrease the value

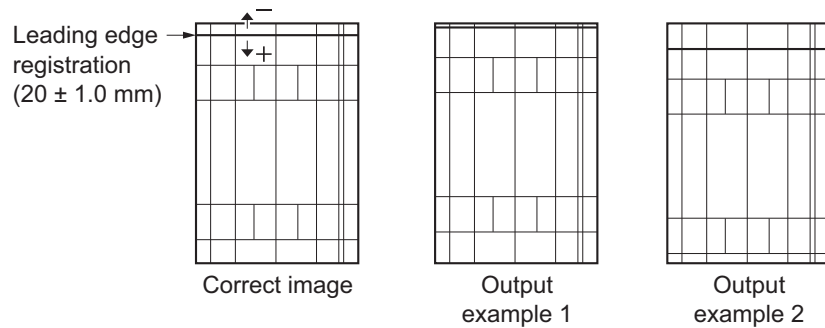

Figure 1-3-4

6. Press the start key. The value is set.

Caution

Check the copy image after the adjustment. If the image is still incorrect, perform the following adjustments in maintenance mode.

U034 ----- U066 ----- U071
 (P.1-3-29) (P.1-3-33)

Adjustment: LSU Out Left

1. Press the system menu key.
2. Press the start key to output a test pattern.
3. Press the system menu key.
4. Select the item to be adjusted.

[LSU Out Left]

Display	Description	Setting range	Initial setting	Change in value per step
Left	The standard value of Center line	0 to 1180	642	1 dot
MPT	Paper feed from MP tray.	-70 to 70	-14	1 dot
Cass1	Paper feed from cassette1.	-70 to 70	0	1 dot
Cass2	Paper feed from optional cassette2.	-70 to 70	0	1 dot
Cass3	Paper feed from optional cassette3.	-70 to 70	0	1 dot
Cass4	Paper feed from optional cassette4.	-70 to 70	0	1 dot
Cass5	Paper feed from optional cassette5.	-70 to 70	0	1 dot
Dup	Duplex mode. (second)	-70 to 70	-4	1 dot

5. Change the setting value using the cursor right/left keys or numeric keys.
For output example 1, increase the value. For output example 2, decrease the value.

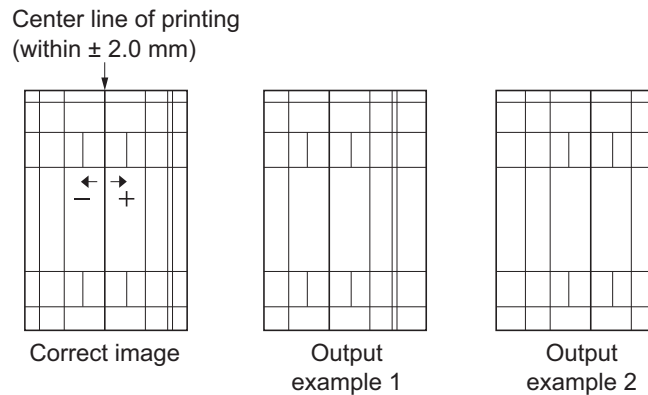

6. Press the start key. The value is set.

Caution

Check the copy image after the adjustment. If the image is still incorrect, perform the following adjustments in maintenance mode.

U034 ----- U067 ----- U072
(P.1-3-30) (P.1-3-35)

Completion

Press the stop key. The screen for selecting a maintenance item No. is displayed.

U065	Adj Scn
-------------	----------------

Description

Adjusts the magnification of the original scanning.

Purpose

Make the adjustment if the magnification in the main scanning direction is incorrect.
Make the adjustment if the magnification in the auxiliary scanning direction is incorrect.

Caution

The magnification adjustment along the main scanning direction could cause black streaks depending on the content of the original document.

Adjust the magnification of the scanner in the following order.

U065 (main scanning direction) ----- U065 (auxiliary scanning direction)

(P.1-3-27)

(P.1-3-27)

Method

1. Press the start key.
2. Press the system menu key.
3. Place an original and press the start key to make a test copy.
4. Press the system menu key.
5. Select the item to be adjusted.

Display	Description	Setting range	Initial setting	Change in value per step
Main Scan	Scanner magnification in the main scanning direction.	-75 to 75	0	0.02%
Sub Scan	Scanner magnification in the auxiliary scanning direction.	-125 to 125	0	0.02%

Adjustment: Main Scan

1. Change the setting value using the cursor right/left keys or numeric keys.
For copy example 1, increase the value. For copy example 2, decrease the value.
Increasing the setting enlarges the image and decreasing it narrows the image.

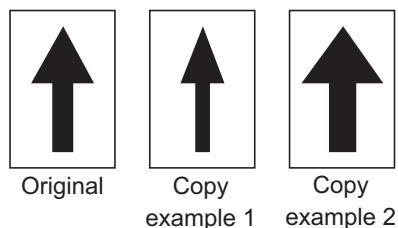
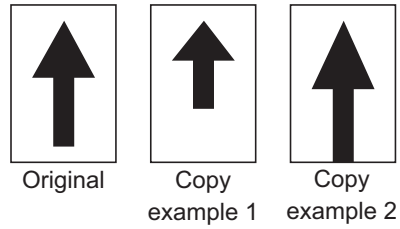

Figure 1-3-5

2. Press the start key. The value is set.

Adjustment: Sub Scan

1. Change the setting value using the cursor right/left keys or numeric keys.
For copy example 1, increase the value. For copy example 2, decrease the value.
Increasing the value makes the image longer, while decreasing the value makes the image shorter.

**Figure 1-3-6**

2. Press the start key. The value is set.

Completion

Press the stop key. The screen for selecting a maintenance item No. is displayed.

U066	Table Timing
-------------	---------------------

Description

Adjusts the scanner leading edge registration of the original scanning.

Purpose

Make the adjustment if there is a regular error between the leading edges of the copy image and original.

Adjustment

1. Press the start key.
2. Press the system menu key.
3. Place an original and press the start key to make a test copy.
4. Press the system menu key.
5. Select the item to be adjusted.

Display	Description	Setting range	Initial setting	Change in value per step
Front	Scanner leading edge registration.	-30 to 30	0	0.158 mm
Rotate	Scanner leading edge registration (rotate copying)	-30 to 30	0	0.158 mm

6. Change the setting value using the cursor right/left keys or numeric keys.
For copy example 1, increase the value. For copy example 2, decrease the value.
Increasing the value moves the image forward and decreasing the value moves the image backward.

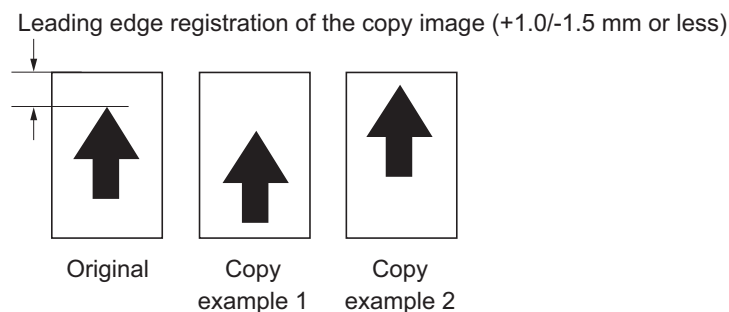
**Figure 1-3-7**

7. Press the start key. The value is set.

Caution

If the above adjustment does not optimize the leading edge registration, proceed with the following maintenance modes.

U034 ----- U065 ----- U066

(P.1-3-24) (P.1-3-27)

Completion

Press the stop key. The screen for selecting a maintenance item No. is displayed.

U067	Table Center
-------------	---------------------

Description

Adjusts the scanner center line of the original scanning.

Purpose

Make the adjustment if there is a regular error between the center lines of the copy image and original.

Adjustment

1. Press the start key.
2. Press the system menu key.
3. Place an original and press the start key to make a test copy.
4. Press the system menu key.
5. Select the item to be adjusted.

Display	Description	Setting range	Initial setting	Change in value per step
Front	Scanner center line	-60 to 60	0	0.085 mm
Rotate	Scanner center line (rotate copying)	-40 to 40	0	0.085 mm

6. Change the setting value using the cursor right/left keys or numeric keys.
For copy example 1, decrease the value. For copy example 2, increase the value.
Increasing the value moves the image leftward and decreasing it moves the image rightward.

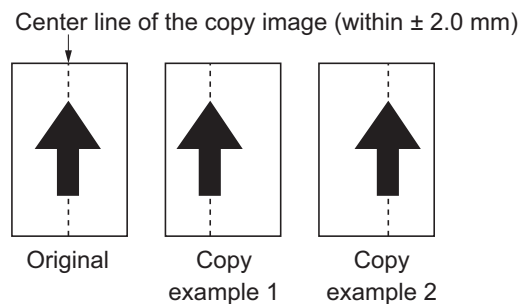
**Figure 1-3-8**

7. Press the start key. The value is set.

Caution

If the above adjustment does not optimize the center line, proceed with the following maintenance modes.

U034 ----- U065 ----- U067
(P.1-3-24) (P.1-3-27)

Completion

Press the stop key. The screen for selecting a maintenance item No. is displayed.

U068	DP Scn Start Pos
-------------	-------------------------

Description

Adjusts the position for scanning originals from the DP. Performs the test copy at the four scanning positions after adjusting.

Purpose

Used when the image fogging occurs because the scanning position is not proper when the DP is used. Run U071 to adjust the timing of DP leading edge when the scanning position is changed.

Method

1. Press the start key.
2. Select the item to be adjust.

Display	Description	Setting range	Initial setting	Change in value per step
DP Read	Starting position adjustment for scanning originals.	-38 to 38	0	0.158 mm
Black Line	Scanning position for the test copy originals.	0 to 3	0	-

Adjustment: DP Read

1. Select [DP Read].
2. Change the setting using the cursor right/left keys or numeric keys.
When the setting value is increased, the scanning position moves to the right and it moves to the left when the setting value is decreased.
3. Press the start key. The value is set.

Adjustment: Black line

1. Select [Black Line].
2. Change the setting using the cursor right/left keys or numeric keys.
3. Press the start key. The value is set.
4. Set the original (the one which density is known) in the DP and press the system menu key.
5. Press the start key. Test copy is executed.
6. Perform the test copy at each scanning position with the setting value from 0 to 3 and check that no black line appears and the image is normally scanned.

Completion

Press the stop key. The screen for selecting a maintenance item No. is displayed.

U070	Adj DP Motor
-------------	---------------------

Description

Adjusts the DP original scanning speed.

Purpose

Make the adjustment if the magnification is incorrect in the auxiliary scanning direction when the DP is used.

Adjustment

1. Press the start key.
2. Press the system menu key.
3. Place an original on the DP and press the start key to make a test copy.
4. Press the system menu key.
5. Select [Convey Speed].

Display	Description	Setting range	Initial setting	Change in value per step
Convey Speed	Sub scanning direction. (Front)	-25 to 25	0	0.1 %

6. Change the setting value using the cursor right/left keys or numeric keys.
For copy example 1, increase the value. For copy example 2, decrease the value.
Increasing the value makes the image longer, while decreasing the value makes the image shorter.

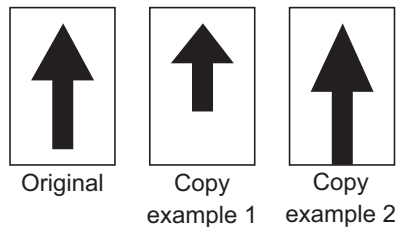

Figure 1-3-9

7. Press the start key. The value is set.

Completion

Press the stop key. The screen for selecting a maintenance item No. is displayed.

U071	DP Timing
-------------	------------------

Description

Adjusts the DP original scanning timing.

Purpose

Make the adjustment if there is a regular error between the leading or trailing edges of the original and the copy image when the DP is used.

Method

1. Press the start key.
2. Press the system menu key.
3. Place an original on the DP and press the start key to make a test copy.
4. Press the system menu key.
5. Select the item to be adjusted.

Display	Description	Setting range	Initial setting	Change in value per step
Front Head	Leading edge registration. (first side)	-32 to 32	-	0.85
Front Tail	Trailing edge registration. (first side)	-32 to 32	-	0.85
Back Head	Trailing edge registration. (first side)	-32 to 32	-	0.85
Back Tail	Trailing edge registration. (second side)	-32 to 32	-	0.85

Adjustment: Leading edge registration

1. Change the setting value using the cursor right/left keys or numeric keys.
For copy example 1, increase the value. For copy example 2, decrease the value.
Increasing the value moves the image forward and decreasing the value moves the image backward.

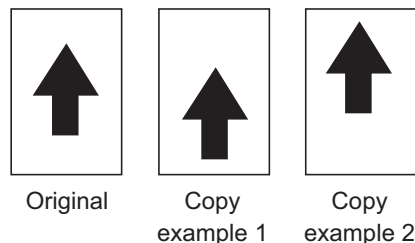
**Figure 1-3-10**

2. Press the start key. The value is set.

Caution

If the first side is adjusted, check the second side and if adjustment is required, carry out the adjustment.

If the above adjustment does not optimize the leading edge registration, proceed with the following maintenance modes.

U034 ----- U071

(P.1-3-24)

Adjustment: Trailing edge registration

1. Change the setting value using the cursor right/left keys or numeric keys.
For copy example 1, increase the value. For copy example 2, decrease the value.

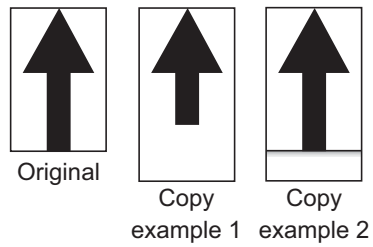
**Figure 1-3-11**

2. Press the start key. The value is set.

Completion

Press the stop key. The screen for selecting a maintenance item No. is displayed.

U072	DP Center
-------------	------------------

Description

Adjusts the scanning start position for the DP original.

Purpose

Make the adjustment if there is a regular error between the centers of the original and the copy image when the DP is used.

Adjustment

1. Press the start key.
2. Press the system menu key.
3. Place an original on the DP and press the start key to make a test copy.
4. Press the system menu key.
5. Select the item to be adjusted.

Display	Description	Setting range	Initial setting	Change in value per step
Front	DP center line. (first side)	-60 to 60	-	0.085 mm
Back	DP center line. (second side)	-60 to 60	-	0.085 mm

6. Change the setting value using the cursor right/left keys or numeric keys.
For copy example 1, increase the value. For copy example 2, decrease the value.
Increasing the value moves the image rightward and decreasing it moves the image leftward.

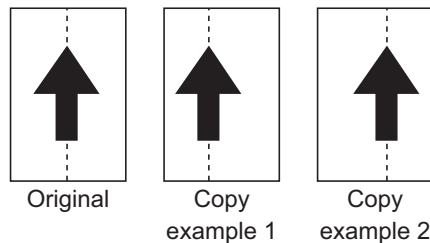

Figure 1-3-12

7. Press the start key. The value is set.

Caution

If the first side is adjusted, check the second side and if adjustment is required, carry out the adjustment.

If the above adjustment does not optimize the center line, proceed with the following maintenance modes.

U034 ----- U065 ----- U067 ----- U072

(P.1-3-24) (P.1-3-27) (P.1-3-30)

Completion

Press the stop key. The screen for selecting a maintenance item No. is displayed.

U130	Set Toner Install
-------------	--------------------------

Description

To set ON/OFF of the toner installation mode.

Purpose

Toner installation is performed at the time of a machine setup.

Setting

1. Press the start key.
2. Select [Mode].
3. Set at On or Off.
4. Press the start key.

Display	Description
Mode	Setting a toner installation mode.

* : 0:Off / 1:On

* : The toner installation is performed when power is turned on and off.

Completion

Press the stop key. The screen for selecting a maintenance item No. is displayed.

U147	Set Toner Apply
-------------	------------------------

Description

A mode setup of the operation which removes the toner in the development unit which carried out the charge rise is performed.

Purpose

The basic target does not need to change a setup.

However, the mode is changed when outputting a manuscript with an always low printing rate in large quantities.

* : If the toner which carried out the charge rise stagnates in a development unit, concentration will fall.

Method

1. Press the start key.
2. Select [SGE] or [PDR].

Display	Description	Setting range	Initial setting	Change in value per step
SGE	Development T7 practice-standard printing rate	0.0 to 3.0	1.0	-
PDR	Drum toner belt magnification setup	0 to 5	1	-

Setting

1. Change the setting value using the cursor right/left keys or numeric keys.
2. Press the start key. The value is set.

Completion

Press the stop key. The screen for selecting a maintenance item No. is displayed.

U201	Init Touch Panel (HyPAS only)
-------------	--------------------------------------

Description

Adjust touch panel detecting positions.

Purpose

When the panel PWB or the operation panel is replaced or if the detecting positions are not aligned, perform this simulation to correct and confirm.

Method

1. Press the start key.
2. Select [Initialize] or [Check].

Display	Description
Initialize	Executes the correction of the touch panel display position.
Check	Confirms the display position of touch panel.

Method: [Initialize]

1. Press the center of the + keys. Be sure to press three + keys displayed in order.
The touch panel is adjusted automatically.
2. Press the indicated three + keys, and then check the display.
* : After complete setting, move to the [Check] screen automatically.

Method: [Check]

1. Press the indicated three + keys, and then check the display.
When adjusting the display, press [Initialize] to execute the adjustment automatically.
2. Press the stop key.

Completion

Press the stop key. The screen for selecting a maintenance item No. is displayed.

U203	Chk DP Ope
-------------	-------------------

Description

Simulates the original conveying operation separately in the DP.

Purpose

To check the DP operation.

Method

1. Press the start key.
2. Place an original in the DP if running this simulation with paper.
3. Select the speed to be operated.

Display	Description
Normal Speed	Normal reading
High Speed	High-speed reading

4. Select the item to be operated.

Display	Description
CCD ADP(Non-P)	Without paper, single-sided original of CCD (continuous operation)
CCD ADP	With paper, single-sided original of CCD
CCD RADP(Non-P)	Without paper, double-sided original of CCD (continuous operation)
CCD RADP	With paper, double-sided original of CCD

5. Press the start key. The operation starts.
6. To stop continuous operation, press the stop key.

Completion

Press the stop key. The screen for selecting a maintenance item No. is displayed.

U207	Chk Panel Key
-------------	----------------------

Description

Checks operation of the operation panel keys.

Purpose

To check operation of all the keys on the operation panel.

Method

1. Press the start key. The screen for executing is displayed.
2. [Count0] is displayed and the left most LED on the operation panel lights.

Display	Description
Cnt	Keypress counter.

3. As the keys lined up in the same line as the lit indicator are pressed in the order from the top to the bottom, the figure shown on the touch panel increases in increments of 1. When all the keys in that line are pressed and if there are any LEDs corresponding to the keys in the line on the immediate right, the top LED in that line will light.
4. When all the keys on the operation panel have been pressed, all the LEDs light for up to 10 seconds.

Completion

Press the stop key. The screen for selecting a maintenance item No. is displayed.

U222	Set IC Card Type
-------------	-------------------------

Setting the IC card type**Description**

Sets the type of IC card.

Purpose

To change the type of IC card.

Setting

1. Press the start key.
2. Select the item.

Display	Description
Other	The type of IC card is not SSFC
SSFC	The type of IC card is SSFC

* : Initial setting: Other

3. Press the start key. The setting is set.

Completion

Press the stop key. The screen for selecting a maintenance item No. is displayed.

U250	Mnt Cnt Pre-set
-------------	------------------------

Description

Changes preset values for maintenance cycle.

Purpose

Provides changing the time when the message to acknowledge to conduct maintenance adjustment is periodically displayed.

Setting

1. Press the start key.
2. Select the item to be set.
3. Change the setting using the +- keys or numeric keys.

Display	Description	Setting range
M.Cnt A	Preset values for maintenance cycle A.	0 to 9999999
Clear	A value is cleared.	0

4. Press the start key. The value is set.

Clearing

1. Select [Clear].
2. Press the start key. The setting value is cleared.

Completion

Press the stop key. The screen for selecting a maintenance item No. is displayed.

U251	Clr Mnt Cnt
-------------	--------------------

Description

Displays and clears or changes the maintenance count.

Purpose

To verify the maintenance counter count.

Also to clear the count during maintenance service.

Setting

1. Press the start key.
2. Select the item to be changed.
3. Change the setting using the cursor right/left keys or numeric keys.

Display	Description	Setting range
M.Cnt A	Count value for maintenance cycle A.	0 to 9999999
Clear	A value is cleared.	0

Clearing

1. Select [Clear].
2. Press the start key. The setting value is cleared.

Completion

Press the stop key. The screen for selecting a maintenance item No. is displayed.

U252	Set Dest
-------------	-----------------

Description

Switches the operations and screens of the machine according to the destination.

Purpose

To be executed after initializing the backup RAM, in order to return the setting to the value before replacement or initialization.

Method

1. Press the start key.
2. Select the destination.

Display	Description
(No Action)	-
Inch	Inch (North America) specifications.
Europe Metric	Metric (Europe) specifications.
Asia Pacific	Metric (Asia Pacific) specifications.
Australia	Australia specifications.
China	China specifications.
Korea	Korea specifications.

3. Press the start key.
4. Turn the main power switch off and on. Allow more than 5 seconds between Off and On.
 - * : An error code is displayed in case of an initialization error.
When errors occurred, turn main power switch off then on, and execute initialization using maintenance item U252.

Error codes

Display	Description
0001	Controller (Entity Error)
0002	Controller (Counter Error)
0020	Engine
0040	Scanner

U253	Sel D/S Count
-------------	----------------------

Description

Switches the count system for the total counter and other counters.

Purpose

Used to select, according to the preference of the user (copy service provider), if folio size paper is to be counted as one sheet (single count) or two sheets (double count).

Setting

1. Press the start key.
2. Select the item to be set.

Display	Description
SGL(All)	Single count for all size paper.
DBL(Folio)	Double count for Folio size or larger.

* : Initial setting: DBL(Folio)

3. Press the start key. The setting is set.

Completion

Press the stop key. The screen for selecting a maintenance item No. is displayed.

* : When the double count is set for the paper other than the sizes of A4, B5, A5, Folio, Legal, Letter, and Statement, the counter value is indicated as "Other 1" in the status page. When in the same way, the single count is set, the counter value is indicated as "Other 2". In the operation panel, the counter values are indicated as "Other(Double)" or "Other(Single)".

U260	Set Count Mode
-------------	-----------------------

Description

Changes the copy count timing for the total counter and other counters.

Purpose

To be set according to user request.

Setting

1. Press the start key.
2. Select the copy count timing.

Display	Description
Feed	When secondary paper feed starts.
Eject	When the paper is ejected

* : Initial setting: Eject

3. Press the start key. The setting is set.

Completion

Press the stop key. The screen for selecting a maintenance item No. is displayed.

U265	Set Model Dest
-------------	-----------------------

Description

Sets the OEM purchaser code.

Purpose

Sets the code when replacing the main board and the like.

Setting

1. Press the start key.
2. Change the setting using the +- keys or numeric keys.

Display	Description
No.	Sets the OEM purchaser code.

3. Press the start key. The setting is set.
4. Turn the main power switch off and on. Allow more than 5 seconds between Off and On.

Completion

Press the stop key. The screen for selecting a maintenance item No. is displayed.

U285	Set Svc Sts Page
-------------	-------------------------

Description

Determines displaying the digital dot coverage report on reporting.

Purpose

According to user request, changes the setting.

Setting

1. Press the start key.
2. Select [On] or [Off].

Display	Description
On	Displays the digital dot coverage.
Off	Not to display the digital dot coverage.

* : Initial setting: On

3. Press the start key. The setting is set.

Completion

Press the stop key. The screen for selecting a maintenance item No. is displayed.

U332	Adj Calc Rate
-------------	----------------------

Description

Sets the coefficient of nonstandard sizes in relation to the A4/Letter size. The coefficient set here is used to convert the black ratio in relation to the A4/Letter size and to display the result in user simulation.

Purpose

To set the coefficient for converting the black ratio for nonstandard sizes in relation to the A4/Letter size.

Setting

1. Press the start key.
2. Change the setting using cursor right/left keys or numeric keys.

Display	Description	Setting range	Initial setting
Rate	Size parameter.	0.1 to 3.0	1.0

3. Press the start key. The value is set.

Completion

Press the stop key. The screen for selecting a maintenance item No. is displayed.

U339	Chk Drum Heater
-------------	------------------------

Description

The change of a system menu display of a drum heater setup is set up.

* : This function is available only Asia area.

Purpose

A setup of a drum heater is performed at the time of the change of a display on a system menu.

1. Press the start key.
2. Select [On] or [Off].

Display	Description
On	A drum heater setup of a system menu is set to On.
Off	A drum heater setup of a system menu is set to Off.

* : Initial setting: Off

* : If a preset value is changed into "Off", a drum heater setup will be set as "Off."

3. Press the start key. The setting is set.

Completion

Press the stop key. The screen for selecting a maintenance item No. is displayed.

U345	Set Mnt Time Disp
-------------	--------------------------

Description

Sets when to display a message notifying that the time for maintenance is about to be reached, by setting the number of copies that can be made before the current maintenance cycle ends. When the difference between the number of copies of the maintenance cycle and that of the maintenance count reaches the set value, the message is displayed.

Purpose

To change the time for maintenance due indication.

Setting

1. Press the start key.
2. Select the item to be changed.
3. Change the setting using the cursor right/left keys or numeric keys.

Display	Description	Setting range	Initial setting
Cnt	Time for maintenance due indication (Remaining number of copies that can be made before the current maintenance cycle ends)	0 to 9999	0
Clear	A value is cleared.	-	-

4. Press the start key. The value is set.

Clearing

1. Select [Clear].
2. Press the start key. The setting value is cleared.

Completion

Press the stop key. The screen for selecting a maintenance item No. is displayed.

U346	Slct Sleep Mode
-------------	------------------------

Description

A sleep mode-related setting change is performed.

Purpose

It uses in order to perform a sleep mode-related setting change.

Method

1. Press the start key.
2. Select the item to be set.

Display	Description
Timer/Sleep Level	BAM conformity country setup
Auto sleep	An On/Off setup of an AutoSleep function

Setting: Timer/Sleep Level

1. Select [More Energy Save] or [Less Energy Save].

Display	Description
More Energy Save	BAM conformity setup On
Less Energy Save	BAM conformity setup Off

- * : Initial setting: More Energy Save
2. Press the start key. The setting is set.
 3. Turn the main power switch off and on. Allow more than 5 seconds between Off and On.

Setting: Auto sleep

1. Select [On] or [Off].

Display	Description
On	AutoSleep setup On
Off	AutoSleep setup Off

- * : Initial setting: On
2. Press the start key. The setting is set.

Completion

Press the stop key. The screen for selecting a maintenance item No. is displayed.

U402	Adjust Margin
-------------	----------------------

Description

Adjusts margins for image printing.

Purpose

Make the adjustment if margins are incorrect.

Adjustment

1. Press the start key.
2. Press the system menu key.
3. Press the start key to output a test pattern.
4. Press the system menu key.
5. Select the item to be adjusted.

Display	Description	Setting range	Initial setting	Change in value per step
Lead	Printer leading edge margin.	0.0 to 10.0	4.0	0.1 mm
A Margin	Printer left margin.	0.0 to 10.0	3.0	0.1 mm
C Margin	Printer right margin.	0.0 to 10.0	3.0	0.1 mm
Trail	Printer trailing edge margin.	0.0 to 10.0	3.9	0.1 mm

6. Change the setting value using the cursor right/left keys or numeric keys.

Increasing the value makes the margin wider, and decreasing it makes the margin narrower.

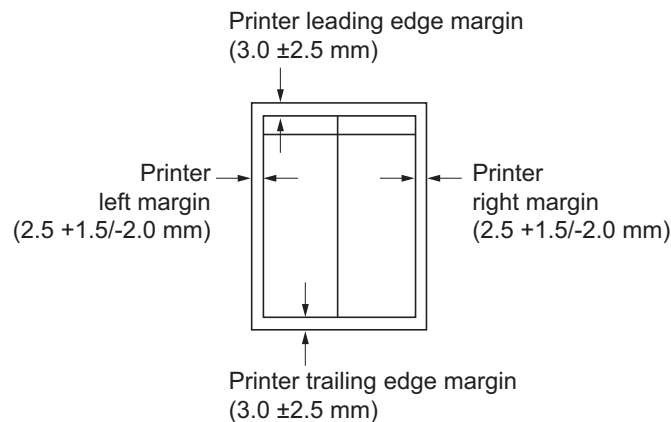

Figure 1-3-13

7. Press the start key. The value is set.

Caution

If the above adjustment does not optimize the margins, perform the following maintenance modes.

U034----- U402

(P.1-3-24)

Completion

Press the stop key. The screen for selecting a maintenance item No. is displayed.

U403	Scan Margin Tbl
-------------	------------------------

Description

Adjusts margins for scanning the original on the contact glass.

Purpose

Make the adjustment if margins are incorrect.

Adjustment

1. Press the start key.
2. Press the system menu key.
3. Place an original and press the start key to make a test copy.
4. Press the system menu key.
5. Select the item to be adjusted.

Display	Description	Setting range	Initial setting	Change in value per step
A Margin	Scanner left margin.	0.0 to 10.0	2.0	0.5
B Margin	Scanner leading edge margin.	0.0 to 10.0	2.0	0.5
C Margin	Scanner right margin.	0.0 to 10.0	2.0	0.5
D Margin	Scanner trailing edge margin.	0.0 to 10.0	2.0	0.5

6. Change the setting value using change the cursor right/left keys or numeric keys.

Increasing the value makes the margin wider, and decreasing it makes the margin narrower.

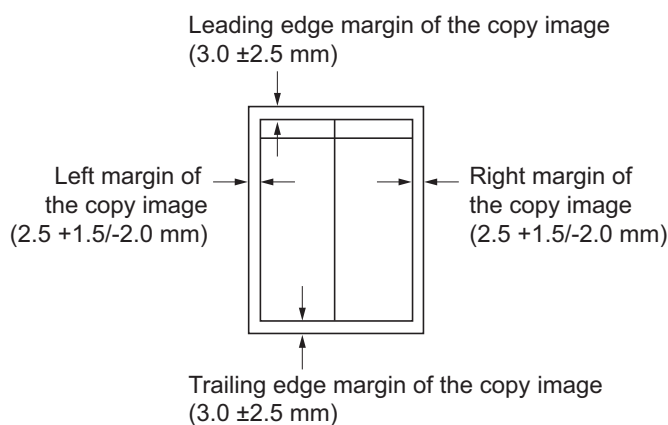

Figure 1-3-14

7. Press the start key. The value is set.

Caution

If the above adjustment does not optimize the margins, perform the following maintenance modes.

U034 ----- U402 ----- U403

(P.1-3-24) (P.1-3-51)

Completion

Press the stop key. The indication for selecting a maintenance item No. appears.

U404	Scan Margin DP
-------------	-----------------------

Description

Adjusts margins for scanning the original from the DP.

Purpose

Make the adjustment if margins are incorrect.

Adjustment

1. Press the start key.
2. Press the system menu key.
3. Place an original on the DP and press the start key to make a test copy.
4. Press the system menu key.
5. Select the item to be adjusted.

Display	Description	Setting range	Initial setting	Change in value per step
A Margin	DP left margin	0.0 to 10.0	3.0	0.5
B Margin	DP leading edge margin	0.0 to 10.0	2.5	0.5
C Margin	DP right margin	0.0 to 10.0	3.0	0.5
D Margin	DP trailing edge margin	0.0 to 10.0	4.0	0.5

6. Change the setting value using change the cursor right/left keys or numeric keys.

Increasing the value makes the margin wider, and decreasing it makes the margin narrower.

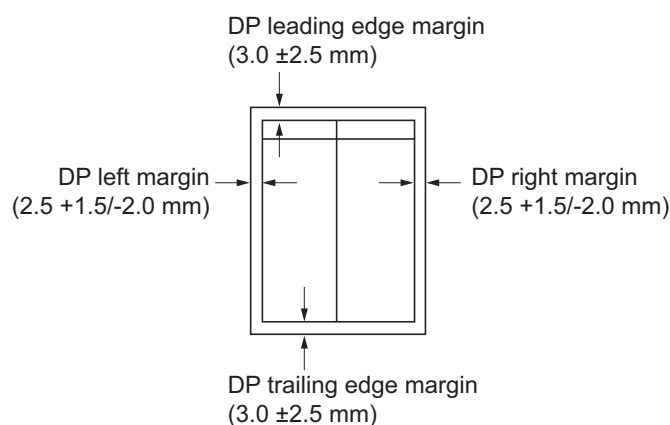

Figure 1-3-15

7. Press the start key. The value is set.

Caution

If the above adjustment does not optimize the margins, perform the following maintenance modes.

U034	-----	U402	-----	U403	-----	U404
(P.1-3-24)		(P.1-3-51)		(P.1-3-52)		

Completion

Press the stop key. The screen for selecting a maintenance item No. is displayed.

U411	Auto Adj Scn
-------------	---------------------

Description

Uses a specified original and automatically adjusts the following items in the scanner and the DP scanning sections.

Scanner section: Original size magnification, leading edge timing, center line, input gamma, input gamma in monochrome mode and matrix.

DP scanning section: Original size magnification, leading edge timing, center line.

Purpose

To perform automatic adjustment of various items in the scanner and the DP scanning sections.

Method

1. Press the start key.
2. Select the item. The screen for executing is displayed.

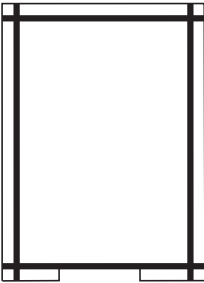
Display	Description	Original to be used for adjustment (P/N)
(No Action) *1	-	-
Table	Automatic adjustment in the scanner section. Equal magnification (sub scanning direction), leading edge timing, center line, input gamma, input gamma in monochrome mode and matrix, chromatic aberration.	302NM94340 
DP	Automatic adjustment in the DP scanning section. Original size magnification, leading edge timing, center line.	302NM94330 
All	Performs automatic adjustment in the DP scanning section following automatic adjustment in the scanner section.	302NM94340 302NM94330
Target	Set-up for obtaining the target value	302NM94340 302NM94330

*1: Basic model only

Method: Table

To Automaticary enter the target value : Usually, it adjusts here.

1. Set a specified original (P/N: 302NM94340) on the platen.
2. Enter maintenance item U411.
3. Select [Target].
4. Select [Auto] and press the start key.
5. Select [Table].
6. Press the start key. Auto adjustment starts.

To manually enter the target value : When adjustment is automatically impossible.

1. Enter the target values which are shown on the specified original (P/N: 302NM94340) executing maintenance item U425.
2. Set a specified original (P/N: 302NM94340) on the platen.
3. Enter maintenance item U411.
4. Select [Target].
5. Select [U425] and press the start key.
6. Select [Table].
7. Press the start key. Auto adjustment starts.

Method: DP

1. Set a specified original (P/N: 302NM94330) on the DP face up.
2. Enter maintenance item U411.
3. Select [DP].
4. Press the start key. Auto adjustment starts.

* : When automatic adjustment has normally completed, [OK] is displayed. If a problem occurs during auto adjustment, error code is displayed and operation stops. Should this happen, determine the details of the problem and repeat the procedure from the beginning.

Error Codes

Codes	Description	Corrective Action
00	Automatic adjustment success	-
01	Black band detection error (scanner auxiliary scanning direction leading edge skew)	1. The original is set correctly and performed again. 2. Check a lighting of the lamp or replace.
04	Black band is not detected (scanner auxiliary scanning direction leading edge)	
05	Black band is not detected (scanner main scanning direction far end)	
06	Black band is not detected (scanner main scanning direction near end)	
07	Black band is not detected (scanner auxiliary scanning direction trailing edge)	

Codes	Description	Corrective Action
08	Black band is not detected (DP main scanning direction far end)	<ol style="list-style-type: none"> 1. Check the attachment position of DP. 2. Check a lighting of the lamp or replace. 3. Check the back and front of an adjustment original.
09	Black band is not detected (DP main scanning direction near end)	
0a	Black band is not detected (DP auxiliary scanning direction leading edge)	
0b	Black band is not detected (DP auxiliary scanning direction leading edge original check)	
0c	Black band is not detected (DP auxiliary scanning direction trailing edge)	
0d	White band is not detected (DP auxiliary scanning direction trailing edge)	
0e	DMA time out	Turn the power supply OFF/ON and performed again.
0f	Auxiliary scanning direction magnification error	<ol style="list-style-type: none"> 1. Turn the power supply OFF/ON and performed again. 2. Adjust the below items in manual operation. (U065 to U067, U070 to U072)
10	Auxiliary scanning direction leading edge error	
11	Auxiliary scanning direction trailing edge error	
12	DP uxiliary scanning direction skew error	
13	Maintenance request error	Turn the power supply OFF/ON and performed again.
14	Main scanning direction center line error	<ol style="list-style-type: none"> 1. Turn the power supply OFF/ON and performed again. Adjust the below items in manual operation. (U065 to U067, U070 to U072)
15	DP main scanning direction skew error	
16	Main scanning direction magnification error	
17	Service call error	Turn the power supply OFF/ON and performed again.
18	DP paper misfeed error	Set the original correctly and perform again.
19	PWB replacement error	-
1a	Original error	<ol style="list-style-type: none"> 1. Clean the contact glass and slit glass. 2. Exchange the adjustment original.
1b	Input gamma adjustment original error	Set the original correctly and perform again.
1c	Matrix adjustment original error	
1d	Original for the white reference compensation coefficient error	

Codes	Description	Corrective Action
1e	Lab value searching error	Check the following and perform again. - Isn't the bar code dirty? - Is the position of a original right? - Is a bar code position right?
1f	Lab value comparing error	Check the following and perform again. - Is the acquired bar code the same? - Is the position of a original right? - Is a bar code position right?
20 21 30	Input gamma correction coefficient error Color correction matrix coefficient error Chromatic aberration adjustment original error	Set the original correctly and perform again.
63	Completed to obtain a test RAW	-

Completion

Press the stop key. The screen for selecting a maintenance item No. is displayed.

U425	Set Target
-------------	-------------------

Description

Enters the lab values that is indicated on the back of the chart (P/N: 302NM94340) used for adjustment.

Purpose

Performs data input in order to correct for differences in originals during automatic adjustment.

Method

1. Press the start key.
2. Select the item to be set.

Display	Description
Table	Setting the value of the table adjustment.
DP	Setting the value of DP adjustment.

Method: Table

1. Press the start key.
2. Select the item to be set.

Display	Description
White	Setting the white patch for the original for adjustment
Black	Setting the black patch for the original for adjustment
Gray1	Setting the Gray1 patch for the original for adjustment
Gray2	Setting the Gray2 patch for the original for adjustment
Gray3	Setting the Gray3 patch for the original for adjustment
C	Setting the cyan patch for the original for adjustment
M	Setting the magenta patch for the original for adjustment
Y	Setting the yellow patch for the original for adjustment
R	Setting the red patch for the original for adjustment
G	Setting the green patch for the original for adjustment
B	Setting the blue patch for the original for adjustment
Adjust Original	Setting the main and auxiliary scanning directions

3. Select the item to be set.

Display	Description	Setting range	Initial setting
L	Setting the L value	0.0 to 100.0	93.6/10.6/76.2/25.2/51.3 72.6/48.1/86.2/46.7/67.8/38.8
a	Setting the a value	-200.0 to 200.0	0.9/-0.2/-0.2/-0.2/-0.3 -32.8/69.9/-18.6/54.2/-51.3/25.3
b	Setting the b value	-200.0 to 200.0	-0.4/-0.7/1.2/-0.2/0.3 -11.5/-6.1/81.7/38.6/48.9/-22.8

4. Enters the value that is indicated on the face of the chart using the cursor right/left keys or numeric keys.
5. Press the start key. The value is set.

Setting: [Adjust Original] *: This setting is usually unnecessary.

Display	Description	Setting range	Initial setting
Dist1	Sets the adjustment value of a leading edge.	4.0 to 6.0	5.0
Dist2	Sets the adjustment value of a left edge.	9.0 to 11.0	10.0
Dist3	Sets the adjustment value of a trailing edge.	265.0 to 267.0	266.0

1. Measure the distance from the leading edge to the top of black belt 1 of the original at A, B and C.

Measurement procedure

- 1) Measure the distance from the leading edge to the top of black belt 1 of the original at A (30 mm from the left edge), B (105 mm from the left edge) and C (180 mm from the left edge), respectively.
- 2) Apply the following formula for the values obtained: $((A + B + C) / 3)$
2. Enter the values solved using the cursor right/left keys or numeric keys in [Dist1].
3. Press the start key. The value is set.
4. Measure the distance from the left edge to the right edge black belt 2 of the original at F.

Measurement procedure

 - 1) Measure the distance from the left edge to the right edge black belt 2 of the original at F (21 mm from the top edge of black belt 1).

5. Enter the values using the cursor right/left keys or numeric keys in [Dist2].
6. Press the start key. The value is set.
7. Measure the distance from the top edge of black belt 1 to the bottom of black belt 3 of the original at D and E.

 - 1) Measure the distance from the top edge of black belt 1 to the bottom of black belt 3 of the original at D (30 mm from the left edge) and E (180 mm from the left edge), respectively.
 - 2) Apply the following formula for the values obtained: $(D/2 + E/2)$

8. Enter the measured value using the cursor right/left keys or numeric keys in [Dist3].
9. Press the start key. The value is set.

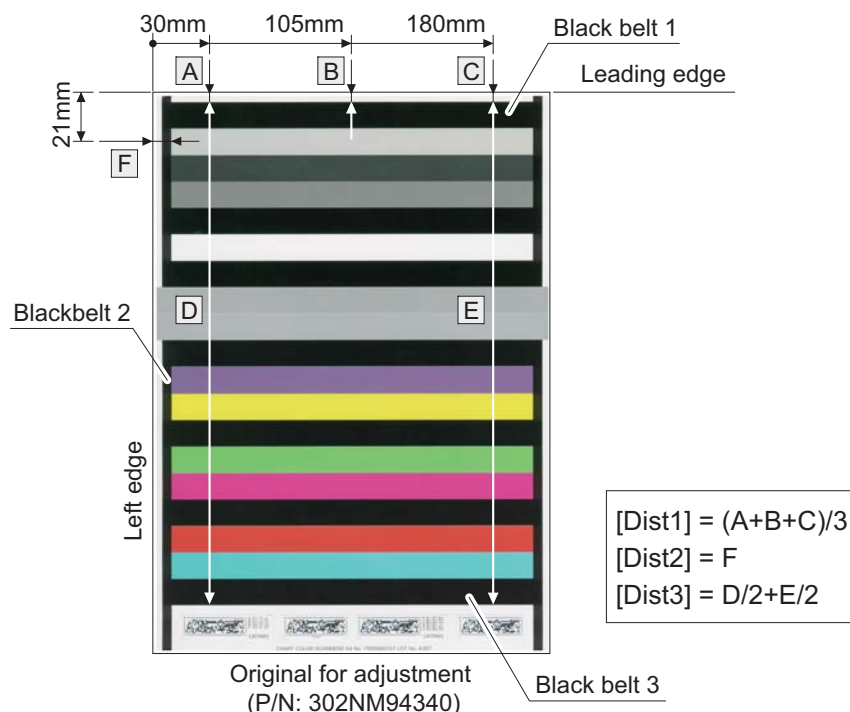
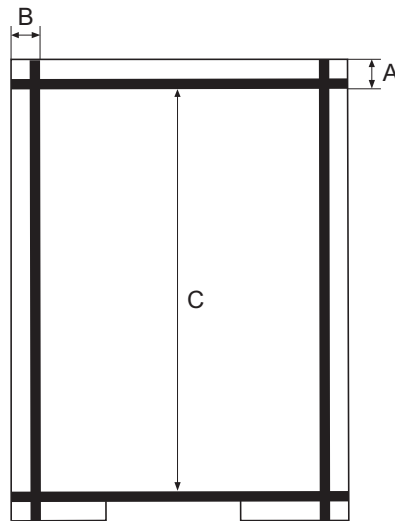

Figure 1-3-16

Setting: [DP] *: This setting is usually unnecessary.

Display	Description	Setting range	Initial setting
Lead	A value of length of detecting the leading edge.	14.0 to 16.0	15.0
Main Scan	A value of width of main scan.	14.0 to 16.0	15.0
Sub Scan	A value of length of sub scan.	265.0 to 269.0	267.0

1. Measure the distance from the leading edge to the black belt (inside) of the original at A.
2. Enter the measured value using the cursor right/left keys or numeric keys in [Lead].
3. Measure the distance from the left edge to the black belt (inside) of the original at B.
4. Enter the measured value using the cursor right/left keys or numeric keys in [Main Scan].
5. Measure the distance from the black belt of leading edge (inside) to the black belt of trailing edge (inside) of the original at C.
6. Enter the measured value using the cursor right/left keys or numeric keys in [Sub Scan].
7. Press the start key. The value is set.



Original for adjustment (P/N: 302NM94330)

Figure 1-3-17

Completion

Press the stop key. The screen for selecting a maintenance item No. is displayed.

U520	Set TDRS
-------------	-----------------

Description

Perform TDRS settings and information views.

Purpose

Perform TDRS settings and information views.

Method

1. Press the start key.
2. Select the item.

Display	Description
Registration	Transition to the TDRS Manager registering dialog
Information	Transition to the Device Agent description dialog
On/Off Config	Transition to the TDRS features dialog

Setting: [Registration]

Select the item.

Display	Description
TDRS User	Registering process using user and password
Access Code	Registering process using an Access Code

Setting: [Access Code]

Select the item.

Display	Description
Regist	Performing registration to TDRS Manager
TDRS Server	TDRS Server URL
TDRS User	TDRS Username
Access Code	TDRS Access Code
Proxy Server	TDRS Proxy Server URL
Proxy Port	TDRS Proxy Port Number
Proxy User	TDRS Proxy Username
Text	TDRS Description

* : The status of Online or Offline will be indicated at the right bottom depending on connection with TDRS Manager.

The Regist button is inoperative if the USB is not installed.

A normal completion will be indicated by Complete in the status of the item that was performed.

An occurrence of an error is indicated by an error number in the status of the item that was performed.

If [User/Processing Registration using a Password] is selected in the previous dialog, the TDRS User will be indicated.

If [Processing Registration using an Access Code] is selected, the Access Code will be indicated.

Error Codes

Codes	Description	Codes	Description
e0001	HDD is unavailable.	t0001	Fatal error.
e0002	USB memory is unavailable.	t0002	Error in processing the network.
e0003	The file to import does not exist in the USB.	t0003	An illegal parameter error.
e0004	Reading from the USB has failed.	t0004	Insufficient resource.
e0005	Unmounting USB has failed.	t0005	Communication error.
e0006	Moving or renaming the file has failed.	t0006	Error in processing communication.
e0007	Opening the file has failed.	t0007	Login error.
e0008	Closing the file has failed.	t0008	External error.
e0009	Error in reading the file.	t0009	Authentication error.
e000A	Copying the file has failed.	t000A	Request error.
e000B	Opening the directory has failed.	t000B	Error due to the server.
e00C	Creating a working directory has failed.	t00C	Error due to the client.
e00D	Deleting a working file has failed.		

Setting: [Information]

1. Select the item.

Display	Description
Agent ID	Agent ID
Agent Type	Agent Type
Model	model name
Serial No	Serial number
Offline	TDRS connection state

Setting: [On/Off Config]

1. Select the item.

Display	Description
On	Enable TDRS
Off	Disable TDRS

2. Press the start key. The value is set.
3. Turn the main power switch off and on. Allow more than 5 seconds between Off and On.

Completion

Press the stop key. The screen for selecting a maintenance item No. is displayed.

U600	Init All Data
-------------	----------------------

Description

Initializes software switches and all data in the backup data on the FAX control board, according to the destination and OEM.

Executes the check of the file system, when abnormality of the file system is detected, initializes the file system, communication past record and register setting contents.

Purpose

To initialize the FAX control board.

Method

1. Press the start key.
The screen for entering the destination code and OEM code is displayed.
2. Select [Country Code] and enter a destination code using the numeric keys (refer to the destination code list on following for the destination code).

Display	Destination
Country Code	Country code.
OEM Code	OEM code.
Execute	Data initialization starts.

* : OEM code is no operation necessary.

3. Select [Execute] and press the start key.
Data initialization starts. To cancel data initialization, press the stop key.
4. After data initialization, the entered destination, OEM codes and ROM version are displayed. A ROM version displays three kinds, application, boot, and IPL.

* : When initialization is successful, "Completed" during 1 second is displayed.

* : Where an irregular value is inputted, when it initializes, the following error displays are performed.

Kind of error
Unknown Country (When Country Code is unknown)
Unknown OEM (When OEM Code is unknown)
Unknown Country (When both are unknown)

Destination code list

Code	Destination	Code	Destination
007	Argentina	115	Mexico
009	Australia	126	New Zealand
022	Brazil	136	Peru
038	China	137	Philippines
080	Hong Kong	152	Middle East
084	Indonesia	156	Singapore
088	Israel	159	South Africa
097	Korea	169	Thailand
108	Malaysia	181	U.S.A.

Code	Destination	Code	Destination
250	Russia	253	Austria
253	CTR21 (European nations)	↑	Switzerland
↑	Italy	↑	Belgium
↑	Germany	↑	Denmark
↑	Spain	↑	Finland
↑	U.K.	↑	Portugal
↑	Netherlands	↑	Ireland
↑	Sweden	↑	Norway
↑	France	254	Taiwan

U601	Init Keep Data
-------------	-----------------------

Description

Initializes software switches on the FAX control board according to the destination and OEM.

Purpose

To initialize the FAX control board without changing user registration data.

1. Press the start key.

The screen for entering the destination code and OEM code is displayed.

2. Select [Country Code] and enter a destination code using the numeric keys (refer to the destination code list on P.1-3-63 for the destination code).

Display	Destination
Country Code	Country code.
OEM Code	OEM code.
Execute	Data initialization starts.

* : OEM code is no operation necessary.

3. Select [Execute] and press the start key.

Data initialization starts. To cancel data initialization, press the back key.

4. After data initialization, the entered destination, OEM codes and ROM version are displayed. A ROM version displays three kinds, application, boot, and IPL.

U603	User Data 1
-------------	--------------------

Description

Makes user settings to enable the use of the machine as a fax.

Purpose

To be executed as required.

Method

1. Press the start key.
2. Select [Line Type] and press the start key.

Display	Description
Line Type	Line Type

3. Select the item to be set.

Display	Description
DTMF	DTMF
10PPS	10PPS
20PPS	20PPS

* : Initial setting: DTMF

4. Press the start key. The setting is set.

Completion

Press the stop key. The screen for selecting a maintenance item No. is displayed.

U604	User Data 2
-------------	--------------------

Description

Makes user settings to enable the use of the machine as a fax.

Purpose

Use this if the user wishes to adjust the number of rings that occur before the unit switches into fax receiving mode when fax/telephone auto-select is enabled.

Method

1. Press the start key.
2. Select [Rings(F/P)#].
3. Change the setting using the cursor right/left keys or numeric keys.

Display	Description	Setting range	Initial setting
Rings(F/T)	Number of fax/telephone rings	0 to 15	2 (120 V)/ 1 (220-240 V)

* : If you set this to 0, the unit will start fax reception without any ringing.

4. Press the start key. The value is set.

Completion

Press the stop key. The screen for selecting a maintenance item No. is displayed.

U605	Clr Data
-------------	-----------------

Description

Initializes data related to the fax transmission such as transmission history.

Purpose

To clear the transmission history.

Method

1. Press the start key.
2. Select [Comm Rec].

Display	Description
Comm Rec	To clear the transmission history.

3. Press the start key. Initialization processing starts. When processing is finished, [Completed] is displayed.

Completion

Press the stop key. The screen for selecting a maintenance item No. is displayed.

U610	System Setting 1
-------------	-------------------------

Description

Makes settings for fax reception regarding the sizes of the fax paper and received images and automatic printing of the protocol list.

Method

1. Press the start key.
2. Select the item to be set.

Display	Description
Cut Line:A4	Sets the number of lines to be ignored when receiving a fax (A4R/LetterR) in the auto reduction mode.
Cut Line:100%	Sets the number of lines to be ignored when receiving a fax at 100% magnification.
Cut Line:Auto	Sets the number of lines to be ignored when receiving a fax in the auto reduction mode.

Setting the number of lines to be ignored when receiving a fax (A4R/LetterR) in the auto reduction mode

Sets the maximum number of lines to be ignored if the received data volume exceeds the recording capacity when the data is recorded in the auto reduction mode onto A4R or LetterR paper under the conditions below.

If the number of excess lines is below the setting, those lines are ignored. If over the setting, the entire data on a page is further reduced so that it can be recorded on the same page.

1. Change the setting using the cursor right/left keys or numeric keys.

Description	Setting range	Initial setting	Change in value per step
Number of lines to be ignored when receiving a fax (A4R, letter) in the auto reduction mode	0 to 22	0	16 lines

* : Increase the setting if a page received in the reduction mode is over-reduced and too much trailing edge margin is left. Decrease it if the received image does not include all transmitted data.

2. Press the start key. The value is set.

Setting the number of lines to be ignored when receiving a fax at 100% magnification

Sets the maximum number of lines to be ignored if the received data volume exceeds the recording capacity when recording the data at 100% magnification. If the number of excess lines is below the setting, those lines are ignored. If over the setting, they are recorded on the next page.

1. Change the setting using the cursor right/left keys or numeric keys.

Description	Setting range	Initial setting	Change in value per step
Number of lines to be ignored when receiving at 100%	0 to 22	3	16 lines

* : Increase the setting if a blank second page is output, and decrease it if the received image does not include the entire transmitted data.

2. Press the start key. The value is set.

Setting the number of lines to be ignored when receiving a fax in the auto reduction mode

Sets the maximum number of lines to be ignored if the received data volume exceeds the recording capacity when the data is recorded in the auto reduction mode. If the number of excess lines is below the setting, those lines are ignored. If over the setting, the entire data on a page is further reduced so that it can be recorded on the same page.

1. Change the setting using the cursor right/left keys or numeric keys.

Description	Setting range	Initial setting	Change in value per step
Number of lines to be ignored when receiving in the auto reduction mode	0 to 22	0	16 lines

* : Increase the setting if a page received in the reduction mode is over-reduced and too much trailing edge margin is left. Decrease it if the received image does not include all transmitted data.

2. Press the start key. The value is set.

Completion

Press the stop key. The screen for selecting a maintenance item No. is displayed.

U611	System Setting 2
------	-------------------------

Description

Sets the number of adjustment lines for automatic reduction.

Purpose

It carries out to set up the number of adjustment lines of automatic reduction.

Method

1. Press the start key.
2. Select the item to be set.

Display	Description
ADJ LINES	Sets the number of adjustment lines for automatic reduction.
ADJ LINES(A4)	Sets the number of adjustment lines for automatic reduction when A4 paper is set.
ADJ LINES(LT)	Sets the number of adjustment lines for automatic reduction when letter size paper is set.

Setting: ADJ LINES

Sets the number of adjustment lines for automatic reduction.

1. Change the setting using the cursor right/left keys or numeric keys.

Description	Setting range	Initial setting
Number of adjustment lines for automatic reduction	0 to 22	7

2. Press the start key. The value is set.

Setting: ADJ LINES(A4)

Sets the number of adjustment lines for automatic reduction when A4 paper is set.

1. Change the setting using the cursor right/left keys or numeric keys.

Description	Setting range	Initial setting
Number of adjustment lines for automatic reduction when A4 paper is set	0 to 22	22

2. Press the start key. The value is set.

Setting: ADJ LINES(LT)

Sets the number of adjustment lines for automatic reduction when letter size paper is set.

1. Change the setting using the cursor right/left keys or numeric keys.

Description	Setting range	Initial setting
Number of adjustment lines for automatic reduction when letter size paper is set	0 to 22	22

2. Press the start key. The value is set.

Completion

Press the stop key. The screen for selecting a maintenance item No. is displayed.

U612	System Setting 3
-------------	-------------------------

Description

Makes settings for fax transmission regarding operation and automatic printing of the protocol list.

Method

1. Press the start key.
2. Select the item to be set.

Display	Description
Auto Reduct	Selects if auto reduction in the auxiliary direction is to be performed.
Protocol List	Sets the automatic printing of the protocol list.

Selecting if auto reduction in the auxiliary direction is to be performed

Sets whether to receive a long document by automatically reducing it in the auxiliary direction or at 100% magnification.

1. Select the setting using the cursor right/left keys.

Display	Description
On	Auto reduction is performed if the received document is longer than the fax paper.
Off	Auto reduction is not performed.

* : Initial setting: On

2. Press the start key. The setting is set.

Setting the automatic printing of the protocol list

Sets if the protocol list is automatically printed out.

1. Select the setting using the cursor right/left keys.

Display	Description
Err	The protocol list is automatically printed out after communication only if a communication error occurs.
On	The protocol list is automatically printed out after communication.
Off	The protocol list is not printed out automatically.

* : Initial setting: Off

2. Press the start key. The setting is set.

Completion

Press the stop key. The screen for selecting a maintenance item No. is displayed.

U620	FAX System
-------------	-------------------

Description

Sets the signal detection method for remote switching. Be sure to change the setting according to the type of telephone connected to the machine.

Purpose

The decision system of a remote change is set up to compensate for a user's telephone classification, peculiarity.

Setting

1. Press the start key.
2. Select [Remort Mode] and press the start key.

Display	Description
Remort Mode	setting the mode

3. Select the item to be set.

Display	Description
One	One-shot detection
Cont	Continuous detection

* : Initial setting: One

4. Press the start key. The setting is set.

Completion

Press the stop key. The screen for selecting a maintenance item No. is displayed.

U625	Set Comm
-------------	-----------------

Description

Makes settings for the auto redialing interval and the number of times of auto redialing.

Purpose

Change the setting to prevent the following problems:

fax transmission is not possible due to too short redial interval, or fax transmission takes too much time to complete due to too long redial interval.

Method

1. Press the start key.
2. Select the item to be set.

Display	Description
Interval	Setting the auto redialing interval
Times	Setting the number of times of auto redialing

Setting: interval

1. Change the setting using the cursor right/left keys.

Description	Setting range	Initial setting
Redialing interval	1 to 9 (min.)	3 (120 V)/ 2 (220-240 V)

2. Press the start key. The value is set.

Setting: times

1. Change the setting using the cursor right/left keys or numeric keys.

Description	Setting range	Initial setting
Number of redialing	0 to 15	2 (120 V)/ 3 (220-240 V)

2. Press the start key. The value is set.

Completion

Press the stop key. The screen for selecting a maintenance item No. is displayed.

U630	Comm Ctrl 1
-------------	--------------------

Description

Makes settings for fax transmission regarding the communication.

Purpose

The event of a request for user.

Reduce transmission time and the reception of accuracy when using poor quality line.

Improve the accuracy of communication at international communication.

Method

1. Press the start key.
2. Select the item to be set.

Display	Description
TX Speed	Sets the communication starting speed.
RX Speed	Sets the reception speed.
TX Echo	Sets the waiting period to prevent echo problems at the sender.
RX Echo	Sets the waiting period to prevent echo problems at the receiver.

Setting the communication starting speed

Sets the initial communication speed when starting transmission. When the destination unit has V.34 capability, V.34 is selected for transmission, regardless of this setting.

1. Select the setting.

Display	Description
14400bps/V17	V.17, 14400 bps
9600bps/V29	V.17, 9600 bps
4800bps/V27ter	V.27ter, 4800 bps
2400bps/V27ter	V.27ter, 2400 bps

* : Initial setting: 14400bps/V17

2. Press the start key. The setting is set.

Setting the reception speed

Sets the reception speed that the sender is informed of using the DIS or NSF signal. When the destination unit has V.34 capability, V.34 is selected, regardless of the setting.

1. Select the setting.

Display	Description
14400bps	V.17, V.33, V.29, V.27ter
9600bps	V.29, V.27ter
4800bps	V.27ter
2400bps	V.27ter (fallback only)

* : Initial setting: 14400bps

2. Press the start key. The setting is set.

Setting the waiting period to prevent echo problems at the sender

Sets the period before a DCS signal is sent after a DIS signal is received. Used when problems occur due to echoes at the sender.

1. Select the setting.

Display	Description
500	Sends a DCS 500 ms after receiving a DIS.
300	Sends a DCS 300 ms after receiving a DIS.

* : Initial setting: 300

2. Press the start key. The setting is set.

Setting the waiting period to prevent echo problems at the receiver

Sets the period before an NSF, CSI or DIS signal is sent after a CED signal is received. Used when problems occur due to echoes at the receiver.

1. Select the setting.

Display	Description
500	Sends an NSF, CSI or DIS 500 ms after receiving a CED.
75	Sends an NSF, CSI or DIS 75 ms after receiving a CED.

* : Initial setting: 75

2. Press the start key. The setting is set.

Completion

Press the stop key. The screen for selecting a maintenance item No. is displayed.

U631	Comm Ctrl 2
-------------	--------------------

Description

Makes settings regarding fax transmission.

Purpose

Transmission and reception of ECM are set up.

The frequency of CED is set up.

1. Press the start key.
2. Select the item to be set.

Display	Description
ECM TX	Sets ECM transmission.
ECM RX	Sets ECM reception.
CED Freq.	Sets the frequency of the CED signal.

Setting: ECM TX

To be set to OFF when reduction of transmission costs is of higher priority than image quality. This should not be set to OFF when connecting to the IP (Internet Protocol) telephone line.

1. Select the setting.

Display	Description
On	ECM transmission is enabled.
Off	ECM transmission is disabled.

* : Initial setting: ON

2. Press the start key. The setting is set.

Setting: ECM RX

To be set to OFF when reduction of transmission costs is of higher priority than image quality. This should not be set to OFF when connecting to the IP (Internet Protocol) telephone line.

1. Select the setting.

Display	Description
On	ECM reception is enabled.
Off	ECM reception is disabled.

* : Initial setting: ON

2. Press the start key. The setting is set.

Setting: Freq.

Sets the frequency of the CED signal. Used as one of the measures to improve transmission performance for international communications.

1. Select the setting.

Display	Description
2100	2100Hz
1100	1100Hz

* : Initial setting: 2100

2. Press the start key. The setting is set.

Completion

Press the stop key. The screen for selecting a maintenance item No. is displayed.

U632	Comm Ctrl 3
-------------	--------------------

Description

Makes settings for fax transmission regarding the communication.

Purpose

Reduction of error communication when a low quality circuit is used.
When changing a FAX/TEL automatic change.

Method

1. Press the start key.
2. Select the item to be set.

Display	Description
DIS 4Byte	Sets the DIS signal to 4 bytes.
Num OF CNG(F/T)	Sets the CNG detection times in the fax/telephone auto select mode.

Setting: DIS 4 byte

Sets if bit 33 and later bits of the DIS/DTC signal are sent.

1. Select the setting.

Display	Description
On	Bit 33 and later bits of the DIS/DTC signal are not sent.
Off	Bit 33 and later bits of the DIS/DTC signal are sent.

* : Initial setting: Off

2. Press the start key. The setting is set.

Setting: Num CNG detection times in the fax/telephone auto select mode

Sets the CNG detection times in the fax/telephone auto select mode.

1. Select the setting.

Display	Description
1Time	Detects CNG once.
2Time	Detects CNG twice.

* : Initial setting: 1times

2. Press the start key. The setting is set.

Completion

Press the stop key. The screen for selecting a maintenance item No. is displayed.

U633	Comm Ctrl 4
-------------	--------------------

Description

Makes settings for fax transmission regarding the communication.

Purpose

To reduce transmission errors when a low quality line is used.

Method

1. Press the start key.
2. Select the item to be set.

Display	Description
V.34	Enables or disables V.34 communication.
V.34-3429Hz	Sets the V.34 symbol speed (3429 Hz).
DIS 2Res	Sets the number of times of DIS signal reception.
RTN Check	Sets the reference for RTN signal output.

Enabling/disabling V.34 communication

Sets whether V.34 communication is enabled/disabled for transmission and reception.

1. Select the setting.

Display	Description
On	V.34 communication is enabled for both transmission and reception.
TX	V.34 communication is enabled for transmission only.
RX	V.34 communication is enabled for reception only.
Off	V.34 communication is disabled for both transmission and reception.

* : Initial setting: ON

2. Press the start key. The setting is set.

Setting the V.34 symbol speed (3429 Hz)

Sets if the V.34 symbol speed 3429 Hz is used.

1. Select the setting.

Display	Description
On	V.34 symbol speed 3429 Hz is used.
Off	V.34 symbol speed 3429 Hz is not used.

* : Initial setting: ON

2. Press the start key. The setting is set.

Setting the number of times of DIS signal reception

Sets the number of times to receive the DIS signal to once or twice. Used as one of the correction measures for transmission errors and other problems.

1. Select the setting.

Display	Description
Once	Responds to the first signal.
Twice	Responds to the second signal.

* : Initial setting: ONCE

2. Press the start key. The setting is set.

Setting the reference for RTN signal output

Sets the error line rate as the reference for RTN signal output. If transmission errors occur frequently due to the quality of the line, they can be reduced by lowering this setting.

1. Select the setting.

Display	Description
5%	Error line rate of 5%
10%	Error line rate of 10
15%	Error line rate of 15%
20%	Error line rate of 20%

* : Initial setting: 15%

2. Press the start key. The setting is set.

Completion

Press the stop key. The screen for selecting a maintenance item No. is displayed.

U634	Comm Ctrl 5
-------------	--------------------

Description

Sets the maximum number of error bytes judged acceptable when receiving a TCF signal. Used as a measure to ease transmission conditions if transmission errors occur.

Purpose

Do to alleviate the communication conditions.

Setting

1. Press the start key.
2. Select [TCF Check].
3. Change the setting using the cursor right/left keys or numeric keys.

Display	Description	Setting range
TCF Check	Number of allowed error bytes when detecting TCF	1 to 255

4. Press the start key. The value is set.

Completion

Press the stop key. The screen for selecting a maintenance item No. is displayed.

U640	Comm Time 1
-------------	--------------------

Description

Sets the detection time when one-shot detection is selected for remote switching. (This setting item will be displayed, but the setting made is ineffective.)

Sets the detection time when continuous detection is selected for remote switching. (This setting item will be displayed, but the setting made is ineffective.)

Purpose

The decision system of a remote change is set up to compensate for a user's telephone classification, peculiarity, etc.

Method

1. Press the start key.
2. Select the item to be set.
3. Change the setting using the cursor right/left keys.

Display	Description	Setting range	Initial setting
Time(One)	Sets the one-shot detection time for remote switching.	0 to 255	7
Time(Cont)	Sets the continuous detection time for remote switching.	0 to 255	80

4. Press the start key. The value is set.

Completion

Press the stop key. The screen for selecting a maintenance item No. is displayed.

U641	Comm Time 2
-------------	--------------------

Description

Sets the time-out time for fax transmission.

Purpose

To improve transmission performance for international communications mainly.

Method

1. Press the start key.
2. Select the item to be set.

Display	Description
T0 TIME OUT	Sets the T0 time-out time.
T1 TIME OUT	Sets the T1 time-out time.
T2 TIME OUT	Sets the T2 time-out time.
Ta TIME OUT	Sets the Ta time-out time.
Tb1 TIME OUT	Sets the Tb1 time-out time.
Tb2 TIME OUT	Sets the Tb2 time-out time.
Tc TIME OUT	Sets the Tc time-out time.
Td TIME OUT	Sets the Td time-out time.

Setting: T0 time out

Sets the time before detecting a CED or DIS signal after a dialing signal is sent.

Depending on the quality of the exchange, or when the auto select function is selected at the destination unit, a line can be disconnected. Change the setting to prevent this problem.

1. Change the setting using the cursor right/left keys.

Description	Setting range	Initial setting
T0 time-out time	30 to 90 s	56

2. Press the start key. The value is set.

Setting: T1 time out

Sets the time before receiving the correct signal after call reception. No change is necessary for this maintenance item.

1. Change the setting using the cursor right/left keys.

Description	Setting range	Initial setting
T1 time-out time	30 to 90 s	36

2. Press the start key. The value is set.

Setting: T2 time out

The T2 time-out time decides the following.

From CFR signal output to image data reception

From image data reception to the next signal reception

In ECM, from RNR signal detection to the next signal reception

1. Change the setting using the cursor right/left keys.

Description	Setting range	Initial setting
T2 time-out time	1 to 255	69

2. Press the start key. The value is set.

Setting: Ta time out

In the fax/telephone auto select mode, sets the time to continue ringing an operator through the connected telephone after receiving a call as a fax machine (see figure 1-3-18). A fax signal is received within the Ta set time, or the fax mode is selected automatically when the time elapses. In fax/telephone auto select mode, change the setting when fax reception is unsuccessful or a telephone fails to receive a call.

1. Change the setting using the cursor right/left keys.

Description	Setting range	Initial setting
Ta time-out time	1 to 255	30

2. Press the start key. The value is set.

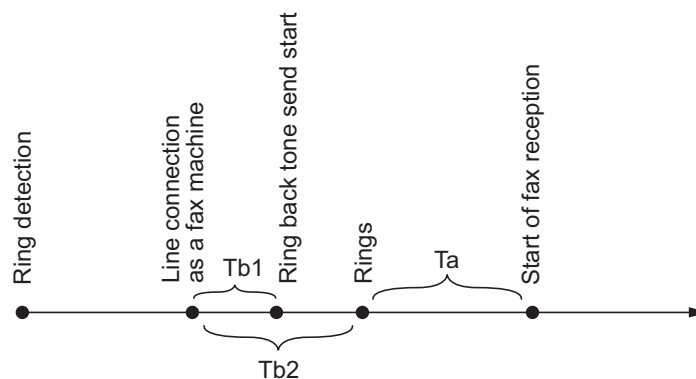

Figure 1-3-18 Ta/Tb1/Tb2 time-out time

Setting: Tb1 time out

In the fax/telephone auto select mode, sets the time to start sending the ring back tone after receiving a call as a fax machine (see figure 1-3-18). In fax/telephone auto select mode, change the setting when fax reception is unsuccessful or a telephone fails to receive a call.

1. Change the setting using the cursor right/left keys.

Description	Setting range	Initial setting
Tb1 time-out time	1 to 255	20

2. Press the start key. The value is set.

Setting: Tb2 time out

In the fax/telephone auto select mode, sets the time to start ringing an operator through the connected telephone after receiving a call as a fax machine (see figure 1-3-18). In the fax/telephone auto select mode, change the setting when fax reception is unsuccessful or a telephone fails to receive a call.

1. Change the setting using the cursor right/left keys.

Description	Setting range	Initial setting
Tb2 time-out time	1 to 255	100 ms

2. Press the start key. The value is set.

Setting: Tc time out

In the TAD mode, set the time to check if there are any triggers for shifting to fax reception after a connected telephone receives a call. Only the telephone function is available if shifting is not made within the set Tc time.

In the TAD mode, change the setting when fax reception is unsuccessful or a telephone fails to receive a call.

1. Change the setting using the cursor right/left keys.

Description	Setting range	Initial setting
Tc time-out time	1 to 255	60

2. Press the start key. The value is set.

Setting: Td time out

Sets the length of the time required to determine silent status (fax), one of the triggers for Tc time check. In the TAD mode, change the setting when fax reception is unsuccessful or a telephone fails to receive a call. Be sure not to set it too short; otherwise, the mode may be shifted to fax while the unit is being used as a telephone.

1. Change the setting using the cursor right/left keys.

Description	Setting range	Initial setting
Td time-out time	1 to 255	9 (120 V)/ 6 (220-240 V)

2. Press the start key. The value is set.

Completion

Press the stop key. The screen for selecting a maintenance item No. is displayed.

U650	Modem 1
-------------	----------------

Description

Sets the G3 cable equalizer. Sets the modem detection level.

Purpose

Perform the following adjustment to make the equalizer compatible with the line characteristics. To improve the transmission performance when a low quality line is used.

Method

1. Press the start key.
2. Select the item to be set.

Display	Description
Reg G3 TX Eqr	Sets the G3 transmission cable equalizer.
Reg G3 RX Eqr	Sets the G3 reception cable equalizer.
RX Mdm Level	Sets the modem detection level.

Setting: Reg G3 TX Eqr

1. Select [0dB], [4dB], [8dB] or [12dB].
* : Initial setting: 0dB
2. Press the start key. The setting is set.

Setting: Reg G3 RX Eqr

1. Select [0dB], [4dB], [8dB] or [12dB].
* : Initial setting: 0dB
2. Press the start key. The setting is set.

Setting: RX Mdm Level

1. Select [33dBm], [38dBm], [43dBm] or [48dBm].
* : Initial setting: 43dBm
2. Press the start key. The setting is set.

Completion

Press the stop key. The screen for selecting a maintenance item No. is displayed.

U651	Modem 2
-------------	----------------

Description

Sets the modem output level.

Sets the DTMF output level of a push-button dial telephone.

Purpose

Used if problems occur when sending a signal with a push-button dial telephone.

Setting

1. Press the start key.
2. Select the item to be set.
3. Change the setting using the cursor right/left keys or numeric keys.

Display	Description	Setting range
Sgl LV Mdm	Modem output level	-15 to 0
DTMF LV(C)	DTMF output level (main value)	-15 to 0
DTMF LEV(D)	DTMF output level (level difference)	0 to 5.5

4. Press the start key. The setting is set.

Completion

Press the stop key. The screen for selecting a maintenance item No. is displayed.

U660	Set Calls
-------------	------------------

Description

Makes setting regarding the network control unit (NCU).

Purpose

To be executed as required.

Method

1. Press the start key.
2. Select the item to be set.

Display	Description
Exchange	Sets the connection to PBX/PSTN.
Dial Tone	Sets PSTN dial tone detection.
Busy Tone	Sets busy tone detection.
PBX Setting	Setting for a PBX.
DC Loop	Sets the loop current detection before dialing.

Setting: Exchange

Selects if a fax is to be connected to either a PBX or public switched telephone network.

1. Select the setting.

Display	Description
PSTN	Connected to the public switched telephone network.
PBX	Connected to a PBX.

* : Initial setting: PSTN

2. Press the start key. The setting is set.

Setting: Dial Tone

Selects if the dial tone is detected to check the telephone is off the hook when a fax is connected to a public switched telephone network.

1. Select the setting.

Display	Description
On	Detects the dial tone.
Off	Does not detect the dial tone.

* : Initial setting: On

2. Press the start key. The setting is set.

Setting: Busy tone

When a fax signal is sent, sets whether the line is disconnected immediately after a busy tone is detected, or the busy tone is not detected and the line remains connected until T0 time-out time. Fax transmission may fail due to incorrect busy tone detection. When set to 2, this problem may be prevented. However, the line is not disconnected within the T0 time-out time even if the destination line is busy.

1. Select the setting.

Display	Description
On	Detects busy tone.
Off	Does not detect busy tone.

* : Initial setting: On

2. Press the start key. The setting is set.

Setting: PBX Setting

Selects the mode to connect an outside call when connected to a PBX. According to the type of the PBX connected, select the mode to connect an outside call.

1. Select the setting.

Display	Description
Flash	Flashing mode
Loop	Code number mode

* : Initial setting: Loop

2. Press the start key. The setting is set.

Setting: DC loop

Sets if the loop current detection is performed before dialing.

1. Select the setting.

Display	Description
On	Performs loop current detection before dialing.
Off	Does not perform loop current detection before dialing.

* : Initial setting: On

2. Press the start key. The setting is set.

Completion

Press the stop key. The screen for selecting a maintenance item No. is displayed.

U670	Output List
-------------	--------------------

Description

Outputs a list of data regarding fax transmissions.

Printing a list is disabled either when a job is remaining in the buffer or when [Pause All Print Jobs] is pressed to halt printing.

Purpose

To check conditions of use, settings and transmission procedures of the fax.

Method

1. Press the start key.
2. Select the item to be output.
3. Press the start key. The selected list is output.

Display	Description
Sys Conf Report	Outputs a list of software switches, self telephone number, confidential boxes, ROM versions and other information.
Action List	Outputs a list of error history, transmission line details and other information.
Self Sts Report	Outputs a list of settings in maintenance mode (own-status report) regarding fax transmission only.
Protocol List	Outputs a list of transmission procedures.
Error List	Outputs a list of error.
Addr List(No.)	Outputs address book in order IDs were added
Addr List(Idx)	Outputs address book in order of names
One-touch List	Outputs a list of one-touch.
Group List	Outputs a list of group.

Completion

Press the stop key. The screen for selecting a maintenance item No. is displayed.

U695	Custom FAX Func
-------------	------------------------

Description

Sets fax batch transmission ON/OFF. Also changes the print size priority at the time of small size reception.

Purpose

To be executed as required.

Setting

* : Select the setting.

Display	Description
FAX Bulk TX	fax batch transmission On/Off
A5 Pt Pri Chg	Change of print size priority at the time of small size reception

Setting: [FAX Bulk TX]

1. Select [On] or [Off] using the cursor right/left keys.

Display	Description
On	Fax batch transmission is enabled.
Off	Fax batch transmission is disabled.

* : Initial setting: On

2. Press the start key. The setting is set.

Setting: [A5 Pt Pri Chg]

1. Select [On] or [Off] using the cursor right/left keys.

Display	Description
On	At the time of A5 size reception: A5→B5→A4→B4→A3
Off	At the time of A5 size reception: A5→A4→B5→A3→B4

* : Initial setting: Off

2. Press the start key. The setting is set.

Completion

Press the stop key. The screen for selecting a maintenance item No. is displayed.

U699	Set Soft SW
-------------	--------------------

Description

Sets the software switches on the FAX control board individually.

Purpose

To change the setting when a problem such as split output of received originals occurs. Since the communication performance is largely affected, normally this setting need not be changed.

Method

1. Press the start key.
2. Press [SW No.].
3. Enter the desired software switch number (3 digits) using the numeric keys and press the enter key.

Display	Description
SW No.	SW No.

4. Use numeric keys 7 to 0 to switch each bit between 0 and 1.

Display	Description
Bit	Set the soft switch.

5. Press the start key to set the value.

Completion

Press the stop key. The screen for selecting a maintenance item No. is displayed.

List of Software Switches of Which the Setting Can Be Changed

<Communication control procedure>

No.	bit	Description
36	7654	Coding format in transmission
	3210	Coding format in reception
37	5	33600bps/V34
	4	31200bps/V34
	3	28800bps/V34
	2	26400bps/V34
	1	24000bps/V34
	0	21600bps/V34
38	7	19200bps/V34
	6	16800bps/V34
	5	14400bps/V34
	4	12000bps/V34
	3	9600bps/V34
	2	7200bps/V34
	1	4800bps/V34

No.	bit	Description
	0	2400bps/V34
41	3	FSK detection in V.8
42	4	4800 bps when low-speed setting is active
	2	FIF length in transmission of more than 4 times of DIS/DTC signal

<Communication time setting>

No.	bit	Description
53	76543210	T3 timeout setting
54	76543210	T4 timeout setting (automatic equipment)
55	76543210	T5 timeout setting
60	76543210	Time before transmission of CNG (1100 Hz) signal
63	76543210	T0 timeout setting (manual equipment)
64	7	Phase C timeout in ECM reception
66	76543210	Timeout 1 in countermeasures against echo
68	76543210	Timeout for FSK detection start in V.8

<Modem setting>

No.	bit	Description
89	76543	RX gain adjust

<NCU setting>

No.	bit	Description
121	7654	Dial tone/busy tone detection pattern
122	7654	Busy tone detection pattern
	1	Busy tone detection in automatic FAX/TEL switching
125	76543210	Access code registration for connection to PSTN
126	7654	FAX/TEL automatic switching ringback tone ON/OFF cycle

<Calling time setting>

No.	bit	Description
133	76543210	DTMF signal transmission time
134	76543210	DTMF signal pause time
141	76543210	Ringer detection cycle (minimum)
142	76543210	Ringer detection cycle (maximum)
143	76543210	Ringer ON time detection
144	76543210	Ringer OFF time detection
145	76543210	Ringer OFF non-detection time
147	76543210	Dial tone detection time (continuous tone)

No.	bit	Description
148	76543210	Allowable dial tone interruption time
149	76543210	Time for transmitting selection signal after closing the DC circuit
151	76543210	Ringer frequency detection invalid time

U901	Clr Paper FD Cnt
-------------	-------------------------

Description

Displays copy counts by paper feed locations.

Purpose

To check the time to replace consumable parts.

Method

1. Press the start key. The counts by paper feed locations are displayed.

Display	Description
MPT	MP tray
Cass1	Cassette 1
Cass2	Cassette 2 (paper feeder)
Cass3	Cassette 3 (paper feeder)
Cass4	Cassette 4 (paper feeder)
Cass5	Cassette 5 (paper feeder)
Dup	Duplex unit

* : When an optional paper feed unit is not installed, the corresponding count is not displayed.

Completion

Press the stop key. The screen for selecting a maintenance item No. is displayed.

U905	Option Cnt
-------------	-------------------

Description

Displays the counts of DP.

Purpose

To check the use of DP.

Method

1. Press the start key.
2. Select [DP]. The count is displayed.

Display	Description
DP	Counts of DP

Method: [DP]

Display	Description
ADP	Counts of single-sided originals that has passed through the DP.
RADP	Counts of double-sided originals that has passed through the DP.
Clear	Clears all counters

Clearing

1. Select [Clear].
2. Press the start key. All counters are cleared.

Completion

Press the stop key. The screen for selecting a maintenance item No. is displayed.

U910	Clr Coverage Dat
-------------	-------------------------

Description

Clears the accumulated data for the print coverage per A4 size paper and its period of time (as shown on the service status report).

Purpose

To clear data as required at times such as during maintenance service.

Method

1. Press the start key.
2. Select [Execute].

Display	Description
(No Action)	-
Execute	The print coverage data is cleared.

3. Press the start key. The print coverage data is cleared.

Completion

Press the stop key. The screen for selecting a maintenance item No. is displayed.

U917	R/W Bkup Data
-------------	----------------------

Description

Retrieves the backup data to a USB memory from the machine; or writes the data from the USB memory to the machine.

Purpose

Machine information is backed up and restored.

Method

1. Press the power key on the operation panel, and after verifying the power indicator has gone off, switch off the main power switch.
2. Insert USB memory in USB memory slot.
3. Turn the main power switch on.
Wait for 10 seconds to allow the machine to recognize the USB memory.
4. Enter maintenance item U917.
5. Select [Export] or [Import] and press the start key

Display	Description
Import	Writing data from the USB memory to the machine
Export	Retrieving from the machine to a USB memory

6. Slect the item.

Display	Description	Depending data
Address	Address book	-
Job Acnt	Job accounting	-
One Touch	Information on one-touch key	Address Book
User	User managements	Job Account
Document	Document box information	Job Account, User
Shortcut	Shortcut information	Job Account, User, Document Box
Fax Fwd	FAX transfer information	Job Account, User, Document Box
System	System information	-
Network	Network information	-
Job Set	Job Setting information	-
Printer	Printer information	-
Fax Set	Fax Setting information	-
Program	Program information	Address Book, Job Account, User, Document Box, Fax Forward, Fax Setting
Panel Set	Panel Setting information	Address Book, Job Account, User, Document Box, Fax Forward, Fax Setting, Program

* : Since data are dependent with each other, data other than those assigned are also retrieved or written in.

7. Select [On] using the cursor right/left keys.
8. Press the start key. Starts reading or writing.
The progress of selected item is displayed in %.
When an error occurs, the operation is canceled and an error code is displayed.
9. When normally completed, [Fin] is displayed.
10. Turn the main power switch off and on after completing writing when selecting [Import].

Error Codes

Codes	Description
e000	Unspecified error
e0001	Parameter error
e0002	Failed to generate a Dummy file
e0003	The target XML file to import does not exist
e0004	The exported file does not exist
e0100 to e01ff	Error in handling the addressbook
e0200 to e02ff	Error in handling One-touch
e0300 to e03ff	Error in handling user management
e0400 to e04ff	Error in handling panel-program data
e0500 to e05ff	Error in handling forwarding Fax data
e0600 to e06ff	Error in handling system configurations
e0700 to e07ff	Error in handling network parameters
e0800 to e08ff	Error in handling job accounting
e0900 to e09ff	Error in handling short-cuts
e0a00 to e0aff	Error in handling job information
e0b00 to e0bff	Error in handling Fax data
e0c00 to e0cff	Error in handling printer data
e0d00 to e0dff	Error in handling panel data
e0e00 to e0eff	Error in handling document boxes
e1000 to e1fff	Error in handling device-related information
e2000 to e2fff	Error in handling SOAP IF
e3000 to e3fff	Error in handling KM-WSDL IF
e4000 to e4fff	A file mandatory for importing is missing (e4002)/Invalid file header (e4008)
e5000 to e5fff	Error in handling rewriting SOAP data

Completion

Press the stop key. The screen for selecting a maintenance item No. is displayed.

U920	Chg Cnt
-------------	----------------

Description

Checks the copy counts.

Purpose

To check the copy counts.

Method

1. Press the start key.
2. Select the item to be set.

Display	Description
Main Function	Counts of main function
Sub Function	Counts of sub function

[Setting: Main Function]

1. Select the item.
* : The current counts are displayed.

Display	Description
B/W Copy	Count value of black/white copy
B/W Prn	Count value of black/white print
B/W Fax	Count value of black/white FAX

[Setting: Sub Function]

1. Select the item.
* : The current counts are displayed.

Display	Description
Simplex	Count value of Simplex copy
Dup	Count value of Duplex copy
Comb(Off)	Count value of Combine copy (Off)
Comb(2in1)	Count value of Combine copy (2in1)
Comb(4in1)	Count value of Combine copy (4in1)

Completion

Press the stop key. The screen for selecting a maintenance item No. is displayed.

U927	Clr Chg/Life Cnt
-------------	-------------------------

Description

Resets all of the counts back to zero.

Purpose

The total account counter and the machine life counter can be cleared only once if all count values are 1000 or less.

Method

1. Press the start key.
2. Select [Execute].

Display	Description
(No Action)	-
Execute	All copy counts and machine life counts are cleared.

3. Press the start key. All copy counts and machine life counts are cleared.

Completion

Press the stop key. The screen for selecting a maintenance item No. is displayed.

U928	Life Cnt
-------------	-----------------

Description

Displays the machine life counts.

Purpose

To check the machine life counts.

Method

1. Press the start key. The current machine life counts is displayed.

Display	Description
Cnt	Machine life counts

Completion

Press the stop key. The screen for selecting a maintenance item No. is displayed.

U969	Toner Area Code
-------------	------------------------

Description

Displays the toner area code.

Purpose

To check the toner area code.

Method

1. Press the start key. The toner area code is displayed.

Display	Description
(Code)	Toner area code is displayed.

Completion

Press the stop/clear key. The screen for selecting a maintenance item No. is displayed.

U977	Data capture mode
-------------	--------------------------

Description

Store the print data sent to the machine into USB memory.

Purpose

In case to occur the error at printing, check the print data sent to the machine.

Method

1. Press the power switch and turn the power off.
2. Insert USB memory in USB memory slot.
3. Turn the main power switch on.
4. Enter maintenance item U977.
5. Select [Execute].

Display	Description
Execute	Data capture mode

6. Press the start key.
7. Send the print data to the machine.
Once the print data is stored into USB memory, [Finish] will be displayed.

Completion

Press the stop key. The screen for selecting a maintenance item No. is displayed.

U995	Mem Data Indi
-------------	----------------------

Description

Displays the memory data.

Purpose

To check the memory data.

Method

1. Press the start key.
2. Select [Print Engine].

Display	Description
Print Engine	A display and setup of the Engine section memory

3. Press the start key.

Display	Description
Mode	-
Offset	Reference offset
Data	Reference data

4. Press the start key. The setting is set.
5. Turn the main power switch off and on. Allow more than 5 seconds between Off and On.

Completion

Press the stop key. The screen for selecting a maintenance item No. is displayed.

1-3-2 Service mode

The machine is equipped with a maintenance function which can be used to maintain and service the machine.

(1) Executing a service mode

[Message Display]

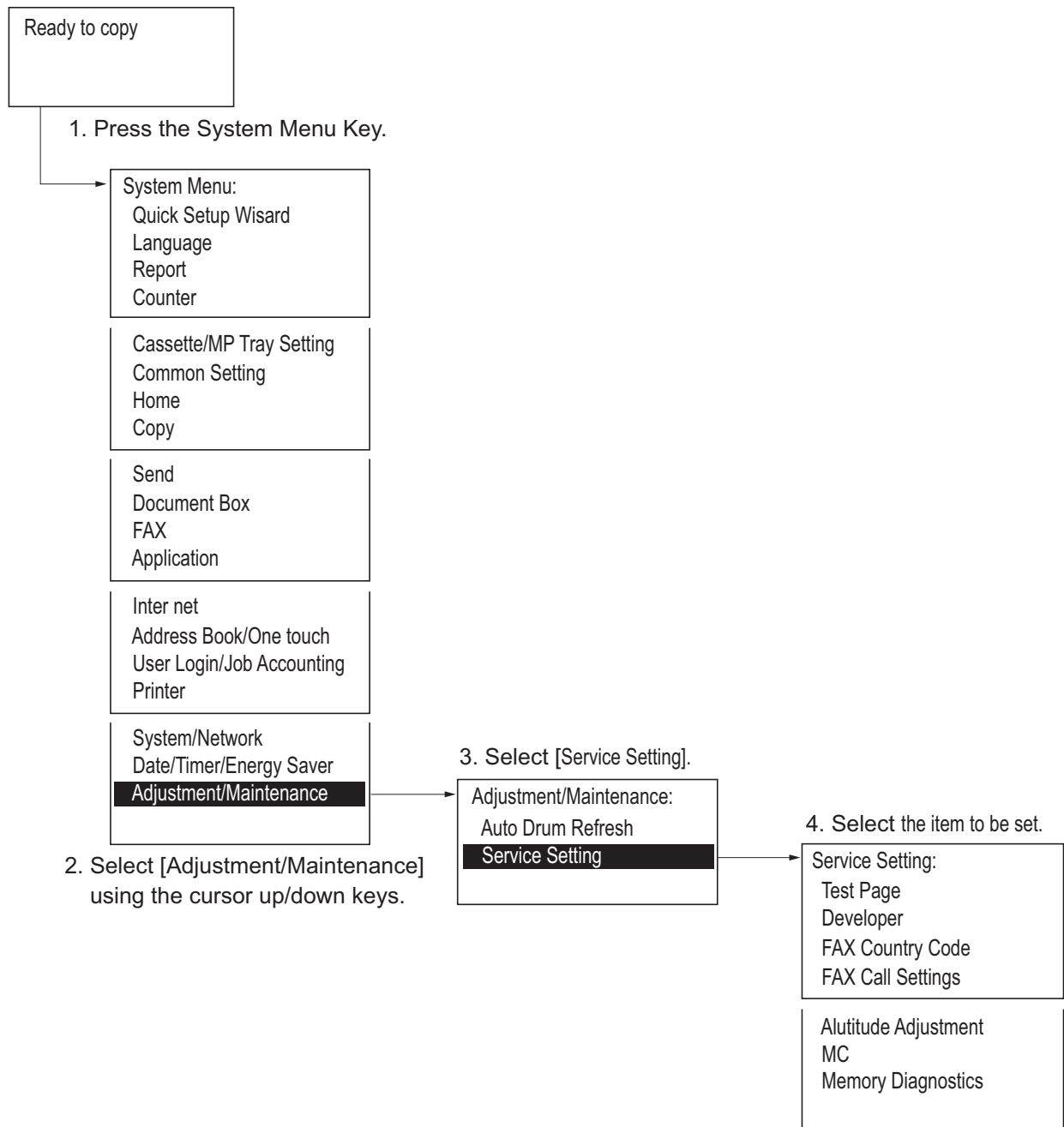

Service setting

Display	Description	Page
Test page	The test page is printed with halftones.	P.1-3-105
Developer	Installs the toner to the developer unit.	P.1-3-106
FAX Country Code	Initializes software switches and all data.	P.1-3-107
FAX Call Settings	Sets FAX for connection.	P.1-3-108
Alutitude Adjustment	Sets the altitude adjustment mode.	P.1-3-109
MC	Sets the main charger output.	P.1-3-109
Memory Diagnostics	Diagnose memory at power up (whether reading and writing are executable).	P.1-3-110

(2) Description of service mode

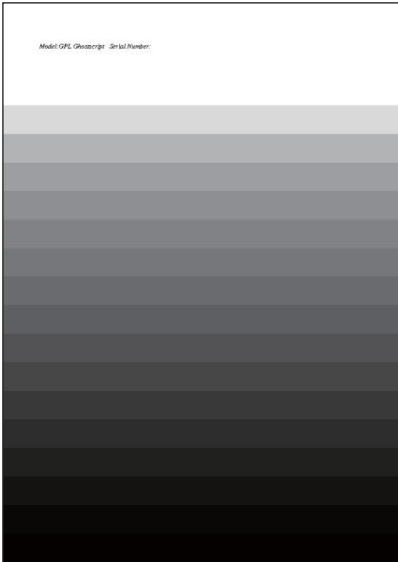
Service items	Description
Test Page	<p>Printing a test page</p> <p>Description The halftones of sixteen different levels are printed for test.</p> <p>Purpose The developmental time of image error, the test print is performed for judgement of the engine-side or the scanner-side.</p> <p>Method</p> <ol style="list-style-type: none"> 1. Enter the Service Setting menu. 2. Select [Test Page]. 3. Press the start key. 4. Press [Yes] (the Left Select key). Test page will be printed. <div style="display: flex; align-items: center; margin: 10px 0;"> <div style="margin-right: 20px;">Gray scale (16 levels)</div>  </div> <p style="text-align: center;">Figure 1-3-19</p> <p>Completion Press the stop key.</p>

Service items	Description
Developer	<p data-bbox="386 241 1013 271">Initializing the developer unit (toner install mode)</p> <p data-bbox="386 309 536 338">Description</p> <p data-bbox="386 340 1430 495">The new developer unit is shipped from the factory with no toner contained. The developer unit can be automatically replete with toner when a toner container is installed onto it and the printer is turned on. However, because the toner reservoir in the developer unit has a large capacity, it requires a lengthy period of time until a substantial amount of toner has been fed to get the machine ready.</p> <p data-bbox="386 501 496 530">Purpose</p> <p data-bbox="386 533 1054 562">To execute when the developing unit has been replaced.</p> <p data-bbox="386 600 483 629">Method</p> <ol data-bbox="402 631 919 763" style="list-style-type: none"> <li data-bbox="402 631 810 660">1. Enter the Service Setting menu. <li data-bbox="402 663 719 692">2. Select [New Developer]. <li data-bbox="402 694 647 723">3. Press the OK key. <li data-bbox="402 725 919 763">4. Select the [YES] using the left select key. <p data-bbox="432 770 715 799">[Accepted] is displayed.</p> <p data-bbox="432 801 1230 831">The toner installation is performed when power is turned on and off.</p> <p data-bbox="416 833 1305 862">NOTE: Toner supply is stopped when toner installation mode is performing.</p> <p data-bbox="386 909 536 938">Completion</p> <p data-bbox="386 940 612 969">Press the stop key.</p>

Service items	Description																																																																												
FAX country code	<p>FAX Country Code</p> <p>Description Initializes software switches and all data in the backup data on the FAX control PWB, according to the destination.</p> <p>Purpose To initialize the FAX control PWB.</p> <p>Method</p> <ol style="list-style-type: none"> 1. Enter the Service Setting menu. 2. Select [FAX Country Code]. 3. Press the start key. 4. Enter a destination code using the numeric keys. 5. Press the start key. The setting is set. 6. Press the start key. Data initialization starts. <p>Destination code list</p> <table border="1" data-bbox="437 842 1394 1751"> <thead> <tr> <th>Code</th> <th>Destination</th> <th>Code</th> <th>Destination</th> </tr> </thead> <tbody> <tr> <td>007</td> <td>Argentina</td> <td>250</td> <td>Russia</td> </tr> <tr> <td>009</td> <td>Australia</td> <td>253</td> <td>CTR21 (European nations)</td> </tr> <tr> <td>022</td> <td>Brazil</td> <td>↑</td> <td>Italy</td> </tr> <tr> <td>038</td> <td>China</td> <td>↑</td> <td>Germany</td> </tr> <tr> <td>080</td> <td>Hong Kong</td> <td>↑</td> <td>Spain</td> </tr> <tr> <td>084</td> <td>Indonesia</td> <td>↑</td> <td>U.K.</td> </tr> <tr> <td>088</td> <td>Israel</td> <td>↑</td> <td>Netherlands</td> </tr> <tr> <td>097</td> <td>Korea</td> <td>↑</td> <td>Sweden</td> </tr> <tr> <td>108</td> <td>Malaysia</td> <td>↑</td> <td>Austria</td> </tr> <tr> <td>115</td> <td>Mexico</td> <td>↑</td> <td>Switzerland</td> </tr> <tr> <td>126</td> <td>New Zealand</td> <td>↑</td> <td>Belgium</td> </tr> <tr> <td>136</td> <td>Peru</td> <td>↑</td> <td>Denmark</td> </tr> <tr> <td>137</td> <td>Philippines</td> <td>↑</td> <td>Finland</td> </tr> <tr> <td>152</td> <td>Middle East</td> <td>↑</td> <td>Portugal</td> </tr> <tr> <td>156</td> <td>Singapore</td> <td>↑</td> <td>Ireland</td> </tr> <tr> <td>159</td> <td>South Africa</td> <td>↑</td> <td>Norway</td> </tr> <tr> <td>169</td> <td>Thailand</td> <td>254</td> <td>Taiwan</td> </tr> <tr> <td>181</td> <td>U.S.A.</td> <td></td> <td></td> </tr> </tbody> </table> <p>Completion Press the stop key.</p>	Code	Destination	Code	Destination	007	Argentina	250	Russia	009	Australia	253	CTR21 (European nations)	022	Brazil	↑	Italy	038	China	↑	Germany	080	Hong Kong	↑	Spain	084	Indonesia	↑	U.K.	088	Israel	↑	Netherlands	097	Korea	↑	Sweden	108	Malaysia	↑	Austria	115	Mexico	↑	Switzerland	126	New Zealand	↑	Belgium	136	Peru	↑	Denmark	137	Philippines	↑	Finland	152	Middle East	↑	Portugal	156	Singapore	↑	Ireland	159	South Africa	↑	Norway	169	Thailand	254	Taiwan	181	U.S.A.		
Code	Destination	Code	Destination																																																																										
007	Argentina	250	Russia																																																																										
009	Australia	253	CTR21 (European nations)																																																																										
022	Brazil	↑	Italy																																																																										
038	China	↑	Germany																																																																										
080	Hong Kong	↑	Spain																																																																										
084	Indonesia	↑	U.K.																																																																										
088	Israel	↑	Netherlands																																																																										
097	Korea	↑	Sweden																																																																										
108	Malaysia	↑	Austria																																																																										
115	Mexico	↑	Switzerland																																																																										
126	New Zealand	↑	Belgium																																																																										
136	Peru	↑	Denmark																																																																										
137	Philippines	↑	Finland																																																																										
152	Middle East	↑	Portugal																																																																										
156	Singapore	↑	Ireland																																																																										
159	South Africa	↑	Norway																																																																										
169	Thailand	254	Taiwan																																																																										
181	U.S.A.																																																																												

Service items	Description								
FAX call Setting	<p>FAX call setting</p> <p>Description Selects if a fax is to be connected to either a PBX or public switched telephone network. Selects the mode to connect an outside call when connected to a PBX. Access code registration for connection to PSTN.</p> <p>Purpose To be executed as required.</p> <p>Method</p> <ol style="list-style-type: none"> 1. Enter the Service Setting menu. 2. Select [FAX Call Set.]. 3. Press the start key. <table border="1" data-bbox="437 701 1385 896"> <thead> <tr> <th data-bbox="437 701 703 745">Display</th> <th data-bbox="703 701 1385 745">Description</th> </tr> </thead> <tbody> <tr> <td data-bbox="437 745 703 790">Exchange Select.</td> <td data-bbox="703 745 1385 790">Setting the connection to PBX/PSTN</td> </tr> <tr> <td data-bbox="437 790 703 835">PBX Setting</td> <td data-bbox="703 790 1385 835">Setting for a PBX</td> </tr> <tr> <td data-bbox="437 835 703 880">Dial No. to PSTN</td> <td data-bbox="703 835 1385 880">Setting access code to PSTN</td> </tr> </tbody> </table> <p>Setting the connection to PBX/PSTN</p> <ol style="list-style-type: none"> 1. Select [Exchange Select.]. 2. Press the start key. 3. Select [PBX] or [PSTN]. 4. Press the start key. The setting is set. <p>Setting for PBX</p> <ol style="list-style-type: none"> 1. Select [PBX Setting]. 2. Press the start key. 3. Select [Loop], [Flash] or [Earth]. 4. Press the start key. The setting is set. <p>Setting access code to PSTN</p> <ol style="list-style-type: none"> 1. Select [Dial No. to PSTN]. 2. Press the start key. 3. Enter access code using the numeric keys. (0 to 9, 00 to 99) 4. Press the start key. The setting is set. <p>Completion Press the stop key.</p>	Display	Description	Exchange Select.	Setting the connection to PBX/PSTN	PBX Setting	Setting for a PBX	Dial No. to PSTN	Setting access code to PSTN
Display	Description								
Exchange Select.	Setting the connection to PBX/PSTN								
PBX Setting	Setting for a PBX								
Dial No. to PSTN	Setting access code to PSTN								

Service items	Description
Altitude adjustment	<p>Setting altitude adjustment</p> <p>Description Sets the altitude adjustment mode.</p> <p>Purpose Used when print quality deteriorates in an installation at the altitude of 1,500 meters or higher.</p> <p>Method</p> <ol style="list-style-type: none"> 1. Enter the Service Setting menu. 2. Select [Altitude Adj.]. 3. Press the OK key. 4. Select [Normal], [High 1] or [High 2]. 5. Press the OK key. The setting is set. <p>Completion Press the stop key.</p>
MC	<p>Setting main charger output</p> <p>Description Sets the main charger output. Execution is possible only when the altitude adjustment mode is set to [Normal].</p> <p>Purpose Execute when the image density declines, dirt of a background or an offset has occurred.</p> <p>Method</p> <ol style="list-style-type: none"> 1. Enter the Service Setting menu. 2. Select [MC]. 3. Press the OK key. 4. Select [1] to [5]. 5. Press the OK key. The setting is set. <p>Completion Press the stop key.</p>

Service items	Description
Memory Diagnostics	<p>Perform a memory diagnostic</p> <p>Description Diagnose memory at power up (whether reading and writing are executable).</p> <p>Purpose Execute memory check in purpose of rectifying a defective memory device which may possibly cause an unresolvable F call, locking, or abnormal images.</p> <p>Method</p> <ol style="list-style-type: none"> 1. Enter the Service Setting menu. 2. Select [Memory Diagnostics]. 3. Press [Start]. 4. Turn the main power switch off and on. Allow more than 5 seconds between Off and On. <p>Completion Press the stop key.</p>

1-4-1 Paper misfeed detection

(1) Paper misfeed indication

When a paper misfeed occurs, the machine immediately stops printing and displays the paper misfeed message on the operation panel. To remove paper misfed in the machine, pull out the cassette, open the paper conveying unit or paper conveying cover.

The positions are displayed on the operation panel when a paper jam has occurred.

Jam location indicators

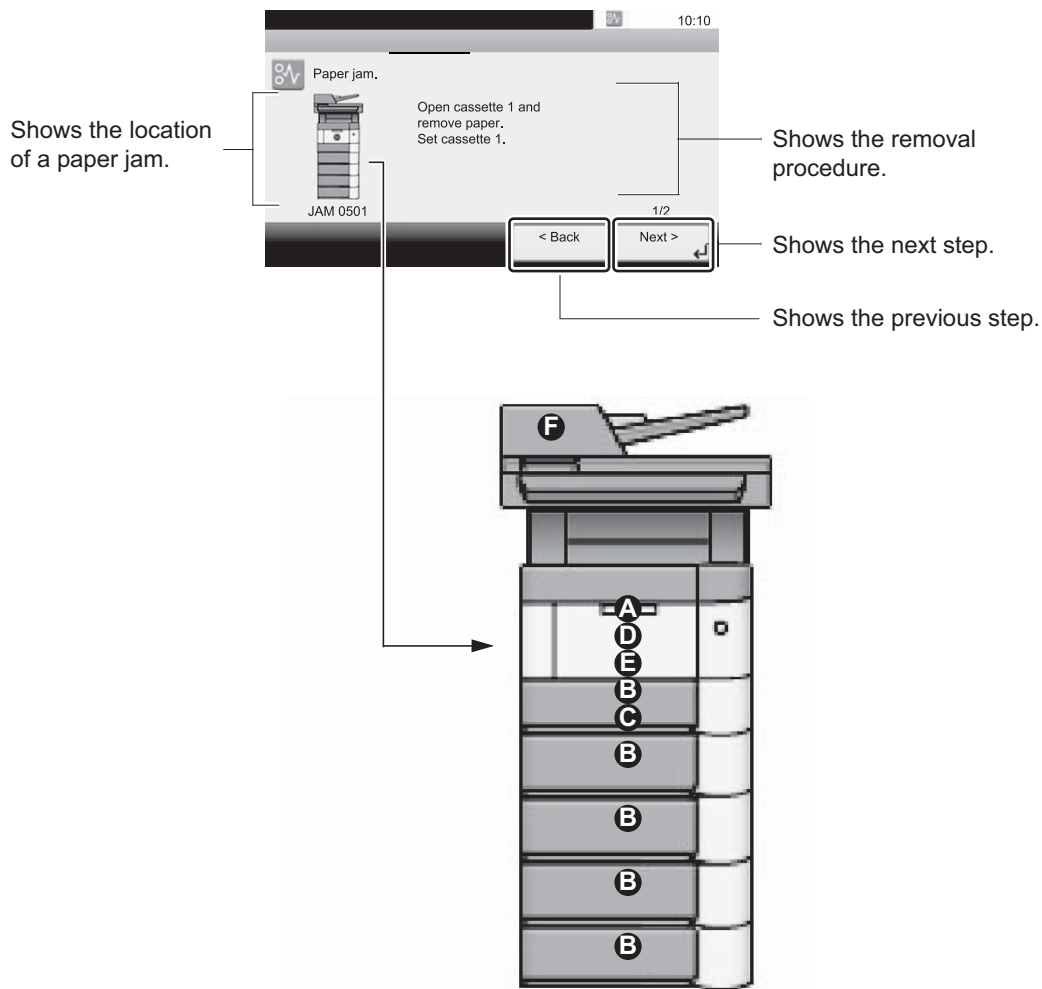

Figure 1-4-1

- A. Misfeed in MP tray
- B. Misfeed in the cassette 1 to 5
- C. Misfeed in the duplex unit
- D. Misfeed inside the machine
- E. Misfeed inside the rear cover or the inner tray
- F. Misfeed in the document processor

(2) Paper misfeed detection condition

Machine + PF (Option)

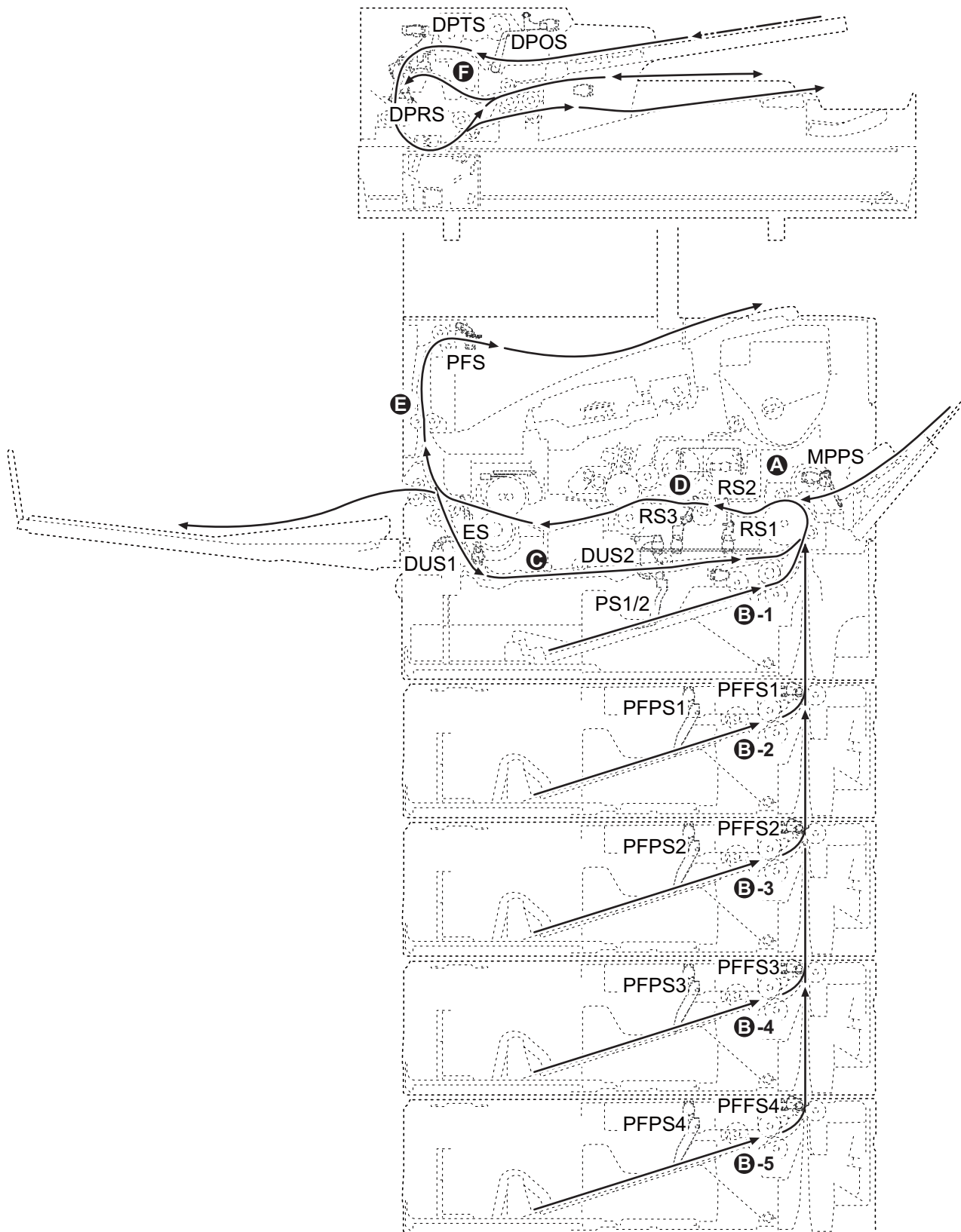

Figure 1-4-2

List of JAM Code

Code	Contents	Conditions	Jam location*
0000	Initial jam	The power is turned on when a sensor in the conveying system is on.	-
0100	Secondary feeding timeout	Secondary paper feed request given by the controller is unreachable.	D
0101	Wait for ready of print-process package	Process package won't become ready.	D
0104	Wait for ready of conveying package	Conveying package won't become ready.	D
0105	Driving prevention	A drive does not stop.	D
0106	Paper feeding request for duplex printing time out	Paper feeding request for duplex printing given by the controller is unreachable.	C
0107	Wait for ready of fuser package	Fuser package won't become ready.	D
0110	Rear cover open	The rear cover is opened during printing.	-
0111	Top cover open	The top cover is opened during printing.	-
0120	Receiving a duplex paper feeding request while paper is empty	Paper feed request was received from the duplex section despite the absence of paper in the duplex section.	C
0121	Exceeding number of duplex pages circulated	The controller issued the duplex section a request for more pages than the duplex print cycle contains.	C
0501	No paper feed jam	The registration sensor 1 (RS1)*1 or sensor 3 (RS3)*2 does not turn on during paper feed from cassette 1.	B-1
0502		PF feed sensor 1 (PFFS1) does not turn on during paper feed from cassette 2.	B-2
0503		PF feed sensor 2 (PFFS2) does not turn on during paper feed from cassette 3.	B-3
0504		PF feed sensor 3 (PFFS3) does not turn on during paper feed from cassette 4.	B-4
0505		PF feed sensor 4 (PFFS4) does not turn on during paper feed from cassette 5.	B-5
0508		The registration sensor 1 (RS1)*1 or sensor 3 (RS3)*2 does not turn on during paper feed from duplex section.	C
0509		The registration sensor 1 (RS1)*1 or sensor 3 (RS3)*2 does not turn on during paper feed from MP tray.	A

Code	Contents	Conditions	Jam location*
0511	Multiple sheets jam	The registration sensor 1 (RS1)*1 or registration sensor 3 (RS3)*2 does not turn off during paper feed from cassette 1.	D
0512		PF feed sensor 1 (PFFS1) does not turn off during paper feed from cassette 2.	B-2
0513		PF feed sensor 2 (PFFS2) does not turn off during paper feed from cassette 3.	B-3
0514		PF feed sensor 3 (PFFS3) does not turn off during paper feed from cassette 4.	B-4
0515		PF feed sensor 4 (PFFS4) does not turn off during paper feed from cassette 5.	B-5
0518		The registration sensor 1 (RS1)*1 or registration sensor 3 (RS3)*2 does not turn off during paper feed from duplex section.	D
0519		The registration sensor 1 (RS1)*1 or registration sensor 3 (RS3)*2 does not turn off during paper feed from MP tray.	D
1403	PF feed sensor 2 non arrival jam	PF feed sensor 2 (PFFS2) does not turn on during paper feed from cassette 3.	B-3
1404		PF feed sensor 2 (PFFS2) does not turn on during paper feed from cassette 4.	B-4
1405		PF feed sensor 2 (PFFS2) does not turn on during paper feed from cassette 5.	B-5
1413	PF feed sensor 2 stay jam	PF feed sensor 2 (PFFS2) does not turn off during paper feed from cassette 3.	B-2
1414		PF feed sensor 2 (PFFS2) does not turn off during paper feed from cassette 4.	B-2
1415		PF feed sensor 2 (PFFS2) does not turn off during paper feed from cassette 5.	B-2
1604	PF feed sensor 3 non arrival jam	PF feed sensor 3 (PFFS3) does not turn on during paper feed from cassette 4.	B-4
1605		PF feed sensor 3 (PFFS3) does not turn on during paper feed from cassette 5.	B-5
1614	PF feed sensor 3 stay jam	PF feed sensor 3 (PFFS3) does not turn off during paper feed from cassette 4.	B-3
1615		PF feed sensor 3 (PFFS3) does not turn off during paper feed from cassette 5.	B-3
1805	PF feed sensor 4 non arrival jam	PF feed sensor 4 (PFFS4) does not turn on during paper feed from cassette 5.	B-5
1815	PF feed sensor 4 stay jam	PF feed sensor 4 (PFFS4) does not turn off during paper feed from cassette 5.	B-4

Code	Contents	Conditions	Jam location*
4002	Registration sensor 1 or 3 non arrival jam	The registration sensor 1 (RS1)*1 or registration sensor 3 (RS3)*2 does not turn on during paper feed from cassette 2.	B-1
4003		The registration sensor 1 (RS1)*1 or registration sensor 3 (RS3)*2 does not turn on during paper feed from cassette 3.	B-1
4004		The registration sensor 1 (RS1)*1 or registration sensor 3 (RS3)*2 does not turn on during paper feed from cassette 4.	B-1
4005		The registration sensor 1 (RS1)*1 or registration sensor 3 (RS3)*2 does not turn on during paper feed from cassette 5.	B-1
4012	Registration sensor 1 or 3 stay jam	The registration sensor 1 (RS1)*1 or registration sensor 3 (RS3)*2 does not turn off during paper feed from cassette 2.	D
4013		The registration sensor 1 (RS1)*1 or registration sensor 3 (RS3)*2 does not turn off during paper feed from cassette 3.	D
4014		The registration sensor 1 (RS1)*1 or registration sensor 3 (RS3)*2 does not turn off during paper feed from cassette 4.	D
4015		The registration sensor 1 (RS1)*1 or registration sensor 3 (RS3)*2 does not turn off during paper feed from cassette 5.	D
4101	Registration sensor 2 non arrival jam *2	The registration sensor 2 (RS2) does not turn on during paper feed from cassette 1.	D
4102		The registration sensor 2 (RS2) does not turn on during paper feed from cassette 2.	D
4103		The registration sensor 2 (RS2) does not turn on during paper feed from cassette 3.	D
4104		The registration sensor 2 (RS2) does not turn on during paper feed from cassette 4.	D
4105		The registration sensor 2 (RS2) does not turn on during paper feed from cassette 5.	D
4108		The registration sensor 2 (RS2) does not turn on during paper feed from duplex section.	D
4109		The registration sensor 2 (RS2) does not turn on during paper feed from MP tray.	D

Code	Contents	Conditions	Jam location*
4111	Registration sensor 2 stay jam *2	The registration sensor 2 (RS2) does not turn off during paper feed from cassette 1.	D
4112		The registration sensor 2 (RS2) does not turn off during paper feed from cassette 2.	D
4113		The registration sensor 2 (RS2) does not turn off during paper feed from cassette 3.	D
4114		The registration sensor 2 (RS2) does not turn off during paper feed from cassette 4.	D
4115		The registration sensor 2 (RS2) does not turn off during paper feed from cassette 5.	D
4118		The registration sensor 2 (RS2) does not turn off during paper feed from duplex section.	D
4119		The registration sensor 2 (RS2) does not turn off during paper feed from MP tray.	D
4201	Eject sensor non arrival jam	The eject sensor (ES) does not turn on during paper feed from cassette 1.	D
4202		The eject sensor (ES) does not turn on during paper feed from cassette 2.	D
4203		The eject sensor (ES) does not turn on during paper feed from cassette 3.	D
4204		The eject sensor (ES) does not turn on during paper feed from cassette 4.	D
4205		The eject sensor (ES) does not turn on during paper feed from cassette 5.	D
4208		The eject sensor (ES) does not turn on during paper feed from duplex section.	D
4209		The eject sensor (ES) does not turn on during paper feed from MP tray.	D
4211	Eject sensor stay jam	The eject sensor (ES) does not turn off during paper feed from cassette 1.	E
4212		The eject sensor (ES) does not turn off during paper feed from cassette 2.	E
4213		The eject sensor (ES) does not turn off during paper feed from cassette 3.	E
4214		The eject sensor (ES) does not turn off during paper feed from cassette 4.	E
4215		The eject sensor (ES) does not turn off during paper feed from cassette 5.	E
4218		The eject sensor (ES) does not turn off during paper feed from duplex section.	E
4219		The eject sensor (ES) does not turn off during paper feed from MP tray.	E

Code	Contents	Conditions	Jam location*
4301	Duplex sensor 1 non arrival jam	The duplex sensor 1 (DUS1) does not turn on during paper feed from cassette 1.	E
4302		The duplex sensor 1 (DUS1) does not turn on during paper feed from cassette 2.	E
4303		The duplex sensor 1 (DUS1) does not turn on during paper feed from cassette 3.	E
4304		The duplex sensor 1 (DUS1) does not turn on during paper feed from cassette 4.	E
4305		The duplex sensor 1 (DUS1) does not turn on during paper feed from cassette 5.	E
4309		The duplex sensor 1 (DUS1) does not turn on during paper feed from MP tray or bulk feeder.	E
4401	Duplex sensor 2 non arrival jam	The duplex sensor 2 (DUS2) does not turn on during paper feed from cassette 1.	C
4402		The duplex sensor 2 (DUS2) does not turn on during paper feed from cassette 2.	C
4403		The duplex sensor 2 (DUS2) does not turn on during paper feed from cassette 3.	C
4404		The duplex sensor 2 (DUS2) does not turn on during paper feed from cassette 4.	C
4405		The duplex sensor 2 (DUS2) does not turn on during paper feed from cassette 5.	C
4409		The duplex sensor 2 (DUS2) does not turn on during paper feed from MP tray or bulk feeder.	C
4418	Duplex sensor 2 stay jam	The duplex sensor 2 (DUS2) does not turn off during paper feed from duplex section.	C
9000	DP original timing sensor ON undetected	DP feed sensor (DPTS) does not turn on within specified time during the first sheet feeding (Retry 5 times).	F
9010	DP unit open	Document processor is opened during original feeding.	F
9110	DP original timing sensor OFF undetected	DP original timing sensor (DPTS) does not turn off within specified time of DP registration sensor (DPRS) turning on.	F
9120	Initial jam of DP timing sensor	When DP reading is begun in the state where the manuscript remains in the conveyance way	F
9200	DP registration sensor ON undetected	DP registration sensor (DPRS) does not turn on within specified time of DP timing sensor (DPTS) turning on.	F
9210	DP registration sensor stay jam	DP registration sensor (DPRS) does not turn off within specified time of DP timing sensor (DPTS) turning off.	F

Code	Contents	Conditions	Jam location*
9220	Initial jam of DP registration sensor	When DP reading is begun in the state where the manuscript remains in the conveyance way	F

*1: 40 ppm model only

*2: 50/60 ppm model only

*: Refer to figure 1-4-1 and 1-4-2 for paper misfeed indication (see page 1-4-1,1-4-2).

1-4-2 Troubleshooting

(1) First check items

If the paper is fed askew, jammed, curled, or leading-edge dog-eared, first perform to check the following items.

Check items	Check description	Corrective measures
Paper	1. Check the paper delivered is dog-eared, skewed or rumped.	If a dog-ear has happened, check there are no objects existing in the conveying paths and, if any, fix. If the paper is fed askew or crumpled, perform the following No.2.
	2. Check how paper is loaded in the cassette (paper feeder). Check that the paper has been properly aligned with width adjuster cursor and the rear guide; it has been loaded without skewing; or it is not damaged. (Crumpled paper, main unit jam)	Adjust the cursors to the size of the paper.
	3. Check how paper is loaded. Check if the cutting edge of the paper bundle inside is crumpled or bent.	If the cutting edge of the paper bundle is crumpled, fan the paper before loading. If the paper is folded, stretch before loading in the cassette
	4. Check the paper is damp, wavy, or curled.	1. Load the paper bundle in the cassette upside down. 2. Load the paper bundle after rotating it 180°and reload. 3. Change the paper.
	5. Check if the paper loaded was stored in a continuously humid place.	Instruct the user to store paper in a dry, less humid place.
	6. Check if the paper conforms to the requirements.	Isolate the cause of the problem by replacing the paper with the recommended paper. (see page 1-1-1)

Check items	Check description	Corrective measures
Settings/ Detection	1. Check if the margin is 4.0±2.5mm from the leading edge of paper.	If the check line is not situated at 20mm±1mm from the leading edge, adjust the leading margin by U402. (see page 1-3-51)
	2. Check the panel if the paper size is correctly detected and the cassette size is not fixed.(Paper jam caused by continuously fed paper) Perform U000 to obtain a Event Log to check if the paper size and the size of the paper loaded are met when jam has occurred and if the size of the original document and the paper size are met. see page 1-3-7)	If the paper size is incorrectly displayed, adjust the positions of the paper set guide cursors in accordance with the paper size, making sure that the paper is not askew to activate the size detector switch.
	3. Check that paper settings are made in accordance with the paper being used. (Jam caused by faulty separation)	Select Original/ Paper settings under common settings in the system menu to set media type and weight of paper.
Rear cover	Check the rear cover of the main unit are slightly strained and closed.	To open, first open the rear cover and close firmly. (Check the position of the safety switch)
Conveying guide, approaching guide, feed-shift guide	1. Check that the foreign objects including scrips, paper clips, etc., do not exist in the paper conveying paths.	If foreign objects such as scrips, etc., remain in the paper conveying path, remove.
	2. Check that the paper conveying guide and the separation needles are not contaminated with toner, paper dusts, etc.	If dirty, clean the guide, ribs (by a cloth), and the separation needles (by a cleaning brush).If the ribs of the conveying guides were broken or deposited with toner, replace.
	3. Check that the paper conveying guide has no barrs, deformations, or abrasions; and it is properly mounted without being floated.	Clean the conveying guide or the paper approaching guide.Remove any protrusions including barrs.If floated, fix it properly.If deformation or abrasion is observed, replace.
	4. Check that the guide. Check that the guide is smoothly operative when manipulated.	If the guide is inoperative or won't operate smoothly, replace the guide or the unit.
	5. Check the action of the guide.	If the guide is inoperative or won't operate smoothly, re-assemble the guide or replace the solenoid or the unit.

Check items	Check description	Corrective measures
Conveying roller, feed roller	1. Check the conveying rollers have no paper dusts, toner, or foreign objects stucked. Check a variation of the external diameter of the roller or abrasion is not observed with the conveying roller.	Clean the conveying rollers or the pulleys. If variation in the external diameter or abrasion is observed, replace.
	2. Turn the cover safety switch and check the motor and the clutch are operated normally.	If the conveying motor or the clutch is inoperative, replace. If stained, replace the clutch. If the clutch is kept turned on due to a tensioned wire, reroute wires.
	3. Check the conveying roller rotates without overloading. Check the axle holder or the roller shaft are not contaminated. Check that the spring has not fallen off and is mounted so that it is properly applying pressure against the rollers or pulleys.	Clean the roller axle or the axle holder. Re-assemble it while checking the pressure of the spring.
Sensor	1. Check if it does not operate with smoothness due to an abnormal move or dropping off of the actuator of the conveying switch.	Re-assemble the actuator or the return spring.
	2. Check that the surface of the sensor and the receptor black felt pieces are not contaminated with toner, paper dusts, etc.	If dirty, clean the sensor or the black felt piece.
	3. Check the sensors are operated normally.	If the sensor is inoperative, replace the switch.
Static	Check if the location is susceptible to build static discharge at the conveying guide during printing.	Re-assemble and re-wire the static discharge sheet at the ejection unit or the metal guide at the transfer unit so that they are properly grounded.

(2) Items and corrective actions relating to the device that will cause paper jam

Jam types	Check description	Corrective measures
No-paper-feed jam or the leading edge of paper is curled back at the position of the roller (J0501, J0502, J0503, J0504, J0505, J0509)	1. Check if the jammed paper or the printed paper has a tear caused by the roller at its leading edge.	Replace the paper feed roller.(Service life of rubber roller is 300000 images *1) Increase the spring pressure to pinch the separation rollers if the component is undue to its expected life.Replace the spring.
	2. Check abrasion and paper dusts on the feed roller and forward rollers.	Clean the paper feed roller and the pickup roller. Or, if not amended, replace.
	3. Check the pickup roller and paper feed roller are rotating.	If disconnected or or stained, replace the primary paper feed clutch.
	4. Check that the conveying force of the pickup roller is sufficient.	Increase the conveying force during paper pickup by increasing the spring load of the pickup roller.

*1: 40 ppm model (Service life of 50/60 ppm model is 500000 images.)

Jam types	Check description	Corrective measures
Multiple-feed Jam (J0511, J0512, J0513, J0514, J0515, J0519)	1. Check if the cutting edge of the paper bundle is crumpled or the cassette is loaded with multiple times of replenishing paper.	If the cutting edge of the paper bundle is crumpled or the cassette is loaded with multiple times of replenishing paper, load new paper.
	2. Checking paper size. Check that the size of the loaded paper and the paper size chosen on the operator panel are met.	If the paper size does not agree. 1. If the cassette cursors are open against the paper, set it properly. 2. Insert the cassette until the cassette size detector switch is turned on. If the size is not detectable while automatic sizing is enabled, replace the size detection switch.
		If the paper size agrees 1. If paper other than complying the requirements such as coated paper, inkjet paper, etc., is used, replace the paper. 2. RE-assemble the retard roller in the primary paper feed unit if it is mounted to the opposite direction. 3. Check if the retard spring has not been fallen off of the mounting position. * : If the retard spring is not dropped off of the mount position, decrease the spring pressure that is applied to the separation rollers. 4. Replace the primary paper feed unit.
	3. Check if paper dusts and abrasion are observed on the paper fanning roller and retard roller.	If the paper fanning roller is dirty, clean. If abrasion is observed, replace.
4. Check the clutch that are rotating following the other component when the motor is turned on.	If the clutch rotates following the other component and its stain is observed, replace the clutch.	
Duplex No-paper-feed Jam (J0508)/Duplex Multiple-feed Jam (J0518)	Check if the registration sensor is detected.	If the registration sensor is not working, replace the registration sensor.

*1: 40 ppm model (Service life of 50/60 ppm model is 500000 images.)

Jam types	Check description	Corrective measures
PF conveying sensor stay jam (J1413, J1414, J1415, J1614, J1615, J1815)	1. Check to see if the actuator is operative without hinderance.	If it won't operate without hinderance, re-assemble or replace the actuator's return spring.
	2. Check the operation of the sensor.	If the sensor is inoperative, replace.
	3. Check if the PF paper feed clutch rotates following the other component.	If stained, replace the clutch.Re-assmeble the clutch so that it is not continuously energized. (Change of wirings, etc.)
	4. Check if the conveying guide is twisted to be mounted.(If the mounting parts of the guide is floated, the actuator won't protrude sufficiently.)	If the bracket is twisted to be mounted, remove the screw fixing the conveying guide and properly mount the bracket in the right position and fix again.
	5. Check no wrinkles are observed at the sluck of paper during paper feeding.	Adjust the cursors to the size of the paper.
PF conveying sensor non arrival jam (J1403/J1404, J1405, J1604, J1605, J1805)	1. Check to see if the actuator is operative without hinderance.	Re-assemble or replace the actuator's return spring.
	2. Check the operation of the motor. Check the transmission of the gear drive . * : Check the conveying roller rotates and is movable in the direction of thrust without hinderance.	If the roller won't rotate without hinderance, loosen the screws for adjusting the position (at the gear train bracket) to mount the driving gears, and tighten so that a gap between the gears and frame is eliminated.
Fuser eject sensor stay jam (J421X)	1. If paper jam occurs at the feedshift guide in the rear cover assembly, check if the guide is operative without hinderance.	If the distance between the housing and the feedshift guide is too small for the guide to move without hinderance, replace the rear cover assembly.
	2. Check if the eject sensor does not show a false detection.	Replace the defective eject sensor or the fuserunit.

*1: 40 ppm model (Service life of 50/60 ppm model is 500000 images.)

(3) Paper jam at feeding from cassette 1**Electrical parts that could cause paper jam during paper travelling at the primary feeding (to regist roller)**

Timing of detection

Jam code
J0501, J0511, J4101 *2, J4111 *2

Measures

Related parts	
Registration sensor (RS)	Control PWB (CONPWB)
Paper feed clutch (PFCL)	Drum PWB (DRPWB) *2
Main motor(MM)	Connect right PWB (C-RPWB)

Checking procedure at the occurrence of J0501/J502 J4101/J4111 *2	Corrective action at the occurrence	On/Off control signal output connector (terminal), point of checking connection
1	Items for Initial Checks	See page 1-4-9
2	Registration sensor (RS): Conduct connectivity check, mounting location check, operation check	CONPWB YC19-12 D-RPWB YC6-2 *2
3	Control PWB: Replace	
4	Drum PWB: Replace *2	
5	Paper feed clutch (PFCL): Operation check	C-RPWB YC12-4
6	Main motor : Operation check	C-RPWB YC10-1/2/3/4
7	Connect right PWB: Replace	

*2: 50/60 ppm model only

(4) Paper jam at feeding from cassette 2 (paper feeder)**Electrical parts that could cause paper jam during paper travelling at the primary feeding (to regist roller)**

Timing of detection

Jam code
J0502, J0512, J4002, J4012, J4102 2*, J4112 *2

Corrective Action

Related parts	
PF paper feed sensor (PFFS)	PF main PWB (PF PWB)
PF paper feed clutch (PFPFCL)	Control PWB (CONPWB)
PF paper feed motor (PFPFM)	Drum PWB (DRPWB)
	Connect right PWB (C-RPWB)

Checking procedure at the occurrence of J0502/J0512	Corrective action at the occurrence	On/Off control signal output connector (terminal), point of checking connection
1	Items for Initial Checks	See page 1-4-9
2	PF Feed sensor 1 (PFFS1): Conduct connectivity check, mounting location check, operation check	PF main PWB YC5-6
3	PF paper feed clutch (PFPFCL1): Operation check	PF main PWB 2 YC4-1
4	PF paper feed motor : Operation check	PF main PWB YC4-3(RDY), 5(REM)
5	PF main PWB : Replace	

Checking procedure at the occurrence of J4002/J4012 J4102/J4112 *2	Corrective action at the occurrence	On/Off control signal output connector (terminal), point of checking connection
1	Items for Initial Checks	See page 1-4-9
2	Registration sensor (RS): Conduct connectivity check, mounting location check, operation check	CONPWB YC19-12 DRPWB YC6-2 *2
3	Control PWB : Replace	
4	Drum PWB : Replace *2	

Checking procedure at the occurrence of J4002/J4012 J4102/J4112 *2	Corrective action at the occurrence	On/Off control signal output connector (terminal), point of checking connection
5	Paper feed clutch (PFCL): Operation check	C-RPWB YC12-4
6	Main motor : Operation check	C-RPWB YC10-1/2/3/4
7	Connect right PWB : Replace	

*2: 50/60 ppm model only

(5) Paper jam at feeding from multi paper feed

Electrical parts that could cause paper jam during paper travelling at the primary feeding (to regist roller)

Timing of detection

Jam code
J0509,J0519

Corrective Action

Related parts	
Registration sensor (RS)	Control PWB (CONPWB)
MP solenoid (MPSOL)	Connect right PWB (C-RPWB)
Main motor (MM)	

Checking procedure at the occurrence of J0509/J0519	Corrective action at the occurrence	On/Off control signal output connector (terminal), point of checking connection
1	Items for Initial Checks	See page 1-4-9
2	Registration sensor (RS): Conduct connectivity check, mounting location check, operation check	CONPWB YC19-12
3	MP solenoid (MPSOL): Operation check	C-RPWB YC11-2
4	Main motor : Operation check	C-RPWB YC10-1/2/3/4
5	Control PWB : Replace	

(6) Paper jam at the duplex re-feeding part

Electrical parts that could cause paper jam during paper travelling at the primary feeding (to regist roller)

Timing of detection

Jam code
J0508,J0518

Corrective Action

Related parts	
Registration sensor (RS)	Control PWB (CONPWB)
Duplex clutch (DUCL) *2	Connect right PWB (C-RPWB)
Middle clutch (MIDCL) *2	
Main motor (MM)	

Checking procedure at the occurrence of J0508/J0518	Corrective action at the occurrence	On/Off control signal output connector (terminal), point of checking connection
1	Items for Initial Checks	See page 1-4-9
2	Registration sensor (RS): Conduct connectivity check, mounting location check, operation check	CONPWB YC19-12
3	Control PWB : Replace	
4	Duplex clutch : Operation check	C-RPWB YC12-10 *2
5	Middle clutch : Operation check	C-RPWB YC12-8 *2
6	Main motor : Operation check	C-RPWB YC10-1/2/3/4
7	Connect right PWB : Replace	

*2: 50/60 ppm model only

(7) Electrical parts that could cause paper jam at the transfer , the fuser and the eject parts

Timing of detection

Jam code
J4201,J4211

Corrective Action

Related parts	
Eject sensor (ES)	Control PWB (CONPWB)
Registration clutch (RCL)	Connect right PWB (C-RPWB)
Main motor (MM)	Connect left PWB (C-LPWB)
Eject motor (EM)	

Checking procedure at the occurrence of J4201/J4211	Corrective action at the occurrence	On/Off control signal output connector (terminal), point of checking connection
1	Items for Initial Checks	See page 1-4-9
2	Eject sensor (ES) : Conduct connectivity check, mounting location check, operation check	CONPWB YC26-1
3	Control PWB : Replace	
4	Registration clutch (RCL) : Operation check (U032)	C-RPWB YC12-6
5	Main motor : Operation check	C-RPWB YC10-1/2/3/4
6	Connect right PWB : Replace	
7	Eject motor : Operation check	C-LPWB YC12-1/2/3/4
8	Connect left PWB : Replace	

1-4-3 Self-diagnostic function

(1) Self-diagnostic function

This machine is equipped with self-diagnostic function. When a problem is detected, the machine stops printing and display an error message on the operation panel. An error message consists of a message prompting a contact to service personnel and a four-digit error code indicating the type of the error.

(2) Self diagnostic codes

If the part causing the problem was not supplied, use the unit including the part for replacement

Caution:

Before attempting to check the power supply and the fuser unit, be sure to turn the power switch off and unplug the machine from power. Allow at least 5 seconds before starting to conduct service until the capacitors on the circuit boards have been completely discharged.

Code	Contents	Related parts	Check procedures/ corrective measures
0030	FAX control PWB system error Processing with the fax software was disabled due to a software problem.	FAX control PWB	<ol style="list-style-type: none"> 1. Turn the main power switch off and after 5 seconds, re-mount the FAX controller PWB, then turn power on. 2. Reinstall the fax software. 3. Replace the FAX control PWB.
0060	Control PWB mismatch Unmatching engine and engine sub boards. Defective engine subboard	Control PWB	<ol style="list-style-type: none"> 1. Turn the main power switch off and after 5 seconds, then turn power on. 2. Replace the control PWB and check for correct operation (see page 2-2-12).
0070	FAX control PWB incompatible detection error Abnormal detection of FAX control PWB incompatibility In the initial communication with the FAX control PWB, any normal communication command is not transmitted.	FAX control PWB (The FAX PWB installed will not be the one designed for the machine.)	<ol style="list-style-type: none"> 1. Install the FAX system designed for the model. 2. Reinstall the fax software.
0100	Backup memory device error	EEPROM (Control PWB)	<ol style="list-style-type: none"> 1. Turn the main power switch off and after 5 seconds, then turn power on. 2. Check that the EEPROM on the main circuit PWB is properly installed on the main circuit PWB and, if not, re-install it. 3. Replace the control PWB and check for correct operation (see page 2-2-12).

Code	Contents	Related parts	Check procedures/ corrective measures
0110	Backup memory data error	EEPROM (Control PWB)	<ol style="list-style-type: none"> 1. Turn the main power switch off and after 5 seconds, then turn power on. 2. Check that the EEPROM on the main circuit PWB is properly installed on the main circuit PWB and, if not, re-install it. 3. Replace the control PWB and check for correct operation (see page 2-2-12).
0120	MAC address data error For data in which the MAC address is invalid.	EEPROM (Control PWB)	<ol style="list-style-type: none"> 1. Turn the main power switch off and after 5 seconds, then turn power on. 2. Check the MAC address on the network status page. 3. If it is blank, obtain an EEPROM with its MAC address written from the service support and install. 4. Replace the control PWB and check for correct operation (see page 2-2-12).
0130	Backup memory read/write error (main NAND)	Flash memory (Control PWB)	<ol style="list-style-type: none"> 1. Turn the main power switch off and after 5 seconds, then turn power on. 2. Replace the control PWB and check for correct operation (see page 2-2-12).
0140	Backup memory data error (main NAND)	Flash memory (Control PWB)	<ol style="list-style-type: none"> 1. Turn the main power switch off and after 5 seconds, then turn power on. 2. Replace the control PWB and check for correct operation (see page 2-2-12).
0150	Backup memory read/write error (control PWB) No response is issued from the device in reading/writing for 5 ms or more and this problem is repeated 5 times successively. Mismatch of reading data from 2 locations occurs 8 times successively. Mismatch between writing data and reading data occurs 8 times successively.	EEPROM (Control PWB)	<ol style="list-style-type: none"> 1. Turn the main power switch off and after 5 seconds, then turn power on. 2. Check that the EEPROM is properly installed on the control PWB and re-install it. 3. Replace the control PWB and check for correct operation (see page 2-2-12). 4. Check the EEPROM and if the data are corrupted, contact the service support.
0160	Backup memory data error (control PWB) Reading data from EEPROM is abnormal.	EEPROM	<ol style="list-style-type: none"> 1. Turn the main power switch off and after 5 seconds, then turn power on. 2. Execute U021 - memory initializing.(see page 1-3-22) 3. If the EEPROM data are corrupted, contact the service support.

Code	Contents	Related parts	Check procedures/ corrective measures
0170	Billing counting error The values on the main circuit PWB and on the engine do not match for any of charging counter, life counter, and scanner counter.	EEPROM	1. Check that the EEPROMs installed in the control PWB are correct and, if not, use the correct EEPROM for the model. 2. If the EEPROM data are corrupted, contact the service support.
		Control PWB	Replace the control PWB and check for correct operation (see page 2-2-12).
0180	Machine number mismatch Machine number of control does not match.	Data damage of EEPROM	1. Confirm the machine data for the control units by using U004 (see page 1-3-19). 2. If the serial number data of different models is alternately displayed, install the correct EEPROM in the PWB of the wrong serial number data. 3. Contact the Service Support.
0190	Backup memory device error (control PWB)	Control PWB	Replace the control PWB and check for correct operation (see page 2-2-12).
0800	Image processing error JAM010X is detected twice.	Control PWB	Replace the control PWB and check for correct operation (see page 2-2-12).
0830	FAX control PWB flash program area checksum error A checksum error occurred with the program of the FAX control PWB.	FAX software	1. Reinstall the fax software.
		FAX control PWB	1. Execute initializing by U600.(Refer to the FAX service manual) 2. Replace the FAX control PWB.
0840	Faults of RTC ("Time for maintenance T" is displayed) [Check at power up] The RTC setting has reverted to a previous state. The machine has not been powered for 5 years (compared to the settings stored periodically in the EEPROM). The RTC setting is older than 00:01 on January 1, 2000. [Checked periodically (in 5-minute interval) after powered up] The RTC setting has reverted to a state older than the last time it was checked. 10 minutes have been passed since the previous check.	Battery (Control PWB)	1. Make sure that the back-up batteries on the control PWB are not short-circuited. 2. If the same C call is displayed when power is switched on and off, replace the back up battery. 3. If communication error (due to a noise, etc.) is present with the RTC on the control PWB, check the PWB is properly grounded.
		Control PWB	Replace the control PWB and check for correct operation (see page 2-2-12).

Code	Contents	Related parts	Check procedures/ corrective measures
0870	PCFAX control PWB to main PWB high capacity data transfer error High-capacity data transfer between the FAX control PWB and the main PWB of the machine was not normally performed even if the data transfer was retried the specified times.	FAX control PWB	1. Turn the main power switch off and after 5 seconds, re-mount the FAX controller PWB, then turn power on. 2. Replace the FAX control PWB.
		Control PWB	Replace the control PWB and check for correct operation (see page 2-2-12).
0920	Fax file system error The backup data is not retained for file system abnormality of flash memory of the FAX control PWB.	FAX control PWB	1. Execute initializing by U600 (Refer to the FAX service manual). 2. Replace the FAX control PWB.
0970	24 V power down detect If a 24V power disconnection signal is observed and a 12V power disconnection signal is observed simultaneously for one second.	Connect right PWB	1. Check the +24V output is given at YC4-10 to 13 of the connect right PWB. 2. Replace the connect right PWB (see page 2-2-31)
		Control PWB	Replace the control PWB (see page 2-2-12)
1010	Lift motor error (50/60 ppm model only) After cassette 1 is inserted, lift sensor does not turn on within 10 s. This error is detected four times successively.	Bottom plate elevation mechanism in the cassette	Check to see if the bottom plate can move smoothly and repair it if any problem is found.
		Connector cable or poor contact in the connector	Reinsert the connector. Also check for continuity within the connector cable. If none, replace the cable. Lift motor and connect right PWB (YC9) Connect right PWB and control PWB (YC29)
		Drive transmission system of the lift motor	Check if the gears rotate smoothly. If not, grease the bushes and gears. Check for broken gears and replace if any.
		Lift motor	Replace the lift motor.
		Connect right PWB	Replace the connect right PWB (see page 2-2-31).
		Control PWB	Replace the control PWB and check for correct operation (see page 2-2-12).

Code	Contents	Related parts	Check procedures/ corrective measures
1020	PF lift motor 1 error (paper feeder) After cassette 2 is inserted, PF lift sensor 1 does not turn on. This error is detected four times successively.	Bottom plate elevation mechanism in the cassette	Check to see if the bottom plate can move smoothly and repair it if any problem is found.
		Connector cable or poor contact in the connector	Reinsert the connector. Also check for continuity within the connector cable. If none, replace the cable. PF lift motor 1 and PF main PWB (YC7)
		Drive transmission system of the PF lift motor	Check if the gears rotate smoothly. If not, grease the bushes and gears. Check for broken gears and replace if any.
		PF lift motor	Replace the PF lift motor 1.
		PF main PWB	Replace the PF main PWB (Refer to the service manual for the paper feeder).
1030	PF lift motor 2 error (paper feeder) After cassette 3 is inserted, PF lift sensor 2 does not turn on. This error is detected four times successively.	Bottom plate elevation mechanism in the cassette	Check to see if the bottom plate can move smoothly and repair it if any problem is found.
		Connector cable or poor contact in the connector	Reinsert the connector. Also check for continuity within the connector cable. If none, replace the cable. PF lift motor 2 and PF main PWB (YC7)
		Drive transmission system of the PF lift motor	Check if the gears rotate smoothly. If not, grease the bushes and gears. Check for broken gears and replace if any.
		PF lift motor	Replace the PF lift motor 2.
		PF main PWB	Replace the PF main PWB (Refer to the service manual for the paper feeder).
1040	PF lift motor 3 error (paper feeder) After cassette 4 is inserted, PF lift sensor 3 does not turn on. This error is detected four times successively.	Bottom plate elevation mechanism in the cassette	Check to see if the bottom plate can move smoothly and repair it if any problem is found.
		Connector cable or poor contact in the connector	Reinsert the connector. Also check for continuity within the connector cable. If none, replace the cable. PF lift motor 3 and PF main PWB (YC7)
		Drive transmission system of the PF lift motor	Check if the gears rotate smoothly. If not, grease the bushes and gears. Check for broken gears and replace if any.
		PF lift motor	Replace the PF lift motor 3.
		PF main PWB	Replace the PF main PWB (Refer to the service manual for the paper feeder).

Code	Contents	Related parts	Check procedures/ corrective measures
1050	PF lift motor 4 error (paper feeder) After cassette 5 is inserted, PF lift sensor 4 does not turn on. This error is detected four times successively.	Bottom plate elevation mechanism in the cassette	Check to see if the bottom plate can move smoothly and repair it if any problem is found.
		Connector cable or poor contact in the connector	Reinsert the connector. Also check for continuity within the connector cable. If none, replace the cable. PF lift motor 4 and PF main PWB (YC7)
		Drive transmission system of the PF lift motor	Check if the gears rotate smoothly. If not, grease the bushes and gears. Check for broken gears and replace if any.
		PF lift motor	Replace the PF lift motor 4.
		PF main PWB	Replace the PF main PWB (Refer to the service manual for the paper feeder).
1800	Paper feeder 1 communication error A communication error is detected 10 times in succession.	Paper feeder	Follow installation instruction carefully again.
		Connector cable or poor contact in the connector	Reinsert the connector. Also check for continuity within the connector cable. If none, replace the cable. PF main PWB (YC3) and control PWB (YC22)
		PF main PWB	Replace the PF main PWB (Refer to the service manual for the paper feeder).
		Control PWB	Replace the control PWB and check for correct operation (see page 2-2-12).
1810	Paper feeder 2 communication error A communication error from paper feeder is detected 10 times in succession.	Paper feeder	Check the wiring connection status with the main unit and, if necessary, try connecting it again.
		PF main PWB	<ol style="list-style-type: none"> 1. Confirm that the wiring connector is firmly connected and, if necessary, connect the connector all the way in. PF main PWB (YC1) and control PWB (YC22) 2. If the wiring is disconnected, shorted or grounded, replace the wiring. 3. Replace the PF main PWB.
		Control PWB	<ol style="list-style-type: none"> 1. Check the control software and upgrade to the latest, if necessary. 2. Replace the control PWB and check for correct operation (see page 2-2-12).

Code	Contents	Related parts	Check procedures/ corrective measures
1820	Paper feeder 3 communication error A communication error from paper feeder is detected 10 times in succession.	Paper feeder	Check the wiring connection status with paper feeder unit 2 and, if necessary, try connecting it again.
		PF main PWB	1. Confirm that the wiring connector is firmly connected and, if necessary, connect the connector all the way in. PF main PWB (YC1) and PF main PWB (YC22). 2. If the wiring is disconnected, shorted or grounded, replace the wiring. 3. Replace the PF main PWB.
		Control PWB	1. Check the control software and upgrade to the latest, if necessary. 2. Replace the control PWB and check for correct operation (see page 2-2-12).
1830	Paper feeder 4 communication error A communication error from paper feeder is detected 10 times in succession.	Paper feeder	Check the wiring connection status with paper feeder unit 3 and, if necessary, try connecting it again.
		PF main PWB	1. Confirm that the wiring connector is firmly connected and, if necessary, connect the connector all the way in. PF main PWB (YC1) and PF main PWB (YC22). 2. If the wiring is disconnected, shorted or grounded, replace the wiring. 3. Replace the PF main PWB.
		Control PWB	1. Check the control software and upgrade to the latest, if necessary. 2. Replace the control PWB and check for correct operation (see page 2-2-12).
1900	Paper feeder 1 EEPROM error When writing the data, read and write data does not match 4 times in succession.	PF main PWB (EEPROM)	1. Confirm that the wiring connector is firmly connected and, if necessary, connect the connector all the way in. 2. Replace the PF main PWB.
1910	Paper feeder 2 EEPROM error When writing the data, read and write data does not match 4 times in succession.	PF main PWB (EEPROM)	1. Confirm that the wiring connector is firmly connected and, if necessary, connect the connector all the way in. Replace the PF main PWB.
1920	Paper feeder 3 EEPROM error When writing the data, read and write data does not match 4 times in succession.	PF main PWB (EEPROM)	1. Confirm that the wiring connector is firmly connected and, if necessary, connect the connector all the way in. 2. Replace the PF main PWB.

Code	Contents	Related parts	Check procedures/ corrective measures
1930	Paper feeder 4 EEPROM error When writing the data, read and write data does not match 4 times in succession.	PF main PWB (EEPROM)	<ol style="list-style-type: none"> 1. Confirm that the wiring connector is firmly connected and, if necessary, connect the connector all the way in. 2. Replace the PF main PWB.
2000	Main motor startup error Main motor is not stabilized within 2 s since the motor is activated.	Main motor	<ol style="list-style-type: none"> 1. Confirm that the wiring connector is firmly connected and, if necessary, connect the connector all the way in. Main motor and connect right PWB (YC10) Connect right PWB and control PWB (YC29) 2. If the wiring is disconnected, shorted or grounded, replace the wiring. 3. Replace the main motor (see page 1-5-97).
		Connect right PWB	Replace the connect right PWB (see page 2-2-12).
		Control PWB	<ol style="list-style-type: none"> 1. Check the control software and upgrade to the latest, if necessary. 2. Replace the control PWB and check for correct operation (see page 2-2-12).
2010	Main motor steady-state error After main motor is stabilized, the ready signal is not ready for 2 s continuously.	Main motor	<ol style="list-style-type: none"> 1. Check the drive gear can rotate or they are not unusually loaded and, if necessary, replace. 2. Confirm that the wiring connector is firmly connected and, if necessary, connect the connector all the way in. Main motor and connect right PWB (YC10) Connect right PWB and control PWB (YC29) 3. If the wiring is disconnected, shorted or grounded, replace the wiring. 4. Replace the main motor (see page 1-5-97).
		Connect right PWB	Replace the connect right PWB (see page 2-2-12).
		Control PWB	<ol style="list-style-type: none"> 1. Check the control software and upgrade to the latest, if necessary. 2. Replace the control PWB and check for correct operation (see page 2-2-12).

Code	Contents	Related parts	Check procedures/ corrective measures
2200	Drum motor drive error (50/60 ppm model only) The drum motor is not stabilized within 2 s after driving starts.	Connector cable or poor contact in the connector	Reinsert the connector. Also check for continuity within the connector cable. If none, replace the cable. Drum motor and connect right PWB (YC10) Connect right PWB and control PWB (YC29)
		Drive transmission system of the drum motor	Check if the rollers and gears rotate smoothly. If not, grease the bushes and gears. Check for broken gears and replace if any.
		Drum motor	Replace the drum motor.
		Connect right PWB	Replace the connect right PWB (see page 2-2-31).
		Control PWB	Replace the control PWB and check for correct operation (see page 2-2-12).
2210	Drum motor steady-state error (50/60 ppm model only) Stable OFF is detected for 2 s continuously after drum motor stabilized.	Connector cable or poor contact in the connector	Reinsert the connector. Also check for continuity within the connector cable. If none, replace the cable. Drum motor and connect right PWB (YC10) Connect right PWB and control PWB (YC29)
		Drive transmission system of the drum motor	Check if the rollers and gears rotate smoothly. If not, grease the bushes and gears. Check for broken gears and replace if any.
		Drum motor	Replace the drum motor.
		Connect right PWB	Replace the connect right PWB (see page 2-2-31).
		Control PWB	Replace the control PWB and check for correct operation (see page 2-2-12).
2330	Envelope motor error (Over-current) (50/60 ppm model only) The over-current detection signal of the motor is detected continuously twenty times.	Connector cable or poor contact in the connector	Reinsert the connector. Also check for continuity within the connector cable. If none, replace the cable. Envelope motor and connect left PWB (YC11) Connect left PWB and control PWB (YC2)
		Drive transmission system of the envelope motor	Check if the gears rotate smoothly. If not, grease the bushes and gears. Check for broken gears and replace if any.
		Envelope motor	Replace the envelope motor.
		Connect left PWB.	Replace the connect left PWB (See Page 2-2-20).
		Control PWB	Replace the control PWB and check for correct operation (See Page 2-2-12).

Code	Contents	Related parts	Check procedures/ corrective measures
2340	Envelope motor error (Timeout) (50/60 ppm model only) The position detection sensor is not detected continuously for 30 s.	Connector cable or poor contact in the connector	Reinsert the connector. Also check for continuity within the connector cable. If none, replace the cable. Envelope motor and connect left PWB (YC11) Connect left PWB and control PWB (YC2)
		Drive transmission system of the envelope motor	Check if the gears rotate smoothly. If not, grease the bushes and gears. Check for broken gears and replace if any.
		Envelope motor	Replace the envelope motor.
		Connect left PWB	Replace the connect left PWB (See Page 2-2-20).
		Control PWB	Replace the control PWB and check for correct operation (See Page 2-2-12).
2600	PF drive motor 1 error (paper feeder 1) When the PF drive motor is driven, error signal is detected continuously for 2 s.	Connector cable or poor contact in the connector	Reinsert the connector. Also check for continuity within the connector cable. If none, replace the cable. PF drive motor 1 and PF main PWB (YC6)
		Drive transmission system of the PF drive motor	Check if the rollers and gears rotate smoothly. If not, grease the bushes and gears. Check for broken gears and replace if any.
		DPF drive motor	Replace the PF drive motor 1.
		DPF main PWB	Replace the PF main PWB (Refer to the service manual for the paper feeder).
2610	PF drive motor 2 error (paper feeder 2) When the PF drive motor is driven, error signal is detected continuously for 2 s.	Connector cable or poor contact in the connector	Reinsert the connector. Also check for continuity within the connector cable. If none, replace the cable. PF drive motor 2 and PF main PWB (YC6)
		Drive transmission system of the PF drive motor	Check if the rollers and gears rotate smoothly. If not, grease the bushes and gears. Check for broken gears and replace if any.
		PF drive motor	Replace the PF drive motor 2.
		PF main PWB	Replace the PF main PWB (Refer to the service manual for the paper feeder).

Code	Contents	Related parts	Check procedures/ corrective measures
2620	PF drive motor 3 error (paper feeder 3) When the PF drive motor is driven, error signal is detected continuously for 2 s.	Connector cable or poor contact in the connector	Reinsert the connector. Also check for continuity within the connector cable. If none, replace the cable. PF drive motor 3 and PF main PWB (YC6)
		Drive transmission system of the PF drive motor	Check if the rollers and gears rotate smoothly. If not, grease the bushes and gears. Check for broken gears and replace if any.
		PF drive motor	Replace the PF drive motor 3.
		PF main PWB	Replace the PF main PWB (Refer to the service manual for the paper feeder).
2630	PF drive motor 4 error (paper feeder 4) When the PF drive motor is driven, error signal is detected continuously for 2 s.	Connector cable or poor contact in the connector	Reinsert the connector. Also check for continuity within the connector cable. If none, replace the cable. PF drive motor 4 and PF main PWB (YC6)
		Drive transmission system of the PF drive motor	Check if the rollers and gears rotate smoothly. If not, grease the bushes and gears. Check for broken gears and replace if any.
		PF drive motor	Replace the PF drive motor 4.
		PF main PWB	Replace the PF main PWB (Refer to the service manual for the paper feeder).

Code	Contents	Related parts	Check procedures/ corrective measures
3100	Scanner carriage error The home position is not correct when the power is turned on, at the end of a reading process of the table and document processor.	Image scanner motor	<ol style="list-style-type: none"> 1. Move the scanner by the hand to check whether it is unusually difficult to move. 2. Check that the scanner driving belt is not disengaged. 3. Confirm that the wiring connector is firmly connected and, if necessary, connect the connector all the way in. Image scanner motor and control PWB (YC1002) 4. If the wiring is disconnected, shorted or grounded, replace the wiring. 5. Replace the image scanner motor.
		Home position sensor	<ol style="list-style-type: none"> 1. Check that the sensor is correctly positioned. 2. Confirm that the wiring connector is firmly connected and, if necessary, connect the connector all the way in. Home position sensor and CCD PWB (YC3) CCD PWB and control PWB (YC1000) 3. Replace the home position sensor.
		CCD PWB	Replace the image scanner unit and execute U411 (see page 1-3-54).
		Control PWB	Replace the control PWB and check for correct operation (see page 2-2-12).
3200	Exposure lamp error When a lamp is made to turn on one side at a time, the white standard data at the time of an initial is lower than a rated value.	LED PWB	<ol style="list-style-type: none"> 1. Reinsert the connector. Also check for continuity within the connector cable. If none, replace the cable. LED PWB and CCD PWB (YC2) CCD PWB and control PWB (YC1000) 2. Replace the image scanner unit (see page 1-5-20).
		CCD PWB	Replace the image scanner unit and execute U411 (see page 1-3-54).
		Control PWB	Replace the control PWB and check for correct operation (see page 2-2-12).
3500	Communication error between scanner and ASIC An error code is detected.	CCD PWB	<ol style="list-style-type: none"> 1. Confirm that the wiring connector is firmly connected and, if necessary, connect the connector all the way in. CCD PWB and control PWB (YC1000) 2. If the wiring is disconnected, shorted or grounded, replace the wiring. 3. Replace the image scanner unit and execute U411 (see page 1-3-54).
		Control PWB	Replace the control PWB and check for correct operation (see page 2-2-12).

Code	Contents	Related parts	Check procedures/ corrective measures
4000	Polygon motor steady-state error After Polygon motor is stabilized, the ready signal is at the H level for 20 s continuously.	Polygon motor (LSU)	<ol style="list-style-type: none"> 1. Confirm that the wiring connector is firmly connected and, if necessary, connect the connector all the way in. Laser scanner unit and control PWB (YC15) 2. If the wiring is disconnected, shorted or grounded, replace the wiring. 3. Replace the laser scanner unit (see page 1-5-28).
		Control PWB	<ol style="list-style-type: none"> 1. Check the control software and upgrade to the latest, if necessary. 2. Replace the control PWB and check for correct operation (see page 2-2-12).
4200	BD steady-state error The BD signal is not detected.	PD PWB (LSU)	<ol style="list-style-type: none"> 1. Confirm that the FCC wiring connector is not distorted and connect the FCC wiring all the way in. Laser scanner unit and control PWB (YC16) 2. If the FCC wiring is disconnected, shorted or grounded, replace the FCC wiring. 3. Replace the laser scanner unit (see page 1-5-28).
		Control PWB	<ol style="list-style-type: none"> 1. Check the control software and upgrade to the latest, if necessary. 2. Replace the control PWB and check for correct operation (see page 2-2-12).
5100	Chager current error When the current value measured at the time of potential adjustment is less than 20 μ A. The error of the charge current before toner installation. The error of the charge current before printing.	Connector cable or poor contact in the connector	Reinsert the connector. Also check for continuity within the connector cable. If none, replace the cable. Chager unit and high voltage PWB High voltage PWB and control PWB (YC19)
		High voltage PWB	Replace the high voltage PWB and check for correct operation (see page 2-2-36).
		Control PWB	Replace the control PWB and check for correct operation (see page 2-2-12).

Code	Contents	Related parts	Check procedures/ corrective measures
6000	Broken fuser heater wire (Center) (50/60 ppm model) Fuser thermistor 2 detects a temperature less than 100°C/ 212°F continuously for 30 s after a warm-up start. (40 ppm model) Fuser thermistor 1 detects a temperature less than 100°C/ 212°F continuously for 30 s after a warm-up start.	Fuser unit	1. Check that no paper jam is present. 2. Confirm that the wiring connector is firmly connected and, if necessary, connect the connector all the way in. Fuser unit and fuser thermistor connect PWB (YC2) Fuser thermistor connect PWB and control PWB (YC21) 3. If the wiring is disconnected, shorted or grounded, replace the wiring. 4. Replace the Fuser unit (see page 1-5-47). (Deteriorated sensitivity due to the toner adhered to the center thermistor.)
		Fuser thermistor connect PWB	Replace the fuser thermistor connect PWB.
		Control PWB	1. Check the control software and upgrade to the latest, if necessary. 2. Replace the control PWB and check for correct operation (see page 2-2-12).
		Power source PWB	1. Confirm that the wiring connector is firmly connected and, if necessary, connect the connector all the way in. Power source PWB and connect right PWB (YC4) Connect right PWB and control PWB (YC1) 2. Replace the power source PWB (see page 2-2-36).
		Fuser heater	1. Replace the Fuser unit (see page 1-5-47).

Code	Contents	Related parts	Check procedures/ corrective measures
6020	<p>Abnormally high fuser thermistor 2 temperature (Center) (50/60 ppm model only)</p> <p>Fuser thermistor 2 detects a temperature higher than 235°C/455°F. In a heater-off state, the detection temperature of fuser thermistor 2 is higher than 195°C/383°F after the detection temperature of fuser thermistor 2 was 155°C/311°F or less.</p>	Fuser unit	<ol style="list-style-type: none"> 1. Confirm that the wiring connector is firmly connected and, if necessary, connect the connector all the way in. Fuser unit and fuser thermistor connect PWB (YC2) Fuser thermistor connect PWB and control PWB (YC21) 2. If the wiring is disconnected, shorted or grounded, replace the wiring. 3. Replace the Fuser unit (see page 1-5-47).
		Fuser thermistor connect PWB	Replace the fuser thermistor connect PWB.
		Control PWB	<ol style="list-style-type: none"> 1. Check the control software and upgrade to the latest, if necessary. 2. Replace the control PWB and check for correct operation (see page 2-2-12).

Code	Contents	Related parts	Check procedures/ corrective measures
6030	Broken fuser thermistor 2 wire (Center) (50/60 ppm model only) Input from fuser thermistor 2 is 1019 or more (A/D value) continuously for 4 s.	Fuser unit	1. Check that no paper jam is present. 2. Confirm that the wiring connector is firmly connected and, if necessary, connect the connector all the way in. Fuser unit and fuser thermistor connect PWB (YC2) Fuser thermistor connect PWB and control PWB (YC21) 3. If the wiring is disconnected, shorted or grounded, replace the wiring. 4. Replace the Fuser unit (see page 1-5-47). (Deteriorated sensitivity due to the toner adhered to the center thermistor.)
		Fuser thermistor connect PWB	Replace the fuser thermistor connect PWB.
		Control PWB	1. Check the control software and upgrade to the latest, if necessary. 2. Replace the control PWB (see page 2-2-12).
		Fuser thermistor 2	1. Replace the Fuser unit (see page 1-5-47).
		Fuser thermostat (triggered)	1. Confirm that the wiring connector is firmly connected and, if necessary, connect the connector all the way in. Fuser unit and power source PWB (YC2) 2. If the wiring is disconnected, shorted or grounded, replace the wiring. 3. Replace the Fuser unit (see page 1-5-47).
		Power source PWB	Replace the power source PWB (see page 2-2-12).

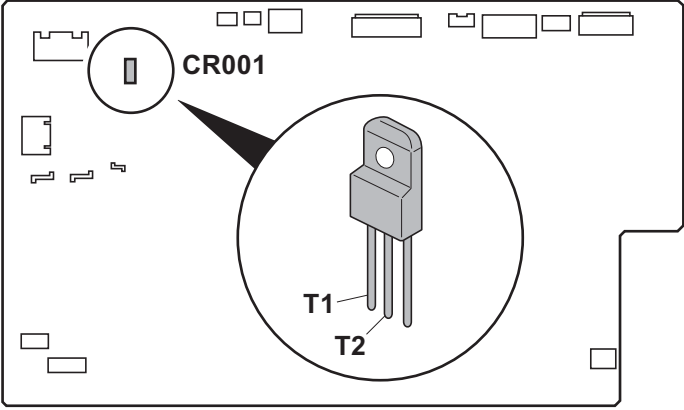
Code	Contents	Related parts	Check procedures/ corrective measures
6000/ 6020/ 6030/ 6120/ 6130/ Com- bined	Broken fuser heater wire Abnormally high fuser thermistor 2 temperature Broken fuser thermistor 2 wire Abnormally high fuser thermistor 1 temperature Broken fuser thermistor 1 wire	Connector pin Triac	If the I/F connector pins of the fuser unit and the main unit are deformed owing to foreign matters, replace the connectors or the units including the connectors. Remove the power cord and check that the resistance between terminals T1 and T2 of the triac TRA31 and triac TRA41 (the triac TRA41 is 60/50 ppm model only) are of several Mega-Ohms and not shorted (see figure 1-4-3). If failed, replace the power source PWB (see page 2-2-48).
			 <p data-bbox="874 1234 1118 1263">Power source PWB</p> <p data-bbox="967 1317 1118 1346">Figure 1-4-3</p>

Code	Contents	Related parts	Check procedures/ corrective measures
6120 Abnormally high fuser thermistor 1 temperature (50/60 ppm model) The detection temperature of fuser thermistor 1 is higher than 245°C/473°F. In a heater-off state, the detection temperature of fuser thermistor 1 is higher than 195°C/383°F after the detection temperature of fuser thermistor 1 was 155°C/311°F or less. (40 ppm model) The detection temperature of fuser thermistor 1 is higher than 250°C/482°F. In a heater-off state, the detection temperature of fuser thermistor 1 is higher than 170°C/338°F after the detection temperature of fuser thermistor 1 was 155°C/311°F or less.	Connector pin	See page 1-4-36.	
	Triac	See page 1-4-36.	
	Fuser thermistor	Replace the fuser unit (see page 1-5-47).	
	Contrl PWB	Replace the control PWB and check for correct operation (see page 2-2-12).	
6130 Broken fuser thermistor 1 wire (50/60 ppm model only) A/D value of the fuser thermistor 1 exceeds 1019 bit continuously for 4 s during warming up.	Connector cable or poor contact in the connector	Reinsert the connector. Also check for continuity within the connector cable. If none, replace the cable. Fuser thermistor and fuser thermistor connect PWB (YC1) Fuser thermistor connect PWB and control PWB (YC21)	
	Connector pin	See page 1-4-36.	
	Triac	See page 1-4-36.	
	Fuser thermistor	Replace the fuser unit (see page 1-5-47).	
	Fuser thermistor connect PWB	Replace the fuser thermistor connect PWB.	
	Control PWB	Replace the control PWB and check for correct operation (see page 2-2-12).	

Code	Contents	Related parts	Check procedures/ corrective measures
6400	Zero-cross signal error While fuser heater ON/OFF control is performed, the zero-cross signal is not input within 2 s.	Fuser unit	1. Confirm that the wiring connector is firmly connected and, if necessary, connect the connector all the way in. Power source PWB and connect right PWB (YC4) Connect right PWB and control PWB (YC29) 2. If the wiring is disconnected, shorted or grounded, replace the wiring.
		Power source PWB	Replace the power source PWB (see page 2-2-12).
		Connect right PWB	Replace the connect right PWB (see page 2-2-12).
		Control PWB	Replace the control PWB (see page 2-2-12).
7000	Toner motor error During driving the toner motor, an over-current detection signal is detected at intervals of 10 ms as for 300 accumulation.	Connector cable or poor contact in the connector	Reinsert the connector. Also check for continuity within the connector cable. If none, replace the cable. Toner motor and drum PWB (YC4) Drum PWB and drum connect PWB (YC1) Drum connect PWB and connect left PWB (YC3) Connect left PWB and control PWB (YC3)
		Drum unit	Replace the drum unit.
		Connect left PWB	Replace the connect left PWB (see page 2-2-12).
		Control PWB	Replace the control PWB and check for correct operation (see page 2-2-12).

Code	Contents	Related parts	Check procedures/ corrective measures
7100	Toner sensor error Sensor output value of 930 or more continuously for 5 s.	Toner sensor	<ol style="list-style-type: none"> 1. Check the toner sensor output. 2. Confirm that the wiring connector is firmly connected and, if necessary, connect the connector all the way in. Toner sensor and drum PWB (YC3) Drum PWB and drum connect PWB (YC1) Drum connect PWB and connect left PWB (YC3) Connect left PWB and control PWB (YC3) 3. If the wiring is disconnected, shorted or grounded, replace the wiring. 4. Check that the gears of the Developer unit are not damaged and the spiral can rotate. 5. Replace the Developer unit (see page 1-5-33).
		Toner motor	<ol style="list-style-type: none"> 1. Draw out the toner container. 2. Check the drive gear can rotate or they are not unusually loaded and, if necessary, replace. 3. Confirm that the wiring connector is firmly connected and, if necessary, connect the connector all the way in. Toner motor and drum PWB (YC4) Drum PWB and drum connect PWB (YC1) Drum connect PWB and connect left PWB (YC3) Connect left PWB and control PWB (YC3) 4. If the wiring is disconnected, shorted or grounded, replace the wiring. 5. Replace the Toner motor.
		Connect left PWB	Replace the connect left PWB (see page 2-2-12).
		Control PWB	<ol style="list-style-type: none"> 1. Check the control software and upgrade to the latest, if necessary. 2. Replace the control PWB and check for correct operation (see page 2-2-12).

Code	Contents	Related parts	Check procedures/ corrective measures
7400	Developer unit non-installing error Sensor output value of 31 or less continuously for 5 s.	Connector cable or poor contact in the connector	Reinsert the connector. Also check for continuity within the connector cable. If none, replace the cable. Developer unit and drum PWB (YC3) Drum PWB and drum connect PWB (YC1) Drum connect PWB and connect left PWB (YC3) Connect left PWB and control PWB (YC2)
		Toner sensor	Replace the developer unit. (See Page 1-5-33)
		Connect left PWB	Replace the connect left PWB (see page 2-2-12).
		Control PWB	Replace the control PWB and check for correct operation (see page 2-2-12).
7410	Drum unit type mismatch error The drum PWB EEPROM does not communicate normally. Absence of the drum unit is detected.	Connector cable or poor contact in the connector	Reinsert the connector. Also check for continuity within the connector cable. If none, replace the cable. Drum unit and drum connect PWB (YC1) Drum connect PWB and connect left PWB (YC3) Connect left PWB and control PWB (YC2)
		Toner sensor	Replace the drum unit. (See Page 1-5-37)
		Connect left PWB	Replace the connect left PWB (see page 2-2-12).
		Control PWB	Replace the control PWB and check for correct operation (see page 2-2-12).
7800	Broken temperature sensor wire Input from temperature sensor is 1019 or more continuously for 160 ms. Input from temperature sensor is 930 or more continuously for 5 s.	Temperature sensor	1. Confirm that the wiring connector is firmly connected and, if necessary, connect the connector all the way in. Temperature sensor and control PWB (YC30) 2. If the wiring is disconnected, shorted or grounded, replace the wiring. 3. Replace the key right PWB.
		Control PWB	1. Check the control software and upgrade to the latest, if necessary. 2. Replace the control PWB and check for correct operation (see page 2-2-12).

Code	Contents	Related parts	Check procedures/ corrective measures
7810	Short-circuited temperature sensor wire Input from temperature sensor is 31 or less continuously for 5 s.	Temperature sensor	1. Confirm that the wiring connector is firmly connected and, if necessary, connect the connector all the way in. Temperature sensor and control PWB (YC30) 2. If the wiring is disconnected, shorted or grounded, replace the wiring. 3. Replace the key right PWB.
		Control PWB	1. Check the control software and upgrade to the latest, if necessary. 2. Replace the control PWB and check for correct operation (see page 2-2-12).
7900	Drum EEPROM error No response is issued from the device in reading/writing for 5 ms or more and this problem is repeated 5 times successively. Mismatch of reading data from 2 locations occurs 8 times successively. Mismatch between writing data and reading data occurs 8 times successively.	DR PWB	1. Confirm that the wiring connector is firmly connected and, if necessary, connect the connector all the way in. DR PWB and drum connect PWB (YC1) Drum connect PWB and connect left PWB (YC3) Connect left PWB and control PWB (YC2) 2. If the wiring is disconnected, shorted or grounded, replace the wiring. 3. Replace the Drum unit (see page 1-5-39).
		Connect left PWB	Replace the connect left PWB (see page 2-2-12).
		Control PWB	1. Check the control software and upgrade to the latest, if necessary. 2. Replace the control PWB and check for correct operation (see page 2-2-12).

Code	Contents	Related parts	Check procedures/ corrective measures
9180	<p>DP switchback motor error</p> <p>When the home position was not detected even if the processing was retried three consecutive times.</p> <p>Condition of the home position detection: When detecting the home position by driving one rotation the DP switchback motor.</p>	DP switchback motor	<ol style="list-style-type: none"> 1. Unplug the power cord from the wall outlet, and wait five seconds. Then plug the power cord and then turn on the power switch. 2. Confirm that the connector of the DP switchback motor is firmly connected, and if necessary, push the unit all the way in. 3. Confirm that the wiring connector is firmly connected and, if necessary, connect the connector all the way in. DP switchback motor and the control PWB (YC1001) 4. If the wiring is disconnected, shorted or grounded, or the connector pin is deformed, remedy or replace the wire. 5. Replace the DP switchback motor. (see page 1-5-82)
		DP switchback sensor (DPSBS)	<ol style="list-style-type: none"> 1. Rotate the DP switchback-feedshift motor by the hand to check that it is not unusually difficult to rotate. 2. Check that the DP switchback sensor (DPSBS) is not disengaged and is correctly positioned. And check that the actuator correctly shields the light. 3. Confirm that the wiring connector is firmly connected and, if necessary, connect the connector all the way in. DP switchback sensor (DPSBS) and the control PWB (YC1003) 4. If the wiring is disconnected, shorted or grounded remedy or replace the wire. 5. Replace the DP switchback sensor (DPSBS).
		Control PWB	<ol style="list-style-type: none"> 1. Check the engine firmware and upgrade to the latest version, if necessary. 2. Replace the control PWB. (see page 2-2-12)

Code	Contents	Related parts	Check procedures/ corrective measures
F000	Communication error between Control PWB and Operation PWB	Control PWB	<ol style="list-style-type: none"> 1. Turn the main power switch off and after 5 seconds, then turn power on. 2. Check that the wirings and connetors between the control PWB and the operation panel PWB are normal. Operation PWB and control PWB (YC2002) 3. Check that the DIMM memories in the control PWB are well conducted and, if not, replace. 4. Execute U021initialize memory. (see page 1-3-22) 5. Replace the control PWB.
		Operation PWB	Replace the operation PWB (see page 2-2-56).
F010	Control PWB checksum error	Control PWB	Turn the main power switch off/on to restart the machine. If the error is not resolved, replace control PWB and check for correct operation (see page 2-2-12).
F020	Control PWB RAM check sum error	Main memory (RAM)	Turn the main power switch off/on to restart the machine. If the error is not resolved, replace control PWB and check for correct operation (see page 2-2-12).
F040	Communication error between Controller and Print engine	Control PWB	<ol style="list-style-type: none"> 1. Turn the main power switch off and after 5 seconds, then turn power on. 2. Repair or replace the wire from the control PWB, that may be grounded. (Check short-circuit between 5V and 3.3V.) 3. Check the control software and upgrade to the latest, if necessary. 4. If not corrected, replace the control PWB and check for correct operation (see page 2-2-12).
F041	Communication error between Controller and Scan engine	Control PWB	<ol style="list-style-type: none"> 1. Turn the main power switch off and after 5 seconds, then turn power on. 2. Repair or replace the wire from the control PWB, that may be grounded. (Check short-circuit between 5V and 3.3V.) 3. Check the control software and upgrade to the latest, if necessary. 4. If not corrected, replace the control PWB and check for correct operation (see page 2-2-12).

Code	Contents	Related parts	Check procedures/ corrective measures
F050	Print engine ROM check-sum error	Control PWB	<ol style="list-style-type: none"> 1. Turn the main power switch off and after 5 seconds, then turn power on. 2. Confirm that the EEPROM has been properly installed. 3. Check the control software and upgrade to the latest, if necessary. 4. If not corrected, Replace the control PWB and check for correct operation (see page 2-2-12).
F051	Scan engine ROM check-sum error	Control PWB	<ol style="list-style-type: none"> 1. Turn the main power switch off and after 5 seconds, then turn power on. 2. Confirm that the EEPROM has been properly installed. 3. Check the control software and upgrade to the latest, if necessary. 4. If not corrected, Replace the control PWB and check for correct operation (see page 2-2-12).

NOTE:

The other F codes are indicated to the appendix (see page 2-3-12).

1-4-4 Image formation problems

Isolate the component an image defect has occurred from.

<A guide to isolate the component of the cause.>

Print a test page and check whether an image defect happens.

(System Menu > Adjustment/Maintenance > Service setting)

YES: Main unit as the cause of defect

NO: Scanner as the cause of defect

Perform enlarged or reduced copying and verify if the defective images are enlarged or reduced, accordingly.

YES: Scanner as the cause of defect

1. Scanner as the cause of defect:

If the defect occurs with copying or sending, refer to P.1-4-46.

(Defects caused by a reading error that occurs at the original (glass) LED lamp to CCD.)

Isolate the problem at the location that the originals are scanned.

a. DP (read by CCD)

b. On the contact glass (read by CCD)

2. Main unit as the cause of defect: refer to P. 1-4-46.

(A defect of image forming occurs from the rendering process that involves charging, drum, LSU, developer, and primary transferring.)

<Flow of image data>

Copying :



Sending :

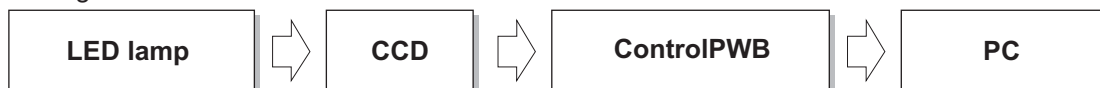

Printing data from PC :

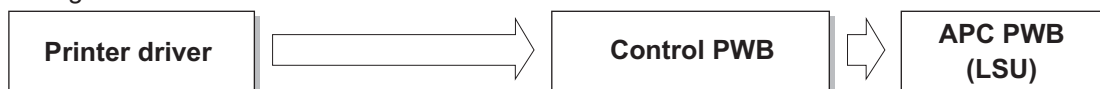

1-4-5 Poor image (due to DP and scanner reading)

(1) No image appears (entirely white).

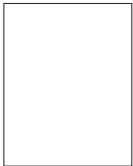

See page1-4-47

(2) No image appears (entirely black).



See page1-4-49

(3) Image is too light.



See page1-4-50

(4) The background is colored.



See page1-4-52

(5) White streaks are printed vertically.



See page1-4-54

(6) Black streaks appear longitudinally.

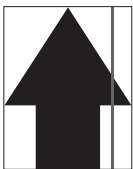

See page1-4-56

(7) Streaks are printed horizontally.

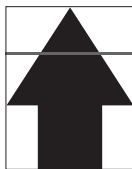

See page1-4-58

(8) One side of the print image is darker or brighter than the other.



See page1-4-60

(9) Black dots appear on the image.



See page1-4-62

(10) Image is blurred.



See page1-4-63

(11) The leading edge of the image is consistently misaligned with the original.



See page1-4-65

(12) Part of image is missing.



See page1-4-66

(13) Image is out of focus.



See page1-4-68

(14) Image center does not align with the original center.



See page1-4-70

(15) Moires

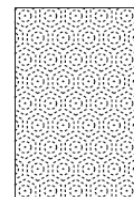

See page1-4-71

(16) Skewed image



See page1-4-72

(17) Abnormal image

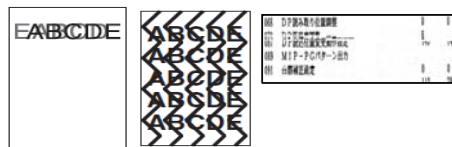

See page1-4-73

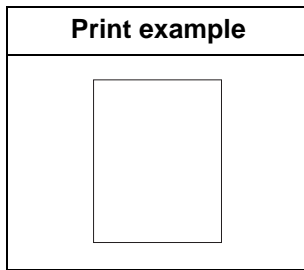
(1) No image appears (entirely white).

1. Table scanning

	Defective part	Check description	Corrective Action
1	Contact glass assy	Check the location the contact glass is mounted.	Re-mount the contact glass if it is hanged off.
2	FFC cable CCD	Check the FFC cable between the CCD and control PWB is properly connected. Or, verify conduction of the wire.	Reinsert the connector if it its connection is loose. Or, if conduction is lot, replace the wire.
3	Home position sensor	Check the location the home position sensor is mounted.	Re-mount the home position sensor if it is hanged off.
4	Scanner drive belt	Check that the scanner drive belt is loosely mounted.	If the scanner drive belt is loosely mounted, secure the screws.
5	Scanner drive gear	Check that the scanner drive gear is loosely mounted.	If the scanner drive gear loosely mounted, secure the screw.
6	CCD PWB	The CCD PWB is defective.	Replace the ISU and perform U411. (see page 1-3-54)
7	Control PWB	The control PWB is defective.	Replace the control PWB.(see page 2-2-12)

2. DP-scanning

	Defective part	Check description	Corrective Action
1	Original document	Verify the sides of the original document.	If the sides of the original document are reversed, place the original document properly.
2	Contact glass assy	Check the location the contact glass is mounted.	Re-mount the contact glass if it is hanged off.
3	FFC cable CCD	Check the FFC cable between the CCD and control PWB is properly connected. Or, verify conduction of the wire.	Reinsert the connector if it its connection is loose. Or, if conduction is lot, replace the wire.
4	Home position sensor	Check the location the home position sensor is mounted.	Re-mount the home position sensor if it is hanged off.
5	Scanner drive belt	Check that the scanner drive belt is loosely mounted.	If the scanner drive belt is loosely mounted, secure the screws.
6	Scanner drive gear	Check that the scanner drive gear is loosely mounted.	If the scanner drive gear loosely mounted, secure the screw.
7	CCD PWB	The CCD PWB is defective.	Replace the ISU and perform U411. (see page 1-3-54)
8	Control PWB	The control PWB is defective.	Replace the control PWB.(see page 2-2-12)

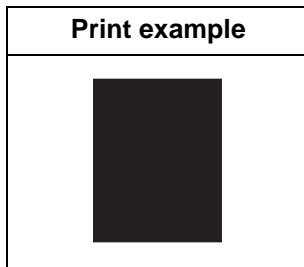
(2) No image appears (entirely black).

1. Table scanning

	Defective part	Check description	Corrective Action
1	FFC cable CCD	Check the FFC cable between the CCD and control PWB is properly connected. Or, verify conduction of the wire.	Reinsert the connector if its connection is loose. Or, if conduction is lot, replace the wire.
2	CCD PWB	The CCD PWB is defective.	Replace the ISU and perform U411. (see page 1-3-54)
3	Control PWB	The control PWB is defective.	Replace the control PWB.(see page 2-2-12)

2. DP-scanning

	Defective part	Check description	Corrective Action
1	Scanning position of the DP	Confirm the value using maintenance mode U068, DP Read.	If a large value is observed in maintenance mode U068, DP Read, perform adjustment.(see page 1-3-31)
2	FFC cable CCD	Check the FFC cable between the CCD and control PWB is properly connected. Or, verify conduction of the wire.	Reinsert the connector if its connection is loose. Or, if conduction is lot, replace the wire.
3	CCD PWB	The CCD PWB is defective.	Replace the ISU and perform U411. (see page 1-3-54)
4	Control PWB	The control PWB is defective.	Replace the control PWB.(see page 2-2-12)

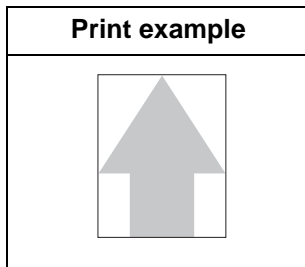
(3) Image is too light.

1. Table scanning

	Defective part	Check description	Corrective Action
1	The settings of the adjustment of density	Check the settings of the adjustment of density.	1. Deactivate EcoPrint if it is activated. Or, if the density is too low, choose an image quality that suits the original document in type. 2. Increase density. 3. Perform the background color adjustment using the system menu.
2	Settings of anti-offset	Check the settings of anti-offset.	If anti-offset is set to on, set it to off.
3	Adjustment of the scanner	Check the automatic adjustment of the scanner.	Perform maintenance mode U411, table(Chart1)_All. (see page 1-3-54)
4	Contact glass	Check whether the contact glass is dirty.	If the contact glass is dirty, clean the contact glass, and the bottom part of the shading plate.
5	Home position sensor	Check the location the home position sensor is mounted.	Re-mount the home position sensor if it is hanged off.
6	FFC cable CCD	Check the FFC cable between the CCD and control PWB is properly connected. Or, verify conduction of the wire.	Reinsert the connector if its connection is loose. Or, if conduction is lot, replace the wire.
7	Lamp unit	Check the location the lamp unit is mounted.	Re-mount the lamp unit if it is hanged off.
8	LED PWB	Check that the LED is lit.	If the LED is not lit, replace the ISU and perform U411.
9	CCD PWB	CCD PWB is defective.	Replace the ISU and perform U411.
10	Control PWB	The control PWB is defective.	Replace the control PWB.(see page 2-2-12)

2. DP-scanning

	Defective part	Check description	Corrective Action
1	The settings of the adjustment of density	Check the settings of the adjustment of density.	<ol style="list-style-type: none"> 1. Deactivate EcoPrint if it is activated. Or, if the density is too low, choose an image quality that suits the original document in type. 2. Increase density. 3. Perform the background color adjustment using the system menu.
2	Settings of anti-offset	Check the settings of anti-offset.	If anti-offset is set to on, set it to off.
3	Adjustment of the scanner	Check the automatic adjustment of the scanner.	Perform maintenance mode U411, table(Chart1)_All. (see page 1-3-54)
4	Contact glass	Check whether the contact glass is dirty.	If the contact glass is dirty, clean the contact glass, and the bottom part of the shading plate.
5	Home position sensor	Check the location the home position sensor is mounted.	Re-mount the home position sensor if it is hanged off.
6	Scanning position of the DP	Check whether the scanning position of the DP is wrong.	If the scanning position of the DP is shifted, perform maintenance mode U068, DP Read.(see page 1-3-31)
7	FFC cable CCD	Check the FFC cable between the CCD and control PWB is properly connected. Or, verify conduction of the wire.	Reinsert the connector if its connection is loose. Or, if conduction is lot, replace the wire.
8	Lamp unit	Check the location the lamp unit is mounted.	Re-mount the lamp unit if it is hanged off.
9	LED PWB	Check that the LED is lit.	If the LED is not lit, replace the ISU and perform U411.
10	CCD PWB	CCD PWB is defective.	Replace the ISU and perform U411.
11	Control PWB	The control PWB is defective.	Replace the control PWB.(see page 2-2-12)

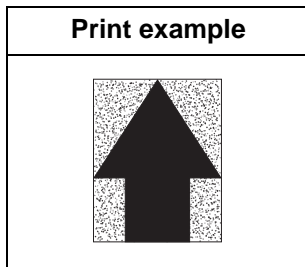
(4) The background is colored.

1. Table scanning

	Defective part	Check description	Corrective Action
1	Original document	1. Check if the background density of the original document is too dense. 2. Check if the original document is floated during scanning.	1. If the background density of the original document is too dense, perform automatic background adjustment. Or, adjust density with background adjustment. 2. If the original document is floated during scanning, press down the original document.
2	Adjustment of the scanner	Check the automatic adjustment of the scanner.	Perform maintenance mode U411, table(Chart1)_All. (see page 1-3-54)
3	Contact glass	Check whether the contact glass is dirty.	If the contact glass is dirty, clean the contact glass, and the bottom part of the shading plate.
4	Contact glass assy	Check the location the contact glass is mounted.	Re-mount the contact glass if it is hanged off.
5	Home position sensor	Check the location the home position sensor is mounted.	Re-mount the home position sensor if it is hanged off.
6	FFC cable CCD	Check the FFC cable between the CCD and control PWB is properly connected. Or, verify conduction of the wire.	Reinsert the connector if its connection is loose. Or, if conduction is lot, replace the wire.
7	Lamp unit	Check the location the lamp unit is mounted.	Re-mount the lamp unit if it is hanged off.
8	LED PWB	Check that the LED is lit.	If the LED is not lit, replace the ISU and perform U411.
9	CCD PWB	CCD PWB is defective.	Replace the ISU and perform U411.
10	Control PWB	The control PWB is defective.	Replace the control PWB.(see page 2-2-12)

2. DP-scanning

	Defective part	Check description	Corrective Action
1	Original document	1. Check if the background density of the original document is too dense. 2. Check if the original document is floated during scanning.	1. If the background density of the original document is too dense, perform automatic background adjustment.Or, adjust density with background adjustment. 2. If the original document is floated during scanning, press down the original document.
2	Adjustment of the scanner	Check the automatic adjustment of the scanner.	Perform maintenance mode U411, table(Chart1)_All. (see page 1-3-54)
3	Contact glass	Check whether the contact glass is dirty.	If the contact glass is dirty, clean the contact glass, and the bottom part of the shading plate.
4	Contact glass assy	Check the location the contact glass is mounted.	Re-mount the contact glass if is hanged off.
5	Home position sensor	Check the location the home position sensor is mounted.	Re-mount the home position sensor if it is hanged off.
6	Installing DP	Check whether the DP frame is distorted or the hinges are damaged.	Replace the DP.
7	FFC cable CCD	Check the FFC cable between the CCD and control PWB is properly connected. Or, verify conduction of the wire.	Reinsert the connector if its connection is loose. Or, if conduction is lot, replace the wire.
8	Lamp unit	Check the location the lamp unit is mounted.	Re-mount the lamp unit if it is hanged off.
9	LED PWB	Check that the LED is lit.	If the LED is not lit, replace the ISU and perform U411.
10	CCD PWB	CCD PWB is defective.	Replace the ISU and perform U411.
11	Control PWB	The control PWB is defective.	Replace the control PWB.(see page 2-2-12)

(5) White streaks are printed vertically.

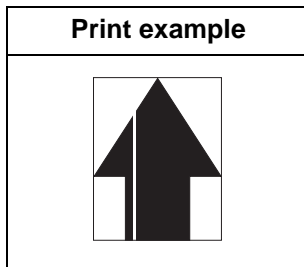

1. Table scanning

	Defective part	Check description	Corrective Action
1	Original document	Check whether the original document is dirty.	If the original document is dirty, replace.
2	Contact glass	Check whether the contact glass is dirty.	If the contact glass is dirty, clean the contact glass, and the bottom part of the shading plate.
3	Mirror	Check whether the mirrors are dirty.	If the mirrors are dirty, clean the three mirrors.
4	Lamp unit	Check that the lamp unit is contaminated with dusts.	If dusts are observed on the lamp unit, remove the dusts in the light paths.
5	ISU	Check whether the lens cover is hanged off.	Re-mount the lens cover if it is hanged off.
6	Shading plate	Check whether the shading plate is dirty.	If the shading plate is dirty, perform maintenance mode U063 to modify the shading position. If it does not cure, replace the contact glass assembly. (see page 1-5-16)
7	CCD PWB	The CCD PWB is defective.	Replace the ISU and perform U411. (see page 1-3-54)
8	Control PWB	The control PWB is defective.	Replace the control PWB.(see page 2-2-12)

2. DP-scanning

	Defective part	Check description	Corrective Action
1	Original document	Check whether the original document is dirty.	If the original document is dirty, replace.
2	Slit glass	Check whether the slit glass is dirty.	If the slit glass is dirty, clean the slit glass, and the bottom part of the shading plate.
3	Mirror	Check whether the mirrors are dirty.	If the mirrors are dirty, clean the three mirrors.
4	Lamp unit	Check that the lamp unit is contaminated with dusts.	If dusts are observed on the lamp unit, remove the dusts in the light paths.

	Defective part	Check description	Corrective Action
5	ISU	Check whether the lens cover is hanged off.	Re-mount the lens cover if it is hanged off.
6	Shading plate	Check whether the shading plate is dirty.	If the shading plate is dirty, perform maintenance mode U063 to modify the shading position. If it does not cure, replace the contact glass assembly. (see page 1-5-16)
7	CCD PWB	The CCD PWB is defective.	Replace the ISU and perform U411. (see page 1-3-54)
8	Control PWB	The control PWB is defective.	Replace the control PWB.(see page 2-2-12)

(6) Black streaks appear longitudinally.

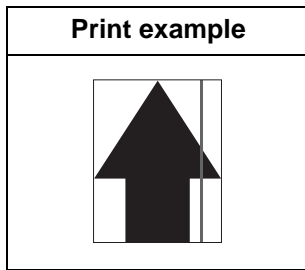

1. Table scanning

	Defective part	Check description	Corrective Action
1	Original document	Check whether the original document is dirty.	If the original document is dirty, replace.
2	Original document	Check if the size of the original document and its reference size match.	If the size of the original document and its reference size do not match, set the correct document size or activate border erasure.
3	Contact glass assy	Check the location the contact glass is mounted.	Re-mount the contact glass if it is hanged off.
4	Adjustment of the scanner	Check whether the outer areas of the original document have streaks or lines.	1. Perform maintenance mode U067, Front.(see page 1-3-30) 2. Perform maintenance mode U411, table (Chart1)_Input. (see page 1-3-54)
5	Contact glass	Check whether the outer areas of the original document have streaks or lines.	If the contact glass is dirty, clean.
6	Mirror	Check whether the mirrors are dirty.	If the mirrors are dirty, clean the three mirrors.
7	Lamp unit	Check that the lamp unit is contaminated with dusts.	If dusts are observed on the lamp unit, remove the dusts in the light paths.
8	Shading plate	Check whether the shading plate is dirty.	If the shading plate is dirty, perform maintenance mode U063 to modify the shading position. If it does not cure, replace the contact glass assembly. (see page 1-5-16)
9	CCD sensor	Check that the CCD sensor glass is contaminated with dusts.	If dusts are observed on the CCD sensor glass,remove the dusts by an air blower.
10	CCD PWB	The CCD PWB is defective.	Replace the ISU and perform U411. (see page 1-3-54)
11	Control PWB	The control PWB is defective.	Replace the control PWB.(see page 2-2-12)

2. DP-scanning

	Defective part	Check description	Corrective Action
1	Original document	Check whether the original document is dirty.	If the original document is dirty, replace.
2	Original document	Check if the size of the original document and its reference size match.	If the size of the original document and its reference size do not match, set the correct document size or activate border erasure.
3	Scanning position of the DP	Check whether the scanning position of the DP is wrong.	If the scanning position of the DP is shifted, perform maintenance mode U068, DP Read. (see page 1-3-31)
4	Adjustment of the scanner	Check whether the outer areas of the original document have streaks or lines.	1. Perform maintenance mode U067, Front.(see page 1-3-30) 2. Perform maintenance mode U411, table (Chart1)_Input. (see page 1-3-54)
5	Slit glass, Contact glass	Check whether the slit glass and contact glass are dirty.	If the slit glass and contact glass are dirty, clean the contact glass, the slit glass, the bottom part of the shading plate, and the conveying guide.
6	Mirror	Check whether the mirrors are dirty.	If the mirrors are dirty, clean the three mirrors.
7	Lamp unit	Check that the lamp unit is contaminated with dusts.	If dusts are observed on the lamp unit, remove the dusts in the light paths.
8	Shading plate	Check whether the shading plate is dirty.	If the shading plate is dirty, perform maintenance mode U063 to modify the shading position. If it does not cure, replace the contact glass assembly. (see page 1-5-16)
9	CCD sensor	Check that the CCD sensor glass is contaminated with dusts.	If dusts are observed on the CCD sensor glass,remove the dusts by an air blower.
10	CCD PWB	The CCD PWB is defective.	Replace the ISU and perform U411. (see page 1-3-54)
11	Control PWB	The control PWB is defective.	Replace the control PWB.(see page 2-2-12)

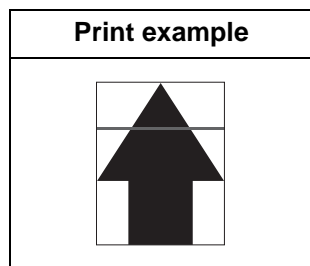
(7) Streaks are printed horizontally.

1. Table scanning

	Defective part	Check description	Corrective Action
1	Original document	Check whether the original document is dirty.	If the original document is dirty, replace.
2	Contact glass	Check whether the contact glass is dirty.	If the contact glass is dirty, clean the contact glass, and the bottom part of the shading plate.
3	Ajusting scanner	Check that the image at the back of the size indicator has been rendered.	1. If the image at the back of the size indicator, has been rendered perform maintenance mode U066, Front. (see page 1-3-29) 2. Perform maintenance mode U411, Table(Char1)_Input.(see page 1-3-54)
4	FFC cable CCD	Check the FFC cable between the CCD and control PWB is properly connected. Or, verify conduction of the wire.	Reinsert the connector if its connection is loose. Or, if conduction is lot, replace the wire.
5	LED PWB	Check that the LED is lit.	If the LED is not lit, replace the LED PWB and perform U411.
6	Control PWB	The control PWB is defective.	Replace the control PWB.(see page 2-2-12)

2. DP-scanning

	Defective part	Check description	Corrective Action
1	Original document	Check whether the original document is dirty.	If the original document is dirty, replace.
2	Slit glass	Check whether the slit glass is dirty.	If the slit glass is dirty, clean the slit glass, and the bottom part of the shading plate.
3	FFC cable CCD	Check the FFC cable between the CCD and control PWB is properly connected. Or, verify conduction of the wire.	Reinsert the connector if its connection is loose. Or, if conduction is lot, replace the wire.
4	LED PWB	Check that the LED is lit.	If the LED is not lit, replace the LED PWB and perform U411.

	Defective part	Check description	Corrective Action
5	Control PWB	The control PWB is defective.	Replace the control PWB.(see page 2-2-12)

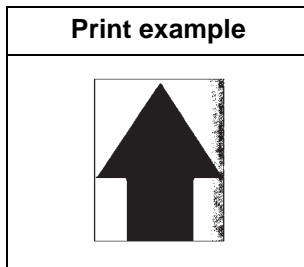
(8) One side of the print image is darker or brighter than the other.

1. Table scanning

	Defective part	Check description	Corrective Action
1	Original document	Check whether the original document is dirty.	If the original document is dirty, replace.
2	Original document	Check if the original document has creases or foldings or wrinkles.	If the original document has foldings or creases, remove them.
3	Position of the mat of the platen	Check whether the position of the mat of the DP or the platen is wrong.	If the position of the mat of the DP or the platen is shifted, re-mount.
4	Contact glass	Check whether the contact glass is dirty.	If the contact glass is dirty, clean the contact glass, and the bottom part of the shading plate.
5	Contact glass assy	Check the location the contact glass is mounted.	If the light guide panel has been fallen off of the mounting position, fix it properly.
6	Lamp unit	Check the position at which the light guide panel is mounted.	If the contact part of the lamp unit and the rail is distorted, replace the lamp unit.
7	Mirror	Check whether the mirrors are dirty.	If the mirrors are dirty, clean the three mirrors.
8	CCD PWB	The CCD PWB is defective.	Replace the ISU and perform U411. (see page 1-3-54)
9	Control PWB	The control PWB is defective.	Replace the control PWB.(see page 2-2-12)

2. DP-scanning

	Defective part	Check description	Corrective Action
1	Original document	Check whether the original document is dirty.	If the original document is dirty, replace.
2	Original document	Check if the original document has creases or foldings or wrinkles.	If the original document has foldings or creases, remove them.
3	DP scanning guide	Check that the scanning guide is smoothly operative.	If the scanning guide does not rotate smoothly, re-install.

	Defective part	Check description	Corrective Action
4	Contact glass	Check whether the contact glass is dirty.	If the contact glass is dirty, clean the contact glass, and the bottom part of the shading plate.
5	Contact glass assy	Check the location the contact glass is mounted.	Re-mount the contact glass if it is hanged off.
6	Lamp unit	Check the position at which the light guide panel is mounted.	If the contact part of the lamp unit and the rail is distorted, replace the lamp unit.
7	Mirror	Check whether the mirrors are dirty.	If the mirrors are dirty, clean the three mirrors.
8	CCD PWB	The CCD PWB is defective.	Replace the ISU and perform U411. (see page 1-3-54)
9	Control PWB	The control PWB is defective.	Replace the control PWB.(see page 2-2-12)

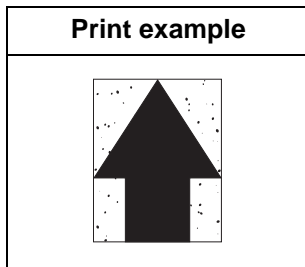
(9) Black dots appear on the image.

1. Table scanning

	Defective part	Check description	Corrective Action
1	Original document	Check whether the original document is dirty.	If the original document is dirty, replace.
2	Contact glass	Check whether the contact glass is dirty.	If the contact glass is dirty, clean the contact glass, and the bottom part of the shading plate.
3	FFC cable CCD	Check the FFC cable between the CCD and control PWB is properly connected. Or, verify conduction of the wire.	Reinsert the connector if its connection is loose. Or, if conduction is lot, replace the wire.
4	Control PWB	The control PWB is defective.	Replace the control PWB.(see page 2-2-12)

2. DP-scanning

	Defective part	Check description	Corrective Action
1	Original document	Check whether the original document is dirty.	If the original document is dirty, replace.
2	Slit glass	Check whether the slit glass is dirty.	If the contact glass is dirty, clean the contact glass, and the bottom part of the shading plate.
3	FFC cable CCD	Check the FFC cable between the CCD and control PWB is properly connected. Or, verify conduction of the wire.	Reinsert the connector if its connection is loose. Or, if conduction is lot, replace the wire.
4	Control PWB	The control PWB is defective.	Replace the control PWB.(see page 2-2-12)

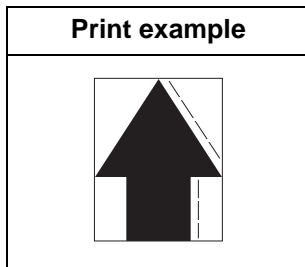
(10) Image is blurred.

1. Table scanning

	Defective part	Check description	Corrective Action
1	Rail	Check that the carriage is smoothly operative.	If the carriage does not travel smoothly, remove foreign objects on the front and back optical rails.
2	Lamp unit	Check that the carriage is smoothly operative.	If the carriage does not travel smoothly because the lamp unit contacts with the frame, rectify.
3	Scanner drive belt	Confirm that a foreign object exists between the drive belt and the scanner drive pulleys.	If a foreign object exists, remove.
4	Drive belt	Confirm that the drive belt has a foreign object stuck or has a scuff.	If a foreign object exists on the drive belt, remove the foreign object. Or, if it is damaged, replace.

2. DP-scanning

	Defective part	Check description	Corrective Action
1	DP conveying pulley	Check that the conveying pulley is smoothly operative.	If the conveying pulley does not rotate smoothly, re-assemble the conveying roller and springs.
2	Install DP	Check how DP is mounted on the main unit.	If mounting to the main unit is improper, check positioning and secure the screws.
3	DP hinge	Check that the DP hinge is operative in both ascending and descending directions and kept open.	If the DP is not operative smoothly or is not held stably open, replace the hinges.
4	DP document mat	Check the location the document mat of the DP is mounted.	Re-mount the document mat of the DP if it is hanged off.
5	Original document	Check that the leading edge of the original document is dog-eared.	If the leading edge of the original document is dog-eared, straighten.
6	Scanning guide	Check if the scanning guide is distorted.	If the scanning guide deformed, replace.

	Defective part	Check description	Corrective Action
7	Scopper guide	Check that the scopper guide is smoothly operative.	If the scopper guide does not rotate smoothly, re-install.
8	Conveying roller (before and after of scanning)	Check whether the conveying roller is dirty.	If the conveying roller is dirty, clean.
9	Drive belt	Check if the drive belt is jumping gear teeth.	If the drive belt is jumping gear teeth, re-mount the belt tensioner.

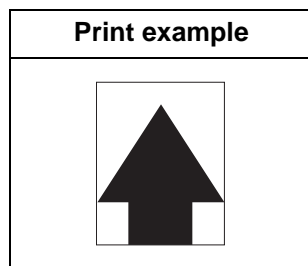
(11) The leading edge of the image is consistently misaligned with the original.

1. Table scanning

	Defective part	Check description	Corrective Action
1	Original document	Check if the original document is loaded correctly on the contact glass.	If the original document is not properly placed on the contact glass, place it correctly.
2	Secures the lamp unit	Confirm the orientation of the bracket that secures the drive belt and the lamp unit.	If the bracket that fixes the drive belt and the lamp unit is misaligned, align the bracket properly.
3	Adjustment of the scanner	Check the scanning adjustment of the scanner.	1. Perform maintenance mode U066, Front. (see page 1-3-29) 2. Perform maintenance mode U411, table(Char1)_Input. (see page 1-3-54)
4	Home position sensor	Check the location the home position sensor is mounted.	Re-mount the home position sensor if it is hanged off.
5	Drive belt	Check if the tension of the drive belt is insufficient.	If the tension of the drive belt is insufficient, tense the belt.
6	Scanner drive pulley	Check if the scanner drive pulley is loosely fixed.	If the scanner drive pulley is loosely fixed, secure the screws.

2. DP-scanning

	Defective part	Check description	Corrective Action
1	Adjustment of the scanner	Check the scanning adjustment of DP scanning.	1. Perform maintenance mode U071, CCD Head. (see page 1-3-33) 2. Perform maintenance mode U411, FaceUp(Char2)_Input. (see page 1-3-54)
2	Original conveying roller	Check if the conveyer roller is contaminated or worn.	If the conveying roller is dirty, clean the conveying roller and its axles. If the roller is worn out, replace.
3	DP drive motor	Check whether the DP drive motor is fluctuated in rotation.	If the DP motor is fluctuated in rotation, apply grease with the drive gear. If no improvement is observed, replace the motor.

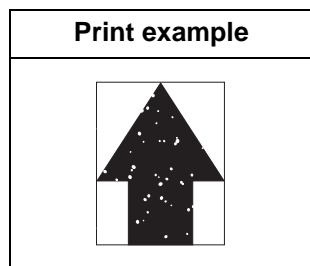
(12) Part of image is missing.

1. Table scanning

	Defective part	Check description	Corrective Action
1	Original document	Check if the original document is loaded correctly on the contact glass.	If the original document is not properly placed on the contact glass, place it correctly.
2	Original document	<ol style="list-style-type: none"> 1. Check that the size of the original document and the paper size match on the panel. 2. Check that the copying position has been automatically rotated. 	<ol style="list-style-type: none"> 1. If the sizes of the original document and the paper size do not match, manually set the proper paper size for the original document. 2. Check the paper size automatic detection switch and replace if faulty. 3. If the copying position is automatically rotated, deactivate automatic image
3	Settings of Border removal	Check the value of border removal.	If a large value is given to bordere erasure, change it to a smaller value.
4	Contact glass	Check whether the contact glass is dirty.	If the contact glass is dirty, clean the contact glass, and the bottom part of the shading plate.
5	Contact glass assy	Check the location the contact glass is mounted.	Re-mount the contact glass if it is hanged off.
6	FFC cable CCD	Check the FFC cable between the CCD sensor and control PWB is properly connected. Or, verify conduction of the wire.	Reinsert the connector if its connection is loose. Or, if conduction is lot, replace the wire.
7	Lamp unit	Check the location the lamp unit is mounted.	Re-mount the lamp unit if it is hanged off.
8	CCD PWB	The CCD PWB is defective.	Replace the ISU and perform U411. (see page 1-3-54)
9	Control PWB	The control PWB is defective.	Replace the control PWB.(see page 2-2-12)

2. DP-scanning

	Defective part	Check description	Corrective Action
1	Original document	Check if the original document is loaded correctly in the DP.	If the original document is not properly placed in the DP, place it correctly.

	Defective part	Check description	Corrective Action
2	Original document	<ol style="list-style-type: none"> 1. Check that the size of the original document and the paper size match on the panel. 2. Check that the copying position has been automatically rotated. 	<ol style="list-style-type: none"> 1. If the sizes of the original document and the paper size do not match, manually set the proper paper size for the original document. 2. Check the paper size automatic detection switch and replace if faulty. 3. If the copying position is automatically rotated, deactivate automatic image rotation by the system menu.
3	Settings of Border removal	Check the value of border removal.	If a large value is given to bordere erasure, change it to a smaller value.
4	Slit glass	Check whether the slit glass is dirty.	If the slit glass is dirty, clean the slit glass, and the bottom part of the shading plate.
5	FFC cable CCD	Check the FFC cable between the CCD sensor and control PWB is properly connected. Or, verify conduction of the wire.	Reinsert the connector if its connection is loose. Or, if conduction is lot, replace the wire.
6	CCD PWB	The CCD PWB is defective.	Replace the ISU and perform U411. (see page 1-3-54)
7	Control PWB	The control PWB is defective.	Replace the control PWB.(see page 2-2-12)

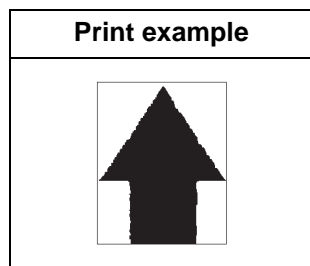
(13) Image is out of focus.

1. Table scanning

	Defective part	Check description	Corrective Action
1	Original document	Check whether the original document is wavy.	If the original document is wavy, straighten.Or, replace the original document.
2	Contact glass	Check whether the contact glass is dew condensed.	If the contact glass is dew condensed, remove the dew.
3	Mirror	Check whether the mirror is dew condensed.	If the mirrors are dew-condensed, remove the dew.
4	Lens	Check whether the lens is dew condensed.	If the lens is dew condensed, remove the dew.
5	CCD sensor	Check whether the CCD sensor glass is dew condensed.	If the CCD sensor glass is dew condensed, remove the dew.
6	Adjustment of the scanner	Check the automatic adjustment of the scanner.	Perform maintenance mode U411, table(Chart1)_All. (see page 1-3-54)
7	ISU	Confirm the position of the lens and the CCD sensor.	If the lenses and the CCD sensor are misaligned, replace the ISU and perform U411. (see page 1-3-54)
8	Control PWB	The control PWB is defective.	Replace the control PWB.(see page 2-2-12)

2. DP-scanning

	Defective part	Check description	Corrective Action
1	Original document	Check whether the original document is wavy.	If the original document is wavy, straighten.Or, replace the original document.
2	Slit glass	Check whether the slit glass is dew condensed.	If the slit glass is dew condensed, remove the dew.
3	Mirror	Check whether the mirror is dew condensed.	If the mirrors are dew-condensed, remove the dew.
4	Lens	Check whether the lens is dew condensed.	If the lens is dew condensed, remove the dew.

	Defective part	Check description	Corrective Action
5	CCD sensor	Check whether the CCD sensor glass is dew condensed.	If the CCD sensor glass is dew condensed, remove the dew.
6	Adjustment of the scanner	Check the automatic adjustment of the scanner.	Perform maintenance mode U411, table(Chart1)_All. (see page 1-3-54)
7	ISU	Confirm the position of the lens and the CCD sensor.	If the lenses and the CCD sensor are misaligned, replace the ISU and perform U411. (see page 1-3-54)
8	Control PWB	The control PWB is defective.	Replace the control PWB.(see page 2-2-12)

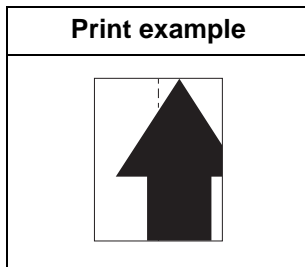
(14) Image center does not align with the original center.

1. Table scanning

	Defective part	Check description	Corrective Action
1	Original document	Check if the original document is loaded correctly on the contact glass.	If the original document is not properly placed on the contact glass, place it correctly.
2	Contact glass assy	Check the location the contact glass is mounted.	Re-mount the contact glass if it is hanged off.
3	Adjustment of the scanner	Check the scanning adjustment of the scanner.	1. Perform maintenance mode U067, Front.(see page 1-3-30) 2. Perform maintenance mode U411, Table(Char1)_Input. (see page 1-3-54)

2. DP-scanning

	Defective part	Check description	Corrective Action
1	Original document	Check if the original document is loaded correctly in the DP.	If the original document is not properly placed in the DP, place it correctly.
2	Adjustment of the scanner	Check the scanning adjustment of DP scanning.	1. Perform maintenance mode U072. 2. Perform maintenance mode U411, DP FaceUp(Char2)_Input. (see page 1-3-54)

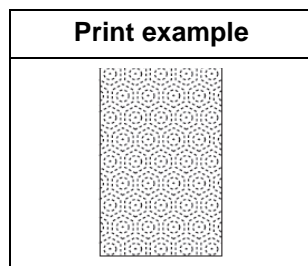
(15) Moires

1. Table scanning

	Defective part	Check description	Corrective Action
1	Settings of print quality mode	Confirm whether the moire varies depending on print quality mode.	Switch print quality mode if the moire varies depending on print quality mode. 1. Execute printing in text or print mode. 2. Reduce the sharpness (to minus).
2	Original document	Check if moire is observed along the direction of scanning of the original document.	If moire is observed, place the original document after rotating it 90-degree.
3	Scaling factor	Happens with the zoom ratio of 100%.	Reduce the real-size ratio of the main scan direction by U065. (see page 1-3-27)
4	Adjustment of the scanner	Check the automatic adjustment of the scanner.	Perform maintenance mode U411, Table(Chart1)_All. (see page 1-3-54)

2. DP-scanning

	Defective part	Check description	Corrective Action
1	Settings of print quality mode	Confirm whether the moire varies depending on print quality mode.	Switch print quality mode if the moire varies depending on print quality mode. 1. Execute printing in text or print mode. 2. Reduce the sharpness (to minus).
2	Adjustment of the scanner	Check the automatic adjustment of the scanner.	Perform maintenance mode U411, Table(Chart1)_All. (see page 1-3-54)

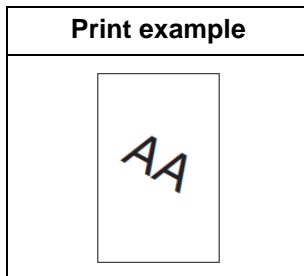
(16) Skewed image

1. Table scanning

	Defective part	Check description	Corrective Action
1	Original document	Check if the original document is fed askew.	If the original document is not placed askew on the contact glass, place it correctly.
2	Adjustment of height of main unit and scanner unit	Check the scanner unit is quite level.	If the scanner unit is not quite level, perform the height adjustment of the entire scanner unit.
3	Lamp unit	Check the location the lamp unit is mounted.	Re-mount the lamp unit if it is hanged off.

2. DP-scanning

	Defective part	Check description	Corrective Action
1	Original document	Check if the original document has creases or foldings or wrinkles.	If the original document has foldings or creases, remove them.
2	DP paper feed	Check if the original document is fed askew.	If the original document is fed askew, set the width guides correctly.
3	Lamp unit	Check the location the lamp unit is mounted.	Re-mount the lamp unit if it is hanged off.
4	DP feed roller	Check whether the feed roller is dirty.	If the feed roller is dirty, clean.Or, if not cured, replace the feed roller.
5	DP regist roller	Check whether the DP regist roller is dirty.	If the DP regist roller is dirty, clean.
6	DP regist pulley	Check that the DP regist pulley is smoothly operative.	If the DP regist pulley does not rotate smoothly, re-install.
7	Original document setting	Check that the cursor fits with the original document.	Align the cursor to fit with the original document, if necessary.
8	Adjustment positions of the hinge	Check the front and back adjustment positions of the right hinge.	If the front and back adjustment positions of the right hinge are improper, perform adjustment.

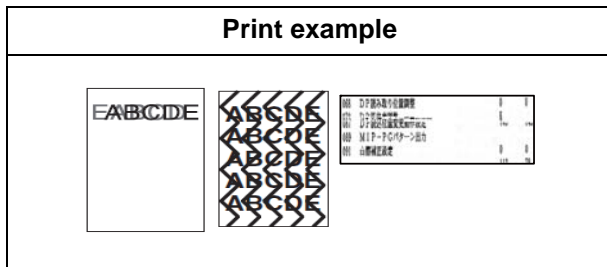
(17) Abnormal image

1. Table scanning

	Defective part	Check description	Corrective Action
1	FFC cable CCD	Check the FFC cable between the CCD and control PWB is properly connected. Or, verify conduction of the wire.	Reinsert the connector if its connection is loose. Or, if conduction is lot, replace the wire.
2	CCD PWB	The CCD PWB is defective.	Replace the ISU and perform U411. (see page 1-3-54)
3	Control PWB	The control PWB is defective.	Replace the control PWB.(see page 2-2-12)

2. DP-scanning

	Defective part	Check description	Corrective Action
1	FFC cable CCD	Check the FFC cable between the CCD and control PWB is properly connected. Or, verify conduction of the wire.	Reinsert the connector if its connection is loose. Or, if conduction is lot, replace the wire.
2	CCD PWB	The CCD PWB is defective.	Replace the ISU and perform U411. (see page 1-3-54)
3	Control PWB	The control PWB is defective.	Replace the control PWB.(see page 2-2-12)

1-4-6 Poor image (Image rendering problems: printer engine)

(1) No image appears (entirely white).

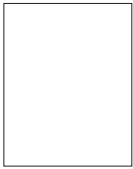

See page 1-4-76

(2) No image appears (entirely black).



See page 1-4-77

(3) Image is too light.



See page 1-4-78

(4) The background is colored.



See page 1-4-80

(5) White streaks are printed vertically.



See page 1-4-81

(6) Black streaks appear longitudinally.

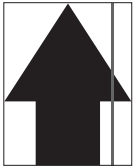

See page 1-4-82

(7) Black or white streaks appear horizontally.

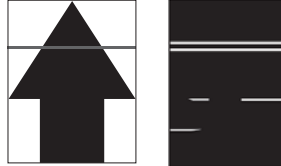

See page 1-4-84

(8) Uneven density longitudinally.



See page 1-4-85

(9) Uneven density horizontally.



See page 1-4-86

(10) Black dots appear on the image.



See page 1-4-87

(11) Offset occurs.



See page 1-4-88

(12) Image is partly missing.



See page 1-4-89

(13) Image is out of focus.



See page 1-4-90

(14) Poor grayscale reproducibility.

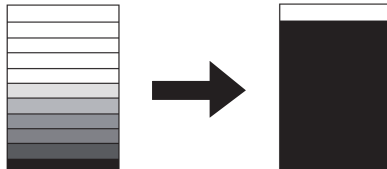

See page 1-4-90

(15) Unevenly repeating horizontal streaks in the printed objects. Spots in the printed objects.



See page 1-4-91

(16) Image is blurred (Shifted transferring).

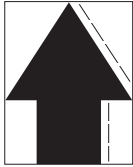

See page1-4-92

(17) The leading edge of the image is consistently misaligned with the original.



See page1-4-93

(18) The leading edge of the image is sporadically misaligned with the original.



See page1-4-94

(19) Paper is wrinkled.

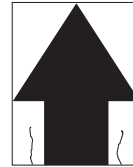

See page1-4-94

(20) Fusing is loose.



See page1-4-95

(21) Image center does not align with the original center.



See page1-4-96

(22) Dirty paper edges with toner.



See page1-4-96

(23) Dirty reverse side of paper.



See page1-4-97

(24) Carrier leaking occurs.

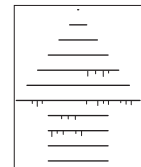

See page1-4-98

(1) No image appears (entirely white).

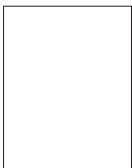
Print example	Cause of trouble
	<ol style="list-style-type: none"> 1. No or defective developing bias output. 2. Failure of the rotation of the developing roller. 3. Defective transfer. 4. Laser is not dispersed from the laser scanner unit (LSU). 5. The drum does not rotate.

	Defective part	Check description	Corrective Action
1	Developing unit	Generate PGs by service mode and check the following : Check whether the developer drive gear is damaged. Check the developing roller is rotated by hand. Check contamination and deformation on the terminals of developer unit or the high-voltage PWB1.	If the gear is damaged, replace the developer unit. If the developer unit is in fault, replace the developer unit. (see page 1-5-33) If the connecting terminals are dirty, clean. If the connecting terminals are deformed, correct for a proper conduction.
2	High voltage PWB	Check the connection of the connector(s) and the high voltage PWB. Or, verify conduction of the wires.	Reinsert the connector if its connection is loose. Replace the cable if it has no conduction. High voltage PWB (YC101) and control PWB (YC19)
3	Transfer unit	Check if the right cover is closed.	If the right cover has not been closed, check how the conveying guide is locked and open the conveying guide once, then close.
4	Laser scanner unit (LSU)	Check the connection of the connectors. Or, verify conduction of the wires.	<ol style="list-style-type: none"> 1. Reinsert the FFC wire if its connection is loose. Replace the cable if it has no conduction. 2. Replace the LSU (see page 1-5-28).
5	Control PWB	A control signal is not derived from the control PWB.	Replace the control PWB. (see page 2-2-12)

(2) No image appears (entirely black).

Print example	Cause of trouble
	1. No main charging. 2. The laser from the LSU is activated simultaneously.

	Defective part	Check description	Corrective Action
1	Charging roller	Check whether the charging roller is properly mounted.	If the charging roller is not fixed properly, fix the roller properly.
		Check whether the connecting terminals of the charging roller and high-voltage PWB are deformed.	If the connecting terminals are deformed, correct for a proper conduction.
2	High voltage PWB	Check the connection of the connectors. Or, verify conduction of the wires.	Reinsert the connector if its connection is loose. Replace the cable if it has no conduction. High voltage PWB (YC101) and control PWB (YC19) :Charger
		Main charging current supplied by the high voltage PWB is faulty.	Replace the high voltage PWB. (see page 2-2-20)
3	Laser scanner unit (LSU)	Switching on and off the laser diode on the LSU PWB is out of control.	Replace the LSU. (see page 1-5-28)
4	Control PWB	The control PWB is defective.	Replace the control PWB.(see page 2-2-12)

(3) Image is too light.

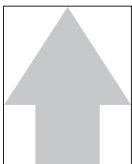
Print example	Cause of trouble
	<ol style="list-style-type: none"> 1. Variance in environments (dew formation). 2. Toner is under supplied, or deteriorated in quality.(Under charged) 3. The volatage of the developing bias is too low. 4. The volatage of the transfer current is too low. 5. The power of LSU laser is too low. 6. The surface potential of the drum is too high. 7. The contact pressure at the trasnfer roller and the drum is too low.

	Defective part	Check description	Corrective Action
1	Paper	Check that the paper has moisture absorbed. Check that the paper has stored in a humid place.	If the paper is damp, replace.Choose a dry place to store paper.
2	Drum unit	<p>Check that the drum has dew condensation.</p> <ol style="list-style-type: none"> 1. Check if the discharging lamp is dirty. 2. Check whether it is lit. 	<p>If a dew condensation is observed, perform drum refreshing. (System Menu >Adjustment / Maintenance)</p> <ol style="list-style-type: none"> 1. If the discharging lamp is dirty, clean. 2. If not cured, or it does not light, replace the drum unit.
3	Developer unit	<ol style="list-style-type: none"> 1. Generate PGs by service mode and check the following : (see page 1-3-105) 2. Check if the connecting terminals for developer bias are deformed. 	If the connecting terminals are deformed, correct for a proper conduction.
4	Toner container	<p>Shake the toner container up and down approx. 10 times, and check the following:</p> <ol style="list-style-type: none"> 1. Check remaining toner by the indicator. 2. Check whether the toner supply inlet is open. 	If the message prompting toner replenishing is shown, the toner inlet is not open, replace the toner container.
5	High voltage PWB		Replace the high voltage PWB.
6	Transfer roller unit	<ol style="list-style-type: none"> 1. Check whether the connecting terminals. 2. Check if the contact between the transfer roller and durm is correct. 	<ol style="list-style-type: none"> 1. If the connecting terminals are deformed, correct for a proper conduction. 2. Replace transfer roller unit. <p>Re-mount the transfer roller.</p>

	Defective part	Check description	Corrective Action
7	LSU	1. The laser diode on the LSU APC PWB is out of control. 2. Check whether the internal mirrors are contaminated.	Replace the LSU. (see page 1-5-28)
8	Control PWB	The control PWB is defective.	Replace the control PWB.(see page 2-2-12)

(4) The background is colored.

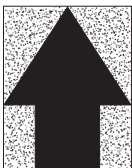
Print example	Cause of trouble
	<ol style="list-style-type: none"> 1. Toner is deteriorated in quality (under-charged). 2. Toner is over-supplied. 3. Developing bias is too high. 4. The layer of toner is too thick on the developing roller (too much toner). 5. The surface potential of the drum is too low (under low temperature environment).

	Defective part	Check description	Corrective Action
1	Developer unit	Generate PGs by service mode and check the following : (see page 1-3-105)	
		<ol style="list-style-type: none"> 1. Check contamination and deformation on the connecting terminals for developer bias. 	If the connecting terminals for developer bias are dirty, clean. If the connecting terminals are deformed, correct for a proper conduction.
2	Toner supply motor	Check the toner supply motor is continuously rotating. Check wires for shortcircuiting.	If the harnesses are short-circuited and the toner motor is continuously rotating, replace the toner supply motor.
3	Drum unit	<ol style="list-style-type: none"> 1. Check that the ground terminal is not contaminated or the conductive grease is not applied with the connecting terminals. 	If the connecting terminals are dirty, clean. If the amount of the grease applied is too small, apply conductive grease to the bearing on the receiver side of the drum drive axle. Replace the drum unit. (Performs U119)
4	Transfer roller unit	<ol style="list-style-type: none"> 1. Check if the roller is bleached on its surface. 2. Check if the ground tab of the transfer roller unit is deformed. 	<ol style="list-style-type: none"> 1. If the connecting terminals are deformed, correct for a proper conduction. 2. If the MagDC increased to its maximum won't cure, replace the transfer roller unit. (see page 1-5-41)
5	High voltage PWB	The developing bias and charging current supplied by the high voltage PWB is faulty.	Replace the high voltage PWB. (see page 2-2-20)
6	Control PWB	The control PWB is defective.	Replace the control PWB. (see page 2-2-12)

(5) White streaks are printed vertically.

Print example	Cause of trouble
	<ol style="list-style-type: none"> 1. Dirty LSU slit glass. 2. Foreign objects inside the developer unit. 3. Internal contamination 4. Dirty drum inside.

	Defective part	Check description	Corrective Action
1	Developer unit	Generate PGs by service mode. (see page 1-3-105)	Replace the developer unit. (see page 1-5-33)
2	Light path between the LSU and the drum	Check if there are dusts, dirt, or toner obstructing the light paths.	If a foreign object exists on the frame or the sealings between the developer unit and the drum unit, remove.
3	Drum unit	Check if the charging roller is dirty.	If the charging roller is dirty, clean. Or replace it.
		Check if the discharging lamp is dirty.	If the discharging lamp is dirty, clean.
4	LSU	Check if the LSU slit glass is dirty.	If the LSU slit glass is dirty, perform laser scanner cleaning.
5	Transfer roller unit	Check whether a white streak occurs at the same position as the smear on the transfer roller.	Clean the transfer roller if it is dirty. Replace the drum unit. (see page 1-5-39)

(6) Black streaks appear longitudinally.

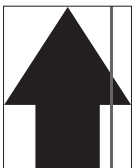
Print example	Cause of trouble
	<ol style="list-style-type: none"> 1. Dirty charging roller 2. Flawed or dirty drum unit 3. Damaged or paper dust bitten cleaning blade

	Defective part	Check description	Corrective Action
1	Separation brush	Check if the separation brush is dirty with paper dusts and waste toner.	If the separation brush is dirty, clean it using a brush.
2	Drum unit	Check if drum is dirty on its surface.	Execute drum refreshing. (System Menu >Adjustment / Maintenance)
<ol style="list-style-type: none"> 1. Check if the drum has scratches. 2. Check whether the edge of the cleaning blade is damaged. 3. Check whether it is abraded or paper dusts are accumulated. 4. Check whether toner is accumulated in the cleaning section. 		Replace the drum unit. (see page 1-5-39)	
3	Charging roller unit	Check if there is no toner streaks on the surface of the charging roller.	If the charging roller has streaks on its surface, clean the charging roller. Replace the charging roller, if necessary.
4	Transfer roller unit	1. Check if the transfer roller is contaminated on its surface or damaged.	If smears and scuff are observed on the transfer roller unit, replace the unit. (see page 1-5-41)
2. Check the connecting terminals of high voltage are not dirty or deformed.		If the connector or terminals are dirty, clean. If the connecting terminals are deformed, correct for a proper conduction. Replace the high voltage PWB. (see page 2-2-20)	
5	Fuser unit	1. Check if the paper separation puddle is contaminated with toner.	If the paper separation puddle is dirty, clean the paper separation puddle.
2. Check the device is adjusted for a correct paper weight that matches the paper in use.		If the settings for paper weight and the paper being used do not match, make a proper configuration.	

	Defective part	Check description	Corrective Action
6	Eject guide	The Rib is contaminated with toner.	If it is duty,clean.

(7) Black or white streaks appear horizontally.

Print example	Cause of trouble
	<ol style="list-style-type: none"> 1. Dirty developer unit or terminals 2. Flawed or dirty drum unit Improper grounding 3. Dirty transfer roller terminals

	Defective part	Check description	Corrective Action
1	Developer unit	<ol style="list-style-type: none"> 1. Check the print image on paper has a problem at an interval equivalent to the circumference of the developing roller. 2. Check that the developing roller is dirty at its ends or at the developing bias tab. 	<ol style="list-style-type: none"> 1. If the ends of the developing roller and the connecting terminals for developer bias are dirty, clean. 2. Replace the developer unit. (see page 1-5-33)
2	Drum unit	<ol style="list-style-type: none"> 1. Check the print image on paper has a problem at an interval equivalent to the circumference of the drum . 2. Check if the drum has scratches. 3. Check the grounding tab of the drum or the drum drive shaft. 	<p>Execute drum refreshing. (System Menu >Adjustment / Maintenance)</p> <p>Replace the drum unit. (see page 1-5-39)</p> <ol style="list-style-type: none"> 1. Check how the drive unit is mounted, and correct, if necessary. 2. Replace the drum unit. (see page 1-5-39)
3	Transfer roller unit	<ol style="list-style-type: none"> 1. Check the print image that implies dirt, deformation, or scratches on the transfer roller, which will be appearing at an interval equal to its circumference . 2. Check contamination and deformation on the terminals . 	<p>If the print image has a problem, clean the transfer roller by a soft cloth.</p> <ol style="list-style-type: none"> 1. If the connecting terminals are deformed, correct for a proper conduction 2. Replace transfer roller unit.(see page 1-5-41)
4	Fuser unit	Check the print image on paper has a problem at an interval equivalent to the circumference of the fuser roller.	If the print image has a problem, clean the fuser roller.
5	High voltage PWB	The bias voltage output supplied by the high voltage PWB is not even.	Replace the high voltage PWB. (see page 2-2-20)

(8) Uneven density longitudinally.

Print example	Cause of trouble
	<ol style="list-style-type: none"> 1. Dirty LSU inside 2. The transfer roller is not pressed against the drum properly. 3. Drum condensation.

	Defective part	Check description	Corrective Action
1	Transfer roller unit	Check that the transfer roller unit is properly fit.	<ol style="list-style-type: none"> 1. If it is not fixed properly, fix it properly. 2. If the rear cover has not been closed, check how the conveying guide is locked and open the conveying guide once, then close. 3. Replace the transfer roller unit. (see page 1-5-41)
2	Drum unit	<ol style="list-style-type: none"> 1. Check toner is evenly layered on its surface. 2. Check whether the device has been operated under a highly humid environment. 	<ol style="list-style-type: none"> 1. Execute drum refreshing. 2. Install a cassette heater. 3. Replace the drum unit. (see page 1-5-39)
3	Developer unit	Check that toner is evenly layered on the developer roller.	Replace the developer unit.. (see page 1-5-33)
4	LSU	The emission of laser dispersed from the LSU is not even. (Mirror is dropped off inside.)	Replace the LSU. (see page 1-5-28)

(9) Uneven density horizontally.

Print example	Cause of trouble
	<ol style="list-style-type: none"> 1. Defective laser scanner unit. 2. Improper charging roller rotation 3. Improper contact on the developer unit terminals

	Defective part	Check description	Corrective Action
1	LSU	Check the emission of laser is even.	Replace the LSU. (see page 1-5-28)
2	Charging roller	Check if the charging roller is improperly mounted.	<ol style="list-style-type: none"> 1. Fix the charging roller properly. 2. Replace the charging roller. (see page 1-5-39)
3	Developer unit	Check If the connecting terminals of the developer bias is contaminated by toner.	<ol style="list-style-type: none"> 1. If the connecting terminals is dirty. 2. Replace the developer unit. (see page 1-5-33)
4	Transfer roller unit.	1. Check if the transfer roller is contaminated on its surface or damaged.	1. Replace the transfer roller unit.
		2. Check if the connecting terminals of high voltage are dirty or deformed.	<ol style="list-style-type: none"> 1. If the connector or terminals are dirty, clean.If the connecting terminals are deformed, correct for a proper conduction. 2. Replace the high voltage PWB.
5	Fuser unit	Check that the roller, its driving unit, or the fusing pressure release mechanism is deformed, abraded, or damaged.	If the roller, its driving unit, or the fusing pressure release mechanism is deformed, abraded, or damaged, replace the fuser unit.

(10) Black dots appear on the image.

Print example	Cause of trouble
	<ol style="list-style-type: none"> 1. Dirty charging roller 2. Flawed or dirty drum unit 3. Damaged or paper dust bitten cleaning blade

	Defective part	Check description	Corrective Action
1	Drum unit	Check the print image on paper has a problem at an interval equivalent to the circumference of the drum (126mm).	If the drum has scratches, replace the drum unit. (see page 1-5-39)
2	Charging roller	Check the print image on paper has a problem at an interval equivalent to the circumference of the charging roller (38mm).	A problem is observed at a constant interval of the charging roller (38 mm), replace the charging roller. (see page 1-5-39)
3	Developer unit	Check the print image on paper has a problem at an interval equivalent to the circumference of the developing roller (39mm).	<ol style="list-style-type: none"> 1. If the print image on paper has a problem at an interval equivalent to the circumference of the developer roller, clean the developer unit. 2. Replace the developer unit. (see page 1-5-33)
4	Transfer roller unit.	1. Check if the transfer roller is contaminated on its surface or damaged.	Replace the transfer roller unit.
		2. Check the cleaning bias connector or the connecting terminals of high voltage are not dirty or deformed.	<ol style="list-style-type: none"> 1. If the connector or terminals are dirty, clean.If the connecting terminals are deformed, correct for a proper conduction. 2. Replace the high-voltage circuit PWB.
5	Fuser unit	Check the print image on paper has a problem at an interval equivalent to the circumference of the fuser roller.	<ol style="list-style-type: none"> 1. If the print image has a problem, clean the fuser roller. 2. If cleaning does not help improve the symptom, replace the fuser unit.

(11) Offset occurs.

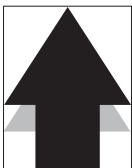
Print example	Cause of trouble
	1. Flawed or dirty drum unit 2. Developing bias leakage.

	Defective part	Check description	Corrective Action
1	Paper	Check that the type of the paper used falls within the range of specifications. Check the settings of the type and weight of the paper.	1. If the type of the paper being used falls outside the requirements, replace and use a suitable type of paper. 2. If the settings made for the paper being used is inadequate, configure the settings according to the paper being used.
2	Drum unit	Check the print image on paper has a problem at an interval equivalent to the circumference of the drum (94 mm).	If the print image on paper has a problem at an interval equivalent to the circumference of the drum, replace the drum unit. (see page 1-5-39)
3	Developer unit	Check if offsets are observed at an constant interval of 63 mm, which is equivalent to the circumference of the developing roller.	If offsets are observed at an constant interval of 39 mm, which is equivalent to the circumference of the developing roller, replace the developer unit. (Waste toner is not properly swept from the developing roller.) (see page 1-5-33)
4	Transfer roller unit	Check if offsets are occurred at a pitch of the outer circumference of the transfer roller. (50 mm)	If an offset happens at a pitch of the outer circumference, clean the transfer roller.
5	Fuser unit	Check the print image on paper has a problem at an interval equivalent to the circumference of the fuser roller.	If the fuser unit roller is dirty, replace the unit.

(12) Image is partly missing.

Print example	Cause of trouble
	<ol style="list-style-type: none"> 1. Flawed or dirty drum unit. 2. Deformed or dirty transfer roller on its surface.

	Defective part	Check description	Corrective Action
1	Paper	<ol style="list-style-type: none"> 1. Check that the paper has moisture absorbed. 2. Check that the paper has stored in a humid place. 	<ol style="list-style-type: none"> 1. If the paper is damp, replace. Choose a dry place to store paper. 2. If necessary, set a drum heater. (see page 1-3-48)
2	Drum unit	Check the print image on paper has a problem at an interval equivalent to the circumference of the drum (94mm)	If the print image on paper has a problem at an interval equivalent to the circumference of the drum, execute drum refreshing (System Menu > Adjustment/Maintenance).
3	Transfer roller unit	Check if the transfer roller is deformed or contaminated on its surface.	If the transfer roller unit is deformed or contaminated, replace the transfer roller unit.

(13) Image is out of focus.

Print example	Cause of trouble
	<ol style="list-style-type: none"> 1. Drum condensation. 2. Dirty LSU slit glass.

	Defective part	Check description	Corrective Action
1	Paper	<ol style="list-style-type: none"> 1. Check that the paper has moisture absorbed. 2. Check that the paper has stored in a humid place. 	<ol style="list-style-type: none"> 1. If the paper is damp, replace. Choose a dry place to store paper. 2. If necessary, set a drum heater. (see page 1-3-48)
2	Drum unit	Check that the surface of the drum has dew condensation.	Execute Drum refreshing. System Menu > Adjustment/Maintenance
3	LSU	Check whether the LSU slit glass is contaminated in its entirety.	<ol style="list-style-type: none"> 1. If the LSU slit glass is dirty, execute Laser scanner cleaning. 2. Replace the LSU. (see page 1-5-28)

(14) Poor grayscale reproducibility.

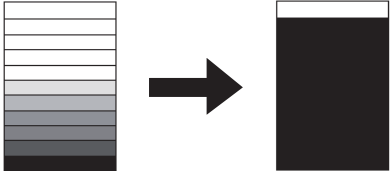
Print example	Cause of trouble
	<ol style="list-style-type: none"> 1. Poor image adjustment.

	Defective part	Check description	Corrective Action
1	Image adjustmen	Check if color adjustment is insufficient.	

(15) Unevenly repeating horizontal streaks in the printed objects. Spots in the printed objects.

Print example	Cause of trouble
	<ol style="list-style-type: none"> 1. Installation at a high altitude. 2. Using the paper with high surface resistance.

	Defective part	Check description	Corrective Action
1	Developer unit	The device is installed in an altitude higher than 1500 m sea level.	If the device is installed in an altitude greater than 1500 m sea level, perform altitude setting. (System menu > Adjustment/Maintenance)
2	Paper	Check if paper is of high surface resistance.	Change the paper to another.

(16) mage is blurred (Shifted transferring).

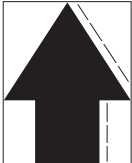
Print example	Cause of trouble
	<ol style="list-style-type: none"> 1. The paper used does not conform to the requirement. 2. Imbalanced fuser unit pressures.

	Defective part	Check description	Corrective Action
1	Paper	<ol style="list-style-type: none"> 1. Check that the type of the paper used falls within the range of specifications. 2. Check the settings of the type and weight of the paper. 	<ol style="list-style-type: none"> 1. If the type of the paper being used falls outside the requirements, replace and use a suitable type of paper. 2. If the settings made for the paper being used is inadequate, configure the settings according to the paper being used.
2	Fuser unit	<ol style="list-style-type: none"> 1. Check the fuser pressure balance. 2. Check if the fuser paper-inserting guide is deformed. 	<ol style="list-style-type: none"> 1. If the pressures at the front and rear are unbalanced, replace the fuser unit. (see page 1-5-47) 2. If the fuser unit is deformed, replace. (see page 1-5-47)
3	Paper conveying motor	Check to see if the driving mechanism for paper conveying is operative without a hinderance.	If the drive does not operate normally, apply grease.
4	Paper conveying guide	The paper conveying guide is deformed.	If the paper conveying guide is deformed, replace the paper conveying guide.

(17) The leading edge of the image is consistently misaligned with the original.

Print example	Cause of trouble
	<ol style="list-style-type: none"> 1. Improperly adjusted leading edge timing. 2. Improper amount of slack of the original document in front of the registration.

	Defective part	Check description	Corrective Action
1	Regist roller	Check whether the leading-edge timing is adequately adjusted.	If the adjustment is not sufficient, execute U034 to adjust the leading edge timing. (see page 1-3-24)

(18) The leading edge of the image is sporadically misaligned with the original.

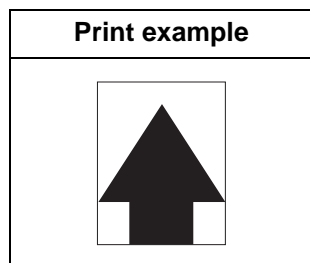

	Defective part	Check description	Corrective Action
1	Paper feed clutch, Registration clutch	Check that the clutches are properly fit. IOr, check they are operative without a hinderance.	1. If it is not fixed properly, fix it properly. 2. If it does not operate without a hinderance, replace the clutch.

(19) Paper is wrinkled.

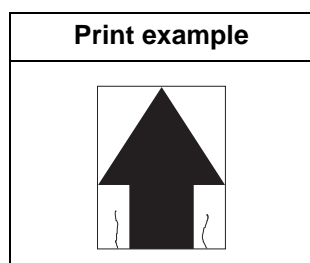

	Defective part	Check description	Corrective Action
1	Paper-width guides	Check the paper-width guides are flush with the paper.	If the width adjuster cursors are not flush with paper, set them correctly.
2	Paper	1. Check if paper is curled or wavy. 2. Check if paper is stored in a humid place.	1. If the paper is curled or wavy, replace. 2. Choose a dry place to store paper.
3	Regist roller	The pressures at the front and back springs are unbalanced.	Replace the spring with the one having a correct pressure.
4	Fuser unit	The pressuring spring of the fuser unit is defective.	Replace the fuser unit. (see page 1-5-47)

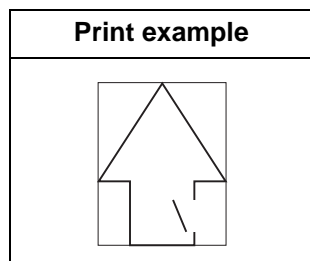
(20) Fusing is loose.

	Defective part	Check description	Corrective Action
1	Paper	<ol style="list-style-type: none"> 1. Check that the type of the paper used falls within the range of specifications. 2. Check the settings of the type and weight of the paper. 	<ol style="list-style-type: none"> 1. If the type of the paper being used falls outside the requirements, replace and use a suitable type of paper. 2. If the settings made for the paper being used is inadequate, configure the settings according to the paper being used.
2	Paper weight setting	Check If the weight of the paper is correctly set.	If the weight of the paper is not correctly set, choose the correct weight that matches the paper being used.
3	Fuser unit	Check the fuser pressure setting.	Replace the fuser unit. (see page 1-5-47)

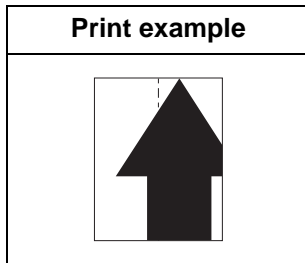
(21) Image center does not align with the original center.

	Defective part	Check description	Corrective Action
1	Paper setting	Check if paper is set correctly.	Reload paper if the paper was not loaded correctly.
2	Image position adjustment	Excute U034 to check the center alignment during writing images.	Perform adjustment if the value of U034 Center Line Adjustment is inadequate. (see page 1-3-24)

(22) Dirty paper edges with toner.

Print example	Cause of trouble
	1. Toner scattering due to an internal temperature increase.(Developer unit)

	Defective part	Check description	Corrective Action
1	Conveying guide	Check if the conveying guide is dirty with toner.	If the conveying guide is dirty with toner, clean the developer unit and the cooling ducts.
2	Internal temperature increase (Developer unit)	Check the device has been used for printing a large amount of data or for printing in duplex mode with a high density.	If the device has been used for printing a large amount of data or for printing in duplex mode with a high density, clean the developer unit.

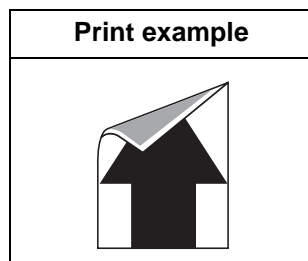
(23) Dirty reverse side of paper.

	Defective part	Check description	Corrective Action
1	Conveying guide	Check if the conveying guide is dirty with toner.	If the conveying guide is dirty with toner, clean the conveying guide, the developer unit and the cooling ducts.
2	Fuser pressure roller	Check that a foreign object is stuck on the fuser pressure roller.	<ol style="list-style-type: none"> 1. If a foreign object exists, clean the fuser pressure roller. 2. If the paper and the paper weight setting do not match, choose the proper paper weight setting.
3	Transfer roller unit	Check if the transfer roller is dirty with toner on its surface.	Clean the transfer roller.

(24) Carrier leaking occurs.

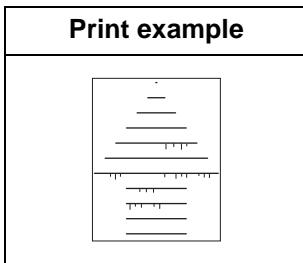

	Defective part	Check description	Corrective Action
1	Paper creased.	<p>Check the state of the paper.</p> <p>The paper kinds are changed and printed.</p>	<p>Replace the paper.</p> <p>A paper setup of a printer is changed.</p> <pre> graph TD Menu[Menu] --> PaperSettings[Paper Settings] PaperSettings --> MediaTypeSet[Media Type Set.] MediaTypeSet --> CUSTOM8[CUSTOM 8] CUSTOM8 --> PaperWeight[Paer Weight] PaperWeight --> Normal3[Normal 3] Normal3 --> Exit[Press the [EXIT] key.] </pre> <p>A setup of a driver is changed. By basic setup, the kind of paper is made "CUSTOM 8".</p>

1-4-7 Electric problems

If the part causing the problem was not supplied, use the unit including the part for replacement.
Troubleshooting to each failure must be in the order of the numbered symptoms.

Problem	Causes	Check procedures/corrective measures
(1) The machine does not operate when the main power switch is turned on.	1. No electricity at the power outlet.	Measure the input voltage.
	2. The power cord is not plugged in properly.	Check the contact between the power plug and the outlet.
	3. Broken power cord.	Check for continuity. If none, replace the cord.
	4. Defective main power switch.	Check for continuity across the contacts. If none, replace the main power switch.
	5. Defective power source PWB.	Replace the power source PWB (see page 2-2-36).
	6. Defective connect right PWB.	Replace the connect right PWB (see page 2-2-36).
	7. Defective control PWB.	Replace the control PWB and check for correct operation (see page 2-2-12).
(2) Image scanner motor does not operate.	1. Defective connector cable or poor contact in the connector.	Reinsert the connector. Also check for continuity within the connector cable. If none, replace the cable. Image scanner motor and control PWB (YC1002)
	2. Defective drive transmission system.	Check if the gears rotate smoothly. If not, grease the bushes and gears. Check for broken gears and replace if any.
	3. Defective motor.	Replace the image scanner motor.
	4. Defective PWB.	Replace the control PWB and check for correct operation (see page 2-2-12).
(3) Eject motor does not operate.	1. Defective connector cable or poor contact in the connector.	Reinsert the connector. Also check for continuity within the connector cable. If none, replace the cable. Eject motor and connect left PWB (YC12) Connect left PWB and control PWB (YC2)
	2. Defective drive transmission system.	Check if the rollers and gears rotate smoothly. If not, grease the bushes and gears. Check for broken gears and replace if any.
	3. Defective motor.	Replace the eject motor.
	4. Defective connect left PWB.	Replace the connect left PWB (see page 2-2-36).
	5. Defective PWB.	Replace the control PWB and check for correct operation (see page 2-2-12).

Problem	Causes	Check procedures/corrective measures
(4) Toner motor does not operate.	1. Defective connector cable or poor contact in the connector.	Reinsert the connector. Also check for continuity within the connector cable. If none, replace the cable. Toner motor and drum PWB (YC3) Drum PWB and connect left PWB (YC3) Connect left PWB and control PWB (YC2)
	2. Defective motor.	Replace the toner motor.
	3. Defective drum PWB.	Replace the drum unit (see page 2-2-36).
	4. Defective connect left PWB.	Replace the connect left PWB (see page 2-2-36).
	5. Defective PWB.	Replace the control PWB and check for correct operation (see page 2-2-12).
(5) Power source fan motor does not operate.	1. Defective connector cable or poor contact in the connector.	Reinsert the connector. Also check for continuity within the connector cable. If none, replace the cable. Power source fan motor and engine PWB (YC10)
	2. Defective motor.	Replace the power source fan motor.
	3. Defective PWB.	Replace the control PWB and check for correct operation (see page 2-2-12).
(6) LSU fan motor does not operate.	1. Defective connector cable or poor contact in the connector.	Reinsert the connector. Also check for continuity within the connector cable. If none, replace the cable. LSU fan motor and connect left PWB (YC4) Connect left PWB and control PWB (YC2)
	2. Defective motor.	Replace the LSU fan motor.
	3. Defective connect left PWB.	Replace the connect left PWB (see page 2-2-36).
	4. Defective PWB.	Replace the control PWB and check for correct operation (see page 2-2-12).
(7) Developer fan motor does not operate.	1. Defective connector cable or poor contact in the connector.	Reinsert the connector. Also check for continuity within the connector cable. If none, replace the cable. Developer fan motor and control PWB (YC31)
	2. Defective motor.	Replace the developer fan motor.
	3. Defective PWB.	Replace the control PWB and check for correct operation (see page 2-2-12).
(8) Paper feed clutch does not operate.	1. Defective connector cable or poor contact in the connector.	Reinsert the connector. Also check for continuity within the connector cable. If none, replace the cable. Paper feed clutch and connect right PWB (YC12) Connect right PWB and control PWB (YC29)
	2. Defective clutch.	Replace the paper feed clutch.
	3. Defective connect right PWB.	Replace the connect right PWB (see page 2-2-36).
	4. Defective PWB.	Replace the control PWB and check for correct operation (see page 2-2-12).

Problem	Causes	Check procedures/corrective measures
(9) Registration clutch does not operate.	1. Defective connector cable or poor contact in the connector.	Reinsert the connector. Also check for continuity within the connector cable. If none, replace the cable. Registration clutch and connect right PWB (YC12) Connect right PWB and control PWB (YC29)
	2. Defective clutch.	Replace the registration clutch.
	3. Defective connect right PWB.	Replace the connect right PWB (see page 2-2-36).
	4. Defective PWB.	Replace the control PWB and check for correct operation (see page 2-2-12).
(10) Duplex clutch does not operate. (50/60 ppm model only)	1. Defective connector cable or poor contact in the connector.	Reinsert the connector. Also check for continuity within the connector cable. If none, replace the cable. Duplex clutch and connect right PWB (YC12) Connect right PWB and control PWB (YC29)
	2. Defective clutch.	Replace the duplex clutch.
	3. Defective connect right PWB.	Replace the connect right PWB (see page 2-2-36).
	4. Defective PWB.	Replace the control PWB and check for correct operation (see page 2-2-12).
(11) Developer clutch does not operate.	1. Defective connector cable or poor contact in the connector.	Reinsert the connector. Also check for continuity within the connector cable. If none, replace the cable. Developer clutch and connect right PWB (YC12) Connect right PWB and control PWB (YC29)
	2. Defective clutch.	Replace the developer clutch.
	3. Defective connect right PWB.	Replace the connect right PWB (see page 2-2-36).
	4. Defective PWB.	Replace the control PWB and check for correct operation (see page 2-2-12).
(12) Middle clutch does not operate. (50/60 ppm model only)	1. Defective connector cable or poor contact in the connector.	Reinsert the connector. Also check for continuity within the connector cable. If none, replace the cable. Middle clutch and connect right PWB (YC12) Connect right PWB and control PWB (YC29)
	2. Defective clutch.	Replace the middle clutch.
	3. Defective connect right PWB.	Replace the connect right PWB (see page 2-2-36).
	4. Defective PWB.	Replace the control PWB and check for correct operation (see page 2-2-12).

Problem	Causes	Check procedures/corrective measures
(13) MP solenoid does not operate.	1. Defective connector cable or poor contact in the connector.	Reinsert the connector. Also check for continuity within the connector cable. If none, replace the cable. MP solenoid and connect right PWB (YC11) Connect right PWB and control PWB (YC29)
	2. Defective solenoid.	Replace the MP solenoid.
	3. Defective connect right PWB.	Replace the connect right PWB (see page 2-2-36).
	4. Defective PWB.	Replace the control PWB and check for correct operation (see page 2-2-12).
(14) Faceup solenoid does not operate. (50/60 ppm model only)	1. Defective connector cable or poor contact in the connector.	Reinsert the connector. Also check for continuity within the connector cable. If none, replace the cable. Faceup solenoid and connect left PWB (YC13) Connect left PWB and control PWB (YC2)
	2. Defective solenoid.	Replace the faceup solenoid.
	3. Defective connect left PWB.	Replace the connect left PWB (see page 2-2-36).
	4. Defective PWB.	Replace the control PWB and check for correct operation (see page 2-2-12).
(15) The message requesting paper to be loaded is shown when paper is present on the cassette.	1. Defective connector cable or poor contact in the connector.	Reinsert the connector. Also check for continuity within the connector cable. If none, replace the cable. High voltage PWB and engine PWB (YC19)
	2. Deformed actuator of the paper sensor.	Check visually and replace if necessary.
	3. Defective paper sensor.	Replace the high voltage PWB (see page 2-2-36).
	4. Defective PWB.	Replace the control PWB and check for correct operation (see page 2-2-12).
(16) The message requesting paper to be loaded is shown when paper is present on the MP tray.	1. Defective connector cable or poor contact in the connector.	Reinsert the connector. Also check for continuity within the connector cable. If none, replace the cable. MP paper sensor and connect left PWB (YC8) Connect left PWB and control PWB (YC2)
	2. Deformed actuator of the MP paper sensor.	Check visually and replace if necessary.
	3. Defective MP paper sensor.	Replace the MP paper sensor.
	4. Defective connect left PWB.	Replace the connect left PWB (see page 2-2-36).
	5. Defective PWB.	Replace the control PWB and check for correct operation (see page 2-2-12).

Problem	Causes	Check procedures/corrective measures
(17) The size of paper on the cassette is not displayed correctly.	1. Defective connector cable or poor contact in the connector.	Reinsert the connector. Also check for continuity within the connector cable. If none, replace the cable. Cassette size switch and connect right PWB (YC2) Connect right PWB and control PWB (YC29)
	2. Defective cassette size switch.	Replace the cassette size switch.
	3. Defective connect right PWB.	Replace the connect right PWB (see page 2-2-36).
	4. Defective PWB.	Replace the control PWB and check for correct operation (see page 2-2-12).
(18) A paper jam in the paper feed, paper conveying or eject section is indicated when the main power switch is turned on.	1. Defective connector cable or poor contact in the connector.	Reinsert the connector. Also check for continuity within the connector cable. If none, replace the cable. Regist sensor 2 and drum PWB (YC6) DU sensor 1 and connect left PWB (YC9) Eject full sensor and control PWB (YC12) Eject sensor and control PWB (YC26)
	2. A piece of paper torn from paper is caught around registration sensor, duplex sensor, PF feed sensor, eject full sensor or eject sensor.	Check visually and remove it, if any.
	3. Defective sensor.	Replace the registration sensor, duplex sensor, eject full sensor or eject sensor.
	4. Defective connect left PWB.	Replace the connect left PWB (see page 2-2-36).
	5. Defective PWB.	Replace the control PWB and check for correct operation (see page 2-2-12).
(19) A message indicating cover open is displayed when the top cover is closed.	1. Defective connector cable or poor contact in the connector.	Reinsert the connector. Also check for continuity within the connector cable. If none, replace the cable. Interlock switch and connect right PWB (YC8) Connect right PWB and control PWB (YC27)
	2. Defective interlock switch.	Check and replace if necessary.
	3. Defective connect right PWB.	Replace the connect right PWB (see page 2-2-36).
	4. Defective PWB.	Replace the control PWB and check for correct operation (see page 2-2-12).

Problem	Causes	Check procedures/corrective measures
(20) A message indicating cover open is displayed when the rear cover is closed. (50/60 ppm model only)	1. Defective connector cable or poor contact in the connector.	Reinsert the connector. Also check for continuity within the connector cable. If none, replace the cable. Rear cover switch and connect left PWB (YC10) Connect left PWB and control PWB (YC2)
	2. Defective rear cover switch.	Check and replace if necessary.
	3. Defective connect left PWB.	Replace the connect left PWB (see page 2-2-36).
	4. Defective PWB.	Replace the control PWB and check for correct operation (see page 2-2-12).
(21) DP paper feed motor does not operate.	1. Defective connector cable or poor contact in the connector.	Reinsert the connector. Also check for continuity within the connector cable. If none, remedy or replace the cable. DP paper feed motor and control PWB (YC1001)
	2. Defective drive transmission system.	Check if the rollers and gears rotate smoothly. If not, grease the bushes and gears. Check for broken gears and replace if any.
	3. Defective motor.	Replace the DP paper feed motor.
	4. Defective PWB.	Replace the control PWB and check for correct operation (see page 2-2-12).
(22) DP paper conveying motor does not operate.	1. Defective connector cable or poor contact in the connector.	Reinsert the connector. Also check for continuity within the connector cable. If none, remedy or replace the cable. DP conveying motor and control PWB (YC1001)
	2. Defective drive transmission system.	Check if the rollers and gears rotate smoothly. If not, grease the bushes and gears. Check for broken gears and replace if any.
	3. Defective motor.	Replace the DP conveying motor.
	4. Defective PWB.	Replace the control PWB and check for correct operation (see page 2-2-12).
(23) DP switchback motor does not operate.	1. Defective connector cable or poor contact in the connector.	Reinsert the connector. Also check for continuity within the connector cable. If none, remedy or replace the cable. DP switchback motor and control PWB (YC1001)
	2. Defective motor.	Replace the DP switchback motor.
	3. Defective PWB.	Replace the control PWB and check for correct operation (see page 2-2-12).
(24) An original jams when the main power switch is turned on.	1. A piece of paper torn from an original is caught around the DP timing sensor, DP registration sensor or DP switchback sensor.	Check visually and remove it, if any.
	2. Defective DP timing sensor.	Replace the DP timing sensor, DP registration sensor or DP switchback sensor.
	3. Defective PWB.	Replace the control PWB and check for correct operation (see page 2-2-12).

Problem	Causes	Check procedures/corrective measures
(25) A message indicating cover open is displayed when the DP top cover is closed.	1. Defective connector cable or poor contact in the connector.	Reinsert the connector. Also check for continuity within the connector cable. If none, remedy or replace the cable. DP open/close sensor and control PWB (YC1001)
	2. Defective DP open/close sensor.	Replace the DP open/close sensor.
	3. Defective PWB.	Replace the control PWB and check for correct operation (see page 2-2-12).

1-4-8 Mechanical problems

If the part causing the problem was not supplied, use the unit including the part for replacement.

Problem	Causes/check procedures	Corrective measures
(1) No primary paper feed.	1. Check if the surfaces of the following rollers are dirty with paper powder. Pickup roller Paper feed roller MP paper feed pulley	Clean with isopropyl alcohol.
	2. Check if the following rollers is deformed. Pickup roller Paper feed roller MP paper feed pulley	Check visually and replace any deformed (see page 1-5-5, 1-5-9).
	3. Defective paper feed clutch installation.	Check visually and remedy if necessary.
(2) No secondary paper feed.	1. Check if the surfaces of the following rollers are dirty with paper powder. Upper registration roller Lower registration roller	Clean with isopropyl alcohol.
	2. Defective registration clutch installation.	Check visually and remedy if necessary.
(3) Skewed paper feed.	Paper width guide in a cassette installed incorrectly.	Check the paper width guide visually and remedy or replace if necessary.
(4) Multiple sheets of paper are fed.	1. Check if the paper is excessively curled.	Change the paper.
	2. Paper is loaded incorrectly.	Load the paper correctly.
	3. Check if the retard roller is worn.	Replace the retard roller if it is worn (see page 1-5-9).
(5) Paper jams.	1. Check if the paper is excessively curled.	Change the paper.
	2. Check if the contact between the upper and lower registration rollers is correct.	Check visually and remedy if necessary.
	3. Check if the heat roller or press roller is extremely dirty or deformed.	Check visually and replace the fuser unit (see page 1-5-47).
(6) Toner drops on the paper conveying path.	Check if the drum unit or developer unit is extremely dirty.	Clean the drum unit or developer unit.

Problem	Causes/check procedures	Corrective measures
(7) Abnormal noise is heard.	1. Check if the rollers, pulleys and gears operate smoothly.	Grease the bushes and gears.
	2. Check if the following clutches are installed correctly. Paper feed clutch Registration clutch Duplex clutch	Check visually and remedy if necessary.

1-4-9 Send error code

This section describes the scanning errors and descriptions, preventive actions, as well as corrective actions. Error codes not described here could fall within software errors.

If such an error is encountered, turn power off then on, and advise the service representative.

(1) Scan to SMB error codes

Code	Contents	Check procedures/corrective measures
1101	Host destined does not exist on the network.	<ol style="list-style-type: none"> 1. Confirm destined host. 2. Confirm device's network parameters. 3. Confirm the network parameters the device is connected.
1102	Login to the host has failed.	<ol style="list-style-type: none"> 1. Confirm user name and password. 2. Confirm the network parameters the device is connected. 3. Check the host if the folder is properly shared.
1103	Destined host, folder, and/or file names are invalid.	<ol style="list-style-type: none"> 1. Check illegal characters are not contained within these names. 2. Check the name of the folder and files conform with the naming syntax. 3. Confirm destined host and folder.
1105	SMB protocol is not enabled.	<ol style="list-style-type: none"> 1. Confirm device's SMB protocols.
2101	Login to the host has failed.	<ol style="list-style-type: none"> 1. Confirm destined host. 2. Confirm that the LAN cable is properly connected to the device. 3. Check the SMB port number. 4. Confirm device's network parameters. 5. Confirm the network parameters the device is connected.
2201	Writing scanned data has failed.	<ol style="list-style-type: none"> 1. Check the scanning file name. 2. Confirm device's network parameters. 3. Confirm the network parameters the device is connected.
2203	No response from the host during a certain period of time.	<ol style="list-style-type: none"> 1. Confirm the network parameters the device is connected. 2. Confirm that the LAN cable is properly connected to the device.

(2) Scan to FTP error codes

Code	Contents	Check procedures/corrective measures
1101	FTP server does not exist on the network.	<ol style="list-style-type: none"> 1. Check the FTP server name. 2. Confirm device's network parameters. 3. Confirm the network parameters the device is connected.
1102	Login to the FTP server has failed.	<ol style="list-style-type: none"> 1. Confirm user name and password. 2. Check the FTP server name.
1103	Destined folder is invalid.	<ol style="list-style-type: none"> 1. Check illegal characters are not contained within these names. 2. Check the FTP server name.
1105	FTP protocol is not enabled.	<ol style="list-style-type: none"> 1. Confirm device's FTP protocols.
1131	Initializing TLS has failed.	<ol style="list-style-type: none"> 1. Confirm device's security parameters.
1132	TLS negotiation has failed.	<ol style="list-style-type: none"> 1. Confirm device's security parameters. 2. Check the FTP server name.
2101	Access to the FTP server has failed.	<ol style="list-style-type: none"> 1. Check the FTP server name. 2. Confirm that the LAN cable is properly connected to the device. 3. Check the FTP port number. 4. Confirm device's network parameters. 5. Confirm the network parameters the device is connected. 6. Check the FTP server name.
2102	Access to the FTP server has failed. (Connection timeout)	<ol style="list-style-type: none"> 1. Check the FTP server name. 2. Check the FTP port number. 3. Confirm device's network parameters. 4. Confirm the network parameters the device is connected. 5. Check the FTP server name.
2103	The server cannot establish communication.	<ol style="list-style-type: none"> 1. Check the FTP server name. 2. Check the FTP port number. 3. Confirm device's network parameters. 4. Confirm the network parameters the device is connected. 5. Check the FTP server name.
2201	Connection with the FTP server has failed.	<ol style="list-style-type: none"> 1. Confirm device's network parameters. 2. Confirm the network parameters the device is connected. 3. Confirm destined folder. 4. Check the FTP server name.
2202	Connection with the FTP server has failed. (Timeout)	<ol style="list-style-type: none"> 1. Confirm device's network parameters. 2. Confirm the network parameters the device is connected.
2203	No response from the server during a certain period of time.	<ol style="list-style-type: none"> 1. Confirm device's network parameters. 2. Confirm the network parameters the device is connected.

Code	Contents	Check procedures/corrective measures
2231	Connection with the FTP server has failed. (FTPS communication)	1. Confirm device's network parameters. 2. Confirm the network parameters the device is connected.
3101	FTP server responded with an error.	1. Confirm device's network parameters. 2. Confirm the network parameters the device is connected. 3. Check the FTP server.

(3) Scan to E-mail error codes

Code	Contents	Check procedures/corrective measures
1101	SMTP/POP3 server does not exist on the network.	<ol style="list-style-type: none"> 1. Check the SMTP/POP3 server name. 2. Confirm device's network parameters. 3. Confirm the network parameters the device is connected.
1102	Login to the SMTP/POP3 server has failed.	<ol style="list-style-type: none"> 1. Confirm user name and password. 2. Check the SMTP/POP3 server.
1104	The domain the destined address belongs is prohibited by scanning restriction.	<ol style="list-style-type: none"> 1. Confirm device's SMTP parameters.
1105	SMTP protocol is not enabled.	<ol style="list-style-type: none"> 1. Confirm device's SMTP protocols.
1106	Sender's address is not specified.	<ol style="list-style-type: none"> 1. Confirm device's SMTP protocols.
2101	Connection to the SMTP/POP3 server has failed.	<ol style="list-style-type: none"> 1. Check the SMTP/POP3 server name. 2. Confirm that the LAN cable is properly connected to the device. 3. Check the SMTP/POP3 port number. 4. Confirm device's network parameters. 5. Confirm the network parameters the device is connected. 6. Check the SMTP/POP3 server.
2102	Connection to the SMTP/POP3 server has failed. (Connection timeout)	<ol style="list-style-type: none"> 1. Check the SMTP/POP3 server name. 2. Check the SMTP/POP3 port number. 3. Confirm device's network parameters. 4. Confirm the network parameters the device is connected. 5. Check the SMTP/POP3 server.
2103	The server cannot establish communication.	<ol style="list-style-type: none"> 1. Check the SMTP/POP3 server name. 2. Check the SMTP/POP3 port number. 3. Confirm device's network parameters. 4. Confirm the network parameters the device is connected. 5. Check the SMTP/POP3 server.
2201	Connection to the SMTP/POP3 server has failed.	<ol style="list-style-type: none"> 1. Confirm device's network parameters. 2. Confirm the network parameters the device is connected.
2202	Connection to the SMTP/POP3 server has failed. (Timeout)	<ol style="list-style-type: none"> 1. Confirm device's network parameters. 2. Confirm the network parameters the device is connected.
2204	The size of scanning exceeded its limit.	<ol style="list-style-type: none"> 1. Confirm device's network parameters.
3101	SMTP/POP3 server responded with an error.	<ol style="list-style-type: none"> 1. Confirm device's network parameters. 2. Confirm the network parameters the device is connected. 3. Check the SMTP/POP3 server.
3102	Error: Server Response.	<ol style="list-style-type: none"> 1. Check the SMTP/POP3 server. 2. Wait a minute and trye again.

Code	Contents	Check procedures/corrective measures
3201	No SMTP authentication is found.	1. Check the SMTP server. The device supports SMTP authentication services including CRAM-MD5, DIGEST-MD5, PLAIN and LOGIN.
4803	Failed to establish the SSL session.	1. Verify the self certificate of the device. 2. Check the server certificate of the SMTP/POP3 server. 3. Check the SMTP/POP3 configuration of the device and the SMTP/POP3 server.

1-4-10 Error codes

(1) Error code

Error codes are listed on the communication reports, activity report, etc. The codes consist of an error code indication U followed by a 5-digit number. (Error codes for V34 communication errors start with an E indication, followed by five digits.)

The upper three of the five digits indicate general classification of the error and its cause, while the lower two indicate the detailed classification. Items for which detailed classification is not necessary have 00 as the last two digits.

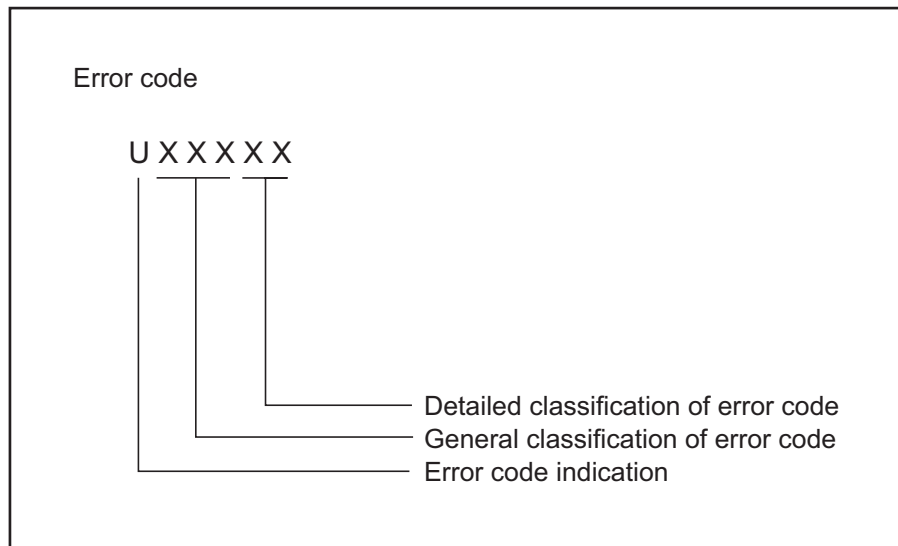

Figure 1-4-4

(2) Table of general classification

Error code	Description
U00000	No response or busy after the set number of redials.
U00100	Transmission was interrupted by a press of the stop/clear key.
U00200	Reception was interrupted by a press of the stop/clear key.
U00300	Recording paper on the destination unit has run out during transmission.
U004XX	A connection was made but interrupted during handshake with the receiver unit (See page 1-4-117).
U00500	Multiple communication was interrupted and call was not made on destination units after interruption.
U006XX	Communication was interrupted because of a machine problem (See page 1-4-118).
U00700	Communication was interrupted because of a problem in the destination unit.
U008XX	A page transmission error occurred in G3 mode (See page 1-4-118).
U009XX	A page reception error occurred in G3 mode (See page 1-4-118).
U010XX	Transmission in G3 mode was interrupted by a signal error (See page 1-4-119).
U011XX	Reception in G3 mode was interrupted by a signal error (See page 1-4-121).
U01400	An invalid one-touch key was specified during communication.
U01500	A communication error occurred when calling in V.8 mode.
U01600	A communication error occurred when called in V.8 mode.
U017XX	A communication error occurred before starting T.30 protocol during transmission in V.34 mode (See page 1-4-122).
U018XX	A communication error occurred before starting T.30 protocol during reception in V.34 mode (See page 1-4-123).
U02000	Relay broadcast was refused by a relay station because of a mismatch in permit ID number and permit telephone number when a relay command was issued.
U02100	A relay command failed because the destination unit (relay station) had no relay broadcast capability.
U02200	A relay command from a command station failed because a telephone number that was not registered in the relay station was specified. Or, relay broadcast was requested to a relay station but failed because a telephone number that was not registered in the relay station was specified. Or, Subaddress-based relay broadcast transmission failed because the data registered in the Subaddress relay box was deleted.
U023XX	Receiving station information was not normally received in reception of a relay command (See page 1-4-123).
U02400	An interoffice subaddress-based relay transmission was interrupted because of a mismatch in the specified relay box number.
U03000	No document was present in the destination unit when polling reception started.
U03100	In reverse polling, although no original was set in the destination unit, transmission was complete.
U03200	In confidential polling reception, data was not accumulated in the specified box in the destination unit. Or, in interoffice subaddress-based bulletin board reception, data was not stored in the box specified by the destination unit.

Error code	Description
U03300	In polling reception from a unit of our make, operation was interrupted due to a mismatch in permit ID or telephone number. Or, in interoffice subaddress-based bulletin board reception, operation was interrupted due to a mismatch in permit ID or telephone number.
U03400	Polling reception was interrupted because of a mismatch in individual numbers (destination unit is either of our make or by another manufacturer).
U03500	In confidential polling reception, the specified confidential box No. was not registered in the destination. Or, in interoffice subaddress-based bulletin board reception, the specified Subaddress confidential box number was not registered in the destination unit. Or, the destination was being accessed.
U03600	Confidential polling reception was interrupted because of a mismatch in specified confidential box No. Or, an interoffice subaddress-based bulletin board reception was interrupted because of a mismatch in the specified subaddress confidential box number.
U03700	Confidential polling reception failed because the destination unit had no confidential polling transmission capability or data was not accumulated in any box in the destination unit. Or, interoffice subaddress-based bulletin board reception failed because the destination unit had no subaddress-based bulletin board transmission capability, or data was not stored in any subaddress confidential box in the destination unit.
U04000	The confidential box specified for confidential transmission was not registered in the destination unit. Or, in interoffice subaddress-based transmission mode, the specified subaddress box number was not registered in the destination unit. Or, the destination was being accessed.
U04100	Confidential transmission failed because the destination unit had no confidential capability. Or, subaddress-based transmission failed because the destination unit had no subaddress-based reception capability.
U04200	In encrypted transmission, the specified encryption box was not registered in the destination unit.
U04300	Encrypted transmission failed because the destination unit had no encrypted communication capability.
U044XX	Communication was interrupted because of an encryption key error during encrypted transmission (See page 1-4-123).
U04500	Encrypted reception was interrupted because of a mismatch in encryption keys.
U05000	In transmission with a specified number, the set number of originals was different from the number of transmitted originals.
U05100	Password check transmission or restricted transmission was interrupted because the permit ID's did not agree with.
U05200	Password check reception or restricted reception was interrupted because the permit ID's did not match, the rejected FAX number's did match, or the destination receiver did not return its phone number.
U05300	The password check reception or the restricted reception was interrupted because the permitted numbers did not match, the rejected numbers did match, or the machine in question did not acknowledge its phone number.
U09000	G3 communication was attempted but failed because the destination unit was a G2 machine.

Error code	Description
U12000	Relay broadcast was requested from a command station but memory overflowed during reception. Or, in subaddress-based relay reception, memory overflowed.
U12100	Relay was commanded but memory overflowed in the destination unit (relay station).
U14000	Memory overflowed during confidential reception. Or, in subaddress-based confidential reception, memory overflowed.
U14100	Memory overflowed in the destination unit during confidential transmission. Or, in interface subaddress-based transmission, memory overflowed in the destination unit.
U19000	Memory overflowed during memory reception.
U19100	Memory overflowed in the destination unit during transmission.
U19200	Memory transmission failed because a decoding error occurred.
U19300	Transmission failed because an error occurred during JBIG encoding.
U19400	Reception failed because an error occurred during JBIG decoding.

(2-1) U004XX error code table: Interrupted phase B

Error code	Description
U00420	A relay request was received from the host center but interrupted because of a mismatch in permit ID or telephone number.
U00421	Subaddress-based relay reception was interrupted because of a mismatch in the specified subaddress relay box number.
U00430	Polling request (confidential or reverse) was received but interrupted because of a mismatch in permit number. Or, subaddress-based bulletin board transmission request was received but interrupted because of a mismatch in permit ID in the transmitting unit.
U00431	Confidential polling transmission was interrupted because the specified confidential box No. was not registered. Or, an subaddress-based bulletin board transmission was interrupted because the specified subaddress confidential box was not registered.
U00432	Confidential polling transmission was interrupted because of a mismatch in confidential box ID number. Or, an subaddress-based bulletin board transmission was interrupted because of a mismatch in Subaddress confidential box numbers.
U00433	Confidential polling request was received but data was not present in the confidential box. Or, subaddress-based bulletin board transmission request was received but data was not present in the subaddress confidential box.
U00434	Confidential polling request was received but interrupted because the specified confidential box No. was intended for encryption.
U00435	Confidential polling request was received but interrupted because the specified confidential box was being accessed. Or, subaddress-based bulletin board transmission request was received but interrupted because the specified subaddress confidential box was being accessed.
U00440	Confidential reception was interrupted because the specified confidential box No. was not registered. Or, subaddress-based confidential reception or subaddress-based relay reception was interrupted because the specified subaddress box was not registered. Or, subaddress based confidential reception or subaddress relay command reception was interrupted because the specified subaddress box No. was being accessed.
U00441	Confidential reception was interrupted because the specified confidential box No. was intended for encryption.
U00450	The destination transmitter disconnected because the permit ID's did not agree with while the destination transmitter is in password-check transmission or restricted transmission.
U00460	Encrypted reception was interrupted because the specified encryption box number was not registered. Or, encrypted reception request was received but interrupted because the specified encryption box was being accessed.
U00462	Encrypted reception was interrupted because the encryption key for the specified encryption box was not registered.

(2-2) U006XX error code table: Problems with the unit

Error code	Description
U00600	The document processor cover is open.
U00601	Document jam or the document length exceeds the maximum.
U00602	Image scanning section problem.
U00603	No document feed.
U00604	Document length exceeded the limit of the bitmap memory capacity.
U00610	Recording section cover is open.
U00611	Recording paper JAM
U00613	Image writing section problem
U00614	Nearly empty of recording paper
U00615	Empty of recording paper
U00620	Copier fixing unit problem
U00622	Copier drive motor problem
U00655	CTS was not activated after RTS due to a modem error.
U00656	Data was not transmitted after CTS was activated due to a modem error.
U00670	Power was cut off during communication.
U00677	There was no file to transmit in the memory transmission mode.
U00690	System error.

(2-3) U008XX error code table: Page transmission error

Error code	Description
U00800	A page transmission error occurred because of reception of a RTN or PIN signal.
U00810	A page transmission error reoccurred after retry of transmission in the ECM mode.

(2-4) U009XX error code table: Page reception error

Error code	Description
U00900	An RTN or PIN signal was transmitted because of a page reception error.
U00910	A page reception error remained after retry of transmission in the ECM mode.

(2-5) U010XX error code table: G3 transmission

Error code	Description
U01000	An FTT signal was received for a set number of times after TCF signal transmission at 2400 bps. Or, an RTN signal was received in response to a Q signal (excluding EOP) after transmission at 2400 bps.
U01001	Function of the unit differs from that indicated by a DIS signal.
U01010	No relevant signal was received after transmission of a DNL (MPS or EOM) signal, and the preset number of command retransfers was exceeded (between units of our make).
U01011	No relevant signal was received after transmission of a DCS, TCF signal, and the preset number of command retransfers was exceeded.
U01012	No relevant signal was received after transmission of an NSS1, NSS2 (TCF) signal, and the preset number of command retransfers was exceeded (between units of our make).
U01013	No relevant signal was received after transmission of an NSS3, TCF signal, and the preset number of command retransfers was exceeded (between units of our make).
U01014	No relevant signal was received after transmission of an MPS signal, and the preset number of command retransfers was exceeded.
U01015	No relevant signal was received after transmission of an EOM signal, and the preset number of command retransfers was exceeded.
U01016	An MCF signal was received but no DIS signal was received after transmission of an EOM signal, and T1 timeout was detected.
U01017	No relevant signal was received after transmission of an EOP signal, and the preset number of command retransfers was exceeded.
U01018	No relevant signal was received after transmission of a PRI-EOP signal, and the preset number of command retransfers was exceeded.
U01019	No relevant signal was received after transmission of a CNC signal, and the preset number of command retransfers was exceeded (between units of our make).
U01020	No relevant signal was received after transmission of a CTC signal, and the preset number of command retransfers was exceeded (ECM).
U01021	No relevant signal was received after transmission of an EOR.Q signal, and the preset number of command retransfers was exceeded (ECM).
U01022	No relevant signal was received after transmission of an RR signal, and the preset number of command retransfers was exceeded (ECM).
U01023	No relevant signal was received after transmission of a PSS.NULL signal, and the preset number of command retransfers was exceeded (ECM).
U01024	No relevant signal was received after transmission of a PSS.MPS signal, and the preset number of command retransfers was exceeded (ECM).
U01025	No relevant signal was received after transmission of a PPS.EOM signal, and the preset number of command retransfers was exceeded (ECM).
U01026	No relevant signal was received after transmission of a PPS.EOP signal, and the preset number of command retransfers was exceeded (ECM).
U01027	No relevant signal was received after transmission of a PPS.PRI-EOP signal, and the preset number of command retransfers was exceeded (ECM).
U01028	T5 time-out was detected during ECM transmission (ECM).

Error code	Description
U01040	A DCN or other inappropriate signal was received during standby for DIS signal reception.
U01041	A DCN signal was received after transmission of a DNL (MPS or EOM) signal (between units of our make).
U01042	A DCN signal was received after transmission of a DCS, TCF signal.
U01043	A DCN signal was received after transmission of an NSS1, NSS2 (TCF) signal (between units of our make).
U01044	A DCN signal was received after transmission of an NSS3, TCF signal (between units of our make).
U01045	A DCN or other inappropriate signal was received after transmission of an MPS signal.
U01046	A DCN or other inappropriate signal was received after transmission of an EOM signal.
U01047	A DCN or other inappropriate signal was received after transmission of an EOP signal.
U01048	A DCN signal was received after transmission of a PRI-EOP signal.
U01049	A DCN signal was received after transmission of a CNC signal (between units of our make).
U01050	A DCN signal was received after transmission of a CTC signal (ECM).
U01051	A DCN signal was received after transmission of an EOR.Q signal (ECM).
U01052	A DCN signal was received after transmission of an RR signal (ECM).
U01053	A DCN signal was received after transmission of a PPS.NULL signal (ECM).
U01054	A DCN signal was received after transmission of a PPS.MPS signal (ECM).
U01055	A DCN signal was received after transmission of a PPS.EOM signal (ECM).
U01056	A DCN signal was received after transmission of a PPS.EOP signal (ECM).
U01057	A DCN signal was received after transmission of a PPS.PRI-EOP signal (ECM).
U01070	Polarity reversal was detected during handshake.
U01071	Polarity reversal was detected during message transmission.
U01072	A break in loop current was detected during transmission.
U01073	During reverse polling in V.34 mode at the receiver unit, a CM signal was not detected when transmitting after reception.
U01080	A PIP signal was received after transmission of a PPS.NULL signal.
U01091	During transmission in V.34 mode, communication was interrupted because a PPR signal was received over 10 times even after reducing the communication speed to the minimum with the symbol speed maintained at the level of connection.
U01092	During transmission in V.34 mode, communication was interrupted because of an impossible combination of the symbol speed and communication speed.

(2-6) U011XX error code table: G3 reception

Error code	Description
U01100	Function of the unit differs from that indicated by a DCS signal.
U01101	Function of the unit (excl. communication mode select) differs from that indicated by an NSS signal.
U01102	A DTC (NSC) signal was received when no transmission data was in the unit.
U01110	No response after transmission of a DIS signal.
U01111	No response after transmission of a DTC (NSC) signal.
U01112	No training reception after reception of a DCS or NSS signal.
U01113	No response after transmission of an FTT signal.
U01114	No message reception after transmission of a CFR signal.
U01115	No message reception after transmission of an MCF signal.
U01116	No message reception after transmission of a PPR signal.
U01117	No message reception after transmission of a CTR signal.
U01118	No message reception after transmission of an ERR signal.
U01119	No further signals were received after reception of a message.
U01120	No response after transmission of an MCF signal.
U01121	No response after transmission of an RTP signal.
U01122	No response after transmission of an RTN signal.
U01123	No response after transmission of a PIP signal.
U01124	No response after transmission of a PIN signal.
U01125	No response after transmission of a CNS signal (between units of our make).
U01126	No response after transmission of a PPR signal (ECM).
U01127	No response after transmission of an ERR signal (ECM).
U01128	No response after transmission of an RNR signal (ECM).
U01129	No response after transmission of an SPA signal (short protocol).
U01140	A DCN signal was received after transmission of a DIS signal.
U01141	A DCN signal was received after transmission of a DTC signal.
U01142	A DCN signal was received after transmission of a DCS or NSS signal.
U01143	A DCN signal was received after transmission of an FTT signal.
U01144	A DCN signal was received after transmission of a CFR signal.
U01145	A DCN signal was received after reception of a message.
U01146	A DCN signal was received after transmission of an MCF signal (interoffice communication after reception of an MPS, EOM signal or confidential interoffice communication).
U01147	A DCN signal was received after transmission of an RTP signal.
U01148	A DCN signal was received after transmission of an RTN signal.
U01149	A DCN signal was received after transmission of a PIP signal.
U01150	A DCN signal was received after transmission of a PIN signal.
U01151	A DCN signal was received after transmission of a PPR signal (ECM).

Error code	Description
U01152	A DCN signal was received after transmission of a CTR signal (ECM).
U01153	A DCN signal was received after transmission of an ERR signal (ECM).
U01154	A DCN signal was received after transmission of an RNR signal (ECM).
U01155	A DCN signal was received after transmission of an SPA signal (short protocol).
U01160	During message reception, transmission time exceeded the maximum transmission time per line.
U01161	Number of error lines exceeded limits during message reception.
U01162	A break in loop current was detected during message reception.
U01163	Polarity reversal was detected during message reception.
U01164	One page length exceeded the specified length during message reception.
U01170	A decoding error occurred during MMR message reception.
U01172	During reverse polling in V.34 mode at the transmitting unit, a JM signal was not detected after transmission of a CM signal when receiving after transmission.
U01191	Communication was interrupted because an error occurred during an image data reception sequence in the V.34 mode.
U01199	A DIS signal with different FIF was received after transmission of a DIS signal.

(2-7) U017XX error code table: V.34 transmission

Error code	Description
U01700	A communication error occurred in phase 2 (line probing).
U01720	A communication error occurred in phase 4 (modem parameter exchange).
U01721	Operation was interrupted due to the absence of a common communication speed between units.

U01700: A communication error that occurs at the transmitting unit in the period after transmission of INFO0 before entering phase 3 (primary channel equivalent device training). For example, INFO0/A/Abar (B/Bbar, for polling transmission)/INFOh was not detected.

U01720: A communication error that occurs at the transmitting unit in the period after initiating the control channel before entering the T.30 process. For example, PPh/ALT/MPh/E was not detected.

U01721: In the absence of a common communication speed between units (including when an impossible combination of communication speed and symbol speed occurs) after MPh exchange; 1) a DCN signal was received from the destination unit, and the line was cut; or 2) a DIS (NSF, CSI) signal was received from the destination unit and, in response to the signal, the unit transmitted a DCN signal, and the line was cut.

(2-8) U018XX error code table: V.34 reception

Error code	Description
U01800	A communication error occurred in phase 2 (line probing).
U01810	A communication error occurred in phase 3 (primary channel equivalent device training).
U01820	A communication error occurred in phase 4 (modem parameter exchange).
U01821	Operation was interrupted due to the absence of a common communication speed between units.

U01800: A communication error that occurs at the receiver unit in the period after transmission of INFO0 before entering phase 3 (primary channel equivalent device training). For example, INFO0/B/Bbar (A/Abar, for polling reception)/probing tone was not detected.

U01810: A communication error that occurs at the receiver unit in phase 3 (primary channel equivalent device training).

For example, S/Sbar/PP/TRN was not detected.

U01820: A communication error that occurs at the receiver unit in the period after initiating the control channel before entering the T.30 process. For example, PPh/ALT/MPh/E was not detected.

U01821: In the absence of a common communication speed between units (including when an impossible combination of communication speed and symbol speed occurs) after MPh exchange, a DCN signal was transmitted to the destination unit and the line was cut.

(2-9) U023XX error code table: Relay command abnormal reception

Error code	Description
U02303	Timeout was detected before a correct DNL signal was received.
U02304	A signal other than MPS or EOM signal was received after a DNL signal was received.

(2-10) U044XX error code table: Encrypted transmission

Error code	Description
U04400	Encrypted transmission was interrupted because encryption keys did not agree.
U04401	Calling failed during encrypted transmission because the encryption key was not registered.

This page is intentionally left blank.

1-5-1 Precautions for assembly and disassembly

(1) Precautions

Before starting disassembly, press the Power key on the operation panel to off. Make sure that the Power lamp is off before turning off the main power switch. Unplug the power cable from the wall outlet.

When the fax kit is installed, be sure to disconnect the modular code before starting disassembly.

When handling PWBs (printed wiring boards), do not touch parts with bare hands.

The PWBs are susceptible to static charge.

Do not touch any PWB containing ICs with bare hands or any object prone to static charge.

When removing the hook of the connector, be sure to release the hook.

Take care not to get the cables caught.

To reassemble the parts, use the original screws. If the types and the sizes of screws are not known, refer to the PARTS LIST.

(2) Drum unit

Note the following when handling or storing the drum unit.

When removing the drum unit, never expose the drum surface to strong direct light.

Keep the drum unit at an ambient temperature between -20°C/-4°F and 40°C/104°F and at a relative humidity not higher than 85% RH. Avoid abrupt changes in temperature and humidity.

Avoid exposure to any substance which is harmful to or may affect the quality of the drum unit.

Do not touch the drum surface with any object. Should it be touched by hands or stained with oil, clean it.

(3) Toner

Store the toner container in a cool, dark place.

Avoid direct light and high humidity.

(4) How to tell a genuine Kyocera toner container

As a means of brand protection, the Kyocera toner container utilizes an optical security technology to enable visual validation. A validation viewer is required to accomplish this.

Hold the validation viewer over the left side part of the brand protection seal on the toner container. Through each window of the validation viewer, the left side part of the seal should be seen as follows:

A black-colored band when seen through the left side window (●)

A shiny or gold-colored band when seen through the right side window (☀)

The above will reveal that the toner container is a genuine Kyocera branded toner container, otherwise, it is a counterfeit.

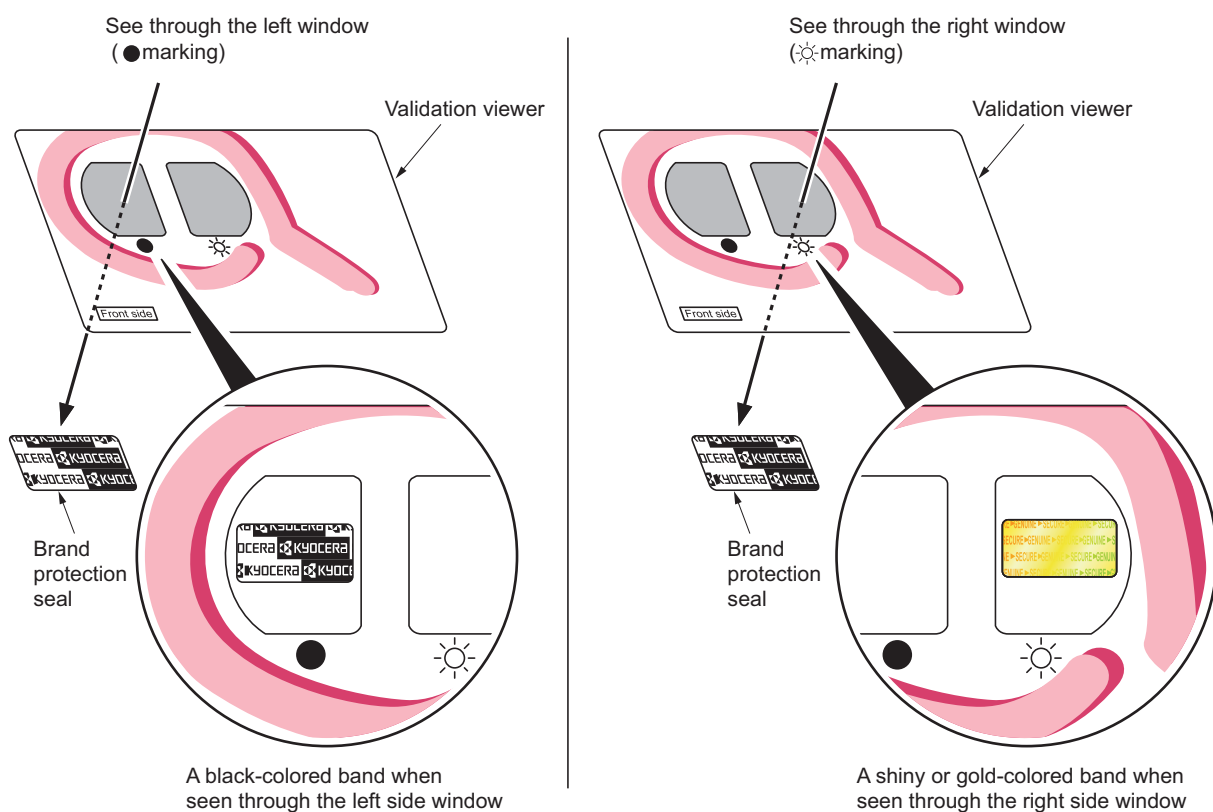

Figure 1-5-1

The brand protection seal has an incision as shown below to prohibit reuse.

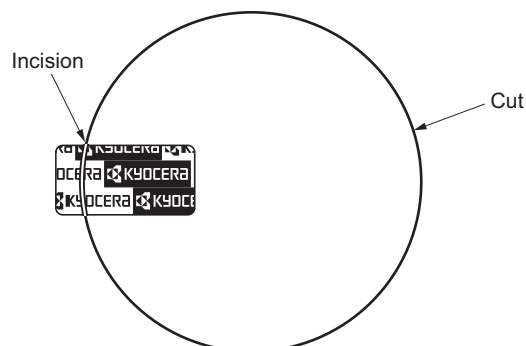

Figure 1-5-2

1-5-2 Paper feed / conveying section

Paper feed/conveying section consists of the paper feed unit that feeds paper from the cassette and the MP tray paper feed unit that feeds paper from the MP tray, and the paper conveying section that conveys the fed paper to the transfer/separation section.

(1) Cassette paper feed section

The cassette can contain 500 sheets. The sheet from the cassette is pulled out by rotation of the pickup roller and sent to the paper conveying section by rotation of the paper feed roller. Also the retard roller prevents multiple feeding of paper.

[Component formation]

1. Paper feed roller
2. Pickup roller
3. Feed holder
4. Retard roller
5. Retard holder
6. Friction pad
7. Bottom plate
8. Paper width guide
9. Paper length guide
10. Cassette base
11. Actuator (paper sensor)

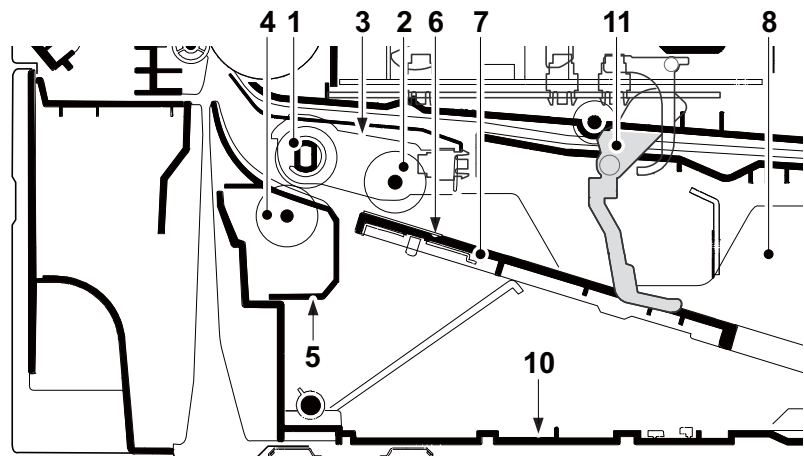

Figure 1-5-3

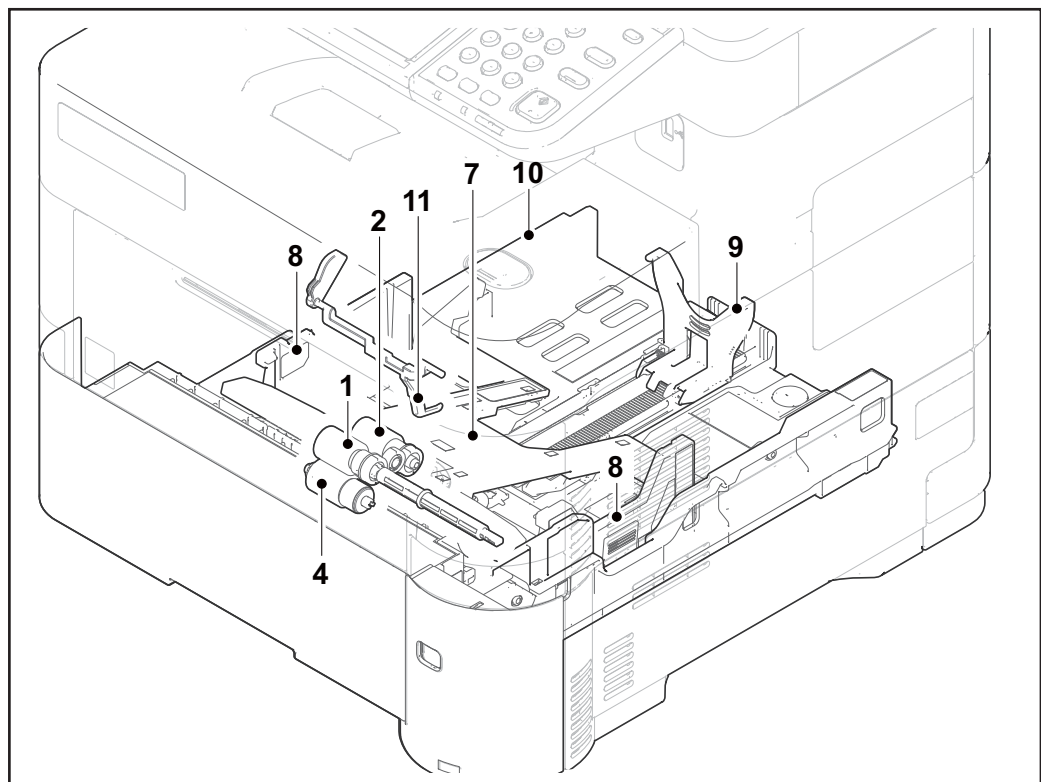

Figure 1-5-4

[Control block diagram]

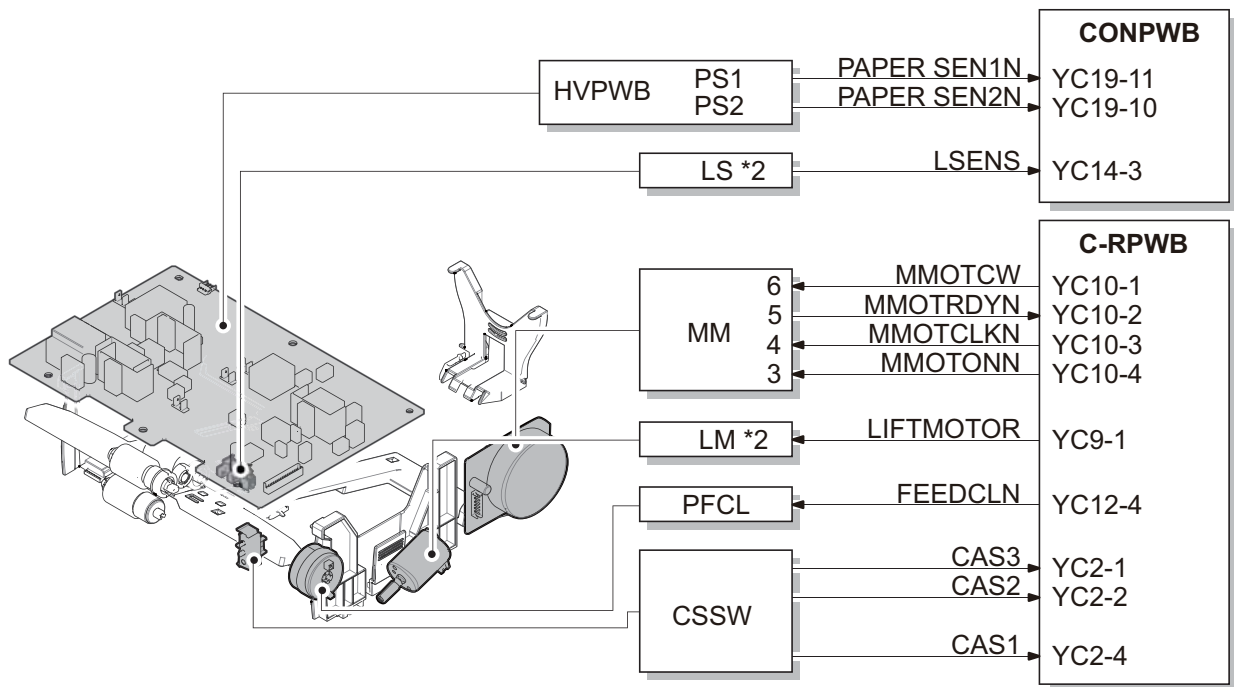

Figure 1-5-5

*2: 50/60 ppm model only

(1-1) Detaching and refitting the primary paper feed unit and the pickup roller**Procedure**

1. Pull out the cassette.
2. Release the lock by pulling the lever.
3. Remove the paper feed roller assembly by pulling and raising and then sliding forward.
4. Check or replace the paper feed roller and refit all the removed parts.

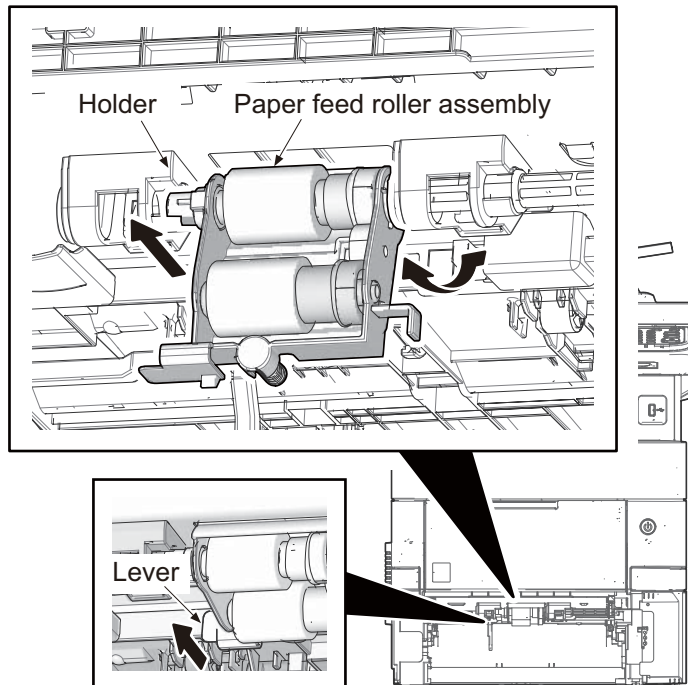

Figure 1-5-6

(1-2) Detaching and refitting the retard roller**Procedure**

1. Release two hooks in backside of cassette and then remove the retard roller assembly.

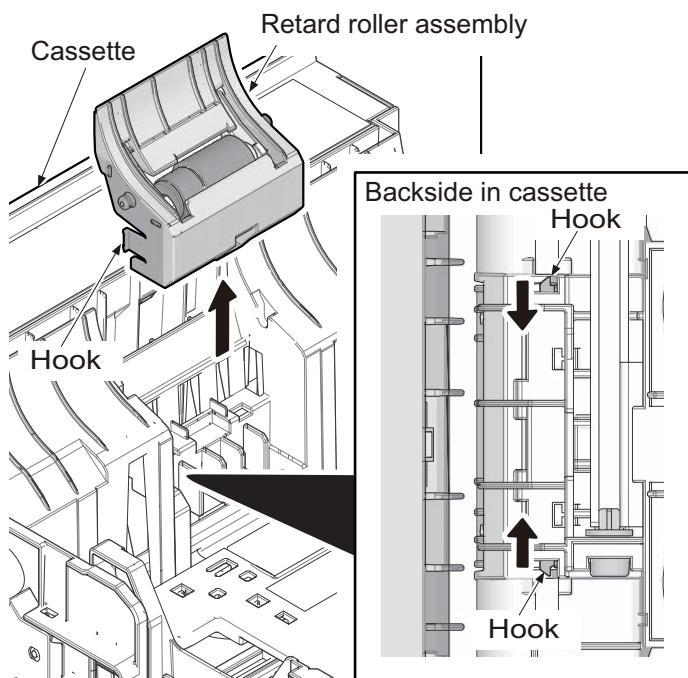

Figure 1-5-7

2. Remove the spring.
3. Remove the retard roller holder by rotating.
4. Check or replace the retard roller and refit all the removed parts.

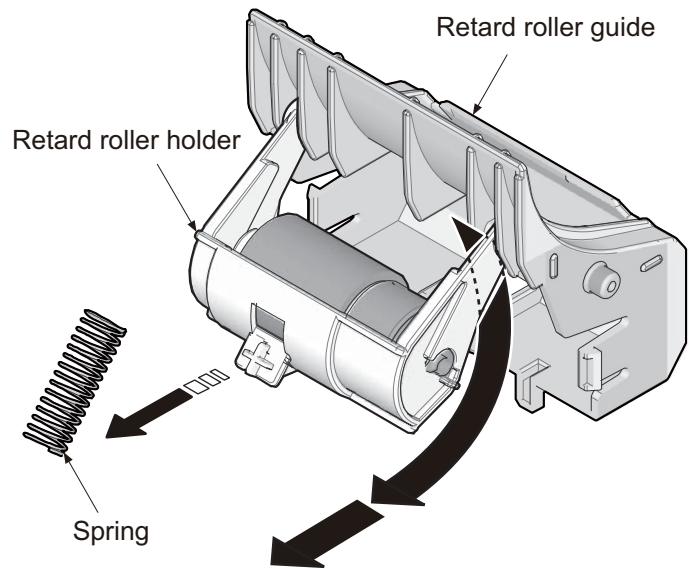

Figure 1-5-8

(2) MP tray paper feed section

The MP tray can contain 100 sheets. Feeding from the MP tray is performed by the rotation of the MP paper feed roller. Also, function of the MP separation pad prevents paper from multiple feeding.

[Component formation]

1. MP paper feed pulley
2. MP separation pad
3. MP bottom plate
4. MP (multi purpose)tray
5. MP frame
6. MP paper width guide
7. Actuator (MP paper sensor)

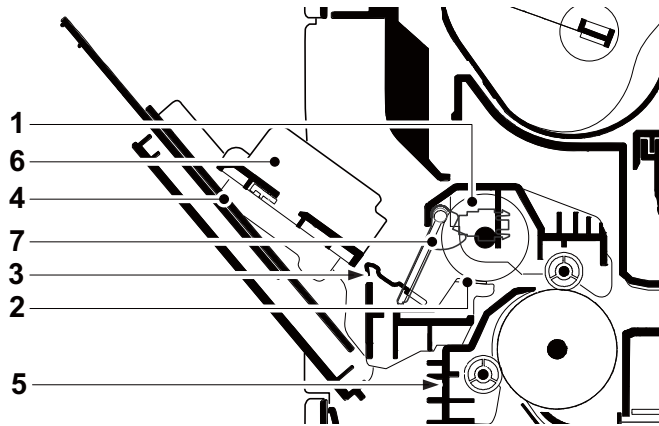

Figure 1-5-9

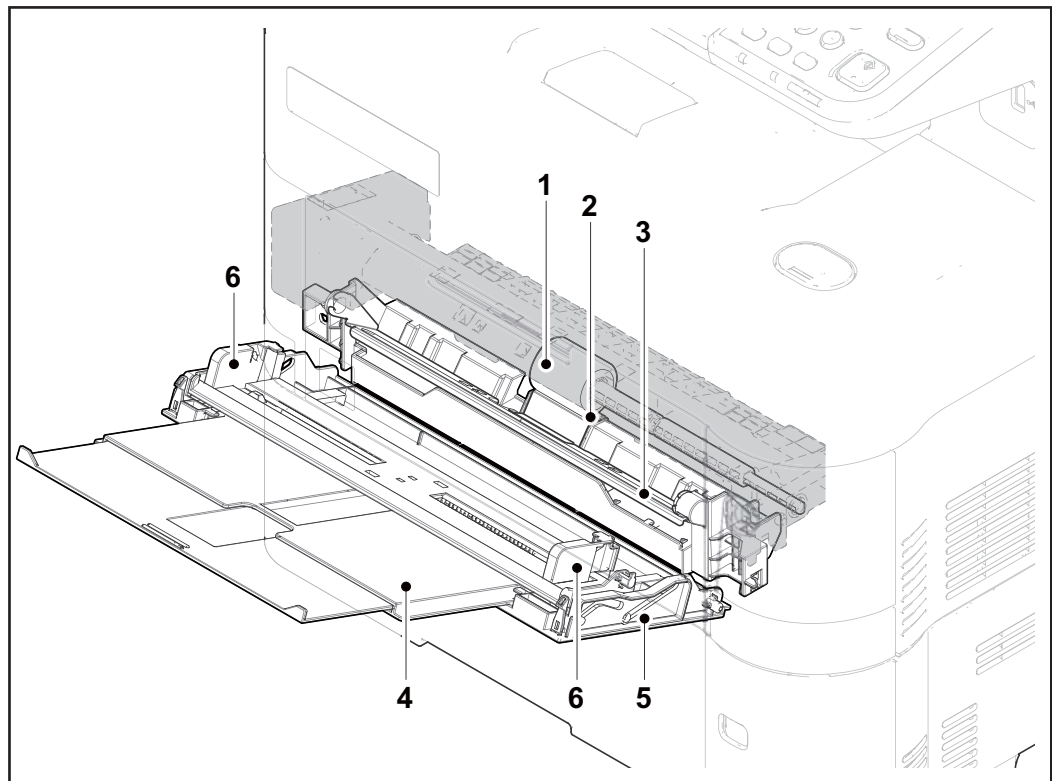

Figure 1-5-10

[Control block diagram]

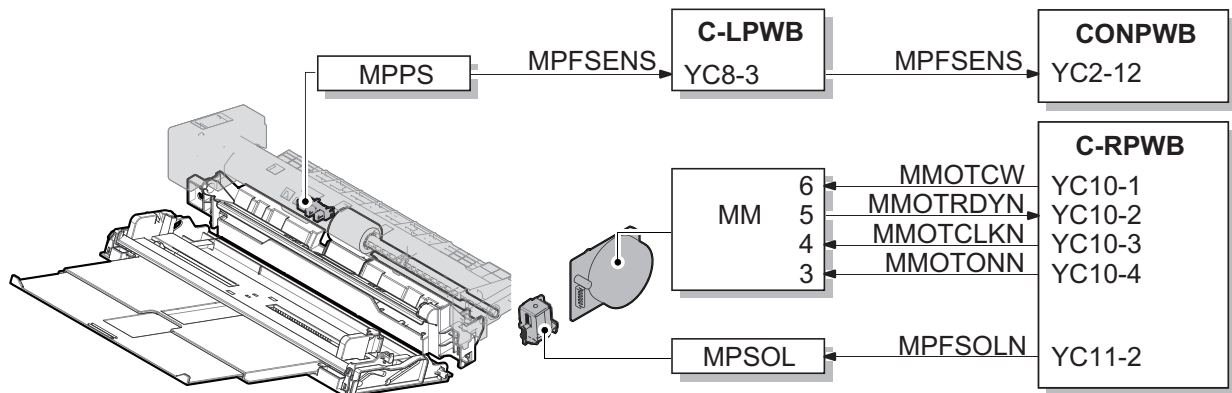

Figure 1-5-11

(2-1) Detaching and refitting the MP paper feed pulley

Procedure

1. Push the button and open the front cover.

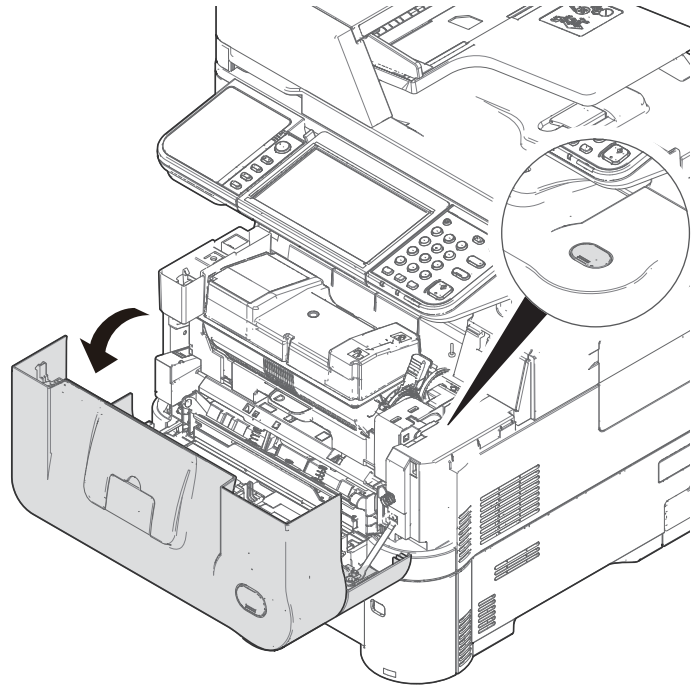

Figure 1-5-12

2. Remove the MP tray from the printer while bending it.
3. Remove two screws and two straps.

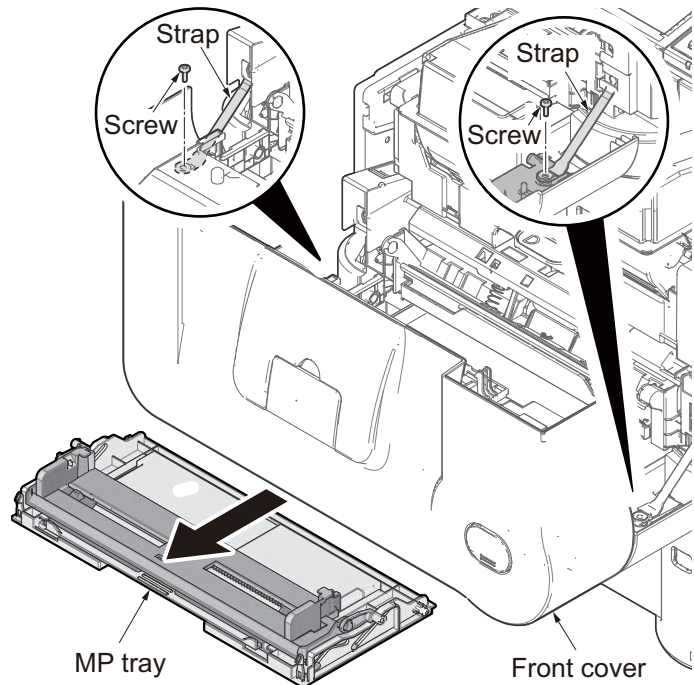

Figure 1-5-13

4. Remove the fulcrum of leftside by extending a cover.
5. Remove the fulcrum of rightside during twisting a cover.
6. Remove the front cover forward.

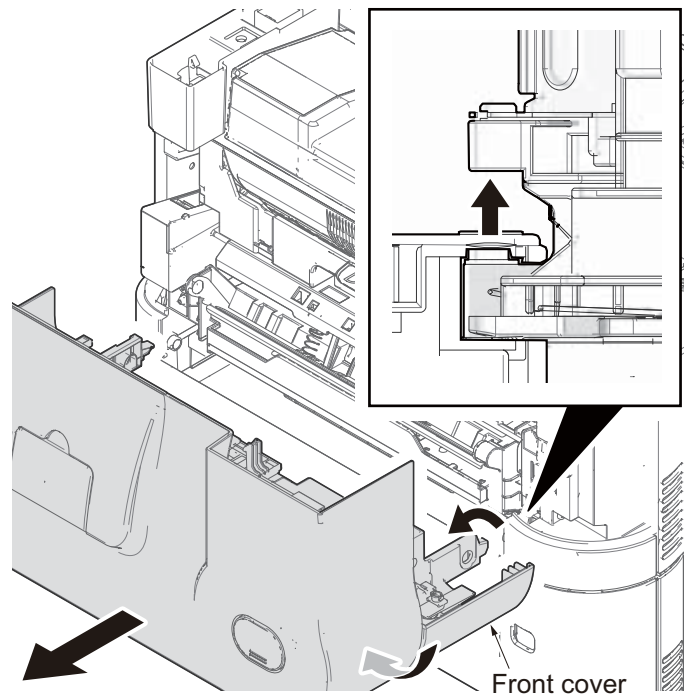
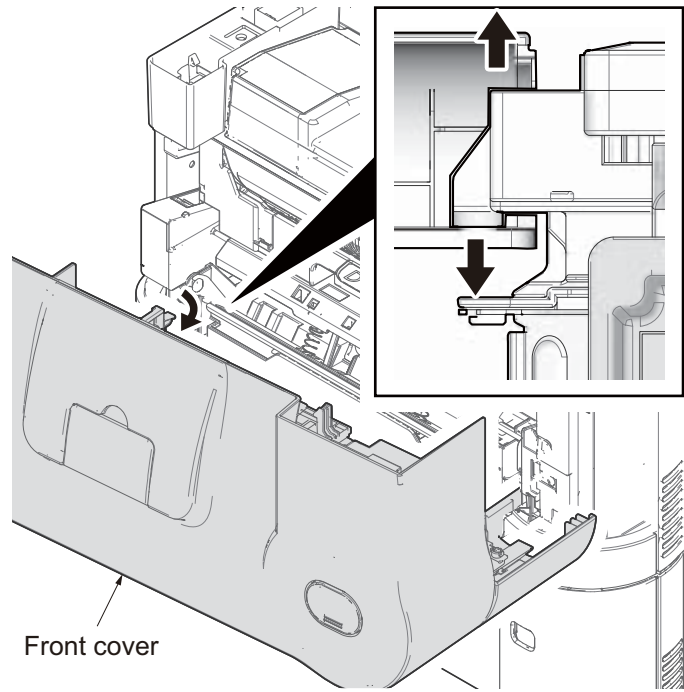

Figure 1-5-14

7. Remove two screws on the MP paper feed unit.
8. Remove the MP paper feed unit from the main unit.

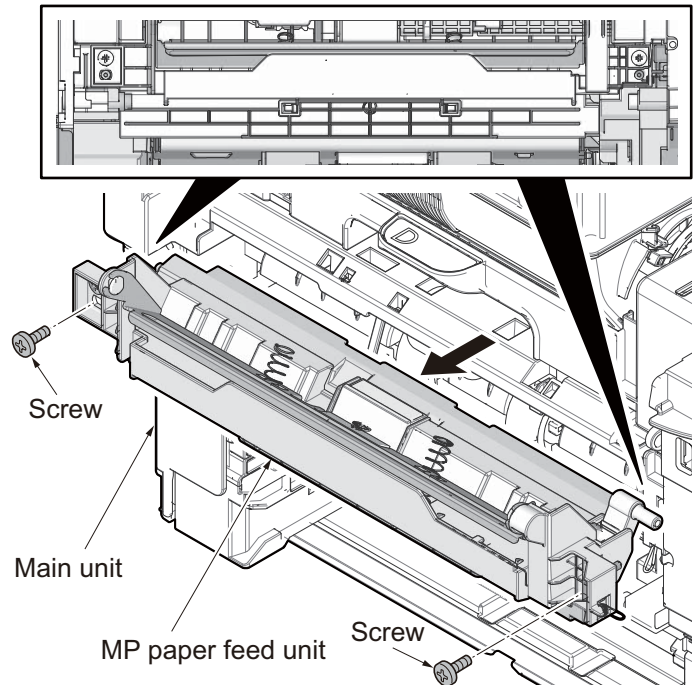

Figure 1-5-15

9. Release the lock lever and then slide the MP paper feed pulley axis.
10. Remove MP paper feed pulley.
11. Check or replace the MP paper feed pulley and refit all the removed parts.

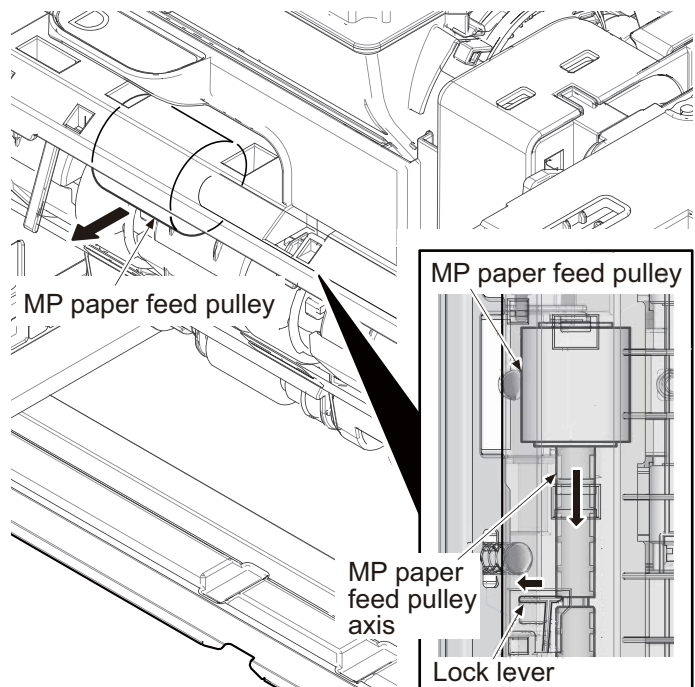

Figure 1-5-16

(3) Conveying section

The conveying section conveys paper to the transfer/separation section as paper feeding from the cassette or MP tray, or as paper refeeding for duplex printing. Paper by feeding is conveyed by the paper feed roller to the position where the registration sensor (RS) is turned on, and then sent to the transfer/separation section by the upper registration roller and lower registration roller.

[Component formation]

1. Middle roller
2. Middle pulley
3. Upper registration guide
4. Actuator *1
(Registration sensor 1 (RS1))
5. Upper registration roller
6. Lower registration roller
7. Actuator *2
(Registration sensor 3 (RS3))

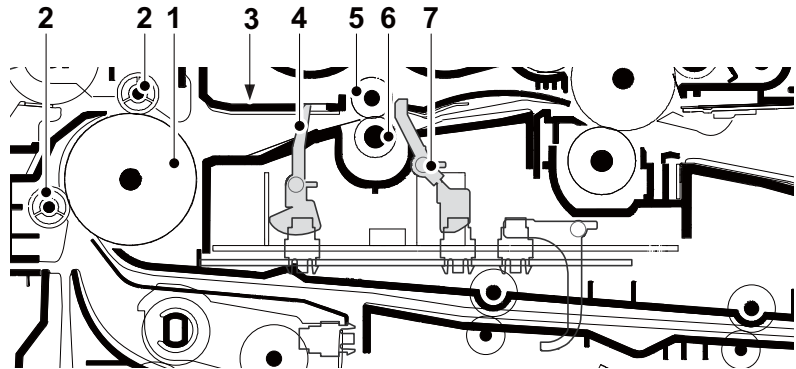

Figure 1-5-17

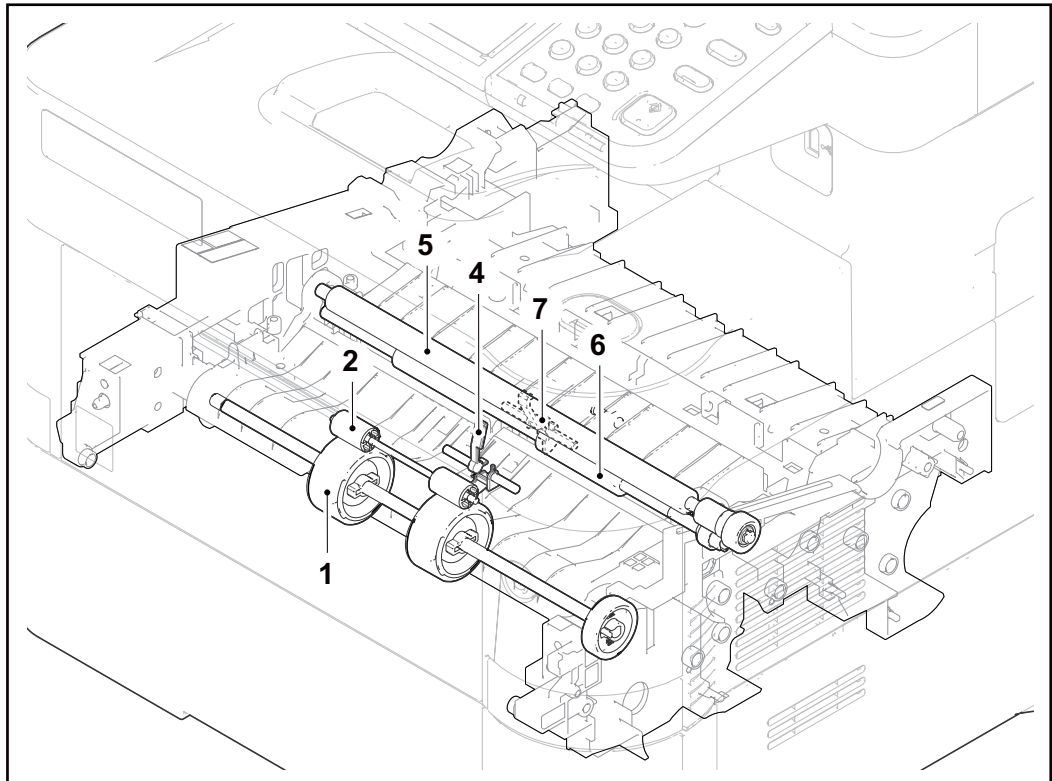

Figure 1-5-18

[Control block diagram]

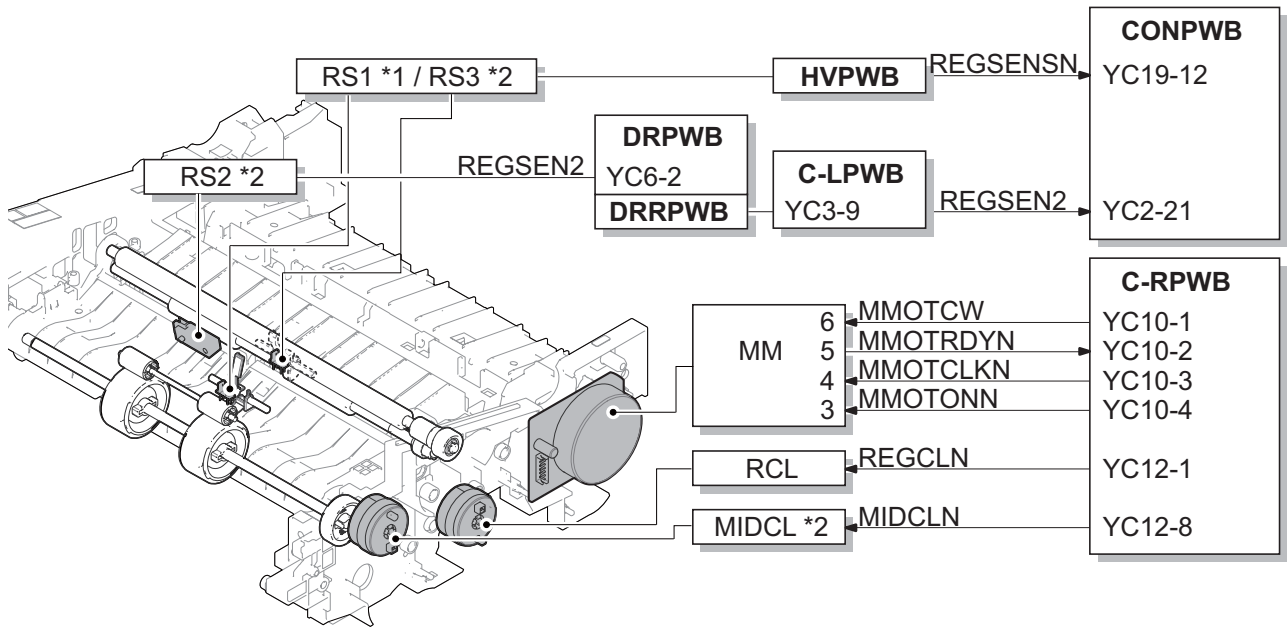

Figure 1-5-19

*1: 40 ppm model only

*2: 50/60 ppm model only

1-5-3 Optical section

The optical section consists of the image scanner section for scanning and the laser scanner section for printing.

(1) Image scanner section

The original image is illuminated by the exposure lamp (EL) and scanned by the CCD, the reflected light being converted to an electrical signal.

If a document processor is used, the image scanner unit stops at the position of the DP contact glass and scans sequentially one row of the image on the original in synchronization with the moving timing of the original in the sub scan direction by driving the DP.

[Component formation]

1. CCD
2. Carriage
3. ISU frame
4. Contact glass
5. Original size indicator plate
6. Slit glass
7. Lens
8. Mirror

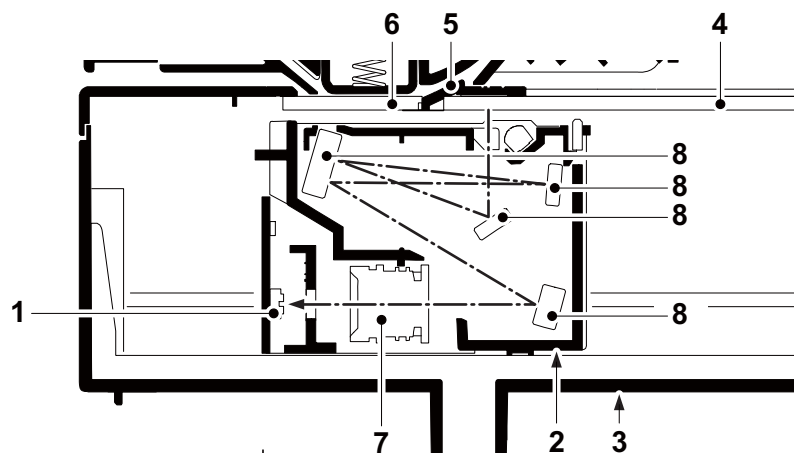

Figure 1-5-20

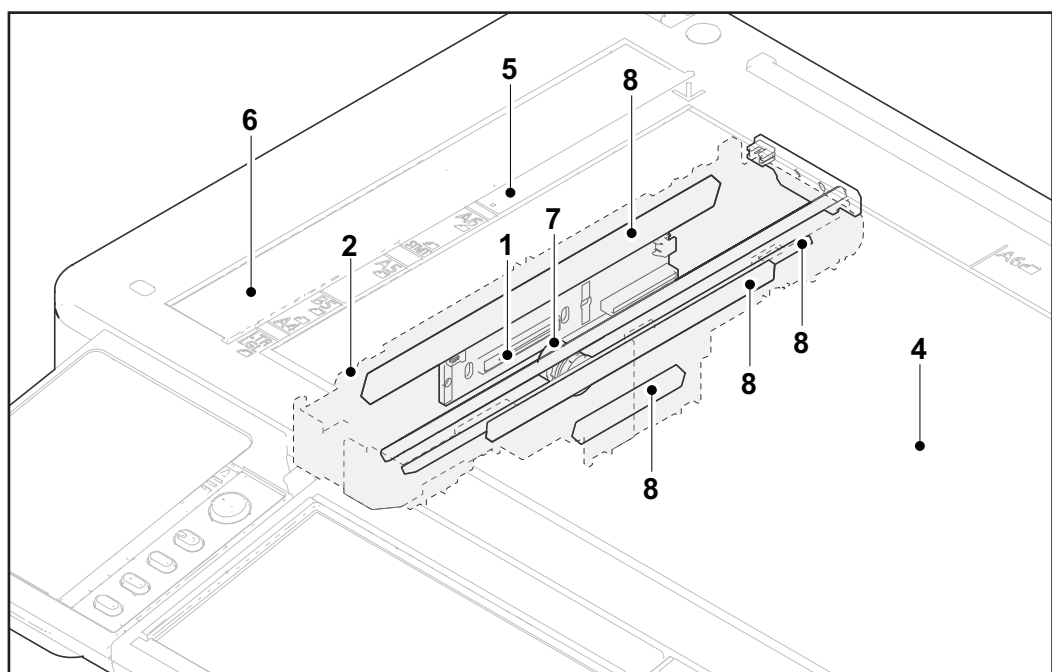

Figure 1-5-21

[Control block diagram]

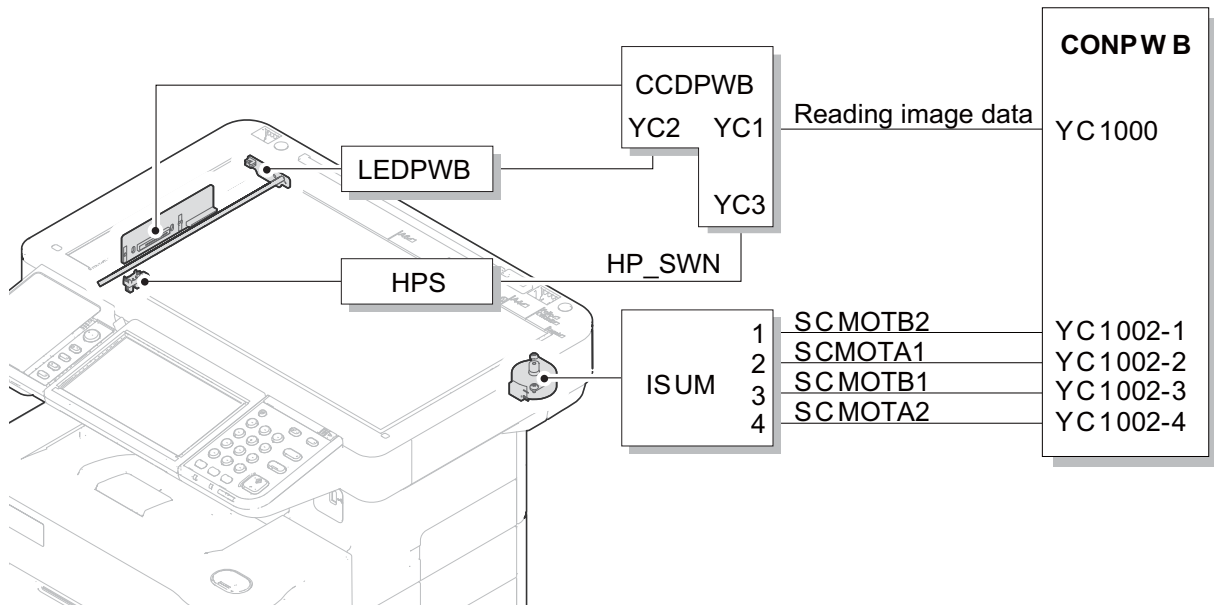

Figure 1-5-22

(1-1) Detaching and refitting the exposure lamp

Procedure

1. Slide the right operation lid and the left operation lid.
2. Remove the their lids.

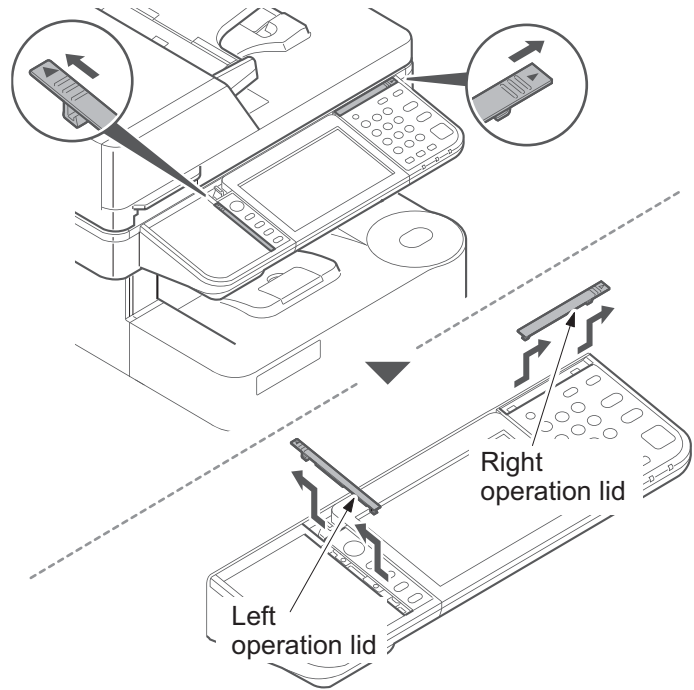

Figure 1-5-23

3. Remove the operation panel cover.
4. Replace it to the operation panel sheet of the corresponding language.

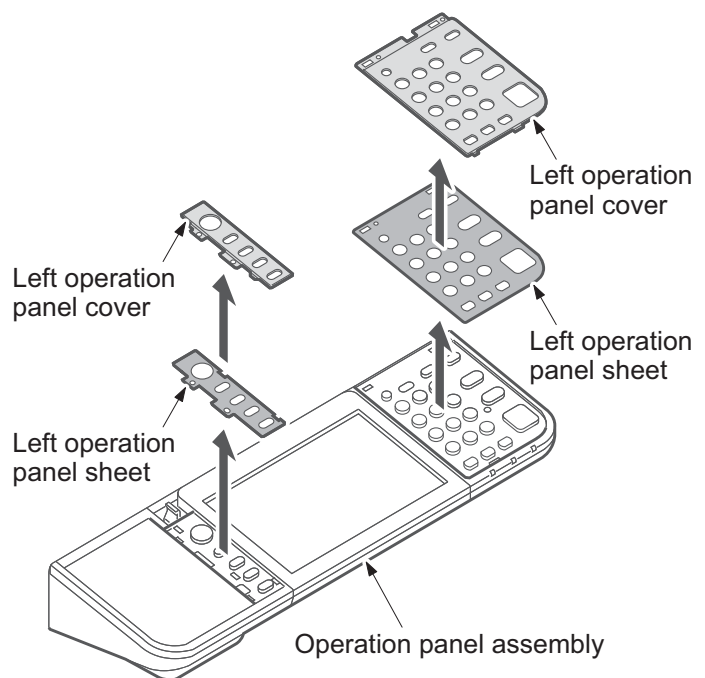

Figure 1-5-24

- Remove the card reader cover and LCD lower cover.

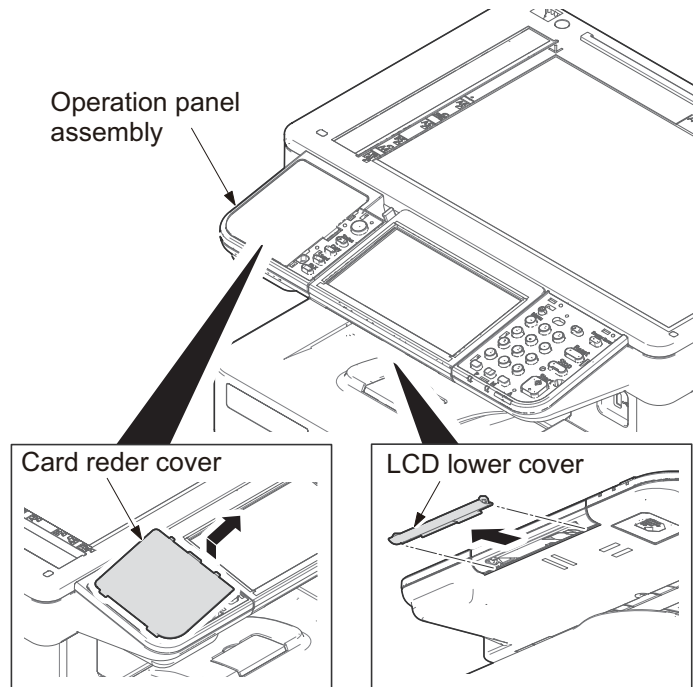

Figure 1-5-25

- Pull the LCD up forward during pressing the lock lever and bending the LCD cover.
- Remove the FFC from the operation panel PWB.

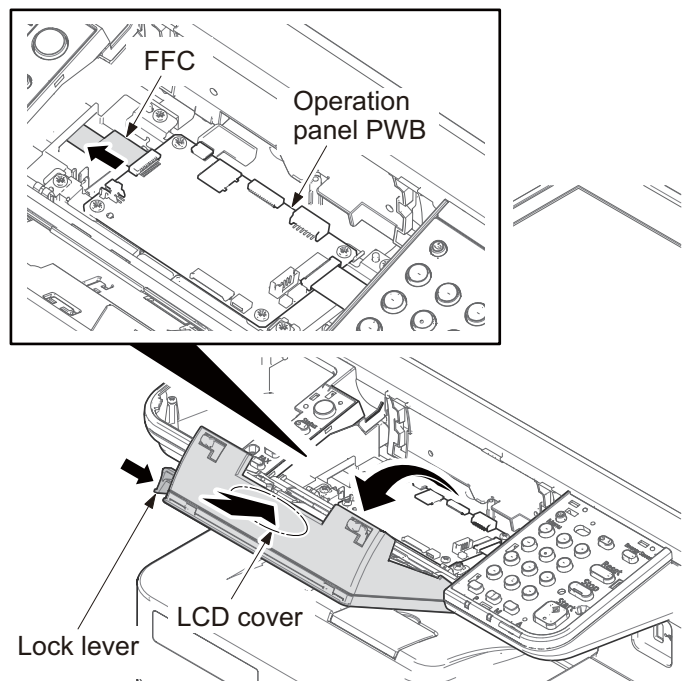

Figure 1-5-26

8. Remove two screws.
9. Release two hooks and remove the left key cover forward.
10. Remove two FFCs from the Key Right PWB.
11. Release the hook and remove the right key cover forward.

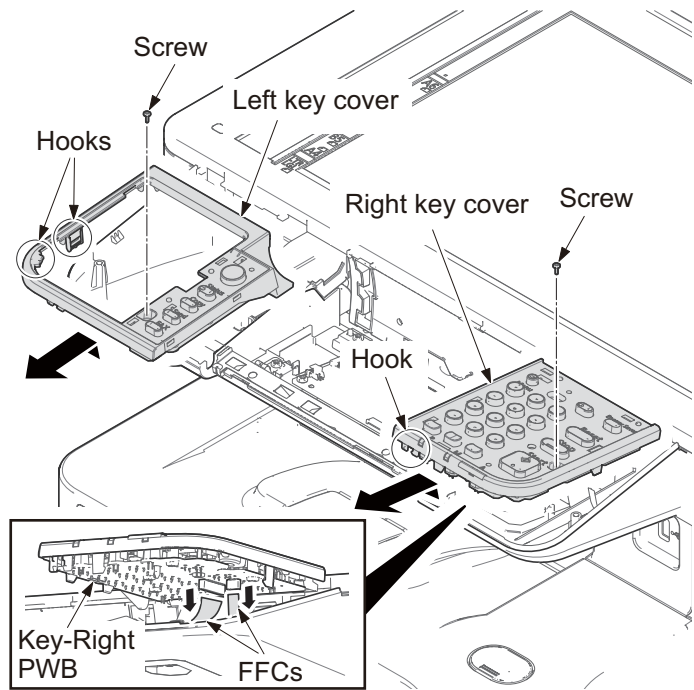

Figure 1-5-27

12. Remove two screws.
13. Release two hooks and remove the ISU upper assembly from the image scanner unit.

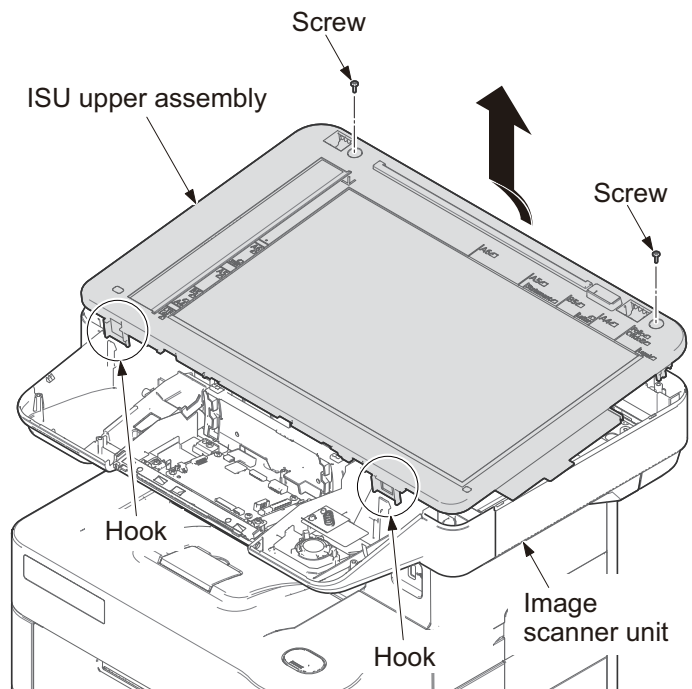

Figure 1-5-28

14. Remove the drive belt from two pulleys.
15. Remove the carriage assembly, ISU shaft and the lower ISU frame upward.

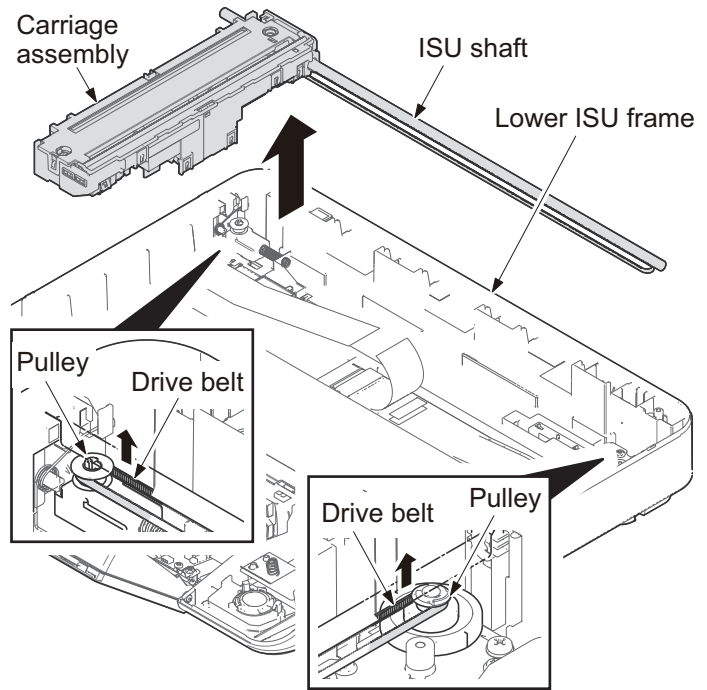

Figure 1-5-29

16. Pull the carriage assembly out.
17. Remove the drive belt from the holding part of the carriage assembly.
18. Check or replace the exposure lamp and refit all the removed parts.

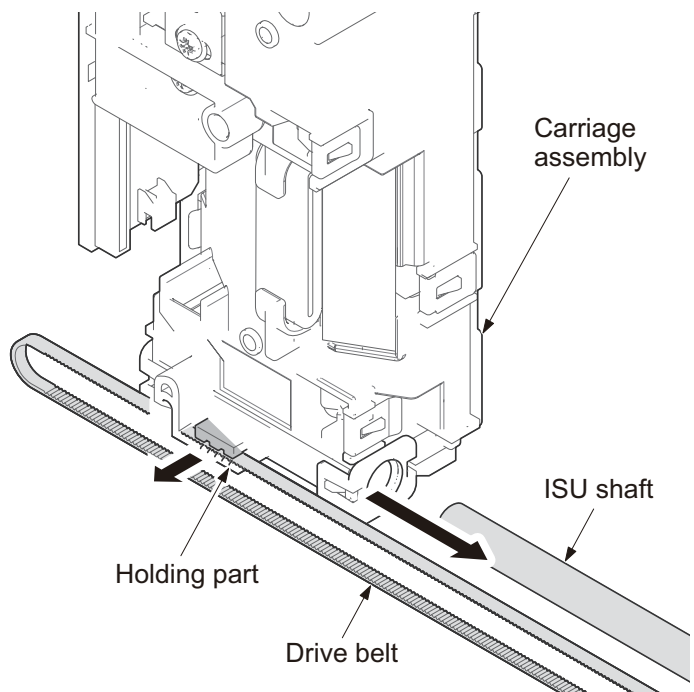

Figure 1-5-30

(1-2) Detaching and refitting the image scanner unit

Procedure

1. Remove the upper interface cover.
2. Release two hooks using a flat screw driver and remove the right stay cover.

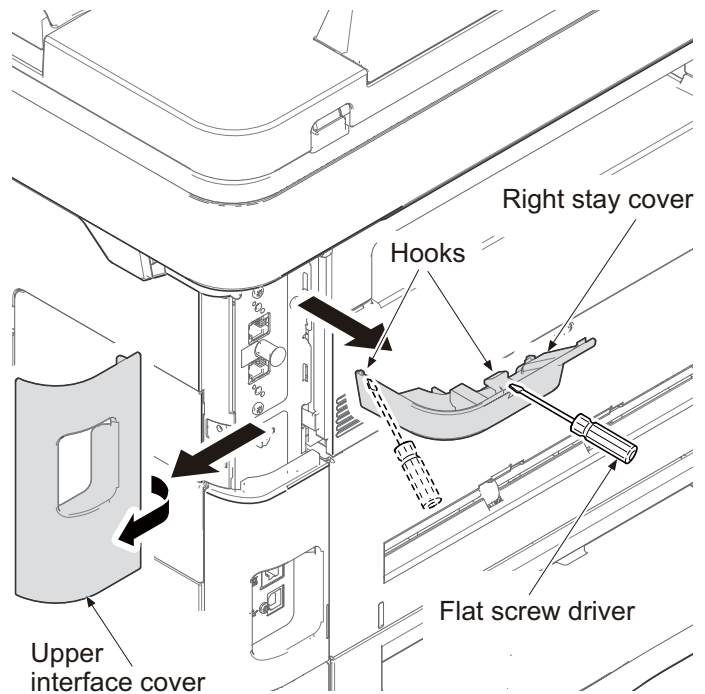

Figure 1-5-31

3. Remove the controller cover.
4. Open the front cover.
5. Remove the screw from the right upper cover.
6. Release two hooks using a flat screw driver and remove the right upper cover.

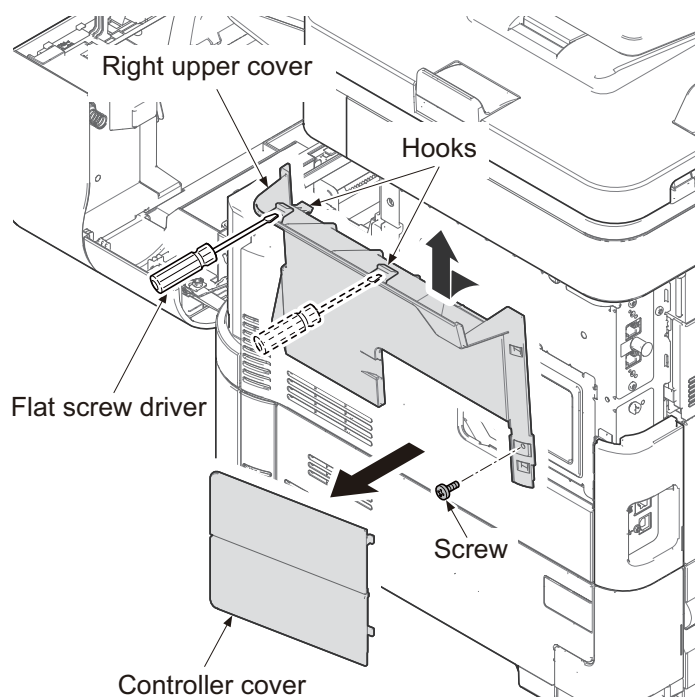

Figure 1-5-32

7. Release two hooks using a flat screw driver and remove the left upper cover.

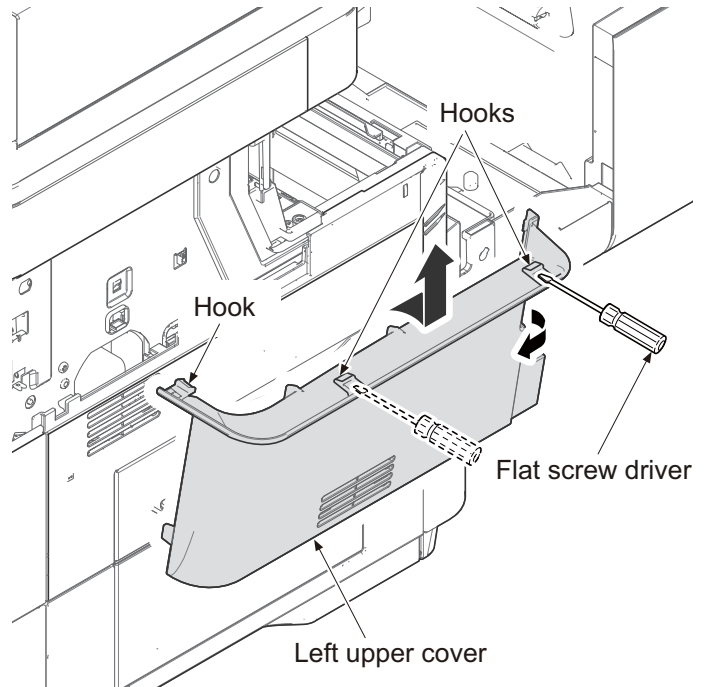

Figure 1-5-33

8. Remove the screw from the center stay cover.
9. Release two hooks using a flat screw driver and remove the center stay cover.

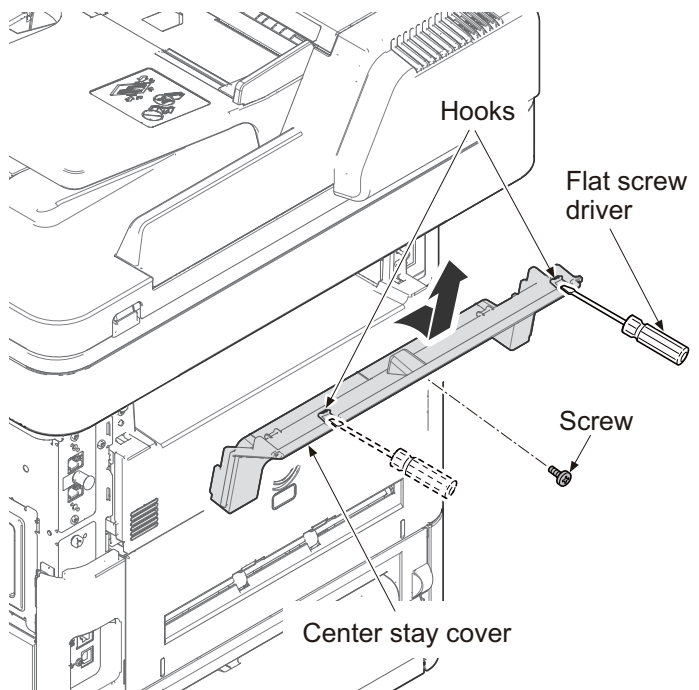

Figure 1-5-34

10. Remove the front right cover forward.

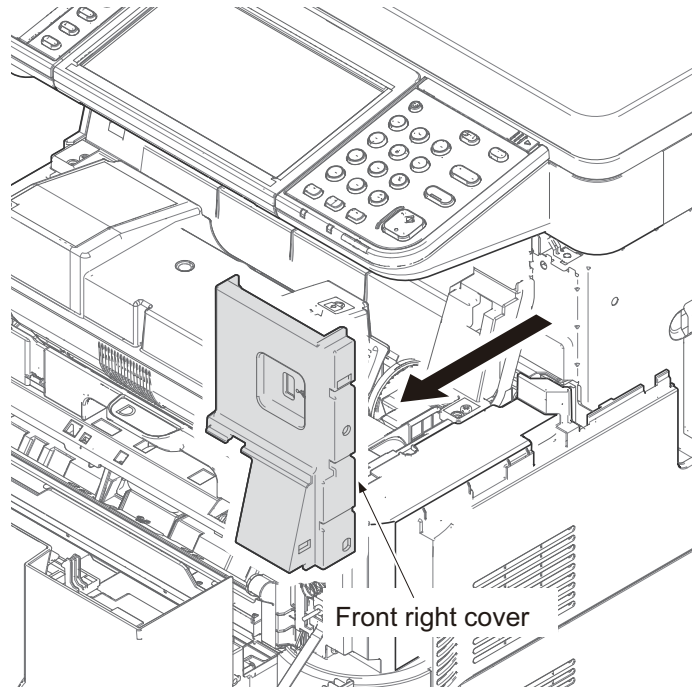

Figure 1-5-35

11. Remove three connectors, two FFCs and two USB connectors from the Control PWB.
 12. Remove three screws and grounding terminal from the image scanner unit.
 13. Remove it by sliding the image scanner unit backward and then taking upward.

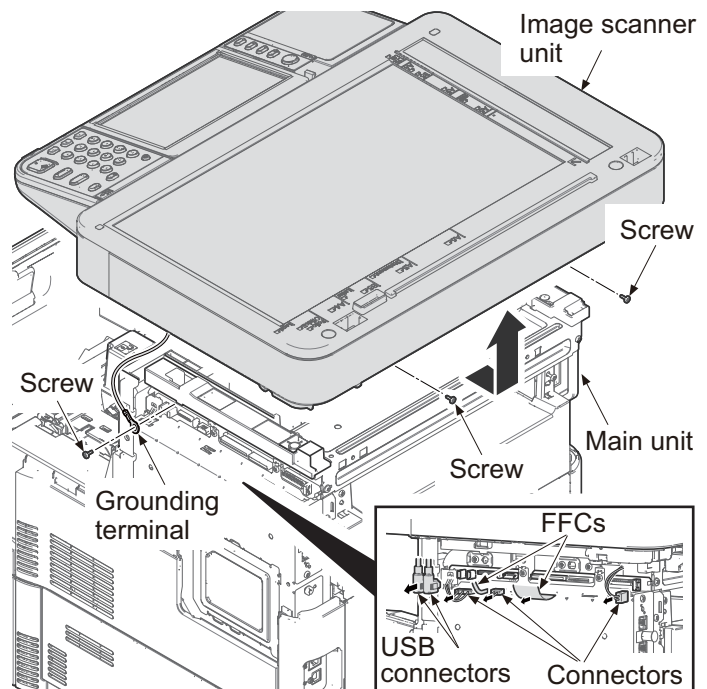

Figure 1-5-36

(1-3) Detaching and refitting the LCD

Procedure

1. Remove the operation panel left sheet.
(See page 1-5-16)
2. Remove the IC card reader cover.
(See page 1-5-16)
3. Remove the LCD lower cover by bending using a flat screw driver.

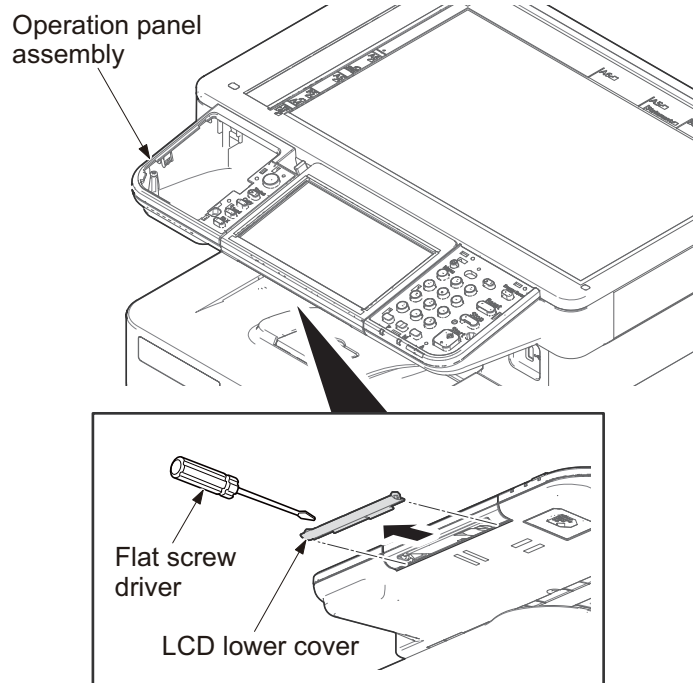

Figure 1-5-37

4. Pull the LCD up forward during pressing the lock lever and bending the LCD cover.
5. Remove the FFC from the operation panel PWB.

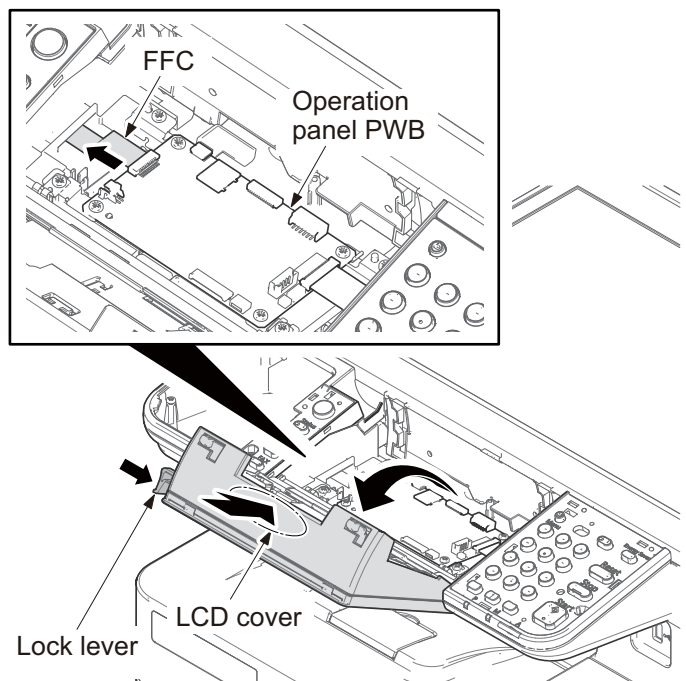

Figure 1-5-38

6. Remove the screw.
7. Release two hooks and remove the left key cover forwards.

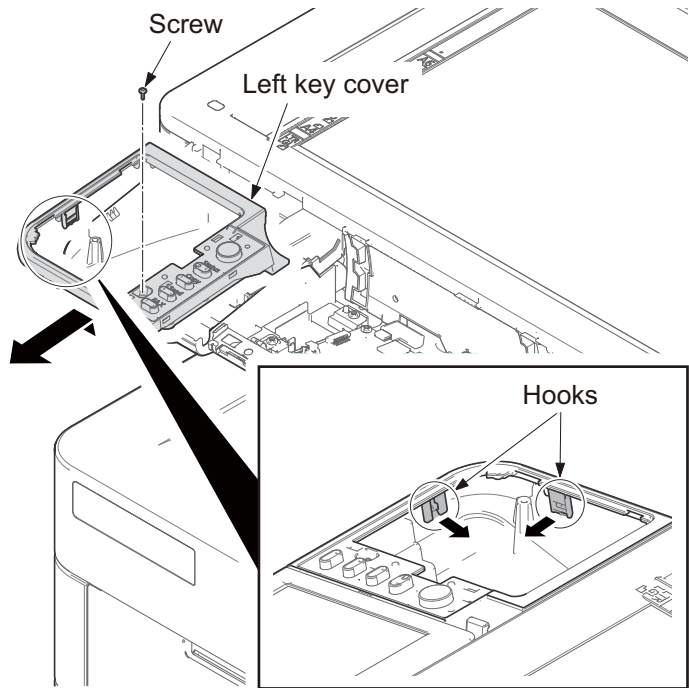

Figure 1-5-39

8. Remove two FFCs.
9. Disconnect the connector and release two hooks.
10. Remove the panel unit by lifting up.

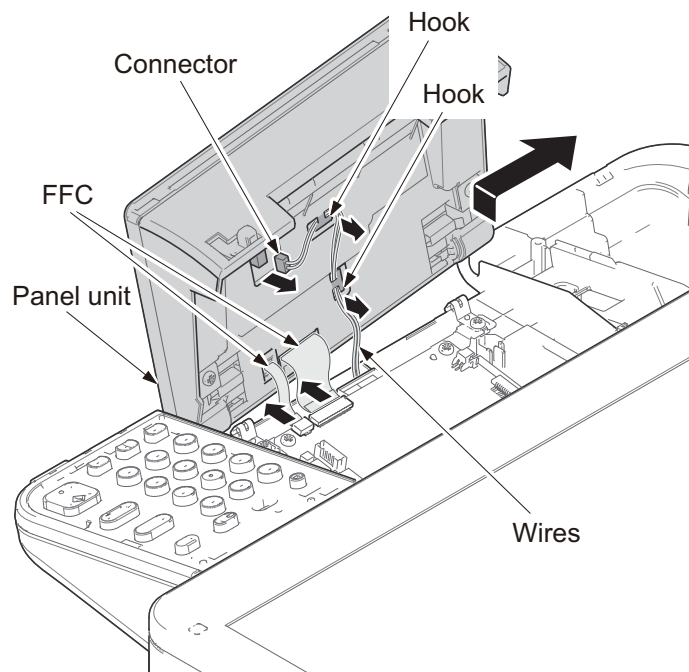

Figure 1-5-40

11. Release two hooks using flat screw driver.
12. Remove the LCD lower cover.
13. Check or replace the LCD and refit all the removed parts.

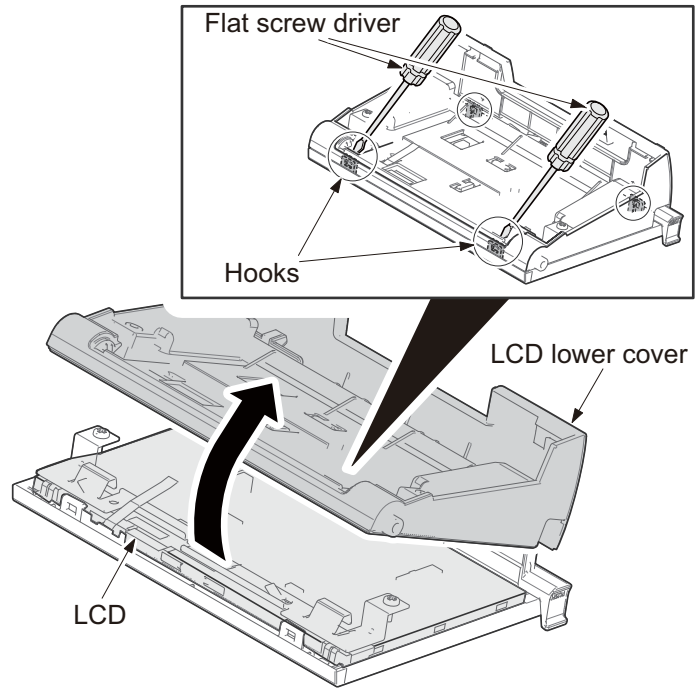

Figure 1-5-41

(Note for reassembly)

Check if two hooks are surely fastened.

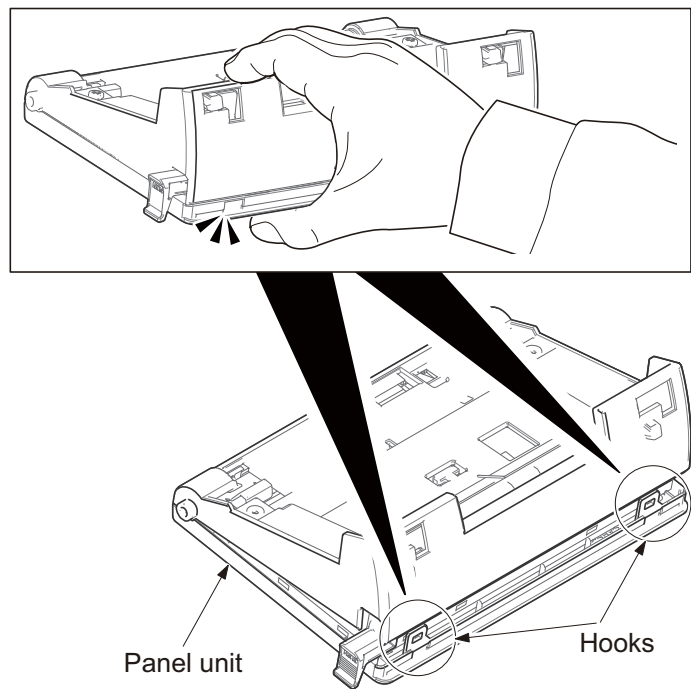

Figure 1-5-42

(2) Laser scanner section

The charged surface of the drum is then scanned by the laser beam from the laser scanner unit. The laser beam is dispersed as the polygon motor (PM) revolves to reflect the laser beam over the drum. Various lenses and mirror are housed in the LSU (Laser Scanning Unit), adjust the diameter of the laser beam, and focalize it at the drum surface.

[Component formation]

1. Polygon motor (PM)
2. $f\theta$ main lens
3. LSU dust shield glass
4. LSU base
5. LSU cover
6. Mirror

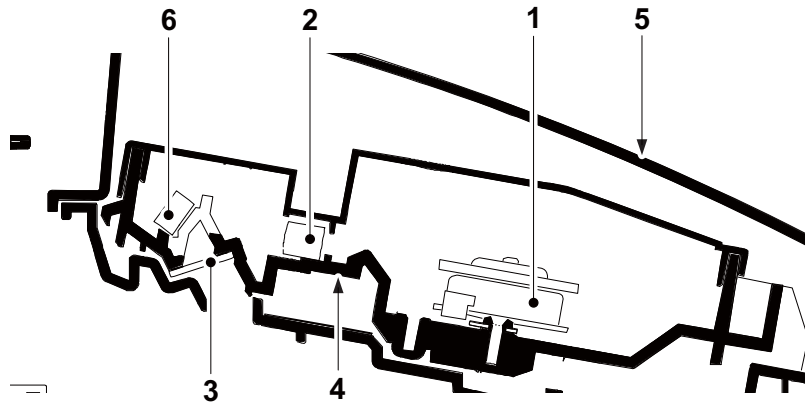

Figure 1-5-43

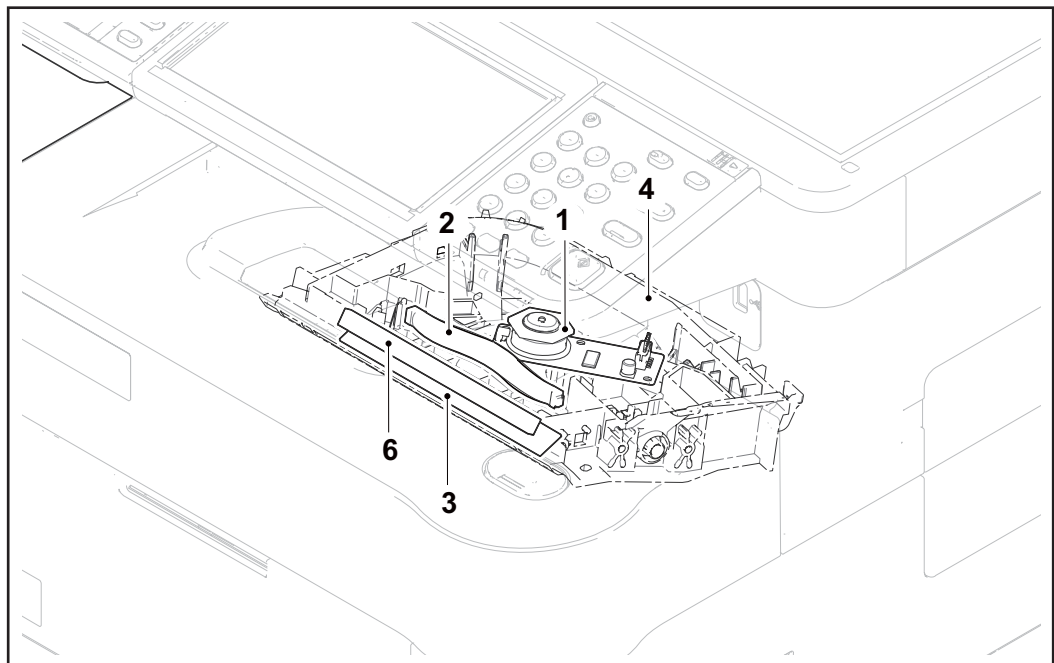

Figure 1-5-44

[Control block diagram]

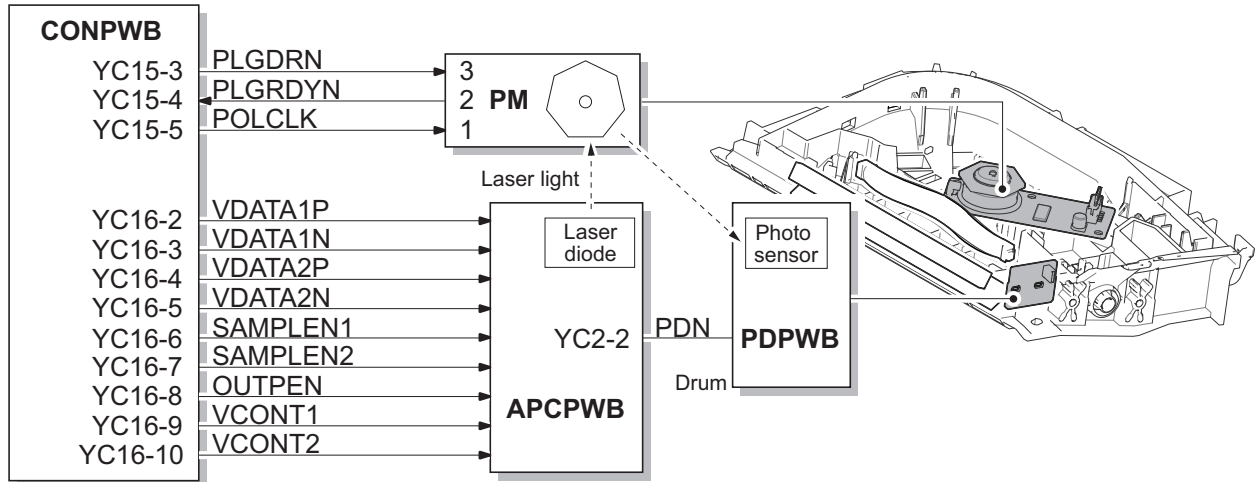

Figure 1-5-45

(2-1) Detaching and refitting the laser scanner unit

Procedure

1. Remove the image scanner unit.
2. Remove two screws.
3. (50/60 ppm model only)
Slide the right inner spacer and the left inner spacer forward and then remove it upward.

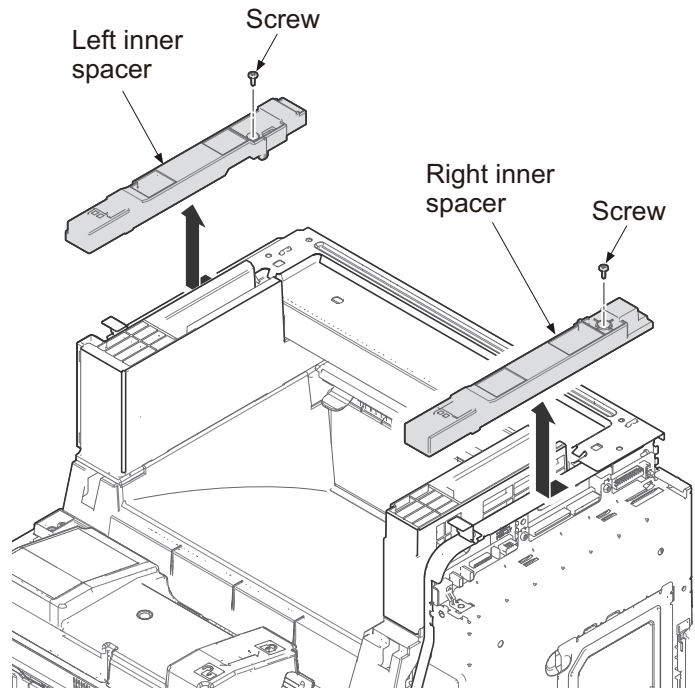

Figure 1-5-46

4. Remove two screws.
5. Remove the center stay cover.

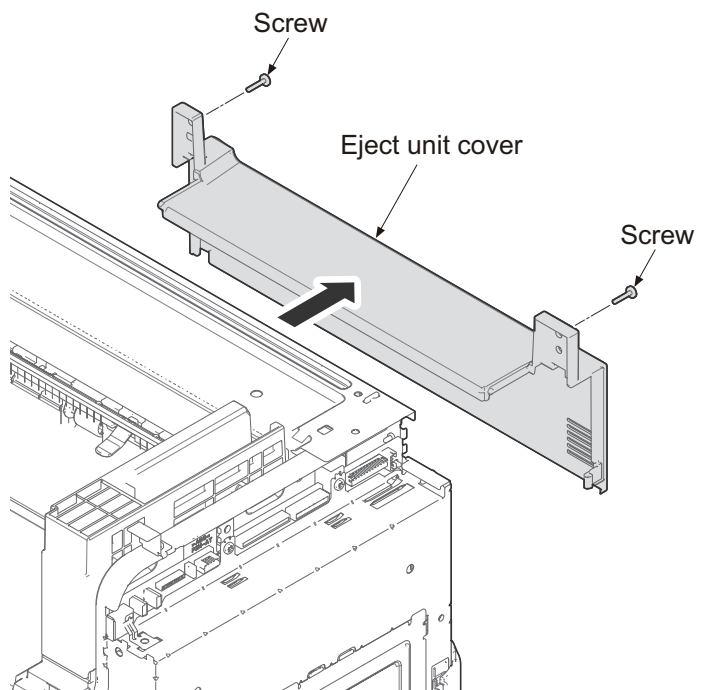

Figure 1-5-47

6. Remove four screws.
7. Remove the upper stay assembly upward.

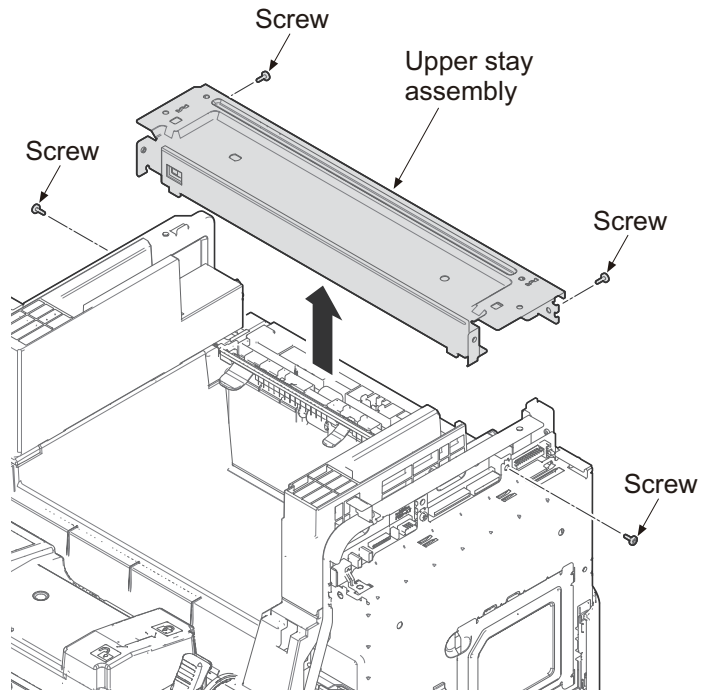

Figure 1-5-48

8. Remove the screw and then remove the right inner cover by leaning it inside and lifting it.
9. Remove two screws and then remove the left inner cover by leaning it inside and lifting it.

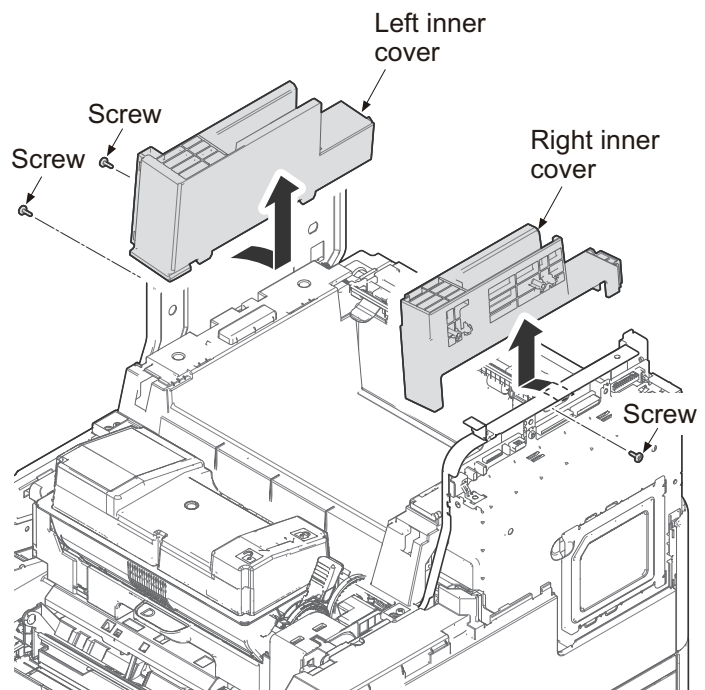

Figure 1-5-49

10. Remove two screws.
11. Remove the top tray cover upward.

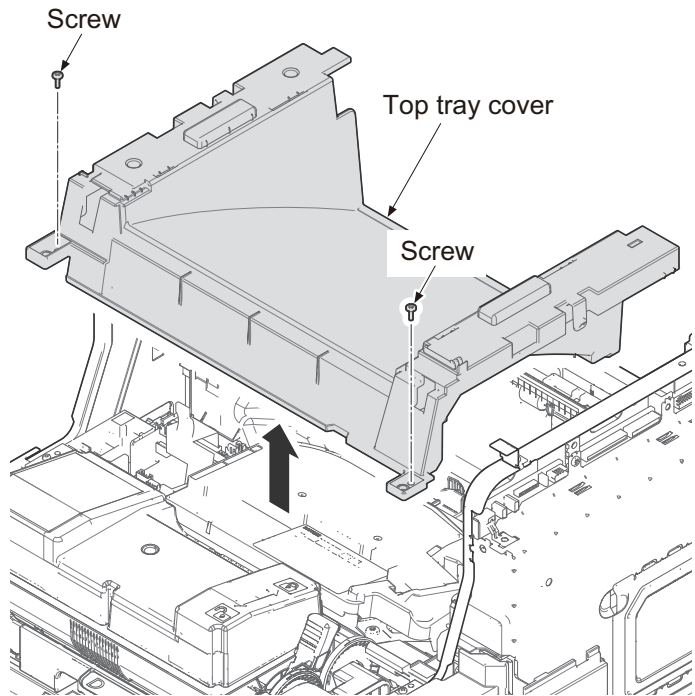

Figure 1-5-50

12. Pull the connector and FFC from control PWB out.
13. Pull the connector and FFC out through the apertures.
14. Remove four screws and then remove the laser scanner unit upward.
15. Check or replace the laser scanner unit and refit all the removed parts.

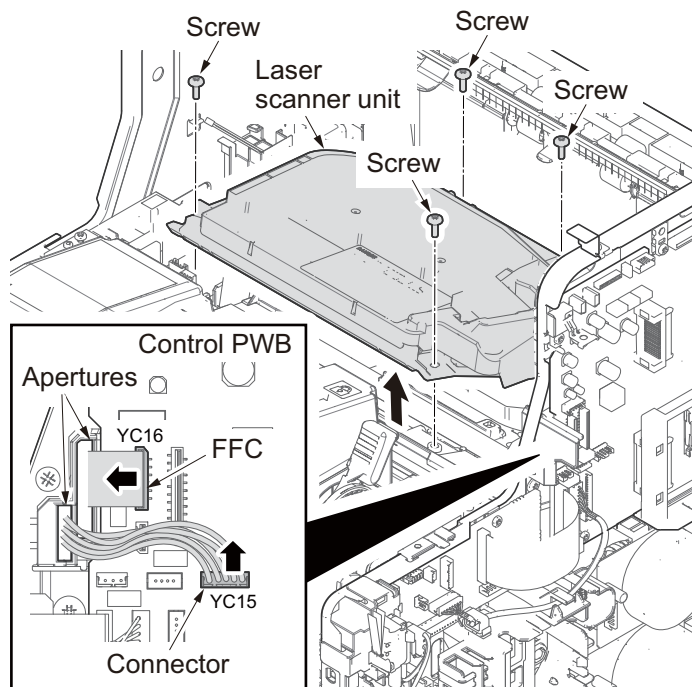

Figure 1-5-51

1-5-4 Developer section

(1) Developer unit

The developing unit consists of the developing roller that forms the magnetic brush, the developing blade and the developing screws that agitate the toner. Also, the toner sensor (TS) checks whether or not toner remains in the developing unit.

[Component formation]

1. Developing roller
2. Developing blade
3. Developing screw A
4. Developing screw B
5. Developer case
6. Toner supply roller
7. Toner agitater
8. Toner container

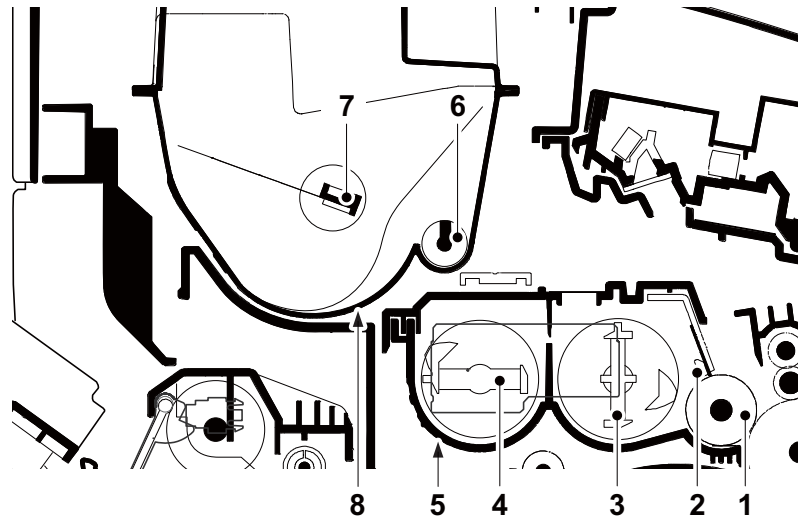

Figure 1-5-52

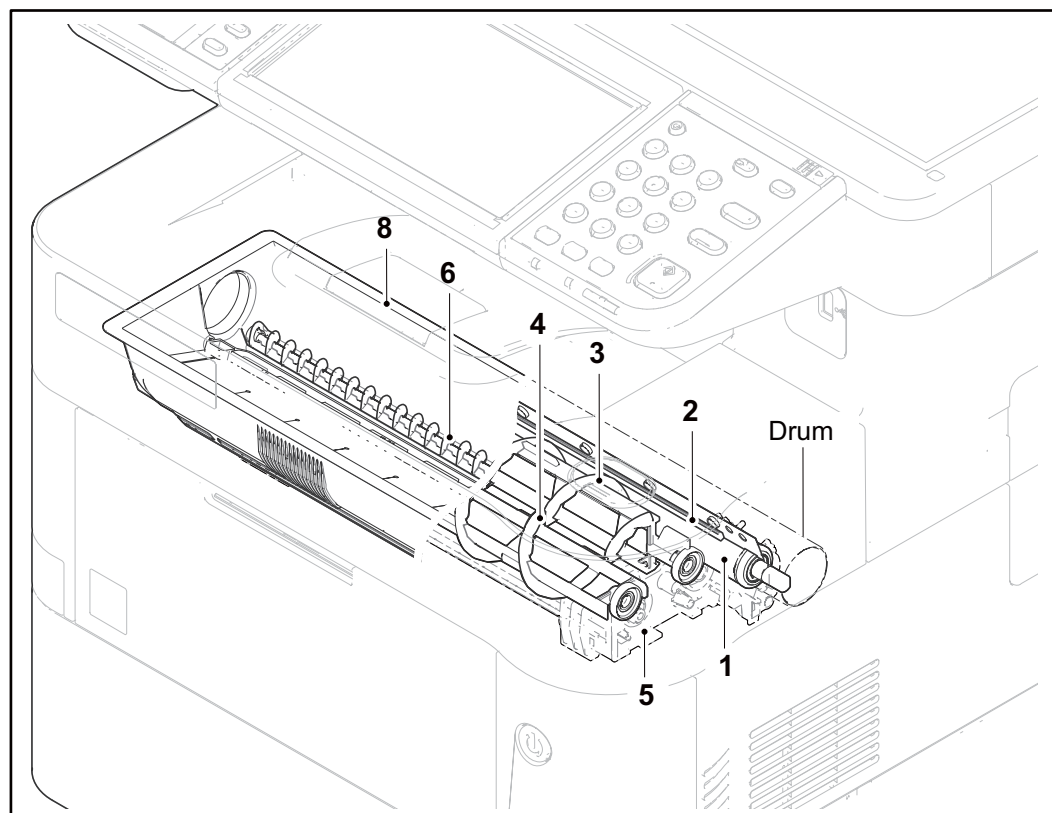

Figure 1-5-53

[Control block diagram]

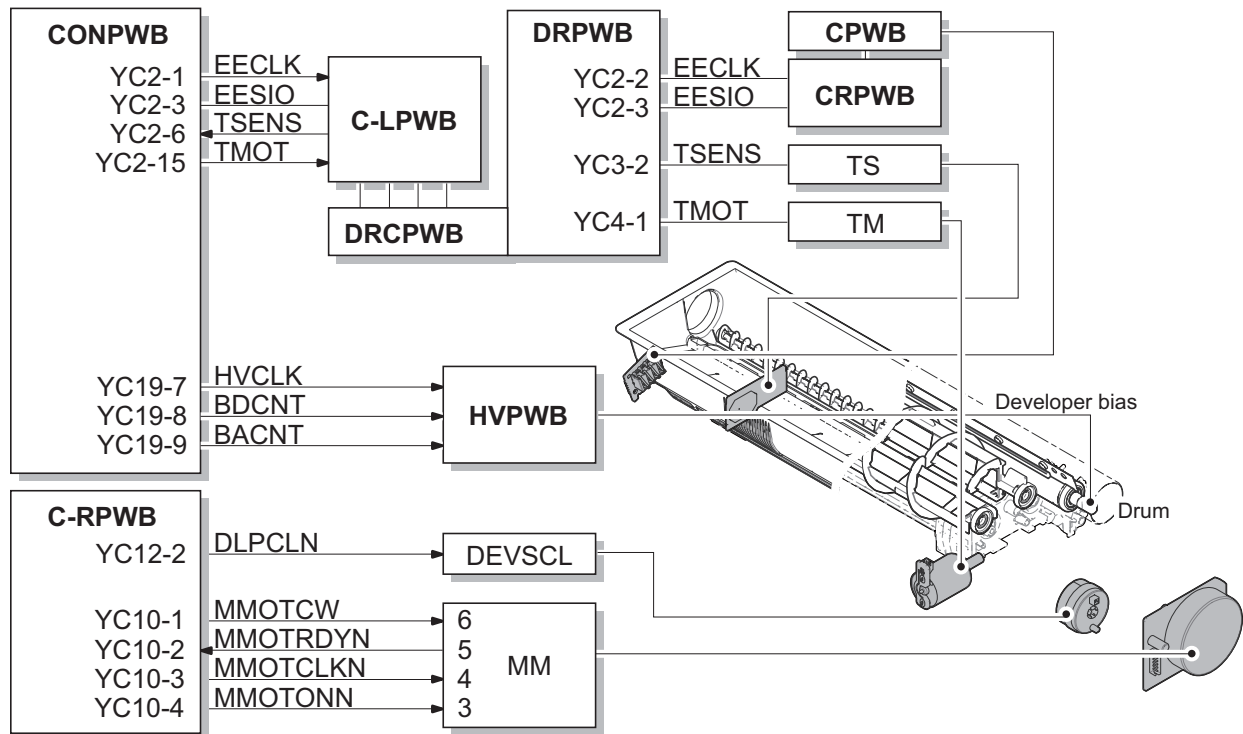

Figure 1-5-54

(1-1) Detaching and refitting the developer unit

Procedure

1. Open the front cover.

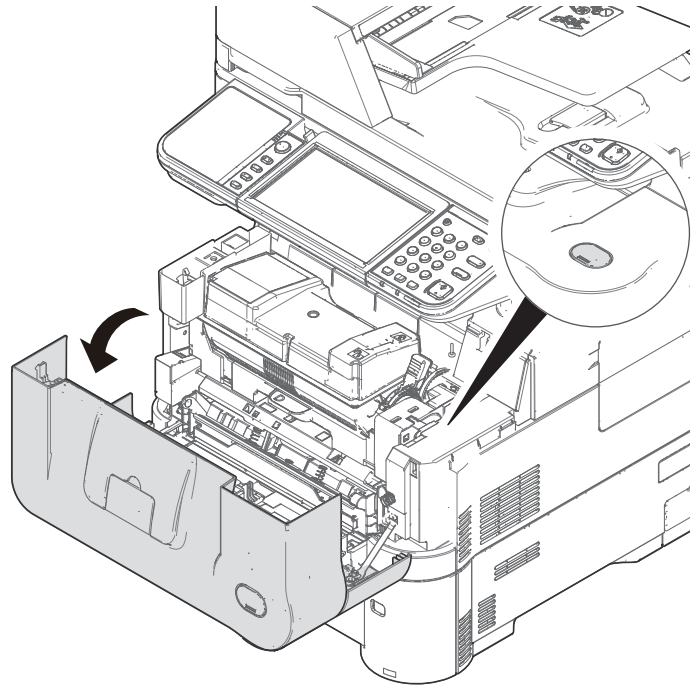

Figure 1-5-55

2. Release the lock lever by rotating and then remove the toner container.

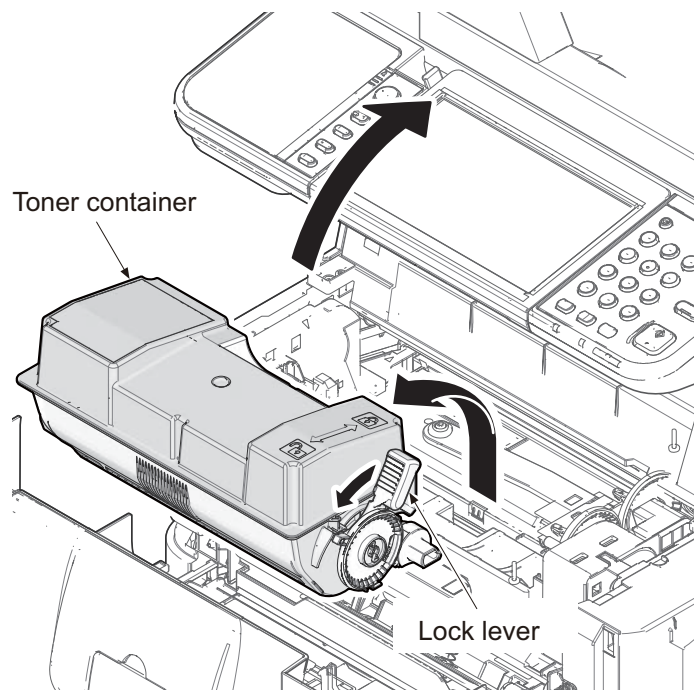

Figure 1-5-56

3. Pull the imaging unit forward.
4. Release the hook and then remove the container guide by sliding backwards.

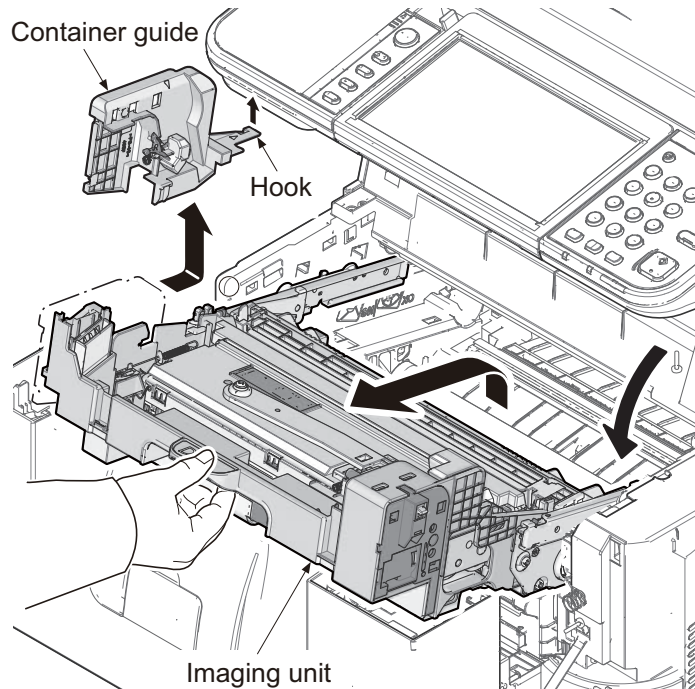

Figure 1-5-57

5. Pull the connector out.
6. Release the lock lever and then remove the developer unit upward.
7. Check or replace the developer unit and refit all the removed parts.

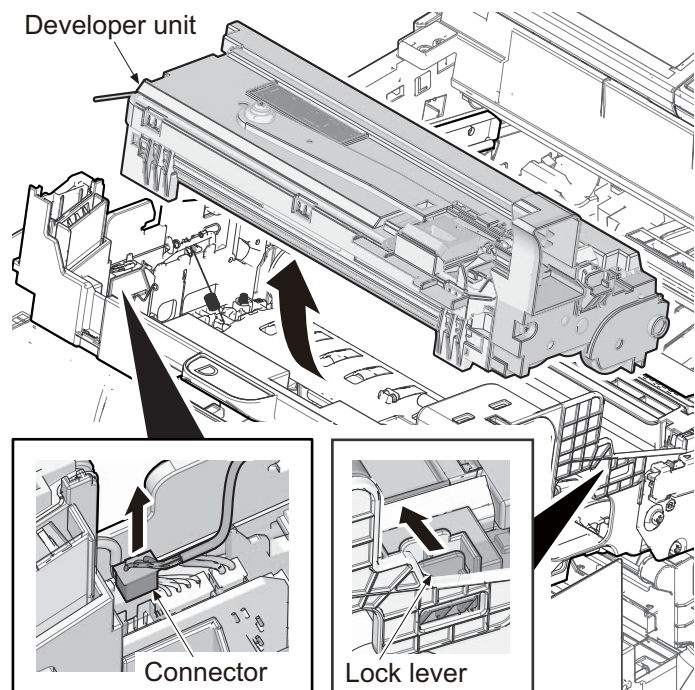

Figure 1-5-58

1-5-5 Drum section

(1) Chager roller unit

The drum section consists of the drum, the charger roller unit, and the cleaning unit, and the drum surface is uniformly charged in preparation for formation of residual image by laser beam.

After transfer is complete, toner remaining on the drum surface is chipped off with the cleaning blade and is collected to the waste toner box with the drum screw. The cleaning lamp (CL) consists of LEDs and removes residual charge on the drum before main charging.

[Component formation]

1. Drum
2. Charger roller
3. Chager cleaning roller
4. Charger case

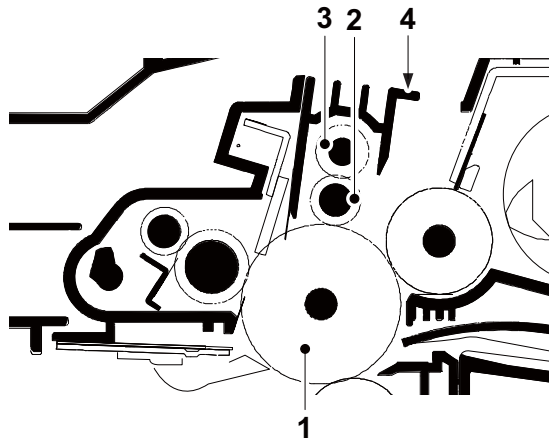

Figure 1-5-59

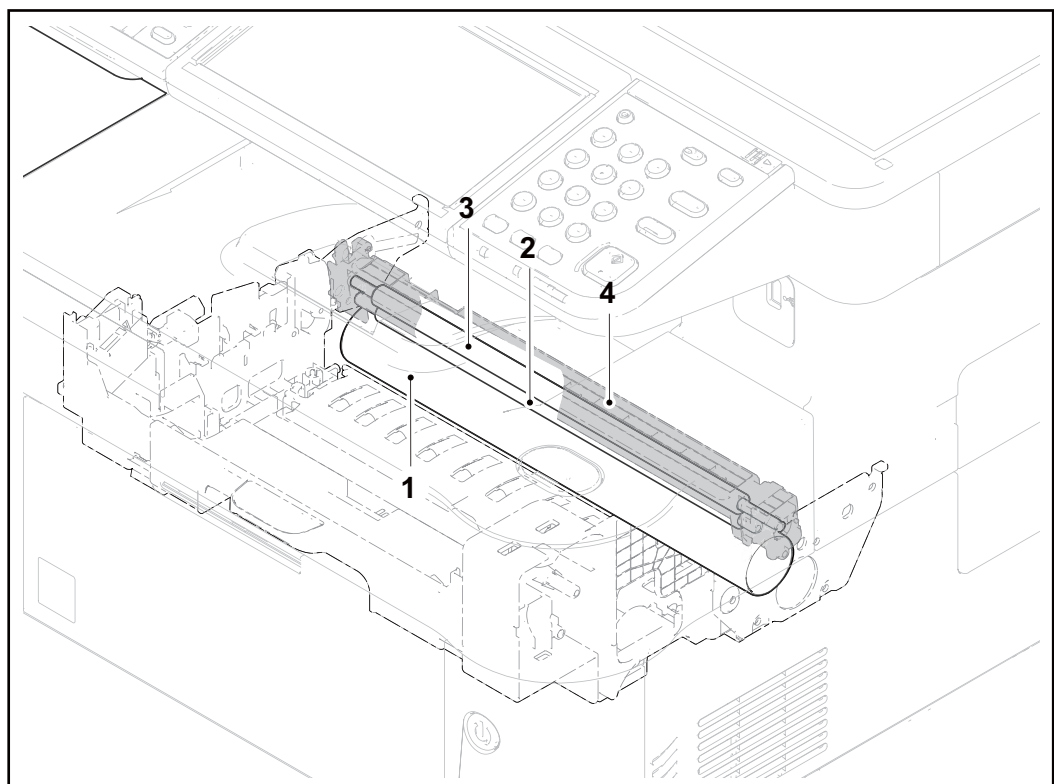

Figure 1-5-60

[Control block diagram]

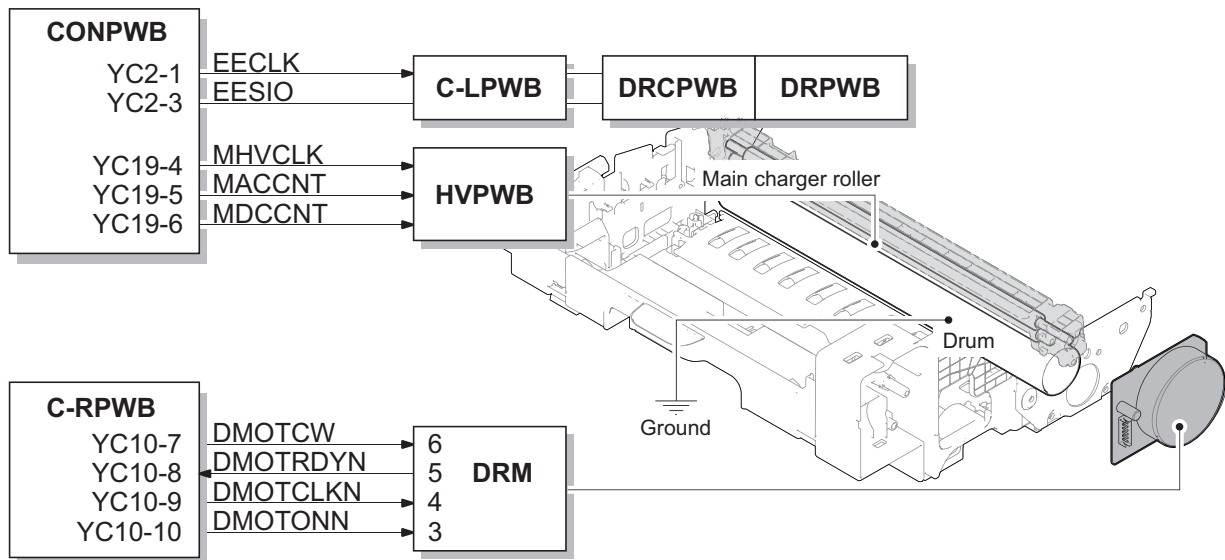

Figure 1-5-61

(1-1) Detaching and refitting the drum unit

Procedure

1. Remove the developer unit.
(See page 1-5-33)
2. Remove the lock lever L.
3. Remove the lock lever R by sliding backward.
4. Remove the drum unit by sliding forward.
5. Check or replace the drum unit and refit all the removed parts.

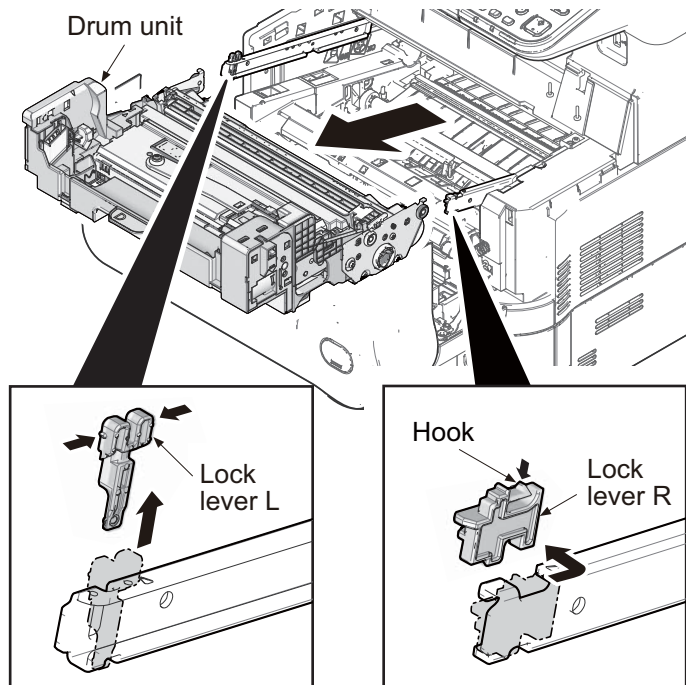

Figure 1-5-62

(1-2) Detaching and refitting the charger unit

Procedure

1. Release the lock lever and then remove the charger roller unit.
2. Check or replace the charger roller unit and refit all the removed parts.

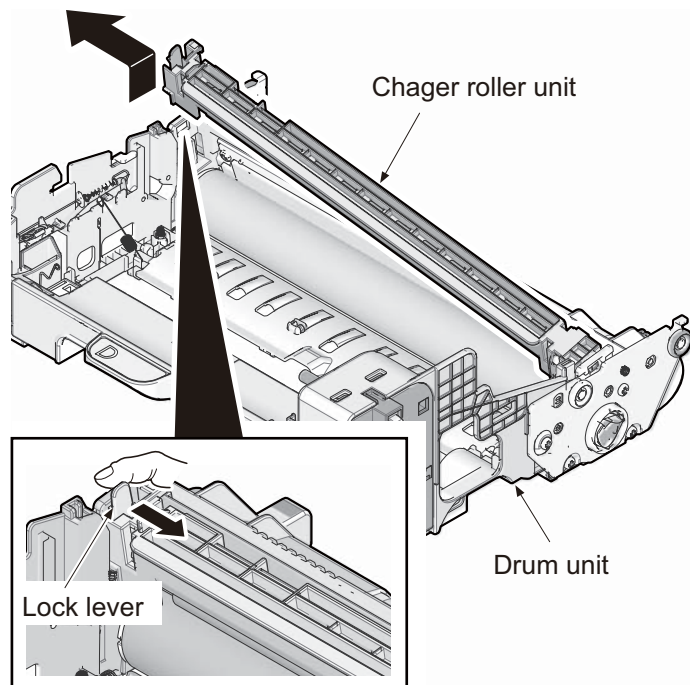

Figure 1-5-63

(2) Cleaning unit

The drum section consists of the drum, the charger roller unit, and the cleaning unit, and the drum surface is uniformly charged in preparation for formation of residual image by laser beam.

After transfer is complete, toner remaining on the drum surface is chipped off with the cleaning blade and is collected to the waste toner box with the drum screw. The cleaning lamp (CL) consists of LEDs and removes residual charge on the drum before main charging.

[Component formation]

1. Drum
2. Cleaning blade
3. Cleaning roller
4. Control roller
5. Scraper
6. Drum frame
7. Sweep roller
8. Cleaning lamp (CL)

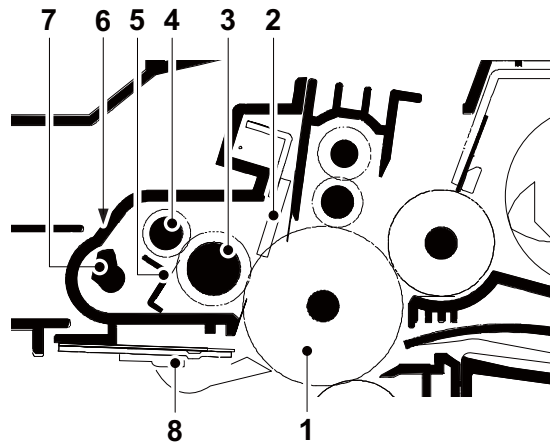

Figure 1-5-64

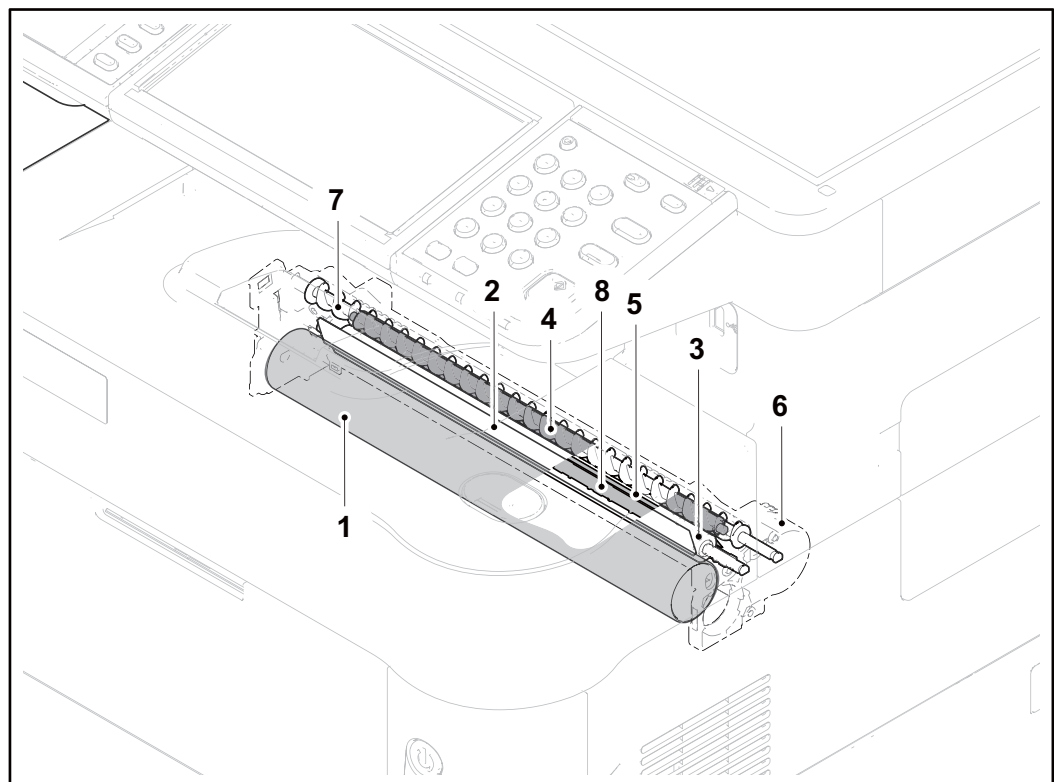

Figure 1-5-65

1-5-6 [Transfer/Separation section]

(1) Transfer/Separation

The transfer and separation section consists mainly of the transfer roller, separation electrode and drum separation claws.

A high voltage generated by the high voltage PWB (HVPWB) is applied to the transfer roller for transfer charging.

Paper after transfer is separated from the drum by applying separation charging that is output from the high voltage PWB (HVPWB) to the separation electrode.

[Component formation]

1. Paper chute guide
2. Drum
3. Transfer roller
4. Separation needle

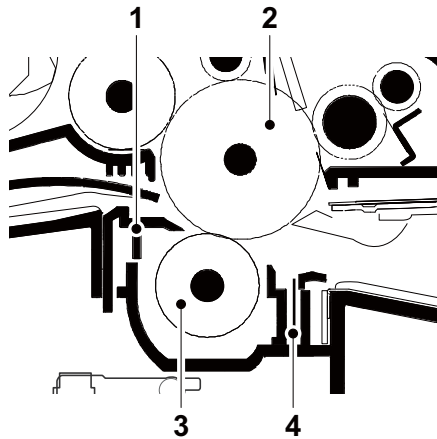

Figure 1-5-66

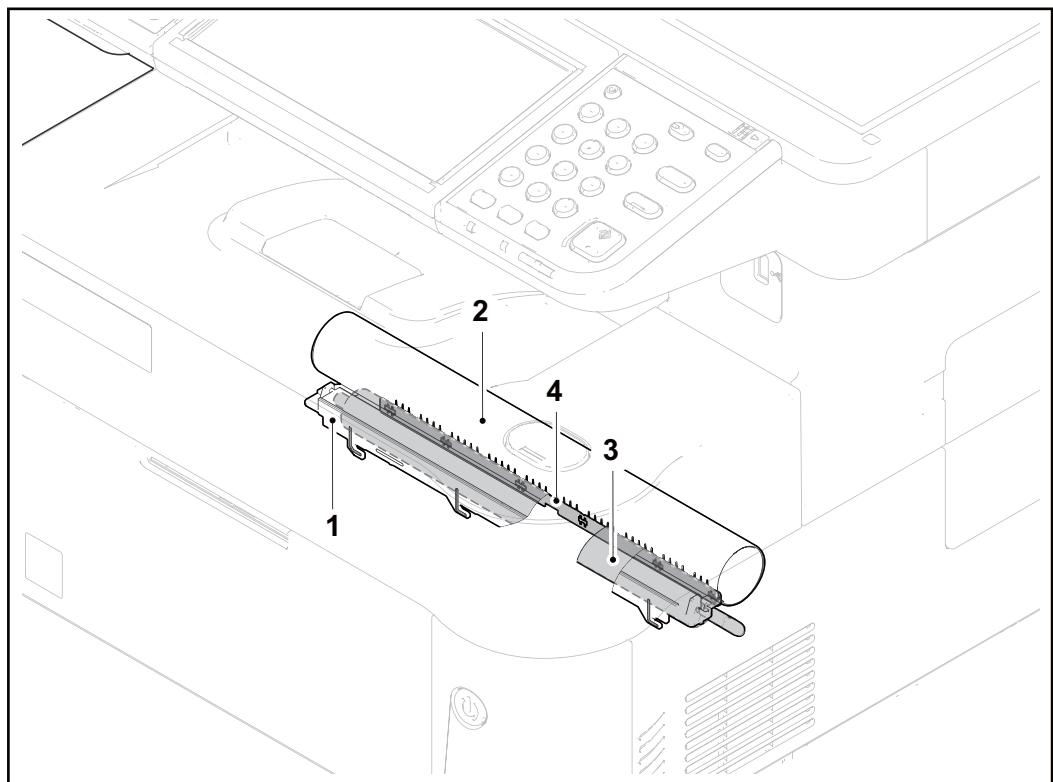

Figure 1-5-67

[Control block diagram]

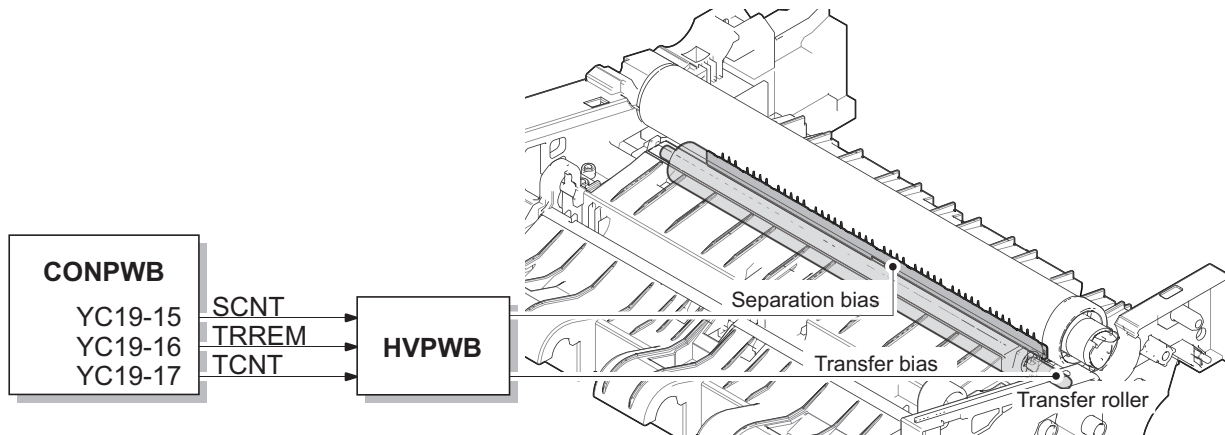

Figure 1-5-68

(1-1) Detaching and refitting the transfer roller

Procedure

1. Remove the drum unit.
(See page 1-5-37)
2. Release four hooks by sliding to left the paper chute guide.
3. Remove the paper chute guide upward.

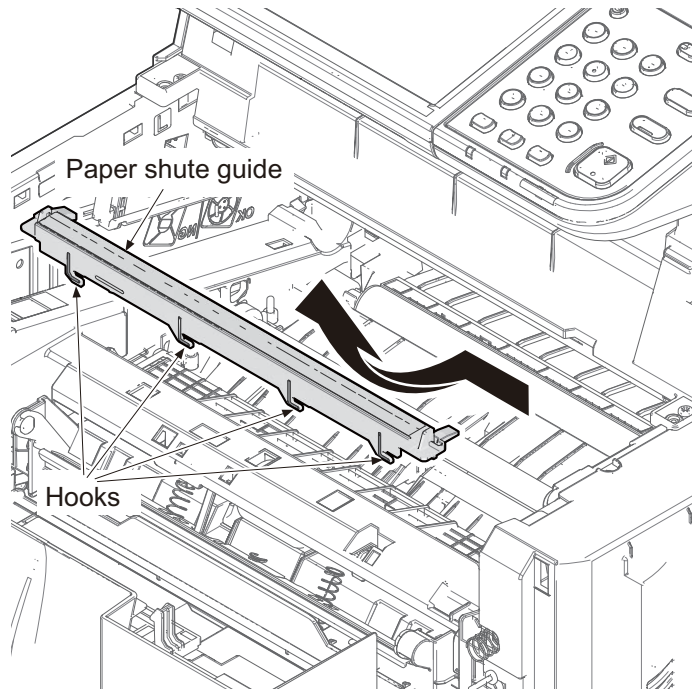

Figure 1-5-69

4. Remove the axes of transfer roller from each bush.
5. Remove the transfer roller assembly upward.
6. Check or replace the transfer roller assembly and refit all the removed parts.

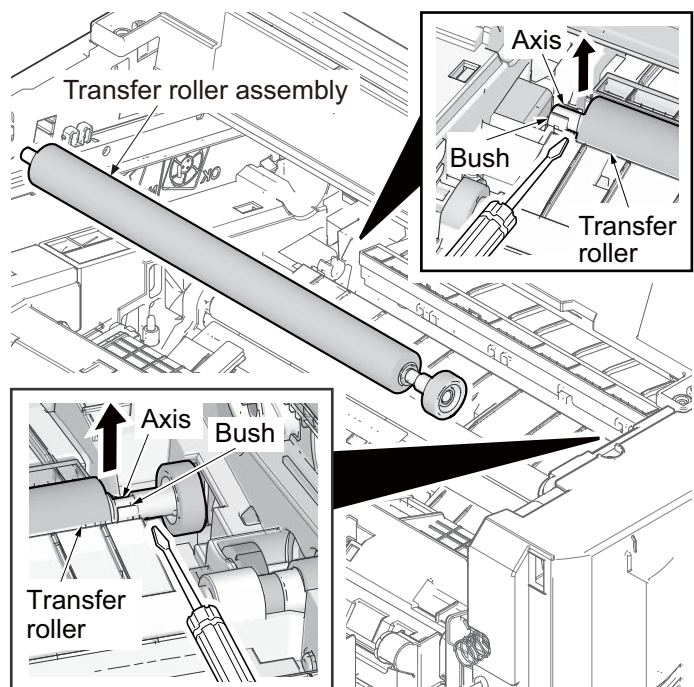

Figure 1-5-70

(1-2) Detaching and refitting the separation needle holder

Procedure

1. Remove the transfer roller unit.
2. Release four hooks of separation needle unit by rotating and then remove the separation needle unit upward.
3. Check or replace the separation needle unit and refit all the removed parts.

Caution: Check certainly being fixed at the time of attachment.

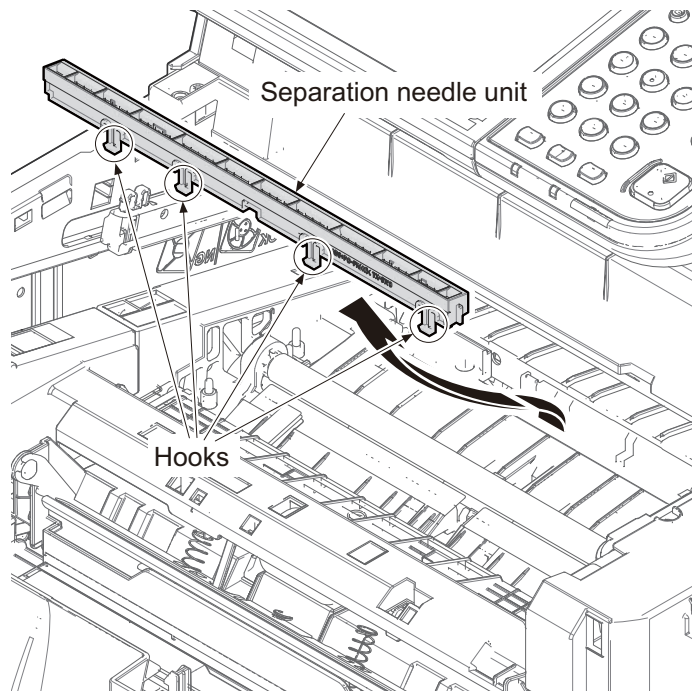

Figure 1-5-71

1-5-7 Fuser and eject/feedshift section

The paper sent from the transfer/separation section is interleaved between the heat roller and the press roller. The heat roller is heated by the fuser heater (FUH), and the toner is fused by heat and pressure and fixed onto the paper because the press roller is pressed by the fuser press spring. The surface temperature of heat roller is detected by the fuser thermistor (FTH) and controlled by the control PWB (CONPWB). If the fuser section shows extremely high temperature, the power line will be shut off and the fuser heater (FUH) is forced to turn off.

The paper eject/feedshift section consists of the conveying path which sends the paper that has passed the fuser section to the inner tray or the duplex conveying section.

(1) 50/60 ppm model

[Component formation]

1. Heat roller
2. Fuser heater (FUH)
3. Fuser thermostat (FUTS)
4. Fuser thermistor (FUTH)
5. Separators
6. Press roller
7. Actuator
(Eject sensor (ES))
8. Fuser eject roller
9. Fuser eject pulley
10. Fuser thermistor (FUTH2)
11. Fuser pre guide

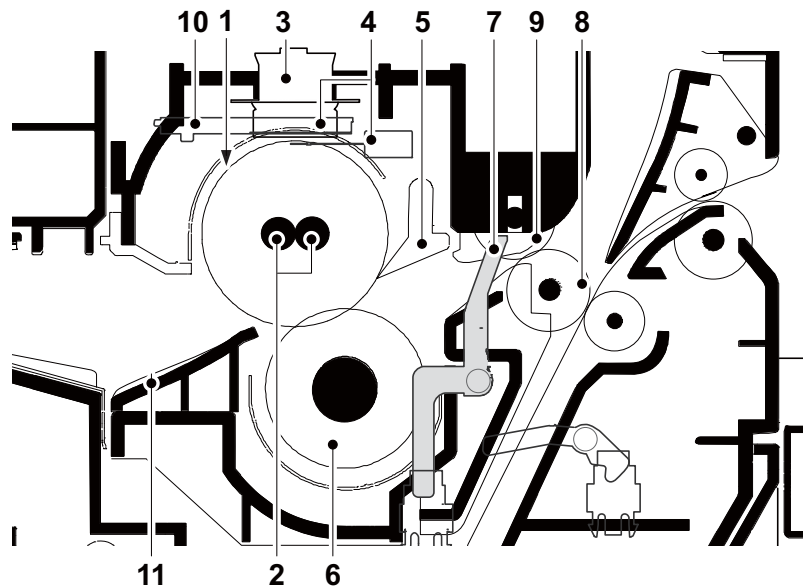

Figure 1-5-72

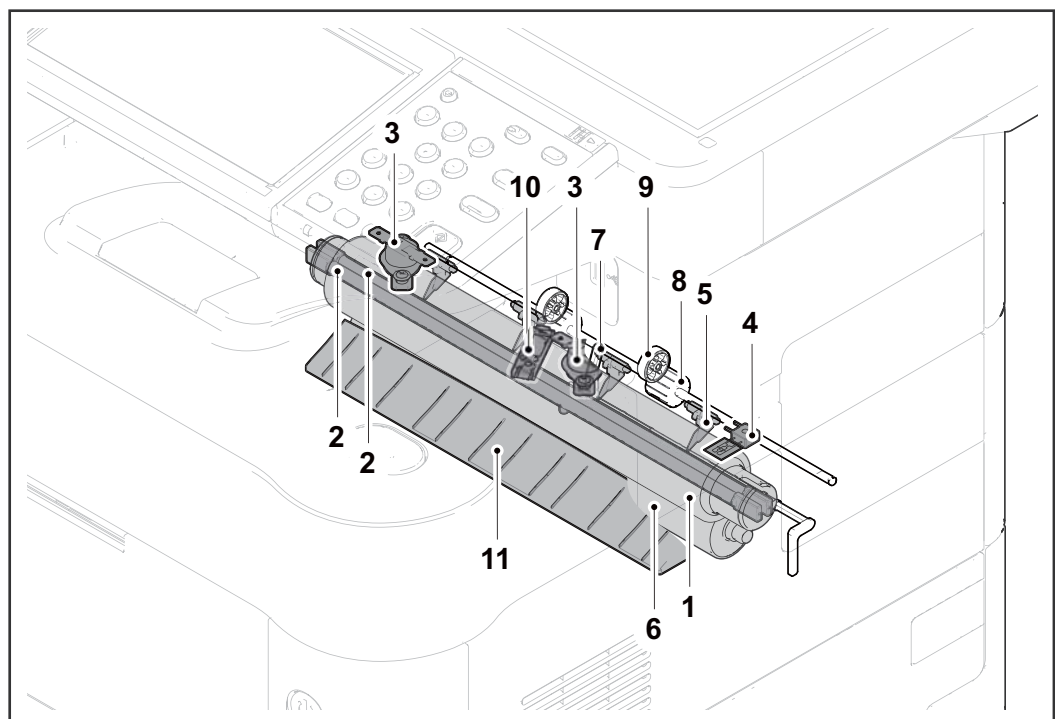

Figure 1-5-73

[Control block diagram]

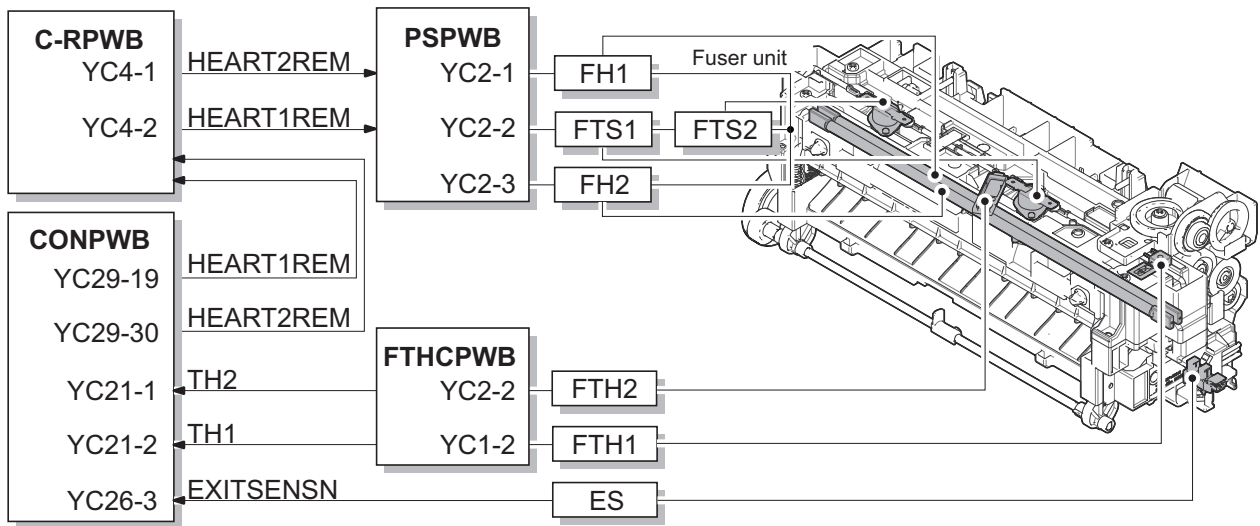

Figure 1-5-74

(2) 40 ppm model

[Component formation]

- 1. Heat roller
- 2. Fuser heater (FUH)
- 3. Fuser thermostat (FUTS)
- 4. Fuser thermistor (FUTH)
- 5. Separators
- 6. Press roller
- 7. Actuator
(Eject sensor (ES))
- 8. Fuser eject roller
- 9. Fuser eject pulley
- 10. Fuser thermistor (FUTH2)
- 11. Fuser pre guide

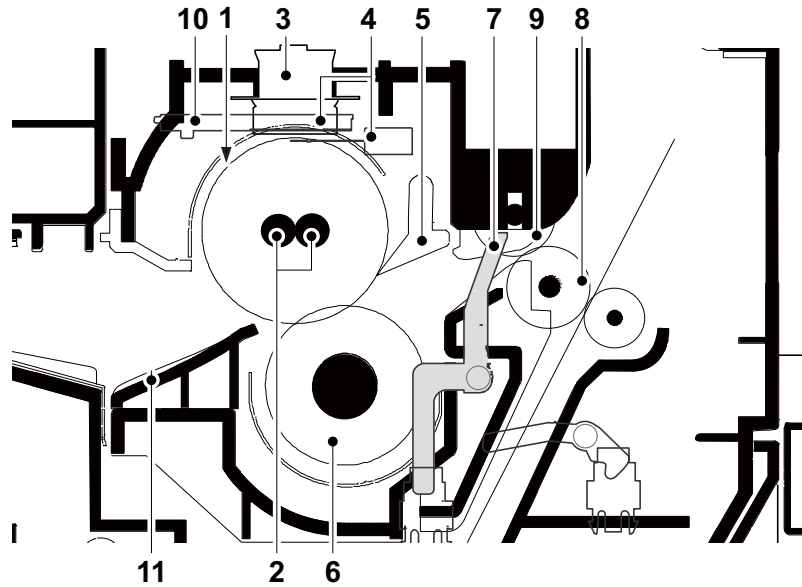

Figure 1-5-75

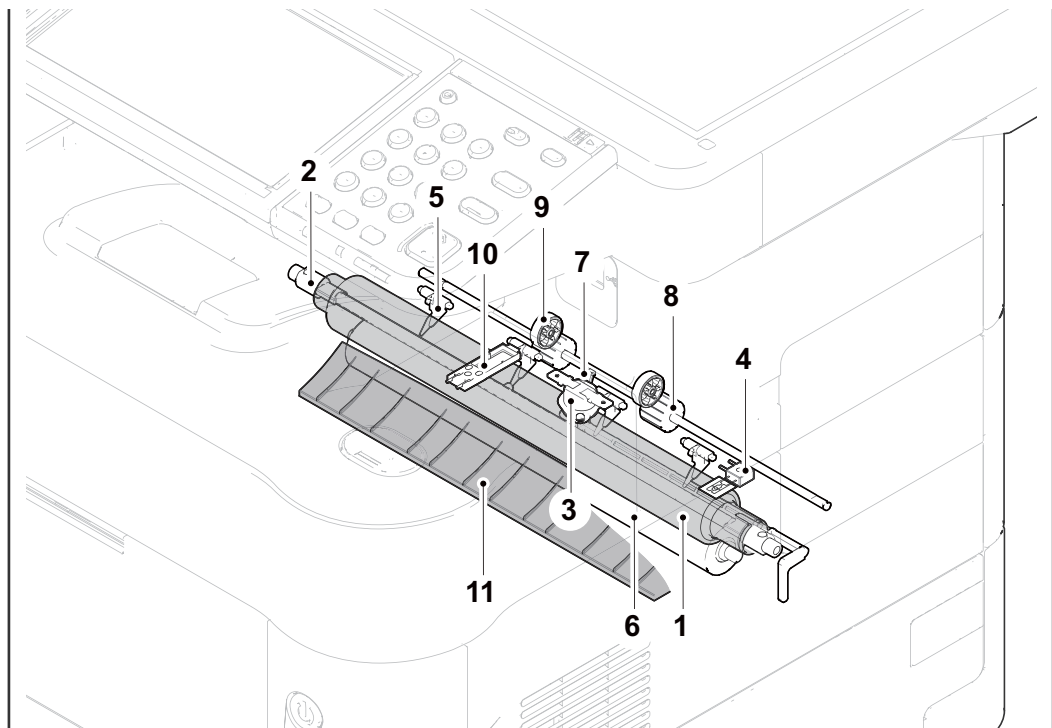

Figure 1-5-76

[Control block diagram]

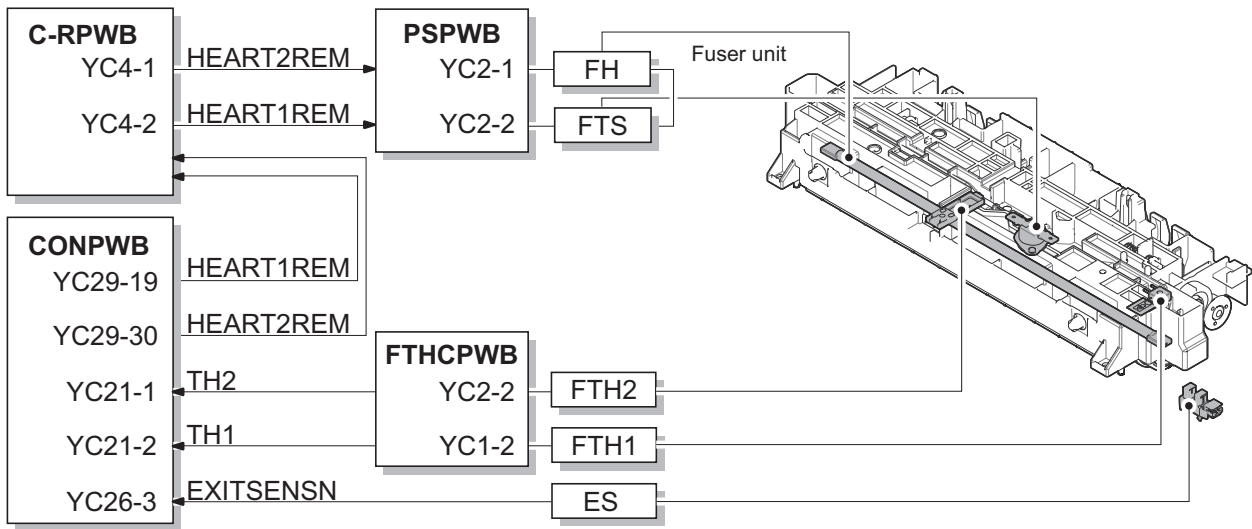

Figure 1-5-77

(2-1) Detaching and refitting the fuser unit

Procedure

1. Open the rear cover.
2. Release two hooks of the rear left cover while pulling forward.
3. Remove the rear left cover by rotating.

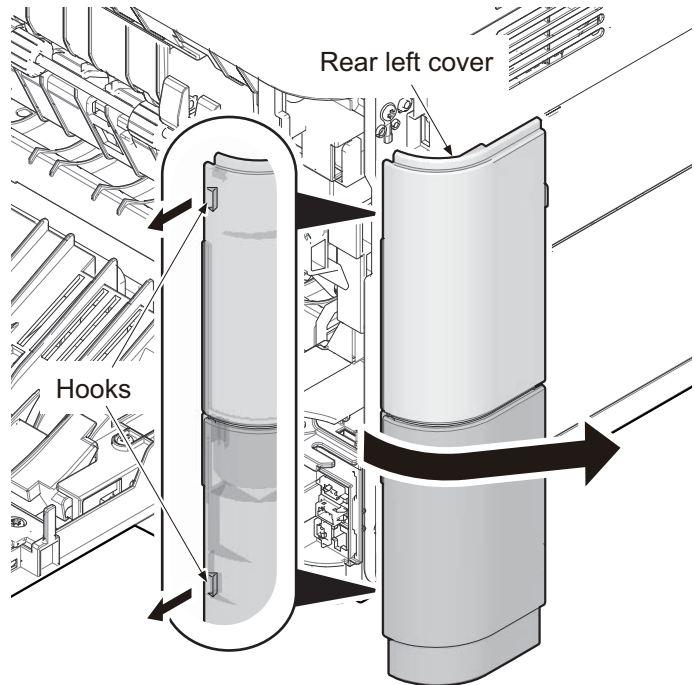

Figure 1-5-78

(50/60 ppm model only)

- (1) Remove the screw and then the grounding wire.
- (2) Open the connector cover and then remove three connectors.

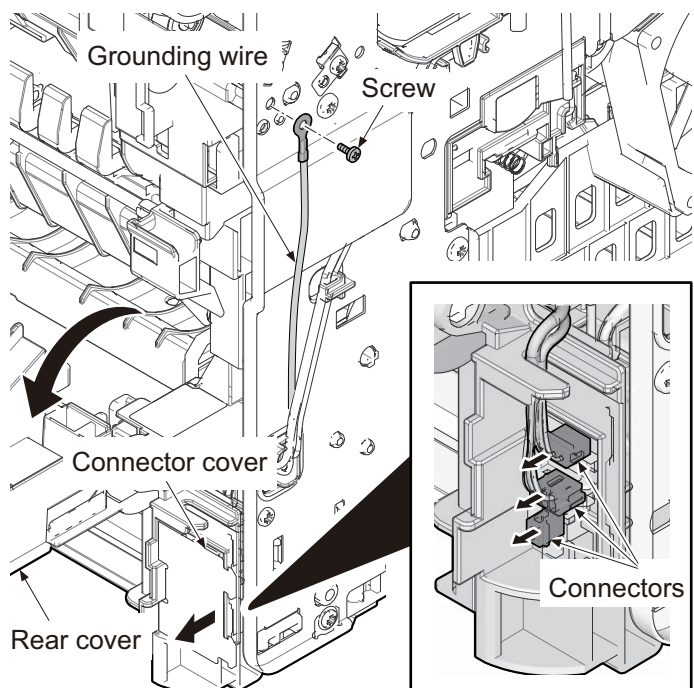

Figure 1-5-79

4. Remove the fulcrum axis by sliding the rear cover assembly while avoiding rear cover and then remove the rear cover assembly.

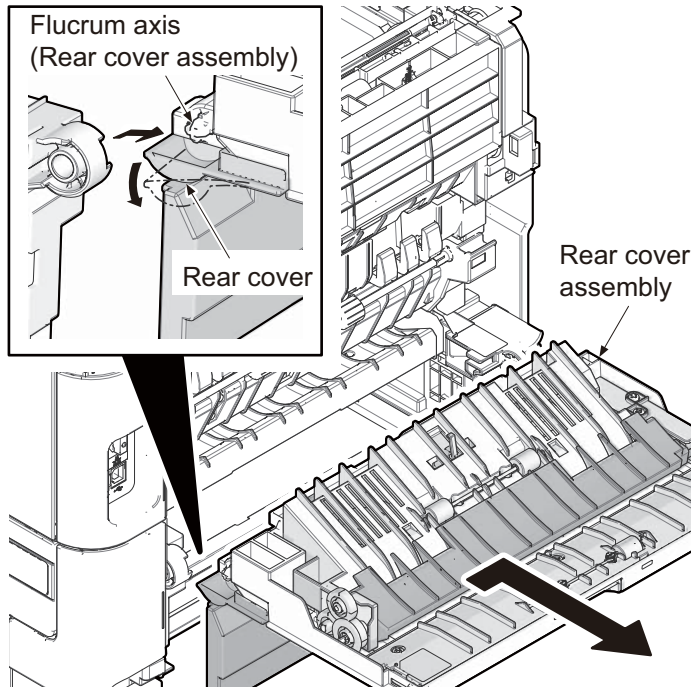

Figure 1-5-80

5. Remove the screw and then remove the connector cover A.
6. Pull two connectors out.

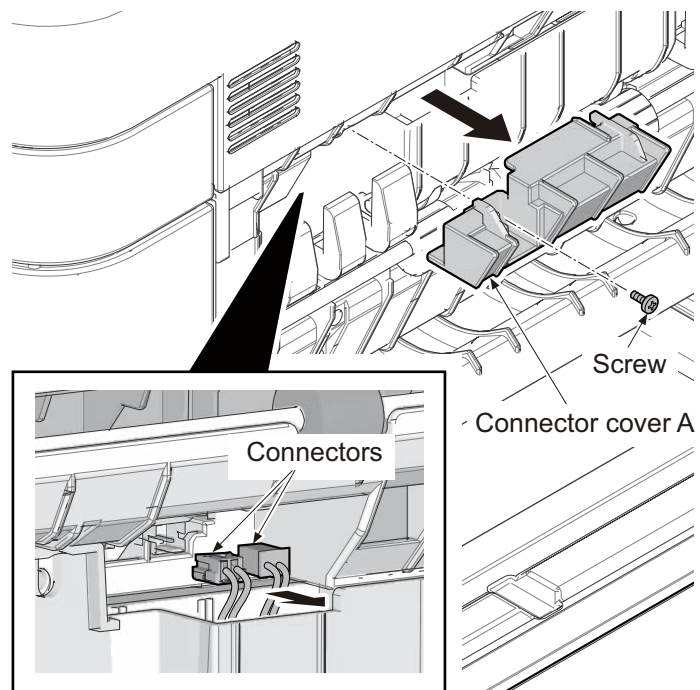

Figure 1-5-81

7. Remove the connector cover B by releasing the hook.
8. Remove the screw of connector cover C.
9. Remove the connector cover C by releasing the hook.
10. Pull two connectors out.

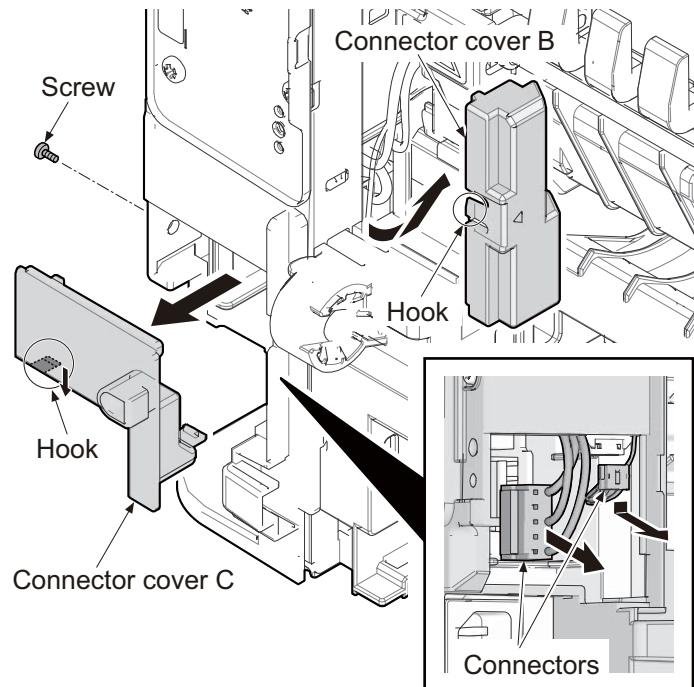

Figure 1-5-82

[50/60 ppm model]

11. Remove the screw and then remove the fuser unit forward.
12. Check or replace the fuser unit and refit all the removed parts.

Caution: when refitting the fuser unit, perform the following procedures.

- (1) Turn on the power switch while opening the rear cover after removing the fuser unit.
- (2) Turn off the power switch after 5-second or more progress. (release state of fixing pressure)
- (3) Refit the fuser unit.

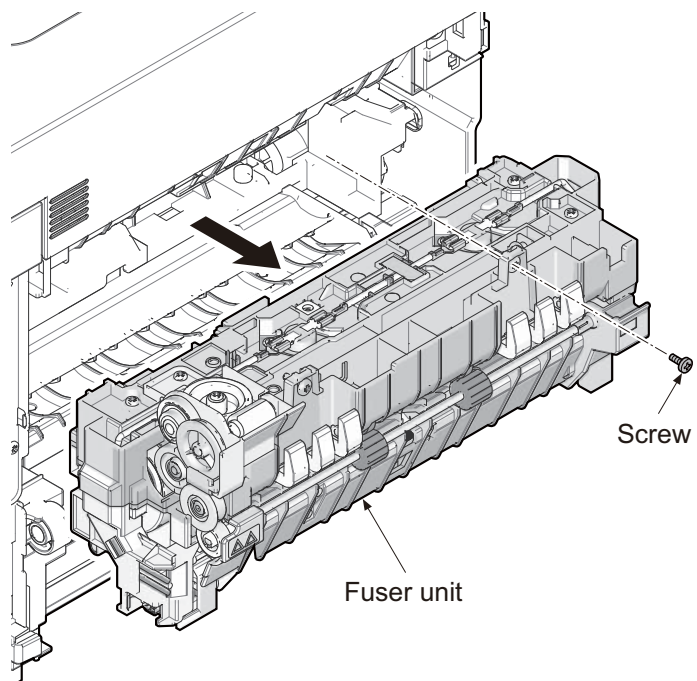

Figure 1-5-83

[40 ppm model]

11. Pull up the release lever of fixing pressure.
12. Remove the screw and then remove the fuser unit forward.
13. Check or replace the fuser unit and refit all the removed parts.

Caution: Pull down the release lever of fixing pressure after refitting the fuser unit.(pressurization state)

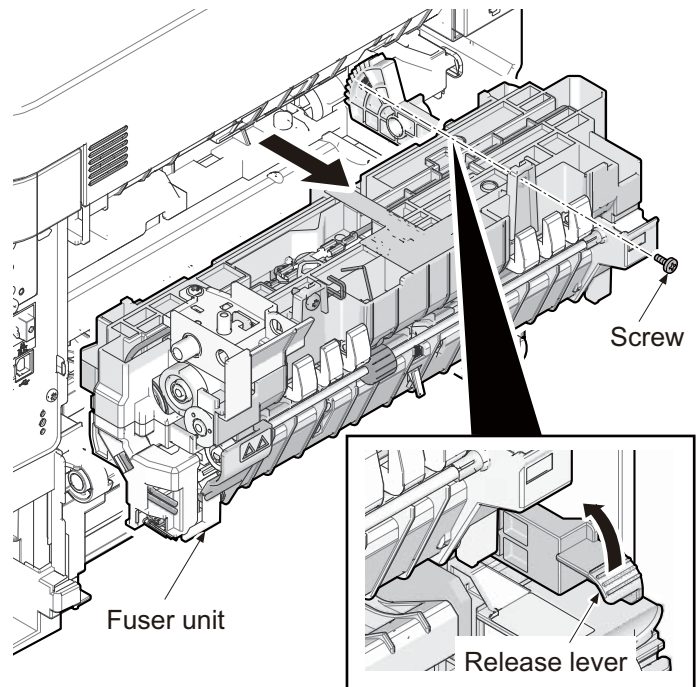

Figure 1-5-84

1-5-8 Eject section

The duplex conveying section consists of conveying path which sends the paper sent from the eject/feedshift section to the paper feed/conveying section when duplex printing.

(1) 50/60 ppm model

[Component formation]

1. Upper eject pulley
2. Upper eject roller
3. Actuator
(Paper full sensor (PFS))
4. LowerEject roller
5. Lower eject pulley
6. Eject upper cover
7. DU feed pulley
8. Faceup roller
9. Faceup pulley
10. Faceup guide

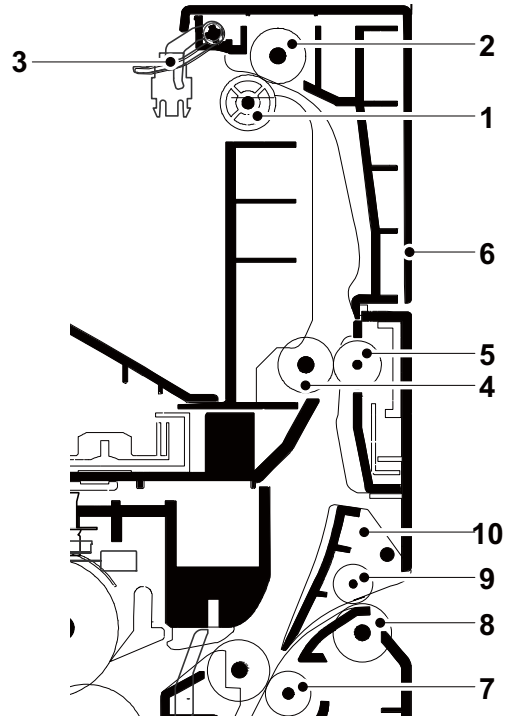

Figure 1-5-85

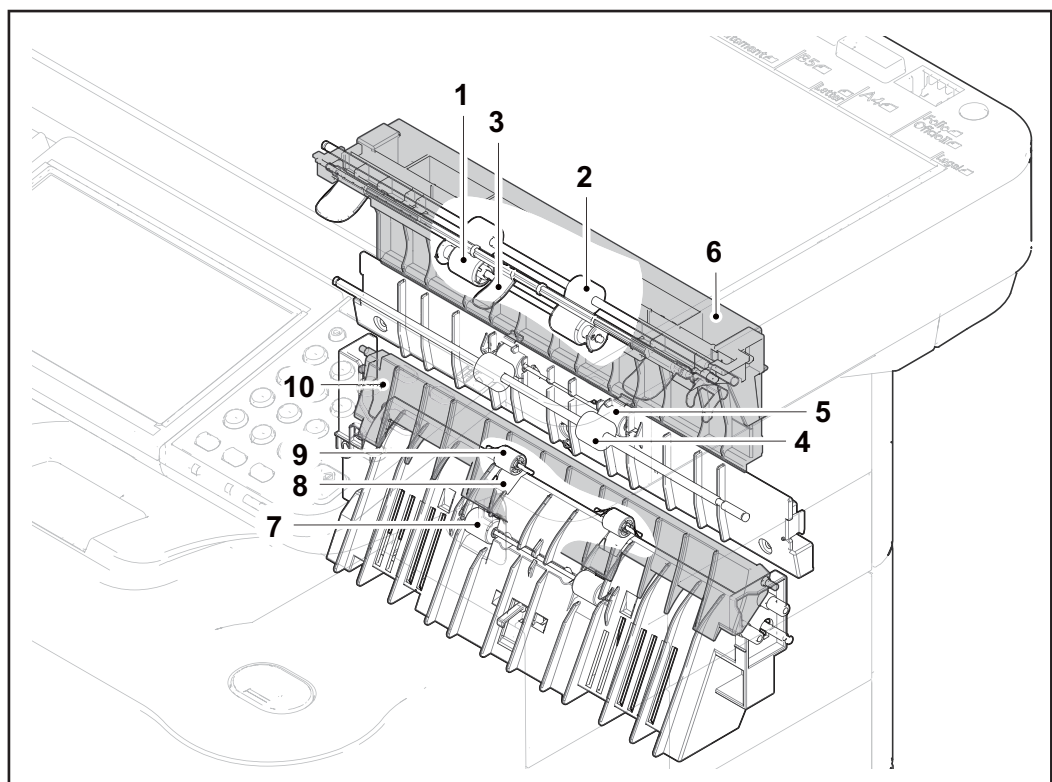

Figure 1-5-86

[Control block diagram]

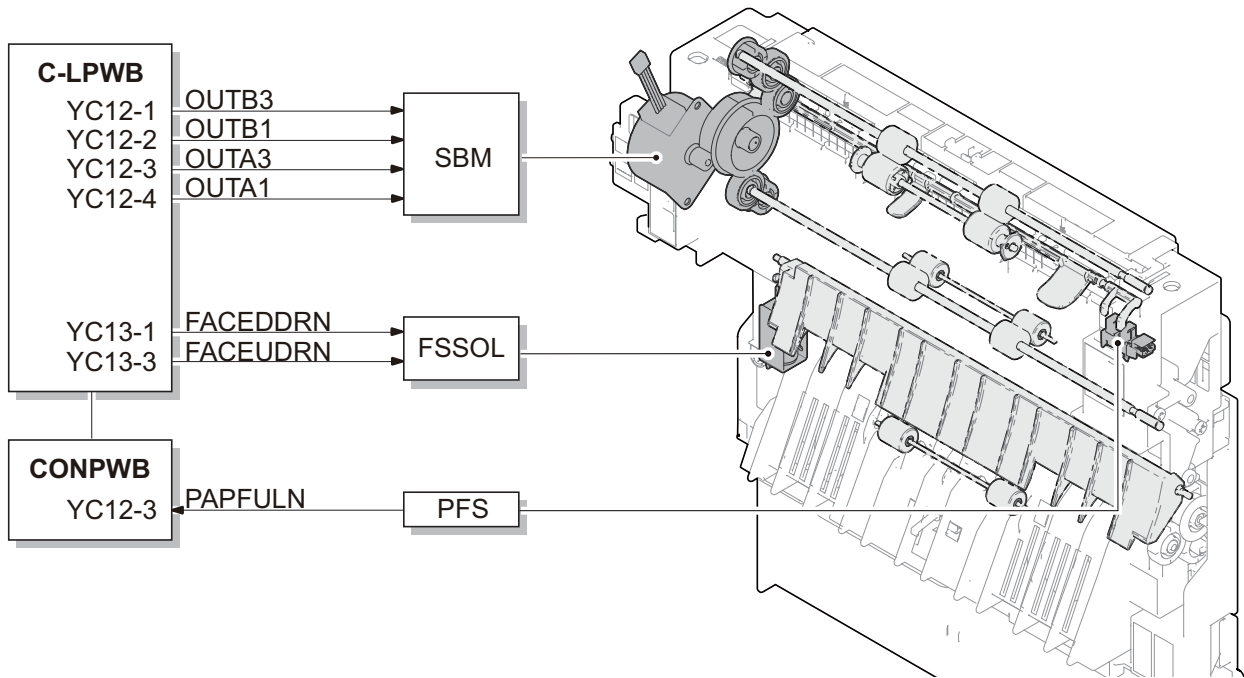
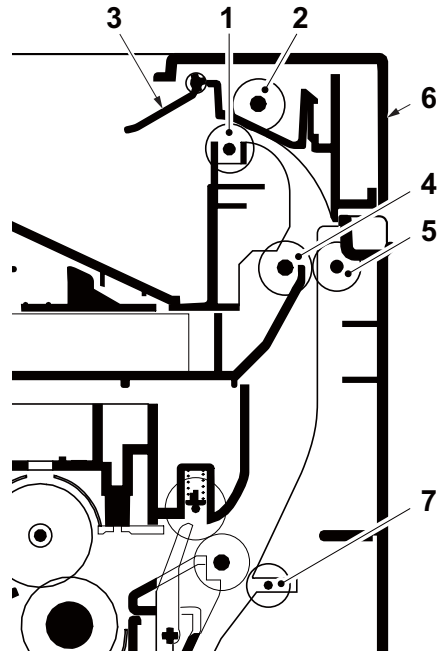
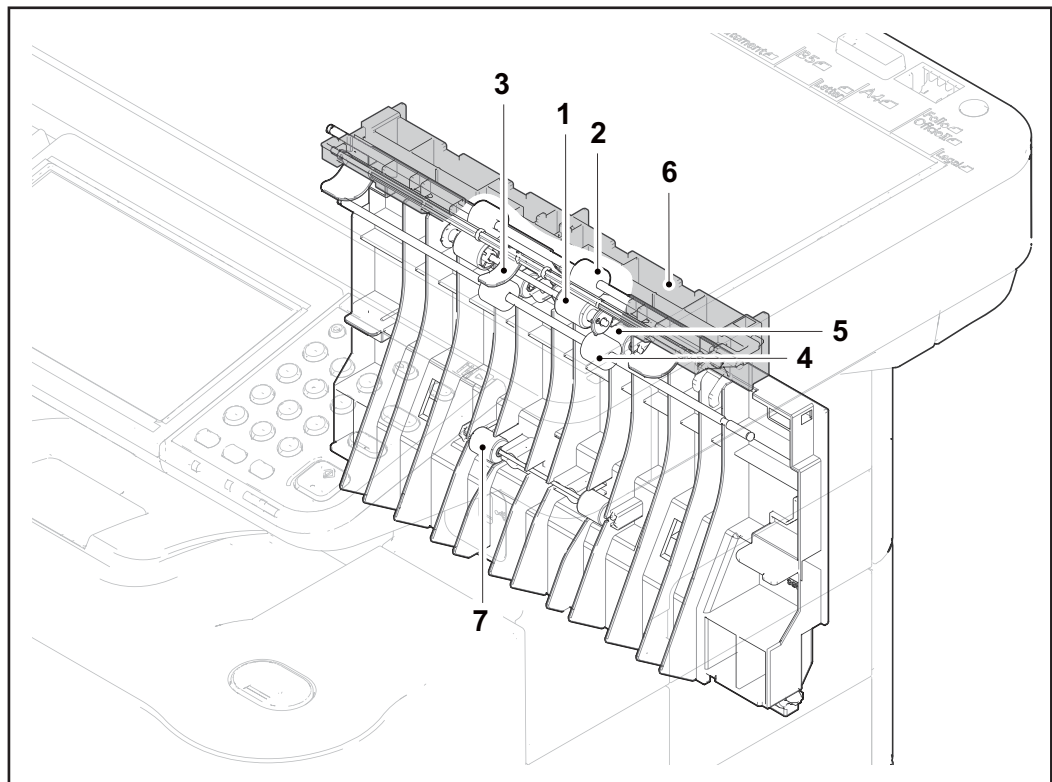

Figure 1-5-87

(2) 40 ppm model**[Component formation]**

1. Upper eject pulley
2. Upper eject roller
3. Actuator
(Paper full sensor (PFS))
4. LowerEject roller
5. Lower eject pulley
6. Eject upper cover
7. DU feed pulley

**Figure 1-5-88****Figure 1-5-89**

[Control block diagram]

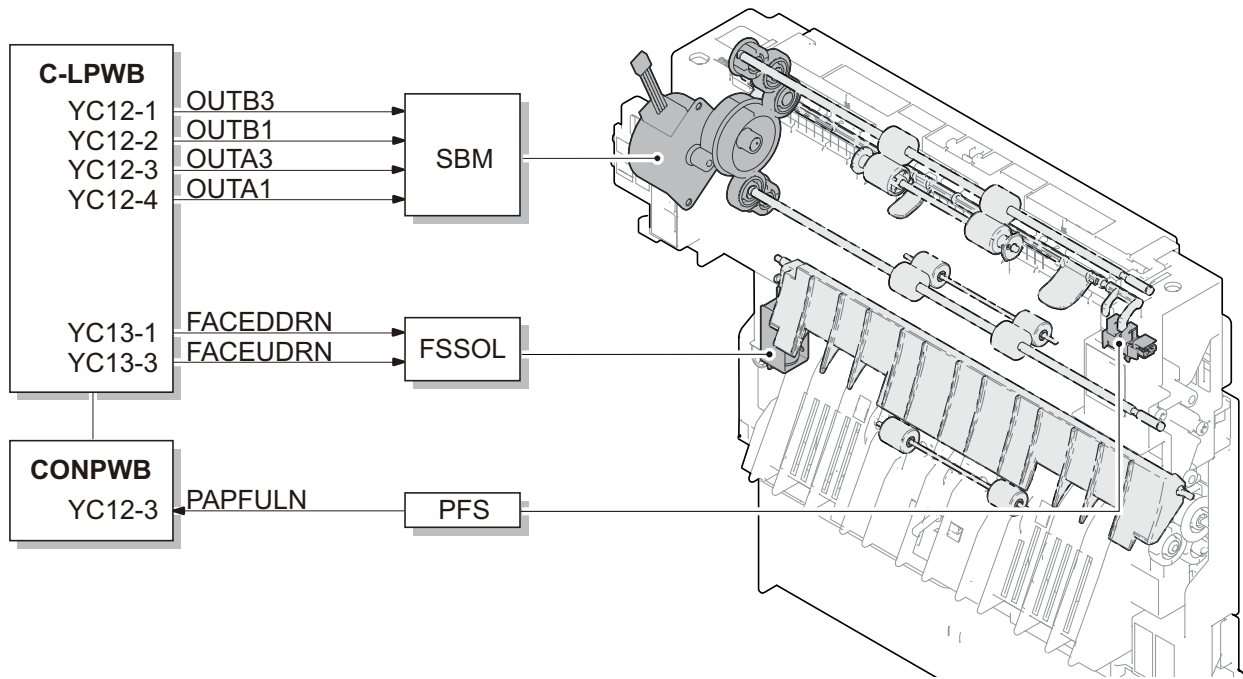

Figure 1-5-90

(2-1) Detaching and refitting the eject unit

Procedure

1. Remove the upper interface cover.
2. Release two hooks using a flat screw driver and remove the right stay cover.

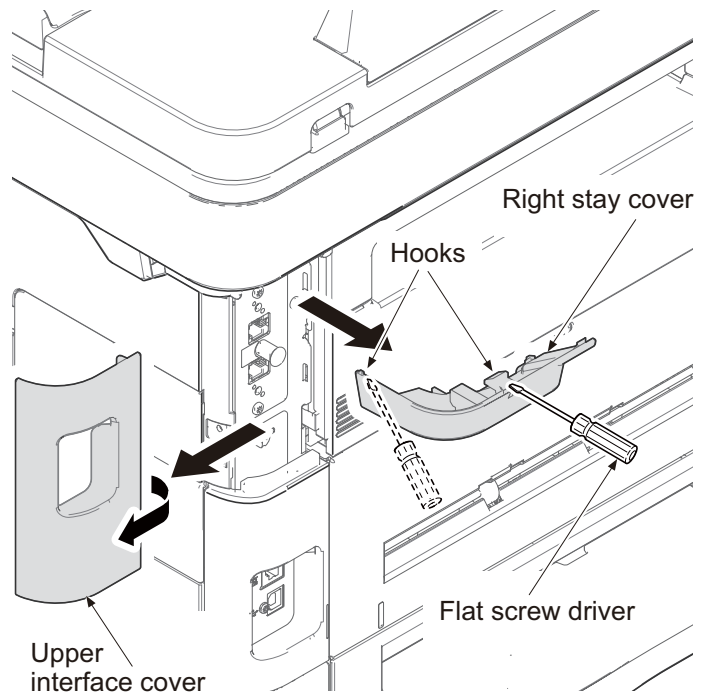

Figure 1-5-91

3. Remove the controller cover.
4. Open the front cover.
5. Remove the screw from the right upper cover.
6. Release two hooks using a flat screw driver and remove the right upper cover.

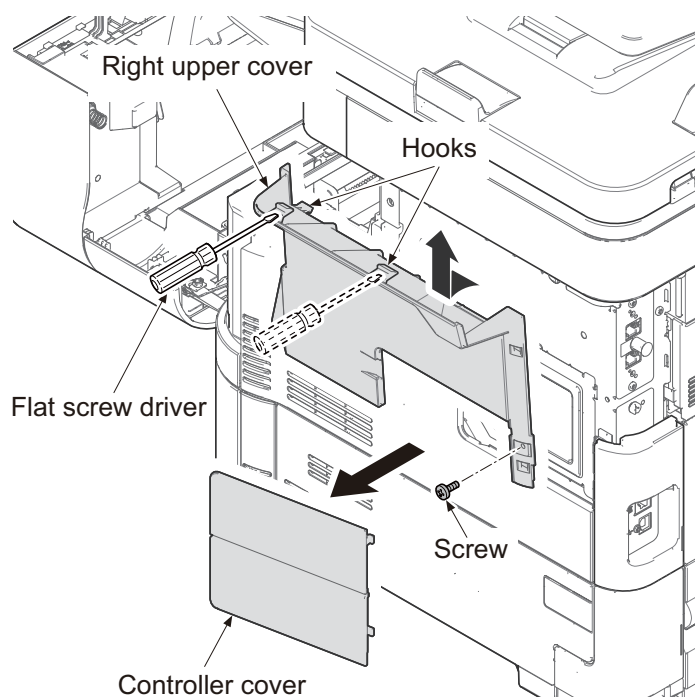

Figure 1-5-92

7. Release two hooks using a flat screw driver and remove the left upper cover.

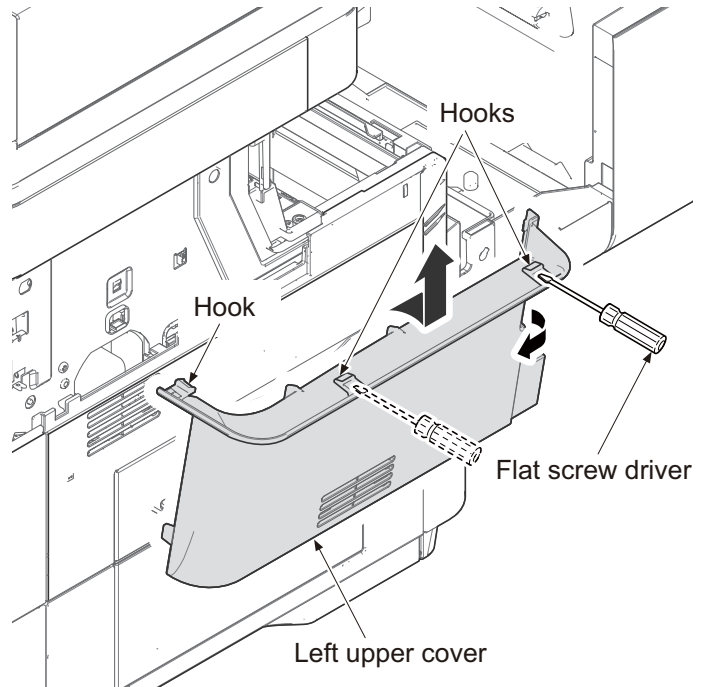

Figure 1-5-93

8. Remove the screw from the center stay cover.
9. Release two hooks using a flat screw driver and remove the center stay cover.

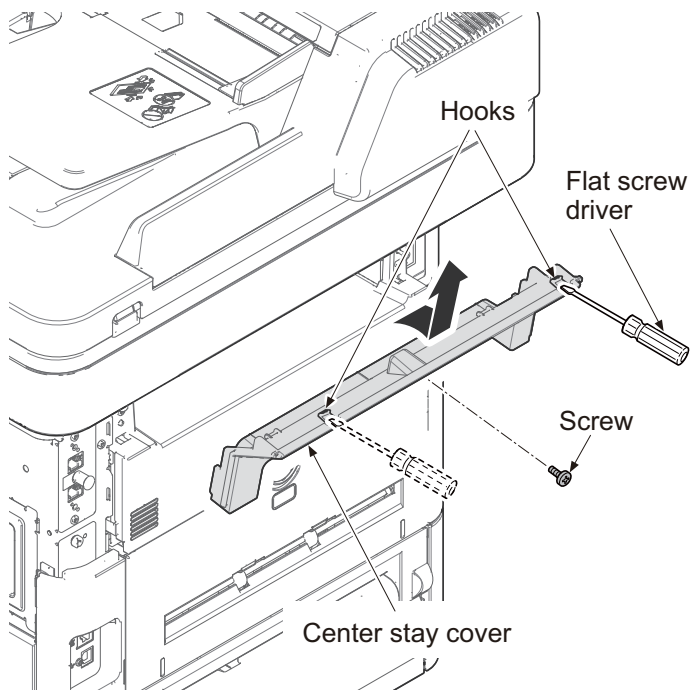

Figure 1-5-94

10. Remove the front right cover forward.

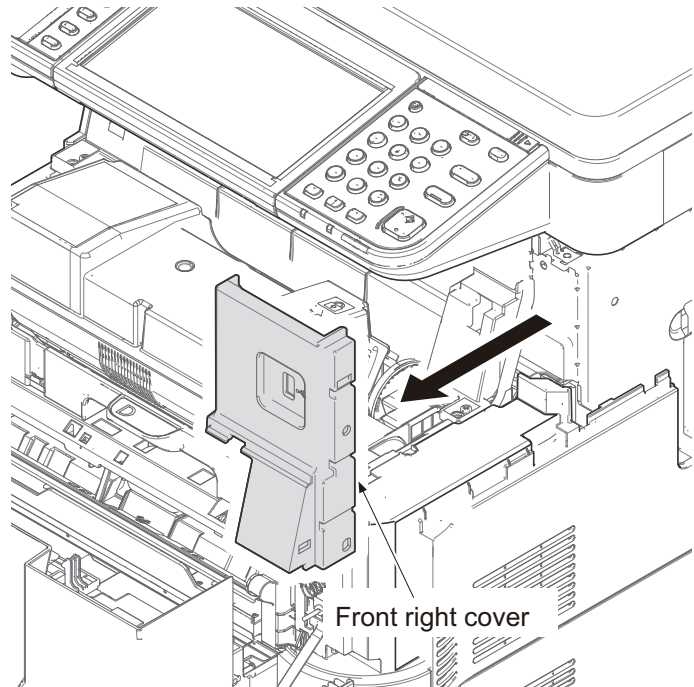

Figure 1-5-95

11. Remove three connectors, two FFCs and two USB connectors from the Control PWB.
12. Remove three screws and grounding terminal from the image scanner unit.
13. Remove it by sliding the image scanner unit backward and then taking upward.

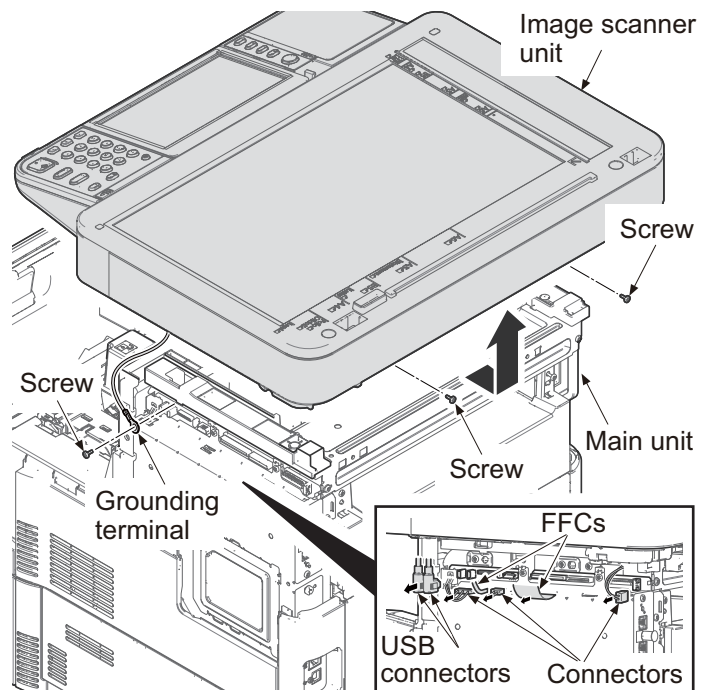

Figure 1-5-96

14. Remove two screws.

(50/60 ppm model only)

(1) Slide the right inner spacer and the left inner spacer forward and then remove it upward.

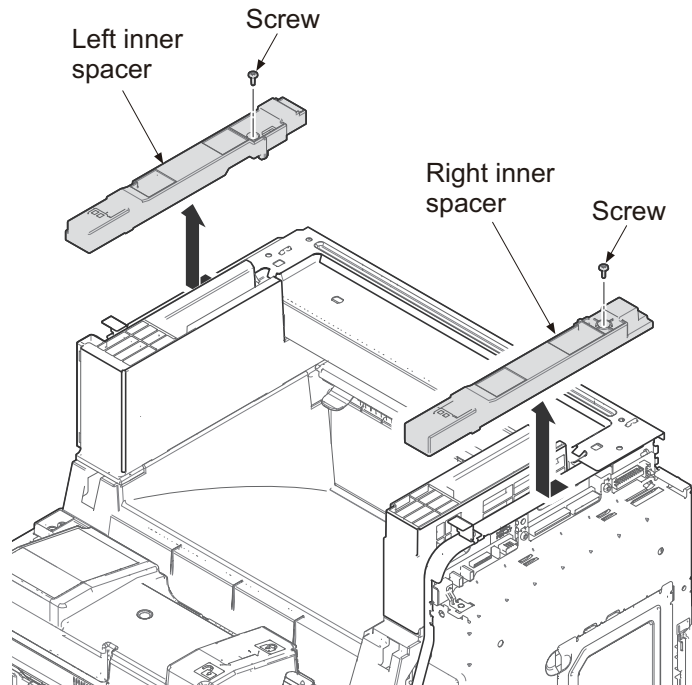

Figure 1-5-97

15. Remove two screws.

16. Remove the eject unit cover.

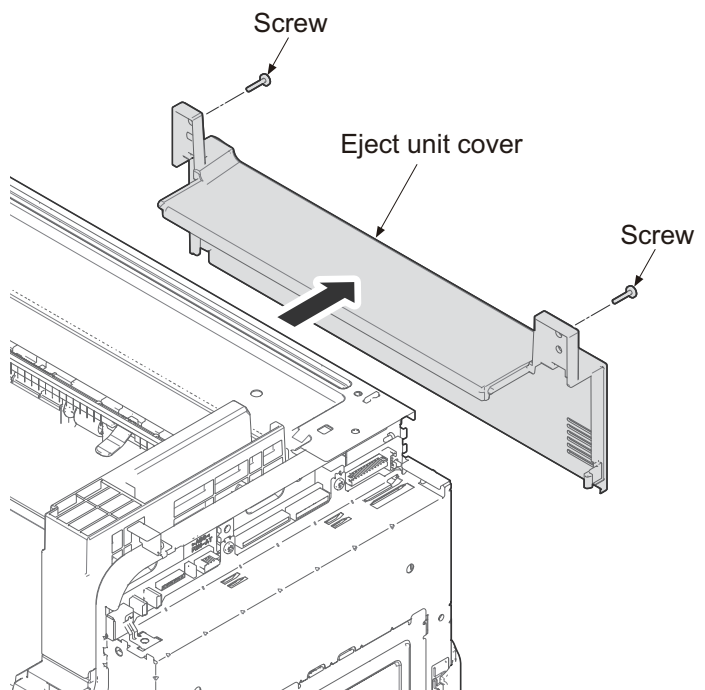

Figure 1-5-98

17. Remove four screws.
18. Remove the upper stay assembly upward.

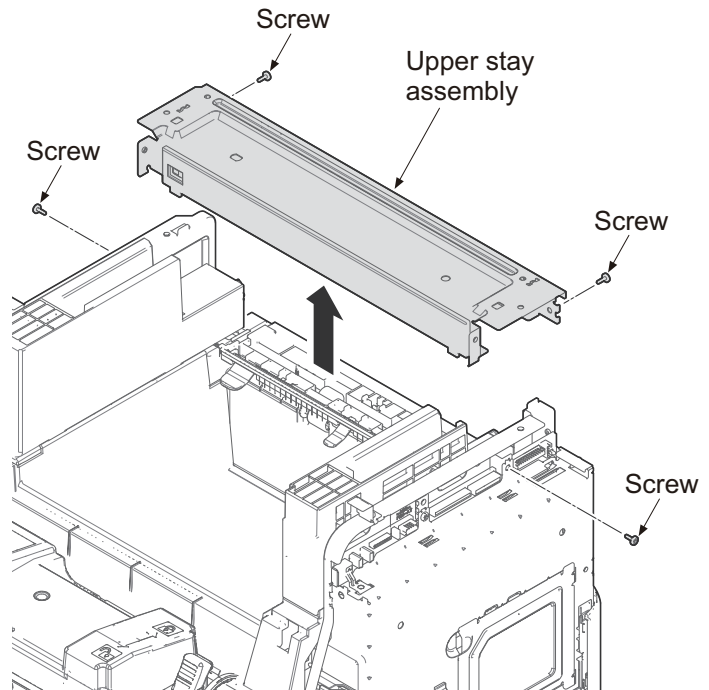

Figure 1-5-99

19. Remove the screw and then remove the right inner cover by leaning it inside and lifting it.
20. Remove two screws and then remove the left inner cover by leaning it inside and lifting it.

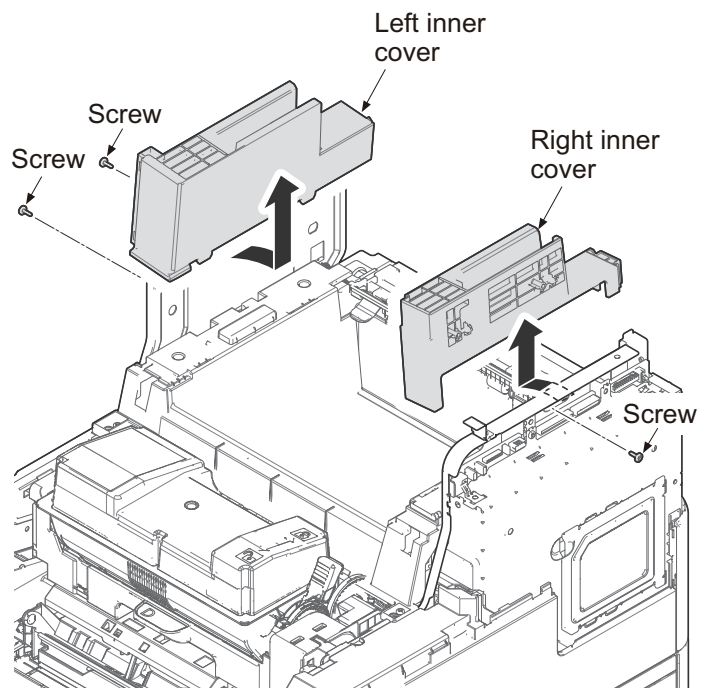

Figure 1-5-100

21. Open the rear cover.
22. Remove the lower interface cover and the inlet cover.

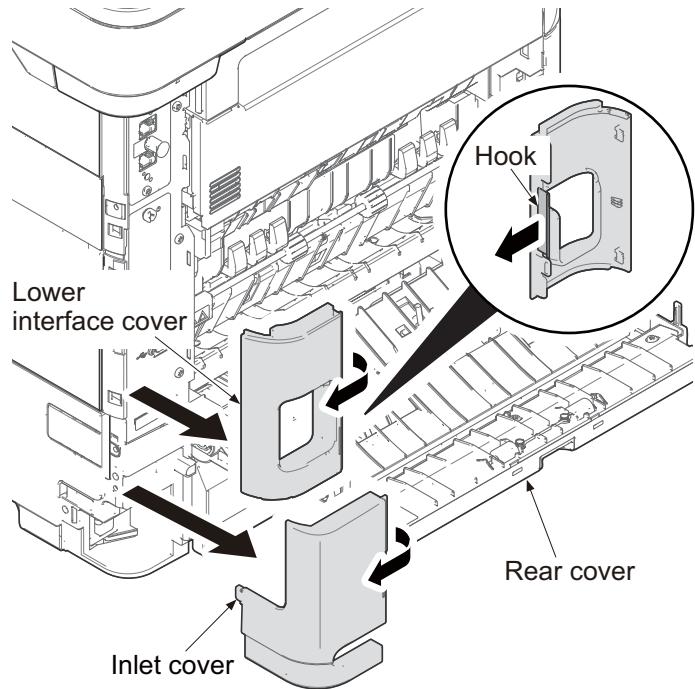

Figure 1-5-101

23. Remove two screws.
24. Release the hooks by bending both-side of the right middle cover and then remove it by pulling and lifting up forward.

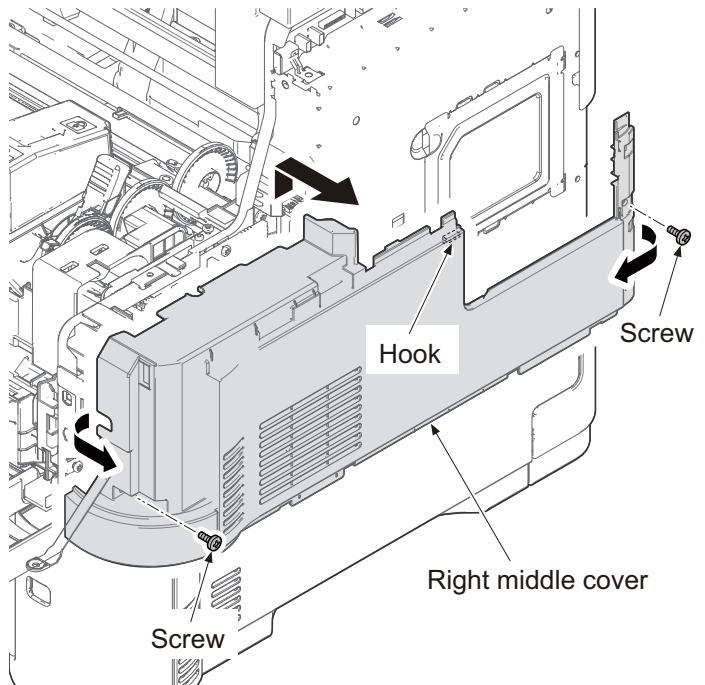

Figure 1-5-102

25. Pull out the cassette.
26. Remove three screws.
27. Release two hooks by sliding the right lower cover upward and then remove the right lower cover.

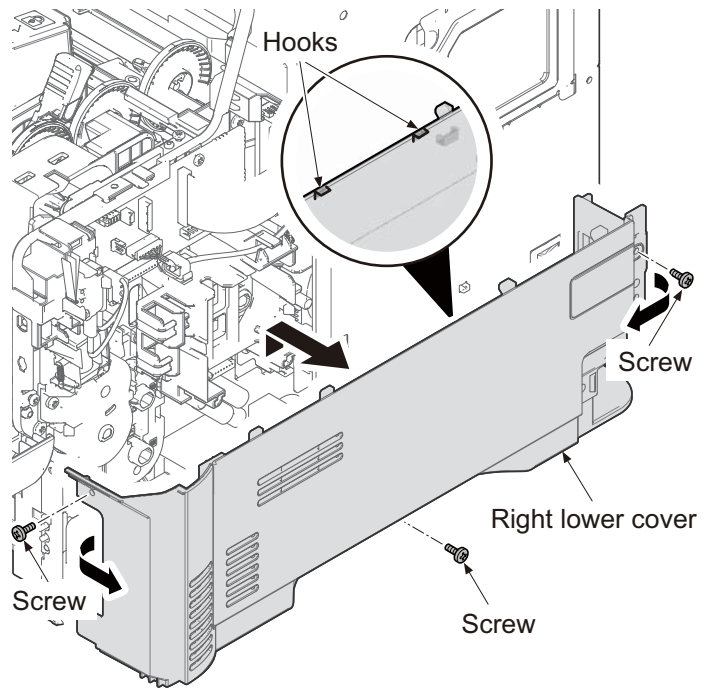

Figure 1-5-103

28. Release two hooks of the rear left cover while pulling forward.
29. Remove the rear left cover by rotating.

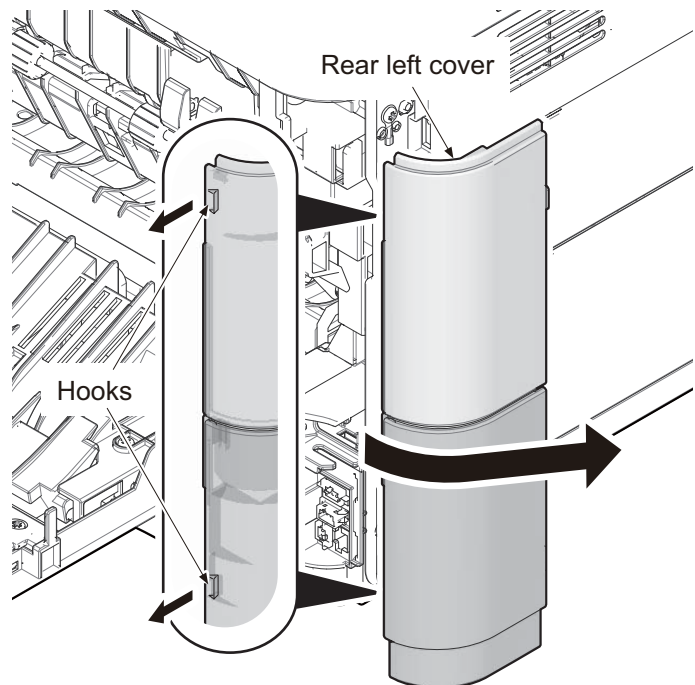

Figure 1-5-104

30. Release the hook A by sliding the left middle cover upward.
31. Release the hook B and hook C and then remove the left middle cover and the waste toner box cover.

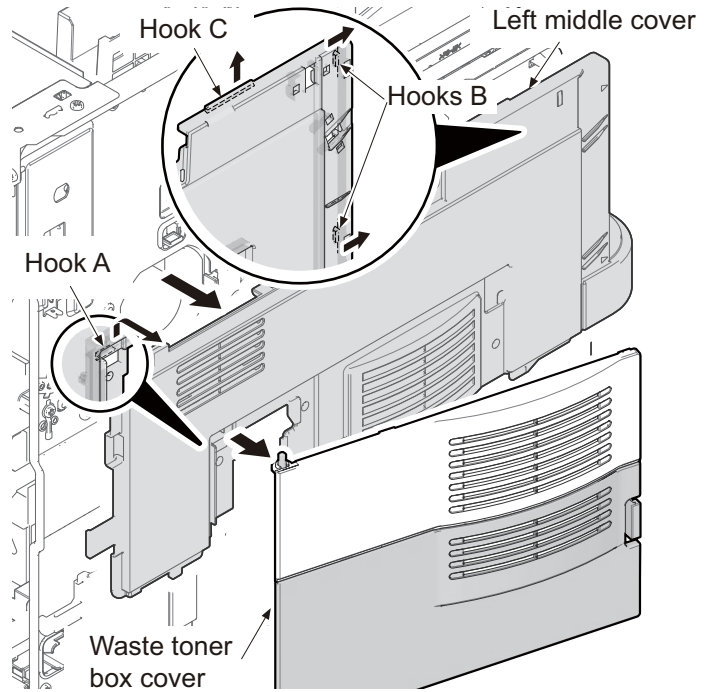

Figure 1-5-105

32. Remove eight screws and grounding terminal.
33. Remove the controller box.

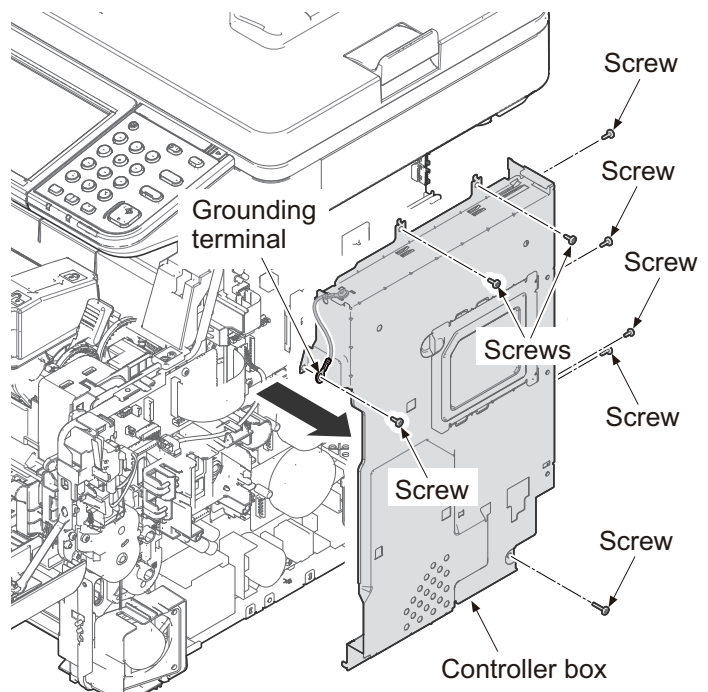

Figure 1-5-106

- 34. Remove all connectors and FFCs from the control PWB.
- 35. Remove six screws and control PWB from the main unit.

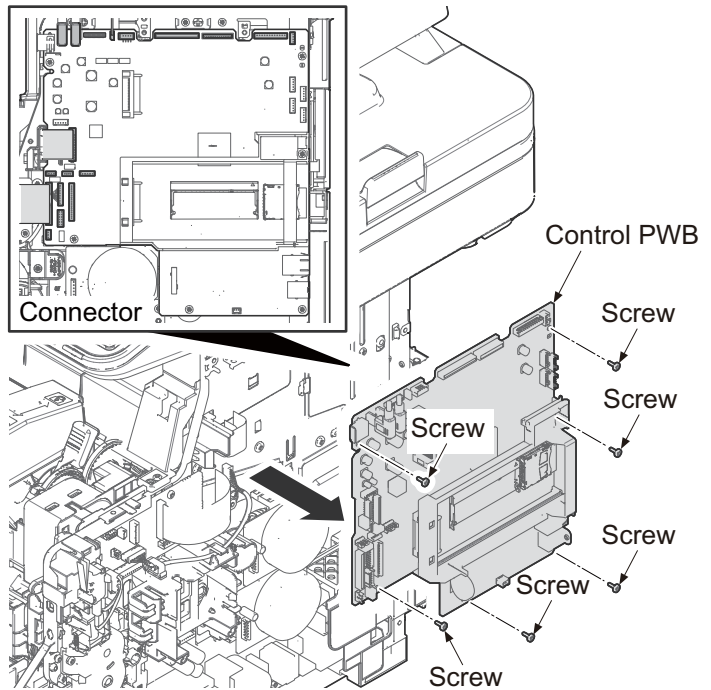

Figure 1-5-107

- 36. Pull the connector out and then release the wires from Hooks.
- 37. Remove three screws and then remove the eject unit.
- 38. Check or replace the ejection unit and refit all the removed parts.

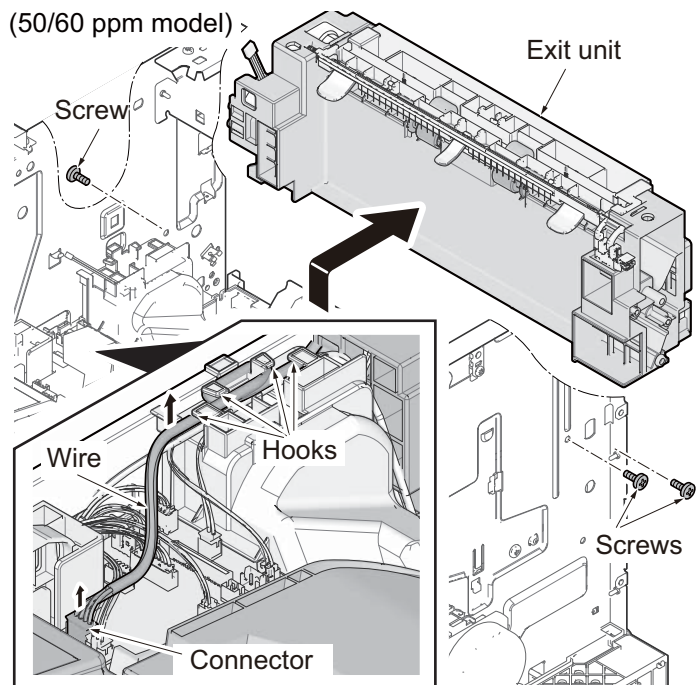

Figure 1-5-108

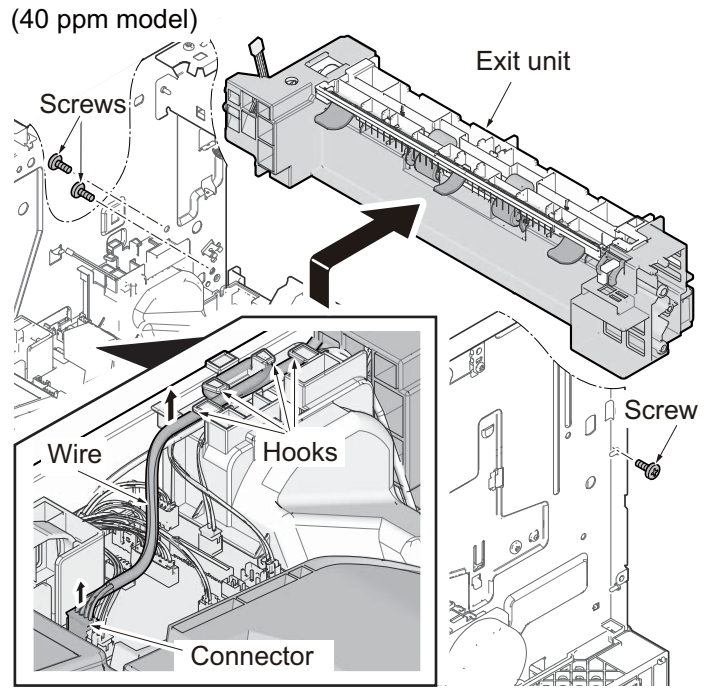

Figure 1-5-109

1-5-9 Duplex conveying section

(1) Duplex conveying unit

The duplex conveying section consists of conveying path which sends the paper sent from the eject/feedshift section to the paper feed/conveying section when duplex printing.

[Component formation]

1. DU conveying roller
2. DU conveying pulley
3. Actuator (Duplex sensor 1) *2
4. Actuator (Duplex sensor 2)
5. DU base
6. DU lower guide
7. Feed upper guide

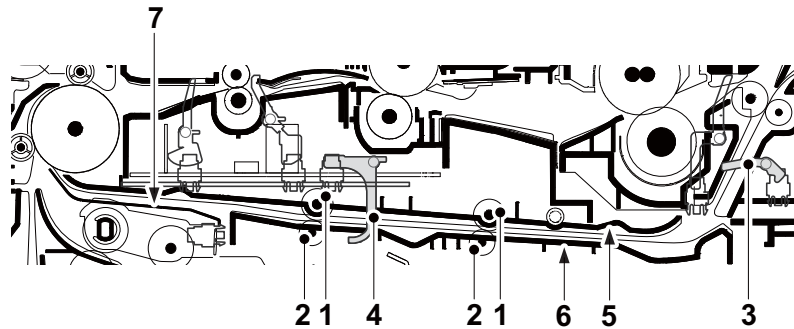

Figure 1-5-110

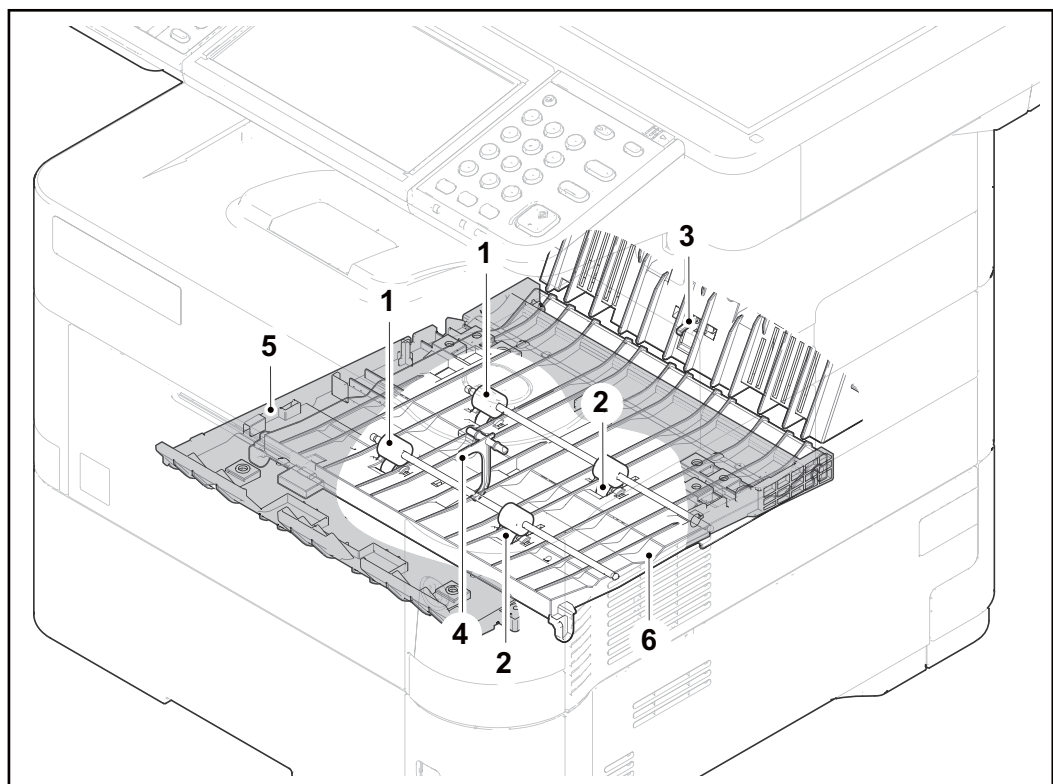

Figure 1-5-111

[Control block diagram]

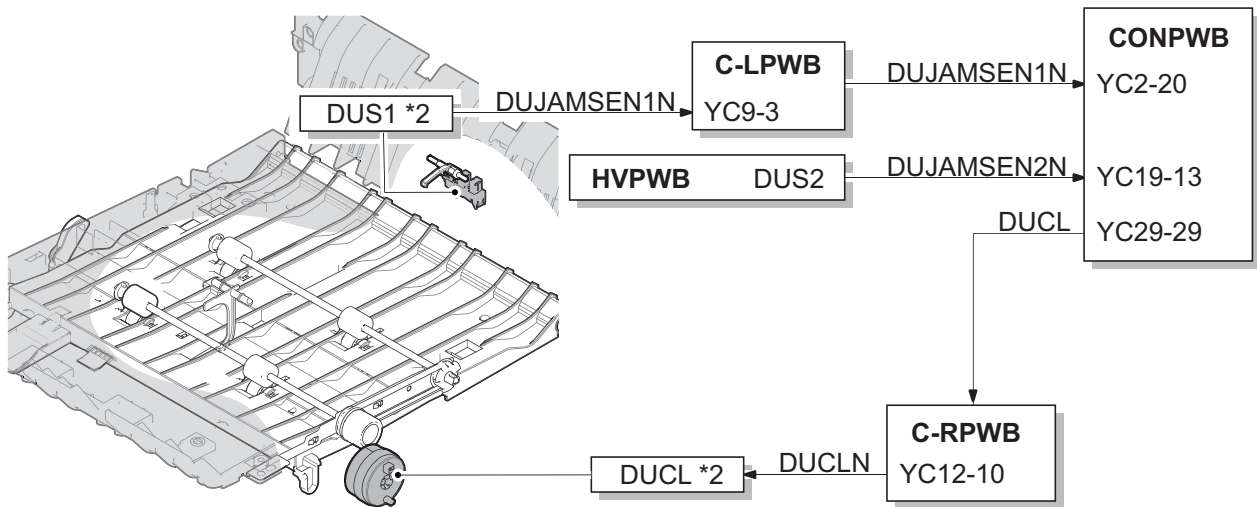

Figure 1-5-112

*2: 50/60 ppm model only

(1-1) Detaching and refitting the duplex conveying unit

Procedure

1. Remove the upper interface cover.
2. Release two hooks using a flat screw driver and remove the right stay cover.

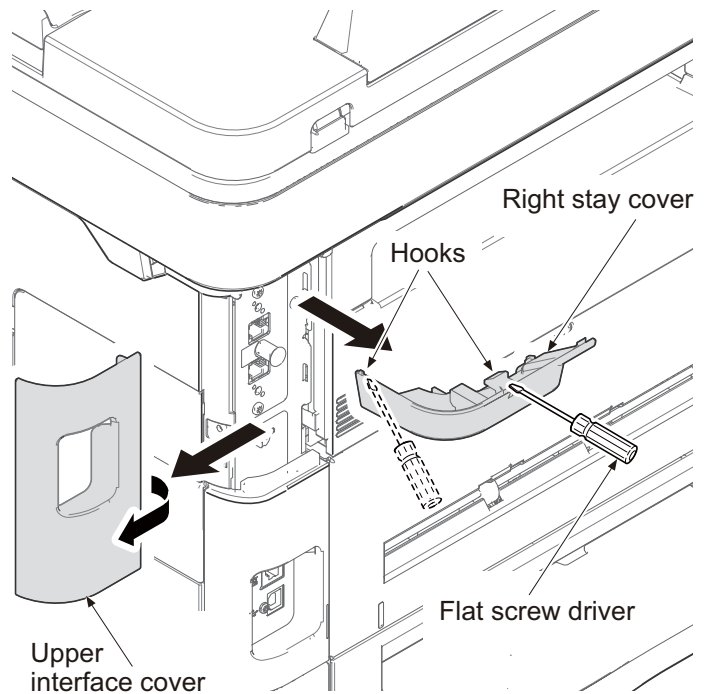

Figure 1-5-113

3. Remove the controller cover.
4. Open the front cover.
5. Remove the screw from the right upper cover.
6. Release two hooks using a flat screw driver and remove the right upper cover.

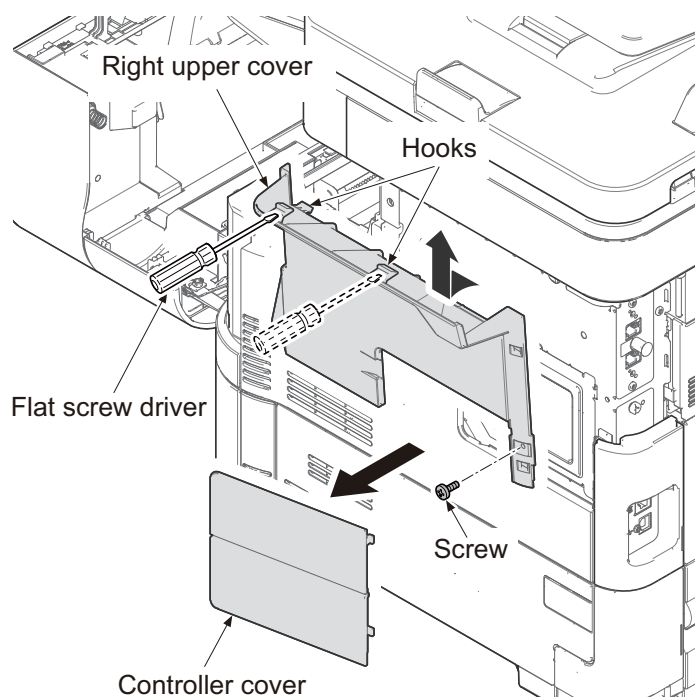

Figure 1-5-114

7. Release two hooks using a flat screw driver and remove the left upper cover.

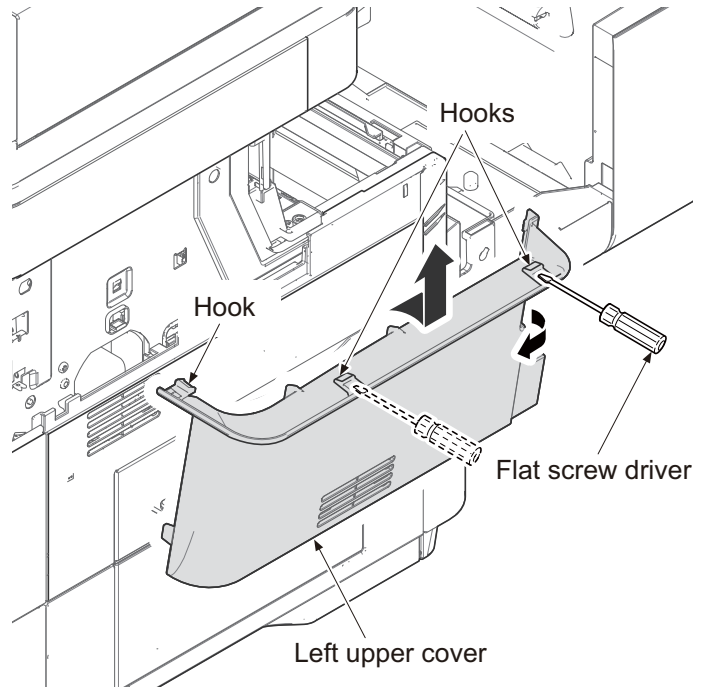

Figure 1-5-115

8. Open the rear cover.
9. Remove the lower interface cover and the inlet cover.

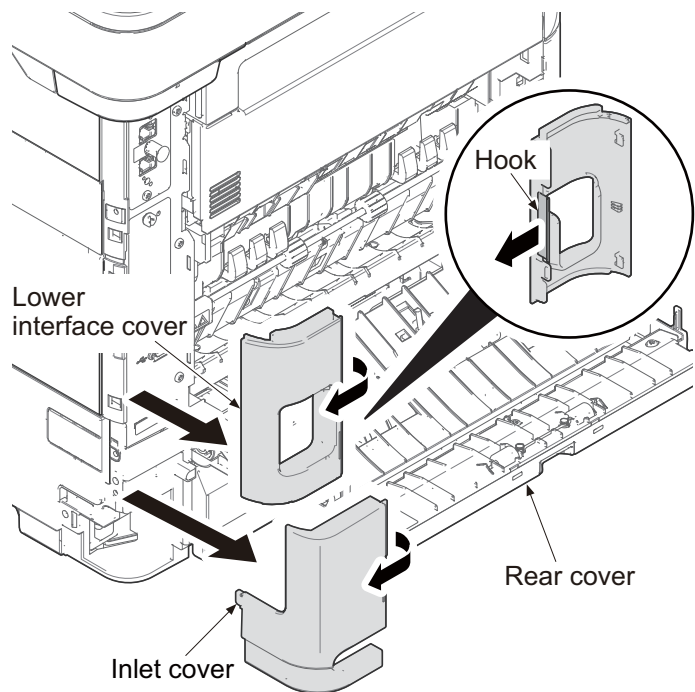

Figure 1-5-116

10. Remove two screws.
11. Release the hooks by bending both-side of the right middle cover and then remove it by pulling and lifting up forward.

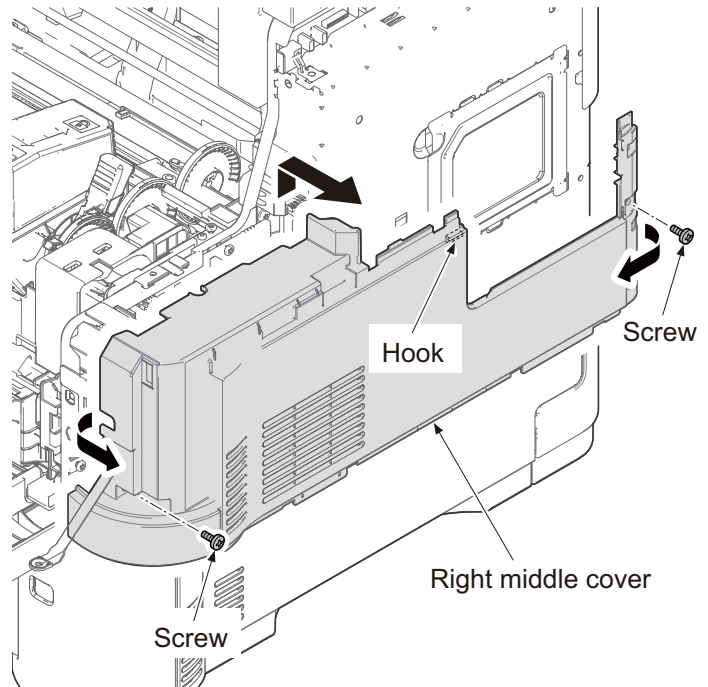

Figure 1-5-117

12. Pull out the cassette.
13. Remove three screws.
14. Release two hooks by sliding the right lower cover upward and then remove the right lower cover.

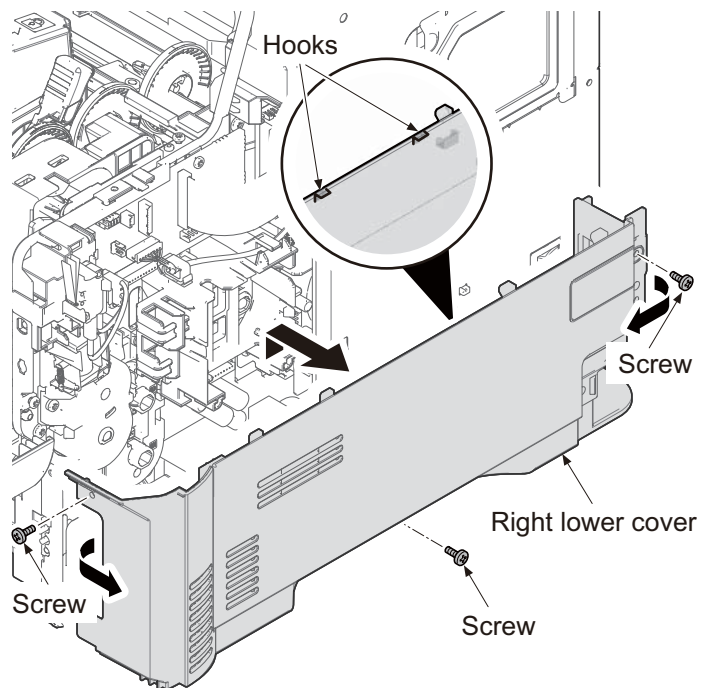

Figure 1-5-118

15. Release two hooks of the rear left cover while pulling forward.
16. Remove the rear left cover by rotating.

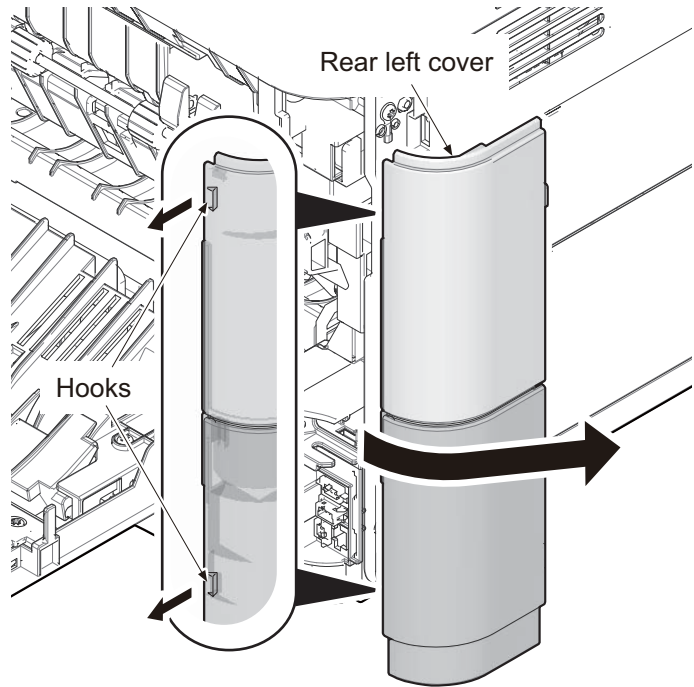

Figure 1-5-119

17. Release the hook A by sliding the left middle cover upward.
18. Release the hook B and hook C and then remove the left middle cover and the waste toner box cover.

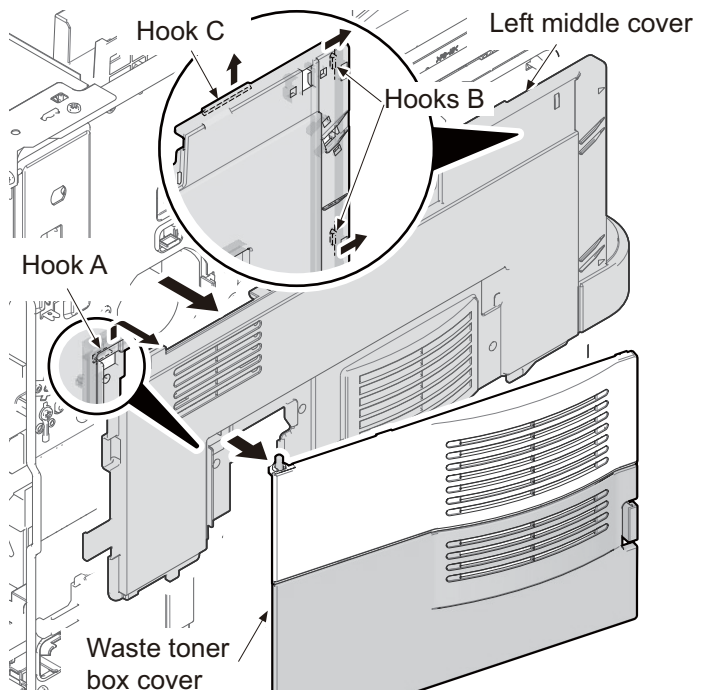

Figure 1-5-120

19. Remove the screw.
20. Release the hook A.
21. Release two hooks B by sliding the left lower cover upward and then remove the left lower cover.

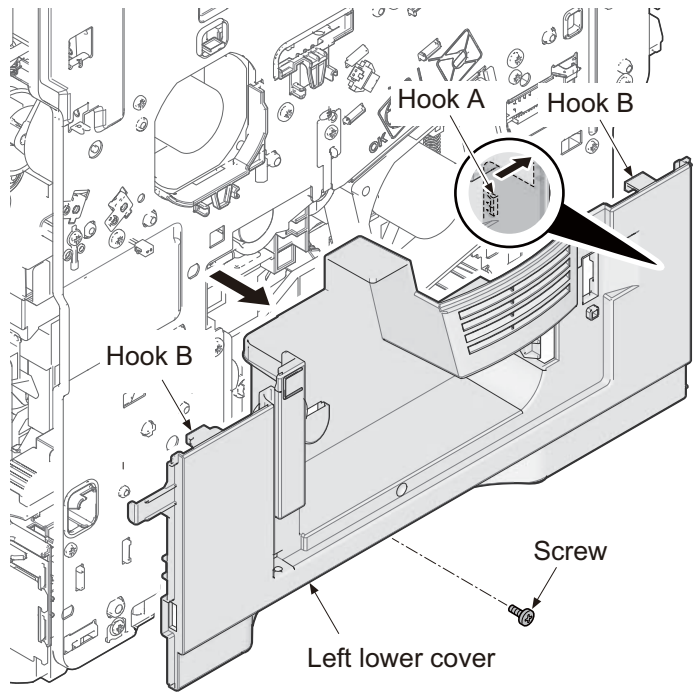

Figure 1-5-121

22. Remove eight screws and grounding terminal.
23. Remove the controller box.

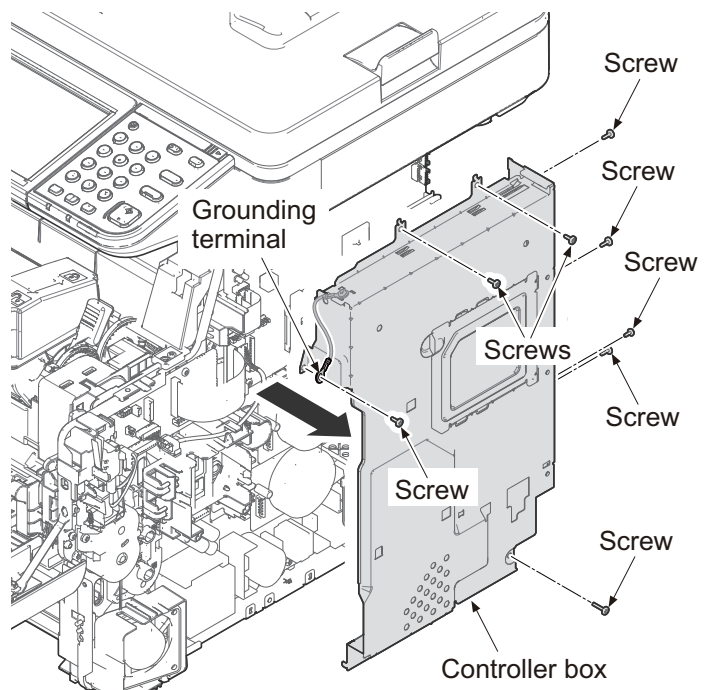

Figure 1-5-122

24. Remove the connector cover B by releasing the hook.
25. Remove the screw of connector cover C.
26. Remove the connector cover C by releasing the hook.
27. Pull two connectors out.

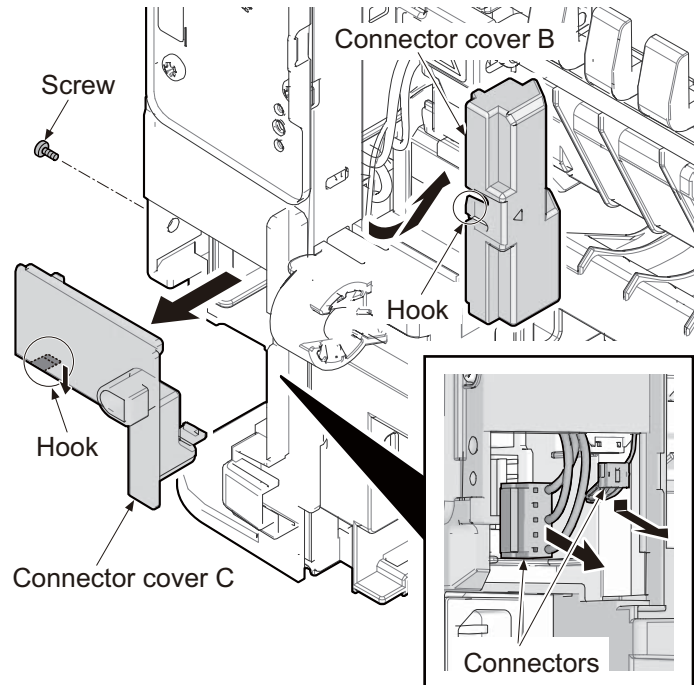

Figure 1-5-123

28. Remove the connector from the power source PWB assembly.
29. Remove the grounding wire by removing the screw.
30. Remove three screws and then remove the power source PWB assembly.
31. Check or replace the power source PWB and refit all the removed parts.

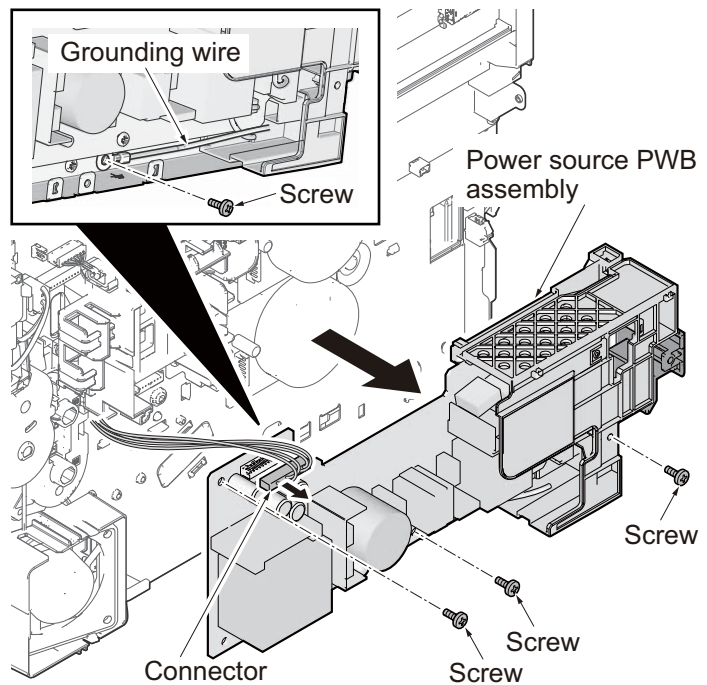

Figure 1-5-124

32. Stand the main unit front side up.
33. Remove four screws each and then remove the bottom plate 1 and the bottom plate 2.

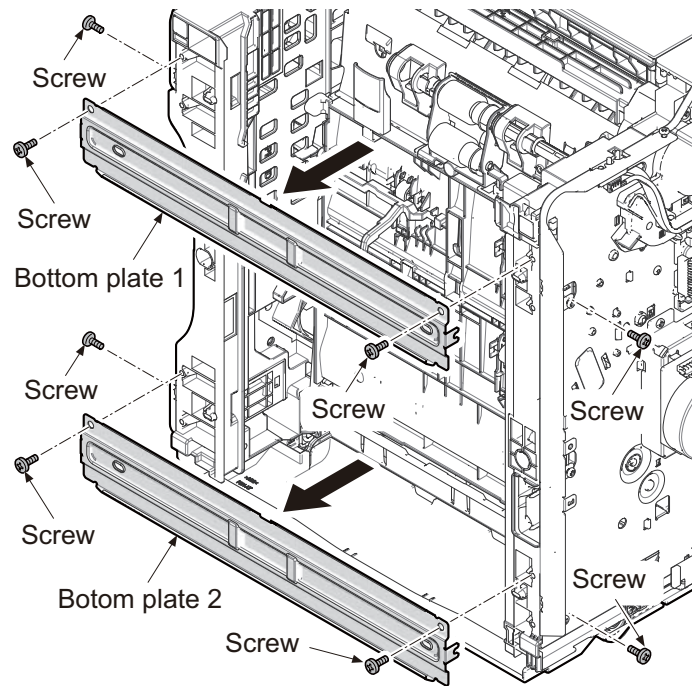

Figure 1-5-125

(50/60 ppm model only)

- (1) Release two hooks and then remove the wire cover.
- (2) Pull the connector of lift sensor out.

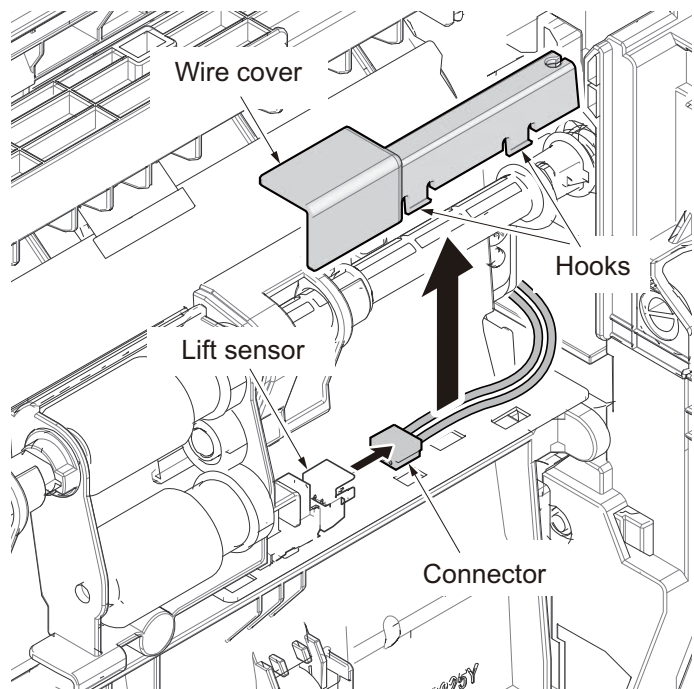

Figure 1-5-126

34. Remove seven screws.
35. Extract the feed roller axis by pushing the joint part.
36. Remove the duplex conveying unit to the front.
37. Check or replace the duplex conveying unit and refit all the removed parts.

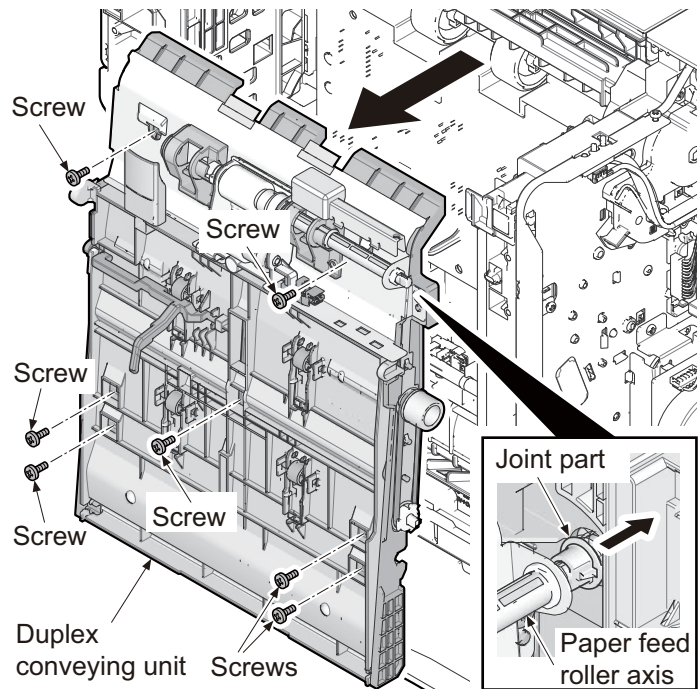

Figure 1-5-127

1-5-10 Document processor

(1) Original feed section

The original feed section consists of the parts shown in figure. An original placed on the original tray is conveyed to the original conveying section. Original is fed by the rotation of the DP forwarding pulley and DP paper feed roller.

[Component formation]

1. DP pickup pulley
2. DP paper feed roller
3. DP feed holder
4. DP separation pad
5. Pre separation pad
6. Acuator
(DP original sensor)
7. Original tray
8. Acuator
(DP original timing sensor)

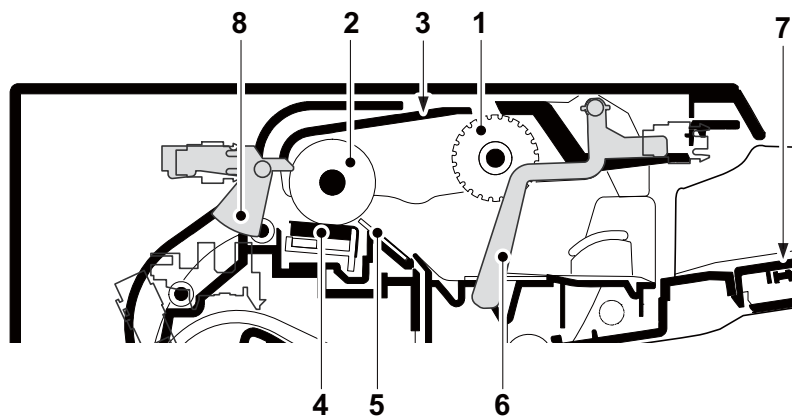

Figure 1-5-128

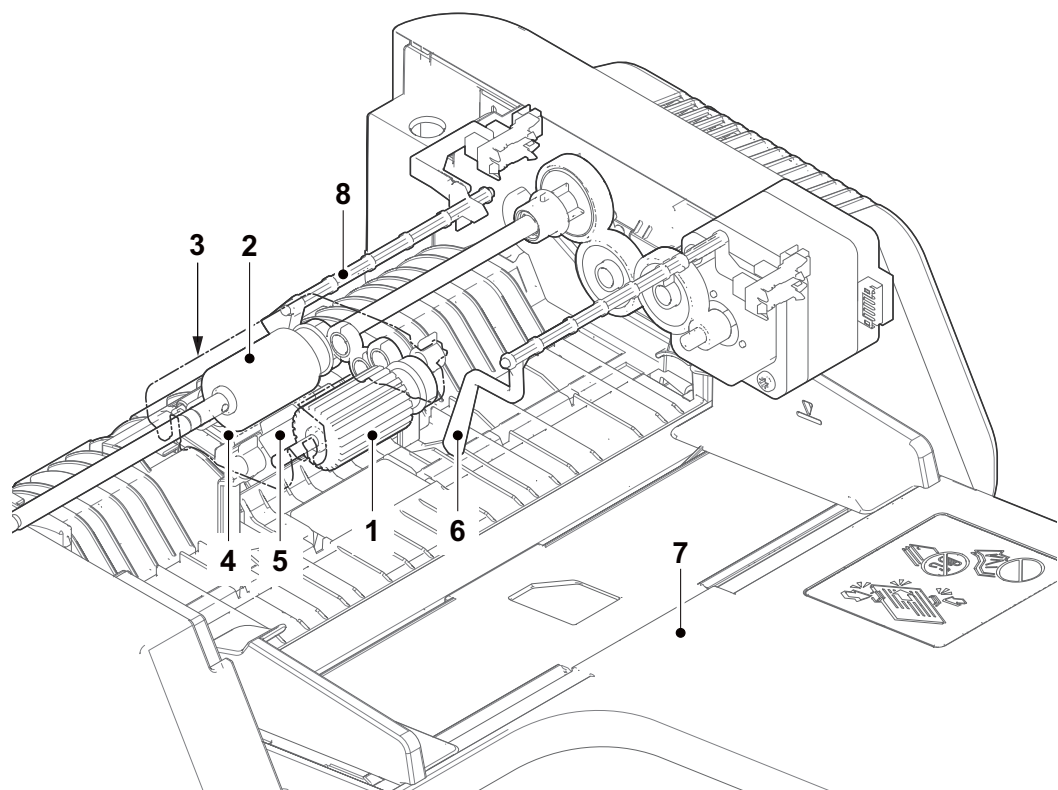

Figure 1-5-129

[Control block diagram]

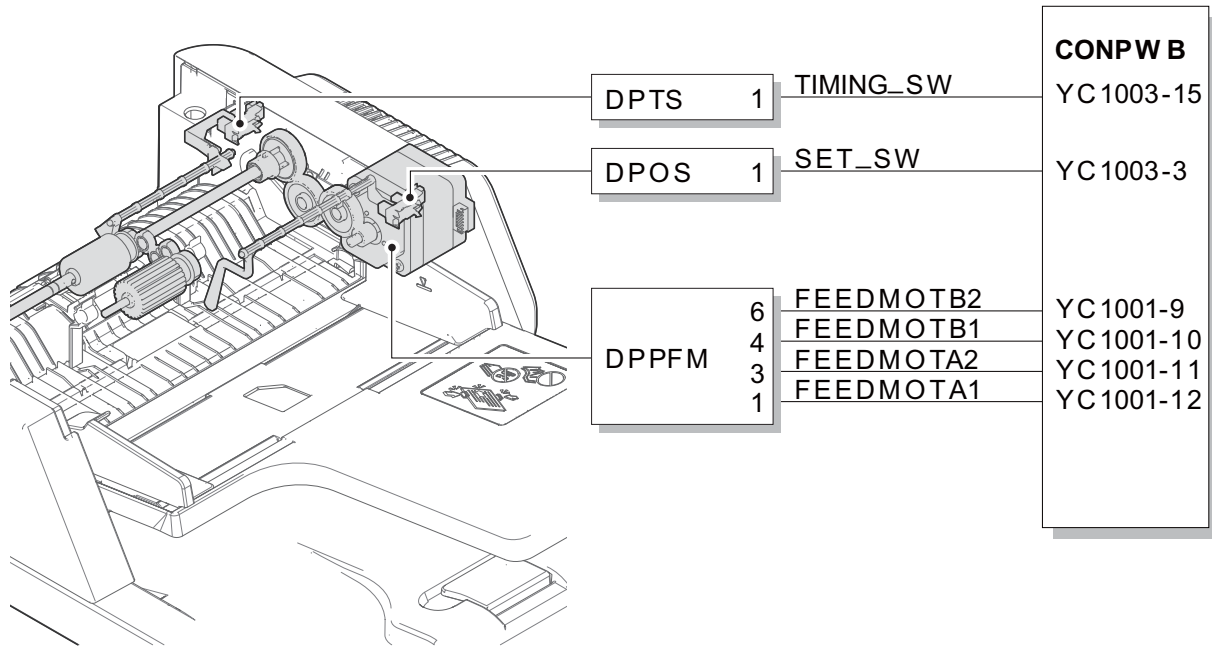
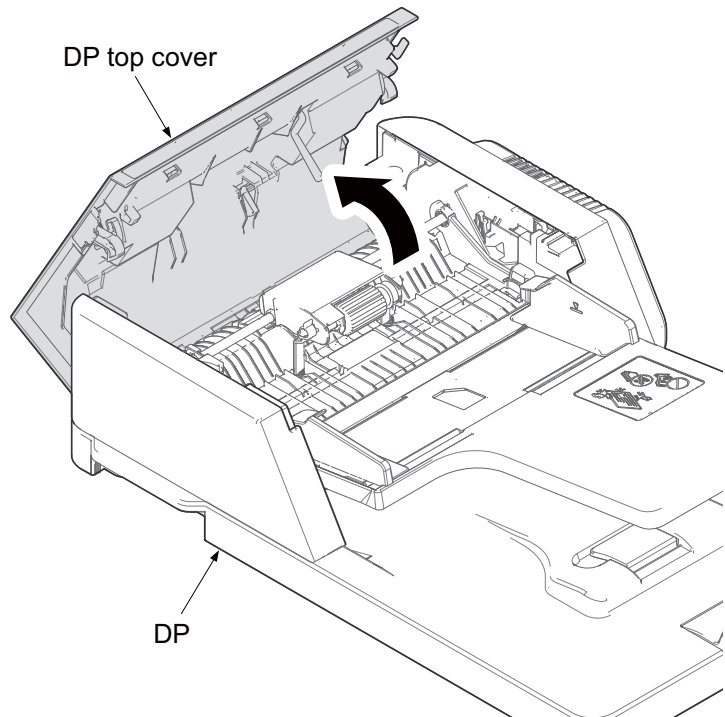

Figure 1-5-130

(1-1) Detaching and refitting DP paper feed roller or DP pickup pulley**Procedure**

1. Open the DP top cover.

**Figure 1-5-131**

2. Rotate the lock lever to unlock position.
3. Pick the frontside of DP paper feed roller axis up and then pull DP paper feed roller assembly out forward.

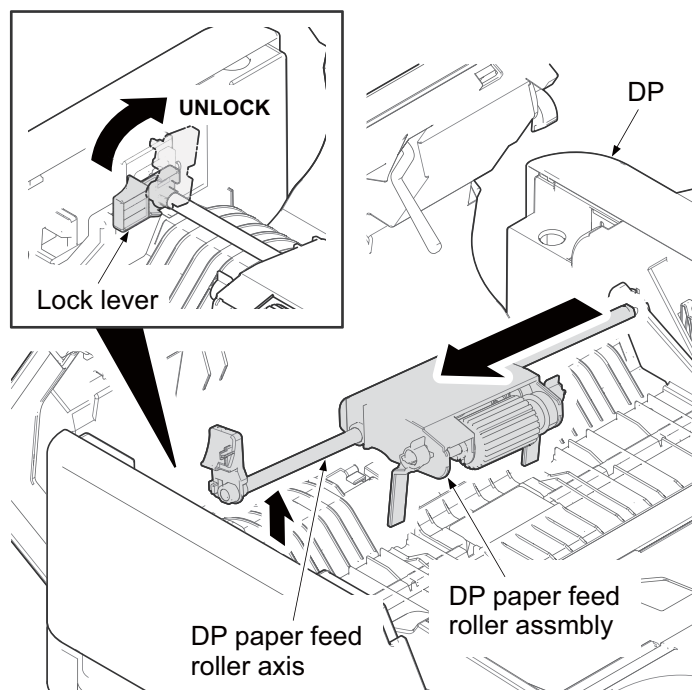
**Figure 1-5-132**

4. Remove two stop-ring and the spring-pin.
5. Pull DP paper feed roller axis out.
6. Check or replace DP paper feed roller or DP pickup pulley and refit all the removed parts.

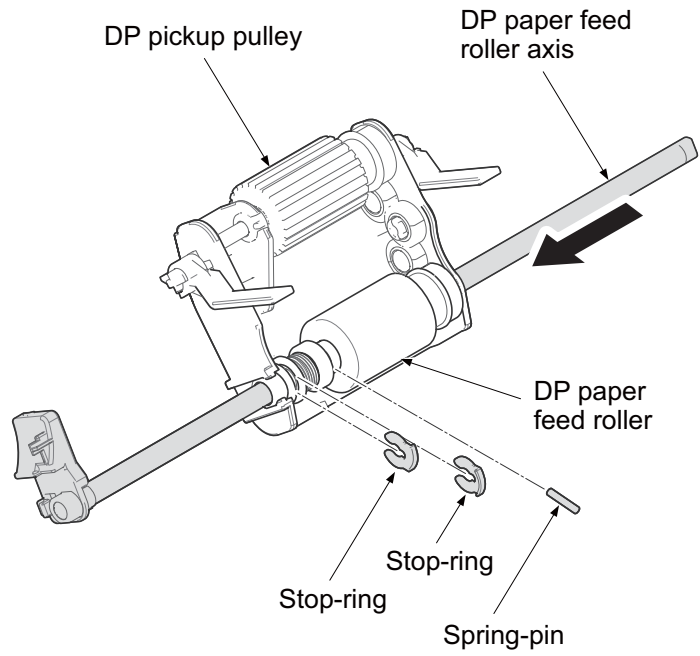

Figure 1-5-133

(1-2) Detaching and refitting the DP separation pad

Procedure

1. Push two hooks inside and pull DP separation pad assembly up.
2. Check or replace DP separation pad and refit all the removed parts.

*: Check whether the pressure spring is contained in the projection.

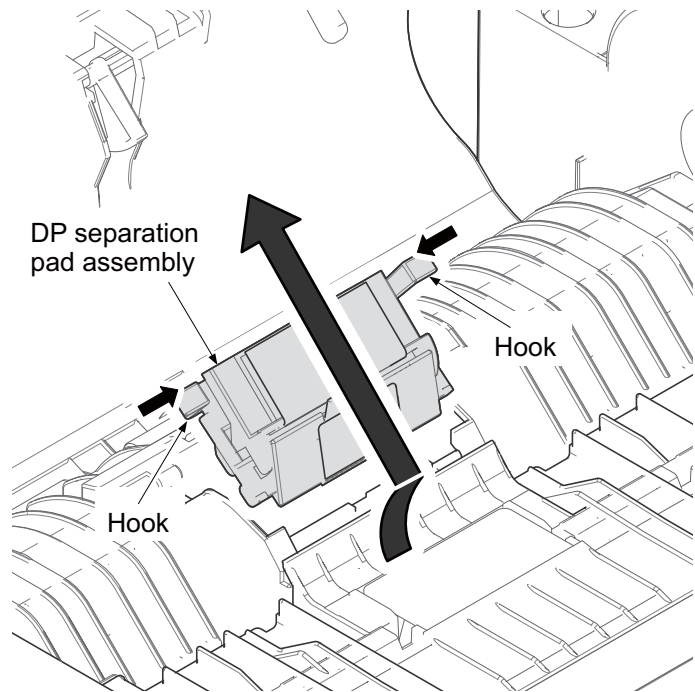

Figure 1-5-134

(2) Original conveying section and switchback/eject section

The original conveying section consists of the parts shown in figure. A conveyed original is scanned by the optical section (CCD) of main unit when it passes through the slit glass of main unit.

The original switchback/eject sections consists of the parts shown in figure. An original of which scanning is complete is ejected to the original eject table by the eject roller.

An original is conveyed temporarily to the original eject table and conveyed again to the original conveying section by the switchback roller.

[Component formation]

1. Actuator
(DP registration sensor)
2. DP registration roller
3. DP registration pulley
4. Reading guide
5. Slit glass
6. DP conveying roller
7. DP conveying pulley
8. Switchback guide
9. Switchback roller
10. Switchback pulley
11. DP eject roller
12. DP eject pulley
13. Switchback guide
14. Eject table

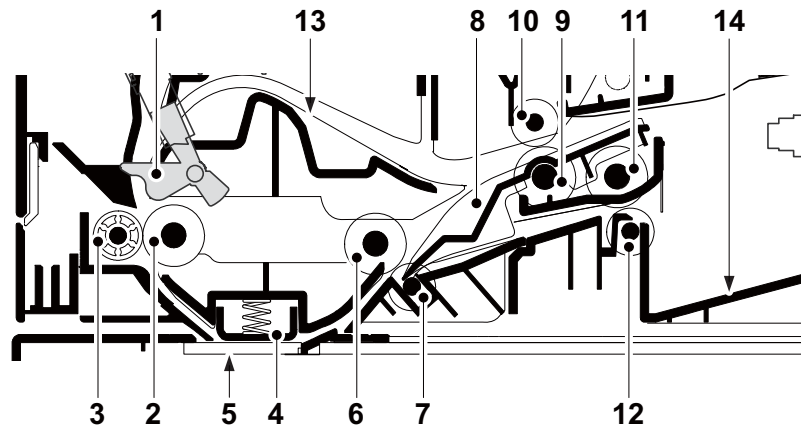

Figure 1-5-135

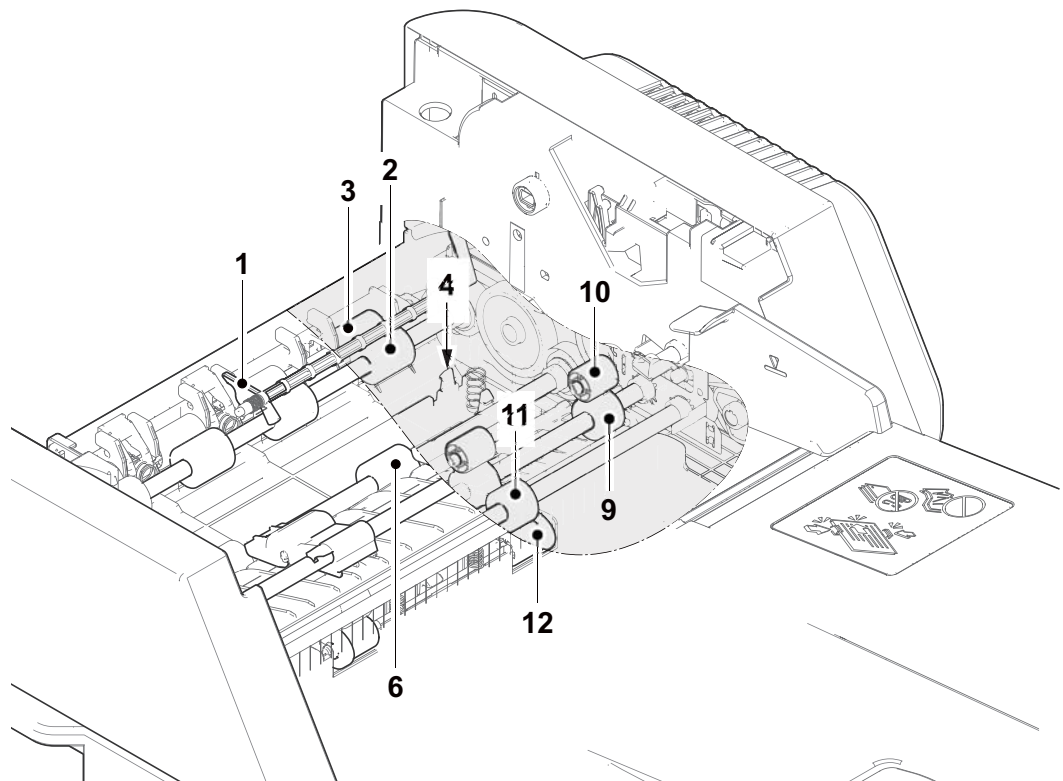

Figure 1-5-136

[Control block diagram]

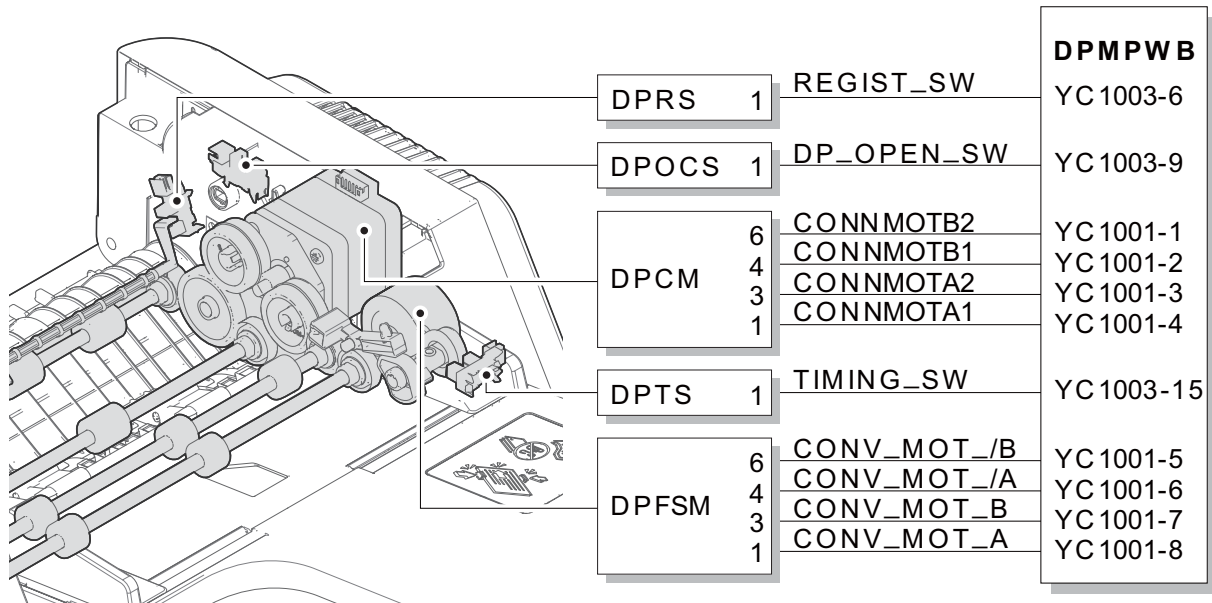

Figure 1-5-137

(2-1) Detaching and refitting the DP switchback motor

Procedure

1. Open DP top cover.
2. Release two hooks using a flat screw draiver and remove DP rear cover.

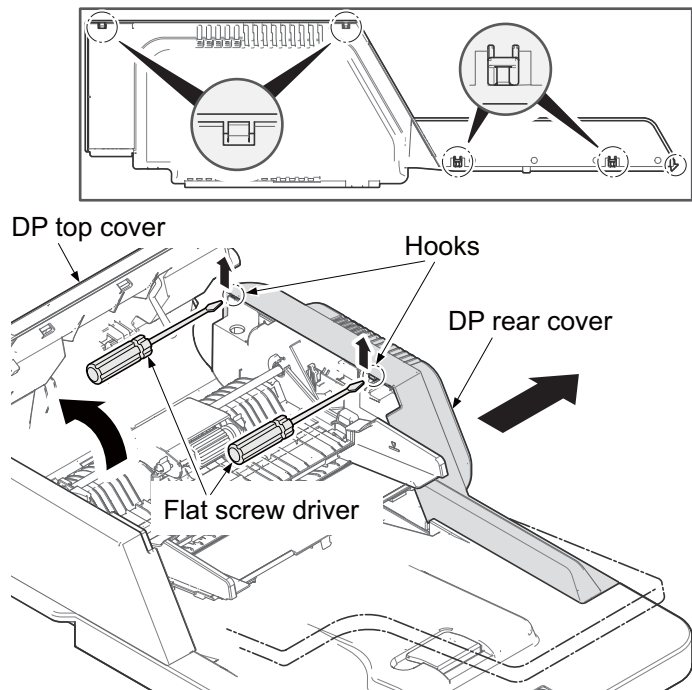

Figure 1-5-138

3. Remove the connector from DP shiftback motor.
4. Remove two screws and DP shiftback motor from DP.
5. Check or replace the DP shiftback motor and refit all the removed parts.

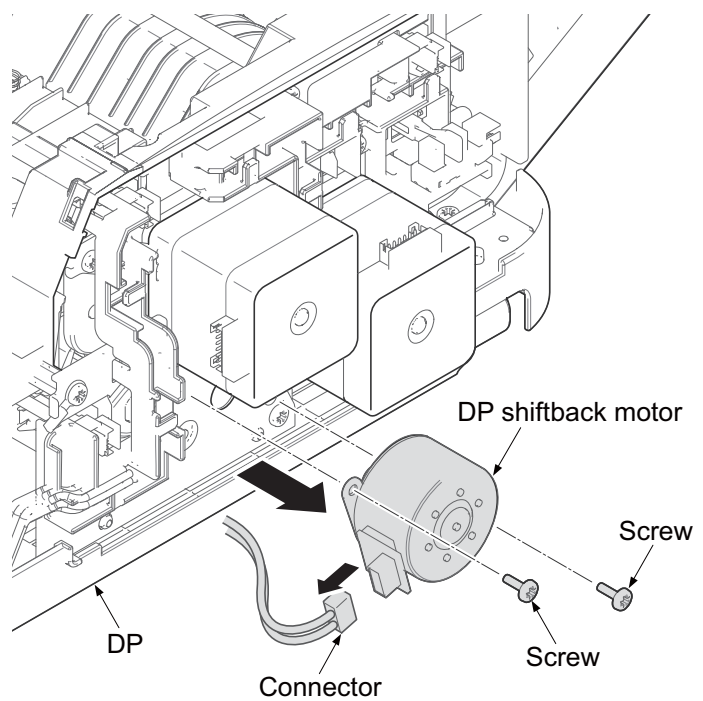
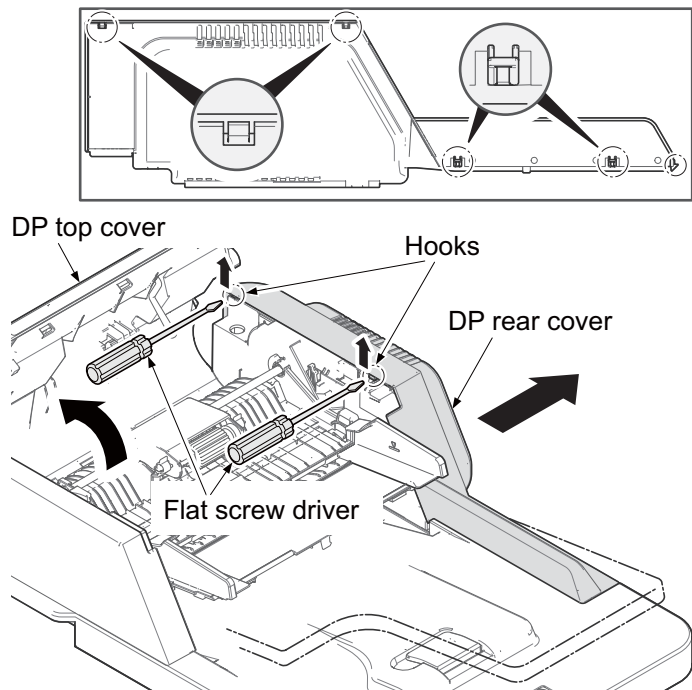

Figure 1-5-139

(2-2) Detaching and refitting the DP paper feed motor and the DP conveying motor**Procedure**

1. Open DP top cover.
2. Release two hooks using a flat screw driver and remove DP rear cover.

**Figure 1-5-140**

3. Remove five connectors from the motor and the sensor.
4. Release the wires from six hooks of the wire guide.

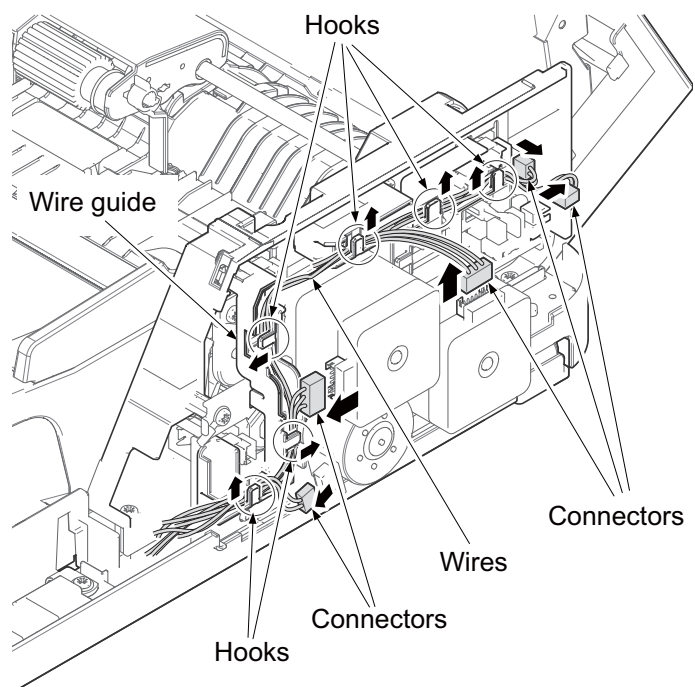
**Figure 1-5-141**

5. Remove two screws and the grounding terminal.
6. Remove the Drive B unit from DP.

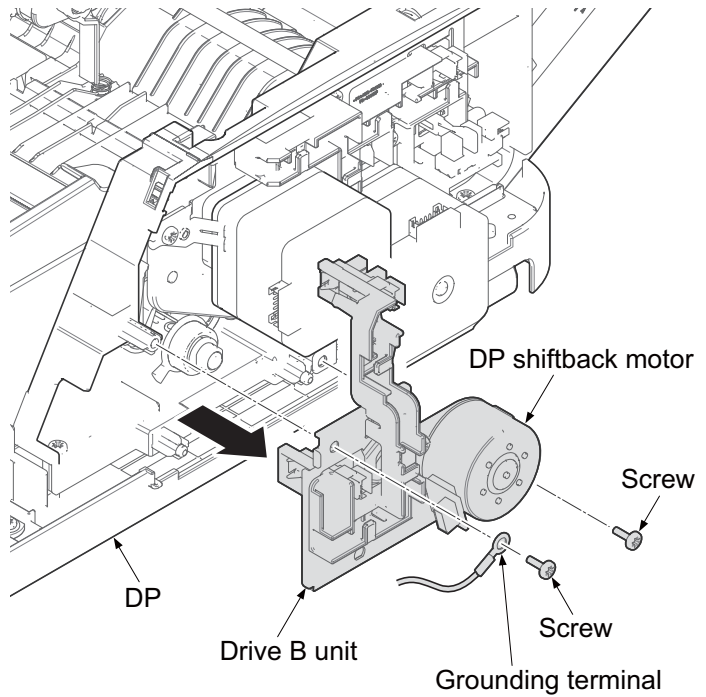

Figure 1-5-142

7. Remove four screws and then remove Drive A unit.

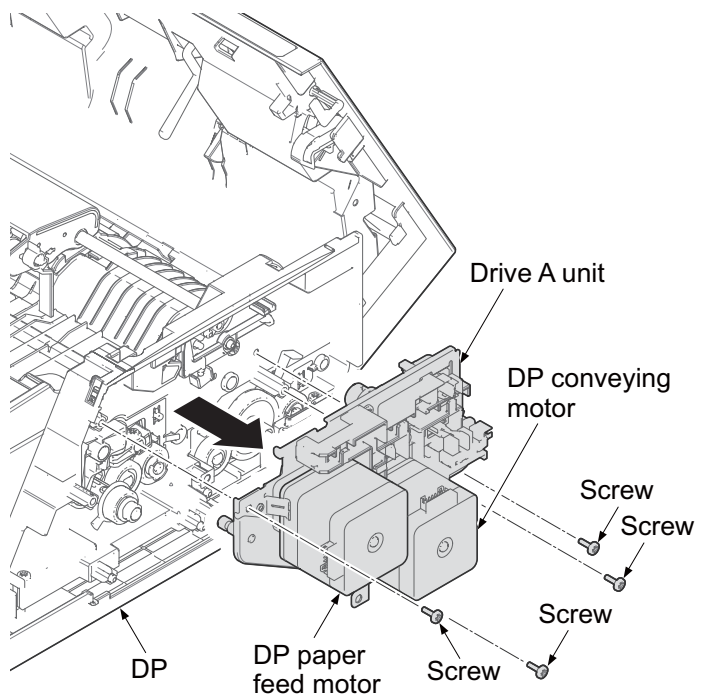

Figure 1-5-143

8. Remove two gear.
9. Remove four screws and drive cover.
10. Remove DP paper feed motor and DP conveying motor.
11. Check or replace DP paper feed motor and DP conveying motor and refit all the removed parts.

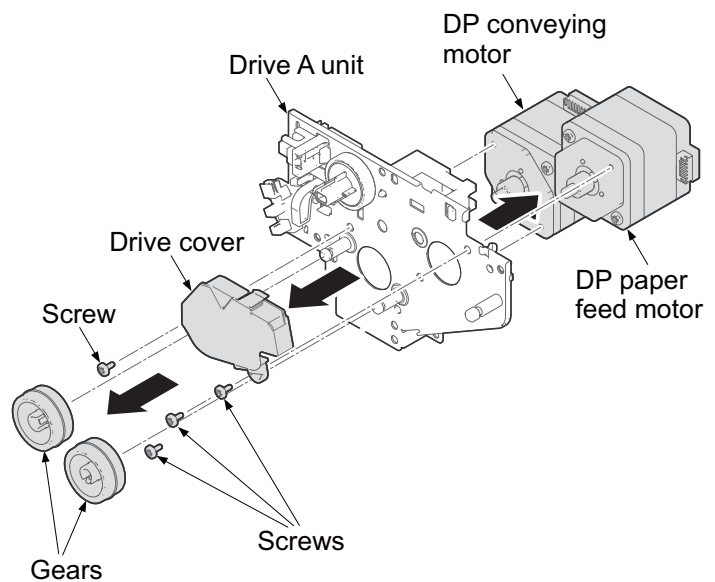

Figure 1-5-144

(2-3) Detaching and refitting the DP unit

Procedure

1. Open the rear cover and remove the upper interface cover.
2. Remove the right stay cover.
3. Remove the screws and the right upper cover.
4. Remove the screw and grounding terminal.
5. Remove two connector from the control PWB.
6. Release DP wires from the hook and the wire saddle.
7. Open DP unit and lift up out.

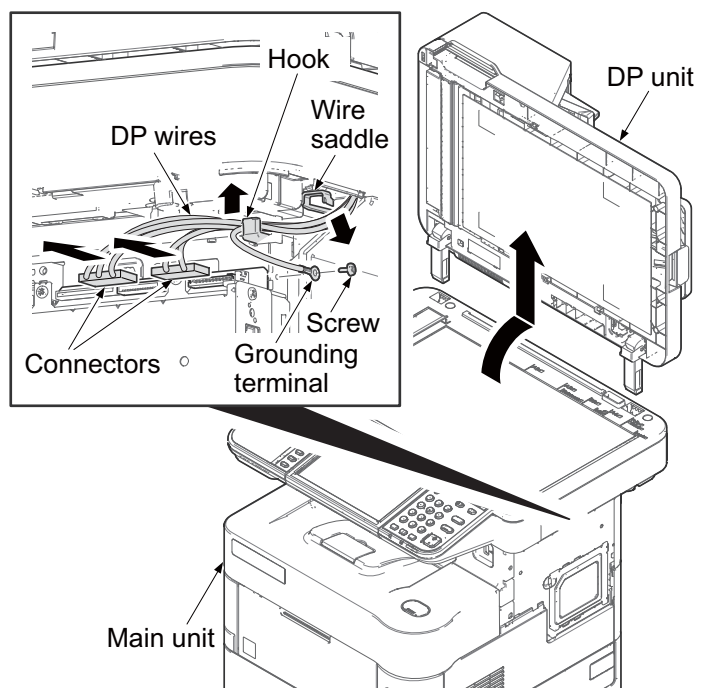

Figure 1-5-145

1-5-11 Covers

(1) Detaching and refitting the MP paper feed pulley

Procedure

1. Push the button and open the front cover.

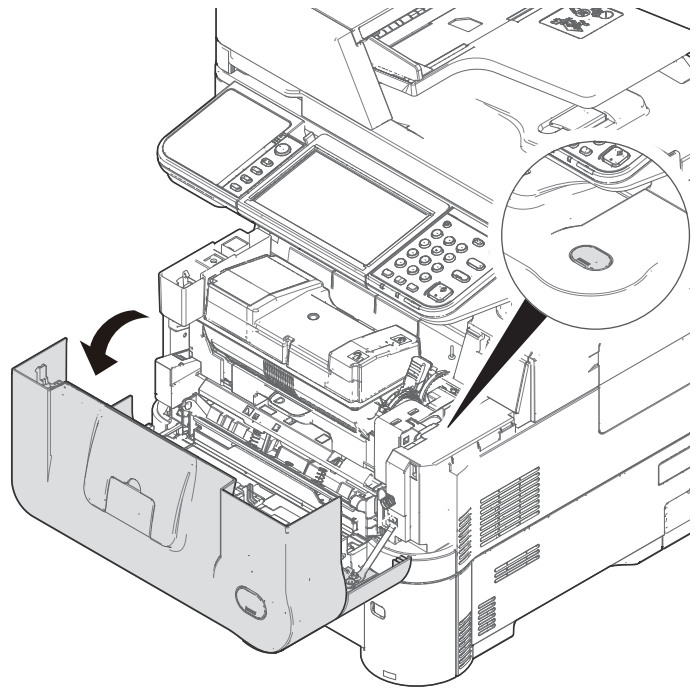

Figure 1-5-146

2. Remove the MP tray from the printer while bending it.
3. Remove two screws and two straps.

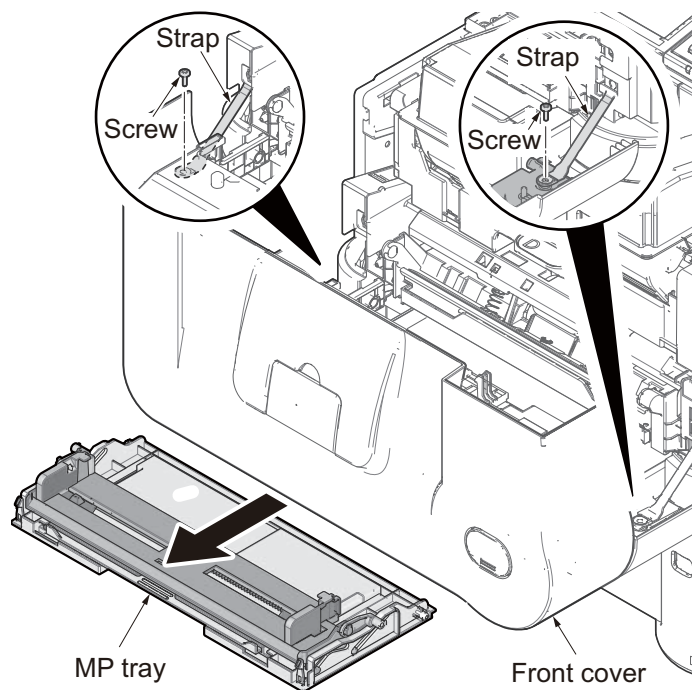

Figure 1-5-147

4. Remove the fulcrum of leftside by extending a cover.
5. Remove the fulcrum of rightside during twisting a cover.
6. Remove the front cover forward.

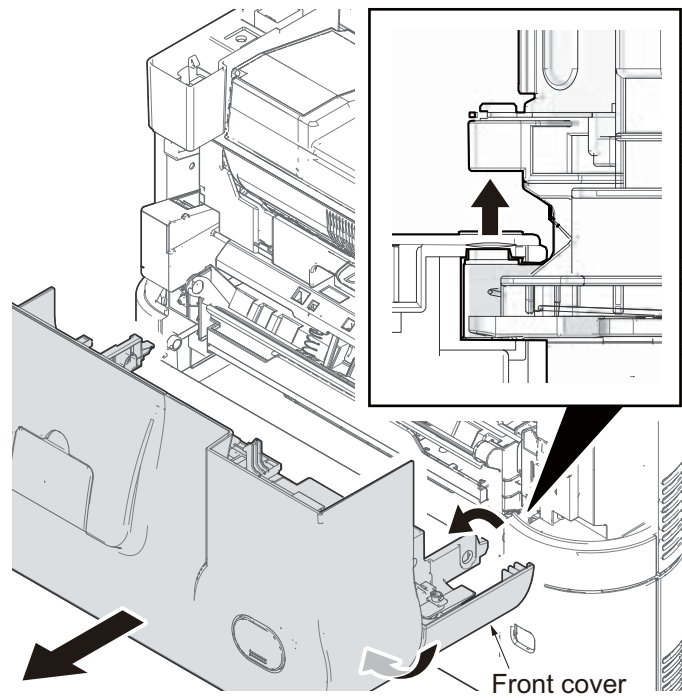
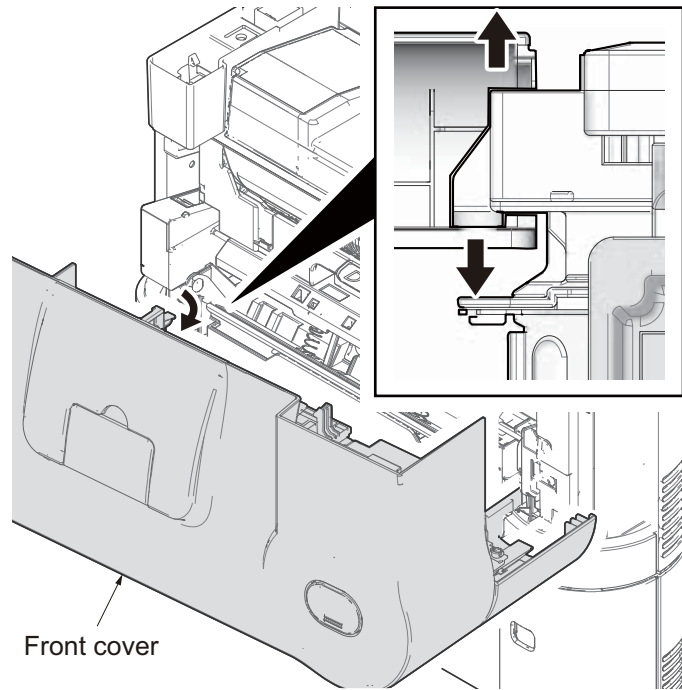

Figure 1-5-148

(2) Detaching and refitting the inlet cover and the interface slot cover

Procedure

1. Open the rear cover.
2. Remove the Upper interface cover and then lower interface cover.
3. Remove the inlet cover.

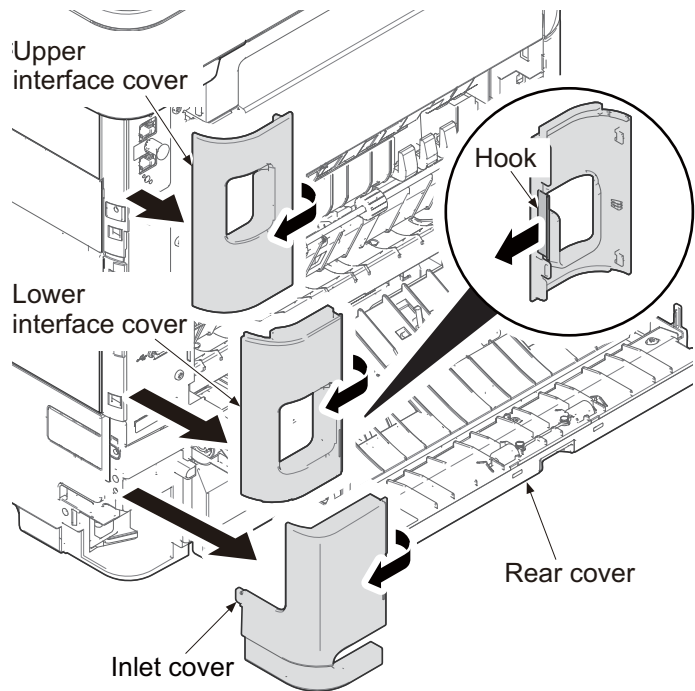

Figure 1-5-149

(3) Detaching and refitting the right stay cover

Procedure

1. Remove the upper interface cover.
2. Release two hooks using a flat screw driver and remove the right stay cover.

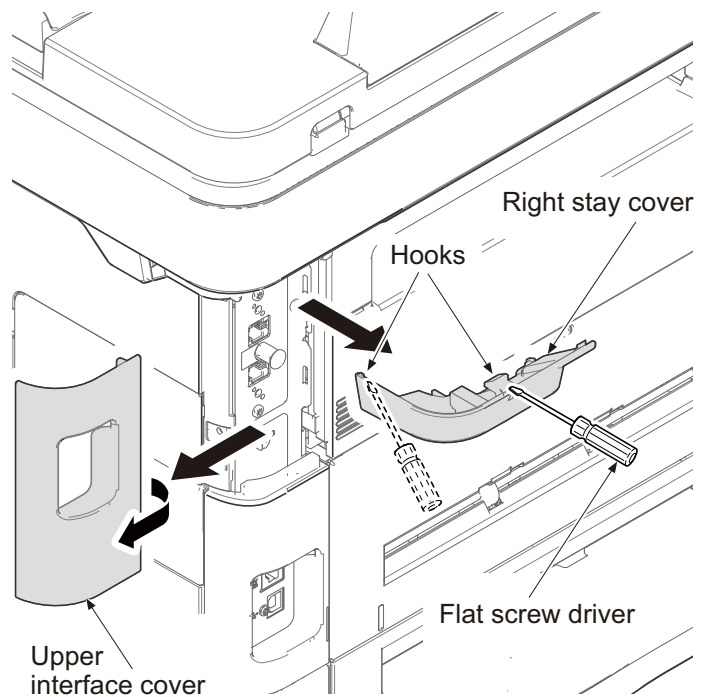

Figure 1-5-150

(4) Detaching and refitting the right upper cover

Procedure

1. Remove the controller cover.
2. Remove the screw from the right upper cover.
3. Release two hooks using a flat screw driver and remove the right upper cover.

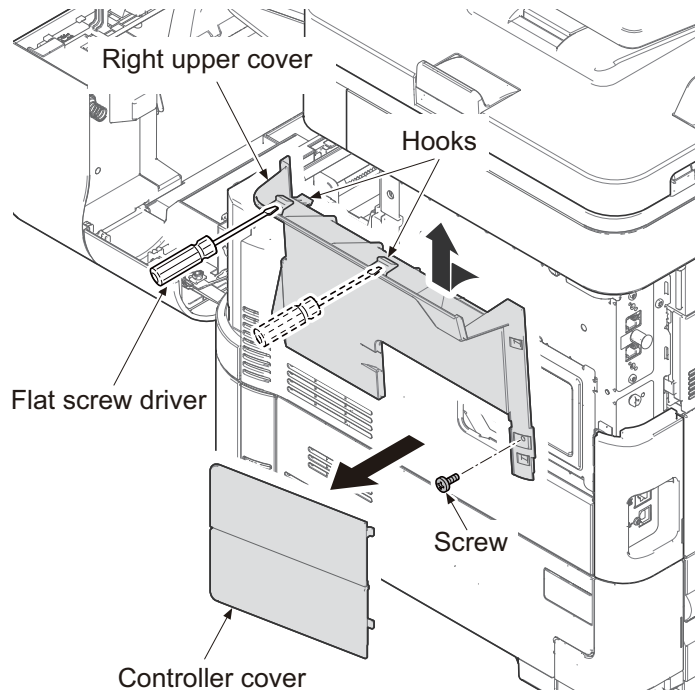

Figure 1-5-151

(5) Detaching and refitting the left upper cover

Procedure

1. Release two hooks using a flat screw driver and remove the left upper cover.

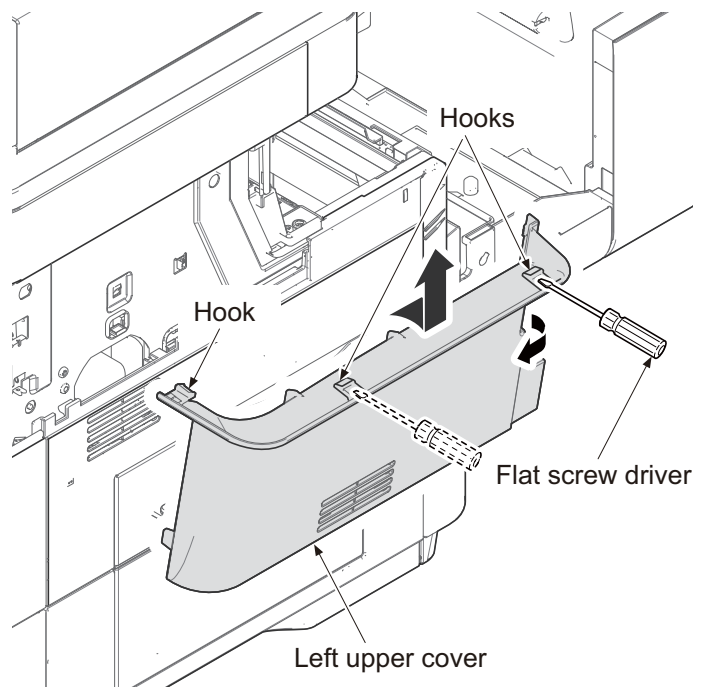

Figure 1-5-152

(6) Detaching and refitting the center stay cover

Procedure

1. Remove the screw from the center stay cover.
2. Release two hooks using a flat screw driver and remove the center stay cover.

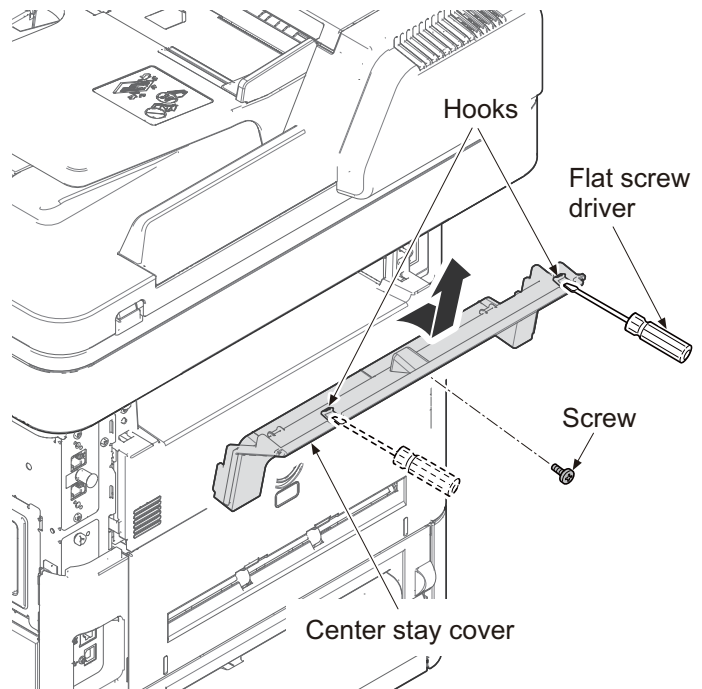

Figure 1-5-153

(7) Detaching and refitting the front right cover

Procedure

1. Remove the front right cover forward.

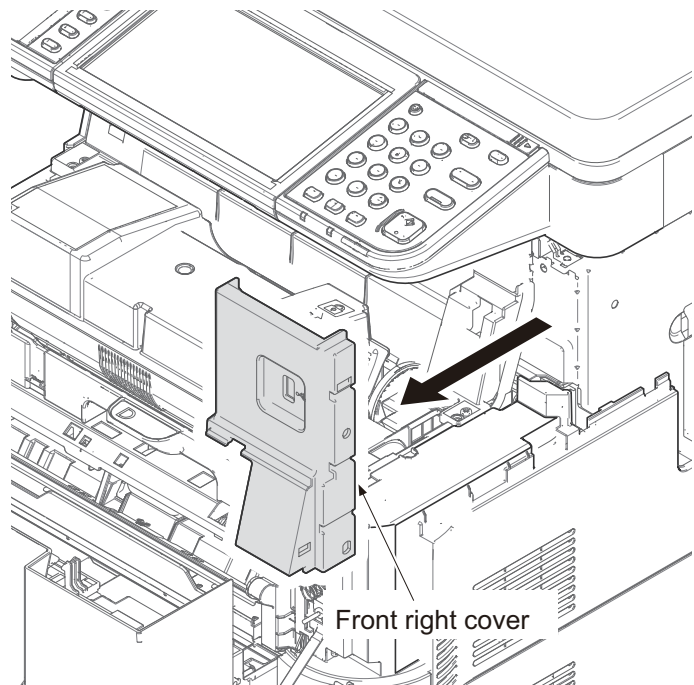

Figure 1-5-154

(8) Detaching and refitting the top tray cover

Procedure

1. Remove two screws.

(50/60 ppm model only)

- (1) Slide the right inner spacer and the left inner spacer forward and then remove it upward.

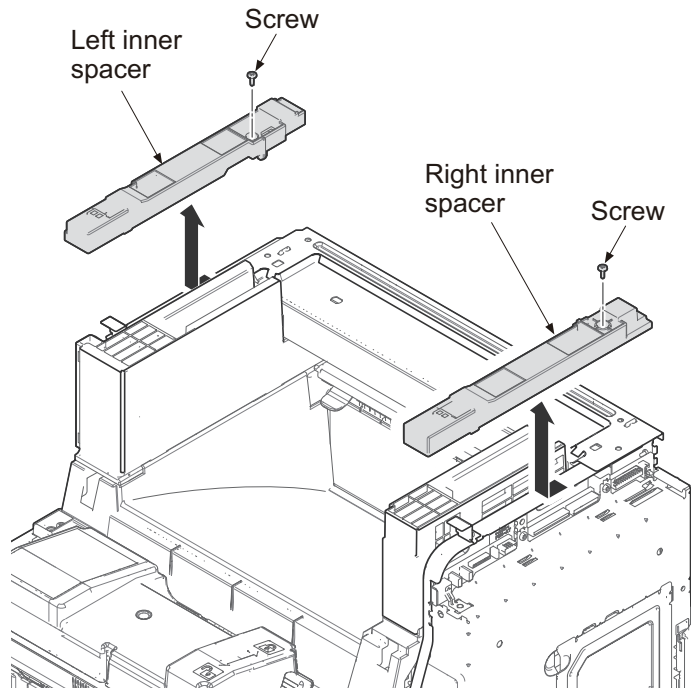

Figure 1-5-155

2. Remove two screws.
3. Remove the eject unit cover.

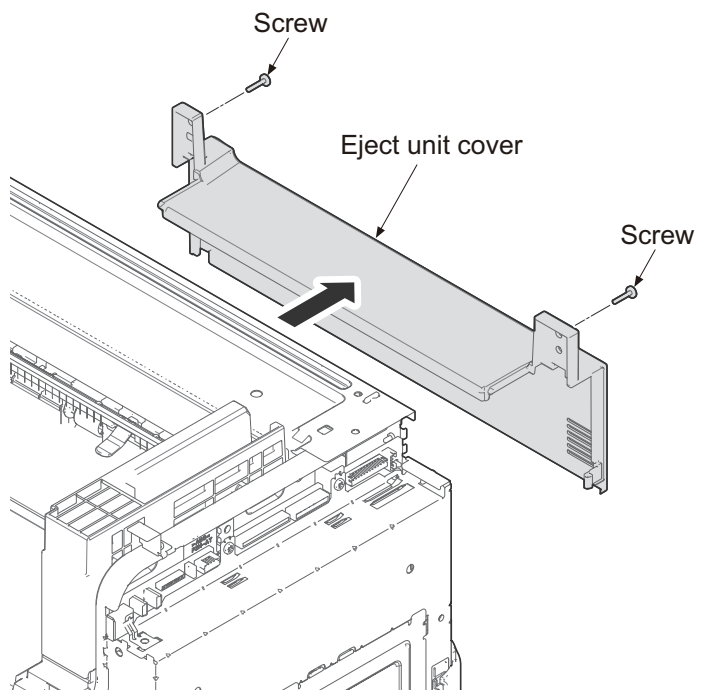

Figure 1-5-156

4. Remove four screws.
5. Remove the upper stay assembly upward.

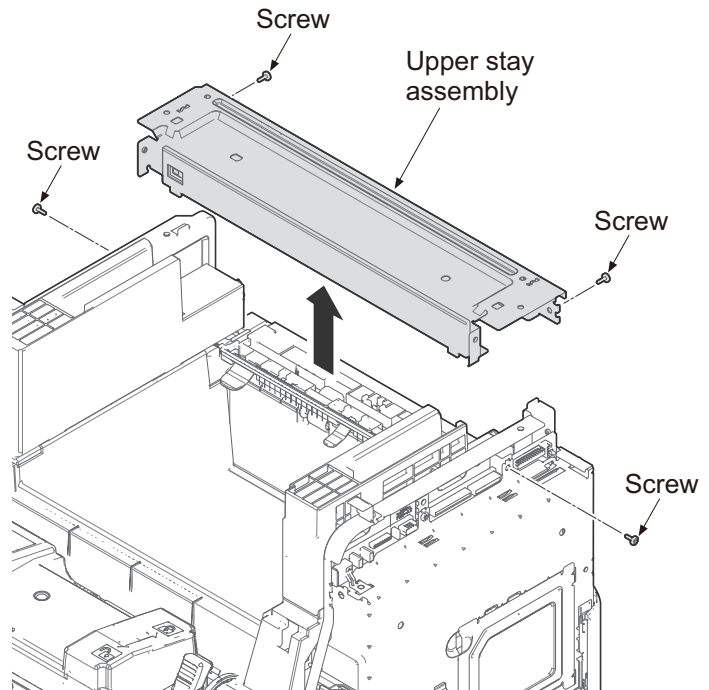

Figure 1-5-157

6. Remove the screw and then remove the right inner cover by leaning it inside and lifting it.
7. Remove two screws and then remove the left inner cover by leaning it inside and lifting it.

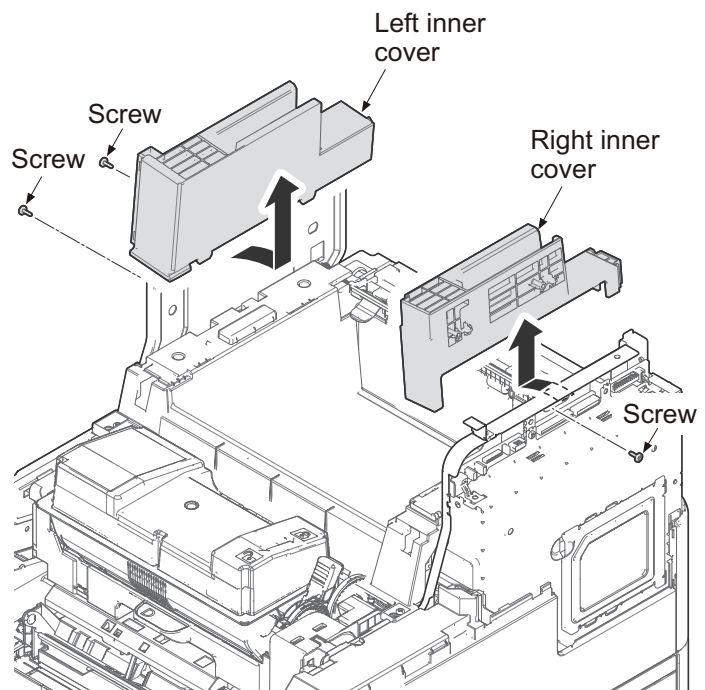

Figure 1-5-158

8. Remove two screws.
9. Remove the top tray cover upward.

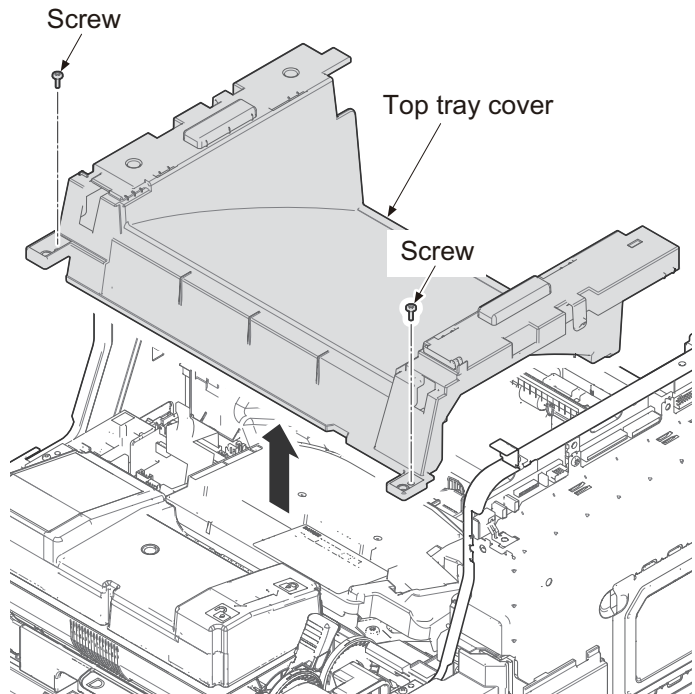

Figure 1-5-159

(9) Detaching and refitting the right middle cover

Procedure

1. Remove two screws.
2. Release the hooks by bending both-side of the right middle cover and then remove it by pulling and lifting up forward.

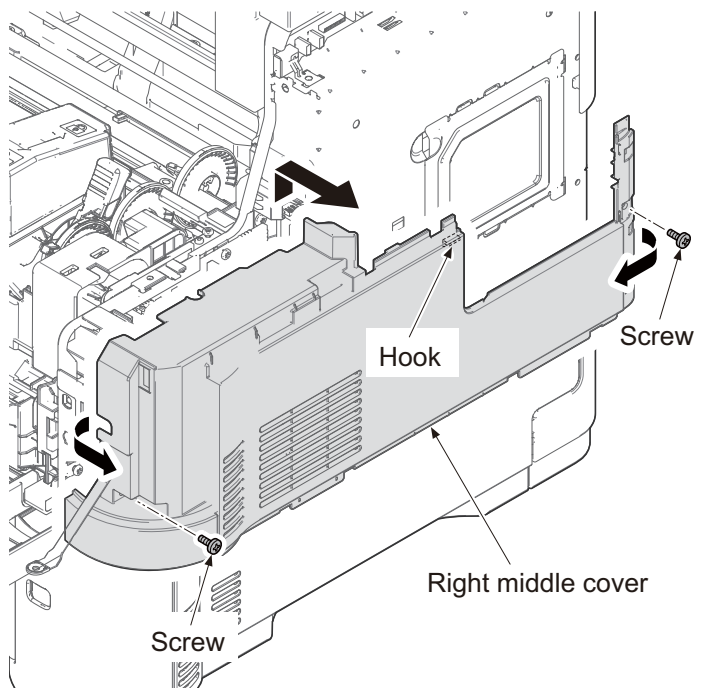

Figure 1-5-160

(10) Detaching and refitting the right lower cover

Procedure

1. Pull out the cassette.
2. Remove three screws.
3. Release two hooks by sliding the right lower cover upward and then remove the right lower cover.

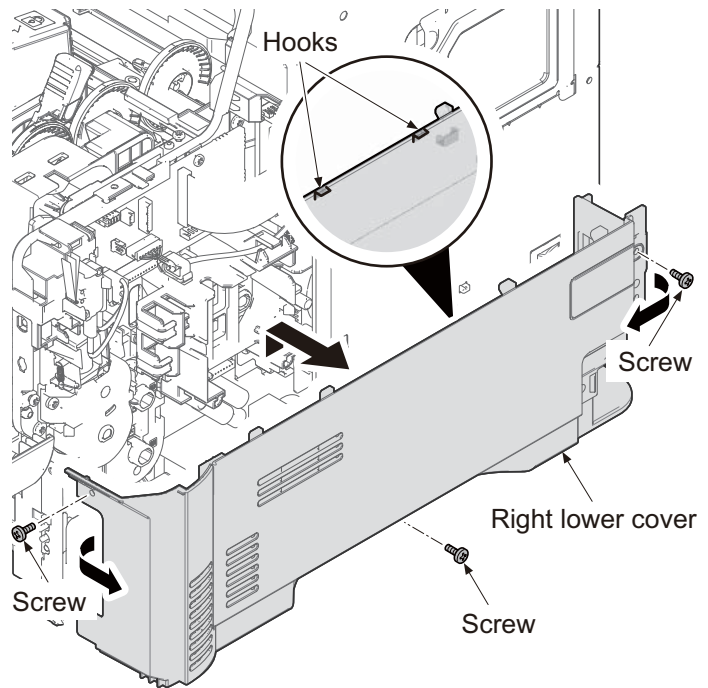

Figure 1-5-161

(11) Detaching and refitting the rear left cover

Procedure

1. Open the rear cover.
2. Release two hooks of the rear left cover while pulling forward.
3. Remove the rear left cover by rotating.

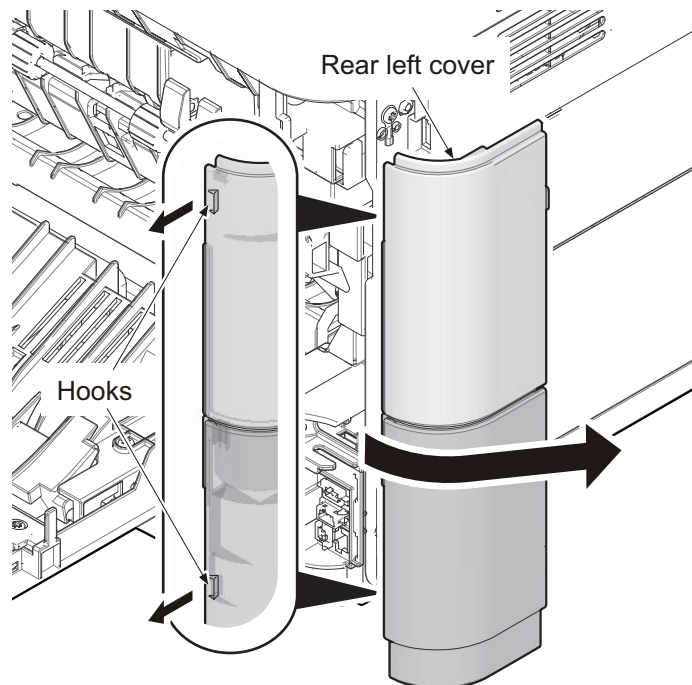
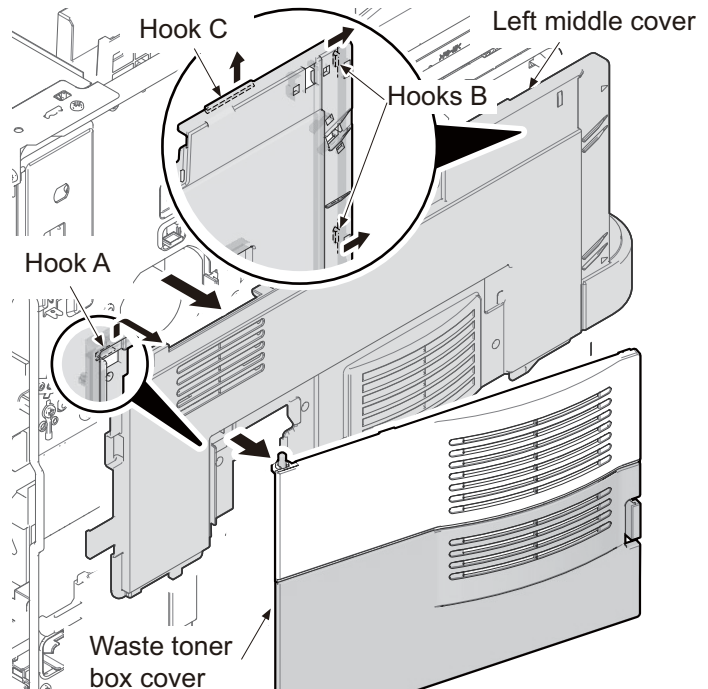

Figure 1-5-162

(12) Detaching and refitting the left middle cover and the waste toner box cover**Procedure**

1. Release the hook A by sliding the left upper cover upward.
2. Release the hook B and hook C and then remove the left middle cover and the waste toner box cover.

**Figure 1-5-163****(13) Detaching and refitting the left lower cover****Procedure**

1. Remove the screw.
2. Release the hook A.
3. Release two hooks B by sliding the left lower cover upward and then remove the left lower cover.

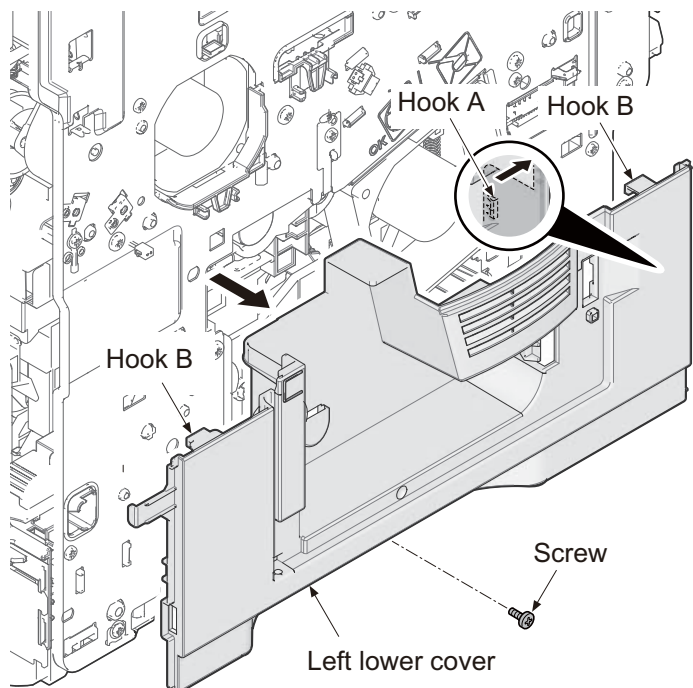
**Figure 1-5-164**

(14) Detaching and refitting the rear cover

Procedure

1. Open the rear cover.

(50/60 ppm model only)

- (1) Remove the screw and then the grounding wire.
- (2) Open the connector cover and then remove three connectors.

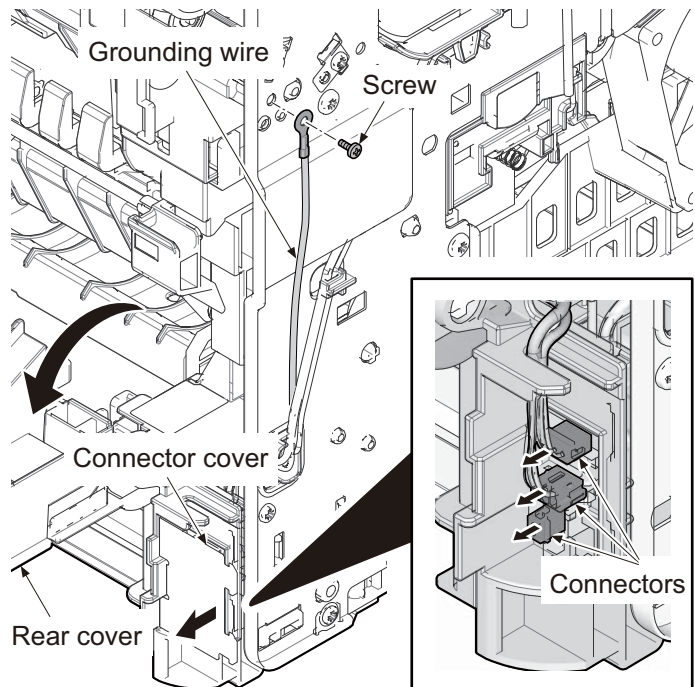

Figure 1-5-165

2. Remove the fulcrum axis by sliding the rear cover assembly while avoiding rear cover and then remove the rear cover assembly.

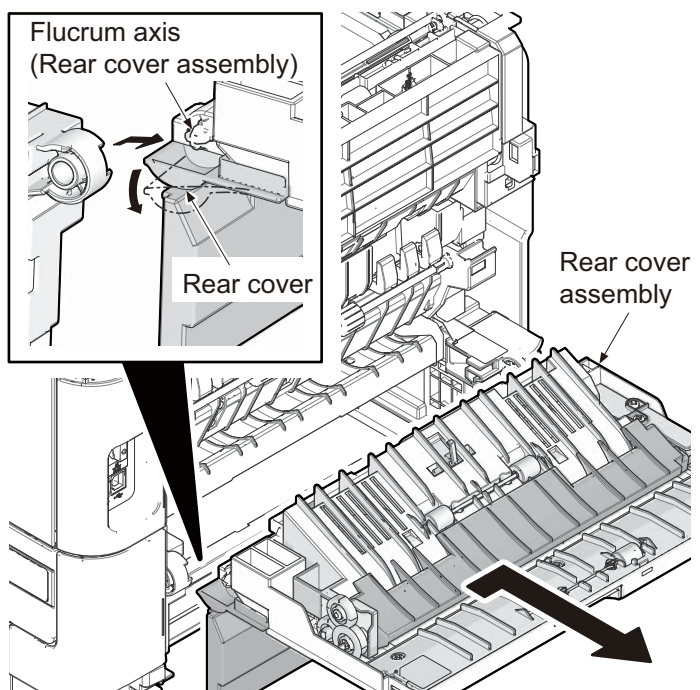

Figure 1-5-166

1-5-12 Othes

(1) Detaching and refitting the main driving motor unit

Procedure

1. Remove right middle cover.
(See page 1-5-93)
2. Remove right lower cover.
(See Page 1-5-94)
3. Pull the connector out from the motor and then release the wires from wire holder.
4. Remove three screws and then remove the main driving motor unit.
5. Check or replace the main driving motor unit and refit all the removed parts.

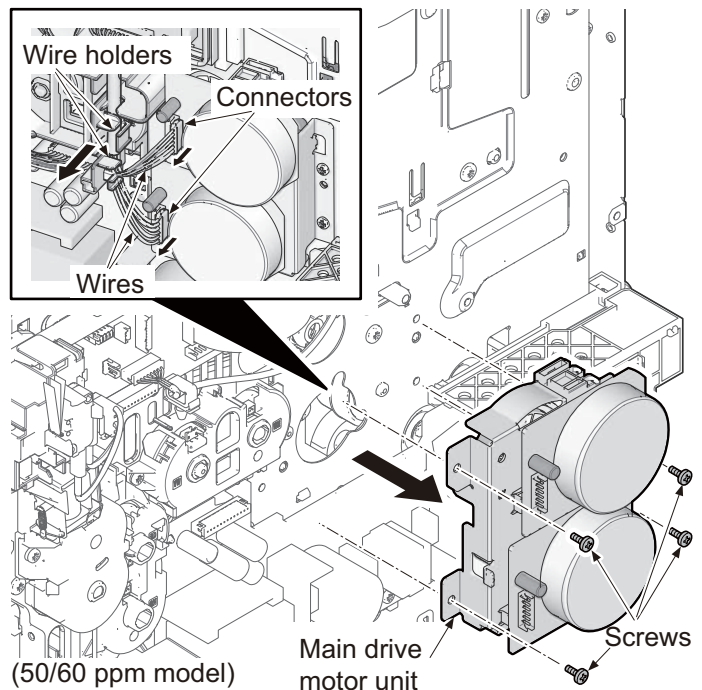

Figure 1-5-167

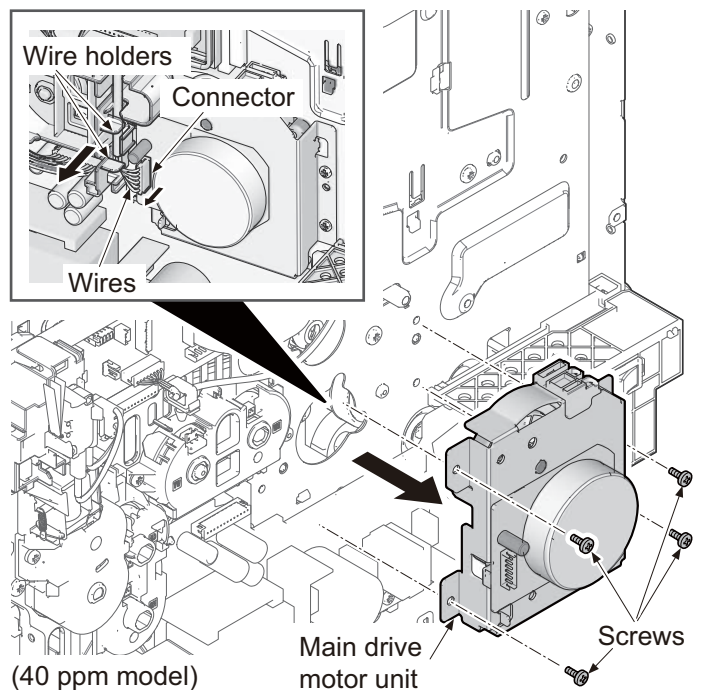

Figure 1-5-168

(2) Detaching and refitting the paper feed driving motor unit

Procedure

1. Remove right middle cover.
(See page 1-5-93)
2. Remove right lower cover.
(See Page 1-5-94)
3. Pull the connectors of clutches and solenoid out.
4. Remove three screws and then remove the paper feed driving motor unit.
5. Check or replace the paper feed driving motor unit and refit all the removed parts.

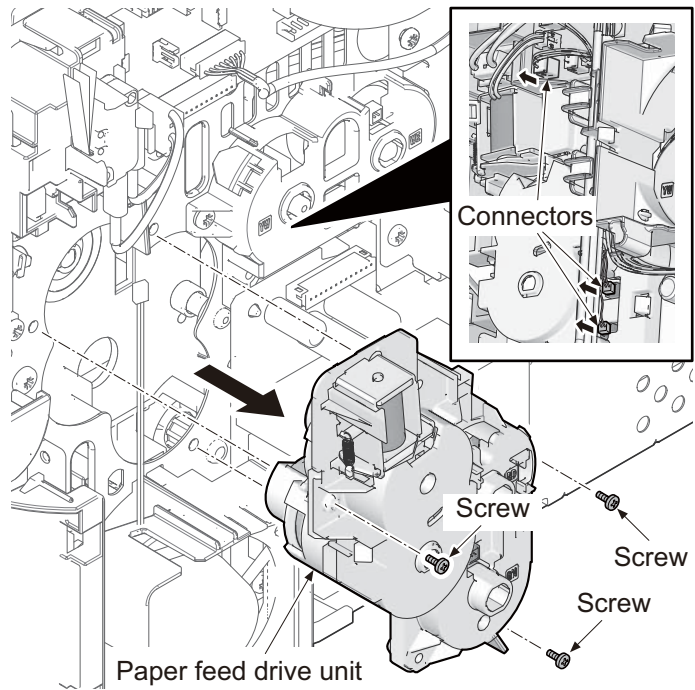

Figure 1-5-169

(3) Detaching and refitting the language sheets

(3-1) HyPAS model

Procedure

1. Slide the right operation lid and left.
2. Remove the their lids.

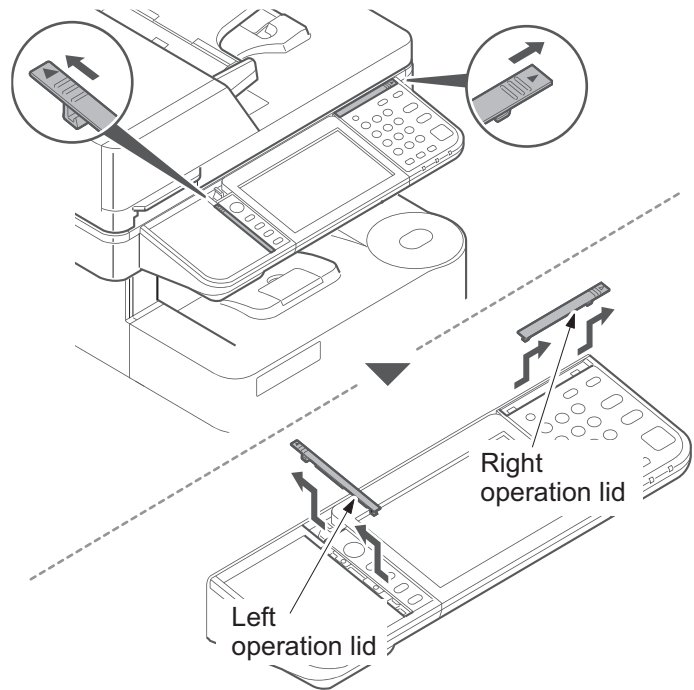

Figure 1-5-170

3. Remove the operation panel cover.
4. Replace it to the operation panel sheet of the corresponding language.
5. Refit all the removed parts.

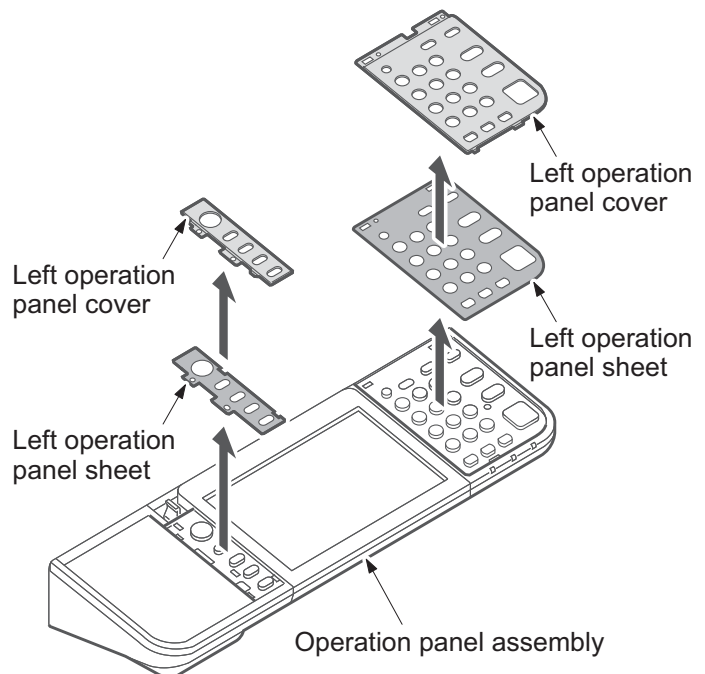
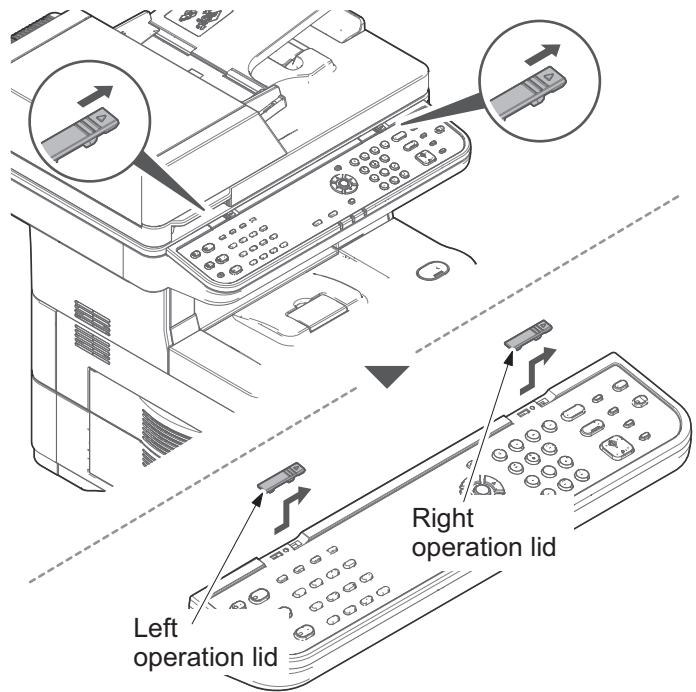

Figure 1-5-171

(3-2) Basic model**Procedure**

1. Slide the right operation lid and left.
2. Remove the their lids.

**Figure 1-5-172**

3. Remove the operation panel cover.
4. Replace it to the operation panel sheet of the corresponding language.
5. Refit all the removed parts.

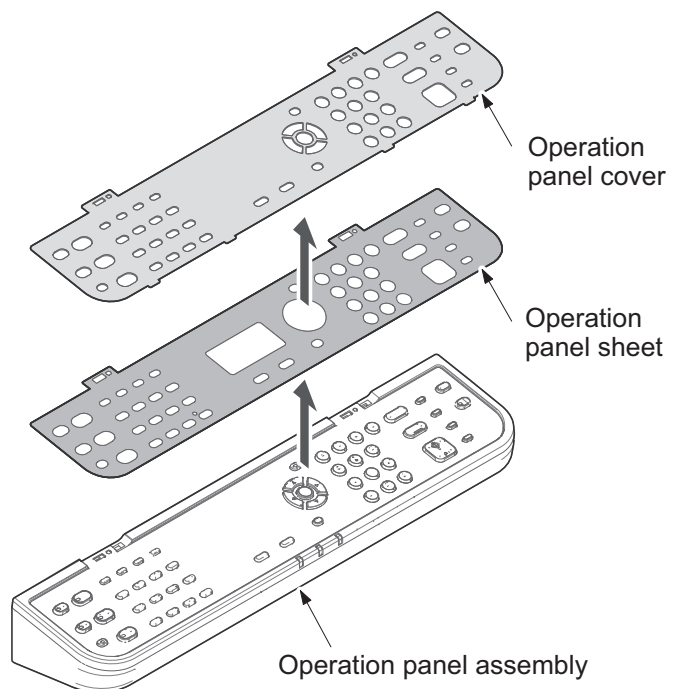
**Figure 1-5-173**

(4) Detaching and refitting the FAX control PWB (FAX model only)

Procedure

1. Remove the upper interface cover.
2. Release two hooks using a flat screw driver and remove the right stay cover.

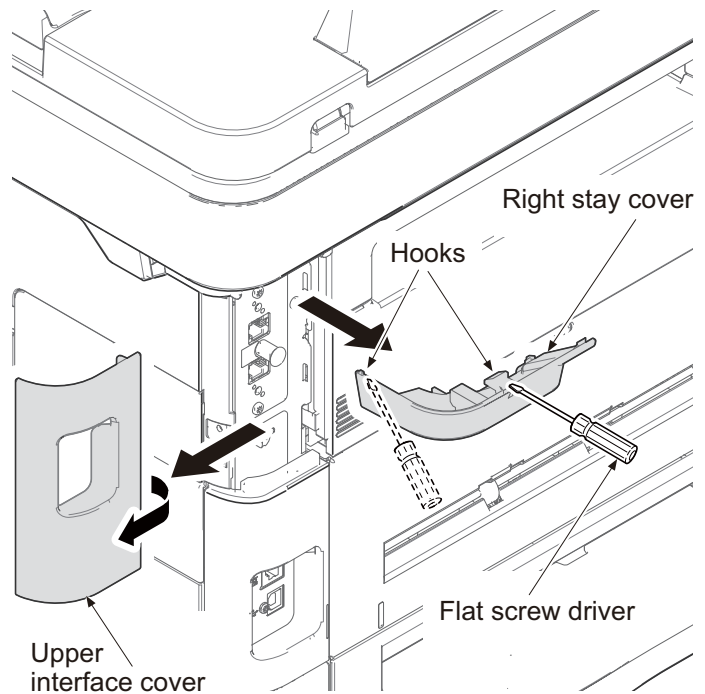

Figure 1-5-174

3. Remove two screws and then pull the FAX control PWB out.
4. Check or replace the FAX control PWB and refit all the removed parts.

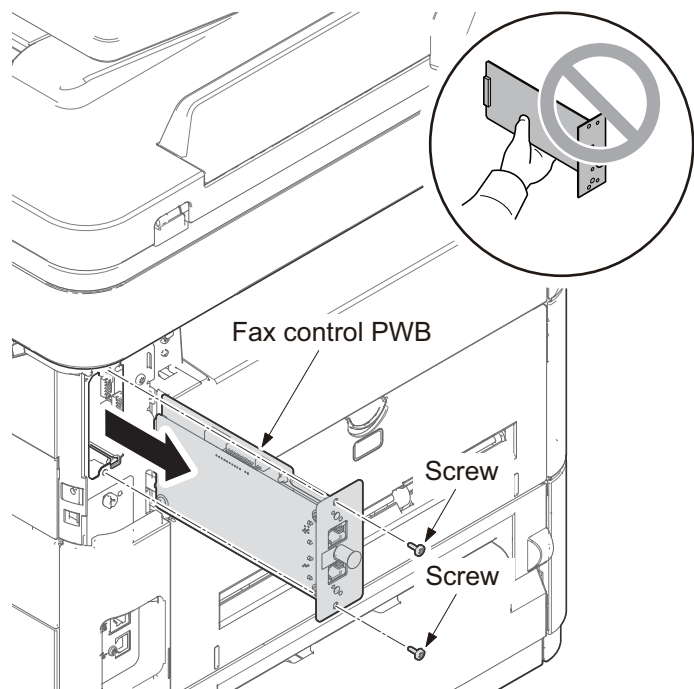
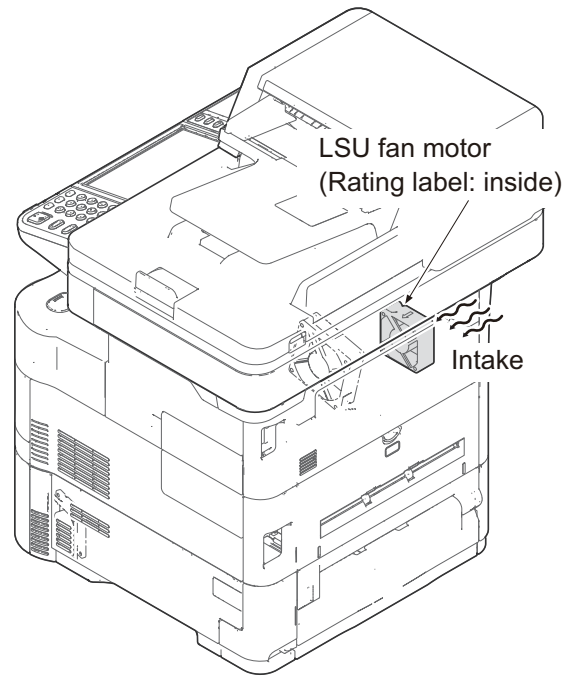
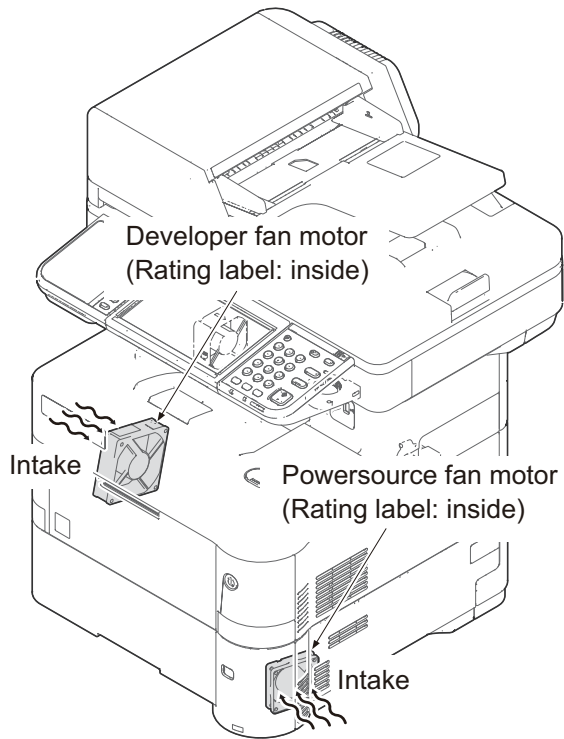

Figure 1-5-175

(5) Direction of installing the principal fan motors

When detaching or refitting the fan motor, be careful of the airflow direction (intake or exhaust).



2-1-1 PWBs

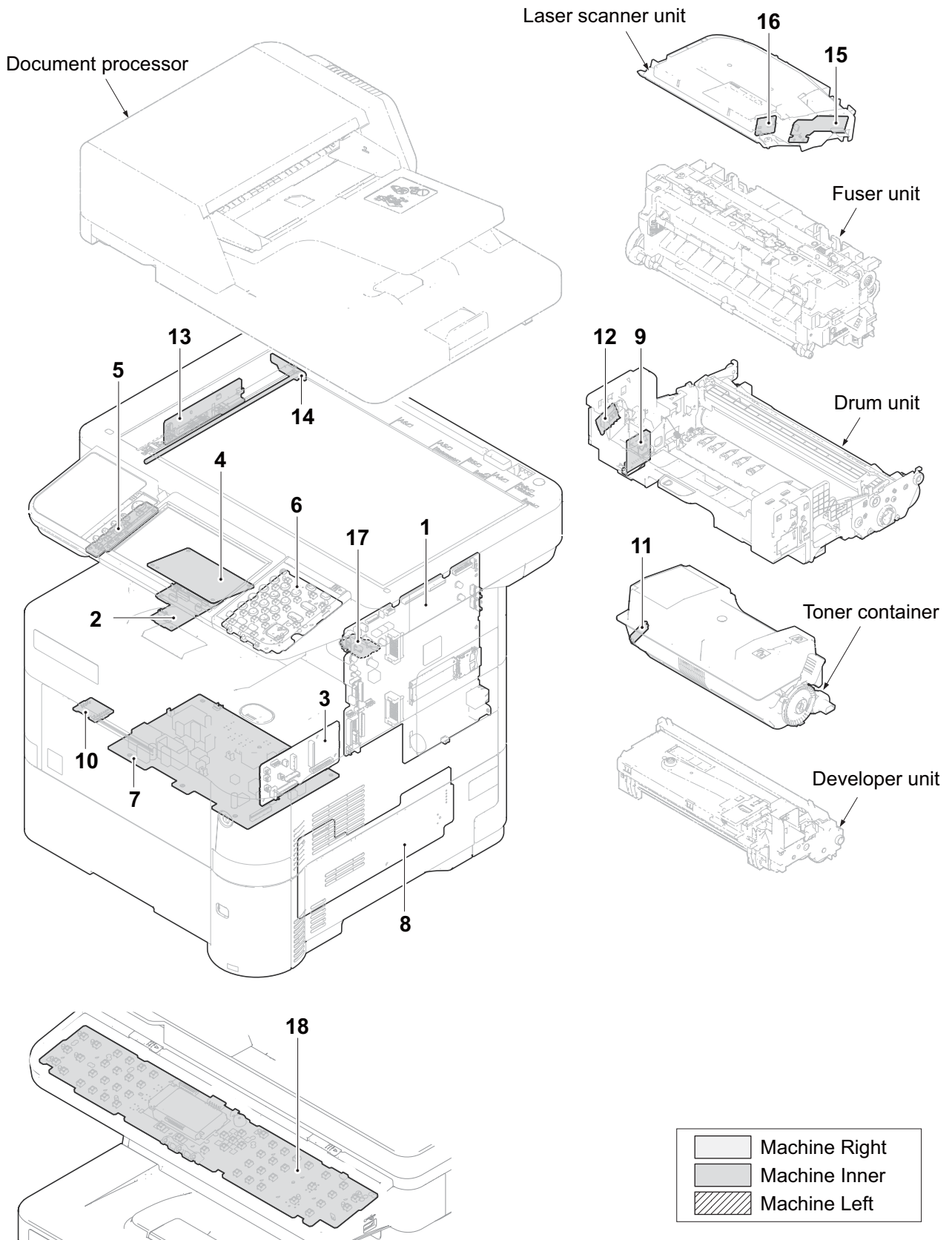

Figure 2-1-1

1. Control PWB (CONPWB)..... Controls the software such as the print data processing and provides the interface with computers.
Controls printer hardware such as high voltage/bias output control, paper conveying system control, and fuser temperature control, etc.
2. Connect -Left PWB (C-LPWB)..... Consists of wiring relay circuit between control PWB and drum connect PWB.
3. Connect-Right PWB (C-RPWB)..... Consists of wiring relay circuit between control PWB and power-source PWB.
4. Operation panel PWB (OPPWB) *4 Consists of wiring that relay circuit between control PWB and right/left key PWB and LCD.
5. Key-Left PWB (K-LPWB) *4 Consists the LED indicators and key switches.
6. Key-Right PWB (K-RPWB) *4 Consists the LED indicators and key switches.
7. High voltage PWB (HVPWB) Generates main charging, developing bias, transfer bias and separation bias.
8. Power source PWB (PSPWB) After full-wave rectification of AC power source input, switching for converting to 24 V DC for output. Controls the fuser heater.
9. Drum PWB (DRPWB) Relays wirings from electrical components on the drum unit.
10. Drum connect PWB (DRCPWB)..... Consists of wiring relay circuit between connect left PWB and the drum unit.
11. Toner container PWB (TCONPWB) Reads the container information.
12. Toner container connect PWB
(TCONCPWB)..... Consists of wiring relay circuit between control PWB and the toner container.
13. CCD PWB (CCDPWB)..... Reads the image of originals.
14. LED PWB (LEDPWB) Controls the LED.
15. APC PWB (APCPWB) Generates and controls the laser beam.
16. PD PWB (PDPWB) Controls horizontal synchronizing timing of laser beam.
17. Thermister connect PWB
(FTHCPWB)..... Consists of wiring relay circuit between fuser thermistor, fan motor and the control PWB.
18. Operation panel PWB (OPPWB) *3 Consists of wiring that relay circuit between control PWB and LCD.

List of correspondences of PWB names

No.	Name used in service manual	Name used in parts list	Part.No.
1	Control PWB (CONPWB)	PARTS PWB ASSY CONTROLLER SP	302NY94020 *1,*4,*5 302P094020 *1,*3,*5 302NX94030 *1,*4,*6 302NZ94020 *1,*3,*6 302NM94040 *8 302P694020 *7
		PARTS PWB ASSY CONTROLLER SP EU	302NY94030 *1,*4,*5 302P094030 *1,*3,*5 302NX94040 *1,*4,*6 302NZ94030 *1,*3,*6 302NM94050 *8 302P694030 *7
2	Connect -Left PWB (C-LPWB)	PARTS PWB ASSY CONNECT-L SP	302L294092 *1 302LV94192 *2
3	Connect-Right PWB (C-RPWB)	PARTS PWB ASSY CONNECT-R SP	302NX94060 *1 302NM94070 *2
4	Operation panel PWB (OPPWB) *4	PARTS PWB ASSY H PANEL MAIN SP	302NM94080
5	Key-Left PWB (K-LPWB) *4	PARTS PWB ASSY H PANEL KEY-L SP	302NM94100
6	Key-Right PWB (K-RPWB) *4	PARTS PWB ASSY H PANEL KEY-R SP	302NM94090
7	High voltage PWB (HVPWB)	PARTS HIGH VOLTAGE UNIT SP	302L294030 *1 302LV94060 *2
8	Power source PWB (PSPWB)	PARTS SWITCHING REGULATOR 120V SP	302NX94050 *1 302LV94080 *2
		PARTS SWITCHING REGULATOR 230V SP	302L294040 *1 302LV94070 *2
9	Drum PWB (DRPWB)	P.W.BOARD ASSY DRUM (DK-3100(U)) *1 (DK-3100(E)) *1 (DK-3100(AO)) *1 (DK-3130(U)) *2 (DK-3130(E)) *2 (DK-3130(AO)) *2	- (302MS93042) (302MS93022) (302MS93052) (302LV93062) (302LV93042) (302LV93072)
10	Drum connect PWB (DRCPWB)	PARTS PWB ASSY DRUM CONNECT SP	302LV94200
11	Toner container PWB (TCONPWB)	P.W. BOAD ASSY CONTAINER (TK-3100) *1 (TK-3102) *1 (TK-3104) *1 (TK-3122) *8 (TK-3130) *2 (TK-3132) *7 (TK-3134) *2	- (1T02MS0NL0) (1T02MS0US0) (1T02MS0AS0) (1T02L10US0) (1T02LV0NL0) (1T02LV0US0) (1T02LV0AS0)

No.	Name used in service manual	Name used in parts list	Part.No.
12	Toner container connect PWB (TCONCPWB)	P.W.BOARD ASSY CONTAINER CONN (DK-3100(U)) *1 (DK-3100(E)) *1 (DK-3100(AO)) *1 (DK-3130(U)) *2 (DK-3130(E)) *2 (DK-3130(AO)) *2	- (302MS93042) (302MS93022) (302MS93052) (302LV93062) (302LV93042) (302LV93072)
13	CCD PWB (CCDPWB)	P.W.BOARD ASSY CCD (PARTS ISU ASSY SP)	- (302NM93010)
14	LED PWB (LEDPWB)	P.W.BOARD ASSY LED (PARTS ISU ASSY SP)	- (302NM93010)
15	APC PWB (APCPWB)	P.B. BOARD ASSY APC (LK-3200) *1 *8 (LK-3230) *7	- (302NZ93010) (302P693010)
16	PD PWB (PDPWB)	P.B. BOARD ASSY PD (LK-3200) *1 *8 (LK-3230) *7	- (302NZ93010) (302P693010)
17	Thermister connect PWB (FTHCPWB)	PARTS PWB ASSY TH CONNECT SP	302LV94220
18	Operation panel PWB (OPPWB) *3	PARTS PANEL UNIT B SP	302P094040 *5 302NZ94040 *6

*1: 40 ppm model only

*2: 50/60 ppm model only

*3: Basic model only

*4: HyPAS model only

*5: Without FAX model only

*6: With FAX model only

*7: 60 ppm model only

*8: 50 ppm model only

2-1-2 Switches and sensors

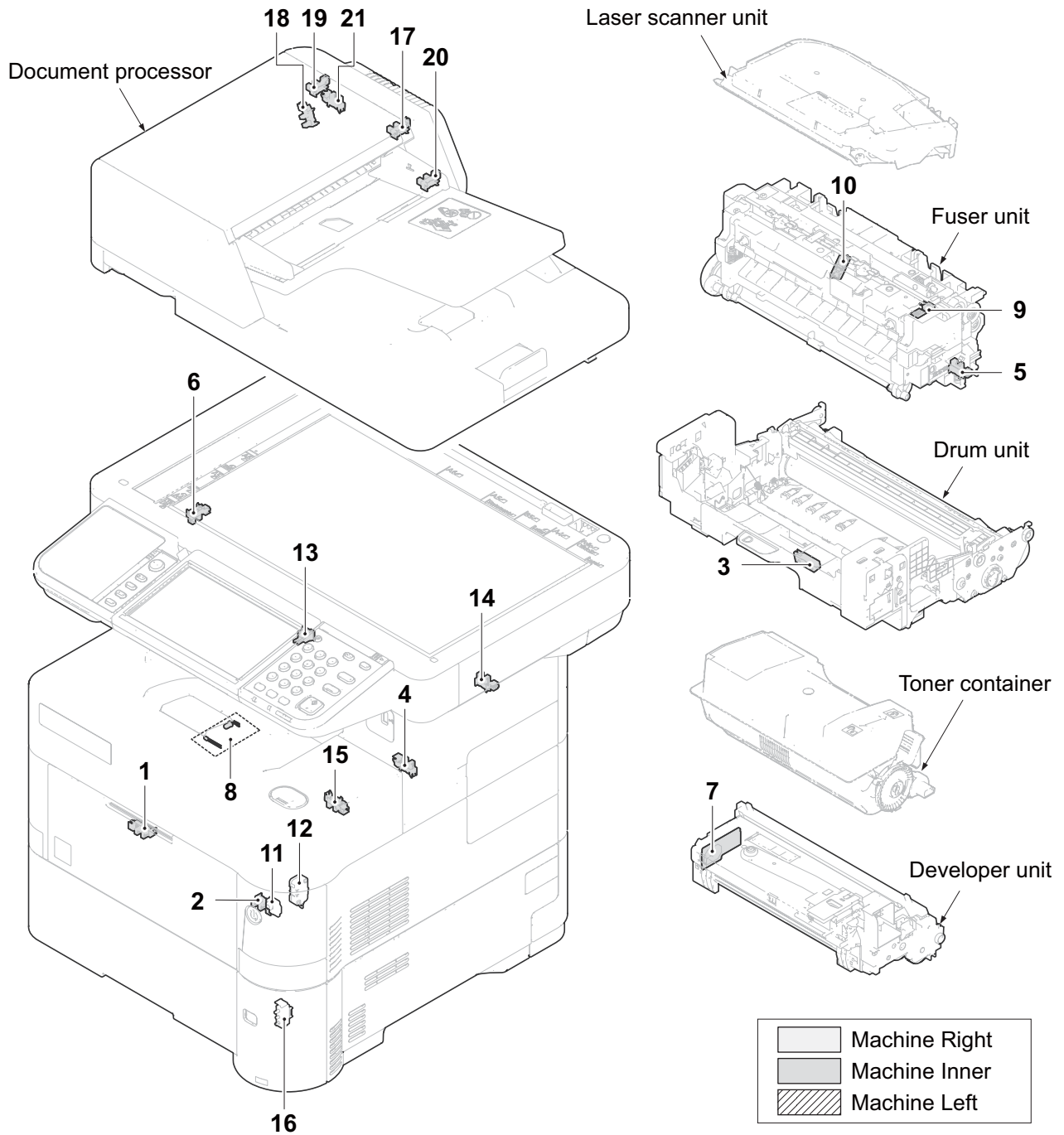

Figure 2-1-2

1. MP paper sensor (MPPS) Detects the presence of paper on the MP tray.
2. Lift sensor (LS) *2 Detects the top limit of the bottom plate.
3. Registration sensor 2 (RS2) *2 Controls the secondary paper feed start timing.
4. Duplex sensor 1 (DUS1) *2..... Detects a paper jam in the duplex section.
5. Eject sensor (ES)..... Detects a paper misfeed in the fuser or eject section.
6. Home position sensor (HPS) Detects the ISU in the home position.
7. Toner sensor (TS)..... Detects the amount of toner remaining in the toner container.
8. Waste toner sensor (WTS)..... Detects when the waste toner box is full.
9. Fuser thermistor1 (FTH1) Detects the heat roller temperature (Edge).
10. Fuser thermistor2 (FTH2) Detects the heat roller temperature (Center).
11. Power source switch (PSSW)..... Change ON/OFF the power supply of a control PWB, an operation PWB, etc.
12. Inter lock switch (ILSW) Detects the opening and closing of the top cover.
13. Rear cover switch (RCSW) *2..... Detects the opening and closing of the rear cover.
Shuts off 24 V DC power line when the right cover is opened.
14. Paper full sensor (PFS)..... Detects the paper full in the main tray (Facedown).
15. Envelope sensor (ENVS) Detects the change state of pressure in fuser unit.
16. Cassette size switch (CSSW) Detects the paper size dial setting of the paper setting dial.
17. DP original sensor (DPOS)..... Detects the presence of an original.
18. DP registration sensor (DPRS)..... Detects the original conveying timing.
19. DP timing sensor (DPTS)..... Detects the original scanning timing.
20. DP switchback sensor (DPSBS)..... Detects the position of the shift guide.
21. DP open/close sensor (DPOCS)..... Detects the opening/closing of the DP.

List of correspondences of switch and sensor names

No.	Name used in service manual	Name used in parts list	Part.No.
1	MP paper sensor (MPPS)	SENSOR OPT.	303M894260
2	Lift sensor (LS) *2	SENSOR OPT.	303M894260
3	Registration sensor 2 (RS2) *2	SENSOR OPT.	-
4	Duplex sensor1 (DUS1) *2	SENSOR OPT.	303M894260
5	Eject sensor (ES)	SENSOR OPT. (FK-3100(U)) *1 (FK-3100(E)) *1 (FK-3130(U)) *2 (FK-3130(E)) *2	- (302MS93094) (302MS93074) (302LV93132) (302LV93112)
6	Home position sensor (HPS)	SENSOR OPT.	303M894260
7	Toner sensor (TS)	P.W.BOARD ASSY TONER SENSOR (DV-3100)	- (302LV93080)
8	Waste toner sensor (WTS)	PARTS TONER FULL DETECT ASSY SP	302LV94120
9	Fuser thermistor1 (FTH1)	THERMISTOR FUSER (FK-3100(U)) *1 (FK-3100(E)) *1 (FK-3130(U)) *2 (FK-3130(E)) *2	- (302MS93094) (302MS93074) (302LV93132) (302LV93112)

No.	Name used in service manual	Name used in parts list	Part.No.
10	Fuser thermistor2 (FTH2)	THERMISTOR ASSY (FK-3100(U)) *1 (FK-3100(E)) *1 (FK-3130(U)) *2 (FK-3130(E)) *2	- (302MS93094) (302MS93074) (302LV93132) (302LV93112)
11	Power source switch (PSSW)	PARTS PWB ASSY SWITCH SP	302LV94210
12	Inter lock switch (ILSW)	INTER LOCK SWITCH	2FB27160
13	Rear cover switch (RCSW) *2	SW.PUSH	7SP01000006+H01
14	Paper full sensor (PFS)	SENSOR OPT.	303M894260
15	Envelope sensor (ENVS)	SENSOR OPT.	303M894260
16	Cassette size switch (CSSW)	SW.PUSH	-
17	DP original sensor (DPOS)	SENSOR OPT.	-
18	DP registration sensor (DPRS)	SENSOR OPT. (PARTS DRIVE ASSY A SP)	- (302NM94230)
19	DP timing sensor (DPTS)	SENSOR OPT. (PARTS DRIVE ASSY A SP)	- (302NM94230)
20	DP switchback sensor (DPSBS)	SENSOR OPT.	-
21	DP open/close sensor (DPOCS)	SENSOR OPT. (PARTS DRIVE ASSY A SP)	- (302NM94230)

*1: 40 ppm model only

*2: 50/60 ppm model only

2-1-3 Motors

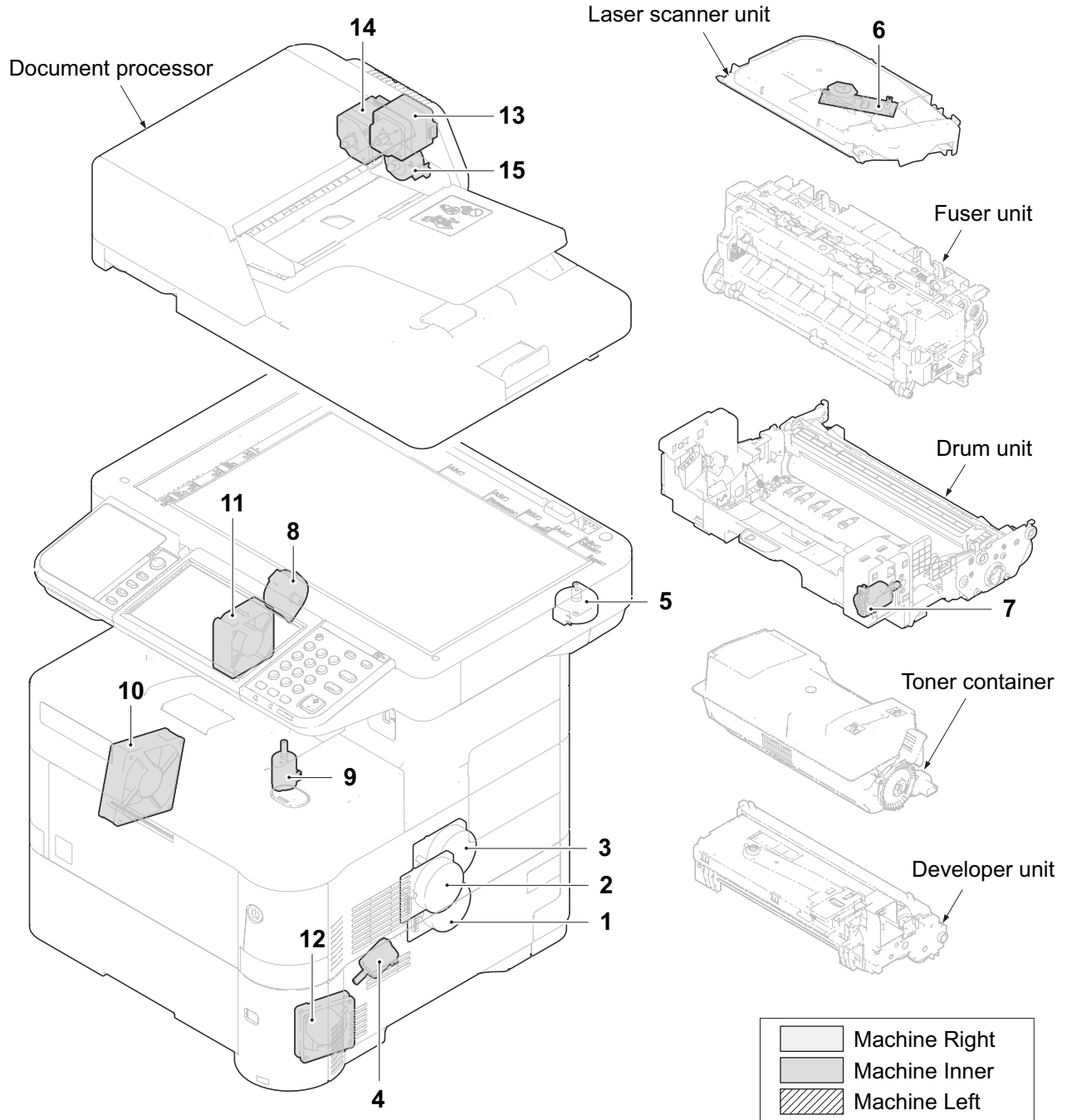

Figure 2-1-3

1. Main motor (MM) *1 Drives the paper feed section and conveying section.
2. Main motor (MM) *2 Drives the paper feed section and conveying section.
3. Drum motor (DRM) *2 Drives the drum unit and transfer roller.
4. Lift motor (LM)*2 Operates the bottom plate in the cassette.
5. Image scanner motor (ISUM)..... Drives the ISU.
6. Polygon motor (PM) Drives the polygon mirror.
7. Toner motor (TM) Replenishes toner to the developing unit.
8. Eject motor (EM) Drives the duplex section.
9. Envelope motor (ENVM) *2..... Drives the change mechanism of fixing pressure in fuser unit.
10. Developer fan motor (DEVFM) Cools the developer section.
11. LSU fan motor (LSUFM) Cools the LSU unit.
12. Power source fan motor (PSFM) Cools the power source PWB.
13. DP paper feed motor (DPPFM)..... Drives the original feed section.
14. DP paper conveying motor (DPCM) Drives the original conveying section.
15. DP switchback motor (DPSBM) Drives the switchback roller.

List of correspondences of motor names

No.	Name used in service manual	Name used in parts list	Part.No.
1	Main motor (MM) *1	PARTS MOTOR-BL W30 SP	302K394201
2	Main motor (MM) *2	PARTS MOTOR-BL W30 SP	302K394201
3	Drum motor (DRM) *2	PARTS MOTOR-BL W30 SP	302K394201
4	Lift motor (LM) *2	PARTS DC MOTOR ASSY SP	302LV94230
5	Image scanner motor (ISUM)	MOTOR ISU	302H994270
6	Polygon motor (PM)	MOTOR POLYGON (LK-3200) (LK-3230) *7	- (302NZ93010) (302P693010)
7	Toner motor (TM)	TONER MOTOR ASSY (DK-3100(U)) *1 (DK-3100(E)) *1 (DK-3100(AO)) *1 (DK-3130(U)) *2 (DK-3130(E)) *2 (DK-3130(AO)) *2	- (302MS93042) (302MS93022) (302MS93052) (302LV93062) (302LV93042) (302LV93072)
8	Eject motor (EM)	MOTOR EJECT	302F944131
9	Envelope motor (ENVM)	PARTS DC MOTOR ASSY SP	302LV94230
10	Developer fan motor (DEVFM)	FAN MOTOR	302HN44010
11	LSU fan motor (LSUFM)	FAN LSU 60-25	302GR44080
12	Power source fan motor (PSFM)	PARTS,FAN COOLING CONVEYING SP	302FZ94420
13	DP paper feed motor (DPPFM)	MOTOR PAPER FEED (PARTS DRIVE ASSY A SP)	- (302NM94230)
14	DP paper conveying motor (DPCM)	MOTOR-HB PAPER FEED (PARTS DRIVE ASSY A SP)	- (302NM94230)

No.	Name used in service manual	Name used in parts list	Part.No.
15	DP switchback motor (DPSBM)	MOTOR ROTARY (PARTS DRIVE ASSY B SP)	- (302NM94240)

*1: 40 ppm model only

*2: 50/60 ppm model only

*7: 60 ppm model only

2-1-4 Others

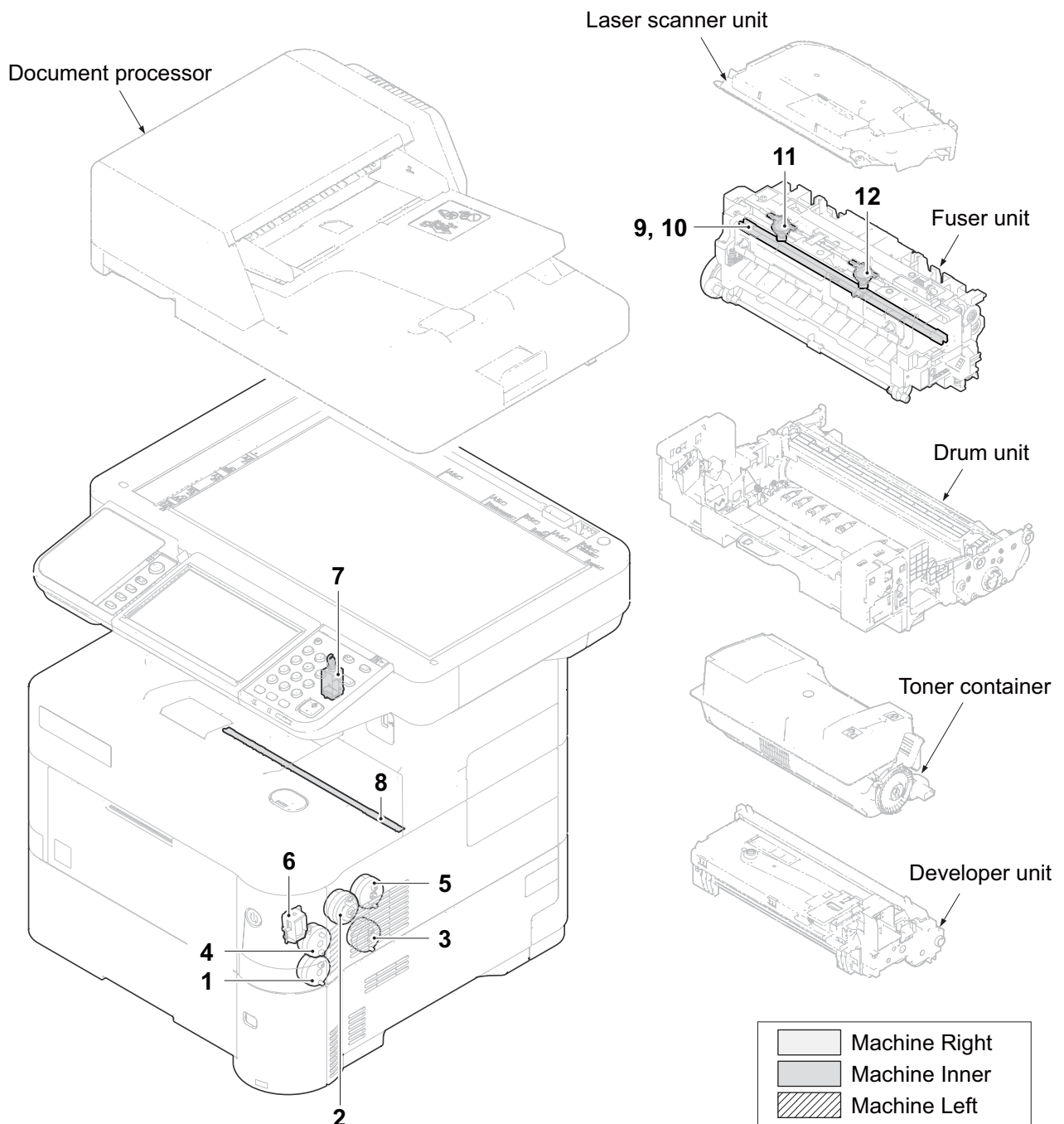

Figure 2-1-4

1. Paper feed clutch (PFCL) Primary paper feed from cassette.
2. Registration clutch (RCL)..... Controls the secondary paper feed.
3. Duplex clutch (DUCL) *2..... Controls the drive of the duplex feed roller.
4. Middle clutch (MIDCL) *2..... Controls the paper conveying at the conveying section.
5. Developer clutch (DEVCL)..... Controls the drive of the developer.
6. MP solenoid (MPSOL) Controls the MP bottom plate.
7. Faceup solenoid (FUSOL) *2..... Operates the feedshift guide.
8. Cleaning lamp (CL)..... Eliminates the residual electrostatic charge on the drum.
9. Fuser heater 1 (FUH1)..... Heats the heat roller.
10. Fuser heater 2 (FUH2) *2 Heats the heat roller.
11. Fuser thermostat 1 (FUTS1)..... Prevents overheating of the heat roller.
12. Fuser thermostat 2 (FUTS2) *2..... Prevents overheating of the heat roller.

List of correspondences of other names

No.	Name used in service manual	Name used in parts list	Part.No.
1	Paper feed clutch (PFCL)	PARTS CLUTCH 20-2W Z35R (RARTS DRIVE FEED ASSY SP)	- (302LV94251)
2	Registration clutch (RCL)	CLUTCH 50 Z35R	302KV44041
3	Duplex clutch (DUCL) *2	PARTS CLUTCH 20-2W Z35R	-
4	Middle clutch (MIDCL) *2	PARTS CLUTCH 20-2W Z35R (RARTS DRIVE FEED ASSY SP)	- (302LV94251)
5	Developer clutch (DEVCL)	PARTS CLUTCH 20-2W Z35R	302VL94161
6	MP solenoid (MPSOL)	SOLENOID MPF (RARTS DRIVE FEED ASSY SP)	- (302LV94251)
7	Faceup solenoid (FUSOL) *2	SOLENOID EXIT	-
8	Cleaning lamp (CL)	P.W.BOARD ASSY ERASER (DK-3100(U)) *1 (DK-3100(E)) *1 (DK-3100(AO)) *1 (DK-3130(U)) *2 (DK-3130(E)) *2 (DK-3130(AO)) *2	- (302MS93042) (302MS93022) (302MS93052) (302LV93062) (302LV93042) (302LV93072)
9	Fuser heater 1 (FH1)	HEATER LAMP 120 *1 (FK-3100(U)) *1	- (302MS93094)
10	Fuser heater 2 (FH2) *2	HEATER LAMP 240 *1 (FK-3100(E)) *1 HEATER LAMP 120 *2 (FK-3130(U)) *2 HEATER LAMP 240 *2 (FK-3130(E)) *2	302L244030 (302MS93074) 302LV44020 (302LV93132) 302LV44031 (302LV93112)
11	Fuser thermostat 1 (FTS1)	THERMAL-CUTOUT 202 FUSER (FK-3100(U)) *1	- (302MS93094)
12	Fuser thermostat 2 (FTS2) *2	(FK-3100(E)) *1 (FK-3130(U)) *2 (FK-3130(E)) *2	(302MS93074) (302LV93132) (302LV93112)

*1: 40 ppm model only, *2: 50/60 ppm model only

2-2-1 Upgrading the firmware

Follow the procedure to upgrade the firmware below.

- * Controller Firmware
 - * Operation Panel Firmware *1
 - * Engine Firmware
 - * Option Language Data
 - * Dictionary Data *1
 - * Browser Data *1
 - * FAX Firmware
 - * PF (Paper Feeder) Firmware
- *1: HyPAS model only

Preparation

Extract the file that has the download firmware and store them in a USB memory.

NOTE: To improve Firmware Upgrade speed, a separate SKIP file can be added to the USB memory with the Firmware Upgrade package. The Skip file will allow ONLY the Firmware that has been Upgraded to a New Version to load, skipping duplicate Firmware Levels.

Procedure

1. Turn ON the main power switch and confirm if the screen shows "Ready to print" then, turn OFF the main power switch.
2. Insert USB memory that has the firmware in the USB memory slot.
3. Turn ON the power switch.
4. About 10 seconds later, "FW-Update" will be displayed (this shows that downloading is ready to start).
5. Confirm that upgrading is completed.
6. Confirm that the version of the firmware is correctly displayed.
7. Unplug the power cord and then remove the USB memory.
8. Connect the power cord and confirm that the screen shows "Ready to print", and then turn the main power switch OFF.

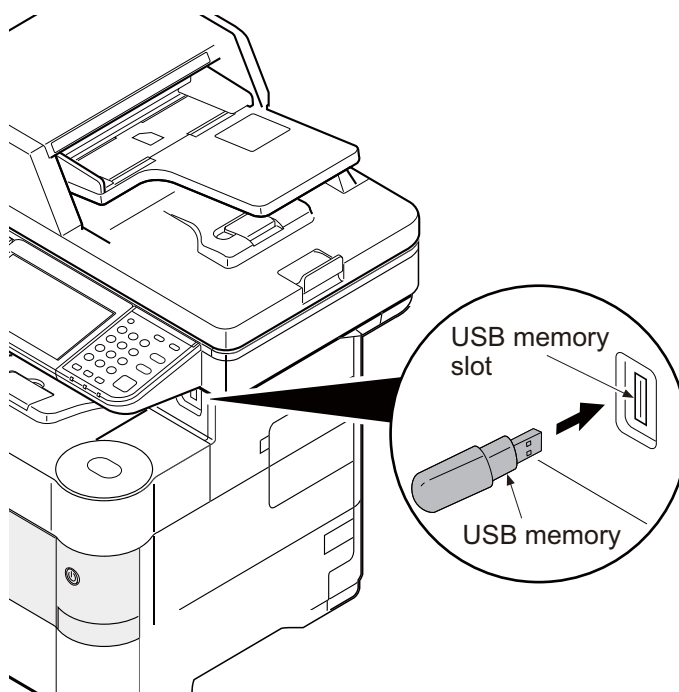

Figure 2-2-1

Caution: Never turn off the power switch or remove the USB memory during upgrading.

Safe-UPDATE

If the device is accidentally switched off or the USB memory is disconnected and upgrading is incomplete, perform the following.

If the power is accidentally switched off, turn the power on without removing the USB memory and perform the above steps 3 through 8.

If the USB memory is disconnected, reinsert it, then turn the power on and perform the above steps 3 through 8.

In any case, complete the steps to the end.

Emergency-UPDATE

If Safe Update is processed to the end, the firmware update is complete. In case the message below is indicated, update the firmware after recovery with the steps below.

Note that this is unoperable when the device is operating normally.

FW-Update	
Error	FFFF

Preparation

The USB memory must be formatted in FAT or FAT32 in advance.

Extract the main firmware to download from the file.

Rename the file which was extracted from the archive.

[DL_CTRL.2NM] to [KM_EMRG.2NM]

[DL_CTRL.2NY] to [KM_EMRG.2NY]

[DL_CTRL.2NZ] to [KM_EMRG.2NZ]

[DL_CTRL.2N0] to [KM_EMRG.2N0]

Copy the all extracted files to the root of the USB memory.

Procedure

1. Turn the main power switch off.
2. Install the USB memory which contains the firmware into the USB memory slot on the machine.
3. Turn the main power switch on.
4. Rewriting of the PWB software will start for restoration.
"Emergency Update" is displayed on the LCD of the operation panel.
5. "Completed" will be displayed when rewriting is successful.
* : "Failed" will be displayed when rewriting is failed.
6. Turn the main power switch off.
7. Wait for several seconds and then remove the USB memory from the USB memory slot.
8. Extract the firmware to download from the archive and copy to the root of the USB memory.

NOTE: Deletes the "ES_SKIP.on" file
When it is contained directly under the
USB memory.

9. Insert the USB memory in which the firmware was copied into the slot on the machine.
10. Perform steps 3 to 8 on the previous page.
11. Turn the main power switch on.
12. Perform maintenance item U000 (Print a maintenance report) to check that the version of ROM U109 has been upgraded.

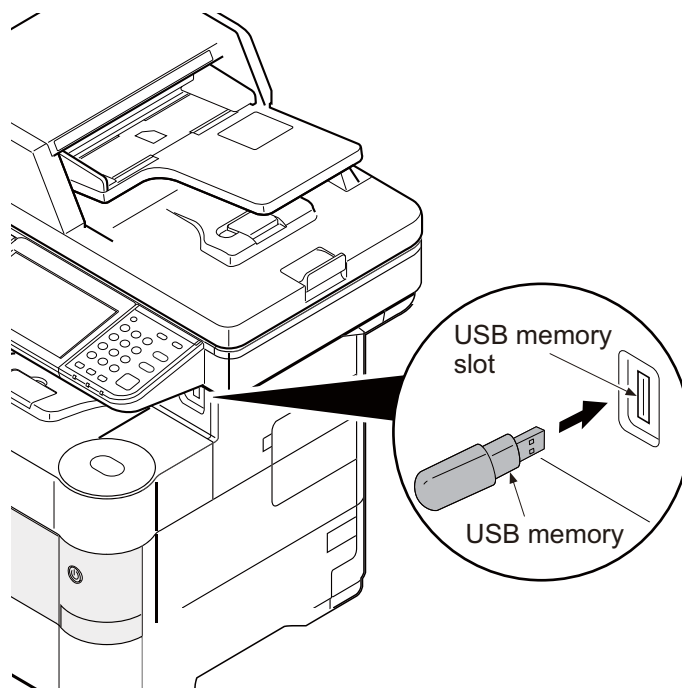

Figure 2-2-2

(3) Connector lists

Connector	Pin	Signal	I/O	Voltage	Description
YC2 Connected to the connect-left PWB	1	EECLK	I	0/3.3 V DC(pulse)	Clock signal
	2	GND	-	-	Ground
	3	EESIO	I/O	0/3.3 V DC	Data signal
	4	ERASER	I	0/3.3 V DC	CL control signal
	5	+3.3V2_E2	I	3.3 V DC	3.3 V DC power input
	6	TSENS	O	Analog	TS output signal
	7	SBMDIR	I	0/5 V DC	SBM: On/Off
	8	WTSSENS	O	Analog	WTS output signal
	9	SBMENBLN	I	0/3.3 V DC	SBM output control signal
	10	WTLED	I	0/3.3 V DC	Waste toner LED control
	11	SBMSTEP	I	0/3.3 V DC	SBM step signal
	12	MPFSSENS	O	0/3.3 V DC	MPS: On/Off
	13	SBMMODE	I	0/3.3 V DC	SBM mode control signal
	14	+3.3V1_E1	I	3.3 V DC	3.3 V DC power input
	15	TMOT	I	0/3.3 V DC	TM: On/Off
	16	LFANN	I	0/24 V DC	LFM: On/Off
	17 *1	FUDR	I	0/24 V DC	FUSOL: On/Off
	18 *1	ENVMOT	I	0/5 V DC	ENVM: On/Off
	19 *1	FDDR	I	0/24 V DC	FUSOL: On/Off
	20 *1	DUJAMSEN1 N	O	0/3.3 V DC	DUS1: On/Off
	21 *1	REGSEN2	O	0/3.3 V DC	RS2: On/ Off
	22 *1	REARSWN	O	0/3.3 V DC	RECSW: On/Off
YC3 Connected to the connect-left PWB	1	+24V0_E3	I	24 V DC	24 V DC power input
	2	GND	-	-	Ground
	3	GND	-	-	Ground
	4	+24V2_E2	I	24 V DC	24 V DC power input
YC12 Connected to the paper feed sesor	1	+3.3V2_E2	O	3.3 V DC	3.3 V DC power output
	2	GND	-	-	Ground
	3	PAPFULN	I	0/3.3 V DC	FS: On/Off
YC14 *1 Connected to the lift sensor	1	+3.3V2_E2	O	3.3 V DC	3.3 V DC power output
	2	GND	-	-	Ground
	3	LSSENS	I	0/3.3 V DC	LS: On/Off

Connector	Pin	Signal	I/O	Voltage	Description
YC15 Connected to the polygon motor	1	+24V2_E2	O	24 V DC	24 V DC power output
	2	GND	-	-	Ground
	3	PLGDRN	O	0/5 V DC	PM: On/Off
	4	PLGRDYN	I	0/3.3 V DC	PM ready signal
	5	POLCLK	O	0/3.3 V DC(pulse)	PM clock signal
YC16 Connected to the APC PWB	1	+5V2_E1	O	5 V DC	5 V DC power output
	2	VDATA1P	O	LVDS	Video data 1 signal (+)
	3	VDATA1N	O	LVDS	Video data 1 signal (-)
	4	VDATA2P	O	LVDS	Video data 2 signal (+)
	5	VDATA2N	O	LVDS	Video data 2 signal (-)
	6	SAMPLEN1	O	0/3.3 V DC	Sample / hold signal 1
	7	SAMPLEN2	O	0/3.3 V DC	Sample / hold signal 2
	8	OUTPEN	O	0/3.3 V DC	Laser enable
	9	VCONT1	O	Analog	LD-1 Light volume adjustment
	10	VCONT2	O	Analog	LD-2 Light volume adjustment
	11	GND	-	-	Ground
	12	PDN	I	0/3.3 V DC (pulse)	Main scanning synchronizing signal
	13	+3.3V2_E2	O	3.3 V DC	3.3 V DC power output
YC19 Connected to the high voltage PWB	1	ENVSENSN	I	0/3.3 V DC	ENVS: On/Off
	2	GND	-	-	Ground
	3	MISENS	I	Analog	MC output signal
	4	MHVCLK	O	0/3.3 V DC (pulse)	MC clock signal
	5	MACCNT	O	Analog	MC AC control signal
	6	MDCCNT	O	Analog	MC DC control signal
	7	HVCLK	O	0/3.3 V DC (pulse)	DEV clock signal
	8	BDCNT	O	Analog	DEV DC control signal
	9	BACNT	O	Analog	DEV AC control signal
	10	PAPERSEN2 N	I	0/3.3 V DC	EFS2: On/Off
	11	PAPERSEN1 N	I	0/3.3 V DC	EFS1: On/Off
	12	REGSENSN	I	0/3.3 V DC	RS: On/Off
	13	DUJAMSEN2 N	I	0/3.3 V DC	DUS: On/Off
	14	+3.3V2_E2	O	3.3 V DC	3.3 V DC power output

Connector	Pin	Signal	I/O	Voltage	Description
YC19 Connected to the high volt- age PWB	15	SCNT	O	0/3.3 V DC	Separation output control signal
	16	TRREM	O	0/3.3 V DC	TC remote signal
	17	TCNT	O	Analog	TC control signal
	18	+24V2_E1	O	24 V DC	24 V DC power output
YC21 Connected to the fuser thermistor connect PWB	1	TH2	I	Analog	FUTH2 output signal
	2	TH1	I	Analog	FUTH1 output signal
	3	GND	-	-	Ground
	4	REARFANN	O	24 V DC	REFM: On/Off
	5	+24V0_E3	O	24 V DC	24 V DC power output
YC22 Connected to the Paper Feeder (Option)	1	+24V0_E1	O	24 V DC	24 V DC power output to PF
	2	OPSDO	O	0/3.3 V DC (pulse)	PF communication serial data signal
	3	OPSDI	I	0/3.3 V DC (pulse)	PF communication serial data signal
	4	OPCLK	O	0/3.3 V DC (pulse)	PF communication serial clock signal
	5	OPRDYN	I	0/3.3 V DC	Option communication ready signal
	6	+3.3V1_E1	O	3.3 V DC	3.3 V DC power output
	7	GND	-	-	Ground
	8	OPSEL2	O	0/3.3 V DC	PF select signal
	9	OPSEL1	O	0/3.3 V DC	PF select signal
	10	OPSEL0	O	0/3.3 V DC	PF select signal
	11	OPPAUSEN	O	0/3.3 V DC	Paper stop signal
	12	GND	-	-	Ground
YC26 Connected to the eject sen- sor	1	+3.3V2_E2	O	3.3 V DC	3.3 V DC power output
	2	GND	-	-	Ground
	3	EXITSENSN	I	0/3.3 V DC	ES: On/Off
YC27 Connected to the connect right PWB	1	+24V0_E1	O	24 V DC	24 V DC power output
	2	+24V0_E1	O	24 V DC	24 V DC power output
	3	GND	-	-	Ground
	4	GND	-	-	Ground
	5	GND	-	-	Ground
	6	GND	-	-	Ground
	7	+24V2_E1	I	24 V DC	24 V DC power input
	8	+24V2_E1	I	24 V DC	24 V DC power input

Connector	Pin	Signal	I/O	Voltage	Description
YC29	1	DEEP_SLEEP N	O	0/3.3 V DC	Sleep signal
Connected to the connect right PWB	2	RFANH	O	0/24 V DC	RFM: On/Off
	3	MPFSOL	O	0/24 V DC	MPSOL: On/Off
	4	COVOPN	O	0/3.3 V DC	ILSW: On/Off
	5	LIFTMOTOR	O	0/5 V DC	LM: On/Off
	6	RFANL	O	0/24 V DC	RFM: On/Off
	7	DLPCL	O	0/3.3 V DC	DEVCL: On/Off
	8	DHEATER_R EM	O	0/24 V DC	DH: On/Off
	9	FEEDCL	O	0/24 V DC	PFCL: On/Off
	10	POWERSW	I	0/3.3 V DC	PSSW: On/Off
	11	REGCL	O	0/24 V DC	RCL: On/Off
	12	CASSET	O	Analog	CSSW: On/Off
	13	PSLEEPN	I	0/5 V DC	Sleep mode signal
	14	MMOTCWN	O	0/5 V DC	MM drive shift signal
	15	RELAY	I	0/5 V DC	Relay control
	16	MMOTRDYN	I	0/3.3 V DC	MM ready signal
	17	ZCROSSN	O	0/5 V DC(pulse)	Zero crossing signal
	18	MMOTON	O	0/5 V DC	MM: On/Off
	19	HEAT1REM	O	0/24 V DC	Fuser heater control
	20	TYPE	-	-	Not used
	21	GND	-	-	Ground
	22	MMOTCLK	O	0/5 V DC(pulse)	MM clock signal
	23 *1	GND	-	-	Ground
	24 *1	DMOTCLK	O	0/5 V DC(pulse)	DRM clock signal
	25 *1	GND	-	-	Ground
	26 *1	DMOTRDYN	I	0/3.3 V DC	DRM ready signal
	27 *1	MIDCL	O	0/24 V DC	PCCL: On/Off
	28 *1	DMOTON	O	0/5 V DC	DRM: On/Off
	29 *1	DUCL	O	0/24 V DC	DUCL: On/Off
	30 *1	HEAT2REM	O	0/24 V DC	Fuser heater control

Connector	Pin	Signal	I/O	Voltage	Description
YC30 Connected to the key right PWB *3 or the operation panel PWB *2	1	AIRTEMP	I	Analog	Temperature sensor input signal
	2	AIR WET	I	Analog	Humid sensor input signal
	3	GND	-	-	Ground
	4	WETCLK	O	0/3.3 V DC (pulse)	Humid sensor clock signal
YC31 Connected to the developer fan motor	1	GND	-	-	Ground
	2	+24V0_E3	O	24 V DC	24 V DC power output
YC1000 Connected to the CCD PWB	1	12V3 E2	O	12 V DC	12 V DC power output
	2	12V3 E2	O	12 V DC	12 V DC power output
	3	N.C.			
	4	+5V3 E3	O	5 V DC	5 V DC power output
	5	+5V3 E3	O	5 V DC	5 V DC power output
	6	N.C.	-	-	Not used
	7	GND	-	-	Ground
	8	CCDOSR	I	Analog	Image analog signal RED
	9	GND	-	-	Ground
	10	CCDOSG(EVEN)	I	Analog	Image analog signal GREEN
	11	GND	-	-	Ground
	12	CCDOSB(ODD)	I	Analog	Image analog signal BLUE
	13	GND	-	-	Ground
	14	CCDSW	O	0/3.3 V DC	CCD color/BW change signal
	15	CCDSH	O	0/3.3 V DC	Shift gate signal
	16	GND	-	-	Ground
	17	GND	-	-	Ground
	18	CCDPH1+	O	LVDS	CCD shift register clock signal
	19	CCDPH1-	O	LVDS	CCD shift register clock signal
	20	GND	-	-	Ground
	21	CCDCP-	O	LVDS	CCD clamp signal
	22	CCDCP+	O	LVDS	CCD clamp signal
	23	GND	-	-	Ground
	24	CCDRS+	O	LVDS	CCD reset signal

Connector	Pin	Signal	I/O	Voltage	Description
YC1000 Connected to the CCD PWB	25	CCDRS-	O	LVDS	CCD reset signal
	26	GND	-	-	Ground
	27	N.C.	-	-	Not used
	28	+3.3V3 E1	O	3.3 V DC	3.3 V DC power output
	29	HP SWN	I	0/3.3 V DC	HPS: On/Off
	30	GND	-	-	Ground
	31	M LED C	I	0 to 2 V DC	LED CATHODE
	32	M LED A	O	3 V DC	LED ANODE
YC1001 Connected to the conveying motor, DP switchback motor, DP paper feed motor	1	CONNMOTB2	O	0/24 V DC(pulse)	DPCM drive control signal
	2	CONNMOTB1	O	0/24 V DC(pulse)	DPCM drive control signal
	3	CONNMOTA2	O	0/24 V DC(pulse)	DPCM drive control signal
	4	CONNMOTA1	O	0/24 V DC(pulse)	DPCM drive control signal
	5	JNCMOTB2	O	0/24 V DC(pulse)	DPSBM drive control signal
	6	JNCMOTA2	O	0/24 V DC(pulse)	DPSBM drive control signal
	7	JNCMOTB1	O	0/24 V DC(pulse)	DPSBM drive control signal
	8	JNCMOTA1	O	0/24 V DC(pulse)	DPSBM drive control signal
	9	FEEDMOTB2	O	0/24 V DC(pulse)	DPPFM drive control signal
	10	FEEDMOTB1	O	0/24 V DC(pulse)	DPPFM drive control signal
	11	FEEDMOTA2	O	0/24 V DC(pulse)	DPPFM drive control signal
	12	FEEDMOTA1	O	0/24 V DC(pulse)	DPPFM drive control signal
YC1002 Connected to the image scanner motor	1	SCMOTB2	O	0/24 V DC(pulse)	ISUM drive control signal
	2	SCMOTA1	O	0/24 V DC(pulse)	ISUM drive control signal
	3	SCMOTB1	O	0/24 V DC(pulse)	ISUM drive control signal
	4	SCMOTA2	O	0/24 V DC(pulse)	ISUM drive control signal
YC1003 Connected to the DP original sensor, theDP regist sensor, DP open/close sensor, DP switchback sensor, DP timing sensor	1	+3.3V3S	O	3.3 V DC	3.3 V DC power output
	2	GND	-	-	Ground
	3	SET_SW	I	0/3.3 V DC	DPOS: On/Off
	4	+3.3V3S	O	3.3 V DC	3.3 V DC power output
	5	GND	-	-	Ground
	6	REGIST_SW	I	0/3.3 V DC	DPRS: On/Off
	7	+3.3V3S	O	3.3 V DC	3.3 V DC power output
	8	GND	-	-	Ground
	9	DP_OPEN_SW	I	0/3.3 V DC	DPOCS: On/Off
	10	+3.3V3S	O	3.3 V DC	3.3 V DC power output

Connector	Pin	Signal	I/O	Voltage	Description
YC1003 Connected to the DP original sensor, the DP regist sensor, DP open/close sensor, DP switchback sensor, DP timing sensor	11	GND	-	-	Ground
	12	JHP_SW	I	0/3.3 V DC	DPSBS: On/Off
	13	+3.3V3S	O	3.3 V DC	3.3 V DC power output
	14	GND	-	-	Ground
	15	TIMING_SW	I	0/3.3 V DC	DPTS: On/Off
YC2002 *3 Connected to the operation panel PWB	1	GND	-	-	Ground
	2	PANEL STATUS	I	0/3.3 V DC	Operation panel status signal
	3	INT POWERKEY_N	I	0/3.3 V DC	Power key: On/Off
	4	PANEL_RESET	O	0/3.3 V DC	OPPWB-M reset signal
	5	AUDIO	O	Analog	Voice output signal
	6	LIGHTOFF_POWERON	O	0/3.3 V DC	Sleep return signal 1
	7	SHUTDOWN	O	0/3.3 V DC	24 V down signal
	8	LED PROCESSING N	O	0/3.3 V DC	Processing LED control signal
	9	LED ATTENTION N	O	0/3.3 V DC	Attention LED control signal
	10	LED MEMORY N	O	0/3.3 V DC	Memory LED control signal
	11	SUSPEND_POWER	O	5 V DC	5 V DC power output
	12	ENERGY_SAVE	O	0/3.3 V DC	Energy save signal
	13	BEEP_POWERON	O	0/3.3 V DC	Sleep return signal 0
	14	SECOND_TRAY_SW	-	-	Not used
	15	GND	-	-	Ground

Connector	Pin	Signal	I/O	Voltage	Description
YC2002 *2	1	GND	-	-	Ground
Connected to the operation panel PWB	2	-	-	-	Not used
	3	INT_POWER KEY_N	I	0/3.3 V DC	Power key: On/Off
	4	FPRST	O	0/3.3 V DC	Panel reset signal
	5	AUDIO	O	Analog	Voice output signal
	6	-	-	-	Not used
	7	PAN_TXD	O	0/3.3 V DC	Serial communication data signal
	8	PAN_RXD	I	0/3.3 V DC	Serial communication data signal
	9	-	-	-	Not used
	10	-	-	-	Not used
	11	5.0V2_C	O	5 V DC	5 V DC power output
	12	-	-	-	Not used
	13	LCDCON	O	0/3.3 V DC	LCD control signal
	14	3.3V1_C	O	0/3.3 V DC	3.3 V DC power output
	15	GND	-	-	Ground
YC2003 *3	1	+5V0 PANEL	O	5 V DC	5 V DC power output
Connected to the operation panel PWB	2	+5V0 PANEL	O	5 V DC	5 V DC power output
	3	GND	-	-	Ground
	4	GND	-	-	Ground

*1: 50/60 ppm model only

*2: Basic model only

*3: HyPAS model only

(4) Detaching and refitting the PWB. (CONPWB)

Procedure

1. Remove the upper interface cover.
2. Release two hooks using a flat screw driver and remove the right stay cover.

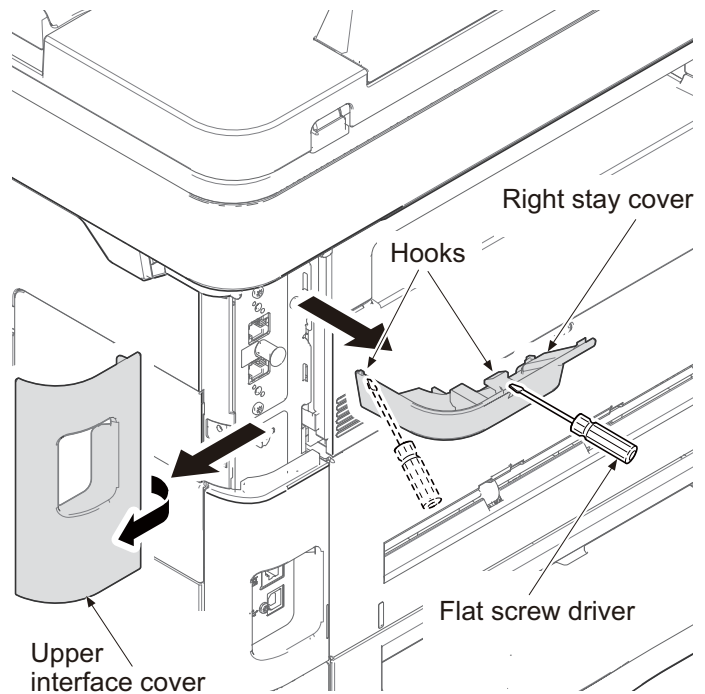

Figure 2-2-5

3. Remove the controller cover.
4. Open the front cover.
5. Remove the screw from the right upper cover.
6. Release two hooks using a flat screw driver and remove the right upper cover.

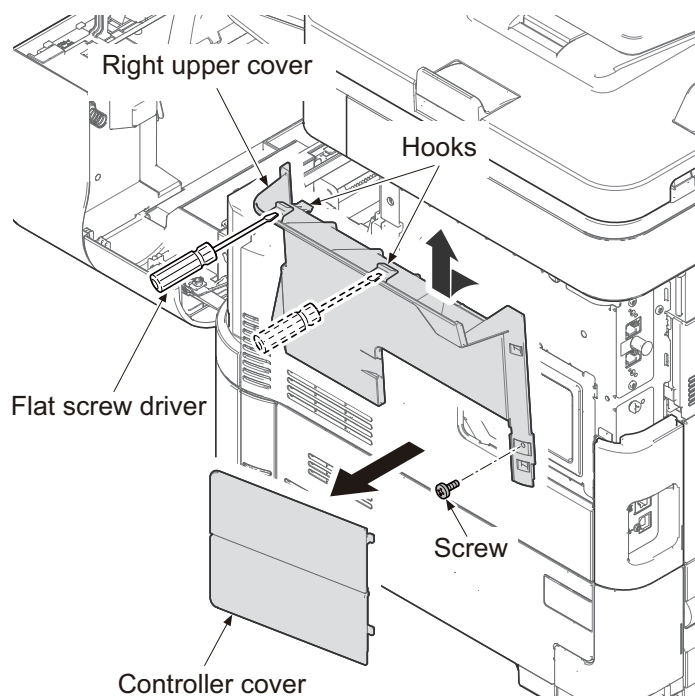

Figure 2-2-6

7. Open the rear cover.
8. Remove the lower interface cover and the inlet cover.

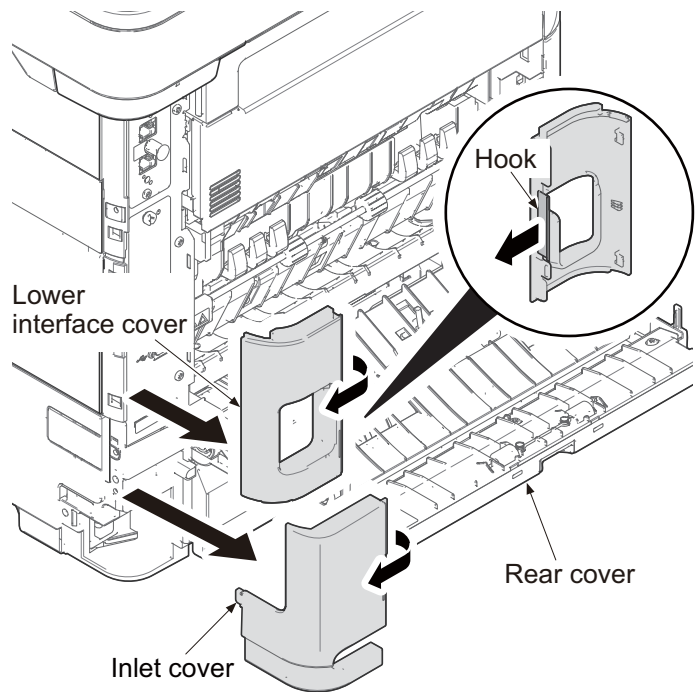

Figure 2-2-7

9. Remove two screws.
10. Release the hooks by bending both-side of the right middle cover and then remove it by pulling and lifting up forward.

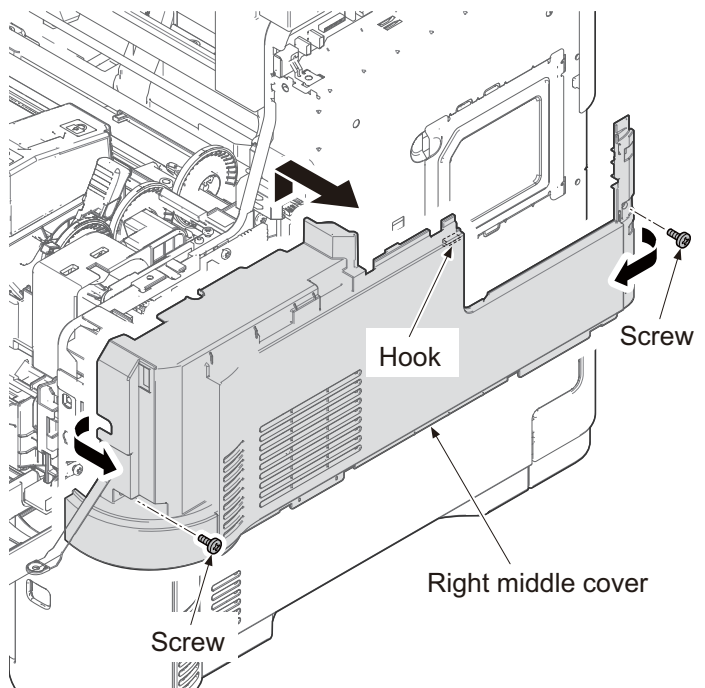

Figure 2-2-8

11. Pull out the cassette.
12. Remove three screws.
13. Release two hooks by sliding the right lower cover upward and then remove the right lower cover.

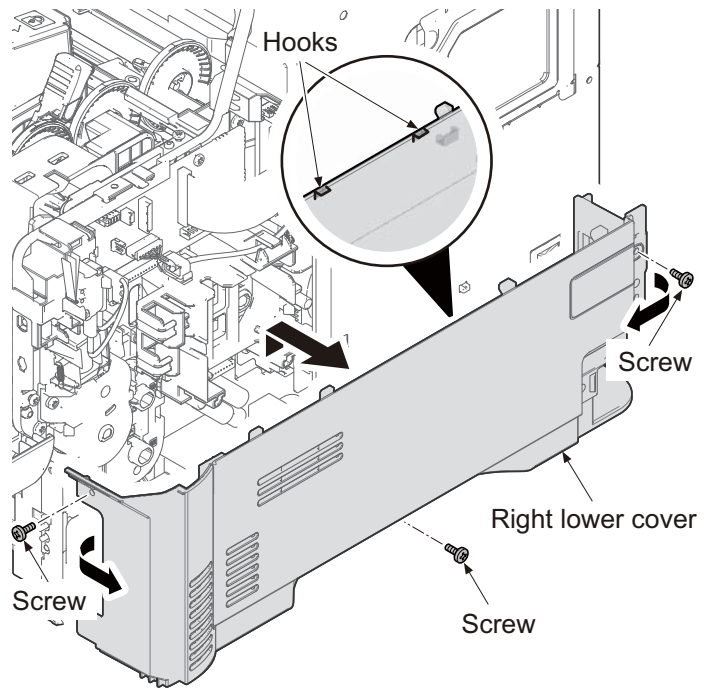

Figure 2-2-9

14. Remove eight screws and grounding terminal.
15. Remove the controller box.

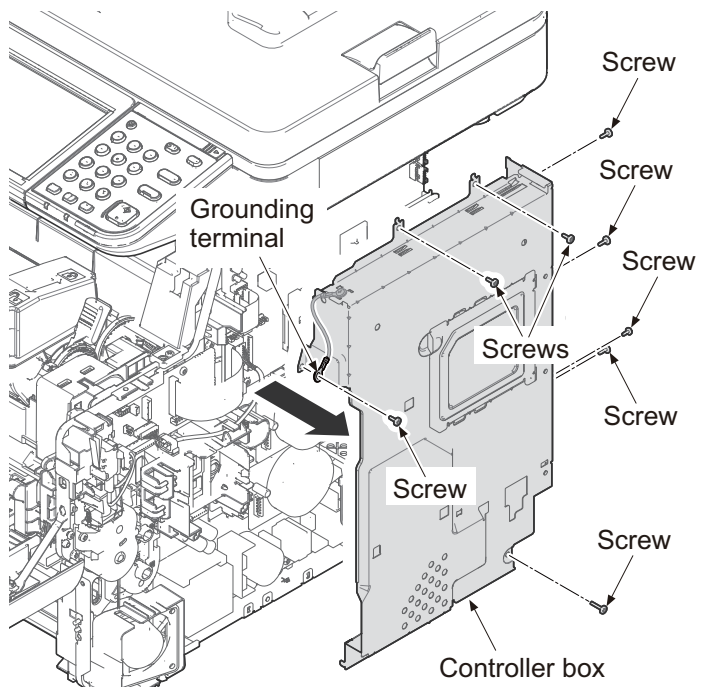

Figure 2-2-10

16. Remove all connectors and FFCs from the control PWB.
17. Remove six screws and control PWB from the main unit.
18. Check or replace the control PWB and refit all the removed parts.

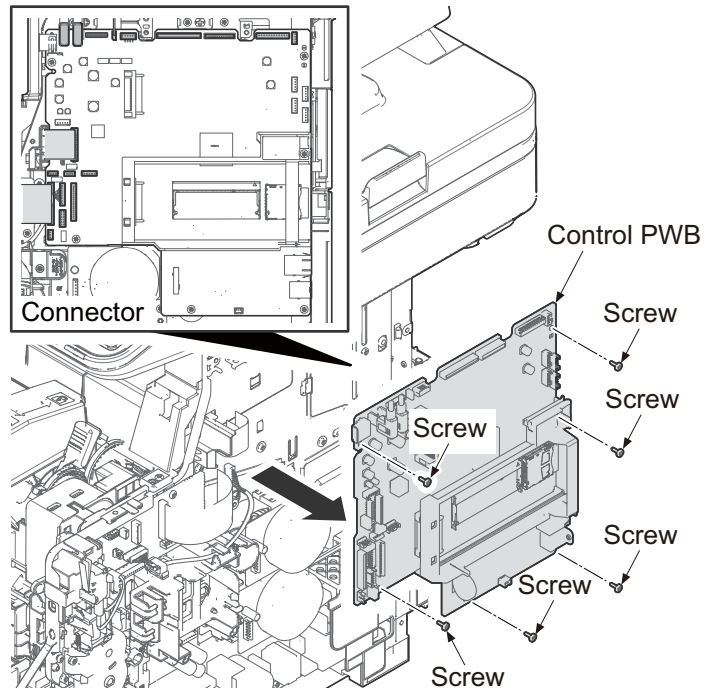

Figure 2-2-11

(5) Remarks on Control PWB replacement

NOTE: When replacing the PWB, remove the EEPROM (U14) from the control PWB and then reattach it to the new PWB.

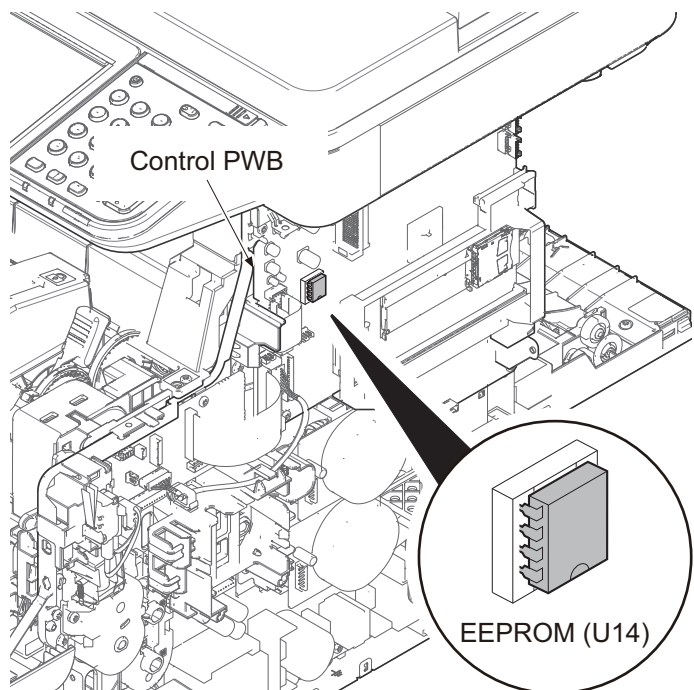

Figure 2-2-12

NOTE:The following operations are required when replacing the main board.

1. Execute maintenance mode U004 to resolve machine number mismatch that appears after replacing the main board.
* : When the machine number of control board does not match, C0180 will be displayed.
2. Adjust the scanner image.
(1)Input the value in the auto scanner adjustment chart by using the maintenance mode U425.
(2)Execute the maintenance mode U411 with the auto scanner adjustment chart.
(3)Execute [Half-tone adjustment] from the system menu
3. Reactivate the license for optional products if any were installed.
(1)Reactivate ID CARD AUTHENTICATION KIT B).
(2)Register an ID card again by using the maintenance mode U222.
4. Import data if any was exported from the machine before replacing the main board by using the maintenance mode U917. (The export and import is also available via KM-Net Viewer)
5. Register the initial user settings and FAX settings from the system menu or command center.
6. Execute the maintenance mode as below if necessary.

No.	Main machine related maintenance modes	No.	Fax related maintenance modes
U250	Checking/clearing the maintenance cycle	U603	Setting user data 1
U251	Checking/clearing the maintenance counter	U604	Setting user data 2
U253	Switching between double and single counts	U610	Setting system 1
U260	Selecting the timing for copy counting	U611	Setting system 2
U345	Setting the value for maintenance due indication	U612	Setting system 3
U402	Adjusting margins of image printing	U625	Setting the transmission system 1
U403	Adjusting margins for scanning an original on the contact glass	U695	FAX function customize
U404	Adjusting margins for scanning an original from the DP		
U425	Setting the target		

2-2-3 Connect Left PWB (CLPWB)

(1) Connector position

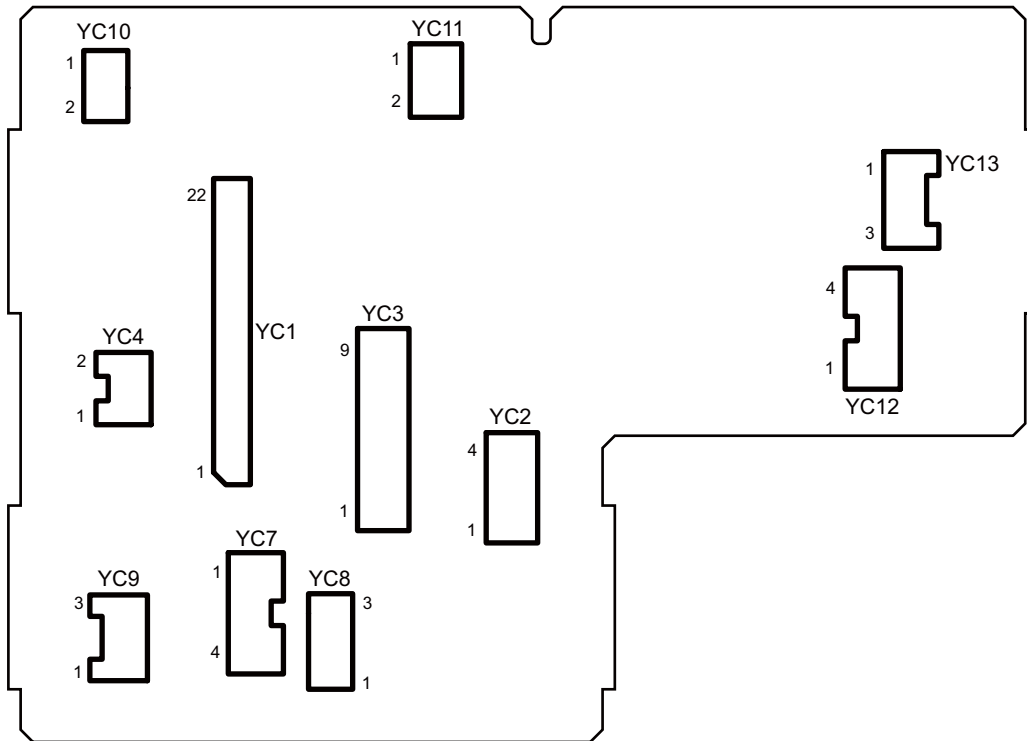

Figure 2-2-13

(2) PWB photograph

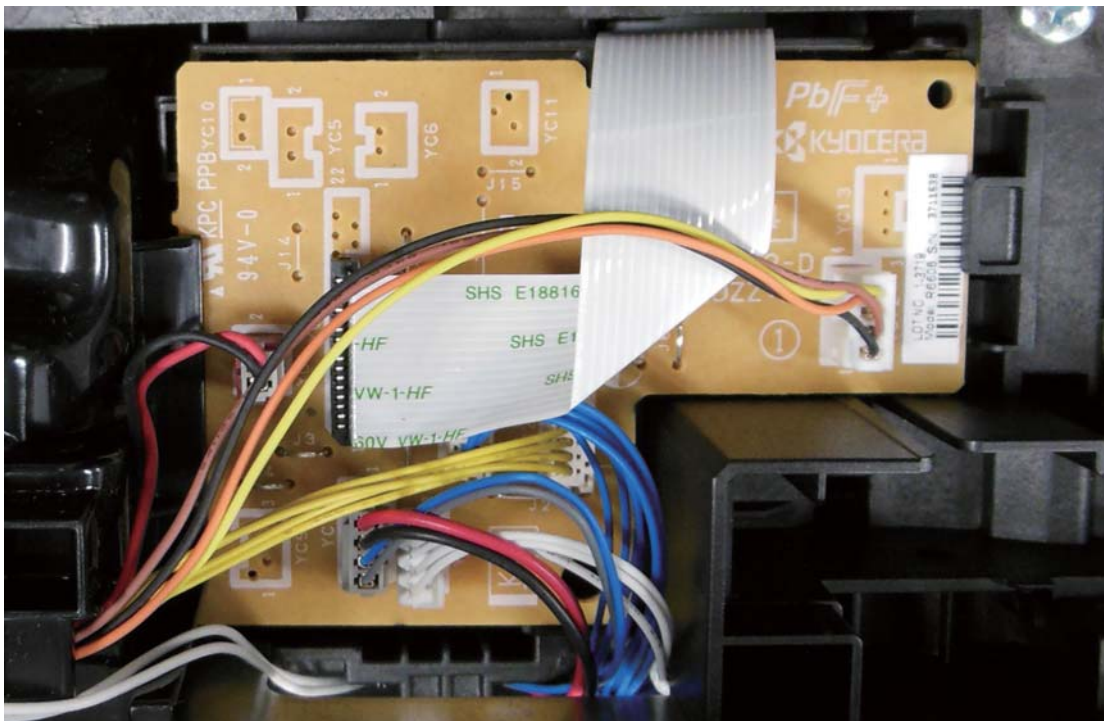

Figure 2-2-14

(3) Connector lists

Connector	Pin	Signal	I/O	Voltage	Description
YC1 Connected to the controll PWB	1	EECLK	I	0/3.3 V DC(pulse)	Clock signal
	2	GND	-	-	Ground
	3	EESIO	I/O	0/3.3 V DC	Data signal
	4	ERASER	I	0/3.3 V DC	CL control signal
	5	+3.3V2_E2	I	3.3 V DC	3.3 V DC power input
	6	TSENS	O	Analog	TS output signal
	7	SBMDIR	I	0/5 V DC	SBM: On/Off
	8	WTSENS	O	Analog	WTS output signal
	9	SBMENBLN	I	0/3.3 V DC	SBM output control signal
	10	WTLED	I	0/3.3 V DC	Waste toner LED control
	11	SBMSTEP	I	0/3.3 V DC	SBM step signal
	12	MPFSSENS	O	0/3.3 V DC	MPS: On/Off
	13	SBMMODE	I	0/3.3 V DC	SBM mode control signal
	14	+3.3V1_E1	I	3.3 V DC	3.3 V DC power input
	15	TMOT	I	0/3.3 V DC	TM: On/Off
	16	LFANN	I	0/24 V DC	LFM: On/Off
	17 *1	FUDR	I	0/24 V DC	FUSOL: On/Off
	18 *1	ENVMOT	I	0/5 V DC	ENVM: On/Off
	19 *1	FDDR	I	0/24 V DC	FUSOL: On/Off
	20 *1	DUJAMSEN1 N	O	0/3.3 V DC	DUS1: On/Off
	21 *1	REGSEN2	O	0/3.3 V DC	RS2: On/ Off
	22 *1	REARSWN	O	0/3.3 V DC	RECSW: On/Off
YC2 Connected to the controll PWB	1	+24V2_E2	I	24 V DC	24 V DC power input
	2	GND	-	-	Ground
	3	GND	-	-	Ground
	4	+24V0_E3	I	24 V DC	24 V DC power input
YC3 Connected to the drum connect PWB	1	TSENS	I	Analog	TS output signal
	2	+24V2_E2	O	24 V DC	24 V DC power output
	3	ERASERN	O	0/24 V DC	CL: On/Off
	4	EECLK	O	0/24 V DC(pulse)	Clock signal
	5	EESIO	I/O	0/3.3 V DC	Data signal
	6	TMOT	O	0/5 V DC	TM control signal
	7	+3.3V2_E2	O	3.3 V DC	3.3 V DC power output
	8	GND	-	-	Ground
	9 *1	REGSEN2	I	0/3.3 V DC	RS2: On/Off

Connector	Pin	Signal	I/O	Voltage	Description
YC4 Connected to the LSU fan motor	1	LFANN	-	0/24 V DC	LFM: On/Off
	2	+24V0_E3	O	24 V DC	24 V DC power output
YC7 Connected to the waste toner sesor	1	+3.3V2_E2	O	3.3 V DC	3.3 V DC power output
	2	WTLEDN	I	0/3.3 V DC	WTS(LED): On/Off
	3	WTSSENS	I	Analog	WTS output signal
	4	+3.3V2_E2	O	3.3 V DC	3.3 V DC power output
YC8 Connected to the MP paper sesor	1	+3.3V1_E1	O	-	3.3 V DC power output
	2	GND	-	-	Ground
	3	MPFSENS	I	0/3.3 V DC	MPS: On/Off
YC9 *1 Connected to the duplex sesor 1	1	3.3V2_E2	O	3.3 V DC	3.3 V DC power output
	2	GND	-	-	Ground
	3	DUJAMSEN1 N	I	0/3.3 V DC	DUS: On/Off
YC10 *1 Connected to the right cover switch	1	REARSWN	I	0/3.3 V DC	RECSW: On/Off
	2	GND	-	-	Ground
YC11 *1 Connected to the envelope motor	1	ENVMOT	O	0/5 V DC	ENVM: On/Off
	2	GND	-	-	Ground
YC12 Connected to the eject motor	1	OUTB3	O	0/3.3 V DC	EM B3 drive control signal
	2	OUTB1	O	0/3.3 V DC	EM B1 drive control signal
	3	OUTA3	O	0/3.3 V DC	EM A3 drive control signal
	4	OUTA1	O	0/3.3 V DC	EM A1 drive control signal
YC13 *1 Connected to the faceup solenoid	1	FACEUDRN	O	0/24 V DC	FUSOL: On/Off
	2	+24V2_E2	O	24 V DC	24 V DC power output
	3	FACEDDRN	O	0/24 V DC	FUSOL: On/Off

*1: 50/60 ppm model only

(4) Detaching and refitting the PWB. (C-LPWB)

Procedure

1. Remove the upper interface cover.
2. Release two hooks using a flat screw driver and remove the right stay cover.

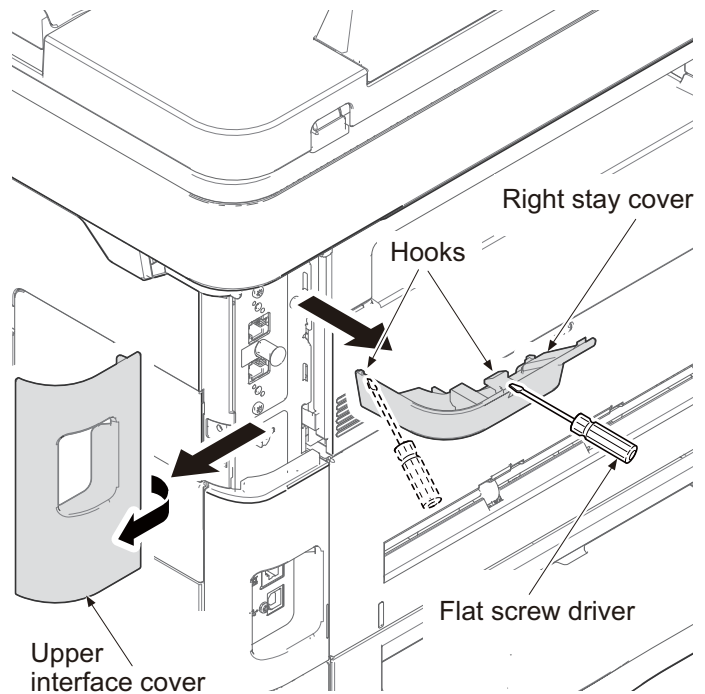

Figure 2-2-15

3. Remove the controller cover.
4. Open the front cover.
5. Remove the screw from the right upper cover.
6. Release two hooks using a flat screw driver and remove the right upper cover.

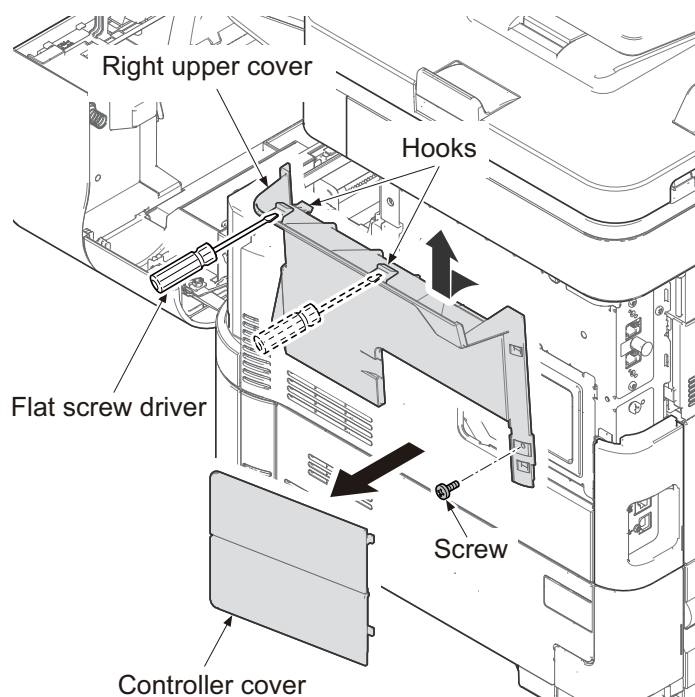

Figure 2-2-16

7. Release two hooks using a flat screw driver and remove the left upper cover.

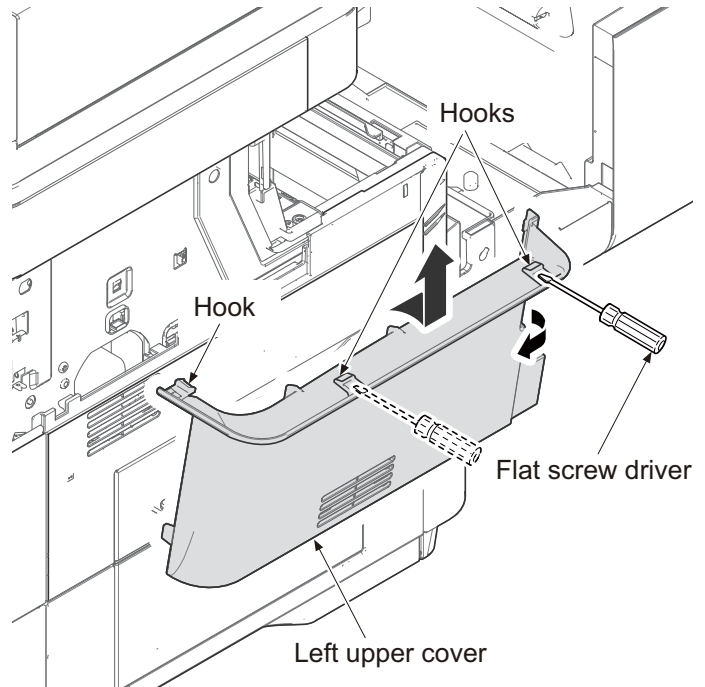

Figure 2-2-17

8. Remove the screw from the center stay cover.
9. Release two hooks using a flat screw driver and remove the center stay cover.

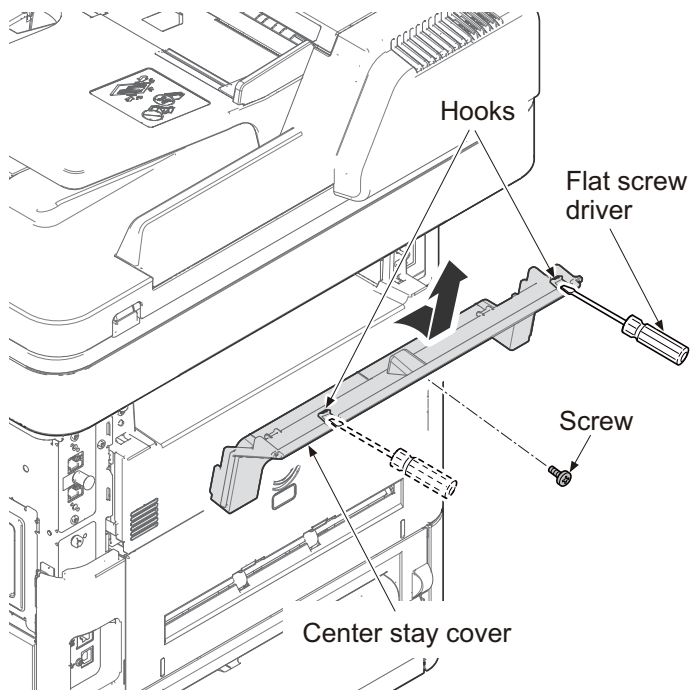

Figure 2-2-18

10. Remove the front right cover forward.

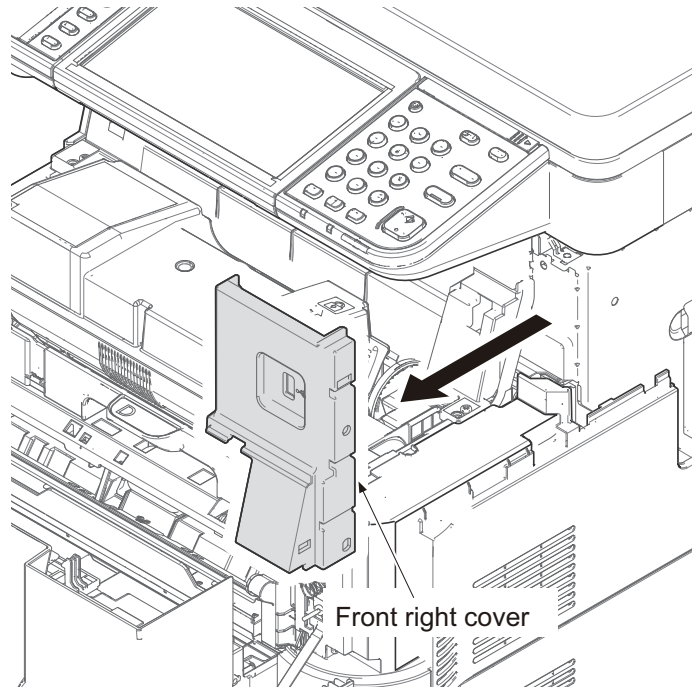

Figure 2-2-19

11. Remove three connectors, two FFCs and two USB connectors from the Control PWB.
12. Remove three screws and grounding terminal from the image scanner unit.
13. Remove it by sliding the image scanner unit backward and then taking upward.

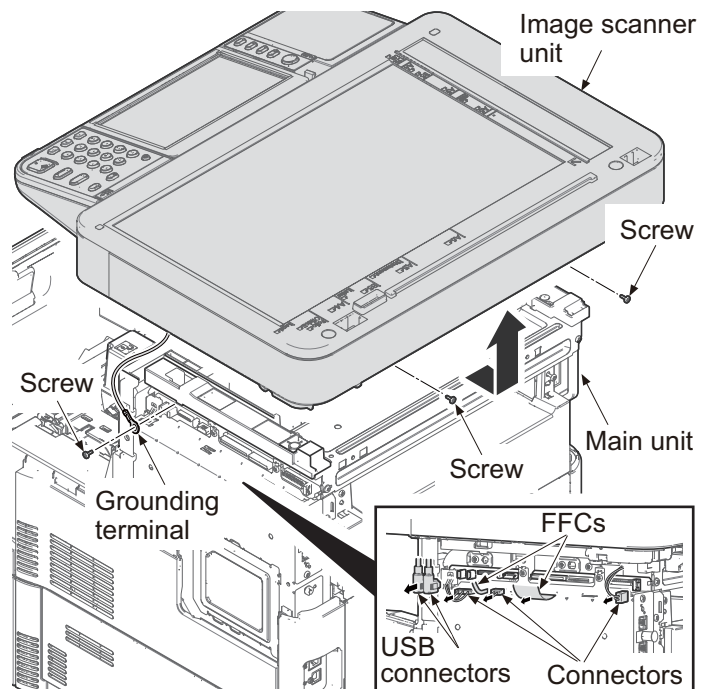

Figure 2-2-20

14. Remove two screws.

(50/60 ppm model only)

(1) Slide the right inner spacer and the left inner spacer forward and then remove it upward.

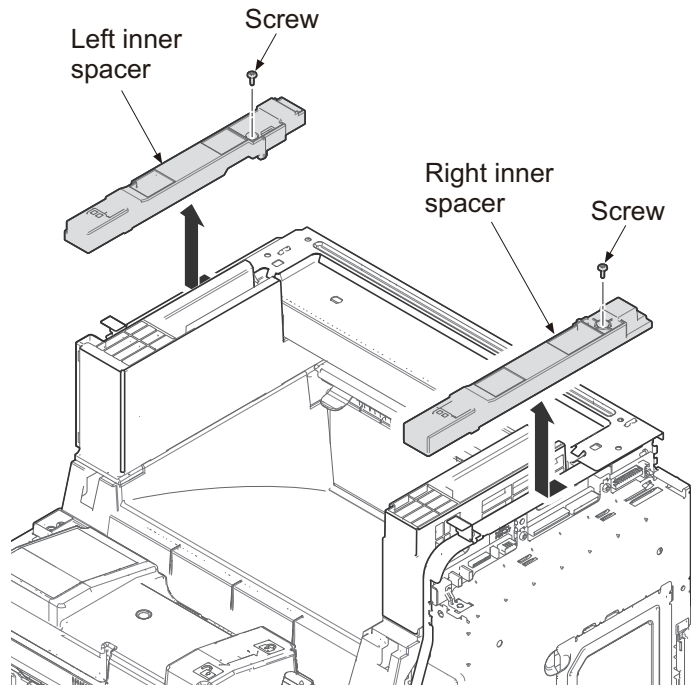

Figure 2-2-21

15. Remove two screws.

16. Remove the center stay cover.

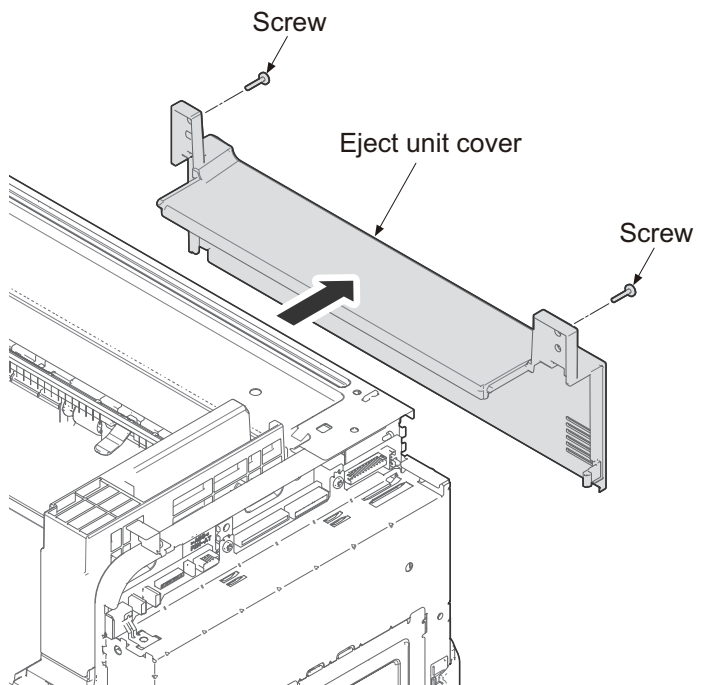

Figure 2-2-22

17. Remove four screws.
18. Remove the upper stay assembly upward.

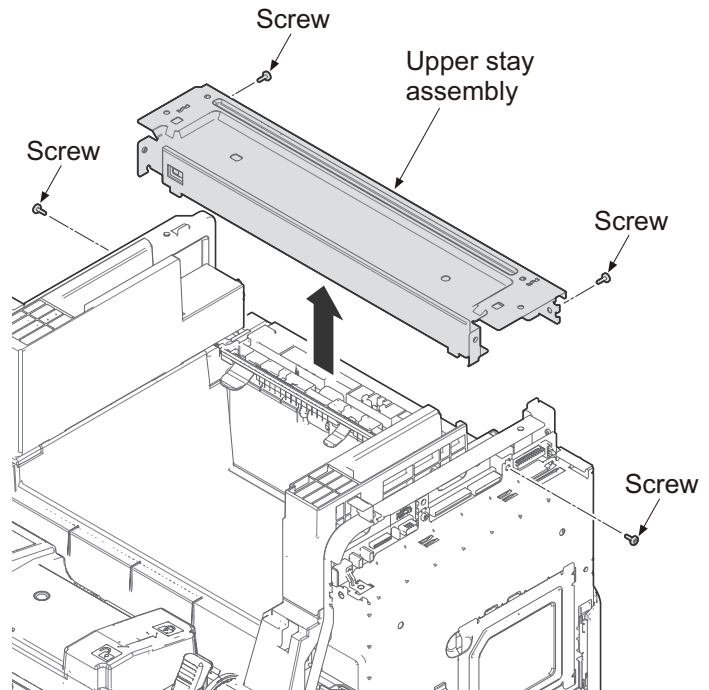

Figure 2-2-23

19. Remove the screw and then remove the right inner cover by leaning it inside and lifting it.
20. Remove two screws and then remove the left inner cover by leaning it inside and lifting it.

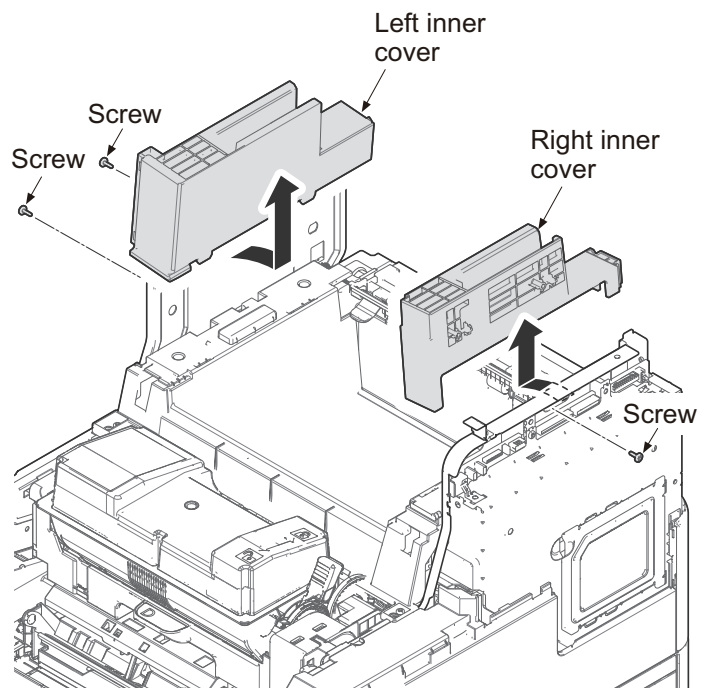

Figure 2-2-24

- 21. Remove two screws.
- 22. Remove the top tray cover upward.

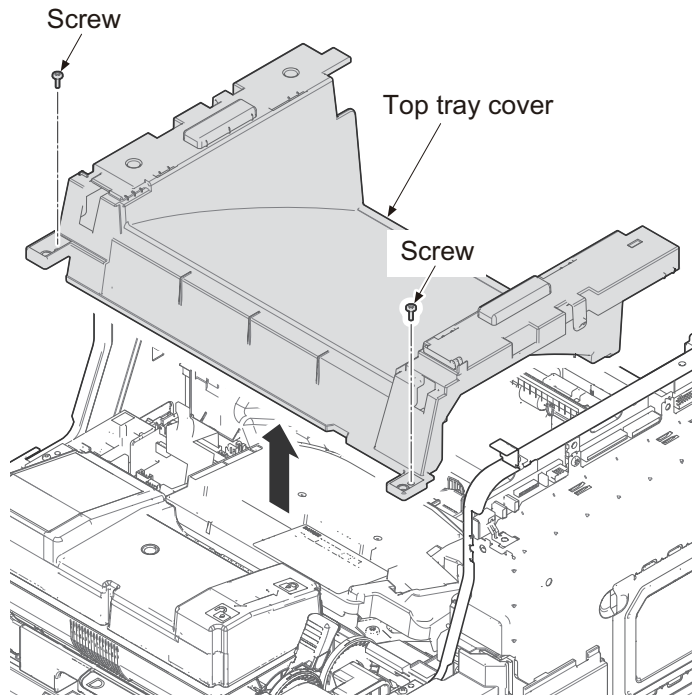

Figure 2-2-25

- 23. Remove the connectors from the connect left PWB and then release the wires from the hooks.
- 24. Remove the LSU fan motor assembly upward.

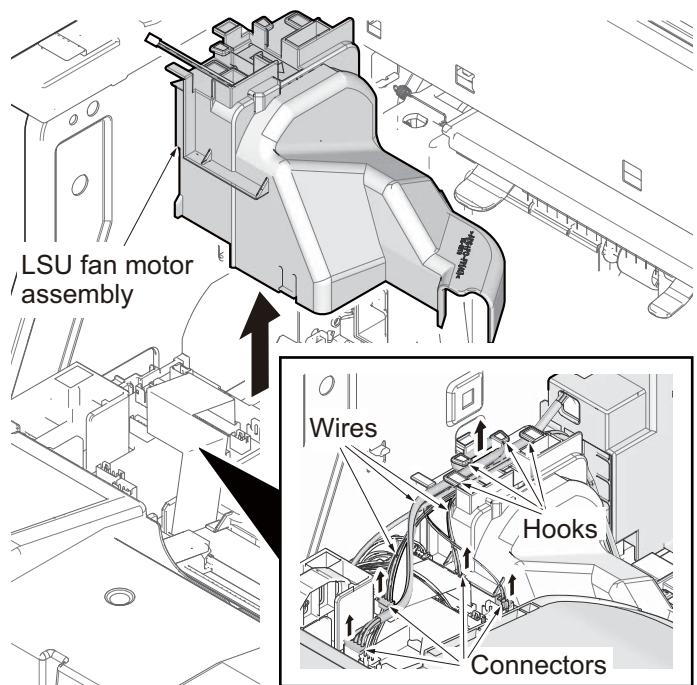

Figure 2-2-26

25. Remove the connectors and FFC and then remove the connect left PWB.
26. Check or replace the connect left PWB and refit all the removed parts.

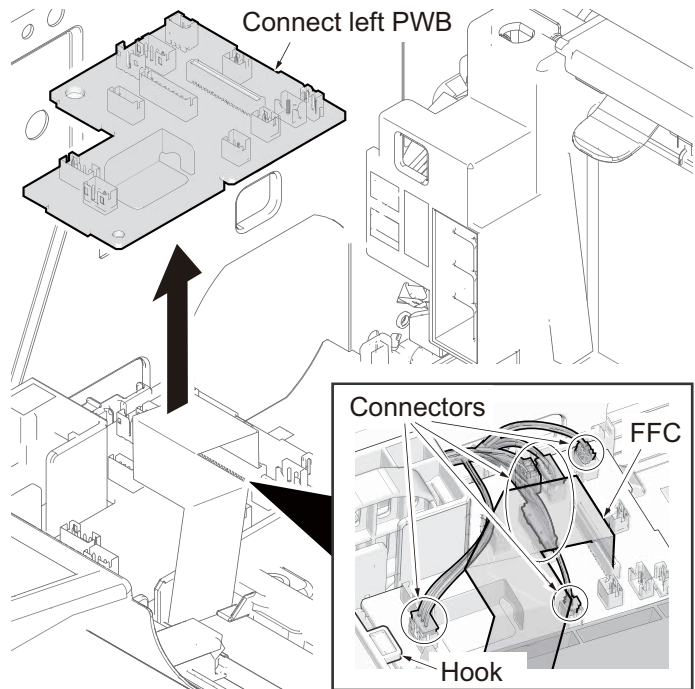

Figure 2-2-27

2-2-4 Connect Right PWB (CRPWB)

(1) Connector position

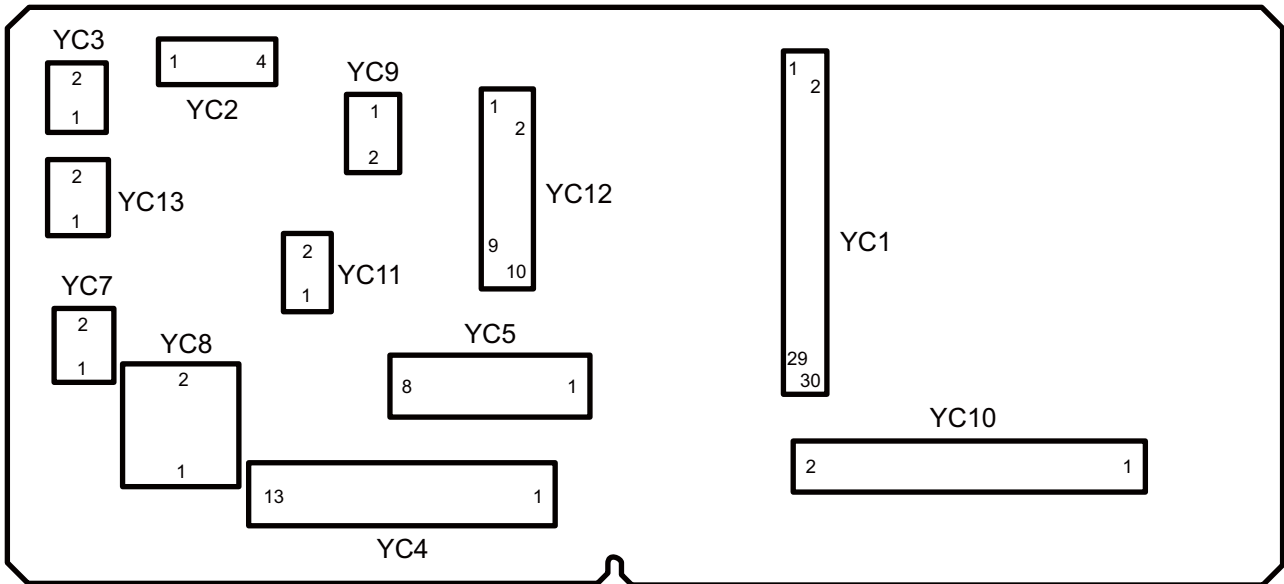

Figure 2-2-28

(2) PWB photograph

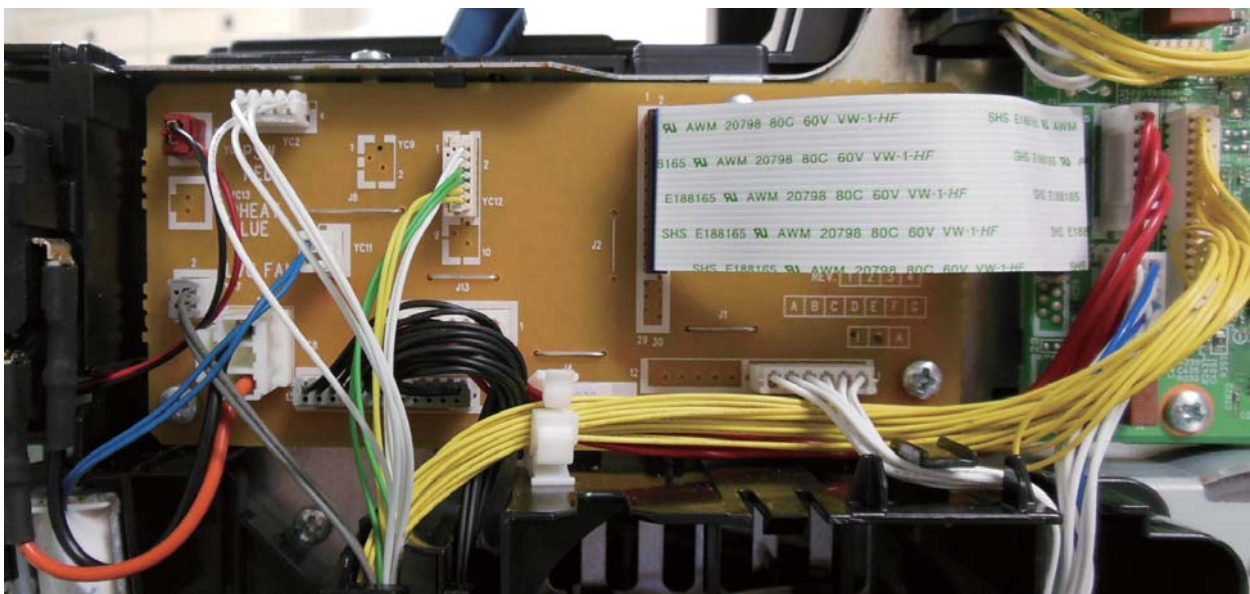

Figure 2-2-29

(3) Connector lists

Connector	Pin	Signal	I/O	Voltage	Description
YC1	1	DEEP_SLEEP N	I	0/3.3 V DC	Sleep signal
Connected to the control PWB	2	RFANH	I	0/24 V DC	RFM: On/Off
	3	MPFSOL	I	0/24 V DC	MPSOL: On/Off
	4	COVOPN	I	0/3.3 V DC	ILSW: On/Off
	5	LIFTMOTOR	I	0/5 V DC	LM: On/Off
	6	RFANL	I	0/24 V DC	RFM: On/Off
	7	DLPCL	I	0/3.3 V DC	DEVCL: On/Off
	8	DHEATER_R EM	I	0/24 V DC	DH: On/Off
	9	FEEDCLN	I	0/24 V DC	PFCL: On/Off
	10	POWERSW	O	0/3.3 V DC	PSSW: On/Off
	11	REGCL	I	0/24 V DC	RCL: On/Off
	12	CASSET	I	Analog	CSSW: On/Off
	13	PSLEEPN	O	0/5 V DC	Sleep mode signal
	14	MMOTCWN	I	0/5 V DC	MM drive shift signal
	15	RELAY	O	0/5 V DC	Relay control
	16	MMOTRDYN	O	0/3.3 V DC	MM ready signal
	17	ZCROSSN	I	0/5 V DC(pulse)	Zero crossing signal
	18	MMOTON	I	0/5 V DC	MM: On/Off
	19	HEAT1REM	I	0/24 V DC	Fuser heater control
	20	TYPE	-	-	Not used
	21	GND	-	-	Ground
	22	MMOTCLK	O	0/5 V DC(pulse)	MM clock signal
	23 *1	GND	-	-	Ground
	24 *1	DMOTCLK	O	0/5 V DC(pulse)	DRM clock signal
	25 *1	GND	-	-	Ground
	26 *1	DMOTRDYN	I	0/3.3 V DC	DRM ready signal
	27 *1	MIDCL	O	0/24 V DC	PCCL: On/Off
	28 *1	DMOTON	O	0/5 V DC	DRM: On/Off
	29 *1	DUCL	O	0/24 V DC	DUCL: On/Off
	30 *1	HEAT2REM	O	0/24 V DC	Fuser heater control

Connector	Pin	Signal	I/O	Voltage	Description
YC2 Connected to the cassette size switch	1	CAS3	I	0/24 V DC	CSSW: On/Off
	2	CAS2	I	0/3.3 V DC	CSSW: On/Off
	3	CASSET	-	-	CSSW common signal
	4	CAS1	I	0/3.3 V DC	CSSW: On/Off
YC3 Connected to the switch PWB	1	GND	-	-	Ground
	2	POWERSW	I	0/3.3 V DC	PSSW: On/Off
YC4 Connected to the power source PWB	1	HEAT1REM	O	0/3.3 V DC	TH1 remote signal
	2	ZCROSSN	I	0/3.3 V DC	Zero crossing detection signal
	3	RELAY	O	0/3.3 V DC	Relay driving signal
	4	PSLEEPN	O	0/3.3 V DC	Sleep signal
	5	GND	-	-	Ground
	6	GND	-	-	Ground
	7	GND	-	-	Ground
	8	GND	-	-	Ground
	9	+24V0_E1	I	24 V DC	24 V DC power input
	10	+24V0_E1	I	24 V DC	24 V DC power input
	11	+24V0_E1	I	24 V DC	24 V DC power input
	12	+24V0_E1	I	24 V DC	24 V DC power input
	13 *1	HEAT2REM	O	0/3.3 V DC	TH2 remote signal
YC5 Connected to the control PWB	1	+24V2_E1	O	24 V DC	24 V DC power output
	2	+24V2_E1	O	24 V DC	24 V DC power output
	3	GND	-	-	Ground
	4	GND	-	-	Ground
	5	GND	-	-	Ground
	6	GND	-	-	Ground
	7	+24V0_E1	I	24 V DC	24 V DC power input
	8	+24V0_E1	I	24 V DC	24 V DC power input
YC7 Connected to the power source fan motor	1	+24V0_E1	O	24 V DC	24 V DC power output
	2	FANRN	O	0/24 V DC	PSFM: On/Off
YC8 Connected to the inter lock switch	1	+24V0_E1	O	24 V DC	24 V DC power output
	2	+24V0_E2	O	24 V DC	24 V DC power output

Connector	Pin	Signal	I/O	Voltage	Description
YC9 *1	1	LIFTMOTOR	O	0/5 V DC	LM: On/Off
Connected to the lift motor	2	GND	-	-	Ground
YC10	1	MMOTCW	O	0/5 V DC	MM drive shift signal
Connected to the main motor and the durm motor	2	MMOTRDYN	I	0/3.3 V DC	MM ready signal
	3	MMOTCLKN	O	0/5 V DC(pulse)	MM clock signal
	4	MMOTONN	O	0/5 V DC	MM: On/Off
	5	GND	-	-	Ground
	6	+24V2_E1	O	24 V DC	24 V DC power output
	7 *1	+24V2_E1	O	24 V DC	24 V DC power output
	8 *1	GND	-	-	Ground
	9 *1	DMOTONN	O	0/5 V DC	DRM: On/Off
	10 *1	DMOTCLKN	O	0/5 V DC(pulse)	DRM clock signal
	11 *1	DMOTRDYN	I	0/3.3 V DC	DRM ready signal
	12 *1	DMOTCW	O	0/5 V DC	DRM rotation direction
YC11	1	+24V2_E1	O	24 V DC	24 V DC power output
Connected to the MP solenoid	2	MPFSOLN	O	0/24 V DC	MPSOL: On/Off
YC12	1	+24V2_E1	O	24 V DC	24 V DC power output
Connected to the developer clutch, feed clutch, regist clutch, mid clutch and duplex clutch	2	DLPCLN	O	0/3.3 V DC	DEVCL: On/Off
	3	+24V2_E1	O	24 V DC	24 V DC power output
	4	FEEDCLN	O	0/24 V DC	PFCL: On/Off
	5	+24V2_E1	O	24 V DC	24 V DC power output
	6	REGCLN	O	0/24 V DC	RCL: On/Off
	7 *1	+24V2_E1	O	24 V DC	24 V DC power output
	8 *1	MIDCLN	O	0/24 V DC	PCCL: On/Off
	9 *1	+24V2_E1	O	24 V DC	24 V DC power output
	10 *1	DUCLN	O	0/24 V DC	DUCL: On/Off

*1: 50/60 ppm model only

(4) Detaching and refitting the PWB. (CRPWB)

Procedure

1. Remove the upper interface cover.
2. Release two hooks using a flat screw driver and remove the right stay cover.

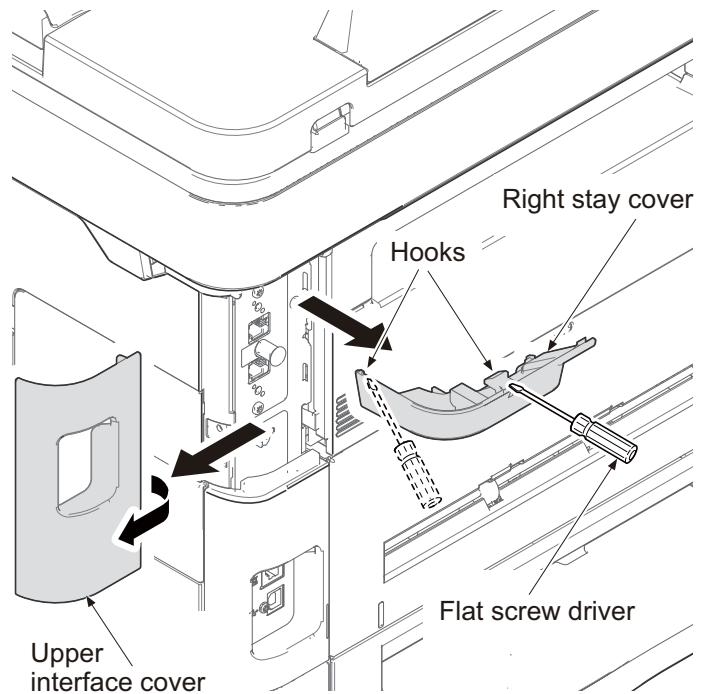

Figure 2-2-30

3. Remove the controller cover.
4. Open the front cover.
5. Remove the screw from the right upper cover.
6. Release two hooks using a flat screw driver and remove the right upper cover.

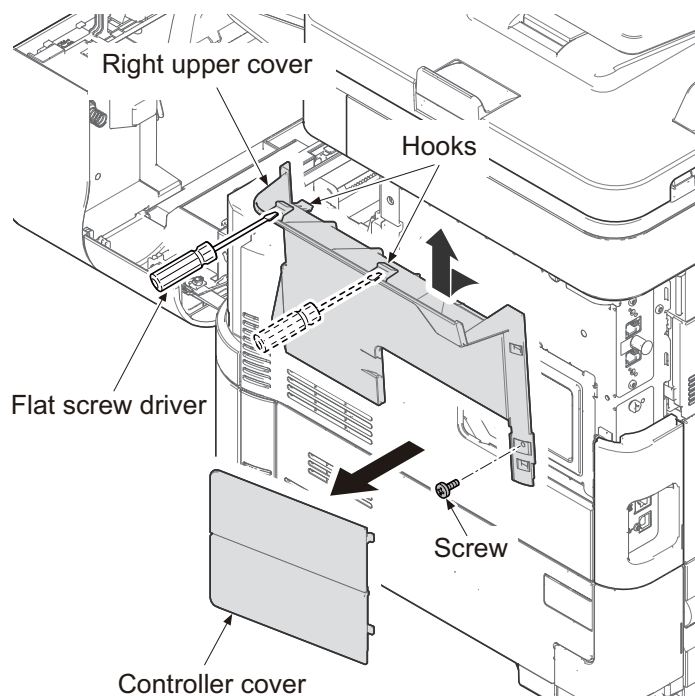

Figure 2-2-31

7. Open the rear cover.
8. Remove the lower interface cover and the inlet cover.

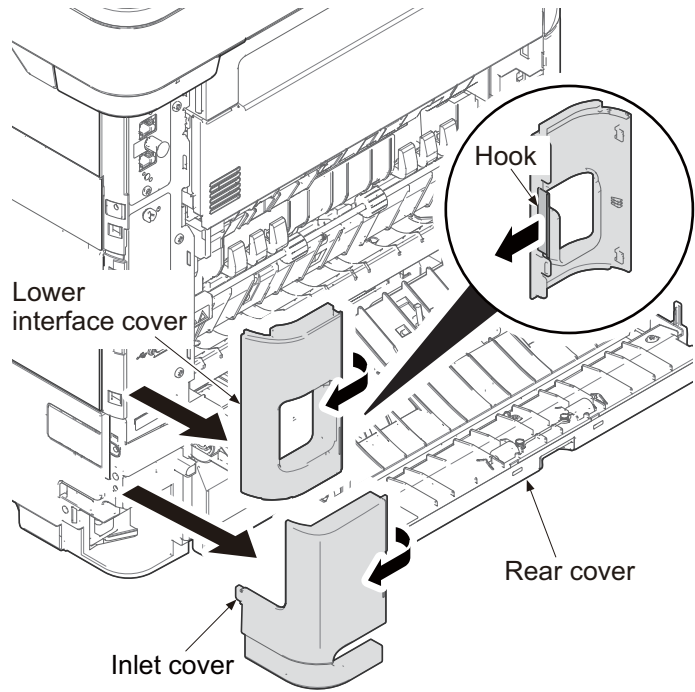

Figure 2-2-32

9. Remove two screws.
10. Release the hooks by bending both-side of the right middle cover and then remove it by pulling and lifting up forward.

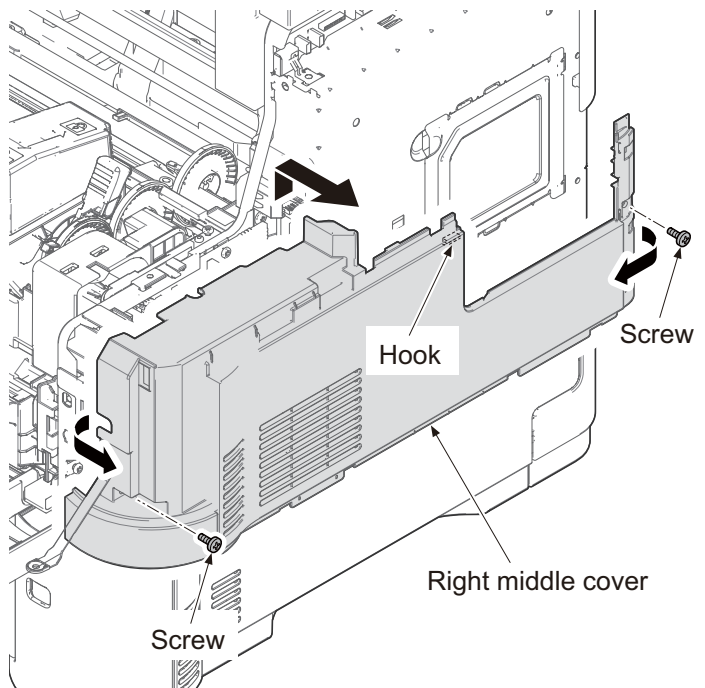

Figure 2-2-33

11. Remove all connectors and FFC from the connect right PWB.
12. Remove three screws and connect right PWB from the main unit.
13. Check or replace the connect right PWB and refit all the removed parts.

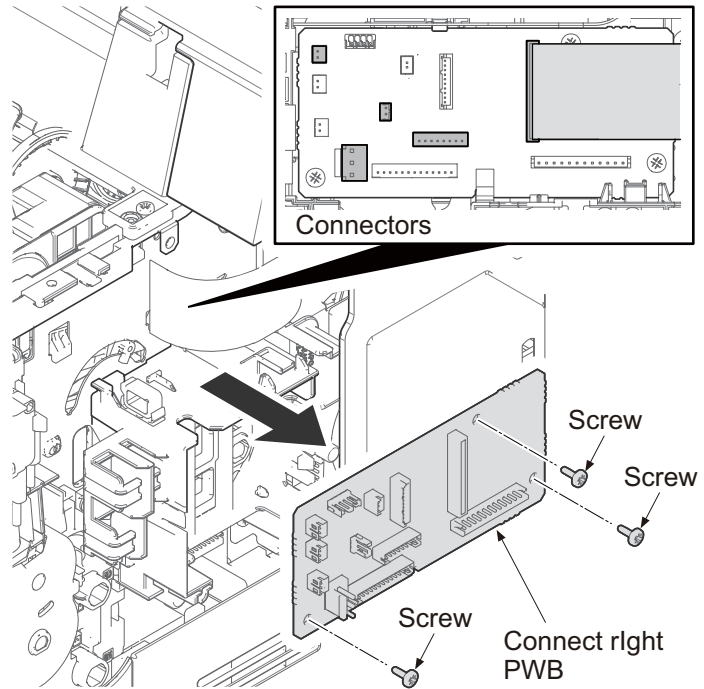

Figure 2-2-34

2-2-5 High Voltage PWB (HVPWB)

(1) Connector position

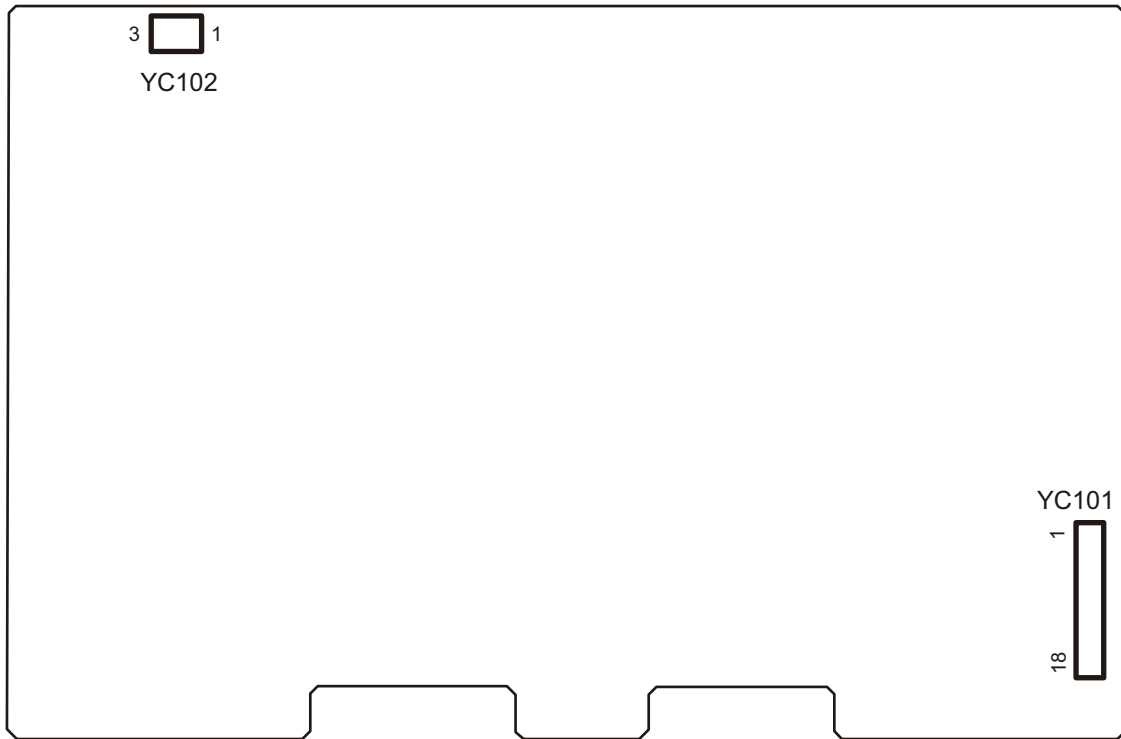

Figure 2-2-35

(2) PWB photograph

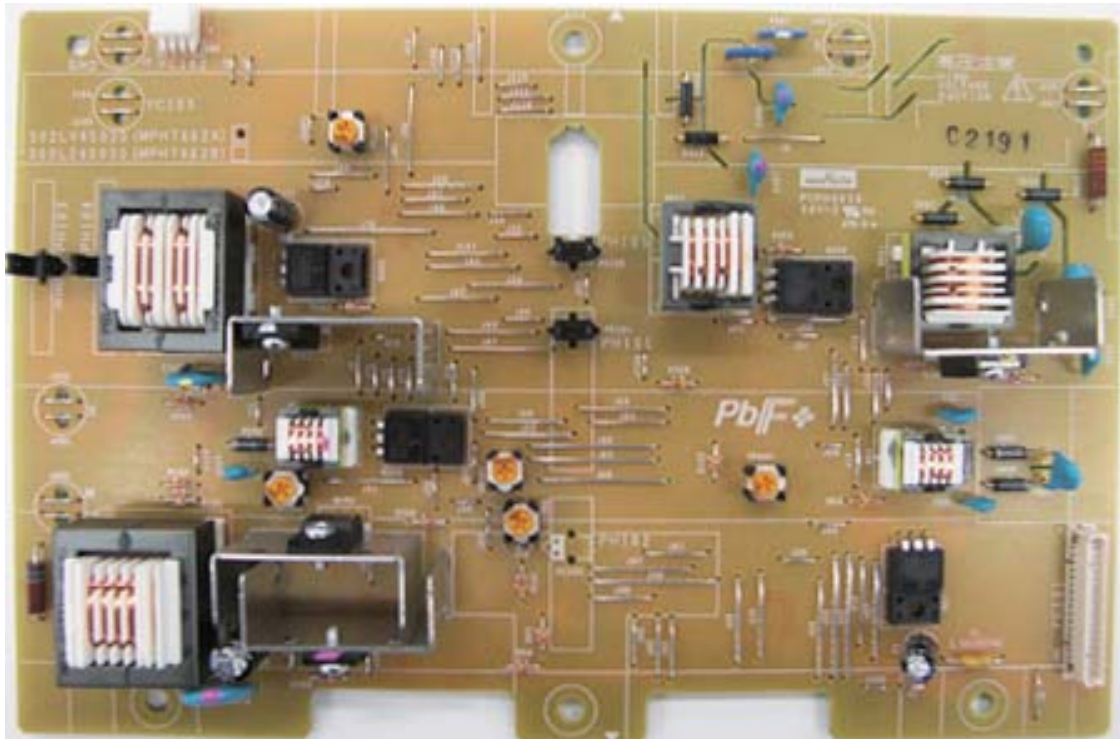

Figure 2-2-36

(3) Connector lists

Connector	Pin	Signal	I/O	Voltage	Description
YC101	1	+24V2_E1	O	24 V DC	24 V DC power output
Connected to the control PWB	2	TCNT	O	Analog	Transfer control
	3	TRREM	O	0/3.3 V DC	Transfer remote signal
	4	SCNT	O	Analog	Separation control
	5	+3.3V2_E2	O	3.3 V DC	3.3 V DC power output
	6	DUJAMSEN2 N	I	0/3.3 V DC	DUS2:On/Off
	7	REGSENSN	I	0/3.3 V DC	RS:On/Off
	8	PAPERSEN1 N	I	0/3.3 V DC	PS1:On/Off
	9	PAPERSEN2 N	I	0/3.3 V DC	PS2:On/Off
	10	BACNT	I	Analog	Developer AC control
	11	BDCNT	I	Analog	Developer DC control
	12	HVCLK	O	0/3.3 V DC	Developer clock signal
	13	MDCCNT	I	Analog	Charger DC control
	14	MACCNT	I	Analog	Charger AC control
	15	MHVCLK	O	0/3.3 V DC	Charger clock signal
	16	MISENS	O	Analog	Charger current detection
	17	GND	-	-	Ground
	18	ENVSENSN	I	0/3.3 V DC	ES:On/Off
YC102	1	+3.3V2_E2	O	3.3 V DC	3.3 V DC power output
Connected to the envelope sensor	2	GND	-	-	Ground
	3	ENVSENSN	I	0/3.3 V DC	FUPRS:On/Off

(4) Detaching and refitting the PWB. (HVPWB)

Procedure

1. Remove the upper interface cover.
2. Release two hooks using a flat screw driver and remove the right stay cover.

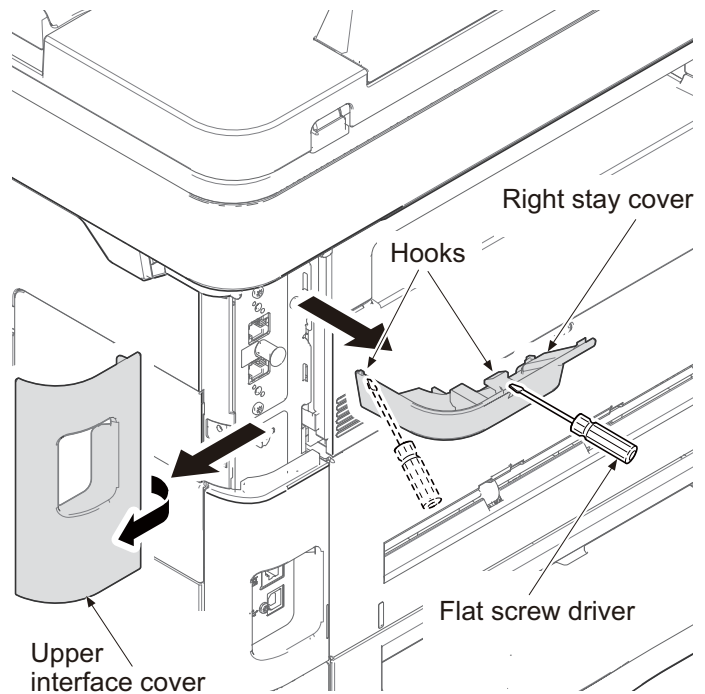

Figure 2-2-37

3. Remove the controller cover.
4. Open the front cover.
5. Remove the screw from the right upper cover.
6. Release two hooks using a flat screw driver and remove the right upper cover.

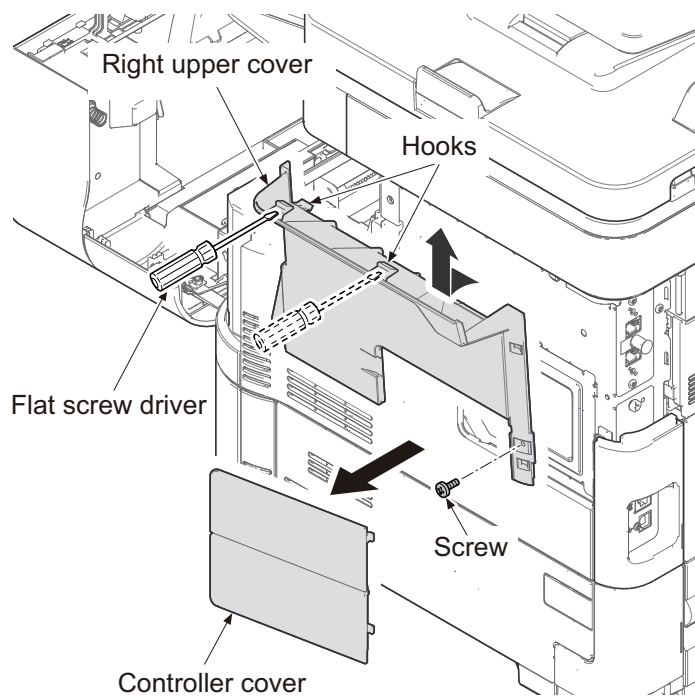

Figure 2-2-38

7. Release two hooks using a flat screw driver and remove the left upper cover.

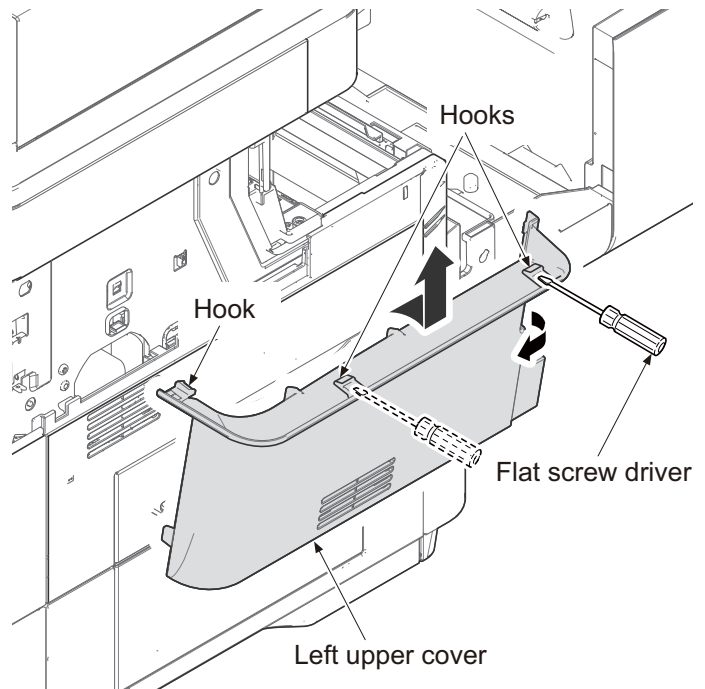

Figure 2-2-39

8. Remove the screw from the center stay cover.
9. Release two hooks using a flat screw driver and remove the center stay cover.

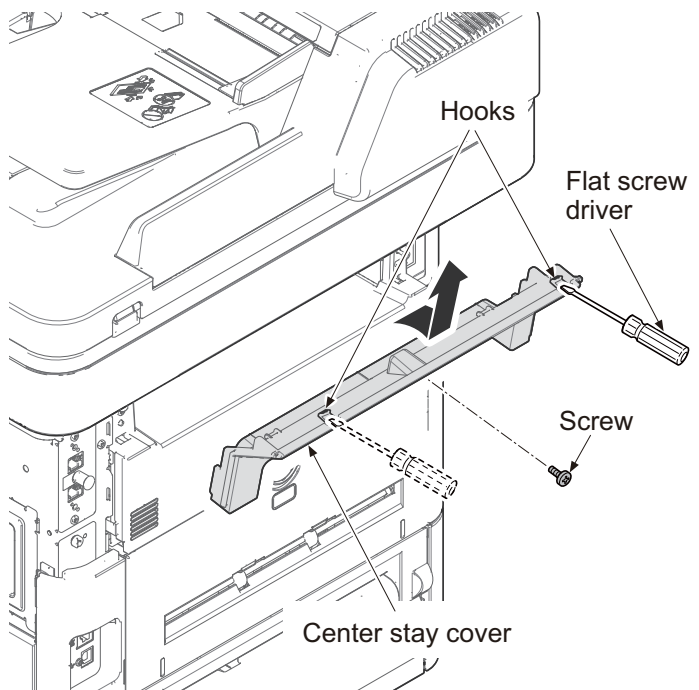

Figure 2-2-40

10. Remove the front right cover forward.

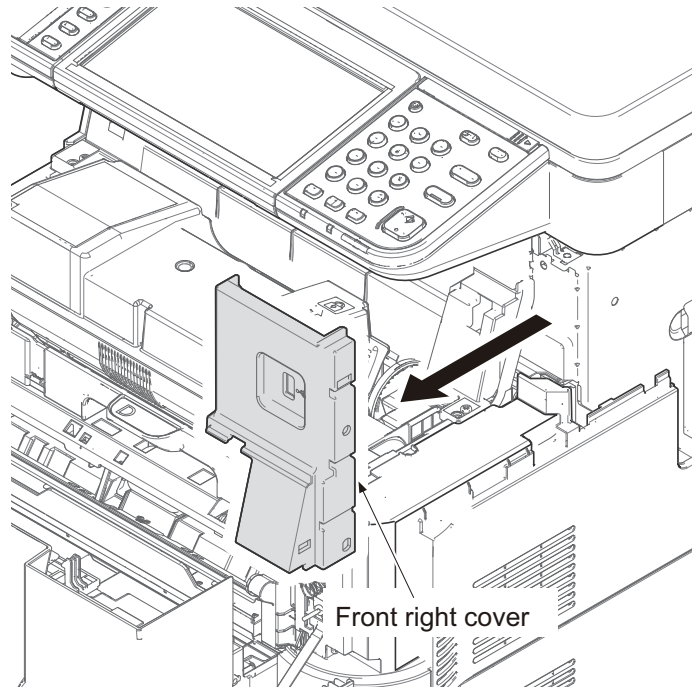

Figure 2-2-41

11. Remove three connectors, two FFCs and two USB connectors from the Control PWB.
12. Remove three screws and grounding terminal from the image scanner unit.
13. Remove it by sliding the image scanner unit backward and then taking upward.

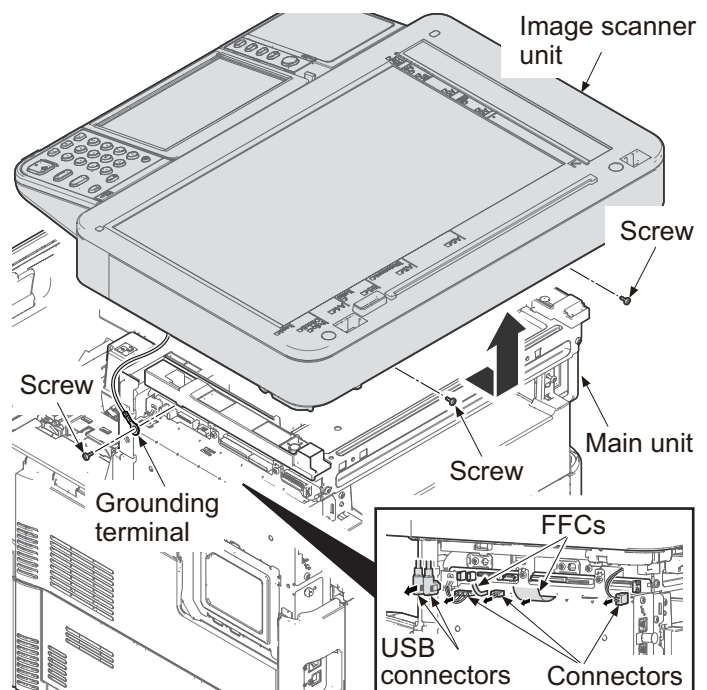

Figure 2-2-42

14. Open the rear cover.
15. Remove the lower interface cover and the inlet cover.

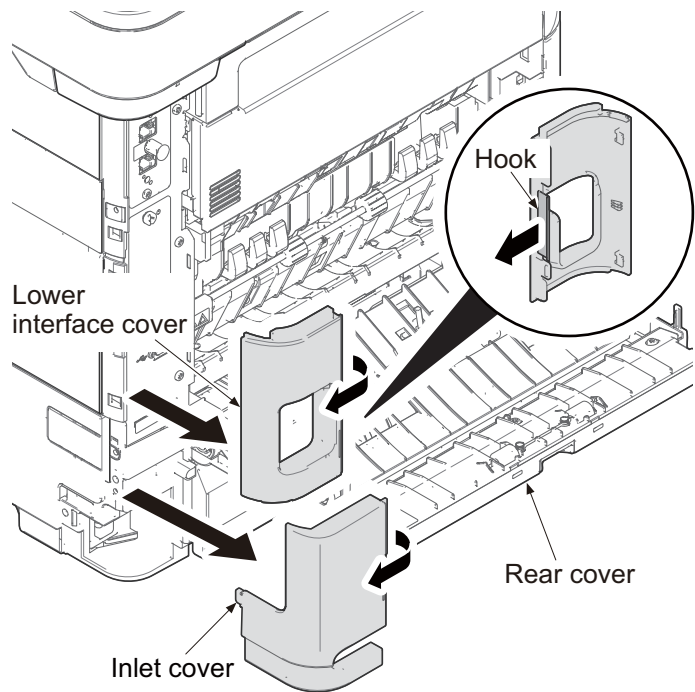

Figure 2-2-43

16. Remove two screws.
17. Release the hooks by bending both-side of the right middle cover and then remove it by pulling and lifting up forward.

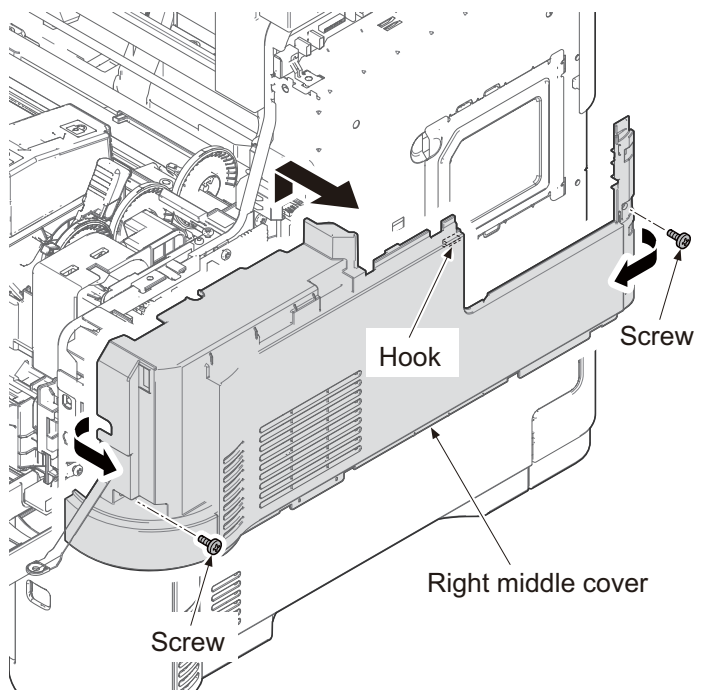

Figure 2-2-44

18. Pull out the cassette.
19. Remove three screws.
20. Release two hooks by sliding the right lower cover upward and then remove the right lower cover.

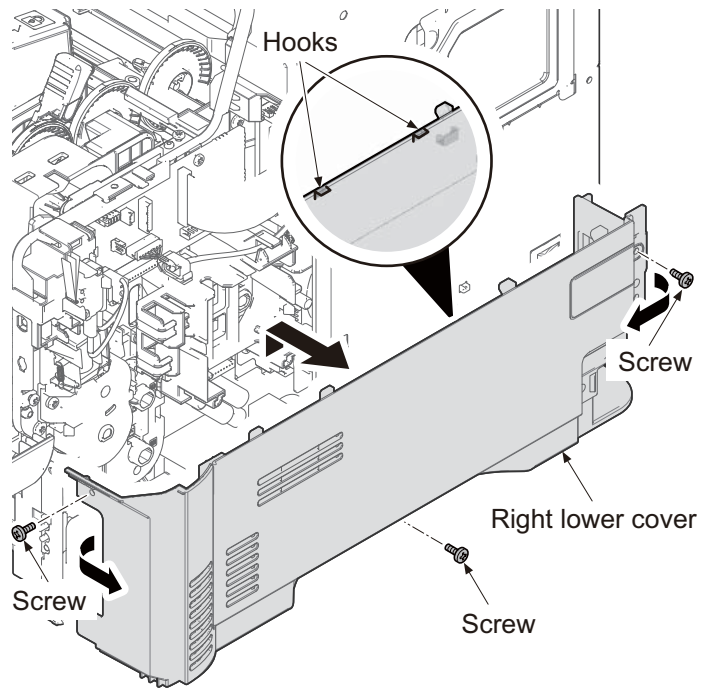

Figure 2-2-45

21. Release two hooks of the rear left cover while pulling forward.
22. Remove the rear left cover by rotating.

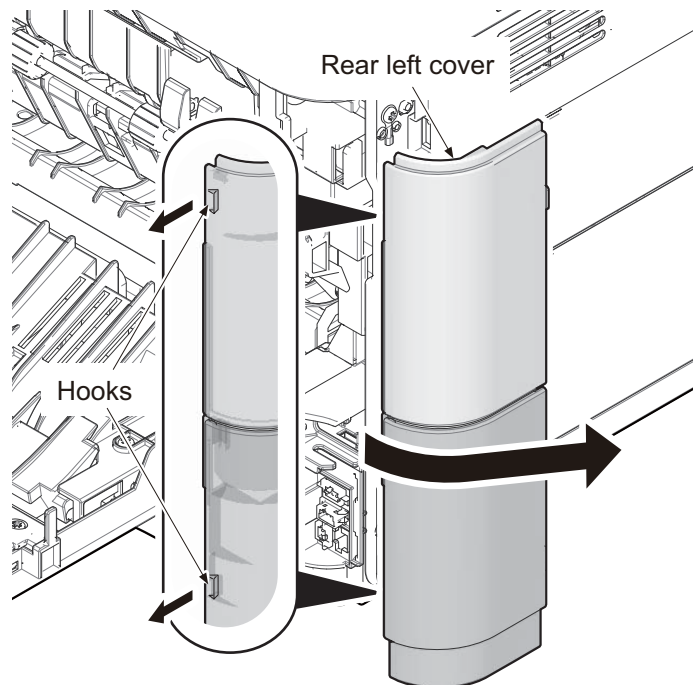

Figure 2-2-46

23. Release the hook A by sliding the left upper cover upward.
24. Release the hook B and hook C and then remove the left middle cover and the waste toner box cover.

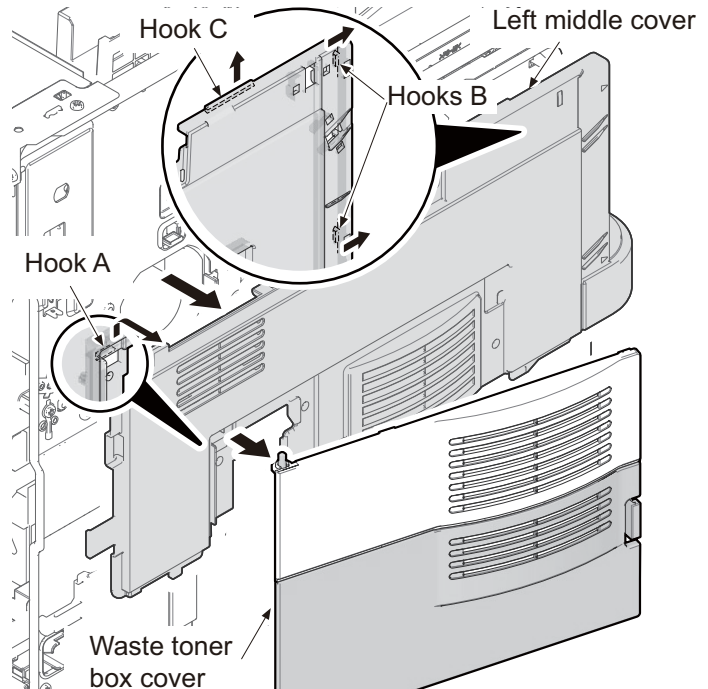

Figure 2-2-47

25. Remove the screw.
26. Release the hook A.
27. Release two hooks B by sliding the left lower cover upward and then remove the left lower cover.

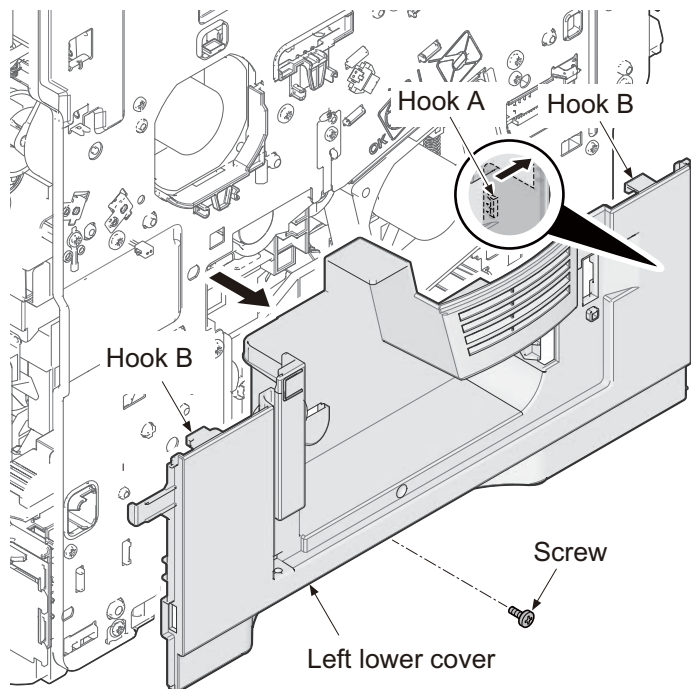

Figure 2-2-48

28. Remove eight screws and grounding terminal.
29. Remove the controller box.

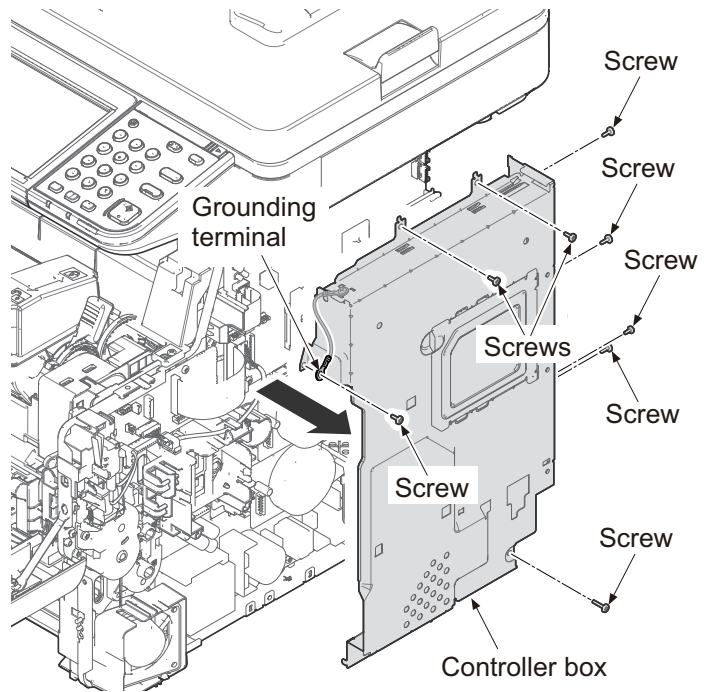

Figure 2-2-49

30. Remove the connector cover B by releasing the hook.
31. Remove the screw of connector cover C.
32. Remove the connector cover C by releasing the hook.
33. Pull two connectors out.

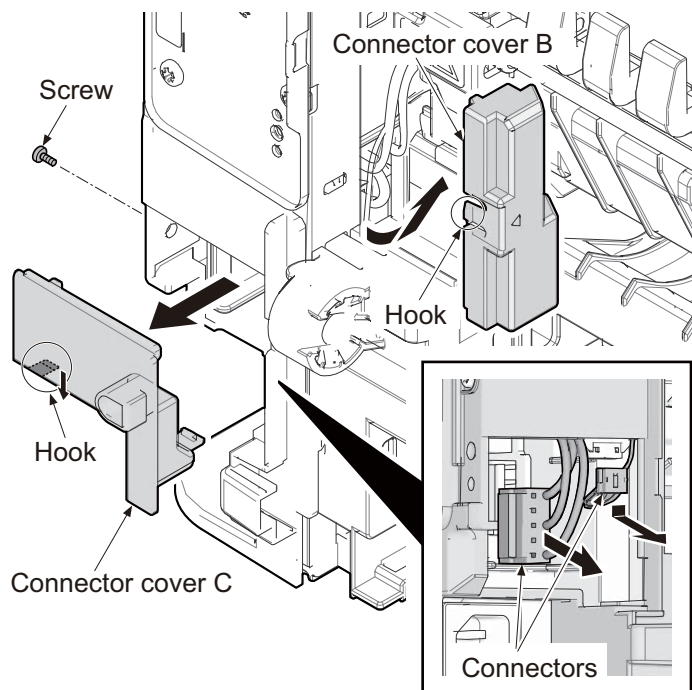

Figure 2-2-50

34. Remove the grounding wire by removing the screw.
35. Remove the connector from the power source PWB.
36. Remove three screws and then remove the power source PWB assembly.

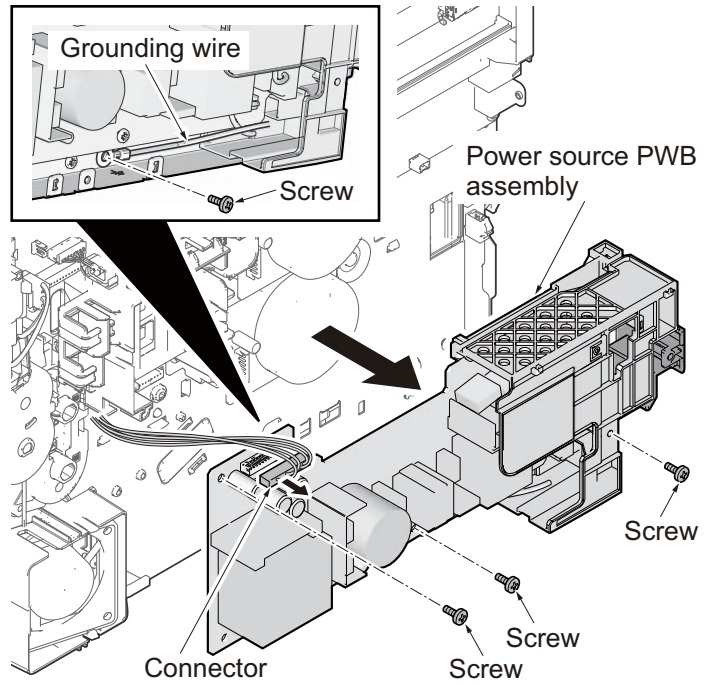

Figure 2-2-51

37. Stand the main unit front side up.
38. Remove four screws each and then remove the bottom plate 1 and the bottom plate 2.

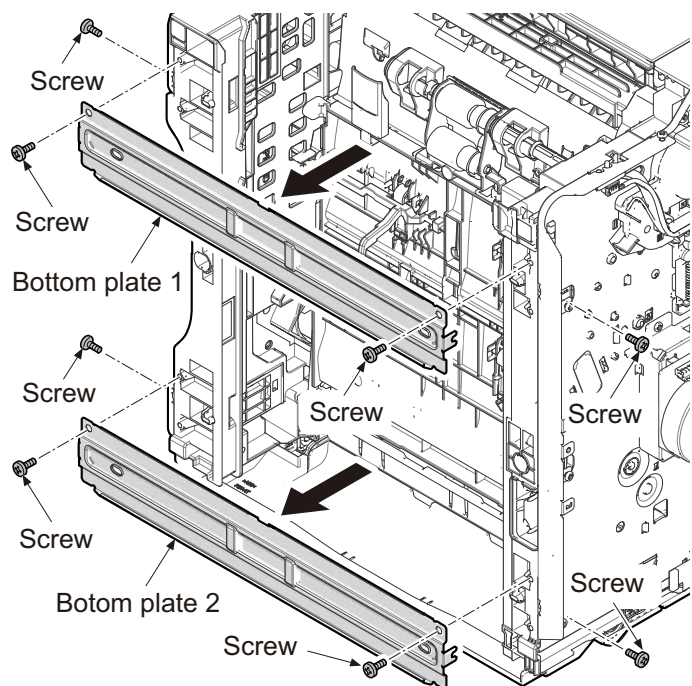

Figure 2-2-52

39. [50/60 ppm model only]
 Release two hooks and then remove the wire cover.
 Pull the connector of lift sensor out.

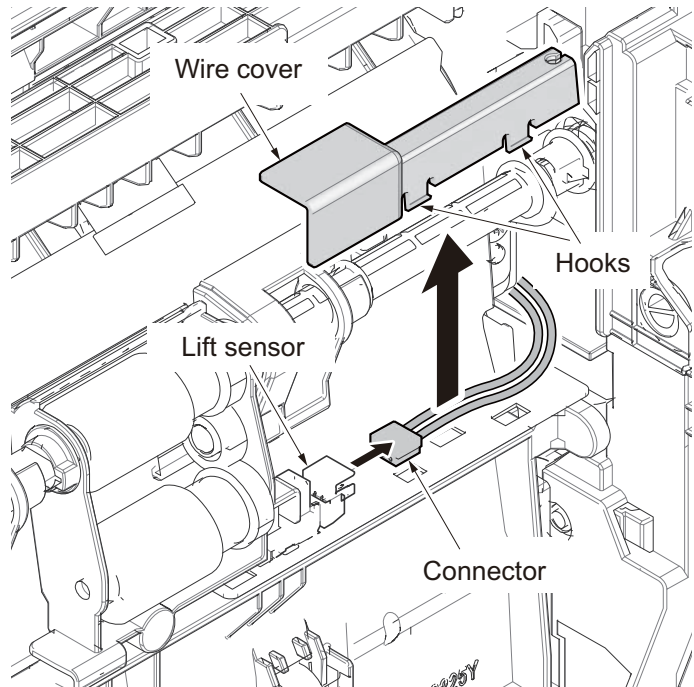

Figure 2-2-53

40. Remove seven screws.
 41. Extract the feed roller axis by pushing the joint part.
 42. Remove the duplex assembly to the front.

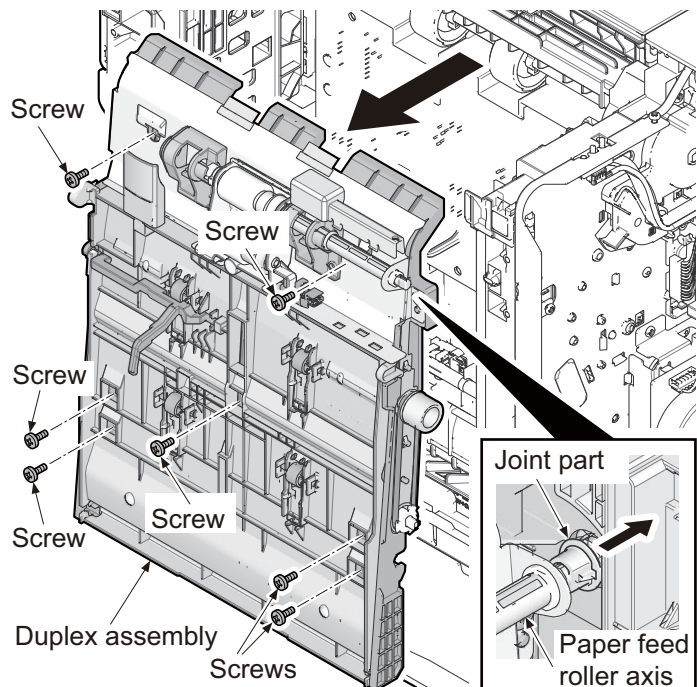

Figure 2-2-54

43. Remove the screw.
44. Pull two connectors out and then remove the high voltage PWB.
45. Check or replace the high voltage PWB and refit all the removed parts.

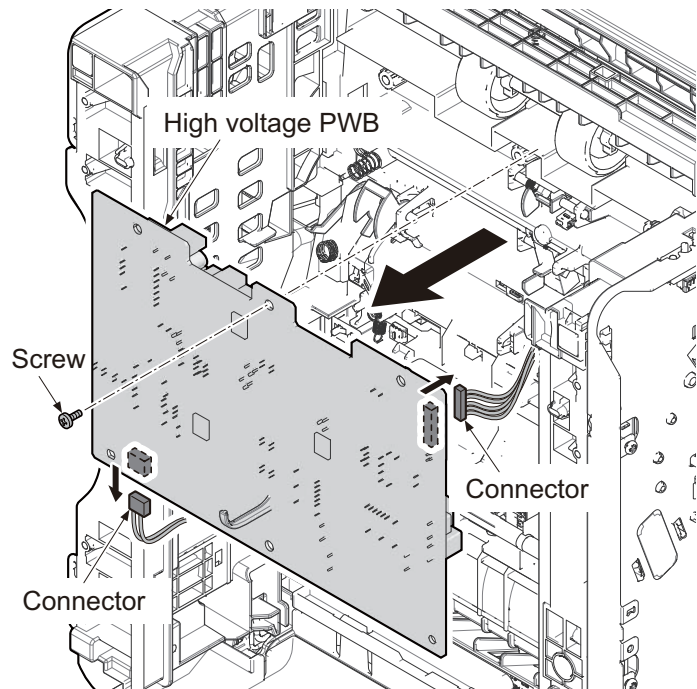

Figure 2-2-55

2-2-6 Power source PWB (PSPWB)

(1) Connector position

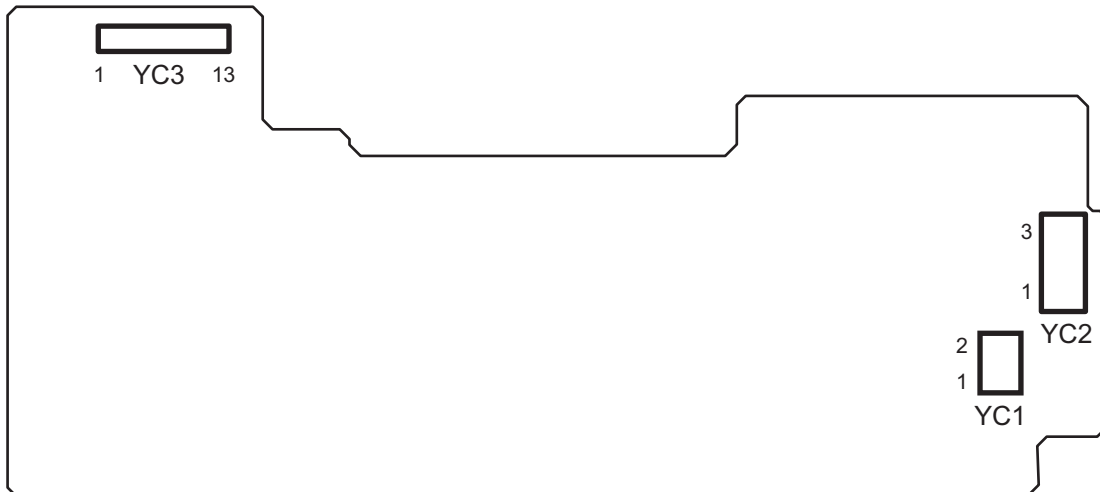

Figure 2-2-56

(2) PWB photograph

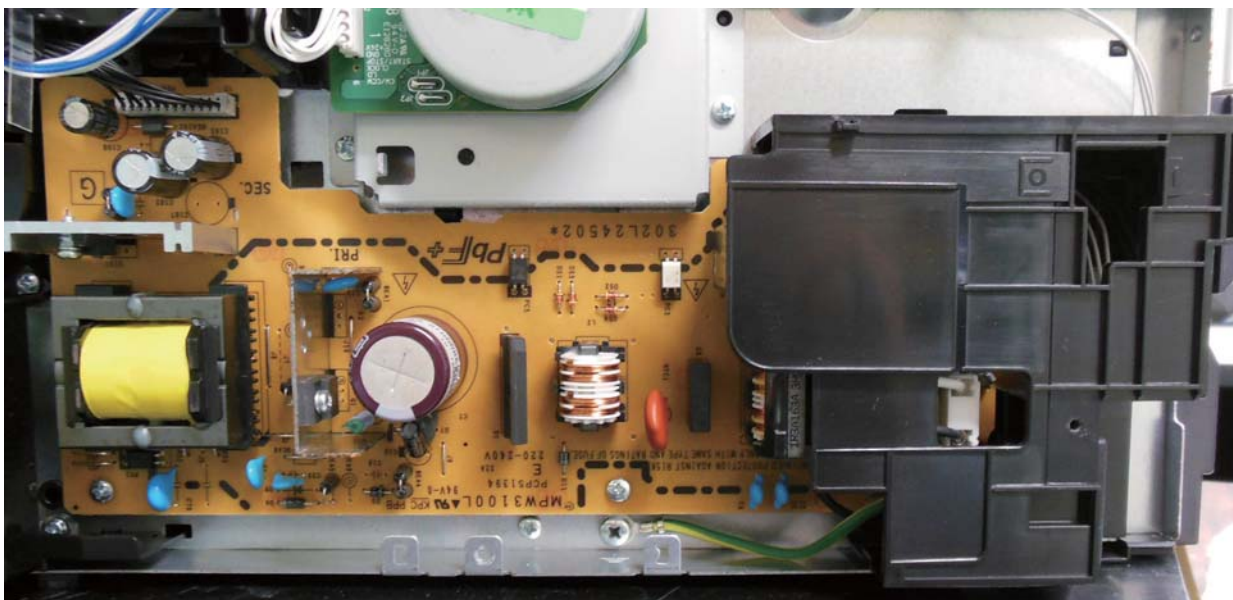

Figure 2-2-57

(3) Connector lists

Connector	Pin	Signal	I/O	Voltage	Description
YC1	1	LIVE	I	100 V AC	AC power input
Connected to the inlet	2	NEUTRAL	I	100 V AC	AC power input
YC2	1	NEUTRAL	I	100 V AC	Fuser heater
Connected to the fuser unit	2	LIVE	O	100 V AC	AC power input
YC3	1	+24V0_E1	O	24 V DC	24 V DC power output
Connected to the connect right PWB	2	+24V0_E1	O	24 V DC	24 V DC power output
	3	+24V0_E1	O	24 V DC	24 V DC power output
	4	+24V0_E1	O	24 V DC	24 V DC power output
	5	GND	-	-	Ground
	6	GND	-	-	Ground
	7	GND	-	-	Ground
	8	GND	-	-	Ground
	9	PSLEEPN	I	0/5 V DC	Sleep mode signal
	10	RELAY	I	0/5 V DC	Relay control
	11	ZCROSSN	O	0/5 V DC(pulse)	Zero crossing signal
	12	HEAT1REM	I	0/24 V DC	Fuser heater control
	13 *1	HEAT2REM	I	0/24 V DC	Fuser heater control

*1: 50/60 ppm model only

(4) Detaching and refitting the PWB. (PSPWB)

Procedure

1. Remove the upper interface cover.
2. Release two hooks using a flat screw driver and remove the right stay cover.

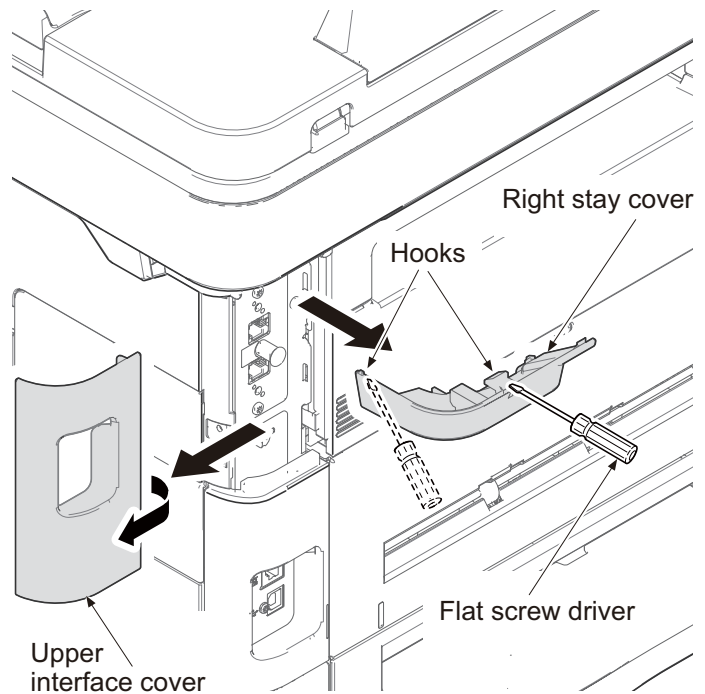

Figure 2-2-58

3. Remove the controller cover.
4. Open the front cover.
5. Remove the screw from the right upper cover.
6. Release two hooks using a flat screw driver and remove the right upper cover.

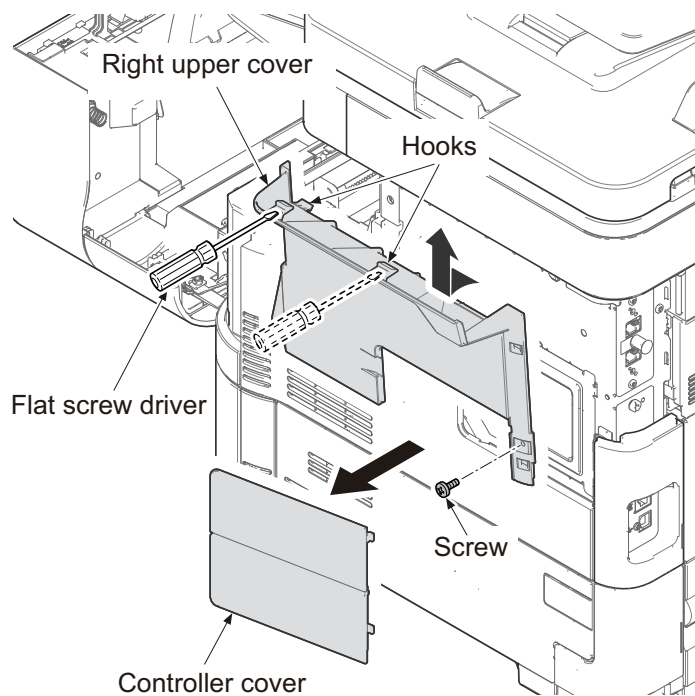

Figure 2-2-59

7. Open the rear cover.
8. Remove the lower interface cover and the inlet cover.

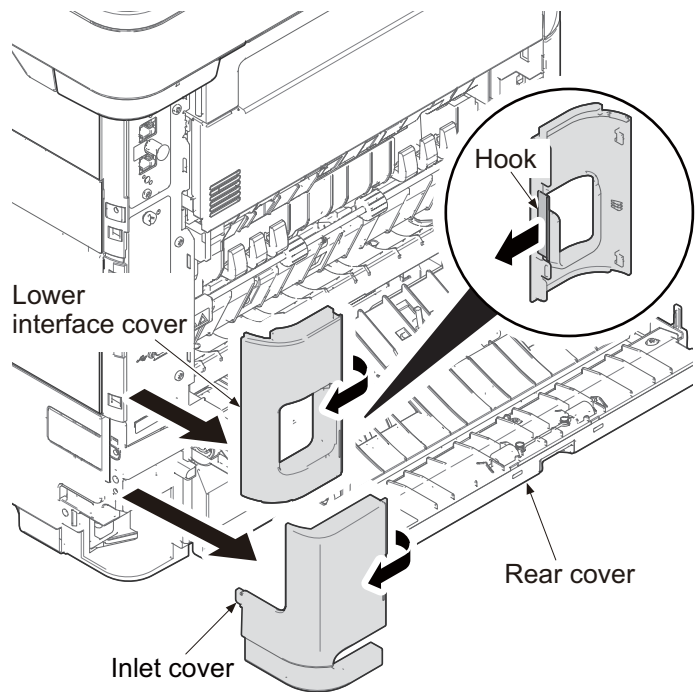

Figure 2-2-60

9. Remove two screws.
10. Release the hooks by bending both-side of the right middle cover and then remove it by pulling and lifting up forward.

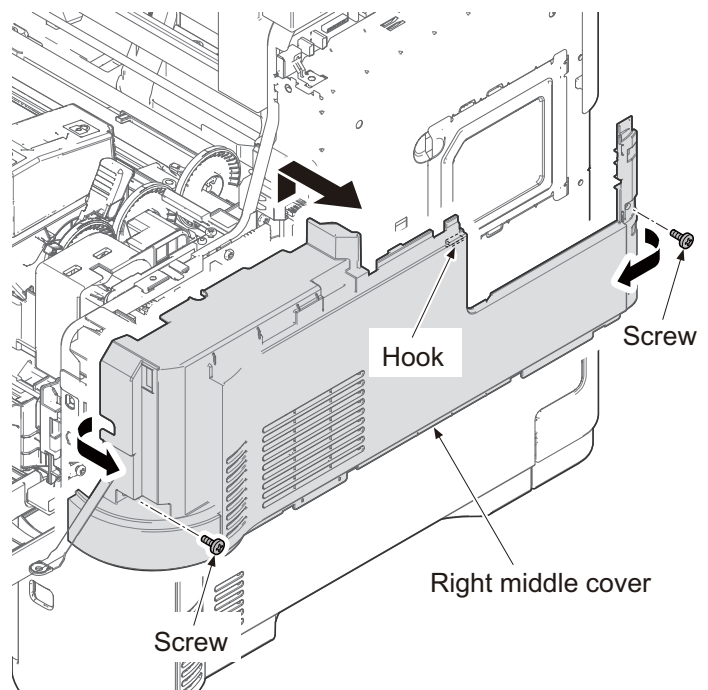

Figure 2-2-61

11. Pull out the cassette.
12. Remove three screws.
13. Release two hooks by sliding the right lower cover upward and then remove the right lower cover.

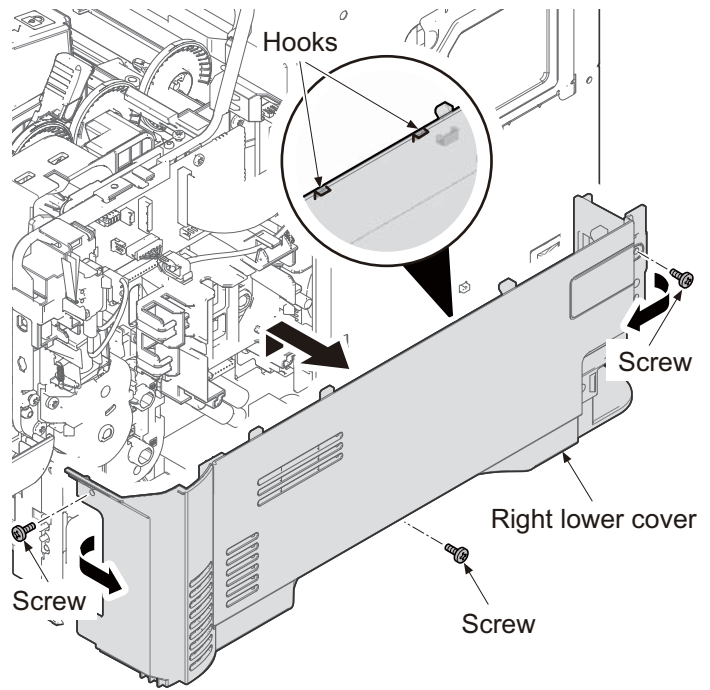

Figure 2-2-62

14. Remove eight screws and grounding terminal.
15. Remove the controller box.

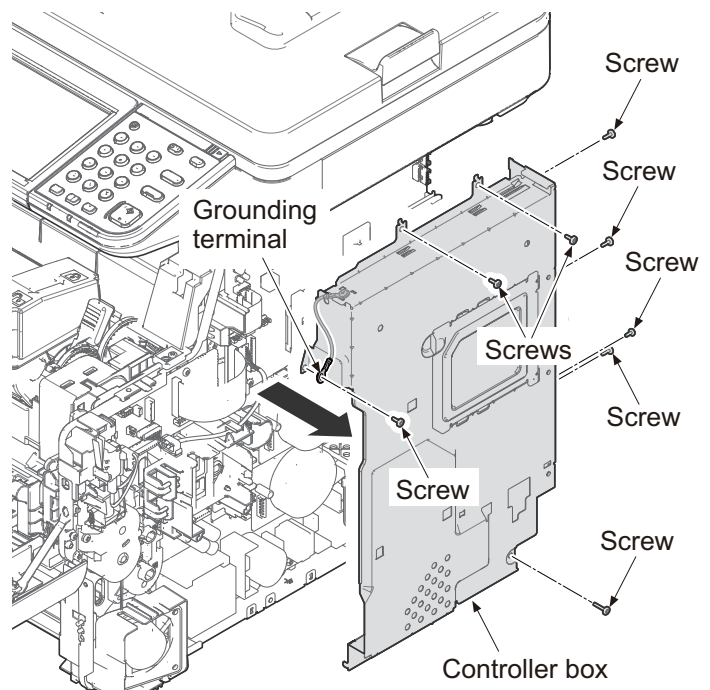

Figure 2-2-63

16. Remove the connector cover B by releasing the hook.
17. Remove the screw of connector cover C.
18. Remove the connector cover C by releasing the hook.
19. Pull two connectors out.

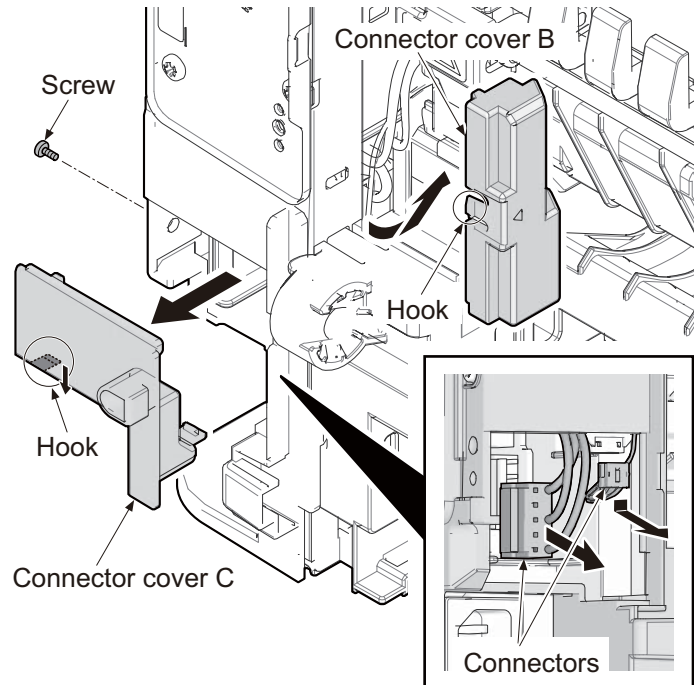

Figure 2-2-64

20. Remove the grounding wire by removing the screw.
21. Remove the connector from the power source PWB.
22. Remove three screws and then remove the power source PWB assembly.
23. Check or replace the power source PWB and refit all the removed parts.

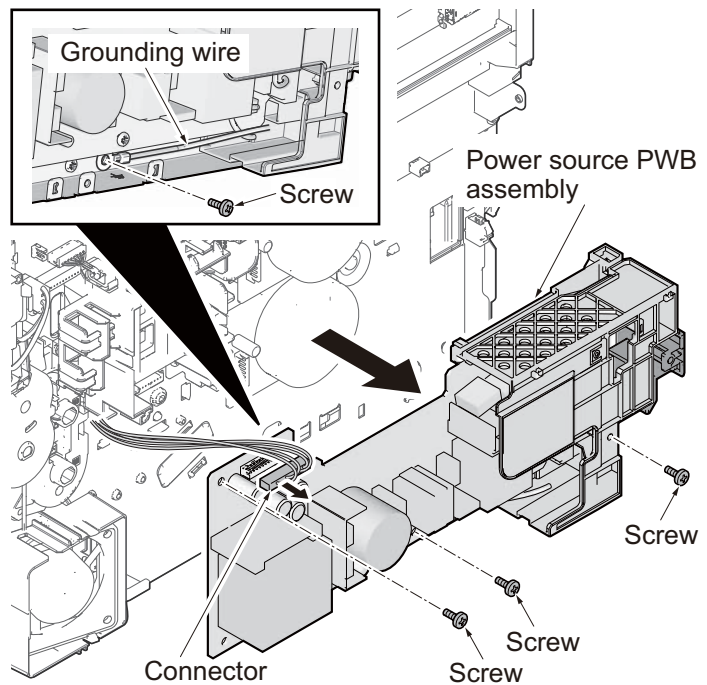

Figure 2-2-65

2-2-7 Operation panel PWB (OPPWB) for HyPAS model

(1) Connector position

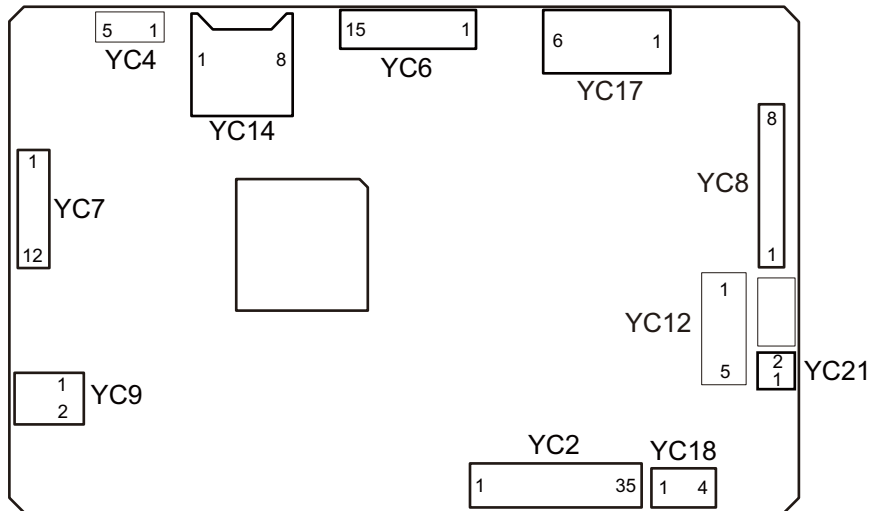

Figure 2-2-66

(2) PWB photograph



Figure 2-2-67

(3) Connector lists

Connector	Pin	Signal	I/O	Voltage	Description
YC2	1	GND	-	-	Ground
Connected to the LCD	2	R0	O	0/3.3 V DC	LCD Control signal
	3	R1	O	0/3.3 V DC	LCD Control signal
	4	R2	O	0/3.3 V DC	LCD Control signal
	5	R3	O	0/3.3 V DC	LCD Control signal
	6	R4	O	0/3.3 V DC	LCD Control signal
	7	R5	O	0/3.3 V DC	LCD Control signal
	8	GND	-	-	Ground
	9	G0	O	0/3.3 V DC	LCD Control signal
	10	G1	O	0/3.3 V DC	LCD Control signal
	11	G2	O	0/3.3 V DC	LCD Control signal
	12	G3	O	0/3.3 V DC	LCD Control signal
	13	G4	O	0/3.3 V DC	LCD Control signal
	14	G5	O	0/3.3 V DC	LCD Control signal
	15	GND	-	-	Ground
	16	B0	O	0/3.3 V DC	LCD Control signal
	17	B1	O	0/3.3 V DC	LCD Control signal
	18	B2	O	0/3.3 V DC	LCD Control signal
	19	B3	O	0/3.3 V DC	LCD Control signal
	20	B4	O	0/3.3 V DC	LCD Control signal
	21	B5	O	0/3.3 V DC	LCD Control signal
	22	GND	-	-	Ground
	23	DCLK	O	0/3.3 V DC	LCD dot clock signal
	24	3.3V	O	3.3V DC	3.3 V DC power output
	25	3.3V	O	3.3V DC	3.3 V DC power output
	26	3.3V	O	3.3V DC	3.3 V DC power output
	27	3.3V	O	3.3V DC	3.3 V DC power output
	28	DE	O	0/3.3 V DC(pulse)	LCD data enabling signal
	29	HSYNC	O	0/3.3 V DC(pulse)	Horizontal synchronizing signal
	30	VSYNC	O	0/3.3 V DC(pulse)	Vertical synchronizing signal
	31	LED_EN	O	0/3.3 V DC	Backlight LED enabling signal
	32	LED_PWM	O	0/3.3 V DC	Backlight LED control signal
	33	TSC_INT	-	-	Not used
	34	I2C_SDA	-	-	Not used
	35	I2C_SCL	-	-	Not used

Connector	Pin	Signal	I/O	Voltage	Description
YC6	1	GND	-	-	Ground
Connected to the control PWB	2	SECOND_TRAY_SW	I	0/3.3 V DC	JEPS: On/Off
	3	BEEP_POWERON	I	0/3.3 V DC	Acknowledging beep restoration signal
	4	ENERGY_SAVE	I	0/3.3 V DC	Energy save signal
	5	SUSPEND_POWER	I	3.3V DC	3.3 V DC power input
	6	LED MEMORY N	I	0/3.3 V DC	Memory LED control signal
	7	LED ATTENTION N	I	0/3.3 V DC	Attention LED control signal
	8	LED PROCESSING N	I	0/3.3 V DC	Processing LED control signal
	9	SHUTDOWN	I	0/3.3 V DC	24 V down signal
	10	LIGHTOFF_POWERON	I	0/3.3 V DC	LCD power On/ Off signal
	11	AUDIO	I	Analog	Audio output signal
	12	PANEL_RESET	I	0/3.3 V DC	Reset signal
	13	INT_POWERKEY_N	O	0/3.3 V DC	Power key: On/Off
	14	PANEL STATUS	O	0/3.3 V DC	Operation panel status signal
	15	GND	-	-	Ground
YC7	1	GND	-	-	Ground
Connected to the key-left PWB	2	SCAN0	O	0/3.3 V DC (pulse)	Scan signal 0
	3	KEYLEFT1	I	0/3.3 V DC (pulse)	Operation panel key scan return signal 1
	4	LEDLEFT1	O	0/3.3 V DC (pulse)	Operation panel LED display drive signal 1
	5	KEYLEFT2	I	0/3.3 V DC (pulse)	Operation panel key scan return signal 2
	6	SCAN1	O	0/3.3 V DC (pulse)	Scan signal 1
	7	SCAN2	O	0/3.3 V DC (pulse)	Scan signal 2
	8	SCAN3	O	0/3.3 V DC (pulse)	Scan signal 3
	9	KEYLEFT0	I	0/3.3 V DC (pulse)	Operation panel key scan return signal 0
	10	LEDLEFT0	O	0/3.3 V DC (pulse)	Operation panel LED display drive signal 0
	11	LEDLEFT2	O	0/3.3 V DC (pulse)	Operation panel LED display drive signal 2
	12	S LED	O	0/3.3 V DC	Memory LED control signal

Connector	Pin	Signal	I/O	Voltage	Description
YC8 Connected to the key-right PWB	1	SCAN0	O	0/3.3 V DC (pulse)	Scan signal 0
	2	SCAN1	O	0/3.3 V DC (pulse)	Scan signal 1
	3	SCAN2	O	0/3.3 V DC (pulse)	Scan signal 2
	4	SCAN3	O	0/3.3 V DC (pulse)	Scan signal 3
	5	SCAN4	O	0/3.3 V DC (pulse)	Scan signal 4
	6	LEDRIGHT0	O	0/3.3 V DC (pulse)	Operation panel LED display drive signal 0
	7	KEYRIGHT0	I	0/3.3 V DC (pulse)	Operation panel key scan return signal 0
	8	KEYRIGHT1	I	0/3.3 V DC (pulse)	Operation panel key scan return signal 1
	9	KEYRIGHT2	I	0/3.3 V DC (pulse)	Operation panel key scan return signal 2
	10	KEYRIGHT3	I	0/3.3 V DC (pulse)	Operation panel key scan return signal 3
	11	KEYRIGHT4	I	0/3.3 V DC (pulse)	Operation panel key scan return signal 4
	12	LEDRIGHT1	O	0/3.3 V DC (pulse)	Operation panel LED display drive signal 1
	13	P LED	O	0/3.3 V DC	Processing LED control signal
	14	M LED	O	0/3.3 V DC	Memory LED control signal
	15	A LED	O	0/3.3 V DC	Attention LED control signal
	16	INT_POWER KEY_N	I	0/3.3 V DC	Power key: On/Off
	17	SUPEND_PO WER	O	3.3V DC	3.3 V DC power input from MPWB
	18	GND	-	-	Ground
YC9	1	SPK+	O	Analog	Speaker sound signal (+)
Connected to the speaker	2	SPK-	O	Analog	Speaker sound signal (-)
YC17	1	-	-	-	Not used
Connected to the control PWB	2	+5V0 PANEL	I	5 V DC	5 V DC power input
	3	+5V0 PANEL	I	5 V DC	5 V DC power input
	4	GND	-	-	Ground
	5	GND	-	-	Ground
	6	-	-	-	Not used
YC18	1	X2	I/O	Analog	Touch panel control signal
Connected to the touch panel	2	Y2	I/O	Analog	Touch panel control signal
	3	X1	I/O	Analog	Touch panel control signal
	4	Y1	I/O	Analog	Touch panel control signal
YC21	1	LEDA_OR_5V	O	0/20 V DC	Backlight LED Anode
Connected to the back light	2	LEDC_OR_G ND	O	0/5 V DC	Backlight LED Cathode

(4) Detaching and refitting the PWB. (OPPWB)

Procedure

1. Remove the LCD lower cover from the operation panel assembly.

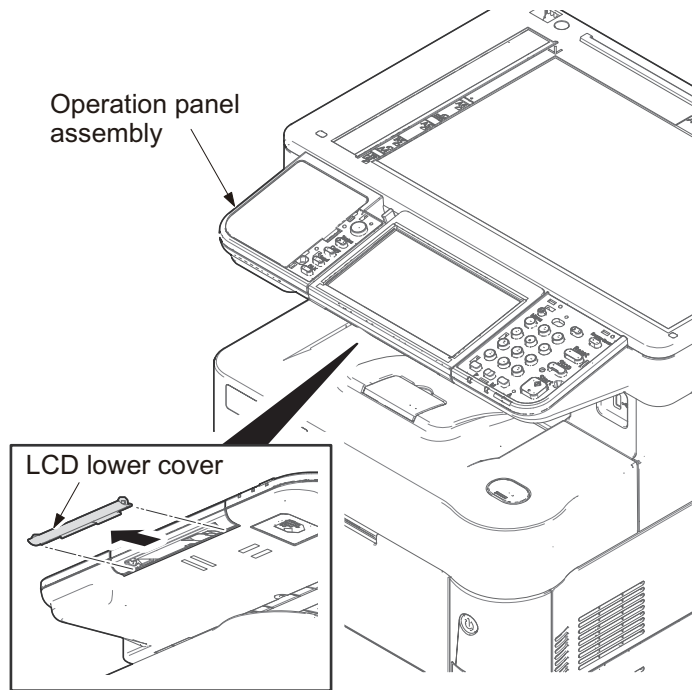

Figure 2-2-68

2. Raise the LCD forward during pushing the lock lever.
3. Remove a USB connector, two FFCs and four connectors from the operation panel PWB.

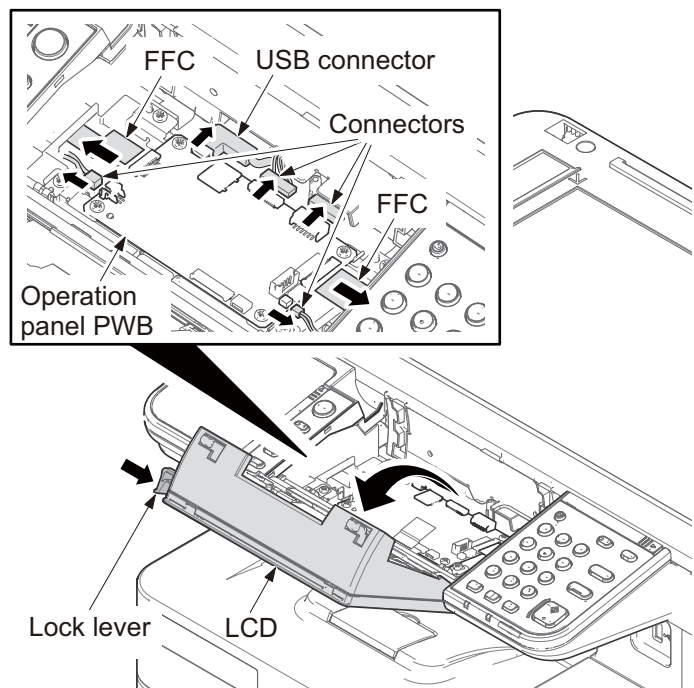

Figure 2-2-69

4. Remove four screws and the operation panel PWB.
5. Check or replace the operation panel PWB and refit all the removed parts.

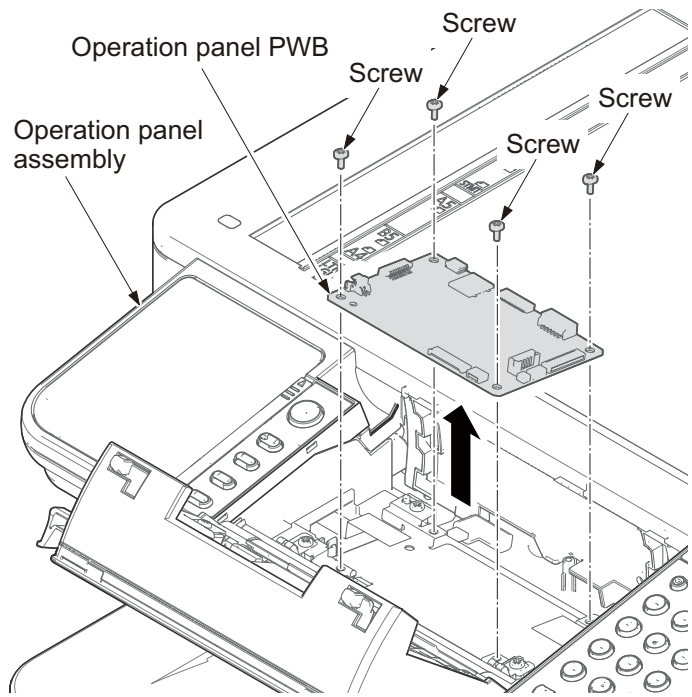

Figure 2-2-70

2-2-8 Operation panel PWB (OPPWB) for Basic model

(1) Connector position

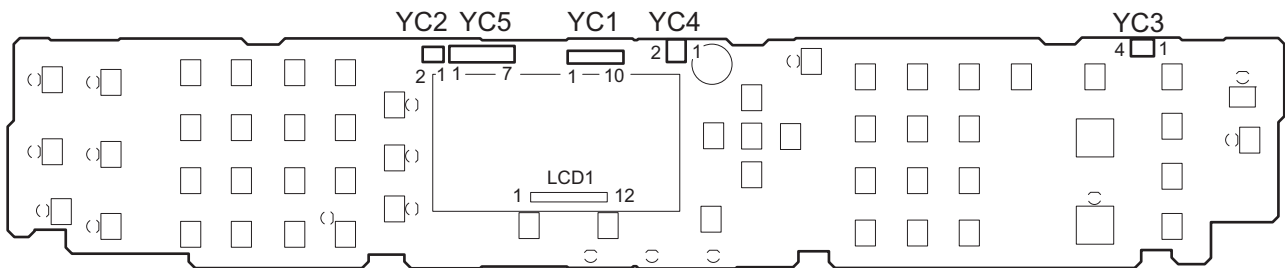

Figure 2-2-71

(2) PWB photograph

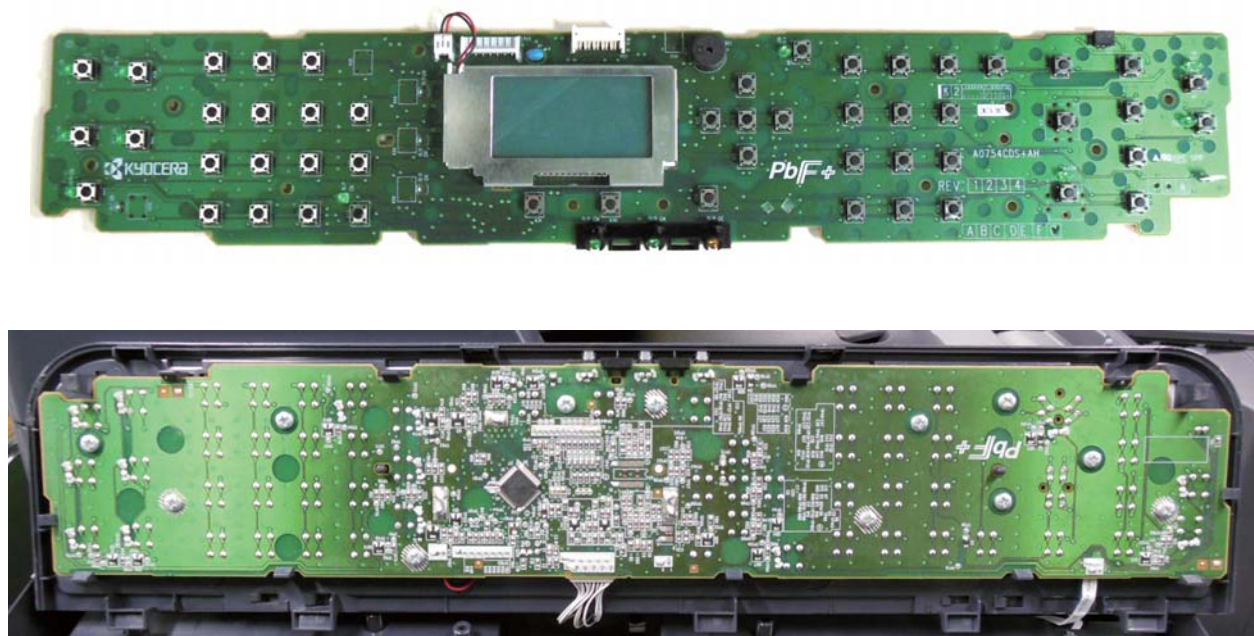

Figure 2-2-72

(3) Connector lists

Connector	Pin	Signal	I/O	Voltage	Description
YC1 Connected to the control PWB	1	GND	-	-	Ground
	2	3.3V1_C	I	3.3 V DC	3.3 V DC power input
	3	LCDCON	I	0/3.3 V DC	LCD control signal
	4	5.0V2_C	I	5V DC	5 V DC power input
	5	PAN_RXD	O	0/3.3 V DC	Serial communication data signal
	6	PAN_TXD	I	0/3.3 V DC	Serial communication data signal
	7	AUDIO	I	Analog	AUDIO signal
	8	FPRST	I	0/3.3 V DC	Panel reset signal
	9	INT_POWER KEY	O	0/3.3 V DC	Power key: On/Off
	10	GND	-	-	Ground
YC2 Connected to the back light PWB	1	+5V5	O	5V DC	5 V DC power output
	2	BLIGHT	O	5 V DC	BLPWB: On/Off
YC3 Connected to the control PWB	1	WETCLK	O	0/3.3 V DC (pulse)	Humid sensor clock signal
	2	GND	-	-	Ground
	3	AIRWET	O	Analog	Humid sensor input signal
	4	AIRTEMP	O	Analog	Temperature sensor input signal
YC4 Connected to the speaker (FAX model only)	1	SPK+	O	Analog	Speaker sound signal (+)
	2	SPK-	O	Analog	Speaker sound signal (-)

(4) Detaching and refitting the PWB. (OPPWB)

Procedure

1. Raise the operation panel assembly by releasing four hooks using a flat screw driver.
2. Remove the connector and FFC from the operation panel PWB.

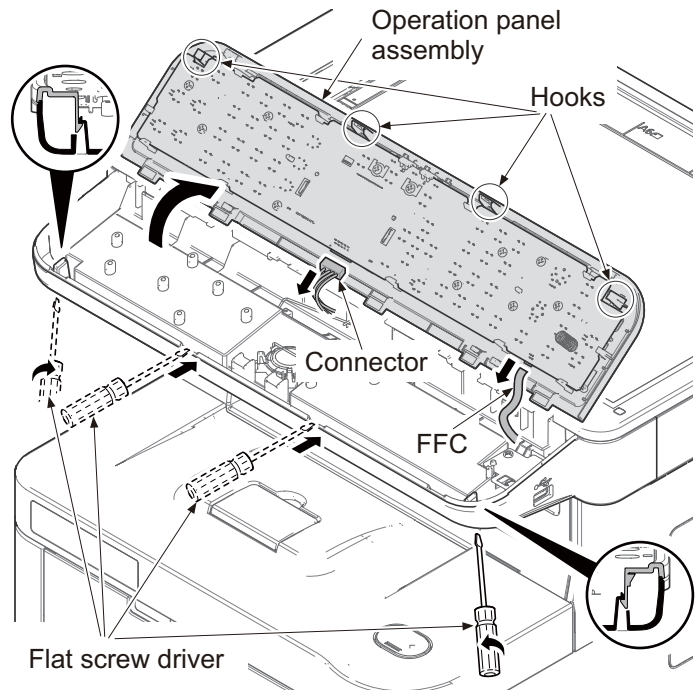

Figure 2-2-73

3. Remove twelve screws.
 4. Release thirteen hooks and then remove the operation panel PWB.
 5. Check or replace the operation panel PWB and refit all the removed parts.
- *: Be careful not to lose a spring.

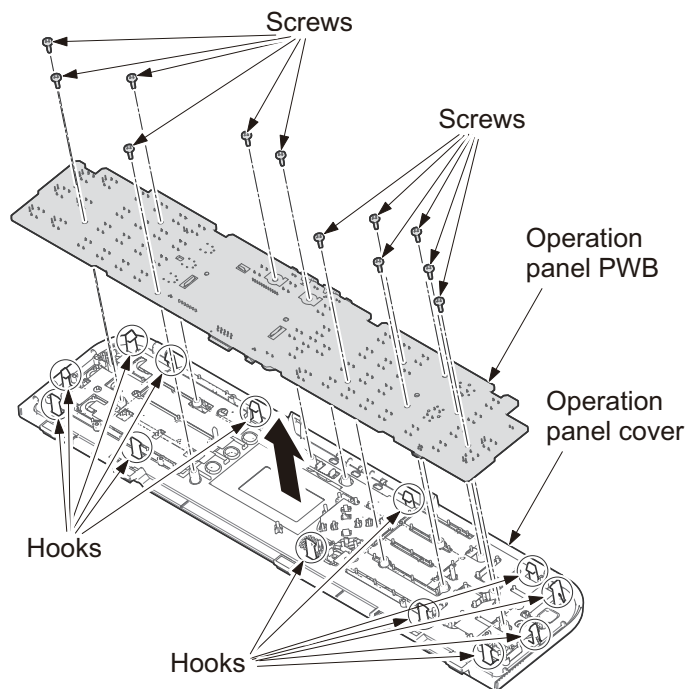

Figure 2-2-74

2-3-1 Appendixes

(1) List of maintenance parts

Maintenance part name		Part No.	Alternative part No.
Name used in service manual	Name used in parts list		
Paper feed pulley Pickup pulley	PULLEY FEED ASSY PARTS PULLEY PICKUP ASSY SP (PARTS HOLDER FEED ASSY SP)	302F906230 - (302LV94270)	2F906230 - (2LV94270)
Separation pulley	RETARD ROLLER ASSY (CT-3100)	302F909171 (302MS93011)	2F909171 (2MS93011)
Contact glass Slit glass	CONTACT GLASS CONTACT GLASS DP (PARTS FRAME ISU TOP ASSY SP)	- - (302NM94030)	- - (2NM94030)
CCD LED	P.W.BOARD ASSY CCD P.W.BOARD ASSY LED (PARTS ISU ASSY SP)	- - (302NM93010)	- - (2NM93010)
MP paper feed roller	ROLLER M/P ASSY	302HS08260	2HS08260
MP separation pad	PAD SEPARATION MPF	-	-
Upper registration roller	PARTS ROLLER REGIST UP SP	302LV94180	2LV94180
Lower registration roller	PARTS ROLLER REGIST LOW SP	302LV94170	2LV94170
Transfer roller	PARTS ROLLER TRANSFER SP	302LV94130	2LV94130
Paper chute guide	PARTS GUIDE PAPER CHUTE SP	302LV94261	2LV94261
DU conveying roller	ROLLER DU ASSY	-	-
DU conveying pulley	PULLEY PA	-	-
Upper eject roller	ROLLER FD UP	-	-
Upper eject pulley	PULLEY EXIT	-	-
Lower eject roller	ROLLER FD UP	-	-
Lower eject pulley	PULLEY EXIT FUSER	-	-
DP pickup pulley DP paper feed roller DP separation pad	PULLEY PICKUP ASSY PULLEY PAPER FEED ASSY PAD SEPARATION (PARTS DP UNIT SP)	- - - (302NZ94060)	- - - (2NZ94060)

(2) Maintenance kits**(2-1) 40 ppm model**

[120 V]

Maintenance part name		Parts No.	Alternative part No.
Name used in service	Name used in parts list		
MK-3102/MAINTENANCE KIT (300,000 images)	MK-3102/MAINTENANCE KIT	1702MS7USV	072MS7UV

[220 V to 240 V]

Maintenance part name		Parts No.	Alternative part No.
Name used in service	Name used in parts list		
MK-3100/MAINTENANCE KIT (300,000 images) [for Basic]	MK-3100/MAINTENANCE KIT	1702MS8NLV	072MS8NV
MK-3150/MAINTENANCE KIT (300,000 images) [for HyPAS]	MK-3150/MAINTENANCE KIT	1702NX8NL0	072NX8N0
MK-3104/MAINTENANCE KIT (300,000 images)	MK-3104/MAINTENANCE KIT	1702MS8ASV	072MS8AV

(2-2) 50/60 ppm model

[120 V]

Maintenance part name		Parts No.	Alternative part No.
Name used in service	Name used in parts list		
MK-3132/MAINTENANCE KIT (500,000 images)	MK-3132/MAINTENANCE KIT	1702MT7USV	072MT7UV

[220 V to 240 V]

Maintenance part name		Parts No.	Alternative part No.
Name used in service	Name used in parts list		
MK-3130/MAINTENANCE KIT (500,000 images)	MK-3130/MAINTENANCE KIT	1702MT8NLV	072MT8NV
MK-3134/MAINTENANCE KIT (500,000 images)	MK-3134/MAINTENANCE KIT	1702MT8ASV	072MT8AV

(2-3) For DP

Maintenance part name		Parts No.	Alternative part No.
Name used in service	Name used in parts list		
MK-3140/MAINTENANCE KIT (200,000 images)	MK-3140/MAINTENANCE KIT	1702P60UN0	072P60UN

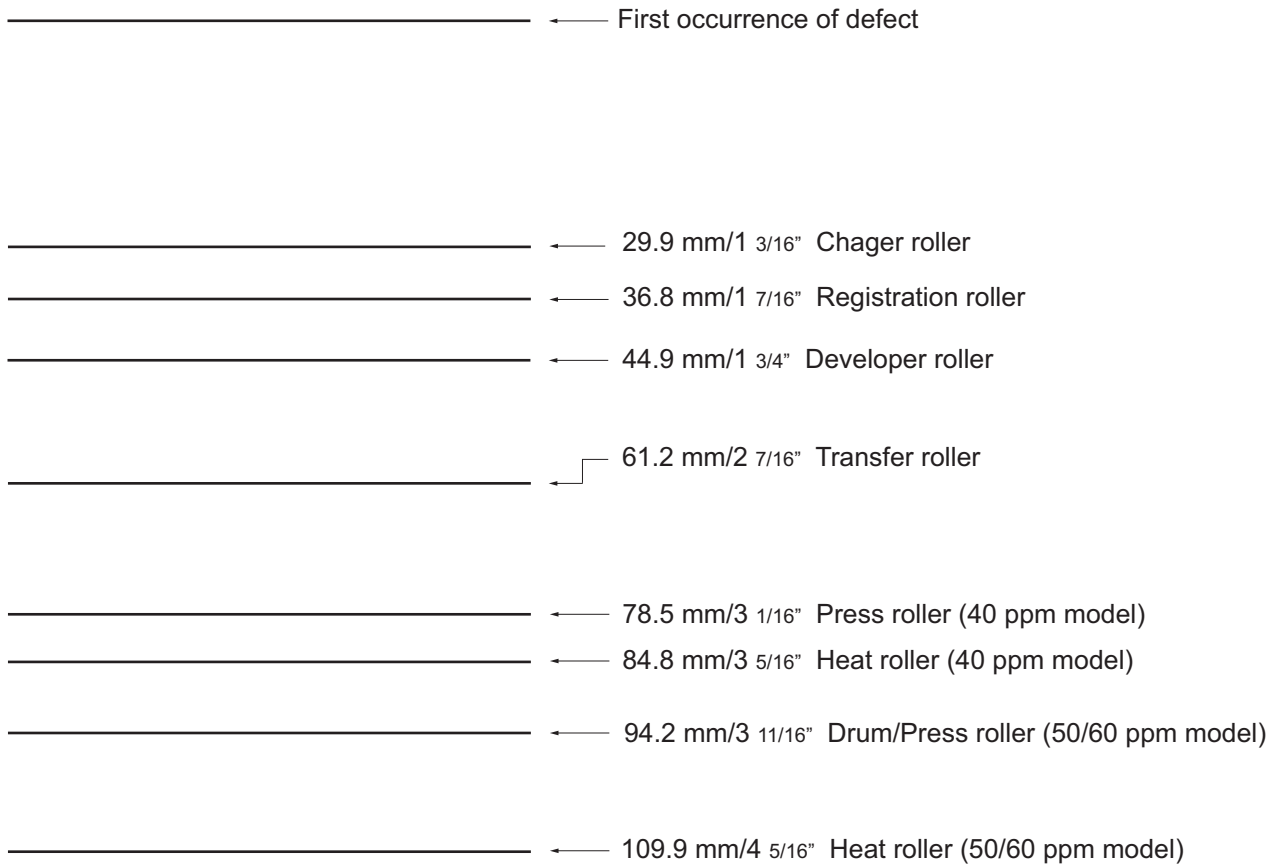
(3) Repetitive defects gauge

* : The repetitive marks interval may vary depending on operating conditions.

(4) Firmware environment commands

The printer maintains a number of printing parameters in its memory. These parameters may be changed permanently with the FRPO (Firmware RePrOgram) commands.

This section provides information on how to use the FRPO command and its parameters using examples.

Using FRPO commands for reprogramming the firmware

The current settings of the FRPO parameters are listed as the optional values on the service status page.

Note: Before changing any FRPO parameters, print out a service status page, so you will know the parameter values before the changes are made. To return FRPO parameters to their factory default values, send the FRPO INIT (FRPO-INITialize) command.(!R! FRPO INIT; EXIT;)

The FRPO command is sent to the printer in the following sequence:

!R! FRPO parameter, value; EXIT;

Example: Changing emulation mode to PC-PR201/65A

!R! FRPO P1, 11; EXIT;

FRPO parameters

Item	FRPO	Setting values	Factory setting
Top margin	A1	Integer value in inches	0
	A2	Fraction value in 1/100 inches	0
Left margin	A3	Integer value in inches	0
	A4	Fraction value in 1/100 inches	0
Page length	A5	Integer value in inches	13
	A6	Fraction value in 1/100 inches	61
Page width	A7	Integer value in inches	13
	A8	Fraction value in 1/100 inches	61
Default pattern resolution	B8	0: 300 dpi 1: 600 dpi	0
Copy count	C0	Number of copies to print:1-999	1
Page orientation	C1	0: Portrait 1: Landscape	0
Default font No.	C2	Middle two digits of power-up font	0
	C3	Last two digits of power-up font	0
	C5	First two digits of power-up font	0
PCL font switch	C8	0:HP compatibility mode (Characters higher than 127 are not printed.) 32:Conventional mode (Characters higher than 127 are printed. Supported symbol sets: ISO-60 Norway [00D], ISO-15 Italian [00I], ISO-11 Sweden [00S], ISO-6 ASCII [00U], ISO-4 U.K. [01E], ISO-69 France [01F], ISO-21 Germany [01G], ISO-17 Spain [02S], Symbol [19M])	0

Item	FRPO	Setting values	Factory setting
Printing concentration	D4	1: Thin. 2: Slightly Thin. 3: Standard 4: Slightly Deep. 5: Deep.	3
Total host buffer size	H8	0 to 99 in units of the size defined by FRPO S5	5
Form feed time-out value	H9	Value in units of 5 seconds (0 to 99).	6
KIR mode	N0	0: Off 2: On	2
Duplex binding	N4	0: Off 1: Long edge 2: Short edge	0
Sleep timer time-out time	N5	1 to 240 minutes [0: Off] (U.S.A and other) 1 to 120 minutes [0: Off] (Euro only)	1 1 11(40ppm with network)
Ecoprint level	N6	0: Off 2: On	0
Resolution	N8	0: 300dpi 1: 600dpi 3: 1200dpi	1
Default emulation mode	P1	0 : Line printer 1 : IBM proprinter 2 : DIABLO 630 5 : Epson LQ-850 6 : PCL6 (except PCL XL) 8 : KC-GL 9 : KPDL 11 : PC-PR201 12 : IBM 5577 13 : VP-1000 14 : N5200 15 : FMPR-359F1	9(U.S.A) or 6(Euro and other)
Carriage-return action *	P2	0: Ignores 0x0d 1: Carriage-return 2: Carriage-return+linefeed	1
Linefeed action *	P3	0: Ignores 0x0d 1: Linefeed 2: Linefeed+carriage-return	1
Automatic emulation sensing (For KPDL3)	P4	0: AES disabled 1: AES enabled	1(U.S.A) or 0(Euro and other)
Alternative emulation	P5	6: PCL 6	6

Item	FRPO	Setting values	Factory setting
Automatic emulation switching trigger (For KPDL3)	P7	0: Page eject commands 1: None 2: Page eject and PRESCRIBE EXIT 3: PRESCRIBE EXIT 4: Formfeed (^L) 6: Page eject, PRESCRIBE EXIT and formfeed 10: Page eject commands; if AES fails, resolves to KPDL	11(U.S.A) or 10(Euro and other)
Command recognition character	P9	ASCII code of 33 to 126	82 (R)
Default stacker (HyPAS model only)	R0	1 (inner tray) 2	1
Default paper size	R2	0: Size of the default paper cassette (See R4.) 1: Monarch (3-7/8 × 7-1/2 inches) 2: Business (4-1/8 × 9-1/2 inches) 3: International DL (11 × 22 cm) 4: International C5 (16.2 × 22.9 cm) 5: Executive (7-1/4 × 10-1/2 inches) 6: US Letter (8-1/2 × 11 inches) 7: US Legal (8-1/2 × 14 inches) 8: A4 (21.0 × 29.7 cm) 9: JIS B5 (18.2 × 25.7 cm) 10: A3 (29.7 × 42 cm) 11: B4 (25.7 × 36.4 cm) 12: US Ledger (11 × 17 inches) 13: ISO A5 14: A6 (10.5 × 14.8 cm) 15: JIS B6 (12.8 × 18.2 cm) 16: Commercial #9 (3-7/8 × 8-7/8 inches) 17: Commercial #6 (3-5/8 × 6-1/2 inches) 18: ISO B5 (17.6 × 25 cm) 19: Custom (11.7 × 17.7 inches) 30: C4 (22.9 × 32.4 cm) 31: Hagaki (10 × 14.8 cm) 32: Ofuku-hagaki (14.8 × 20 cm) 33: Officio II 39: 8K 40: 16K 42: 216x340 50: Statement 51: Folio 52: Youkei 2 53: Youkei 4	0
Default cassette	R4	0: MP tray 1: Cassette 1 2: Cassette 2 3: Cassette 3	1

Item	FRPO	Setting values	Factory setting
MP tray paper size	R7	Same as the R2 values except: 0	6 (U.S.A) or 8 (Euro and other)
A4/letter equation	S4	0: Off 1: On	1
Host buffer size	S5	0: 10kB (x H8) 1: 100kB (x H8) 2: 1024kB (x H8)	1
RAM disk size	S6	1 to 1024 MB	400
RAM disk mode	S7	0: Off 1: On	0 (Euro) 1
Wide A4	T6	0: Off 1: On	0
Line spacing	U0	Lines per inch (integer value)	6
Line spacing	U1	Lines per inch (fraction value)	0
Character spacing	U2	Characters per inch (integer value)	10
Character spacing	U3	Characters per inch (fraction value)	0
Country code	U6	0: US-ASCII 1: France 2: Germany 3: UK 4: Denmark 5: Sweden 6: Italy 7: Spain 8: Japan 9: US Legal 10: IBM PC-850 (Multilingual) 11: IBM PC-860 (Portuguese) 12: IBM PC-863 (Canadian French) 13: IBM PC-865 (Norwegian) 14: Norway 15: Denmark 2 16: Spain 2 17: Latin America 21: US ASCII (U7 = 50 SET) 77: HP Roman-8 (U7 = 52 SET)	41

Item	FRPO	Setting values	Factory setting
Code set at power up in daisy-wheel emulation	U7	0: Same as the default emulation mode (P1) 1: IBM 6: IBM PC-8 50: US ASCII (U6 = 21 SET) 52: HP Roman-8 (U6 = 77 SET)	53
Font pitch for fixed pitch scalable font	U8	Integer value in cpi: 0 to 99	10
	U9	Fraction value in 1/100 cpi: 0 to 99	0
Font height for the default scalable font	V0	Integer value in 100 points: 0 to 9	0
	V1	Integer value in points: 0 to 99	12
	V2	Fraction value in 1/100 points: 0, 25, 50, 75	0
Default scalable font	V3	Name of typeface of up to 32 characters, enclosed with single or double quotation marks	Courier
Default weight (courier and letter Gothic)	V9	0: Courier = darkness Letter Gothic = darkness 1: Courier = regular Letter Gothic = darkness 4: Courier = darkness Letter Gothic = regular 5: Courier = regular Letter Gothic = regular	5

Item	FRPO	Setting values	Factory setting
Paper type for the MP tray	X0	1: Plain 1 2: Transparency 3: Preprinted 4: Label 5: Bond 6: Recycle 7: Vellum 9: Letterhead 10: Color 11: Prepunched 12: Envelope 13: Cardstock 16: Thick 17: High quality 21: Custom1 22: Custom2 23: Custom3 24: Custom4 25: Custom5 26: Custom6 27: Custom7 28: Custom8	1
Paper type for paper cassettes 1	X1	1: Plain 3: Preprinted 5: Bond 6: Recycled 9: Letterhead 10: Color 11: Prepunched 17: High quality 21: Custom1 22: Custom2 23: Custom3 24: Custom4 25: Custom5 26: Custom6 27: Custom7 28: Custom8	1

Item	FRPO	Setting values	Factory setting
Paper type for paper cassettes 2 to 5	X2	1: Plain	1
	X3	3: Preprinted	
	X4	5: Bond	
	X5	6: Recycled	
		9: Letterhead	
		10: Color	
		11: Prepunched	
		17: High quality	
		21: Custom1	
		22: Custom2	
		23: Custom3	
		24: Custom4	
		25: Custom5	
		26: Custom6	
	27: Custom7		
	28: Custom8		
PCL paper source	X9	0: Paper selection depending on an escape sequence compatible with HP-LJ5Si. 2: Paper selection depending on an escape sequence compatible with HP-LJ8000.	0
Automatic continue for 'Press GO'	Y0	0: Off 1: On	0
Automatic continue timer	Y1	Number from 0 to 99 in increments of 5 seconds	6 (30 seconds)
Error message for device error	Y3	0: Not detect 1: Detect	0

Item	FRPO	Setting values	Factory setting
Duplex operation for specified paper type (Prepunched, Preprinted and Letterhead)	Y4	0: Off 1: On	0
Default operation for PDF direct printing	Y5	0: Enlarges or reduces the image to fit in the current paper size. Loads paper from the current paper cassette. 1: Through the image. Loads paper which is the same size as the image. 2: Enlarges or reduces the image to fit in the current paper size. Loads Letter, A4 size paper depending on the image size. 3: Through the image. Loads Letter, A4 size paper depending on the image size. 8: Through the image. Loads paper from the current paper cassette. 9: Through the image. Loads Letter, A4 size paper depending on the image size. 10: Enlarges or reduces the image to fit in the current paper size. Loads Letter, A4 size paper depending on the image size.	0
e-MPS error	Y6	0: Does not print the error report and display the error message. 1: Prints the error report. 2: Displays the error message. 3: Prints the error report and displays the error message.	3

(5) System Error (Fxxxx) Outline

The document is described for the outline of the factors of the Fxxx errors that are not described in the self-diagnosis error code list of Chapter 1-4. Please utilize it to refer for checking the factors.

Please utilize it as the measures when the system is not recovered after power off/on or it frequently occurs.

(Note) Please initially check the following when the error (Fxxx) is indicated.

- Check the DIMM (DDR memory) and neighboring parts
 - : Check the contact on the control PWB by releasing and reinserting the DIMM.
- If the error repeats after that, replace the DIMM.

No.	Content	Check procedure & check point	Remark (Common)	M3540dn, M3040dn [Basic(LED) model]	M3560idn, M3550idn, M3540idn, M3040idn [HyPAS model]
—	<p>Lock-up at Welcome display (Ecosys) (The display unchanges after a certain time (Note))</p> <p>(Note) Basic: 60 s HyPAS: 70 s or immediately displayed.</p>	<ol style="list-style-type: none"> 1) Check the wire and the connection of the connectors between the operation panel PWB and the control PWB, and check function. 2) Check contact of the DIMM by releasing and reinserting, and check the function. Replace DIMM if available, and check function. 3) Execute U021 (Init memory) and check function. 4) Replace the operation panel PWB and check function. 5) Replace the control PWB and check function. 6) Retrieve the USBLOG and contact the Service Administrative Division. 		<p>[Control PWB-Operation panel PWB interface] Control PWB: YC30, YC2002 Operation panel PWB: YC1, YC3</p> <p>[Check the DIMM contact] Control PWB: YS2000</p> <p>A certain section of the DIMM might have some problem. The occurrence frequency differs depending on the access frequency to the bit with the problem. If the DIMM has no sensitiveness, ASIC might have problem.</p>	<p>[Control PWB-Operation panel PWB interface] Control PWB: YC30(*1), YC2002, YC2003 Operation panel PWB: YC6, YC2(*1), YC17</p> <p>(*1) Via Key-Right PWB</p> <p>[Check the DIMM contact] Control PWB: YS2000</p> <p>A certain section of the DIMM might have some problem. The occurrence frequency differs depending on the access frequency to the bit with the problem. If the DIMM has no sensitiveness, ASIC might have problem.</p>
F000	<p>F000 appears in a certain time (Note) after the Welcome display continues</p> <p>Operation panel—Main board communication error</p> <p>(Note) Basic: 60 s HyPAS: 70 s or immediately displayed.</p>	<ol style="list-style-type: none"> 1) Check the wire and the connection of the connectors between the operation panel PWB and the control PWB, and check function. 2) Check contact of the DIMM by releasing and reinserting, and check the function. Replace DIMM if available, and check function. 3) Execute U021 (Init memory) and check function. 4) Replace the control PWB and check function. 5) Replace the operation panel PWB and check function. 6) Retrieve the USBLOG and contact the Service Administrative Division. 		<p>[Control PWB-Operation panel PWB interface] Control PWB: YC30, YC2002 Operation panel PWB: YC1, YC3</p> <p>[Check the DIMM contact] Control PWB: YS2000</p> <p>A certain section of the DIMM might have some problem. The occurrence frequency differs depending on the access frequency to the bit with the problem. If the DIMM has no sensitiveness, ASIC might have problem.</p>	<p>[Control PWB-Operation panel PWB interface] Control PWB: YC30(*1), YC2002, YC2003 Operation panel PWB: YC6, YC2(*1), YC17</p> <p>(*1) Via Key-Right PWB</p> <p>[Check the DIMM contact] Control PWB: YS2000</p> <p>A certain section of the DIMM might have some problem. The occurrence frequency differs depending on the access frequency to the bit with the problem. If the DIMM has no sensitiveness, ASIC might have problem.</p>
F12X	<p>An error is detected at the Scan control section</p>	<ol style="list-style-type: none"> 1) Check the wire and the connection of the connectors between the control PWB and CCD PWB, or the control PWB and DP, and then check function. 2) Execute U021 (Init memory) and check function. 3) Replace the CCD PWB and check function. 4) Replace the control PWB and check function. 5) Retrieve the USBLOG and contact the Service Administrative Division. 		<p>[Control PWB-CCD PWB interface] Control PWB: YC1000 CCD PWB: YC1</p> <p>[Control PWB-DP I/F] Control PWB: YC1001, YC1003</p>	<p>[Control PWB-CCD PWB interface] Control PWB: YC1000 CCD PWB: YC1</p> <p>[Control PWB-DP I/F] Control PWB: YC1001, YC1003</p>

No.	Content	Check procedure & check point	Remark (Common)	M3540dn, M3040dn [Basic(LED) model]	M3560idn, M3550idn, M3540idn, M3040idn [HyPAS model]
F14X	An error is detected at the FAX control section	1) Check the connection between the FAX control PWB and control PWB and function. 2) Execute U021 (Init memory) and check function. 3) FAX Replace the control PWB and check function. 4) Replace the control PWB and check function. 5) Retrieve the USBLOG and contact the Service Administrative Division.	[Check the connection of the KUIO connector] -Check if it is inserted into the upper slot. -Check if the direction of the FAX control PWB is correct.	[Check the connection to the FAX control PWB] Control PWB: YC2012	[Check the connection to the FAX control PWB] Control PWB: YC2012
F15X	An error is detected at the authentication device control section	1) Check the wire and the connection of the connectors between the authentication device and the main board, and function. 2) Execute U021 (Init memory) and check function. 3) Replace the control PWB and check function. 4) Retrieve the USBLOG and contact the Service Administrative Division.	Authentication device: Card Reader, etc.	-	-
F17X	An error is detected at the print data control section	1) Execute U021 (Init memory) and check function. 2) Replace the control PWB and check function. 3) Retrieve the USBLOG and contact the Service Administrative Division.		-	-
F18X	An error is detected at the Video control section	1) Execute U021 (Init memory) and check function. 2) Replace the control PWB and check function. 3) Retrieve the USBLOG and contact the Service Administrative Division.		-	-
F1DX	An error is detected at the Image memory management section	1) Execute U021 (Init memory) and check function. 2) Replace the control PWB and check function. 3) Retrieve the USBLOG and contact the Service Administrative Division.	F1D4: RAM location failure	-	-
F21X	An error is detected at the Image processing section	1) Check contact of the DIMM by releasing and reinserting, and check the function. Replace DIMM if available, and check function. 2) Execute U021 (Init memory) and check function. 3) Replace the control PWB and check function. 4) Retrieve the USBLOG and contact the Service Administrative Division.		[Check the DIMM contact] Control PWB: YS2000	[Check the DIMM contact] Control PWB: YS2000
F22X				A certain section of the DIMM might have some problem. The occurrence frequency differs depending on the access frequency to the bit with the problem. If the DIMM has no sensitiveness, ASIC might have problem.	A certain section of the DIMM might have some problem. The occurrence frequency differs depending on the access frequency to the bit with the problem. If the DIMM has no sensitiveness, ASIC might have problem.
F23X					
F24X	An error is detected at the System management section	1) Check contact of the DIMM by releasing and reinserting, and check the function. Replace DIMM if available, and check function. 2) Execute U021 (Init memory) and check function. 3) Replace the control PWB and check function. 4) Retrieve the USBLOG and contact the Service Administrative Division.	-Turn the main power off and on to solve the problem. -F248 error is printer process error. If it repeats with a certain print data, retrieve the capture data and USBLOG.	[Check the DIMM contact] Control PWB: YS2000 A certain section of the DIMM might have some problem. The occurrence frequency differs depending on the access frequency to the bit with the problem. If the DIMM has no sensitiveness, ASIC might have problem.	[Check the DIMM contact] Control PWB: YS2000 A certain section of the DIMM might have some problem. The occurrence frequency differs depending on the access frequency to the bit with the problem. If the DIMM has no sensitiveness, ASIC might have problem.
F26X	An error is detected at the System management section	1) Execute U021 (Init memory) and check function. 2) Replace the control PWB and check function. 3) Retrieve the USBLOG and contact the Service Administrative Division.	F2AX appears in the HyPAS model only.	-	-
F2AX				No appearance	

No.	Content	Check procedure & check point	Remark (Common)	M3540dn, M3040dn [Basic(LED) model]	M3560idn, M3550idn, M3540idn, M3040idn [HyPAS model]
F33X	An error is detected at the Scan management section	1) Check the wire and the connection of the connectors between the control PWB and CCD, and check function. 2) Execute U021 (Init memory) and check function. 3) Replace the CCD PWB and check function. 4) Replace the control PWB and check function. 5) Retrieve the USBLOG and contact the Service Administrative Division.		[Control PWB-CCD PWB interface] Control PWB: YC1000 CCD PWB: YC1	[Control PWB-CCD PWB interface] Control PWB: YC1000 CCD PWB: YC1
F34X	An error is detected at the Panel management section	1) Check the wire and the connection of the connectors between the operation panel PWB and the control PWB, and check function.(For HyPAS model only) 2) Execute U021 (Init memory) and check function. 3) Replace the operation panel PWB and check function.(For HyPAS model only) 4) Replace the control PWB and check function. 5) Retrieve the USBLOG and contact the Service Administrative Division.	Error in the panel processing (Timeout for waiting the response from command, etc.)	1) at the left is unnecessary because the F34X error is caused by the software.	As the hardware cause, it will be caused by disconnecting the connector of the wire between the control PWB and the operation panel PWB.
F35X	An error is detected at the Print control section	1) Execute U021 (Init memory) and check function. 2) Replace the control PWB and check function. 3) Retrieve the USBLOG and contact the Service Administrative Division.		-	-
F37X	An error is detected at the FAX management section	1) Execute U021 (Init memory) and check function. 2) Replace the control PWB and check function. 3) Retrieve the USBLOG and contact the Service Administrative Division.		-	-
F38X	An error is detected at the Authentication/permit management section	1) Execute U021 (Init memory) and check function. 2) Replace the control PWB and check function. 3) Retrieve the USBLOG and contact the Service Administrative Division.		-	-
F48X	An error is detected at the Image edit process control section	1) Execute U021 (Init memory) and check function. 2) Replace the control PWB and check function. 3) Retrieve the USBLOG and contact the Service Administrative Division.		-	-
F4DX	An error is detected at the Entity control section	1) Execute U021 (Init memory) and check function. 2) Replace the control PWB and check function. 3) Retrieve the USBLOG and contact the Service Administrative Division.		-	-
F50X	An error is detected at the FAX control section	1) Execute U021 (Init memory) and check function. 2) Replace the control PWB and check function. 3) Retrieve the USBLOG and contact the Service Administrative Division.		-	-
F61X	An error is detected at the Report compiling section	1) Execute U021 (Init memory) and check function. 2) Replace the control PWB and check function. 3) Retrieve the USBLOG and contact the Service Administrative Division.	[Fault in the controller] Turn the main power off and on to solve the problem. USBLOG is required for investigation.	-	-
F63X	An error is detected at the Device control section	1) Execute U021 (Init memory) and check function. 2) Replace the control PWB and check function. 3) Retrieve the USBLOG and contact the Service Administrative Division.		-	-
F68X	An error is detected at the Storage device control section	1) Execute U021 (Init memory) and check function. 2) Replace the control PWB and check function. 3) Retrieve the USBLOG and contact the Service Administrative Division.	System error F684 means the overwriting error with the hard disk security kit	-	-

(6) Chart of image adjustment procedures

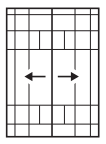
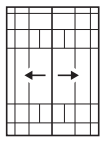
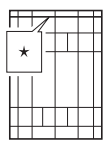
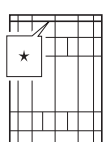
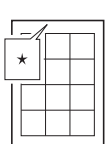
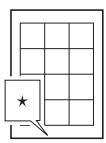
Adjusting order	Item	Image	Maintenance mode		Page	Setting procedure		Remarks
			Item No.	Mode		Method	Setting	
1	Adjusting the center line of the MP tray (printing adjustment) Adjusting the LSU print start timing		U034	LSU Out Left	P.1-3-24	1. Press the start key. 2. Select [Lsu Out Left] to be adjusted. 3. Press the start key. 4. Press the system menu key. 5. Press the start key. (output a test pattern) 6. Press the system menu key. 7. Select [MPT] to be adjusted.	1. Change the setting value using the cursor +/- or numeric keys. 2. Press the start key. The value is set. Completion: Press the stop key.	If a preset value is raised, a picture will move to the left. To make an adjustment for duplex copying, select [Dup].
2	Adjusting the center line of the cassettes (printing adjustment) Adjusting the LSU print start timing		U034	LSU Out Left	P.1-3-24	1. Press the start key. 2. Select [Lsu Out Left] to be adjusted. 3. Press the start key. 4. Press the system menu key. 5. Press the start key. (output a test pattern) 6. Press the system menu key. 7. Select the item to be adjusted. [Cassette1] to [Cassette7]	1. Change the setting value using the cursor +/- or numeric keys. 2. Press the start key. The value is set. Completion: Press the stop key.	If a preset value is raised, a picture will move to the left. To make an adjustment for duplex copying, select [Dup].
3	Adjusting the leading edge registration of the MP tray (printing adjustment) secondary paper feed start timing		U034	LSU Out Top	P.1-3-24	1. Press the start key. 2. Select [Lsu Out Top] to be adjusted. 3. Press the start key. 4. Press the system menu key. 5. Press the start key. (output a test pattern) 6. Press the system menu key. 7. Select [MPT(L)] or [MPT(S)] to be adjusted.	1. Change the setting value using the cursor +/- or numeric keys. 2. Press the start key. The value is set. Completion: Press the stop key.	If a preset value is raised, a picture will move downward. To make an adjustment for duplex copying, select [Dup].
4	Adjusting the leading edge registration of the cassette (printing adjustment) secondary paper feed start timing		U034	LSU Out Top	P.1-3-24	1. Press the start key. 2. Select [Lsu Out Top] to be adjusted. 3. Press the start key. 4. Press the system menu key. 5. Press the start key. (output a test pattern) 6. Press the system menu key. 7. Select [Cassette(L)] or [Cassette(S)] to be adjusted.	1. Change the setting value using the cursor +/- or numeric keys. 2. Press the start key. The value is set. Completion: Press the stop key.	If a preset value is raised, a picture will move downward. To make an adjustment for duplex copying, select [Dup].
5	Adjusting the leading edge margin (printing adjustment) LSU illumination start timing		U402	Lead	P.1-3-51	1. Press the start key. 2. Press the system menu key. 3. Press the start key. (output a test pattern) 4. Press the system menu key. 5. Select [Lead] to be adjusted.	1. Change the setting value using the cursor +/- or numeric keys. 2. Press the start key. The value is set. Completion: Press the stop key.	A margin will become large if a preset value is raised.
6	Adjusting the trailing edge margin (printing adjustment) LSU illumination end timing		U402	Trail	P.1-3-51	1. Press the start key. 2. Press the system menu key. 3. Press the start key. (output a test pattern) 4. Press the system menu key. 5. Select [Trail] to be adjusted.	1. Change the setting value using the cursor +/- or numeric keys. 2. Press the start key. The value is set. Completion: Press the stop key.	A margin will become large if a preset value is raised.

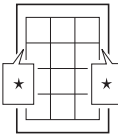
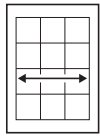
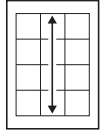
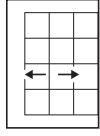
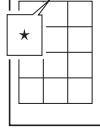
Adjusting order	Item	Image	Maintenance mode		Page	Setting procedure		Remarks
			Item No.	Mode		Method	Setting	
7	Adjusting the left and right margins (printing adjustment) LSU illumination start/end timing		U402	A Margin C Margin	P.1-3-51	1. Press the start key. 2. Press the system menu key. 3. Press the start key. (output a test pattern) 4. Press the system menu key. 5. Select [A Margin] or [C Margin] to be adjusted.	1. Change the setting value using the cursor +/- or numeric keys. 2. Press the start key. The value is set. Completion: Press the stop key.	A margin will become large if a preset value is raised.
8	Adjusting magnification of the scanner in the main scanning direction (scanning adjustment) Data processing		U065 U070	Main Scan Convey Speed	P.1-3-27 P.1-3-32	1. Press the start key. 2. Press the system menu key. 3. Set aoriginal and then press the start key. (output a test copy) 4. Press the system menu key. 5. Select [Main Scan] to be adjusted.	1. Change the setting value using the cursor +/- or numeric keys. 2. Press the start key. The value is set. Completion: Press the stop key.	U065: When using on the contact glass If a preset value is raised, a picture will spread. U070: When using document processor A picture will become long if a preset value is raised.
9	Adjusting magnification of the scanner in the auxiliary scanning direction (scanning adjustment) Original scanning speed		U065	Sub Scan	P.1-3-27	1. Press the start key. 2. Press the system menu key. 3. Set aoriginal and then press the start key. (output a test copy) 4. Press the system menu key. 5. Select [Sub Scan] to be adjusted.	1. Change the setting value using the cursor +/- or numeric keys. 2. Press the start key. The value is set. Completion: Press the stop key.	U065: When using on the contact glass If a preset value is raised, a picture will spread.
10	Adjusting the center line (scanning adjustment) Adjusting the original scan data (image adjustment)		U067 U072	Front Front Back	P.1-3-30 P.1-3-35	1. Press the start key. 2. Press the system menu key. 3. Set aoriginal and then press the start key. (output a test copy) 4. Press the system menu key. 5. Select the item to be adjusted. U067: [Front] U072: [Front] or [Back]	1. Change the setting value using the cursor +/- or numeric keys. 2. Press the start key. The value is set. Completion: Press the stop key.	U067: When using on the contact glass If a preset value is raised, a picture will move to the left. U072: When using document processor Back adjustment selects [Back] at the time of duplex mode. If a preset value is raised, a picture will move to the right.
11	Adjusting the leading edge registration (scanning adjustment) Original scan start timing		U066 U071	Front Front Head Back Head	P.1-3-29 P.1-3-33	1. Press the start key. 2. Press the system menu key. 3. Set aoriginal and then press the start key. (output a test copy) 4. Press the system menu key. 5. Select the item to be adjusted. U066: [Front] U071: [Front Head] or [Back Head]	1. Change the setting value using the cursor +/- or numeric keys. 2. Press the start key. The value is set. Completion: Press the stop key.	U066: When using on the contact glass If a preset value is raised, a picture will move forward. U071: When using document processor Back adjustment selects [Back Head] at the time of duplex mode.If a preset value is raised, a picture will move forward.

When maintenance item U411 (Automatic adjustment in the scanner) is run using the specified original (P/N 302NM94340) the following adjustments are automatically made:
 Adjusting the scanner magnification (U065)
 Adjusting the scanner leading edge registration (U066)
 Adjusting the scanner center line (U067)

When maintenance item U411 (Automatic adjustment in the DP) is run using the specified original (P/N 302NM94330) the following adjustments are automatically made:
 * : When running this test chart, you first must clean the feed rollers with alcohol and ensure the DP width guides are correctly positioned against the original.
 Adjusting the DP magnification (U070)
 Adjusting the DP leading edge registration (U071)
 Adjusting the DP center line (U072)

Image quality

Item	Specifications
100% magnification	Print: $\pm 0.8\%$ Copy: $\pm 1.5\%$ Using DP: $\pm 2.0\%$
Enlargement/reduction	Copy: $\pm 2.0\%$ Using DP: $\pm 2.5\%$
Lateral squareness	Copy: $\pm 2.0\text{mm}/200\text{mm}$ Using DP: $\pm 2.5\text{mm}/200\text{mm}$
Leading edge registration	Print: 1.5 mm or less Copy: 2.5mm or less Using DP: 2.5mm or less
Skewed paper feed (left-right difference)	Print: 1mm /100mm or less Copy: 1mm /100mm or less Using DP: 1.5mm /100mm or less
Lateral image shifting	Print: 2.0 mm or less Copy: 3.0mm or less Using DP: 3.0mm or less

(7) Wiring diagram (40 ppm (LED model))

No.1

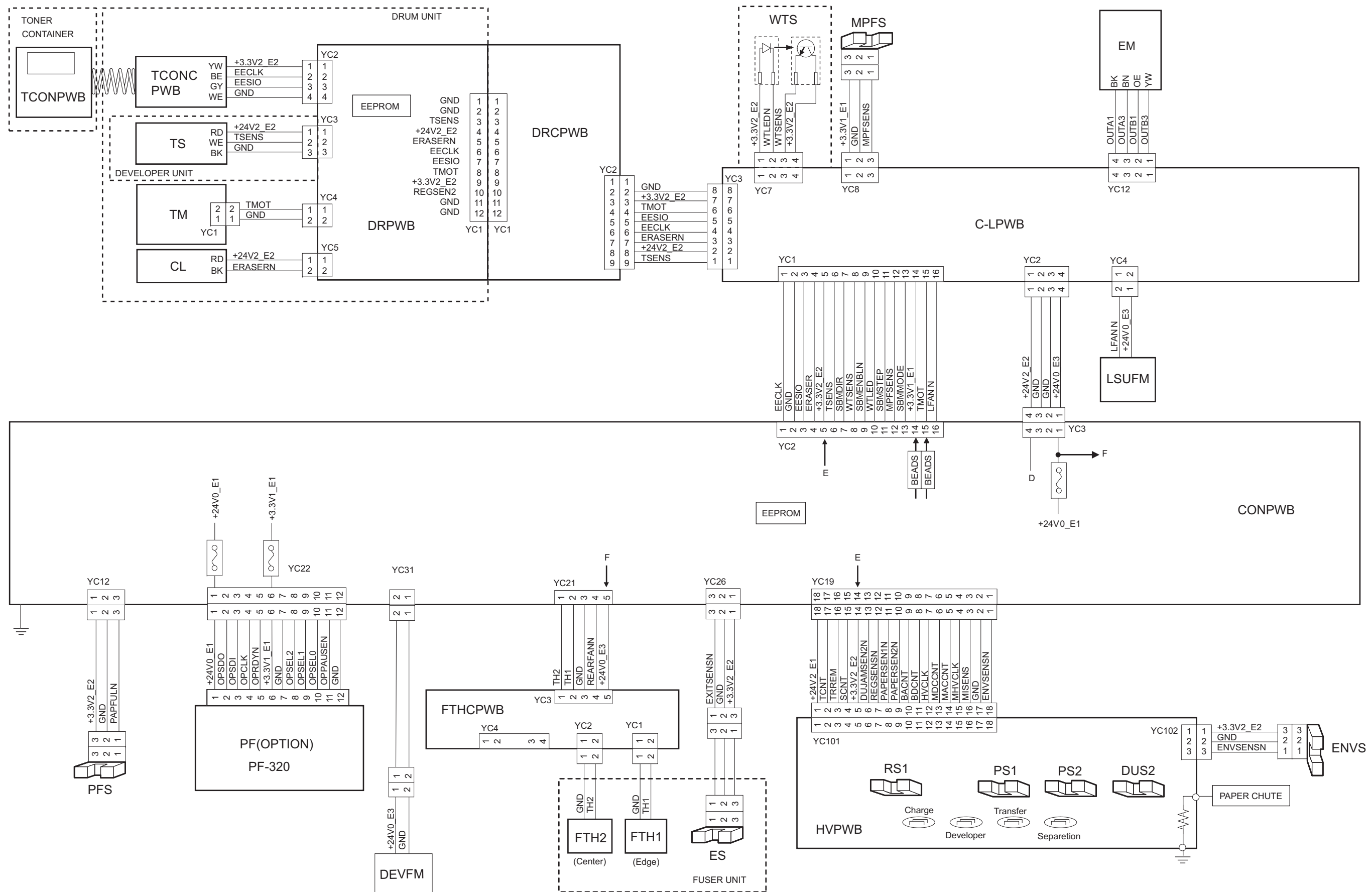

No.2

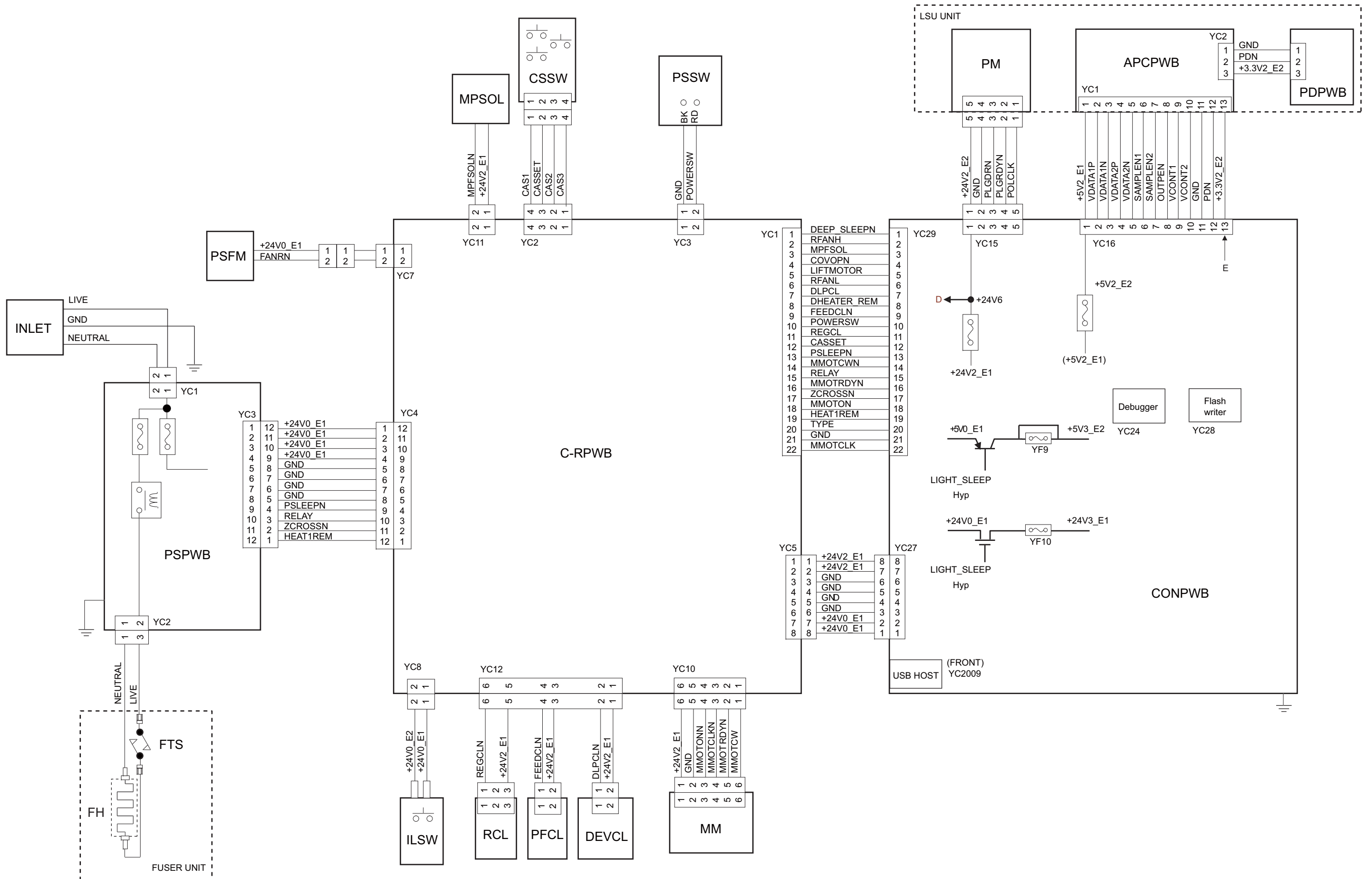

No.3

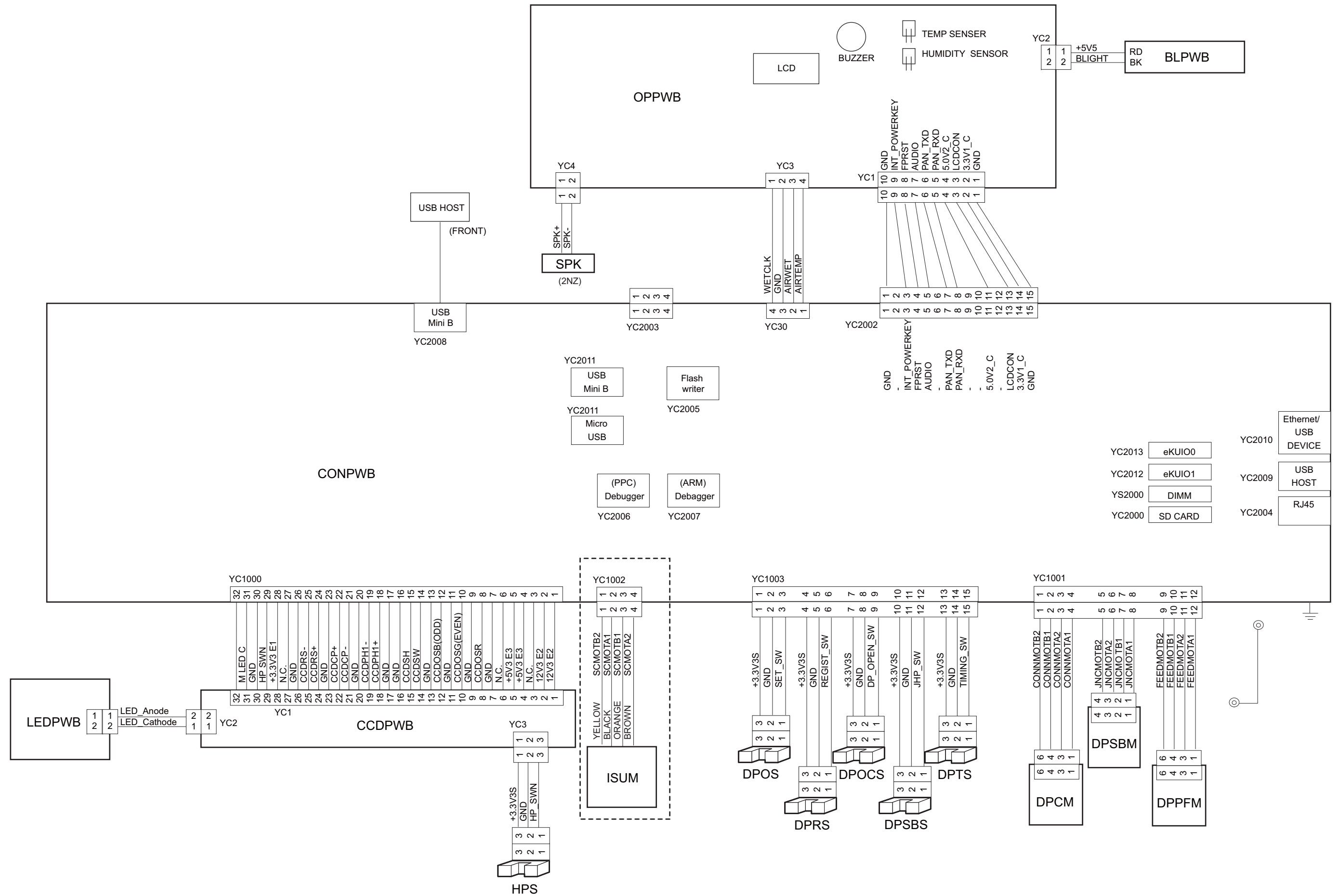

(8) Wiring diagram (40 ppm (HyPAS model))

No.1

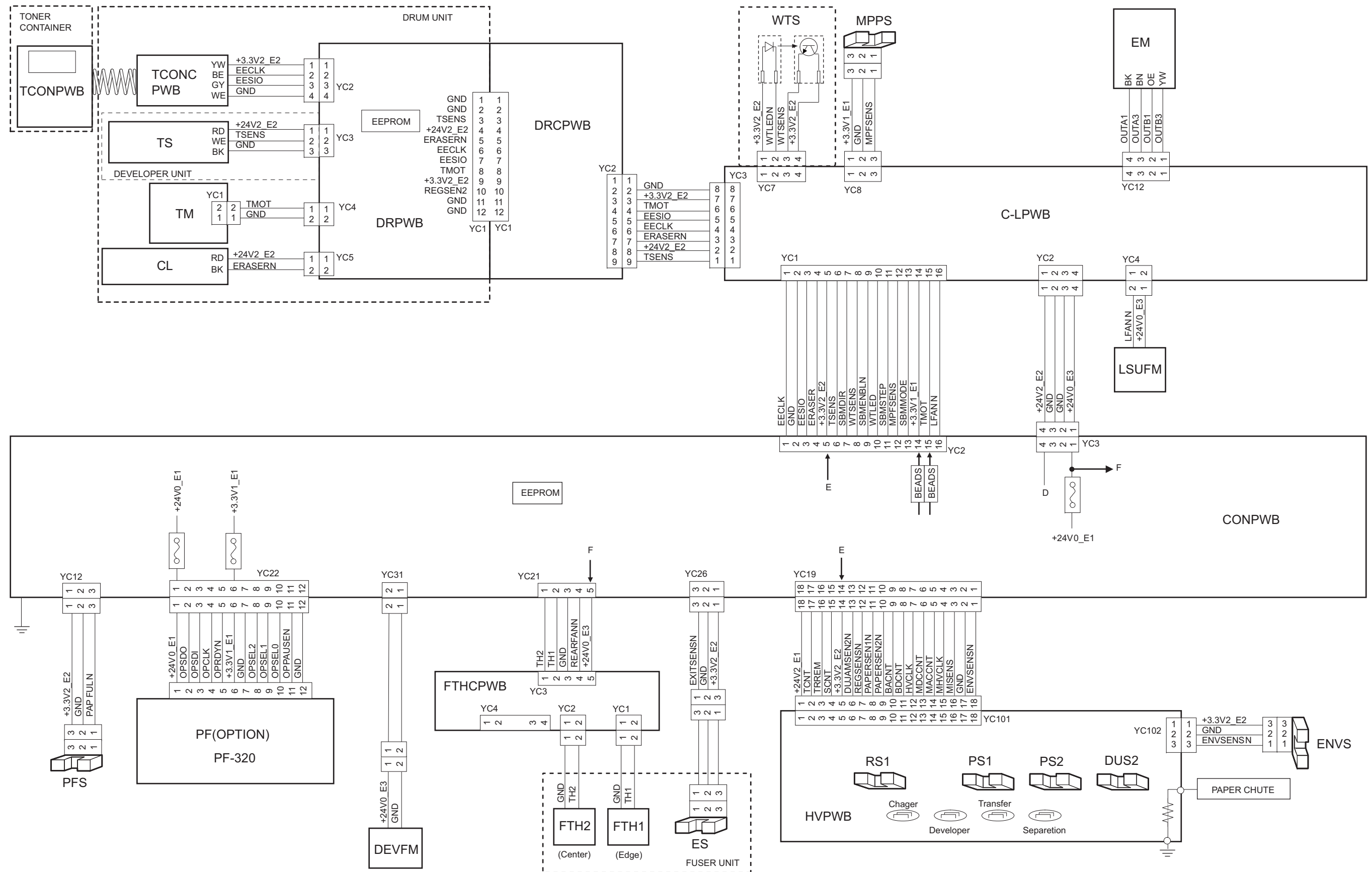

No.2

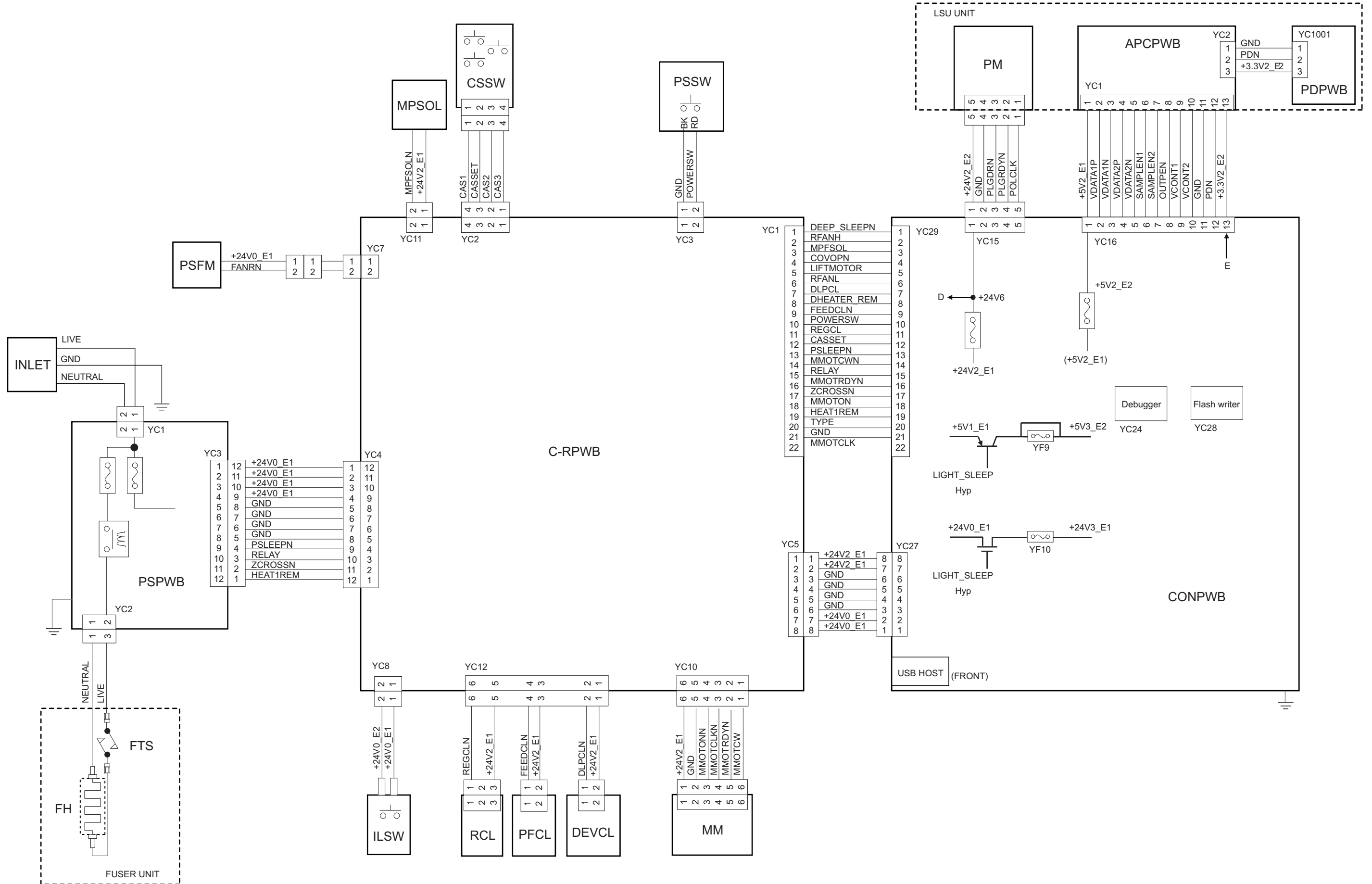

No.3

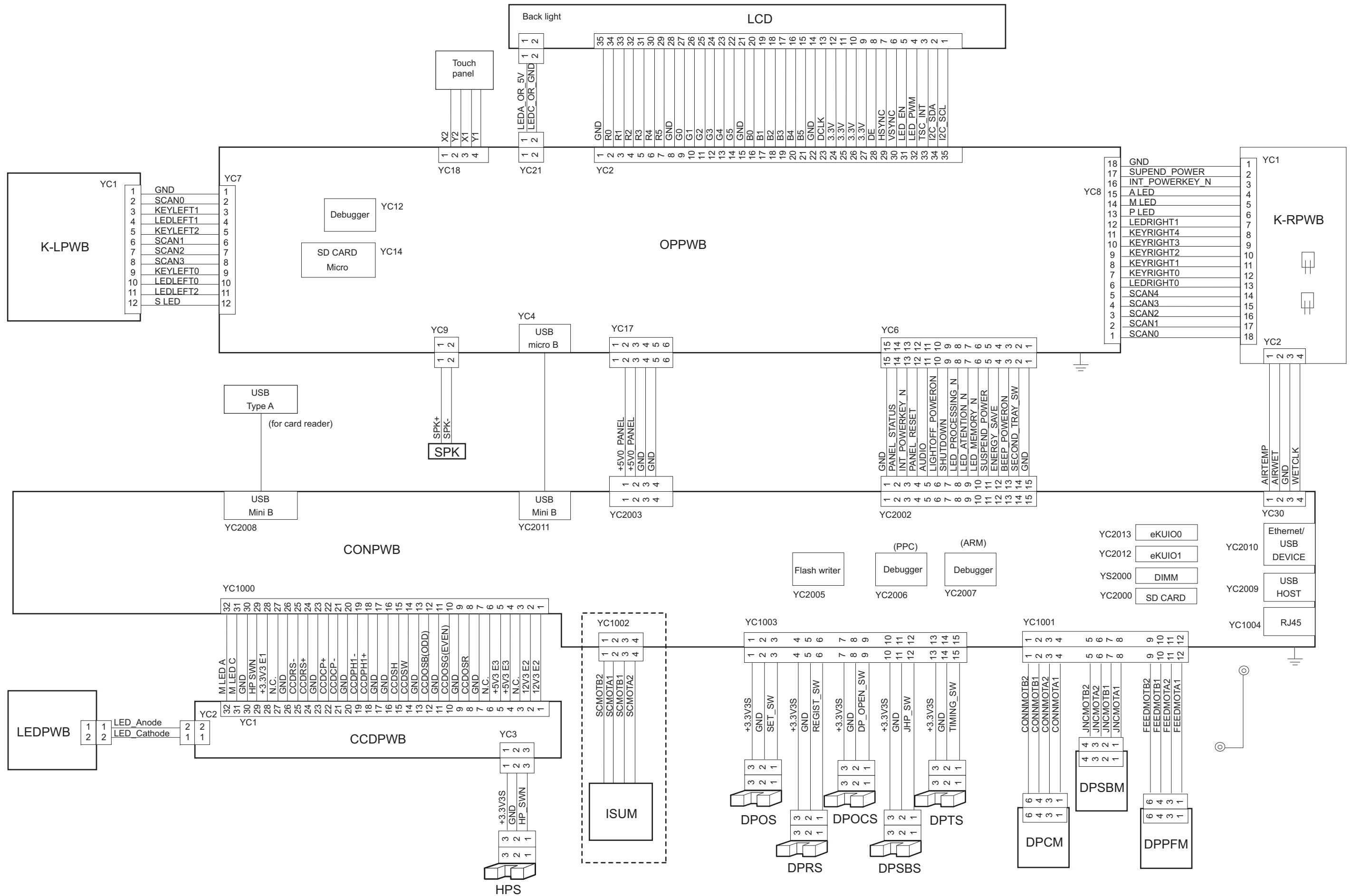

(9) Wiring diagram (50/60 ppm (HyPAS model))

No.1

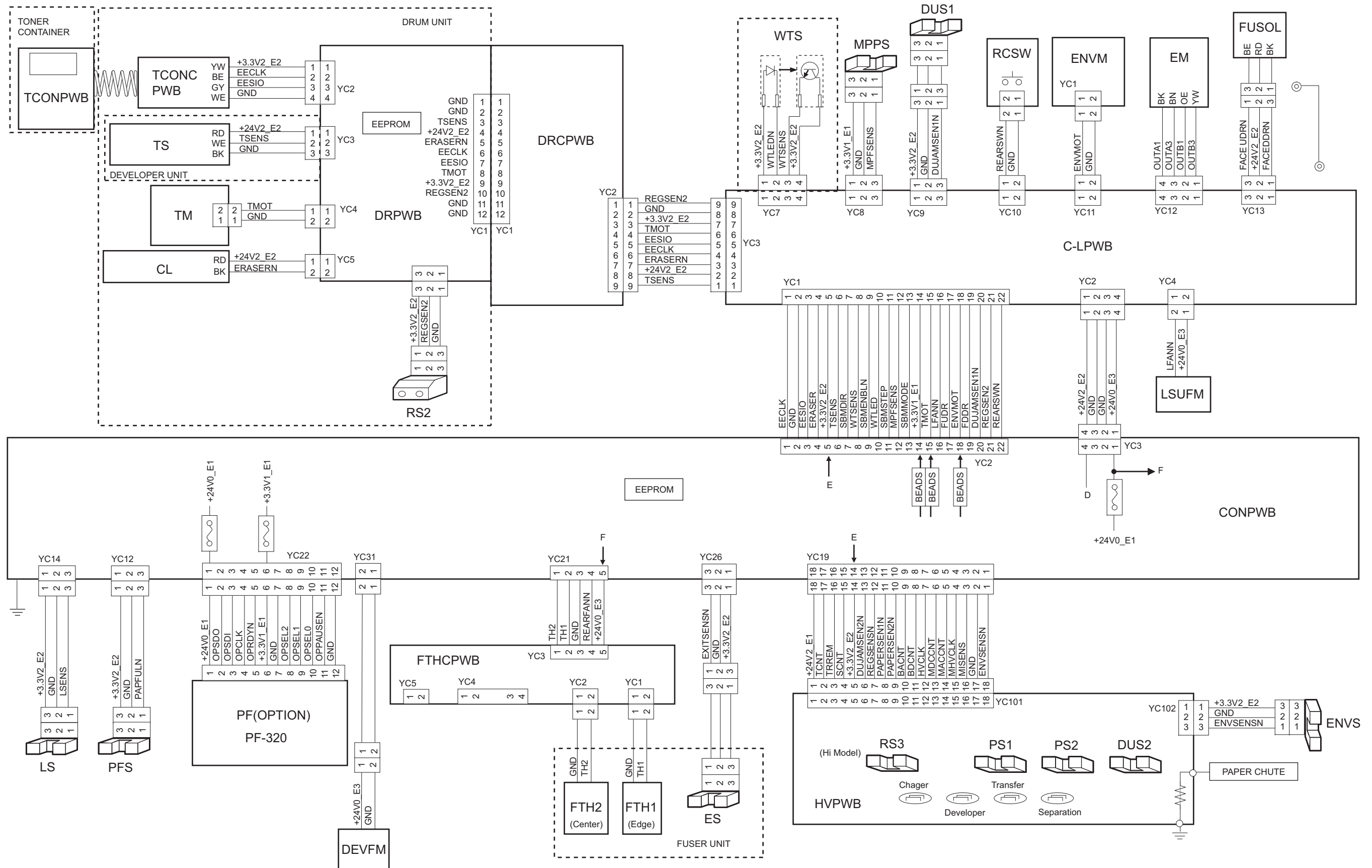

No.2

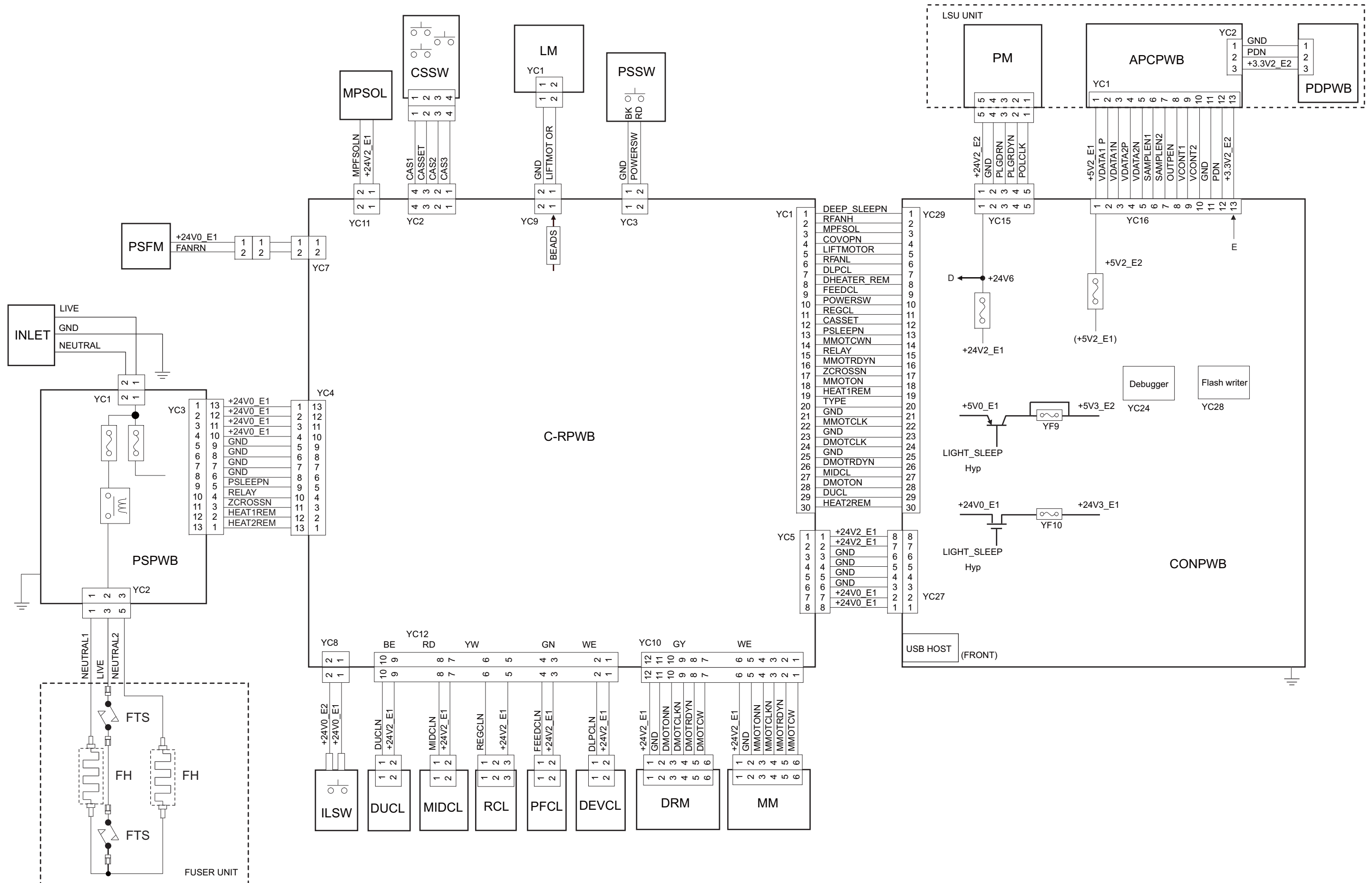

No.3

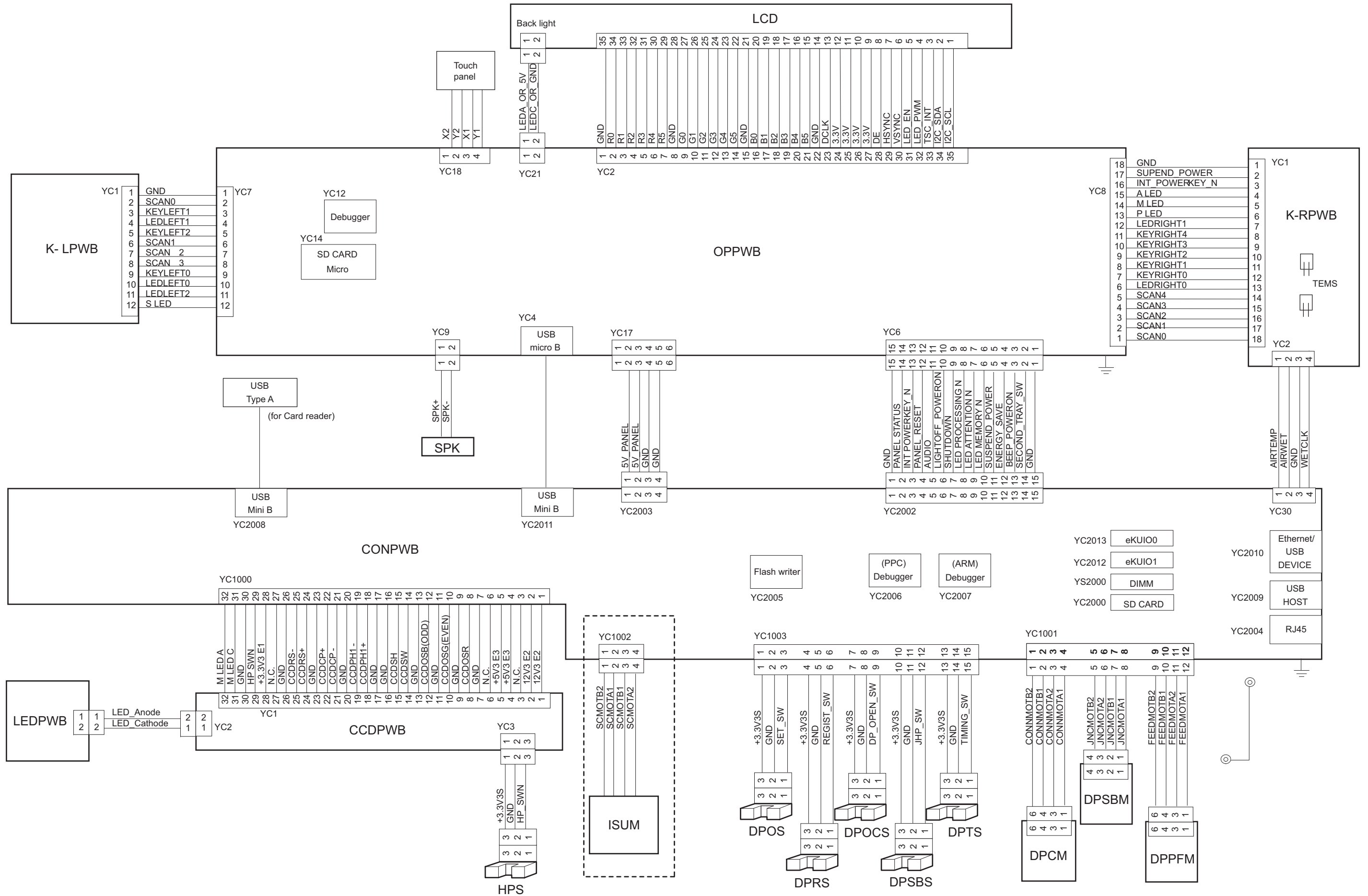

PF-320 (Paper Feeder)

Installation Guide

PF-320



Installation Guide
Installationsanleitung
Guide d'installation

Guida all'installazione
Guía de instalación

安装手册
설치안내서
インストールガイド

For U.S.A.:

To install the optional paper feeder unit, contact your service representative.

This unit is for use only with Laser Printers, FS-2100DN, Models FS-4100DN, FS-4200DN, FS-4300DN, ECOSYS M3040idn, ECOSYS M3540idn, ECOSYS M3550idn and ECOSYS M3560idn.

For Canada:

CAN ICES-3B/NMB-3B

Installation of PF-320
Installation von PF-320
Installation de PF-320

Installazione di PF-320
Instalación de PF-320

PF-320 的安装
PF-320 설치
PF-320の設置

1

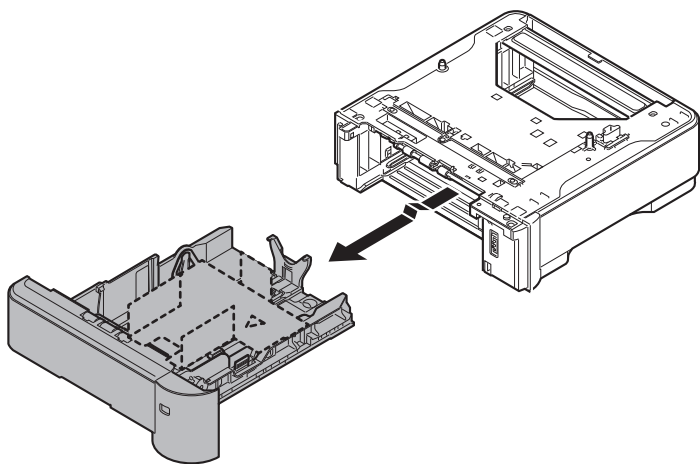

2

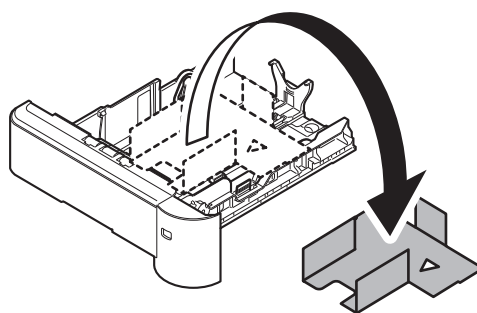

3

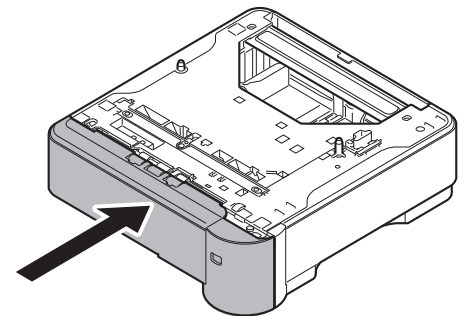

4

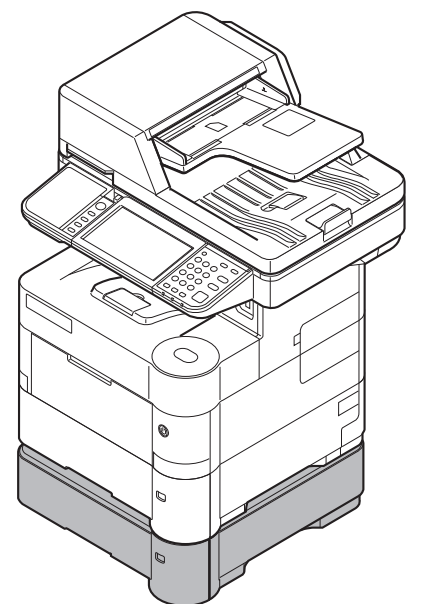
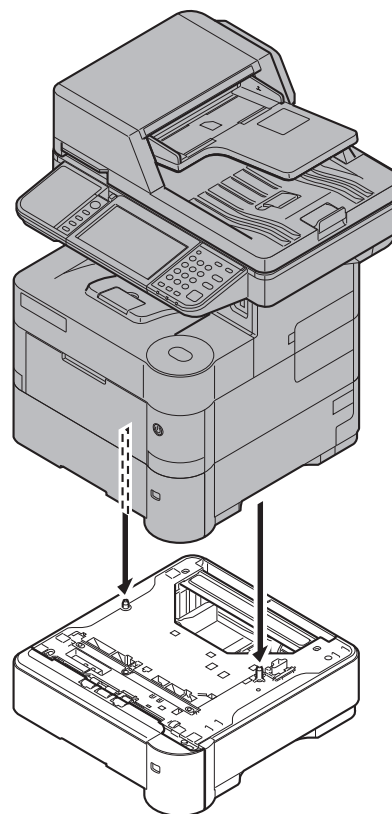
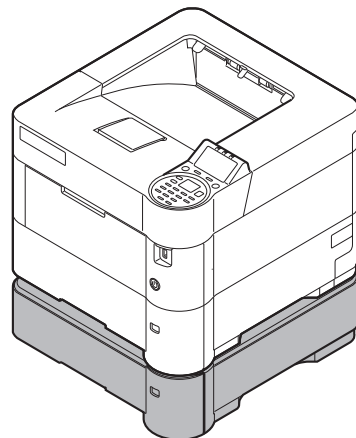
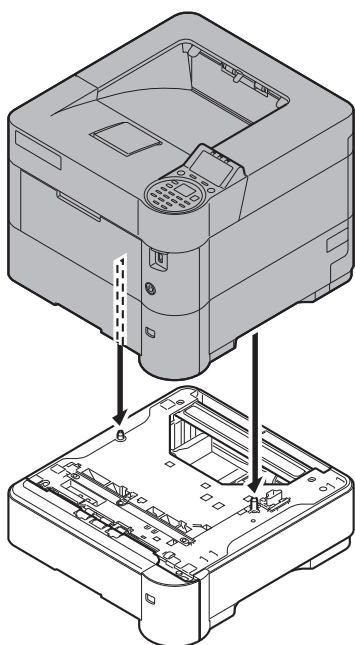

Adjustment of paper size
 Justage des Papierformats
 Ajustement de format papier

Registrazione del formato carta
 Ajuste del tamaño del papel

纸张大小的调整
 용지 크기의 조정
 用紙サイズの調整

1

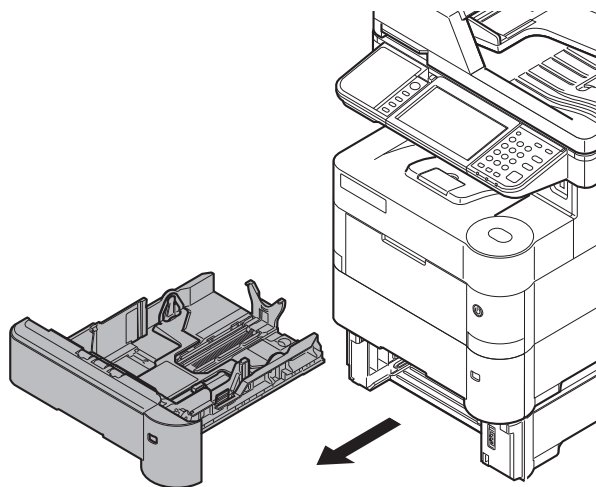
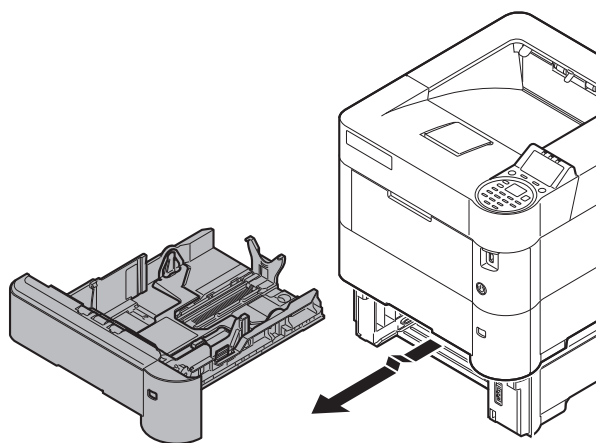

2

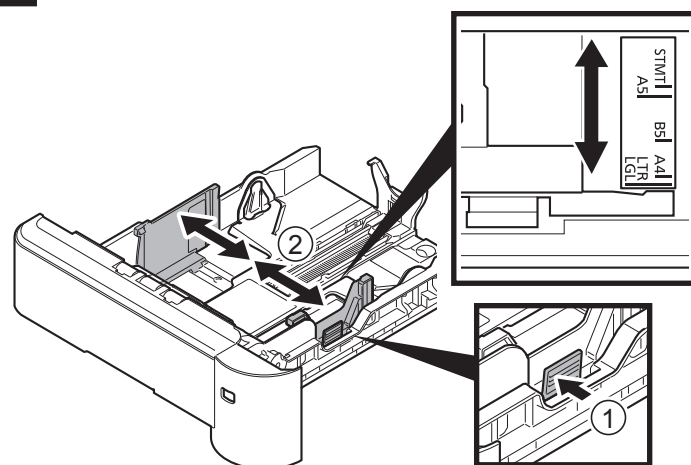

3

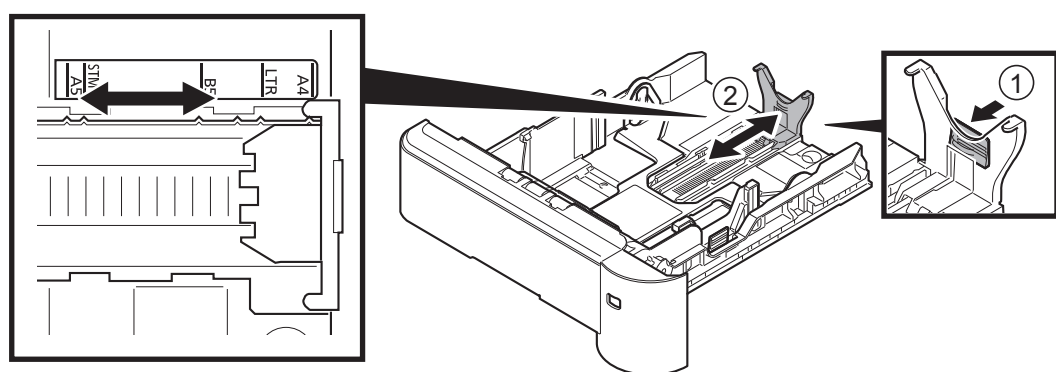

4

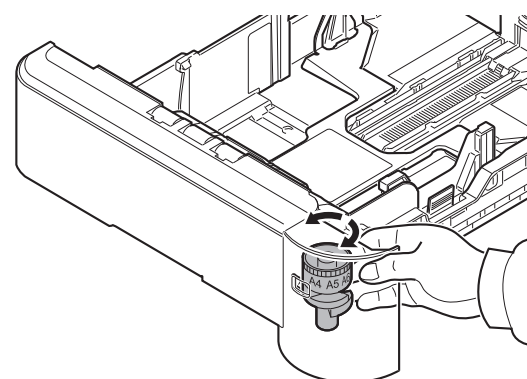

(For Legal/Folio/OficioII)

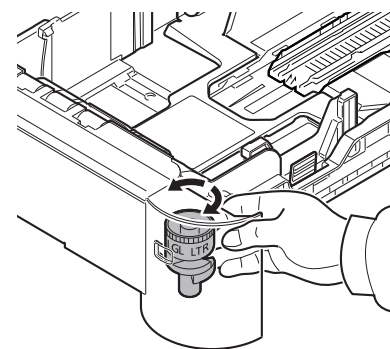
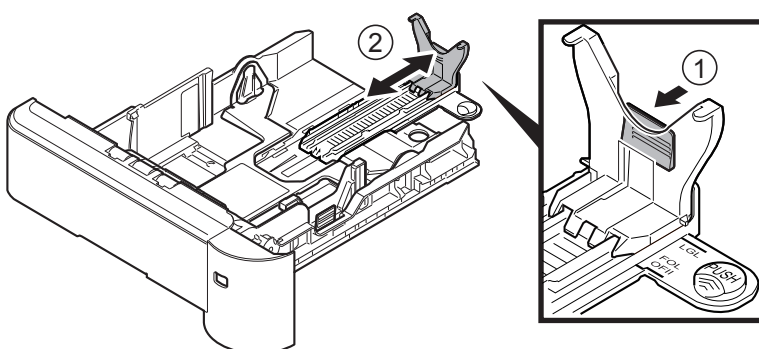
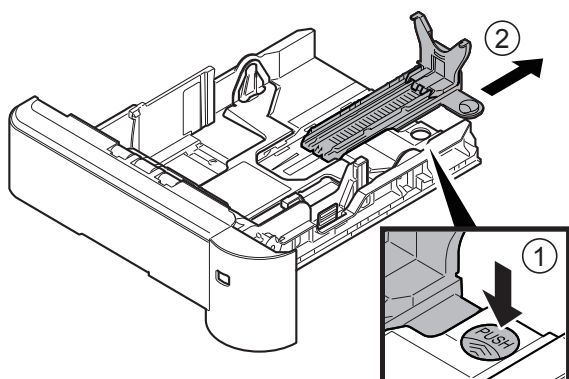

Loading paper
 Ladenpapier
 Papier de chargement

Carta da caricamento
 Papel del cargamento

装紙
 용지 적재
 用紙のセット

5

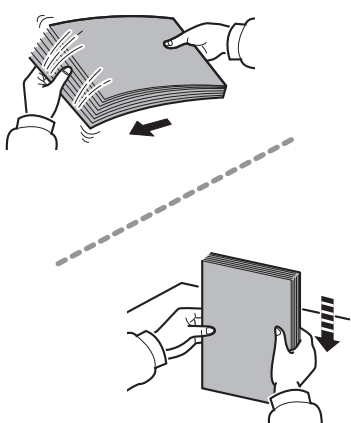

6

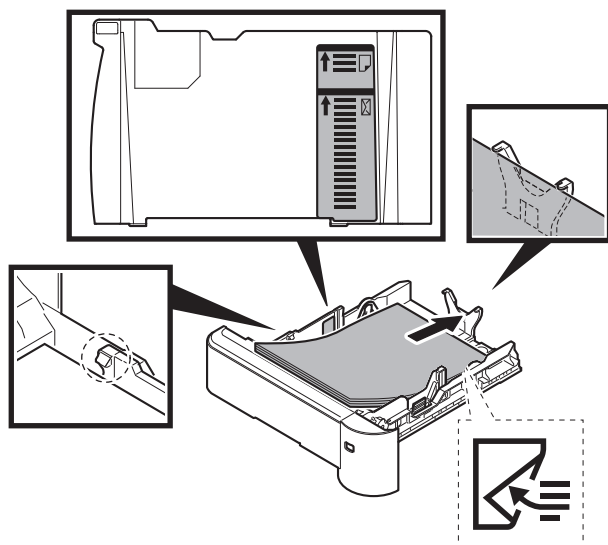

7

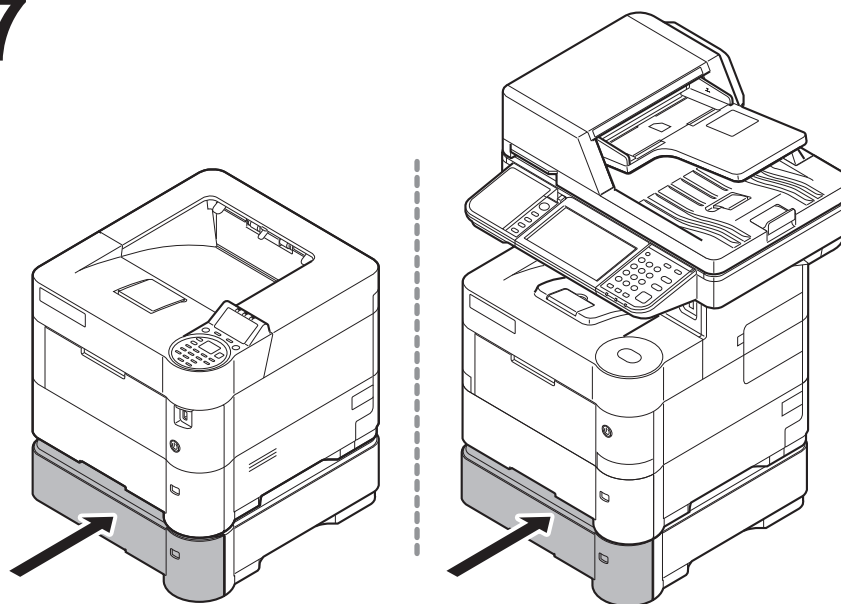

KYOCERA Document Solutions America, Inc.**Headquarters**

225 Sand Road,
Fairfield, New Jersey 07004-0008, USA
Phone: +1-973-808-8444
Fax: +1-973-882-6000

Latin America

8240 NW 52nd Terrace Dawson Building, Suite 100
Miami, Florida 33166, USA
Phone: +1-305-421-6640
Fax: +1-305-421-6666

KYOCERA Document Solutions Canada, Ltd.

6120 Kestrel Rd., Mississauga, ON L5T 1S8,
Canada
Phone: +1-905-670-4425
Fax: +1-905-670-8116

**KYOCERA Document Solutions
Mexico, S.A. de C.V.**

Calle Arquimedes No. 130, 4 Piso, Colonia Polanco
Chapultepec, Delegacion Miguel Hidalgo,
Distrito Federal, C.P. 11560, México
Phone: +52-555-383-2741
Fax: +52-555-383-7804

KYOCERA Document Solutions Brazil, Ltda.

Alameda África, 545, Pólo Empresarial Consbrás,
Tamboré, Santana de Parnaíba-SP, CEP 06543-306,
Brazil
Phone: +55-11-4195-8496
Fax: +55-11-4195-6167

KYOCERA Document Solutions Chile SpA

Jose Ananias 505, Macul. Santiago, Chile
Phone: +562-2350-7000
Fax: +562-2350-7150

**KYOCERA Document Solutions
Australia Pty. Ltd.**

Level 3, 6-10 Talavera Road North Ryde N.S.W, 2113,
Australia
Phone: +61-2-9888-9999
Fax: +61-2-9888-9588

**KYOCERA Document Solutions
New Zealand Ltd.**

Ground Floor, 19 Byron Avenue, Takapuna, Auckland,
New Zealand
Phone: +64-9-415-4517
Fax: +64-9-415-4597

KYOCERA Document Solutions Asia Limited

16/F., Mita Centre, 552-566, Castle Peak Road
Tsuenwan, NT, Hong Kong
Phone: +852-2610-2181
Fax: +852-2610-2063

**KYOCERA Document Solutions
(China) Corporation**

8F, No. 288 Nanjing Road West, Huangpu District,
Shanghai, 200003, China
Phone: +86-21-5301-1777
Fax: +86-21-5302-8300

**KYOCERA Document Solutions
(Thailand) Corp., Ltd.**

335 Ratchadapisek Road, Bangsue, Bangkok 10800,
Thailand
Phone: +66-2-586-0333
Fax: +66-2-586-0278

**KYOCERA Document Solutions
Singapore Pte. Ltd.**

12 Tai Seng Street #04-01A,
Luxasia Building, Singapore 534118
Phone: +65-6741-8733
Fax: +65-6748-3788

**KYOCERA Document Solutions
Hong Kong Limited**

16/F., Mita Centre, 552-566, Castle Peak Road
Tsuenwan, NT, Hong Kong
Phone: +852-3582-4000
Fax: +852-3185-1399

**KYOCERA Document Solutions
Taiwan Corporation**

6F., No.37, Sec. 3, Minquan E. Rd.,
Zhongshan Dist., Taipei 104, Taiwan R.O.C.
Phone: +886-2-2507-6709
Fax: +886-2-2507-8432

KYOCERA Document Solutions Korea Co., Ltd.

18F, Kangnam bldg, 1321-1,
Seocho-Dong, Seocho-Gu, Seoul, Korea
Phone: +822-6933-4050
Fax: +822-747-0084

**KYOCERA Document Solutions
India Private Limited**

Second floor, Centrum Plaza, Golf Course Road,
Sector-53, Gurgaon, Haryana 122002, India
Phone: +91-0124-4671000
Fax: +91-0124-4671001

KYOCERA Document Solutions Europe B.V.

Bloemlaan 4, 2132 NP Hoofddorp,
The Netherlands
Phone: +31-20-654-0000
Fax: +31-20-653-1256

KYOCERA Document Solutions Nederland B.V.

Beechavenue 25, 1119 RA Schiphol-Rijk,
The Netherlands
Phone: +31-20-5877200
Fax: +31-20-5877260

KYOCERA Document Solutions (U.K.) Limited

Eldon Court, 75-77 London Road,
Reading, Berkshire RG1 5BS,
United Kingdom
Phone: +44-118-931-1500
Fax: +44-118-931-1108

KYOCERA Document Solutions Italia S.p.A.

Via Verdi, 89/91 20063 Cernusco s/N.(MI),
Italy
Phone: +39-02-921791
Fax: +39-02-92179-600

KYOCERA Document Solutions Belgium N.V.

Sint-Martinusweg 199-201 1930 Zaventem,
Belgium
Phone: +32-2-7209270
Fax: +32-2-7208748

KYOCERA Document Solutions France S.A.S.

Espace Technologique de St Aubin
Route de l'Orme 91195 Gif-sur-Yvette CEDEX,
France
Phone: +33-1-69852600
Fax: +33-1-69853409

KYOCERA Document Solutions Espana, S.A.

Edificio Kyocera, Avda. de Manacor No.2,
28290 Las Matas (Madrid), Spain
Phone: +34-91-6318392
Fax: +34-91-6318219

KYOCERA Document Solutions Finland Oy

Atomitie 5C, 00370 Helsinki,
Finland
Phone: +358-9-47805200
Fax: +358-9-47805390

**KYOCERA Document Solutions
Europe B.V., Amsterdam (NL) Zürich Branch**

Hohlstrasse 614, 8048 Zürich,
Switzerland
Phone: +41-44-9084949
Fax: +41-44-9084950

**KYOCERA Document Solutions
Deutschland GmbH**

Otto-Hahn-Strasse 12, 40670 Meerbusch,
Germany
Phone: +49-2159-9180
Fax: +49-2159-918100

KYOCERA Document Solutions Austria GmbH

Eduard-Kittenberger-Gasse 95, 1230 Vienna,
Austria
Phone: +43-1-863380
Fax: +43-1-86338-400

KYOCERA Document Solutions Nordic AB

Esbogatan 16B 164 75 Kista, Sweden
Phone: +46-8-546-550-00
Fax: +46-8-546-550-10

KYOCERA Document Solutions Norge Nuf

Postboks 150 Oppsal, 0619 Oslo,
Norway
Phone: +47-22-62-73-00
Fax: +47-22-62-72-00

KYOCERA Document Solutions Danmark A/S

Ejby Industrivej 60, DK-2600 Glostrup,
Denmark
Phone: +45-70223880
Fax: +45-45765850

KYOCERA Document Solutions Portugal Lda.

Rua do Centro Cultural, 41 (Alvalade) 1700-106 Lisboa,
Portugal
Phone: +351-21-843-6780
Fax: +351-21-849-3312

**KYOCERA Document Solutions
South Africa (Pty) Ltd.**

KYOCERA House, Hertford Office Park,
90 Bekker Road (Cnr. Allandale), Midrand, South Africa.
Phone: +27-11-540-2600
Fax: +27-11-466-3050

KYOCERA Document Solutions Russia LLC.

Building 2, 51/4, Schepkina St., 129110, Moscow,
Russia
Phone: +7(495)741-0004
Fax: +7(495)741-0018

KYOCERA Document Solutions Middle East

Dubai Internet City, Bldg. 17,
Office 157 P.O. Box 500817, Dubai,
United Arab Emirates
Phone: +971-04-433-0412

KYOCERA Document Solutions Inc.

2-28, 1-chome, Tamatsukuri, Chuo-ku
Osaka 540-8585, Japan
Phone: +81-6-6764-3555
<http://www.kyoceradocumentsolutions.com>