



---

*Ecosys FS-C8008N  
Color Laser Printer*

**PARTS LIST**

Published in June 23, 2003  
2CK70770

*WWW.SERVICE-MANUAL.NET*

## Contents

Exterior Covers (01-)	3
Upper Frame Unit (02-)	5
Drive Unit (03-)	11
Controller Box (04-)	17
Paper Feed Unit (05-)	19
Fuser Unit (06-)	24
Drum Unit (07-)	27
Developer Unit — Y (08Y-)	29
Developer Unit — M (08M-)	31
Developer Unit — C (08C-)	33
Developer Unit — K (08K-)	35
Face-down Unit (9-)	37
MP Tray (10-)	41
Primary Transfer Unit (11-)	44
Electrical Parts (12-)	47

## Notes on Ordering

- Parts with + are component parts or sub-assemblies of the assembly appearing above them.
- Parts with ++ are component parts of the assembly marked with + immediately above them.
- SP means service parts that are available for ordering.

# 1. Exterior Covers (01-)

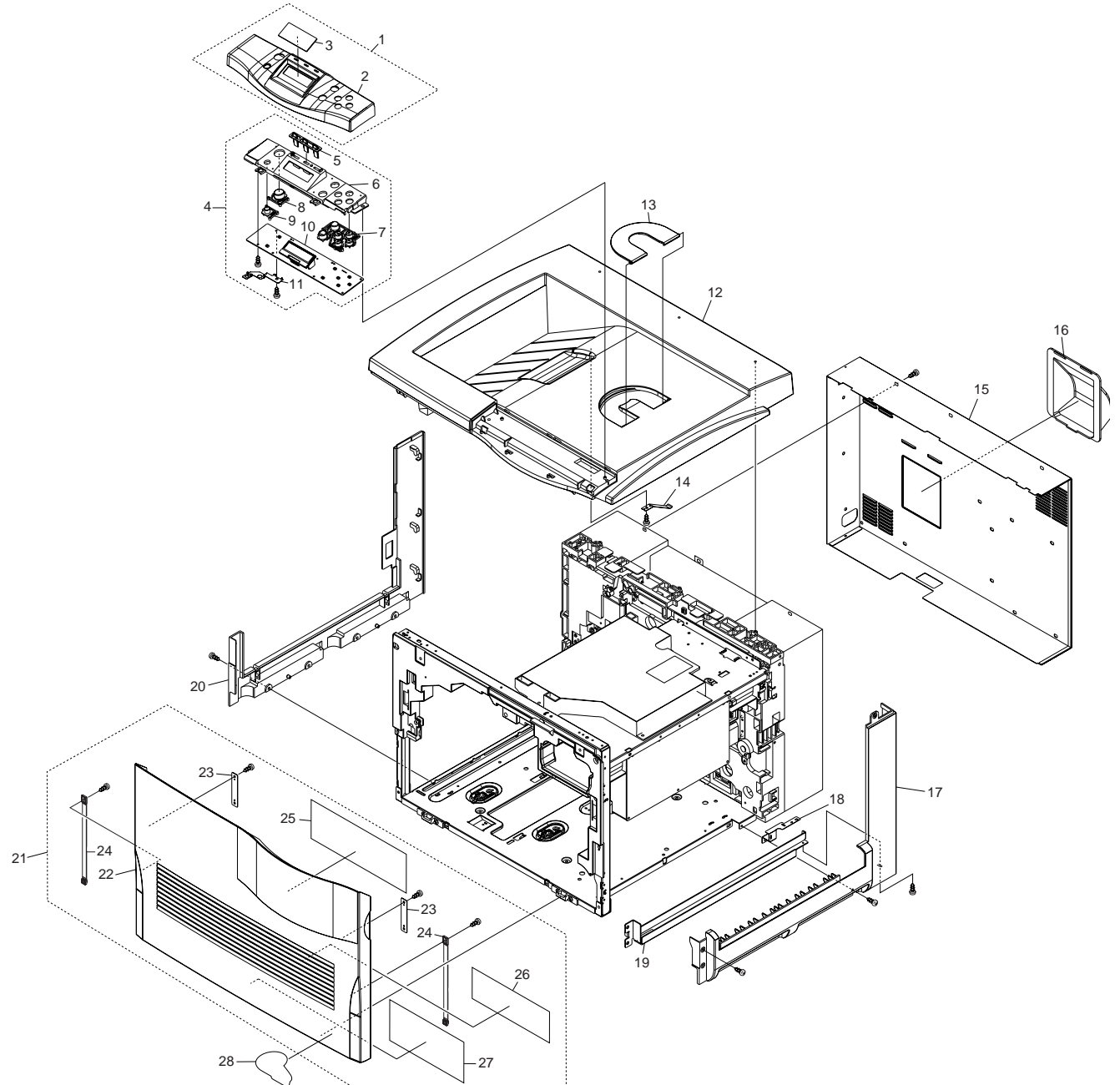

## List 1 - Exterior Covers (01-)

Ref. No.	Part Code	Description	Applicable Model	SP	120V	230V	Remarks
01-001	2BM68010	PANEL ASSY ENGLISH	Excl.KMFR/KMIT	X	1	1	
01-001	2BM68020	PANEL ASSY FRENCH	KMFR only	X	-	1	
01-001	2BM68030	PANEL ASSY ITALIAN	KMIT only	X	-	1	
01-002	+ 2BM04120	PANEL KEY ENGLISH	Excl.KMFR/KMIT	-	1	1	
01-002	+ 2BM04130	PANEL KEY FRENCH	KMFR only	-	-	1	
01-002	+ 2BM04140	PANEL KEY ITALIAN	KMIT only	-	-	1	
01-003	+ 2BM00870	PANEL LCD ASSY		-	1	1	
01-004	2BM68050	KEY TOP ASSY		X	1	1	
01-005	+ 2BM04080	LENS LED		-	1	1	
01-006	+ 2BM04040	HOLDER PANEL PWB		-	1	1	
01-007	+ 2BM04050	KEY TOP1		-	1	1	
01-008	+ 2BM04060	KEY TOP2		-	1	1	
01-009	+ 2BM04070	KEY TOP3		-	1	1	
01-010	+ 2BM01080	P.W.BOARD KP-805 ASSY FRONT PANEL		-	1	1	
01-011	+ 2BM04300	PLATE EARTH PANEL		-	1	1	
01-012	2BM04010	COVER TOP		X	1	1	
01-013	2BM04020	STOPPER PAPER		X	1	1	
01-014	2BM04030	SP PRESS2 DLP		-	1	1	
01-015	2CK04030	COVER REAR		X	1	1	
01-016	2BM04270	PROTECTOR OZONE		X	1	1	
01-017	2BM04150	COVER RIGHT		X	1	1	
01-018	2BM04290	PLATE EARTH RC		-	1	1	
01-019	2BM04160	SUPPORT COVER ASSY		-	1	1	
01-020	2BM04170	COVER LEFT		X	1	1	
01-021	2CK00010	COVER FRONT ASSY		X	1	1	
01-022	+ 2CK04010	COVER FRONT		-	1	1	
01-023	+ 2BM04100	PLATE MAGCHATCH		-	2	2	
01-024	+ 2BM04280	BAND COVER		X	2	2	
01-025	+ 2CK05050	LABEL DIAGRAM D		-	1	1	
01-026	+ 2CK05060	LABEL DIAGRAM C		-	1	1	
01-027	+ 2BM05020	LABEL DIAGRAM B		-	1	1	
01-028	2CK05070	SEAL COLOR SYMBOL		X	1	1	

## 2. Upper Frame Unit (02-)

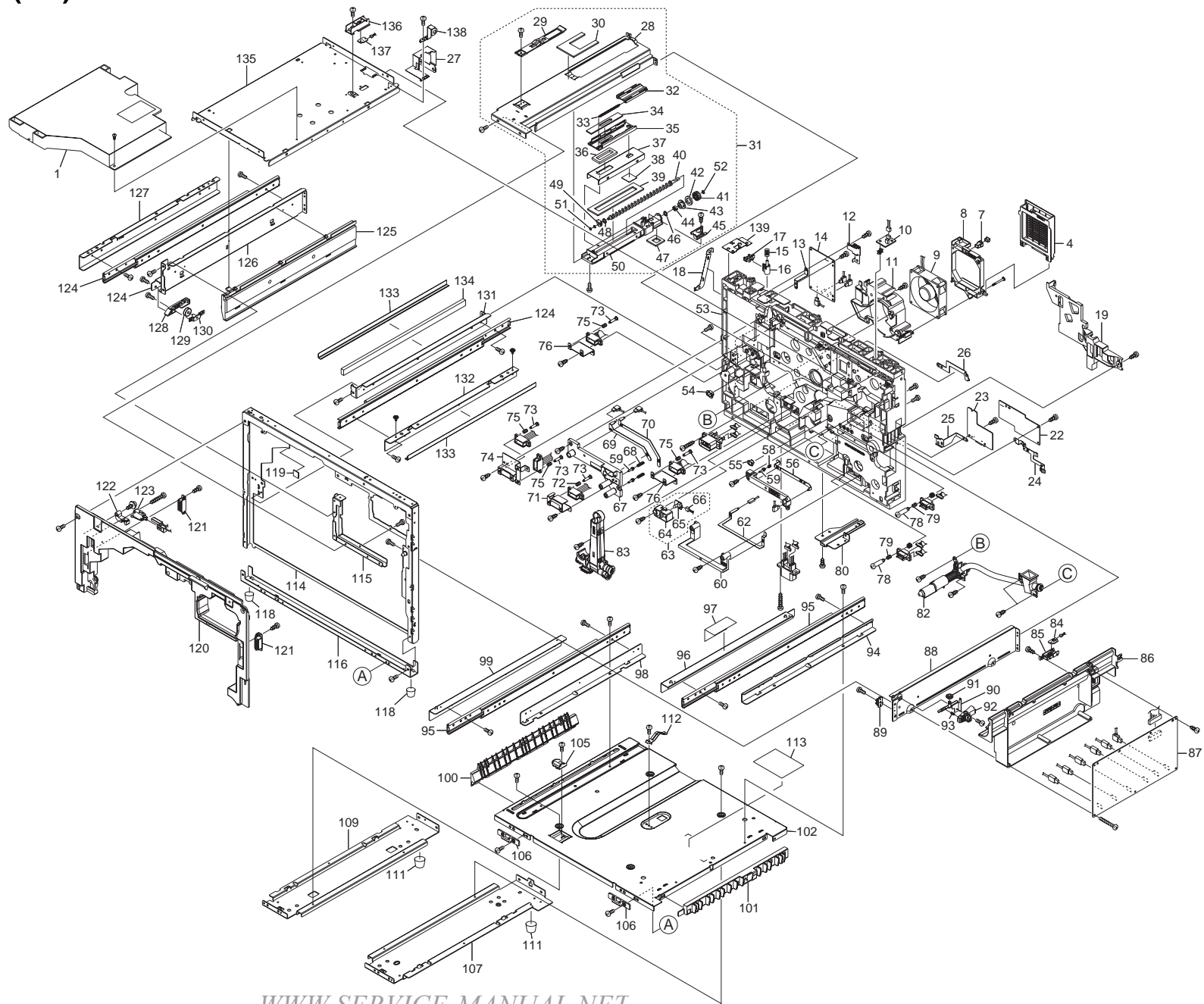

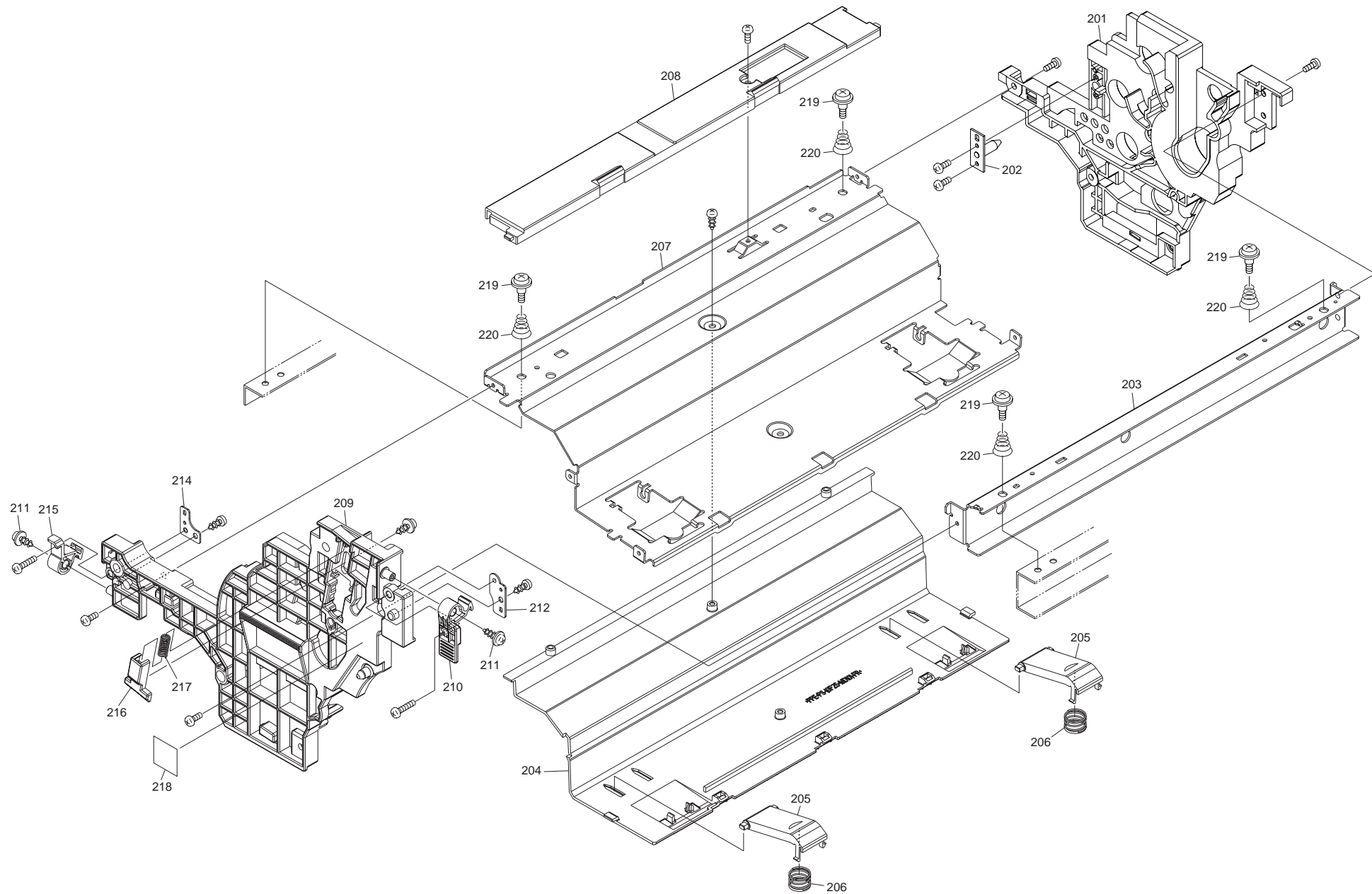

## List 2 - Upper Frame Unit (02-)

Ref. No.	Part Code	Description	Applicable Model	SP	120V	230V	Remarks
02-001	2BM93410	LK-800 SCANNER UNIT		X	1	1	
02-004	2BM02470	COVER OZONE		-	1	1	
02-007	2BM02460	LATCH		-	1	1	
02-008	2BM02450	HOLDER OF		-	1	1	
02-009	2CK27560	FAN FUSER 12V		X	1	1	
02-010	2BM27890	HUMIDITY SENSOR		X	1	1	
02-011	2BM23010	DUCT FAN		-	1	1	
02-012	2BM42530	PLATE EARTH MAIN B		-	1	1	
02-013	2BM02390	PLATE EARTH MAIN		-	1	1	
02-014	2CK28170	PWB HV MAIN		X	1	1	
02-015	2BM02900	SPRING SW DU		-	1	1	
02-016	2BM02910	SWITCH DU		-	1	1	
02-017	2BM27240	PT.SENSOR GP1S74P		X	1	1	
02-018	2BM42560	PLATE EARTH L		-	1	1	
02-019	2BM02480	HOLDER HARNESS		-	1	1	
02-022	2CK28180	PWB HV TC		X	1	1	
02-023	2CK01170	OPR KP-995 ASSY		X	1	1	
02-024	2BM02410	PLATE EARTH TC		-	1	1	
02-025	2BM02420	PLATE EARTH OP		-	1	1	
02-026	2BM42520	PLATE EARTH DRV FUS		-	1	1	
02-027	2BM42540	PLATE EARTH DRV TK A		-	1	1	
02-031	2CK00370	FEED TONER D4 ASSY		X	1	1	
02-028	+ 2BM00150	STAY MIDDLE ASSY		-	1	1	
02-029	+ 2BM14120	LOCK SHUTTER D1234		X	1	1	
02-030	+ 2BM42600	SEAL FEED TONER		-	1	1	
02-032	+ 2BM14240	SHUTTER D1234		-	1	1	
02-033	+ 2BM14230	SPRING SHUTTER D1234		-	2	2	
02-034	+ 2BM14250	SEAL SHUTTER D1234		-	1	1	
02-035	+ 2BM14200	GUIDE SHUTTER D1234		-	1	1	
02-036	+ 2BM14260	SEAL GUIDE T D1234		-	1	1	
02-037	+ 2BM15940	PLATE FEED TK		-	1	1	
02-038	+ 2BM42310	SEAL FEED TK D		-	1	1	
02-039	+ 2BM15950	SEAL FEED TK A		-	2	2	
02-040	+ 2BM15930	SCREW FEED TK		-	1	1	
02-041	+ 2BM42250	GEAR FEED TK Z23		-	1	1	
02-042	+ 2BM42220	BUSH SCREW TK F		-	1	1	
02-043	+ 2BM42240	BKT SEAL OIL		-	1	1	
02-044	+ 4AK73480	SEAL TONER A		-	1	1	
02-045	+ 2BM14640	GUIDE SCREW D14		-	1	1	

WWW.SERVICE-MANUAL.NET

Ref. No.	Part Code	Description	Applicable Model	SP	120V	230V	Remarks
02-046	+ 2BM15960	SEAL FEED TK B		-	1	1	
02-047	+ 2BM15970	SEAL FEED TK C		-	2	2	
02-048	+ 2BM15960	SEAL FEED TK B		-	1	1	
02-049	+ 2BM15920	BUSH FEED TK		-	2	2	
02-050	+ 2BM15910	CASE FEED TK		-	2	2	
02-051	+ 2BM42280	CUT WASHER		-	1	1	
02-052	+ 2BM40060	CUT WASHER		-	1	1	
02-053	2BM02070	FRAME REAR		-	1	1	
02-054	2BM02440	BUSH PIN OVAL		X	2	2	
02-055	2BM02430	BUSH PIN		X	1	1	
02-056	2BM02150	PLATE HV IM		-	1	1	
02-057	2BM02140	COVER HV IMAGE		-	1	1	
02-058	2BM02160	SPRING HV S		-	2	2	
02-059	2BM02110	PIN CONTACT HV		-	4	4	
02-060	2BM02170	COVER HV FEED		-	1	1	
02-062	2BM02180	PLATE HV TC		-	1	1	
02-063	2CK68050	TONER SENSOR ASSY		X	1	1	
02-064	+ 2CK02220	BKT SENSOR WASTE A		-	1	1	
02-065	+ 2BM01230	P.W.BOARD KP-849 ASSY	W TONER	-	1	1	
02-066	+ 2BM28780	CONN.CORD T.SENSOR ASSY		-	1	1	
02-067	2BM02080	COVER HV DRUM		-	1	1	
02-068	2BM02120	SPRING HV L		-	2	2	
02-069	2BM02090	PLATE HV D1		-	1	1	
02-070	2BM02100	PLATE HV D2		-	1	1	
02-071	2BM42030	BRACKET CONN DRUM		-	2	2	
02-072	2BM42440	SPRING CONN DRUM		-	2	2	
02-073	2BM02210	SCREW CONNECTOR		-	10	10	
02-074	2CK02250	BKT CONN D12 A		-	1	1	
02-075	2CK02240	SPRING CONN DLP		-	8	8	
02-076	2CK02260	BKT CONN D34 A		-	2	2	
02-078	2BM42450	STUD SCREW 485		-	4	4	
02-079	2BM42010	SPRING CONN FEED		-	4	4	
02-080	2BM02490	PLATE ANCHOR A		-	1	1	
02-082	2CK00380	TUBE TONER D4 ASSY		X	1	1	
02-083	2CK00540	DUCT WASTE TONER UNIT A		X	1	1	
02-084	2BM01270	P.W.BOARD KP-896 ASSY	K TONER LOW	X	1	1	
02-085	2BM42260	BKT SENSOR LOW D4		-	1	1	
02-086	2BM02890	COVER HV DLP		-	1	1	
02-087	2CK28190	PWB HV DLP		X	1	1	
02-088	2BM02780	RAIL IMAGE R		-	1	1	
02-089	2BM42040	STOPPER IMAGE		X	1	1	

WWW.SERVICE-MANUAL.NET



Ref. No.	Part Code	Description	Applicable Model	SP	120V	230V	Remarks
02-090	2BM02790	BRACKET LOCK IMAGE		-	1	1	
02-091	2BM02810	PULLEY IMAGE		X	1	1	
02-092	2BM02800	LEVER LOCK IMAGE		X	1	1	
02-093	2BM02820	SPRING LOCK IMAGE		-	1	1	
02-094	2BM02630	STAY RAIL LOW R A		-	1	1	
02-095	2CK02130	SLIDE RAIL LOW		-	2	2	
02-096	2BM02640	STAY RAIL LOW R B		-	1	1	
02-097	2CK02190	SHIELD REG SENSOR A		-	1	1	
02-098	2BM02650	STAY RAIL LOW L A		-	1	1	
02-099	2BM02660	STAY RAIL LOW L B		-	1	1	
02-100	2BM02570	GUIDE PAPER OUT		-	1	1	
02-101	2BM02560	GUIDE PAPER IN		-	1	1	
02-102	2CK02040	FRAME BASE		-	1	1	
02-105	2BM02520	LOCK PIN		-	1	1	
02-106	2BM02930	HOLDER FRONT		-	2	2	
02-107	2BM02860	STAY BASE R		-	1	1	
02-109	2BM02870	STAY BASE L		-	1	1	
02-111	2BM42290	FOOT R		X	2	2	
02-112	2BM02550	PLATE EARTH LOWER		-	1	1	
02-113	2BM42740	SHIELD REG SENSOR B		-	1	1	
02-114	2CK02120	FRAME FRONT		-	1	1	
02-115	2BM02030	STAY RAIL FRONT		-	1	1	
02-116	2BM02020	CHANNEL BOTTOM		-	1	1	
02-118	2BM42300	FOOT F		X	2	2	
02-119	2CK02010	SHEET INNER FRONT		-	1	1	
02-120	2BM04310	INNER FRONT COVER		-	1	1	
02-121	60804120	MAGNET CATCH		-	2	2	
02-122	2BM02060	LEVER INTER LOCK		-	1	1	
02-123	2CK27590	INTERLOCK SWITCH		X	1	1	
02-124	2CK02140	SLIDE RAIL PRO		-	2	2	
02-125	2BM02710	GUIDE CONTAINER D4		-	1	1	
02-126	2BM02680	STAY PRO R ASSY		-	1	1	
02-127	2BM02690	STAY RAIL PRO R B		-	1	1	
02-128	2BM02730	SUPPORT PULLEY TRANS		-	1	1	
02-129	2BM02740	PULLEY IMAGE L		X	1	1	
02-130	2BM02720	BKT PULLEY IMAGE		-	1	1	
02-131	2BM02750	STAY RAIL PRO L A		-	1	1	
02-132	2BM02760	STAY RAIL PRO L B		-	1	1	
02-133	2CK02170	SEAL RAIL PRO B		-	2	2	
02-134	2BM42620	SEAL STAY PRO A		-	1	1	
02-135	2BM02850	PLATE SCANNER BASE		-	1	1	

Ref. No.	Part Code	Description	Applicable Model	SP	120V	230V	Remarks
02-136	2BM42270	BKT SENSOR UP D4		-	1	1	
02-137	2BM01260	P.W.BOARD KP-895 ASSY	K TONER UP	X	1	1	
02-138	2BM42550	PLATE EARTH DRV TK B		-	1	1	
	2BM02960	SPONG REAR		-	1	1	
02-201	2CK02060	FRAME REAR PROCESS		-	1	1	
02-202	2CK02160	PIN REAR PROCESS		-	1	1	
02-203	2BM08540	STAY ACCURIDE PRO R		-	1	1	
02-204	2BM08550	COVER BOTTOM PROCESS		-	1	1	
02-205	2BM08610	PRESS ARM D4		-	2	2	
02-206	2BM08620	SPRING D4 PROCESS		-	2	2	
02-207	2BM08530	STAY PROCESS BASE		-	1	1	
02-208	2BM02830	COVER LEFT PROCESS		-	1	1	
02-209	2BM08510	FRAME FRONT PROCESS		-	1	1	
02-210	2BM42430	LOCK PROCESS R		X	1	1	
02-211	2BM08600	TP SCREW		X	2	2	
02-212	2BM02990	PLATE LOCK R		-	1	1	
02-214	2BM02980	PLATE LOCK L		-	1	1	
02-215	2BM08590	LOCK PROCESS		X	1	1	
02-216	2BM08570	LOCK MCH		-	1	1	
02-217	2BM08580	SPRING LOCK MCH		-	1	1	
02-218	2BM05220	LABEL CLEANER		-	1	1	
02-219	2BM02840	SCREW PROCESS		-	4	4	
02-220	2BM42660	SPRING FRAME PRO		-	4	4	

### 3. Drive Unit (03-)

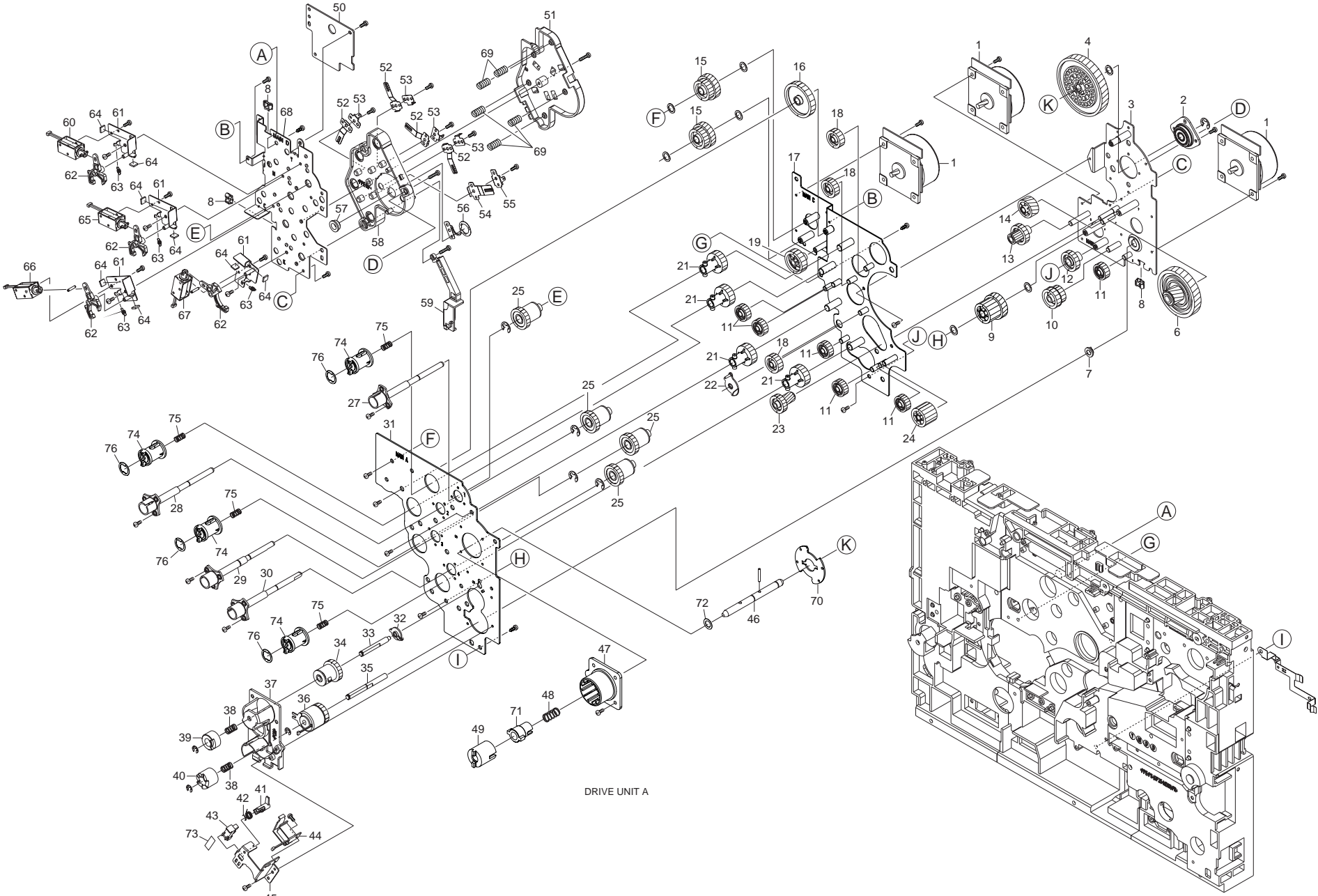

DRIVE UNIT A

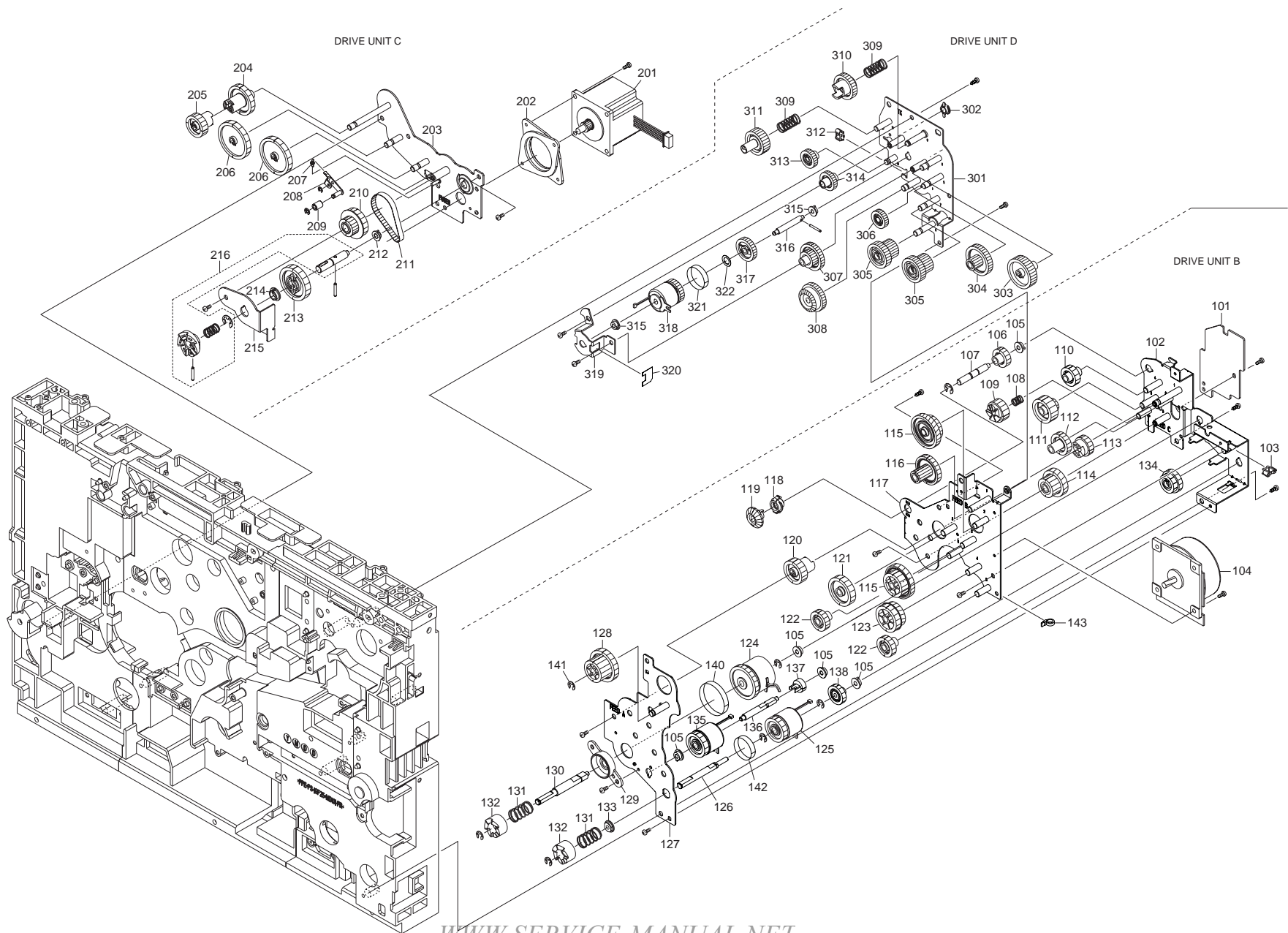

WWW.SERVICE-MANUAL.NET

## List 3 - Drive Unit (03-)

Ref. No.	Part Code	Description	Applicable Model	SP	120V	230V	Remarks
	2CK93180	DR-803A DRIVE UNIT A		X	1	1	
03-001	+ 2BM27690	MOTOR MAIN		X	3	3	
03-002	+ 2BM22200	HOLDER ASSY B		X	1	1	
03-003	+ 2BM22020	PLATE DRIVE MAIN B		-	1	1	
03-004	+ 2BM23870	GEAR Z144H BT		X	1	1	
03-005	+ 2BM27700	MOTOR DLP		X	2	2	
03-006	+ 2BM22060	GEAR Z36H Z117H		X	1	1	
03-007	+ 2BM22360	BUSH 6-9-4		X	1	1	
03-008	+ M2104260	EDGING EDS-0607U		-	3	3	
03-009	+ 2CK22060	GEAR Z30 Z58H		X	1	1	
03-010	+ 2BM22090	GEAR Z25 Z29		X	1	1	
03-011	+ 2BM22170	GEAR Z23 IDLE		X	6	6	
03-012	+ 2BM22100	GEAR Z29 IDLE		X	1	1	
03-013	+ 2BM22160	GEAR Z14 Z29		X	1	1	
03-014	+ 2BM22140	GEAR Z43H		X	1	1	
03-015	+ 2CK22070	GEAR Z30 Z57H		X	2	2	
03-016	+ 2BM23760	GEAR Z53		X	1	1	
03-017	+ 2CK22050	PLATE DRIVE MAIN C		-	1	1	
03-018	+ 2BM22110	GEAR Z26 IDLE		X	3	3	
03-019	+ 2BM23750	GEAR Z34		X	1	1	
03-021	+ 2CK22020	GEAR Z30 JOINT MIX		X	4	4	
03-022	+ 2BM23800	BUSH MAIN C		X	1	1	
03-023	+ 2BM22150	GEAR Z21H Z26		X	1	1	
03-024	+ 2BM22180	GEAR Z28		X	1	1	
03-025	+ 2CK22130	CLUTCH ASSY 2		X	4	4	
03-027	+ 2CK22150	HOLDER ASSY CHY		X	1	1	
03-028	+ 2CK22160	HOLDER ASSY CHM		X	1	1	
03-029	+ 2CK22170	HOLDER ASSY CHC		X	1	1	
03-030	+ 2CK22140	HOLDER ASSY CHK		X	1	1	
03-031	+ 2CK22030	PLATE DRIVE MAIN A		-	1	1	
03-032	+ 2BM22270	BUSH CL CAM		X	1	1	
03-033	+ 2BM22420	SHAFT JOINT CAM		-	1	1	
03-034	+ 2BM22280	CLUTCH ASSY CAM		X	1	1	
03-035	+ 2BM22430	SHAFT JOINT SCREW		-	1	1	
03-036	+ 2BM27630	CLUTCH 26-C		X	1	1	
03-037	+ 2BM22260	HOUSING CL CAM		-	1	1	
03-038	+ 2BM22460	SPRING JOINT CAM		-	2	2	
03-039	+ 2BM22330	JOINT CAM		X	1	1	
03-040	+ 2BM22320	JOINT ROLL SCREW		X	1	1	

WWW.SERVICE-MANUAL.NET

Ref. No.	Part Code	Description	Applicable Model	SP	120V	230V	Remarks
03-041	+ 2BM22350	ACTUATOR CAM		-	1	1	
03-042	+ 2BM22470	SPRING ACTUATOR		-	1	1	
03-043	+ 2BM27240	PT.SENSOR GP1S74P		X	1	1	
03-044	+ 2BM27640	SOLENOID CAM		X	1	1	
03-045	+ 2BM22380	PLATE SENSOR		-	1	1	
03-046	+ 2CK22430	SHAFT JOINT DRUM A		-	1	1	
03-047	+ 2CK22180	HOLDER ASSY A		X	1	1	
03-048	+ 2BM23910	SPRING JOINT DRUM BT		-	1	1	
03-049	+ 2BM23900	JOINT DRUM BT		-	1	1	
03-050	+ 2BM01170	P.W.BOARD KP-824 ASSY DRIVE A		X	1	1	
03-051	+ 2BM22500	LID HV UNIT		-	1	1	
03-052	+ 2BM22510	EARTH DLP		-	4	4	
03-053	+ 2BM22530	PLATE HV JOINT		-	4	4	
03-054	+ 2BM22520	EARTH DRUM		-	1	1	
03-055	+ 2BM22540	PLATE HV DRUM		-	1	1	
03-056	+ 2BM23810	EARTH DRUM T1		-	1	1	
03-057	+ 84363280	METAL BUSH KD		X	1	1	
03-058	+ 2BM22490	CASE HV JOINT DLP		-	1	1	
03-059	+ 2BM23730	HOLDER HARNESS D		-	1	1	
03-060	+ 2BM27650	SOLENOID Y		X	1	1	
03-061	+ 2BM22370	PLATE SOLENOID		-	4	4	
03-062	+ 2BM22340	LEVER SOLENOID		-	4	4	
03-063	+ 2BM22440	SPRING LEVER		-	4	4	
03-064	+ 2BM22480	SEAL SOLENOID		-	8	8	
03-065	+ 2BM27660	SOLENOID M		X	1	1	
03-066	+ 2BM27670	SOLENOID C		X	1	1	
03-067	+ 2BM27680	SOLENOID K		X	1	1	
03-068	+ 2BM22040	PLATE DRIVE MAIN D		-	1	1	
03-069	+ 2BM23780	SPRING HV		-	5	5	
03-070	+ 2BM23860	PLATE GEAR Z144H BT		-	1	1	
03-071	+ 2BM23890	JOINT GEAR BT		-	1	1	
03-072	+ 2CK22210	WASHER DRIVE SHAFT		-	1	1	
03-073	+ 2BM17990	STOPPER PI		-	1	1	
03-074	+ 2CK22010	JOINT MIX		-	4	4	
03-075	+ 2CK22040	SPRING JOINT MIX		-	4	4	
03-076	+ 2CK22080	RING JOINT MIX		-	4	4	
	2CK93190	DR-803B DRIVE UNIT B		X	1	1	
03-101	+ 2CK01150	DVF KP-1011 ASSY		X	1	1	
03-102	+ 2CK22360	PLATE DRIVE FEED C		-	1	1	
03-103	+ M2104260	EDGING EDS-0607U		-	1	1	

Ref. No.	Part Code	Description	Applicable Model	SP	120V	230V	Remarks
03-104	+ 2BM27690	MOTOR MAIN		X	1	1	
03-105	+ 2BM07330	BUSH METAL		X	3	3	
03-106	+ 2CK22410	GEAR Z22 JOINT BE		X	1	1	
03-107	+ 2BM22830	SHAFT JOINT BEVEL		-	1	1	
03-108	+ 2BM22850	SPRING JOINT LOW		-	1	1	
03-109	+ 2BM22660	GEAR Z25 JOINT		X	1	1	
03-111	+ 2BM22630	GEAR Z14 Z30		X	1	1	
03-112	+ 2BM22620	GEAR Z26		X	1	1	
03-113	+ 2BM22640	GEAR Z23 JO		X	1	1	
03-114	+ 2BM22650	GEAR Z33 Z23		X	1	1	
03-115	+ 2BM22580	GEAR Z30 Z66H		X	2	2	
03-116	+ 2BM22700	GEAR Z14 Z36		X	1	1	
03-117	+ 2CK22350	PLATE DRIVE FEED B		-	1	1	
03-118	+ 2BM22760	BUSH SHAFT 6		X	1	1	
03-119	+ 2BM22680	GEAR BEVEL Z20		X	1	1	
03-120	+ 2BM22740	GEAR Z29 JO		X	1	1	
03-121	+ 2BM22610	GEAR Z36		X	1	1	
03-122	+ 2BM22600	GEAR Z24		X	2	2	
03-123	+ 2BM22590	GEAR Z33 Z47H		X	1	1	
03-124	+ 2CK27580	CLUTCH REGIST 8		X	1	1	
03-125	+ 2BM27760	CLUTCH 26-A		X	1	1	
03-126	+ 2CK22370	SHAFT JOINT MID		-	1	1	
03-127	+ 2CK22340	PLATE DRIVE FEED A		-	1	1	
03-128	+ 2BM22710	GEAR Z27 Z40		X	1	1	
03-129	+ 2BM22750	HOUSING CL REGIST		-	1	1	
03-130	+ 2CK22390	SHAFT JOINT REGIST		-	1	1	
03-131	+ 2BM22840	SPRING JOINT REGIST		-	2	2	
03-132	+ 2BM22790	JOINT ROLL REGIST		X	2	2	
03-133	+ 2BM14060	BUSH CLUTCH D1234		X	1	1	
03-137	+ 2CK22300	GEAR Z14		X	1	1	
03-134	+ 2CK22320	GEAR Z22 Z27		X	1	1	
03-136	+ 2CK22330	SHAFT CL MID		X	1	1	
03-138	+ 2CK22380	GEAR Z23 BEA ASSY		X	1	1	
03-110	+ 2CK22400	GEAR Z23 S		X	1	1	
03-135	+ 2CK27530	CLUTCH 26-I		X	1	1	
03-140	+ 2BM23840	SEAL CLUTH REG		X	1	1	
03-141	+ 2BM40060	CUT WASHER		X	1	1	
03-142	+ 2BM40150	SEAL CLUTH D1234		X	1	1	
03-143	+ M2109180	WIRE SADDLE,LWS-1S		X	1	1	
	2CK68030	DR-803C DRIVE UNIT C		X	1	1	

Ref. No.	Part Code	Description	Applicable Model	SP	120V	230V	Remarks
03-201	+ 2CK27510	MOTOR STEP		X	1	1	
03-202	+ 2BM23610	HOLDER STMOTOR		-	1	1	
03-203	+ 2BM23510	PLATE DRIVE FUSER A		-	1	1	
03-204	+ 2BM23570	GEAR Z40 JO		X	1	1	
03-205	+ 2BM22740	GEAR Z29 JO		X	1	1	
03-206	+ 2BM23560	GEAR Z51		X	2	2	
03-207	+ 2BM22440	SPRING LEVER		-	1	1	
03-208	+ 2BM23530	PLATE PULLEY		-	1	1	
03-209	+ 2BM23580	PULLEY BELT		X	1	1	
03-210	+ 2BM23540	GEAR P50 Z23		X	1	1	
03-211	+ 2BM23630	BELT S2M138		X	1	1	
03-212	+ 84363285	BUSHING SBK		X	1	1	
03-213	+ 2BM23550	GEAR Z46 JOINT FUSER		X	1	1	
03-214	+ 84395640	BUSH MAG		X	1	1	
03-215	+ 2BM23520	HOLDER SHAFT FUSER		-	1	1	
03-216	+ 2BM68240	SHAFT JOINT FUSER ASSY		X	1	1	
	2CK93200	DR-803D DRIVE UNIT D		X	1	1	
03-301	+ 2BM22860	PLATE DRIVE TK		-	1	1	
03-302	+ 2BM22770	BUSH POM MID		X	1	1	
03-303	+ 2BM22940	GEAR Z41		X	1	1	
03-304	+ 2BM22930	GEAR Z14 Z40		X	1	1	
03-305	+ 2BM22910	GEAR Z23 Z33		X	2	2	
03-306	+ 2BM23690	GEAR Z23 TK1		X	1	1	
03-307	+ 2BM22920	GEAR Z21 Z36		X	1	1	
03-308	+ 2BM23710	GEAR Z37 BEVEL Z25		X	1	1	
03-309	+ 2BM22990	SPRING JOINT TK		-	2	2	
03-310	+ 2BM22890	JOINT SCRAPER TK		X	1	1	
03-311	+ 2BM22880	JOINT TK FEED		X	1	1	
03-312	+ M2104260	EDGING EDS-0607U		-	1	1	
03-313	+ 2BM23700	GEAR Z23 TK2		X	1	1	
03-314	+ 2BM22950	GEAR Z24 L		X	1	1	
03-315	+ 2BM07330	BUSH METAL		X	2	2	
03-316	+ 2BM22980	SHAFT JOINT TK		-	1	1	
03-317	+ 2BM22970	GEAR Z30 CL TK		X	1	1	
03-318	+ 2BM27950	CLUTCH 26-G		X	1	1	
03-319	+ 2BM22870	HOLDER CL TK		-	1	1	
03-320	+ 2CK22420	SEAL TK		-	1	1	
03-321	+ 2BM23920	SEAL CLUTCH TK		-	1	1	
03-322	+ C2893950	SHIM 6.2-0.25T		-	1	1	



## 4. Controller Box (04-)

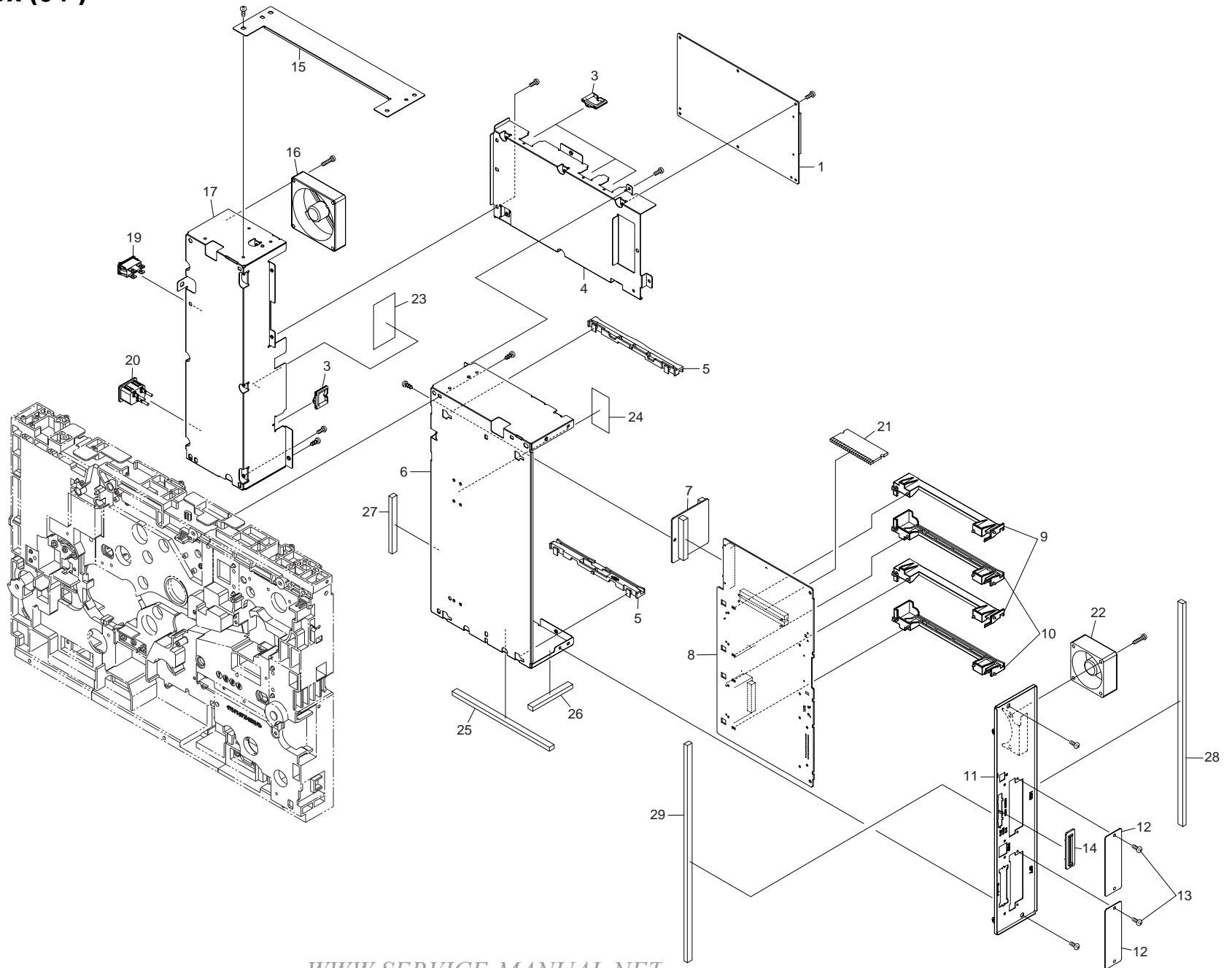

WWW.SERVICE-MANUAL.NET

## List 4 - Controller Box

Ref. No.	Part Code	Description	Applicable Model	SP	120V	230V	Remarks
04-001	2CK01060	ECU KP-992 ASSY E	Incl. KMTW	X	-	1	
04-001	2CK01270	ECU KP-992 ASSY U	Excl. KMTW	X	1	-	
04-003	M2104220	EDGING EDS-1717U		-	4	4	
04-004	2CK26050	BOX ENGINE		-	1	1	
04-005	2BM26050	RAIL PWB		-	2	2	
04-006	2CK26060	BOX CONTROLLER ASSY		-	1	1	
04-007	2CK01070	RER KP-993 ASSY		X	1	1	
04-008	2CK01300	P.W.BOARD ASSY	MAIN KP-991	X	1	1	
04-009	2BL26210	RAIL OPTION A		-	2	2	
04-010	2BL26220	RAIL OPTION B		-	2	2	
04-011	2CK26010	PANEL CONTROLLER		-	1	1	
04-012	84363345	PLATE OPTION		-	2	2	
04-013	84393785	SCREW OP		X	4	4	
04-014	84395650	GUIDE CF CARD		-	1	1	
04-015	2BM42510	PLATE CONTROLLER A		-	1	1	
04-016	2CK27630	FAN PSU		X	1	1	
04-018	2CK01250	POWER SUPPLY 200 UNIT		X	-	1	
04-018	2CK01260	POWER SUPPLY 120 UNIT		X	1	-	
04-019	2CK27600	AC SWITCH		X	1	1	
04-020	2CK27220	CONN.CORD PS1-B ASSY		-	1	1	
04-021	2CK01320	P.W.BOARD ASSY	DIMM KP-839	X	1	1	
04-022	2CK26030	FAN MOTOR		X	1	1	
04-023	2BM26220	SEAL BOX C		-	1	1	
04-024	2CK26070	SEAL EARTH PWB		-	1	1	
04-025	2CK27680	SHIELD FORM GASKET L		-	1	1	
04-026	2BM26200	SHIELD FORM GASKET		-	1	1	
04-027	2BM26210	SHIELD FORM GASKET 7		-	1	1	
04-028	2BM26160	SHIELD FORM GASKET 1		-	1	1	
04-029	2BM26180	SHIELD FORM GASKET 3		-	1	1	

# 5. Paper Feed Unit (05-)

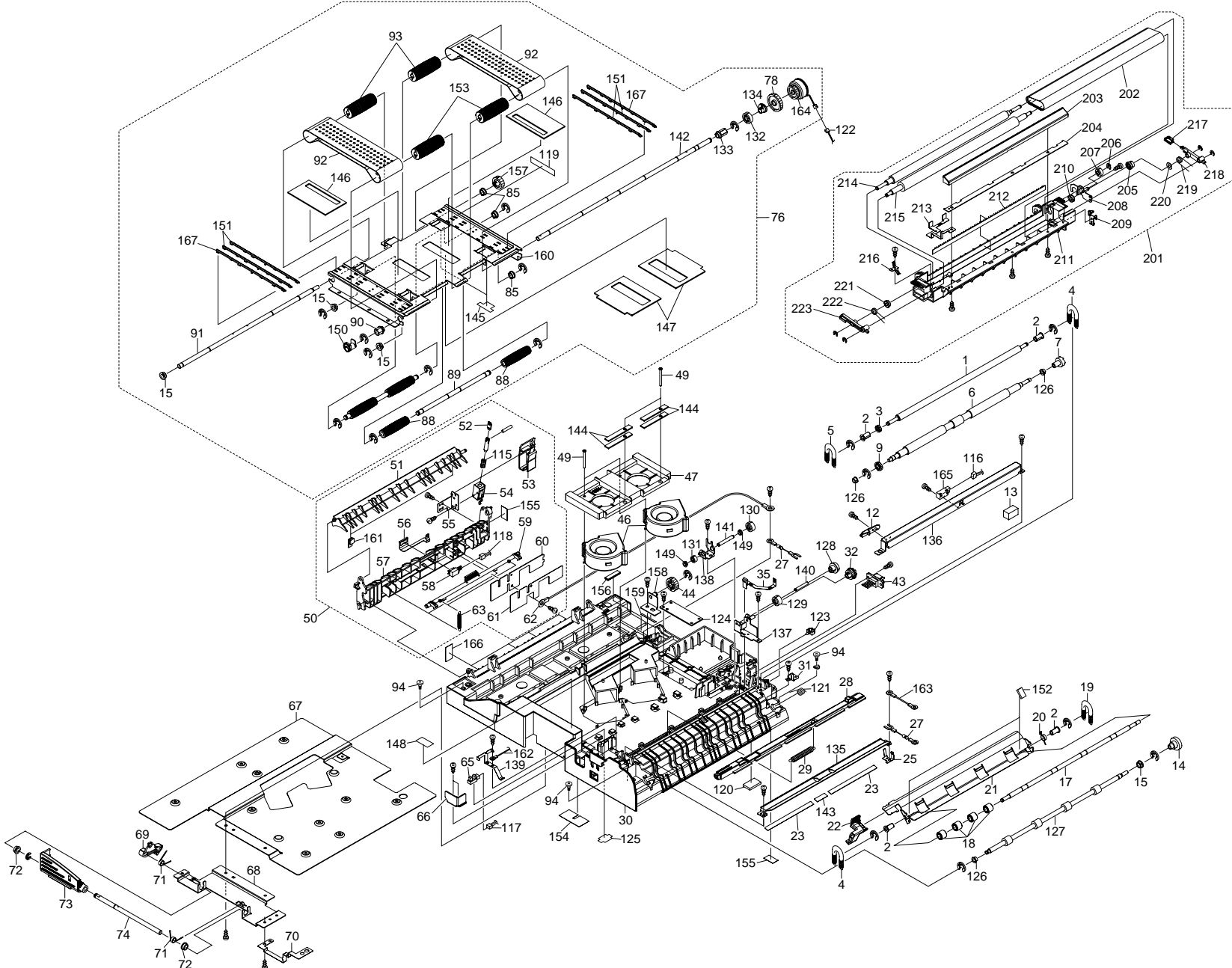

## List 5 - Paper Feed Unit (05-)

Ref. No.	Part Code	Description	Applicable Model	SP	120V	230V	Remarks
	2CK93160	FE-803 FEED UNIT		X	1	1	
05-001	+ 2BM17400	ROLLER REGIST UP		X	1	1	
05-002	+ 2BM17330	BUSH REGIST UP		X	4	4	
05-003	+ 2BM17950	GEAR REGIST Z24		X	1	1	
05-004	+ 2BM17350	SPRING MIDDLE F		X	2	2	
05-005	+ 2BM17420	SPRING REGIST F		X	1	1	
05-006	+ 2BM17370	ROLLER REGIST LOW		X	1	1	
05-007	+ 2BM17390	JOINT ROLL TRANS		X	1	1	
05-009	+ 2BM17380	GEAR REGIST Z32		X	1	1	
05-012	+ 2BM43010	SLOPE IMAGE UNIT		-	1	1	
05-013	+ 2BM17440	PAD REG SENSOR		-	1	1	
05-014	+ 2BM17930	LATCH JOINT		X	1	1	
05-015	+ 84363280	METAL BUSH KD		X	4	4	
05-017	+ 2BM17300	SHAFT PULLEY MIDDLE		-	1	1	
05-018	+ 2BM17310	PULLEY MIDDLE		X	4	4	
05-019	+ 2BM17360	SPRING MIDDLE R		X	1	1	
05-020	+ 2BM17340	SPRING GUIDE MIDDLE		-	1	1	
05-021	+ 2BM17290	GUIDE MIDDLE		-	1	1	
05-022	+ 2BM17320	LEVER GUIDE MIDDLE		-	1	1	
05-023	+ 2BM17500	SHEET REGIST B		X	2	2	
05-025	+ 2BM17460	PLATE EARTH REG A		-	1	1	
05-027	+ 2BM17480	HIGH-MEG R ASSY		X	2	2	
05-028	+ 2BM17120	PLATE RELEASE		-	1	1	
05-029	+ 2BM17130	SPRING RELEASE		-	1	1	
05-030	+ 2BM17013	CASE LOW		-	1	1	
05-031	+ 2BM17970	PLATE EARTH FEED		-	1	1	
05-032	+ 2BM17260	GEAR JOINT Z22S		X	1	1	
05-035	+ 2BM17090	PLATE CONTACT TRANS		-	1	1	
05-043	+ 2BM27260	CONN CORD FEED2 ASSY		X	1	1	
05-044	+ 2CK17420	GEAR Z23S		X	1	1	
05-046	+ 2BM27230	FAN BELT		X	2	2	
05-047	+ 2CK17750	DUCT FEED WIDE		-	1	1	
05-049	+ 2BM17960	SCREW FAN BELT		-	4	4	
05-062	+ 2BM27940	CONN.CORD EXIT JAM DU		-	1	1	
05-065	+ 2BM27240	PT.SENSOR GP1S74P		X	1	1	
05-066	+ 2BM43060	PLATE SUPPORT FEED		-	1	1	
05-067	+ 2BM17020	PLATE BOTTOM FEED		-	1	1	
05-068	+ 2BM17030	PLATE FRONT LEVER		-	1	1	
05-069	+ 2BM17060	HOOK LEVER FRONT		X	1	1	

WWW.SERVICE-MANUAL.NET

Ref. No.	Part Code	Description	Applicable Model	SP	120V	230V	Remarks
05-070	+	2BM43070	PLATE EARTH BOTTOM	-	1	1	
05-071	+	2BM17070	SPRING FRONT LEVER	-	2	2	
05-072	+	84365850	BUSH POM	X	2	2	
05-073	+	2BM17050	LEVER FEED FRONT	X	1	1	
05-074	+	2BM17040	SHAFT FRONT LEVER	-	1	1	
05-094	+	2BM02920	SCREW FEED UNIT	-	3	3	
05-116	+	2BM27200	CONN.CORD REG ASSY	-	1	1	
05-117	+	2BM27250	CONN CORD FEED1 ASSY	-	1	1	
05-120	+	2BM43040	PAD BOTTOM FEED	-	1	1	
05-121	+	2BM43050	SPRING EARTH FEED	-	1	1	
05-122	+	2BM44060	CONN. CORD FEED CL ASSY	-	1	1	
05-123	+	M2105740	MINIATURE CLAMP,UAMS-05S-2	-	1	1	
05-124	+	2CK01160	FED KP-1013 ASSY	X	1	1	
05-125	+	2CK02030	STOPPER PI	-	1	1	
05-126	+	2CK16010	BUSH CONDUCTIVE	X	3	3	
05-127	+	2CK17010	ROLLER MIDDLE	X	1	1	
05-128	+	2CK17020	GEAR Z22S-Z14S	X	1	1	
05-129	+	2CK17040	GEAR IDLE Z22S	X	1	1	
05-130	+	2CK17060	GEAR IDLE Z26S	X	1	1	
05-131	+	2CK17050	GEAR IDLE Z14S	X	1	1	
05-135	+	2CK17110	GUIDE PAPER REGIST	-	1	1	
05-136	+	2CK17120	PLATE REG SENSOR	-	1	1	
05-137	+	2CK17140	PLATE TC GEAR	-	1	1	
05-138	+	2CK17150	PLATE GEAR IDLE	-	1	1	
05-139	+	2CK17160	PLATE EARTH CASE	-	1	1	
05-140	+	2CK17170	SHAFT TC GEAR	-	1	1	
05-141	+	2CK17180	SHAFT GEAR IDLE	-	1	1	
05-143	+	2CK17200	SHEET REGIST	X	1	1	
05-144	+	2CK17241	SEAL BELT LOW	X	4	4	
05-148	+	2CK17310	LABEL CAUTION TC	-	1	1	
05-149	+	2CK17320	BUSH TC	-	1	1	
05-149	+	2CK17440	SEAL COVER FG	-	1	1	
05-152	+	2CK17370	SHEET MIDDLE	-	1	1	
05-154	+	2CK17390	SEAL FEED FRONT	-	1	1	
05-155	+	2CK17400	SEAL FEED BOTTOM	-	1	1	
05-156	+	2CK17410	TAPE EARTH BELT	-	1	1	
05-158	+	2CK17430	PLATE GEAR FUSER A	-	1	1	
05-161	+	2CK17460	SHEET GUIDE DU	-	1	1	
05-162	+	2CK27280	CONN.CORD EARTH CASE ASSY	-	1	1	
05-163	+	2CK27330	CONN.CORD REGIST EARTH AS	-	1	1	
05-165	+	2CK27650	PT.SENSOR KR1207-KM2	X	1	1	

Ref. No.	Part Code	Description	Applicable Model	SP	120V	230V	Remarks
05-050	+	2BM68160	GUIDE LEFT ASSY	X	1	1	
05-051	++	2BM17151	GUIDE CHANGE DU	-	1	1	
05-052	++	2BM17180	PLATE LEVER SOL	-	1	1	
05-053	++	2BM17170	HOOK LOCK FUSER	-	1	1	
05-054	++	2BM27160	SOLENOID FEED	X	1	1	
05-055	++	2BM17190	ANGLE SOLENOID	-	1	1	
05-056	++	2BM43100	PLATE DU SENSOR	-	1	1	
05-057	++	2BM17140	GUIDE CASE LOW LEFT	-	1	1	
05-058	++	2BM27170	PT.SENSOR GP2S30	X	1	1	
05-059	++	2BM17160	LEVER LOCK CASE LOW	-	1	1	
05-060	++	2BM17200	COVER GUIDE DU	-	1	1	
05-061	++	2BM43120	REFLECTOR DU SENSOR	-	1	1	
05-062	++	2BM44030	CONN.CORD FEED EARTH ASSY	-	1	1	
05-063	++	2BM17210	SPRING LOCK FUSER	-	2	2	
05-076	+	2CK68040	BELT ASSY	X	1	1	
05-078	++	2BM17620	GEAR Z42S	X	1	1	
05-085	++	84365850	BUSH POM	X	3	3	
05-088	++	2BM17630	PULLEY TENSION BELT	X	4	4	
05-089	++	2CK17790	SHAFT TENSION WIDE	-	2	2	
05-090	++	2BM43080	METAL BUSH TRANS	X	1	1	
05-091	++	2CK17780	SHAFT BELT L-WIDE	-	1	1	
05-092	++	2CK17480	BELT TRANS	X	2	2	
05-093	++	2CK17760	PULLEY BELT L-WIDE	X	2	2	
05-119	++	2BM42760	SEAL SIDE SENS WASTE	-	1	1	
05-133	++	2CK17070	BUSH TRANS UNIT	X	1	1	
05-134	++	2CK17080	CAM TRANS R	X	1	1	
05-142	++	2CK17191	SHAFT BELT R	-	1	1	
05-146	++	2CK17271	SEAL PLATE BELT	X	2	2	
05-147	++	2CK17281	SEAL BELT UP	-	1	1	
05-150	++	2CK17330	CAM TRANS F	X	1	1	
05-151	++	2CK17340	RIB BELT	-	6	6	
05-153	++	2CK17770	PULLEY BELT R-WIDE	X	2	2	
05-157	++	2CK17030	GEAR Z22S	X	1	1	
05-160	++	2CK17490	PLATE BELT WIDE	-	1	1	
05-164	++	2CK27520	CLUTCH SP CAM	X	1	1	
05-167	++	2CK17800	RIB BELT SIDE	-	2	2	
05-201	+	2CK93170	TR-803S SEC TRANSFER UNIT	X	1	1	
05-202	++	2CK17530	BELT SEPARATOR	-	1	1	
05-203	++	2BM17710	GUIDE CHUTE LOW	-	1	1	
05-204	++	2CK17670	PLATE SPACER TC	-	1	1	
05-205	++	2CK17580	GEAR TC Z18S	X	1	1	

Ref. No.	Part Code	Description	Applicable Model	SP	120V	230V	Remarks
05-206	++ 2BC06980	STOPPER 5		X	1	1	
05-207	++ 2CK17570	GEAR TC Z14S		X	1	1	
05-208	++ 2CK17590	PLATE TC JOINT		-	1	1	
05-209	++ 2CK17610	PLATE CONTACT TC		-	1	1	
05-211	++ 2CK17540	HOUSING TRANS		-	1	1	
05-212	++ 2CK17650	ERASER TC		X	1	1	
05-213	++ 2CK17600	PLATE EARTH TC		-	1	1	
05-214	++ 2CK17510	ROLLER TRANSFER D		X	1	1	
05-215	++ 2CK17520	ROLLER TRANSFER U		X	1	1	
05-216	++ 2CK17660	PLATE CONTACT ERASER		-	1	1	
05-217	++ 2BM17740	LEVER TRANS B		X	1	1	
05-218	++ 2CK17560	LEVER TRANS R		X	1	1	
05-219	++ 2CK17630	SPRING TC R		-	1	1	
05-221	++ 2CK17640	BEARING SEPARATOR		X	1	1	
05-222	++ 2CK17620	SPRING TC L		-	1	1	
05-223	++ 2CK17550	LEVER TRANS F		-	1	1	

# 6. Fuser Unit (06-)

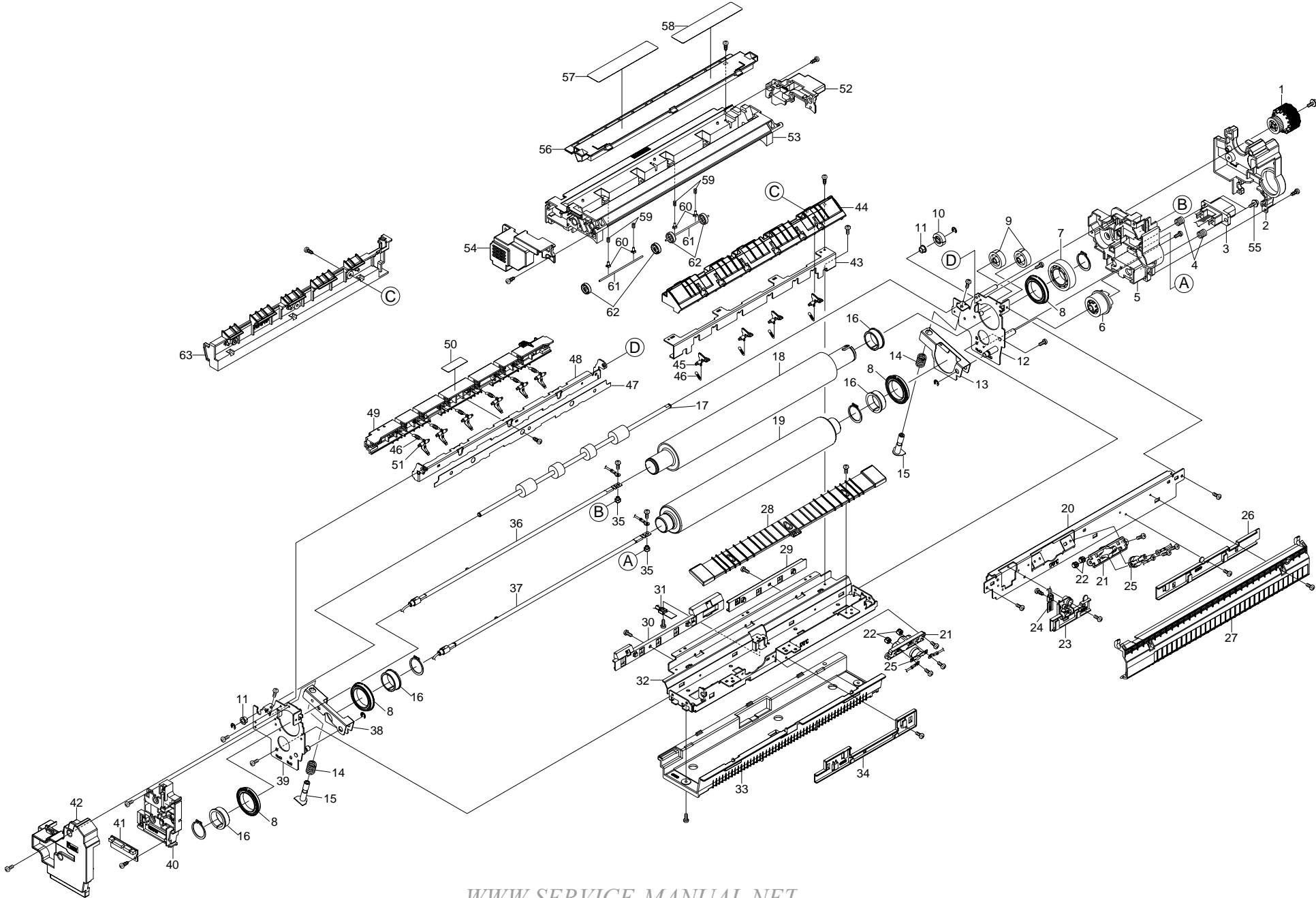



## List 6 - Fuser Unit (06-)

Ref. No.	Part Code	Description	Applicable Model	SP	120V	230V	Remarks
	2CK93130	FK-803(E) FUSER UNIT (E)		X	-	1	
	2CK93140	FK-803(U) FUSER UNIT (U)		X	1	-	
06-001	+ 2BM20500	HANDLE GEAR		X	1	1	
06-002	+ 2BM20380	COVER REAR FUSER		-	1	1	
06-003	+ 2BM27930	CONN.CORD INNER FUSER		-	1	1	
06-004	+ 2BM20430	SPRING CONNECTOR		-	2	2	
06-005	+ 2CK20170	BKT LAMP REAR		-	1	1	
06-006	+ 2CK20110	GEAR INPUT Z30		X	1	1	
06-007	+ 2CK20100	GEAR FUSER Z43		X	1	1	
06-008	+ 2CK20030	BEARING 6806ZNR		X	4	4	
06-009	+ 2CK20220	GEAR FUSER IDLE Z24		X	2	2	
06-010	+ 2BM20520	GEAR EXIT ROLL Z18		X	1	1	
06-011	+ 2CK16010	BUSH CONDUCTIVE		X	2	2	
06-012	+ 2CK20060	FRAME REAR FUSER		-	1	1	
06-013	+ 2CK20080	PLATE PRESS REAR		-	1	1	
06-014	+ 2CK20320	SPRING PRESSURE		X	2	2	
06-015	+ 2CK20120	SHAFT PRESS FUSER		-	2	2	
06-016	+ 2CK20040	BUSH HEAT ROLLER		X	4	4	
06-017	+ 2CK20090	ROLLER EXIT		X	1	1	
06-018	+ 2CK20010	ROLLER HEAT		X	1	1	
06-019	+ 2CK20020	ROLLER PRESS		X	1	1	
06-020	+ 2BM20270	FRAME TOP FUSER		-	1	1	
06-021	+ 2BM20310	BKT THERMOSTAT		-	2	2	
06-022	+ 84395660	NUT FUSER A		-	4	4	
06-023	+ 2BM20290	BKT THERMISTER UP		-	1	1	
06-024	+ 2BM20830	THERMISTOR UP		X	1	1	
06-025	+ 2BM20850	THERMOSTAT		X	2	2	
06-026	+ 2BM20280	HOLDER HERNESS TOP R		-	1	1	
06-027	+ 2CK20190	GUIDE UPPER ENTRANCE		-	1	1	
06-028	+ 2CK20210	GUIDE LOWER EXIT		-	1	1	
06-029	+ 2BM20070	HOLDER HARNESS RR		-	1	1	
06-030	+ 2BM20060	HOLDER HARNESS R.F		-	1	1	
06-031	+ 2BM20840	THERMISTOR LOW		X	1	1	
06-032	+ 2BM20050	FRAME BOTTOM		-	1	1	
06-033	+ 2BM20360	COVER BOTTOM FUSER		-	1	1	
06-034	+ 2BM20080	HOLDER HARNESS LOWER		-	1	1	
06-035	+ 84395675	NUT FUSER		-	2	2	
06-036	+ 2CK20270	LAMP HEATER UP 240		X	-	1	

Ref. No.	Part Code	Description	Applicable Model	SP	120V	230V	Remarks
06-036	+ 2CK20250	LAMP HEATER UP 120		X	1	-	
06-037	+ 2CK20280	LAMP HEATER LOW 240		X	-	1	
06-037	+ 2CK20260	LAMP HEATER LOW 120		X	1	-	
06-038	+ 2CK20070	PLATE PRESS FRONT		-	1	1	
06-039	+ 2CK20050	FRAME FRONT FUSER		-	1	1	
06-040	+ 2CK20160	BKT LAMP FRONT		-	1	1	
06-041	+ 2CK01080	FSR KP-997 ASSY		-	1	1	
06-042	+ 2CK20180	COVER FRONT FUSER		-	1	1	
06-043	+ 2CK20150	STAY LOWER SEPARATOR		-	1	1	
06-045	+ 2BM20210	SEPARATOR LOW		X	4	4	
06-046	+ 2CK20340	SPRING SEPARATOR		X	6	6	
06-046	+ 2BM20260	SPRING SEPARATOR		X	4	4	
06-047	+ 2CK20330	SHEET PROTECT STAY		-	1	1	
06-048	+ 2CK20140	STAY UPPER SEPARATOR		-	1	1	
06-049	+ 2BM20220	BKT SEPARATOR UP		-	1	1	
06-050	+ 2BM42710	LABEL CAUTION S		-	1	1	
06-051	+ 2BM20240	SEPARATOR UP		X	6	6	
06-052	+ 2CK20550	COVER REAR FIX CLN		-	1	1	
06-053	+ 2CK20530	COVER UPPER FUSER		-	1	1	
06-054	+ 2CK20540	COVER FRONT FIX CLN		-	1	1	
06-055	+ 2BM41080	STUD SCREW 465		X	2	2	
06-056	+ 2CK20560	LID FUSER CLN		-	1	1	
06-057	+ 2CK20300	LABEL OPERATE FUSER		-	1	1	
06-058	+ 2BM05090	LABEL CAUTION FUSER		-	1	1	
06-059	+ 2BM20790	SPRING EXIT		-	4	4	
06-060	+ 2BM20610	BUSH SP		X	4	4	
06-061	+ 84395665	SHAFT EXIT		-	2	2	
06-062	+ 84394400	PULLEY EXIT		X	4	4	
06-063	+ 2BM20390	COVER EXIT FUSER		-	1	1	

# 7. Drum Unit (07-)

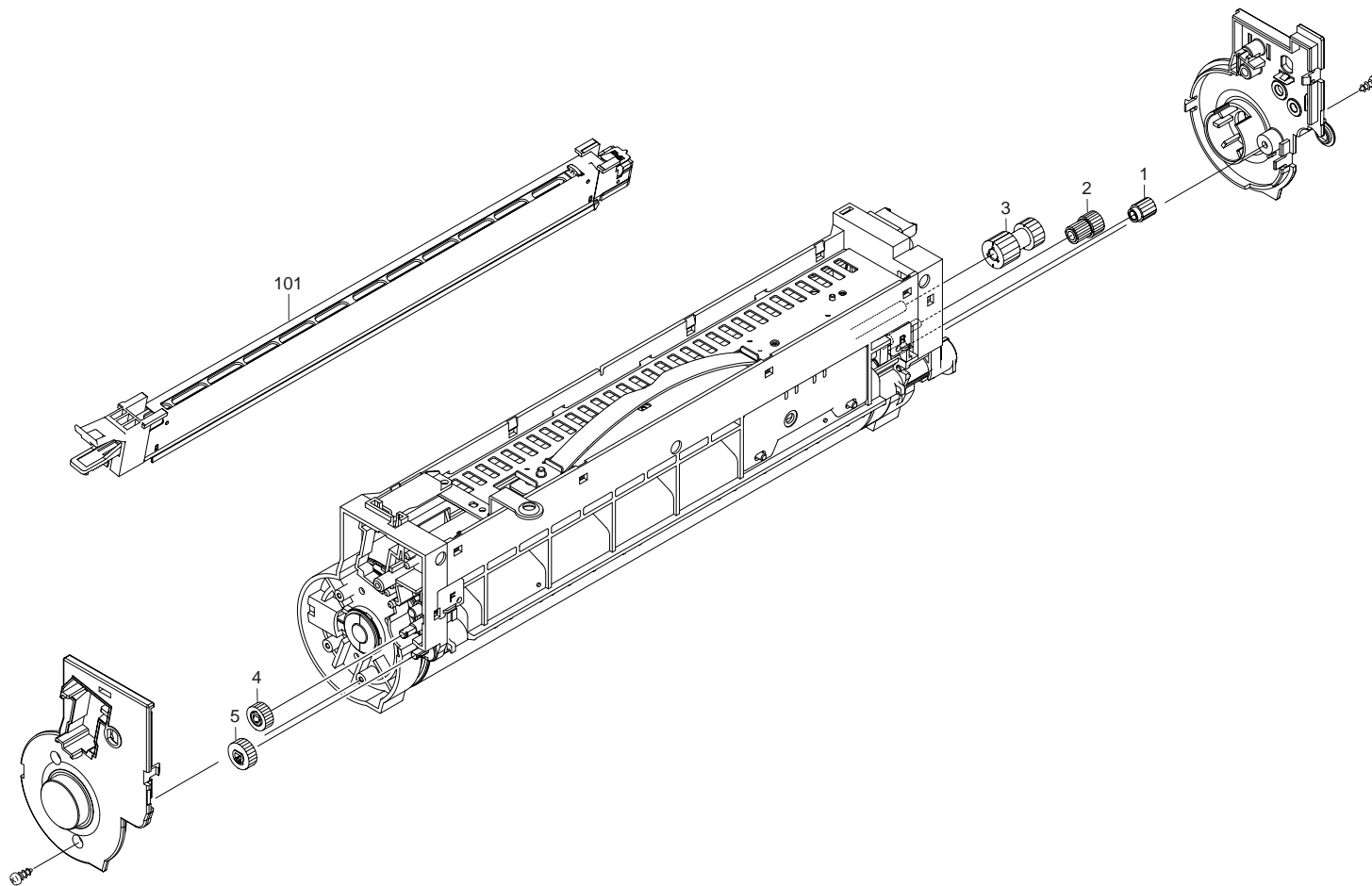

**List 7 - Drum Unit (07-)**

Ref. No.	Part Code	Description	Applicable Model	SP	120V	230V	Remarks
	2CK93010	DK-803 DRUM UNIT		X	1	1	
07-001	+ 2BM18080	GEAR Z17H CLN		X	1	1	
07-002	+ 2BM18380	GEAR Z17HZ22H IDLE		X	1	1	
07-003	+ 2BM19140	GEAR Z28HZ28H DRUM BT		X	1	1	
07-004	+ 2BM18140	GEAR Z16S CLN		X	1	1	
07-005	+ 2BM18130	GEAR Z18S SCREW		X	1	1	
07-101	+ 2CK93230	MC-803 MAIN CHARGER ASSY		X	1	1	

## 8. Developer Unit — Y (08Y-)

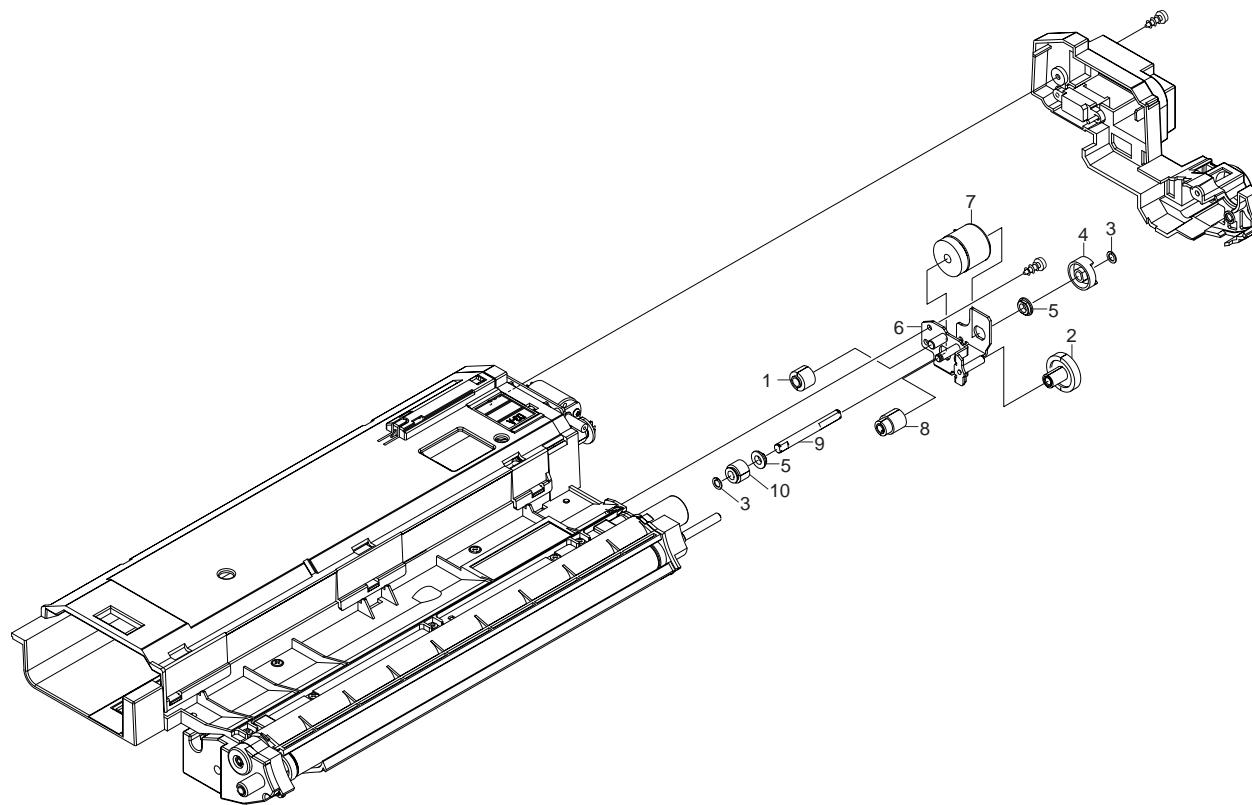

**List 8 - Developer Unit — Y (08Y-)**

Ref. No.	Part Code	Description	Applicable Model	SP	120V	230V	Remarks
	2CK93030	DV-803Y DEVELOPER YELLOW		X	1	1	
08Y-001	+ 2CK14240	SHAFT GEAR D12		X	1	1	
08Y-002	+ 2BM40060	CUT WASHER		X	2	2	
08Y-003	+ 2CK14300	JOINT D1234		X	1	1	
08Y-004	+ 2BM14060	BUSH CLUTCH D1234		X	2	2	
08Y-005	+ 2BM14530	BUSH		X	1	1	
08Y-006	+ 2CK14020	BKT CLUTCH D1		X	1	1	
08Y-007	+ 2BM27350	CLUTCH 26-D		X	1	1	
08Y-008	+ 2CK14430	GEAR Z14-8 JOINT D12		X	1	1	
08Y-009	+ 2CK14250	GEAR Z30H-Z17H D12		X	1	1	
08Y-010	+ 2CK14290	GEAR Z15-Z10 D123		X	1	1	
08Y-011	+ 2CK14310	SHAFT CLUTCH D1234		X	1	1	
08Y-012	+ 2CK14330	GEAR Z14D-8 D1234		X	1	1	
08Y-013	+ 2CK14280	GEAR Z15-8 D123		X	1	1	
08Y-014	+ 2CK14060	BUSH BKT CLUTCH D1		X	1	1	

## 9. Developer Unit — M (08M-)

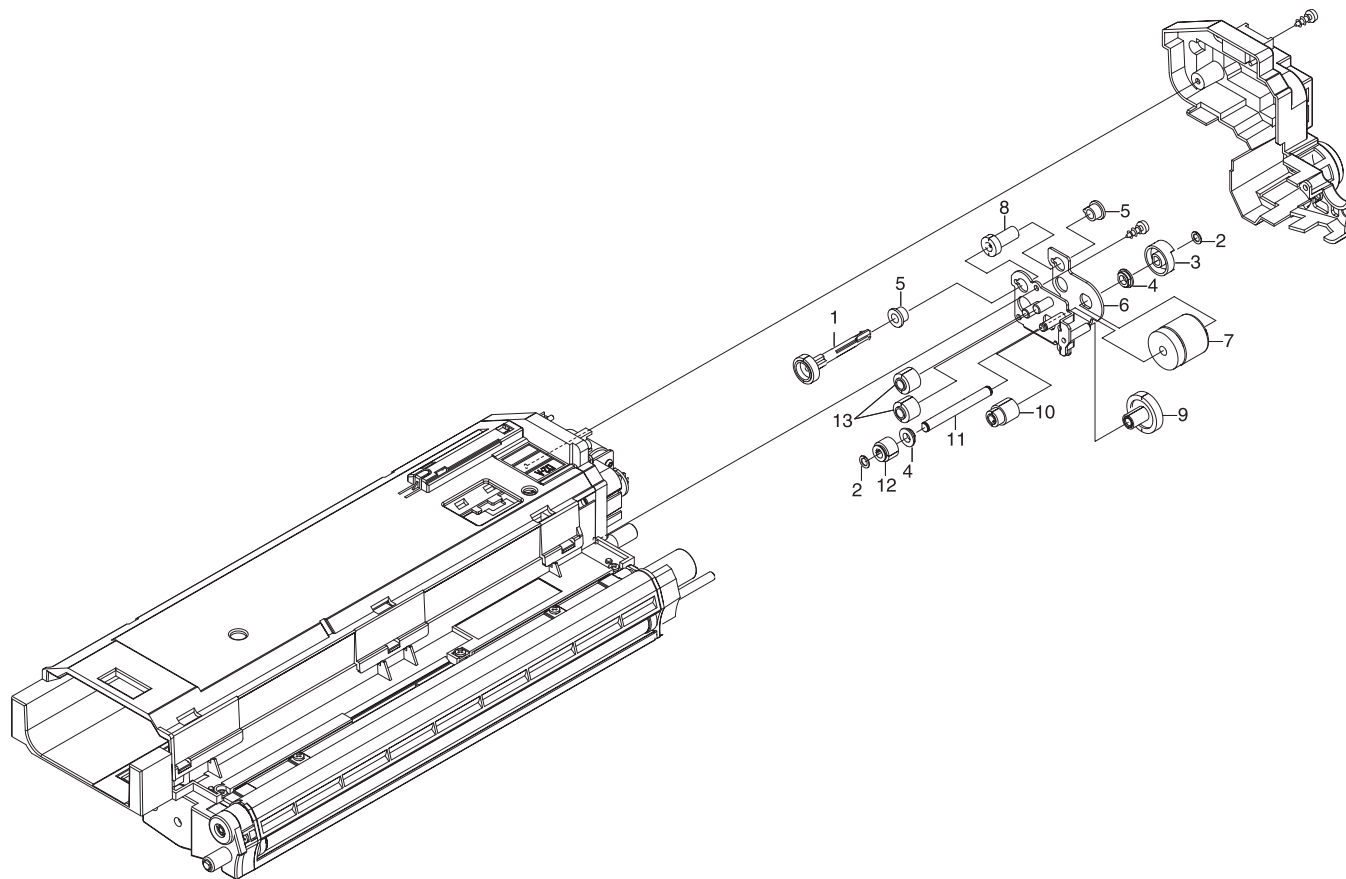

**List 9 - Developer Unit — M (08M-)**

Ref. No.	Part Code	Description	Applicable Model	SP	120V	230V	Remarks
	2CK93050	DV-803M DEVELOPER MAGENTA		X	1	1	
08M-001	+ 2CK14240	SHAFT GEAR D12		X	1	1	
08M-002	+ 2BM40060	CUT WASHER		X	2	2	
08M-003	+ 2CK14300	JOINT D1234		X	1	1	
08M-004	+ 2BM14060	BUSH CLUTCH D1234		X	2	2	
08M-005	+ 2BM14530	BUSH		X	1	1	
08M-006	+ 2CK14080	BKT CLUTCH D2		X	1	1	
08M-007	+ 2BM27420	CLUTCH 26-E		X	1	1	
08M-008	+ 2CK14430	GEAR Z14-8 JOINT D12		X	1	1	
08M-009	+ 2CK14250	GEAR Z30H-Z17H D12		X	1	1	
08M-010	+ 2CK14290	GEAR Z15-Z10 D123		X	1	1	
08M-011	+ 2CK14310	SHAFT CLUTCH D1234		X	1	1	
08M-012	+ 2CK14330	GEAR Z14D-8 D1234		X	1	1	
08M-013	+ 2CK14280	GEAR Z15-8 D123		X	1	1	



## 10. Developer Unit — C (08C-)

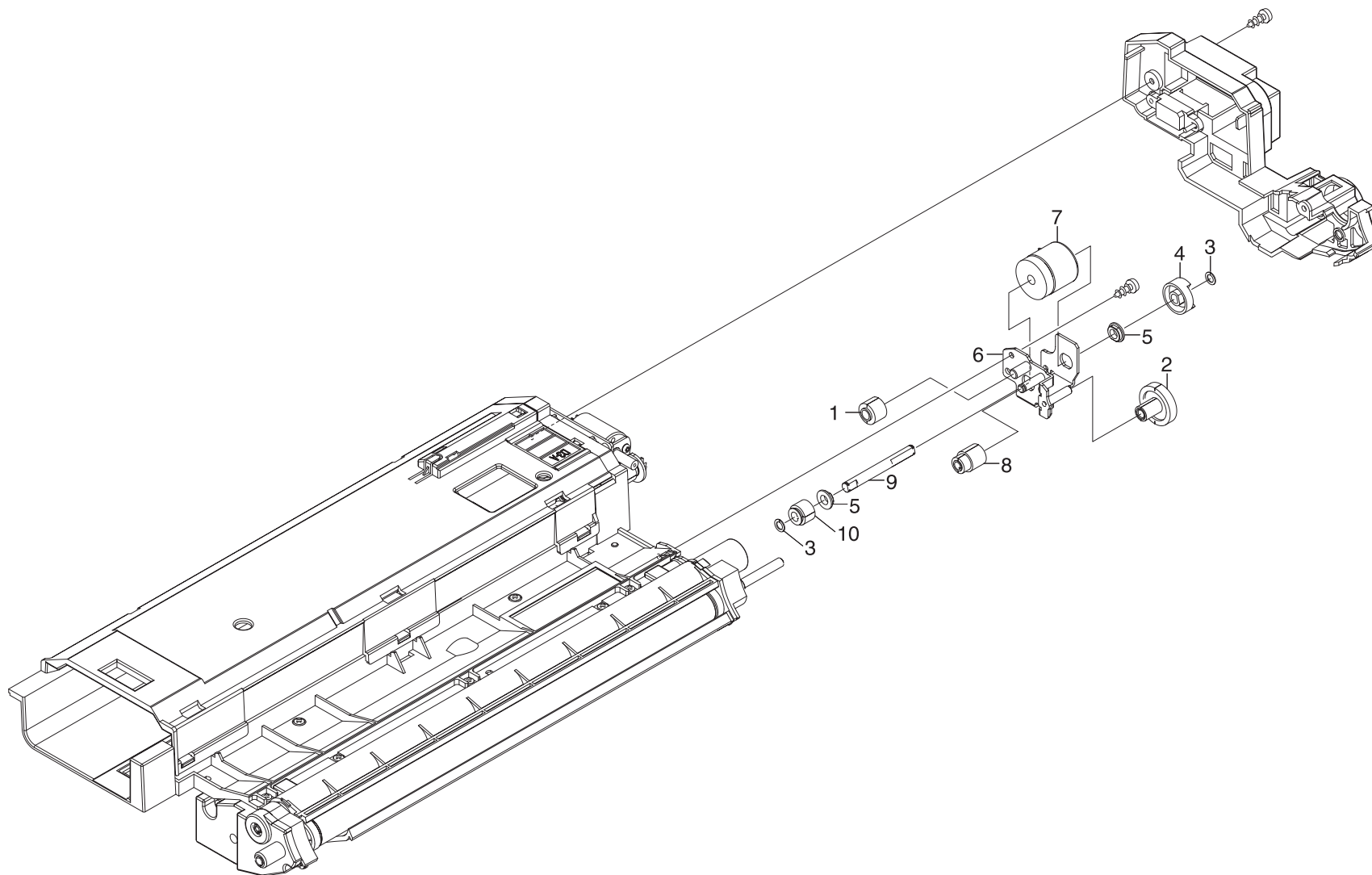

**List 10 - Developer Unit — C (08C-)**

Ref. No.	Part Code	Description	Applicable Model	SP	120V	230V	Remarks
	2CK93070	DV-803C DEVELOPER CYAN		X	1	1	
08C-001	+ 2CK14280	GEAR Z15-8 D123		X	1	1	
08C-002	+ 2CK14420	GEAR Z30H-Z17H D3		X	1	1	
08C-003	+ 2BM40060	CUT WASHER		X	2	2	
08C-004	+ 2CK14300	JOINT D1234		X	1	1	
08C-005	+ 2BM14060	BUSH CLUTCH D1234		X	2	2	
08C-006	+ 2CK14120	BKT CLUTCH D3		X	1	1	
08C-007	+ 2BM27490	CLUTCH 26-F		X	1	1	
08C-008	+ 2CK14290	GEAR Z15-Z10 D123		X	1	1	
08C-009	+ 2CK14310	SHAFT CLUTCH D1234		X	1	1	
08C-010	+ 2CK14330	GEAR Z14D-8 D1234		X	1	1	

## 11. Developer Unit — K (08K-)

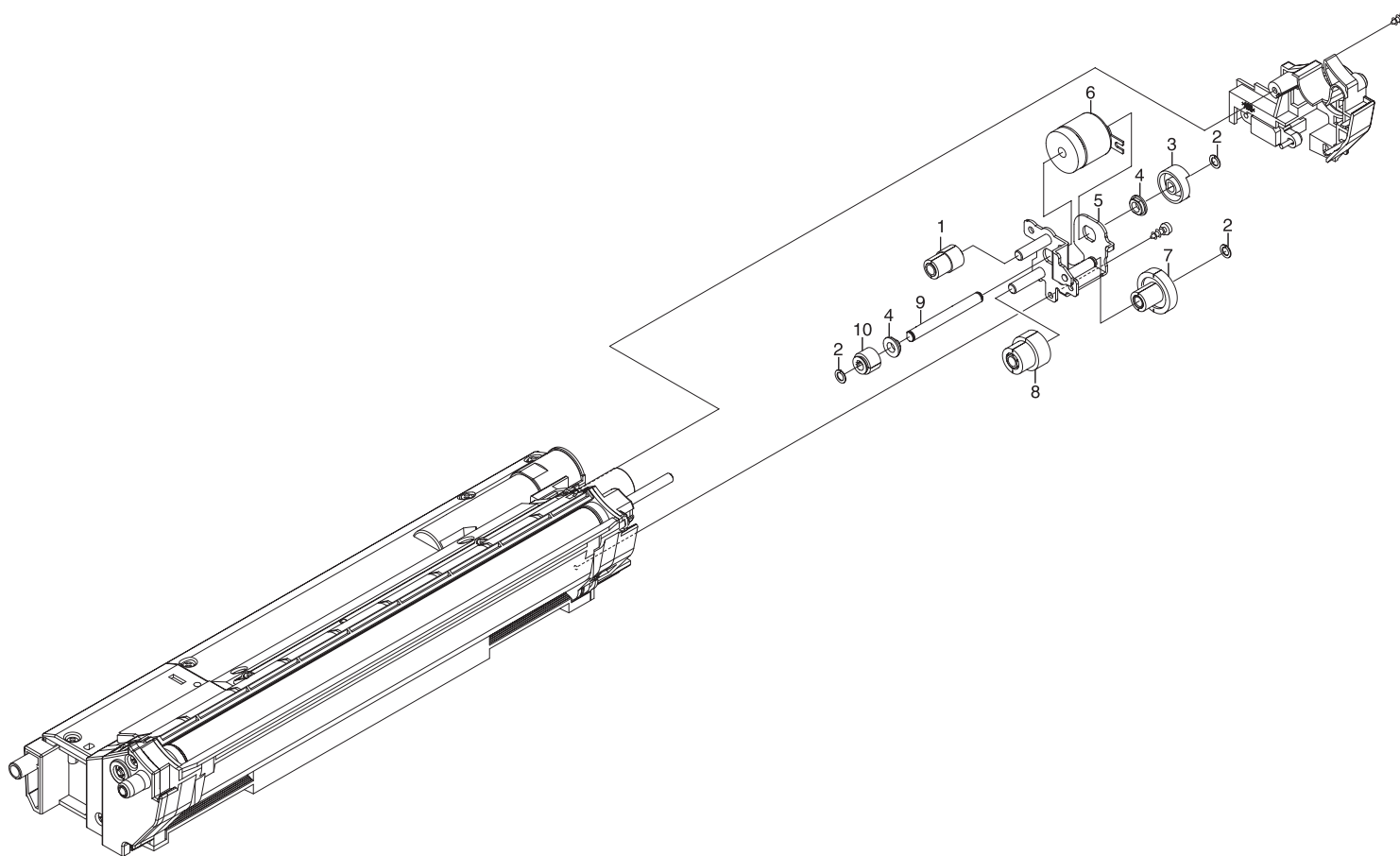

**List 11 - Developer Unit — K (08K-)**

Ref. No.	Part Code	Description	Applicable Model	SP	120V	230V	Remarks
	2CK93090	DV-803K DEVELOPER BLACK		X	1	1	
08K-001	+ 2CK14230	GEAR Z14-Z12 D4		X	1	1	
08K-002	+ 2BM40060	CUT WASHER		X	3	3	
08K-003	+ 2CK14300	JOINT D1234		X	1	1	
08K-004	+ 2BM14060	BUSH CLUTCH D1234		X	2	2	
08K-005	+ 2CK14170	BKT CLUTCH D4		X	1	1	
08K-006	+ 2BM27960	CLUTCH 26-H		X	1	1	
08K-007	+ 2CK14440	GEAR Z30H-Z22H D4		X	1	1	
08K-008	+ 2CK14220	GEAR Z24-Z18-8 D4		X	1	1	
08K-009	+ 2CK14310	SHAFT CLUTCH D1234		X	1	1	
08K-010	+ 2CK14330	GEAR Z14D-8 D1234		X	1	1	

## 12. Face-down Unit (9-)

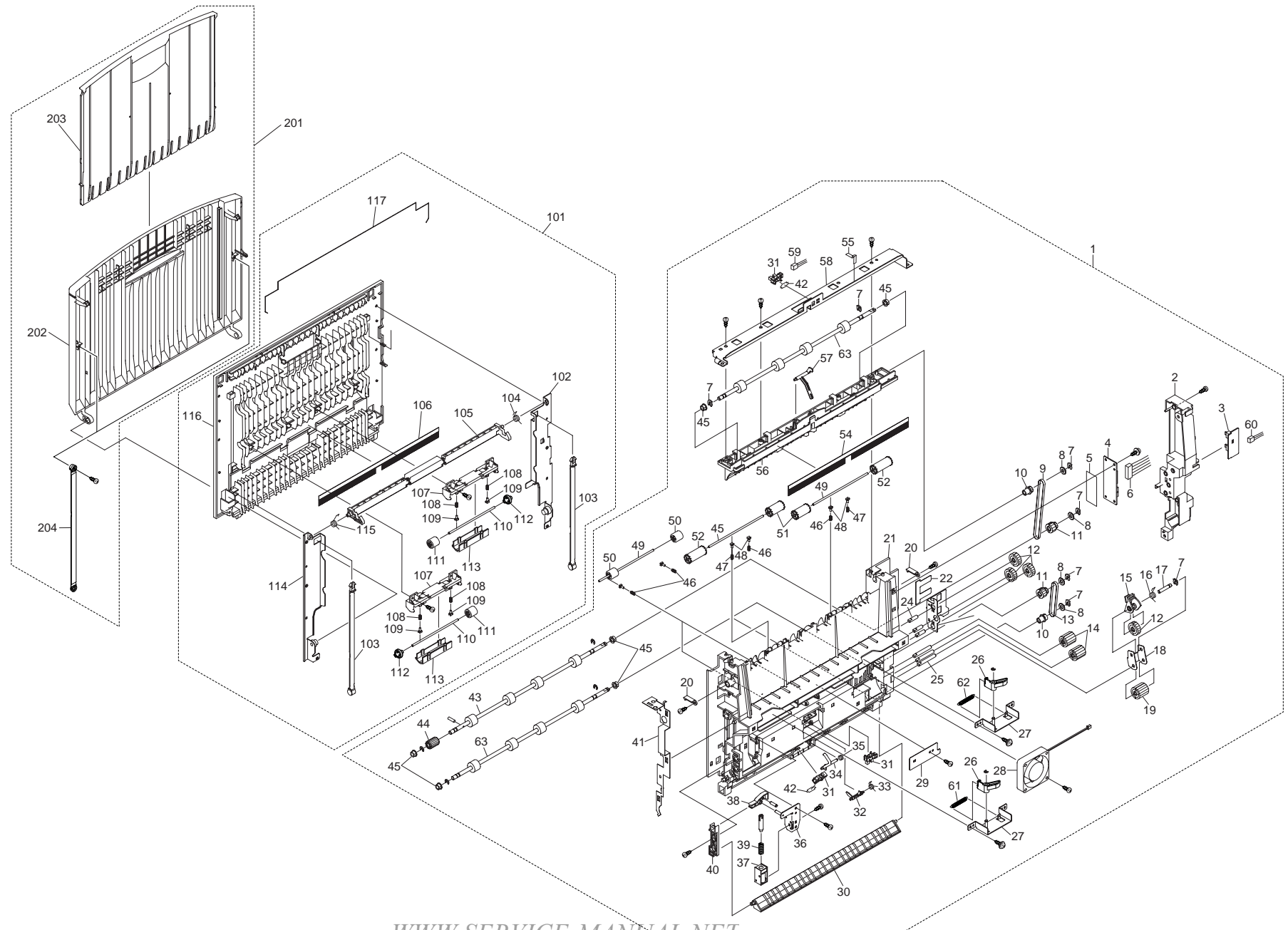

WWW.SERVICE-MANUAL.NET

## List 12 - Face-down Unit (9-)

Ref. No.	Part Code	Description	Applicable Model	SP	120V	230V	Remarks
09-001	2CK00230	FACE DOWN UNIT		X	1	1	
09-002	+ 2BM21031	COVER GEAR FD		-	1	1	
09-003	+ 2CK01190	FCD KP-1022 ASSY		X	1	1	
09-004	+ 2BM01090	P.W.BOARD KP-809 ASSY	LEFT COVER	X	1	1	
09-005	+ 2BM21600	PROTECT BOARD		-	1	1	
09-006	+ 2CK27170	CONN. CORD F.DOWN-B ASSY		-	1	1	
09-007	+ 2A806250	RING STOPPER		X	7	7	
09-008	+ 2BM21230	FD FLANGE BELT		X	4	4	
09-009	+ 2BM21270	BELT FD 264		X	1	1	
09-010	+ 2BM21220	FD PULLEY BELT Z18		X	2	2	
09-011	+ 2BM21250	FD PULLEY GEAR Z18		X	2	2	
09-012	+ 2BM21140	GEAR Z26		X	4	4	
09-013	+ 2BM21280	BELT FD 156		X	1	1	
09-014	+ 2BM21330	GEAR Z22		X	2	2	
09-015	+ 2BM21470	BKT PITCH JOINT		-	1	1	
09-016	+ 2BM21420	SPRING PLATE JOINT		-	1	1	
09-017	+ 2CK21030	PIN JOINT		-	1	1	
09-018	+ 2BM21410	PLATE JOINT		-	1	1	
09-019	+ 2BM21340	GEAR INPUT Z24		X	1	1	
09-020	+ 2BM21350	LOCK COVER FU		X	2	2	
09-021	+ 2BM21010	FRAME FD		-	1	1	
09-022	+ 2BM21650	FILM SWITCH		-	1	1	
09-023	+ 2BM21450	PLATE EARTH SWITCH		-	1	1	
09-024	+ 2CK21040	PIN IDLE 1		-	3	3	
09-025	+ 2CK21050	PIN IDLE 2		-	3	3	
09-026	+ 2CK21070	ARM PRESS DLP		-	2	2	
09-027	+ 2BM21090	PLATE PRESS DLP BASE		-	2	2	
09-028	+ 2CK21090	FAN FD		X	1	1	
09-029	+ 2BM21640	COVER CORD FD		-	1	1	
09-030	+ 2BM21080	GUIDE CHANGE		-	1	1	
09-031	+ 2BM27240	PT.SENSOR GP1S74P		X	3	3	
09-032	+ 2BM21130	ACTUATOR SENSOR FD		X	1	1	
09-033	+ 2BM21390	SPRING ACT MIDDLE		X	1	1	
09-034	+ 2BM21260	ACTUATOR SENSOR FU		X	1	1	
09-035	+ 2BM21400	SPRING ACT FU		-	1	1	
09-036	+ 2BM21040	FD PLATE SOLENOID		-	1	1	
09-037	+ 2BM27800	SOLENOID FD		X	1	1	
09-038	+ 2BM21050	LEVER SOLENOID		-	1	1	
09-039	+ 84364105	SPRING SOL		-	1	1	

WWW.SERVICE-MANUAL.NET

Ref. No.	Part Code	Description	Applicable Model	SP	120V	230V	Remarks
09-040	+ 2BM21070	LEVER GUIDE CHANGE		-	1	1	
09-041	+ 2BM21290	PLATE EARTH FD		-	1	1	
09-042	+ 2BM17990	STOPPER PI		-	2	2	
09-043	+ 2CK21110	ROLLER FD A		X	1	1	
09-063	+ 2CK21120	ROLLER FD B		X	2	2	
09-044	+ 2BM21440	KNOB ROLL FD		X	1	1	
09-045	+ 2BM21210	BUSH DRUM		X	8	8	
09-046	+ 2BM21530	SPRING EXIT		X	6	6	
09-047	+ 2BM21480	SPRING EXIT		X	2	2	
09-048	+ 2BM20610	BUSH SP		X	8	8	
09-049	+ 2BM21170	SHAFT ROLLER FD		-	4	4	
09-050	+ 2BM21160	PULLEY EXIT A		X	4	4	
09-051	+ 2CK21270	PULLEY EXIT A		X	2	2	
09-052	+ 2A621280	PULLEY B,EJECT		X	2	2	
09-054	+ 2CK21150	BRUSH ERASER		X	1	1	
09-055	+ 2BM21620	TAPE BRUSH		-	1	1	
09-056	+ 2BM21020	GUIDE FD		-	1	1	
09-057	+ 2BM21150	ACTUATOR FULL SENSOR		X	1	1	
09-058	+ 2BM21240	STAY TOP FD		-	1	1	
09-059	+ 2BM27820	CONN.CORD P.FULLASSY		-	1	1	
09-060	+ 2BM27830	CONN.CORD C.SWITCHASSY		-	1	1	
09-061	+ 2CK21140	SPRING PRESS DLP 1		-	1	1	
09-062	+ 2CK21100	SPRING PRESS DLP		-	1	1	
09-101	2BM68200	COVER FD ASSY		X	1	1	
09-102	+ 2BM21560	PLATE FDC R		-	1	1	
09-103	+ 2BM21380	STOPPER COVER FD		X	2	2	
09-104	+ 2BM21570	SPRING LEVER FD R		-	1	1	
09-105	+ 2BM21500	LEVER COVER FD		-	1	1	
09-106	+ 2CK21150	BRUSH ERASER		-	1	1	
09-107	+ 2BM21510	CASE EXIT FU		-	2	2	
09-108	+ 2BM21530	SPRING EXIT		X	4	4	
09-109	+ 2BM20610	BUSH SP		X	4	4	
09-110	+ 2BM21520	SHAFT ROLLER FU		-	2	2	
09-111	+ 2BM21160	PULLEY EXIT A		X	2	2	
09-112	+ 2BM21670	PULLEY EXIT C		X	2	2	
09-113	+ 2BM21540	COVER EXIT FU		-	2	2	
09-114	+ 2BM21550	PLATE FDC F		-	1	1	
09-115	+ 2BM21580	SPRING LEVER FD F		-	1	1	
09-116	+ 2BM21490	COVER FD		-	1	1	
09-117	+ 2BM42590	WIRE EARTH FD		-	1	1	
09-201	2BM68190	TRAY FU ASSY		X	1	1	

Ref. No.	Part Code	Description	Applicable Model	SP	120V	230V	Remarks
09-202	+ 2BM04190	TRAY FU A		-	1	1	
09-203	+ 2BM04200	TRAY FU B		-	1	1	
09-204	+ 2BM04210	BAND TRAY		X	2	2	



# 13. MP Tray (10-)

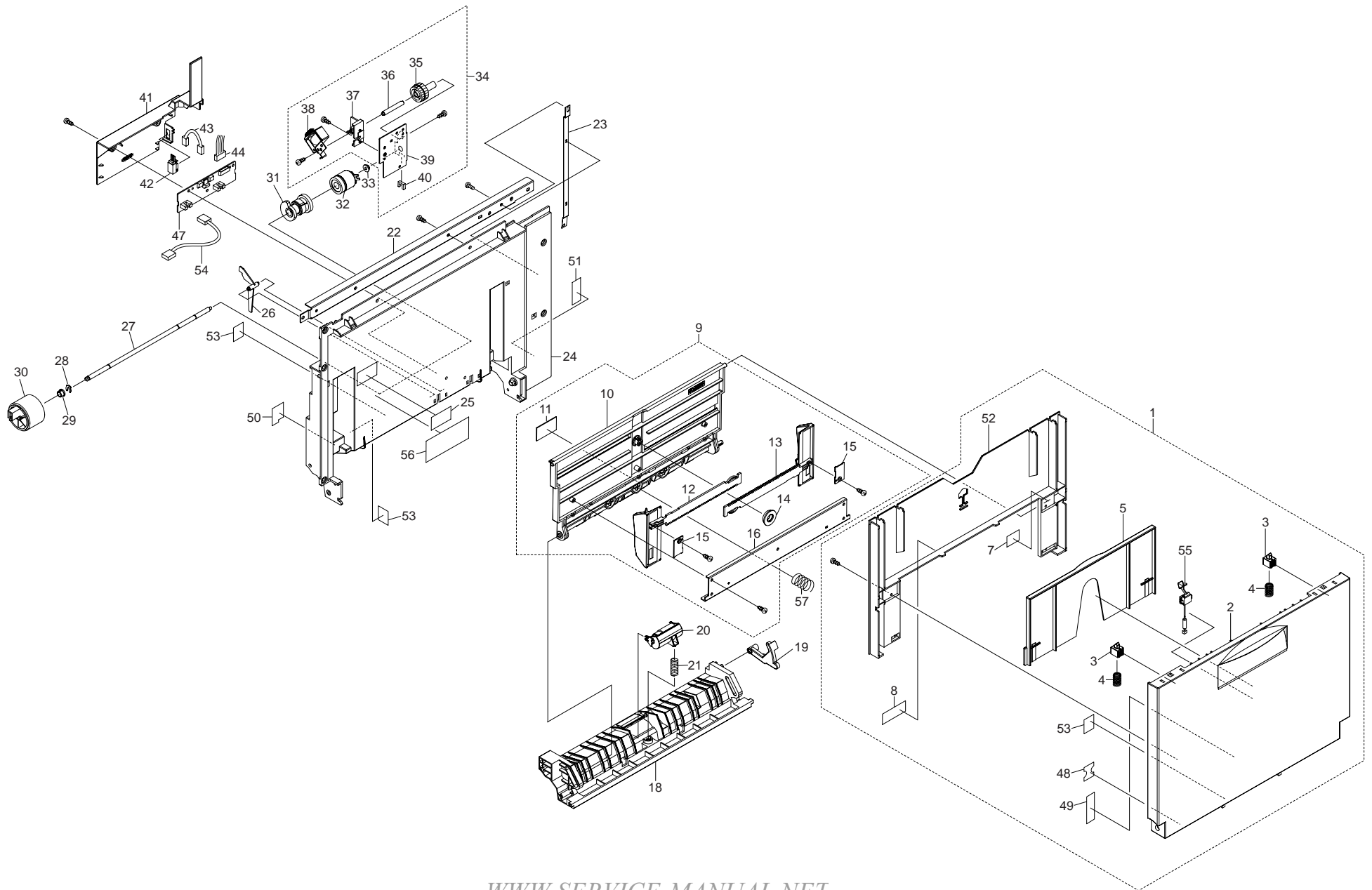

## List 13 - MP Tray (10-)

Ref. No.	Part Code	Description	Applicable Model	SP	120V	230V	Remarks
10-001	2CK68060	COVER RIGHT MPF ASSY		X	1	1	
10-002	+ 2BM07102	COVER RIGHT MPF		-	1	1	
10-003	+ 2BM07130	LOCK COVER MPF		-	2	2	
10-004	+ 2BM07140	SPRING LOCK MPF		-	2	2	
10-005	+ 2BM07121	TRAY EXTENSION MPF		-	1	1	
10-007	+ 2BM07370	LABEL MPF		-	1	1	
10-008	+ 2BM07350	LABEL SIZE		-	1	1	
10-048	+ 2CK07510	HOLDER CONN.CORD		-	1	1	
10-049	+ 2CK07520	SEAL CONN.CORD MPF		-	1	1	
10-052	+ 2CK07550	BASE TRAY MPF		-	1	1	
10-053	+ 2CK07560	SEAL CONN.CORD MPF B		-	1	1	
10-055	+ 2CK27540	SWITCH BYPASS		X	1	1	
10-009	2BM68140	PLATE BOTTOM MPF ASSY		X	1	1	
10-010	+ 2BM07150	PLATE BOTTOM A		-	1	1	
10-011	+ 2BM07170	PAD FRICTION		X	1	1	
10-012	+ 2BM07200	GUIDE PAPER SIDE F		-	1	1	
10-013	+ 2BM07180	GUIDE PAPER SIDE R		-	1	1	
10-014	+ 2BM07310	GEAR GUIDE SIDE		X	1	1	
10-015	+ 2BM07210	HOLDER GUIDE SIDE		X	2	2	
10-016	+ 2BM07160	PLATE BOTTOM B		-	1	1	
10-018	2BM07020	GUIDE PAPER MPF		-	1	1	
10-019	2BM07050	ACTUATOR CAM MPF		-	2	2	
10-020	2BM07340	RETARD ROLL ASSY		X	1	1	
10-021	2BM07290	SPRING RETARD MPF		X	1	1	
10-022	2BM07090	STAY RIGHT MPF		-	1	1	
10-023	2BM07070	PLATE EARTH MPF		-	1	1	
10-024	2BM07011	FRAME RIGHT MPF		-	1	1	
10-025	2BM07360	LABEL MP TRAY		-	1	1	
10-026	2BM07060	ACTUATOR PAPER MPF		X	1	1	
10-027	2BM07260	SHAFT ROLL MPF		-	1	1	
10-028	2A806250	RING STOPPER		X	2	2	
10-029	2BM07320	BUSH POM B		X	1	1	
10-030	2BM07270	ROLL FEED MPF ASSY		X	1	1	
10-031	2BM27120	CLUTCH MPF ASSY		X	1	1	
10-032	2BM27780	CLUTCH 26-B		X	1	1	
10-033	2BM07330	BUSH METAL		X	1	1	
10-041	2BM07030	COVER PWB MPF		-	1	1	
10-042	2BM27170	PT.SENSOR GP2S30		X	1	1	
10-043	2BM27140	CONN.CORD P.SIZE ASSY		-	1	1	

Ref. No.	Part Code	Description	Applicable Model	SP	120V	230V	Remarks
10-044	2BM27130	CONN.CORD MPF ASSY		-	1	1	
10-047	2CK01180	MPF KP-1015 ASSY		X	1	1	
10-050	2CK07530	COVER CONN.CORD MPF		-	1	1	
10-051	2CK07540	SEAL MPF		-	2	1	
10-054	2CK27240	CONN.CORD P.LENGTH ASSY		-	1	2	
10-056	2CK05080	LABEL PAPER TYPE E		X	1	1	
10-057	2CK07580	SPRING BOTTOM MPF		X	1	1	
10-034	2BM68150	PLATE DRIVE MPF ASSY		X	1	1	
10-035	+ 2BM07240	GEAR MPF Z28 Z30		X	1	1	
10-036	+ 2BM07250	SHAFT GEAR MPF		-	1	1	
10-037	+ 2BM07230	HOLDER DRIVE MPF		-	1	1	
10-038	+ 2BM27100	SOLENOID MPF		X	1	1	
10-039	+ 2BM07220	PLATE DRIVE MPF		-	1	1	
10-040	+ M2504030	EDGING,ES-0505-2		-	1	1	

# 14. Primary Transfer Unit (11-)

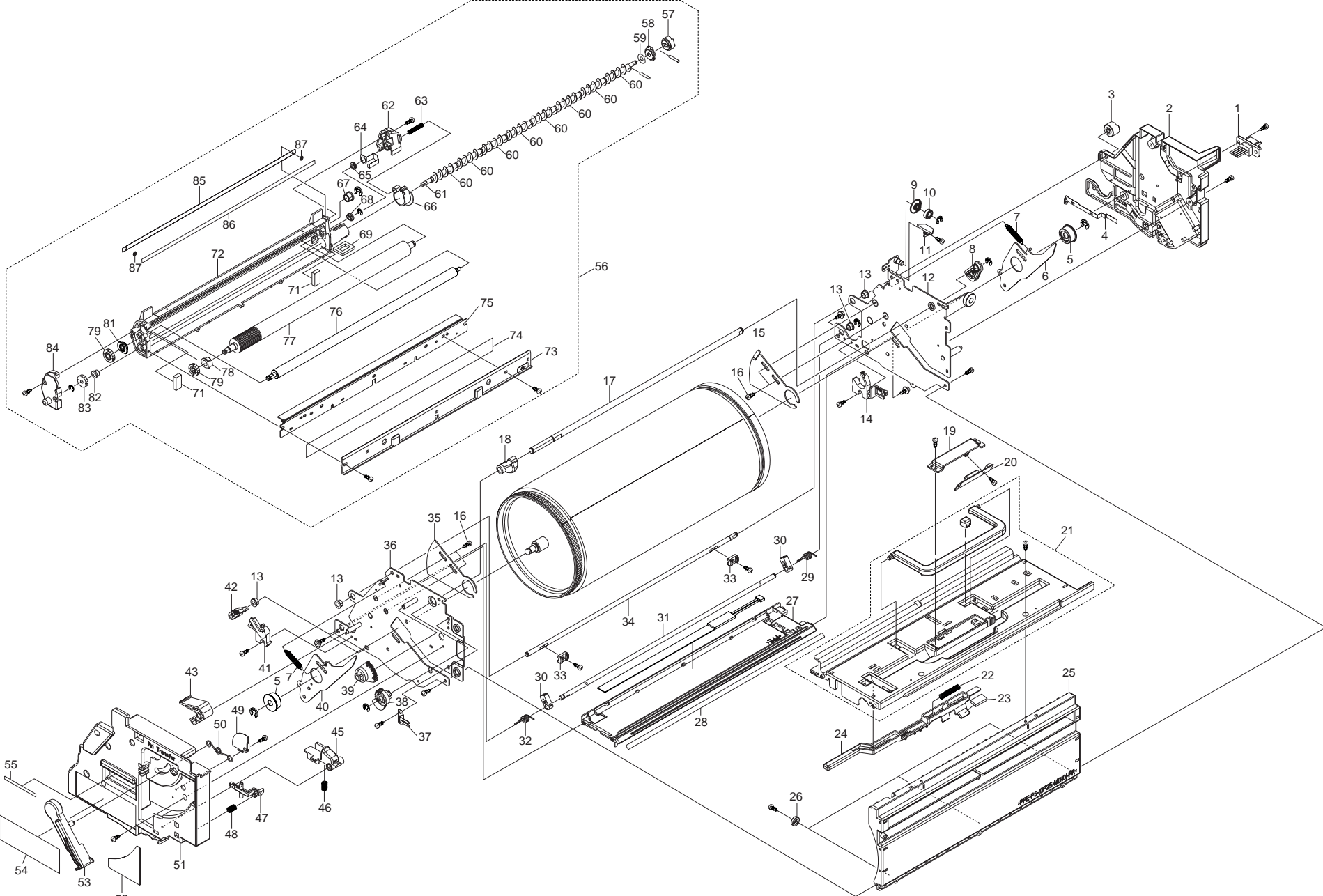

## List 14 - Primary Transfer Unit (11-)

Ref. No.	Part Code	Description	Applicable Model	SP	120V	230V	Remarks
	2CK93110	TR-803P PRI TRANSFER UNIT		X	1	1	
11-002	+	2BM16160 COVER IMAGE R		-	1	1	
11-003	+	2BM16200 JOINT CAM CL		X	1	1	
11-004	+	2BM16460 PLATE BIAS FLICKER B		-	1	1	
11-007	+	2CK16220 SPRING IMAGE PRESS		X	2	2	
11-009	+	2BM16990 SPRING PLATE IMAGE		-	1	1	
11-010	+	2CK16020 PULLY RAIL		-	1	1	
11-011	+	2BM16500 STOPPER GUIDE		-	1	1	
11-013	+	2CK16010 BUSH CONDUCTIVE		X	4	4	
11-037	+	2BM16930 EARTH FRAME		-	1	1	
11-038	+	2BM16340 CAM PRESS F		-	1	1	
11-039	+	2BM16010 GEAR LEVER FRAME		-	1	1	
11-041	+	2BM16210 HOLDER CL F		-	1	1	
11-042	+	2BM16420 LEVER CL RELEASE A		-	1	1	
11-043	+	2BM16430 LEVER CL RELEASE B		-	1	1	
11-045	+	2BM16300 STOPPER LEVER IMAGE		-	1	1	
11-046	+	2BM16310 SPRING STOPPER LEVER		-	1	1	
11-047	+	2BM16410 LEVER LOCK		-	3	3	
11-048	+	2BM16920 SPRING LEVER LOCK		-	1	1	
11-049	+	2BM16480 STOPPER SPRING		-	1	1	
11-050	+	2BM16490 SPRING LEVER FRAME		-	2	2	
11-051	+	2BM16290 COVER IMAGE F		-	1	1	
11-052	+	2BM16550 LABEL IMAGE C		-	1	1	
11-053	+	2BM16020 LEVER FRAME IMAGE		-	1	1	
11-054	+	2BM16530 LABEL IMAGE A		-	1	1	
11-055	+	2BM16540 LABEL IMAGE B		-	1	1	
11-056	+	2CK93240 BC-803 BRUSH CLEANER		X	1	1	
11-057	++	2BM16660 JOINT SCREW		X	1	1	
11-058	++	2BM16690 BUSH SCREW R		X	2	2	
11-060	++	2BM16640 SCREW CLEANER		-	8	8	
11-061	++	2BM16760 SHAFT SCREW		-	1	1	
11-062	++	2BM16630 COVER CLEANER R		-	1	1	
11-063	++	2BM16590 SPRING SHUTTER		-	1	1	
11-064	++	2BM16870 PLATE BIAS SWEEP		-	1	1	
11-065	++	2BM16900 BUSH EARTH		-	1	1	
11-066	++	2BM16570 SHUTTER CLEANER		-	1	1	
11-067	++	2BM16670 BUSH BRUSH R		X	1	1	
11-068	++	2CK16130 BUSH SWEEP R		X	1	1	
11-069	++	2BM16580 SEAL SHUTTER		-	1	1	

Ref. No.	Part Code	Description	Applicable Model	SP	120V	230V	Remarks
11-071	++ 2CK16170	SEAL SWEEP SIDE F		-	2	2	
11-072	++ 2BM16611	FRAME CLEANER		-	1	1	
11-073	++ 2BM16741	GUIDE TONER		-	1	1	
11-074	++ 2BM16780	SEAL GUIDE TONER		X	1	1	
11-075	++ 2BM68270	BLADE CLEANER ASSY		X	1	1	
11-076	++ 2CK16150	ROLLER SWEEP		-	1	1	
11-077	++ 2BM16600	BRUSH FUR		X	1	1	
11-078	++ 2BM16680	BUSH BRUSH F		X	1	1	
11-079	++ 2BM16730	GEAR BRUSH Z19		X	2	2	
11-081	++ 2CK16140	BUSH SWEEP F		X	1	1	
11-082	++ 2BM16700	BUSH SCREW F		X	1	1	
11-083	++ 2BM16860	GEAR SCREW Z19		X	1	1	
11-084	++ 2BM16620	COVER CLEANER F		-	1	1	
11-085	++ 2BM16980	PLATE GUIDE SWEEP		-	1	1	
11-086	++ 2CK16180	SEAL GUIDE SWEEP		-	1	1	
11-087	++ 2BM45020	PUSH NUT		-	2	2	

# 15. Electrical Parts (12-)

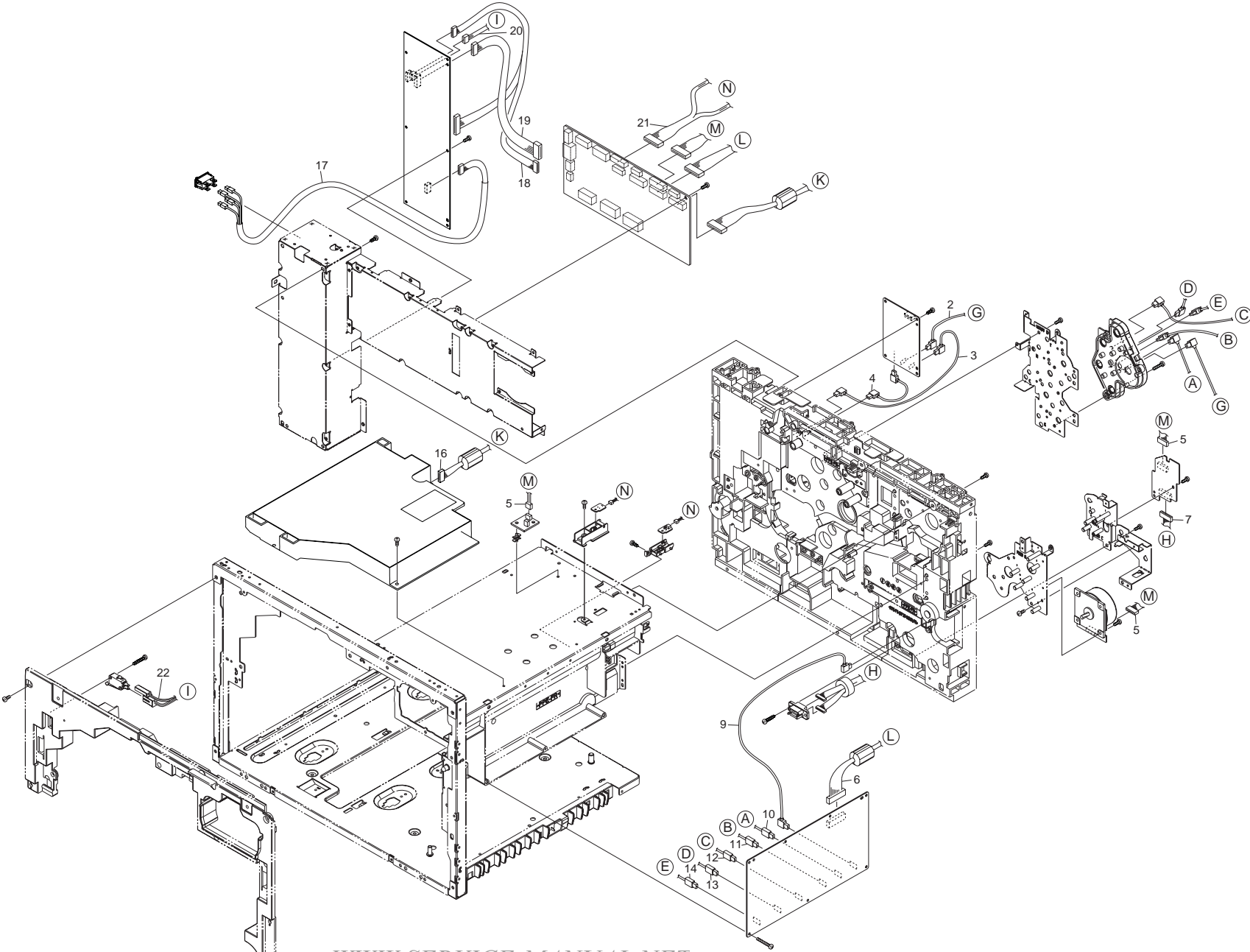

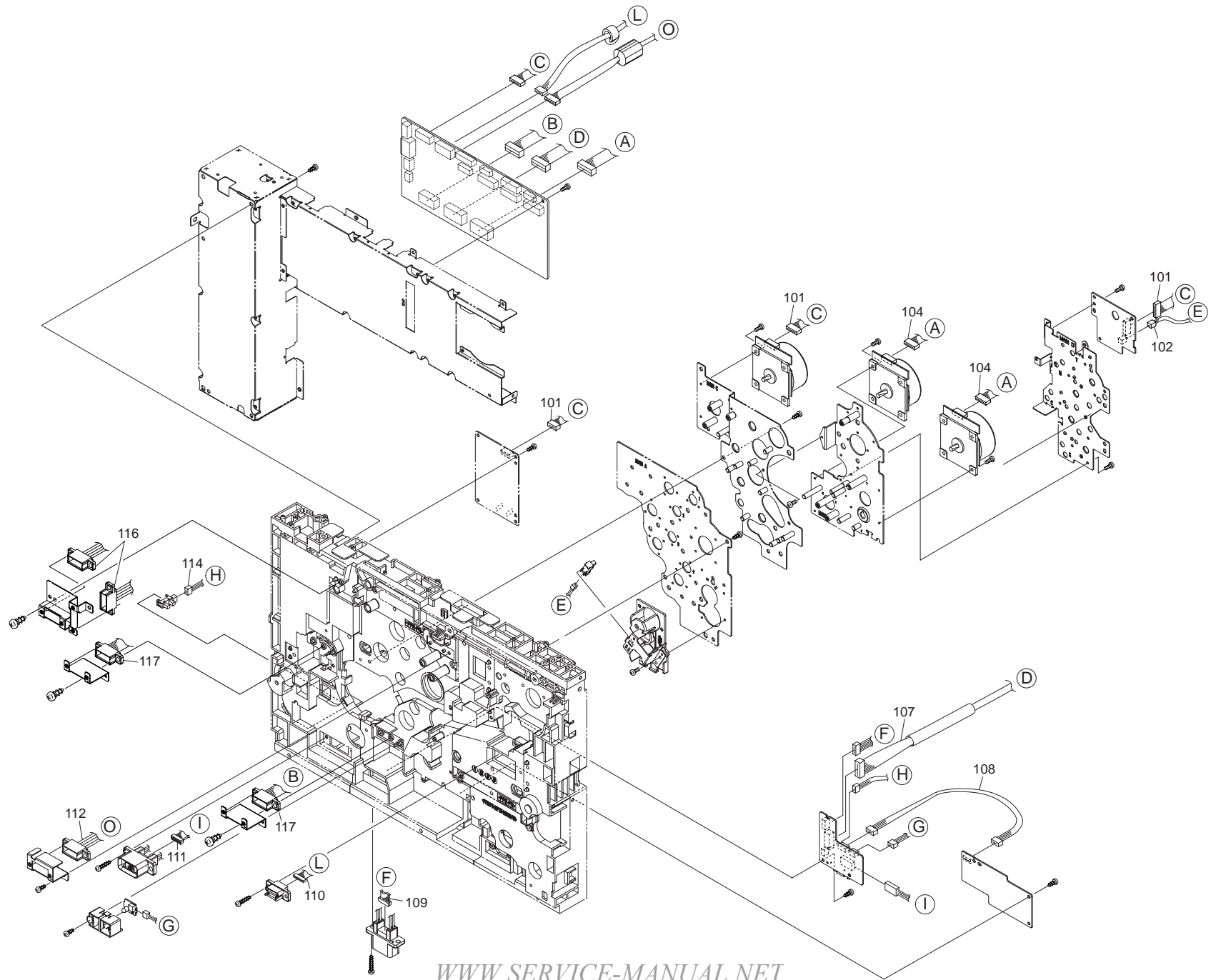



## List 15 - Electrical Parts (12-)

Ref. No.	Part Code	Description	Applicable Model	SP	120V	230V	Remarks
12-002	2BM28790	CONN. CORD HV T2 ASSY		-	1	1	
12-003	2BM28860	CONN. CORD HV G ASSY		-	1	1	
12-004	2BM28870	CONN. CORD HV MAIN ASSY		-	1	1	
12-005	2CK27070	CONN. CORD FEED-HUMIDITY ASSY		-	1	1	
12-007	2BM28670	CONN. CORD FEED ASSY		X	1	1	
12-009	2BM28850	CONN. CORD HV CR ASSY		-	1	1	
12-010	2BM28800	CONN. CORD HV T1 ASSY		-	1	1	
12-011	2BM28840	CONN. CORD HV BK ASSY		-	1	1	
12-012	2BM28830	CONN. CORD HV BC ASSY		-	1	1	
12-013	2BM28820	CONN. CORD HV BM ASSY		-	1	1	
12-014	2BM28810	CONN. CORD HV BY ASSY		-	1	1	
12-016	2CK27000	CONN. CORD APC-B ASSY		-	1	1	
12-017	2CK27300	CONN. CORD PS2-B ASSY		-	1	1	
12-018	2CK27210	CONN. CORD HEAT CONT-B ASSY		-	1	1	
12-019	2CK27200	CONN. CORD POWER E.-B ASSY		-	1	1	
12-020	2CK27310	CONN. CORD SW.RELAY ASSY		-	1	1	
12-021	2CK27230	CONN. CORD E2P-KTS ASSY		-	1	1	
12-022	2CK27180	CONN. CORD COVER SW.-B ASSY		-	1	1	
12-101	2CK27100	CONN. CORD CMT-DRV-HVM ASSY		-	1	1	
12-102	2BM27610	CONN. CORD DRIVE MAIN ASSY		-	1	1	
12-104	2CK27110	CONN. CORD KMT-DRMT ASSY		-	1	1	
12-107	2CK27190	CONN. CORD OP.RERAY-B ASSY		-	1	1	
12-108	2CK27160	CONN. CORD HV-T2-B ASSY		-	1	1	
12-109	2BM28720	CONN. CORD PF/DU ASSY		X	1	1	
12-110	2CK27080	CONN. CORD TRANSFER-B ASSY		X	1	1	
12-111	2CK27120	CONN. CORD FUSER-B ASSY		X	1	1	
12-112	2BM28640	CONN. CORD DRUM ASSY		X	1	1	
12-114	2BM28760	CONN. CORD S02597 ASSY		-	1	1	
12-116	2BM28540	CONN. CORD DLP YM ASSY		X	1	1	
12-117	2CK27020	CONN. CORD DLP CK-B ASSY		X	1	1	

## 16. Packing Assemblies (P-)

Ref. No.	Part Code	Description	Applicable Model	SP	120V	230V	Remarks
P-001	2CK77010	PACKING ASSY CE		X	-	1	
P-001	2CK77020	PACKING ASSY CU		X	1	-	

## 17. Accessories (A-)

Ref. No.	Part Code	Description	Applicable Model	SP	120V	230V	Remarks
A-001	2CK93210	TB-800 WASTE TONER BOTTLE		X	1	1	
A-002	2BM04270	PROTECTOR OZONE		X	1	1	
A-003	2BM00270	CASE MANUAL ASSY		X	1	1	
A-004	4AK85050	GRID CLEANER 3 ASSY		X	1	1	

## INDEX

Ref No.		Part Code	Description		Applicable Model	SP	120V	230V	Remarks
09-052	+	2A621280	PULLEY B,EJECT			X	2	2	
09-007	+	2A806250	RING STOPPER			X	7	7	
10-028		2A806250	RING STOPPER			X	2	2	
05-206	++	2BC06980	STOPPER 5			X	1	1	
04-009		2BL26210	RAIL OPTION A			-	2	2	
04-010		2BL26220	RAIL OPTION B			-	2	2	
02-028	+	2BM00150	STAY MIDDLE ASSY			-	1	1	
A-003		2BM00270	CASE MANUAL ASSY			X	1	1	
01-003	+	2BM00870	PANEL LCD ASSY			-	1	1	
01-010	+	2BM01080	P.W.BOARD KP-805 ASSY	FRONT PANEL		-	1	1	
09-004	+	2BM01090	P.W.BOARD KP-809 ASSY	LEFT COVER		X	1	1	
03-050	+	2BM01170	P.W.BOARD KP-824 ASSY	DRIVE A		X	1	1	
02-065	+	2BM01230	P.W.BOARD KP-849 ASSY	W TONER		-	1	1	
02-137		2BM01260	P.W.BOARD KP-895 ASSY	K TONER UP		X	1	1	
02-084		2BM01270	P.W.BOARD KP-896 ASSY	K TONER LOW		X	1	1	
02-116		2BM02020	CHANNEL BOTTOM			-	1	1	
02-115		2BM02030	STAY RAIL FRONT			-	1	1	
02-122		2BM02060	LEVER INTER LOCK			-	1	1	
02-053		2BM02070	FRAME REAR			-	1	1	
02-067		2BM02080	COVER HV DRUM			-	1	1	
02-069		2BM02090	PLATE HV D1			-	1	1	
02-070		2BM02100	PLATE HV D2			-	1	1	
02-059		2BM02110	PIN CONTACT HV			-	4	4	
02-068		2BM02120	SPRING HV L			-	2	2	
02-057		2BM02140	COVER HV IMAGE			-	1	1	
02-056		2BM02150	PLATE HV IM			-	1	1	
02-058		2BM02160	SPRING HV S			-	2	2	
02-060		2BM02170	COVER HV FEED			-	1	1	
02-062		2BM02180	PLATE HV TC			-	1	1	
02-073		2BM02210	SCREW CONNECTOR			-	10	10	
02-013		2BM02390	PLATE EARTH MAIN			-	1	1	
02-024		2BM02410	PLATE EARTH TC			-	1	1	
02-025		2BM02420	PLATE EARTH OP			-	1	1	
02-055		2BM02430	BUSH PIN			X	1	1	
02-054		2BM02440	BUSH PIN OVAL			X	2	2	
02-008		2BM02450	HOLDER OF			-	1	1	
02-007		2BM02460	LATCH			-	1	1	
02-004		2BM02470	COVER OZONE			-	1	1	
02-019		2BM02480	HOLDER HARNESS			-	1	1	
02-080		2BM02490	PLATE ANCHOR A			-	1	1	

## INDEX

Ref No.		Part Code	Description	Applicable Model	SP	120V	230V	Remarks
02-105		2BM02520	LOCK PIN		-	1	1	
02-112		2BM02550	PLATE EARTH LOWER		-	1	1	
02-101		2BM02560	GUIDE PAPER IN		-	1	1	
02-100		2BM02570	GUIDE PAPER OUT		-	1	1	
02-094		2BM02630	STAY RAIL LOW R A		-	1	1	
02-096		2BM02640	STAY RAIL LOW R B		-	1	1	
02-098		2BM02650	STAY RAIL LOW L A		-	1	1	
02-099		2BM02660	STAY RAIL LOW L B		-	1	1	
02-126		2BM02680	STAY PRO R ASSY		-	1	1	
02-127		2BM02690	STAY RAIL PRO R B		-	1	1	
02-125		2BM02710	GUIDE CONTAINER D4		-	1	1	
02-130		2BM02720	BKT PULLEY IMAGE		-	1	1	
02-128		2BM02730	SUPPORT PULLEY TRANS		-	1	1	
02-129		2BM02740	PULLEY IMAGE L		X	1	1	
02-131		2BM02750	STAY RAIL PRO L A		-	1	1	
02-132		2BM02760	STAY RAIL PRO L B		-	1	1	
02-088		2BM02780	RAIL IMAGE R		-	1	1	
02-090		2BM02790	BRACKET LOCK IMAGE		-	1	1	
02-092		2BM02800	LEVER LOCK IMAGE		X	1	1	
02-091		2BM02810	PULLEY IMAGE		X	1	1	
02-093		2BM02820	SPRING LOCK IMAGE		-	1	1	
02-208		2BM02830	COVER LEFT PROCESS		-	1	1	
02-219		2BM02840	SCREW PROCESS		-	4	4	
02-135		2BM02850	PLATE SCANNER BASE		-	1	1	
02-107		2BM02860	STAY BASE R		-	1	1	
02-109		2BM02870	STAY BASE L		-	1	1	
02-086		2BM02890	COVER HV DLP		-	1	1	
02-015		2BM02900	SPRING SW DU		-	1	1	
02-016		2BM02910	SWITCH DU		-	1	1	
05-094	+	2BM02920	SCREW FEED UNIT		-	3	3	
02-106		2BM02930	HOLDER FRONT		-	2	2	
		2BM02960	SPONG REAR		-	1	1	
02-214		2BM02980	PLATE LOCK L		-	1	1	
02-212		2BM02990	PLATE LOCK R		-	1	1	
01-012		2BM04010	COVER TOP		X	1	1	
01-013		2BM04020	STOPPER PAPER		X	1	1	
01-014		2BM04030	SP PRESS2 DLP		-	1	1	
01-006	+	2BM04040	HOLDER PANEL PWB		-	1	1	
01-007	+	2BM04050	KEY TOP1		-	1	1	
01-008	+	2BM04060	KEY TOP2		-	1	1	

## INDEX

Ref No.		Part Code	Description	Applicable Model	SP	120V	230V	Remarks
01-009	+	2BM04070	KEY TOP3		-	1	1	
01-005	+	2BM04080	LENS LED		-	1	1	
01-023	+	2BM04100	PLATE MAGCHATCH		-	2	2	
01-002	+	2BM04120	PANEL KEY ENGLISH	Excl.KMFR/KMIT	-	1	1	
01-002	+	2BM04130	PANEL KEY FRENCH	KMFR only	-	-	1	
01-002	+	2BM04140	PANEL KEY ITALIAN	KMIT only	-	-	1	
01-017		2BM04150	COVER RIGHT		X	1	1	
01-019		2BM04160	SUPPORT COVER ASSY		-	1	1	
01-020		2BM04170	COVER LEFT		X	1	1	
09-202	+	2BM04190	TRAY FU A		-	1	1	
09-203	+	2BM04200	TRAY FU B		-	1	1	
09-204	+	2BM04210	BAND TRAY		X	2	2	
01-016		2BM04270	PROTECTOR OZONE		X	1	1	
A-002		2BM04270	PROTECTOR OZONE		X	1	1	
01-024	+	2BM04280	BAND COVER		X	2	2	
01-018		2BM04290	PLATE EARTH RC		-	1	1	
01-011	+	2BM04300	PLATE EARTH PANEL		-	1	1	
02-120		2BM04310	INNER FRONT COVER		-	1	1	
01-027	+	2BM05020	LABEL DIAGRAM B		-	1	1	
06-058	+	2BM05090	LABEL CAUTION FUSER		-	1	1	
02-218		2BM05220	LABEL CLEANER		-	1	1	
10-024		2BM07011	FRAME RIGHT MPF		-	1	1	
10-018		2BM07020	GUIDE PAPER MPF		-	1	1	
10-041		2BM07030	COVER PWB MPF		-	1	1	
10-019		2BM07050	ACTUATOR CAM MPF		-	2	2	
10-026		2BM07060	ACTUATOR PAPER MPF		X	1	1	
10-023		2BM07070	PLATE EARTH MPF		-	1	1	
10-022		2BM07090	STAY RIGHT MPF		-	1	1	
10-002	+	2BM07102	COVER RIGHT MPF		-	1	1	
10-005	+	2BM07121	TRAY EXTENSION MPF		-	1	1	
10-003	+	2BM07130	LOCK COVER MPF		-	2	2	
10-004	+	2BM07140	SPRING LOCK MPF		-	2	2	
10-010	+	2BM07150	PLATE BOTTOM A		-	1	1	
10-016	+	2BM07160	PLATE BOTTOM B		-	1	1	
10-011	+	2BM07170	PAD FRICTION		X	1	1	
10-013	+	2BM07180	GUIDE PAPER SIDE R		-	1	1	
10-012	+	2BM07200	GUIDE PAPER SIDE F		-	1	1	
10-015	+	2BM07210	HOLDER GUIDE SIDE		X	2	2	
10-039	+	2BM07220	PLATE DRIVE MPF		-	1	1	
10-037	+	2BM07230	HOLDER DRIVE MPF		-	1	1	

## INDEX

Ref No.		Part Code	Description	Applicable Model	SP	120V	230V	Remarks
10-035	+	2BM07240	GEAR MPF Z28 Z30		X	1	1	
10-036	+	2BM07250	SHAFT GEAR MPF		-	1	1	
10-027		2BM07260	SHAFT ROLL MPF		-	1	1	
10-030		2BM07270	ROLL FEED MPF ASSY		X	1	1	
10-021		2BM07290	SPRING RETARD MPF		X	1	1	
10-014	+	2BM07310	GEAR GUIDE SIDE		X	1	1	
10-029		2BM07320	BUSH POM B		X	1	1	
03-105	+	2BM07330	BUSH METAL		X	3	3	
03-315	+	2BM07330	BUSH METAL		X	2	2	
10-033		2BM07330	BUSH METAL		X	1	1	
10-020		2BM07340	RETARD ROLL ASSY		X	1	1	
10-008	+	2BM07350	LABEL SIZE		-	1	1	
10-025		2BM07360	LABEL MP TRAY		-	1	1	
10-007	+	2BM07370	LABEL MPF		-	1	1	
02-209		2BM08510	FRAME FRONT PROCESS		-	1	1	
02-207		2BM08530	STAY PROCESS BASE		-	1	1	
02-203		2BM08540	STAY ACCURIDE PRO R		-	1	1	
02-204		2BM08550	COVER BOTTOM PROCESS		-	1	1	
02-216		2BM08570	LOCK MCH		-	1	1	
02-217		2BM08580	SPRING LOCK MCH		-	1	1	
02-215		2BM08590	LOCK PROCESS		X	1	1	
02-211		2BM08600	TP SCREW		X	2	2	
02-205		2BM08610	PRESS ARM D4		-	2	2	
02-206		2BM08620	SPRING D4 PROCESS		-	2	2	
03-133	+	2BM14060	BUSH CLUTCH D1234		X	1	1	
08Y-004	+	2BM14060	BUSH CLUTCH D1234		X	2	2	
08M-004	+	2BM14060	BUSH CLUTCH D1234		X	2	2	
08C-005	+	2BM14060	BUSH CLUTCH D1234		X	2	2	
08K-004	+	2BM14060	BUSH CLUTCH D1234		X	2	2	
02-029	+	2BM14120	LOCK SHUTTER D1234		X	1	1	
02-035	+	2BM14200	GUIDE SHUTTER D1234		-	1	1	
02-033	+	2BM14230	SPRING SHUTTER D1234		-	2	2	
02-032	+	2BM14240	SHUTTER D1234		-	1	1	
02-034	+	2BM14250	SEAL SHUTTER D1234		-	1	1	
02-036	+	2BM14260	SEAL GUIDE T D1234		-	1	1	
08Y-005	+	2BM14530	BUSH		X	1	1	
08M-005	+	2BM14530	BUSH		X	1	1	
02-045	+	2BM14640	GUIDE SCREW D14		-	1	1	
02-050	+	2BM15910	CASE FEED TK		-	2	2	
02-049	+	2BM15920	BUSH FEED TK		-	2	2	

## INDEX

Ref No.		Part Code	Description	Applicable Model	SP	120V	230V	Remarks
02-040	+	2BM15930	SCREW FEED TK		-	1	1	
02-037	+	2BM15940	PLATE FEED TK		-	1	1	
02-039	+	2BM15950	SEAL FEED TK A		-	2	2	
02-046	+	2BM15960	SEAL FEED TK B		-	1	1	
02-048	+	2BM15960	SEAL FEED TK B		-	1	1	
02-047	+	2BM15970	SEAL FEED TK C		-	2	2	
11-039	+	2BM16010	GEAR LEVER FRAME		-	1	1	
11-053	+	2BM16020	LEVER FRAME IMAGE		-	1	1	
11-002	+	2BM16160	COVER IMAGE R		-	1	1	
11-003	+	2BM16200	JOINT CAM CL		X	1	1	
11-041	+	2BM16210	HOLDER CL F		-	1	1	
11-051	+	2BM16290	COVER IMAGE F		-	1	1	
11-045	+	2BM16300	STOPPER LEVER IMAGE		-	1	1	
11-046	+	2BM16310	SPRING STOPPER LEVER		-	1	1	
11-038	+	2BM16340	CAM PRESS F		-	1	1	
11-047	+	2BM16410	LEVER LOCK		-	3	3	
11-042	+	2BM16420	LEVER CL RELEASE A		-	1	1	
11-043	+	2BM16430	LEVER CL RELEASE B		-	1	1	
11-004	+	2BM16460	PLATE BIAS FLICKER B		-	1	1	
11-049	+	2BM16480	STOPPER SPRING		-	1	1	
11-050	+	2BM16490	SPRING LEVER FRAME		-	2	2	
11-011	+	2BM16500	STOPPER GUIDE		-	1	1	
11-054	+	2BM16530	LABEL IMAGE A		-	1	1	
11-055	+	2BM16540	LABEL IMAGE B		-	1	1	
11-052	+	2BM16550	LABEL IMAGE C		-	1	1	
11-066	++	2BM16570	SHUTTER CLEANER		-	1	1	
11-069	++	2BM16580	SEAL SHUTTER		-	1	1	
11-063	++	2BM16590	SPRING SHUTTER		-	1	1	
11-077	++	2BM16600	BRUSH FUR		X	1	1	
11-072	++	2BM16611	FRAME CLEANER		-	1	1	
11-084	++	2BM16620	COVER CLEANER F		-	1	1	
11-062	++	2BM16630	COVER CLEANER R		-	1	1	
11-060	++	2BM16640	SCREW CLEANER		-	8	8	
11-057	++	2BM16660	JOINT SCREW		X	1	1	
11-067	++	2BM16670	BUSH BRUSH R		X	1	1	
11-078	++	2BM16680	BUSH BRUSH F		X	1	1	
11-058	++	2BM16690	BUSH SCREW R		X	2	2	
11-082	++	2BM16700	BUSH SCREW F		X	1	1	
11-079	++	2BM16730	GEAR BRUSH Z19		X	2	2	
11-073	++	2BM16741	GUIDE TONER		-	1	1	



## INDEX

Ref No.		Part Code	Description	Applicable Model	SP	120V	230V	Remarks
11-061	++	2BM16760	SHAFT SCREW		-	1	1	
11-074	++	2BM16780	SEAL GUIDE TONER		X	1	1	
11-083	++	2BM16860	GEAR SCREW Z19		X	1	1	
11-064	++	2BM16870	PLATE BIAS SWEEP		-	1	1	
11-065	++	2BM16900	BUSH EARTH		-	1	1	
11-048	+	2BM16920	SPRING LEVER LOCK		-	1	1	
11-037	+	2BM16930	EARTH FRAME		-	1	1	
11-085	++	2BM16980	PLATE GUIDE SWEEP		-	1	1	
11-009	+	2BM16990	SPRING PLATE IMAGE		-	1	1	
05-030	+	2BM17013	CASE LOW		-	1	1	
05-067	+	2BM17020	PLATE BOTTOM FEED		-	1	1	
05-068	+	2BM17030	PLATE FRONT LEVER		-	1	1	
05-074	+	2BM17040	SHAFT FRONT LEVER		-	1	1	
05-073	+	2BM17050	LEVER FEED FRONT		X	1	1	
05-069	+	2BM17060	HOOK LEVER FRONT		X	1	1	
05-071	+	2BM17070	SPRING FRONT LEVER		-	2	2	
05-035	+	2BM17090	PLATE CONTACT TRANS		-	1	1	
05-028	+	2BM17120	PLATE RELEASE		-	1	1	
05-029	+	2BM17130	SPRING RELEASE		-	1	1	
05-057	++	2BM17140	GUIDE CASE LOW LEFT		-	1	1	
05-051	++	2BM17151	GUIDE CHANGE DU		-	1	1	
05-059	++	2BM17160	LEVER LOCK CASE LOW		-	1	1	
05-053	++	2BM17170	HOOK LOCK FUSER		-	1	1	
05-052	++	2BM17180	PLATE LEVER SOL		-	1	1	
05-055	++	2BM17190	ANGLE SOLENOID		-	1	1	
05-060	++	2BM17200	COVER GUIDE DU		-	1	1	
05-063	++	2BM17210	SPRING LOCK FUSER		-	2	2	
05-032	+	2BM17260	GEAR JOINT Z22S		X	1	1	
05-021	+	2BM17290	GUIDE MIDDLE		-	1	1	
05-017	+	2BM17300	SHAFT PULLEY MIDDLE		-	1	1	
05-018	+	2BM17310	PULLEY MIDDLE		X	4	4	
05-022	+	2BM17320	LEVER GUIDE MIDDLE		-	1	1	
05-002	+	2BM17330	BUSH REGIST UP		X	4	4	
05-020	+	2BM17340	SPRING GUIDE MIDDLE		-	1	1	
05-004	+	2BM17350	SPRING MIDDLE F		X	2	2	
05-019	+	2BM17360	SPRING MIDDLE R		X	1	1	
05-006	+	2BM17370	ROLLER REGIST LOW		X	1	1	
05-009	+	2BM17380	GEAR REGIST Z32		X	1	1	
05-007	+	2BM17390	JOINT ROLL TRANS		X	1	1	
05-001	+	2BM17400	ROLLER REGIST UP		X	1	1	

## INDEX

Ref No.		Part Code	Description	Applicable Model	SP	120V	230V	Remarks
05-005	+	2BM17420	SPRING REGIST F		X	1	1	
05-013	+	2BM17440	PAD REG SENSOR		-	1	1	
05-025	+	2BM17460	PLATE EARTH REG A		-	1	1	
05-027	+	2BM17480	HIGH-MEG R ASSY		X	2	2	
05-023	+	2BM17500	SHEET REGIST B		X	2	2	
05-078	++	2BM17620	GEAR Z42S		X	1	1	
05-088	++	2BM17630	PULLEY TENSION BELT		X	4	4	
05-203	++	2BM17710	GUIDE CHUTE LOW		-	1	1	
05-217	++	2BM17740	LEVER TRANS B		X	1	1	
05-014	+	2BM17930	LATCH JOINT		X	1	1	
05-003	+	2BM17950	GEAR REGIST Z24		X	1	1	
05-049	+	2BM17960	SCREW FAN BELT		-	4	4	
05-031	+	2BM17970	PLATE EARTH FEED		-	1	1	
03-073	+	2BM17990	STOPPER PI		-	1	1	
09-042	+	2BM17990	STOPPER PI		-	2	2	
07-001	+	2BM18080	GEAR Z17H CLN		X	1	1	
07-005	+	2BM18130	GEAR Z18S SCREW		X	1	1	
07-004	+	2BM18140	GEAR Z16S CLN		X	1	1	
07-002	+	2BM18380	GEAR Z17HZ22H IDLE		X	1	1	
07-003	+	2BM19140	GEAR Z28HZ28H DRUM BT		X	1	1	
06-032	+	2BM20050	FRAME BOTTOM		-	1	1	
06-030	+	2BM20060	HOLDER HARNESS R.F		-	1	1	
06-029	+	2BM20070	HOLDER HARNESS RR		-	1	1	
06-034	+	2BM20080	HOLDER HARNESS LOWER		-	1	1	
06-045	+	2BM20210	SEPARATOR LOW		X	4	4	
06-049	+	2BM20220	BKT SEPARATOR UP		-	1	1	
06-051	+	2BM20240	SEPARATOR UP		X	6	6	
06-046	+	2BM20260	SPRING SEPARATOR		X	4	4	
06-020	+	2BM20270	FRAME TOP FUSER		-	1	1	
06-026	+	2BM20280	HOLDER HERNESS TOP R		-	1	1	
06-023	+	2BM20290	BKT THERMISTER UP		-	1	1	
06-021	+	2BM20310	BKT THERMOSTAT		-	2	2	
06-028	+	2BM20330	GUIDE ENTRANCE LOW		-	1	1	
06-033	+	2BM20360	COVER BOTTOM FUSER		-	1	1	
06-002	+	2BM20380	COVER REAR FUSER		-	1	1	
06-063	+	2BM20390	COVER EXIT FUSER		-	1	1	
06-004	+	2BM20430	SPRING CONNECTOR		-	2	2	
06-001	+	2BM20500	HANDLE GEAR		X	1	1	
06-010	+	2BM20520	GEAR EXIT ROLL Z18		X	1	1	
06-060	+	2BM20610	BUSH SP		X	4	4	

## INDEX

Ref No.		Part Code	Description	Applicable Model	SP	120V	230V	Remarks
09-048	+	2BM20610	BUSH SP		X	8	8	
09-109	+	2BM20610	BUSH SP		X	4	4	
06-059	+	2BM20790	SPRING EXIT		-	4	4	
06-024	+	2BM20830	THERMISTOR UP		X	1	1	
06-031	+	2BM20840	THERMISTOR LOW		X	1	1	
06-025	+	2BM20850	THERMOSTAT		X	2	2	
09-021	+	2BM21010	FRAME FD		-	1	1	
09-056	+	2BM21020	GUIDE FD		-	1	1	
09-002	+	2BM21031	COVER GEAR FD		-	1	1	
09-036	+	2BM21040	FD PLATE SOLENOID		-	1	1	
09-038	+	2BM21050	LEVER SOLENOID		-	1	1	
09-040	+	2BM21070	LEVER GUIDE CHANGE		-	1	1	
09-030	+	2BM21080	GUIDE CHANGE		-	1	1	
09-027	+	2BM21090	PLATE PRESS DLP BASE		-	2	2	
09-032	+	2BM21130	ACTUATOR SENSOR FD		X	1	1	
09-012	+	2BM21140	GEAR Z26		X	4	4	
09-057	+	2BM21150	ACTUATOR FULL SENSOR		X	1	1	
09-050	+	2BM21160	PULLEY EXIT A		X	4	4	
09-111	+	2BM21160	PULLEY EXIT A		X	2	2	
09-049	+	2BM21170	SHAFT ROLLER FD		-	4	4	
09-045	+	2BM21210	BUSH DRUM		X	8	8	
09-010	+	2BM21220	FD PULLEY BELT Z18		X	2	2	
09-008	+	2BM21230	FD FLANGE BELT		X	4	4	
09-058	+	2BM21240	STAY TOP FD		-	1	1	
09-011	+	2BM21250	FD PULLEY GEAR Z18		X	2	2	
09-034	+	2BM21260	ACTUATOR SENSOR FU		X	1	1	
09-009	+	2BM21270	BELT FD 264		X	1	1	
09-013	+	2BM21280	BELT FD 156		X	1	1	
09-041	+	2BM21290	PLATE EARTH FD		-	1	1	
09-014	+	2BM21330	GEAR Z22		X	2	2	
09-019	+	2BM21340	GEAR INPUT Z24		X	1	1	
09-020	+	2BM21350	LOCK COVER FU		X	2	2	
09-103	+	2BM21380	STOPPER COVER FD		X	2	2	
09-033	+	2BM21390	SPRING ACT MIDDLE		X	1	1	
09-035	+	2BM21400	SPRING ACT FU		-	1	1	
09-018	+	2BM21410	PLATE JOINT		-	1	1	
09-016	+	2BM21420	SPRING PLATE JOINT		-	1	1	
09-044	+	2BM21440	KNOB ROLL FD		X	1	1	
09-023	+	2BM21450	PLATE EARTH SWITCH		-	1	1	
09-015	+	2BM21470	BKT PITCH JOINT		-	1	1	

## INDEX

Ref No.		Part Code	Description	Applicable Model	SP	120V	230V	Remarks
09-047	+	2BM21480	SPRING EXIT		X	2	2	
09-116	+	2BM21490	COVER FD		-	1	1	
09-105	+	2BM21500	LEVER COVER FD		-	1	1	
09-107	+	2BM21510	CASE EXIT FU		-	2	2	
09-110	+	2BM21520	SHAFT ROLLER FU		-	2	2	
09-046	+	2BM21530	SPRING EXIT		X	6	6	
09-108	+	2BM21530	SPRING EXIT		X	4	4	
09-113	+	2BM21540	COVER EXIT FU		-	2	2	
09-114	+	2BM21550	PLATE FDC F		-	1	1	
09-102	+	2BM21560	PLATE FDC R		-	1	1	
09-104	+	2BM21570	SPRING LEVER FD R		-	1	1	
09-115	+	2BM21580	SPRING LEVER FD F		-	1	1	
09-005	+	2BM21600	PROTECT BOARD		-	1	1	
09-055	+	2BM21620	TAPE BRUSH		-	1	1	
09-029	+	2BM21640	COVER CORD FD		-	1	1	
09-022	+	2BM21650	FILM SWITCH		-	1	1	
09-112	+	2BM21670	PULLEY EXIT C		X	2	2	
03-003	+	2BM22020	PLATE DRIVE MAIN B		-	1	1	
03-068	+	2BM22040	PLATE DRIVE MAIN D		-	1	1	
03-006	+	2BM22060	GEAR Z36H Z117H		X	1	1	
03-010	+	2BM22090	GEAR Z25 Z29		X	1	1	
03-012	+	2BM22100	GEAR Z29 IDLE		X	1	1	
03-018	+	2BM22110	GEAR Z26 IDLE		X	3	3	
03-014	+	2BM22140	GEAR Z43H		X	1	1	
03-023	+	2BM22150	GEAR Z21H Z26		X	1	1	
03-013	+	2BM22160	GEAR Z14 Z29		X	1	1	
03-011	+	2BM22170	GEAR Z23 IDLE		X	6	6	
03-024	+	2BM22180	GEAR Z28		X	1	1	
03-002	+	2BM22200	HOLDER ASSY B		X	1	1	
03-037	+	2BM22260	HOUSING CL CAM		-	1	1	
03-032	+	2BM22270	BUSH CL CAM		X	1	1	
03-034	+	2BM22280	CLUTCH ASSY CAM		X	1	1	
03-040	+	2BM22320	JOINT ROLL SCREW		X	1	1	
03-039	+	2BM22330	JOINT CAM		X	1	1	
03-062	+	2BM22340	LEVER SOLENOID		-	4	4	
03-041	+	2BM22350	ACTUATOR CAM		-	1	1	
03-007	+	2BM22360	BUSH 6-9-4		X	1	1	
03-061	+	2BM22370	PLATE SOLENOID		-	4	4	
03-045	+	2BM22380	PLATE SENSOR		-	1	1	
03-033	+	2BM22420	SHAFT JOINT CAM		-	1	1	

## INDEX

Ref No.		Part Code	Description	Applicable Model	SP	120V	230V	Remarks
03-035	+	2BM22430	SHAFT JOINT SCREW		-	1	1	
03-063	+	2BM22440	SPRING LEVER		-	4	4	
03-207	+	2BM22440	SPRING LEVER		-	1	1	
03-038	+	2BM22460	SPRING JOINT CAM		-	2	2	
03-042	+	2BM22470	SPRING ACTUATOR		-	1	1	
03-064	+	2BM22480	SEAL SOLENOID		-	8	8	
03-058	+	2BM22490	CASE HV JOINT DLP		-	1	1	
03-051	+	2BM22500	LID HV UNIT		-	1	1	
03-052	+	2BM22510	EARTH DLP		-	4	4	
03-054	+	2BM22520	EARTH DRUM		-	1	1	
03-053	+	2BM22530	PLATE HV JOINT		-	4	4	
03-055	+	2BM22540	PLATE HV DRUM		-	1	1	
03-115	+	2BM22580	GEAR Z30 Z66H		X	2	2	
03-123	+	2BM22590	GEAR Z33 Z47H		X	1	1	
03-122	+	2BM22600	GEAR Z24		X	2	2	
03-121	+	2BM22610	GEAR Z36		X	1	1	
03-112	+	2BM22620	GEAR Z26		X	1	1	
03-111	+	2BM22630	GEAR Z14 Z30		X	1	1	
03-113	+	2BM22640	GEAR Z23 JO		X	1	1	
03-114	+	2BM22650	GEAR Z33 Z23		X	1	1	
03-109	+	2BM22660	GEAR Z25 JOINT		X	1	1	
03-119	+	2BM22680	GEAR BEVEL Z20		X	1	1	
03-116	+	2BM22700	GEAR Z14 Z36		X	1	1	
03-128	+	2BM22710	GEAR Z27 Z40		X	1	1	
03-120	+	2BM22740	GEAR Z29 JO		X	1	1	
03-205	+	2BM22740	GEAR Z29 JO		X	1	1	
03-129	+	2BM22750	HOUSING CL REGIST		-	1	1	
03-118	+	2BM22760	BUSH SHAFT 6		X	1	1	
03-302	+	2BM22770	BUSH POM MID		X	1	1	
03-132	+	2BM22790	JOINT ROLL REGIST		X	2	2	
03-107	+	2BM22830	SHAFT JOINT BEVEL		-	1	1	
03-131	+	2BM22840	SPRING JOINT REGIST		-	2	2	
03-108	+	2BM22850	SPRING JOINT LOW		-	1	1	
03-301	+	2BM22860	PLATE DRIVE TK		-	1	1	
03-319	+	2BM22870	HOLDER CL TK		-	1	1	
03-311	+	2BM22880	JOINT TK FEED		X	1	1	
03-310	+	2BM22890	JOINT SCRAPER TK		X	1	1	
03-305	+	2BM22910	GEAR Z23 Z33		X	2	2	
03-307	+	2BM22920	GEAR Z21 Z36		X	1	1	
03-304	+	2BM22930	GEAR Z14 Z40		X	1	1	

## INDEX

Ref No.		Part Code	Description	Applicable Model	SP	120V	230V	Remarks
03-303	+	2BM22940	GEAR Z41		X	1	1	
03-314	+	2BM22950	GEAR Z24 L		X	1	1	
03-317	+	2BM22970	GEAR Z30 CL TK		X	1	1	
03-316	+	2BM22980	SHAFT JOINT TK		-	1	1	
03-309	+	2BM22990	SPRING JOINT TK		-	2	2	
02-011		2BM23010	DUCT FAN		-	1	1	
03-203	+	2BM23510	PLATE DRIVE FUSER A		-	1	1	
03-215	+	2BM23520	HOLDER SHAFT FUSER		-	1	1	
03-208	+	2BM23530	PLATE PULLEY		-	1	1	
03-210	+	2BM23540	GEAR P50 Z23		X	1	1	
03-213	+	2BM23550	GEAR Z46 JOINT FUSER		X	1	1	
03-206	+	2BM23560	GEAR Z51		X	2	2	
03-204	+	2BM23570	GEAR Z40 JO		X	1	1	
03-209	+	2BM23580	PULLEY BELT		X	1	1	
03-202	+	2BM23610	HOLDER STMOTOR		-	1	1	
03-211	+	2BM23630	BELT S2M138		X	1	1	
03-306	+	2BM23690	GEAR Z23 TK1		X	1	1	
03-313	+	2BM23700	GEAR Z23 TK2		X	1	1	
03-308	+	2BM23710	GEAR Z37 BEVEL Z25		X	1	1	
03-059	+	2BM23730	HOLDER HARNESS D		-	1	1	
03-019	+	2BM23750	GEAR Z34		X	1	1	
03-016	+	2BM23760	GEAR Z53		X	1	1	
03-069	+	2BM23780	SPRING HV		-	5	5	
03-022	+	2BM23800	BUSH MAIN C		X	1	1	
03-056	+	2BM23810	EARTH DRUM T1		-	1	1	
03-140	+	2BM23840	SEAL CLUTH REG		X	1	1	
03-070	+	2BM23860	PLATE GEAR Z144H BT		-	1	1	
03-004	+	2BM23870	GEAR Z144H BT		X	1	1	
03-071	+	2BM23890	JOINT GEAR BT		-	1	1	
03-049	+	2BM23900	JOINT DRUM BT		-	1	1	
03-048	+	2BM23910	SPRING JOINT DRUM BT		-	1	1	
03-321	+	2BM23920	SEAL CLUTCH TK		-	1	1	
04-005		2BM26050	RAIL PWB		-	2	2	
04-028		2BM26160	SHIELD FORM GASKET 1		-	1	1	
04-029		2BM26180	SHIELD FORM GASKET 3		-	1	1	
04-026		2BM26200	SHIELD FORM GASKET		-	1	1	
04-027		2BM26210	SHIELD FORM GASKET 7		-	1	1	
04-023		2BM26220	SEAL BOX C		-	1	1	
10-038	+	2BM27100	SOLENOID MPF		X	1	1	
10-031		2BM27120	CLUTCH MPF ASSY		X	1	1	

## INDEX

Ref No.		Part Code	Description	Applicable Model	SP	120V	230V	Remarks
10-044		2BM27130	CONN.CORD MPF ASSY		-	1	1	
10-043		2BM27140	CONN.CORD P.SIZE ASSY		-	1	1	
05-054	++	2BM27160	SOLENOID FEED		X	1	1	
05-058	++	2BM27170	PT.SENSOR GP2S30		X	1	1	
10-042		2BM27170	PT.SENSOR GP2S30		X	1	1	
05-116	+	2BM27200	CONN.CORD REG ASSY		-	1	1	
05-046	+	2BM27230	FAN BELT		X	2	2	
02-017		2BM27240	PT.SENSOR GP1S74P		X	1	1	
03-043	+	2BM27240	PT.SENSOR GP1S74P		X	1	1	
05-065	+	2BM27240	PT.SENSOR GP1S74P		X	1	1	
09-031	+	2BM27240	PT.SENSOR GP1S74P		X	3	3	
05-117	+	2BM27250	CONN CORD FEED1 ASSY		-	1	1	
05-043	+	2BM27260	CONN CORD FEED2 ASSY		X	1	1	
08Y-007	+	2BM27350	CLUTCH 26-D		X	1	1	
08M-007	+	2BM27420	CLUTCH 26-E		X	1	1	
08C-007	+	2BM27490	CLUTCH 26-F		X	1	1	
12-102		2BM27610	CONN. CORD DRIVE MAIN ASSY		-	1	1	
03-036	+	2BM27630	CLUTCH 26-C		X	1	1	
03-044	+	2BM27640	SOLENOID CAM		X	1	1	
03-060	+	2BM27650	SOLENOID Y		X	1	1	
03-065	+	2BM27660	SOLENOID M		X	1	1	
03-066	+	2BM27670	SOLENOID C		X	1	1	
03-067	+	2BM27680	SOLENOID K		X	1	1	
03-001	+	2BM27690	MOTOR MAIN		X	3	3	
03-104	+	2BM27690	MOTOR MAIN		X	1	1	
03-005	+	2BM27700	MOTOR DLP		X	2	2	
03-125	+	2BM27760	CLUTCH 26-A		X	1	1	
10-032		2BM27780	CLUTCH 26-B		X	1	1	
09-037	+	2BM27800	SOLENOID FD		X	1	1	
09-059	+	2BM27820	CONN.CORD P.FULLASSY		-	1	1	
09-060	+	2BM27830	CONN.CORD C.SWITCHASSY		-	1	1	
02-010		2BM27890	HUMIDITY SENSOR		X	1	1	
06-003	+	2BM27930	CONN.CORD INNER FUSER		-	1	1	
05-062	+	2BM27940	CONN.CORD EXIT JAM DU		-	1	1	
03-318	+	2BM27950	CLUTCH 26-G		X	1	1	
08K-006	+	2BM27960	CLUTCH 26-H		X	1	1	
12-116		2BM28540	CONN. CORD DLP YM ASSY		X	1	1	
12-112		2BM28640	CONN. CORD DRUM ASSY		X	1	1	
12-007		2BM28670	CONN. CORD FEED ASSY		X	1	1	
12-109		2BM28720	CONN. CORD PF/DU ASSY		X	1	1	

## INDEX

Ref No.		Part Code	Description	Applicable Model	SP	120V	230V	Remarks
12-114		2BM28760	CONN. CORD S02597 ASSY		-	1	1	
02-066	+	2BM28780	CONN.CORD T.SENSOR ASSY		-	1	1	
12-002		2BM28790	CONN. CORD HV T2 ASSY		-	1	1	
12-010		2BM28800	CONN. CORD HV T1 ASSY		-	1	1	
12-014		2BM28810	CONN. CORD HV BY ASSY		-	1	1	
12-013		2BM28820	CONN. CORD HV BM ASSY		-	1	1	
12-012		2BM28830	CONN. CORD HV BC ASSY		-	1	1	
12-011		2BM28840	CONN. CORD HV BK ASSY		-	1	1	
12-009		2BM28850	CONN. CORD HV CR ASSY		-	1	1	
12-003		2BM28860	CONN. CORD HV G ASSY		-	1	1	
12-004		2BM28870	CONN. CORD HV MAIN ASSY		-	1	1	
02-052	+	2BM40060	CUT WASHER		-	1	1	
03-141	+	2BM40060	CUT WASHER		X	1	1	
08Y-002	+	2BM40060	CUT WASHER		X	2	2	
08M-002	+	2BM40060	CUT WASHER		X	2	2	
08C-003	+	2BM40060	CUT WASHER		X	2	2	
08K-002	+	2BM40060	CUT WASHER		X	3	3	
03-142	+	2BM40150	SEAL CLUTH D1234		X	1	1	
06-055	+	2BM41080	STUD SCREW 465		X	2	2	
02-079		2BM42010	SPRING CONN FEED		-	4	4	
02-071		2BM42030	BRACKET CONN DRUM		-	2	2	
02-089		2BM42040	STOPPER IMAGE		X	1	1	
02-042	+	2BM42220	BUSH SCREW TK F		-	1	1	
02-043	+	2BM42240	BKT SEAL OIL		-	1	1	
02-041	+	2BM42250	GEAR FEED TK Z23		-	1	1	
02-085		2BM42260	BKT SENSOR LOW D4		-	1	1	
02-136		2BM42270	BKT SENSOR UP D4		-	1	1	
02-051	+	2BM42280	CUT WASHER		-	1	1	
02-111		2BM42290	FOOT R		X	2	2	
02-118		2BM42300	FOOT F		X	2	2	
02-038	+	2BM42310	SEAL FEED TK D		-	1	1	
02-210		2BM42430	LOCK PROCESS R		X	1	1	
02-072		2BM42440	SPRING CONN DRUM		-	2	2	
02-078		2BM42450	STUD SCREW 485		-	4	4	
04-015		2BM42510	PLATE CONTROLLER A		-	1	1	
02-026		2BM42520	PLATE EARTH DRV FUS		-	1	1	
02-012		2BM42530	PLATE EARTH MAIN B		-	1	1	
02-027		2BM42540	PLATE EARTH DRV TK A		-	1	1	
02-138		2BM42550	PLATE EARTH DRV TK B		-	1	1	
02-018		2BM42560	PLATE EARTH L		-	1	1	



## INDEX

Ref No.		Part Code	Description	Applicable Model	SP	120V	230V	Remarks
09-117	+	2BM42590	WIRE EARTH FD		-	1	1	
02-030	+	2BM42600	SEAL FEED TONER		-	1	1	
02-134		2BM42620	SEAL STAY PRO A		-	1	1	
02-220		2BM42660	SPRING FRAME PRO		-	4	4	
06-050	+	2BM42710	LABEL CAUTION S		-	1	1	
02-113		2BM42740	SHIELD REG SENSOR B		-	1	1	
05-119	++	2BM42760	SEAL SIDE SENS WASTE		-	1	1	
05-012	+	2BM43010	SLOPE IMAGE UNIT		-	1	1	
05-120	+	2BM43040	PAD BOTTOM FEED		-	1	1	
05-121	+	2BM43050	SPRING EARTH FEED		-	1	1	
05-066	+	2BM43060	PLATE SUPPORT FEED		-	1	1	
05-070	+	2BM43070	PLATE EARTH BOTTOM		-	1	1	
05-090	++	2BM43080	METAL BUSH TRANS		X	1	1	
05-056	++	2BM43100	PLATE DU SENSOR		-	1	1	
05-061	++	2BM43120	REFLECTOR DU SENSOR		-	1	1	
05-062	++	2BM44030	CONN.CORD FEED EARTH ASSY		-	1	1	
05-122	+	2BM44060	CONN. CORD FEED CL ASSY		-	1	1	
11-087	++	2BM45020	PUSH NUT		-	2	2	
01-001		2BM68010	PANEL ASSY ENGLISH	Excl.KMFR/KMIT	X	1	1	
01-001		2BM68020	PANEL ASSY FRENCH	KMFR only	X	-	1	
01-001		2BM68030	PANEL ASSY ITALIAN	KMIT only	X	-	1	
01-004		2BM68050	KEY TOP ASSY		X	1	1	
10-009		2BM68140	PLATE BOTTOM MPF ASSY		X	1	1	
10-034		2BM68150	PLATE DRIVE MPF ASSY		X	1	1	
05-050	+	2BM68160	GUIDE LEFT ASSY		X	1	1	
09-201		2BM68190	TRAY FU ASSY		X	1	1	
09-101		2BM68200	COVER FD ASSY		X	1	1	
03-216	+	2BM68240	SHAFT JOINT FUSER ASSY		X	1	1	
11-075	++	2BM68270	BLADE CLEANER ASSY		X	1	1	
02-001		2BM93410	LK-800 SCANNER UNIT		X	1	1	
01-021		2CK00010	COVER FRONT ASSY		X	1	1	
09-001		2CK00230	FACE DOWN UNIT		X	1	1	
02-031		2CK00370	FEED TONER D4 ASSY		X	1	1	
02-082		2CK00380	TUBE TONER D4 ASSY		X	1	1	
02-083		2CK00540	DUCT WASTE TONER UNIT A		X	1	1	
04-001		2CK01060	ECU KP-992 ASSY E	Incl. KMTW	X	-	1	
04-007		2CK01070	RER KP-993 ASSY		X	1	1	
06-041	+	2CK01080	FSR KP-997 ASSY		-	1	1	
03-101	+	2CK01150	DVF KP-1011 ASSY		X	1	1	
05-124	+	2CK01160	FED KP-1013 ASSY		X	1	1	

## INDEX

Ref No.	Part Code	Description		Applicable Model	SP	120V	230V	Remarks
02-023	2CK01170	OPR KP-995 ASSY			X	1	1	
10-047	2CK01180	MPF KP-1015 ASSY			X	1	1	
09-003	+ 2CK01190	FCD KP-1022 ASSY			X	1	1	
04-018	2CK01250	POWER SUPPLY 200 UNIT			X	-	1	
04-018	2CK01260	POWER SUPPLY 120 UNIT			X	1	-	
04-001	2CK01270	ECU KP-992 ASSY U		Excl. KMTW	X	1	-	
04-008	2CK01300	P.W.BOARD ASSY	MAIN KP-991		X	1	1	
04-021	2CK01320	P.W.BOARD ASSY	DIMM KP-839		X	1	1	
02-119	2CK02010	SHEET INNER FRONT			-	1	1	
05-125	+ 2CK02030	STOPPER PI			-	1	1	
02-102	2CK02040	FRAME BASE			-	1	1	
02-201	2CK02060	FRAME REAR PROCESS			-	1	1	
02-114	2CK02120	FRAME FRONT			-	1	1	
02-095	2CK02130	SLIDE RAIL LOW			-	2	2	
02-124	2CK02140	SLIDE RAIL PRO			-	2	2	
02-202	2CK02160	PIN REAR PROCESS			-	1	1	
02-133	2CK02170	SEAL RAIL PRO B			-	2	2	
02-097	2CK02190	SHIELD REG SENSOR A			-	1	1	
02-064	+ 2CK02220	BKT SENSOR WASTE A			-	1	1	
02-075	2CK02240	SPRING CONN DLP			-	8	8	
02-074	2CK02250	BKT CONN D12 A			-	1	1	
02-076	2CK02260	BKT CONN D34 A			-	2	2	
01-022	+ 2CK04010	COVER FRONT			-	1	1	
01-015	2CK04030	COVER REAR			X	1	1	
01-025	+ 2CK05050	LABEL DIAGRAM D			-	1	1	
01-026	+ 2CK05060	LABEL DIAGRAM C			-	1	1	
01-028	2CK05070	SEAL COLOR SYMBOL			X	1	1	
10-056	2CK05080	LABEL PAPER TYPE E			X	1	1	
10-048	+ 2CK07510	HOLDER CONN.CORD			-	1	1	
10-049	+ 2CK07520	SEAL CONN.CORD MPF			-	1	1	
10-050	2CK07530	COVER CONN.CORD MPF			-	1	1	
10-051	2CK07540	SEAL MPF			-	2	1	
10-052	+ 2CK07550	BASE TRAY MPF			-	1	1	
10-053	+ 2CK07560	SEAL CONN.CORD MPF B			-	1	1	
10-057	2CK07580	SPRING BOTTOM MPF			X	1	1	
08Y-006	+ 2CK14020	BKT CLUTCH D1			X	1	1	
08Y-014	+ 2CK14060	BUSH BKT CLUTCH D1			X	1	1	
08M-006	+ 2CK14080	BKT CLUTCH D2			X	1	1	
08C-006	+ 2CK14120	BKT CLUTCH D3			X	1	1	
08K-005	+ 2CK14170	BKT CLUTCH D4			X	1	1	

## INDEX

Ref No.		Part Code	Description	Applicable Model	SP	120V	230V	Remarks
08K-008	+	2CK14220	GEAR Z24-Z18-8 D4		X	1	1	
08K-001	+	2CK14230	GEAR Z14-Z12 D4		X	1	1	
08Y-001	+	2CK14240	SHAFT GEAR D12		X	1	1	
08M-001	+	2CK14240	SHAFT GEAR D12		X	1	1	
08Y-009	+	2CK14250	GEAR Z30H-Z17H D12		X	1	1	
08M-009	+	2CK14250	GEAR Z30H-Z17H D12		X	1	1	
08Y-013	+	2CK14280	GEAR Z15-8 D123		X	1	1	
08M-013	+	2CK14280	GEAR Z15-8 D123		X	1	1	
08C-001	+	2CK14280	GEAR Z15-8 D123		X	1	1	
08Y-010	+	2CK14290	GEAR Z15-Z10 D123		X	1	1	
08M-010	+	2CK14290	GEAR Z15-Z10 D123		X	1	1	
08C-008	+	2CK14290	GEAR Z15-Z10 D123		X	1	1	
08Y-003	+	2CK14300	JOINT D1234		X	1	1	
08M-003	+	2CK14300	JOINT D1234		X	1	1	
08C-004	+	2CK14300	JOINT D1234		X	1	1	
08K-003	+	2CK14300	JOINT D1234		X	1	1	
08Y-011	+	2CK14310	SHAFT CLUTCH D1234		X	1	1	
08M-011	+	2CK14310	SHAFT CLUTCH D1234		X	1	1	
08C-009	+	2CK14310	SHAFT CLUTCH D1234		X	1	1	
08K-009	+	2CK14310	SHAFT CLUTCH D1234		X	1	1	
08Y-012	+	2CK14330	GEAR Z14D-8 D1234		X	1	1	
08M-012	+	2CK14330	GEAR Z14D-8 D1234		X	1	1	
08C-010	+	2CK14330	GEAR Z14D-8 D1234		X	1	1	
08K-010	+	2CK14330	GEAR Z14D-8 D1234		X	1	1	
08C-002	+	2CK14420	GEAR Z30H-Z17H D3		X	1	1	
08Y-008	+	2CK14430	GEAR Z14-8 JOINT D12		X	1	1	
08M-008	+	2CK14430	GEAR Z14-8 JOINT D12		X	1	1	
08K-007	+	2CK14440	GEAR Z30H-Z22H D4		X	1	1	
05-126	+	2CK16010	BUSH CONDUCTIVE		X	3	3	
06-011	+	2CK16010	BUSH CONDUCTIVE		X	2	2	
11-013	+	2CK16010	BUSH CONDUCTIVE		X	4	4	
11-010	+	2CK16020	PULLY RAIL		-	1	1	
11-068	++	2CK16130	BUSH SWEEP R		X	1	1	
11-081	++	2CK16140	BUSH SWEEP F		X	1	1	
11-076	++	2CK16150	ROLLER SWEEP		-	1	1	
11-071	++	2CK16170	SEAL SWEEP SIDE F		-	2	2	
11-086	++	2CK16180	SEAL GUIDE SWEEP		-	1	1	
11-007	+	2CK16220	SPRING IMAGE PRESS		X	2	2	
05-127	+	2CK17010	ROLLER MIDDLE		X	1	1	
05-128	+	2CK17020	GEAR Z22S-Z14S		X	1	1	

## INDEX

Ref No.		Part Code	Description	Applicable Model	SP	120V	230V	Remarks
05-157	++	2CK17030	GEAR Z22S		X	1	1	
05-129	+	2CK17040	GEAR IDLE Z22S		X	1	1	
05-131	+	2CK17050	GEAR IDLE Z14S		X	1	1	
05-130	+	2CK17060	GEAR IDLE Z26S		X	1	1	
05-133	++	2CK17070	BUSH TRANS UNIT		X	1	1	
05-134	++	2CK17080	CAM TRANS R		X	1	1	
05-135	+	2CK17110	GUIDE PAPER REGIST		-	1	1	
05-136	+	2CK17120	PLATE REG SENSOR		-	1	1	
05-137	+	2CK17140	PLATE TC GEAR		-	1	1	
05-138	+	2CK17150	PLATE GEAR IDLE		-	1	1	
05-139	+	2CK17160	PLATE EARTH CASE		-	1	1	
05-140	+	2CK17170	SHAFT TC GEAR		-	1	1	
05-141	+	2CK17180	SHAFT GEAR IDLE		-	1	1	
05-142	++	2CK17191	SHAFT BELT R		-	1	1	
05-143	+	2CK17200	SHEET REGIST		X	1	1	
05-144	+	2CK17241	SEAL BELT LOW		X	4	4	
05-146	++	2CK17271	SEAL PLATE BELT		X	2	2	
05-147	++	2CK17281	SEAL BELT UP		-	1	1	
05-148	+	2CK17310	LABEL CAUTION TC		-	1	1	
05-149	+	2CK17320	BUSH TC		-	1	1	
05-150	++	2CK17330	CAM TRANS F		X	1	1	
05-151	++	2CK17340	RIB BELT		-	6	6	
05-152	+	2CK17370	SHEET MIDDLE		-	1	1	
05-154	+	2CK17390	SEAL FEED FRONT		-	1	1	
05-155	+	2CK17400	SEAL FEED BOTTOM		-	1	1	
05-156	+	2CK17410	TAPE EARTH BELT		-	1	1	
05-044	+	2CK17420	GEAR Z23S		X	1	1	
05-158	+	2CK17430	PLATE GEAR FUSER A		-	1	1	
05-149	+	2CK17440	SEAL COVER FG		-	1	1	
05-161	+	2CK17460	SHEET GUIDE DU		-	1	1	
05-092	++	2CK17480	BELT TRANS		X	2	2	
05-160	++	2CK17490	PLATE BELT WIDE		-	1	1	
05-214	++	2CK17510	ROLLER TRANSFER D		X	1	1	
05-215	++	2CK17520	ROLLER TRANSFER U		X	1	1	
05-202	++	2CK17530	BELT SEPARATOR		-	1	1	
05-211	++	2CK17540	HOUSING TRANS		-	1	1	
05-223	++	2CK17550	LEVER TRANS F		-	1	1	
05-218	++	2CK17560	LEVER TRANS R		X	1	1	
05-207	++	2CK17570	GEAR TC Z14S		X	1	1	
05-205	++	2CK17580	GEAR TC Z18S		X	1	1	

## INDEX

Ref No.		Part Code	Description	Applicable Model	SP	120V	230V	Remarks
05-208	++	2CK17590	PLATE TC JOINT		-	1	1	
05-213	++	2CK17600	PLATE EARTH TC		-	1	1	
05-209	++	2CK17610	PLATE CONTACT TC		-	1	1	
05-222	++	2CK17620	SPRING TC L		-	1	1	
05-219	++	2CK17630	SPRING TC R		-	1	1	
05-221	++	2CK17640	BEARING SEPARATOR		X	1	1	
05-212	++	2CK17650	ERASER TC		X	1	1	
05-216	++	2CK17660	PLATE CONTACT ERASER		-	1	1	
05-204	++	2CK17670	PLATE SPACER TC		-	1	1	
05-047	+	2CK17750	DUCT FEED WIDE		-	1	1	
05-093	++	2CK17760	PULLEY BELT L-WIDE		X	2	2	
05-153	++	2CK17770	PULLEY BELT R-WIDE		X	2	2	
05-091	++	2CK17780	SHAFT BELT L-WIDE		-	1	1	
05-089	++	2CK17790	SHAFT TENSION WIDE		-	2	2	
05-167	++	2CK17800	RIB BELT SIDE		-	2	2	
06-018	+	2CK20010	ROLLER HEAT		X	1	1	
06-019	+	2CK20020	ROLLER PRESS		X	1	1	
06-008	+	2CK20030	BEARING 6806ZNR		X	4	4	
06-016	+	2CK20040	BUSH HEAT ROLLER		X	4	4	
06-039	+	2CK20050	FRAME FRONT FUSER		-	1	1	
06-012	+	2CK20060	FRAME REAR FUSER		-	1	1	
06-038	+	2CK20070	PLATE PRESS FRONT		-	1	1	
06-013	+	2CK20080	PLATE PRESS REAR		-	1	1	
06-017	+	2CK20090	ROLLER EXIT		X	1	1	
06-007	+	2CK20100	GEAR FUSER Z43		X	1	1	
06-006	+	2CK20110	GEAR INPUT Z30		X	1	1	
06-015	+	2CK20120	SHAFT PRESS FUSER		-	2	2	
06-048	+	2CK20140	STAY UPPER SEPARATOR		-	1	1	
06-043	+	2CK20150	STAY LOWER SEPARATOR		-	1	1	
06-040	+	2CK20160	BKT LAMP FRONT		-	1	1	
06-005	+	2CK20170	BKT LAMP REAR		-	1	1	
06-042	+	2CK20180	COVER FRONT FUSER		-	1	1	
06-027	+	2CK20190	GUIDE UPPER ENTRANCE		-	1	1	
06-028	+	2CK20210	GUIDE LOWER EXIT		-	1	1	
06-009	+	2CK20220	GEAR FUSER IDLE Z24		X	2	2	
06-036	+	2CK20250	LAMP HEATER UP 120		X	1	-	
06-037	+	2CK20260	LAMP HEATER LOW 120		X	1	-	
06-036	+	2CK20270	LAMP HEATER UP 240		X	-	1	
06-037	+	2CK20280	LAMP HEATER LOW 240		X	-	1	
06-057	+	2CK20300	LABEL OPERATE FUSER		-	1	1	

## INDEX

Ref No.		Part Code	Description	Applicable Model	SP	120V	230V	Remarks
06-014	+	2CK20320	SPRING PRESSURE		X	2	2	
06-047	+	2CK20330	SHEET PROTECT STAY		-	1	1	
06-046	+	2CK20340	SPRING SEPARATOR		X	6	6	
06-053	+	2CK20530	COVER UPPER FUSER		-	1	1	
06-054	+	2CK20540	COVER FRONT FIX CLN		-	1	1	
06-052	+	2CK20550	COVER REAR FIX CLN		-	1	1	
06-056	+	2CK20560	LID FUSER CLN		-	1	1	
09-017	+	2CK21030	PIN JOINT		-	1	1	
09-024	+	2CK21040	PIN IDLE 1		-	3	3	
09-025	+	2CK21050	PIN IDLE 2		-	3	3	
09-026	+	2CK21070	ARM PRESS DLP		-	2	2	
09-028	+	2CK21090	FAN FD		X	1	1	
09-062	+	2CK21100	SPRING PRESS DLP		-	1	1	
09-043	+	2CK21110	ROLLER FD A		X	1	1	
09-063	+	2CK21120	ROLLER FD B		X	2	2	
09-061	+	2CK21140	SPRING PRESS DLP 1		-	1	1	
09-054	+	2CK21150	BRUSH ERASER		X	1	1	
09-106	+	2CK21150	BRUSH ERASER		-	1	1	
09-051	+	2CK21270	PULLEY EXIT A		X	2	2	
03-074	+	2CK22010	JOINT MIX		-	4	4	
03-021	+	2CK22020	GEAR Z30 JOINT MIX		X	4	4	
03-031	+	2CK22030	PLATE DRIVE MAIN A		-	1	1	
03-075	+	2CK22040	SPRING JOINT MIX		-	4	4	
03-017	+	2CK22050	PLATE DRIVE MAIN C		-	1	1	
03-009	+	2CK22060	GEAR Z30 Z58H		X	1	1	
03-015	+	2CK22070	GEAR Z30 Z57H		X	2	2	
03-076	+	2CK22080	RING JOINT MIX		-	4	4	
03-025	+	2CK22130	CLUTCH ASSY 2		X	4	4	
03-030	+	2CK22140	HOLDER ASSY CHK		X	1	1	
03-027	+	2CK22150	HOLDER ASSY CHY		X	1	1	
03-028	+	2CK22160	HOLDER ASSY CHM		X	1	1	
03-029	+	2CK22170	HOLDER ASSY CHC		X	1	1	
03-047	+	2CK22180	HOLDER ASSY A		X	1	1	
03-072	+	2CK22210	WASHER DRIVE SHAFT		-	1	1	
03-137	+	2CK22300	GEAR Z14		X	1	1	
03-134	+	2CK22320	GEAR Z22 Z27		X	1	1	
03-136	+	2CK22330	SHAFT CL MID		X	1	1	
03-127	+	2CK22340	PLATE DRIVE FEED A		-	1	1	
03-117	+	2CK22350	PLATE DRIVE FEED B		-	1	1	
03-102	+	2CK22360	PLATE DRIVE FEED C		-	1	1	

## INDEX

Ref No.		Part Code	Description	Applicable Model	SP	120V	230V	Remarks
03-126	+	2CK22370	SHAFT JOINT MID		-	1	1	
03-138	+	2CK22380	GEAR Z23 BEA ASSY		X	1	1	
03-130	+	2CK22390	SHAFT JOINT REGIST		-	1	1	
03-110	+	2CK22400	GEAR Z23 S		X	1	1	
03-106	+	2CK22410	GEAR Z22 JOINT BE		X	1	1	
03-320	+	2CK22420	SEAL TK		-	1	1	
03-046	+	2CK22430	SHAFT JOINT DRUM A		-	1	1	
04-011		2CK26010	PANEL CONTROLLER		-	1	1	
04-022		2CK26030	FAN MOTOR		X	1	1	
04-004		2CK26050	BOX ENGINE		-	1	1	
04-006		2CK26060	BOX CONTROLLER ASSY		-	1	1	
04-024		2CK26070	SEAL EARTH PWB		-	1	1	
12-016		2CK27000	CONN. CORD APC-B ASSY		-	1	1	
12-117		2CK27020	CONN. CORD DLP CK-B ASSY		X	1	1	
12-005		2CK27070	CONN. CORD FEED-HUMIDITY ASSY		-	1	1	
12-110		2CK27080	CONN. CORD TRANSFER-B ASSY		X	1	1	
12-101		2CK27100	CONN. CORD CMT-DRV-HVM ASSY		-	1	1	
12-104		2CK27110	CONN. CORD KMT-DRMT ASSY		-	1	1	
12-111		2CK27120	CONN. CORD FUSER-B ASSY		X	1	1	
12-108		2CK27160	CONN. CORD HV-T2-B ASSY		-	1	1	
09-006	+	2CK27170	CONN. CORD F.DOWN-B ASSY		-	1	1	
12-022		2CK27180	CONN. CORD COVER SW.-B ASSY		-	1	1	
12-107		2CK27190	CONN. CORD OP.RERAY-B ASSY		-	1	1	
12-019		2CK27200	CONN. CORD POWER E.-B ASSY		-	1	1	
12-018		2CK27210	CONN. CORD HEAT CONT-B ASSY		-	1	1	
04-020		2CK27220	CONN.CORD PS1-B ASSY		-	1	1	
12-021		2CK27230	CONN. CORD E2P-KTS ASSY		-	1	1	
10-054		2CK27240	CONN.CORD P.LENGTH ASSY		-	1	2	
05-162	+	2CK27280	CONN.CORD EARTH CASE ASSY		-	1	1	
12-017		2CK27300	CONN. CORD PS2-B ASSY		-	1	1	
12-020		2CK27310	CONN. CORD SW.RELAY ASSY		-	1	1	
05-163	+	2CK27330	CONN.CORD REGIST EARTH AS		-	1	1	
03-201	+	2CK27510	MOTOR STEP		X	1	1	
05-164	++	2CK27520	CLUTCH SP CAM		X	1	1	
03-135	+	2CK27530	CLUTCH 26-I		X	1	1	
10-055	+	2CK27540	SWITCH BYPASS		X	1	1	
02-009		2CK27560	FAN FUSER 12V		X	1	1	
03-124	+	2CK27580	CLUTCH REGIST 8		X	1	1	
02-123		2CK27590	INTERLOCK SWITCH		X	1	1	
04-019		2CK27600	AC SWITCH		X	1	1	

## INDEX

Ref No.		Part Code	Description	Applicable Model	SP	120V	230V	Remarks
04-016		2CK27630	FAN PSU		X	1	1	
05-165	+	2CK27650	PT.SENSOR KR1207-KM2		X	1	1	
04-025		2CK27680	SHIELD FORM GASKET L		-	1	1	
02-014		2CK28170	PWB HV MAIN		X	1	1	
02-022		2CK28180	PWB HV TC		X	1	1	
02-087		2CK28190	PWB HV DLP		X	1	1	
		2CK68030	DR-803C DRIVE UNIT C		X	1	1	
05-076	+	2CK68040	BELT ASSY		X	1	1	
02-063		2CK68050	TONER SENSOR ASSY		X	1	1	
10-001		2CK68060	COVER RIGHT MPF ASSY		X	1	1	
P-001		2CK77010	PACKING ASSY CE		X	-	1	
P-001		2CK77020	PACKING ASSY CU		X	1	-	
		2CK93010	DK-803 DRUM UNIT		X	1	1	
		2CK93030	DV-803Y DEVELOPER YELLOW		X	1	1	
		2CK93050	DV-803M DEVELOPER MAGENTA		X	1	1	
		2CK93070	DV-803C DEVELOPER CYAN		X	1	1	
		2CK93090	DV-803K DEVELOPER BLACK		X	1	1	
		2CK93110	TR-803P PRI TRANSFER UNIT		X	1	1	
		2CK93130	FK-803(E) FUSER UNIT (E)		X	-	1	
		2CK93140	FK-803(U) FUSER UNIT (U)		X	1	-	
		2CK93160	FE-803 FEED UNIT		X	1	1	
05-201	+	2CK93170	TR-803S SEC TRANSFER UNIT		X	1	1	
		2CK93180	DR-803A DRIVE UNIT A		X	1	1	
		2CK93190	DR-803B DRIVE UNIT B		X	1	1	
		2CK93200	DR-803D DRIVE UNIT D		X	1	1	
A-001		2CK93210	TB-800 WASTE TONER BOTTLE		X	1	1	
07-101	+	2CK93230	MC-803 MAIN CHARGER ASSY		X	1	1	
11-056	+	2CK93240	BC-803 BRUSH CLEANER		X	1	1	
02-044	+	4AK73480	SEAL TONER A		-	1	1	
A-004		4AK85050	GRID CLEANER 3 ASSY		X	1	1	
02-121		60804120	MAGNET CATCH		-	2	2	
03-057	+	84363280	METAL BUSH KD		X	1	1	
05-015	+	84363280	METAL BUSH KD		X	4	4	
03-212	+	84363285	BUSHING SBK		X	1	1	
04-012		84363345	PLATE OPTION		-	2	2	
09-039	+	84364105	SPRING SOL		-	1	1	
05-072	+	84365850	BUSH POM		X	2	2	
05-085	++	84365850	BUSH POM		X	3	3	
04-013		84393785	SCREW OP		X	4	4	
06-062	+	84394400	PULLEY EXIT		X	4	4	



## INDEX

Ref No.		Part Code	Description	Applicable Model	SP	120V	230V	Remarks
03-214	+	84395640	BUSH MAG		X	1	1	
04-014		84395650	GUIDE CF CARD		-	1	1	
06-022	+	84395660	NUT FUSER A		-	4	4	
06-061	+	84395665	SHAFT EXIT		-	2	2	
06-035	+	84395675	NUT FUSER		-	2	2	
03-322	+	C2893950	SHIM 6.2-0.25T		-	1	1	
04-003		M2104220	EDGING EDS-1717U		-	4	4	
03-008	+	M2104260	EDGING EDS-0607U		-	3	3	
03-103	+	M2104260	EDGING EDS-0607U		-	1	1	
03-312	+	M2104260	EDGING EDS-0607U		-	1	1	
05-123	+	M2105740	MINIATURE CLAMP,UAMS-05S-2		-	1	1	
03-143	+	M2109180	WIRE SADDLE,LWS-1S		X	1	1	
10-040	+	M2504030	EDGING,ES-0505-2		-	1	1	

## **KYOCERA MITA AMERICA, INC.**

### **Headquarters:**

225 Sand Road, P.O. Box 40008  
Fairfield, New Jersey 07004-0008  
TEL : (973) 808-8444  
FAX : (973) 882-6000

### **New York Show Room:**

1410 Broadway 23rd floor  
New York, NY 10018  
TEL : (917) 286-5400  
FAX : (917) 286-5402

### **Northeastern Region:**

225 Sand Road, P.O. Box 40008  
Fairfield, New Jersey 07004-0008  
TEL : (973) 808-8444  
FAX : (973) 882-4401

### **Midwestern Region:**

201 Hansen Court Suite 119  
Wood Dale, Illinois 60191  
TEL : (630) 238-9982  
FAX : (630) 238-9487

### **Western Region:**

14101 Alton Parkway,  
Irvine, California 92618-7006  
TEL : (949) 457-9000  
FAX : (949) 457-9119

### **Southeastern Region:**

1500 Oakbrook Drive,  
Norcross, Georgia 30093  
TEL : (770) 729-9786  
FAX : (770) 729-9873

### **Southwestern Region:**

2825 West Story Road,  
Irving, Texas 75038-5299  
TEL : (972) 550-8987  
FAX : (972) 570-4704

### **Dallas Parts Distribution Center & National Training Center:**

2825 West Story Road,  
Irving, Texas 75038-5299  
TEL : (972) 659-0055  
FAX : (972) 570-5816

## **KYOCERA MITA CANADA, LTD.**

6120 Kestrel Road, Mississauga,  
Ontario L5T 1S8, Canada  
TEL : (905) 670-4425  
FAX : (905) 670-8116

## **KYOCERA MITA MEXICO, S.A. DE C.V.**

Av. 16 de Septiembre #407  
Col. Santa Inés,  
02130 Azcapotzalco  
México, D.F. México  
TEL : (55) 5383-2741  
FAX : (55) 5383-7804

©2003 KYOCERA MITA CORPORATION

<http://www.kyoceramita.com>

 **KYOCERA** is a trademark of Kyocera Corporation

**mita** is a registered trademark of KYOCERA MITA CORPORATION

Printed in U.S.A.

*WWW.SERVICE-MANUAL.NET*