



---

# **FS-3540MFP**

# **FS-3640MFP**

## **PARTS LIST**

Published in December 2014  
2MCPL072  
Rev.2



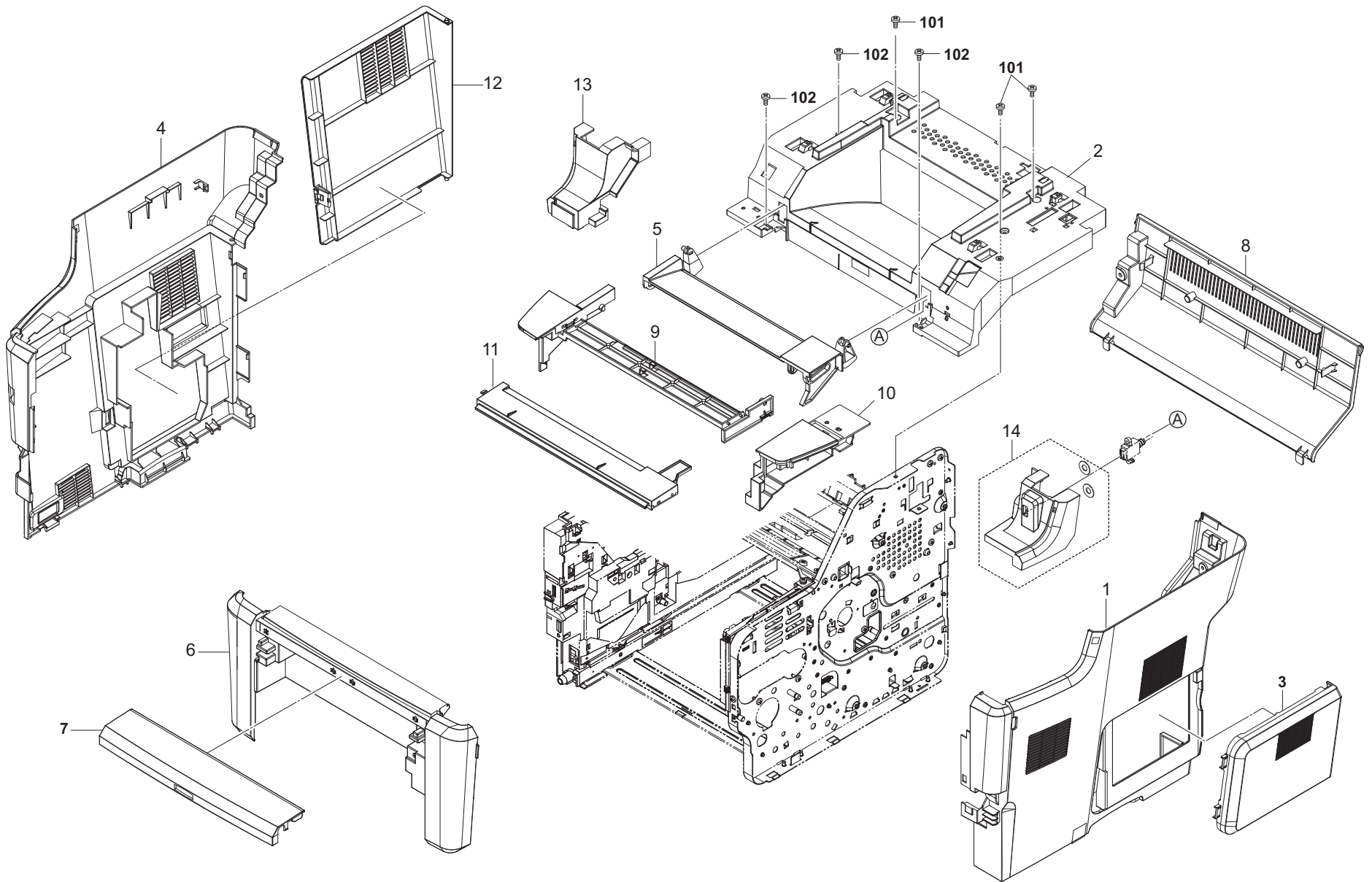


FIG. 1 Covers

2MC/2MD-1

Ref. No.	Part.No.	Alternative.	Description	Quantity		
				120	230	240
1	302MC94040	2MC94040	PARTS COVER RIGHT ASSY SP	1	1	1
2	302LW94170	2LW94170	PARTS COVER TOP ASSY	1	1	1
3	302MC04020	2MC04020	COVER DIMM	1	1	1
4	302MC94050	2MC94050	PARTS COVER LEFT ASSY SP	1	1	1
5	302LW94110	2LW94110	PARTS LID TOP A ASSY SP	1	1	1
6	302MC94060	2MC94060	PARTS COVER FRONT ASSY SP	1	1	1
7	302LW94140	2LW94140	PARTS COVER FRONT B ASSY SP	1	1	1
8	302MC04070	2MC04070	COVER REAR A	1	1	1
9	302MC04080	2MC04080	LID TOP C	1	1	1
10	302MC04100	2MC04100	COVER INNER R B	1	1	1
11	302LW04030	2LW04030	LID TOP B	1	1	1
12	302MC94081	2MC94081	PARTS COVER SIDE ASSY SP	1	1	1
13	302MC04050	2MC04050	COVER INNER L	1	1	1
14	302MC94070	2MC94070	PARTS COVER INNER R ASSY SP	1	1	1

Ref. No.	Part.No.	Alternative.	Description	Quantity		
				120	230	240
101	7BB200410H	BB105700	+BIND T.T P SCREW 4X10			
102	7BB100408H1	BB105830	+BIND T.T S SCREW 4X8			

•Parts with Ref.No. indicate maintenance parts and the ones without it indicate out of the above.

•Parts with "•" are component parts or sub-assemblies of the assembly appearing immediately above them.  
 •Parts with "••" are component parts or sub-assembly with "•" appearing immediately above them.

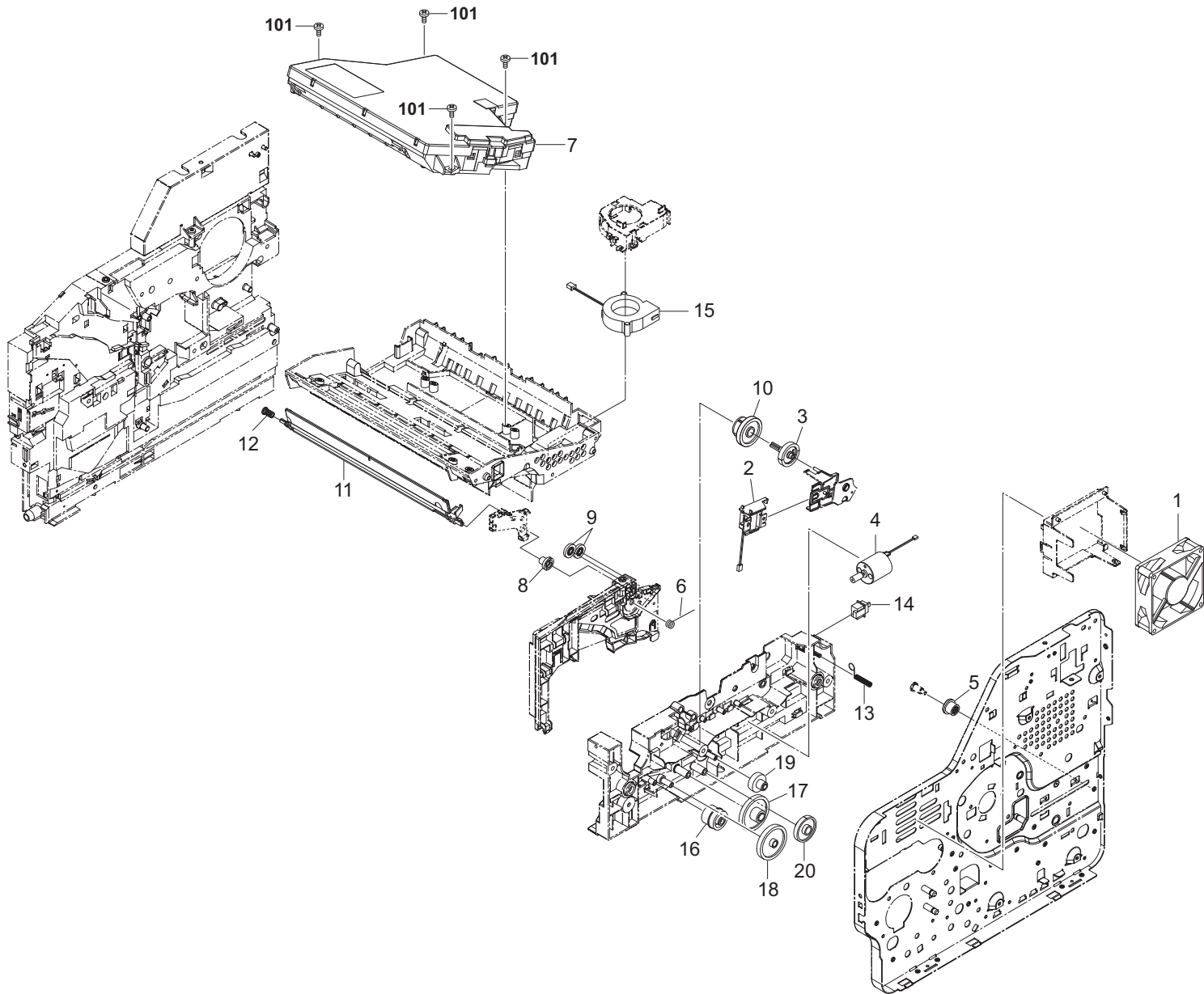


FIG. 2 Frames 1

2MC/2MD-1

Ref. No.	Part.No.	Alternative.	Description	Quantity		
				120	230	240
1	302J044040	2J044040	FAN R 80	1	1	1
2	302F944071	2F944071	SOLENOID DLP	1	1	1
3	302F931191	2F931191	GEAR DLP Z31H	1	1	1
4	302F994320	2F994320	PARTS MOTOR LIFT ASSY SP	1	1	1
5	302F925480	2F925480	PULLEY RAIL DOUBLE	1	1	1
6	302F912360	2F912360	SPRING SHUTTER ARM	1	1	1
7	302J193040	2J193040	LK-350	1	1	1
8	302F912340	2F912340	GEAR SHUTTER Z16S	1	1	1
9	302F912330	2F912330	GEAR SHUTTER Z18S	2	2	2
10	302F931600	2F931600	CLUTCH DLP	1	1	1
11	302F912310	2F912310	COVER DRUM SHUTTER	1	1	1
12	302F912370	2F912370	SPRING SHUTTER L	1	1	1
13	302F925872	2F925872	SPRING RAIL SW	1	1	1
14	7SP01000001+H01	SP044290	SW.PUSH	1	1	1
15	302J044071	2J044071	FAN MOTOR	1	1	1
16	302F909550	2F909550	GEAR Z26Z15	1	1	1
17	302F909530	2F909530	GEAR Z50Z16	1	1	1
18	302F909540	2F909540	GEAR Z49	1	1	1
19	302F909510	2F909510	GEAR Z40HZ18	1	1	1
20	302F909520	2F909520	GEAR Z60Z16	1	1	1

Ref. No.	Part.No.	Alternative.	Description	Quantity		
				120	230	240
101	7BB200416H1	BB105840	+BIND T.T P SCREW 4X16			

•Parts with Ref.No. indicate maintenance parts and the ones without it indicate out of the above.

•Parts with "•" are component parts or sub-assemblies of the assembly appearing immediately above them.  
 •Parts with "••" are component parts or sub-assembly with "•" appearing immediately above them.

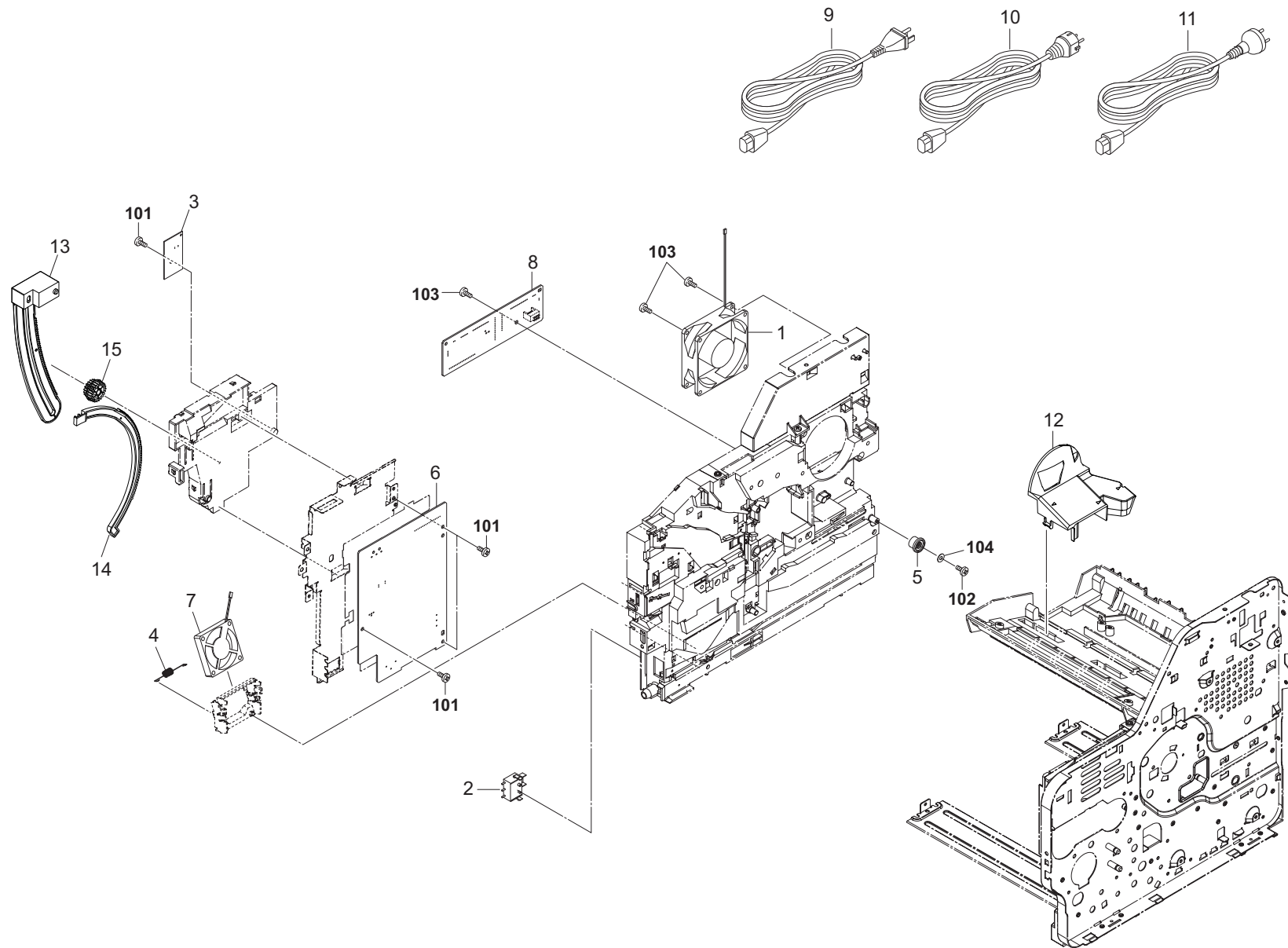


FIG. 3 Frames 2

2MC/2MD-2

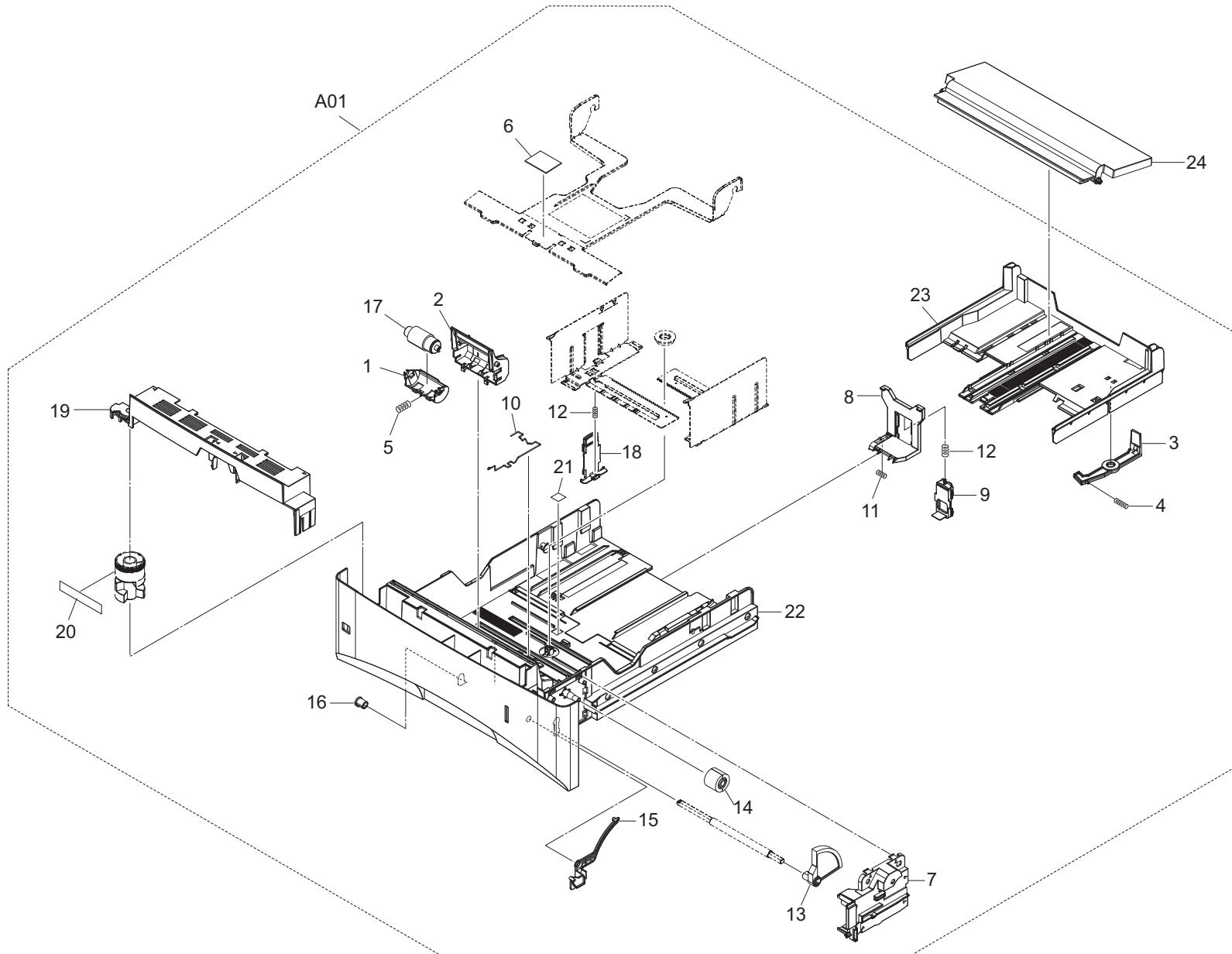
Ref. No.	Part.No.	Alternative.	Description	Quantity		
				120	230	240
1	302F944150	2F944150	FAN L 80	1	1	1
2	5FSP03090001+01	SP0A0360	PUSH SWITCH 03 SN /SW-192 N	1	1	1
3	302LW94200	2LW94200	PARTS PWB ASSY RELAY SP	1	1	1
4	302F902410	2F902410	SPRING EARTH FAN	1	1	1
5	302F925480	2F925480	PULLEY RAIL DOUBLE	1	1	1
6	302LW94040	2LW94040	PARTS SWITCHING REGULATOR (U) SP	1		
6	302LW94050	2LW94050	PARTS SWITCHING REGULATOR (E) SP		1	1
7	302F944160	2F944160	FAN POWER PWB 50	1	1	1
8	302LW94190	2LW94190	PARTS PWB ASSY CONNECT-L SP	1	1	1
9	7AAACCUS+10H001	AA068380	AC CORD ASSY US	1		
10	302FV94010	2FV94010	PARTS AC CORD EU SP		1	
11	302FV45040	2FV45040	AC CORD ASSY			1
12	302F902221	2F902221	COOLING DUCT LEFT	1	1	1
13	302LW02040	2LW02040	RACK LID	1	1	1
14	302LW02050	2LW02050	RACK FRONT	1	1	1
15	302LW02060	2LW02060	GEAR RACK Z19-22	1	1	1

Ref. No.	Part.No.	Alternative.	Description	Quantity		
				120	230	240
101	7BB100306H1	BB105820	+BIND T.T S SCREW 3X6			
102	7BB202308H	BB105690	+TP-FLAT T.T P SCREW 3X8			
103	7BB200410H	BB105700	+BIND T.T P SCREW 4X10			
104	C2804100	C2804100	POLYESTER SLIDER WASHER 4.1X10X0.5T			

•Parts with Ref.No. indicate maintenance parts and the ones without it indicate out of the above.

•Parts with "." are component parts or sub-assemblies of the assembly appearing immediately above them.  
 •Parts with ".•" are component parts or sub-assembly with "." appearing immediately above them.







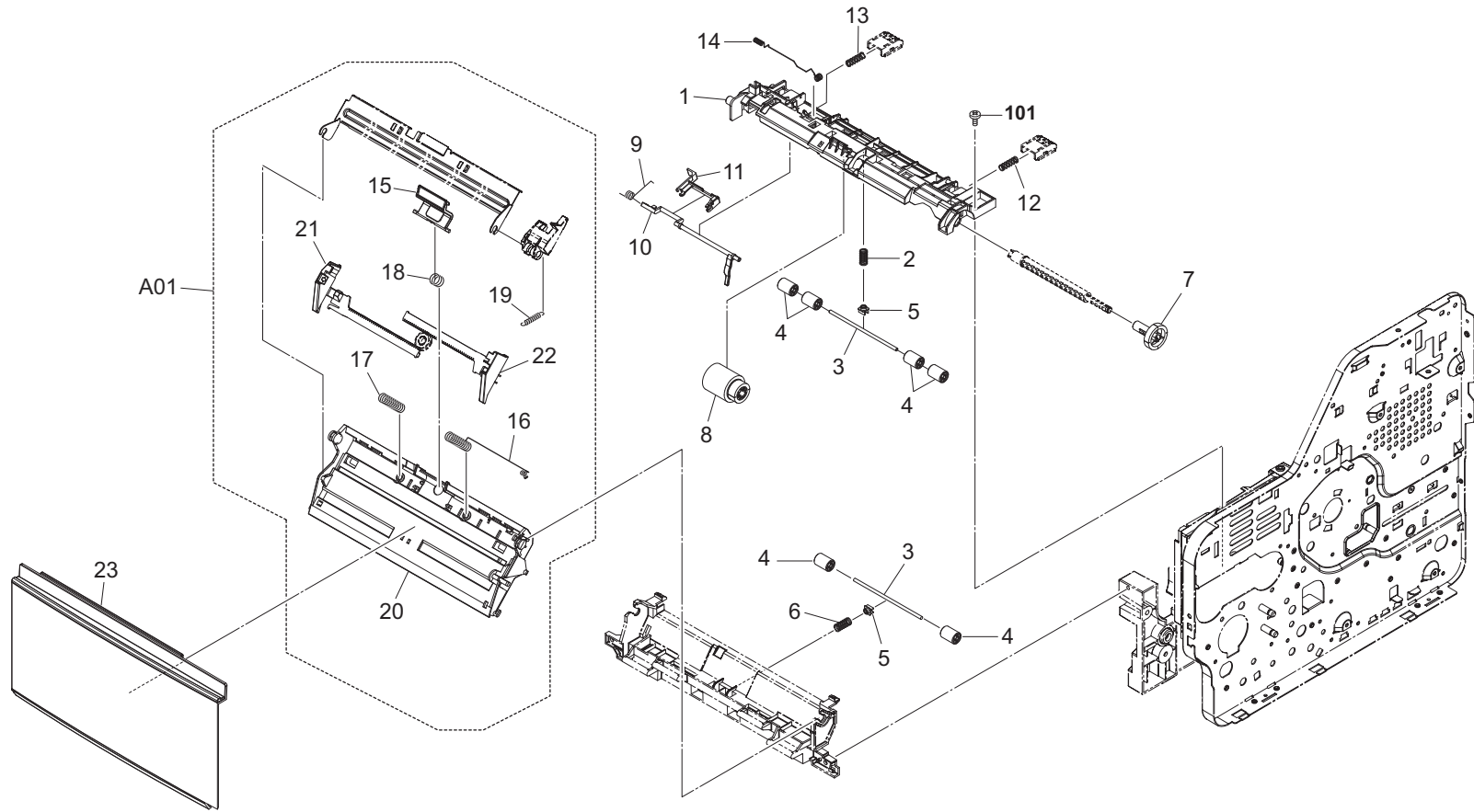


FIG. 5 Paper Feed Section 1

2MC/2MD-1

Ref. No.	Part.No.	Alternative.	Description	Quantity		
				120	230	240
1	302MC08010	2MC08010	FRAME MPF	1	1	1
2	302F908380	2F908380	SP PULLEY FEED	1	1	1
3	302F929060	2F929060	SHAFT FEED DU	2	2	2
4	302F929050	2F929050	PULLEY FEED DU	6	6	6
5	5MVX111DN002	3B706590	BUSH SP PULLEY /40283V0099 A4	2	2	2
6	302F908150	2F908150	SP PULLEY TURN	1	1	1
7	302F908130	2F908130	GEAR MPF Z30	1	1	1
8	5AAVR0LL+051	2CL16130	ROLLER M/P ASSY /43487B0027 A4	1	1	1
9	302F908280	2F908280	SP ACTUATOR MPF	1	1	1
10	302F908120	2F908120	ACTUATOR MPF A	1	1	1
11	302F908210	2F908210	ACTUATOR MPF B	1	1	1
12	302F908330	2F908330	SPRING LEVER LOCK R	1	1	1
13	302J008050	2J008050	SPRING LEVER LOCK L	1	1	1
14	302F908230	2F908230	SPRING EARTH CONNECTOR	1	1	1
A01	302MC94030	2MC94030	PARTS BASE MPF SP	1	1	1
15	•302F994070	2F994070	SEPARATOR MP ASSY	1	1	1
16	•302F908100	2F908100	SPRING BOTTOM MPF R	1	1	1
17	•302F908270	2F908270	SP BOTTOM MPF L	1	1	1
18	•302F908290	2F908290	SP SEPARATOR MPF	1	1	1
19	•302F908300	2F908300	SPRING LOCK MPF	1	1	1
20	•302MC08020	2MC08020	BASE MPF	1	1	1
21	•302MC08030	2MC08030	CURSOR MPF L	1	1	1
22	•302MC08040	2MC08040	CURSOR MPF R	1	1	1
23	302LW94091	2LW94091	PARTS COVER MPF ASSY SP	1	1	1

•Parts with Ref.No. indicate maintenance parts and the ones without it indicate out of the above.

Ref. No.	Part.No.	Alternative.	Description	Quantity		
				120	230	240
101	7BB100408H1	BB105830	+BIND T.T S SCREW 4X8			

•Parts with "•" are component parts or sub-assemblies of the assembly appearing immediately above them.  
 •Parts with "••" are component parts or sub-assembly with "•" appearing immediately above them.

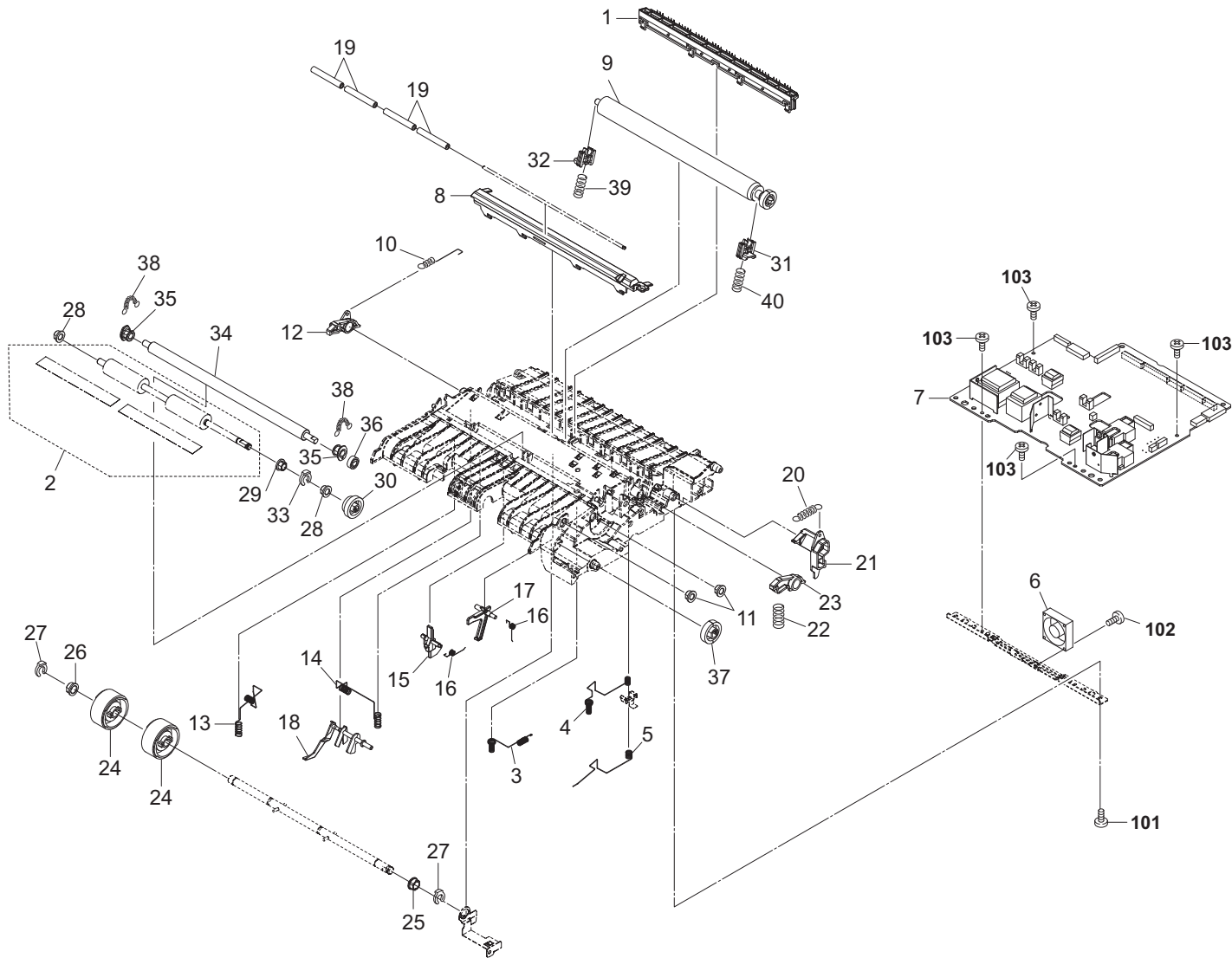


FIG. 6 Paper Feed Section 2

2MC/2MD

Ref. No.	Part.No.	Alternative.	Description	Quantity		
				120	230	240
1	302F994110	2F994110	DC BRUSH ASSY	1	1	1
2	302F994120	2F994120	REGIST KIT	1	1	1
3	302F924120	2F924120	SPRING TC CHARGE	1	1	1
4	302J024020	2J024020	SPRING SEP CHARGE	1	1	1
5	302F924140	2F924140	SPRING EARTH	1	1	1
6	302J044030	2J044030	FAN ENGINE PWB 35	1	1	1
7	302MC94140	2MC94140	PARTS PWB ENGINE ASSY SP	1	1	1
8	302F924071	2F924071	GUIDE PAPER CHUTE	1	1	1
9	302F994300	2F994300	ROLLER TRNSFER ASSY SP	1	1	1
10	302F924520	2F924520	SP RELEASE TC L	1	1	1
11	302F931490	2F931490	BUSH FEED DRIVE	2	2	2
12	302F924480	2F924480	LEVER RELEASE DLP L	1	1	1
13	302F924280	2F924280	SPRING MAIN CHARGE	1	1	1
14	302F924340	2F924340	SPRING BIAS CHARGE	1	1	1
15	302F924150	2F924150	ACTUATOR REGIST	1	1	1
16	302F924270	2F924270	SPRING REGIST SENSOR	2	2	2
17	302F924220	2F924220	ACTUATOR DU	1	1	1
18	302F924090	2F924090	LEVER EMPTY	1	1	1
19	302F924760	2F924760	PULLEY GUIDE	4	4	4
20	302F924380	2F924380	SPRING RELEASE FUSER R	1	1	1
21	302F924240	2F924240	LEVER RELEASE FUSER R	1	1	1
22	302F924320	2F924320	SPRING RELEASE DLP R	1	1	1
23	302F924490	2F924490	LEVER RELEASE DLP R	1	1	1
24	302GA24030	2GA24030	ROLLER MIDDLE ASSY	2	2	2
25	2BC06510	2BC06510	BUSHING 8	1	1	1
26	302H024830	2H024830	BUSH 8	1	1	1
27	2BC06910	2BC06910	STOPPER 6	2	2	2
28	302H702590	2H702590	BUSH SCREW	2	2	2
29	302H024370	2H024370	BUSH 6 EW	1	1	1
30	302F924700	2F924700	GEAR REG Z26H-Z33H	1	1	1
31	302F924190	2F924190	BUSH TRANSFER R	1	1	1
32	302F924830	2F924830	BUSH TRANSFER L	1	1	1
33	2BC06980	2BC06980	STOPPER 5	1	1	1
34	302F924020	2F924020	ROLLER REGIST UP	1	1	1
35	302F924160	2F924160	BUSH REGIST	2	2	2
36	302F924430	2F924430	GEAR REGIST Z23H	1	1	1
37	302F931430	2F931430	GEAR FEED ROLL Z27H	1	1	1
38	302F924460	2F924460	SPRING REGIST R	2	2	2
39	302F924390	2F924390	SPRING TC L	1	1	1
40	302F924400	2F924400	SPRING TC R	1	1	1

•Parts with Ref.No. indicate maintenance parts and the ones without it indicate out of the above.

Ref. No.	Part.No.	Alternative.	Description	Quantity		
				120	230	240
101	7BB200410H	BB105700	+BIND T.T P SCREW 4X10			
102	7BB100314H	BB112130	+BIND T.T S SCREW 3X14			
103	7BB100306H1	BB105820	+BIND T.T S SCREW 3X6			

•Parts with "•" are component parts or sub-assemblies of the assembly appearing immediately above them.  
 •Parts with "••" are component parts or sub-assembly with "•" appearing immediately above them.

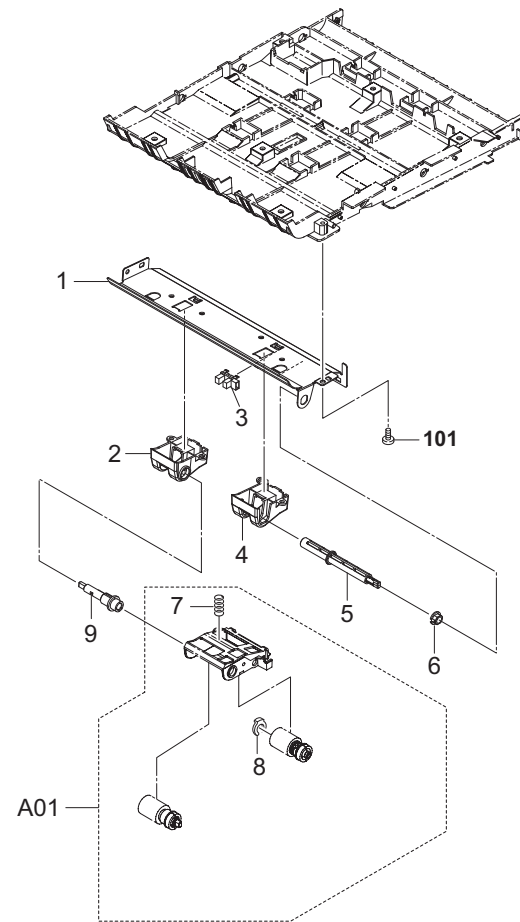


FIG. 7 Paper Feed Section 3

2MC/2MD-2

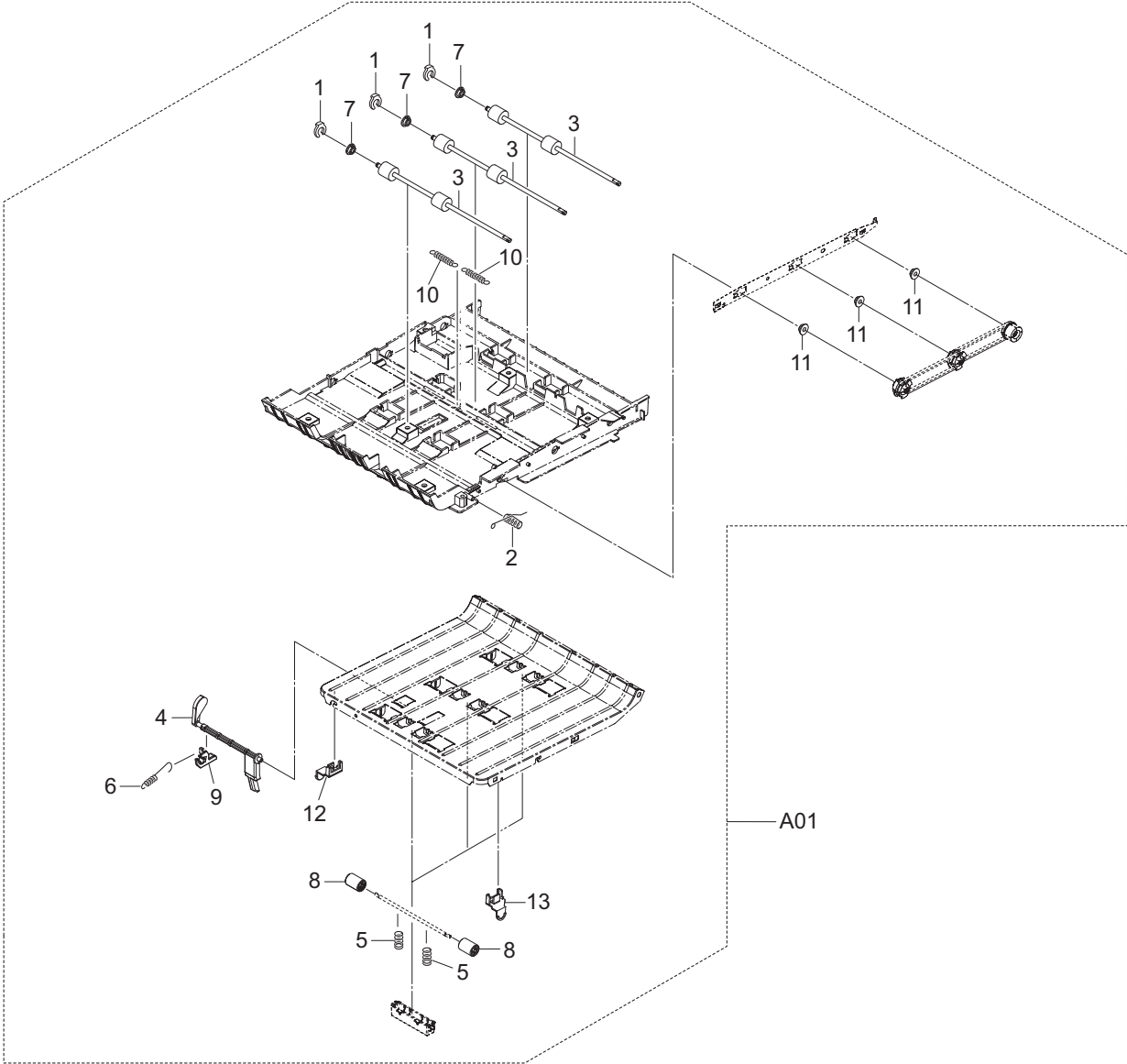
Ref. No.	Part.No.	Alternative.	Description	Quantity		
				120	230	240
1	302F906010	2F906010	GUIDE FEED UP	1	1	1
2	302F906190	2F906190	GUIDE FEED L	1	1	1
3	7NXGP1A273LCH01	NX131540	SENSOR OPT.	1	1	1
4	302F906200	2F906200	GUIDE FEED R	1	1	1
5	302F906290	2F906290	SHAFT FEED R	1	1	1
6	302H702590	2H702590	BUSH SCREW	1	1	1
A01	302F994062	2F994062	FEED HOLDER ASSY	1	1	1
7	•302F906120	2F906120	SPRING PICK UP	1	1	1
8	•5MVX1111DN003	2A806250	RING STOPPER /A-49 FEED A4	1	1	1
9	302F906110	2F906110	PIN FEED ROLL	1	1	1

•Parts with Ref.No. indicate maintenance parts and the ones without it indicate out of the above.

Ref. No.	Part.No.	Alternative.	Description	Quantity		
				120	230	240
101	7BB200410H	BB105700	+BIND T.T P SCREW 4X10			

•Parts with "•" are component parts or sub-assemblies of the assembly appearing immediately above them.  
 •Parts with "••" are component parts or sub-assembly with "•" appearing immediately above them.







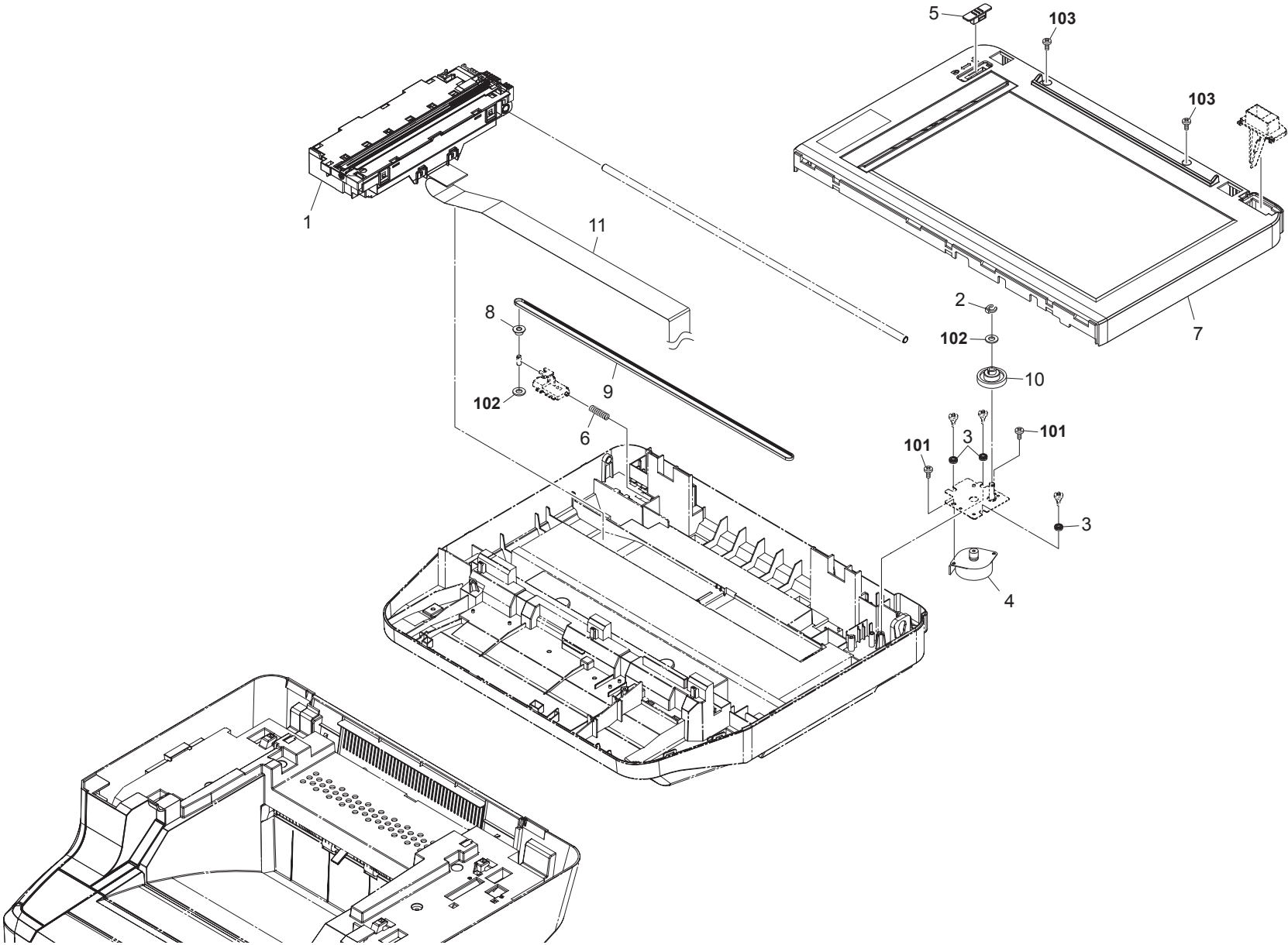


FIG. 9 Scanner Section

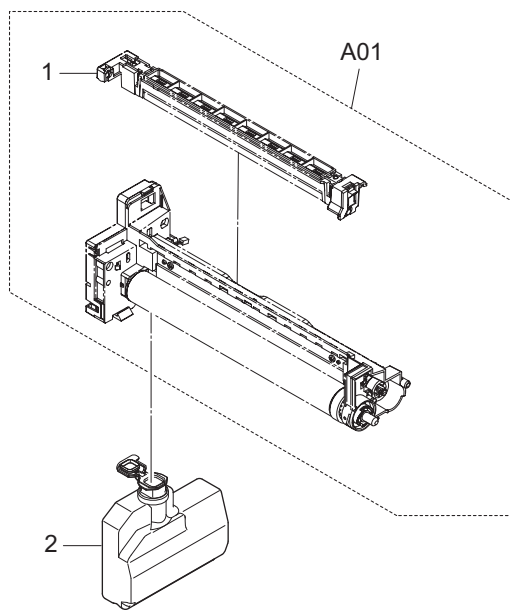
2MC/2MD-2

Ref. No.	Part.No.	Alternative.	Description	Quantity		
				120	230	240
1	302MC93010	2MC93010	PARTS ISU ASSY(L)	1	1	1
2	5MVX111DN003	2A806250	RING STOPPER /A-49 FEED A4	1	1	1
3	302JD19140	2JD19140	BUSHING FAN	3	3	3
4	302LW94060	2LW94060	PARTS MOTOR ISU SP	1	1	1
5	302H917330	2H917330	STOPPER ISU	1	1	1
6	302H917270	2H917270	SPRING TENSION	1	1	1
7	302LW94100	2LW94100	PARTS FRAME ISU TOP ASSY SP	1	1	1
8	302H917240	2H917240	PULLEY TENSION	1	1	1
9	302H917230	2H917230	BELT ISU	1	1	1
10	302H917220	2H917220	GEAR ISU 63/32	1	1	1
11	302LW46010	2LW46010	CONN.CORD ASSY S03613	1	1	1

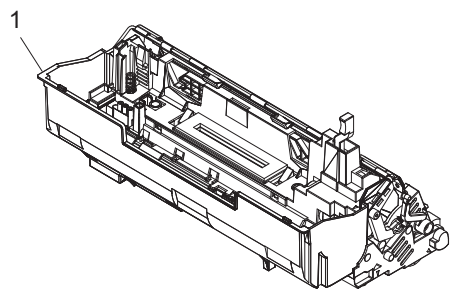
Ref. No.	Part.No.	Alternative.	Description	Quantity		
				120	230	240
101	7BB700308H	BB105600	+BIND T.T S SCREW 3X8 SR			
102	C2893960	C2893960	SHIM 6.2-13-0.13T			
103	7BB200308H	BB105660	+BIND T.T P SCREW 3X8			

•Parts with Ref.No. indicate maintenance parts and the ones without it indicate out of the above.

•Parts with "•" are component parts or sub-assemblies of the assembly appearing immediately above them.  
 •Parts with "••" are component parts or sub-assembly with "•" appearing immediately above them.

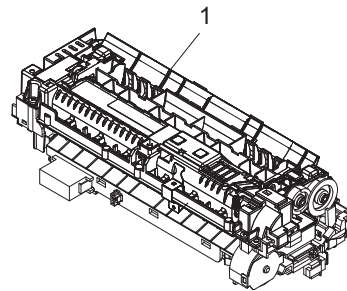














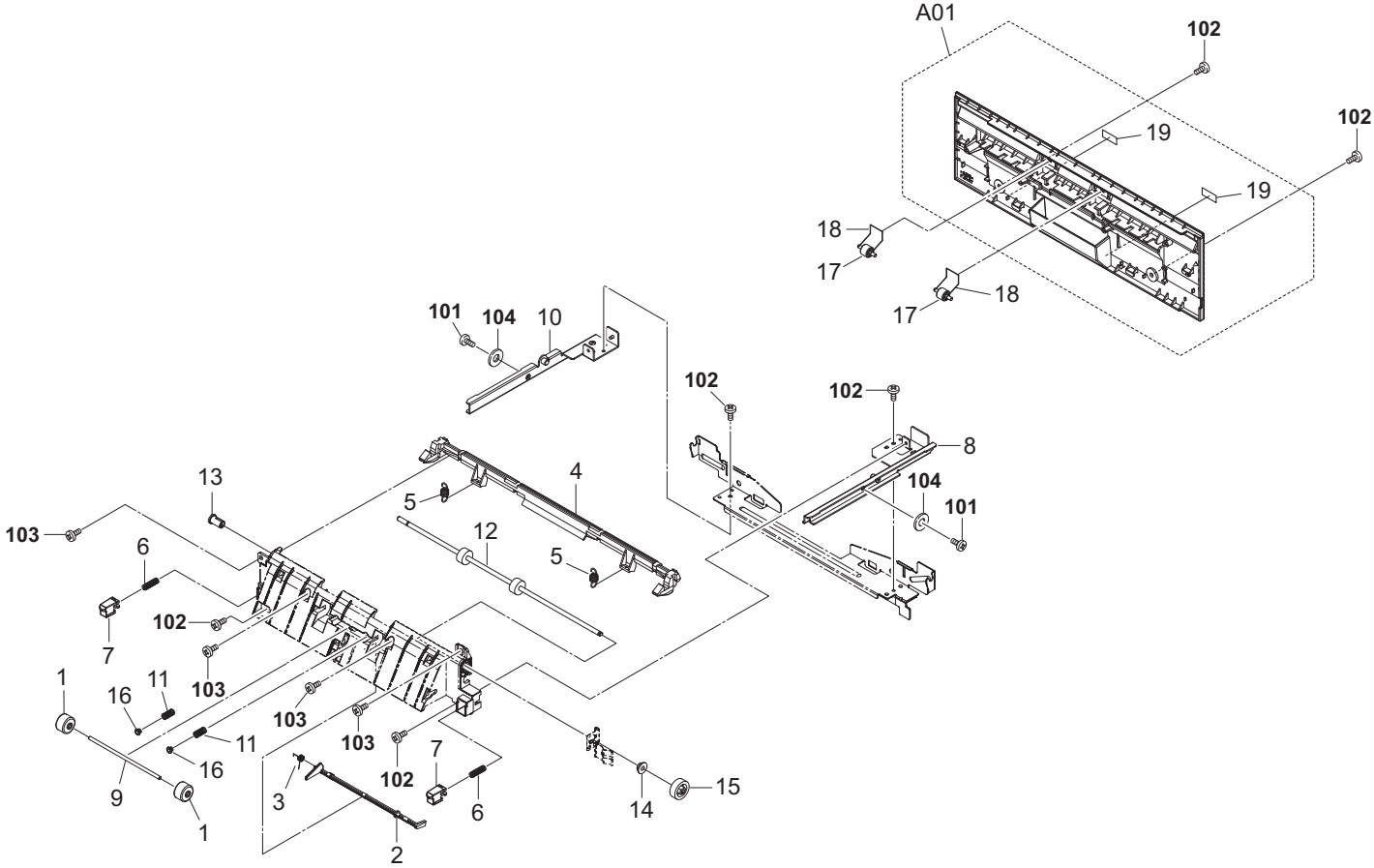


FIG. 13 Fuser Section 2

2MC/2MD-1

Ref. No.	Part.No.	Alternative.	Description	Quantity		
				120	230	240
1	302F926060	2F926060	PULLEY SWITCH BACK	2	2	2
2	302F925180	2F925180	ACTUATOR DU	1	1	1
3	302F925371	2F925371	SPRING ACTUATOR DU	1	1	1
4	302J025200	2J025200	LEVER FUSER RELEASE	1	1	1
5	302F925750	2F925750	SPRING FUSER RELEASE	2	2	2
6	302F925560	2F925560	SPRING LOCK	2	2	2
7	302F925550	2F925550	LOCK FUSER	2	2	2
8	302F925440	2F925440	INNER RAIL R	1	1	1
9	302F929060	2F929060	SHAFT FEED DU	1	1	1
10	302F925450	2F925450	INNER RAIL L	1	1	1
11	302F925780	2F925780	SPRING DU	2	2	2
12	302F925300	2F925300	ROLLER FACE UP	1	1	1
13	302FV02470	2FV02470	BUSH FD	1	1	1
14	302F929140	2F929140	BUSH DU	1	1	1
15	302F925141	2F925141	GEAR EXIT Z21	1	1	1
16	2FM04150	2FM04150	CAP SPRING /B-11 ENCLOSURE A4	2	2	2
17	302F925160	2F925160	PULLEY FACE UP	2	2	2
18	302F925350	2F925350	SPRING FACE UP	2	2	2
A01	302MC94090	2MC94090	PARTS COVER REAR B ASSY SP	1	1	1
19	•302MC34040	2MC34040	LABEL PUSH	2	2	2

•Parts with Ref.No. indicate maintenance parts and the ones without it indicate out of the above.

Ref. No.	Part.No.	Alternative.	Description	Quantity		
				120	230	240
101	7BB100304H	BB105580	+BIND T.T S SCREW 3X4			
102	7BB100306H1	BB105820	+BIND T.T S SCREW 3X6			
103	7BB200308H	BB105660	+BIND T.T P SCREW 3X8			
104	5MBWK32808NN	C2803080	POLY SLIDER /M3.2X 8 X0.8T XX			

•Parts with "•" are component parts or sub-assemblies of the assembly appearing immediately above them.  
 •Parts with "••" are component parts or sub-assembly with "•" appearing immediately above them.

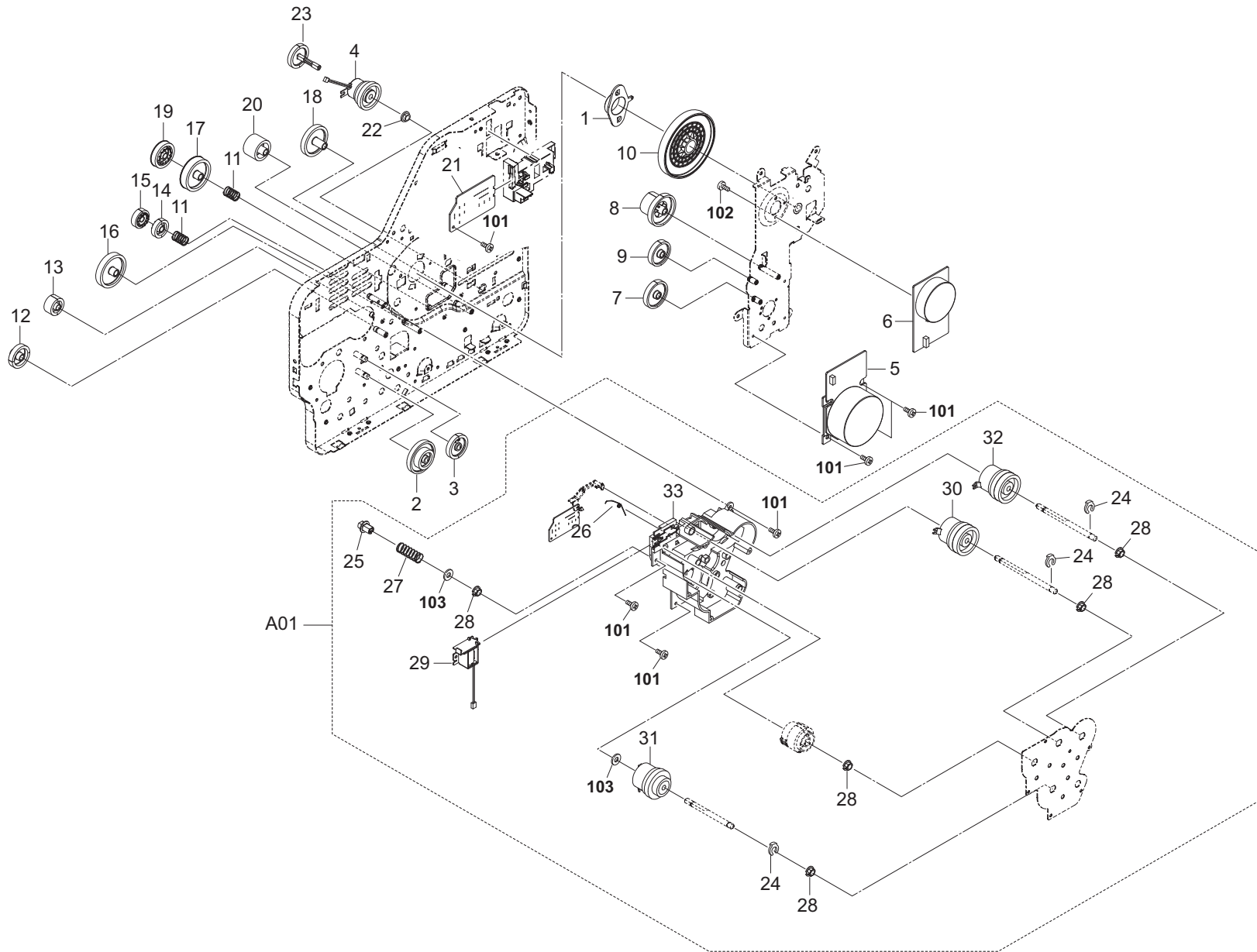


FIG. 14 Drive Section

2MC/2MD-1

Ref. No.	Part.No.	Alternative.	Description	Quantity		
				120	230	240
1	302F831060	2F831060	BUSH DRUM	1	1	1
2	302F931110	2F931110	GEAR Z95H Z28H	1	1	1
3	302F931500	2F931500	GEAR FEED Z34H	1	1	1
4	302F944040	2F944040	CLUTCH DUPLEX	1	1	1
5	302J031022	2J031022	MOTOR MAIN Z16	1	1	1
6	302J031030	2J031030	MOTOR DRUM Z16	1	1	1
7	302F931020	2F931020	GEAR Z77H	1	1	1
8	302F931040	2F931040	GEAR Z90H Z30H	1	1	1
9	302F931030	2F931030	GEAR Z70H	1	1	1
10	302F931590	2F931590	GEAR Z191H	1	1	1
11	302F931270	2F931270	SPRING FUSER	2	2	2
12	302F931200	2F931200	GEAR DLP Z32H	1	1	1
13	302F931290	2F931290	GEAR DLP Z24H	1	1	1
14	302F931300	2F931300	GEAR DLP JOINT Z25H	1	1	1
15	302F931310	2F931310	GEAR DLP Z25H	1	1	1
16	302F931051	2F931051	GEAR Z48H	1	1	1
17	302F931060	2F931060	GEAR Z46H	1	1	1
18	302F931081	2F931081	GEAR Z45S	1	1	1
19	302F931070	2F931070	GEAR Z37S	1	1	1
20	302F931090	2F931090	GEAR Z30S	1	1	1
21	302J101050	2J101050	P.W.BOARD ASSY CONNECT-R	1	1	1
22	302F931490	2F931490	BUSH FEED DRIVE	1	1	1
23	302F931100	2F931100	GEAR Z34S	1	1	1
A01	302F994031	2F994031	FEED DRIVE ASSY SP	1	1	1
24	•2BC06980	2BC06980	STOPPER 5	3	3	3
25	•302F931350	2F931350	JOINT SHAFT CASSETTE	1	1	1
26	•302F931381	2F931381	SPRING MPF CAM	1	1	1
27	•302F931450	2F931450	SPRING FEED	1	1	1
28	•302F931490	2F931490	BUSH FEED DRIVE	5	5	5
29	•302F944060	2F944060	SOLENOID MPF	1	1	1
30	•302F944200	2F944200	CLUTCH MID FEED	1	1	1
31	•302F944210	2F944210	CLUTCH CASSETTE	1	1	1
32	•302F944220	2F944220	CLUTCH REGIST	1	1	1
33	•302F931222	2F931222	HOUSING FEED DRIVE B	1	1	1

•Parts with Ref.No. indicate maintenance parts and the ones without it indicate out of the above.

Ref. No.	Part.No.	Alternative.	Description	Quantity		
				120	230	240
101	7BB100306H1	BB105820	+BIND T.T S SCREW 3X6			
102	7BB000304H	BB105720	+BIND M SCREW 3X4			
103	C2806120	C2806120	POLYESTER SLIDER WASHER 6.2X12X0.5T			

•Parts with "•" are component parts or sub-assemblies of the assembly appearing immediately above them.  
 •Parts with "••" are component parts or sub-assembly with "•" appearing immediately above them.

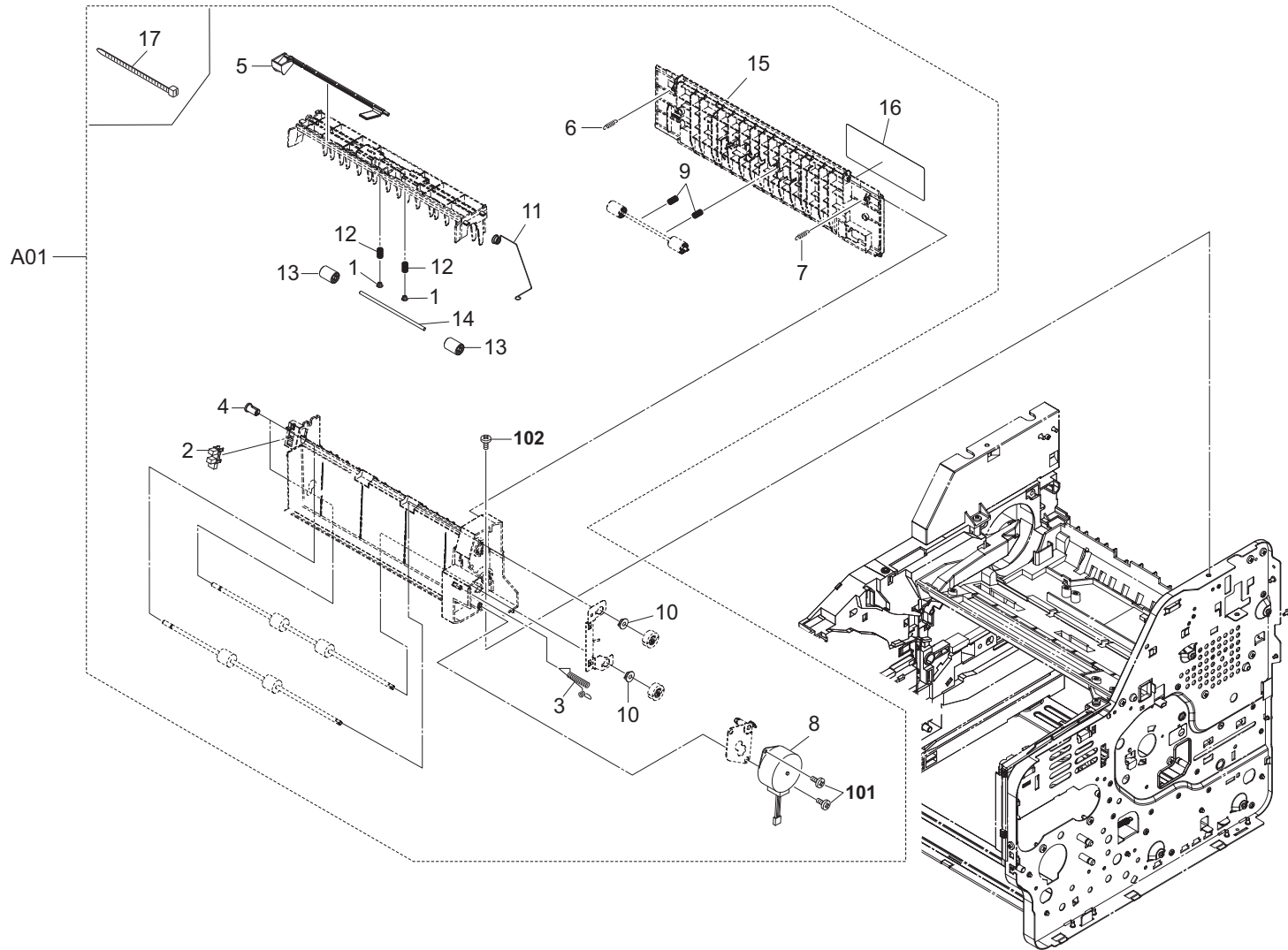


FIG. 15 Exit Section

2MC/2MD-1

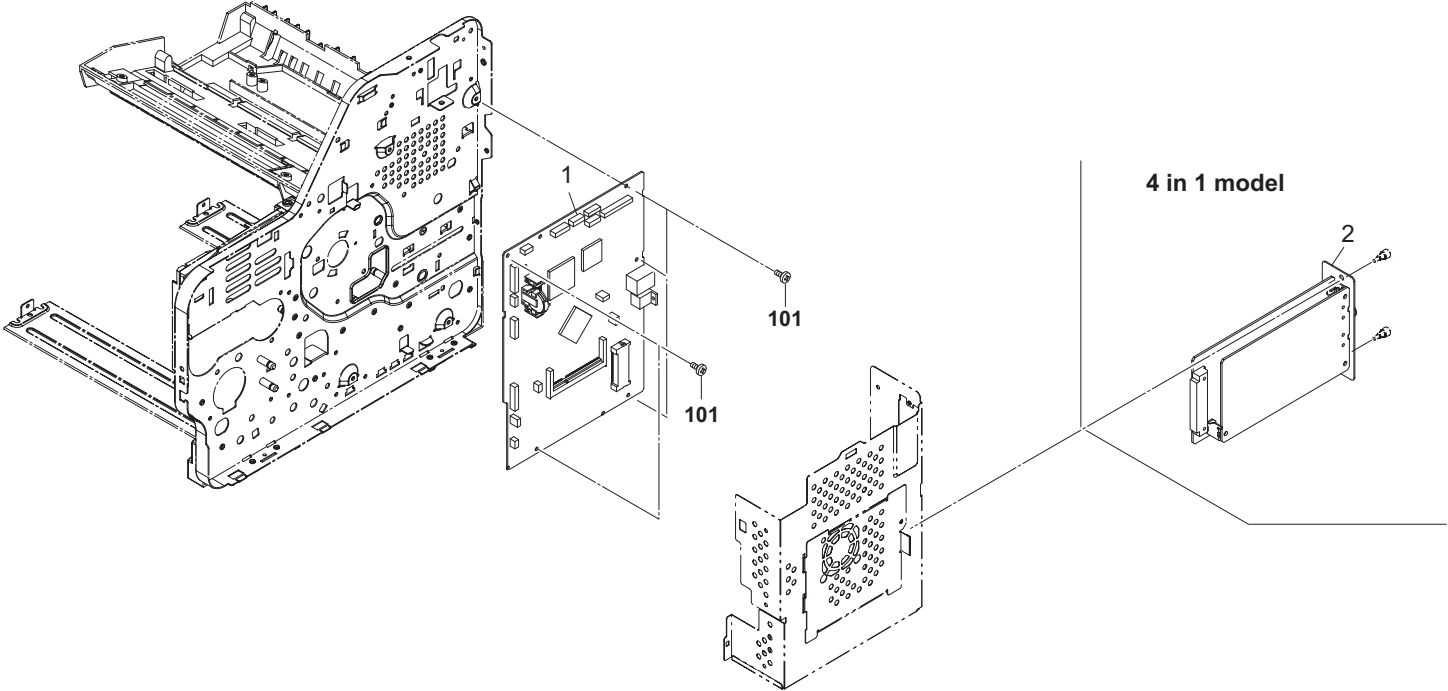
Ref. No.	Part.No.	Alternative.	Description	Quantity		
				120	230	240
A01	302MC94011	2MC94011	PARTS FD UNIT SP	1	1	1
1	•2FM04150	2FM04150	CAP SPRING /B-11 ENCLOSURE A4	2	2	2
2	•7NXGP1A273LCH01	NX131540	SENSOR OPT.	1	1	1
3	•302MC28020	2MC28020	SPRING EARTH MOTOR	1	1	1
4	•302FV02470	2FV02470	BUSH FD	2	2	2
5	•302F928100	2F928100	ACTUATOR OVERFLOW	1	1	1
6	•302F928130	2F928130	SPRING COVER FD L	1	1	1
7	•302F928140	2F928140	SPRING COVER FD R	1	1	1
8	•302F944131	2F944131	MOTOR EJECT	1	1	1
9	•302F928170	2F928170	SPRING PULLEY	2	2	2
10	•302F929140	2F929140	BUSH DU	2	2	2
11	•302F928231	2F928231	SPRING DISCHARGER	1	1	1
12	•302F928310	2F928310	SPRING PULLEY 35	2	2	2
13	•302F929050	2F929050	PULLEY FEED DU	2	2	2
14	•302F929060	2F929060	SHAFT FEED DU	1	1	1
15	•302MC28010	2MC28010	COVER FD	1	1	1
16	•302MC34030	2MC34030	LABEL OPERATION ENVELOPE	1	1	1
17	•7YZM420003++H01	YZ052580	ACCESS.BAND	1	1	1

•Parts with Ref.No. indicate maintenance parts and the ones without it indicate out of the above.

Ref. No.	Part.No.	Alternative.	Description	Quantity		
				120	230	240
101	5MBSPP3006NW++R	B0B03060	PAN HEAD SCREW(+)/ M3 X 6 CRFREE			
102	7BB100408H1	BB105830	+BIND T.T S SCREW 4X8			

•Parts with "•" are component parts or sub-assemblies of the assembly appearing immediately above them.  
 •Parts with "••" are component parts or sub-assembly with "•" appearing immediately above them.







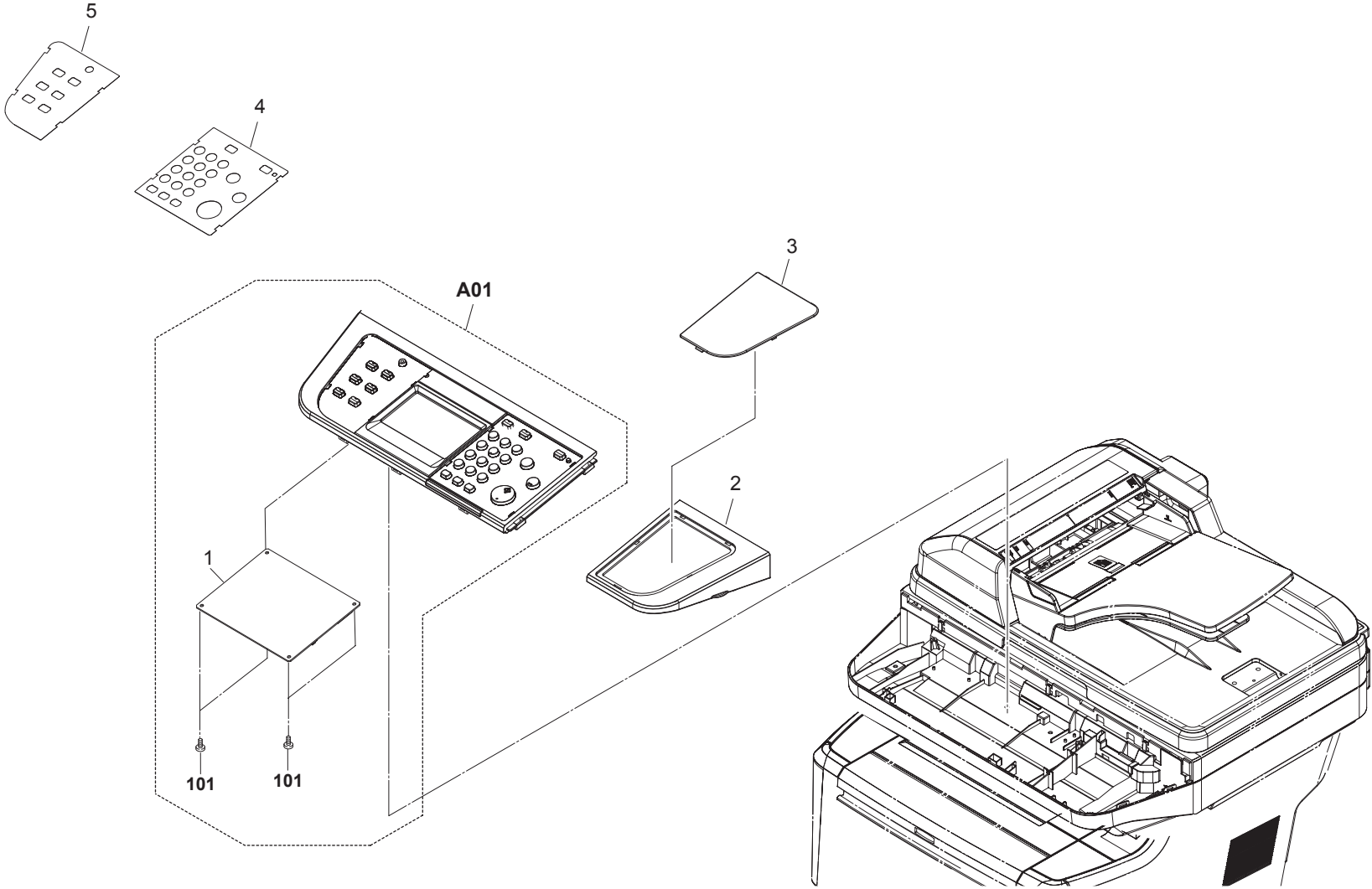


FIG. 17 Operation Section

2MC/2MD

Ref. No.	Part.No.	Alternative.	Description	Quantity		
				120	230	240
A01	302MC94020	2MC94020	PARTS OPERATION UNIT SP (3 in 1 model)	1	1	1
A01	302MD94010	2MD94010	PARTS OPERATION UNIT SP ((4 in 1 model)	1	1	1
1	•302MC94150	2MC94150	PARTS PWB PANEL MAIN ASSY SP	1	1	1
2	302MC05090	2MC05090	COVER CARD READER	1	1	1
3	302MC05300	2MC05300	COVER CARD READER C	1	1	1
4	302MC05220	2MC05220	LABEL OPERATION R	1	1	1
5	302MC05020	2MC05020	PANEL OPERATION L (3 in 1 model)	1	1	1
5	302MD05010	2MD05010	PANEL OPERATION L ((4 in 1 model)	1	1	1

•Parts with Ref.No. indicate maintenance parts and the ones without it indicate out of the above.

Ref. No.	Part.No.	Alternative.	Description	Quantity		
				120	230	240
101	7BB700308H	BB105600	+BIND T.T S SCREW 3X8 SR			

•Parts with "•" are component parts or sub-assemblies of the assembly appearing immediately above them.  
 •Parts with "••" are component parts or sub-assembly with "•" appearing immediately above them.

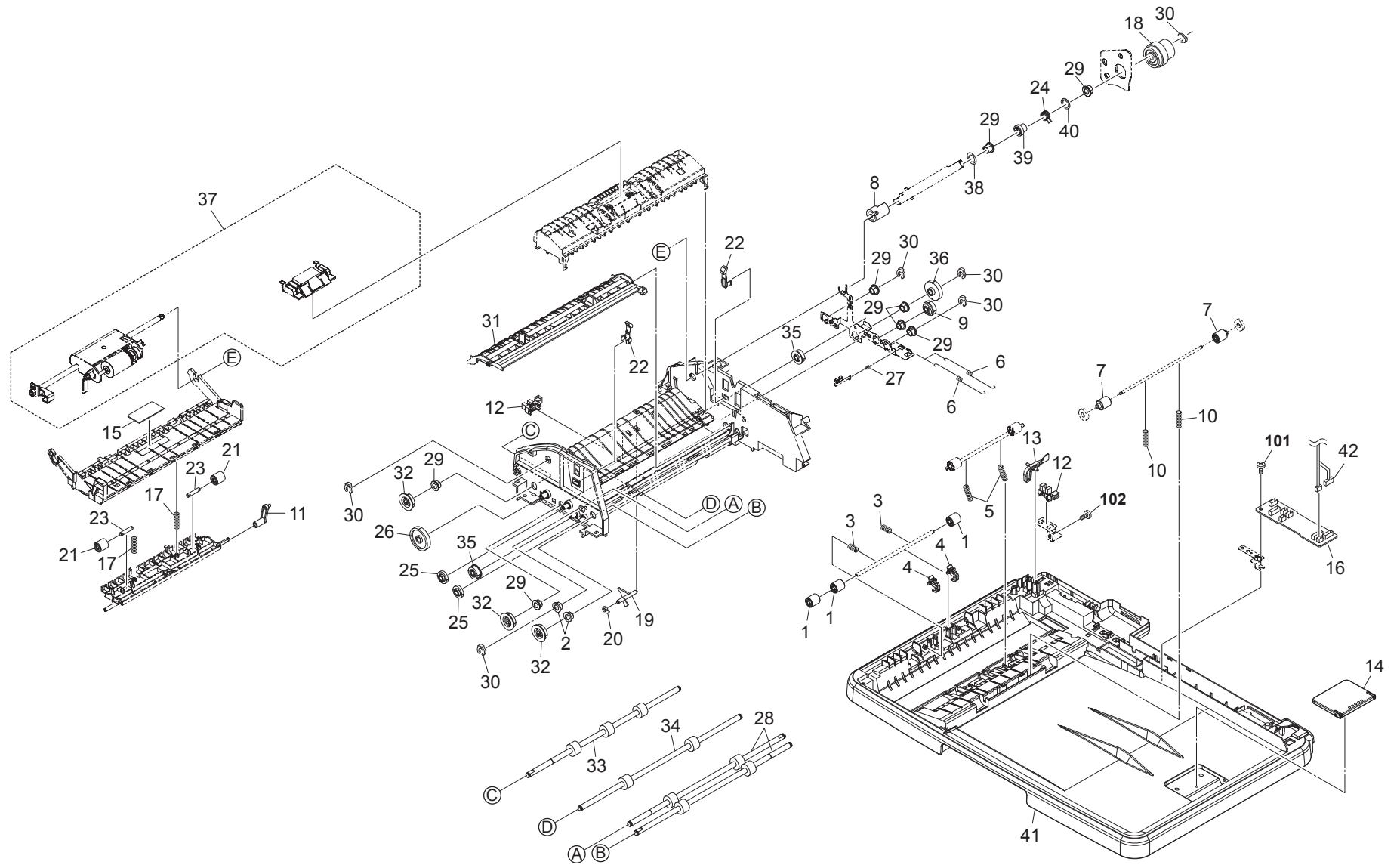


FIG. 18 Document Processor 1

2MC/2MD-2

Ref. No.	Part.No.	Alternative.	Description	Quantity		
				120	230	240
1	303JX29160	3JX29160	PULLEY CONVEYING	3	3	3
2	302H702590	2H702590	BUSH SCREW	2	2	2
3	303LJ24230	3LJ24230	SPRING REGIST	2	2	2
4	303LJ02150	3LJ02150	LEVER RELEASE	2	2	2
5	303LJ24121	3LJ24121	SPRING CONVEYING	2	2	2
6	303LJ02240	3LJ02240	SPRING GND A	2	2	2
7	3HK10030	3HK10030	PULLEY EJECT	2	2	2
8	302LW07060	2LW07060	JOINT PF ROLLER	1	1	1
9	303LJ31060	3LJ31060	GEAR Z32S	1	1	1
10	303LJ24150	3LJ24150	SPRING EXIT	2	2	2
11	303LJ29060	3LJ29060	LEVER PRESSURE	1	1	1
12	7NXSG2481+++H01	NX052600	SENSOR OPT.	2	2	2
13	303K502200	3K502200	ACTUATOR BASE	1	1	1
14	303M602070	3M602070	STOPPER ORIGINAL	1	1	1
15	3HK07240	3HK07240	FRICTION PLATE LF	1	1	1
16	303LJ94010	3LJ94010	PARTS DRIVER PWB ASSY SP	1	1	1
17	303LJ29040	3LJ29040	SPRING LOOP PRESSURE	2	2	2
18	303LJ44040	3LJ44040	CLUTCH PAPER FEED	1	1	1
19	303LJ24080	3LJ24080	ACTUATOR TIMING	1	1	1
20	303LJ24090	3LJ24090	SPRING TIMING	1	1	1
21	3HL10140	3HL10140	PULLEY LOOP	2	2	2
22	303LJ24190	3LJ24190	HOOK PF COVER	2	2	2
23	3H608150	3H608150	SHAFT C PULLEY	2	2	2
24	3HK07140	3HK07140	SPRING LF	1	1	1
25	303LJ31050	3LJ31050	GEAR Z28S	2	2	2
26	303LJ31090	3LJ31090	GEAR Z56S	1	1	1
27	303LJ02250	3LJ02250	SPRING GND B	1	1	1
28	303LJ94040	3LJ94040	PARTS ROLLER EXIT SP	2	2	2
29	3CY07080	3CY07080	BUSHING 6	8	8	8
30	5MVX111DN003	2A806250	RING STOPPER /A-49 FEED A4	6	6	6
31	303LJ24101	3LJ24101	GUIDE SEPARATION	1	1	1
32	303LJ31080	3LJ31080	GEAR Z35S	3	3	3
33	303LJ94020	3LJ94020	PARTS ROLLER A CONVEYING SP	1	1	1
34	303LJ94030	3LJ94030	PARTS ROLLER B CONVEYING SP	1	1	1
35	303LJ31100	3LJ31100	GEAR T Z28S	2	2	2
36	303LJ94050	3LJ94050	PARTS GEAR Z46S ONEWAY SP	1	1	1
37	1702LX0UN0	072LX0UN	MK-370/MAINTENANCE KIT (OPTION)	1	1	1
38	303HL22200	3HL22200	PLATE GND	1	1	1
39	3HK07080	3HK07080	COLLAR S SPRING	1	1	1
40	3HK07270	3HK07270	COLLAR PF	1	1	1
41	302MC07011	2MC07011	BASE DP	1	1	1
42	302LW46040	2LW46040	CONN.CORD ASSY S03616	1	1	1

•Parts with Ref.No. indicate maintenance parts and the ones without it indicate out of the above.

Ref. No.	Part.No.	Alternative.	Description	Quantity		
				120	230	240
101	7BB202308H	BB105690	+TP-FLAT T.T P SCREW 3X8			
102	7BB700308H	BB105600	+BIND T.T S SCREW 3X8 SR			

•Parts with "•" are component parts or sub-assemblies of the assembly appearing immediately above them.  
 •Parts with "••" are component parts or sub-assembly with "•" appearing immediately above them.

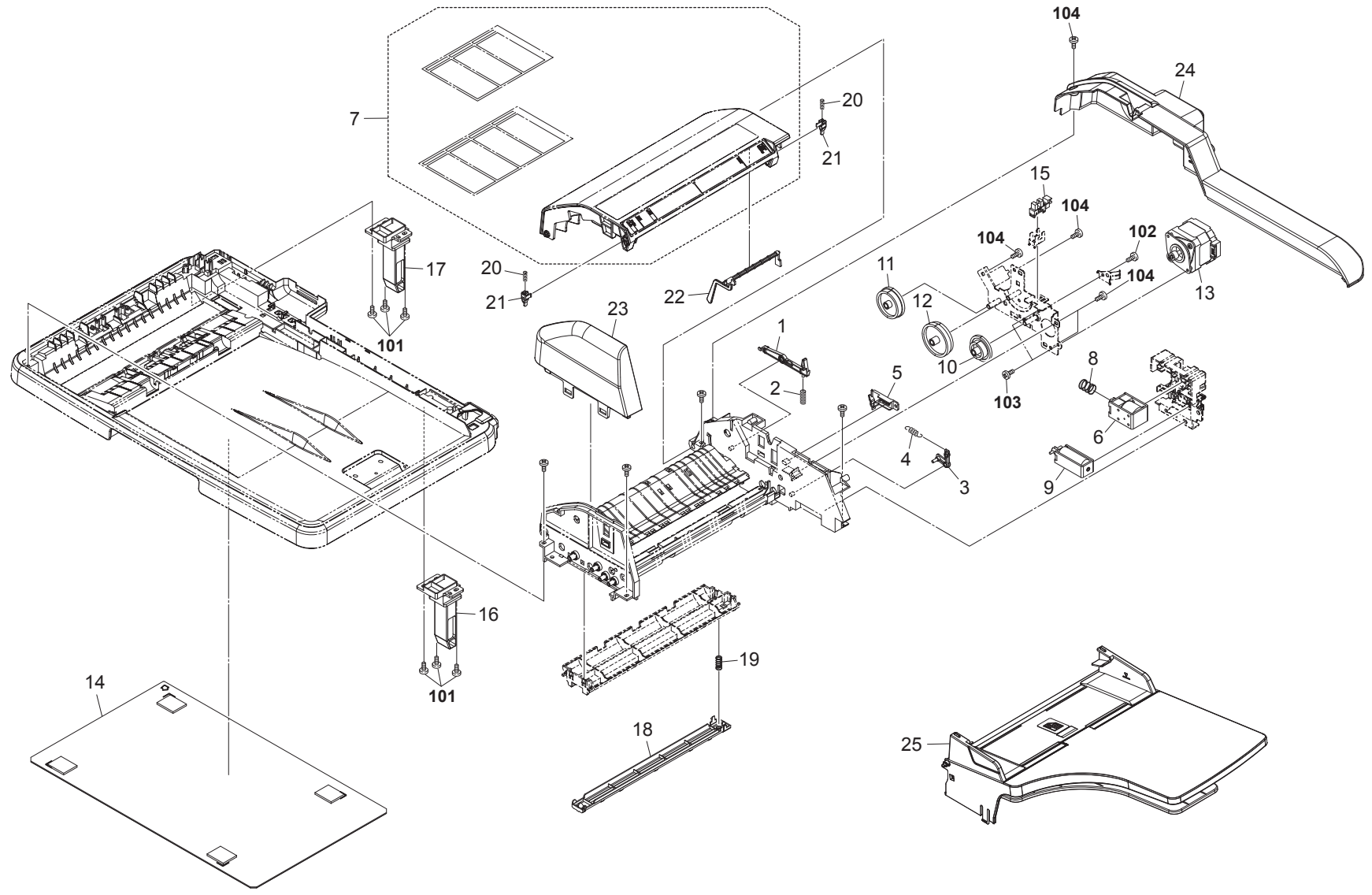


FIG. 19 Document Processor 2

2MC/2MD

Ref. No.	Part.No.	Alternative.	Description	Quantity		
				120	230	240
1	303LJ02080	3LJ02080	ACTUATOR PUSH	1	1	1
2	303LJ02060	3LJ02060	SPRING RELEASE	1	1	1
3	303LJ24041	3LJ24041	LEVER SEPARATE	1	1	1
4	3HL10090	3HL10090	SPRING,LF SHIFT GUIDE	1	1	1
5	303LJ24050	3LJ24050	LEVER LOOP	1	1	1
6	303LJ94140	3LJ94140	PARTS SOLENOID PRESSURE PULLEY SP	1	1	1
7	302MC94100	2MC94100	PARTS COVER PF ASSY SP	1	1	1
8	303HL10200	3HL10200	SPRING LOOP	1	1	1
9	303LJ94150	3LJ94150	PARTS SOLENOID FEED SHIFT SP	1	1	1
10	303LJ31040	3LJ31040	GEAR Z66S Z70S	1	1	1
11	303LJ31020	3LJ31020	GEAR Z40S Z61S	1	1	1
12	303LJ31030	3LJ31030	GEAR Z46S Z79S	1	1	1
13	303LJ94061	3LJ94061	PARTS MOTOR DP SP	1	1	1
14	303LJ94070	3LJ94070	PARTS PLATE ORIGINAL SP	1	1	1
15	7NXSG2481+++H01	NX052600	SENSOR OPT.	1	1	1
16	303LJ02040	3LJ02040	HINGE R	1	1	1
17	303LJ02030	3LJ02030	HINGE L	1	1	1
18	303LJ02020	3LJ02020	GUIDE READING	1	1	1
19	303LJ02070	3LJ02070	SPRING READING	1	1	1
20	303LJ07070	3LJ07070	SPRING PUSH DU	2	2	2
21	303LJ07060	3LJ07060	LEVER PUSH DU	2	2	2
22	303LJ07050	3LJ07050	ACTUATOR ORIGINAL	1	1	1
23	302MC07020	2MC07020	COVER FRONT	1	1	1
24	302MC07030	2MC07030	COVER REAR	1	1	1
25	303LJ94120	3LJ94120	PARTS TABLE ASSY SP	1	1	1

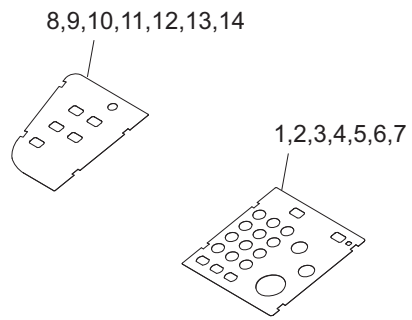
•Parts with Ref.No. indicate maintenance parts and the ones without it indicate out of the above.

Ref. No.	Part.No.	Alternative.	Description	Quantity		
				120	230	240
101	7BB202308H	BB105690	+TP-FLAT T.T P SCREW 3X8			
102	7BB700308H	BB105600	+BIND T.T S SCREW 3X8 SR			
103	7BB000306H	BB106880	+BIND M SCREW 3X6			
104	7BB200308H	BB105660	+BIND T.T P SCREW 3X8			

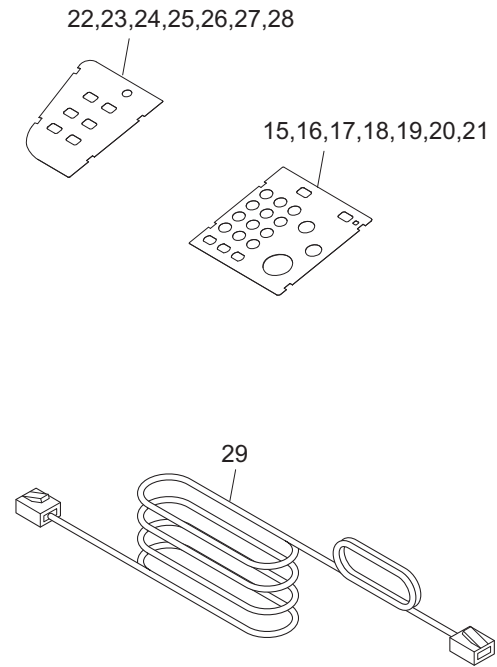
•Parts with "." are component parts or sub-assemblies of the assembly appearing immediately above them.  
 •Parts with ".•" are component parts or sub-assembly with "." appearing immediately above them.



3 in 1 model



4 in 1 model







INDEX

2MC/2MD-2

Part.No.	Alternative.	Description	Fig.No.
1702LX0UN0	072LX0UN	MK-370/MAINTENANCE KIT	18,21
1702LX7US0	072LX7US	MK-350/MAINTENANCE KIT	21
1702LX8AS0	072LX8AS	MK-350/MAINTENANCE KIT	21
1702LX8NLO	072LX8NL	MK-350/MAINTENANCE KIT	21
2BC06510	2BC06510	BUSHING 8	6
2BC06910	2BC06910	STOPPER 6	6
2BC06980	2BC06980	STOPPER 5	6,14
2FM04150	5MVM163DN005	CAP SPRING /B-11 ENCLOSURE A4	13,15
302F831060	2F831060	BUSH DRUM	14
302F902410	2F902410	SPRING EARTH FAN	3
302F906010	2F906010	GUIDE FEED UP	7
302F906110	2F906110	PIN FEED ROLL	7
302F906120	2F906120	SPRING PICK UP	7
302F906190	2F906190	GUIDE FEED L	7
302F906200	2F906200	GUIDE FEED R	7
302F906290	2F906290	SHAFT FEED R	7
302F908100	2F908100	SPRING BOTTOM MPF R	5
302F908120	2F908120	ACTUATOR MPF A	5
302F908130	2F908130	GEAR MPF Z30	5
302F908150	2F908150	SP PULLEY TURN	5
302F908210	2F908210	ACTUATOR MPF B	5
302F908230	2F908230	SPRING EARTH CONNECTOR	5
302F908270	2F908270	SP BOTTOM MPF L	5
302F908280	2F908280	SP ACTUATOR MPF	5
302F908290	2F908290	SP SEPARATOR MPF	5
302F908300	2F908300	SPRING LOCK MPF	5
302F908330	2F908330	SPRING LEVER LOCK R	5
302F908380	2F908380	SP PULLEY FEED	5
302F909031	2F909031	LEVER BASE CAS REAR	4
302F909040	2F909040	SPRING BASE CAS REAR	4
302F909070	2F909070	LEVER SIDE CURSOR	4
302F909090	2F909090	LEVER END CURSOR	4
302F909131	2F909131	GEAR LIFT Z64	4
302F909140	2F909140	GEAR JOINT Z16	4
302F909151	2F909151	LEVER INDICATOR	4
302F909160	2F909160	BUSH LIFT 6	4
302F909171	2F909171	RETARD ROLLER ASSY	4
302F909180	2F909180	HOLDER RETARD	4
302F909191	2F909191	GUIDE RETARD	4
302F909200	2F909200	SPRING RETARD	4
302F909210	2F909210	PAD BOTTOM	4
302F909250	2F909250	SPRING SIZE FIX	4
302F909510	2F909510	GEAR Z40HZ18	2
302F909520	2F909520	GEAR Z60Z16	2
302F909530	2F909530	GEAR Z50Z16	2
302F909540	2F909540	GEAR Z49	2
302F909550	2F909550	GEAR Z26Z15	2
302F912310	2F912310	COVER DRUM SHUTTER	2
302F912330	2F912330	GEAR SHUTTER Z18S	2
302F912340	2F912340	GEAR SHUTTER Z16S	2

Part.No.	Alternative.	Description	Fig.No.
302F912360	2F912360	SPRING SHUTTER ARM	2
302F912370	2F912370	SPRING SHUTTER L	2
302F924020	2F924020	ROLLER REGIST UP	6
302F924071	2F924071	GUIDE PAPER CHUTE	6
302F924090	2F924090	LEVER EMPTY	6
302F924120	2F924120	SPRING TC CHARGE	6
302F924140	2F924140	SPRING EARTH	6
302F924150	2F924150	ACTUATOR REGIST	6
302F924160	2F924160	BUSH REGIST	6
302F924190	2F924190	BUSH TRANSFER R	6
302F924220	2F924220	ACTUATOR DU	6
302F924240	2F924240	LEVER RELEASE FUSER R	6
302F924270	2F924270	SPRING REGIST SENSOR	6
302F924280	2F924280	SPRING MAIN CHARGE	6
302F924320	2F924320	SPRING RELEASE DLP R	6
302F924340	2F924340	SPRING BIAS CHARGE	6
302F924380	2F924380	SPRING RELEASE FUSER R	6
302F924390	2F924390	SPRING TC L	6
302F924400	2F924400	SPRING TC R	6
302F924430	2F924430	GEAR REGIST Z23H	6
302F924460	2F924460	SPRING REGIST R	6
302F924480	2F924480	LEVER RELEASE DLP L	6
302F924490	2F924490	LEVER RELEASE DLP R	6
302F924520	2F924520	SP RELEASE TC L	6
302F924700	2F924700	GEAR REG Z26H-Z33H	6
302F924760	2F924760	PULLEY GUIDE	6
302F924830	2F924830	BUSH TRANSFER L	6
302F925141	2F925141	GEAR EXIT Z21	13
302F925160	2F925160	PULLEY FACE UP	13
302F925180	2F925180	ACTUATOR DU	13
302F925300	2F925300	ROLLER FACE UP	13
302F925350	2F925350	SPRING FACE UP	13
302F925371	2F925371	SPRING ACTUATOR DU	13
302F925440	2F925440	INNER RAIL R	13
302F925450	2F925450	INNER RAIL L	13
302F925480	2F925480	PULLEY RAIL DOUBLE	2,3
302F925550	2F925550	LOCK FUSER	13
302F925560	2F925560	SPRING LOCK	13
302F925750	2F925750	SPRING FUSER RELEASE	13
302F925780	2F925780	SPRING DU	13
302F925872	2F925872	SPRING RAIL SW	2
302F926060	2F926060	PULLEY SWITCH BACK	13
302F928100	2F928100	ACTUATOR OVERFLOW	15
302F928130	2F928130	SPRING COVER FD L	15
302F928140	2F928140	SPRING COVER FD R	15
302F928170	2F928170	SPRING PULLEY	15
302F928231	2F928231	SPRING DISCHARGER	15
302F928310	2F928310	SPRING PULLEY 35	15
302F929030	2F929030	ROLLER DU	8
302F929041	2F929041	ACTUATOR PE	8

Part.No.	Alternative.	Description	Fig.No.
302F929050	2F929050	PULLEY FEED DU	5,15
302F929060	2F929060	SHAFT FEED DU	5,13,15
302F929070	2F929070	SPRING PULLEY FEED	8
302F929080	2F929080	SPRING PE RELEASE	8
302F929140	2F929140	BUSH DU	8,13,15
302F929151	2F929151	LEVER LIFT DU L	8
302F929160	2F929160	LEVER LIFT DU R	8
302F929170	2F929170	SPRING DU LIFT	8
302F929191	2F929191	BUSH PE	8
302F929260	2F929260	PULLEY DU LOW	8
302F931020	2F931020	GEAR Z77H	14
302F931030	2F931030	GEAR Z70H	14
302F931040	2F931040	GEAR Z90H Z30H	14
302F931050	2F931050	GEAR Z48H	14
302F931060	2F931060	GEAR Z46H	14
302F931070	2F931070	GEAR Z37S	14
302F931090	2F931090	GEAR Z30S	14
302F931100	2F931100	GEAR Z34S	14
302F931110	2F931110	GEAR Z95H Z28H	14
302F931190	2F931190	GEAR DLP Z31H	2
302F931200	2F931200	GEAR DLP Z32H	14
302F931270	2F931270	SPRING FUSER	14
302F931290	2F931290	GEAR DLP Z24H	14
302F931300	2F931300	GEAR DLP JOINT Z25H	14
302F931310	2F931310	GEAR DLP Z25H	14
302F931350	2F931350	JOINT SHAFT CASSETTE	14
302F931381	2F931381	SPRING MPF CAM	14
302F931430	2F931430	GEAR FEED ROLL Z27H	6
302F931450	2F931450	SPRING FEED	14
302F931490	2F931490	BUSH FEED DRIVE	6,14
302F931500	2F931500	GEAR FEED Z34H	14
302F931590	2F931590	GEAR Z191H	14
302F931600	2F931600	CLUTCH DLP	2
302F931610	2F931610	GEAR Z45S	14
302F944040	2F944040	CLUTCH DUPLEX	14
302F944060	2F944060	SOLENOID MPF	14
302F944071	2F944071	SOLENOID DLP	2
302F944131	2F944131	MOTOR EJECT	15
302F944150	2F944150	FAN L 80	3
302F944160	2F944160	FAN POWER PWB 50	3
302F944200	2F944200	CLUTCH MID FEED	14
302F944210	2F944210	CLUTCH CASSETTE	14
302F944220	2F944220	CLUTCH REGIST	14
302F994031	2F994031	FEED DRIVE ASSY SP	14
302F994062	2F994062	FEED HOLDER ASSY	7
302F994070	2F994070	SEPARATOR MP ASSY	5
302F994091	2F994091	WASTE BOTTLE ASSY	10
302F994110	2F994110	DC BRUSH ASSY	6
302F994120	2F994120	REGIST KIT	6
302F994300	2F994300	ROLLER TRNSFER ASSY SP	6

Part.No.	Alternative.	Description	Fig.No.
302F994320	2F994320	PARTS MOTOR LIFT ASSY SP	2
302FV02470	2FV02470	BUSH FD	13,15
302FV45020	2FV45020	AC CORD ASSY	3
302FV45040	2FV45040	AC CORD ASSY	3
302GA24030	2GA24030	ROLLER MIDDLE ASSY	6
302H024370	2H024370	BUSH 6 EW	6
302H024830	2H024830	BUSH 8	6
302H702590	2H702590	BUSH SCREW	6,7,18
302H917220	2H917220	GEAR ISU 63/32	9
302H917230	2H917230	BELT ISU	9
302H917240	2H917240	PULLEY TENSION	9
302H917270	2H917270	SPRING TENSION	9
302H917330	2H917330	STOPPER ISU	9
302HS25220	2HS25220	BUSH FUSER	8
302J008050	2J008050	SPRING LEVER LOCK L	5
302J024020	2J024020	SPRING SEP CHARGE	6
302J025200	2J025200	LEVER FUSER RELEASE	13
302J028020	2J028020	SPRING EARTH A	15
302J029020	2J029020	SPRING EARTH DU	8
302J031020	2J031020	MOTOR MAIN Z16	14
302J031030	2J031030	MOTOR DRUM Z16	14
302J044030	2J044030	FAN ENGINE PWB 35	6
302J044040	2J044040	FAN R 80	2
302J044071	2J044071	FAN MOTOR	2
302J093092	2J093092	MC-320	10
302J094010	2J094010	DU ASSY SP	8
302J101050	2J101050	P.W.BOARD ASSY CONNECT-R	14
302J193040	2J193040	LK-350	2
302J193051	2J193051	FK-350(E)	12
302J193061	2J193061	FK-350(U)	12
302J393033	2J393033	DK-320	10
302JD19140	2JD19140	BUSHING FAN	9
302KX94041	2KX94041	PARTS FAX UNIT E SP (4in1 model)	16
302KX94051	2KX94051	PARTS FAX UNIT U SP (4in1 model)	16
302LW02040	2LW02040	RACK LID	3
302LW02050	2LW02050	RACK FRONT	3
302LW02060	2LW02060	GEAR RACK Z19-22	3
302LW04030	2LW04030	LID TOP B	1
302LW07060	2LW07060	JOINT PF ROLLER	18
302LW46010	2LW46010	CONN.CORD ASSY S03613	9
302LW46040	2LW46040	CONN.CORD ASSY S03616	18
302LW93010	2LW93010	DV-350(E) B	11
302LW93020	2LW93020	DV-352(U) B	11
302LW93030	2LW93030	DV-354(AO) B	11
302LW94040	2LW94040	PARTS SWITCHING REGULATOR (U) SP	3
302LW94050	2LW94050	PARTS SWITCHING REGULATOR (E) SP	3
302LW94060	2LW94060	PARTS MOTOR ISU SP	9
302LW94090	2LW94090	PARTS COVER MPF ASSY SP	5
302LW94100	2LW94100	PARTS FRAME ISU TOP ASSY SP	9
302LW94110	2LW94110	PARTS LID TOP A ASSY SP	1

Part.No.	Alternative.	Description	Fig.No.
302LW94140	2LW94140	PARTS COVER FRONT B ASSY SP	1
302LW94170	2LW94170	PARTS COVER TOP ASSY	1
302LW94190	2LW94190	PARTS PWB ASSY CONNECT-L SP	3
302LW94200	2LW94200	PARTS PWB ASSY RELAY SP	3
302MC04020	2MC04020	COVER DIMM	1
302MC04050	2MC04050	COVER INNER L	1
302MC04070	2MC04070	COVER REAR A	1
302MC04080	2MC04080	LID TOP C	1
302MC04100	2MC04100	COVER INNER R B	1
302MC05020	2MC05020	PANEL OPERATION L (3in1 model)	17
302MC05090	2MC05090	COVER CARD READER	16
302MC05130	2MC05130	LABEL OPERATION L(GER) (3in1 model)	20
302MC05140	2MC05140	LABEL OPERATION R(GER) (3in1 model)	20
302MC05150	2MC05150	LABEL OPERATION L(FRA) (3in1 model)	20
302MC05160	2MC05160	LABEL OPERATION R(FRA) (3in1 model)	20
302MC05170	2MC05170	LABEL OPERATION L(ITA) (3in1 model)	20
302MC05180	2MC05180	LABEL OPERATION R(ITA) (3in1 model)	20
302MC05190	2MC05190	LABEL OPERATION L(SPA) (3in1 model)	20
302MC05200	2MC05200	LABEL OPERATION R(SPA) (3in1 model)	20
302MC05220	2MC05220	LABEL OPERATION R	17
302MC05230	2MC05230	LABEL OPERATION L(POR) (3in1 model)	20
302MC05240	2MC05240	LABEL OPERATION R(POR) (3in1 model)	20
302MC05250	2MC05250	LABEL OPERATION L(DUT) (3in1 model)	20
302MC05260	2MC05260	LABEL OPERATION R(DUT) (3in1 model)	20
302MC05270	2MC05270	LABEL OPERATION L(RUS) (3in1 model)	20
302MC05280	2MC05280	LABEL OPERATION R(RUS) (3in1 model)	20
302MC05300	2MC05300	COVER CARD READER C	16
302MC07010	2MC07010	BASE DP	18
302MC07020	2MC07020	COVER FRONT	19
302MC07030	2MC07030	COVER REAR	19
302MC08010	2MC08010	FRAME MPF	5
302MC08020	2MC08020	BASE MPF	5
302MC08030	2MC08030	CURSOR MPF L	5
302MC08040	2MC08040	CURSOR MPF R	5
302MC09010	2MC09010	BASE CASSETTE	4
302MC09020	2MC09020	BASE CASSETTE REAR	4
302MC09030	2MC09030	COVER LIFT GEAR	4
302MC09040	2MC09040	LID CASSETTE	4
302MC09050	2MC09050	COVER CASSETTE TOP	4
302MC09060	2MC09060	CURSOR END	4
302MC09070	2MC09070	LABEL DIAL A6	4
302MC09080	2MC09080	LABEL A6	4
302MC28010	2MC28010	COVER FD	15
302MC34030	2MC34030	LABEL OPERATION ENVELOPE	15
302MC34040	2MC34040	LABEL PUSH	13
302MC93010	2MC93010	PARTS ISU ASSY(L)	9
302MC93020	2MC93020	CT-360	4
302MC94010	2MC94010	PARTS FD UNIT SP	15
302MC94020	2MC94020	PARTS OPERATION UNIT SP (3in1 model)	17
302MC94030	2MC94030	PARTS BASE MPF SP	5

Part.No.	Alternative.	Description	Fig.No.
302MC94040	2MC94040	PARTS COVER RIGHT ASSY SP	1
302MC94050	2MC94050	PARTS COVER LEFT ASSY SP	1
302MC94060	2MC94060	PARTS COVER FRONT ASSY SP	1
302MC94070	2MC94070	PARTS COVER INNER R ASSY SP	1
302MC94080	2MC94080	PARTS COVER SIDE ASSY SP	1
302MC94090	2MC94090	PARTS COVER REAR B ASSY SP	13
302MC94100	2MC94100	PARTS COVER PF ASSY SP	19
302MC94121	2MC94121	PARTS PWB MAIN ASSY SP (3in1 model)	16
302MC94131	2MC94131	PARTS PWB MAIN ASSY SP EU (3in1 model)	16
302MC94140	2MC94140	PARTS PWB ENGINE ASSY SP	6
302MC94150	2MC94150	PARTS PWB PANEL MAIN ASSY SP	17
302MD05010	2MD05010	PANEL OPERATION L (4in1 model)	17
302MD05050	2MD05050	LABEL OPERATION L(GER) (4in1 model)	20
302MD05060	2MD05060	LABEL OPERATION L(FRA) (4in1 model)	20
302MD05070	2MD05070	LABEL OPERATION L(ITA) (4in1 model)	20
302MD05080	2MD05080	LABEL OPERATION L(SPA) (4in1 model)	20
302MD05090	2MD05090	LABEL OPERATION L(POR) (4in1 model)	20
302MD05100	2MD05100	LABEL OPERATION L(DUT) (4in1 model)	20
302MD05110	2MD05110	LABEL OPERATION L(RUS) (4in1 model)	20
302MD94010	2MD94010	PARTS OPERATION UNIT SP (4in1 model)	17
302MD94021	2MD94021	PARTS PWB MAIN ASSY SP (4in1 model)	16
302MD94031	2MD94031	PARTS PWB MAIN ASSY SP EU (4in1 model)	16
303HL10200	3HL10200	SPRING LOOP	19
303HL22200	3HL22200	PLATE GND	18
303HZ45010	3HZ45010	MODULAR CORD (4in1 model)	20
303JX29160	3JX29160	PULLEY CONVEYING	18
303K502200	3K502200	ACTUATOR BASE	18
303LJ02020	3LJ02020	GUIDE READING	19
303LJ02030	3LJ02030	HINGE L	19
303LJ02040	3LJ02040	HINGE R	19
303LJ02060	3LJ02060	SPRING RELEASE	19
303LJ02070	3LJ02070	SPRING READING	19
303LJ02080	3LJ02080	ACTUATOR PUSH	19
303LJ02150	3LJ02150	LEVER RELEASE	18
303LJ02240	3LJ02240	SPRING GND A	18
303LJ02250	3LJ02250	SPRING GND B	18
303LJ07050	3LJ07050	ACTUATOR ORIGINAL	19
303LJ07060	3LJ07060	LEVER PUSH DU	19
303LJ07070	3LJ07070	SPRING PUSH DU	19
303LJ24041	3LJ24041	LEVER SEPARATE	19
303LJ24050	3LJ24050	LEVER LOOP	19
303LJ24080	3LJ24080	ACTUATOR TIMING	18
303LJ24090	3LJ24090	SPRING TIMING	18
303LJ24101	3LJ24101	GUIDE SEPARATION	18
303LJ24121	3LJ24121	SPRING CONVEYING	18
303LJ24150	3LJ24150	SPRING EXIT	18
303LJ24190	3LJ24190	HOOK PF COVER	18
303LJ24230	3LJ24230	SPRING REGIST	18
303LJ29040	3LJ29040	SPRING LOOP PRESSURE	18
303LJ29060	3LJ29060	LEVER PRESSURE	18



**KYOCERA Document Solutions America, Inc.**  
**Headquarters**  
225 Sand Road,  
Fairfield, New Jersey 07004-0008, USA  
Phone: +1-973-808-8444  
Fax: +1-973-882-6000

**Latin America**  
8240 NW 52nd Terrace Dawson Building, Suite 100  
Miami, Florida 33166, USA  
Phone: +1-305-421-6640  
Fax: +1-305-421-6666

**KYOCERA Document Solutions Canada, Ltd.**  
6120 Kestrel Rd., Mississauga, ON L5T 1S8,  
Canada  
Phone: +1-905-670-4425  
Fax: +1-905-670-8116

**KYOCERA Document Solutions  
Mexico, S.A. de C.V.**  
Calle Arquimedes No. 130, 4 Piso, Colonia Polanco  
Chapultepec, Delegacion Miguel Hidalgo,  
Distrito Federal, C.P. 11560, México  
Phone: +52-555-383-2741  
Fax: +52-555-383-7804

**KYOCERA Document Solutions Brazil, Ltda.**  
Alameda África, 545, Pólo Empresarial Consbrás,  
Tamboré, Santana de Parnaíba-SP, CEP 06543-306,  
Brazil  
Phone: +55-11-4195-8496  
Fax: +55-11-4195-6167

**KYOCERA Document Solutions  
Australia Pty. Ltd.**  
Level 3, 6-10 Talavera Road North Ryde N.S.W, 2113,  
Australia  
Phone: +61-2-9888-9999  
Fax: +61-2-9888-9588

**KYOCERA Document Solutions  
New Zealand Ltd.**  
Ground Floor, 19 Byron Avenue, Takapuna, Auckland,  
New Zealand  
Phone: +64-9-415-4517  
Fax: +64-9-415-4597

**KYOCERA Document Solutions Asia Limited**  
16/F., Mita Centre, 552-566, Castle Peak Road  
Tsuenwan, NT, Hong Kong  
Phone: +852-2610-2181  
Fax: +852-2610-2063

**KYOCERA Document Solutions  
(China) Corporation**  
8F, No. 288 Nanjing Road West, Huangpu District,  
Shanghai, 200003, China  
Phone: +86-21-5301-1777  
Fax: +86-21-5302-8300

**KYOCERA Document Solutions  
(Thailand) Corp., Ltd.**  
335 Ratchadapisek Road, Bangsue, Bangkok 10800,  
Thailand  
Phone: +66-2-586-0333  
Fax: +66-2-586-0278

**KYOCERA Document Solutions  
Singapore Pte. Ltd.**  
12 Tai Seng Street #04-01A,  
Luxasia Building, Singapore 534118  
Phone: +65-6741-8733  
Fax: +65-6748-3788

**KYOCERA Document Solutions  
Hong Kong Limited**  
16/F., Mita Centre, 552-566, Castle Peak Road  
Tsuenwan, NT, Hong Kong  
Phone: +852-3582-4000  
Fax: +852-3185-1399

**KYOCERA Document Solutions  
Taiwan Corporation**  
6F., No.37, Sec. 3, Minquan E. Rd.,  
Zhongshan Dist., Taipei 104, Taiwan R.O.C.  
Phone: +886-2-2507-6709  
Fax: +886-2-2507-8432

**KYOCERA Document Solutions Korea Co., Ltd.**  
18F, Kangnam bldg, 1321-1,  
Seocho-Dong, Seocho-Gu, Seoul, Korea  
Phone: +822-6933-4050  
Fax: +822-747-0084

**KYOCERA Document Solutions  
India Private Limited**  
Second floor, Centrum Plaza, Golf Course Road,  
Sector-53, Gurgaon, Haryana 122002, India  
Phone: +91-0124-4671000  
Fax: +91-0124-4671001



**KYOCERA Document Solutions Europe B.V.**

Bloemlaan 4, 2132 NP Hoofddorp,  
The Netherlands  
Phone: +31-20-654-0000  
Fax: +31-20-653-1256

**KYOCERA Document Solutions Nederland B.V.**

Beechavenue 25, 1119 RA Schiphol-Rijk,  
The Netherlands  
Phone: +31-20-5877200  
Fax: +31-20-5877260

**KYOCERA Document Solutions (U.K.) Limited**

Eldon Court, 75-77 London Road,  
Reading, Berkshire RG1 5BS,  
United Kingdom  
Phone: +44-118-931-1500  
Fax: +44-118-931-1108

**KYOCERA Document Solutions Italia S.p.A.**

Via Verdi, 89/91 20063 Cernusco s/N.(MI),  
Italy  
Phone: +39-02-921791  
Fax: +39-02-92179-600

**KYOCERA Document Solutions Belgium N.V.**

Sint-Martinusweg 199-201 1930 Zaventem,  
Belgium  
Phone: +32-2-7209270  
Fax: +32-2-7208748

**KYOCERA Document Solutions France S.A.S.**

Espace Technologique de St Aubin  
Route de l'Orme 91195 Gif-sur-Yvette CEDEX,  
France  
Phone: +33-1-69852600  
Fax: +33-1-69853409

**KYOCERA Document Solutions Espana, S.A.**

Edificio Kyocera, Avda. de Manacor No.2,  
28290 Las Matas (Madrid), Spain  
Phone: +34-91-6318392  
Fax: +34-91-6318219

**KYOCERA Document Solutions Finland Oy**

Atomitie 5C, 00370 Helsinki,  
Finland  
Phone: +358-9-47805200  
Fax: +358-9-47805390

**KYOCERA Document Solutions  
Europe B.V., Amsterdam (NL) Zürich Branch**

Hohlstrasse 614, 8048 Zürich,  
Switzerland  
Phone: +41-44-9084949  
Fax: +41-44-9084950

**KYOCERA Document Solutions  
Deutschland GmbH**

Otto-Hahn-Strasse 12, 40670 Meerbusch,  
Germany  
Phone: +49-2159-9180  
Fax: +49-2159-918100

**KYOCERA Document Solutions Austria GmbH**

Eduard-Kittenberger-Gasse 95, 1230 Vienna,  
Austria  
Phone: +43-1-863380  
Fax: +43-1-86338-400

**KYOCERA Document Solutions Nordic AB**

Esbogatan 16B 164 75 Kista, Sweden  
Phone: +46-8-546-550-00  
Fax: +46-8-546-550-10

**KYOCERA Document Solutions Norge Nuf**

Postboks 150 Oppsal, 0619 Oslo,  
Norway  
Phone: +47-22-62-73-00  
Fax: +47-22-62-72-00

**KYOCERA Document Solutions Danmark A/S**

Ejby Industrivej 60, DK-2600 Glostrup,  
Denmark  
Phone: +45-70223880  
Fax: +45-45765850

**KYOCERA Document Solutions Portugal Lda.**

Rua do Centro Cultural, 41 (Alvalade) 1700-106 Lisboa,  
Portugal  
Phone: +351-21-843-6780  
Fax: +351-21-849-3312

**KYOCERA Document Solutions  
South Africa (Pty) Ltd.**

KYOCERA House, Hertford Office Park,  
90 Bekker Road (Cnr. Allandale), Midrand, South Africa.  
Phone: +27-11-540-2600  
Fax: +27-11-466-3050

**KYOCERA Document Solutions Russia LLC**

Botanichesky pereulok 5, Moscow, 129090,  
Russia  
Phone: +7(495)741-0004  
Fax: +7(495)741-0018

**KYOCERA Document Solutions Middle East**

Dubai Internet City, Bldg. 17,  
Office 157 P.O. Box 500817, Dubai,  
United Arab Emirates  
Phone: +971-04-433-0412

**KYOCERA Document Solutions Inc.**

2-28, 1-chome, Tamatsukuri, Chuo-ku  
Osaka 540-8585, Japan  
Phone: +81-6-6764-3555  
<http://www.kyoceradocumentsolutions.com>

© 2014 KYOCERA Document Solutions Inc.

 is a trademark of KYOCERA Corporation