



FS-3040MFP

FS-3140MFP

PARTS LIST

Published in December 2014
2LWPL072
Rev.2

NOTES

1. Indicate parts number and parts description together with the machine model name when placing an order.

e.g.	Parts Number	Parts Name	Machine Model	Quantity
	302LW94010	PARTS MAIN PWB ASSY SP (3in1 model)	FS-3040MFP	1
	302LX94010	PARTS MAIN PWB ASSY SP (4in1 model)	FS-3140MFP	1

2. Parts with "*" are component parts or sub-assemblies of the assembly appearing immediately above them.

e.g.	Parts Number	Parts Name	Parts Number	Parts Name
	302J393032	DK-320	• 302J093092	MC-320

— CONTENTS —

FIG. 1	Covers	2	FIG. 16	Electrical Components	32
FIG. 2	Frames 1	4	FIG. 17	Operation Section	34
FIG. 3	Frames 2	6	FIG. 18	Document Processor 1	36
FIG. 4	Paper Cassette	8	FIG. 19	Document Processor 2	38
FIG. 5	Paper Feed Section 1	10	FIG. 20	Accessories	40
FIG. 6	Paper Feed Section 2	12	FIG. 21	Maintenance Kits	42
FIG. 7	Paper Feed Section 3	14			
FIG. 8	Paper Feed Section 4	16		• INDEX	43
FIG. 9	Scanner Section	18			
FIG. 10	Image Formation Section	20			
FIG. 11	Developing Section	22			
FIG. 12	Fuser Section 1	24			
FIG. 13	Fuser Section 2	26			
FIG. 14	Drive Section	28			
FIG. 15	Exit Section	30			

FIG. 1 Covers

2LW/2LX

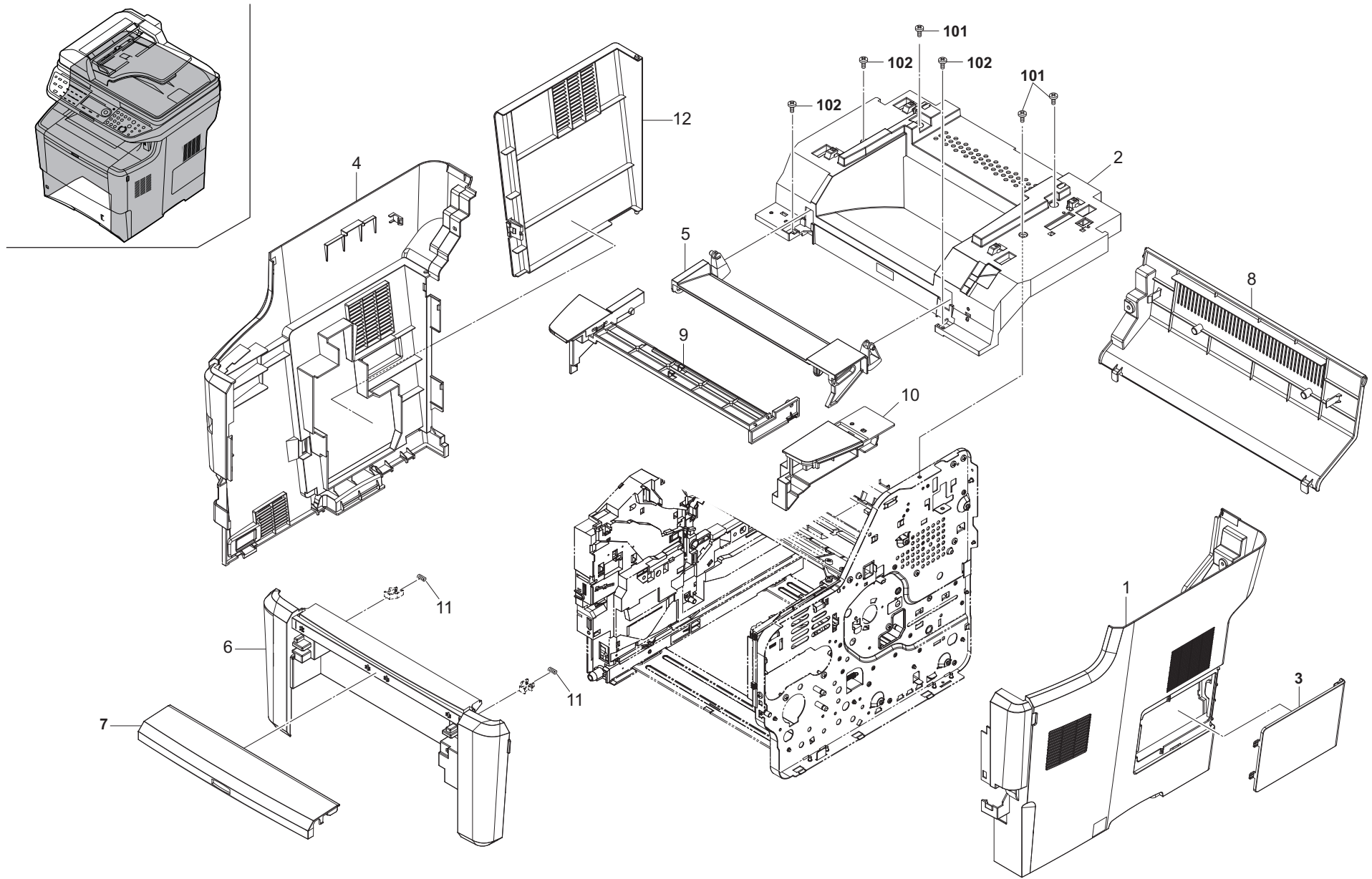

FIG. 1 Covers

2LW/2LX

Ref. No.	Part.No.	Alternative.	Description	Quantity		
				120	230	240
1	302LW94160	2LW94160	PARTS COVER RIGHT ASSY	1	1	1
2	302LW94170	2LW94170	PARTS COVER TOP ASSY	1	1	1
3	302LW04070	2LW04070	COVER CONTROLLER	1	1	1
4	302LW94130	2LW94130	PARTS COVER LEFT ASSY SP	1	1	1
5	302LW94110	2LW94110	PARTS LID TOP A ASSY SP	1	1	1
6	302LW94150	2LW94150	PARTS COVER FRONT ASSY SP	1	1	1
7	302LW94140	2LW94140	PARTS COVER FRONT B ASSY SP	1	1	1
8	302LW04120	2LW04120	COVER REAR	1	1	1
9	302LW04150	2LW04150	LID TOP C	1	1	1
10	302LW04180	2LW04180	COVER INNER R B	1	1	1
11	302H904210	2H904210	SPRING COVER HOOK	2	2	2
12	302LW04170	2LW04170	COVER SIDE	1	1	1

Ref. No.	Part.No.	Alternative.	Description	Quantity		
				120	230	240
101	7BB200410H	BB105700	+BIND T.T P SCREW 4X10			
102	7BB100408H1	BB105830	+BIND T.T S SCREW 4X8			

- Parts with "*" are component parts or sub-assemblies of the assembly appearing immediately above them.

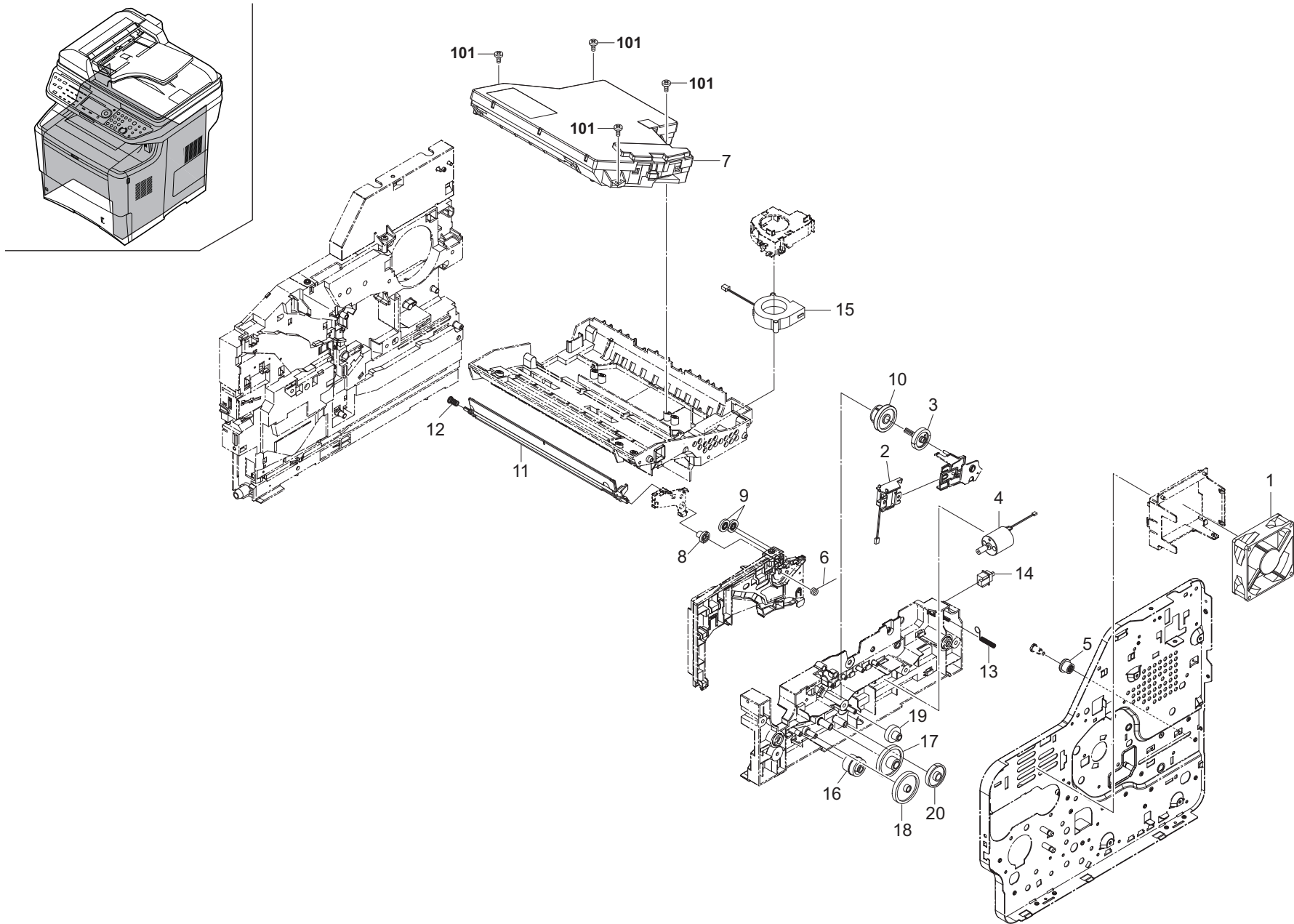

FIG. 2 Frames 1

2LW/2LX

Ref. No.	Part.No.	Alternative.	Description	Quantity		
				120	230	240
1	302J044040	2J044040	FAN R 80	1	1	1
2	302F944071	2F944071	SOLENOID DLP	1	1	1
3	302F931190	2F931190	GEAR DLP Z31H	1	1	1
4	302F994320	2F994320	PARTS MOTOR LIFT ASSY SP	1	1	1
5	302F925480	2F925480	PULLEY RAIL DOUBLE	1	1	1
6	302F912360	2F912360	SPRING SHUTTER ARM	1	1	1
7	302J193040	2J193040	LK-350	1	1	1
8	302F912340	2F912340	GEAR SHUTTER Z16S	1	1	1
9	302F912330	2F912330	GEAR SHUTTER Z18S	2	2	2
10	302F931600	2F931600	CLUTCH DLP	1	1	1
11	302F912310	2F912310	COVER DRUM SHUTTER	1	1	1
12	302F912370	2F912370	SPRING SHUTTER L	1	1	1
13	302F925872	2F925872	SPRING RAIL SW	1	1	1
14	7SP01000001+H01	SP044290	SW.PUSH	1	1	1
15	302J044070	2J044070	FAN MOTOR	1	1	1
16	302F909550	2F909550	GEAR Z26Z15	1	1	1
17	302F909530	2F909530	GEAR Z50Z16	1	1	1
18	302F909540	2F909540	GEAR Z49	1	1	1
19	302F909510	2F909510	GEAR Z40HZ18	1	1	1
20	302F909520	2F909520	GEAR Z60Z16	1	1	1

Ref. No.	Part.No.	Alternative.	Description	Quantity		
				120	230	240
101	7BB200416H1	BB105840	+BIND T.T P SCREW 4X16			

- Parts with "*" are component parts or sub-assemblies of the assembly appearing immediately above them.

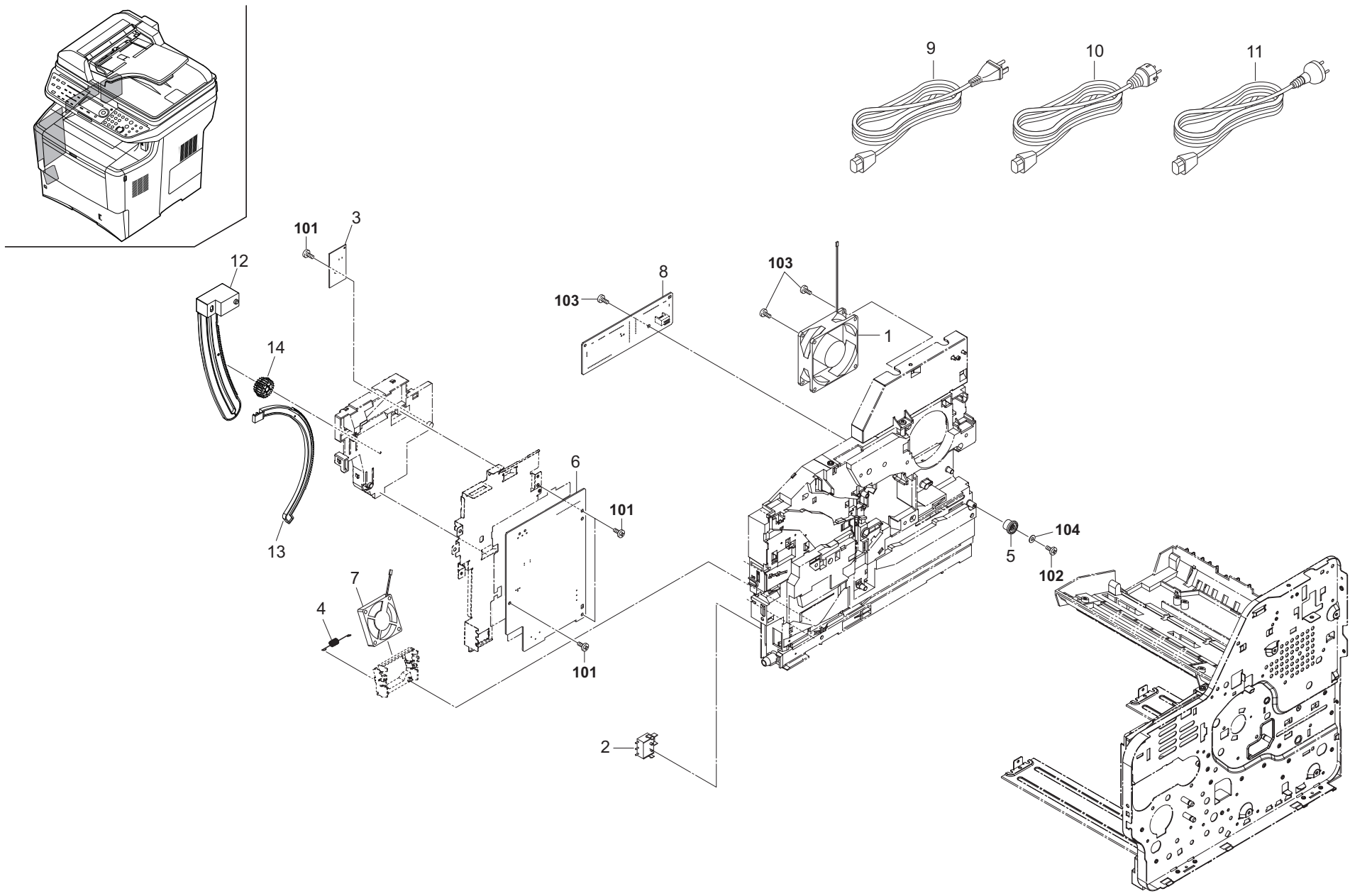

FIG. 3 Frames 2

2LW/2LX-2

Ref. No.	Part.No.	Alternative.	Description	Quantity		
				120	230	240
1	302F944150	2F944150	FAN L 80	1	1	1
2	5FSP03090001+01	SP0A0360	PUSH SWITCH 03 SN /SW-192 N	1	1	1
3	302LW94200	2LW94200	PARTS PWB ASSY RELAY SP	1	1	1
4	302F902410	2F902410	SPRING EARTH FAN	1	1	1
5	302F925480	2F925480	PULLEY RAIL DOUBLE	1	1	1
6	302LW94040	2LW94040	PARTS SWITCHING REGULATOR (U) SP	1		
6	302LW94050	2LW94050	PARTS SWITCHING REGULATOR (E) SP		1	1
7	302F944160	2F944160	FAN POWER PWB 50	1	1	1
8	302LW94190	2LW94190	PARTS PWB ASSY CONNECT-L SP	1	1	1
9	7AAACCUS+10H001	AA068380	AC CORD ASSY US	1		
10	302FV45020	2FV45020	AC CORD ASSY		1	
11	302FV45040	2FV45040	AC CORD ASSY			1
12	302LW02040	2LW02040	RACK LID	1	1	1
13	302LW02050	2LW02050	RACK FRONT	1	1	1
14	302LW02060	2LW02060	GEAR RACK Z19-22	1	1	1

Ref. No.	Part.No.	Alternative.	Description	Quantity		
				120	230	240
101	7BB100306H1	BB105820	+BIND T.T S SCREW 3X6			
102	7BB202308H	BB105690	+TP-FLAT T.T P SCREW 3X8			
103	7BB200410H	BB105700	+BIND T.T P SCREW 4X10			
104	C2804100	C2804100	POLYESTER SLIDER WASHER 4.1X10X0.5T			

- Parts with "*" are component parts or sub-assemblies of the assembly appearing immediately above them.

FIG. 4 Paper Cassette

2LW/2LX

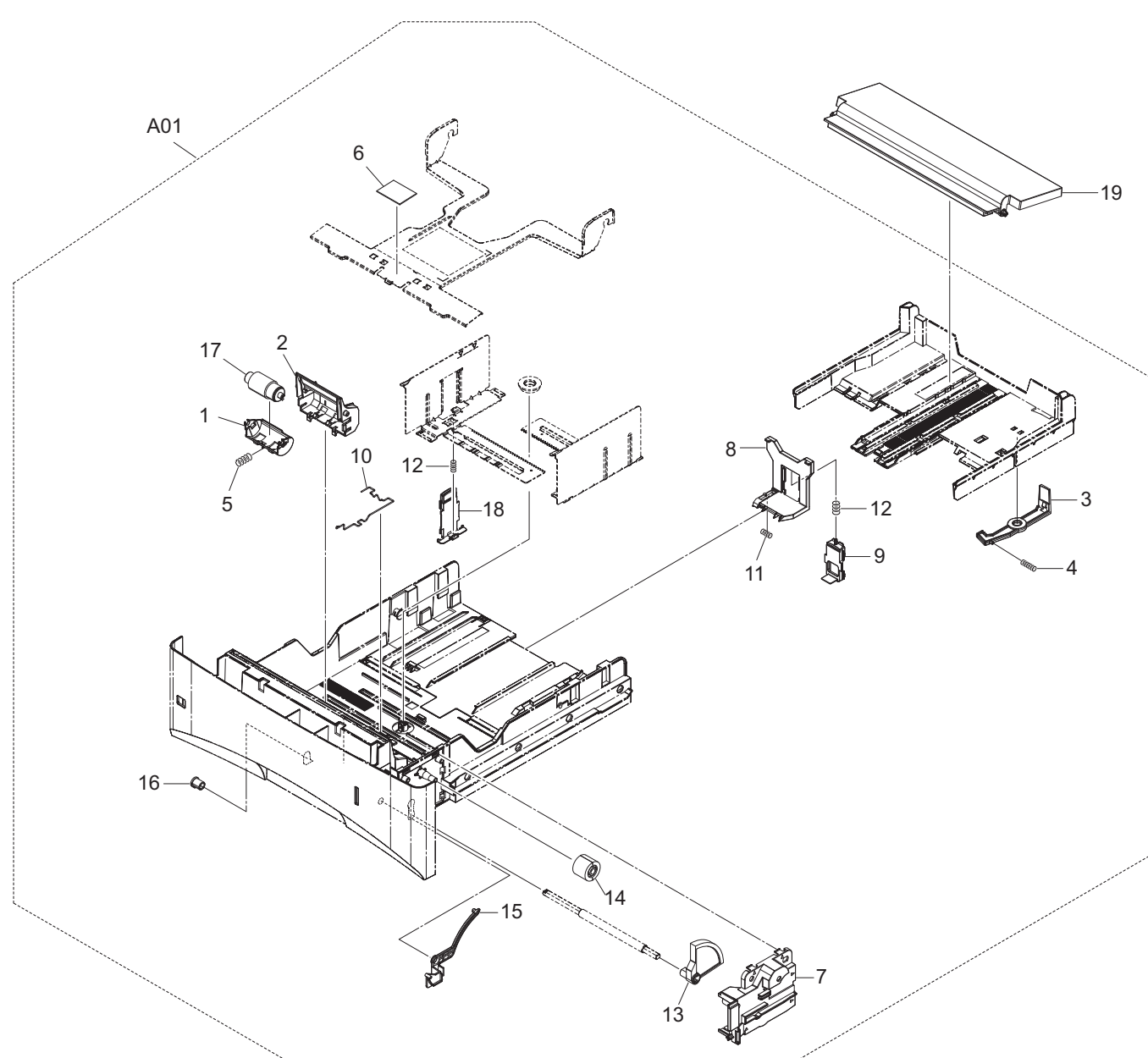
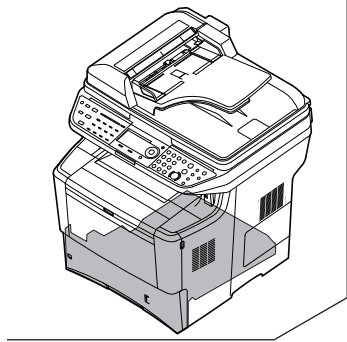

FIG. 5 Paper Feed Section 1

2LW/2LX

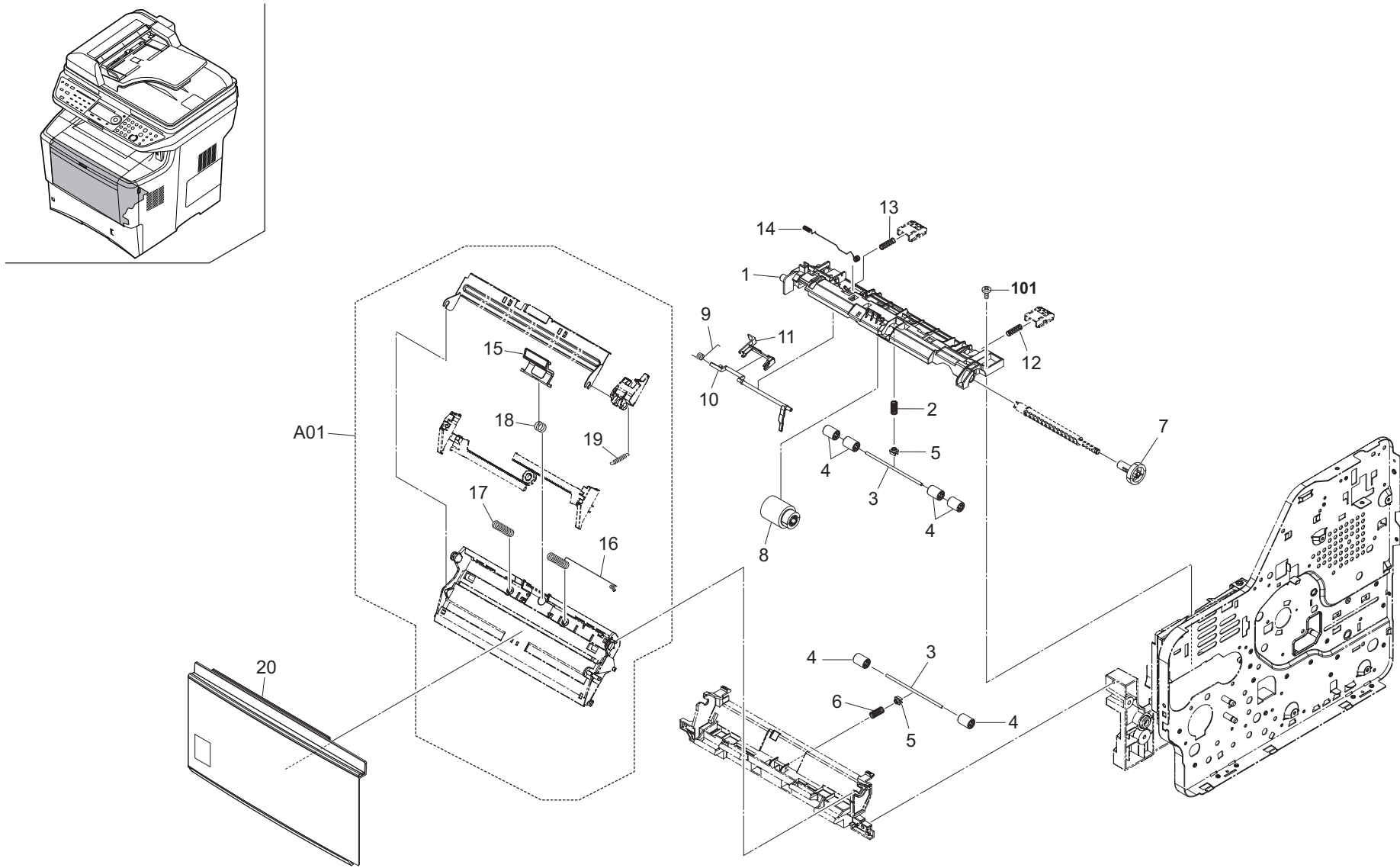

FIG. 5 Paper Feed Section 1

2LW/2LX

Ref. No.	Part.No.	Alternative.	Description	Quantity		
				120	230	240
1	302F908021	2F931381	FRAME MPF	1	1	1
2	302F908380	2F908380	SP PULLEY FEED	1	1	1
3	302F929060	2F929060	SHAFT FEED DU	2	2	2
4	302F929050	2F929050	PULLEY FEED DU	6	6	6
5	5MVX111DN002	3B706590	BUSH SP PULLEY /40283V0099 A4	2	2	2
6	302F908150	2F908150	SP PULLEY TURN	1	1	1
7	302F908130	2F908130	GEAR MPF Z30	1	1	1
8	5AAVR0LL+051	2CL16130	ROLLER M/P ASSY /43487B0027 A4	1	1	1
9	302F908280	2F908280	SP ACTUATOR MPF	1	1	1
10	302F908120	2F908120	ACTUATOR MPF A	1	1	1
11	302F908210	2F908210	ACTUATOR MPF B	1	1	1
12	302F908330	2F908330	SPRING LEVER LOCK R	1	1	1
13	302J008050	2J008050	SPRING LEVER LOCK L	1	1	1
14	302F908230	2F908230	SPRING EARTH CONNECTOR	1	1	1
A01	302J094060	2J094060	BASE MPF ASSY SP	1	1	1
15	•302F994070	2F994070	SEPARATOR MP ASSY	1	1	1
16	•302F908100	2F908100	SPRING BOTTOM MPF R	1	1	1
17	•302F908270	2F908270	SP BOTTOM MPF L	1	1	1
18	•302F908290	2F908290	SP SEPARATOR MPF	1	1	1
19	•302F908300	2F908300	SPRING LOCK MPF	1	1	1
20	302LW94090	2LW94090	PARTS COVER MPF ASSY SP	1	1	1

Ref. No.	Part.No.	Alternative.	Description	Quantity		
				120	230	240
101	7BB100408H1	BB105830	+BIND T.T S SCREW 4X8			

- Parts with "•" are component parts or sub-assemblies of the assembly appearing immediately above them.

FIG. 6 Paper Feed Section 2

2LW/2LX

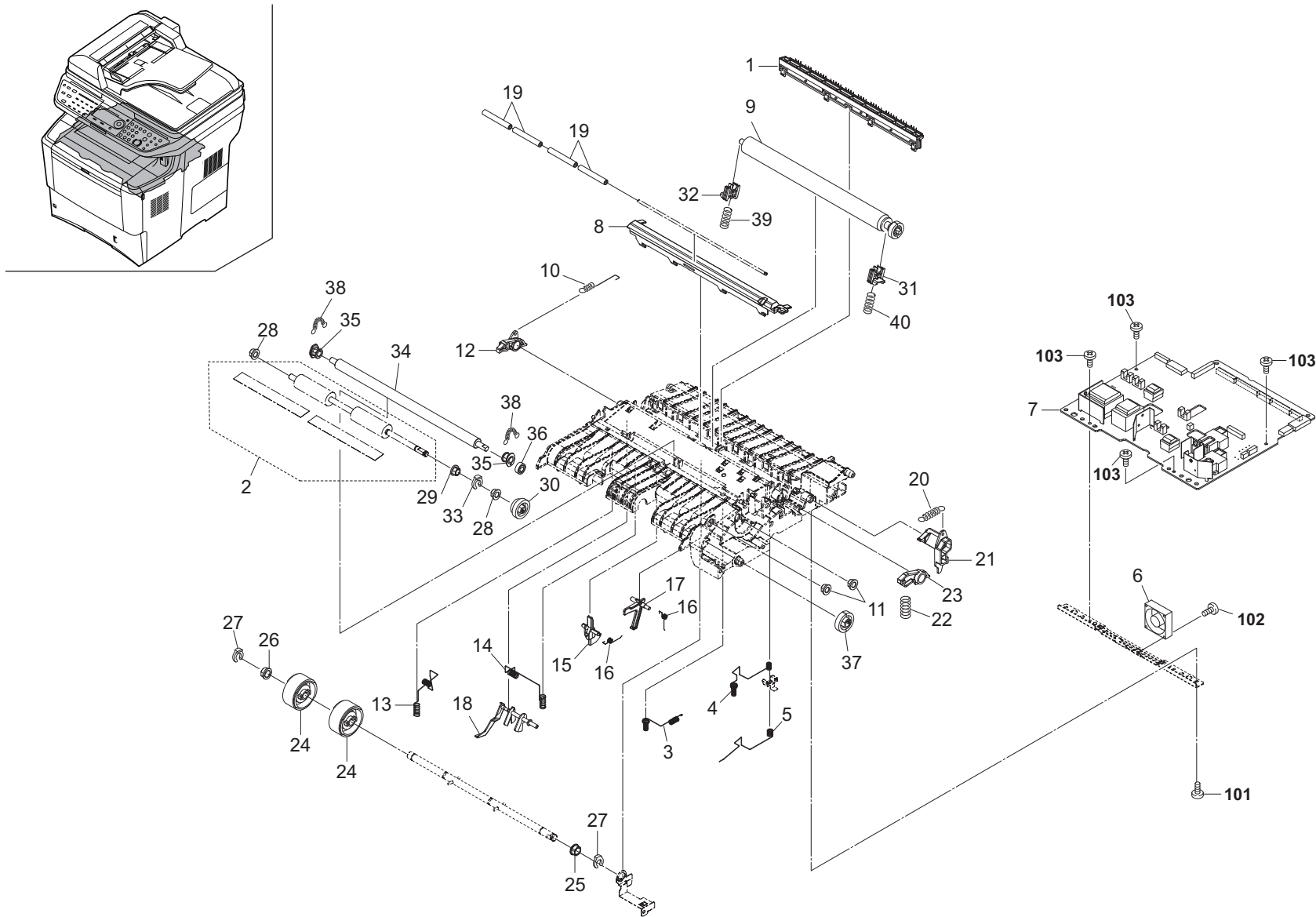

FIG. 6 Paper Feed Section 2

2LW/2LX

Ref. No.	Part.No.	Alternative.	Description	Quantity		
				120	230	240
1	302F994110	2F994110	DC BRUSH ASSY	1	1	1
2	302F994120	2F994120	REGIST KIT	1	1	1
3	302F924120	2F924120	SPRING TC CHARGE	1	1	1
4	302J024020	2J024020	SPRING SEP CHARGE	1	1	1
5	302F924140	2F924140	SPRING EARTH	1	1	1
6	302J044030	2J044030	FAN ENGINE PWB 35	1	1	1
7	302LW94030	2LW94030	PARTS ENGINE PWB ASSY SP	1	1	1
8	302F924071	2F924071	GUIDE PAPER CHUTE	1	1	1
9	302F994300	2F994300	ROLLER TRNSFER ASSY SP	1	1	1
10	302F924520	2F924520	SP RELEASE TC L	1	1	1
11	302F931490	2F931490	BUSH FEED DRIVE	2	2	2
12	302F924480	2F924480	LEVER RELEASE DLP L	1	1	1
13	302F924280	2F924280	SPRING MAIN CHARGE	1	1	1
14	302F924340	2F924340	SPRING BIAS CHARGE	1	1	1
15	302F924150	2F924150	ACTUATOR REGIST	1	1	1
16	302F924270	2F924270	SPRING REGIST SENSOR	2	2	2
17	302F924220	2F924220	ACTUATOR DU	1	1	1
18	302F924090	2F924090	LEVER EMPTY	1	1	1
19	302F924760	2F924760	PULLEY GUIDE	4	4	4
20	302F924380	2F924380	SPRING RELEASE FUSER R	1	1	1
21	302F924240	2F924240	LEVER RELEASE FUSER R	1	1	1
22	302F924320	2F924320	SPRING RELEASE DLP R	1	1	1
23	302F924490	2F924490	LEVER RELEASE DLP R	1	1	1
24	302GA24030	2GA24030	ROLLER MIDDLE ASSY	2	2	2
25	2BC06510	2BC06510	BUSHING 8	1	1	1
26	302H024830	2H024830	BUSH 8	1	1	1
27	2BC06910	2BC06910	STOPPER 6	2	2	2
28	302H702590	2H702590	BUSH SCREW	2	2	2
29	302H024370	2H024370	BUSH 6 EW	1	1	1
30	302F924700	2F924700	GEAR REG Z26H-Z33H	1	1	1
31	302F924190	2F924190	BUSH TRANSFER R	1	1	1
32	302F924830	2F924830	BUSH TRANSFER L	1	1	1
33	2BC06980	2BC06980	STOPPER 5	1	1	1
34	302F924020	2F924020	ROLLER REGIST UP	1	1	1
35	302F924160	2F924160	BUSH REGIST	2	2	2
36	302F924430	2F924430	GEAR REGIST Z23H	1	1	1
37	302F931430	2F931430	GEAR FEED ROLL Z27H	1	1	1
38	302F924460	2F924460	SPRING REGIST R	2	2	2
39	302F924390	2F924390	SPRING TC L	1	1	1
40	302F924400	2F924400	SPRING TC R	1	1	1

Ref. No.	Part.No.	Alternative.	Description	Quantity		
				120	230	240
101	7BB200410H	BB105700	+BIND T.T P SCREW 4X10			
102	7BB100314H	BB112130	+BIND T.T S SCREW 3X14			
103	7BB100306H1	BB105820	+BIND T.T S SCREW 3X6			

- Parts with "*" are component parts or sub-assemblies of the assembly appearing immediately above them.

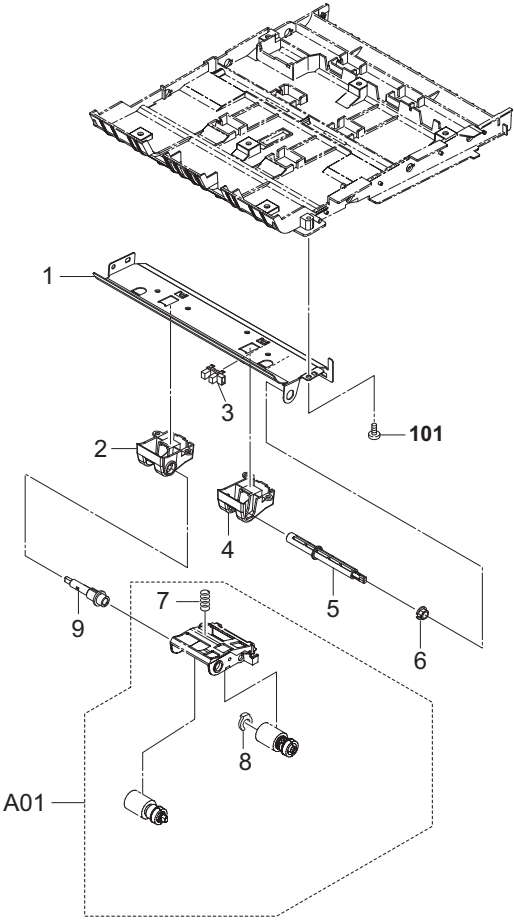
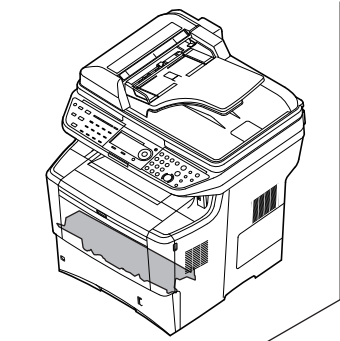

FIG. 8 Paper Feed Section 4

2LW/2LX

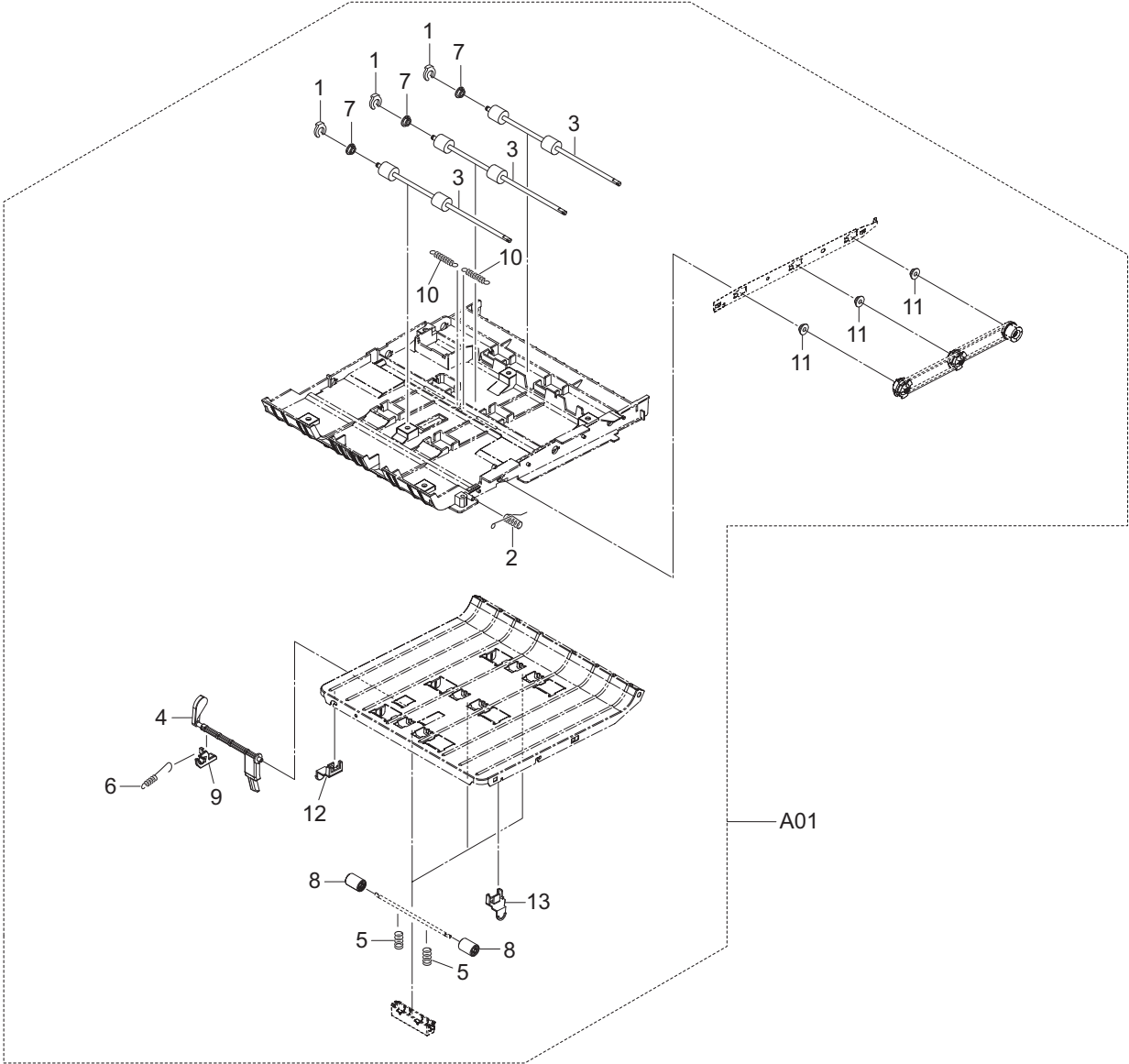
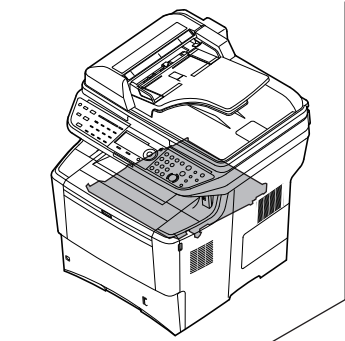
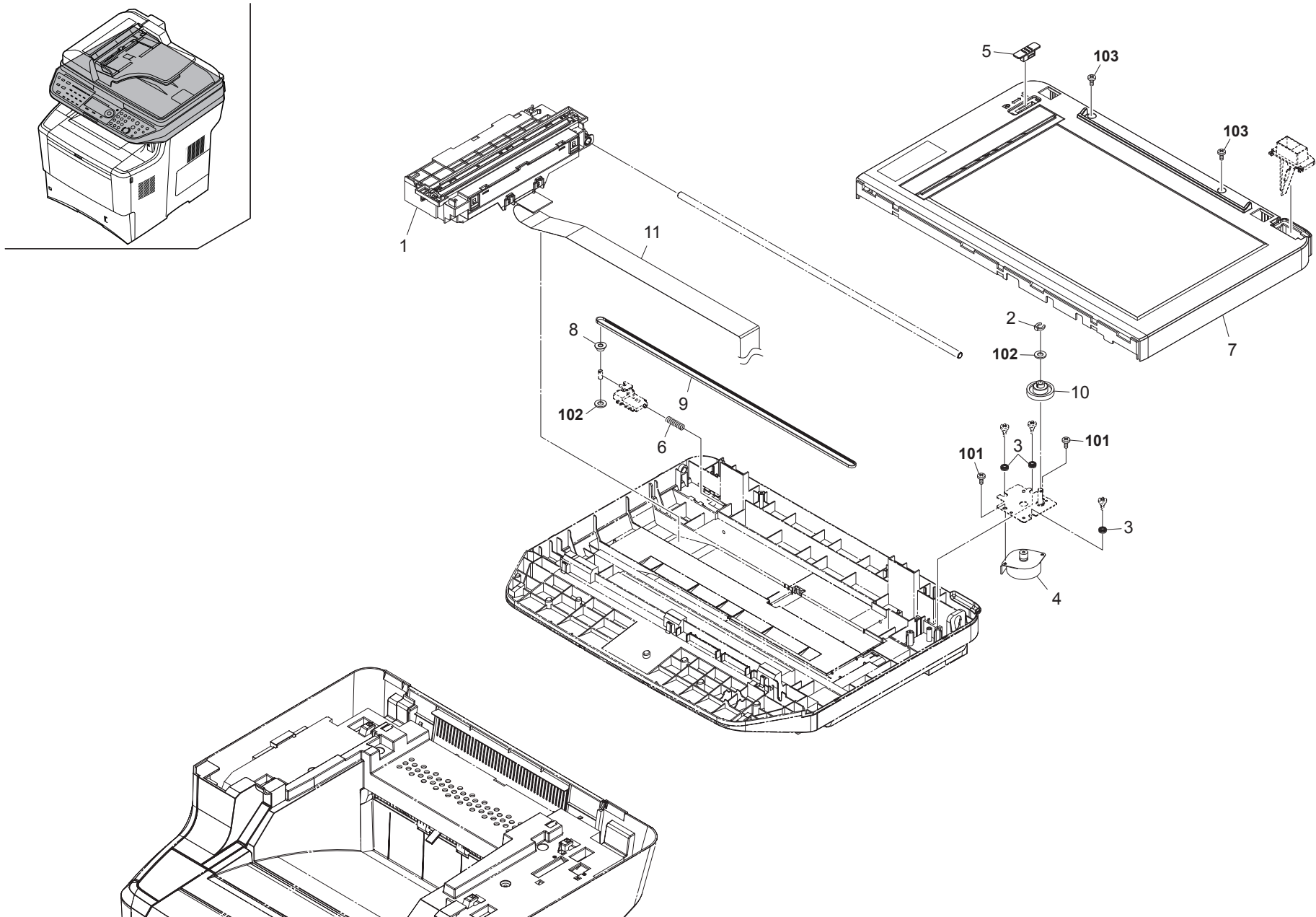
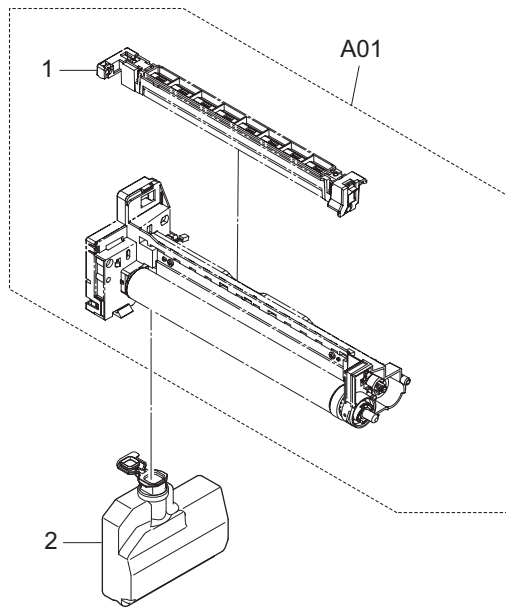
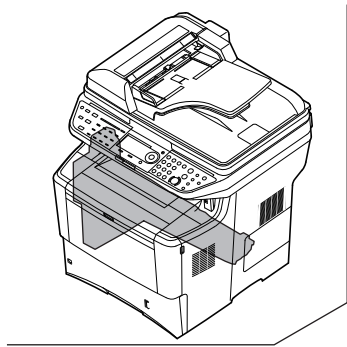
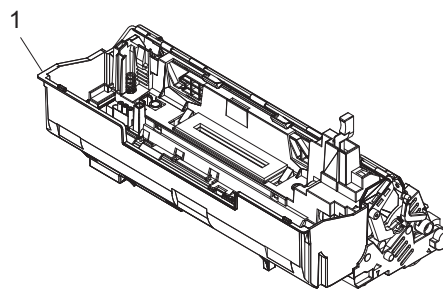
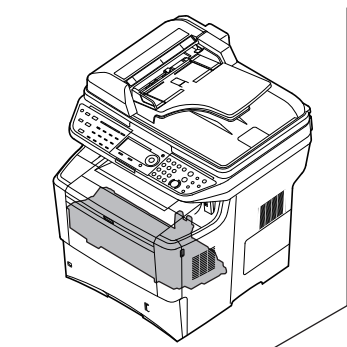

FIG. 9 Scanner Section

2LW/2LX-2







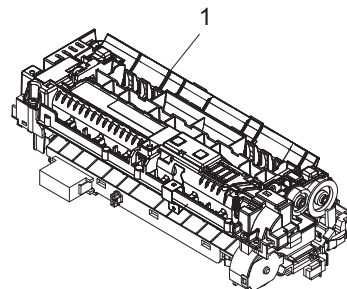
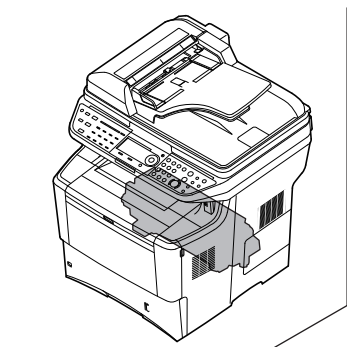

FIG. 13 Fuser Section 2

2LW/2LX

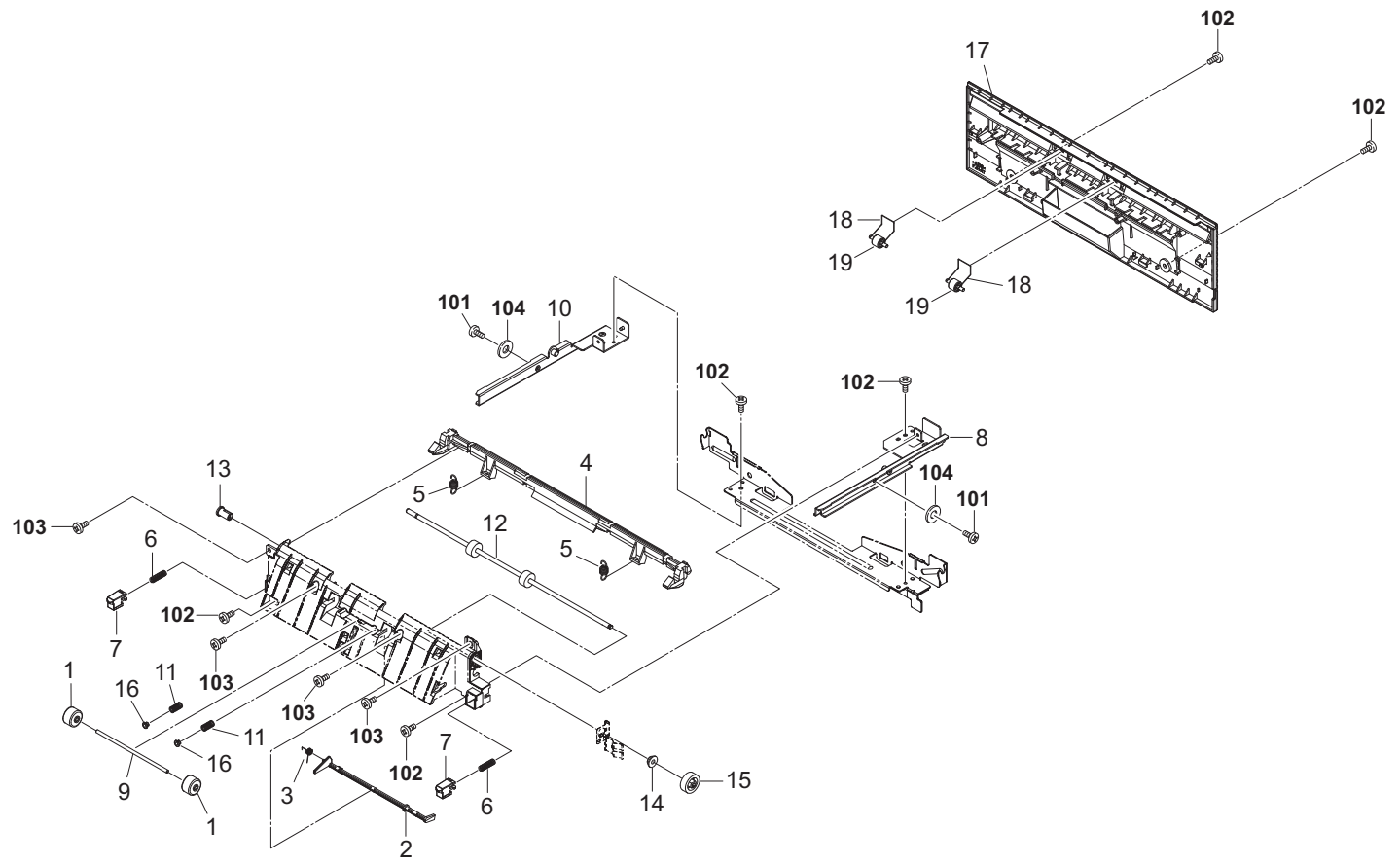
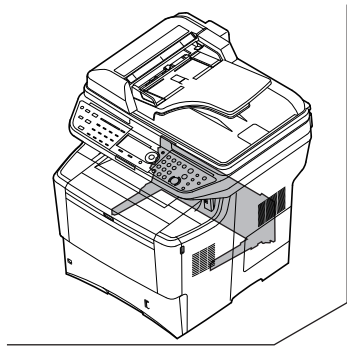

FIG. 13 Fuser Section 2

2LW/2LX

Ref. No.	Part.No.	Alternative.	Description	Quantity		
				120	230	240
1	302F926060	2F926060	PULLEY SWITCH BACK	2	2	2
2	302F925180	2F925180	ACTUATOR DU	1	1	1
3	302F925371	2F925371	SPRING ACTUATOR DU	1	1	1
4	302J025200	2J025200	LEVER FUSER RELEASE	1	1	1
5	302F925750	2F925750	SPRING FUSER RELEASE	2	2	2
6	302F925560	2F925560	SPRING LOCK	2	2	2
7	302F925550	2F925550	LOCK FUSER	2	2	2
8	302F925440	2F925440	INNER RAIL R	1	1	1
9	302F929060	2F929060	SHAFT FEED DU	1	1	1
10	302F925450	2F925450	INNER RAIL L	1	1	1
11	302F925780	2F925780	SPRING DU	2	2	2
12	302F925300	2F925300	ROLLER FACE UP	1	1	1
13	302FV02470	2FV02470	BUSH FD	1	1	1
14	302F929140	2F929140	BUSH DU	1	1	1
15	302F925141	2F925141	GEAR EXIT Z21	1	1	1
16	2FM04150	5MVM163DN005	CAP SPRING /B-11 ENCLOSURE A4	2	2	2
17	302J194080	2J194080	COVER REAR ASSY	1	1	1
18	302F925350	2F925350	SPRING FACE UP	2	2	2
19	302F925160	2F925160	PULLEY FACE UP	2	2	2

Ref. No.	Part.No.	Alternative.	Description	Quantity		
				120	230	240
101	7BB100304H	BB105580	+BIND T.T S SCREW 3X4			
102	7BB100306H1	BB105820	+BIND T.T S SCREW 3X6			
103	7BB200308H	BB105660	+BIND T.T P SCREW 3X8			
104	5MBWK32808NN	C2803080	POLY SLIDER /M3.2X 8 X0.8T XX			

- Parts with "*" are component parts or sub-assemblies of the assembly appearing immediately above them.

FIG. 14 Drive Section

2LW/2LX

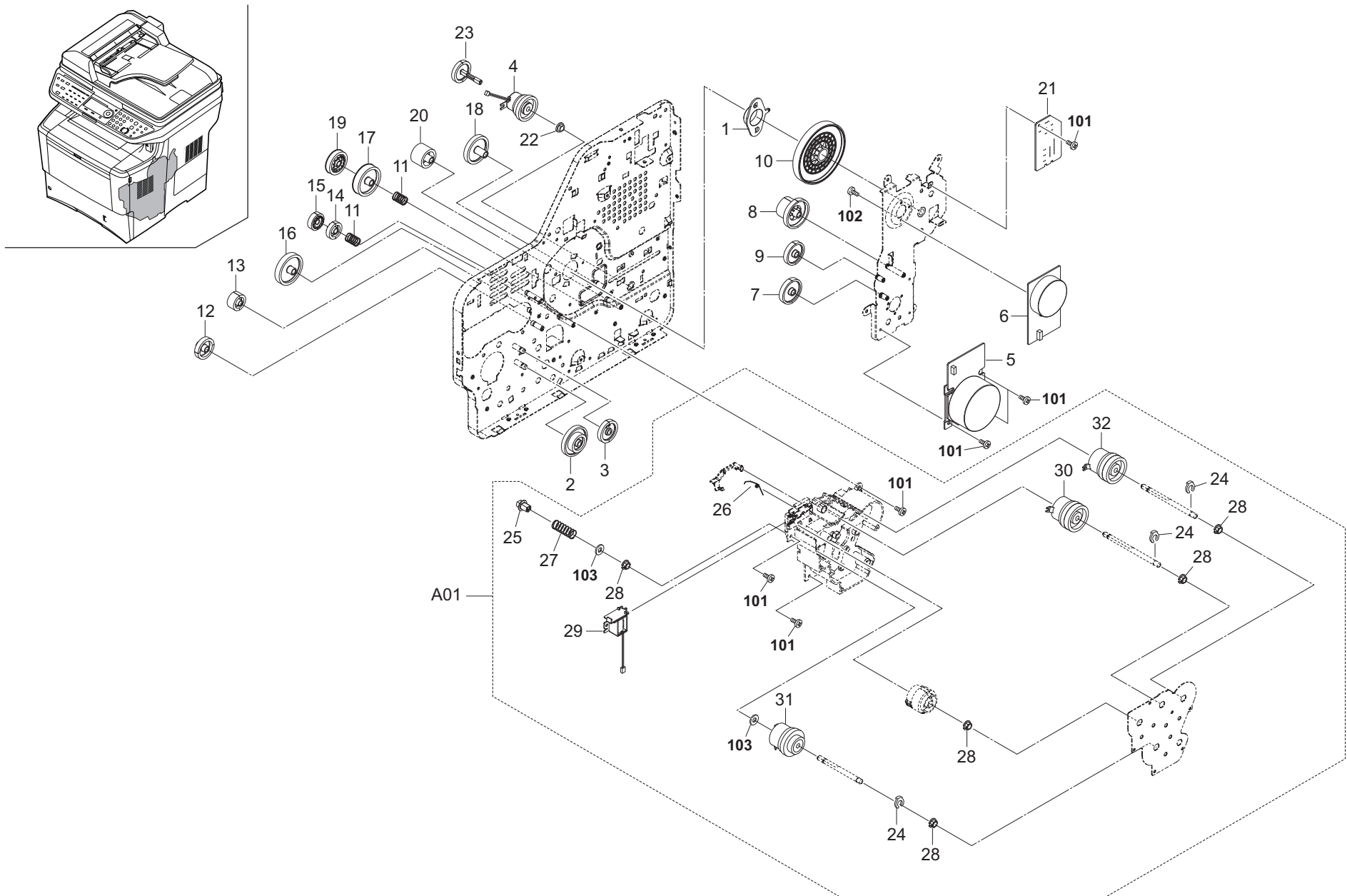

FIG. 14 Drive Section

2LW/2LX

Ref. No.	Part.No.	Alternative.	Description	Quantity		
				120	230	240
1	302F831060	2F831060	BUSH DRUM	1	1	1
2	302F931110	2F931110	GEAR Z95H Z28H	1	1	1
3	302F931500	2F931500	GEAR FEED Z34H	1	1	1
4	302F944040	2F944040	CLUTCH DUPLEX	1	1	1
5	302J031020	2J031020	MOTOR MAIN Z16	1	1	1
6	302J031030	2J031030	MOTOR DRUM Z16	1	1	1
7	302F931020	2F931020	GEAR Z77H	1	1	1
8	302F931040	2F931040	GEAR Z90H Z30H	1	1	1
9	302F931030	2F931030	GEAR Z70H	1	1	1
10	302F931590	2F931590	GEAR Z191H	1	1	1
11	302F931270	2F931270	SPRING FUSER	2	2	2
12	302F931200	2F931200	GEAR DLP Z32H	1	1	1
13	302F931290	2F931290	GEAR DLP Z24H	1	1	1
14	302F931300	2F931300	GEAR DLP JOINT Z25H	1	1	1
15	302F931310	2F931310	GEAR DLP Z25H	1	1	1
16	302F931050	2F931050	GEAR Z48H	1	1	1
17	302F931060	2F931060	GEAR Z46H	1	1	1
18	302F931080	2F931080	GEAR Z45S	1	1	1
19	302F931070	2F931070	GEAR Z37S	1	1	1
20	302F931090	2F931090	GEAR Z30S	1	1	1
21	302J101050	2J101050	P.W.BOARD ASSY CONNECT-R	1	1	1
22	302F931490	2F931490	BUSH FEED DRIVE	1	1	1
23	302F931100	2F931100	GEAR Z34S	1	1	1
A01	302F994031	2F994031	FEED DRIVE ASSY SP	1	1	1
24	*2BC06980	2BC06980	STOPPER 5	3	3	3
25	*302F931350	2F931350	JOINT SHAFT CASSETTE	1	1	1
26	*302F931381	2F931381	SPRING MPF CAM	1	1	1
27	*302F931450	2F931450	SPRING FEED	1	1	1
28	*302F931490	2F931490	BUSH FEED DRIVE	5	5	5
29	*302F944060	2F944060	SOLENOID MPF	1	1	1
30	*302F944200	2F944200	CLUTCH MID FEED	1	1	1
31	*302F944210	2F944210	CLUTCH CASSETTE	1	1	1
32	*302F944220	2F944220	CLUTCH REGIST	1	1	1

Ref. No.	Part.No.	Alternative.	Description	Quantity		
				120	230	240
101	7BB100306H1	BB105820	+BIND T.T S SCREW 3X6			
102	7BB000304H	BB105720	+BIND M SCREW 3X4			
103	C2806120	C2806120	POLYESTER SLIDER WASHER 6.2X12X0.5T			

- Parts with "*" are component parts or sub-assemblies of the assembly appearing immediately above them.

FIG. 15 Exit Section

2LW/2LX

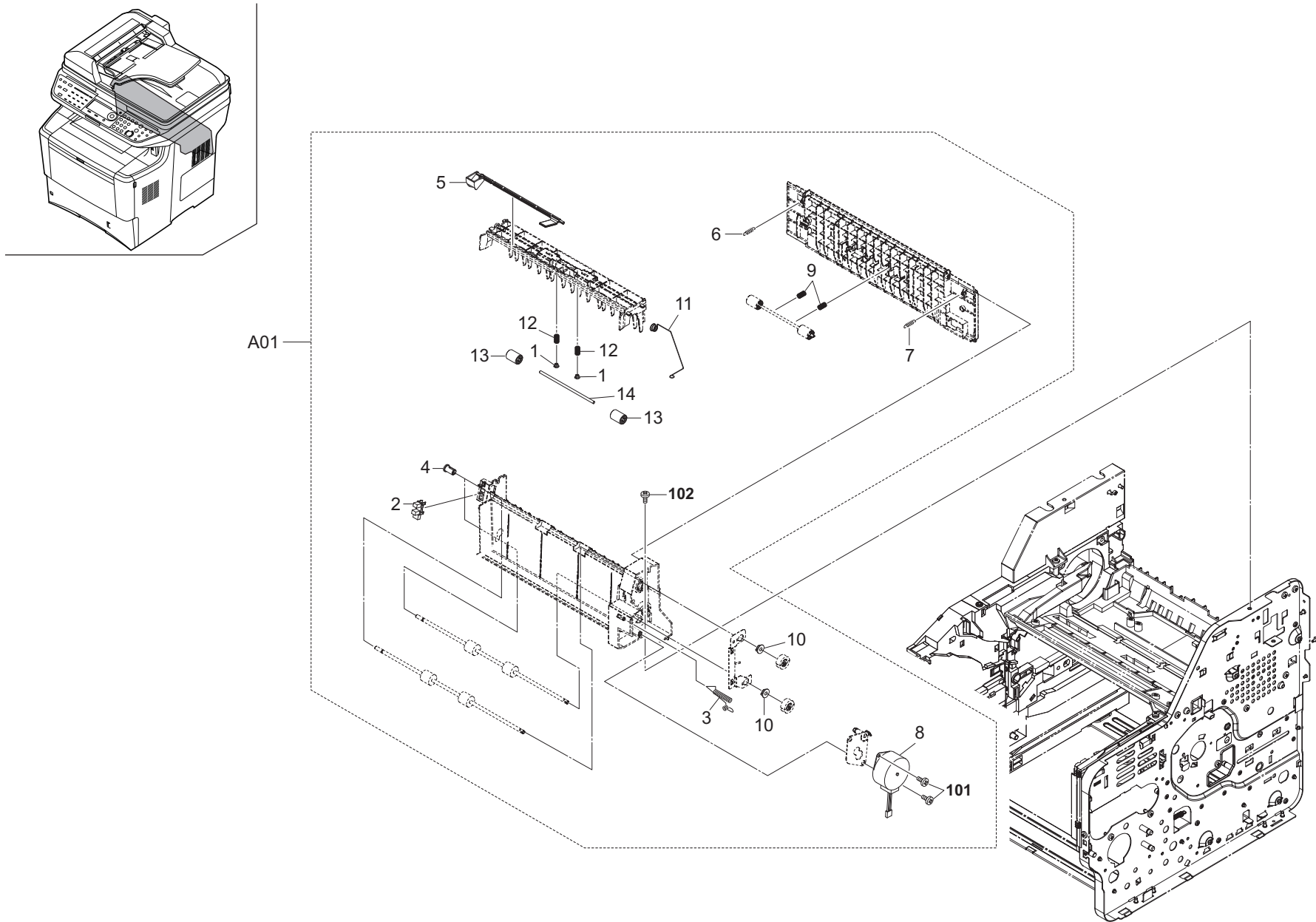

FIG. 15 Exit Section

2LW/2LX

Ref. No.	Part.No.	Alternative.	Description	Quantity		
				120	230	240
A01	302LW94180	2LW94180	PARTS FD UNIT SP	1	1	1
1	•2FM04150	5MVM163DN005	CAP SPRING /B-11 ENCLOSURE A4	2	2	2
2	•7NXTLP1255++H01	NX046610	SENSOR OPT.	1	1	1
3	•302J028020	2J028020	SPRING EARTH A	1	1	1
4	•302FV02470	2FV02470	BUSH FD	2	2	2
5	•302F928100	2F928100	ACTUATOR OVERFLOW	1	1	1
6	•302F928130	2F928130	SPRING COVER FD L	1	1	1
7	•302F928140	2F928140	SPRING COVER FD R	1	1	1
8	•302F944130	2F944130	MOTOR EJECT	1	1	1
9	•302F928170	2F928170	SPRING PULLEY	2	2	2
10	•302F929140	2F929140	BUSH DU	2	2	2
11	•302F928231	2F928231	SPRING DISCHARGER	1	1	1
12	•302F928310	2F928310	SPRING PULLEY 35	2	2	2
13	•302F929050	2F929050	PULLEY FEED DU	2	2	2
14	•302F929060	2F929060	SHAFT FEED DU	1	1	1

Ref. No.	Part.No.	Alternative.	Description	Quantity		
				120	230	240
101	5MBSPP3006NW++R	B0B03060	PAN HEAD SCREW(+) / M3 X 6 CRFREE			
102	7BB100408H1	BB105830	+BIND T.T S SCREW 4X8			

- Parts with "*" are component parts or sub-assemblies of the assembly appearing immediately above them.

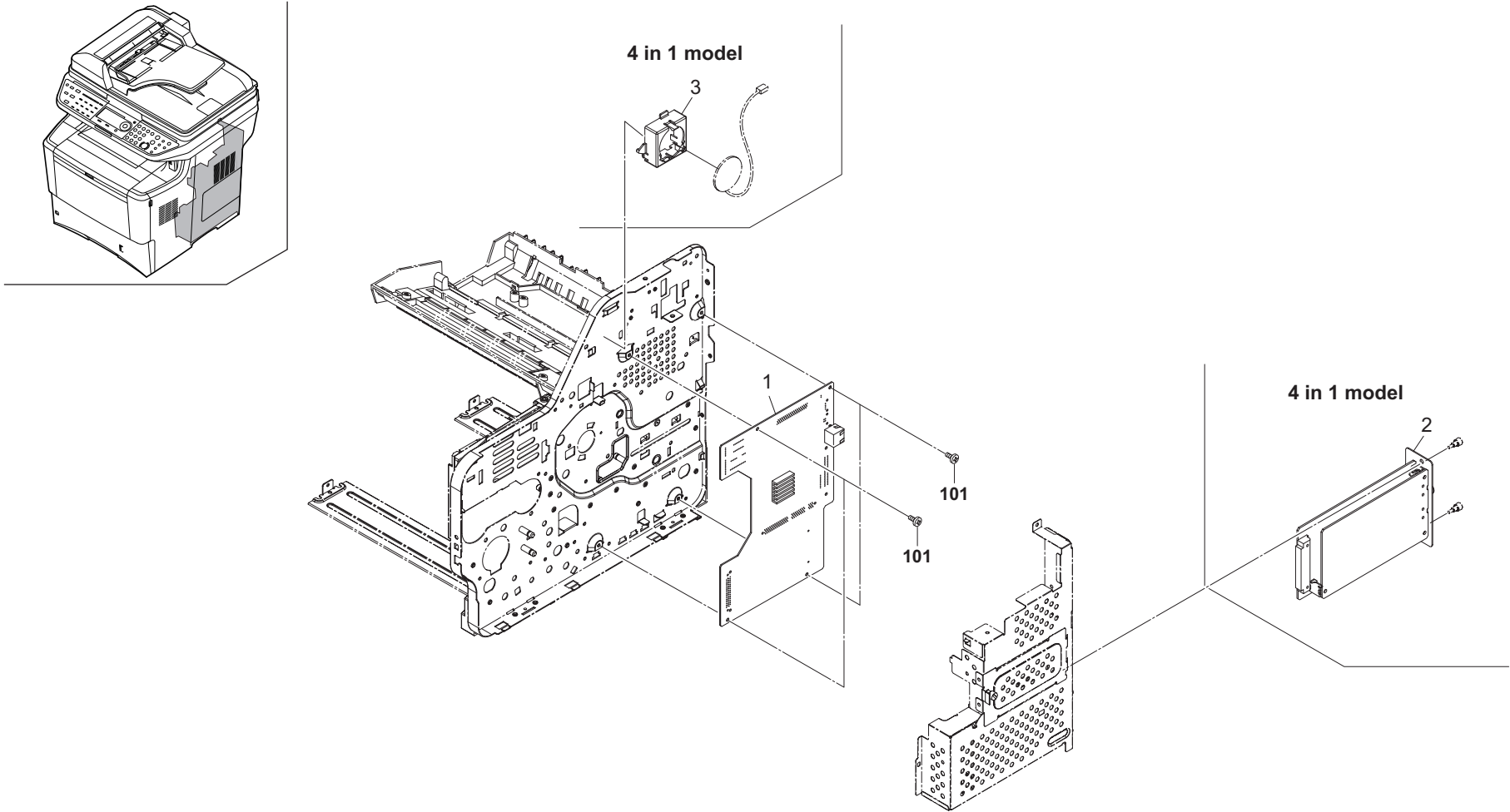

FIG. 16 Electrical Components

2LW/2LX-1

Ref. No.	Part.No.	Alternative.	Description	Quantity		
				120	230	240
1	302LW94011	2LW94011	PARTS MAIN PWB ASSY SP (3in1 model)	1		1
1	302LW94021	2LW94021	PARTS MAIN PWB ASSY E SP (3in1 model)		1	
1	302LX94011	2LX94011	PARTS MAIN PWB ASSY SP (4in1 model)	1		1
1	302LX94021	2LX94021	PARTS MAIN PWB ASSY E SP (4in1 model)		1	
2	302LX94070	2LX94070	PARTS FAX UNIT(E) SP (4in1 model)		1	
2	302LX94080	2LX94080	PARTS FAX UNIT(U) SP (4in1 model)	1		
2	302LX94100	2LX94100	PARTS FAX UNIT(AS) SP (4in1 model)			1
3	302JN02010	2JN02010	MOUNT SPEAKER (4in1 model)	1	1	1

Ref. No.	Part.No.	Alternative.	Description	Quantity		
				120	230	240
101	7BB100306H1	BB105820	+BIND T.T S SCREW 3X6			

- Parts with "*" are component parts or sub-assemblies of the assembly appearing immediately above them.

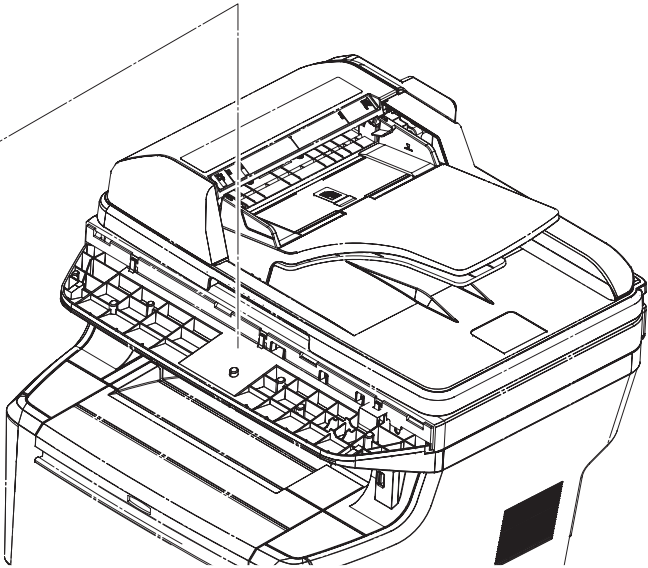
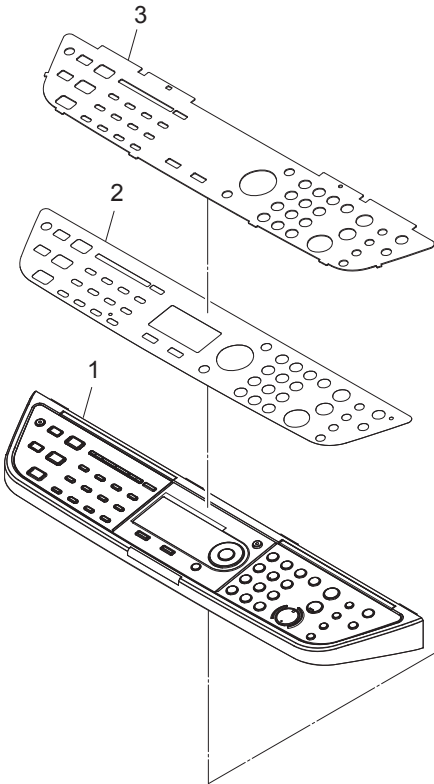
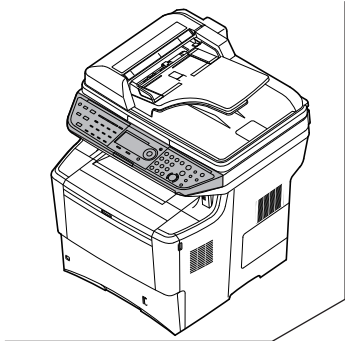

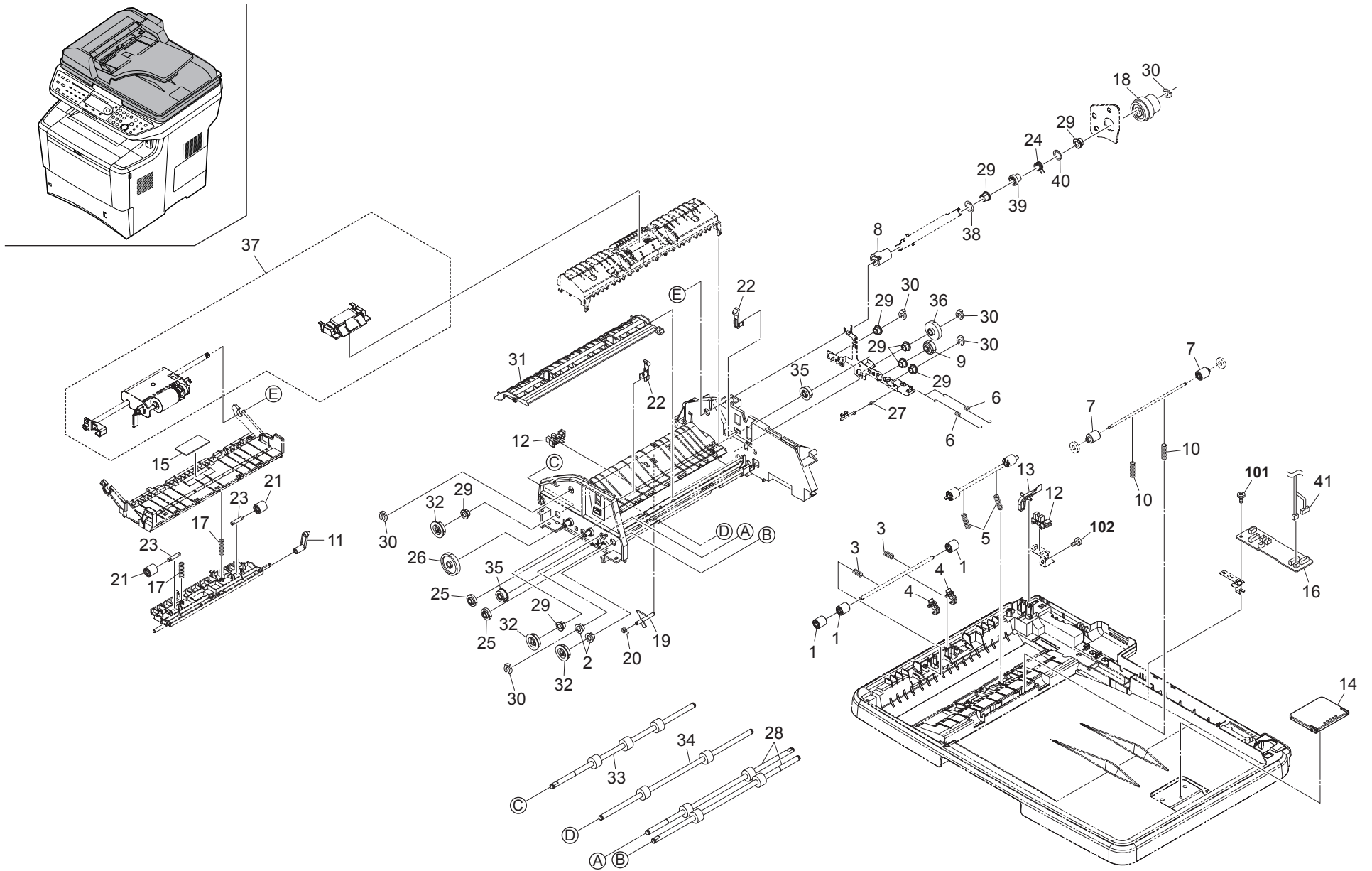

FIG. 18 Document Processor 1

2LW/2LX-2

Ref. No.	Part.No.	Alternative.	Description	Quantity		
				120	230	240
1	303JX29160	3JX29160	PULLEY CONVEYING	3	3	3
2	302H702590	2H702590	BUSH SCREW	2	2	2
3	303LJ24230	3LJ24230	SPRING REGIST	2	2	2
4	303LJ02150	3LJ02150	LEVER RELEASE	2	2	2
5	303LJ24121	3LJ24121	SPRING CONVEYING	2	2	2
6	303LJ02240	3LJ02240	SPRING GND A	2	2	2
7	3HK10030	3HK10030	PULLEY EJECT	2	2	2
8	302LW07060	2LW07060	JOINT PF ROLLER	1	1	1
9	303LJ31060	3LJ31060	GEAR Z32S	1	1	1
10	303LJ24150	3LJ24150	SPRING EXIT	2	2	2
11	303LJ29060	3LJ29060	LEVER PRESSURE	1	1	1
12	7NXSG2481+++H01	NX052600	SENSOR OPT.	2	2	2
13	303K502200	3K502200	ACTUATOR BASE	1	1	1
14	303LJ02120	3LJ02120	STOPPER ORIGINAL	1	1	1
15	3HK07240	3HK07240	FRICION PLATE LF	1	1	1
16	303LJ94010	3LJ94010	PARTS DRIVER PWB ASSY SP	1	1	1
17	303LJ29040	3LJ29040	SPRING LOOP PRESSURE	2	2	2
18	303LJ44040	3LJ44040	CLUTCH PAPER FEED	1	1	1
19	303LJ24080	3LJ24080	ACTUATOR TIMING	1	1	1
20	303LJ24090	3LJ24090	SPRING TIMING	1	1	1
21	3HL10140	3HL10140	PULLEY LOOP	2	2	2
22	303LJ24190	3LJ24190	HOOK PF COVER	2	2	2
23	3H608150	3H608150	SHAFT C PULLEY	2	2	2
24	3HK07140	3HK07140	SPRING LF	1	1	1
25	303LJ31050	3LJ31050	GEAR Z28S	2	2	2
26	303LJ31090	3LJ31090	GEAR Z56S	1	1	1
27	303LJ02250	3LJ02250	SPRING GND B	1	1	1
28	303LJ94040	3LJ94040	PARTS ROLLER EXIT SP	2	2	2
29	3CY07080	3CY07080	BUSHING 6	8	8	8
30	5MVX111DN003	2A806250	RING STOPPER /A-49 FEED A4	6	6	6
31	303LJ24101	3LJ24101	GUIDE SEPARATION	1	1	1
32	303LJ31080	3LJ31080	GEAR Z35S	3	3	3
33	303LJ94020	3LJ94020	PARTS ROLLER A CONVEYING SP	1	1	1
34	303LJ94030	3LJ94030	PARTS ROLLER B CONVEYING SP	1	1	1
35	303LJ31100	3LJ31100	GEAR T Z28S	2	2	2
36	303LJ94050	3LJ94050	PARTS GEAR Z46S ONEWAY SP	1	1	1
37	1702LX0UN0	072LX0UN	MK-370/MAINTENANCE KIT (OPTION)	1	1	1
38	303HL22200	3HL22200	PLATE GND	1	1	1
39	3HK07080	3HK07080	COLLAR S SPRING	1	1	1
40	3HK07270	3HK07270	COLLAR PF	1	1	1
41	302LW46040	2LW46040	CONN.CORD ASSY S03616	1	1	1

Ref. No.	Part.No.	Alternative.	Description	Quantity		
				120	230	240
101	7BB202308H	BB105690	+TP-FLAT T.T P SCREW 3X8			
102	7BB700308H	BB105600	+BIND T.T S SCREW 3X8 SR			

- Parts with "*" are component parts or sub-assemblies of the assembly appearing immediately above them.

FIG. 19 Document Processor 2

2LW/2LX

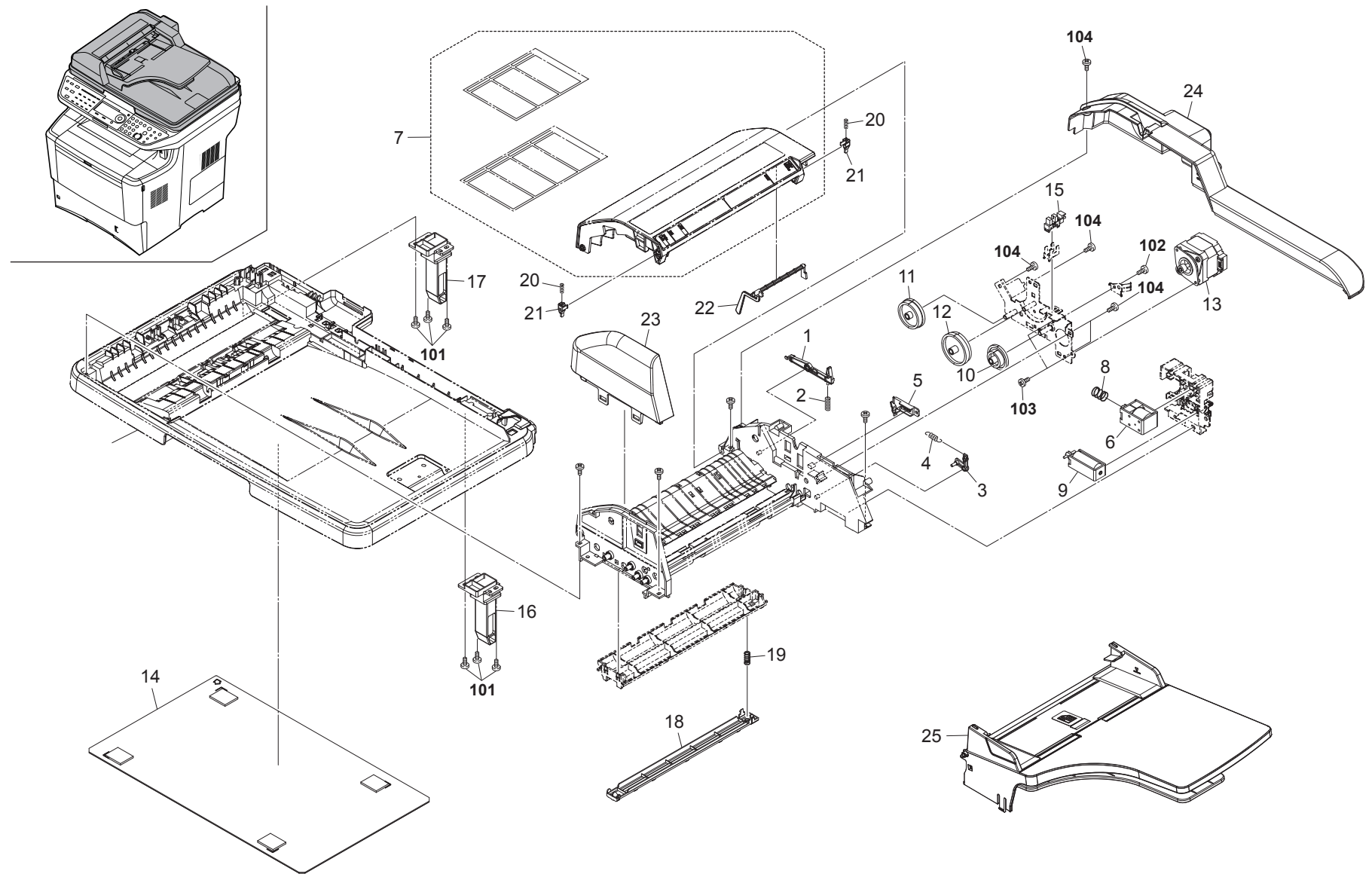

FIG. 19 Document Processor 2

2LW/2LX

Ref. No.	Part.No.	Alternative.	Description	Quantity		
				120	230	240
1	303LJ02080	3LJ02080	ACTUATOR PUSH	1	1	1
2	303LJ02060	3LJ02060	SPRING RELEASE	1	1	1
3	303LJ24041	3LJ24041	LEVER SEPARATE	1	1	1
4	3HL10090	3HL10090	SPRING,LF SHIFT GUIDE	1	1	1
5	303LJ24050	3LJ24050	LEVER LOOP	1	1	1
6	303LJ94140	3LJ94140	PARTS SOLENOID PRESSURE PULLEY SP	1	1	1
7	302LW94210	2LW94210	PARTS COVER PF ASSY SP	1	1	1
8	303HL10200	3HL10200	SPRING LOOP	1	1	1
9	303LJ94150	3LJ94150	PARTS SOLENOID FEED SHIFT SP	1	1	1
10	303LJ31040	3LJ31040	GEAR Z66S Z70S	1	1	1
11	303LJ31020	3LJ31020	GEAR Z40S Z61S	1	1	1
12	303LJ31030	3LJ31030	GEAR Z46S Z79S	1	1	1
13	303LJ94060	3LJ94060	PARTS MOTOR DP SP	1	1	1
14	303LJ94070	3LJ94070	PARTS PLATE ORIGINAL SP	1	1	1
15	7NXSG2481+++H01	NX052600	SENSOR OPT.	1	1	1
16	303LJ02040	3LJ02040	HINGE R	1	1	1
17	303LJ02030	3LJ02030	HINGE L	1	1	1
18	303LJ02020	3LJ02020	GUIDE READING	1	1	1
19	303LJ02070	3LJ02070	SPRING READING	1	1	1
20	303LJ07070	3LJ07070	SPRING PUSH DU	2	2	2
21	303LJ07060	3LJ07060	LEVER PUSH DU	2	2	2
22	303LJ07050	3LJ07050	ACTUATOR ORIGINAL	1	1	1
23	303LJ04010	3LJ04010	COVER FRONT	1	1	1
24	303LJ04021	3LJ04021	COVER REAR	1	1	1
25	303LJ94120	3LJ94120	PARTS TABLE ASSY SP	1	1	1

Ref. No.	Part.No.	Alternative.	Description	Quantity		
				120	230	240
101	7BB202308H	BB105690	+TP-FLAT T.T P SCREW 3X8			
102	7BB700308H	BB105600	+BIND T.T S SCREW 3X8 SR			
103	7BB000306H	BB106880	+BIND M SCREW 3X6			
104	7BB200308H	BB105660	+BIND T.T P SCREW 3X8			

- Parts with "*" are component parts or sub-assemblies of the assembly appearing immediately above them.

3 in 1 model

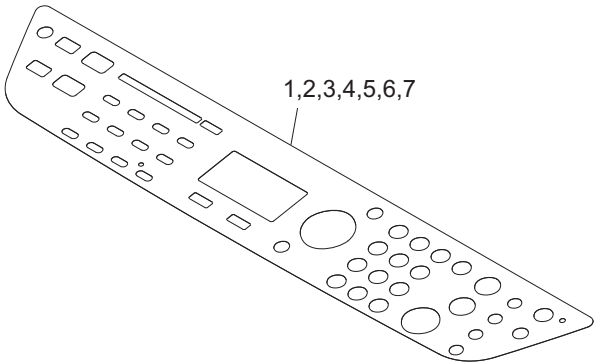

4 in 1 model

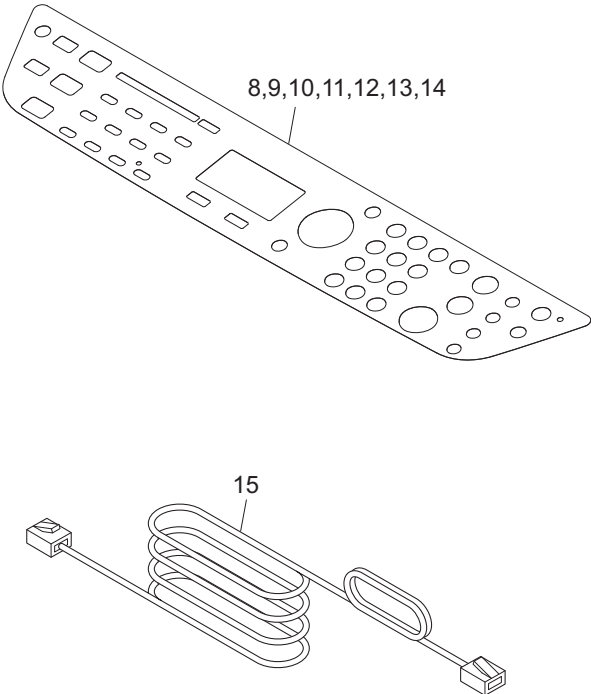

FIG. 20 Accessories

Ref. No.	Part.No.	Alternative.	Description	Quantity		
				120	230	240
1	302LW05020	2LW05020	LABEL OPE GER (3in1 model)		1	
2	302LW05030	2LW05030	LABEL OPE FRA (3in1 model)	1	1	
3	302LW05040	2LW05040	LABEL OPE ITA (3in1 model)		1	
4	302LW05050	2LW05050	LABEL OPE SPA (3in1 model)	1	1	
5	302LW05060	2LW05060	LABEL OPE POR (3in1 model)	1	1	
6	302LW05070	2LW05070	LABEL OPE DUT (3in1 model)		1	
7	302LW05080	2LW05080	LABEL OPE RUS (3in1 model)		1	
8	302LX05030	2LX05030	LABEL OPE GER (4in1 model)		1	
9	302LX05040	2LX05040	LABEL OPE FRA (4in1 model)	1	1	
10	302LX05050	2LX05050	LABEL OPE ITA (4in1 model)		1	
11	302LX05060	2LX05060	LABEL OPE SPA (4in1 model)	1	1	
12	302LX05070	2LX05070	LABEL OPE POR (4in1 model)	1	1	
13	302LX05080	2LX05080	LABEL OPE DUT (4in1 model)		1	
14	302LX05090	2LX05090	LABEL OPE RUS (4in1 model)		1	
15	303HZ45010	3HZ45010	MODULAR CORD (4in1 model)	1		
15	3063527482	63527482	MODULAR CORD AUSTRALIA (4in1 model)			1

- Parts with "*" are component parts or sub-assemblies of the assembly appearing immediately above them.

FIG. 21 Maintenance Kits

Ref. No.	Part.No.	Alternative.	Description	Quantity		
				120	230	240
	1702LX7US0	072LX7US	MK-350/MAINTENANCE KIT(OPTION)	1		
			RETARD ROLLER ASSY	1		
			FEED HOLDER ASSY	1		
			DC BRUSH ASSY	1		
			ROLLER TRANSFER ASSY	1		
			FK-350(U)	1		
			DV-352(U)	1		
			DK-320	1		
	1702LX8NL0	072LX8NL	MK-350/MAINTENANCE KIT (OPTION)		1	
			RETARD ROLLER ASSY		1	
			FEED HOLDER ASSY		1	
			DC BRUSH ASSY		1	
			ROLLER TRANSFER ASSY		1	
			DV-350(E)		1	
			FK-350(E)		1	
			DK-320		1	
	1702LX8AS0	072LX8AS	MK-350/MAINTENANCE KIT (OPTION)			1
			RETARD ROLLER ASSY			1
			FEED HOLDER ASSY			1
			DC BRUSH ASSY			1
			ROLLER TRANSFER ASSY			1
			FK-350(E)			1
			DV-354(AO)			1
			DK-320			1

- Parts with "*" are component parts or sub-assemblies of the assembly appearing immediately above them.

INDEX

2LW/2LX-2

Part.No.	Alternative.	Description	Fig.No.
1702LX0UN0	072LX0UN	MK-370/MAINTENANCE KIT	18
1702LX7US0	072LX7US	MK-350/MAINTENANCE KIT	21
1702LX8AS0	072LX8AS	MK-350/MAINTENANCE KIT	21
1702LX8NL0	072LX8NL	MK-350/MAINTENANCE KIT	21
2BC06510	2BC06510	BUSHING 8	6
2BC06910	2BC06910	STOPPER 6	6
2BC06980	2BC06980	STOPPER 5	6,14
2FM04150	5MVM163DN005	CAP SPRING /B-11 ENCLOSURE A4	13,15
302F831060	2F831060	BUSH DRUM	14
302F902410	2F902410	SPRING EARTH FAN	3
302F906010	2F906010	GUIDE FEED UP	7
302F906110	2F906110	PIN FEED ROLL	7
302F906120	2F906120	SPRING PICK UP	7
302F906190	2F906190	GUIDE FEED L	7
302F906200	2F906200	GUIDE FEED R	7
302F906290	2F906290	SHAFT FEED R	7
302F908021	2F931381	FRAME MPF	5
302F908100	2F908100	SPRING BOTTOM MPF R	5
302F908120	2F908120	ACTUATOR MPF A	5
302F908130	2F908130	GEAR MPF Z30	5
302F908150	2F908150	SP PULLEY TURN	5
302F908210	2F908210	ACTUATOR MPF B	5
302F908230	2F908230	SPRING EARTH CONNECTOR	5
302F908270	2F908270	SP BOTTOM MPF L	5
302F908280	2F908280	SP ACTUATOR MPF	5
302F908290	2F908290	SP SEPARATOR MPF	5
302F908300	2F908300	SPRING LOCK MPF	5
302F908330	2F908330	SPRING LEVER LOCK R	5
302F908380	2F908380	SP PULLEY FEED	5
302F909031	2F909031	LEVER BASE CAS REAR	4
302F909040	2F909040	SPRING BASE CAS REAR	4
302F909070	2F909070	LEVER SIDE CURSOR	4
302F909080	2F909080	CURSOR END	4
302F909090	2F909090	LEVER END CURSOR	4
302F909131	2F909131	GEAR LIFT Z64	4
302F909140	2F909140	GEAR JOINT Z16	4
302F909151	2F909151	LEVER INDICATOR	4
302F909160	2F909160	BUSH LIFT 6	4
302F909171	2F909171	RETARD ROLLER ASSY	4
302F909180	2F909180	HOLDER RETARD	4
302F909191	2F909191	GUIDE RETARD	4
302F909200	2F909200	SPRING RETARD	4
302F909210	2F909210	PAD BOTTOM	4
302F909231	2F909231	COVER LIFT GEAR	4
302F909240	2F909240	LID CASSETTE	4
302F909250	2F909250	SPRING SIZE FIX	4
302F909510	2F909510	GEAR Z40HZ18	2
302F909520	2F909520	GEAR Z60Z16	2
302F909530	2F909530	GEAR Z50Z16	2
302F909540	2F909540	GEAR Z49	2

Part.No.	Alternative.	Description	Fig.No.
302F909550	2F909550	GEAR Z26Z15	2
302F912310	2F912310	COVER DRUM SHUTTER	2
302F912330	2F912330	GEAR SHUTTER Z18S	2
302F912340	2F912340	GEAR SHUTTER Z16S	2
302F912360	2F912360	SPRING SHUTTER ARM	2
302F912370	2F912370	SPRING SHUTTER L	2
302F924020	2F924020	ROLLER REGIST UP	6
302F924071	2F924071	GUIDE PAPER CHUTE	6
302F924090	2F924090	LEVER EMPTY	6
302F924120	2F924120	SPRING TC CHARGE	6
302F924140	2F924140	SPRING EARTH	6
302F924150	2F924150	ACTUATOR REGIST	6
302F924160	2F924160	BUSH REGIST	6
302F924190	2F924190	BUSH TRANSFER R	6
302F924220	2F924220	ACTUATOR DU	6
302F924240	2F924240	LEVER RELEASE FUSER R	6
302F924270	2F924270	SPRING REGIST SENSOR	6
302F924280	2F924280	SPRING MAIN CHARGE	6
302F924320	2F924320	SPRING RELEASE DLP R	6
302F924340	2F924340	SPRING BIAS CHARGE	6
302F924380	2F924380	SPRING RELEASE FUSER R	6
302F924390	2F924390	SPRING TC L	6
302F924400	2F924400	SPRING TC R	6
302F924430	2F924430	GEAR REGIST Z23H	6
302F924460	2F924460	SPRING REGIST R	6
302F924480	2F924480	LEVER RELEASE DLP L	6
302F924490	2F924490	LEVER RELEASE DLP R	6
302F924520	2F924520	SP RELEASE TC L	6
302F924700	2F924700	GEAR REG Z26H-Z33H	6
302F924760	2F924760	PULLEY GUIDE	6
302F924830	2F924830	BUSH TRANSFER L	6
302F925141	2F925141	GEAR EXIT Z21	13
302F925160	2F925160	PULLEY FACE UP	13
302F925180	2F925180	ACTUATOR DU	13
302F925300	2F925300	ROLLER FACE UP	13
302F925350	2F925350	SPRING FACE UP	13
302F925371	2F925371	SPRING ACTUATOR DU	13
302F925440	2F925440	INNER RAIL R	13
302F925450	2F925450	INNER RAIL L	13
302F925480	2F925480	PULLEY RAIL DOUBLE	2,3
302F925550	2F925550	LOCK FUSER	13
302F925560	2F925560	SPRING LOCK	13
302F925750	2F925750	SPRING FUSER RELEASE	13
302F925780	2F925780	SPRING DU	13
302F925872	2F925872	SPRING RAIL SW	2
302F926060	2F926060	PULLEY SWITCH BACK	13
302F928100	2F928100	ACTUATOR OVERFLOW	15
302F928130	2F928130	SPRING COVER FD L	15
302F928140	2F928140	SPRING COVER FD R	15
302F928170	2F928170	SPRING PULLEY	15

Part.No.	Alternative.	Description	Fig.No.
302F928231	2F928231	SPRING DISCHARGER	15
302F928310	2F928310	SPRING PULLEY 35	15
302F929030	2F929030	ROLLER DU	8
302F929041	2F929041	ACTUATOR PE	8
302F929050	2F929050	PULLEY FEED DU	5,15
302F929060	2F929060	SHAFT FEED DU	5,13,15
302F929070	2F929070	SPRING PULLEY FEED	8
302F929080	2F929080	SPRING PE RELEASE	8
302F929140	2F929140	BUSH DU	8,13,15
302F929151	2F929151	LEVER LIFT DU L	8
302F929160	2F929160	LEVER LIFT DU R	8
302F929170	2F929170	SPRING DU LIFT	8
302F929191	2F929191	BUSH PE	8
302F929260	2F929260	PULLEY DU LOW	8
302F931020	2F931020	GEAR Z77H	14
302F931030	2F931030	GEAR Z70H	14
302F931040	2F931040	GEAR Z90H Z30H	14
302F931050	2F931050	GEAR Z48H	14
302F931060	2F931060	GEAR Z46H	14
302F931070	2F931070	GEAR Z37S	14
302F931080	2F931080	GEAR Z45S	14
302F931090	2F931090	GEAR Z30S	14
302F931100	2F931100	GEAR Z34S	14
302F931110	2F931110	GEAR Z95H Z28H	14
302F931190	2F931190	GEAR DLP Z31H	2
302F931200	2F931200	GEAR DLP Z32H	14
302F931270	2F931270	SPRING FUSER	14
302F931290	2F931290	GEAR DLP Z24H	14
302F931300	2F931300	GEAR DLP JOINT Z25H	14
302F931310	2F931310	GEAR DLP Z25H	14
302F931350	2F931350	JOINT SHAFT CASSETTE	14
302F931381	2F931381	SPRING MPF CAM	14
302F931430	2F931430	GEAR FEED ROLL Z27H	6
302F931450	2F931450	SPRING FEED	14
302F931490	2F931490	BUSH FEED DRIVE	6,14
302F931500	2F931500	GEAR FEED Z34H	14
302F931590	2F931590	GEAR Z191H	14
302F931600	2F931600	CLUTCH DLP	2
302F944040	2F944040	CLUTCH DUPLEX	14
302F944060	2F944060	SOLENOID MPF	14
302F944071	2F944071	SOLENOID DLP	2
302F944130	2F944130	MOTOR EJECT	15
302F944150	2F944150	FAN L 80	3
302F944160	2F944160	FAN POWER PWB 50	3
302F944200	2F944200	CLUTCH MID FEED	14
302F944210	2F944210	CLUTCH CASSETTE	14
302F944220	2F944220	CLUTCH REGIST	14
302F994031	2F994031	FEED DRIVE ASSY SP	14
302F994062	2F994062	FEED HOLDER ASSY	7
302F994070	2F994070	SEPARATOR MP ASSY	5

Part.No.	Alternative.	Description	Fig.No.
302F994091	2F994091	WASTE BOTTLE ASSY	10
302F994110	2F994110	DC BRUSH ASSY	6
302F994120	2F994120	REGIST KIT	6
302F994300	2F994300	ROLLER TRNSFER ASSY SP	6
302F994320	2F994320	PARTS MOTOR LIFT ASSY SP	2
302FV02470	2FV02470	BUSH FD	13,15
302FV45020	2FV45020	AC CORD ASSY	3
302FV45040	2FV45040	AC CORD ASSY	3
302GA24030	2GA24030	ROLLER MIDDLE ASSY	6
302H024370	2H024370	BUSH 6 EW	6
302H024830	2H024830	BUSH 8	6
302H702590	2H702590	BUSH SCREW	6
302H904210	2H904210	SPRING COVER HOOK	1
302H905370	2H905370	PANEL OPE	17
302H917220	2H917220	GEAR ISU 63/32	9
302H917230	2H917230	BELT ISU	9
302H917240	2H917240	PULLEY TENSION	9
302H917270	2H917270	SPRING TENSION	9
302H917330	2H917330	STOPPER ISU	9
302HS25220	2HS25220	BUSH FUSER	8
302J008050	2J008050	SPRING LEVER LOCK L	5
302J024020	2J024020	SPRING SEP CHARGE	6
302J025200	2J025200	LEVER FUSER RELEASE	13
302J028020	2J028020	SPRING EARTH A	15
302J029020	2J029020	SPRING EARTH DU	8
302J031020	2J031020	MOTOR MAIN Z16	14
302J031030	2J031030	MOTOR DRUM Z16	14
302J044030	2J044030	FAN ENGINE PWB 35	6
302J044040	2J044040	FAN R 80	2
302J044070	2J044070	FAN MOTOR	2
302J093092	2J093092	MC-320	10
302J094010	2J094010	DU ASSY SP	8
302J094060	2J094060	BASE MPF ASSY SP	5
302J101050	2J101050	P.W.BOARD ASSY CONNECT-R	14
302J193040	2J193040	LK-350	2
302J193050	2J193050	FK-350(E)	12
302J193060	2J193060	FK-350(U)	12
302J193070	2J193070	CT-350	4
302J194080	2J194080	COVER REAR ASSY	13
302J393032	2J393032	DK-320	10
302JD19140	2JD19140	BUSHING FAN	9
302JN02010	2JN02010	MOUNT SPEAKER	16
302JN05060	2JN05060	PANEL OPE	17
302LW02040	2LW02040	RACK LID	3
302LW02050	2LW02050	RACK FRONT	3
302LW02060	2LW02060	GEAR RACK Z19-22	3
302LW04070	2LW04070	COVER CONTROLLER	1
302LW04120	2LW04120	COVER REAR	1
302LW04150	2LW04150	LID TOP C	1
302LW04170	2LW04170	COVER SIDE	1

Part.No.	Alternative.	Description	Fig.No.
302LW04180	2LW04180	COVER INNER R B	1
302LW05010	2LW05010	LABEL OPE E	17
302LW05020	2LW05020	LABEL OPE GER	20
302LW05030	2LW05030	LABEL OPE FRA	20
302LW05040	2LW05040	LABEL OPE ITA	20
302LW05050	2LW05050	LABEL OPE SPA	20
302LW05060	2LW05060	LABEL OPE POR	20
302LW05070	2LW05070	LABEL OPE DUT	20
302LW05080	2LW05080	LABEL OPE RUS	20
302LW07060	2LW07060	JOINT PF ROLLER	18
302LW46010	2LW46010	CONN.CORD ASSY S03613	9
302LW46040	2LW46040	CONN.CORD ASSY S03616	18
302LW93010	2LW93010	DV-350(E)	11
302LW93020	2LW93020	DV-352(U)	11
302LW93030	2LW93030	DV-354(AO)	11
302LW93040	2LW93040	PARTS ISU ASSY	9
302LW94011	2LW94011	PARTS MAIN PWB ASSY SP	16
302LW94021	2LW94021	PARTS MAIN PWB ASSY E SP	16
302LW94030	2LW94030	PARTS ENGINE PWB ASSY SP	6
302LW94040	2LW94040	PARTS SWITCHING REGULATOR (U) SP	3
302LW94050	2LW94050	PARTS SWITCHING REGULATOR (E) SP	3
302LW94060	2LW94060	PARTS MOTOR ISU SP	9
302LW94080	2LW94080	PARTS OPERATION UNIT SP	17
302LW94090	2LW94090	PARTS COVER MPF ASSY SP	5
302LW94100	2LW94100	PARTS FRAME ISU TOP ASSY SP	9
302LW94110	2LW94110	PARTS LID TOP A ASSY SP	1
302LW94130	2LW94130	PARTS COVER LEFT ASSY SP	1
302LW94140	2LW94140	PARTS COVER FRONT B ASSY SP	1
302LW94150	2LW94150	PARTS COVER FRONT ASSY SP	1
302LW94160	2LW94160	PARTS COVER RIGHT ASSY	1
302LW94170	2LW94170	PARTS COVER TOP ASSY	1
302LW94180	2LW94180	PARTS FD UNIT SP	15
302LW94190	2LW94190	PARTS PWB ASSY CONNECT-L SP	3
302LW94200	2LW94200	PARTS PWB ASSY RELAY SP	3
302LW94210	2LW94210	PARTS COVER PF ASSY SP	19
302LX05010	2LX05010	LABEL OPE E	17
302LX05030	2LX05030	LABEL OPE GER	20
302LX05040	2LX05040	LABEL OPE FRA	20
302LX05050	2LX05050	LABEL OPE ITA	20
302LX05060	2LX05060	LABEL OPE SPA	20
302LX05070	2LX05070	LABEL OPE POR	20
302LX05080	2LX05080	LABEL OPE DUT	20
302LX05090	2LX05090	LABEL OPE RUS	20
302LX94011	2LX94011	PARTS MAIN PWB ASSY SP	16
302LX94021	2LX94021	PARTS MAIN PWB ASSY E SP	16
302LX94040	2LX94040	PARTS OPERATION UNIT SP	17
302LX94070	2LX94070	PARTS FAX UNIT(E) SP	16
302LX94080	2LX94080	PARTS FAX UNIT(U) SP	16
302LX94100	2LX94100	PARTS FAX UNIT(AS) SP	16
303HL10200	3HL10200	SPRING LOOP	19

Part.No.	Alternative.	Description	Fig.No.
303HL22200	3HL22200	PLATE GND	18
303HZ45010	3HZ45010	MODULAR CORD	20
303JX29160	3JX29160	PULLEY CONVEYING	18
303K502200	3K502200	ACTUATOR BASE	18
303LJ02020	3LJ02020	GUIDE READING	19
303LJ02030	3LJ02030	HINGE L	19
303LJ02040	3LJ02040	HINGE R	19
303LJ02060	3LJ02060	SPRING RELEASE	19
303LJ02070	3LJ02070	SPRING READING	19
303LJ02080	3LJ02080	ACTUATOR PUSH	19
303LJ02120	3LJ02120	STOPPER ORIGINAL	18
303LJ02150	3LJ02150	LEVER RELEASE	18
303LJ02240	3LJ02240	SPRING GND A	18
303LJ02250	3LJ02250	SPRING GND B	18
303LJ04010	3LJ04010	COVER FRONT	19
303LJ04021	3LJ04021	COVER REAR	19
303LJ07050	3LJ07050	ACTUATOR ORIGINAL	19
303LJ07060	3LJ07060	LEVER PUSH DU	19
303LJ07070	3LJ07070	SPRING PUSH DU	19
303LJ24041	3LJ24041	LEVER SEPARATE	19
303LJ24050	3LJ24050	LEVER LOOP	19
303LJ24080	3LJ24080	ACTUATOR TIMING	18
303LJ24090	3LJ24090	SPRING TIMING	18
303LJ24101	3LJ24101	GUIDE SEPARATION	18
303LJ24121	3LJ24121	SPRING CONVEYING	18
303LJ24150	3LJ24150	SPRING EXIT	18
303LJ24190	3LJ24190	HOOK PF COVER	18
303LJ24230	3LJ24230	SPRING REGIST	18
303LJ29040	3LJ29040	SPRING LOOP PRESSURE	18
303LJ29060	3LJ29060	LEVER PRESSURE	18
303LJ31020	3LJ31020	GEAR Z40S Z61S	19
303LJ31030	3LJ31030	GEAR Z46S Z79S	19
303LJ31040	3LJ31040	GEAR Z66S Z70S	19
303LJ31050	3LJ31050	GEAR Z28S	18
303LJ31060	3LJ31060	GEAR Z32S	18
303LJ31080	3LJ31080	GEAR Z35S	18
303LJ31090	3LJ31090	GEAR Z56S	18
303LJ31100	3LJ31100	GEAR T Z28S	18
303LJ44040	3LJ44040	CLUTCH PAPER FEED	18
303LJ94010	3LJ94010	PARTS DRIVER PWB ASSY SP	18
303LJ94020	3LJ94020	PARTS ROLLER A CONVEYING SP	18
303LJ94030	3LJ94030	PARTS ROLLER B CONVEYING SP	18
303LJ94040	3LJ94040	PARTS ROLLER EXIT SP	18
303LJ94050	3LJ94050	PARTS GEAR Z46S ONEWAY SP	18
303LJ94060	3LJ94060	PARTS MOTOR DP SP	19
303LJ94070	3LJ94070	PARTS PLATE ORIGINAL SP	19
303LJ94120	3LJ94120	PARTS TABLE ASSY SP	19
303LJ94140	3LJ94140	PARTS SOLENOID PRESSURE PULLEY SP	19
303LJ94150	3LJ94150	PARTS SOLENOID FEED SHIFT SP	19
3063527482	63527482	MODULAR CORD AUSTRALIA	20

KYOCERA Document Solutions America, Inc.**Headquarters**

225 Sand Road,
Fairfield, New Jersey 07004-0008, USA
Phone: +1-973-808-8444
Fax: +1-973-882-6000

Latin America

8240 NW 52nd Terrace Dawson Building, Suite 100
Miami, Florida 33166, USA
Phone: +1-305-421-6640
Fax: +1-305-421-6666

KYOCERA Document Solutions Canada, Ltd.

6120 Kestrel Rd., Mississauga, ON L5T 1S8,
Canada
Phone: +1-905-670-4425
Fax: +1-905-670-8116

**KYOCERA Document Solutions
Mexico, S.A. de C.V.**

Calle Arquimedes No. 130, 4 Piso, Colonia Polanco
Chapultepec, Delegacion Miguel Hidalgo,
Distrito Federal, C.P. 11560, México
Phone: +52-555-383-2741
Fax: +52-555-383-7804

KYOCERA Document Solutions Brazil, Ltda.

Alameda África, 545, Pólo Empresarial Consbrás,
Tamboré, Santana de Parnaíba-SP, CEP 06543-306,
Brazil
Phone: +55-11-4195-8496
Fax: +55-11-4195-6167

**KYOCERA Document Solutions
Australia Pty. Ltd.**

Level 3, 6-10 Talavera Road North Ryde N.S.W, 2113,
Australia
Phone: +61-2-9888-9999
Fax: +61-2-9888-9588

**KYOCERA Document Solutions
New Zealand Ltd.**

Ground Floor, 19 Byron Avenue, Takapuna, Auckland,
New Zealand
Phone: +64-9-415-4517
Fax: +64-9-415-4597

KYOCERA Document Solutions Asia Limited

16/F., Mita Centre, 552-566, Castle Peak Road
Tsuenwan, NT, Hong Kong
Phone: +852-2610-2181
Fax: +852-2610-2063

**KYOCERA Document Solutions
(China) Corporation**

8F, No. 288 Nanjing Road West, Huangpu District,
Shanghai, 200003, China
Phone: +86-21-5301-1777
Fax: +86-21-5302-8300

**KYOCERA Document Solutions
(Thailand) Corp., Ltd.**

335 Ratchadapisek Road, Bangsue, Bangkok 10800,
Thailand
Phone: +66-2-586-0333
Fax: +66-2-586-0278

**KYOCERA Document Solutions
Singapore Pte. Ltd.**

12 Tai Seng Street #04-01A,
Luxasia Building, Singapore 534118
Phone: +65-6741-8733
Fax: +65-6748-3788

**KYOCERA Document Solutions
Hong Kong Limited**

16/F., Mita Centre, 552-566, Castle Peak Road
Tsuenwan, NT, Hong Kong
Phone: +852-3582-4000
Fax: +852-3185-1399

**KYOCERA Document Solutions
Taiwan Corporation**

6F., No.37, Sec. 3, Minquan E. Rd.,
Zhongshan Dist., Taipei 104, Taiwan R.O.C.
Phone: +886-2-2507-6709
Fax: +886-2-2507-8432

KYOCERA Document Solutions Korea Co., Ltd.

18F, Kangnam bldg, 1321-1,
Seocho-Dong, Seocho-Gu, Seoul, Korea
Phone: +822-6933-4050
Fax: +822-747-0084

**KYOCERA Document Solutions
India Private Limited**

Second floor, Centrum Plaza, Golf Course Road,
Sector-53, Gurgaon, Haryana 122002, India
Phone: +91-0124-4671000
Fax: +91-0124-4671001

KYOCERA Document Solutions Europe B.V.

Bloemlaan 4, 2132 NP Hoofddorp,
The Netherlands
Phone: +31-20-654-0000
Fax: +31-20-653-1256

KYOCERA Document Solutions Nederland B.V.

Beechavenue 25, 1119 RA Schiphol-Rijk,
The Netherlands
Phone: +31-20-5877200
Fax: +31-20-5877260

KYOCERA Document Solutions (U.K.) Limited

Eldon Court, 75-77 London Road,
Reading, Berkshire RG1 5BS,
United Kingdom
Phone: +44-118-931-1500
Fax: +44-118-931-1108

KYOCERA Document Solutions Italia S.p.A.

Via Verdi, 89/91 20063 Cernusco s/N.(MI),
Italy
Phone: +39-02-921791
Fax: +39-02-92179-600

KYOCERA Document Solutions Belgium N.V.

Sint-Martinusweg 199-201 1930 Zaventem,
Belgium
Phone: +32-2-7209270
Fax: +32-2-7208748

KYOCERA Document Solutions France S.A.S.

Espace Technologique de St Aubin
Route de l'Orme 91195 Gif-sur-Yvette CEDEX,
France
Phone: +33-1-69852600
Fax: +33-1-69853409

KYOCERA Document Solutions Espana, S.A.

Edificio Kyocera, Avda. de Manacor No.2,
28290 Las Matas (Madrid), Spain
Phone: +34-91-6318392
Fax: +34-91-6318219

KYOCERA Document Solutions Finland Oy

Atomitie 5C, 00370 Helsinki,
Finland
Phone: +358-9-47805200
Fax: +358-9-47805390

**KYOCERA Document Solutions
Europe B.V., Amsterdam (NL) Zürich Branch**

Hohlstrasse 614, 8048 Zürich,
Switzerland
Phone: +41-44-9084949
Fax: +41-44-9084950

**KYOCERA Document Solutions
Deutschland GmbH**

Otto-Hahn-Strasse 12, 40670 Meerbusch,
Germany
Phone: +49-2159-9180
Fax: +49-2159-918100

KYOCERA Document Solutions Austria GmbH

Eduard-Kittenberger-Gasse 95, 1230 Vienna,
Austria
Phone: +43-1-863380
Fax: +43-1-86338-400

KYOCERA Document Solutions Nordic AB

Esbogatan 16B 164 75 Kista, Sweden
Phone: +46-8-546-550-00
Fax: +46-8-546-550-10

KYOCERA Document Solutions Norge Nuf

Postboks 150 Oppsal, 0619 Oslo,
Norway
Phone: +47-22-62-73-00
Fax: +47-22-62-72-00

KYOCERA Document Solutions Danmark A/S

Ejby Industrivej 60, DK-2600 Glostrup,
Denmark
Phone: +45-70223880
Fax: +45-45765850

KYOCERA Document Solutions Portugal Lda.

Rua do Centro Cultural, 41 (Alvalade) 1700-106 Lisboa,
Portugal
Phone: +351-21-843-6780
Fax: +351-21-849-3312

**KYOCERA Document Solutions
South Africa (Pty) Ltd.**

KYOCERA House, Hertford Office Park,
90 Bekker Road (Cnr. Allandale), Midrand, South Africa.
Phone: +27-11-540-2600
Fax: +27-11-466-3050

KYOCERA Document Solutions Russia LLC

Botanichesky pereulok 5, Moscow, 129090,
Russia
Phone: +7(495)741-0004
Fax: +7(495)741-0018

KYOCERA Document Solutions Middle East

Dubai Internet City, Bldg. 17,
Office 157 P.O. Box 500817, Dubai,
United Arab Emirates
Phone: +971-04-433-0412

KYOCERA Document Solutions Inc.

2-28, 1-chome, Tamatsukuri, Chuo-ku
Osaka 540-8585, Japan
Phone: +81-6-6764-3555
<http://www.kyoceradocumentsolutions.com>

© 2014 KYOCERA Document Solutions Inc.

 is a trademark of KYOCERA Corporation