



FS-2000D
FS-3900DN
FS-4000DN

PARTS LIST

Published in February 2006

2GAPL071

842GA121

Rev.1

NOTES

1. Indicate parts number and machine model when placing an order.

e.g.	Parts Number	Parts Name	Machine Model	Cycle	Quantity
	302F904060	COVER LEFT	FS-3900DN	60Hz / 50Hz	1

2. Service calls and freight will be charged separately.

3. Symbols in the "Parts Number" column.

- Parts with "•" are component parts or sub-assemblies of the assembly appearing immediately above them.

e.g.	Parts Number	Parts Name	Parts Number	Parts Name
	302F894030	COVER TOP ASSY	•302F804110	SPONGE TOP TRAY
			•302F804120	SPONGE TOP TRAY REAR

- Parts with "⊙" indicates the spare parts and the parts without "⊙" can not be supplied.

— CONTENTS —

FIG. 1	Covers (FS-2000D)	2	FIG.10	Fuser Unit II (FS-2000D)	26
FIG. 1	Covers (FS-3900/4000DN)	4	FIG.10	Fuser Unit II (FS-3900/4000DN)	28
FIG. 2	Frames I	6	FIG.11	Driving Unit	30
FIG. 3	Frames II	8	FIG.12	Duplex Unit	32
FIG. 4	Paper Cassette (FS-2000D)	10	FIG.13	Paper Exit (FS-2000D)	34
FIG. 4	Paper Cassette (FS-3900/4000DN)	12	FIG.13	Paper Exit (FS-3900/4000DN)	36
FIG. 5	Cassette Feed	14	FIG.14	MPF	38
FIG. 6	Paper Feed	16	FIG.15	Controller Box	40
FIG. 7	Imaging Unit	18	FIG.16	Parts Package	42
FIG. 8	Developer Unit	20			
FIG. 9	Fuser Unit I (FS-2000D)	22		• INDEX	43
FIG. 9	Fuser Unit I (FS-3900/4000DN)	24			

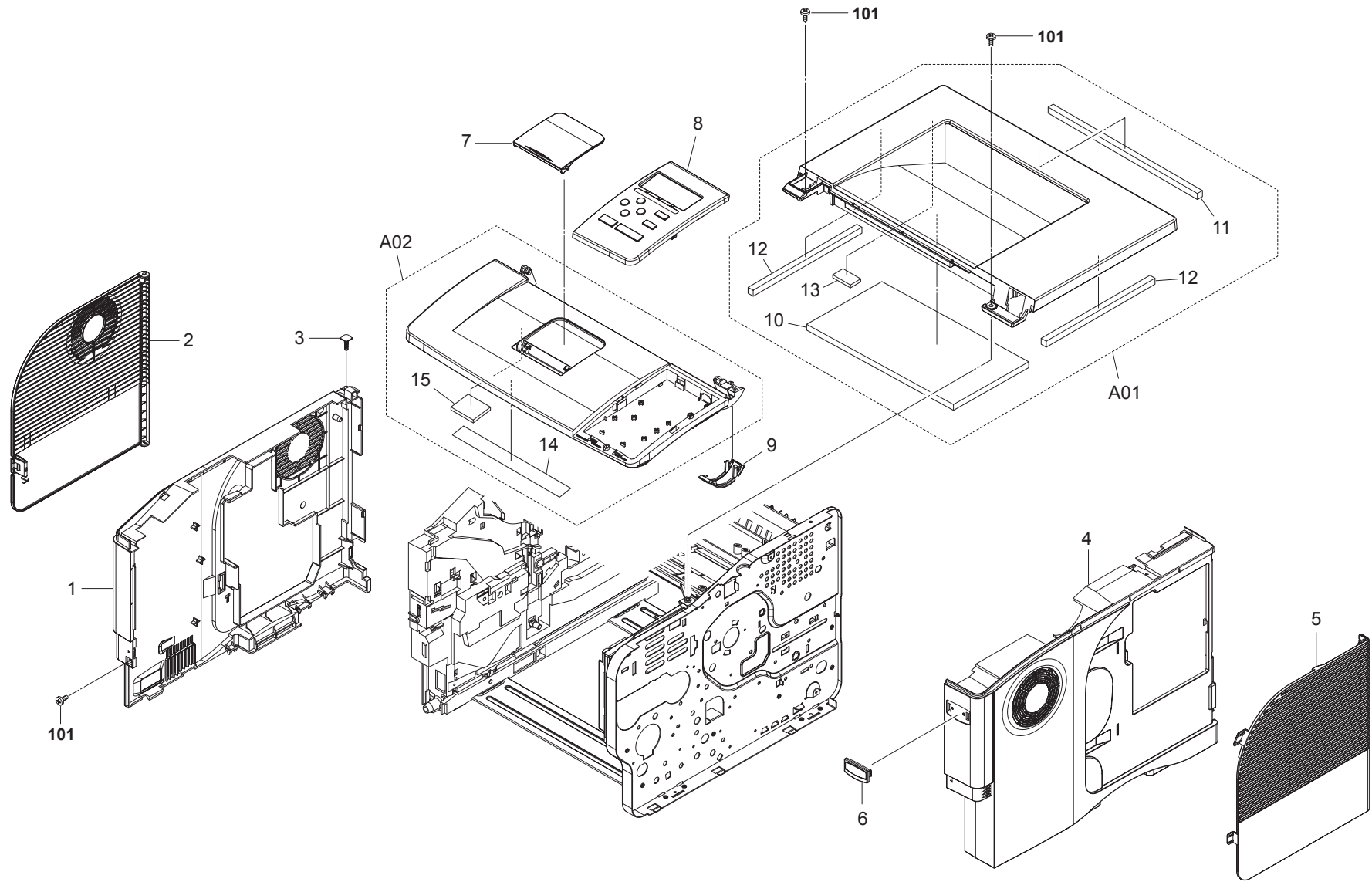

FIG. 1 Covers (FS-2000D)

2F8/2F9/2GA

SP	Ref. No.	Part.No.	Alternative.	Description	Quantity		
					120	230	240
⊙	1	302F904060	2F904060	COVER LEFT	1	1	1
⊙	2	302F904080	2F904080	COVER SIDE	1	1	1
	3	302F904140	2F904140	HINGE SIDE	1	1	1
⊙	4	302F904070	2F904070	COVER RIGHT	1	1	1
⊙	5	302F904090	2F904090	COVER CONTROLLER	1	1	1
⊙	6	302F994100	2F994100	EMBLEM ASSY	1	1	1
⊙	7	302F804030	2F804030	STOPPER FD	1	1	1
⊙	8	302F894020	2F894020	KEY BOARD ASSY (E)	1	1	1
⊙	9	302F804100	2F804100	COVER CABLE	1	1	1
⊙	A01	302F894030	2F894030	COVER TOP ASSY	1	1	1
⊙	10	*302F804110	2F804110	SPONGE TOP TRAY	1	1	1
⊙	11	*302F804120	2F804120	SPONGE TOP TRAY REAR	1	1	1
⊙	12	*302F804130	2F804130	SPONGE TOP TRAY SIDE	2	2	2
⊙	13	*302F904170	2F904170	SPONGE COVER TOP	1	1	1
⊙	A02	302F894050	2F894050	LID TOP ASSY	1	1	1
⊙	14	*302F834040	2F834040	LABEL JAM OPERATION	1	1	1
⊙	15	*302F934100	2F934100	LABEL INSTALL DLP	1	1	1

SP	Ref. No.	Part.No.	Alternative.	Description	Quantity		
					120	230	240
	101	5MBTPB4010PW++R	B1A64100	BIND T.T SCREW(+)/ M4 X 10 CRFREE P-T			

- Parts with "*" are component parts or sub-assemblies of the assembly appearing immediately above them.
- Parts with "⊙" indicates the spare parts.

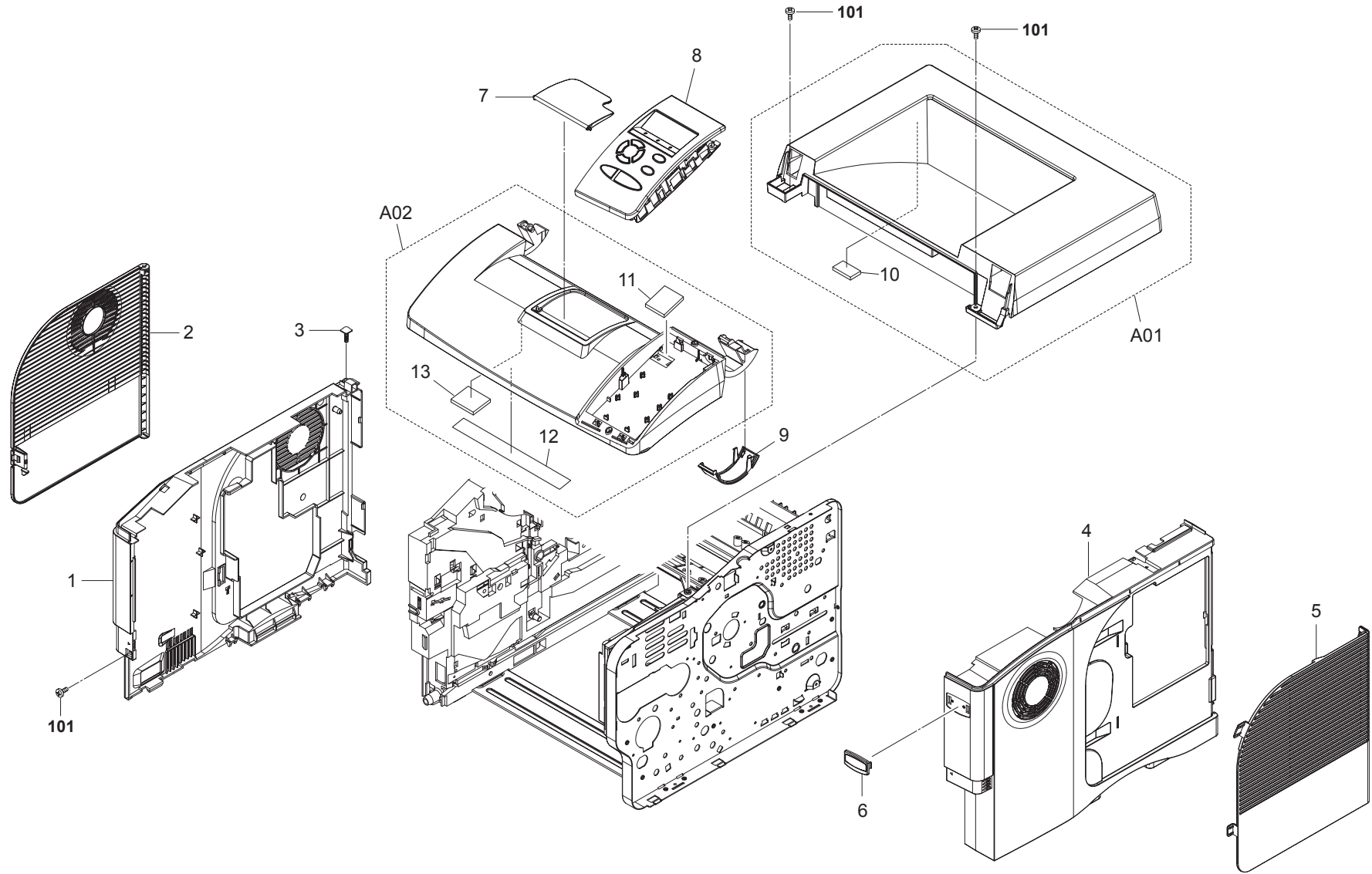

FIG. 1 Covers (FS-3900/4000DN)

2F8/2F9/2GA

SP	Ref. No.	Part.No.	Alternative.	Description	Quantity		
					120	230	240
⊙	1	302F904060	2F904060	COVER LEFT	1	1	1
⊙	2	302F904080	2F904080	COVER SIDE	1	1	1
	3	302F904140	2F904140	HINGE SIDE	1	1	1
⊙	4	302F904070	2F904070	COVER RIGHT	1	1	1
⊙	5	302F904090	2F904090	COVER CONTROLLER	1	1	1
⊙	6	302F994100	2F994100	EMBLEM ASSY	1	1	1
⊙	7	302F904030	2F904030	STOPPER FD	1	1	1
⊙	8	302F994040	2F994040	KEY BOARD ASSY (E) (FS-3900DN)	1	1	1
⊙	8	302GA94010	2GA94010	KEY BOARD ASSY (E) (FS-4000DN)	1	1	1
⊙	9	302F904100	2F904100	COVER CABLE	1	1	1
⊙	A01	302F994130	2F994130	COVER TOP ASSY	1	1	1
⊙	10	*302F904170	2F904170	SPONGE COVER TOP	1	1	1
⊙	A02	302F994140	2F994140	LID TOP ASSY (FS-3900DN)	1	1	1
⊙	A02	302GA94020	2GA94020	LID TOP ASSY (FS-4000DN)	1	1	1
⊙	11	*302F904180	2F904180	SHEET ATTACHMENT	1	1	1
⊙	12	*302F934080	2F934080	LABEL JAM OPERATION	1	1	1
⊙	13	*302F934100	2F934100	LABEL INSTALL DLP	1	1	1

SP	Ref. No.	Part.No.	Alternative.	Description	Quantity		
					120	230	240
	101	5MBTPB4010PW++R	B1A64100	BIND T.T SCREW(+)/ M4 X 10 CRFREE P-T			

- Parts with "*" are component parts or sub-assemblies of the assembly appearing immediately above them.
- Parts with "⊙" indicates the spare parts.

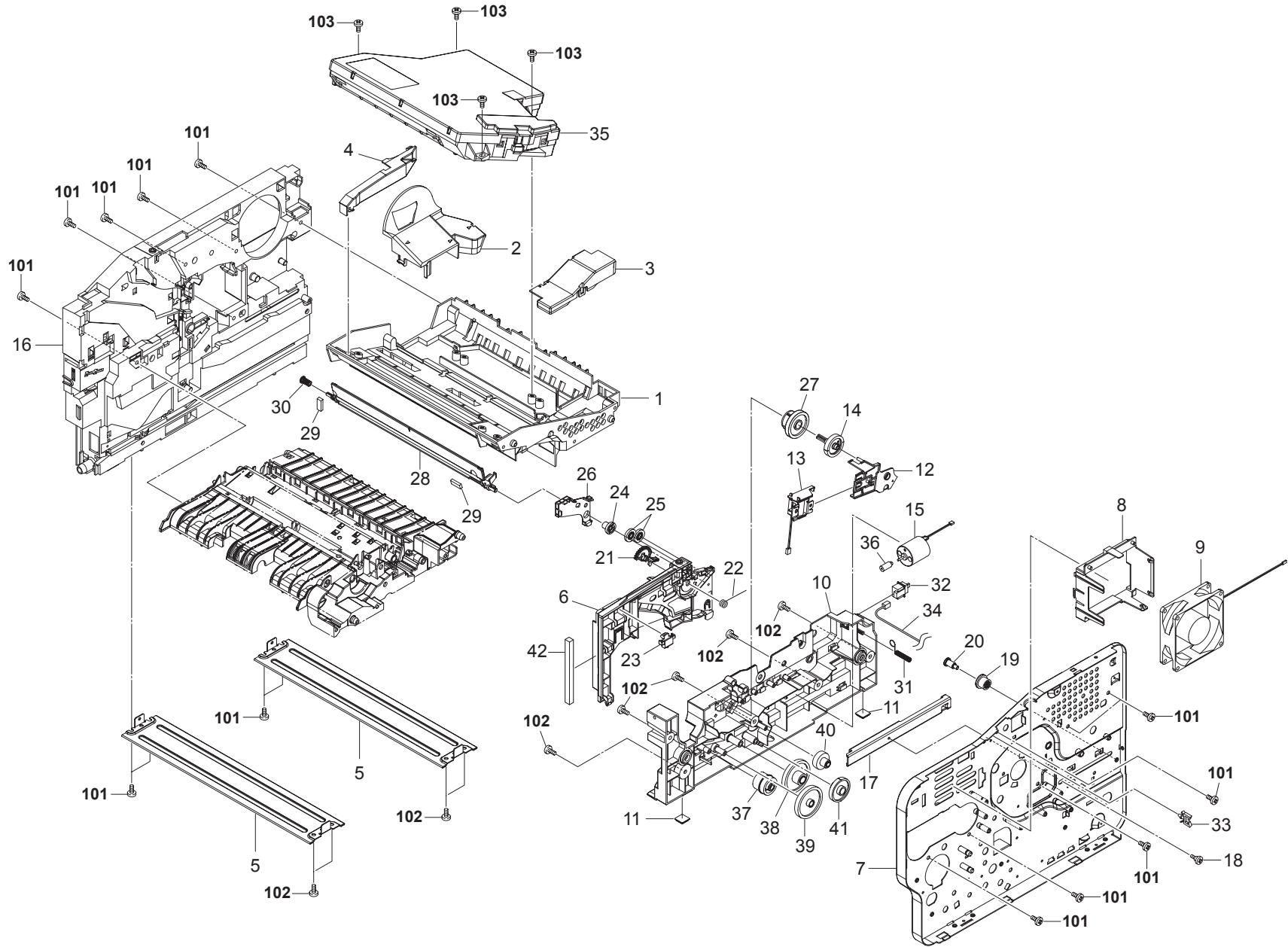

FIG. 2 Frames I

2F8/2F9/2GA

SP	Ref. No.	Part.No.	Alternative.	Description	Quantity		
					120	230	240
	1	302F902030	2F902030	FRAME CENTER	1	1	1
	2	302F902220	2F902220	COOLING DUCT LEFT	1	1	1
	3	302F902230	2F902230	COOLING DUCT RIGHT	1	1	1
	4	302F902380	2F902380	COOLING DUCT LEFT A	1	1	1
	5	302F902040	2F902040	PLATE BOTTOM	2	2	2
	6	302F902060	2F902060	GUIDE DLP R	1	1	1
	7	302F902020	2F902020	FRAME RIGHT	1	1	1
	8	302F902070	2F902070	DUCT RIGHT FRAME	1	1	1
⊙	9	302F844040	2F844040	FAN R 80 (FS-2000D)	1	1	1
⊙	9	302F944140	2F944140	FAN R 80 (FS-3900/4000DN)	1	1	1
	10	302F802010	2F802010	GUIDE CASSETTE (FS-2000D)	1	1	1
	10	302F902050	2F902050	GUIDE CASSETTE (FS-3900/4000DN)	1	1	1
⊙	11	5MVX221RB014	2BS03110	FOOT	2	2	2
⊙	12	302F931230	2F931230	HOLDER DLP CLUTCH	1	1	1
⊙	13	302F944070	2F944070	SOLENOID DLP	1	1	1
⊙	14	302F931190	2F931190	GEAR DLP Z31H	1	1	1
⊙	15	302F944170	2F944170	MOTOR LIFT (FS-3900/4000DN)	1	1	1
	16	302F902010	2F902010	FRAME LEFT	1	1	1
⊙	17	302F925460	2F925460	OUTER RAIL R	1	1	1
	18	3C202230		PIN,HOOK FULCRUM	1	1	1
⊙	19	302F925480	2F925480	PULLEY RAIL DOUBLE	1	1	1
⊙	20	302F925500	2F925500	PIN PULLEY	1	1	1
⊙	21	302F912320	2F912320	ARM DRUM SHUTTER	1	1	1
	22	302F912360	2F912360	SPRING SHUTTER ARM	1	1	1
⊙	23	302F902420	2F902420	LOCK COVER TOP R	1	1	1
⊙	24	302F912340	2F912340	GEAR SHUTTER Z16S	1	1	1
⊙	25	302F912330	2F912330	GEAR SHUTTER Z18S	2	2	2
⊙	26	302F912350	2F912350	LID DRUM SHUTTER	1	1	1
⊙	27	302F931600	2F931600	CLUTCH DLP	1	1	1
⊙	28	302F912310	2F912310	COVER DRUM SHUTTER	1	1	1
	29	2C906260		SHEET ABSORBER	2	2	2
	30	302F912370	2F912370	SPRING SHUTTER L	1	1	1
	31	302F925870	2F925870	SPRING RAIL SW	1	1	1
	32	2C927140		SWITCH CONTAINER	1	1	1
	33	M70AK010		WIRE SADDLE	1	1	1
	34	302F846350	2F846350	CONN.CORD ASSY S03175	1	1	1
⊙	35	302F893010	2F893010	LK-310 (FS-2000D)	1	1	1
⊙	35	302F993040	2F993040	LK-320 (FS-3900DN)	1	1	1
⊙	35	302GA93010	2GA93010	LK-321 (FS-4000DN)	1	1	1
⊙	36	302F909500	2F909500	GEAR WORM (FS-3900/4000DN)	1	1	1
⊙	37	302F909550	2F909550	GEAR Z26Z15 (FS-3900/4000DN)	1	1	1
⊙	38	302F909530	2F909530	GEAR Z50Z16 (FS-3900/4000DN)	1	1	1
⊙	39	302F909540	2F909540	GEAR Z49 (FS-3900/4000DN)	1	1	1
⊙	40	302F909510	2F909510	GEAR Z40HZ18 (FS-3900/4000DN)	1	1	1
⊙	41	302F909520	2F909520	GEAR Z60Z16 (FS-3900/4000DN)	1	1	1
	42	302F902480	2F902480	SPONGE MULTI	1	1	1

SP	Ref. No.	Part.No.	Alternative.	Description	Quantity		
					120	230	240
	101	5MBTPB4010PW++R	B1A64100	BIND T.T SCREW(+)/ M4 X 10 CRFREE P-T			
	102	B1A54080		+BIND TAP-TITE S SCREW M4X08			
	103	5MBTPB4016PW++R	B1B64160	BIND T.T SCREW(+)/ M4 X 16 CRFREE P-T			

- Parts with "*" are component parts or sub-assemblies of the assembly appearing immediately above them.
- Parts with "⊙" indicates the spare parts.

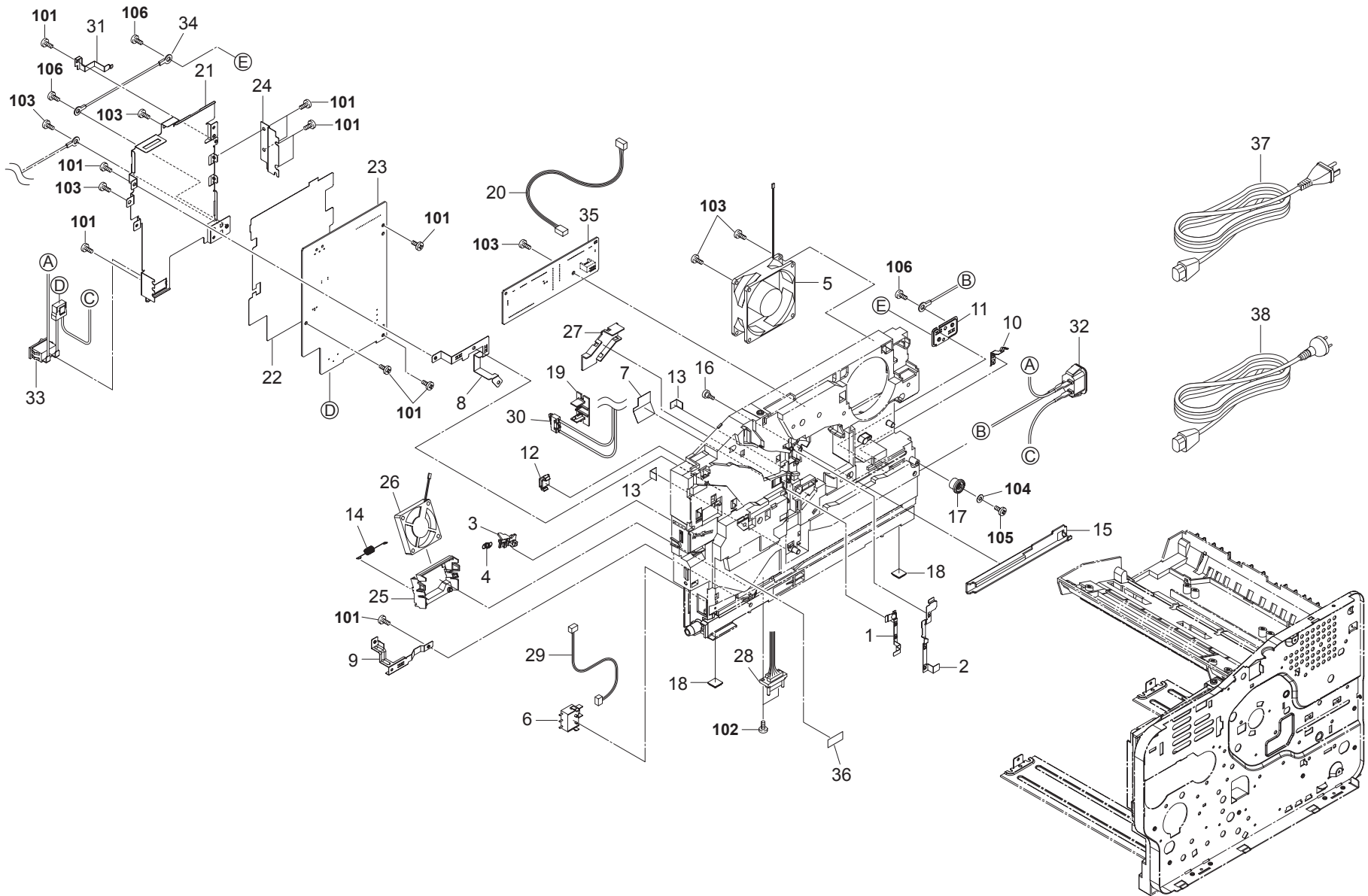

FIG. 3 Frames II

2F8/2F9/2GA-1

SP	Ref. No.	Part.No.	Alternative.	Description	Quantity		
					120	230	240
⊙	1	302F902270	2F902270	CONTACT BIAS	1	1	1
⊙	2	302F902160	2F902160	CONTACT MAIN	1	1	1
⊙	3	302F902170	2F902170	LEVER EF (FS-3900/4000DN)	1	1	1
	4	302F902180	2F902180	SPRING LEVER EF (FS-3900/4000DN)	1	1	1
⊙	5	302F844050	2F844050	FAN L 80 (FS-2000D)	1	1	1
⊙	5	302F944150	2F944150	FAN L 80 (FS-3900/4000DN)	1	1	1
⊙	6	5FSP03090001+01	SP0A0360	PUSH SWITCH 03 SN	1	1	1
	7	302F902340	2F902340	SHEET BIAS	1	1	1
	8	302F902320	2F902320	PLATE EARTH FEED	1	1	1
	9	302F902280	2F902280	PLATE EARTH BOTTOM	1	1	1
	10	302F902390	2F902390	PLATE EARTH RAIL	1	1	1
	11	302F902400	2F902400	PLATE EARTH MAIN	1	1	1
⊙	12	302F902430	2F902430	LOCK COVER TOP L	1	1	1
	13	302F902450	2F902450	SHEET WIRE	2	2	2
	14	302F902410	2F902410	SPRING EARTH FAN	1	1	1
⊙	15	302F925470	2F925470	OUTER RAIL L	1	1	1
	16	3CZ02230	3CZ02230	PIN,HOOK FULCRUM	1	1	1
	17	302F925480	2F925480	PULLEY RAIL DOUBLE	1	1	1
	18	5MVX221RB014	2BS03110	FOOT	2	2	2
	19	302F902310	2F902310	MOUNT INTERLOCK SW	1	1	1
	20	302F846060	2F846060	CONN.CORD ASSY S03047	1	1	1
	21	302F902100	2F902100	PLATE POWER PWB	1	1	1
	22	302F902110	2F902110	SHEET POWER PWB	1	1	1
⊙	23	302F845020	2F845020	SWITCHING REGULATOR (E) (FS-2000D)		1	1
⊙	23	302F845010	2F845010	SWITCHING REGULATOR (U) (FS-2000D)	1		
⊙	23	302F945020	2F945020	SWITCHING REGULATOR (E) (FS-3900/4000DN)		1	1
⊙	23	302F945010	2F945010	SWITCHING REGULATOR (U) (FS-3900/4000DN)	1		
	24	302F902330	2F902330	PLATE HEAT SINK	1	1	1
	25	302F902250	2F902250	MOUNT FAN MOTOR	1	1	1
⊙	26	302F944160	2F944160	FAN POWER PWB 50	1	1	1
	27	302F902240	2F902240	COVER WIRE A	1	1	1
	28	302F846040	2F846040	CONN.CORD ASSY S03045	1	1	1
	29	302F846050	2F846050	CONN.CORD ASSY S03046	1	1	1
	30	302F846280	2F846280	CONN.CORD ASSY S03119	1	1	1
	31	302F902260	2F902260	PLATE EARTH DRUM	1	1	1
	32	302F846320	2F846320	CONN.CORD ASSY S03130	1	1	1
	33	302F846200	2F846200	CONN.CORD ASSY S03068	1	1	1
	34	302F846330	2F846330	CONN.CORD ASSY S03172	1	1	1
⊙	35	302F801340	2F801340	P.W.BOARD ASSY CONNECT-L	1	1	1
	36	5MVVL611WN06	2FV20100	LABEL FUSER CAUTION	1	1	1
	37	302FV45020	2FV45020	AC CORD ASSY		1	
	37	302FV45040	2FV45040	AC CORD ASSY			1
	38	2DC27410		AC CORD 120 ASSY	1		

SP	Ref. No.	Part.No.	Alternative.	Description	Quantity		
					120	230	240
	101	5MBTPB3006TW++R	B1A53060	BIND T.T SCREW(+)/ M3 X 6 CRFREE S-T			
	102	5MBTPB3008PW++R	B1A63080	BIND T.T SCREW(+)/ M3 X 8 CRFREE P-T			
	103	5MBTPB4010PW++R	B1A64100	BIND T.T SCREW(+)/ M4 X 10 CRFREE P-T			
	104	C2804100		POLYESTER SLIDER WASHER 4.1X10X0.5T			
	105	BAA63080		+TP TAP-TITE P SCREW M3X08			
	106	B1A54080		+BIND TAP-TITE S SCREW M4X08			

- Parts with "*" are component parts or sub-assemblies of the assembly appearing immediately above them.
- Parts with "⊙" indicates the spare parts.

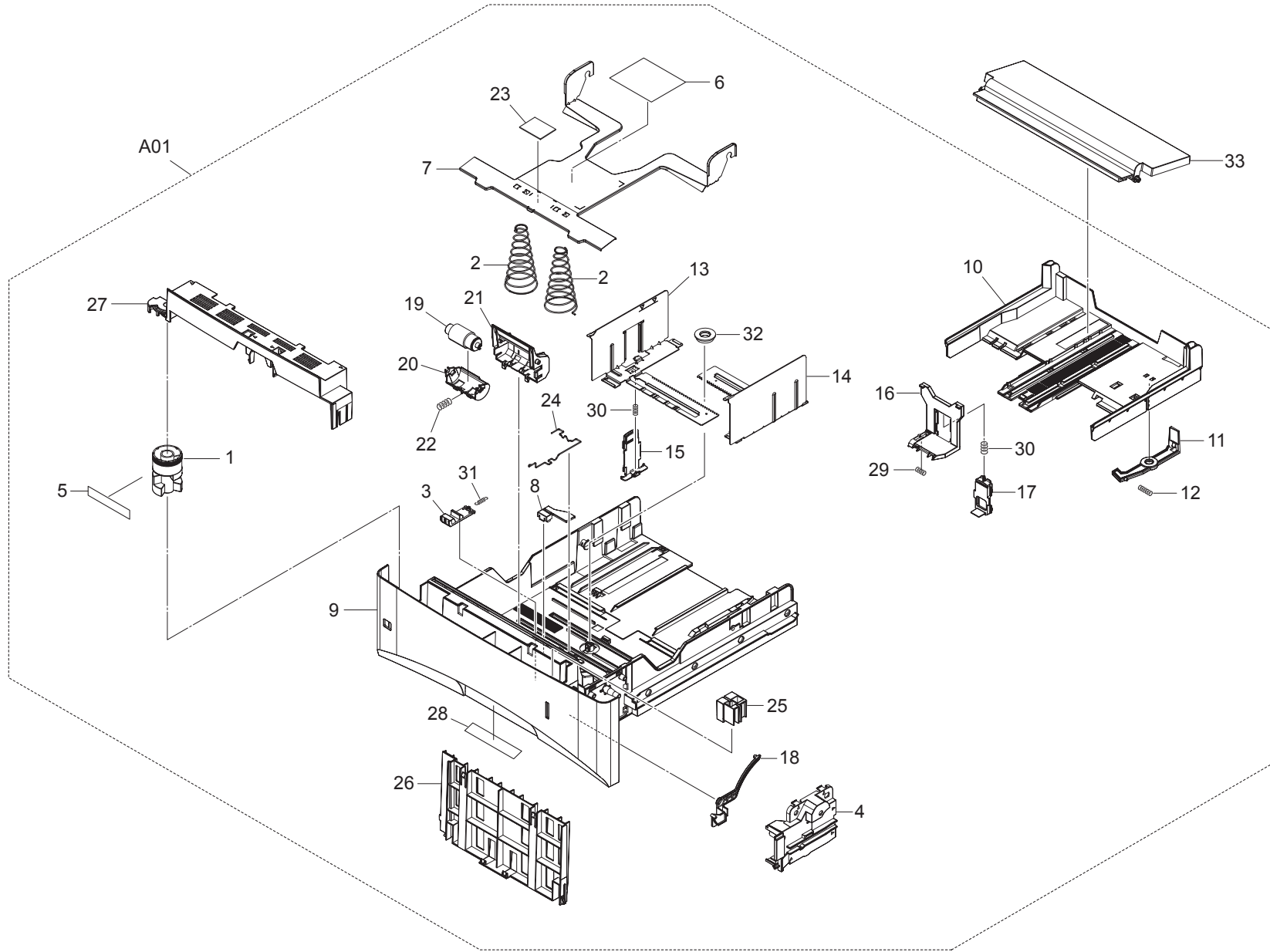

FIG. 4 Paper Cassette (FS-2000D)

2F8/2F9/2GA-1

SP	Ref. No.	Part.No.	Alternative.	Description	Quantity		
					120	230	240
⊙	A01	302F893050	2F893050	CT-310 (E)		1	1
⊙	A01	302F893060	2F893060	CT-310 (U)	1		
	1	*2BZ06070	5MVM686SH001	DIAL CASSETTE	1	1	1
⊙	2	*302F809010	2F809010	SPRING BOTTOM	2	2	2
⊙	3	*302F809020	2F809020	LOCK BOTTOM	1	1	1
	4	*302F809040	2F809040	COVER LIFT GEAR	1	1	1
	5	*302F809050	2F809050	LABEL DIAL	1	1	1
	6	*302F809060	2F809060	LABEL OPERATION	1	1	1
	7	*302F809070	2F809070	PLATE BOTTOM	1	1	1
	8	*302F809080	2F809080	STOPPER A5	1	1	1
	9	*302F909010	2F909010	BASE CASSETTE	1	1	1
	10	*302F909020	2F909020	BASE CASSETTE REAR	1	1	1
⊙	11	*302F909030	2F909030	LEVER BASE CAS REAR	1	1	1
	12	*302F909040	2F909040	SPRING BASE CAS REAR	1	1	1
	13	*302F909050	2F909050	CURSOR LEFT	1	1	1
	14	*302F909060	2F909060	CURSOR RIGHT	1	1	1
⊙	15	*302F909070	2F909070	LEVER SIDE CURSOR	1	1	1
	16	*302F909080	2F909080	CURSOR END	1	1	1
⊙	17	*302F909090	2F909090	LEVER END CURSOR	1	1	1
⊙	18	*302F909150	2F909150	LEVER INDICATOR	1	1	1
⊙	19	*302F909170	2F909170	RETARD ROLLER ASSY	1	1	1
	20	*302F909180	2F909180	HOLDER RETARD	1	1	1
	21	*302F909190	2F909190	GUIDE RETARD	1	1	1
	22	*302F909200	2F909200	SPRING RETARD	1	1	1
⊙	23	*302F909210	2F909210	PAD BOTTOM	1	1	1
	24	*302F909250	2F909250	SPRING SIZE FIX	1	1	1
	25	*302F909260	2F909260	MARKER INDICATOR	1	1	1
	26	*302F909270	2F909270	GUIDE PAPER CASSETTE	1	1	1
	27	*302F909280	2F909280	COVER CASSETTE TOP	1	1	1
	28	*302F909560	2F909560	SHEET CASSETTE	1	1	1
	29	*5MMW151SD003	2BS06100	SPRING END	1	1	1
	30	*5MMW166LD010	2B700070	SPRING LOCK GUIDE	2	2	2
	31	*5MMW251LD048	2BS06150	SP STOPPER BOTTOM	1	1	1
	32	*5MVG127DB046	2B700190	GEAR CASSETTE	1	1	1
	33	302F909240	2F909240	LID CASSETTE	1	1	1

• Parts with "*" are component parts or sub-assemblies of the assembly appearing immediately above them.

• Parts with "⊙" indicates the spare parts.

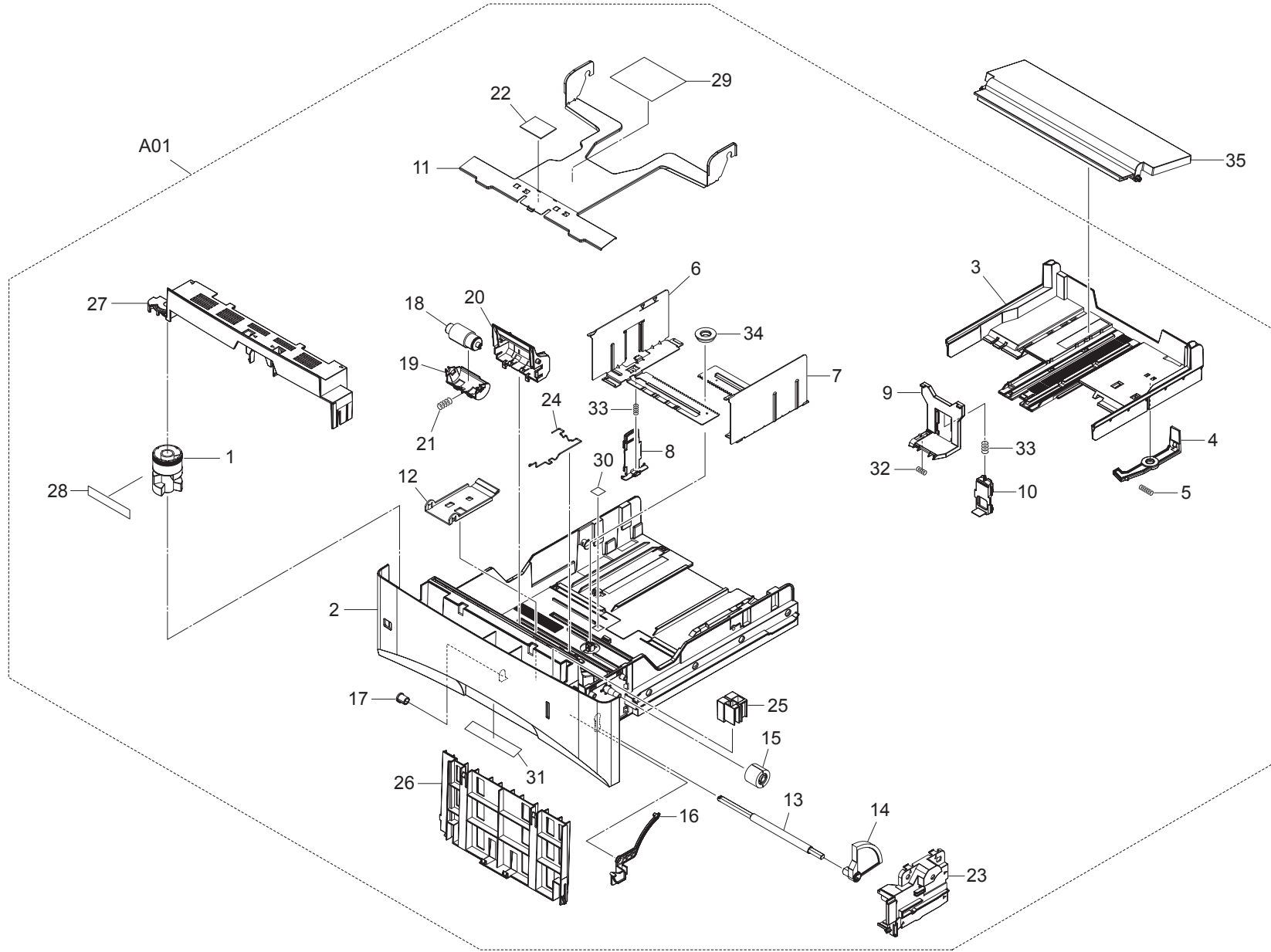

FIG. 4 Paper Cassette (FS-3900/4000DN)

2F8/2F9/2GA-1

SP	Ref. No.	Part.No.	Alternative.	Description	Quantity		
					120	230	240
⊙	A01	302F993090	2F993090	CT-320 (E)		1	1
⊙	A01	302F993100	2F993100	CT-320 (U)	1		
	1	*2BZ06070	5MVM686SH001	DIAL CASSETTE	1	1	1
	2	*302F909010	2F909010	BASE CASSETTE	1	1	1
	3	*302F909020	2F909020	BASE CASSETTE REAR	1	1	1
⊙	4	*302F909030	2F909030	LEVER BASE CAS REAR	1	1	1
	5	*302F909040	2F909040	SPRING BASE CAS REAR	1	1	1
	6	*302F909050	2F909050	CURSOR LEFT	1	1	1
	7	*302F909060	2F909060	CURSOR RIGHT	1	1	1
⊙	8	*302F909070	2F909070	LEVER SIDE CURSOR	1	1	1
	9	*302F909080	2F909080	CURSOR END	1	1	1
⊙	10	*302F909090	2F909090	LEVER END CURSOR	1	1	1
	11	*302F909100	2F909100	PLATE BOTTOM	1	1	1
	12	*302F909110	2F909110	WORKPLATE LIFT	1	1	1
	13	*302F909120	2F909120	SHAFT WORKPLATE	1	1	1
⊙	14	*302F909130	2F909130	GEAR LIFT Z64	1	1	1
⊙	15	*302F909140	2F909140	GEAR JOINT Z16	1	1	1
⊙	16	*302F909150	2F909150	LEVER INDICATOR	1	1	1
⊙	17	*302F909160	2F909160	BUSH LIFT 6	1	1	1
⊙	18	*302F909170	2F909170	RETARD ROLLER ASSY	1	1	1
	19	*302F909180	2F909180	HOLDER RETARD	1	1	1
	20	*302F909190	2F909190	GUIDE RETARD	1	1	1
	21	*302F909200	2F909200	SPRING RETARD	1	1	1
⊙	22	*302F909210	2F909210	PAD BOTTOM	1	1	1
	23	*302F909230	2F909230	COVER LIFT GEAR	1	1	1
	24	*302F909250	2F909250	SPRING SIZE FIX	1	1	1
	25	*302F909260	2F909260	MARKER INDICATOR	1	1	1
	26	*302F909270	2F909270	GUIDE PAPER CASSETTE	1	1	1
	27	*302F909280	2F909280	COVER CASSETTE TOP	1	1	1
	28	*302F909290	2F909290	LABEL DIAL A6	1	1	1
	29	*302F909300	2F909300	LABEL OPERATION	1	1	1
	30	*302F909310	2F909310	LABEL A6	1	1	1
	31	*302F909560	2F909560	SHEET CASSETTE	1	1	1
	32	*5MMW151SD003	2BS06100	SPRING END	1	1	1
	33	*5MMW166LD010	2B700070	SPRING LOCK GUIDE	2	2	2
	34	*5MVG127DB046	2B700190	GEAR CASSETTE	1	1	1
	35	302F909240	2F909240	LID CASSETTE	1	1	1

- Parts with "*" are component parts or sub-assemblies of the assembly appearing immediately above them.
- Parts with "⊙" indicates the spare parts.

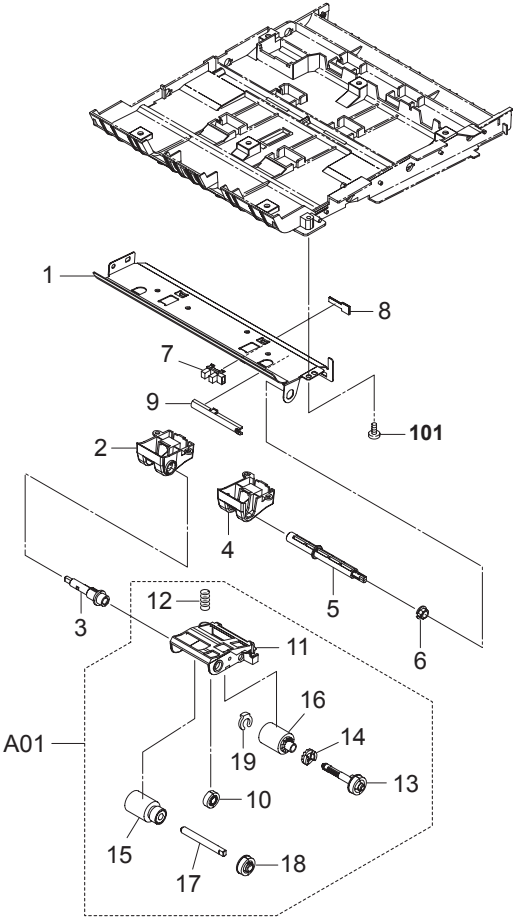

FIG. 5 Cassette Feed

2F8/2F9/2GA

SP	Ref. No.	Part.No.	Alternative.	Description	Quantity		
					120	230	240
	1	302F806010	2F806010	GUIDE FEED UP (FS-2000D)	1	1	1
	1	302F906010	2F906010	GUIDE FEED UP (FS-3900/4000DN)	1	1	1
	2	302F906190	2F906190	GUIDE FEED L	1	1	1
	3	302F906110	2F906110	PIN FEED ROLL	1	1	1
	4	302F906200	2F906200	GUIDE FEED R	1	1	1
	5	302F906290	2F906290	SHAFT FEED R	1	1	1
⊙	6	2BG22960		BUSH 6	1	1	1
⊙	7	302F944080	2F944080	PHOTO INTERRUPTER (FS-3900/4000DN)	1	1	1
	8	302F906220	2F906220	STOPPER SENSOR (FS-3900/4000DN)	1	1	1
	9	302F906300	2F906300	COVER WIRE (FS-3900/4000DN)	1	1	1
⊙	A01	302F894040	2F894040	FEED HOLDER ASSY (FS-2000D)	1	1	1
⊙	A01	302F994060	2F994060	FEED HOLDER ASSY (FS-3900/4000DN)	1	1	1
	10	*302F906030	2F906030	GEAR FEED Z26H	1	1	1
	11	*302F906060	2F906060	HOLDER FEED	1	1	1
	12	*302F906120	2F906120	SPRING PICK UP (FS-3900/4000DN)	1	1	1
	13	*302F906170	2F906170	JOINT PICKUP A	1	1	1
	14	*302F906180	2F906180	JOINT PICKUP B	1	1	1
	15	*302F906230	2F906230	PULLEY FEED ASSY	1	1	1
	16	*302F906240	2F906240	PULLEY PICKUP ASSY	1	1	1
	17	*302F906270	2F906270	SHAFT FEED L	1	1	1
	18	*302F906280	2F906280	GEAR FEED Z30H	1	1	1
	19	*5MVX111DN003	2A806250	RING STOPPER	1	1	1

SP	Ref. No.	Part.No.	Alternative.	Description	Quantity		
					120	230	240
	101	5MBTPB4010PW++R	B1A64100	BIND T.T SCREW(+)/ M4 X 10 CRFREE P-T			

- Parts with "*" are component parts or sub-assemblies of the assembly appearing immediately above them.
- Parts with "⊙" indicates the spare parts.

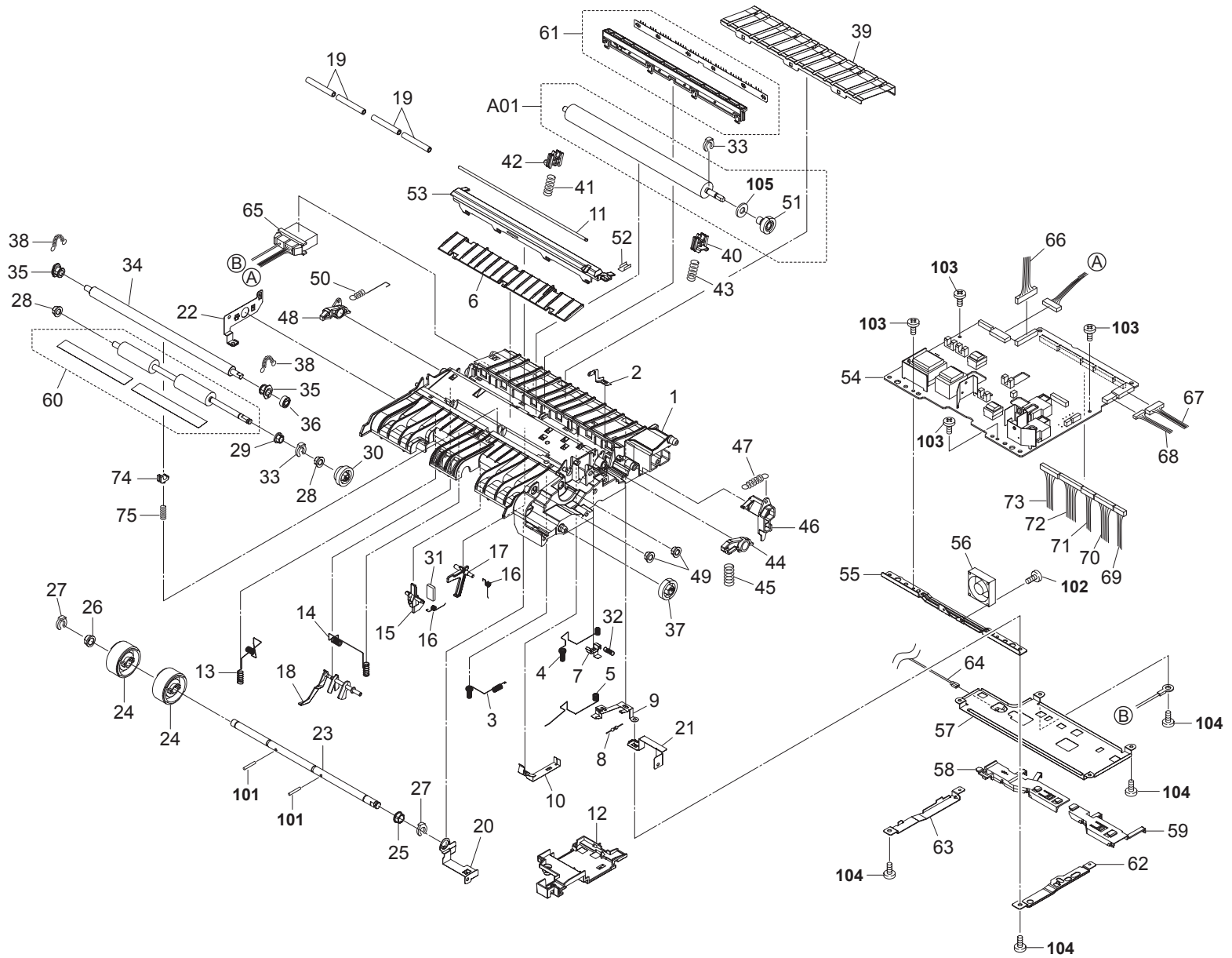

FIG. 6 Paper Feed

2F8/2F9/2GA

SP	Ref. No.	Part.No.	Alternative.	Description	Quantity		
					120	230	240
	1	302F924050	2F924050	FRAME FEED	1	1	1
	2	302F924600	2F924600	PLATE TC CHARGE	1	1	1
	3	302F924120	2F924120	SPRING TC CHARGE	1	1	1
	4	302F924130	2F924130	SPRING SEP CHARGE (FS-3900/4000DN)	1	1	1
	5	302F924140	2F924140	SPRING EARTH	1	1	1
	6	302F924810	2F924810	GUIDE FEED LOW	1	1	1
	7	302F924590	2F924590	PLATE SEP CHARGE	1	1	1
	8	302F924800	2F924800	HIGH MEG	1	1	1
	9	302F924580	2F924580	PLATE EARTH M	1	1	1
	10	302F924570	2F924570	PLATE HIGH MEG EARTH	1	1	1
	11	302F924750	2F924750	SHAFT GUIDE	1	1	1
	12	302F924620	2F924620	COVER PWB FEED	1	1	1
	13	302F924280	2F924280	SPRING MAIN CHARGE	1	1	1
	14	302F924340	2F924340	SPRING BIAS CHARGE	1	1	1
⊙	15	302F924150	2F924150	ACTUATOR REGIST	1	1	1
	16	302F924270	2F924270	SPRING REGIST SENSOR	2	2	2
⊙	17	302F924220	2F924220	ACTUATOR DU	1	1	1
⊙	18	302F924090	2F924090	LEVER EMPTY	1	1	1
	19	302F924760	2F924760	PULLEY GUIDE	4	4	4
	20	302F924660	2F924660	PLATE HV R	1	1	1
	21	302F924560	2F924560	PLATE EARTH R	1	1	1
	22	302F924650	2F924650	PLATE HV L	1	1	1
	23	302F924040	2F924040	SHAFT MID	1	1	1
⊙	24	302F924640	2F924640	ROLLER MIDDLE ASSY	2	2	2
	25	2BC06510		BUSHING 8	1	1	1
⊙	26	2BG22980		BUSH 8	1	1	1
	27	2BC06910		STOPPER 6	2	2	2
	28	2BG22960		BUSH 6	2	2	2
	29	2BG22970		BUSH 6 EW	1	1	1
⊙	30	302F924700	2F924700	GEAR REG Z26H-Z33H	1	1	1
	31	302F924780	2F924780	SPONGE REGIST	1	1	1
	32	302F924680	2F924680	SPRING SEP EARTH (FS-2000D)	1	1	1
	33	2BC06980		STOPPER 5	1	1	1
⊙	34	302F924020	2F924020	ROLLER REGIST UP	1	1	1
⊙	35	302F924160	2F924160	BUSH REGIST	2	2	2
⊙	36	302F924430	2F924430	GEAR REGIST Z23H	1	1	1
⊙	37	302F931430	2F931430	GEAR FEED ROLL Z27H	1	1	1
⊙	38	302F924460	2F924460	SPRING REGIST R	2	2	2
	39	302F924100	2F924100	GUIDE EARTH	1	1	1
⊙	40	302F924190	2F924190	BUSH TRANSFER R	1	1	1
	41	302F924390	2F924390	SPRING TC L	1	1	1
⊙	42	302F924180	2F924180	BUSH TRANSFER L	1	1	1
	43	302F924400	2F924400	SPRING TC R	1	1	1
⊙	44	302F924490	2F924490	LEVER RELEASE DLP R	1	1	1
	45	302F924320	2F924320	SPRING RELEASE DLP R	1	1	1
⊙	46	302F924240	2F924240	LEVER RELEASE FUSER R	1	1	1
	47	302F924380	2F924380	SPRING RELEASE FUSER R	1	1	1
⊙	48	302F924480	2F924480	LEVER RELEASE DLP L	1	1	1
	49	302F931490	2F931490	BUSH FEED DRIVE	2	2	2
	50	302F924520	2F924520	SP RELEASE TC L	1	1	1

SP	Ref. No.	Part.No.	Alternative.	Description	Quantity		
					120	230	240
⊙	A01	302F980100	2F980100	ROLLER TRANSFER ASSY	1	1	1
⊙	51	*302F924210	2F924210	GEAR TC Z22H	1	1	1
	52	302F924720	2F924720	SHEET INSULATOR	1	1	1
	53	302F924070	2F924070	GUIDE PAPER CHUTE	1	1	1
⊙	54	302F801420	2F801420	P.W.BOARD ASSY ENGINE WITH SOFTWARE (SP) (FS-2000D)	1	1	1
⊙	54	302F901160	2F901160	P.W.BOARD ASSY ENGINE WITH SOFTWARE (SP) (FS-3900DN)	1	1	1
⊙	54	302GA01160	2GA01160	P.W.BOARD ASSY ENGINE WITH SOFTWARE (SP) (FS-4000DN)	1	1	1
	55	302F924550	2F924550	PLATE HV	1	1	1
⊙	56	302F944120	2F944120	FAN ENGINE PWB 35	1	1	1
	57	302F924470	2F924470	PLATE ENGINE	1	1	1
	58	302F924500	2F924500	GUIDE CABLE L	1	1	1
	59	302F924510	2F924510	GUIDE CABLE R	1	1	1
⊙	60	302F994120	2F994120	REGIST KIT	1	1	1
⊙	61	302F994110	2F994110	DC BRUSH ASSY	1	1	1
	62	302F924740	2F924740	PLATE EARTH ENGINE R	1	1	1
	63	302F924730	2F924730	PLATE EARTH ENGINE L	1	1	1
	64	302F846290	2F846290	CONN.CORD ASSY S03122	1	1	1
⊙	65	302F846210	2F846210	CONN.CORD ASSY S03072 (FS-2000D)	1	1	1
⊙	65	302F946020	2F946020	CONN.CORD ASSY S03071 (FS-3900/4000DN)	1	1	1
	66	302F846110	2F846110	CONN.CORD ASSY S03054	1	1	1
	67	302F846100	2F846100	CONN.CORD ASSY S03052	1	1	1
	68	302F846080	2F846080	CONN.CORD ASSY S03050	1	1	1
	69	302F846090	2F846090	CONN.CORD ASSY S03051	1	1	1
	70	302F846150	2F846150	CONN.CORD ASSY S03061	1	1	1
	71	302F846140	2F846140	CONN.CORD ASSY S03060	1	1	1
	72	302F846130	2F846130	CONN.CORD ASSY S03056	1	1	1
	73	302F846120	2F846120	CONN.CORD ASSY S03055	1	1	1
⊙	74	2FM02180	5MVX221DN020	BUSH REGIST C (FS-4000DN)	1	1	1
	75	302F724260	2F724260	SPRING REGIST C (FS-4000DN)	1	1	1
	101	5MBP2012WPLD	E5120120	PARALLEL PIN / M2 X 12 SUS-DP			
	102	5MBTPB3014TW++R	B1A53140	BIND T.T SCREW(+)/ M3 X 14 CRFREE S-T			
	103	5MBTPB3006TW++R	B1A53060	BIND T.T SCREW(+)/ M3 X 6 CRFREE S-T			
	104	5MBTPB4010PW++R	B1A64100	BIND T.T SCREW(+)/ M4 X 10 CRFREE P-T			
	105	5MBW6295#NN	C2806100	POLYESTER SLIDER WASHER 6.2X10X1.0T			

• Parts with "*" are component parts or sub-assemblies of the assembly appearing immediately above them.

• Parts with "⊙" indicates the spare parts.

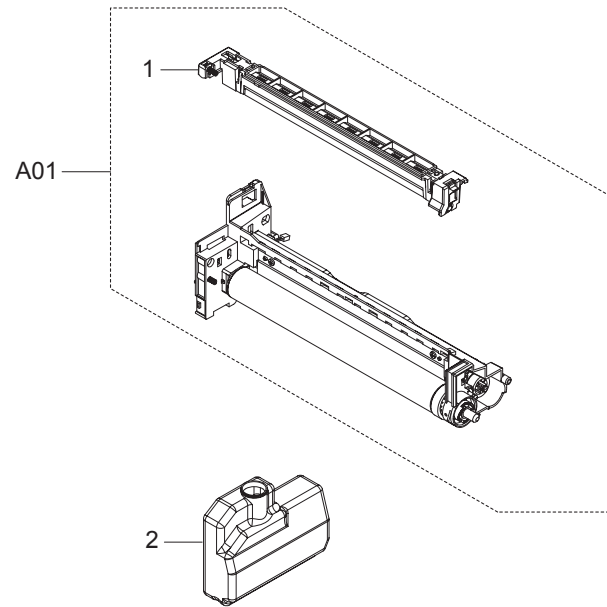

FIG. 7 Imaging Unit

2F8/2F9/2GA

SP	Ref. No.	Part.No.	Alternative.	Description	Quantity		
					120	230	240
⊙	A01	302F993010	2F993010	DK-310	1	1	1
⊙	1	*302F993080	2F993080	MC-310	1	1	1
⊙	2	302F994090	2F994090	WASTE BOTTLE ASSY	1	1	1

- Parts with "*" are component parts or sub-assemblies of the assembly appearing immediately above them.
- Parts with "⊙" indicates the spare parts.

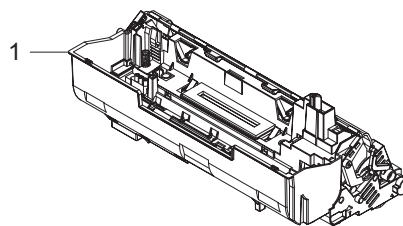

FIG. 8 Developer Unit

2F8/2F9/2GA-1

SP	Ref. No.	Part.No.	Alternative.	Description	Quantity		
					120	230	240
⊙	1	302F993020	2F993020	DV-320 (E)		1	1
⊙	1	302F993030	2F993030	DV-322 (U)	1		

- Parts with "*" are component parts or sub-assemblies of the assembly appearing immediately above them.
- Parts with "⊙" indicates the spare parts.

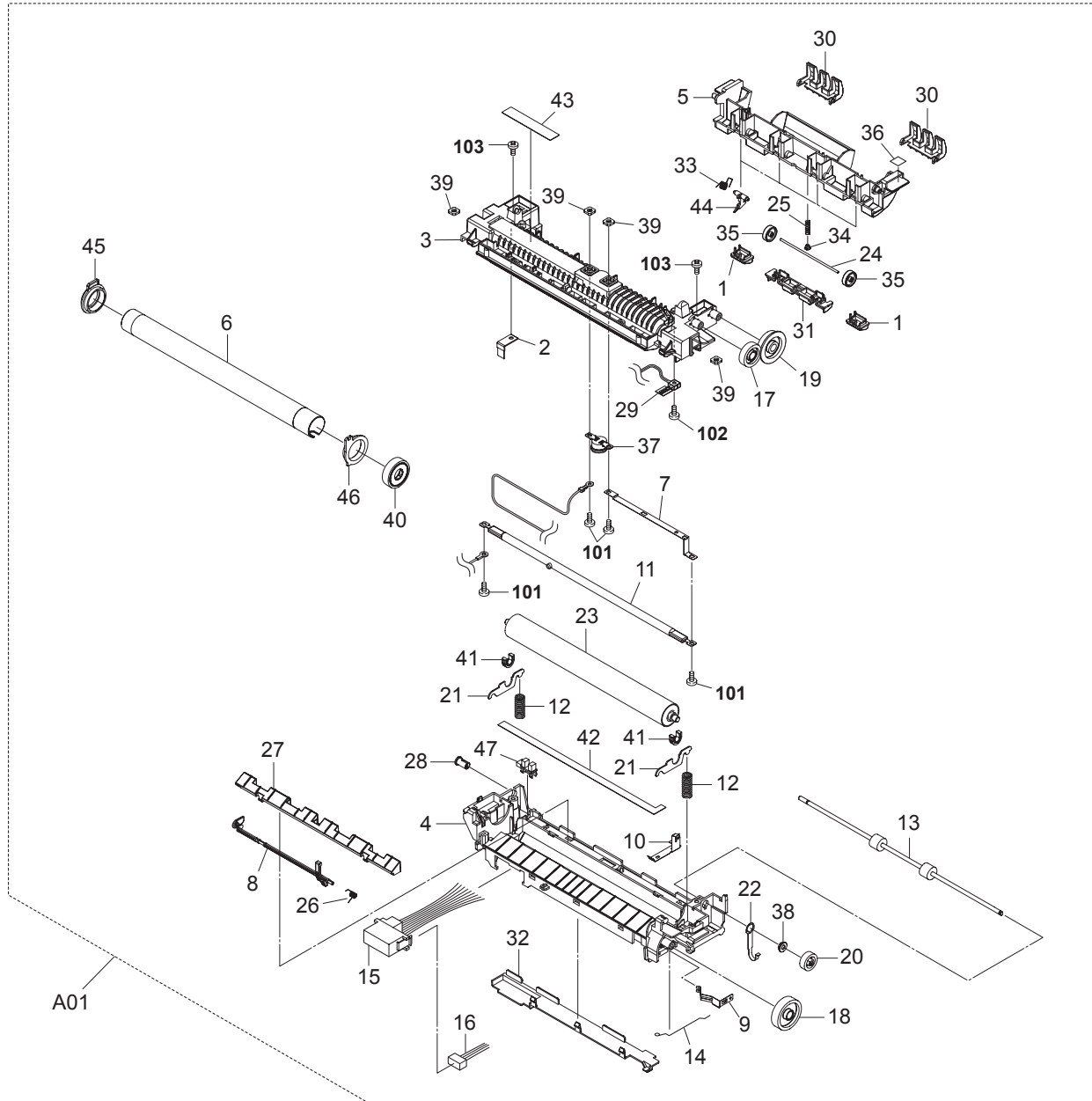

FIG. 9 Fuser Unit I (FS-2000D)

2F8/2F9/2GA

SP	Ref. No.	Part.No.	Alternative.	Description	Quantity		
					120	230	240
⊙	A01	302F893030	2F893030	FK-310 (E)		1	1
⊙	A01	302F893040	2F893040	FK-310 (U)	1		
	1	*302F725400	2F725400	CAP SEPARATOR	2	2	2
	2	*302F725430	2F725430	STATIC ELIMINATOR HEAT ROLLER	1	1	1
	3	*302F825010	2F825010	FRAME FUSER UP	1	1	1
	4	*302F825020	2F825020	FRAME FUSER LOW	1	1	1
	5	*302F825040	2F825040	GUIDE EXIT UP	1	1	1
⊙	6	*302F825050	2F825050	ROLLER HEAT	1	1	1
	7	*302F825060	2F825060	PLATE CORD	1	1	1
⊙	8	*302F825070	2F825070	ACTUATOR EXIT	1	1	1
	9	*302F825080	2F825080	PLATE EARTH FUSER	1	1	1
	10	*302F825090	2F825090	PLATE EARTH PRESS	1	1	1
⊙	11	*302F825120	2F825120	HEATER LAMP E		1	1
⊙	11	*302F825130	2F825130	HEATER LAMP U	1		
	12	*302F825150	2F825150	SPRING PRESS	2	2	2
⊙	13	*302F825170	2F825170	ROLLER EXIT	1	1	1
	14	*302F825180	2F825180	SPRING EARTH FUSER	1	1	1
⊙	15	*302F846220	2F846220	CONN.CORD ASSY S03076		1	1
⊙	15	*302F846230	2F846230	CONN.CORD ASSY S03077	1		
	16	*302F846380	2F846380	CONN.CORD ASSY S03183	1	1	1
⊙	17	*302F925080	2F925080	GEAR IDLE A Z29	1	1	1
⊙	18	*302F925090	2F925090	GEAR INPUT	1	1	1
⊙	19	*302F925130	2F925130	GEAR IDLE Z36	1	1	1
⊙	20	*302F925140	2F925140	GEAR EXIT Z21	1	1	1
	21	*302F925240	2F925240	PLATE PRESS	2	2	2
	22	*302F925250	2F925250	PLATE EARTH EXIT	1	1	1
⊙	23	*302F925270	2F925270	ROLLER PRESS	1	1	1
	24	*302F925310	2F925310	SHAFT EXIT	1	1	1
	25	*302F925340	2F925340	SPRING EXIT	1	1	1
	26	*302F925360	2F925360	SPRING ACTUATOR EXIT	1	1	1
	27	*302F925540	2F925540	GUIDE EXIT LOW	1	1	1
⊙	28	*302F925570	2F925570	BUSH EXIT	1	1	1
⊙	29	*302F925650	2F925650	THERMISTOR ASSY	1	1	1
	30	*302F925710	2F925710	GUIDE CHANGE	2	2	2
	31	*302F925720	2F925720	CAP SEPARATOR	1	1	1
	32	*302F925730	2F925730	COVER CORD	1	1	1
	33	*302F925800	2F925800	SPRING SEPARATOR	4	4	4
	34	*302F925900	2F925900	CAP SPRING EXIT	1	1	1
⊙	35	*302F925920	2F925920	PULLEY EXIT PFA	2	2	2
	36	*302F934020	2F934020	LABEL FUSER OPERATION	1	1	1
⊙	37	*302FP25110	2FP25110	THERMOSTAT 250V 170C	1	1	1
⊙	38	*5MMM176CJ007	2BM07330	BUSH METAL	1	1	1
	39	*5MMS111SL002	2BY20050	NUT FUSER A	4	4	4
⊙	40	*5MVG148XN010	2BR20200	GEAR HEAT Z36	1	1	1
⊙	41	*5MVV188XN014	2BS20230	BUSH PRESS	2	2	2
	42	*5MVS862XF005	2FP20200	SHEET DISCHARGER	1	1	1
	43	*5MVVL611WN06	2FV20100	LABEL FUSER CAUTION	1	1	1
	44	*5MVX222XN002	2A820530	SEPARATOR	4	4	4
⊙	45	*5MVX441XN001	2BR20180	BUSH HEAT L	1	1	1
	46	*5MVX441XN002	2BR20190	BUSH HEAT R	1	1	1
⊙	47	*7NXTLP1255++H01	NX046610	SENSOR OPT.	1	1	1

SP	Ref. No.	Part.No.	Alternative.	Description	Quantity		
					120	230	240
	101	7BB002304H	BB045310	TP SCREW M3X4			
	102	5MBTPB3012PW++R	B1A63120	BIND T.T SCREW(+)/ M3 X 12 CRFREE P-T			
	103	5MBTPB4010PW++R	B1A64100	BIND T.T SCREW(+)/ M4 X 10 CRFREE P-T			

- Parts with "*" are component parts or sub-assemblies of the assembly appearing immediately above them.
- Parts with "⊙" indicates the spare parts.

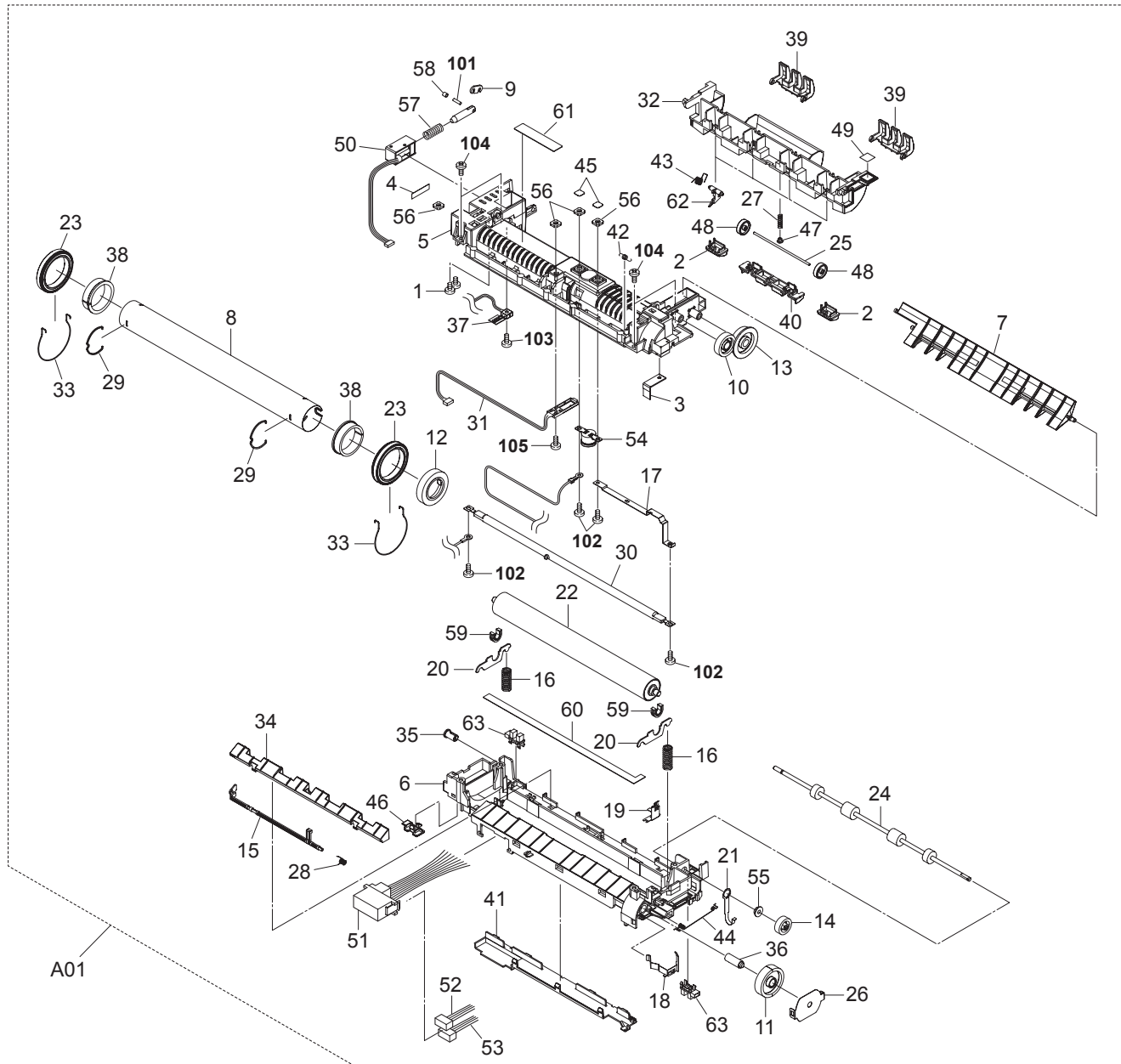

FIG. 9 Fuser Unit I (FS-3900/4000DN)

2F8/2F9/2GA

SP	Ref. No.	Part.No.	Alternative.	Description	Quantity		
					120	230	240
⊙	A01	302F993060	2F993060	FK-320 (E)		1	1
⊙	A01	302F993070	2F993070	FK-320 (U)	1		
1		*302F325010	2F325010	STUD SCREW M3	2	2	2
2		*302F725400	2F725400	CAP SEPARATOR	2	2	2
3		*302F725430	2F725430	STATIC ELIMINATOR HEAT ROLLER	1	1	1
4		*302F725500	2F725500	SHEET FUSER HEATER	1	1	1
5		*302F925010	2F925010	FRAME FUSER UP	1	1	1
6		*302F925020	2F925020	FRAME FUSER LOW	1	1	1
7		*302F925040	2F925040	GUIDE FACE UP	1	1	1
⊙	8	*302F925050	2F925050	ROLLER HEAT	1	1	1
⊙	9	*302F925060	2F925060	ACTUATOR SOL	1	1	1
⊙	10	*302F925080	2F925080	GEAR IDLE A Z29	1	1	1
⊙	11	*302F925090	2F925090	GEAR INPUT	1	1	1
⊙	12	*302F925100	2F925100	GEAR HEAT Z46	1	1	1
⊙	13	*302F925130	2F925130	GEAR IDLE Z36	1	1	1
⊙	14	*302F925140	2F925140	GEAR EXIT Z21	1	1	1
⊙	15	*302F925170	2F925170	ACTUATOR EXIT	1	1	1
16		*302F925190	2F925190	SPRING PRESS	2	2	2
17		*302F925200	2F925200	PLATE CORD	1	1	1
18		*302F925210	2F925210	PLATE EARTH FUSER	1	1	1
19		*302F925230	2F925230	PLATE EARTH PRESS	1	1	1
20		*302F925240	2F925240	PLATE PRESS	2	2	2
21		*302F925250	2F925250	PLATE EARTH EXIT	1	1	1
⊙	22	*302F925270	2F925270	ROLLER PRESS	1	1	1
⊙	23	*302F925280	2F925280	BEARING HEAT	2	2	2
⊙	24	*302F925290	2F925290	ROLLER EXIT	1	1	1
25		*302F925310	2F925310	SHAFT EXIT	1	1	1
26		*302F925320	2F925320	MOUNT GEAR	1	1	1
27		*302F925340	2F925340	SPRING EXIT	1	1	1
28		*302F925360	2F925360	SPRING ACTUATOR EXIT	1	1	1
29		*302F925390	2F925390	STOPPER HEAT ROLLER	2	2	2
⊙	30	*302F925400	2F925400	HEATER LAMP E		1	1
⊙	30	*302F925410	2F925410	HEATER LAMP U	1		
⊙	31	*302F925430	2F925430	THERMISTOR ASSY	1	1	1
32		*302F925520	2F925520	GUIDE EXIT UP	1	1	1
33		*302F925530	2F925530	RING BEARING	2	2	2
34		*302F925540	2F925540	GUIDE EXIT LOW	1	1	1
⊙	35	*302F925570	2F925570	BUSH EXIT	1	1	1
36		*302F925610	2F925610	PIN MOUNT GEAR	1	1	1
⊙	37	*302F925650	2F925650	THERMISTOR ASSY	1	1	1
⊙	38	*302F925660	2F925660	BUSHING HEAT ROLLER	2	2	2
39		*302F925710	2F925710	GUIDE CHANGE	2	2	2
40		*302F925720	2F925720	CAP SEPARATOR	1	1	1
41		*302F925730	2F925730	COVER CORD	1	1	1
42		*302F925770	2F925770	SPRING EARTH HEAT	1	1	1
43		*302F925800	2F925800	SPRING SEPARATOR	4	4	4
44		*302F925820	2F925820	SPRING EARTH	1	1	1
45		*302F925830	2F925830	SHEET FUSER A	2	2	2
46		*302F925880	2F925880	LID FUSER	1	1	1
47		*302F925900	2F925900	CAP SPRING EXIT	1	1	1

SP	Ref. No.	Part.No.	Alternative.	Description	Quantity		
					120	230	240
⊙	48	*302F925920	2F925920	PULLEY EXIT PFA	2	2	2
49		*302F934020	2F934020	LABEL FUSER OPERATION	1	1	1
⊙	50	*302F944090	2F944090	SOLENOID ASSY	1	1	1
⊙	51	*302F946030	2F946030	CONN.CORD ASSY S03074		1	1
⊙	51	*302F946040	2F946040	CONN.CORD ASSY S03075	1		
52		*302F946080	2F946080	CONN.CORD ASSY S03153	1	1	1
53		*302F946090	2F946090	CONN.CORD ASSY S03154	1	1	1
⊙	54	*302FP25110	2FP25110	THERMOSTAT 250V 170C	1	1	1
⊙	55	*5MMM176CJ007	2BM07330	BUSH METAL	1	1	1
56		*5MMS111SL002	2BY20050	NUT FUSER A	4	4	4
57		*5MMW261LJ032	2BM21060	SPRING SOL	1	1	1
58		*5MVM111RB002	2BR20450	RUBBER PIN	1	1	1
⊙	59	*5MVM188XN014	2BS20230	BUSH PRESS	2	2	2
60		*5MVS862XF005	2FP20200	SHEET DISCHARGER	1	1	1
61		*5MVVL611WN06	2FV20100	LABEL FUSER CAUTION	1	1	1
62		*5MVX222XN002	2A820530	SEPARATOR	4	4	4
⊙	63	*7NXTLP1255++H01	NX046610	SENSOR OPT.	2	2	2
101		5MBP2518WXSP	E0025180	SPRING PIN / M2.5 X 18 S-BLK			
102		7BB002304H	BB045310	TP SCREW M3X4			
103		5MBTPB3012PW++R	B1A63120	BIND T.T SCREW(+)/ M3 X 12 CRFREE P-T			
104		5MBTPB4010PW++R	B1A64100	BIND T.T SCREW(+)/ M4 X 10 CRFREE P-T			
105		B1B03080		+BIND SCREW M3X08			

- Parts with "*" are component parts or sub-assemblies of the assembly appearing immediately above them.
- Parts with "⊙" indicates the spare parts.

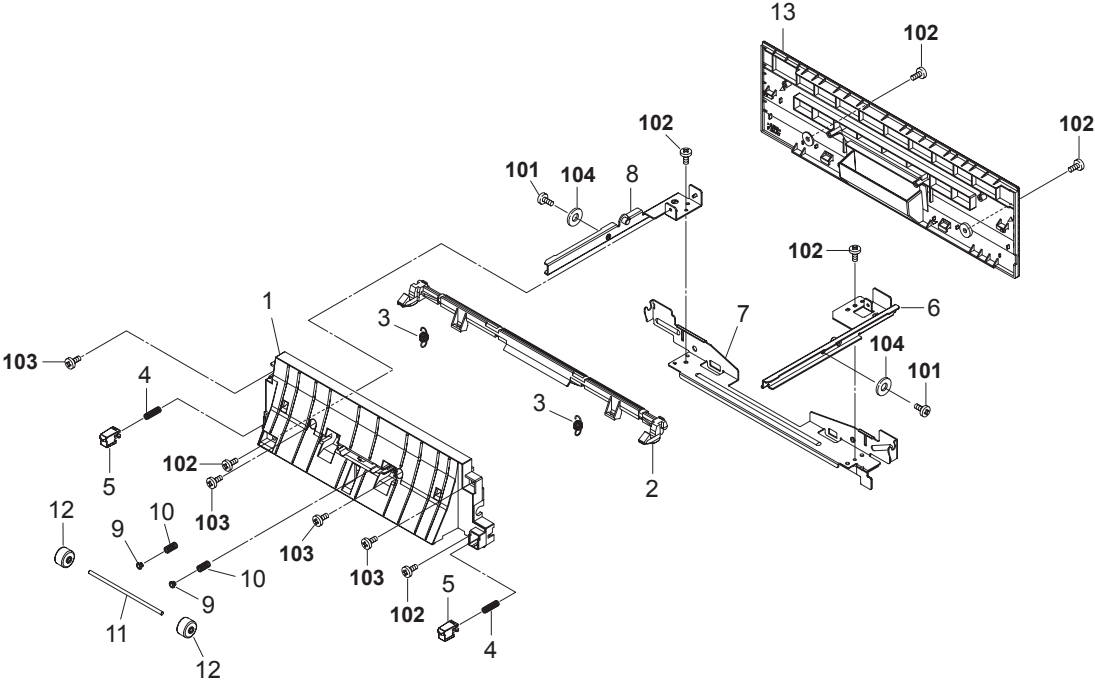

FIG. 10 Fuser Unit II (FS-2000D)

2F8/2F9/2GA

SP	Ref. No.	Part.No.	Alternative.	Description	Quantity		
					120	230	240
	1	302F825030	2F825030	GUIDE DU	1	1	1
⊙	2	302F925740	2F925740	LEVER FUSER RELEASE	1	1	1
	3	302F925750	2F925750	SPRING FUSER RELEASE	2	2	2
	4	302F925560	2F925560	SPRING LOCK	2	2	2
⊙	5	302F925550	2F925550	LOCK FUSER	2	2	2
⊙	6	302F925440	2F925440	INNER RAIL R	1	1	1
	7	302F925760	2F925760	PLATE RAIL FIX	1	1	1
⊙	8	302F925450	2F925450	INNER RAIL L	1	1	1
	9	2FM04150	5MVM163DN005	CAP SPRING	2	2	2
	10	302F925780	2F925780	SPRING DU	2	2	2
	11	302F929060	2F929060	SHAFT FEED DU	1	1	1
	12	302F925930	2F925930	PULLEY SWITCH BACK	2	2	2
⊙	13	302F825160	2F825160	COVER REAR	1	1	1

SP	Ref. No.	Part.No.	Alternative.	Description	Quantity		
					120	230	240
	101	5MBTPB3004TW++R	B1B53040	BIND T.T SCREW(+) / M3 X 4 CRFREE S-T			
	102	5MBTPB3006TW++R	B1A53060	BIND T.T SCREW(+) / M3 X 6 CRFREE S-T			
	103	5MBTPB3008PW++R	B1A63080	BIND T.T SCREW(+) / M3 X 8 CRFREE P-T			
	104	5MBWK32808NN	C2803080	POLY SLIDER /M3.2X 8 X0.8T XX			

- Parts with "*" are component parts or sub-assemblies of the assembly appearing immediately above them.
- Parts with "⊙" indicates the spare parts.

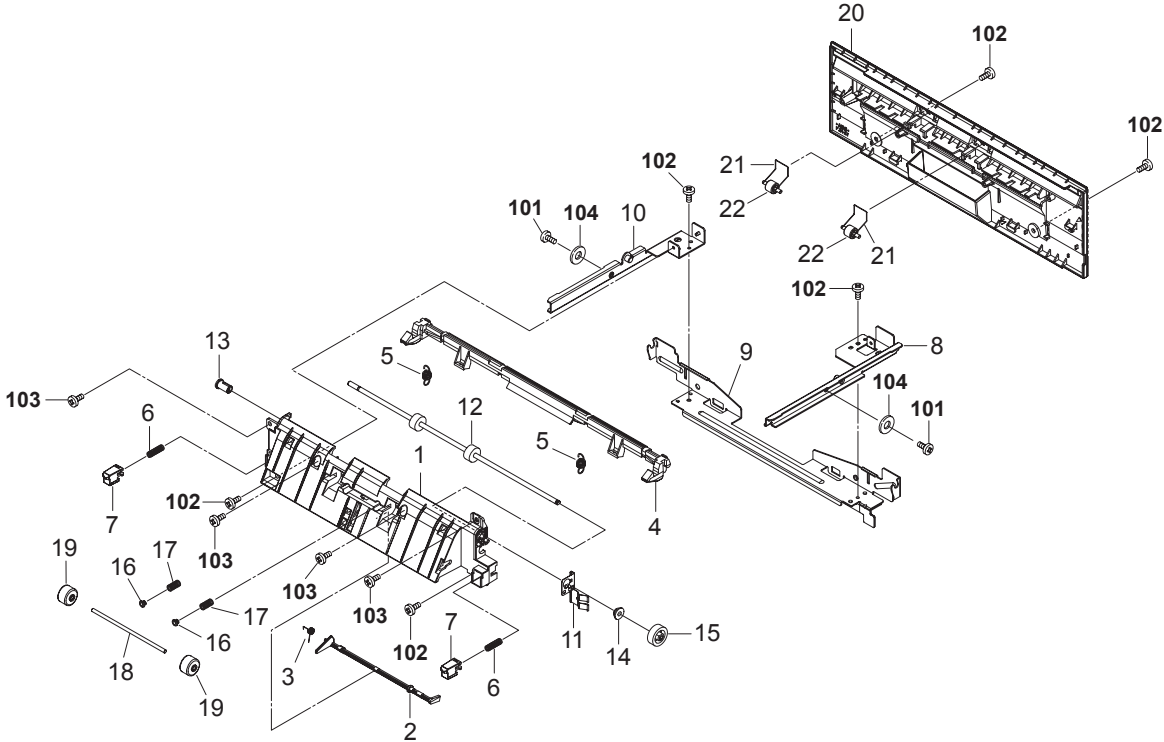

FIG. 10 Fuser Unit II (FS-3900/4000DN)

2F8/2F9/2GA

SP	Ref. No.	Part.No.	Alternative.	Description	Quantity		
					120	230	240
	1	302F925030	2F925030	GUIDE DU	1	1	1
⊙	2	302F925180	2F925180	ACTUATOR DU	1	1	1
	3	302F925370	2F925370	SPRING ACTUATOR DU	1	1	1
⊙	4	302F925740	2F925740	LEVER FUSER RELEASE	1	1	1
	5	302F925750	2F925750	SPRING FUSER RELEASE	2	2	2
	6	302F925560	2F925560	SPRING LOCK	2	2	2
⊙	7	302F925550	2F925550	LOCK FUSER	2	2	2
⊙	8	302F925440	2F925440	INNER RAIL R	1	1	1
	9	302F925760	2F925760	PLATE RAIL FIX	1	1	1
⊙	10	302F925450	2F925450	INNER RAIL L	1	1	1
	11	302F925260	2F925260	PLATE EARTH FACE UP	1	1	1
⊙	12	302F925300	2F925300	ROLLER FACE UP	1	1	1
⊙	13	302FV02470	2FV02470	BUSH FD	1	1	1
⊙	14	302F929140	2F929140	BUSH DU	1	1	1
⊙	15	302F925140	2F925140	GEAR EXIT Z21	1	1	1
	16	2FM04150	5MVM163DN005	CAP SPRING	2	2	2
	17	302F925780	2F925780	SPRING DU	2	2	2
	18	302F929060	2F929060	SHAFT FEED DU	1	1	1
	19	302F925930	2F925930	PULLEY SWITCH BACK	2	2	2
⊙	20	302F925510	2F925510	COVER REAR	1	1	1
	21	302F925350	2F925350	SPRING FACE UP	2	2	2
	22	302F925160	2F925160	PULLEY FACE UP	2	2	2

SP	Ref. No.	Part.No.	Alternative.	Description	Quantity		
					120	230	240
	101	5MBTPB3004TW++R	B1B53040	BIND T.T SCREW(+) / M3 X 4 CRFREE S-T			
	102	5MBTPB3006TW++R	B1A53060	BIND T.T SCREW(+) / M3 X 6 CRFREE S-T			
	103	5MBTPB3008PW++R	B1A63080	BIND T.T SCREW(+) / M3 X 8 CRFREE P-T			
	104	5MBWK32808NN	C2803080	POLY SLIDER /M3.2X 8 X0.8T XX			

- Parts with "*" are component parts or sub-assemblies of the assembly appearing immediately above them.
- Parts with "⊙" indicates the spare parts.

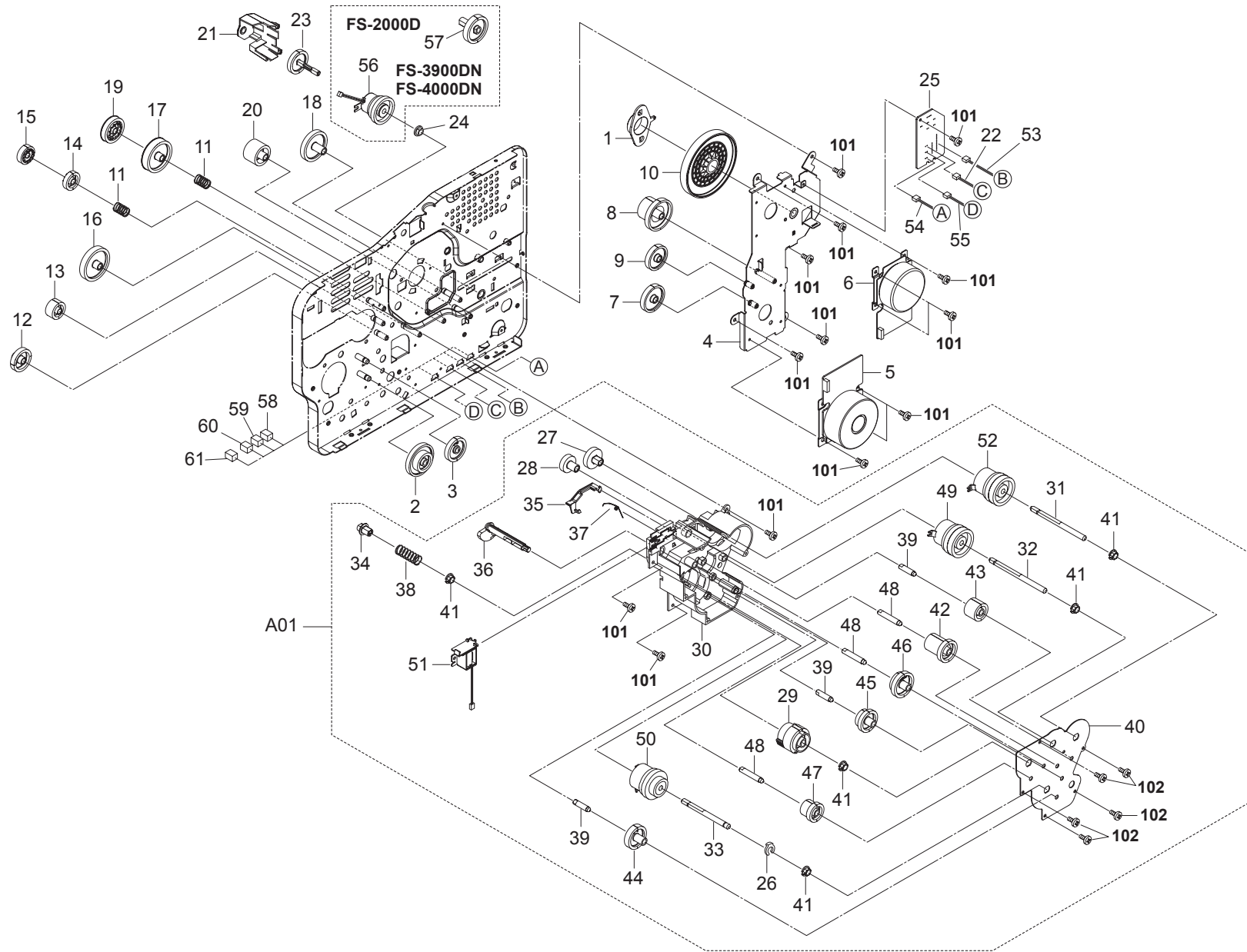

FIG. 11 Driving Unit

2F8/2F9/2GA

SP	Ref. No.	Part.No.	Alternative.	Description	Quantity		
					120	230	240
⊙	1	302F831060	2F831060	BUSH DRUM	1	1	1
⊙	2	302F931110	2F931110	GEAR Z95H Z28H	1	1	1
⊙	3	302F931500	2F931500	GEAR FEED Z34H	1	1	1
⊙	4	302F731010	2F731010	PLATE DRIVE B (FS-2000D)	1	1	1
⊙	4	302F931470	2F931470	PLATE DRIVE C (FS-3900/4000DN)	1	1	1
⊙	5	302F944010	2F944010	MOTOR MAIN	1	1	1
⊙	6	302F844030	2F844030	MOTOR DRUM (FS-2000D)	1	1	1
⊙	6	302F944180	2F944180	MOTOR DRUM B (FS-3900/4000DN)	1	1	1
⊙	7	302F931020	2F931020	GEAR Z77H	1	1	1
⊙	8	302F931040	2F931040	GEAR Z90H Z30H	1	1	1
⊙	9	302F931030	2F931030	GEAR Z70H	1	1	1
⊙	10	302F931590	2F931590	GEAR Z191H	1	1	1
⊙	11	302F931270	2F931270	SPRING FUSER	2	2	2
⊙	12	302F931200	2F931200	GEAR DLP Z32H	1	1	1
⊙	13	302F931290	2F931290	GEAR DLP Z24H	1	1	1
⊙	14	302F931300	2F931300	GEAR DLP JOINT Z25H	1	1	1
⊙	15	302F931310	2F931310	GEAR DLP Z25H	1	1	1
⊙	16	302F931050	2F931050	GEAR Z48H	1	1	1
⊙	17	302F931060	2F931060	GEAR Z46H	1	1	1
⊙	18	302F931080	2F931080	GEAR Z45S	1	1	1
⊙	19	302F931070	2F931070	GEAR Z37S	1	1	1
⊙	20	302F931090	2F931090	GEAR Z30S	1	1	1
⊙	21	302F931320	2F931320	HOLDER DU	1	1	1
⊙	22	302F846240	2F846240	CONN.CORD ASSY S03099	1	1	1
⊙	23	302F931100	2F931100	GEAR Z34S	1	1	1
⊙	24	302F931490	2F931490	BUSH FEED DRIVE	1	1	1
⊙	25	302F801350	2F801350	P.W.BOARD ASSY CONNECT-R (FS-2000D)	1	1	1
⊙	25	302F901150	2F901150	P.W.BOARD ASSY CONNECT-R (FS-3900/4000DN)	1	1	1
⊙	A01	302F994030	2F994030	FEED DRIVE ASSY	1	1	1
⊙	26	*2BC06980		STOPPER 5	1	1	1
⊙	27	*302F931130	2F931130	GEAR REGIST Z28H	1	1	1
⊙	28	*302F931160	2F931160	GEAR FEED CLUTCH Z23H	1	1	1
⊙	29	*302F931180	2F931180	GEAR MPF Z37S	1	1	1
⊙	30	*302F931220	2F931220	HOUSING FEED DRIVE B	1	1	1
⊙	31	*302F931250	2F931250	SHAFT REGIST	1	1	1
⊙	32	*302F931260	2F931260	SHAFT MID FEED	1	1	1
⊙	33	*302F931340	2F931340	SHAFT CASSETTE	1	1	1
⊙	34	*302F931350	2F931350	JOINT SHAFT CASSETTE	1	1	1
⊙	35	*302F931360	2F931360	LEVER MPF LIFT	1	1	1
⊙	36	*302F931370	2F931370	CAM MPF LIFT	1	1	1
⊙	37	*302F931380	2F931380	SPRING MPF CAM	1	1	1
⊙	38	*302F931450	2F931450	SPRING FEED	1	1	1
⊙	39	*302F931460	2F931460	PIN IDLE FEED	3	3	3
⊙	40	*302F931480	2F931480	PLATE FEED DRIVE	1	1	1
⊙	41	*302F931490	2F931490	BUSH FEED DRIVE	5	5	5
⊙	42	*302F931510	2F931510	GEAR FEED Z23HZ31H	1	1	1
⊙	43	*302F931520	2F931520	GEAR FEED Z25H	1	1	1
⊙	44	*302F931530	2F931530	GEAR FEED Z33H	1	1	1
⊙	45	*302F931540	2F931540	GEAR FEED Z31HZ24H	1	1	1

SP	Ref. No.	Part.No.	Alternative.	Description	Quantity		
					120	230	240
⊙	46	*302F931550	2F931550	GEAR FEED Z36HZ27H	1	1	1
⊙	47	*302F931560	2F931560	GEAR FEED Z26H Z22S	1	1	1
⊙	48	*302F931570	2F931570	PIN IDLE FEED A	3	3	3
⊙	49	*302F944030	2F944030	CLUTCH MID FEED	1	1	1
⊙	50	*302F944050	2F944050	CLUTCH CASSETTE	1	1	1
⊙	51	*302F944060	2F944060	SOLENOID MPF	1	1	1
⊙	52	*302F944900	2F944900	CLUTCH REGIST	1	1	1
⊙	53	302F846340	2F846340	CONN.CORD ASSY S03174	1	1	1
⊙	54	302F946050	2F946050	CONN.CORD ASSY S03098 (FS-3900/4000DN)	1	1	1
⊙	55	302F946060	2F946060	CONN.CORD ASSY S03100 (FS-3900/4000DN)	1	1	1
⊙	56	302F944040	2F944040	CLUTCH DUPLEX (FS-3900/4000DN)	1	1	1
⊙	57	302F831040	2F831040	GEAR DU (FS-2000D)	1	1	1
⊙	58	7YCC02B1003+H01	YC013860	CONNECTOR 292254-2 (FS-3900/4000DN)	1	1	1
⊙	59	7YCC02B1007+H01	YC014270	CONNECTOR	1	1	1
⊙	60	7YCC02B1111+H01	YC045130	CONNECTOR	1	1	1
⊙	61	7YCC02B1005+H01	YC013990	CONNECTOR 2-292254-2 (FS-3900/4000DN)	1	1	1
	101	5MBTPB3006TW++R	B1A53060	BIND T.T SCREW(+) / M3 X 6 CRFREE S-T			
	102	5MBTPB3008PW++R	B1A63080	BIND T.T SCREW(+) / M3 X 8 CRFREE P-T			

• Parts with "*" are component parts or sub-assemblies of the assembly appearing immediately above them.

• Parts with "⊙" indicates the spare parts.

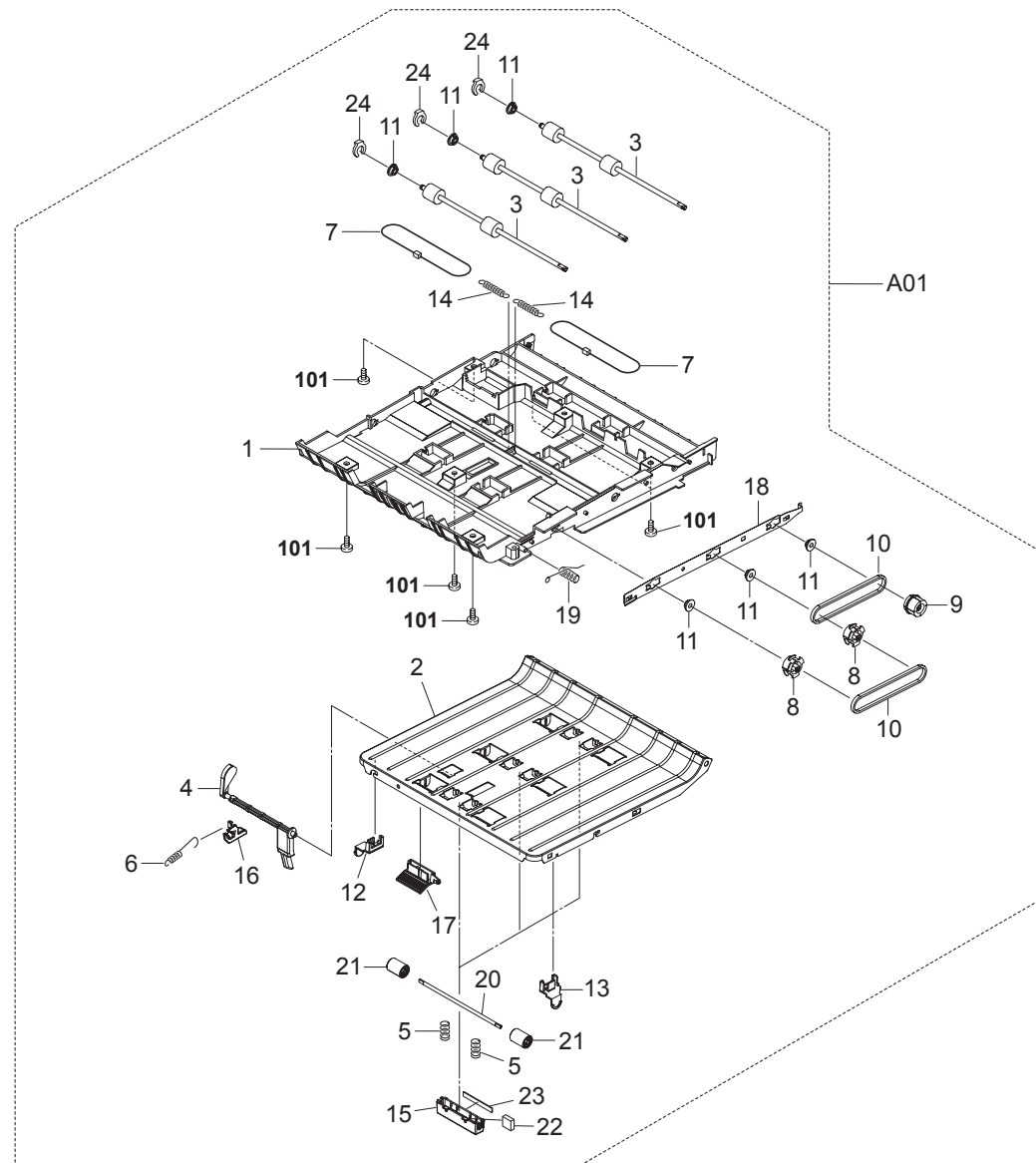

FIG. 12 Duplex Unit

2F8/2F9/2GA

SP	Ref. No.	Part.No.	Alternative.	Description	Quantity		
					120	230	240
⊙	A01	302F994010	2F994010	DU ASSY	1	1	1
	1	*302F929010	2F929010	BASE DU	1	1	1
	2	*302F929020	2F929020	GUIDE DU LOW	1	1	1
⊙	3	*302F929030	2F929030	ROLLER DU	3	3	3
⊙	4	*302F929040	2F929040	ACTUATOR PE	1	1	1
	5	*302F929070	2F929070	SPRING PULLEY FEED	6	6	6
	6	*302F929080	2F929080	SPRING PE RELEASE	1	1	1
	7	*302F929090	2F929090	WIRE LIFT DU	2	2	2
⊙	8	*302F929100	2F929100	PULLEY P25 DU	2	2	2
⊙	9	*302F929110	2F929110	GEAR Z18S-P25	1	1	1
⊙	10	*302F929120	2F929120	BELT DU	2	2	2
⊙	11	*302F929140	2F929140	BUSH DU	6	6	6
⊙	12	*302F929150	2F929150	LEVER LIFT DU L	1	1	1
⊙	13	*302F929160	2F929160	LEVER LIFT DU R	1	1	1
	14	*302F929170	2F929170	SPRING DU LIFT	2	2	2
	15	*302F929180	2F929180	HOLDER DU PULLEY	3	3	3
⊙	16	*302F929190	2F929190	BUSH PE	1	1	1
⊙	17	*302F929200	2F929200	LEVER DU RELEASE	1	1	1
	18	*302F929220	2F929220	PLATE EARTH DU	1	1	1
	19	*302F929240	2F929240	SPRING EARTH DU	1	1	1
	20	*302F929250	2F929250	SHAFT DU LOW	3	3	3
	21	*302F929260	2F929260	PULLEY DU LOW	6	6	6
	22	*302F929270	2F929270	SEAL HOLDER	3	3	3
	23	*302F929280	2F929280	SEAL HOLDER B	3	3	3
	24	*5MVX111DN007	2BT11070	STOPPER 3	3	3	3

SP	Ref. No.	Part.No.	Alternative.	Description	Quantity		
					120	230	240
	101	5MBTPB4010PW++R	B1A64100	BIND T.T SCREW(+)/ M4 X 10 CRFREE P-T			

- Parts with "*" are component parts or sub-assemblies of the assembly appearing immediately above them.
- Parts with "⊙" indicates the spare parts.

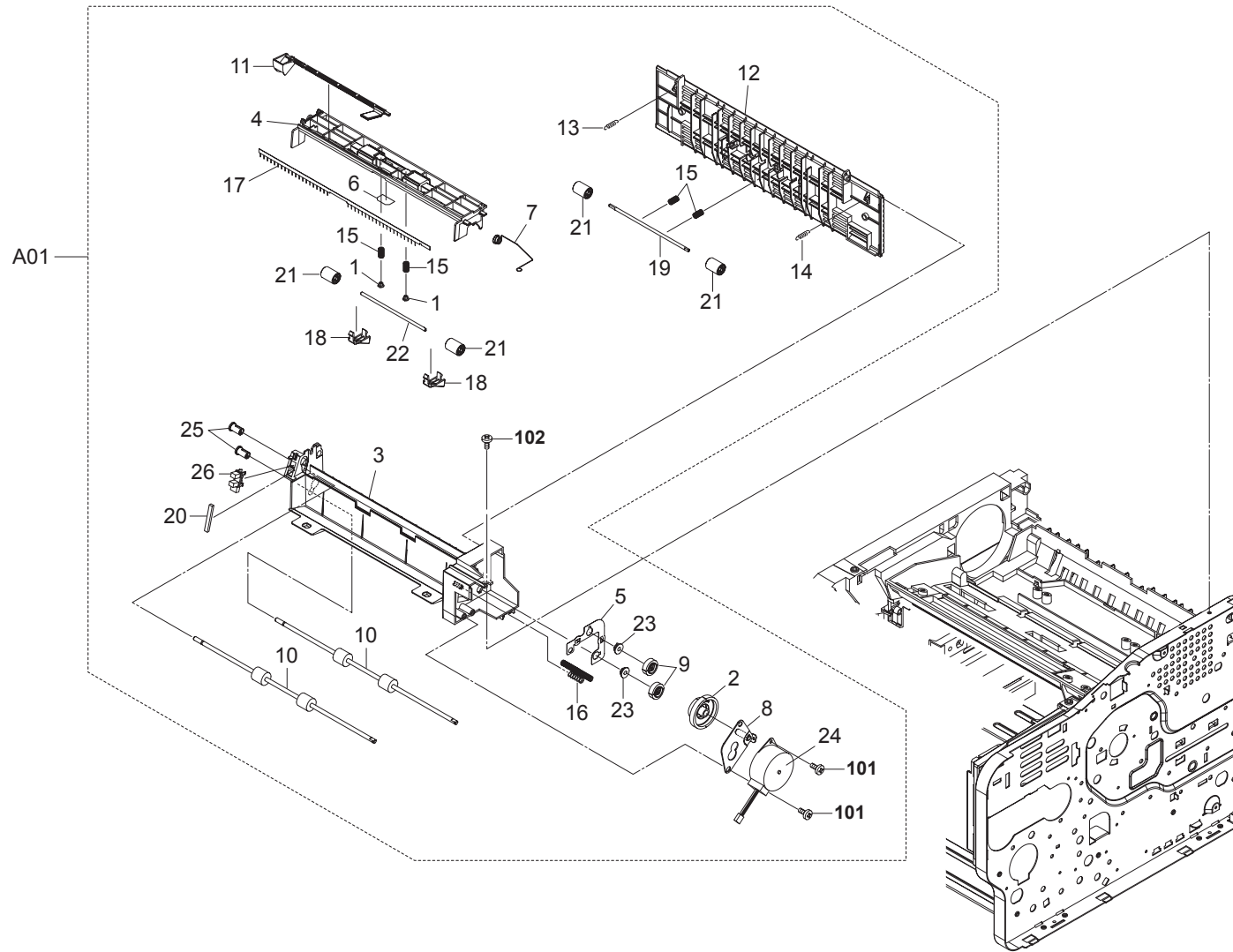

FIG. 13 Paper Exit (FS-2000D)

2F8/2F9/2GA

SP	Ref. No.	Part.No.	Alternative.	Description	Quantity		
					120	230	240
⊙	A01	302F894010	2F894010	FD ASSY	1	1	1
	1	*2FM04150	5MVM163DN005	CAP SPRING	2	2	2
⊙	2	*302F828030	2F828030	GEAR Z66HZ25H	1	1	1
	3	*302F828040	2F828040	GUIDE VERTICAL 30	1	1	1
	4	*302F828060	2F828060	GUIDE EJECT 30	1	1	1
	5	*302F828070	2F828070	EARTH PLATE EJECT	1	1	1
	6	*302F828120	2F828120	FILM EJECT	1	1	1
	7	*302F828130	2F828130	SPRING DISCHARGER	1	1	1
	8	*302F928040	2F928040	PLATE MOTOR	1	1	1
⊙	9	*302F928060	2F928060	GEAR Z18H FD	2	2	2
⊙	10	*302F928070	2F928070	ROLLER FD UP	2	2	2
⊙	11	*302F928100	2F928100	ACTUATOR OVERFLOW	1	1	1
⊙	12	*302F928120	2F928120	COVER FD	1	1	1
	13	*302F928130	2F928130	SPRING COVER FD L	1	1	1
	14	*302F928140	2F928140	SPRING COVER FD R	1	1	1
	15	*302F928170	2F928170	SPRING PULLEY	4	4	4
	16	*302F928190	2F928190	SPRING EARTH A	1	1	1
⊙	17	*302F928240	2F928240	DISCHARGER FD	1	1	1
	18	*302F928250	2F928250	GUIDE CORRUGATION	2	2	2
	19	*302F928290	2F928290	SHAFT EJECT PULLEY	1	1	1
	20	*302F928300	2F928300	SPONGE EXIT	1	1	1
⊙	21	*302F929050	2F929050	PULLEY FEED DU	4	4	4
	22	*302F929060	2F929060	SHAFT FEED DU	1	1	1
⊙	23	*302F929140	2F929140	BUSH DU	2	2	2
⊙	24	*302F944130	2F944130	MOTOR EJECT	1	1	1
⊙	25	*302FV02470	2FV02470	BUSH FD	2	2	2
⊙	26	*7NXTLP1255++H01	NX046610	SENSOR OPT.	1	1	1

SP	Ref. No.	Part.No.	Alternative.	Description	Quantity		
					120	230	240
	101	5MBTPB3008PW++R	B1A63080	BIND T.T SCREW(+)/ M3 X 8 CRFREE P-T			
	102	B1A54080		+BIND TAP-TITE S SCREW M4X08			

- Parts with "*" are component parts or sub-assemblies of the assembly appearing immediately above them.
- Parts with "⊙" indicates the spare parts.

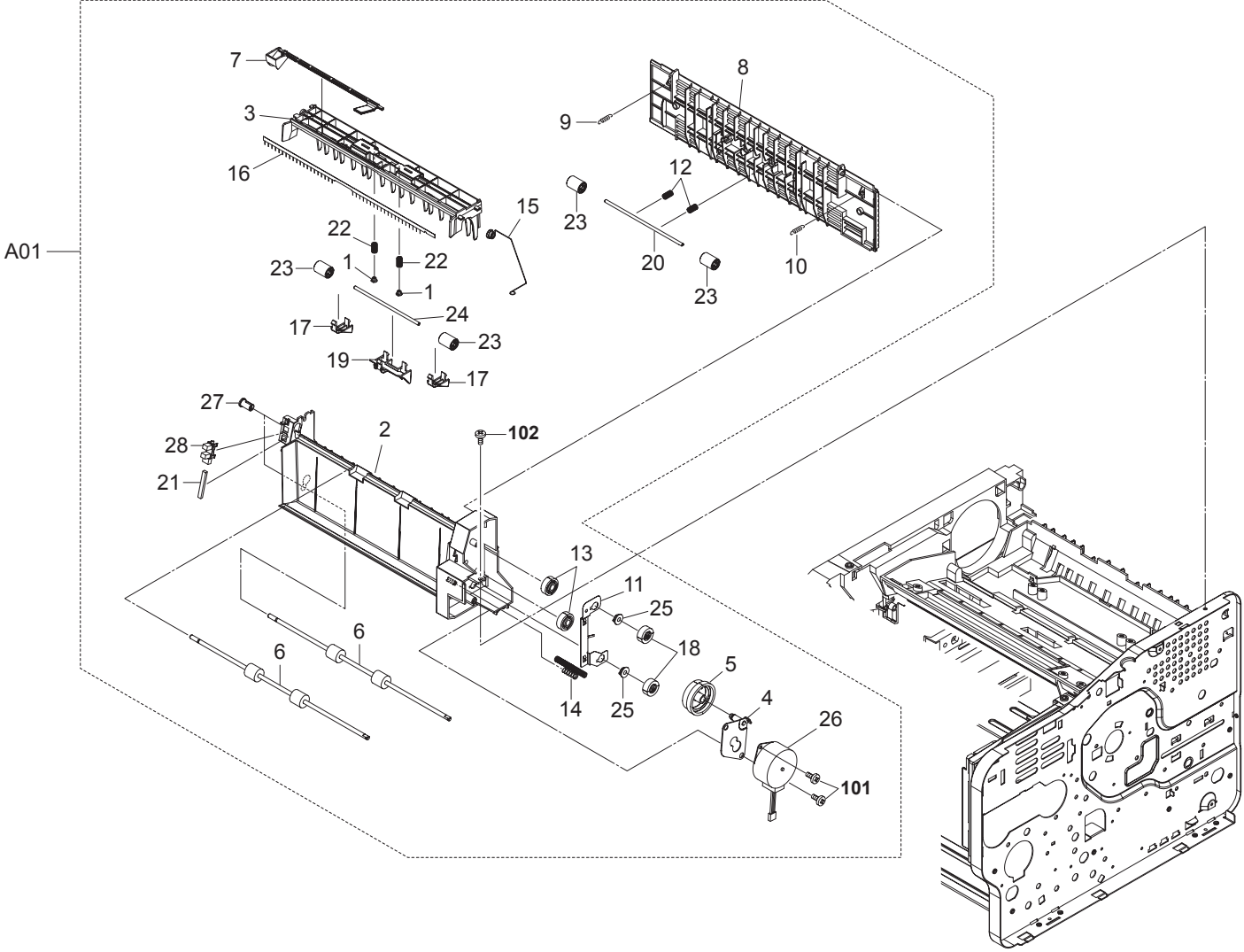

FIG. 13 Paper Exit (FS-3900/4000DN)

2F8/2F9/2GA

SP	Ref. No.	Part.No.	Alternative.	Description	Quantity		
					120	230	240
⊙	A01	302F994020	2F994020	FD ASSY	1	1	1
	1	*2FM04150	5MVM163DN005	CAP SPRING	2	2	2
	2	*302F928020	2F928020	GUIDE VERTICAL 35	1	1	1
	3	*302F928030	2F928030	GUIDE EJECT 35	1	1	1
	4	*302F928040	2F928040	PLATE MOTOR	1	1	1
⊙	5	*302F928050	2F928050	GEAR Z66HZ36H	1	1	1
⊙	6	*302F928070	2F928070	ROLLER FD UP	2	2	2
⊙	7	*302F928100	2F928100	ACTUATOR OVERFLOW	1	1	1
⊙	8	*302F928120	2F928120	COVER FD	1	1	1
	9	*302F928130	2F928130	SPRING COVER FD L	1	1	1
	10	*302F928140	2F928140	SPRING COVER FD R	1	1	1
	11	*302F928150	2F928150	EARTH PLATE ROLLER 35	1	1	1
	12	*302F928170	2F928170	SPRING PULLEY	2	2	2
⊙	13	*302F928180	2F928180	GEAR Z20H	2	2	2
	14	*302F928190	2F928190	SPRING EARTH A	1	1	1
	15	*302F928230	2F928230	SPRING DISCHARGER	1	1	1
⊙	16	*302F928240	2F928240	DISCHARGER FD	1	1	1
	17	*302F928250	2F928250	GUIDE CORRUGATION	2	2	2
⊙	18	*302F928260	2F928260	GEAR Z18H FD35	2	2	2
	19	*302F928270	2F928270	GUIDE PULLEY	1	1	1
	20	*302F928290	2F928290	SHAFT EJECT PULLEY	1	1	1
	21	*302F928300	2F928300	SPONGE EXIT	1	1	1
	22	*302F928310	2F928310	SPRING PULLEY 35	2	2	2
⊙	23	*302F929050	2F929050	PULLEY FEED DU	4	4	4
	24	*302F929060	2F929060	SHAFT FEED DU	1	1	1
⊙	25	*302F929140	2F929140	BUSH DU	2	2	2
⊙	26	*302F944130	2F944130	MOTOR EJECT	1	1	1
⊙	27	*302FV02470	2FV02470	BUSH FD	2	2	2
⊙	28	*7NXTLP1255++H01	NX046610	SENSOR OPT.	1	1	1

SP	Ref. No.	Part.No.	Alternative.	Description	Quantity		
					120	230	240
	101	5MBTPB3008PW++R	B1A63080	BIND T.T SCREW(+)/ M3 X 8 CRFREE P-T			
	102	B1A54080		+BIND TAP-TITE S SCREW M4X08			

- Parts with "*" are component parts or sub-assemblies of the assembly appearing immediately above them.
- Parts with "⊙" indicates the spare parts.

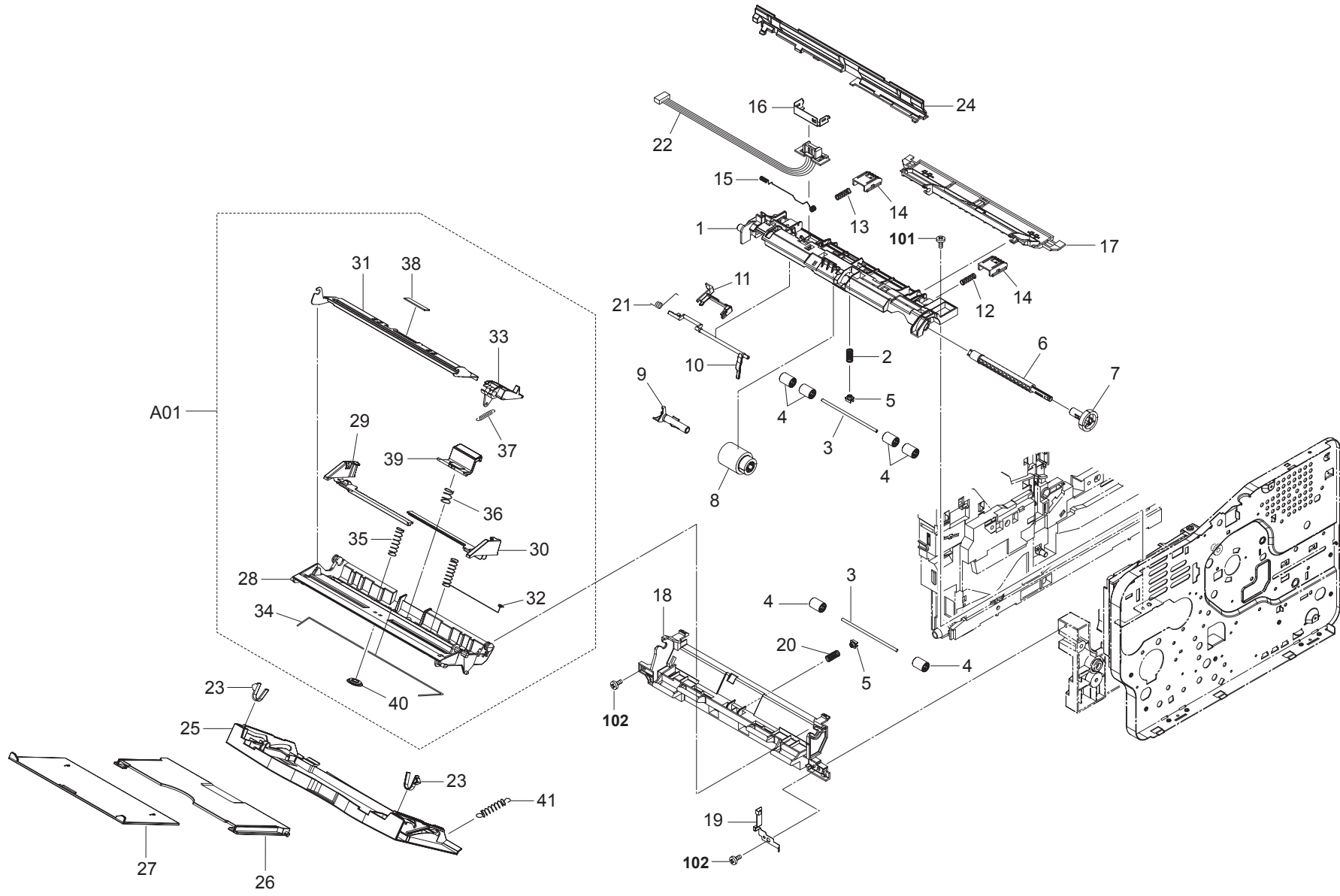

FIG. 14 MPF

2F8/2F9/2GA

SP	Ref. No.	Part.No.	Alternative.	Description	Quantity		
					120	230	240
	1	302F908020	2F908020	FRAME MPF	1	1	1
	2	302F908380	2F908380	SP PULLEY FEED	1	1	1
	3	302F929060	2F929060	SHAFT FEED DU	2	2	2
	4	302F929050	2F929050	PULLEY FEED DU	6	6	6
⊙	5	5MVX111DN002	3B706590	BUSH SP PULLEY	2	2	2
	6	302F908110	2F908110	SHAFT FEED MPF	1	1	1
	7	302F908130	2F908130	GEAR MPF Z30	1	1	1
⊙	8	5AAVROLL+051	2CL16130	ROLLER M/P ASSY	1	1	1
	9	5MVX422DN007	2BS02370	HOLDER FEED M/P	1	1	1
⊙	10	302F908120	2F908120	ACTUATOR MPF A	1	1	1
⊙	11	302F908210	2F908210	ACTUATOR MPF B	1	1	1
	12	302F908330	2F908330	SPRING LEVER LOCK R	1	1	1
	13	302F908320	2F908320	SPRING LEVER LOCK L	1	1	1
⊙	14	302F908340	2F908340	LOCK DLP	2	2	2
	15	302F908230	2F908230	SPRING EARTH CONNECTOR	1	1	1
	16	302F908220	2F908220	BKT CONECTOR	1	1	1
	17	302F924060	2F924060	GUIDE REGIST UP	1	1	1
	18	302F908010	2F908010	GUIDE TURN MPF	1	1	1
	19	302F908170	2F908170	PLATE EARTH BOTTOM	1	1	1
	20	302F908150	2F908150	SP PULLEY TURN	1	1	1
	21	302F908280	2F908280	SP ACTUATOR MPF	1	1	1
	22	302F846070	2F846070	CONN.CORD ASSY S03048	1	1	1
⊙	23	302F908200	2F908200	LOCK COVER	2	2	2
⊙	24	302F908180	2F908180	COVER FRONT MPF	1	1	1
⊙	25	302F908030	2F908030	COVER MPF	1	1	1
⊙	26	302F908040	2F908040	TRAY MPF MID	1	1	1
⊙	27	302F908050	2F908050	TRAY MPF TOP	1	1	1
⊙	A01	302F994080	2F994080	BASE MPF ASSY	1	1	1
	28	*302F908060	2F908060	BASE MPF	1	1	1
	29	*302F908070	2F908070	GUIDE SIDE MPF L	1	1	1
	30	*302F908080	2F908080	GUIDE SIDE MPF R	1	1	1
	31	*302F908090	2F908090	PLATE BOTTOM MPF	1	1	1
	32	*302F908100	2F908100	SPRING BOTTOM MPF R	1	1	1
	33	*302F908240	2F908240	BRACKET BOTTOM	1	1	1
	34	*302F908260	2F908260	WIRE BASE MPF	1	1	1
	35	*302F908270	2F908270	SP BOTTOM MPF L	1	1	1
	36	*302F908290	2F908290	SP SEPARATOR MPF	1	1	1
	37	*302F908300	2F908300	SPRING LOCK MPF	1	1	1
	38	*302F908310	2F908310	PAD FRICTION MPF	1	1	1
⊙	39	*302F994070	2F994070	SEPARATOR MP ASSY	1	1	1
	40	*5MVG127DH001	2B700380	GEAR MANUAL	1	1	1
	41	302F908350	2F908350	SP COVER MPF	1	1	1

SP	Ref. No.	Part.No.	Alternative.	Description	Quantity		
					120	230	240
	101	B1A54080		+BIND TAP-TITE S SCREW M4X08			
	102	5MBTPB4010PW++R	B1A64100	BIND T.T SCREW(+)/ M4 X 10 CRFREE P-T			

- Parts with "*" are component parts or sub-assemblies of the assembly appearing immediately above them.
- Parts with "⊙" indicates the spare parts.

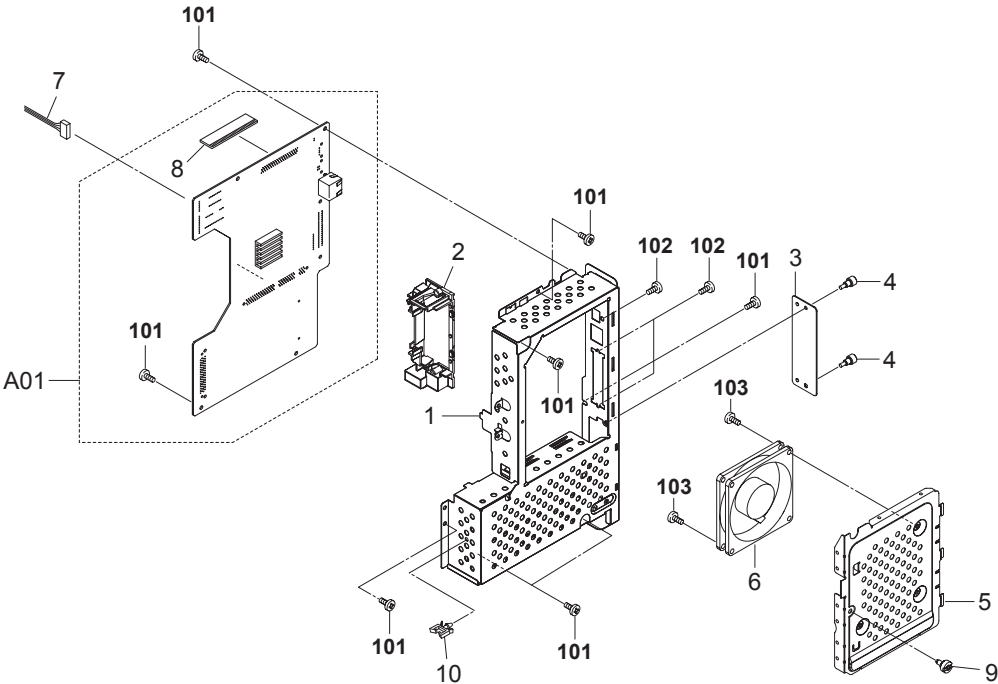

FIG. 15 Controller Box

2F8/2F9/2GA

SP	Ref. No.	Part.No.	Alternative.	Description	Quantity		
					120	230	240
	1	302F939010	2F939010	BOX CONTROLLER (FS-3900/4000DN)	1	1	1
	1	302F839010	2F839010	BOX CONTROLLER (FS-2000D)	1	1	1
	2	302F939020	2F939020	GUIDE OPTION	1	1	1
⊙	3	302F939070	2F939070	PLATE OPTION	1	1	1
⊙	4	5MMT263SN012++R	2D903100	SCREW OP	2	2	2
	5	302F939030	2F939030	PLATE SHIELD	1	1	1
⊙	6	302F944190	2F944190	FAN MAIN PWB 80 (FS-3900/4000DN)	1	1	1
	7	302F846270	2F846270	CONN.CORD ASSY S03117	1	1	1
⊙	A01	302F801280	2F801280	P.W.BOARD ASSY MAIN WITH SOFTWARE (FS-2000D)	1	1	1
⊙	A01	302F901100	2F901100	P.W.BOARD ASSY MAIN WITH SOFTWARE (FS-3900DN)	1	1	1
⊙	A01	302GA01100	2GA01100	P.W.BOARD ASSY MAIN WITH SOFTWARE (FS-4000DN)	1	1	1
⊙	8	*302F801320	2F801320	P.W.BOARD ASSY DIMM WITH SOFTWARE (FS-2000D)	1	1	1
⊙	8	*302F901140	2F901140	P.W.BOARD ASSY DIMM WITH SOFTWARE (FS-3900/4000DN)	1	1	1
	9	302F939080	2F939080	SCREW BOX	1	1	1
	10	M70AK010		WIRE SADDLE	1	1	1

SP	Ref. No.	Part.No.	Alternative.	Description	Quantity		
					120	230	240
	101	5MBTPB3006TW++R	B1A53060	BIND T.T SCREW(+)/ M3 X 6 CRFREE S-T			
	102	5MBSP3006NW++R	B0B03060	PAN HEAD SCREW(+)/ M3 X 6 CRFREE			
	103	5MBTPB3020TW++R	B1A53200	BIND T.T SCREW(+)/ M3 X 20 CRFREE S-T			

- Parts with "*" are component parts or sub-assemblies of the assembly appearing immediately above them.
- Parts with "⊙" indicates the spare parts.

FIG. 16 Parts Package

2F8/2F9/2GA

SP	Ref. No.	Part.No.	Alternative.	Description	Quantity		
					120	230	240
⊙		302F880010	2F880010	PACKING ASSY (FS-2000D)	1	1	1
⊙		302F980060	2F980060	PACKING ASSY (FS-3900DN)	1	1	1
⊙		302GA80010	2GA80010	PACKING ASSY (FS-4000DN)	1	1	1

- Parts with "*" are component parts or sub-assemblies of the assembly appearing immediately above them.
- Parts with "⊙" indicates the spare parts.

INDEX

2F8/2F9/2GA-1

SP	Part.No.	Alternative.	Description	Fig.No.
	2BC06510		BUSHING 8	6
	2BC06910		STOPPER 6	6
	2BC06980		STOPPER 5	6,11
⊙	2BG22960		BUSH 6	5,6
⊙	2BG22970		BUSH 6 EW	6
⊙	2BG22980		BUSH 8	6
	2BZ06070	5MVM686SH001	DIAL CASSETTE	4
	2C906260		SHEET ABSORBER	2
	2C927140		SWITCH CONTAINER	2
	2DC27410		AC CORD 120 ASSY	3
⊙	2FM02180	5MVX221DN020	BUSH REGIST C	6
	2FM04150	5MVM163DN005	CAP SPRING	10,13
	302F325010	2F325010	STUD SCREW M3	9
	302F724260	2F724260	SPRING REGIST C	6
	302F725400	2F725400	CAP SEPARATOR	9
	302F725430	2F725430	STATIC ELIMINATOR HEAT ROLLER	9
	302F725500	2F725500	SHEET FUSER HEATER	9
	302F731010	2F731010	PLATE DRIVE B	11
⊙	302F801280	2F801280	P.W.BOARD ASSY MAIN WITH SOFTWARE	15
⊙	302F801320	2F801320	P.W.BOARD ASSY DIMM WITH SOFTWARE	15
⊙	302F801340	2F801340	P.W.BOARD ASSY CONNECT-L	3
⊙	302F801350	2F801350	P.W.BOARD ASSY CONNECT-R	11
⊙	302F801420	2F801420	P.W.BOARD ASSY ENGINE WITH SOFTWARE	6
	302F802010	2F802010	GUIDE CASSETTE	2
⊙	302F804030	2F804030	STOPPER FD	1
⊙	302F804100	2F804100	COVER CABLE	1
⊙	302F804110	2F804110	SPONGE TOP TRAY	1
⊙	302F804120	2F804120	SPONGE TOP TRAY REAR	1
⊙	302F804130	2F804130	SPONGE TOP TRAY SIDE	1
	302F806010	2F806010	GUIDE FEED UP	5
⊙	302F809010	2F809010	SPRING BOTTOM	4
⊙	302F809020	2F809020	LOCK BOTTOM	4
	302F809040	2F809040	COVER LIFT GEAR	4
	302F809050	2F809050	LABEL DIAL	4
	302F809060	2F809060	LABEL OPERATION	4
	302F809070	2F809070	PLATE BOTTOM	4
	302F809080	2F809080	STOPPER A5	4
	302F825010	2F825010	FRAME FUSER UP	9
	302F825020	2F825020	FRAME FUSER LOW	9
	302F825030	2F825030	GUIDE DU	10
	302F825040	2F825040	GUIDE EXIT UP	9
⊙	302F825050	2F825050	ROLLER HEAT	9
⊙	302F825060	2F825060	PLATE CORD	9
⊙	302F825070	2F825070	ACTUATOR EXIT	9
	302F825080	2F825080	PLATE EARTH FUSER	9
	302F825090	2F825090	PLATE EARTH PRESS	9
⊙	302F825120	2F825120	HEATER LAMP E	9
⊙	302F825130	2F825130	HEATER LAMP U	9
	302F825150	2F825150	SPRING PRESS	9
⊙	302F825160	2F825160	COVER REAR	10

SP	Part.No.	Alternative.	Description	Fig.No.
⊙	302F825170	2F825170	ROLLER EXIT	9
	302F825180	2F825180	SPRING EARTH FUSER	9
⊙	302F828030	2F828030	GEAR Z66HZ25H	13
	302F828040	2F828040	GUIDE VERTICAL 30	13
	302F828060	2F828060	GUIDE EJECT 30	13
	302F828070	2F828070	EARTH PLATE EJECT	13
	302F828120	2F828120	FILM EJECT	13
	302F828130	2F828130	SPRING DISCHARGER	13
⊙	302F831040	2F831040	GEAR DU	11
⊙	302F831060	2F831060	BUSH DRUM	11
⊙	302F834040	2F834040	LABEL JAM OPERATION	1
	302F839010	2F839010	BOX CONTROLLER	15
⊙	302F844030	2F844030	MOTOR DRUM	11
⊙	302F844040	2F844040	FAN R 80	2
⊙	302F844050	2F844050	FAN L 80	3
⊙	302F845010	2F845010	SWITCHING REGULATOR (U)	3
⊙	302F845020	2F845020	SWITCHING REGULATOR (E)	3
	302F846040	2F846040	CONN.CORD ASSY S03045	3
	302F846050	2F846050	CONN.CORD ASSY S03046	3
	302F846060	2F846060	CONN.CORD ASSY S03047	3
	302F846070	2F846070	CONN.CORD ASSY S03048	14
	302F846080	2F846080	CONN.CORD ASSY S03050	6
	302F846090	2F846090	CONN.CORD ASSY S03051	6
	302F846100	2F846100	CONN.CORD ASSY S03052	6
	302F846110	2F846110	CONN.CORD ASSY S03054	6
	302F846120	2F846120	CONN.CORD ASSY S03055	6
	302F846130	2F846130	CONN.CORD ASSY S03056	6
	302F846140	2F846140	CONN.CORD ASSY S03060	6
	302F846150	2F846150	CONN.CORD ASSY S03061	6
	302F846200	2F846200	CONN.CORD ASSY S03068	3
⊙	302F846210	2F846210	CONN.CORD ASSY S03072	6
⊙	302F846220	2F846220	CONN.CORD ASSY S03076	9
⊙	302F846230	2F846230	CONN.CORD ASSY S03077	9
	302F846240	2F846240	CONN.CORD ASSY S03099	11
	302F846270	2F846270	CONN.CORD ASSY S03117	15
	302F846280	2F846280	CONN.CORD ASSY S03119	3
	302F846290	2F846290	CONN.CORD ASSY S03122	6
	302F846320	2F846320	CONN.CORD ASSY S03130	3
	302F846330	2F846330	CONN.CORD ASSY S03172	3
	302F846340	2F846340	CONN.CORD ASSY S03174	11
	302F846350	2F846350	CONN.CORD ASSY S03175	2
	302F846380	2F846380	CONN.CORD ASSY S03183	9
⊙	302F880010	2F880010	PACKING ASSY	16
⊙	302F893010	2F893010	LK-310	2
⊙	302F893030	2F893030	FK-310 (E)	9
⊙	302F893040	2F893040	FK-310 (U)	9
⊙	302F893050	2F893050	CT-310 (E)	4
⊙	302F893060	2F893060	CT-310 (U)	4

• Parts with "⊙" indicates the spare parts.

SP	Part.No.	Alternative.	Description	Fig.No.	SP	Part.No.	Alternative.	Description	Fig.No.
	302F894010	2F894010	FD ASSY	13		302F906030	2F906030	GEAR FEED Z26H	5
	302F894020	2F894020	KEY BOARD ASSY (E)	1		302F906060	2F906060	HOLDER FEED	5
	302F894030	2F894030	COVER TOP ASSY	1		302F906110	2F906110	PIN FEED ROLL	5
	302F894040	2F894040	FEED HOLDER ASSY	5		302F906120	2F906120	SPRING PICK UP	5
	302F894050	2F894050	LID TOP ASSY	1		302F906170	2F906170	JOINT PICKUP A	5
	302F901100	2F901100	P.W.BOARD ASSY MAIN WITH SOFTWARE	15		302F906180	2F906180	JOINT PICKUP B	5
	302F901140	2F901140	P.W.BOARD ASSY DIMM WITH SOFTWARE	15		302F906190	2F906190	GUIDE FEED L	5
	302F901150	2F901150	P.W.BOARD ASSY CONNECT-R	11		302F906200	2F906200	GUIDE FEED R	5
	302F901160	2F901160	P.W.BOARD ASSY ENGINE WITH SOFTWARE	6		302F906220	2F906220	STOPPER SENSOR	5
	302F902010	2F902010	FRAME LEFT	2		302F906230	2F906230	PULLEY FEED ASSY	5
	302F902020	2F902020	FRAME RIGHT	2		302F906240	2F906240	PULLEY PICKUP ASSY	5
	302F902030	2F902030	FRAME CENTER	2		302F906270	2F906270	SHAFT FEED L	5
	302F902040	2F902040	PLATE BOTTOM	2		302F906280	2F906280	GEAR FEED Z30H	5
	302F902050	2F902050	GUIDE CASSETTE	2		302F906290	2F906290	SHAFT FEED R	5
	302F902060	2F902060	GUIDE DLP R	2		302F906300	2F906300	COVER WIRE	5
	302F902070	2F902070	DUCT RIGHT FRAME	2		302F908010	2F908010	GUIDE TURN MPF	14
	302F902100	2F902100	PLATE POWER PWB	3		302F908020	2F908020	FRAME MPF	14
	302F902110	2F902110	SHEET POWER PWB	3		302F908030	2F908030	COVER MPF	14
	302F902160	2F902160	CONTACT MAIN	3		302F908040	2F908040	TRAY MPF MID	14
	302F902170	2F902170	LEVER EF	3		302F908050	2F908050	TRAY MPF TOP	14
	302F902180	2F902180	SPRING LEVER EF	3		302F908060	2F908060	BASE MPF	14
	302F902220	2F902220	COOLING DUCT LEFT	2		302F908070	2F908070	GUIDE SIDE MPF L	14
	302F902230	2F902230	COOLING DUCT RIGHT	2		302F908080	2F908080	GUIDE SIDE MPF R	14
	302F902240	2F902240	COVER WIRE A	3		302F908090	2F908090	PLATE BOTTOM MPF	14
	302F902250	2F902250	MOUNT FAN MOTOR	3		302F908100	2F908100	SPRING BOTTOM MPF R	14
	302F902260	2F902260	PLATE EARTH DRUM	3		302F908110	2F908110	SHAFT FEED MPF	14
	302F902270	2F902270	CONTACT BIAS	3		302F908120	2F908120	ACTUATOR MPF A	14
	302F902280	2F902280	PLATE EARTH BOTTOM	3		302F908130	2F908130	GEAR MPF Z30	14
	302F902310	2F902310	MOUNT INTERLOCK SW	3		302F908150	2F908150	SP PULLEY TURN	14
	302F902320	2F902320	PLATE EARTH FEED	3		302F908170	2F908170	PLATE EARTH BOTTOM	14
	302F902330	2F902330	PLATE HEAT SINK	3		302F908180	2F908180	COVER FRONT MPF	14
	302F902340	2F902340	SHEET BIAS	3		302F908200	2F908200	LOCK COVER	14
	302F902380	2F902380	COOLING DUCT LEFT A	2		302F908210	2F908210	ACTUATOR MPF B	14
	302F902390	2F902390	PLATE EARTH RAIL	3		302F908220	2F908220	BKT CONECTOR	14
	302F902400	2F902400	PLATE EARTH MAIN	3		302F908230	2F908230	SPRING EARTH CONNECTOR	14
	302F902410	2F902410	SPRING EARTH FAN	3		302F908240	2F908240	BRACKET BOTTOM	14
	302F902420	2F902420	LOCK COVER TOP R	2		302F908260	2F908260	WIRE BASE MPF	14
	302F902430	2F902430	LOCK COVER TOP L	3		302F908270	2F908270	SP BOTTOM MPF L	14
	302F902450	2F902450	SHEET WIRE	3		302F908280	2F908280	SP ACTUATOR MPF	14
	302F902480	2F902480	SPONGE MULTI	2		302F908290	2F908290	SP SEPARATOR MPF	14
	302F904030	2F904030	STOPPER FD	1		302F908300	2F908300	SPRING LOCK MPF	14
	302F904060	2F904060	COVER LEFT	1		302F908310	2F908310	PAD FRICTION MPF	14
	302F904070	2F904070	COVER RIGHT	1		302F908320	2F908320	SPRING LEVER LOCK L	14
	302F904080	2F904080	COVER SIDE	1		302F908330	2F908330	SPRING LEVER LOCK R	14
	302F904090	2F904090	COVER CONTROLLER	1		302F908340	2F908340	LOCK DLP	14
	302F904100	2F904100	COVER CABLE	1		302F908350	2F908350	SP COVER MPF	14
	302F904140	2F904140	HINGE SIDE	1		302F908380	2F908380	SP PULLEY FEED	14
	302F904170	2F904170	SPONGE COVER TOP	1		302F909010	2F909010	BASE CASSETTE	4
	302F904180	2F904180	SHEET ATTACHMENT	1		302F909020	2F909020	BASE CASSETTE REAR	4
	302F906010	2F906010	GUIDE FEED UP	5		302F909030	2F909030	LEVER BASE CAS REAR	4

• Parts with "⊙" indicates the spare parts.

SP	Part.No.	Alternative.	Description	Fig.No.	SP	Part.No.	Alternative.	Description	Fig.No.
	302F909040	2F909040	SPRING BASE CAS REAR	4		302F924140	2F924140	SPRING EARTH	6
	302F909050	2F909050	CURSOR LEFT	4	⊙	302F924150	2F924150	ACTUATOR REGIST	6
	302F909060	2F909060	CURSOR RIGHT	4	⊙	302F924160	2F924160	BUSH REGIST	6
⊙	302F909070	2F909070	LEVER SIDE CURSOR	4	⊙	302F924180	2F924180	BUSH TRANSFER L	6
	302F909080	2F909080	CURSOR END	4	⊙	302F924190	2F924190	BUSH TRANSFER R	6
⊙	302F909090	2F909090	LEVER END CURSOR	4	⊙	302F924210	2F924210	GEAR TC Z22H	6
	302F909100	2F909100	PLATE BOTTOM	4	⊙	302F924220	2F924220	ACTUATOR DU	6
	302F909110	2F909110	WORKPLATE LIFT	4	⊙	302F924240	2F924240	LEVER RELEASE FUSER R	6
	302F909120	2F909120	SHAFT WORKPLATE	4		302F924270	2F924270	SPRING REGIST SENSOR	6
⊙	302F909130	2F909130	GEAR LIFT Z64	4		302F924280	2F924280	SPRING MAIN CHARGE	6
⊙	302F909140	2F909140	GEAR JOINT Z16	4		302F924320	2F924320	SPRING RELEASE DLP R	6
⊙	302F909150	2F909150	LEVER INDICATOR	4		302F924340	2F924340	SPRING BIAS CHARGE	6
⊙	302F909160	2F909160	BUSH LIFT 6	4		302F924380	2F924380	SPRING RELEASE FUSER R	6
⊙	302F909170	2F909170	RETARD ROLLER ASSY	4		302F924390	2F924390	SPRING TC L	6
	302F909180	2F909180	HOLDER RETARD	4		302F924400	2F924400	SPRING TC R	6
	302F909190	2F909190	GUIDE RETARD	4	⊙	302F924430	2F924430	GEAR REGIST Z23H	6
	302F909200	2F909200	SPRING RETARD	4	⊙	302F924460	2F924460	SPRING REGIST R	6
⊙	302F909210	2F909210	PAD BOTTOM	4		302F924470	2F924470	PLATE ENGINE	6
	302F909230	2F909230	COVER LIFT GEAR	4	⊙	302F924480	2F924480	LEVER RELEASE DLP L	6
	302F909240	2F909240	LID CASSETTE	4	⊙	302F924490	2F924490	LEVER RELEASE DLP R	6
	302F909250	2F909250	SPRING SIZE FIX	4		302F924500	2F924500	GUIDE CABLE L	6
	302F909260	2F909260	MARKER INDICATOR	4		302F924510	2F924510	GUIDE CABLE R	6
	302F909270	2F909270	GUIDE PAPER CASSETTE	4		302F924520	2F924520	SP RELEASE TC L	6
	302F909280	2F909280	COVER CASSETTE TOP	4		302F924550	2F924550	PLATE HV	6
	302F909290	2F909290	LABEL DIAL A6	4		302F924560	2F924560	PLATE EARTH R	6
	302F909300	2F909300	LABEL OPERATION	4		302F924570	2F924570	PLATE HIGH MEG EARTH	6
	302F909310	2F909310	LABEL A6	4		302F924580	2F924580	PLATE EARTH M	6
⊙	302F909500	2F909500	GEAR WORM	2		302F924590	2F924590	PLATE SEP CHARGE	6
⊙	302F909510	2F909510	GEAR Z40HZ18	2		302F924600	2F924600	PLATE TC CHARGE	6
⊙	302F909520	2F909520	GEAR Z60Z16	2		302F924620	2F924620	COVER PWB FEED	6
⊙	302F909530	2F909530	GEAR Z50Z16	2		302F924640	2F924640	ROLLER MIDDLE ASSY	6
⊙	302F909540	2F909540	GEAR Z49	2	⊙	302F924650	2F924650	PLATE HV L	6
⊙	302F909550	2F909550	GEAR Z26Z15	2		302F924660	2F924660	PLATE HV R	6
	302F909560	2F909560	SHEET CASSETTE	4		302F924680	2F924680	SPRING SEP EARTH	6
⊙	302F912310	2F912310	COVER DRUM SHUTTER	2	⊙	302F924700	2F924700	GEAR REG Z26H-Z33H	6
⊙	302F912320	2F912320	ARM DRUM SHUTTER	2		302F924720	2F924720	SHEET INSULATOR	6
⊙	302F912330	2F912330	GEAR SHUTTER Z18S	2		302F924730	2F924730	PLATE EARTH ENGINE L	6
⊙	302F912340	2F912340	GEAR SHUTTER Z16S	2		302F924740	2F924740	PLATE EARTH ENGINE R	6
⊙	302F912350	2F912350	LID DRUM SHUTTER	2		302F924750	2F924750	SHAFT GUIDE	6
	302F912360	2F912360	SPRING SHUTTER ARM	2		302F924760	2F924760	PULLEY GUIDE	6
	302F912370	2F912370	SPRING SHUTTER L	2		302F924780	2F924780	SPONGE REGIST	6
⊙	302F924020	2F924020	ROLLER REGIST UP	6		302F924800	2F924800	HIGH MEG	6
	302F924040	2F924040	SHAFT MID	6		302F924810	2F924810	GUIDE FEED LOW	6
	302F924050	2F924050	FRAME FEED	6		302F925010	2F925010	FRAME FUSER UP	9
	302F924060	2F924060	GUIDE REGIST UP	14		302F925020	2F925020	FRAME FUSER LOW	9
	302F924070	2F924070	GUIDE PAPER CHUTE	6		302F925030	2F925030	GUIDE DU	10
⊙	302F924090	2F924090	LEVER EMPTY	6		302F925040	2F925040	GUIDE FACE UP	9
	302F924100	2F924100	GUIDE EARTH	6	⊙	302F925050	2F925050	ROLLER HEAT	9
	302F924120	2F924120	SPRING TC CHARGE	6	⊙	302F925060	2F925060	ACTUATOR SOL	9
	302F924130	2F924130	SPRING SEP CHARGE	6	⊙	302F925080	2F925080	GEAR IDLE A Z29	9

• Parts with "⊙" indicates the spare parts.

SP	Part.No.	Alternative.	Description	Fig.No.	SP	Part.No.	Alternative.	Description	Fig.No.
⊙	302F925090	2F925090	GEAR INPUT	9		302F925770	2F925770	SPRING EARTH HEAT	9
⊙	302F925100	2F925100	GEAR HEAT Z46	9		302F925780	2F925780	SPRING DU	10
⊙	302F925130	2F925130	GEAR IDLE Z36	9		302F925800	2F925800	SPRING SEPARATOR	9
⊙	302F925140	2F925140	GEAR EXIT Z21	9,10		302F925820	2F925820	SPRING EARTH	9
	302F925160	2F925160	PULLEY FACE UP	10		302F925830	2F925830	SHEET FUSER A	9
⊙	302F925170	2F925170	ACTUATOR EXIT	9		302F925870	2F925870	SPRING RAIL SW	2
⊙	302F925180	2F925180	ACTUATOR DU	10		302F925880	2F925880	LID FUSER	9
	302F925190	2F925190	SPRING PRESS	9	⊙	302F925900	2F925900	CAP SPRING EXIT	9
	302F925200	2F925200	PLATE CORD	9		302F925920	2F925920	PULLEY EXIT PFA	9
	302F925210	2F925210	PLATE EARTH FUSER	9		302F925930	2F925930	PULLEY SWITCH BACK	10
	302F925230	2F925230	PLATE EARTH PRESS	9		302F928020	2F928020	GUIDE VERTICAL 35	13
	302F925240	2F925240	PLATE PRESS	9		302F928030	2F928030	GUIDE EJECT 35	13
	302F925250	2F925250	PLATE EARTH EXIT	9		302F928040	2F928040	PLATE MOTOR	13
	302F925260	2F925260	PLATE EARTH FACE UP	10	⊙	302F928050	2F928050	GEAR Z66HZ36H	13
⊙	302F925270	2F925270	ROLLER PRESS	9	⊙	302F928060	2F928060	GEAR Z18H FD	13
⊙	302F925280	2F925280	BEARING HEAT	9	⊙	302F928070	2F928070	ROLLER FD UP	13
⊙	302F925290	2F925290	ROLLER EXIT	9	⊙	302F928100	2F928100	ACTUATOR OVERFLOW	13
⊙	302F925300	2F925300	ROLLER FACE UP	10	⊙	302F928120	2F928120	COVER FD	13
	302F925310	2F925310	SHAFT EXIT	9		302F928130	2F928130	SPRING COVER FD L	13
	302F925320	2F925320	MOUNT GEAR	9		302F928140	2F928140	SPRING COVER FD R	13
	302F925340	2F925340	SPRING EXIT	9		302F928150	2F928150	EARTH PLATE ROLLER 35	13
	302F925350	2F925350	SPRING FACE UP	10		302F928170	2F928170	SPRING PULLEY	13
	302F925360	2F925360	SPRING ACTUATOR EXIT	9	⊙	302F928180	2F928180	GEAR Z20H	13
	302F925370	2F925370	SPRING ACTUATOR DU	10		302F928190	2F928190	SPRING EARTH A	13
	302F925390	2F925390	STOPPER HEAT ROLLER	9		302F928230	2F928230	SPRING DISCHARGER	13
⊙	302F925400	2F925400	HEATER LAMP E	9	⊙	302F928240	2F928240	DISCHARGER FD	13
⊙	302F925410	2F925410	HEATER LAMP U	9		302F928250	2F928250	GUIDE CORRUGATION	13
⊙	302F925430	2F925430	THERMISTOR ASSY	9	⊙	302F928260	2F928260	GEAR Z18H FD35	13
⊙	302F925440	2F925440	INNER RAIL R	10		302F928270	2F928270	GUIDE PULLEY	13
⊙	302F925450	2F925450	INNER RAIL L	10		302F928290	2F928290	SHAFT EJECT PULLEY	13
⊙	302F925460	2F925460	OUTER RAIL R	2		302F928300	2F928300	SPONGE EXIT	13
⊙	302F925470	2F925470	OUTER RAIL L	3		302F928310	2F928310	SPRING PULLEY 35	13
⊙	302F925480	2F925480	PULLEY RAIL DOUBLE	2,3		302F929010	2F929010	BASE DU	12
⊙	302F925500	2F925500	PIN PULLEY	2		302F929020	2F929020	GUIDE DU LOW	12
⊙	302F925510	2F925510	COVER REAR	10	⊙	302F929030	2F929030	ROLLER DU	12
	302F925520	2F925520	GUIDE EXIT UP	9	⊙	302F929040	2F929040	ACTUATOR PE	12
	302F925530	2F925530	RING BEARING	9	⊙	302F929050	2F929050	PULLEY FEED DU	13,14
	302F925540	2F925540	GUIDE EXIT LOW	9		302F929060	2F929060	SHAFT FEED DU	10,13,14
⊙	302F925550	2F925550	LOCK FUSER	10		302F929070	2F929070	SPRING PULLEY FEED	12
	302F925560	2F925560	SPRING LOCK	10		302F929080	2F929080	SPRING PE RELEASE	12
⊙	302F925570	2F925570	BUSH EXIT	9		302F929090	2F929090	WIRE LIFT DU	12
	302F925610	2F925610	PIN MOUNT GEAR	9	⊙	302F929100	2F929100	PULLEY P25 DU	12
⊙	302F925650	2F925650	THERMISTOR ASSY	9	⊙	302F929110	2F929110	GEAR Z18S-P25	12
⊙	302F925660	2F925660	BUSHING HEAT ROLLER	9	⊙	302F929120	2F929120	BELT DU	12
	302F925710	2F925710	GUIDE CHANGE	9	⊙	302F929140	2F929140	BUSH DU	10,12,13
	302F925720	2F925720	CAP SEPARATOR	9	⊙	302F929150	2F929150	LEVER LIFT DU L	12
	302F925730	2F925730	COVER CORD	9	⊙	302F929160	2F929160	LEVER LIFT DU R	12
⊙	302F925740	2F925740	LEVER FUSER RELEASE	10		302F929170	2F929170	SPRING DU LIFT	12
	302F925750	2F925750	SPRING FUSER RELEASE	10		302F929180	2F929180	HOLDER DU PULLEY	12
	302F925760	2F925760	PLATE RAIL FIX	10	⊙	302F929190	2F929190	BUSH PE	12

• Parts with "⊙" indicates the spare parts.

SP	Part.No.	Alternative.	Description	Fig.No.	SP	Part.No.	Alternative.	Description	Fig.No.
⊙	302F929200	2F929200	LEVER DU RELEASE	12	⊙	302F931590	2F931590	GEAR Z191H	11
	302F929220	2F929220	PLATE EARTH DU	12	⊙	302F931600	2F931600	CLUTCH DLP	2
	302F929240	2F929240	SPRING EARTH DU	12		302F934020	2F934020	LABEL FUSER OPERATION	9
	302F929250	2F929250	SHAFT DU LOW	12	⊙	302F934080	2F934080	LABEL JAM OPERATION	1
	302F929260	2F929260	PULLEY DU LOW	12	⊙	302F934100	2F934100	LABEL INSTALL DLP	1
	302F929270	2F929270	SEAL HOLDER	12		302F939010	2F939010	BOX CONTROLLER	15
	302F929280	2F929280	SEAL HOLDER B	12		302F939020	2F939020	GUIDE OPTION	15
⊙	302F931020	2F931020	GEAR Z77H	11		302F939030	2F939030	PLATE SHIELD	15
⊙	302F931030	2F931030	GEAR Z70H	11	⊙	302F939070	2F939070	PLATE OPTION	15
⊙	302F931040	2F931040	GEAR Z90H Z30H	11		302F939080	2F939080	SCREW BOX	15
⊙	302F931050	2F931050	GEAR Z48H	11	⊙	302F944010	2F944010	MOTOR MAIN	11
⊙	302F931060	2F931060	GEAR Z46H	11	⊙	302F944030	2F944030	CLUTCH MID FEED	11
⊙	302F931070	2F931070	GEAR Z37S	11	⊙	302F944040	2F944040	CLUTCH DUPLEX	11
⊙	302F931080	2F931080	GEAR Z45S	11	⊙	302F944050	2F944050	CLUTCH CASSETTE	11
⊙	302F931090	2F931090	GEAR Z30S	11	⊙	302F944060	2F944060	SOLENOID MPF	11
⊙	302F931100	2F931100	GEAR Z34S	11	⊙	302F944070	2F944070	SOLENOID DLP	2
⊙	302F931110	2F931110	GEAR Z95H Z28H	11	⊙	302F944080	2F944080	PHOTO INTERRUPTER	5
⊙	302F931130	2F931130	GEAR REGIST Z28H	11	⊙	302F944090	2F944090	SOLENOID ASSY	9
⊙	302F931160	2F931160	GEAR FEED CLUTCH Z23H	11	⊙	302F944120	2F944120	FAN ENGINE PWB 35	6
⊙	302F931180	2F931180	GEAR MPF Z37S	11	⊙	302F944130	2F944130	MOTOR EJECT	13
⊙	302F931190	2F931190	GEAR DLP Z31H	2	⊙	302F944140	2F944140	FAN R 80	2
⊙	302F931200	2F931200	GEAR DLP Z32H	11	⊙	302F944150	2F944150	FAN L 80	3
	302F931220	2F931220	HOUSING FEED DRIVE B	11	⊙	302F944160	2F944160	FAN POWER PWB 50	3
⊙	302F931230	2F931230	HOLDER DLP CLUTCH	2	⊙	302F944170	2F944170	MOTOR LIFT	2
	302F931250	2F931250	SHAFT REGIST	11	⊙	302F944180	2F944180	MOTOR DRUM B	11
	302F931260	2F931260	SHAFT MID FEED	11	⊙	302F944190	2F944190	FAN MAIN PWB 80	15
⊙	302F931270	2F931270	SPRING FUSER	11	⊙	302F944900	2F944900	CLUTCH REGIST	11
⊙	302F931290	2F931290	GEAR DLP Z24H	11	⊙	302F945010	2F945010	SWITCHING REGULATOR (U)	3
⊙	302F931300	2F931300	GEAR DLP JOINT Z25H	11	⊙	302F945020	2F945020	SWITCHING REGULATOR (E)	3
⊙	302F931310	2F931310	GEAR DLP Z25H	11	⊙	302F946020	2F946020	CONN.CORD ASSY S03071	6
⊙	302F931320	2F931320	HOLDER DU	11	⊙	302F946030	2F946030	CONN.CORD ASSY S03074	9
	302F931340	2F931340	SHAFT CASSETTE	11	⊙	302F946040	2F946040	CONN.CORD ASSY S03075	9
	302F931350	2F931350	JOINT SHAFT CASSETTE	11		302F946050	2F946050	CONN.CORD ASSY S03098	11
⊙	302F931360	2F931360	LEVER MPF LIFT	11		302F946060	2F946060	CONN.CORD ASSY S03100	11
⊙	302F931370	2F931370	CAM MPF LIFT	11		302F946080	2F946080	CONN.CORD ASSY S03153	9
	302F931380	2F931380	SPRING MPF CAM	11		302F946090	2F946090	CONN.CORD ASSY S03154	9
⊙	302F931430	2F931430	GEAR FEED ROLL Z27H	6	⊙	302F980060	2F980060	PACKING ASSY	16
	302F931450	2F931450	SPRING FEED	11	⊙	302F980100	2F980100	ROLLER TRANSFER ASSY	6
	302F931460	2F931460	PIN IDLE FEED	11	⊙	302F993010	2F993010	DK-310	7
	302F931470	2F931470	PLATE DRIVE C	11	⊙	302F993020	2F993020	DV-320 (E)	8
	302F931480	2F931480	PLATE FEED DRIVE	11	⊙	302F993030	2F993030	DV-322 (U)	8
	302F931490	2F931490	BUSH FEED DRIVE	6,11	⊙	302F993040	2F993040	LK-320	2
⊙	302F931500	2F931500	GEAR FEED Z34H	11	⊙	302F993060	2F993060	FK-320 (E)	9
⊙	302F931510	2F931510	GEAR FEED Z23HZ31H	11	⊙	302F993070	2F993070	FK-320 (U)	9
⊙	302F931520	2F931520	GEAR FEED Z25H	11	⊙	302F993080	2F993080	MC-310	7
⊙	302F931530	2F931530	GEAR FEED Z33H	11	⊙	302F993090	2F993090	CT-320 (E)	4
⊙	302F931540	2F931540	GEAR FEED Z31HZ24H	11	⊙	302F993100	2F993100	CT-320 (U)	4
⊙	302F931550	2F931550	GEAR FEED Z36HZ27H	11	⊙	302F994010	2F994010	DU ASSY	12
⊙	302F931560	2F931560	GEAR FEED Z26H Z22S	11	⊙	302F994020	2F994020	FD ASSY	13
	302F931570	2F931570	PIN IDLE FEED A	11	⊙	302F994030	2F994030	FEED DRIVE ASSY	11

• Parts with "⊙" indicates the spare parts.

SP	Part.No.	Alternative.	Description	Fig.No.
⊙	302F994040	2F994040	KEY BOARD ASSY (E)	1
⊙	302F994060	2F994060	FEED HOLDER ASSY	5
⊙	302F994070	2F994070	SEPARATOR MP ASSY	14
⊙	302F994080	2F994080	BASE MPF ASSY	14
⊙	302F994090	2F994090	WASTE BOTTLE ASSY	7
⊙	302F994100	2F994100	EMBLEM ASSY	1
⊙	302F994110	2F994110	DC BRUSH ASSY	6
⊙	302F994120	2F994120	REGIST KIT	6
⊙	302F994130	2F994130	COVER TOP ASSY	1
⊙	302F994140	2F994140	LID TOP ASSY	1
⊙	302FP25110	2FP25110	THERMOSTAT 250V 170C	9
⊙	302FV02470	2FV02470	BUSH FD	10,13
	302FV45020	2FV45020	AC CORD ASSY	3
	302FV45040	2FV45040	AC CORD ASSY	3
⊙	302GA01100	2GA01100	P.W.BOARD ASSY MAIN WITH SOFTWARE	15
⊙	302GA01160	2GA01160	P.W.BOARD ASSY ENGINE WITH SOFTWARE	6
⊙	302GA80010	2GA80010	PACKING ASSY	16
⊙	302GA93010	2GA93010	LK-321	2
⊙	302GA94010	2GA94010	KEY BOARD ASSY (E)	1
⊙	302GA94020	2GA94020	LID TOP ASSY	1
	3CZ02230		PIN,HOOK FULCRUM	2,3
⊙	5AAVR0LL+051	2CL16130	ROLLER M/P ASSY	14
⊙	5FSP03090001+01	SP0A0360	PUSH SWITCH 03 SN	3
⊙	5MMM176CJ007	2BM07330	BUSH METAL	9
	5MMS111SL002	2BY20050	NUT FUSER A	9
⊙	5MMT263SN012++R	2D903100	SCREW OP	15
	5MMW151SD003	2BS06100	SPRING END	4
	5MMW166LD010	2B700070	SPRING LOCK GUIDE	4
	5MMW251LD048	2BS06150	SP STOPPER BOTTOM	4
	5MMW261LJ032	2BM21060	SPRING SOL	9
	5MVG127DB046	2B700190	GEAR CASSETTE	4
	5MVG127DH001	2B700380	GEAR MANUAL	14
⊙	5MVG148XN010	2BR20200	GEAR HEAT Z36	9
	5MVM111RB002	2BR20450	RUBBER PIN	9
⊙	5MVM188XN014	2BS20230	BUSH PRESS	9
	5MVS862XF005	2FP20200	SHEET DISCHARGER	9
	5MVVL611VN06	2FV20100	LABEL FUSER CAUTION	3,9
⊙	5MVX111DN002	3B706590	BUSH SP PULLEY	14
	5MVX111DN003	2A806250	RING STOPPER	5
	5MVX111DN007	2BT11070	STOPPER 3	12
⊙	5MVX221RB014	2BS03110	FOOT	2,3
	5MVX222XN002	2A820530	SEPARATOR	9
	5MVX422DN007	2BS02370	HOLDER FEED M/P	14
⊙	5MVX441XN001	2BR20180	BUSH HEAT L	9
⊙	5MVX441XN002	2BR20190	BUSH HEAT R	9
⊙	7NXTLP1255++H01	NX046610	SENSOR OPT.	9,13
	7YCC02B1003+H01	YC013860	CONNECTOR 292254-2	11
	7YCC02B1005+H01	YC013990	CONNECTOR 2-292254-2	11
	7YCC02B1007+H01	YC014270	CONNECTOR	11
	7YCC02B1111+H01	YC045130	CONNECTOR	11
	M70AK010		WIRE SADDLE	2

• Parts with "⊙" indicates the spare parts.