



*Ecosys FS-1920/3820N/3830N
Laser Printers*

PARTS LIST

Published on January 15, 2004
2FP70770 2FY70770 2FR70770
842FP120 842FY120 842FR120

Contents

Enclosure (01-)	3
Upper Frame Unit (02-)	5
Drive Unit (03-)	8
Controller Box (04-)	10
Paper Feed Unit (05-)	12
Fuser Unit (06-)	15
Drum Unit (07-)	18
Developer Unit	20
Frame MP Assembly (11-)	22
Paper Cassette (13-)	24
Tray MP Assembly (20-)	27
Packing Assemblies (P-)	29
Accessories (A-)	30

Notes on Ordering

- Parts with + are component parts or sub-assemblies of the assembly appearing above them.
- Parts with ++ are component parts of the assembly marked with + immediately above them.
- SP means service parts that are available for ordering.

1. Enclosure (01-)

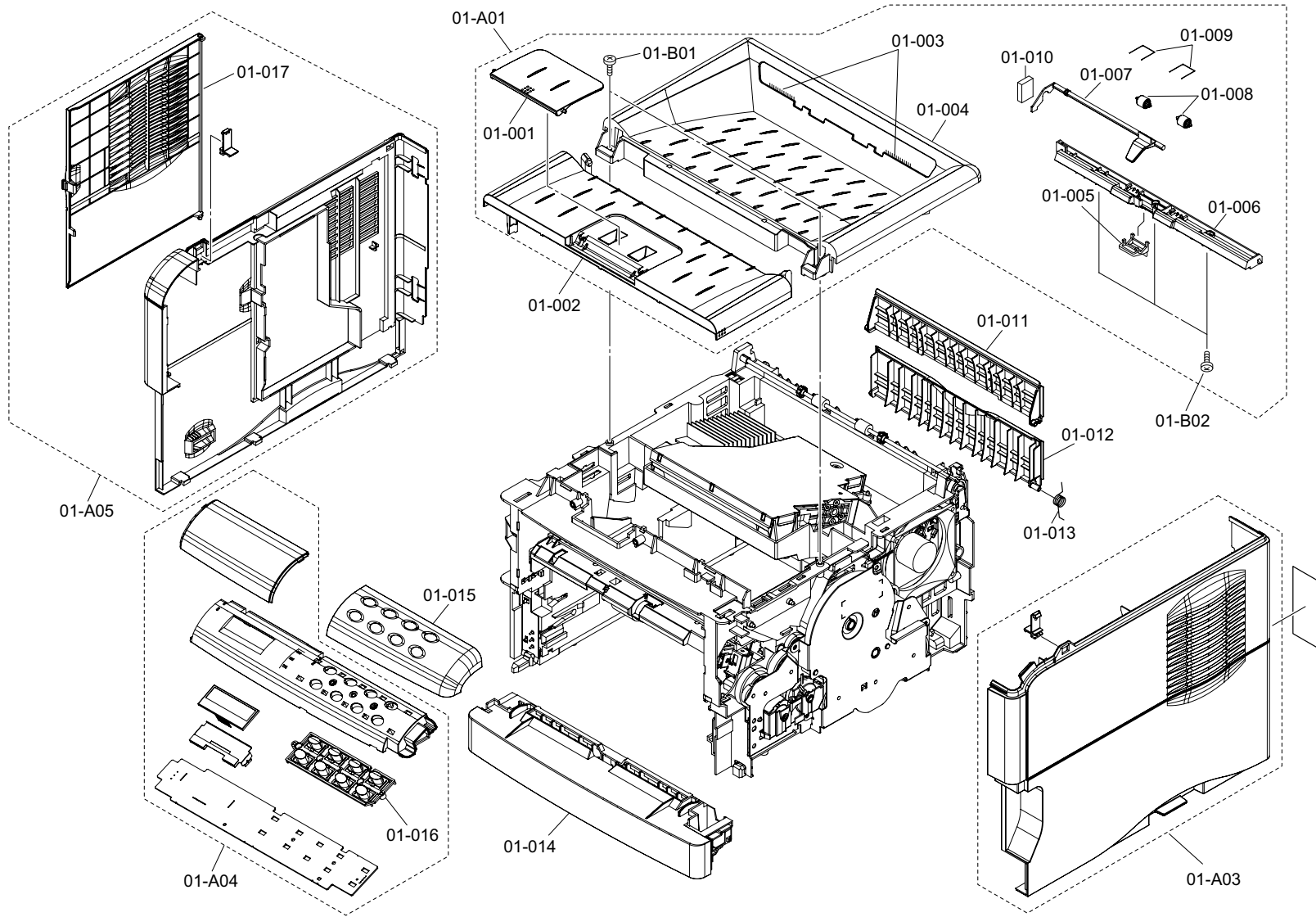

List 1 - Enclosure (01-)

Ref. No.	Part Code	Alternative	Description	Applicable Model	SP	120V	230V	Remarks
01-A01	2FP04040		COVER TOP ASSY	FS-1920	X	-	1	
01-A01	2FP04050		COVER TOP ASSY	FS-1920	X	1	-	
01-A01	2FR04010		COVER TOP ASSY	FS-3820N/3830N	X	-	1	
01-A01	2FR04020		COVER TOP ASSY	FS-3820N/3830N	X	1	-	
01-001	+ 2BS04070	5MVB662SH024	STOPPER FD		-	1	1	
01-002	+ 2B104170	5MVB874CH010	LID TOP	FS-1920	-	-	1	
01-002	+ 2B104180	5MVB874CH011	LID TOP	FS-1920	-	1	-	
01-002	+ 2BR04410	5MVB874CH005	LID TOP CHU	FS-3820N/3830N	-	-	1	
01-002	+ 5MVB874CH007		LID TOP S	FS-3820N/3830N	-	1	-	
01-003	+ 2BP21010	5MVS711XF003	DISCHARGER FD		-	2	2	
01-004	+ 2BS04140	5MVB886CH010	COVER TOP		-	1	1	
01-005	+ 2BS04300	5MVX332DB014	GUIDE STOCK		X	1	1	
01-006	+ 2BS04340	5MVX852CH002	FRAME FD		-	1	1	
01-007	+ 2BS04310	5MVX732CB003	ACTUATOR FD		X	1	1	
01-008	+ 2BS04170	5MVM273DB006	ROLLER PINCH		X	2	2	
01-009	+ 2BS04050	5MMW251LD046	SPRING PINCH		-	2	2	
01-010	+ 2FP04020		SPACER FD A		-	1	1	
01-011	2BS04100	5MVB862CH003	COVER FD		X	1	1	
01-012	2BS04090	5MVB862CH002	COVER REAR		X	1	1	
01-013	2BR04050	5MMW611LD003	SPRING COVER		-	1	1	
01-014	2BS04110	5MVB866CH022	COVER FRONT		X	1	1	
01-015	2BR04350	5MVS751SH001	PANEL ENGLISH	Excl. KMFR/KMIT	X	1	1	
01-015	2BR04400	5MVS751SH003	PANEL ITALIAN	KMIT only	X	-	1	
01-015	2BR24010	5MVS751SH002	PANEL FRENCH	KMFR only	X	-	1	
01-A03	2BR04040	5AAVC0VER249	COVER RIGHT ASSY		X	1	1	
01-A04	2FP68570		KEY BOARD ASSY		X	1	1	
01-016	+ 2FP04010		BUTTON PANEL		-	1	1	
01-A05	2BR04020	5AAVC0VER246	COVER LEFT ASSY		X	1	1	
01-017	+ 2BS04120	5MVB873CH004	COVER SIDE					

2. Upper Frame Unit (02-)

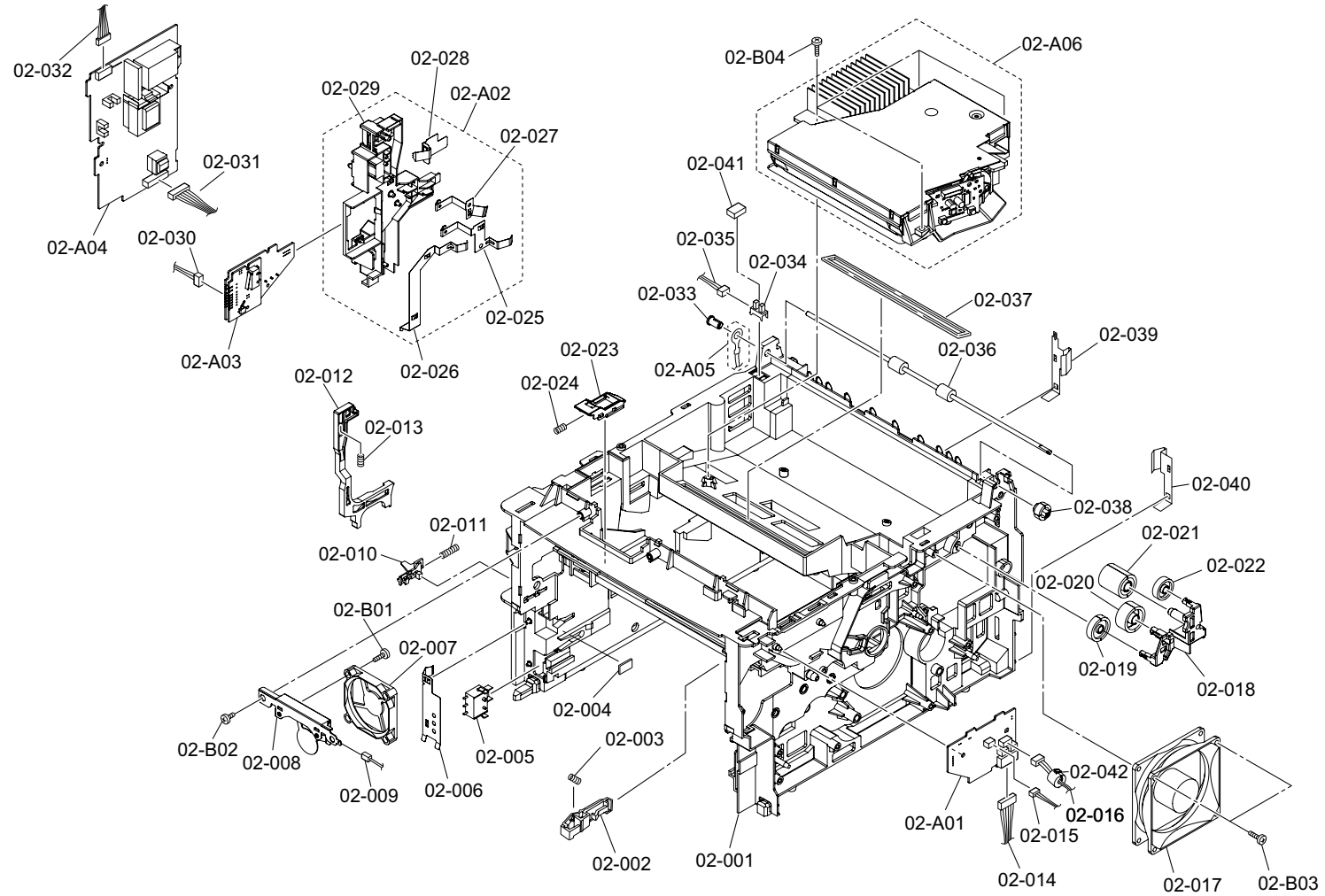

List 2 - Upper Frame Unit (02-)

Ref. No.	Part Code	Alternative	Description	Applicable Model	SP	120V	230V	Remarks
02-A01	2FP01160		P.W.BOARD ASSY ENGRLY KP-1071		X	1	1	
02-001	2FP02030		FRAME BASE		-	1	1	
02-002	2BS02390	5MVX522DB006	LOCK COVER M/P		X	1	1	
02-003	2BR02340	5MMW261LD051	SP LOCK COVER M/P		-	1	1	
02-004	2BR27010	5MVS216SF001	SPACER BASE		-	1	1	
02-005	SP0A0360		PUSH SWITCH 03 SN		X	1	1	
02-006	2BS02180	5MMX631LD004	PLATE EARTH HV		-	1	1	
02-007	WNAA1150		FAN MOTOR		X	1	1	
02-008	2FP02040		BKT FAN		-	1	1	
02-009	2FP26230		CONN. CORD ASSY		-	1	1	
02-010	2BS02350	5MVX322DB023	LEVER EF		X	1	1	
02-011	2BR02280	5MMW222LD002	SPRING LEVER EF		-	1	1	
02-012	2B102330	5MVX762SB018	ROD INTER LOCK	FS-1920	-	1	1	
02-012	2BS02450	5MVX762SB013	ROD INTER LOCK	FS-3820N/3830N	-	1	1	
02-013	2BR02550	5MMW451LD002	SPRING INTER LOCK	FS-1920	-	1	1	
02-013	2B700570	5MMW451LD001	SPRING INTER LOCK	FS-3820N/3830N	-	1	1	
02-014	2FP26080		CONN. CORD ASSY		-	1	1	
02-015	2FP26250		CONN. CORD ASSY		-	1	1	
02-016	2FP26280		CONN. CORD ASSY		-	1	1	
02-017	WNAA1160		FAN MOTOR	FS-1920N/3820N	X	1	1	
02-017	WNAA1140		FAN MOTOR	FS-3830N	X	1	1	
02-018	2BD02450	5MVX655SB001	BRACKET FD GEAR A	FS-1920N/3820N	X	1	1	
02-018	2BS02430	5MVX655SB002	BRACKET FD GEAR B	FS-3830N	X	1	1	
02-019	2BD02270	5MVG138DN048	GEAR FD Z29	FS-1920N/3820N	X	1	1	
02-019	2BS02250	5MVG137DN038	GEAR FD Z23	FS-3830N	X	1	1	
02-020	2BS02270	5MVG138DN049	GEAR FD Z33		X	1	1	
02-021	2BS02260	5MVG138DN047	GEAR FD Z28		X	1	1	
02-022	2BS02240	5MVG137DN014	GEAR IDLE Z25		X	1	1	
02-023	2BS02420	5MVX632DH001	LEVER LOCK DLP		-	1	1	
02-024	2BR02190	5MMW261LX005	SPRING LOCK DLP		-	1	1	
02-A02	2BR04030	5AAVC0VER247	COVER HV SUB ASSY		X	1	1	
02-025	+ 2BS02190	5MMX631LD005	PLATE CONTACT TC		-	1	1	
02-026	+ 2BS02200	5MMX662LD006	PLATE CONTACT EARTH		-	1	1	
02-027	+ 2BS02170	5MMX543LD005	PLATE CONTACT BIAS		-	1	1	
02-028	+ 2BS02160	5MMX521LD006	PLATE CONTACT MCH		-	1	1	
02-029	+ 2BS02460	5MVX773SB007	COVER HV		-	1	1	
02-030	2D926160		CONN. CORD ASSY		-	1	1	
02-031	2FP26130		CONN. CORD ASSY		-	1	1	
02-032	2FP26070		CONN. CORD ASSY		-	1	1	

Ref. No.	Part Code	Alternative	Description	Applicable Model	SP	120V	230V	Remarks
02-033	2BS02290	5MVM266DN006	BUSH FD		X	1	1	
02-034	2DC27180		PT.SENSOR GP1A73AJ00		X	1	1	
02-035	2FP26180		CONN. CORD ASSY		-	1	1	
02-036	2BR02160	5MMT874SN008	ROLLER FD		X	1	1	
02-037	2BS02310	5MVS727RF006	SEAL BASE B		-	1	1	
02-038	2BS02220	5MVG127DN076	GEAR ROLL FD Z18		X	1	1	
02-039	2BR02220	5MMX431LD015	PLATE EARTH SO L		-	1	1	
02-040	2BR02560	5MMX431LD016	PLATE EARTH SO R	FS-1920N/3820N	-	1	1	
02-041	2FP02050		SPACER SENSOR FD		-	1	1	
02-042	M21C0010		FERRITE CORE		-	1	1	
02-A03	2FP01230		P.W.BOARD ASSY SENSOR KP-1077		X	1	1	
02-A04	2FP28290		TRANS ASSY		X	1	1	
02-A06	2FP93030		LK-67 SCANNER UNIT	FS-1920N/3820N	X	1	1	
02-A06	2FR93020		LK-68 SCANNER UNIT	FS-3830N	X	1	1	

3. Drive Unit (03-)

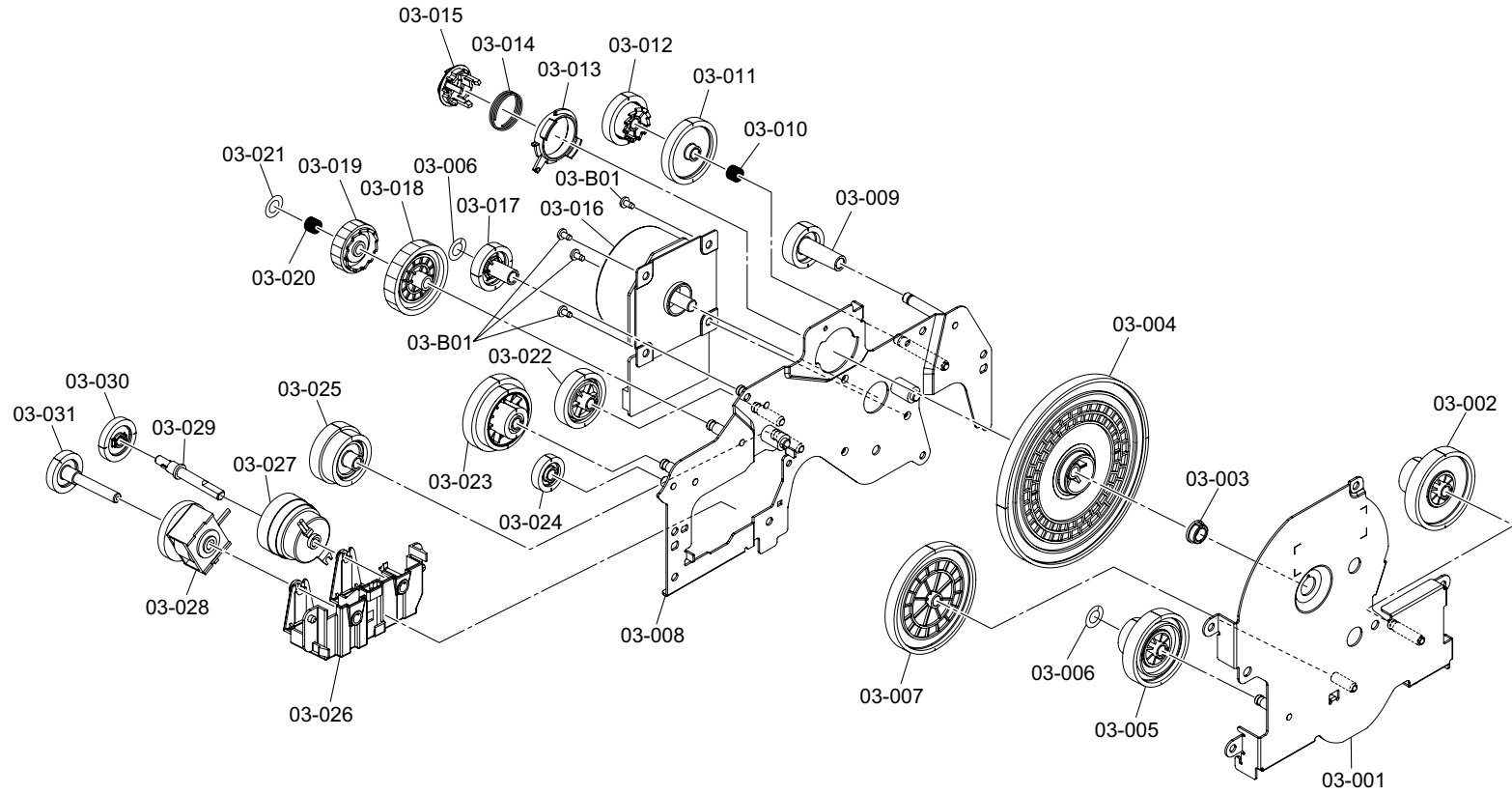

List 3 - Drive Unit (03-)

Ref. No.	Part Code	Alternative	Description	Applicable Model	SP	120V	230V	Remarks
	2FP93040		DR-67 DRIVE UNIT	FS-1920/3820N	X	1	1	
	2FR93030		DR-68 DRIVE UNIT	FS-3830N	X	1	1	
03-001	+ 2FP22130		PLATE DRIVE B		-	1	1	
03-002	+ 2FP22050		GEAR Z88H-Z24H		X	1	1	
03-003	+ 2BM17940	5MMM176CJ003	METAL BUSH KD		X	1	1	
03-004	+ 2FP22020		GEAR Z214H		X	1	1	
03-005	+ 2FP22040		GEAR Z82H-Z25H		X	1	1	
03-006	+ C2891080		POLY CUT WASHER		X	2	2	
03-007	+ 2FP22030		GEAR Z123H		X	1	1	
03-008	+ 2FP22120		PLATE DRIVE A		-	1	1	
03-009	+ 2BS22140	5MVG138BN001	GEAR Z30S		X	1	1	
03-010	+ 2BR22160	5MMW261LD041	SPRING FREE DR		-	1	1	
03-011	+ 2FP22170		GEAR Z45H		X	1	1	
03-012	+ 2BS22160	5MVG148DN057	GEAR FREE Z36S		X	1	1	
03-013	+ 2FP22090		BUSH DRIVE		X	1	1	
03-014	+ 2FP22210		SPRING JOINT DRIVE		-	1	1	
03-015	+ 2FP22160		JOINT DRIVE		X	1	1	
03-016	+ 2FP27170		MOTOR MAIN	FS-1920/3820N	X	1	1	
03-016	+ 2FR27020		MOTOR MAIN	FS-3830N	X	1	1	
03-017	+ 2FP22080		GEAR Z31H		X	1	1	
03-018	+ 2FP22180		GEAR Z50H		X	1	1	
03-019	+ 2BS22190	5MVG148DN087	GEAR FREE Z34H		X	1	1	
03-020	+ 2BS22050	5MMW371LD005	SPRING REVERSE DR		X	1	1	
03-021	+ 2BR20530	5MBWL52D55NN	POLY CUT WASHER		X	1	1	
03-022	+ 2FP22070		GEAR Z39H		X	1	1	
03-023	+ 2BS22250	5MVG169DN036	GEAR Z54S-Z44H-Z22S		X	1	1	
03-024	+ 2BS22130	5MVG137DN033	GEAR Z23S		X	1	1	
03-025	+ 2FP22060		GEAR Z44S-Z36H		X	1	1	
03-026	+ 2FP22010		HOLDER CLUTCH		X	1	1	
03-027	+ 2FP27130		CLUTCH REGIST		X	1	1	
03-028	+ 2FP22190		CLUTCH FEED		X	1	1	
03-029	+ 2FP02010		SHAFT CLUTCH		X	1	1	
03-030	+ 2BS22150	5MVG138DN044	GEAR CL R Z22S		X	1	1	
03-031	+ 2BS22120	5MVG038XN001	GEAR CL F Z21S		X	1	1	

4. Controller Box (04-)

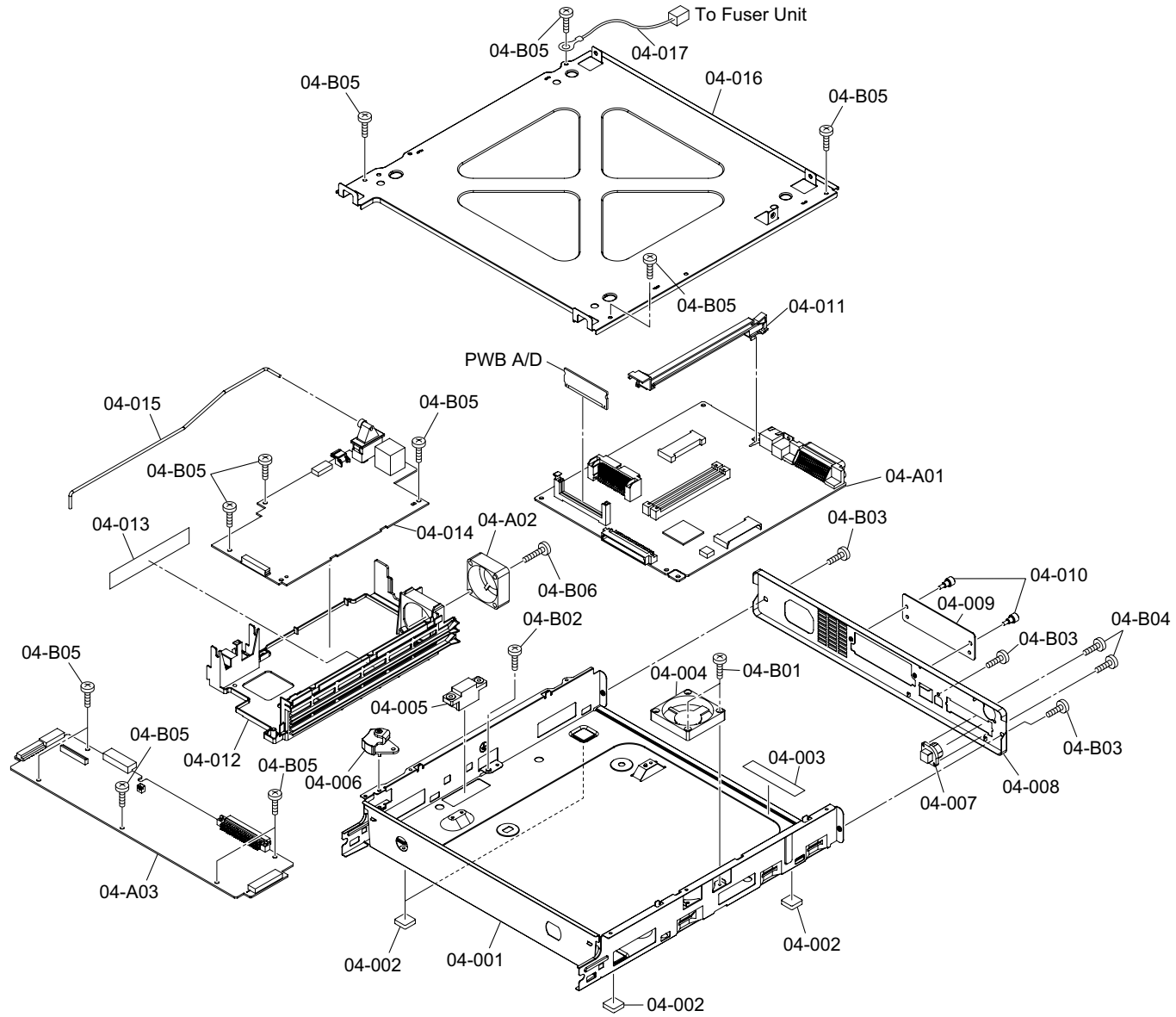

List 4 - Controller Box (04-)

Ref. No.	Part Code	Alternative	Description	Applicable Model	SP	120V	230V	Remarks
04-001	2FP03010		BOX CONTROLLER		-	1	1	
04-002	2BS03110	5MVX221RB014	FOOT		X	4	4	
04-003	2BS03090	5MVS622KF008	SHEET CONTROLLER		-	1	1	
04-004	WNAA1130		FAN MOTOR	FS-3820N/3830N	X	1	1	
04-005	2FP26240		CONN. CORD ASSY		X	1	1	
04-006	2BS03120	5MVX433SH002	LEVER SW		X	1	1	
04-007	2FP26210		CONN. CORD ASSY		-	1	1	
04-008	2B103040	5MMB851SD007	PANEL REAR		-	1	1	
04-008	2FR03010		PANEL REAR		-	1	1	
04-009	3BH26020	5MMS636SD009	PLATE OPTION		-	1	1	
04-010	2D903100		SCREW OP		X	2	2	
04-011	2D903070	5MVX733SL001	RAIL OPTION		-	1	1	
04-012	2BS03140	5MVX875SB005	COVER PWB POWER		-	1	1	
04-013	2FP03020		SHEET COVER PWB		-	1	1	
04-014	2FP28310		SWITCHING REGULATOR	FS-1920	X	-	1	
04-014	2FP28300		SWITCHING REGULATOR	FS-1920	X	1	-	
04-014	2FR28060		SWITCHING REGULATOR	FS-3820N/3830N	X	-	1	
04-014	2FR28050		SWITCHING REGULATOR	FS-3820N/3830N	X	1	-	
04-015	2BS03070	5MMX833LD001	ROD SW POWER		-	1	1	
04-016	2BR03030	5MMB881SD001	LID CONTROLLER		-	1	1	
04-017	2FP26270		CONN. CORD ASSY		-	1	1	
04-A01	2FP01370		P.W.BOARD ASSY MAIN KP-1053	FS-1920	X	1	1	
04-A01	2FR01010		P.W.BOARD ASSY MAIN KP-1033	FS-3830N	X	1	1	
04-A01	2FK01040		P.W.BOARD ASSY MAIN KP-1033	FS-3820N	X	1	1	
04-A02	WNAA1120		FAN MOTOR	FS-1920	X	1	1	
04-A02	WNAA1100		FAN MOTOR	FS-3820N/3830N	X	1	1	
04-A03	2FP01320		P.W.BOARD ASSY ENGINE KP-1081	FS-1920 Incl.KMTW,Excl.Philippines	X	-	1	
04-A03	2FP01340		P.W.BOARD ASSY ENGINE KP-1081	FS-1920 Excl.KMTW,Incl.Philippines	X	1	-	
04-A03	2FP01250		P.W.BOARD ASSY ENGINE KP-1081	FS-3830N Incl.KMTW,Excl.Philippines	X	-	1	
04-A03	2FP01270		P.W.BOARD ASSY ENGINE KP-1081	FS-3830N Excl.KMTW,Incl.Philippines	X	1	-	
04-A03	2FY01010		P.W.BOARD ASSY ENGINE KP-1081	FS-3820N Incl.KMTW,Excl.Philippines	X	-	1	
04-A03	2FY01030		P.W.BOARD ASSY ENGINE KP-1081	FS-3820N Excl.KMTW,Incl.Philippines	X	1	-	
PWB-A/D	2FP01200		P.W.BOARD ASSY DIMM KP-1059	FS-1920	X	1	1	
PWB-A/D	2FR01030		P.W.BOARD ASSY DIMM KP-893	FS-3820N/3830N	X	1	1	

5. Paper Feed Unit (05-)

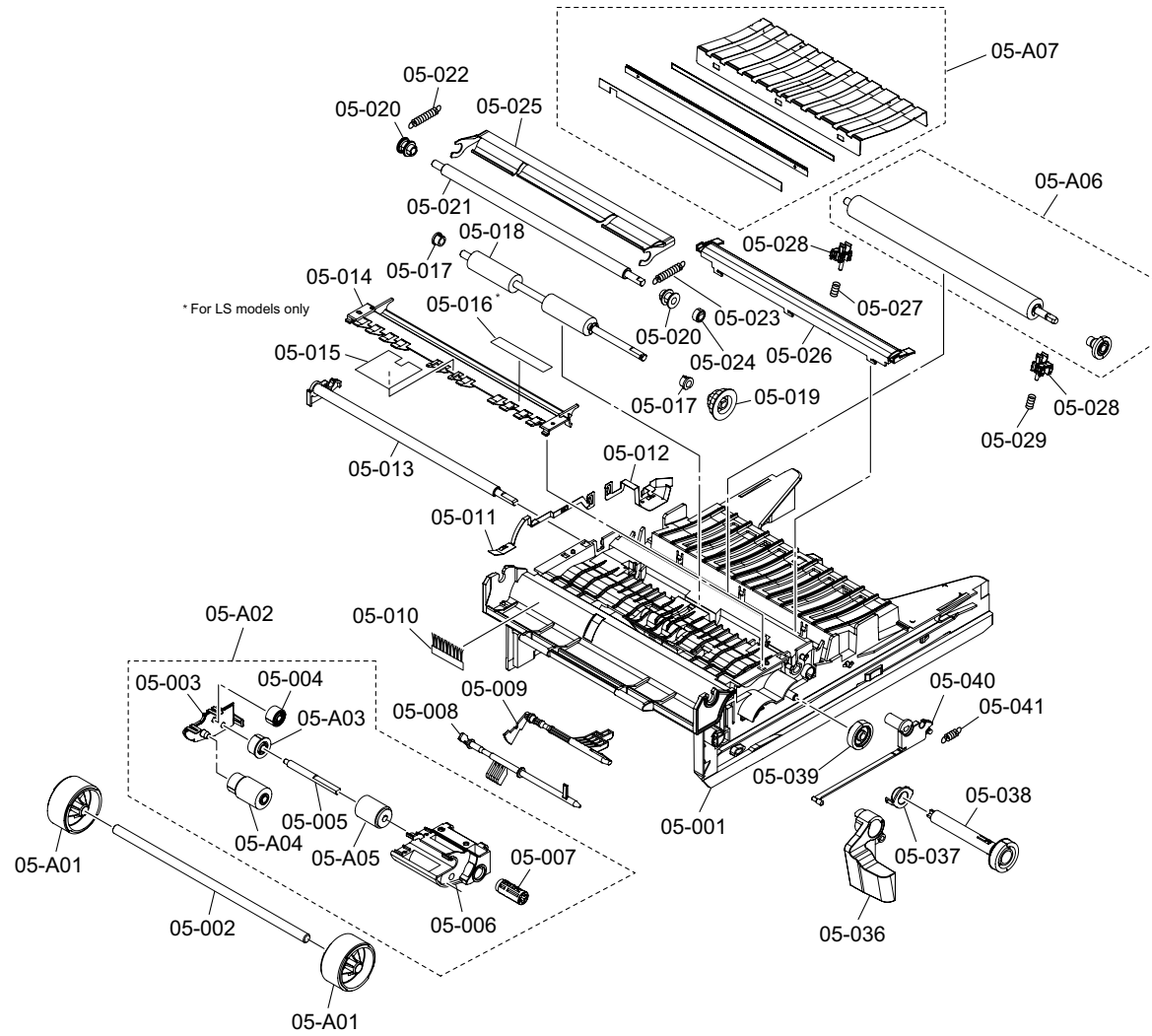

List 5 - Paper Feed Unit (05-)

Ref. No.	Part Code	Alternative	Description	Applicable Model	SP	120V	230V	Remarks
	2FP93050		FE-67 FEED TRANS UNIT		X	1	1	
05-A01	+	2CL16110 5AAVR0LL+049	ROLLER GUIDE ASSY		X	2	2	
05-001	+	S9000240 5MVB886SB010	BASE FEED		-	1	1	
05-002	+	2BR16200 5MMT860SN002	SHAFT ROLL GUIDE		-	1	1	
05-A02	+	2BR68470 5AAYA37E++35	HOLDER FEED ASSY		X	1	1	
05-A03	++	2FP16010	GEAR PICK ASSY		X	1	1	
05-A04	++	2FP16050	ROLLER FEED ASSY		X	1	1	
05-A05	++	2CL16100 5AAVR0LL+048	ROLLER PICKUP ASSY		X	1	1	
05-003	++	2BS16400 5MVX642DH001	COVER BKT FEED		-	1	1	
05-004	++	2FP16020	GEAR Z27H		X	1	1	
05-005	++	2BR16370 5MMT664SN002	SHAFT PICKUP		-	1	1	
05-006	++	2BS16420 5MVX664SH004	BRACKET FEED		-	1	1	
05-007	++	2BS16390 5MVX376DN001	HOLDER RELEASE		X	1	1	
05-008	+	2BS16410 5MVX663SB013	ACTUATOR PAPER		X	1	1	
05-009	+	2BS16450 5MVX742SB008	SENSOR DOC		X	1	1	
05-010	+	2BP21010 5MVS711XF003	DISCHARGER FD		-	1	1	
05-011	+	2BS16190 5MMX742LD002	PLATE EARTH MP		-	1	1	
05-012	+	2BS16180 5MMX633LD001	PLATE EARTH TC		-	1	1	
05-013	+	2BS16470 5MVX843CB004	SHAFT RELEASE		-	1	1	
05-014	+	2BS16480 5MVX862SB005	GUIDE PAPER		-	1	1	
05-015	+	2FP20170	SHEET GUIDE FLAPPER		-	1	1	
05-017	+	2B716270 5MVM176DN019	BUSH POM A		X	2	2	
05-018	+	2BR16220 5MMT876SN076	ROLLER REGIST LOW		X	1	1	
05-019	+	2BS16270 5MVG148DN060	GEAR REG Z22S-Z32S		X	1	1	
05-020	+	2BS16290 5MVM221DB002	BUSH REGIST		X	2	2	
05-021	+	2BR16210 5MMT866SN032	ROLLER REGIST UP		-	1	1	
05-022	+	2BR16230 5MMW341LD007	SPRING REGIST L		X	1	1	
05-023	+	2BR16240 5MMW341LD008	SPRING REGIST R		X	1	1	
05-024	+	2BS16240 5MVG126DN015	GEAR REGIST Z19S		X	1	1	
05-025	+	2BS16200 5MMX852LD003	PLATE GUIDE CHUTE		-	1	1	
05-026	+	2BS16460 5MVX832BB001	PAPER CHUTE		X	1	1	
05-027	+	2B716140 5MMW241SX004	SPRING TRANS L		X	1	1	
05-028	+	2BS16380 5MVX322DB019	BUSH TRANSFER		X	2	2	
05-029	+	2BR16280 5MMW241LX004	SPRING TRANS R		X	1	1	
05-036	+	2BS16430 5MVX666SH005	LEVER LOCK		X	1	1	
05-037	+	2BS16300 5MVM222XN001	BUSH FEED		X	1	1	
05-038	+	2D916230 5MVG038DN002	GEAR JOINT Z26S		X	1	1	
05-039	+	2BS16260 5MVG138DN045	GEAR IDLE Z23S		X	1	1	
05-040	+	2BS16440 5MVX733DN001	SHAFT LOCK R		-	1	1	

Ref. No.	Part Code	Alternative	Description	Applicable Model	SP	120V	230V	Remarks
05-041	+	2BR16250	5MMW251SD002	SPRING LOCK R	-	1	1	
05-A06	+	2BS68320	5AAYA38E++27	ROLLER TRANSFER ASSY	X	1	1	
05-A07	+	2BR68480	5AAYA37E++36	DISCHARGER ASSY	-	1	1	

6. Fuser Unit (06-)

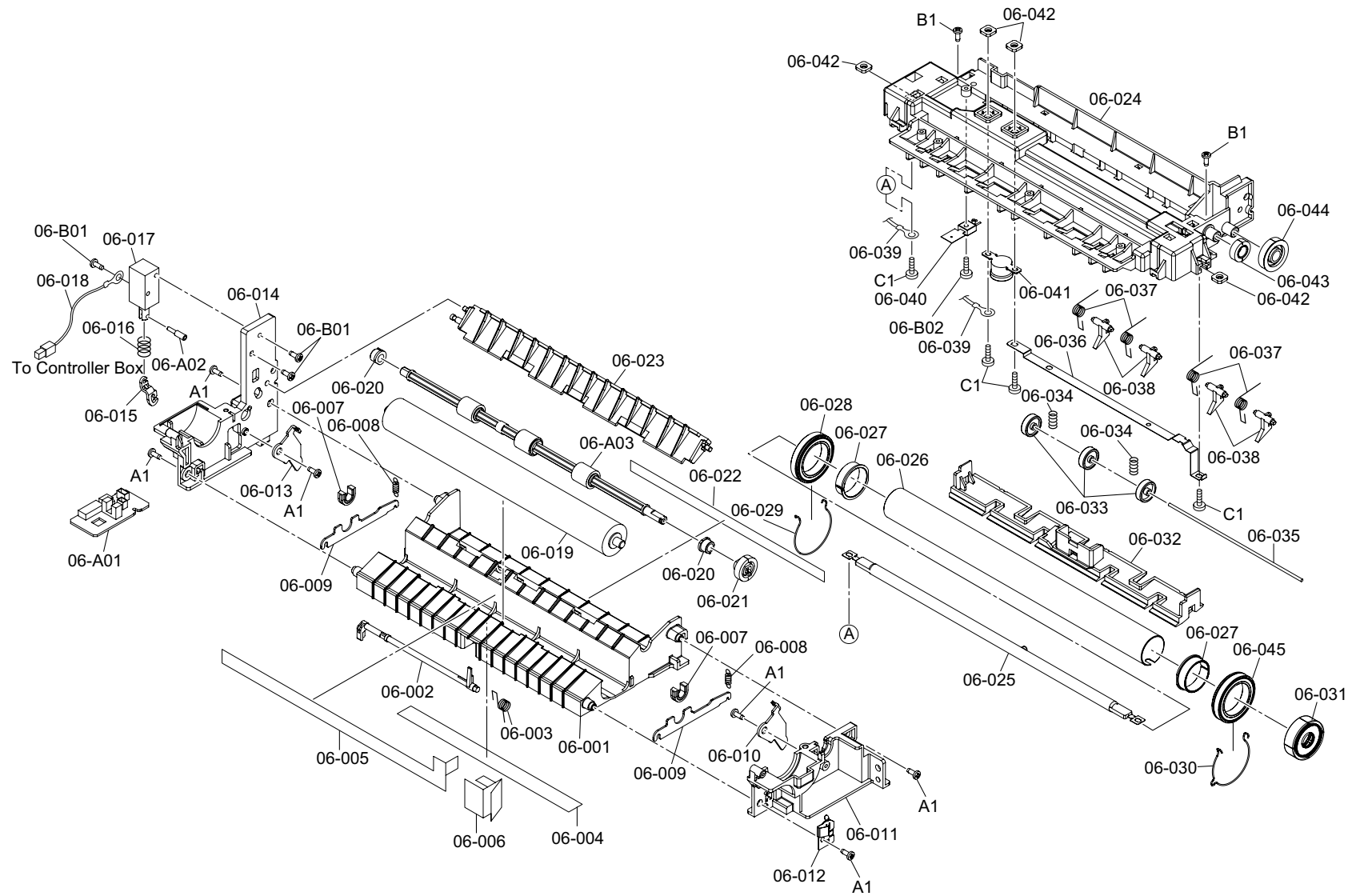

List 6 - Fuser Unit (06-)

Ref. No.	Part Code	Alternative	Description	Applicable Model	SP	120V	230V	Remarks
	2FP93060		FK-67(E) FUSER UNIT	FS-1920/3820N,Excl.KMSG/KMTH/KMHG/Philippines	X	-	1	
	2FP93070		FK-67(U) FUSER UNIT	FS-1920/3820N,Excl.KMTW	X	1	-	
	2FP93130		FK-67(ASIA)E FUSER UNIT	FS-1920/3820N,KMSG/KMTH/KMHG/Philippines	X	-	1	
	2FP93140		FK-67(ASIA)U FUSER UNIT	FS-1920/3820N,KMTW only	X	1	-	
	2FR93040		FK-68(E) FUSER UNIT	FS-3830N,Excl.KMSG/KMTH/KMHG/Philippines	X	-	1	
	2FR93050		FK-68(U) FUSER UNIT	FS-3830N,Excl.KMTW	X	1	-	
	2FR93110		FK-68(ASIA)E FUSER UNIT	FS-3830N,KMSG/KMTH/KMHG/Philippines	X	-	1	
	2FR93120		FK-68(ASIA)U FUSER UNIT	FS-3830N,KMTW only	X	1	-	
06-001	+ 2BR20050	5MVX874KB002	FRAME FUSER LOW		-	1	1	
06-002	+ 2BR20110	5MVX731CB003	ACTUATOR FUSER		X	1	1	
06-003	+ 2A820520	5MMW261LD017	SPRING ACTUATOR		-	1	1	
06-004	+ 2FP20190		SHEET FUSER LOW		-	1	1	
06-005	+ 2FP20200		SHEET DISCHRGER	Excl.KMTW/KMSG/KMTH/KMHG/Philippines	-	1	1	
06-006	+ 2FP20180		SHEET EARTH PRESS	Excl.KMTW/KMSG/KMTH/KMHG/Philippines	-	1	1	
06-007	+ 2BS20230	5MVM188XN014	BUSH PRESS		X	2	2	
06-008	+ 2FP20130		SPRING PRESS		-	2	2	
06-009	+ 2BR20290	5MMS621SL001	PLATE PRESS		-	2	2	
06-010	+ 2BR20280	5MMX431SL002	PLATE RELEASE R		-	1	1	
06-011	+ 2FP20020		FRAME FUSER R	FS-1920/3820N	-	1	1	
06-011	+ 2FR20020		FRAME FUSER R	FS-3830N	-	1	1	
06-012	+ 2FP20070		PLATE EARTH FU		-	1	1	
06-013	+ 2BR20270	5MMX431SL001	PLATE RELEASE L		-	1	1	
06-014	+ 2FP20030		FRAME FUSER L	FS-1920/3820N	-	1	1	
06-014	+ 2FR20030		FRAME FUSER L	FS-3830N	-	1	1	
06-015	+ 2BR20160	5MVX311DB009	ACTUATOR SOL		-	1	1	
06-016	+ 2BM21060	5MMW261LJ032	SPRING SOL		-	1	1	
06-017	+ 2BR21050	5EZSA2401020307	SOLENOID TDS-KN07A		X	1	1	
06-018	+ 2FP26260		CONN. CORD ASSY		-	1	1	
06-019	+ 2FP20100		ROLLER PRESS	Excl.KMTW/KMSG/KMTH/KMHG/Philippines	X	1	1	
06-019	+ 5MMT886SN028		ROLLER PRESS	KMTW/KMSG/KMTH/KMHG/Philippines	X	1	1	
06-020	+ 2B716270	5MVM176DN019	BUSH POM A		X	2	2	
06-021	+ 2BR20140	5MVG137DN034	GEAR EXIT Z21		X	1	1	
06-022	+ 2A805020	5MVVL731WN14	LABEL FUSER CAUTION		-	1	1	
06-023	+ 2BR20100	5MVX832SB012	GUIDE CHANGE		-	1	1	
06-024	+ 2FP20010		FRAME FUSER UP	FS-1920/3820N	-	1	1	
06-024	+ 2FR20010		FRAME FUSER UP	FS-3830N	-	1	1	
06-025	+ WPAAA570		HEATER LAMP		X	-	1	
06-025	+ WPAAA580		HEATER LAMP		X	1	-	
06-026	+ 2FP20110		ROLLER HEAT	FS-1920/3820N,Excl.KMTW/KMSG/KMTH/KMHG/Philippines	X	1	1	

Ref. No.	Part Code	Alternative	Description	Applicable Model	SP	120V	230V	Remarks
06-026	+ 2FP20120		ROLLER HEAT	FS-1920/3820N,KMTW/KMSG/KMTH/KMHG/Philippines	X	1	1	
06-026	+ 2FR20080		ROLLER HEAT	FS-3830N,Excl.KMTW/KMSG/KMTH/KMHG/Philippines	X	1	1	
06-026	+ 2FR20090		ROLLER HEAT	FS-3830N,KMTW/KMSG/KMTH/KMHG/Philippines	X	1	1	
06-027	+ 2FP20080		BUSH FUSER	FS-1920/3820N	X	2	2	
06-027	+ 2FR20070		BUSH FUSER	FS-3830N	X	2	2	
06-028	+ 2FP20160		BEARING HEAT	FS-1920/3820N	X	1	1	
06-028	+ G3268060		BEARING HEAT	FS-3830N	X	1	1	
06-029	+ 2FP20140		SPRING EARTH FUSER L	FS-1920/3820N	X	1	1	
06-029	+ 2FR20100		SPRING EARTH FUSER L	FS-3830N	X	1	1	
06-030	+ 2FP20150		SPRING EARTH FUSER R	FS-1920/3820N	X	1	1	
06-030	+ 2FR20110		SPRING EARTH FUSER R	FS-3830N	X	1	1	
06-031	+ 2FP20050		GEAR HEAT Z36	FS-1920/3820N	X	1	1	
06-031	+ 2FR20040		GEAR HEAT Z46	FS-3830N	X	1	1	
06-032	+ 2BR20080	5MVX833KB002	GUIDE EXIT UP	FS-1920/3820N	-	1	1	
06-032	+ 2BS20080	5MVX833KB003	GUIDE EXIT UP	FS-3830N	-	1	1	
06-033	+ 2BR20520	5MVM176DB018	PULLEY EXIT		X	3	3	
06-034	+ 2BR20330	5MMW261LD033	SPRING PULLEY A		-	2	2	
06-035	+ 2BR20370	5MMT722SZ001	SHAFT EXIT		-	1	1	
06-036	+ 2FP20060		PLATE CORD	FS-1920/3820N	-	1	1	
06-036	+ 2FR20050		PLATE CORD	FS-3830N	-	1	1	
06-037	+ 2BR16440	5MMW261LD058	SPRING SEPARATOR		-	4	4	
06-038	+ 2A820530	5MVX222XN002	SEPARATOR		X	4	4	
06-039	+ 2FP26040		CONN.CORD ASSY		-	-	1	
06-039	+ 2FP26050		CONN.CORD ASSY		-	1	-	
06-040	+ 2BR21010	5AAXTM015GEA	THERMISTOR ASSY		X	1	1	
06-041	+ 2BM21680		THERMOSTAT 250V170C		X	1	1	
06-042	+ 2BY20050	5MMS111SL002	NUT FUSER A		-	4	4	
06-043	+ 2BR20120	5MVG138DN037	GEAR IDLE Z28	FS-1920/3820N	X	1	1	
06-043	+ 2BS20130	5MVG137XN001	GEAR JOINT Z21	FS-3830N	X	1	1	
06-044	+ 2BR20150	5MVG127DN047	GEAR IDLE Z18	FS-1920/3820N	X	1	1	
06-044	+ 2BR20120	5MVG138DN037	GEAR IDLE Z28	FS-3830N	X	1	1	
06-045	+ 2FP20160		BEARING HEAT	FS-1920/3820N	X	1	1	
06-045	+ 2FR20120		BEARING HEAT	FS-3830N	X	1	1	
06-A01	+ 2FP01180		P.W.BOARD ASSY FUSER		X	1	1	
06-A02	+ 2BR20380	5AAVSHAFT001	PIN ASSY		-	1	1	
06-A03	+ 2CL16080	5AAVROLL+046	ROLLER EXIT ASSY		X	1	1	

7. Drum Unit (07-)

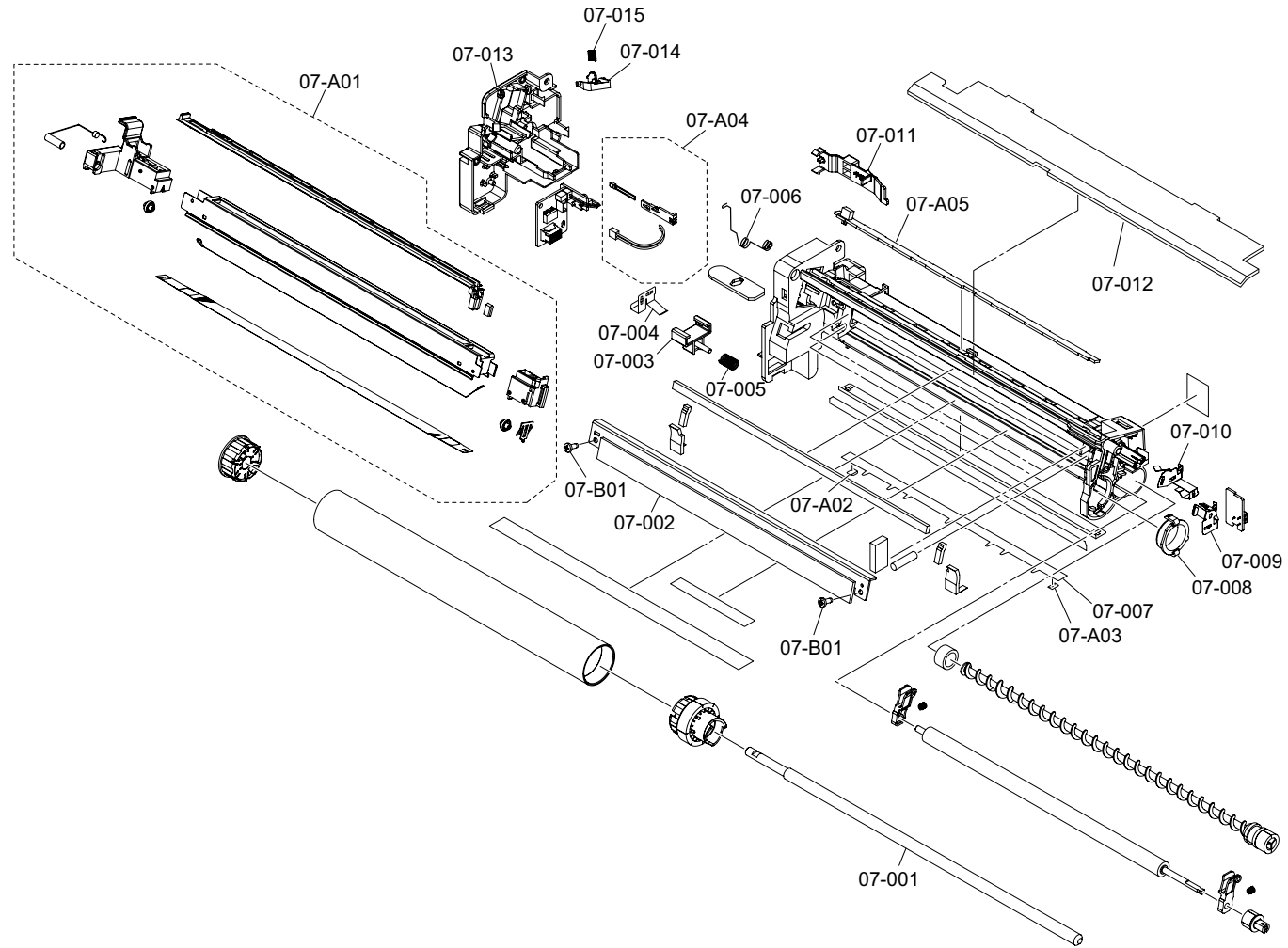

List 7 - Drum Unit (07-)

Ref. No.	Part Code	Alternative	Description	Applicable Model	SP	120V	230V	Remarks
	2FP93010		DK-67 DRUM UNIT	FS-1920/3820N	X	1	1	
	2FR03010		DK-68 DRUM UNIT	FS-3830N	X	1	1	
07-001	+ 2FP08010		SHAFT DRUM		-	1	1	
07-002	+ 2FP08040		BLADE ASSY		X	1	1	
07-003	+ 2BS08510	5MVX332DB020	SHUTTER WASTE		-	1	1	
07-004	+ 2BS08220	5MMX432LD007	PLATE EARTH LEFT		-	1	1	
07-005	+ 2BR08120	5MMW361LD017	SPRING SHUTTER		-	1	1	
07-006	+ 2BR08370	5MMW161LD053	SP EARTH DRUM		-	1	1	
07-007	+ 2B981120	5MVS821KN022	SHEET GUIDE DRUM		X	1	1	
07-008	+ 2BS08290	5MVM288XN002	BUSH DRUM RIGHT		X	1	1	
07-009	+ 2BR08050	5MMX332LD011	PLATE ZENNER		-	1	1	
07-010	+ 2BR08060	5MMX332LD012	PLATE EARTH ZENNER		-	1	1	
07-011	+ 2BS08530	5MVX622DH001	LOCK DRUM		-	1	1	
07-012	+ 2BR08510	5MVX843SB006	COVER DRUM TOP		-	1	1	
07-013	+ 2BS08240	5MVB662CB002	COVER DRUM LEFT		-	1	1	
07-014	+ 2BS08490	5MVX322DN004	LOCK MCH		-	1	1	
07-015	+ 2BR08110	5MMW141LD019	SPRING LOCK		-	1	1	
07-A01	+ 2BR93410	5PLPXZ1APKX	MC-60 MCH ASSY		X	1	1	
07-A02	+ 2BR69260	5AAYA91J++16	PLATE SEPA R ASSY		X	1	1	
07-A03	+ 2BR69250	5AAYA91J++15	SHEET SEPARATOR ASSY		X	1	1	
07-A04	+ 2FP69000		LED ASSY		X	1	1	
07-A05	+ 2FP01140		P.W.BOARD ASSY ERASER		X	1	1	

8. Developer Unit

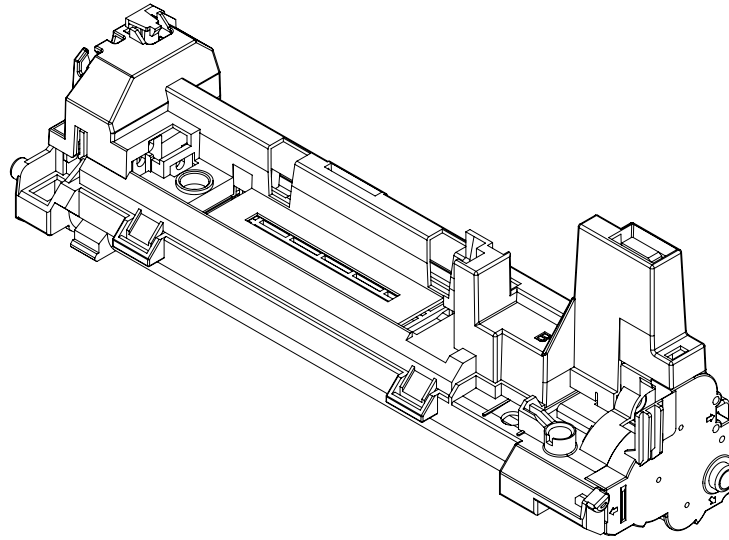

List 8 - Developer Unit

Ref. No.	Part Code	Description	SP	120V	230V	Remarks
	2FP93020	DV-67 DEVELOPER UNIT	X	1	1	

9. Frame MP Assembly (11-)

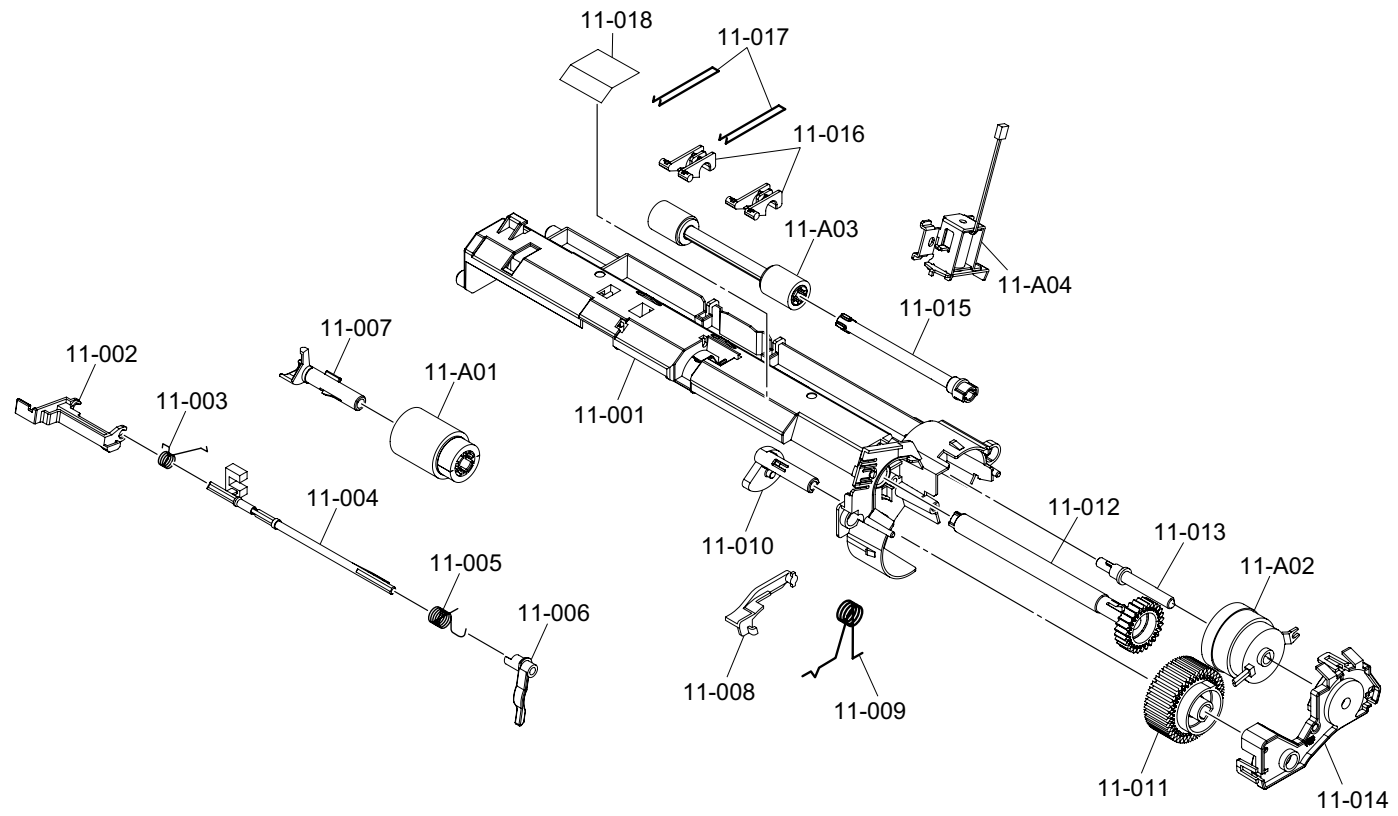

List 9 - Frame MP Assembly (11-)

Ref. No.	Part Code	Alternative	Description	Applicable Model	SP	120V	230V	Remarks
	2FP68190		FRAME M/P ASSY		X	1	1	
11-001	+ 2BS02470	5MVX866CH001	FRAME M/P		-	1	1	
11-002	+ 2BS02410	5MVX621SB010	ACTUATOR M/P B		-	1	1	
11-003	+ 2BR02520	5MMW161SD010	SP ACTUATOR M/P B		-	1	1	
11-004	+ 2BS02330	5MVT754SB001	ACTUATOR M/P A		-	1	1	
11-005	+ 2BR02530	5MMW161SD009	SP ACTUATOR M/P C		-	1	1	
11-006	+ 2BS02360	5MVX421SB021	ACTUATOR M/P C		X	1	1	
11-007	+ 2BS02370	5MVX422DN007	HOLDER FEED M/P		X	1	1	
11-008	+ 2BS02400	5MVX522DN004	LEVER CAM		X	1	1	
11-009	+ 2BR02450	5MMW161LD043	SPRING CAM M/P		-	1	1	
11-010	+ 2BS02380	5MVX433DN002	CAM M/P		X	1	1	
11-011	+ 2BS02280	5MVG148DN063	GEAR M/P Z40		X	1	1	
11-012	+ 2BS02230	5MVG133DN008	GEAR M/P Z27		X	1	1	
11-013	+ 2FP02010		SHAFT CLUTCH		-	1	1	
11-014	+ 2FP02020		HOLDER CLUTCH M/P		-	1	1	
11-015	+ 2BS02320	5MVT676CB003	SHAFT MID B		-	1	1	
11-016	+ 2BS02340	5MVX321DN014	BUSH MID M/P		X	2	2	
11-017	+ 2BR02440	5MMW601SD001	SPRING MID M/P		-	2	2	
11-018	+ 2FP06020		LABEL M/P		-	1	1	
11-A01	+ 2CL16130	5AAVR0LL+051	ROLLER M/P ASSY		X	1	1	
11-A02	+ 2FP27120		CLUTCH MID		X	1	1	
11-A03	+ 2CL16120	5AAVR0LL+050	ROLL MID M/P ASSY		X	1	1	
11-A04	+ WSA00050	5EZSA2401310101	SOLENOID M/P ASSY		X	1	1	

10. Paper Cassette (13-)

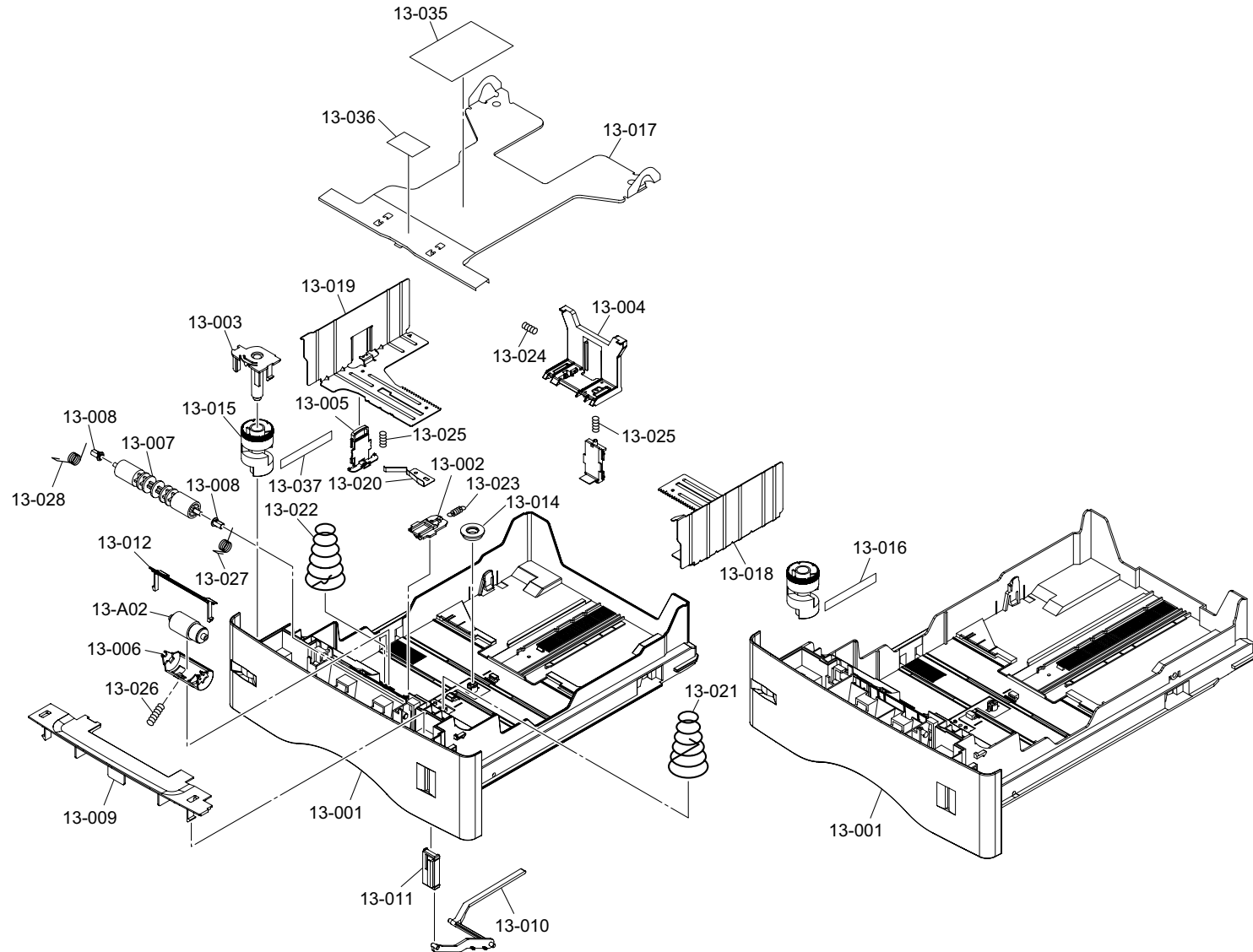

List 10 - Paper Cassette (13-)

Ref. No.	Part Code	Alternative	Description	Applicable Model	SP	120V	230V	Remarks
	2BR93320	5PLPXY8APKX	PC-60A4 CASSETTE ASSY	Excl.Philippines	X	-	1	
	2BR93400	5PLPXZ6APKX	PC-60LTR CASSETTE ASSY	Excl.KMTW	X	1	-	
	2BR93360	5PLPXZ7APKX	PC-60LG(A4) CASSETTE ASSY		X	-	1	
	2BR93390	5PLPXCUIAPKX	PC-60LG(LTR) CASSETTE ASSY	Excl.KMTW	X	1	-	
	2BR93430	5PLPXDRAKX	PC-60A4 CASSETTE ASSY	KMTW only	X	1	-	
	2BR93530	5PLPXQTA0KX	PC-60LTR CASSETTE ASSY	Philippines only	X	-	1	
	2BR93380	5PLPXDAPKX	PC-60LG(A4) CASSETTE ASSY	KMTW/Philippines	X	1	1	
13-A02	+ 2BR06520	5AAVR0LL+052	RETARD ROLL ASSY		X	1	1	
13-001	+ 2BS06270	5MVB887SH027	BASE CASSETTE A4	PC-60	-	1	1	
13-001	+ 3DD06010	5MVB987SH018	BASE CASSETTE LGL	PC-60LG	-	1	1	
13-002	+ 2BS06450	5MVX432DN005	LOCK BOTTOM		X	1	1	
13-003	+ 2BS06470	5MVX543DH002	HOLDER DIAL		-	1	1	
13-004	+ 2BS06520	5MVX664DN001	END FENCE		-	1	1	
13-005	+ 2BS06490	5MVX642DG001	LOCK LEVER SIDE		-	1	1	
13-006	+ 2BS06510	5MVX644DN001	HOLDER RETARD		-	1	1	
13-007	+ 2BS06410	5MVT774DN001	ROLLER FEED		X	1	1	
13-008	+ 2BS06320	5MVM164DN007	BUSH4		X	2	2	
13-009	+ 2BS06540	5MVX853SH003	COVER ROLLER		-	1	1	
13-010	+ 2BS06530	5MVX764DN001	LEVER INDICATOR		X	1	1	
13-011	+ 2BS06440	5MVX422SD002	INDICATER PAPER		-	1	1	
13-012	+ 2BS06480	5MVX632SH005	GUIDE RETARD		-	1	1	
13-013	+ 2BS06500	5MVX642DG002	LOCK LEVER END		-	1	1	
13-014	+ 2B700190	5MVG127DB046	GEAR CASSETTE		-	1	1	
13-015	+ 2B700210	5MVM586SH001	DIAL CASSETTE		-	1	1	
13-016	+ 3DD06160	5MVVL171WN03	LABEL SIZE LGL	PC-60LG	-	1	1	
13-017	+ 2BS06230	5MMX883SD004	PLATE BOTTOM		-	1	1	
13-018	+ 2BS06050	5MML877SN001	PLATE SIDE R		-	1	1	
13-019	+ 2BS06060	5MML877SN002	PLATE SIDE L		-	1	1	
13-020	+ 2BS06220	5MMX653LD004	EARTH PLATE		-	1	1	
13-021	+ 2BS06200	5MMW682LD004	SPRING BOTTOM	Excl.KMTW/Philippines	-	1	1	
13-021	+ 2BR06380	5MMW682LD006	SPRING BOTTOM	KMTW/Philippines	-	1	1	
13-022	+ 2BS06210	5MMW682LD005	SPRING BOTTOM EARTH	Excl.KMTW/Philippines	-	1	1	
13-022	+ 2BR06390	5MMW682LD007	SPRING BOTTOM EARTH	KMTW/Philippines	-	1	1	
13-023	+ 2BS06150	5MMW251LD048	SP STOPPER BOTTOM		-	1	1	
13-024	+ 2BS06100	5MMW151SD003	SPRING END		-	1	1	
13-025	+ 2B700070	5MMW166LD010	SPRING LOCK GUIDE		-	2	2	
13-026	+ 2BS06090	5MMW151LD004	SPRING RETARD		-	1	1	
13-027	+ 2BM22440	5MMW161LD044	SPRING FEED R		-	1	1	
13-028	+ 2BS06120	5MMW161LD045	SPRING FEED L		-	1	1	

Ref. No.	Part Code	Alternative	Description	Applicable Model	SP	120V	230V	Remarks
13-035	+	2BS06430	5MVVL221GE1H	LABEL OPERATION	Excl.KMTW/Philippines	-	1	1
13-035	+	2BR06510	5MVVL221GE1J	LABEL OPERATION J	KMTW/Philippines	-	1	1
13-036	+	2BR06530	5MVS421RN003	SHEET FRICTION		X	1	1
13-037	+	2BS06420	5MVVL171WN02	LABEL SIZE PAPER	PC-60	-	1	1

11. Tray MP Assembly (20-)

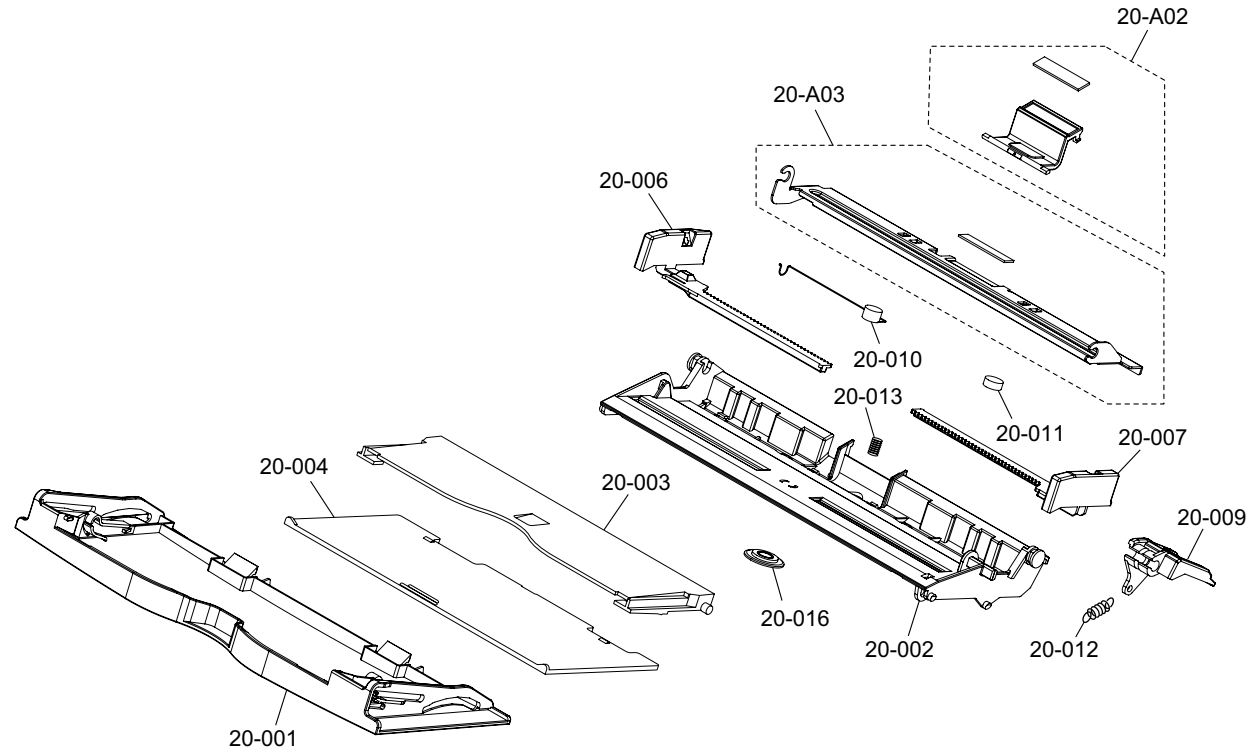

List 11 - Tray MP Assembly (20-)

Ref. No.	Part Code	Alternative	Description	Applicable Model	SP	120V	230V	Remarks
	2FP93100		TRAY M/P ASSY	FS-1920	X	1	1	
	2FR93080		TRAY M/P ASSY	FS-3830N	X	1	1	
	2FY00010		TRAY M/P ASSY	FS-3820N	X	1	1	
20-001	+ 2FP06010		COVER M/P	FS-1920	X	1	1	
20-001	+ 2FR06010		COVER M/P	FS-3830N	X	1	1	
20-001	+ 2FY07010		COVER M/P	FS-3820N	X	1	1	
20-002	+ 2BS06250	5MVB864SH009	BASE M/P		X	1	1	
20-003	+ 2BS06240	5MVB862SH016	TRAY M/P MID		X	1	1	
20-004	+ 2BS06400	5MVS768SH007	TRAY M/P TOP		-	1	1	
20-006	+ 2BS06300	5MVL673DH001	GUIDE M/P L		-	1	1	
20-007	+ 2BS06310	5MVL673DH002	GUIDE M/P R		-	1	1	
20-009	+ 2BS06460	5MVX533DN002	BRACKET BOTTOM		-	1	1	
20-010	+ 2BS06180	5MMW461SD003	SP BOTTOM M/P L		-	1	1	
20-011	+ 2BS06190	5MMW461SD004	SP BOTTOM M/P R		-	1	1	
20-012	+ 2BS06170	5MMW261SM001	SPRING LOCK M/P		-	1	1	
20-013	+ 2BS06170	5MMW261LD039	SPRING SEPARATOR		-	1	1	
20-016	+ 2BS06160	5MVG127DH001	GEAR MANUAL		-	1	1	
20-A02	+ 2B700380	5AAVCASET248	SEPARATOR M/P ASSY		X	1	1	
20-A03	+ 2BR00150	5AAVCASET249	BOTTOM MALTI PAD ASY		X	1	1	

12. Packing Assemblies (P-)

Ref. No.	Part Code	Alternative	Description	Applicable Model	SP	120V	230V	Remarks
P-001	2FP77010		PACKING ASSY	FS-1920	X	-	1	
P-001	2FP77020		PACKING ASSY	FS-1920	X	1	-	
P-001	2FR77010		PACKING ASSY	FS-3830N	X	-	1	
P-001	2FR77020		PACKING ASSY	FS-3830N	X	1	-	
P-001	2FY77020		PACKING ASSY	FS-3820N	X	-	1	
P-001	2FY77010		PACKING ASSY	FS-3820N	X	1	-	
P-002	2BR80400	5KKFB88000C4	POLY BAG		X	1	1	
P-003	2BR80370	5KKF254800C4	POLY BAG	For DV	X	1	1	

13. Accessories (A-)

Ref. No.	Part Code	Alternative	Description	Applicable Model	SP	120V	230V	Remarks
A-001	082BR2KX	5PLPXY9APKX	TB-60 BOTTLE ASSY		X	1	1	
A-002	2BR04090	5AAVC0VER255	COVER CASSETTE ASSY	Excl.KMTW	X	1	-	
A-003	4AK85050	5AAYTK20**03	GRID CLEANER 3 ASSY		X	1	1	

KYOCERA MITA EUROPE B.V.

Hoeksteen 40, 2132 MS Hoofddorp,
The Netherlands
Phone: +31.(0)20.654.000
Home page: <http://www.kyoceramita-europe.com>
Email: info@kyoceramita-europe.com

KYOCERA MITA NEDERLAND B.V.

Hoeksteen 40 2132 MS Hoofddorp
The Netherlands
Phone: +31.(0)20.587.7200

KYOCERA MITA (UK) LTD.

8 Beacontree Plaza
Gillette Way,
Reading Berks RG2 0BS, UK
Phone: +44.(0)118.931.1500

KYOCERA MITA ITALIA S.P.A.

Via Verdi 89 / 91 20063 Cernusco sul Naviglio,
Italy
Phone: +39.02.92179.1

S.A. KYOCERA MITA BELGIUM N.V.

Hermesstraat 8A 1930 Zaventem Belgium
Phone: +32.(0)2.720.9270

KYOCERA MITA FRANCE S.A.

Parc Les Algorithmes
Saint Aubin
91194 GIF-SUR-YVETTE
France
Phone: +33.(0)1.6985.2600

KYOCERA MITA ESPAÑA S.A.

Edificio Kyocera, Avda de Manacor N. 2,
Urb. Parque Rozas 28290 Las Rozas,
Madrid, Spain
Phone: +34.(0)91.631.8392

KYOCERA MITA FINLAND OY

Kirvesmiehenkatu 4 00810 Helsinki,
Finland
Phone: +358.(0)9.4780.5200

KYOCERA MITA (SCHWEIZ) AG

Holzliwisen Industriestrasse 28
8604 Volketswil, Switzerland
Phone: +41.(0)1.908.4949

KYOCERA MITA DEUTSCHLAND GMBH

Mollsfeld 12 D-40670 Meerbusch,
Germany
Phone: +49.(0)2159.918.0

KYOCERA MITA GMBH AUSTRIA

Eduard-Kittenberger Gasse 95
1230 Wien, Austria
Phone: +43.(0)1.86338.0

KYOCERA MITA SVENSKA AB

Box 1402 171 27 Solna, Sweden
Phone: +46.(0)8.546.550.00

KYOCERA MITA NORGE

Postboks 150 Oppsal, NO 0619 Oslo
Olaf Helsetsvvei 6, NO 0694 Oslo
Phone: +47.(0)22.62.73.00

KYOCERA MITA DANMARK A/S

Hovedkontor: Slotsmarken 11,
DK-2970 Hørsholm, Denmark
Phone: +45.(70)22.3880

KYOCERA MITA PORTUGAL LDA.

Rua de Campolide 55-5 Dt 1070-029
Lisboa, Portugal
Phone: +351.(0)21.032.0900

**KYOCERA MITA SOUTH AFRICA
(PTY) LTD.**

527 Kyalami Boulevard,
Kyalami Business Park 1685 Midrand South
Phone: +27.(0)11.466.3290

KYOCERA MITA AMERICA, INC.

Headquarters:
225 Sand Road, P.O. Box 40008,
Fairfield, New Jersey 07004-0008,
U.S.A.
Phone: (973) 808-8444

**KYOCERA MITA AUSTRALIA PTY.
LTD.**

Level 3, 6-10 Talavera Road, North Ryde,
N.S.W. 2113 Australia
Phone: (02) 9888-9999

KYOCERA MITA NEW ZEALAND LTD.

1-3 Parkhead Place, Albany
P.O. Box 302 125 NHPC, Auckland,
New Zealand
Phone: (09) 415-4517

**KYOCERA MITA (THAILAND) CORP.,
LTD.**

9/209 Ratchada-Prachachem Road,
Bang Sue, Bangkok 10800, Thailand
Phone: (02) 586-0320

**KYOCERA MITA SINGAPORE
PTE LTD.**

121 Genting Lane, 3rd Level,
Singapore 349572
Phone: 67418733

**KYOCERA MITA HONG KONG
LIMITED**

11/F., Mita Centre,
552-566, Castle Peak Road,
Tsuen Wan, New Territories,
Hong Kong
Phone: 24297422

**KYOCERA MITA TAIWAN
CORPORATION**

7F-1-2, No.41, Lane 221, Gangchi Rd.
Neihu District, Taipei, Taiwan, 114. R.O.C.
Phone: (02) 87511560

KYOCERA MITA CORPORATION

2-28, 1-chome, Tamatsukuri, Chuo-ku
Osaka 540-8585, Japan
Phone: (06) 6764-3555
<http://www.kyoceramita.com>

© 2003 KYOCERA MITA CORPORATION

 is a trademark of Kyocera Corporation