



FS-1028MFP DP-110

PARTS LIST

Published in November 2009

2H9PL072

Rev.2

NOTES

1. Indicate parts number and parts description together with the machine model name when placing an order.

e.g.	Parts Number	Parts Name	Machine Model	Quantity
	302H902270	PLATE EARTH	FS-1028MFP	1

2. Symbols in the "Parts Number" column.

- Parts with "•" are component parts or sub-assemblies of the assembly appearing immediately above them.

e.g.	Parts Number	Parts Name	Parts Number	Parts Name
	302H994400	PARTS COVER LEFT ASSY U SP	• 302H904031	COVER LEFT
			• 302H934030	LABEL CAUTION HG

- Parts with "••" are component parts or sub-assembly with "•" appearing immediately above them.

e.g.	Parts Number	Parts Name	Parts Number	Parts Name
	•302HS94000	PLATE BOTTOM ASSY	••302F909210	PAD BOTTOM
			••302HS09170	CAP BOTTOM

- Parts with "⊙" indicate regular maintenance parts.

3. Items indicated in Description column as (OPTION) are Consumable parts.

FS-1028MFP

———— CONTENTS ————

FIG. 1	Covers	2
FIG. 2	Frames	4
FIG. 3	Paper Cassette	6
FIG. 4	Paper Feed Section 1	8
FIG. 5	Paper Feed Section 2	10
FIG. 6	Scanner Section	12
FIG. 7	Image Formation Section	14
FIG. 8	Developing Section	16
FIG. 9	Fuser Section	18
FIG. 10	Drive Section	20
FIG. 11	Paper Conveying Section	22
FIG. 12	Electrical Components	24
FIG. 13	Operation Section & Original Holder	26
FIG. 14	Accessories	28
FIG. 15	Maintenance Kits	30
	• INDEX	31

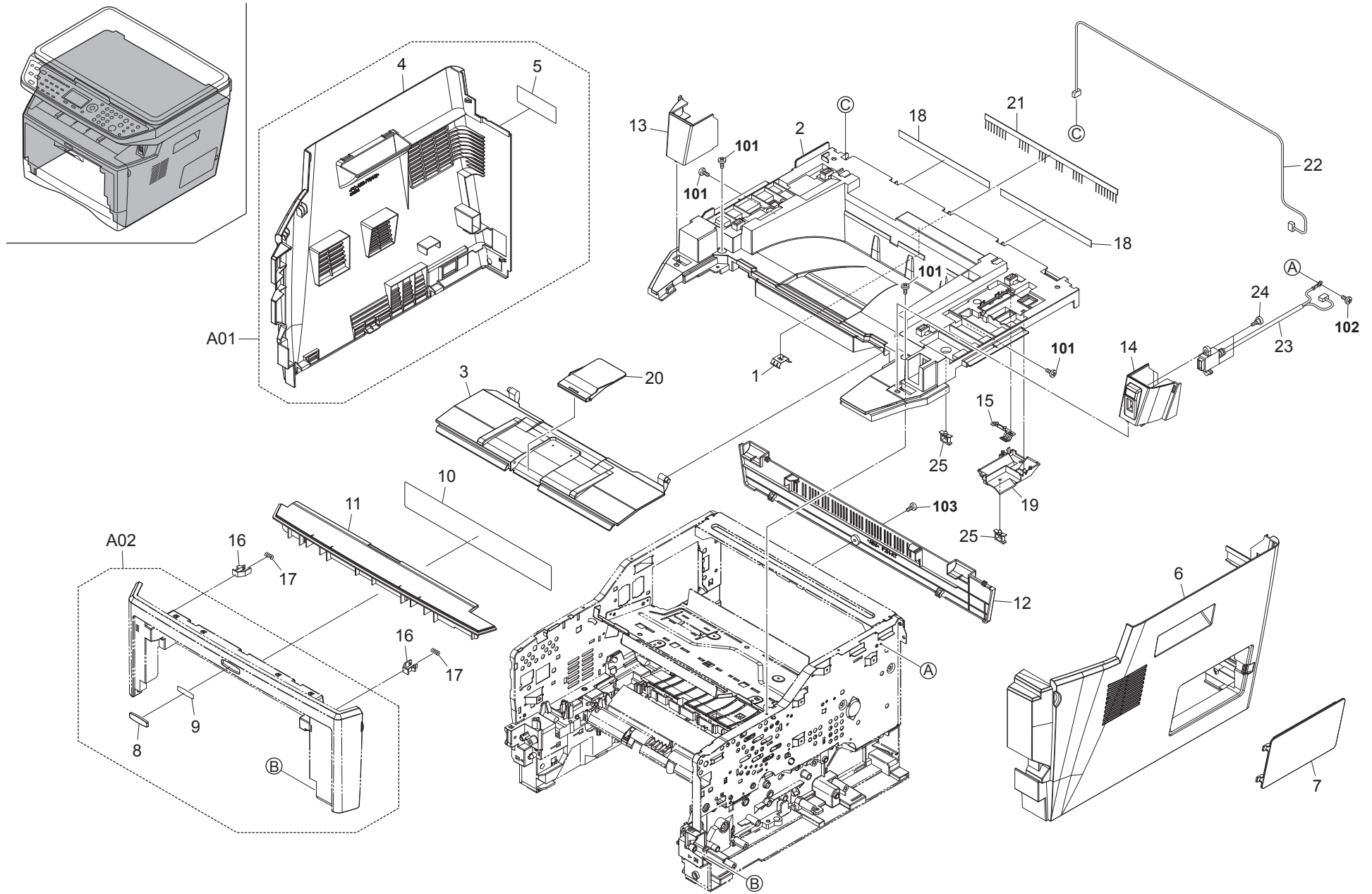

FIG. 1 Covers

2H9-1

	Ref. No.	Part.No.	Alternative.	Description	Quantity		
					120	230	240
	1	302H902270	2H902270	PLATE EARTH	1	1	1
⊙	2	302H904010	2H904010	COVER TOP	1	1	1
⊙	3	302H904020	2H904020	LID TOP	1	1	1
⊙	A01	302H994400	2H994400	PARTS COVER LEFT ASSY U SP	1		
⊙	4	*302H904031	2H904031	COVER LEFT	1	1	1
	5	*302H934030	2H934030	LABEL CAUTION HG	1		
⊙	6	302H904041	2H904041	COVER RIGHT	1	1	1
⊙	7	302H904051	2H904051	COVER DIMM	1	1	1
⊙	A02	302H994320	2H994320	PARTS COVER FRONT ASSY SP	1	1	1
	8	*302H904150	2H904150	EMBLEM	1	1	1
	9	*302H904170	2H904170	TAPE EMBLEM	1	1	1
	10	*302H934010	2H934010	LABEL JAM TK OPERATION	1	1	1
⊙	11	302H904070	2H904070	COVER FRONT B	1	1	1
⊙	12	302H904090	2H904090	COVER REAR	1	1	1
⊙	13	302H904110	2H904110	COVER INNER L	1	1	1
⊙	14	302H904120	2H904120	COVER INNER R	1	1	1
	15	302H904180	2H904180	PLATE EARTH REAR	1	1	1
	16	302H904200	2H904200	HOOK COVER	2	2	2
	17	302H904210	2H904210	SPRING COVER HOOK	2	2	2
	18	302H904230	2H904230	SHEET HARNESS	2	2	2
	19	302H904260	2H904260	GUIDE HARNESS	1	1	1
⊙	20	302H904270	2H904270	STOPPER PAPER D	1	1	1
	21	302H904280	2H904280	DISCHARGER FD	1	1	1
	22	302H946050	2H946050	CONN.CORD ASSY LVU-SCN	1	1	1
	23	302H946070	2H946070	CONN.CORD ASSY USB-MAIN	1	1	1
	24	302JD19150	2JD19150	PIN LSU	2	2	2
	25	7YZM610008++H01	YZ037940	ACCESS.SADDLE	2	2	2

	Ref. No.	Part.No.	Alternative.	Description	Quantity		
					120	230	240
	101	7BB700308H	BB105600	+BIND T.T S SCREW 3X8 SR			
	102	7BB100306H1	BB105820	+BIND T.T S SCREW 3X6			
	103	7BB600306H	BB105730	+BIND M SCREW 3X6 R			

- Parts with "*" are component parts or sub-assemblies of the assembly appearing immediately above them.
- Parts with "⊙" indicate regular maintenance parts.

- Parts with "••" are component parts or sub-assembly with "•" appearing immediately above them.

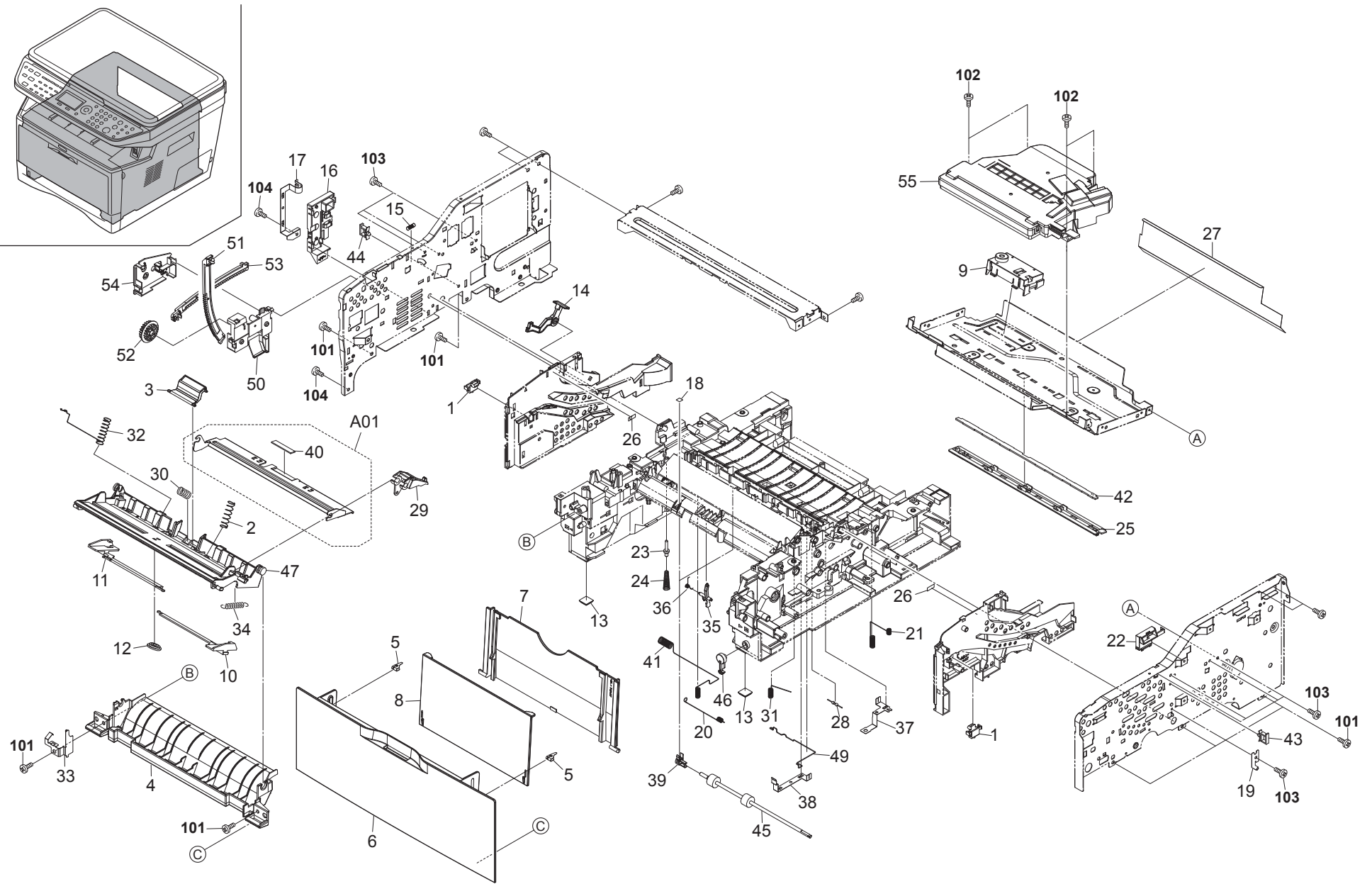

FIG. 2 Frames

2H9

	Ref. No.	Part.No.	Alternative.	Description	Quantity		
					120	230	240
	1	302F902420	2F902420	LOCK COVER TOP R	2	2	2
	2	302F908270	2F908270	SP BOTTOM MPF L	1	1	1
⊙	3	302HS94040	2HS94040	SEPARATOR MPF ASSY	1	1	1
	4	302H908040	2H908040	GUIDE TURN MPF	1	1	1
	5	302H908020	2H908020	PLATE COVER MPF	2	2	2
⊙	6	302H908010	2H908010	COVER MPF	1	1	1
	7	302HS08060	2HS08060	TRAY MPF MID	1	1	1
	8	302HS08220	2HS08220	TRAY MPF TOP	1	1	1
⊙	9	302H994360	2H994360	PARTS FULL SENSOR ASSY SP	1	1	1
	10	302HS08241	2HS08241	GUIDE MPF R	1	1	1
	11	302HS08251	2HS08251	GUIDE MPF L	1	1	1
	12	5MVG137DN032	2A806720	GEAR MPF /A-49 MPF A4	1	1	1
⊙	13	302J002010	2J002010	FOOT	2	2	2
⊙	14	302HS02090	2HS02090	LEVER STOPPER DLP	1	1	1
	15	302HS02100	2HS02100	SPRING STOPPER DLP	1	1	1
	16	302HS02131	2HS02131	HOLDER MC	1	1	1
	17	302HS02140	2HS02140	PLATE CONTACT MC	1	1	1
⊙	18	302HS02700	2HS02700	SHEET BUSH DU	1	1	1
	19	302HS02291	2HS02291	PLATE EARTH DRUM	1	1	1
	20	302H402060	2H402060	SPRING EARTH DU FEED	1	1	1
	21	302HS02330	2HS02330	SPRING EARTH DU PLATE	1	1	1
	22	302HS02350	2HS02350	COVER CABLE B	1	1	1
	23	302HS02460	2HS02460	PIN CONTACT BIAS	1	1	1
	24	302HS02470	2HS02470	SPRING PIN BIAS	1	1	1
	25	302H402020	2H402020	HOLDER ERASER	1	1	1
	26	302FV14500	2FV14500	LABEL GUIDE DLP	2	2	2
	27	302HS02590	2HS02590	SHEET DUCT FD	1	1	1
	28	7RHA2H10701+H01	RH043740	M.GLAZE R. 100MJ 1/2W	1	1	1
	29	302HS08100	2HS08100	BRACKET BOTTOM	1	1	1
	30	302HS08170	2HS08170	SPRING SEPARATOR	1	1	1
	31	302HS24300	2HS24300	SPRING CONTACT TC	1	1	1
	32	302HS08210	2HS08210	SPRING EARTH MPF	1	1	1
	33	302HS08230	2HS08230	PLATE EARTH BOTTOM	1	1	1
	34	302HS08270	2HS08270	SPRING BRACKET	1	1	1
	35	302HS24060	2HS24060	ACTUATOR REGIST	1	1	1
	36	302HS24070	2HS24070	SPRING ACTUATOR REG	1	1	1
	37	302HS24080	2HS24080	PLATE EARTH HV	1	1	1
	38	302HS24110	2HS24110	PLATE ERATH PAPER CHUTE	1	1	1
	39	302HS24130	2HS24130	BUSH 4 DU ROLL	2	2	2
⊙	A01	302HS94050	2HS94050	PLATE BOTTOM MPF ASSY	1	1	1
	40	*302F908310	2F908310	PAD FRICTION MPF	1	1	1
⊙	41	302HS02160	2HS02160	SPRING MC	1	1	1
	42	302H494020	2H494020	ERASER KIT (N) SP	1	1	1
	43	7YZM610008++H01	YZ037940	ACCESS.SADDLE	1	1	1
	44	7YZM610007++H01	YZ023340	ACCESS.SADDLE	1	1	1
⊙	45	302HS24160	2HS24160	ROLLER DU	2	2	2
⊙	46	302HS02650	2HS02650	HOOK PF	1	1	1
	47	302HS08050	2HS08050	BASE MPF	1	1	1
	48	302G634070	2G634070	LABEL ENERGY STAR	1	1	1
	49	302H402040	2H402040	SPRING REG GND	1	1	1

	Ref. No.	Part.No.	Alternative.	Description	Quantity		
					120	230	240
	51	302H902110	2H902110	HOLDER GEAR A	1	1	1
	51	302H902030	2H902030	RACK LID L	1	1	1
⊙	52	302H902070	2H902070	GEAR RACK Z20-23	1	1	1
	53	302H902050	2H902050	RACK FRONT L	1	1	1
	54	302H902120	2H902120	HOLDER GEAR B	1	1	1
⊙	55	302HS93092	2HS93092	LK-130	1	1	1
	101	7BB200410H	BB105700	+BIND T.T P SCREW 4X10			
	102	7BB600308H	BB055190	+BIND SCREW M3X8 CRFREE SR			
	103	7BB700308H	BB105600	+BIND T.T S SCREW 3X8 SR			
	104	7BB200308H	BB105660	+BIND T.T P SCREW 3X8			

- Parts with "*" are component parts or sub-assemblies of the assembly appearing immediately above them.
- Parts with "⊙" indicate regular maintenance parts.

- Parts with "••" are component parts or sub-assembly with "•" appearing immediately above them.

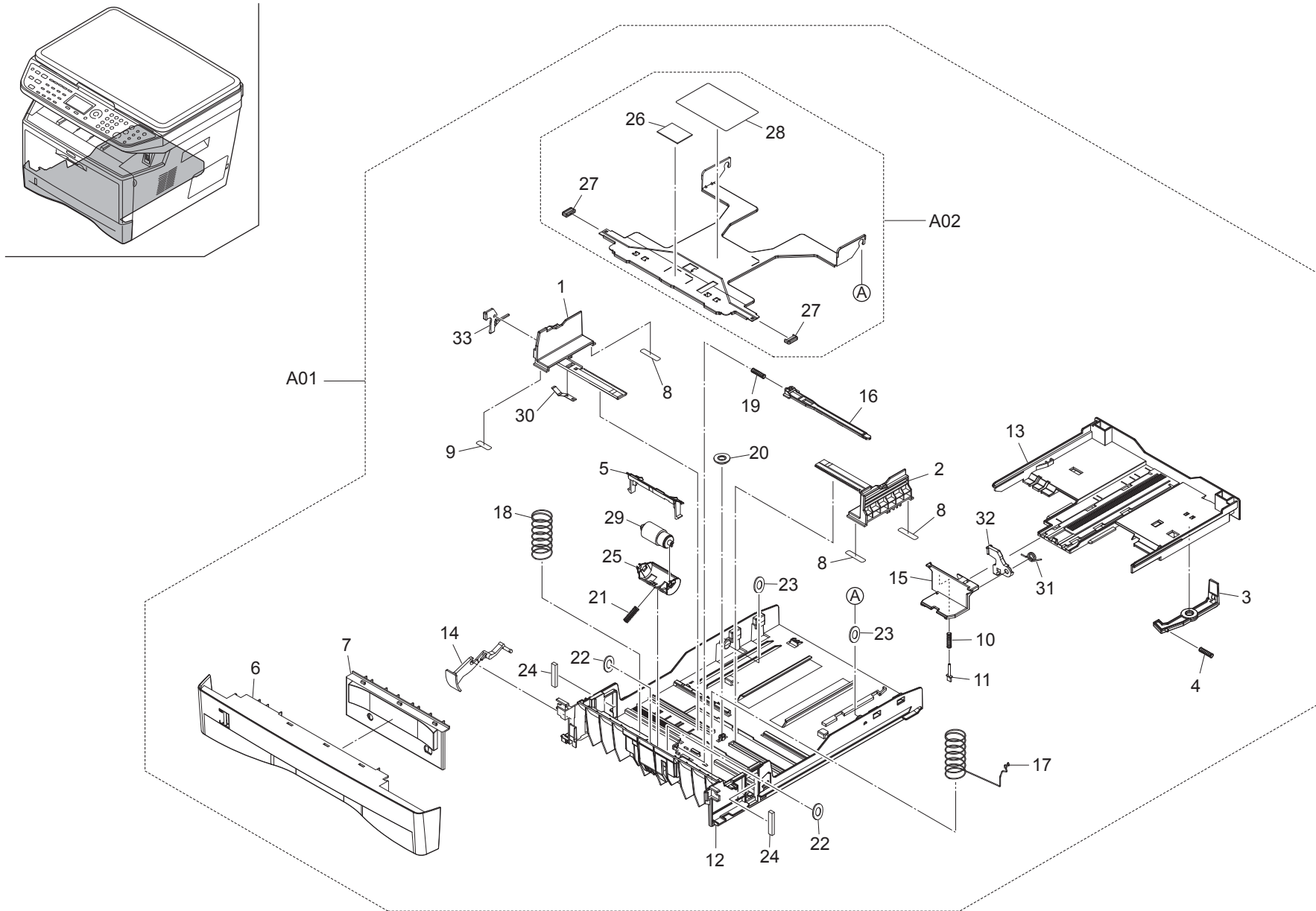

FIG. 3 Paper Cassette

2H9-2

	Ref. No.	Part.No.	Alternative.	Description	Quantity		
					120	230	240
⊙	A01	302H993031	2H993031	CT-132	1	1	1
	1	*2FM06010	5MVX765SH004	GUIDE SIDE L /B-11 CASSETTE A2	1	1	1
	2	*2FM06020	5MVX765SH005	GUIDE SIDE R /B-11 CASSETTE A2	1	1	1
	3	*302F909031	2F909031	LEVER BASE CAS REAR	1	1	1
	4	*302F909040	2F909040	SPRING BASE CAS REAR	1	1	1
	5	*302GJ09111	2GJ09111	GUIDE RETARD	1	1	1
⊙	6	*302H909010	2H909010	COVER CASSETTE	1	1	1
⊙	7	*302H909020	2H909020	GUIDE CASSETTE	1	1	1
	8	*302H909030	2H909030	SPACER CASS A	3	3	3
	9	*302H909040	2H909040	SPACER CASS B	1	1	1
	10	*302HN09190	2HN09190	SPRING FIX	1	1	1
	11	*302HN09240	2HN09240	SIZE FIX	1	1	1
	12	*302HS09010	2HS09010	BASE CASSETTE	1	1	1
	13	*302HS09040	2HS09040	BASE CASSETTE REAR	1	1	1
	14	*302HS09070	2HS09070	PAPER INDICATOR	1	1	1
	15	*302HS09081	2HS09081	CURSOR END	1	1	1
	16	*302HS09100	2HS09100	LOCK BOTTOM	1	1	1
	17	*302HS09120	2HS09120	SPRING BOTTOM L	1	1	1
	18	*302HS09130	2HS09130	SPRING BOTTOM R	1	1	1
	19	*302HS09140	2HS09140	SPRING LOCK BOTTOM	1	1	1
	20	*302HS09160	2HS09160	GEAR CASSETTE	1	1	1
	21	*302HS09180	2HS09180	SPRING RETARD	1	1	1
	22	*302HS09210	2HS09210	SEAL RETARD WASHER	2	2	2
	23	*302HS09220	2HS09220	CUT POLYSLIDER 11_8	2	2	2
	24	*302HS09231	2HS09231	SPONGE CASSETTE	2	2	2
	25	*302HS09260	2HS09260	HOLDER RETARD	1	1	1
⊙	A02	*302HS94000	2HS94000	PLATE BOTTOM ASSY	1	1	1
	26	**302F909210	2F909210	PAD BOTTOM	1	1	1
	27	**302HS09170	2HS09170	CAP BOTTOM	2	2	2
	28	**302HS34030	2HS34030	LABEL OPERATION	1	1	1
⊙	29	*5AAVR0LL+052	2BR06520	RETARD ROLL ASSY /43487V0005 A4	1	1	1
	30	*5MMP141LD002	2A807510	PLATE SIDE GUIDE /A49 CASSETTE A4	1	1	1
	31	*5MMW171LD006	2A807530	SPRING STOPPER /A49 CASSETTE A4	1	1	1
	32	*5MVX541DG002	2A807191	LEVER REAR /A-49 CASSETTE A3	1	1	1
	33	*5MVX541DG003	2A807161	LEVER SIDE /A-49 CASSETTE A3	1	1	1

- Parts with "*" are component parts or sub-assemblies of the assembly appearing immediately above them.
- Parts with "⊙" indicate regular maintenance parts.

- Parts with "*•" are component parts or sub-assembly with "*" appearing immediately above them.

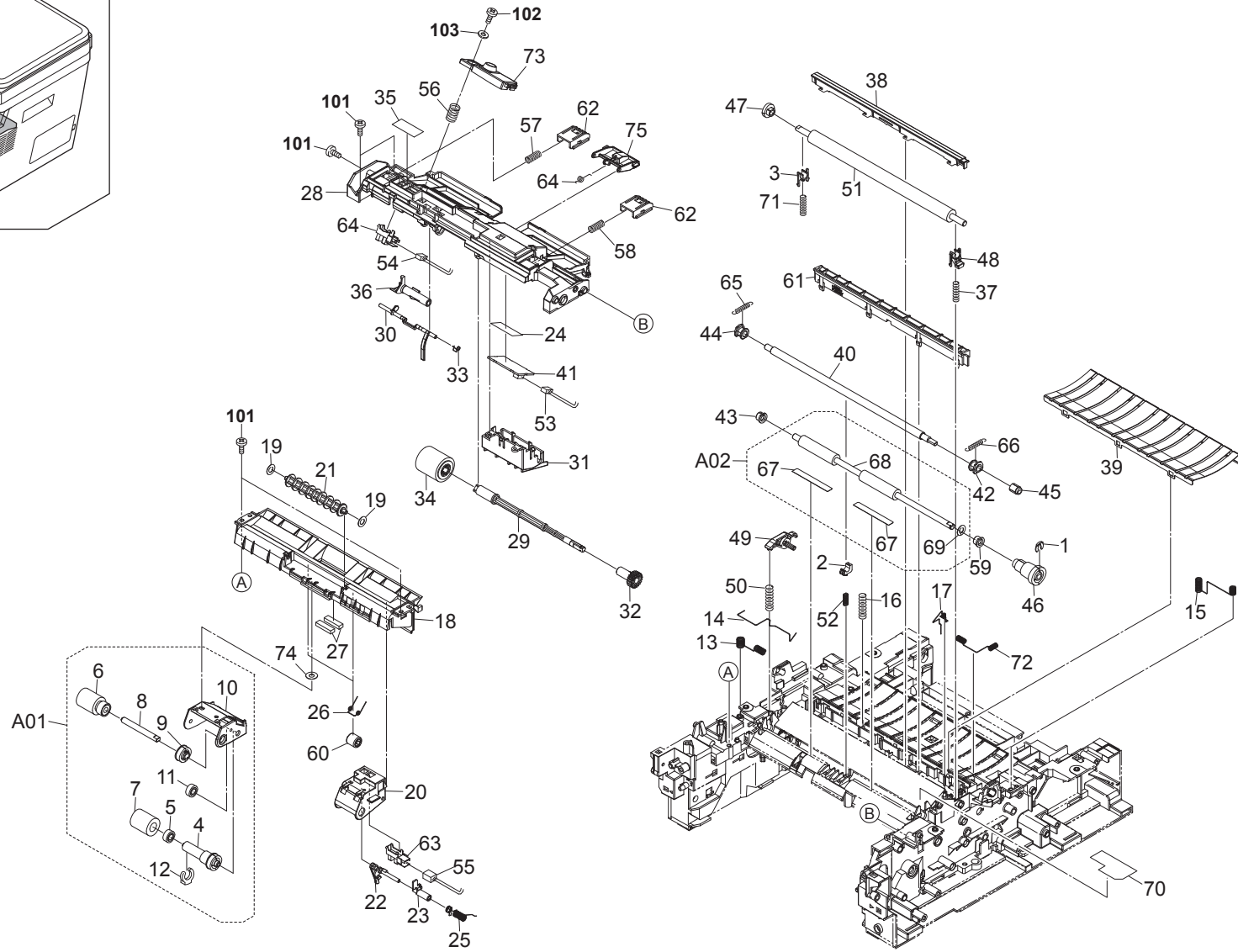
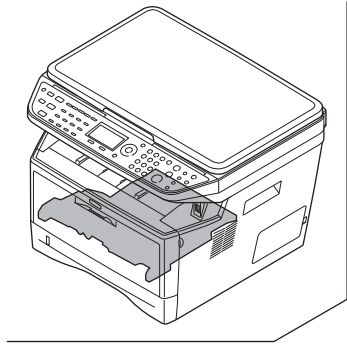

FIG. 4 Paper Feed Section 1

2H9-2

Ref. No.	Part.No.	Alternative.	Description	Quantity			
				120	230	240	
	1	5MVX111DN003	2A806250	RING STOPPER /A-49 FEED A4	1	1	1
	2	2FM02180	5MVX221DN020	BUSH REGIST C /B-11 FRAME A3	1	1	1
	3	302A816031	2A816031	BUSH TC R /A-49 FEED A4	1	1	1
⊙	A01	302HS94032	2HS94032	HOLDER FEED ASSY	1	1	1
	4	*302F906170	2F906170	JOINT PICKUP A	1	1	1
	5	*302F906180	2F906180	JOINT PICKUP B	1	1	1
	6	*302F906230	2F906230	PULLEY FEED ASSY	1	1	1
	7	*302F906240	2F906240	PULLEY PICKUP ASSY	1	1	1
	8	*302F906272	2F906272	SHAFT FEED L	1	1	1
	9	*302F906280	2F906280	GEAR FEED Z30H	1	1	1
	10	*302HS06020	2HS06020	HOLDER FEED	1	1	1
⊙	11	*302HS06090	2HS06090	GEAR Z22S FEED	1	1	1
	12	*5MVX111DN003	2A806250	RING STOPPER /A-49 FEED A4	1	1	1
	13	302HS02250	2HS02250	SPRING EARTH REG UP	1	1	1
	14	302HS02260	2HS02260	SPRING EARTH REG LOW	1	1	1
	15	302HS02340	2HS02340	SPRING EARTH RIGHT	1	1	1
	16	302HS02410	2HS02410	SPRING EARTH DU MID	1	1	1
	17	302HS02440	2HS02440	SPRING EARTH DLP PLATE	1	1	1
	18	302HS06010	2HS06010	FRAME FEED	1	1	1
	19	302HS06150	2HS06150	SEAL FEED PULLEY	2	2	2
	20	302HS06040	2HS06040	GUIDE FEED R	1	1	1
	21	302HS06050	2HS06050	PULLEY FEED	1	1	1
⊙	22	302HS06060	2HS06060	ACTUATOR EMPTY A	1	1	1
⊙	23	302HS06071	2HS06071	ACTUATOR EMPTY B	1	1	1
	24	302HS19220	2HS19220	TAPE FFC	1	1	1
	25	302HS06120	2HS06120	SPRING ACTUATOR	1	1	1
	26	302HS06130	2HS06130	SPRING PULLEY	2	2	2
	27	302HS06140	2HS06140	SEAL FRAME FEED	2	2	2
	28	302HS08011	2HS08011	FRAME MPF	1	1	1
	29	302HS08080	2HS08080	SHAFT FEED MPF	1	1	1
⊙	30	302HS08110	2HS08110	ACTUATOR MPF	1	1	1
	31	302HS08140	2HS08140	BASE IC PWB	1	1	1
⊙	32	302HS08160	2HS08160	GEAR Z20S MPF	1	1	1
	33	302HS08190	2HS08190	SPRING ACTUATOR	1	1	1
⊙	34	302HS08260	2HS08260	ROLLER M/P ASSY	1	1	1
	35	302HS08290	2HS08290	FILM SENSOR	1	1	1
	36	302HS08300	2HS08300	HOLDER FEED M/P	1	1	1
	37	302HS24400	2HS24400	SPRING TC R	1	1	1
	38	302HS24010	2HS24010	GUIDE PAPER CHUTE	1	1	1
	39	302HS24020	2HS24020	GUIDE EARTH	1	1	1
⊙	40	302HS24040	2HS24040	ROLLER REGIST UP	1	1	1
⊙	41	302H994430	2H994430	PARTS PWB RFID SP	1	1	1
	42	302HS24120	2HS24120	BUSH REGIST	1	1	1
	43	302HS24140	2HS24140	BUSH 6 EW	1	1	1
	44	302H402050	2H402050	BUSH REGIST	1	1	1
⊙	45	302HS24190	2HS24190	GEAR Z14R REG UP	1	1	1
⊙	46	302HS24200	2HS24200	GEAR Z21L-Z23L REG LOW	1	1	1
⊙	47	302HS24210	2HS24210	GEAR Z16L TC	1	1	1
⊙	48	302HS24250	2HS24250	BUSH TC R	1	1	1
	49	302HS24260	2HS24260	LEVER RELEASE TC L	1	1	1

- Parts with "*" are component parts or sub-assemblies of the assembly appearing immediately above them.
- Parts with "⊙" indicate regular maintenance parts.

Ref. No.	Part.No.	Alternative.	Description	Quantity			
				120	230	240	
⊙	50	302HS24280	2HS24280	SPRING RELEASE TC L	1	1	1
⊙	51	302HS24340	2HS24340	ROLLER TRANSFER U	1	1	1
	51	302HS24170	2HS24170	ROLLER TRANSFER E	1	1	1
	52	302HS24360	2HS24360	SPRING REGIST C	1	1	1
	53	302HS46050	2HS46050	CONN.CORD ASSY CONTROL-RFID S03244	1	1	1
	54	302HS46150	2HS46150	CONN.CORD ASSY CONTROL-MPFSSENSOR S03	1	1	1
	55	302HS46160	2HS46160	CONN.CORD ASSY CONTROL-P.SENSOR S0330	1	1	1
	56	5MMW261LD036	2A814570	SPRING TE SENSOR /A-49 DLP A4	1	1	1
	57	5MMW261LD067	2FV02270	SPRING LEVER LOCK L	1	1	1
	58	5MMW261LD068	2FV02280	SPRING LEVER LOCK R	1	1	1
	59	302HS24460	2HS24460	BUSH REGIST R	1	1	1
	60	5MVM273DB005	2A820100	PULLEY EXIT /A-49 FUSER A3	2	2	2
⊙	61	302H494080	2H494080	HOLDER DC BRUSH ASSY	1	1	1
⊙	62	5MVX431DN005	2FV02100	LEVER LOCK DLP	2	2	2
	63	7NXSG2481+++H01	NX052600	SENSOR OPT.	2	2	2
	64	302HS08351	2HS08351	SPRING COVER REG	1	1	1
⊙	65	302HS24350	2HS24350	SPRING REGIST L	1	1	1
⊙	66	302HS24240	2HS24240	SPRING REGIST R	1	1	1
⊙	A02	302HS94081	2HS94081	REGIST LOW KIT	1	1	1
	67	*302HS24181	2HS24181	SHEET REGIST	2	2	2
	68	*302HS24410	2HS24410	ROLLER REGIST LOW	1	1	1
	69	*7BC460529080H01	BC059590	CUT WASHER 5.2X9.0X0.8T(BLACK)	1	1	1
	70	302HS24420	2HS24420	FILM REGIST GUIDE	1	1	1
	71	302HS24390	2HS24390	SPRING TC L	1	1	1
	72	302HS24310	2HS24310	SPRING EARTH BRUSH	1	1	1
⊙	73	302HS94150	2HS94150	EMPTY SENSOR KIT SP	1	1	1
	74	302H906010	2H906010	SPACER FEED	1	1	1
	75	302HS08340	2HS08340	COVER REG SW	1	1	1
	101	7BB200410H	BB105700	+BIND T.T P SCREW 4X10			
	102	7BB202308H	BB105690	+TP-FLAT T.T P SCREW 3X8			
	103	7BC00030A080H01	BC046150	WASHER M3X10X0.8T			

- Parts with "•" are component parts or sub-assembly with "•" appearing immediately above them.

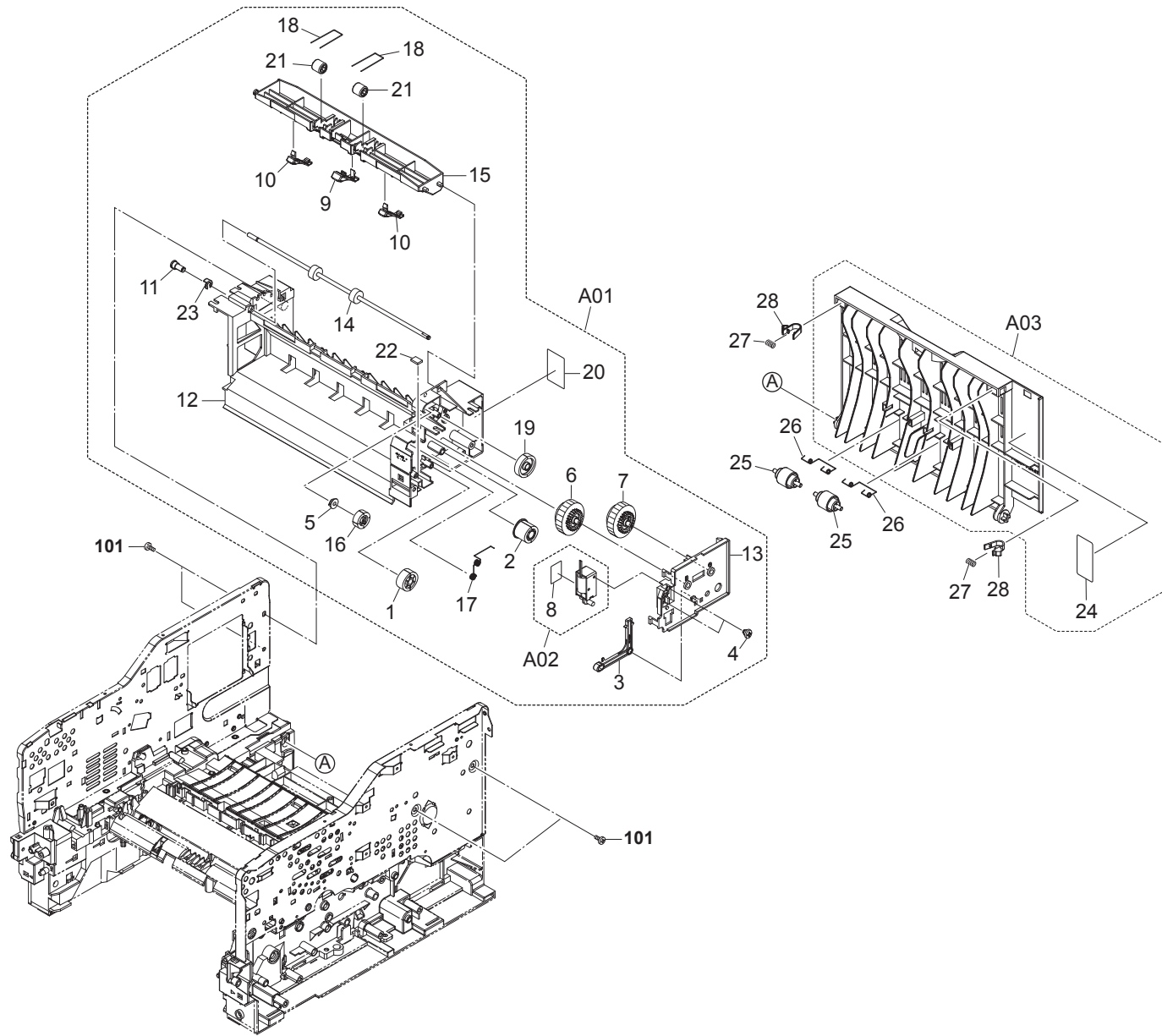
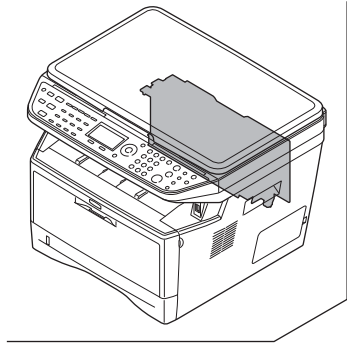

FIG. 5 Paper Feed Section 2

2H9

Ref. No.	Part.No.	Alternative.	Description	Quantity		
				120	230	240
⊙ A01	302H994380	2H994380	PARTS FD ASSY (2H9) SP	1	1	1
⊙ 1	*2BL06380	2BL06380	GEAR Z25 JOINT	1	1	1
⊙ 2	*2FM02350	5MVG133DN022	GEAR Z22 /B-11 FRAME A4	1	1	1
⊙ 3	*2FM20050	5MVX651DN001	LEVER SOLENOID /B-11 FD A3	1	1	1
⊙ 4	*302F325010	2F325010	STUD SCREW M3	2	2	2
⊙ 5	*302F929140	2F929140	BUSH DU	1	1	1
⊙ 6	*302FM94020	2FM94020	GEAR CLUTCH ASSY A SP	1	1	1
⊙ 7	*302FM94030	2FM94030	GEAR CLUTCH ASSY B SP	1	1	1
⊙ A02	*302H494070	2H494070	SOLENOID ASSY SP	1	1	1
⊙ 8	**302H428010	2H428010	FILM SOLENOID	1	1	1
⊙ 9	*302H928010	2H928010	GUIDE FD CENTER	1	1	1
⊙ 10	*302H928020	2H928020	GUIDE FD SIDE	2	2	2
⊙ 11	*302H929050	2HN29050	BUSH DU	1	1	1
⊙ 12	*302HS28012	2HS28012	FRAME FD	1	1	1
⊙ 13	*302HS28021	2HS28021	COVER FRAME FD	1	1	1
⊙ 14	*302HS28030	2HS28030	ROLLER FD UP	1	1	1
⊙ 15	*302HS28041	2HS28041	COVER FD	1	1	1
⊙ 16	*302HS28060	2HS28060	GEAR Z21S	1	1	1
⊙ 17	*302HS28110	2HS28110	SPRING EARTH	1	1	1
⊙ 18	*302HS28141	2HS28141	SPRING PULLEY	2	2	2
⊙ 19	*302HS28170	2HS28170	GEAR FD Z29S	1	1	1
⊙ 20	*302JA34280	2JA34280	LABEL FUSER CAUTION	1	1	1
⊙ 21	*5MVM273DB005	2A820100	PULLEY EXIT /A-49 FUSER A3	2	2	2
⊙ 22	*5MVS217SN002	2A806280	PAD SOLENOID /FS-1000 A4	1	1	1
⊙ 23	*5MVX111DN007	2BT11070	STOPPER 3 /2BT1107 A4	1	1	1
⊙ A03	302HS94160	2HS94160	COVER REAR ASSY SP	1	1	1
⊙ 24	*302HS34020	2HS34020	LABEL FUSER JAM	1	1	1
⊙ 25	302HS28070	2HS28070	PULLEY EXIT	2	2	2
⊙ 26	302HS28120	2HS28120	SPRING EXIT	2	2	2
⊙ 27	302HS08320	2HS08320	SPRING COVER MPF	2	2	2
⊙ 28	302F908200	2F908200	LOCK COVER	2	2	2

Ref. No.	Part.No.	Alternative.	Description	Quantity		
				120	230	240
101	7BB200410H	BB105700	+BIND T.T P SCREW 4X10			

- Parts with "*" are component parts or sub-assemblies of the assembly appearing immediately above them.
- Parts with "⊙" indicate regular maintenance parts.

- Parts with "••" are component parts or sub-assembly with "•" appearing immediately above them.

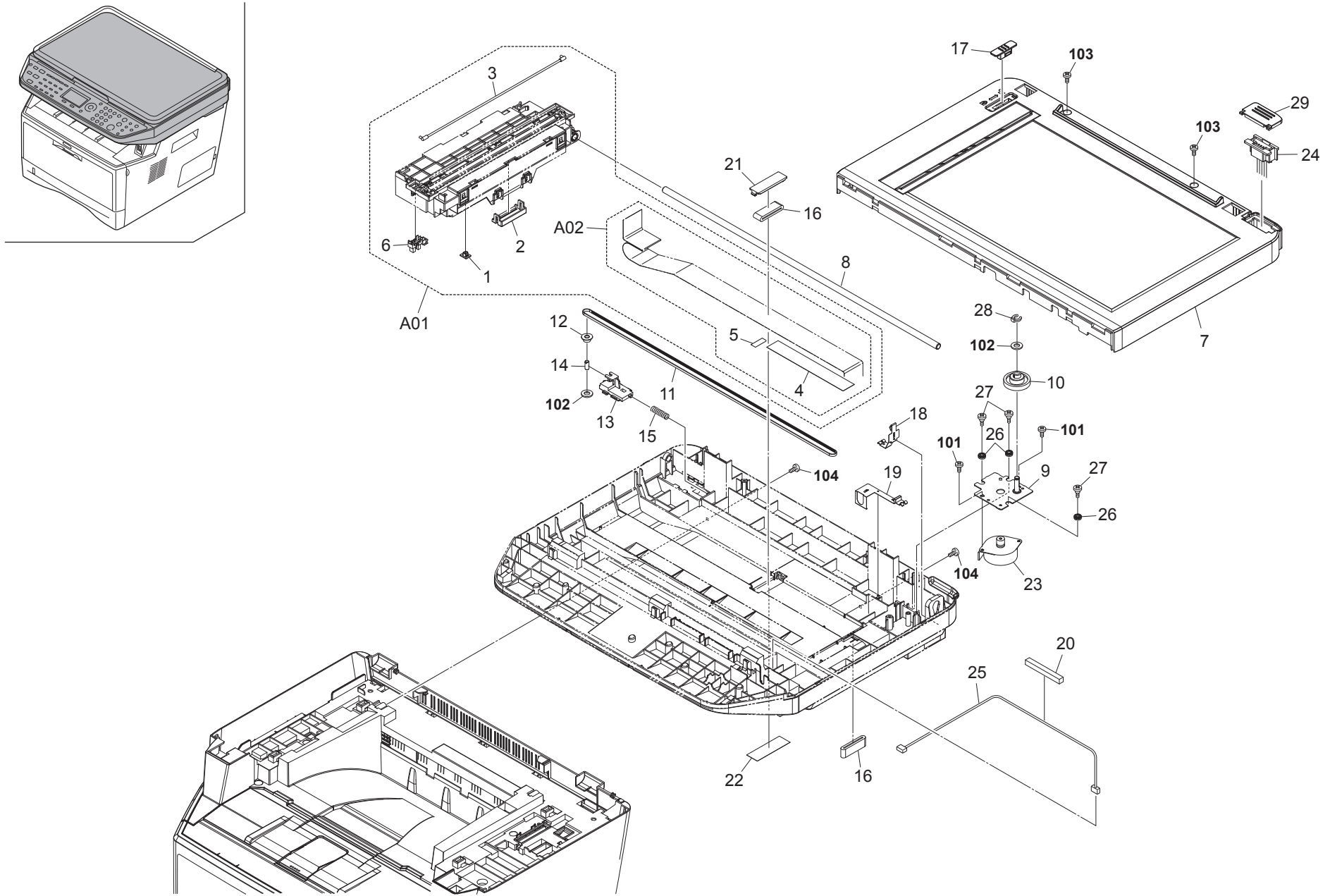

FIG. 6 Scanner Section

2H9-1

Ref. No.	Part.No.	Alternative.	Description	Quantity		
				120	230	240
⊙ A01	302H993040	2H993040	PARTS ISU ASSY	1	1	1
1	*302H917450	2H917450	SLIDER ISU	1	1	1
2	*302H917510	2H917510	HOLDER FFC	1	1	1
⊙ 3	*302H994260	2H994260	PARTS LAMP ISU SP	1	1	1
A02	*302H994310	2H994310	PARTS FFC MAIN-CCD KIT SP	1	1	1
4	**302H917380	2H917380	TAPE FFC A	1	1	1
5	**302H917530	2H917530	TAPE FFC D	1	1	1
6	*7NXSG2481+++H01	NX052600	SENSOR OPT.	1	1	1
⊙ 7	302H994420	2H994420	PARTS FRAME ISU SP	1	1	1
8	302H917051	2H917051	SHAFT ISU	1	1	1
9	302H917210	2H917210	MOUNT MOTOR ISU	1	1	1
⊙ 10	302H917220	2H917220	GEAR ISU 63/32	1	1	1
⊙ 11	302H917230	2H917230	BELT ISU	1	1	1
⊙ 12	302H917240	2H917240	PULLEY TENSION	1	1	1
13	302H917251	2H917251	MOUNT TENSION PULLEY	1	1	1
14	302H917260	2H917260	PIN TENSION PULLEY	1	1	1
15	302H917270	2H917270	SPRING TENSION	1	1	1
16	7YBFZZ65C002H01	YB114070	FERRITE CORE	2	2	2
17	302H917330	2H917330	STOPPER ISU	1	1	1
18	302H917410	2H917410	PLATE EARTH ISU A	1	1	1
19	302H917420	2H917420	PLATE EARTH ISU B	1	1	1
20	302H917500	2H917500	SPONGE HARNESS	1	1	1
21	302H917520	2H917520	STOPPER FFC CENTER	1	1	1
22	302H917540	2H917540	SHEET FRAME BOTTOM	1	1	1
⊙ 23	302H994270	2H994270	PARTS MOTOR ISU SP	1	1	1
24	302H946040	2H946040	CONN.CORD ASSY INTERFACE	1	1	1
25	302H946060	2H946060	CONN.CORD ASSY MAIN-PANEL	1	1	1
26	302JD19140	2JD19140	BUSHING FAN	3	3	3
27	302JD19150	2JD19150	PIN LSU	3	3	3
28	5MVX111DN003	2A806250	RING STOPPER /A-49 FEED A4	1	1	1
29	302H917320	2H917320	COVER DP HARNESS	1	1	1

Ref. No.	Part.No.	Alternative.	Description	Quantity		
				120	230	240
101	7BB700308H	BB105600	+BIND T.T S SCREW 3X8 SR			
102	C2893960	C2893960	SHIM 6.2-13-0.13T			
103	7BB200308H	BB105660	+BIND T.T P SCREW 3X8			
104	7BB200410H	BB105700	+BIND T.T P SCREW 4X10			

- Parts with "*" are component parts or sub-assemblies of the assembly appearing immediately above them.
- Parts with "⊙" indicate regular maintenance parts.

- Parts with "*•" are component parts or sub-assembly with "*" appearing immediately above them.

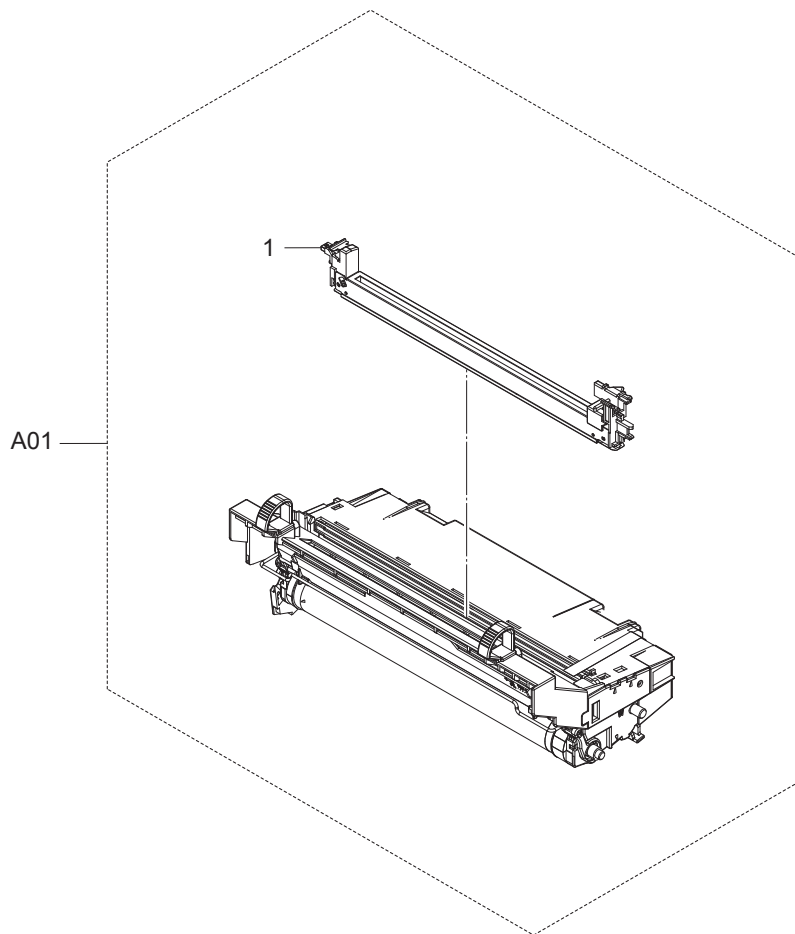
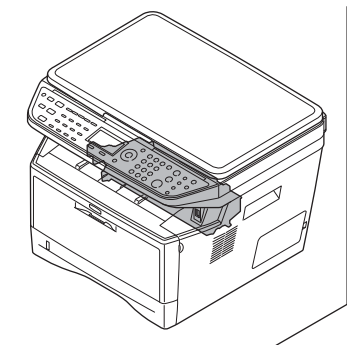

FIG. 7 Image Formation Section

2H9

	Ref. No.	Part.No.	Alternative.	Description	Quantity		
					120	230	240
⊙	A01	302H493010	2H493010	DK-150	1	1	1
⊙	1	•302HS93070	2HS93070	MC-130	1	1	1

- Parts with "•" are component parts or sub-assemblies of the assembly appearing immediately above them.
- Parts with "⊙" indicate regular maintenance parts.

- Parts with "••" are component parts or sub-assembly with "•" appearing immediately above them.

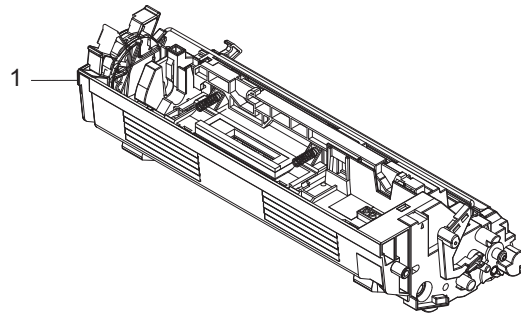
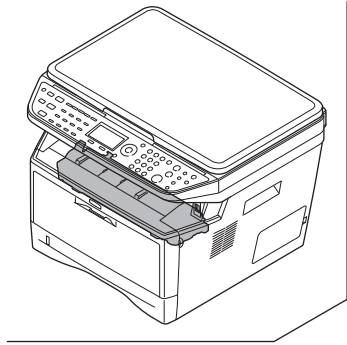

FIG. 8 Developing Section

	Ref. No.	Part.No.	Alternative.	Description	Quantity		
					120	230	240
⊙	1	302HS93101	2HS93101	DV-132(U)	1		
⊙	1	302HS93021	2HS93021	DV-130(E)		1	
⊙	1	302HS93141	2HS93141	DV-134(AO)			1

- Parts with "•" are component parts or sub-assemblies of the assembly appearing immediately above them.
- Parts with "⊙" indicate regular maintenance parts.

- Parts with "••" are component parts or sub-assembly with "•" appearing immediately above them.

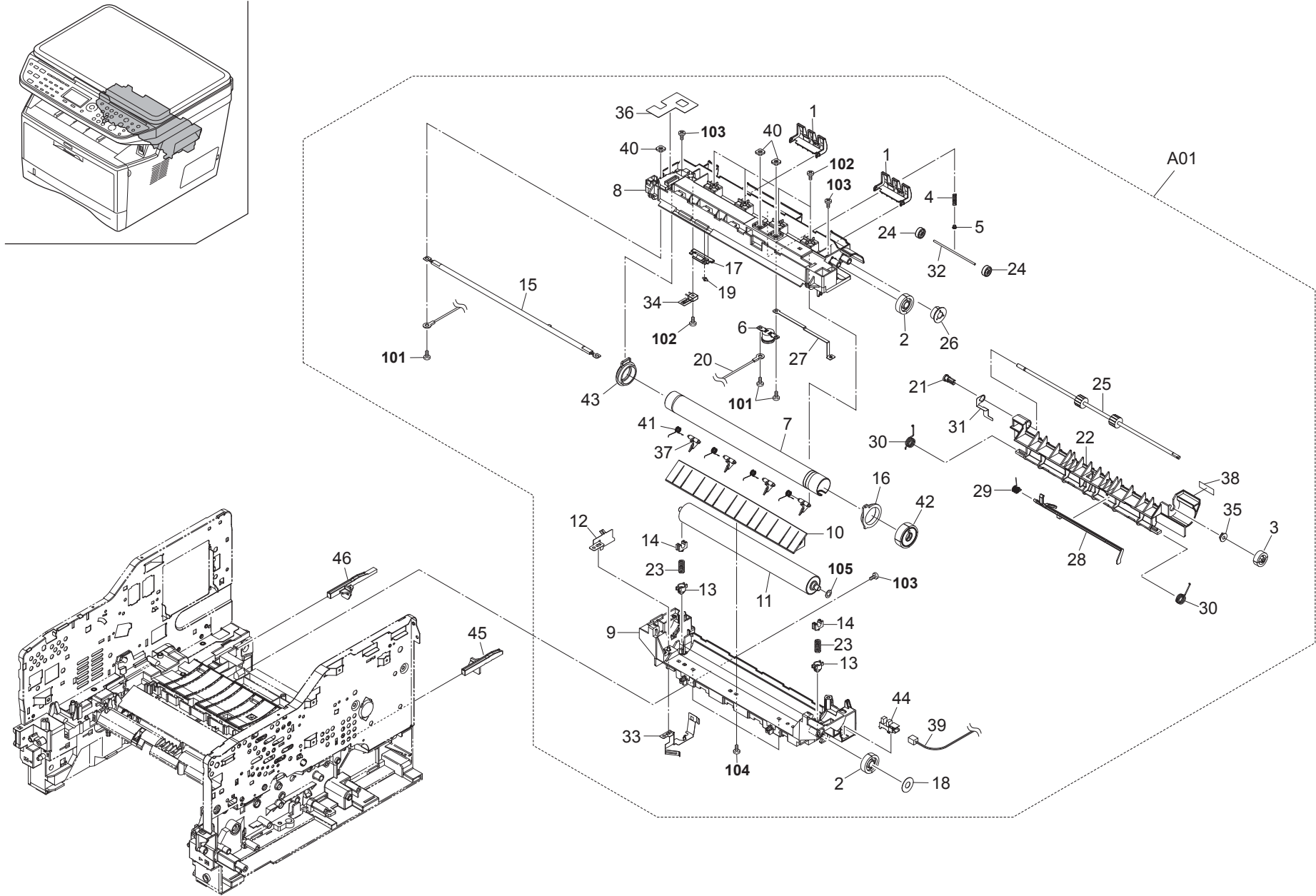

FIG. 9 Fuser Section

2H9-2

Ref. No.	Part.No.	Alternative.	Description	Quantity		
				120	230	240
⊙ A01	302H493031	2H493031	FK-150(U)	1		
⊙ A01	302H493021	2H493021	FK-150(E)		1	1
1	*2FM02190	5MVX532DN004	GUIDE CHANGE /B-11 FRAME A3	2	2	2
⊙ 2	*302F925080	2F925080	GEAR IDLE A Z29	2	2	2
⊙ 3	*302F925141	2F925141	GEAR EXIT Z21	1	1	1
⊙ 4	*302F925340	2F925340	SPRING EXIT	1	1	1
5	*302F925901	2F925901	CAP SPRING EXIT	1	1	1
⊙ 6	*302GR25290	2GR25290	THERMOSTAT M FUSER	1	1	1
⊙ 7	*302H425010	2H425010	ROLLER HEAT	1	1	1
8	*302H425050	2H425050	FRAME FUSER UP	1	1	1
9	*302H425061	2H425061	FRAME FUSER LOW	1	1	1
10	*302H425070	2H425070	GUIDE FUSER	1	1	1
⊙ 11	*302H425090	2H425090	ROLLER PRESS	1	1	1
12	*302H425100	2H425100	PLATE EARTH ROLLER	1	1	1
13	*302H425110	2H425110	HOLDER SPRING PRESS	2	2	2
⊙ 14	*302H425121	2H425121	BUSH PRESS	2	2	2
⊙ 15	*302H425140	2H425140	HEATER LAMP U	1		
⊙ 15	*302H425130	2H425130	HEATER LAMP E		1	1
⊙ 16	*302H425150	2H425150	BUSH HEAT R	1	1	1
17	*302H425170	2H425170	HOLDER PULLEY	1	1	1
18	*302H425180	2H425180	FILM GEAR PROTECT	1	1	1
19	*302H425190	2H425190	PULLEY GUIDE FUSER	1	1	1
20	*302H446060	2H446060	CONN.CORD ASSY PWS-HEATER(U) S03509	1		
20	*302H446050	2H446050	CONN.CORD ASSY PWS-HEATER(E) S03508		1	1
21	*302H25450	2H25450	BUSH EXIT	1	1	1
22	*302HS25030	2HS25030	GUIDE EXIT LOW	1	1	1
23	*302HS25040	2HS25040	SPRING PRESSURE	2	2	2
⊙ 24	*302HS25050	2HS25050	PULLEY EXIT FUSER	2	2	2
⊙ 25	*302HS25060	2HS25060	ROLLER EXIT	1	1	1
⊙ 26	*302HS25070	2HS25070	GEAR Z18S IDLE	1	1	1
27	*302HS25080	2HS25080	PLATE CODE	1	1	1
28	*302HS25110	2HS25110	ACTUATOR FUSER	1	1	1
29	*302HS25120	2HS25120	SPRING ACTUATOR	1	1	1
30	*302HS25130	2HS25130	SPRING EXIT L	2	2	2
31	*302HS25140	2HS25140	PLATE EARTH EXIT	1	1	1
32	*302HS25150	2HS25150	SHAFT EXIT	1	1	1
⊙ 33	*302HS25160	2HS25160	PLATE EARTH L	1	1	1
⊙ 34	*302HS25190	2HS25190	THERMISTOR FUSER	1	1	1
35	*302HS25220	2HS25220	BUSH FUSER	1	1	1
36	*302HS25400	2HS25400	SHEET FUSER	1	1	1
⊙ 37	*302HS25460	2HS25460	SEPARATOR	4	4	4
38	*302HS34120	2HS34120	LABEL FUSER OPERATION	1	1	1
39	*302HS46140	2HS46140	CONN.CORD ASSY CONTROL-EXITSSENSOR S03	1	1	1
40	*5MMS111SL002	2BY20050	NUT FUSER A /FS-1800/3800 A4	3	3	3
41	*5MMW261LD055	2A820350	SPRING SEPARATOR /FS-1000 A4	4	4	4
⊙ 42	*5MVG148XN010	2BR20200	GEAR HEAT Z36 /43307P0005 A4	1	1	1
⊙ 43	*5MVX441XN001	2BR20180	BUSH HEAT L /43307P0003 A4	1	1	1
44	*7NXSG2481+++H01	NX052600	SENSOR OPT.	1	1	1
45	302HS25200	2HS25200	LEVER FUSER R	1	1	1
46	302HS25210	2HS25210	LEVER FUSER L	1	1	1

Ref. No.	Part.No.	Alternative.	Description	Quantity		
				120	230	240
101	7BB007306H	BB112570	+TP-CUP M SCREW 3X6			
102	7BB200312H	BB105680	+BIND T.T P SCREW 3X12			
103	7BB200410H	BB105700	+BIND T.T P SCREW 4X10			
104	7BB200308H	BB105660	+BIND T.T P SCREW 3X8			
105	7BC04060A050H01	BC057930	FLAT A WASHER M6X10X0.5T SUS			

- Parts with "*" are component parts or sub-assemblies of the assembly appearing immediately above them.
- Parts with "⊙" indicate regular maintenance parts.

- Parts with "••" are component parts or sub-assembly with "•" appearing immediately above them.

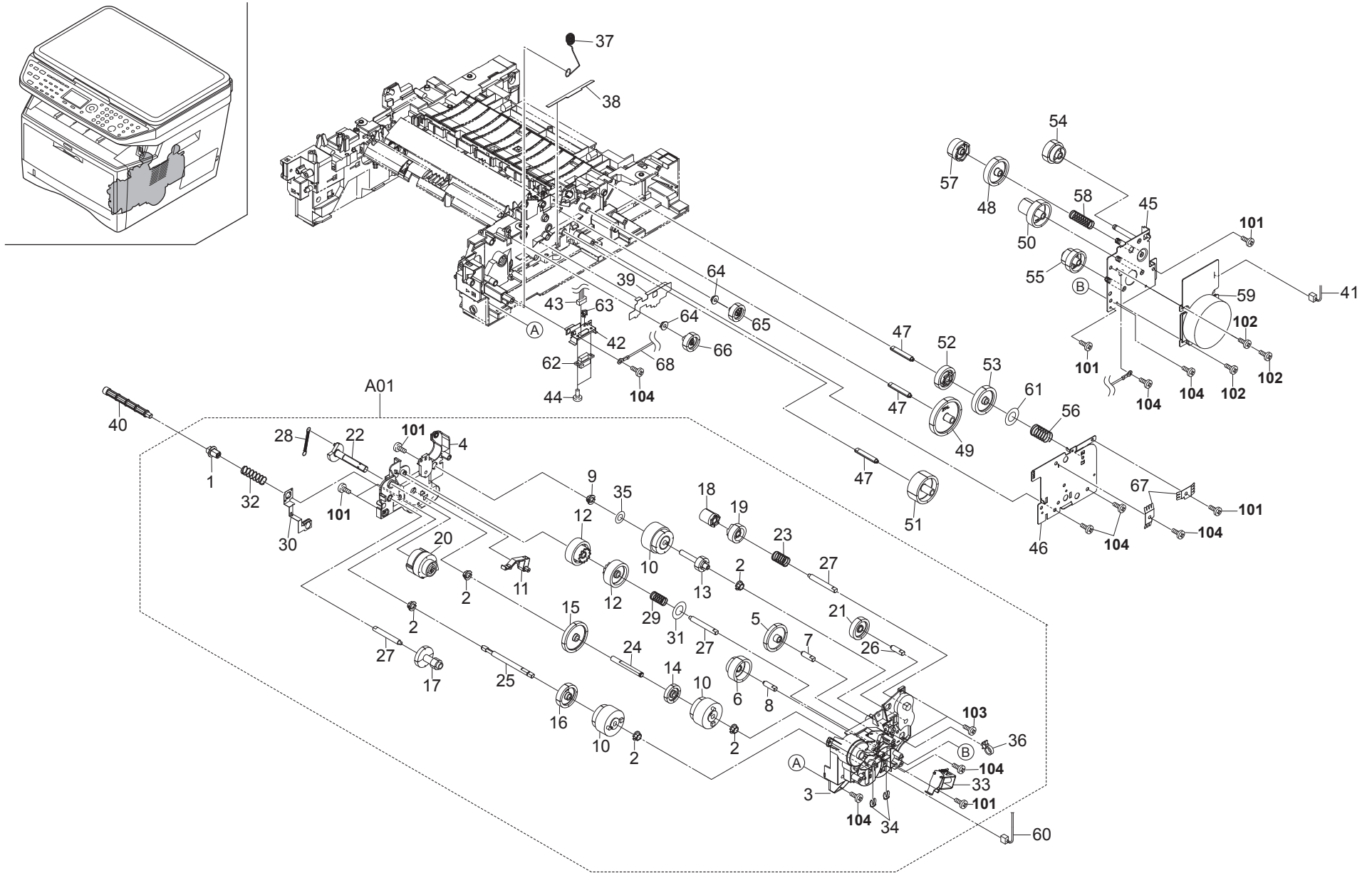

FIG. 10 Drive Section

2H9

Ref. No.	Part.No.	Alternative.	Description	Quantity		
				120	230	240
⊙ A01	302H493040	2H493040	DR-150	1	1	1
1	*302F931350	2F931350	JOINT SHAFT CASSETTE	1	1	1
2	*302F931490	2F931490	BUSH FEED DRIVE	5	5	5
3	*302H431010	2H431010	HOLDER DRIVE	1	1	1
4	*302H431020	2H431020	COVER HOLDER DRIVE	1	1	1
⊙ 5	*302H431030	2H431030	GEAR Z42R	1	1	1
⊙ 6	*302H431040	2H431040	GEAR Z34L-Z24L	1	1	1
7	*302H431050	2H431050	PIN HOLDER A	1	1	1
8	*302H431060	2H431060	PIN HOLDER B	1	1	1
9	*302H431070	2H431070	BUSH DRIVE 6	1	1	1
⊙ 10	*302HN44110	2HN44110	CLUTCH FEED	3	3	3
11	*302HS31050	2HS31050	LEVER LIFT BOTTOM	1	1	1
⊙ 12	*302HS31090	2HS31090	GEAR Z37L FREE	2	2	2
⊙ 13	*302HS31100	2HS31100	GEAR Z20L CLUTCH	1	1	1
⊙ 14	*302HS31120	2HS31120	GEAR Z27L CLUTCH	1	1	1
⊙ 15	*302HS31130	2HS31130	GEAR Z45R CLUTCH	1	1	1
⊙ 16	*302HS31140	2HS31140	GEAR Z35R IDLE	1	1	1
⊙ 17	*302HS31150	2HS31150	GEAR Z31L-Z14S	1	1	1
⊙ 18	*302HS31190	2HS31190	GEAR Z17R FREE	1	1	1
⊙ 19	*302HS31200	2HS31200	GEAR Z26L FREE	1	1	1
⊙ 20	*302HS31230	2HS31230	GEAR Z38S MPF	1	1	1
⊙ 21	*302HS31260	2HS31260	GEAR Z32R	1	1	1
⊙ 22	*302HS31281	2HS31281	LIFT BOTTOM	1	1	1
23	*302HS31320	2HS31320	SPRING FREE MAG	1	1	1
24	*302HS31330	2HS31330	PIN CLUTCH	1	1	1
25	*302HS31340	2HS31340	SHAFT CASSETTE	1	1	1
26	*302HS31360	2HS31360	PIN HOLDER A	1	1	1
27	*302HS31370	2HS31370	PIN HOLDER B	3	3	3
28	*302HS31380	2HS31380	SPRING LIFT BOTTOM	1	1	1
29	*302HS31410	2HS31410	SPRING FREE Z37L	1	1	1
30	*302HS31420	2HS31420	EARTH PLATE DRIVE	1	1	1
31	*302HS31430	2HS31430	POLYSLIDER 9.5	1	1	1
32	*302HS31440	2HS31440	SPRING FEED	1	1	1
⊙ 33	*302HS44020	2HS44020	SOLENOID MPF	1	1	1
34	*5MVX1111DN003	2A806250	RING STOPPER /A-49 FEED A4	2	2	2
35	*7BC06062C020H01	BC045240	POLY SLIDER WASHER M6.2X12X0.2T	1	1	1
36	*M2107250	M2107250	BAND,RSG-100(KITAGAWA)	1	1	1
37	302HS02370	2HS02370	SPRING EARTH CASSETTE	1	1	1
38	302HS02520	2HS02520	COVER CABLE E	1	1	1
39	302HS02530	2HS02530	COVER CABLE F	1	1	1
40	302HS06110	2HS06110	SHAFT FEED	1	1	1
41	302HS46040	2HS46040	CONN.CORD ASSY CONTROL-MAIN MOTOR S0	1	1	1
42	302HS02381	2HS02381	PLATE PF CONNECTOR	1	1	1
43	302HS46030	2HS46030	CONN.CORD ASSY CONTROL-PF S03247	1	1	1
44	302HS02540	2HS02540	PIN DRAWER	2	2	2
⊙ 45	302HS31020	2HS31020	PLATE DRIVE	1	1	1
46	302HS31041	2HS31041	PLATE GEAR DRIVE	1	1	1
47	302HS31060	2HS31060	PIN GEAR DRIVE	3	3	3
⊙ 48	302HS31070	2HS31070	GEAR Z42R FREE 2	1	1	1
⊙ 49	302HS31110	2HS31110	GEAR Z58L	1	1	1

- Parts with "*" are component parts or sub-assemblies of the assembly appearing immediately above them.
- Parts with "⊙" indicate regular maintenance parts.

Ref. No.	Part.No.	Alternative.	Description	Quantity		
				120	230	240
⊙ 50	302H431080	2H431080	GEAR Z64R-Z21L	1	1	1
⊙ 51	302HS31180	2HS31180	GEAR Z44R	1	1	1
⊙ 52	302HS31210	2HS31210	GEAR Z35S FREE	1	1	1
⊙ 53	302HS31220	2HS31220	GEAR Z42R FREE	1	1	1
⊙ 54	302HS31240	2HS31240	GEAR Z32L DRUM	1	1	1
⊙ 55	302HS31250	2HS31250	GEAR Z54R-Z24R	1	1	1
56	302HS31310	2HS31310	SPRING FREE FUSER	1	1	1
⊙ 57	302HS31390	2HS31390	GEAR Z27R FREE 2	1	1	1
58	302HS31400	2HS31400	SPRING FREE DRUM	1	1	1
⊙ 59	302HS44010	2HS44010	MOTOR MAIN	1	1	1
60	302HS46210	2HS46210	CONN.CORD ASSY CONTROL-F/RCLUTCH S033	1	1	1
61	302HS31430	2HS31430	POLYSLIDER 9.5	1	1	1
62	7YCC08B1112+H01	YC058670	CONNECTOR	1	1	1
63	7YZM610007++H01	YZ023340	ACCESS.SADDLE	1	1	1
64	302F929140	2F929140	BUSH DU	2	2	2
⊙ 65	302HS24220	2HS24220	GEAR Z25R DU FEED	1	1	1
⊙ 66	302HS24230	2HS24230	GEAR Z26L DU MID	1	1	1
67	302H902280	2H902280	PLATE EARTH DRIVE	2	2	2
68	302H946130	2H946130	CONN.CORD ASSY FG	1	1	1
101	7BB700308H	BB105600	+BIND T.T S SCREW 3X8 SR			
102	BAB53060	BAB53060	+TP TAP-TITE S SCREW M3X06			
103	7BB100306H1	BB105820	+BIND T.T S SCREW 3X6			
104	7BB200410H	BB105700	+BIND T.T P SCREW 4X10			

- Parts with "•" are component parts or sub-assembly with "•" appearing immediately above them.

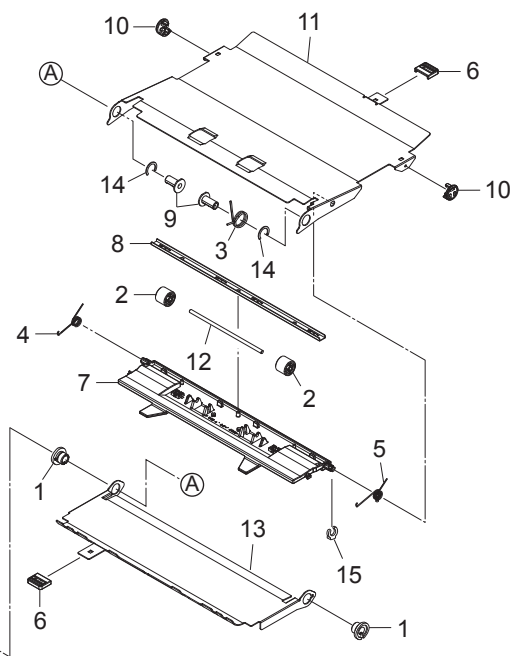
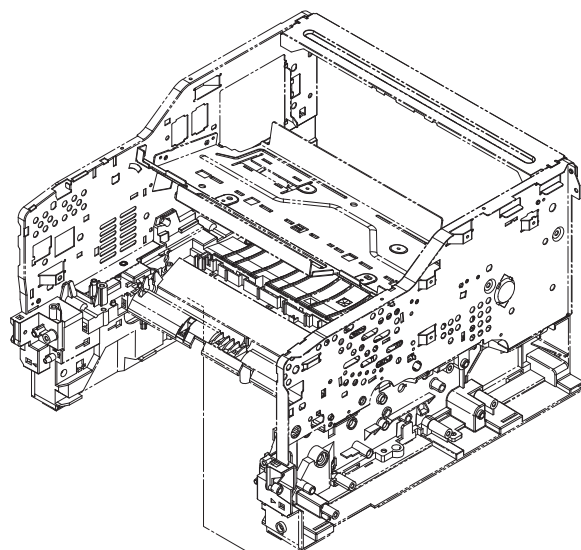
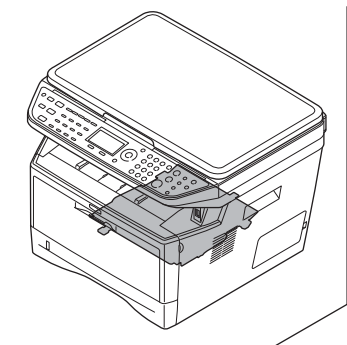

FIG. 11 Paper Conveying Section

Ref. No.	Part.No.	Alternative.	Description	Quantity			
				120	230	240	
⊙	1	2FM02140	5MVM786XB001	BUSH DU /B-11 FRAME A3	2	2	2
	2	2FM02210	5MVM274DN002	PULLEY MID /B-11 FRAME A4	2	2	2
	3	2FM02500	5MMW176SD002	SPRING DU R /B-11 FRAME A4	1	1	1
	4	2FM02510	5MMW166SD002	SPRING HOLDER L /B-11 FRAME A4	1	1	1
	5	2FM02520	5MMW166SD003	SPRING HOLDER R /B-11 FRAME A4	1	1	1
	6	2FM02690	5MVX221DG002	LEVER DU /B-11 DU A3	2	2	2
	7	2FM21010	5MVX861XB001	HOLDER DU /B-11 DU A1	1	1	1
	8	2FM21020	5MML821SD009	STAY DU /B-11 DU A3	1	1	1
	9	2FM21030	5MVM276DN017	STOPPER BUSH /B-11 DU A4	2	2	2
	10	2FM21050	5MVX173DN001	COLLER DU /B-11 DU A3	2	2	2
	11	302HS29020	2HS29020	PLATE COVER DU B	1	1	1
	12	302FM02421	2FM02421	SHAFT PULLEY /B-11 FRAME A4	1	1	1
	13	302HS29010	2HS29010	PLATE COVER DU	1	1	1
	14	5MBCK9560XSC	D4103700	C STOP RING /X9.5 X 0.6T S-CR	2	2	2
	15	5MVX111DN003	2A806250	RING STOPPER /A-49 FEED A4	1	1	1

- Parts with "•" are component parts or sub-assemblies of the assembly appearing immediately above them.
- Parts with "⊙" indicate regular maintenance parts.

- Parts with "••" are component parts or sub-assembly with "•" appearing immediately above them.

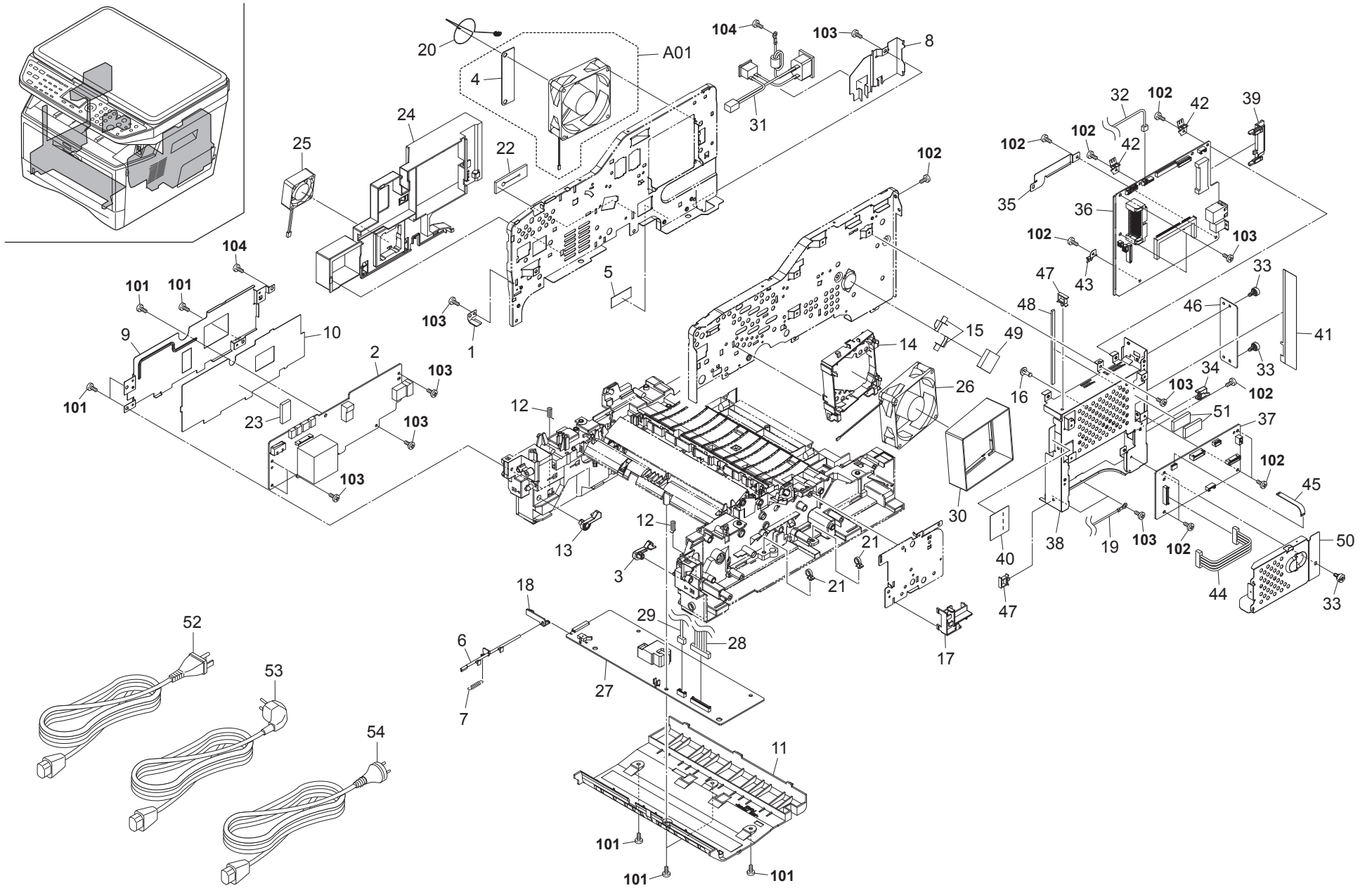

FIG. 12 Electrical Components

2H9-1

Ref. No.	Part.No.	Alternative.	Description	Quantity		
				120	230	240
1	302H902210	2H902210	PLATE EARTH MPF	1	1	1
2	302H994290	2H994290	PARTS SWITCHING REGULATOR 120V SP	1		
2	302H994300	2H994300	PARTS SWITCHING REGULATOR 230V SP		1	1
3	302HS02070	2HS02070	LEVER LOCK CASSETTE	1	1	1
A01	302H994440	2H994440	PARTS MOTOR FAN ASSY SP	1	1	1
4	*302H902300	2H902300	SHEET FAN L	1	1	1
5	302H902260	2H902260	SHEET PWB	1	1	1
6	302HS02180	2HS02180	PIN CASSETTE	1	1	1
7	302HS02190	2HS02190	SPRING PIN CASSETTE	1	1	1
8	302H902220	2H902220	MOUNT INLET	1	1	1
9	302H902100	2H902100	PLATE POWER SUPPLY	1	1	1
10	302H902191	2H902191	SHEET REGULATOR PWB	1	1	1
11	302HS02280	2HS02280	COVER BASE LOW	1	1	1
12	302HS02360	2HS02360	SPRING LOCK CASSETTE	2	2	2
13	302HS02390	2HS02390	LEVER LOCK CASSETTE L	1	1	1
14	302HS02420	2HS02420	BKT FAN R	1	1	1
15	302H902290	2H902290	HOLDER THERMAL SHEET	2	2	2
16	7ZS25253001+H01	ZS113220	THERMAL SHEET	1	1	1
17	302HS02510	2HS02510	COVER CABLE D	1	1	1
18	302HS02561	2HS02561	HOLDER PIN CASSETTE	1	1	1
19	302H946120	2H946120	CONN.CORD ASSY LVU-MAIN	1	1	1
20	302HS02620	2HS02620	SPRING EARTH FAN	1	1	1
21	M2107250	M2107250	BAND,RSG-100(KITAGAWA)	2	2	2
22	302H902310	2H902310	SEAL FRAME L	1	1	1
23	7ZS29154001+H01	ZS114200	THERMAL SHEET	1	1	1
24	302H902160	2H902160	DUCT FRAME L	1	1	1
25	302H994280	2H994280	PARTS MOTOR FAN 40 SP	1	1	1
26	302HS44050	2HS44050	MOTOR FAN 80	1	1	1
27	302H445040	2H445040	HIGH VOLTAGE UNIT	1	1	1
28	302JA46020	2JA46020	CONN.CORD ASSY CONTROL-H.V.UNIT S03391	1	1	1
29	302HS46070	2HS46070	CONN.CORD ASSY CONTROL-H.V.UNIT S03303	1	1	1
30	302H902170	2H902170	DUCT FRAME R	1	1	1
31	302H946100	2H946100	CONN.CORD ASSY PWS-INLET	1	1	1
32	302HS46130	2HS46130	CONN.CORD ASSY CONTROL-ERASER S03252	1	1	1
33	302F939081	2F939081	SCREW BOX	3	3	3
34	302F939090	2F939090	CAP NETWORK	1	1	1
35	302H439020	2H439020	PLATE EARTH BOX	1	1	1
36	302H994011	2H994011	PART MAIN PWB ASSY SP	1		1
36	302H994021	2H994021	PART MAIN PWB ASSY SP EU		1	
37	302H994030	2H994030	PARTS SCANNER PWB ASSY SP	1	1	1
38	302H939011	2H939011	BOX CONTROLLER	1	1	1
39	302H939030	2H939030	GUIDE CF	1	1	1
40	302H939070	2H939070	SHEET PWB	1	1	1
41	302H939080	2H939080	SHEET BOX	1	1	1
42	302H939100	2H939100	PLATE EARTH CONTBOX A	2	2	2
43	302H939110	2H939110	PLATE EARTH CONTBOX B	1	1	1
44	302H946010	2H946010	CONN.CORD ASSY MAIN-SCN	1	1	1
45	302H946110	2H946110	FFC SCN-MAIN	1	1	1
46	302HS39040	2HS39040	PLATE OPTION	1	1	1
47	7YZM610008++H01	YZ037940	ACCESS.SADDLE	2	2	2

Ref. No.	Part.No.	Alternative.	Description	Quantity		
				120	230	240
48	7ZGSTGR55120H01	ZG114640	SHIELD GASKET	1	1	1
49	M2108670	M2108670	SPACER,KGPS-6RF(KITAGAWA)	1	1	1
50	302H939020	2H939020	PLATE SHIELD	1	1	1
51	7ZS29154001+H01	ZS114200	THERMAL SHEET	2	2	2
52	7AAACCUS+10H001	AA068380	AC CORD ASSY US	1		
53	302FV45020	2FV45020	AC CORD ASSY		1	
54	302FV45040	2FV45040	AC CORD ASSY			1
101	7BB200410H	BB105700	+BIND T.T P SCREW 4X10			
102	7BB600306H	BB105730	+BIND M SCREW 3X6 R			
103	7BB700308H	BB105600	+BIND T.T S SCREW 3X8 SR			
104	7BB100406H	BB106920	+BIND T.T S SCREW 4X6			

- Parts with "*" are component parts or sub-assemblies of the assembly appearing immediately above them.
- Parts with "⊙" indicate regular maintenance parts.

- Parts with "••" are component parts or sub-assembly with "•" appearing immediately above them.

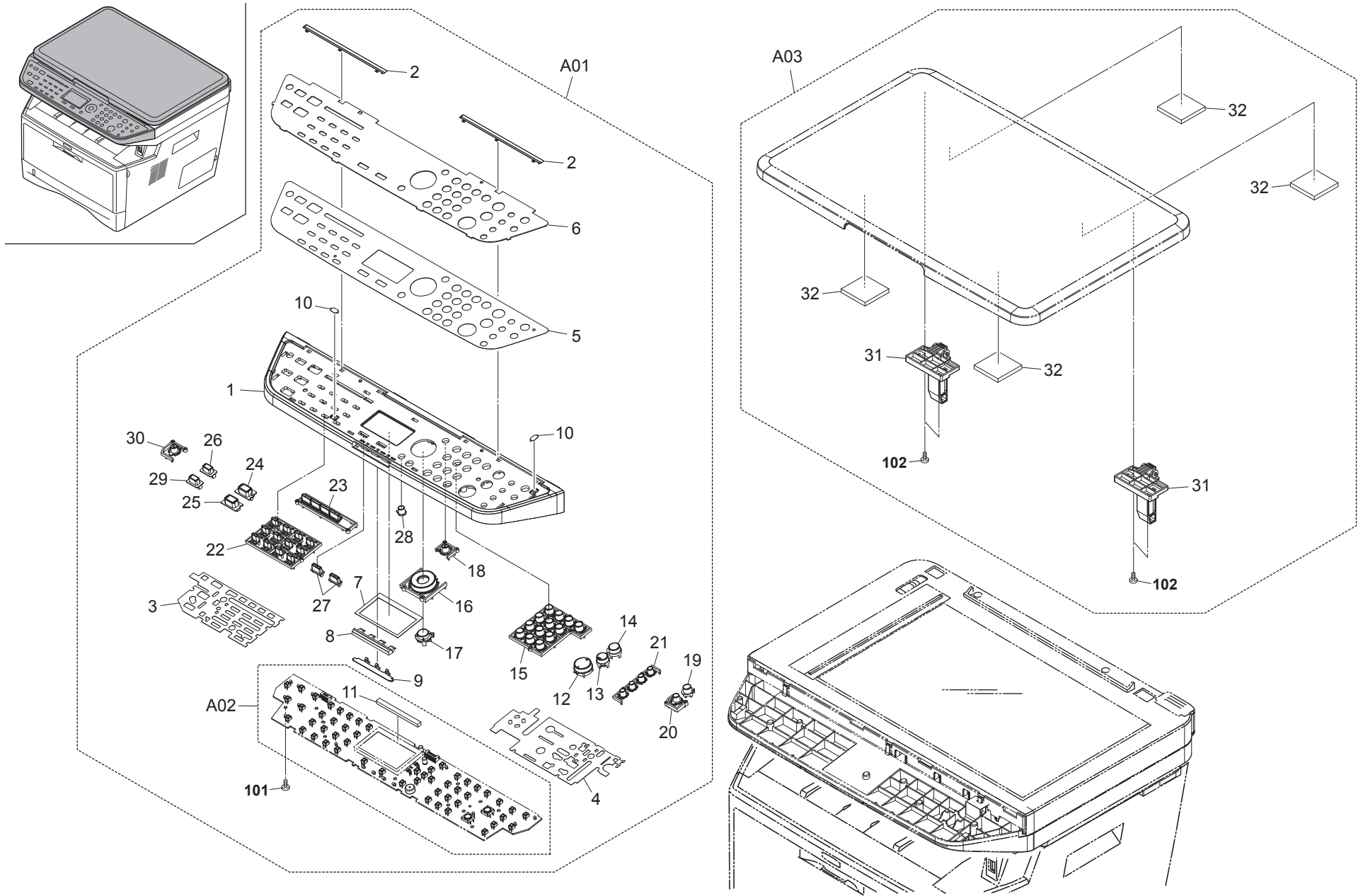

FIG. 13 Operation Section & Original Holder

2H9-1

Ref. No.	Part.No.	Alternative.	Description	Quantity			Ref. No.	Part.No.	Alternative.	Description	Quantity		
				120	230	240					120	230	240
⊙ A01	302H994340	2H994340	PARTS OPERATION UNIT SP	1	1	1	101	7BB200308H	BB105660	+BIND T.T P SCREW 3X8			
1	*302H905010	2H905010	COVER OPERATION	1	1	1	102	7BB202308H	BB105690	+TP-FLAT T.T P SCREW 3X8			
2	*302H905240	2H905240	LID OPE SHEET	2	2	2							
3	*302H905300	2H905300	SHIELD DUST LEFT	1	1	1							
4	*302H905330	2H905330	SHIELD DUST RIGHT	1	1	1							
5	*302H905360	2H905360	LABEL OPE E	1	1	1							
6	*302H905370	2H905370	PANEL OPE	1	1	1							
7	*302H905390	2H905390	SHEET STATIC LCD	1	1	1							
8	*302H905410	2H905410	LENS INFORMATION	1	1	1							
9	*302H905420	2H905420	HOLDER LENS	1	1	1							
10	*302H905430	2H905430	FILM DIFFUSION	2	2	2							
⊙ A02	*302H994040	2H994040	PARTS PANEL PWB ASSY SP	1	1	1							
11	**7ZGSTGR55060H01	ZG112780	SHIELD GASKET	1	1	1							
12	*302H994060	2H994060	PARTS KEY START SP	1	1	1							
13	*302H994070	2H994070	PARTS KEY STOP SP	1	1	1							
14	*302H994080	2H994080	PARTS KEY RESET SP	1	1	1							
15	*302H994090	2H994090	PARTS KEY OPERATION 10 SP	1	1	1							
16	*302H994100	2H994100	PARTS KEY CONTROL SP	1	1	1							
17	*302H994110	2H994110	PARTS KEY OK SP	1	1	1							
18	*302H994120	2H994120	PARTS KEY MENU SP	1	1	1							
19	*302H994130	2H994130	PARTS KEY POWER SP	1	1	1							
20	*302H994140	2H994140	PARTS KEY LOGOUT SP	1	1	1							
21	*302H994150	2H994150	PARTS KEY PROGRAM SP	1	1	1							
22	*302H994160	2H994160	PARTS KEY ONE TOUCH SP	1	1	1							
23	*302H994170	2H994170	PARTS KEY ADDRESS SP	1	1	1							
24	*302H994180	2H994180	PARTS KEY COPY SP	1	1	1							
25	*302H994190	2H994190	PARTS KEY SEND SP	1	1	1							
26	*302H994210	2H994210	PARTS KEY STATUS SP	1	1	1							
27	*302H994220	2H994220	PARTS KEY LCD SP	2	2	2							
28	*302H994230	2H994230	PARTS KEY BACK SP	1	1	1							
29	*302H994240	2H994240	PARTS KEY BOX SP	1	1	1							
30	*302H994250	2H994250	PARTS KEY SYSTEM SP	1	1	1							
⊙ A03	302H993050	2H993050	PARTS PLATEN COVER	1	1	1							
31	*2DC11060	2DC11060	HINGE ORIGINAL COVER	2	2	2							
32	*302H918041	2H918041	SPONGE ORIGINAL MAT	4	4	4							

- Parts with "*" are component parts or sub-assemblies of the assembly appearing immediately above them.
- Parts with "⊙" indicate regular maintenance parts.

- Parts with "*•" are component parts or sub-assembly with "*" appearing immediately above them.

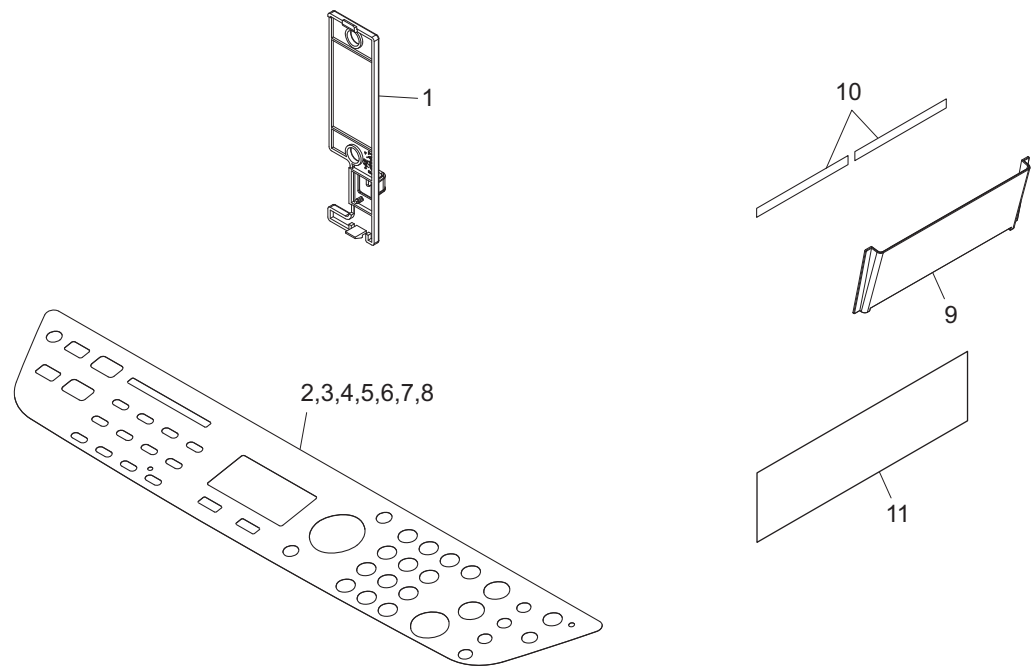

FIG. 14 Accessories

2H9-1

	Ref. No.	Part.No.	Alternative.	Description	Quantity		
					120	230	240
⊙	1	302H939061	2H939061	COVER BOX	1	1	1
	2	302H905441	2H905441	LABEL OPE GER		1	
	3	302H905450	2H905450	LABEL OPE FRA	1	1	
	4	302H905460	2H905460	LABEL OPE ITA		1	
	5	302H905470	2H905470	LABEL OPE SPA	1	1	
	6	302H905480	2H905480	LABEL OPE POR	1	1	
	7	302H905490	2H905490	LABEL OPE DUT		1	
	8	302H905500	2H905500	LABEL OPE RUS		1	
	9	302H904290	2H904290	HOLDER GUIDEBOOK	1	1	1
	10	302H904300	2H904300	TAPE GUIDEBOOK	2	2	2
	11	302H934080	2H934080	LABEL GUIDEBOOK	1	1	1

- Parts with "•" are component parts or sub-assemblies of the assembly appearing immediately above them.
- Parts with "⊙" indicate regular maintenance parts.

- Parts with "••" are component parts or sub-assembly with "•" appearing immediately above them.

FIG. 15 Maintenance Kits

Ref. No.	Part.No.	Alternative.	Description	Quantity		
				120	230	240
	1702H97US0	072H97US	MK-132/MAINTENANCE KIT (OPTION) •DK-150 •DV-132(U)	1 1 1		
	1702H98EU0	072H98EU	MK-130/MAINTENANCE KIT (OPTION) •DK-150 •DV-130(E)		1 1 1	
	1702H98AS0	072H98AS	MK-134/MAINTENANCE KIT (OPTION) •DK-150 •DV-134(AO)			1 1 1

- Parts with "•" are component parts or sub-assemblies of the assembly appearing immediately above them.
- Parts with "⊙" indicate regular maintenance parts.

- Parts with "• •" are component parts or sub-assembly with "•" appearing immediately above them.

	Part.No.	Alternative.	Description	Fig.No.		Part.No.	Alternative.	Description	Fig.No.
	1702H97US0	072H97US	MK-132/MAINTENANCE KIT (OPTION)	15		302FV45040	2FV45040	AC CORD ASSY	12
	1702H98AS0	072H98AS	MK-134/MAINTENANCE KIT (OPTION)	15		302G634070	2G634070	LABEL ENERGY STAR	2
	1702H98EU0	072H98EU	MK-130/MAINTENANCE KIT (OPTION)	15		302GJ09111	2GJ09111	GUIDE RETARD	3
⊙	2BL06380	2BL06380	GEAR Z25 JOINT	5	⊙	302GR25290	2GR25290	THERMOSTAT M FUSER	9
	2DC11060	2DC11060	HINGE ORIGINAL COVER	13		302H402020	2H402020	HOLDER ERASER	2
	2FM02140	5MVM786XB001	BUSH DU /B-11 FRAME A3	11		302H402040	2H402040	SPRING REG GND	2
	2FM02180	5MVX221DN020	BUSH REGIST C /B-11 FRAME A3	4		302H402050	2H402050	BUSH REGIST	4
	2FM02190	5MVX532DN004	GUIDE CHANGE /B-11 FRAME A3	9		302H402060	2H402060	SPRING EARTH DU FEED	2
⊙	2FM02210	5MVM274DN002	PULLEY MID /B-11 FRAME A4	11	⊙	302H425010	2H425010	ROLLER HEAT	9
⊙	2FM02350	5MVG133DN022	GEAR Z22 /B-11 FRAME A4	5		302H425050	2H425050	FRAME FUSER UP	9
	2FM02500	5MMW176SD002	SPRING DU R /B-11 FRAME A4	11		302H425061	2H425061	FRAME FUSER LOW	9
	2FM02510	5MMW166SD002	SPRING HOLDER L /B-11 FRAME A4	11		302H425070	2H425070	GUIDE FUSER	9
	2FM02520	5MMW166SD003	SPRING HOLDER R /B-11 FRAME A4	11	⊙	302H425090	2H425090	ROLLER PRESS	9
	2FM02690	5MVX221DG002	LEVER DU /B-11 DU A3	11		302H425100	2H425100	PLATE EARTH ROLLER	9
	2FM06010	5MVX765SH004	GUIDE SIDE L /B-11 CASSETTE A2	3		302H425110	2H425110	HOLDER SPRING PRESS	9
	2FM06020	5MVX765SH005	GUIDE SIDE R /B-11 CASSETTE A2	3	⊙	302H425121	2H425121	BUSH PRESS	9
	2FM20050	5MVX651DN001	LEVER SOLENOID /B-11 FD A3	5	⊙	302H425130	2H425130	HEATER LAMP E	9
	2FM21010	5MVX861XB001	HOLDER DU /B-11 DU A1	11	⊙	302H425140	2H425140	HEATER LAMP U	9
	2FM21020	5MML821SD009	STAY DU /B-11 DU A3	11	⊙	302H425150	2H425150	BUSH HEAT R	9
	2FM21030	5MVM276DN017	STOPPER BUSH /B-11 DU A4	11		302H425170	2H425170	HOLDER PULLEY	9
	2FM21050	5MVX173DN001	COLLER DU /B-11 DU A3	11		302H425180	2H425180	FILM GEAR PROTECT	9
	302A816031	2A816031	BUSH TC R /A-49 FEED A4	4		302H425190	2H425190	PULLEY GUIDE FUSER	9
	302F325010	2F325010	STUD SCREW M3	5		302H428010	2H428010	FILM SOLENOID	5
	302F902420	2F902420	LOCK COVER TOP R	2		302H431010	2H431010	HOLDER DRIVE	10
	302F906170	2F906170	JOINT PICKUP A	4		302H431020	2H431020	COVER HOLDER DRIVE	10
	302F906180	2F906180	JOINT PICKUP B	4	⊙	302H431030	2H431030	GEAR Z42R	10
	302F906230	2F906230	PULLEY FEED ASSY	4	⊙	302H431040	2H431040	GEAR Z34L-Z24L	10
	302F906240	2F906240	PULLEY PICKUP ASSY	4		302H431050	2H431050	PIN HOLDER A	10
	302F906272	2F906272	SHAFT FEED L	4		302H431060	2H431060	PIN HOLDER B	10
	302F906280	2F906280	GEAR FEED Z30H	4		302H431070	2H431070	BUSH DRIVE 6	10
	302F908200	2F908200	LOCK COVER	5	⊙	302H431080	2H431080	GEAR Z64R-Z21L	10
	302F908270	2F908270	SP BOTTOM MPF L	2		302H439020	2H439020	PLATE EARTH BOX	12
	302F908310	2F908310	PAD FRICTION MPF	2	⊙	302H445040	2H445040	HIGH VOLTAGE UNIT	12
	302F909031	2F909031	LEVER BASE CAS REAR	3		302H446050	2H446050	CONN.CORD ASSY PWS-HEATER(E) S03508	9
	302F909040	2F909040	SPRING BASE CAS REAR	3		302H446060	2H446060	CONN.CORD ASSY PWS-HEATER(U) S03509	9
	302F909210	2F909210	PAD BOTTOM	3	⊙	302H493010	2H493010	DK-150	7
⊙	302F925080	2F925080	GEAR IDLE A Z29	9	⊙	302H493021	2H493021	FK-150(E)	9
⊙	302F925141	2F925141	GEAR EXIT Z21	9		302H493031	2H493031	FK-150(U)	9
	302F925340	2F925340	SPRING EXIT	9	⊙	302H493040	2H493040	DR-150	10
	302F925901	2F925901	CAP SPRING EXIT	9	⊙	302H494020	2H494020	ERASER KIT (N) SP	2
	302F929140	2F929140	BUSH DU	5,10	⊙	302H494070	2H494070	SOLENOID ASSY SP	5
	302F931350	2F931350	JOINT SHAFT CASSETTE	10	⊙	302H494080	2H494080	HOLDER DC BRUSH ASSY	4
	302F931490	2F931490	BUSH FEED DRIVE	10		302H902030	2H902030	RACK LID L	2
	302F939081	2F939081	SCREW BOX	12		302H902050	2H902050	RACK FRONT L	2
	302F939090	2F939090	CAP NETWORK	12	⊙	302H902070	2H902070	GEAR RACK Z20-23	2
	302FM02421	2FM02421	SHAFT PULLEY /B-11 FRAME A4	11		302H902100	2H902100	PLATE POWER SUPPLY	12
⊙	302FM94020	2FM94020	GEAR CLUTCH ASSY A SP	5		302H902110	2H902110	HOLDER GEAR A	2
⊙	302FM94030	2FM94030	GEAR CLUTCH ASSY B SP	5		302H902120	2H902120	HOLDER GEAR B	2
	302FV14500	2FV14500	LABEL GUIDE DLP	2		302H902160	2H902160	DUCT FRAME L	12
	302FV45020	2FV45020	AC CORD ASSY	12		302H902170	2H902170	DUCT FRAME R	12

• Parts with "⊙" indicate regular maintenance parts.

	Part.No.	Alternative.	Description	Fig.No.		Part.No.	Alternative.	Description	Fig.No.
	302H902191	2H902191	SHEET REGULATOR PWB	12	⊙	302H909010	2H909010	COVER CASSETTE	3
	302H902210	2H902210	PLATE EARTH MPF	12	⊙	302H909020	2H909020	GUIDE CASSETTE	3
	302H902220	2H902220	MOUNT INLET	12		302H909030	2H909030	SPACER CASS A	3
	302H902260	2H902260	SHEET PWB	12		302H909040	2H909040	SPACER CASS B	3
	302H902270	2H902270	PLATE EARTH	1		302H917051	2H917051	SHAFT ISU	6
	302H902280	2H902280	PLATE EARTH DRIVE	10		302H917210	2H917210	MOUNT MOTOR ISU	6
	302H902290	2H902290	HOLDER THERMAL SHEET	12	⊙	302H917220	2H917220	GEAR ISU 63/32	6
	302H902300	2H902300	SHEET FAN L	12	⊙	302H917230	2H917230	BELT ISU	6
	302H902310	2H902310	SEAL FRAME L	12	⊙	302H917240	2H917240	PULLEY TENSION	6
⊙	302H904010	2H904010	COVER TOP	1		302H917251	2H917251	MOUNT TENSION PULLEY	6
⊙	302H904020	2H904020	LID TOP	1		302H917260	2H917260	PIN TENSION PULLEY	6
⊙	302H904031	2H904031	COVER LEFT	1		302H917270	2H917270	SPRING TENSION	6
⊙	302H904041	2H904041	COVER RIGHT	1		302H917320	2H917320	COVER DP HARNESS	6
⊙	302H904051	2H904051	COVER DIMM	1		302H917330	2H917330	STOPPER ISU	6
⊙	302H904070	2H904070	COVER FRONT B	1		302H917380	2H917380	TAPE FFC A	6
⊙	302H904090	2H904090	COVER REAR	1		302H917410	2H917410	PLATE EARTH ISU A	6
⊙	302H904110	2H904110	COVER INNER L	1		302H917420	2H917420	PLATE EARTH ISU B	6
⊙	302H904120	2H904120	COVER INNER R	1		302H917450	2H917450	SLIDER ISU	6
	302H904150	2H904150	EMBLEM	1		302H917500	2H917500	SPONGE HARNESS	6
	302H904170	2H904170	TAPE EMBLEM	1		302H917510	2H917510	HOLDER FFC	6
	302H904180	2H904180	PLATE EARTH REAR	1		302H917520	2H917520	STOPPER FFC CENTER	6
	302H904200	2H904200	HOOK COVER	1		302H917530	2H917530	TAPE FFC D	6
	302H904210	2H904210	SPRING COVER HOOK	1		302H917540	2H917540	SHEET FRAME BOTTOM	6
	302H904230	2H904230	SHEET HARNESS	1		302H918041	2H918041	SPONGE ORIGINAL MAT	13
	302H904260	2H904260	GUIDE HARNESS	1		302H928010	2H928010	GUIDE FD CENTER	5
⊙	302H904270	2H904270	STOPPER PAPER D	1		302H928020	2H928020	GUIDE FD SIDE	5
	302H904280	2H904280	DISCHARGER FD	1		302H934010	2H934010	LABEL JAM TK OPERATION	1
	302H904290	2H904290	HOLDER GUIDEBOOK	14		302H934030	2H934030	LABEL CAUTION HG	1
	302H904300	2H904300	TAPE GUIDEBOOK	14		302H934080	2H934080	LABEL GUIDEBOOK	14
	302H905010	2H905010	COVER OPERATION	13		302H939011	2H939011	BOX CONTROLLER	12
	302H905240	2H905240	LID OPE SHEET	13		302H939020	2H939020	PLATE SHIELD	12
	302H905300	2H905300	SHIELD DUST LEFT	13	⊙	302H939030	2H939030	GUIDE CF	12
	302H905330	2H905330	SHIELD DUST RIGHT	13		302H939061	2H939061	COVER BOX	14
	302H905360	2H905360	LABEL OPE E	13		302H939070	2H939070	SHEET PWB	12
	302H905370	2H905370	PANEL OPE	13		302H939080	2H939080	SHEET BOX	12
	302H905390	2H905390	SHEET STATIC LCD	13		302H939100	2H939100	PLATE EARTH CONTBOX A	12
	302H905410	2H905410	LENS INFORMATION	13		302H939110	2H939110	PLATE EARTH CONTBOX B	12
	302H905420	2H905420	HOLDER LENS	13		302H946010	2H946010	CONN.CORD ASSY MAIN-SCN	12
	302H905430	2H905430	FILM DIFFUSION	13		302H946040	2H946040	CONN.CORD ASSY INTERFACE	6
	302H905441	2H905441	LABEL OPE GER	14		302H946050	2H946050	CONN.CORD ASSY LVU-SCN	1
	302H905450	2H905450	LABEL OPE FRA	14		302H946060	2H946060	CONN.CORD ASSY MAIN-PANEL	6
	302H905460	2H905460	LABEL OPE ITA	14		302H946070	2H946070	CONN.CORD ASSY USB-MAIN	1
	302H905470	2H905470	LABEL OPE SPA	14		302H946100	2H946100	CONN.CORD ASSY PWS-INLET	12
	302H905480	2H905480	LABEL OPE POR	14		302H946110	2H946110	FFC SCN-MAIN	12
	302H905490	2H905490	LABEL OPE DUT	14		302H946120	2H946120	CONN.CORD ASSY LVU-MAIN	12
	302H905500	2H905500	LABEL OPE RUS	14		302H946130	2H946130	CONN.CORD ASSY FG	10
	302H906010	2H906010	SPACER FEED	4	⊙	302H993031	2H993031	CT-132	3
⊙	302H908010	2H908010	COVER MPF	2		302H993040	2H993040	PARTS ISU ASSY	6
	302H908020	2H908020	PLATE COVER MPF	2	⊙	302H993050	2H993050	PARTS PLATEN COVER	13
	302H908040	2H908040	GUIDE TURN MPF	2	⊙	302H994011	2H994011	PART MAIN PWB ASSY SP	12

• Parts with "⊙" indicate regular maintenance parts.

	Part.No.	Alternative.	Description	Fig.No.		Part.No.	Alternative.	Description	Fig.No.
⊙	302H994021	2H994021	PART MAIN PWB ASSY SP EU	12		302HS02260	2HS02260	SPRING EARTH REG LOW	4
⊙	302H994030	2H994030	PARTS SCANNER PWB ASSY SP	12		302HS02280	2HS02280	COVER BASE LOW	12
⊙	302H994040	2H994040	PARTS PANEL PWB ASSY SP	13		302HS02291	2HS02291	PLATE EARTH DRUM	2
	302H994060	2H994060	PARTS KEY START SP	13		302HS02330	2HS02330	SPRING EARTH DU PLATE	2
	302H994070	2H994070	PARTS KEY STOP SP	13		302HS02340	2HS02340	SPRING EARTH RIGHT	4
	302H994080	2H994080	PARTS KEY RESET SP	13		302HS02350	2HS02350	COVER CABLE B	2
	302H994090	2H994090	PARTS KEY OPERATION 10 SP	13		302HS02360	2HS02360	SPRING LOCK CASSETTE	12
	302H994100	2H994100	PARTS KEY CONTROL SP	13		302HS02370	2HS02370	SPRING EARTH CASSETTE	10
	302H994110	2H994110	PARTS KEY OK SP	13		302HS02381	2HS02381	PLATE PF CONNECTOR	10
	302H994120	2H994120	PARTS KEY MENU SP	13	⊙	302HS02390	2HS02390	LEVER LOCK CASSETTE L	12
	302H994130	2H994130	PARTS KEY POWER SP	13		302HS02410	2HS02410	SPRING EARTH DU MID	4
	302H994140	2H994140	PARTS KEY LOGOUT SP	13		302HS02420	2HS02420	BKT FAN R	12
	302H994150	2H994150	PARTS KEY PROGRAM SP	13		302HS02440	2HS02440	SPRING EARTH DLP PLATE	4
	302H994160	2H994160	PARTS KEY ONE TOUCH SP	13		302HS02460	2HS02460	PIN CONTACT BIAS	2
	302H994170	2H994170	PARTS KEY ADDRESS SP	13		302HS02470	2HS02470	SPRING PIN BIAS	2
	302H994180	2H994180	PARTS KEY COPY SP	13		302HS02510	2HS02510	COVER CABLE D	12
	302H994190	2H994190	PARTS KEY SEND SP	13		302HS02520	2HS02520	COVER CABLE E	10
	302H994210	2H994210	PARTS KEY STATUS SP	13		302HS02530	2HS02530	COVER CABLE F	10
	302H994220	2H994220	PARTS KEY LCD SP	13		302HS02540	2HS02540	PIN DRAWER	10
	302H994230	2H994230	PARTS KEY BACK SP	13		302HS02561	2HS02561	HOLDER PIN CASSETTE	12
	302H994240	2H994240	PARTS KEY BOX SP	13		302HS02590	2HS02590	SHEET DUCT FD	2
	302H994250	2H994250	PARTS KEY SYSTEM SP	13		302HS02620	2HS02620	SPRING EARTH FAN	12
⊙	302H994260	2H994260	PARTS LAMP ISU SP	6	⊙	302HS02650	2HS02650	HOOK PF	2
⊙	302H994270	2H994270	PARTS MOTOR ISU SP	6	⊙	302HS02700	2HS02700	SHEET BUSH DU	2
⊙	302H994280	2H994280	PARTS MOTOR FAN 40 SP	12		302HS06010	2HS06010	FRAME FEED	4
⊙	302H994290	2H994290	PARTS SWITCHING REGULATOR 120V SP	12		302HS06020	2HS06020	HOLDER FEED	4
⊙	302H994300	2H994300	PARTS SWITCHING REGULATOR 230V SP	12		302HS06040	2HS06040	GUIDE FEED R	4
	302H994310	2H994310	PARTS FFC MAIN-CCD KIT SP	6		302HS06050	2HS06050	PULLEY FEED	4
⊙	302H994320	2H994320	PARTS COVER FRONT ASSY SP	1	⊙	302HS06060	2HS06060	ACTUATOR EMPTY A	4
⊙	302H994340	2H994340	PARTS OPERATION UNIT SP	13	⊙	302HS06071	2HS06071	ACTUATOR EMPTY B	4
⊙	302H994360	2H994360	PARTS FULL SENSOR ASSY SP	2	⊙	302HS06090	2HS06090	GEAR Z22S FEED	4
⊙	302H994380	2H994380	PARTS FD ASSY (2H9) SP	5		302HS06110	2HS06110	SHAFT FEED	10
⊙	302H994400	2H994400	PARTS COVER LEFT ASSY U SP	1		302HS06120	2HS06120	SPRING ACTUATOR	4
⊙	302H994420	2H994420	PARTS FRAME ISU SP	6		302HS06130	2HS06130	SPRING PULLEY	4
⊙	302H994430	2H994430	PARTS PWB RFID SP	4		302HS06140	2HS06140	SEAL FRAME FEED	4
⊙	302H994440	2H994440	PARTS MOTOR FAN ASSY SP	12		302HS06150	2HS06150	SEAL FEED PULLEY	4
	302HN09190	2HN09190	SPRING FIX	3		302HS08011	2HS08011	FRAME MPF	4
	302HN09240	2HN09240	SIZE FIX	3		302HS08050	2HS08050	BASE MPF	2
	302HN25450	2HN25450	BUSH EXIT	9		302HS08060	2HS08060	TRAY MPF MID	2
	302HN29050	2HN29050	BUSH DU	5		302HS08080	2HS08080	SHAFT FEED MPF	4
⊙	302HN44110	2HN44110	CLUTCH FEED	10		302HS08100	2HS08100	BRACKET BOTTOM	2
⊙	302HS02070	2HS02070	LEVER LOCK CASSETTE	12	⊙	302HS08110	2HS08110	ACTUATOR MPF	4
⊙	302HS02090	2HS02090	LEVER STOPPER DLP	2		302HS08140	2HS08140	BASE IC PWB	4
	302HS02100	2HS02100	SPRING STOPPER DLP	2	⊙	302HS08160	2HS08160	GEAR Z20S MPF	4
	302HS02131	2HS02131	HOLDER MC	2		302HS08170	2HS08170	SPRING SEPARATOR	2
	302HS02140	2HS02140	PLATE CONTACT MC	2		302HS08190	2HS08190	SPRING ACTUATOR	4
	302HS02160	2HS02160	SPRING MC	2		302HS08210	2HS08210	SPRING EARTH MPF	2
⊙	302HS02180	2HS02180	PIN CASSETTE	12		302HS08220	2HS08220	TRAY MPF TOP	2
	302HS02190	2HS02190	SPRING PIN CASSETTE	12		302HS08230	2HS08230	PLATE EARTH BOTTOM	2
	302HS02250	2HS02250	SPRING EARTH REG UP	4		302HS08241	2HS08241	GUIDE MPF R	2

• Parts with "⊙" indicate regular maintenance parts.

	Part.No.	Alternative.	Description	Fig.No.		Part.No.	Alternative.	Description	Fig.No.
⊙	302HS08251	2HS08251	GUIDE MPF L	2		302HS24360	2HS24360	SPRING REGIST C	4
	302HS08260	2HS08260	ROLLER M/P ASSY	4		302HS24390	2HS24390	SPRING TC L	4
	302HS08270	2HS08270	SPRING BRACKET	2		302HS24400	2HS24400	SPRING TC R	4
	302HS08290	2HS08290	FILM SENSOR	4		302HS24410	2HS24410	ROLLER REGIST LOW	4
	302HS08300	2HS08300	HOLDER FEED M/P	4		302HS24420	2HS24420	FILM REGIST GUIDE	4
	302HS08320	2HS08320	SPRING COVER MPF	5		302HS24460	2HS24460	BUSH REGIST R	4
	302HS08340	2HS08340	COVER REG SW	4		302HS25030	2HS25030	GUIDE EXIT LOW	9
	302HS08351	2HS08351	SPRING COVER REG	4		302HS25040	2HS25040	SPRING PRESSURE	9
	302HS09010	2HS09010	BASE CASSETTE	3	⊙	302HS25050	2HS25050	PULLEY EXIT FUSER	9
	302HS09040	2HS09040	BASE CASSETTE REAR	3	⊙	302HS25060	2HS25060	ROLLER EXIT	9
	302HS09070	2HS09070	PAPER INDICATOR	3	⊙	302HS25070	2HS25070	GEAR Z18S IDLE	9
	302HS09081	2HS09081	CURSOR END	3	⊙	302HS25080	2HS25080	PLATE CODE	9
	302HS09100	2HS09100	LOCK BOTTOM	3		302HS25110	2HS25110	ACTUATOR FUSER	9
	302HS09120	2HS09120	SPRING BOTTOM L	3		302HS25120	2HS25120	SPRING ACTUATOR	9
	302HS09130	2HS09130	SPRING BOTTOM R	3		302HS25130	2HS25130	SPRING EXIT L	9
	302HS09140	2HS09140	SPRING LOCK BOTTOM	3		302HS25140	2HS25140	PLATE EARTH EXIT	9
	302HS09160	2HS09160	GEAR CASSETTE	3		302HS25150	2HS25150	SHAFT EXIT	9
	302HS09170	2HS09170	CAP BOTTOM	3		302HS25160	2HS25160	PLATE EARTH L	9
	302HS09180	2HS09180	SPRING RETARD	3	⊙	302HS25190	2HS25190	THERMISTOR FUSER	9
	302HS09210	2HS09210	SEAL RETARD WASHER	3		302HS25200	2HS25200	LEVER FUSER R	9
	302HS09220	2HS09220	CUT POLYSLIDER 11_8	3		302HS25210	2HS25210	LEVER FUSER L	9
	302HS09231	2HS09231	SPONGE CASSETTE	3		302HS25220	2HS25220	BUSH FUSER	9
	302HS09260	2HS09260	HOLDER RETARD	3		302HS25400	2HS25400	SHEET FUSER	9
	302HS19220	2HS19220	TAPE FFC	4	⊙	302HS25460	2HS25460	SEPARATOR	9
	302HS24010	2HS24010	GUIDE PAPER CHUTE	4		302HS28012	2HS28012	FRAME FD	5
	302HS24020	2HS24020	GUIDE EARTH	4		302HS28021	2HS28021	COVER FRAME FD	5
⊙	302HS24040	2HS24040	ROLLER REGIST UP	4	⊙	302HS28030	2HS28030	ROLLER FD UP	5
	302HS24060	2HS24060	ACTUATOR REGIST	2		302HS28041	2HS28041	COVER FD	5
	302HS24070	2HS24070	SPRING ACTUATOR REG	2	⊙	302HS28060	2HS28060	GEAR Z21S	5
	302HS24080	2HS24080	PLATE EARTH HV	2		302HS28070	2HS28070	PULLEY EXIT	5
	302HS24110	2HS24110	PLATE ERATH PAPER CHUTE	2		302HS28110	2HS28110	SPRING EARTH	5
	302HS24120	2HS24120	BUSH REGIST	4		302HS28120	2HS28120	SPRING EXIT	5
	302HS24130	2HS24130	BUSH 4 DU ROLL	2		302HS28141	2HS28141	SPRING PULLEY	5
	302HS24140	2HS24140	BUSH 6 EW	4	⊙	302HS28170	2HS28170	GEAR FD Z29S	5
⊙	302HS24160	2HS24160	ROLLER DU	2		302HS29010	2HS29010	PLATE COVER DU	11
⊙	302HS24170	2HS24170	ROLLER TRANSFER E	4		302HS29020	2HS29020	PLATE COVER DU B	11
	302HS24181	2HS24181	SHEET REGIST	4	⊙	302HS31020	2HS31020	PLATE DRIVE	10
⊙	302HS24190	2HS24190	GEAR Z14R REG UP	4		302HS31041	2HS31041	PLATE GEAR DRIVE	10
⊙	302HS24200	2HS24200	GEAR Z21L-Z23L REG LOW	4		302HS31050	2HS31050	LEVER LIFT BOTTOM	10
⊙	302HS24210	2HS24210	GEAR Z16L TC	4		302HS31060	2HS31060	PIN GEAR DRIVE	10
⊙	302HS24220	2HS24220	GEAR Z25R DU FEED	10	⊙	302HS31070	2HS31070	GEAR Z42R FREE 2	10
⊙	302HS24230	2HS24230	GEAR Z26L DU MID	10	⊙	302HS31090	2HS31090	GEAR Z37L FREE	10
⊙	302HS24240	2HS24240	SPRING REGIST R	4	⊙	302HS31100	2HS31100	GEAR Z20L CLUTCH	10
⊙	302HS24250	2HS24250	BUSH TC R	4	⊙	302HS31110	2HS31110	GEAR Z58L	10
	302HS24260	2HS24260	LEVER RELEASE TC L	4	⊙	302HS31120	2HS31120	GEAR Z27L CLUTCH	10
	302HS24280	2HS24280	SPRING RELEASE TC L	4	⊙	302HS31130	2HS31130	GEAR Z45R CLUTCH	10
	302HS24300	2HS24300	SPRING CONTACT TC	2	⊙	302HS31140	2HS31140	GEAR Z35R IDLE	10
	302HS24310	2HS24310	SPRING EARTH BRUSH	4	⊙	302HS31150	2HS31150	GEAR Z31L-Z14S	10
⊙	302HS24340	2HS24340	ROLLER TRANSFER U	4	⊙	302HS31180	2HS31180	GEAR Z44R	10
⊙	302HS24350	2HS24350	SPRING REGIST L	4	⊙	302HS31190	2HS31190	GEAR Z17R FREE	10

• Parts with "⊙" indicate regular maintenance parts.

	Part.No.	Alternative.	Description	Fig.No.		Part.No.	Alternative.	Description	Fig.No.
⊙	302HS31200	2HS31200	GEAR Z26L FREE	10		302JA34280	2JA34280	LABEL FUSER CAUTION	5
⊙	302HS31210	2HS31210	GEAR Z35S FREE	10		302JA46020	2JA46020	CONN.CORD ASSY CONTROL-H.V.UNIT S03391	12
⊙	302HS31220	2HS31220	GEAR Z42R FREE	10		302JD19140	2JD19140	BUSHING FAN	6
⊙	302HS31230	2HS31230	GEAR Z38S MPF	10		302JD19150	2JD19150	PIN LSU	1,6
⊙	302HS31240	2HS31240	GEAR Z32L DRUM	10	⊙	5AAVR0LL+052	2BR06520	RETARD ROLL ASSY /43487V0005 A4	3
⊙	302HS31250	2HS31250	GEAR Z54R-Z24R	10		5MBCK9560XSC	D4103700	C STOP RING /X9.5 X 0.6T S-CR	11
⊙	302HS31260	2HS31260	GEAR Z32R	10		5MMP141LD002	2A807510	PLATE SIDE GUIDE /A49 CASSETTE A4	3
	302HS31281	2HS31281	LIFT BOTTOM	10		5MMS111SL002	2BY20050	NUT FUSER A /FS-1800/3800 A4	9
	302HS31310	2HS31310	SPRING FREE FUSER	10		5MMW171LD006	2A807530	SPRING STOPPER /A49 CASSETTE A4	3
	302HS31320	2HS31320	SPRING FREE MAG	10		5MMW261LD036	2A814570	SPRING TE SENSOR /A-49 DLP A4	4
	302HS31330	2HS31330	PIN CLUTCH	10		5MMW261LD055	2A820350	SPRING SEPARATOR /FS-1000 A4	9
	302HS31340	2HS31340	SHAFT CASSETTE	10		5MMW261LD067	2FV02270	SPRING LEVER LOCK L	4
	302HS31360	2HS31360	PIN HOLDER A	10		5MMW261LD068	2FV02280	SPRING LEVER LOCK R	4
	302HS31370	2HS31370	PIN HOLDER B	10		5MVG137DN032	2A806720	GEAR MPF /A-49 MPF A4	2
	302HS31380	2HS31380	SPRING LIFT BOTTOM	10	⊙	5MVG148XN010	2BR20200	GEAR HEAT Z36 /43307P0005 A4	9
⊙	302HS31390	2HS31390	GEAR Z27R FREE 2	10		5MVM273DB005	2A820100	PULLEY EXIT /A-49 FUSER A3	4,5
	302HS31400	2HS31400	SPRING FREE DRUM	10		5MVS217SN002	2A806280	PAD SOLENOID /FS-1000 A4	5
	302HS31410	2HS31410	SPRING FREE Z37L	10		5MVX111DN003	2A806250	RING STOPPER /A-49 FEED A4	4,6,10,11
	302HS31420	2HS31420	EARTH PLATE DRIVE	10		5MVX111DN007	2BT11070	STOPPER 3 /2BT1107 A4	5
	302HS31430	2HS31430	POLYSLIDER 9.5	10	⊙	5MVX431DN005	2FV02100	LEVER LOCK DLP	4
	302HS31440	2HS31440	SPRING FEED	10	⊙	5MVX441XN001	2BR20180	BUSH HEAT L /43307P0003 A4	9
	302HS34020	2HS34020	LABEL FUSER JAM	5	⊙	5MVX541DG002	2A807191	LEVER REAR /A-49 CASSETTE A3	3
	302HS34030	2HS34030	LABEL OPERATION	3		5MVX541DG003	2A807161	LEVER SIDE /A-49 CASSETTE A3	3
	302HS34120	2HS34120	LABEL FUSER OPERATION	9		7AAACCUS+10H001	AA068380	AC CORD ASSY US	12
	302HS39040	2HS39040	PLATE OPTION	12		7BC06062C020H01	BC045240	POLY SLIDER WASHER M6.2X12X0.2T	10
⊙	302HS44010	2HS44010	MOTOR MAIN	10		7BC460529080H01	BC059590	CUT WASHER 5.2X9.0X0.8T(BLACK)	4
⊙	302HS44020	2HS44020	SOLENOID MPF	10		7NXSG2481+++H01	NX052600	SENSOR OPT.	4,6,9
⊙	302HS44050	2HS44050	MOTOR FAN 80	12		7RHA2H10701+H01	RH043740	M.GLAZE R. 100MJ 1/2W	2
	302HS46030	2HS46030	CONN.CORD ASSY CONTROL-PF S03247	10		7YBFZ65C002H01	YB114070	FERRITE CORE	6
	302HS46040	2HS46040	CONN.CORD ASSY CONTROL-MAIN MOTOR S03245	10		7YCC08B1112+H01	YC058670	CONNECTOR	10
	302HS46050	2HS46050	CONN.CORD ASSY CONTROL-RFID S03244	4		7YZM610007++H01	YZ023340	ACCESS.SADDLE	2,10
	302HS46070	2HS46070	CONN.CORD ASSY CONTROL-H.V.UNIT S03303	12		7YZM610008++H01	YZ037940	ACCESS.SADDLE	1,2,12
	302HS46130	2HS46130	CONN.CORD ASSY CONTROL-ERASER S03252	12		7ZGSGTR55060H01	ZG112780	SHIELD GASKET	13
	302HS46140	2HS46140	CONN.CORD ASSY CONTROL-EXITSENSOR S03248	9		7ZGSGTR55120H01	ZG114640	SHIELD GASKET	12
	302HS46150	2HS46150	CONN.CORD ASSY CONTROL-MPFSENSOR S03251	4		7ZS25253001+H01	ZS113220	THERMAL SHEET	12
	302HS46160	2HS46160	CONN.CORD ASSY CONTROL-P.SENS0R S03304	4		7ZS29154001+H01	ZS114200	THERMAL SHEET	12
	302HS46210	2HS46210	CONN.CORD ASSY CONTROL-F/RCLUTCH S03308	10		M2107250	M2107250	BAND,RSG-100(KITAGAWA)	10,12
⊙	302HS93021	2HS93021	DV-130(E)	8		M2108670	M2108670	SPACER,KGPS-6RF(KITAGAWA)	12
⊙	302HS93070	2HS93070	MC-130	7					
⊙	302HS93092	2HS93092	LK-130	2					
⊙	302HS93101	2HS93101	DV-132(U)	8					
⊙	302HS93141	2HS93141	DV-134(AO)	8					
⊙	302HS94000	2HS94000	PLATE BOTTOM ASSY	3					
⊙	302HS94032	2HS94032	HOLDER FEED ASSY	4					
⊙	302HS94040	2HS94040	SEPARATOR MPF ASSY	2					
⊙	302HS94050	2HS94050	PLATE BOTTOM MPF ASSY	2					
⊙	302HS94081	2HS94081	REGIST LOW KIT	4					
⊙	302HS94150	2HS94150	EMPTY SENSOR KIT SP	4					
⊙	302HS94160	2HS94160	COVER REAR ASSY SP	5					
⊙	302J002010	2J002010	FOOT	2					

• Parts with "⊙" indicate regular maintenance parts.

DP-110

—— CONTENTS ——

FIG. 1 Document Processor 12
FIG. 2 Document Processor 24
• INDEX6

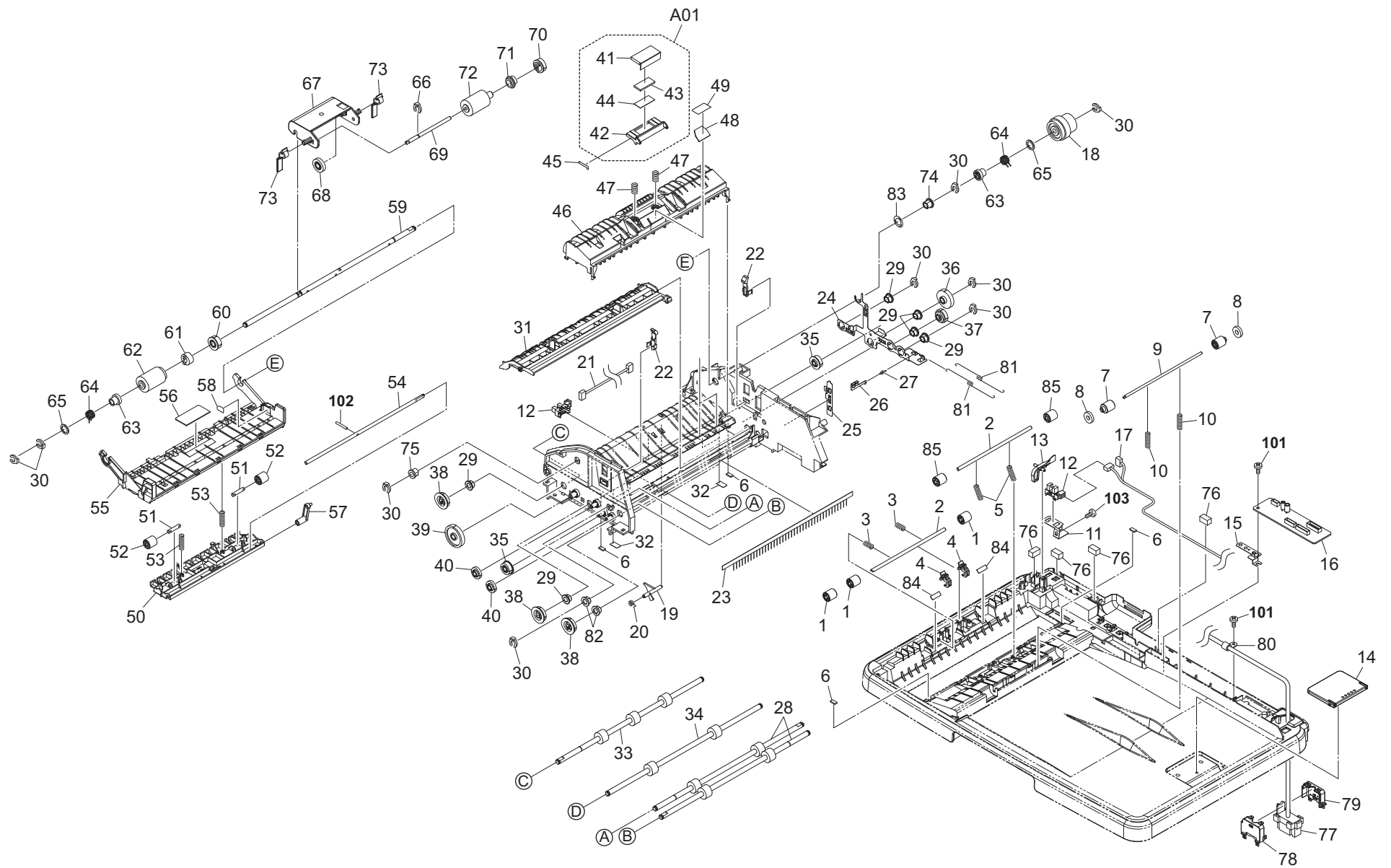

FIG. 1 Document Processor 1

3LJ-2

Ref. No.	Part.No.	Alternative.	Description	Quantity		
				120	230	240
⊙ 1	303JX29160	3JX29160	PULLEY CONVEYING	3	3	3
2	303LJ24110	3LJ24110	SHAFT CONVEYING	2	2	2
3	303LJ24230	3LJ24230	SPRING REGIST	2	2	2
4	303LJ02150	3LJ02150	LEVER RELEASE	2	2	2
5	303LJ24121	3LJ24121	SPRING CONVEYING	2	2	2
6	303LJ02260	3LJ02260	CUSHION GUIDE	4	4	4
⊙ 7	3HK10030	3HK10030	PULLEY EJECT	2	2	2
⊙ 8	3HK10060	3HK10060	SPONGE EJECT	2	2	2
9	303LJ28020	3LJ28020	SHAFT EXIT	1	1	1
10	303LJ24150	3LJ24150	SPRING EXIT	2	2	2
11	303LJ02200	3LJ02200	PLATE EARTH PI	1	1	1
12	7NXSG2481+++H01	NX052600	SENSOR OPT.	2	2	2
13	303K502200	3K502200	ACTUATOR BASE	1	1	1
⊙ 14	303LJ02120	3LJ02120	STOPPER ORIGINAL	1	1	1
15	303LJ02220	3LJ02220	PLATE EARTH PWB SUB	1	1	1
⊙ 16	303LJ94010	3LJ94010	PARTS DRIVER PWB ASSY SP	1	1	1
17	303LJ46040	3LJ46040	CONN. CORD ASSY SOL CL	1	1	1
⊙ 18	303LJ44040	3LJ44040	CLUTCH PAPER FEED	1	1	1
19	303LJ24080	3LJ24080	ACTUATOR TIMING	1	1	1
20	303LJ24090	3LJ24090	SPRING TIMING	1	1	1
21	303LJ46030	3LJ46030	CONN.CORD ASSY TIM SW	1	1	1
22	303LJ24190	3LJ24190	HOOK PF COVER	2	2	2
⊙ 23	303LJ28040	3LJ28040	STATIC ELIMINATOR	1	1	1
24	303LJ24060	3LJ24060	PLATE EARTH CONVEYING	1	1	1
25	303LJ02110	3LJ02110	PLATE EARTH SOL	1	1	1
26	303LJ28030	3LJ28030	PLATE EARTH EXIT	1	1	1
27	303LJ02250	3LJ02250	SPRING GND B	1	1	1
⊙ 28	303LJ94040	3LJ94040	PARTS ROLLER EXIT SP	2	2	2
29	3CY07080	3CY07080	BUSHING 6	6	6	6
30	5MVX111DN003	2A806250	RING STOPPER /A-49 FEED A4	9	9	9
31	303LJ24101	3LJ24101	GUIDE SEPARATION	1	1	1
32	303LJ24210	3LJ24210	FILM CONVEYING	4	4	4
⊙ 33	303LJ94020	3LJ94020	PARTS ROLLER A CONVEYING SP	1	1	1
⊙ 34	303LJ94030	3LJ94030	PARTS ROLLER B CONVEYING SP	1	1	1
⊙ 35	303LJ31100	3LJ31100	GEAR T Z28S	2	2	2
⊙ 36	303LJ94050	3LJ94050	PARTS GEAR Z46S ONEWAY SP	1	1	1
⊙ 37	303LJ31060	3LJ31060	GEAR Z32S	1	1	1
⊙ 38	303LJ31080	3LJ31080	GEAR Z35S	3	3	3
⊙ 39	303LJ31090	3LJ31090	GEAR Z56S	1	1	1
⊙ 40	303LJ31050	3LJ31050	GEAR Z28S	2	2	2
⊙ A01	303LJ94130	3LJ94130	PARTS SEPARATION PAD ASSY SP	1	1	1
41	*303K507060	3K507060	PAD SEPARATION	1	1	1
42	*303LJ07030	3LJ07030	MOUNT PAD	1	1	1
43	*3HK07290	3HK07290	WEIGHT PAD	1	1	1
44	*3HK07300	3HK07300	TAPE WEIGHT	1	1	1
45	303LJ07080	3LJ07080	CUSHION SEPARATION	1	1	1
46	303LJ24280	3LJ24280	UPPER GUIDE B	1	1	1
47	303LJ24140	3LJ24140	SPRING PAD	2	2	2
⊙ 48	303K507101	3K507101	PAD FRONT SEP	1	1	1
49	303LJ07090	3LJ07090	FILM FRONT SEP	1	1	1

Ref. No.	Part.No.	Alternative.	Description	Quantity		
				120	230	240
50	303LJ29022	3LJ29022	MOUNT PULLEY LOOP	1	1	1
51	3H608150	3H608150	SHAFT C PULLEY	2	2	2
⊙ 52	3HL10140	3HL10140	PULLEY LOOP	2	2	2
53	303LJ29040	3LJ29040	SPRING LOOP PRESSURE	2	2	2
54	303LJ29030	3LJ29030	SHAFT LOOP	1	1	1
55	303LJ29010	3LJ29010	GUIDE LOOP	1	1	1
⊙ 56	3HK07240	3HK07240	FRICTION PLATE LF	1	1	1
57	303LJ29060	3LJ29060	LEVER PRESSURE	1	1	1
58	303LJ34060	3LJ34060	LABEL A	1	1	1
59	303LJ07010	3LJ07010	SHAFT PF	1	1	1
⊙ 60	3HK07070	3HK07070	GR PF PULLEY	1	1	1
⊙ 61	3BC07130	3BC07130	ONE-WAY CLUTCH 6	1	1	1
⊙ 62	3BR07040	3BR07040	PULLEY,PAPER FEED	1	1	1
63	3HK07080	3HK07080	COLLAR S SPRING	2	2	2
⊙ 64	3HK07140	3HK07140	SPRING LF	2	2	2
⊙ 65	3HK07270	3HK07270	COLLAR PF	2	2	2
66	5MVX111DN007	2BT11070	STOPPER 3 /2BT1107 A4	1	1	1
67	303LJ07021	3LJ07021	HOLDER LF	1	1	1
⊙ 68	35322020	35322020	GEAR 20,PAPER FEED DRIVE	1	1	1
69	303HK07051	3HK07051	SHAFT LF	1	1	1
⊙ 70	3HK07200	3HK07200	GR 18 LF	1	1	1
⊙ 71	36211500	36211500	GEAR,LEADING FEED JOINT	1	1	1
⊙ 72	36211110	36211110	PULLEY,LEADING FEED ADF	1	1	1
⊙ 73	3HK07130	3HK07130	STOPPER PF	2	2	2
74	2BC06520	2BC06520	BUSHING 6,REGISTRATION	1	1	1
⊙ 75	29806560	29806560	BUSHING 6	1	1	1
76	303K502070	3K502070	SEAL WIRE	4	4	4
77	303LJ46010	3LJ46010	CONN. CORD ASSY INTERFACE	1	1	1
78	303LJ02170	3LJ02170	PLUG COVER A	1	1	1
79	303LJ02180	3LJ02180	PLUG COVER B	1	1	1
80	M2105010	M2105010	NYLON CLAMP 3N,NK-3N	1	1	1
81	303LJ02240	3LJ02240	SPRING GND A	2	2	2
82	302H702590	2H702590	BUSH SCREW	2	2	2
83	303HL22200	3HL22200	PLATE GND	1	1	1
84	303LJ02270	3LJ02270	FILM BASE	2	2	2
⊙ 85	303LJ24200	3LJ24200	PULLEY 13 CONVEYING	2	2	2
101	7BB202308H	BB105690	+TP-FLAT T.T.P SCREW 3X8			
102	E0020160	E0020160	SPRING PIN 2X16			
103	7BB700308H	BB105600	+BIND T.T S SCREW 3X8 SR			

- Parts with "*" are component parts or sub-assemblies of the assembly appearing immediately above them.
- Parts with "⊙" indicate regular maintenance parts.

- Parts with "••" are component parts or sub-assembly with "•" appearing immediately above them.

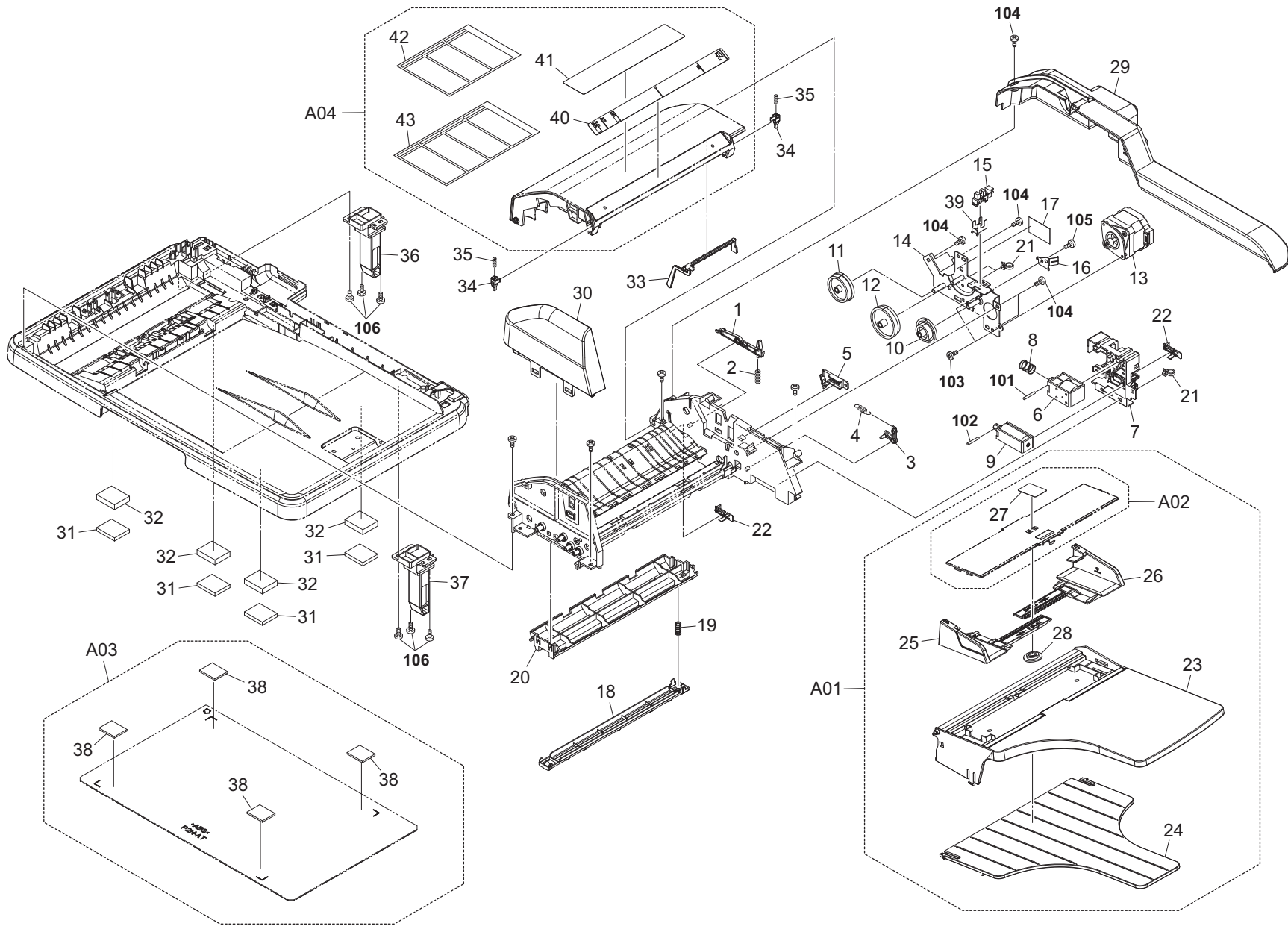

FIG. 2 Document Processor 2

3LJ-1

	Ref. No.	Part.No.	Alternative.	Description	Quantity		
					120	230	240
	1	303LJ02080	3LJ02080	ACTUATOR PUSH	1	1	1
	2	303LJ02060	3LJ02060	SPRING RELEASE	1	1	1
	3	303LJ24041	3LJ24041	LEVER SEPARATE	1	1	1
	4	3HL10090	3HL10090	SPRING,LF SHIFT GUIDE	1	1	1
	5	303LJ24050	3LJ24050	LEVER LOOP	1	1	1
⊙	6	303LJ94140	3LJ94140	PARTS SOLENOID PRESSURE PULLEY SP	1	1	1
	7	303LJ02050	3LJ02050	MOUNT SOLENOID	1	1	1
⊙	8	303HL10200	3HL10200	SPRING LOOP	1	1	1
⊙	9	303LJ94150	3LJ94150	PARTS SOLENOID FEED SHIFT SP	1	1	1
⊙	10	303LJ31040	3LJ31040	GEAR Z66S Z70S	1	1	1
⊙	11	303LJ31020	3LJ31020	GEAR Z40S Z61S	1	1	1
⊙	12	303LJ31030	3LJ31030	GEAR Z46S Z79S	1	1	1
⊙	13	303LJ94060	3LJ94060	PARTS MOTOR DP SP	1	1	1
	14	303LJ31010	3LJ31010	MOUNT DRIVE	1	1	1
	15	7NXSG2481+++H01	NX052600	SENSOR OPT.	1	1	1
	16	303LJ02100	3LJ02100	PLATE EARTH MOTOR	1	1	1
	17	303LJ24260	3LJ24260	FILM WIRE	1	1	1
	18	303LJ02020	3LJ02020	GUIDE READING	1	1	1
	19	303LJ02070	3LJ02070	SPRING READING	1	1	1
	20	303LJ24130	3LJ24130	BOTTOM CONVEYING	1	1	1
	21	7YZM410002++H01	YZ042720	ACCESS.BAND	3	3	3
	22	303LJ24170	3LJ24170	COVER WIRE	2	2	2
⊙	A01	303LJ94120	3LJ94120	PARTS TABLE ASSY SP	1	1	1
⊙	23	*303LJ06010	3LJ06010	TABLE MAIN	1	1	1
⊙	24	*303LJ06020	3LJ06020	TABLE SUB	1	1	1
⊙	25	*303LJ06031	3LJ06031	FRONT CURSOR	1	1	1
⊙	26	*303LJ06041	3LJ06041	REAR CURSOR	1	1	1
⊙	A02	*303LJ94100	3LJ94100	PARTS COVER CURSOR ASSY SP	1	1	1
	27	**303LJ34020	3LJ34020	LABEL FACE UP	1	1	1
	28	*5MVG127DN071	2A807050	GEAR CASSETTE /A-49 CASSETTE A4	1	1	1
⊙	29	303LJ04021	3LJ04021	COVER REAR	1	1	1
	30	303LJ04010	3LJ04010	COVER FRONT	1	1	1
	31	303MX02031	3MX02031	CUSHION ORIGINAL MAT B	4	4	4
	32	303MX02060	3MX02060	SPONGE ORIGINAL MAT	4	4	4
	33	303LJ07050	3LJ07050	ACTUATOR ORIGINAL	1	1	1
	34	303LJ07060	3LJ07060	LEVER PUSH DU	2	2	2
	35	303LJ07070	3LJ07070	SPRING PUSH DU	2	2	2
	36	303LJ02030	3LJ02030	HINGE L	1	1	1
	37	303LJ02040	3LJ02040	HINGE R	1	1	1
⊙	A03	303LJ94070	3LJ94070	PARTS PLATE ORIGINAL SP	1	1	1
	38	*303MX02021	3MX02021	CUSHION ORIGINAL MAT A	4	4	4
	39	3HP07420	3HP07420	EARTH PLATE D	1	1	1
⊙	A04	303LJ94080	3LJ94080	PARTS COVER PF ASSY SP	1	1	1
	40	*303LJ34031	3LJ34031	LABEL SIZE DIRECTION	1	1	1
	41	*303LJ34041	3LJ34041	LABEL CAUTION	1	1	1
	42	*303LJ34121	3LJ34121	LABEL CAUTION SET (A)	1	1	1
	43	*303LJ34131	3LJ34131	LABEL CAUTION SET (E)	1	1	1

	Ref. No.	Part.No.	Alternative.	Description	Quantity		
					120	230	240
	101	E0130280	E0130280	SPRING PIN 3X28(SUS)			
	102	5MBP2020WWLD	E1120200	SPRING PIN / M2 X 20 SUS-DP XX			
	103	7BB000306H	BB106880	+BIND M SCREW 3X6			
	104	7BB200308H	BB105660	+BIND T.T P SCREW 3X8			
	105	7BB700308H	BB105600	+BIND T.T S SCREW 3X8 SR			
	106	7BB202308H	BB105690	+TP-FLAT T.T P SCREW 3X8			

- Parts with "*" are component parts or sub-assemblies of the assembly appearing immediately above them.
- Parts with "⊙" indicate regular maintenance parts.

- Parts with "••" are component parts or sub-assembly with "•" appearing immediately above them.

INDEX

3LJ-2

	Part.No.	Alternative.	Description	Fig.No.
⊙	29806560	29806560	BUSHING 6	1
	2BC06520	2BC06520	BUSHING 6.REGISTRATION	1
	302H702590	2H702590	BUSH SCREW	1
	303HK07051	3HK07051	SHAFT LF	1
⊙	303HL10200	3HL10200	SPRING LOOP	2
	303HL22200	3HL22200	PLATE GND	1
⊙	303JX29160	3JX29160	PULLEY CONVEYING	1
	303K502070	3K502070	SEAL WIRE	1
	303K502200	3K502200	ACTUATOR BASE	1
	303K507060	3K507060	PAD SEPARATION	1
⊙	303K507101	3K507101	PAD FRONT SEP	1
	303LJ02020	3LJ02020	GUIDE READING	2
	303LJ02030	3LJ02030	HINGE L	2
	303LJ02040	3LJ02040	HINGE R	2
	303LJ02050	3LJ02050	MOUNT SOLENOID	2
	303LJ02060	3LJ02060	SPRING RELEASE	2
	303LJ02070	3LJ02070	SPRING READING	2
	303LJ02080	3LJ02080	ACTUATOR PUSH	2
	303LJ02100	3LJ02100	PLATE EARTH MOTOR	2
	303LJ02110	3LJ02110	PLATE EARTH SOL	1
⊙	303LJ02120	3LJ02120	STOPPER ORIGINAL	1
	303LJ02150	3LJ02150	LEVER RELEASE	1
	303LJ02170	3LJ02170	PLUG COVER A	1
	303LJ02180	3LJ02180	PLUG COVER B	1
	303LJ02200	3LJ02200	PLATE EARTH PI	1
	303LJ02220	3LJ02220	PLATE EARTH PWB SUB	1
	303LJ02240	3LJ02240	SPRING GND A	1
	303LJ02250	3LJ02250	SPRING GND B	1
	303LJ02260	3LJ02260	CUSHION GUIDE	1
	303LJ02270	3LJ02270	FILM BASE	1
	303LJ04010	3LJ04010	COVER FRONT	2
⊙	303LJ04021	3LJ04021	COVER REAR	2
⊙	303LJ06010	3LJ06010	TABLE MAIN	2
⊙	303LJ06020	3LJ06020	TABLE SUB	2
⊙	303LJ06031	3LJ06031	FRONT CURSOR	2
⊙	303LJ06041	3LJ06041	REAR CURSOR	2
	303LJ07010	3LJ07010	SHAFT PF	1
	303LJ07021	3LJ07021	HOLDER LF	1
	303LJ07030	3LJ07030	MOUNT PAD	1
	303LJ07050	3LJ07050	ACTUATOR ORIGINAL	2
	303LJ07060	3LJ07060	LEVER PUSH DU	2
	303LJ07070	3LJ07070	SPRING PUSH DU	2
	303LJ07080	3LJ07080	CUSHION SEPARATION	1
	303LJ07090	3LJ07090	FILM FRONT SEP	1
	303LJ24041	3LJ24041	LEVER SEPARATE	2
	303LJ24050	3LJ24050	LEVER LOOP	2
	303LJ24060	3LJ24060	PLATE EARTH CONVEYING	1
	303LJ24080	3LJ24080	ACTUATOR TIMING	1
	303LJ24090	3LJ24090	SPRING TIMING	1
	303LJ24101	3LJ24101	GUIDE SEPARATION	1

	Part.No.	Alternative.	Description	Fig.No.
	303LJ24110	3LJ24110	SHAFT CONVEYING	1
	303LJ24121	3LJ24121	SPRING CONVEYING	1
	303LJ24130	3LJ24130	BOTTOM CONVEYING	2
	303LJ24140	3LJ24140	SPRING PAD	1
	303LJ24150	3LJ24150	SPRING EXIT	1
	303LJ24170	3LJ24170	COVER WIRE	2
	303LJ24190	3LJ24190	HOOK PF COVER	1
⊙	303LJ24200	3LJ24200	PULLEY 13 CONVEYING	1
	303LJ24210	3LJ24210	FILM CONVEYING	1
	303LJ24230	3LJ24230	SPRING REGIST	1
	303LJ24260	3LJ24260	FILM WIRE	2
	303LJ24280	3LJ24280	UPPER GUIDE B	1
	303LJ28020	3LJ28020	SHAFT EXIT	1
	303LJ28030	3LJ28030	PLATE EARTH EXIT	1
⊙	303LJ28040	3LJ28040	STATIC ELIMINATOR	1
	303LJ29010	3LJ29010	GUIDE LOOP	1
	303LJ29022	3LJ29022	MOUNT PULLEY LOOP	1
	303LJ29030	3LJ29030	SHAFT LOOP	1
	303LJ29040	3LJ29040	SPRING LOOP PRESSURE	1
	303LJ29060	3LJ29060	LEVER PRESSURE	1
	303LJ31010	3LJ31010	MOUNT DRIVE	2
⊙	303LJ31020	3LJ31020	GEAR Z40S Z61S	2
⊙	303LJ31030	3LJ31030	GEAR Z46S Z79S	2
⊙	303LJ31040	3LJ31040	GEAR Z66S Z70S	2
⊙	303LJ31050	3LJ31050	GEAR Z28S	1
⊙	303LJ31060	3LJ31060	GEAR Z32S	1
⊙	303LJ31080	3LJ31080	GEAR Z35S	1
⊙	303LJ31090	3LJ31090	GEAR Z56S	1
⊙	303LJ31100	3LJ31100	GEAR T Z28S	1
	303LJ34020	3LJ34020	LABEL FACE UP	2
	303LJ34031	3LJ34031	LABEL SIZE DIRECTION	2
	303LJ34041	3LJ34041	LABEL CAUTION	2
	303LJ34060	3LJ34060	LABEL A	1
	303LJ34121	3LJ34121	LABEL CAUTION SET (A)	2
	303LJ34131	3LJ34131	LABEL CAUTION SET (E)	2
⊙	303LJ44040	3LJ44040	CLUTCH PAPER FEED	1
	303LJ46010	3LJ46010	CONN. CORD ASSY INTERFACE	1
	303LJ46030	3LJ46030	CONN.CORD ASSY TIM SW	1
	303LJ46040	3LJ46040	CONN. CORD ASSY SOL CL	1
⊙	303LJ94010	3LJ94010	PARTS DRIVER PWB ASSY SP	1
⊙	303LJ94020	3LJ94020	PARTS ROLLER A CONVEYING SP	1
⊙	303LJ94030	3LJ94030	PARTS ROLLER B CONVEYING SP	1
⊙	303LJ94040	3LJ94040	PARTS ROLLER EXIT SP	1
⊙	303LJ94050	3LJ94050	PARTS GEAR Z46S ONEWAY SP	1
⊙	303LJ94060	3LJ94060	PARTS MOTOR DP SP	2
⊙	303LJ94070	3LJ94070	PARTS PLATE ORIGINAL SP	2
⊙	303LJ94080	3LJ94080	PARTS COVER PF ASSY SP	2
⊙	303LJ94100	3LJ94100	PARTS COVER CURSOR ASSY SP	2
⊙	303LJ94120	3LJ94120	PARTS TABLE ASSY SP	2
⊙	303LJ94130	3LJ94130	PARTS SEPARATION PAD ASSY SP	1

• Parts with "⊙" indicate regular maintenance parts.

	Part.No.	Alternative.	Description	Fig.No.
⊙	303LJ94140	3LJ94140	PARTS SOLENOID PRESSURE PULLEY SP	2
⊙	303LJ94150	3LJ94150	PARTS SOLENOID FEED SHIFT SP	2
	303MX02021	3MX02021	CUSHION ORIGINAL MAT A	2
	303MX02031	3MX02031	CUSHION ORIGINAL MAT B	2
	303MX02060	3MX02060	SPONGE ORIGINAL MAT	2
⊙	35322020	35322020	GEAR 20,PAPER FEED DRIVE	1
⊙	36211110	36211110	PULLEY,LEADING FEED ADF	1
⊙	36211500	36211500	GEAR,LEADING FEED JOINT	1
⊙	3BC07130	3BC07130	ONE-WAY CLUTCH 6	1
⊙	3BR07040	3BR07040	PULLEY,PAPER FEED	1
	3CY07080	3CY07080	BUSHING 6	1
	3H608150	3H608150	SHAFT C PULLEY	1
⊙	3HK07070	3HK07070	GR PF PULLEY	1
	3HK07080	3HK07080	COLLAR S SPRING	1
⊙	3HK07130	3HK07130	STOPPER PF	1
⊙	3HK07140	3HK07140	SPRING LF	1
⊙	3HK07200	3HK07200	GR 18 LF	1
⊙	3HK07240	3HK07240	FRICTION PLATE LF	1
⊙	3HK07270	3HK07270	COLLAR PF	1
	3HK07290	3HK07290	WEIGHT PAD	1
	3HK07300	3HK07300	TAPE WEIGHT	1
⊙	3HK10030	3HK10030	PULLEY EJECT	1
⊙	3HK10060	3HK10060	SPONGE EJECT	1
	3HL10090	3HL10090	SPRING,LF SHIFT GUIDE	2
⊙	3HL10140	3HL10140	PULLEY LOOP	1
	3HP07420	3HP07420	EARTH PLATE D	2
	5MVG127DN071	2A807050	GEAR CASSETTE /A-49 CASSETTE A4	2
	5MVX111DN003	2A806250	RING STOPPER /A-49 FEED A4	1
	5MVX111DN007	2BT11070	STOPPER 3 /2BT1107 A4	1
	7NXSG2481+++H01	NX052600	SENSOR OPT.	1,2
	7YZM410002++H01	YZ042720	ACCESS.BAND	2
	M2105010	M2105010	NYLON CLAMP 3N,NK-3N	1

• Parts with "⊙" indicate regular maintenance parts.

KYOCERA MITA EUROPE B.V.

Hoeksteen 40, 2132 MS Hoofddorp,
The Netherlands
Phone: +31.20.654.0000
Home page: <http://www.kyoceramita-europe.com>
Email: info@kyoceramita-europe.com

KYOCERA MITA NEDERLAND B.V.
Beechavenue 25, 1119RA Schiphol-Rijk
The Netherlands
Phone: +31.20.58.77.200

KYOCERA MITA (UK) LTD
8 Beacontree Plaza
Gillette Way Reading Berks RG2 0BS,
U.K.
Phone: +44.1189.311.500

KYOCERA MITA ITALIA S.p.A.
Via G. Verdi, 89 / 91, 20063 Cernusco s/N
Milano, Italy
Phone: +39.02.92179.1

S.A. KYOCERA MITA BELGIUM N.V.
Hermestraat 8A, 1930 Zaventem,
Belgium
Phone: +32.2.720.9270

KYOCERA MITA FRANCE S.A.
Parc Les Algorithmes Saint Aubin
91194 GIF-SUR-YVETTE,
France
Phone: +33.1.6985.2600

KYOCERA MITA ESPAÑA S.A.
Edificio Kyocera, Avda de Manacor No. 2,
28290 Las Matas (Madrid),
Spain
Phone: +34.91.631.8392

KYOCERA MITA FINLAND OY
Kirvesmiehenkatu 4, 00880 Helsinki,
Finland
Phone: +358.9.4780.5200

KYOCERA MITA (SCHWEIZ)
Hohlstrasse 614, 8048 Zürich
Switzerland
Phone: +41.1.908.4949

KYOCERA MITA DEUTSCHLAND GMBH
Otto-Hahn-Str. 12 D-40670 Meerbusch,
Germany
Phone: +49.2159.918.0

KYOCERA MITA GMBH AUSTRIA
Eduard-Kittenberger-Gasse 95,
1230 Wien,
Austria
Phone: +43.1.86338.210

KYOCERA MITA SVENSKA AB
Esbogatan 16B 164 75 Kista,
Sweden
Phone: +46.8.546.55000

KYOCERA MITA NORGE
Postboks 150 Oppsal, NO 0619 Oslo
Olaf Helsetsvei 6, NO 0694 Oslo,
Norway
Phone: +47.22.62.73.00

KYOCERA MITA DANMARK A/S
Ejby Industrivej 1, DK-2600 Glostrup,
Denmark
Phone: +45.5687.1100

KYOCERA MITA PORTUGAL LDA.
Rua do Centro Cultural, 41 (Alvalade) 1700-106 Lisbon,
Portugal
Phone: +351.21.842.9100

KYOCERA MITA SOUTH AFRICA (PTY) LTD.
527 Kyalami Boulevard,
Kyalami Business Park Midrand,
South Africa
Phone: +27.(0)11.540.2600

KYOCERA MITA AMERICA, INC.

Headquarters:
225 Sand Road,
Fairfield, New Jersey 07004-0008,
U.S.A.
Phone: (973) 808-8444

KYOCERA MITA AUSTRALIA PTY. LTD.
Level 3, 6-10 Talavera Road, North Ryde,
N.S.W. 2113 Australia
Phone: (02) 9888-9999

KYOCERA MITA NEW ZEALAND LTD.
1-3 Parkhead Place, Albany
P.O. Box 302 125 NHPC, Auckland,
New Zealand
Phone: (09) 415-4517

KYOCERA MITA (THAILAND) CORP., LTD.
9/209 Ratchada-Prachachem Road,
Bang Sue, Bangkok 10800, Thailand
Phone: (02) 586-0320

KYOCERA MITA SINGAPORE PTE LTD.
121 Genting Lane, 3rd Level,
Singapore 349572
Phone: 67418733

KYOCERA MITA HONG KONG LIMITED
11/F., Mita Centre,
552-566, Castle Peak Road,
Tsuen Wan, New Territories,
Hong Kong
Phone: 24297422

KYOCERA MITA TAIWAN Corporation.
7F-1~2, No.41, Lane 221, Gangchi Rd.
Neihu District, Taipei, Taiwan, 114. R.O.C.
Phone: (02) 87511560

KYOCERA MITA Corporation

2-28, 1-chome, Tamatsukuri, Chuo-ku
Osaka 540-8585, Japan
Phone: (06) 6764-3555
<http://www.kyoceramita.com>

KYOCERA MITA AMERICA, INC.

Headquarters:

225 Sand Road,
Fairfield, New Jersey 07004-0008
TEL : (973) 808-8444
FAX : (973) 882-6000

New York Branch:

1410 Broadway 23rd floor
New York, NY 10018
TEL : (917) 286-5400
FAX : (917) 286-5402

Northeastern Region:

225 Sand Road,
Fairfield, New Jersey 07004-0008
TEL : (973) 808-8444
FAX : (973) 882-4401

Midwestern Region:

201 Hansen Court Suite 119
Wood Dale, Illinois 60191
TEL : (630) 238-9982
FAX : (630) 238-9487

Western Region:

14101 Alton Parkway,
Irvine, California 92618-7006
TEL : (949) 457-9000
FAX : (949) 457-9119

Southeastern Region:

1500 Oakbrook Drive,
Norcross, Georgia 30093
TEL : (770) 729-9786
FAX : (770) 729-9873

Southwestern Region:

2825 West Story Road,
Irving, Texas 75038-5299
TEL : (972) 550-8987
FAX : (972) 252-9786

National Operation Center & National Training Center:

2825 West Story Road,
Irving, Texas 75038-5299
TEL : (972) 659-0055
FAX : (972) 570-5816

Latin America Division:

8240 N.W. 52nd. Terrace Dawson Building,
Suite 108 Miami, Florida 33166
TEL : (305) 421-6640
FAX : (305) 421-6666

KYOCERA MITA CANADA, LTD.

6120 Kestrel Road, Mississauga,
Ontario L5T 1S8, Canada
TEL : (905) 670-4425
FAX : (905) 670-8116

KYOCERA MITA MEXICO, S.A. DE C.V.

Av. 16 de Septiembre #407
Col. Santa Inés,
Azcapotzalco México,
D.F. 02130, México
TEL : (55) 5383-2741
FAX : (55) 5383-7804

©2009 KYOCERA MITA Corporation

<http://www.kyoceramita.com>

 **KYOCERA** is a trademark of Kyocera Corporation

Printed in U.S.A.