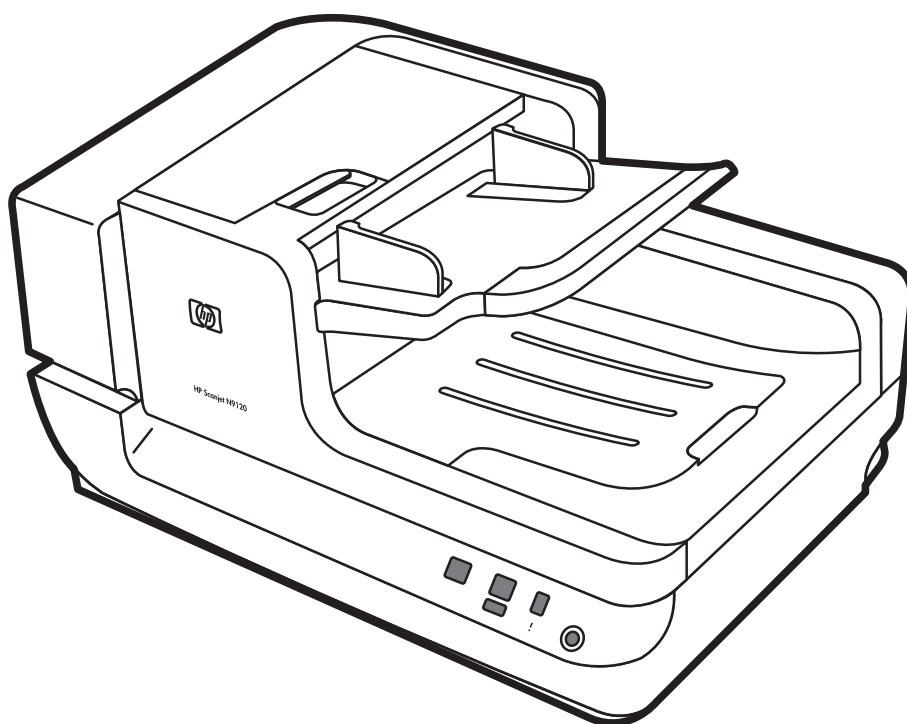


HP Scanjet N9120  
HP Scanjet Enterprise Flow N9120  
Service Manual







N9120

Service Manual

## Copyright information

© 2013 Copyright Hewlett-Packard Development Company, L.P.

Reproduction, adaptation, or translation without prior written permission is prohibited, except as allowed under the copyright laws.

The information contained herein is subject to change without notice.

The only warranties for HP products and services are set forth in the express warranty statements accompanying such products and services. Nothing herein should be construed as constituting an additional warranty. HP shall not be liable for technical or editorial errors or omissions contained herein.

Part number L2683-90022

Edition 2, 10/2013

## Safety information

WARNING!

Potential Shock Hazard

Always follow basic safety precautions when using the product to reduce risk of injury from fire or electric shock.

Read and understand all instructions in the user guide.

Observe all warnings and instructions marked on the product.

Use only a grounded electrical outlet when connecting the product to a power source. If you do not know whether the outlet is grounded, check with a qualified electrician.

Do not touch the contacts on the end of any of the sockets on the product. Replace damaged cords immediately.

Unplug the product from wall outlets before cleaning.

Do not install or use the product near water or when you are wet.

Install the product securely on a stable surface.

Install the product in a protected location where no one can step on or trip over the power cord and where the power cord will not be damaged.

## Trademark credits

Microsoft(r), Windows(r), and Windows(r) XP are U.S. registered trademarks of Microsoft Corporation.

Windows Vista® is either a registered trademark or trademark of Microsoft Corporation in the United States and/or other countries.

ENERGY STAR and the ENERGY STAR mark are registered U.S. marks.

---

# Table of contents

<b>1 Product basics</b> .....	<b>1</b>
Quick access to product information .....	2
Product basics .....	3
Product features .....	3
Product walkaround .....	4
Front and right-side view .....	4
Back view .....	5
Side view (left) .....	5
Model and serial numbers .....	6
Control-panel walkaround .....	7
Supported product software .....	8
Supported operating systems .....	8
Supported scanner drivers .....	8
Supported scanner-management software .....	8
System requirements .....	9
Paper handling .....	10
ADF specifications .....	10
Media specifications .....	10
Media to avoid .....	11
<b>2 Installation and configuration</b> .....	<b>13</b>
Prepare the site .....	14
Unpack the device .....	15
Install the software .....	19
<b>3 Manage and maintain</b> .....	<b>21</b>
Manage supplies .....	22
HP Scanner Tools Utility scanner maintenance information .....	22
Parts life expectancy .....	22
Clean the product .....	23
Clean the exterior .....	23

Clean the ADF .....	24
Clean the scanner glass .....	27
Clean the fan filters .....	28

#### **4 Theory of operation ..... 29**

Basic operation .....	30
Modes and control-panel indicators .....	31
Circuit board assemblies .....	32
Fans .....	33
ADF feed system .....	34
Sensors .....	34
Motors .....	35
Service block diagram .....	36

#### **5 Removal and replacement ..... 37**

Removal and replacement strategy .....	38
General cautions during removal and replacement .....	38
Electrostatic discharge .....	38
Required tools .....	39
Cleaning supplies .....	39
Screws and fasteners .....	39
Before performing service .....	39
After performing service .....	40
User-replaceable parts .....	41
Imprinter cartridge .....	42
Fan filters .....	44
ADF base reflector .....	45
Reinstall the ADF base reflector .....	46
Pickup-roller assembly .....	47
Reinstall the pickup-roller assembly .....	48
Separation-pad assembly .....	50
Reinstall the separation-pad assembly .....	51
External covers .....	52
Scanner control-panel cover .....	53
Scanner back-filter cover .....	54
Scanner right-filter cover .....	54
ADF front cover .....	55
ADF back cover .....	58
Scanner back cover .....	60
Automatic document feeder FRUs .....	61
Automatic document feeder (ADF) .....	63

Reinstall the ADF .....	67
ADF height adjustment .....	72
NVRAM data management .....	75
Repair menu .....	75
Repair menu options .....	76
Replacement scenarios .....	77
NVRAM data file examples .....	84
NVRAM content adjustment .....	85
Download factory NVRAM data .....	86
Backup current NVRAM data .....	89
Repair NVRAM data .....	91
Adjust NVRAM counter items .....	96
Align the ADF .....	98
Create the factory calibration data for ADF-A .....	101
ADF motor fan .....	103
ADF carriage fan .....	104
ADF input-tray lift-motor assembly .....	105
ADF exit-motor assembly .....	107
ADF feed-motor assembly .....	111
Reinstall the ADF feed-motor drive belt .....	114
Reinstall the ADF feed-motor assembly .....	115
ADF pick-motor assembly .....	118
Reinstall the ADF pick-motor assembly .....	121
Upper multi-pick sensor PCA .....	124
Lower multi-pick sensor PCA .....	126
ADF controller PCA .....	128
Imprinter PCA .....	130
Reinstall the imprinter PCA .....	131
Input-tray sensor .....	134
Flatbed scan position sensor .....	135
Reinstall the flatbed scan position sensor .....	136
Exit 1 sensor .....	138
Exit 2 sensor .....	139
Pick-up roller sensor .....	140
Elevator arm sensor .....	142
Background solenoid sensor .....	143
Paper-present sensor .....	144
Registration sensor .....	145
Jam door 1 sensor .....	146
Jam door 2 sensor .....	147
Jam door 3 sensor .....	148

Imprinter paper-present sensor .....	149
ADF scan position sensor .....	151
ADF bottom corner outer paper path guide .....	152
ADF bottom corner inner paper path guide .....	154
ADF cal-strip assembly .....	155
Reinstall the cal-strip assembly .....	158
ADF exit inner paper path guide .....	162
ADF top corner inner paper path guide .....	165
Lower multi-pick sensor cover .....	166
Flatbed scan position sensor arm .....	168
Reinstall the flatbed scan position sensor arm .....	169
Exit 1 sensor arm .....	172
Exit 2 sensor arm .....	173
Paper-present-sensor arm .....	175
Input-tray-elevator arm .....	176
Registration sensor arm .....	179
Scan position sensor arm .....	181
Pick-up roller spring .....	182
Separation-pad spring .....	183
ADF input-tray assembly .....	184
ADF output tray .....	186
Reinstall the ADF output tray .....	188
Pickup-roller cover .....	190
ADF hinge limiters .....	192
ADF jam door 3 .....	193
Paper present sensor and imprinter PCA holder .....	195
ADF shingle wall .....	197
A4 paper-stop .....	200
ADF background-solenoid assembly .....	201
Reinstall the ADF background-solenoid assembly .....	204
Imprinter carriage and FFC .....	206
Flatbed scanner FRUs .....	208
Flatbed .....	209
Scanner carriage-motor fan .....	210
Scanner carriage fan .....	213
Scanner carriage motor .....	215
Control-panel PCA .....	218
Scanner controller PCA .....	220
Power-supply PCA .....	223
Scanner-glass assembly .....	227
ADF power-cable assembly .....	228



Carriage-motor cable .....	230
Power switch and power receptacle assembly .....	231

## **6 Solve problems ..... 233**

Troubleshooting process .....	234
Pre-troubleshooting checklist .....	235
Basic troubleshooting checks .....	236
Power-on checks .....	237
LED diagnostics .....	238
Check the USB connection .....	239
Uninstall and then reinstall the HP Scanjet utilities .....	239
Control-panel buttons .....	240
Control-panel buttons diagnostics .....	240
Locked control-panel buttons .....	240
Troubleshooting diagnostic software .....	242
Main screen .....	242
Scan dialog box .....	244
Sensor check dialog box .....	246
Control panel check dialog box .....	251
ADF feed test dialog box .....	253
Actuators dialog box .....	255
NVRAM dialog box .....	258
Update dialog box .....	260
Repair menu .....	261
Version information dialog box .....	262
Diagrams .....	263
Component locator diagrams .....	263
Major components .....	263
ADF motors and fans .....	266
Printed circuit assemblies .....	268
Image-quality troubleshooting tools .....	270
Repetitive-image-defect ruler .....	270
Computer-display error messages .....	271
Computer-display error messages .....	271
Solve paper-handling problems .....	275
Jams .....	275
Common causes of jams .....	275
Solve common ADF jams .....	276
Clear jams from the ADF .....	277
The bottom of the scanned image is cut off .....	280
Scan extra long documents .....	280

Disable misfeed (multipick) detection .....	280
ADF does not feed paper .....	281
Solve image-quality problems .....	282
Image defects .....	282
Set the background color for scans from the ADF .....	284
Filter out color from a document (color dropout) .....	285
Solve performance problems .....	286
Solve connectivity problems .....	289
Solve direct-connect problems .....	289

## **7 Parts and diagrams ..... 291**

Ordering parts and supplies .....	292
Service part numbers .....	293
N9120 documentation .....	293
Imprinter cartridges .....	293
Power Cords .....	294
Maintenance kits .....	294
Field replaceable units (FRUs) .....	295
How to use the parts diagrams and lists .....	297
ADF components .....	298
Flatbed scanner assemblies .....	326
Alphabetical parts list .....	344
Numerical parts list .....	353

## **Appendix A Service and support ..... 363**

Hewlett-Packard limited warranty statement .....	364
Customer self repair warranty service .....	366
Repack the product .....	367

## **Appendix B Specifications ..... 369**

Physical specifications .....	370
Electrical specifications .....	370
Acoustic emissions .....	370
Power consumption specifications .....	370
Environmental specifications .....	371

## **Appendix C Regulatory information ..... 373**

Regulatory Model Identification Number .....	374
Materials disposal .....	374
Disposal of waste equipment by users in private households in the European Union .....	374

Country/region specific statements ..... 374  
    Korean regulatory ..... 374

**Index ..... 375**



---

# List of tables

Table 1-1	Product guides .....	2
Table 1-2	Product specifications .....	3
Table 1-3	Control-panel features .....	7
Table 1-4	ADF specifications .....	10
Table 1-5	Media specifications .....	10
Table 2-1	Box contents .....	17
Table 3-1	Replacement guidelines .....	22
Table 4-1	Main assemblies .....	30
Table 4-2	Modes and control-panel indicators .....	31
Table 4-3	Circuit board assemblies .....	32
Table 4-4	Sensors .....	34
Table 6-1	Initial troubleshooting checklist .....	235
Table 6-2	Control-panel LEDs .....	238
Table 6-3	Main screen .....	242
Table 6-4	<b>Scan</b> dialog box .....	244
Table 6-5	<b>Sensor in motion</b> tab .....	246
Table 6-6	<b>Sensor</b> tab .....	248
Table 6-7	<b>Control panel check</b> dialog box .....	252
Table 6-8	<b>ADF feed test</b> dialog box .....	254
Table 6-9	<b>Actuators</b> dialog box .....	256
Table 6-10	<b>Repair</b> menu .....	261
Table 6-11	Major components (1 of 3) .....	263
Table 6-12	Major components (2 of 3) .....	264
Table 6-13	Major components (3 of 3) .....	265
Table 6-14	ADF motors and fans (1 of 2) .....	266
Table 6-15	ADF motors and fans (2 of 2) .....	267
Table 6-16	Scanner motors and fans .....	267
Table 6-17	ADF controller PCA .....	268
Table 6-18	Scanner PCAs .....	269
Table 6-19	Repetitive defects .....	270
Table 6-20	ISIS driver communicated message .....	271
Table 6-21	SDSS error message displayed .....	273

Table 6-22	Image defect examples .....	282
Table 6-23	Solve performance problems .....	286
Table 7-1	N9120 documentation .....	293
Table 7-2	Imprinter cartridges .....	293
Table 7-3	Power cords .....	294
Table 7-4	Maintenance kits .....	294
Table 7-5	Field replaceable units (FRUs) .....	295
Table 7-6	ADF assemblies (1 of 14) .....	299
Table 7-7	ADF assemblies (2 of 14) .....	301
Table 7-8	ADF assemblies (3 of 14) .....	303
Table 7-9	ADF assemblies (4 of 14) .....	305
Table 7-10	ADF assemblies (5 of 14) .....	307
Table 7-11	ADF assemblies (6 of 14) .....	309
Table 7-12	ADF assemblies (7 of 14) .....	311
Table 7-13	ADF assemblies (8 of 14) .....	313
Table 7-14	ADF assemblies (9 of 14) .....	315
Table 7-15	ADF assemblies (10 of 14) .....	317
Table 7-16	ADF assemblies (11 of 14) .....	319
Table 7-17	ADF assemblies (12 of 14) .....	321
Table 7-18	ADF assemblies (13 of 14) .....	323
Table 7-19	ADF assemblies (14 of 14) .....	325
Table 7-20	Flatbed scanner assemblies (1 of 9) .....	327
Table 7-21	Flatbed scanner assemblies (2 of 9) .....	329
Table 7-22	Flatbed scanner assemblies (3 of 9) .....	331
Table 7-23	Flatbed scanner assemblies (4 of 9) .....	333
Table 7-24	Flatbed scanner assemblies (5 of 9) .....	335
Table 7-25	Flatbed scanner assemblies (6 of 9) .....	337
Table 7-26	Flatbed scanner assemblies (7 of 9) .....	339
Table 7-27	Flatbed scanner assemblies (8 of 9) .....	341
Table 7-28	Flatbed scanner assemblies (9 of 9) .....	343
Table 7-29	Alphabetical parts list .....	344
Table 7-30	Numerical parts list .....	353
Table B-1	Physical specifications .....	370
Table B-2	Electrical specifications .....	370
Table B-3	N9120 <sup>1,2</sup> .....	370
Table B-4	Environmental specifications .....	371

---

# List of figures

Figure 1-1	Front and right-side view .....	4
Figure 1-2	Back view .....	5
Figure 1-3	Side view (left) .....	5
Figure 1-4	Model and serial number (1 of 2) .....	6
Figure 1-5	Model and serial number (2 of 2) .....	6
Figure 1-6	Control-panel features .....	7
Figure 2-1	Site dimensions .....	14
Figure 2-2	Unpack the device (1 of 9) .....	15
Figure 2-3	Unpack the device (2 of 9) .....	15
Figure 2-4	Unpack the device (3 of 9) .....	16
Figure 2-5	Unpack the device (4 of 9) .....	16
Figure 2-6	Unpack the device (5 of 9) .....	17
Figure 2-7	Unpack the device (6 of 9) .....	17
Figure 2-8	Unpack the device (7 of 9) .....	18
Figure 2-9	Unpack the device (8 of 9) .....	18
Figure 2-10	Unpack the device (9 of 9) .....	18
Figure 2-11	Electrical connection .....	19
Figure 2-12	USB connection .....	19
Figure 2-13	Power switch .....	20
Figure 3-1	Clean the ADF (1 of 5) .....	24
Figure 3-2	Clean the ADF (2 of 5) .....	25
Figure 3-3	Clean the ADF (3 of 5) .....	25
Figure 3-4	Clean the ADF (4 of 5) .....	26
Figure 3-5	Clean the ADF (5 of 5) .....	26
Figure 3-6	Clean the scanner glass .....	27
Figure 3-7	Clean the scanner fan filters (1 of 2) .....	28
Figure 3-8	Clean the scanner fan filters (2 of 2) .....	28
Figure 4-1	Sensors .....	34
Figure 4-2	Motors .....	35
Figure 4-3	Service block diagram .....	36
Figure 5-1	Phillips and pozidrive screwdriver comparison .....	39
Figure 5-2	Remove the imprinter cartridge (1 of 4) .....	42

Figure 5-3	Remove the imprinter cartridge (2 of 4)	42
Figure 5-4	Remove the imprinter cartridge (3 of 4)	43
Figure 5-5	Remove the imprinter cartridge (4 of 4)	43
Figure 5-6	Remove the fan filter (1 of 2)	44
Figure 5-7	Remove the fan filter (2 of 2)	44
Figure 5-8	Remove the ADF base reflector (1 of 2)	45
Figure 5-9	Remove the ADF base reflector (2 of 2)	45
Figure 5-10	Reinstall the ADF base reflector	46
Figure 5-11	Remove the pickup-roller assembly	47
Figure 5-12	Reinstall the pickup-roller assembly (1 of 2)	48
Figure 5-13	Reinstall the pickup-roller assembly (2 of 2)	49
Figure 5-14	Remove the separation-pad assembly (1 of 3)	50
Figure 5-15	Remove the separation-pad assembly (2 of 3)	50
Figure 5-16	Remove the separation-pad assembly (3 of 3)	51
Figure 5-17	Reinstall the separation-pad assembly	51
Figure 5-18	Remove the scanner control-panel cover	53
Figure 5-19	Remove the ADF front cover (1 of 5)	55
Figure 5-20	Remove the ADF front cover (2 of 5)	55
Figure 5-21	Remove the ADF front cover (3 of 5)	56
Figure 5-22	Remove the ADF front cover (4 of 5)	56
Figure 5-23	Remove the ADF front cover (5 of 5)	57
Figure 5-24	Remove the ADF back cover (1 of 3)	58
Figure 5-25	Remove the ADF back cover (2 of 3)	58
Figure 5-26	Remove the ADF back cover (3 of 3)	59
Figure 5-27	Remove the scanner back cover (1 of 2)	60
Figure 5-28	Remove the scanner back cover (2 of 2)	60
Figure 5-29	Remove the ADF (1 of 8)	63
Figure 5-30	Remove the ADF (2 of 8)	64
Figure 5-31	Remove the ADF (3 of 8)	64
Figure 5-32	Remove the ADF (4 of 8)	65
Figure 5-33	Remove the ADF (5 of 8)	65
Figure 5-34	Remove the ADF (6 of 8)	66
Figure 5-35	Remove the ADF (7 of 8)	66
Figure 5-36	Remove the ADF (8 of 8)	67
Figure 5-37	Reinstall the ADF (1 of 7)	67
Figure 5-38	Reinstall the ADF (2 of 7)	68
Figure 5-39	Reinstall the ADF (3 of 7)	68
Figure 5-40	Reinstall the ADF (4 of 7)	69
Figure 5-41	Reinstall the ADF (5 of 7)	69
Figure 5-42	Reinstall the ADF (6 of 7)	70
Figure 5-43	Reinstall the ADF (7 of 7)	70



Figure 5-44	ADF height adjustment (1 of 6)	72
Figure 5-45	ADF height adjustment (2 of 6)	72
Figure 5-46	ADF height adjustment (3 of 6)	72
Figure 5-47	ADF height adjustment (4 of 6)	73
Figure 5-48	ADF height adjustment (5 of 6)	73
Figure 5-49	ADF height adjustment (6 of 6)	74
Figure 5-50	Repair menu (1 of 11)	75
Figure 5-51	Repair menu (2 of 11)	76
Figure 5-52	Replacement scenario #1 (3 of 11)	77
Figure 5-53	Replacement scenario #2 (4 of 11)	78
Figure 5-54	Replacement scenario #3 (5 of 11)	79
Figure 5-55	Replacement scenario #4 (6 of 7)	80
Figure 5-56	Replacement scenario #5 (7 of 11)	81
Figure 5-57	Replacement scenario #6 (8 of 11)	82
Figure 5-58	Replacement scenario #7 (9 of 11)	83
Figure 5-59	Repair menu (10 of 11)	84
Figure 5-60	Repair menu (11 of 11)	85
Figure 5-61	Download factory NVRAM data (1 of 6)	86
Figure 5-62	Download factory NVRAM data (2 of 6)	86
Figure 5-63	Download factory NVRAM data (3 of 6)	87
Figure 5-64	Download factory NVRAM data (4 of 6)	87
Figure 5-65	Download factory NVRAM data (5 of 6)	88
Figure 5-66	Download factory NVRAM data (6 of 6)	88
Figure 5-67	Backup current NVRAM data (1 of 3)	89
Figure 5-68	Backup current NVRAM data (2 of 3)	90
Figure 5-69	Backup current NVRAM data (3 of 3)	90
Figure 5-70	Repair NVRAM data (1 of 5)	91
Figure 5-71	Repair NVRAM data (2 of 5)	92
Figure 5-72	Repair NVRAM data (3 of 5)	93
Figure 5-73	Repair NVRAM data (4 of 5)	94
Figure 5-74	Repair NVRAM data (5 of 5)	95
Figure 5-75	Adjust NVRAM counter items (1 of 2)	96
Figure 5-76	Adjust NVRAM counter items (2 of 2)	97
Figure 5-77	ADF alignment (1 of 6)	98
Figure 5-78	ADF alignment (2 of 6)	99
Figure 5-79	ADF alignment (3 of 6)	99
Figure 5-80	ADF alignment (4 of 6)	99
Figure 5-81	ADF alignment (5 of 6)	100
Figure 5-82	Create the factory calibration data for ADF-A (1 of 3)	101
Figure 5-83	Create the factory calibration data for ADF-A (2 of 3)	102
Figure 5-84	Create the factory calibration data for ADF-A (3 of 3)	102

Figure 5-85	Remove the ADF motor fan (1 of 2)	103
Figure 5-86	Remove the ADF motor fan (2 of 2)	103
Figure 5-87	Remove the ADF carriage fan	104
Figure 5-88	Remove the ADF input-tray lift-motor assembly (1 of 2)	105
Figure 5-89	Remove the ADF input-tray lift-motor assembly (2 of 2)	106
Figure 5-90	Remove the ADF exit-motor assembly (1 of 7)	107
Figure 5-91	Remove the ADF exit-motor assembly (2 of 7)	107
Figure 5-92	Remove the ADF exit-motor assembly (3 of 7)	108
Figure 5-93	Remove the ADF exit-motor assembly (4 of 7)	108
Figure 5-94	Remove the ADF exit-motor assembly (5 of 7)	109
Figure 5-95	Remove the ADF exit-motor assembly (6 of 7)	109
Figure 5-96	Remove the ADF exit-motor assembly (7 of 7)	110
Figure 5-97	Remove the ADF feed-motor assembly (1 of 4)	111
Figure 5-98	Remove the ADF feed-motor assembly (2 of 4)	112
Figure 5-99	Remove the ADF feed-motor assembly (3 of 4)	112
Figure 5-100	Remove the ADF feed-motor assembly (4 of 4)	113
Figure 5-101	Reinstall the ADF feed-motor drive belt (1 of 3)	114
Figure 5-102	Reinstall the ADF feed-motor drive belt (2 of 3)	114
Figure 5-103	Reinstall the ADF feed-motor drive belt (3 of 3)	115
Figure 5-104	Reinstall the ADF feed-motor assembly (1 of 5)	115
Figure 5-105	Reinstall the ADF feed-motor assembly (2 of 5)	116
Figure 5-106	Reinstall the ADF feed-motor assembly (3 of 5)	116
Figure 5-107	Reinstall the ADF feed-motor assembly (4 of 5)	117
Figure 5-108	Reinstall the ADF feed-motor assembly (5 of 5)	117
Figure 5-109	Remove the ADF pick-motor assembly (1 of 5)	118
Figure 5-110	Remove the ADF pick-motor assembly (2 of 5)	119
Figure 5-111	Remove the ADF pick-motor assembly (3 of 5)	119
Figure 5-112	Remove the ADF pick-motor assembly (4 of 5)	120
Figure 5-113	Remove the ADF pick-motor assembly (5 of 5)	120
Figure 5-114	Reinstall the ADF pick-motor assembly (1 of 5)	121
Figure 5-115	Reinstall the ADF pick-motor assembly (2 of 5)	121
Figure 5-116	Reinstall the ADF pick-motor assembly (3 of 5)	122
Figure 5-117	Reinstall the ADF pick-motor assembly (4 of 5)	122
Figure 5-118	Reinstall the ADF pick-motor assembly (5 of 5)	123
Figure 5-119	Remove the upper multi-pick sensor PCA (1 of 3)	124
Figure 5-120	Remove the upper multi-pick sensor PCA (2 of 3)	125
Figure 5-121	Remove the upper multi-pick sensor PCA (3 of 3)	125
Figure 5-122	Remove the lower multi-pick sensor PCA (1 of 2)	126
Figure 5-123	Remove the lower multi-pick sensor PCA (2 of 2)	127
Figure 5-124	Remove the ADF controller PCA (1 of 2)	128
Figure 5-125	Remove the ADF controller PCA (2 of 2)	129

Figure 5-126	Remove the imprinter PCA (1 of 2)	130
Figure 5-127	Remove the imprinter PCA (2 of 2)	131
Figure 5-128	Reinstall the imprinter PCA (1 of 4)	131
Figure 5-129	Reinstall the imprinter PCA (2 of 4)	132
Figure 5-130	Reinstall the imprinter PCA (3 of 4)	132
Figure 5-131	Reinstall the imprinter PCA (4 of 4)	133
Figure 5-132	Remove the input-tray sensor	134
Figure 5-133	Remove the flatbed scan position sensor (1 of 2)	135
Figure 5-134	Remove the flatbed scan position sensor (2 of 2)	136
Figure 5-135	Reinstall the flatbed scan position sensor	136
Figure 5-136	Remove the exit 1 sensor	138
Figure 5-137	Remove the exit 2 sensor	139
Figure 5-138	Remove the pick-up roller sensor (1 of 4)	140
Figure 5-139	Remove the pick-up roller sensor (2 of 4)	140
Figure 5-140	Remove the pick-up roller sensor (3 of 4)	141
Figure 5-141	Remove the pick-up roller sensor (4 of 4)	141
Figure 5-142	Remove the elevator arm sensor	142
Figure 5-143	Remove the background solenoid sensor (1 of 2)	143
Figure 5-144	Remove the background solenoid sensor (2 of 2)	143
Figure 5-145	Remove the paper-present sensor	144
Figure 5-146	Remove the registration sensor	145
Figure 5-147	Remove the jam door 1 sensor	146
Figure 5-148	Remove jam door 2 sensor	147
Figure 5-149	Remove the jam door 3 sensor	148
Figure 5-150	Remove the imprinter paper-present sensor (1 of 2)	149
Figure 5-151	Remove the imprinter paper-present sensor (2 of 2)	150
Figure 5-152	Remove the ADF scan position sensor	151
Figure 5-153	Remove the ADF bottom corner outer paper path guide (1 of 2)	152
Figure 5-154	Remove the ADF bottom corner outer paper path guide (2 of 2)	152
Figure 5-155	Reinstall the ADF bottom corner outer paper path guide	153
Figure 5-156	Remove the ADF bottom corner inner paper path guide (1 of 2)	154
Figure 5-157	Remove the ADF bottom corner inner paper path guide (2 of 2)	154
Figure 5-158	Remove the ADF cal-strip assembly (1 of 5)	155
Figure 5-159	Remove the ADF cal-strip assembly (2 of 5)	156
Figure 5-160	Remove the ADF cal-strip assembly (3 of 5)	156
Figure 5-161	Remove the ADF cal-strip assembly (4 of 5)	157
Figure 5-162	Remove the ADF cal-strip assembly (5 of 5)	157
Figure 5-163	Reinstall the ADF cal-strip assembly (1 of 7)	158
Figure 5-164	Reinstall the ADF cal-strip assembly (2 of 7)	158
Figure 5-165	Reinstall the ADF cal-strip assembly (3 of 7)	159
Figure 5-166	Reinstall the ADF cal-strip assembly (4 of 7)	159

Figure 5-167	Reinstall the ADF cal-strip assembly (5 of 7)	160
Figure 5-168	Reinstall the ADF cal-strip assembly (6 of 7)	160
Figure 5-169	Reinstall the ADF cal-strip assembly (7 of 7)	161
Figure 5-170	Remove the ADF exit inner paper path guide (1 of 4)	162
Figure 5-171	Remove the ADF exit inner paper path guide (2 of 4)	163
Figure 5-172	Remove the ADF exit inner paper path guide (3 of 4)	163
Figure 5-173	Remove the ADF exit inner paper path guide (4 of 4)	164
Figure 5-174	Remove the ADF top corner inner paper path guide (1 of 2)	165
Figure 5-175	Remove the ADF top corner inner paper path guide (2 of 2)	165
Figure 5-176	Remove the lower multi-pick sensor cover (1 of 3)	166
Figure 5-177	Remove the lower multi-pick sensor cover (2 of 3)	167
Figure 5-178	Remove the lower multi-pick sensor cover (3 of 3)	167
Figure 5-179	Remove the flatbed scan position sensor arm (1 of 2)	168
Figure 5-180	Remove the flatbed scan position sensor arm (2 of 2)	169
Figure 5-181	Reinstall the flatbed scan position sensor arm (1 of 3)	169
Figure 5-182	Reinstall the flatbed scan position sensor arm (2 of 3)	170
Figure 5-183	Reinstall the flatbed scan position sensor arm (3 of 3)	170
Figure 5-184	Remove the exit 1 sensor arm	172
Figure 5-185	Remove the exit 2 sensor arm (1 of 3)	173
Figure 5-186	Remove the exit 2 sensor arm (2 of 3)	174
Figure 5-187	Remove the exit 2 sensor arm (3 of 3)	174
Figure 5-188	Remove the paper-present-sensor arm (1 of 2)	175
Figure 5-189	Remove the paper-present-sensor arm (2 of 2)	175
Figure 5-190	Remove the input-tray-elevator arm (1 of 5)	176
Figure 5-191	Remove the input-tray-elevator arm (2 of 5)	176
Figure 5-192	Remove the input-tray-elevator arm (3 of 5)	177
Figure 5-193	Remove the input-tray-elevator arm (4 of 5)	177
Figure 5-194	Remove the input-tray-elevator arm (5 of 5)	178
Figure 5-195	Remove the registration sensor arm (1 of 2)	179
Figure 5-196	Remove the registration sensor arm (2 of 2)	180
Figure 5-197	Remove the scan position sensor arm (1 of 2)	181
Figure 5-198	Remove the scan position sensor arm (2 of 2)	181
Figure 5-199	Remove the pickup-roller spring	182
Figure 5-200	Remove the separation-pad spring	183
Figure 5-201	Remove the ADF input-tray assembly (1 of 3)	184
Figure 5-202	Remove the ADF input-tray assembly (2 of 3)	184
Figure 5-203	Remove the ADF input-tray assembly (3 of 3)	185
Figure 5-204	Remove the ADF output tray (1 of 3)	186
Figure 5-205	Remove the ADF output tray (2 of 3)	186
Figure 5-206	Remove the ADF output tray (3 of 3)	187
Figure 5-207	Reinstall the ADF output tray (1 of 4)	188

Figure 5-208	Reinstall the ADF output tray (2 of 4)	188
Figure 5-209	Reinstall the ADF output tray (3 of 4)	189
Figure 5-210	Reinstall the ADF output tray (4 of 4)	189
Figure 5-211	Remove the pickup-roller cover (1 of 3)	190
Figure 5-212	Remove the pickup-roller cover (2 of 3)	190
Figure 5-213	Remove the pickup-roller cover (3 of 3)	191
Figure 5-214	Remove the ADF hinge limiters	192
Figure 5-215	Remove ADF jam door 3 (1 of 4)	193
Figure 5-216	Remove ADF jam door 3 (2 of 4)	193
Figure 5-217	Remove ADF jam door 3 (3 of 4)	194
Figure 5-218	Remove ADF jam door 3 (4 of 4)	194
Figure 5-219	Remove the paper present sensor and imprinter PCA holder (1 of 3)	195
Figure 5-220	Remove the paper present sensor and imprinter PCA holder (2 of 3)	196
Figure 5-221	Remove the paper present sensor and imprinter PCA holder (3 of 3)	196
Figure 5-222	Remove the ADF shingle wall (1 of 4)	197
Figure 5-223	Remove the ADF shingle wall (2 of 4)	198
Figure 5-224	Remove the ADF shingle wall (3 of 4)	198
Figure 5-225	Remove the ADF shingle wall (4 of 4)	199
Figure 5-226	Remove the A4 paper-stop (1 of 2)	200
Figure 5-227	Remove the A4 paper-stop (2 of 2)	200
Figure 5-228	Remove the ADF background-solenoid assembly (1 of 5)	201
Figure 5-229	Remove the ADF background-solenoid assembly (2 of 5)	201
Figure 5-230	Remove the ADF background-solenoid assembly (3 of 5)	202
Figure 5-231	Remove the ADF background-solenoid assembly (4 of 5)	202
Figure 5-232	Remove the ADF background-solenoid assembly (5 of 5)	203
Figure 5-233	Reinstall the ADF background-solenoid assembly (1 of 3)	204
Figure 5-234	Reinstall the ADF background-solenoid assembly (1 of 3)	204
Figure 5-235	Reinstall the ADF background-solenoid assembly (3 of 3)	205
Figure 5-236	Imprinter carriage and FFC (1 of 3)	206
Figure 5-237	Imprinter carriage and FFC (2 of 3)	207
Figure 5-238	Imprinter carriage and FFC (3 of 3)	207
Figure 5-239	Remove the scanner carriage-motor fan (1 of 5)	210
Figure 5-240	Remove the scanner carriage-motor fan (2 of 5)	210
Figure 5-241	Remove the scanner carriage-motor fan (3 of 5)	211
Figure 5-242	Remove the scanner carriage-motor fan (4 of 5)	211
Figure 5-243	Remove the scanner carriage-motor fan (5 of 5)	212
Figure 5-244	Remove the scanner carriage fan (1 of 3)	213
Figure 5-245	Remove the scanner carriage fan (2 of 3)	213
Figure 5-246	Remove the scanner carriage fan (3 of 3)	214
Figure 5-247	Remove the scanner carriage motor (1 of 5)	215
Figure 5-248	Remove the scanner carriage motor (2 of 5)	215

Figure 5-249	Remove the scanner carriage motor (3 of 5)	216
Figure 5-250	Remove the scanner carriage motor (4 of 5)	216
Figure 5-251	Remove the scanner carriage motor (5 of 5)	217
Figure 5-252	Remove the control-panel PCA (1 of 3)	218
Figure 5-253	Remove the control-panel PCA (2 of 3)	219
Figure 5-254	Remove the control-panel PCA (3 of 3)	219
Figure 5-255	Remove the scanner controller PCA (1 of 4)	220
Figure 5-256	Remove the scanner controller PCA (2 of 4)	221
Figure 5-257	Remove the scanner controller PCA (3 of 4)	221
Figure 5-258	Remove the scanner controller PCA (4 of 4)	222
Figure 5-259	Remove the power-supply PCA (1 of 6)	223
Figure 5-260	Remove the power-supply PCA (2 of 6)	224
Figure 5-261	Remove the power-supply PCA (3 of 6)	224
Figure 5-262	Remove the power-supply PCA (4 of 6)	225
Figure 5-263	Remove the power-supply PCA (5 of 6)	225
Figure 5-264	Remove the power-supply PCA (6 of 6)	226
Figure 5-265	Remove the scanner-glass assembly (1 of 2)	227
Figure 5-266	Remove the scanner-glass assembly (2 of 2)	227
Figure 5-267	Remove the ADF power-cable assembly (1 of 3)	228
Figure 5-268	Remove the ADF power-cable assembly (2 of 3)	228
Figure 5-269	Remove the ADF power-cable assembly (3 of 3)	229
Figure 5-270	Remove the carriage-motor cable	230
Figure 5-271	Remove the power switch and power receptacle assembly (1 of 3)	231
Figure 5-272	Remove the power switch and power receptacle assembly (2 of 3)	231
Figure 5-273	Remove the power switch and power receptacle assembly (3 of 3)	232
Figure 6-1	Control-panel LEDs	238
Figure 6-2	Main screen	242
Figure 6-3	Scan dialog box	244
Figure 6-4	Sensor in motion tab	246
Figure 6-5	Sensor tab	248
Figure 6-6	Control panel check dialog box	251
Figure 6-7	ADF feed test dialog box	253
Figure 6-8	<b>Actuators</b> dialog box	255
Figure 6-9	<b>Get/SetNVRAMValue(String)</b> tab	258
Figure 6-10	<b>Get/SetNVRAMValue(String)</b> tab	259
Figure 6-11	<b>Repair</b> menu	261
Figure 6-12	Version information dialog box	262
Figure 6-13	Major components (1 of 3)	263
Figure 6-14	Major components (2 of 3)	264
Figure 6-15	Major components (3 of 3)	265
Figure 6-16	ADF motors and fans (1 of 2)	266

Figure 6-17	ADF motors and fans (2 of 2)	267
Figure 6-18	ADF PCAs	268
Figure 6-19	Scanner PCAs	269
Figure 6-20	Clear jams from the ADF (1 of 5)	277
Figure 6-21	Clear jams from the ADF (2 of 5)	277
Figure 6-22	Clear jams from the ADF (3 of 5)	278
Figure 6-23	Clear jams from the ADF (4 of 5)	278
Figure 6-24	Clear jams from the ADF (5 of 5)	279
Figure 7-1	ADF assemblies (1 of 14)	298
Figure 7-2	ADF assemblies (2 of 14)	300
Figure 7-3	ADF assemblies (3 of 14)	302
Figure 7-4	ADF assemblies (4 of 14)	304
Figure 7-5	ADF assemblies (5 of 14)	306
Figure 7-6	ADF assemblies (6 of 14)	308
Figure 7-7	ADF assemblies (7 of 14)	310
Figure 7-8	ADF assemblies (8 of 14)	312
Figure 7-9	ADF assemblies (9 of 14)	314
Figure 7-10	ADF assemblies (10 of 14)	316
Figure 7-11	ADF assemblies (11 of 14)	318
Figure 7-12	ADF assemblies (12 of 14)	320
Figure 7-13	ADF assemblies (13 of 14)	322
Figure 7-14	ADF assemblies (14 of 14)	324
Figure 7-15	Flatbed scanner assemblies (1 of 9)	326
Figure 7-16	Flatbed scanner assemblies (2 of 9)	328
Figure 7-17	Flatbed scanner assemblies (3 of 9)	330
Figure 7-18	Flatbed scanner assemblies (4 of 9)	332
Figure 7-19	Flatbed scanner assemblies (5 of 9)	334
Figure 7-20	Flatbed scanner assemblies (6 of 9)	336
Figure 7-21	Flatbed scanner assemblies (7 of 9)	338
Figure 7-22	Flatbed scanner assemblies (8 of 9)	340
Figure 7-23	Flatbed scanner assemblies (9 of 9)	342
Figure A-1	Repack the product (1 of 3)	367
Figure A-2	Repack the product (2 of 3)	367
Figure A-3	Repack the product (3 of 3)	368





---

# 1 Product basics

- [Quick access to product information](#)
- [Product basics](#)
- [System requirements](#)
- [Paper handling](#)

# Quick access to product information

Use the following Web site to find information about the product:

- [www.hp.com/support](http://www.hp.com/support)

**Table 1-1 Product guides**

Guide	Description
User Guide	<p>The scanner User Guide is the primary source for scanner information. It provides information about using, maintaining, and troubleshooting the scanner.</p> <p><b>View the User Guide in the installed (system) language</b></p> <ol style="list-style-type: none"><li>1. Click <b>Start</b>.</li><li>2. Point to <b>Programs</b> or <b>All Programs</b>.</li><li>3. Point to <b>Scanjet</b>, and then point to <b>N9120</b>.</li><li>4. Click <b>User Guide</b>.</li></ol> <p><b>View the User Guide in a different language</b></p> <ol style="list-style-type: none"><li>1. Insert the HP software CD that came with the scanner into the computer compact-disk drive. Wait for the installation dialog box to appear.</li><li>2. Click <b>View or print guides</b>.</li><li>3. Click a language for the User Guide.</li></ol>
HP Smart Document Scan software help	<p>The HP Smart Document Scan software help explains how to use HP Smart Document Scan software features such as creating and editing profiles.</p> <ol style="list-style-type: none"><li>1. Double-click the <b>HP Smart Document Scan</b> icon on your computer desktop.</li><li>2. Click <b>Help</b> on the menu bar.</li></ol>
HP Scanner Tools Utility help	<p>The HP Scanner Tools Utility help explains the scanner settings, information about scanner status and maintenance, and how to assign functionality to the scanner front-panel buttons.</p> <ol style="list-style-type: none"><li>1. Press the <b>Tools</b> button on the scanner front panel.</li><li>2. Click <b>Help</b> in HP Scanner Tools Utility dialog box (this dialog box appears on the computer that is connected to the N9120).</li></ol>

# Product basics

## Product features

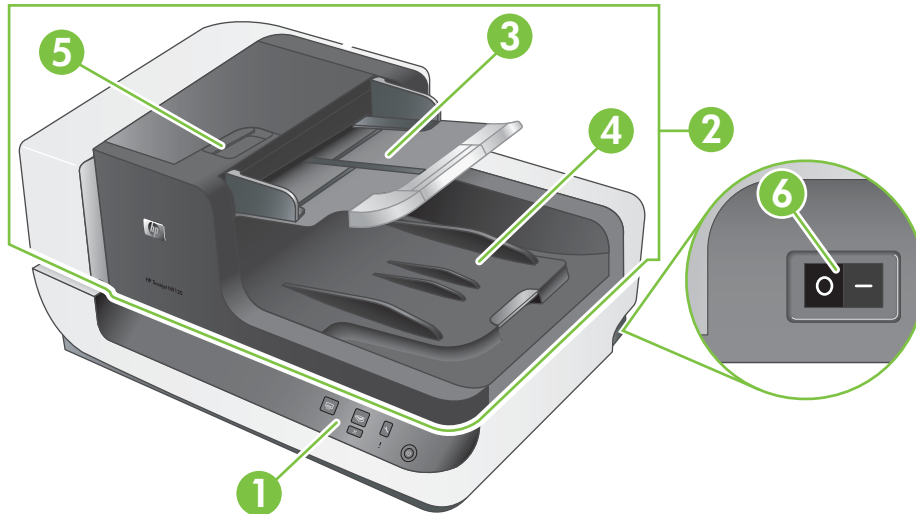
**Table 1-2 Product specifications**

<b>Description</b>	<b>Specification</b>
Scanner type	Scanner with ADF
Overall size	692 x 558 x 343 mm (27.3 x 22.0 x 13.5 in)
Weight	38.5 kg (85 lb)
Scanning element	Charge-coupled device (CCD)
Interface	USB 2.0 high speed (compatible with USB 1.1)
Optical resolution	600 x 600 dpi hardware
AC power	100–240 V~, 50/60 Hz, 1.8 A
Power consumption	For power consumption information, see the regulatory_supplement.htm file on the HP Scanning Software CD.
Energy information	To learn if your HP scanner is ENERGY STAR® qualified, go to <a href="http://www.hp.com">www.hp.com</a> , select your country/region, and then search on Energy Star.

# Product walkaround

## Front and right-side view

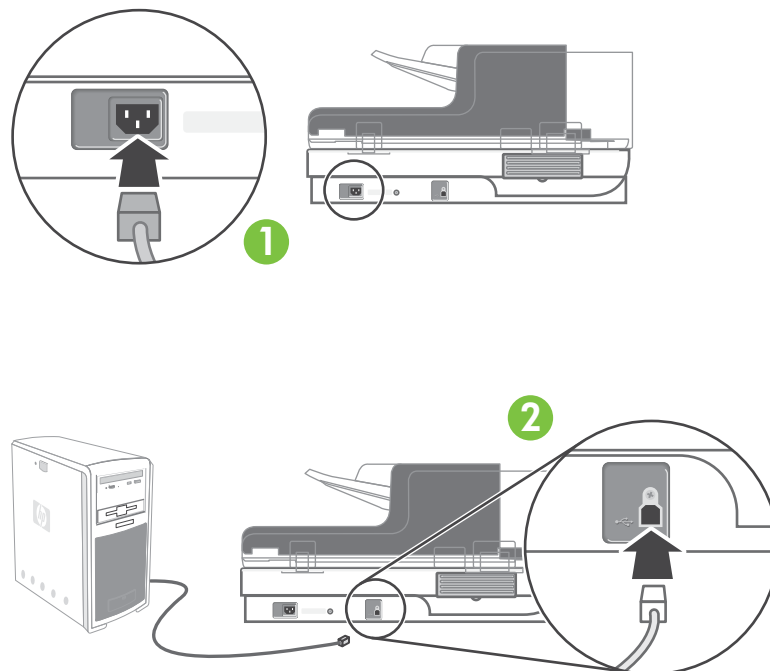
Figure 1-1 Front and right-side view



- 
- 1 Front panel
  - 2 ADF
  - 3 ADF input tray
  - 4 ADF output tray
  - 5 Latch for opening the ADF jam door 1
  - 6 Power switch
-

## Back view

Figure 1-2 Back view



---

1 Power receptacle

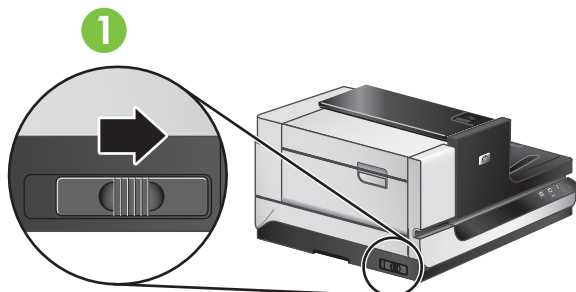
---

2 USB port

---

## Side view (left)

Figure 1-3 Side view (left)



---

1 Scanner carriage lock

---

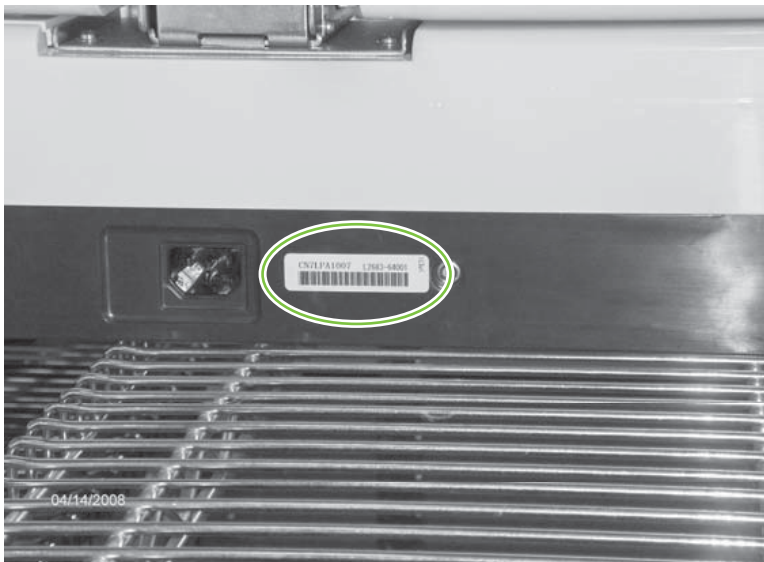
## Model and serial numbers

The model and serial numbers are listed on identification labels located on the ADF and flatbed scanner.

**Figure 1-4** Model and serial number (1 of 2)



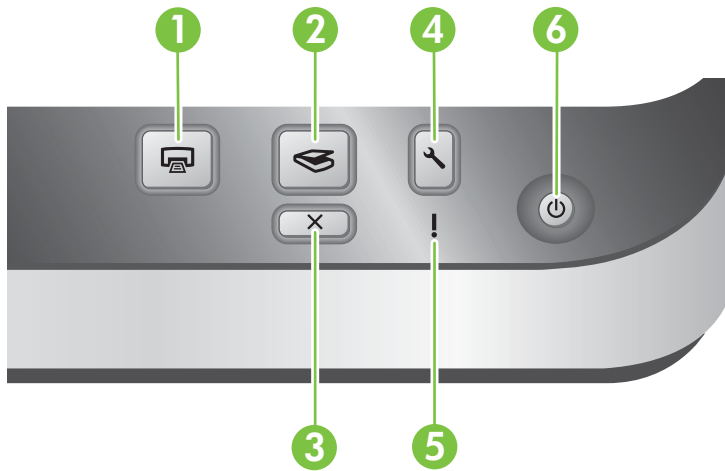
**Figure 1-5** Model and serial number (2 of 2)









**NOTE:** If the product is owned by the U.S. government, the ADF and flatbed scanner have a special serial-number designation. Replacement components for these products must have a similar serial-number designation.

## Control-panel walkaround

**Figure 1-6** Control-panel features



**Table 1-3** Control-panel features

Item	Icon	Button name	Description
1		Copy	By default, print the number of copies currently configured in HP Document Copy.  Alternatively, start the scanning software that is assigned to this button.
2		Scan	By default, start a scan that uses the HP Smart Document Scan software profile that is assigned to this button.  Alternatively, start the scanning software that is assigned to this button.
3		Cancel	Cancel a scan or copy in progress.
4		Tools	Open the HP Scanner Tools Utility where you can do the following tasks: <ul style="list-style-type: none"> <li>• Associate the scanner control-panel buttons with scanning software.</li> <li>• Configure the buttons on the scanner front panel.</li> <li>• Manage the imprinter.</li> <li>• View information about scanner settings, status, and maintenance.</li> </ul>
5		Attention LED	The <b>Attention LED</b> provides status information about the scanner.
6		Power Save	Press the <b>Power Save</b> button to put the scanner in Power Save mode when you are not using the scanner. When you are ready to begin scanning again, press the <b>Power Save</b> button to wake up the scanner.

## Supported product software

### Supported operating systems

The product supports the following operating systems:

- Microsoft® Windows 2000
- Windows® XP Home/Professional
- Windows Vista®
- Linux 2.4 and 2.6 Kernel Available

### Supported scanner drivers

The product supports the following scanner drivers:

- Twain
- ISIS
- WIA

### Supported scanner-management software

HP Scanning Software CD

- HP Scanner Tools Utility
- HP Smart Document Scan
- Kofax VRS Pro
- Third-party document-management software



# System requirements

The host computer must meet the minimum system hardware requirements to load and utilize the in-box software.

- Minimum system hardware requirements:
  - 1.4 GHz processor
  - 600 MB free hard disk space
  - USB 2.0 and higher
  - CD-ROM drive
  - 1024 x 768 SVGA monitor, 16-bit color
- HP recommends that the host computer system hardware meet the following requirements to assure the optimum performance of the scanner at the quoted speed specifications.

Recommended system hardware requirements:

- USB 1.1 and higher
- CD-ROM drive
- 1024 x 768 SVGA monitor, 16-bit color
- 80 MB (drivers only)
- 300 MB (minimum) free hard disk space
- For Microsoft Windows XP Home, Windows XP Professional or Windows 2000:
  - 1 GB RAM (recommended)
  - 256 MB RAM (minimum)
  - 500 MHz processor
  - Internet Explorer 6 and higher
- For Windows Vista:
  - 1 GB RAM (recommended)
  - 512 MB RAM (minimum)
  - 800 MHz processor
  - Microsoft Internet Explorer 7 and higher

# Paper handling

## ADF specifications

**Table 1-4 ADF specifications**

Description	Specification
Paper-tray capacity	200 sheets of 75 g/m <sup>2</sup> (20 lb)
Minimum paper size	70 x 148 mm (2.75 x 5.8 in)
Maximum paper size	300 x 864 mm (11.8 x 34 in)
Minimum paper weight	49 g/m <sup>2</sup> (13 lb)
Minimum paper weight	120 g/m <sup>2</sup> (32 lb)

## Media specifications

The ADF supports the following widths, lengths, and weights of paper.

**Table 1-5 Media specifications**

Description	Specification
Width	70–300 mm (2.75–11.8 in)
Length	148–864 mm (5.8–34 in)
Weight	49–120 g/m <sup>2</sup> (13–32 lb)



**NOTE:** The ADF input tray supports up to 200 sheets of 75 g/m<sup>2</sup> (20 lb) paper.

## Media to avoid

Scanning certain types of documents through the ADF might result in jams or damage to the document. HP recommends scanning these types of documents by using the scanner only:

- Wrinkled or creased documents
- Torn documents
- Carbon paper
- Extremely thin, translucent paper
- Photos
- Papers that are stuck together
- Curled documents
- Documents with paperclips or staples
- Coated paper
- Paper with adhesive notes or flags attached
- Overhead transparencies
- Paper with wet substances such as glue or correction fluid



---

## 2 Installation and configuration

- [Prepare the site](#)
- [Unpack the device](#)
- [Install the software](#)

## Prepare the site

The scanner must be installed in a well-ventilated, dust-free area. Place the product on a sturdy, level surface.

For information about product specifications, see [Specifications on page 369](#).

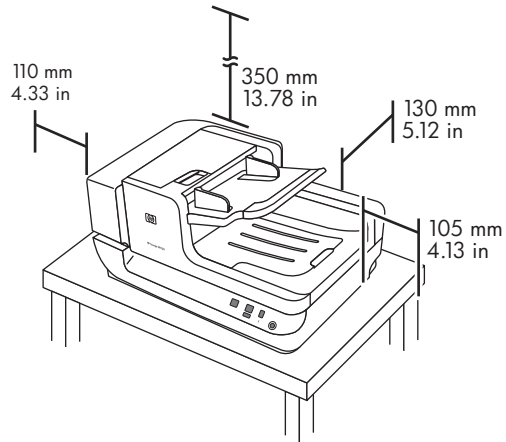
---

**CAUTION:** To avoid injury, use two people to unpack and lift the scanner.

---

Verify that there is enough clearance to use and maintain the scanner.

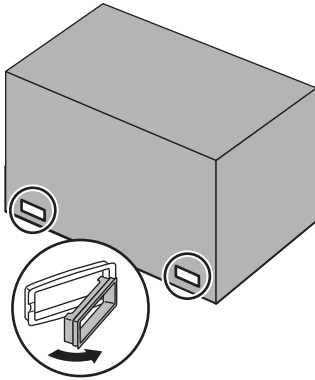
**Figure 2-1** Site dimensions



# Unpack the device

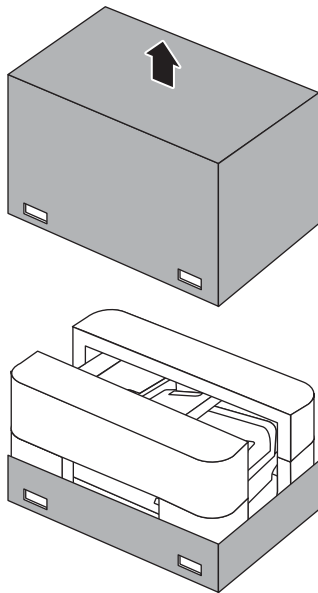
1. Unlock the box.

**Figure 2-2** Unpack the device (1 of 9)



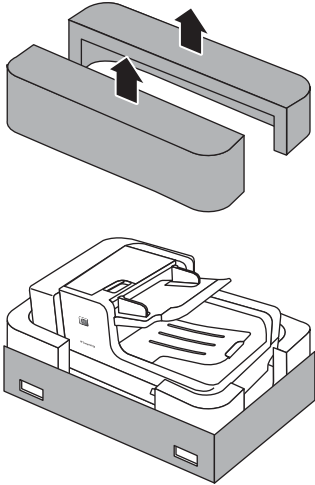
2. Remove the top of the box.

**Figure 2-3** Unpack the device (2 of 9)



3. Remove the top packing material, and then remove all remaining packing material and tape from the outside of the ADF.

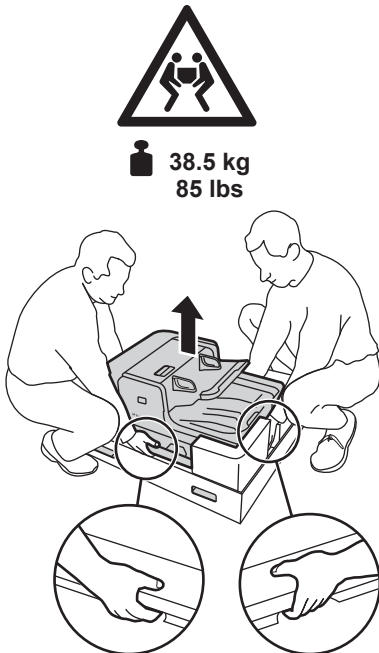
**Figure 2-4** Unpack the device (3 of 9)



4. Remove the scanner from the box.

**CAUTION:** To avoid injury, use two people to lift the device from the box.

**Figure 2-5** Unpack the device (4 of 9)



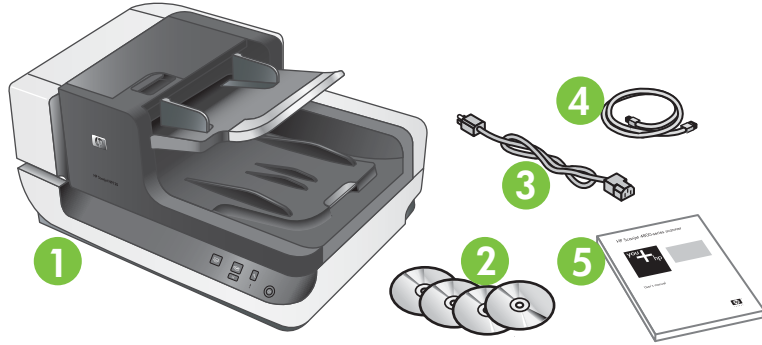
5. Take an inventory of the contents.

The following items should be included with each N9120 scanner.

**NOTE:** The contents might vary by country/region.



**Figure 2-6** Unpack the device (5 of 9)

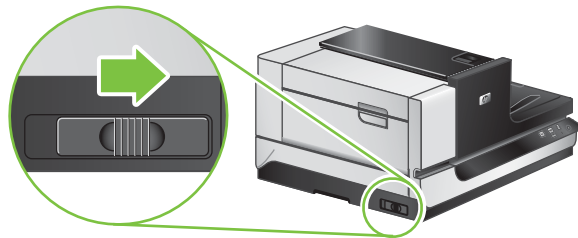


**Table 2-1** Box contents

Item	Description
1	N9120 scanner
2	Scanning software CDs
3	Power cable
4	USB cable
5	Getting Started Guide

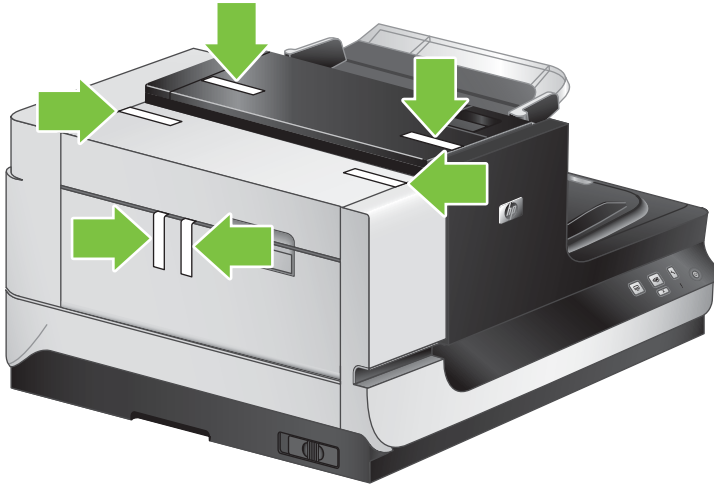
6. Place the product on a sturdy, level surface.
7. Release the carriage lock.

**Figure 2-7** Unpack the device (6 of 9)



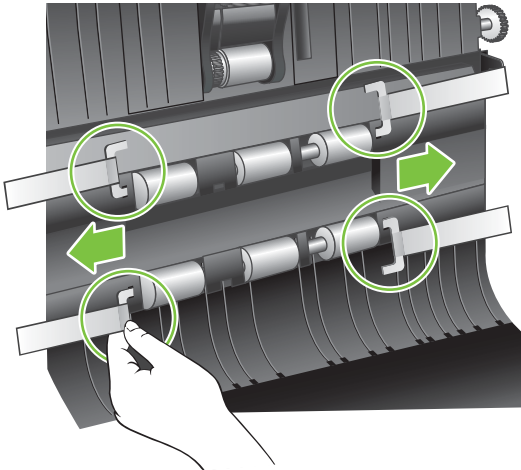
8. Remove the spacer tape from ADF jam door 1 and ADF jam door 2.

**Figure 2-8** Unpack the device (7 of 9)



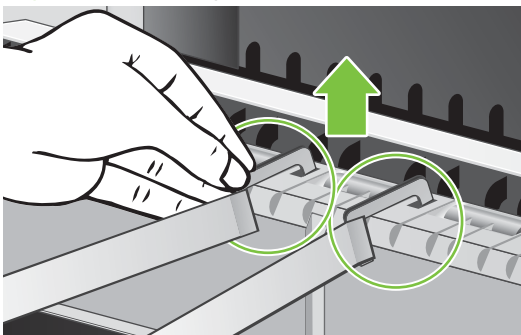
9. Open ADF jam door 1, and then remove the spacers.

**Figure 2-9** Unpack the device (8 of 9)



10. Open ADF jam door 2, and then remove the spacers.

**Figure 2-10** Unpack the device (9 of 9)



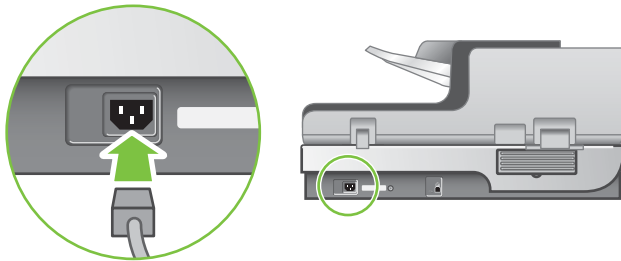
11. Remove any remaining packing material, and then close ADF jam door 1 and ADF jam door 2.

# Install the software

**⚠ CAUTION:** Do not connect the USB cable until you are prompted during the software installation.

1. Decide what software to install.
  - If you will be using the scanner with document-management and scanning software that you already own, you only need to install the HP Scanjet utilities drivers and tools.
  - If you do not already have document-management and scanning software, you can use the software that is shipped with the scanner. Read the onscreen descriptions of the software during the installation to decide what software to install.
2. Insert the HP Scanning Software CD into the computer CD drive. Wait for the installation dialog box to appear.
3. Click **Install Software**, and then follow the instructions on the screen.
4. Use the power cable to connect the scanner to an electrical outlet.

**Figure 2-11** Electrical connection

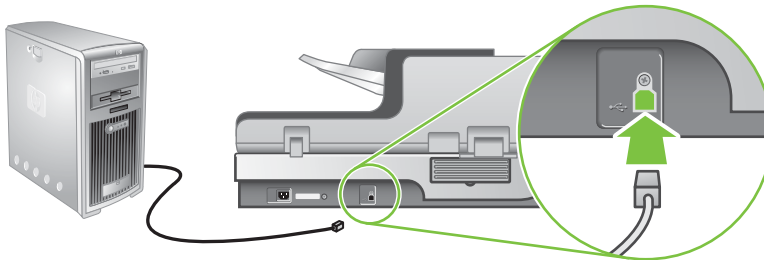


5. Use the USB cable that came with the scanner to connect the scanner to the computer.

**⚠ CAUTION:** Be sure that you install the HP scanning software before connecting the scanner to your computer with the USB cable.

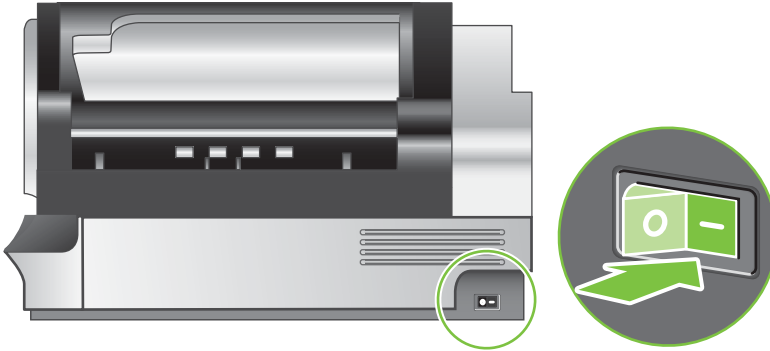
**📝 NOTE:** HP recommends using a USB port on the back of the computer for a more reliable connection to the scanner.

**Figure 2-12** USB connection



6. Press the power switch on the right side of the scanner to the on position.

**Figure 2-13** Power switch



7. Test the installation. Place a single document page in the ADF, and then do one of the following:
  - If you installed the HP Smart Document Scan software, press the **Scan** button.
  - If you did not install the HP Smart Document Scan software, scan from the software that you intend to use for scanning.

If the scan does not proceed as expected, uninstall and reinstall the HP Scanjet utilities, and then try scanning again. If reinstalling the utilities does not work, see the scanning software documentation for information on how to troubleshoot that program.

For information on uninstalling and reinstalling the HP Scanjet utilities, see the product user guide.

---

## 3 Manage and maintain

- Manage supplies
- Clean the product

# Manage supplies

## HP Scanner Tools Utility scanner maintenance information

The **Maintenance** tab of the HP Scanner Tools Utility displays the scanner usage and maintenance history. You can use this tab to record scanner maintenance.

The **Imprinter** tab of the HP Scanner Tools Utility displays information about the scanner imprinter and the imprinter print cartridge. You can use this tab to record that the print cartridge has been replaced.

To open the HP Scanner Tools Utility, press the **Tools** button on the scanner front panel.



**NOTE:** For detailed information on using the HP Scanner Tools Utility, see the HP Scanner Tools Utility help.

## Parts life expectancy

**Table 3-1 Replacement guidelines**

Item	Guideline	How to
ADF base reflector	<p>The ADF base reflector needs to be replaced only if it is damaged or if you see vertical streaks on the scanned images.</p> <p><b>NOTE:</b> Before you replace the white ADF base reflector, try cleaning the product. See <a href="#">Clean the product on page 23</a>.</p>	To replace the ADF base reflector, see <a href="#">ADF base reflector on page 45</a> .
Pickup-roller assembly	<p>The pickup-roller assembly needs to be replaced after 100,000 scans.</p> <p><b>NOTE:</b> HP recommends that you clean the pickup roller every 50,000 pages. See <a href="#">Clean the product on page 23</a>.</p>	To replace the pickup-roller assembly, see <a href="#">Pickup-roller assembly on page 47</a> .
Separation-pad assembly	<p>The separation pad needs to be replaced after 100,000 scans.</p>	To replace the separation-pad assembly, see <a href="#">Separation-pad assembly on page 50</a> .
Imprinter cartridge	<p>Replace the imprinter cartridge when it is out of ink.</p>	To replace the imprinter cartridge, see <a href="#">Imprinter cartridge on page 42</a> .
Fan filters	<p>The fan filters should be replaced when a user-replaceable part is installed or when filters are damaged or worn from cleaning.</p>	To replace a fan filter, see <a href="#">Fan filters on page 44</a> .

## Clean the product

During the scanning process, paper and dust particles can accumulate inside the product. Over time, this buildup can cause problems, such as specks or streaks on scanned documents.


Occasional cleaning of the product helps ensure high-quality scans. The amount of care necessary depends upon several factors, including the amount of use and the environment. You should perform routine cleaning as necessary.

Routine cleaning and maintenance should include cleaning the ADF, the scanner glass, and the fan filters.

## Clean the exterior

Use a soft, damp, lint-free cloth to wipe dust, smudges, and stains off of the exterior of the product.

## Clean the ADF

 **NOTE:** The customer should be advised to clean the ADF only when scanned documents show streaks, specks, or other signs of degradation that can be directly attributed to the scanning process.

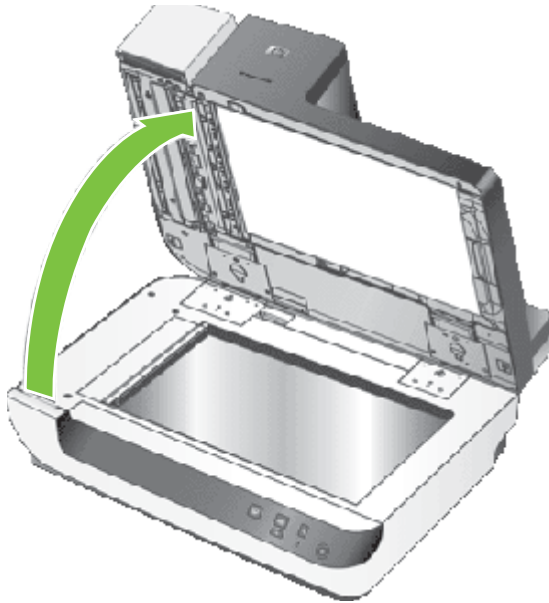
The ADF requires periodic maintenance depending on the amount of use and the type of paper that is fed through it. Clean the ADF under the following conditions:

- The ADF has trouble feeding documents.
- Vertical streaks appear in images scanned by the ADF.
- Scanned documents are dusty, dirty, or have pencil writing (graphite) on them.
- The environment is dusty.

Clean the ADF:

1. Press the power switch to the off position, and then disconnect the USB cable and power cable from the scanner.
2. Open the ADF.

**Figure 3-1** Clean the ADF (1 of 5)



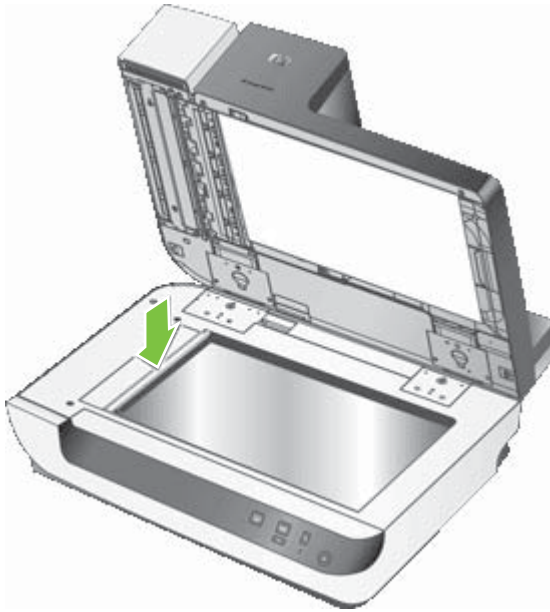


3. Clean the clear scanning strip on the scanner bed. Wipe the clear area with a clean, dry, lint-free cloth.

**⚠ CAUTION:** Use only glass cleaner to clean the scanning strip. Avoid cleaners that contain abrasives, acetone, benzene, or carbon tetrachloride, all of which can damage the scanner glass. Avoid isopropyl alcohol because it can leave streaks on the glass.

Do not spray the glass cleaner directly on the glass. If too much glass cleaner is applied, the cleaner could leak under the glass and damage the scanner.

**Figure 3-2** Clean the ADF (2 of 5)



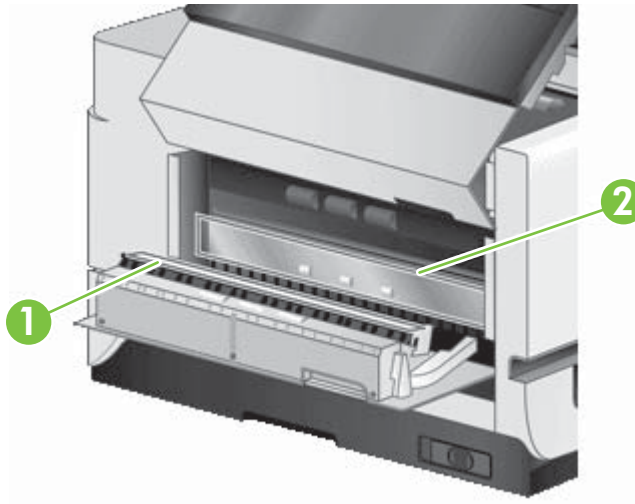
4. Close the ADF.
5. Open jam door 1 (callout 1) and jam door 2.

**Figure 3-3** Clean the ADF (3 of 5)



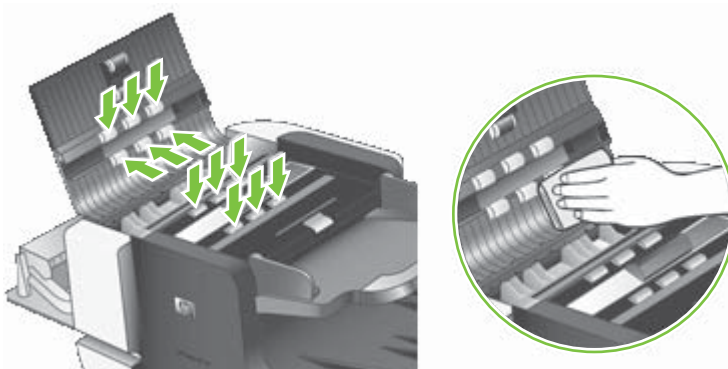
6. Locate the white strip (callout 1) on jam door 2 and the scan window (callout 2) inside the ADF, and then wipe both of these areas with a clean, dry, lint-free cloth.

**Figure 3-4** Clean the ADF (4 of 5)



7. Wipe the rollers with a clean, damp, lint-free cloth.

**Figure 3-5** Clean the ADF (5 of 5)



8. Wait several minutes for the rollers to dry, and then close jam door 1 and jam door 2.
9. Reconnect the USB cable and power cable to the scanner, and then press the power switch to the on position.

## Clean the scanner glass

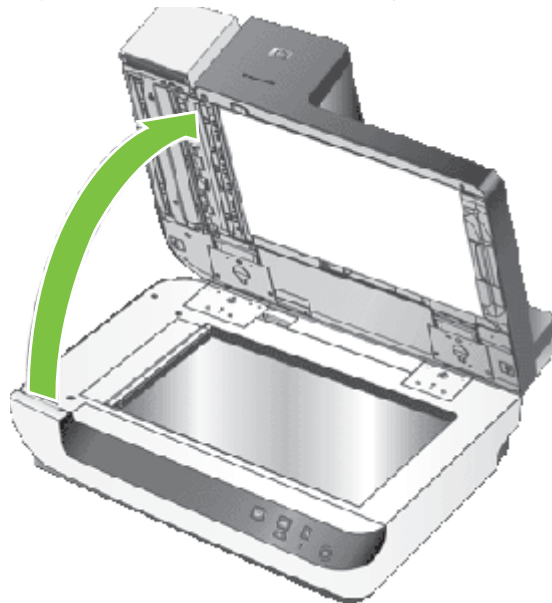
Clean the scanner glass under the following conditions:

- Streaks, scratches, or spots appear in images scanned from the scanner glass.
- Dusty or dirty documents have been scanned using the glass.
- The environment is dusty.

Clean the scanner glass:

1. Press the power switch to the off position, and then disconnect the USB cable and power cable from the scanner.
2. Open the ADF.

**Figure 3-6** Clean the scanner glass



3. Clean the glass with a soft, lint-free cloth that has been sprayed with a mild glass cleaner.


**⚠ CAUTION:** Use only glass cleaner to clean the scanner glass. Avoid cleaners that contain abrasives, acetone, benzene, or carbon tetrachloride, all of which can damage the scanner glass. Avoid isopropyl alcohol because it can leave streaks on the glass.

Do not spray the glass cleaner directly on the glass. If too much glass cleaner is applied, the cleaner could leak under the glass and damage the scanner.

4. Dry the glass with a dry, soft, lint-free cloth.
5. Reconnect the USB cable and power cable to the scanner, and then press the power switch to the on position.

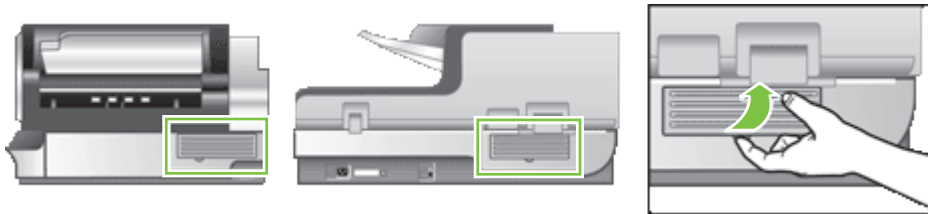
## Clean the fan filters

The flatbed scanner includes two fan filters. These filters prevent dust and debris from entering the fans. If the scanner is in a dirty or dusty environment, clean the filters monthly.


 **NOTE:** The ADF filter cover is not removable.

1. Press the power switch to the off position, and then disconnect the USB cable and power cable from the scanner.
2. Remove the filter cover.

**Figure 3-7** Clean the scanner fan filters (1 of 2)

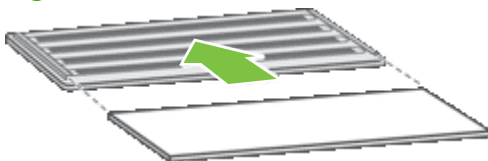


3. Clean the filter in one of the following ways:
  - Use compressed air to blow the debris off of the filter.
  - Use a vacuum to remove the debris from the filter.
  - Rinse the filter with water.
4. Inspect the filter cover. If it is dirty, use a clean, damp, lint-free cloth to remove the dirt.
5. Make sure that the filter and the filter cover are completely dry.

 **CAUTION:** The filter *must* be completely dry before you reinstall it in the product and turn the power on. If the filter is damp, the fan could pull moisture into the product and cause damage to the product.

6. Place the clean, dry filter in the filter cover, and then replace the cover on the scanner.

**Figure 3-8** Clean the scanner fan filters (2 of 2)



7. Reconnect the USB cable and power cable to the scanner, and then press the power switch to the on position.

---

# 4 Theory of operation

- [Basic operation](#)
- [Modes and control-panel indicators](#)
- [Circuit board assemblies](#)
- [Fans](#)
- [ADF feed system](#)
- [Service block diagram](#)

# Basic operation

The N9120 consists of two main assemblies.

**Table 4-1 Main assemblies**

Name	Description
ADF	<ul style="list-style-type: none"><li data-bbox="440 415 735 443">• ADF motor control circuitry</li><li data-bbox="440 470 746 497">• Media transport mechanism</li><li data-bbox="440 525 762 552">• Ultrasonic multi-pick detection</li><li data-bbox="440 579 571 606">• Imprinter</li><li data-bbox="440 634 651 661">• Optical assembly</li></ul>
Flatbed scanner	<ul style="list-style-type: none"><li data-bbox="440 680 715 707">• Scanner control circuitry</li><li data-bbox="440 735 687 762">• System power supply</li><li data-bbox="440 789 619 816">• Control panel</li><li data-bbox="440 844 651 871">• Optical assembly</li></ul>

# Modes and control-panel indicators

**Table 4-2 Modes and control-panel indicators**

Mode	Description
Power on	The period of time from when the power switch is turned on until the green LED illuminates the sleep button on the control panel.
Initialization/ Warm-up	The period of time after the power-on sequence or sleep mode wake-up event and before the scanner is ready to scan. During this time, the scanner and ADF initialization sequences are completed, the Cold Cathode Fluorescent Lamps (CCFL) are turned on and complete their warm up cycle, scanner and ADF calibration are completed, ADF motors are enabled, and sensor states are verified to ensure that no media is in the media transport path. This period of time is indicated by a slowly blinking green attention LED on the control panel.
Scan	The period of time immediately following the request for a scan, from either the ADF or the scanner. This period of time is indicated by a quickly blinking green attention LED on the control panel.
Sleep	This mode starts in either of the following ways: The user presses the sleep button on the control panel, or the scanner is not used for 15 minutes or longer. This period of time is indicated by an amber LED illumination of the sleep button on the control panel.
Error	The period of time in which the scanner is unable to complete the task it was directed to perform. This can be the result of a paper jam, communication error with the PC, or similar event. This period of time is indicated by a blinking amber attention LED illumination on the control panel.
Maintenance event	This mode is indicated by a solid amber attention LED illumination on the control panel and starts when a maintenance event is triggered (such as the need for separation pad replacement). Maintenance events occur during predefined intervals to help ensure that the scanner or ADF mechanisms continue to perform as specified.

# Circuit board assemblies

**Table 4-3 Circuit board assemblies**

Location	Name	Description
ADF	ADF controller board	This board controls all of the ADF motor operation, including the background color solenoid, and sensor detection within the ADF mechanism. Additionally, it controls the firing timing of the imprinter ink cartridge. This board is composed of a Gate Array, an Analog to Digital Converter, and various motor control devices. It is located in the ADF assembly.
	CCD board	Composed of CCD, AFE, and various discrete devices. Located on the ADF optical carriage assembly. This board is not serviceable.
	Lamp inverter board	Used to control the CCFL lamps and heater wires. Located on the bottom of the ADF optical carriage assemblies. This board is not serviceable.
	Ultrasonic sensor transmitter board	Transmits the ultrasonic signal to the receiver on the other side of the media transportation path of the ADF assembly. Located on the bottom of the media transportation path in the ADF assembly.
	Ultrasonic sensor receiver board	Receives the ultrasonic signal from the transmitter on the other side of the media transportation path in the ADF assembly. Located on the top side of the media transportation path in the ADF assembly.
	Imprinter board	This board consists of the power transistors that are used to control the firing of the 12 ink nozzles on the imprinter ink cartridge. It is located in the ADF assembly.
Flatbed scanner	Scanner control board	This is the main board in the entire system, which is composed of the main control and image pipe ASIC, the JPEG compression chip, SRAM, SDRAM, Flash RAM, DDR2 Memory, FPGA (for sensor data reordering), LVDS receivers, DC/DC converters, etc. This board controls Analog Front End (AFE) and CCD timing and receives and processes the information from both of the optical heads in the scan system, performs all requested operations from the user, and transfers the output image data through the high speed USB interface to the attached Host PC. Located in the scanner assembly.
	Power supply	Supplies 5V and 24V outputs for all system operation. Located in the scanner assembly.
	Relay board	Cabling interface board between the scanner control board and the CCD board. Located on the scanner optical assembly and the control panel circuit board. This board is not serviceable.
	CCD board	Composed of CCD, AFE, and various discrete devices. Located on the optical carriage assembly. This board is not serviceable.
	Lamp inverter board	Used to control the CCFL lamps and heater wires. Located on the bottom of the optical carriage assemblies. This board is not serviceable.
	Control panel board	Communicates to the scanner control board through the microcontroller USB 1.1 interface, which passes through the relay board. This board consists of a microcontroller, Flash RAM, switches, and LEDs. Located on the front of the scanner assembly.



# Fans

The N9120 system has four fans, each of which have failure detection algorithms included in the system firmware:

- ADF motor fan. See [ADF motor fan on page 103](#).
- ADF carriage fan. See [ADF carriage fan on page 104](#).
- Scanner carriage-motor fan. See [Scanner carriage-motor fan on page 210](#).
- Scanner carriage fan. See [Scanner carriage fan on page 213](#).

# ADF feed system

## Sensors

Figure 4-1 Sensors

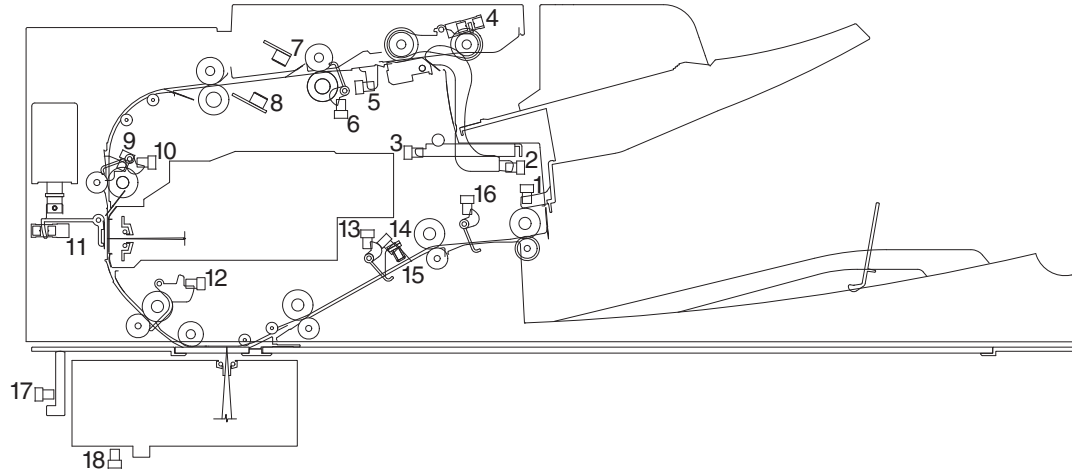
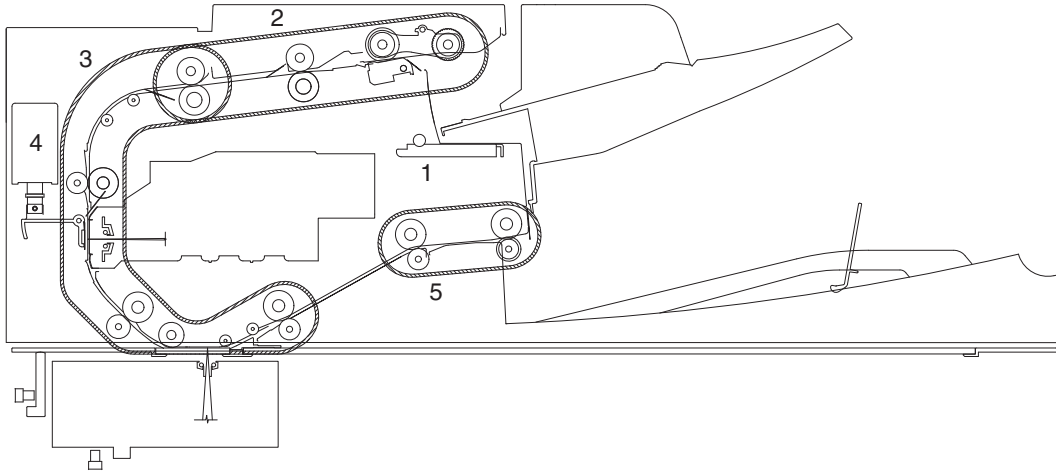


Table 4-4 Sensors

Item	Description
1	Input-tray sensor (open). See <a href="#">Input-tray sensor on page 134</a> .
2	Paper-present sensor. See <a href="#">Paper-present sensor on page 144</a> .
3	Elevator arm sensor. See <a href="#">Elevator arm sensor on page 142</a> .
4	Pick-up roller sensor. See <a href="#">Pick-up roller sensor on page 140</a> .
5	Jam door 1 sensor. See <a href="#">Jam door 1 sensor on page 146</a> .
6	Registration sensor. See <a href="#">Registration sensor on page 145</a> .
7	Upper multi-pick sensor PCA. See <a href="#">Upper multi-pick sensor PCA on page 124</a> .
8	Lower multi-pick sensor PCA. See <a href="#">Lower multi-pick sensor PCA on page 126</a> .
9	Jam door 2 sensor. See <a href="#">Jam door 2 sensor on page 147</a> .
10	ADF scan position sensor. See <a href="#">ADF scan position sensor on page 151</a> .
11	Background solenoid sensor. See <a href="#">Background solenoid sensor on page 143</a> .
12	Flatbed scan position sensor. See <a href="#">Flatbed scan position sensor on page 135</a> .
13	Exit 1 sensor. See <a href="#">Exit 1 sensor on page 138</a> .
14	Jam door 3 sensor. See <a href="#">Jam door 3 sensor on page 148</a> .
15	Imprinter paper-present sensor. See <a href="#">Imprinter paper-present sensor on page 149</a> .
16	Exit 2 sensor. See <a href="#">Exit 2 sensor on page 139</a> .
17	ADF open sensor (not serviceable).
18	Carriage home position sensor (not serviceable).

## Motors

**Figure 4-2** Motors

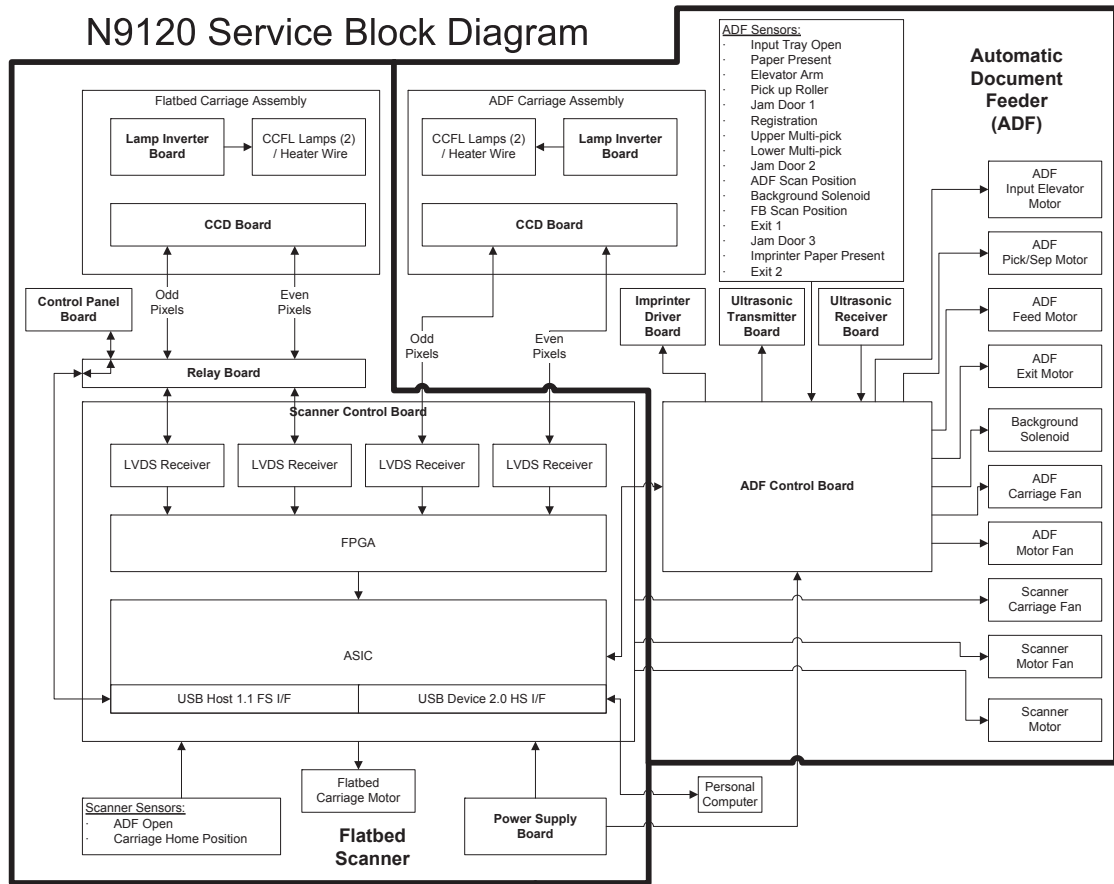


Item	Description
1	Driven by ADF input-tray lift-motor assembly. See <a href="#">ADF input-tray lift-motor assembly on page 105</a> .
2	Driven by ADF pick-motor assembly. See <a href="#">ADF pick-motor assembly on page 118</a> .
3	Driven by ADF feed-motor assembly. See <a href="#">ADF feed-motor assembly on page 111</a> .
4	ADF background-solenoid assembly. See <a href="#">ADF background-solenoid assembly on page 201</a> .
5	Driven by ADF exit-motor assembly. See <a href="#">ADF exit-motor assembly on page 107</a> .

# Service block diagram

Figure 4-3 Service block diagram

N9120 Service Block Diagram



---

# 5 Removal and replacement

- [Removal and replacement strategy](#)
- [User-replaceable parts](#)
- [External covers](#)
- [Automatic document feeder FRUs](#)
- [Flatbed scanner FRUs](#)

# Removal and replacement strategy

This chapter discusses the removal and replacement of field-replaceable units (FRUs) only.

Replacing FRUs is generally the reverse of removal. Occasionally, notes and tips are included to provide directions for difficult or critical replacement procedures.


HP does *not* support repairing individual subassemblies or problem solving at the component level.

Note the length, diameter, color, type, and location of each screw. Be sure to return each screw to its original location during reassembly.


Incorrectly routed or loose wire harnesses can interfere with other internal components and can become damaged or broken. Frayed or pinched harness wires can be difficult to locate. When replacing wire harnesses, always use the provided wire loops, lance points, or wire-harness guides.

## General cautions during removal and replacement


---

 **WARNING!** Turn the product off, wait 5 seconds, and then remove the power cord before attempting to service the product. If this warning is not followed, severe injury can result, as well as damage to the product. The power must be on for certain functional checks during problem solving. However, the power supply should be disconnected during parts removal.

The sheet-metal parts can have sharp edges. Be careful when handling sheet-metal parts.

 **CAUTION:** Do not bend or fold the flat flexible cables (FFCs) during removal or installation. Also, do not straighten folds in the FFCs. You *must* make sure that all FFCs are fully seated in their connectors. Failure to fully seat an FFC into a connector can cause a short circuit in a PCA.



Avoid pulling directly on wires to disconnect wire-harness connectors. Pull on the plastic body of a connector if possible to avoid damaging the connector wires.

 **NOTE:** To install a self-tapping screw, first turn it counterclockwise to align it with the existing thread pattern, and then carefully turn it clockwise to tighten. Do not overtighten. If a screw hole becomes stripped, repair the screw hole or replace the affected assembly.

---

## Electrostatic discharge

---

 **CAUTION:**  Some parts are sensitive to electrostatic discharge (ESD). Look for the ESD reminder when removing product parts. Always perform service work at an ESD-protected workstation or mat. If an ESD workstation or mat is not available, ground yourself by touching the sheet-metal chassis *before* touching an ESD-sensitive part.

Protect the ESD-sensitive parts by placing them in ESD pouches when they are out of the product.

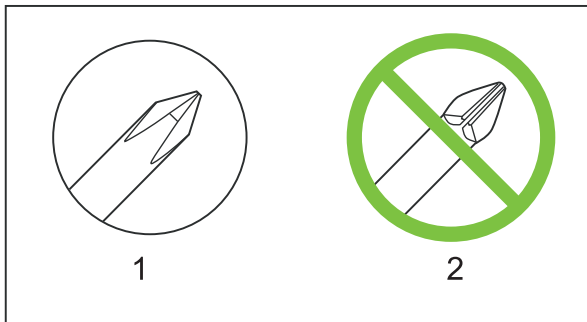
---

## Required tools

- #2 Phillips screwdriver with a magnetic tip and a 152 mm (6.0 inch) shaft length
- Short #2 Phillips screwdriver with a magnetic tip and a 76 mm (3.0 inch) shaft length
- Small flat-blade screwdriver
- Needle-nose pliers
- ESD mat (if available; see the preceding ESD caution)
- Penlight (optional)

**CAUTION:** Always use a Phillips screwdriver (callout 1). Do not use a pozidrive screwdriver (callout 2) or any motorized screwdriver. These can damage screws or screw threads.

**Figure 5-1** Phillips and pozidrive screwdriver comparison



## Cleaning supplies

The scanner glass and ADF must be cleaned with appropriate supplies.

When cleaning the scanner glass, see [Clean the scanner glass on page 27](#).

When cleaning the ADF, see [Clean the ADF on page 24](#).

## Screws and fasteners

Make sure that components are replaced with the correct screw type. Using the incorrect screw (for example, substituting a long screw for the correct shorter screw) can cause damage to the product or interfere with product operation. Do not intermix screws that are removed from one component with the screws that are removed from another component.

For a complete list of screws and fasteners, see [Field replaceable units \(FRUs\) on page 295](#).

## Before performing service

1. Turn off the power by using the power switch.
2. Unplug the power cable and interface cable(s).
3. Remove all media from the product.

4. Place the product on an ESD mat (if one is available). If an ESD workstation or mat is not available, ground yourself by touching the sheet-metal chassis *before* touching an ESD-sensitive part.
5. Remove the imprinter cartridge. See [Imprinter cartridge on page 42](#).

## After performing service

1. Clean the outside of the product with a damp cloth.
2. If the ADF had an imprinter cartridge installed, reinstall it. See [Imprinter cartridge on page 42](#).
3. Replace media in the ADF input tray.
4. Plug in the power cable and interface cable(s).
5. Turn on the power by using the power switch, and then verify that the expected startup sounds occur.
6. Verify host computer and scanner connectivity.
7. Verify that the most recent firmware is installed by using the Scanner Tools Utility.
8. Verify NVRAM data and make changes as required.
9. Perform scan-quality tests:
  - a. Perform a scan job from the ADF, and then verify that the output meets expectations.
  - b. Perform a scan job from the glass, and then verify that the output meets expectations.
  - c. Send a scan job from the host computer, and then verify that the output meets expectations.
10. If the imprinter cartridge was reinstalled, open the HP Scanner Tools Utility, click the **Imprinter** tab, and then click **Test imprinter**.



# User-replaceable parts

- [Imprinter cartridge](#)
- [Fan filters](#)
- [ADF base reflector](#)
- [Pickup-roller assembly](#)
- [Separation-pad assembly](#)

## Imprinter cartridge

1. Raise the ADF input tray until it clicks into place.

**Figure 5-2** Remove the imprinter cartridge (1 of 4)



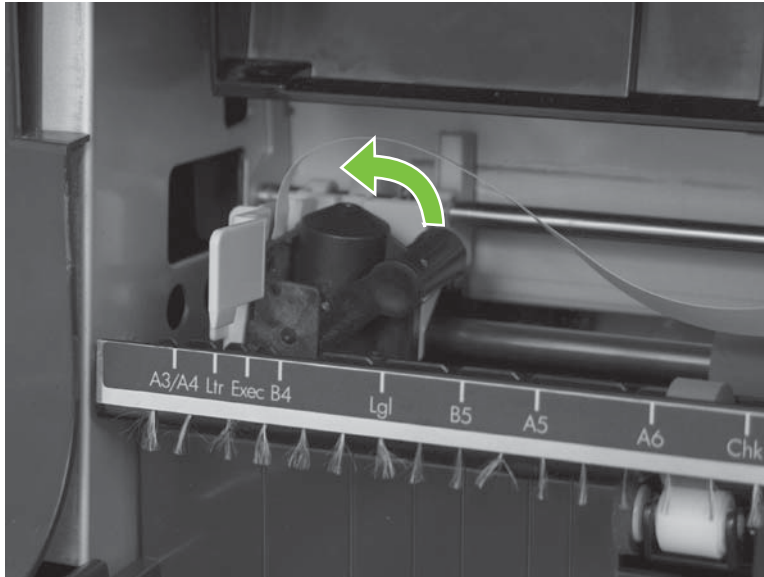
2. Lift the green lever on the imprinter carriage to disengage it from the page-size slot, and then slide the imprinter carriage completely to the left.

**Figure 5-3** Remove the imprinter cartridge (2 of 4)



3. Raise the imprinter-cartridge latch.

**Figure 5-4** Remove the imprinter cartridge (3 of 4)




4. Slide the cartridge to the right, and then remove it from the imprinter carriage.

**Figure 5-5** Remove the imprinter cartridge (4 of 4)



## Fan filters

 **NOTE:** Fan filters are located behind the back-filter cover (shown in this procedure) and the right-filter cover. The back-upper cover does not contain a filter. Use this procedure to remove either of the fan-filter covers or fan filters.

---

1. Remove the fan-filter cover.

**Figure 5-6** Remove the fan filter (1 of 2)



2. Rotate the fan-filter cover away from the product, and then remove the fan filter.

**Figure 5-7** Remove the fan filter (2 of 2)



## ADF base reflector

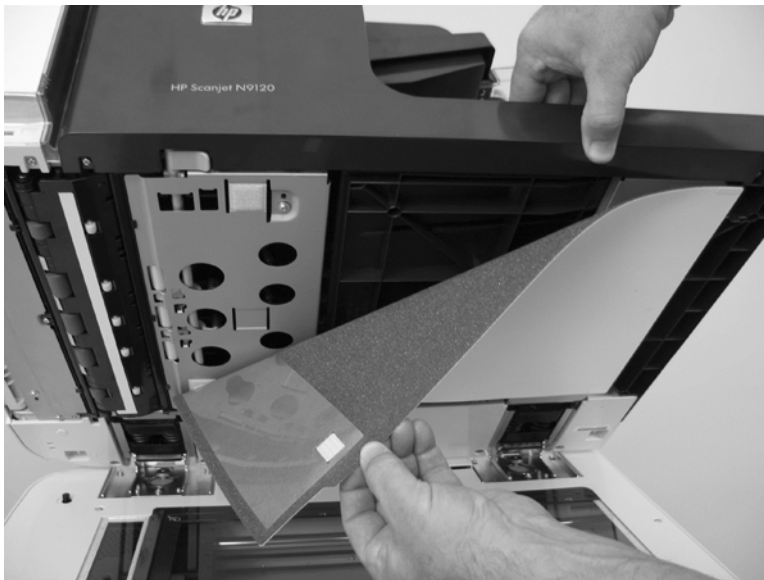
1. Open the ADF.

**Figure 5-8** Remove the ADF base reflector (1 of 2)



2. Pull the ADF base reflector from the bottom of the ADF.

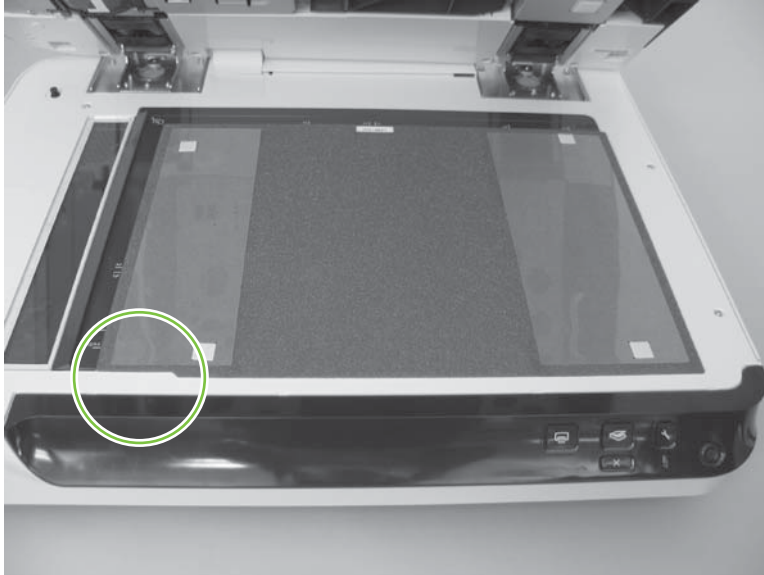
**Figure 5-9** Remove the ADF base reflector (2 of 2)



## Reinstall the ADF base reflector

Place the ADF base reflector on the scanner glass with the white adhesive squares facing up and the tab-like cutout toward the front, and then close the ADF.

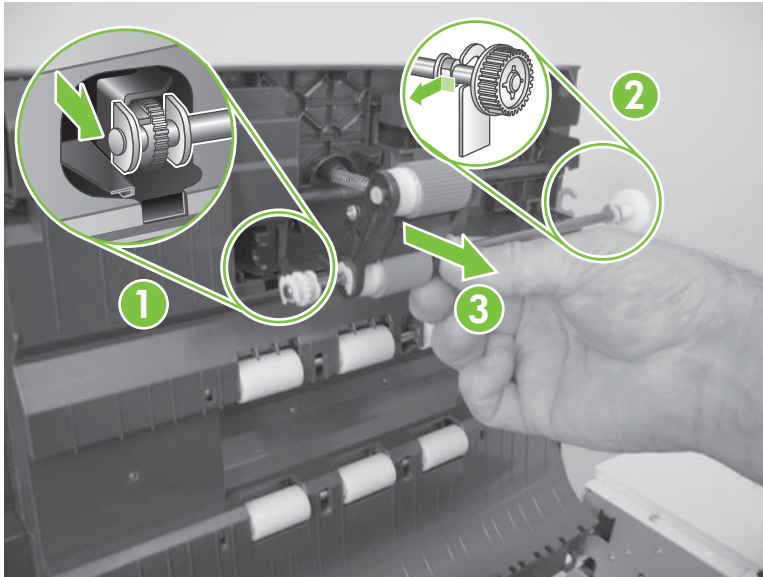
**Figure 5-10** Reinstall the ADF base reflector



## Pickup-roller assembly


1. Remove the pickup-roller cover. See [Pickup-roller cover on page 190](#).
2. Pull the roller end of the shaft away from the product to disengage it (callout 1), slide the assembly toward the front of the product to release the drive-gear end of the shaft (callout 2), and then remove the pickup-roller assembly (callout 3).

**Figure 5-11** Remove the pickup-roller assembly



## Reinstall the pickup-roller assembly

1. When you reinstall the pickup-roller assembly, make sure that the spring is correctly positioned between the pickup-roller assembly and the ADF jam door 1.

 **NOTE:** Replace the pickup-roller spring if it is bent or damaged. See [Pick-up roller spring on page 182](#).

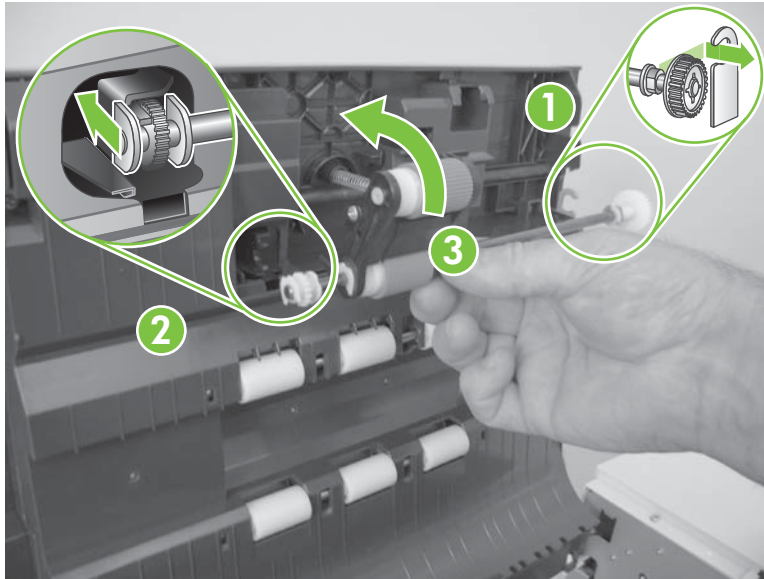
**Figure 5-12** Reinstall the pickup-roller assembly (1 of 2)





2. Install the drive-gear end of the shaft (callout 1) into the retainer, and then slide the assembly toward the back of the product.
  - a. Push the roller end of the shaft into the retainer (callout 2).
  - b. Rotate the assembly into place (callout 3).

**Figure 5-13** Reinstall the pickup-roller assembly (2 of 2)



3. Replace the pickup-roller cover.

## Separation-pad assembly

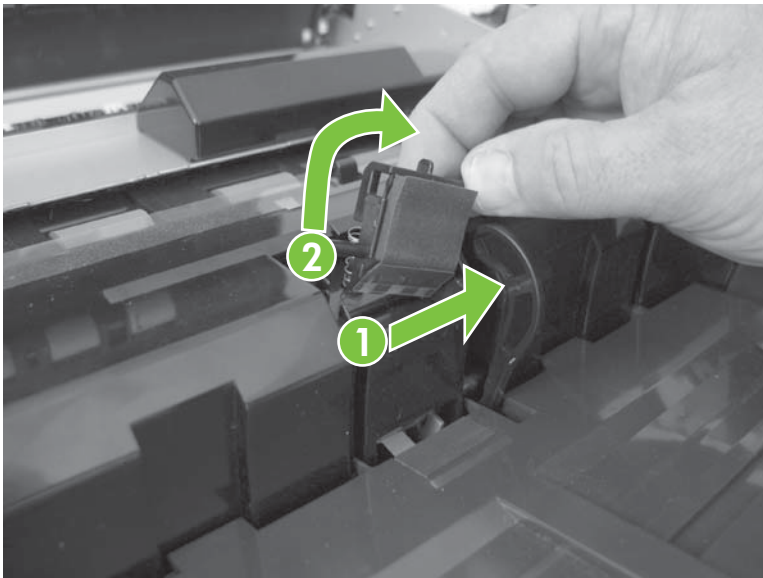
1. Release one tab.

**Figure 5-14** Remove the separation-pad assembly (1 of 3)



2. Slide the separation-pad assembly to the right (callout 1), and then rotate the separation-pad assembly toward the front of the product to release the left-side hinge pin (callout 2).

**Figure 5-15** Remove the separation-pad assembly (2 of 3)




3. Remove the separation-pad assembly.

**Figure 5-16** Remove the separation-pad assembly (3 of 3)

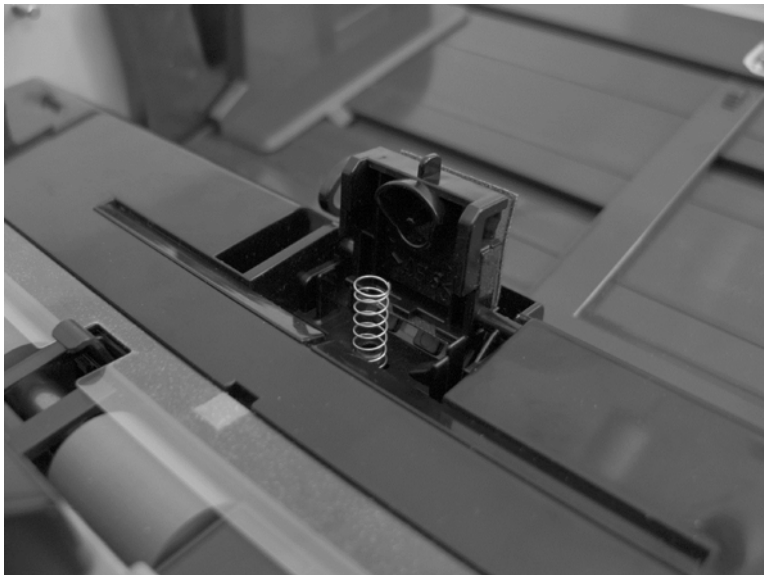


## Reinstall the separation-pad assembly

When reinstalling the separation-pad assembly, make sure that the spring is correctly positioned under the assembly.

 **NOTE:** Replace the separation-pad spring if it is bent or damaged. See [Separation-pad spring on page 183](#).

**Figure 5-17** Reinstall the separation-pad assembly



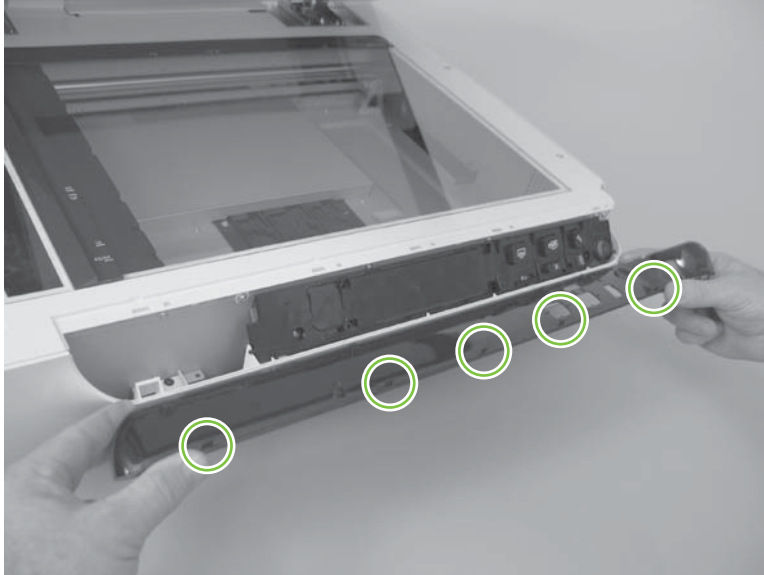
## External covers

- [Scanner control-panel cover](#)
- [Scanner back-filter cover](#)
- [Scanner right-filter cover](#)
- [ADF front cover](#)
- [ADF back cover](#)
- [Scanner back cover](#)

## Scanner control-panel cover

Release five tabs, and then rotate the front scanner control-panel cover away from the product to remove it.

**Figure 5-18** Remove the scanner control-panel cover



## Scanner back-filter cover

Remove the scanner back-filter cover. See [Fan filters on page 44](#).

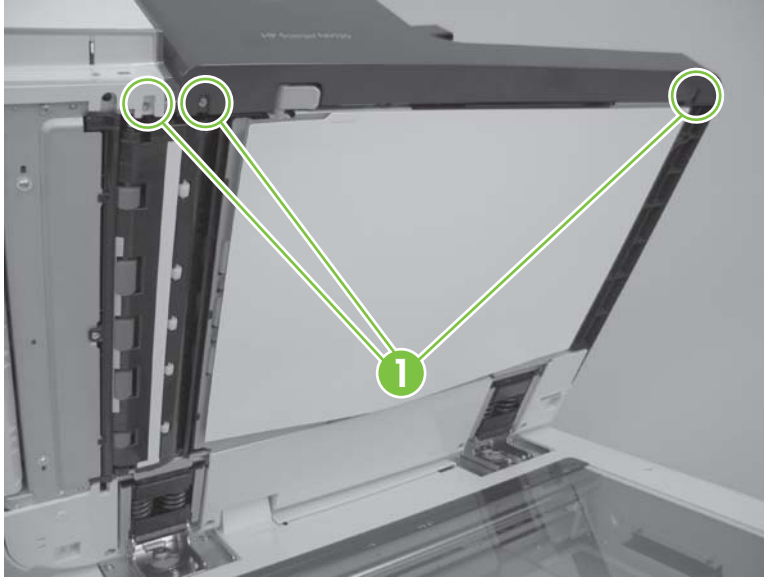
## Scanner right-filter cover

Remove the scanner right-filter cover. See [Fan filters on page 44](#).

## ADF front cover

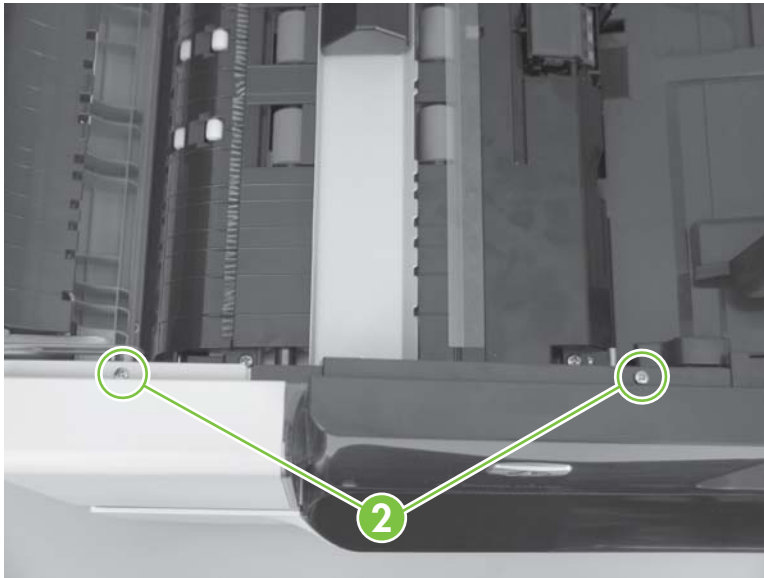
1. Open the ADF.
2. Remove three screws (callout 1).

**Figure 5-19** Remove the ADF front cover (1 of 5)




3. Remove two screws (callout 2).

**Figure 5-20** Remove the ADF front cover (2 of 5)



4. Rotate the top of the ADF front cover away from the ADF.

 **NOTE:** Pull cover away from the ADF to create a small space between the cover and ADF.

**Figure 5-21** Remove the ADF front cover (3 of 5)



5. Release three tabs (callout 3).

**Figure 5-22** Remove the ADF front cover (4 of 5)





6. Remove the ADF front cover.

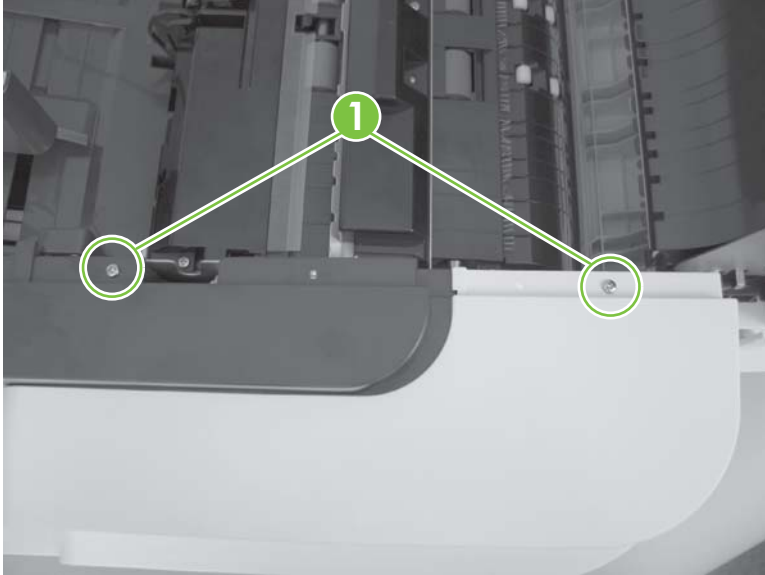
**Figure 5-23** Remove the ADF front cover (5 of 5)



## ADF back cover

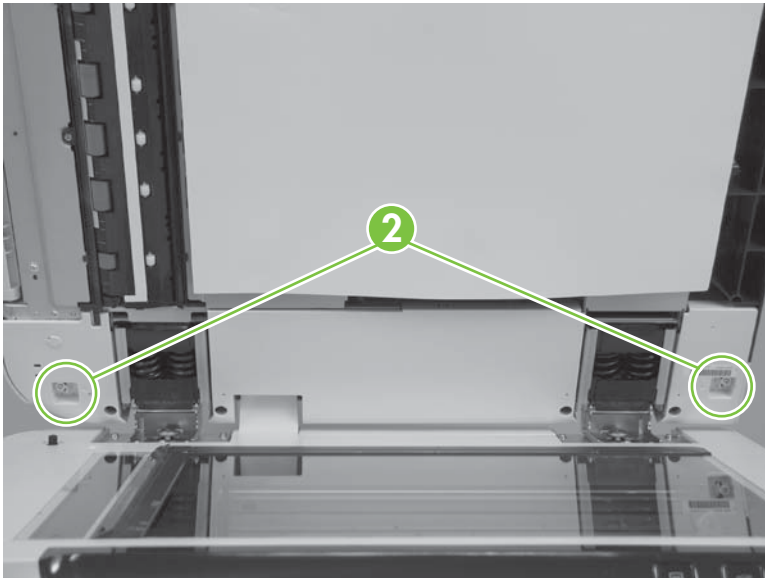
1. Open the ADF jam door 1.
2. Remove two screws (callout 1).

**Figure 5-24** Remove the ADF back cover (1 of 3)



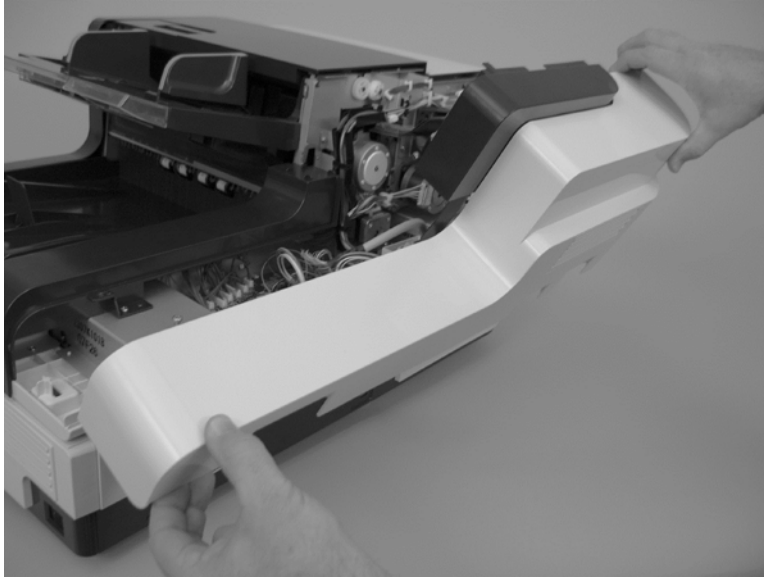
3. Remove two screws and two tabs (callout 2).

**Figure 5-25** Remove the ADF back cover (2 of 3)



4. Rotate the top of the cover away from the product to release it, and then remove the cover.

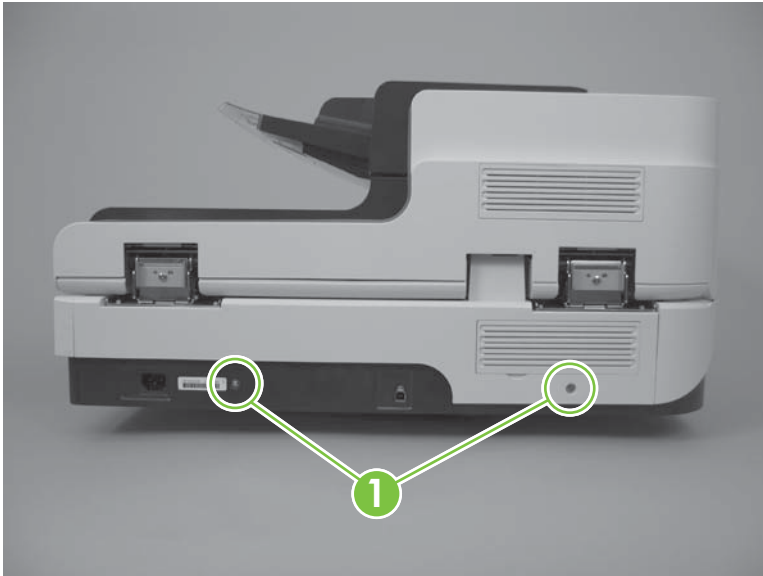
**Figure 5-26** Remove the ADF back cover (3 of 3)



## Scanner back cover

1. Remove two screws (callout 1).

**Figure 5-27** Remove the scanner back cover (1 of 2)



2. Firmly pull the cover away from the product to remove it.

**Figure 5-28** Remove the scanner back cover (2 of 2)




# Automatic document feeder FRUs

- [Automatic document feeder \(ADF\)](#)
- [ADF motor fan](#)
- [ADF carriage fan](#)
- [ADF input-tray lift-motor assembly](#)
- [ADF exit-motor assembly](#)
- [ADF feed-motor assembly](#)
- [ADF pick-motor assembly](#)
- [Upper multi-pick sensor PCA](#)
- [Lower multi-pick sensor PCA](#)
- [ADF controller PCA](#)
- [Imprinter PCA](#)
- [Input-tray sensor](#)
- [Flatbed scan position sensor](#)
- [Exit 1 sensor](#)
- [Exit 2 sensor](#)
- [Pick-up roller sensor](#)
- [Elevator arm sensor](#)
- [Background solenoid sensor](#)
- [Paper-present sensor](#)
- [Registration sensor](#)
- [Jam door 1 sensor](#)
- [Jam door 2 sensor](#)
- [Jam door 3 sensor](#)
- [Imprinter paper-present sensor](#)
- [ADF scan position sensor](#)
- [ADF bottom corner outer paper path guide](#)
- [ADF bottom corner inner paper path guide](#)
- [ADF cal-strip assembly](#)

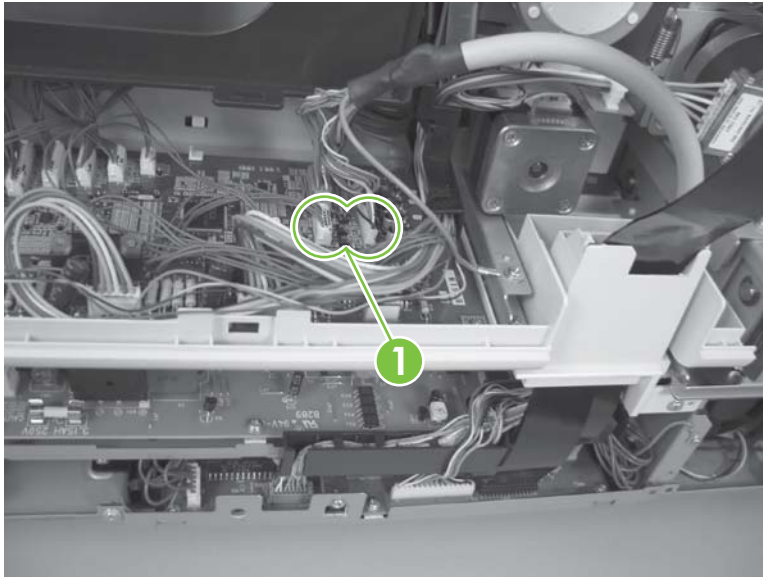
- [ADF exit inner paper path guide](#)
- [ADF top corner inner paper path guide](#)
- [Lower multi-pick sensor cover](#)
- [Flatbed scan position sensor arm](#)
- [Exit 1 sensor arm](#)
- [Exit 2 sensor arm](#)
- [Paper-present-sensor arm](#)
- [Input-tray-elevator arm](#)
- [Registration sensor arm](#)
- [Scan position sensor arm](#)
- [Pick-up roller spring](#)
- [Separation-pad spring](#)
- [ADF input-tray assembly](#)
- [ADF output tray](#)
- [Pickup-roller cover](#)
- [ADF hinge limiters](#)
- [ADF jam door 3](#)
- [Paper present sensor and imprinter PCA holder](#)
- [ADF shingle wall](#)
- [A4 paper-stop](#)
- [ADF background-solenoid assembly](#)
- [Imprinter carriage and FFC](#)

## Automatic document feeder (ADF)

 **NOTE:** Factory NVRAM data should be downloaded before the service call.

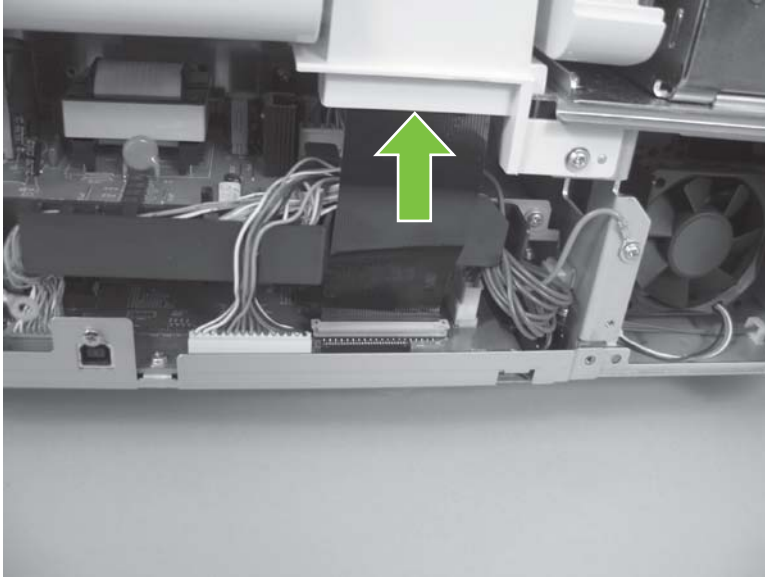
1. Remove the following components:
  - ADF back cover. See [ADF back cover on page 58](#).
  - Scanner back cover. See [Scanner back cover on page 60](#).
  - ADF hinge limiters. See [ADF hinge limiters on page 192](#).
2. Remove two connectors (callout 1).

**Figure 5-29** Remove the ADF (1 of 8)




3. Remove two FFC connectors, and then feed two FFCs through the wire guide.

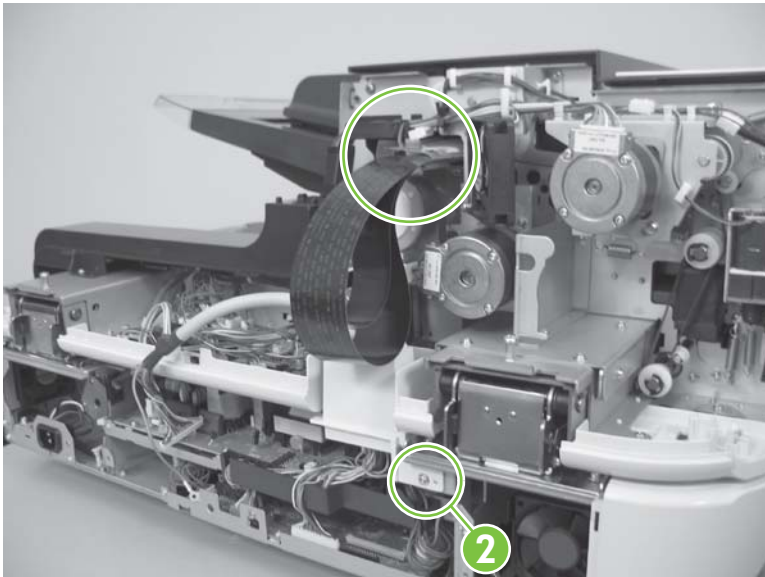
**Figure 5-30** Remove the ADF (2 of 8)



4. Remove one screw (callout 2).

 **TIP:** Place the loose ends of the two FFC connectors into the sleeve on the ADF to prevent them from being damaged when the ADF is removed.

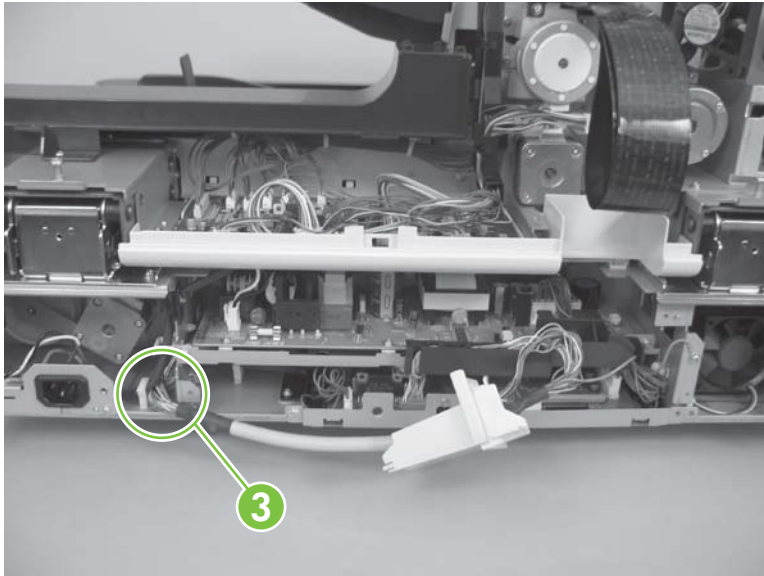
**Figure 5-31** Remove the ADF (3 of 8)





5. Remove the wire guide, and then place the two connectors under the power-feed cable in the scanner chassis (callout 3).

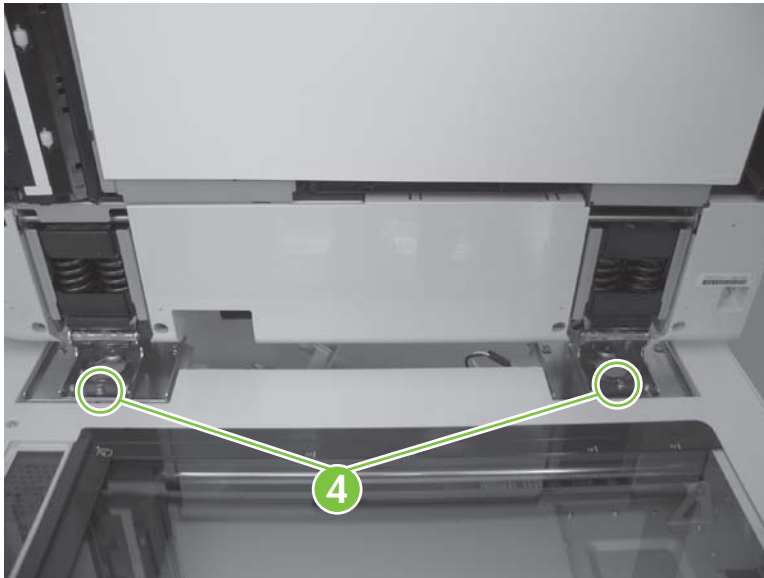
**Figure 5-32** Remove the ADF (4 of 8)



6. Open the ADF, and then remove two screws (callout 4).

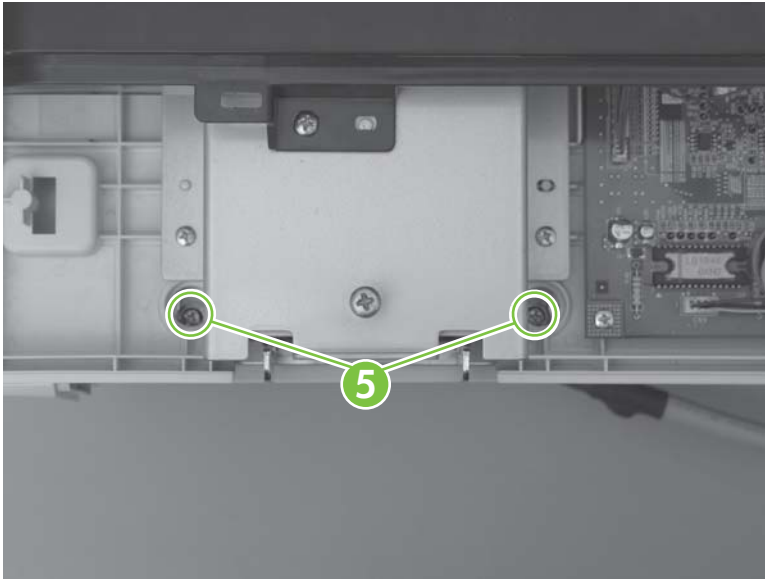
**⚠ WARNING!** The ADF is not restrained when opened and the hinge limiters are removed. The product can tip over if the ADF is opened too far.

**Figure 5-33** Remove the ADF (5 of 8)



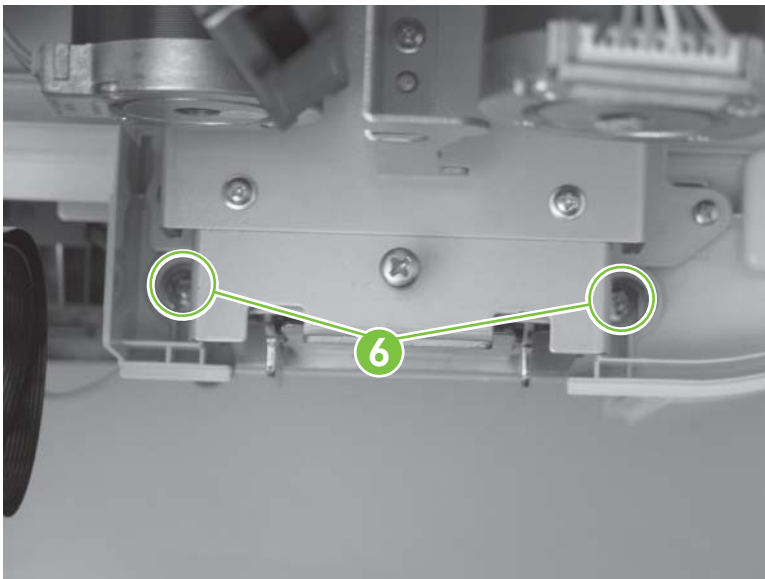
7. Close the ADF, and then remove two screws (callout 5).

**Figure 5-34** Remove the ADF (6 of 8)



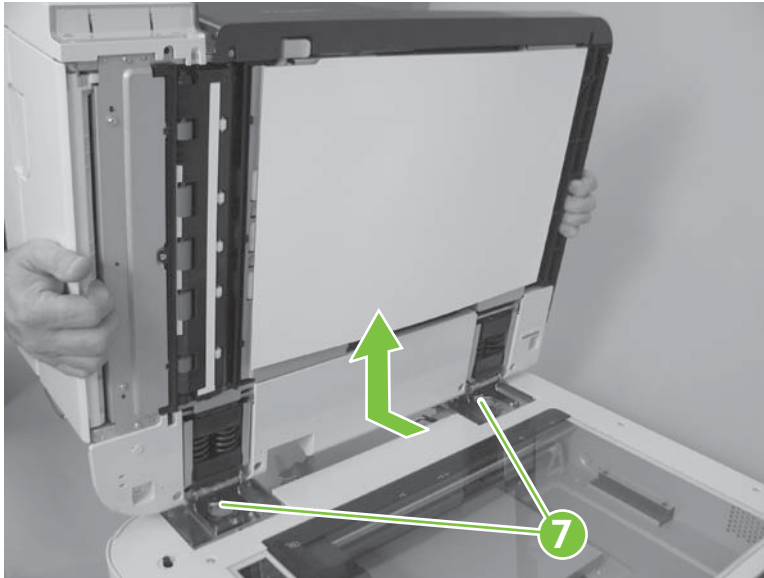
8. Remove two screws (callout 6).

**Figure 5-35** Remove the ADF (7 of 8)




- Slide the ADF toward the rear of the product to disengage the locator pins (callout 7), and then lift up on the ADF to remove it.

**Figure 5-36** Remove the ADF (8 of 8)

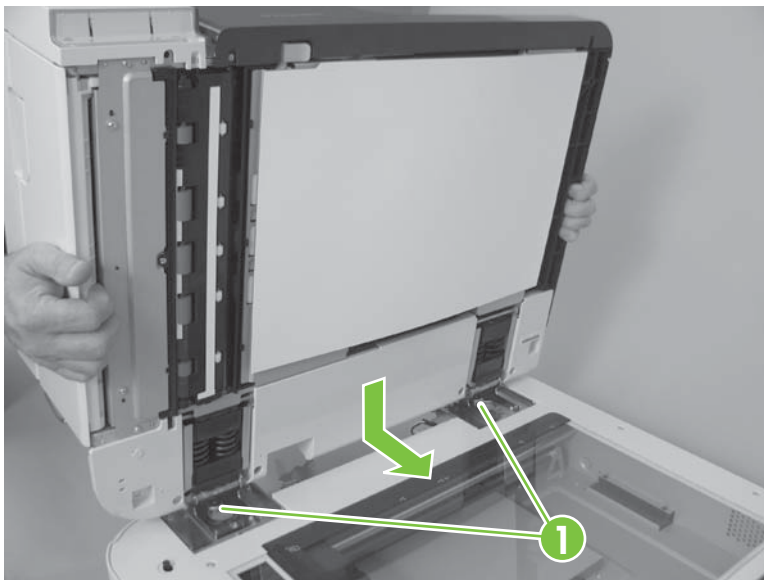


## Reinstall the ADF

 **NOTE:** Factory NVRAM data should be downloaded before the service call.

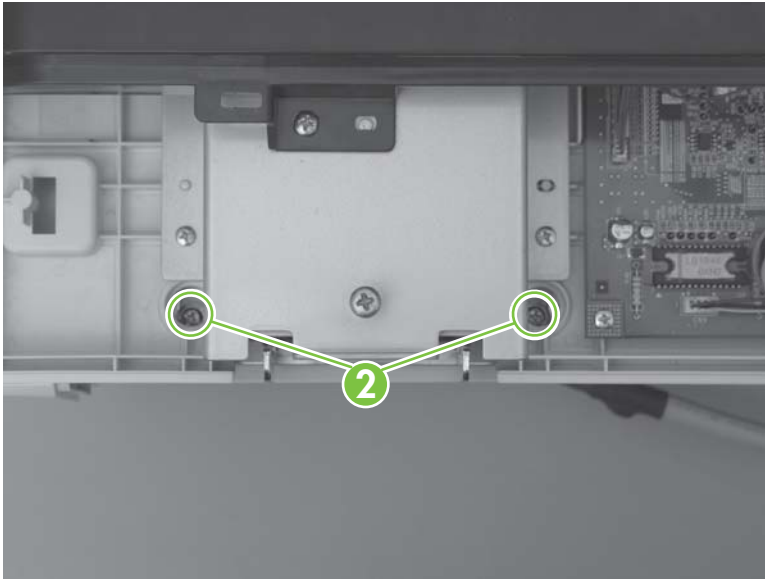
- Place the ADF on the flatbed scanner, and then slide the ADF toward the front of the product to engage the locator pins (callout 1).

**Figure 5-37** Reinstall the ADF (1 of 7)



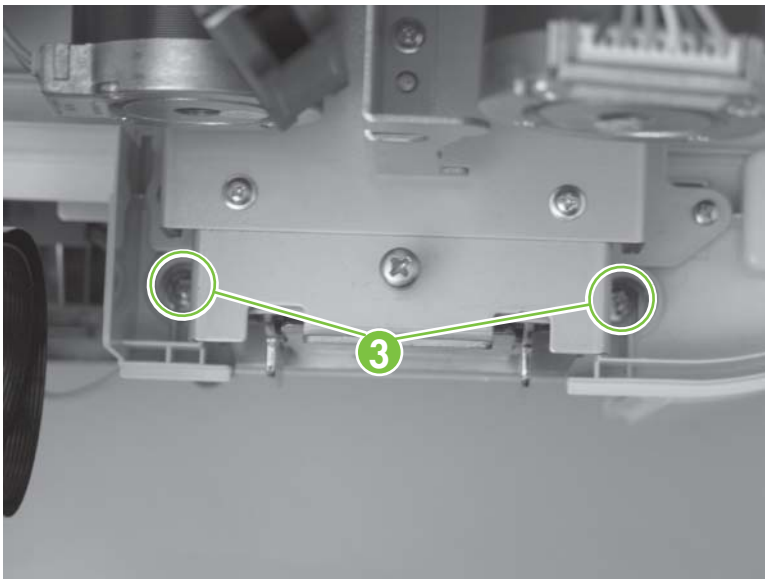
2. Close the ADF, and then install, *but do not tighten*, two screws (callout 2).

**Figure 5-38** Reinstall the ADF (2 of 7)



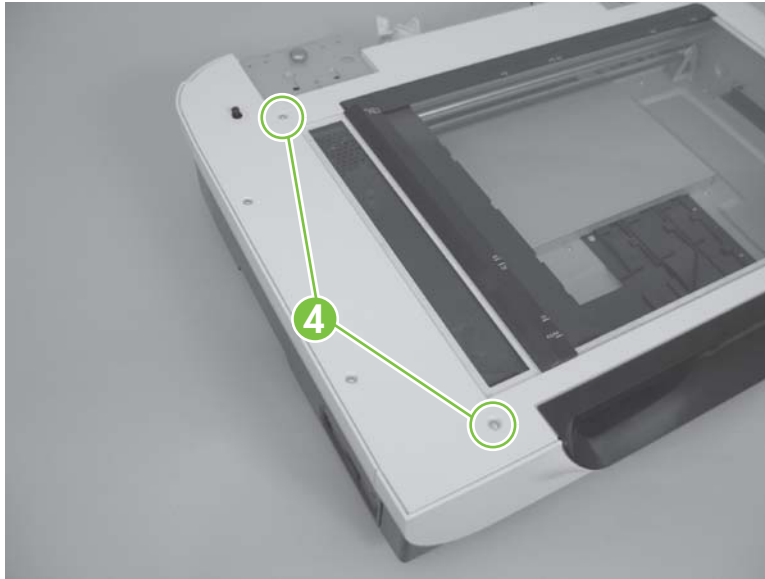
3. Install, *but do not tighten*, two screws (callout 3).

**Figure 5-39** Reinstall the ADF (3 of 7)



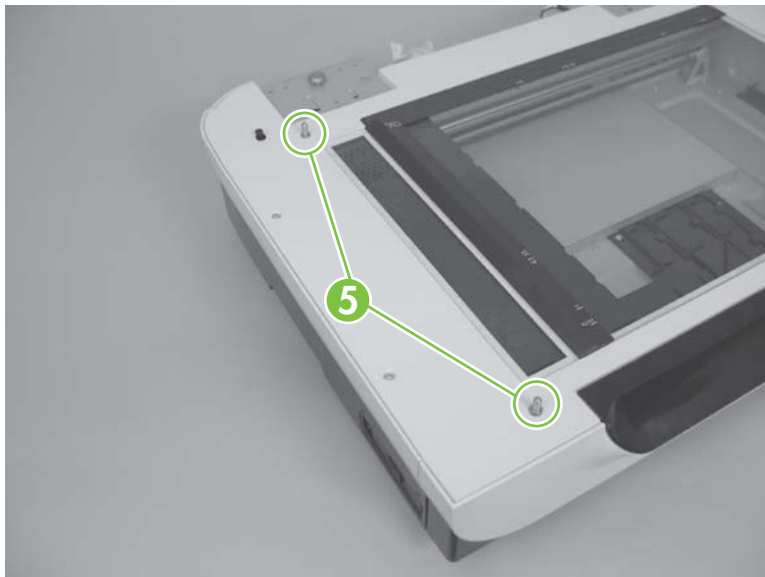
4. Remove two screws (callout 4).

**Figure 5-40** Reinstall the ADF (4 of 7)



5. Install and hand tighten two alignment pins (callout 5).

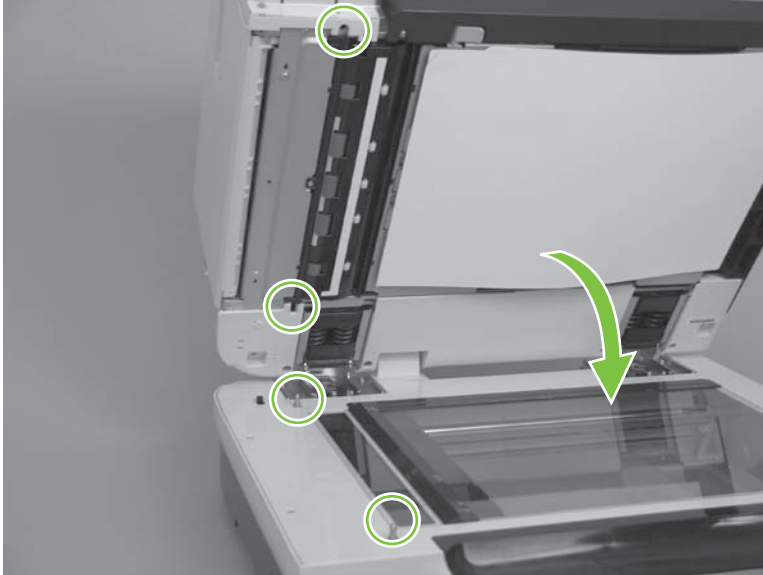
**Figure 5-41** Reinstall the ADF (5 of 7)



- Carefully close the ADF and adjust it as necessary so that the alignment pins fit into the holes in the ADF chassis.

**⚠ CAUTION:** Make sure that the ADF closes completely and is in full contact with the flatbed scanner.

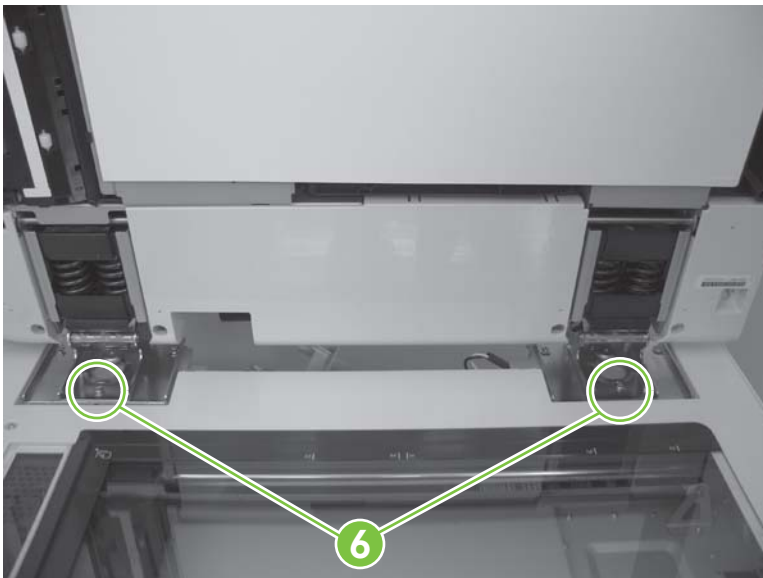
**Figure 5-42** Reinstall the ADF (6 of 7)



- Carefully open the ADF, and then Install, but *do not* fully tighten, two screws (callout 6).

**⚠ WARNING!** The ADF is not restrained when opened and the hinge limiters are removed. The product can tip over if the ADF is opened too far.

**Figure 5-43** Reinstall the ADF (7 of 7)



- Close the ADF and verify that it is correctly positioned on the alignment pins and the flatbed scanner. Adjust if necessary. See [Figure 5-42 Reinstall the ADF \(6 of 7\) on page 70](#).

9. With the ADF in the closed position, fully tighten the four screws at the back of the product. See [Figure 5-38 Reinstall the ADF \(2 of 7\) on page 68](#) and [Figure 5-39 Reinstall the ADF \(3 of 7\) on page 68](#).
10. Open the ADF, and then fully tighten the remaining two screws. See [Figure 5-43 Reinstall the ADF \(7 of 7\) on page 70](#).


---

**⚠ WARNING!** The ADF is not restrained when opened and the hinge limiters are removed. The product can tip over if the ADF is opened too far.

---

11. Reinstall the wire guide, reconnect the FFCs and wire-harness connectors, and then reinstall the hinge limiters.
12. Replace the scanner back cover. See [Scanner back cover on page 60](#).
13. Adjust the height of the ADF. See [ADF height adjustment on page 72](#).
14. Adjust the NVRAM data. See [NVRAM data management on page 75](#).
15. Align the ADF. See [Align the ADF on page 98](#).
16. Create the factory calibration data for ADF-A. See [Create the factory calibration data for ADF-A on page 101](#).

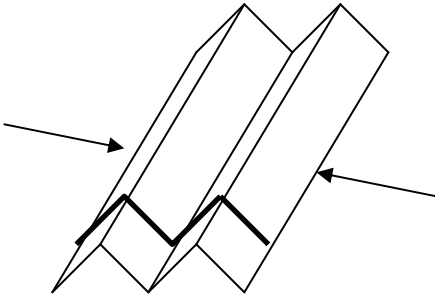
## ADF height adjustment

 **NOTE:** Factory NVRAM data should be downloaded before the service call.

---

1. Remove the ADF back cover. See [ADF back cover on page 58](#).
2. Fold the paper template (use 20# paper).

**Figure 5-44** ADF height adjustment (1 of 6)




3. Open the ADF, place the folded shim between the ADF and flatbed scanner, with the back edge of the shim aligned with the back edge of jam door 2, and then close the ADF.

**Figure 5-45** ADF height adjustment (2 of 6)

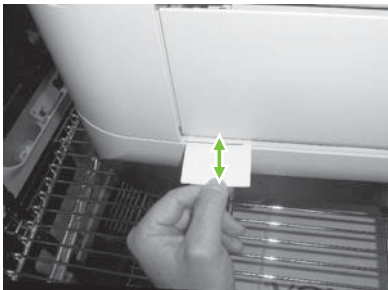


4. Slide the shim approximately 3.0 mm in and out of the product.

 **NOTE:** The ADF should create a slight amount of resistance on the shim as it moves between the ADF and flatbed scanner.

---

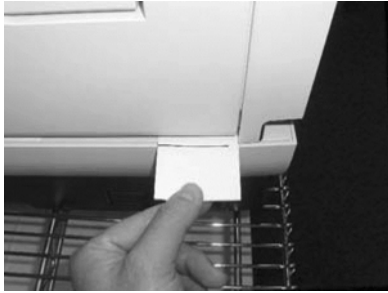
**Figure 5-46** ADF height adjustment (3 of 6)






5. Open the ADF, place the folded shim between the ADF and flatbed scanner with the left edge of the shim aligned with the front edge of jam door 2, and then close the ADF.

**Figure 5-47** ADF height adjustment (4 of 6)



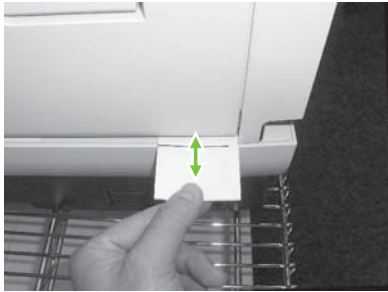
6. Slide the shim approximately 3.0 mm in and out of the product.

---


 **NOTE:** The ADF should create a slight amount of resistance on the shim as it moves between the ADF and flatbed scanner.

---

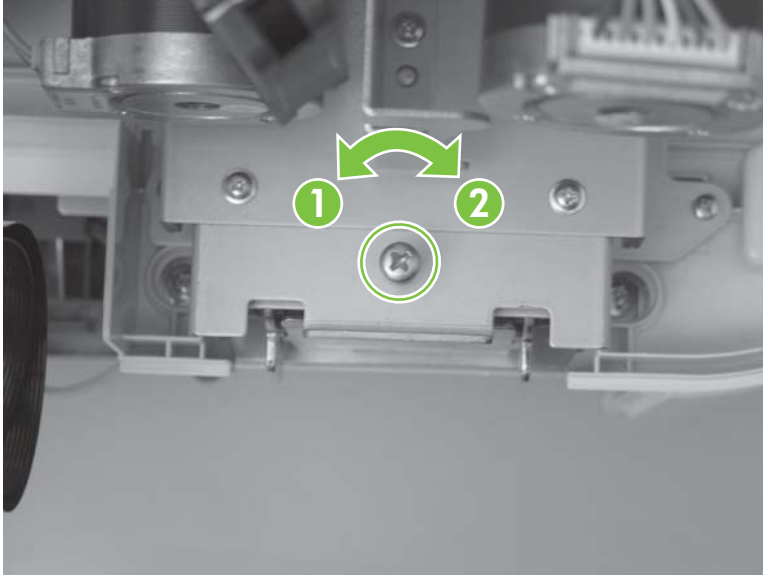
**Figure 5-48** ADF height adjustment (5 of 6)



7. Turn the ADF height adjustment screw counterclockwise (callout 1) to adjust the height of the back edge or clockwise (callout 2) to adjust the height of the front edge of the ADF.

 **NOTE:** Do not adjust the screw on the right-side hinge.


**Figure 5-49** ADF height adjustment (6 of 6)



8. Replace the ADF back cover. See [ADF back cover on page 58](#).

## NVRAM data management

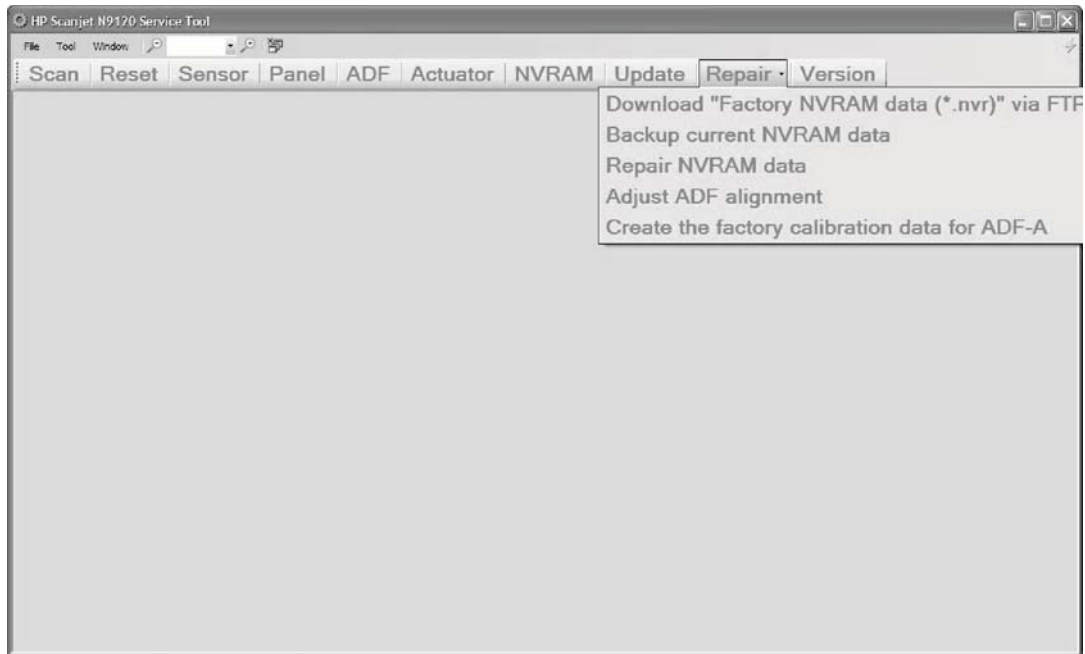
After replacing the ADF, ADF controller PCA, flatbed, or scanner controller PCA in the field, NVRAM data between the scanner controller PCA and the ADF controller PCA must be manipulated. The N9120 Service Tool provides tools to manage NVRAM Data, adjust the ADF alignment, and calibrate the calibration strip of a replacement ADF to an existing scanner controller PCA.

 **NOTE:** Factory NVRAM data should be downloaded before the service call.

## Repair menu

The following shows the selections available from the **Repair** menu:

**Figure 5-50** Repair menu (1 of 11)



## Repair menu options

The following provides descriptions and options available from the **Repair** menu:

**Figure 5-51** Repair menu (2 of 11)

N9120 Service Tool Repair Tab Functions		
Function	Description	Options
Download "Factory NVRAM data (*.nvr)" via FTP site	When connected to the intranet, the tool will search the FTP site for the factory NVRAM data of the ADF or Flatbed's Serial number that is entered. It will then provide storage of the file to a default location on the computer hard drive (My Documents\N9120_Calibration_Data ). <i>Note: It is highly recommended that you download the factory calibration data for the unit you are going to service prior to going to the Customer's site.</i>	<ul style="list-style-type: none"> <li>- Serial number entry (ADF or Flatbed)</li> <li>- FTP Site search methods</li> <li>- NVRAM data file (*.nvr) storage location</li> <li>* - accepting the default allows for ease of search by the tool later on</li> </ul>
Backup current NVRAM data	It is always desirable to restore the current NVRAM values of the ADF and Flatbed whenever possible. This assures that current scan count, maintenance, and imprinter ink level readings are maintained. This option is only possible if the respective units NVRAM data is accessible. If not, the only other option is the download of the factory NVRAM data.	<ul style="list-style-type: none"> <li>- NVRAM data file (*.nvr) storage location</li> <li>* - accepting the default allows for ease of search by the tool later on</li> </ul>
Repair NVRAM data	This feature allows for the upload of previously stored NVRAM Data from the computer's hard drive to the NVRAM of the selected device. It also provides the ability to change certain NVRAM values as required by various repair scenarios.  The selections to the right are provided as options. You must choose which option best fits the repair scenario. The tool searches the computers hard drive for the information base upon the option selected. It will recommend an alternative source option if it determines a better one is available.	<p><b>Replaced Units/Parts:</b></p> <ul style="list-style-type: none"> <li>- ADF Unit</li> <li>- FB Unit</li> <li>- ADF Circuit-board (ADF Controller PCA)</li> <li>- FB Circuit board (FB Controller PCA)</li> </ul> <p><b>NVRAM Data Backup File Source:</b></p> <ul style="list-style-type: none"> <li>- NVRAM Backup file for damaged unit</li> <li>- NVRAM Factory file for damaged unit</li> <li>- NVRAM Factory file for replacement</li> </ul>
Adjust ADF Alingment	The removal and replacement of the ADF from the Flatbed requires numerous adjustment and alignment steps (ADF alingment to the FB base, ADF height adjustment, ADF calibration strip calibration to the FB, and ADF alingment adjustment. This features facilitates the adjustment of the ADF Alingment. It is accomplished via the use of an ADF alingment target that is fed through the ADF seven times. One for each of the seven native resolutions. The Service Tool will prompt the user to reinsert the target at the appropriate times.	<ul style="list-style-type: none"> <li>- There are no options for this feature.</li> </ul>
Create the factory calibration data for ADF-A	The replacement of an existing ADF on a replacement Flatbed or the assembly of a replacement ADF on an existing Flatbed necessitates the Calibration of the ADF Calibration Strip to the Flatbed. This is the last step performed in the ADF Removal and Replacement process, after all other steps have been completed.  The Service Tool automates this process. When selected, the Tool will calibrate the Flatbed to the ADF Calibration strip for each of the native resolutions.	<ul style="list-style-type: none"> <li>- There are no options for this feature.</li> </ul>

## Replacement scenarios

The following seven scenarios provide data selection recommendations for ADF, flatbed scanner, whole-unit, and controller PCA replacement scenarios:

### Scenario #1: Whole ADF replacement

Scenario #1 applies when replacing the whole ADF and NVRAM data is accessible.

**Figure 5-52** Replacement scenario #1 (3 of 11)

Scenario # - 1	NA Defectice Unit NVRAM Data is Accessible
Whole ADF Replacement	NA Defectice Unit NVRAM Data <u>IS NOT</u> Accessible
<b>NVRAM Files to Download/Backup</b>	
Download defective unit NVRAM data via FTP site	* Default download file prior to Onsite Visit
Serial number entered	CN7B5B201C054Y
Filename downloaded and saved	CN7B5B101F054W-CN7B5B201C054Y-20080122094031.nvr
Download replacement unit NVRAM data via FTP site	
Serial number entered	CN86PD6001054Y
Filename downloaded and saved	XXXXXXXXXXXXXXXX-CN86PD6001054Y-20080621112346.nvr
Units/Parts Replaced	ADF
<b>Alingment/Calibration/NVRAM Count Adjustment Procedures Required</b>	
<input checked="" type="checkbox"/> Align ADF to Flatbed	<input checked="" type="checkbox"/> NVRAM Count Adjustments Required (see NVRAM Count Adjustment Table)
<input checked="" type="checkbox"/> ADF Height Adjustment	
<input checked="" type="checkbox"/> ADF Alingment with Service Tool	
<input checked="" type="checkbox"/> On-site calibration of replacement ADF Calbration Strip to Flatbed (ADF-A)	
<b>Repair NVRAM Restore file recommendation (Browse to in N9120_Calibration_Data directory)</b>	
<b>Replaced Unit/Parts</b>	NVRAM Backup file for damaged unit
<input checked="" type="checkbox"/> ADF Unit	
<input type="checkbox"/> FB Unit	NVRAM Factory file for damaged unit
<input type="checkbox"/> ADF Circuit Board	
<input type="checkbox"/> CNT Circuit board	NVRAM Factory File for replaced unit
	XXXXXXXXXXXXXXXX-CN86PD6001054Y-20080621112346.nvr

## Scenario #2: ADF controller PCA replacement

Scenario #2 applies when replacing the ADF controller PCA and NVRAM data is accessible.

**Figure 5-53** Replacement scenario #2 (4 of 11)

Scenario # - 2	<input checked="" type="checkbox"/> Defective Unit NVRAM Data is Accessible
ADF Controller PCA Replacment	<input type="checkbox"/> Defectice Unit NVRAM Data <i>IS NOT</i> Accessible
<b>NVRAM Files to Download/Backup</b>	
Download defective unit NVRAM data via FTP site	* Default download file prior to Onsite Visit
Serial number entered	CN7B5B101F054W
Filename downloaded and saved	CN7B5B101F054W-CN7B5B201C054Y-20080122094031.nvr
On-site Backup NVRAM data from the defective unit	
Filename downloaded and saved	HP Scanjet N9120(07-19-2008_15h31m39s)
Units/Parts Replaced	ADF Controller PCA
<b>Alingment/Calibration/NVRAM Count Adjustment Procedures Required</b>	
<input type="checkbox"/> Align ADF to Flatbed	NVRAM Count Adjustments Required (see NVRAM Count Adjustment Table)
<input type="checkbox"/> ADF Height Adjustment	
<input type="checkbox"/> ADF Alingment with Service Tool	
<input type="checkbox"/> On-site calibration of replacement ADF Calbration Strip to Flatbed (ADF-A)	
Repair NVRAM <i>Restore file recommendation (Browse to in N9120_Calibration_Data directory)</i>	
<b>Replaced Unit/Parts</b>	NVRAM Backup file for damaged unit
<input type="checkbox"/> ADF Unit	HP Scanjet N9120(07-19-2008_15h31m39s)
<input type="checkbox"/> FB Unit	NVRAM Factory file for damaged unit
<input checked="" type="checkbox"/> ADF Circuit Board	
<input type="checkbox"/> CNT Circuit board	NVRAM Factory File for replaced unit

### Scenario #3: ADF controller PCA replacement

Scenario #3 applies when replacing the ADF controller PCA and NVRAM data is not accessible.

**Figure 5-54** Replacement scenario #3 (5 of 11)

Scenario # - 3	Defectice Unit NVRAM Data is Accessible
ADF Controller PCA Replacement	<input checked="" type="checkbox"/> Defectice Unit NVRAM Data <i>IS NOT</i> Accessible
<b>NVRAM Files to Download/Backup</b>	
Download defective unit NVRAM data via FTP site	* Default download file prior to Onsite Visit
Serial number entered	CN7B5B201C054Y
Filename downloaded and saved	CN7B5B101F054W-CN7B5B201C054Y-20080122094031.nvr
Units/Parts Replaced	ADF Controller PCA
<b>Alingment/Calibration/NVRAM Count Adjustment Procedures Required</b>	
<input type="checkbox"/> Align ADF to Flatbed	NVRAM Count Adjustments Required (see NVRAM Count Adjustment Table)
<input type="checkbox"/> ADF Height Adjustment	
<input type="checkbox"/> ADF Alingment with Service Tool	
<input type="checkbox"/> On-site calibration of replacement ADF Calbration Strip to Flatbed (ADF-A)	
Repair NVRAM <i>Restore file recommendation</i> (Browse to in N9120_Calibration_Data directory)	
<b>Replaced Unit/Parts</b>	NVRAM Backup file for damaged unit
<input type="checkbox"/> ADF Unit	
<input type="checkbox"/> FB Unit	NVRAM Factory file for damaged unit
<input checked="" type="checkbox"/> ADF Circuit Board	CN7B5B101F054W-CN7B5B201C054Y-20080122094031.nvr
<input type="checkbox"/> CNT Circuit board	NVRAM Factory File for replaced unit

### Scenario #4: Whole flatbed scanner replacement

Scenario #4 applies when replacing the whole flatbed scanner and NVRAM data is accessible.

**Figure 5-55** Replacement scenario #4 (6 of 7)

Scenario # - 4	<input checked="" type="checkbox"/> Defective Unit NVRAM Data is Accessible
Whole Flatbed Unit Replacement	<input type="checkbox"/> Defective Unit NVRAM Data <i>IS NOT</i> Accessible
<b>NVRAM Files to Download/Backup</b>	
Download defective unit NVRAM data via FTP site	
Serial number entered	CN7B5B101F054W
Filename downloaded and saved	CN7B5B101F054W.CN7B5B201C054Y-20080122094031.nvr
* Default download file prior to Onsite Visit	
On-site Backup NVRAM data from the defective unit	
Filename downloaded and saved	HP Scanjet N9120(07-19-2008_15h31m39s)
Units/Parts Replaced	Whole Flatbed Unit
<b>Alignment/Calibration/NVRAM Count Adjustment Procedures Required</b>	
<input checked="" type="checkbox"/> Align ADF to Flatbed	<input checked="" type="checkbox"/> NVRAM Count Adjustments Required (see NVRAM Count Adjustment Table)
<input checked="" type="checkbox"/> ADF Height Adjustment	
<input checked="" type="checkbox"/> ADF Alingment with Service Tool	
<input checked="" type="checkbox"/> On-site calibration of replacement ADF Calbration Strip to Flatbed (ADF-A)	
Repair NVRAM <i>Restore file recommendation (Browse to in N9120_Calibration_Data directory)</i>	
<b>Replaced Unit/Parts</b>	NVRAM Backup file for damaged unit
<input type="checkbox"/> ADF Unit	HP Scanjet N9120(07-19-2008_15h31m39s)
<input checked="" type="checkbox"/> FB Unit	NVRAM Factory file for damaged unit
<input type="checkbox"/> ADF Circuit Board	
<input type="checkbox"/> CNT Circuit board	NVRAM Factory File for replaced unit



## Scenario #5: Whole flatbed scanner replacement

Scenario #5 applies when replacing the whole flatbed scanner and NVRAM data is not accessible.

**Figure 5-56** Replacement scenario #5 (7 of 11)

Scenario # - 5	Defectice Unit NVRAM Data is Accessible
Whole Flatbed Unit Replacement	<input checked="" type="checkbox"/> Defectice Unit NVRAM Data <i>IS NOT</i> Accessible
<b>NVRAM Files to Download/Backup</b>	
Download defective unit NVRAM data via FTP site	* Default download file prior to Onsite Visit
Serial number entered	CN7B5B101F054W
Filename downloaded and saved	CN7B5B101F054W-CN7B5B201C054Y-20080122094031.nvr
Units/Parts Replaced	Whole Flatbed Unit
<b>Alingment/Calibration/NVRAM Count Adjustment Procedures Required</b>	
<input checked="" type="checkbox"/> Align ADF to Flatbed	<input checked="" type="checkbox"/> NVRAM Count Adjustments Required (see NVRAM Count Adjustment Table)
<input checked="" type="checkbox"/> ADF Height Adjustment	
<input checked="" type="checkbox"/> ADF Alingment with Service Tool	
<input checked="" type="checkbox"/> On-site calibration of replacement ADF Calbration Strip to Flatbed (ADF-A)	
<b>Repair NVRAM Restore file recommendation (Browse to in N9120_Calibration_Data directory)</b>	
<b>Replaced Unit/Parts</b>	<b>NVRAM Backup file for damaged unit</b>
<input type="checkbox"/> ADF Unit	
<input checked="" type="checkbox"/> FB Unit	
<input type="checkbox"/> ADF Circuit Board	
<input type="checkbox"/> CNT Circuit board	
	<b>NVRAM Factory file for damaged unit</b>
	CN7B5B101F054W-CN7B5B201C054Y-20080122094031.nvr
	<b>NVRAM Factory File for replaced unit</b>

## Scenario #6: Scanner controller PCA replacement

Scenario #6 applies when replacing the scanner controller PCA and NVRAM data is accessible.

**Figure 5-57** Replacement scenario #6 (8 of 11)

Scenario # - 6	<input checked="" type="checkbox"/> Defective Unit NVRAM Data is Accessible
Flatbed Controller PCA Replacement	<input type="checkbox"/> Defective Unit NVRAM Data <i>IS NOT</i> Accessible
<b>NVRAM Files to Download/Backup</b>	
Download defective unit NVRAM data via FTP site	* Default download file prior to Onsite Visit
Serial number entered	CN7B5B101F054W
Filename downloaded and saved	CN7B5B101F054W.CN7B5B201C054Y-20080122094031.nvr
On-site Backup NVRAM data from the defective unit	
Filename downloaded and saved	HP Scanjet N9120(07-19-2008_15h31m39s)
Units/Parts Replaced	Flatbed Controller PCA
<b>Alignment/Calibration/NVRAM Count Adjustment Procedures Required</b>	
<input type="checkbox"/> Align ADF to Flatbed	NVRAM Count Adjustments Required (see NVRAM Count Adjustment Table)
<input type="checkbox"/> ADF Height Adjustment	
<input type="checkbox"/> ADF Alingment with Service Tool	
<input type="checkbox"/> On-site calibration of replacement ADF Calbration Strip to Flatbed (ADF-A)	
Repair NVRAM <i>Restore file recommendation (Browse to in N9120_Calibration_Data directory)</i>	
<b>Replaced Unit/Parts</b>	NVRAM Backup file for damaged unit
<input type="checkbox"/> ADF Unit	HP Scanjet N9120(07-19-2008_15h31m39s)
<input type="checkbox"/> FB Unit	NVRAM Factory file for damaged unit
<input type="checkbox"/> ADF Circuit Board	
<input checked="" type="checkbox"/> CNT Circuit board	NVRAM Factory File for replaced unit

## Scenario #7: Scanner controller PCA replacement


Scenario #7 applies when replacing the scanner controller PCA and NVRAM data is not accessible.

**Figure 5-58** Replacement scenario #7 (9 of 11)

Scenario # - 7		<input type="checkbox"/> Defectice Unit NVRAM Data is Accessible	
Flatbed Controller PCA Replacement		<input checked="" type="checkbox"/> Defectice Unit NVRAM Data <i>IS NOT</i> Accessible	
<b>NVRAM Files to Download/Backup</b>			
Download defective unit NVRAM data via FTP site		* Default download file prior to Onsite Visit	
Serial number entered	CN7B5B101F054W		
Filename downloaded and saved	CN7B5B101F054W-CN7B5B201C054Y-20080122094031.nvr		
Units/Parts Replaced		Flatbed Contoller PCA	
<b>Alingment/Calibration/NVRAM Count Adjustment Procedures Required</b>			
<input type="checkbox"/> Align ADF to Flatbed	<input type="checkbox"/> NVRAM Count Adjustments Required (see NVRAM Count Adjustment Table)		
<input type="checkbox"/> ADF Height Adjustment			
<input type="checkbox"/> ADF Alingment with Service Tool			
<input type="checkbox"/> On-site calibration of replacement ADF Calbration Strip to Flatbed (ADF-A)			
Repair NVRAM <i>Restore file recommendation</i> (Browse to in N9120_Calibration_Data directory)			
<b>Replaced Unit/Parts</b>		<b>NVRAM Backup file for damaged unit</b>	
<input type="checkbox"/> ADF Unit			
<input type="checkbox"/> FB Unit	<b>NVRAM Factory file for damaged unit</b>		
<input type="checkbox"/> ADF Circuit Board	CN7B5B101F054W-CN7B5B201C054Y-20080122094031.nvr		
<input checked="" type="checkbox"/> CNT Circuit board	<b>NVRAM Factory File for replaced unit</b>		

## NVRAM data file examples

The following provides example NVRAM file names:

 **NOTE:** The file name for a replacement flatbed shows “XXXXXXXXXXXXXXXX” in place of the ADF file number since the ADF is not being replaced. The file name for a replacement ADF shows “XXXXXXXXXXXXXXXX” in place of the flatbed file number since the flatbed is not being replaced.

**Figure 5-59** Repair menu (10 of 11)

N9120 NVRAM File Type Examples		
FRU Type	Serial Number:	Filename:
Original Flatbed	CN7B5B101FO54W	CN7B5B101F054W-CN7B5B201C054Y-20080122094031.nvr
Original ADF	CN7B5B201C054Y	CN7B5B101F054W-CN7B5B201C054Y-20080122094031.nvr
Replacement Flatbed	CN85VD3001054X	CN85PD100H054W-XXXXXXXXXXXXXXXX-20080521185330.nvr
Replacement ADF	CN86PD600B054Y	XXXXXXXXXXXXXXXX-CN86PD600B054Y-20080621181552.nvr
Original Unit NVRAM Backup	CN7B5B101FO54W	HP Scanjet N9120(07-19-2008_15h31m39s)

## NVRAM content adjustment


The following provides recommendations for adjusting NVRAM values for the following replacement scenarios:


- Scenario #1. See [Scenario #1: Whole ADF replacement on page 77](#).
- Scenario #4. See [Scenario #4: Whole flatbed scanner replacement on page 80](#).
- Scenario #5. See [Scenario #5: Whole flatbed scanner replacement on page 81](#).

**Figure 5-60** Repair menu (11 of 11)

<i>Whole Unit Replacement Scenarios and NVRAM Count Adjustments Required</i>			
<i>Scenarios</i>	<i>#1</i>	<i>#4</i>	<i>#5</i>
<b>Whole Unit or Controller PCA Replacement</b>	Whole ADF	Whole Flatbed Unit	Whole Flatbed Unit
<b>Defective Unit NVRAM Data Accessible?</b>	N/A	Yes	No
<b>Adjustable NVRAM Content</b>	<b>Recommended Value Adjustment</b>		
Number of Repairs	No Change	No Change	No Change
Flatbed Err 1 Scan Count	No Change	Clear	Clear
Flatbed Err 2 Scan Count	No Change	Clear	Clear
Flatbed Err 3 Scan Count	No Change	Clear	Clear
Scan Count (All scans ADF or FB)	No Change	Clear	Clear
Jam Error Count	Clear	No Change	No Change
Pick Error Count	Clear	No Change	No Change
ADF Page Count at Last Cleaning	Clear	No Change	No Change
ADF ERR1 Page Count	Clear	No Change	No Change
ADF ERR2 Page Count	Clear	No Change	No Change
ADF ERR3 Page Count	Clear	No Change	No Change
ADF Page Count at First Cleaning Message	Clear	No Change	No Change
ADF Page Count at First Roller Replacement Message	Clear	No Change	No Change
ADF Page Count at Separation pad Replacement	Clear	No Change	No Change
ADF Page Count at 1st Separation Pad Replacement Msg.	Clear	No Change	No Change
Imprinter Ink Cartridge Replacement Count	Clear	No Change	No Change
Number of times the ADF has been Cleaned	Clear	No Change	No Change
Number of times ADF Rollers has been replaced	Clear	No Change	No Change
Page Count	Clear	No Change	No Change
ADF ERR1 plus number of times occurred	Clear	No Change	No Change
ADF ERR2 plus number of times occurred	Clear	No Change	No Change
ADF ERR3 plus number of times occurred	Clear	No Change	No Change
Number of times ADF Separation pad has been replaced	Clear	No Change	No Change
Total number of batches	No Change	No Change	No Change
Average Pages in a day	No Change	No Change	No Change
Imprinter Total number of firing	No Change	No Change	No Change

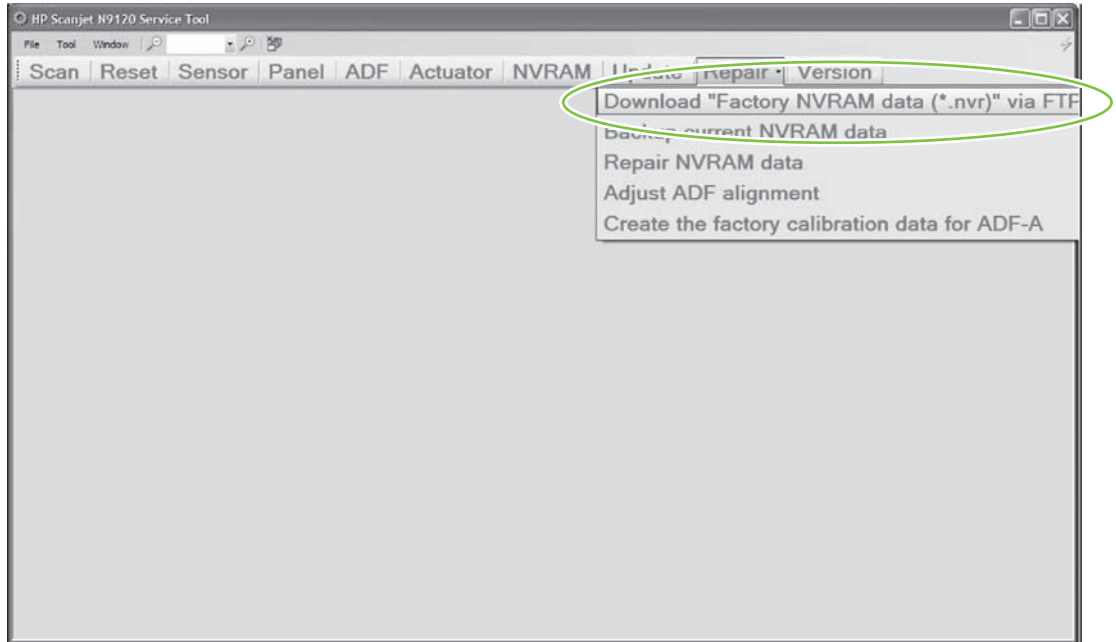
## Download factory NVRAM data

 **NOTE:** Factory NVRAM data should be downloaded before the service call.

 **WARNING!** Do not make changes in the **Date items** dialog box.

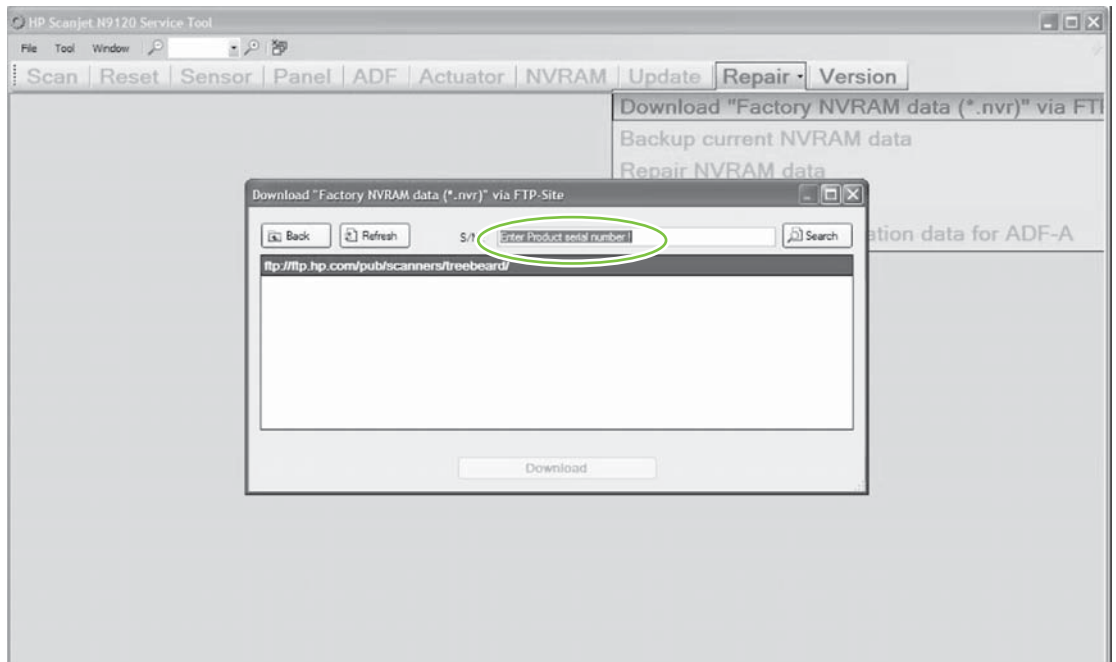
1. Click **Repair**, and then click **Download "Factory NVRAM data (\*.nvr)" via FTP**.

**Figure 5-61** Download factory NVRAM data (1 of 6)




2. Enter the unit serial number, and then click **Search**. See [NVRAM data file examples on page 84](#).

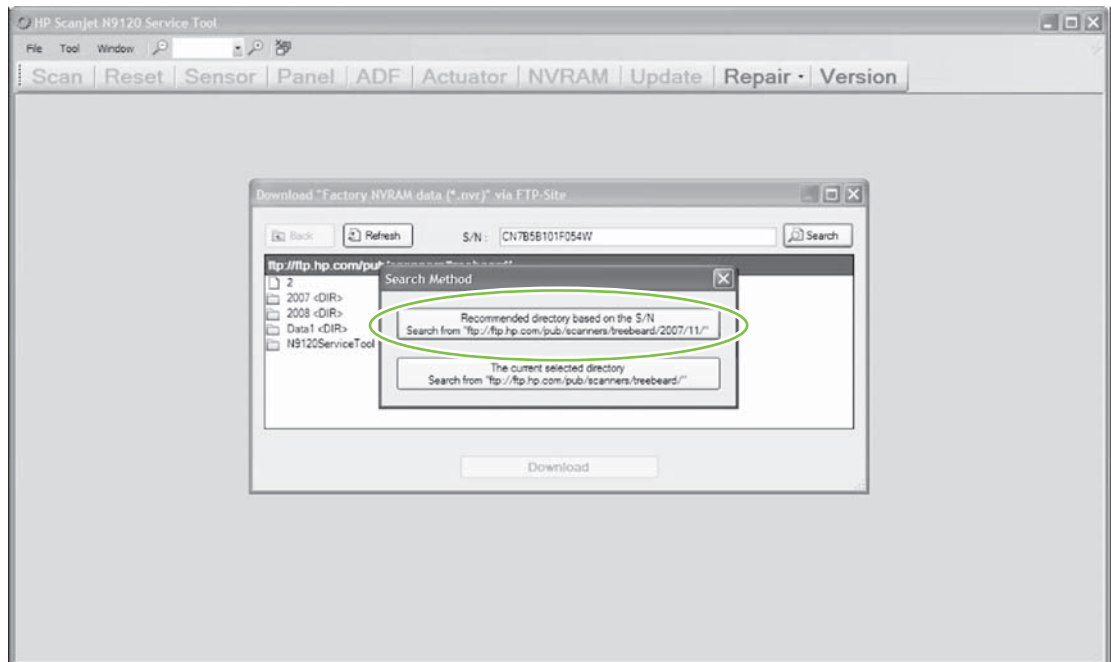
**Figure 5-62** Download factory NVRAM data (2 of 6)




3. Click **Recommended directory based on the S/N.**

 **NOTE:** Always choose this option to use the automatic search function.

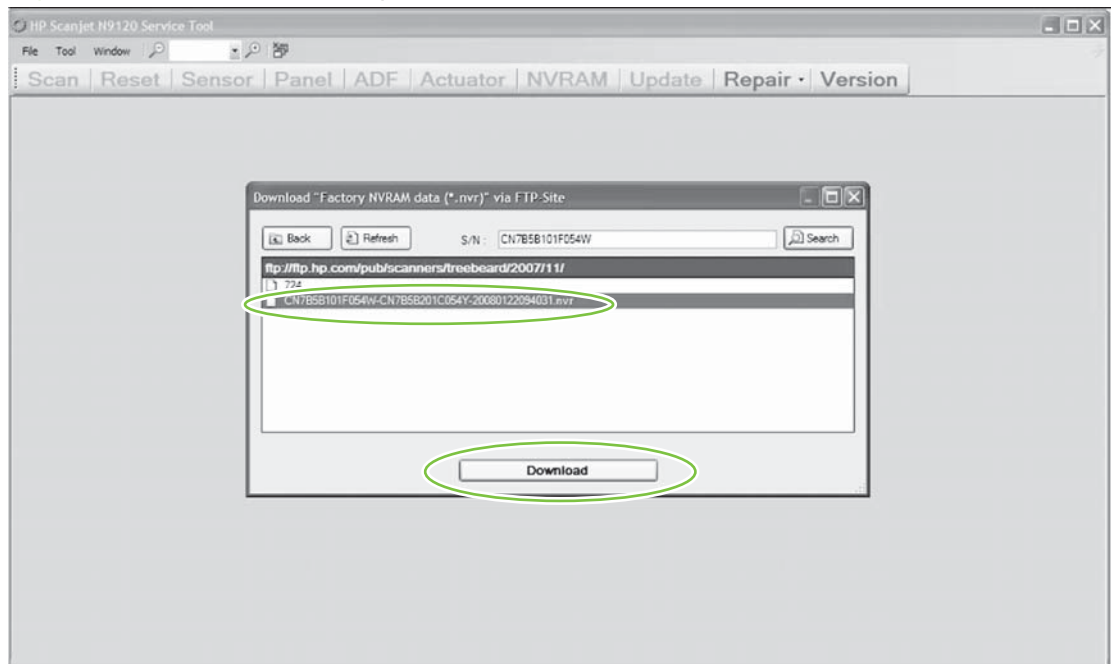
**Figure 5-63** Download factory NVRAM data (3 of 6)



4. Verify the correct file has been found, and then click **Download.**

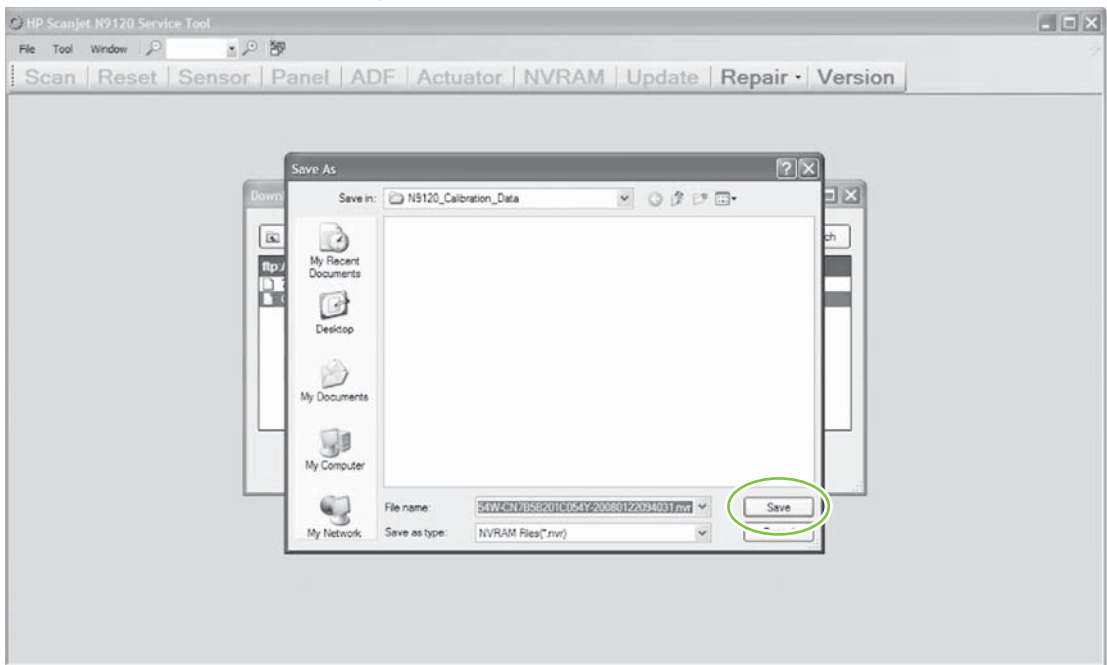
 **NOTE:** Always use the default directory when downloading NVRAM files to the service computer.

**Figure 5-64** Download factory NVRAM data (4 of 6)



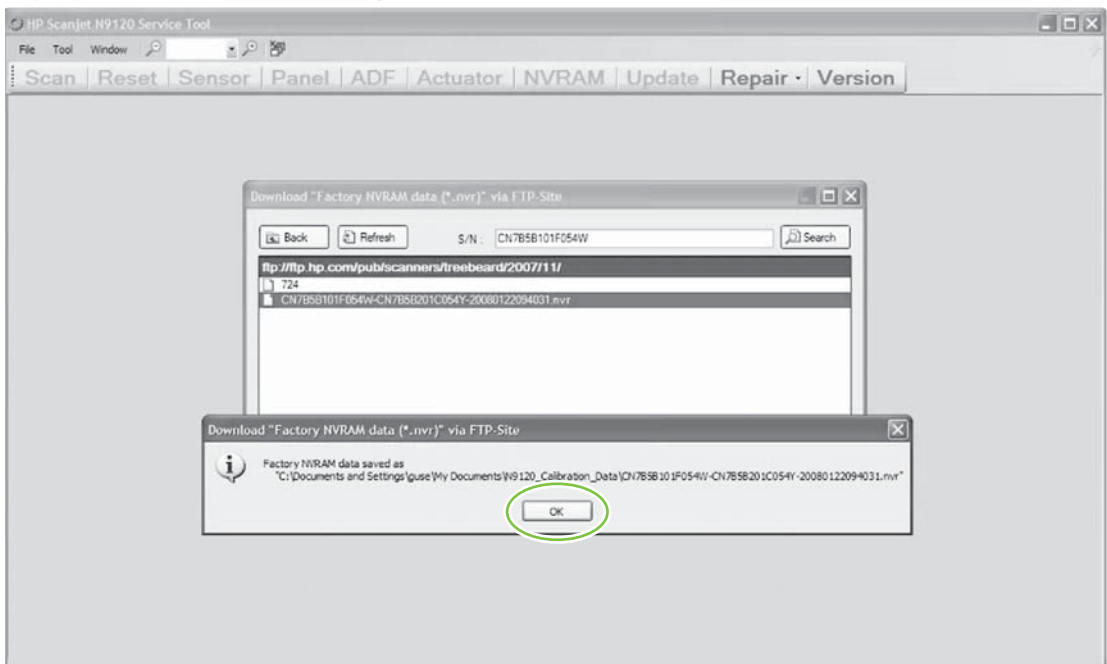
5. Verify the correct file has been found, and then click **Save**.

**Figure 5-65** Download factory NVRAM data (5 of 6)




6. Click **OK**.

**Figure 5-66** Download factory NVRAM data (6 of 6)



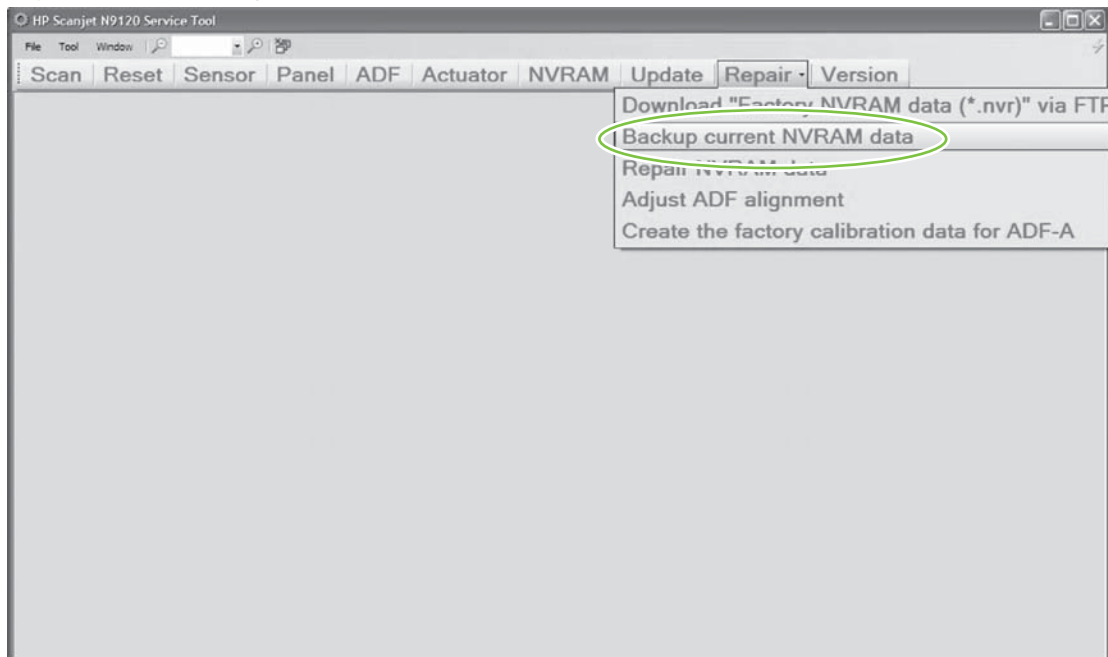


## Backup current NVRAM data


 **NOTE:** Factory NVRAM data should be downloaded before the service call.

1. Click **Repair**, and then click **Backup current NVRAM data**.

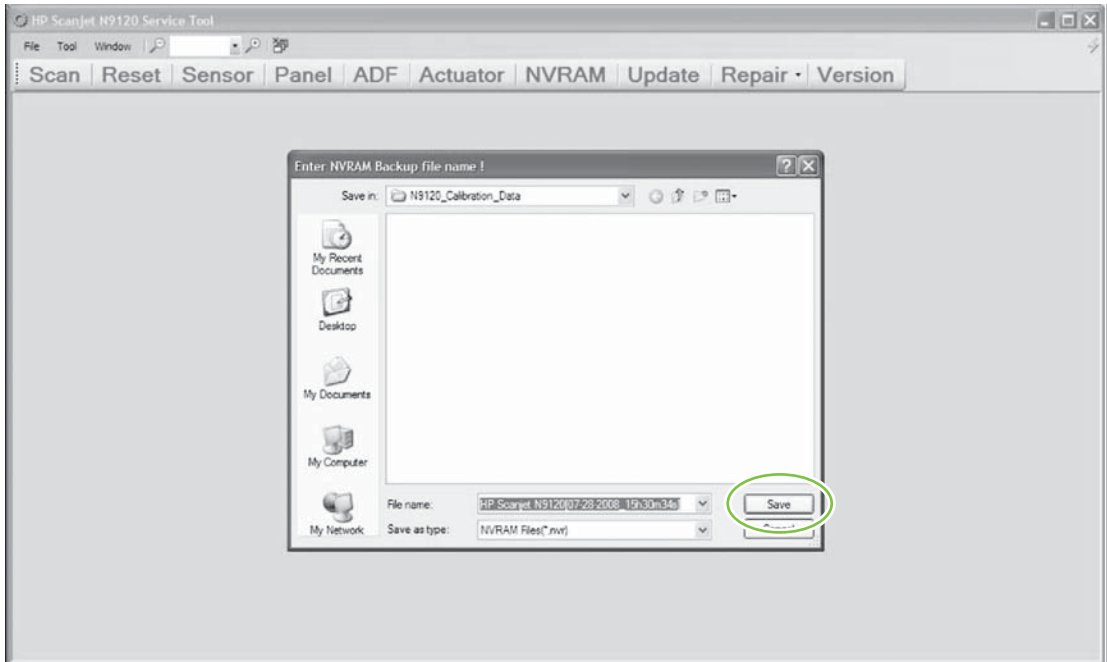
**Figure 5-67** Backup current NVRAM data (1 of 3)



2. Click **Save**.

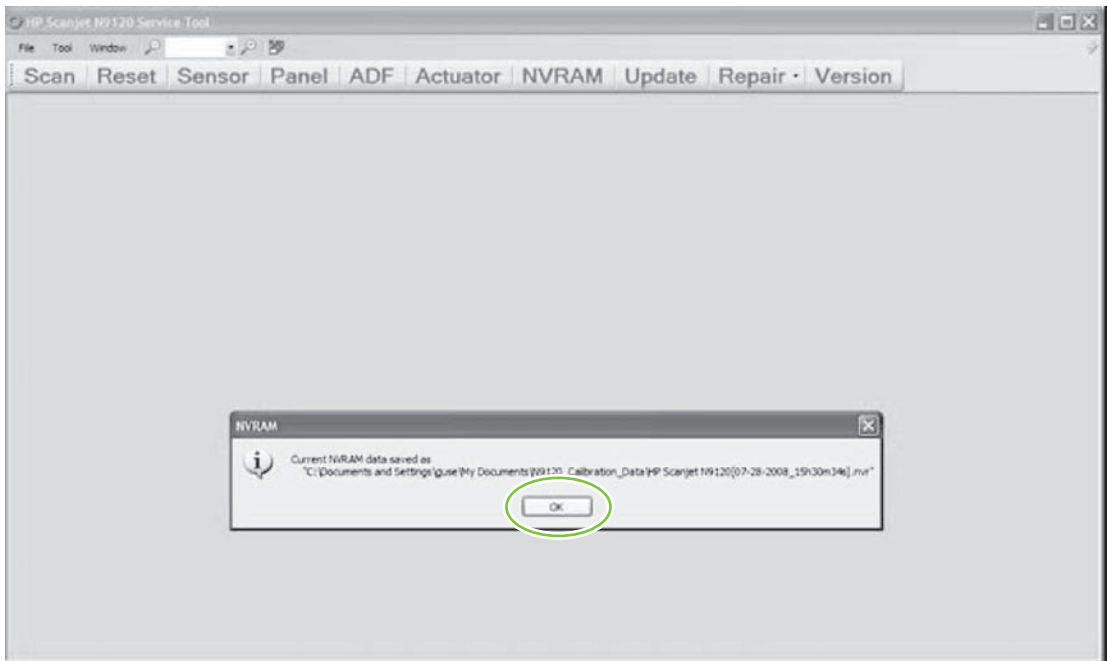
 **NOTE:** Always use the default directory when downloading NVRAM files to the service computer.

**Figure 5-68** Backup current NVRAM data (2 of 3)





3. Click **OK**.

**Figure 5-69** Backup current NVRAM data (3 of 3)



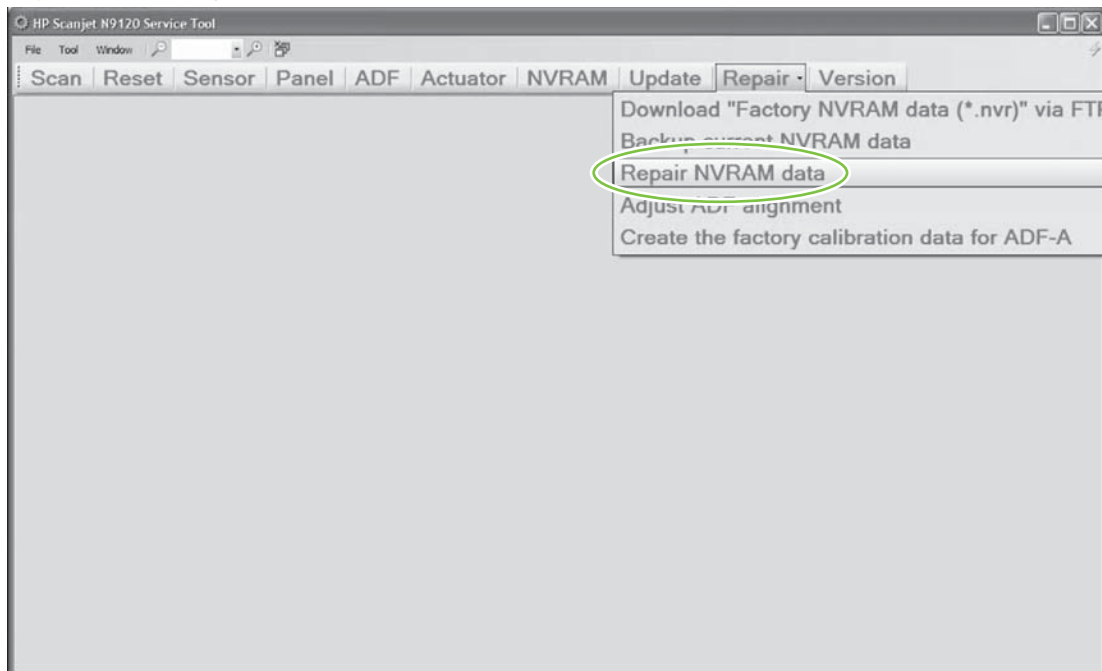
## Repair NVRAM data

 **NOTE:** Factory NVRAM data should be downloaded before the service call.


 **WARNING!** Do not make changes in the **Date items** dialog box.


1. Click **Repair**, and then click **Repair NVRAM data**.

**Figure 5-70** Repair NVRAM data (1 of 5)



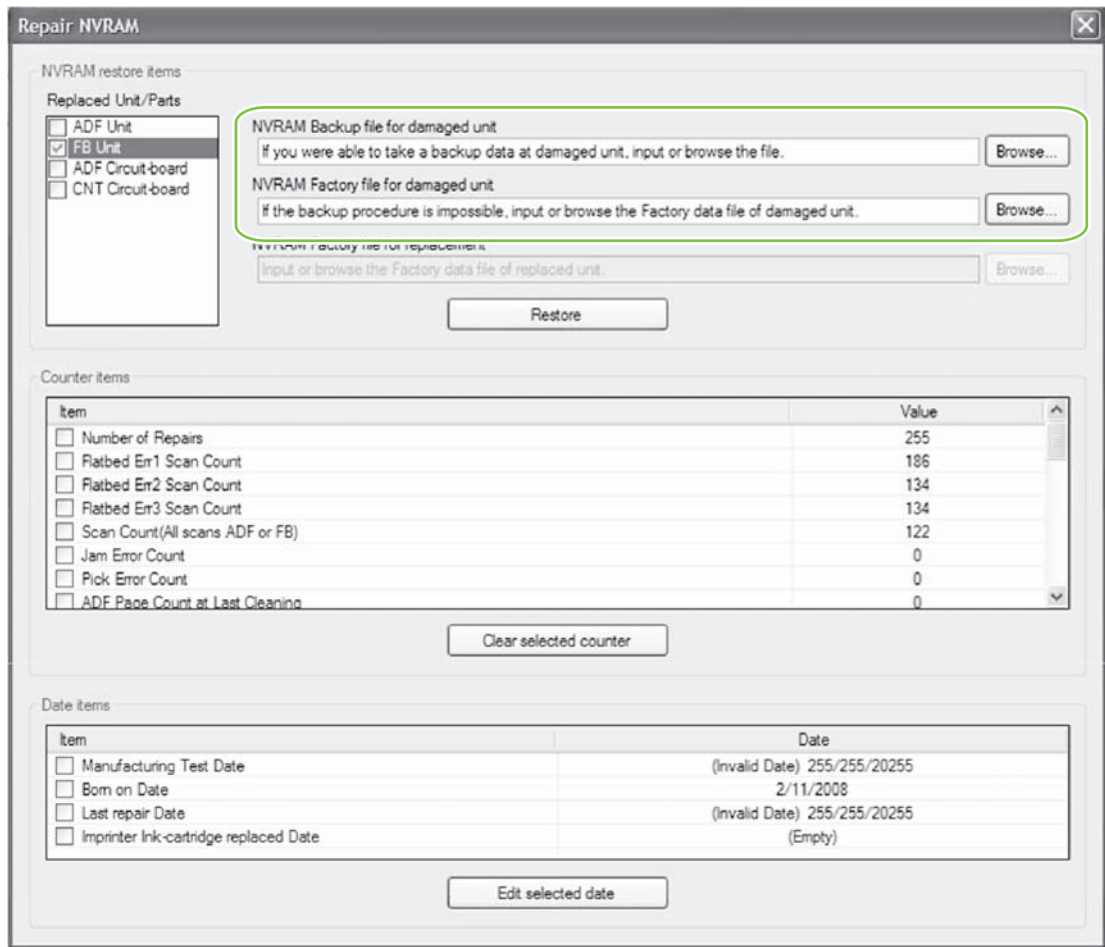
2. Select an option from **Replaced Unit/Parts** menu, and then click **Browse...**

 **NOTE:** Factory NVRAM data should be downloaded before the service call.

 **NOTE:** In this procedure, **FB Unit** has been selected from the **Replaced Unit/Parts** menu for purposes of illustration. See [Replacement scenarios on page 77](#) for options to choose for specific replacement scenarios.

 **NOTE:** Always choose **NVRAM Backup file for damaged unit** if the NVRAM was backed up from the damaged unit. Choose **NVRAM Factory file for damaged unit** if the NVRAM was not backed up from the damaged unit.

**Figure 5-71** Repair NVRAM data (2 of 5)




Item	Value
<input type="checkbox"/> Number of Repairs	255
<input type="checkbox"/> Flatbed Err1 Scan Count	186
<input type="checkbox"/> Flatbed Err2 Scan Count	134
<input type="checkbox"/> Flatbed Err3 Scan Count	134
<input type="checkbox"/> Scan Count(All scans ADF or FB)	122
<input type="checkbox"/> Jam Error Count	0
<input type="checkbox"/> Pick Error Count	0
<input type="checkbox"/> ADF Page Count at Last Cleaning	0

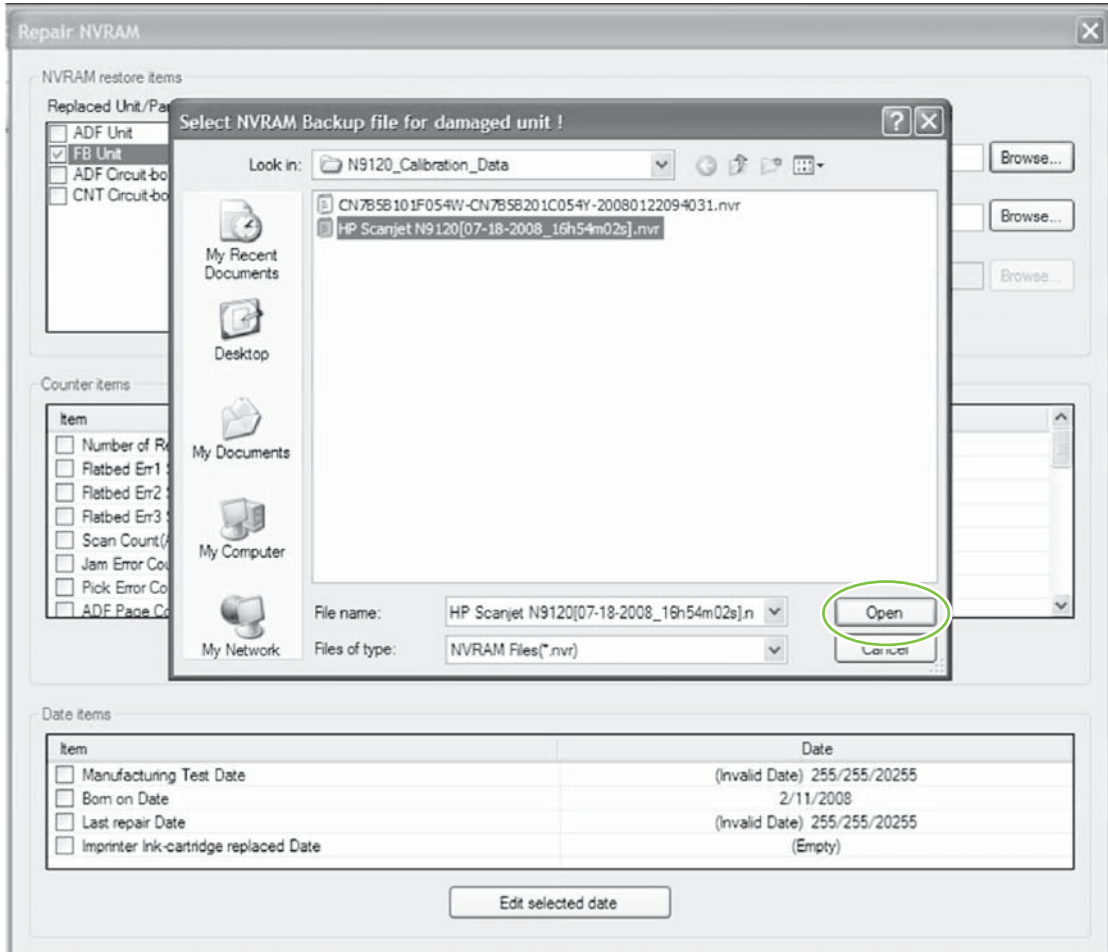
  

Item	Date
<input type="checkbox"/> Manufacturing Test Date	(Invalid Date) 255/255/20255
<input type="checkbox"/> Born on Date	2/11/2008
<input type="checkbox"/> Last repair Date	(Invalid Date) 255/255/20255
<input type="checkbox"/> Imprinter Ink-cartridge replaced Date	(Empty)


3. Verify the correct file has been selected, and then click **Open**.

 **NOTE:** Always use the default directory when downloading NVRAM files to the service computer.

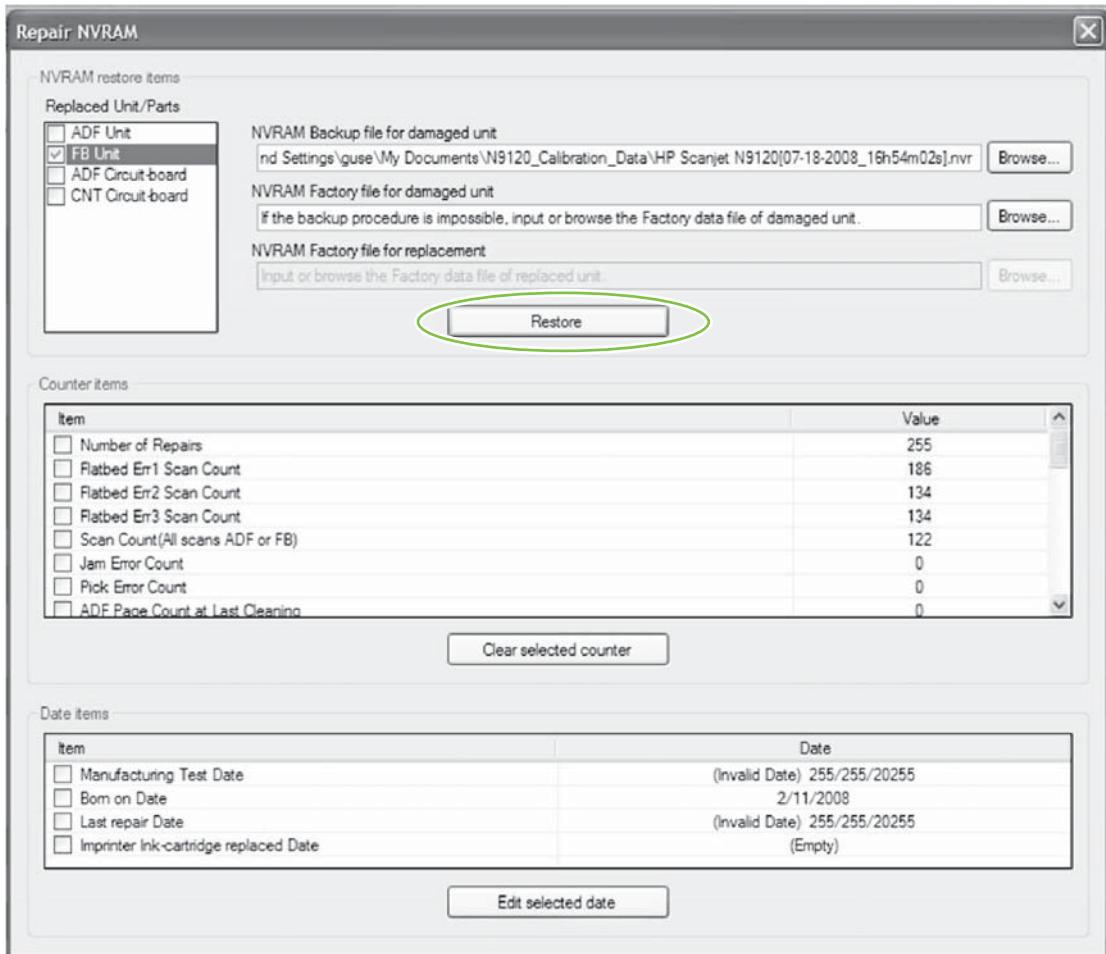
**Figure 5-72** Repair NVRAM data (3 of 5)



4. Click **Restore**.

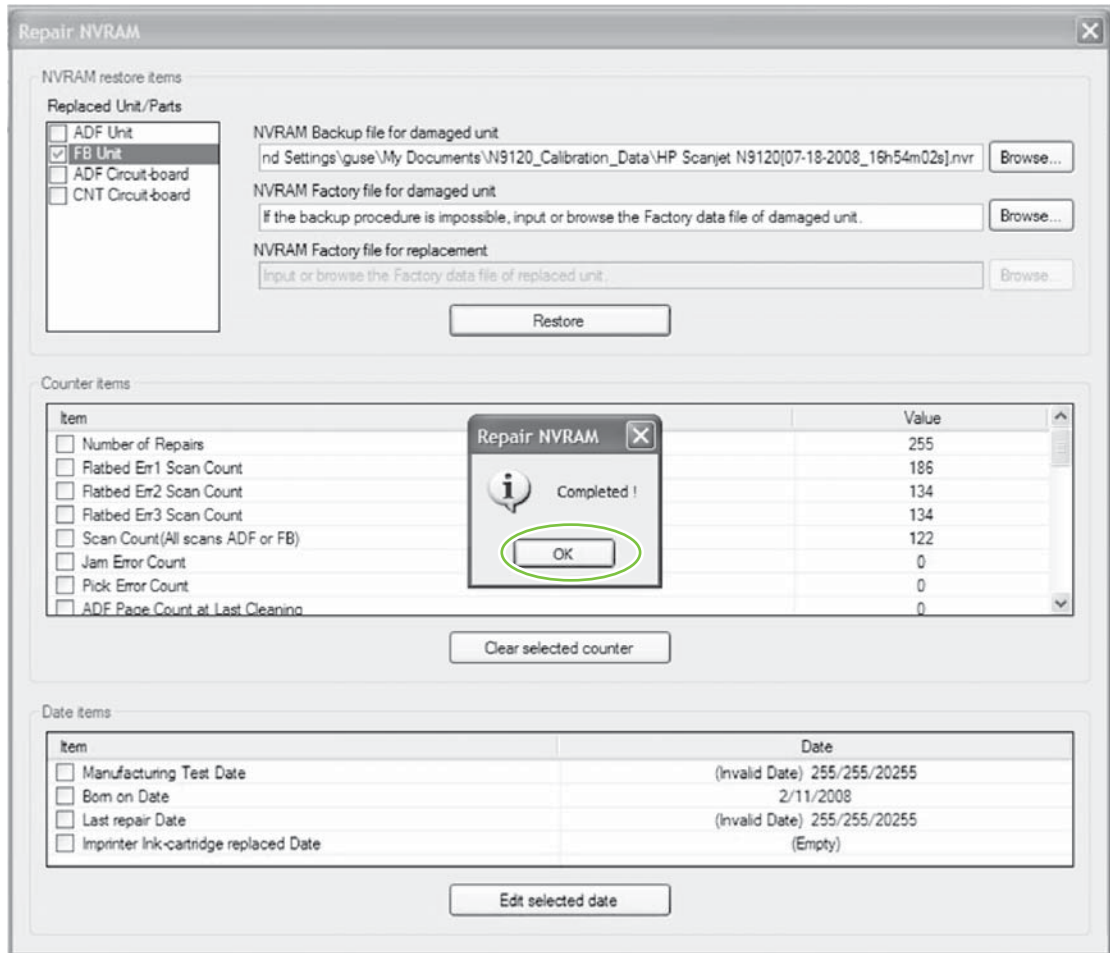
 **NOTE:** The NVRAM backup file name will not be shown in the **NVRAM Backup file for damaged unit** or **NVRAM Factory file for damaged unit** file path dialog boxes.

**Figure 5-73** Repair NVRAM data (4 of 5)





- Click **OK**.

**Figure 5-74** Repair NVRAM data (5 of 5)



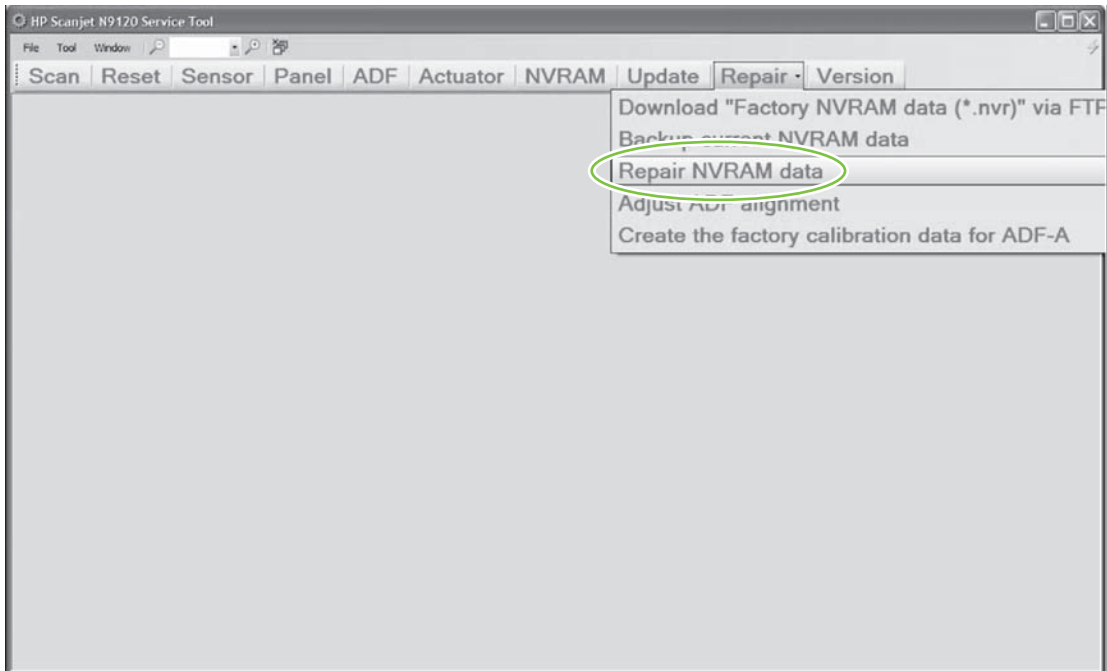
## Adjust NVRAM counter items

 **NOTE:** Factory NVRAM data should be downloaded before the service call.

 **WARNING!** Do not make changes in the **Date items** dialog box.

1. Click **Repair**, and then click **Repair NVRAM data**.

**Figure 5-75** Adjust NVRAM counter items (1 of 2)



2. Repair the NVRAM data. See [Repair NVRAM data on page 91](#).



3. From the **Counter items** menu, select items to clear, and then click **Clear selected counter**.

**Figure 5-76** Adjust NVRAM counter items (2 of 2)

**Repair NVRAM**

NVRAM restore items

Replaced Unit/Parts

- ADF Unit
- FB Unit
- ADF Circuit-board
- CNT Circuit-board

NVRAM Backup file for damaged unit  
if you were able to take a backup data at damaged unit, input or browse the file.  Browse...

NVRAM Factory file for damaged unit  
if the backup procedure is impossible, input or browse the Factory data file of damaged unit.  Browse...

NVRAM Factory file for replacement  
input or browse the Factory data file of replaced unit.  Browse...

Counter items


Item	Value
<input type="checkbox"/> Number of Repairs	255
<input type="checkbox"/> Flatbed Err1 Scan Count	134
<input type="checkbox"/> Flatbed Err2 Scan Count	134
<input type="checkbox"/> Flatbed Err3 Scan Count	134
<input type="checkbox"/> Scan Count(All scans ADF or FB)	174
<input type="checkbox"/> Jam Error Count	0
<input type="checkbox"/> Pick Error Count	2
<input type="checkbox"/> ADF Page Count at Last Cleaning	0

Date items

Item	Date
<input type="checkbox"/> Manufacturing Test Date	(Invalid Date) 255/255/20255
<input type="checkbox"/> Bom on Date	2/11/2008
<input type="checkbox"/> Last repair Date	(Invalid Date) 255/255/20255
<input type="checkbox"/> Imprinter Ink-cartridge replaced Date	6/19/2008

## Align the ADF

ADF alignment must be implemented after removing the ADF from the flatbed scanner.

 **NOTE:** Factory NVRAM data should be downloaded before the service call.

1. On an A4 size paper, print out the ADF alignment target. Place the alignment target in the ADF alignment input tray.

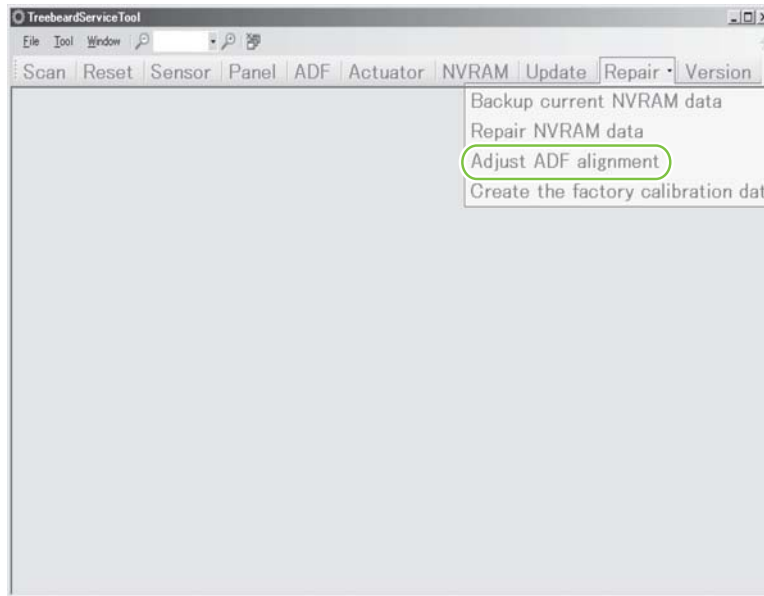
**Figure 5-77** ADF alignment (1 of 6)



2. Open the N9120 Service Tool.

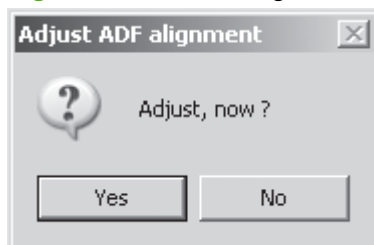
3. Click **Repair**, and then click **Adjust ADF alignment**.

**Figure 5-78** ADF alignment (2 of 6)




4. Click **Yes**.

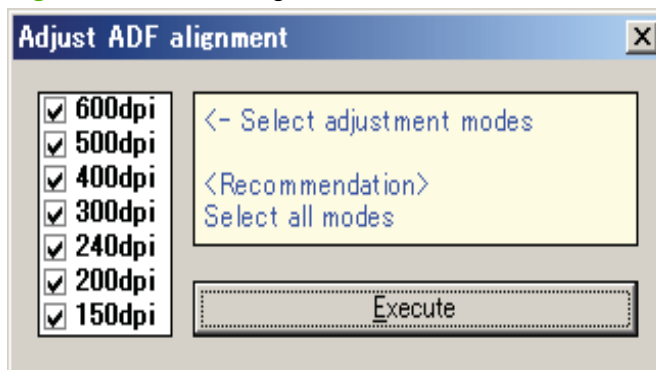
**Figure 5-79** ADF alignment (3 of 6)



5. Select seven check boxes, and then click **Execute** to adjust the alignment for 600dpi.

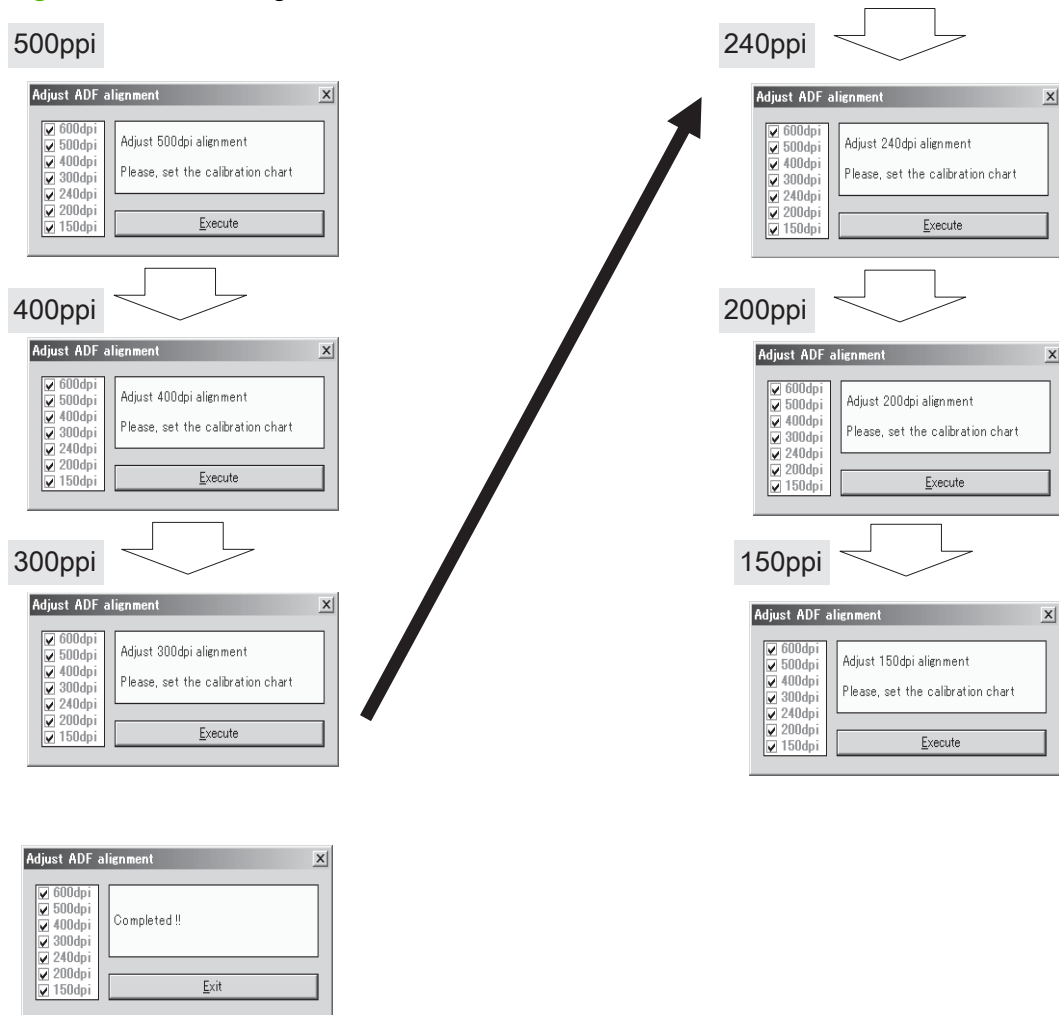
 **NOTE:** When seven check boxes are selected, the product automatically adjusts alignment beginning with 600dpi.

**Figure 5-80** ADF alignment (4 of 6)




6. Reinstall the alignment target, and then click **Execute**. Repeat this step until the 150dpi adjustment is accomplished.

**Figure 5-81** ADF alignment (5 of 6)



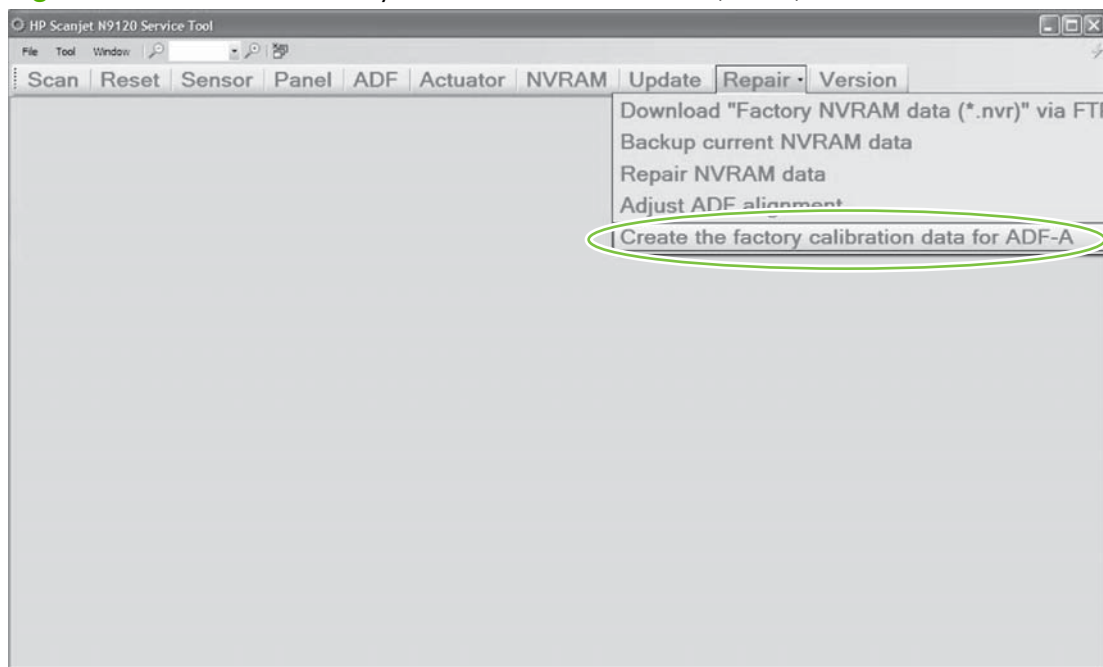
7. Click **Exit**.

## Create the factory calibration data for ADF-A

 **NOTE:** Factory NVRAM data should be downloaded before the service call.

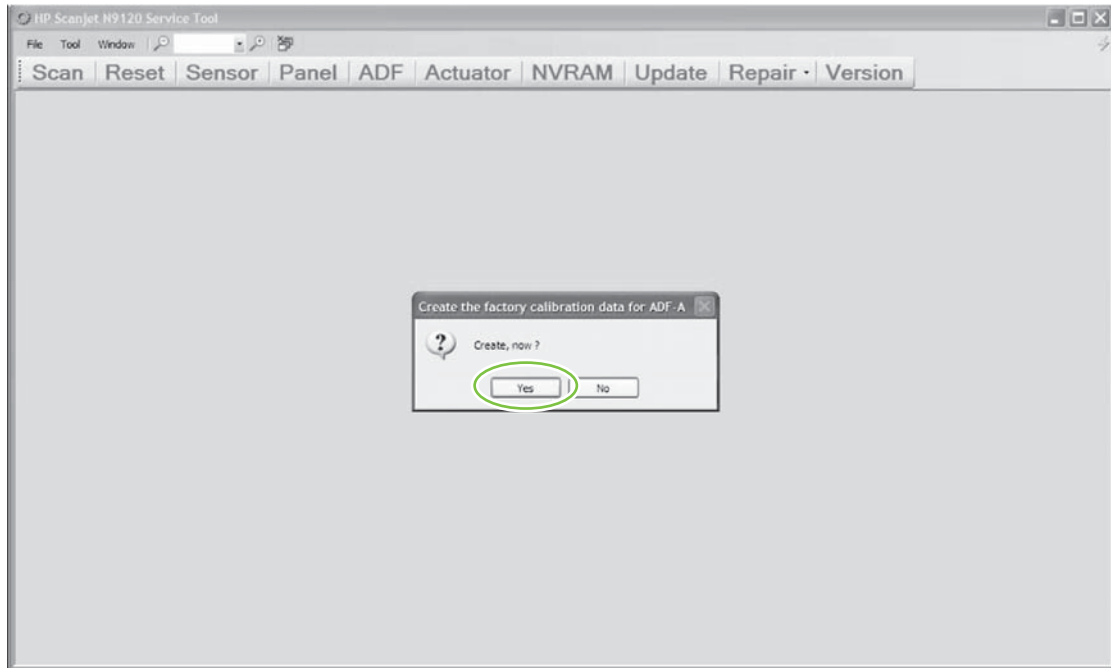
1. Click **Repair**, and then click **Create the factory calibration data for ADF-A**.


**Figure 5-82** Create the factory calibration data for ADF-A (1 of 3)



2. Click **Yes**.

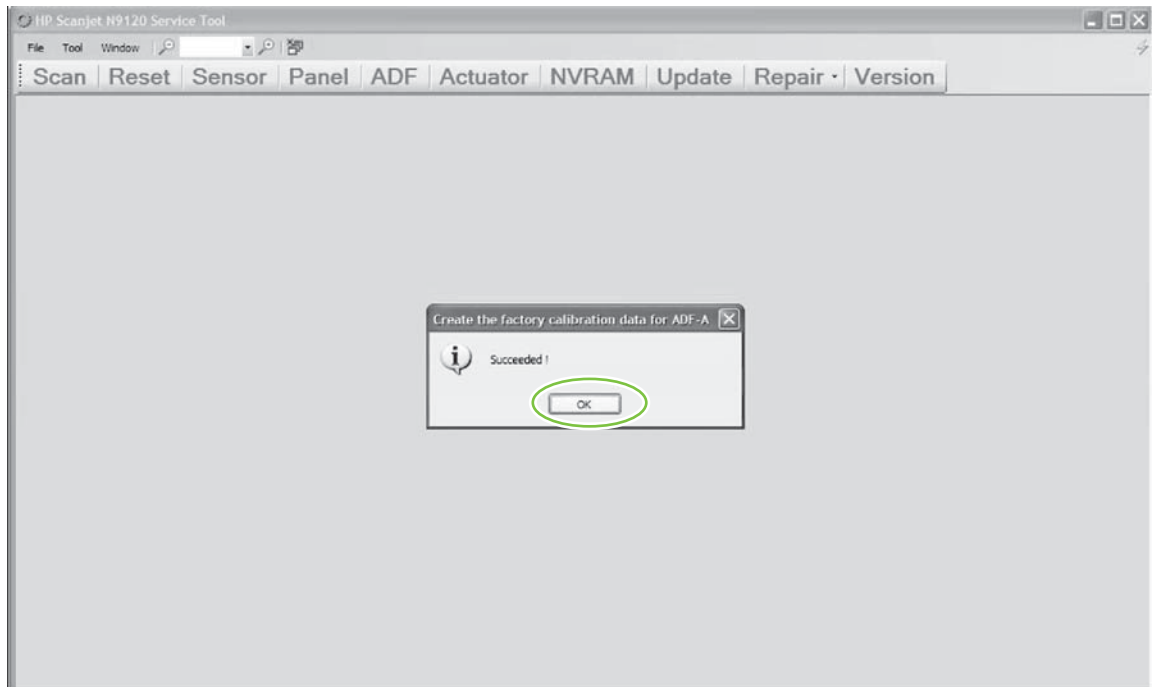
**Figure 5-83** Create the factory calibration data for ADF-A (2 of 3)



 **NOTE:** Two graphs will be displayed automatically as the Service Tool creates the factory calibration data.

3. Click **OK**.

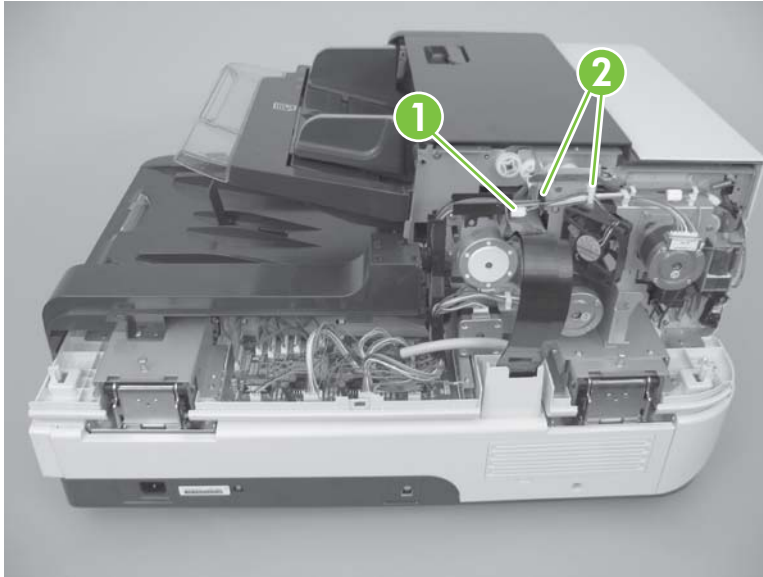
**Figure 5-84** Create the factory calibration data for ADF-A (3 of 3)



## ADF motor fan

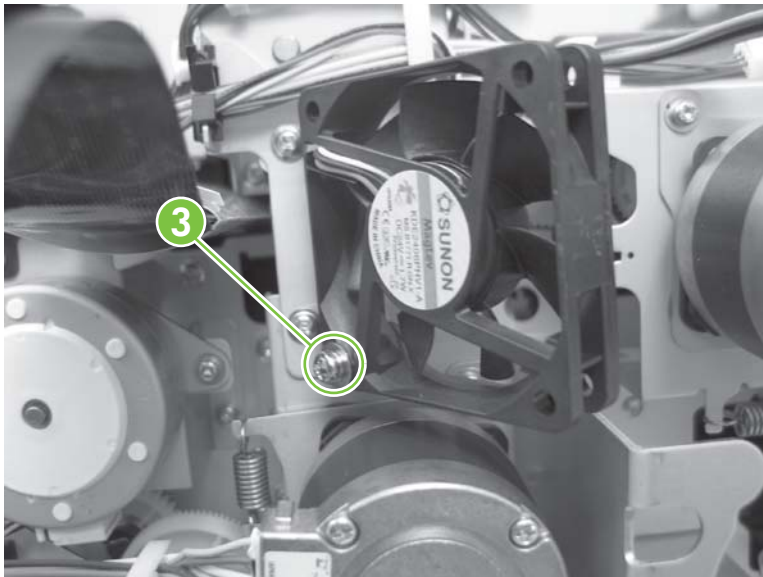
1. Remove the ADF back cover. See [ADF back cover on page 58](#).
2. Disconnect one connector (callout 1), and then release the wire harness from the retainers (callout 2).

**Figure 5-85** Remove the ADF motor fan (1 of 2)



3. Remove one screw (callout 3), and then remove the ADF motor fan.

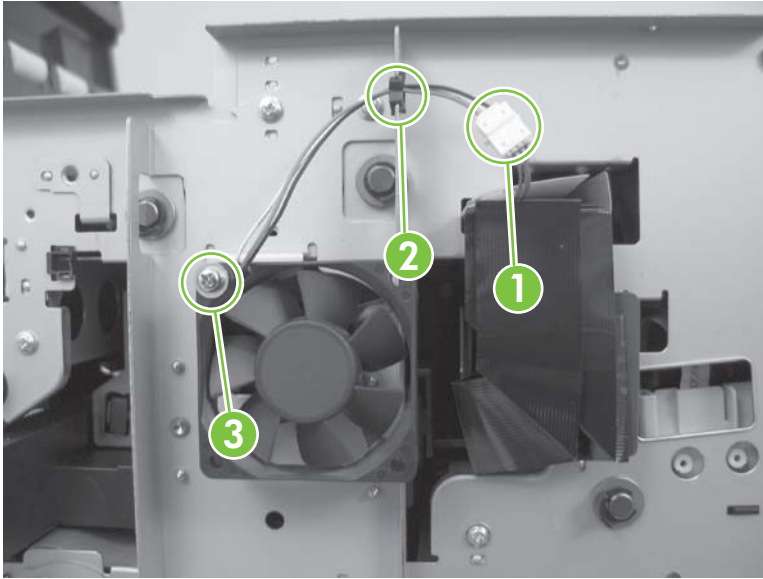
**Figure 5-86** Remove the ADF motor fan (2 of 2)



## ADF carriage fan

1. Remove the ADF front cover. See [ADF front cover on page 55](#).
2. Disconnect one connector (callout 1), release the wire harness from the retainer (callout 2), and then remove one screw (callout 3).

**Figure 5-87** Remove the ADF carriage fan



3. Remove the ADF carriage fan.

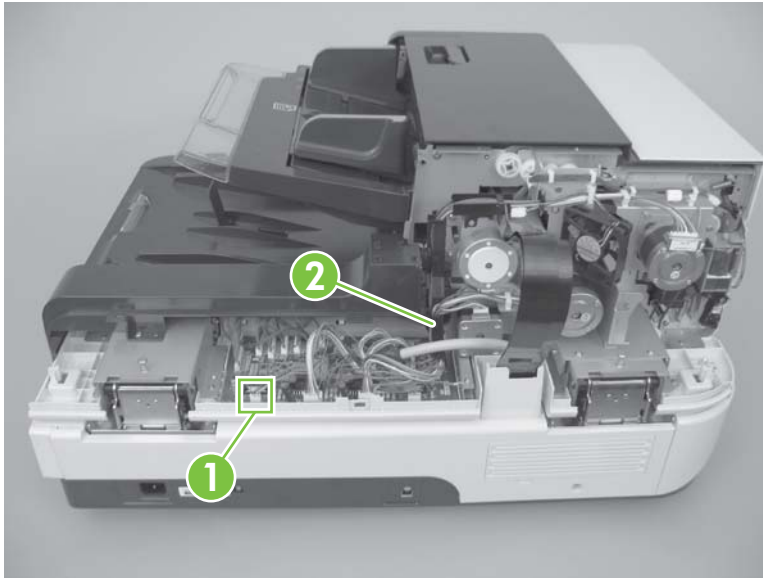


## ADF input-tray lift-motor assembly


**⚠ WARNING!** When removing the ADF input-tray lift-motor assembly, do not bend, tear, pinch, stretch, or damage the two FFCs.

1. Remove the ADF back cover. See [ADF back cover on page 58](#).
2. Disconnect one connector (callout 1), and then release the wire harness from the retainer (callout 2).

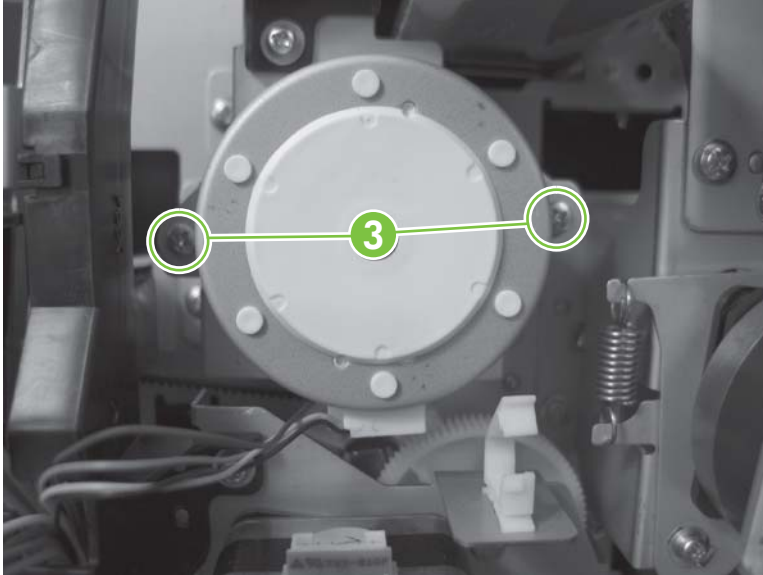
**Figure 5-88** Remove the ADF input-tray lift-motor assembly (1 of 2)



3. Remove two screws (callout 3), and then remove the ADF input-tray lift-motor assembly.

 **NOTE:** The cable harness does not terminate at the ADF input-tray lift-motor. Remove the CN9 connector on the ADF controller PCA to remove the ADF input-tray lift-motor. See [Figure 5-88 Remove the ADF input-tray lift-motor assembly \(1 of 2\) on page 105](#).

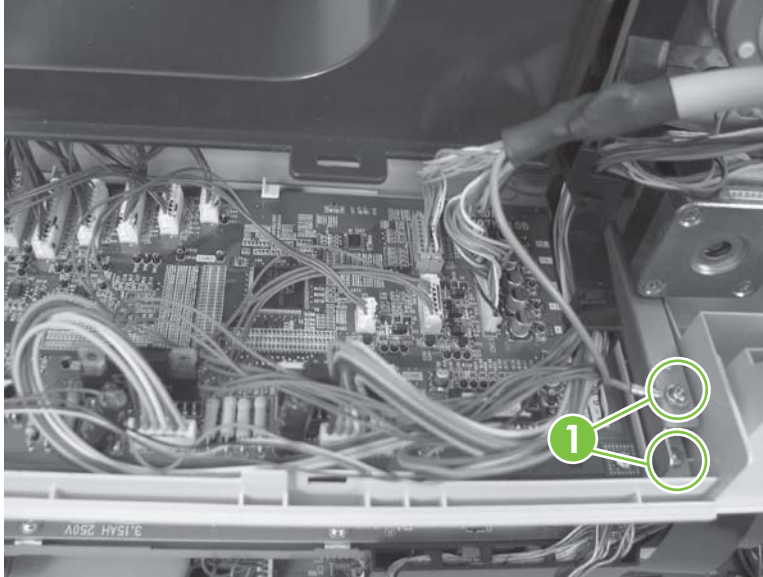
**Figure 5-89** Remove the ADF input-tray lift-motor assembly (2 of 2)



## ADF exit-motor assembly

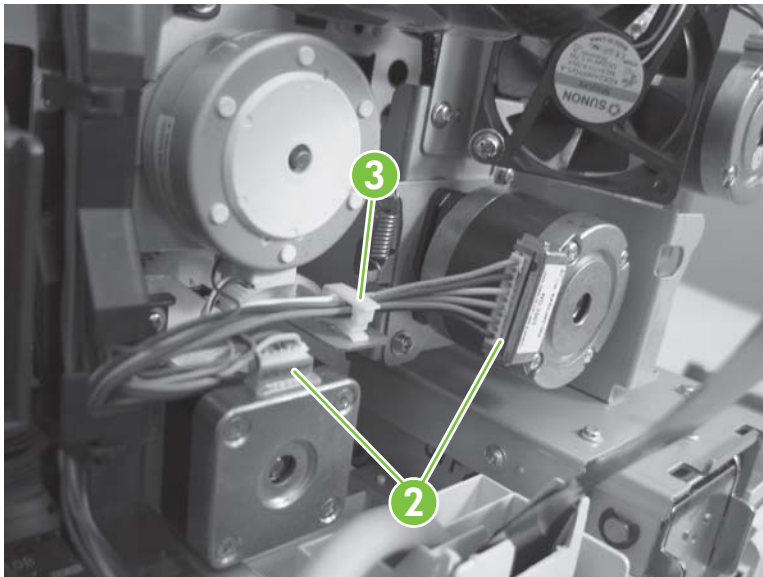
1. Remove the ADF back cover.
2. Remove two screws (callout 1).

**Figure 5-90** Remove the ADF exit-motor assembly (1 of 7)




3. Disconnect two connectors (callout 2), and then release the wire harness from the retainer (callout 3).

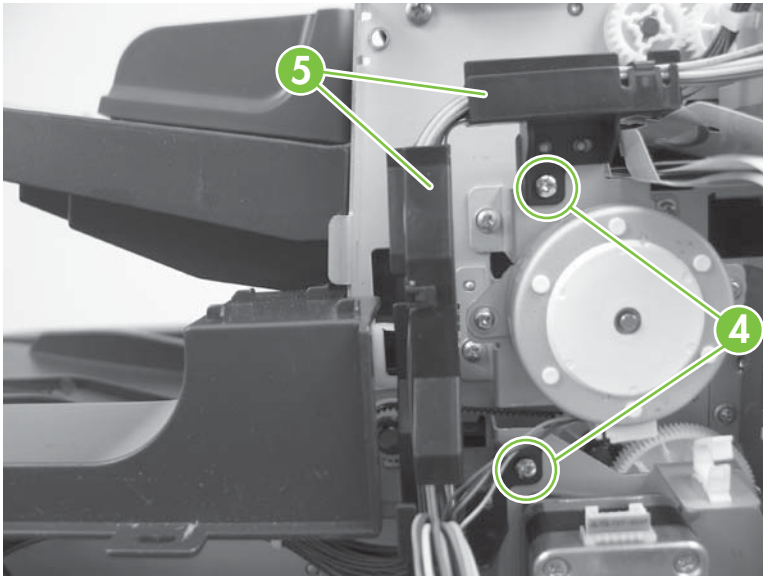
**Figure 5-91** Remove the ADF exit-motor assembly (2 of 7)



4. Remove two screws (callout 4).

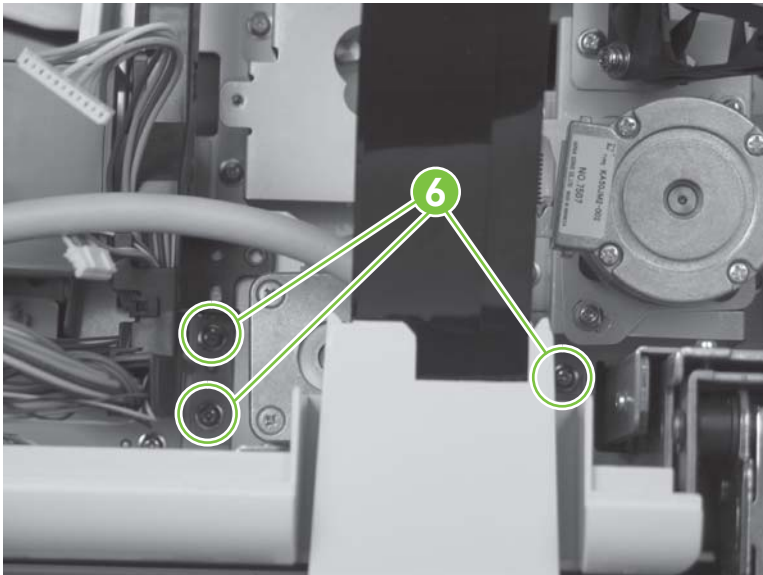
 **NOTE:** This allows the wire retainer (callout 5) to be moved out of the way when the motor is removed.

**Figure 5-92** Remove the ADF exit-motor assembly (3 of 7)



5. Remove three screws (callout 6).

**Figure 5-93** Remove the ADF exit-motor assembly (4 of 7)



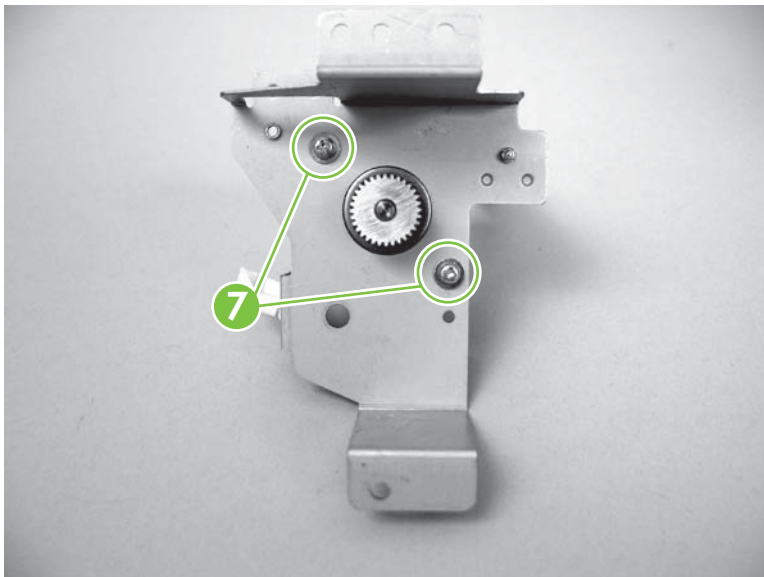
6. Remove the ADF exit-motor assembly.

**Figure 5-94** Remove the ADF exit-motor assembly (5 of 7)



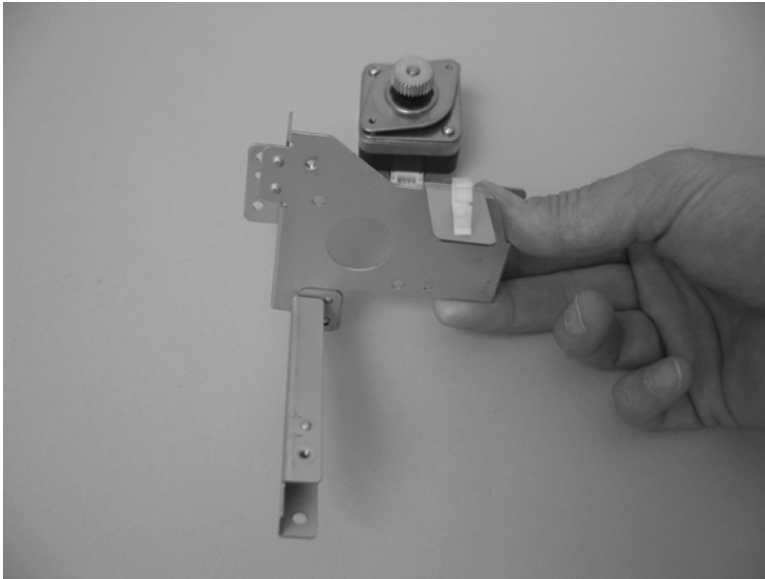
7. Remove two screws (callout 7).

**Figure 5-95** Remove the ADF exit-motor assembly (6 of 7)




8. Remove the mounting bracket from the ADF exit-motor assembly.

**Figure 5-96** Remove the ADF exit-motor assembly (7 of 7)



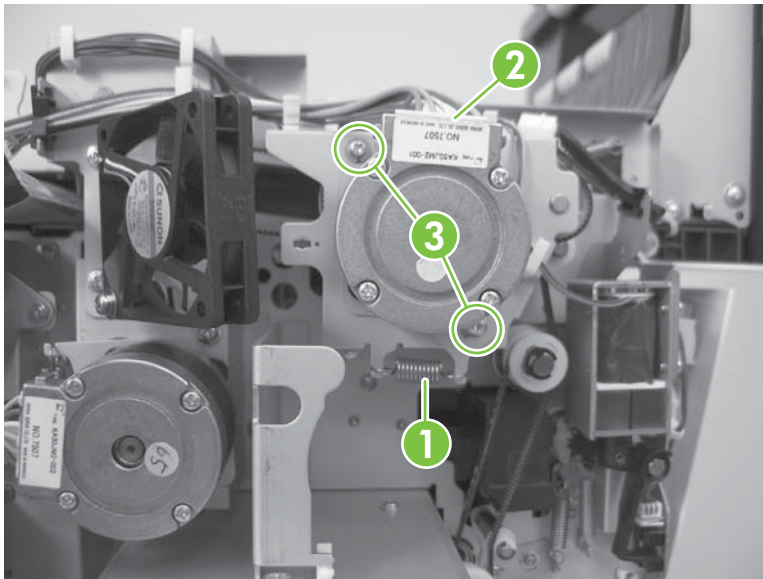
## ADF feed-motor assembly

1. Remove the following components:
  - ADF back cover. See [ADF back cover on page 58](#).
  - ADF motor fan. See [ADF motor fan on page 103](#).

 **TIP:** You do not need to completely remove the fan. It might be easier to remove one screw, and then set the fan out of the way. See [Figure 5-86 Remove the ADF motor fan \(2 of 2\) on page 103](#).

2. Remove one spring (callout 1), disconnect one connector (callout 2), and then remove two screws (callout 3).

**Figure 5-97** Remove the ADF feed-motor assembly (1 of 4)



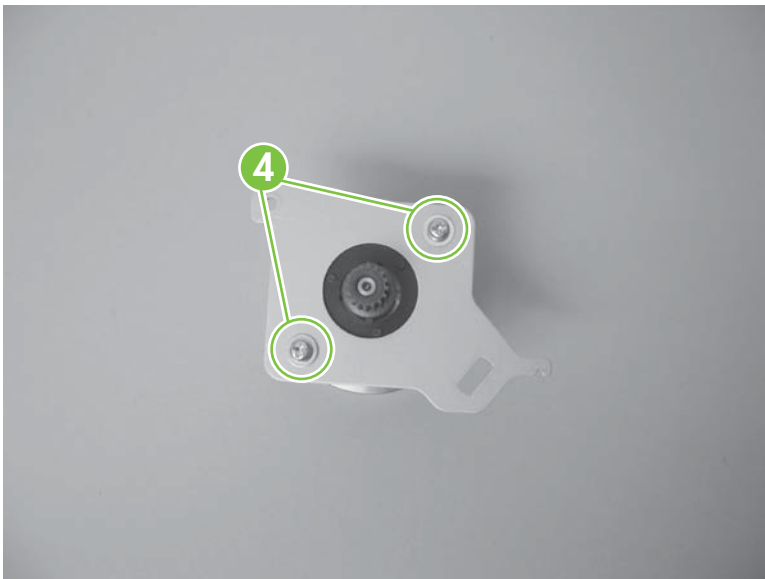
3. Remove the ADF feed-motor assembly.

**Figure 5-98** Remove the ADF feed-motor assembly (2 of 4)



4. Remove two screws (callout 4).

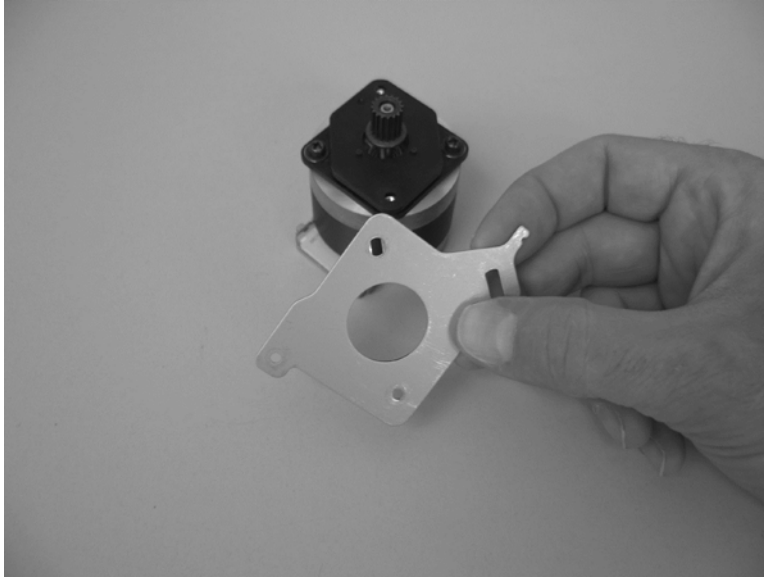
**Figure 5-99** Remove the ADF feed-motor assembly (3 of 4)






5. Remove the feed-motor mounting plate from the feed-motor assembly.

**Figure 5-100** Remove the ADF feed-motor assembly (4 of 4)



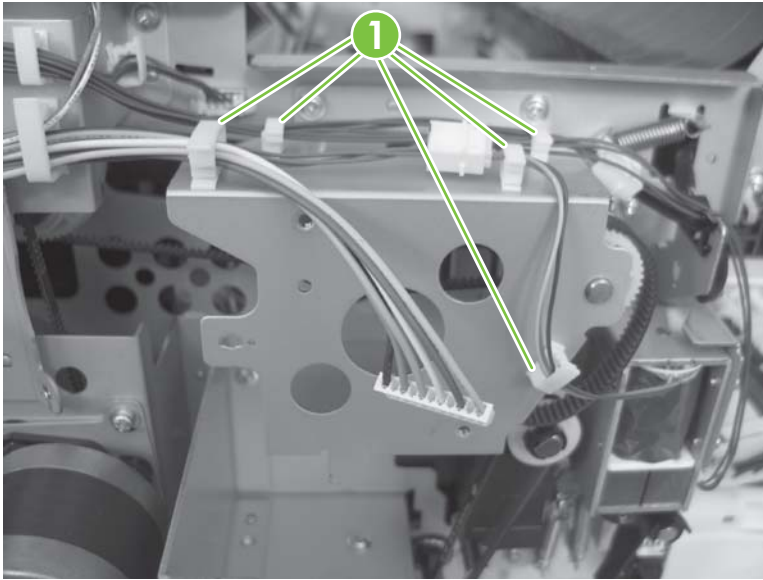
## Reinstall the ADF feed-motor drive belt

The ADF feed-motor drive belt can become dislodged when the ADF feed-motor assembly is removed. Use this procedure to reinstall the belt if necessary.

 **NOTE:** If the belt is correctly positioned on the drive gear, skip this procedure and proceed to [Reinstall the ADF feed-motor assembly on page 115](#).

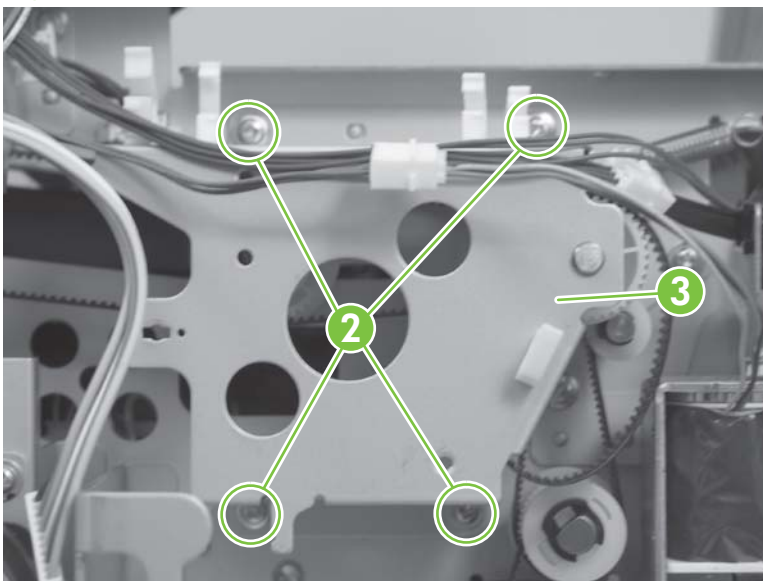
1. Release the wire harnesses from the retainers (callout 1).

**Figure 5-101** Reinstall the ADF feed-motor drive belt (1 of 3)



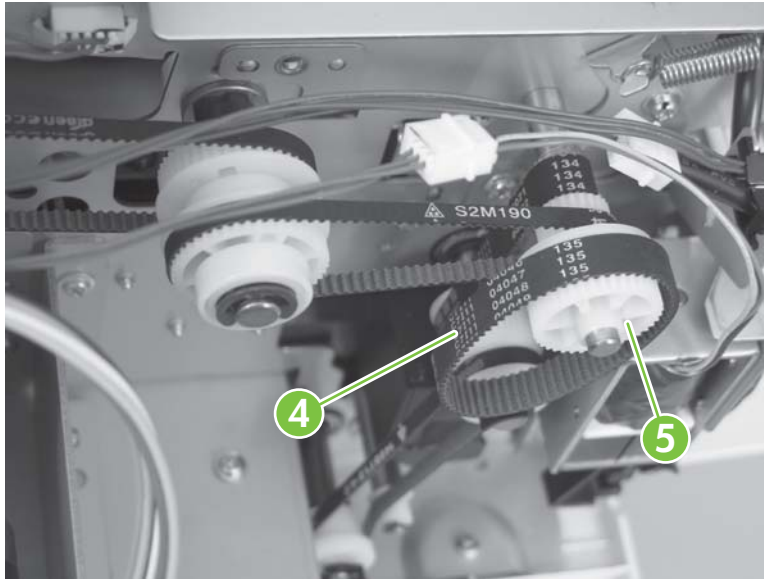
2. Remove four screws (callout 2), and then remove the sheet-metal motor bracket (callout 3).

**Figure 5-102** Reinstall the ADF feed-motor drive belt (2 of 3)



3. Position the drive belt (callout 4) on the drive gear (callout 5).

**Figure 5-103** Reinstall the ADF feed-motor drive belt (3 of 3)

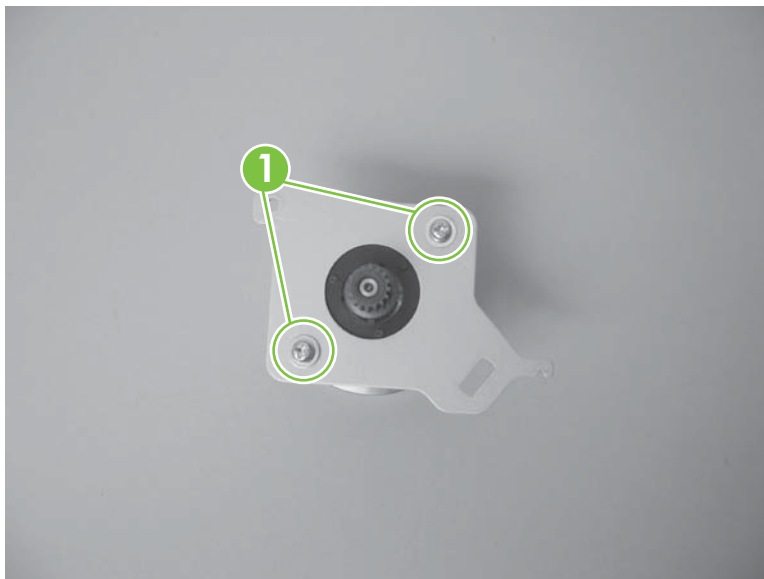


4. Reinstall the feed-motor bracket, and then restrain the wire harnesses with the retainers.


### Reinstall the ADF feed-motor assembly

1. Reinstall two screws (callout 1).

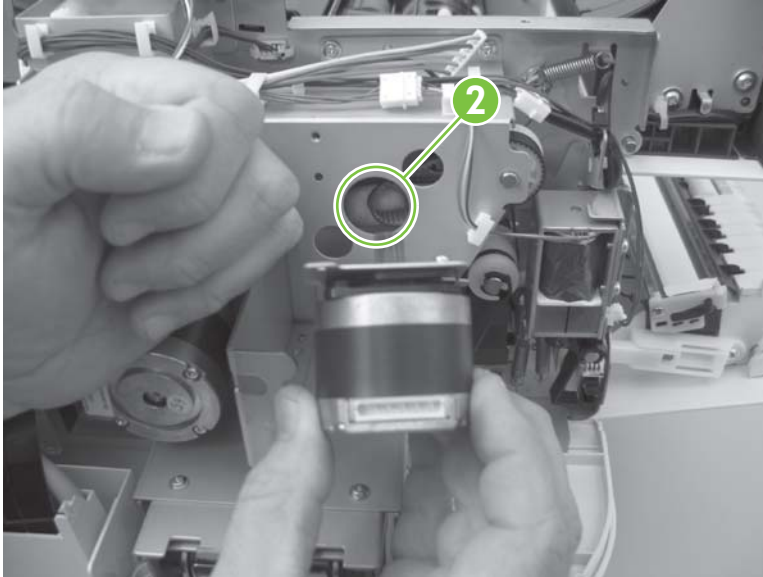
**Figure 5-104** Reinstall the ADF feed-motor assembly (1 of 5)




2. Use your finger to pull on the feed-motor drive belt so that it loops back and can be seen through the feed-motor mounting hole in the chassis (callout 2).

 **NOTE:** If the feed-motor drive belt slips off the drive gear, see [Reinstall the ADF feed-motor drive belt on page 114](#).

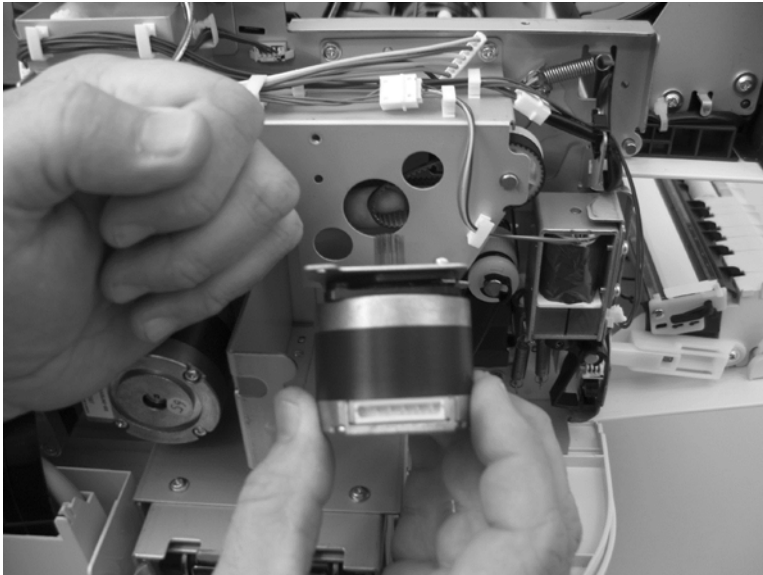
**Figure 5-105** Reinstall the ADF feed-motor assembly (2 of 5)



3. Keep pressure on the belt, and then carefully slide the motor into the mounting hole in the chassis.

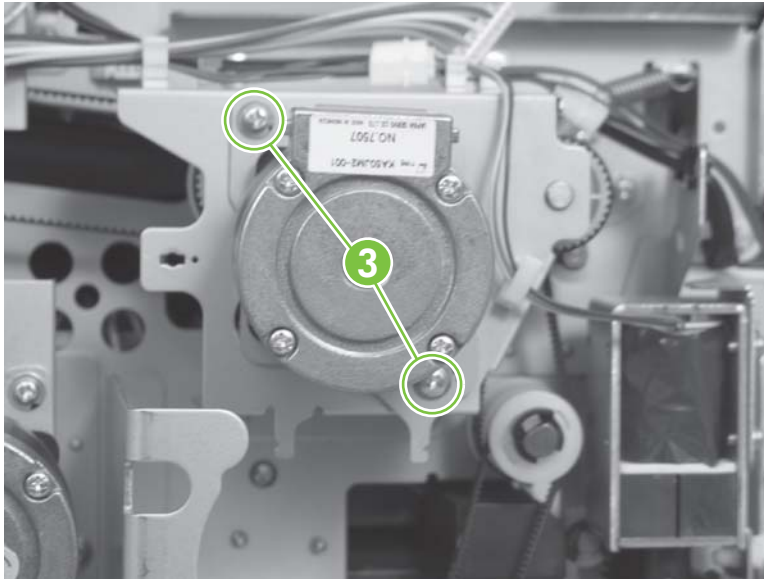
 **NOTE:** Make sure that the motor-drive gear engages the inside of the drive-belt loop.

**Figure 5-106** Reinstall the ADF feed-motor assembly (3 of 5)



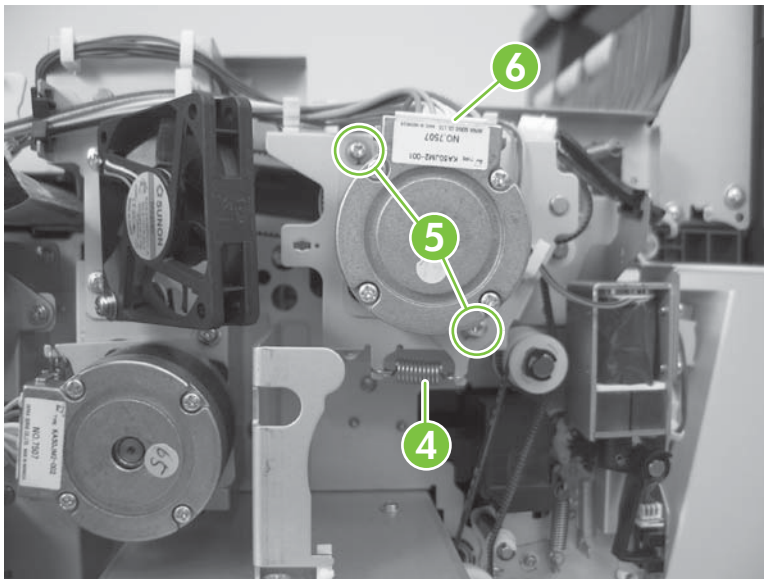
4. Install, but *do not* fully tighten, the two motor-mounting screws (callout 3).

**Figure 5-107** Reinstall the ADF feed-motor assembly (4 of 5)



5. Install the motor-tension spring (callout 4), fully tighten the screws (callout 5), and then connect the connector (callout 6).


**Figure 5-108** Reinstall the ADF feed-motor assembly (5 of 5)



## ADF pick-motor assembly

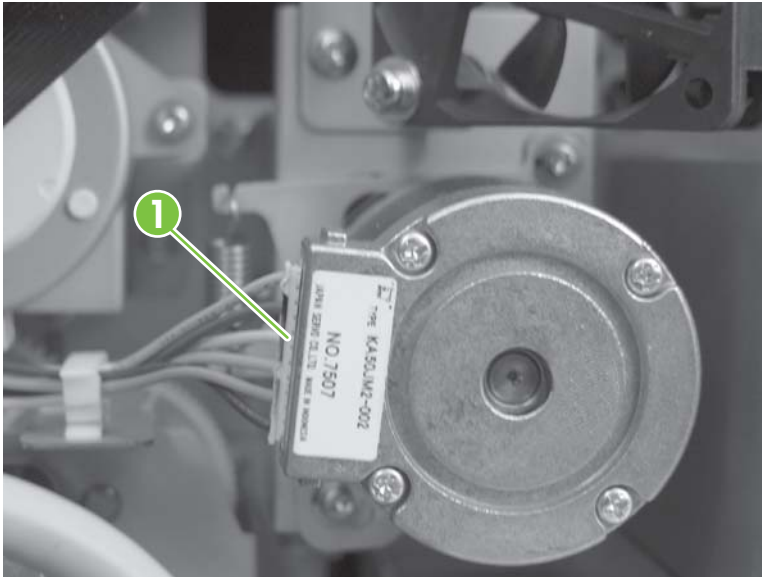
1. Remove the following components:

- ADF back cover. See [ADF back cover on page 58](#).
- ADF motor fan. See [ADF motor fan on page 103](#).

 **TIP:** You do not need to completely remove the fan. It might be easier to remove one screw, and then set the ADF motor fan out of the way. See [Figure 5-86 Remove the ADF motor fan \(2 of 2\) on page 103](#).

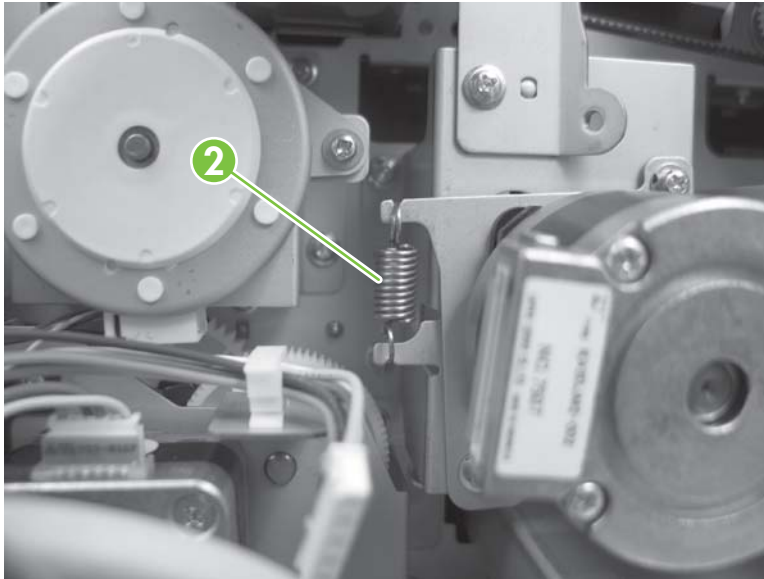
2. Disconnect one connector (callout 1).

**Figure 5-109** Remove the ADF pick-motor assembly (1 of 5)



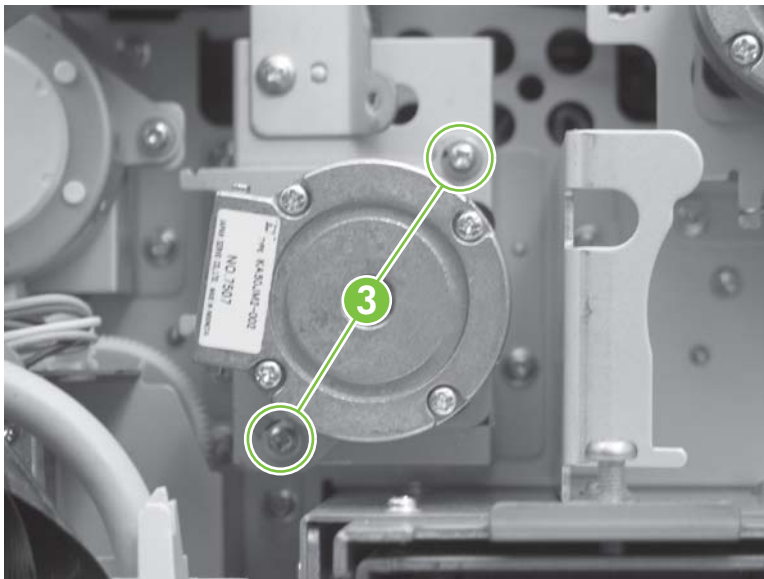
3. Remove one spring (callout 2).

**Figure 5-110** Remove the ADF pick-motor assembly (2 of 5)



4. Remove two screws (callout 3), and then remove the ADF pick-motor assembly.

**Figure 5-111** Remove the ADF pick-motor assembly (3 of 5)



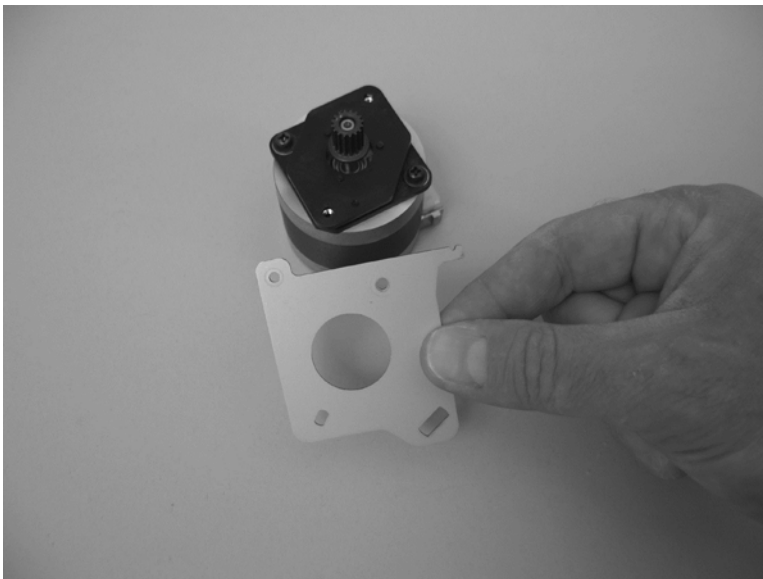
5. Remove two screws (callout 4).

**Figure 5-112** Remove the ADF pick-motor assembly (4 of 5)



6. Remove the mounting plate from the ADF pick-motor assembly.

**Figure 5-113** Remove the ADF pick-motor assembly (5 of 5)





## Reinstall the ADF pick-motor assembly

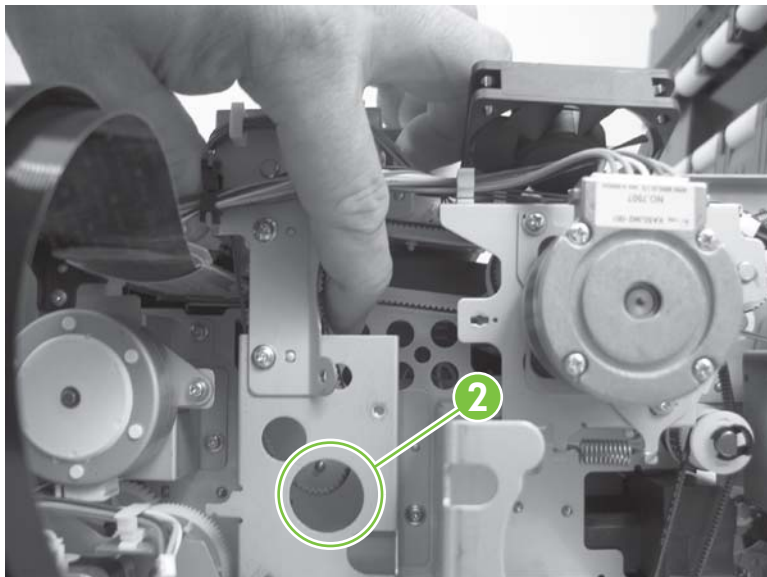
1. Reinstall two screws (callout 1).

**Figure 5-114** Reinstall the ADF pick-motor assembly (1 of 5)




2. Use your finger to push the pick-motor drive belt down so that it loops down and can be seen through the pick-motor mounting hole in the chassis (callout 2).

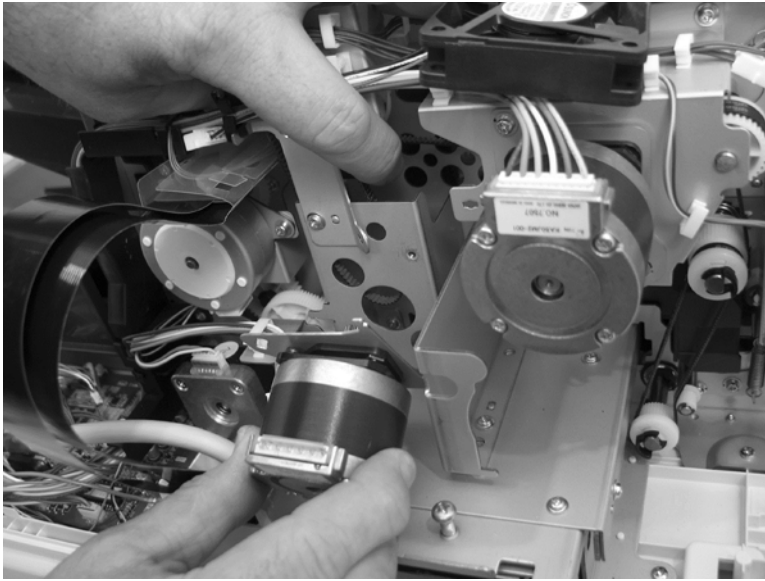
**Figure 5-115** Reinstall the ADF pick-motor assembly (2 of 5)



3. Keep pressure on the belt, and then carefully slide the motor into the mounting hole in the chassis.

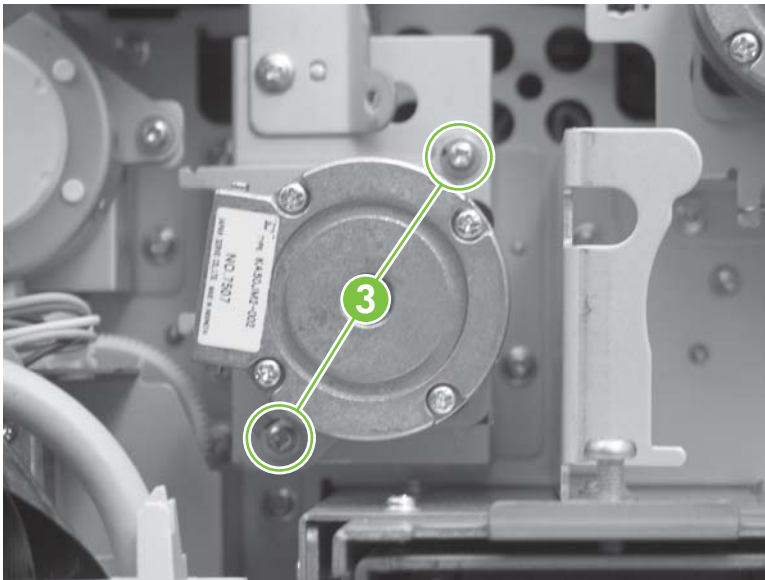
 **NOTE:** Make sure that the motor-drive gear engages the inside of the drive-belt loop.


**Figure 5-116** Reinstall the ADF pick-motor assembly (3 of 5)



4. Install, but *do not* fully tighten, the two motor-mounting screws (callout 3).

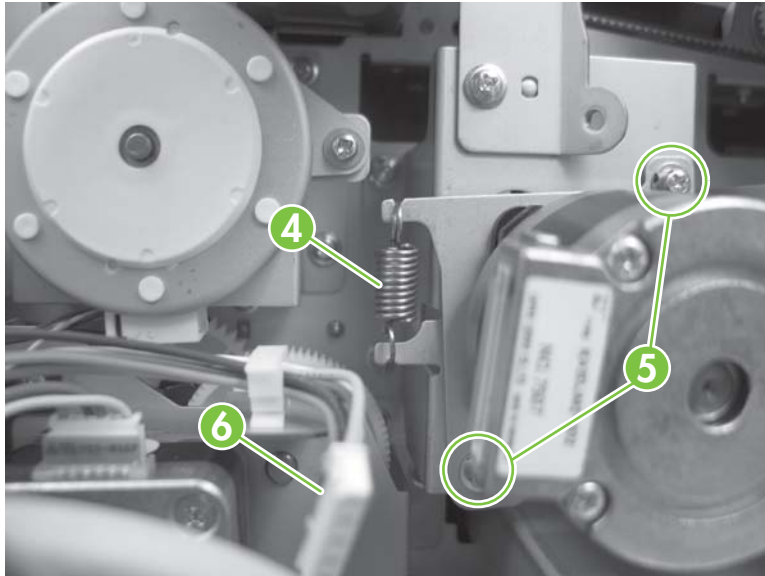
**Figure 5-117** Reinstall the ADF pick-motor assembly (4 of 5)



 **NOTE:** Check the position of the drive belt on the gears.

5. Install the motor-tension spring (callout 4), fully tighten the screws (callout 5), and then connect the connector (callout 6).

**Figure 5-118** Reinstall the ADF pick-motor assembly (5 of 5)



## Upper multi-pick sensor PCA

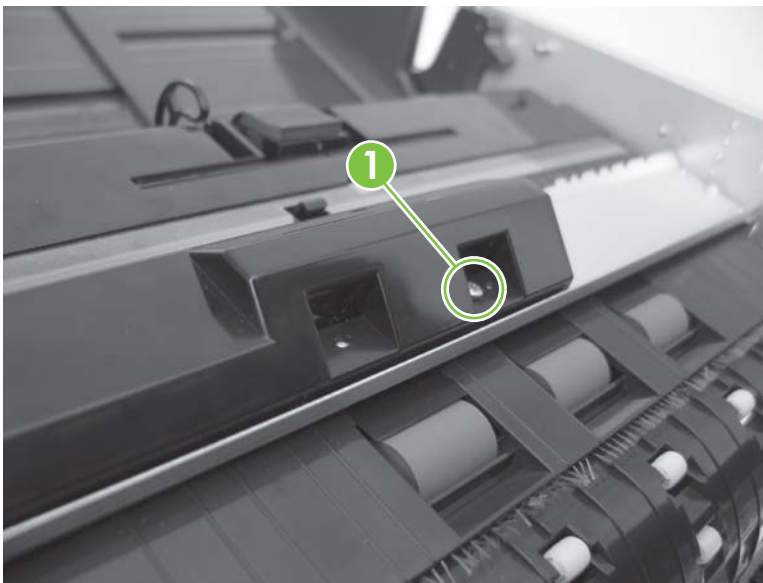
**CAUTION:** Do not bend or fold the flat flexible cables (FFCs) during removal or installation. Also, do not straighten pre-folds in the FFCs. You *must* make sure that all FFCs are fully seated in their connectors. Failure to fully seat an FFC into a connector can cause a short circuit in a PCA.



Some parts are sensitive to electrostatic discharge (ESD). Always perform service work at an ESD-protected workstation or mat. If an ESD workstation or mat is not available, ground yourself by touching the sheet-metal chassis *before* touching an ESD-sensitive part.

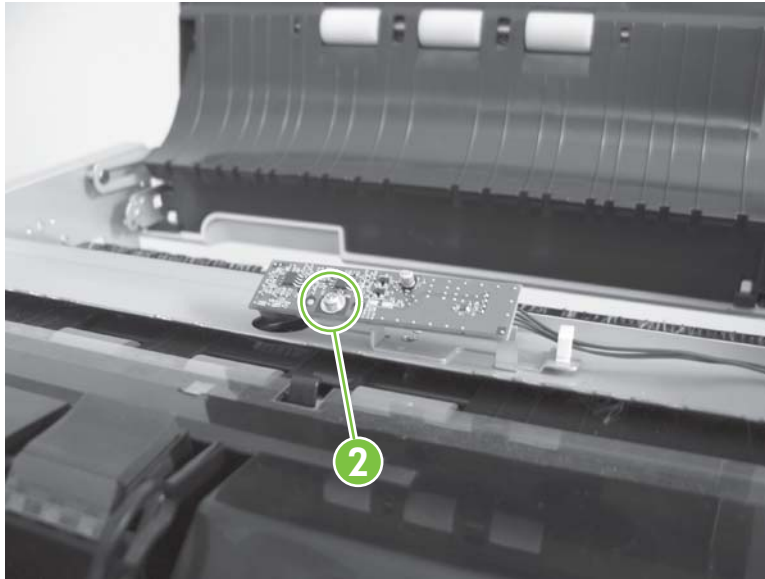
1. Open ADF jam door 1.
2. Remove one screw (callout 1).

**Figure 5-119** Remove the upper multi-pick sensor PCA (1 of 3)



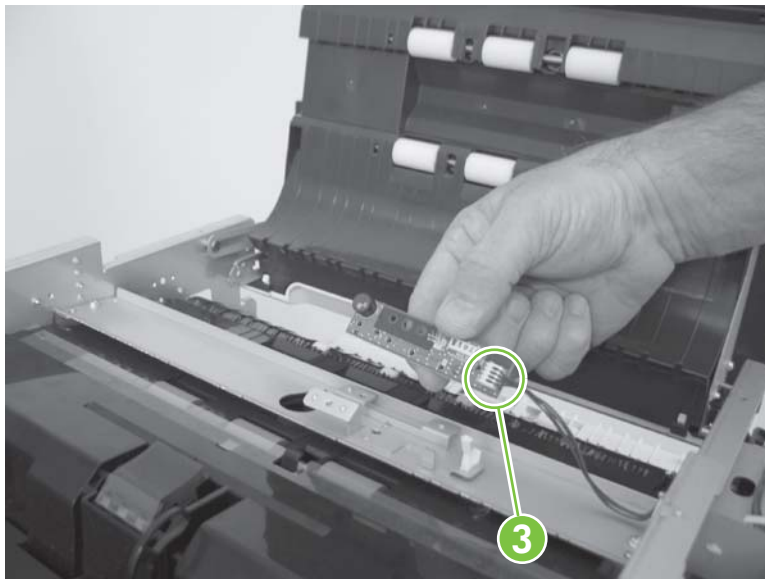
3. Remove one screw (callout 2).

**Figure 5-120** Remove the upper multi-pick sensor PCA (2 of 3)



4. Disconnect one connector (callout 3), and then remove the upper multi-pick sensor PCA.

**Figure 5-121** Remove the upper multi-pick sensor PCA (3 of 3)



## Lower multi-pick sensor PCA

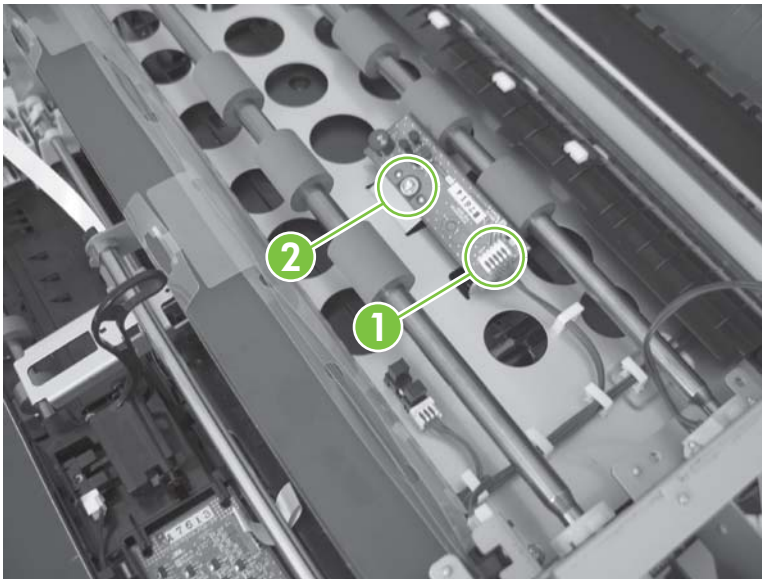
**CAUTION:** Do not bend or fold the flat flexible cables (FFCs) during removal or installation. Also, do not straighten prefolds in the FFCs. You *must* make sure that all FFCs are fully seated in their connectors. Failure to fully seat an FFC into a connector can cause a short circuit in a PCA.



Some parts are sensitive to electrostatic discharge (ESD). Always perform service work at an ESD-protected workstation or mat. If an ESD workstation or mat is not available, ground yourself by touching the sheet-metal chassis *before* touching an ESD-sensitive part.

1. Remove the following components:
  - ADF input-tray assembly. See [ADF input-tray assembly on page 184](#).
  - ADF shingle wall. See [ADF shingle wall on page 197](#).
  - Upper multi-pick sensor PCA. See [Upper multi-pick sensor PCA on page 124](#).
  - Lower multi-pick sensor cover. See [Lower multi-pick sensor cover on page 166](#).
2. Remove one connector (callout 1) and one screw (callout 2).

**Figure 5-122** Remove the lower multi-pick sensor PCA (1 of 2)






3. Remove the lower multi-pick sensor PCA.

**Figure 5-123** Remove the lower multi-pick sensor PCA (2 of 2)



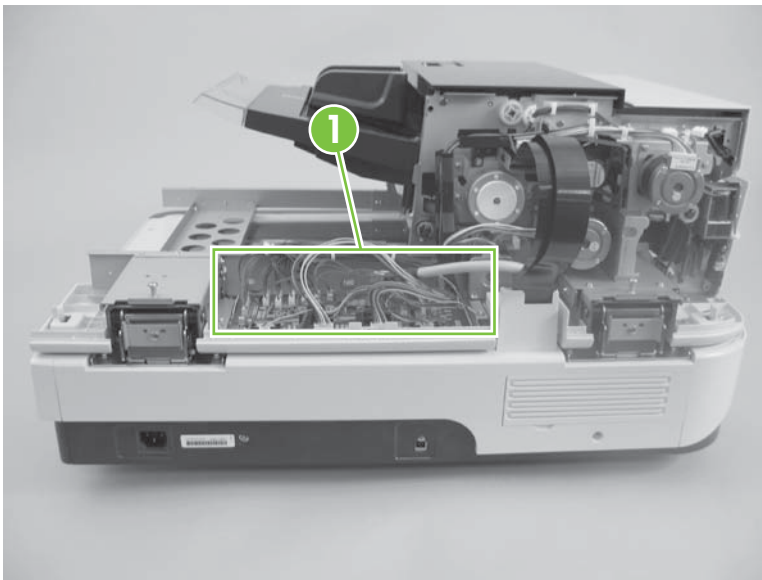
## ADF controller PCA

 **NOTE:** After replacing the ADF controller PCA, update the NVRAM data. See [NVRAM data management on page 75](#).

 **CAUTION:**  Some parts are sensitive to electrostatic discharge (ESD). Always perform service work at an ESD-protected workstation or mat. If an ESD workstation or mat is not available, ground yourself by touching the sheet-metal chassis *before* touching an ESD-sensitive part.


1. Remove the following components:
  - ADF back cover. See [ADF back cover on page 58](#).
  - ADF output tray. See [ADF output tray on page 186](#).
2. Disconnect all of the connectors on the ADF controller PCA (callout 1).

**Figure 5-124** Remove the ADF controller PCA (1 of 2)

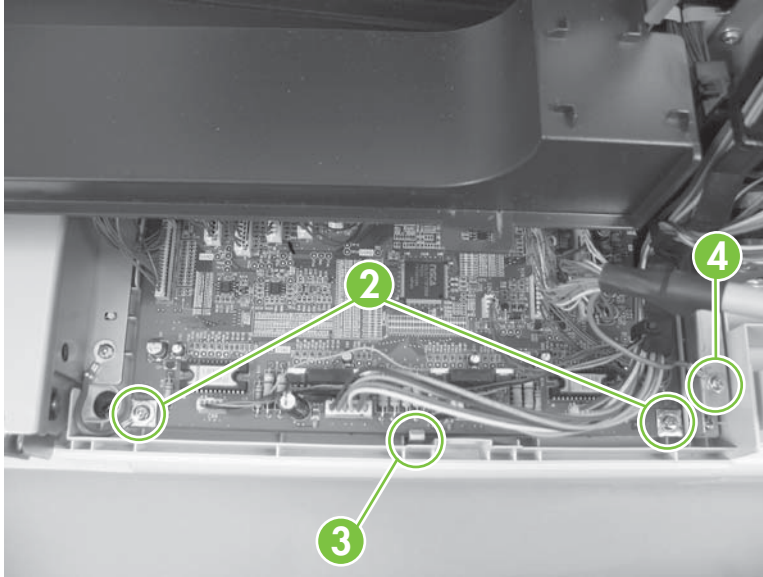




3. Remove two screws (callout 2), release one tab (callout 3), and then remove the ADF controller PCA.

 **NOTE:** You might have to loosen one ground screw (callout 4) to move the ground-wire harness out of the way to remove the ADF controller PCA.

**Figure 5-125** Remove the ADF controller PCA (2 of 2)



4. Update the NVRAM data. See [NVRAM data management on page 75](#).

## Imprinter PCA

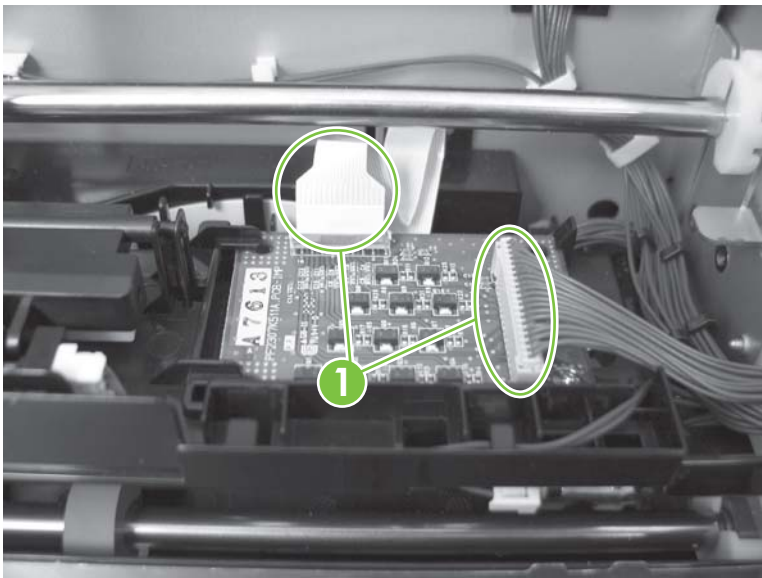
**CAUTION:** Do not bend or fold the flat flexible cables (FFCs) during removal or installation. Also, do not straighten prefolds in the FFCs. You *must* make sure that all FFCs are fully seated in their connectors. Failure to fully seat an FFC into a connector can cause a short circuit in a PCA.

**ESD** Some parts are sensitive to electrostatic discharge (ESD). Always perform service work at an ESD-protected workstation or mat. If an ESD workstation or mat is not available, ground yourself by touching the sheet-metal chassis *before* touching an ESD-sensitive part.

1. Remove the following components:
  - ADF back cover. See [ADF back cover on page 58](#).
  - ADF front cover. See [ADF front cover on page 55](#).
  - ADF input-tray assembly. See [ADF input-tray assembly on page 184](#).
  - ADF shingle wall. See [ADF shingle wall on page 197](#).
2. Remove one FFC and one connector (callout 1).

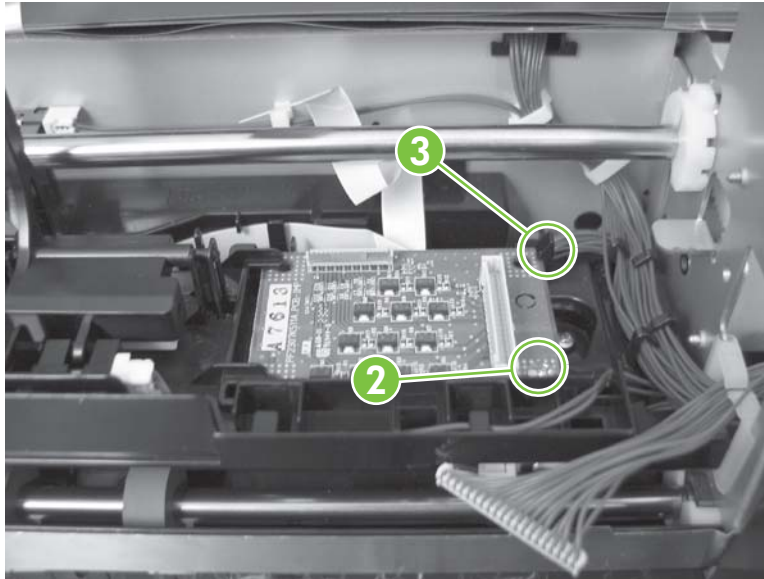
**NOTE:** To remove the FFC, move the connector lever to the up position.

**Figure 5-126** Remove the imprinter PCA (1 of 2)



3. Remove one screw (callout 2) and one tab (callout 3).

**Figure 5-127** Remove the imprinter PCA (2 of 2)

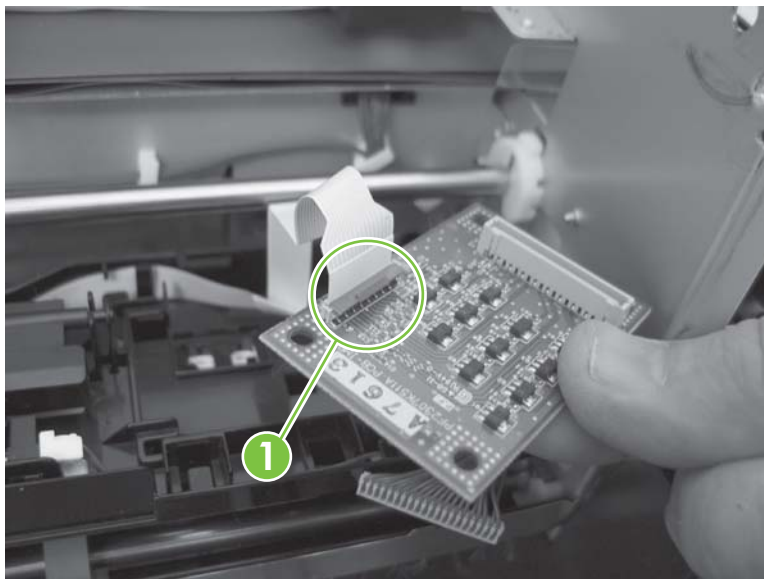


4. Remove the imprinter PCA.

## Reinstall the imprinter PCA

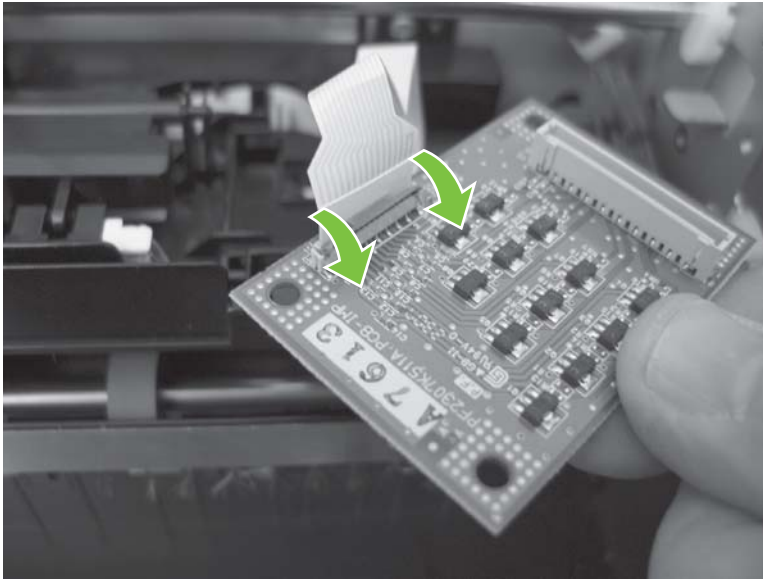
1. Insert the FFC into the connector (callout 1).

**Figure 5-128** Reinstall the imprinter PCA (1 of 4)



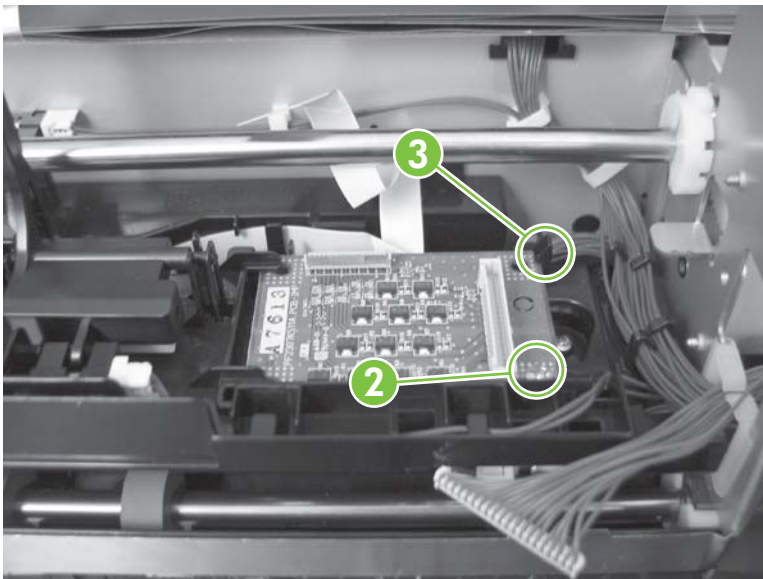
2. Move the connector lever to the down position.

**Figure 5-129** Reinstall the imprinter PCA (2 of 4)



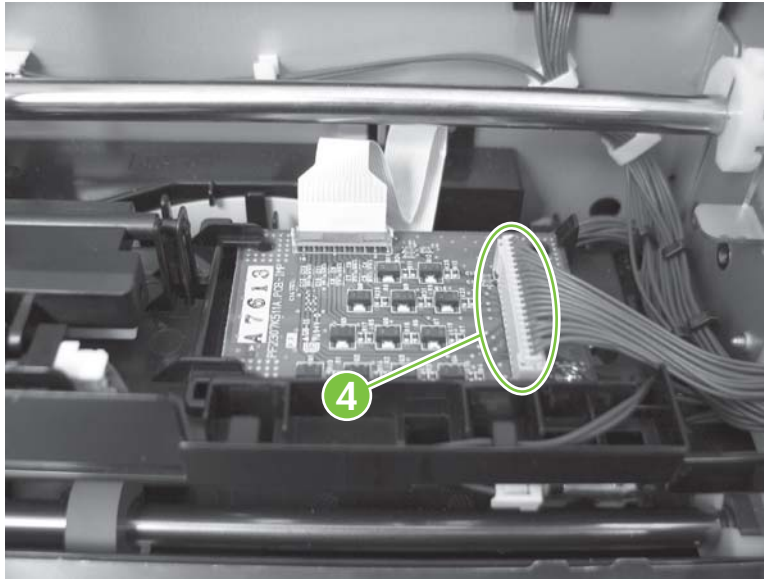
3. Reinstall one screw (callout 2) and one tab (callout 3).

**Figure 5-130** Reinstall the imprinter PCA (3 of 4)



4. Reconnect one connector (callout 4).

**Figure 5-131** Reinstall the imprinter PCA (4 of 4)

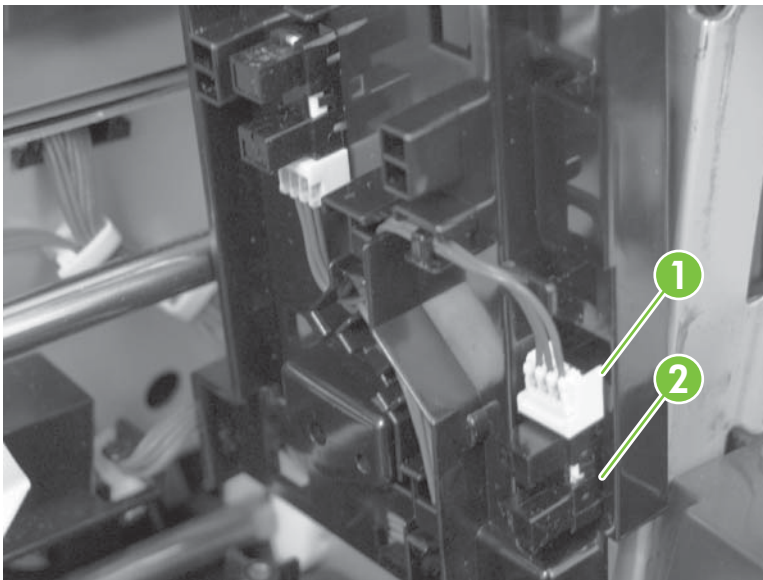


5. Reinstall the following components:
  - ADF shingle wall. See [ADF shingle wall on page 197](#).
  - ADF input-tray assembly. See [ADF input-tray assembly on page 184](#).
  - ADF back cover. See [ADF back cover on page 58](#).
  - ADF front cover. See [ADF front cover on page 55](#).

## Input-tray sensor

1. Remove the following components:
  - ADF front cover. See [ADF front cover on page 55](#).
  - ADF back cover. See [ADF back cover on page 58](#).
  - ADF input-tray assembly. See [ADF input-tray assembly on page 184](#).
  - ADF shingle wall. See [ADF shingle wall on page 197](#).
  - Paper present sensor and imprinter PCA holder. See [Paper present sensor and imprinter PCA holder on page 195](#).
2. Remove one connector (callout 1), and then remove the input-tray sensor (callout 2).

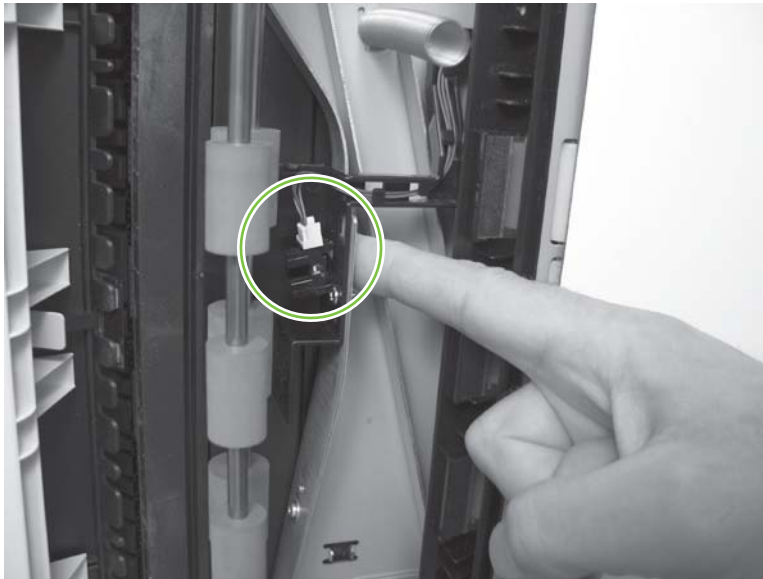
**Figure 5-132** Remove the input-tray sensor



## Flatbed scan position sensor

1. Remove the following components:
  - ADF front cover. See [ADF front cover on page 55](#).
  - ADF bottom corner, outer paper path guide. See [ADF bottom corner outer paper path guide on page 152](#).
  - ADF bottom corner, inner paper path guide. See [ADF bottom corner inner paper path guide on page 154](#).
  - ADF cal-strip assembly. See [ADF cal-strip assembly on page 155](#).
2. Remove one tab.

**Figure 5-133** Remove the flatbed scan position sensor (1 of 2)



3. Remove the flatbed scan position sensor.

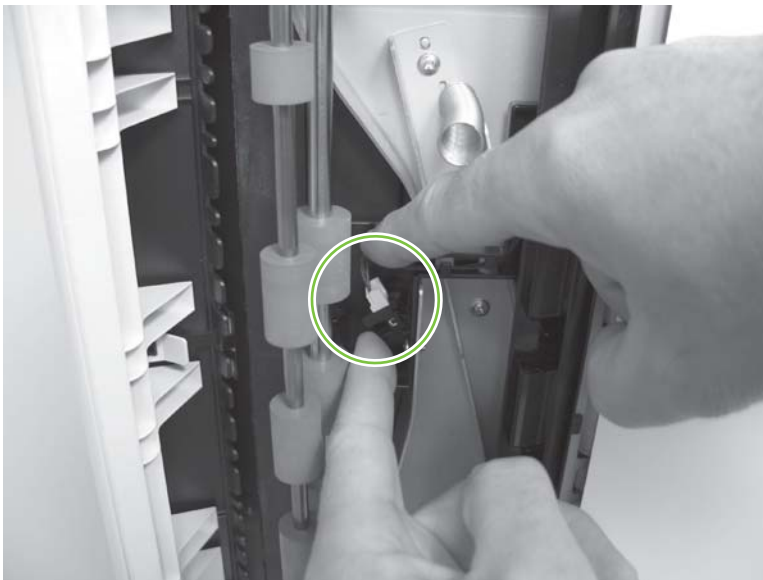
**Figure 5-134** Remove the flatbed scan position sensor (2 of 2)



## Reinstall the flatbed scan position sensor

1. Reinstall one connector, and then reinstall the flatbed scan position sensor.

**Figure 5-135** Reinstall the flatbed scan position sensor



2. Reinstall the following components:
  - ADF cal-strip assembly. See [ADF cal-strip assembly on page 155](#).
  - ADF bottom corner, inner paper path guide. See [ADF bottom corner inner paper path guide on page 154](#).



- ADF bottom corner, outer paper path guide. See [ADF bottom corner outer paper path guide on page 152](#).
- ADF front cover. See [ADF front cover on page 55](#).

## Exit 1 sensor

**1.** Remove the following components:

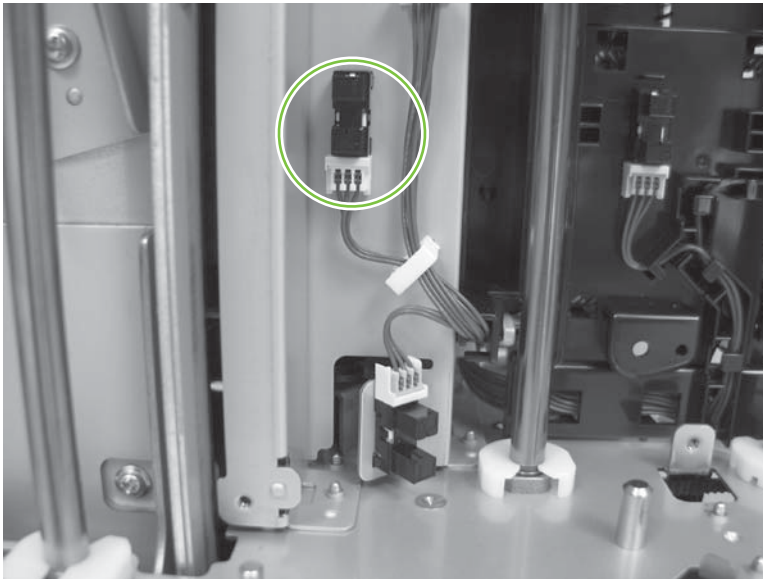
- ADF front cover. See [ADF front cover on page 55](#).
- ADF back cover. See [Scanner back cover on page 60](#).

**⚠ WARNING!** Place the back of the product against a wall after removing the scanner back cover. The ADF hinge springs could actuate and cause the product to flip over backward.

- ADF input-tray assembly. See [ADF input-tray assembly on page 184](#).
- ADF output tray. See [ADF output tray on page 186](#).
- ADF shingle wall. See [ADF shingle wall on page 197](#).
- ADF bottom corner, outer paper path guide. See [ADF bottom corner outer paper path guide on page 152](#).
- ADF bottom corner, inner paper path guide. See [ADF bottom corner inner paper path guide on page 154](#).
- ADF cal-strip assembly. See [ADF cal-strip assembly on page 155](#).
- ADF exit inner paper path guide. See [ADF exit inner paper path guide on page 162](#).

**2.** Remove one connector, and then remove the exit 1 sensor.

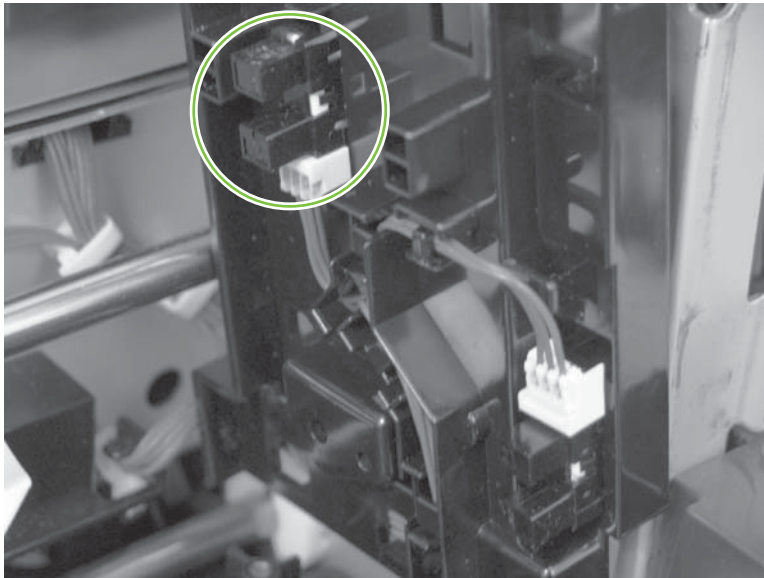
**Figure 5-136** Remove the exit 1 sensor



## Exit 2 sensor

1. Remove the following components:
  - ADF front cover. See [ADF front cover on page 55](#).
  - ADF back cover. See [ADF back cover on page 58](#).
  - ADF input-tray assembly. See [ADF input-tray assembly on page 184](#).
  - ADF shingle wall. See [ADF shingle wall on page 197](#).
  - Paper present sensor and imprinter PCA holder. See [Paper present sensor and imprinter PCA holder on page 195](#).
2. Remove one connector, and then remove the exit 2 sensor.

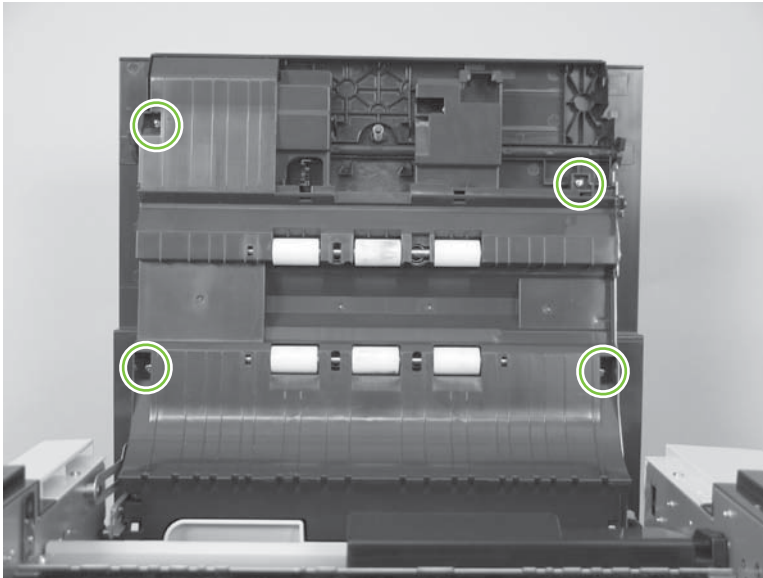
**Figure 5-137** Remove the exit 2 sensor



## Pick-up roller sensor

1. Remove the following components:
  - Pickup-roller cover. See [Pickup-roller cover on page 190](#).
  - Pickup-roller assembly. See [Pickup-roller assembly on page 47](#).
2. Remove four screws.

**Figure 5-138** Remove the pick-up roller sensor (1 of 4)



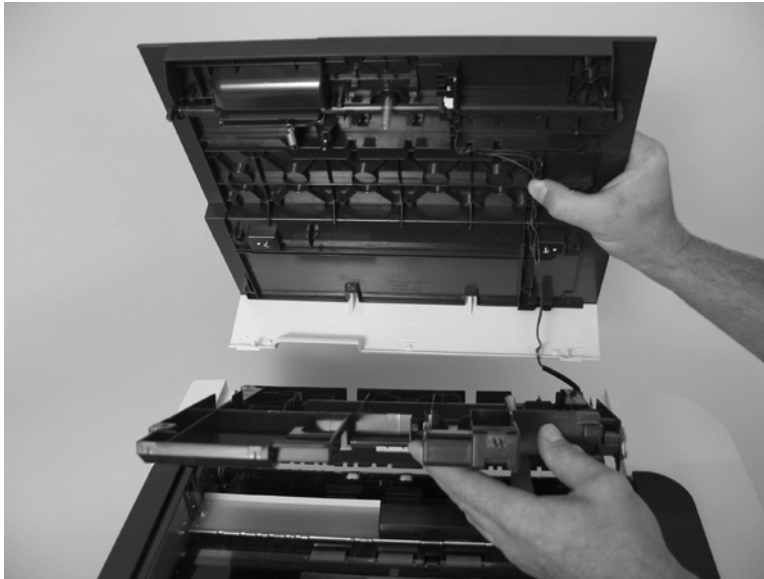
3. Rotate the roller assembly away from the jam door 1 cover.

**Figure 5-139** Remove the pick-up roller sensor (2 of 4)



4. Separate the roller assembly from the jam door 1 cover.

**Figure 5-140** Remove the pick-up roller sensor (3 of 4)



5. Remove the pick-up roller sensor.

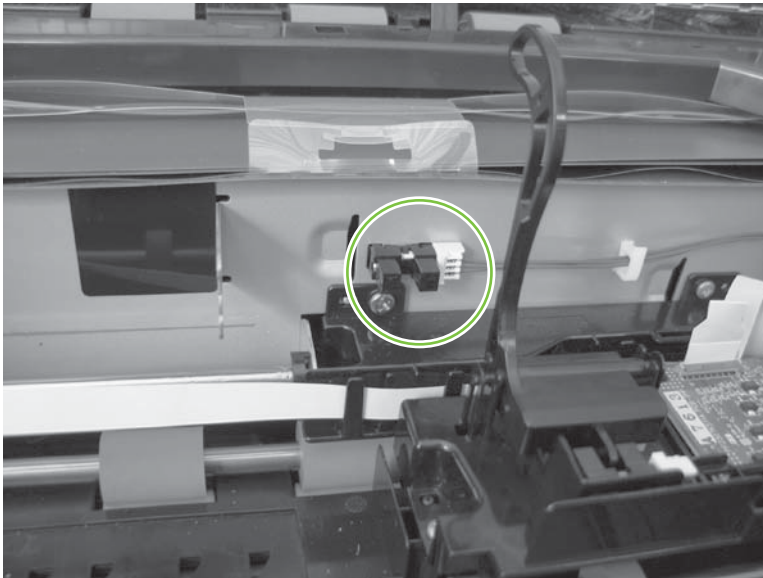
**Figure 5-141** Remove the pick-up roller sensor (4 of 4)



## Elevator arm sensor

1. Remove the following components:
  - ADF front cover. See [ADF front cover on page 55](#).
  - ADF back cover. [ADF back cover on page 58](#).
  - ADF shingle wall. See [ADF shingle wall on page 197](#).
  - ADF input-tray lift-motor assembly. See [ADF input-tray lift-motor assembly on page 105](#).
  - Input-tray-elevator arm. See [Input-tray-elevator arm on page 176](#).
2. Remove one connector, and then remove the elevator arm sensor.

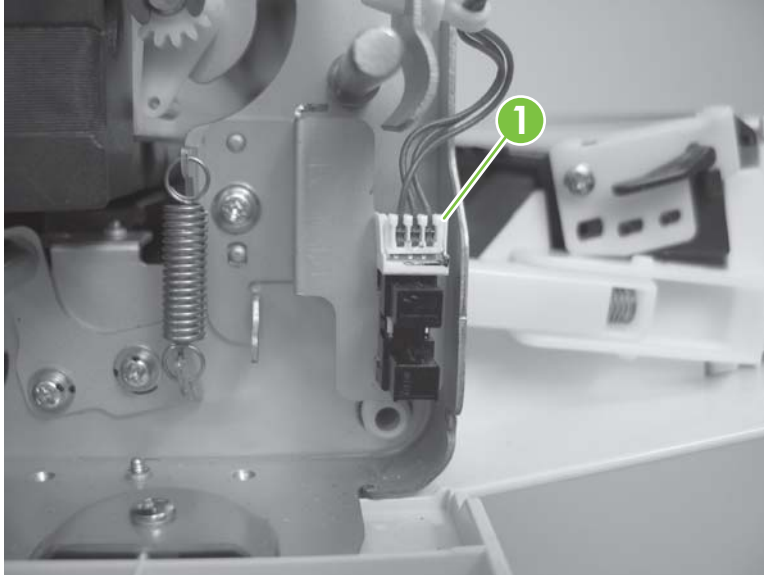
**Figure 5-142** Remove the elevator arm sensor



## Background solenoid sensor

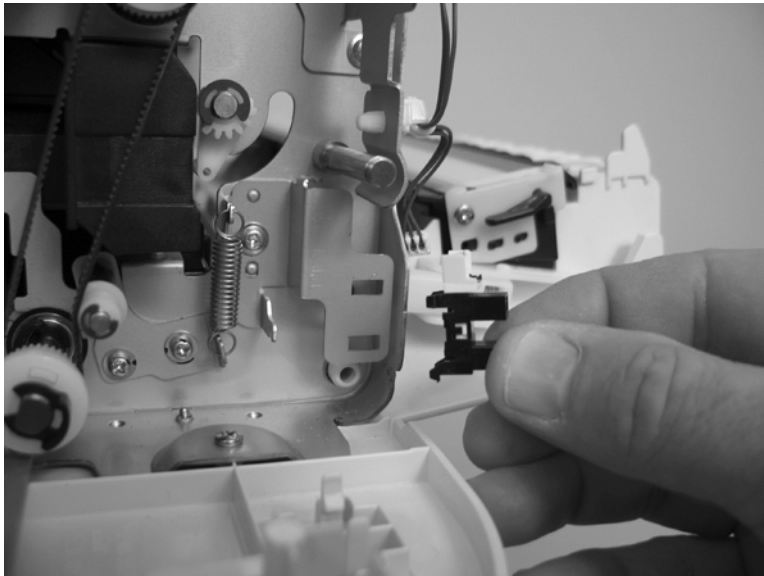
1. Remove the ADF back cover. See [ADF back cover on page 58](#).
2. Disconnect one connector (callout 1).

**Figure 5-143** Remove the background solenoid sensor (1 of 2)



3. Remove the background solenoid sensor.

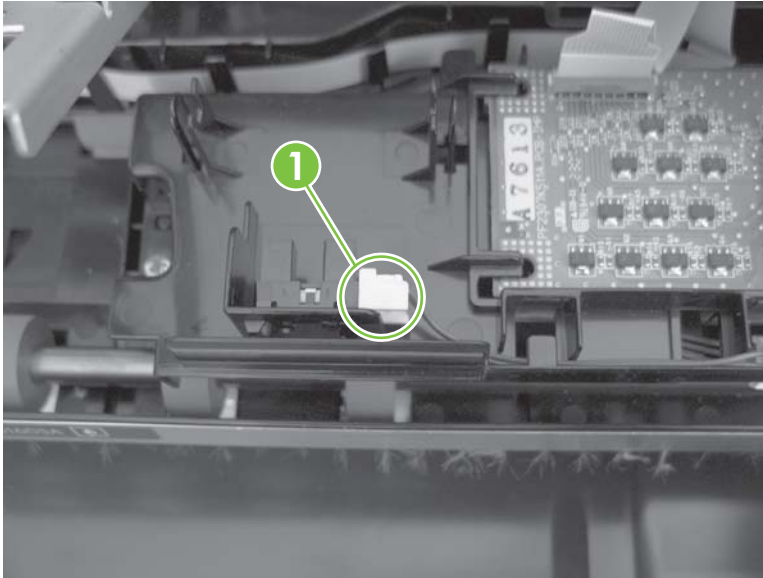
**Figure 5-144** Remove the background solenoid sensor (2 of 2)



## Paper-present sensor

1. Remove the following components:
  - ADF front cover. See [ADF front cover on page 55](#).
  - ADF back cover. See [ADF back cover on page 58](#).
  - Paper-present-sensor arm. See [Paper-present-sensor arm on page 175](#).
2. Remove one connector (callout 1), and then remove the paper-present sensor.

**Figure 5-145** Remove the paper-present sensor



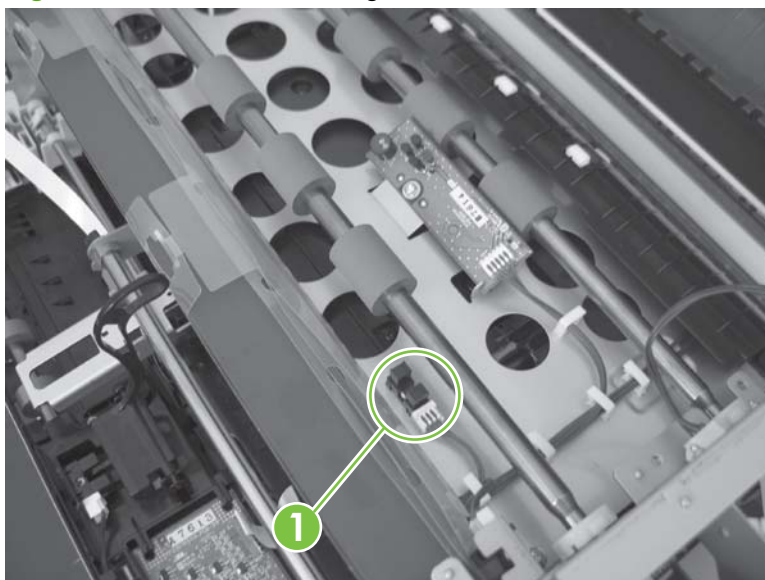
3. Remove the paper-present sensor.



## Registration sensor

1. Remove the following components:
  - ADF front cover. See [ADF front cover on page 55](#).
  - ADF back cover. See [ADF back cover on page 58](#).
  - ADF input-tray assembly. See [ADF input-tray assembly on page 184](#).
  - ADF shingle wall. See [ADF shingle wall on page 197](#).
  - Upper multi-pick sensor PCA. See [Upper multi-pick sensor PCA on page 124](#).
  - Lower multi-pick sensor cover. See [Lower multi-pick sensor cover on page 166](#).
2. Remove one connector (callout 1), and then remove the registration sensor.

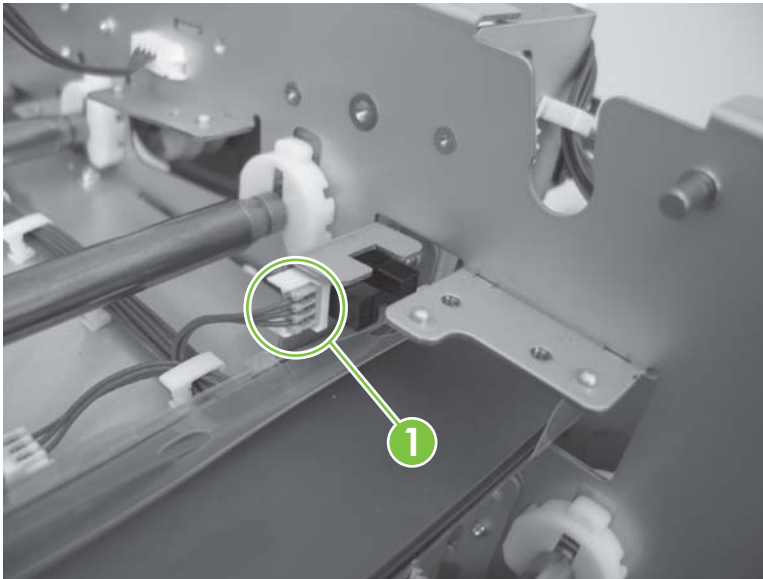
**Figure 5-146** Remove the registration sensor



## Jam door 1 sensor

1. Remove the following components:
  - ADF front cover. See [ADF front cover on page 55](#).
  - ADF back cover. See [ADF back cover on page 58](#).
  - ADF input-tray assembly. See [ADF input-tray assembly on page 184](#).
  - ADF shingle wall. See [ADF shingle wall on page 197](#).
  - Upper multi-pick sensor PCA. See [Upper multi-pick sensor PCA on page 124](#).
  - Lower multi-pick sensor cover. See [Lower multi-pick sensor cover on page 166](#).
2. Remove one connector (callout 1), and then remove the jam door 1 sensor.

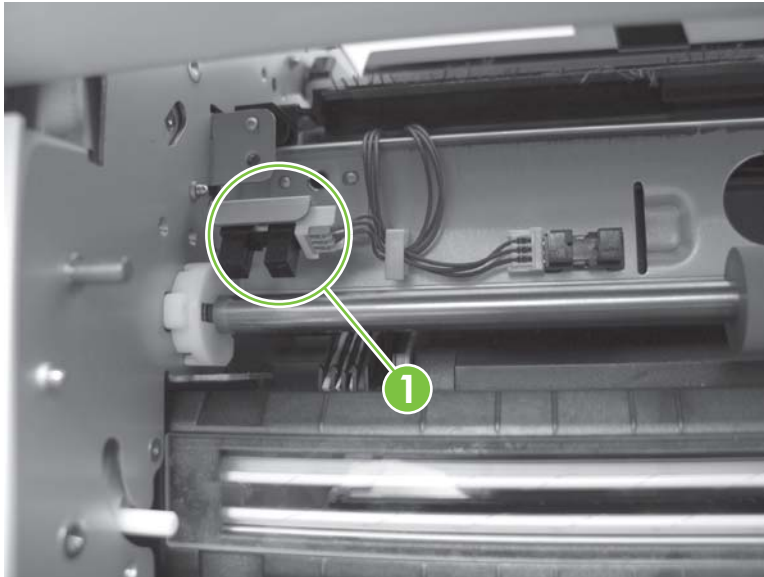
**Figure 5-147** Remove the jam door 1 sensor



## Jam door 2 sensor

1. Remove the ADF top corner inner paper path guide. See [ADF top corner inner paper path guide on page 165](#).
2. Open ADF jam door 1 and ADF jam door 2.
3. Remove one connector (callout 1), and then remove the jam door 2 sensor.

**Figure 5-148** Remove jam door 2 sensor



## Jam door 3 sensor

1. Remove the following components:

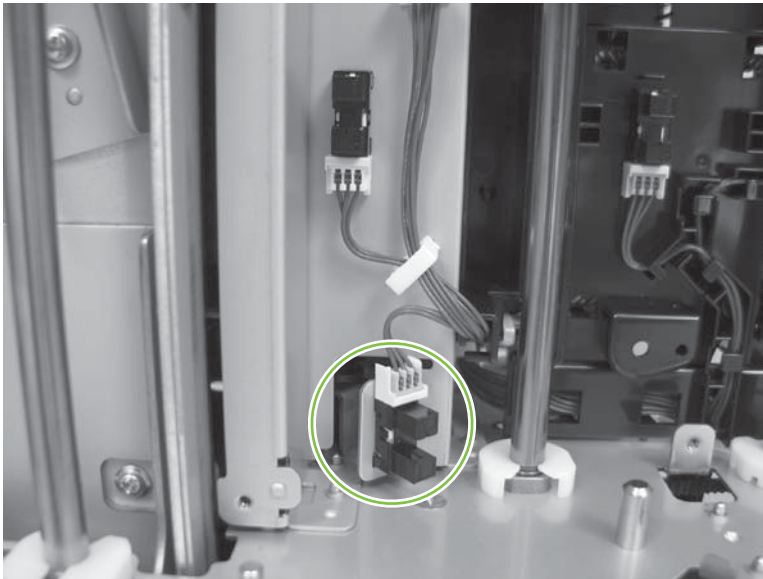
- ADF front cover. See [ADF front cover on page 55](#).
- ADF back cover. See [Scanner back cover on page 60](#).

**⚠ WARNING!** Place the back of the product against a wall after removing the scanner back cover. The ADF hinge springs could actuate and cause the product to flip over backward.

- ADF input-tray assembly. See [ADF input-tray assembly on page 184](#).
- ADF output tray. See [ADF output tray on page 186](#).
- ADF shingle wall. See [ADF shingle wall on page 197](#).
- ADF bottom corner, outer paper path guide. See [ADF bottom corner outer paper path guide on page 152](#).
- ADF bottom corner, inner paper path guide. See [ADF bottom corner inner paper path guide on page 154](#).
- ADF cal-strip assembly. See [ADF cal-strip assembly on page 155](#).
- ADF exit inner paper path guide. See [ADF exit inner paper path guide on page 162](#).

2. Remove one connector, and then remove the jam door 3 sensor.

**Figure 5-149** Remove the jam door 3 sensor



## Imprinter paper-present sensor

1. Remove the following components:

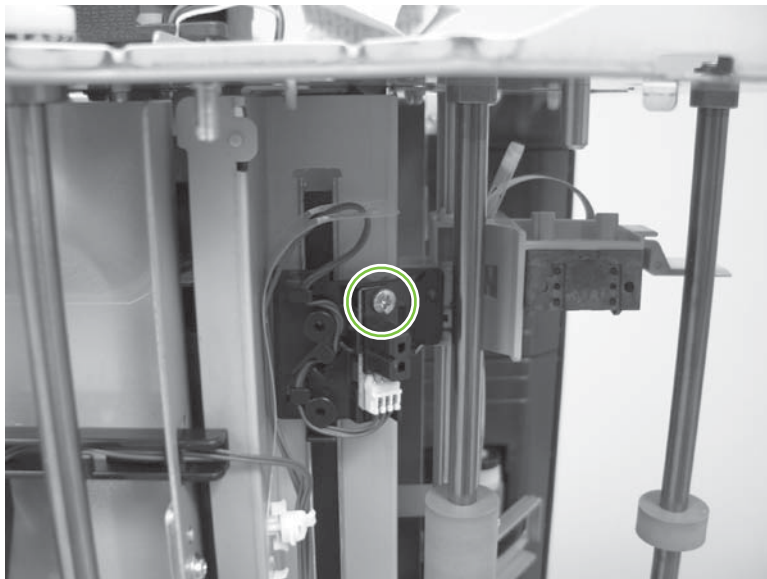
- ADF front cover. See [ADF front cover on page 55](#).
- ADF back cover. See [Scanner back cover on page 60](#).

**⚠ WARNING!** Place the back of the product against a wall after removing the scanner back cover. The ADF hinge springs could actuate and cause the product to flip over backward.

- ADF input-tray assembly. See [ADF input-tray assembly on page 184](#).
- ADF output tray. See [ADF output tray on page 186](#).
- ADF shingle wall. See [ADF shingle wall on page 197](#).
- ADF bottom corner, outer paper path guide. See [ADF bottom corner outer paper path guide on page 152](#).
- ADF bottom corner, inner paper path guide. See [ADF bottom corner inner paper path guide on page 154](#).
- ADF cal-strip assembly. See [ADF cal-strip assembly on page 155](#).
- ADF exit inner paper path guide. See [ADF exit inner paper path guide on page 162](#).

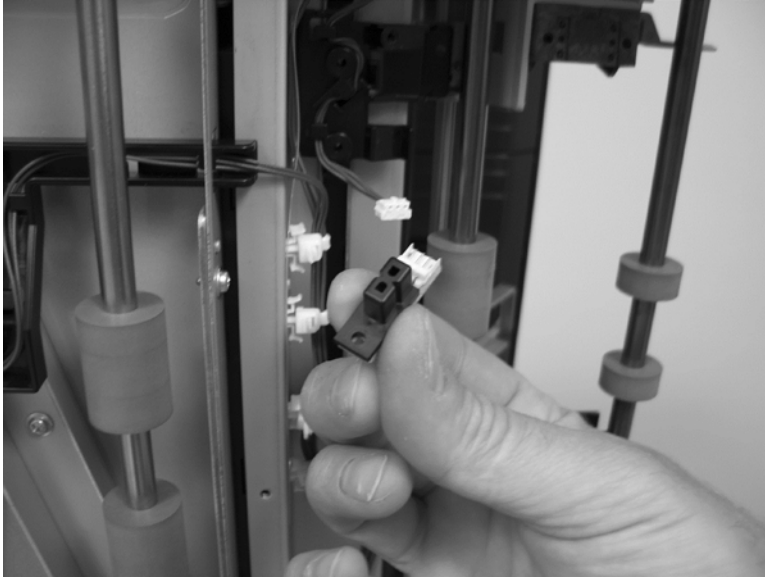
2. Remove one screw.

**Figure 5-150** Remove the imprinter paper-present sensor (1 of 2)



3. Remove the imprinter paper-present sensor.

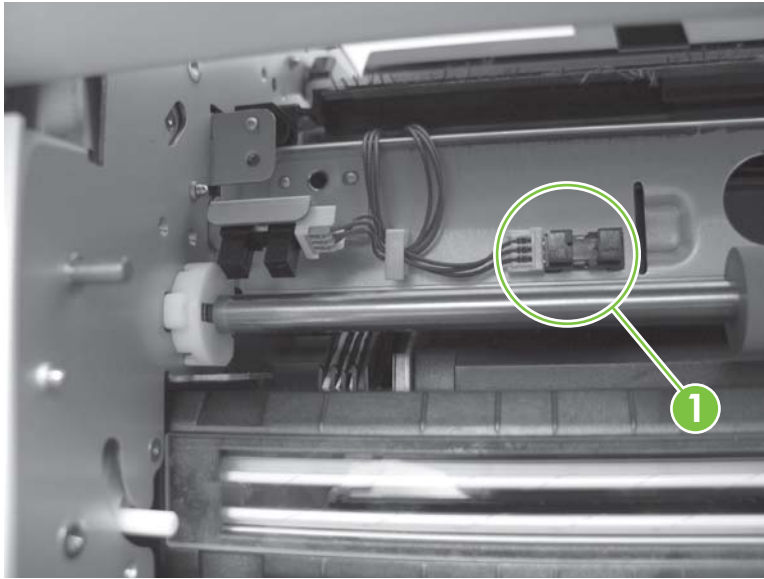
**Figure 5-151** Remove the imprinter paper-present sensor (2 of 2)



## ADF scan position sensor

1. Remove the ADF top corner inner paper path guide. See [ADF top corner inner paper path guide on page 165](#).
2. Open ADF jam door 1 and ADF jam door 2.
3. Remove one connector (callout 1), and then remove the ADF scan position sensor.

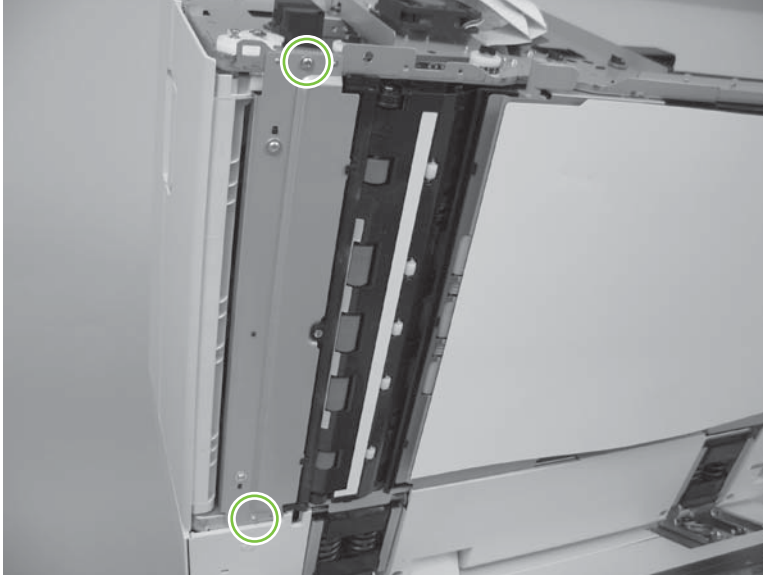
**Figure 5-152** Remove the ADF scan position sensor



## ADF bottom corner outer paper path guide

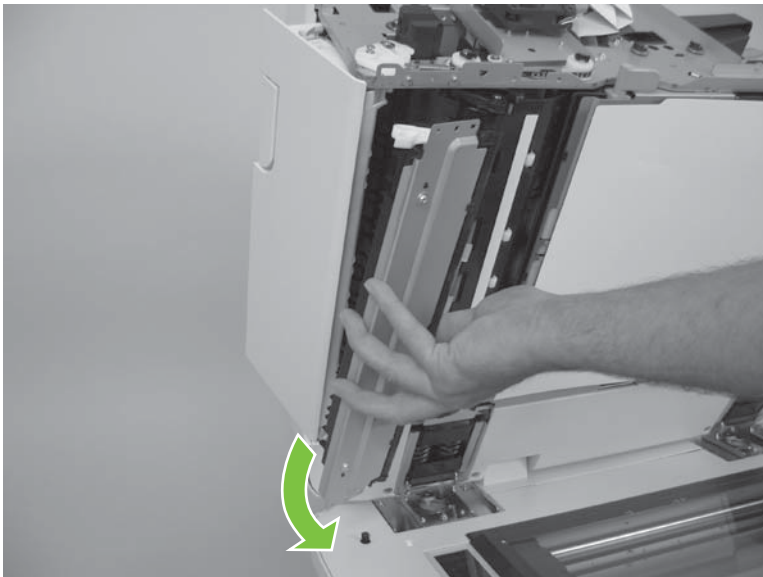
1. Remove the ADF front cover. See [ADF front cover on page 55](#).
2. Remove two screws.


**Figure 5-153** Remove the ADF bottom corner outer paper path guide (1 of 2)



3. Rotate the back end away from the ADF, and then remove the ADF bottom corner, outer paper path guide .

**Figure 5-154** Remove the ADF bottom corner outer paper path guide (2 of 2)



 **NOTE:** When reinstalling the ADF bottom corner, outer paper path guide, slide the lever into the slot, rotate the back end toward the ADF until it is in position, and then reinstall two screws.



**Figure 5-155** Reinstall the ADF bottom corner outer paper path guide



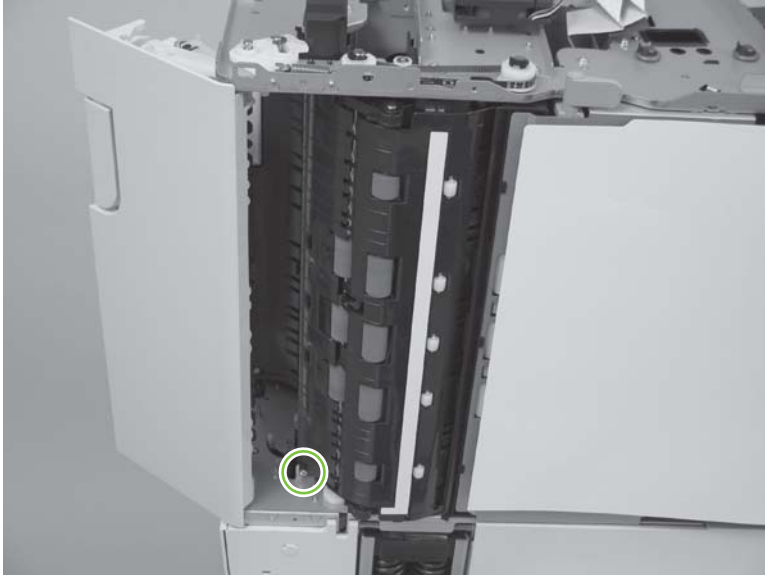
## ADF bottom corner inner paper path guide

1. Remove the following components:

- ADF front cover. See [ADF front cover on page 55](#).
- ADF bottom corner, outer paper path guide. See [ADF bottom corner outer paper path guide on page 152](#).

2. Remove one screw.

**Figure 5-156** Remove the ADF bottom corner inner paper path guide (1 of 2)



3. Remove the ADF bottom corner, inner paper path guide.

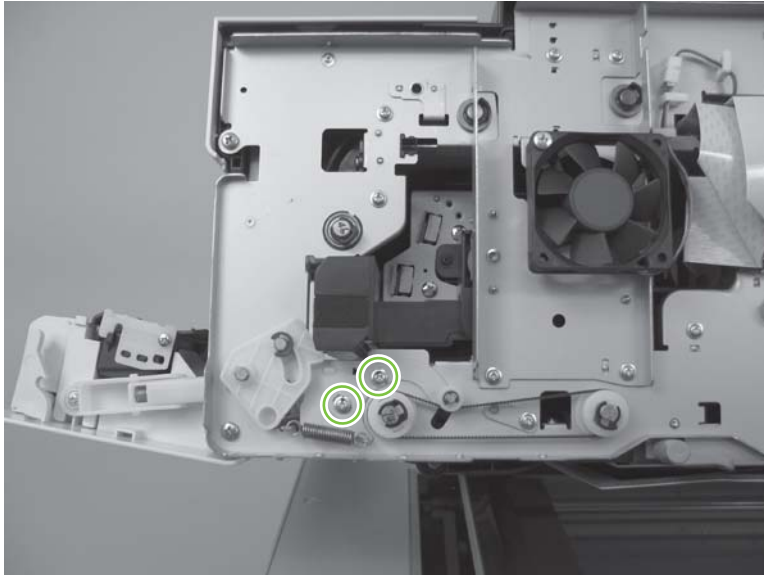
**Figure 5-157** Remove the ADF bottom corner inner paper path guide (2 of 2)



## ADF cal-strip assembly

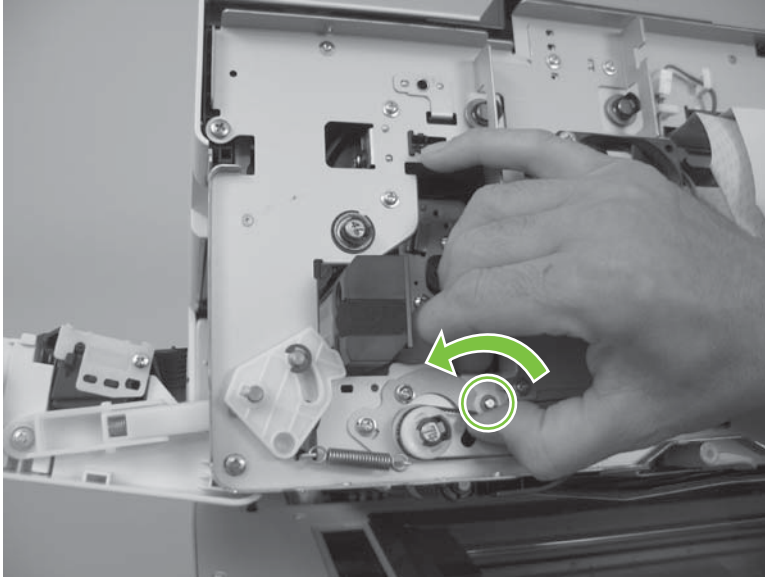
1. Remove the following components:
  - ADF front cover. See [ADF front cover on page 55](#).
  - ADF bottom corner, outer paper path guide. See [ADF bottom corner outer paper path guide on page 152](#).
  - ADF bottom corner, inner paper path guide. See [ADF bottom corner inner paper path guide on page 154](#).
2. Loosen, *but do not remove*, two screws.

**Figure 5-158** Remove the ADF cal-strip assembly (1 of 5)



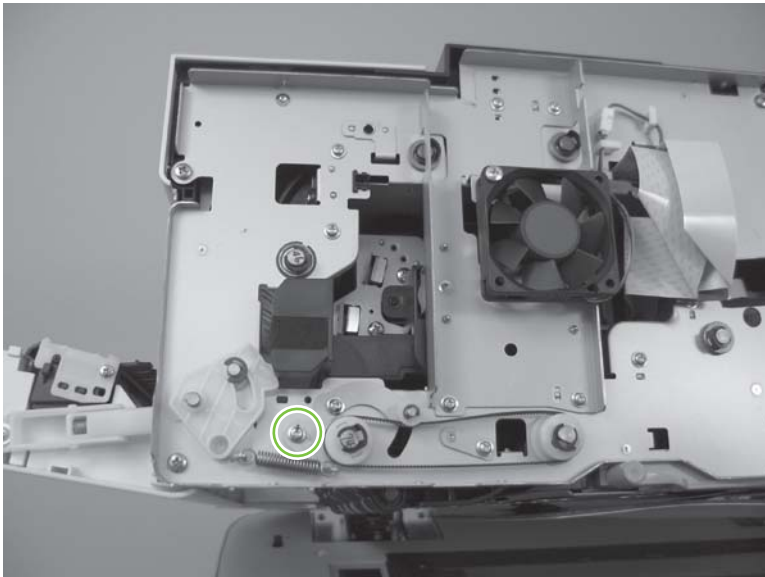
3. Rotate the belt tensioner and hold it in place.


**Figure 5-159** Remove the ADF cal-strip assembly (2 of 5)



4. Tighten one screw, and then release the belt tensioner.

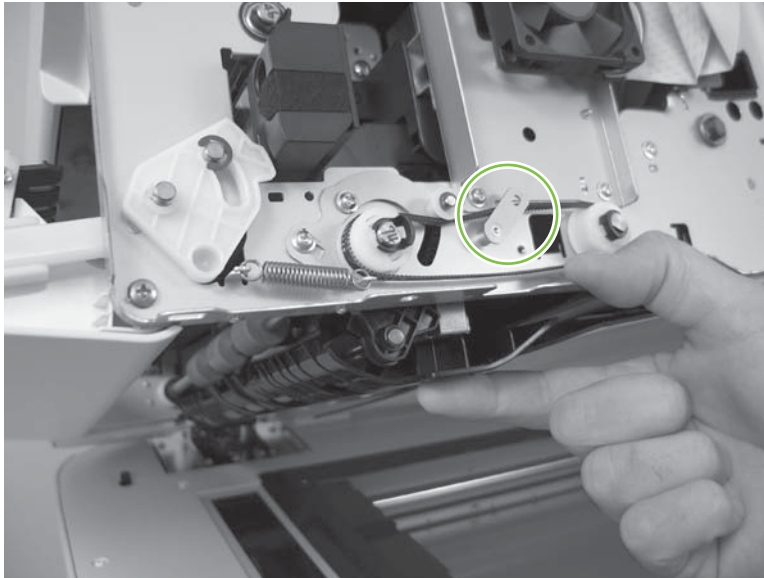
**Figure 5-160** Remove the ADF cal-strip assembly (3 of 5)



 **NOTE:** After tightening the screw and releasing the belt tensioner, the belt should be loose. If tension remains, repeat this step.

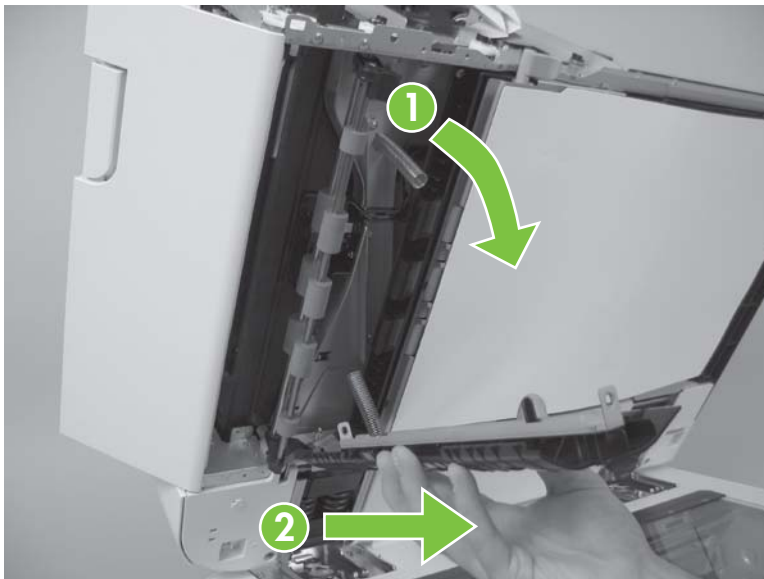
5. Hold the ADF cal-strip assembly in place, remove one screw, and then slide the cal-strip pin outward *but do not remove it*.

**Figure 5-161** Remove the ADF cal-strip assembly (4 of 5)



6. Rotate the front of the cal-strip assembly away from the ADF (callout 1), and then remove the cal-strip assembly (callout 2).

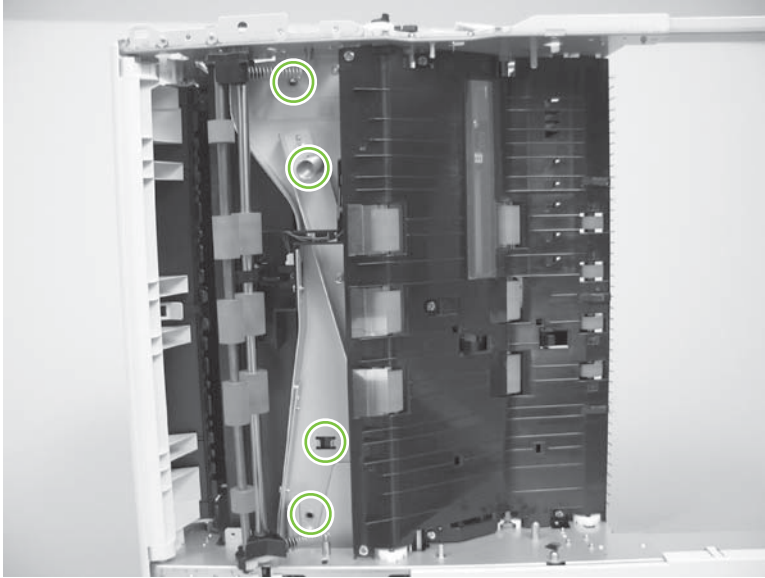
**Figure 5-162** Remove the ADF cal-strip assembly (5 of 5)



## Reinstall the cal-strip assembly

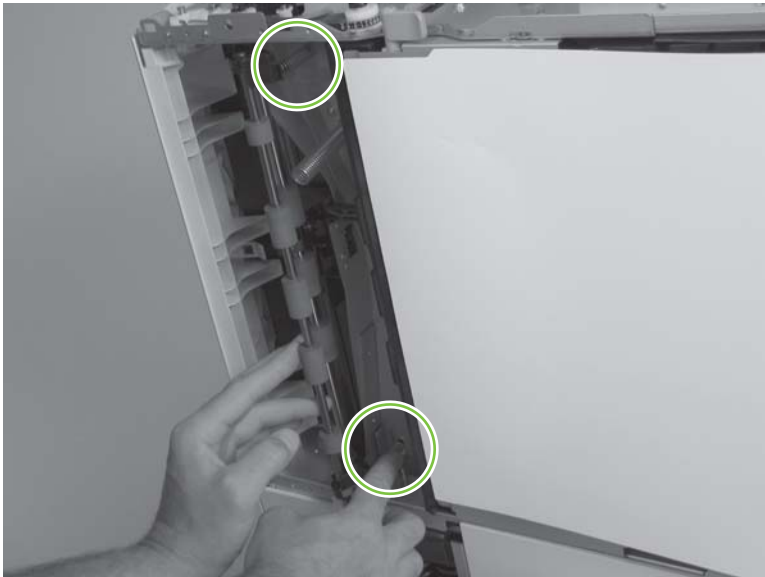
1. Locate the four spring mounting positions on the ADF.

**Figure 5-163** Reinstall the ADF cal-strip assembly (1 of 7)



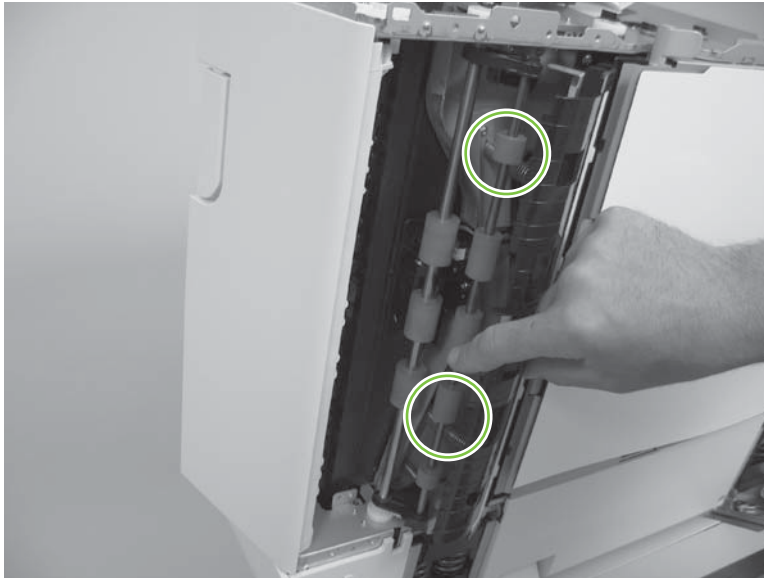
2. Rotate the roller shaft toward the ADF, place two small springs in position, and then hold the roller shaft in place.

**Figure 5-164** Reinstall the ADF cal-strip assembly (2 of 7)



3. Slide the cal-strip assembly in position, place two large springs in position, and then hold the cal-strip assembly in place.

**Figure 5-165** Reinstall the ADF cal-strip assembly (3 of 7)



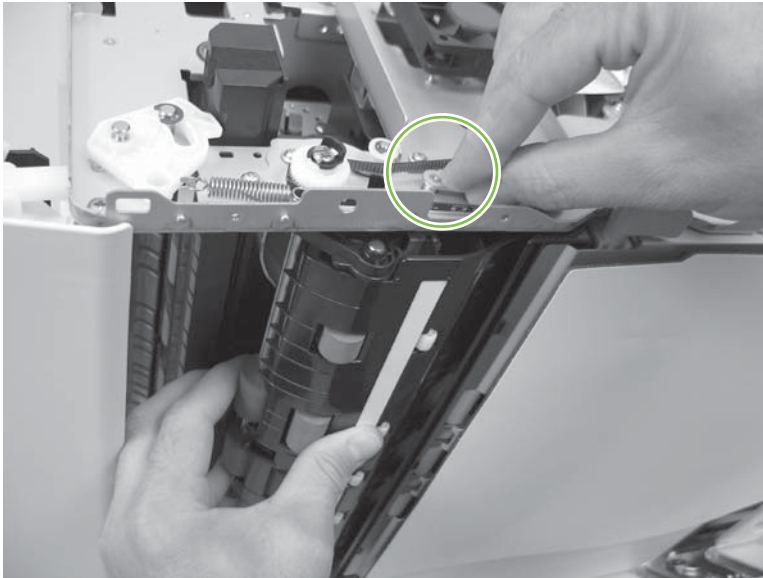
4. Rotate five rollers into five holes, and hold the cal-strip assembly in place.


**Figure 5-166** Reinstall the ADF cal-strip assembly (4 of 7)



5. Hold the cal-strip assembly in place, push the cal-strip pin into position, and then reinstall one screw.

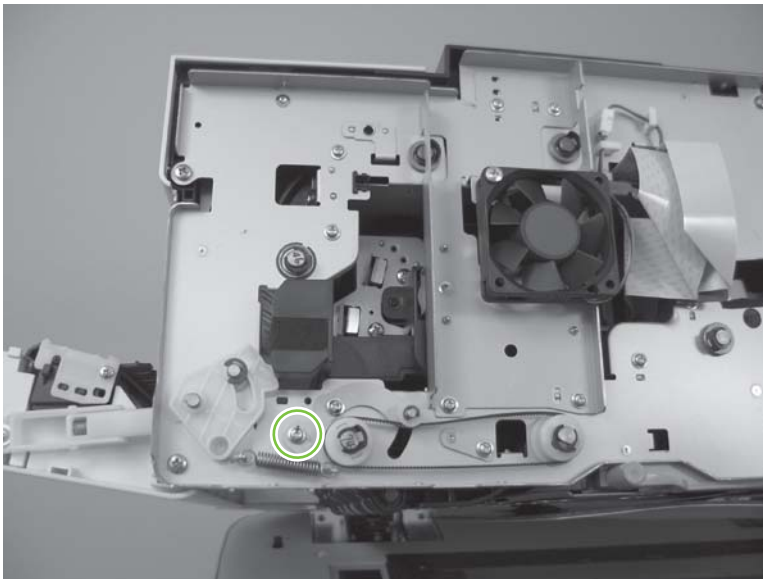
**Figure 5-167** Reinstall the ADF cal-strip assembly (5 of 7)



 **NOTE:** Check that all four springs are positioned correctly.

6. Loosen, *but do not remove*, one screw to allow the belt tensioner to spring back into place.

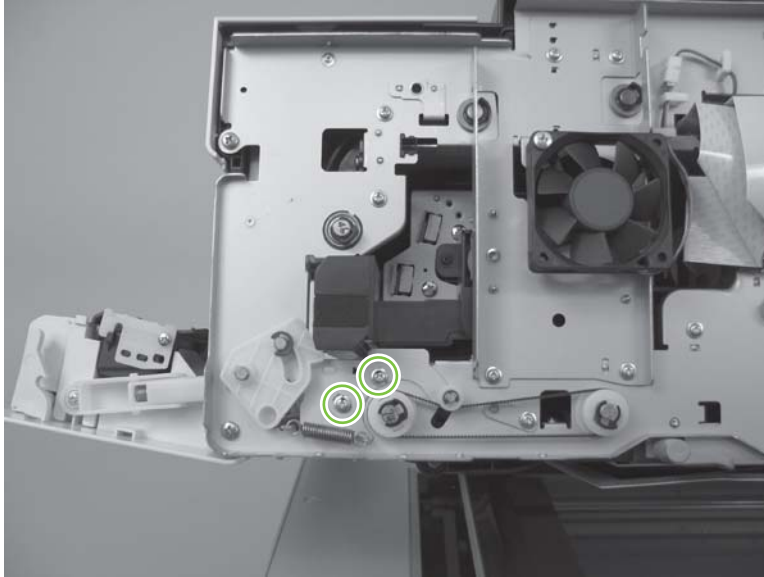
**Figure 5-168** Reinstall the ADF cal-strip assembly (6 of 7)





7. Reinstall and tighten two screws.

**Figure 5-169** Reinstall the ADF cal-strip assembly (7 of 7)



8. Reinstall the following components:
  - ADF bottom corner, inner paper path guide. See [ADF bottom corner inner paper path guide on page 154](#).
  - ADF bottom corner, outer paper path guide. See [ADF bottom corner outer paper path guide on page 152](#).
  - ADF front cover. See [ADF front cover on page 55](#).

## ADF exit inner paper path guide

### 1. Remove the following components:

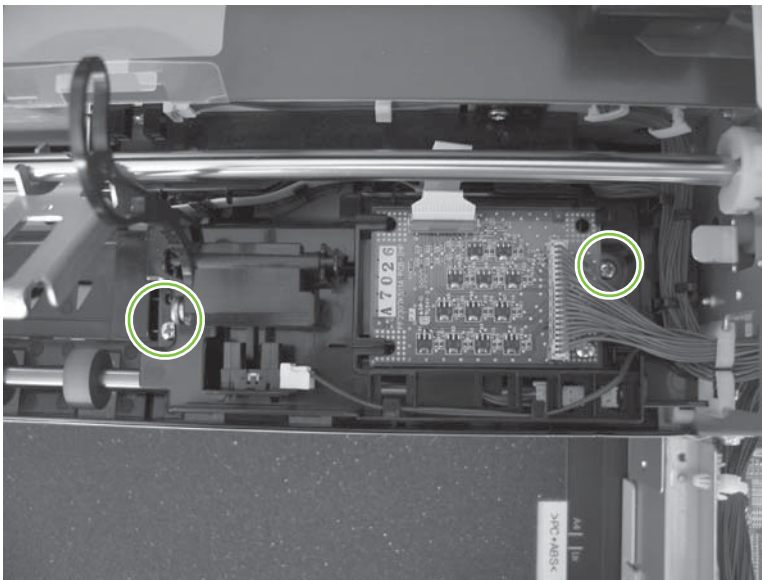
- ADF front cover. See [ADF front cover on page 55](#).
- ADF back cover. See [Scanner back cover on page 60](#).

**⚠ WARNING!** Place the back of the product against a wall after removing the scanner back cover. The ADF hinge springs could actuate and cause the product to flip over backward.

- ADF input-tray assembly. See [ADF input-tray assembly on page 184](#).
- ADF output tray. See [ADF output tray on page 186](#).
- ADF shingle wall. See [ADF shingle wall on page 197](#).
- ADF bottom corner, outer paper path guide. See [ADF bottom corner outer paper path guide on page 152](#).
- ADF bottom corner, inner paper path guide. See [ADF bottom corner inner paper path guide on page 154](#).
- ADF cal-strip assembly. See [ADF cal-strip assembly on page 155](#).

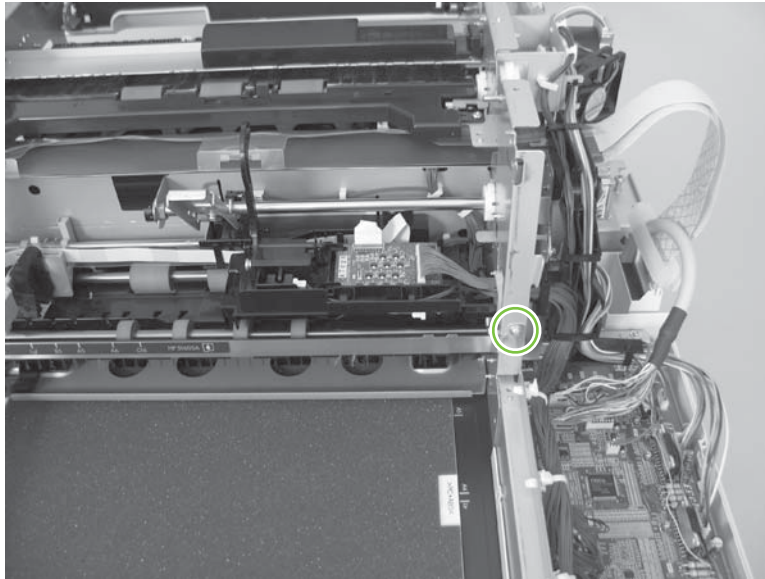
### 2. Remove two screws.

**Figure 5-170** Remove the ADF exit inner paper path guide (1 of 4)



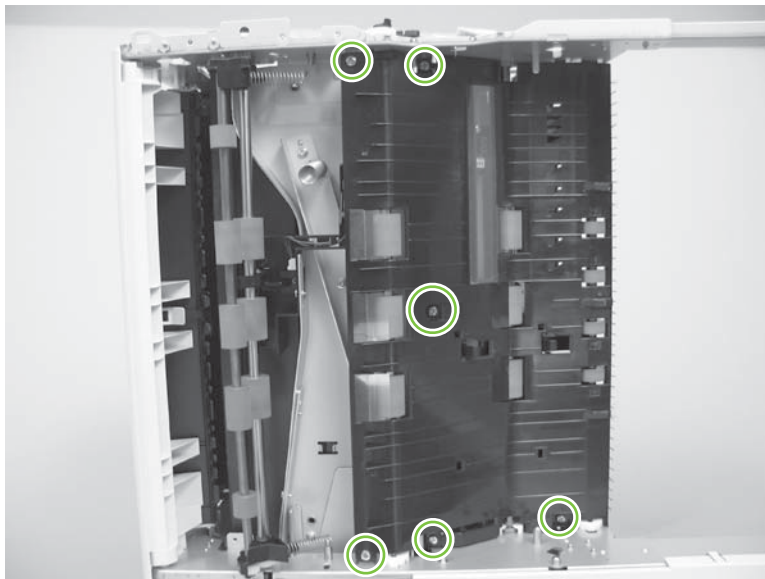
3. Remove one screw.

**Figure 5-171** Remove the ADF exit inner paper path guide (2 of 4)



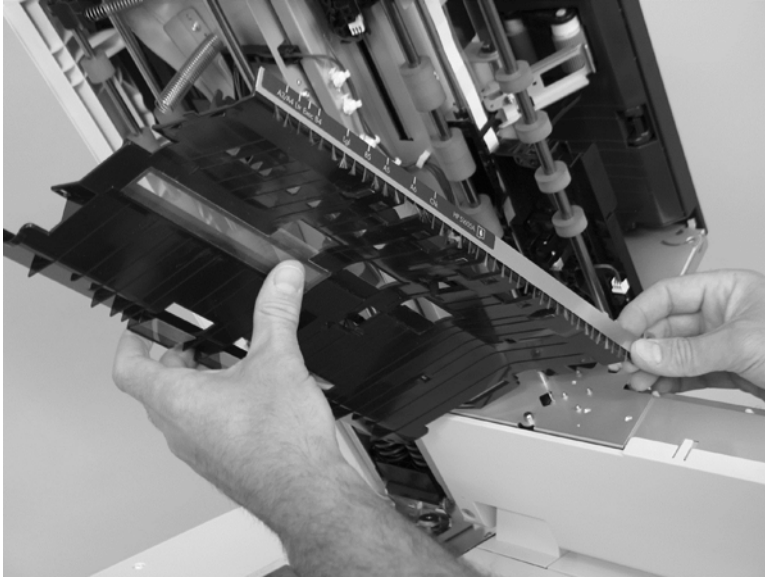
4. Remove six screws.

**Figure 5-172** Remove the ADF exit inner paper path guide (3 of 4)



5. Remove the ADF exit inner paper path guide.

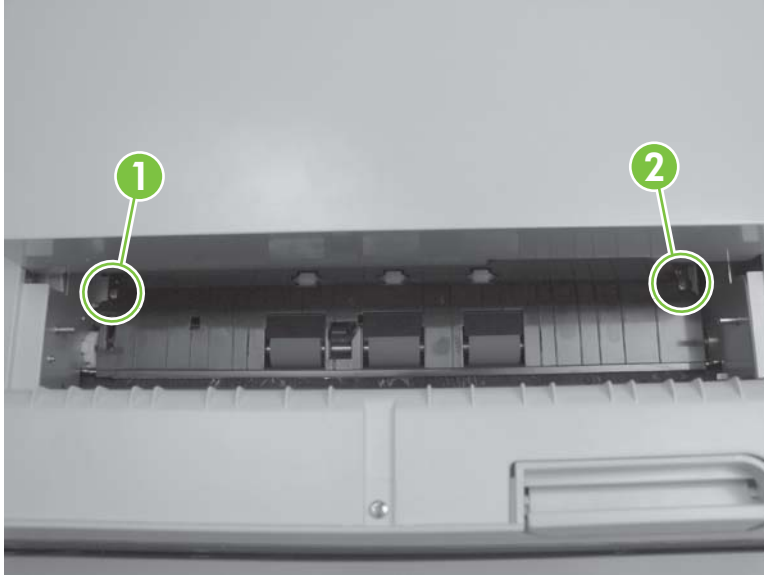
**Figure 5-173** Remove the ADF exit inner paper path guide (4 of 4)



## ADF top corner inner paper path guide

1. Open ADF jam door 1 and ADF jam door 2.
2. Remove one screw (callout 1) and one shoulder screw (callout 2).

**Figure 5-174** Remove the ADF top corner inner paper path guide (1 of 2)



3. Remove the ADF top corner inner paper path guide.

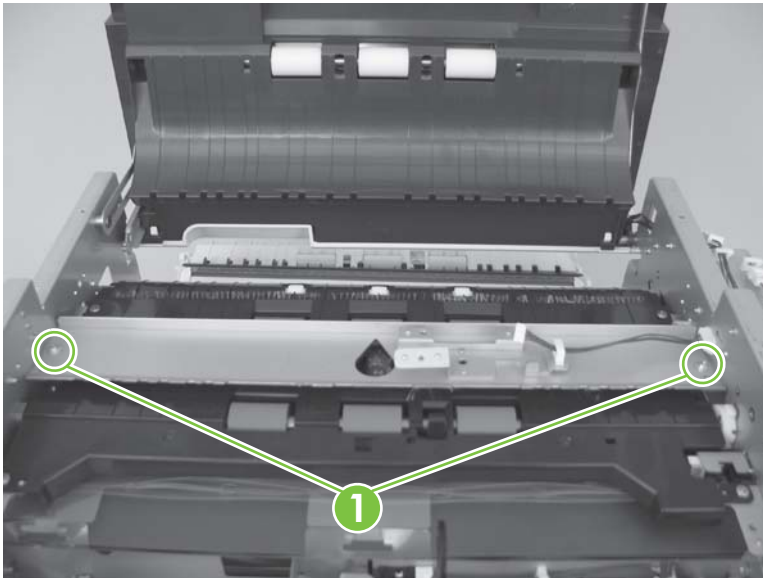
**Figure 5-175** Remove the ADF top corner inner paper path guide (2 of 2)



## Lower multi-pick sensor cover

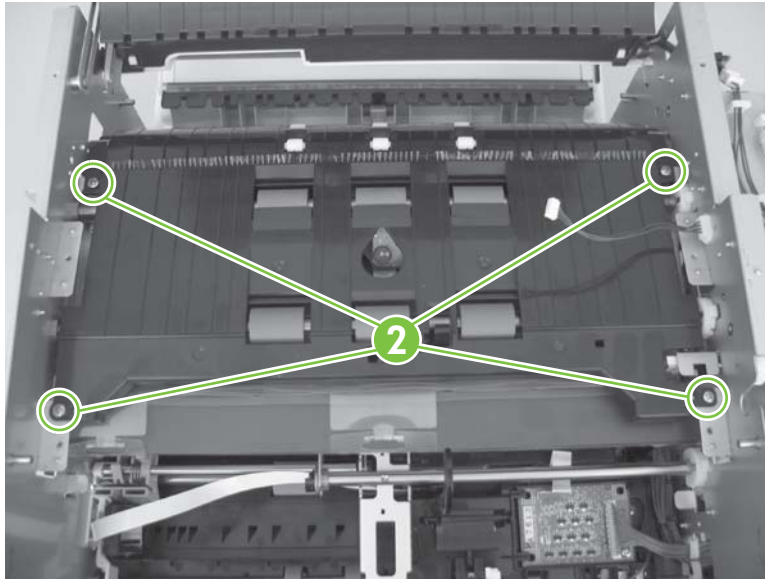
1. Remove the following components:
  - ADF front cover. See [ADF front cover on page 55](#).
  - ADF back cover. See [ADF back cover on page 58](#).
  - ADF input-tray assembly. See [ADF input-tray assembly on page 184](#).
  - ADF shingle wall. See [ADF shingle wall on page 197](#).
  - Upper multi-pick sensor PCA. See [Upper multi-pick sensor PCA on page 124](#).
2. Remove two screws (callout 1) and the sheet metal.

**Figure 5-176** Remove the lower multi-pick sensor cover (1 of 3)



3. Remove four screws (callout 2).

**Figure 5-177** Remove the lower multi-pick sensor cover (2 of 3)



4. Remove the upper feed-guide.

**Figure 5-178** Remove the lower multi-pick sensor cover (3 of 3)



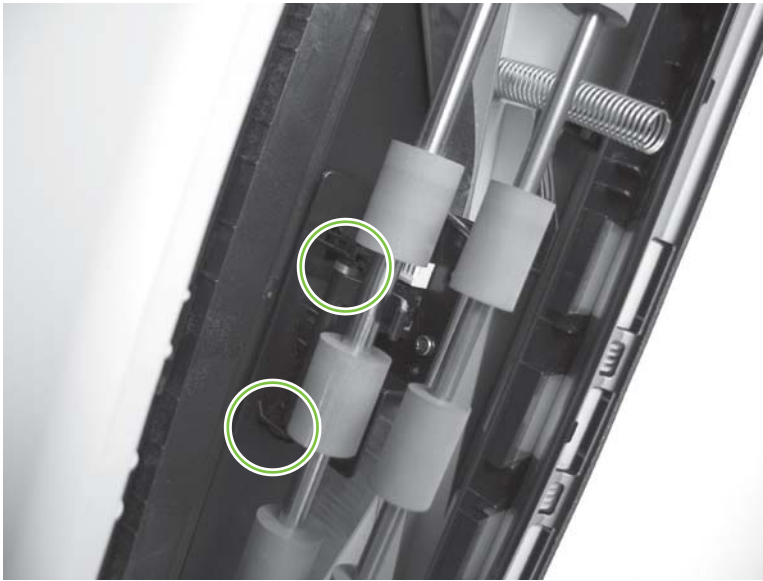
## Flatbed scan position sensor arm

**1.** Remove the following components:

- ADF front cover. See [ADF front cover on page 55](#).
- ADF bottom corner, outer paper path guide. See [ADF bottom corner outer paper path guide on page 152](#).
- ADF bottom corner, inner paper path guide. See [ADF bottom corner inner paper path guide on page 154](#).
- ADF cal-strip assembly. See [ADF cal-strip assembly on page 155](#).

**2.** Remove two tabs.

**Figure 5-179** Remove the flatbed scan position sensor arm (1 of 2)





3. Rotate the flatbed scan position sensor arm over the roller shaft to remove it from the ADF.

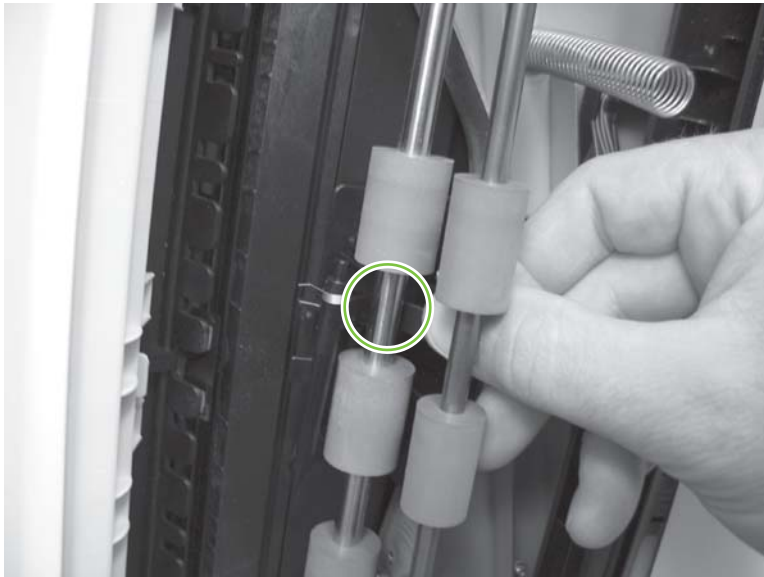
**Figure 5-180** Remove the flatbed scan position sensor arm (2 of 2)



### Reinstall the flatbed scan position sensor arm

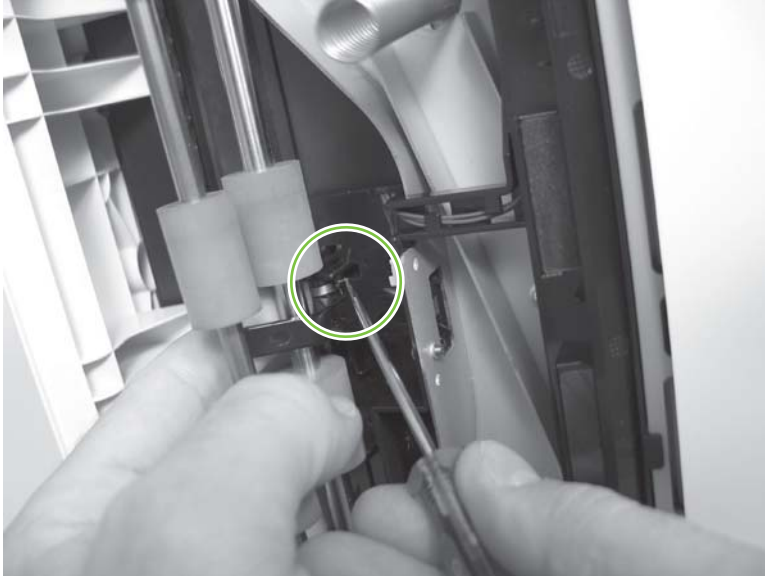
1. Check that the spring is correctly positioned, and then insert the flatbed scan position sensor arm over the roller shaft.

**Figure 5-181** Reinstall the flatbed scan position sensor arm (1 of 3)



2. Push the flatbed scan position sensor arm over the roller shaft, reinstall one tab, and then reinstall the spring end.

**Figure 5-182** Reinstall the flatbed scan position sensor arm (2 of 3)



3. Reinstall one tab.

**Figure 5-183** Reinstall the flatbed scan position sensor arm (3 of 3)



4. Reinstall the following components:

- ADF cal-strip assembly. See [ADF cal-strip assembly on page 155](#).
- ADF bottom corner, inner paper path guide. See [ADF bottom corner inner paper path guide on page 154](#).

- ADF bottom corner, outer paper path guide. See [ADF bottom corner outer paper path guide on page 152](#).
- ADF front cover. See [ADF front cover on page 55](#).

## Exit 1 sensor arm

1. Remove the following components:

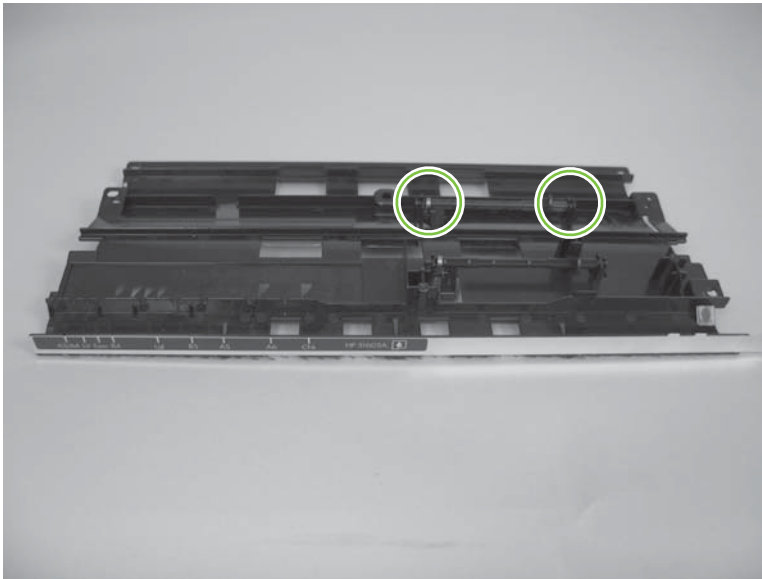
- ADF front cover. See [ADF front cover on page 55](#).
- ADF back cover. See [Scanner back cover on page 60](#).

**⚠ WARNING!** Place the back of the product against a wall after removing the scanner back cover. The ADF hinge springs could actuate and cause the product to flip over backward.

- ADF input-tray assembly. See [ADF input-tray assembly on page 184](#).
- ADF output tray. See [ADF output tray on page 186](#).
- ADF shingle wall. See [ADF shingle wall on page 197](#).
- ADF bottom corner, outer paper path guide. See [ADF bottom corner outer paper path guide on page 152](#).
- ADF bottom corner, inner paper path guide. See [ADF bottom corner inner paper path guide on page 154](#).
- ADF cal-strip assembly. See [ADF cal-strip assembly on page 155](#).
- ADF exit inner paper path guide. See [ADF exit inner paper path guide on page 162](#).

2. Remove two tabs, and then remove the exit 1 sensor arm.

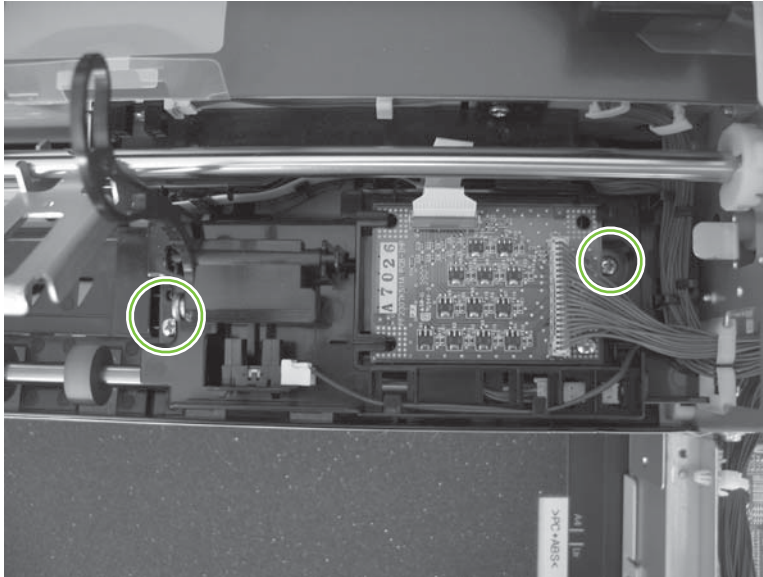
**Figure 5-184** Remove the exit 1 sensor arm



## Exit 2 sensor arm

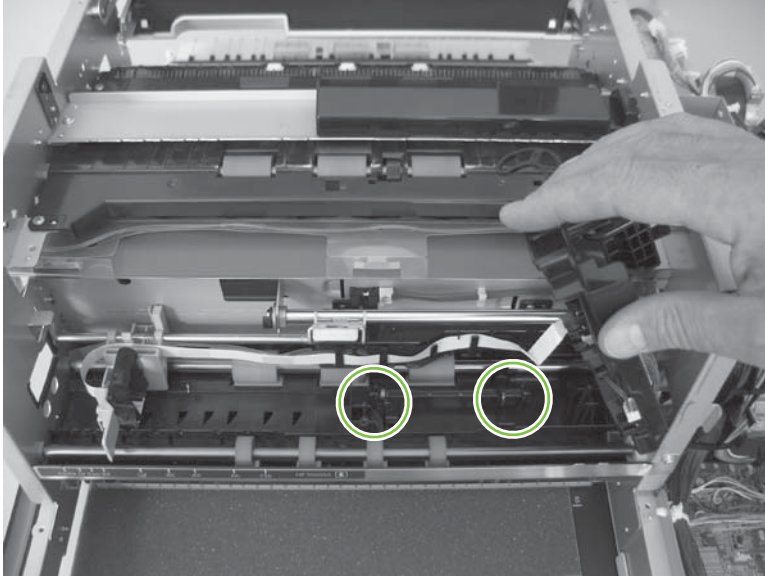
1. Remove the following components:
  - ADF front cover. See [ADF front cover on page 55](#).
  - ADF back cover. See [ADF back cover on page 58](#).
  - ADF input-tray assembly. See [ADF input-tray assembly on page 184](#).
  - ADF shingle wall. See [ADF shingle wall on page 197](#).
2. Remove two screws.

**Figure 5-185** Remove the exit 2 sensor arm (1 of 3)



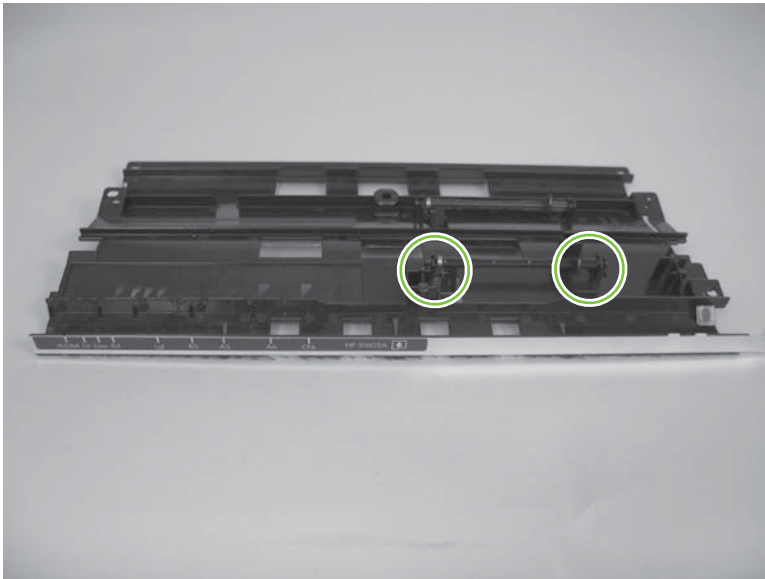
3. Rotate the paper present sensor and imprinter PCA holder, remove two tabs, and then remove the exit 2 sensor arm.

**Figure 5-186** Remove the exit 2 sensor arm (2 of 3)



 **NOTE:** The exit 2 sensor arm can also be accessed by removing the ADF exit inner paper path guide. See [ADF exit inner paper path guide on page 162](#).

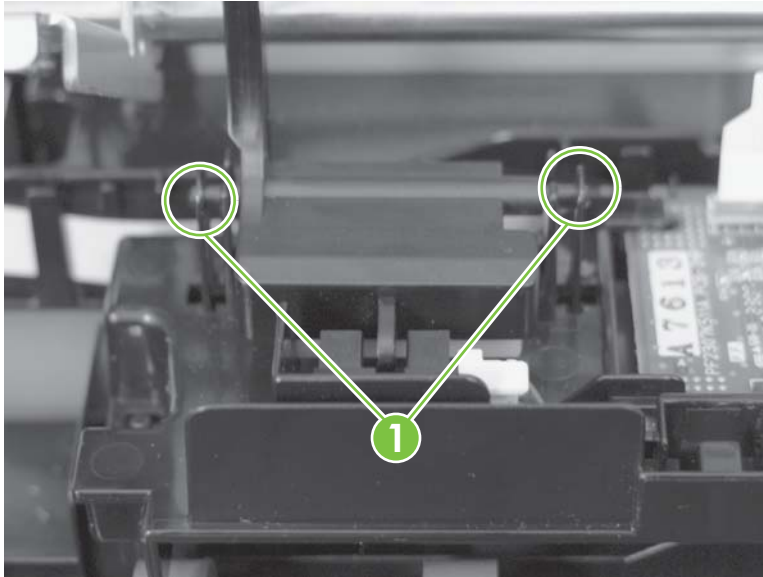
**Figure 5-187** Remove the exit 2 sensor arm (3 of 3)



## Paper-present-sensor arm

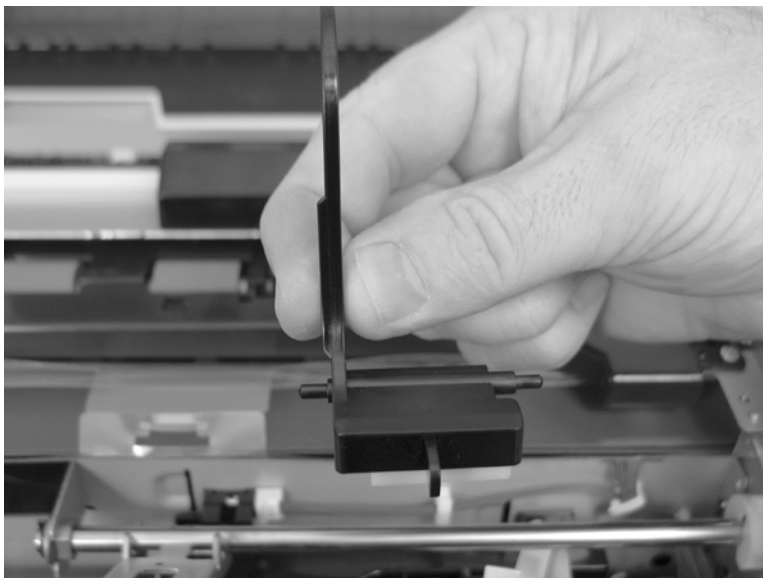
1. Remove the following components:
  - ADF front cover. See [ADF front cover on page 55](#).
  - ADF back cover. See [ADF back cover on page 58](#).
  - ADF input-tray assembly. See [ADF input-tray assembly on page 184](#).
  - ADF shingle wall. See [ADF shingle wall on page 197](#).
2. Remove two tabs (callout 1).

**Figure 5-188** Remove the paper-present-sensor arm (1 of 2)



3. Remove the paper-present-sensor arm.

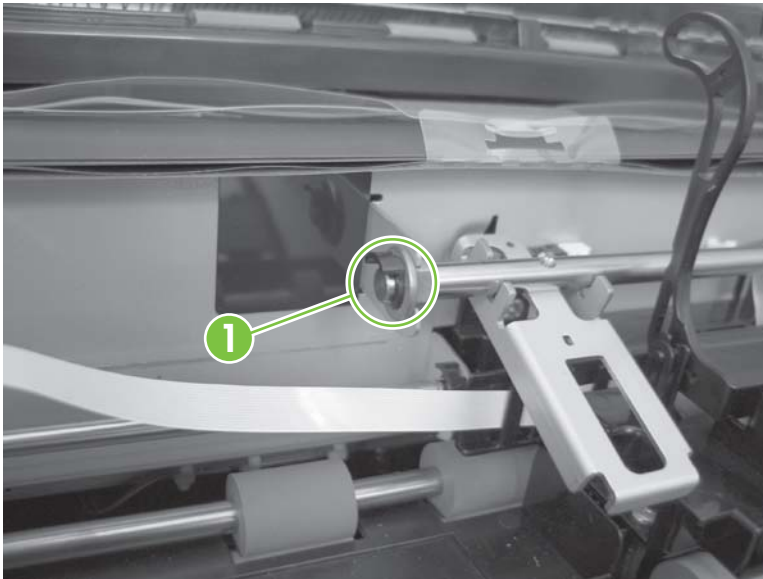
**Figure 5-189** Remove the paper-present-sensor arm (2 of 2)



## Input-tray-elevator arm

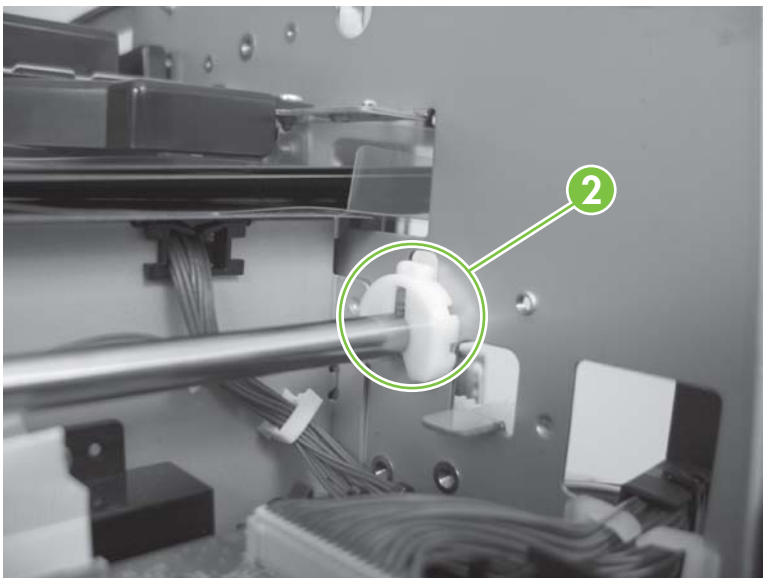
1. Remove the following components:
  - ADF back cover. See [ADF back cover on page 58](#).
  - ADF front cover. See [ADF front cover on page 55](#).
  - ADF shingle wall. See [ADF shingle wall on page 197](#).
  - ADF input-tray lift-motor assembly. See [ADF input-tray lift-motor assembly on page 105](#).
2. Remove one clip-bushing (callout 1).

**Figure 5-190** Remove the input-tray-elevator arm (1 of 5)



3. Remove one clip-bushing (callout 2).

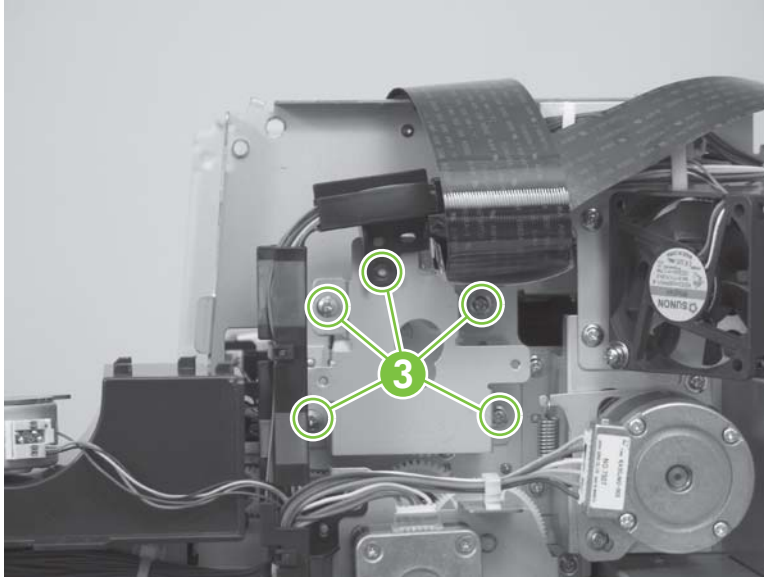
**Figure 5-191** Remove the input-tray-elevator arm (2 of 5)





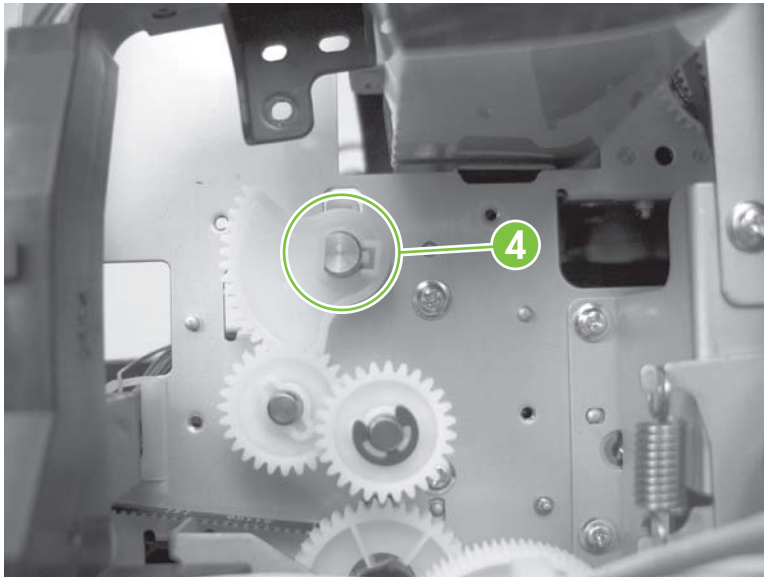
4. Remove five screws (callout 3).

**Figure 5-192** Remove the input-tray-elevator arm (3 of 5)



5. Remove one cam-collar (callout 4).


**Figure 5-193** Remove the input-tray-elevator arm (4 of 5)



6. Remove the input-tray-elevator arm.

**Figure 5-194** Remove the input-tray-elevator arm (5 of 5)

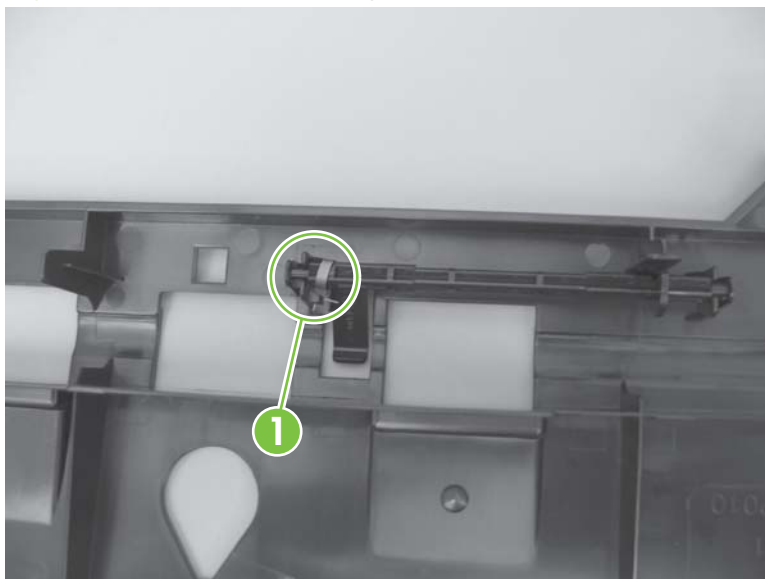


 **NOTE:** When reinstalling the input-tray-elevator arm, align the gears so that the elevator arm is in the down position. When the tray is empty, the sensor should show active in the N9120 Service Tool.

## Registration sensor arm

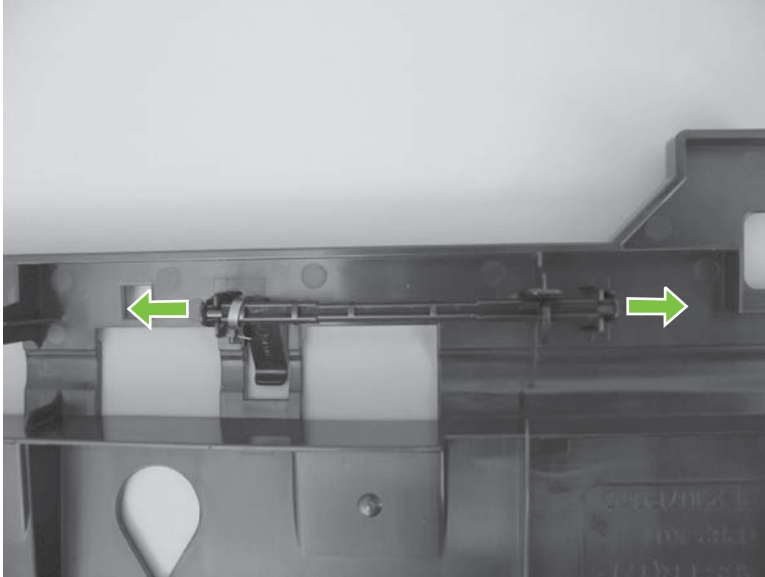
1. Remove the following components:
  - ADF front cover. See [ADF front cover on page 55](#).
  - ADF back cover. See [ADF back cover on page 58](#).
  - ADF input-tray assembly. See [ADF input-tray assembly on page 184](#).
  - ADF shingle wall. See [ADF shingle wall on page 197](#).
  - Upper multi-pick sensor PCA. See [Upper multi-pick sensor PCA on page 124](#).
  - Lower multi-pick sensor cover. See [Lower multi-pick sensor cover on page 166](#).
2. Take note of the location of the spring ends (callout 1) so that the spring can be correctly reinstalled.

**Figure 5-195** Remove the registration sensor arm (1 of 2)



3. Release two tabs, and then remove the registration sensor arm.

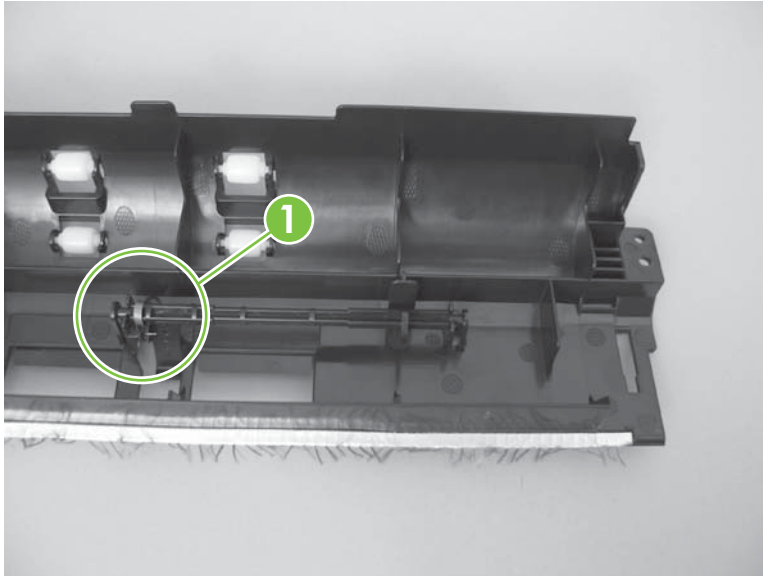
**Figure 5-196** Remove the registration sensor arm (2 of 2)



## Scan position sensor arm

1. Remove the ADF top corner inner paper path guide. See [ADF top corner inner paper path guide on page 165](#).
2. Take note of the location of the spring ends (callout 1) so that the spring can be correctly reinstalled.

**Figure 5-197** Remove the scan position sensor arm (1 of 2)



3. Release two tabs, and then remove the scan position sensor arm.

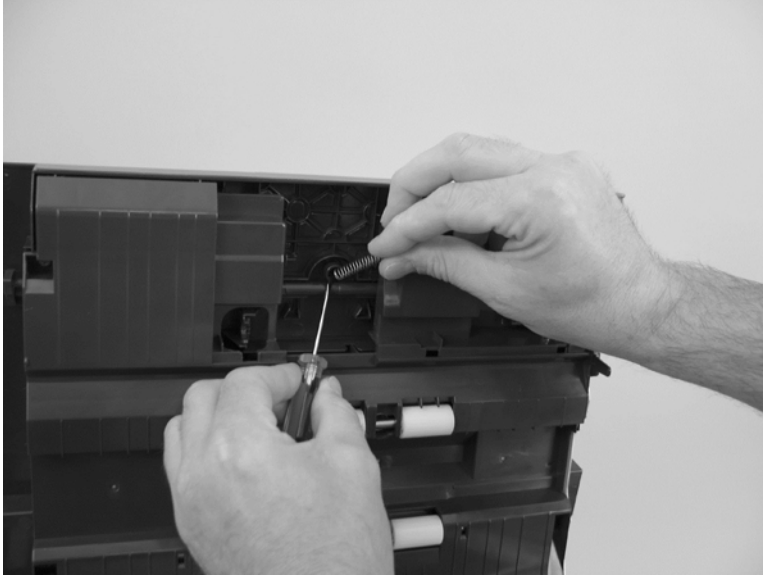
**Figure 5-198** Remove the scan position sensor arm (2 of 2)



## Pick-up roller spring

1. Remove the pickup-roller assembly. See [Pickup-roller assembly on page 47](#).
2. Remove the pickup-roller spring.

**Figure 5-199** Remove the pickup-roller spring



## Separation-pad spring

1. Remove the separation-pad assembly. See [Separation-pad assembly on page 50](#).
2. Remove the separation-pad spring.

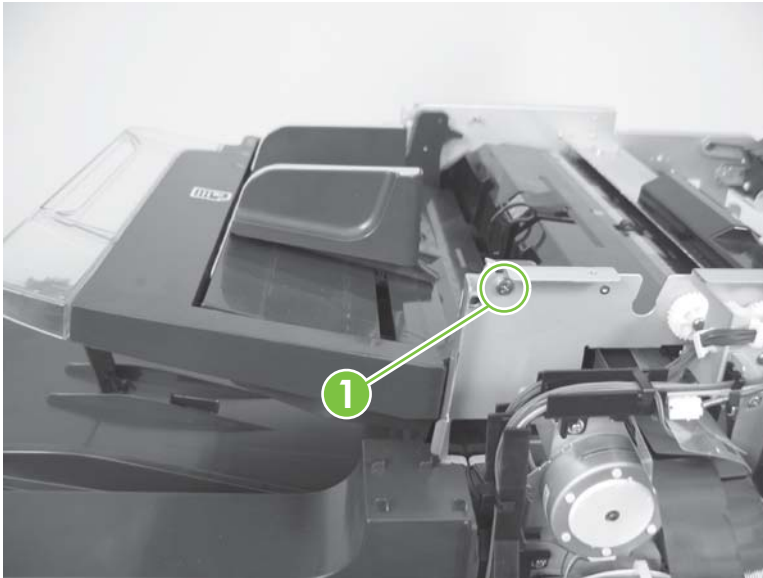
**Figure 5-200** Remove the separation-pad spring



## ADF input-tray assembly

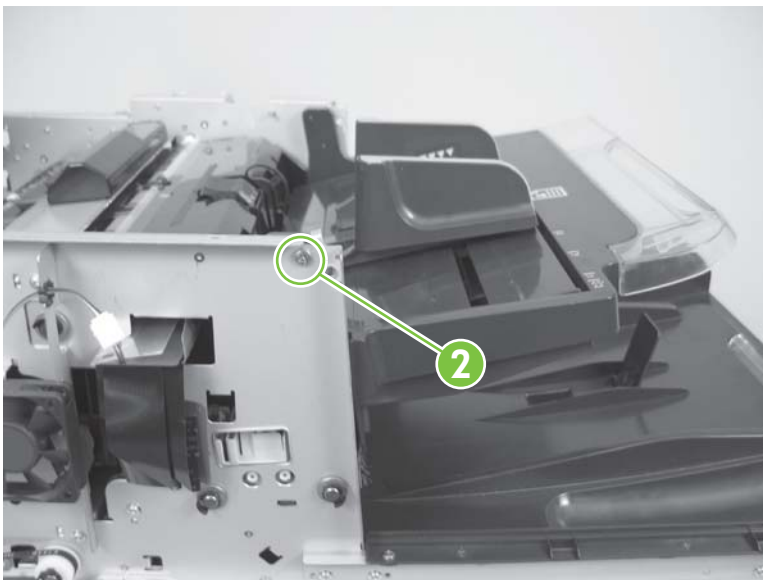
1. Remove the following components:
  - Remove the ADF back cover. See [ADF back cover on page 58](#).
  - Remove the ADF front cover. See [ADF front cover on page 55](#).
2. Remove one screw (callout 1).

**Figure 5-201** Remove the ADF input-tray assembly (1 of 3)



3. Remove one screw (callout 2).

**Figure 5-202** Remove the ADF input-tray assembly (2 of 3)





4. Remove the ADF input-tray assembly.

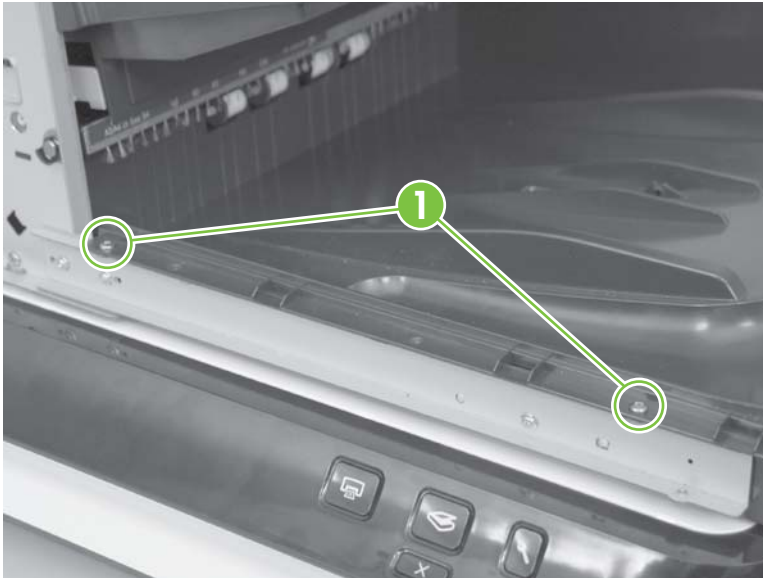
**Figure 5-203** Remove the ADF input-tray assembly (3 of 3)



## ADF output tray

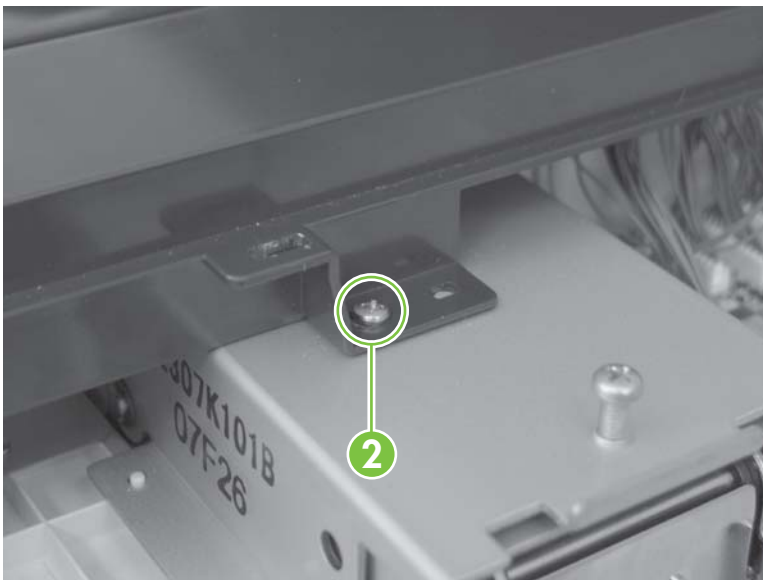
1. Remove the following components:
  - ADF front cover. See [ADF front cover on page 55](#).
  - ADF back cover. See [ADF back cover on page 58](#).
2. Remove two screws (callout 1).

**Figure 5-204** Remove the ADF output tray (1 of 3)



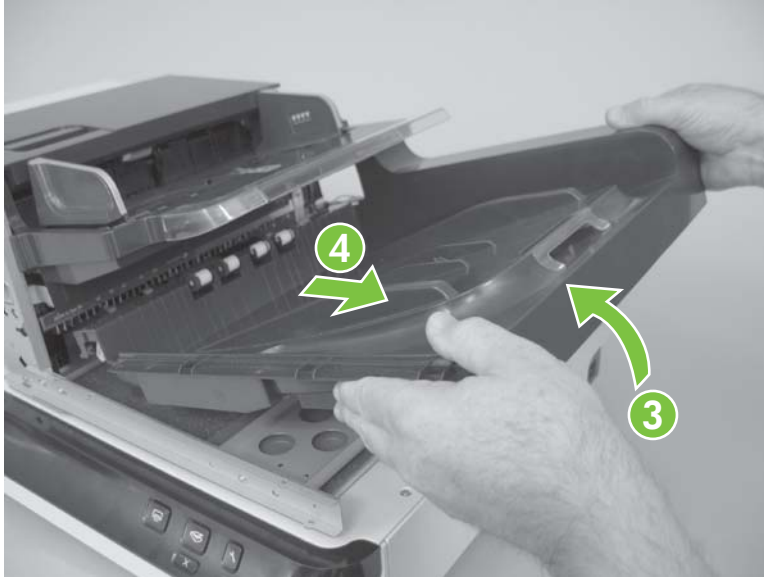
3. Remove one screw (callout 2).

**Figure 5-205** Remove the ADF output tray (2 of 3)



4. Rotate the output tray up (callout 3), and then pull the output tray out (callout 4).

**Figure 5-206** Remove the ADF output tray (3 of 3)




## Reinstall the ADF output tray

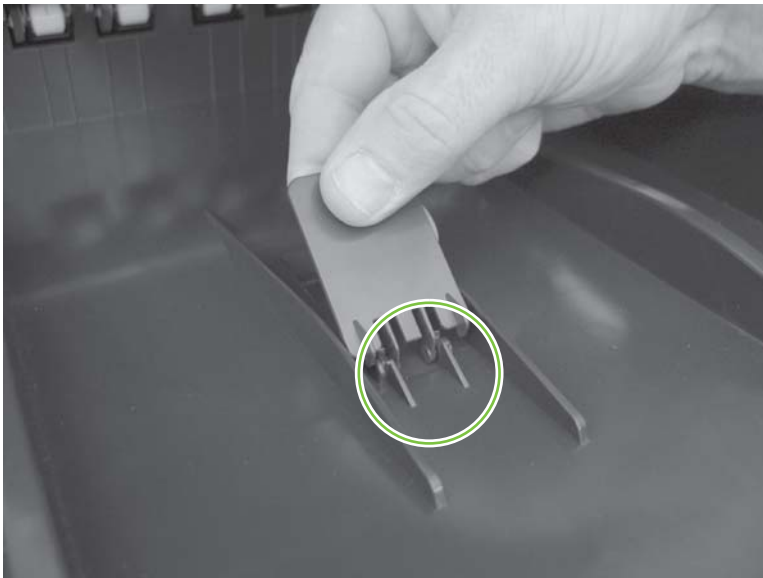
1. Slide the output tray into the ADF.

**Figure 5-207** Reinstall the ADF output tray (1 of 4)



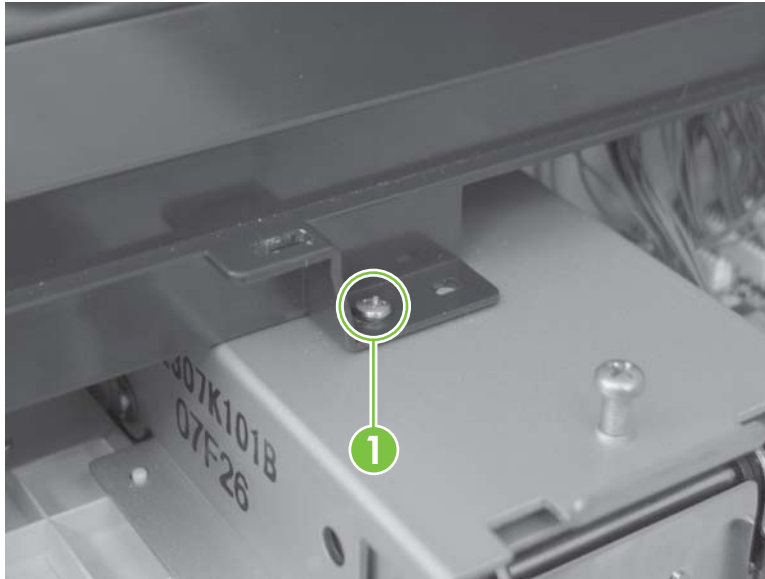
 **NOTE:** If replacing the ADF output tray, remove the A4 paper-stop from the original ADF output tray, and then reinstall it in the replacement ADF output tray. See [A4 paper-stop on page 200](#).

**Figure 5-208** Reinstall the ADF output tray (2 of 4)



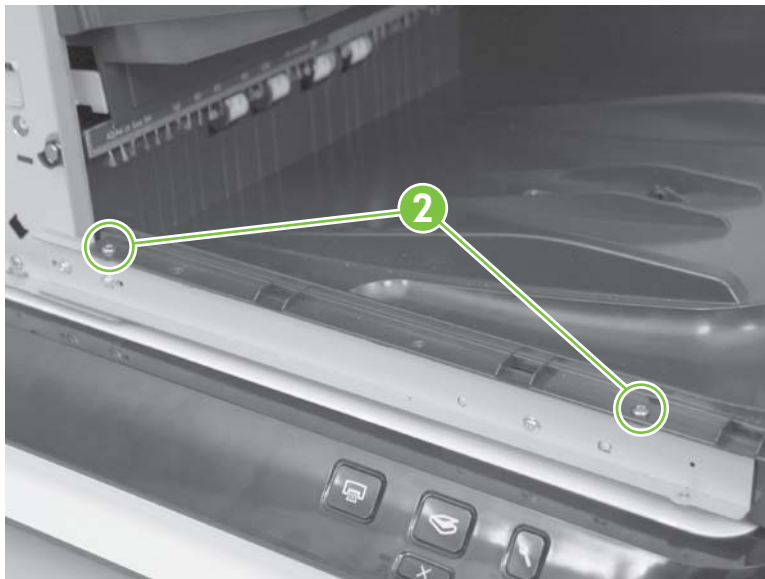
2. Reinstall one screw (callout 1).

**Figure 5-209** Reinstall the ADF output tray (3 of 4)



3. Reinstall two screws (callout 2).

**Figure 5-210** Reinstall the ADF output tray (4 of 4)



4. Reinstall the following components:
  - ADF back cover. See [ADF back cover on page 58](#).
  - ADF front cover. See [ADF front cover on page 55](#).

## Pickup-roller cover

1. Open the ADF jam door 1 (callout 1).

**Figure 5-211** Remove the pickup-roller cover (1 of 3)



2. Press the locking tab (callout 2) on the pickup-roller cover.

**Figure 5-212** Remove the pickup-roller cover (2 of 3)



3. Rotate the top of the assembly away from the ADF, and then remove the pickup-roller cover.

**Figure 5-213** Remove the pickup-roller cover (3 of 3)

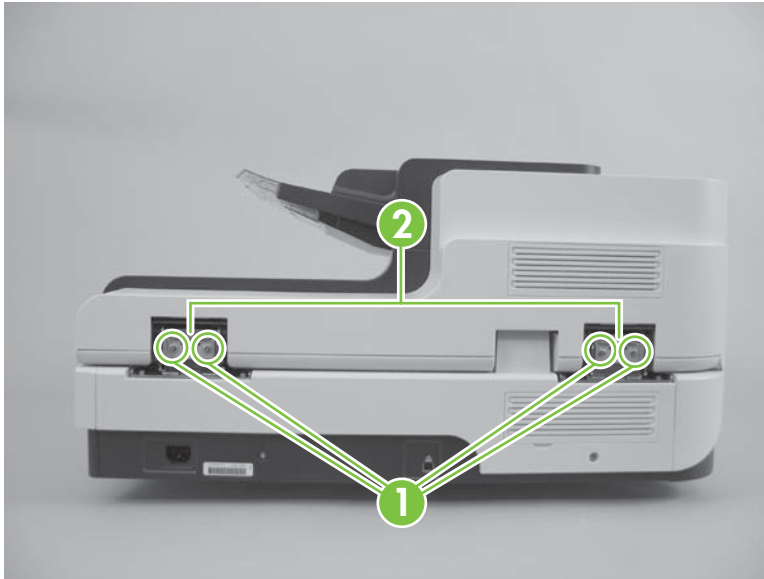


## ADF hinge limiters

Remove four screws (callout 1), and then remove the ADF hinge limiters (callout 2).

**⚠ WARNING!** The ADF is not restrained when opened if the hinge limiters are removed. The product can tip over if the ADF is opened too far.

**Figure 5-214** Remove the ADF hinge limiters

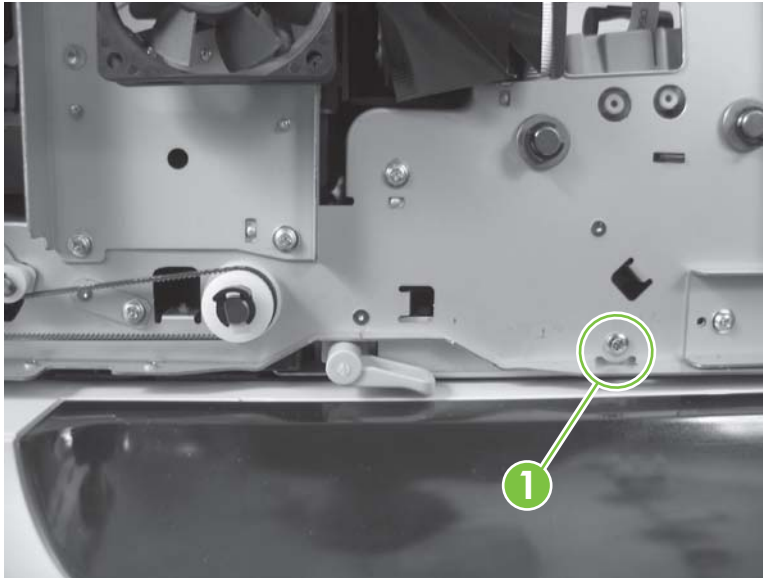




## ADF jam door 3

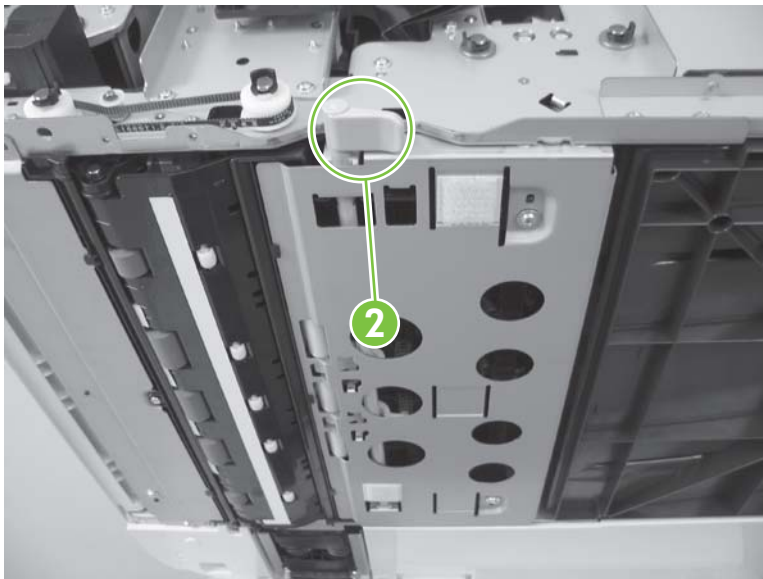
1. Remove the following components:
  - ADF front cover. See [ADF front cover on page 55](#).
  - ADF base reflector. See [ADF base reflector on page 45](#).
2. Remove one screw (callout 1).

**Figure 5-215** Remove ADF jam door 3 (1 of 4)



3. Open the ADF.
4. Support the ADF jam door 3, and then turn the green handle (callout 2).

**Figure 5-216** Remove ADF jam door 3 (2 of 4)



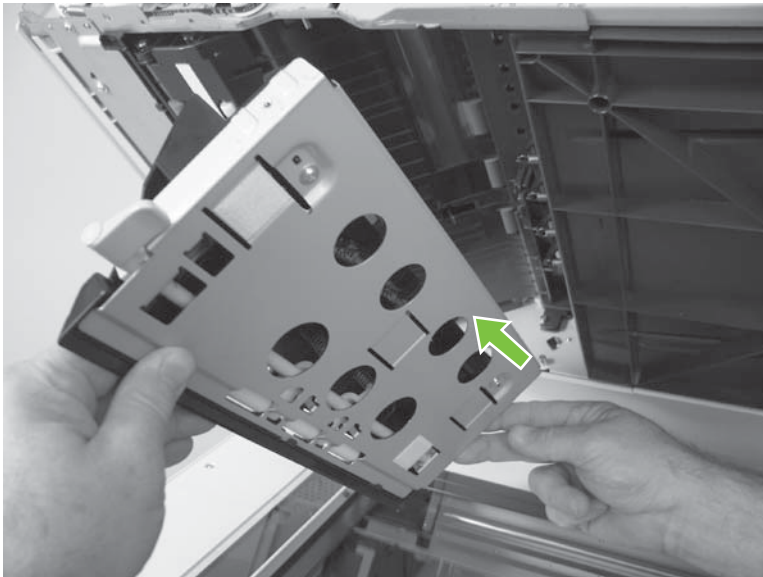
5. Rotate the loose side of the ADF jam door 3 toward the scanner glass.

**Figure 5-217** Remove ADF jam door 3 (3 of 4)



6. Remove ADF jam door 3.

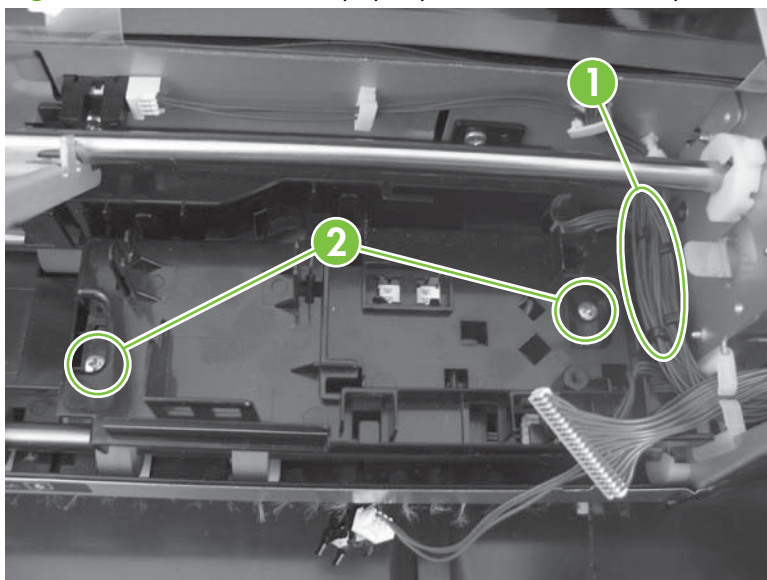
**Figure 5-218** Remove ADF jam door 3 (4 of 4)



## Paper present sensor and imprinter PCA holder

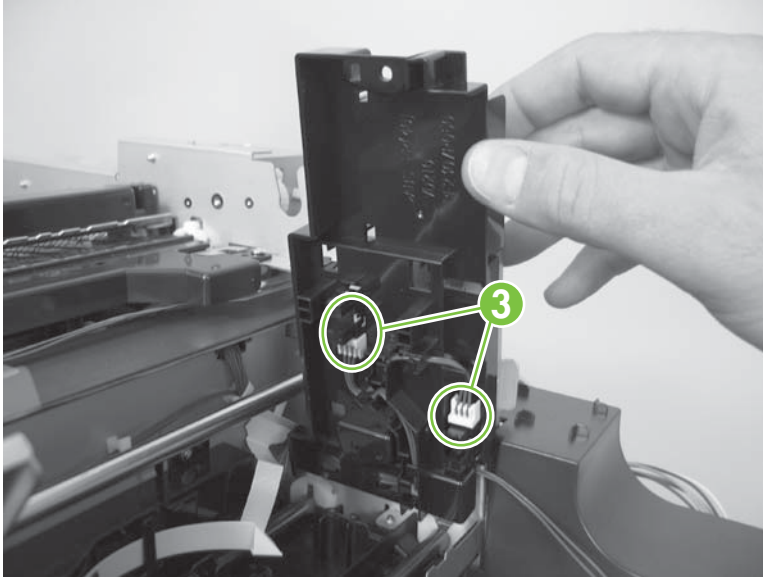
1. Remove the following components:
  - ADF front cover. See [ADF front cover on page 55](#).
  - ADF back cover. See [ADF back cover on page 58](#).
  - ADF input-tray assembly. See [ADF input-tray assembly on page 184](#).
  - ADF shingle wall. See [ADF shingle wall on page 197](#).
  - Paper-present-sensor arm. See [Paper-present-sensor arm on page 175](#).
  - Imprinter paper-present sensor. See [Imprinter paper-present sensor on page 149](#).
  - Imprinter PCA. See [Imprinter PCA on page 130](#).
2. Remove wire retainers (callout 1) and two screws (callout 2).

**Figure 5-219** Remove the paper present sensor and imprinter PCA holder (1 of 3)



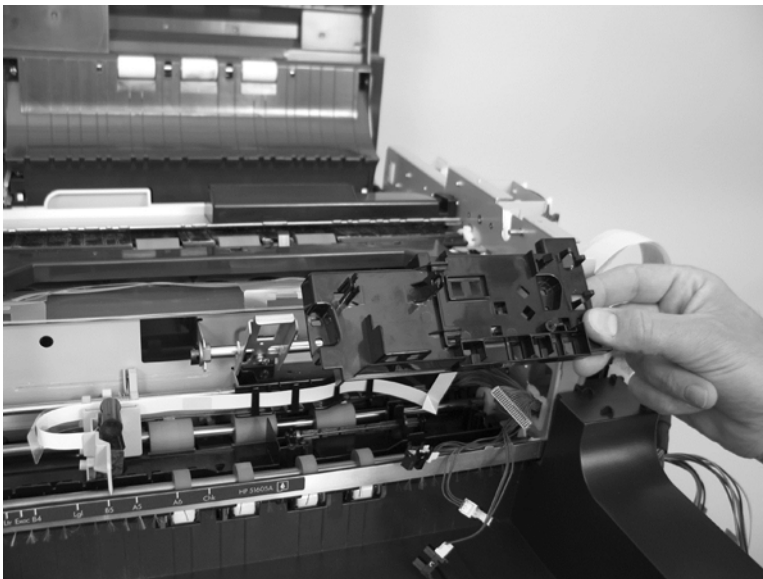
3. Remove two sensors (callout 3).

**Figure 5-220** Remove the paper present sensor and imprinter PCA holder (2 of 3)




4. Remove the paper present sensor and imprinter PCA holder.

**Figure 5-221** Remove the paper present sensor and imprinter PCA holder (3 of 3)

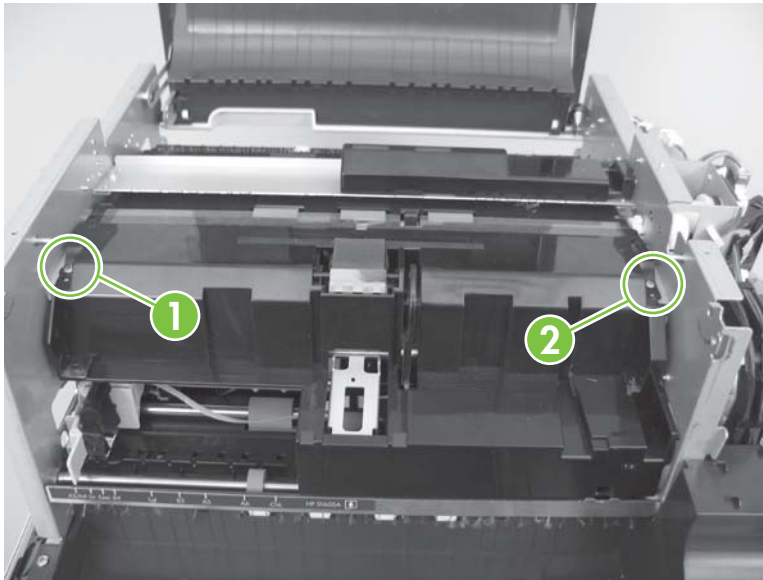


## ADF shingle wall

1. Remove the following components:
  - ADF back cover. See [ADF back cover on page 58](#).
  - ADF front cover. See [ADF front cover on page 55](#).
  - ADF input-tray assembly. See [ADF input-tray assembly on page 184](#).
2. Remove one screw (callout 1) and one shoulder screw (callout 2).

 **NOTE:** When reinstalling the ADF shingle wall, make sure that the shoulder screw is installed in the correct location (callout 2) .

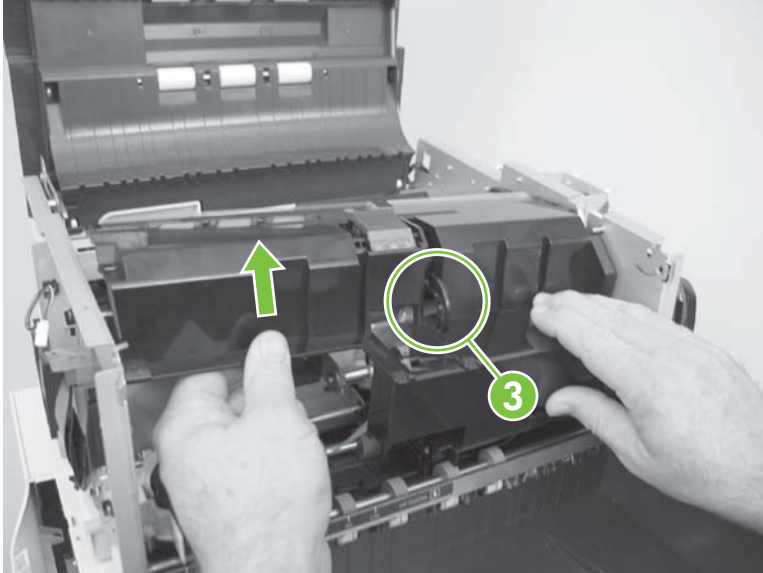
**Figure 5-222** Remove the ADF shingle wall (1 of 4)



3. Lift up the ADF shingle wall.

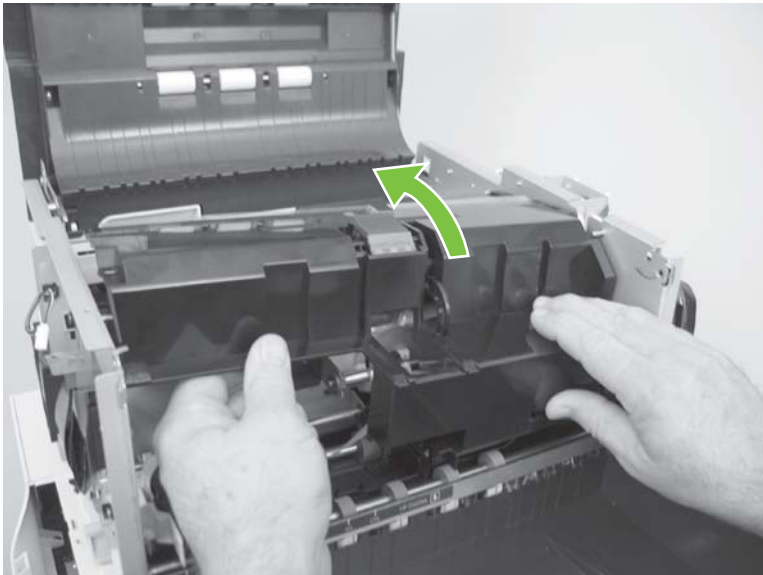
**⚠ WARNING!** Do not damage the paper-present-sensor arm (callout 3) when removing the ADF shingle wall.

**Figure 5-223** Remove the ADF shingle wall (2 of 4)



4. Rotate the ADF shingle wall toward jam door 1.

**Figure 5-224** Remove the ADF shingle wall (3 of 4)



5. Remove the ADF shingle wall.

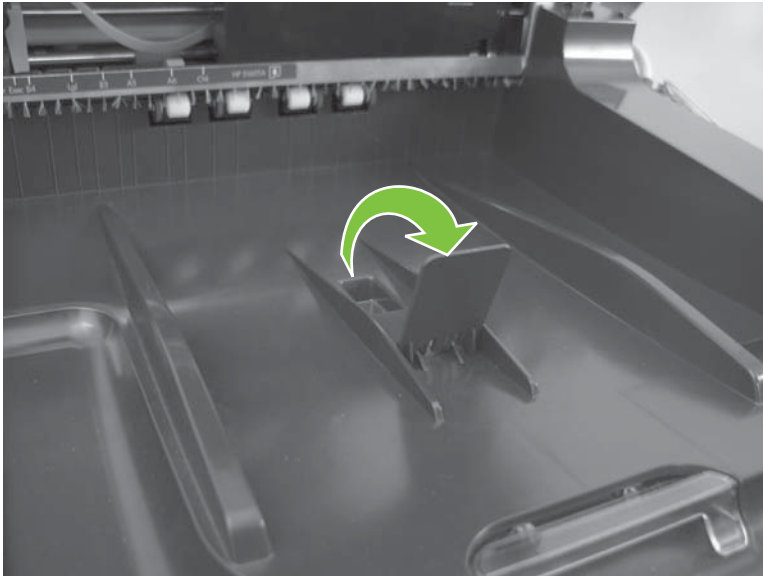
**Figure 5-225** Remove the ADF shingle wall (4 of 4)



## A4 paper-stop

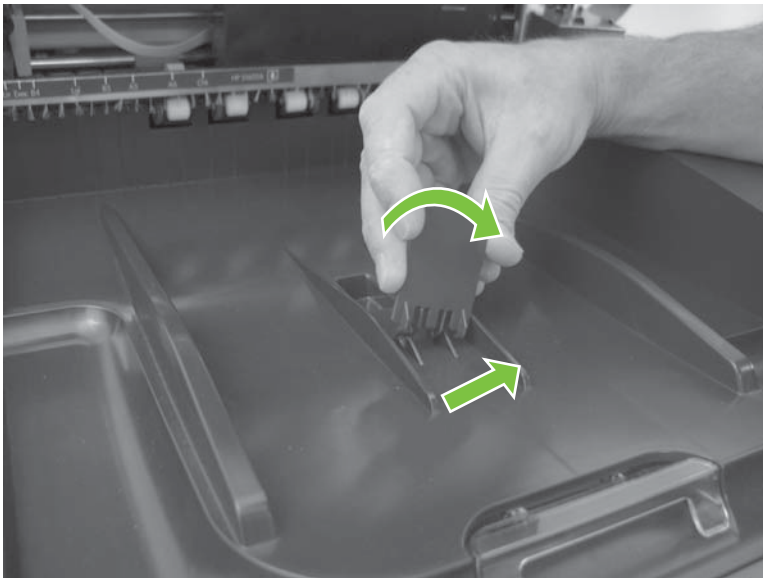
1. Move the A4 paper-stop to the upright position.

**Figure 5-226** Remove the A4 paper-stop (1 of 2)



2. Move the bottom of the A4 paper-stop to the right, rotate the top of the A4 paper-stop down and to the right, and then remove the A4 paper-stop.

**Figure 5-227** Remove the A4 paper-stop (2 of 2)

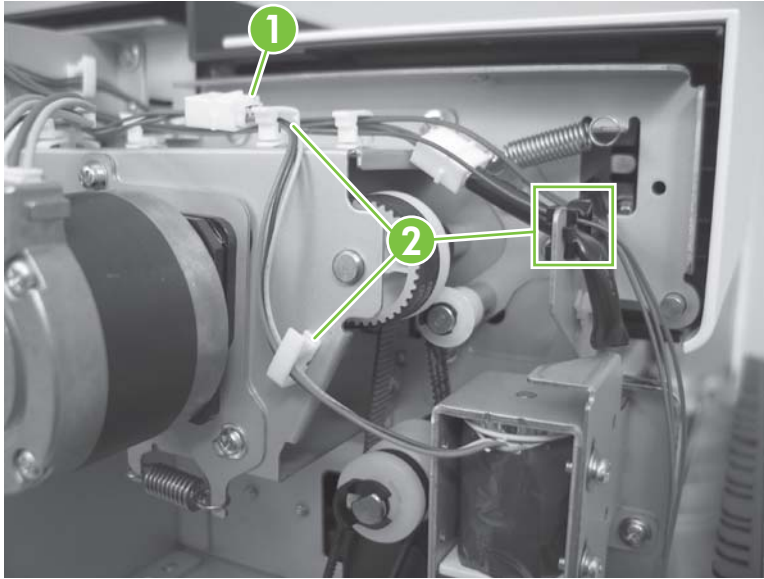




## ADF background-solenoid assembly

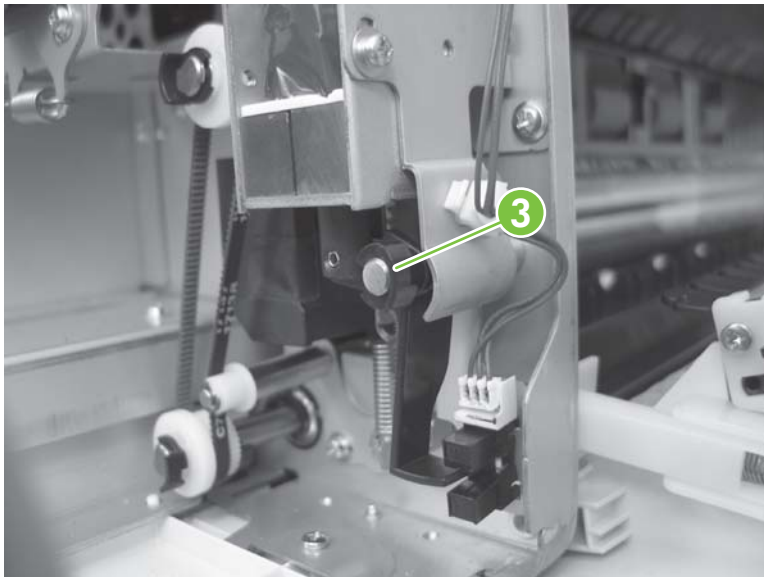
1. Remove the ADF back cover. See [ADF back cover on page 58](#).
2. Disconnect one connector (callout 1), and then release the wire harnesses from three retainers (callout 2).

**Figure 5-228** Remove the ADF background-solenoid assembly (1 of 5)



3. Remove one clip (callout 3).

**Figure 5-229** Remove the ADF background-solenoid assembly (2 of 5)



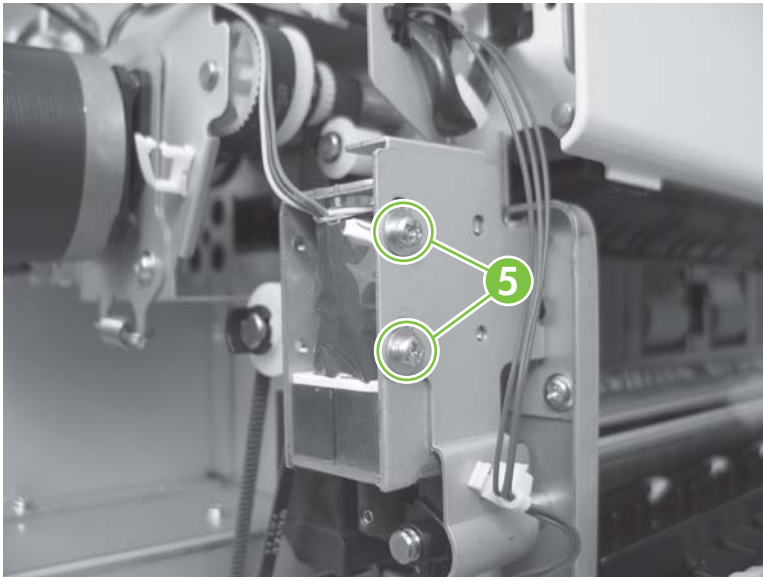
4. Remove one spring (callout 4).

**Figure 5-230** Remove the ADF background-solenoid assembly (3 of 5)



5. Remove two screws (callout 5).

**Figure 5-231** Remove the ADF background-solenoid assembly (4 of 5)



6. Remove the solenoid and flag.



**NOTE:** If you are replacing the solenoid, you must install the flag on the replacement solenoid.

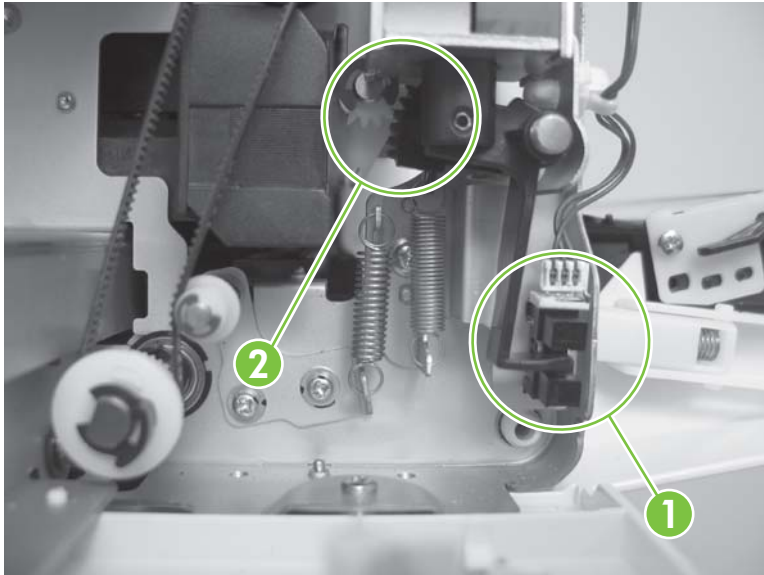
**Figure 5-232** Remove the ADF background-solenoid assembly (5 of 5)



## Reinstall the ADF background-solenoid assembly

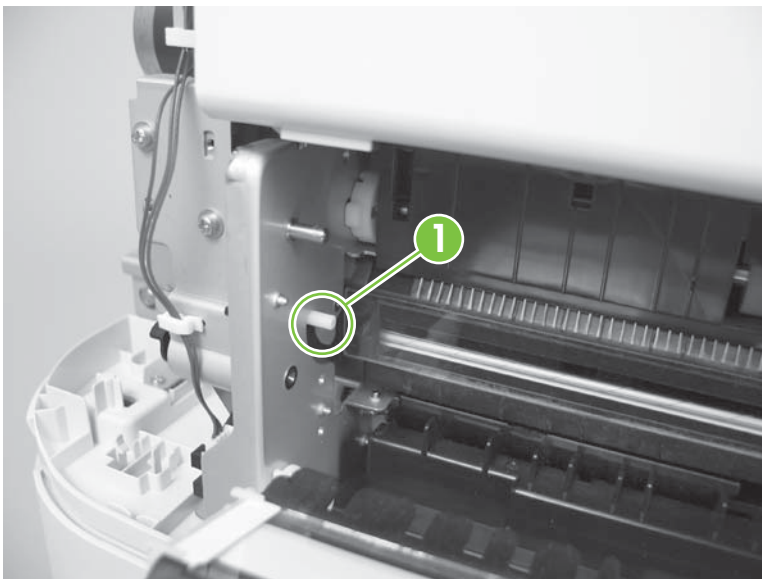
When you reinstall the solenoid and flag, make sure that the flag is correctly positioned in relationship to the sensor (callout 1). You can change the position of the flag by adjusting the position of the flag gear with the drive gear (callout 2).

**Figure 5-233** Reinstall the ADF background-solenoid assembly (1 of 3)



1. Open jam door 2, and then measure the distance between the top of the solenoid lever and the top of the slot (callout 1).

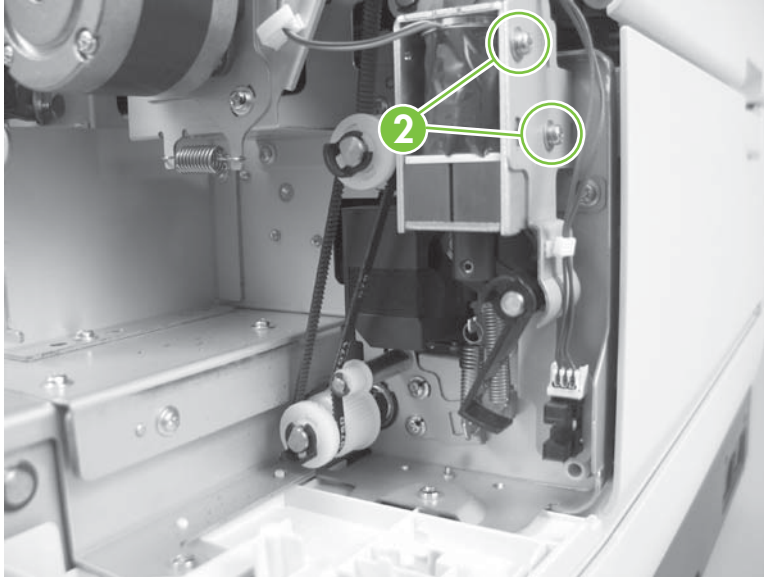
**Figure 5-234** Reinstall the ADF background-solenoid assembly (1 of 3)



**NOTE:** The distance between the top of the solenoid lever and the top of the slot should be between 0.0 mm and 5.0 mm.

2. Install, *but do not tighten*, two screws (callout 2).

**Figure 5-235** Reinstall the ADF background-solenoid assembly (3 of 3)

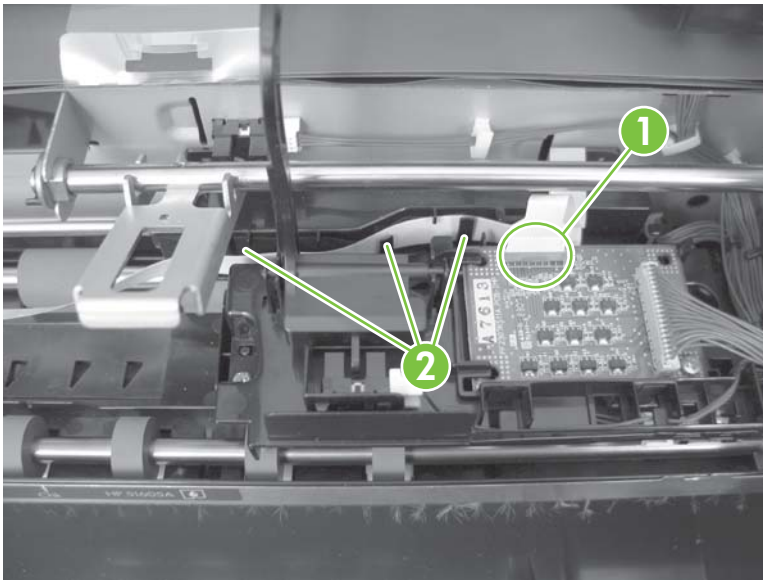


3. Slide the background-solenoid assembly up or down to adjust the distance between the top of the solenoid lever and the top of the slot:
  - Slide the background-solenoid assembly up if the distance between the top of the solenoid lever and the top of the slot is greater than 5.0 mm.
  - Slide the background-solenoid assembly down if the distance between the top of the solenoid lever and the top of the slot is 0.0 mm.
4. Tighten two screws, close jam door 2, and then replace the ADF back cover.

## Imprinter carriage and FFC

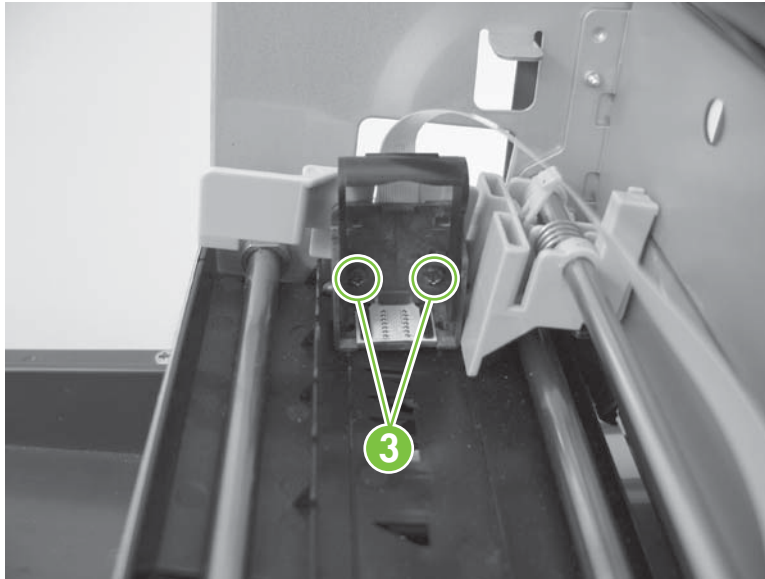
1. Remove the following components:
  - ADF front cover. See [ADF front cover on page 55](#).
  - ADF back cover. See [ADF back cover on page 58](#).
  - ADF input-tray assembly. See [ADF input-tray assembly on page 184](#).
  - ADF shingle wall. See [ADF shingle wall on page 197](#).
2. Disconnect the FFC by pressing down the connector lever (callout 1), and then release the FFC from three retainers (callout 2).

**Figure 5-236** Imprinter carriage and FFC (1 of 3)



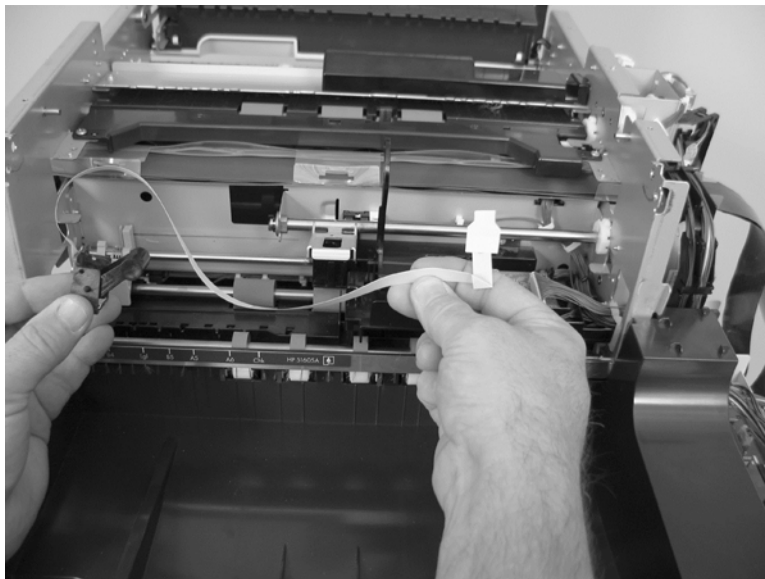
3. Remove two screws (callout 3).

**Figure 5-237** Imprinter carriage and FFC (2 of 3)



4. Remove the imprinter carriage and FFC.

**Figure 5-238** Imprinter carriage and FFC (3 of 3)




## Flatbed scanner FRUs

- [Flatbed](#)
- [Scanner carriage-motor fan](#)
- [Scanner carriage fan](#)
- [Scanner carriage motor](#)
- [Control-panel PCA](#)
- [Scanner controller PCA](#)
- [Power-supply PCA](#)
- [Scanner-glass assembly](#)
- [ADF power-cable assembly](#)
- [Carriage-motor cable](#)
- [Power switch and power receptacle assembly](#)



## Flatbed

---

 **NOTE:** Factory NVRAM data should be downloaded before the service call.

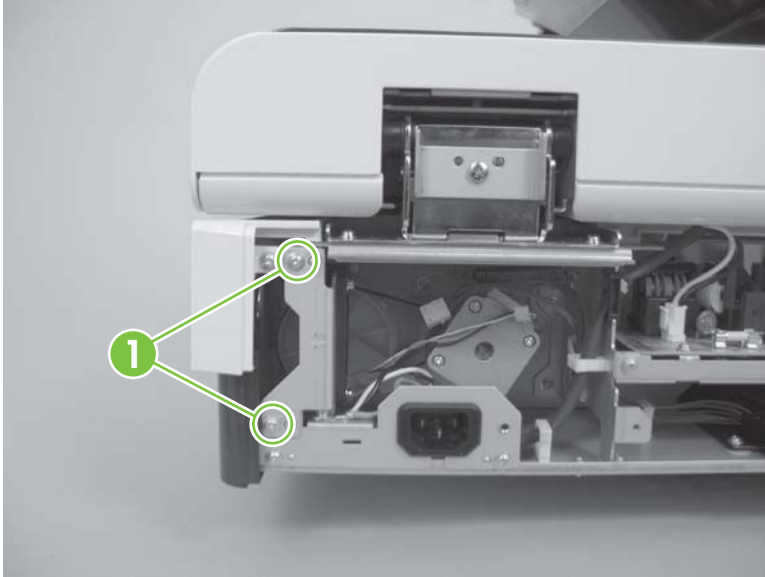
---

1. Remove the ADF. See [Automatic document feeder \(ADF\) on page 63](#).
2. Remove the flatbed from the work space.
3. Install the ADF on the replacement flatbed, adjust ADF height, manage the NVRAM data, and calibrate the product. See [Automatic document feeder \(ADF\) on page 63](#).

## Scanner carriage-motor fan

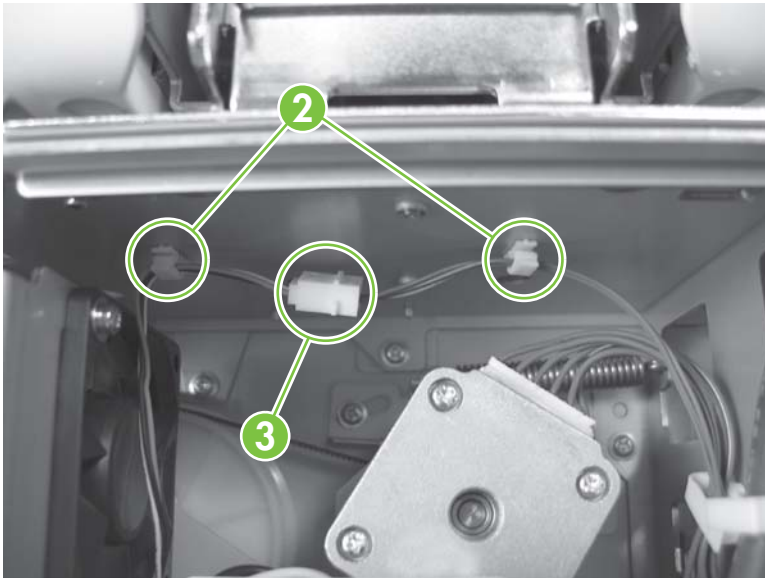
1. Remove the scanner back cover. See [Scanner back cover on page 60](#).
2. Remove two screws (callout 1).

**Figure 5-239** Remove the scanner carriage-motor fan (1 of 5)



3. Remove two retainers (callout 2) and one connector (callout 3).

**Figure 5-240** Remove the scanner carriage-motor fan (2 of 5)



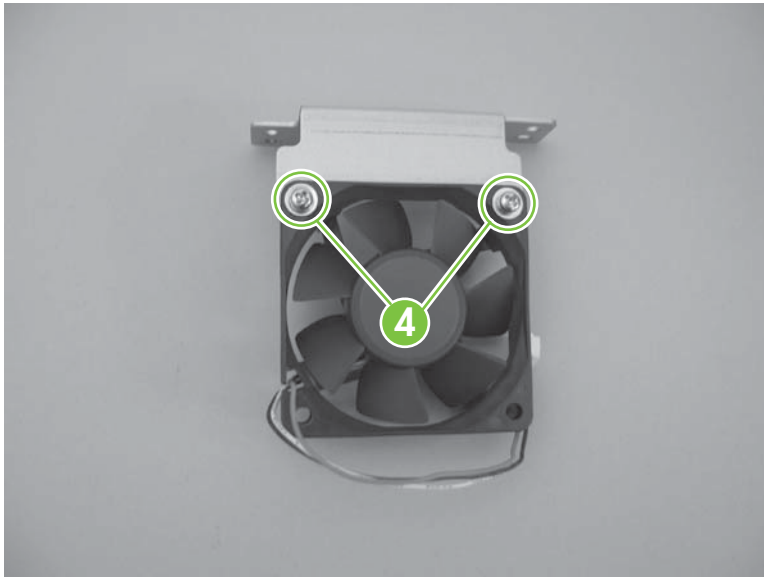
4. Remove the scanner carriage-motor fan.

**Figure 5-241** Remove the scanner carriage-motor fan (3 of 5)



5. Remove two screws (callout 4), and then remove the scanner carriage-motor fan.

**Figure 5-242** Remove the scanner carriage-motor fan (4 of 5)



6. Remove the mounting bracket from the scanner carriage-motor fan.

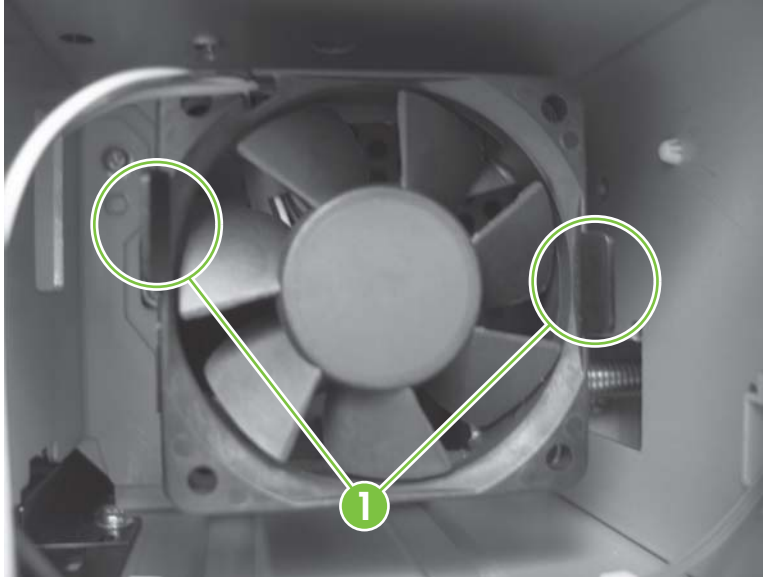
**Figure 5-243** Remove the scanner carriage-motor fan (5 of 5)



## Scanner carriage fan

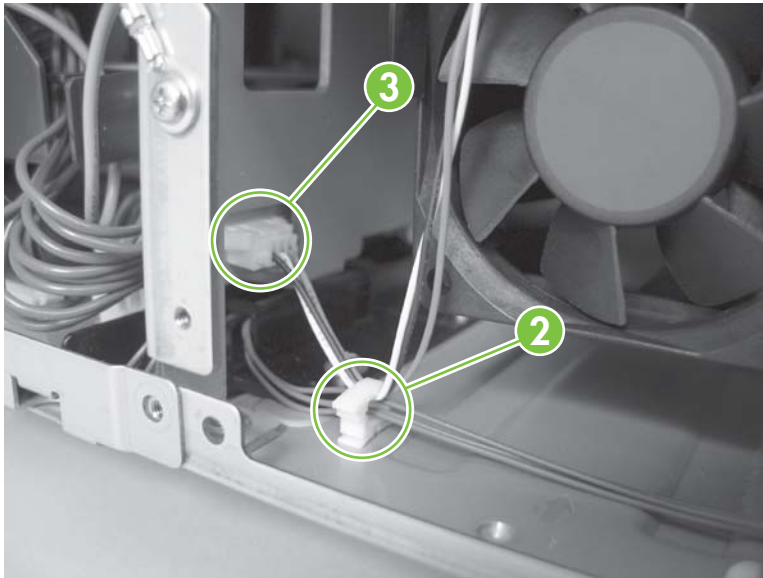
1. Remove the scanner back cover. See [Scanner back cover on page 60](#).
2. Remove two tabs (callout 1).

**Figure 5-244** Remove the scanner carriage fan (1 of 3)



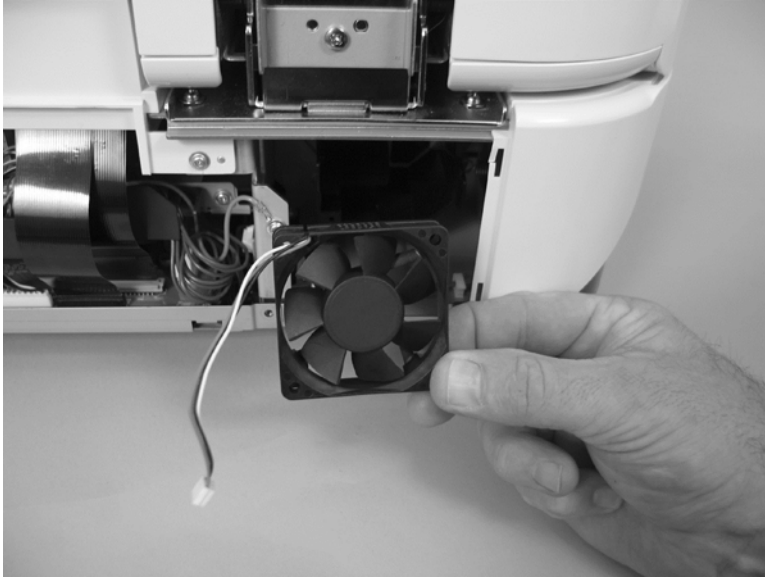
3. Remove one retainer (callout 2) and one connector (callout 3).

**Figure 5-245** Remove the scanner carriage fan (2 of 3)



4. Remove the carriage fan.

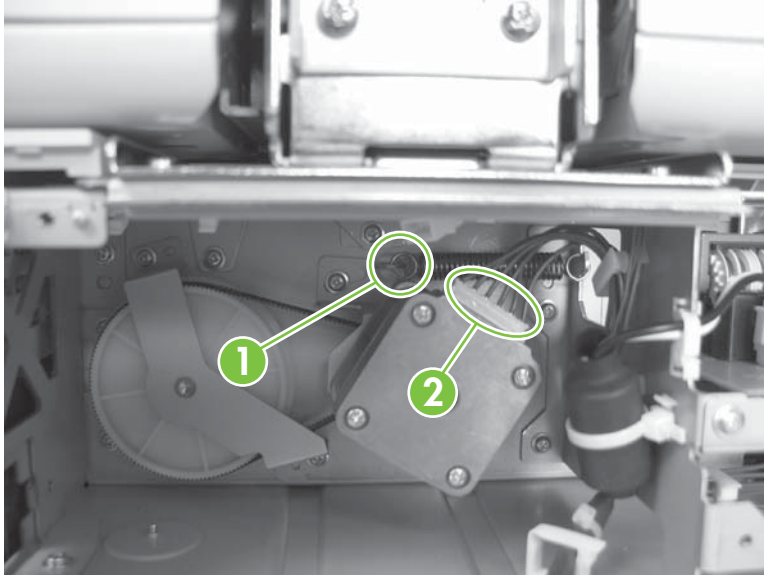
**Figure 5-246** Remove the scanner carriage fan (3 of 3)



## Scanner carriage motor

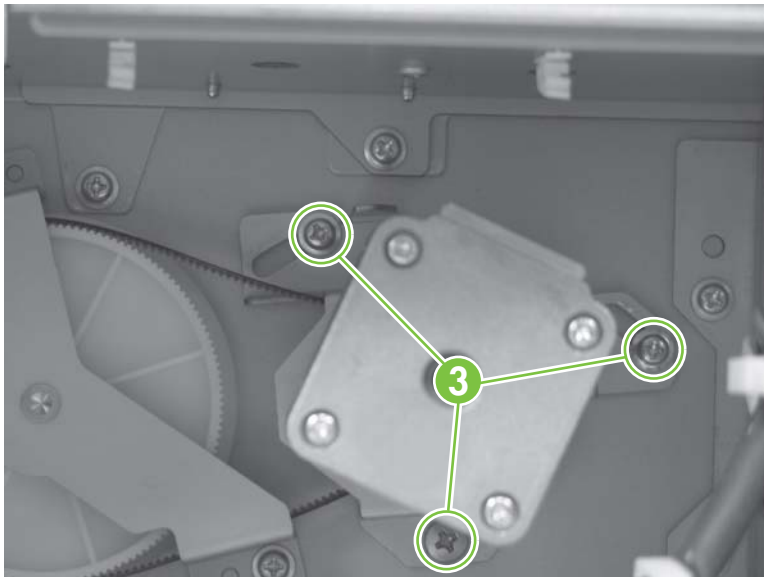
1. Remove the following components:
  - Scanner carriage-motor fan. See [Scanner carriage-motor fan on page 210](#).
  - Power switch and power receptacle assembly. See [Power switch and power receptacle assembly on page 231](#).
2. Remove one spring (callout 1) and one connector (callout 2).

**Figure 5-247** Remove the scanner carriage motor (1 of 5)



3. Remove three screws (callout 3).

**Figure 5-248** Remove the scanner carriage motor (2 of 5)



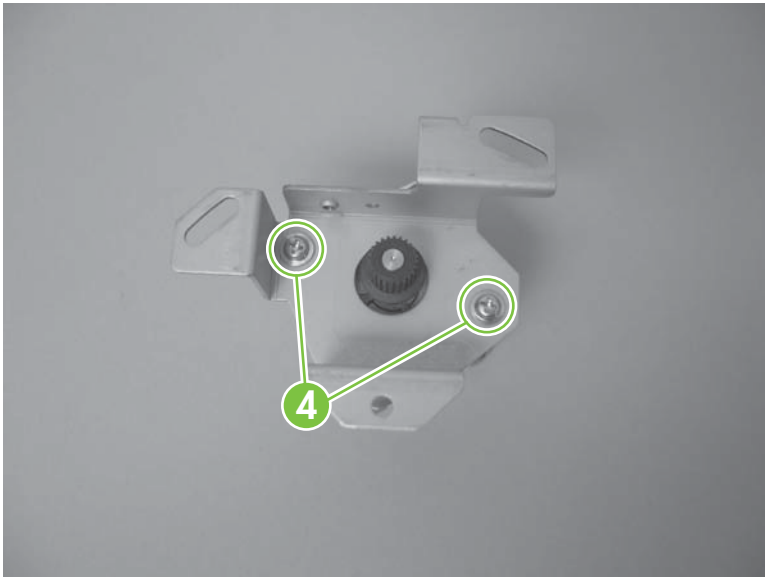
4. Remove the scanner carriage motor.

**Figure 5-249** Remove the scanner carriage motor (3 of 5)



5. Remove two screws (callout 4).

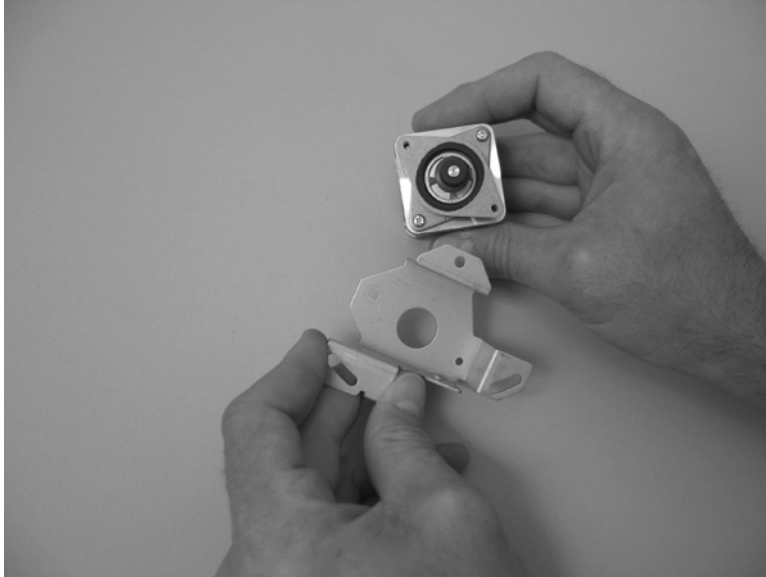
**Figure 5-250** Remove the scanner carriage motor (4 of 5)





6. Remove the mounting bracket from the scanner carriage motor.

**Figure 5-251** Remove the scanner carriage motor (5 of 5)



## Control-panel PCA

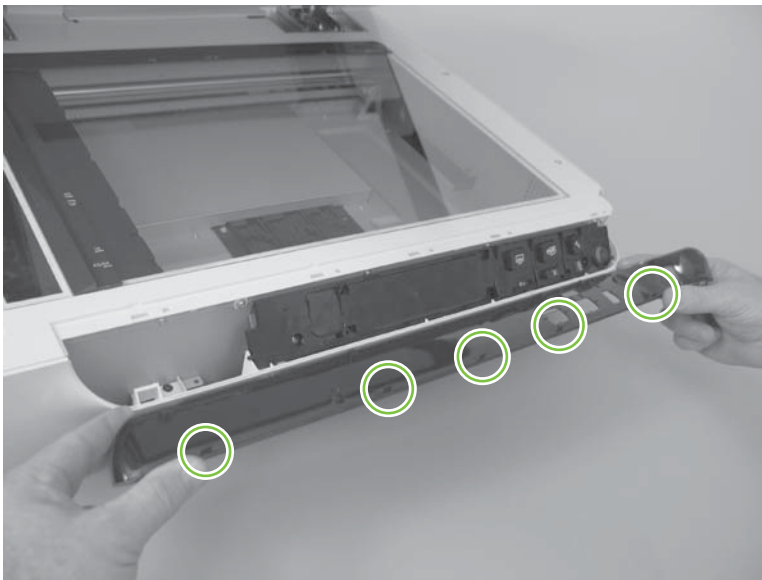
**CAUTION:** Do not bend or fold the flat flexible cables (FFCs) during removal or installation. Also, do not straighten prefolds in the FFCs. You *must* make sure that all FFCs are fully seated in their connectors. Failure to fully seat an FFC into a connector can cause a short circuit in a PCA.



Some parts are sensitive to electrostatic discharge (ESD). Always perform service work at an ESD-protected workstation or mat. If an ESD workstation or mat is not available, ground yourself by touching the sheet-metal chassis *before* touching an ESD-sensitive part.

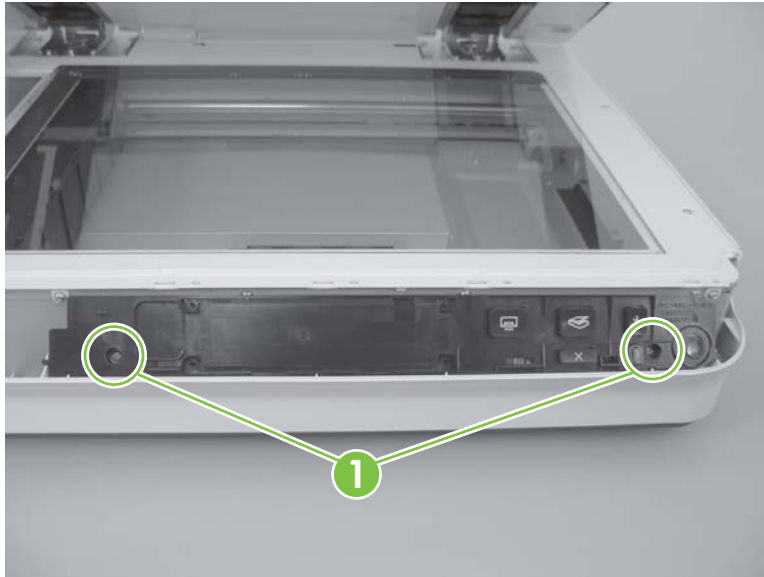
1. Release five tabs, and then rotate the front scanner control-panel cover away from the product to remove it.

**Figure 5-252** Remove the control-panel PCA (1 of 3)



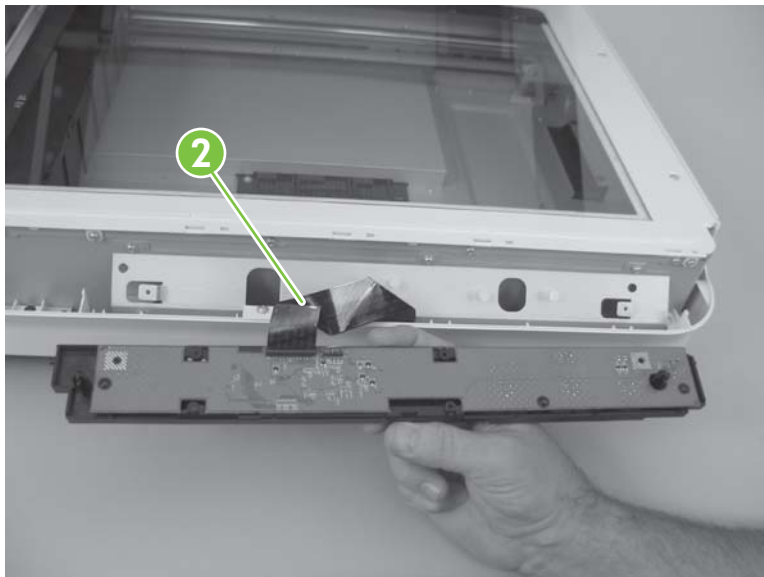
2. Remove two screws (callout 1).

**Figure 5-253** Remove the control-panel PCA (2 of 3)





3. Remove the scanner control-panel PCA, and then disconnect one FFC (callout 2).


**Figure 5-254** Remove the control-panel PCA (3 of 3)



## Scanner controller PCA

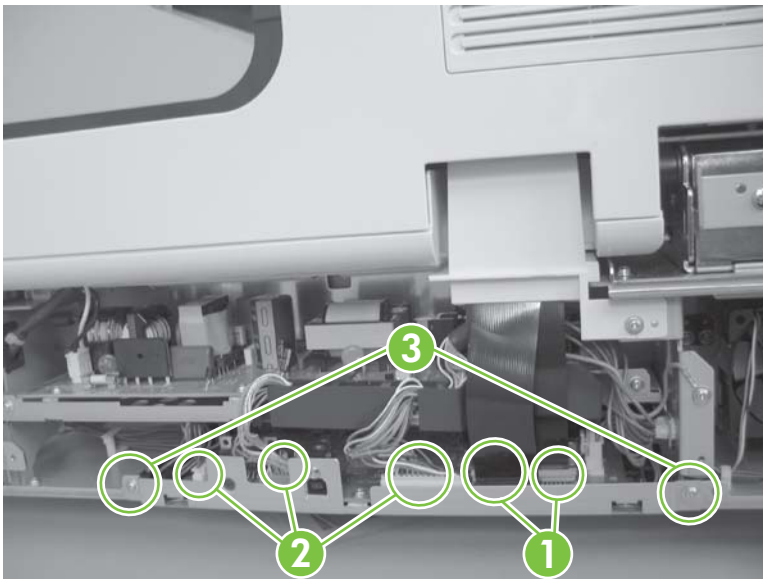
 **NOTE:** After replacing the scanner controller PCA, update the NVRAM data. See [NVRAM data management on page 75](#).

 **CAUTION:** Do not bend or fold the flat flexible cables (FFCs) during removal or installation. Also, do not straighten prefolds in the FFCs. You *must* make sure that all FFCs are fully seated in their connectors. Failure to fully seat an FFC into a connector can cause a short circuit in a PCA.

 Some parts are sensitive to electrostatic discharge (ESD). Always perform service work at an ESD-protected workstation or mat. If an ESD workstation or mat is not available, ground yourself by touching the sheet-metal chassis *before* touching an ESD-sensitive part.

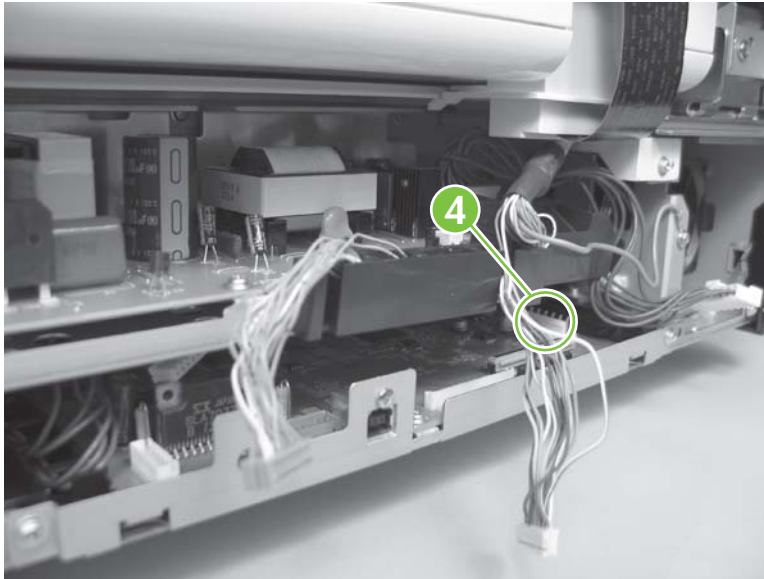
1. Remove the scanner back cover. See [Scanner back cover on page 60](#).
2. Remove two FFCs (callout 1), three connectors (callout 2), and two screws (callout 3).

**Figure 5-255** Remove the scanner controller PCA (1 of 4)



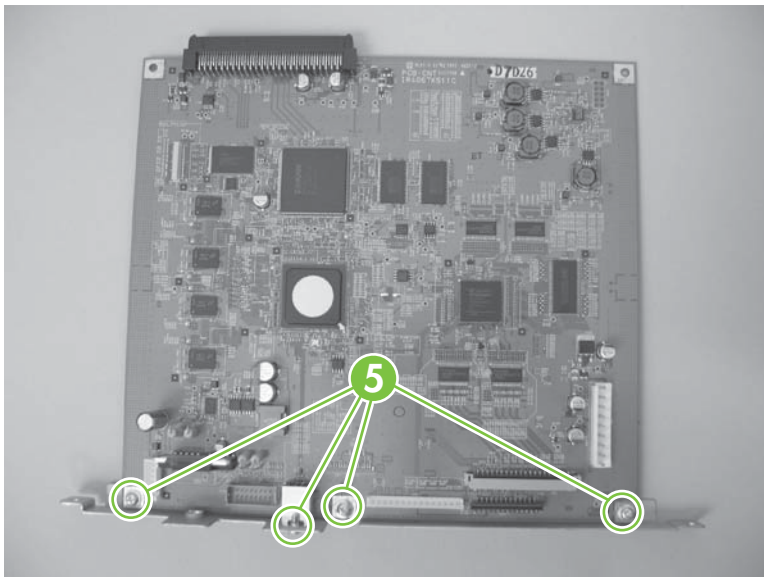
3. Pull the scanner controller PCA out partially and remove one connector (callout 4).

**Figure 5-256** Remove the scanner controller PCA (2 of 4)



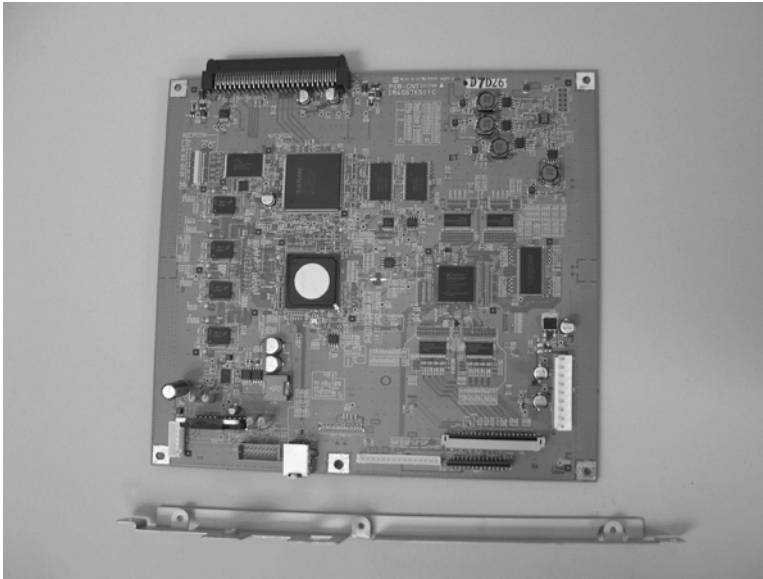
4. Remove the scanner controller PCA, and then remove four screws (callout 5).

**Figure 5-257** Remove the scanner controller PCA (3 of 4)



5. Remove the mounting bracket from the scanner controller PCA.

**Figure 5-258** Remove the scanner controller PCA (4 of 4)



6. Update the NVRAM data. See [NVRAM data management on page 75](#).

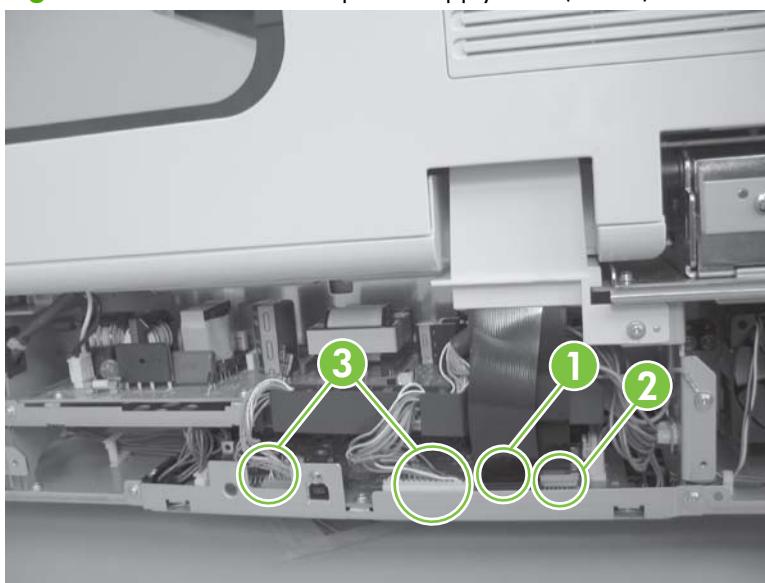
## Power-supply PCA

**⚠ CAUTION:** Do not bend or fold the flat flexible cables (FFCs) during removal or installation. Also, do not straighten prefolds in the FFCs. You *must* make sure that all FFCs are fully seated in their connectors. Failure to fully seat an FFC into a connector can cause a short circuit in a PCA.

**⚠ ESD** Some parts are sensitive to electrostatic discharge (ESD). Always perform service work at an ESD-protected workstation or mat. If an ESD workstation or mat is not available, ground yourself by touching the sheet-metal chassis *before* touching an ESD-sensitive part.

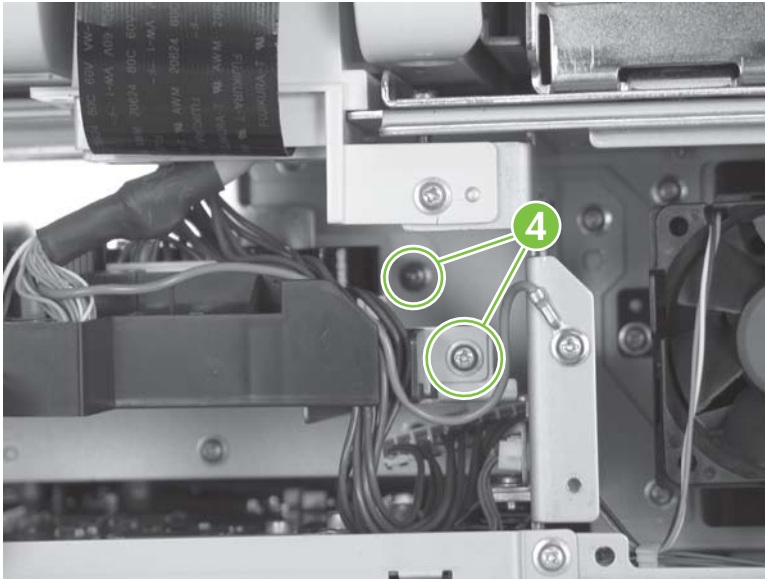
1. Remove the scanner back cover. See [Scanner back cover on page 60](#).
2. Remove two FFCs (callout 1 and callout 2) and two connectors (callout 3).

**Figure 5-259** Remove the power-supply PCA (1 of 6)



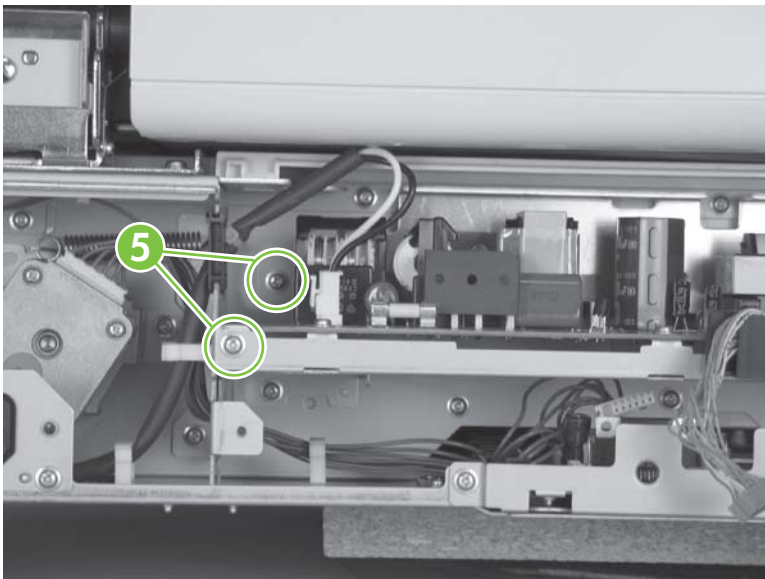
3. Remove two screws (callout 4).

**Figure 5-260** Remove the power-supply PCA (2 of 6)



4. Remove two screws (callout 5).

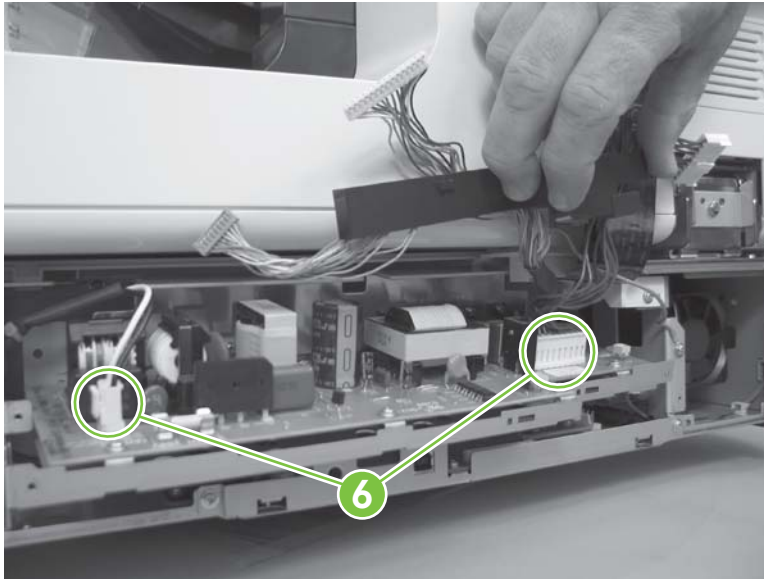
**Figure 5-261** Remove the power-supply PCA (3 of 6)





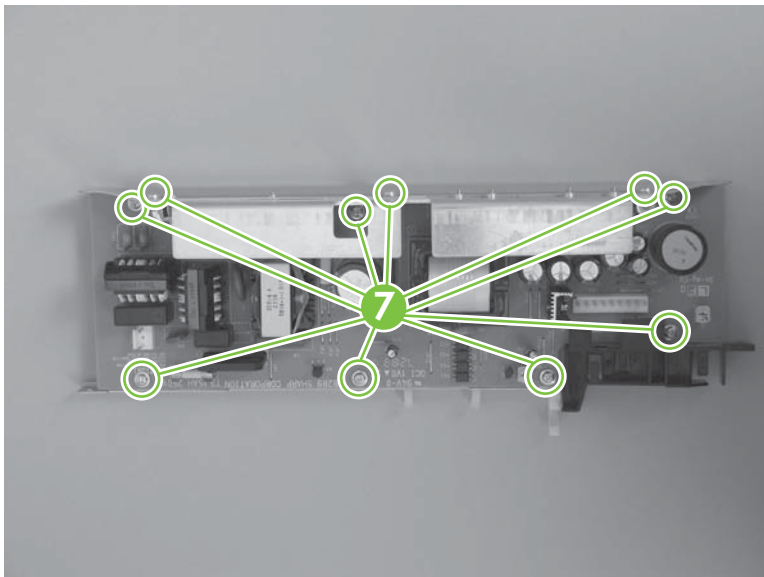
5. Remove two connectors (callout 6).

**Figure 5-262** Remove the power-supply PCA (4 of 6)



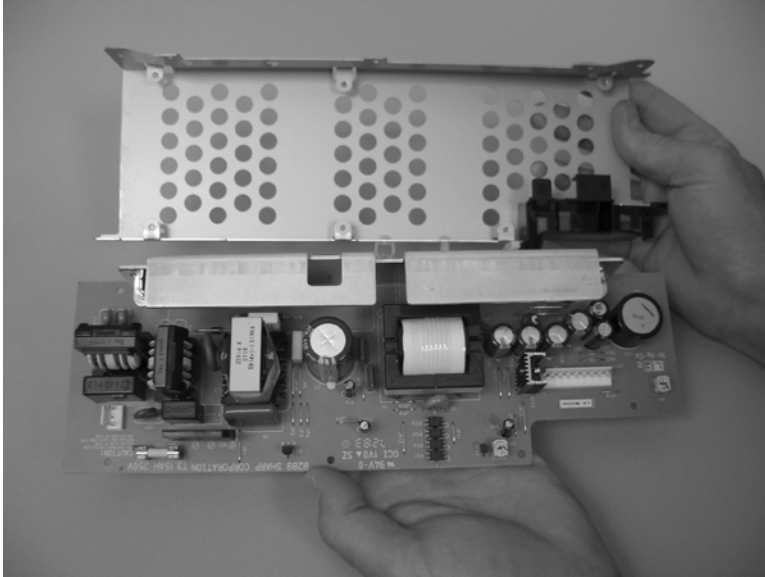
6. Remove the power-supply PCA, and then remove 10 screws (callout 7).

**Figure 5-263** Remove the power-supply PCA (5 of 6)



7. Remove the heat sink from the power-supply PCA.

**Figure 5-264** Remove the power-supply PCA (6 of 6)

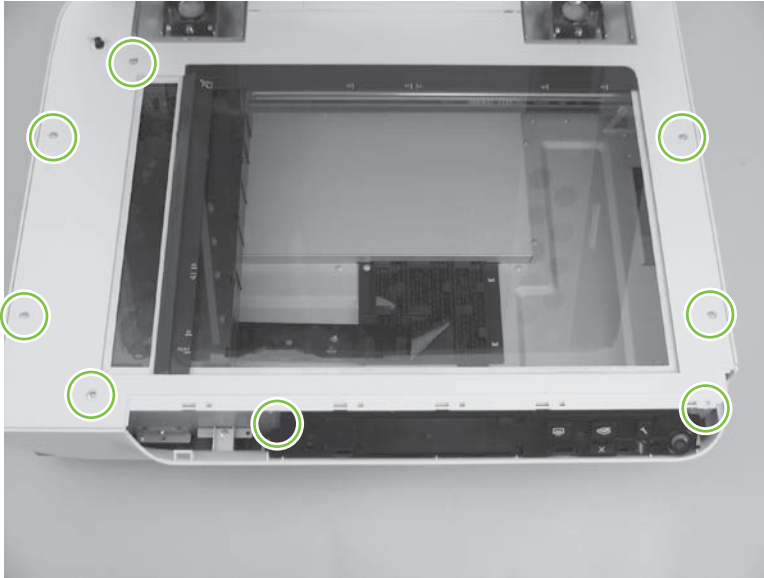


## Scanner-glass assembly

**⚠ WARNING!** Remove the scanner-glass assembly only in a clean-room environment.

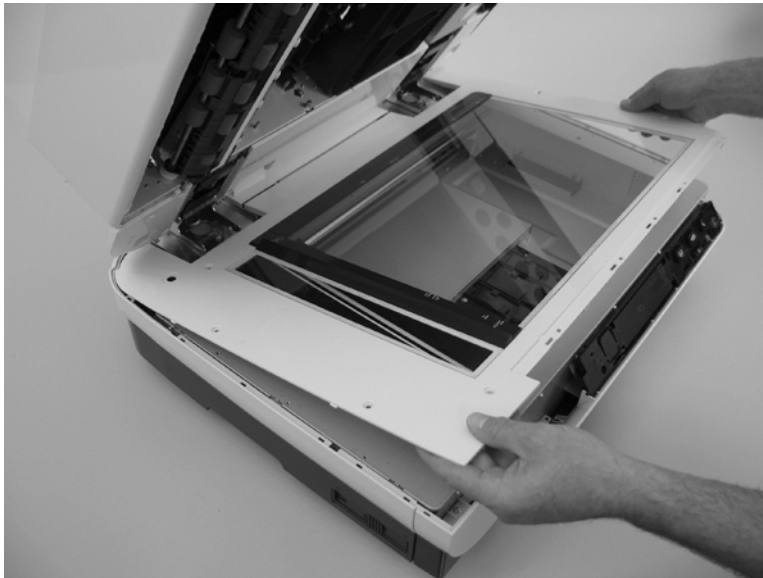
1. Verify that the work area is a clean-room environment.
2. Remove the control-panel cover. See [Scanner control-panel cover on page 53](#).
3. Remove eight screws.

**Figure 5-265** Remove the scanner-glass assembly (1 of 2)



4. Remove the scanner-glass assembly.

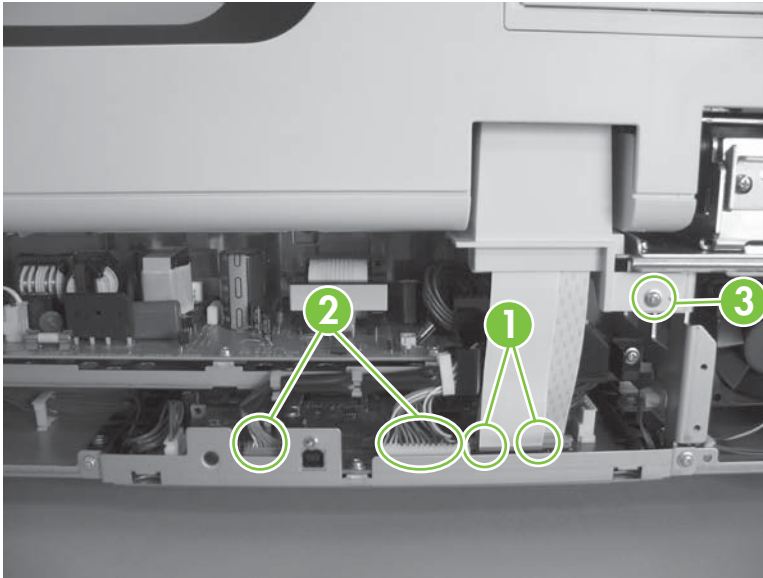
**Figure 5-266** Remove the scanner-glass assembly (2 of 2)



## ADF power-cable assembly

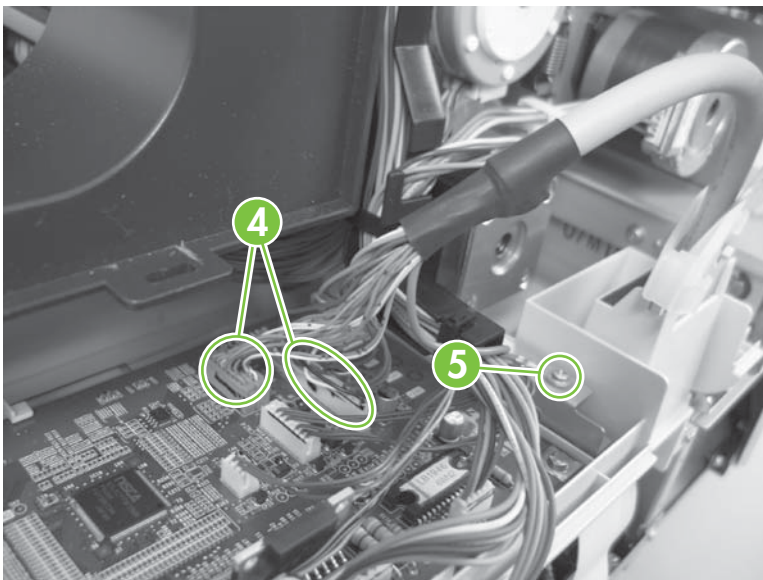
1. Remove the following components:
  - ADF back cover. See [ADF back cover on page 58](#).
  - Scanner back cover. See [Scanner back cover on page 60](#).
2. Remove two FFCs (callout 1), two connectors (callout 2), and one screw (callout 3).

**Figure 5-267** Remove the ADF power-cable assembly (1 of 3)



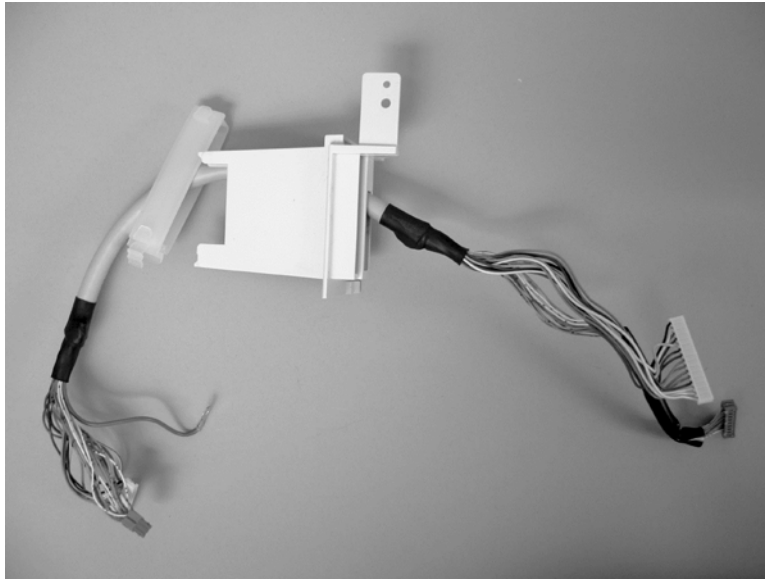
3. Remove two connectors (callout 4) and one screw (callout 5).

**Figure 5-268** Remove the ADF power-cable assembly (2 of 3)



4. Remove the ADF power-cable assembly.

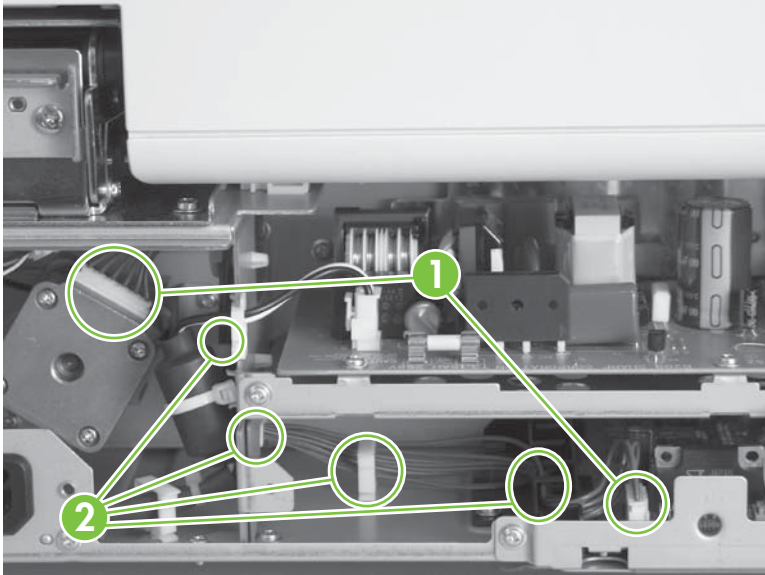
**Figure 5-269** Remove the ADF power-cable assembly (3 of 3)



## Carriage-motor cable

1. Remove the scanner back cover. See [Scanner back cover on page 60](#).
2. Remove two connectors (callout 1) and four retainers (callout 2).

**Figure 5-270** Remove the carriage-motor cable

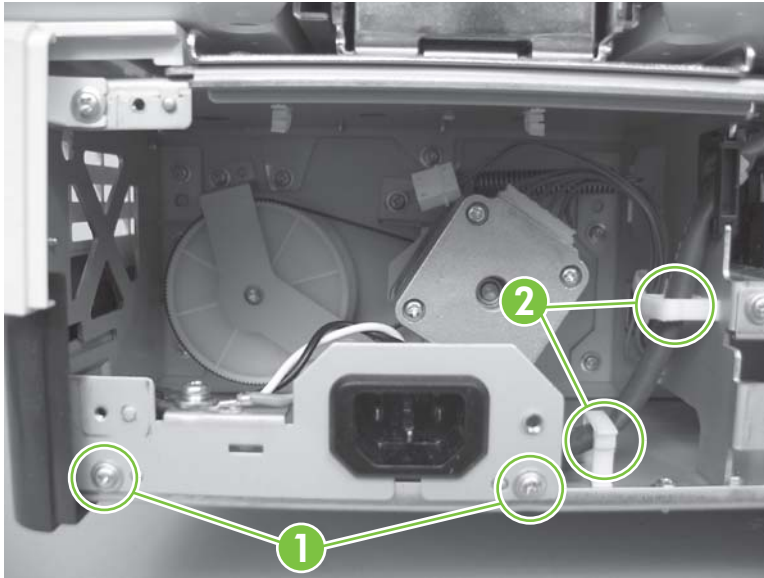


3. Remove the carriage-motor cable.

## Power switch and power receptacle assembly

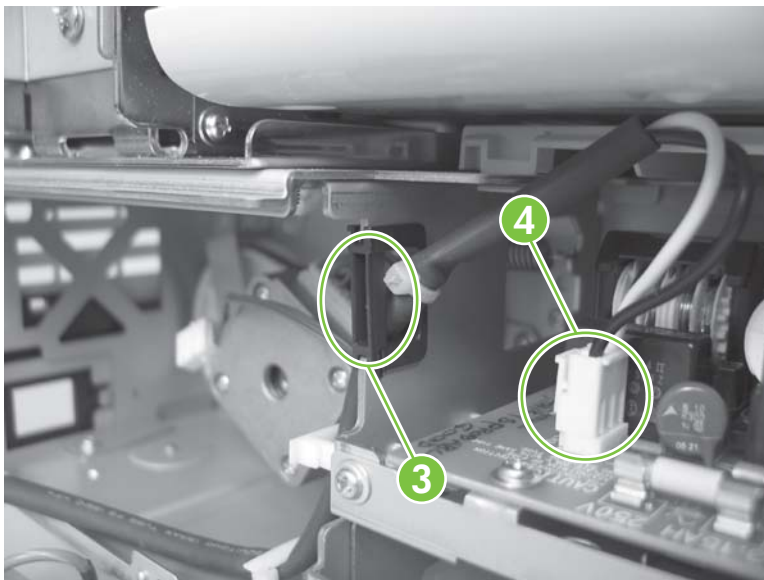
1. Remove the following components:
  - Scanner back cover. See [Scanner back cover on page 60](#)
  - Scanner carriage-motor fan. [Scanner carriage-motor fan on page 210](#)
2. Remove two screws (callout 1) and two retainers (callout 2).

**Figure 5-271** Remove the power switch and power receptacle assembly (1 of 3)



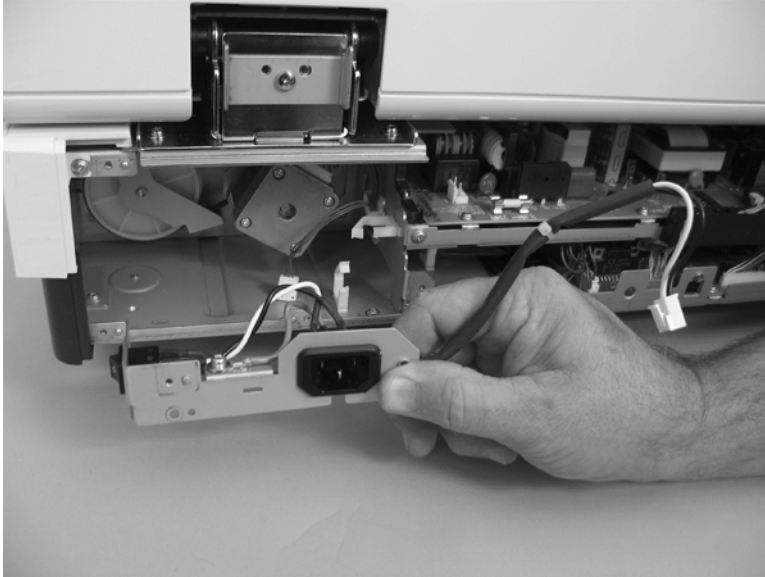
3. Remove one retainer (callout 3) and one connector (callout 4).

**Figure 5-272** Remove the power switch and power receptacle assembly (2 of 3)



4. Remove the power switch and power receptacle assembly.

**Figure 5-273** Remove the power switch and power receptacle assembly (3 of 3)





---

# 6 Solve problems

- [Troubleshooting process](#)
- [Pre-troubleshooting checklist](#)
- [Basic troubleshooting checks](#)
- [Troubleshooting diagnostic software](#)
- [Computer-display error messages](#)
- [Solve paper-handling problems](#)
- [Solve image-quality problems](#)
- [Solve performance problems](#)
- [Solve connectivity problems](#)

# Troubleshooting process

The troubleshooting process includes gathering information from the customer, conducting basic troubleshooting routines, and identifying FRUs that could be the source of problems with a scanner.

- Use the pre-troubleshooting checklist to gather preliminary information from the customer.
- Use the basic troubleshooting checks to evaluate the condition of the scanner, to identify potential problems, and to reduce the number of steps that are required to fix problems.
- Use the troubleshooting service software to identify FRUs that could be the cause of problems and to select appropriate removal and replacement procedures.

# Pre-troubleshooting checklist

The following checklist contains questions that you can ask the customer to help define any problem(s) quickly. For more information about product and media specifications, see [Paper handling on page 10](#) and [Media specifications on page 10](#).

**Table 6-1 Initial troubleshooting checklist**

Environment	<ul style="list-style-type: none"><li>• Is the product installed in a suitable environment? See <a href="#">Installation and configuration on page 13</a>.</li><li>• Is the product installed on a solid, level surface?</li><li>• Is the supply voltage (from the wall receptacle) within <math>\pm 10\%</math> of the product's rated voltage (see <a href="#">Quick access to product information on page 2</a>)?</li><li>• Is the power cord fully seated into both the product and the electrical receptacle in the wall?</li><li>• Is the product exposed to ammonia gas, such as that produced by diazo copiers or office-cleaning materials?  <b>NOTE:</b> Diazo copiers produce ammonia gas as part of the copying processes. Ammonia gas can have an adverse affect on some product components (for example, the pickup roller).</li><li>• Is the product exposed to direct sunlight?</li></ul>
Media	<ul style="list-style-type: none"><li>• Is suitable media used in the product? See <a href="#">Paper handling on page 10</a> and <a href="#">Media specifications on page 10</a>.</li><li>• Does the customer use only supported print media?</li><li>• Is the media in good condition (no curl, folds, or other flaws)?</li><li>• Is the source media stored correctly and within environmental limits?</li></ul>
ADF input tray	<ul style="list-style-type: none"><li>• Is the correct amount of source media loaded in the tray (not stacked above the arrows embossed in the tray)?</li><li>• Is the media placed in the tray correctly?</li><li>• Are the paper guides aligned with the stack?</li></ul>
Imprinter cartridge	<ul style="list-style-type: none"><li>• Is the imprinter cartridge installed correctly?</li></ul>
Doors	<ul style="list-style-type: none"><li>• Are the ADF jam doors closed?</li></ul>
Condensation	<ul style="list-style-type: none"><li>• Does condensation occur following a temperature change (particularly in winter following cold storage)? If so, wipe off the affected parts or leave the product on for 10 to 20 minutes, and then attempt to resume scanning.</li><li>• Was an imprinter cartridge opened soon after it was moved from a cold room to a warm one? If so, allow the imprinter cartridge and the product to acclimate to room temperature for 1 to 2 hours.</li></ul>

## Basic troubleshooting checks

Before beginning any troubleshooting procedure, check the following issues:

- Are supply items (for example, the imprinter cartridge, separation pad, and rollers) within their rated life? See [Parts life expectancy on page 22](#).
- Can the expected startup sounds be heard when the product power is turned on?



---

**NOTE:** The customer is responsible for checking and maintaining supplies and for using supplies that are in good condition. The customer is responsible for imprinter-cartridge supplies and for replacing the pickup roller and separation pad.

---

# Power-on checks

## Scanner initialization or hardware problems

If the scanner does not work after installation or if the scanner has stopped working correctly, you might see a message on the computer screen that is similar to one of the following:

- **The scanner could not be initialized.**
- **The scanner could not be found.**
- **An internal error has occurred.**
- **The computer cannot communicate with the scanner.**

## Turn on the power

When you turn on the power, if it does not make any sound or does not initialize, check the following items:

- Verify that the product is plugged directly into an active electrical outlet that has the correct voltage. Do not plug the product into a surge protector or power strip.
- Verify that the power switch is in the on position.
- Verify that the USB cable is correctly connected to the product and host computer.
  - Use the USB cable that was included with the scanner. Another USB cable might not be compatible with the scanner. See [Service part numbers on page 293](#) for part number and specifications.
  - Make sure that the USB cable is securely connected between the scanner and the computer or USB hub. The trident icon on the USB cable faces up when the cable is properly connected to the scanner.
- Make sure that the control-panel FFC is connected correctly.
- Check the connectors on the power supply PCA and the scanner-controller PCA.

Use the following to identify or fix the problem:

- LED diagnostics (see [LED diagnostics on page 238](#))
- USB connection (see [Check the USB connection on page 239](#))
- HP Scanjet utilities (see [Uninstall and then reinstall the HP Scanjet utilities on page 239](#))
- Control-panel buttons diagnostics (see [Control-panel buttons on page 240](#))

## LED diagnostics

The scanner has two LED lights on the front panel that indicate scanner functions and error conditions. The LED in the shape of an exclamation point (!) is the **Attention** LED, and the LED in the **Power Save** button is the Power LED. The table below explains how to interpret the indicator LEDs.

**Figure 6-1** Control-panel LEDs



**Table 6-2** Control-panel LEDs

LED indications	Scanner action or condition
The <b>Attention</b> LED quickly blinks amber, and the <b>Power</b> LED is lit with a steady green light.	Error condition—check your computer screen for an error message.
The <b>Attention</b> LED is lit with a steady amber light, and the <b>Power</b> LED is lit with a steady green light.	Attention condition—check your computer screen for a <b>Maintenance Recommended</b> message.
The <b>Attention</b> LED slowly blinks green, and the <b>Power</b> LED is lit with a steady green light.	The scanner is warming up.
The <b>Power</b> LED is lit with a steady, dim amber light.	The scanner is in Power Save mode.
The <b>Power</b> LED is lit with a steady green light.	The scanner is on and ready to scan.
The <b>Attention</b> LED blinks green at a medium speed, and the <b>Power</b> LED is lit with a steady green light.	The scanner is scanning an original.
Both LEDs are off.	There is no power to the scanner.

## Check the USB connection

If the problem persists after verifying the control-panel LEDs, try the following:

1. Turn off the computer.
2. Do one of the following tasks:
  - If the USB cable is connected to a USB hub or a docking station for a laptop, disconnect the USB cable from the USB hub or the docking station, and then connect the USB cable directly to the computer.
  - If the USB cable is directly connected to the computer, plug it into another USB port on the computer.
  - Remove all other USB devices from the computer except for the keyboard and the mouse.
3. Press the power switch to the off position, wait 30 seconds, and then press the power switch to the on position.
4. Restart the computer.
5. After the computer has restarted, try using the scanner.
  - If the scanner works and you changed its USB connection, the communication problem might involve the USB hub, the docking station, a USB port, or another USB device. Leave the scanner directly connected to the computer. Try using the scanner after reconnecting each additional USB device, and disconnect any USB devices that prevent the scanner from working correctly.
  - If the scanner does not work, uninstall and then reinstall the HP Scanjet drivers and utilities.

## Uninstall and then reinstall the HP Scanjet utilities

If checking the USB cable and USB connections did not solve the problem, the problem might have occurred because of an incomplete software installation. Try uninstalling and then reinstalling the HP Scanjet utilities.

1. Press the power switch to the off position, and then disconnect the USB cable and power cable from the scanner.
2. Use the **Add/Remove** tool (in Windows Vista®, the **Programs and Features** tool) from the **Control Panel** to uninstall the following items:
  - N9120 Document ISIS/TWAIN
  - N9120 Utilities
3. Restart the computer.

4. Use the HP Scanning Software CD that came with the scanner to reinstall the HP Scanjet drivers and tools.
5. Reconnect the USB cable and power cable to the scanner, and then press the power switch to the on position.

After 30 seconds, the **Power** LED is lit with a steady green light and the **Attention** LED is off.

## Control-panel buttons

### Control-panel buttons diagnostics

After each of the following steps, press a button to see if the scanner is working correctly. If the problem persists, proceed with the next step.

1. Make sure that the **Disable front panel buttons** setting in the HP Scanner Tools Utility is cleared.
2. Check that the USB cable and the power cable are securely connected to the host computer and the scanner.
3. Turn off the scanner, wait 30 seconds, and then turn the scanner back on.
4. Restart your computer.
5. If the problem persists, the buttons might be disabled outside of the HP scanning software. Try the following:
  - a. Open **Control Panel**, select **Scanners and Cameras**, and then select your scanner model from the list.
  - b. Examine the buttons setting for your scanner and do one of the following:
    - **Windows 2000:** Make sure that the **Disable Device Events** option is not selected.
    - **Windows XP and Vista:** Make sure that the **Take No Action** option is not selected.

### Locked control-panel buttons

To prevent buttons from being pushed accidentally, you can disable the buttons on the scanner front panel.



---

**NOTE:** When the buttons are disabled, you always start scans and copies from the computer using scanning software. You can still press the **Cancel** button on the scanner front panel to stop a scan or copy and the **Power Save** button to put the scanner into Power Save mode.

---





---

**TIP:** You must have administrative privileges on the computer to lock or unlock the control-panel buttons.

---

1. Open the HP Scanner Tools Utility.
2. On the Buttons tab, either select or clear the **Disable front panel buttons** check box to lock or unlock the buttons.

**-or-**

On the Buttons tab, clear the **Disable front panel buttons** check box to unlock the buttons.

# Troubleshooting diagnostic software

## Main screen

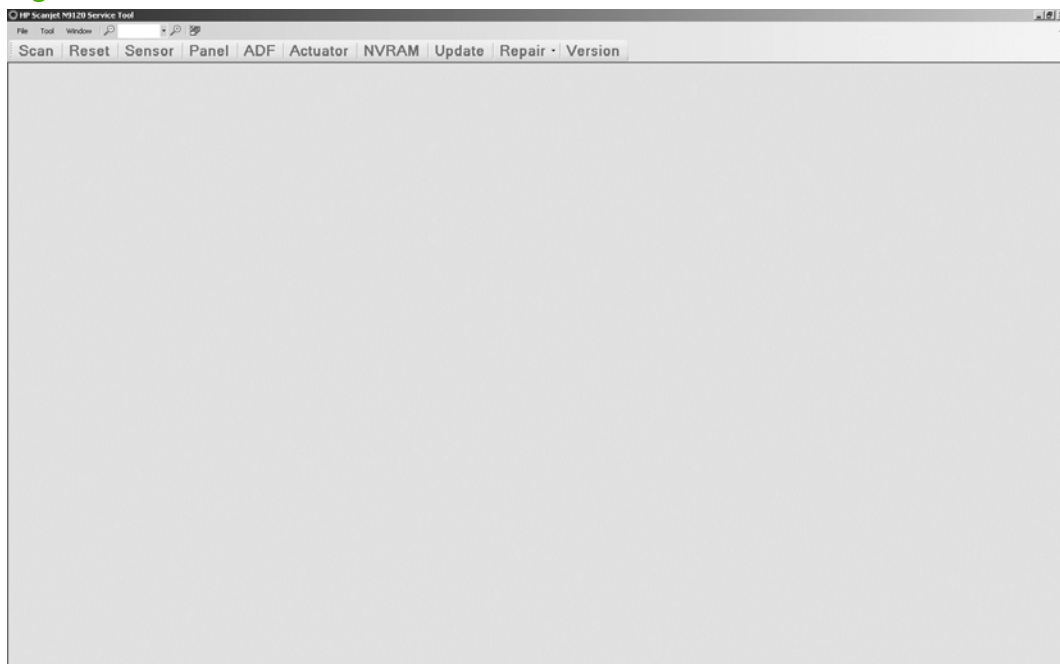
**⚠ WARNING!** Do not add, delete, or modify NVRAM values in the NVRAM dialog box. Doing so might render the product inoperable. See [NVRAM dialog box on page 258](#).

You can download a copy of the N9120 Service Tool by going to the following FTP site: <ftp.hp.com/pub/scanners/treebeard/>. Once you have accessed the site, look for the folder titled N9120 Service Tool. Open it and copy the N9120 Service Tool.zip file to your Hard drive. Once downloaded, extract the files from the Win.Zip file you just downloaded. Open the Readme file and follow the instructions to install the N9120 Service Tool.

### Open the N9120 Service Tool:

1. Click **Start** and then click **Programs**.
2. Click **N9120 Service Tool**.

**Figure 6-2** Main screen



**Table 6-3** Main screen

Item	Button description	Function
1	<b>Scan</b>	Click <b>Scan</b> to open the <b>Scan</b> dialog box. See <a href="#">Scan dialog box on page 244</a> .
2	<b>Reset</b>	Click <b>Reset</b> to reset the scanner.
3	<b>Sensor</b>	Click <b>Sensor</b> to open the <b>Sensor check</b> dialog box. See <a href="#">Sensor check dialog box on page 246</a> .

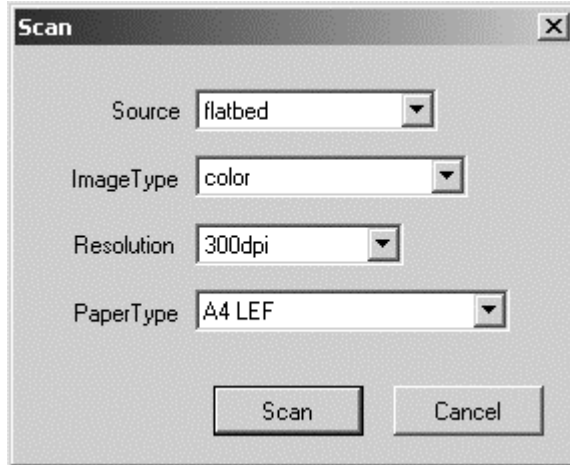
**Table 6-3 Main screen (continued)**

Item	Button description	Function
4	<b>Panel</b>	Click <b>Panel</b> to open the <b>Control panel check</b> dialog box. See <a href="#">Control panel check dialog box on page 251</a> .
5	<b>ADF</b>	Click the <b>ADF</b> button to open the <b>ADF feed test</b> dialog box. See <a href="#">ADF feed test dialog box on page 253</a> .
6	<b>Actuator</b>	Click <b>Actuator</b> to open the <b>Actuators</b> dialog box. See <a href="#">Actuators dialog box on page 255</a> .
7	<b>NVRAM</b>	Click <b>NVRAM</b> to open the <b>NVRAM</b> dialog box. See <a href="#">NVRAM dialog box on page 258</a> .  <b>WARNING!</b> Do not add, delete, or modify NVRAM values. Doing so might render the product inoperable.
8	<b>Update</b>	Click <b>Update</b> to open the <b>Open</b> dialog box. See <a href="#">Update dialog box on page 260</a> .
9	<b>Repair</b>	Click <b>Repair</b> to open the Repair menu. See <a href="#">Repair menu on page 261</a> .
10	<b>Version</b>	Click <b>Version</b> to open the <b>Version information</b> dialog box. See <a href="#">Version information dialog box on page 262</a> .



## Scan dialog box

1. Open the N9120 Service Tool.
2. On the toolbar, click **Scan**.



**Figure 6-3** Scan dialog box



**Table 6-4** Scan dialog box

Item	Description	Function
1	<b>Source</b> list	Click the <b>Source</b> list down arrow  . <ul style="list-style-type: none"><li>• Select <b>Flatbed</b> to scan a document from the scanner glass.</li><li>• Select <b>adf simplex</b> to scan a single-sided document from the ADF input tray.</li><li>• Select <b>adf duplex</b> to scan a double-sided document from the ADF input tray.</li></ul>
2	<b>Image Type</b> list	Click the <b>Image Type</b> list down arrow  . <ul style="list-style-type: none"><li>• Select <b>black/white</b> to scan a black and white document.</li><li>• Select <b>grayscale</b> to scan a gray scale document.</li><li>• Select <b>color</b> to scan a color document.</li><li>• Select <b>jpeg@color</b> to scan a color image.</li><li>• Select <b>jpeg@grayscale</b> to scan a gray scale image.</li></ul>

**Table 6-4 Scan dialog box (continued)**

Item	Description	Function
3	<b>Resolution</b> list	Click the <b>Resolution</b> list down arrow  and select a resolution setting. <ul style="list-style-type: none"><li>• <b>75dpi</b></li><li>• <b>100dpi</b></li><li>• <b>150dpi</b></li><li>• <b>200dpi</b></li><li>• <b>240dpi</b></li><li>• <b>300dpi</b></li><li>• <b>400dpi</b></li><li>• <b>500dpi</b></li><li>• <b>600dpi</b></li></ul>
4	<b>Paper Type</b> list	Click the <b>Paper Type</b> list down arrow  to select a paper type. <ul style="list-style-type: none"><li>• <b>Ledger SEF</b></li><li>• <b>Letter LEF</b></li><li>• <b>Letter SEF</b></li><li>• <b>Legal SEF</b></li><li>• <b>Executive LEF</b></li><li>• <b>Executive SEF</b></li><li>• <b>A3 SEF</b></li><li>• <b>A4 LEF</b></li><li>• <b>A4 SEF</b></li><li>• <b>A5 LEF</b></li><li>• <b>A5 SEF</b></li><li>• <b>A6 SEF</b></li><li>• <b>B4 SEF</b></li><li>• <b>B5 LEF</b></li><li>• <b>B5 SEF</b></li></ul>
5	<b>Scan</b> button	Click the <b>Scan</b> button to start the scan job.
6	<b>Cancel</b> button	Click the <b>Cancel</b> button to close the <b>Scan</b> dialog box.

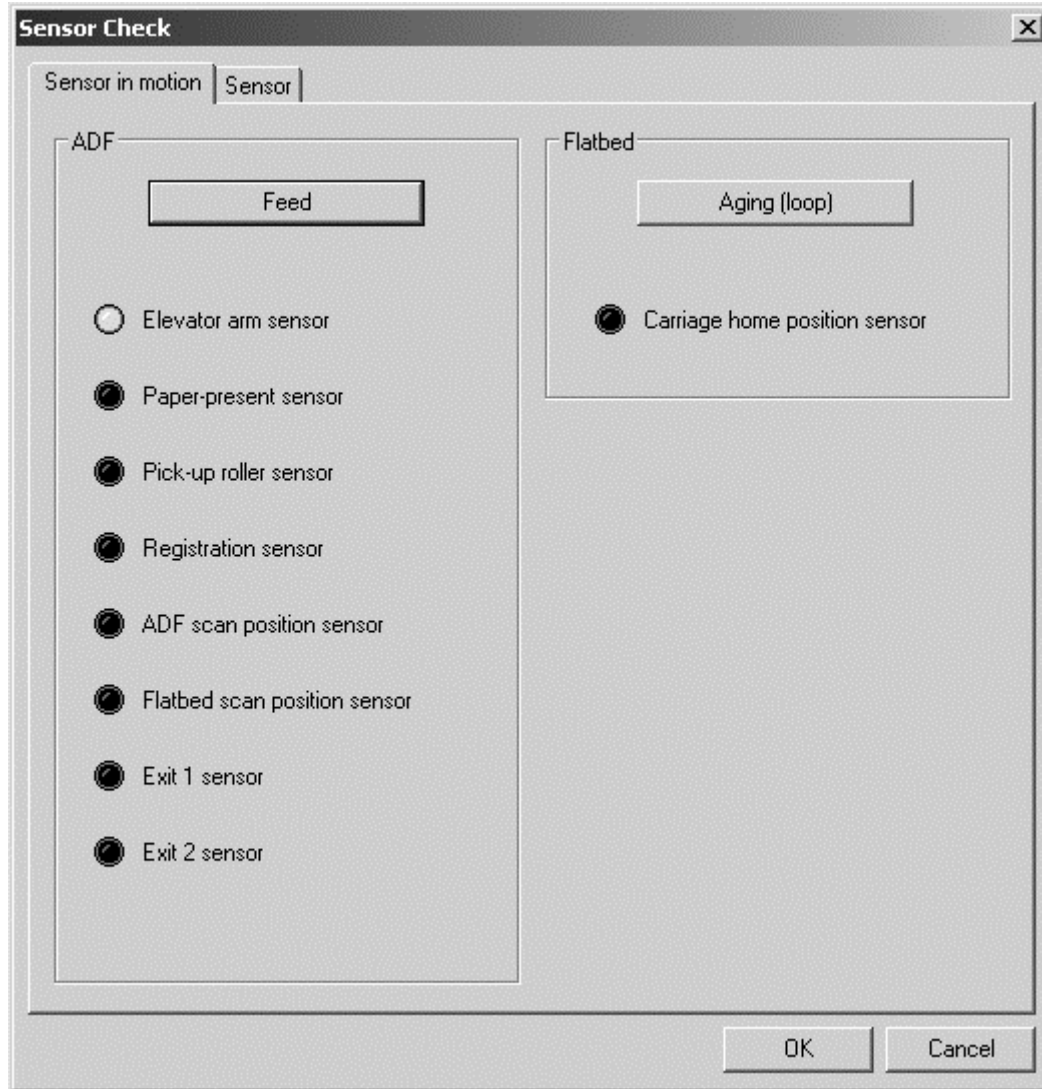
## Sensor check dialog box

1. Open the N9120 Service Tool.
2. On the toolbar, click **Sensor**.

The **Sensor check** dialog box contains two tabs:

- Sensor in motion
- Sensor

**Figure 6-4** Sensor in motion tab



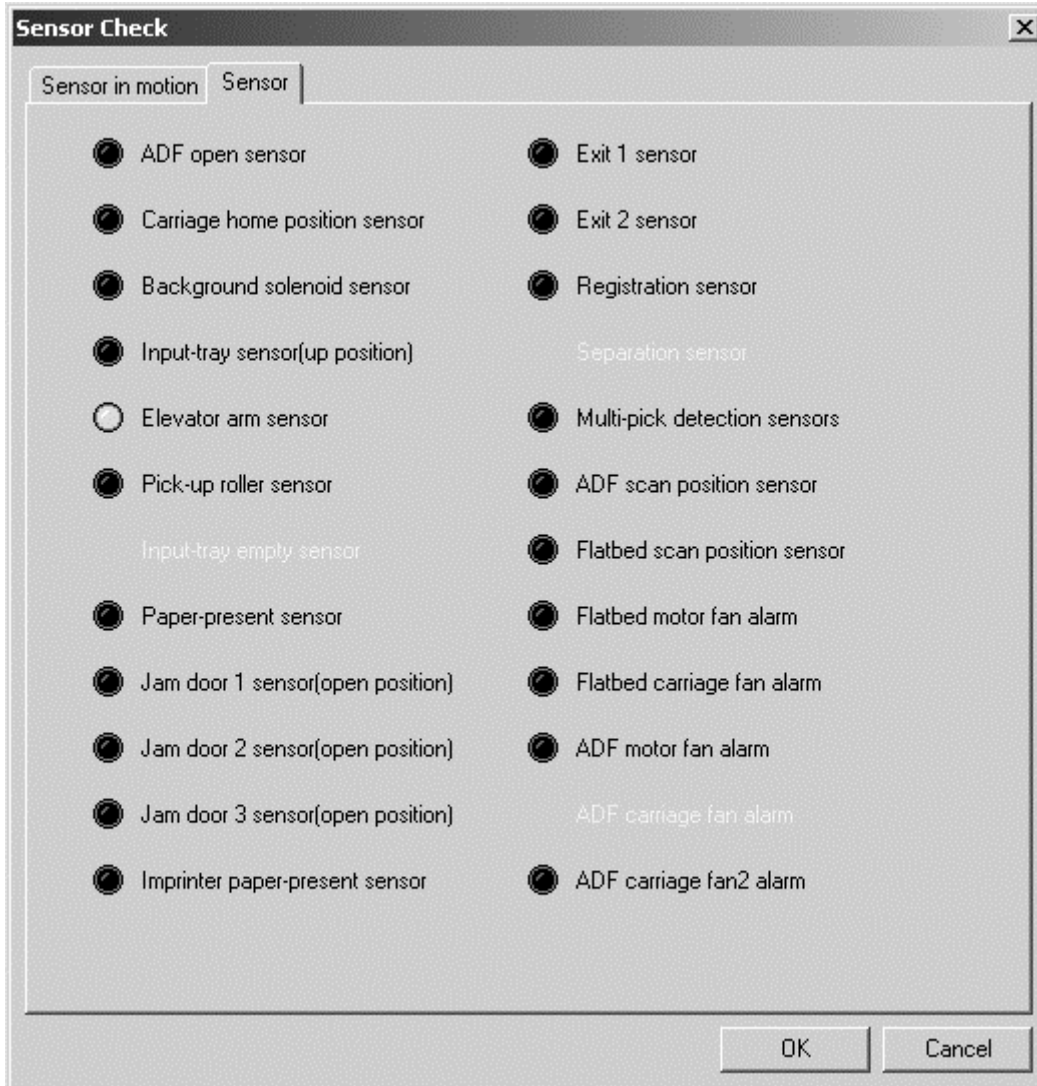
**Table 6-5** Sensor in motion tab

Item	Description	Function
1	<b>Feed</b> button	Click the <b>Feed</b> button to scan a test document from the ADF.
2	<b>Elevator arm sensor</b> indicator	<ul style="list-style-type: none"><li>• Indicator is green (on) when the elevator arm is in the home (down) position.</li><li>• Indicator is black (off) when the elevator arm is not in the home (down) position.</li></ul>

**Table 6-5 Sensor in motion tab (continued)**

Item	Description	Function
3	<b>Paper-present sensor</b> indicator	<ul style="list-style-type: none"><li>Indicator is green (on) when the paper-present sensor detects paper in the ADF input tray.</li><li>Indicator is black (off) when the paper-present sensor does not detected paper in the ADF input tray.</li></ul>
4	<b>Pick-up roller sensor</b> indicator	<ul style="list-style-type: none"><li>Indicator is green (on) when the pick-up roller sensor detects paper at the pick-up roller assembly.</li><li>Indicator is black (off) when the pick-up roller sensor does not detect paper at the pickup roller assembly.</li></ul>
5	<b>Registration sensor</b> indicator	<ul style="list-style-type: none"><li>Indicator is green (on) when the registration sensor detects paper after the pickup roller assembly.</li><li>Indicator is black (off) when the registration sensor does not detect paper after the pickup roller assembly.</li></ul>
6	<b>ADF scan position sensor</b> indicator	<ul style="list-style-type: none"><li>Indicator is green (on) when the ADF scan position sensor detects paper after the multi-pick sensors.</li><li>Indicator is black (off) when the ADF scan position sensor does not detect paper after the multi-pick sensors.</li></ul>
7	<b>Flatbed scan position sensor</b> indicator	<ul style="list-style-type: none"><li>Indicator is green (on) when the scan position sensor detects paper after the ADF scan position sensor.</li><li>Indicator is black (off) when the scan position sensor does not detect paper after the ADF scan position sensor.</li></ul>
8	<b>Exit 1 sensor</b> indicator	<ul style="list-style-type: none"><li>Indicator is green (on) when the exit 1 sensor detects paper after the scan position sensor.</li><li>Indicator is black (off) when the exit 1 sensor does not detect paper after the scan position sensor.</li></ul>
9	<b>Exit 2 sensor</b> indicator	<ul style="list-style-type: none"><li>Indicator is green (on) when the exit 2 sensor detects paper after the exit 1 sensor.</li><li>Indicator is black (off) when the exit 2 sensor does not detect paper after the exit 1 sensor.</li></ul>
10	<b>Aging (loop)</b> button	Click the <b>Aging (loop)</b> button to test the carriage home position sensor.
11	<b>Carriage home position sensor</b> indicator	<ul style="list-style-type: none"><li>Indicator is green (on) when the scanner carriage has reached the home position.</li><li>Indicator is black (off) when the scanner carriage has not reached the home position.</li></ul>
12	<b>OK</b> button	Click the <b>OK</b> button to close the <b>Sensor check</b> dialog box.
13	<b>Cancel</b> button	Click the <b>Cancel</b> button to close the <b>Sensor check</b> dialog box.

**Figure 6-5** Sensor tab



**Table 6-6** Sensor tab

Item	Description	Function
1	<b>ADF open sensor</b> indicator	<ul style="list-style-type: none"> <li>Indicator is green (on) when the ADF is open.</li> <li>Indicator is black (off) when the ADF is closed.</li> </ul>
2	<b>Carriage home position sensor</b> indicator	<ul style="list-style-type: none"> <li>Indicator is green (on) when the when the scanner carriage has reached the home position.</li> <li>Indicator is black (off) when the scanner carriage has not reached the home position.</li> </ul>
3	<b>Background solenoid sensor</b> indicator	<ul style="list-style-type: none"> <li>Indicator is green (on) when the background is black.</li> <li>Indicator is black (off) when the background is white.</li> </ul>
4	<b>Input-tray sensor (up position)</b> indicator	<ul style="list-style-type: none"> <li>Indicator is green (on) when the input tray is not in the home position.</li> <li>Indicator is black (off) when input tray is in the home (down) position.</li> </ul>



**Table 6-6 Sensor tab (continued)**


Item	Description	Function
5	<b>Elevator arm sensor</b> indicator	<ul style="list-style-type: none"><li>Indicator is green (on) when the elevator arm is in the home (down) position.</li><li>Indicator is black (off) when the elevator arm is not in the home (down) position.</li></ul>
6	<b>Pick-up roller sensor</b> indicator	<ul style="list-style-type: none"><li>Indicator is green (on) when the pick-up roller sensor detects paper at the pick-up roller assembly.</li><li>Indicator is black (off) when the pick-up roller sensor does not detect paper at the pickup roller assembly.</li></ul>
8	<b>Paper-present sensor</b> indicator	<ul style="list-style-type: none"><li>Indicator is green (on) when the paper-present sensor detects paper in the ADF input tray.</li><li>Indicator is black (off) when the paper-present sensor does not detected paper in the ADF input tray.</li></ul>
9	<b>Jam door 1 sensor</b> indicator	<ul style="list-style-type: none"><li>Indicator is green (on) when jam door 1 is open.</li><li>Indicator is black (off) when jam door 1 is closed.</li></ul>
10	<b>Jam door 2 sensor</b> indicator	<ul style="list-style-type: none"><li>Indicator is green (on) when jam door 2 is open.</li><li>Indicator is black (off) when jam door 2 is closed.</li></ul>
11	<b>Jam door 3 sensor</b> indicator	<ul style="list-style-type: none"><li>Indicator is green (on) when jam door 3 is open.</li><li>Indicator is black (off) when jam door 3 is closed.</li></ul>
12	<b>Imprinter paper-present sensor</b> indicator	<ul style="list-style-type: none"><li>Indicator is green (on) when the imprinter paper-present sensor detects paper at the imprinter.</li><li>Indicator is black (off) when the imprinter paper-present sensor does not detect paper at the imprinter.</li></ul>
13	<b>Exit 1 sensor</b> indicator	<ul style="list-style-type: none"><li>Indicator is green (on) when the exit 1 sensor detects paper after the scan position sensor.</li><li>Indicator is black (off) when the exit 1 sensor does not detect paper after the scan position sensor.</li></ul>
14	<b>Exit 2 sensor</b> indicator	<ul style="list-style-type: none"><li>Indicator is green (on) when the exit 2 sensor detects paper after the exit 1 sensor.</li><li>Indicator is black (off) when the exit 2 sensor does not detect paper after the exit 1 sensor.</li></ul>
15	<b>Registration sensor</b> indicator	<ul style="list-style-type: none"><li>Indicator is green (on) when the registration sensor detects paper after the pickup roller assembly.</li><li>Indicator is black (off) when the registration sensor does not detect paper after the pickup roller assembly.</li></ul>
17	<b>Multi-pick detection sensor</b> indicator	<ul style="list-style-type: none"><li>Indicator is green (on) when the multi-pick detection sensors detect two or more sheets moving through the paper path simultaneously.</li><li>Indicator is black (off) when either no paper is present in the paper path or only one sheet of paper is present in the paper path.</li></ul>
18	<b>ADF scan position sensor</b> indicator	<ul style="list-style-type: none"><li>Indicator is green (on) when the ADF scan position sensor detects paper after the multi-pick sensors.</li><li>Indicator is black (off) when the ADF scan position sensor does not detect paper after the multi-pick sensors.</li></ul>

**Table 6-6 Sensor tab (continued)**

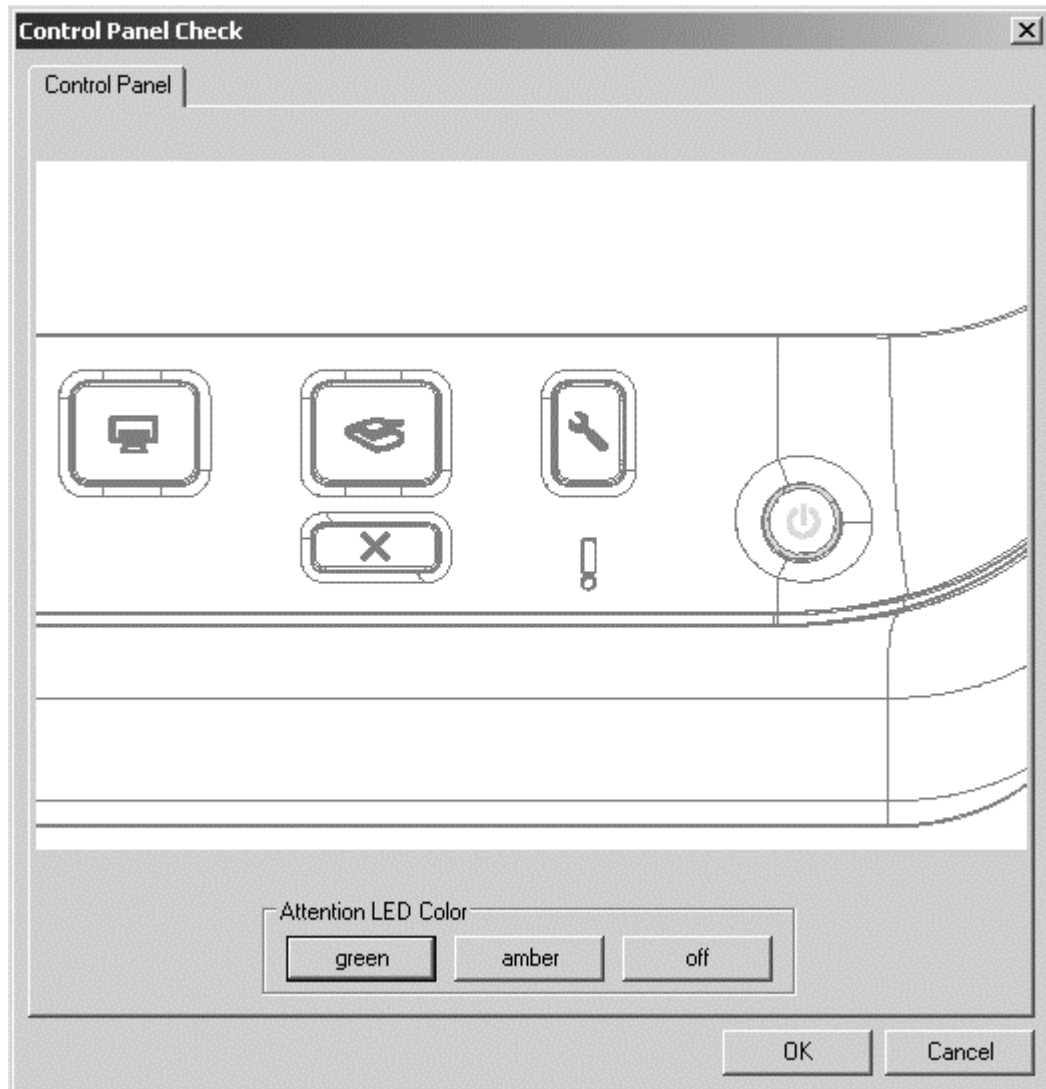
<b>Item</b>	<b>Description</b>	<b>Function</b>
19	<b>Flatbed scan position sensor</b> indicator	<ul style="list-style-type: none"><li>● Indicator is green (on) when the scan position sensor detects paper after the ADF scan position sensor.</li><li>● Indicator is black (off) when the scan position sensor does not detect paper after the ADF scan position sensor.</li></ul>
20	<b>Flatbed motor fan alarm</b> indicator	<ul style="list-style-type: none"><li>● Indicator is green (on) when the fan is not operating.</li><li>● Indicator is black (off) when the fan is operating.</li></ul>
21	<b>Flatbed carriage fan alarm</b> indicator	<ul style="list-style-type: none"><li>● Indicator is green (on) when the fan is not operating.</li><li>● Indicator is black (off) when the fan is operating.</li></ul>
22	<b>ADF motor fan alarm</b> indicator	<ul style="list-style-type: none"><li>● Indicator is green (on) when the fan is not operating.</li><li>● Indicator is black (off) when fan is operating.</li></ul>
24	<b>ADF carriage fan2 alarm</b> indicator	<ul style="list-style-type: none"><li>● Indicator is green (on) when the fan is not operating.</li><li>● Indicator is black (off) when the fan is operating.</li></ul>
27	<b>OK</b> button	Click the <b>OK</b> button to close the <b>Sensor check</b> dialog box.
28	<b>Cancel</b> button	Click the <b>Cancel</b> button to close the <b>Sensor check</b> box.

## Control panel check dialog box

1. Open the N9120 Service Tool.
2. On the toolbar, click **Panel**.

 **NOTE:** When the Control panel check dialog box is open and any button, except the power button, is pressed on the control panel, the corresponding button will illuminate on the Control panel check dialog box. This is an effective way to check if control panel buttons are working properly.

**Figure 6-6** Control panel check dialog box



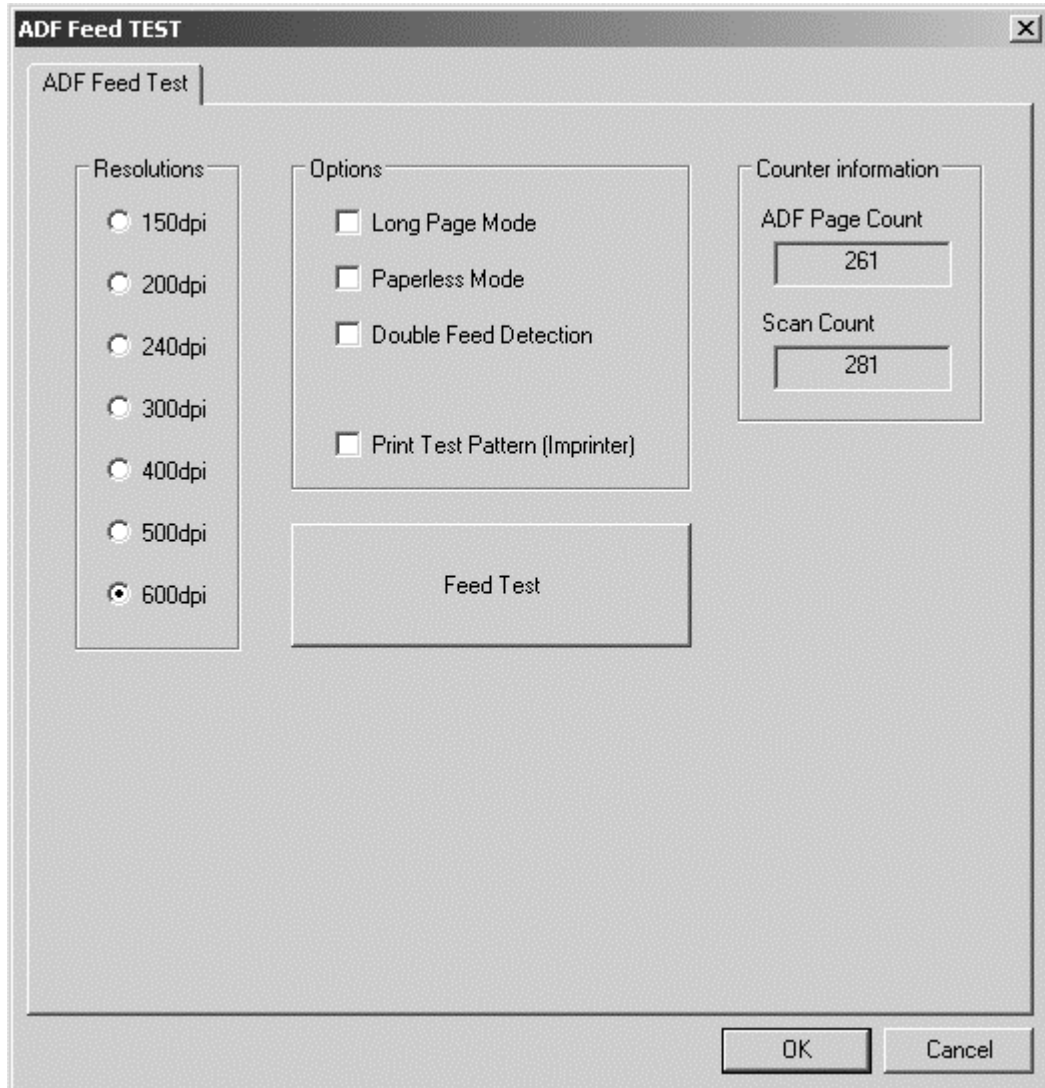
**Table 6-7 Control panel check dialog box**

<b>Item</b>	<b>Description</b>	<b>Function</b>
1	<b>Attention LED color</b> area	<ul style="list-style-type: none"><li>• Click the <b>green</b> button to change the <b>Attention LED</b> color to green.</li><li>• Click the <b>amber</b> button to change the <b>Attention LED</b> color to amber.</li><li>• Click the <b>off</b> button to turn off the <b>Attention LED</b>.</li></ul>
2	<b>OK</b> button	Click the <b>OK</b> button to close the <b>Control panel check</b> dialog box.
3	<b>Cancel</b> button	Click the <b>Cancel</b> button to close the <b>Control panel check</b> dialog box.

## ADF feed test dialog box

1. Open the N9120 Service Tool.
2. On the toolbar, click **ADF**.

**Figure 6-7** ADF feed test dialog box



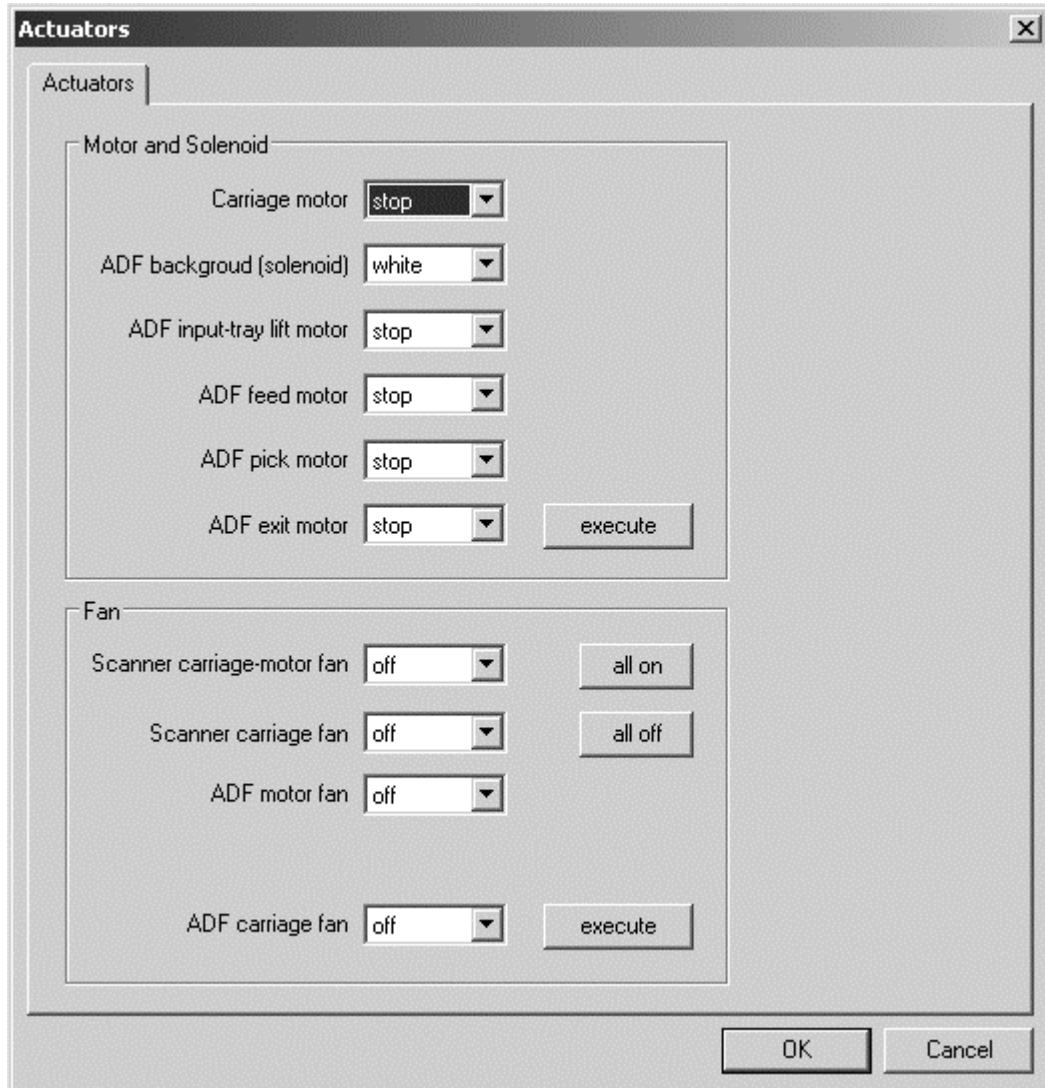
**Table 6-8 ADF feed test dialog box**

Item	Description	Function
1	<b>Resolutions</b> area	Select a resolution setting for an ADF feed test. <ul style="list-style-type: none"><li>● <b>150dpi</b></li><li>● <b>200dpi</b></li><li>● <b>240dpi</b></li><li>● <b>300dpi</b></li><li>● <b>400dpi</b></li><li>● <b>500dpi</b></li><li>● <b>600dpi</b></li></ul>
2	<b>Options</b> area	Select options for an ADF feed test: <ul style="list-style-type: none"><li>● <b>Long Page Mode</b></li><li>● <b>Paperless Mode</b></li><li>● <b>Double Feed Detection Mode</b></li><li>● <b>Print Test Pattern (Imprinter)</b></li></ul>
3	<b>Counter information</b> area	View page count and scan count information: <ul style="list-style-type: none"><li>● <b>ADF page count</b></li><li>● <b>Scan count</b></li></ul>
4	<b>Feed Test</b> button	Click <b>Feed Test</b> to start a feed test from the ADF input tray after resolution and options are selected.
5	<b>OK</b> button	Click <b>OK</b> to close the <b>ADF feed test</b> dialog box.
6	<b>Cancel</b> button	Click <b>Cancel</b> to close the <b>ADF feed test</b> dialog box.

## Actuators dialog box

1. Open the N9120 Service Tool.
2. On the toolbar, click **Actuator**.

**Figure 6-8** Actuators dialog box



**Table 6-9 Actuators dialog box**

Item	Description	Function
1	<b>Motor and Solenoid</b> area	<ol style="list-style-type: none"><li>1. Select from the following options to diagnose motor or solenoid problems:<ul style="list-style-type: none"><li>◦ Click the <b>Carriage motor</b> down arrow.<ul style="list-style-type: none"><li>● Select <b>aging</b> to activate the carriage motor.</li><li>● Select <b>stop</b> to deactivate the carriage motor.</li></ul></li><li>◦ Click the <b>ADF background (solenoid)</b> down arrow.<ul style="list-style-type: none"><li>● Select <b>black</b> to activate the ADF background solenoid and set the background to black.</li><li>● Select <b>white</b> to activate the ADF background solenoid and set the background to white.</li></ul></li><li>◦ Click the <b>ADF input-tray lift motor</b> down arrow.<ul style="list-style-type: none"><li>● Select <b>aging</b> to activate the lift motor.</li><li>● Select <b>stop</b> to deactivate the lift motor.</li></ul></li><li>◦ Click the <b>ADF feed motor</b> down arrow.<ul style="list-style-type: none"><li>● Select <b>rotation</b> to activate the feed motor.</li><li>● Select <b>stop</b> to deactivate the feed motor.</li></ul></li><li>◦ Click the <b>ADF pick motor</b> down arrow.<ul style="list-style-type: none"><li>● Select <b>cw</b> to activate the pickup motor in a clockwise direction.</li><li>● Select <b>ccw</b> to activate the pickup motor in a counterclockwise direction.</li><li>● Select <b>stop</b> to deactivate the feed motor.</li></ul></li><li>◦ Click the <b>ADF exit motor</b> down arrow.<ul style="list-style-type: none"><li>● Select <b>rotation</b> to activate the feed motor.</li><li>● Select <b>stop</b> to deactivate the feed motor.</li></ul></li></ul></li><li>2. Click the <b>execute</b> button to activate selections.</li></ol>
2	<b>Fan</b> area	<p>Click the <b>all on</b> button to turn on all fans or click the <b>all off</b> button to turn off all fans. The fans may also be selected individually.</p> <ol style="list-style-type: none"><li>1. Select individual fans.<ul style="list-style-type: none"><li>◦ Click the <b>Scanner carriage-motor fan</b> down arrow.<ul style="list-style-type: none"><li>● Select <b>on</b> to activate the motor fan.</li><li>● Select <b>stop</b> to deactivate the motor fan.</li></ul></li><li>◦ Click the <b>Scanner carriage fan</b> down arrow.<ul style="list-style-type: none"><li>● Select <b>on</b> to activate the carriage fan.</li><li>● Select <b>stop</b> to deactivate the carriage fan.</li></ul></li></ul></li></ol>



**Table 6-9 Actuators dialog box (continued)**

Item	Description	Function
		<ul style="list-style-type: none"><li>◦ Click the <b>ADF motor fan</b> down arrow.<ul style="list-style-type: none"><li>● Select <b>on</b> to activate the ADF motor fan.</li><li>● Select <b>stop</b> to deactivate the ADF motor fan.</li></ul></li><li>◦ Click the <b>ADF carriage fan</b> down arrow.<ul style="list-style-type: none"><li>● Select <b>on</b> to activate the ADF carriage fan.</li><li>● Select <b>stop</b> to deactivate the ADF carriage fan.</li></ul></li></ul> <p><b>2.</b> Click the <b>execute</b> button to activate or deactivate selections.</p>
5	<b>OK</b> button	Click the <b>OK</b> button to close the <b>Actuators</b> dialog box.
6	<b>Cancel</b> button	Click the <b>Cancel</b> button to close the <b>Actuators</b> dialog box.

## NVRAM dialog box

**WARNING!** Do not add, delete, or modify NVRAM values. Doing so might render the product inoperable.

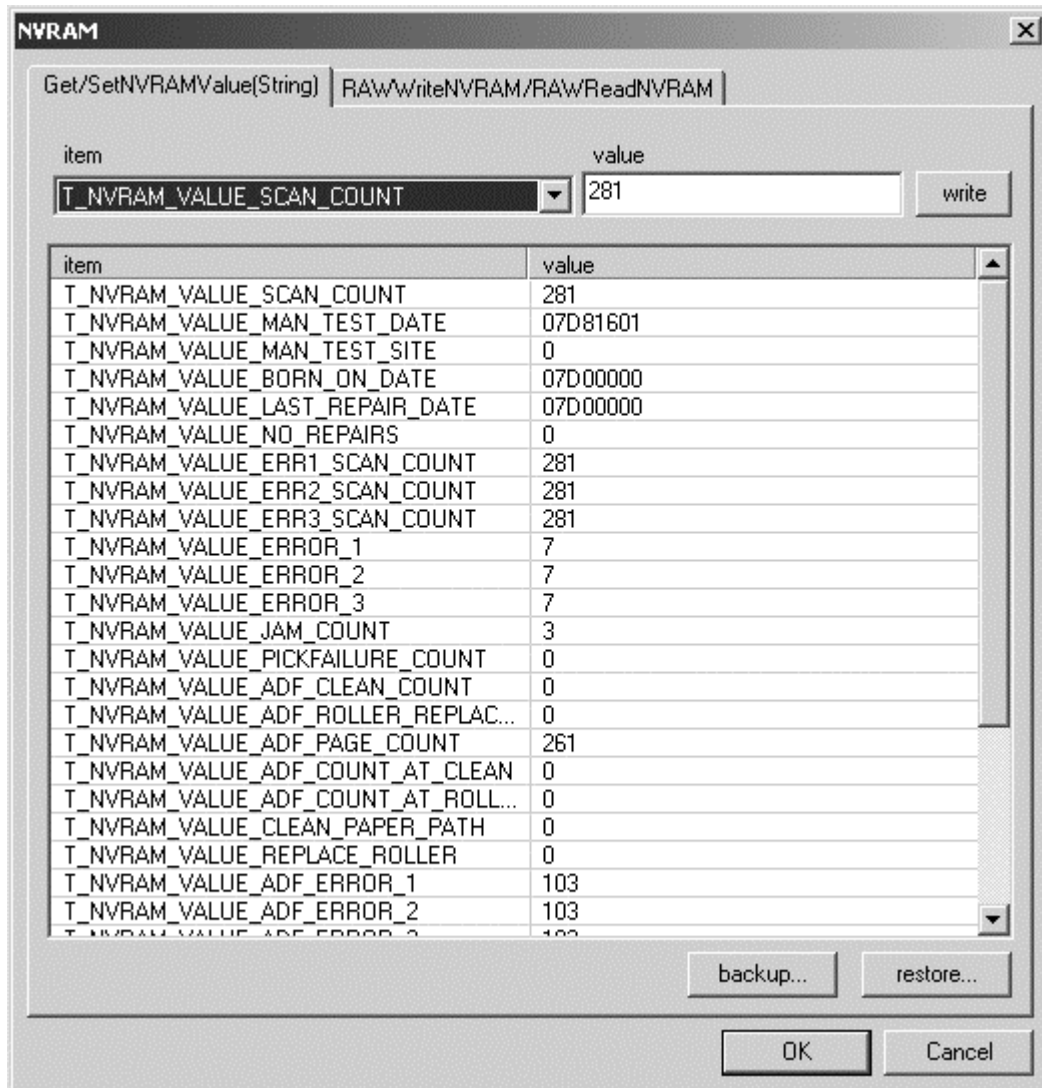
1. Open the N9120 Service Tool.
2. On the toolbar, click **NVRAM**.

The **NVRAM** dialog box contains two tabs:

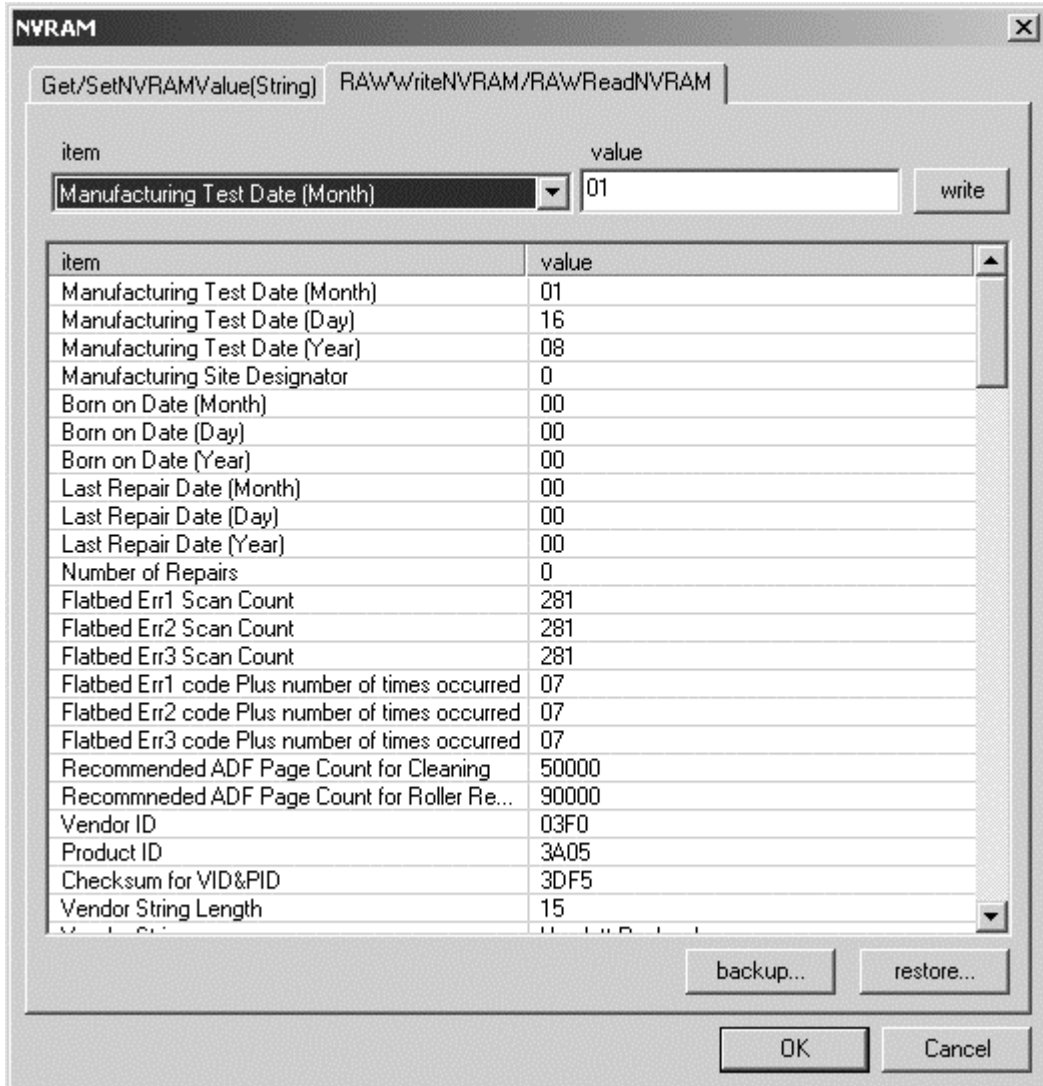
- Get/SetNVRAMValue(String)
- RAWWriteNVRAM/RAWReadNVRAM

**WARNING!** Do not add, delete, or modify NVRAM values. Doing so might render the product inoperable.

**Figure 6-9** Get/SetNVRAMValue(String) tab



**Figure 6-10** Get/SetNVRAMValue(String) tab



**WARNING!** Do not add, delete, or modify NVRAM values. Doing so might render the product inoperable.

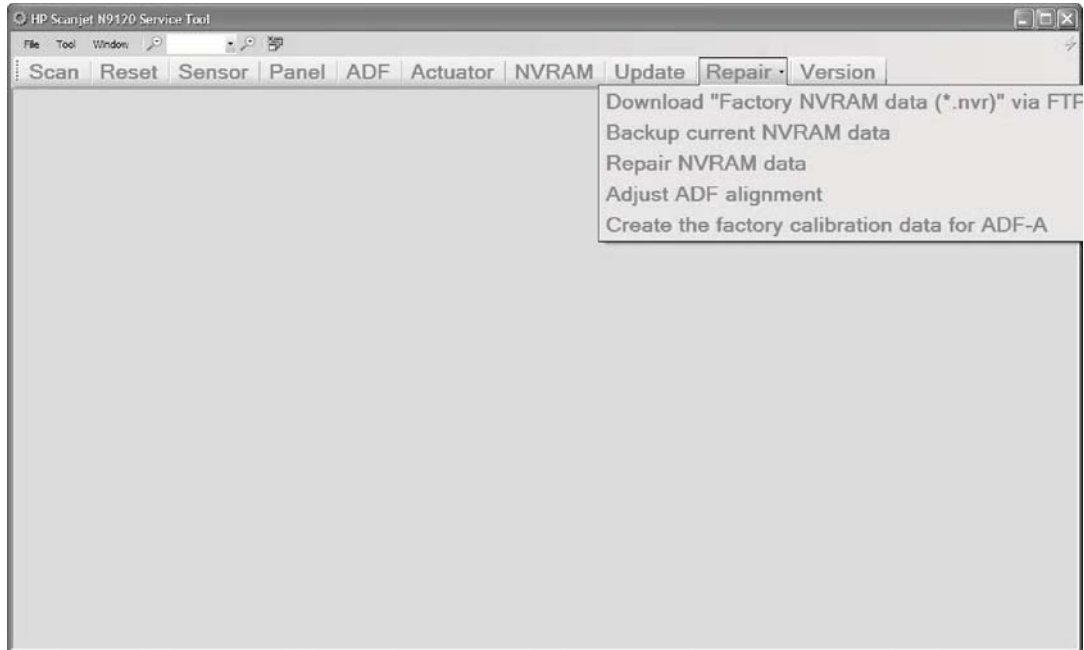
## Update dialog box

1. Open the N9120 Service Tool.
2. On the toolbar, click **Update**.
3. Use the Update dialog box to update the product firmware.

## Repair menu

1. Open the N9120 Service Tool.
2. On the toolbar, click **Repair**.

**Figure 6-11** Repair menu



**Table 6-10** Repair menu

Item	Description	Function
1	<b>Download "Factory NVRAM data (*.nvr)" via FTP</b>	Click <b>Download "Factory NVRAM data (*.nvr)" via FTP</b> to search the FTP site for the factory NVRAM data and then save it on the computer's hard drive. See <a href="#">Download factory NVRAM data on page 86</a> .
2	<b>Backup current NVRAM data</b>	Click <b>Backup current NVRAM data</b> to restore the current NVRAM values of the ADF and flatbed. See <a href="#">Backup current NVRAM data on page 89</a> .
3	<b>Repair NVRAM data</b>	Click <b>Repair NVRAM data</b> to upload of previously stored NVRAM data from the computer's hard drive to the NVRAM of the selected device and then change certain NVRAM values as required by various repair scenarios. See <a href="#">Repair NVRAM data on page 91</a> .
4	<b>Adjust ADF alignment</b>	Click <b>Adjust ADF alignment</b> to adjust resolution settings. See <a href="#">Align the ADF on page 98</a> .
5	<b>Create the factory calibration data for ADF-A</b>	Click <b>Create the factory calibration data for ADF-A</b> to adjust resolution settings. See <a href="#">Create the factory calibration data for ADF-A on page 101</a> .

## Version information dialog box

1. Open the N9120 Service Tool.
2. On the toolbar, click **Version**.

**Figure 6-12** Version information dialog box



# Diagrams

## Component locator diagrams

### Major components

#### Major components (1 of 3)

**Figure 6-13** Major components (1 of 3)

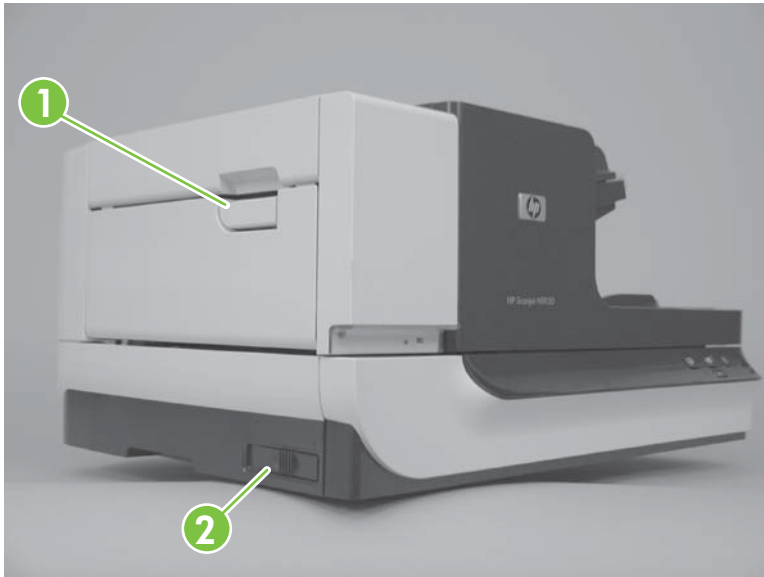


**Table 6-11** Major components (1 of 3)

Item	Description
1	ADF jam door 1
2	ADF
3	ADF input-tray assembly
4	ADF output tray
5	Scanner motor fan-filter cover
6	Control panel
7	Scanner base

## Major components (2 of 3)

**Figure 6-14** Major components (2 of 3)



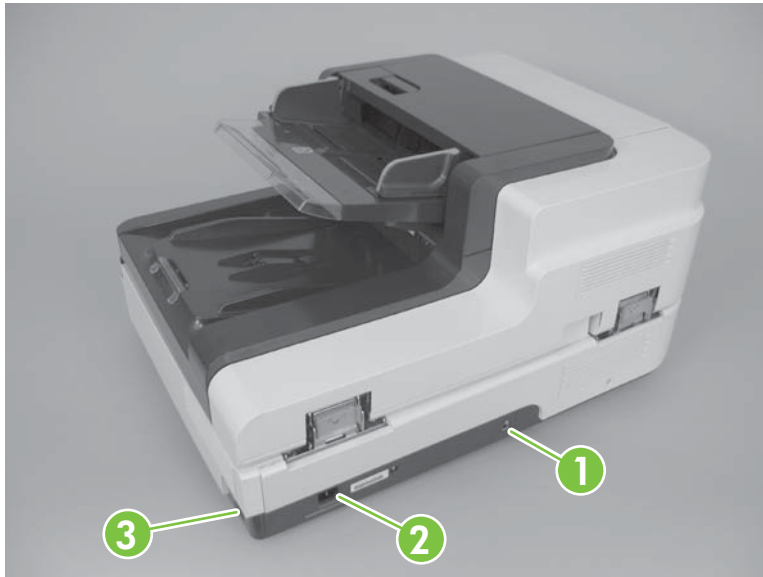
**Table 6-12** Major components (2 of 3)

Item	Description
1	ADF jam door 2
2	Scanner optical-carriage lock



## Major components (2 of 3)

**Figure 6-15** Major components (3 of 3)



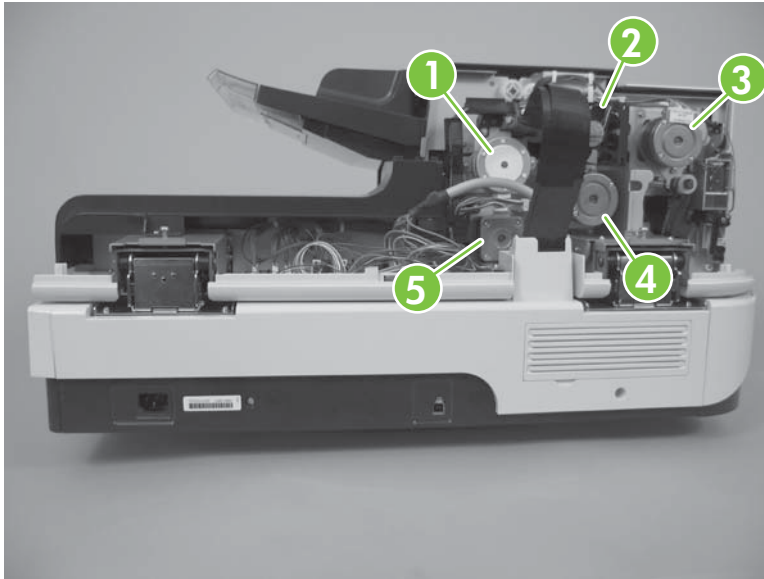
**Table 6-13** Major components (3 of 3)

Item	Description
1	USB port
2	Power-cord receptacle
3	Power switch

## ADF motors and fans

### ADF motors and fans (1 of 2)

**Figure 6-16** ADF motors and fans (1 of 2)

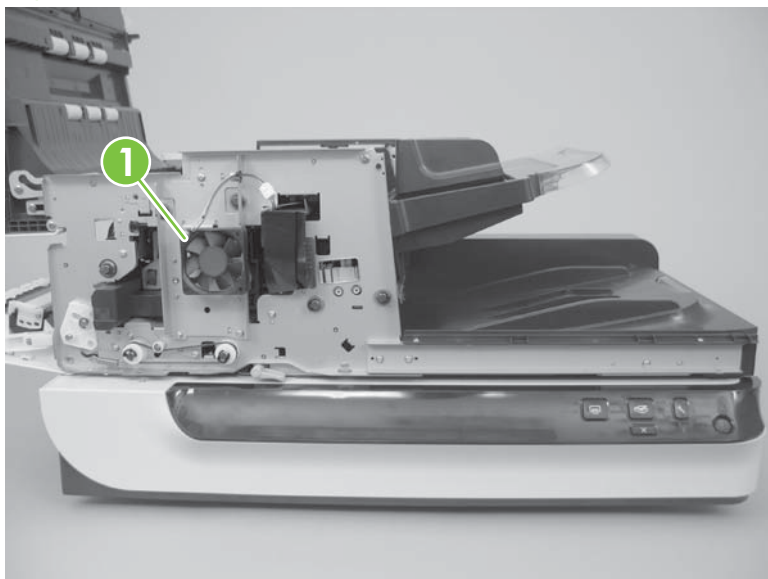


**Table 6-14** ADF motors and fans (1 of 2)

item	Description
1	ADF input-tray lift-motor assembly
2	ADF motor fan
3	ADF feed-motor assembly
4	ADF pick-motor assembly
5	ADF exit-motor assembly

## ADF motors and fans (2 of 2)

**Figure 6-17** ADF motors and fans (2 of 2)



**Table 6-15** ADF motors and fans (2 of 2)

Item	Description
1	ADF carriage fan

## Scanner motors and fans

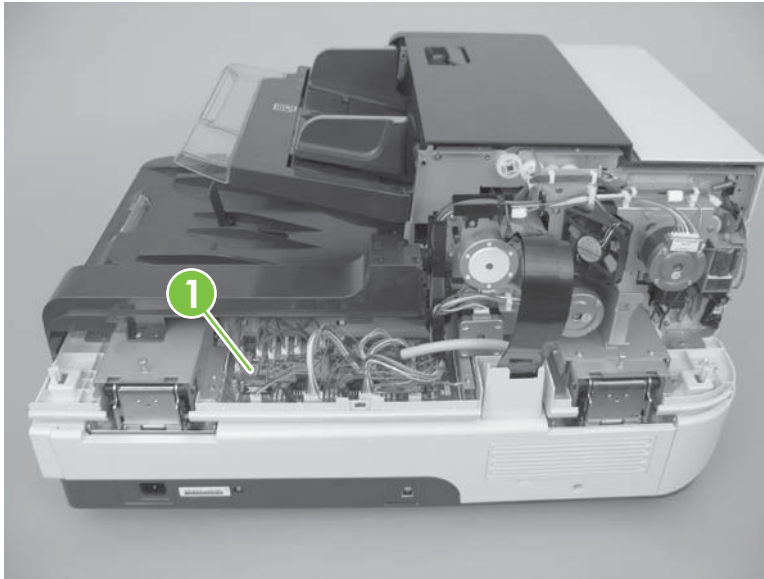
**Table 6-16** Scanner motors and fans

Item	Description
Not shown	Scanner carriage-motor fan
Not shown	Scanner carriage fan
Not shown	Scanner carriage motor

## Printed circuit assemblies

### ADF PCAs

**Figure 6-18** ADF PCAs

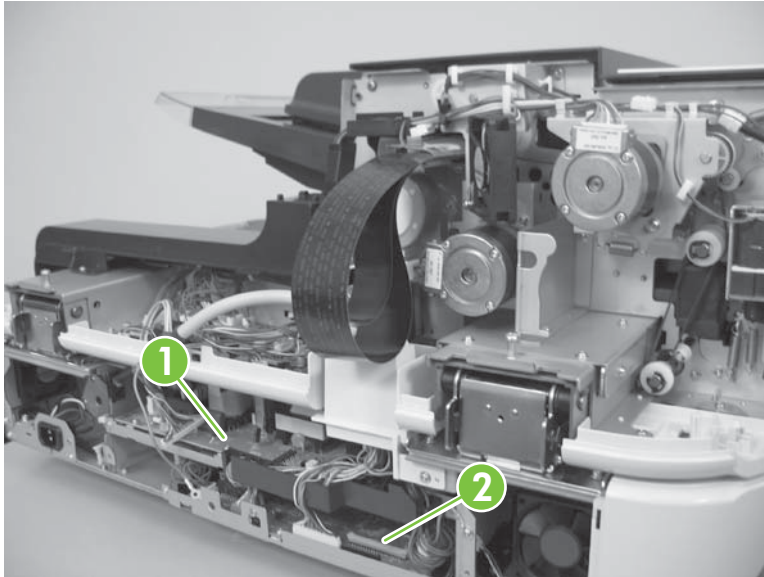


**Table 6-17** ADF controller PCA

Item	Description
1	ADF controller PCA
Not shown	Imprinter PCA
Not shown	ADF upper- and lower-multipick sensor PCAs

## Scanner PCAs

**Figure 6-19** Scanner PCAs



**Table 6-18** Scanner PCAs

Item	Description
1	Scanner controller PCA
2	Power-supply PCA
Not shown	Control-panel PCA

# Image-quality troubleshooting tools

## Repetitive-image-defect ruler

Defects on product rollers can cause image defects to appear at regular intervals on the scanned page, corresponding to the circumference of the roller that is causing the defect. Measure the distance between defects that recur on a scanned page. Use the following table or the repetitive-defect ruler to determine which roller is causing the defect. To resolve the problem, try cleaning the roller first. If the roller remains dirty after cleaning or if it is damaged, replace the part that is indicated in [Table 6-19 Repetitive defects on page 270](#).



**NOTE:** You can make a graphical repetitive-defect ruler by using these measurements. For the most accurate results, use a metric ruler.

**Table 6-19 Repetitive defects**

Component	Distance between defects
ADF pickup roller	## mm (#.# inches)
ADF feed rollers	## mm (#.# inches)
ADF separation pad	## mm (#.# inches)

# Computer-display error messages

Error conditions can cause the product to display error messages on the host computer. Use the following table to find a solution to these problems.

## Computer-display error messages

**Table 6-20** ISIS driver communicated message

Control panel message	Description	Recommended action
<b>A document feeder paper jam has been detected in the cleanout (-4725)</b>	Not applicable	Check ADF paper-path for jams starting at input tray, then jam doors 1, 2, and 3 clear all jams. Review the thumbnails of the pages that have already been scanned in the <b>Scan Progress</b> window, reinsert any necessary pages into the input tray, and click <b>Scan More Pages</b> .
<b>A document feeder paper jam has been detected in the input tray (-4723)</b>	Not applicable	Check ADF paper-path for jams starting at input tray, then jam doors 1, 2, and 3 clear all jams. Review the thumbnails of the pages that have already been scanned in the <b>Scan Progress</b> window, reinsert any necessary pages into the input tray, and click <b>Scan More Pages</b> .
<b>A document feeder paper jam has been detected in the output tray (-4724)</b>	Not applicable	Check ADF paper-path for jams starting at input tray, then jam doors 1, 2, and 3 clear all jams. Review the thumbnails of the pages that have already been scanned in the <b>Scan Progress</b> window, reinsert any necessary pages into the input tray, and click <b>Scan More Pages</b> .
<b>Can't talk to scanner</b>	Not applicable	Check that USB connections are secure on both sides. Power cycle scanner and try operation again.
<b>Imprinter is off paper. It is positioned incorrectly or it has reached the edge of the page. (-4729)</b>	Not applicable	Reposition the imprinter cartridge and try scan again.
<b>Multiple-page misfeed in ADF or scanned page is longer than expected. (-4726)</b>	Not applicable	A page was longer than expected or multiple pages were picked. Ensure the correct paper size is specified in Profile Settings. Remove misfed pages from the output tray and ensure the pages are not stuck together. Return pages to the document feeder and click <b>Scan More Pages</b> to continue scanning..
<b>No page was found in the feeder. (-4401)</b>	Not applicable	Place paper in the input tray and try operation again or change scan parameters to scanning.

**Table 6-20 ISIS driver communicated message (continued)**

<b>Control panel message</b>	<b>Description</b>	<b>Recommended action</b>
<b>Paper jammed in scanner; clear paper and continue. (-4426)</b>	Not applicable	Check ADF paper-path for jams starting at input tray, then jam doors 1, 2, and 3 clear all jams. Review the thumbnails of the pages that have already been scanned in the <b>Scan Progress</b> window, reinsert any necessary pages into the input tray, and click <b>Scan More Pages</b> .
<b>Problem with scanner transport mechanism</b>	Not applicable	Power cycle scanner and attempt operation again. If this does not work, contact support.
<b>Scanner cover is open. (-4429)</b>	Not applicable	Lower ADF and try operation again.
<b>Scanner door is open. (-4618)</b>	Not applicable	Lower ADF and try operation again.
<b>Scanner hardware problem</b>	Not applicable	Check paper path for jams, power cycle, and tray scan again.
<b>Scanner is busy</b>	Not applicable	Wait one minute for scanner to become available again and reattempt scan. If this does not work, power cycle scanner and attempt operation again. If this does not work, contact support.
<b>Scanner is not ready. (Power might have been cycled.)</b>	Not applicable	Check that USB connections are secure on both sides. Power cycle scanner and try operation again.
<b>Scanner is not responding</b>	Not applicable	Check that USB connections are secure on both sides. Power cycle scanner and try operation again.
<b>Scanner overheated</b>	Not applicable	Power cycle scanner and attempt operation again. If this does not work, contact support.
<b>The ADF cannot pick up the paper or it is jammed. Remove the paper and leaf through the stack. (-4722)</b>	Not applicable	Check ADF paper-path for jams starting at input tray, then jam doors 1, 2, and 3 clear all jams. Review the thumbnails of the pages that have already been scanned in the <b>Scan Progress</b> window, reinsert any necessary pages into the input tray, and click <b>Scan More Pages</b> .
<b>The imprinter ink level is low. Please replace the ink cartridge. (-4728)</b>	Not applicable	Refer to the Setup and use the imprinter section of the N9120 User Guide for tips on Installing or replacing imprinter cartridges and imprinter maintenance.
<b>The scanner carriage failed to return to its home position. (-4713)</b>	Not applicable	Power cycle scanner and attempt operation again. If this does not work, contact support.
<b>The scanner device failed its calibration. (-4715)</b>	Not applicable	Power cycle scanner and attempt operation again. If this does not work, contact support.



**Table 6-21 SDSS error message displayed**

<b>Control panel message</b>	<b>Description</b>	<b>Recommended action</b>
<b>A paper jam has occurred. Clear the jam, review the thumbnails of the pages that have already been scanned in the Scan Progress window, reinsert any necessary pages into the input tray, and click Scan More Pages.</b>	Not applicable	Check ADF paper-path for jams starting at input tray, then jam doors 1, 2, and 3 clear all jams. Review the thumbnails of the pages that have already been scanned in the <b>Scan Progress</b> window, reinsert any necessary pages into the input tray, and click <b>Scan More Pages</b> .
<b>A paper jam has occurred. Clear the jam, review the thumbnails of the pages that have already been scanned in the Scan Progress window, reinsert any necessary pages into the input tray, and click Scan More Pages.</b>	Not applicable	Check ADF paper-path for jams starting at input tray, then jam doors 1, 2, and 3 clear all jams. Review the thumbnails of the pages that have already been scanned in the <b>Scan Progress</b> window, reinsert any necessary pages into the input tray, and click <b>Scan More Pages</b> .
<b>A paper jam has occurred. Clear the jam, review the thumbnails of the pages that have already been scanned in the Scan Progress window, reinsert any necessary pages into the input tray, and click Scan More Pages.</b>	Not applicable	Check ADF paper-path for jams starting at input tray, then jam doors 1, 2, and 3 clear all jams. Review the thumbnails of the pages that have already been scanned in the <b>Scan Progress</b> window, reinsert any necessary pages into the input tray, and click <b>Scan More Pages</b> .
<b>A paper jam has occurred. Clear the jam, review the thumbnails of the pages that have already been scanned in the Scan Progress window, reinsert any necessary pages into the input tray, and click Scan More Pages.</b>	Not applicable	Check ADF paper-path for jams starting at input tray, then jam doors 1, 2, and 3 clear all jams. Review the thumbnails of the pages that have already been scanned in the <b>Scan Progress</b> window, reinsert any necessary pages into the input tray, and click <b>Scan More Pages</b> .
<b>A paper jam has occurred. Clear the jam, review the thumbnails of the pages that have already been scanned in the Scan Progress window, reinsert any necessary pages into the input tray, and click Scan More Pages.</b>	Not applicable	Check ADF paper-path for jams starting at input tray, then jam doors 1, 2, and 3 clear all jams. Review the thumbnails of the pages that have already been scanned in the <b>Scan Progress</b> window, reinsert any necessary pages into the input tray, and click <b>Scan More Pages</b> .
<b>Imprinter is off paper. It is positioned incorrectly or it has reached the edge of the page.</b>	Not applicable	Reposition the imprinter cartridge and try scan again.
<b>Multiple-page misfeed detected in scanner document feeder. A page was longer than expected or multiple pages were picked. Please ensure the correct paper size is specified in Profile Settings. Remove misfed pages from the output tray and ensure the pages are not stuck together. Return pages to the document feeder and click Scan More Pages to continue scanning.</b>	Not applicable	A page was longer than expected or multiple pages were picked. Ensure the correct paper size is specified in Profile Settings. Remove misfed pages from the output tray and ensure the pages are not stuck together. Return pages to the document feeder and click <b>Scan More Pages</b> to continue scanning.

**Table 6-21 SDSS error message displayed (continued)**

<b>Control panel message</b>	<b>Description</b>	<b>Recommended action</b>
<b>No memory available</b>	Not applicable	Close unnecessary applications to free up usable memory and re-scan documents.
<b>No page was found in the feeder</b>	Not applicable	Place paper in the input tray and try operation again or change scan parameters to scanning.
<b>Scanner busy</b>	Not applicable	Wait one minute for scanner to become available again and reattempt scan. If this does not work, power cycle scanner and attempt operation again. If this does not work, contact support.
<b>Scanner cover open</b>	Not applicable	Lower ADF and try operation again.
<b>Scanner cover open</b>	Not applicable	Lower ADF and try operation again.
<b>Scanner not connected</b>	Not applicable	Check that USB connections are secure on both sides. Power cycle scanner and try operation again.
<b>Scanner not connected</b>	Not applicable	Check that USB connections are secure on both sides. Power cycle scanner and try operation again.
<b>Scanner not ready</b>	Not applicable	Check that USB connections are secure on both sides. Power cycle scanner and try operation again.
<b>The imprinter ink level is low. Please replace the ink cartridge.</b>	Not applicable	Refer to the Setup and use the imprinter section of the N9120 User Guide for tips on Installing or replacing imprinter cartridges and imprinter maintenance.
<b>Unspecified scanner error</b>	Not applicable	Check paper path for jams, power cycle, and tray scan again.
<b>Unspecified scanner error</b>	Not applicable	Power cycle scanner and attempt operation again. If this does not work, contact support.

# Solve paper-handling problems

## Jams

### Common causes of jams

#### The product is jammed.

Cause	Solution
The source document does not meet specifications.	Make sure that the document to be scanned meets the ADF and media specifications. See <a href="#">Paper handling on page 10</a> and <a href="#">Media specifications on page 10</a> .
A component is installed incorrectly.	Verify that the imprinter cartridge, the ADF pickup roller, and the ADF separation pad are correctly installed.  If the product was recently serviced, make sure that any replaced or reinstalled components are correctly installed and that all wire-harness connectors and FFCs are fully seated at the PCA or component.
The ADF tray is loaded incorrectly.	Remove any excess paper from the tray. Make sure that the stack is below the maximum stack height mark in the tray. See <a href="#">Paper handling on page 10</a> .
The source documents loaded in the ADF input tray are skewed.	The ADF tray guides are not adjusted correctly. Adjust them so that they hold the stack firmly in place without bending it.
The source documents are binding or sticking together.	Remove the documents and flex them to break any static charge in the stack. Reload the paper into the tray.
The source documents are in poor condition.	Make sure that the source documents are in good condition. If the documents are in poor condition, use the glass to scan the document.  Photocopy the damaged page, and then add the photocopy to the input stack in the ADF input tray.
The internal pickup roller in the ADF is not picking up the source document.	Remove the top sheet of the stack. If the source document is too heavy, it might not be picked from the tray.
The source document is perforated or embossed.	Perforated or embossed documents do not separate easily. Use the scanner glass to scan the document.

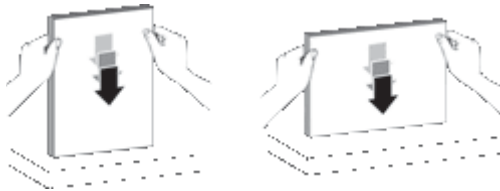
## Solve common ADF jams

You can use this procedure when a jam occurs during a multiple-page ADF scan job or when a jam occurs during a single-page ADF scan job.

1. At the scan destination, examine the scan output to determine which page was the last to be completely scanned.
2. Reload the unscanned pages in the ADF input tray. If any pages are damaged, do one of the following:
  - Photocopy the damaged page, and then add the photocopy to the input stack.
  - Scan the damaged page from the scanner glass.
  - Reprint the original document.
3. Prepare the stack as follows:
  - a. Fan the stack of document pages to ensure that the pages do not stick together. Fan the edge that will be pointing into the feeder in one direction, and then fan that same edge in the opposite direction.



- b. Align the edges of the documents by tapping the bottom of the stack against the table top. Rotate the stack 90 degrees and repeat.

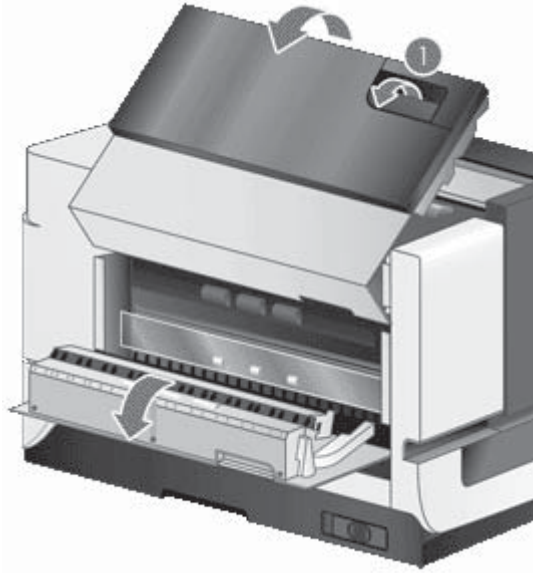


- c. Resume scanning.

## Clear jams from the ADF

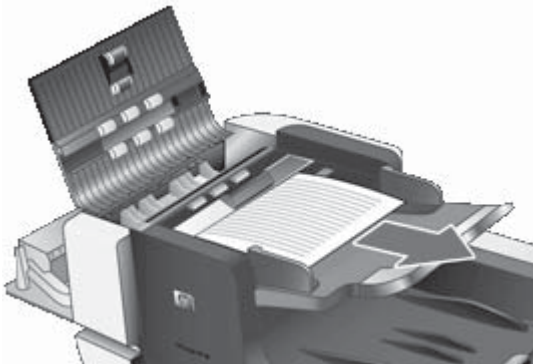
1. Remove any loose pages from the ADF input tray.
2. Lift the latch on top of the ADF to open the top and side ADF access doors (jam door 1 and jam door 2).

**Figure 6-20** Clear jams from the ADF (1 of 5)



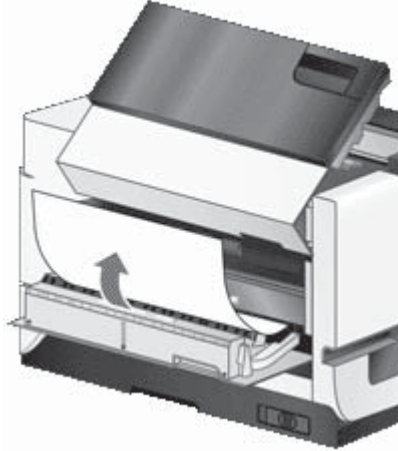
3. Remove any jammed pages from the ADF input tray.

**Figure 6-21** Clear jams from the ADF (2 of 5)



4. Remove any jammed pages from inside the ADF.

**Figure 6-22** Clear jams from the ADF (3 of 5)



5. Remove any jammed pages from the ADF output tray.

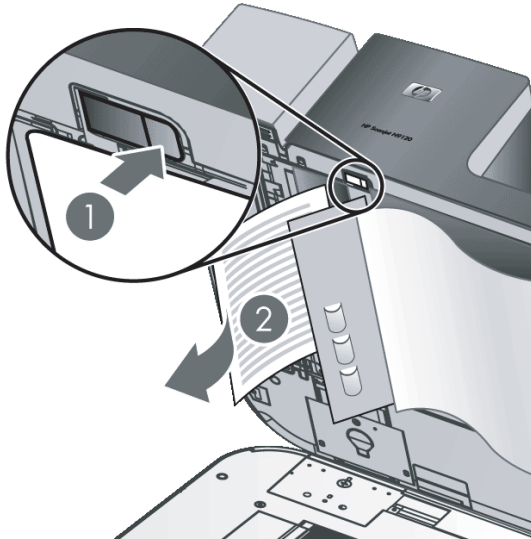
Be careful not to dislodge or damage the imprinter cartridge or carriage.

**Figure 6-23** Clear jams from the ADF (4 of 5)



6. If the jammed page still cannot be removed, follow these steps:
  - a. Open the ADF.
  - b. Push the green tab toward the ADF to open ADF jam door 3. If the door does not open automatically, gently pry it open.
  - c. Gently pull the page out of the ADF.

**Figure 6-24** Clear jams from the ADF (5 of 5)



7. Close jam door 1 and jam door 2), and then close the ADF. If the jam occurred during a multiple-page ADF scan job, see [Solve common ADF jams on page 276](#) for information about solving ADF jams.

## The bottom of the scanned image is cut off

By default, the scanner can scan paper that is up to 420 mm (16.5 in) long. If the document is longer, the end of the document is not included in the scanned image. For more information about paper handling specifications, see [Paper handling on page 10](#) and [Media specifications on page 10](#).

Verify that you have specified an appropriate page size in the scanning software.

## Scan extra long documents

By default, the ADF accepts a stack of originals up to 300 x 420 mm (11.8 x 16.5 in). You can choose to scan pages up to 300 x 864 mm (11.8 x 34 in) through the ADF.

Use the following procedure to enable long-page scans in an HP Smart Document Scan software profile.

### Enable long-page scans in an HP Smart Document Scan software profile

1. Open the HP Smart Document Scan software.
2. Select a scan profile, and then click **Edit**.
3. On the **Scan** tab of the **Profile Settings** dialog box, click **Custom** in the **Size** drop-down list, and then type the actual page dimensions, up to 300 x 864 mm (11.8 x 34 in), in the **Width** and **Height** boxes.



**NOTE:** In other scanning software, the page-size settings are on the **Layout** tab of the ISIS or TWAIN **Advanced Settings** dialog box.

Some scanning and destination software (including the Kofax VirtualReScan driver) might not support all of the page sizes that the scanner accepts.

HP recommends scanning long pages individually at a resolution of 300 dpi or lower.

## Disable misfeed (multipick) detection

The Misfeed (Multipick) Detection feature stops the scan or copy process if it senses that multiple pages are fed into the scanner at one time. This feature is enabled by default; however, you can disable it if you want.

### Disable the misfeed (multipick) detection feature in an HP Smart Document Scan software profile

1. Open the HP Smart Document Scan software.
2. Select a scan profile, and then click **Edit**.



3. On the **Scan** tab of the **Profile Settings** dialog box, click **Advanced Settings**.
4. On the **More** tab of the **Properties** dialog box, clear the **Enable** check box.



---

**NOTE:** To disable the Misfeed (Multipick) Detection feature in another scanning software, navigate to the ISIS or TWAIN **Advanced Settings** dialog box. On the **More** tab, clear the **Enable** check box.

---

## ADF does not feed paper


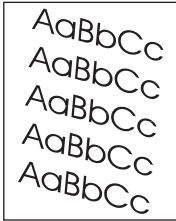

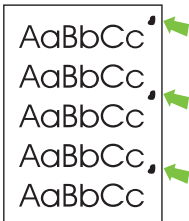
- The ADF access doors (jam door 1 and jam door 2) might not be securely latched. Open the ADF access doors, and then close the doors by pressing firmly.
- A problem with the ADF hardware might exist. Try the following:
  - a. Disconnect the USB cable and the power cable from the scanner. Check that the power cable is still connected to the power source.
  - b. Make sure that the ADF has at least one piece of paper in the input tray.
  - c. Reconnect the power cable to the scanner, and then turn the scanner on.
  - d. Try to scan another page through the ADF.

# Solve image-quality problems



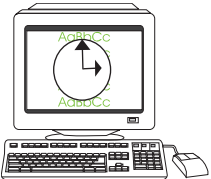
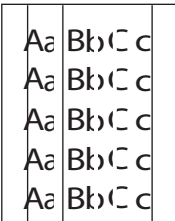
## Image defects

These examples identify the most common image-quality problems. If you still have problems after trying the suggested solutions, contact HP customer support.

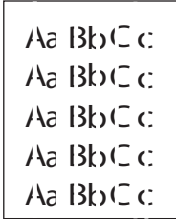

**Table 6-22 Image defect examples**

Problem	Image example	Solution
Scanned image is all black or all white.		<ul style="list-style-type: none"> <li>When scanning with the ADF, check the paper orientation.</li> <li>When scanning from the scanner glass, make sure that the item you are trying to scan is placed face down on the glass and the ADF is closed.</li> </ul>
Scanned image is skewed.		<ul style="list-style-type: none"> <li>When scanning with the ADF, make sure that the paper guides touch the edges of the original. Make sure that all documents are the same size.</li> <li>When scanning from the scanner glass, straighten the original on the scanner glass, and then scan again.</li> </ul>
Scanned image is cut off.		<p>By default, the scanner can scan paper that is up to 420 mm (16.5 in) long. If the document is longer, the end of the document is not included in the scanned image.</p> <p>Verify that you have specified an appropriate page size in the scanning software.</p> <p>See <a href="#">The bottom of the scanned image is cut off on page 280</a>.</p>
Scanned image contains repetitive defects.		<p>A component might be need dirty, damaged, or past its expected life.</p> <p>See <a href="#">Clean the ADF on page 24</a>, <a href="#">Repetitive-image-defect ruler on page 270</a> , or <a href="#">Parts life expectancy on page 22</a>.</p>

**Table 6-22 Image defect examples (continued)**

Problem	Image example	Solution
Scanner scans only one side of a double-sided page.		<ul style="list-style-type: none"> <li>For single-pass duplex scanning, scan pages through the ADF.</li> <li>Select the <b>Duplex</b> setting in the scanning or copy software.</li> </ul>
Scanned image is fuzzy.		<p>For images scanned by using the ADF, check the following:</p> <ol style="list-style-type: none"> <li>Verify that the document original is not fuzzy.</li> <li>Check for any obstructions in the scanner paper path and make sure that the paper guides are positioned appropriately. Try another scan.</li> <li>If the scanned image is still of poor quality, clean the ADF. See <a href="#">Clean the ADF on page 24</a>.</li> </ol> <p>For images scanned by using the scanner glass, check the following:</p> <p><b>NOTE:</b> It is important that the item you scan comes in close contact with the scanner glass.</p> <ol style="list-style-type: none"> <li>Verify that the document original is not fuzzy.</li> <li>Check to see that the item is in full contact with the scanner glass.</li> <li>If the scanned image is still of poor quality, clean the scanner glass. See <a href="#">Clean the scanner glass on page 27</a>.</li> </ol>
Scanner is scanning items very slowly.		<ul style="list-style-type: none"> <li>If you are scanning to edit text, the optical character recognition (OCR) software program causes the scanner to scan more slowly, which is normal. Wait for the item to scan.</li> <li>The resolution might be set too high. Reset the resolution to a lower level in the scanning software.</li> </ul>
Scanned images contain streaks or scratches.		<ul style="list-style-type: none"> <li>Check that the originals are clean and unwrinkled.</li> <li>Clean the ADF or the scanner glass. See <a href="#">Clean the ADF on page 24</a> or <a href="#">Clean the scanner glass on page 27</a>.</li> <li>Replace the separation pad and the feed roller. See <a href="#">Pickup-roller assembly on page 47</a> or <a href="#">Separation-pad assembly on page 50</a>.</li> </ul>

**Table 6-22 Image defect examples (continued)**


Problem	Image example	Solution
Vertical white stripes appear on the printed page.		<ul style="list-style-type: none"><li>• The destination printer might be out of toner or ink. Scan a different original to the same printer to see if the issue lies with the printer.</li><li>• If the second original has the same problem, clean the ADF or the scanner glass. See <a href="#">Clean the ADF on page 24</a> or <a href="#">Clean the scanner glass on page 27</a>.</li></ul>
Scanned image has poor contrast.		<ul style="list-style-type: none"><li>• Try filtering out color from the document. See <a href="#">Filter out color from a document (color dropout) on page 285</a>.</li><li>• Change the background color when using the ADF. See <a href="#">Set the background color for scans from the ADF on page 284</a>.</li></ul>

## Set the background color for scans from the ADF

When you scan from the ADF, you can choose a white or black background for the scan. When the scan background contrasts with the color at the outside edges of the document, the scanning software is better able to distinguish the edges of the scanned document. For example, use the black background to scan a document that is printed on white paper.

### Select the scan background color in an HP Smart Document Scan software profile

1. Open the HP Smart Document Scan software.
2. Select a scan profile, and then click **Edit**.
3. On the **Scan** tab of the **Profile Settings** dialog box, click **Advanced Settings**.
4. On the **More** tab of the **Properties** dialog box, select a color from the **ADF Background** drop-down list.

 **NOTE:** To set the scan background color in another scanning software, navigate to the ISIS or TWAIN **Advanced Settings** dialog box. On the **More** tab, select a color from the **ADF Background** drop-down list.

## Filter out color from a document (color dropout)

You can filter out a dark background from the image content, for example black text on green paper or red instructions on a form. Removing colors from the scan reduces the scan file size. You can select to filter out a color channel (red, green, or blue) or up to three specific colors. For specific colors, the sensitivity setting controls how closely a scanned color must approximate the specified color.

### Select colors to eliminate from a scan in an HP Smart Document Scan software profile

1. Open the HP Smart Document Scan software.
2. Select a scan profile, and then click **Edit**.
3. On the **Scan** tab of the **Profile Settings** dialog box, click **Advanced Settings**.
4. On the **Color Dropout** tab of the **Properties** dialog box, specify the color-dropout settings.



**NOTE:** For 24-bit color scans, you must select specific colors to be dropped out.

To filter out color in another scanning software, navigate to the ISIS or TWAIN **Advanced Settings** dialog box. On the **Color Dropout** tab, specify the color-dropout settings.

For more information about the color-dropout settings, see the online help for the scanning software that you are using.

---

# Solve performance problems

**Table 6-23 Solve performance problems**

Problem	Solution
Scanner will not turn on.	<p>Verify that power is being supplied to the scanner.</p> <hr/> <p>The scanner power switch might be turned off. Be sure that the power switch located on the back of the scanner is turned on.</p> <hr/> <p>The scanner might have been unplugged. Check to see that the power cable has not become disconnected from the scanner or unplugged from the power source.</p>
Scanner is scanning items very slowly.	<p>If you are scanning to edit text, the optical character recognition (OCR) software program causes the scanner to scan more slowly, which is normal. Wait for the item to scan.</p> <hr/> <p>The resolution might be set too high. Reset the resolution to a lower level. Change the resolution in the scanning software.</p>
<p>Scanner lamp stays on.</p> <p><b>NOTE:</b> The scanner lamp does not turn off when paper is in the ADF input tray.</p>	<p>The scanner lamp should time out and turn off automatically after a period of inactivity (about 15 minutes). If the scanner lamp remains on after a long period of inactivity, turn off the scanner, wait 30 seconds, and then turn the scanner back on.</p> <hr/> <p>If the scanner lamp remains on after a long period of inactivity, turn off the scanner, wait 30 seconds, and then turn the scanner back on.</p>
Scanner does not scan right away.	<p>Make sure that the power switch on the right side of the scanner is turned on.</p> <hr/> <p>If the scanner has not been used for a while, the scanner lamp might need to go through a warm-up period before scanning can begin. If the scanner lamp needs to warm up, it takes a moment after starting the software or pressing a scanner button for scanning to begin.</p> <p><b>NOTE:</b> You can enable Instant Lamp On mode in the HP Scanner Tools Utility.</p>
Scanner scans only one side of a double-sided page.	<ul style="list-style-type: none"> <li>• For single-pass duplex scanning, scan pages through the ADF.</li> <li>• Select the <b>Duplex</b> setting in the scanning or copy software.</li> </ul>
Scanned pages are out of order at the scan destination.	<p>Insert a multiple-page document with the printed first page of the document facing up and with the top or left edge of the document pointing into the feeder.</p>
Scanned pages are missing at the scan destination.	<p>When the ADF is used, pages that stick together are scanned as one item. The hidden pages are not scanned. Enable Misfeed (Multipick) Detection to stop the scan or copy process if multiple pages are fed into the scanner at one time.</p> <p>See <a href="#">Disable misfeed (multipick) detection on page 280</a> (on the <b>More</b> tab, select the <b>Enable</b> check box).</p>
Scan files are too large.	<ul style="list-style-type: none"> <li>• Verify the scan resolution setting.</li> </ul>

**Table 6-23 Solve performance problems (continued)**

Problem	Solution
	<p><b>NOTE:</b> Scanning at a higher resolution than necessary creates a larger file with no additional benefit.</p> <ul style="list-style-type: none"><li>◦ 200 dpi is sufficient for storing documents as images.</li><li>◦ For most fonts, 300 dpi is sufficient for using optical character recognition (OCR) to create editable text.</li><li>◦ For Asian fonts and small fonts, 400 dpi is the recommended resolution.</li><li>● Color scans create larger files than black and white scans.</li><li>● If you are scanning a large number of pages at one time, consider scanning fewer pages at a time to create more, smaller files.</li><li>● Use the Kofax VirtualReScan software to process the scanned data. Kofax VirtualReScan compresses the data, which can result in a smaller file.</li></ul>
<p>The imprinter is not printing or the print quality is poor.</p> <p><b>NOTE:</b> To use the imprinter, load originals in the ADF. The imprinter cannot print on pages placed on the scanner glass.</p>	<p>If you reset the ink level in the HP Scanner Tools Utility the last time that you replaced the imprinter cartridge, you will receive imprinter status alerts when the ink level is running low. If you did not reset the ink level at the time that you replaced the ink cartridge, you might receive erroneous imprinter status alerts or the imprinter might run out of ink before the HP Scanner Tools Utility reports that the ink level is low.</p> <ol style="list-style-type: none"><li>1. Verify that the <b>Enable Imprinting</b> check box is selected in the scanning software.</li><li>2. If the imprinter ink is smearing or leaving blobs of ink on the paper, remove the print cartridge, and then gently wipe the copper contacts of the print cartridge with a clean, damp, lint-free cloth. Reinstall the imprinter cartridge, but do not reset the ink level in the HP Scanner Tools Utility.</li><li>3. Verify that the cartridge stall latch holds the imprinter cartridge firmly in place. See <a href="#">Imprinter cartridge on page 42</a>.</li><li>4. Verify that the imprinter is positioned at one of the predefined locations that is inside the width of the paper as it is fed through the ADF.</li><li>5. Clean and test the imprinter.<ol style="list-style-type: none"><li>a. Press the <b>Tools</b> button on the scanner front panel to open the HP Scanner Tools Utility. Click the <b>Imprinter</b> tab, and then click <b>Clean Imprinter</b>.</li><li>b. Make sure that the ADF has at least one piece of paper in the input tray.</li><li>c. In the HP Scanner Tools Utility, click <b>Test Imprinter</b>.</li><li>d. If the imprinter print quality is good, continue scanning. Otherwise, replace the imprinter cartridge.</li></ol></li></ol>

**Table 6-23 Solve performance problems (continued)**

<b>Problem</b>	<b>Solution</b>
<p>Control-panel buttons do not operate or behave unexpectedly.</p> <p><b>NOTE:</b> The <b>Scan</b> and <b>Copy</b> button settings can be changed in the HP Scanner Tools Utility. You cannot change the settings for the <b>Cancel</b>, <b>Tools</b>, or <b>Power Save</b> buttons.</p>	<p>If the buttons do not function, see <a href="#">Control-panel buttons on page 240</a>.</p> <p>If the control-panel buttons are behaving unexpectedly, try the following procedure:</p> <p><b>NOTE:</b> After each step, press a button to see if it is working correctly. If the problem persists, proceed with the next step.</p> <ol style="list-style-type: none"><li>1. On the <b>Buttons</b> tab of the HP Scanner Tools Utility, determine the associations for the <b>Scanner Front Panel Buttons</b>. If necessary, change the software that is assigned to a button.</li><li>2. Verify that the expected program is installed on the computer by looking at the <b>Start</b> menu.  If necessary, install the program.</li><li>3. If the problem persists, the buttons might be assigned outside of the HP Scanner Tools Utility. Try the following procedure:<ol style="list-style-type: none"><li>a. Open <b>Control Panel</b>, select <b>Scanners and Cameras</b>, and then select your scanner model from the list.</li><li>b. Examine the buttons settings for your scanner.<ul style="list-style-type: none"><li>• Make sure that the <b>Start this program</b> option is selected and that the correct application is selected in the drop-down list.</li><li>• Windows 2000: Make sure that the <b>Disable Device Events</b> option is not selected.</li><li>• Windows XP and Vista: Make sure that the <b>Take No Action</b> option is not selected.</li></ul></li></ol></li></ol>
<p>Wrong profile is used when the <b>Scan</b> button is pressed.</p> <p><b>NOTE:</b> For information about assigning control-panel button functions, see your product user guide.</p>	<ol style="list-style-type: none"><li>• If you are using the HP Smart Document Scan software, use the HP Scanner Tools Utility to determine which HP Smart Document Scan software profile is assigned to the <b>Scan</b> button. If necessary, reset the profile assigned to the button.  <b>NOTE:</b> You can also assign an HP Smart Document Scan software profile to the <b>Copy</b> button.</li><li>• If you are using other scanning software, see the online help for that program.</li></ol>



# Solve connectivity problems

## Solve direct-connect problems

If you have connected the product directly to a computer, check the USB cable.

- Verify that the cable is connected to the computer and to the product.
- Verify that the cable is not longer than 2 meters (6 feet). Replace the cable if necessary.
- Verify that the cable is working correctly by connecting it to another product. Replace the cable if necessary.
- For more information, see [Check the USB connection on page 239](#).



---

# 7 Parts and diagrams

- [Ordering parts and supplies](#)
- [Service part numbers](#)
- [How to use the parts diagrams and lists](#)
- [ADF components](#)
- [Flatbed scanner assemblies](#)
- [Alphabetical parts list](#)
- [Numerical parts list](#)

## Ordering parts and supplies

1. Visit the HP scanner support Web site at [www.hp.com/support](http://www.hp.com/support).
2. Select your country/region, and then select your language.
3. Enter the scanner model number, and then press **Enter**.

# Service part numbers

## N9120 documentation

**Table 7-1 N9120 documentation**

Part	Part number	Description
Getting Started Guide (includes setup poster and warranty information)	L2683-90009	English/Bahasa Ind/Thai
	L2683-90010	English/French/Spanish/Portuguese
	L2683-90011	German
	L2683-90012	German, Italian, French, Dutch
	L2683-90013	Spanish, Catalan, Portuguese, Greek, Polish
	L2683-90014	English, Arabic, French, Portuguese
	L2683-90015	Bulgarian, Croatian, Romanian, Slovenian
	L2683-90016	Turkish, Czech, Slovakian, Hungarian
	L2683-90017	Estonian, Lithuanian, Latvian, Hebrew, Russian
	L2683-90018	Swedish, Finnish, Norwegian, Danish
	L2683-90019	English/Simp Chinese
L2683-90020	English/Trad Chinese/Korean	

## Imprinter cartridges

**Table 7-2 Imprinter cartridges**

Part	Part number	Description
Imprinter cartridge	HP 51604A	Black
	HP 51605B	Blue
	HP 51605R	Red

## Power Cords

**Table 7-3 Power cords**

Part	Part number	Description
Power cord	8121-0740	PWR-CORD OPT-903 3-COND 1.9-M-LG (NA, Mexico)
	8121-0731	PWR-CORD OPT-902 3-COND 1.9-M-LG (Europe, Korean)
	8121-0733	PWR-CORD OPT-912 3-COND 1.9-M-LG (Denmark)
	8121-0739	PWR-CORD OPT-900 3-COND 1.9-M-LG 5A-FUS (UK, HK, Sing)
	8121-1004	PWR-CORD OPT-919 3-COND 1.9-M-LG ROHS (Israel)
	8121-0738	PWR-CORD OPT-906 3-COND 1.9-M-LG (Switzerland)
	8121-0737	PWR-CORD OPT-917 3-COND 1.9-M-LG (South Africa)
	8121-0964	PWR-CORD OPT-934 3-COND 1.9-M-LG ROHS (Taiwan)
	8121-0742	PWR-CORD-OPT-922 3-COND 1.9-M-LG (China)
	8121-0734	PWR-CORD OPT-927 3-COND 1.9-M-LG (Philippines/Thailand)
	8121-0837	PWR-CORD OPT-901 3-COND 1.9-M-LG (Australia)
	8121-0564	PWR-CORD OPT-923 3-COND 1.9-M-LG (India)
	8121-0729	PWR-CORD OPT-920 3-COND 1.9-M-LG (Argentina)
	8121-0735	PWR-CORD OPT-921 3-COND 1.9-M-LG (Chile)
	8121-1071	PWR-CORD OPT-940 3-COND 1.9-M-LG (Brazil)

## Maintenance kits

**Table 7-4 Maintenance kits**

Part	Part number	Description
Package	L2683-00001	Carton - HP p/n: L2683-00001
	L2683-00002	Bottom Tray - HP p/n: L2683-00002
	L2683-60003	Cushion - Bottom Assy - HP p/n: L2683-60003
	L2683-60004	Cushion - Top Assy - HP p/n: L2683-60004
	L2683-80009	ADF tray pad - HP p/n: L2683-80009
	L2683-80008	Pad platen - HP p/n: L2683-80008
	9223-0831	Corru Clips - HP p/n: 9223-0831

## Field replaceable units (FRUs)

**Table 7-5 Field replaceable units (FRUs)**

Location	Part number	Description
ADF	L2684-69001	Scanjet ENT Flow N9120 ADF only
ADF	PF2307-SVPNI	Entire ADF with ADF alignment pins / (preliminary) 6 unit per pallet
ADF	PF2307-GSPNI	Entire ADF with ADF alignment pins made in japan / (preliminary) 6 unit per pallet
ADF	PF2307K201NI	ADF alignment screws
ADF	PF2307K253NI	A4 paper-stop
ADF	PF2307K254NI	Pickup-roller cover
ADF	PF2307K202NI	ADF jam door 3
ADF	PF2307K203NI	ADF input-tray assembly
ADF	PF2307K204NI	Paper present and imprinter PCA holder
ADF	PF2307K205NI	Imprinter PCA
ADF	PF2307K206NI	Paper-present-sensor arm
ADF	PF2307K207NI	Input-tray-elevator arm and attachment screw
ADF	PF2307K208NI	ADF shingle wall with Mylar strip and separation pad and spring
ADF	PF2307K209NI	Lower multi-pick sensor cover
ADF	PF2307K210NI	ADF top corner inner paper path guide
ADF	PF2307K211NI	ADF bottom corner, inner paper path guide
ADF	PF2307K212NI	ADF bottom corner, outer paper path guide
ADF	PF2307K213NI	ADF exit inner paper path guide
ADF	PF2307K214NI	ADF front cover
ADF	PF2307K215NI	ADF back cover
ADF	PF2307K216NI	ADF output tray and cover
ADF	PF2307K217NI	ADF bottom cover
ADF	PF2307K218NI	ADF exit-motor assembly
ADF	PF2307K219NI	ADF input-tray lift-motor assembly
ADF	PF2307K220NI	ADF feed-motor assembly (includes pulley)
ADF	PF2307K221NI	ADF pick-motor assembly (includes pulley)
ADF	PF2307K222NI	ADF motor fan and ADF carriage fan
ADF	PF2307K223NI	ADF background-solenoid assembly

**Table 7-5 Field replaceable units (FRUs) (continued)**

<b>Location</b>	<b>Part number</b>	<b>Description</b>
ADF	PF2307K224NI	Upper multi-pick sensor PCA
ADF	PF2307K225NI	Lower multi-pick sensor PCA
ADF	PF2307K226NI	Sensor used in numerous ADF applications
ADF	PF2307K227NI	Imprinter carriage and FFC
ADF	PF2307K228NI	Imprinter paper-present sensor
ADF	PF2307K229NI	ADF controller PCA
ADF	PF2307K230NI	Exit 1 and Exit 2 sensor arms
ADF	PF2307K231NI	ADF carriage wide flex cable
ADF	PF2307K232NI	ADF carriage narrow flex cable
ADF	PF2307K233NI	Pickup-roller assembly
ADF	PF2307K234NI	Pick-up roller spring
ADF	PF2307K235NI	Separation-pad assembly
ADF	PF2307K236NI	Separation-pad spring
ADF	PF2307K237NI	ADF base reflector
ADF	PF2307K260NI	Flatbed scan position sensor arm
Scanner	L2683-69002	Scanjet ENT Flow N9120 w/ADF
Scanner	L2683-69003	Scanjet ENT Flow N9120 w/ADF China
Scanner	L2683-69005	Scanjet ENT Flow N9120 Base Only
Scanner	L2683-69004	Scanjet ENT Flow N9120 w/ADF US GOV
Scanner	IR4067-WSPNI	Scanner and ADF without any lower-level materials (i.e., power cords, manuals, CDs, USB cable) including ADF alignment pins. / (preliminary) 6 unit per pallet
Scanner	IR4067-SVPNI	Entire flatbed scanner with ADF alignment pins / (preliminary) 6 unit per pallet
Scanner	IR4067-GWSNI	G-SKU scanner and ADF without any lower-level materials (i.e., power cords, manuals, CDs, USB cable) including ADF alignment pins. / (preliminary) 6 unit per pallet
Scanner	IR4067-GSPNI	G-SKU entire flatbed scanner with ADF alignment pins / (preliminary) 6 unit per pallet
Scanner	PF2307K201NI	ADF alignment screws
Scanner	IR4067K201NI	Scanner control-panel cover
Scanner	IR4067K202NI	Control-panel PCA
Scanner	IR4067K203NI	Scanner back cover




**Table 7-5 Field replaceable units (FRUs) (continued)**

Location	Part number	Description
Scanner	IR4067K204NI	ADF power-cable assembly
Scanner	IR4067K205NI	Scanner controller PCA
Scanner	IR4067K206NI	Scanner carriage fan and motor fan
Scanner	IR4067K207NI	Scanner carriage motor
Scanner	IR4067K208NI	Carriage-motor cable
Scanner	IR4067K209NI	Power switch and power receptacle assembly
Scanner	IR4067K210NI	Power supply PCA
Scanner	IR4067K211NI	Fan filter
Scanner	IR4067K212NI	Scanner back-filter cover

## How to use the parts diagrams and lists

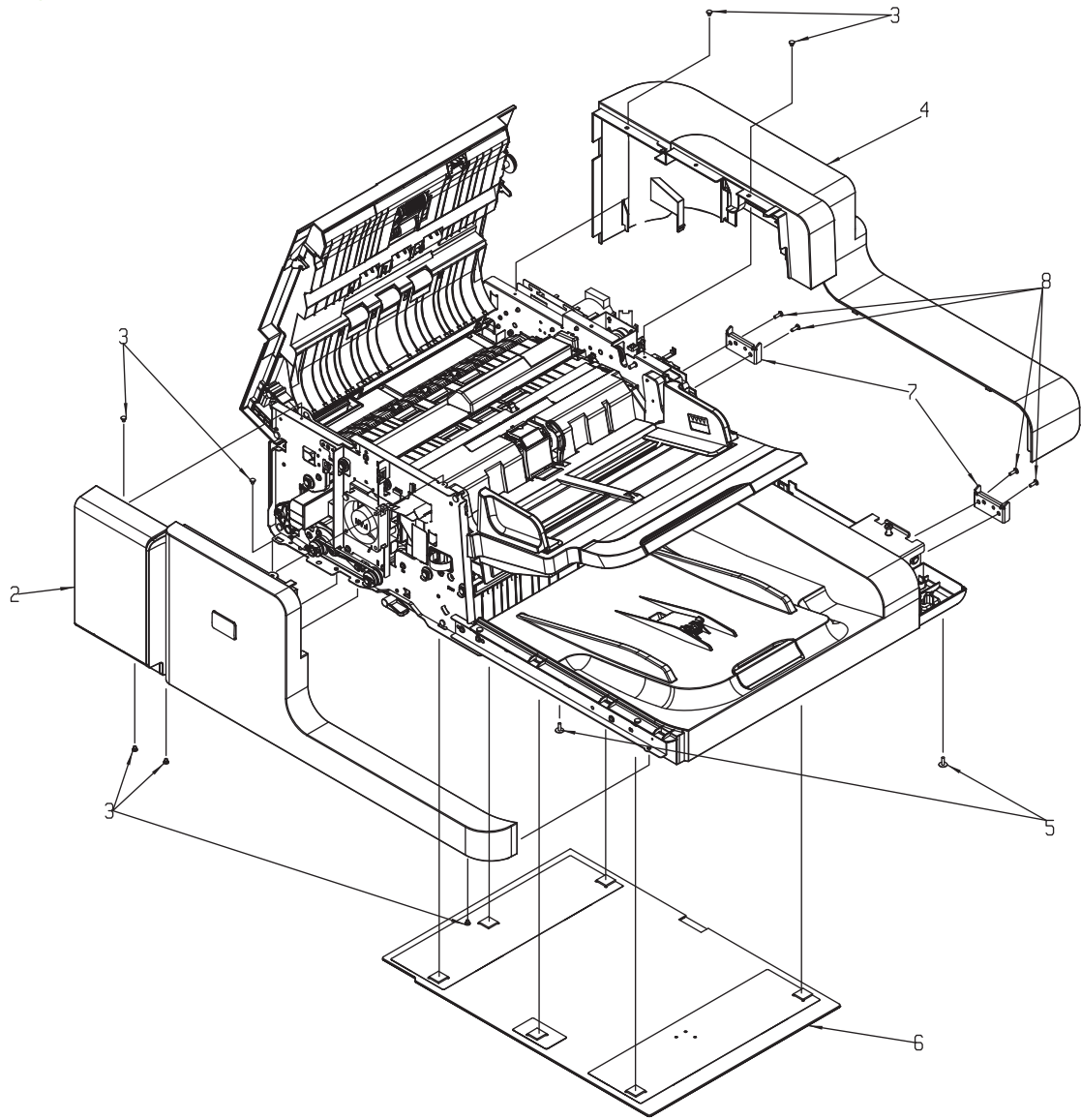
The figures in this chapter show the major subassemblies in the product and their component parts. A parts list table follows each exploded-view assembly diagram. Each table lists the item number, the associated part number, and the description of each part. If a part is not listed in the table, it is not a FRU.

 **NOTE:** If the product is owned by the U.S. government, the ADF and flatbed scanner have a special serial-number designation. Replacement components for these products must have a similar serial-number designation.

In this manual, the abbreviation “PCA” stands for “printed circuit-board assembly.” A component described as a PCA might consist of a single circuit board or a circuit board plus other parts, such as cables and sensors.

# ADF components

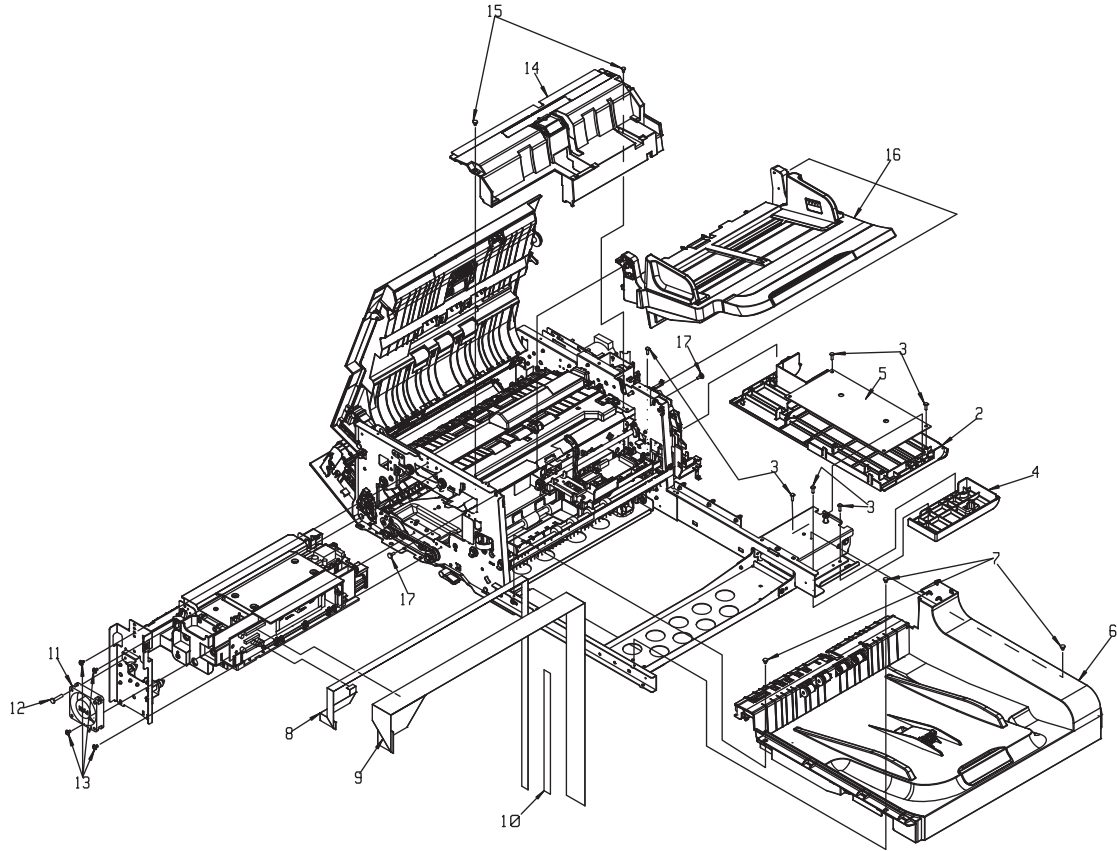
Figure 7-1 ADF assemblies (1 of 14)



**Table 7-6 ADF assemblies (1 of 14)**

<b>Ref</b>	<b>Description</b>	<b>Part number</b>	<b>Qty</b>
2	ADF front cover	PF2307K214NI	1
3	Screw	PF2307K239NI	7
4	ADF back cover	PF2307K215NI	1
5	Screw	NS-SCR00084	2
6	ADF base reflector	PF2307K237NI	1
7	Hinge limiter	PF2307P147	2
8	Screw	O40080FNBI	4

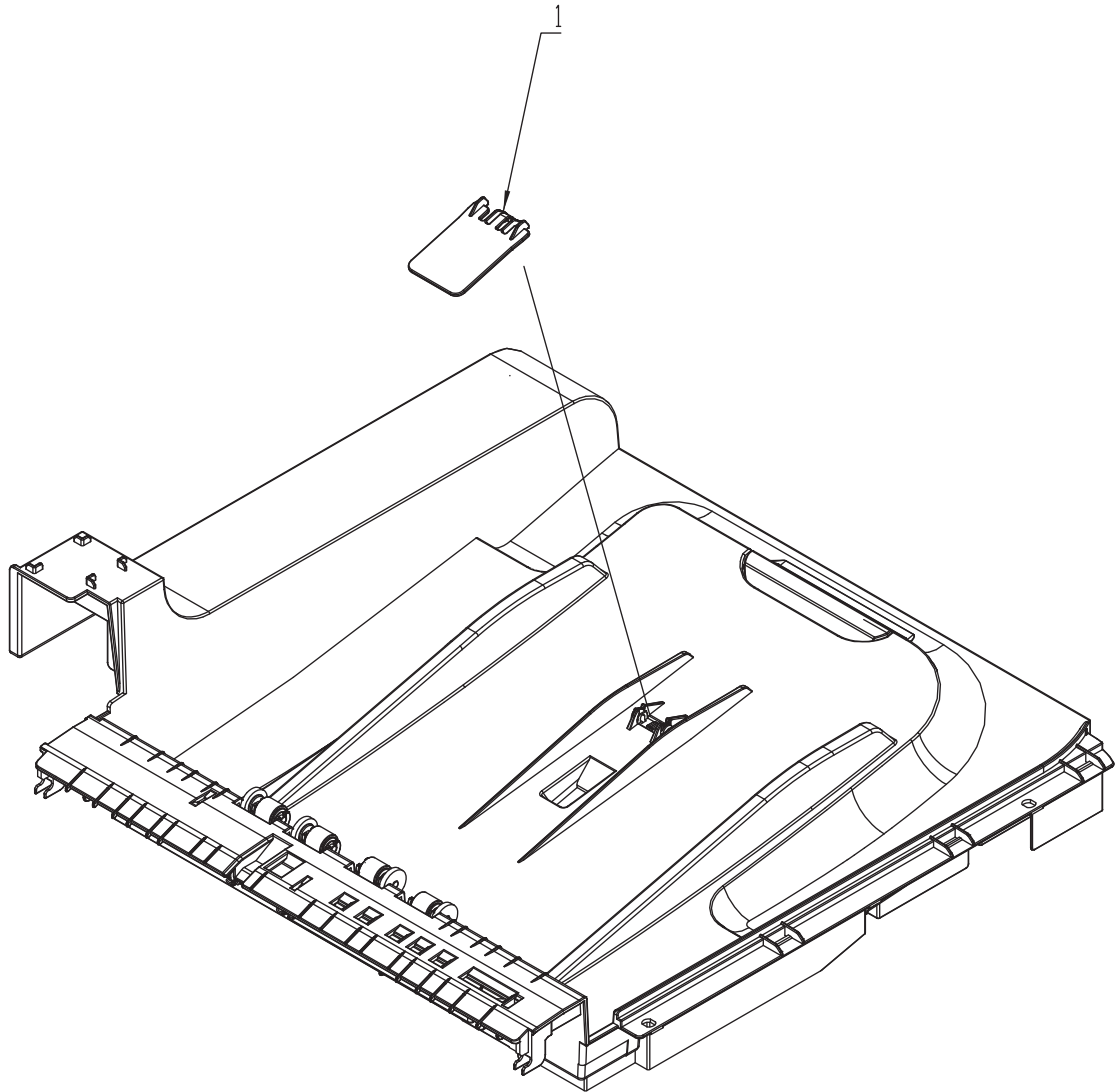
**Figure 7-2** ADF assemblies (2 of 14)



**Table 7-7 ADF assemblies (2 of 14)**

<b>Ref</b>	<b>Description</b>	<b>Part number</b>	<b>Qty</b>
2	Bottom cover	PF2307K217NI	1
3	Screw	PF2307K246A	6
5	ADF controller PCA	PF2307K229NI	1
6	ADF output tray	PF2307K216NI	1
7	Screw	PF2307K248NI	3
8	Flat flexible cable	PF2307K231NI	1
9	Flat flexible cable	PF2307K232NI	1
10	FFC separation shield	PF2307P392	1
11	ADF carriage fan	PF2307K222NI	1
12	Screw	PF2307K245NI	1
13	Screw	IR4067K214NI	4
14	ADF shingle wall	PF2307K208NI	1
15	Screw	IR4067K220NI	1
16	ADF input tray assembly	PF2307K203NI	1
17	Screw	PF2307K241NI	2

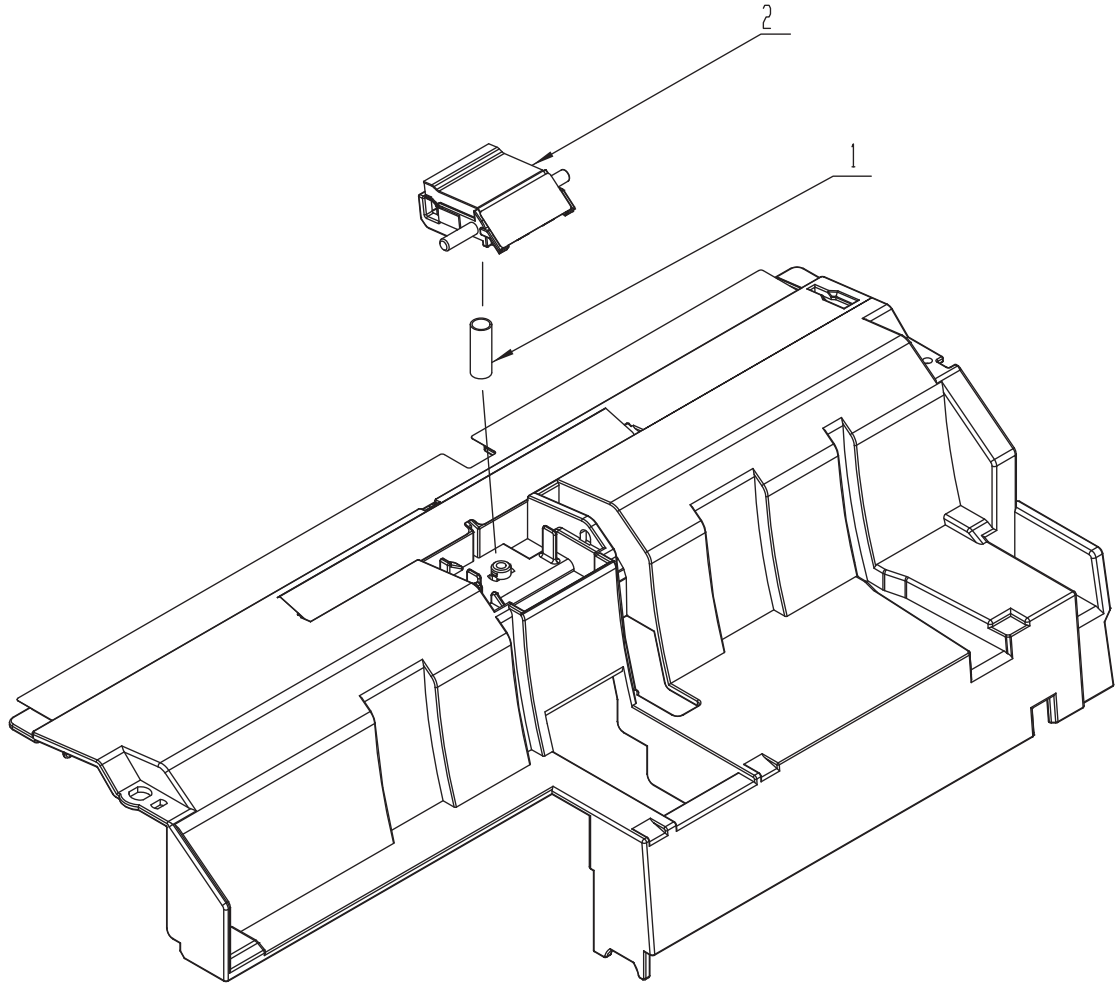
**Figure 7-3** ADF assemblies (3 of 14)



**Table 7-8 ADF assemblies (3 of 14)**

<b>Ref</b>	<b>Description</b>	<b>Part number</b>	<b>Qty</b>
1	A4 paper-stop	PF2307K253NI	1

**Figure 7-4** ADF assemblies (4 of 14)

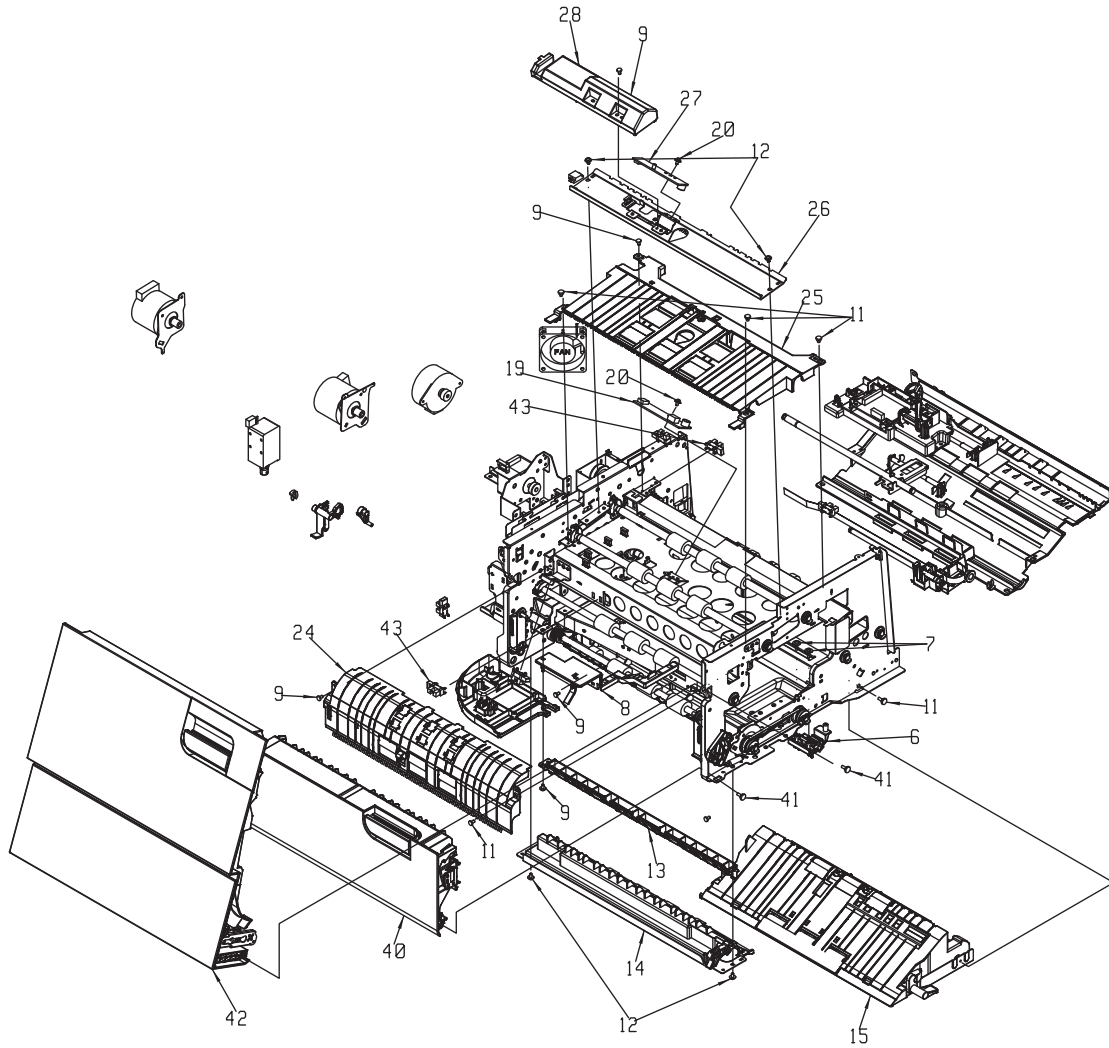




**Table 7-9 ADF assemblies (4 of 14)**

<b>Ref</b>	<b>Description</b>	<b>Part number</b>	<b>Qty</b>
1	Separation pad spring	PF2307K236NI	1
2	Separation pad assembly	PF2307K235NI	1

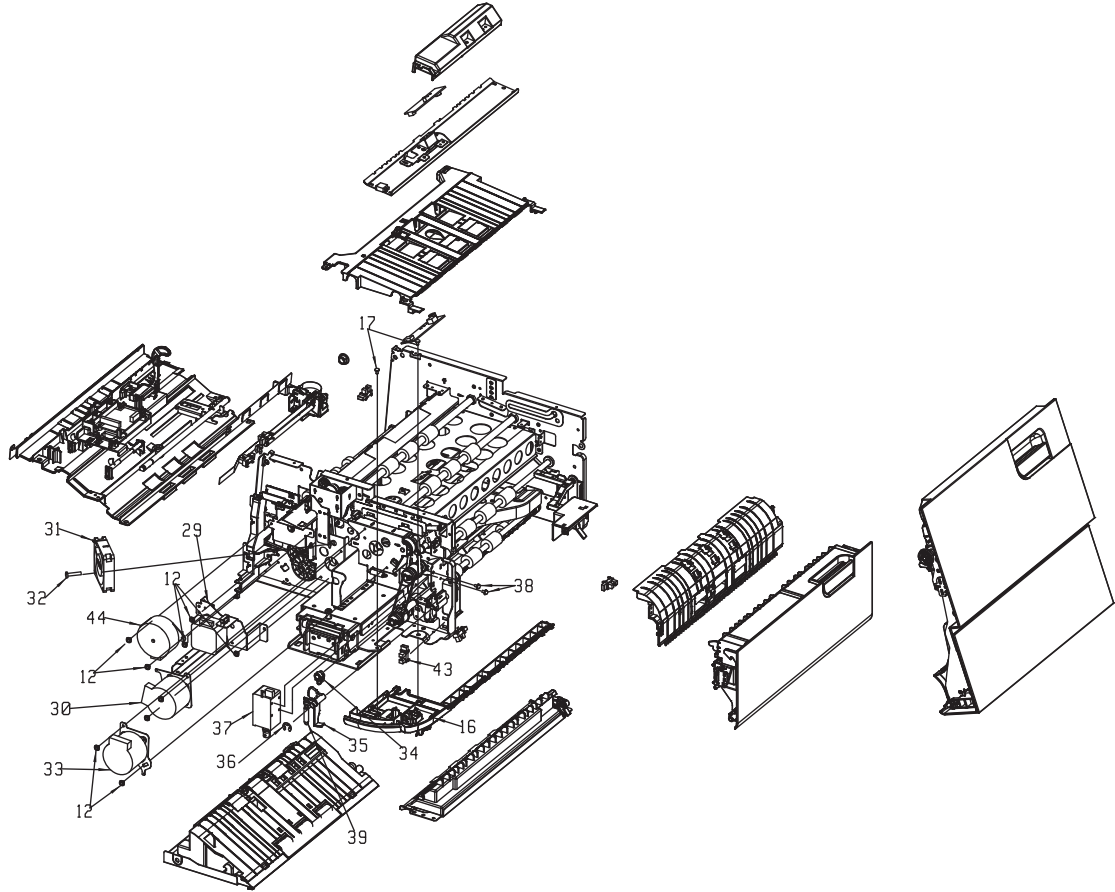
**Figure 7-5** ADF assemblies (5 of 14)



**Table 7-10 ADF assemblies (5 of 14)**

<b>Ref</b>	<b>Description</b>	<b>Part number</b>	<b>Qty</b>
6	Bracket	PF2307K010A	1
7	Screw	NS-SCR00084B	2
8	Flatbed scan position sensor bracket	PF2307K011	1
9	Screw	PF2307K239NI	6
11	Screw	PF2307K248A	8
12	Screw	IR4067K214NI	5
13	ADF bottom corner, inner paper path guide	PF2307K211NI	1
14	ADF bottom corner, outer paper path guide	PF2307K212NI	1
15	ADF jam door 3	PF2307K202NI	1
19	Lower multi-pick sensor PCA	PF2307K225NI	1
20	Screw	PF2307K239NI	1
24	ADF top corner inner paper path guide	PF2307K210NI	1
25	Lower multi-pick sensor cover	PF2307K209NI	1
26	Upper multi-pick sensor tray	PF2307K042	1
27	Upper multi-pick sensor PCA	PF2307K224NI	1
28	Upper multi-pick sensor cover	PF2307K240NI	1
28	Upper multipick sensor cover	PF2307P007	1
40	ADF jam door 2	PF2307K051	1
41	Screw	PF2307K241NI	2
42	ADF jam door 1	PF2307K058	1
43	Sensor	PF2307K226NI	4

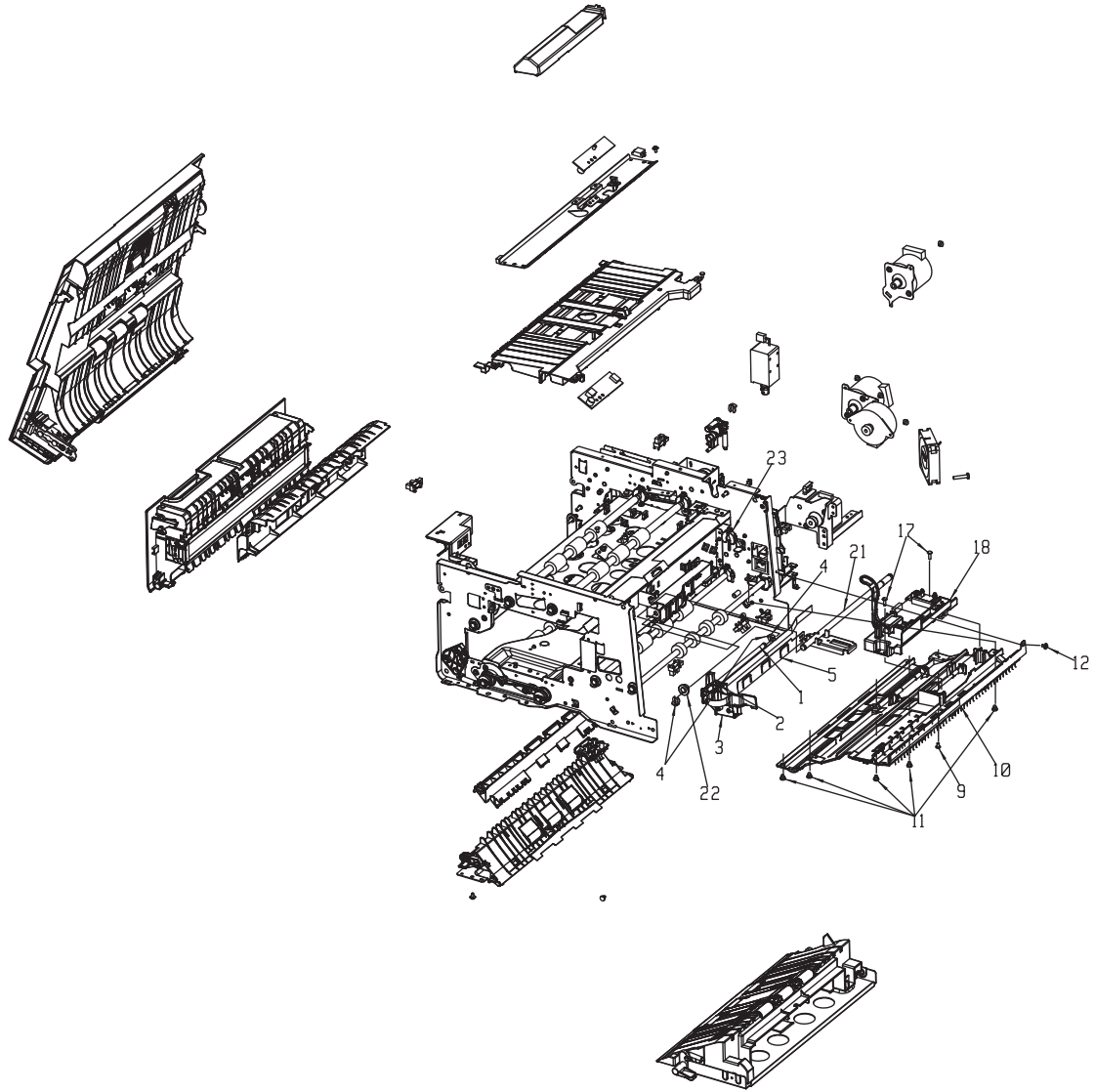
**Figure 7-6** ADF assemblies (6 of 14)



**Table 7-11 ADF assemblies (6 of 14)**

<b>Ref</b>	<b>Description</b>	<b>Part number</b>	<b>Qty</b>
12	Screw	IR4067K214NI	9
16	ADF bottom cover	PF2307K217NI	1
17	Screw	PF2307K246NI	2
29	ADF exit motor assembly	PF2307K218NI	1
30	ADF pick motor assembly	PF2307K221NI	1
31	ADF motor fan	PF2307K222NI	1
32	Screw	PF2307K245NI	1
33	ADF feed motor assembly	PF2307K220NI	1
34	Background solenoid assembly	PF2307K223NI	1
35	Background solenoid assembly	PF2307K223NI	1
36	Background solenoid assembly	PF2307K223NI	2
37	Background solenoid assembly	PF2307K223NI	1
38	Screws	PF2307K238NI	2
39	Background solenoid assembly spring	PF2307P350	1
43	Sensor	PF2307K226NI	4
44	ADF input-tray lift-motor assembly	PF2307K219NI	1

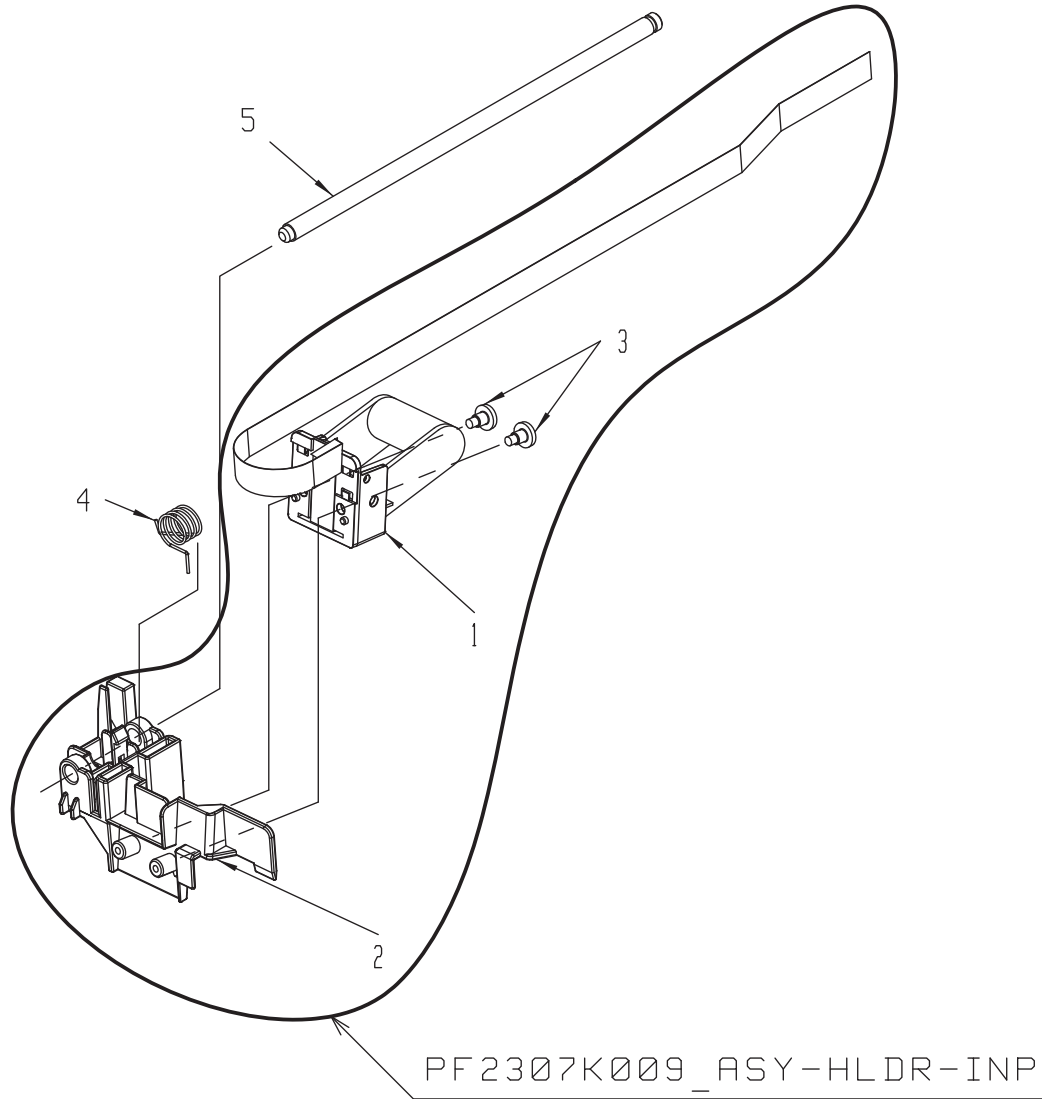
**Figure 7-7** ADF assemblies (7 of 14)



**Table 7-12 ADF assemblies (7 of 14)**

<b>Ref</b>	<b>Description</b>	<b>Part number</b>	<b>Qty</b>
1	Imprinter carriage rod	PF2307P229A	1
2	Imprinter cartridge holder clasp	PF2307P360A	1
3	Imprinter carriage frame and cable	PF2307K227NI	1
4	Clip	PF2307K250NI	2
5	Imprinter cable channel	PF2307P359C	1
10	ADF exit inner paper path guide	PF2307K213NI	1
17	Screw	NS-SCR00027	2
18	Paper present and imprinter PCA holder	PF2307K204NI	1
21	Input tray elevator arm	PF2307K207NI	1
22	Bushing	NS-MTL00017	2
23	Clip	PF2307K255NI	1

**Figure 7-8** ADF assemblies (8 of 14)

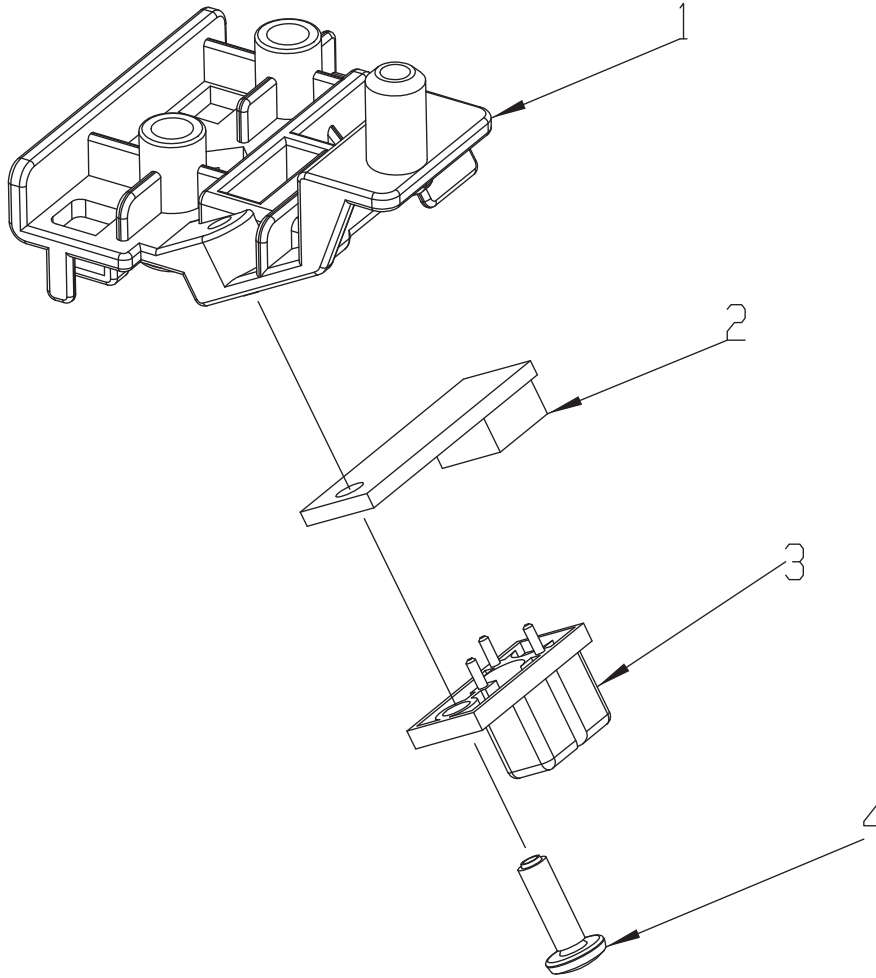




**Table 7-13 ADF assemblies (8 of 14)**

<b>Ref</b>	<b>Description</b>	<b>Part number</b>	<b>Qty</b>
1	Imprinter carriage latch	PF2307P680A	1
2	Imprinter carriage seat	PF2307P054B	2
3	Screw	O26080FDDB	2
4	Spring	PF2307P360	1
5	Imprinter carriage guide	PF2307P229	1

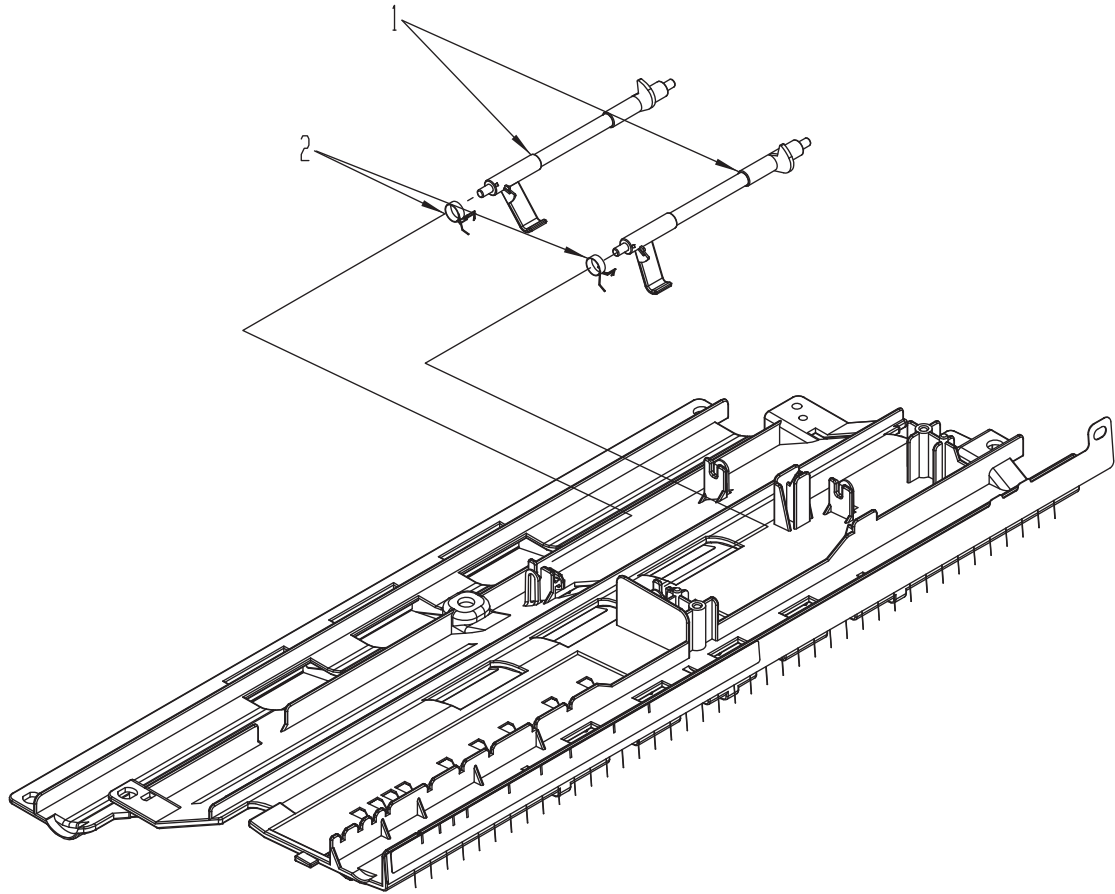
**Figure 7-9** ADF assemblies (9 of 14)



**Table 7-14 ADF assemblies (9 of 14)**

<b>Ref</b>	<b>Description</b>	<b>Part number</b>	<b>Qty</b>
1	Imprinter paper-present sensor holder	PF2307P055B	1
2	Imprinter sensor mount	PF2307K228NI	1
3	Imprinter paper-present sensor	PF2307K228NI	1
4	Screw	NS-SCR00027B	1

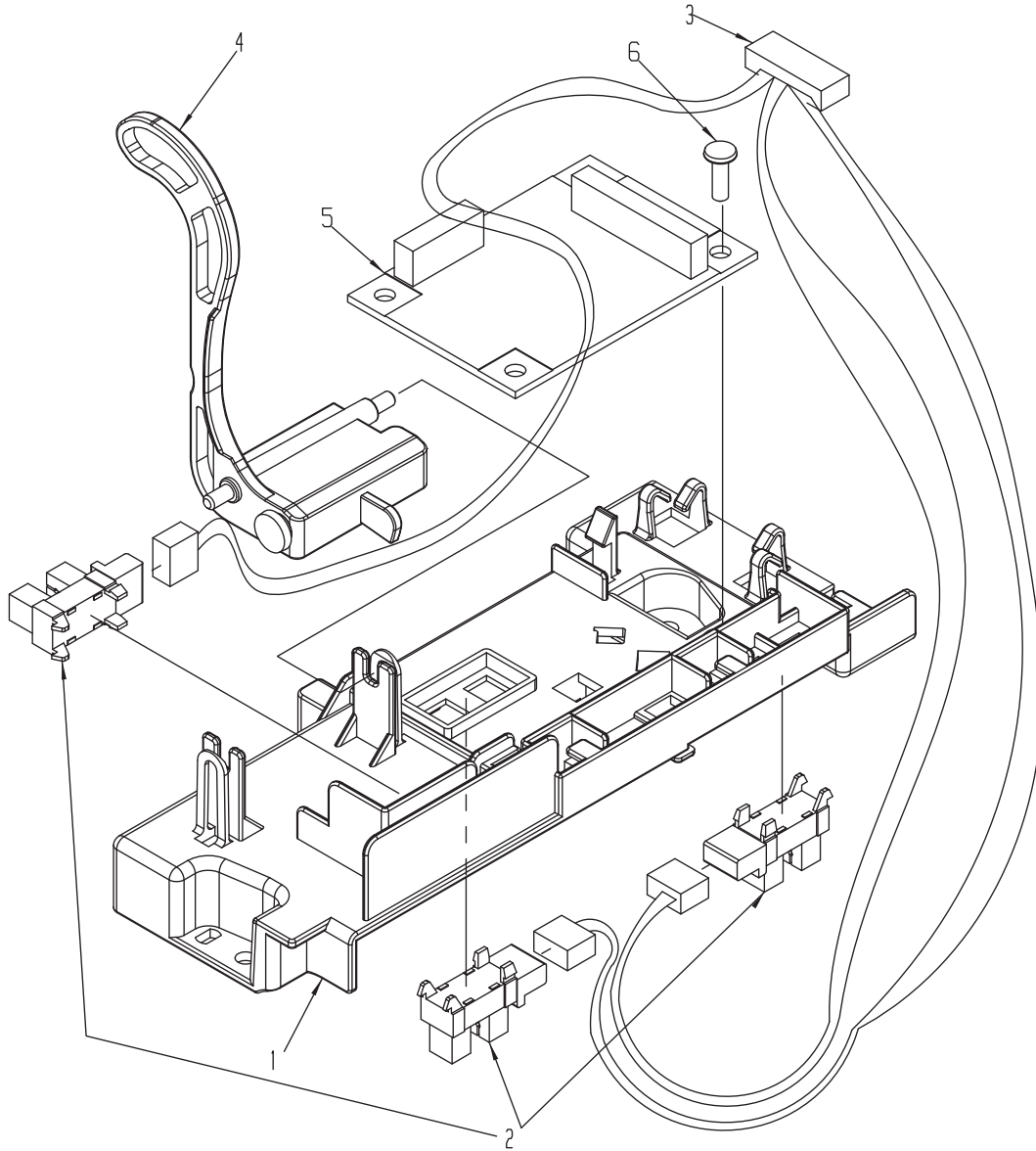
**Figure 7-10** ADF assemblies (10 of 14)



**Table 7-15 ADF assemblies (10 of 14)**

<b>Ref</b>	<b>Description</b>	<b>Part number</b>	<b>Qty</b>
1	Sensor arm	PF2307K230NI	2
2	Spring	PF2261P310C1	2

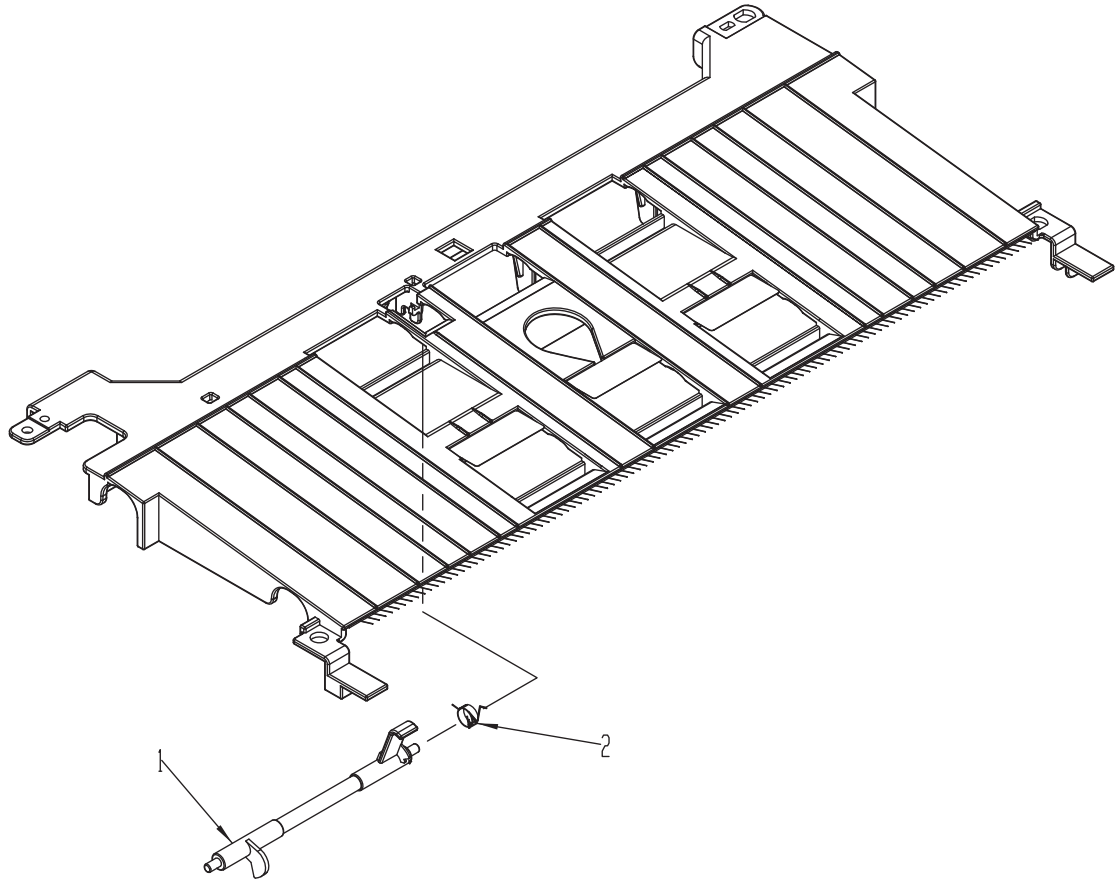
**Figure 7-11** ADF assemblies (11 of 14)



**Table 7-16 ADF assemblies (11 of 14)**

<b>Ref</b>	<b>Description</b>	<b>Part number</b>	<b>Qty</b>
1	Paper presence sensor and imprinter PCA holder	PF2307K204NI	1
2	Sensor	PF2307K226NI	3
3	Flat flexible cable	PF2307K627	1
4	Paper-present-sensor arm	PF2307K206NI	1
5	Imprinter PCA	PF2307K205NI	1
6	Screw	-	1

**Figure 7-12** ADF assemblies (12 of 14)

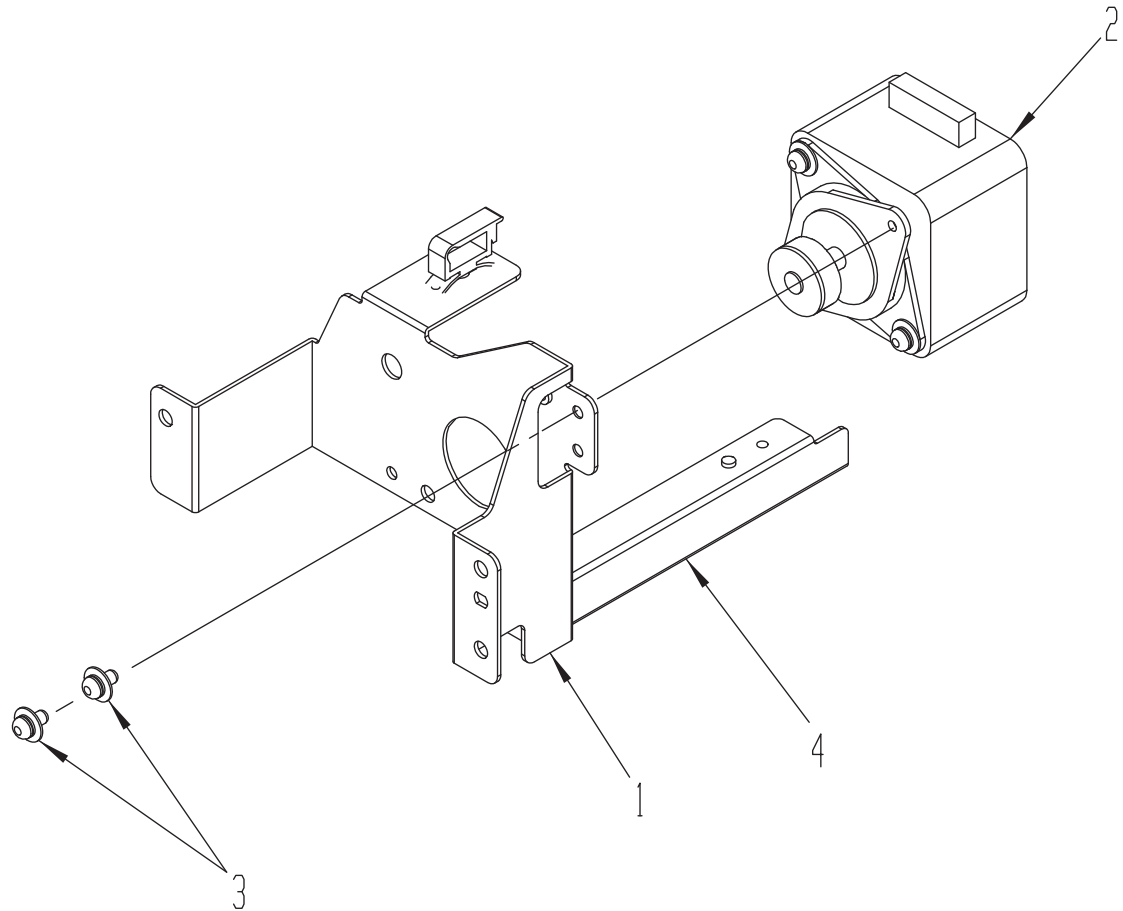




**Table 7-17 ADF assemblies (12 of 14)**

<b>Ref</b>	<b>Description</b>	<b>Part number</b>	<b>Qty</b>
1	Registration sensor arm	PF2307K230NI	1
2	Spring	PF2261P310	1

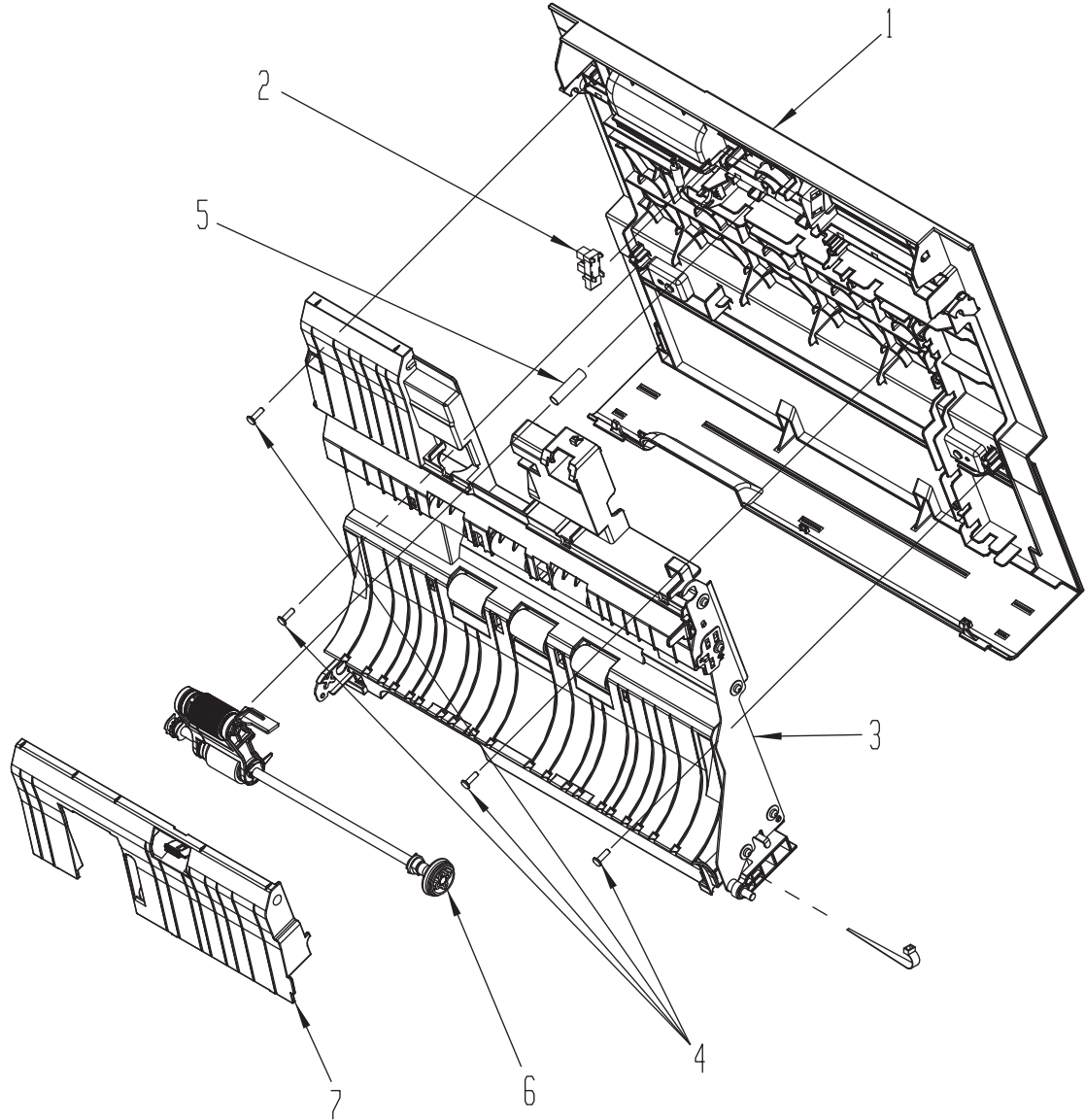
**Figure 7-13** ADF assemblies (13 of 14)



**Table 7-18 ADF assemblies (13 of 14)**

<b>Ref</b>	<b>Description</b>	<b>Part number</b>	<b>Qty</b>
1	Mounting bracket	PF2307P132	1
2	ADF exit motor	PF2307K218NI	1
3	Screw	PF2307K239NI	2
4	Mounting bracket	PF2307P132	1

**Figure 7-14** ADF assemblies (14 of 14)

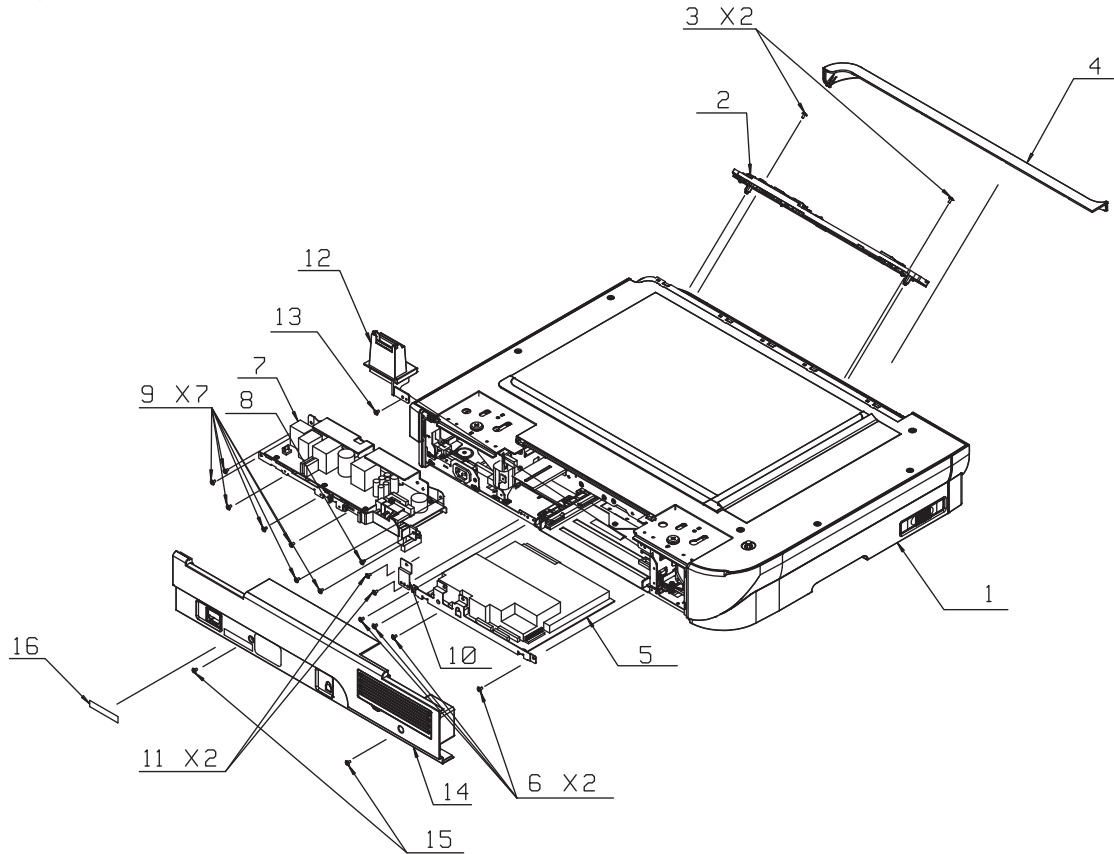


**Table 7-19 ADF assemblies (14 of 14)**

<b>Ref</b>	<b>Description</b>	<b>Part number</b>	<b>Qty</b>
1	Jam door 2 top cover	PF2307K059A	1
2	Sensor	PF2307K226NI	1
3	Jam door 2 bottom cover	PF2307K062A	1
4	Screw	NS-SCR00027B	4
5	Pick-up roller spring	PF2307K234NI	1
6	Pickup-roller assembly	PF2307K233NI	1
7	Pickup-roller cover	PF2307K254NI	1

# Flatbed scanner assemblies

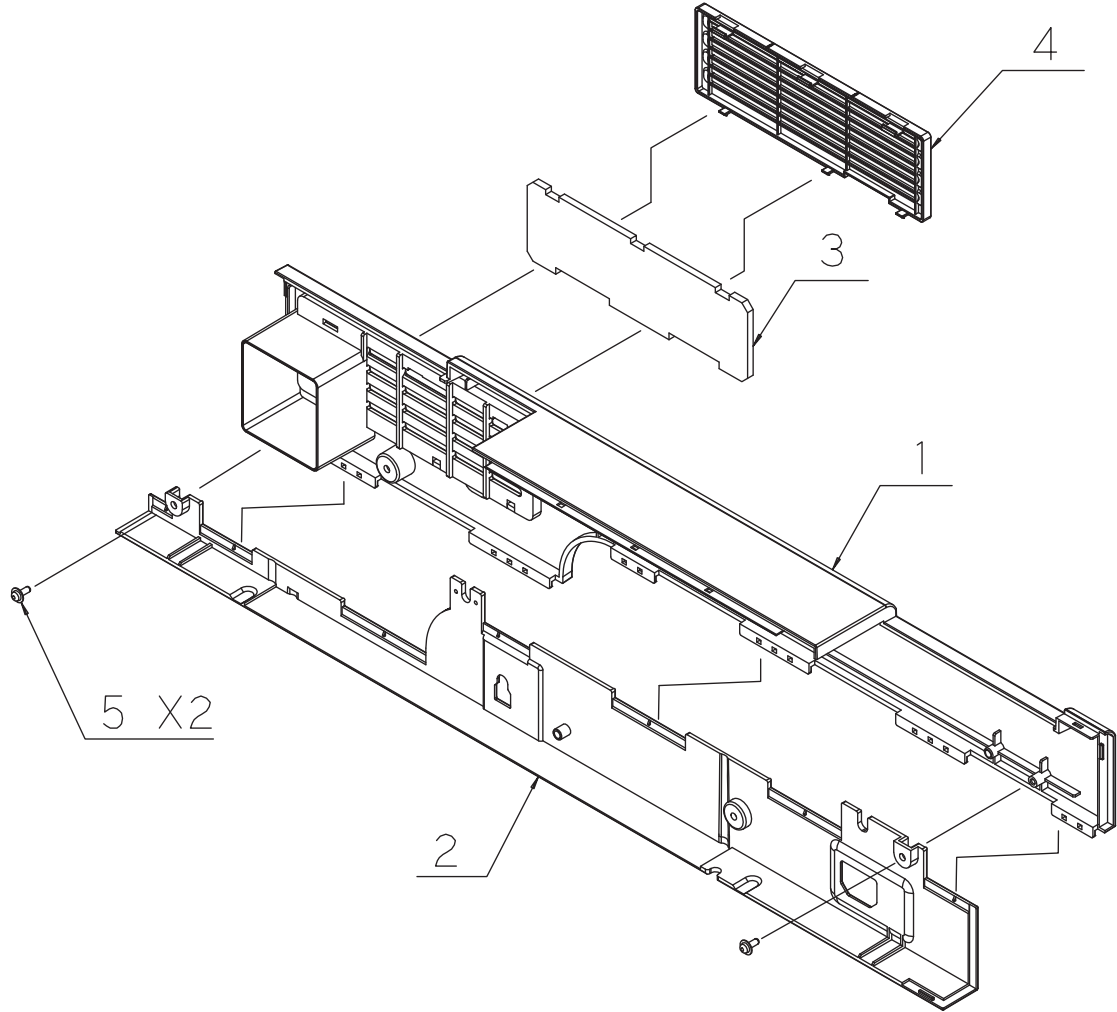
Figure 7-15 Flatbed scanner assemblies (1 of 9)



**Table 7-20 Flatbed scanner assemblies (1 of 9)**

<b>Ref</b>	<b>Description</b>	<b>Part number</b>	<b>Qty</b>
1	Scanner right side cover	IR4067K061	1
2	Scanner control panel PCA	IR4067K202NI	1
3	Screw	IR4067K218NI/ IR4067K232NI	2
4	Scanner control panel cover	IR4067K201NI	1
5	Scanner controller PCA	IR4067K205NI	1
6	Screw	IR4067K220NI/ IR4067K234NI	4
7	Power-supply PCA	IR4067K210NI	1
8	Screw	IR4067K214NI/ IR4067K228NI	1
9	Screw	IR4067K220NI/ IR4067K234NI	7
10	Bracket	IR4067P141	1
11	Screw	IR4067K220NI/ IR4067K234NI	2
12	ADF cable duct	IR4067K204NI	1
13	Screw	IR4067K214NI/ IR4067K228NI	1
14	Scanner back cover	IR4067K203NI	1
15	Screw	IR4067K214NI/ IR4067K228NI	2
16	Label	IR4067P410	1

**Figure 7-16** Flatbed scanner assemblies (2 of 9)

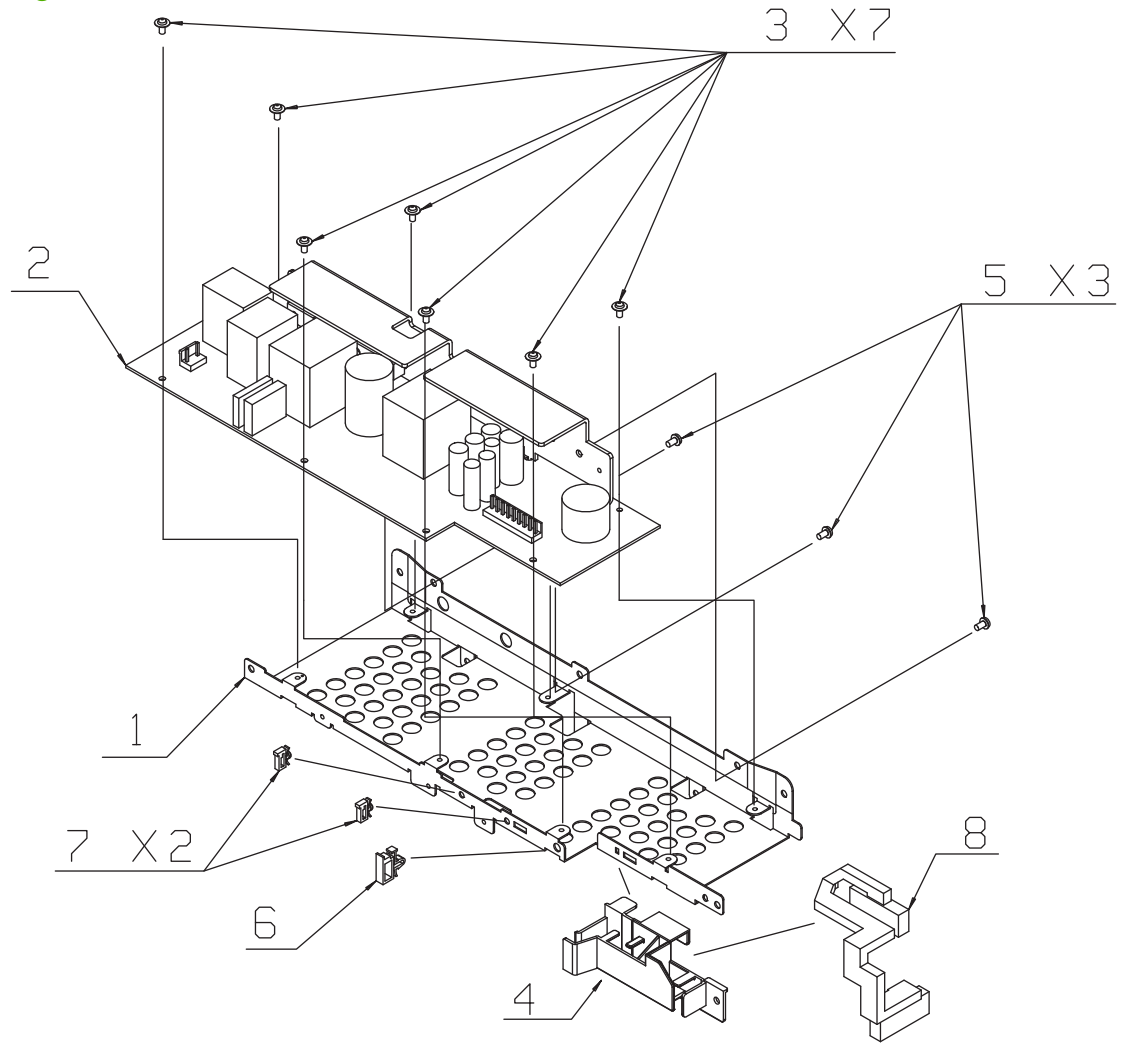




**Table 7-21 Flatbed scanner assemblies (2 of 9)**

<b>Ref</b>	<b>Description</b>	<b>Part number</b>	<b>Qty</b>
1	Cover MT	IR4067P012	1
2	Cover bottom MT	IR4067P016	1
3	Filter	IR4067K211NI	1
4	Scanner back-filter cover	IR4067K212NI	1
5	Screw	IR4067K213NI/ IR4067K235NI	2

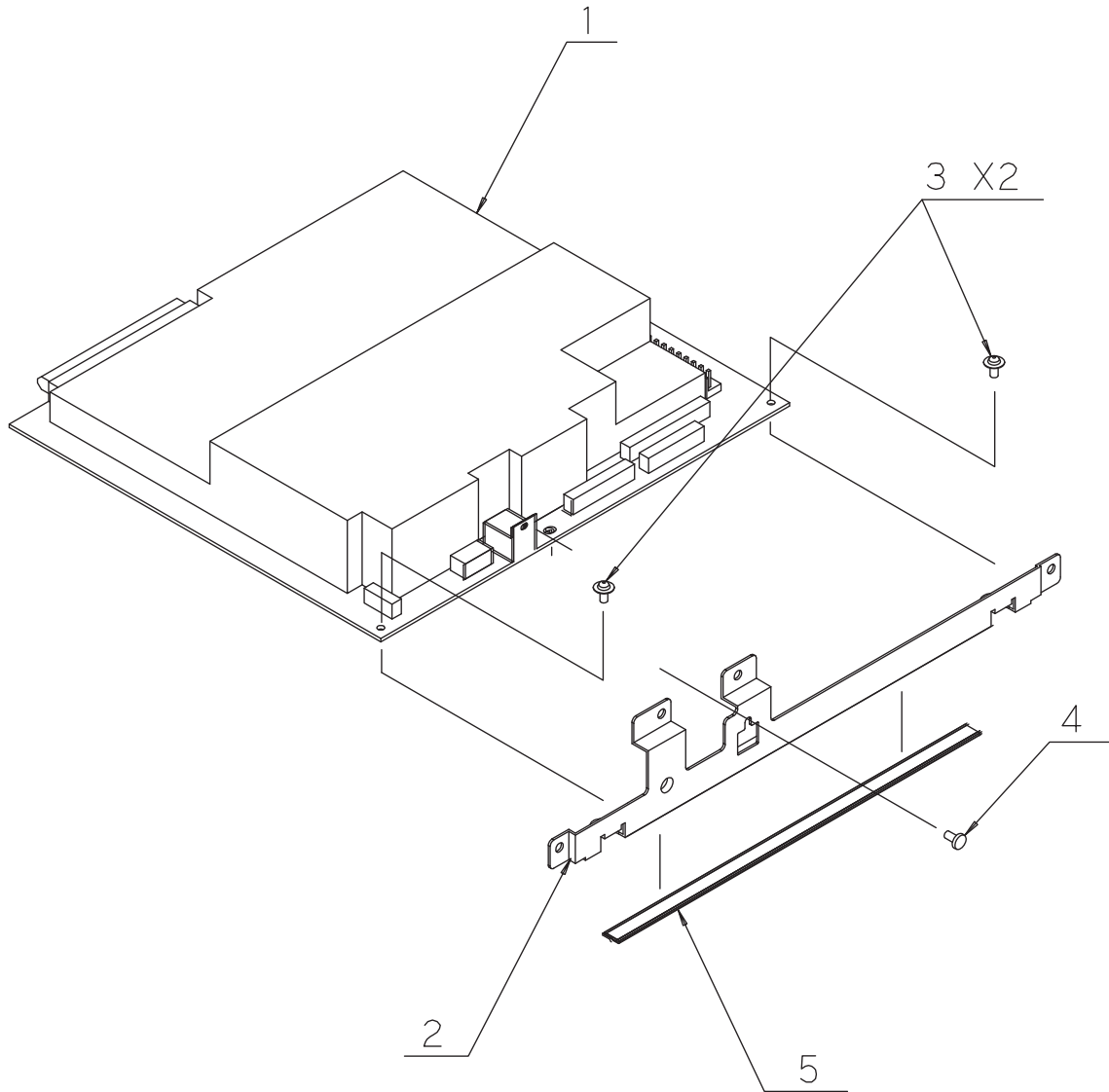
**Figure 7-17** Flatbed scanner assemblies (3 of 9)



**Table 7-22 Flatbed scanner assemblies (3 of 9)**

<b>Ref</b>	<b>Description</b>	<b>Part number</b>	<b>Qty</b>
1	Bracket	IR4067P131	1
2	Power-supply PCA	IR4067K210NI	1
3	Screw	IR4067K214NI/ IR4067K228NI	7
4	Duct	IR4067P027	1
5	Screw	IR4067K220NI/ IR4067K234NI	3
6	Clip	E450001208	1
7	Clip	E450000575	2
8	Bracket	IR4067K612	1

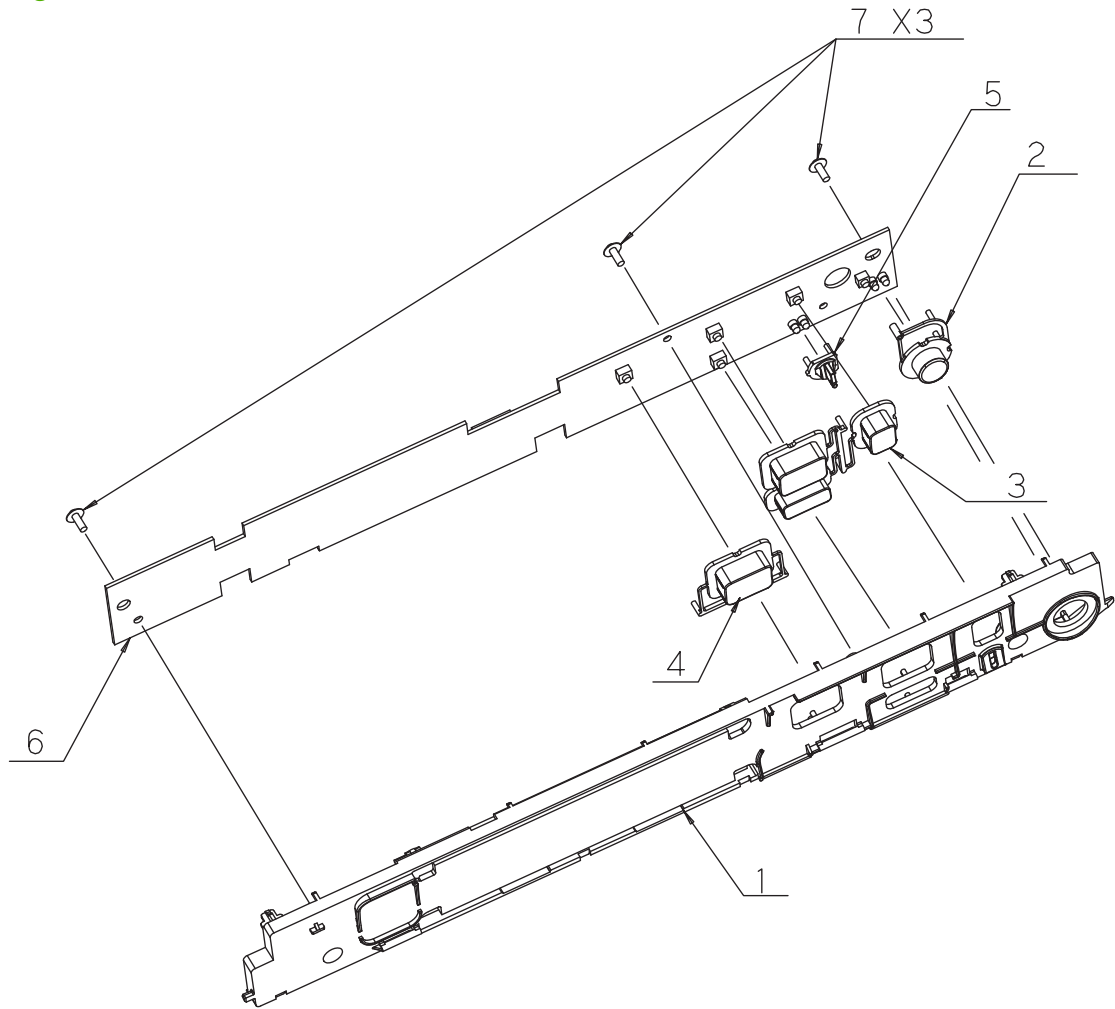
**Figure 7-18** Flatbed scanner assemblies (4 of 9)



**Table 7-23 Flatbed scanner assemblies (4 of 9)**

<b>Ref</b>	<b>Description</b>	<b>Part number</b>	<b>Qty</b>
1	Scanner controller PCA	IR4067K205NI	1
2	Bracket	IR4067P127	1
3	Screw	IR4067K214NI/ IR4067K228NI	2
4	Screw	O30060FNBI	1
5	STGP	IR4067P368	1

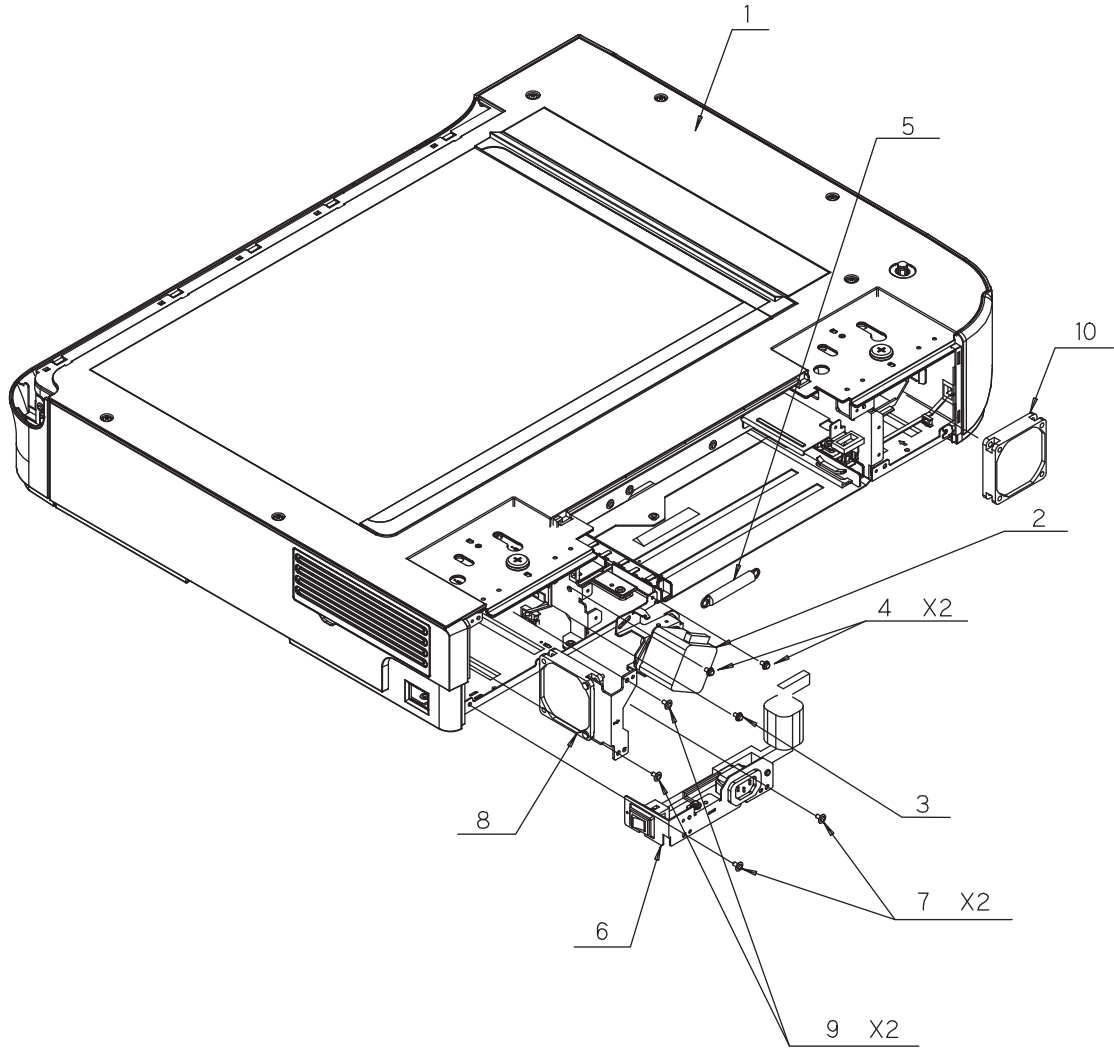
**Figure 7-19** Flatbed scanner assemblies (5 of 9)



**Table 7-24 Flatbed scanner assemblies (5 of 9)**

<b>Ref</b>	<b>Description</b>	<b>Part number</b>	<b>Qty</b>
1	GID-PCB	IR4067P044	1
2	SW-DC	IR4067P034	1
3	SW-GO	IR4067P035	1
4	SW-COPY2	IR4067P046	1
5	GID-LED	IR4067P047	1
6	ASY-PBA-PANEL	IR4067K505	1
7	Screw	IR4067K213NI/ IR4067K235NI	3

**Figure 7-20** Flatbed scanner assemblies (6 of 9)

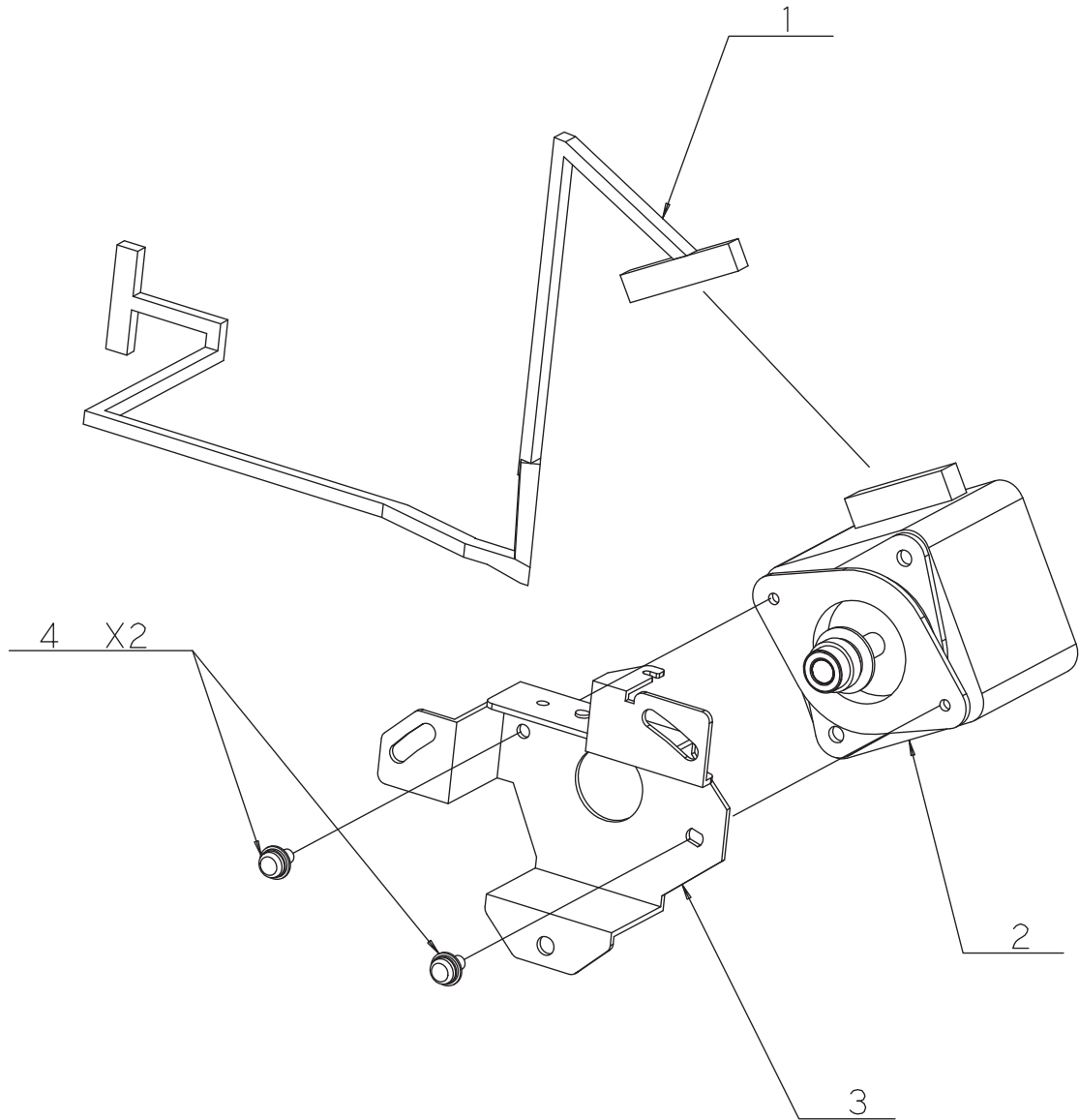




**Table 7-25 Flatbed scanner assemblies (6 of 9)**

<b>Ref</b>	<b>Description</b>	<b>Part number</b>	<b>Qty</b>
1	FB-UNIT	IR4067K--	1
2	ASY-BKT-MOT	IR4067K052	2
3	Screw	NS-SCR00201	1
4	Screw	IR4067K214NI/ IR4067K228NI	2
5	SP-T-080-656-29662	IR4067P311	1
6	Power switch and power receptacle assembly	IR4067K209NI	1
7	Screw	IR4067K220NI/ IR4067K234NI	2
8	Scanner carriage-motor fan	IR4067K206NI	1
9	Screw	IR4067K220NI/ IR4067K234NI	2
10	Flatbed carriage fan	IR4067K206NI	1

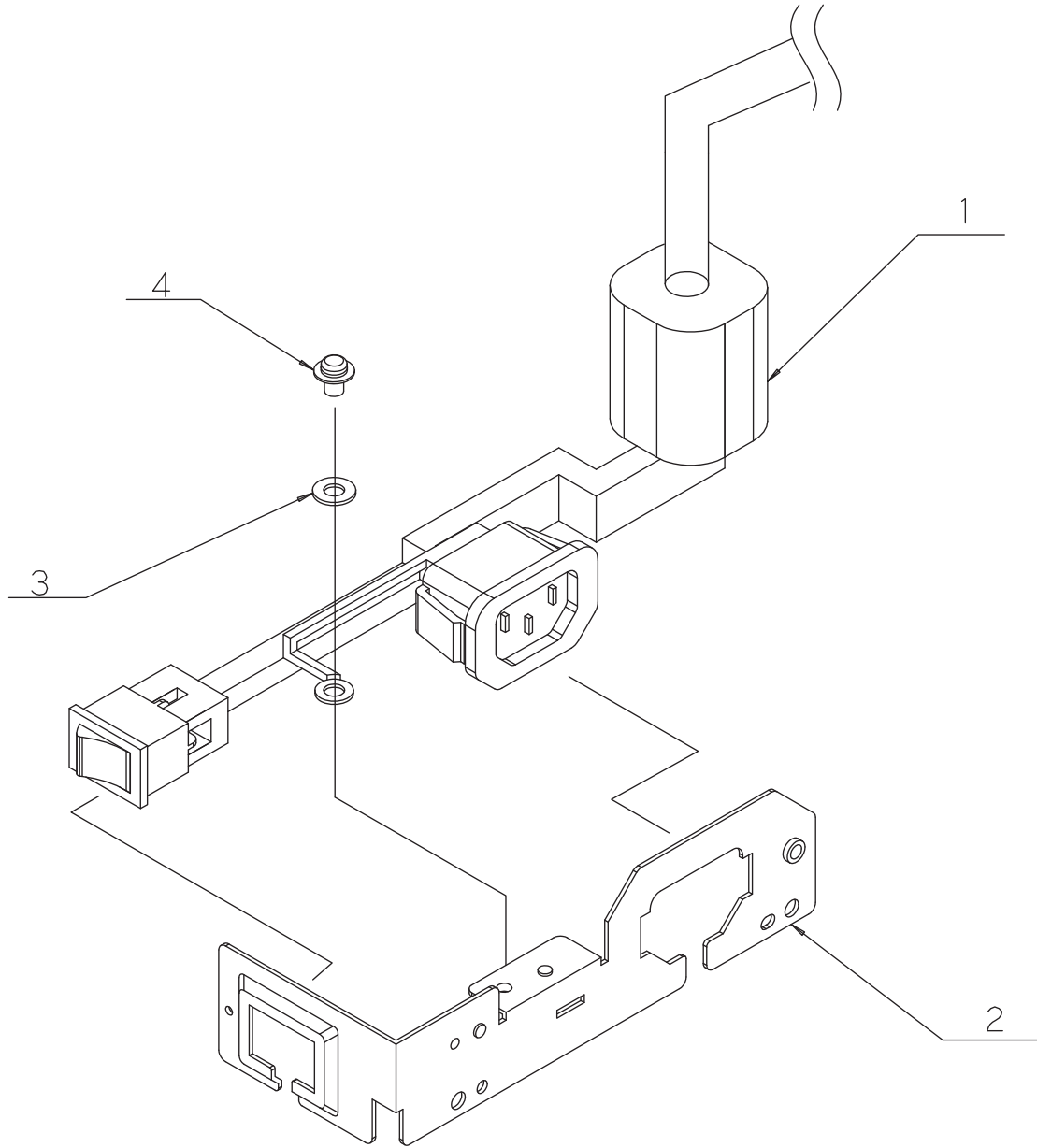
**Figure 7-21** Flatbed scanner assemblies (7 of 9)



**Table 7-26 Flatbed scanner assemblies (7 of 9)**

<b>Ref</b>	<b>Description</b>	<b>Part number</b>	<b>Qty</b>
1	Scanner carriage motor cable	IR4067K208NI	1
2	Scanner carriage motor	IR4067K207NI	1
3	Bracket	IR4067P119	1
4	Screw	IR4067K214NI/ IR4067K228NI	2

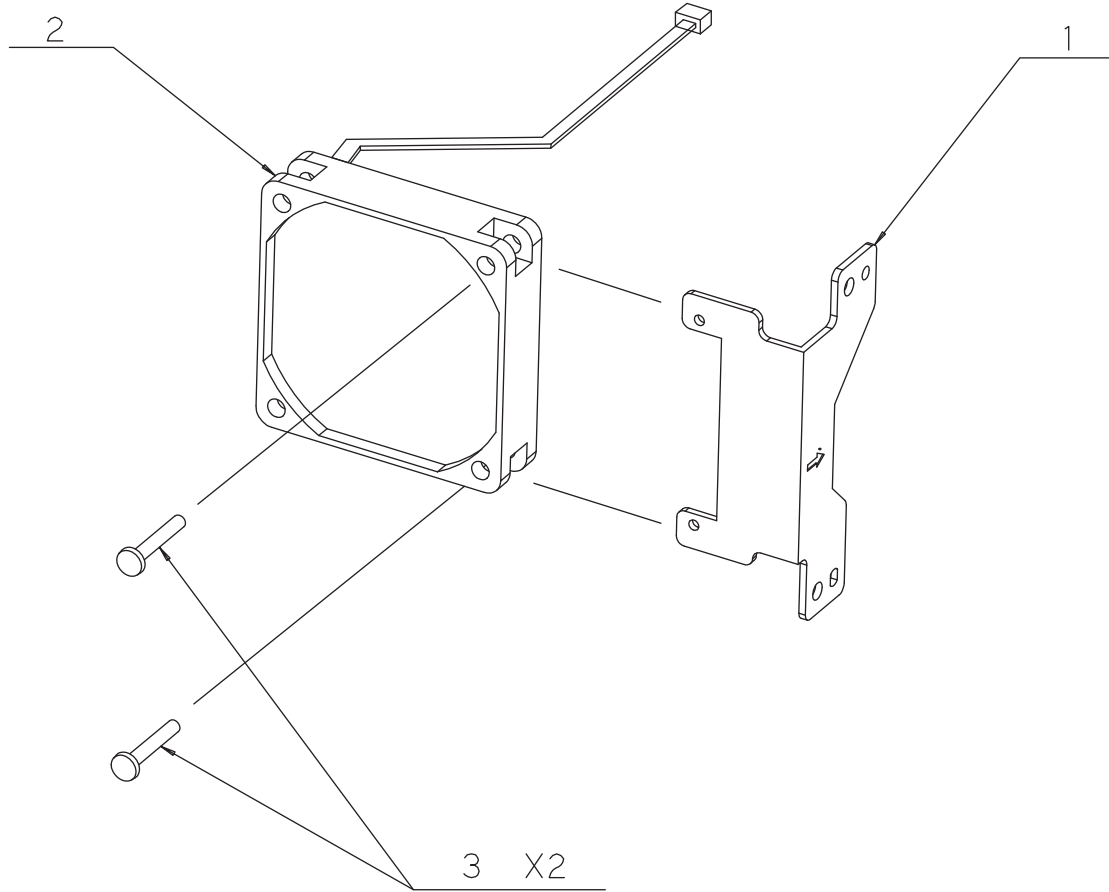
**Figure 7-22** Flatbed scanner assemblies (8 of 9)



**Table 7-27 Flatbed scanner assemblies (8 of 9)**

<b>Ref</b>	<b>Description</b>	<b>Part number</b>	<b>Qty</b>
1	ASM-ACIN	IR4067K610	1
2	PLT-INL	IR4067P130	1
3	Washer	IR4067K217NI/ IR4067K231NI	1
4	Screw	IR4067K216NI/ IR4067K230NI	1

**Figure 7-23** Flatbed scanner assemblies (9 of 9)



**Table 7-28 Flatbed scanner assemblies (9 of 9)**

<b>Ref</b>	<b>Description</b>	<b>Part number</b>	<b>Qty</b>
1	Bracket	IR4067P129	1
2	Flatbed carriage fan	IR4067K206NI	1
3	Screw	IR4067K219NI/ IR4067K233NI	2

# Alphabetical parts list

**Table 7-29 Alphabetical parts list**

<b>Description</b>	<b>Part number</b>	<b>Table and page</b>
A4 paper-stop	PF2307K253NI	<a href="#">ADF assemblies (3 of 14) on page 303</a>
ADF back cover	PF2307K215NI	<a href="#">ADF assemblies (1 of 14) on page 299</a>
ADF base reflector	PF2307K237NI	<a href="#">ADF assemblies (1 of 14) on page 299</a>
ADF bottom corner, inner paper path guide	PF2307K211NI	<a href="#">ADF assemblies (5 of 14) on page 307</a>
ADF bottom corner, outer paper path guide	PF2307K212NI	<a href="#">ADF assemblies (5 of 14) on page 307</a>
ADF bottom cover	PF2307K217NI	<a href="#">ADF assemblies (6 of 14) on page 309</a>
ADF cable duct	IR4067K204NI	<a href="#">Flatbed scanner assemblies (1 of 9) on page 327</a>
ADF carriage fan	PF2307K222NI	<a href="#">ADF assemblies (2 of 14) on page 301</a>
ADF controller PCA	PF2307K229NI	<a href="#">ADF assemblies (2 of 14) on page 301</a>
ADF exit inner paper path guide	PF2307K213NI	<a href="#">ADF assemblies (7 of 14) on page 311</a>
ADF exit motor	PF2307K218NI	<a href="#">ADF assemblies (13 of 14) on page 323</a>
ADF exit motor assembly	PF2307K218NI	<a href="#">ADF assemblies (6 of 14) on page 309</a>
ADF feed motor assembly	PF2307K220NI	<a href="#">ADF assemblies (6 of 14) on page 309</a>
ADF front cover	PF2307K214NI	<a href="#">ADF assemblies (1 of 14) on page 299</a>
ADF input tray assembly	PF2307K203NI	<a href="#">ADF assemblies (2 of 14) on page 301</a>
ADF input-tray lift-motor assembly	PF2307K219NI	<a href="#">ADF assemblies (6 of 14) on page 309</a>
ADF jam door 1	PF2307K058	<a href="#">ADF assemblies (5 of 14) on page 307</a>
ADF jam door 2	PF2307K051	<a href="#">ADF assemblies (5 of 14) on page 307</a>
ADF jam door 3	PF2307K202NI	<a href="#">ADF assemblies (5 of 14) on page 307</a>



**Table 7-29 Alphabetical parts list (continued)**

<b>Description</b>	<b>Part number</b>	<b>Table and page</b>
ADF motor fan	PF2307K222NI	<a href="#">ADF assemblies (6 of 14) on page 309</a>
ADF output tray	PF2307K216NI	<a href="#">ADF assemblies (2 of 14) on page 301</a>
ADF pick motor assembly	PF2307K221NI	<a href="#">ADF assemblies (6 of 14) on page 309</a>
ADF shingle wall	PF2307K208NI	<a href="#">ADF assemblies (2 of 14) on page 301</a>
ADF top corner inner paper path guide	PF2307K210NI	<a href="#">ADF assemblies (5 of 14) on page 307</a>
ASM-ACIN	IR4067K610	<a href="#">Flatbed scanner assemblies (8 of 9) on page 341</a>
ASY-BKT-MOT	IR4067K052	<a href="#">Flatbed scanner assemblies (6 of 9) on page 337</a>
ASY-PBA-PANEL	IR4067K505	<a href="#">Flatbed scanner assemblies (5 of 9) on page 335</a>
Background solenoid assembly	PF2307K223NI	<a href="#">ADF assemblies (6 of 14) on page 309</a>
Background solenoid assembly	PF2307K223NI	<a href="#">ADF assemblies (6 of 14) on page 309</a>
Background solenoid assembly	PF2307K223NI	<a href="#">ADF assemblies (6 of 14) on page 309</a>
Background solenoid assembly	PF2307K223NI	<a href="#">ADF assemblies (6 of 14) on page 309</a>
Background solenoid assembly spring	PF2307P350	<a href="#">ADF assemblies (6 of 14) on page 309</a>
Bottom cover	PF2307K217NI	<a href="#">ADF assemblies (2 of 14) on page 301</a>
Bracket	PF2307K010A	<a href="#">ADF assemblies (5 of 14) on page 307</a>
Bracket	IR4067P141	<a href="#">Flatbed scanner assemblies (1 of 9) on page 327</a>
Bracket	IR4067P131	<a href="#">Flatbed scanner assemblies (3 of 9) on page 331</a>
Bracket	IR4067K612	<a href="#">Flatbed scanner assemblies (3 of 9) on page 331</a>
Bracket	IR4067P127	<a href="#">Flatbed scanner assemblies (4 of 9) on page 333</a>
Bracket	IR4067P119	<a href="#">Flatbed scanner assemblies (7 of 9) on page 339</a>

**Table 7-29 Alphabetical parts list (continued)**

<b>Description</b>	<b>Part number</b>	<b>Table and page</b>
Bracket	IR4067P129	<a href="#">Flatbed scanner assemblies (9 of 9) on page 343</a>
Bushing	NS-MTL00017	<a href="#">ADF assemblies (7 of 14) on page 311</a>
Clip	PF2307K250NI	<a href="#">ADF assemblies (7 of 14) on page 311</a>
Clip	PF2307K255NI	<a href="#">ADF assemblies (7 of 14) on page 311</a>
Clip	E450001208	<a href="#">Flatbed scanner assemblies (3 of 9) on page 331</a>
Clip	E450000575	<a href="#">Flatbed scanner assemblies (3 of 9) on page 331</a>
Cover bottom MT	IR4067P016	<a href="#">Flatbed scanner assemblies (2 of 9) on page 329</a>
Cover MT	IR4067P012	<a href="#">Flatbed scanner assemblies (2 of 9) on page 329</a>
Duct	IR4067P027	<a href="#">Flatbed scanner assemblies (3 of 9) on page 331</a>
FB-UNIT	IR4067K--	<a href="#">Flatbed scanner assemblies (6 of 9) on page 337</a>
FFC separation shield	PF2307P392	<a href="#">ADF assemblies (2 of 14) on page 301</a>
Filter	IR4067K211NI	<a href="#">Flatbed scanner assemblies (2 of 9) on page 329</a>
Flat flexible cable	PF2307K231NI	<a href="#">ADF assemblies (2 of 14) on page 301</a>
Flat flexible cable	PF2307K232NI	<a href="#">ADF assemblies (2 of 14) on page 301</a>
Flat flexible cable	PF2307K627	<a href="#">ADF assemblies (11 of 14) on page 319</a>
Flatbed carriage fan	IR4067K206NI	<a href="#">Flatbed scanner assemblies (6 of 9) on page 337</a>
Flatbed carriage fan	IR4067K206NI	<a href="#">Flatbed scanner assemblies (9 of 9) on page 343</a>
Flatbed scan position sensor bracket	PF2307K011	<a href="#">ADF assemblies (5 of 14) on page 307</a>
GID-LED	IR4067P047	<a href="#">Flatbed scanner assemblies (5 of 9) on page 335</a>
GID-PCB	IR4067P044	<a href="#">Flatbed scanner assemblies (5 of 9) on page 335</a>

**Table 7-29 Alphabetical parts list (continued)**

<b>Description</b>	<b>Part number</b>	<b>Table and page</b>
Hinge limiter	PF2307P147	<a href="#">ADF assemblies (1 of 14) on page 299</a>
Imprinter cable channel	PF2307P359C	<a href="#">ADF assemblies (7 of 14) on page 311</a>
Imprinter carriage frame and cable	PF2307K227NI	<a href="#">ADF assemblies (7 of 14) on page 311</a>
Imprinter carriage guide	PF2307P229	<a href="#">ADF assemblies (8 of 14) on page 313</a>
Imprinter carriage latch	PF2307P680A	<a href="#">ADF assemblies (8 of 14) on page 313</a>
Imprinter carriage rod	PF2307P229A	<a href="#">ADF assemblies (7 of 14) on page 311</a>
Imprinter carriage seat	PF2307P054B	<a href="#">ADF assemblies (8 of 14) on page 313</a>
Imprinter cartridge holder clasp	PF2307P360A	<a href="#">ADF assemblies (7 of 14) on page 311</a>
Imprinter paper-present sensor	PF2307K228NI	<a href="#">ADF assemblies (9 of 14) on page 315</a>
Imprinter paper-present sensor holder	PF2307P055B	<a href="#">ADF assemblies (9 of 14) on page 315</a>
Imprinter PCA	PF2307K205NI	<a href="#">ADF assemblies (11 of 14) on page 319</a>
Imprinter sensor mount	PF2307K228NI	<a href="#">ADF assemblies (9 of 14) on page 315</a>
Input tray elevator arm	PF2307K207NI	<a href="#">ADF assemblies (7 of 14) on page 311</a>
Jam door 2 bottom cover	PF2307K062A	<a href="#">ADF assemblies (14 of 14) on page 325</a>
Jam door 2 top cover	PF2307K059A	<a href="#">ADF assemblies (14 of 14) on page 325</a>
Label	IR4067P410	<a href="#">Flatbed scanner assemblies (1 of 9) on page 327</a>
Lower multi-pick sensor cover	PF2307K209NI	<a href="#">ADF assemblies (5 of 14) on page 307</a>
Lower multi-pick sensor PCA	PF2307K225NI	<a href="#">ADF assemblies (5 of 14) on page 307</a>
Mounting bracket	PF2307P132	<a href="#">ADF assemblies (13 of 14) on page 323</a>
Mounting bracket	PF2307P132	<a href="#">ADF assemblies (13 of 14) on page 323</a>

**Table 7-29 Alphabetical parts list (continued)**

<b>Description</b>	<b>Part number</b>	<b>Table and page</b>
Paper presence sensor and imprinter PCA holder	PF2307K204NI	<a href="#">ADF assemblies (11 of 14) on page 319</a>
Paper present and imprinter PCA holder	PF2307K204NI	<a href="#">ADF assemblies (7 of 14) on page 311</a>
Paper-present-sensor arm	PF2307K206NI	<a href="#">ADF assemblies (11 of 14) on page 319</a>
Pick-up roller spring	PF2307K234NI	<a href="#">ADF assemblies (14 of 14) on page 325</a>
Pickup-roller assembly	PF2307K233NI	<a href="#">ADF assemblies (14 of 14) on page 325</a>
Pickup-roller cover	PF2307K254NI	<a href="#">ADF assemblies (14 of 14) on page 325</a>
PLT-INL	IR4067P130	<a href="#">Flatbed scanner assemblies (8 of 9) on page 341</a>
Power switch and power receptacle assembly	IR4067K209NI	<a href="#">Flatbed scanner assemblies (6 of 9) on page 337</a>
Power-supply PCA	IR4067K210NI	<a href="#">Flatbed scanner assemblies (1 of 9) on page 327</a>
Power-supply PCA	IR4067K210NI	<a href="#">Flatbed scanner assemblies (3 of 9) on page 331</a>
Registration sensor arm	PF2307K230NI	<a href="#">ADF assemblies (12 of 14) on page 321</a>
Scanner back cover	IR4067K203NI	<a href="#">Flatbed scanner assemblies (1 of 9) on page 327</a>
Scanner back-filter cover	IR4067K212NI	<a href="#">Flatbed scanner assemblies (2 of 9) on page 329</a>
Scanner carriage motor	IR4067K207NI	<a href="#">Flatbed scanner assemblies (7 of 9) on page 339</a>
Scanner carriage motor cable	IR4067K208NI	<a href="#">Flatbed scanner assemblies (7 of 9) on page 339</a>
Scanner carriage-motor fan	IR4067K206NI	<a href="#">Flatbed scanner assemblies (6 of 9) on page 337</a>
Scanner control panel cover	IR4067K201NI	<a href="#">Flatbed scanner assemblies (1 of 9) on page 327</a>
Scanner control panel PCA	IR4067K202NI	<a href="#">Flatbed scanner assemblies (1 of 9) on page 327</a>
Scanner controller PCA	IR4067K205NI	<a href="#">Flatbed scanner assemblies (1 of 9) on page 327</a>
Scanner controller PCA	IR4067K205NI	<a href="#">Flatbed scanner assemblies (4 of 9) on page 333</a>

**Table 7-29 Alphabetical parts list (continued)**

<b>Description</b>	<b>Part number</b>	<b>Table and page</b>
Scanner right side cover	IR4067K061	<a href="#">Flatbed scanner assemblies (1 of 9) on page 327</a>
Screw	PF2307K239NI	<a href="#">ADF assemblies (1 of 14) on page 299</a>
Screw	NS-SCR00084	<a href="#">ADF assemblies (1 of 14) on page 299</a>
Screw	040080FNBI	<a href="#">ADF assemblies (1 of 14) on page 299</a>
Screw	PF2307K246A	<a href="#">ADF assemblies (2 of 14) on page 301</a>
Screw	PF2307K248NI	<a href="#">ADF assemblies (2 of 14) on page 301</a>
Screw	PF2307K245NI	<a href="#">ADF assemblies (2 of 14) on page 301</a>
Screw	IR4067K214NI	<a href="#">ADF assemblies (2 of 14) on page 301</a>
Screw	IR4067K220NI	<a href="#">ADF assemblies (2 of 14) on page 301</a>
Screw	PF2307K241NI	<a href="#">ADF assemblies (2 of 14) on page 301</a>
Screw	NS-SCR00084B	<a href="#">ADF assemblies (5 of 14) on page 307</a>
Screw	PF2307K239NI	<a href="#">ADF assemblies (5 of 14) on page 307</a>
Screw	PF2307K248A	<a href="#">ADF assemblies (5 of 14) on page 307</a>
Screw	IR4067K214NI	<a href="#">ADF assemblies (5 of 14) on page 307</a>
Screw	PF2307K239NI	<a href="#">ADF assemblies (5 of 14) on page 307</a>
Screw	PF2307K241NI	<a href="#">ADF assemblies (5 of 14) on page 307</a>
Screw	IR4067K214NI	<a href="#">ADF assemblies (6 of 14) on page 309</a>
Screw	PF2307K246NI	<a href="#">ADF assemblies (6 of 14) on page 309</a>
Screw	PF2307K245NI	<a href="#">ADF assemblies (6 of 14) on page 309</a>
Screw	NS-SCR00027	<a href="#">ADF assemblies (7 of 14) on page 311</a>

**Table 7-29 Alphabetical parts list (continued)**

<b>Description</b>	<b>Part number</b>	<b>Table and page</b>
Screw	026080FDBB	<a href="#">ADF assemblies (8 of 14) on page 313</a>
Screw	NS-SCR00027B	<a href="#">ADF assemblies (9 of 14) on page 315</a>
Screw	-	<a href="#">ADF assemblies (11 of 14) on page 319</a>
Screw	PF2307K239NI	<a href="#">ADF assemblies (13 of 14) on page 323</a>
Screw	NS-SCR00027B	<a href="#">ADF assemblies (14 of 14) on page 325</a>
Screw	IR4067K218NI/ IR4067K232NI	<a href="#">Flatbed scanner assemblies (1 of 9) on page 327</a>
Screw	IR4067K220NI/ IR4067K234NI	<a href="#">Flatbed scanner assemblies (1 of 9) on page 327</a>
Screw	IR4067K214NI/ IR4067K228NI	<a href="#">Flatbed scanner assemblies (1 of 9) on page 327</a>
Screw	IR4067K220NI/ IR4067K234NI	<a href="#">Flatbed scanner assemblies (1 of 9) on page 327</a>
Screw	IR4067K220NI/ IR4067K234NI	<a href="#">Flatbed scanner assemblies (1 of 9) on page 327</a>
Screw	IR4067K214NI/ IR4067K228NI	<a href="#">Flatbed scanner assemblies (1 of 9) on page 327</a>
Screw	IR4067K214NI/ IR4067K228NI	<a href="#">Flatbed scanner assemblies (1 of 9) on page 327</a>
Screw	IR4067K213NI/ IR4067K235NI	<a href="#">Flatbed scanner assemblies (2 of 9) on page 329</a>
Screw	IR4067K214NI/ IR4067K228NI	<a href="#">Flatbed scanner assemblies (3 of 9) on page 331</a>
Screw	IR4067K220NI/ IR4067K234NI	<a href="#">Flatbed scanner assemblies (3 of 9) on page 331</a>
Screw	IR4067K214NI/ IR4067K228NI	<a href="#">Flatbed scanner assemblies (4 of 9) on page 333</a>
Screw	030060FNBI	<a href="#">Flatbed scanner assemblies (4 of 9) on page 333</a>
Screw	IR4067K213NI/ IR4067K235NI	<a href="#">Flatbed scanner assemblies (5 of 9) on page 335</a>
Screw	NS-SCR00201	<a href="#">Flatbed scanner assemblies (6 of 9) on page 337</a>
Screw	IR4067K214NI/ IR4067K228NI	<a href="#">Flatbed scanner assemblies (6 of 9) on page 337</a>

**Table 7-29 Alphabetical parts list (continued)**

<b>Description</b>	<b>Part number</b>	<b>Table and page</b>
Screw	IR4067K220NI/ IR4067K234NI	<a href="#">Flatbed scanner assemblies (6 of 9) on page 337</a>
Screw	IR4067K220NI/ IR4067K234NI	<a href="#">Flatbed scanner assemblies (6 of 9) on page 337</a>
Screw	IR4067K214NI/ IR4067K228NI	<a href="#">Flatbed scanner assemblies (7 of 9) on page 339</a>
Screw	IR4067K216NI/ IR4067K230NI	<a href="#">Flatbed scanner assemblies (8 of 9) on page 341</a>
Screw	IR4067K219NI/ IR4067K233NI	<a href="#">Flatbed scanner assemblies (9 of 9) on page 343</a>
Screws	PF2307K238NI	<a href="#">ADF assemblies (6 of 14) on page 309</a>
Sensor	PF2307K226NI	<a href="#">ADF assemblies (5 of 14) on page 307</a>
Sensor	PF2307K226NI	<a href="#">ADF assemblies (6 of 14) on page 309</a>
Sensor	PF2307K226NI	<a href="#">ADF assemblies (11 of 14) on page 319</a>
Sensor	PF2307K226NI	<a href="#">ADF assemblies (14 of 14) on page 325</a>
Sensor arm	PF2307K230NI	<a href="#">ADF assemblies (10 of 14) on page 317</a>
Separation pad assembly	PF2307K235NI	<a href="#">ADF assemblies (4 of 14) on page 305</a>
Separation pad spring	PF2307K236NI	<a href="#">ADF assemblies (4 of 14) on page 305</a>
SP-T-080-656-29662	IR4067P311	<a href="#">Flatbed scanner assemblies (6 of 9) on page 337</a>
Spring	PF2307P360	<a href="#">ADF assemblies (8 of 14) on page 313</a>
Spring	PF2261P310C1	<a href="#">ADF assemblies (10 of 14) on page 317</a>
Spring	PF2261P310	<a href="#">ADF assemblies (12 of 14) on page 321</a>
STGP	IR4067P368	<a href="#">Flatbed scanner assemblies (4 of 9) on page 333</a>
SW-COPY2	IR4067P046	<a href="#">Flatbed scanner assemblies (5 of 9) on page 335</a>
SW-DC	IR4067P034	<a href="#">Flatbed scanner assemblies (5 of 9) on page 335</a>

**Table 7-29 Alphabetical parts list (continued)**

<b>Description</b>	<b>Part number</b>	<b>Table and page</b>
SW-GO	IR4067P035	<a href="#">Flatbed scanner assemblies (5 of 9) on page 335</a>
Upper multi-pick sensor cover	PF2307K240NI	<a href="#">ADF assemblies (5 of 14) on page 307</a>
Upper multi-pick sensor PCA	PF2307K224NI	<a href="#">ADF assemblies (5 of 14) on page 307</a>
Upper multi-pick sensor tray	PF2307K042	<a href="#">ADF assemblies (5 of 14) on page 307</a>
Upper multipick sensor cover	PF2307P007	<a href="#">ADF assemblies (5 of 14) on page 307</a>
Washer	IR4067K217NI/ IR4067K231NI	<a href="#">Flatbed scanner assemblies (8 of 9) on page 341</a>



# Numerical parts list

**Table 7-30 Numerical parts list**

Part number	Description	Table and page
-	Screw	<a href="#">ADF assemblies (11 of 14) on page 319</a>
026080FDBB	Screw	<a href="#">ADF assemblies (8 of 14) on page 313</a>
030060FNBI	Screw	<a href="#">Flatbed scanner assemblies (4 of 9) on page 333</a>
040080FNBI	Screw	<a href="#">ADF assemblies (1 of 14) on page 299</a>
E450000575	Clip	<a href="#">Flatbed scanner assemblies (3 of 9) on page 331</a>
E450001208	Clip	<a href="#">Flatbed scanner assemblies (3 of 9) on page 331</a>
IR4067K--	FB-UNIT	<a href="#">Flatbed scanner assemblies (6 of 9) on page 337</a>
IR4067K052	ASY-BKT-MOT	<a href="#">Flatbed scanner assemblies (6 of 9) on page 337</a>
IR4067K061	Scanner right side cover	<a href="#">Flatbed scanner assemblies (1 of 9) on page 327</a>
IR4067K201NI	Scanner control panel cover	<a href="#">Flatbed scanner assemblies (1 of 9) on page 327</a>
IR4067K202NI	Scanner control panel PCA	<a href="#">Flatbed scanner assemblies (1 of 9) on page 327</a>
IR4067K203NI	Scanner back cover	<a href="#">Flatbed scanner assemblies (1 of 9) on page 327</a>
IR4067K204NI	ADF cable duct	<a href="#">Flatbed scanner assemblies (1 of 9) on page 327</a>
IR4067K205NI	Scanner controller PCA	<a href="#">Flatbed scanner assemblies (1 of 9) on page 327</a>
IR4067K205NI	Scanner controller PCA	<a href="#">Flatbed scanner assemblies (4 of 9) on page 333</a>
IR4067K206NI	Scanner carriage-motor fan	<a href="#">Flatbed scanner assemblies (6 of 9) on page 337</a>
IR4067K206NI	Flatbed carriage fan	<a href="#">Flatbed scanner assemblies (6 of 9) on page 337</a>
IR4067K206NI	Flatbed carriage fan	<a href="#">Flatbed scanner assemblies (9 of 9) on page 343</a>
IR4067K207NI	Scanner carriage motor	<a href="#">Flatbed scanner assemblies (7 of 9) on page 339</a>

**Table 7-30 Numerical parts list (continued)**

<b>Part number</b>	<b>Description</b>	<b>Table and page</b>
IR4067K208NI	Scanner carriage motor cable	<a href="#">Flatbed scanner assemblies (7 of 9) on page 339</a>
IR4067K209NI	Power switch and power receptacle assembly	<a href="#">Flatbed scanner assemblies (6 of 9) on page 337</a>
IR4067K210NI	Power-supply PCA	<a href="#">Flatbed scanner assemblies (1 of 9) on page 327</a>
IR4067K210NI	Power-supply PCA	<a href="#">Flatbed scanner assemblies (3 of 9) on page 331</a>
IR4067K211NI	Filter	<a href="#">Flatbed scanner assemblies (2 of 9) on page 329</a>
IR4067K212NI	Scanner back-filter cover	<a href="#">Flatbed scanner assemblies (2 of 9) on page 329</a>
IR4067K213NI/ IR4067K235NI	Screw	<a href="#">Flatbed scanner assemblies (2 of 9) on page 329</a>
IR4067K213NI/ IR4067K235NI	Screw	<a href="#">Flatbed scanner assemblies (5 of 9) on page 335</a>
IR4067K214NI	Screw	<a href="#">ADF assemblies (2 of 14) on page 301</a>
IR4067K214NI	Screw	<a href="#">ADF assemblies (5 of 14) on page 307</a>
IR4067K214NI	Screw	<a href="#">ADF assemblies (6 of 14) on page 309</a>
IR4067K214NI/ IR4067K228NI	Screw	<a href="#">Flatbed scanner assemblies (1 of 9) on page 327</a>
IR4067K214NI/ IR4067K228NI	Screw	<a href="#">Flatbed scanner assemblies (1 of 9) on page 327</a>
IR4067K214NI/ IR4067K228NI	Screw	<a href="#">Flatbed scanner assemblies (1 of 9) on page 327</a>
IR4067K214NI/ IR4067K228NI	Screw	<a href="#">Flatbed scanner assemblies (3 of 9) on page 331</a>
IR4067K214NI/ IR4067K228NI	Screw	<a href="#">Flatbed scanner assemblies (4 of 9) on page 333</a>
IR4067K214NI/ IR4067K228NI	Screw	<a href="#">Flatbed scanner assemblies (6 of 9) on page 337</a>
IR4067K214NI/ IR4067K228NI	Screw	<a href="#">Flatbed scanner assemblies (7 of 9) on page 339</a>
IR4067K216NI/ IR4067K230NI	Screw	<a href="#">Flatbed scanner assemblies (8 of 9) on page 341</a>
IR4067K217NI/ IR4067K231NI	Washer	<a href="#">Flatbed scanner assemblies (8 of 9) on page 341</a>

**Table 7-30 Numerical parts list (continued)**

<b>Part number</b>	<b>Description</b>	<b>Table and page</b>
IR4067K218NI/ IR4067K232NI	Screw	<a href="#">Flatbed scanner assemblies (1 of 9) on page 327</a>
IR4067K219NI/ IR4067K233NI	Screw	<a href="#">Flatbed scanner assemblies (9 of 9) on page 343</a>
IR4067K220NI	Screw	<a href="#">ADF assemblies (2 of 14) on page 301</a>
IR4067K220NI/ IR4067K234NI	Screw	<a href="#">Flatbed scanner assemblies (1 of 9) on page 327</a>
IR4067K220NI/ IR4067K234NI	Screw	<a href="#">Flatbed scanner assemblies (1 of 9) on page 327</a>
IR4067K220NI/ IR4067K234NI	Screw	<a href="#">Flatbed scanner assemblies (1 of 9) on page 327</a>
IR4067K220NI/ IR4067K234NI	Screw	<a href="#">Flatbed scanner assemblies (3 of 9) on page 331</a>
IR4067K220NI/ IR4067K234NI	Screw	<a href="#">Flatbed scanner assemblies (6 of 9) on page 337</a>
IR4067K220NI/ IR4067K234NI	Screw	<a href="#">Flatbed scanner assemblies (6 of 9) on page 337</a>
IR4067K505	ASY-PBA-PANEL	<a href="#">Flatbed scanner assemblies (5 of 9) on page 335</a>
IR4067K610	ASM-ACIN	<a href="#">Flatbed scanner assemblies (8 of 9) on page 341</a>
IR4067K612	Bracket	<a href="#">Flatbed scanner assemblies (3 of 9) on page 331</a>
IR4067P012	Cover MT	<a href="#">Flatbed scanner assemblies (2 of 9) on page 329</a>
IR4067P016	Cover bottom MT	<a href="#">Flatbed scanner assemblies (2 of 9) on page 329</a>
IR4067P027	Duct	<a href="#">Flatbed scanner assemblies (3 of 9) on page 331</a>
IR4067P034	SW-DC	<a href="#">Flatbed scanner assemblies (5 of 9) on page 335</a>
IR4067P035	SW-GO	<a href="#">Flatbed scanner assemblies (5 of 9) on page 335</a>
IR4067P044	GID-PCB	<a href="#">Flatbed scanner assemblies (5 of 9) on page 335</a>
IR4067P046	SW-COPY2	<a href="#">Flatbed scanner assemblies (5 of 9) on page 335</a>
IR4067P047	GID-LED	<a href="#">Flatbed scanner assemblies (5 of 9) on page 335</a>

**Table 7-30 Numerical parts list (continued)**

<b>Part number</b>	<b>Description</b>	<b>Table and page</b>
IR4067P119	Bracket	<a href="#">Flatbed scanner assemblies (7 of 9) on page 339</a>
IR4067P127	Bracket	<a href="#">Flatbed scanner assemblies (4 of 9) on page 333</a>
IR4067P129	Bracket	<a href="#">Flatbed scanner assemblies (9 of 9) on page 343</a>
IR4067P130	PLT-INL	<a href="#">Flatbed scanner assemblies (8 of 9) on page 341</a>
IR4067P131	Bracket	<a href="#">Flatbed scanner assemblies (3 of 9) on page 331</a>
IR4067P141	Bracket	<a href="#">Flatbed scanner assemblies (1 of 9) on page 327</a>
IR4067P311	SP-T-080-656-29662	<a href="#">Flatbed scanner assemblies (6 of 9) on page 337</a>
IR4067P368	STGP	<a href="#">Flatbed scanner assemblies (4 of 9) on page 333</a>
IR4067P410	Label	<a href="#">Flatbed scanner assemblies (1 of 9) on page 327</a>
NS-MTL00017	Bushing	<a href="#">ADF assemblies (7 of 14) on page 311</a>
NS-SCR00027	Screw	<a href="#">ADF assemblies (7 of 14) on page 311</a>
NS-SCR00027B	Screw	<a href="#">ADF assemblies (9 of 14) on page 315</a>
NS-SCR00027B	Screw	<a href="#">ADF assemblies (14 of 14) on page 325</a>
NS-SCR00084	Screw	<a href="#">ADF assemblies (1 of 14) on page 299</a>
NS-SCR00084B	Screw	<a href="#">ADF assemblies (5 of 14) on page 307</a>
NS-SCR00201	Screw	<a href="#">Flatbed scanner assemblies (6 of 9) on page 337</a>
PF2261P310	Spring	<a href="#">ADF assemblies (12 of 14) on page 321</a>
PF2261P310C1	Spring	<a href="#">ADF assemblies (10 of 14) on page 317</a>
PF2307K010A	Bracket	<a href="#">ADF assemblies (5 of 14) on page 307</a>
PF2307K011	Flatbed scan position sensor bracket	<a href="#">ADF assemblies (5 of 14) on page 307</a>

**Table 7-30 Numerical parts list (continued)**

<b>Part number</b>	<b>Description</b>	<b>Table and page</b>
PF2307K042	Upper multi-pick sensor tray	<a href="#">ADF assemblies (5 of 14) on page 307</a>
PF2307K051	ADF jam door 2	<a href="#">ADF assemblies (5 of 14) on page 307</a>
PF2307K058	ADF jam door 1	<a href="#">ADF assemblies (5 of 14) on page 307</a>
PF2307K059A	Jam door 2 top cover	<a href="#">ADF assemblies (14 of 14) on page 325</a>
PF2307K062A	Jam door 2 bottom cover	<a href="#">ADF assemblies (14 of 14) on page 325</a>
PF2307K202NI	ADF jam door 3	<a href="#">ADF assemblies (5 of 14) on page 307</a>
PF2307K203NI	ADF input tray assembly	<a href="#">ADF assemblies (2 of 14) on page 301</a>
PF2307K204NI	Paper present and imprinter PCA holder	<a href="#">ADF assemblies (7 of 14) on page 311</a>
PF2307K204NI	Paper presence sensor and imprinter PCA holder	<a href="#">ADF assemblies (11 of 14) on page 319</a>
PF2307K205NI	Imprinter PCA	<a href="#">ADF assemblies (11 of 14) on page 319</a>
PF2307K206NI	Paper-present-sensor arm	<a href="#">ADF assemblies (11 of 14) on page 319</a>
PF2307K207NI	Input tray elevator arm	<a href="#">ADF assemblies (7 of 14) on page 311</a>
PF2307K208NI	ADF shingle wall	<a href="#">ADF assemblies (2 of 14) on page 301</a>
PF2307K209NI	Lower multi-pick sensor cover	<a href="#">ADF assemblies (5 of 14) on page 307</a>
PF2307K210NI	ADF top corner inner paper path guide	<a href="#">ADF assemblies (5 of 14) on page 307</a>
PF2307K211NI	ADF bottom corner, inner paper path guide	<a href="#">ADF assemblies (5 of 14) on page 307</a>
PF2307K212NI	ADF bottom corner, outer paper path guide	<a href="#">ADF assemblies (5 of 14) on page 307</a>
PF2307K213NI	ADF exit inner paper path guide	<a href="#">ADF assemblies (7 of 14) on page 311</a>
PF2307K214NI	ADF front cover	<a href="#">ADF assemblies (1 of 14) on page 299</a>
PF2307K215NI	ADF back cover	<a href="#">ADF assemblies (1 of 14) on page 299</a>

**Table 7-30 Numerical parts list (continued)**

<b>Part number</b>	<b>Description</b>	<b>Table and page</b>
PF2307K216NI	ADF output tray	<a href="#">ADF assemblies (2 of 14) on page 301</a>
PF2307K217NI	Bottom cover	<a href="#">ADF assemblies (2 of 14) on page 301</a>
PF2307K217NI	ADF bottom cover	<a href="#">ADF assemblies (6 of 14) on page 309</a>
PF2307K218NI	ADF exit motor assembly	<a href="#">ADF assemblies (6 of 14) on page 309</a>
PF2307K218NI	ADF exit motor	<a href="#">ADF assemblies (13 of 14) on page 323</a>
PF2307K219NI	ADF input-tray lift-motor assembly	<a href="#">ADF assemblies (6 of 14) on page 309</a>
PF2307K220NI	ADF feed motor assembly	<a href="#">ADF assemblies (6 of 14) on page 309</a>
PF2307K221NI	ADF pick motor assembly	<a href="#">ADF assemblies (6 of 14) on page 309</a>
PF2307K222NI	ADF carriage fan	<a href="#">ADF assemblies (2 of 14) on page 301</a>
PF2307K222NI	ADF motor fan	<a href="#">ADF assemblies (6 of 14) on page 309</a>
PF2307K223NI	Background solenoid assembly	<a href="#">ADF assemblies (6 of 14) on page 309</a>
PF2307K223NI	Background solenoid assembly	<a href="#">ADF assemblies (6 of 14) on page 309</a>
PF2307K223NI	Background solenoid assembly	<a href="#">ADF assemblies (6 of 14) on page 309</a>
PF2307K223NI	Background solenoid assembly	<a href="#">ADF assemblies (6 of 14) on page 309</a>
PF2307K224NI	Upper multi-pick sensor PCA	<a href="#">ADF assemblies (5 of 14) on page 307</a>
PF2307K225NI	Lower multi-pick sensor PCA	<a href="#">ADF assemblies (5 of 14) on page 307</a>
PF2307K226NI	Sensor	<a href="#">ADF assemblies (5 of 14) on page 307</a>
PF2307K226NI	Sensor	<a href="#">ADF assemblies (6 of 14) on page 309</a>
PF2307K226NI	Sensor	<a href="#">ADF assemblies (11 of 14) on page 319</a>
PF2307K226NI	Sensor	<a href="#">ADF assemblies (14 of 14) on page 325</a>

**Table 7-30 Numerical parts list (continued)**

<b>Part number</b>	<b>Description</b>	<b>Table and page</b>
PF2307K227NI	Imprinter carriage frame and cable	<a href="#">ADF assemblies (7 of 14) on page 311</a>
PF2307K228NI	Imprinter sensor mount	<a href="#">ADF assemblies (9 of 14) on page 315</a>
PF2307K228NI	Imprinter paper-present sensor	<a href="#">ADF assemblies (9 of 14) on page 315</a>
PF2307K229NI	ADF controller PCA	<a href="#">ADF assemblies (2 of 14) on page 301</a>
PF2307K230NI	Sensor arm	<a href="#">ADF assemblies (10 of 14) on page 317</a>
PF2307K230NI	Registration sensor arm	<a href="#">ADF assemblies (12 of 14) on page 321</a>
PF2307K231NI	Flat flexible cable	<a href="#">ADF assemblies (2 of 14) on page 301</a>
PF2307K232NI	Flat flexible cable	<a href="#">ADF assemblies (2 of 14) on page 301</a>
PF2307K233NI	Pickup-roller assembly	<a href="#">ADF assemblies (14 of 14) on page 325</a>
PF2307K234NI	Pick-up roller spring	<a href="#">ADF assemblies (14 of 14) on page 325</a>
PF2307K235NI	Separation pad assembly	<a href="#">ADF assemblies (4 of 14) on page 305</a>
PF2307K236NI	Separation pad spring	<a href="#">ADF assemblies (4 of 14) on page 305</a>
PF2307K237NI	ADF base reflector	<a href="#">ADF assemblies (1 of 14) on page 299</a>
PF2307K238NI	Screws	<a href="#">ADF assemblies (6 of 14) on page 309</a>
PF2307K239NI	Screw	<a href="#">ADF assemblies (1 of 14) on page 299</a>
PF2307K239NI	Screw	<a href="#">ADF assemblies (5 of 14) on page 307</a>
PF2307K239NI	Screw	<a href="#">ADF assemblies (5 of 14) on page 307</a>
PF2307K239NI	Screw	<a href="#">ADF assemblies (13 of 14) on page 323</a>
PF2307K240NI	Upper multi-pick sensor cover	<a href="#">ADF assemblies (5 of 14) on page 307</a>
PF2307K241NI	Screw	<a href="#">ADF assemblies (2 of 14) on page 301</a>

**Table 7-30 Numerical parts list (continued)**

<b>Part number</b>	<b>Description</b>	<b>Table and page</b>
PF2307K241NI	Screw	<a href="#">ADF assemblies (5 of 14) on page 307</a>
PF2307K245NI	Screw	<a href="#">ADF assemblies (2 of 14) on page 301</a>
PF2307K245NI	Screw	<a href="#">ADF assemblies (6 of 14) on page 309</a>
PF2307K246A	Screw	<a href="#">ADF assemblies (2 of 14) on page 301</a>
PF2307K246NI	Screw	<a href="#">ADF assemblies (6 of 14) on page 309</a>
PF2307K248A	Screw	<a href="#">ADF assemblies (5 of 14) on page 307</a>
PF2307K248NI	Screw	<a href="#">ADF assemblies (2 of 14) on page 301</a>
PF2307K250NI	Clip	<a href="#">ADF assemblies (7 of 14) on page 311</a>
PF2307K253NI	A4 paper-stop	<a href="#">ADF assemblies (3 of 14) on page 303</a>
PF2307K254NI	Pickup-roller cover	<a href="#">ADF assemblies (14 of 14) on page 325</a>
PF2307K255NI	Clip	<a href="#">ADF assemblies (7 of 14) on page 311</a>
PF2307K627	Flat flexible cable	<a href="#">ADF assemblies (11 of 14) on page 319</a>
PF2307P007	Upper multipick sensor cover	<a href="#">ADF assemblies (5 of 14) on page 307</a>
PF2307P054B	Imprinter carriage seat	<a href="#">ADF assemblies (8 of 14) on page 313</a>
PF2307P055B	Imprinter paper-present sensor holder	<a href="#">ADF assemblies (9 of 14) on page 315</a>
PF2307P132	Mounting bracket	<a href="#">ADF assemblies (13 of 14) on page 323</a>
PF2307P132	Mounting bracket	<a href="#">ADF assemblies (13 of 14) on page 323</a>
PF2307P147	Hinge limiter	<a href="#">ADF assemblies (1 of 14) on page 299</a>
PF2307P229	Imprinter carriage guide	<a href="#">ADF assemblies (8 of 14) on page 313</a>
PF2307P229A	Imprinter carriage rod	<a href="#">ADF assemblies (7 of 14) on page 311</a>



**Table 7-30 Numerical parts list (continued)**

<b>Part number</b>	<b>Description</b>	<b>Table and page</b>
PF2307P350	Background solenoid assembly spring	<a href="#">ADF assemblies (6 of 14) on page 309</a>
PF2307P359C	Imprinter cable channel	<a href="#">ADF assemblies (7 of 14) on page 311</a>
PF2307P360	Spring	<a href="#">ADF assemblies (8 of 14) on page 313</a>
PF2307P360A	Imprinter cartridge holder clasp	<a href="#">ADF assemblies (7 of 14) on page 311</a>
PF2307P392	FFC separation shield	<a href="#">ADF assemblies (2 of 14) on page 301</a>
PF2307P680A	Imprinter carriage latch	<a href="#">ADF assemblies (8 of 14) on page 313</a>



---

# A Service and support

# Hewlett-Packard limited warranty statement

HP PRODUCT	DURATION OF LIMITED WARRANTY
HP Scanjet N9120/Scanjet Enterprise Flow N9120	One year

HP warrants to you, the end-user customer, that HP hardware and accessories will be free from defects in materials and workmanship after the date of purchase, for the period specified above. If HP receives notice of such defects during the warranty period, HP will, at its option, either repair or replace products which prove to be defective. Replacement products may be either new or equivalent in performance to new.

HP warrants to you that HP software will not fail to execute its programming instructions after the date of purchase, for the period specified above, due to defects in material and workmanship when properly installed and used. If HP receives notice of such defects during the warranty period, HP will replace software which does not execute its programming instructions due to such defects.

HP does not warrant that the operation of HP products will be uninterrupted or error free. If HP is unable, within a reasonable time, to repair or replace any product to a condition as warranted, you will be entitled to a refund of the purchase price upon prompt return of the product.

HP products may contain remanufactured parts equivalent to new in performance or may have been subject to incidental use.

Warranty does not apply to defects resulting from (a) improper or inadequate maintenance or calibration, (b) software, interfacing, parts or supplies not supplied by HP, (c) unauthorized modification or misuse, (d) operation outside of the published environmental specifications for the product, or (e) improper site preparation or maintenance.

TO THE EXTENT ALLOWED BY LOCAL LAW, THE ABOVE WARRANTIES ARE EXCLUSIVE AND NO OTHER WARRANTY OR CONDITION, WHETHER WRITTEN OR ORAL, IS EXPRESSED OR IMPLIED AND HP SPECIFICALLY DISCLAIMS ANY IMPLIED WARRANTIES OR CONDITIONS OF MERCHANTABILITY, SATISFACTORY QUALITY, AND FITNESS FOR A PARTICULAR PURPOSE. Some countries/regions, states or provinces do not allow limitations on the duration of an implied warranty, so the above limitation or exclusion might not apply to you. This warranty gives you specific legal rights and you might also have other rights that vary from country/region to country/region, state to state, or province to province.

HP's limited warranty is valid in any country/region or locality where HP has a support presence for this product and where HP has marketed this product. The level of warranty service you receive may vary according to local standards. HP will not alter form, fit or function of the product to make it operate in a country/region for which it was never intended to function for legal or regulatory reasons.

TO THE EXTENT ALLOWED BY LOCAL LAW, THE REMEDIES IN THIS WARRANTY STATEMENT ARE YOUR SOLE AND EXCLUSIVE REMEDIES. EXCEPT AS INDICATED ABOVE, IN NO EVENT WILL HP OR ITS SUPPLIERS BE LIABLE FOR LOSS OF DATA OR FOR DIRECT, SPECIAL, INCIDENTAL, CONSEQUENTIAL (INCLUDING LOST PROFIT OR DATA), OR OTHER DAMAGE, WHETHER BASED IN CONTRACT, TORT, OR OTHERWISE. Some countries/regions, states or provinces do not allow the exclusion or limitation of incidental or consequential damages, so the above limitation or exclusion may not apply to you.

THE WARRANTY TERMS CONTAINED IN THIS STATEMENT, EXCEPT TO THE EXTENT LAWFULLY PERMITTED, DO NOT EXCLUDE, RESTRICT OR MODIFY AND ARE IN ADDITION TO THE MANDATORY STATUTORY RIGHTS APPLICABLE TO THE SALE OF THIS PRODUCT TO YOU.

## Customer self repair warranty service

HP products are designed with many Customer Self Repair (CSR) parts to minimize repair time and allow for greater flexibility in performing defective parts replacement. If during the diagnosis period, HP identifies that the repair can be accomplished by the use of a CSR part, HP will ship that part directly to you for replacement. There are two categories of CSR parts: 1) Parts for which customer self repair is mandatory. If you request HP to replace these parts, you will be charged for the travel and labor costs of this service. 2) Parts for which customer self repair is optional. These parts are also designed for Customer Self Repair. If, however, you require that HP replace them for you, this may be done at no additional charge under the type of warranty service designated for your product.

Based on availability and where geography permits, CSR parts will be shipped for next business day delivery. Same-day or four-hour delivery may be offered at an additional charge where geography permits. If assistance is required, you can call the HP Technical Support Center and a technician will help you over the phone. HP specifies in the materials shipped with a replacement CSR part whether a defective part must be returned to HP. In cases where it is required to return the defective part to HP, you must ship the defective part back to HP within a defined period of time, normally five (5) business days. The defective part must be returned with the associated documentation in the provided shipping material. Failure to return the defective part may result in HP billing you for the replacement. With a customer self repair, HP will pay all shipping and part return costs and determine the courier/carrier to be used.

# Repack the product

If your product needs to be moved, shipped to another location, or returned to HP, perform the following procedure to repack it.

**CAUTION:** Shipping damage as a result of inadequate packing is the customer's responsibility. The product must remain upright during shipment.

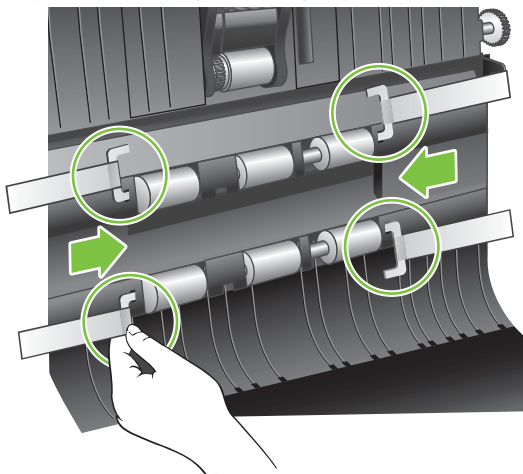
## Repack the product

**CAUTION:** It is *extremely important* to remove the imprinter cartridge before shipping the product. An imprinter cartridge left in the product during shipping can leak and entirely cover the product with toner.

To prevent damage to the imprinter cartridge, store it in the original packing material.

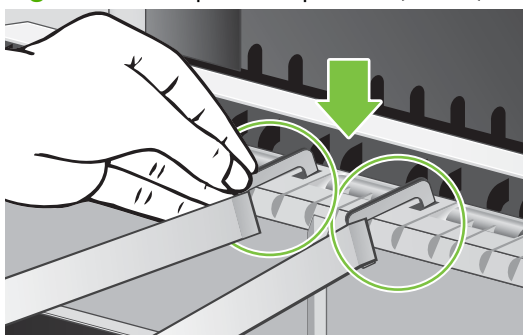
1. Remove the imprinter cartridge and ship separately.
2. Insert four spacers in jam door 1.

**Figure A-1** Repack the product (1 of 3)



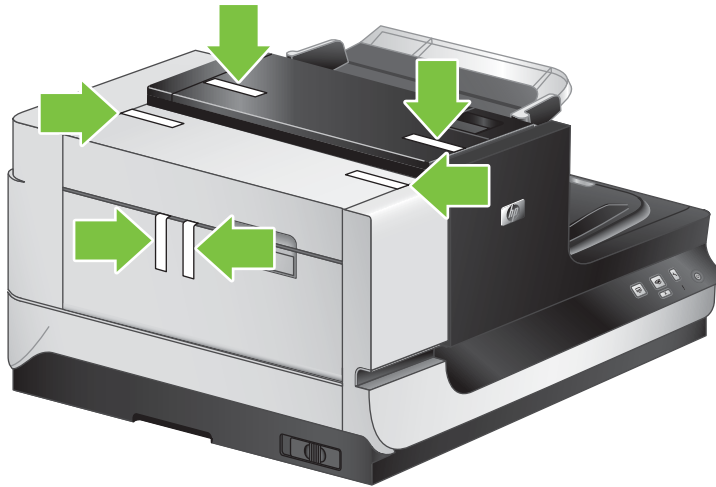
3. Insert two spacers in jam door 2.

**Figure A-2** Repack the product (2 of 3)




4. Attach the spacer tape to the outside of the ADF.

**Figure A-3** Repack the product (3 of 3)



5. Lock the optical scanner carriage.
6. Pack the product.

---

 **NOTE:** Use the original shipping container and packing material, if possible. If you have already disposed of the packing material, contact a local mailing service for information about repacking the product. HP recommends insuring the product for shipment.

---



---

# B Specifications

- [Physical specifications](#)
- [Electrical specifications](#)
- [Acoustic emissions](#)
- [Power consumption specifications](#)
- [Environmental specifications](#)

# Physical specifications

**Table B-1 Physical specifications**

Height	Depth	Width	Weight
342.9 mm (13.50 inches)	693.4 mm (27.3 inches)	558.8 mm (22.0 inches)	38.5 kg (85 lb)

# Electrical specifications

**Table B-2 Electrical specifications**

Power requirements	100-240 V 50/60 Hz
Minimum recommended circuit capacity	1.8 Amp

**! WARNING!** Power requirements are based on the country/region where the device is sold. Do not convert operating voltages. This will damage the digital sender and void the product warranty.

# Acoustic emissions

**Table B-3 N9120<sup>1,2</sup>**

Sound power level	Declared per ISO 9296
Scanning <sup>3</sup>	$L_{WAd} = \#6.\# \text{ Bels (A) [##dB (A)]}$
Ready	$L_{WAd} = \text{Inaudible}$
Sound pressure level: bystander position	Declared per ISO 9296
Scanning (## ppm) <sup>3</sup>	$L_{pAm} = \#\# \text{ dB (A)}$
Ready	$L_{pAm} = \text{Inaudible}$

<sup>1</sup> Values are based on preliminary data, see [www.hp.com/support](http://www.hp.com/support) for current information.

<sup>2</sup> Configuration tested: N9120 using the ADF.

<sup>3</sup> N9120 speed is 50 ppm (ADF scanning ; Letter/A4 size).


# Power consumption specifications

For power consumption information, see the regulatory\_supplement.htm file on the HP Scanning Software CD.

# Environmental specifications

**Table B-4 Environmental specifications**

	<b>Operating</b>	<b>Storage</b>
Temperature	10° to 35°C (50° to 95°F)	-40° to 60°C (-40° to 140°F)
Relative humidity	15% to 80% non-condensing	15% to 85%

 **CAUTION:** The operating environment should be stable, with no abrupt changes in temperature or humidity that might damage the device. If you move the device from a cold environment to a warm one, wait about 2 hours before using it.



---

# C Regulatory information

- [Regulatory Model Identification Number](#)
- [Materials disposal](#)
- [Disposal of waste equipment by users in private households in the European Union](#)
- [Country/region specific statements](#)

## Regulatory Model Identification Number

For regulatory identification purposes your product is assigned a Regulatory Model Number. The Regulatory Model Number for your product is FCLSD-0705. This regulatory number should not be confused with the marketing names HP Scanjet N9120 or HP Scanjet Enterprise Flow N9120 (L2683A). Additional regulatory information about your scanner can be found on the regulatory\_supplement.htm file on the HP Scanning Software CD.

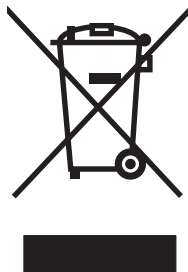
## Materials disposal

This HP product contains the following materials that might require special handling at end of life:

- Mercury in the fluorescent lamp in the scanner and/or transparent materials adapter

Disposal of this material can be regulated because of environmental considerations. For disposal or recycling information, please contact your local authorities or the Electronic Industries Alliance (EIA) at [www.eiae.org](http://www.eiae.org).

## Disposal of waste equipment by users in private households in the European Union



This symbol on the product or on its packaging indicates that this product must not be disposed of with your other household waste. Instead, it is your responsibility to dispose of your waste equipment by handing it over to a designated collection point for the recycling of waste electrical and electronic equipment. The separate collection and recycling of your waste equipment at the time of disposal will help to conserve natural resources and ensure that it is recycled in a manner that protects human health and the environment. For more information about where you can drop off your waste equipment for recycling, please contact your local city office, your household waste disposal service or the shop where you purchased the product.

## Country/region specific statements

### Korean regulatory

사용자 안내문(B급 기기)  
이 기기는 비업무용으로 전자파 적합 등록을 받은 기기로서, 주거지역에서는 물론 모든 지역에서 사용할 수 있습니다.

---

# Index

## A

- acoustic specifications 370
- automatic document feeder (ADF)
  - align 98
  - cleaning 24
  - feed system 34
  - feed test 253
  - height adjustment 72
  - misfeed detection 280, 286
  - motors 35
  - not feeding paper 281
  - operations 34
  - PCAs, locate 268
  - reinstall 67
  - sensors 34
  - specifications 10
- automatic document feeder (ADF)
  - parts replacement 45
    - assemblies diagram and parts list 298
    - FRUs list 61
    - guidelines 22
    - kits 294
  - See also* remove and replace parts

## B

- background settings 284
- black image 282
- blurred image 283

## C

- cables
  - carriage-motor, remove 230
  - included 17
- calibration
  - after parts replacement 75

- capacity
  - circuit, minimum 370
  - tray 10
- cartridge. *See* imprinter cartridge
- circuit board assemblies
  - operations 32
- cleaning
  - ADF 24
  - exterior 23
  - fan filters 28
  - product, about 23
  - scanner glass 27
  - supplies 39
- color
  - filter out from a document 285
  - select background 284
  - select for Attention LED 252
- components. *See* parts
- contents of shipping box 17
- contrast, poor 284
- control panel
  - blank, troubleshooting 237
  - buttons, lock 240
  - buttons, troubleshooting 288
  - check functionality 251, 255
  - cover, remove 53
  - use buttons to troubleshoot 240
  - walkaround 7
- Copy button profile assignment 288
- covers
  - ADF back, remove 58
  - ADF front, remove 55
  - ADF pickup-roller, remove 190
  - back, remove 60
  - back-filter, remove 54
  - control-panel, remove 53

- external, remove 52
- right-filter, remove 54
- crooked image 282
- cut-off image 282

## D

- defects
  - image quality 282
  - repeating 270
  - troubleshooting 282
- delayed scanning 286
- dialog boxes, open and use
  - Actuators 255
  - ADF Feed Test 253
  - Control Panel Check 251
  - NVRAM 258
  - Sensor Check 246
  - Version 262
- disable control-panel buttons 240
- disposal regulations 374
- documentation
  - included 17
  - part numbers, Getting Started Guide languages 293
  - product guides 2
  - Web site 2
- doors
  - ADF jam door 3, remove 193
- drivers
  - supported 8
- duplex scanning
  - troubleshooting 283, 286

## E

- electrical. *See* power
- electrostatic discharge (ESD) 38
- environment specifications 371

error messages  
    computer-display, list and solutions 271  
European Union, waste disposal 374

**F**  
fans  
    ADF carriage, remove 104  
    ADF motor, remove 103  
    ADF, locate 266  
    carriage, remove 213  
    carriage-motor, remove 210  
    filters, remove 44  
    locate 267  
    operations 33  
fasteners list and numbers 39  
feature list  
    control panel 7  
    product 3  
field-replaceable units (FRUs) 38  
    ADF list 61  
    flatbed scanner list 208  
    replacement strategy 38  
    *See also* remove and replace parts; parts list and numbers  
file size and resolution 286  
filters  
    fan, clean 28  
    fan, remove 44  
    replacement guidelines 22  
fuzzy image 283

**G**  
Getting Started Guide  
    languages and part numbers 293  
glass, scanner  
    cleaning 27  
    remove 227  
guides. *See* documentation

**H**  
height adjustment, ADF 72  
HP Scanjet utilities  
    uninstall and reinstall 239  
HP Scanner Tools Utility  
    control-panel button settings 288  
    help 2  
    installation 19

    maintenance 22  
    open 22  
    purpose 22  
    supported 8  
HP Scanning Software  
    installation 19  
HP Smart Document Scan  
    background color setting 284  
    color drop-out settings 285  
    help 2  
    installation 19  
    long page settings 280  
    multipick detection, enable or disable 280  
    supported 8  
humidity specifications 371

**I**  
image quality  
    defects and solutions 282  
    repeating defects 270  
    troubleshooting 282  
imprinter cartridge  
    remove 42  
    replacement guidelines 22  
    use 287  
ink. *See* imprinter cartridge  
input tray. *See* tray  
installation  
    site preparation 14  
    software 19  
    test 20  
    unpack 15

**J**  
jams  
    ADF, clear 277  
    common causes and solutions 275  
    computer-display messages 271  
    media that causes 11  
    solve common ADF 276  
    troubleshooting 275

**K**  
Korean regulatory information 374

**L**  
lamp, scanner  
    not turning off 286  
languages  
    change for documentation 2  
    Getting Started Guide 293  
LEDs  
    Attention LED, change color 252  
    control-panel indicators 31  
    front panel, understand 238  
lock  
    control-panel buttons 240  
long documents scanning 280

**M**  
manuals. *See* documentation  
materials disposal 374  
messages  
    computer-display, list and solutions 271  
Misfeed (Multipick) Detection feature 280, 286  
model number  
    product 6  
    regulatory 374  
modes  
    product 31  
motors  
    ADF exit, remove 107  
    ADF feed, remove and replace 111  
    ADF input-tray lift, remove 105  
    ADF pick, remove and replace 118  
    ADF, locate 266  
    carriage, remove 215  
    locate 267

**N**  
N9120 Service Tool  
    dialog box, Actuators 255  
    dialog box, ADF feed test 253  
    dialog box, Control Panel Check 251  
    dialog box, NVRAM 258  
    dialog box, Sensor Check 246  
    dialog box, Version 262  
    menus 242  
noise specifications 370



- - operating environment
    - specifications 371
  - operating systems supported 8
    - See also* software
  - operation theory
    - basics 30
    - circuit board assemblies 32
    - fans 33
    - modes and indicators 31
    - overview 29
  - overview
    - control panel 7
    - product, feature list 3
    - product, walkaround 4
- P
  - pages
    - extra long 280
    - in wrong order 286
    - missing 286
  - paper
    - not feeding into ADF 281
    - specifications 10
    - types to avoid 11
  - paper path guides
    - ADF bottom corner inner paper path guide 154
    - ADF bottom corner outer 152
    - ADF exit inner 162
    - ADF top corner inner 165
  - parts 22, 263
    - diagrams of 263, 291
    - locator, ADF motors and fans 266
    - locator, ADF PCAs 268
    - locator, major parts 263
    - locator, motors and fans 267
    - locator, PCAs 269
    - ordering 292
    - replacement guidelines 22
    - service block diagram 36
    - user-replaceable 41
    - See also* remove and replace parts; parts diagrams
  - parts diagrams
    - ADF components 298
    - ADF motors and fans 266, 267
    - component locator 263
    - flatbed scanner assemblies 326
    - how to use 297
    - major components 263, 264, 265
    - printed circuit assemblies 268
    - scanner motors and fans 267
    - scanner PCAs 269
  - parts list and numbers
    - ADF and scanner parts 295
    - ADF, with diagram 298
    - documentation 293
    - field-replaceable units (FRUs) 295
    - maintenance kits 294
    - power cords 294
    - scanner assemblies, with diagram 326
    - screws and fasteners 39
    - service 293
  - physical specifications 370
  - power
    - cable, included 17
    - consumption 370
    - cords list 294
    - specifications 370
    - switch and receptacle assembly, remove 231
  - power-on
    - failure 286
    - troubleshooting 237
  - print quality. *See* image quality
  - printed circuit-board assemblies (PCAs)
    - ADF controller, remove 128
    - ADF imprinter, remove and replace 130
    - ADF lower multi-pick, remove 126
    - ADF upper multi-pick, remove 124
    - ADF, locate 268
    - control-panel, remove 218
    - holder for ADF PCA, remove 195
    - locate 269
    - power-supply, remove 223
    - scanner controller, remove 220
  - product overview
    - back 5
    - feature list 3
    - front and right side 4
    - model and serial numbers 6
    - product walkaround 4
    - side (left) 5
- Q
  - quality. *See* image quality
- R
  - regulatory information
    - country/region specific 374
    - materials disposal 374
    - model number 374
  - reinstall
    - ADF 67
    - ADF background-solenoid assembly 204
    - ADF base reflector 46
    - ADF cal-strip assembly 158
    - ADF feed-motor assembly 115
    - ADF feed-motor drive belt 114
    - ADF output tray 188
    - ADF pick-motor assembly 121
    - flatbed scan position sensor 136
    - flatbed scan position sensor arm 169
    - imprinter PCA 131
    - pickup-roller assembly 48
    - separation-pad assembly 51
  - remove
    - colors from a document 285
    - materials for disposal 374
  - remove and replace parts
    - ADF 63
    - ADF A4 paper-stop 200
    - ADF back cover 58
    - ADF background-solenoid assembly 201
    - ADF base reflector 45
    - ADF bottom corner inner paper path guide 154
    - ADF bottom corner outer paper path guide 152
    - ADF cal-strip assembly 155
    - ADF carriage fan 104
    - ADF controller PCA 128

- ADF elevator arm sensor 142
- ADF exit 1 sensor 138
- ADF exit 1 sensor arm 172
- ADF exit 2 sensor 139
- ADF exit 2 sensor arm 173, 181
- ADF exit inner paper path guide 162
- ADF exit-motor assembly 107
- ADF feed-motor assembly 111
- ADF front cover 55
- ADF FRUs list 61
- ADF hinge limiters 192
- ADF imprinter carriage and FFC 206
- ADF imprinter PCA 130
- ADF imprinter PCA holder 195
- ADF input-tray assembly 184
- ADF input-tray lift-motor assembly 105
- ADF input-tray sensor 134
- ADF input-tray-elevator arm 176
- ADF jam door 1 sensor 146
- ADF jam door 2 sensor 147
- ADF jam door 3 193
- ADF lower multi-pick sensor PCA 126
- ADF motor fan 103
- ADF output tray 186
- ADF paper present sensor 195
- ADF paper-present-sensor arm 175
- ADF pick-motor assembly 118
- ADF pickup-roller cover 190
- ADF pickup-roller spring 182
- ADF power-cable assembly 228
- ADF scan position sensor 151
- ADF separation-pad spring 183
- ADF shingle wall 197
- ADF top corner inner paper path guide 165
- ADF upper feed-guide 166
- ADF upper multi-pick sensor PCA 124
- after procedures 40
- back cover 60
- back-filter cover 54

- background solenoid sensor 143
- before procedures 39
- carriage fan 213
- carriage motor 215
- carriage-motor cable 230
- carriage-motor fan 210
- control-panel cover 53
- control-panel PCA 218
- external covers 52
- fan filters 44
- flatbed scan position sensor arm 168
- flatbed scanner 209
- flatbed scanner FRUs list 208
- guidelines 22
- imprinter cartridge 42
- jam door 3 sensor 148
- life expectancy 22
- paper-present sensor 144
- pickup-roller assembly 47
- pickup-roller sensor 140
- power switch and power receptacle assembly 231
- power-supply PCA 223
- registration sensor 145
- registration sensor arm 179
- right-filter cover 54
- safety 38
- scanner controller PCA 220
- scanner-glass assembly 227
- separation-pad assembly 22, 50
- strategy 38
- tools required 39
- user-replaceable parts list 41
- repacking the product 367
- repeating defects ruler 270
- troubleshooting 282
- resolution recommended settings 286
- rollers pickup, remove and replace 47
- replacement guidelines 22

## S

- safety information
  - electrostatic discharge (ESD) 38
  - general ii
  - parts replacement 38
- Scan button profile assignment 288
- scan profiles 280, 284, 285, 288
- scanner
  - diagram and parts list 326
  - drivers supported 8
- screwdrivers for parts replacement 39
- screws
  - parts list and numbers 39
- sensor
  - ADF exit 1 138
- sensors
  - ADF elevator arm, remove 142
  - ADF exit 1 arm 172
  - ADF exit 2 arm 173
  - ADF exit 2, remove 139
  - ADF input-tray, remove 134
  - ADF jam door 1, remove 146
  - ADF jam door 2, remove 147
  - ADF jam door 3, remove 148
  - ADF paper present, remove 195
  - ADF scan position, remove 151
  - background solenoid, remove 143
  - check functionality 246
  - flatbed scan position 135
  - flatbed scan position sensor arm 168
  - imprinter paper-present 149
  - paper present, remove 144
  - pickup roller 140
  - registration, remove 145
- separation pad
  - remove and replace 50
  - replacement guidelines 22
- serial numbers
  - product 6
- service
  - about 363

- after procedures 40
- before procedures 39
- repacking the product 367
- replacing parts 38
- setup instructions 13
- shipping the product 367
- size
  - paper limits 10
- skewed image 282
- slow scanning 283, 286
- software
  - for troubleshooting, use 242
  - included 17
  - installation 19
  - installation for troubleshooting 239
  - scanner management, supported 8
  - supported 8
- solenoids
  - ADF background, remove and replace 201
- specifications
  - acoustic 370
  - ADF 10
  - environment 371
  - media 10
  - physical 370
  - power 370
  - power, about 370
- streaked image 283
- stripes on image 284
- supplies
  - cleaning 39
  - maintenance 22
  - ordering 292
- support Web site 2, 292
- system requirements 9

## T

- temperature specifications 371
- tools for parts replacement 39
- tray
  - ADF input, remove 184
  - capacity 10
- troubleshooting 235
  - ADF not working 281
  - basic checks 236
  - bottom of image cut off 280
  - checklist 235

- computer-display error messages 271
- connectivity 289
- control-panel buttons 288
- control-panel buttons
  - diagnostics 240
- diagnostic software, main screen 242
- diagnostic software, open 242
- dialog box, Actuators 255
- dialog box, ADF feed test 253
- dialog box, Control Panel Check 251
- dialog box, NVRAM 258
- dialog box, Scan 244
- dialog box, Sensor Check 246
- dialog box, Update 260
- dialog box, Version 262
- direct-connect problems 289
- duplex scanning 286
- fans 256
- image quality 270, 282
- imprinter 287
- jams 275
- LEDs 238
- motors 256
- power-on 237
- process, about 234
- repair menu 261
- repeating defects 270
- Scan button 288
- scanner lamp 286
- scanner performance
  - problems 286
- solenoids 256
- USB connection 239
- use control panel buttons 240
- See also* jams

## U

- USB cable
  - check for troubleshooting 239
  - included 17
- User Guide
  - description 2
- user-replaceable parts list 41

## V

- voltage specifications 370

## W

- warranty
  - Customer self repair 366
  - product 364
- Web site, support 2, 292
- weight
  - paper limits 10
- white
  - image 282
  - stripes on image 284





© 2013 Hewlett-Packard Development Company, L.P.



L2683-90022