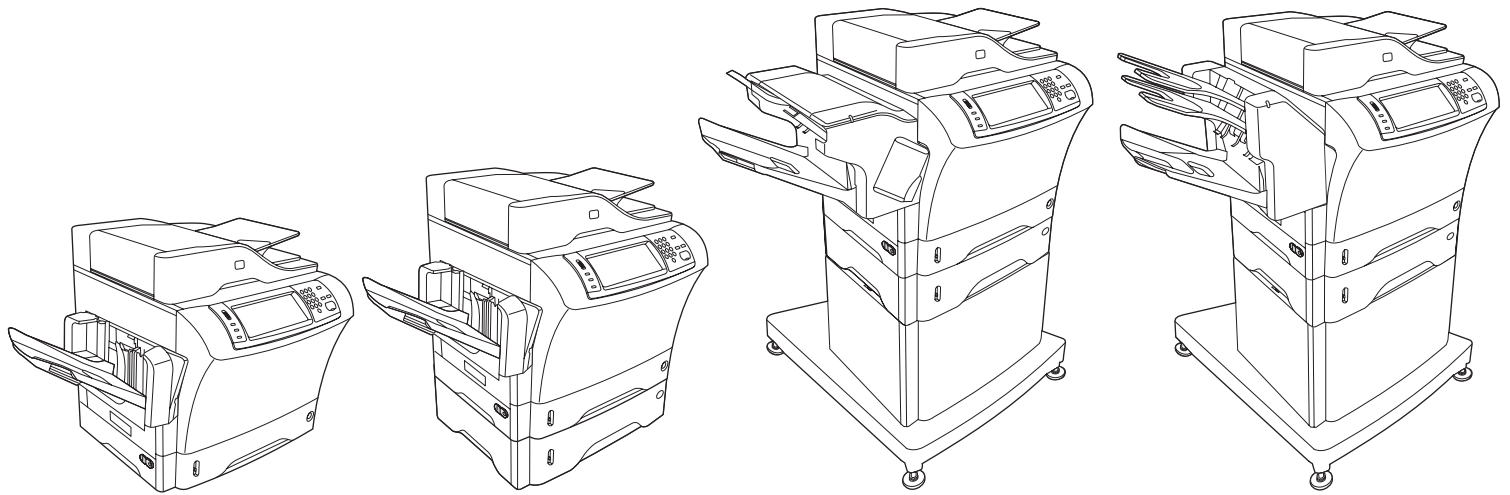


# HP LaserJet M4345 MFP

## Service Manual





# HP LaserJet M4345 MFP

---

Service Manual



## Copyright and License

© 2006 Copyright Hewlett-Packard Development Company, L.P.

Reproduction, adaptation, or translation without prior written permission is prohibited, except as allowed under the copyright laws.

The information contained in this document is subject to change without notice.

The only warranties for HP products and services are set forth in the express warranty statements accompanying such products and services. Nothing herein should be construed as constituting an additional warranty. HP shall not be liable for technical or editorial errors or omissions contained herein.

Part number CB425-90908

Edition 1, 10/2006

## Trademark Credits

Java™ is a US trademark of Sun Microsystems, Inc.

Windows®, Windows® XP, and Windows NT® are U.S. registered trademarks of Microsoft Corporation.

Linux is a U.S. registered trademark of Linus Torvalds.

UNIX® is a registered trademark of The Open Group.

Adobe® and PostScript® are trademarks of Adobe Systems Incorporated.

PANTONE®\* \*Pantone, Inc.'s check-standard trademark for color.

ENERGY STAR® and the ENERGY STAR logo® are U.S. registered marks of the United States Environmental Protection Agency.



# Table of contents

## 1 Product information

Device comparison .....	2
Features comparison .....	3
Walkaround .....	6
Accessories and supplies .....	7
Interface ports .....	8
Locking and unlocking optional accessories .....	8
Media specifications .....	10
Select print media .....	10
General media specifications .....	14
Media considerations .....	14
Envelopes .....	14
Envelopes with double side seams .....	15
Envelopes with adhesive strips or flaps .....	16
Envelope margins .....	16
Envelope storage .....	16
Labels .....	16
Label construction .....	16
Transparencies .....	16
Card stock and heavy media .....	17
Card stock construction .....	17
Card stock guidelines .....	17
Letterhead and preprinted forms .....	17
Select the correct fuser mode .....	18

## 2 Installation

Site preparation .....	22
Operating environment .....	22
Installation checklist .....	24
Optional output and input devices .....	26
Connect to a computer or network .....	27
USB configuration .....	27
Network connection .....	28
Fax connection .....	28
Analog faxing .....	28
Connecting the fax accessory to a phone line .....	28
Configuring and using the fax features .....	29
Digital faxing .....	29
Device software .....	30

Supported operating systems .....	30
Supported operating systems .....	31
Select the correct printer driver .....	32
Universal printer drivers .....	32
Driver Autoconfiguration .....	32
Update Now .....	33
HP Driver Preconfiguration .....	33
Priority for print settings .....	33
Open the printer drivers .....	34
Software for Macintosh computers .....	35
Remove software from Macintosh operating systems .....	35
Utilities .....	36
HP Web Jetadmin .....	36
Embedded Web server .....	36
HP Easy Printer Care software .....	37
Supported operating systems .....	37
Supported browsers .....	37
Other components and utilities .....	37
Network configuration .....	38
Configure TCP/IPv4 parameters .....	38
Change the IP address .....	38
Set the subnet mask .....	39
Set the default gateway .....	39
Configure TCP/IPv6 parameters .....	40
Disable network protocols (optional) .....	40
Disable IPX/SPX .....	40
Disable AppleTalk .....	41
Disable DLC/LLC .....	41
HP Jetdirect EIO print servers .....	41
Security features .....	42
Securing the embedded Web server .....	42
Foreign Interface Harness (FIH) .....	42
Requirements .....	42
Using the FIH .....	42
Secure Disk Erase .....	43
Data affected .....	44
Gaining access to Secure Disk Erase .....	44
Additional Information .....	44
Job-storage features .....	44
HP DSS authentication .....	44
Locking the control-panel menus .....	44
Locking the formatter cage .....	45

### 3 Manage and maintain the device

Control-panel menus .....	48
Use the control panel .....	48
Control-panel layout .....	48
Home screen .....	49
Buttons on the touchscreen .....	50
Control-panel help system .....	50

Navigate the Administration menu .....	50
Information menu .....	51
Default Job Options menu .....	52
Default Options for Originals .....	53
Default Copy Options .....	54
Default Fax Options .....	55
Default E-mail Options .....	56
Default Send to Folder Options .....	57
Default Print Options .....	58
Time/Scheduling menu .....	58
Management menu .....	59
Initial Setup menu .....	60
Networking and I/O .....	60
Fax Setup .....	68
E-mail Setup .....	71
Send Setup menu .....	71
Device Behavior menu .....	71
Print Quality menu .....	75
Troubleshooting menu .....	77
Resets menu .....	79
Service menu .....	80
Use information pages .....	82
Configure e-mail alerts .....	84
HP Easy Printer Care software .....	85
Open the HP Toolbox FX .....	85
HP Toolbox FX sections .....	85
Use the embedded Web server .....	87
Open the embedded Web server by using a network connection .....	87
Embedded Web server sections .....	87
Use HP Web Jetadmin software .....	90
Use the HP Printer Utility for Macintosh .....	91
Open the HP Printer Utility .....	91
HP Printer Utility features .....	91
Manage supplies .....	93
Supplies life expectancy .....	93
Change the print cartridge .....	93
Manage the print cartridge .....	93
Print-cartridge storage .....	93
Use genuine HP print cartridges .....	93
HP policy on non-HP print cartridges .....	94
Print-cartridge authentication .....	94
HP fraud hotline and Web site .....	94
Clean the device .....	95
Clean the exterior .....	95
Clean the scanner glass .....	95
Clean the scanner lid backing .....	96
Clean the paper path .....	96
Clean the document feeder .....	96
Clean the document feeder delivery system .....	97
Clean the document feeder-rollers .....	98

Set the real-time clock .....	100
Set the date and time .....	100
Set the date format .....	100
Set the date .....	100
Set the time format .....	100
Set the time .....	100
Set the wake time .....	101
Set the sleep delay .....	101
Upgrading the firmware .....	102
Determining the current level of firmware .....	102
Downloading the new firmware from the HP Web site .....	102
Transferring the new firmware to the MFP .....	102
Using FTP to upgrade the firmware on a network connection .....	102
Using HP Web Jetadmin to upgrade the firmware .....	104
Using MS-DOS commands to upgrade the firmware .....	104
Upgrading the HP Jetdirect firmware .....	105
Calibrate the scanner .....	106
Calibrate the control panel .....	107
Disable Embedded Jetdirect I/O .....	108
Select the MFP language .....	109

#### 4 Theory of operation

Basic operation .....	112
Sequence of operation (printer) .....	112
Sequence of operation (scanner) .....	113
Formatter system .....	114
Sleep mode .....	114
Resolution Enhancement technology (REt) .....	114
EconoMode .....	115
Input/output .....	115
CPU .....	115
Memory .....	115
Hard disk .....	115
Random-access memory .....	115
DIMM slot .....	115
Firmware .....	115
Nonvolatile memory .....	116
HP Memory Enhancement technology .....	116
PJM overview .....	116
PML .....	116
Control panel .....	116
Scanner interface .....	116
Engine-control system .....	117
DC controller PCA .....	117
Motors and fans .....	119
Motor and fan functions .....	119
Ambient-temperature detection .....	120
Engine power supply circuit .....	120
Fuser control .....	121
Fuser over-temperature protection .....	122



High-voltage power supply .....	124
Low-voltage power supply .....	125
Overcurrent/overvoltage protection .....	127
Toner detection .....	127
Cartridge detection .....	127
Laser/scanner system .....	128
Laser/scanner control .....	129
Image-formation system .....	131
Print cartridge .....	132
Cartridge memory .....	132
Image-formation process .....	133
Pickup, feed, and delivery system .....	135
Pickup-and-feed block .....	138
Printing from tray 1 .....	139
Printing from tray 2 .....	140
Media-size detection .....	141
Cassette media-size detection .....	141
Media-length detection .....	141
Media-width detection .....	141
Cassette pickup operation .....	141
Lifter-driver operation .....	143
Multifeed prevention .....	143
Distance-between-pages adjustment .....	144
Media-skew prevention .....	145
Feed-speed control .....	147
Fusing and reversing/delivery block .....	148
Fusing .....	148
Face-down delivery .....	148
Face-up delivery .....	149
Jam detection .....	151
Pickup delay jam from tray 1 .....	151
Pickup delay jam from tray 2 .....	151
Pickup stationary jam .....	151
Fuser-delivery delay jam .....	152
Fuser wrapping jam .....	152
Fuser-delivery stationary jam when feeding regular-size media .....	152
Fuser-delivery stationary jam when feeding custom-size media .....	152
Reversing delay jam (face-down delivery only) .....	152
Reversing stationary jam (face-down delivery only) .....	152
Delivery delay jam during face-down delivery .....	153
Delivery delay jam during face-up delivery .....	153
Delivery stationary jam during face-down delivery .....	153
Delivery stationary jam during face-up delivery .....	153
Door-open jam .....	153
Residual-media jam .....	153
Printing from the 500-sheet feeder .....	154
500-sheet feeder pickup and feeding .....	155
Duplex-printing unit .....	157
Reversing/duplexing pickup .....	157
Duplex-printing jam detection .....	158

	Duplex-unit-pickup delay jam .....	158
	Duplex-unit stationary jam .....	159
	Duplex-unit delay jam .....	159
3-bin mailbox system .....		160
Stacker mode .....		162
Mailbox mode .....		162
Function-separator mode .....		162
Jam detection .....		162
Feed-delay jam .....		163
Feed-stationary jam .....		163
Residual-media jam .....		163
Power-on sequence .....		163
MBM driver .....		164
MBM switches and sensors .....		167
MBM PCBs .....		168
MBM list of signals .....		169
Stapler/stacker system .....		171
Power-on sequence .....		171
Staple mode .....		172
Jogger operation .....		178
Jogger home-position detection .....		182
Stacker mode .....		184
Jam detection .....		184
Stapler unit .....		185
Staple home position detection .....		186
Self-priming detection .....		186
Staple level detection .....		186
Stapler/stacker switches and sensors .....		187
Stapler/stacker motors, solenoid, and fan .....		189
Stapler/stacker PCBs .....		190
Stapler/stacker driver PCB .....		193
Stapler/stacker driver list of signals .....		195
Scanner system .....		198
Electrical system .....		198
Motors and fans .....		200
Optical assembly .....		200
ADF feed system .....		202
Jam detection .....		202
Residual-media jam .....		202
ADF pickup jam .....		203
ADF jam .....		203
Registration sensor jam .....		203
Read sensor jam .....		203
Exit sensor jam .....		203
ADF cover open jam .....		203
ADF open jam .....		203
Locations of major components .....		204
Sensors and switches .....		204
Cassette sensors .....		204
Sensors in the print-cartridge area .....		205

Sensors on the reversing unit (top side) .....	205
Sensors in the interior of the MFP .....	206
Output-bin detection switch, SW103 .....	207
Tray 1 paper-present sensor, PS105 .....	207
Top-cover switch, SW101 .....	208
Tray 2 jam-access-cover switch, SW105 .....	208
Motors, fans, solenoids, and clutch .....	208
Front-side fans .....	209
Rear-side fans .....	210
Rear-side motors (1 of 2) .....	210
Rear-side motors (2 of 2) .....	211
Rear-side solenoid .....	212
Reversing-unit motors and solenoids .....	213
Right, rear corner components (1 of 2) .....	214
Right, rear corner components (2 of 2) .....	215
Scanner and ADF components .....	215
ADF output-bin-full sensor .....	215
ADF pickup assembly sensors .....	216
ADF motors, solenoid, and sensors .....	216

## 5 Removal and replacement

Service approach .....	220
Removal and replacement strategy .....	221
Required tools .....	221
Before performing service .....	221
After completing service .....	222
Screws that are used in the MFP .....	222
User-replaceable parts .....	224
Print cartridge .....	224
Control-panel overlays .....	224
Control panel .....	225
Transfer roller .....	226
ADF input tray .....	227
ADF pickup and feed rollers .....	228
ADF separation pad .....	229
ADF delivery guide (clear mylar sheet) .....	231
Output-bin assembly .....	233
Duplex-printing unit .....	234
Fuser-entrance guide .....	235
Fuser .....	235
Tray 2, 3, 4, or 5 pickup and feed rollers .....	236
Tray 1 pickup roller .....	237
Scanner filter cover and scanner filter .....	238
ADF-hinge flap .....	239
Formatter cover and formatter .....	240
Hard drive .....	242
DIMM .....	243
Fax accessory .....	244
Covers, doors, and external panels .....	246
Top-cover flatbed flange .....	246

Front cover .....	247
Back cover .....	251
Internal assemblies .....	253
Reversing-separation-guide assembly .....	253
Reversing assembly .....	254
Main fan (FN101) and reversing-unit fan (FN103) .....	258
Thermistor (TH3) .....	263
Tray 2 jam-access-cover switch (SW105) .....	265
Tray 1 assembly .....	267
Front-cover support .....	269
Tray 1 feed-assembly .....	271
Feed-roller assembly .....	278
DC controller .....	280
Main motor (M101) .....	283
DC controller fan (FN104) .....	284
Print-cartridge fan (FN102) .....	285
Print-cartridge motor (M102) .....	287
Top-cover switch (SW101) .....	290
Registration assembly .....	292
Paper-pickup-drive assembly .....	295
Lifter-drive assembly .....	298
Power-factor-correction (PFC) power supply .....	301
Engine power supply .....	306
Paper-feed assembly .....	311
Tray 2 detection switch .....	312
Paper-size-detection switch (SW102) .....	313
Tray 2 paper-present sensor (PS101) .....	314
Laser/scanner .....	315
Output-bin-full sensor .....	316
ADF and scanner components .....	319
ADF assembly .....	319
Scanner assembly .....	321
Scanner-controller PCA .....	326
ADF components .....	327
ADF output-bin extension .....	327
ADF white mylar-backing .....	328
ADF front cover .....	330
ADF rear cover .....	331
ADF left-side cover .....	332
ADF jam-access cover and latch .....	334
ADF leading-edge and paper-present sensors .....	335
ADF hinges .....	337
500-sheet feeder components .....	339
500-sheet-feeder pickup and feed rollers .....	339
Stapler/stacker components .....	340
Delivery tray .....	340
Front cover .....	340
Rear cover .....	340
Left cover .....	341
Top cover .....	341

Bottom cover .....	342
Stapler unit .....	343
Jogger unit .....	344
Stapler/stacker driver PCB .....	348
3-bin mailbox components .....	350
Rear cover .....	350
Front cover .....	350
Delivery tray .....	350
Left cover .....	351
Upper cover .....	351
Right-door unit .....	352
Bottom cover .....	354
MBM driver PCB .....	355

## 6 Problem solving

Problem-solving checklist .....	359
Factors that affect performance .....	359
Problem-solving flowchart .....	360
Power-on checks .....	364
Power-on troubleshooting overview .....	364
Formatter lights .....	366
HP Jetdirect Inside LEDs .....	366
Heartbeat LED .....	366
Fax LED .....	367
Diagrams for troubleshooting .....	368
DC controller connections .....	368
Scanner-controller PCA connections .....	370
General timing chart .....	371
General circuit diagrams .....	373
Solve general device problems .....	379
Control-panel message types .....	382
Control-panel messages .....	383
Common causes of jams .....	399
Clear jams .....	400
Clear jams from the top-cover and print-cartridge areas .....	401
Clear jams from the optional envelope-feeder area .....	403
Clear jams from the tray 1 area .....	405
Clear jams from the tray 2, 3, 4, or 5 areas .....	406
Clear jams from the optional duplexer .....	408
Clear jams from the output areas .....	409
Clear jams from the fuser .....	410
Clear jams from the document feeder .....	413
Solve repeated jams .....	414
Paper-path test .....	415
Clear staple jams .....	416
Solve print-quality problems .....	418
Print-quality problems associated with media .....	418
Print-quality problems associated with the environment .....	418
Print-quality problems associated with jams .....	418
Overhead transparency defects .....	418

Image defect examples .....	419
Light print (partial page) .....	419
Light print (entire page) .....	419
Specs .....	420
Dropouts .....	420
Lines .....	421
Gray background .....	421
Toner smear .....	422
Loose toner .....	423
Repeating defects .....	423
Repeating image .....	424
Misformed characters .....	424
Page skew .....	425
Curl or wave .....	425
Wrinkles or creases .....	426
Vertical white lines .....	427
Tire tracks .....	427
White spots on black .....	428
Scattered lines .....	428
Blurred print .....	429
Random image repetition .....	429
Repetitive defect ruler .....	431
Solve network printing problems .....	433
Solve copy problems .....	434
Prevent copy problems .....	434
Image problems .....	434
Media-handling problems .....	435
Performance problems .....	437
Solve fax problems .....	438
Solve sending problems .....	438
Solve receiving problems .....	439
Solve e-mail problems .....	441
Validate the SMTP gateway address .....	441
Validate the LDAP gateway address .....	441
Solve network connectivity problems .....	442
Troubleshooting network printing problems .....	442
Loopback test .....	442
Ping test .....	443
Solve stapler/stacker problems .....	444
Solve 3-bin mailbox problems .....	451
Functional checks .....	454
Early boot diagnostic test .....	454
Engine test .....	454
Formatter test .....	455
Half self-test .....	455
Drum-rotation test .....	456
MFP resets .....	457
Cold reset .....	457
NVRAM initialization .....	457
Hard-disk initialization .....	458

Individual component diagnostics .....	459
Paper-path-sensor test .....	459
Manual sensor test .....	459
Scanner tests .....	460
Component test .....	461
Service ID .....	462
Restoring the Service ID .....	462
Converting the service ID to an actual date .....	462
Troubleshooting the embedded HP Jetdirect print server .....	463
Firmware-stack trace .....	464
Solve common Windows problems .....	465
Solve common Macintosh problems .....	466
Solve Linux problems .....	469
Solve PostScript problems .....	470
General problems .....	470

## 7 Parts and diagrams

Order parts, accessories, and supplies .....	472
Order directly from HP .....	472
Order through service or support providers .....	472
Order directly through the embedded Web server .....	472
How to use the parts lists and diagrams .....	472
Screws that are used in the MFP .....	473
Customer-replaceable parts and accessories .....	474
Accessories .....	474
Customer-replaceable components (print engine) .....	476
Customer-replaceable components (ADF and scanner) .....	478
Cables and interfaces .....	480
Control panel and control-panel overlays .....	483
Memory .....	485
Print cartridge and maintenance kits .....	487
Documentation, software, and training material .....	490
Assembly locations .....	492
External components .....	496
Print-engine internal components .....	498
Upper-plate assembly .....	498
Internal components (1 of 5) .....	500
Internal components (2 of 5) .....	502
Internal components (3 of 5) .....	504
Internal components (4 of 5) .....	506
Internal components (5 of 5) .....	508
Electrical/forward assembly .....	510
Main drive assembly .....	512
Paper-pickup-drive assembly .....	514
Lifter-drive assembly .....	516
Cassette .....	518
Paper-feed roller assembly .....	520
Registration assembly .....	522
Multipurpose assembly .....	524
Reverse assembly .....	526

Reverse-separation-guide assembly .....	528
Delivery assembly .....	530
Fuser .....	532
ADF components .....	534
ADF assembly .....	534
ADF internal components (1 of 3) .....	536
ADF internal components (2 of 3) .....	538
ADF internal components (3 of 3) .....	540
ADF input tray .....	542
ADF separation pad .....	544
ADF separation-pad case .....	546
ADF pickup-roller assembly .....	548
ADF pickup-roller cover .....	550
ADF mylar-holder assembly .....	552
ADF mylar replacement kit .....	554
Scanner components .....	556
Scanner-base components .....	556
Scanner flatbed-unit assembly .....	558
Scanner covers .....	560
Cassette .....	562
Optional devices .....	564
Duplex-printing accessory .....	564
Stapler/stacker .....	566
3-bin mailbox .....	568
Alphabetical parts list .....	570
Numerical parts list .....	586

## Appendix A Specifications

Physical specifications .....	604
Electrical specifications .....	604
Acoustic specifications .....	605
Operating environment .....	606

## Appendix B Product warranty statements

Hewlett-Packard limited warranty statement .....	607
Customer Self Repair Warranty Service .....	608
HP Customer Care .....	609
Online Services .....	609
Telephone support .....	609
Software utilities, drivers, and electronic information .....	609
Fax accessory support .....	609
HP direct ordering for accessories or supplies .....	609
HP service information .....	609
HP service agreements .....	609
HP Toolbox FX .....	610
HP support and information for Macintosh computers .....	610
HP maintenance agreements .....	611
On-site service agreements .....	611
Next-day on-site service .....	611
Weekly (volume) on-site service .....	611



Repacking the device .....	611
Extended warranty .....	612

### Appendix C Regulatory information

FCC regulations .....	614
Environmental product stewardship program .....	615
Protecting the environment .....	615
Ozone production .....	615
Power consumption .....	615
Toner consumption .....	615
Paper use .....	615
Plastics .....	615
HP LaserJet print supplies .....	616
HP print supplies returns and recycling program information .....	616
Paper .....	616
Material restrictions .....	617
Disposal of waste equipment by users in private households in the European Union ...	617
Material Safety Data Sheet (MSDS) .....	618
For more information .....	618
Telecom statement .....	619
Declaration of conformity .....	620
Safety statements .....	621
Laser safety .....	621
Canadian DOC regulations .....	621
VCCI statement (Japan) .....	621
Power cord statement (Japan) .....	621
EMI statement (Korea) .....	621
Laser statement for Finland .....	621

Index .....	623
-------------	-----



# 1 Product information

The HP LaserJet M4345 is designed to be shared by a workgroup. Use the MFP to copy and print black-and-white documents or to digitally send black-and-white documents. The MFP is a standalone copier that does not require connection to a computer. With the optional *HP LaserJet Analog Fax Accessory 300 User Guide* (included with some models), the MFP can also send and receive faxes.

If you have not done so, see the HP LaserJet M4345 Getting Started Guide for setup instructions.

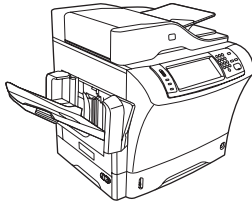
This chapter introduces the following topics:

- [Device comparison](#)
- [Features comparison](#)
- [Walkaround](#)
- [Media specifications](#)

# Device comparison

---

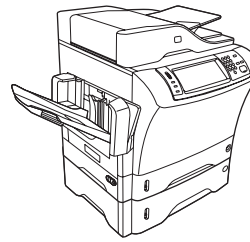
## HP LaserJet M4345 MFP (base model)



The HP LaserJet M4345 is the base model, and comes standard with the following items:

- A 100-sheet multipurpose input tray (tray 1)
- Three 500-sheet input trays
- Automatic document feeder (ADF) that holds up to 50 pages
- HP Jetdirect embedded print server for connecting to a 10/100Base-T network
- 256 megabytes (MB) synchronous dynamic random access memory (SDRAM)

## HP LaserJet M4345x MFP

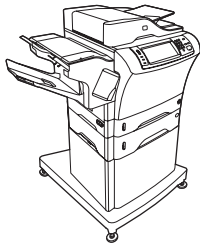


The HP LaserJet M4345x includes all of the features of the base model plus the following items:

- Automatic duplex printing accessory (duplexer)
- Additional 500-sheet feeder (tray 3)
- 33.6 kbps analog-fax accessory

---

## HP LaserJet M4345xs MFP



The HP LaserJet M4345xs includes all of the features of the base model plus the following items:

- Automatic duplex printing accessory (duplexer)
- Additional 500-sheet feeder (tray 3)
- 33.6 kbps analog-fax accessory
- Stapler/stacker accessory
- Cabinet/stand

## HP LaserJet M4345xm MFP



The HP LaserJet M4345xm includes all of the features of the base model plus the following items:

- Automatic duplex printing accessory (duplexer)
  - Additional 500-sheet feeder (tray 3)
  - 33.6 kbps analog-fax accessory
  - 3-bin mailbox accessory
  - Cabinet/stand
-

# Features comparison

Feature	HP LaserJet M4345
Functions	<ul style="list-style-type: none"> <li>● Two-sided copying (duplexing)</li> <li>● Image modification</li> <li>● Color digital sending</li> <li>● Document finishing</li> </ul>
Speed and throughput	<ul style="list-style-type: none"> <li>● 45 pages per minute (ppm) when scanning and printing on letter-size paper; 43(ppm) when copying and printing on A4-size paper</li> <li>● 25% to 400% scalability when using the scanner glass</li> <li>● 25% to 200% scalability when using the automatic document feeder (ADF)</li> <li>● Less than 10 seconds to print the first page</li> <li>● Transmit Once, Raster Image Processing (RIP) ONCE technology</li> <li>● Duty cycle of up to 200,000 pages per month</li> </ul>
Resolution	<ul style="list-style-type: none"> <li>● 1200 dots per inch (dpi) with Resolution Enhancement technology (REt)</li> <li>● FastRes1200 provides 1200 dpi quality at full speed</li> <li>● Up to 220 levels of gray</li> </ul>
Memory	<ul style="list-style-type: none"> <li>● 256 megabytes (MB) of random-access memory (RAM), expandable to 512 MB by using an industry standard 100-pin double data rate memory module (DDR SDRAM DIMM)</li> <li>● Memory Enhancement technology (MEt) that automatically compresses data to use RAM more efficiently</li> </ul>
User interface	<ul style="list-style-type: none"> <li>● Graphical touchscreen control panel</li> <li>● An embedded Web server to gain access to support and order supplies (for network-connected products)</li> <li>● HP Easy Printer Care software (a Web-based status and troubleshooting tool).</li> </ul>
Language and fonts	<ul style="list-style-type: none"> <li>● HP PCL 6</li> <li>● HP PCL5</li> <li>● Printer Management Language</li> <li>● PDF</li> <li>● XHTML</li> <li>● 80 scalable TrueType typefaces</li> <li>● HP PostScript 3 emulation</li> </ul>

---

## Copying and sending

- Modes for text, graphics, and mixed text and graphics formats
- A job-interrupt feature (at copy boundaries)
- Xenon lamp for instant-on copying
- Multiple pages per sheet
- Operator attendance animations (for example, jam recovery)
- E-mail compatibility
- A sleep feature that saves energy
- Automatic duplex (two-sided) scanning



**NOTE** An automatic duplex printing accessory is required for two-sided copying.

**NOTE** To use e-mail functionality, the device must be connected to an IP-based server that has simple mail transfer protocol (SMTP). This server can be on the local area network or at an outside Internet service provider (ISP). HP recommends that the device be located on the same local area network (LAN) as the SMTP server. If you are using an ISP, you must connect to the ISP by using a digital subscriber line (DSL) connection. If you obtain e-mail services from an ISP, ask the ISP to provide the correct SMTP address.

Dial-up connections are not supported. If you do not have an SMTP server on your network, you can purchase third-party software that allows you to create an SMTP server.

---

## Print cartridge

- Prints up to 18,000 pages at 5% coverage.
- No-shake cartridge design
- Authentic HP print cartridge detection

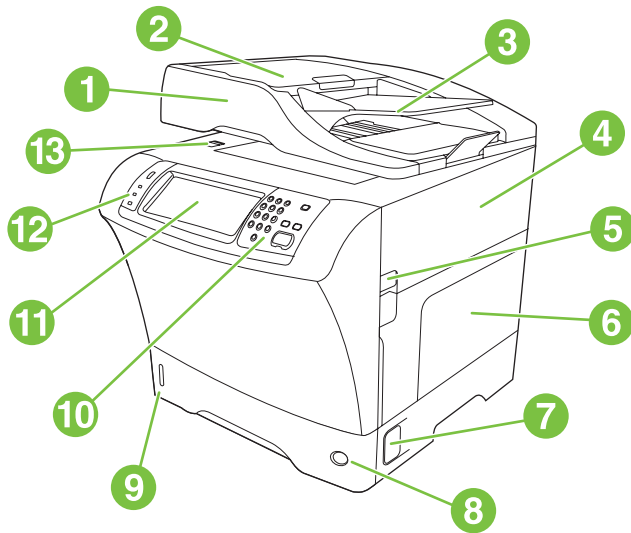
---

## Paper Input

- **Tray 1 (multipurpose tray):** A multipurpose tray for paper, transparencies, labels, and envelopes. Holds up to 100 sheets of paper or 10 envelopes.
  - **Tray 2 and optional trays 3, 4, and 5:** 500-sheet trays. These trays automatically detect standard paper sizes up to Legal and accommodate printing on custom-size paper.
  - **Automatic document feeder (ADF):** Holds up to 50 sheets of paper.
  - **Duplex printing and copying:** With the optional duplexing accessory, provides two-sided printing and copying (printing on both sides of the paper).
  - **ADF duplex scanning:** The ADF has an automatic duplex feature for scanning two-sided documents.
  - **Optional envelope feeder:** Holds up to 75 envelopes.
-

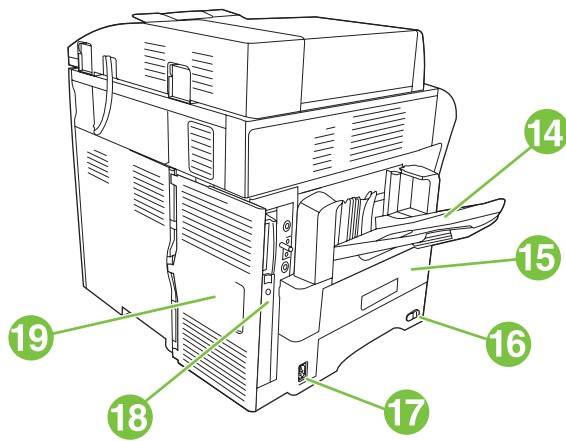
Paper output	<ul style="list-style-type: none"> <li>● <b>Standard output bin:</b> The standard output bin is located on the left side of the device. This bin can hold up to 500 sheets of paper.</li> <li>● <b>ADF output bin:</b> The ADF output bin is underneath the ADF input tray. The bin holds up to 50 sheets, and the device automatically stops when this bin is full.</li> <li>● <b>Optional stapler/stacker:</b> The stapler/stacker staples up to 30 sheets and stacks up to 500 sheets.</li> <li>● <b>Optional 3-bin mailbox:</b> One bin stacks up to 500 sheets, and two bins stack up to 100 sheets each for a total capacity of 700 sheets.</li> </ul>
Connectivity	<ul style="list-style-type: none"> <li>● A Foreign interface harness (FIH) connection (AUX) for connecting other devices</li> <li>● Local area network (LAN) connector (RJ-45) for the embedded HP Jetdirect print server</li> <li>● Optional analog-fax card</li> <li>● Optional HP Digital Sending Software (DSS)</li> <li>● High-speed USB 2.0</li> <li>● Jetlink for paper handling solutions</li> <li>● Optional HP Jetdirect enhanced input/output (EIO) print server cards: <ul style="list-style-type: none"> <li>● LocalTalk</li> <li>● Fast Ethernet 10/100TX</li> <li>● Ethernet 802.11b wireless</li> <li>● Bluetooth wireless printer adapter</li> <li>● Infrared adapter</li> </ul> </li> </ul>
Environmental features	<ul style="list-style-type: none"> <li>● The Sleep setting saves energy (meets ENERGY STAR guidelines).</li> </ul>
Security features	<ul style="list-style-type: none"> <li>● Foreign interface harness (FIH)</li> <li>● Secure Disk Erase</li> <li>● Security lock</li> <li>● Job retention</li> <li>● DSS authentication</li> </ul>

## Walkaround



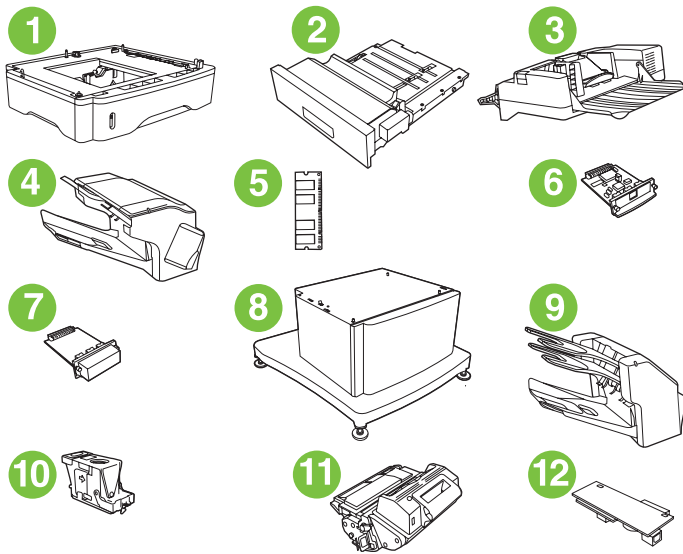
1	Document-feeder assembly
2	Document-feeder top cover
3	Document-feeder input tray
4	Top cover (provides access to the print cartridge)
5	Top-cover lever
6	Tray 1 (multipurpose tray)
7	Jam-access lever
8	Tray-number indicator
9	Paper-level indicator
10	Control-panel keypad
11	Control-panel display
12	Control-panel status lights
13	Scanner lock





14	Output bin
15	Optional duplexer
16	On/off switch
17	Power connection
18	Interface ports
19	Formatter cover (provides access to the memory DIMM slot, hard disk, and analog-fax accessory)

## Accessories and supplies



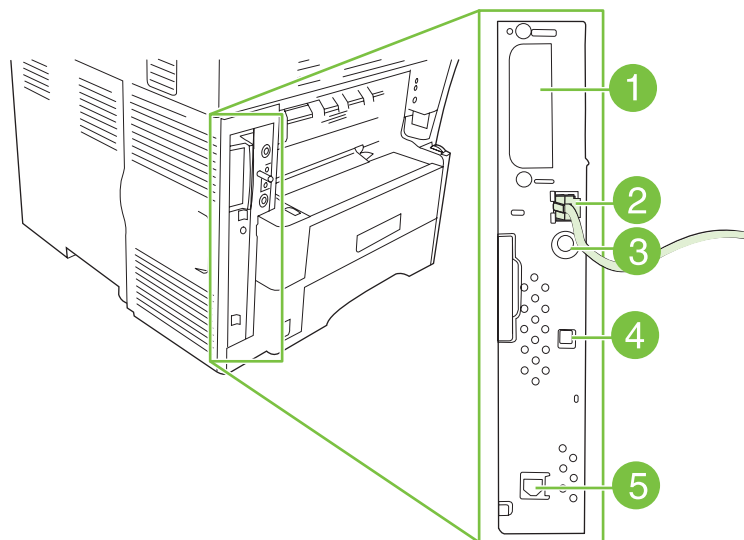
1	500-sheet feeder (Q5968A)
2	Duplexer (Q5969A)
3	Envelope feeder (Q2438B)
4	Stapler/stacker (Q5691A)
5	Memory DIMM

6	HP Jetdirect print server (EIO card)
7	Hard-disk accessory (EIO card)
8	Storage cabinet/stand (Q5970A)
9	3-bin mailbox (Q5692A)
10	Staple cartridge (C8091A)
11	Print cartridge (Q5945A)
12	HP LaserJet Analog Fax Accessory 300 (Q3701A)



**NOTE** The device accommodates up to three optional 500-sheet feeders. HP recommends using a cabinet when using the optional 500-sheet feeders.

## Interface ports

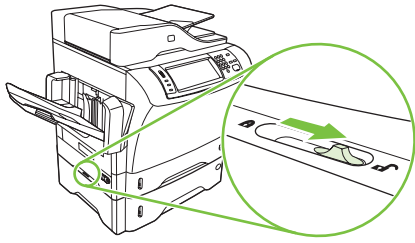


1	EIO slot
2	Network connection (embedded HP Jetdirect print server)
3	Foreign interface harness (FIH) port
4	High-speed USB 2.0 device port
5	Telephone-line connection (for the optional analog-fax accessory)

## Locking and unlocking optional accessories

For more stability to prevent the device from tipping over, the optional 500-sheet feeders and the cabinet are automatically locked to the bottom of the device. When accessories are installed, verify that the lock on each accessory is in the rear (locked) position.

To unlock the accessories, slide the lever to the forward (unlocked) position.



# Media specifications

## Select print media

Table 1-1 Supported types of media

Type of media	Tray 1	Trays 2, 3, 4, and 5	Optional duplexer	Optional envelope feeder	3-bin mailbox or stacker part of stapler/stacker	Stapler part of stapler/stacker
Plain	X	X	X	X	X	X
Preprinted	X	X	X	X	X	X
Letterhead	X	X	X	X	X	X
Transparency	X	X			X	
Prepunched	X	X		X	X	X
Labels	X	X	X	X	X	
Bond	X	X	X	X	X	X
Recycled	X	X	X	X	X	X
Color	X	X	X	X	X	X
Cardstock	X			X	X <sup>12</sup>	
Rough	X	X	X	X	X	X
Envelope	X			X	X <sup>1</sup>	

<sup>1</sup> Face-up delivery only.

<sup>2</sup> If a 3-bin mailbox is installed, select the bottom bin when printing on cardstock. Media weights that are 200g/m<sup>2</sup> or greater are supported only in the bottom bin.

**Table 1-2** Tray 1 supported sizes and weights

Size	Dimensions <sup>1</sup>	Weight	Capacity <sup>2</sup>		
Letter	216 x 279 mm (8.5 x 11 inches)	60 to 200g/m <sup>2</sup> (16 to 53 lb)	100 sheets of 75g/m <sup>2</sup> (20 lb) paper		
A4	210 x 297 mm (8.3 x 11.7 inches)				
Legal	216 x 356 mm (8.5 x 14 inches)				
Executive	184 x 267 mm (7.3 x 10.5 inches)				
Statement	140 x 216 mm (5.5 x 8.5 inches)				
8.5 x 13	216 x 330 mm (8.5 x 13 inches)				
A5	148 x 210 mm (5.8 x 8.3 inches)				
B5 (JIS)	182 x 257 mm (7.2 x 10.1 inches)				
Executive (JIS)	216 x 330 mm (8.5 x 13 inches)				
D Postcard (JIS)	148 x 200 mm (5.8 x 7.9 inches)				
16K	197 x 273 mm (7.75 x 10.75 inches)				
Custom	Minimum: 76 x 127 mm (3 x 5 inches) Maximum: 216 x 356 mm (8.5 x 14 inches)				
Envelope Commercial #10	105 x 241 mm (4.1 x 9.5 inches)			75 to 105g/m <sup>2</sup> (20 to 28 lb)	10 envelopes
Envelope DL ISO	110 x 220 mm (4.3 x 8.7 inches)				
Envelope C5 ISO	162 x 229 mm (6.4 x 9.0 inches)				
Envelope B5 ISO	176 x 250 mm (6.9 x 9.8 inches)				
Envelope Monarch #7-3/4	98 x 191 mm (3.9 x 7.5 inches)				

<sup>1</sup> The MFP supports a wide range of sizes. Check the MFP software for supported sizes.

<sup>2</sup> Capacity can vary depending on paper weight and thickness, as well as environmental conditions.

**Table 1-3** Trays 2, 3, 4, and 5 supported sizes and weights

Size	Dimensions <sup>1</sup>	Weight	Capacity <sup>2</sup>
Letter	216 x 279 mm (8.5 x 11 inches)	60 to 120g/m <sup>2</sup> (16 to 32 lb)	500 sheets of 75g/m <sup>2</sup> (20 lb) paper
A4	210 x 297 mm (8.3 x 11.7 inches)		
Executive	184 x 267 mm (7.3 x 10.5 inches)		
Legal	216 x 356 mm (8.5 x 14 inches)		
B5 (JIS)	182 x 257 mm (7.2 x 10.1 inches)		
A5	148 x 210 mm (5.8 x 8.3 inches)		
8.5 x 13	216 x 330 mm (8.5 x 13 inches)		
Executive (JIS)	216 x 330 mm (8.5 x 13 inches)		
16K	197 x 273 mm (7.75 x 10.75 inches)		
Custom	Minimum: 148 x 210 mm (5.8 x 8.3 inches)  Maximum: 216 x 356 mm (8.5 x 14 inches)		

<sup>1</sup> The MFP supports a wide range of sizes. Check the MFP software for supported sizes.

<sup>2</sup> Capacity can vary depending on paper weight and thickness, as well as environmental conditions.

**Table 1-4** Optional duplexer supported sizes and weights

Size	Dimensions	Weight
Letter	216 x 279 mm (8.5 x 11 inches)	60 to 120g/m <sup>2</sup> (16 to 32 lb)
A4	210 x 297 mm (8.3 x 11.7 inches)	
Executive	184 x 267 mm (7.3 x 10.5 inches)	
Legal	216 x 356 mm (8.5 x 14 inches)	
B5 (JIS)	182 x 257 mm (7.2 x 10.1 inches)	
A5	148 x 210 mm (5.8 x 8.3 inches)	
8.5 x 13	216 x 330 mm (8.5 x 13 inches)	
Executive (JIS)	216 x 330 mm (8.5 x 13 inches)	
16K	197 x 273 mm (7.75 x 10.75 inches)	

**Table 1-5** Optional envelope feeder supported sizes and weights

Size	Dimensions	Weight	Capacity
Monarch #7-3/4	98 x 191 mm (3.9 x 7.5 inches)	75 to 105g/m <sup>2</sup> (20 to 28 lb)	75 envelopes
Commercial #10	105 x 241 mm (4.1 x 9.5 inches)		
DL ISO	110 x 220 mm (4.3 x 8.7 inches)		
C5 ISO	162 x 229 mm (6.4 x 9.0 inches)		
B5 ISO	176 x 250 mm (6.9 x 9.8 inches)		

**Table 1-6** Optional 3-bin mailbox or stacker part of the stapler/stacker supported sizes and weights

Size	Dimensions <sup>1</sup>	Weight	Capacity <sup>2</sup>
Letter	216 x 279 mm (8.5 x 11 inches)		For the stacker on the stapler/stacker or the lower bin on the 3-bin mailbox: 500 sheets of 75g/m <sup>2</sup> (20 lb) paper
A4	210 x 297 mm (8.3 x 11.7 inches)		
Executive	184 x 267 mm (7.3 x 10.5 inches)		
Legal	216 x 356 mm (8.5 x 14 inches)		
B5 (JIS)	182 x 257 mm (7.2 x 10.1 inches)		
A5	148 x 210 mm (5.8 x 8.3 inches)		For the top two bins on the 3-bin mailbox: each can hold 100 sheets of 75g/m <sup>2</sup> (20 lb) paper.
Statement	140 x 216 mm (5.5 x 8.5 inches)		
8.5 x 13	216 x 330 mm (8.5 x 13 inches)		
Executive(JIS)	216 x 330 mm (8.5 x 13 inches)		
DPostcard (JIS)	148 x 200 mm (5.8 x 7.9 inches)		
16K	197 x 273 mm (7.75 x 10.75 inches)		
Envelope #10 <sup>3</sup>	105 x 241 mm (4.1 x 9.5 inches)		
Envelope Monarch #7-3/4 <sup>3</sup>	98 x 191 mm (3.9 x 7.5 inches)		
Envelope C5 ISO <sup>3</sup>	162 x 229 mm (6.4 x 9.0 inches)		
Envelope DL ISO <sup>3</sup>	110 x 220 mm (4.3 x 8.7 inches)		
Envelope B5 ISO <sup>3</sup>	176 x 250 mm (6.7 x 9.8 mm)		
Custom	Minimum: 76 x 127 mm (3 x 5 inches) Maximum: 216 x 356 mm (8.5 x 14 inches)		

<sup>1</sup> The MFP supports a wide range of sizes. Check the MFP software for supported sizes.

<sup>2</sup> Capacity can vary depending on paper weight and thickness, as well as environmental conditions.

<sup>3</sup> Face-up delivery only.

**Table 1-7** Stapler part of the optional stapler/stacker supported sizes and weights

Size	Dimensions	Weight	Capacity
Letter	216 x 279 mm (8.5 x 11 inches)	For plain media: 60 to 120g/m <sup>2</sup> (16 to 32 lb)	For plain media: 30 sheets of 75g/m <sup>2</sup> (20 lb) paper
A4	210 x 297 mm (8.3 x 11.7 inches)		
Legal	216 x 356 mm (8.5 x 14 inches)	For thick media: 128 to 199g/m <sup>2</sup> (34 to 53 lb)	For glossy media: 20 sheets
8.5 x 13	216 x 330 mm (8.5 x 13 inches)		For thick media: the stack height must not exceed 7 mm (0.27 inch)
Executive(JIS)	216 x 330 mm (8.5 x 13 inches)		

**Table 1-8** ADF supported sizes and weights

Size	Dimensions	Weight	Capacity
Letter	216 x 279 mm (8.5 x 11 inches)	60 to 120g/m <sup>2</sup> (16 to 32 lb)	50 sheets of 75g/m <sup>2</sup> (20 lb) paper
A4	210 x 297 mm (8.3 x 11.7 inches)		
A5	148 x 210 mm (5.8 x 8.3 inches)		
Legal	216 x 356 mm (8.5 x 14 inches)		

## General media specifications

For complete paper specifications for all HP LaserJet devices, see the *HP LaserJet Printer Family Print Media Guide* (available at <http://www.hp.com/support/ljpaperguide>).

Category	Specifications
Acid content	5.5 pH to 8.0 pH
Caliper	0.094 to 0.18 mm (3.0 to 7.0 mils)
Curl in ream	Flat within 5 mm (0.02 in)
Cut edge conditions	Cut with sharp blades with no visible fray.
Fusing compatibility	Must not scorch, melt, offset, or release hazardous emissions when heated to 200° C (392°F) for 0.1 second.
Grain	Long grain
Moisture content	4% to 6% by weight
Smoothness	100 to 250 Sheffield

## Media considerations

### Envelopes

Envelope construction is critical. Envelope fold lines can vary considerably, not only between manufacturers, but also within a box from the same manufacturer. Successful printing on envelopes



depends upon the quality of the envelopes. When selecting envelopes, consider the following components:

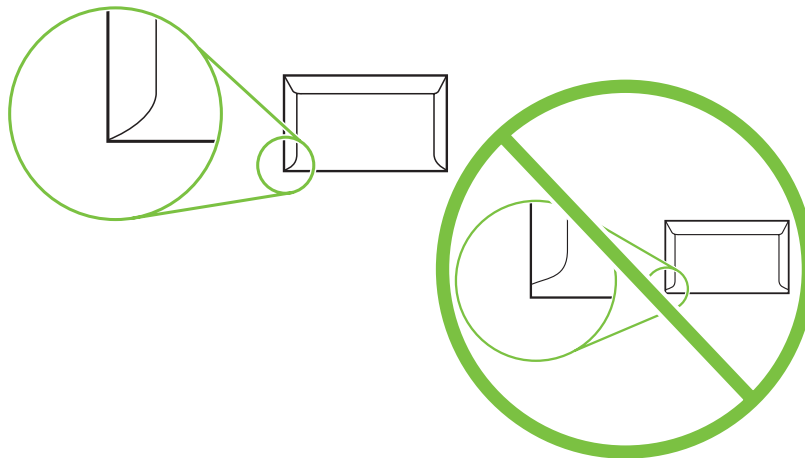
- **Weight:** The weight of the envelope paper should not exceed 105g/m<sup>2</sup> (28 lb) or jamming might occur.
- **Construction:** Prior to printing, envelopes should lie flat with less than 6 mm (0.25 inch) curl, and should not contain air.
- **Condition:** Envelopes should not be wrinkled, nicked, or otherwise damaged.
- **Temperature:** You should use envelopes that are compatible with the heat and pressure of the printer.
- **Size:** You should use only envelopes within the following size ranges.
  - **Minimum:** 76 x 127 mm (3 x 5 inches)
  - **Maximum:** 216 x 356 mm (8.5 x 14 inches)



**NOTE** Use only tray 1 or the optional envelope feeder to print envelopes. You might experience some jams when using any media with a length less than 178 mm (7 inches). This might be caused by paper that has been affected by environmental conditions. For optimum performance, make sure you are storing and handling the paper correctly. Also, choose envelopes in the printer driver.

### Envelopes with double side seams

Double side-seam construction has vertical seams at both ends of the envelope rather than diagonal seams. This style might be more likely to wrinkle. Be sure the seam extends all the way to the corner of the envelope as illustrated below.



- |   |                                    |
|---|------------------------------------|
| 1 | Acceptable envelope construction   |
| 2 | Unacceptable envelope construction |

## Envelopes with adhesive strips or flaps

Envelopes with a peel-off adhesive strip or with more than one flap that folds over to seal must use adhesives compatible with the heat and pressure in the printer. The extra flaps and strips might cause wrinkling, creasing, or even jams and might even damage the fuser.

## Envelope margins

The following gives typical address margins for a commercial #10 or DL envelope.

Type of address	Top margin	Left margin
Return address	15 mm (0.6 inch)	15 mm (0.6 inch)
Delivery address	51 mm (2.0 inches)	89 mm (3.5 inches)



**NOTE** For the best print quality, position margins no closer than 15 mm (0.6 inch) from the edges of the envelope. Avoid printing over the area where the envelope's seams meet.

## Envelope storage

Proper storage of envelopes helps contribute to print quality. Envelopes should be stored flat. If air is trapped in an envelope, creating an air bubble, then the envelope might wrinkle during printing.

## Labels



**CAUTION** To avoid damaging the MFP, use only labels recommended for laser printers. Never print on the same sheet of labels more than once or print on a partial sheet of labels.

## Label construction

When selecting labels, consider the quality of each component:

- **Adhesives:** The adhesive material should be stable at 200°C (392°F), the printer's fusing temperature.
- **Arrangement:** Only use labels with no exposed backing between them. Labels can peel off sheets with spaces between the labels, causing serious jams.
- **Curl:** Prior to printing, labels must lie flat with no more than 13 mm (0.5 inch) of curl in any direction.
- **Condition:** Do not use labels with wrinkles, bubbles, or other indications of separation.



**NOTE** Choose labels in the printer driver.

## Transparencies

Transparencies used in the printer must be able to withstand 200°C (392°F), the printer's fusing temperature.



**CAUTION** To avoid damaging the MFP, use only transparencies recommended for use in HP LaserJet printers, such as HP-brand transparencies.



---

**NOTE** Choose transparencies in the printer driver.

---

## Card stock and heavy media

You can print many types of card stock from the paper input tray, including index cards and postcards. Some card stock performs better than others because its construction is better suited for feeding through a laser printer.

For optimum printer performance, do not use paper heavier than 157g/m<sup>2</sup> (42 lb). Paper that is too heavy might cause misfeeds, stacking problems, paper jams, poor toner fusing, poor print quality, or excessive mechanical wear.



---

**NOTE** You might be able to print on heavier paper if you do not fill the input tray to capacity and if you use paper with a smoothness rating of 100-180 Sheffield.

---

## Card stock construction

- **Smoothness:** 135-157g/m<sup>2</sup> (36-42 lb) card stock should have a smoothness rating of 100-180 Sheffield. 60-135g/m<sup>2</sup> (16-36 lb) card stock should have a smoothness rating of 100-250 Sheffield.
- **Construction:** Card stock should lie flat with less than 5 mm (0.2 in.) of curl.
- **Condition:** Make sure that the card stock is not wrinkled, nicked, or otherwise damaged.
- **Sizes:** Only use card stock within the following size ranges:
  - **Minimum:** 76 x 127 mm (3 x 5 in.)
  - **Maximum:** 216 x 356 mm (8.5 x 14.0 in.)

## Card stock guidelines

Set margins at least 2 mm (0.08 in.) away from the edges.

## Letterhead and preprinted forms

Many manufacturers now offer premium paper advertised as laser-compatible or laser-guaranteed. Some of the rougher surface finishes, such as cockle, laid, or linen, might require the special fuser modes that are available on some printer models in order to achieve adequate toner adhesion.



---

**NOTE** Some page-to-page variation is normal when printing with laser printers. This variation cannot be observed when printing on plain paper. However, this variation is obvious when printing on preprinted forms because the lines and boxes are already placed on the page.

---

To avoid problems when using preprinted forms, embossed paper, and letterhead, observe the following guidelines:

- Avoid using low-temperature inks (the kind used with some types of thermography).
- Use preprinted forms and letterhead paper that have been printed by offset lithography or engraving.

- Use forms that have been created with heat-resistant inks that will not melt, vaporize, or release undesirable emissions when heated to 200°C (392°F) for 0.1 second. Typically, oxidation-set or oil-based inks meet this requirement.
- When the form is preprinted, be careful not to change the moisture content of the paper, and do not use materials that change the paper's electrical or handling properties. Seal the forms in moisture-proof wrap to prevent moisture changes during storage.
- Avoid processing preprinted forms that have a finish or coating.
- Avoid using heavily embossed or raised-letterhead papers.
- Avoid papers that have heavily textured surfaces.
- Avoid using offset powders or other materials that prevent printed forms from sticking together.

### Select the correct fuser mode

The device automatically adjusts the fuser mode based on the media type to which the tray is set. For example, heavy paper, such as card stock, might need a higher fuser-mode setting in order to make the toner adhere better to the page, but transparencies need a lower fuser-mode setting to avoid damage to the device. The default setting generally provides the best performance for most print-media types.

The fuser mode can be changed only if the media type has been set for the tray that you are using. After the media type has been set for the tray, then the fuser mode for that type can be changed on the [Administration](#) menu in the [Print Quality](#) submenu at the device control panel. See [Print Quality menu on page 75](#).




---

**NOTE** Using the [High 1](#) or [High 2](#) fuser mode setting improves the ability of the toner to adhere to paper, but it might cause other problems, such as excessive curl. The device might print at a slower speed when the fuser mode is set to [High 1](#) or [High 2](#). The table below describes the ideal fuser mode setting for supported media types.

---

Media type	Fuser mode setting
Plain	Normal
Preprinted	Normal
Letterhead	Normal
Transparency	Low 2
Prepunched	Normal
Labels	Normal
Bond	Normal
Recycled	Normal
Color	Normal
Light	Low 1
Card stock	Normal
Rough	High 1
Envelope	Normal

To reset the fuser modes to the default settings, touch the [Administration](#) menu at the device control panel. Touch [Print Quality](#), touch [Fuser Modes](#), and then touch [Restore Modes](#).



# 2 Installation

This chapter contains information about the following topics:

- [Site preparation](#)
- [Installation checklist](#)
- [Optional output and input devices](#)
- [Connect to a computer or network](#)
- [Device software](#)
- [Network configuration](#)
- [Security features](#)

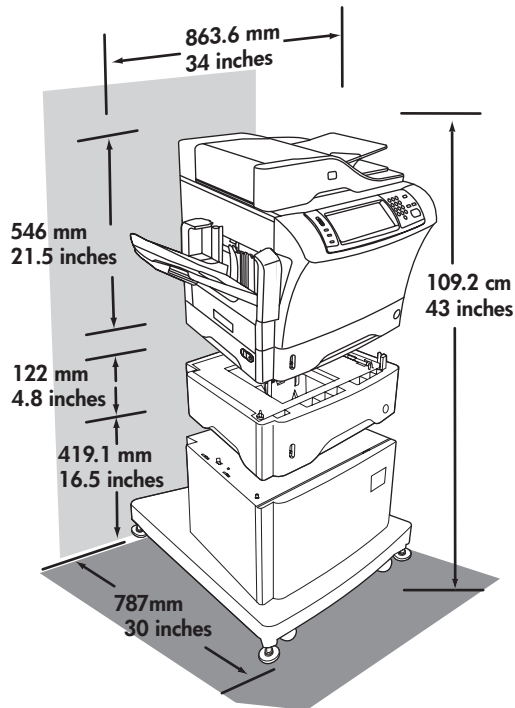
## Site preparation

Below are recommendations for the printer location and placement.

## Operating environment

The printer must be kept in a proper location to maintain the performance level that has been set at the factory.

The printer must have the required clearance around it.



**Figure 2-1** Printer dimensions

Place the MFP in a location that offers the following:

- A well-ventilated, dust-free area
- A constant temperature and humidity (Do not install near water sources, humidifiers, air conditioners, refrigerators, or other major appliances.)
- A hard, level surface (not more than a 2° angle)

Keep the MFP away from the following:

- Direct sunlight, dust, open flames, or water
- Direct flow of exhaust from air ventilation systems
- Magnets and devices that emit a magnetic field



- Areas subject to vibration
- Walls or other objects. There must be enough space around the printer for proper access and ventilation

# Installation checklist

When setting up the MFP for the first time, perform the following tasks to ensure that the MFP is installed correctly.

**Table 2-1** Installation checklist

✓	Task	Details
	Connect the MFP to an adequate power source.	The MFP requires a minimum of 15 amps for 110-volt models or 8 amps for 220-volt models. Do not connect the MFP to a power strip or to an uninterruptible power supply (UPS). Attaching other devices to the same power source can cause intermittent problems.
	Install the MFP in a location that has enough space.	Make sure that all sides of the MFP are easily accessible. If the space around the MFP is too tight, clearing jams and servicing the MFP are more difficult.
	Place the MFP on a sturdy, level surface.	Place the MFP on a hard surface so it does not shift when opening and closing the MFP components. If the MFP is on a cabinet/stand, make sure that the feet are level and stable.
	Install media in tray 2 and install the print cartridge.	Use media that meets HP specifications. See the <i>HP LaserJet Printer Family Print Media Guide</i> , which is available for download in .PDF format at <a href="http://www.hp.com/support/ljpaperguide">http://www.hp.com/support/ljpaperguide</a> .  Be sure to remove the sealing tape from the print cartridge. It is possible to insert the print cartridge without removing the sealing tape, but an error message appears on the control-panel display.
	Connect the network cable to the HP Jetdirect port on the left side of the MFP. Also connect the fax line if an HP LaserJet analog fax accessory 300 is installed.	The fax should be connected to a single analog telephone line that will be used for the fax only and not shared with a telephone or other device.
	Move the scanner shipping lock to the unlocked position.	Raise the ADF. The scanner shipping lock is to the left of the scanner glass. Move the switch toward the front of the MFP to unlock it.
	Set the correct language, date, and time.	During initial setup, follow the directions on the control panel when prompted to set the language, date and time.  To change the language after initial setup, touch <b>Administration</b> , <b>Device Behavior</b> , and <b>Language</b> . Then select the desired language from a list.  To change the current date and time after initial setup, touch <b>Administration</b> , <b>Time/Scheduling</b> , and <b>Date/Time</b> .
	Prepare the MFP for digital sending by configuring the e-mail gateways.	From the Home screen, touch <b>Administration</b> , <b>Initial Setup</b> , <b>E-mail Setup</b> , <b>Find Send Gateways</b> , and <b>OK</b> . If auto-discovery does not find the e-mail gateways, obtain the addresses from your network administrator and manually configure these on the MFP.
	If a fax accessory is installed, configure it for sending and receiving faxes.	Use the Fax Wizard to set up the fax for the first time. To make changes later, use the following procedure:  From the Home screen, touch <b>Administration</b> , <b>Initial Setup</b> , <b>Fax Setup</b> , and <b>Required Settings</b> . Provide the

**Table 2-1** Installation checklist (continued)

✓ Task	Details
	date, time, location, and fax-header information. See details in the <i>HP LaserJet Analog Fax Accessory 300 User Guide</i> .
Print the Configuration page to verify that the MFP is able to print.	From the Home screen, touch <a href="#">Administration, Information, Configuration Page, Configuration Page, and Print</a> .
Verify that each of the following items is listed on the Configuration page: <ul style="list-style-type: none"><li>• The LDAP Gateway Address</li><li>• The SMTP Gateway Address</li><li>• All optional devices</li><li>• If a fax accessory is installed, the Modem Status should indicate "Operational/Enabled."</li><li>• On the embedded Jetdirect page, make sure that the IP address is valid and that the Status indicates "I/O Card Ready."</li></ul>	
Make a copy by using the scanner glass to verify that the scanner is working.	
Make a copy by using the ADF to verify that it is working.	
If a fax accessory is installed, send a test fax to verify that it is set up correctly.	
Digitally send a document by using the e-mail feature.	
Send a print job to the MFP from a computer to verify that the printer driver software is installed correctly.	
Make sure that all users are aware of the user-training CD that came with the MFP.	

## Optional output and input devices

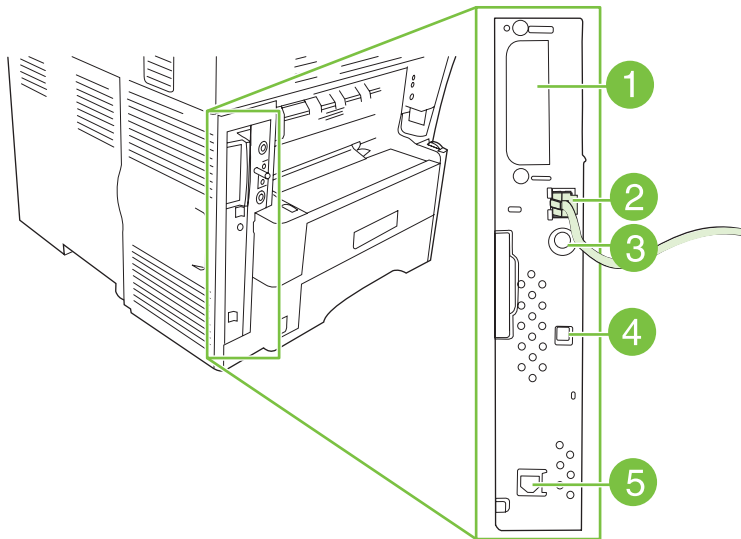
Several paper-handling devices are available for the MFP.

- A 3-bin mailbox
- A stapler/stacker
- Up to three 500-sheet feeders
- An envelope feeder
- A cabinet/stand (use with the optional 500-sheet feeders)

Each of these accessories comes with an installation guide that explains how to install it. After installing an accessory, print a Configuration page to verify that the accessory was installed successfully. If the accessory is installed correctly, it is listed on the Configuration page in the section for **Paper trays and options**.

## Connect to a computer or network

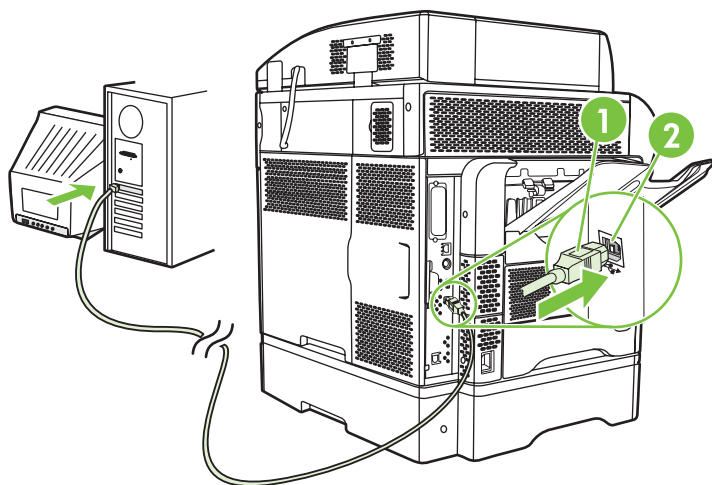
The MFP has five ports for connecting to a computer or a network. The ports are at the left, rear corner of the MFP.



1	EIO slot
2	Network connection (embedded HP Jetdirect print server)
3	Foreign interface harness (FIH) port
4	High-speed USB 2.0 device port
5	Telephone-line connection (for the optional analog-fax accessory)

## USB configuration

This device supports a USB 2.0 connection. You must use an A-to-B type USB cable for printing.



**Figure 2-2** USB connection

1	USB connector
2	USB port (type B)

## Network connection

When installing the MFP on a network, connect the network cable to the embedded HP Jetdirect print server before installing the MFP software.

For complete information about installing the MFP on a network, see the network installation guide that was included with the MFP.

## Fax connection

The HP LaserJet M4345x MFP, HP LaserJet M4345xs MFP, and HP LaserJet M4345xm MFP models come with an HP LaserJet analog fax accessory 300 already installed. For the HP LaserJet M4345 MFP (base model), you can order this accessory as an option. Microsoft® Windows® users can also install the optional HP Digital Sending Software (HP DSS), which provides digital faxing services, and the Send Fax driver, which allows you to use a computer to send a fax through the MFP.

For complete instructions for configuring the fax accessory and for using the fax features, see the *HP LaserJet Analog Fax Accessory 300 User Guide*. This guide is included on the software CD that comes with the MFP.

## Analog faxing

When the HP LaserJet analog fax accessory 300 is installed, the MFP can function as a standalone fax machine.

### Connecting the fax accessory to a phone line

When connecting the fax accessory to a phone line, ensure that the phone line being used for the fax accessory is a dedicated line that is not used by any other devices. Also, this line should be an analog line because the fax will not function correctly if it is connected to some digital PBX systems. If you are not sure whether you have an analog or digital phone line, contact your telecom provider.



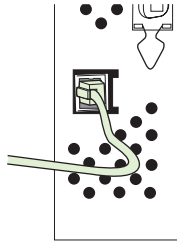
---

**NOTE** HP recommends using the phone cord that comes with the fax accessory to ensure that the accessory functions correctly.

---

Follow these instructions to connect the fax accessory to a phone jack.

1. Locate the phone cord that is included with the fax accessory kit. Connect one end of the phone cord into the fax accessory phone jack that is on the formatter. Push the connector until it clicks.



---

**CAUTION** Be sure to connect the phone line to the fax accessory port, which is near the bottom of the formatter. Do not connect the phone line to the HP Jetdirect LAN port, which is nearer the top of the formatter.

---

2. Connect the other end of the phone cord into the phone jack on the wall. Push the connector until it clicks or until it is firmly seated. Because different types of connectors are used in different countries/regions, the connector might not make an audible click.

### Configuring and using the fax features

Before you can use the fax features, you must configure them in the control-panel menus. For complete information about configuring and using the fax accessory, and for information about troubleshooting problems with the fax accessory, see the *HP LaserJet Analog Fax Accessory 300 User Guide*, which is provided with the fax accessory.

Use the Send Fax driver to send a fax from a computer without going to the MFP control panel. See the *HP LaserJet MFP Analog Fax Accessory 300 Send Fax Driver Guide* for more information.

The *HP LaserJet Analog Fax Accessory 300 User Guide* and the *HP LaserJet MFP Analog Fax Accessory 300 Send Fax Driver Guide* are both available on the MFP software CD.

### Digital faxing

Digital faxing is available when you install the optional HP Digital Sending Software. For information about ordering this software, go to [http://www.hp.com/go/ljm4345mfp\\_software](http://www.hp.com/go/ljm4345mfp_software).

With digital faxing, the MFP does *not* need to be connected directly to a phone line. Instead, the MFP can send a fax in one of three ways:

- **LAN fax** sends faxes through a third-party fax provider.
- **Microsoft Windows 2000 fax** is a fax modem and Digital Sender Module on a computer that allows the computer to operate as a turnkey gateway fax.
- **Internet fax** uses an Internet fax provider to process faxes, and the fax is delivered on a traditional fax machine or sent to the user's e-mail.

For complete information about using digital faxing, see the documentation that is provided with the HP Digital Sending Software.

## Device software

The printing-system software is included with the device. See the getting started guide for installation instructions.

The printing system includes software for end users and network administrators, and printer drivers for access to the features and communication with the computer.



**NOTE** For a list of printer drivers and updated software, go to [http://www.hp.com/go/m4345\\_software](http://www.hp.com/go/m4345_software).

## Supported operating systems

The CD-ROM that accompanies the device contains software that runs on the following operating systems:

- Microsoft Windows 98 and Windows Millennium Edition (Me)
- Microsoft Windows NT 4.0 (printer driver only)
- Microsoft Windows 2000, Windows XP, and Windows Server 2003
- Macintosh OS Version 9.1 and later, and Macintosh OS X Version 10.1 and later

The most recent printer drivers for all the supported operating systems are available at <http://www.hp.com/support/ljm4345mfp>. If you do not have access to the Internet, see the support flyer that came in the box for information about obtaining the most recent software.

The following table lists the available software for the HP LaserJet M4345 Series MFP.

Software	Windows 98/Me	Windows 2000/XP/Server 2003	Mac OS	UNIX/Linux	OS/2
Windows Installer	x	x			
PCL 5 <sup>1</sup>	x	x			
PCL 6	x	x			
PostScript emulation	x	x	x		
HP Easy Printer Care	x	x	x <sup>2</sup>		
HP Web Jetadmin <sup>3</sup>		x		x	
Macintosh Installer			x		
Macintosh PostScript Printer Description (PPD) files			x		
IBM drivers <sup>3</sup>					x
Model scripts <sup>3</sup>				x	

<sup>1</sup> Install by using the **Add Printer** wizard.

<sup>2</sup> Mac OS X V10.2 or higher, TCP/IP required

<sup>3</sup> Available only on the World Wide Web.





---

**NOTE** You can also purchase the optional HP Digital Sending Software, which provides digital-fax capability. For more information, go to <http://www.hp.com/support/ljm4345mfp>.

---

## Supported operating systems

The device supports the following operating systems:

### Full software installation

- Windows XP (32-bit and 64-bit)
- Windows Server 2003 (32-bit and 64-bit)
- Windows 2000
- Mac OS X V10.2.8, V10.3, V10.4 and later

### Printer driver only

- Linux (Web only)
- UNIX model scripts (Web only)



---

**NOTE** For Mac OS V10.4 and later, PPC and Intel Core Processor Macs are supported.

---

## Select the correct printer driver

Printer drivers allow you to gain access to the features of the device and allow the computer to communicate with the device (using a printer language). Check the installation notes and readme files on the CD for additional software and languages.

The device uses the PCL 5, PCL 6, and PostScript 3 emulation printer description language (PDL) drivers.

- Use the PCL 6 printer driver for the best overall performance.
- Use the PCL 5 printer driver for general office printing.
- Use the PS driver for printing from PostScript-based programs, for compatibility with PostScript Level 3 needs, or for PS flash font support.

Operating system <sup>1</sup>	PCL5	PCL6	PS3 emulation
Windows 2000 <sup>2</sup>	✓	✓	✓
Windows XP (32-bit) <sup>3</sup>	✓	✓	✓
Windows Server 2003 (32-bit)	✓	✓	✓
Windows Server 2003 (64-bit)	✓	✓	✓
Mac OS X V10.2 and later			✓

<sup>1</sup> Not all features are available from all drivers or operating systems.

<sup>2</sup> For Windows 2000 and Windows XP (32-bit and 64-bit), download the PCL5 driver from [http://www.hp.com/go/m4345\\_software](http://www.hp.com/go/m4345_software).

<sup>3</sup> For Windows XP (64-bit), download the PCL6 driver from [http://www.hp.com/go/m4345\\_software](http://www.hp.com/go/m4345_software). The printer drivers include online Help that has instructions for common printing tasks and also describes the buttons, checkboxes, and drop-down lists that are in the printer driver.

## Universal printer drivers

The HP Universal Print Driver Series for Windows includes separate HP postscript level 3 emulation and HP PCL 5 versions of a single driver that provides access to almost any HP device while providing system administrator with tools to manage devices more effectively. The Universal Print Driver is included on the device CD, under the Optional Software section. For more information, go to [www.hp.com/go/universalprintdriver](http://www.hp.com/go/universalprintdriver).

## Driver Autoconfiguration

The HP LaserJet PCL 5, PCL 6, and PS level 3 emulation drivers for Windows 2000 and Windows XP feature automatic discovery and driver configuration for device accessories at the time of installation. Some accessories that the Driver Autoconfiguration supports are the duplexing unit, optional paper trays, and dual inline memory modules (DIMMs).

## Update Now

If you have modified the device configuration since installation, the driver can be automatically updated with the new configuration. In the **Properties** dialog box (see [Open the printer drivers on page 34](#)), on the **Device Settings** tab, click the **Update Now** button to update the driver.

## HP Driver Preconfiguration

HP Driver Preconfiguration is a software architecture and set of tools that you can use to customize and distribute HP software in managed corporate printing environments. Using HP Driver Preconfiguration, information technology (IT) administrators can preconfigure the printing and default settings for HP printer drivers before installing the drivers in the network environment. For more information, see the *HP Driver Preconfiguration Support Guide*, which is available at [www.hp.com/go/hpdpc\\_sw](http://www.hp.com/go/hpdpc_sw).

## Priority for print settings

Changes to print settings are prioritized depending on where the changes are made:



---

**NOTE** The names of commands and dialog boxes might vary depending on your software program.

---

- **Page Setup dialog box:** Click **Page Setup** or a similar command on the **File** menu of the program you are working in to open this dialog box. Settings changed here override settings changed anywhere else.
- **Print dialog box:** Click **Print**, **Print Setup**, or a similar command on the **File** menu of the program you are working in to open this dialog box. Settings changed in the **Print** dialog box have a lower priority and do *not* override changes made in the **Page Setup** dialog box.
- **Printer Properties dialog box (printer driver):** Click **Properties** in the **Print** dialog box to open the printer driver. Settings changed in the **Printer Properties** dialog box do not override settings anywhere else in the printing software.
- **Default printer driver settings:** The default printer driver settings determine the settings used in all print jobs, *unless* settings are changed in the **Page Setup**, **Print**, or **Printer Properties** dialog boxes.
- **Printer control panel settings:** Settings changed at the printer control panel have a lower priority than changes made anywhere else.

## Open the printer drivers

Operating System	To change the settings for all print jobs until the software program is closed	To change the default settings for all print jobs	To change the device configuration settings
Windows 2000, XP, and Server 2003	<ol style="list-style-type: none"> <li>1. On the <b>File</b> menu in the software program, click <b>Print</b>.</li> <li>2. Select the driver, and then click <b>Properties</b> or <b>Preferences</b>.</li> </ol> <p>The steps can vary; this procedure is most common.</p>	<ol style="list-style-type: none"> <li>1. Click <b>Start</b>, click <b>Settings</b>, and then click <b>Printers</b> or <b>Printers and Faxes</b>.</li> <li>2. Right-click the driver icon, and then select <b>Printing Preferences</b>.</li> </ol>	<ol style="list-style-type: none"> <li>1. Click <b>Start</b>, click <b>Settings</b>, and then click <b>Printers</b> or <b>Printers and Faxes</b>.</li> <li>2. Right-click the driver icon, and then select <b>Properties</b>.</li> <li>3. Click the <b>Device Settings</b> tab.</li> </ol>
Mac OS X V10.2.8, V10.3, V10.4 and later	<ol style="list-style-type: none"> <li>1. On the <b>File</b> menu, click <b>Print</b>.</li> <li>2. Change the settings that you want on the various pop-up menus.</li> </ol>	<ol style="list-style-type: none"> <li>1. On the <b>File</b> menu, click <b>Print</b>.</li> <li>2. Change the settings that you want on the various pop-up menus.</li> <li>3. On the <b>Presets</b> pop-up menu, click <b>Save as</b> and type a name for the preset.</li> </ol> <p>These settings are saved in the <b>Presets</b> menu. To use the new settings, you must select the saved preset option every time you open a program and print.</p>	<ol style="list-style-type: none"> <li>1. In the Finder, on the <b>Go</b> menu, click <b>Applications</b>.</li> <li>2. Open <b>Utilities</b>, and then open <b>Print Center</b> (OS X V10.2.8) or <b>Printer Setup Utility</b>.</li> <li>3. Click on the print queue.</li> <li>4. On the <b>Printers</b> menu, click <b>Show Info</b>.</li> <li>5. Click the <b>Installable Options</b> menu.</li> </ol>



**NOTE** Configuration settings might not be available in Classic mode.

## Software for Macintosh computers

The HP installer provides PostScript Printer Description (PPD) files, Printer Dialog Extensions (PDEs), and the HP Printer Utility for use with Macintosh computers.

For network connections, use the embedded Web server (EWS) to configure the device.

The printing system software includes the following components:

- **PostScript Printer Description (PPD) files**

The PPDs, in combination with the Apple PostScript printer drivers, provide access to device features. Use the Apple PostScript printer driver that comes with the computer.

- **HP Printer Utility**

Use the HP Printer Utility to set up device features that are not available in the printer driver:

- Name the device.
- Assign the device to a zone on the network.
- Assign an internet protocol (IP) address to the device.
- Download files and fonts.
- Configure the device for IP or AppleTalk printing.

You can use the HP Printer Utility when your device uses a universal serial bus (USB) cable or is connected to a TCP/IP-based network.



---

**NOTE** The HP Printer Utility is supported for Mac OS X V10.2 or later.

---

## Remove software from Macintosh operating systems

To remove the software from a Macintosh computer, drag the PPD files to the trash can.

## Utilities

The device is equipped with several utilities that make it easy to monitor and manage the device on a network.

### HP Web Jetadmin

HP Web Jetadmin is a browser-based management tool for HP Jetdirect-connected printers within your intranet, and it should be installed only on the network administrator's computer.

To download a current version of HP Web Jetadmin and for the latest list of supported host systems, visit [www.hp.com/go/webjetadmin](http://www.hp.com/go/webjetadmin).

When installed on a host server, any client can gain access to HP Web Jetadmin by using a supported Web browser (such as Microsoft® Internet Explorer 4.x or Netscape Navigator 4.x or later) by navigating to the HP Web Jetadmin host.

### Embedded Web server

The device is equipped with an embedded Web server, which provides access to information about device and network activities. This information appears in a Web browser, such as Microsoft Internet Explorer or Netscape Navigator.

The embedded Web server resides on the device. It is not loaded on a network server.

The embedded Web server provides an interface to the device that anyone who has a network-connected computer and a standard Web browser can use. No special software is installed or configured, but you must have a supported Web browser on your computer. To gain access to the embedded Web server, type the IP address for the device in the address line of the browser. (To find the IP address, print a configuration page. For more information about printing a configuration page, see [Use information pages on page 82.](#))

For a complete explanation of the features and functionality of the embedded Web server, see [Embedded Web server on page 36.](#)

## HP Easy Printer Care software

The HP Easy Printer Care software is a program that you can use for the following tasks:

- Checking the device status
- Checking the supplies status
- Setting up alerts
- Viewing device documentation
- Gaining access to troubleshooting and maintenance tools

You can view the HP Easy Printer Care software when the device is directly connected to your computer or when it is connected to a network. To download the HP Easy Printer Care software, go to <http://www.hp.com/go/easyprintercare>.

### Supported operating systems

For information about supported operating systems, go to [www.hp.com/go/easyprintercare](http://www.hp.com/go/easyprintercare).

### Supported browsers

To use the HP Toolbox FX, you must have one of the following browsers:

- Microsoft Internet Explorer 5.5 or later
- Netscape Navigator 7.0 or later
- Opera Software ASA Opera 6.05 or later

All pages can be printed from the browser.

## Other components and utilities

Windows	Macintosh OS
<ul style="list-style-type: none"><li>• Software installer — automates the printing system installation</li><li>• Online Web registration</li></ul>	<ul style="list-style-type: none"><li>• PostScript Printer Description files (PPDs) — use with the Apple PostScript drivers that come with the Mac OS</li><li>• The HP Printer Utility — change device settings, view status, and set up printer-event notification from a Mac. This utility is supported for Mac OS X V10.2 and later.</li></ul>

# Network configuration

You might need to configure certain network parameters on the device. You can configure these parameters in the following locations:

- Installation software
- Device control panel
- Embedded Web server
- Management software (HP Web Jetadmin or HP LaserJet Utility for Macintosh)



---

**NOTE** For more information about using the embedded Web server, see [Embedded Web server on page 36](#)

---

For more information on supported networks and network configuration tools, see the *HP Jetdirect Print Server Administrator's Guide*. The guide comes with printers in which an HP Jetdirect print server is installed.

This section contains the following information about configuring network parameters:

- [Configure TCP/IPv4 parameters](#)
- [Configure TCP/IPv6 parameters](#)
- [Disable network protocols \(optional\)](#)
- [HP Jetdirect EIO print servers](#)

## Configure TCP/IPv4 parameters

If your network doesn't provide automatic IP addressing through DHCP, BOOTP, RARP, or another method, you might need to enter the following parameters manually before you can print over the network:

- IP address (4 bytes)
- Subnet mask (4 bytes)
- Default gateway (4 bytes)

## Change the IP address

You can view the current IP address of the device from the control-panel Home screen by touching [Network Address](#).

Use the following procedure to change the IP address manually.

1. Scroll to and touch [Administration](#).
2. Scroll to and touch [Initial Setup](#).
3. Touch [Networking and I/O](#).
4. Touch [Embedded Jetdirect](#).
5. Touch [TCP/IP](#).



6. Touch **IPV4 Settings**.
7. Touch **Config Method**.
8. Touch **Manual**.
9. Touch **Save**.
10. Touch **Manual Settings**.
11. Touch **IP Address**.
12. Touch the IP Address text box.
13. Use the touchscreen keypad to type the IP address.
14. Touch **OK**.
15. Touch **Save**.

### **Set the subnet mask**

1. Scroll to and touch **Administration**.
2. Scroll to and touch **Initial Setup**.
3. Touch **Networking and I/O**.
4. Touch **Embedded Jetdirect**.
5. Touch **TCP/IP**.
6. Touch **IPV4 Settings**.
7. Touch **Config Method**.
8. Touch **Manual**.
9. Touch **Save**.
10. Touch **Manual Settings**.
11. Touch **Subnet Mask**.
12. Touch the Subnet Mask text box.
13. Use the touchscreen keypad to type the subnet mask.
14. Touch **OK**.
15. Touch **Save**.

### **Set the default gateway**

1. Scroll to and touch **Administration**.
2. Scroll to and touch **Initial Setup**.
3. Touch **Networking and I/O**.

4. Touch **Embedded Jetdirect**.
5. Touch **TCP/IP**.
6. Touch **IPV4 Settings**.
7. Touch **Config Method**.
8. Touch **Manual**.
9. Touch **Save**.
10. Touch **Manual Settings**.
11. Touch **Default Gateway**.
12. Touch the **Default Gateway** text box.
13. Use the touchscreen keyboard to type the default gateway.
14. Touch **OK**.
15. Touch **Save**.

## Configure TCP/IPv6 parameters

For information about configuring the device for a TCP/IPv6 network, see the *HP Jetdirect Print Server Administrator's Guide*.

## Disable network protocols (optional)

By factory default, all supported network protocols are enabled. Disabling unused protocols has the following benefits:

- It decreases device-generated network traffic.
- It prevents unauthorized users from printing to the device.
- It provides only pertinent information on the configuration page.
- It allows the device control panel to display protocol-specific error and warning messages.

## Disable IPX/SPX



---

**NOTE** Do not disable this protocol in Windows-based systems that print to the printer through IPX/SPX.

---

1. Scroll to and touch **Administration**.
2. Scroll to and touch **Initial Setup**.
3. Touch **Networking and I/O**.
4. Touch **Embedded Jetdirect**.
5. Touch **IPX/SPX**.
6. Touch **Enable**.

7. Touch **Off**.
8. Touch **Save**.

## Disable AppleTalk

1. Scroll to and touch **Administration**.
2. Scroll to and touch **Initial Setup**.
3. Touch **Networking and I/O**.
4. Touch **Embedded Jetdirect**.
5. Touch **AppleTalk**.
6. Touch **Enable**.
7. Touch **Off**.
8. Touch **Save**.

## Disable DLC/LLC

1. Scroll to and touch **Administration**.
2. Scroll to and touch **Initial Setup**.
3. Touch **Networking and I/O**.
4. Touch **Embedded Jetdirect**.
5. Touch **DLC/LLC**.
6. Touch **Enable**.
7. Touch **Off**.
8. Touch **Save**.

## HP Jetdirect EIO print servers

HP Jetdirect print servers (network cards) can be installed in the EIO slot. Supported networking features depend on the print server model. For available HP Jetdirect EIO print server models, go to <http://www.hp.com/go/jetdirect>.



---

**NOTE** Configure the card through the control panel, the printer installation software, or HP Web Jetadmin. Refer to the HP Jetdirect print server documentation for more information.

---

## Security features

Several important security features are available for the MFP. Use the information in this section to configure these features to meet the customer's needs.

### Securing the embedded Web server

You can assign a password for access to the embedded Web server so that unauthorized users cannot change the MFP settings.

1. Open the embedded Web server.
2. Click the **Settings** tab.
3. On the left side of the window, click **Security**.
4. Type the password next to **New Password**, and type it again next to **Verify Password**.
5. Click **Apply**. Make note of the password, and store it in a safe place.

### Foreign Interface Harness (FIH)

The Foreign Interface Harness (FIH) provides a portal on the MFP. By using the FIH and third-party equipment, you can track information about copies that are made on the MFP.

#### Requirements

- Windows 9X, Windows Me, Windows NT® 4.0, Windows 2000, or Windows XP
- Access to third-party accounting hardware solutions, such as Equitrac or Copitrac devices

#### Using the FIH

To use the FIH, you must download and install the FIH software. The software is available from [http://www.hp.com/go/ljm4345mfp\\_software](http://www.hp.com/go/ljm4345mfp_software). The software is used to enable or disable the FIH portal. Use the software to set and change the administrator personal identification number (PIN).

Administrators can use the PIN option to configure the FIH to prevent any unauthorized changes. Changes can be made only with the correct PIN authentication.



---

**NOTE** It is important to remember the PIN that is assigned to the FIH administration software. The PIN is required to make any changes to the FIH.

---

#### Enable the FIH portal

1. Double-click the FIH.EXE file. The **Foreign Interface Harness** dialog box appears.
2. Click **OK**.
3. Click **Enable**.
4. If you have not entered a PIN before, click **No**. If you have entered a PIN before, click **Yes**. If you click **No**, type and confirm the PIN, and then click **OK**. If you click **Yes**, type the PIN and click **OK**.



---

**NOTE** The PIN must be numeric.

---

5. Click the appropriate button for the type of connection: **Direct** or **Network**. If you select **Direct**, type the MFP port. If you select **Network**, type the IP address and port for the MFP.



---

**NOTE** The IP address for the MFP can be found on the Configuration page. You can print a Configuration page from the control panel by touching **Menu**, touching **INFORMATION**, and then touching **PRINT CONFIGURATION**.

---

If you typed an incorrect IP address, you will receive an error message. Otherwise, the portal is enabled.

### Disable the FIH portal

1. Double-click the FIH.EXE file. The **Foreign Interface Harness** dialog box appears.
2. Click **OK**.
3. Click **Disable**.
4. Type the PIN and click **OK**.
5. Click the appropriate button for the type of connection: **Direct** or **Network**. If you selected **Direct**, type the MFP port and click **OK**. If you selected **Network**, type the IP address and port for the MFP, and then click **OK**. The portal is disabled.



---

**NOTE** If you lose the PIN number and the portal needs to be disabled, try using the default PIN that is listed to disable it. For assistance, use the HP Instant Support service, which is available through the embedded Web server or at <http://instantsupport.hp.com>.

---

## Secure Disk Erase

You might need to protect deleted data from unauthorized access on the MFP hard drive. Secure Disk Erase is a security feature that you can use to securely erase print and copy jobs from the hard drive.

Secure Disk Erase offers the following levels of disk security:

- **Non-Secure Fast Erase.** This is a simple file-table erase function. Access to the file is removed, but actual data is retained on the disk until it is overwritten by subsequent data-storage operations. This is the fastest mode. Non-Secure Fast Erase is the default erase mode.
- **Secure Fast Erase.** Access to the file is removed, and the data is overwritten with a fixed identical character pattern. This is slower than Non-Secure Fast Erase, but all data is overwritten. Secure Fast Erase meets the U.S. Department of Defense 5220-22.M requirements for the clearing of disk media.
- **Secure Sanitizing Erase.** This level is similar to the Secure Fast Erase mode. In addition, data is repetitively overwritten by using an algorithm that prevents any residual data persistence. This mode will impact performance. Secure Sanitizing Erase meets the U.S. Department of Defense 5220-22.M requirements for the sanitization of disk media.

## Data affected

Data affected (covered) by the Secure Disk Erase feature includes stored jobs, proof and hold jobs, disk-based fonts, disk-based macros (forms), and temporary files that are created during the print and copying process.



---

**NOTE** Stored jobs will be securely overwritten only when they have been deleted through the **RETRIEVE JOB** menu on the MFP after the appropriate erase mode has been set.

---

This feature will not impact data that is stored on flash-based product non-volatile RAM (NVRAM) that is used to store default settings, page counts, and similar data. This feature does not affect data that is stored on a system RAM disk (if one is used). This feature does not impact data that is stored on the flash-based system boot RAM.

Changing the Secure Disk Erase mode does not overwrite previous data on the disk, nor does it immediately perform a full-disk sanitization. Changing the Secure Disk Erase mode changes how the MFP cleans up temporary data for jobs after the erase mode has been changed.

## Gaining access to Secure Disk Erase

Use HP Web Jetadmin to gain access to and set the Secure Disk Erase feature.

## Additional Information

For additional information about the HP Secure Disk Erase feature, see the HP support flyer or go to <http://www.hp.com/go/webjetadmin/>.

## Job-storage features

Several job-storage features are available for this MFP. These features include printing private jobs, storing print jobs, quick-copying jobs, and proofing and holding jobs.

## HP DSS authentication

Optional HP Digital Sending Software (HP DSS) for the MFP is available for purchase separately. The software provides an advanced sending program that contains an authentication process. This process requires users to type a user identification and a password before they can use any of the HP DSS features that require authentication.

## Locking the control-panel menus

To prevent someone from changing MFP configuration, you can lock the control-panel menus. This prevents unauthorized users from changing the configuration settings such as the SMTP server. The following procedure describes how to restrict access to the control-panel menus by using the HP Web Jetadmin software.

1. Open the HP Web Jetadmin program.
2. Open the **DEVICE MANAGEMENT** folder in the drop-down list in the **Navigation** panel. Navigate to the **DEVICE LISTS** folder.
3. Select the MFP.
4. In the **Device Tools** drop-down list, select **Configure**.

5. Select **Security** from the **Configuration Categories** list.
6. Type a **Device Password**.
7. In the **Control Panel Access** section, select **Maximum Lock**. This prevents unauthorized users from gaining access to configuration settings.

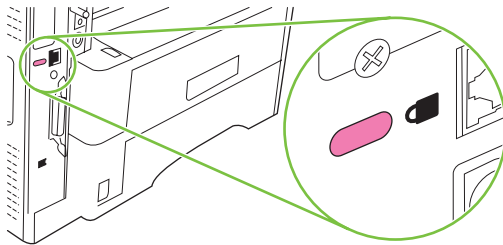
## Locking the formatter cage

You can place a Kensington lock on the formatter cage to prevent unauthorized access to components on the formatter.



**NOTE** A Kensington lock is typically used for locking laptop computers in order to prevent theft.

The following figure indicates where you should place the lock.







# 3 Manage and maintain the device

This chapter describes how to manage the printer:

- [Control-panel menus](#)
- [Use information pages](#)
- [Configure e-mail alerts](#)
- [HP Easy Printer Care software](#)
- [Use the embedded Web server](#)
- [Use HP Web Jetadmin software](#)
- [Use the HP Printer Utility for Macintosh](#)
- [Manage supplies](#)
- [Clean the device](#)
- [Set the real-time clock](#)
- [Upgrading the firmware](#)
- [Calibrate the scanner](#)
- [Calibrate the control panel](#)
- [Disable Embedded Jetdirect I/O](#)
- [Select the MFP language](#)

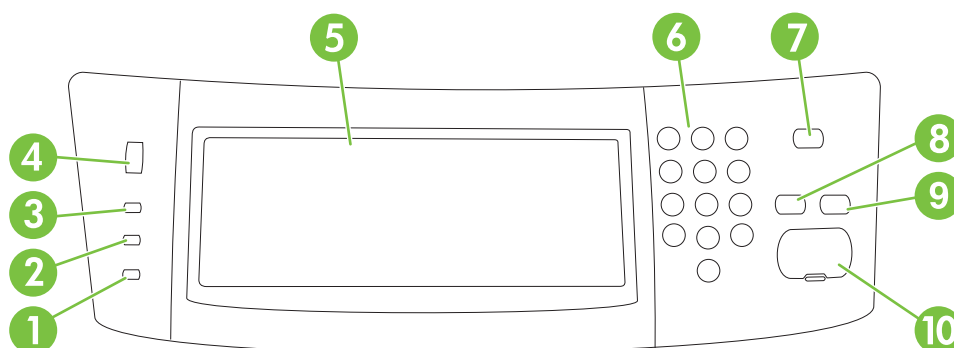
# Control-panel menus

## Use the control panel

The control panel has a VGA touchscreen that provides access to all device functions. Use the buttons and numeric keypad to control jobs and the device status. The LEDs indicate overall device status.

## Control-panel layout

The control panel includes a touchscreen graphical display, job-control buttons, a numeric keypad, and three light-emitting diode (LED) status lights.



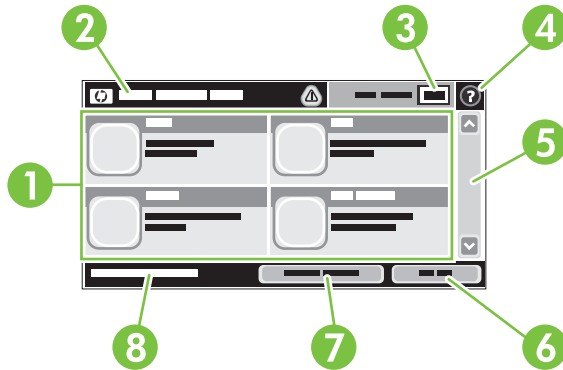
1	<b>Attention</b> light	The <b>Attention</b> light indicates that the device has a condition that requires intervention. Examples include an empty paper tray or an error message on the touchscreen.
2	<b>Data</b> light	The <b>Data</b> light indicates that the device is receiving data.
3	<b>Ready</b> light	The <b>Ready</b> light indicates that the device is ready to begin processing any job.
4	Brightness-adjustment dial	Turn the dial to control the brightness of the touchscreen.
5	Touchscreen graphical display	Use the touchscreen to open and set up all device functions.
6	Numeric keypad	Allows you to type numeric values for number of copies required and other numeric values.
7	<b>Sleep</b> button	If the device is inactive for a long period of time, it automatically enters a sleep mode. To place the device into sleep mode or to reactivate the device, press the <b>Sleep</b> button.
8	<b>Reset</b> button	Resets the job settings to factory or user-defined default values.
9	<b>Stop</b> button	Stops the active job. While stopped, the control panel shows the options for the stopped job (for example, if you press the Stop button while the device is processing a print job, the control panel message prompts you to cancel or resume the print job).
10	<b>Start</b> button	Begins a copy job, starts digital sending, or continues a job that has been interrupted.

## Home screen

The home screen provides access to the device features, and it indicates the current status of the device.



**NOTE** Depending on how the system administrator has configured the device, the features that appear on the home screen can vary.









1	Features	Depending on how the system administrator has configured the device, the features that appear in this area can include any of the following items: <ul style="list-style-type: none"> <li>• Copy</li> <li>• Fax</li> <li>• E-mail</li> <li>• Secondary E-mail</li> <li>• Network Folder</li> <li>• Job Storage</li> <li>• Workflow</li> <li>• Supplies Status</li> <li>• Administration</li> </ul>
2	Device status line	The status line provides information about the overall device status. Various buttons appear in this area, depending on the current status. For a description of each button that can appear in the status line, see <a href="#">Buttons on the touchscreen on page 50</a> .
3	Copy count	The copy count box indicates the number of copies that the device is set to make.
4	Help button	Touch the Help button to open the embedded help system.
5	Scroll bar	Touch the up or down arrows on the scroll bar to see the complete list of available features.
6	Sign Out	Touch <b>Sign Out</b> to sign out of the device if you have signed in for access to restricted features. After you sign out, the device restores all options to the default settings.
7	Network Address	Touch <b>Network Address</b> to find information about the network connection.
8	Date and time	The current date and time appear here. The system administrator can select the format that the device uses to show the date and time, for example 12-hour format or 24-hour format.

## Buttons on the touchscreen

The status line on the touchscreen provides information about the status of the device. Various buttons can appear in this area. The following table describes each button.

---

	<b>Home button.</b> Touch the home button to go to the Home screen from any other screen.
	<b>Start button.</b> Touch the Start button to begin the action for the feature that you are using.
	<b>Stop button.</b> If the device is processing a print or fax job, the Stop button appears instead of the Start button. Touch the Stop button to halt the current job. The device prompts you to cancel the job or to resume it.
	<b>Error button.</b> The error button appears whenever the device has an error that requires attention before it can continue. Touch the error button to see a message that describes the error. The message also has instructions for solving the problem.
	<b>Warning button.</b> The warning button appears when the device has a problem but can continue functioning. Touch the warning button to see a message that describes the problem. The message also has instructions for solving the problem.
	<b>Help button.</b> Touch the help button to open the built-in online Help system. For more information, see <a href="#">Control-panel help system on page 50</a> .

---

## Control-panel help system

The device has a built-in Help system that explains how to use each screen. To open the Help system, touch the Help button (❓) in the upper-right corner of the screen.

For some screens, the Help opens to a global menu where you can search for specific topics. You can browse through the menu structure by touching the buttons in the menu.

For screens that contain settings for individual jobs, the Help opens to a topic that explains the options for that screen.

If the device alerts you of an error or warning, touch the error (❗) or warning (⚠️) button to open a message that describes the problem. The message also contains instructions to help solve the problem.

## Navigate the Administration menu

From the Home screen, touch **Administration** to open the menu structure. You might need to scroll to the bottom of the Home screen to see this feature.

The Administration menu has several sub-menus, which are listed on the left side of the screen. Touch the name of a menu to expand the structure. A plus sign (+) next to a menu name means that it contains sub-menus. Continue opening the structure until you reach the option that you want to configure. To return to the previous level, touch **Back**.

To exit the Administration menu, touch the Home button (🏠) in the upper-left corner of the screen.

The device has built-in Help that explains each of the features that are available through the menus. Help is available for many menus on the right-hand side of the touchscreen. Or, to open the global Help system, touch the Help button (❓) in the upper-right corner of the screen.

The tables in the sections that follow indicate the overall structure of each menu.

## Information menu

Use this menu to print information pages and reports that are stored internally on the device.

**Table 3-1** Information menu

Menu item	Sub-menu item	Sub-menu item	Values	Description
Configuration/Status Pages	Administration Menu Map		Print (button)	Shows the basic structure of the Administration menu and current administration settings.
	Configuration Page		Print (button)	A set of configuration pages that show the current device settings.
	Supplies Status Page		Print (button)	Shows the status of supplies such as cartridges, maintenance kits, and staples.
	Usage Page		Print (button)	Shows information about the number of pages that have been printed on each paper type and size.
	File Directory		Print (button)	A directory page that contains information for any mass-storage devices, such as flash drives, memory cards, or hard disks, that are installed in this device.

**Table 3-1** Information menu (continued)

Menu item	Sub-menu item	Sub-menu item	Values	Description
Fax Reports	Fax Activity Log		Print (button)	Contains a list of the faxes that have been sent from or received by this device.
	Fax Call Report	Fax Call Report	Print (button)	A detailed report of the last fax operation, either sent or received.
		Thumbnail on Report	Yes No (default)	Choose whether or not to include a thumbnail of the first page of the fax on the report.
		When to Print Report	Never auto print After Any Fax Job After Fax Send Jobs After Any Fax Error After Send Errors Only After Receive Errors Only	
		Billing Codes Report	Print	A list of billing codes that have been used for outgoing faxes. This report shows how many sent faxes were billed to each code.
		Blocked Fax List	Print	A list of phone numbers that are blocked from sending faxes to this device.
		Speed Dial List	Print	Shows the speed dials that have been set up for this device.
Sample Pages/Fonts	PCL Font List		Print	A list of printer control language (PCL) fonts that are currently available on the device.
	PS Font List		Print	A list of PostScript (PS) fonts that are currently available on the device.

## Default Job Options menu

Use this menu to define the default job options for each function. If the user does not specify the job options when creating the job, the default options are used.

- Default Options for Originals
- Default Copy Options
- Default Fax Options
- Default E-mail Options (for outgoing e-mail)
- Default Send To Folder Options (for scans to the computer)
- Default Print Options (for jobs sent from a computer)

## Default Options for Originals

**Table 3-2** Default Options for Originals menu

Menu item	Values	Description
Paper Size	Select a paper size from the list.	Select the paper size that is most often used for copy or scan originals.
Number of Sides	1 2	Select whether copy or scan originals are most often single-sided or double-sided.
Orientation	Portrait Landscape	Select the orientation that is most often used for copy or scan originals. Select <b>Portrait</b> if the short edge is at the top or select <b>Landscape</b> if the long edge is at the top.
Optimize Text/Picture	Manually Adjust Text Photograph	Use this setting to optimize the output for a particular type of original: text, pictures, or a mixture of both. Select <b>Manually Adjust</b> to specify the mix of text and pictures.
Darkness	Select a value.	
Background Cleanup	Adjust the value within the range.	Increase the <b>Background Cleanup</b> setting to remove faint images from the background or to remove light background color.
Sharpness	Adjust the value within the range.	Increase the <b>Sharpness</b> setting to clarify or soften the image.

## Default Copy Options

**Table 3-3** Default Copy Options menu

Menu item	Sub-menu item	Values	Description
Number of Copies		Type the number of copies. The factory default setting is 1.	Set the default number of copies for a copy job.
Number of Sides		1 2	Set the default number of sides for copies.
Staple/Collate	Staple	None (default) One left angled	Set up options for stapling and collating sets of copies.
	Collate	Off On (default)	If collation is selected, the device prints a complete copy before starting on the next copy. If collation is not selected, the device prints the first page 1 of all copies, then the second page, and so on.
Edge-To-Edge		Normal (recommended) (default) Edge-To-Edge Output	If the original document is printed close to the edges, use the <b>Edge-To-Edge</b> feature to avoid shadows that can appear along the edges. Combine this feature with the <b>Reduce/Enlarge</b> feature to ensure that the entire page is printed on the copies.



## Default Fax Options

**Table 3-4** Fax Send menu

Menu item	Sub-menu item	Values	Description
Resolution		Standard (100x200dpi) (default)	Set the resolution for sent documents. Higher resolution images have more dots per inch (dpi), so they show more detail. Lower resolution images have fewer dots per inch and show less detail, but the file size is smaller.
		Fine (200x200dpi)	
		Superfine (300x300dpi)	
Fax Header		Prepend	Select the position of the fax header on the page.
		Overlay	Select <b>Prepend</b> to print the fax header above the fax content and move the fax content down on the page. Select <b>Overlay</b> to print the fax header over the top of the fax content without moving the fax content down. Using this option could prevent a single-page fax from flowing onto another page.

**Table 3-5** Fax Receive menu

Menu item	Values	Description
Forward Fax	Fax Forwarding	To forward received faxes to another fax device, select <b>Fax Forwarding</b> and <b>Custom</b> . Type the number of the other fax device into the Fax Forwarding Number field. Set up a PIN to type every time you use this menu. This is the same PIN that is used to access the Fax Printing menu.
	Change PIN	
Stamp Received Faxes	Enabled	Add the date, time, sender's phone number, and page number to each page of the received.
	Disabled (default)	
Fit to Page	Enabled	Use this feature to shrink faxes that are larger than letter-size or A4-size so that they can fit onto a page of that size. If this feature set to <b>Disabled</b> , faxes larger than letter or A4 flow across multiple pages.
	Disabled	
Fax Paper Tray	Select from the list of trays.	Select the tray that holds the size and type of paper that you want to use for incoming faxes.

## Default E-mail Options

Use this menu to set default options for e-mails that are sent from the device.

Menu item	Values	Description
Document File Type	PDF (default) JPEG TIFF M-TIFF	Select the file format for the e-mail.
Output Quality	High (large file) Medium (default) Low (small file)	Selecting higher quality for output increases the size of the output file.
Resolution	75 DPI 150 DPI (default) 200 DPI 300 DPI	Select the resolution. Use a lower setting to create smaller files.
Color/Black	Color scan (default) Black/white scan	Specify whether the e-mail will be in black or in color.
TIFF Version	TIFF 6.0 (default) TIFF (Post 6.0)	Use this feature to specify the TIFF version to use when saving scanned files.

## Default Send to Folder Options

Menu item	Values	Description
Color/Black	Color scan	Specify whether the file will be in black or in color.
	Black/white scan (default)	
Document File Type	PDF (default)	Select the file format for the file.
	M-TIFF	
	TIFF	
	JPEG	
TIFF version	TIFF 6.0 (default)	Specify the TIFF version to use when saving scanned files.
	TIFF (post 6.0)	
Output Quality	High (large file)	Choosing higher quality for output increases the size of the output file.
	Medium (default)	
	Low (small file)	
Resolution	75 DPI	Use this feature to select the resolution. Use a lower setting to create smaller files.
	150 DPI (default)	
	200 DPI	
	300 DPI	
	400 DPI	
	600 DPI	

## Default Print Options

**Table 3-6** Default Print Options menu

Menu item	Sub-menu item	Values	Description
Copies Per Job		Type a value.	Use this feature to set the default number of copies for print jobs.
Default Paper Size		(List of supported sizes.)	Choose a paper size.
Default Custom Paper Size	Unit of measure	Millimeters	Configure the default paper size that is used when the user selects <b>Custom</b> as the paper size for a print job.
		Inches	
	X Dimension	Configure the width measurement for the <b>Default Custom Paper Size</b> .	
	Y Dimension	Configure the height measurement for the <b>Default Custom Paper Size</b> .	
Print Sides		1-sided	Use this feature to select whether print jobs should be single-sided or double-sided by default.
		2-sided	
2-Sided Format		Book style	Use this feature to configure the default style for 2-sided print jobs. If <b>Book style</b> is selected, the back side of the page is printed the right way up. This option is for print jobs that are bound along the left edge. If <b>Flip style</b> is selected, the back side of the page is printed upside-down. This option is for print jobs that are bound along the top edge.
		Flip style	

## Time/Scheduling menu

Use this menu to set options for setting the time and for setting the device to enter and exit sleep mode.



**NOTE** Values shown with "(default)" are the factory-default values. Some menu items have no default.

**Table 3-7** Time/Scheduling menu

Menu item	Sub-menu item	Sub-menu item	Values	Description	
Date/Time	Date Format		YYYY/MMM/DD (default)	Use this feature to set the current date and time, and to set the date format and time format that are used to time-stamp outgoing faxes.	
			MMM/DD/YYYY		
			DD/MMM/YYYY		
	Date	Month			
		Day			
		Year			
	Time Format		12 hour (AM/PM) (default)		
			24 hour		
	Time	Hour			
Minute					
AM					
	PM				
Sleep Delay			1 minute	Use this feature to select the time interval that the device should remain inactive before entering Sleep Mode.	
			20 minutes		
			30 minutes (default)		
			45 minutes		
			1 hour (60 minutes)		
Fax Printing	Fax Printing Mode		Store all received faxes	If you have concerns about the security of private faxes, use this feature to store faxes rather than having them automatically print by creating a printing schedule.	
			Print all received faxes		
			Use Fax Printing Schedule		For the fax printing schedule, the control panel prompts you to select days and times to print faxes.
	Change PIN			Select <b>Change PIN</b> to change the PIN number that users must provide to print faxes.	

## Management menu

Use this menu to set up global device-management options.



**NOTE** Values shown with "(default)" are the factory-default values. Some menu items have no default.

**Table 3-8** Management menu

Menu item	Sub-menu item	Values	Description
Stored Job Management	Quick Copy Job Storage Limit	Select the maximum number of jobs to store	Use this menu to view and manage any jobs that are stored on the device.
	Quick Copy Job Held Timeout	1 Hour	
		4 Hours	
		1 Day	
1 Week			
Sleep mode		Disable	Use this feature to customize the sleep mode settings for this device.
		Use Sleep Delay (default)	Select <b>Use Sleep Delay</b> to set the device to enter sleep mode after the delay that is specified in the <b>Time/Scheduling</b> menu.
Manage Supplies	Supply Low/Order Threshold	Select a value in the range.	Use this menu to carry out administrative supply management tasks such as changing the threshold when supplies should be ordered.
	Replace Black Cartridge	Stop at low	
		Stop at out	
		Override at out (default)	

## Initial Setup menu

The **Initial Setup** menu contains the sub-menus shown:

- **Networking and I/O** menu
- **Fax Setup** menu
- **E-mail Setup** menu
- **Send Setup** menu




**NOTE** Values shown with "(default)" are the factory-default values. Some menu items have no default.

## Networking and I/O

**Table 3-9** Networking and I/O

Menu item	Sub-menu item	Values	Description
I/O Timeout		Select a value in the range. The factory default setting is 15 seconds.	I/O timeout refers to the elapsed time before a print job fails. If the stream of data that the device receives for a print job gets interrupted, this setting indicates how long the device will wait before it reports that the job has failed.

**Table 3-9** Networking and I/O (continued)

Menu item	Sub-menu item	Values	Description
Parallel Input	High Speed	No	Use the <b>High Speed</b> setting to configure the speed that the parallel port uses to communicate with the host.
		Yes (default)	
 <b>NOTE</b> This item appears only if an EIO accessory is installed.	Advanced Functions	Enabled (default)	Use the <b>Advanced Functions</b> setting to enable or disable bidirectional parallel communication.
		Disabled	
Embedded Jetdirect	See <a href="#">Table 3-10 Jetdirect menus on page 61</a> for the list of options.		
EIO <X> Jetdirect			

**Table 3-10** Jetdirect menus

Menu item	Sub-menu item	Sub-menu item	Values and Description
TCP/IP	Enable		Off: Disable the TCP/IP protocol.
			On (default): Enable the TCP/IP protocol.
	Host Name		An alphanumeric string, up to 32 characters, used to identify the device. This name is listed on the HP Jetdirect configuration page. The default host name is NP1xxxxxx, where xxxxxx is the last six digits of the LAN hardware (MAC) address.
	IPv4 Settings	Config Method	Specifies the method that TCP/IPv4 parameters will be configured on the HP Jetdirect print server.  <b>Bootp:</b> Use BootP (Bootstrap Protocol) for automatic configuration from a BootP server.  <b>DHCP:</b> Use DHCP (Dynamic Host Configuration Protocol) for automatic configuration from a DHCPv4 server. If selected and a DHCP lease exists, <b>DHCP Release</b> and <b>DHCP Renew</b> menus are available to set DHCP lease options.  <b>Auto IP:</b> Use automatic link-local IPv4 addressing. An address in the form 169.254.x.x is assigned automatically.  <b>Manual:</b> Use the <b>Manual Settings</b> menu to configure TCP/IPv4 parameters.
		DHCP Release	This menu appears if <b>Config Method</b> was set to <b>DHCP</b> and a DHCP lease for the print server exists.  <b>No</b> (default): The current DHCP lease is saved.  <b>Yes:</b> The current DHCP lease and the leased IP address are released.
		DHCP Renew	This menu appears if <b>Config Method</b> was set to <b>DHCP</b> and a DHCP lease for the print server exists.  <b>No</b> (default): The print server does not request to renew the DHCP lease.  <b>Yes:</b> The print server requests to renew the current DHCP lease.

**Table 3-10** Jetdirect menus (continued)


Menu item	Sub-menu item	Sub-menu item	Values and Description
		Manual Settings	<p>(Available only if <b>Config Method</b> is set to <b>Manual</b>) Configure parameters directly from the printer control panel:</p> <p><b>IP Address:</b> The unique IP address of the printer (n.n.n.n), where n is a value from 0 to 255.</p> <p><b>Subnet Mask:</b> The subnet mask for the printer (m.m.m.m), where m is a value from 0 to 255.</p> <p><b>Syslog Server:</b> The IP address of the syslog server used to receive and log syslog messages.</p> <p><b>Default Gateway:</b> The IP address of the gateway or router used for communications with other networks.</p> <p><b>Idle Timeout:</b> The time period, in seconds, after which an idle TCP print data connection is closed (default is 270 seconds, 0 disables the timeout).</p>
		Default IP	<p>Specify the IP address to default to when the print server is unable to obtain an IP address from the network during a forced TCP/IP reconfiguration (for example, when manually configured to use BootP or DHCP).</p> <p><b>Auto IP:</b> A link-local IP address 169.254.x.x is set.</p> <p><b>Legacy:</b> The address 192.0.0.192 is set, consistent with older HP Jetdirect devices.</p>
		Primary DNS	Specify the IP address (n.n.n.n) of a Primary DNS Server.
		Secondary DNS	Specify the IP address (n.n.n.n) of a Secondary Domain Name System (DNS) Server.
	IPV6 Settings	Enable	<p>Use this item to enable or disable IPv6 operation on the print server.</p> <p><b>Off</b> (default): IPv6 is disabled.</p> <p><b>On:</b> IPv6 is enabled.</p>
		Address	<p>Use this item to manually configure an IPv6 address.</p> <p><b>Manual Settings:</b> Use the <b>Manual Settings</b> menu to enable and manually configure a TCP/ IPv6 address.</p>
		DHCPV6 Policy	<p><b>Router Specified:</b> The stateful auto-configuration method to be used by the print server is determined by a router. The router specifies whether the print server obtains its address, its configuration information, or both from a DHCPv6 server.</p> <p><b>Router Unavailable:</b> If a router is not available, the print server should attempt to obtain its stateful configuration from a DHCPv6 server.</p> <p><b>Always:</b> Whether or not a router is available, the print server always attempts to obtain its stateful configuration from a DHCPv6 server.</p>
		Primary DNS	Use this item to specify an IPv6 address for a primary DNS server that the print server should use.



**Table 3-10** Jetdirect menus (continued)

Menu item	Sub-menu item	Sub-menu item	Values and Description
		Manual Settings	<p>Use this item to manually set IPv6 addresses on the print server.</p> <p><b>Enable:</b> Select this item and choose <b>On</b> to enable manual configuration, or <b>Off</b> to disable manual configuration.</p> <p><b>Address:</b> Use this item to type a 32 hexadecimal digit IPv6 node address that uses the colon hexadecimal syntax.</p>
	Proxy Server		<p>Specifies the proxy server to be used by embedded applications in the device. A proxy server is typically used by network clients for Internet access. It caches Web pages, and provides a degree of Internet security, for those clients.</p> <p>To specify a proxy server, enter its IPv4 address or fully-qualified domain name. The name can be up to 255 octets.</p> <p>For some networks, you may need to contact your Independent Service Provider (ISP) for the proxy server address.</p>
	Proxy Port		<p>Type the port number used by the proxy server for client support. The port number identifies the port reserved for proxy activity on your network, and can be a value from 0 to 65535.</p>
IPX/SPX	Enable		<p><b>Off:</b> Disable the IPX/SPX protocol.</p> <p><b>On (default):</b> Enable the IPX/SPX protocol.</p>
	Frame Type		<p>Selects the frame-type setting for your network.</p> <p><b>Auto:</b> Automatically sets and limits the frame type to the first one detected.</p> <p><b>EN_8023, EN_II, EN_8022, and EN_SNAP:</b> Frame-type selections for Ethernet networks.</p>
AppleTalk	Enable		<p><b>Off (default):</b> Disable the AppleTalk protocol.</p> <p><b>On:</b> Enable the AppleTalk protocol.</p>
DLC/LLC	Enable		<p><b>Off (default):</b> Disable the DLC/LLC protocol.</p> <p><b>On:</b> Enable the DLC/LLC protocol.</p>


**Table 3-10** Jetdirect menus (continued)

Menu item	Sub-menu item	Sub-menu item	Values and Description
Security	Print Sec Page		<p><b>Yes:</b> Prints a page that contains the current security settings on the HP Jetdirect print server.</p> <p><b>No (default):</b> A security settings page is not printed.</p>
		Secure Web	<p>For configuration management, specify whether the embedded Web server will accept communications using HTTPS (Secure HTTP) only, or both HTTP and HTTPS.</p> <p><b>HTTPS Required:</b> For secure, encrypted communications, only HTTPS access is accepted. The print server will appear as a secure site.</p> <p><b>HTTP/HTTPS optional:</b> Access using either HTTP or HTTPS is permitted.</p>
		IPsec or Firewall	<p>Specify the IPsec or Firewall status on the print server.</p> <p><b>Keep:</b> IPsec/Firewall status remains the same as currently configured.</p> <p><b>Disable:</b> IPsec/Firewall operation on the print server is disabled.</p>
		Reset Security	<p>Specify whether the current security settings on the print server will be saved or reset to factory defaults.</p> <p><b>No*:</b> The current security settings are maintained.</p> <p><b>Yes:</b> Security settings are reset to factory defaults.</p>
Diagnostics	Embedded Test		<p>This menu provides tests to help diagnose network hardware or TCP/IP network connection problems.</p> <p>Embedded tests help to identify whether a network fault is internal or external to the device. Use an embedded test to check hardware and communication paths on the print server. After you select and enable a test and set the execution time, you must select <b>Execute</b> to initiate the test.</p> <p>Depending on the execution time, a selected test runs continuously until either the device is turned off, or an error occurs and a diagnostic page is printed.</p>
		LAN HW Test	<p> <b>CAUTION</b> Running this embedded test will erase your TCP/IP configuration.</p> <p>This test performs an internal loopback test. An internal loopback test will send and receive packets only on the internal network hardware. There are no external transmissions on your network.</p> <p>Select <b>Yes</b> to choose this test, or <b>No</b> to not choose it.</p>
		HTTP Test	<p>This test checks operation of HTTP by retrieving predefined pages from the device, and tests the embedded Web server.</p> <p>Select <b>Yes</b> to choose this test, or <b>No</b> to not choose it.</p>

**Table 3-10** Jetdirect menus (continued)

Menu item	Sub-menu item	Sub-menu item	Values and Description
		SNMP Test	This test checks operation of SNMP communications by accessing predefined SNMP objects on the device.  Select <b>Yes</b> to choose this test, or <b>No</b> to not choose it.
		Select All Tests	Use this item to select all available embedded tests.  Select <b>Yes</b> to choose all tests. Select <b>No</b> to select individual tests.
		Data Path Test	This test helps to identify data path and corruption problems on an HP postscript level 3 emulation device. It sends a predefined PS file to the device, However, the test is paperless; the file will not print.  Select <b>Yes</b> to choose this test, or <b>No</b> to not choose it.
		Execution Time [H]	Use this item to specify the length of time (in hours) that an embedded test will be run. You can select a value from 1 to 60 hours. If you select zero (0), the test runs indefinitely until an error occurs or device is turned off.  Data gathered from the HTTP, SNMP, and Data Path tests is printed after the tests have completed.
		Execute	<b>No*</b> : Do not initiate the selected tests.  <b>Yes</b> : Initiate the selected tests.
	Ping Test		This test is used to check network communications. This test sends link-level packets to a remote network host, then waits for an appropriate response. To run a ping test, set the following items:
		Dest Type	Specify whether the target device is an IPv4 or IPv6 node.
		Dest IP	<b>IPV4</b> : Type the IPv4 address.  <b>IPV6</b> : Type the IPv6 address.
		Packet Size	Specify the size of each packet, in bytes, to be sent to the remote host. The minimum is 64 (default) and the maximum is 2048.
		Timeout	Specify the length of time, in seconds, to wait for a response from the remote host. The default is 1 and the maximum is 100.
		Count	Specify the number of ping test packets to send for this test. Select a value from 1 to 100. To configure the test to run continuously, select 0.
		Print Results	If the ping test was not set for continuous operation, you can choose to print the test results. Select <b>Yes</b> to print results. If you select <b>No</b> (default), results are not printed.
		Execute	Specify whether to initiate the ping test. Select <b>Yes</b> to initiate the test, or <b>No</b> to not run the test.

**Table 3-10** Jttdirect menus (continued)

Menu item	Sub-menu item	Sub-menu item	Values and Description
	Ping Results		Use this item to view the ping test status and results using the control panel display. You can select the following items:
		Packets Sent	Shows the number of packets (0 - 65535) sent to the remote host since the most recent test was initiated or completed.
		Packets Received	Shows the number of packets (0 - 65535) received from the remote host since the most recent test was initiated or completed.
		Percent Lost	Shows the percent of ping test packets that were sent with no response from the remote host since the most recent test was initiated or completed.
		RTT Min	Shows the minimum detected roundtrip- time (RTT), from 0 to 4096 milliseconds, for packet transmission and response.
		RTT Max	Shows the maximum detected roundtrip- time (RTT), from 0 to 4096 milliseconds, for packet transmission and response.
		RTT Average	Shows the average round-trip-time (RTT), from 0 to 4096 milliseconds, for packet transmission and response.
		Ping In Progress	Shows whether a ping test is in progress. <b>Yes</b> indicates a test in progress, and <b>No</b> indicates that a test completed or was not run.
		Refresh	When viewing the ping test results, this item updates the ping test data with current results. Select <b>Yes</b> to update the data, or <b>No</b> to maintain the existing data. However, a refresh automatically occurs when the menu times out or you manually return to the main menu.
Link Speed			<p>The link speed and communication mode of the print server must match the network. The available settings depend on the device and installed print server. Select one of the following link configuration settings:</p> <p> <b>CAUTION</b> If you change the link setting, network communications with the print server and network device might be lost.</p> <p><b>Auto</b> (default): The print server uses auto-negotiation to configure itself with the highest link speed and communication mode allowed. If auto-negotiation fails, either 100TX HALF or 10TX HALF is set depending on the detected link speed of the hub/ switch port. (A 1000T half-duplex selection is not supported.)</p> <p><b>10T Half</b>: 10 Mbps, half-duplex operation.</p> <p><b>10T Full</b>: 10 Mbps, Full-duplex operation.</p> <p><b>100TX Half</b>: 100 Mbps, half-duplex operation.</p>

**Table 3-10** Jetdirect menus (continued)

Menu item	Sub-menu item	Sub-menu item	Values and Description
			100TX Full: 100 Mbps, full-duplex operation. 100TX Auto: Limits auto-negotiation to a maximum link speed of 100 Mbps. 1000TX Full: 1000 Mbps, full-duplex operation.
Print Protocols			Use this item to print a page that lists the configuration of the following protocols: IPX/SPX, Novell NetWare, AppleTalk, DLC/LLC.

## Fax Setup

Table 3-11 Fax Setup menu

Menu item	Sub-menu item	Sub-menu item	Values	Description
Required Settings	Location		(Countries/regions listed)	Configure the settings that are legally required for outgoing faxes.
	Date/Time			
	Fax Header Information	Phone Number		
		Company Name		
PC Fax Send			Disabled Enabled (default)	Use this feature to enable or disable PC Fax Send. PC Fax Send enables users to send faxes through the device from their computers if they have the correct driver installed.

**Table 3-11** Fax Setup menu (continued)

Menu item	Sub-menu item	Sub-menu item	Values	Description
Fax Send Settings	Fax Dial Volume		Off	Use this feature to set the volume of the tones that you hear while the device dials the fax number.
			Medium (default)	
			High	
	Error Correction Mode		Enabled (default) Disabled	When Error Correction Mode is enabled and an error occurs during fax transmission, the device sends or receives the error portion again.
	JBIG Compression		Disabled Enabled (default)	The JBIG Compression reduces fax-transmission time, which can result in lower phone charges. However, using JBIG Compression sometimes causes compatibility problems with older fax machines. If this occurs, turn off the JBIG Compression.
	Maximum Baud Rate		Select a value from the list.	Use this feature to set the maximum baud rate for receiving faxes. This can be used as a diagnostic tool for troubleshooting fax problems.
	TCF T.30 Delay Timer		Default (default) Custom	This setting should be left at the default value and only changed when directed by an HP technical support agent. Adjustment procedures associated with this setting are beyond the scope of this guide.
	TCF Extend		Default (default) Custom	This setting should be left at the default value and only changed when directed by an HP technical support agent. Adjustment procedures associated with this setting are beyond the scope of this guide.
	Ring Frequency		Select from a list.	Select the interval between rings for incoming faxes.
	Dialing Mode		Tone (default) Pulse	Select whether the device should use tone or pulse dialing.
	Redial On Busy		The range is between 0 and 9. The factory default is 3 times.	Type the number of times the device should attempt to redial if the line is busy.
	Redial On No Answer		Never (default) Once Twice	Use this feature to specify the number of times the device should attempt to dial if the recipient fax number does not answer.
	Redial Interval		The range is between 1 and 5 minutes. The factory default is 5 minutes.	Use this feature to specify the number of minutes between dialing attempts if the recipient number is busy or not answering.
	Detect Dial Tone		Enabled Disabled (default)	Use this feature to specify whether the device should check for a dial tone before sending a fax.



**NOTE** Twice is available in locations other than the United States and Canada.

**Table 3-11** Fax Setup menu (continued)

Menu item	Sub-menu item	Sub-menu item	Values	Description
	Dialing Prefix		Off (default) Custom	Use this feature to specify a prefix number that must be dialed when sending faxes from the device.
	Billing Codes		Off (default) Custom	When billing codes are enabled, a prompt appears that asks the user to enter the billing code for an outgoing fax.
		Minimum Length		The range is between 1 and 16 digits. The default is 1 digit.
Fax Receive Settings	Rings To Answer		The range varies by location. The factory default is 2 rings.	Use this feature to specify the number of rings that must occur before the fax modem answers.
	Ring Interval		Default (default) Custom	Use this feature to control the time between rings for incoming faxes.
	Ringer Volume		Off Low (default) High	Set the volume for the fax ring-tone.
	Blocked Fax Numbers	Add Blocked Numbers	Type the fax number to add.	Use this feature to add or delete numbers from the blocked fax list. The blocked fax list can contain up to 30 numbers. When the device receives a call from one of the blocked fax numbers, it deletes the incoming fax. It also logs the blocked fax in the activity log along with job-accounting information.
		Remove Blocked Numbers	Select a fax number to remove.	
		Clear All Blocked Numbers	No (default) Yes	



## E-mail Setup

Use this menu to enable the e-mail feature and to configure basic e-mail settings.



**NOTE** To configure advanced e-mail settings, use the embedded Web server. For more information, see [Embedded Web server on page 36](#).

**Table 3-12** E-mail Setup menu

Menu item	Values	Description
Address Validation	On (default) Off	This option enables the device to check e-mail syntax when you type an e-mail address. Valid e-mail addresses require the "@" sign and a ".".
Find Send Gateways		Search the network for SMTP gateways that the device can use to send e-mail.
SMTP Gateway	Enter a value.	Specify the IP address of the SMTP gateway that is used to send e-mail from the device.
Test Send Gateway		Test the configured SMTP gateway to see if it is functional.

## Send Setup menu

**Table 3-13** Send Setup menu

Menu item	Values	Description
Replicate MFP	Enter a value (IP Address).	Copy the local Send settings from one device to another.
Allow Transfer to New DSS		Use this feature to allow the transfer of the device from one HP Digital Sending Software (DSS) server to another.  HP DSS is a software package that handles digital sending tasks such as faxing, e-mail, and sending a scanned document to a network folder.
Allow Use of Digital Send Service		This feature allows you to configure the device for use with an HP Digital Sending Software (DSS) server.



**NOTE** This item appears only for the HP LaserJet M4345 MFP models.



**NOTE** This item appears only for the HP LaserJet M4345 MFP models.

## Device Behavior menu



**NOTE** Values shown with "(default)" are the factory-default values. Some menu items have no default.

**Table 3-14** Device Behavior menu

Menu item	Sub-menu item	Sub-menu item	Values	Description
Language			Select the language from the list.	Use this feature to select a different language for control-panel messages. When you select a new language, the keyboard layout might also change.
Key Press Sound			On (default) Off	Use this feature to specify whether you hear a sound when you touch the screen or press buttons on the control panel.
Inactivity Timeout			Type a value between 10 and 300 seconds. The factory default is 60 seconds.	Use this feature to specify the amount of time that elapses between any activity on the control panel and the device resetting to the default settings.
Warning/Error Behavior	Clearable Warnings		On Job (default)	Use this feature to set the amount of time that a clearable warning appears on the control panel.
		Continuable Events	Auto continue (10 seconds) (default) Touch OK to continue	Use this option to configure the device behavior when the device encounters certain errors.
	Jam Recovery	Auto (default) On Off	Use this feature to configure how the device handles pages that are lost during a jam.	
Stapler/Stacker	Staple		None One	If the optional stapler/stacker is installed, use this feature to set stapling characteristics for the device.
		Staples Out	Continue (default) Stop	

**Table 3-14** Device Behavior menu (continued)

Menu item	Sub-menu item	Sub-menu item	Values	Description	
Tray Behavior	Use Requested Tray		Exclusively (default)	Use this feature to control how the device handles jobs that have specified a specific input tray.	
			First		
	Manually Feed Prompt		Always (default)	Use this feature to indicate whether a prompt should appear when the type or size for a job does not match the specified tray and the device pulls from the multipurpose tray instead.	
			Unless Loaded		
	PS Defer Media		Enabled (default)	Use this feature to choose either the PostScript (PS) or HP paper-handling model.	
			Disabled		
Use Another Tray		Enabled (default)	Use this feature to turn on or off the control-panel prompt to select another tray when the specified tray is empty.		
		Disabled			
Size/Type Prompt			Display	Use this feature to control whether the tray configuration message appears whenever a tray is opened or closed.	
			Do not display (default)		
Duplex Blank Pages			Auto (default)	Use this feature to control how the device handles two-sided jobs (duplexing).	
			Yes		
MBM-3 Configuration	Operation Mode		Function Separator	Use this feature to configure the optional 3-bin mailbox accessory.	
			Mailbox		
			Stacker		
General Copy Behavior	Scan Ahead		Enabled (default)	Use this feature to turn on no-wait scanning. With <b>Scan Ahead</b> enabled, the pages in the original document are scanned to disk and held until the device becomes available.	
			Disabled		
	Auto Print Interrupt		Enabled	When this feature is enabled, copy jobs can interrupt print jobs that are set to print multiple copies.	
			Disabled		
	Copy Interrupt			Enabled	The copy job is inserted into the print queue at the end of one copy of the print job. After the copy job is complete, the device continues printing the remaining copies of the print job.
				Disabled	
Alternative Letterhead Mode			No(default)		
			Yes		

**Table 3-14** Device Behavior menu (continued)

Menu item	Sub-menu item	Sub-menu item	Values	Description
General Print Behavior	Override A4/Letter		No	Use this feature to print on letter-size paper when an A4 job is sent but no A4-size paper is loaded in the device (or to print on A4 paper when a letter-size job is sent but no letter-size paper is loaded). This option will also override A3 with ledger-size paper and ledger with A3-size paper.
			Yes (default)	
	Manual Feed		Enabled Disabled (default)	When this feature is enabled, the user can select manual feed from the control panel as the paper source for a job.
	Courier Font		Regular (default) Dark	Use this feature to select which version of the Courier font you want to use.
	Wide A4		Enabled Disabled (default)	Use this feature to change the printable area of A4-size paper. If you enable this option, eighty 10-pitch characters can be printed on a single line of A4 paper.
	Print PS Errors		Enabled Disabled (default)	Use this feature to select whether a PostScript (PS) error page is printed when the device encounters a PS error.
	Print PDF Errors		Enabled Disabled (default)	Use this feature to select whether a PDF error page is printed when the device encounters a PDF error.
	Personality		Auto (default) PCL PDF PS	Select the printer language that the device should use.  Normally you should not change the language. If you change the setting to a specific language, the device does not automatically switch from one language to another unless specific software commands are sent to the device.

**Table 3-14** Device Behavior menu (continued)

Menu item	Sub-menu item	Sub-menu item	Values	Description
	PCL	Form Length	Type a value between 5 and 128 lines. The factory default is 60 lines.	PCL is a set of printer commands that Hewlett-Packard developed to provide access to printer features.
		Orientation	Portrait (default) Landscape	Select the orientation that is most often used print jobs. Select <b>Portrait</b> if the short edge is at the top or select <b>Landscape</b> if the long edge is at the top.
		Font Source	Select the source from the list.	Use this feature to select the font source for the user-soft default font.
		Font Number	Type the font number. The range is between 0 and 999. The factory default is 0.	Use this feature to specify the font number for the user-soft default font using the source that is specified in the <b>Font Source</b> menu item. The device assigns a number to each font and lists it on the PCL font list (available from the <b>Administration</b> menu).
		Font Pitch	Type a value between 0.44 and 99.99. The factory default is 10.00.	If <b>Font Source</b> and <b>Font Number</b> indicate a contour font, then use this feature to select a default pitch (for a fixed-spaced font).
		Symbol Set	PC-8 (default)  (50 additional symbol sets from which to choose)	Use this feature to select any one of several available symbol sets from the control panel. A symbol set is a unique grouping of all the characters in a font.
		Append CR to LF	No (default) Yes	Use this feature to configure whether a carriage return (CR) is appended to each line feed (LF) encountered in backwards-compatible PCL jobs (pure text, no job control).
		Suppress Blank Pages	No (default) Yes	This option is for users who are generating their own PCL, which could include extra form feeds that would cause blank pages to be printed. When <b>Yes</b> is selected, form feeds are ignored if the page is blank.
		Media Source Mapping	Standard (default) Classic	Use this feature to select and maintain input trays by number when you are not using the device driver, or when the software program has no option for tray selection.

## Print Quality menu



**NOTE** Values shown with "(default)" are the factory-default values. Some menu items have no default.

**Table 3-15** Print Quality menu

Menu item	Sub-menu item	Values	Description
Set Registration	Test Page	Print (button)	Use <a href="#">Set Registration</a> to shift the margin alignment to center the image on the page from top to bottom and from left to right. You can also align the image on the front with the image printed on the back.  Print a test page for setting the registration.
	Source	All trays Tray <X>: <contents> (choose a tray)	Select the source input tray for printing the <a href="#">Set Registration</a> page.
Fuser Modes	<Paper Type>		Configure the fuser mode associated with each media type.
	Restore Modes	Restore (button)	Restore the fuser modes to the default settings.
Optimize	High Transfer	Normal (default)	Optimizes certain parameters for all jobs rather than (or in addition to) optimizing by paper path.
		Increased	
	Line Detail	Off (default) On	
	Restore Optimize		
Resolution		300	Use this feature to select the print resolution.
		600	
		FastRes 1200 (default)	
		ProRes 1200	
REt		Off	Enable Resolution Enhancement technology (REt), which produces print output with smooth angles, curves, and edges. All print resolutions, including FastRes 1200, benefit from REt.
		Light	
		Medium (default)	
		Dark	
Economode		Enabled	When Economode is enabled, the device prints with a reduced amount of toner per page; however, the print quality of the page is slightly reduced.
		Disabled	
Toner Density		Choose from a range of 1 to 5. 3 is the default.	Lighten or darken the print on the page. 1 is the lightest and 5 is the darkest.
Calibration/Cleaning	Auto Cleaning	Enabled Disabled	When auto-cleaning is on, the device prints a cleaning page when the page count reaches the value that is set in <a href="#">Cleaning Interval</a> .
	Process Cleaning Page	Process (button)	Use this feature to create and process a cleaning page for cleaning excess toner off the pressure roller in the fuser. The process takes up to 2.5 minutes.

## Troubleshooting menu



**NOTE** Values shown with "(default)" are the factory-default values. Some menu items have no default.

**Table 3-16** Troubleshooting menu

Menu item	Sub-menu item	Sub-menu item	Values	Description
Event Log			Print (button)	This feature shows the event codes and their corresponding engine cycles on the display, and it allows you to print the full event log.
Calibrate Scanner			Calibrate (button)	Use this feature to compensate for offsets in the scanner imaging system (carriage head) for ADF and flatbed scans.  You might need to calibrate the scanner if it is not capturing the correct sections of scanned documents.
Fax T.30 Trace	Print T.30 Report			Use this feature to print or configure the fax T.30 trace report. T.30 is the standard that specifies handshaking, protocols, and error correction between fax machines.
	When to Print Report		Never auto print	
			Print after any fax job	
			Print after fax send jobs	
			Print after any fax error	
			Print after send errors only	
			Print after receive errors only	
Fax Transmit Signal Loss			A value between 0 and 30.	Use this feature to set loss levels to compensate for phone line signal loss. You should not modify this setting unless requested to do so by an HP service representative because it could cause the fax to stop functioning.
Fax V.34			Normal (default) Off	Use this feature to disable V.34 modulations if several fax failures have occurred or if phone line conditions require it.
Fax Speaker Mode			Normal (default) Diagnostic	This feature can be used by a technician to evaluate and diagnose fax issues by listening to the sounds of fax modulations. The factory default setting is Normal.
Paper Path Sensors				Initiate a test of the paper path sensors.

**Table 3-16** Troubleshooting menu (continued)

Menu item	Sub-menu item	Sub-menu item	Values	Description
Paper Path Test	Test Page		Print (button)	Generate a test page for testing paper handling features. You can define the path that is used for the test in order to test specific paper paths.
		Source	All trays Tray 1 Tray 2  (Additional trays are shown, if applicable.)	Specify whether the test page will be printed from all trays or from a specific tray.
		Duplex	Off (default) On	Select whether the duplexer should be included in the Paper Path test.
		Copies	1, 10, 50, 100, or 500 Default = 1	Select how many pages should be sent from the specified source as part of the Paper Path test.
Finishing Paper Path Test	Staples	Finishing Options	Choose from a list of available options.	Test paper handling features for the finisher. Select the option that you want to test.
		Media Size	Letter Legal A4 8.5 x 13	Select the paper size for the Finishing Paper Path Test.
		Media Type		Select the paper type for the Finishing Paper Path Test.
		Copies	Range: 2-30, Default=2	Select the number of copies to include in the Finishing Paper Path Test.
		Duplex	Off On	Select whether to use the duplexer in the Finishing Paper Path Test.
		Print Test Page	Print (button)	Print a test page to use for the Finishing Paper Path Test.
		Stack	Media Size	Select from a list of sizes.
		Media Type	Select from a list of types.	Select the type of media to use for the Finishing Paper Path Test.
		Copies	Range 2–30 Default = 2	Select the number of copies to include in the Finishing Paper Path Test.
		Duplex	Off On	Select whether to use the duplexer in the Finishing Paper Path Test.
		Print Test Page	Print (button)	Print a test page to use for the Finishing Paper Path Test.



**Table 3-16** Troubleshooting menu (continued)

Menu item	Sub-menu item	Sub-menu item	Values	Description
Manual Sensor Test				Test the device sensors and switches for correct operation. Each sensor is displayed on the control-panel screen, along with its status. Manually trip each sensor and watch for it to change on the screen. Press the Stop button to abort the test.
Component Test				Exercise individual parts independently to isolate noise, leaking, or other issues. To start the test, select one of the components. The test will run the number of times specified by the Repeat option. You might be prompted to remove parts from the device during the test. Press the Stop button to abort the test.
Print/Stop Test			Continuous value from 0 to 60,000 milliseconds. The default is 0 milliseconds.	Isolate faults by stopping the device during the print cycle and observing where in the process the image degrades. To run the test, specify a stop time. The next job that is sent to the device will stop at the specified time in the process.
Scanner Tests				This menu item is used by a service technician to diagnose potential problems with the device scanner.
Control Panel	LEDs			Use this feature to make sure the components of the control panel are functioning correctly.
	Display			
	Buttons			
	Touchscreen			

## Resets menu

**Table 3-17** Resets menu


Menu item	Values	Description
Clear Local Address Book	Clear (button)	Use this feature to clear all addresses from the address books that are stored on the device.
Clear Fax Activity Log	Yes No (default)	Use this feature to clear all events from the Fax Activity Log.
Restore Factory Telecom Setting	Restore (button)	Use this option to restore the telephone-related settings that are in the Initial Setup menu to factory default values.
Restore Factory Settings	Restore (button)	Use this feature to restore all device settings to their factory defaults.
Clear Maintenance Message	Clear (button)	Clear the Order Maintenance Kit and Replace Maintenance Kit warning messages.
Clear Document Feeder Message	Clear (button)	Use this feature to clear the Order Document Feeder Kit and Replace Document Feeder Kit warning messages.
Reset Supplies	New Maintenance Kit (Yes/No)	Notify the device that a new maintenance kit or document feeder kit has been installed.

Menu item	Values	Description
	New Document Feeder Kit (Yes/No)	

## Service menu

The Service menu is locked and requires a PIN for access. The PIN code for this MFP is 11434506.

**Table 3-18** Service menu



Menu item	Description
Clear Event Log	Select this item to clear (reset to zero) the internal event log.
Engine Cycle Count	Select this item to print a report that displays the number of pages the formatter has formatted.
Refurbish Cycle Count	Select this item to set the page count for a refurbished unit. This page count is stored in memory so that the correct Service ID can be restored after the MFP is refurbished.
Maintenance Kit Count	Select this item to set a) the number of pages that have been printed since the last maintenance kit was installed, or b) the total number of pages that have been printed on this MFP if a maintenance kit has not yet been installed (during the first 225,000 pages).
Maintenance Kit Interval	Select this item to specify the number of pages that can be printed before a <b>Perform Printer Maintenance</b> messages appears on the control-panel display to indicate that a maintenance kit is necessary.
Document Feeder Kit Count	Select this item to set a) the number of pages that have been printed since the last document-feeder kit was installed, or b) the total number of pages that have been printed on this MFP if a document-feeder kit has not yet been installed (during the first 90,000 pages).
Document Feeder Kit Interval	Select this item to specify the number of pages that can be printed before a <b>Replace Document Feeder Kit</b> messages appears on the control-panel display to indicate that a document-feeder kit is necessary.
ADF count	Select this item to specify the number of pages that have been fed through the document feeder.
Flatbed Count	Select this item to specify the number of pages that have been scanned on the flatbed glass.
ADF Simplex Count	Select this item to set the number of simplex pages that have been fed through the document feeder.
ADF Duplex Count	Select this item to set the number of duplex pages that have been fed through the document feeder.
Copy Scan Count	Select this item to set the number of copy pages that have been scanned.
Send Scan Count	Select this item to set the number of scanned pages that have been sent to e-mail.
Copy Pages Count	Select this item to set the number of pages that have been copied.
Scanner Settings	 <b>CAUTION</b> The scanner settings are used for factory adjustments and should not be used by service personnel. Use the scanner calibration routine to adjust the scanner settings if necessary.
Serial Number	Select this item to update the serial number if you replace the formatter.



**Table 3-18** Service menu (continued)

Menu item	Description
Service ID	Select this item to specify the date when the MFP was first used, rather than the date when a replacement formatter was installed.
Cold Reset Paper	Select this item to reset the default paper size when you replace the formatter or restore factory settings. For example, when you replace a formatter or restore factory settings in a country/region that uses A4 as the standard paper size, use this item to reset the default paper size to A4. Letter and A4 are the only cold-reset values available.

## Use information pages

From the control panel, print pages that give details about the device and its current configuration. The table below provides the instructions for printing the information pages.

Page description	How to print the page
<b>Menu map</b>  Shows the control-panel menus and available settings.	<ol style="list-style-type: none"><li>1. From the Home screen, touch <a href="#">Administration</a>.</li><li>2. Touch <a href="#">Information</a>.</li><li>3. Touch <a href="#">Configuration Status Pages</a>.</li><li>4. Touch <a href="#">Administration Menu Map</a>.</li><li>5. Touch <a href="#">Print</a>.</li></ol> <p>The content of the menu map varies, depending on the options currently installed in the device.</p> <p>For a complete list of control panel menus and possible values, see <a href="#">Use the control panel on page 48</a>.</p>
<b>Configuration page</b>  Shows device settings and installed accessories.	<ol style="list-style-type: none"><li>1. From the Home screen, touch <a href="#">Administration</a>.</li><li>2. Touch <a href="#">Information</a>.</li><li>3. Touch <a href="#">Configuration Status Pages</a>.</li><li>4. Touch <a href="#">Configuration Page</a>.</li><li>5. Touch <a href="#">Print</a>.</li></ol> <hr/>  <b>NOTE</b> If the device contains an HP Jetdirect print server or an optional hard disk drive, additional configuration pages print that provide information about those devices.
<b>Supplies status page</b>  Shows print-cartridge toner levels.	<ol style="list-style-type: none"><li>1. From the Home screen, touch <a href="#">Administration</a>.</li><li>2. Touch <a href="#">Information</a>.</li><li>3. Touch <a href="#">Configuration Status Pages</a>.</li><li>4. Touch <a href="#">Supplies Status Page</a>.</li><li>5. Touch <a href="#">Print</a>.</li></ol> <hr/>  <b>NOTE</b> If you are using non-HP supplies, the supplies status page might not show the remaining life for those supplies. For more information, see <a href="#">HP policy on non-HP print cartridges on page 94</a> .
<b>Usage page</b>  Shows a page count for each size of paper printed, the number of one-sided (simplex) or two-sided (duplexed) pages, and the average percentage of coverage.	<ol style="list-style-type: none"><li>1. From the Home screen, touch <a href="#">Administration</a>.</li><li>2. Touch <a href="#">Information</a>.</li><li>3. Touch <a href="#">Configuration Status Pages</a>.</li><li>4. Touch <a href="#">Usage Page</a>.</li><li>5. Touch <a href="#">Print</a>.</li></ol>

Page description	How to print the page
<p><b>File directory</b></p> <p>Contains information for any mass storage devices, such as flash drives, memory cards, or hard disks, that are installed in the device.</p>	<ol style="list-style-type: none"> <li>1. From the Home screen, touch <a href="#">Administration</a>.</li> <li>2. Touch <a href="#">Information</a>.</li> <li>3. Touch <a href="#">Configuration Status Pages</a>.</li> <li>4. Touch <a href="#">File Directory</a>.</li> <li>5. Touch <a href="#">Print</a>.</li> </ol>
<p><b>Fax reports</b></p> <p>Five reports show fax activity, fax calls, billing codes, blocked fax numbers, and speed-dial numbers.</p> <p> <b>NOTE</b> Fax reports are available only on device models that have fax capabilities.</p>	<ol style="list-style-type: none"> <li>1. From the Home screen, touch <a href="#">Administration</a>.</li> <li>2. Touch <a href="#">Information</a>.</li> <li>3. Touch <a href="#">Fax Reports</a>.</li> <li>4. Touch one of the following buttons to print the corresponding report: <ul style="list-style-type: none"> <li>• <a href="#">Fax Activity Log</a></li> <li>• <a href="#">Fax Call Report</a></li> <li>• <a href="#">Billing Codes Report</a></li> <li>• <a href="#">Blocked Fax List</a></li> <li>• <a href="#">Speed Dial List</a></li> </ul> </li> <li>5. Touch <a href="#">Print</a>.</li> </ol>
<p><b>Font lists</b></p> <p>Shows which fonts are currently installed in the device.</p>	<ol style="list-style-type: none"> <li>1. From the Home screen, touch <a href="#">Administration</a>.</li> <li>2. Touch <a href="#">Information</a>.</li> <li>3. Touch <a href="#">Sample Pages/Fonts</a>.</li> <li>4. Touch either <a href="#">PCL Font List</a> or <a href="#">PS Font List</a>.</li> <li>5. Touch <a href="#">Print</a>.</li> </ol>
<p> <b>NOTE</b> The font lists also show which fonts reside on a hard disk accessory or DIMM.</p>	

## Configure e-mail alerts



**NOTE** If your company does not have e-mail, this feature might not be available.

You can use HP Web Jetadmin or the embedded Web server to configure the system to alert you of problems with the device. The alerts take the form of e-mail messages to the e-mail account(s) that you specify.

You can configure the following:

- The device(s) you want to monitor
- The alerts you want to receive (for example, alerts for paper jams, paper out, supplies status, and cover open)
- The e-mail account(s) to which the alerts should be forwarded

Software	Information location
HP Web Jetadmin	See <a href="#">Use HP Web Jetadmin software on page 90</a> for general information about HP Web Jetadmin.  See the HP Web Jetadmin Help system for details about alerts and how to set them up.
Embedded Web server	See <a href="#">Embedded Web server on page 36</a> for general information about the embedded Web server.  See the embedded Web server Help system for details about alerts and how to set them up.

# HP Easy Printer Care software

The HP Easy Printer Care software is a program that you can use for the following tasks:

- Check the device status.
- Check supplies status.
- Set up alerts.
- Gain access to troubleshooting and maintenance tools.

Use the HP Easy Printer Care software when the device is directly connected to a computer or when it is connected to a network. To download the HP Easy Printer Care software, go to [www.hp.com/go/easyprintercare](http://www.hp.com/go/easyprintercare).



**NOTE** No Internet access is needed to open and use the HP Easy Printer Care software. However, Internet access is required for the Web-based link.


## Open the HP Toolbox FX

Use one of the following methods to open HP Toolbox FX:

- On the **Start** menu, select **Programs**, select **Hewlett-Packard**, and then select **HP Toolbox FX**.
- In the Windows system tray (in the lower-right corner of the desktop), double-click the HP Toolbox FX icon.
- Double-click the desktop icon.

## HP Toolbox FX sections

Section	Options
<b>Device List</b> tab	<ul style="list-style-type: none"><li>• Device information, including printer name, make, and model</li></ul>
Shows information about each device in the <b>Devices</b> list	<ul style="list-style-type: none"><li>• An icon (if the <b>View as</b> drop-down box is set to <b>Tiles</b>, which is the default setting)</li><li>• Any current alerts for the device</li></ul> <p>If you click a device in the list, the HP Toolbox FX opens the <b>Overview</b> tab for that device.</p>
<b>Support</b> tab	<ul style="list-style-type: none"><li>• Provides device information, including alerts for items needing attention.</li></ul>
Provides help information and links	<ul style="list-style-type: none"><li>• Provides links to troubleshooting and maintenance tools.</li></ul>
<b>Supplies Ordering</b> window	<ul style="list-style-type: none"><li>• Ordering list: Shows the supplies that you can order for each device. If you want to order a certain item, click the <b>Order</b> check box for that item in the supplies list.</li></ul>
Provides access to online or e-mail supplies ordering	<ul style="list-style-type: none"><li>• <b>Shop Online for Supplies</b> button: Opens the HP SureSupply Web site in a new browser window. If you have checked the <b>Order</b> check box for any items, the information about those items can be transferred to the Web site, where you will receive information on options for purchasing your selected supplies.</li><li>• <b>Print Shopping List</b> button: Prints the information for the supplies that have the <b>Order</b> check box selected.</li></ul>

Section	Options
<p><b>Alert Settings</b> window</p> <p>Allows you to configure the device to automatically notify you of device issues</p>	<ul style="list-style-type: none"> <li>Alerts on or off: Activates or deactivates the alerts feature.</li> <li>When alerts appear: Sets when you want alerts to appear—either when you are printing to that particular device, or anytime there is a device event.</li> <li>Alert event type: Sets whether you want alerts for only critical errors, or for any error, including continuable errors.</li> <li>Notification method: Sets what type of alert should appear (pop-up message or desktop alert).</li> </ul>
<p><b>Overview</b> tab</p> <p>Contains basic status information for the device</p>	<ul style="list-style-type: none"> <li><b>Devices</b> list: Shows the devices that you can select.</li> <li><b>Device Status</b> section: Shows device status information. This section will indicate device alert conditions, such as an empty print cartridge. It also shows device-identification information, control-panel messages, and print-cartridge levels. After you correct a problem with the device, click the  button to update the section.</li> <li><b>Supplies Status</b> section: Shows detailed supplies status, such as the percentage of toner remaining in the print cartridge and the status of the media that is loaded in each tray.</li> <li><b>Supplies Details</b> link: Opens the supplies status page to view more detailed information about device supplies, ordering information, and recycling information.</li> </ul>
<p><b>Find Other Printers</b> window</p> <p>Allows you to add more printers to your printer list</p>	<p>Clicking the <b>Find Other Printers</b> link in the <b>Devices</b> list opens the <b>Find Other Printers</b> window. The <b>Find Other Printers</b> window provides a utility that detects other network printers so that you can add them to the <b>Devices</b> list and then monitor those devices from your computer.</p>



# Use the embedded Web server



**NOTE** When the device is directly connected to a computer, use the HP Easy Printer Care software to view the device status.

- View status information.
- Set the type of paper loaded in each tray.
- Determine the remaining life on all supplies and order new ones.
- View and change tray configurations.
- View and change the device control-panel menu configuration.
- View and print internal pages.
- Receive notification of device and supplies events.
- View and change the network configuration.
- View support content that is specific to the current state of the device.

When the device is connected to the network, the embedded Web server is automatically available. Open the embedded Web server from Windows 95 and later.

To use the embedded Web server, you must have Microsoft Internet Explorer 4 and later or Netscape Navigator 4 and later. The embedded Web server works when the device is connected to an IP-based network. The embedded Web server does not support IPX-based or AppleTalk printer connections. You do not need Internet access to open and use the embedded Web server.

## Open the embedded Web server by using a network connection

1. In a supported Web browser on your computer, type the device IP address or host name in the address/URL field. To find the IP address or host name, print a configuration page. See [Use information pages on page 82](#).




**NOTE** After you open the URL, you can bookmark it so that you can return to it quickly in the future.



2. The embedded Web server has three tabs that contain settings and information about the device: the **Information** tab, the **Settings** tab, and the **Networking** tab. Click the tab that you want to view.

See [Embedded Web server sections on page 87](#) for more information about each tab.

## Embedded Web server sections

Tab or section	Options
<b>Information</b> tab Provides device, status, and configuration information	<ul style="list-style-type: none"><li>• <b>Device Status:</b> Shows the device status and shows the life remaining of HP supplies, with 0% indicating that a supply is empty. The page also shows the type and size of print paper set for each tray. To change the default settings, click <b>Change Settings</b>.</li><li>• <b>Configuration Page:</b> Shows the information found on the configuration page.</li></ul>

Tab or section	Options
	<ul style="list-style-type: none"> <li>● <b>Supplies Status:</b> Shows the life remaining of HP supplies, with 0 percent indicating that a supply is empty. This page also provides supplies part numbers. To order new supplies, click <b>Order Supplies</b> in the <b>Other Links</b> area on the left side of the window.</li> <li>● <b>Event log:</b> Shows a list of all device events and errors.</li> <li>● <b>Usage page:</b> Shows a summary of the number of pages the device has printed, grouped by size and type.</li> <li>● <b>Device Information:</b> Shows the device network name, address, and model information. To change these entries, click <b>Device Information</b> on the <b>Settings</b> tab.</li> <li>● <b>Control Panel:</b> Shows messages from the device control panel, such as <b>Ready</b> or <b>Sleep mode on</b>.</li> <li>● <b>Print:</b> Allows you to send print jobs to the device.</li> </ul>
<p><b>Settings tab</b></p> <p>Provides the ability to configure the device from your computer</p>	<ul style="list-style-type: none"> <li>● <b>Configure Device:</b> Allows you to configure device settings. This page contains the traditional menus found on devices using a control-panel display.</li> <li>● <b>E-mail Server:</b> Network only. Used in conjunction with the <b>Alerts</b> page to set up incoming and outgoing e-mail, as well as to set e-mail alerts.</li> <li>● <b>Alerts:</b> Network only. Allows you to set up to receive e-mail alerts for various device and supplies events.</li> <li>● <b>AutoSend:</b> Allows you to configure the device to send automated e-mails regarding device configuration and supplies to specific e-mail addresses.</li> <li>● <b>Security:</b> Allows you to set a password that must be entered to gain access to the <b>Settings</b> and <b>Networking</b> tabs. Enable and disable certain features of the embedded Web server.</li> <li>● <b>Edit Other Links:</b> Allows you to add or customize a link to another Web site. This link is displayed in the <b>Other Links</b> area on all embedded Web server pages.</li> <li>● <b>Device Information:</b> Allows you to name the device and assign an asset number to it. Enter the name and e-mail address for the primary contact who will receive information about the device.</li> <li>● <b>Language:</b> Allows you to determine the language in which to display the embedded Web server information.</li> <li>● <b>Date &amp; Time:</b> Allows time synchronization with a network time server.</li> <li>● <b>Wake Time:</b> Allows you to set or edit a wake time for the device.</li> </ul> <p> <b>NOTE</b> The <b>Settings</b> tab can be password-protected. If this device is on a network, always consult with the system administrator before changing settings on this tab.</p>

Tab or section	Options
<p><b>Networking tab</b></p> <p>Provides the ability to change network settings from your computer</p>	<p>Network administrators can use this tab to control network-related settings for the device when it is connected to an IP-based network. This tab does not appear if the device is directly connected to a computer, or if the device is connected to a network using anything other than an HP Jetdirect print server.</p> <hr/> <p> <b>NOTE</b> The <b>Networking</b> tab can be password-protected.</p>
<p><b>Other links</b></p> <p>Contains links that connect you to the Internet</p>	<ul style="list-style-type: none"> <li>● <b>HP Instant Support™:</b> Connects you to the HP Web site to help you find solutions. This service analyzes your device error log and configuration information to provide diagnostic and support information specific to your device.</li> <li>● <b>Order Supplies:</b> Connects to the HP SureSupply Web site, where you will receive information on options for purchasing original HP supplies, such as print cartridges and paper.</li> <li>● <b>Product Support:</b> Connects to the support site for the device, from which you can search for help regarding general topics.</li> </ul> <hr/> <p> <b>NOTE</b> You must have Internet access in order to use any of these links. If you use a dial-up connection and did not connect when you first opened the embedded Web server, you must connect before you can visit these Web sites. Connecting might require that you close the embedded Web server and reopen it.</p>

## Use HP Web Jetadmin software

HP Web Jetadmin is a Web-based software solution for remotely installing, monitoring, and troubleshooting network-connected peripherals. The intuitive browser interface simplifies cross-platform management of a wide range of devices, including HP and non-HP devices. Management is proactive, allowing network administrators the ability to resolve issues before users are affected. Download this free, enhanced-management software at [www.hp.com/go/webjetadmin\\_software](http://www.hp.com/go/webjetadmin_software).

To obtain plug-ins to HP Web Jetadmin, click **plug-ins**, and then click the **download** link that is next to the name of the plug-in that you want. The HP Web Jetadmin software can automatically notify you when new plug-ins are available. On the **Product Update** page, follow the directions to automatically connect to the HP Web site.

If installed on a host server, HP Web Jetadmin is available to any client through a supported Web browser, such as Microsoft Internet Explorer 6.0 for Windows or Netscape Navigator 7.1 for Linux. Browse to the HP Web Jetadmin host.



**NOTE** Browsers must be Java-enabled. Browsing from an Apple PC is not supported.

---

# Use the HP Printer Utility for Macintosh

Use the HP Printer Utility to configure and maintain a printer from a Mac OS X computer.

## Open the HP Printer Utility

### Open the HP Printer Utility in Mac OS X V10.2.8

1. Open the Finder, and then click **Applications**.
2. Click **Library**, and then click **Printers**.
3. Click **hp**, and then click **Utilities**.
4. Double-click **HP Printer Selector** to open the HP Printer Selector.
5. Select the device that you want to configure, and then click **Utility**.

### Open the HP Printer Utility in Mac OS X V10.3, V10.4 and later

1. In the Dock, click the **Printer Setup Utility** icon.



**NOTE** If the **Printer Setup Utility** icon does not appear in the Dock, open the Finder, click **Applications**, click **Utilities**, and then double-click **Printer Setup Utility**.

2. Select the device that you want to configure, and then click **Utility**.

## HP Printer Utility features

The HP Printer Utility consists of pages that you open by clicking in the **Configuration Settings** list. The following table describes the tasks that you can perform from these pages.

Item	Description
<b>Configuration Page</b>	Prints a configuration page.
<b>Supplies Status</b>	Shows the device supplies status and provides links for online supplies-ordering.
<b>HP Support</b>	Provides access to technical assistance, online supplies ordering, online registration, and recycling and return information.
<b>File Upload</b>	Transfers files from the computer to the device.
<b>Upload Fonts</b>	Transfers font files from the computer to the device.
<b>Firmware Update</b>	Transfers updated firmware files from the computer to the device.
<b>Duplex Mode</b>	Turns on the automatic two-sided printing mode.
<b>Economode &amp; Toner Density</b>	Turns on the Economode setting to conserve toner, or adjusts toner density.
<b>Resolution</b>	Changes the resolution settings, including the REt setting.
<b>Lock Resources</b>	Locks or unlocks storage products, such as a hard disk.
<b>Stored Jobs</b>	Manages print jobs that are stored on the device hard disk.
<b>Trays Configuration</b>	Changes the default tray settings.
<b>IP Settings</b>	Changes the device network settings and provides access to the embedded Web server.

<b>Item</b>	<b>Description</b>
<b>Bonjour Settings</b>	Provides the ability to turn on or off Bonjour support or change the device service name that is listed on a network.
<b>Additional Settings</b>	Provides access to the embedded Web server.
<b>E-mail Alerts</b>	Configures the device to send e-mail notices for certain events.

# Manage supplies

Monitor the print cartridge to ensure high-quality output.

## Supplies life expectancy

The life of the print cartridge depends on both the amount of toner that print jobs require and the durability of components inside the cartridge. When printing text at approximately 5% coverage (typical for a business letter), the HP print cartridge lasts an average of 18,000 pages. The HP page-yield specification is a general guideline. Actual yield can vary according to usage conditions.

## Change the print cartridge

1. Pull the top-cover release to open the top cover.



2. Grasp the print cartridge by the handle, and remove it from the device.
3. Remove the new print cartridge from the packaging.
4. Remove any protective tape from the print cartridge.
5. Insert the new print cartridge in the device, and close the top cover.

## Manage the print cartridge

### Print-cartridge storage

Do not remove the print cartridge from its package until you are ready to use it.



**CAUTION** To prevent damage to the print cartridge, do not expose it to light for more than a few minutes.

### Use genuine HP print cartridges

When you use a genuine new HP print cartridge, you can obtain the following supplies information:

- Percentage of supplies remaining
- Estimated number of pages remaining
- Number of pages printed

## HP policy on non-HP print cartridges

Hewlett-Packard Company cannot recommend the use of non-HP print cartridges, either new or remanufactured. Because they are not HP products, HP cannot influence their design or control their quality.



---

**NOTE** Any damage caused by a non-HP print cartridge is not covered under the HP warranty and service agreements.

---

To install a new HP print cartridge, see [Change the print cartridge on page 93](#). To recycle the used cartridge, follow the instructions included with the new cartridge.

## Print-cartridge authentication

The device automatically authenticates the print cartridge when it is inserted into the device. During authentication, the device notifies you whether a cartridge is a genuine HP print cartridge.

If the device control-panel message states that this is not a genuine HP print cartridge and you believe you purchased an HP print cartridge, see [HP fraud hotline and Web site on page 94](#).

## HP fraud hotline and Web site

Call the HP fraud hotline (1-877-219-3183, toll-free in North America) or go to [www.hp.com/go/anticounterfeit](http://www.hp.com/go/anticounterfeit) when you install an HP print cartridge and the control-panel message says the cartridge is non-HP. HP will help determine if the cartridge is genuine and take steps to resolve the problem.

Your print cartridge might not be a genuine HP print cartridge if you notice the following:

- You are experiencing a high number of problems with the print cartridge.
- The cartridge does not look like it usually does (for example, the orange pull tab is missing, or the packaging differs from HP packaging).



## Clean the device

During the printing process, paper, toner, and dust particles can accumulate inside the product. Over time, this buildup can cause print-quality problems, such as toner specks or smearing. This product has a cleaning mode that can correct and prevent these types of problems.

### Clean the exterior

Use a soft, damp, lint-free cloth to wipe dust, smudges, and stains off of the exterior of the device.

### Clean the scanner glass

Dirty glass, from fingerprints, smudges, hair, and so on, slows down performance and affects the accuracy of special features such as fit-to-page and copy.

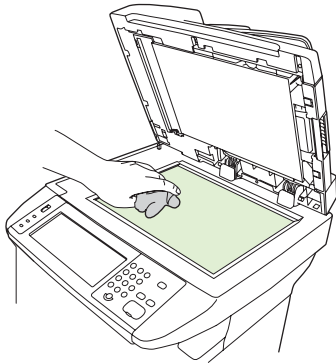


---

**NOTE** If streaks or other defects appear only on copies produced using the automatic document feeder (ADF), clean the scanner strip (step 3). It is not necessary to clean the scanner glass.

---

1. Open the scanner lid.
2. Clean the glass by using a damp, lint-free cloth.

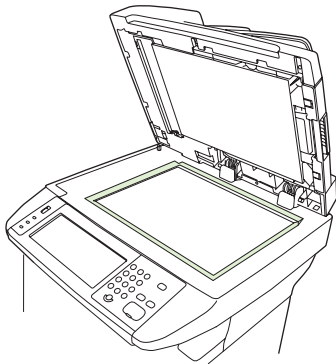


---

**CAUTION** Do not use abrasives, acetone, benzene, ammonia, ethyl alcohol, or carbon tetrachloride on any part of the device; these can damage the device. Do not place liquids directly on the glass. They might seep under it and damage the device.

---

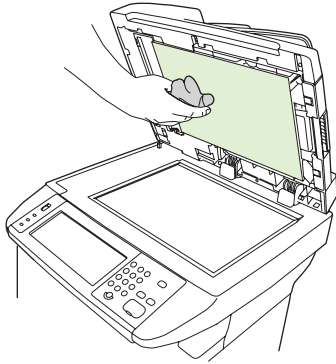
3. Clean the scanner strip by using a damp, lint-free cloth.



## Clean the scanner lid backing

Minor debris can accumulate on the white document lid backing that is located underneath the scanner lid.

1. Open the scanner lid.
2. Clean the white document lid backing by using a soft cloth or sponge that has been moistened with a mild soap and warm water. Also, clean the scanner strip next to the ADF scanner glass.



3. Wash the backing gently to loosen debris; do not scrub the backing.
4. Dry the backing by using a chamois or soft cloth.



**CAUTION** Do not use paper-based wipes because they might scratch the backing.

5. If this does not clean the backing well enough, repeat the previous steps and use isopropyl alcohol to dampen the cloth or sponge, and then wipe the backing thoroughly with a damp cloth to remove any residual alcohol.

## Clean the paper path

1. From the Home screen, touch **Administration**.
2. Touch **Print Quality**.
3. Touch **Calibration/Cleaning**.
4. Touch **Create Cleaning Page**.

The device prints a cleaning page.

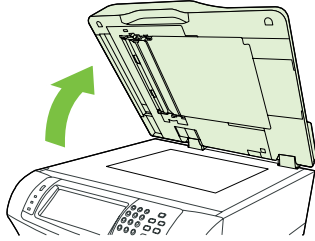
5. Follow the instructions printed on the cleaning page.

## Clean the document feeder

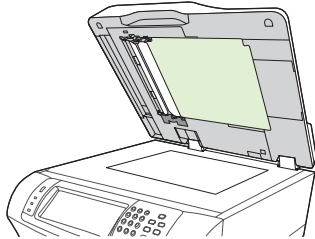
Clean the document feeder only if it is visibly marked or dirty, or if you are experiencing a degradation of copy quality (such as streaking).

## Clean the document feeder delivery system

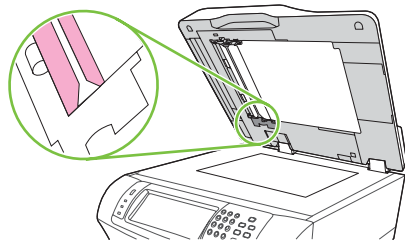
1. Open the scanner lid.



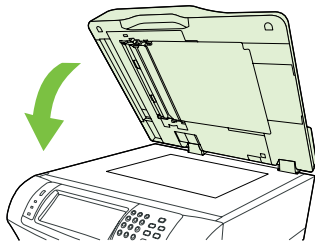
2. Locate the white, vinyl document-feeder backing.



3. Locate the white, vinyl calibration strips.



4. Clean the document-feeder backing and the calibration strips by wiping them with a clean, damp, lint-free cloth. Use an ammonia-based surface cleaner only when a water-dampened cloth does not clean the document-feeder components.
5. Clean the scanner glass by wiping it gently with a clean, slightly damp, lint-free cloth. Use an ammonia-based surface cleaner only when a water-dampened cloth does not clean the scanner glass.
6. Close the scanner lid.



## Clean the document feeder-rollers

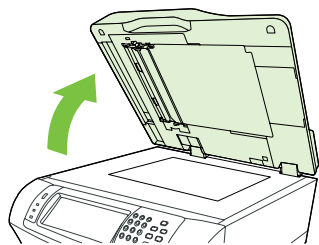
You should clean the rollers in the document feeder if you are experiencing misfeeds or if your originals show marks as they exit the document feeder.

---

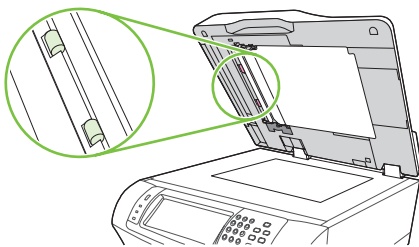
**CAUTION** Clean the rollers only if you experience misfeeds or marks on the originals, and you notice dust on the rollers. Cleaning the rollers frequently could introduce dust into the device.

---

1. Open the scanner lid.



2. Locate the rollers near white, vinyl calibration strips.



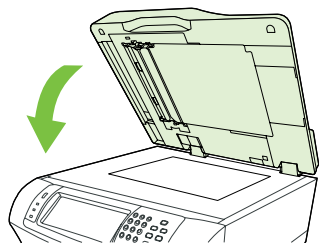
3. Wipe the rollers gently with a clean, water-dampened, lint-free cloth.

---

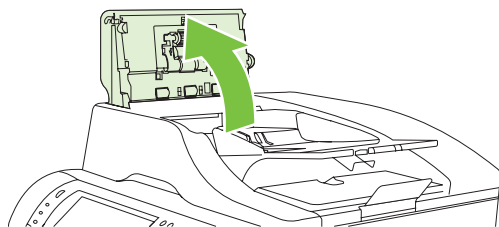
**CAUTION** Do not pour water directly onto the rollers. Doing so might damage the device.

---

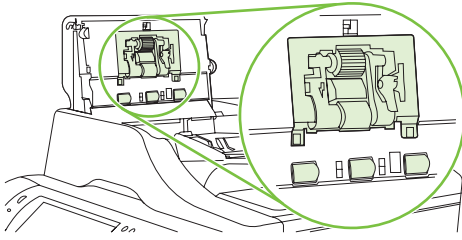
4. Close the scanner lid.



5. Pull the release lever to open the document-feeder cover.



6. Locate the rollers.

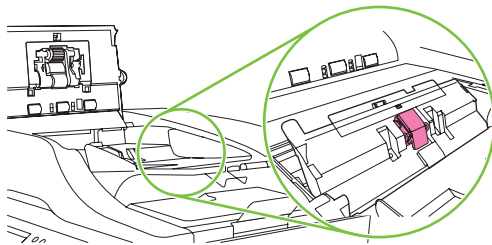


7. Wipe the rollers with a clean, water-dampened, lint-free cloth.



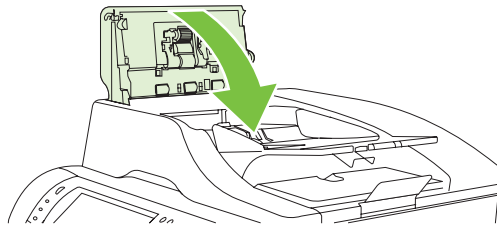
**CAUTION** Do not pour water directly onto the rollers. Doing so might damage the device.

8. Locate the separation pad.



9. Wipe the pad with a clean, water-dampened, lint-free cloth.

10. Close the document-feeder cover.



## Set the real-time clock

Use the real-time clock feature to set the date and time settings. The date and time information is attached to stored print, fax, and digital-send jobs, so you can identify the most recent versions of stored print jobs. You can also set the MFP to automatically warm up and prepare for use at a set time each day.

### Set the date and time

When setting the date and time you can set the date format, date, time format, and time.

#### Set the date format

1. Scroll to and touch **Administration**.
2. Touch **Time/Scheduling**.
3. Touch **Date/Time**.
4. Touch **Date Format**.
5. Touch the desired format.
6. Touch **Save**.

#### Set the date

1. Scroll to and touch **Administration**.
2. Touch **Time/Scheduling**.
3. Touch **Date/Time**.
4. Touch **Date**.
5. Touch the appropriate options to set the correct month, date of the month, and the year.
6. Touch **Save**.

#### Set the time format

1. Scroll to and touch **Administration**.
2. Touch **Time/Scheduling**.
3. Touch **Date/Time**.
4. Touch **Time Format**.
5. Touch the appropriate format.
6. Touch **Save**.

#### Set the time

1. Press **Administration**.
2. Scroll to and touch **Time/Scheduling**.

3. Scroll to and touch **Date/Time**.
4. Touch **Time**.
5. Touch the appropriate options to set the correct hour, minute, and AM/PM setting.
6. Touch **Save**.

## Set the wake time

Use the wake time feature to wake the MFP at a set time each day.

1. Scroll to and touch **Administration**.
2. Touch **Time/Scheduling**.
3. Touch **Wake Time**.
4. Touch the day of the week for the wake time.
5. Touch **Custom**.
6. Touch **Save**.
7. Touch the appropriate options to set the correct hour, minute, and AM/PM setting.
8. If you want to wake the MFP at the same time each day, on the **Apply to All Days** screen, touch **Yes**. If you want to set the time for individual days, touch **No**, and repeat the procedure for each day.

## Set the sleep delay

Use the sleep-delay feature to set the period of time that the MFP must be idle before it enters the sleep mode. The default setting is 45 minutes.

1. Scroll to and touch **Administration**.
2. Touch **Time/Scheduling**.
3. Touch **Sleep Delay**.
4. Touch the sleep-delay setting that you want.

## Upgrading the firmware

The MFP has remote firmware update (RFU) capability. Use the information in this section to upgrade the MFP firmware. The overall process involves the following steps:

1. Determine the current level of firmware that is installed on the MFP.
2. Go to the HP Web site and find out whether a firmware update is available. If an update is available, download the latest firmware to your computer.
3. Transfer the new firmware from your computer to the MFP.

### Determining the current level of firmware

To determine the current level of firmware, view the configuration information on the MFP control panel. To view the configuration information, follow these instructions.

1. Press **Menu**.
2. Touch **INFORMATION**.
3. Touch **PRINT CONFIGURATION**. The Configuration page prints.
4. The firmware datecode is listed in the section called **Device Information**. The firmware datecode has this format: YYYYMMDD XX.XXX.X. The first string of numbers is the date, where YYYY represents the year, MM represents the month, and DD represents the date. For example, a firmware datecode of that begins with 20040225 represents February 25, 2004.

### Downloading the new firmware from the HP Web site

To find the most recent firmware upgrade for the MFP, go to [http://www.hp.com/go/ljm4345mfp\\_software](http://www.hp.com/go/ljm4345mfp_software). This page provides instructions for downloading the new firmware version.

### Transferring the new firmware to the MFP

Use one of the following methods to update the firmware.

#### Using FTP to upgrade the firmware on a network connection



---

**NOTE** The MFP can receive an .RFU file update as long as it is in a "ready" state.

---

The elapsed time for an update depends on the I/O transfer time and the time that it takes for the MFP to reinitialize. The I/O transfer time depends on a number of things, including the speed of the host computer that is sending the update. Any jobs that are ahead of the RFU job in the queue are completed before the update is processed.

If the remote firmware update process is interrupted before the firmware is downloaded (while **Receiving Upgrade** appears on the control panel display), the firmware file must be sent again. If power is disrupted during the flash DIMM update (while the **Performing Upgrade** message appears on the control panel display), the message **Resend Upgrade** appears (in English only) on the control panel display. Send the upgrade by using the parallel port.

Any jobs that are ahead of the RFU job in the queue are completed before the update is processed.



Follow these instructions to perform the upgrade by using FTP.

1. Take note of the IP address on the HP Jetdirect page, the second page of the Configuration page printout.



---

**NOTE** Before upgrading the firmware, make sure that the MFP is not in Sleep mode. Also make sure that any error messages are cleared from the control panel display.

---

2. Open an MS-DOS command prompt.
3. Type: `ftp <TCP/IP ADDRESS>`. For example, if the TCP/IP address is 192.168.0.90, type `ftp 192.168.0.90`.
4. Press **Enter** on the keyboard.
5. When prompted for the user name, press **Enter**.
6. When prompted for the password, press **Enter**.
7. Type `bin` at the command prompt.
8. Press **Enter**. The message **200 Types set to I, Using binary mode to transfer files** appears in the command window.
9. Type `put <filename>` where `<filename>` is the name of the .RFU file that was downloaded from the Web, including the path. For example, type `put C:\LJ\4345FW.RFU`, and then press **Enter**.



---

**NOTE** If the file name or path includes a space, you must enclose the file name or path in quotation marks. For example, type `put "C:\MY DOCUMENTS\LJ\4345FW.RFU"`

---

The following series of messages appears in the command window:

```
200 PORT command successful  
150 Opening BINARY mode data connection  
226 Ready  
226 Processing Job  
226 Transfer complete
```

Then, a message that contains the transfer-speed information appears.

10. The download process begins and the firmware is updated on the MFP. This takes approximately 5 minutes. Let the process finish without further interaction with the MFP or computer.



---

**NOTE** The MFP automatically turns off and then on again after processing the upgrade.

---

11. At the command prompt, type: `bye` to exit the ftp command.
12. At the command prompt, type: `exit` to return to the Windows interface.

## Using HP Web Jetadmin to upgrade the firmware

This procedure requires that you install HP Web Jetadmin Version 7.0 or later on the computer. Complete the following steps to update a single device through HP Web Jetadmin after downloading the .RFU file from the HP Web site.

1. Start HP Web Jetadmin.
2. Open the **Device Management** folder in the drop-down list in the **Navigation** panel. Navigate to the **Device Lists** folder.
3. Expand the **Device Lists** folder and select **All Devices**. Locate the MFP in the list of devices, and then click to select it.

If you need to upgrade the firmware for multiple HP LaserJet M4345 MFPs, select all of them by pressing the **Ctrl** key as you click the name of each MFP.

4. Locate the drop-down box for **Device Tools** in the upper-right corner of the window. Select **Update Printer Firmware** from the action list.
5. If the name of the .RFU file is not listed in the **All Available Images** box, click **Browse** in the **Upload New Firmware Image** dialog box and navigate to the location of the .RFU file that you downloaded from the Web at the start of this procedure. If the filename is listed, select it.
6. Click **Upload** to move the .RFU file from the hard drive to the HP Web Jetadmin server. After the upload is complete, the browser window refreshes.
7. Select the .RFU file from the **Printer Firmware Update** drop-down menu.
8. Click **Update Firmware**. HP Web Jetadmin sends the selected .RFU file to the MFP. The control panel shows messages that indicate the progress of the upgrade. At the end of the upgrade process, the control panel shows the **Ready** message.

## Using MS-DOS commands to upgrade the firmware

1. From a command prompt or in an MS-DOS window, type the following: `copy /B <FILENAME> \\<COMPUTERNAME>\<SHARENAME>`, where <FILENAME> is the name of the .RFU file (including the path), <COMPUTERNAME> is the name of the computer from which the MFP is being shared, and <SHARENAME> is the MFP share name. For example: `C:\>copy /b C:\9200fw.RFU \\YOUR_SERVER\YOUR_COMPUTER.`



**NOTE** If the file name or path includes a space, you must enclose the file name or path in quotation marks. For example, type: `C:\>copy /b "C:\MY DOCUMENTS\3500FW.RFU" \\YOUR_SERVER\YOUR_COMPUTER.`

2. Press **Enter** on the keyboard. The control panel shows a message that indicates the progress of the firmware upgrade. At the end of the upgrade process, the control panel shows the **Ready** message. The message **1 file(s) copied** appears on the computer screen.

## Upgrading the HP Jetdirect firmware

The HP Jetdirect network interface in the MFP has firmware that can be upgraded separately from the MFP firmware. This procedure requires that you install HP Web Jetadmin Version 7.0 or later on the computer. Complete the following steps to update the HP Jetdirect firmware by using HP Web Jetadmin.

1. Open the HP Web Jetadmin program.
2. Open the **Device Management** folder in the drop-down list in the **Navigation** panel. Navigate to the **Device Lists** folder.
3. Select the device that you want to update.
4. In the **Device Tools** drop-down list, select **Jetdirect Firmware Update**.
5. Under **Jetdirect firmware version** the HP Jetdirect model number and current firmware version are listed. Make a note of these.
6. Go to [http://www.hp.com/go/wja\\_firmware](http://www.hp.com/go/wja_firmware).
7. Scroll down to the list of HP Jetdirect model numbers and find the correct model number.
8. Look at the current firmware version for the model, and see if it is later than the version you wrote down. If it is, right-click the firmware link, and follow the instructions on the Web page to download the new firmware file. The file must be saved into the <drive>:\PROGRAM FILES\HP WEB JETADMIN\DOC\PLUGINS\HPWJA\FIRMWARE\JETDIRECT folder on the computer that is running the HP Web Jetadmin software.
9. In HP Web Jetadmin, return to the main device list and select the digital sender again.
10. In the **Device Tools** drop-down list, select **Jetdirect Firmware Update** again.
11. On the HP Jetdirect firmware page, the new firmware version is listed under **Jetdirect Firmware Available on HP Web Jetadmin**. Click the **Update Firmware Now** button to update the Jetdirect firmware.

## Calibrate the scanner

Calibrate the scanner to compensate for offsets in the scanner imaging system (carriage head) for ADF and flatbed scans. Because of mechanical tolerances, the scanner's carriage head might not read the position of the image accurately. During the calibration procedure, scanner offset values are calculated and stored. The offset values are then used when producing scans so that the correct portion of the document is captured.

Scanner calibration should be carried out only if you notice offset problems with the scanned images. The scanner is calibrated before it leaves the factory. It needs to be calibrated again only rarely.

1. From the Home screen, touch **Administration**.
2. Touch **Troubleshooting**.
3. Touch **Calibrate Scanner** and then follow the instructions in the onscreen dialog box.

The device starts the calibration process, and **Calibrating** appears on the touchscreen status line until the process is complete.

## Calibrate the control panel

Use the following procedure to calibrate the control panel:

1. Turn the device off.
2. Press and hold the # key and the C key.
3. Turn the device on.
4. When a small white square appears in the upper-left corner of the control-panel display, touch the square with a stylus.
5. When a small white square appears in the lower-left corner of the control-panel display, touch the square with a stylus.
6. Allow the device to finish the boot process.

## Disable Embedded Jetdirect I/O

Use the following procedure to disable the Embedded Jetdirect functionality:

1. Turn the device off.
2. Turn the device on.
3. After the first LED illuminates (and before the memory count displays), press and hold the 6 key.
4. When all three LEDs illuminate, release the 6 key.
5. Press the 3 key.
6. When **Embedded LAN Disable** displays, press the 6 key.
7. Allow the device to finish the boot process.

## Select the MFP language

Use the following procedure to change the MFP display language:

1. Turn the device off.
2. Press and hold the 6 key.
3. Turn the device on.
4. When the three status LEDs illuminate, release the 6 key.
5. After the MFP finishes the boot process, it prompts you to choose a language.





# 4 Theory of operation

This chapter presents an overview of the relationships between major components in the MFP, and includes information about the following topics:

- [Basic operation](#)
- [Formatter system](#)
- [Engine-control system](#)
- [Laser/scanner system](#)
- [Image-formation system](#)
- [Pickup, feed, and delivery system](#)
- [3-bin mailbox system](#)
- [Stapler/stacker system](#)
- [Scanner system](#)
- [Locations of major components](#)

## Basic operation

All high-level MFP processes are routed through the formatter, which stores font information, processes the print image, and communicates with the host computer.

The basic MFP operation can be divided into five systems:

- The engine control system, which includes the power supply and DC controller PCA
- The laser/scanner system, which forms the latent image on a photosensitive drum
- The image formation system, which transfers a toner image onto the print media
- The pickup and feed system, which consists of various rollers and transports the media through the MFP
- The scanner system, which scans data and sends it to the formatter for copying or for sending to e-mail

## Sequence of operation (printer)

A microprocessor on the DC controller PCA controls the operating sequence. The tables in this section describe the basic operating sequence, from when the MFP power is turned on until the final printed page is delivered to an output bin. For information about the timing of the basic operating sequence, see [Cross Reference TBD].

Period (sequence)	Description
Waiting	The period of time from when the MFP power is turned on until the main motor or drum motor begins to rotate. During this time the transfer roller is cleaned and the microprocessor on the DC controller PCA checks to determine if a print cartridge is installed in the MFP.
Standby	The period of time from the end of the waiting sequence or from the end of the last rotation until a print command is received from the host computer or until the MFP power is turned off. The message <b>Ready</b> appears on the control-panel display.
Initial rotation	The period of time when the photosensitive drum is stabilized to prepare for printing.
Print	The period of time from the initial rotation until the positive bias on the transfer-charging roller is turned off.
Last rotation	The period of time from the completion of the print job until the main motor or drum motor stops. The final page of the job is delivered to an output bin and the transfer roller is cleaned. If another print job is immediately detected (sent by the host computer), then the MFP returns to the initial rotation period. If no print jobs are waiting, then the MFP returns to the standby period.

## Sequence of operation (scanner)

Period (sequence)	Description
Power on	During this time, the scanner motors rotate, the MFP checks the status of all the sensors, the scanner lamp is illuminated, the optical scan head moves from its home position, the scanner calibrates, and then the optical scan head returns to its home position.
Initialization	The period of time after the initial power-on sequence and before the MFP is ready to scan or copy. During this time, the scanner and ADF initialization is completed, scanner calibration is performed, and the ADF checks for media in the input tray.
Standby	The period of time from the end of the initialization sequence until a request for a scan. During this time, the MFP might go into Sleep mode and the scan carriage rests in its home position.
Scan	The period of time immediately following a request for a scan. The scanner fan turns on, the scan start position is adjusted, the MFP performs the scan, and data is sent to the formatter.

## Formatter system

The formatter is responsible for the following procedures:

- Controlling Sleep mode
- Receiving and processing print data from the various MFP interfaces
- Monitoring control-panel functions and relaying MFP-status information (through the control panel and the network or the bidirectional interface)
- Developing and coordinating data placement and timing with the DC controller PCA
- Storing font information
- Communicating with the host computer through the network or the bidirectional interface

The formatter receives a print job from the network or the bidirectional interface and separates it into image information and instructions that control the printing process. The DC controller PCA synchronizes the image-formation system with the paper-input and -output systems, and then signals the formatter to send the print-image data.

The formatter also provides the electrical interface and mounting locations for one EIO card, one memory DIMM, two USB host ports, the hard-disk accessory, and the optional analog fax accessory.

## Sleep mode

This feature conserves power after the MFP has been idle for an adjustable period of time. When the MFP is in Sleep mode, the control-panel backlight is turned off, but the MFP retains all settings, downloaded fonts, and macros. The default setting is for Sleep mode to be enabled, and the MFP enters the Sleep mode after a 30-minute idle time. Sleep mode can also be turned off from the **RESET** menu on the control panel.

The MFP exits Sleep mode and enters the warm-up cycle when any of the following events occurs:

- A print job, valid data, or a PML or PJJL command is received
- A control-panel button is pressed or you touch the touchscreen
- The top cover is opened
- A paper tray is opened
- The engine-test switch is pressed



---

**NOTE** MFP error messages override the Sleep message. The MFP enters Sleep mode at the appropriate time, but the error message continues to appear.

---

## Resolution Enhancement technology (REt)

The formatter contains circuitry for Resolution Enhancement technology (REt), which modifies the standard video dot data on its way to the DC controller PCA to produce “smoothed” line edges. The REt can be turned on or off from the control panel or from some software programs. The default setting is medium.



---

**NOTE** The REt settings that are sent from software programs or printer drivers override the control-panel settings.

---

## EconoMode

The EconoMode setting uses up to 50% less toner than standard mode printing by reducing the dot density. However, using EconoMode does not extend the life of print-cartridge components.

Select EconoMode, which can be thought of as draft mode, from the control panel (**PRINT QUALITY** menu) and through some software programs and printer drivers. The default setting is OFF.



---

**CAUTION** HP does not recommend full-time use of EconoMode. If EconoMode is used full-time, it is possible that the toner supply will outlast the mechanical parts in the print cartridge.

---



---

**NOTE** EconoMode does not affect print speed or memory usage, or extend the life of the print cartridge.

---

## Input/output

The MFP receives print data primarily from the embedded HP Jetdirect print server. The MFP also has a USB device port for connecting directly to a computer, and two USB host ports for connecting third-party devices.

## CPU

The formatter incorporates a 480 MHz RISC processor.

## Memory

The formatter has 256 MB of on-board RAM.



---

**NOTE** If the MFP encounters a problem when managing available memory, a clearable warning message appears on the control panel.

---

## Hard disk

The MFP comes standard with a hard disk that has a capacity of greater than 40 GB. The hard disk can permanently store fonts and forms, make multiple original prints, and accommodate job-storage features.

## Random-access memory

The random-access memory (RAM) contains the page, I/O buffers, and the font storage area. It stores printing and font information received from the host system, and can also serve to temporarily store a full page of print-image data before the data is sent to the print engine.

## DIMM slot

Memory capacity can be increased by adding a memory DIMM to the formatter. Adding a memory DIMM might also increase the print speed for complex graphics.

## Firmware

The firmware is contained on NAND flash on the formatter. A remote firmware upgrade process is available, which overwrites the firmware on the NAND flash.

## Nonvolatile memory

The MFP uses nonvolatile memory (NVRAM) to store I/O and print-environment-configuration information. The contents of NVRAM are retained when the MFP is turned off or disconnected.

## HP Memory Enhancement technology

The HP Memory Enhancement technology (MEt) effectively doubles the standard memory through a variety of font- and data-compression methods.



---

**NOTE** The MEt is available only in PCL mode; it is not functional when printing in PS mode.

---

## PJL overview

The printer job language (PJL) is an integral part of configuration, in addition to the standard printer command language (PCL). With standard cabling, the MFP can use PJL to perform a variety of functions, such as these:

- Two-way communication with the host computer through a network connection or a USB device port. The MFP can inform the host about the control-panel settings, and the control-panel settings can be changed from the host.
- Dynamic I/O switching. The MFP uses this switching to be configured with a host on each I/O. The MFP can receive data from more than one I/O simultaneously, until the I/O buffer is full. This can occur even when the MFP is offline.
- Context-sensitive switching. The MFP can automatically recognize the personality (PS or PCL) of each job and configure itself to serve that personality.
- Isolation of print environment settings from one print job to the next. For example, if a print job is sent to the MFP in landscape mode, the subsequent print jobs print in landscape only if they are formatted for landscape printing.

## PML

The printer management language (PML) allows remote configuration and status readback through the I/O ports.

## Control panel

The formatter sends and receives MFP status and command data to and from a control-panel PCA.

## Scanner interface

The formatter receives data from the scanner to produce copies and to send scanned data in e-mail format.

## Engine-control system

The control system consists of three PCAs: the power supply PCA, the power-factor correction PCA, and the DC controller PCA. This system controls the laser/scanner, image-formation, and pickup-and-feed systems. The microprocessor on the DC controller PCA controls the operating sequence of the printer.

### DC controller PCA

The DC controller PCA controls the operation of the MFP and its components. The DC controller PCA starts the MFP operation when the MFP power is turned on and the power supply sends DC voltage to the DC controller PCA. After the MFP enters the standby sequence, the DC controller PCA sends out various signals to operate motors, solenoids, and other printer components based on the print command and image data that the host computer sends. [Figure 4-1 DC controller PCA block diagram on page 118](#) illustrates the DC controller function.

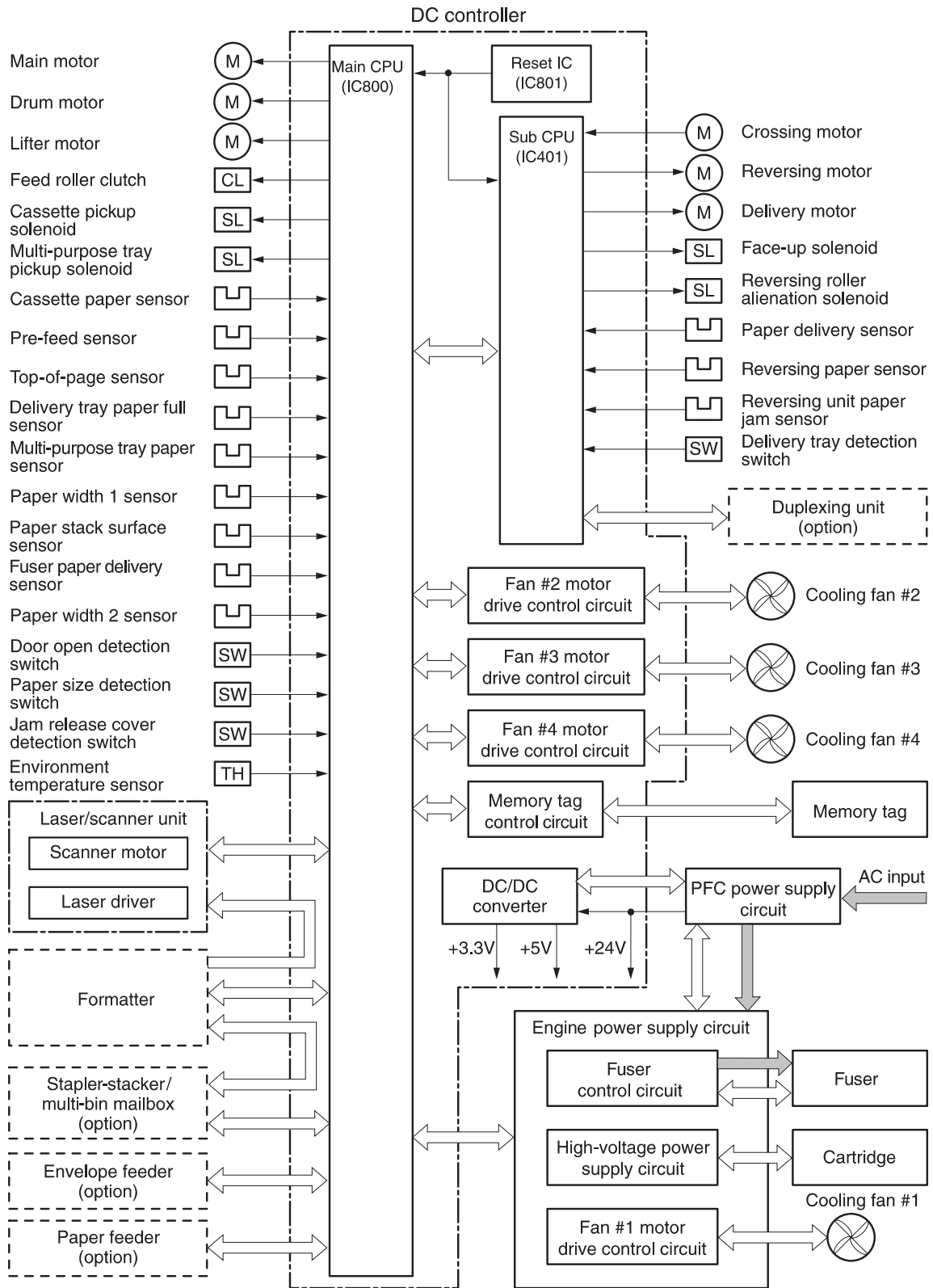


Figure 4-1 DC controller PCA block diagram



## Motors and fans

The MFP print engine has 10 motors: two brushless DC motors, one DC motor that has brushes, four fan motors, and three stepping motors. The MFP print engine also has four cooling fans. [Table 4-1 Print-engine motors on page 119](#) describes the function of each motor, and [Table 4-2 Print-engine fans on page 119](#) describes the function of each fan.

### Motor and fan functions

**Table 4-1** Print-engine motors

Name	Purpose	Type	Rotation	Speed	Failure detection
Main motor (M101)	Drives the following rollers: tray 2 pickup, feed, separation, tray 1 pickup, pre-transfer, pressure, and delivery	DC motor (brushless)	Clockwise	2-speed	Yes
Drum motor (M102)	Drives the transfer-charging roller, photosensitive drum, and developing cylinder	DC motor (brushless)	Clockwise	2-speed	Yes
Lifter motor (M103)	Moves the lifting plate	DC motor (with brushes)	Clockwise	1-speed	Yes
Crossing motor (M104)	Drives the crossing roller	Stepping motor	Clockwise	3-speed	No
			Counterclockwise	2-speed	
Reversing motor (M105)	Drives the reversing roller	Stepping motor	Clockwise	3-speed	No
			Counterclockwise	2-speed	
Delivery motor (M106)	Drives the intermediate delivery roller and the delivery roller	Stepping motor	Clockwise	4-speed	No

**Table 4-2** Print-engine fans

Name	Purpose	Motor type	Motor rotation	Motor speed	Failure detection
Cooling fan 1 (FN101)	Cools the interior of the print engine	DC motor		2-speed	Yes
Cooling fan 2 (FN102)	Cools the print-cartridge area	DC motor		1-speed	Yes
Cooling fan 3 (FN103)	Cools the reversing-unit area	DC motor		1-speed	Yes
Cooling fan 4 (FN104)	Cools the DC controller	DC motor		1-speed	Yes

## Ambient-temperature detection

The MFP contains a sensor that measures the air temperature of the surrounding environment. The MFP automatically adjusts the temperature settings in the fuser to adjust for changes in the ambient temperature.

## Engine power supply circuit

The engine power supply consists of the fuser-control circuit, the high-voltage circuit, and the low-voltage circuit. The fuser-control and high-voltage circuits control the temperature of the fuser and generate high-voltage according to signals from the DC controller PCA. The low-voltage circuit generates the DC voltages that other MFP components use (for example the DC controller PCA, the motors, and fans).

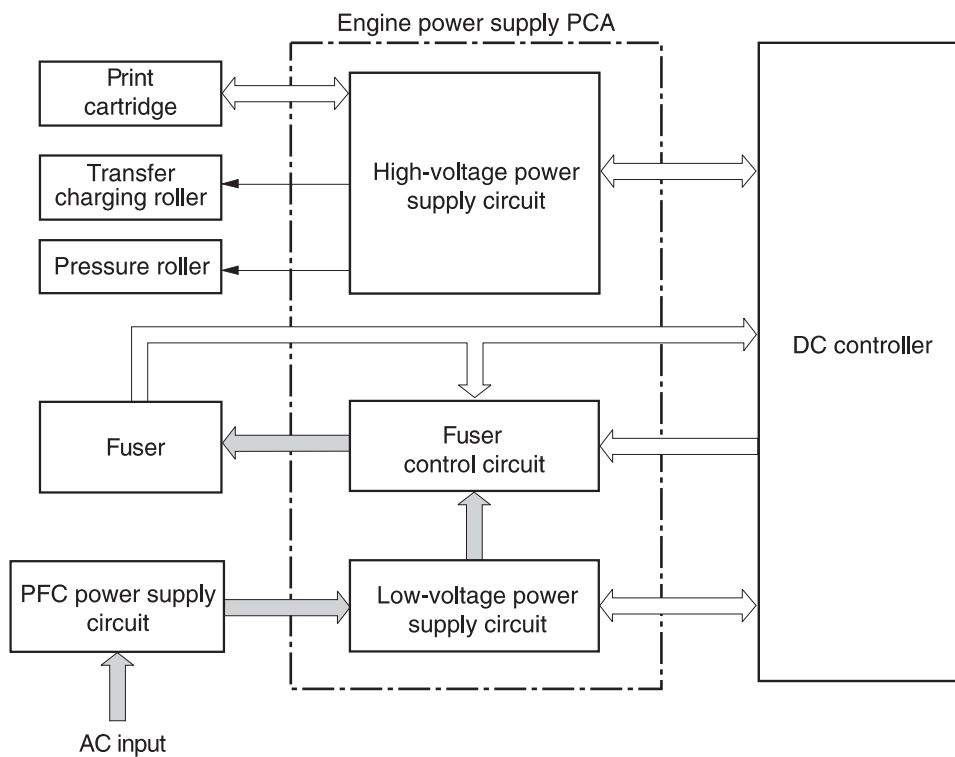
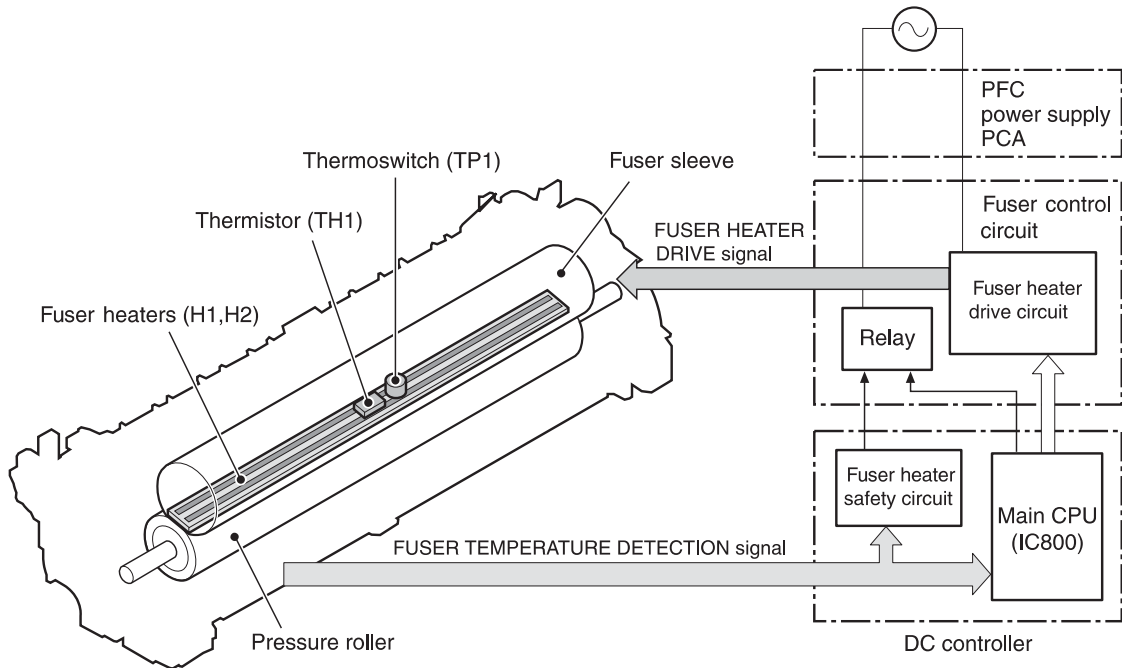


Figure 4-2 Power supply circuit block diagram

## Fuser control

The fuser-control circuit controls the fuser components. The two fuser heaters provide the high temperatures that permanently bond the toner to the media. The fuser thermistor monitors the fuser temperatures. The thermal switch detects abnormally high fuser temperatures and interrupts the supply of voltage to the fuser if the temperature is determined to be too high.



**Figure 4-3** Fuser components

The fusing-heater safety circuit is located on the power supply and constantly monitors the fusing temperature. The fusing heater adjusts the temperature of the fuser as required by the stage in the printing process.

- **Start-up temperature control:** The thermistor on the fuser heater has two different modes depending on the temperature of the fuser when a print job is sent. If the fuser temperature is below 85°C (185°F), the fuser continues to heat until it reaches a temperature of 100°C (212°F), and then the main motor actuates. If the fuser temperature is 85°C (185°F) or higher at the beginning of a print job, the main motor is actuated immediately.
- **Print temperature control:** The fuser temperature is maintained at a target temperature throughout a print job. This target temperature varies depending on the type of media and the number of pages in the print job.
- **Between-pages temperature control:** When printing on smaller-sized media, the fuser temperature is decreased between the pages to prevent an abrupt rise in temperature because of the larger gap between pages.
- **Print-speed adjustment to control temperature:** For certain types of media and when printing several pages continuously, the interval between pages is increased to allow the fuser to maintain the temperature that is required for good fusing. If the fuser cools too much, the toner is not correctly fused to the media.

## Fuser over-temperature protection

To protect the fuser from excessive temperatures, the MFP has the following three protective functions:

- The CPU monitors the voltage of the thermistor. If the fuser temperature reaches 240° C (464° F) or higher, the CPU turns off the relay (RL101) to interrupt the power to the fusing heater.
- If the temperature of the fusing heater continues to rise abnormally and the temperature of the thermistor (TH1) exceeds about 250°C (482°F), the relay 1 (RL101) opens up to cut off the power supply to the fusing heater.
- When the temperature of the heater exceeds about 250°C (482°F), the thermal switch (TP1) is turned off to cut off the power supply to the fusing heater. In the rare instance that this happens, the fuser must be replaced.

[Figure 4-4 Fuser circuit on page 123](#) illustrates the fuser circuit.

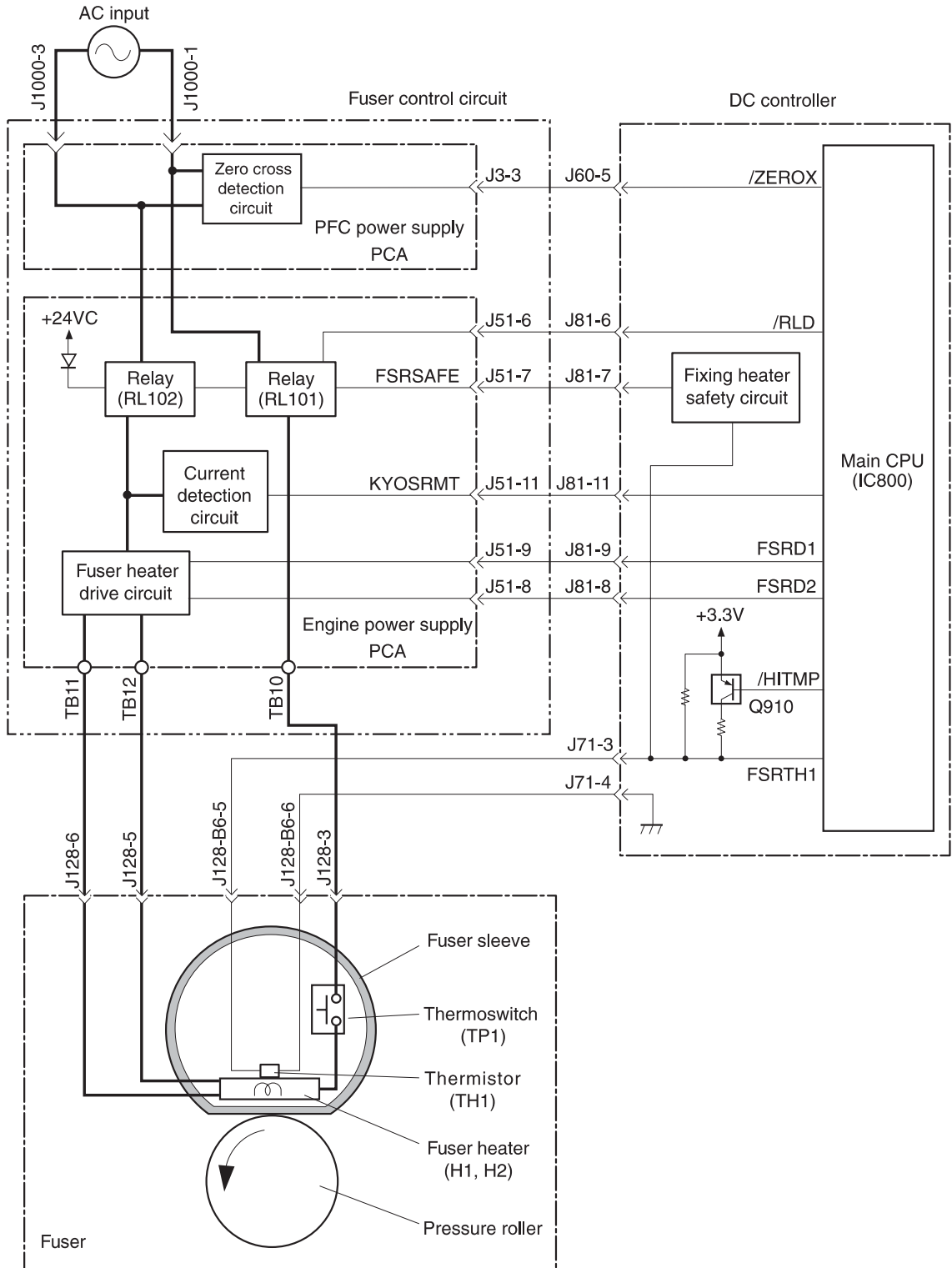
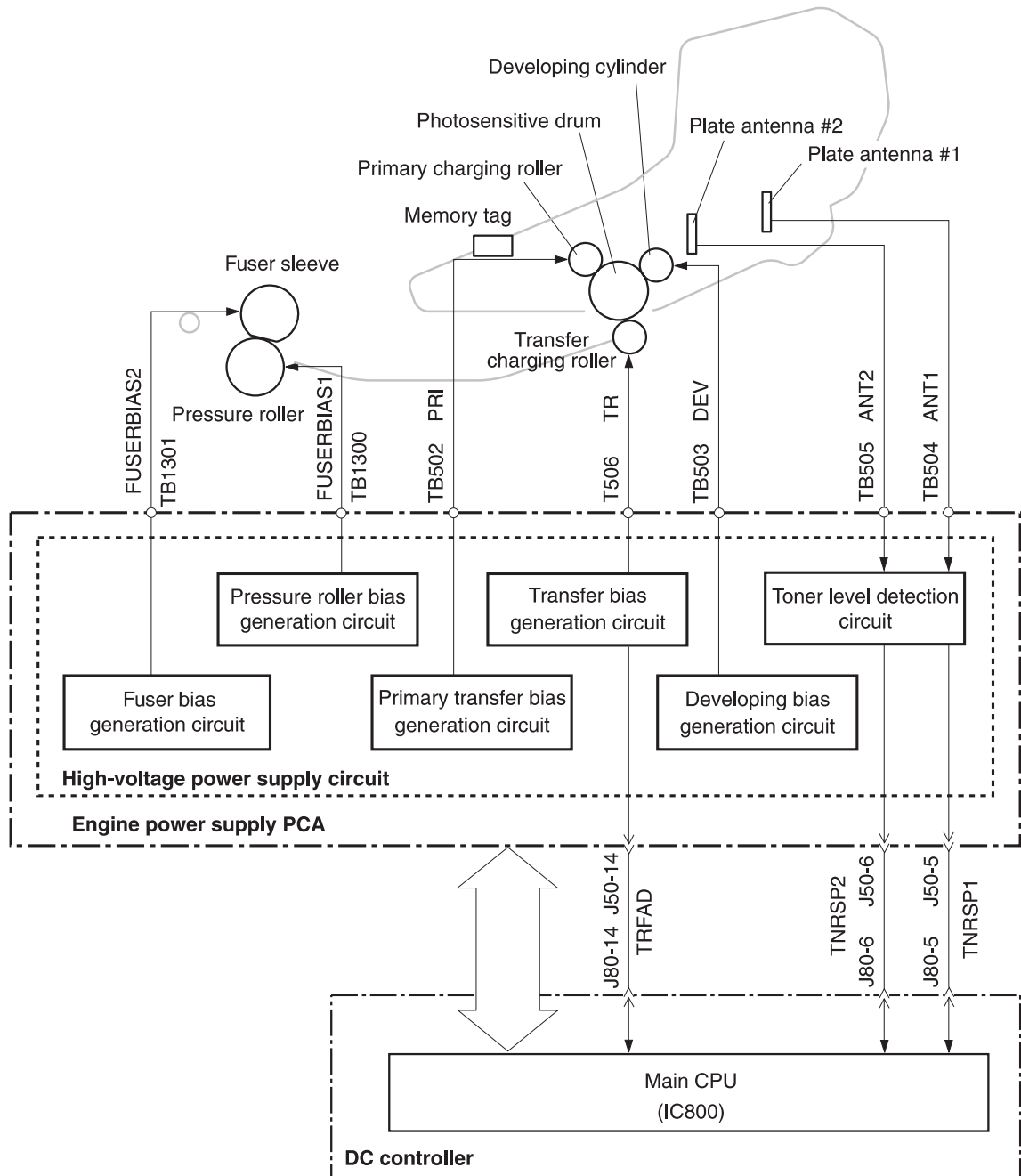


Figure 4-4 Fuser circuit

## High-voltage power supply

The high-voltage circuit produces the voltage biases that are applied to the primary charging roller, the developing cylinder, the transfer charging roller, the fuser sleeve, and the pressure roller.



**Figure 4-5** High-voltage power supply circuit

The primary charging voltage (bias) applies a uniform negative charge to the photosensitive drum in the print cartridge. Two types of primary charging bias are used: the primary charging DC negative voltage and the primary charging AC bias. The high-voltage circuit on the power supply generates both biases. These biases are superimposed on one another and then applied to the primary charging roller, which transfers the biases to the drum. The laser/scanner assembly generates the

electrostatic image on the primary charged photosensitive drum. The electrostatic image cannot be seen until toner is deposited on the drum.

The developing voltage (bias) causes the toner to adhere to the electrostatic image that the laser/scanner assembly created on the photosensitive drum. Two types of developing biases are used: the developing DC negative bias and the developing AC bias. The high-voltage circuit on the power supply generates both biases. These biases are superimposed on one another and then applied to the primary charging roller, which transfers the biases to the drum. The biased developing cylinder picks up toner particles and deposits them onto the electrostatic image on the photosensitive drum. The image is now visible on the drum.

The transfer voltage (bias) transfers the toner image on the photosensitive drum to the media. Two types of developing biases are used: the transfer DC positive bias and the DC negative bias. The high-voltage circuit on the power supply generates both biases. Transfer DC positive bias is applied to the transfer roller during the toner-transfer process. Transfer DC positive bias is applied to the transfer roller during the transfer-roller cleaning process. The DC positive bias attracts the toner to the media (this transfers the toner image on the photosensitive drum to the media). This bias is weakened between pages to prevent residual toner that is on the photosensitive drum from adhering to the transfer-charging roller when media is not present. The DC-negative bias is used to clean residual toner off of the transfer roller.

The fuser pressure-roller voltage (bias) prevents toner on the media from sticking to the fuser's pressure roller. The pressure-roller bias is DC-positive.

The fuser-sleeve voltage (bias) prevents toner on the media from sticking to the fuser sleeve. The fuser-sleeve bias is DC-negative.

## Low-voltage power supply

The low-voltage circuit converts the AC power from the power source into the direct current voltage (Vdc) that the MFP components use. The low-voltage power supply circuit has three components:

- The **power-factor controller power supply** converts the AC voltage to DC voltage.
- The **engine power supply** generates the +24 Vdc that the high-voltage power supply requires.
- The **DC controller** generates the +5 Vdc that the laser/scanner and formatter require, and the +3.3 Vdc that the sensors and control-panel require.

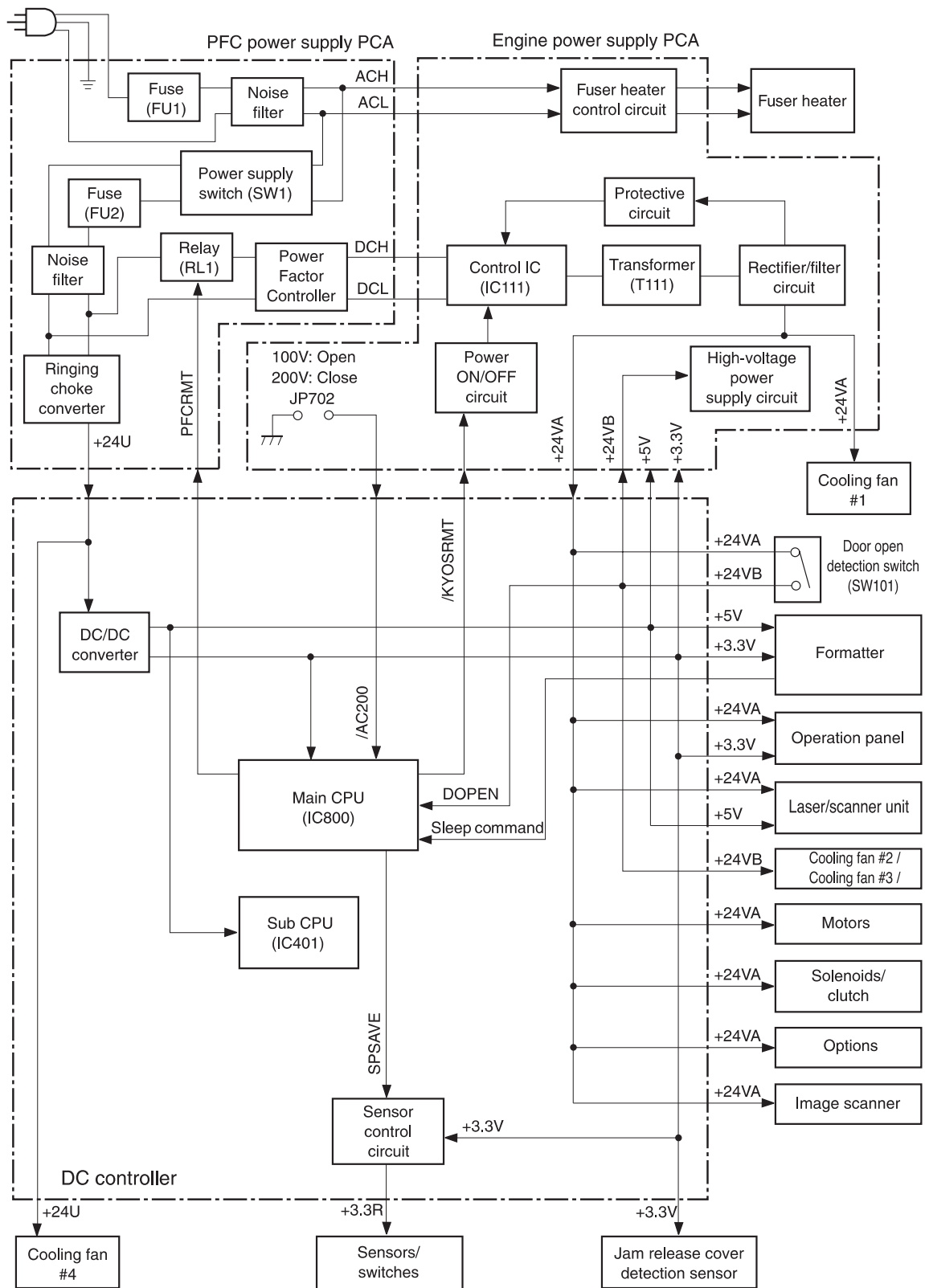
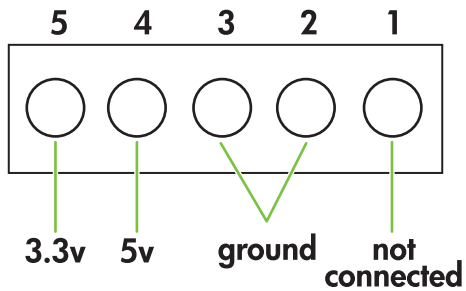


Figure 4-6 Low-voltage power supply circuit





**Figure 4-7** Hard-disk power connector

## Overcurrent/overvoltage protection

If a short-circuit or other problem on the load side causes an excessive current flow or generates abnormal voltage, the overcurrent/overvoltage protection systems automatically cut off the output voltage to protect the power supply circuit.

If the overcurrent or overvoltage protection system is activated and the power supply circuit does not generate DC voltage, turn the power off, correct the problem, and then turn the MFP on again.

The circuit has two fuses (FU1, FU2) that break and cut off the output voltage if overcurrent flows through the AC line.

## Toner detection

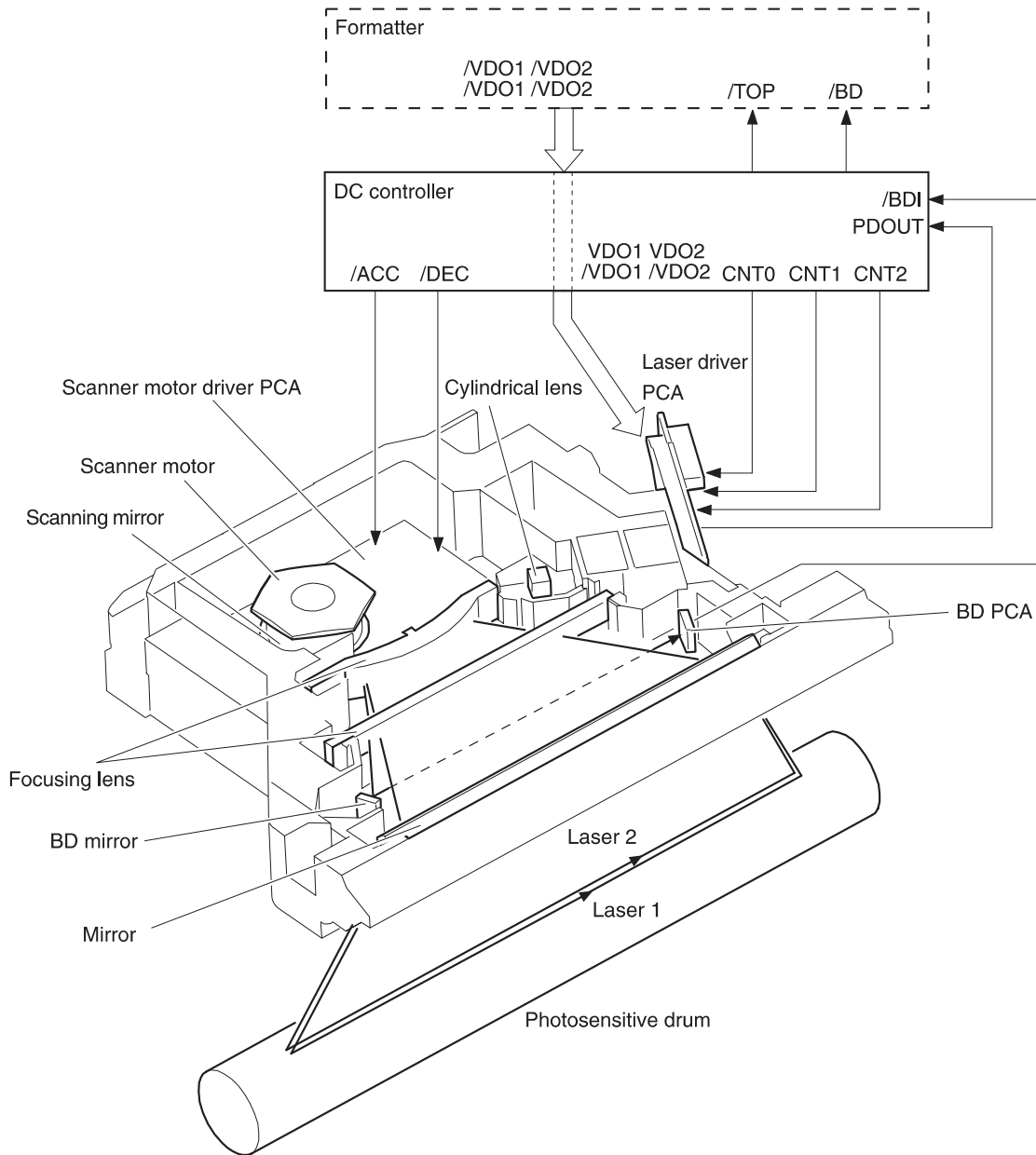
To monitor the toner level, the MFP uses two plate antennas and a toner-level circuit in the high-voltage power supply circuit. The DC controller PCA detects the toner level and monitors the output signal of the toner-level circuit. The signal is fed back to the DC controller PCA from the antennas during the wait and standby operating periods. The DC controller PCA detects toner level from 1% to 100%. If the DC controller PCA detects a low toner level, a message appears on the control-panel display.

## Cartridge detection

The DC controller PCA detects the presence of the cartridge by using information stored in plate antenna 2 and the print-cartridge memory tag. The DC controller PCA detects the presence or absence of the print cartridge during the wait period.

## Laser/scanner system

The laser/scanner produces the latent electrostatic image on the photosensitive drum in the print cartridge. The main components of the laser/scanner assembly are the laser driver PCA, the scanner motor, various mirrors, and the focusing lenses.



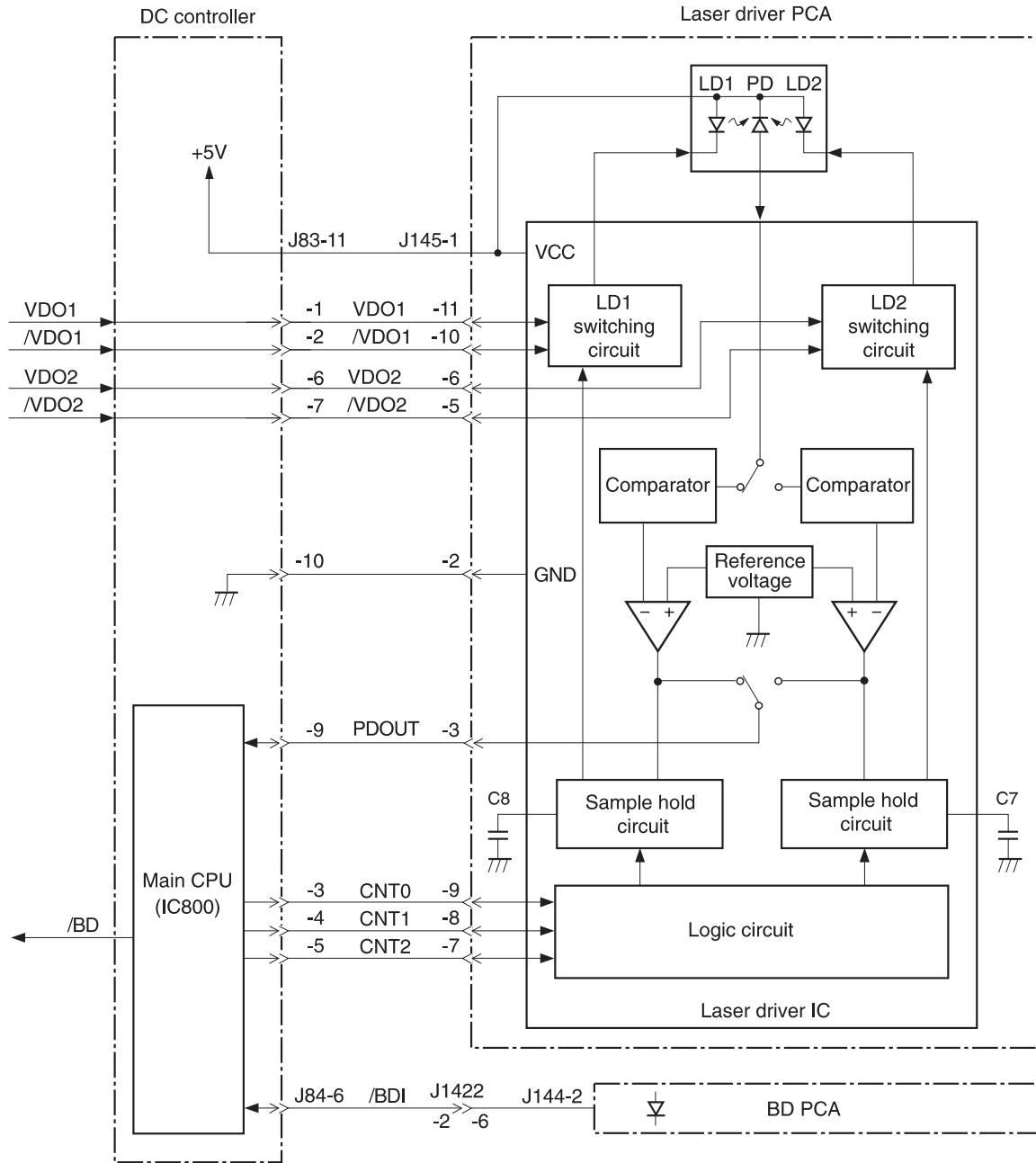
**Figure 4-8** Laser/scanner assembly

The laser scanner uses two laser diodes to scan two lines simultaneously, producing high-speed laser scanning. After receiving the print command from the host computer, the DC controller PCA activates the scanner motor, which rotates the six-sided scanner mirror. The laser driver PCA emits light from the two laser diodes according to signals from the DC controller PCA. The two laser beams strike the six-sided scanning mirror and are directed through the focusing lenses and onto the

photosensitive drum. The modulated laser beams generate the latent electrostatic image on the photosensitive drum according to the image data signals that are received from the DC controller PCA.

## Laser/scanner control

The laser/scanner-control circuit on the laser driver PCA turns the laser diodes on and off according to image-data signals that the DC controller PCA sends. The DC controller PCA sends image-data signals VD01/VD01, VD02, and /VD02 and the laser-control signals CNT0, CNT1, and CNT2 to the logic circuit on the laser driver PCA. The laser-control signals control laser emission, automatic power control (APC), horizontal-synchronization control, and image-mask control. [Figure 4-9 Laser-control-circuit block diagram on page 130](#) illustrates the laser-control system.



**Figure 4-9** Laser-control-circuit block diagram

Laser-emission control simply turns the laser diodes on and off. Automatic power control limits the amount of light that the laser diodes emit. Horizontal-synchronization control determines the starting position for the horizontal direction of the image. Image-mask control prevents laser beams from striking the non-imaging areas of the drum, which is approximately 5 mm (0.2 inch) along the vertical edges and 8 mm (0.3 inch) at the top and bottom.

# Image-formation system

The image-formation system consists of the print cartridge, transfer-charging roller, and fuser.

When the formatter sends a print command, the engine controller drives the main motor to rotate the photosensitive drum, primary-charging roller, developing cylinder, transfer-charging roller, and pressure roller.

The primary charging roller applies a uniform negative charge to the photosensitive drum surface. Laser beams, modulated by the signals from the formatter, focus on the photosensitive drum surface to form a latent image on the photosensitive drum.

The developing cylinder develops the latent image into a visible, toner-based image. The transfer-charging roller then transfers the toner onto media. Heat and pressure in the fuser bonds the toner to the print media in order to form a permanent image. The cleaning blade scrapes residual toner from the photosensitive drum, and the primary-charging roller applies a uniform negative charge to the photosensitive drum surface in preparation for the next latent image.

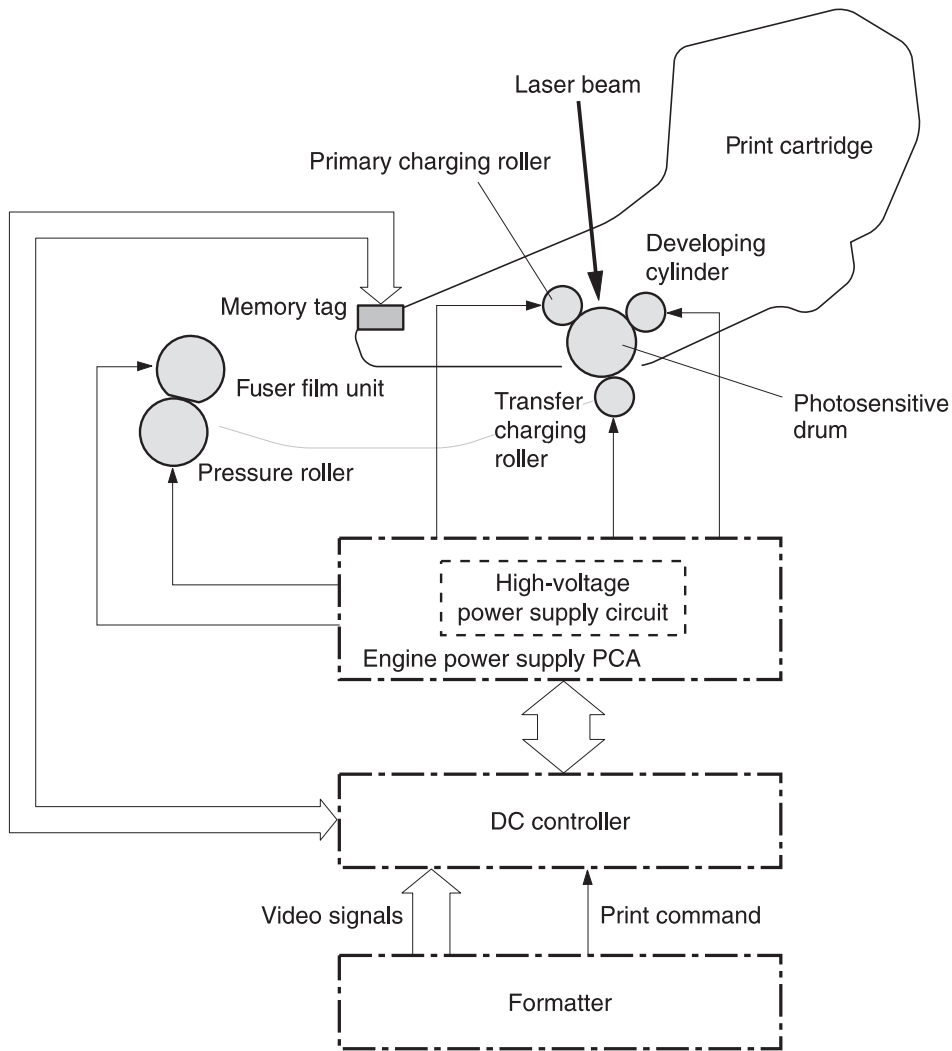


Figure 4-10 Image-formation system

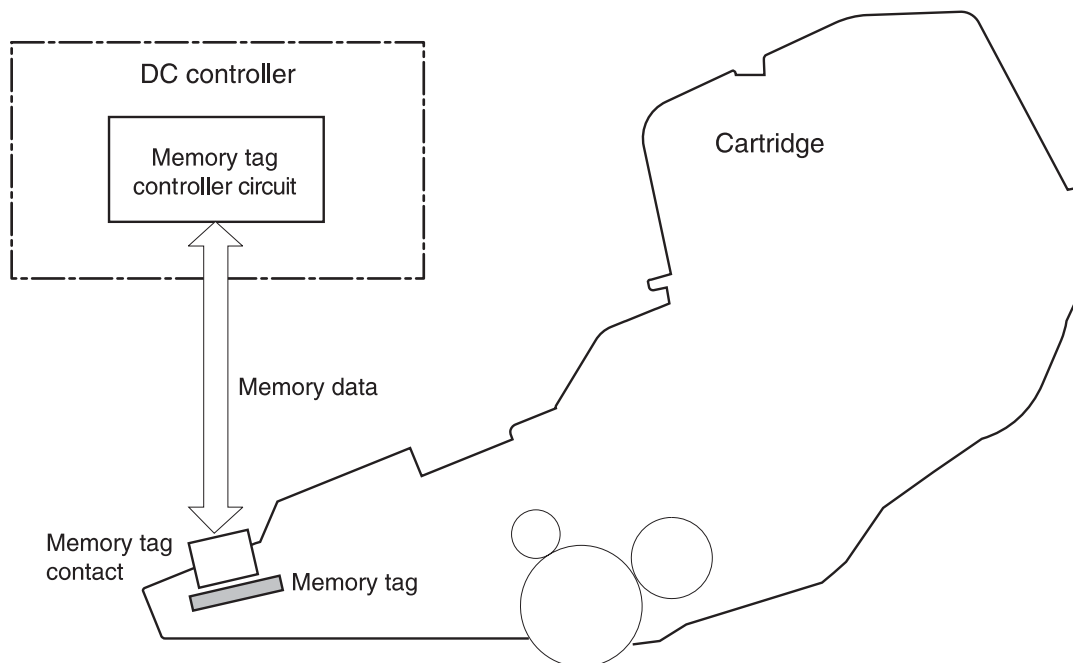
## Print cartridge

The print cartridge contains the primary-charging roller, photosensitive drum, and developing cylinder. The print cartridge has built-in memory that records the number of rotations and the toner level. This information is passed to the DC controller, which sends an alert when the remaining print-cartridge life reaches a low threshold.

## Cartridge memory

The cartridge memory is EEPROM built into the cartridge, so that the MFP can detect the cartridge conditions.

The cartridge memory read/write is performed by the memory controller board through the antenna unit. The DC controller PCA reads the cartridge information and writes that information to the memory. The memory read/write process is implemented when the memory controller board receives a command from the DC controller PCA at the following timing.



**Figure 4-11** Cartridge memory

### Reading timing

- When the power is turned on
- When the door is closed
- When the DC controller PCA receives a command from the formatter

### Writing timing

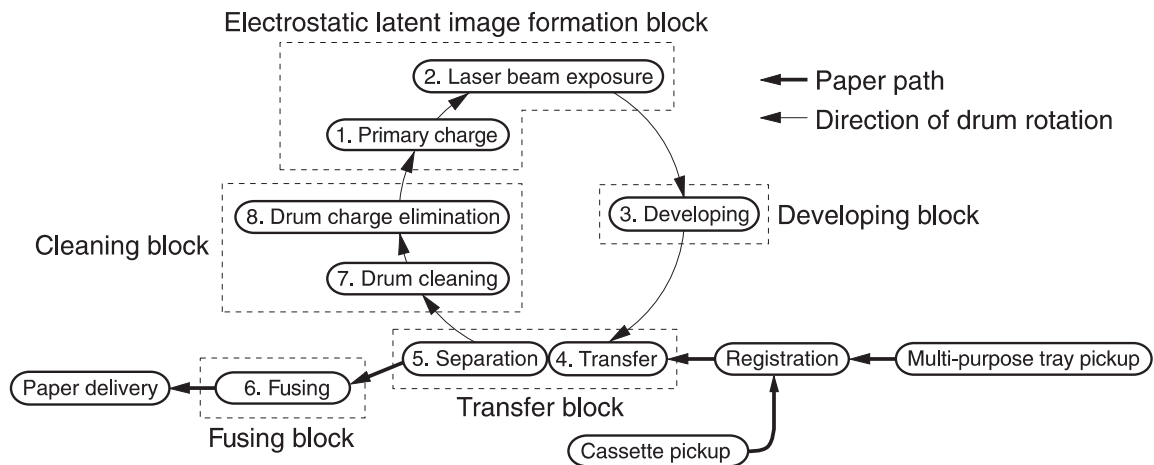
- When printing is completed
- When the DC controller PCA receives a command from the formatter

The memory data that the memory controller sends also contains the status of any error that has occurred during the read/write operation. When the error status is sent, the DC controller PCA makes up to four attempts to read the operation. If the error is not cleared after the operation, the DC controller PCA determines one of the following error conditions: sub-CPU failure, memory-data abnormality, or memory-access abnormality.

**CAUTION** Removing the print cartridge when the top cover interlock is overridden disables the cartridge memory.

## Image-formation process

The image-formation process is divided into stages.



**Figure 4-12** Stages of image-formation

- 1. Primary charge (conditioning)**—The primary-charging roller in the print cartridge applies a uniform negative charge to the surface of the drum. The primary-charging roller is made of conductive rubber. An AC bias is applied to the roller to erase any residual charges from any previous image. A negative DC bias is applied by the charging roller to create a uniform negative potential on the drum surface.
- 2. Laser-beam exposure (writing)**—Two laser diodes project laser beams onto a rotating scanning mirror. As the mirror rotates, the beams reflect off of the mirror, first through a set of focusing lenses, then off a mirror, and finally through a slot in the top of the toner cartridge, and onto the photosensitive drum. The twin beams sweep the drum from left to right, discharging the negative potential wherever the beams strike the surface. This creates a latent electrostatic image, which later is developed into a visible image.
- 3. Developing**—At this stage of the process, the latent electrostatic image is present on the drum. The toner particles obtain a negative surface charge by rubbing against the developing cylinder, which is connected to a negative DC supply. The negatively charged toner is attracted to the discharged (exposed, grounded) areas of the drum, and is repelled from the negatively charged (unexposed) areas.
- 4. Transfer**—During the transfer process, the toner image on the drum surface is transferred to the paper. The transfer charging roller applies a positive charge to the back of the paper and causes the negatively charged toner on the drum surface to be attracted to the paper. After separation, the drum is cleaned and conditioned for the next image.

5. **Separation**—During the separating process, the paper separates from the drum. To stabilize the feed system and to prevent dropouts on the printed image at low temperature and humidity, the static-charge eliminator reduces the charge on the back of the paper.
6. **Fusing**—During the fusing process, heat and pressure fuse the toner to the paper in order to produce a permanent image. The paper passes between a heated fuser element and a soft pressure roller. This melts the toner and presses it into the paper.
7. **Drum cleaning**—The cleaning blade is in contact with the surface of the drum at all times. As the drum rotates during printing, excess toner is scraped off and stored in the waste-toner receptacle.



## Pickup, feed, and delivery system

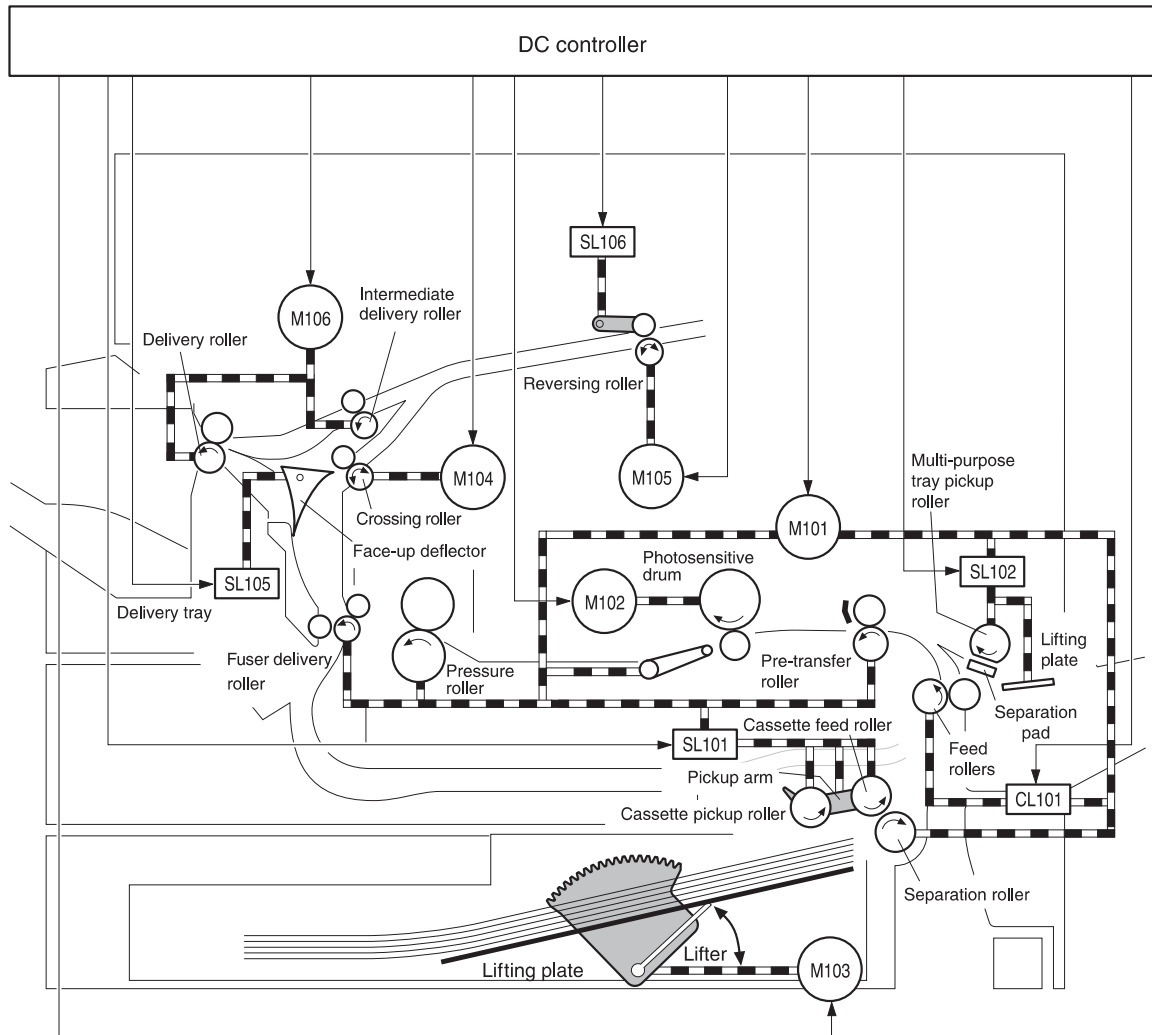
The pickup-and-feed system consists of various rollers that the printer motors drive. The MFP uses tray 1 (the manual feeding tray) and a cassette in tray 2 as media sources. The printed media is delivered to the output device that is installed. The output device can be the standard output bin, the 3-bin mailbox, or the stapler/stacker. Only one output device can be installed. Three additional 500-sheet feeders can be added to the MFP. These input and output accessories are discussed later in this chapter.

The MFP has a built-in reversing unit that can deliver the pages either face-up or face-down. Face-down output, which is the default, is the fastest method, and pages are stacked in the correct order. Face-up output uses the straightest paper path, but pages are stacked in the reverse order.

The tray 1 paper sensor (on the tray 1 pickup assembly; PS105) detects media in tray 1. The tray 2 paper sensor (PS101) detects media in tray 2. The paper-stack-surface sensor (PS107) and the paper-size-detection switch (SW102) detect the media that is loaded in the tray 2 cassette.

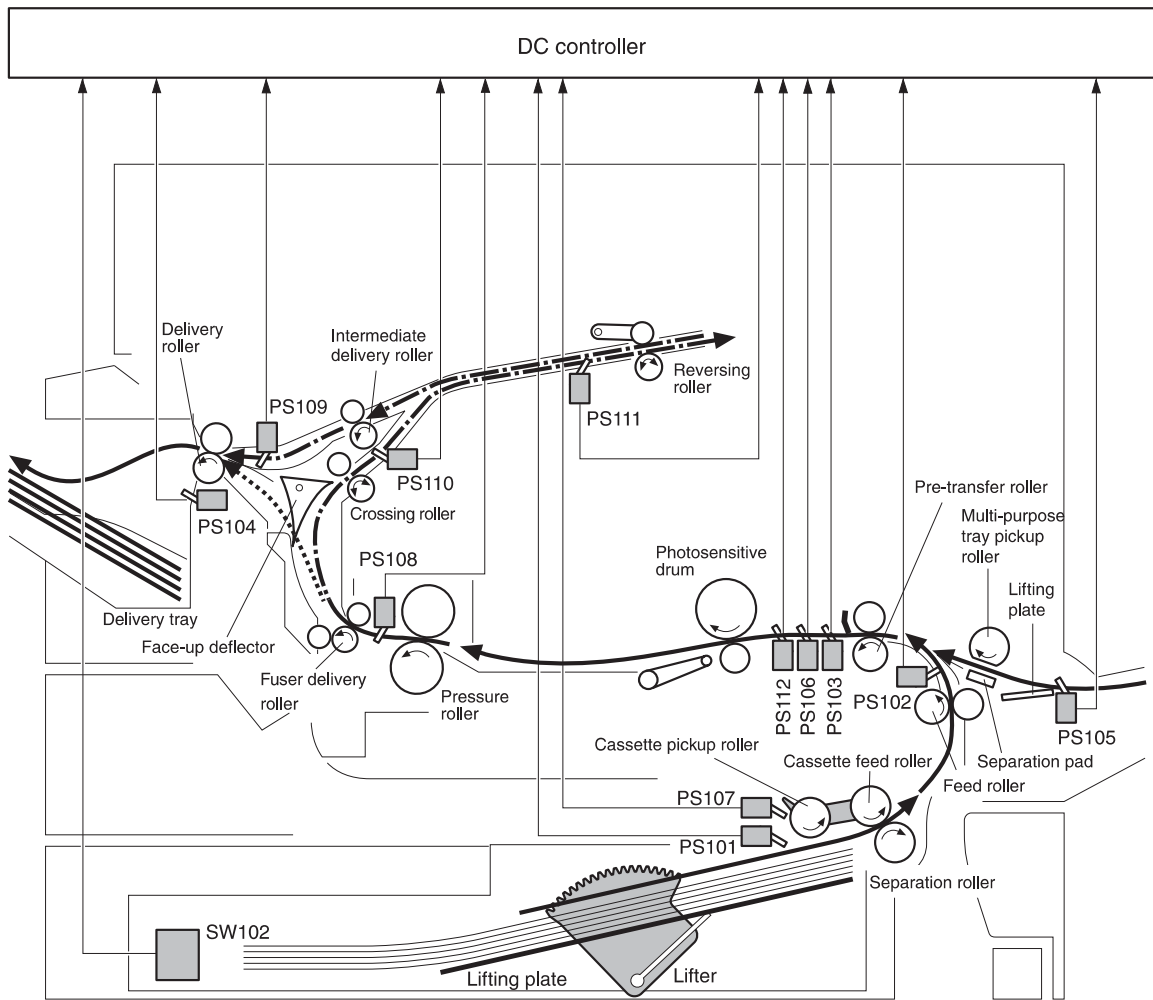
The pickup operation uses three motors (M101, M102, and M103), a clutch (CL101), and two solenoids (SL101 and SL102). The delivery operation uses five motors (M101, M102, M104, M105, and M106) and two solenoids (SL105 and SL106) for the delivery sequence. For the locations of these components, see [Figure 4-13 Motor, clutch, and solenoid locations on page 136](#).

Six photosensors (PS102, PS103, PS108, PS109, PS110, and PS111) detect media arriving and passing along the paper path. For the locations of these sensors, see [Figure 4-14 Sensor and switch locations on page 137](#). If the media does not reach or pass these sensors within a specific amount of time, the microprocessor on the DC controller PCA halts the MFP functions and a jam error message appears on the control-panel display.



- |                        |  |
|------------------------|--|
| M101 : Main motor      | CL101 : Feed roller clutch                   |
| M102 : Drum motor      | SL101 : Cassette pickup solenoid             |
| M103 : Lifter motor    | SL102 : Multi-purpose tray pickup solenoid   |
| M104 : Crossing motor  | SL105 : Face-up solenoid                     |
| M105 : Reversing motor | SL106 : Reversing roller alienation solenoid |
| M106 : Delivery motor  |  |

**Figure 4-13** Motor, clutch, and solenoid locations

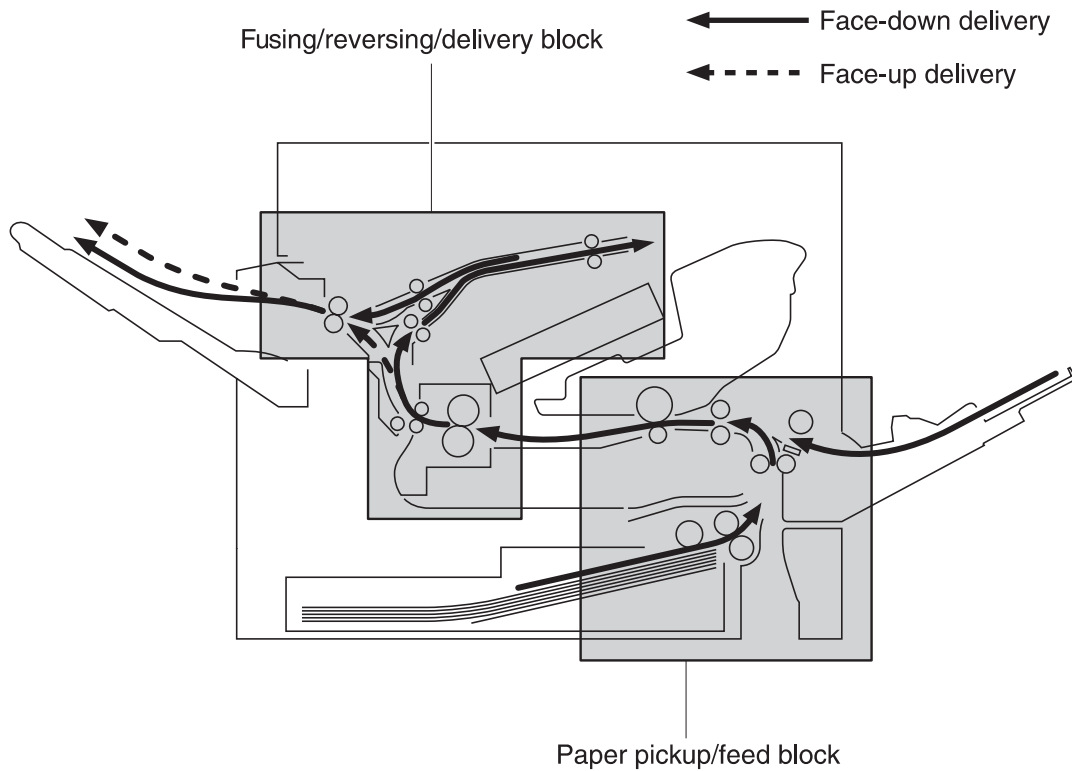


- |   |   |
|---|---|
| PS101 : Cassette paper sensor           | PS108 : Fuser paper delivery sensor     |
| PS102 : Pre-feed sensor                 | PS109 : Paper delivery sensor           |
| PS103 : Top of page sensor              | PS110 : Reversing paper sensor          |
| PS104 : Delivery tray paper full sensor | PS111 : Reversing unit paper jam sensor |
| PS105 : Multi-purpose tray paper sensor | PS112 : Paper width 2 sensor            |
| PS106 : Paper width 1 sensor            | SW102 : Paper size detection switch     |
| PS107 : Paper stack surface sensor      |   |

**Figure 4-14** Sensor and switch locations

The pickup, feed, and delivery system is divided into two parts:

- The **pickup and feed block** contains the paper path from each tray and stops at the fuser entrance.
- The **fusing/reversing/delivery block** contains the paper path from the fuser entrance to the output device.



**Figure 4-15** Pickup, feed, and delivery system

## Pickup-and-feed block

The following functions occur in the pickup-and-feed block:

- Detecting media presence
- Detecting media size
- Detecting when media enters the paper path from the trays
- Lifting the tray 2 paper plate
- Preventing multifeeds
- Adjusting the distance between pages
- Correcting page skew

## Printing from tray 1

The tray 1 paper sensor (PS105) detects the presence of media in tray 1.

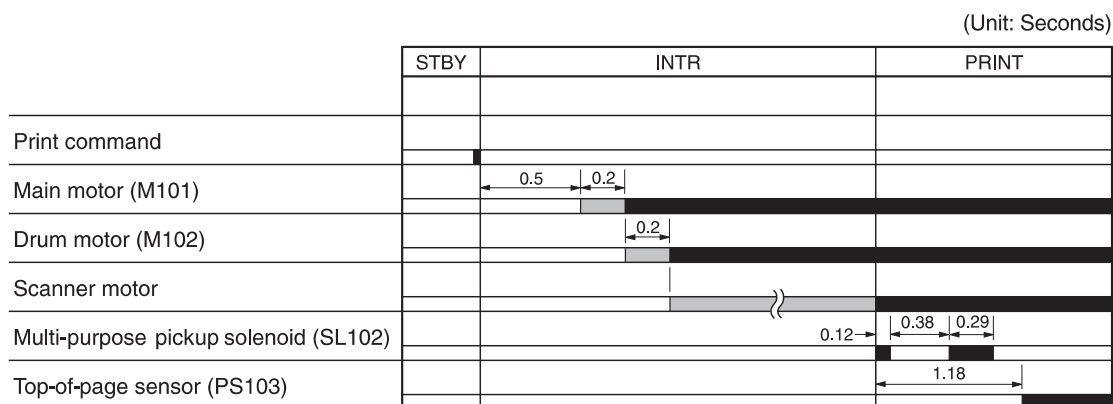
When the DC controller PCA receives the print command, the printer starts the initial rotation phase, which consists of the main motor warm-up, scanner motor warm-up, high-voltage control sequence, and fuser warm-up. When the initial rotation phase ends, the tray 1 pickup solenoid (SL102) is activated.

The cam rotates, the paper-tray lifter rises, and the media comes in contact with the tray 1 pickup roller. At the same time, the tray 1 pickup roller rotates twice and picks up a sheet of media from tray 1. The separation pad prevents additional sheets from feeding with the first sheet.

When the sheet reaches the registration assembly, its skew is corrected. The sheet then passes through the transfer, separation, and fusing stages, and through the delivery unit, and is then delivered to the output bin.



**NOTE** If media is removed from tray 1 after the initial rotation phase but before the pickup roller pulls the media from the tray, the tray 1 pickup roller might continue to rotate up to six times, after which a jam is detected.



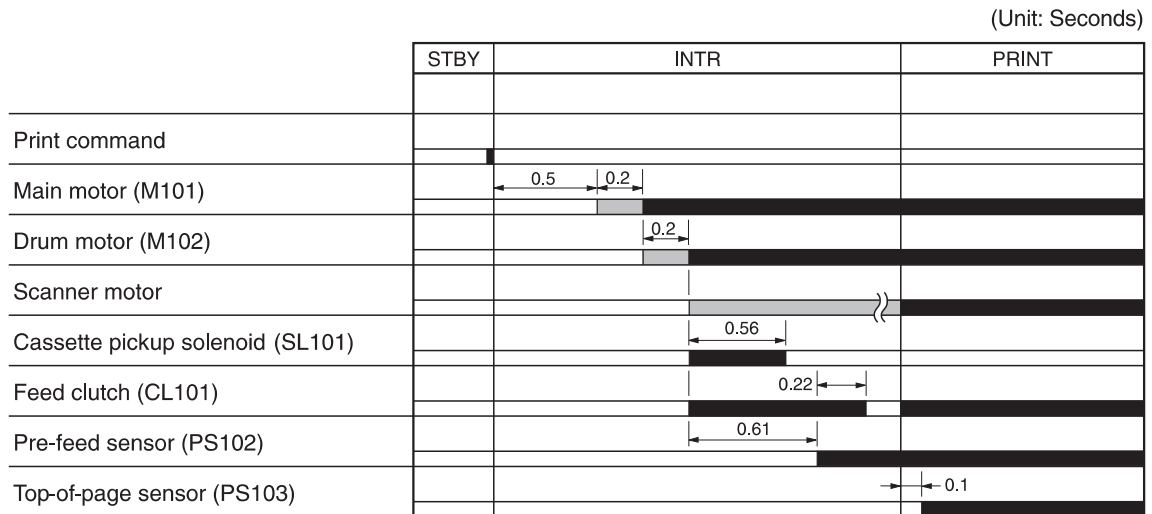
**Figure 4-16** Tray 1 timing

## Printing from tray 2

When the DC controller PCA receives print command, the main motor (M101) and scanner motor start their rotation. When the main motor reaches its prescribed speed, the feed-roller clutch (CL101) and tray 2 pickup solenoid (SL101) are activated. (The main motor rotation drives the tray 2 pickup roller, tray 2 feed roller, tray 2 separation roller, and paper-feed rollers.)

The pickup solenoid activates the tray 2 pickup roller, which rotates once and picks up the media in the tray. The separation roller prevents additional sheets from feeding with the first sheet, and the media is fed to the pre-feed sensor (PS102).

When the sheet reaches the registration assembly, its skew is corrected. The sheet then passes through the transfer, separation, and fusing stages, and through the delivery unit, and then is delivered to the output bin.



**Figure 4-17** Tray 2 timing

## Media-size detection

The MFP has three media-size detection systems:

- Cassette (trays 2, 3, 4, and 5) media-size detection
- Media-length detection
- Media-width detection

## Cassette media-size detection

The media-size detection switch (SW102) has two functions: it detects the presence of the cassette, and it detects the size of the media that is loaded in the cassette. This switch has upper, middle, and lower components that act together to detect the cassette presence and the media size.

**Table 4-3** Cassette media-size detection switch components

Cassette presence or media size	Upper switch	Middle switch	Lower switch
No cassette	Off	Off	Off
A4	Off	Off	On
LTR	Off	On	Off
B5	Off	On	On
A5	On	Off	Off
EXE	On	Off	On
LGL	On	On	Off
UNV	On	On	On

## Media-length detection

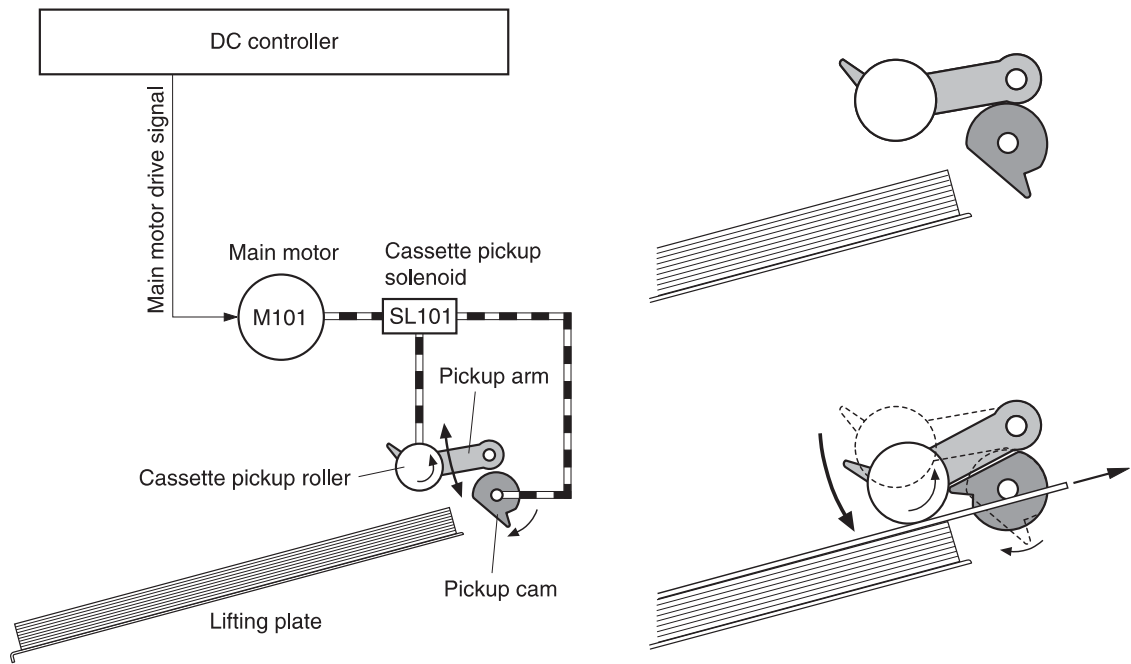
The top-of-page sensor (PS103) determines the length of the media by measuring the time between detecting the leading and trailing edges. If this size does not match the size that SW102 detects or the size that the formatter specifies, the DC controller sends a signal to the formatter. If the media size that PS103 measures is shorter than the media size that the user selected, the formatter masks part of the image to prevent extra toner from transferring from the photosensitive drum to the transfer-charging roller.

## Media-width detection

Two media-width sensors (PS106 and PS112) act together to determine if the media is narrower than expected or is skewed. If either of these conditions is detected, the DC controller adjusts the fuser temperature to prevent overheating. PS106 detects media that is narrower than 122 mm (4.8 inches). PS112 detects media that is narrower than 188 mm (7.4 inches).

## Cassette pickup operation

The DC controller turns on the cassette pickup solenoid (SL101) and the main motor (M101) drives the cassette pickup roller and the cassette pickup cam. The cam causes the arm that is attached to the pickup roller to swing down, and the pickup roller contacts the surface of the paper stack. One sheet of media is fed into the MFP.



**Figure 4-18** Cassette pickup operation



### Lifter-driver operation

The lifter driver keeps the media stack surface at a specific level in order to have a stabilized pickup operation regardless of the size of the media in the tray 2 cassette. The DC controller PCA operates the lifter-driver motor (M103) for 30 milliseconds. The motor stops when the paper-stack-position sensor (PS107) detects the media. If the paper-stack-position sensor does not detect any media within 8 seconds after the lifting operation has begun, the DC controller PCA determines that a lifter-driver motor failure has occurred, and a message appears on the control-panel display. The DC controller PCA stops the lifting operation if the paper-stack-position sensor detects the absence of the tray 2 cassette.

### Multifeed prevention

The MFP uses the separation roller in tray 2 to prevent multiple-feeding. The separation roller rotates in the same direction as the feed roller. The separation roller is equipped with a torque limiter, but because the force of the feed roller exceeds that of the torque limiter, the separation roller is actually driven by the feed roller.

If multiple sheets of media are picked up, however, the low friction force between the sheets weakens the rotational force from the feed roller to the separation roller. Consequently, the torque limiter takes control of the separation roller and rotates it in the reverse direction, which removes the extra sheets.

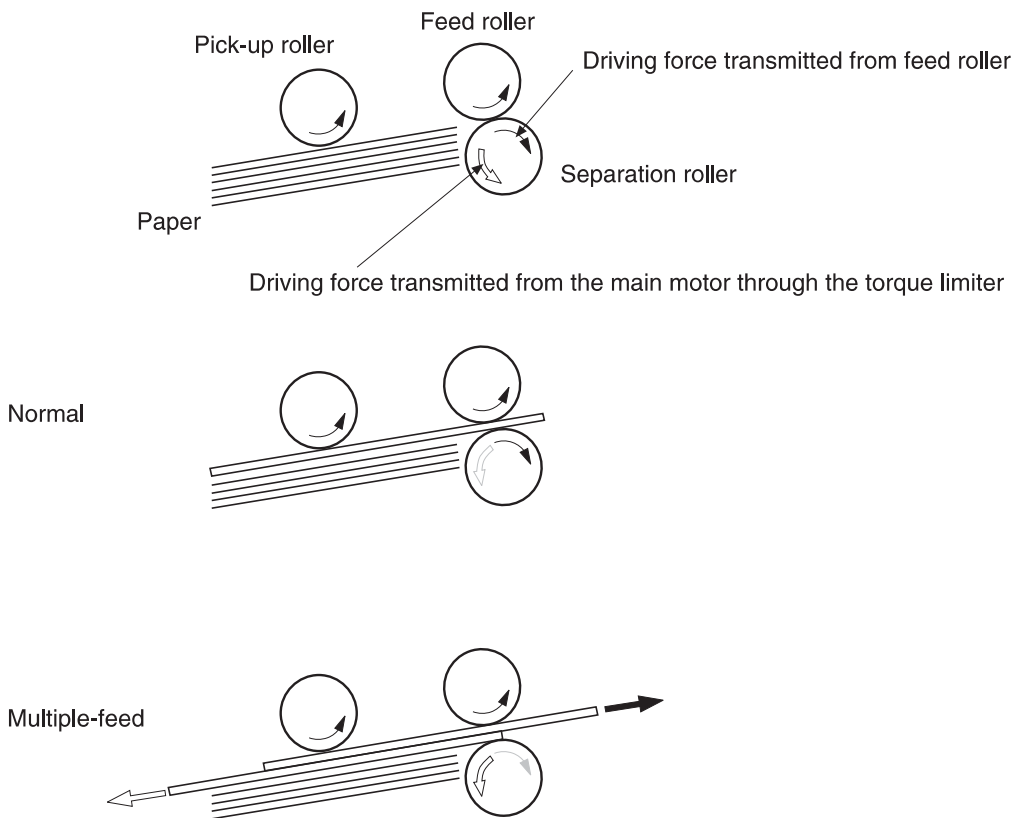
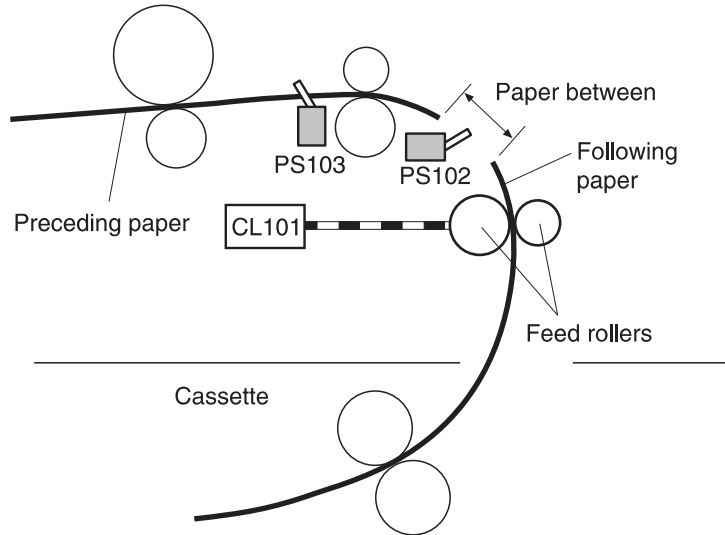


Figure 4-19 Multifeed prevention

## Distance-between-pages adjustment

When a multiple-page print job is sent, the DC controller uses the pre-feed sensor (PS102) to maintain a uniform distance between the pages. If the distance between pages is too small or if the pages overlap, the DC controller turns off the feed clutch (CL101) and stops the next sheet of paper. After a specified time, the DC controller turns the clutch on to allow the paper-feed process to continue.

< Normal >



< Stretching multiple feed >

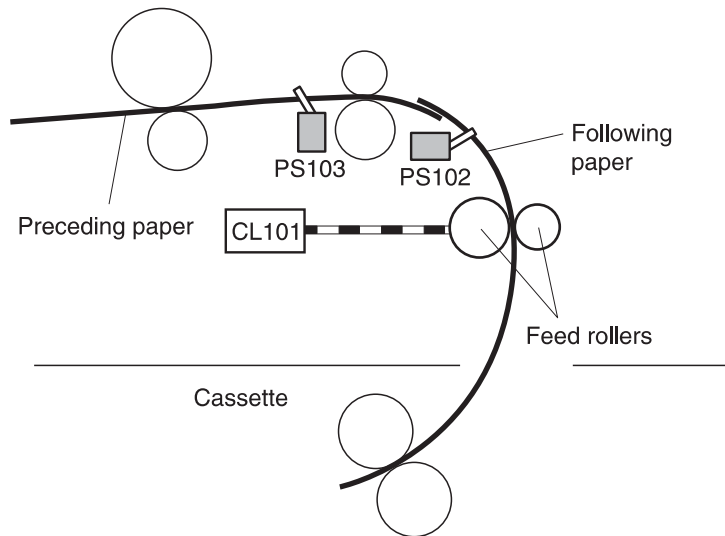
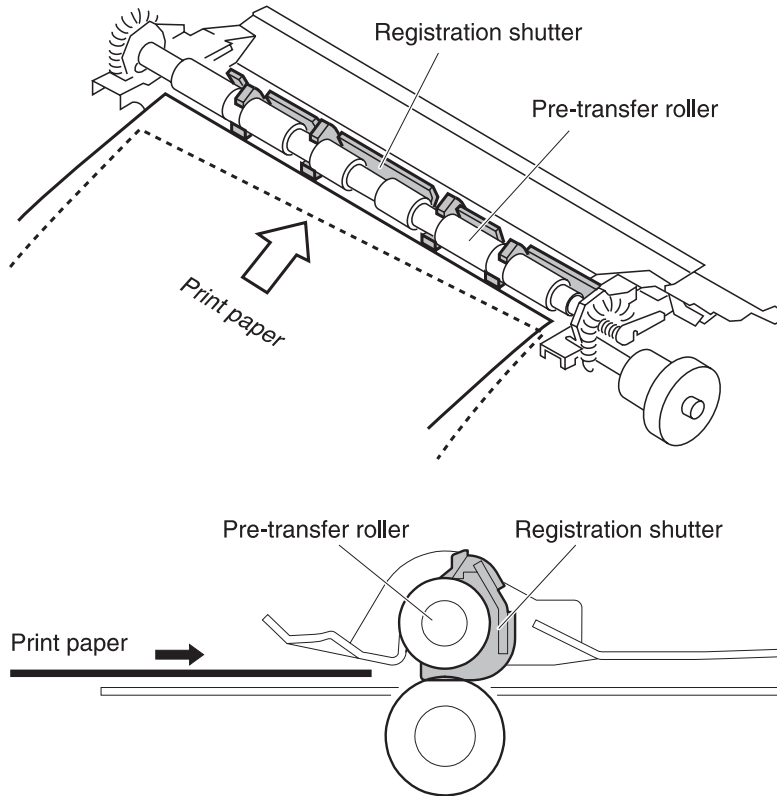


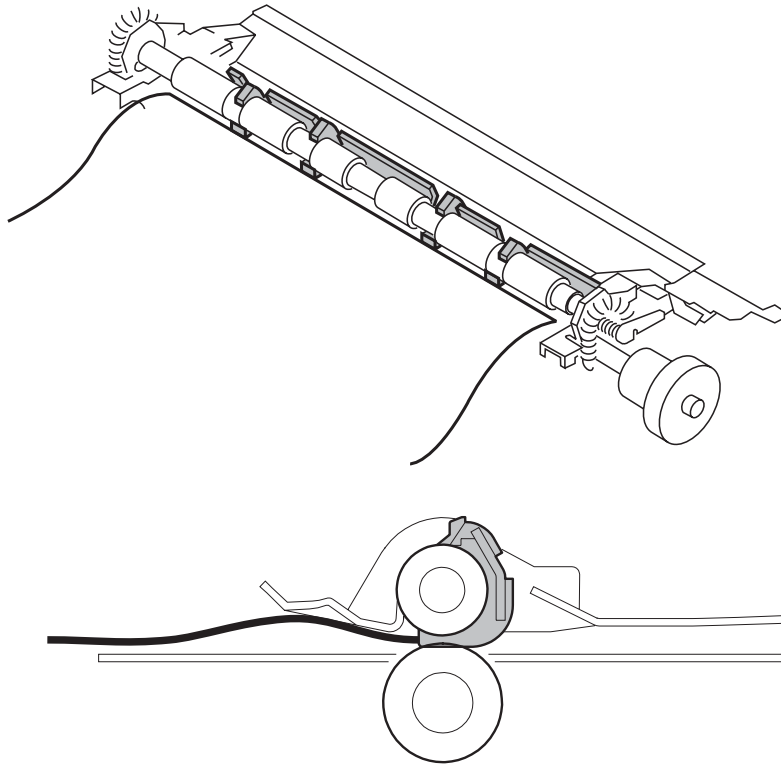
Figure 4-20 Distance-between-pages adjustment

## Media-skew prevention

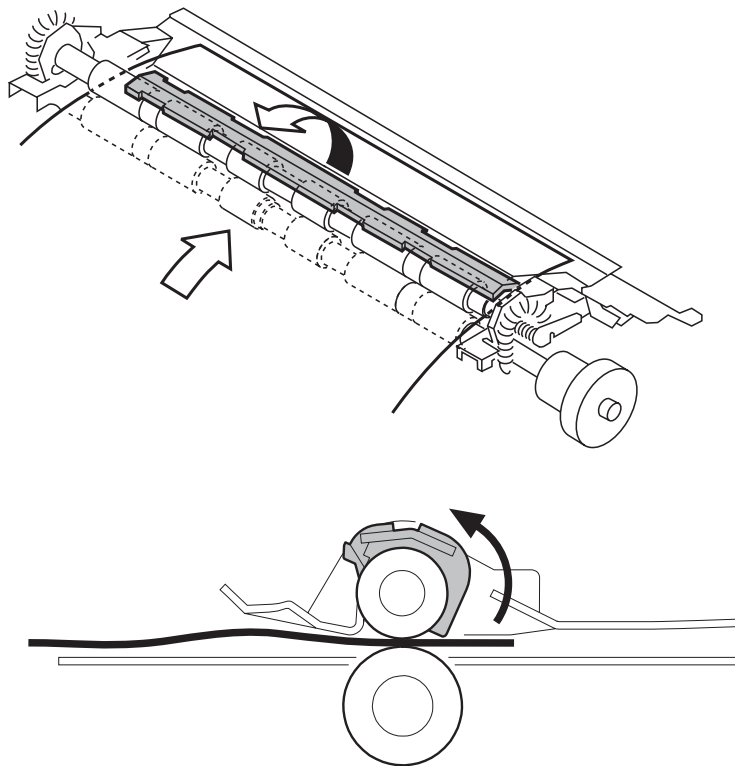
The MFP uses a registration shutter on the registration assembly to prevent skewed media from entering the MFP. When the leading edge of the skewed media contacts the registration shutter, the shutter does not open. The feed roller continues to rotate and the media begins to sag. When the entire leading edge comes in full contact with the shutter, the media skew is corrected and the registration shutter opens. When the shutter opens, the media can continue into the printer paper path. The overall print speed is not affected. The following three figures illustrate this process.



**Figure 4-21** Corner of the media contacts the shutter



**Figure 4-22** Media sags until the entire leading edge contacts the shutter



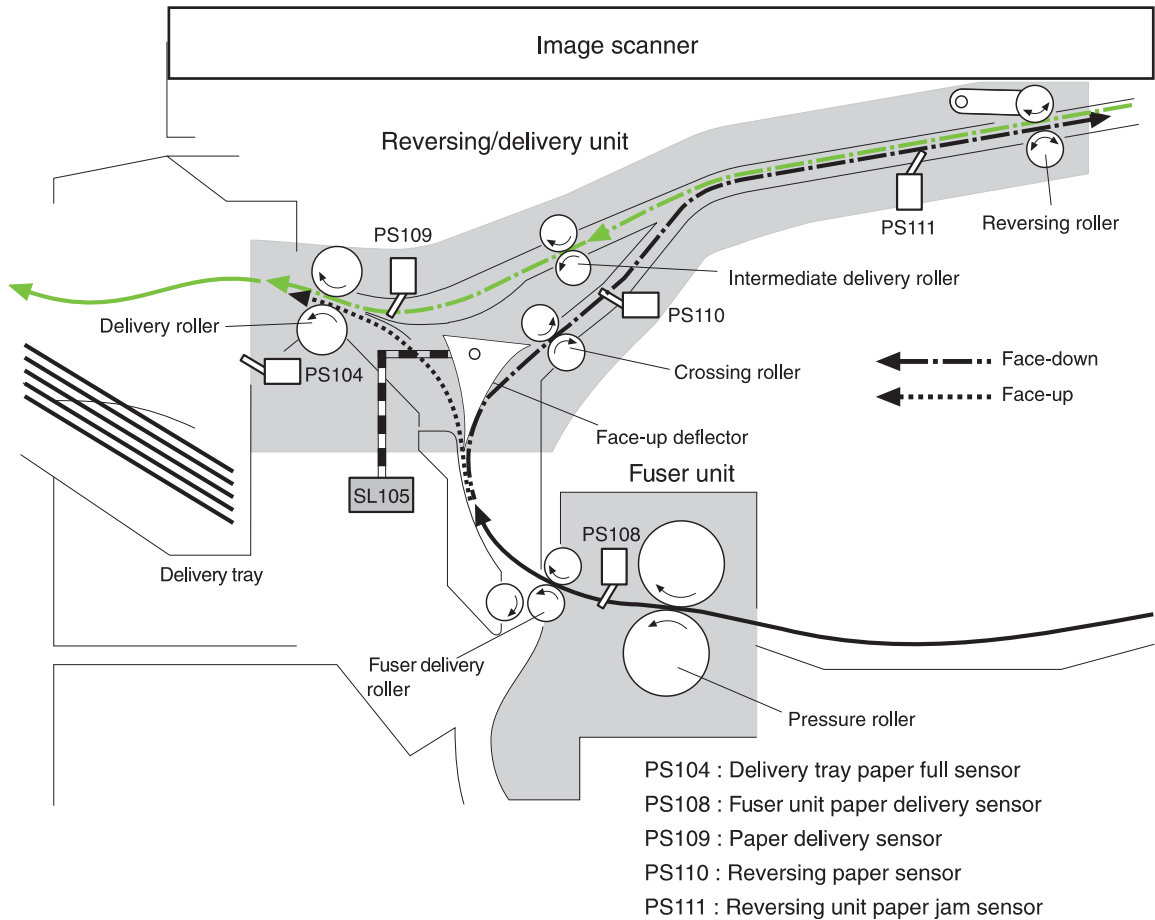
**Figure 4-23** Skew is corrected, and the shutter opens

## Feed-speed control

To ensure that the toner fuses sufficiently, the DC controller adjusts the speed at which media is fed according to the media type that the formatter specifies.

## Fusing and reversing/delivery block

After the toner is fused to the media, the media enters the reversing/delivery unit. The MFP can deliver the media to the output bin either face-up or face-down, depending on instructions from the formatter. To stack pages of a multiple-page print job in the correct order, the pages must be flipped over in the reversing unit before they are delivered to the output bin. This is the default setting. If face-up delivery is requested, the face-up solenoid (SL105) activates the face-up deflector to prevent the media from entering the reversing unit.



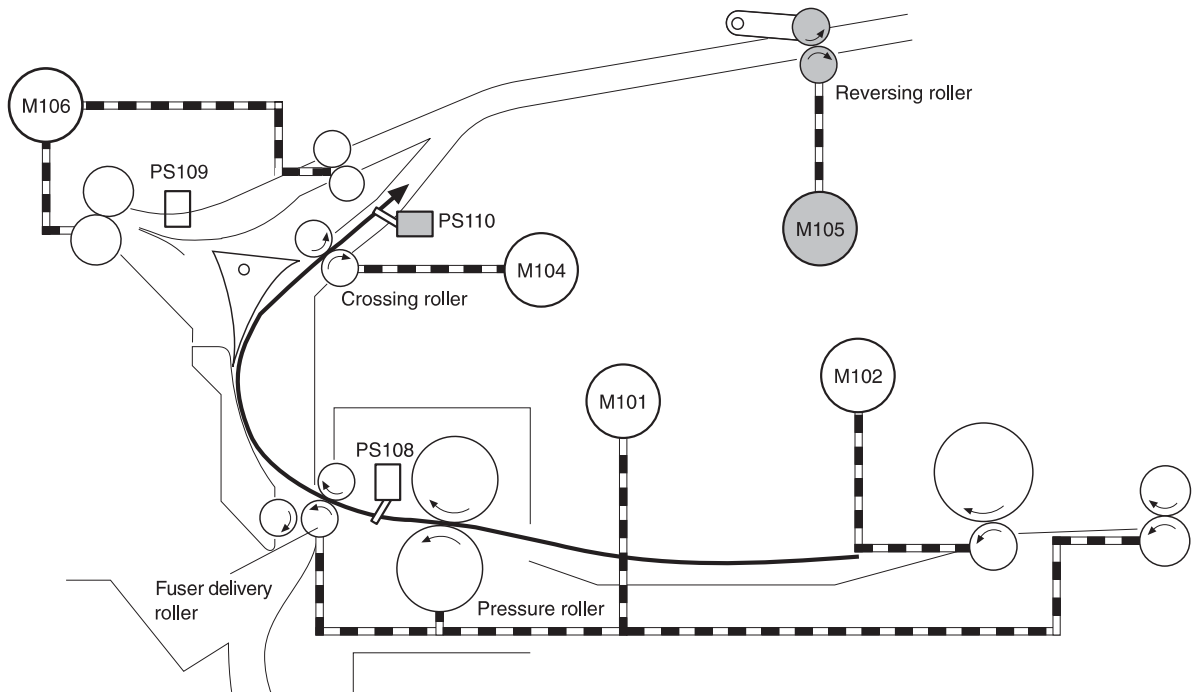
**Figure 4-24** Fusing and reversing/delivery block

## Fusing

The fuser applies heat and pressure to the media to permanently bond the toner image to the media.

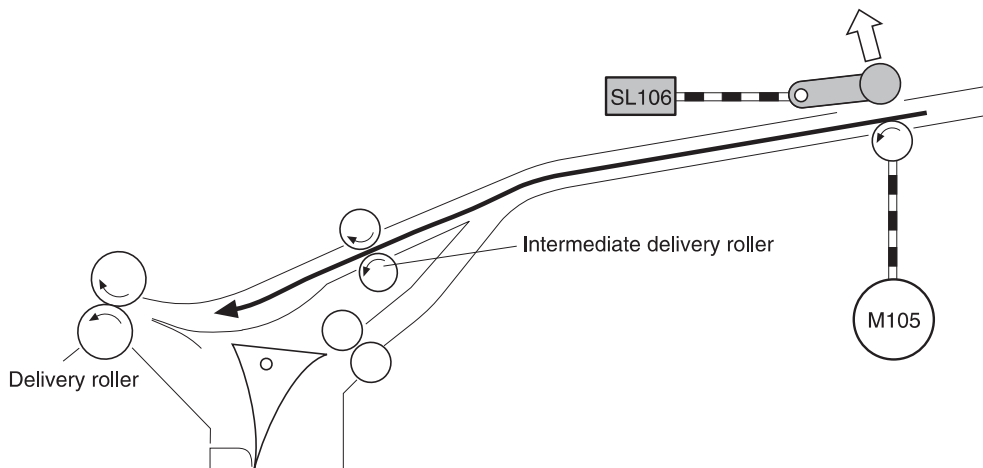
## Face-down delivery

When the fuser-delivery sensor (PS108) detects media, the crossing motor (M104) begins rotating. When the reversing-paper sensor (PS110) detects media, the reversing motor (M105) begins rotating clockwise.



**Figure 4-25** Face-down delivery: media enters the reversing unit

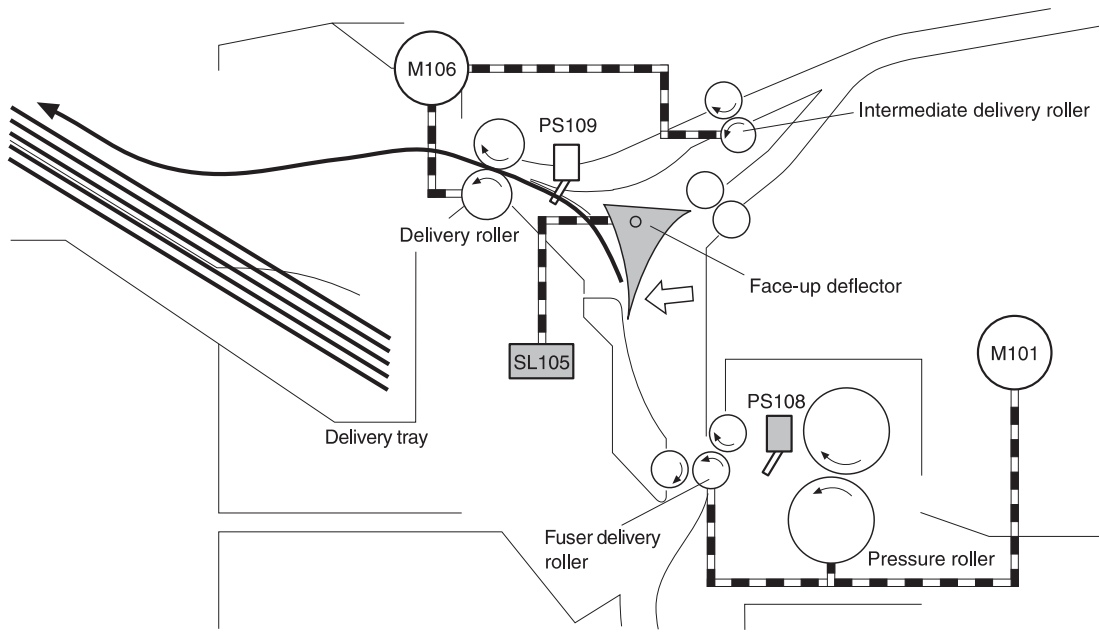
After a specified length of time, both motors stop, and the reversing motor begins rotating counterclockwise. Then, M106 drives the intermediate rollers and the delivery rollers, which guide the media into the output bin. When M106 begins rotating, the reversing-separation solenoid releases the reversing rollers, and the media begins traveling in the opposite direction. When the paper-delivery sensor (PS109) detects the trailing edge of the media, M106 stops rotating.



**Figure 4-26** Face-down delivery: media reverses direction

### Face-up delivery

As media passes through the fuser-delivery sensor (PS108), the face-up solenoid (SL105) activates the face-up deflector to prevent media from entering the reversing unit. M106 rotates clockwise and drives the delivery rollers, which carry the media into the output bin. When PS108 detects the trailing edge of the media, SL105 turns off and the face-up deflector returns to its home position. When the paper-delivery sensor (PS109) detects the trailing edge of the media, M106 stops rotating.



**Figure 4-27** Face-up delivery



## Jam detection

The MFP uses the following sensors to detect the presence of media and to check whether media is being fed correctly or has jammed:

- Pre-feed sensor (PS102)
- Top-of-page sensor (PS103)
- Fuser-delivery sensor (PS108)
- Paper-delivery sensor (PS109)
- Reversing paper-sensor (PS110)
- Reversing-unit paper-jam sensor (PS111)

The microprocessor on the DC controller checks for jams by timing the media as it moves past these sensors. If the media does not pass the sensor in a specific period of time, the transport process is stopped (the motors are turned off and the rollers no longer rotate) and a jam message appears on the control-panel display.

### Pickup delay jam from tray 1

If the top-of-page sensor (PS103) does not detect the leading edge of the media within a specific period of time after the media is picked up, the microprocessor on the DC controller PCA determines that a pickup jam has occurred.



---

**NOTE** The MFP attempts to pick up the media several times before determining that a pickup jam exists. The number of pickup attempts depends on the source (for example, four attempts occur if tray 1 is the source).

---

The transport process stops and a **13.XX.YY JAM** message appears on the control-panel display.

### Pickup delay jam from tray 2

If the pre-feed sensor (PS102) does not detect the leading edge of the media within a specific period of time after the media is picked up, the microprocessor on the DC controller PCA determines that a pickup delay jam has occurred.



---

**NOTE** The MFP attempts to pick up the media several times before determining that a pickup jam exists. The number of pickup attempts depends on the source (for example, four attempts occur if tray 1 is the source).

---

The transport process stops and a **13.XX.YY JAM** message appears on the control-panel display.

### Pickup stationary jam

If the top-of-page sensor (PS103) does not detect the trailing edge of the media within a specific period of time after the media is picked up, the microprocessor on the DC controller PCA determines that a pickup stationary jam has occurred.

The transport process stops and a **13.XX.YY JAM** message appears on the control-panel display.

## Fuser-delivery delay jam

If the fuser-delivery sensor (PS108) does not detect the leading edge of the media within a specific period of time after the top-of-page sensor (PS103) detects the leading edge, the microprocessor on the DC controller PCA determines that a fuser-delivery delay jam has occurred. The time varies according to the length of the media.

The transport process stops and a **13.XX.YY JAM** message appears on the control-panel display.

## Fuser wrapping jam

If the fuser-delivery sensor (PS108) does not detect the trailing edge of the media within a specific period of time after it detects the leading edge, the microprocessor on the DC controller PCA detects that a fuser wrapping jam has occurred.

The transport process stops and a **13.XX.YY JAM** message appears on the control-panel display.

## Fuser-delivery stationary jam when feeding regular-size media



---

**NOTE** Regular-size media is defined as A4, letter, legal, B5, executive or A5.

---

If the fuser-delivery sensor (PS108) does not detect the trailing edge of the media within a specific time period after it detects a fuser wrapping jam, the microprocessor on the DC controller PCA detects that a fuser-delivery stationary jam has occurred.

The transport process stops and a **13.XX.YY JAM** message appears on the control-panel display.

## Fuser-delivery stationary jam when feeding custom-size media

If the fuser-delivery sensor (PS108) does not detect the trailing edge of the media within a specific time period after it detects a fuser wrapping jam, the microprocessor on the DC controller PCA detects that a fuser-delivery stationary jam has occurred.



---

**NOTE** The time period varies according to the length of the media. The interval is longer for media that is 200 mm (7.9 inches) or longer.

---

The transport process stops and a **13.XX.YY JAM** message appears on the control-panel display.

## Reversing delay jam (face-down delivery only)

If the reversing-paper sensor (PS110) does not detect the leading edge of the media within a specific time period after the fuser-delivery sensor (PS108) detects the leading edge, the microprocessor on the DC controller PCA detects that a reversing delay jam has occurred.

The transport process stops and a **13.XX.YY JAM** message appears on the control-panel display.

## Reversing stationary jam (face-down delivery only)

If the reversing-paper sensor (PS110) does not detect the trailing edge of the media within a specific time period after the fuser-delivery sensor (PS108) detects the trailing edge, the microprocessor on the DC controller PCA detects that a reversing delay jam has occurred.

The transport process stops and a **13.XX.YY JAM** message appears on the control-panel display.

### Delivery delay jam during face-down delivery

If the paper-delivery sensor (PS109) does not detect the leading edge of the media within a specific time period after the paper-reversing operation starts, the microprocessor on the DC controller PCA detects that a delivery delay jam has occurred.

The transport process stops and a **13.XX.YY JAM** message appears on the control-panel display.

### Delivery delay jam during face-up delivery

If the paper-delivery sensor (PS109) does not detect the leading edge of the media within a specific time period after the fuser-delivery sensor (PS108) detects the leading edge, the microprocessor on the DC controller PCA detects that a delivery delay jam has occurred.

The transport process stops and a **13.XX.YY JAM** message appears on the control-panel display.

### Delivery stationary jam during face-down delivery

If the paper-delivery sensor (PS109) does not detect the leading edge of the media within a specific time period after the reversing-separation solenoid (SL106) is turned off, the microprocessor on the DC controller PCA detects that a delivery delay jam has occurred.

The transport process stops and a **13.XX.YY JAM** message appears on the control-panel display.

### Delivery stationary jam during face-up delivery

If the paper-delivery sensor (PS109) does not detect the trailing edge of the media within a specific time period after the fuser-delivery sensor (PS108) detects the trailing edge, the microprocessor on the DC controller PCA detects that a delivery delay jam has occurred.

The transport process stops and a **13.XX.YY JAM** message appears on the control-panel display.

### Door-open jam

If the top door is opened during printing, the top-cover switch (SW101) is activated and the microprocessor on the DC controller PCA determines that a door-open jam has occurred.

The transport process stops and a **13.XX.YY JAM** message appears on the control-panel display.

### Residual-media jam

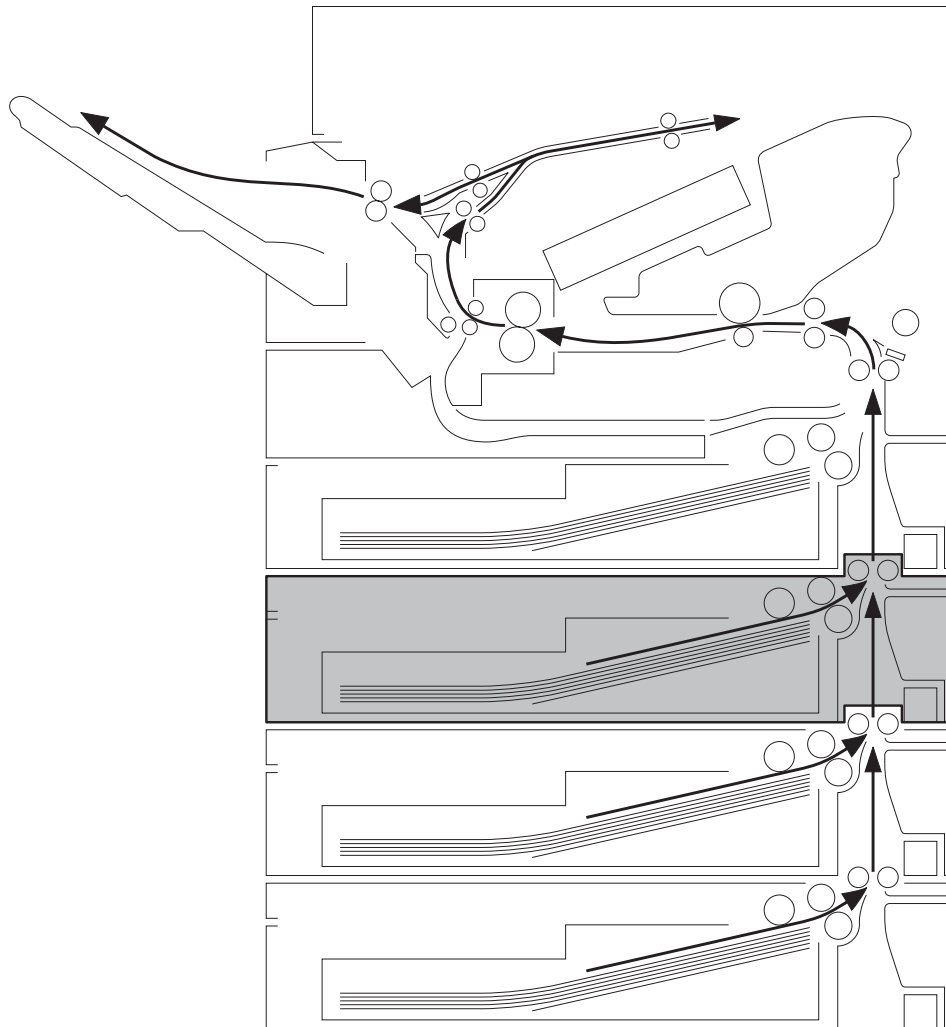
If the top-of-page sensor (PS103), the fuser-delivery sensor (PS108), or the reversing-unit jam sensor (PS111) detects the leading edge of the media at the start of initial rotation, the microprocessor on the DC controller PCA identifies a residual-media jam.

In addition, if the fuser-delivery sensor (PS108) does not detect the leading edge of the media, within 2.1 seconds after the top-of-page sensor (PS103) detects the leading edge, the microprocessor on the DC controller PCA identifies a residual-media jam.

Whenever the MFP is turned on or a print sequence begins, if the pre-feed sensor (PS102) detects the presence of media, an automatic-delivery request is sent to the formatter. The DC controller PCA drives each motor, and the residual media is delivered to the output bin. Normal printing can continue.

## Printing from the 500-sheet feeder

The MFP supports up to three additional 500-sheet feeders (trays 3, 4, and 5).

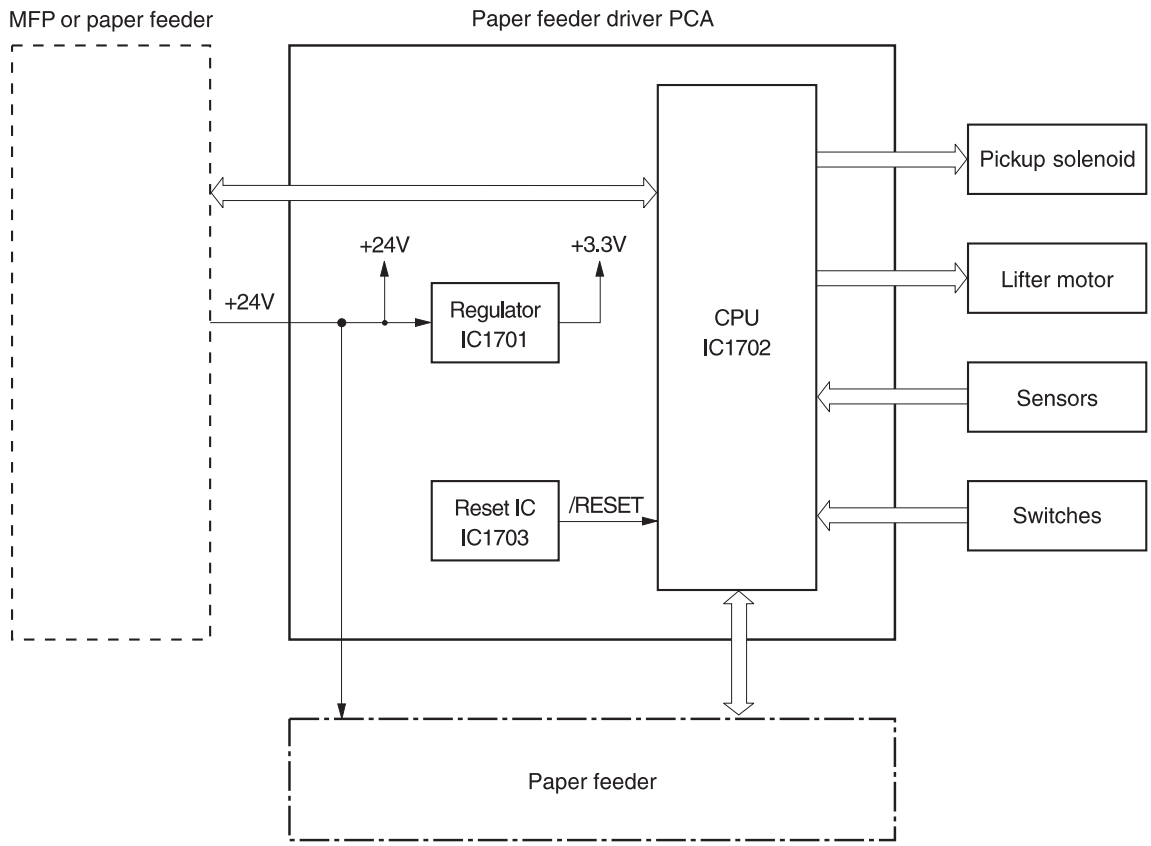


**Figure 4-28** Paper path with 500-sheet feeders installed

The paper-feeder driver controls the 500-sheet feeder operation sequences. An 8-bit microprocessor in the paper-feeder driver controls the 500-sheet feeder sequences and the communication with the DC controller PCA.

The paper-feeder driver drives the solenoid in response to the pickup command. The paper-feeder driver also reports the paper-feeder status to the DC controller PCA.

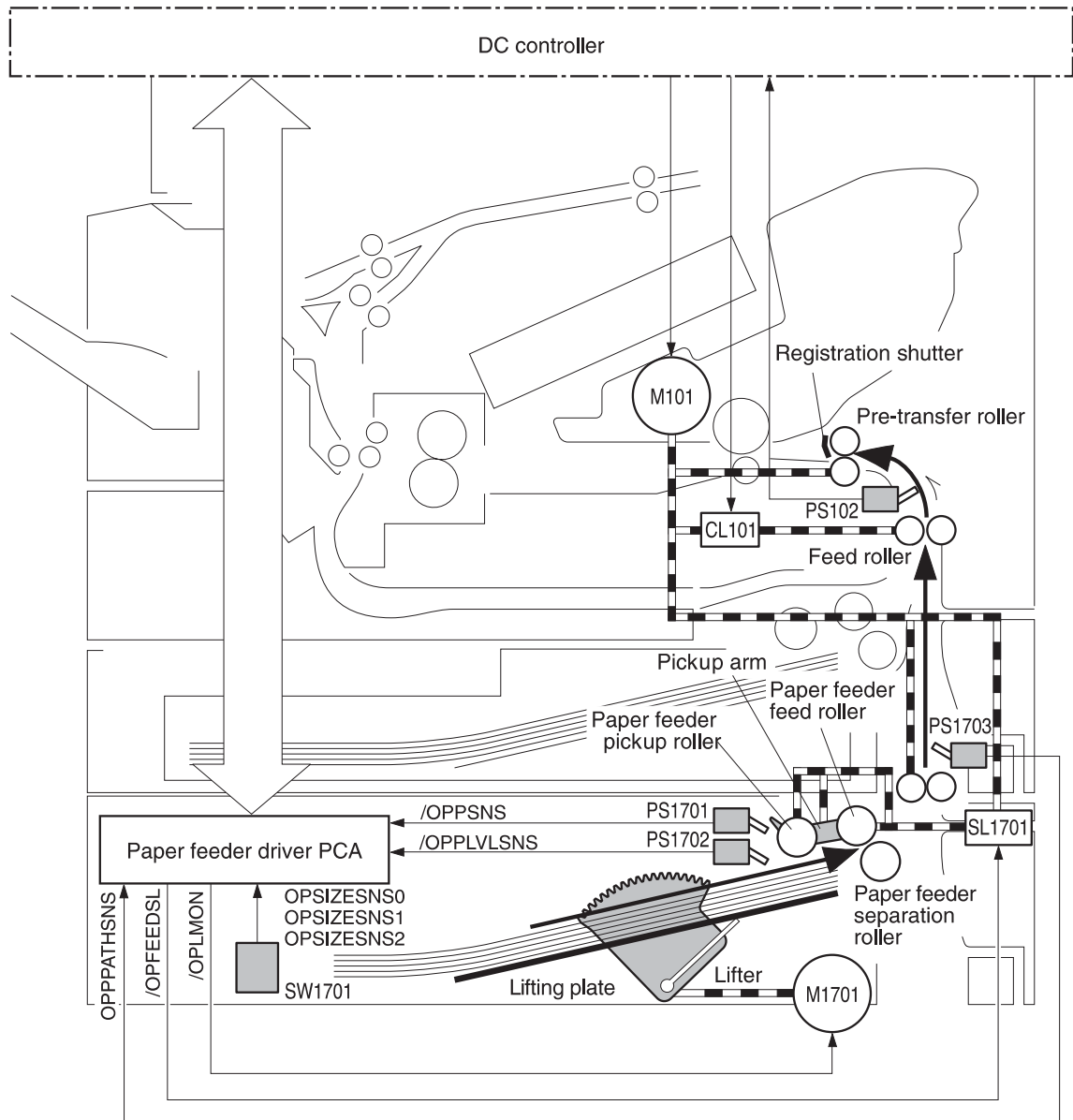
The printer delivers a charge of +24 Vdc to the paper feeder, which then generates +3.3 V for the integrated circuits.



**Figure 4-29** 500-sheet feeder I/O block diagram

### 500-sheet feeder pickup and feeding

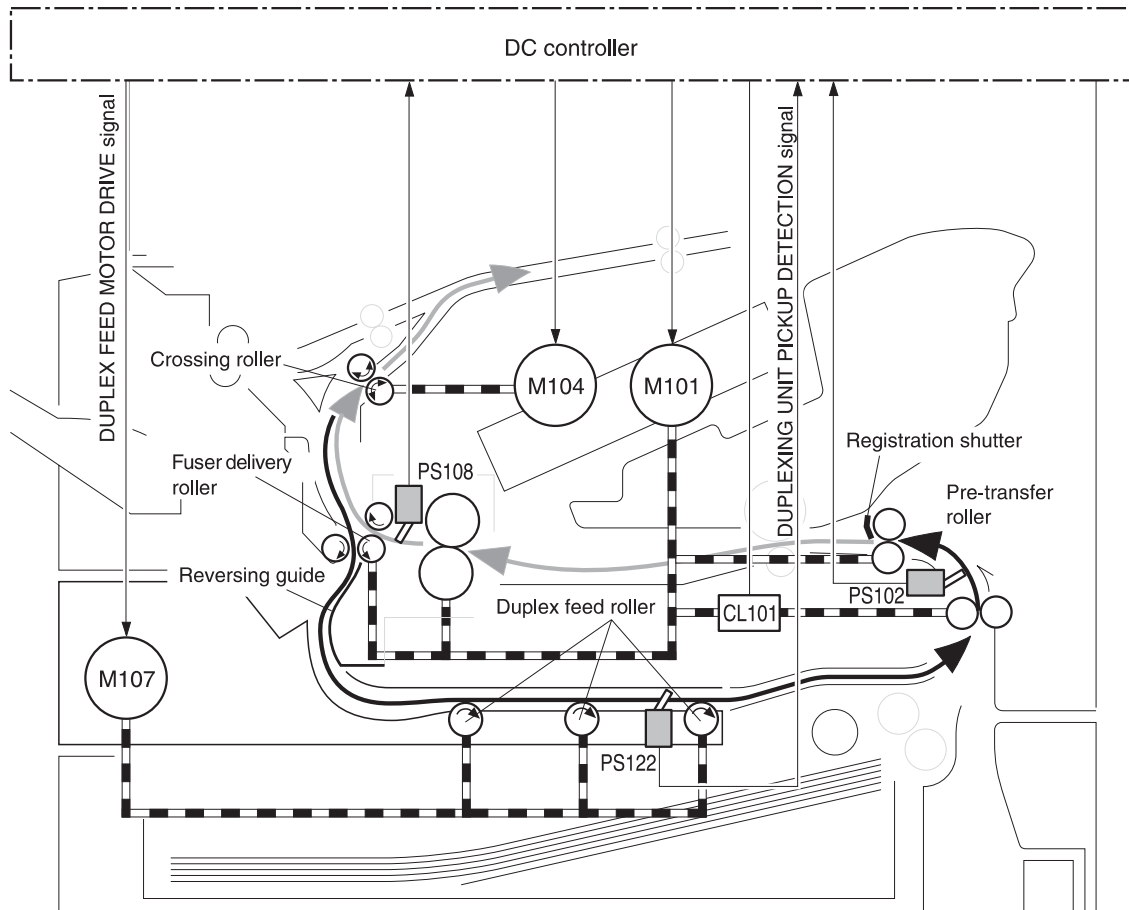
The pickup and feeding processes for the 500-sheet feeder are identical to the processes for tray 2 in the print engine. See [Figure 4-30 500-sheet feeder pickup and feed diagram on page 156](#) to identify the individual switches and sensors for the 500-sheet feeder.



- |   |  |
|---|--|
| M101: Main motor (printer)              | /OPLMON: LIFTER MOTOR DRIVE signal               |
| CL101: Feed roller clutch (printer)     | /OPFEEDSL: PICKUP SOLENOID DRIVE signal          |
| PS102: Pre-feed sensor (printer)        | /OPPSNS: PAPER FEEDER PAPER DETECTION signal     |
| M1701: Lifter motor                     | /OPPATHSNS: PAPER PATH DETECTION signal          |
| SL1701: Paper feeder pickup solenoid    | /OPPLVLSNS: PAPER STACK SURFACE DETECTION signal |
| PS1701: Cassette paper detection sensor | OPSIZESNS0: PAPER SIZE DETECTION signal          |
| PS1702: Paper stack surface sensor      | OPSIZESNS1: PAPER SIZE DETECTION signal          |
| PS1703: Paper path detection sensor     | OPSIZESNS2: PAPER SIZE DETECTION signal          |
| SW1701: Paper size detection switch     |  |

**Figure 4-30** 500-sheet feeder pickup and feed diagram





- M101: Main motor (printer)
- M104: Crossing motor (printer)
- CL101: Feed roller clutch (printer)
- PS102: Pre-feed sensor (printer)
- PS108: Fuser paper delivery sensor (printer)
- M107: Duplexing feed motor
- PS122: Duplexing unit pickup sensor

**Figure 4-32** Duplex-printing control

### Duplex-printing jam detection

The duplex-printing unit uses the duplex-unit-pickup sensor (PS122) to detect jams. The microprocessor on the DC controller PCA determines a jam situation if the sensor indicates that paper is present at an unexpected time or that paper is not present at the expected time. The microprocessor on the DC controller PCA notifies the formatter that a jam has occurred.

When a jam is detected, the transport process stops and a **13.XX.YY JAM** message appears on the control-panel display.

### Duplex-unit-pickup delay jam

If the duplex-unit-pickup sensor (PS122) does not detect the leading edge of the paper within a specific time period after the duplex feed motor (M107) starts driving, the microprocessor on the DC controller PCA determines that a duplex-unit-pickup delay jam has occurred.



### Duplex-unit stationary jam

If the duplex-unit-pickup sensor (PS122) does not detect the trailing edge of the paper within a specific time period after the duplex-unit pickup operation starts, the microprocessor on the DC controller PCA determines that a duplex-unit stationary jam has occurred.

Also, if the microprocessor on the DC controller PCA cannot communicate with the formatter while paper is in the duplexing unit, it determines that a duplex-unit stationary jam has occurred.

### Duplex-unit delay jam

If the duplex-unit-pickup sensor (PS122) does not detect the trailing edge of the paper within a specific time period after the fuser-delivery sensor (PS108) detects the trailing edge, the microprocessor on the DC controller PCA determines that a duplex-unit delay jam has occurred.

## 3-bin mailbox system

When the 3-bin mailbox (MBM) is installed, it receives print media from the print engine and delivers it to one of its three bins. The 3-bin mailbox has the following components:

- One feed motor that drives the rollers
- Two solenoids that operate the inlet deflector and the bin deflector
- Six sensors that detect the presence of print media and the stack height in the output bins
- One switch that determines whether the 3-bin mailbox is attached to the MFP correctly
- One fan that cools components inside the 3-bin mailbox

The 3-bin mailbox has three operating modes: stacker mode, mailbox mode, and function-separator mode.

The MBM-driver PCA controls all functions in the 3-bin mailbox. To deliver media to the different bins, the inlet deflector and the bin deflector change position as required.

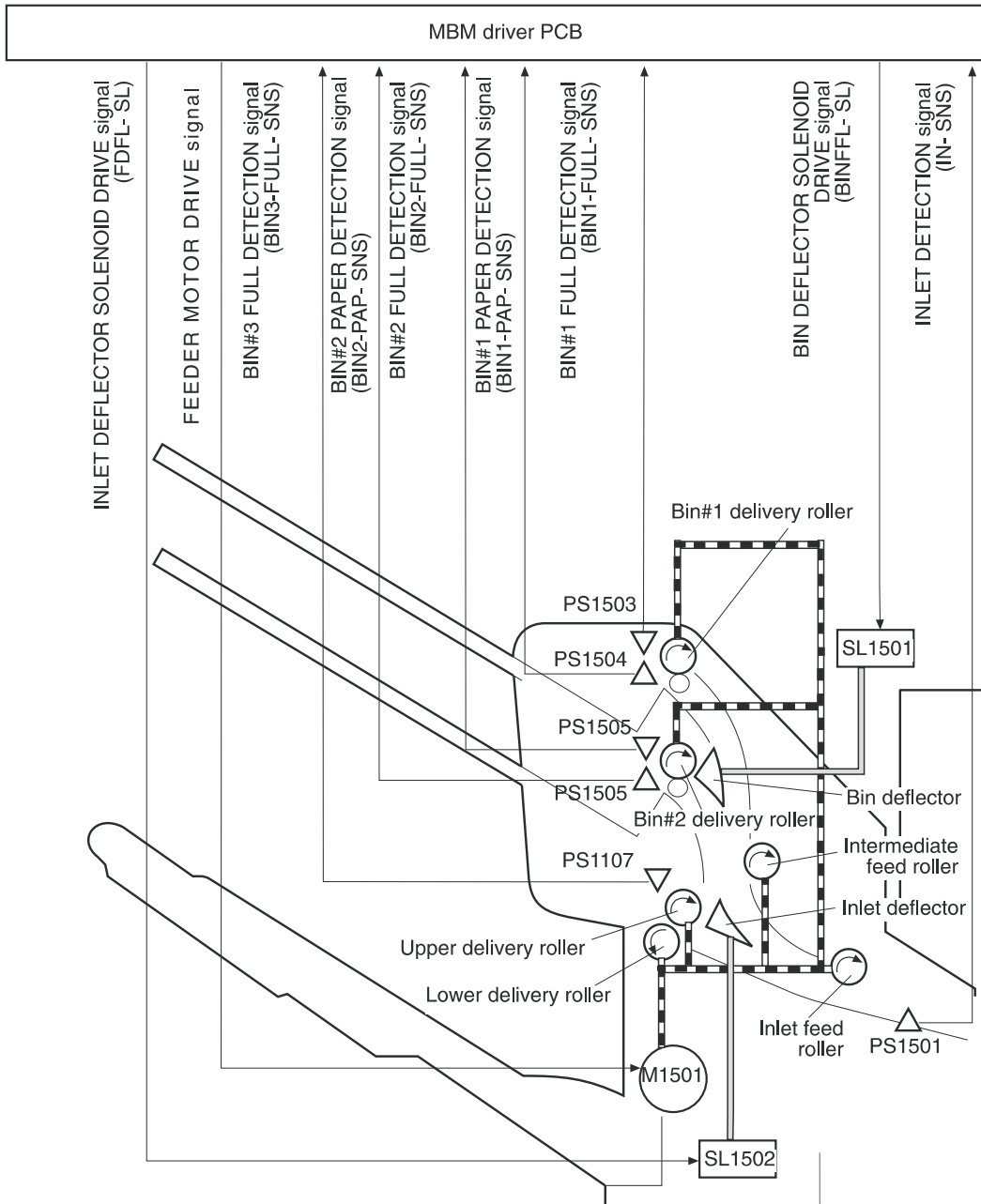


Figure 4-33 3-bin mailbox operation

## Stacker mode

When configured for stacker mode, the 3-bin mailbox fills the bottom output bin (bin 3) first and then fills the next highest bin.

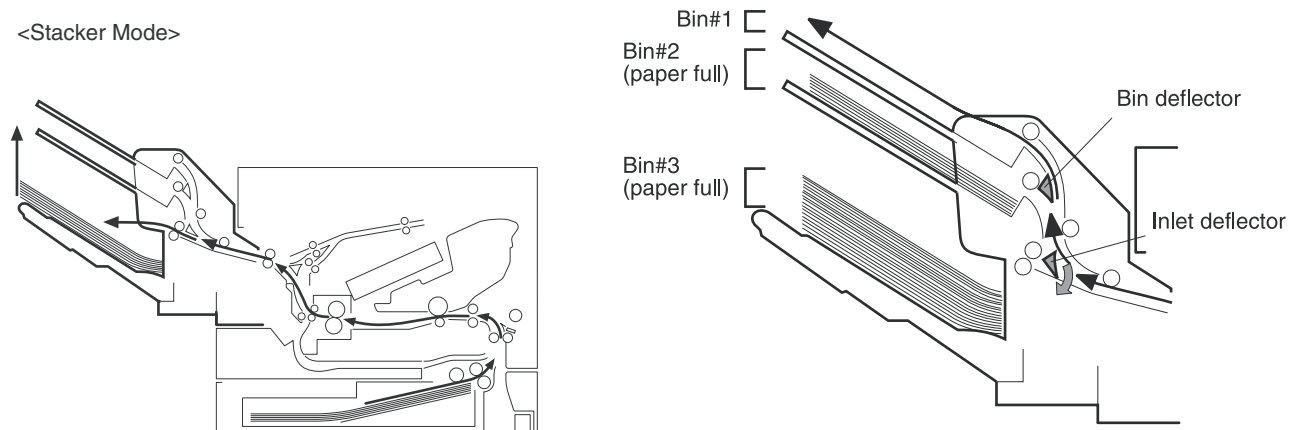


Figure 4-34 Media flow when using the stacker mode

## Mailbox mode

When configured for mailbox mode, the 3-bin mailbox stacks print media in each bin as determined by the print job specifications. For example, one user might have all jobs delivered to the bottom bin, and another user might have all jobs delivered to the top bin.

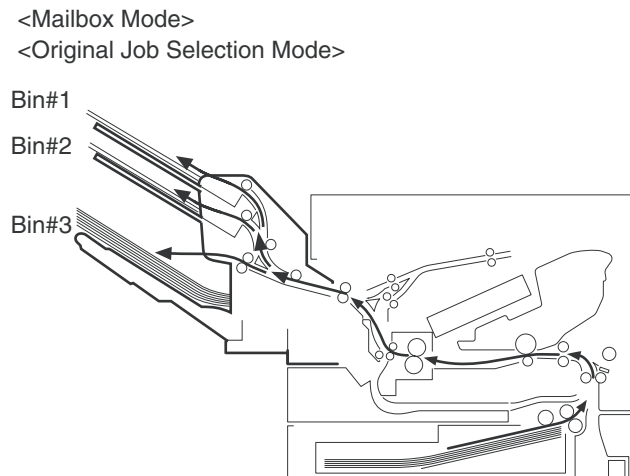


Figure 4-35 Media flow when using the mailbox mode

## Function-separator mode

When configured for function-separator mode, the 3-bin mailbox delivers print media to each bin as specified by the job type. For example, all copy jobs might be delivered to the top bin, and all faxes might be delivered to the middle bin.

## Jam detection

The 3-bin mailbox uses the inlet sensor (PS1501) to detect jams. The microprocessor on the MBM-driver PCA determines a jam situation if the sensor indicates that media is present at an unexpected

time or that media is not present at the expected time. The microprocessor on the MBM-driver PCA notifies the formatter that a jam has occurred.

When a jam is detected, the transport process stops and a **13.XX.YY JAM** message appears on the control-panel display.

### Feed-delay jam

If the inlet sensor (PS1501) does not detect the leading edge of the media within a specific time period after receiving a delivery-notice command, the microprocessor on the MBM-driver PCA determines that a feed-delay jam has occurred. The time interval is longer for face-up delivery than for face-down delivery.

### Feed-stationary jam

If the inlet sensor (PS1501) does not detect the trailing edge of the media within a specific time period after it detects the leading edge, the microprocessor on the MBM-driver PCA determines that a feed-stationary jam has occurred.

### Residual-media jam

If the inlet sensor (PS1501) detects the presence of media during the initial WAIT period, the microprocessor on the MBM-driver PCA determines that a residual-media jam has occurred.

### Power-on sequence

The following figure illustrates the operational sequence of the MBM from power-on to standby.

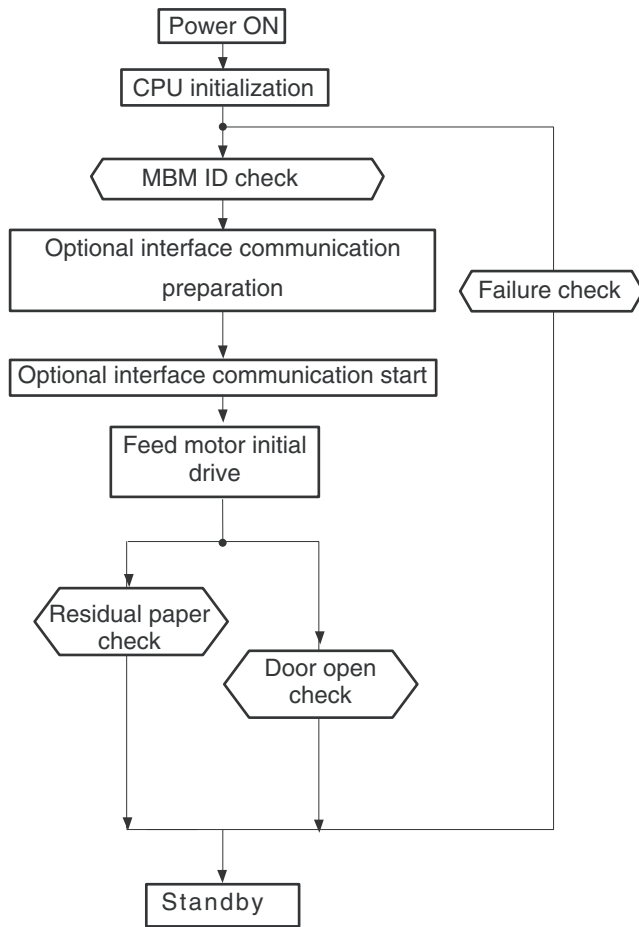


Figure 4-36 Power-on sequence

## MBM driver

The MBM driver controls the operational sequence of the MBM. When the MFP is turned on and DC power is supplied to the MBM driver, the MBM driver communicates with the formatter to start an operational control. Then the MBM enters standby mode and the MBM driver outputs the signals to drive motors and solenoids in response to the command input from the MFP.

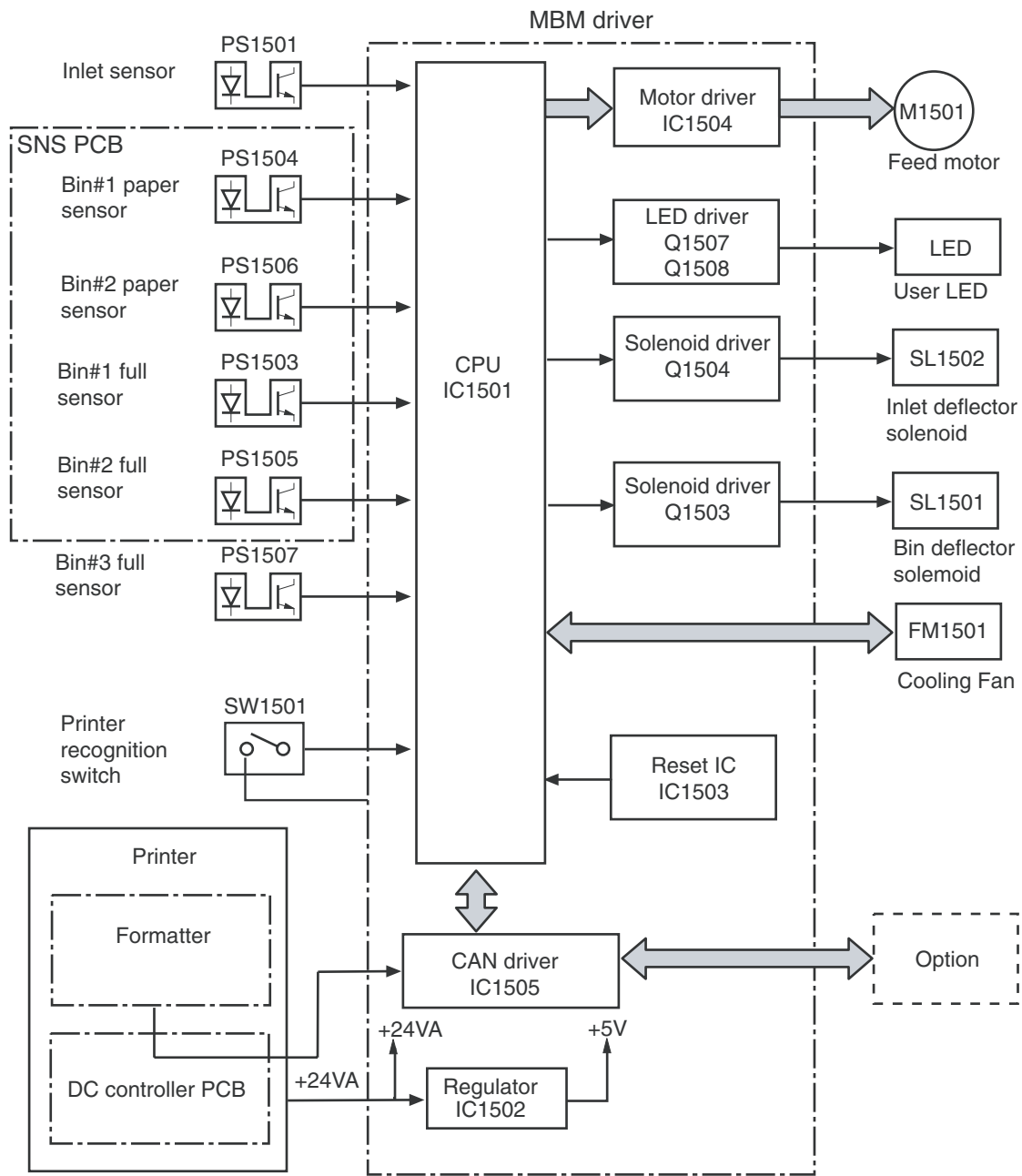


Figure 4-37 MBM driver

Table 4-4 MBM driver components

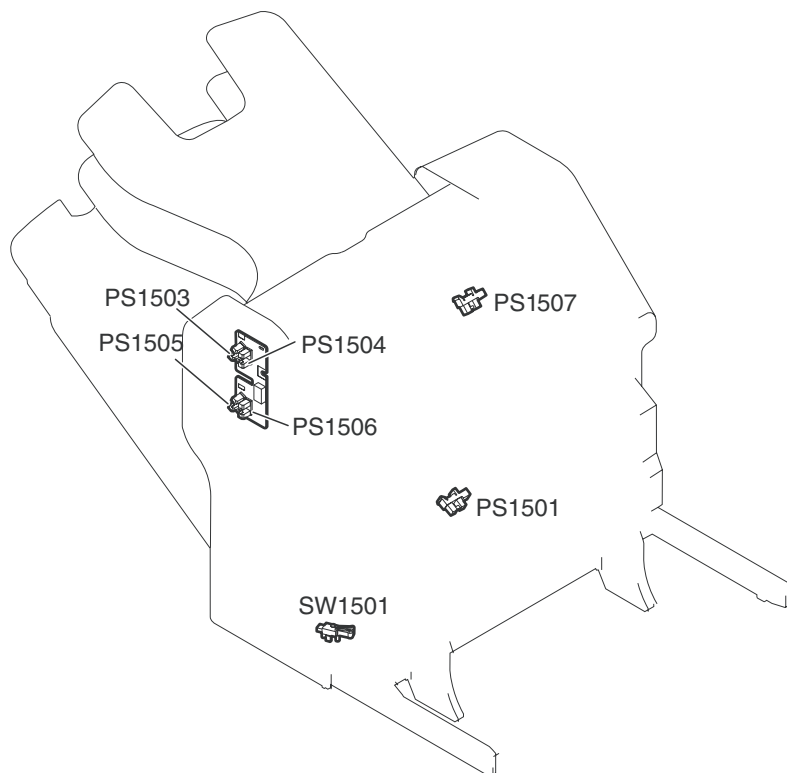
Part		Purpose
Motor	Feed motor (M1501)	Drives the inlet roller and delivery roller
Solenoids	Inlet-deflector solenoid (SL1502)	Shifts the inlet deflector
	Bin-deflector solenoid (SL1501)	Shifts the bin deflector

**Table 4-4** MBM driver components (continued)

<b>Part</b>		<b>Purpose</b>
Sensors	Inlet sensor (PS1501)	Detects paper jams
	Bin 1 paper sensor (PS1504)	Detects whether bin 1 contains paper
	Bin 2 paper sensor (PS1506)	Detects whether bin 2 contains paper
	Bin-1-full sensor (PS1503)	Detects whether bin 1 is full
	Bin-2-full sensor (PS1505)	Detects whether bin 2 is full
	Bin-3-full sensor (PS1507)	Detects whether bin 3 is full
Switch	Printer-recognition switch (SW1501)	Detects whether the MBM and the engine are properly connected (interruption of +5V)
Fan	Cooling fan (FM1501)	Cools the electrical parts under the paper delivery

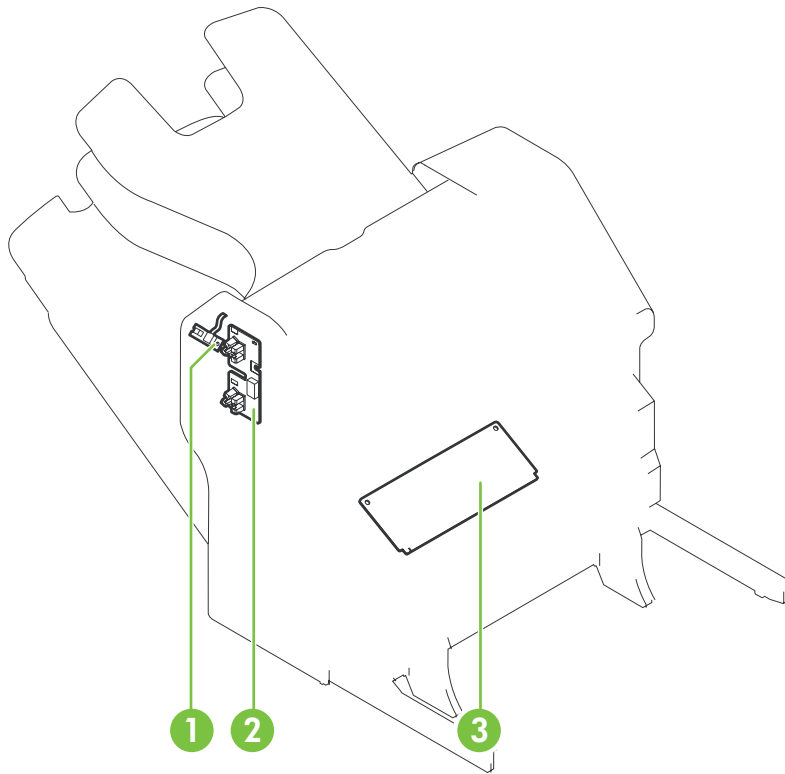


## MBM switches and sensors



<b>PS1501</b>	Inlet sensor
<b>PS1503</b>	Bin 1 paper-full sensor
<b>PS1504</b>	Bin 1 paper sensor
<b>PS1505</b>	Bin 2 paper-full sensor
<b>PS1506</b>	Bin 2 paper sensor
<b>PS1507</b>	Bin 3 paper-full sensor
<b>SW1501</b>	Engine connection switch

## MBM PCBs



1	LED PCB
2	Sensor PCB
3	MBM driver PCB

## MBM list of signals

**Table 4-5** List of signals for the MBM driver PCB

Connector	PIN	Abbreviation	I/O	Logic	Signal name
J1501	1	+24VA			
	2	+24VA			
	3	PWRON	I	L	POWER-ON DETECTION signal
	4	GND			
	5	GND			
	6	CAN-L	I/O		CAN-RECEIVE signal
	7	CAN-H	I/O		CAN-RECEIVE signal
	8	SPD-UP	I	L	SPEED-UP DETECTION signal
	9	+24VA			
	10	GND			
	11	GND			
J1502	1	+5V			
	2	BIN1-FULL	I	H	BIN1 PAPER-FULL signal
	3	BIN1-PAP	I	H	BIN1 PAPER DETECTION signal
	4	BIN2-FULL	I	H	BIN2 PAPER-FULL signal
	5	BIN2-PAP	I	H	BIN2 PAPER DETECTION signal
	6	GND			
	7	ULED-O	O	H	USER LED DRIVE signal (Orange)
	8	ULED-G	O	H	USER LED DRIVE signal (Green)
	9	GND			
	10	JOINT-SW	I	H	PRINTER-RECOGNITION SWITCH signal
J1503	1	+5V			
	2	GND			
	3	IN-SUS	I	H	INLET-DETECTION signal
J1504	1	+5V			
	2	GND			
	3	BIN3-FULL	I	H	BIN3 TRAY PAPER-FULL signal
	4	+24V			
		BINFL-SL	O	H	BIN-DEFLECTOR SOLENOID DRIVE signal

**Table 4-5** List of signals for the MBM driver PCB (continued)

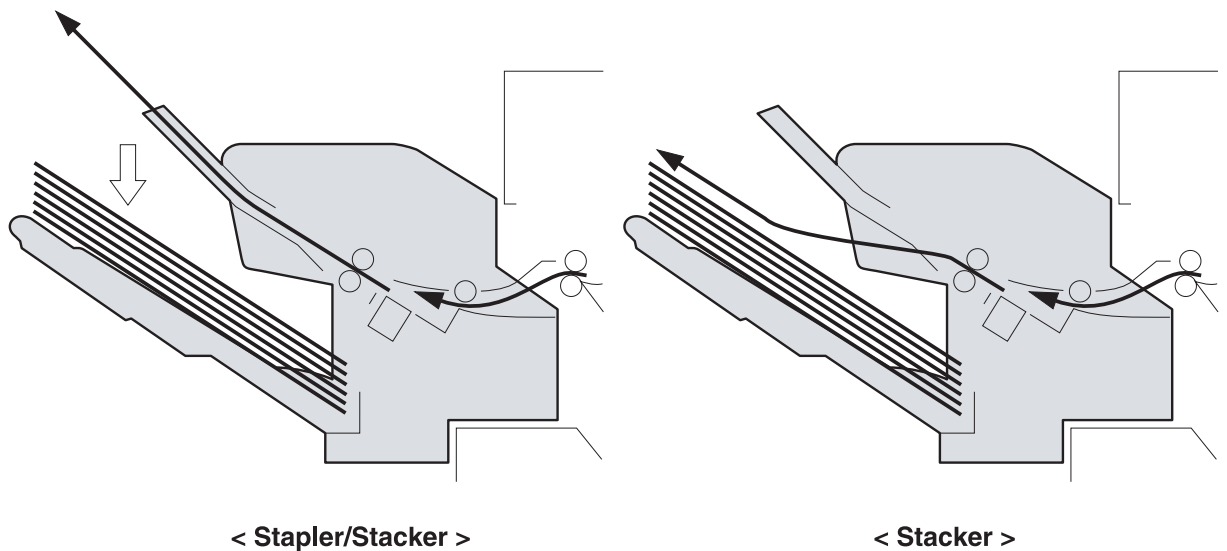
Connector	PIN	Abbreviation	I/O	Logic	Signal name
J1505	1	FD-AD	O	Pulse	FEED-MOTOR DRIVE signal
	2	FD-AND	O	Pulse	FEED-MOTOR DRIVE signal
	3	FD-BD	O	Pulse	FEED-MOTOR DRIVE signal
	4	FD-BND	O	Pulse	FEED-MOTOR DRIVE signal
J1506	1	GND			
	2	PWRON-OUT	O	H	POWER-ON OUTPUT signal
	3	CAN-L-OUT	I/O		CAN-SEND signal
	4	CAN-H-OUT	I/O		CAN-SEND signal
J1507	1	GND			
	2	FLASH-OUT	O		FLASH ROM RECORD signal
	3	FLASH-MD0	I	L	OPERATION ROM RECORD signal
	4	FLASH-CLK-SW4	I		FLASH ROM RECORD signal
	5	FLASH-MD2	I	H	OPERATION-MODE SPECIFYING signal
	6	FLASH-SW3	I		FLASH ROM RECORD signal
	7	FLASH-ACT0-SW1	I		FLASH ROM RECORD signal
	8	+5V			
	9	RCT-CTRL	I	L	RESET signal
	10	GND			
	11	FLASH-ACT1-SW2	I		FLASH ROM RECORD signal
J1508	1	+24V			
	2	FD-SL	O	H	INLET-DEFLECTOR SOLENOID DRIVE signal
J1509	1	FAN-DRV	I/O	L	FAN-DRIVE SIGNAL
	2	FAN-LCK	I	L	FAN-LOCK signal
	3	GND			

## Stapler/stacker system

The stapler/stacker is a paper-handling accessory that can function in the following modes:

- Stacker mode. Printed paper is directed to the delivery tray. The stacker holds up to 500 sheets of paper (75 g/m<sup>2</sup> or 20 lb Bond).
- Stapler/stacker mode. Printed paper is stapled and then directed to the delivery tray. Up to 30 sheets of paper can be stapled, and up to 15 sets of stapled sheets can be stacked.

The following diagram shows the paper flow.



**Figure 4-38** Stapler/stacker paper flow

## Power-on sequence

The following diagram shows the operational sequence of the stapler/stacker from power-on to standby mode.

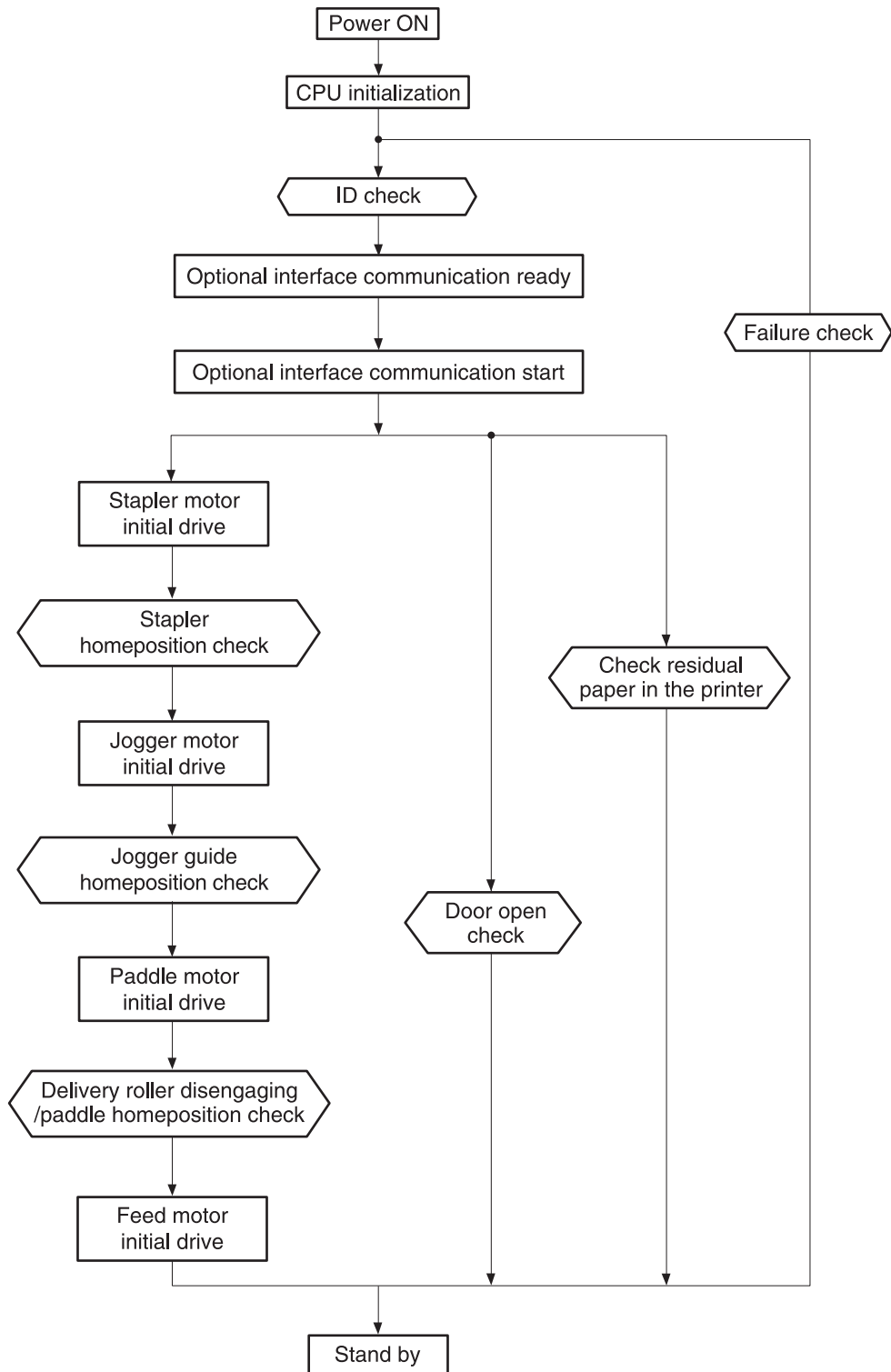


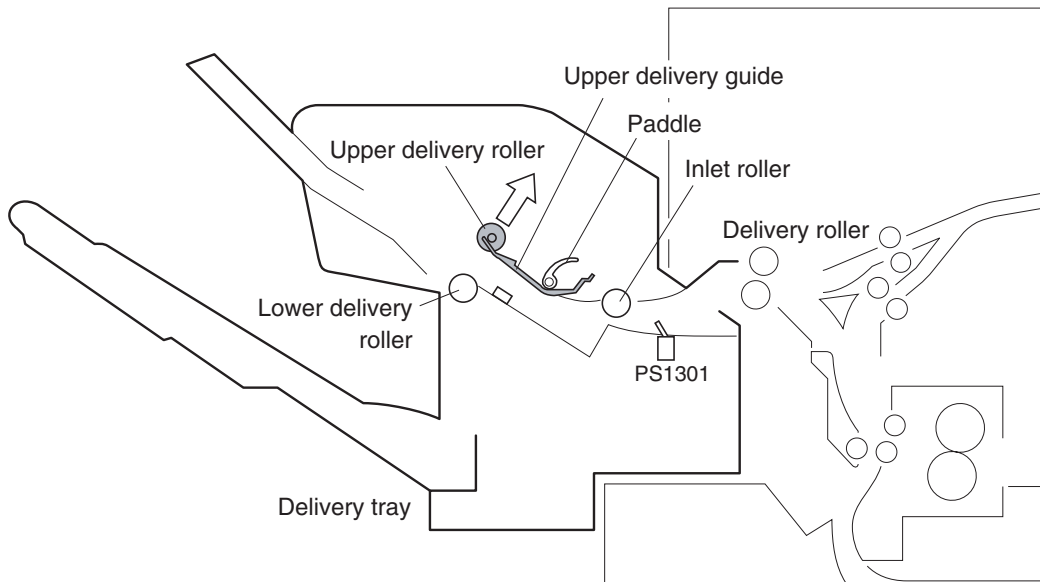
Figure 4-39 Stapler/stacker power-on sequence

## Staple mode

In this mode, up to 30 sheets are stapled in one set and are then stacked in the delivery tray.

The feed operation of this mode is described in the following procedure.

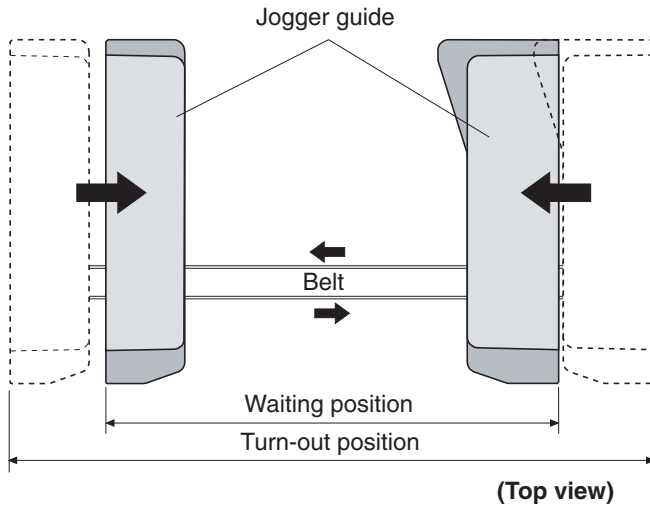
1. The printer engine sends a paper-delivery signal to the formatter when the leading edge of the print paper reaches the fixing-delivery sensor.
2. When the formatter receives the signal, it sends a delivery-notice command to the stapler/stacker driver.
3. The stapler/stacker driver causes the paddle motor (M1301) to rotate counter-clockwise and allows the upper and the lower delivery rollers to be disengaged by the paper-delivery roller engaging operation.



**Figure 4-40** Staple-mode feed operation

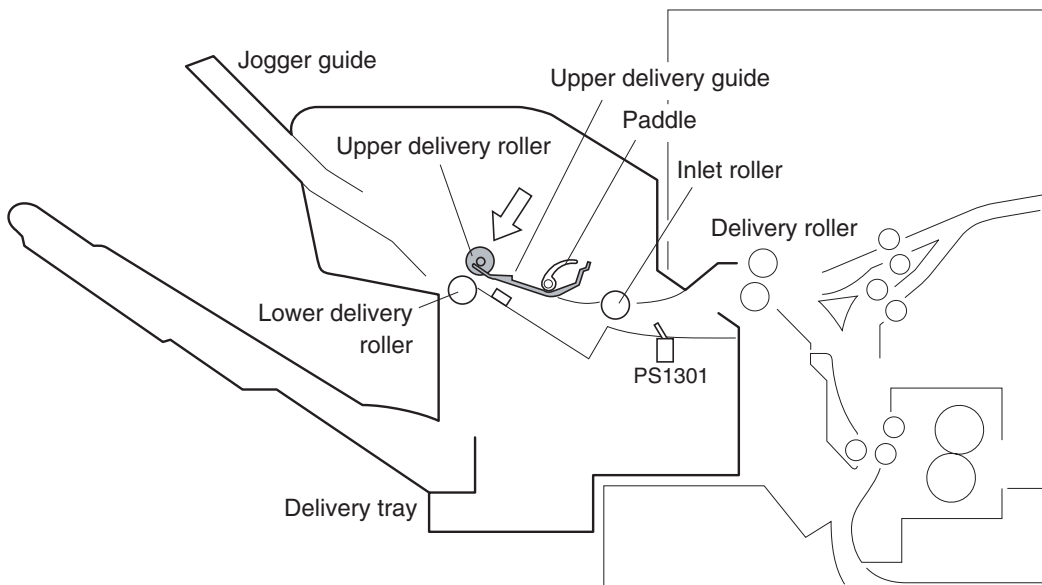
4. After a prescribed period of time, the stapler/stacker driver causes the feed motor (M1303) to drive at the same feed speed as the printer engine. This allows the inlet roller, the upper delivery roller, and the lower delivery roller to rotate, which feeds the paper to the stapler/stacker.

- After the disengaging operation of the feed rollers is normal, the stapler/stacker driver drives the jogger motor (M1302) and shifts the jogger guide from the turn-out position to the waiting position.



**Figure 4-41** Jogger guide

- When the jogger guide is shifted to the waiting position, the stapler/stacker driver rotates M1301 counter-clockwise again to engage the upper and the lower delivery rollers.

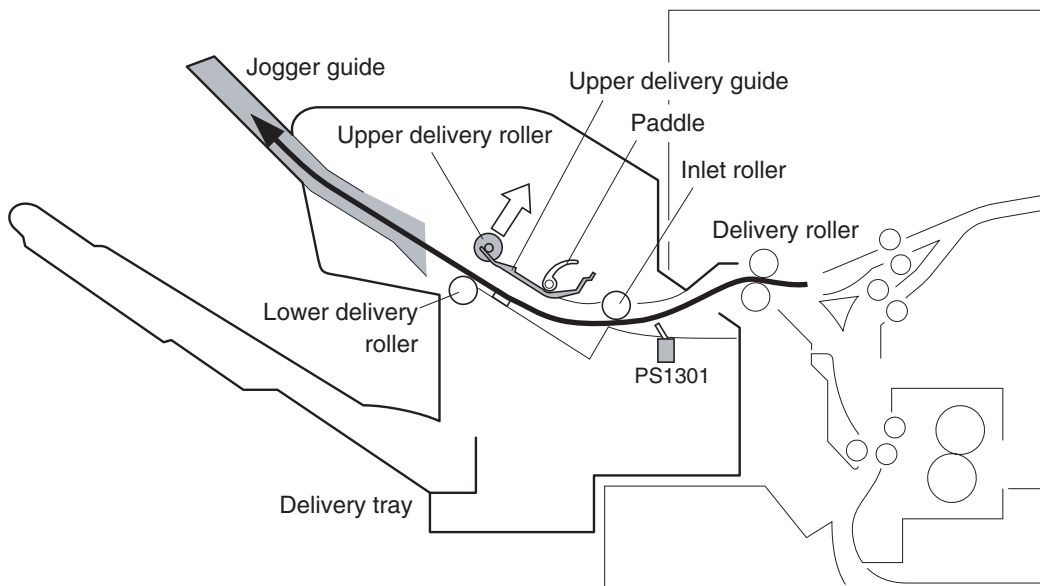


**Figure 4-42** Staple-mode feed operation

- After the leading edge of the paper reaches the paper inlet sensor (PS1301), the stapler/stacker driver changes the feed speed of the M1303 to synchronize it with that of the stapler/stacker.

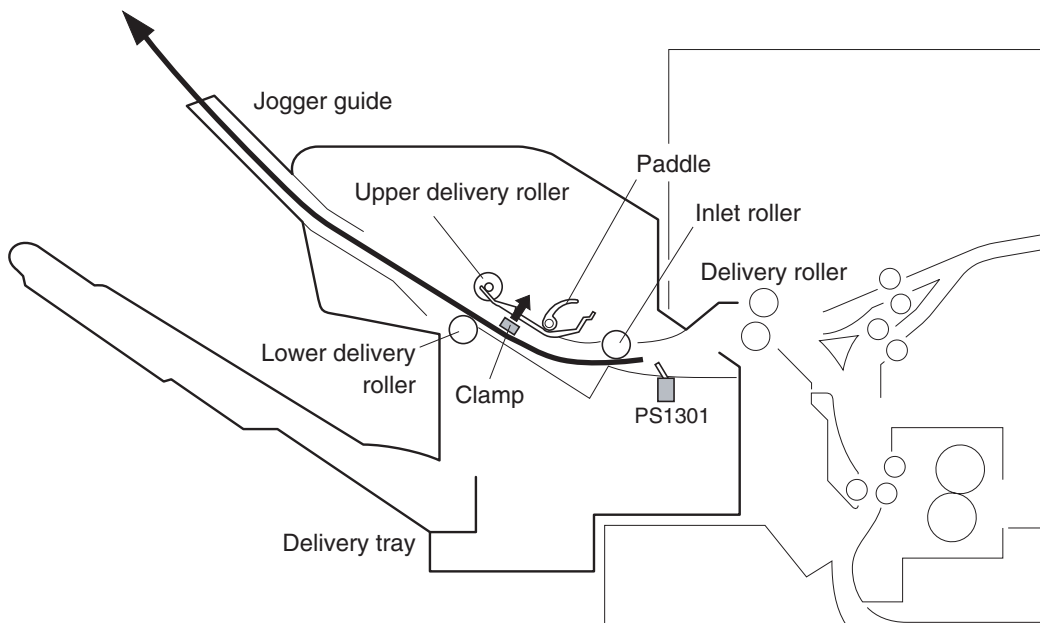


- After the feed speed of the stapler/stacker is changed, the stapler/stacker driver rotates M1301 counter-clockwise again to disengage the upper and the lower disengagement rollers.



**Figure 4-43** Staple-mode feed operation

- After the trailing edge of the paper passes the inlet sensor (PS1301), the stapler/stacker driver activates the clamp solenoid (SL1301). During the clamp-disengagement operation, the stamp is disengaged from the paper so the paper becomes unattached.

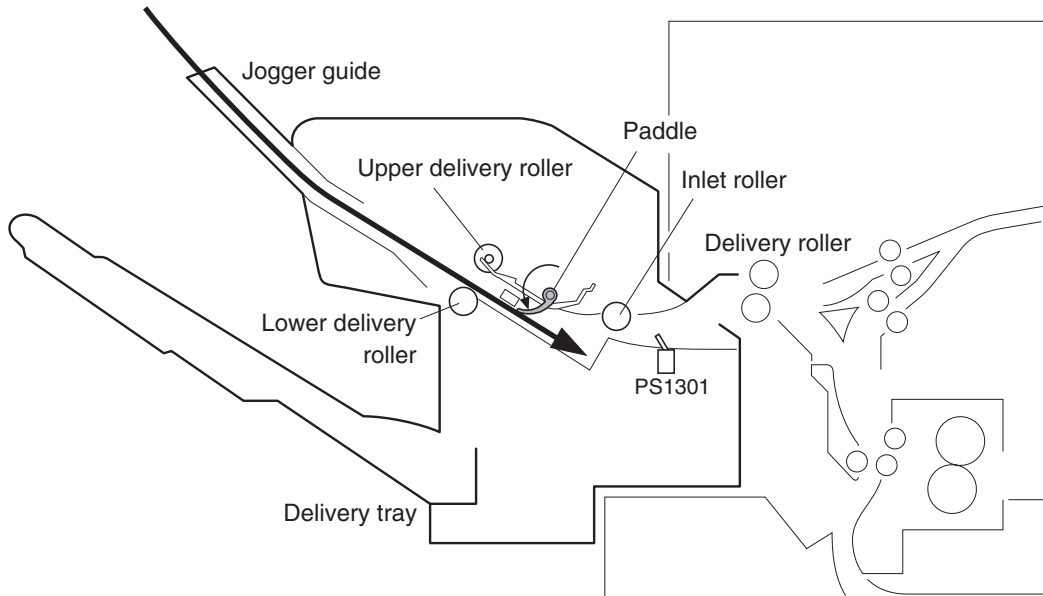


**Figure 4-44** Staple-mode feed operation

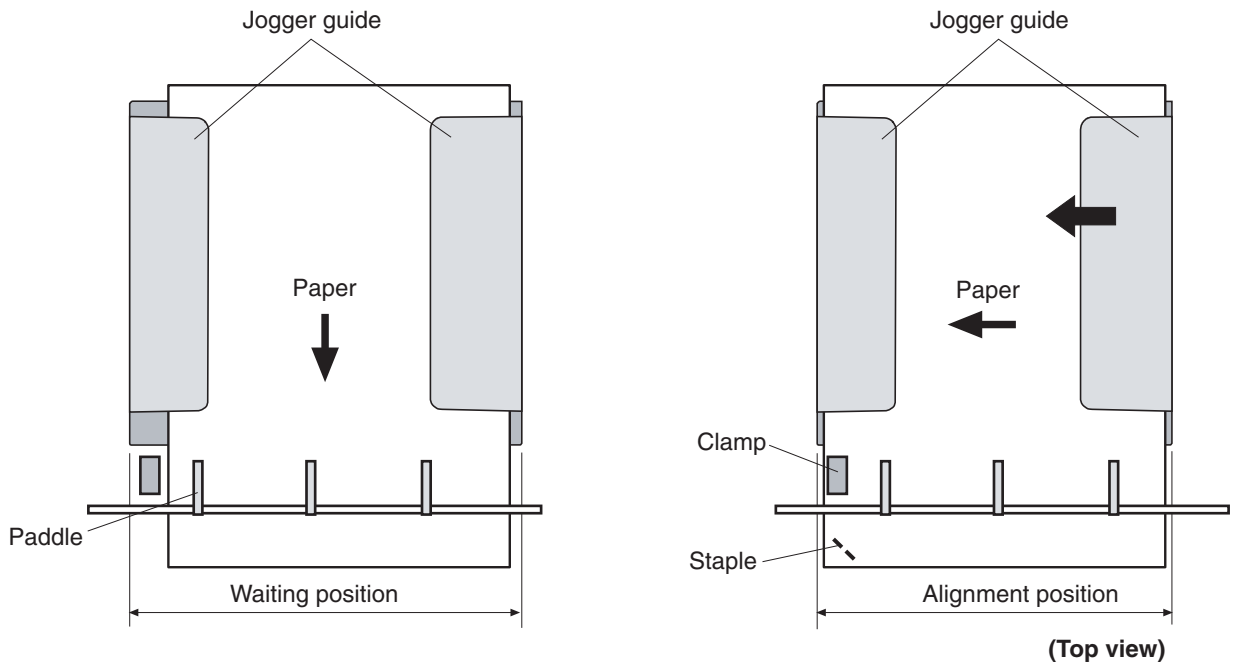
- The stapler/stacker driver changes its control depending on whether the paper that was fed is the last sheet of the job or not.
  - If it is not the last sheet of paper, go to steps 11 and 12, and then go back to step 7.
  - If it is the last paper, go to step 11.

11. The stapler/stacker driver changes the speed of the feed motor (M1303).
  - If it is not the last sheet of paper, the driver drives the feed motor at the printer speed.
  - If it is the last sheet of paper, the driver stops the feed motor.
12. The stapler/stacker driver drives the motors to perform the alignment operation.
  - Horizontal alignment: Drives M1302 and performs the jogger operation.
  - Vertical alignment: Drives M1301 and performs the paddle operation.

Through these alignments, the paper is correctly positioned on the jogger tray.



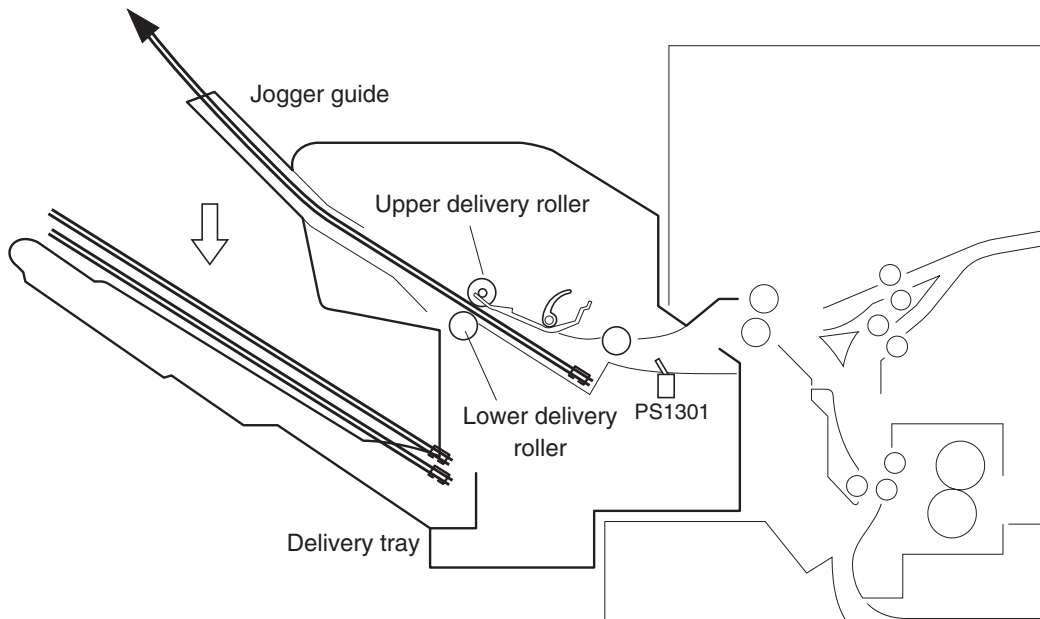
**Figure 4-45** Staple-mode feed operation



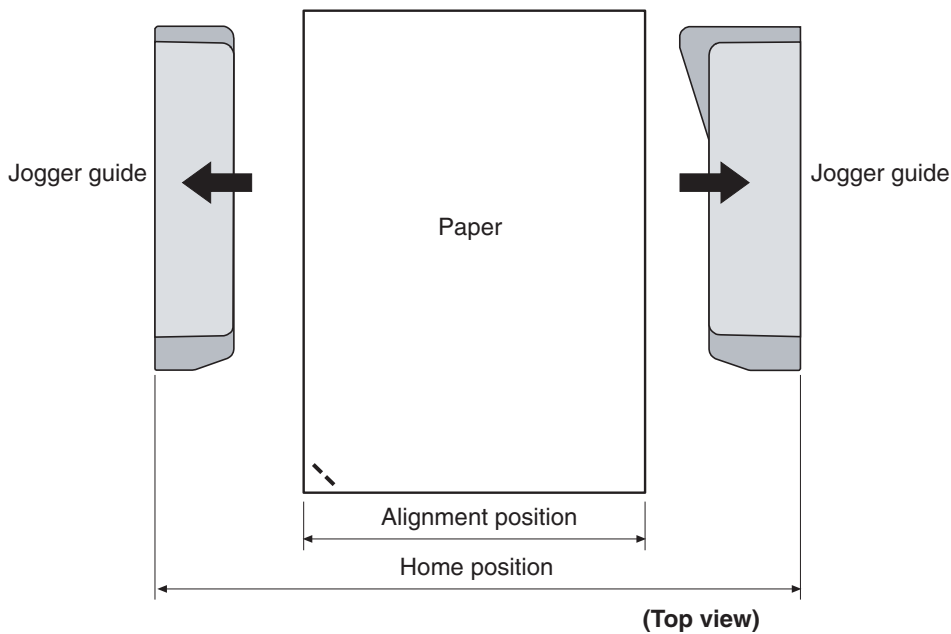
**Figure 4-46** Staple-mode feed operation

13. The stapler/stacker driver performs the staple operation.
14. After the completion of the staple operation, the stapler/stacker driver rotates the paddle motor (M1303) counter-clockwise to engage the upper and the lower delivery rollers.
15. The stapler/stacker driver drives the feed motor (M1303) and feeds the stapled piles of paper.

16. The stapler/stacker driver shifts the jogger guide to the turn-out position. This allows the paper pile on the jogger guide to fall onto the delivery tray.



**Figure 4-47** Staple-mode feed operation



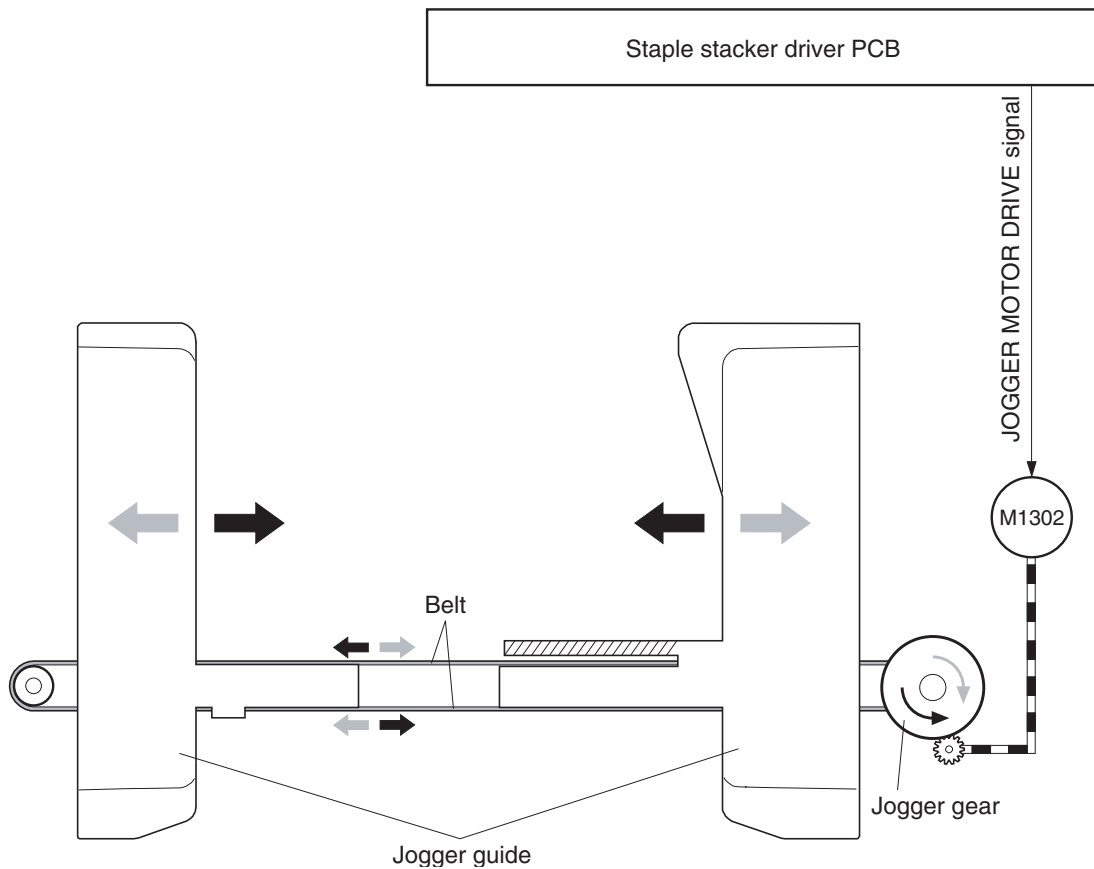
**Figure 4-48** Staple-mode feed operation

When the delivery tray is full of paper, this status is detected by the delivery paper-full sensor (PS1306). When this sensor continuously detects paper presence over a prescribed time interval, the stapler/stacker driver notifies the formatter of this condition.

## Jogger operation

The jogger aligns the edge of the paper in the horizontal direction.

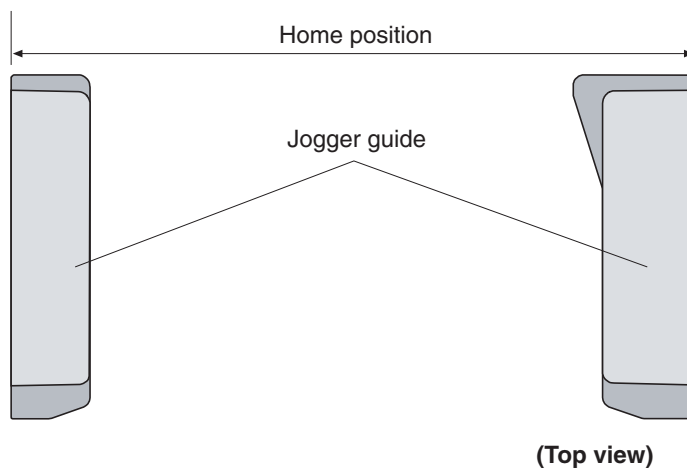
The stapler/stacker driver controls the jogger motor (M1302), which allows the jogger guide to move so it can align the edge of the paper.



**Figure 4-49** Jogger operation

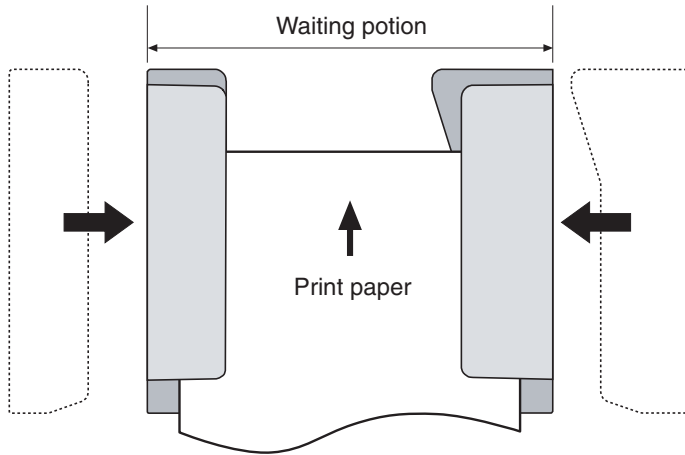
The jogger operation is explained in the following procedure.

1. Before the start of the operation, the jogger guide is stationed at the home position (turn-out position).



**Figure 4-50** Jogger operation

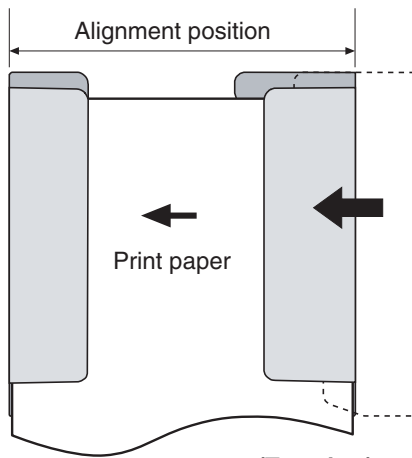
- At the start of the feeding process in staple mode, the stapler/stacker driver rotates M1302 counter-clockwise after it detects that the upper deliver roller is disengaged. It then moves the jogger guide to the waiting position.



(Top view)

**Figure 4-51** Jogger operation

- Within a prescribed period of time after the trailing edge of the paper passes the paper-inlet sensor (PS1301) (when the paper covers the entire jogger guide), the stapler/stacker driver rotates M1302 counter-clockwise to move the jogger guide to the aligned position (adjusted to the width of the paper). The edge of the paper is aligned in the horizontal direction.

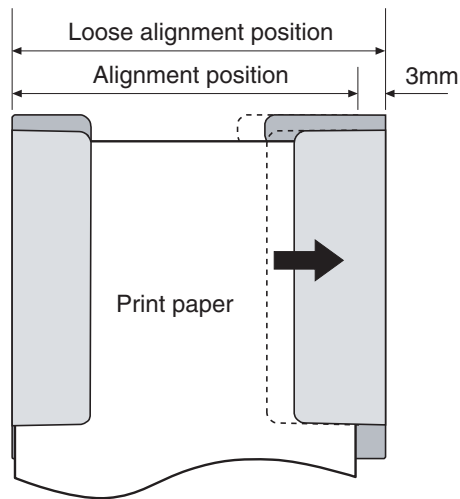


(Top view)

**Figure 4-52** Jogger operation

4. The stapler/stacker driver rotates M1302 clockwise and moves the jogger guide 3 mm out from the aligned position (loosen alignment).

The stapler/stacker driver performs the paddle operation during the loosen alignment.

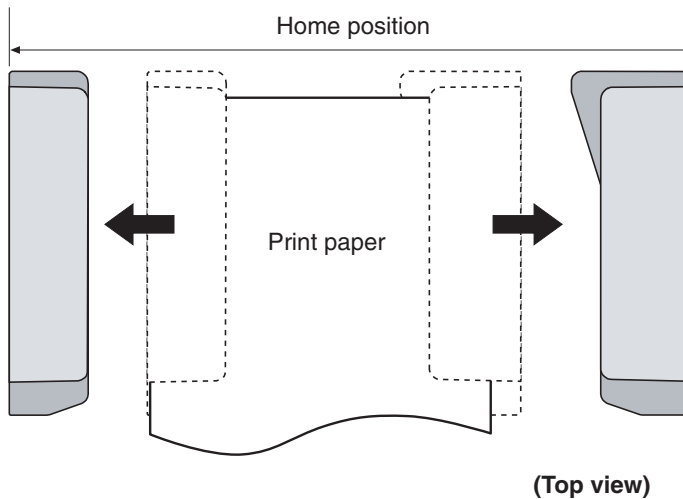


(Top view)

**Figure 4-53** Paddle operation

5. After the completion of the paddle operation, the stapler/stacker driver changes its controls depending on whether the fed paper is the last paper of the job or not.
  - If it is not the last sheet of paper, go to step 2.
  - If it is the last sheet of paper, go to step 6.

6. After the completion of the staple operation, the stapler/stacker driver rotates M1302 clockwise and moves the jogger guide to its home position. This allows the paper pile on the jogger guide to fall into the delivery tray.



**Figure 4-54** Jogger operation

The home position of the jogger guide is monitored by the stapler/stacker driver and the jogger home-position sensor.



**NOTE** Whether the fed paper is the last sheet of the job or not is determined by the page information sent from the formatter. If it is the last sheet, the EOJ (End Of Job) is recorded in its page information.

## Jogger home-position detection

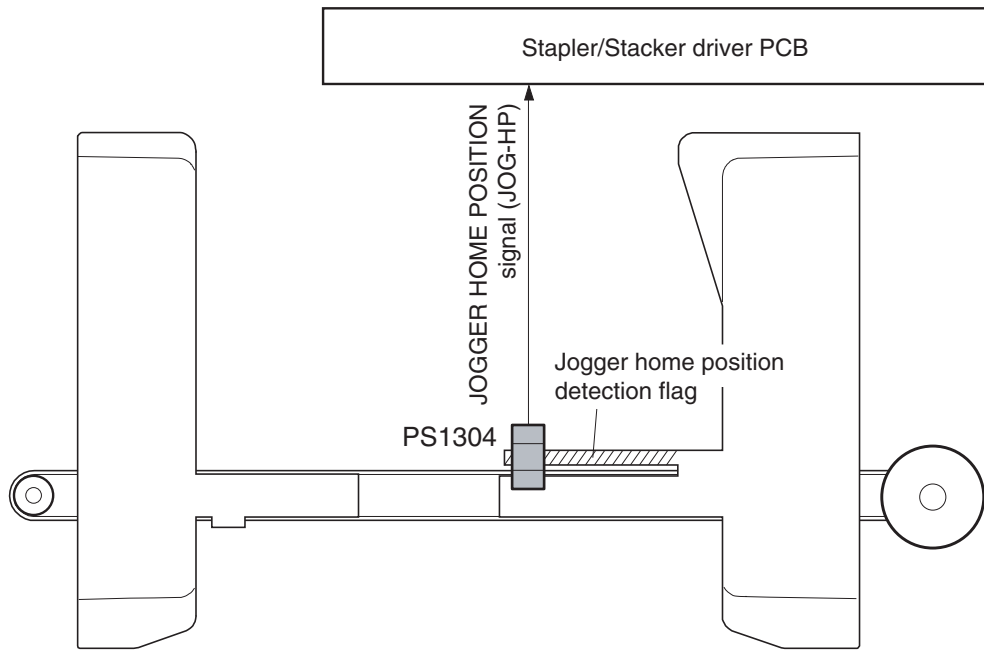
The stapler/stacker detects the home position of the jogger guide by monitoring the jogger home-position signal (JOG-HP) sent from the jogger home-position sensor (PS1304).

A rib-shaped jogger home-position flag is attached to the jogger guide. The flag has a notch, and the position of the jogger guide is detected by PS1304 passing the notch.

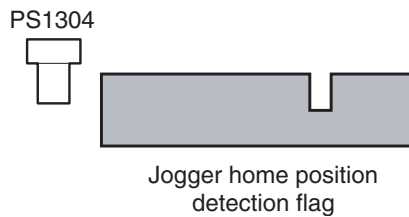
During the jogger-guide operation, PS1304 is interrupted by the jogger home-position flag and the JOG-HP indicates "H". However, PS1304 is not interrupted by the jogger home-position flag during the jogger home-position detection. The JOG-HP becomes "L" and the stapler/stacker driver determines that jogger guide is at its home position.

During the jogger home-position detection, the stapler/stacker driver rotates the jogger motor (M1302) clockwise for a specified period of time. If JOG-HP does not change from "L" to "H", the driver detects a jogger-motor failure and stops the loads. Then it notifies the formatter of the failure.





< Jogger home position >



< During jogger operation >

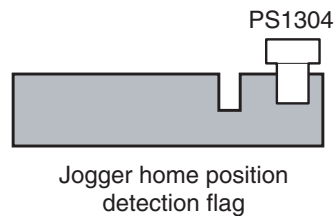


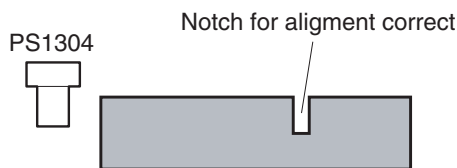
Figure 4-55 Jogger home position



**NOTE** At the start of the detection, the stapler/stacker driver rotates the jogger motor (M1302) clockwise to detect its home position. It does this even when the jogger guide is already set at the home position.

**NOTE** In addition to the notch that detects the home position, the jogger home-position flag also has a notch to correct the alignment position. During the alignment operation, alignment failure might be detected if the jogger motor loses synchronization during rotation. Therefore, a notch for correcting the alignment position is made near the paper-alignment position. When the alignment operation is performed, the alignment operation is corrected after checking the alignment position so that synchronization loss is avoided.

< Jogger home position >



< Alignment position >

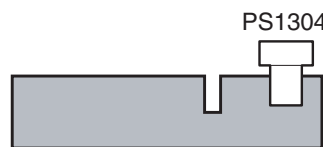


Figure 4-56 Jogger home position

## Stacker mode

In stacker mode, the paper is stacked in the paper delivery tray without being stapled. The feed operation in the stacker mode is explained in the following procedure.

1. The printer engine sends a paper-delivery signal to the formatter after the leading edge of the paper reaches the fixing-delivery sensor.
2. The formatter sends a paper-delivery notifying command to the stapler/stacker driver.
3. The stapler/stacker driver causes the feed motor (M1303) to drive at the same feed speed as the printer engine on order to feed the paper to the stapler/stacker.
4. After a prescribed period of time upon receiving the signal, the stacker driver drives the feed motor (M1303) at the same feed speed as the printer engine to rotate the inlet roller, the upper delivery roller, and the lower delivery roller. Through this process, the paper is fed into the stapler/stacker.
5. After the leading edge of the paper passes the inlet sensor (PS1301) (when the leading edge passes the upper and the lower disengagement rollers), the stapler/stacker driver rotates M1303 at the feed speed of the stapler/stacker.
6. The stapler/stacker driver changes the feed-motor drive depending on whether the paper that was fed is the last sheet of the job or not.
  - If it is not the last sheet of paper, the driver changes the feed-motor speed to the printer speed and returns to step 2.
  - If it is the last sheet of paper, the driver does not change the feed-motor speed.

When the delivery tray is full of paper for a specified period of time, the delivery paper-full sensor (PS1306) detects this status and notifies the formatter.

## Jam detection

The stapler/stacker has sensors that detect whether the print paper is fed correctly.

- Paper-inlet sensor (PS1301)
- Paper-delivery sensor (PS1302)

A jam is detected when paper is present at the sensor unit during check timings conducted by the CPU.

If the CPU determines that a jam has occurred, it stops the print operation and notifies the formatter.

- **Feed-delay jam**

If the paper-inlet sensor (PS1301) does not detect the leading edge of the paper within a prescribed period of time after it has received a paper-delivery notification command, the CPU detects a feed-delay jam.

- **Feed stationary jam**

If PS1301 does not detect the trailing edge of the paper within a prescribed period of time after the paper inlet sensor (PS1301) detects the leading edge of the paper, the CPU detects a feed stationary jam.

- **Delivery stationary jam**

If the paper-delivery sensor (PS1302) does not detect the trailing edge of the paper within a prescribed period of time after the feed motor has started its drive after the staple operation, the CPU detects a delivery stationary jam.

- **Residual-paper jam**

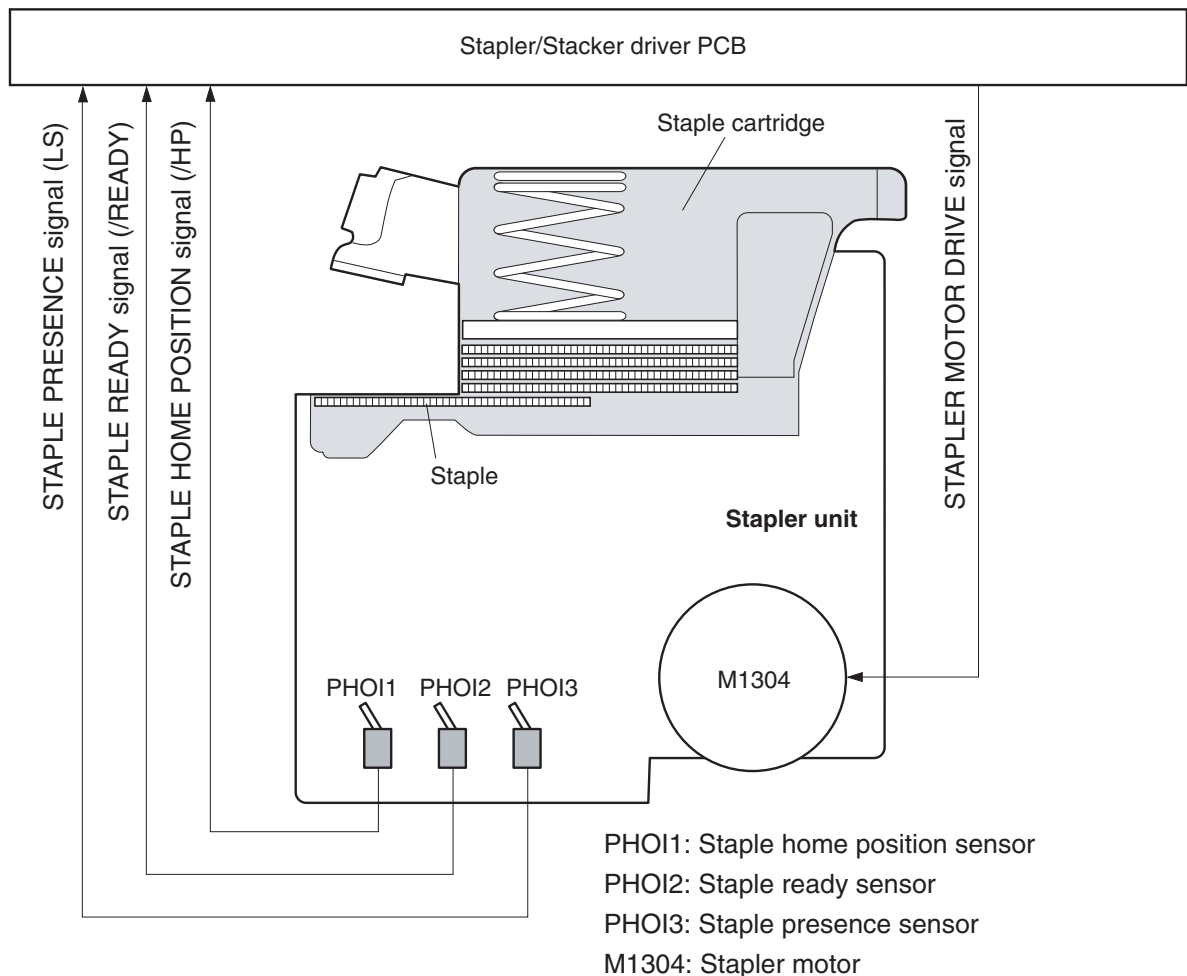
If the paper inlet sensor (PS1301) detects paper during the initial drive period, the CPU detects a residual-paper jam.

## Stapler unit

The stapler motor (M1304) is installed in the stapler unit. The staple operation is performed by the stapler/stacker driver controlling M1304. In addition, the stapler unit has three sensors to detect the condition of the stapler unit.



**NOTE** The staple cartridge holds a maximum of 5,000 staples.



**Figure 4-57** Stapler unit

## Staple home position detection

The staple home position is detected by the stapler/stacker driver as it monitors the staple home-position signal (/HP) from the staple home-position sensor (PHO11).

During the detection, the stapler/stacker driver rotates the staple motor (M1304) clockwise for a prescribed period of time. If the /HP signal does not change from "H" to "L" to "H", the driver detects a stapler failure, stops the loads, and notifies formatter.



---

**NOTE** If the /HP signal does not indicate "H" after it changes from "H" to "L", the stapler/stacker driver rotates M1304 counter-clockwise once. If the /HP signal changes from "L" to "H" during the counter-clockwise rotation, the stapler/stacker driver detects a staple jam and notifies the formatter.

---

## Self-priming detection

The stapler/stacker self-priming when a new staple cartridge is inserted.

The stapler/stacker driver monitors the staple-ready signal (/READY) from the staple-ready sensor (PHO12). Self-priming is initiated when the stapler/stacker driver detects a Staple Presence signal (LS) of "H" (meaning the staple cartridge has been replaced) after the driver has detected a LS signal of "L".

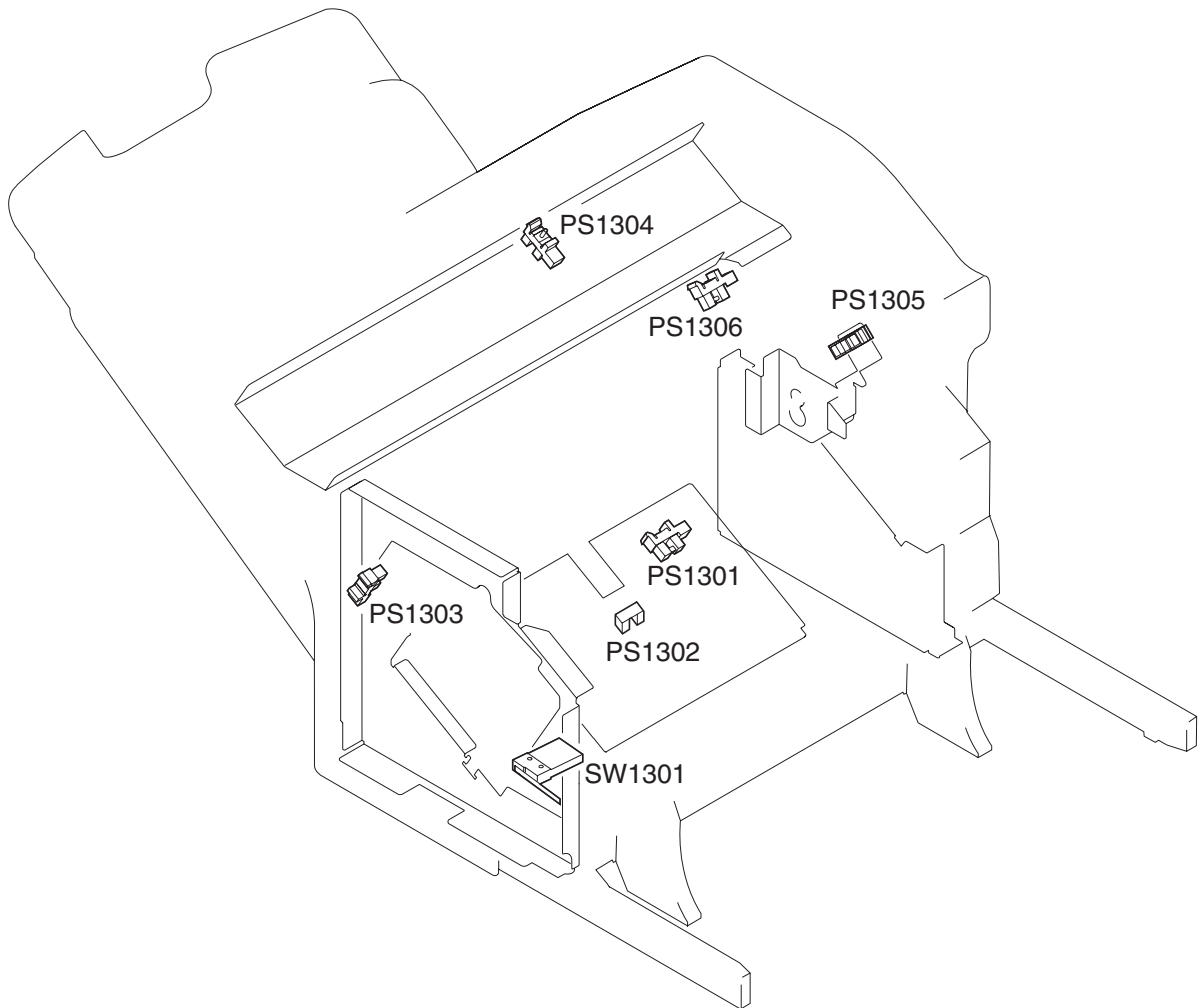
When the stapler/stacker driver detects the /READY signal "H", it performs the staple operation until the /READY signal becomes "L". However, if the /READY signal still indicates "H" after 11 repetitive staple operations, the stapler/stacker driver detects a self-priming failure, stops the loads, and notifies the formatter.

## Staple level detection

The staple level is detected by the stapler/stacker driver as it monitors the Staple Presence signal (LS) from the staple-presence sensor (PHO13).

When the stapler/stacker driver detects an LS signal of "L", it determines that 20 staples remain and sends a warning to the formatter. If the stapler staples 20 more times using the same stapler cartridge, the stapler/stacker driver notifies the formatter that the stapler cartridge is empty.

## Stapler/stacker switches and sensors



**Figure 4-58** Switches and sensors

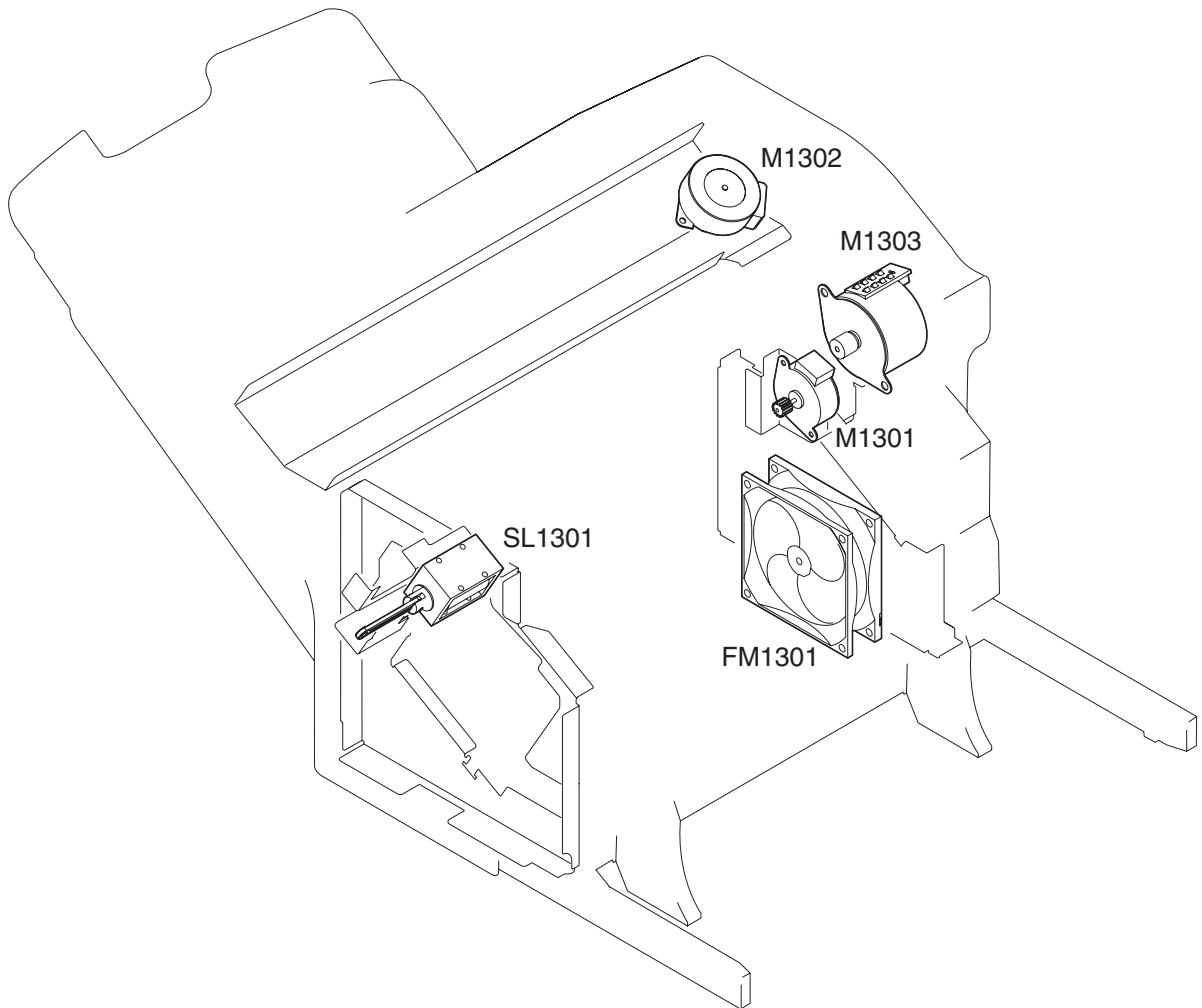
**Table 4-6** Switches and sensors (part 1)

SW1301	Door-open switch
PS1301	Paper-inlet sensor
PS1302	Paper-delivery sensor
PS1303	Delivery-roller disengaging sensor
PS1304	Jogger home-position sensor
PS1305	Paddle home-position sensor
PS1306	Paper-delivery-full sensor

**Table 4-7** Switches and sensors (part 2)

Name		Purpose
Motors	Paddle motor (M1301)	Rotates the paddle (clockwise); disengages the delivery rollers (counter-clockwise)
	Jogger motor (M1302)	Shifts the jogger guide (clockwise: open; counterclockwise: close)
	Feed motor (M1303)	Rotates the inlet roller / delivery roller
	Stapler motor (M1304)	Staple operation (rotation of staple cam)
Solenoids	Clamp solenoid (SL1301)	Drives the clamp
Sensors	Paper-inlet sensor (PS1301)	Detects jams
	Paper-delivery sensor (PS1302)	Detects jams
	Delivery-roller disengaging sensor (PS1303)	Detects the disengagement of the delivery roller
	Jogger home-position sensor (PS1304)	Detects the home position of the jogger guide
	Paddle home-position sensor (PS1305)	Detects the paddle home position
	Delivery paper-full sensor (PS1306)	Detects when the delivery tray is full
	Staple home-position detection sensor (PHO1)	Detects the home position of the staple cam
	Staple-ready detection sensor (PHO2)	Detects self-priming
Switch	Staple detection sensor (PHO3)	Detects the presence of the staples
	Door-open detection switch (SW1301)	Detects if the door is open

## Stapler/stacker motors, solenoid, and fan

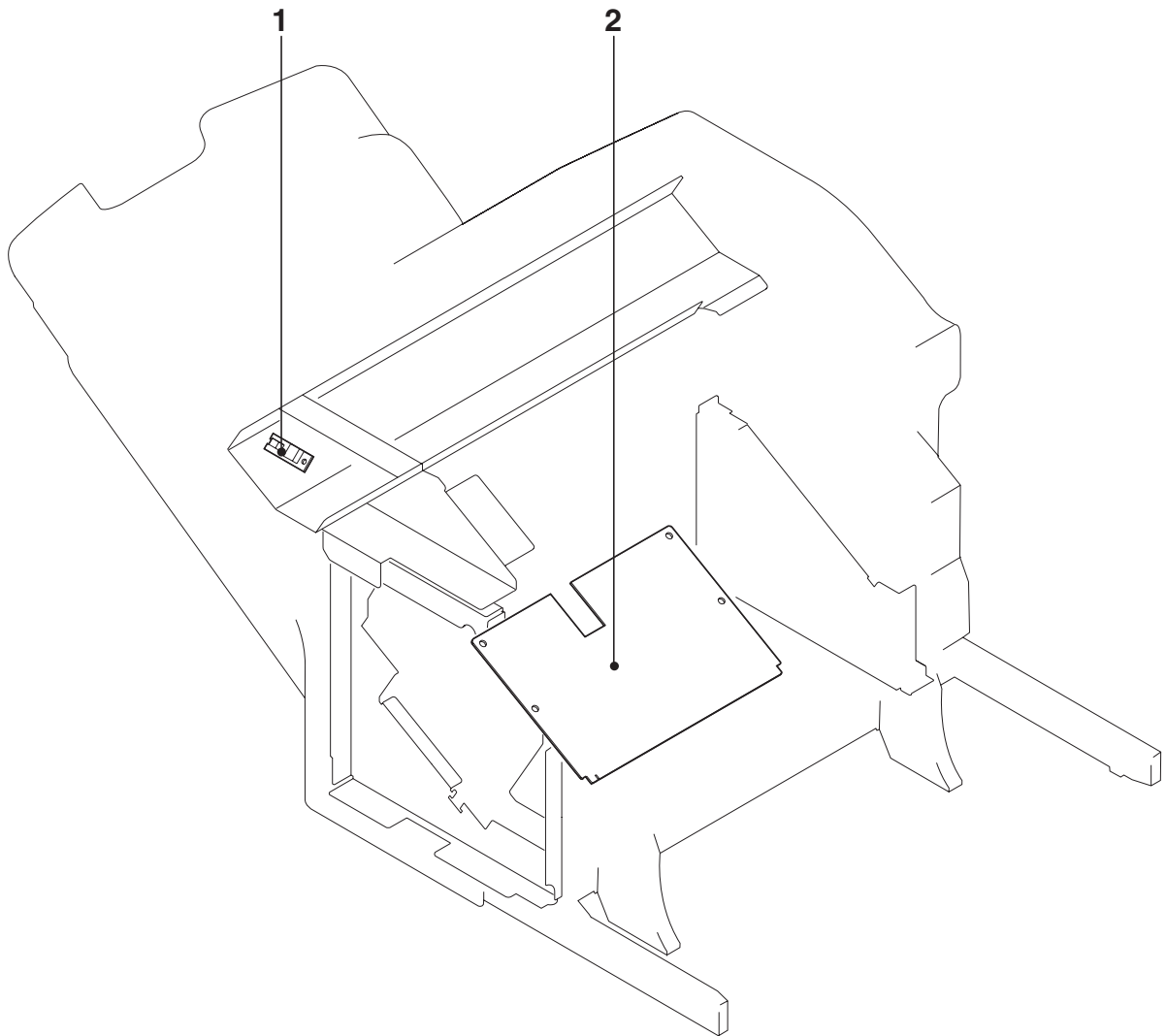


**Figure 4-59** Motors, solenoid, fan

**Table 4-8** Motors, solenoid, fan

M1301	Paddle motor
M1302	Jogger motor
M1303	Feed motor
SL1301	Clamp solenoid
FM1301	Cooling fan

## Stapler/stacker PCBs

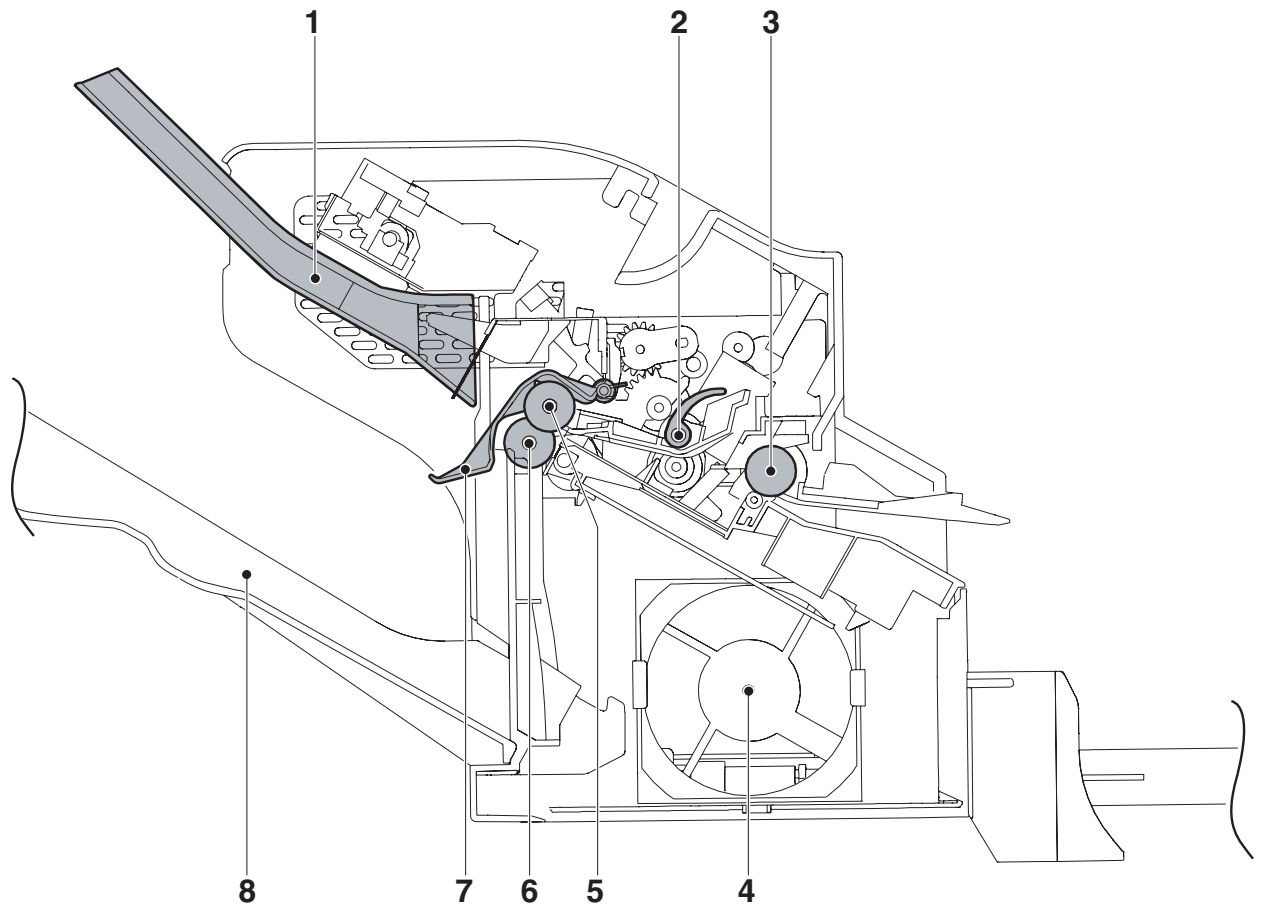


**Figure 4-60** PCBs

**Table 4-9** PCBs

1	LED PCB
2	Staple stacker driver PCB

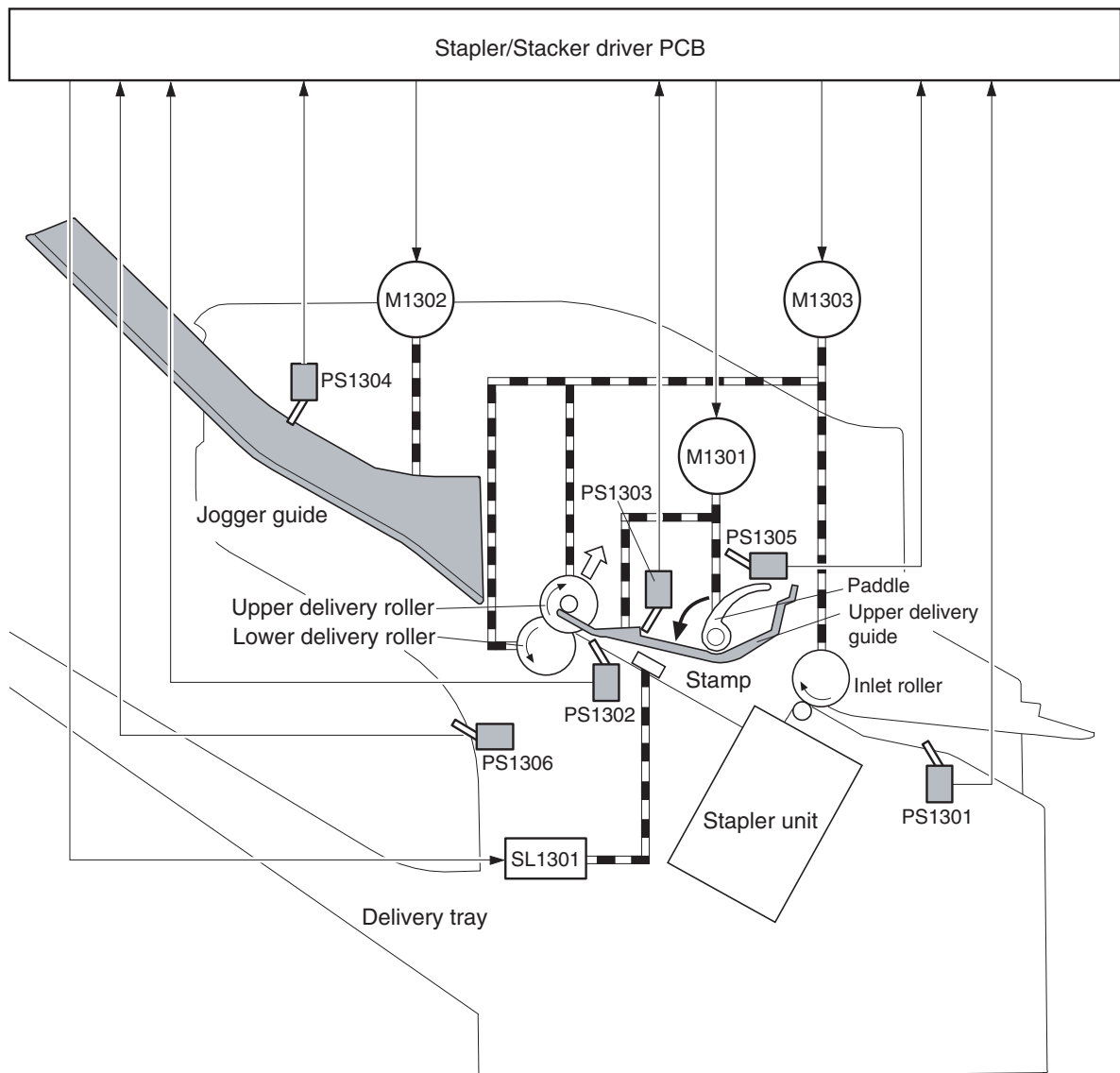




**Figure 4-61** Cross-sectional view (part 1)

**Table 4-10** Cross-sectional view (part 1)

1	Jogger guide
2	Paddle
3	Inlet roller
4	Cooling fan
5	Upper delivery roller
6	Lower delivery roller
7	Delivery tray paper-full sensor
8	Paper delivery tray



**Figure 4-62** Cross-sectional view (part 2)

**Table 4-11** Cross-sectional view (part 2)

M1301	Paddle motor
M1302	Jogger motor
M1303	Feed motor
SL1301	Clamp solenoid
PS1301	Paper inlet sensor
PS1302	Delivery sensor
PS1303	Delivery-roller disengaging sensor
PS1304	Jogger home-position sensor

**Table 4-11** Cross-sectional view (part 2) (continued)

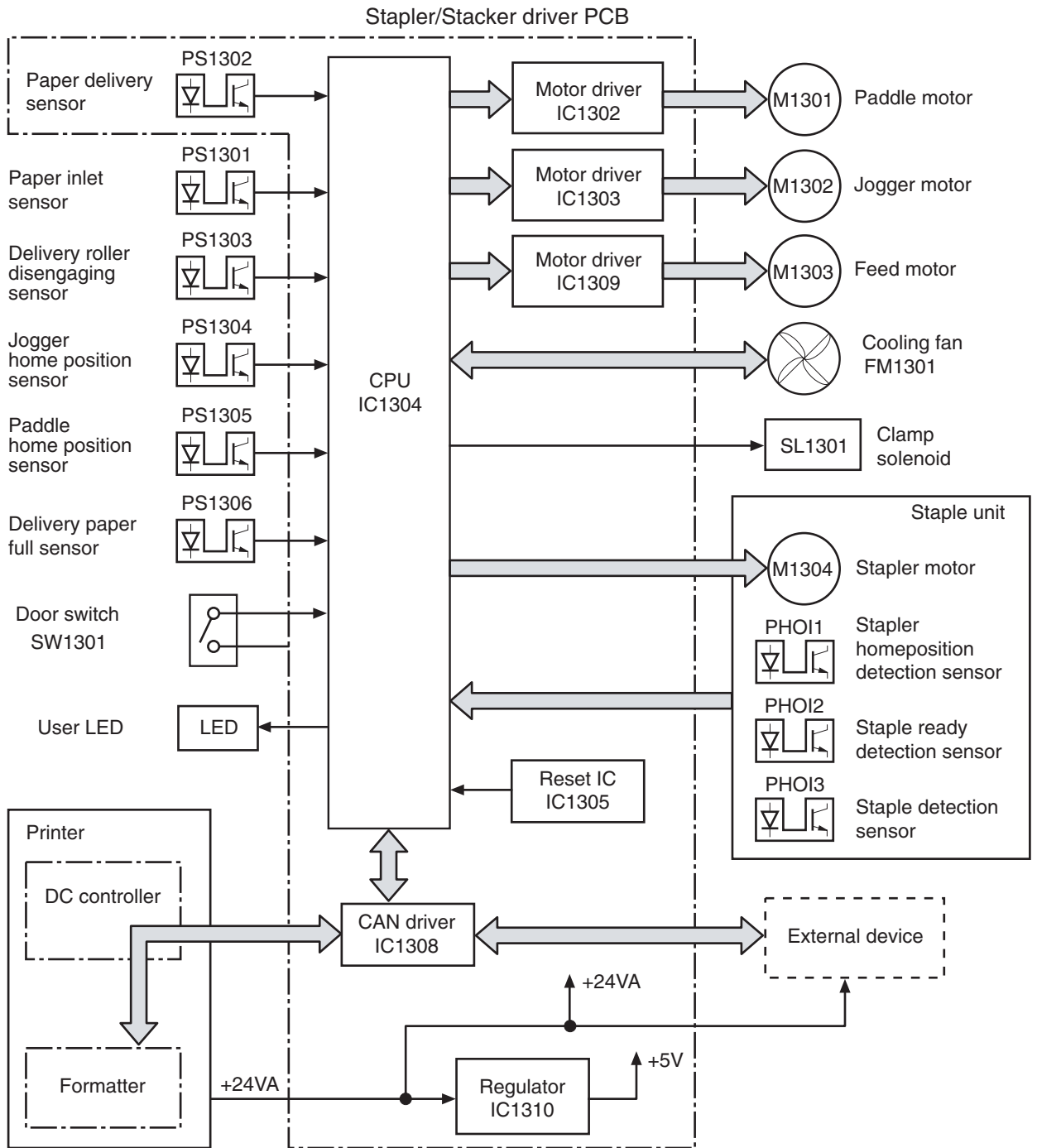
PS1305	Paddle home-position sensor
PS1306	Delivery-full sensor

## Stapler/stacker driver PCB

The stapler/stacker driver controls the operational sequence of the stapler/stacker.

When the MFP is turned on and DC power is supplied to the stapler/stacker driver from the printer, the stapler/stacker driver communicates with the formatter to start operational control. Then the stapler/stacker enters stand-by mode and the stapler/stacker driver sends signals to drive loads, such as motors and solenoids, in response to the command submitted from the printer.

The block diagram of the circuit is shown in the following figure.



**Figure 4-63** Stapler/stacker driver PCB

## Stapler/stacker driver list of signals

Table 4-12 Stapler/stacker driver list of signals

Connector	PIN	Abbreviation	I/O	Logic	Signal name
J1301	1	+24V	I	A	+24V supply
	2	+24V	I	A	+24V supply
	3	POWERON	I	H	POWER ON signal
	4	GND			
	5	GND			
	6	CAN-L	I	H	CAN RECEIVE signal
	7	CAN-H	I	L	CAN RECEIVE signal
	8	/SP-UP	I	H	SPEED UP signal
	9	+24V	I	A	+24V supply
	10	GND			
	11	GND			
J1302	1	ULED-G	O	H	USER LED DRIVE signal (Green)
	2	ULED-O	O	H	USER LED DRIVE signal (Orange)
	3	GND			
	4	NC			
	5	+5V	O		+5V supply
	6	GND			
	7	JOG-HP	I		JOGGER HOME POSITION DETECTION signal
J1303	1	+5V	O	A	+5V supply
	2	GND			
	3	IN-SNS	I	L	INLET PAPER DETECTION signal
J1304	1	+24V	O	A	+24V supply
	2	+24U	I	A	+24V supply
J1305	1	FD-AD	O	P	FEED MOTOR DRIVE signal
	2	FD-AND	O	P	FEED MOTOR DRIVE signal
	3	FD-BD	O	P	FEED MOTOR DRIVE signal
	4	FD-BND	O	P	FEED MOTOR DRIVE signal
J1306	1	GND			
	2	PWRON-OUT	O	H	POWER ON OUTPUT signal
	3	CAN-L-OUT	O	L	CAN SEND signal
	4	CAN-H-OUT	O	H	CAN SEND signal

**Table 4-12** Stapler/stacker driver list of signals (continued)

Connector	PIN	Abbreviation	I/O	Logic	Signal name
J1307	1	GND			
	2	FLASH-OUT	O	H	FLASH ROM RECORD signal
	3	FLASH-MD0	I	L	OPERATION MODE SPECIFYING signal
	4	FLASH-CLK	O	L	FLASH ROM RECORD signal
	5	FLASH-MD2	O	H	OPERATION MODE SPECIFYING signal
	6	FLASH-IN	I	L	FLASH ROM RECORD signal
	7	FLASH-ACT0	I		FLASH ROM RECORD signal
	8	+5V	O	A	+5V supply
	9	RCT	I	H	RESET signal
	10	GND			
	11	FLASH-ACT1	I	L	FLASH ROM RECORD signal
J1308	1	+5V	O	A	+5V supply
	2	GND			
	3	SWNG-HP	I	H	DELIVERY ROLLER DISENGAGING DETECTION signal
J1309	1	FAMDRV	I	A	FAN MOTOR DRIVE signal
	2	/FANLOCK	O	L	FAN LOCK DETECTION signal
	3	GND			
J1310	1	+24U	O	A	+24V supply
	2	STMP-SL	O	H	CLAMP DRIVE signal
J1311	1	JOG-BND	O	P	JOGGER MOTOR DRIVE signal
	2	JOG-BD	O	P	JOGGER MOTOR DRIVE signal
	3	JOG-AND	O	P	JOGGER MOTOR DRIVE signal
	4	JOG-BD	O	P	JOGGER MOTOR DRIVE signal
J1312	1	+5V	O	A	+5V supply
	2	/HP	I	L	STAPLE HOME POSITION DETECTION signal
	3	/READY	I	L	STAPLER READY signal
	4	LS	I	H	STAPLE DECELERATION signal
	5	GND			
	6	MTR-	O	H	STAPLER MOTOR DRIVE signal
	7	MTR-	O	H	STAPLER MOTOR DRIVE signal
	8	MTR+	O	H	STAPLER MOTOR DRIVE signal
	9	MTR+	O	H	STAPLER MOTOR DRIVE signal

**Table 4-12** Stapler/stacker driver list of signals (continued)

Connector	PIN	Abbreviation	I/O	Logic	Signal name
J1313	1	+5V	O	A	+5V supply
	2	GND			
	3	PDL-HP	I	H	PADDLE HOME POSITION DETECTION signal
	4	+5V	O	A	+5V supply
	5	GND			
	6	FULL	I	H	DELIVERY TRAY PAPER FULL signal
J1314	1	NC			
	2	PDL-BND	O	P	PADDLE MOTOR DRIVE signal
	3	PDL-BD	O	P	PADDLE MOTOR DRIVE signal
	4	PDL-AND	O	P	PADDLE MOTOR DRIVE signal
	5	PDL-AD	O	P	PADDLE MOTOR DRIVE signal

## Scanner system

The scanner system adds copying and sending functions to the standard MFP printing function. The scanner assembly consists of an automatic document feeder (ADF) and a flatbed scanner glass surface.

Original documents that are fed through the ADF are delivered to the ADF output bin, which is underneath the ADF input tray. Printed copies are delivered to the output device that is attached to the print engine.

The scanner unit has built-in duplexing capability for scanning two-sided documents.



**NOTE** The MFP delivers two-sided printed copies of original documents only when a duplex printing unit is installed in the print engine. If a duplex printing unit is *not* installed, the copies are printed on one side of the page. If a duplex printing unit is installed, the printed copies can be either one-sided or two-sided, depending on the instructions from the user.

Figure 4-64 ADF mechanical structure on page 198 shows a cross-section of the ADF.

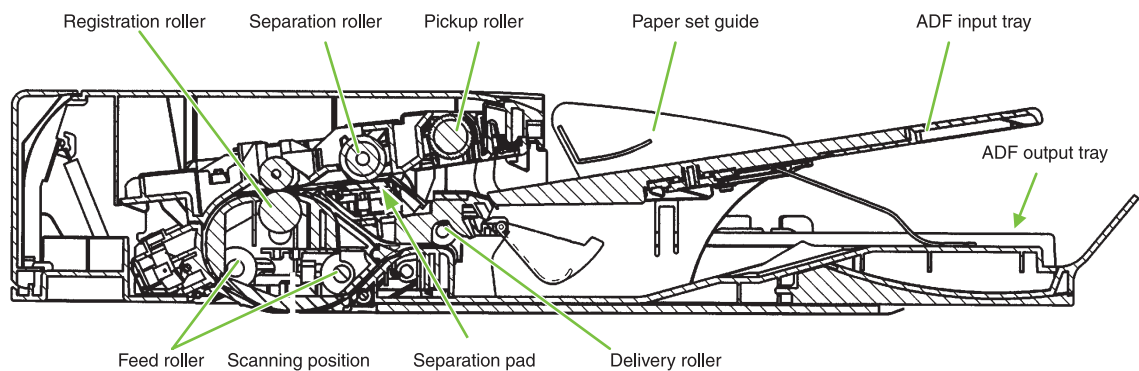


Figure 4-64 ADF mechanical structure

## Electrical system

The scanner assembly electrical system consists of the following components:

- The charged-coupled device (CCD) PCA
- The inverter PCA
- The scanner PCA
- The ADF PCA
- The ADF LED PCA

The scanner assembly is connected to the print-engine formatter through a flat, flexible cable.

Figure 4-65 Scanner assembly electrical structure on page 199 shows the scanner assembly electrical structure.



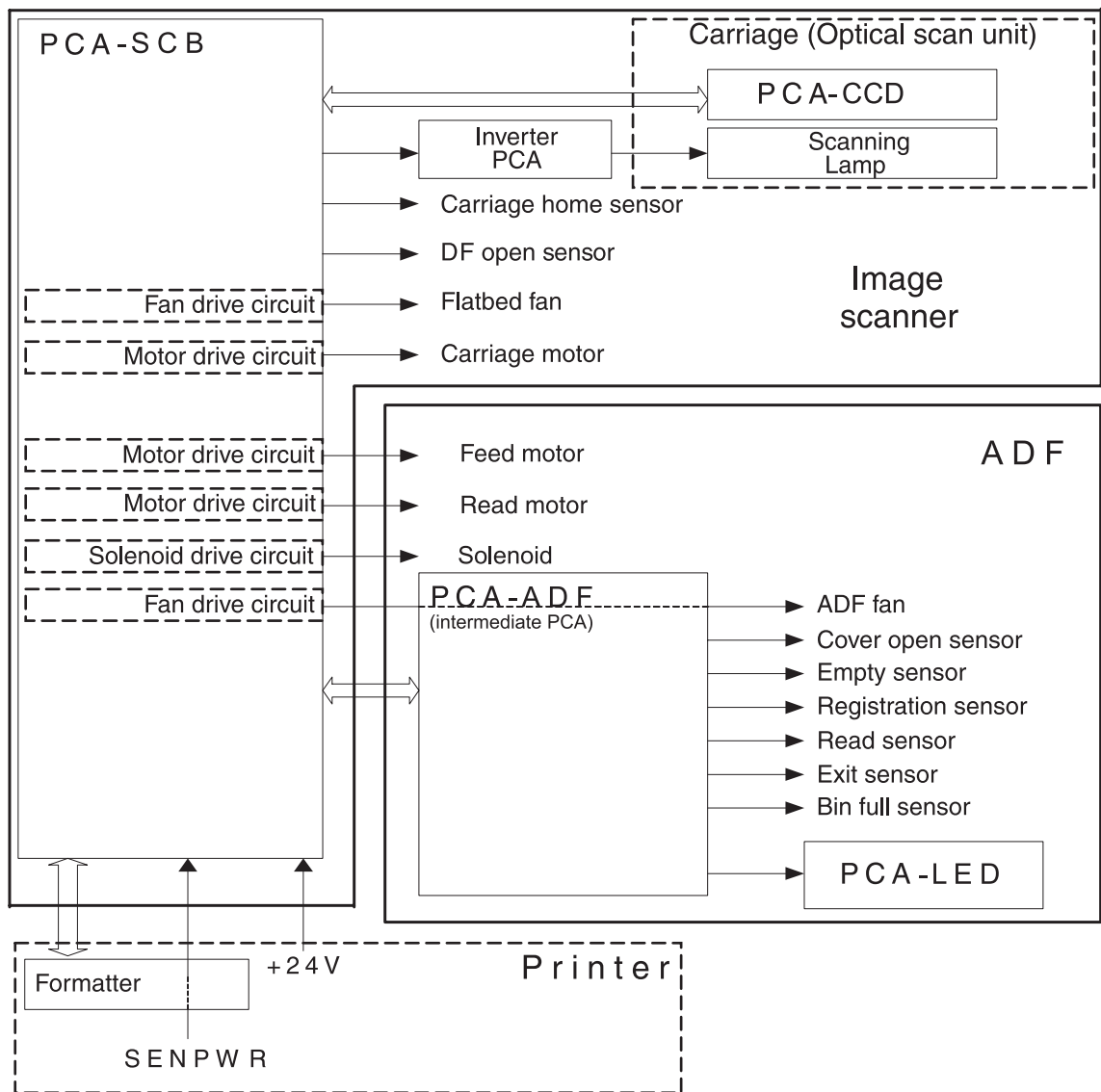


Figure 4-65 Scanner assembly electrical structure

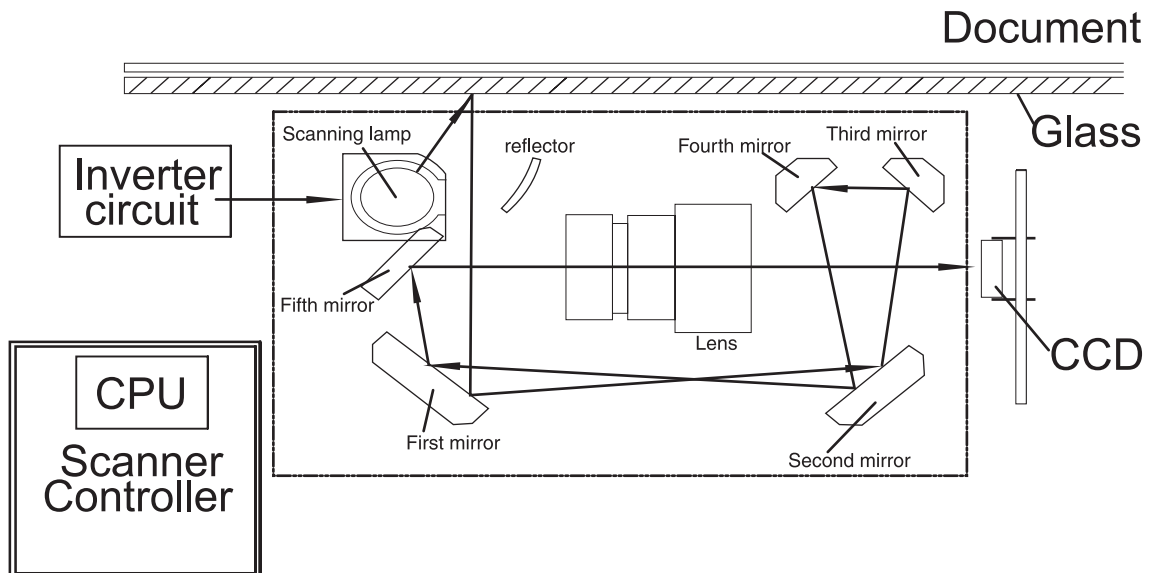
## Motors and fans

The scanner assembly has five motors and two fans. Three of the motors are stepping motors, which drive the components inside the scanner assembly. The remaining two motors are DC motors, which drive the two fans.

Name	Purpose	Type	Rotation	Failure detection
Carriage motor	Drives the carriage unit	Stepping motor	Varies	No
Feed motor	Drives the pickup, separation, and registration rollers	Stepping motor	Varies	No
Read motor	Drives the feed and delivery rollers	Stepping motor	Counterclockwise	No
Flatbed fan	Cools the scanner lamp and the CCD	DC motor	Clockwise	Yes
ADF fan	Cools the motors	DC motor	Clockwise	Yes

## Optical assembly

The optical assembly contains the scan carriage and the scanner glass. The scan carriage contains the lamp, five mirrors, a lens, and the CCD.



**Figure 4-66** Scan carriage components

The scanner lamp illuminates a small strip of the document (called the raster line). The mirrors direct the light through the lens to the CCD. The CCD senses and records the light, creating an analog representation of the raster line. If the ADF is being used, the document then advances in the ADF to the next raster line. If the flatbed is being used, the carriage advances to the next raster line. This advancing and collection process continues to the end of the sheet.

The image data is collected on the scanner controller PCA, where it is processed and sent to the formatter.

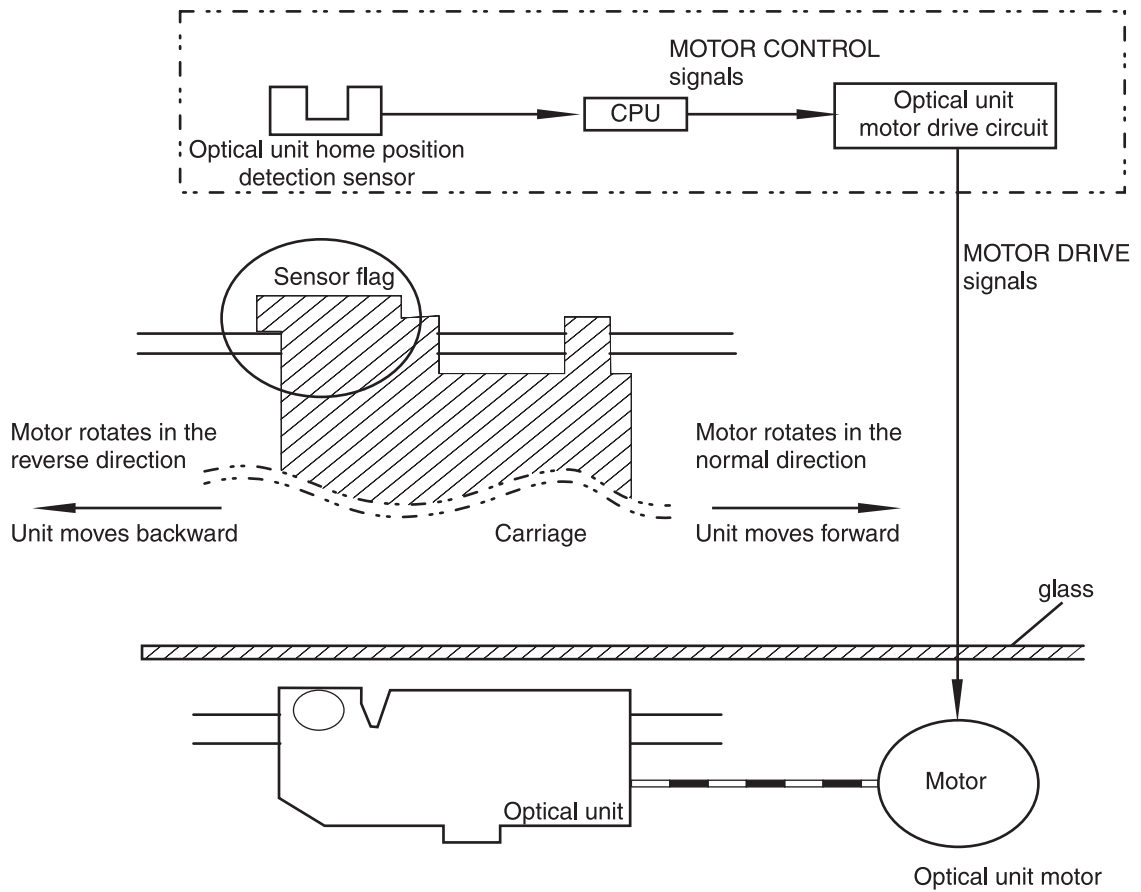


Figure 4-67 Scan carriage movement

## ADF feed system

Pages from the original document enter the ADF from the ADF input tray. A separation roller and separation pad work together to separate the top sheet from the stack. The page passes through a set of registration rollers and two sets of feed rollers that advance the page. A set of delivery rollers delivers the page to the ADF output bin. A bin-full sensor detects when the ADF output bin is full, and stops the feed mechanism until the bin is emptied.

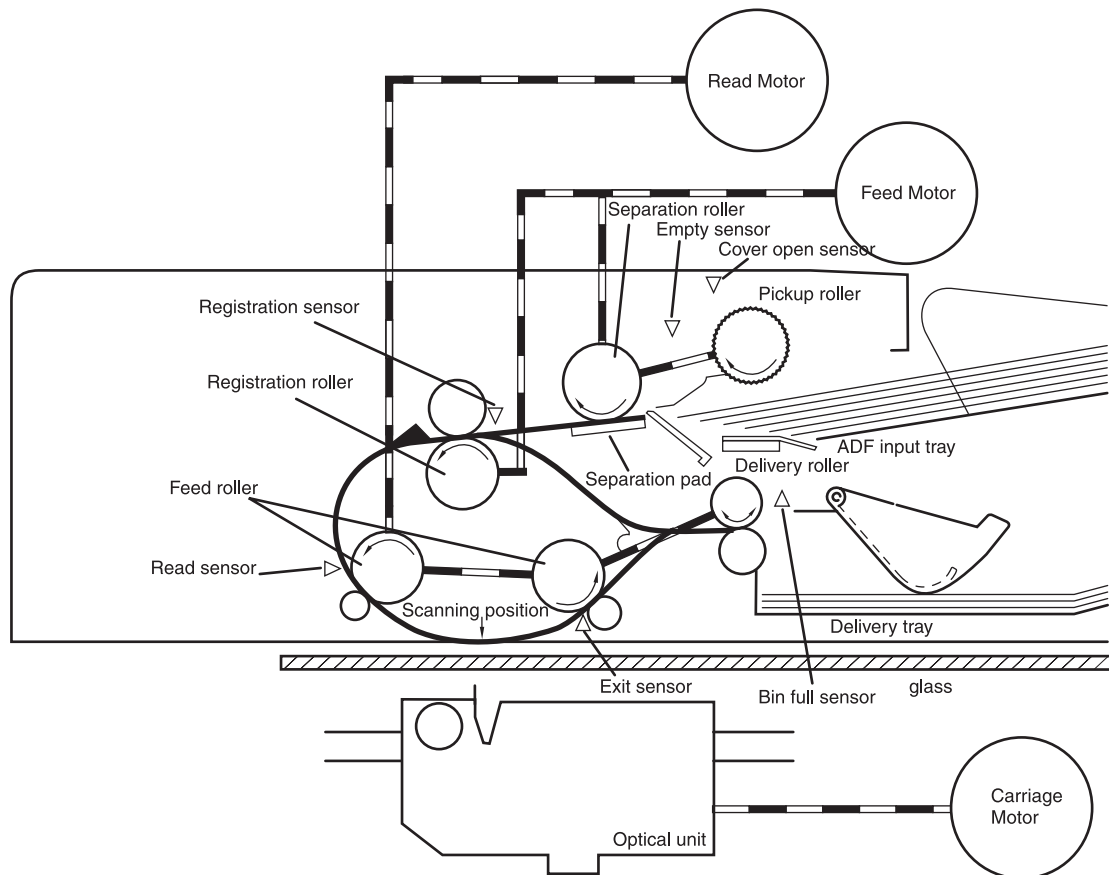


Figure 4-68 ADF paper path and sensors

## Jam detection

When the sensors inside the ADF detect a jam, the feed and read motors immediately stop and send a signal to the scanner controller PCA, which notifies the formatter. An **ADF Paper Jam** message appears on the control-panel display.

To clear a jam, open the jam-access cover and remove the media. When no sensors detect media after entering the jam state, the jam message is cleared from the control-panel display.

## Residual-media jam

During the initialization sequence or after the ADF jam cover has been opened and closed, if the registration sensor, read sensor, or exit sensor detects the presence of media, the scanner controller PCA determines that a residual-media jam has occurred.

## ADF pickup jam

If the leading edge of the media did not reach the registration sensor within a specific period of time, the scanner controller PCA determines that an ADF pickup jam has occurred.

## ADF jam

Jams can occur in three places inside the ADF: at the registration sensor, read sensor, and exit sensor.

### Registration sensor jam

If the registration sensor does not detect the trailing edge of the media after the leading edge reaches the scan-ready position, the scanner-controller PCA determines that an ADF paper jam has occurred.

Also, when the scanner duplexer is being used, if the registration sensor does not detect the leading edge of the media after a specific period of time after media enters the duplexer, the scanner-controller PCA determines that a jam has occurred.

### Read sensor jam

If the read sensor does not detect the leading edge of the media within a specific period of time, or if the read sensor does not detect the trailing edge of the media within a specific period of time after it detects the leading edge, the scanner-controller PCA determines that a jam has occurred.

### Exit sensor jam

If the exit sensor does not detect the leading edge of the media within a specific period of time after the leading edge reaches the read sensor, or if the exit sensor does not detect the trailing edge of the media within a specific period of time after the read sensor detects the trailing edge, the scanner-controller PCA determines that a jam has occurred.

## ADF cover open jam

If the ADF jam-access cover is opened while media is feeding through the ADF, a jam occurs.

## ADF open jam

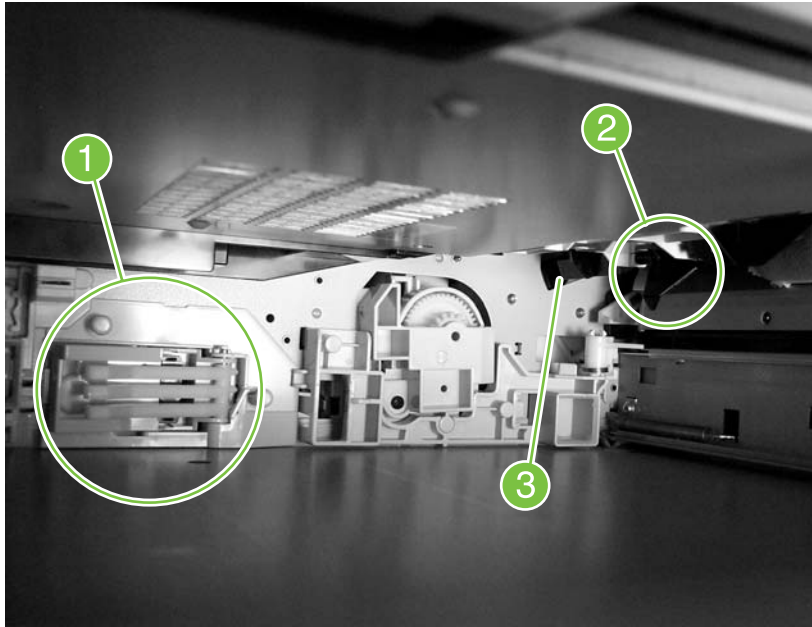
If the ADF is opened while media is feeding through the ADF, a jam occurs.

# Locations of major components

The photos in this section identify the locations of many major components in the MFP.

## Sensors and switches

### Cassette sensors



**Figure 4-69** Cassette sensors

1	SW102, paper-size switches
2	PS101, tray 2 paper-present sensor
3	PS107, tray 2 paper-stack-surface sensor

## Sensors in the print-cartridge area

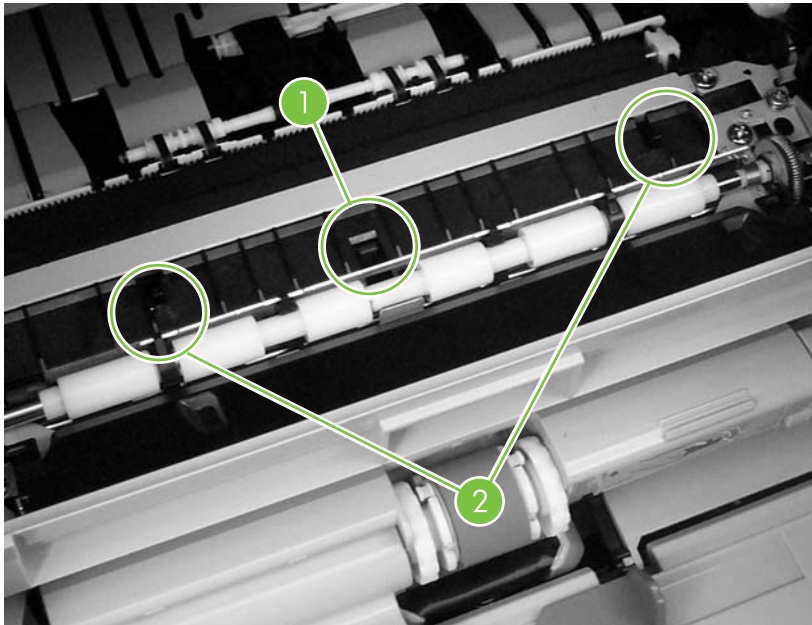


Figure 4-70 Sensors in the print-cartridge area

1	PS103, top-of-page sensor
2	PS106 and PS112, paper-width sensors

## Sensors on the reversing unit (top side)

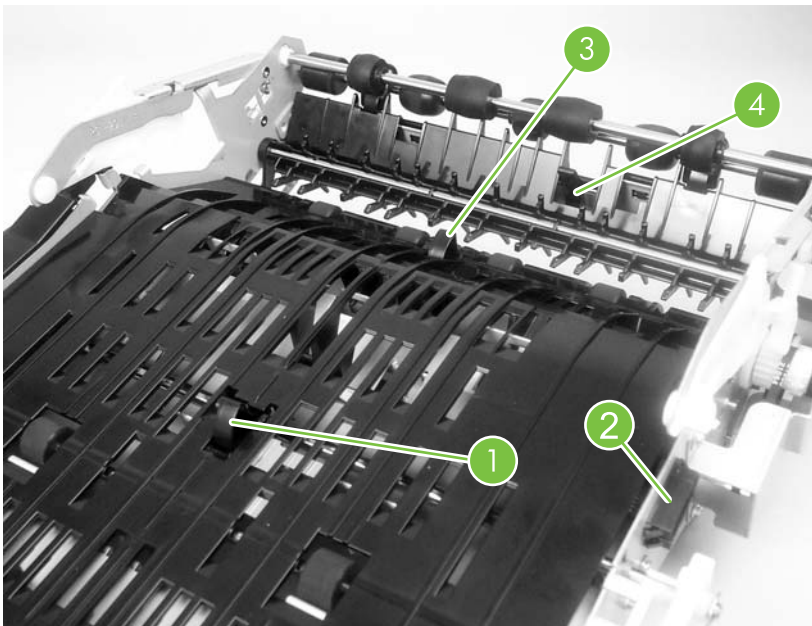
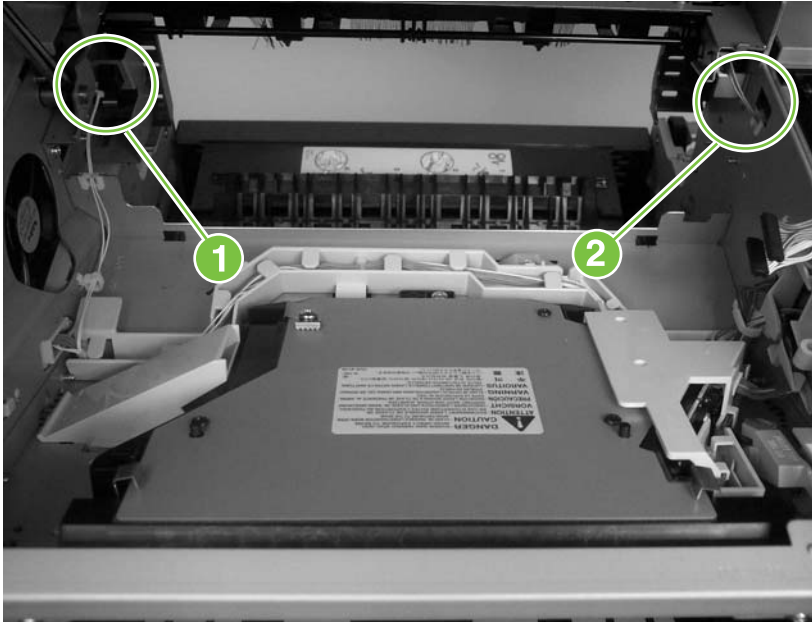


Figure 4-71 Sensors on the reversing unit (top side)

1	PS111, reversing-unit-jam sensor
---	----------------------------------

2	Connectors J140 and J1402
3	PS110, reversing paper sensor
4	PS109, paper-delivery sensor

### Sensors in the interior of the MFP



**Figure 4-72** Sensors in the interior of the MFP

1	connector leading to SW103, output-bin detection switch
2	PS104, output-bin-full sensor



### Output-bin detection switch, SW103

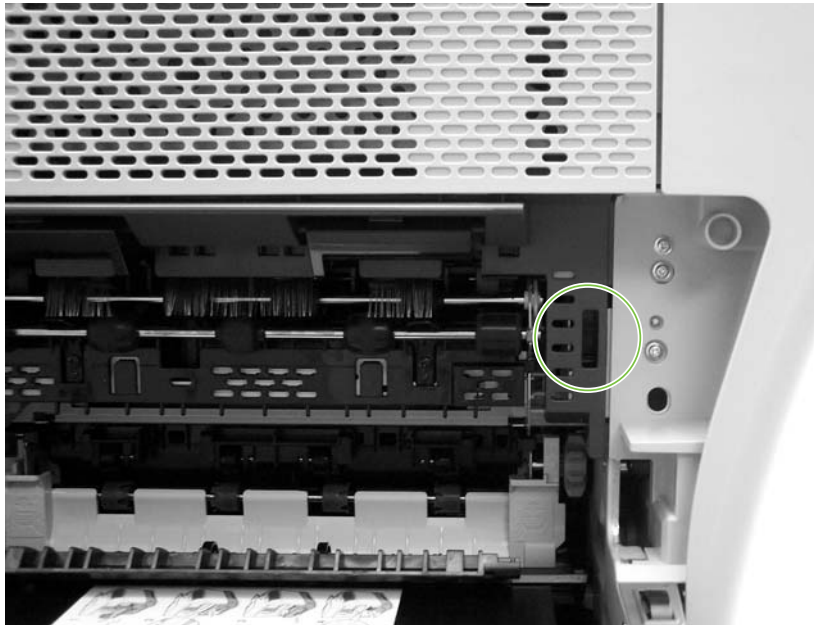


Figure 4-73 Output-bin detection switch, SW103

### Tray 1 paper-present sensor, PS105

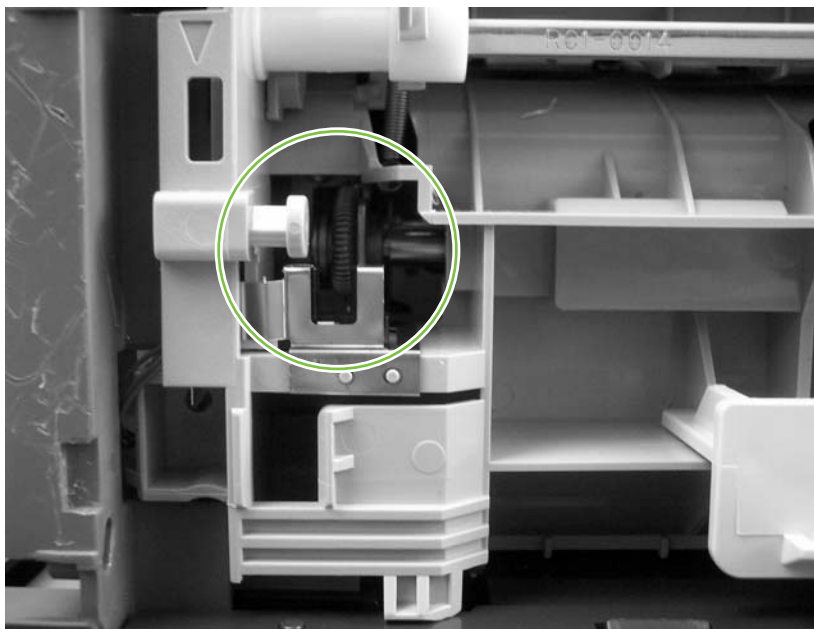


Figure 4-74 Tray 1 paper-present sensor, PS105

## Top-cover switch, SW101

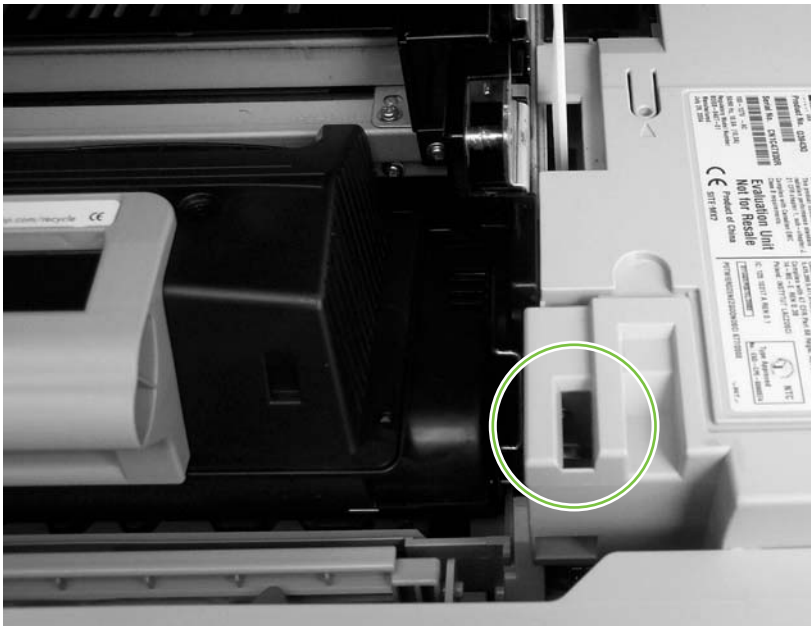


Figure 4-75 Top-cover switch, SW101

## Tray 2 jam-access-cover switch, SW105

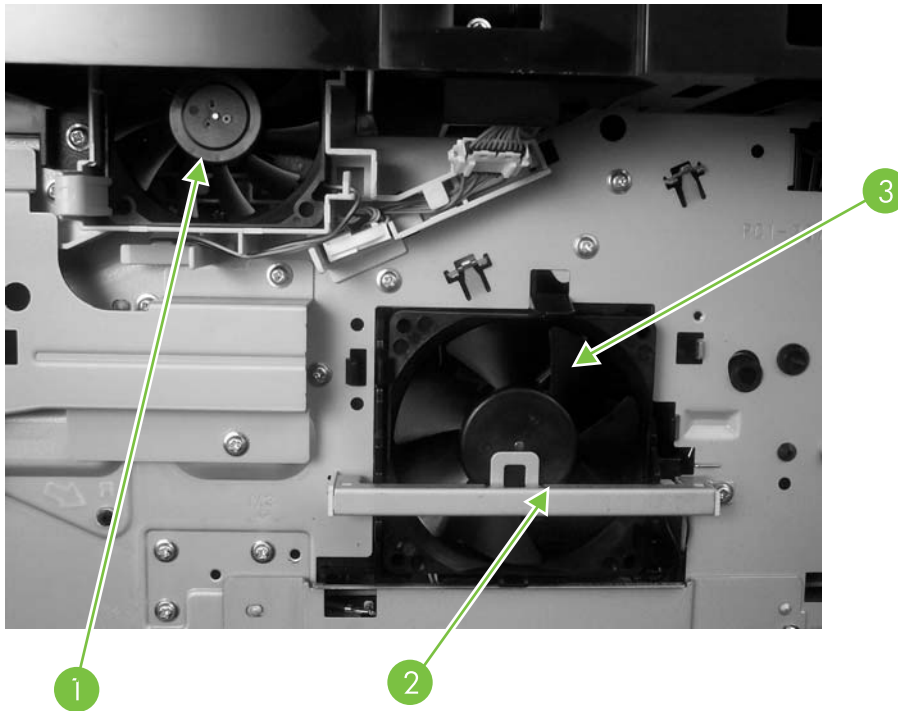


Figure 4-76 Tray 2 jam-access-cover switch, SW105

## Motors, fans, solenoids, and clutch

The photos in this section show the locations of the motors, fans, solenoids, and clutches that are in the MFP print engine.

## Front-side fans



**Figure 4-77** Front-side fans

1	FN103, reversing-unit fan
2	TH3, ambient-air-detection thermistor (on the rear of this metal bracket)
3	FN101, main fan

## Rear-side fans

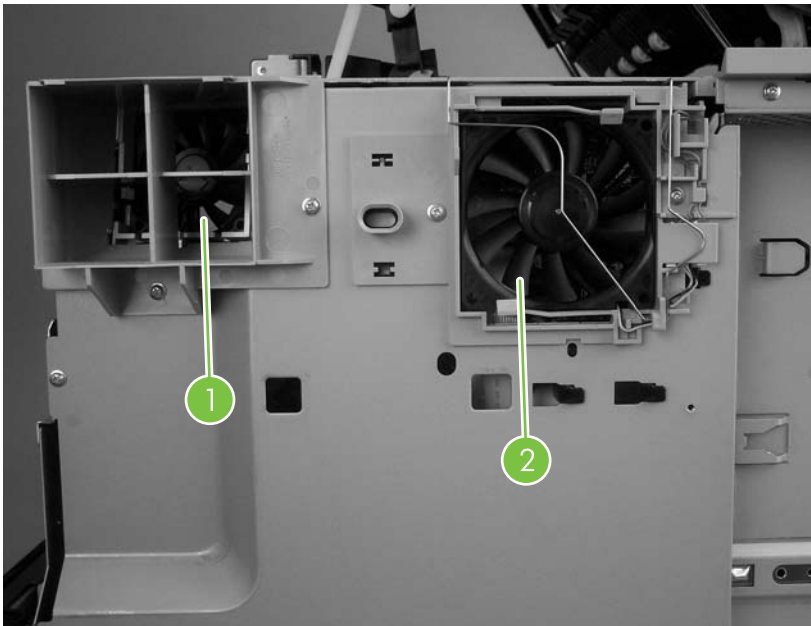


Figure 4-78 Rear-side fans

1	FN102, print-cartridge fan
2	FN104, DC controller fan

## Rear-side motors (1 of 2)

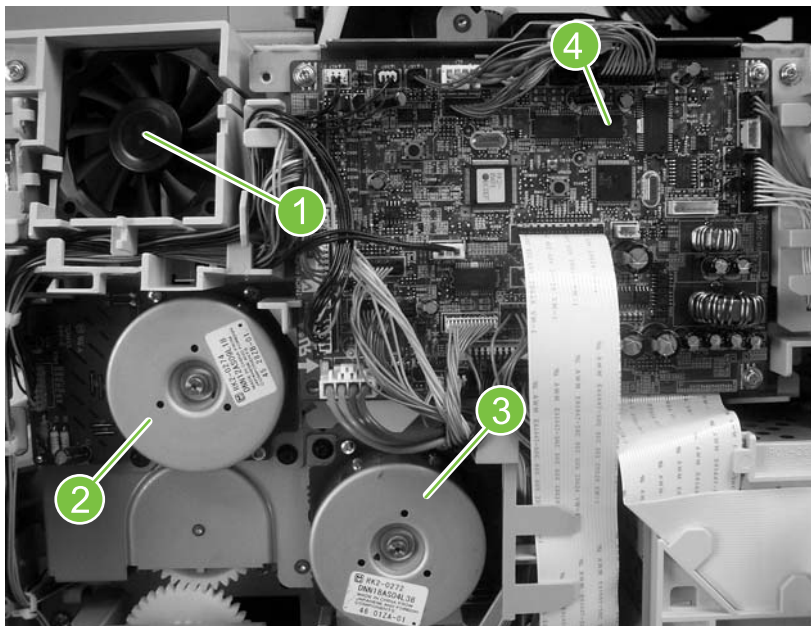
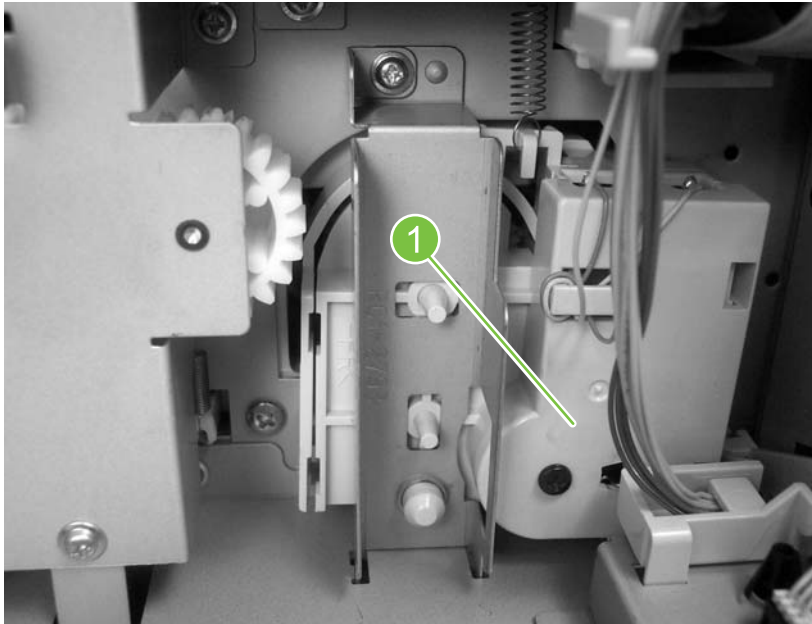


Figure 4-79 Rear-side motors (1 of 2)

1	FN102, print-cartridge fan
---	----------------------------

2	M102, drum motor
3	M101, main motor
4	DC controller PCA

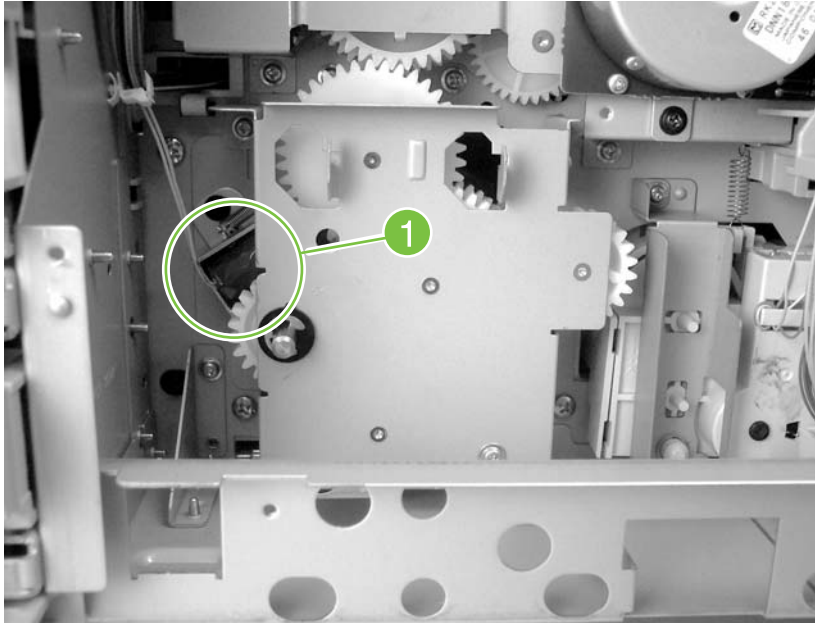
### Rear-side motors (2 of 2)



**Figure 4-80** Rear-side motors (2 of 2)

1	M103, lifter motor
---	--------------------

## Rear-side solenoid



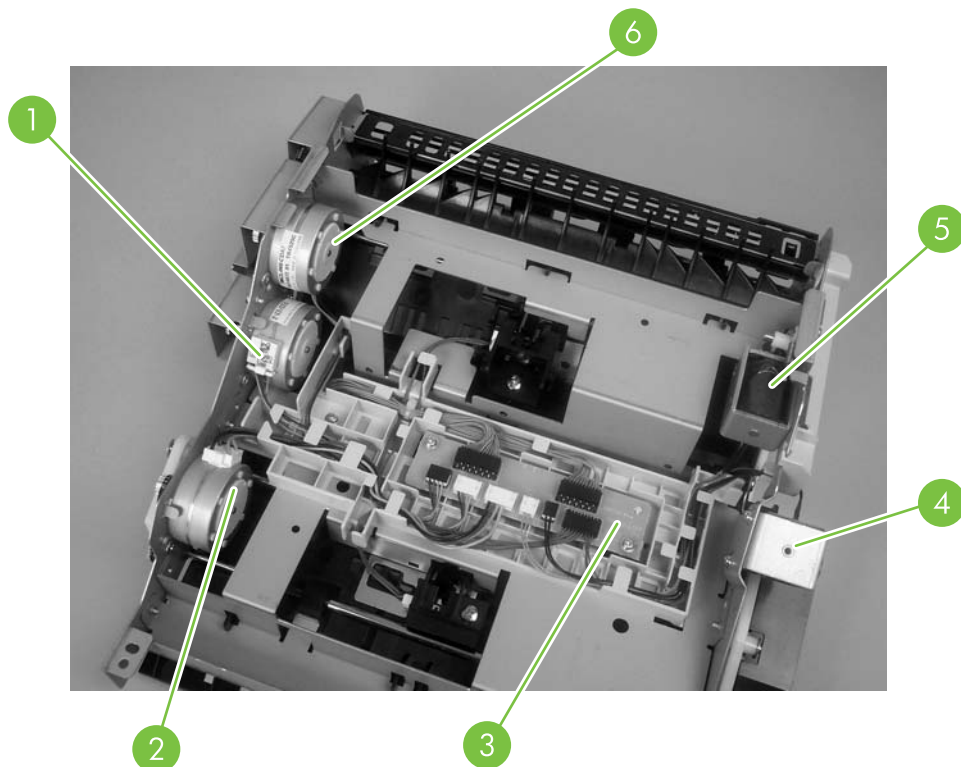
**Figure 4-81** Rear-side solenoid

---

1	SL101, tray 2 pickup solenoid
---	-------------------------------

---

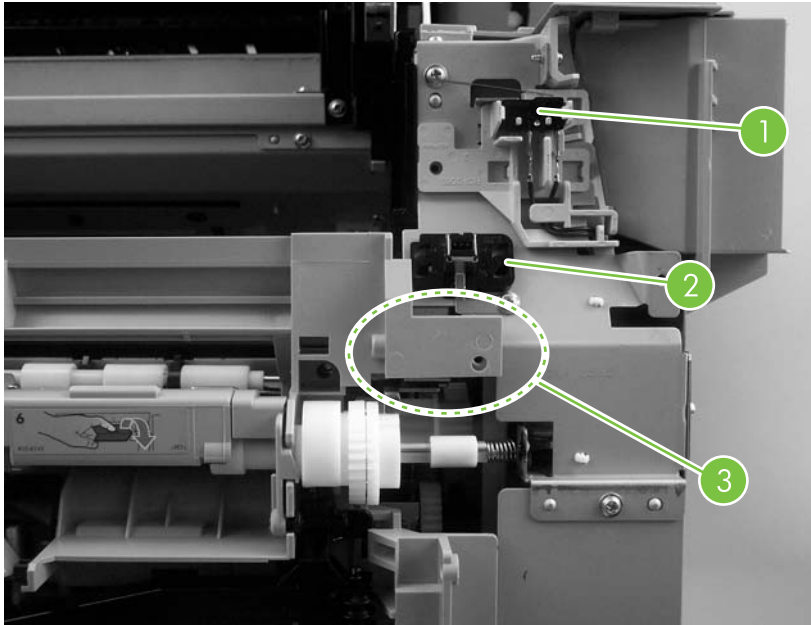
## Reversing-unit motors and solenoids



**Figure 4-82** Reversing-unit motors and solenoids

1	M104, crossing motor
2	M105, reversing roller
3	Reversing-intermediate PCA
4	SL106, reversing-roller alienation solenoid (under the shield)
5	SL105, face-up solenoid
6	M106, delivery motor

## Right, rear corner components (1 of 2)

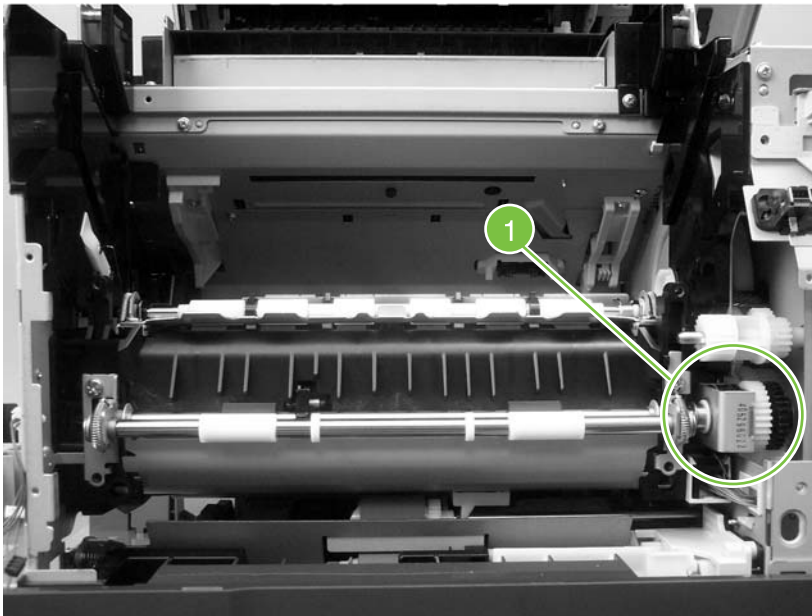


**Figure 4-83** Right, rear corner components (1 of 2)

1	SW101, top-cover switch
2	Envelope-feeder connector
3	SL102, tray 1 pickup solenoid (behind the cover)



## Right, rear corner components (2 of 2)



**Figure 4-84** Right, rear corner components (2 of 2)

---

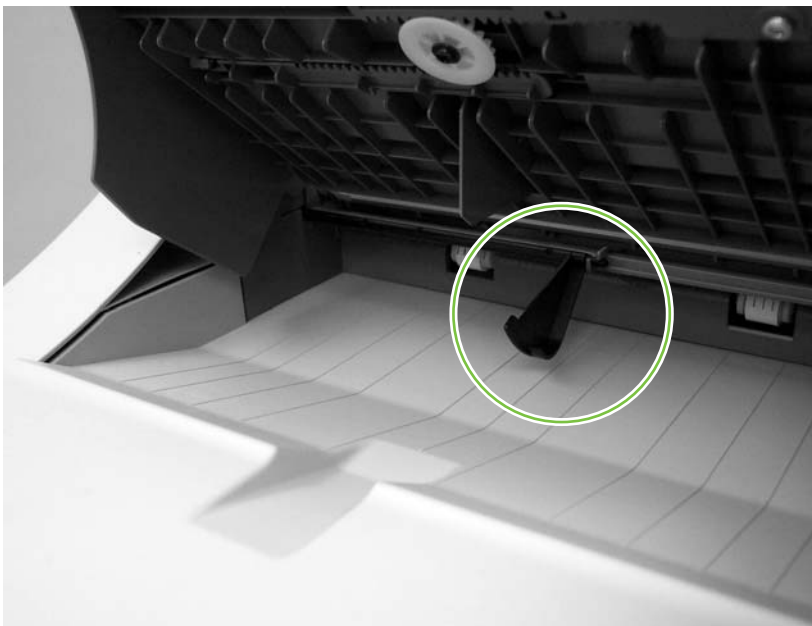
1	CL101, feed-roller clutch
---	---------------------------

---

## Scanner and ADF components

The photos in this section show the locations of the scanner and ADF components.

### ADF output-bin-full sensor



**Figure 4-85** ADF output-bin-full sensor

## ADF pickup assembly sensors

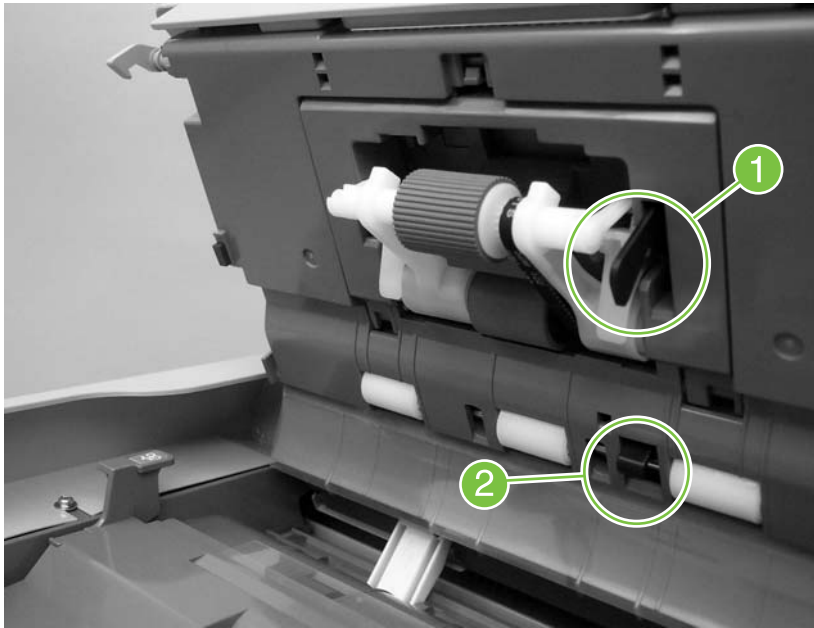


Figure 4-86 ADF pickup assembly sensors

1	ADF paper-present sensor
2	ADF top-of-page sensor

## ADF motors, solenoid, and sensors

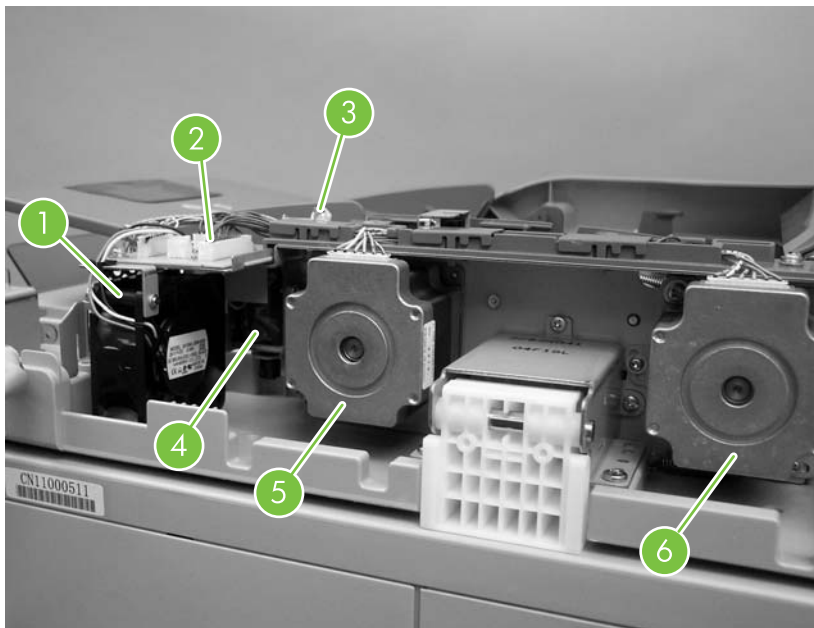


Figure 4-87 ADF motors, solenoid, and sensors

1	ADF fan
---	---------

2	Scanner-controller PCA
3	ADF LED PCA
4	ADF solenoid
5	ADF feed motor
6	ADF read motor



# 5 Removal and replacement

This chapter contains information about the following topics:

- [Service approach](#)
- [Removal and replacement strategy](#)
- [User-replaceable parts](#)
- [Covers, doors, and external panels](#)
- [Internal assemblies](#)
- [ADF and scanner components](#)
- [ADF components](#)
- [500-sheet feeder components](#)
- [Stapler/stacker components](#)
- [3-bin mailbox components](#)

## Service approach

MFP repair normally begins by using the MFP internal diagnostics and the following three-step process.

1. Isolate the problem to the major system (for example, the host computer, the network or server, or the MFP system).
2. Determine if the problem is located in the accessories, the scanner assembly, or the MFP engine.
3. Troubleshoot the problem by using the procedures in chapter 7.

After a faulty part is located, the MFP can usually be repaired at the assembly level by replacing field replaceable units (FRUs). Some mechanical assemblies might need to be repaired at the subassembly level. Hewlett-Packard does not support replacement of components on the printed circuit assemblies.

# Removal and replacement strategy

This chapter describes how to remove, replace, and reassemble the major assemblies of the MFP. Replacement is generally the reverse of removal. Notes are provided to assist with any difficult replacement procedures.

To identify the left side and right side of the MFP, face the control panel.



---

**WARNING!** Unplug the power cord from the power outlet at the wall receptacle before attempting to service the MFP. If you do not follow this warning, severe injury can result. Certain functional checks during troubleshooting might require power to the MFP. However, all power should be turned off and the MFP should be unplugged when you remove any MFP assemblies or components.

Never operate or service the MFP when the protective cover is removed from the laser/scanner assembly. The reflected beams, although invisible, can damage your eyes.

---



---

**CAUTION** The MFP contains components that are sensitive to electrostatic discharge (ESD). Always perform service work at an ESD-protected workstation. If an ESD-protected workstation is not available, discharge body static by grasping the MFP chassis before touching an ESD-sensitive component. Ground the MFP chassis before servicing the MFP.

---

## Required tools

- #2 Phillips screwdriver
- Short #2 Phillips screwdriver (shaft length of 76 mm [3 inches])
- Right-angle #2 Phillips screwdriver
- Small flat-blade screwdriver
- Needle-nose pliers
- ESD mat (if available; see the preceding ESD caution)
- Penlight (optional)
- Tape (optional)



---

**CAUTION** A pozidriv screwdriver can damage screw heads on the MFP. Use a #2 Phillips screwdriver.

---

## Before performing service

- If possible, print a menu map and Configuration page.
- Remove all of the accessories and print media, the print cartridge, and tray 2 from the MFP.
- Unplug the power cord from the power outlet at the wall receptacle.
- Place the MFP on an ESD mat, if one is available. If an ESD-protected workstation is not available, discharge body static by grasping the MFP chassis before touching an ESD-sensitive component. Ground the MFP chassis before servicing the MFP.

## After completing service

- Reinstall the print cartridge.



---

**CAUTION** Do not transport the MFP while the print cartridge is installed.

---

- Reconnect all cables to the MFP.
- Replace all of the accessories and load the media.
- Print a Configuration page and verify that the latest firmware is installed on the MFP.

## Screws that are used in the MFP

The following table describes the screws that are used in the MFP and provides guidelines to help determine where each type of screw is used. The screws can vary in length depending on the thickness of the material that is being fastened. Always note where each type of screw is located and replace each one in its original location.




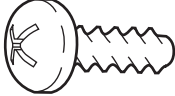

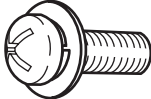

---

**NOTE** When you are disassembling the MFP, place the screws into the chassis holes from which they were removed. This prevents their loss and ensures that the correct type and length of screw for each location is used when the MFP is reassembled.

---



**Table 5-1** Common fasteners used in this MFP

Drawing and description	Purpose
 <p>Phillips-head machine screw with captive star washer</p>	<p>This screw is used to fasten metal to metal when good electrical contact is needed. This screw also provides high resistance to loosening.</p>
 <p>Phillips-head screw with self-tapping threads</p>	<p>This screw is used to fasten sheet metal or plastic to plastic frames. The deep, coarsely spaced threads provide an increased holding capability while decreasing the possibility of stripping the target hole.</p>
	<p><b>NOTE</b> To install a self-tapping screw, first turn it counterclockwise to align it with the existing thread pattern, and then carefully turn it clockwise to tighten it. You will feel resistance and hear the screw click when it engages the existing threads in the hole. Do not overtighten the screw. If a self-tapping screw-hole becomes stripped, repair the screw-hole or replace the affected assembly.</p>
 <p>Phillips washer-head machine screw with a broad, flat washer attached to the screw head</p>	<p>This screw is used to fasten sheet metal parts to the sheet metal chassis. It spans large clearance holes and distributes the load by increasing the bearing surface.</p>
<p>Screw measurement guide</p>	
<p>6mm    8mm    10mm    12mm    M3    M4</p> 	

# User-replaceable parts

The procedures in this section describe the removal and replacement of the following user-replaceable parts:

- [Print cartridge](#)
- [Control-panel overlays](#)
- [Control panel](#)
- [Transfer roller](#)
- [ADF input tray](#)
- [ADF pickup and feed rollers](#)
- [ADF separation pad](#)
- [ADF delivery guide \(clear mylar sheet\)](#)
- [Output-bin assembly](#)
- [Duplex-printing unit](#)
- [Fuser-entrance guide](#)
- [Fuser](#)
- [Tray 2, 3, 4, or 5 pickup and feed rollers](#)
- [Tray 1 pickup roller](#)
- [Scanner filter cover and scanner filter](#)
- [ADF-hinge flap](#)
- [Formatter cover and formatter](#)
- [Hard drive](#)
- [DIMM](#)
- [Fax accessory](#)

## Print cartridge

1. Open the top cover.
2. Grasp the print cartridge, and remove it from the MFP.

## Control-panel overlays

Use a small, flat-blade screwdriver to release the two control-panel overlays (callout 1).



**Figure 5-1** Remove the control-panel overlays

## Control panel

1. Pull the top of the control panel away from the MFP to release the upper locking tabs.



**Figure 5-2** Remove the control panel (1 of 2)

2. Rotate the top of the control panel away from the MFP.

3. Disconnect one connector (callout 1) and remove the control panel.



**Figure 5-3** Remove the control panel (2 of 2)

## Transfer roller

1. Remove the print cartridge.



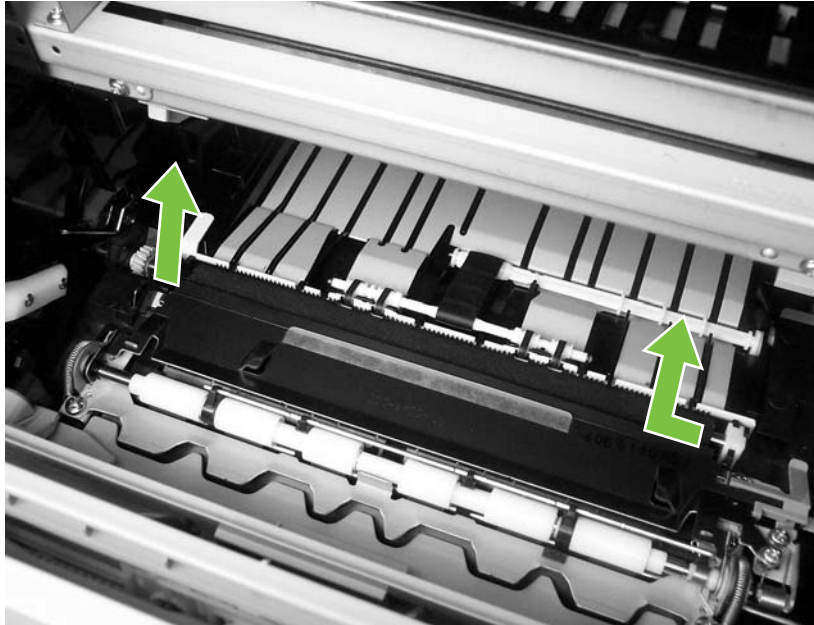
**CAUTION** Do not touch the black rubber on the transfer roller. Skin oils on the roller can cause print-quality problems. Use disposable gloves when you remove the transfer roller.

---

2. Use a flat-blade screwdriver to lift the left end of the metal shaft out of place (near the blue gear). Slide the transfer roller to the left to remove it.



**NOTE** When you install the transfer roller, make sure that the black collar on the left side is oriented correctly, with the open end face-down (the solid end is face-up).



**Figure 5-4** Remove the transfer roller

## ADF input tray

1. Open the ADF top cover.



**Figure 5-5** Remove the ADF input tray (1 of 3)

2. Flex the pivot pin (near the control panel) away from the mounting hole in the ADF chassis.



**Figure 5-6** Remove the ADF input tray (2 of 3)

3. Remove the ADF input tray.

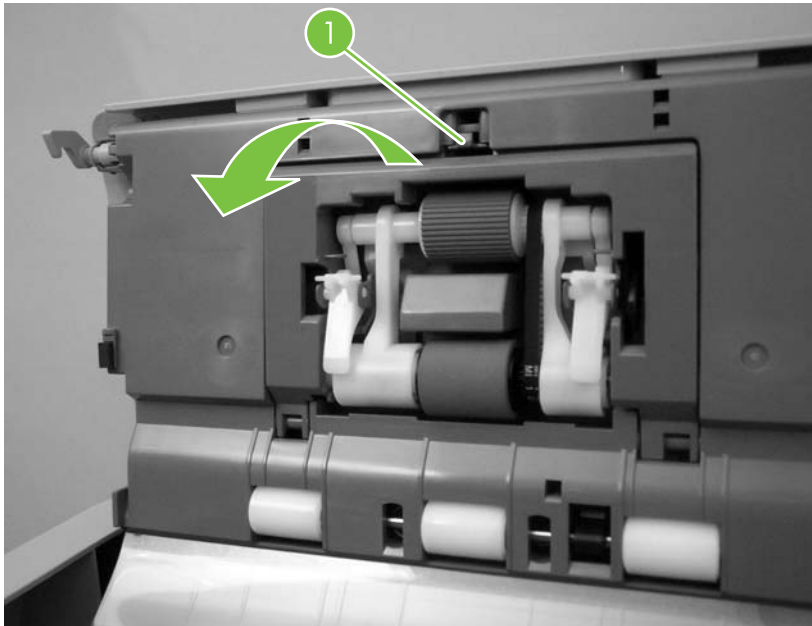


**Figure 5-7** Remove the ADF input tray (3 of 3)

## ADF pickup and feed rollers

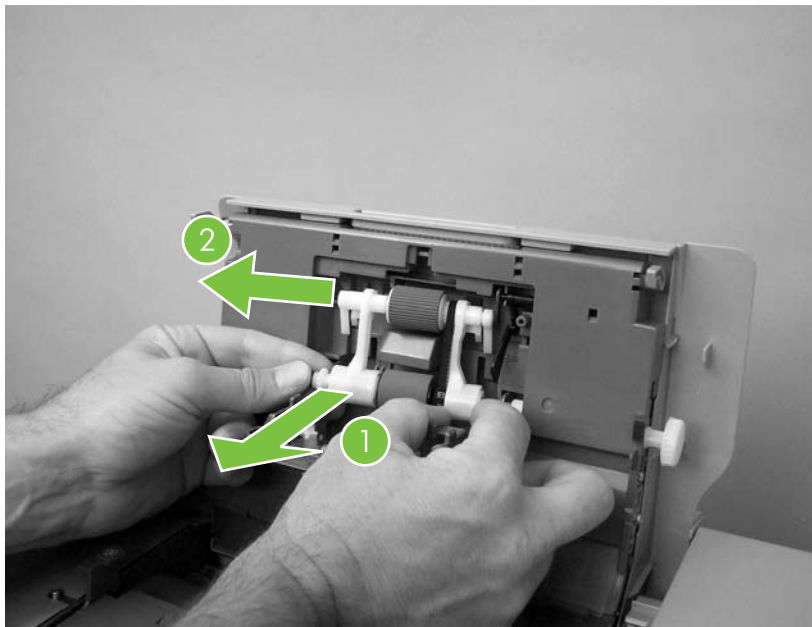
1. Open the ADF top cover.

2. Push down on the locking tab (callout 1), and rotate the top of the assembly away from the ADF.



**Figure 5-8** Remove the ADF pickup and feed rollers (1 of 2)

3. Release the front (gear end) of the roller-assembly drive-shaft, and slide the assembly toward the front of the MFP to remove it.

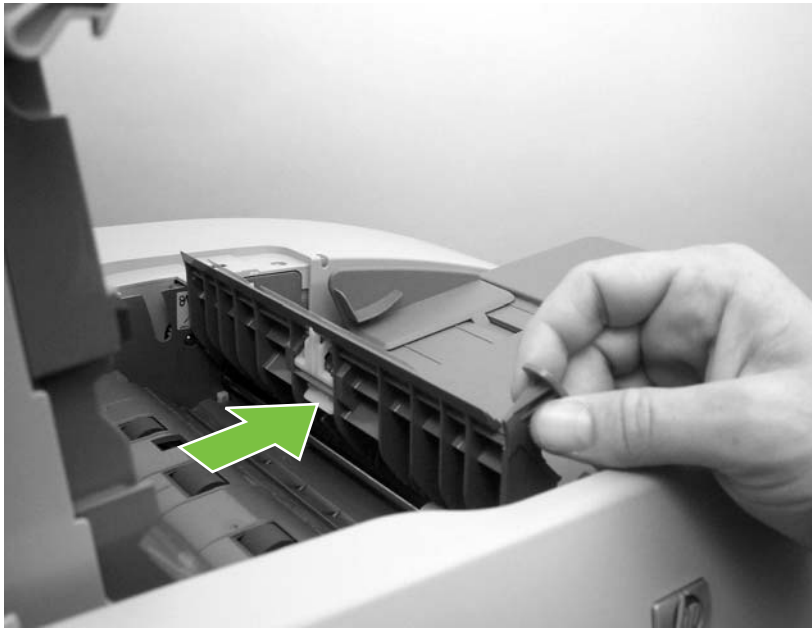


**Figure 5-9** Remove the ADF pickup and feed rollers (2 of 2)

## ADF separation pad

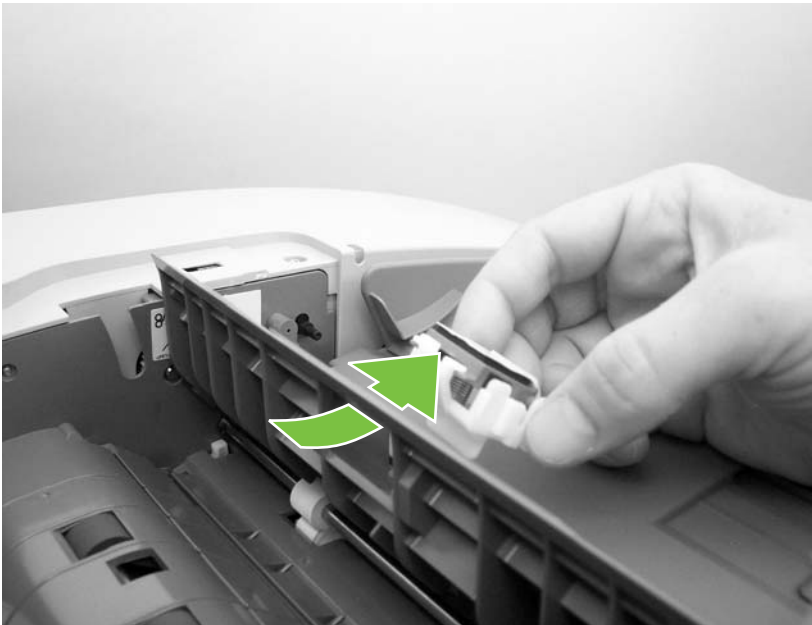
1. Open the ADF top cover

2. Raise the separation-pad-frame assembly, and push the bottom edge of the separation pad away from the frame.



**Figure 5-10** Remove the ADF separation pad (1 of 2)

3. Remove the ADF separation-pad assembly.

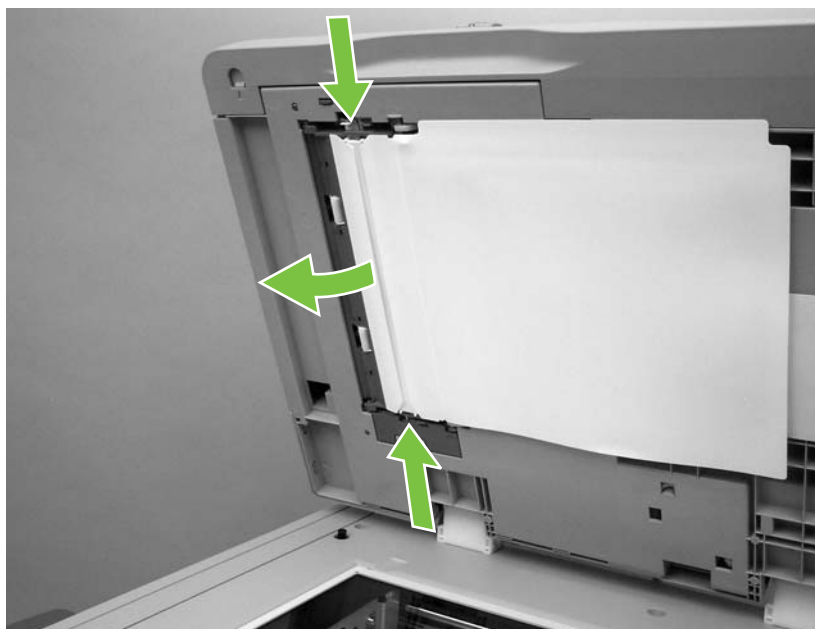


**Figure 5-11** Remove the ADF separation pad (2 of 2)



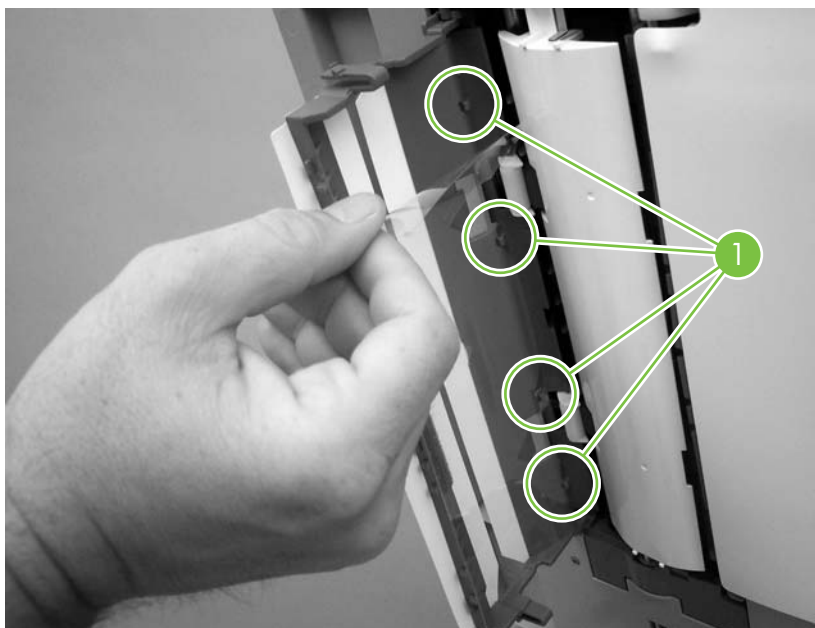
## ADF delivery guide (clear mylar sheet)

1. Open the ADF/scanner assembly and release the two tabs at the top and bottom of the ADF delivery-guide cover.



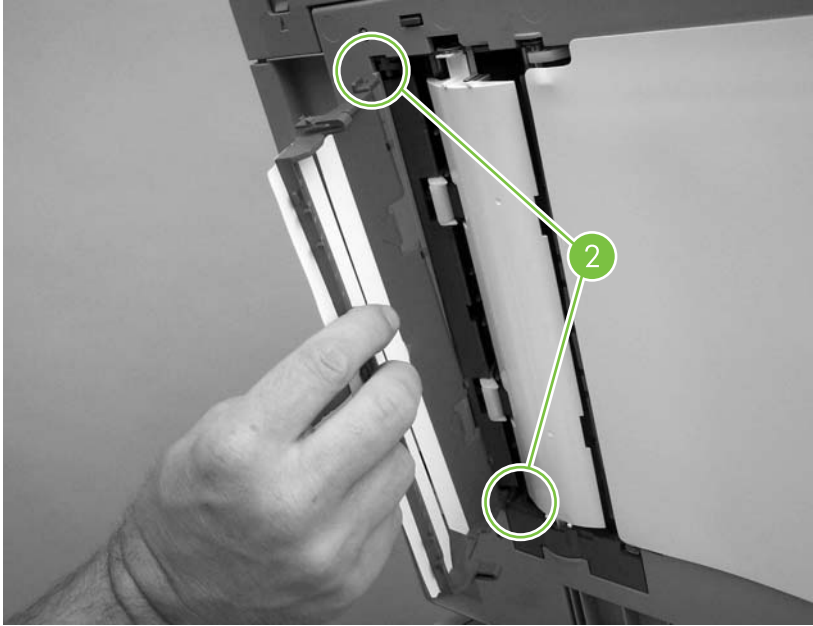
**Figure 5-12** Remove the ADF delivery guide (1 of 3)

2. Carefully unhook the clear mylar sheet from the four tabs on the ADF delivery-guide cover (callout 2), and then remove the mylar sheet.



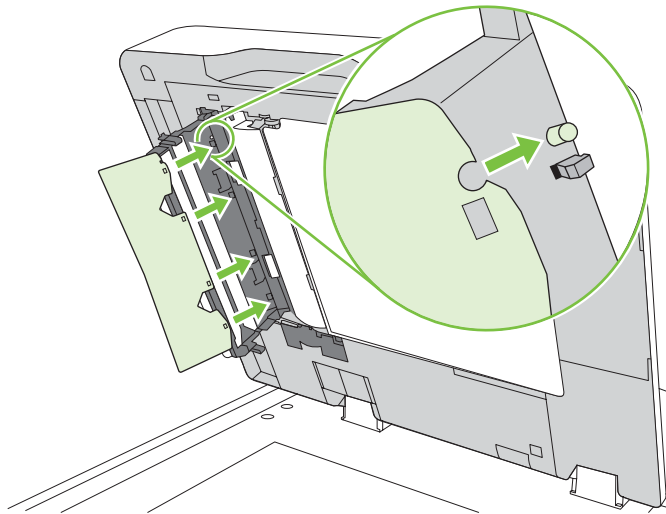
**Figure 5-13** Remove the ADF delivery guide (2 of 3)

3. If necessary, pull the ADF delivery-guide-cover hinges off the hinge pins (callout 2) to remove the cover.



**Figure 5-14** Remove the ADF delivery guide (3 of 3)

4. **Reinstallation tip:** The clear mylar sheet is keyed with a small notch at the top. Be sure to align the notch with the round pin that is on the holder.



**Figure 5-15** Reinstall the clear mylar sheet

## Output-bin assembly

1. Slide the output-bin assembly away from the MFP.



**Figure 5-16** Remove the output-bin assembly (1 of 2)

2. Lift up slightly on the output-bin assembly to disengage the slide rails, and then remove the assembly.



**Figure 5-17** Remove the output-bin assembly (2 of 2)

## Duplex-printing unit

1. Slide the duplex-printing unit away from the MFP.



**Figure 5-18** Remove the duplex-printing unit (1 of 2)

2. Slightly lift up on the duplex-printing unit to disengage the slide rails, and then remove it.



**Figure 5-19** Remove the duplex-printing unit (2 of 2)

## Fuser-entrance guide

1. Remove the following assemblies.
  - Output bin.
  - Duplexer.
2. Flex the rear hinge-pin of the fuser-entrance guide until it clears the mounting hole in the MFP chassis.
3. Rotate the rear of the guide away of the MFP and slide the guide to the left to release the front hinge-pin. Remove the fuser-entrance guide.



**Figure 5-20** Remove the fuser-entrance guide

## Fuser



---

**CAUTION** The fuser is very hot. After turning the MFP power off, allow the fuser to cool for at least 30 minutes before removing it.

---

1. Remove the following assemblies.
  - Output bin.
  - Duplex-printing unit.
  - Fuser-entrance guide.

2. Squeeze the two blue tabs on the fuser to release it, and then slide it out of the MFP.

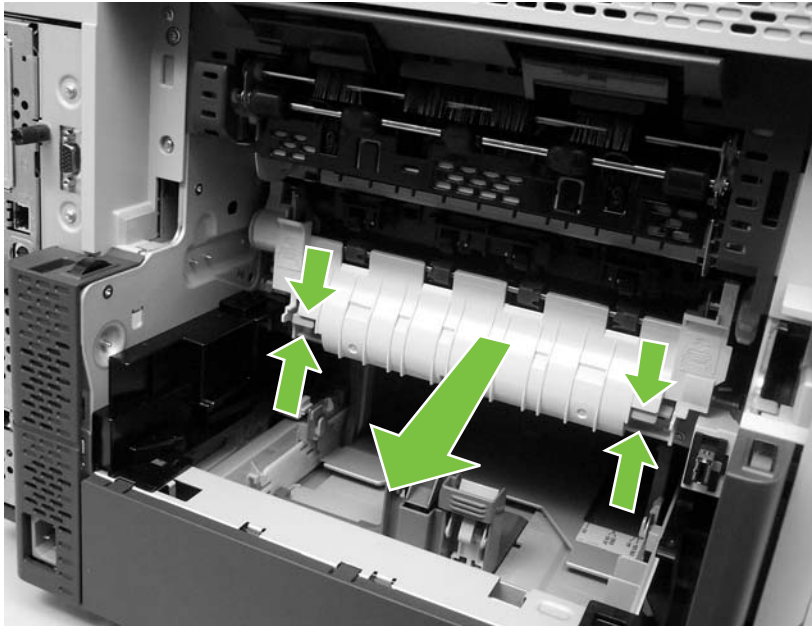


Figure 5-21 Remove the fuser

### Tray 2, 3, 4, or 5 pickup and feed rollers

1. Remove the cassette from the tray.
2. Pinch the roller latch (callout 1) to release the roller, and then slide the roller off of the shaft.

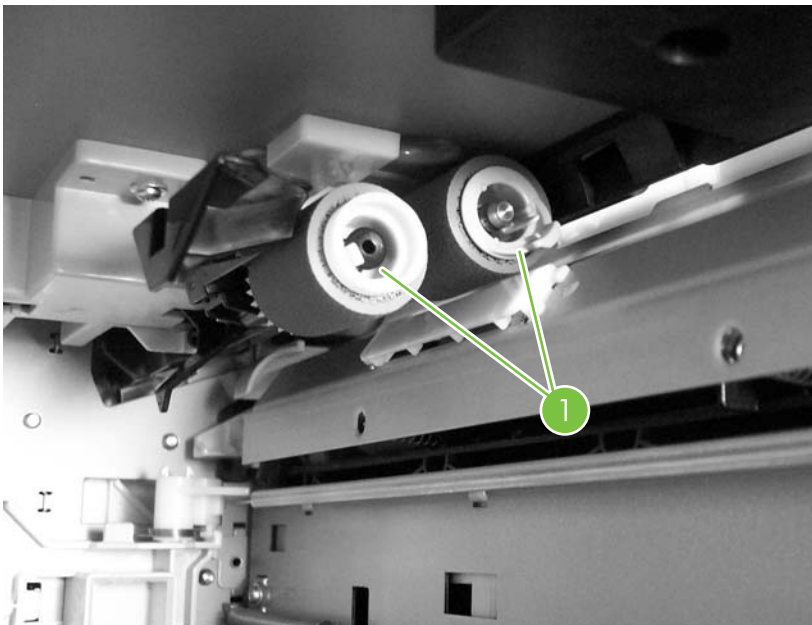
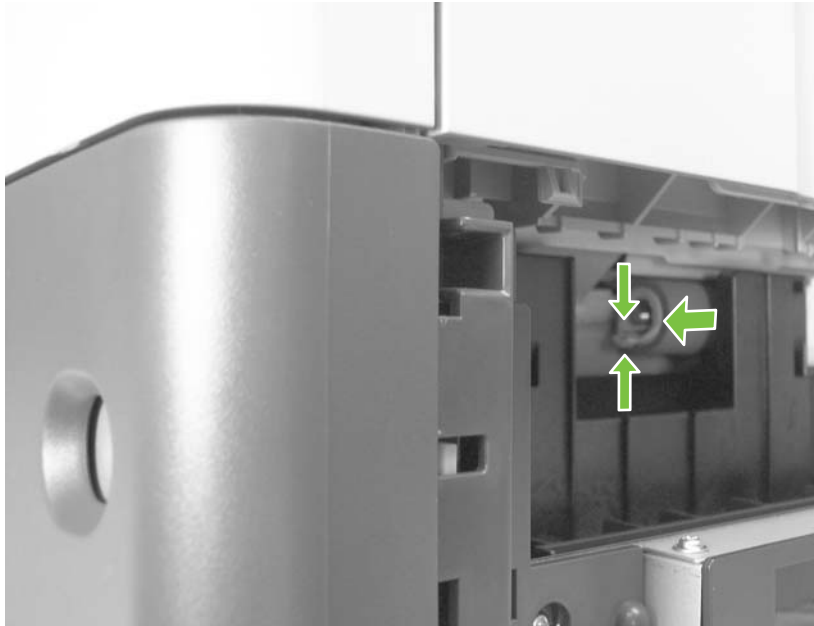


Figure 5-22 Remove the tray 2, 3, 4, or 5 pickup and feed rollers (1 of 2)

3. Open the jam-access door. Pinch the roller latch to release the roller, and then slide the roller off of the shaft.



**Figure 5-23** Remove the tray 2, 3, 4, or 5 pickup and feed rollers (2 of 2)

## Tray 1 pickup roller

1. Open tray 1.



**NOTE** If the optional envelope-feeder accessory is installed, remove it.

2. Release the two locking tabs on the pickup-roller frame and remove the tray 1 pickup roller.



**Figure 5-24** Remove the tray 1 pickup roller

## Scanner filter cover and scanner filter

1. Remove the scanner-filter cover.



**Figure 5-25** Remove the scanner filter (1 of 2)

2. Remove the filter.



**Figure 5-26** Remove the scanner filter (2 of 2)



## ADF-hinge flap

1. Use a small, flat-blade screwdriver to release the locking tabs on one side of the ADF-hinge flap.



**Figure 5-27** Remove the ADF-hinge flap (1 of 3)

2. Repeat step one for the other side of the ADF-hinge flap.



**Figure 5-28** Remove the ADF-hinge flap (2 of 3)

3. Pull the ADF-hinge flap away from the MFP to remove it.



**Figure 5-29** Remove the ADF-hinge flap (3 of 3)



**NOTE** To position the ADF-hinge flap correctly when reinstalling it, insert the locator pins that are in the middle of the plastic mounting-bracket into the first row of slots above the ADF hinge.

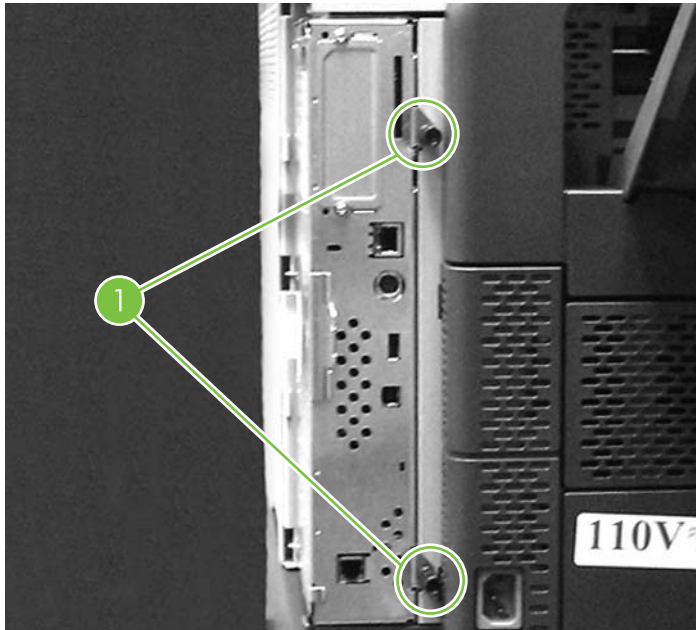
## Formatter cover and formatter

1. Slide the formatter cover toward the left side of the MFP and remove it.



**Figure 5-30** Remove the formatter cover and formatter (1 of 3)

2. Remove two thumb screws (callout 1).



**Figure 5-31** Remove the formatter cover and formatter (2 of 3)

3. Slide the formatter toward the left side of the MFP, and then remove it.



**Figure 5-32** Remove the formatter cover and formatter (3 of 3)



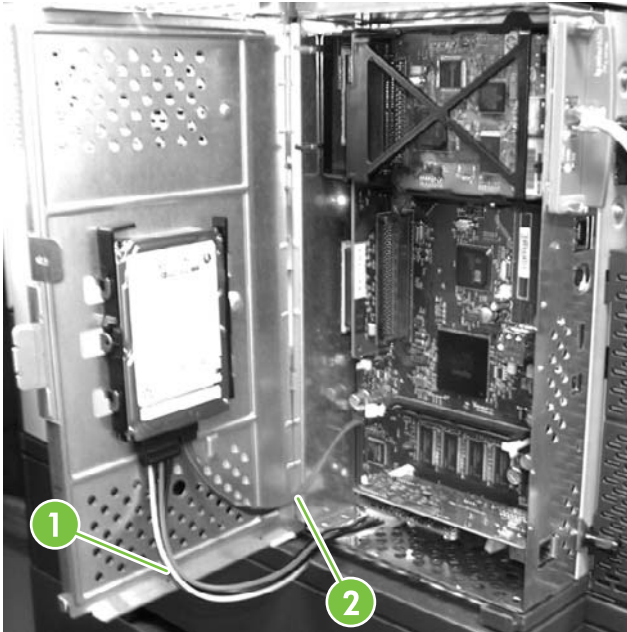
**NOTE** Dislodging the formatter might require considerable force.

## Hard drive



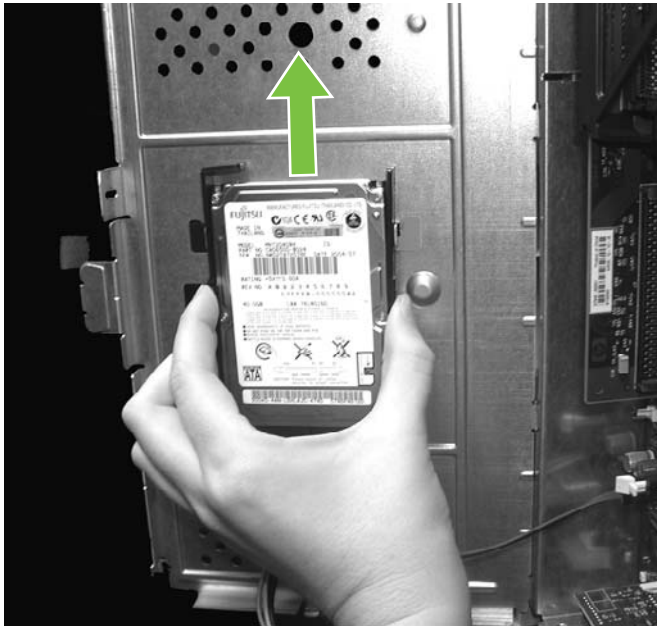
**WARNING!** The MFP contains components that are sensitive to electrostatic discharge (ESD). Always perform service work at an ESD-protected workstation. If an ESD-protected workstation is not available, discharge body static by grasping the MFP chassis before touching an ESD-sensitive component. Ground the MFP chassis before servicing the MFP.

1. Remove the formatter cover, and open the formatter-cage door.
2. Disconnect the power cable (5–wire, callout 1) from the hard drive.
3. Disconnect the data cable (2–wire, callout 2) from the hard drive.



**Figure 5-33** Remove the hard drive (1 of 2)

4. Squeeze the locking tab that is in the center of the left side of the hard drive. Push up on the hard drive to remove it.



**Figure 5-34** Remove the hard drive (2 of 2)

## DIMM



**WARNING!** The MFP contains components that are sensitive to electrostatic discharge (ESD). Always perform service work at an ESD-protected workstation. If an ESD-protected workstation is not available, discharge body static by grasping the MFP chassis before touching an ESD-sensitive component. Ground the MFP chassis before servicing the MFP.



**NOTE** If possible, print a menu map and a Configuration page. Use the information on the these pages to restore any user-set MFP configuration options after you install the replacement DIMM.

1. Remove the formatter cover, and open the formatter cage door.

2. Push the DIMM locking arms away from the DIMM to release it. Remove the DIMM

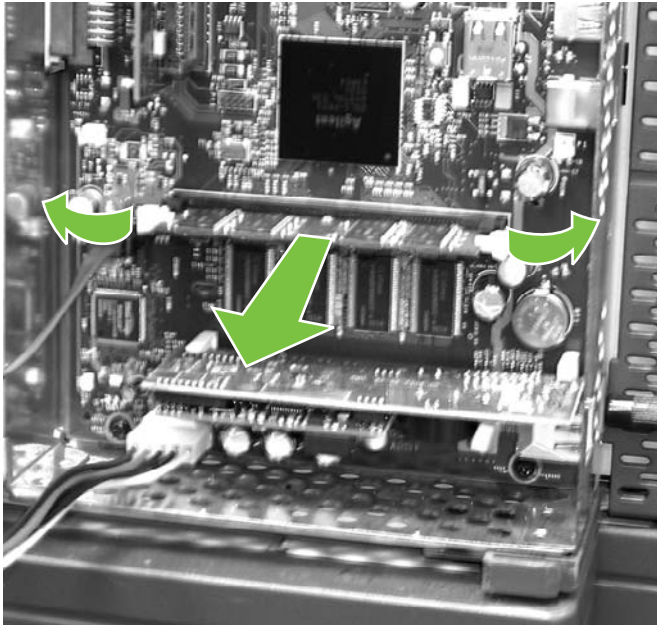


Figure 5-35 Remove the DIMM

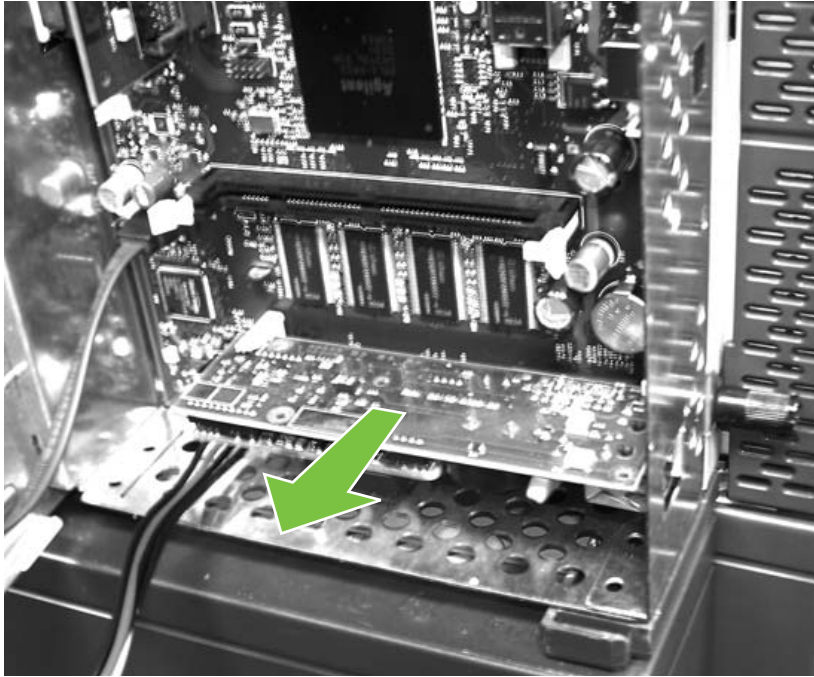
## Fax accessory



**WARNING!** The MFP contains components that are sensitive to electrostatic discharge (ESD). Always perform service work at an ESD-protected workstation. If an ESD-protected workstation is not available, discharge body static by grasping the MFP chassis before touching an ESD-sensitive component. Ground the MFP chassis before servicing the MFP.

1. Remove the formatter cover, and open the formatter-cage door.

2. Grasp the fax-accessory card, and then pull it out of the formatter cage.



**Figure 5-36** Remove the fax accessory

## Covers, doors, and external panels

The procedures in this section describe the removal and replacement of the following components:

- [Top-cover flatbed flange](#)
- [Front cover](#)
- [Back cover](#)

### Top-cover flatbed flange

1. Grasp one end of the flange and push up on it to release the flange locking pins.



**Figure 5-37** Remove the top-cover flatbed flange (1 of 2)



2. Repeat step 1 for the other end of the flange, and then remove the flange.



**Figure 5-38** Remove the top-cover flatbed flange (2 of 2)

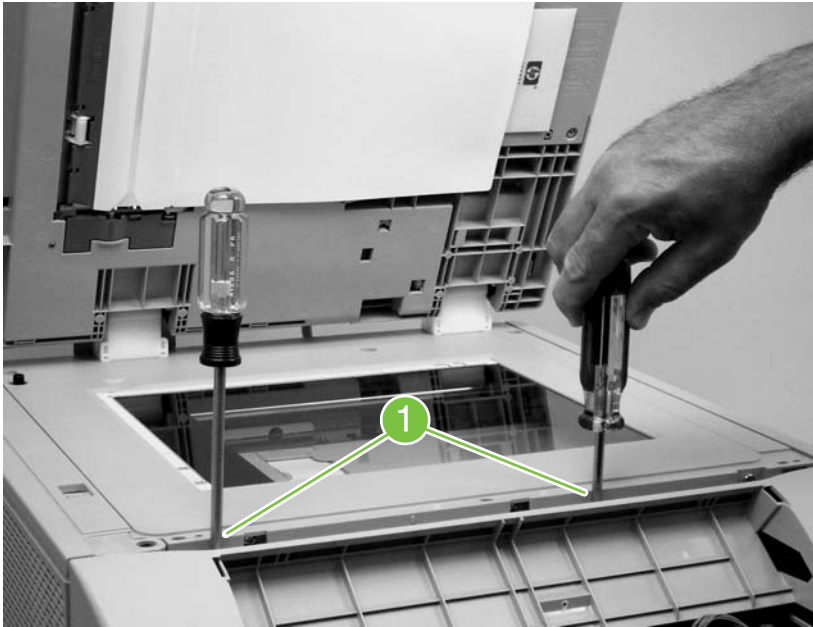
## Front cover

1. Remove the following assemblies.
  - Control panel.
  - Top-cover flatbed flange.

2. Remove two screws (callout 1).

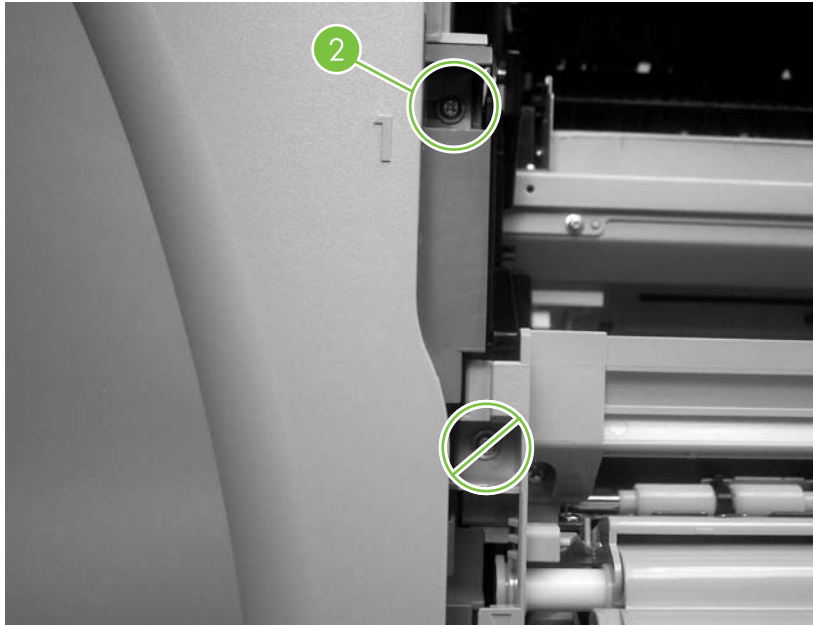


**NOTE** Both screws are behind the control-panel frame.



**Figure 5-39** Remove the front cover (1 of 7)

3. Open the top cover, and remove one screw (callout 2).

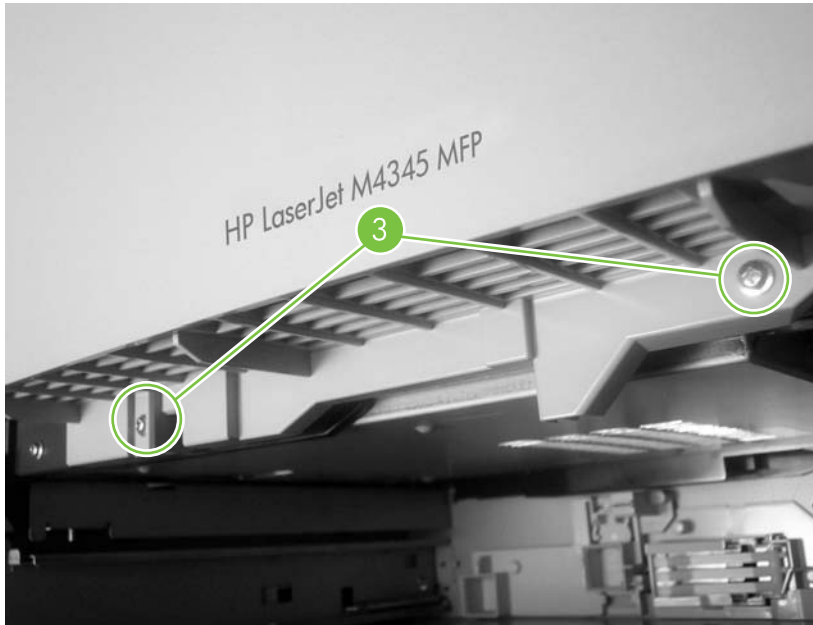


**Figure 5-40** Remove the front cover (2 of 7)



**CAUTION** Do not remove the screw near the feed assembly.

4. Remove the tray 2 cassette, and then remove two screws (callout 3).



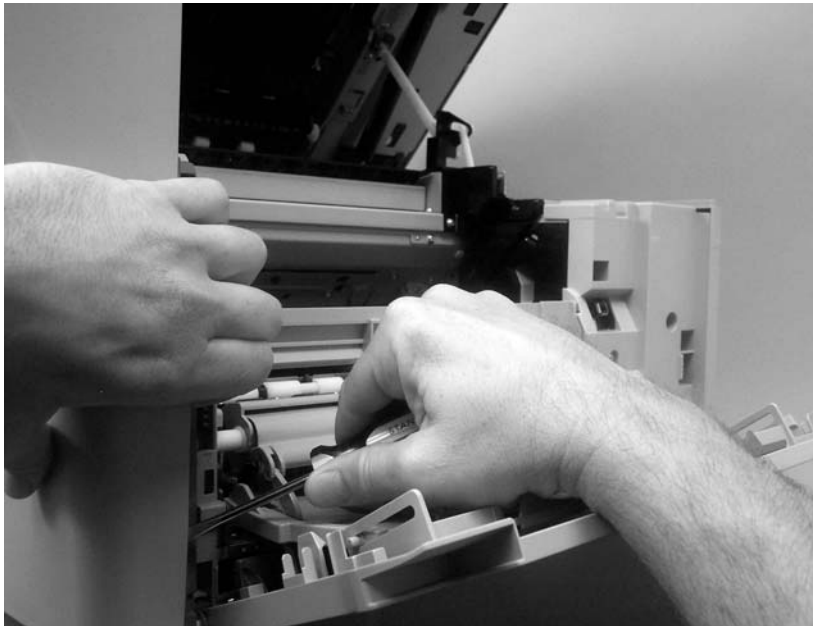
**Figure 5-41** Remove the front cover (3 of 7)

5. Slide the output bin away from the MFP, and release the front-cover retaining tab on the left side.



**Figure 5-42** Remove the front cover (4 of 7)

6. Release the two locking tabs on the right side.



**Figure 5-43** Remove the front cover (5 of 7)

7. Flex the bottom of the cover away from the MFP to release the locking tab at the mid-bottom, and then push up on the cover to raise it slightly.



**Figure 5-44** Remove the front cover (6 of 7)

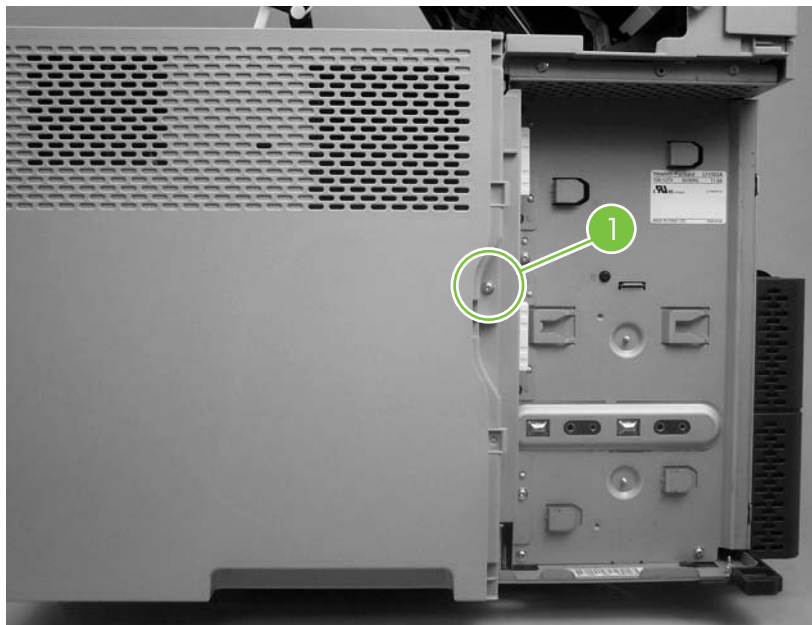
8. Pull the front cover away from the MFP and then up to remove it.



**Figure 5-45** Remove the front cover (7 of 7)

## Back cover

1. Remove the formatter.
2. Remove one screw (callout 1)



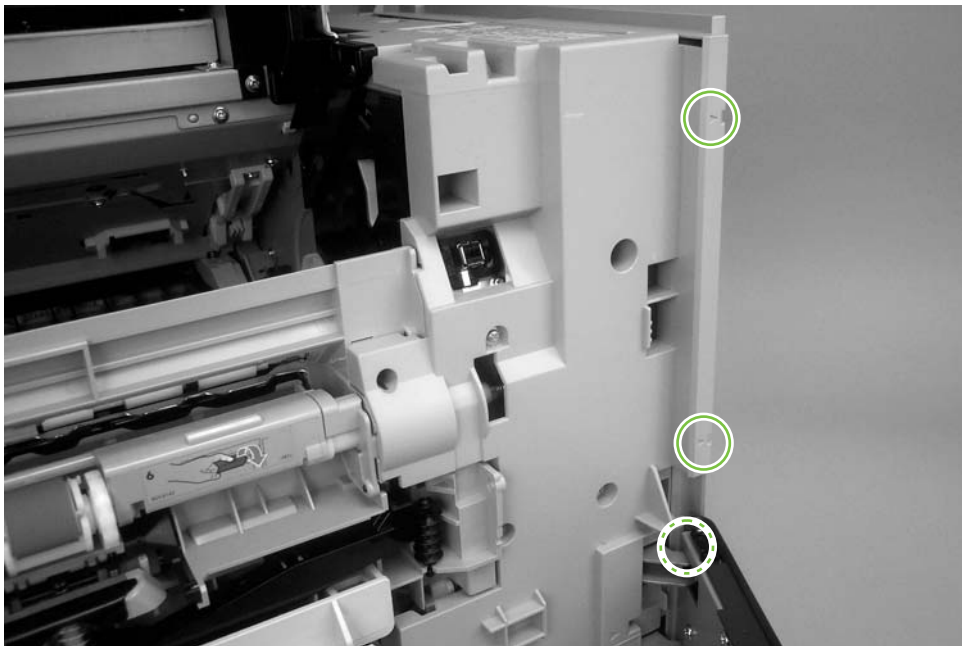
**Figure 5-46** Remove the back cover (1 of 3)

3. Release three locking tabs along the top of the back cover.



**Figure 5-47** Remove the back cover (2 of 3)

4. Release three locking tabs along the side of the back cover. (The bottom tab is behind the hinge for the tray 2 jam-access cover.) Rotate the top of the back cover away from the MFP, and then lift it up and off of the MFP.



**Figure 5-48** Remove the back cover (3 of 3)

# Internal assemblies

The procedures in this section describe the removal and replacement of the following components:

- [Reversing-separation-guide assembly](#)
- [Reversing assembly](#)
- [Main fan \(FN101\) and reversing-unit fan \(FN103\)](#)
- [Thermistor \(TH3\)](#)
- [Tray 2 jam-access-cover switch \(SW105\)](#)
- [Tray 1 assembly](#)
- [Front-cover support](#)
- [Tray 1 feed-assembly](#)
- [Feed-roller assembly](#)
- [DC controller](#)
- [Main motor \(M101\)](#)
- [DC controller fan \(FN104\)](#)
- [Print-cartridge fan \(FN102\)](#)
- [Print-cartridge motor \(M102\)](#)
- [Top-cover switch \(SW101\)](#)
- [Registration assembly](#)
- [Paper-pickup-drive assembly](#)
- [Lifter-drive assembly](#)
- [Power-factor-correction \(PFC\) power supply](#)
- [Engine power supply](#)
- [Paper-feed assembly](#)
- [Tray 2 detection switch](#)
- [Paper-size-detection switch \(SW102\)](#)
- [Tray 2 paper-present sensor \(PS101\)](#)
- [Laser/scanner](#)
- [Output-bin-full sensor](#)

## Reversing-separation-guide assembly

1. Open the top cover.

2. Flex the front tab to release one side of the reversing-separation-guide assembly.



**Figure 5-49** Remove the reversing-separation-guide assembly (1 of 2)

3. Lower the released side, and then pull the rear pivot-pin out of the metal bracket.



**Figure 5-50** Remove the reversing-separation-guide assembly (2 of 2)



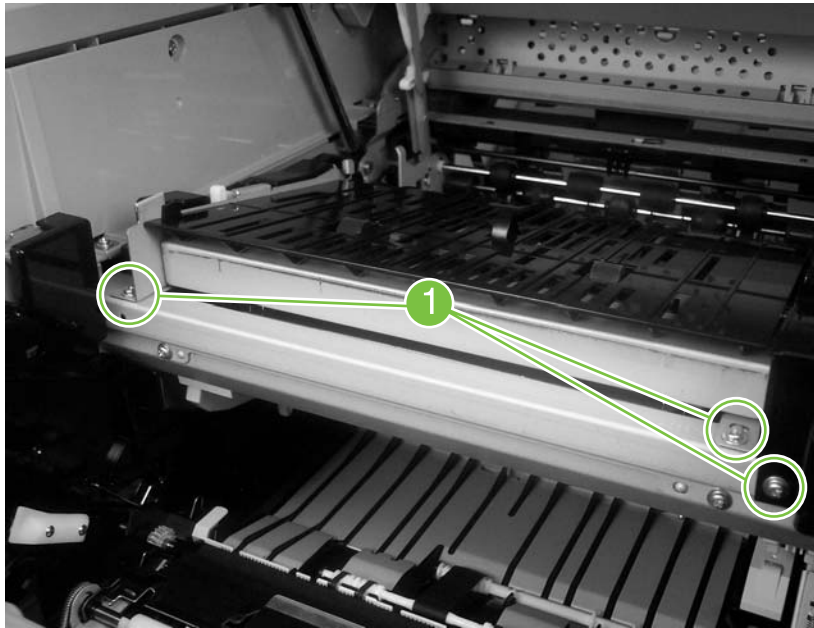
**NOTE** When it is installed, the reversing-separation-guide assembly normally fits loosely.

## Reversing assembly

1. Remove the reversing-separation-guide assembly.



2. Remove three screws (callout 1).



**Figure 5-51** Remove the reversing assembly (1 of 8)

3. Unlock the tab on the right-reverse-assembly-drive cover, and remove the cover.

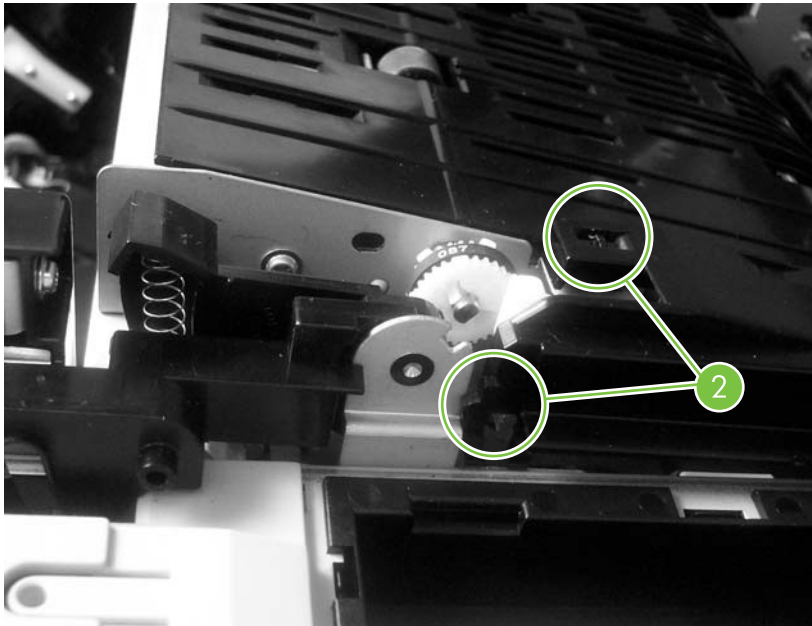


**Figure 5-52** Remove the reversing assembly (2 of 8)



**CAUTION** The spring that is under the right-reversing-assembly lever is not captive. Do not lose the spring that is under the lever when you remove the cover. Make sure you seat the spring correctly on the chassis pedestal when you reinstall the cover.

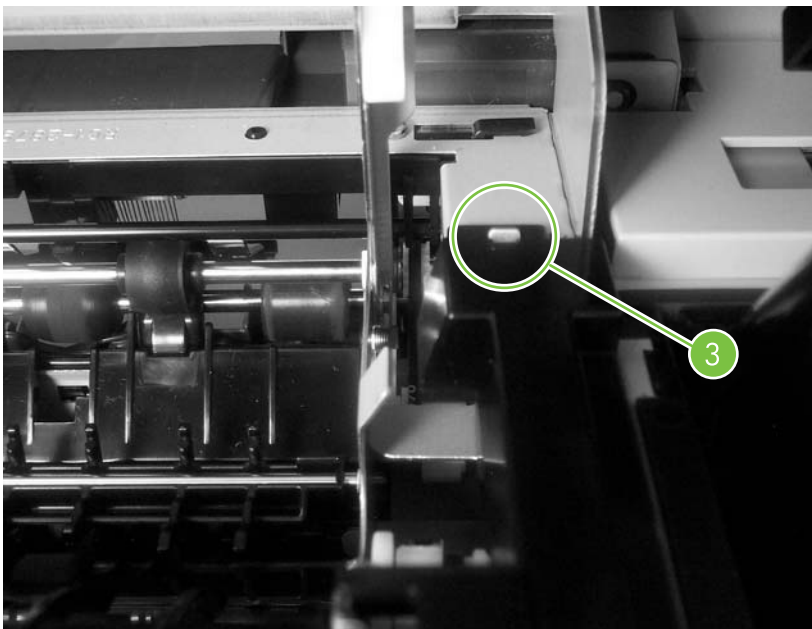
4. Unlock the two tabs (callout 2) on the left-reverse-assembly-drive cover, and remove the cover.



**Figure 5-53** Remove the reversing assembly (3 of 8)

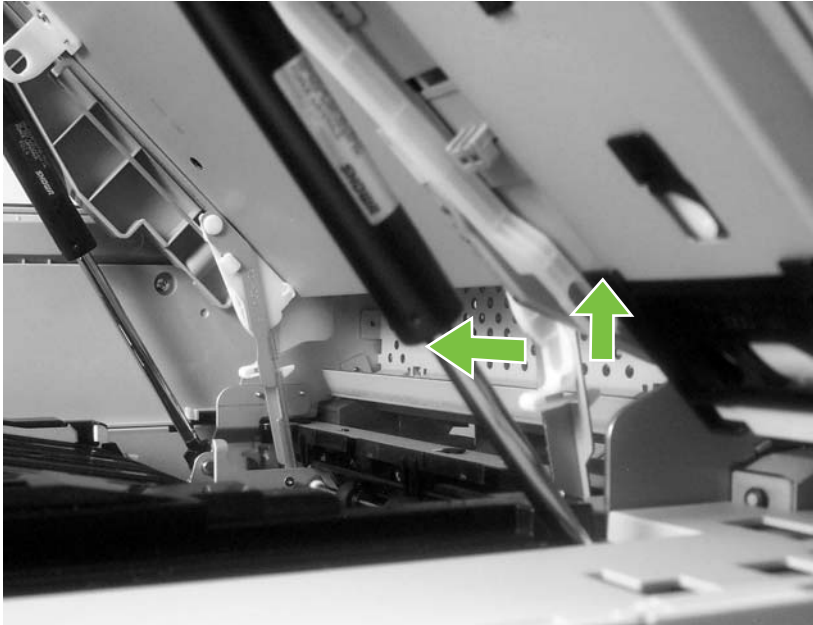


**NOTE** When reinstalling the cover, make sure that the metal tab on the sheet-metal chassis (near the rear door-piston) is in the slot in the cover (callout 3).



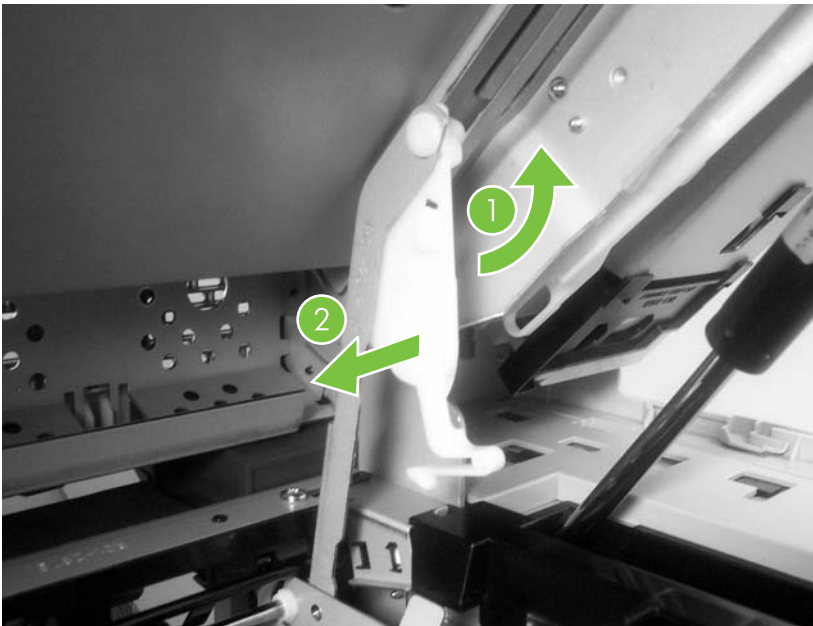
**Figure 5-54** Remove the reversing assembly (4 of 8)

5. Push up on the swing-arm-locking tab, and release the bottom of the swing arm. Repeat for the remaining swing arm (near the front of the MFP).



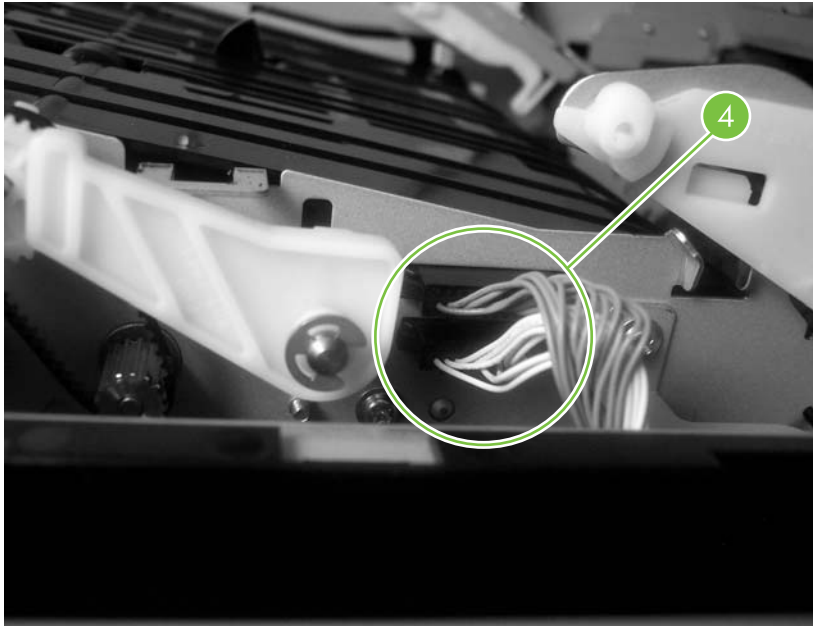
**Figure 5-55** Remove the reversing assembly (5 of 8)

6. Rotate the swing arm up to release the swing-arm pivot. Repeat for the remaining swing arm (near the front of the MFP).



**Figure 5-56** Remove the reversing assembly (6 of 8)

7. Disconnect two connectors (callout 4).



**Figure 5-57** Remove the reversing assembly (7 of 8)

8. Lift out the reversing assembly.



**Figure 5-58** Remove the reversing assembly (8 of 8)

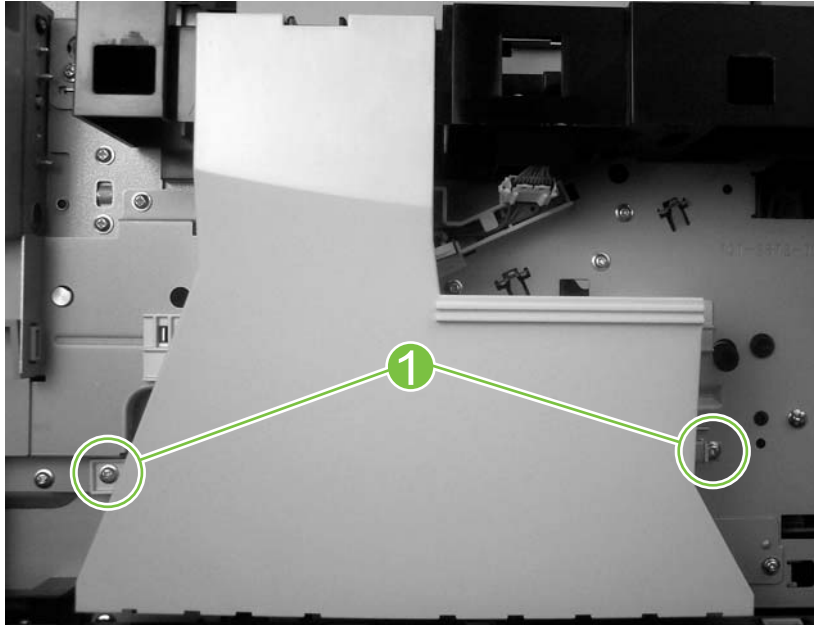


**NOTE** When you reinstall the reversing assembly, make sure that the swing-arm locking tabs are fully seated into the sheet-metal mounting slots.

## Main fan (FN101) and reversing-unit fan (FN103)

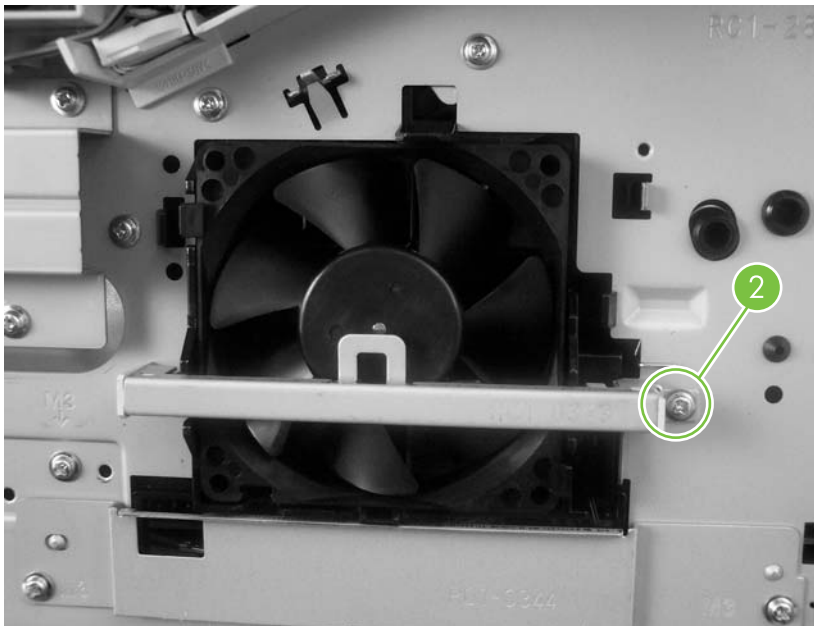
1. Remove the front cover.

2. Remove two screws (callout 1), and then remove the fan duct.



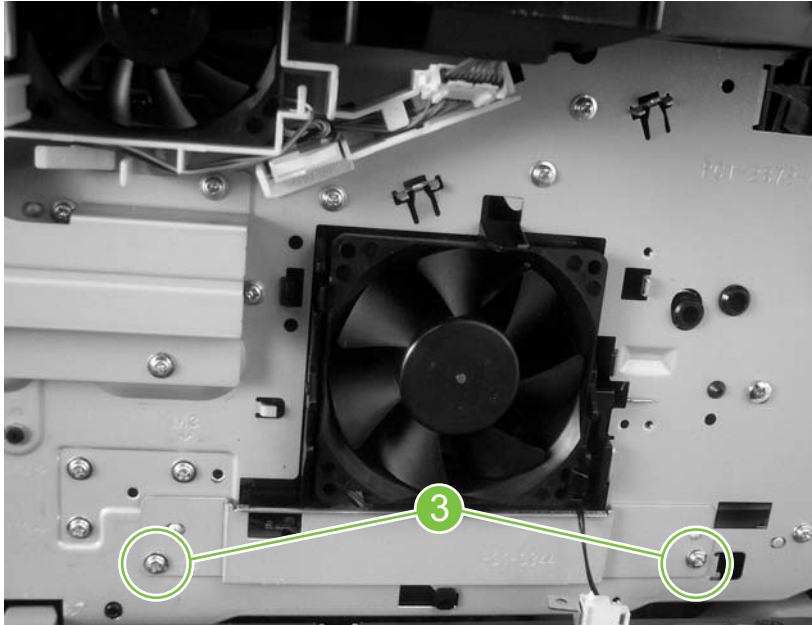
**Figure 5-59** Remove the main fan and reversing-unit fan (1 of 9)

3. **Main fan:** Remove one screw (callout 2), unhook the thermistor, and then move the thermistor to the side.



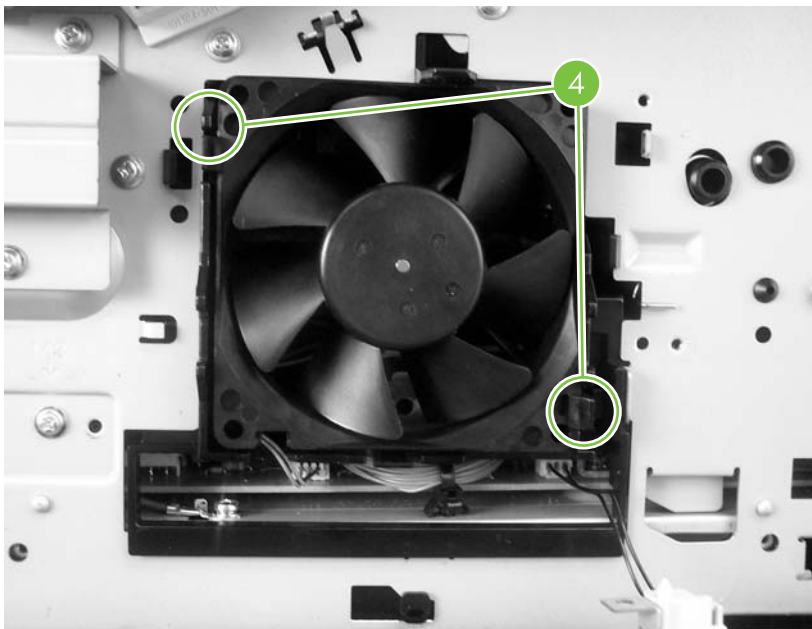
**Figure 5-60** Remove the main fan and reversing-unit fan (2 of 9)

4. Remove two screws (callout 3), and remove the power-supply shield.



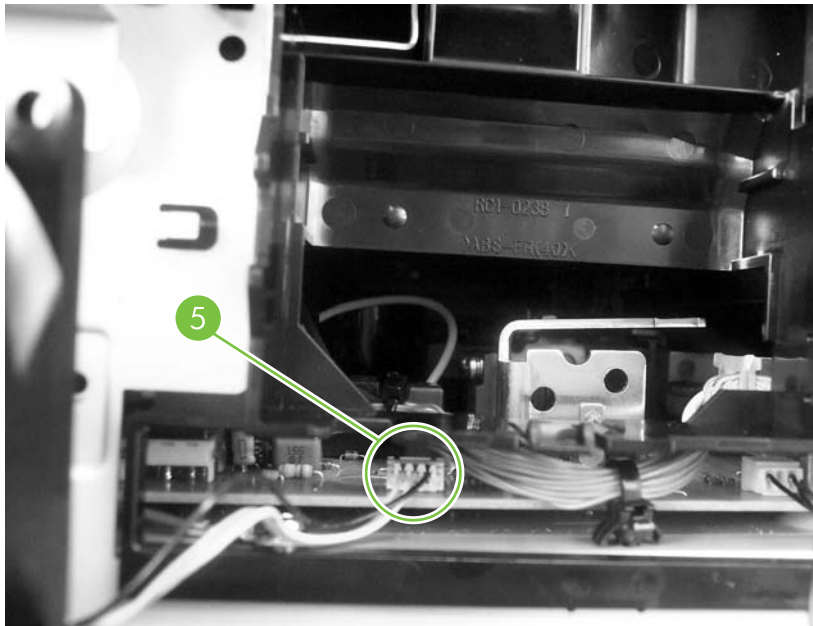
**Figure 5-61** Remove the main and reversing-unit fans (3 of 9)

5. Unclip the two main-fan locking tabs (callout 4), and then remove the main fan.



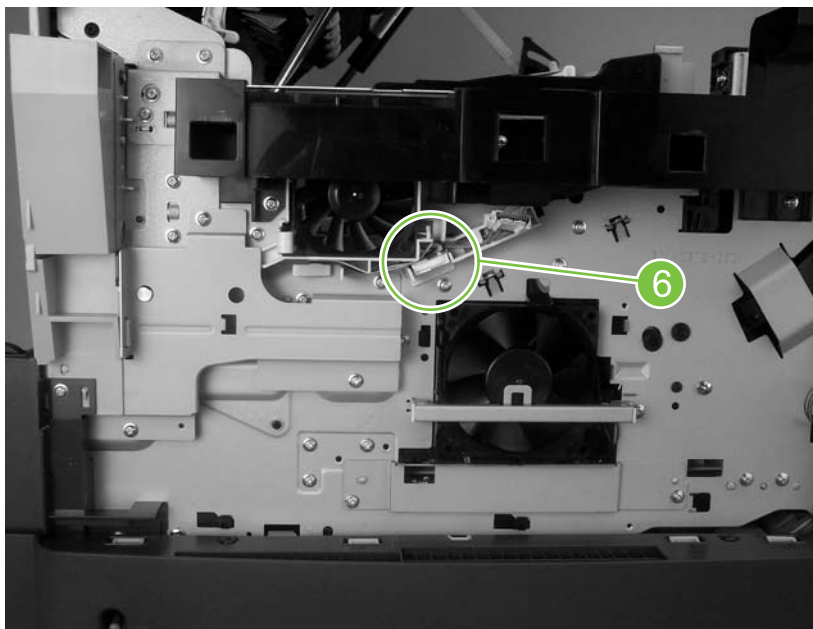
**Figure 5-62** Remove the main and reversing-unit fans (4 of 9)

6. Disconnect one connector (callout 5), and then remove the main fan.



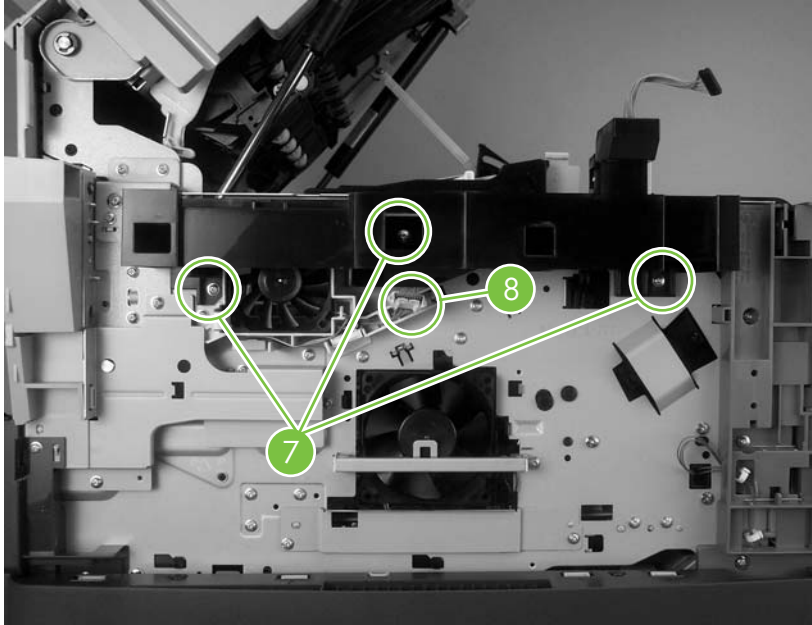
**Figure 5-63** Remove the main and reversing-unit fans (5 of 9)

7. **Reversing-unit fan:** Disconnect one connector (callout 6).



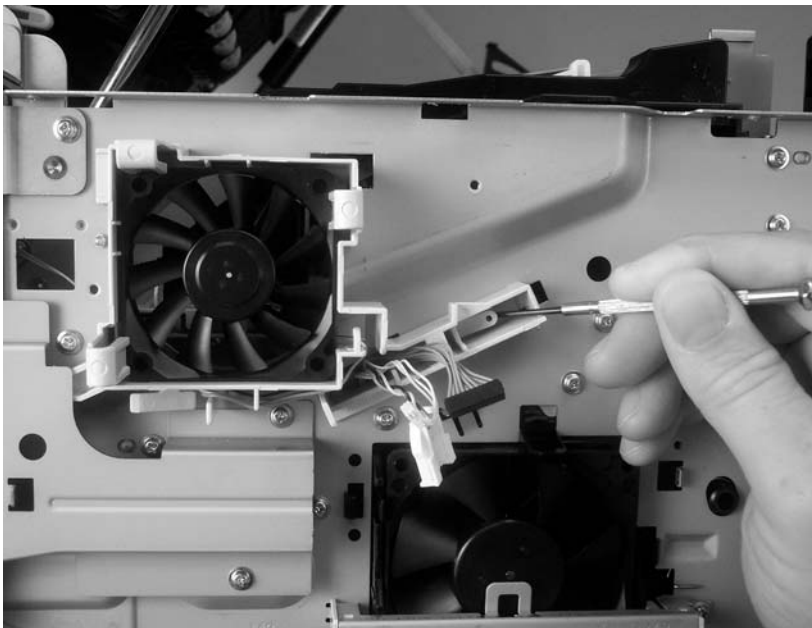
**Figure 5-64** Remove the main and reversing-unit fans (6 of 9)

8. Remove three screws (callout 7), unplug the control-panel connector (callout 8), and then remove the control-panel-cable guide.



**Figure 5-65** Remove the main and reversing-unit fans (7 of 9)

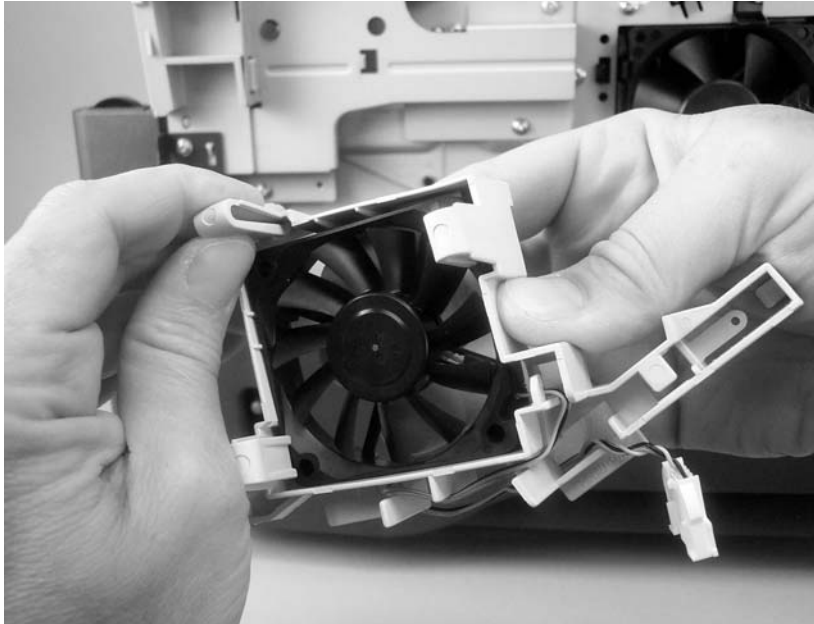
9. Release the locking tab, slide the fan assembly to the right, and then remove the bracket that holds the reversing-unit fan.



**Figure 5-66** Remove the main and reversing-unit fans (8 of 9)



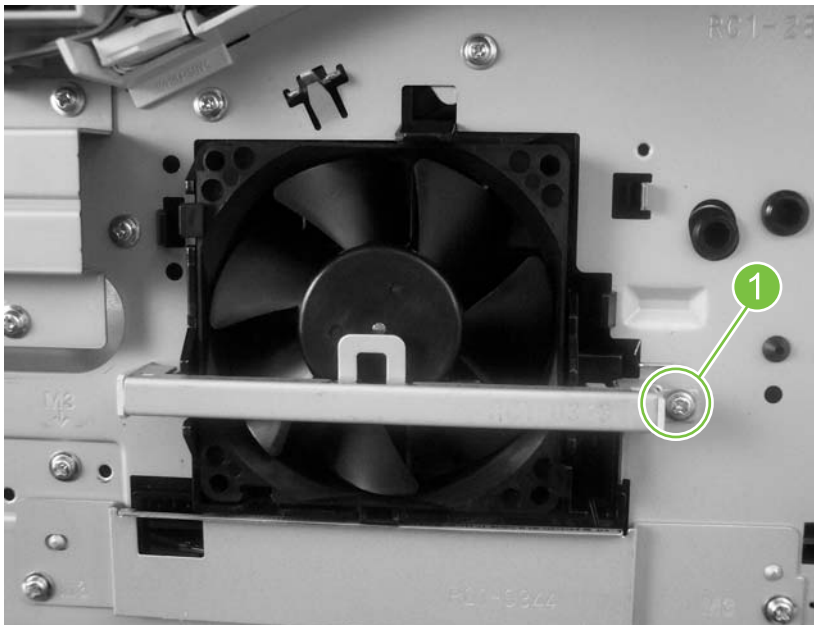
10. Release the three locking tabs on the fan bracket, and then remove the fan from the bracket.



**Figure 5-67** Remove the main and reversing-unit fans (9 of 9)

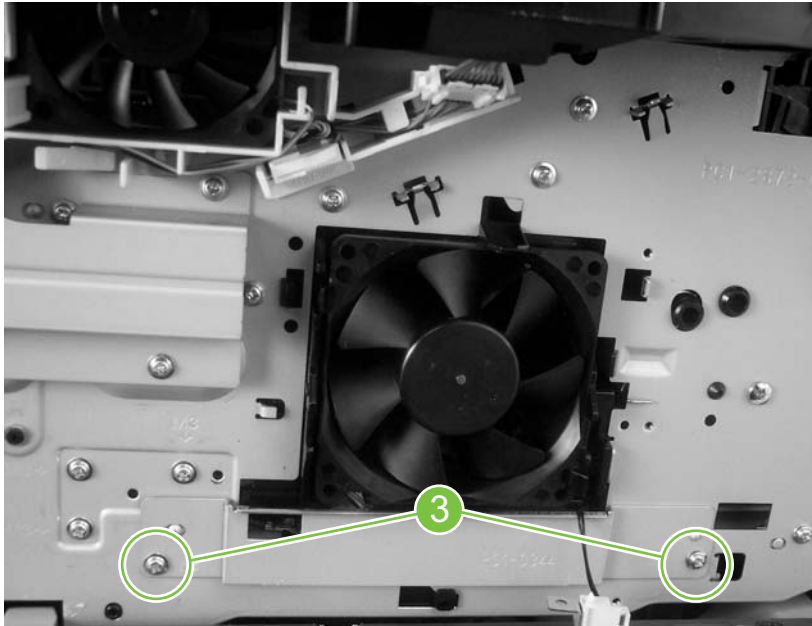
## Thermistor (TH3)

1. Remove the front cover.
2. Remove one screw (callout 1), unhook the thermistor, and then move the thermistor to the side.



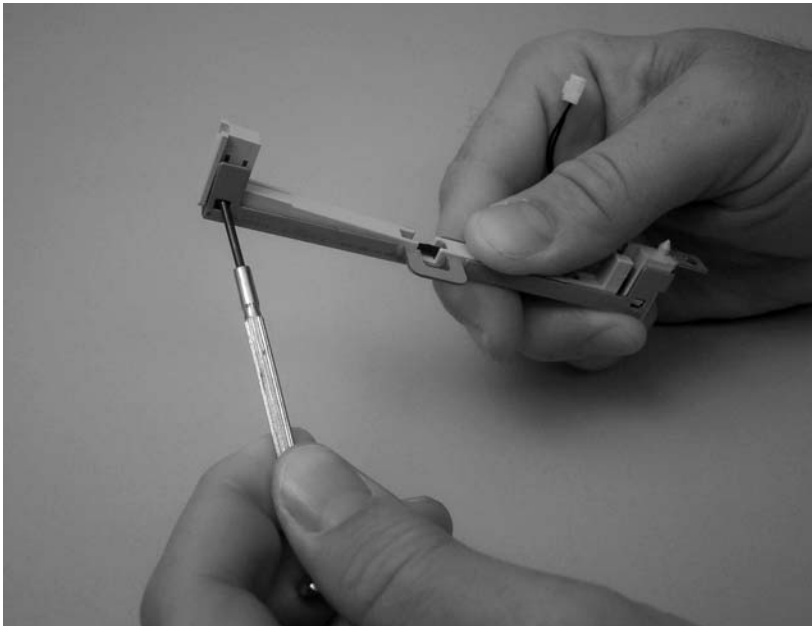
**Figure 5-68** Remove the thermistor (1 of 4)

3. Remove two screws (callout 2), and remove the power-supply shield. Disconnect the thermistor from the power supply, and remove it.



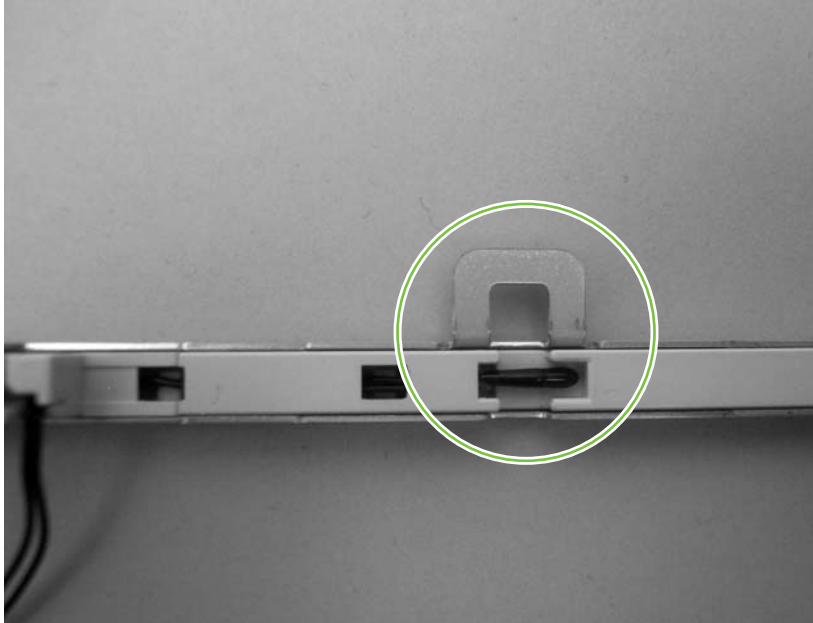
**Figure 5-69** Remove the thermistor (2 of 4)

4. Disconnect two locking tabs (one at each end of the thermistor assembly), and remove the plastic thermistor-bracket from the sheet-metal holder. Thread the thermistor wire-harness out of the plastic bracket.



**Figure 5-70** Remove the thermistor (3 of 4)

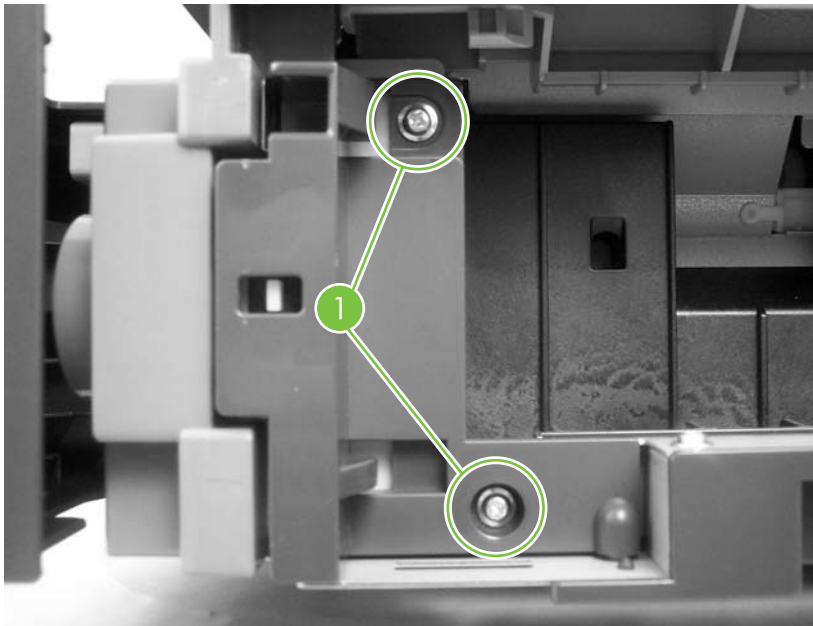
5. When installing the replacement thermistor, make sure that the thermistor body is fully inserted into the plastic bracket.



**Figure 5-71** Remove the thermistor (4 of 4)

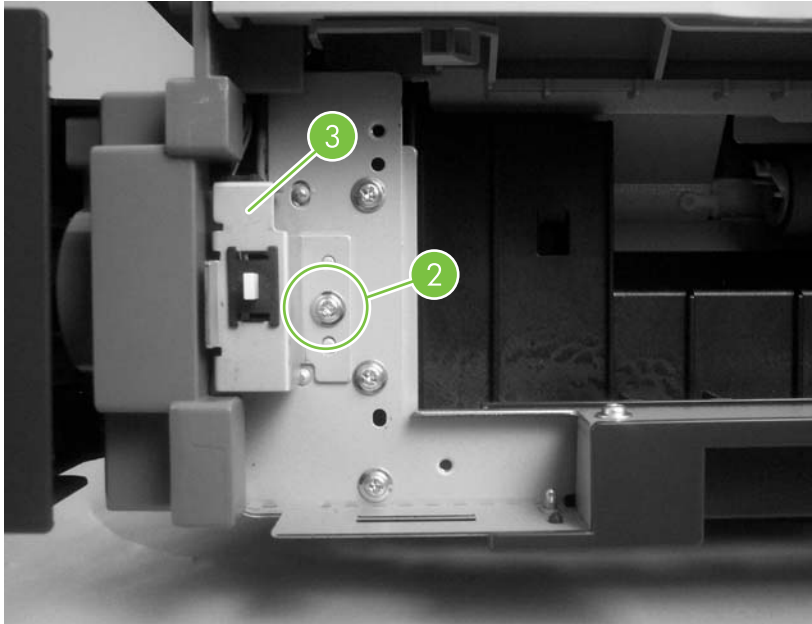
### Tray 2 jam-access-cover switch (SW105)

1. Remove the front cover.
2. Open the jam-access door, and then remove two screws (callout 1) and the jam-access-door-switch cover.



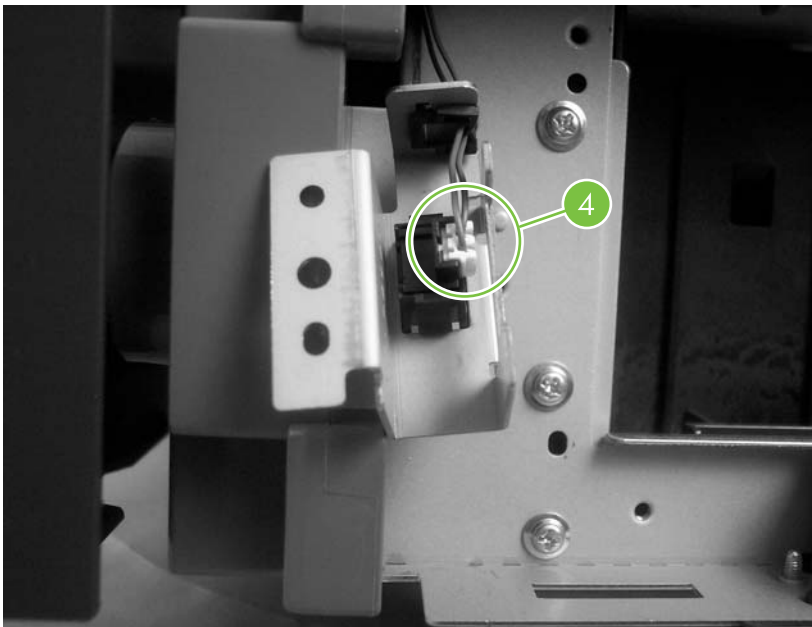
**Figure 5-72** Remove the jam-access-cover switch (1 of 3)

3. Remove one screw (callout 2), and then remove the switch frame (callout 3).



**Figure 5-73** Remove the jam-access-cover switch (2 of 3)

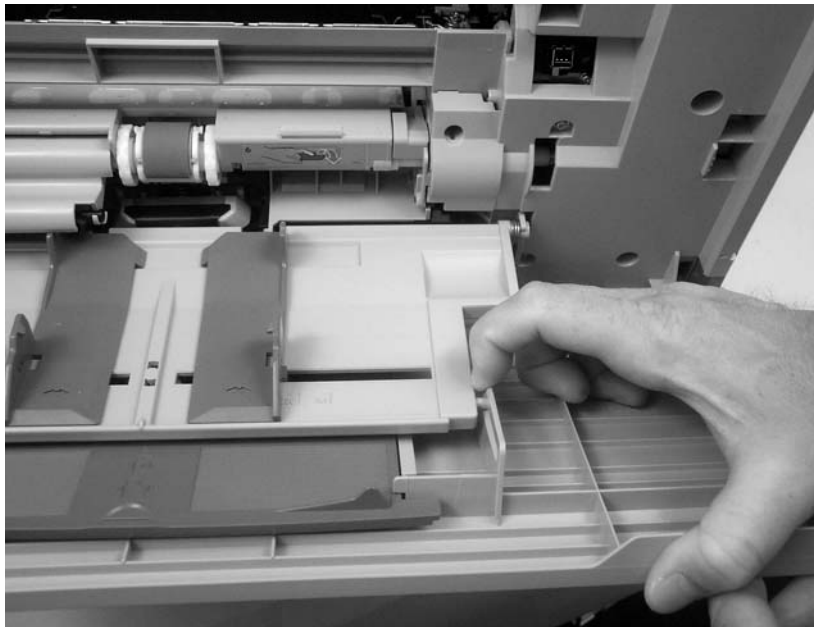
4. Disconnect the jam-access-cover-switch connector (callout 4) and remove the switch.



**Figure 5-74** Remove the jam-access-cover switch (3 of 3)

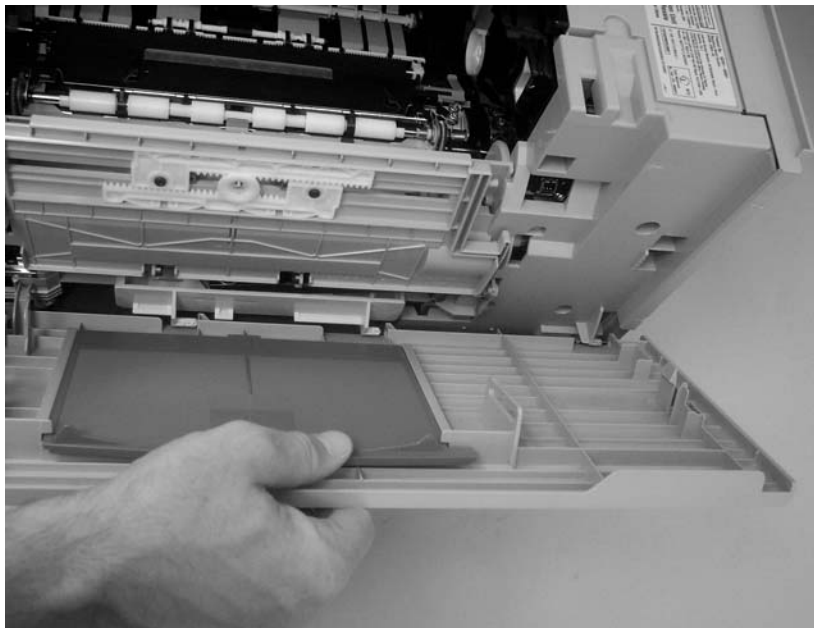
## Tray 1 assembly

1. Open tray 1, and then flex the two door-pin guides to release the two door pins. Separate the tray 1 door from the paper-guide assembly.



**Figure 5-75** Remove the tray 1 assembly (1 of 5)

2. Slide the door toward the rear of the MFP to remove it.



**Figure 5-76** Remove the tray 1 assembly (2 of 5)

3. Unclip the sensor-flag holder from the pickup-roller shaft.



**Figure 5-77** Remove the tray 1 assembly (3 of 5)

4. Rotate the paper guide down, and disengage the front hinge from the pin that is on the feed assembly.



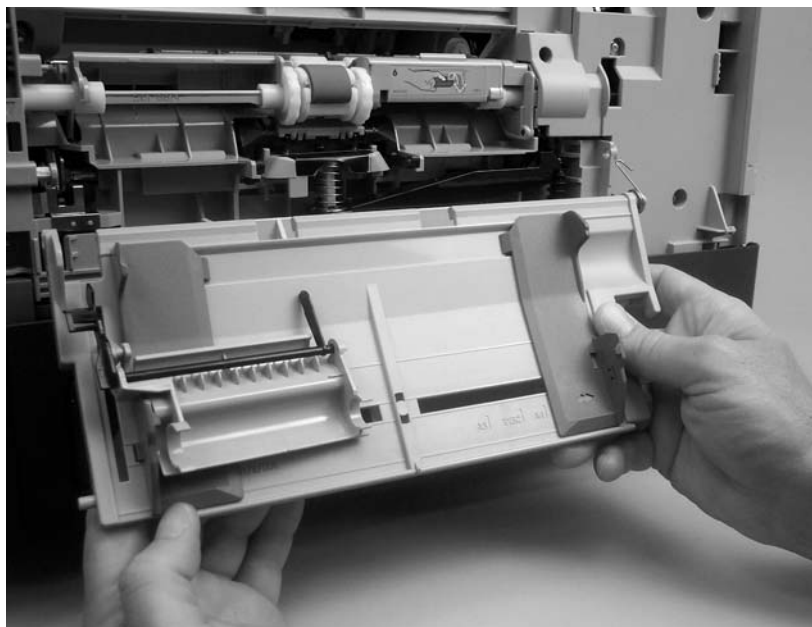
**Figure 5-78** Remove the tray 1 assembly (4 of 5)

5. The spring on the rear hinge is not captive and can easily be lost. Take note of how this spring is installed before removing the tray assembly.



**Figure 5-79** Correct tray 1 rear-hinge-spring placement

6. Move the paper-guide slightly toward the front of the MFP to disengage the paper-guide rear-hinge. Remove the paper guide.

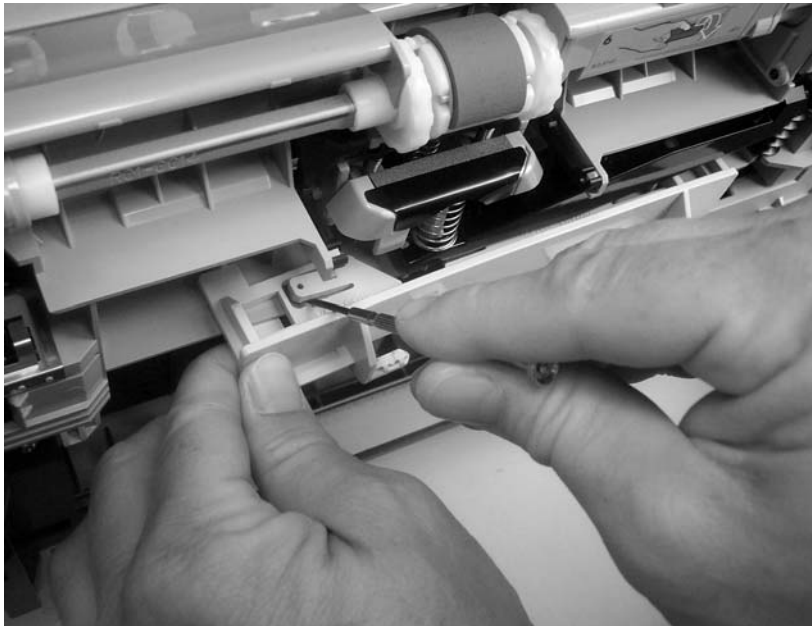


**Figure 5-80** Remove the tray 1 assembly (5 of 5)

## Front-cover support

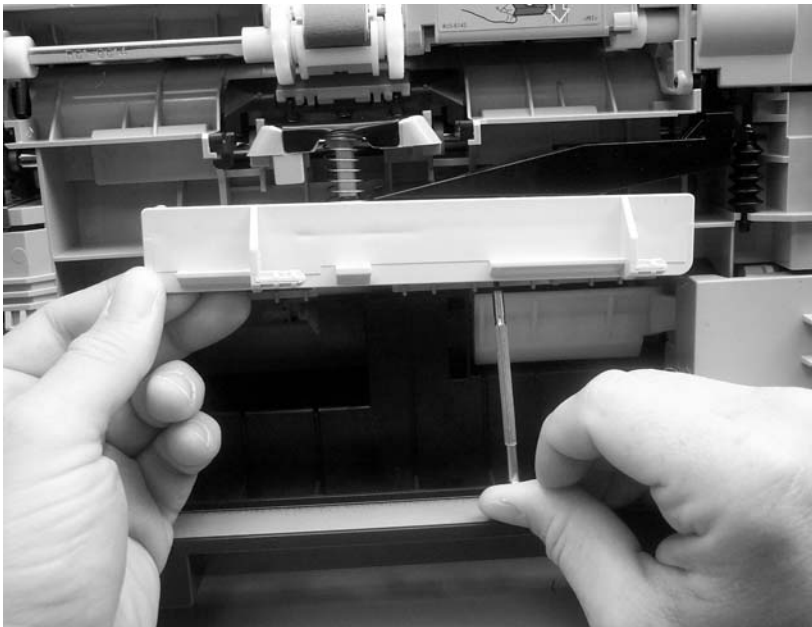
1. Remove the tray 1 assembly.
2. Open the jam-access door.

3. Use a small, flat-blade screwdriver to release the front cover support locking tab.



**Figure 5-81** Remove the front-cover support (1 of 2)

4. Use a small, flat-blade screwdriver to release the rear cover-support locking tab. Remove the front-cover support.



**Figure 5-82** Remove the front-cover support (2 of 2)



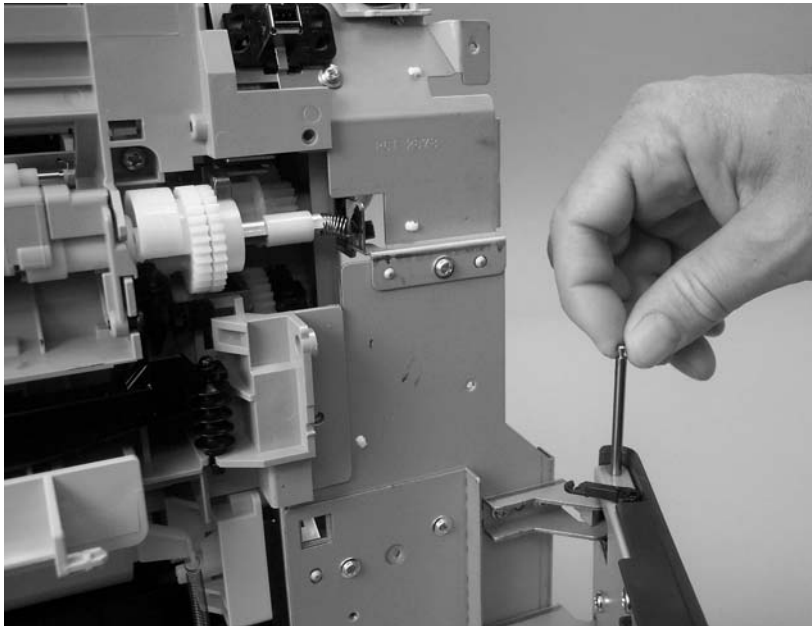
## Tray 1 feed-assembly

1. Remove the following assemblies:
  - Formatter.
  - Front cover.
  - Back cover.
  - Tray 1 assembly.
2. Release the retainer from shaft on the jam-access-door hinge.



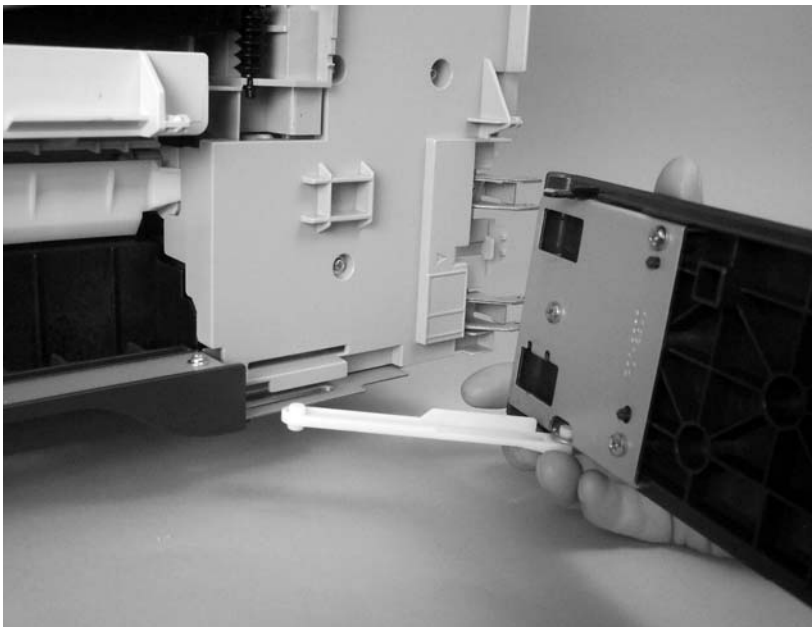
**Figure 5-83** Remove the tray 1 feed-assembly (1 of 13)

3. Remove the shaft from the jam-access-door hinge.



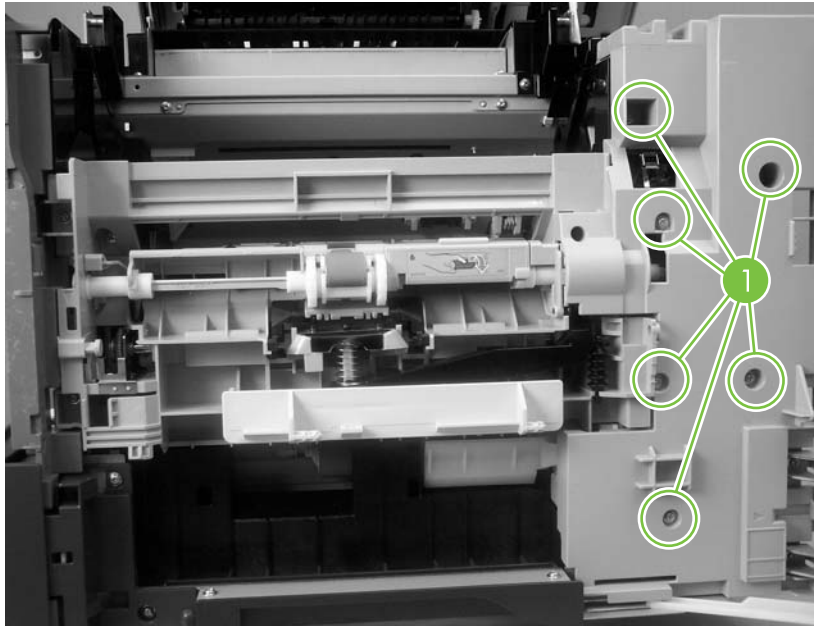
**Figure 5-84** Remove the tray 1 feed-assembly (2 of 13)

4. Slide the door and retainer arm toward the front of the MFP until the arm clears the slot in the chassis.



**Figure 5-85** Remove the tray 1 feed-assembly (3 of 13)

5. Remove six screws (callout 1).



**Figure 5-86** Remove the tray 1 feed-assembly (4 of 13)



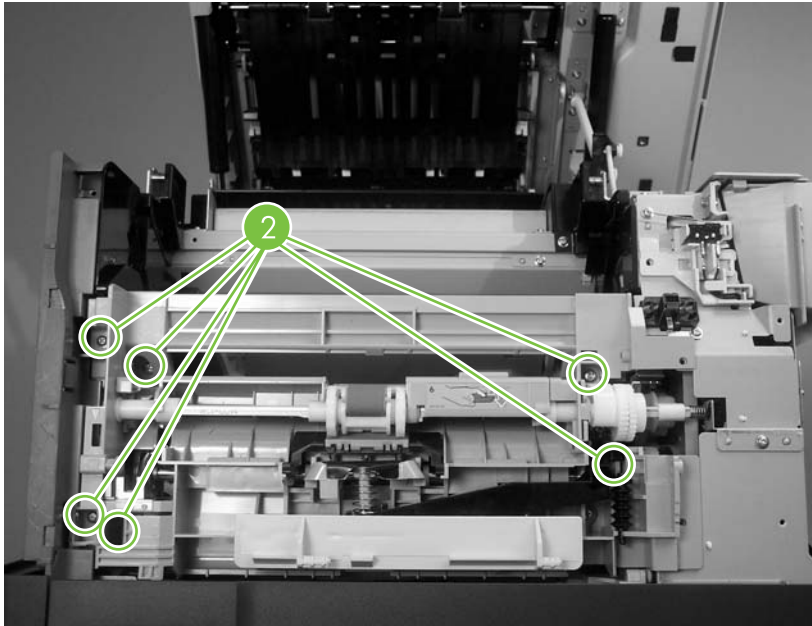
**NOTE** When you reinstall the feed-assembly cover, place the three long screws into the lower holes that are along the left side of the cover.

6. Release the locking tab, and then remove the feed-assembly cover from the MFP.



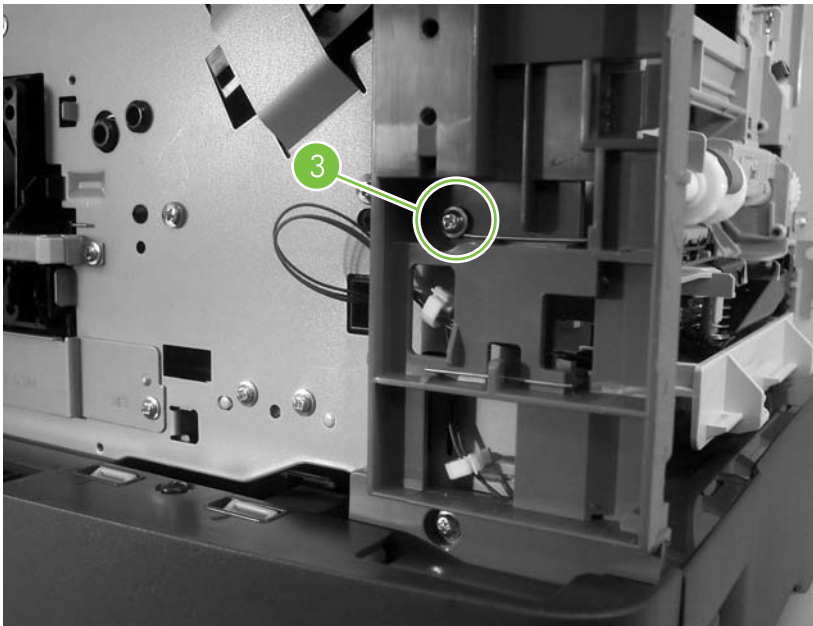
**Figure 5-87** Remove the tray 1 feed-assembly (5 of 13)

7. Remove six screws (callout 2) from the front of the tray 1 feed-assembly.



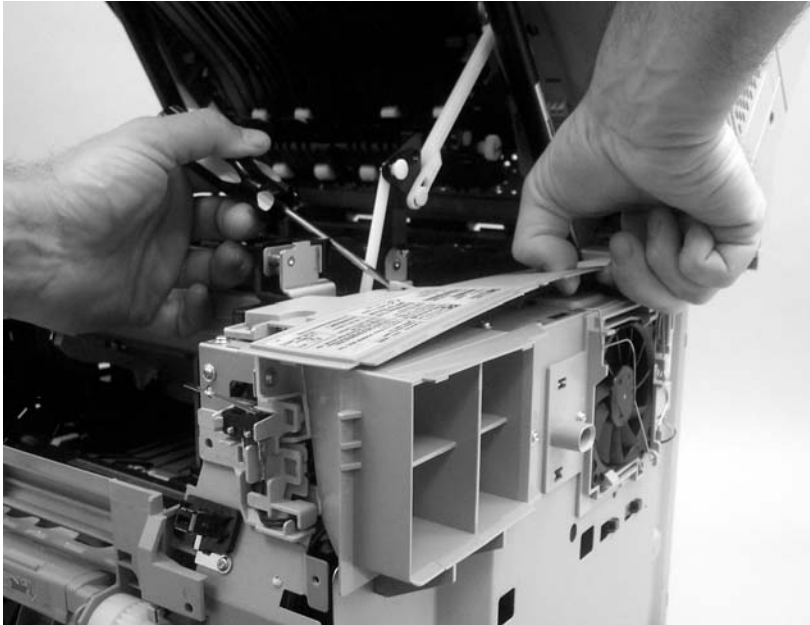
**Figure 5-88** Remove the tray 1 feed-assembly (6 of 13)

8. Remove one grounding screw (callout 3) from the front of the MFP.



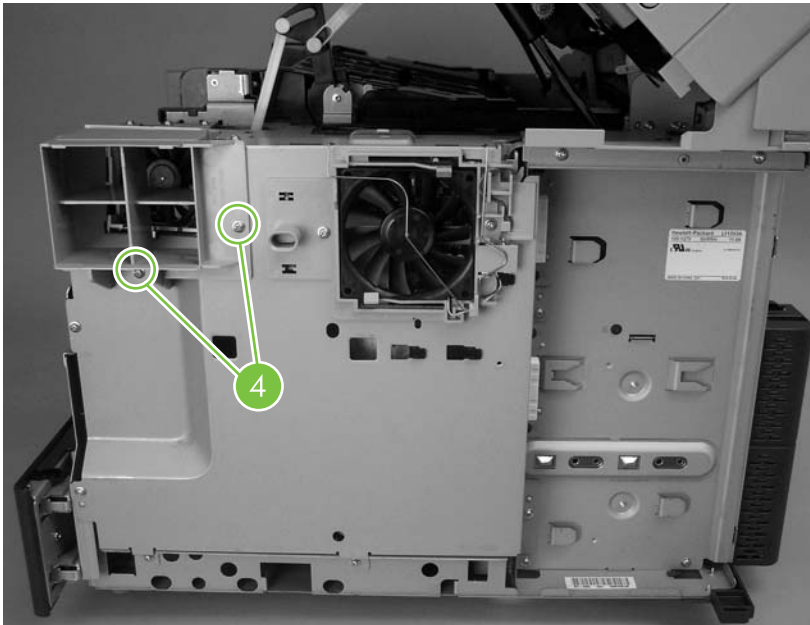
**Figure 5-89** Remove the tray 1 feed-assembly (7 of 13)

9. Use a small, flat-blade screwdriver to release one locking tab. Grasp the middle of the rear-top cover, and slide it toward the tray 1 feed-assembly to remove it.



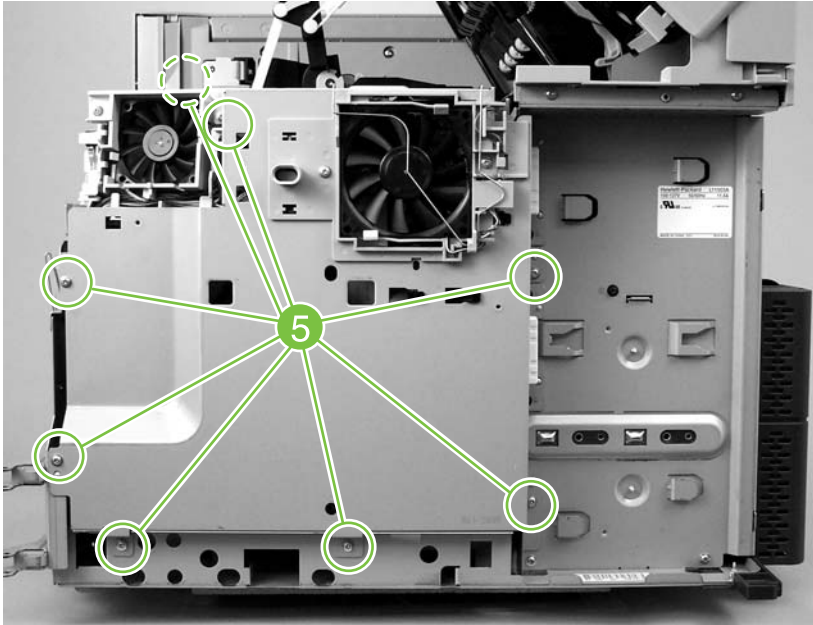
**Figure 5-90** Remove the tray 1 feed-assembly (8 of 13)

10. Remove two screws (callout 4), and remove the fan shroud.



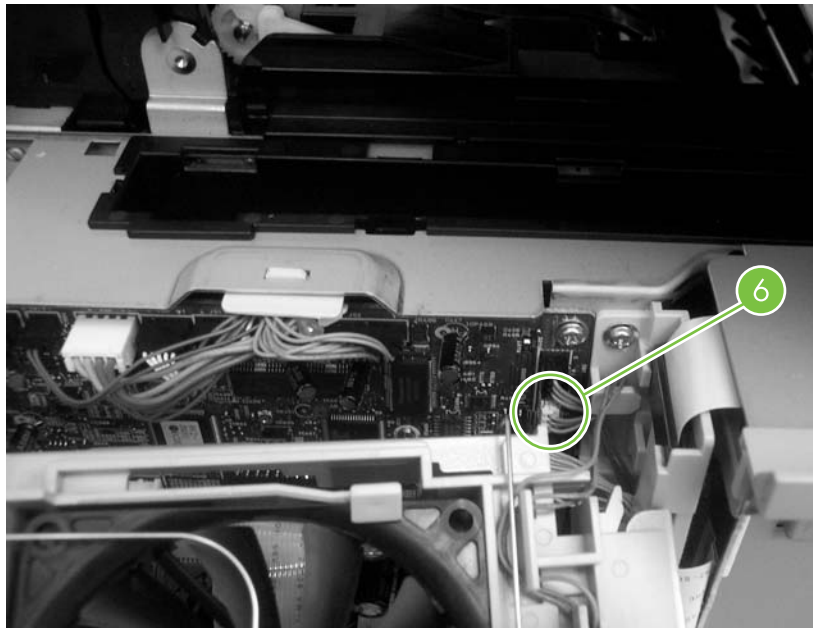
**Figure 5-91** Remove the tray 1 feed-assembly (9 of 13)

11. Remove eight screws (callout 5), and then rotate the rear sheet-metal shield away from the MFP.



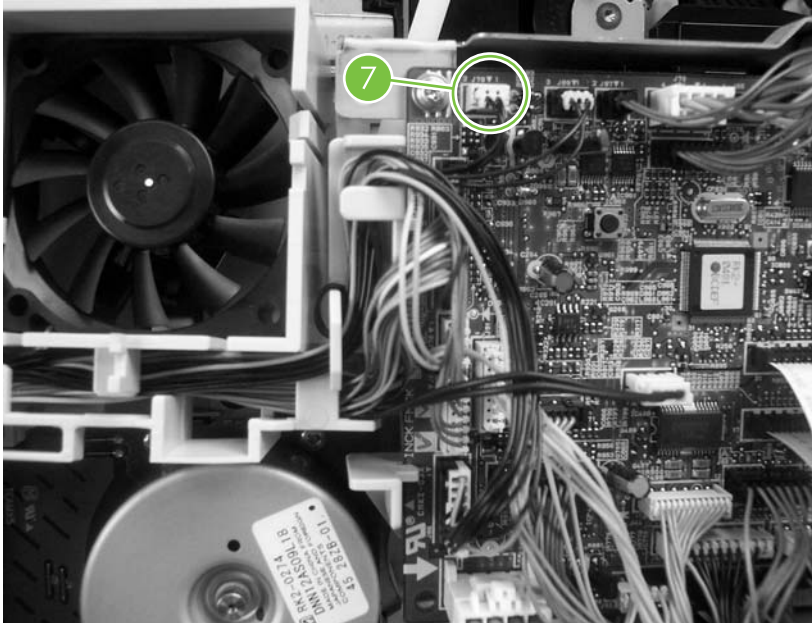
**Figure 5-92** Remove the tray 1 feed-assembly (10 of 13)

12. Disconnect one connector (callout 6; J66) from the DC controller, and remove the sheet-metal shield.



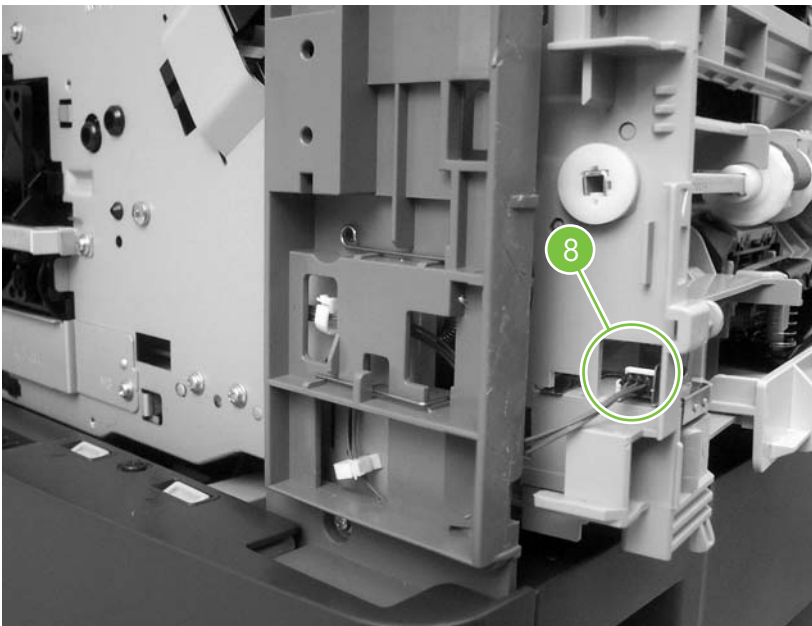
**Figure 5-93** Remove the tray 1 feed-assembly (11 of 13)

13. Disconnect one connector (callout 7; J79) from the DC controller, and unwind the wire harness from the MFP.



**Figure 5-94** Remove the tray 1 feed-assembly (12 of 13)

14. Disconnect one connector (callout 8) from the tray 1 feed-assembly. Remove the tray 1 feed-assembly.



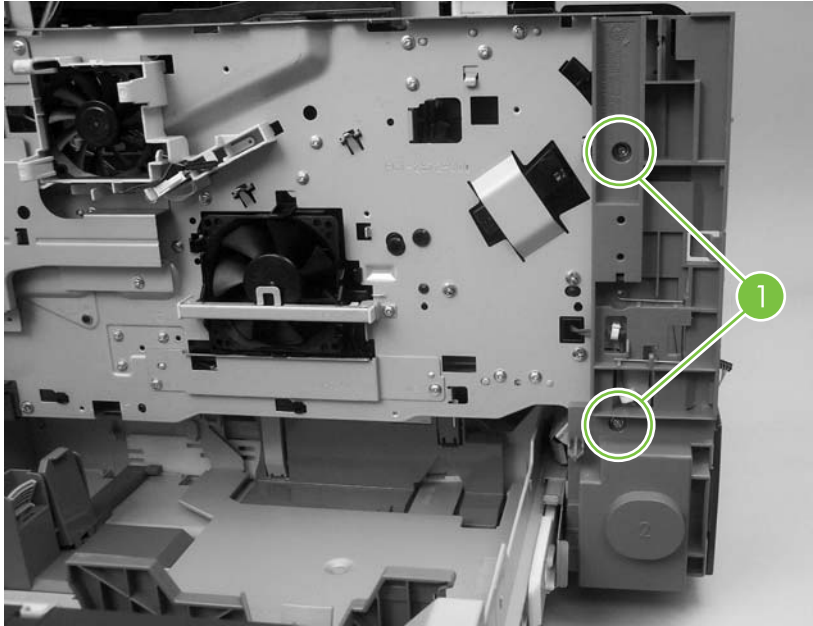
**Figure 5-95** Remove the tray 1 feed-assembly (13 of 13)



**NOTE** The grounding spring that is on the DC-controller side of the feed assembly is not captive and can be easily lost. When you reinstall the feed assembly, make sure that the grounding spring is correctly seated against the sheet-metal chassis.

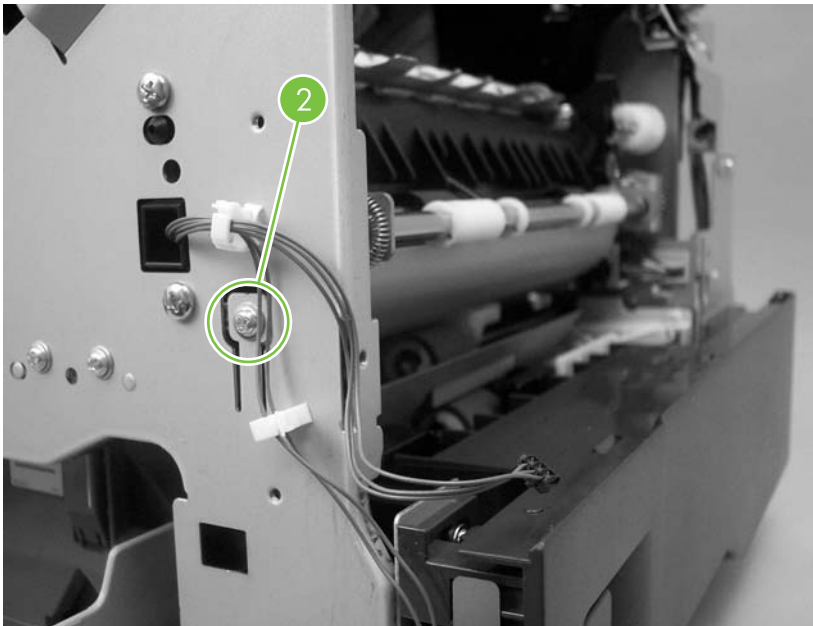
## Feed-roller assembly

1. Remove the tray 1 feed-assembly.
2. Remove two screws (callout 1), and then remove the inner front cover.



**Figure 5-96** Remove the feed-roller assembly (1 of 4)

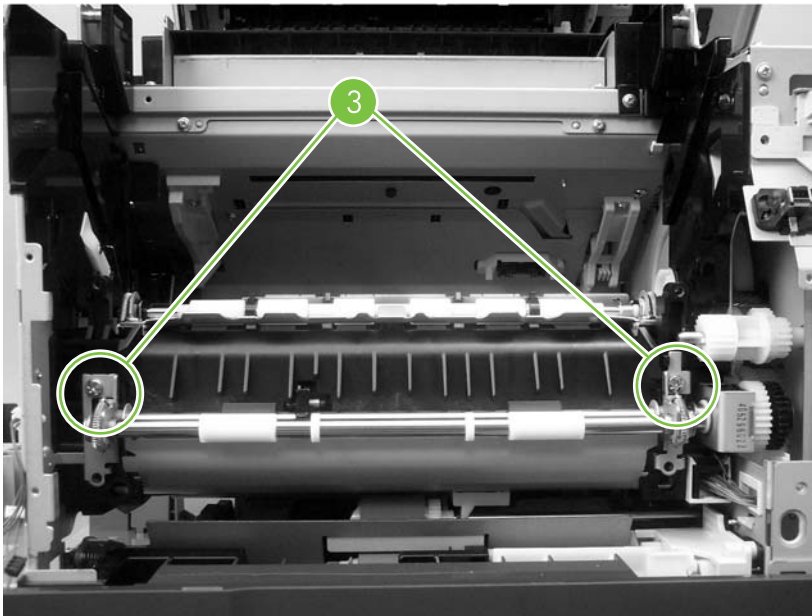
3. Remove one grounding screw (callout 2) on the front of the MFP.



**Figure 5-97** Remove the feed-roller assembly (2 of 4)

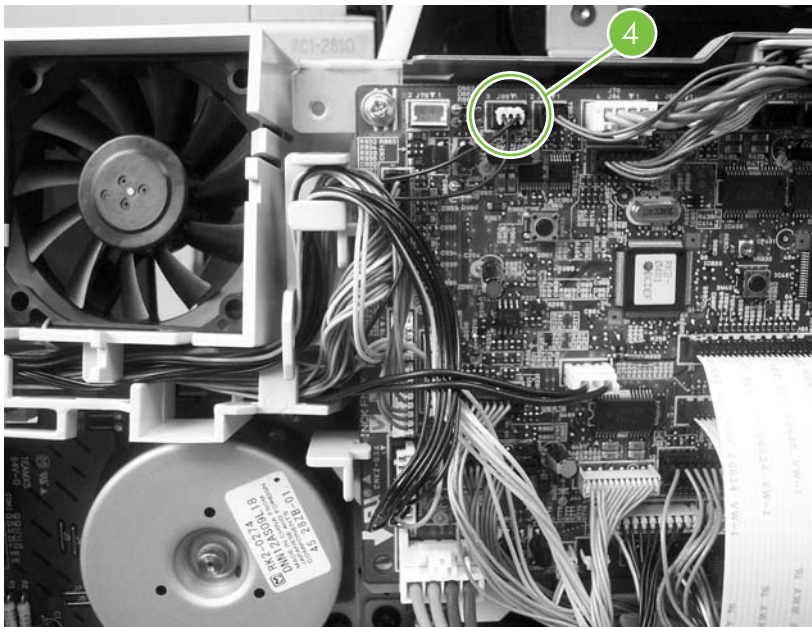


4. Remove two screws (callout 3).



**Figure 5-98** Remove the feed-roller assembly (3 of 4)

5. Disconnect one connector (callout 4; J89) and unwind the wire harness from the MFP. Remove the feed-roller assembly.

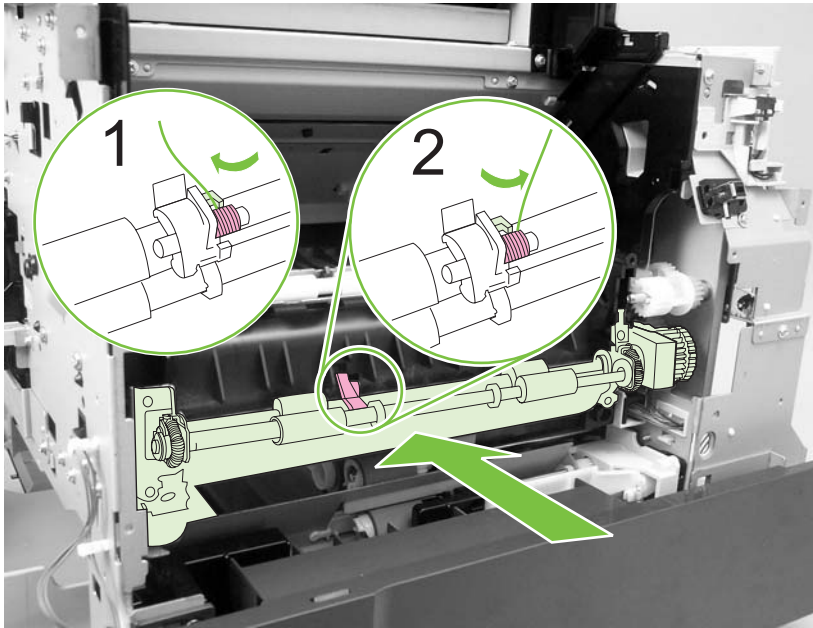


**Figure 5-99** Remove the feed-roller assembly (4 of 4)

- 6. Reinstallation tip:** When the feed-roller assembly is installed, the sensor-flag spring must be correctly positioned in order for the flag to operate. If a paper-jam error message **13.20.00 JAM** appears on the control-panel display after you replace the feed-roller assembly, verify that this sensor-flag spring is installed correctly.

Hook the spring over the flag tab (see callout 1 in [Figure 5-100 Sensor-flag spring placement on page 280](#)). Fasten the feed-roller assembly to the chassis and insert the flag into the hole in the plastic frame. Release the spring from the tab on the flag. Verify that the flag is held in the upright position, can move freely, and always returns to the upright position.

If the flag does not move freely, or does not return to the upright position, an error message **13.20.00 JAM** appears on the control-panel display when the MFP power is turned on.

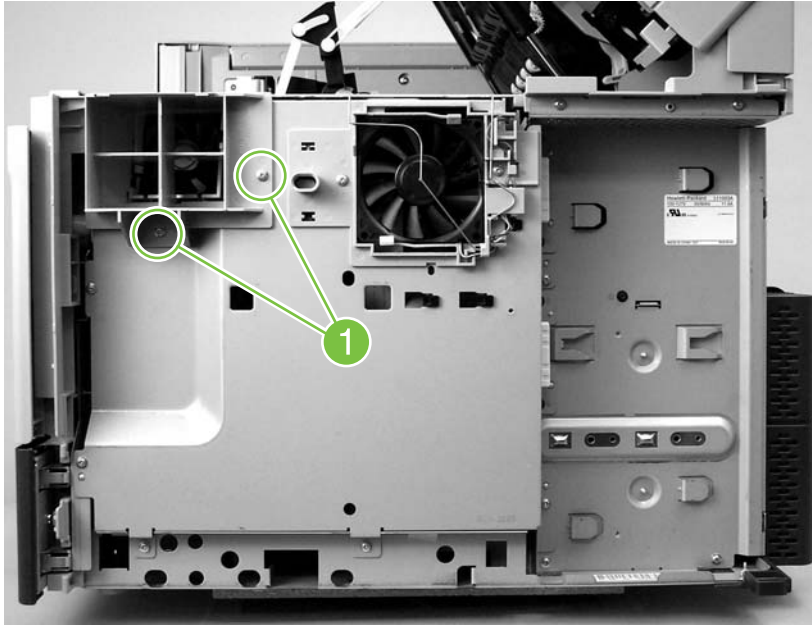


**Figure 5-100** Sensor-flag spring placement

## DC controller

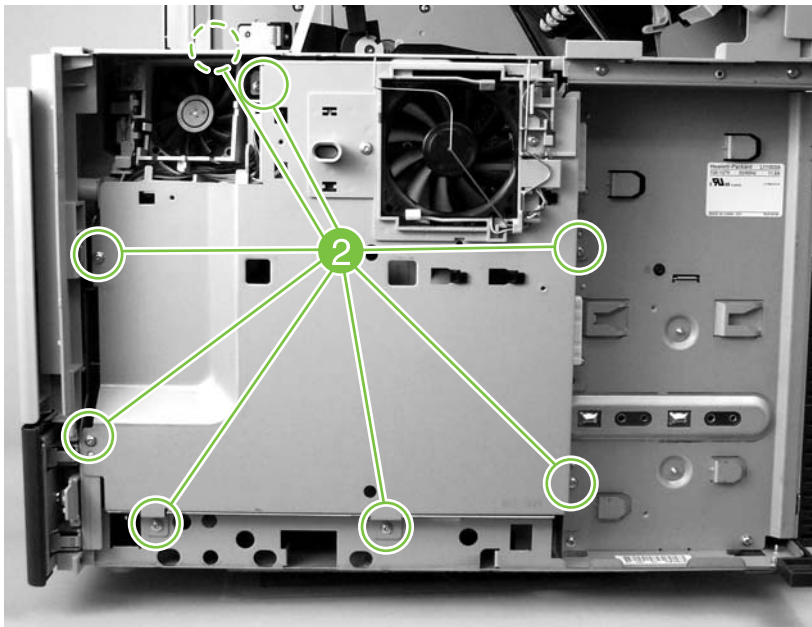
1. Remove the back cover.

2. Remove two screws (callout 1), and remove the fan shroud.



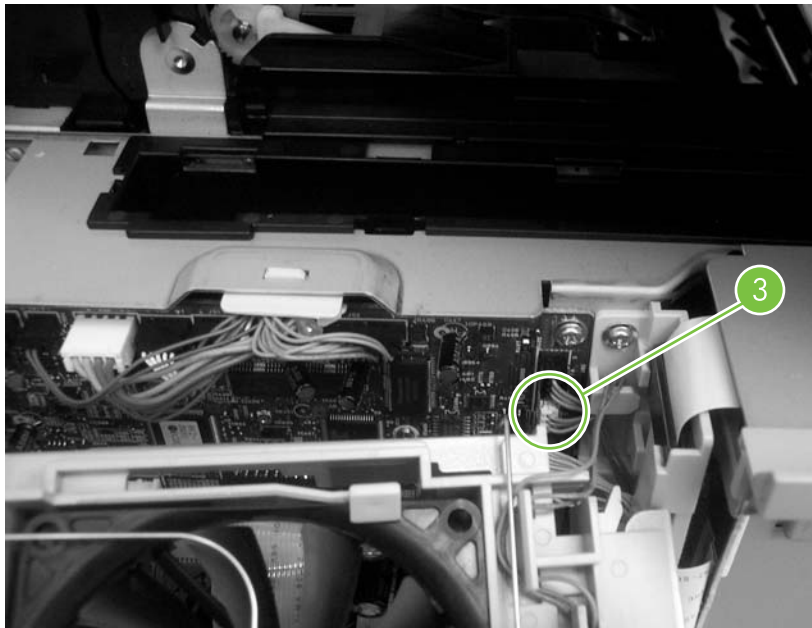
**Figure 5-101** Remove the DC controller (1 of 6)

3. Remove eight screws (callout 2), and then rotate the rear sheet-metal shield away from the MFP.



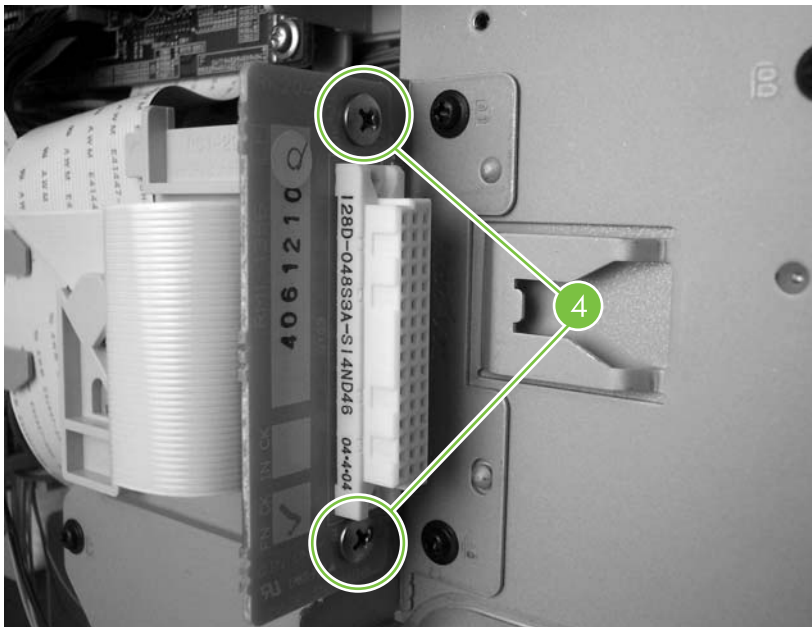
**Figure 5-102** Remove the DC controller (2 of 6)

4. Disconnect one connector (callout 3; J66) from the DC controller and remove the sheet-metal shield.



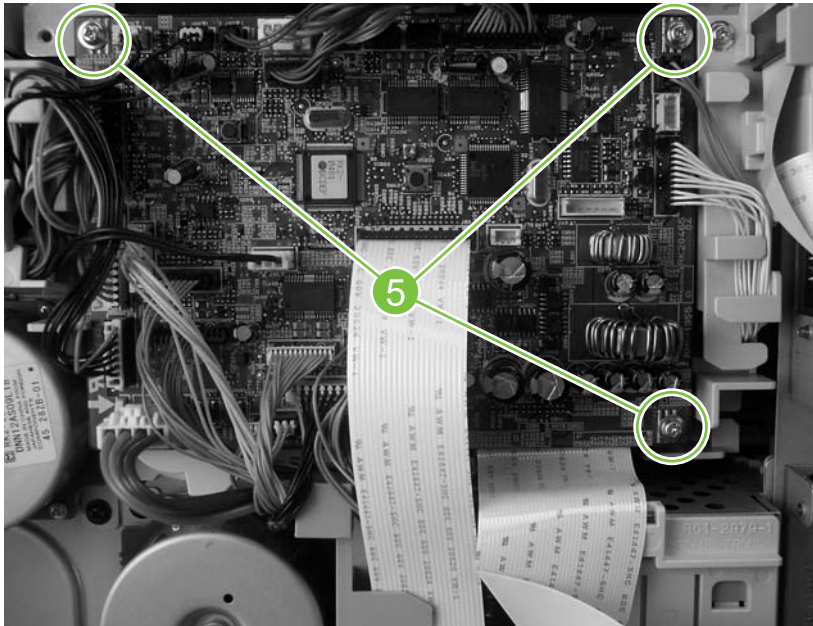
**Figure 5-103** Remove the DC controller (3 of 6)

5. Remove two screws (callout 4), and then remove the formatter connector (callout 5).



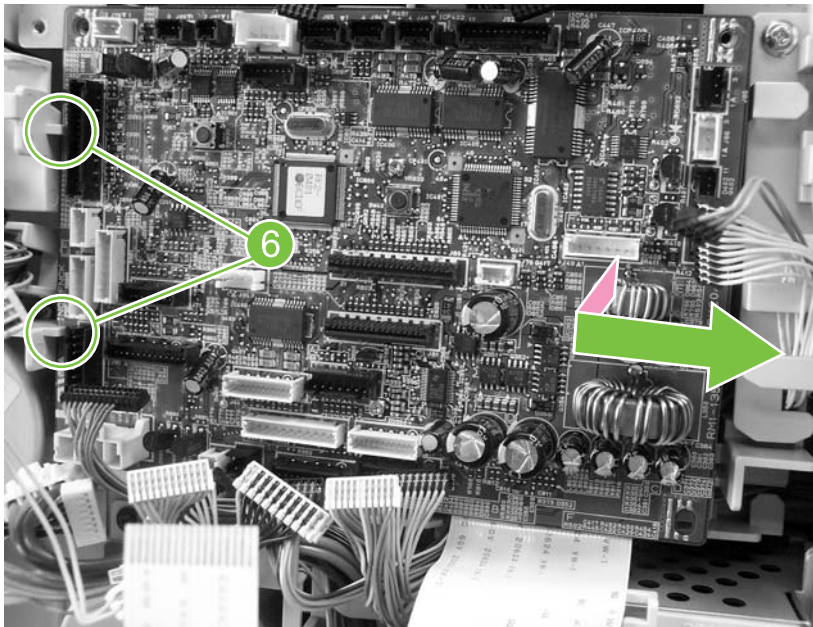
**Figure 5-104** Remove the DC controller (4 of 6)

6. Disconnect all of the connectors on the DC controller, and then remove three screws (callout 5).



**Figure 5-105** Remove the DC controller (5 of 6)

7. Rotate the formatter side of the DC controller away from the MFP. Pull the DC controller out of the two locking tabs (callout 6) on the fan duct to remove it.

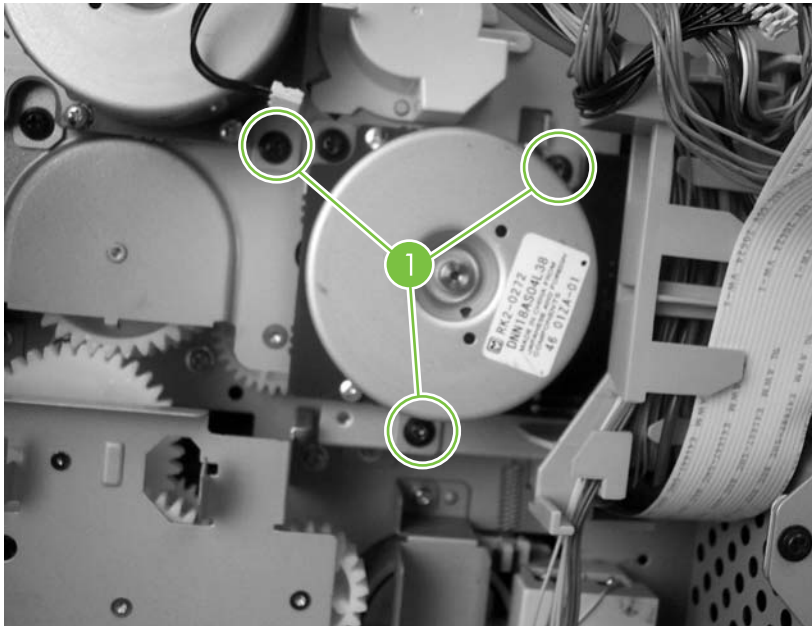


**Figure 5-106** Remove the DC controller (6 of 6)

## Main motor (M101)

1. Remove the DC controller.

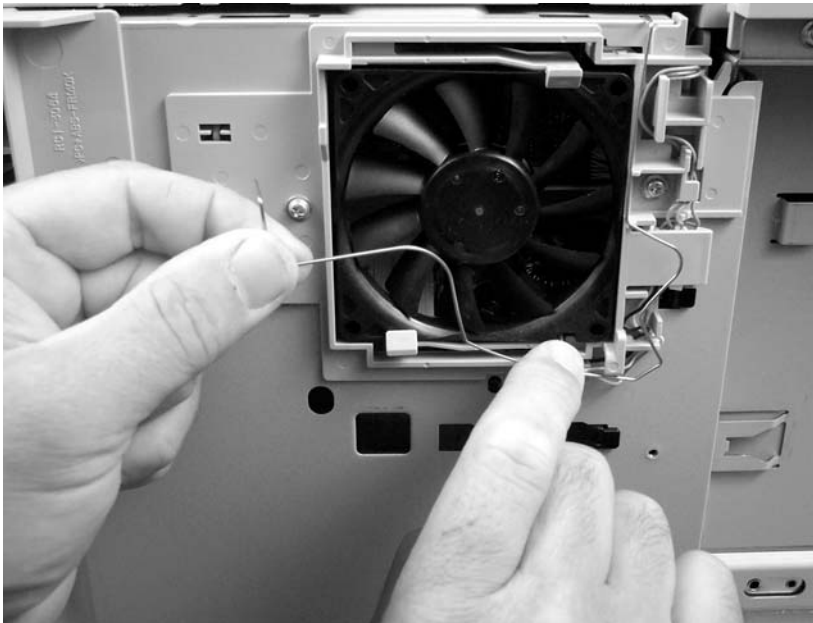
2. Remove three screws (callout 1), and then remove the main motor.



**Figure 5-107** Remove the main motor

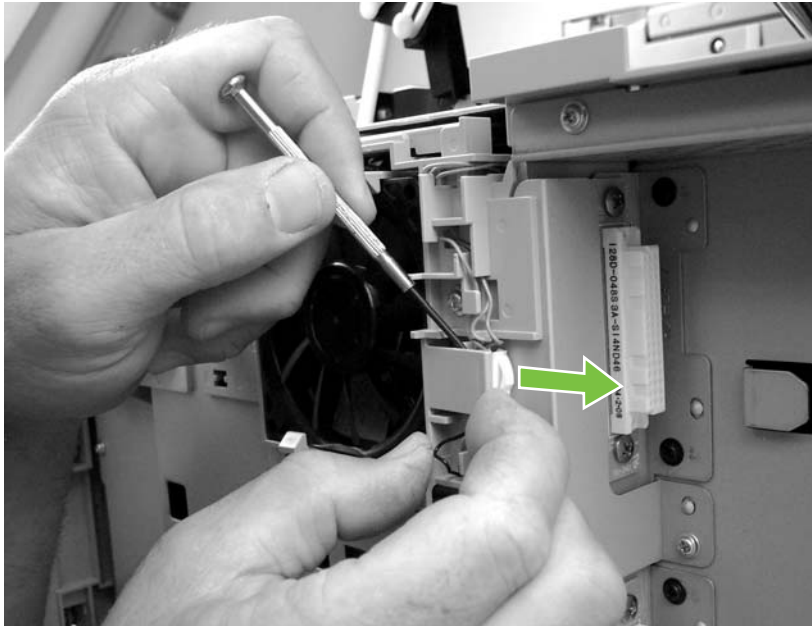
## DC controller fan (FN104)

1. Remove the back cover.
2. Remove the grounding wire that is in front of the DC controller fan.



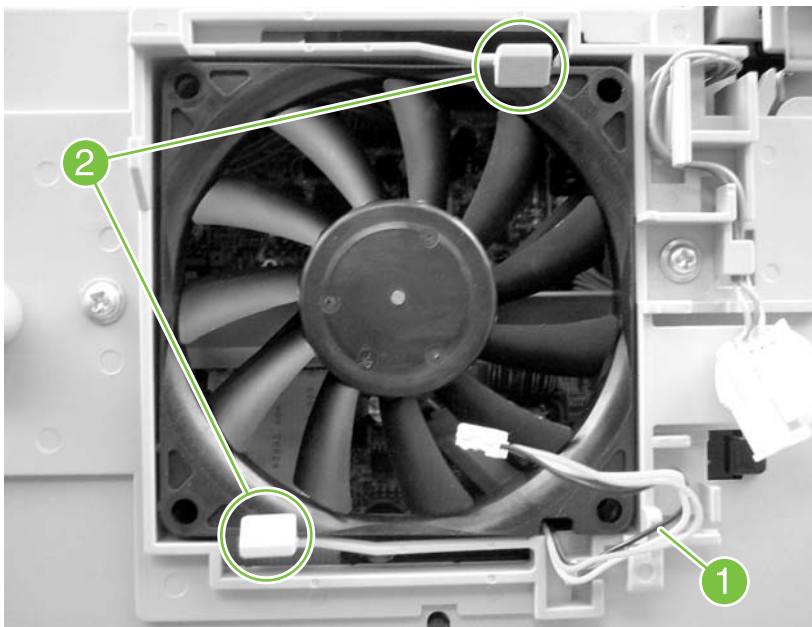
**Figure 5-108** Remove the DC controller fan (1 of 3)

3. Pull away the tab that is to the right of the DC controller fan, and slide out the connector that is behind the tab. Disconnect the fan connector.



**Figure 5-109** Remove the DC controller fan (2 of 3)

4. Unwind the connector wire from the frame (callout 1). Release the two tabs (callout 2), and remove the fan.

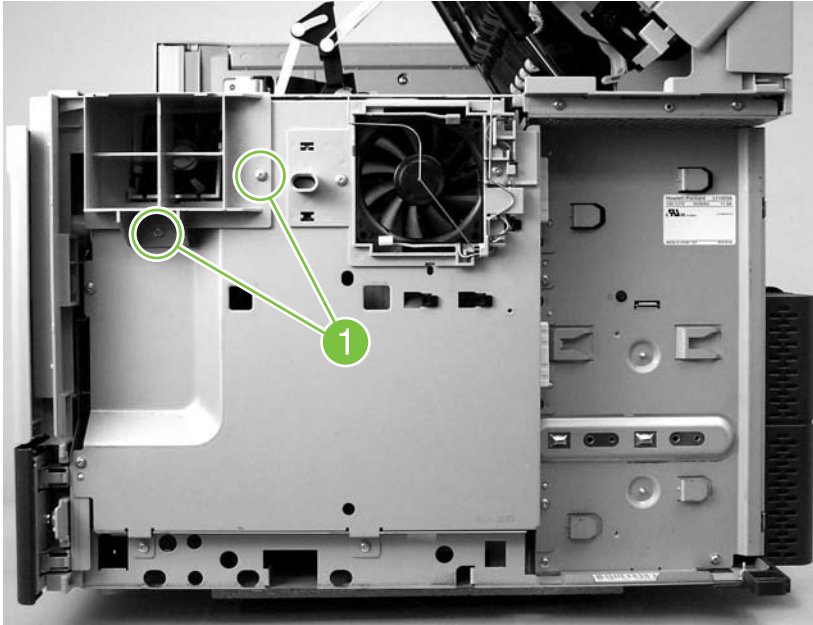


**Figure 5-110** Remove the DC controller fan (3 of 3)

## Print-cartridge fan (FN102)

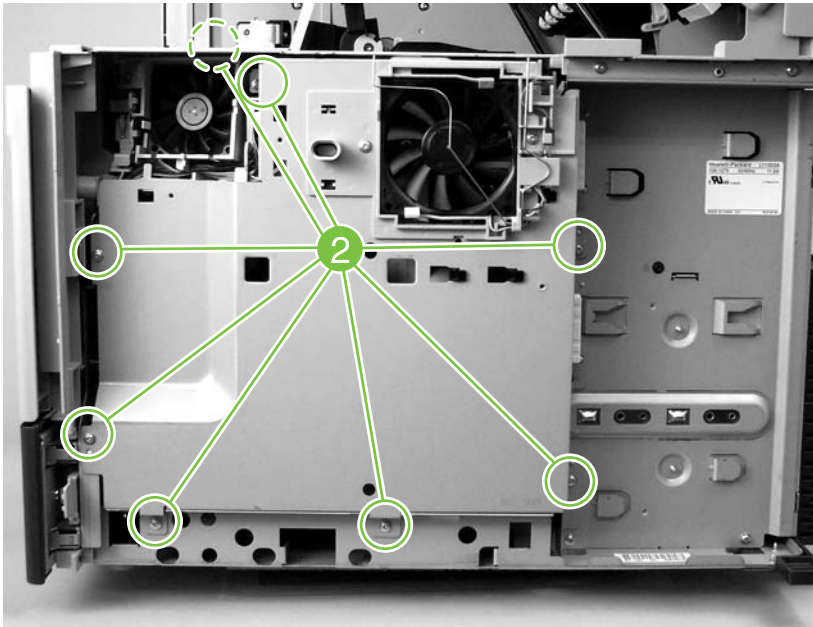
1. Remove the back cover.

2. Remove two screws (callout 1), and remove the fan shroud.



**Figure 5-111** Remove the print-cartridge fan (1 of 4)

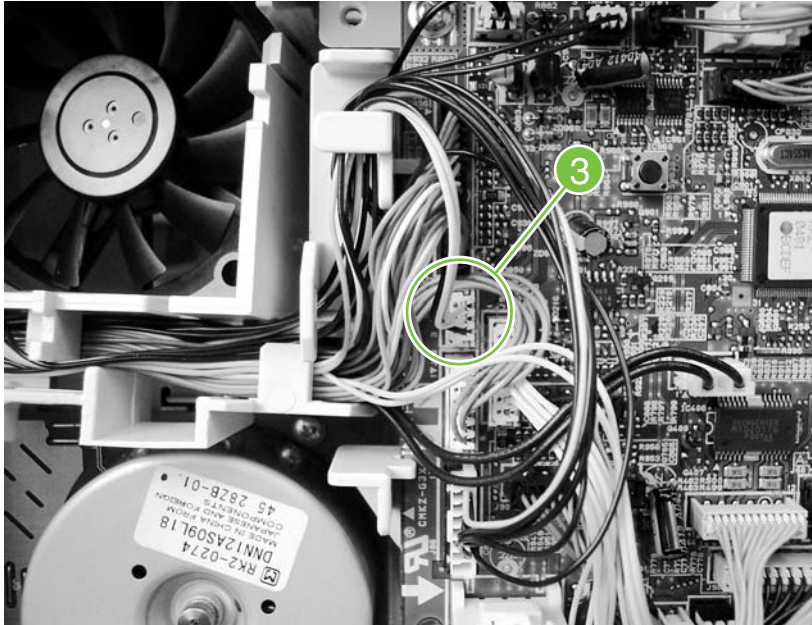
3. Remove eight screws (callout 2), and then rotate the rear sheet-metal shield away from the MFP.



**Figure 5-112** Remove the print-cartridge fan (2 of 4)

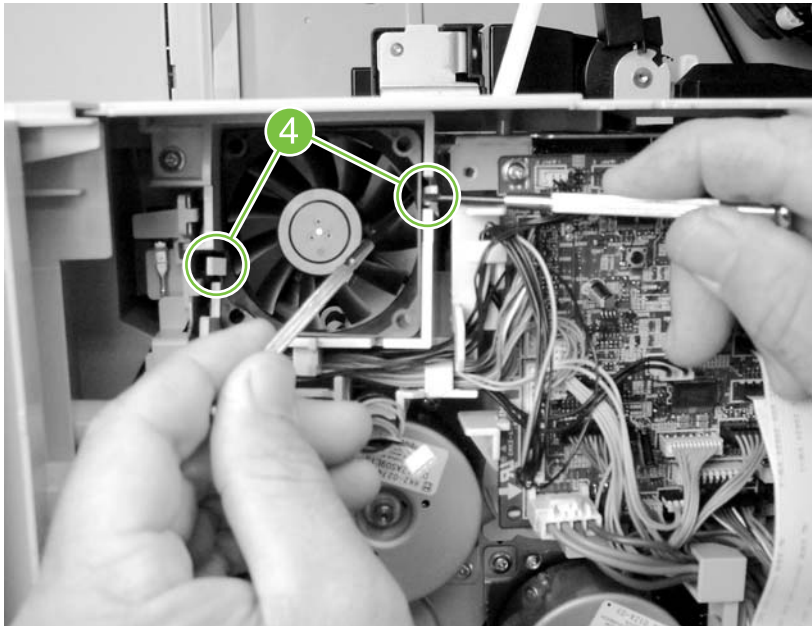


4. Disconnect the fan connector (J78, callout 3) from the DC controller.



**Figure 5-113** Remove the print-cartridge fan (3 of 4)

5. Use a small, flat-blade screwdriver to release the locking tabs that are on each side of the fan (callout 4). Insert a second flat-blade screwdriver behind the fan, and push the fan out.

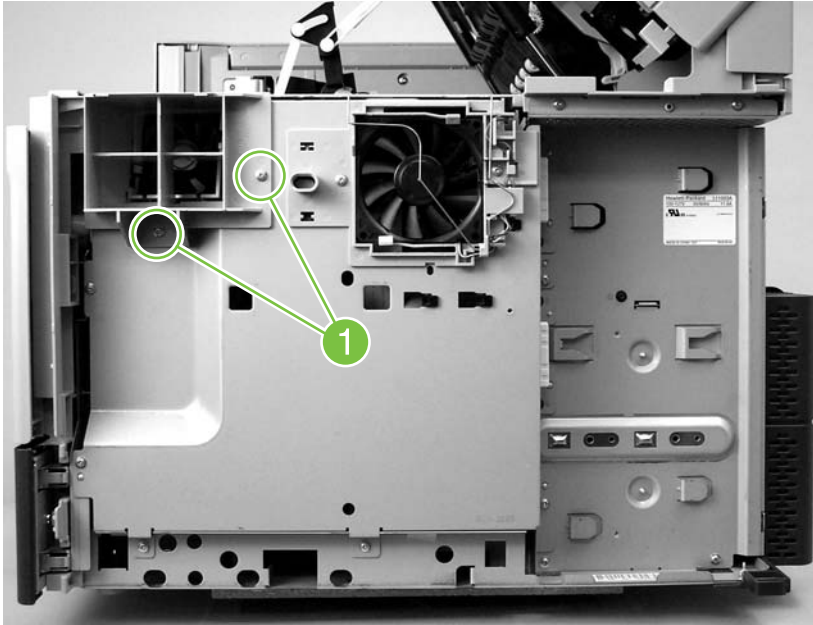


**Figure 5-114** Remove the print-cartridge fan (4 of 4)

## Print-cartridge motor (M102)

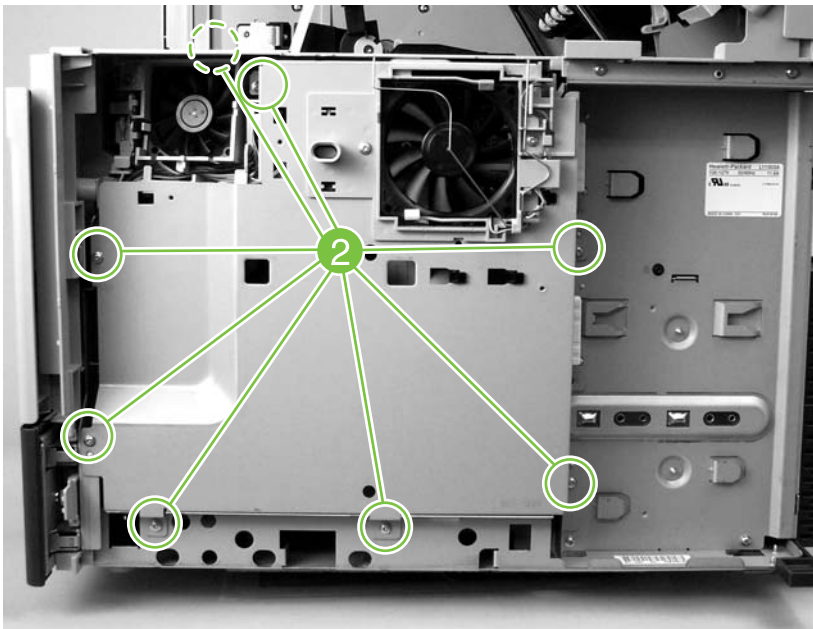
1. Remove the back cover.
2. Remove the print-cartridge fan.

3. Remove two screws (callout 1), and remove the fan shroud.



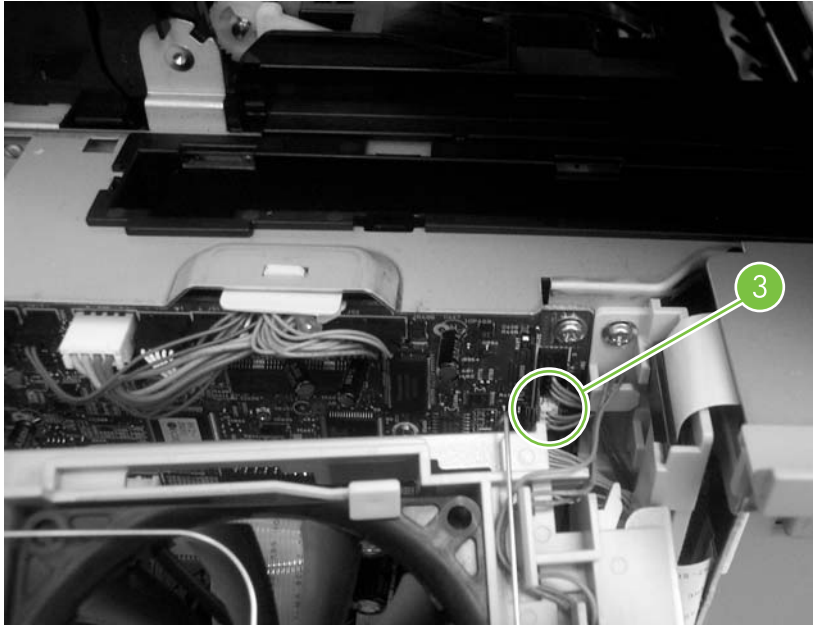
**Figure 5-115** Remove the print-cartridge motor (1 of 4)

4. Remove eight screws (callout 2), and then rotate the rear sheet-metal shield away from the MFP.



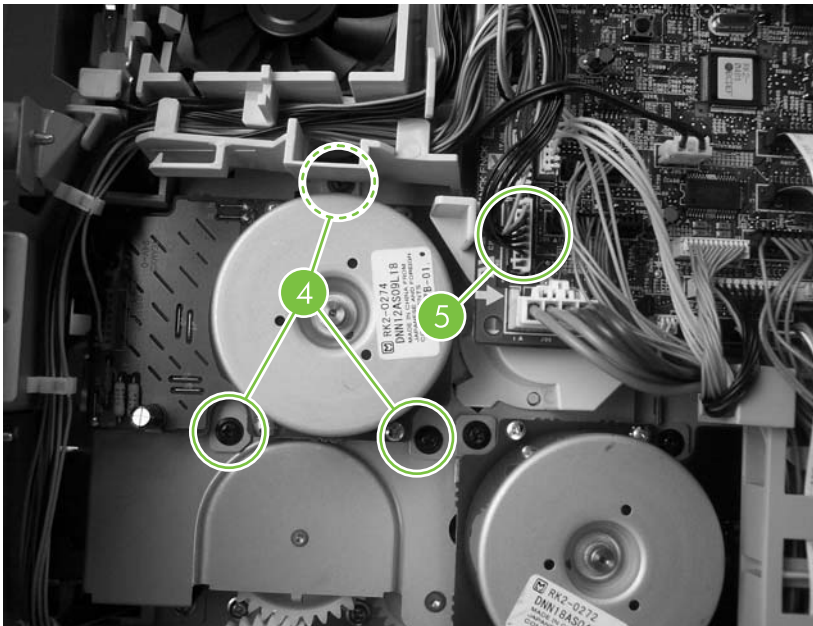
**Figure 5-116** Remove the print-cartridge motor (2 of 4)

5. Disconnect one connector (callout 3; J66) from the DC controller and remove the sheet-metal shield.



**Figure 5-117** Remove the print-cartridge motor (3 of 4)

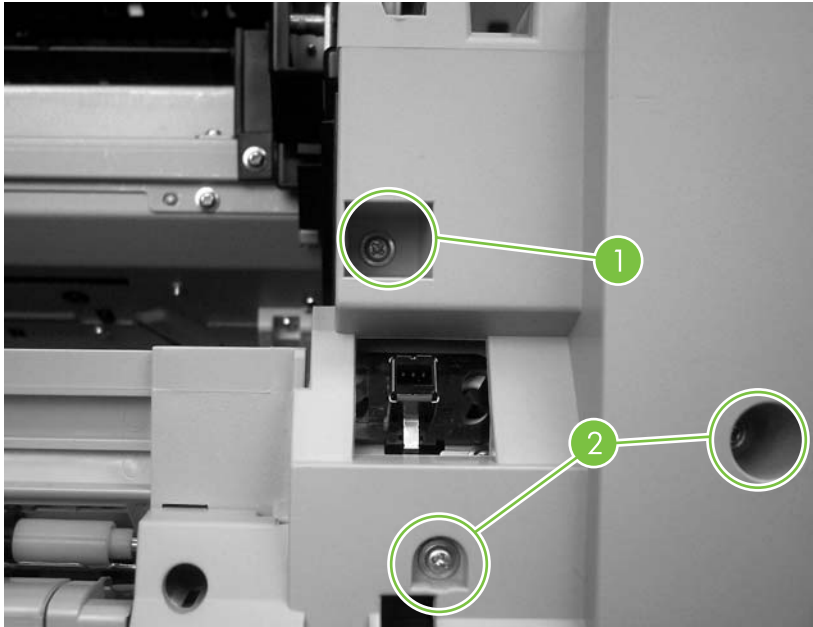
6. Remove three screws (callout 4), disconnect one connector (callout 5; J86), and then remove the print-cartridge motor.



**Figure 5-118** Remove the print-cartridge motor (4 of 4)

## Top-cover switch (SW101)

1. Remove the following assemblies:
  - Back cover.
  - Print-cartridge fan.
2. Remove one screw (callout 1)

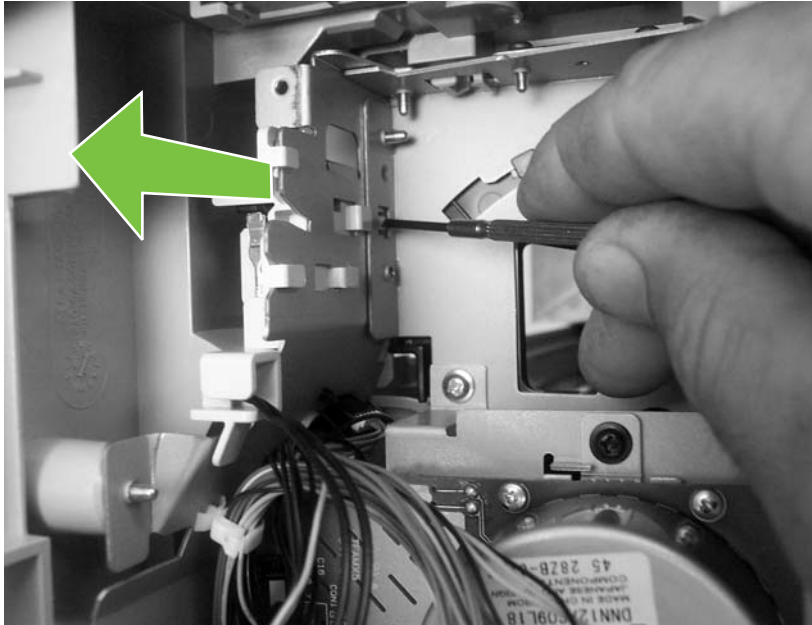


**Figure 5-119** Remove the top-cover switch (1 of 3)



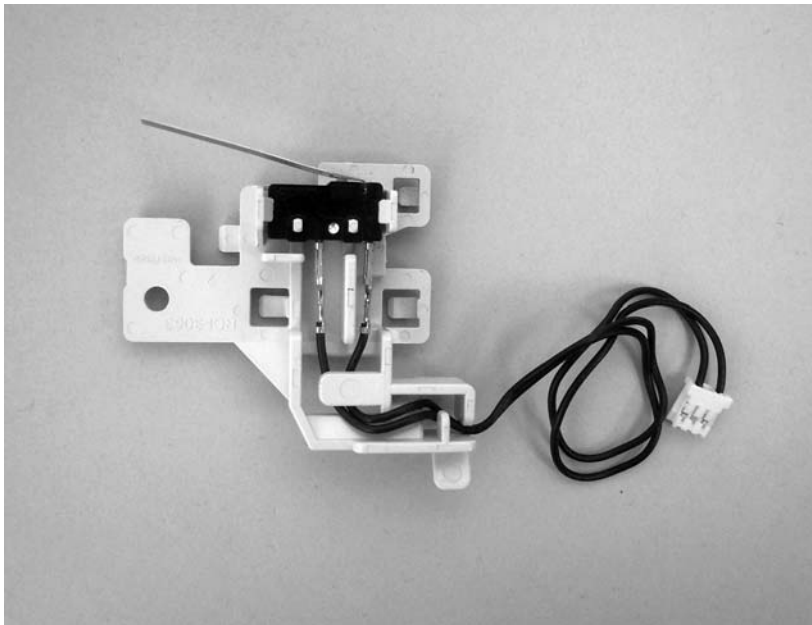
**NOTE** Loosening the two screws (callout 2) that are below the one that you are removing makes it easier to dislodge the sensor bracket.

3. Use a small, flat-blade screwdriver to release one sensor-bracket locking tab, and then pull the sensor bracket out of the chassis.



**Figure 5-120** Remove the top-cover switch (2 of 3)

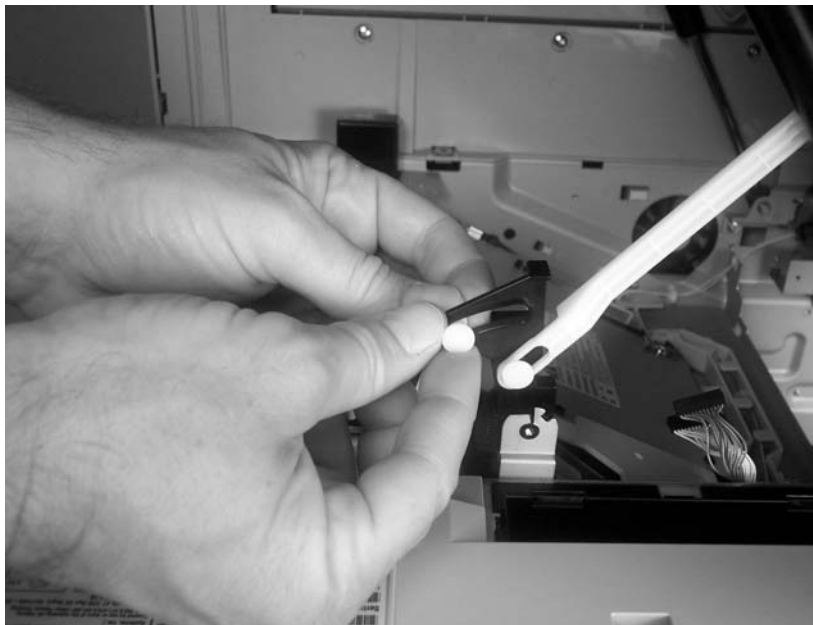
4. Remove the sensor wire-harness and the sensor from the bracket.



**Figure 5-121** Remove the top-cover switch (3 of 3)


## Registration assembly

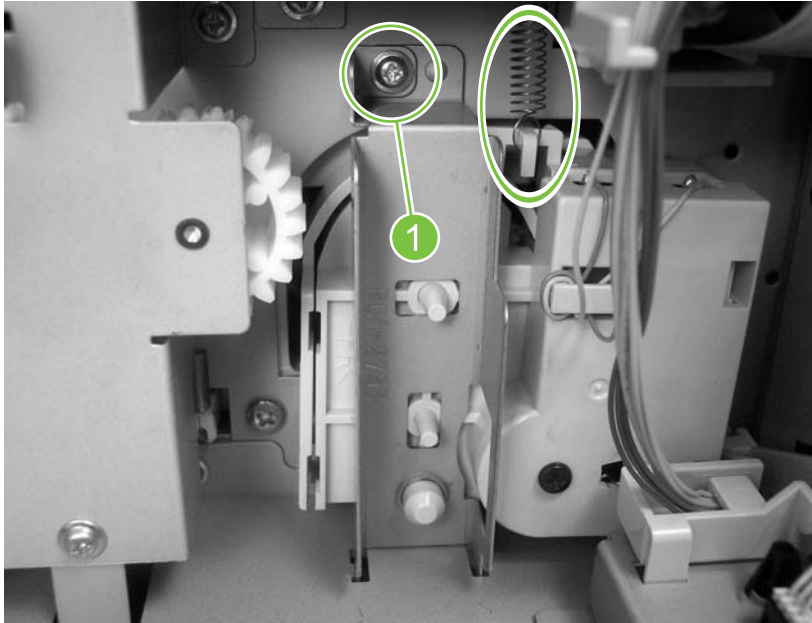
1. Remove the following assemblies:
  - Back cover
  - Main motor
  - Print-cartridge motor
2. Disconnect the print-cartridge arm.



**Figure 5-122** Remove the registration assembly (1 of 6)

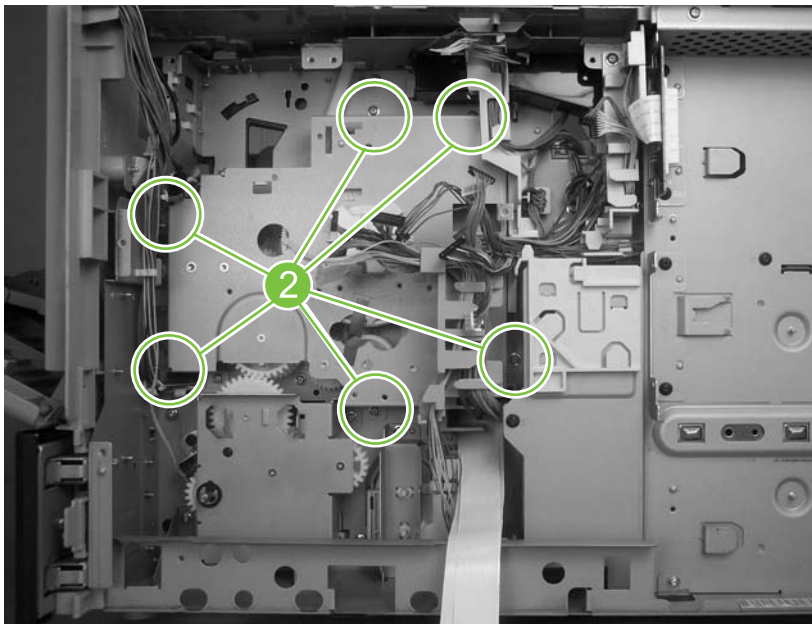
3. Unhook the lifter-drive-assembly tension-spring from the tab on the chassis. Remove one screw (callout 1), and then remove the sheet metal bracket.

 **CAUTION** The lifter-drive-assembly tension-spring is not captive. Do not lose the spring when you remove the assembly.



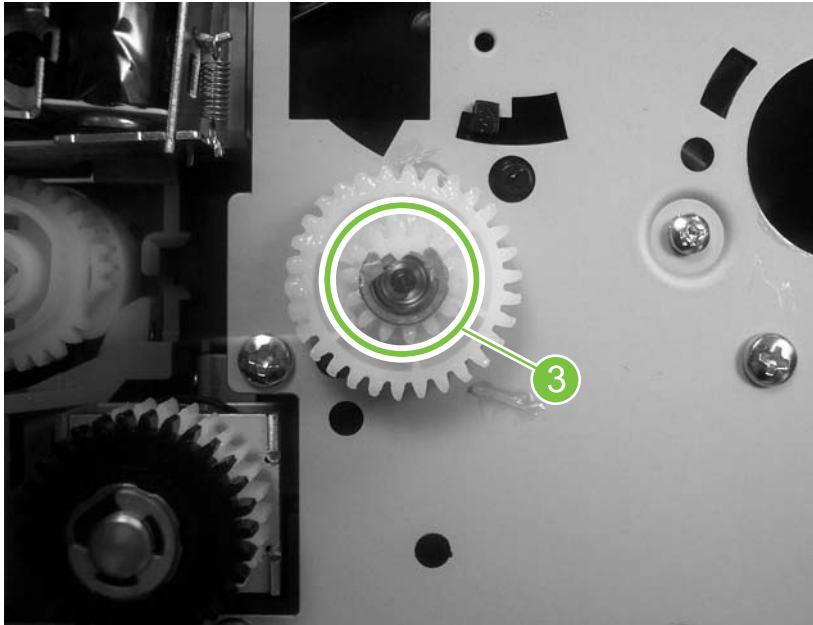
**Figure 5-123** Remove the registration assembly (2 of 6)

4. Remove the wire harnesses from the wire guides, remove six screws (callout 2), and then remove the drive-gear assembly.



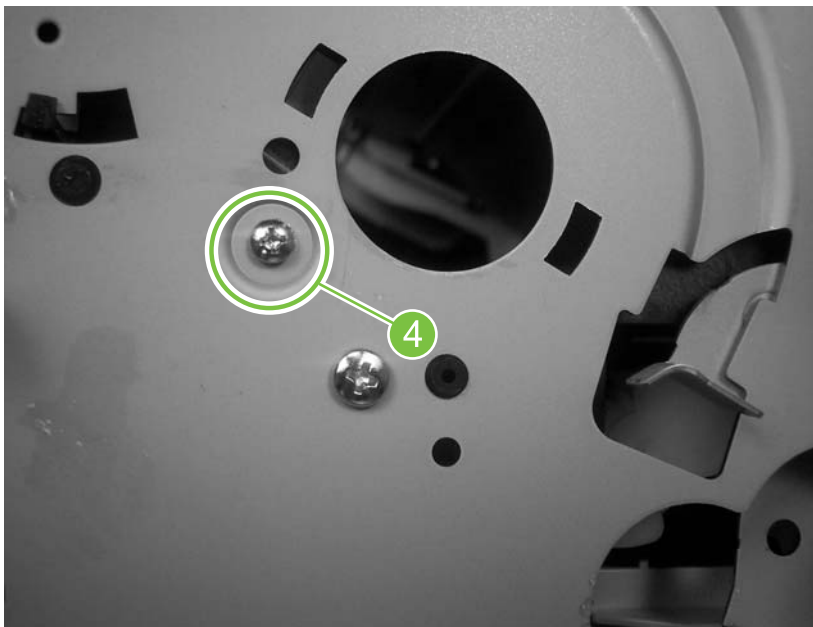
**Figure 5-124** Remove the registration assembly (3 of 6)

5. Remove one e-ring (callout 3), and remove the registration-drive gear.



**Figure 5-125** Remove the registration assembly (4 of 6)

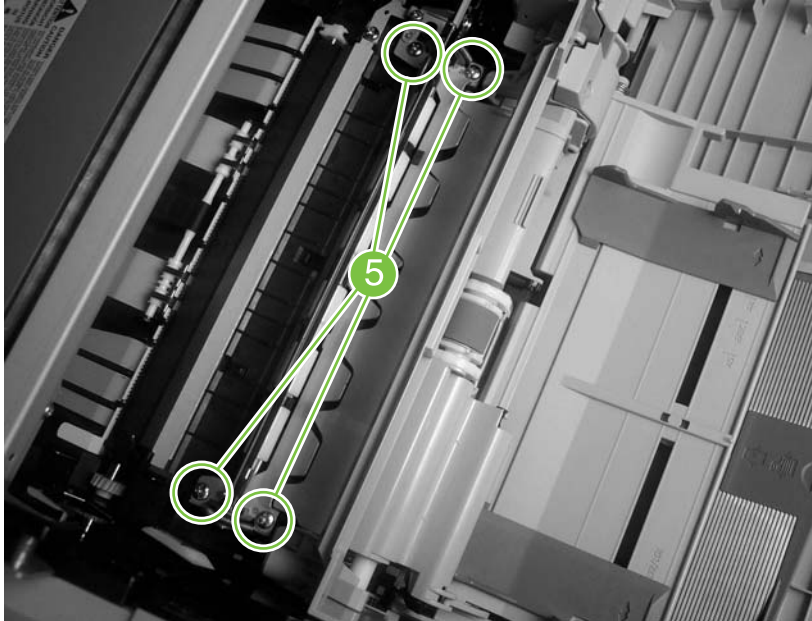
6. Remove one grounding screw (callout 4).



**Figure 5-126** Remove the registration assembly (5 of 6)



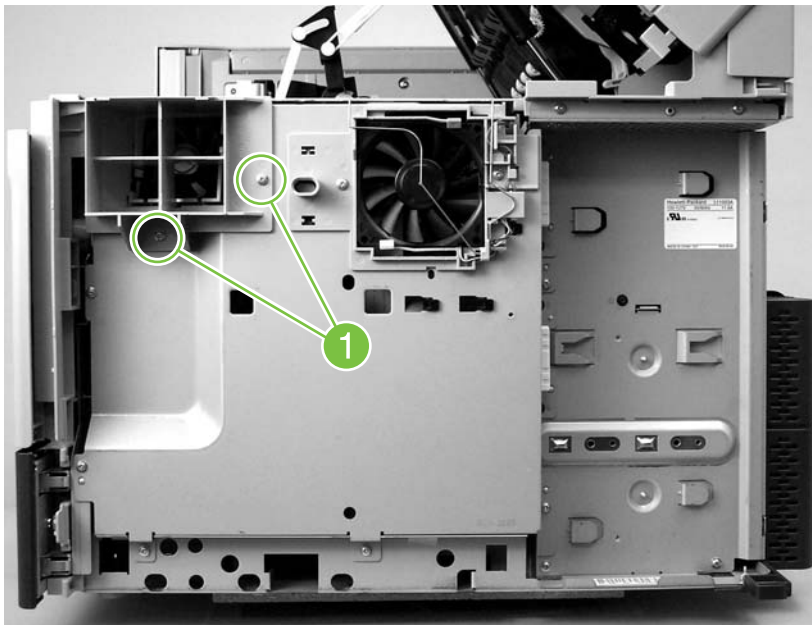
7. Remove four screws (callout 5), and then remove the registration assembly. (Two screws are in the upper, left callout.)



**Figure 5-127** Remove the registration assembly (6 of 6)

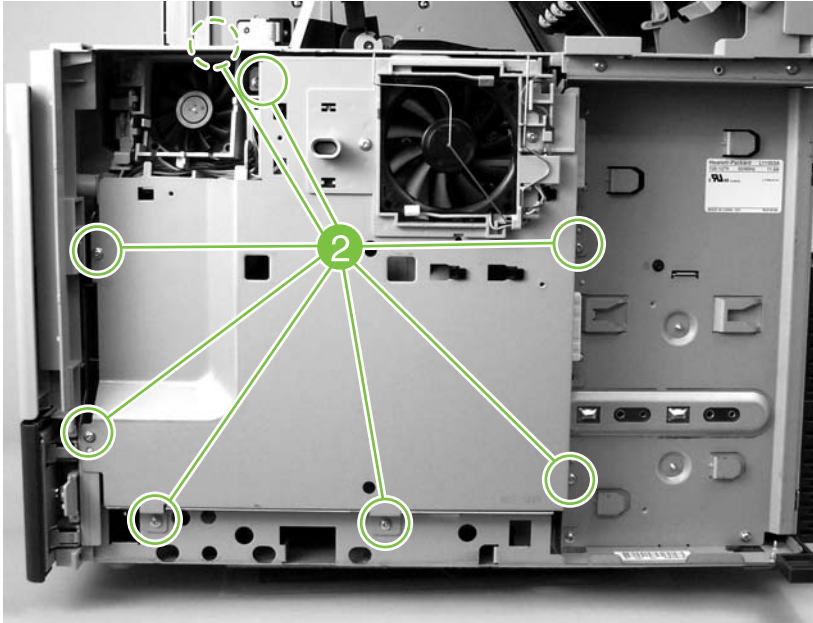
## Paper-pickup-drive assembly

1. Remove the back cover.
2. Remove two screws (callout 1), and remove the fan shroud.



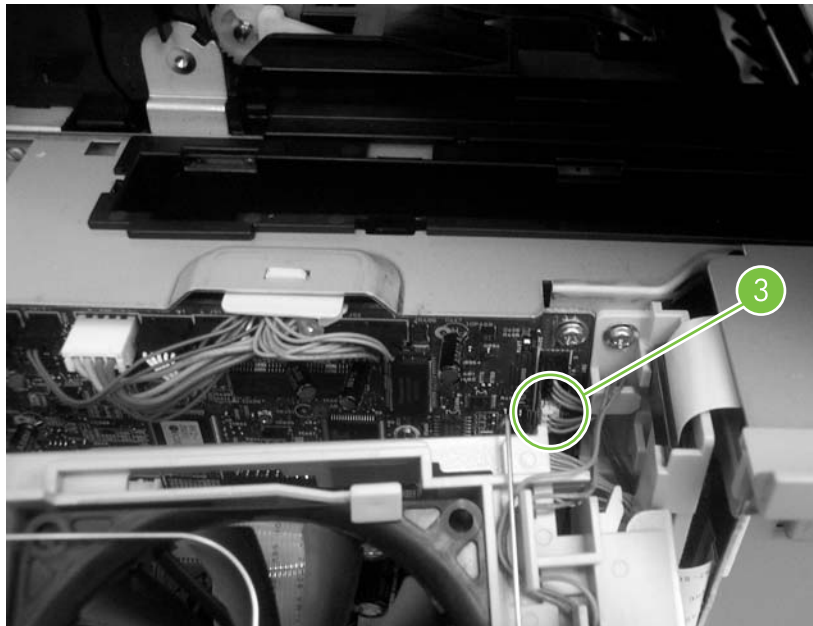
**Figure 5-128** Remove the paper-pickup-drive assembly (1 of 6)

3. Remove eight screws (callout 2), and then rotate the rear sheet-metal shield away from the MFP.



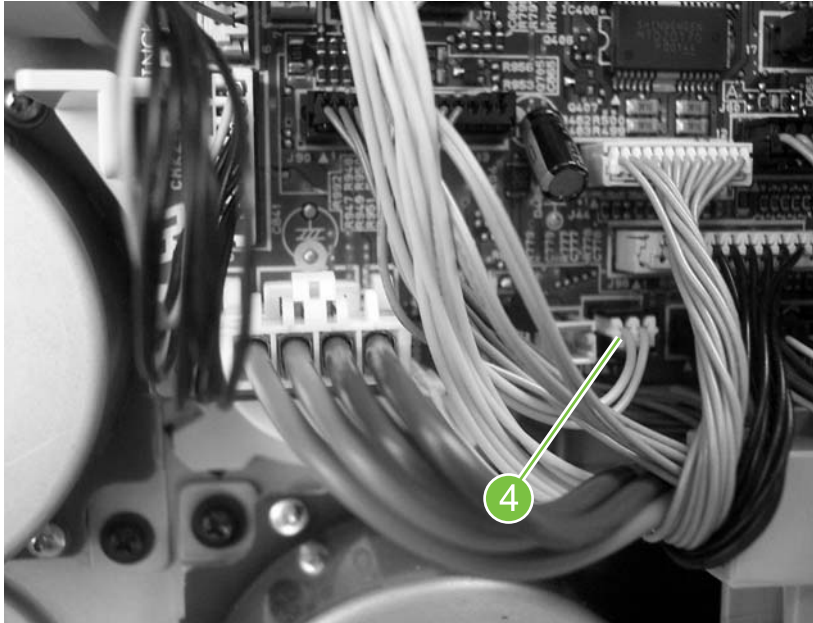
**Figure 5-129** Remove the paper-pickup-drive assembly (2 of 6)

4. Disconnect one connector (callout 3; J66) from the DC controller, and remove the sheet-metal shield.



**Figure 5-130** Remove the paper-pickup-drive assembly (3 of 6)

5. Disconnect one connector (callout 4; J92) from the DC controller.

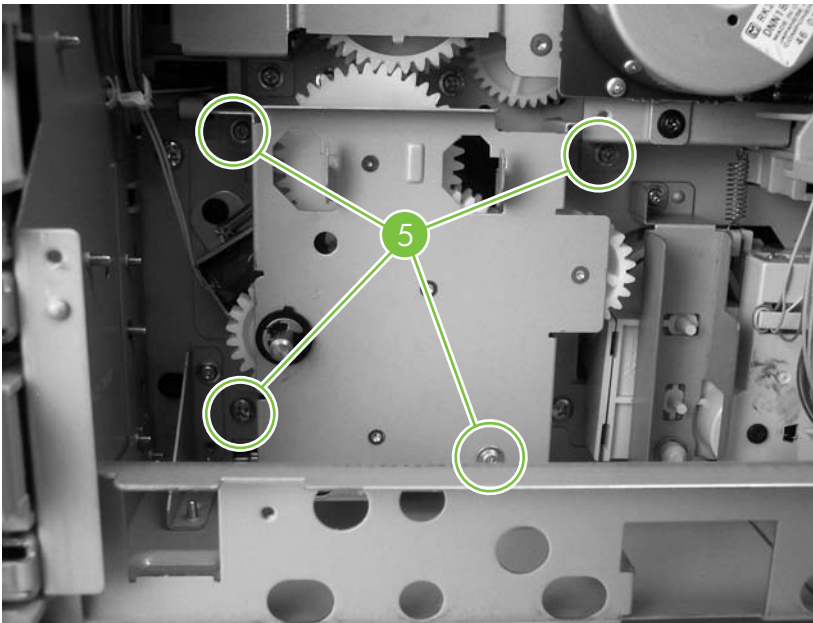


**Figure 5-131** Remove the paper-pickup-drive assembly (4 of 6)



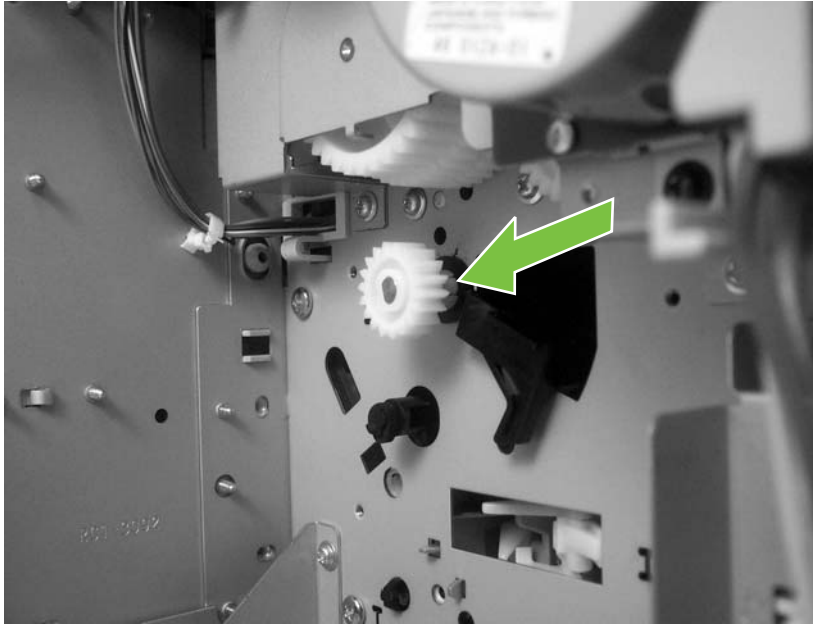
**NOTE** The tray 2 pickup-solenoid (SL101) is part of the paper-pickup-drive assembly.

6. Remove four screws (callout 5), and then remove the paper-pickup-drive assembly.



**Figure 5-132** Remove the paper-pickup-drive assembly (5 of 6)

7. You *must* replace the 18-tooth gear on this assembly, even if it is not worn, when you replace the paper-pickup-drive assembly. Use a small, flat-blade screwdriver to unlatch the retaining hook on the gear, and then remove the gear.



**Figure 5-133** Remove the paper pickup drive assembly (6 of 6)

8. **CAUTION:** Do not let the pickup roller shaft slide into the MFP when you install the gear. The groove on the shaft that the gear clips into can get stuck on the MFP chassis. Put pressure on the cassette feed-roller shaft to keep the shaft from slipping into MFP. See the following figure.

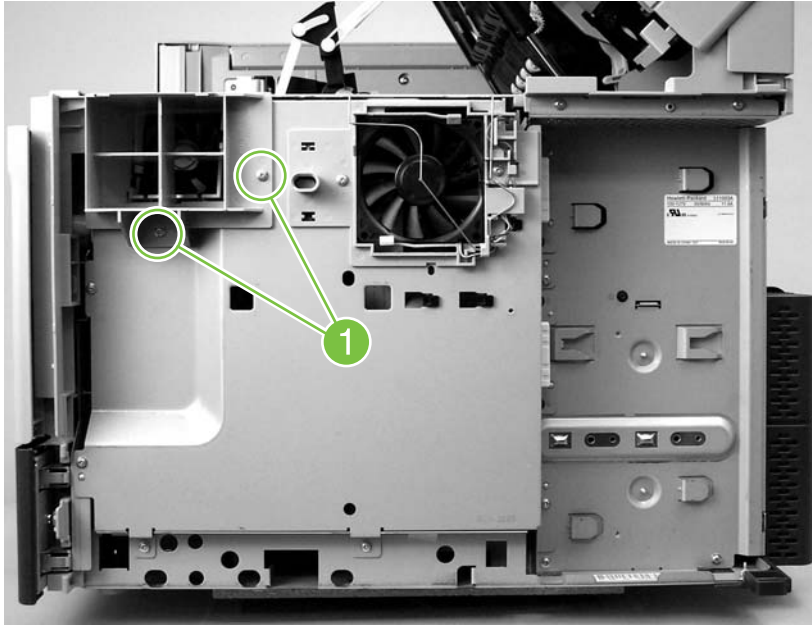


**Figure 5-134** Cassette feed-roller shaft (push here while replacing the gear)

## Lifter-drive assembly

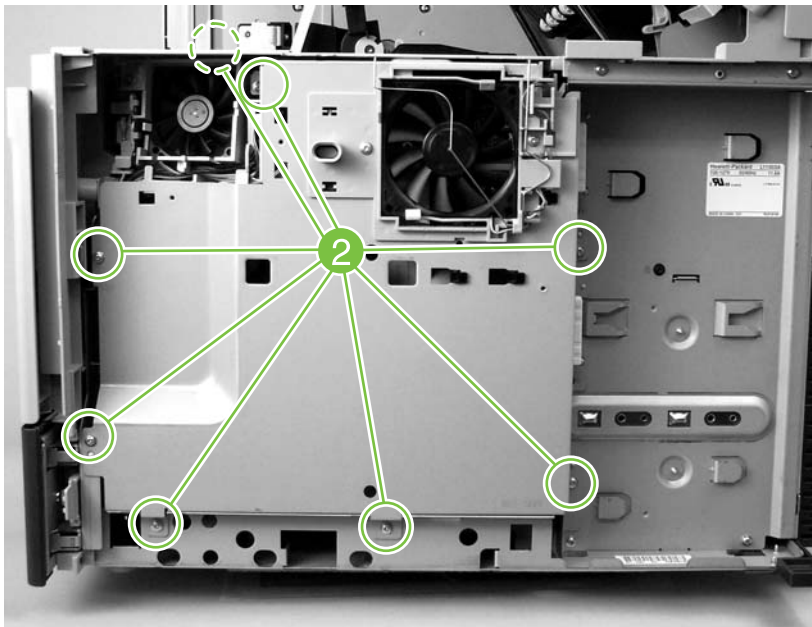
1. Remove the back cover.

2. Remove two screws (callout 1), and remove the fan shroud.



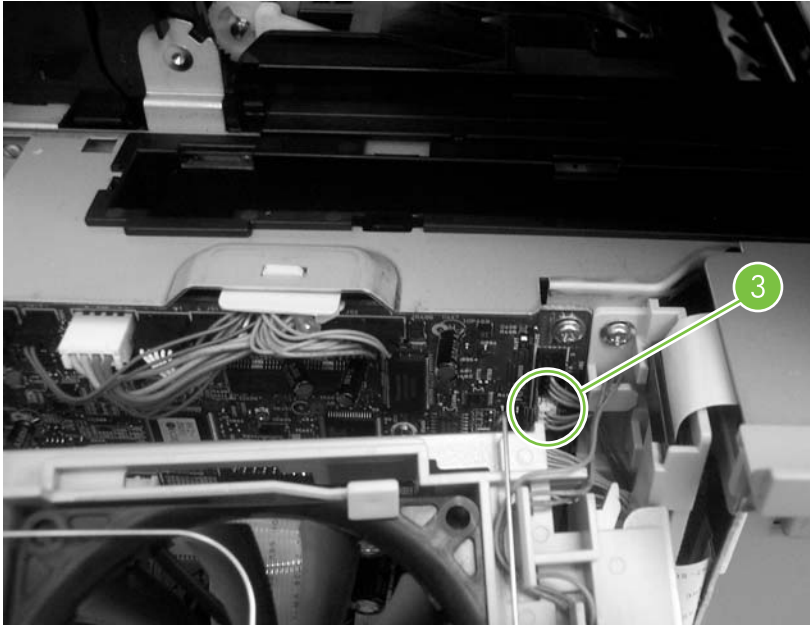
**Figure 5-135** Remove the lifter-drive assembly (1 of 5)

3. Remove eight screws (callout 2), and then rotate the rear sheet-metal shield away from the MFP.



**Figure 5-136** Remove the lifter-drive assembly (2 of 5)

4. Disconnect one connector (callout 3; J66) from the DC controller and remove the sheet-metal shield.

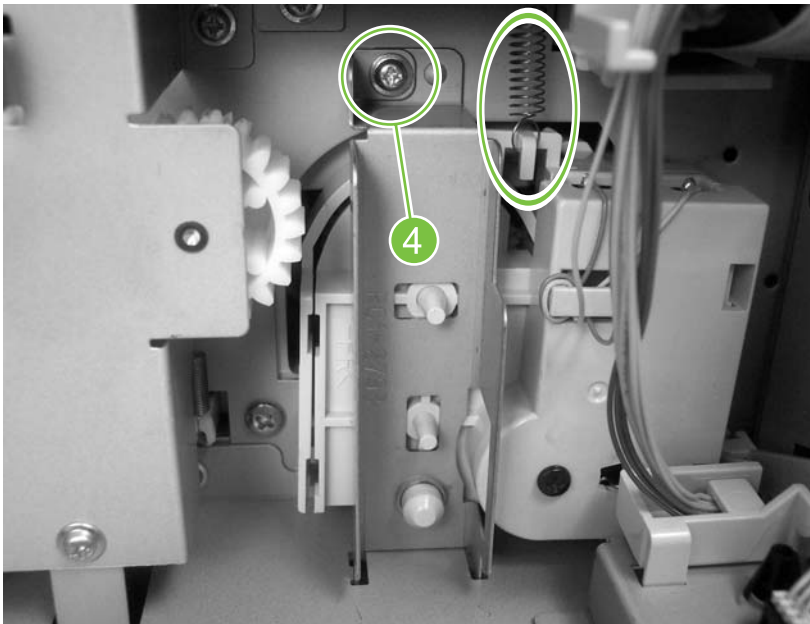


**Figure 5-137** Remove the lifter-drive assembly (3 of 5)

5. Unhook the lifter-drive-assembly tension-spring from the tab on the chassis.

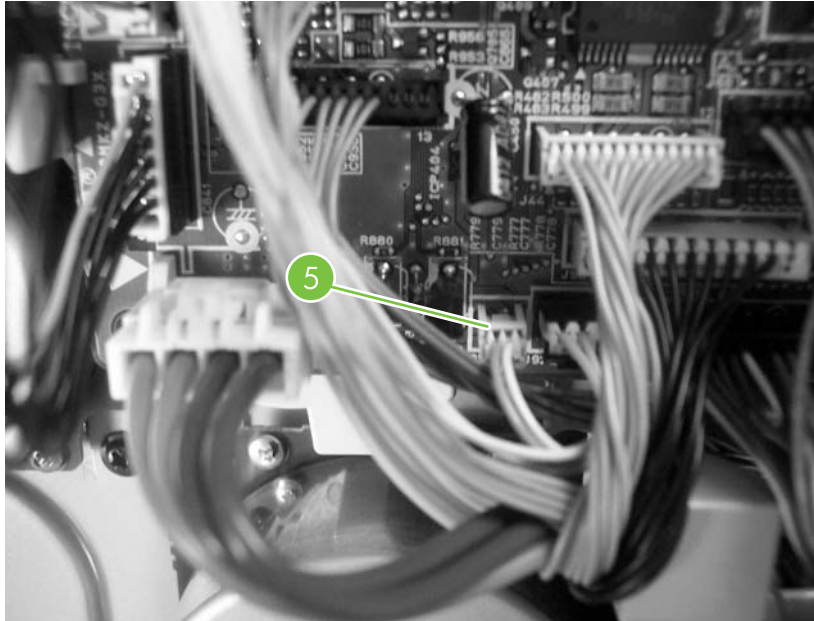


**CAUTION** The lifter-drive-assembly tension-spring is not captive. Do not lose the spring when you remove the assembly. Remove one screw (callout 4), and remove the retaining bracket (callout 3).



**Figure 5-138** Remove the lifter-drive assembly (4 of 5)

6. Disconnect one connector (callout 5; J93) on the DC controller. Slide the lifter-drive assembly toward you, and then remove it.

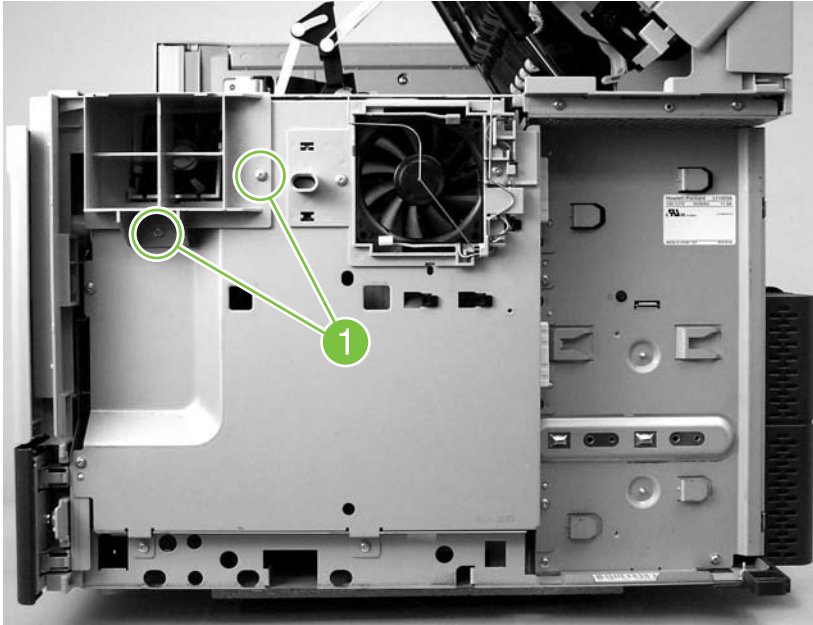


**Figure 5-139** Remove the lifter-drive assembly (5 of 5)

## Power-factor-correction (PFC) power supply

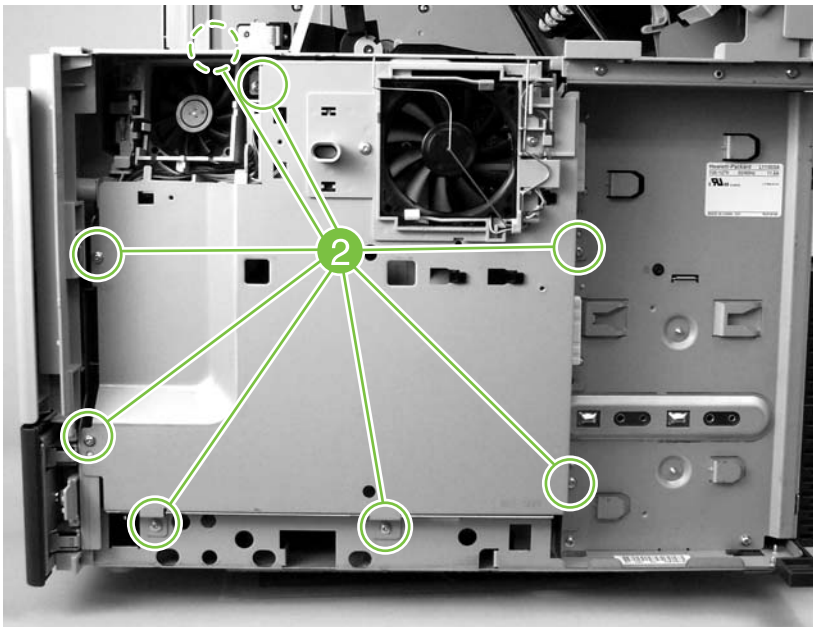
1. Remove the following assemblies:
  - Formatter.
  - Back cover.
  - Output-bin assembly.

2. Remove two screws (callout 1), and remove the fan shroud.



**Figure 5-140** Remove the PFC power supply (1 of 8)

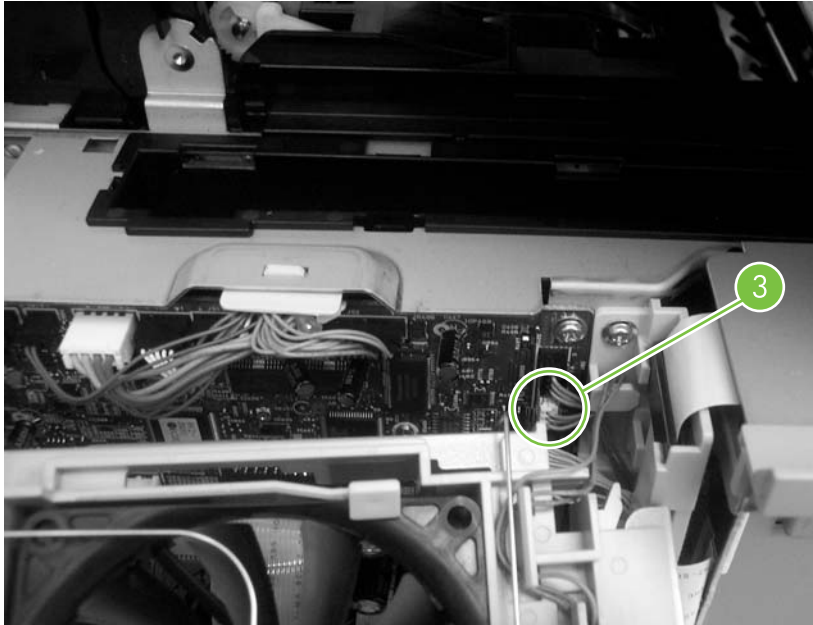
3. Remove eight screws (callout 2), and then rotate the rear sheet-metal shield away from the MFP.



**Figure 5-141** Remove the PFC power supply (2 of 8)

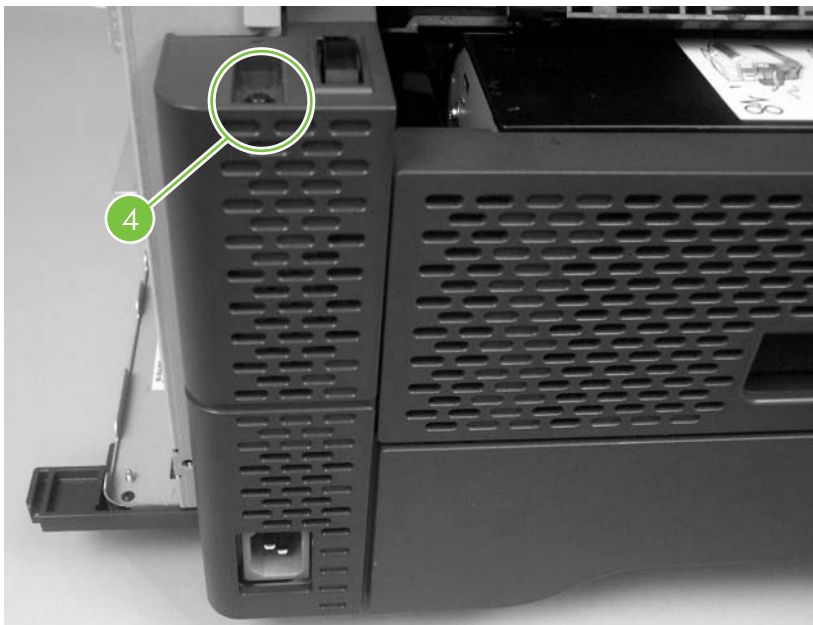


4. Disconnect one connector (callout 3; J66) from the DC controller, and remove the sheet-metal shield.



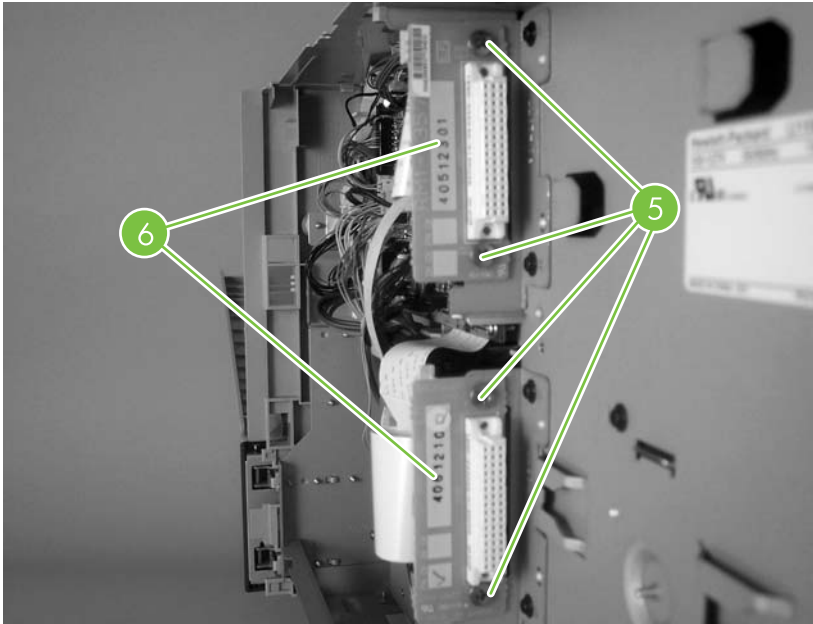
**Figure 5-142** Remove the PFC power supply (3 of 8)

5. Remove one screw (callout 4), push in on the retaining tab at the top of the rear-side cover, and then slide the cover up to remove it.



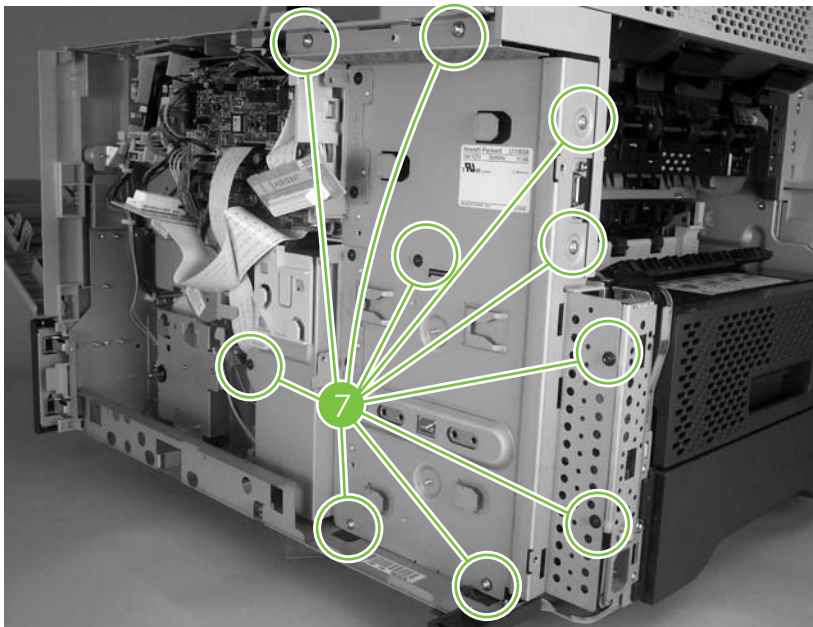
**Figure 5-143** Remove the PFC power supply (4 of 8)

6. Remove four screws (callout 5), and then remove the two formatter FCC connectors (callout 6).



**Figure 5-144** Remove the PFC power supply (5 of 8)

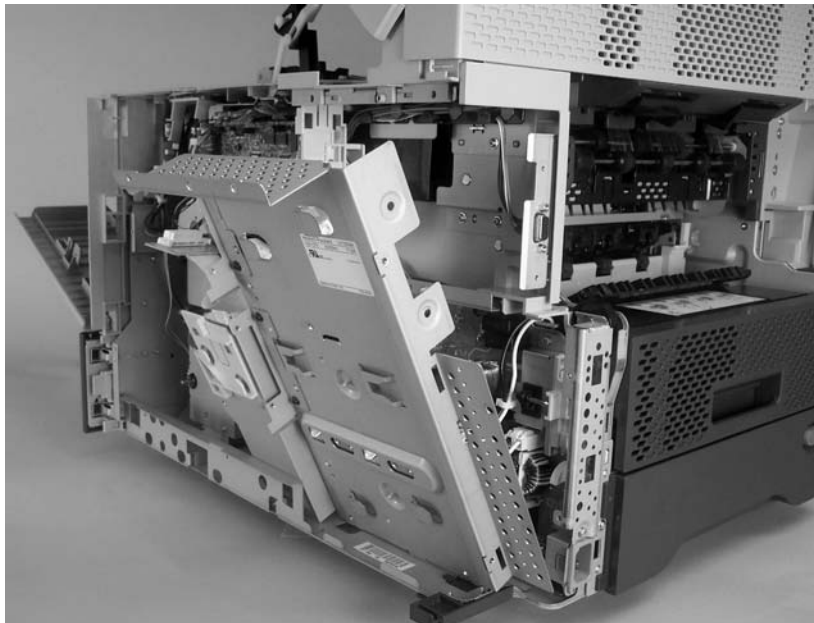
7. Remove ten screws (callout 7).



**Figure 5-145** Remove the PFC power supply (6 of 8)

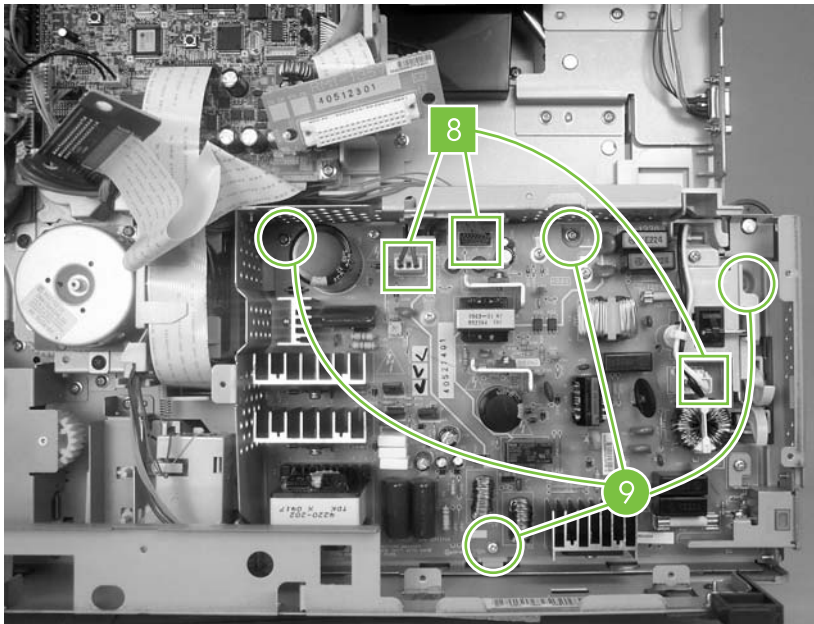
**Reinstallation tip:** Be sure to place the black screws in the holes as shown here. These screws go through printed-circuit assemblies (PCAs). Other screws could cut new threads in the PCAs.

8. Tilt the top of the PFC power-supply shield away from the MFP, and lift it up to remove it



**Figure 5-146** Remove the PFC power supply (7 of 8)

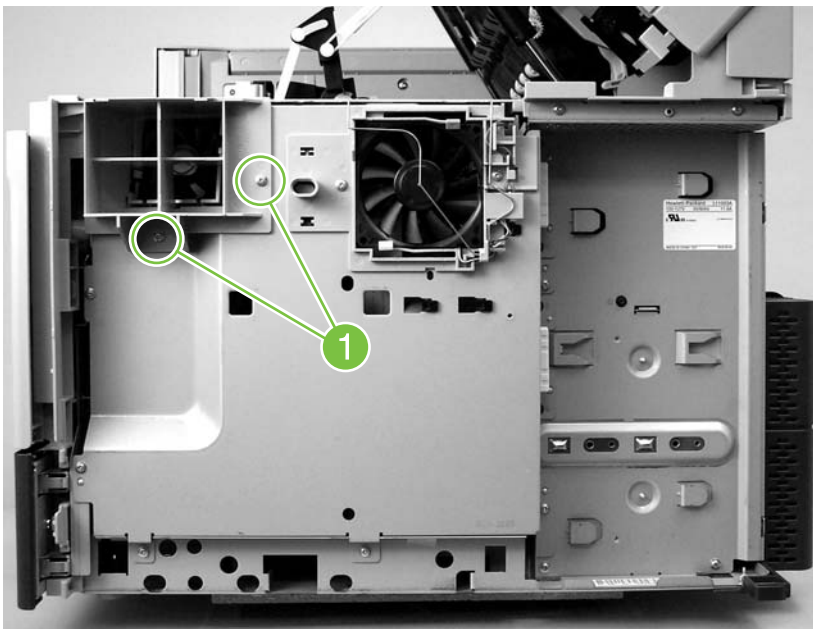
9. Disconnect three connectors (callout 8), remove four screws (callout 9), and then remove the PFC power supply.



**Figure 5-147** Remove the PFC power supply (8 of 8)

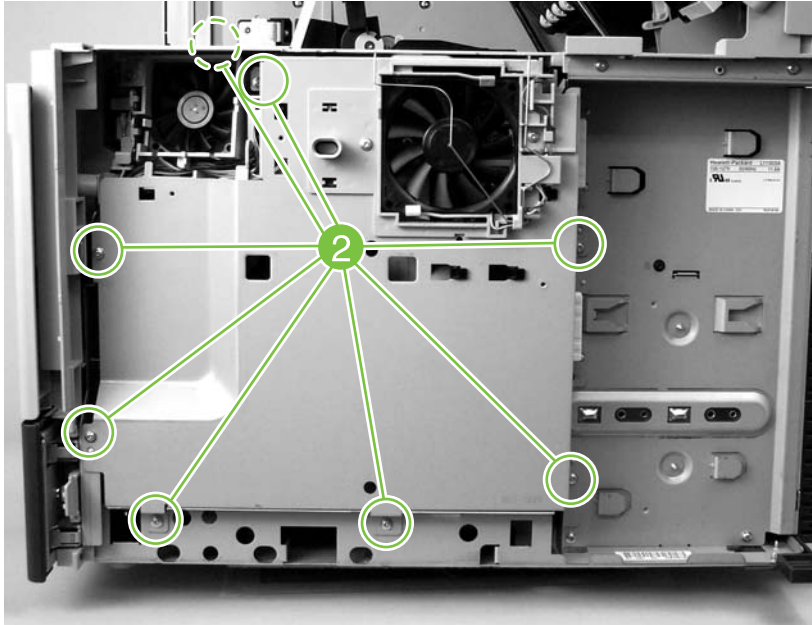
## Engine power supply

1. Remove the following assemblies:
  - Fuser.
  - Output-bin assembly.
  - Duplex-printing unit (or the cover if no duplex-printing unit is installed).
  - Front cover.
  - Back cover.
  - PFC power supply.
2. Remove two screws (callout 1), and remove the fan shroud.



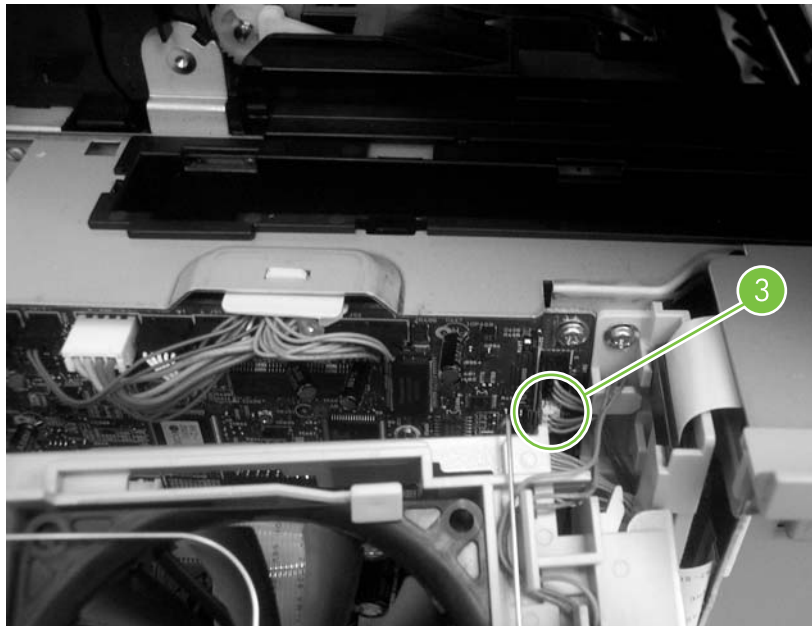
**Figure 5-148** Remove the engine power supply (1 of 10)

3. Remove eight screws (callout 2), and then rotate the rear sheet-metal shield away from the MFP.



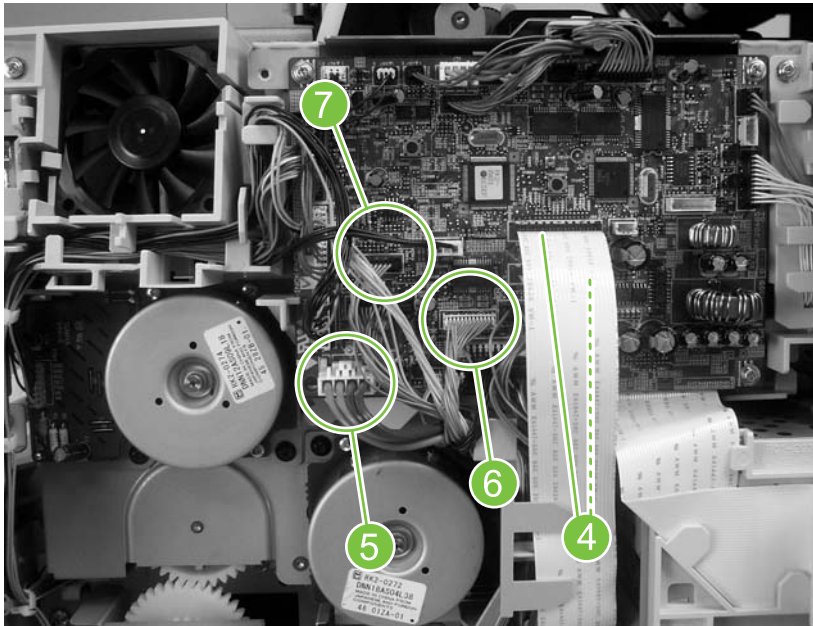
**Figure 5-149** Remove the engine power supply (2 of 10)

4. Disconnect one connector (callout 3; J66) from the DC controller, and remove the sheet-metal shield.



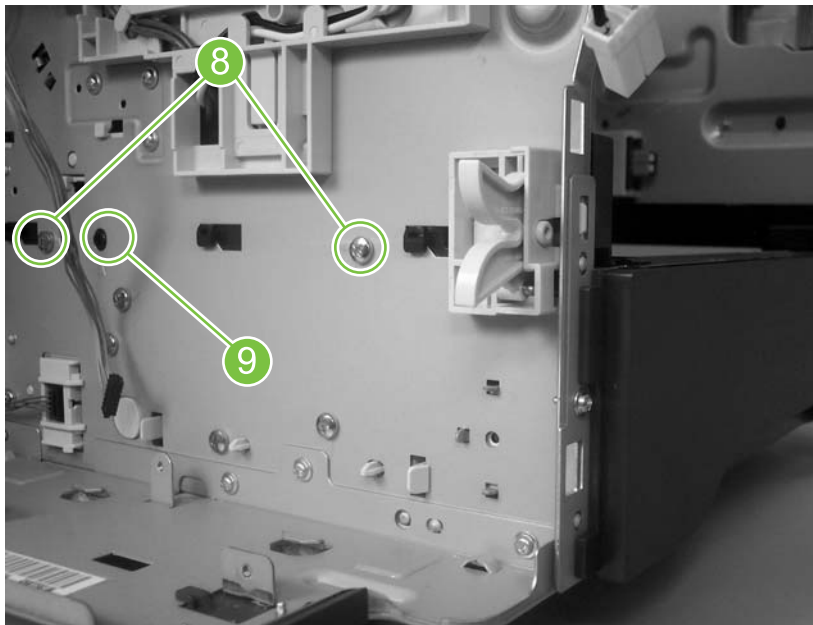
**Figure 5-150** Remove the engine power supply (3 of 10)

5. On the DC controller, disconnect two FFCs (callout 4; J80, J81), the 24-volt connector (callout 5; J99) the duplexer connector (callout 6; J44), and the fuser connector (callout 7; J71).



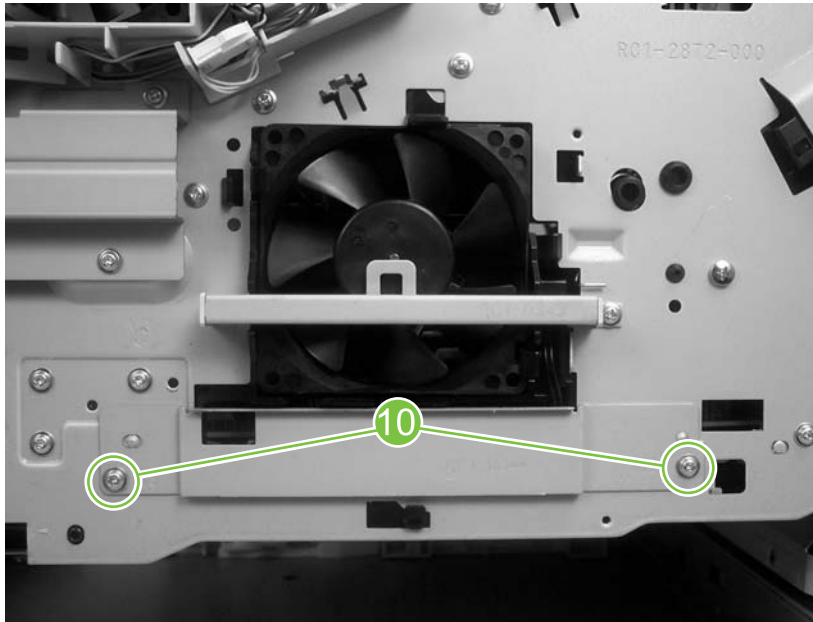
**Figure 5-151** Remove the engine power supply (4 of 10)

6. Remove the cassette from tray 2. Remove two screws (callout 8), release the retaining tab (callout 9), and slide the rear duplexer-guide toward you and remove it.



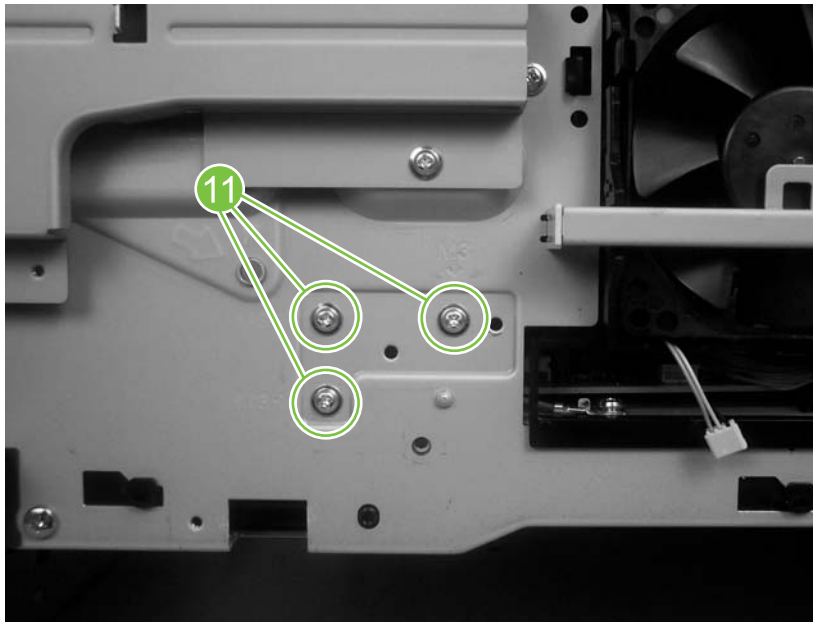
**Figure 5-152** Remove the engine power supply (5 of 10)

7. Remove two screws (callout 10), remove the power supply shield, and then disconnect the thermistor and fan connectors.



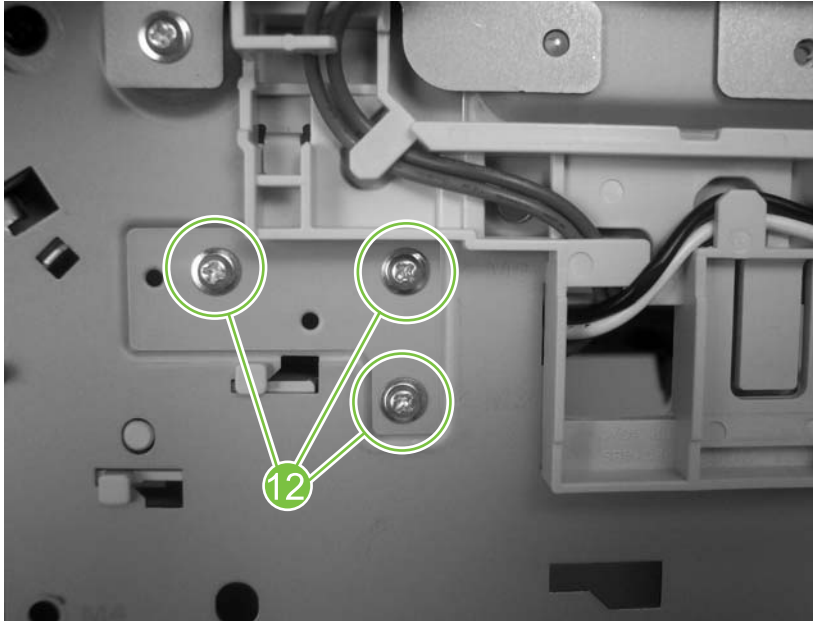
**Figure 5-153** Remove the engine power supply (6 of 10)

8. Remove three screws (callout 11) on front of the MFP.



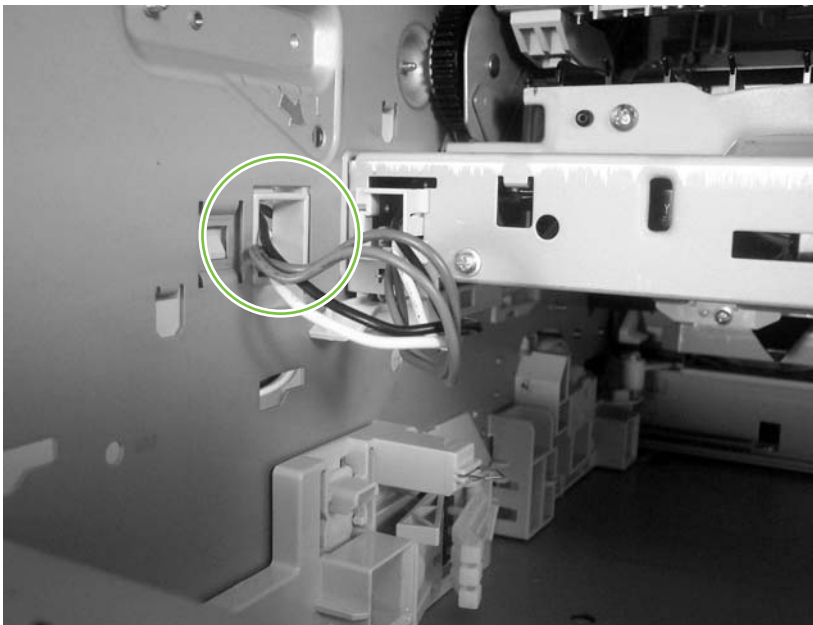
**Figure 5-154** Remove the engine power supply (7 of 10)

9. Remove three screws (callout 12) on rear of the MFP.



**Figure 5-155** Remove the engine power supply (8 of 10)

10. Route the PFC power supply wire-harnesses out through the hole in the chassis.



**Figure 5-156** Remove the engine power supply (9 of 10)



11. Reach inside the MFP, lift up on the power supply, and slide it out of the MFP (make sure that you feed the DC-controller cables through the hole in the chassis as you remove the engine power supply).

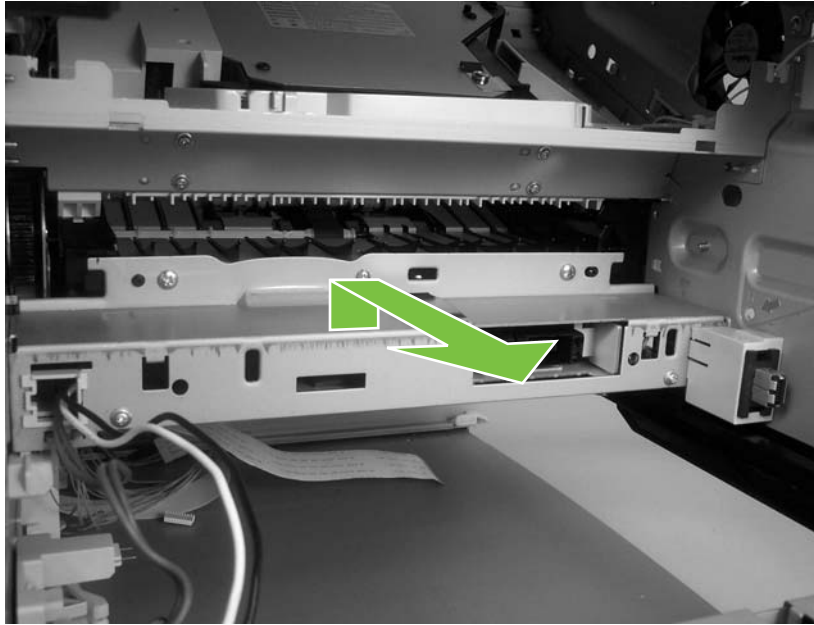


Figure 5-157 Remove the engine power supply (10 of 10)

## Paper-feed assembly

1. Remove the engine power supply.
2. Remove three screws (callout 1).

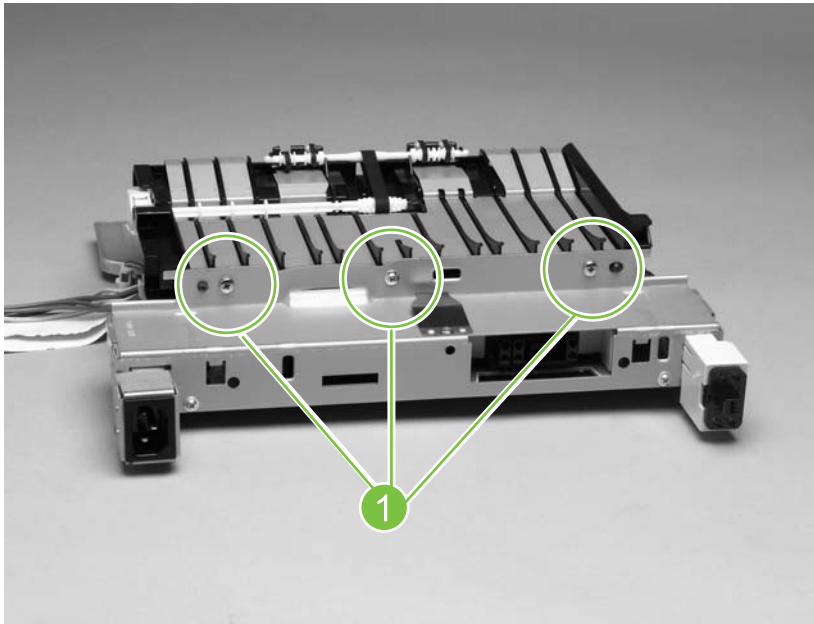
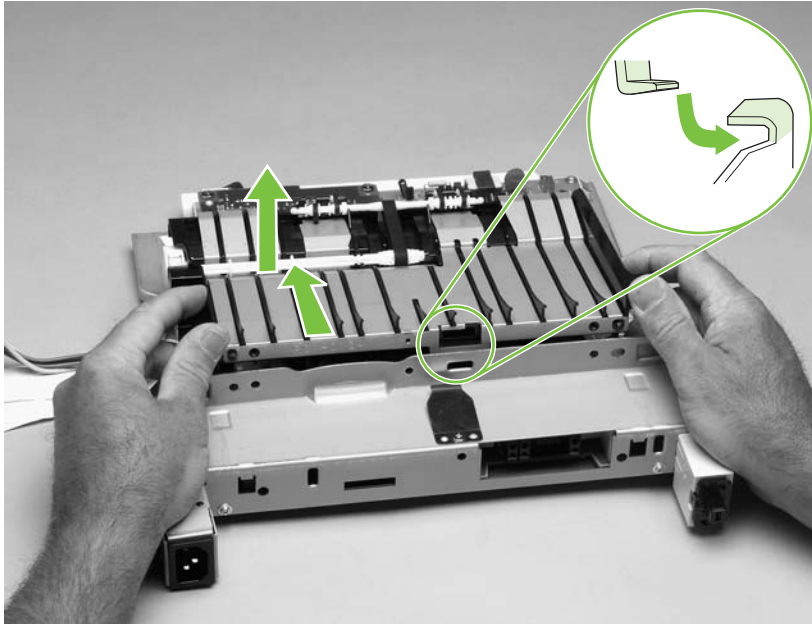


Figure 5-158 Remove the paper-feed assembly (1 of 2)

3. Release the paper-feed-assembly alignment pins. Rotate the assembly toward the back of the power supply, and remove it.



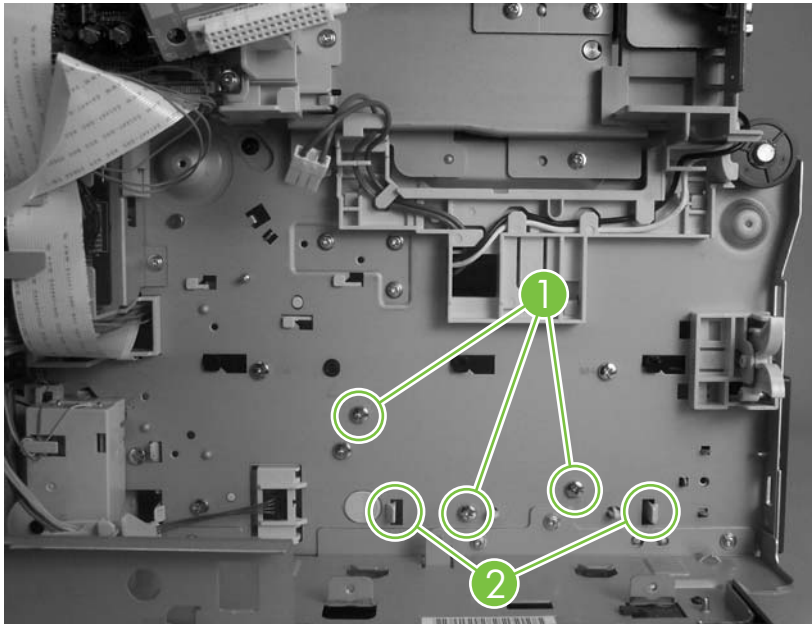
**Figure 5-159** Remove the paper-feed assembly (2 of 2)

**CAUTION** Verify that the four rubber belts and plastic rollers remain in place. These belts and rollers can easily come off and be lost. When you install the paper-feed assembly, verify that the center foot (on the power-supply side) is correctly hooked under the support leg that is on the engine power supply.

## Tray 2 detection switch

1. Remove the PFC power supply.
2. Remove the cassette from tray 2.

3. Remove three screws (callout 1), release the two locking tabs on the tray detection switch (callout 2), and then remove the tray 2 detection switch.



**Figure 5-160** Remove the tray 2 detection switch



**CAUTION** The tray 2 detection-switch spring is not captive. Do not lose this spring when you remove the switch.

## Paper-size-detection switch (SW102)

1. Remove the tray 2 detection switch.

2. Disconnect the paper-size-detection-switch connector (callout 1). Remove one screw (callout 2). Push in on the paper-size-detection switch, and then slide the switch toward the right side of the MFP and remove it.

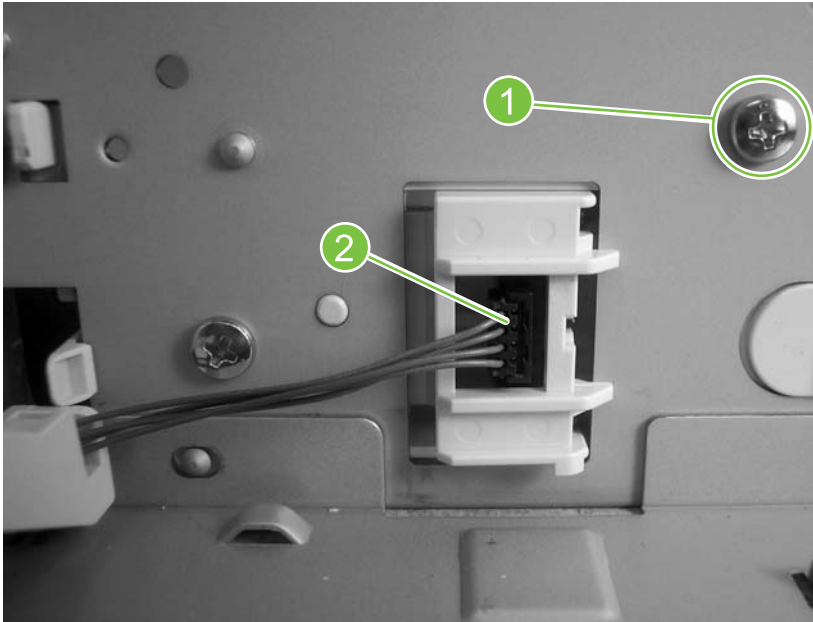


Figure 5-161 Remove the paper-size-detection switch (1 of 2)

## Tray 2 paper-present sensor (PS101)

1. Use a short #2 Phillips screwdriver to remove the screw.

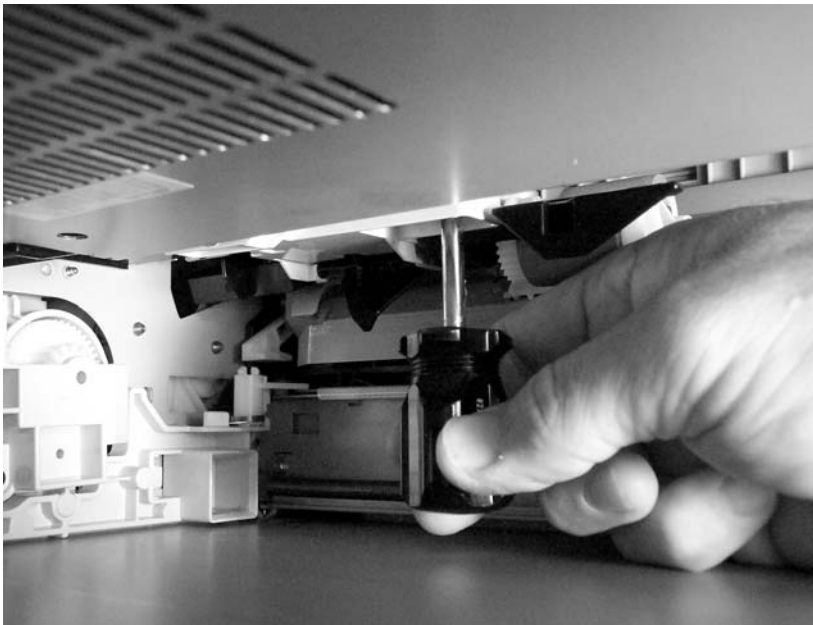


Figure 5-162 Remove the tray 2 paper-present sensor

2. Remove the tray 2 paper-present sensor.

## Laser/scanner

1. Remove the following assemblies:
  - Reversing-separation-guide assembly.
  - Reversing assembly.

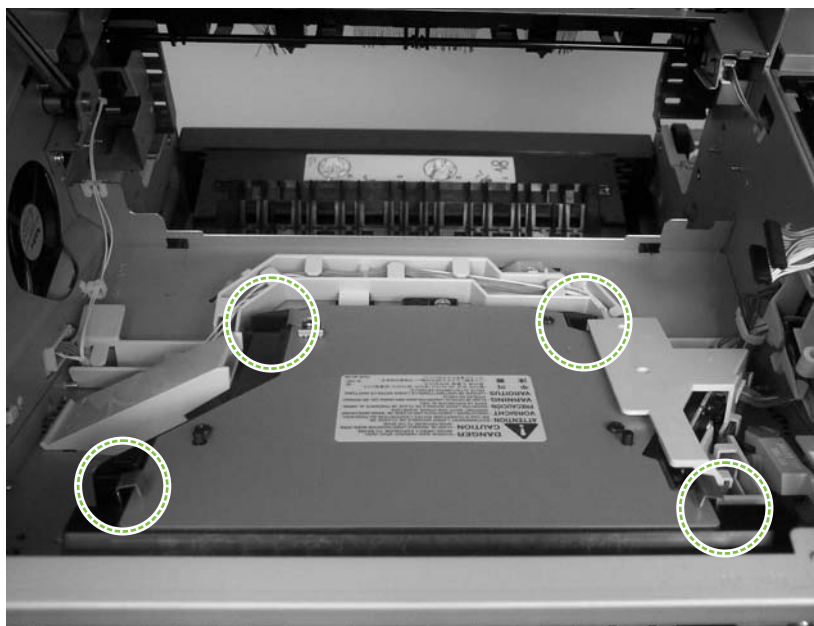


**NOTE** This procedure requires that you use a short #2 Phillips screwdriver.

2. Remove four screws.

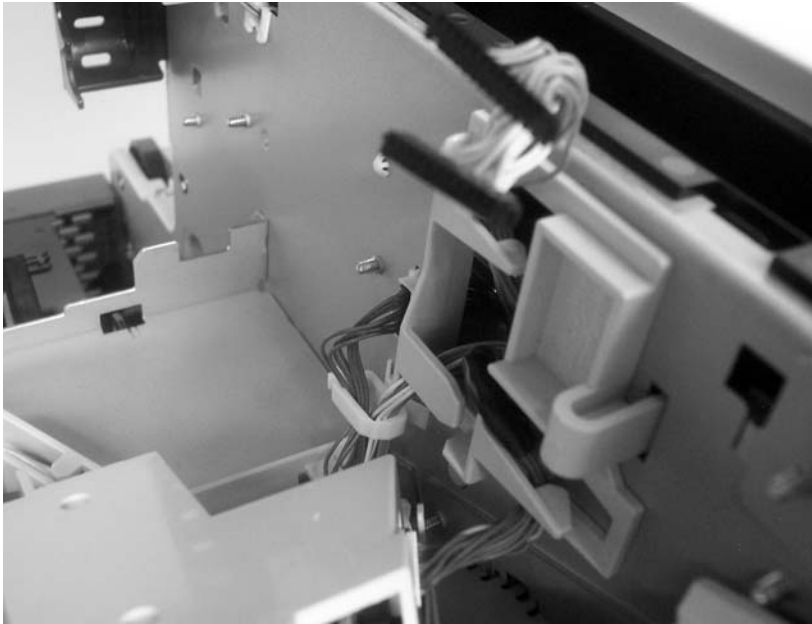


**NOTE** Take note of the orientation of the laser/scanner grounding clips.



**Figure 5-163** Remove the laser/scanner (1 of 2)

3. Disconnect two connectors, and then lift the laser/scanner out of the MFP.

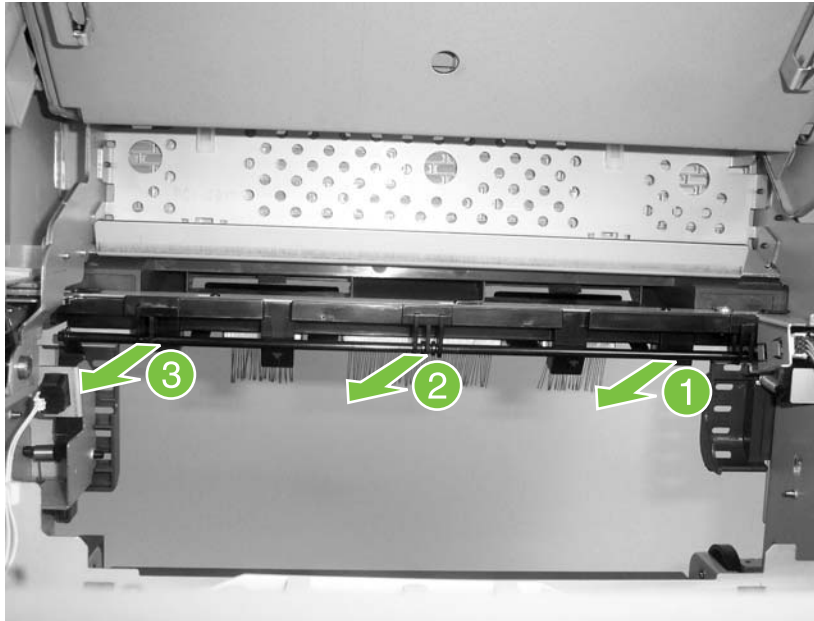


**Figure 5-164** Remove the laser/scanner (1 of 2)

## Output-bin-full sensor

1. Remove the following assemblies:
  - Reversing-separation-guide assembly.
  - Reversing assembly.
  - Output bin.

2. Unsnap the output-bin-full sensor from the retaining clips. Unsnap the clips at the rear of the MFP first, and work toward the front.



**Figure 5-165** Remove the output-bin-full sensor



---

**NOTE** When installing the sensor, make sure that the flag (front end) is in front of the output-bin-detection lever. If the flag is not in front of the lever, this sensor will not function correctly.

---

3. Carefully remove the spring from the from the formatter-end of the output-bin-full sensor.

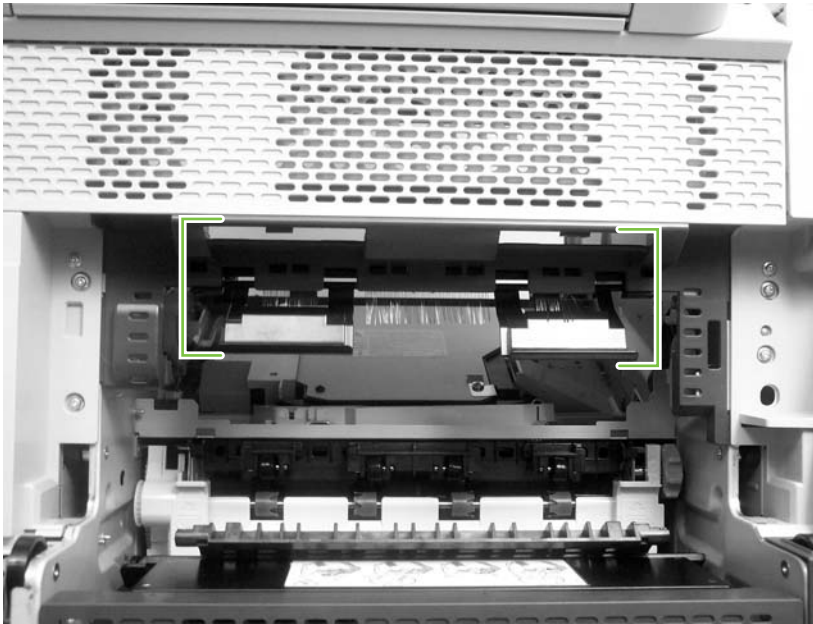


---

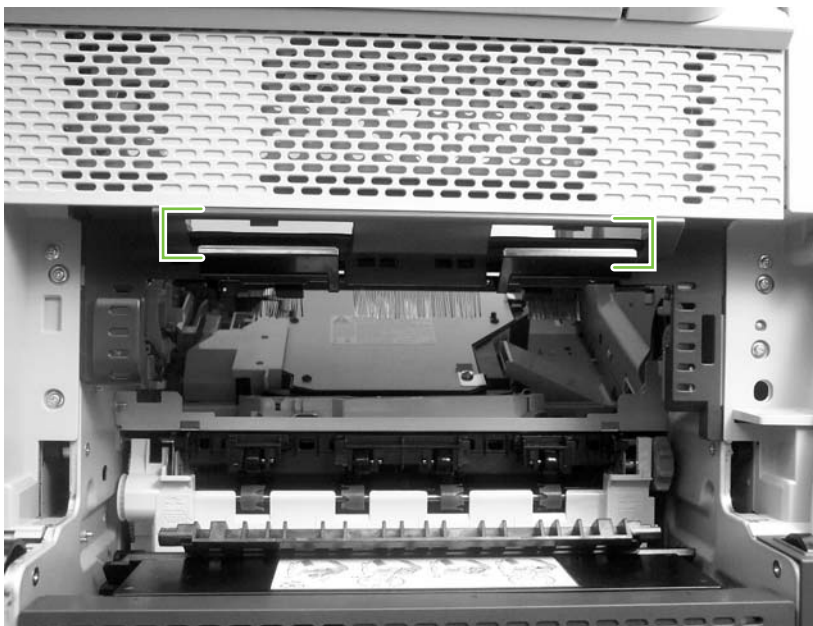
**CAUTION** This spring can easily become dislodged from the chassis. Do not lose this spring when you remove this assembly.

---

4. **Reinstallation tip:** After installing the replacement output-bin-full sensor, verify that it is in the upright position. This ensures that the sensor is correctly installed and will be correctly positioned when the output bin is installed. The lever on the control-panel end of the sensor must be installed between the plastic MFP cover and the output-bin-detection lever.



**Figure 5-166** Incorrect installation of the output-bin-full sensor



**Figure 5-167** Correct installation of the output-bin-full sensor




## ADF and scanner components

The procedures in this section describe the removal and replacement of the following components:

- [ADF assembly](#)
- [Scanner assembly](#)
- [Scanner-controller PCA](#)

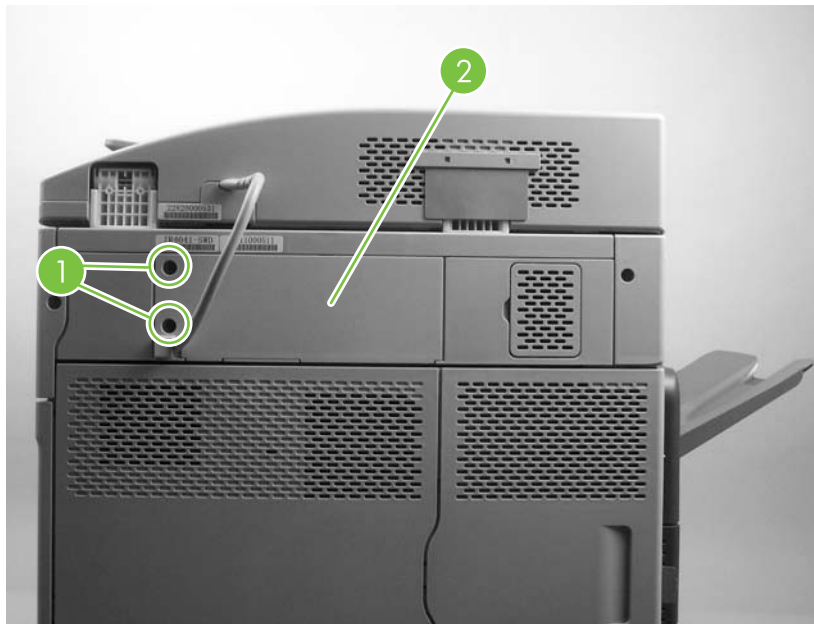
### ADF assembly

---

 **CAUTION** When you remove the ADF assembly, do not use the ADF cable to lift or move the ADF assembly.

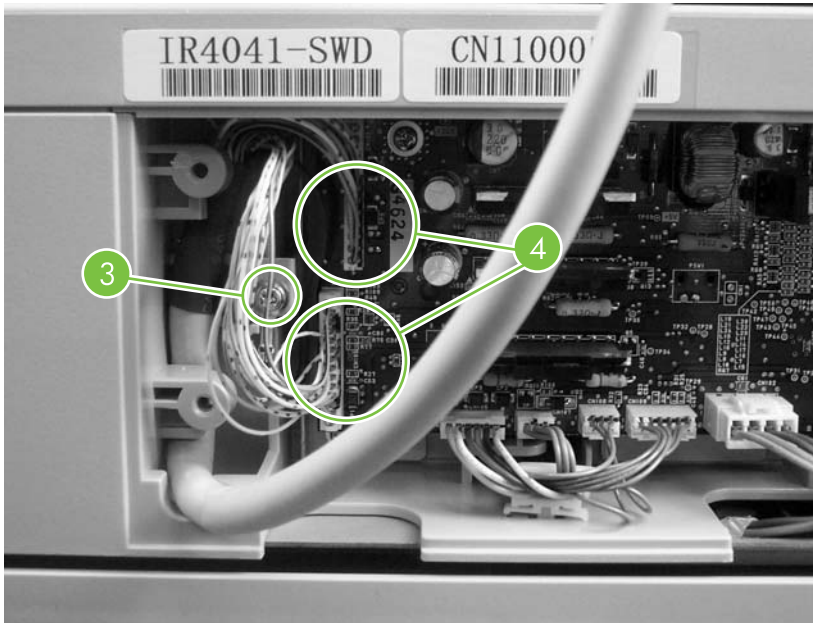
---

1. Remove two screws (callout 1), and then remove the scanner-controller cover (callout 2).



**Figure 5-168** Remove the ADF assembly (1 of 3)

2. Remove one grounding screw (callout 3), and disconnect two cables (callout 4).



**Figure 5-169** Remove the ADF assembly (2 of 3)



**NOTE** When you reinstall the ADF, make sure that the ADF cable is correctly routed through the cable holder into the scanner bed.

3. Open the ADF assembly, and lift it up and off of the scanner.



**Figure 5-170** Remove the ADF assembly (3 of 3)



**CAUTION** The ADF assembly is calibrated to work with the scanner on which it is installed. If the ADF is installed on another scanner, that scanner needs to be calibrated to work correctly with the ADF.

## Scanner assembly

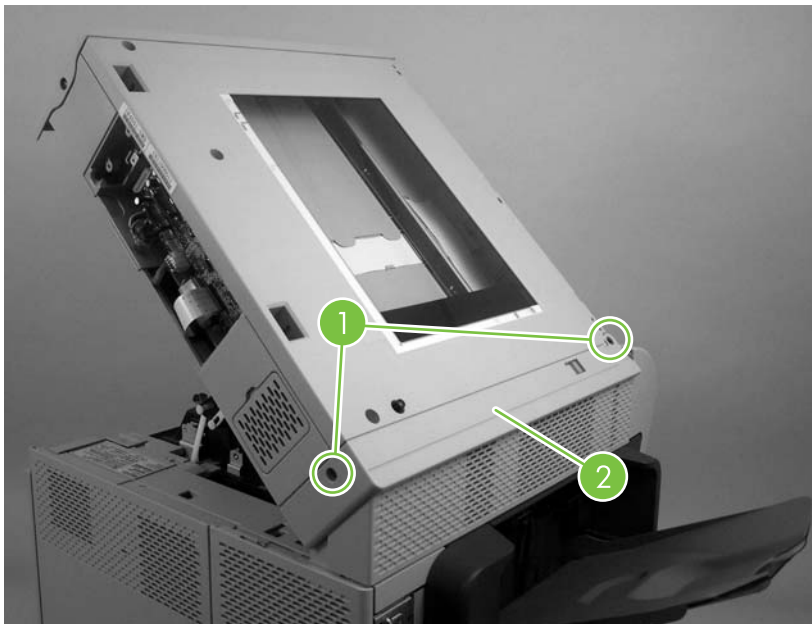
**CAUTION** Do not remove the scanner glass. Any repairs to scanner parts under the scanner glass require a complete scanner-assembly replacement. There are no individual service parts under the scanner glass.

1. Remove the ADF assembly.
2. Raise the scanner, and remove the front-edge flange.



**Figure 5-171** Remove the scanner assembly (1 of 8)

3. Remove two screws (callout 1), and remove the scanner-carriage-lock cover (callout 2).



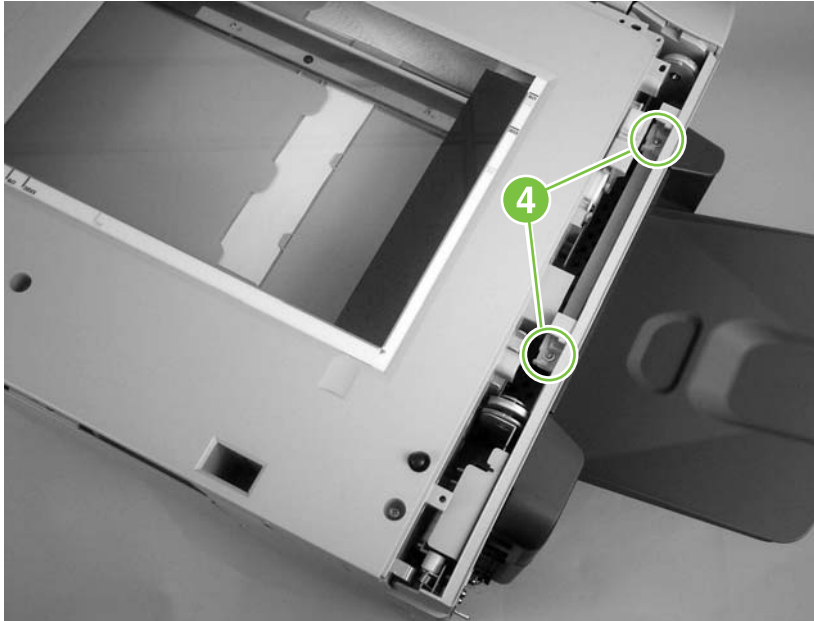
**Figure 5-172** Remove the scanner assembly (2 of 8)

4. Remove the screw (callout 3), and remove the right scanner cover.



**Figure 5-173** Remove the scanner assembly (3 of 8)

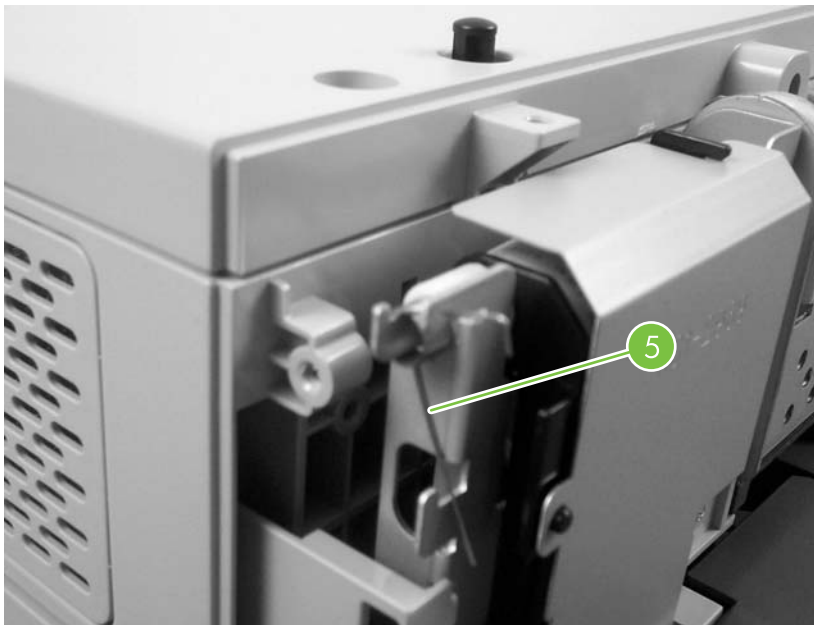
5. Close the top cover. Remove two screws (callout 4), and remove the left scanner-cover.



**Figure 5-174** Remove the scanner assembly (4 of 8)

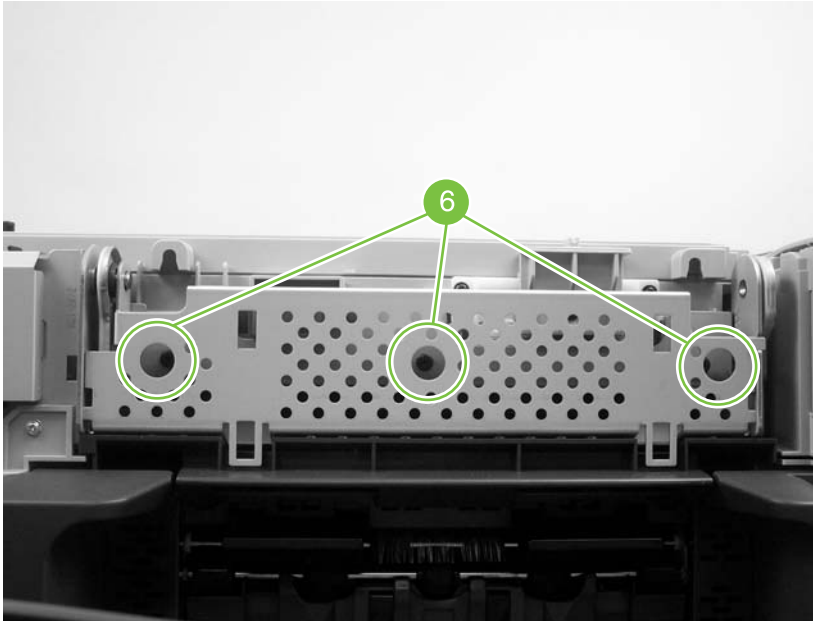


**NOTE** The spring that is near the rear of the MFP (callout 5) is not captive. Do not lose the spring when you remove the cover.



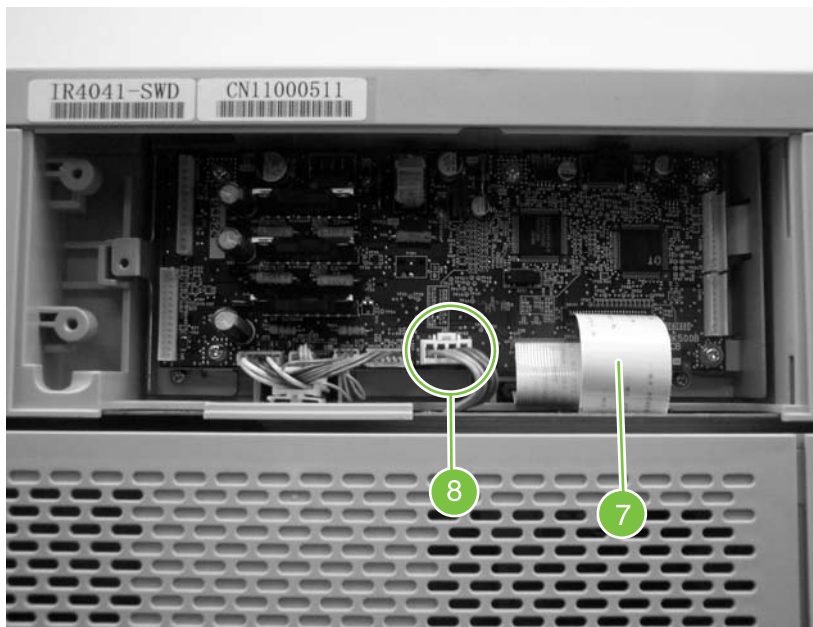
**Figure 5-175** Remove the scanner assembly (5 of 8)

6. Remove three screws (callout 6).



**Figure 5-176** Remove the scanner assembly (6 of 8)

7. Disconnect one FFC (callout 7) and one connector (callout 8).



**Figure 5-177** Remove the scanner assembly (7 of 8)

8. Slide the scanner slightly to the right, and then lift it up and off of the MFP.



**Figure 5-178** Remove the scanner assembly (8 of 8)



**CAUTION** Make sure that you do not release the scanner latch while the scanner assembly is removed. The gas shocks that support the scanner assembly can damage the sheet-metal scanner-assembly platform if the platform is raised when the scanner assembly is not installed.

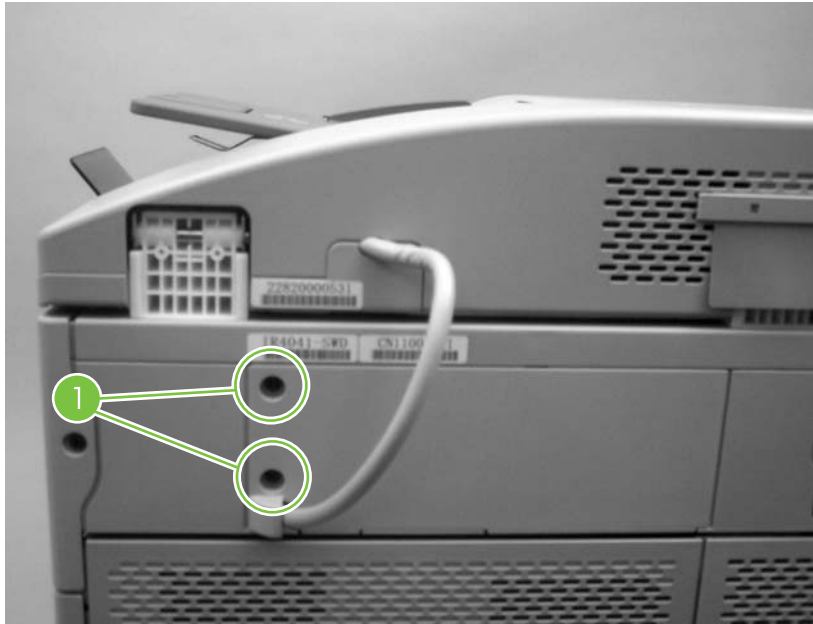
9. **Reinstallation tip:** When you reinstall the scanner assembly, align the mark on the scanner assembly with the mark on the control panel to correctly position the scanner assembly. With the scanner assembly correctly positioned on the sheet metal platform, slide the assembly toward the left side of the MFP until it locks into place.



**Figure 5-179** Correctly positioning the scanner assembly

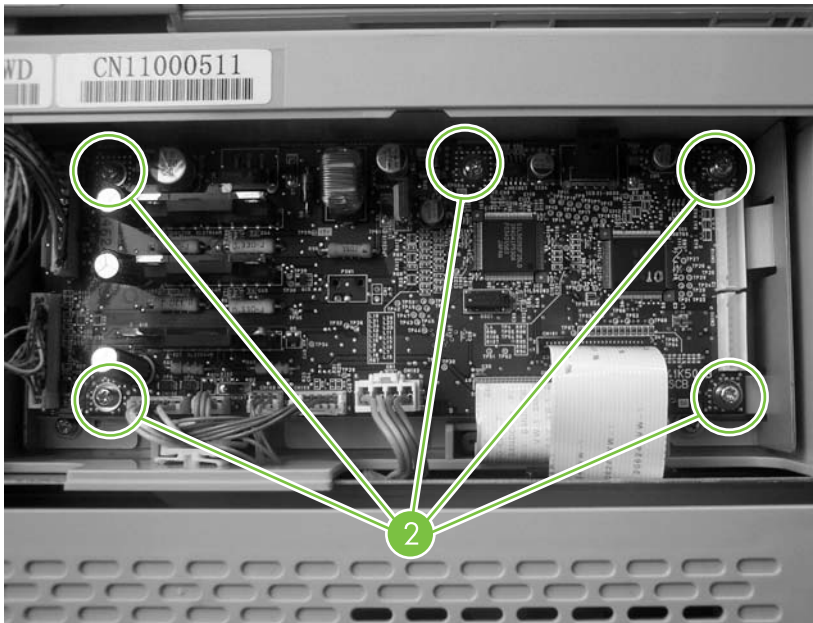
## Scanner-controller PCA

1. Remove two screws (callout 1), and then remove the scanner-controller PCA cover.



**Figure 5-180** Remove the scanner-controller PCA (1 of 2)

2. Disconnect all of the scanner-controller PCA connectors, and then remove five screws (callout 2). Remove the scanner-controller PCA.



**Figure 5-181** Remove the scanner-controller PCA (2 of 2)



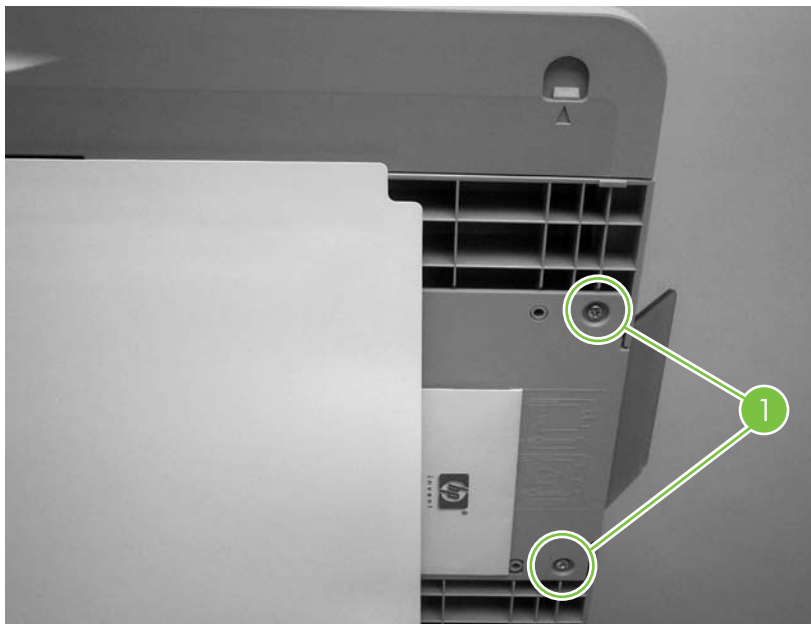
# ADF components

The procedures in this section describe the removal and replacement of the following components:

- [ADF output-bin extension](#)
- [ADF white mylar-backing](#)
- [ADF front cover](#)
- [ADF rear cover](#)
- [ADF left-side cover](#)
- [ADF jam-access cover and latch](#)
- [ADF leading-edge and paper-present sensors](#)
- [ADF hinges](#)

## ADF output-bin extension

1. Open the ADF, and remove two screws (callout 1).

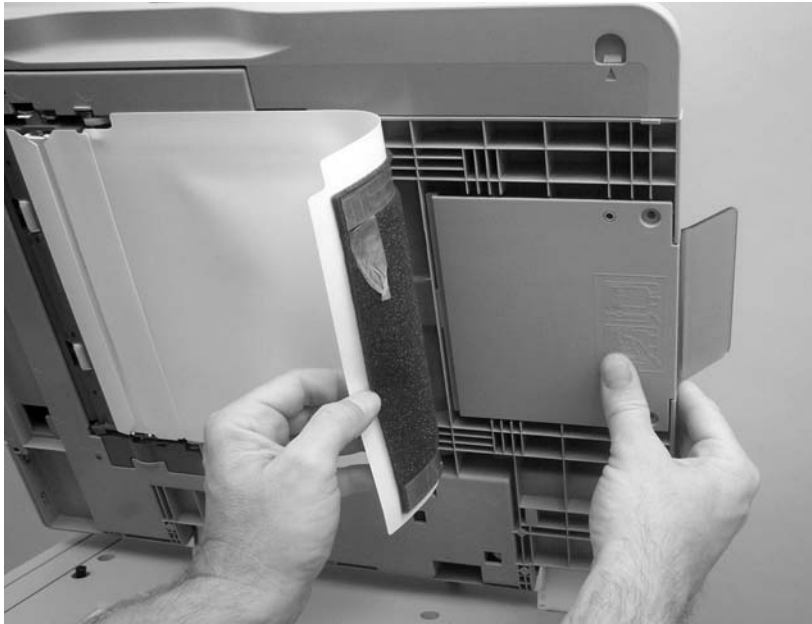


**Figure 5-182** Remove the ADF output-bin extension (1 of 2)



**NOTE** Make sure that you store the envelope that contains the clear mylar sheets under the ADF white, vinyl scan-background after you install the replacement ADF output-bin extension.

2. Peel back the ADF white, vinyl scan-background, and then remove the ADF output-bin extension.



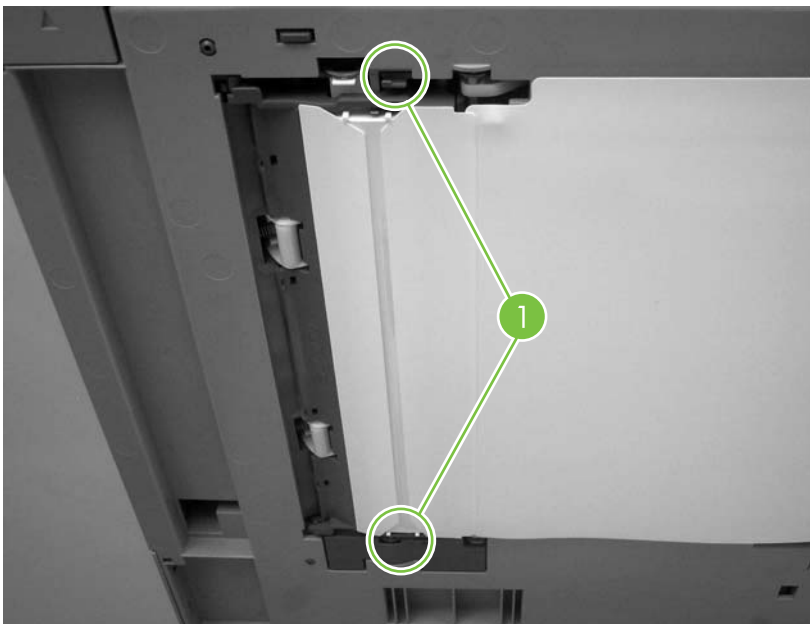
**Figure 5-183** Remove the ADF output-bin extension (2 of 2)



**NOTE** When the two screws are removed, the ADF output-bin extension is not captive. Make sure that you support the ADF output-bin extension before you peel back the ADF white, vinyl scan-background.

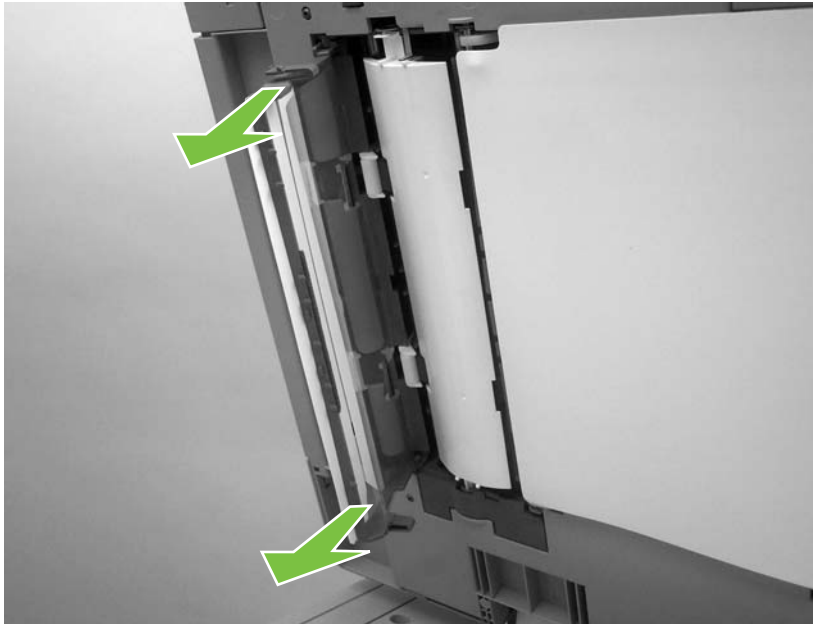
## ADF white mylar-backing

1. Open the ADF, release two locking tabs (callout 1) and then open the mylar-holder assembly.



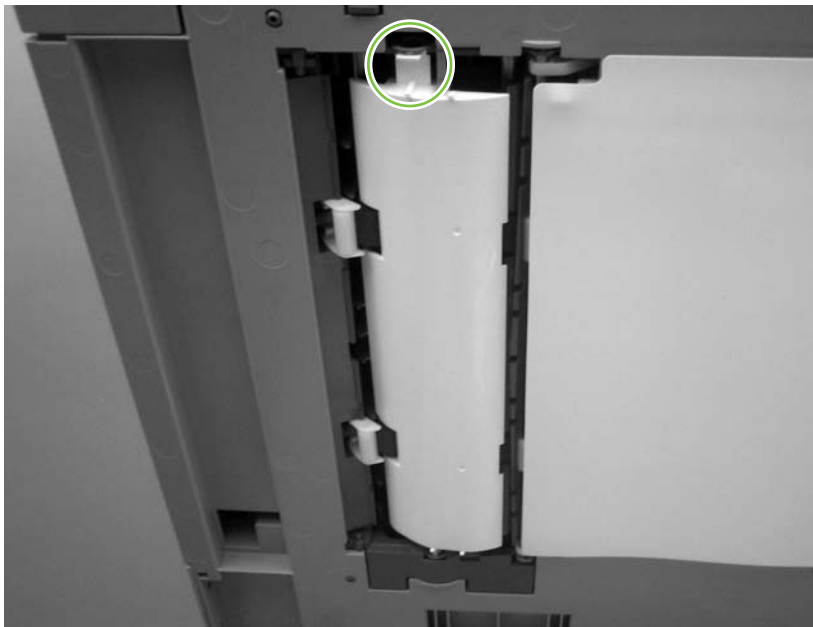
**Figure 5-184** Remove the ADF white mylar-backing (1 of 3)

2. Unsnap the mylar-holder-assembly hinges from the hinge pins.



**Figure 5-185** Remove the ADF white mylar-backing (2 of 3)

3. Release the ADF white mylar-backing locking tab, and lift the assembly up and out of the ADF.

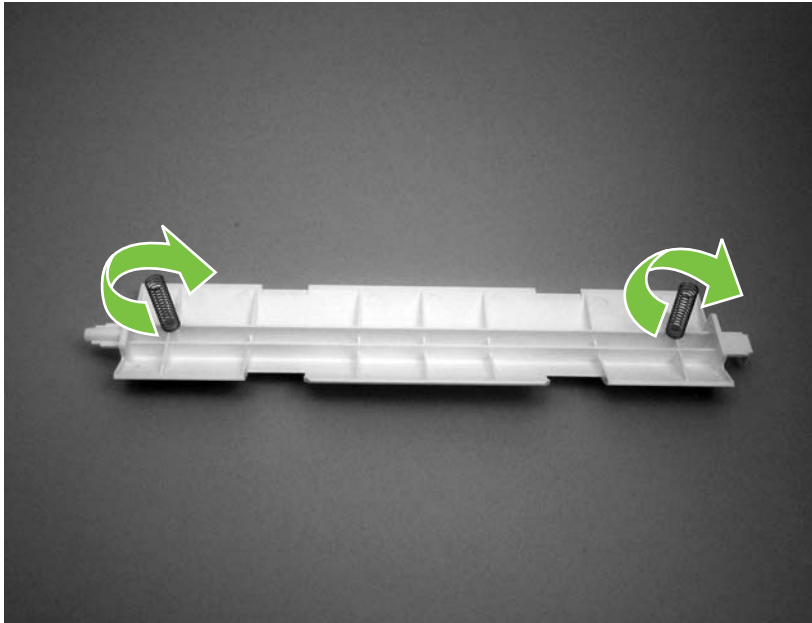


**Figure 5-186** Remove the ADF white mylar-backing (3 of 3)



**NOTE** The springs behind the ADF white mylar-backing assembly are not captive. Do not lose the springs when you remove the ADF white mylar-backing assembly.

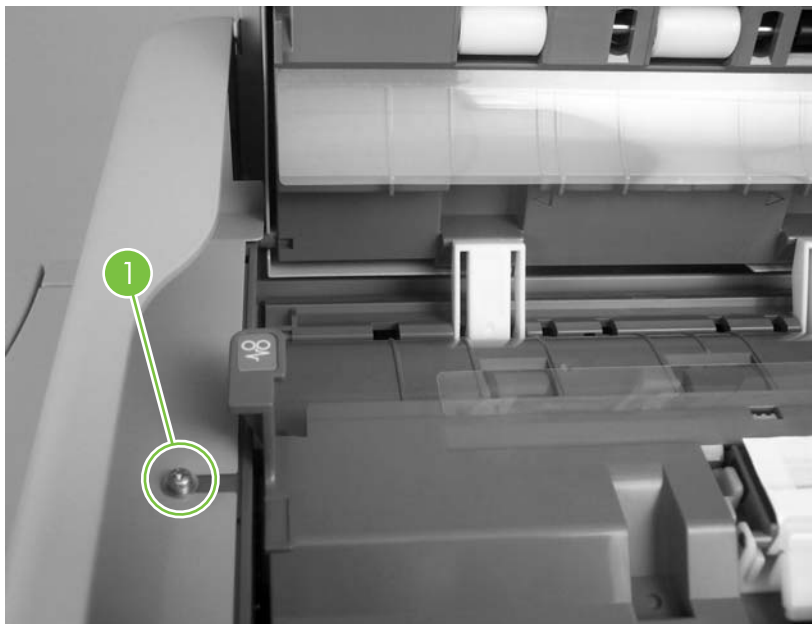
4. **Reinstallation tip:** When you reinstall the ADF white mylar-backing assembly, compress and twist the springs to make sure that they grip the pedestals on the back of the assembly.



**Figure 5-187** Reinstall the ADF white mylar-backing springs

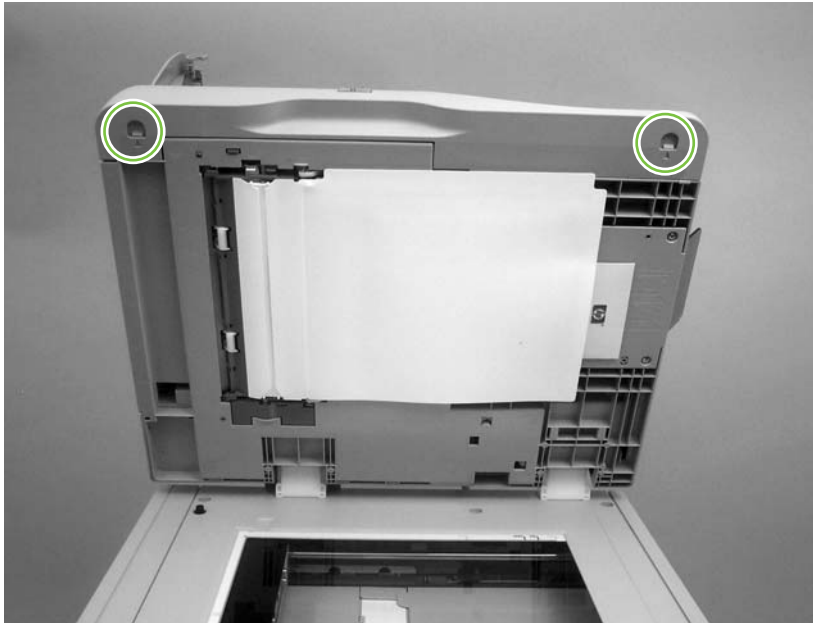
## ADF front cover

1. Remove the ADF input tray.
2. Open the ADF door, and then loosen one screw (callout 1).



**Figure 5-188** Remove the ADF front cover (1 of 2)

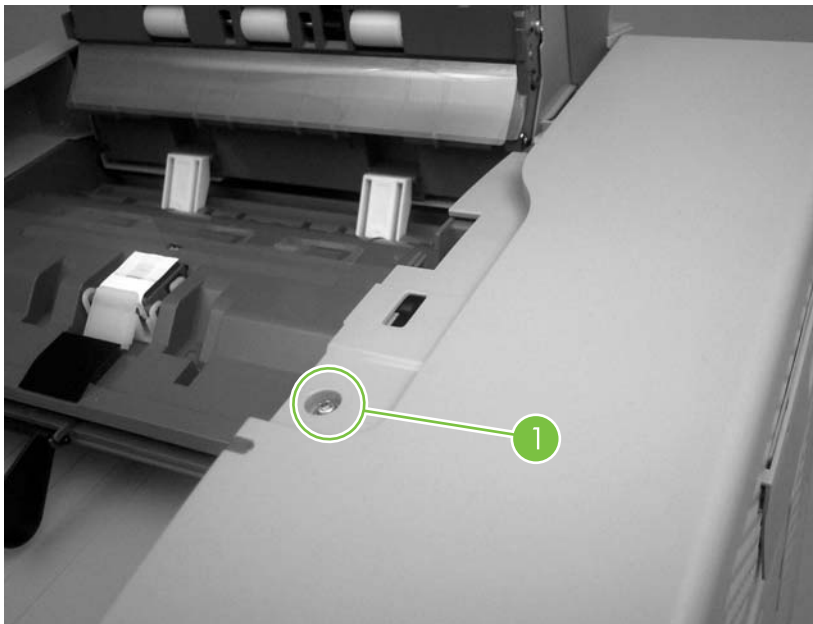
3. Release the two ADF front-cover locking buttons, and then remove the ADF front cover.



**Figure 5-189** Remove the ADF front cover (2 of 2)

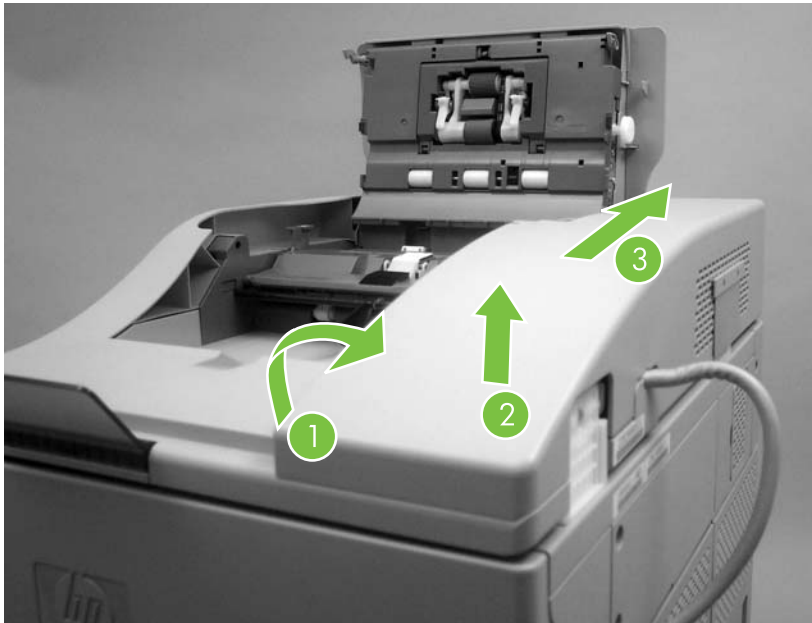
## ADF rear cover

1. Remove one screw (callout 1).



**Figure 5-190** Remove the ADF rear cover (1 of 2)

2. Release the three locking tabs, and then remove the ADF rear cover.

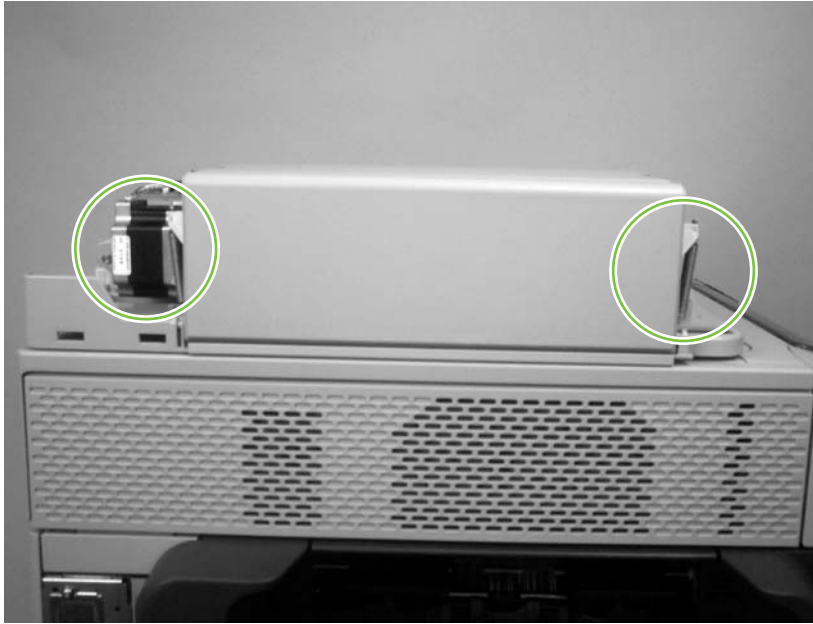


**Figure 5-191** Remove the ADF rear cover (2 of 2)

### ADF left-side cover

1. Remove the following assemblies:
  - ADF front cover.
  - ADF rear cover.

2. Release two springs.

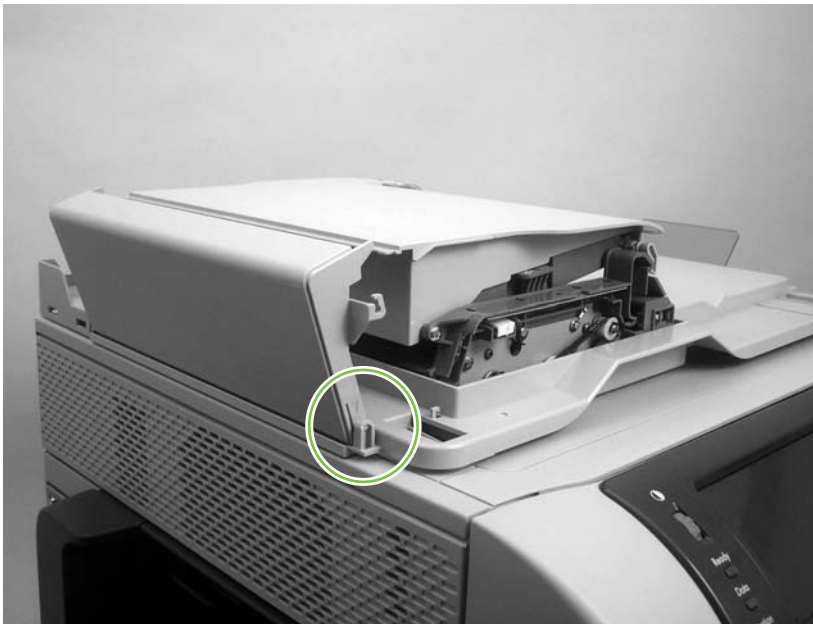


**Figure 5-192** Remove the ADF left cover (1 of 2)



**NOTE** The left-cover tension-springs are not captive. Do not lose the springs when you remove the ADF left cover.

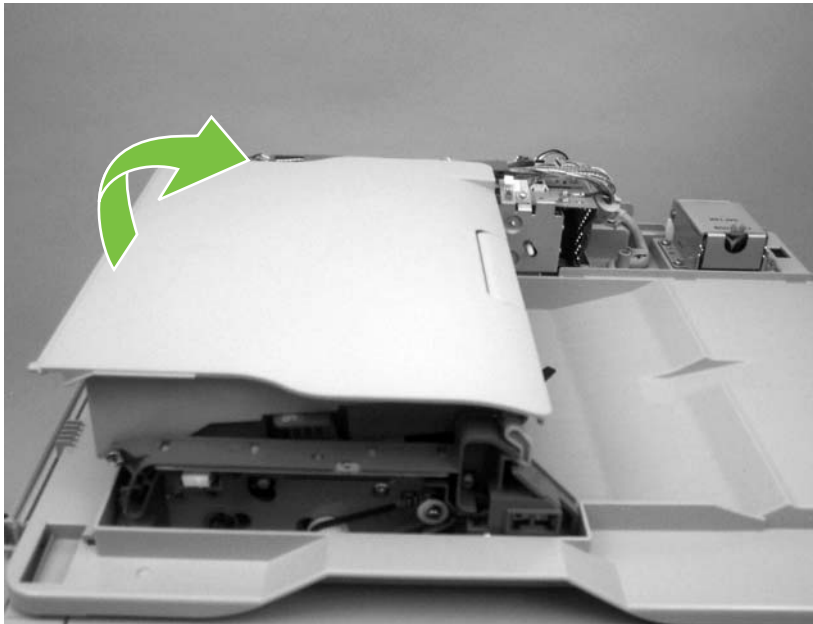
3. Flex the locking tab on the hinge at the control-panel end of the cover to release the hinge. Remove the ADF left cover.



**Figure 5-193** Remove the ADF left cover (2 of 2)

## ADF jam-access cover and latch

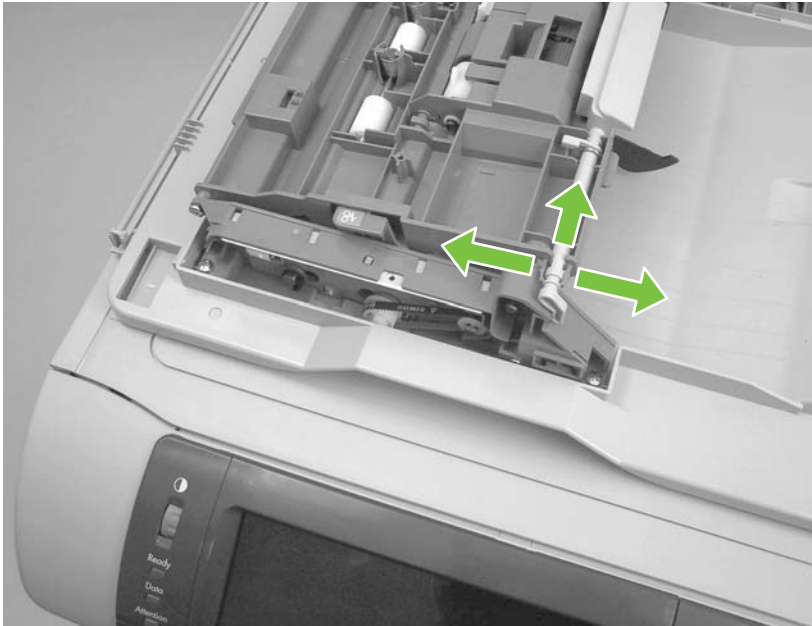
1. Remove the following assemblies:
  - ADF front cover.
  - ADF rear cover.
  - ADF left side cover.
2. Pull up on the left side of the cover to release it, and then remove the ADF jam-access cover.



**Figure 5-194** Remove the ADF jam-access cover and latch (1 of 3)

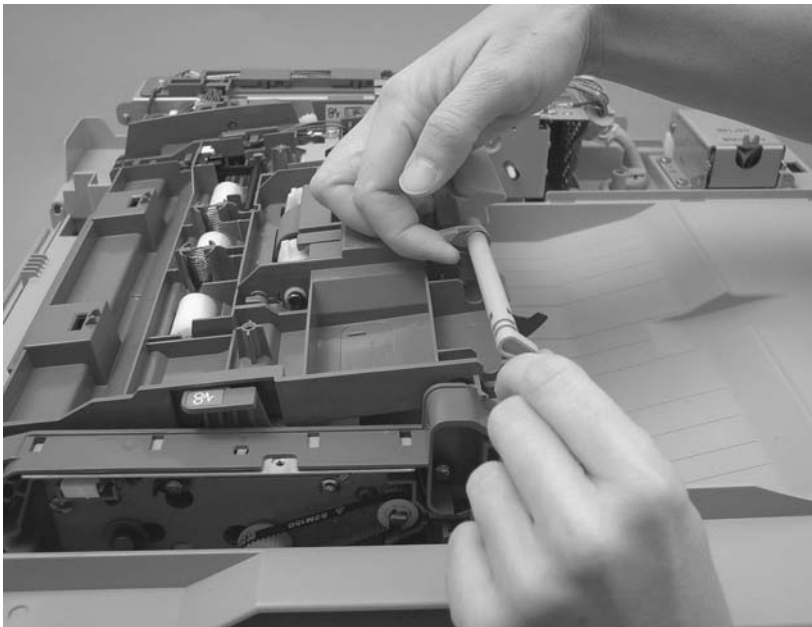


3. To remove the latch, spread the two clips, and slide the latch-rod toward the rear of the ADF and remove it.



**Figure 5-195** Remove the ADF jam-access cover and latch (2 of 3)

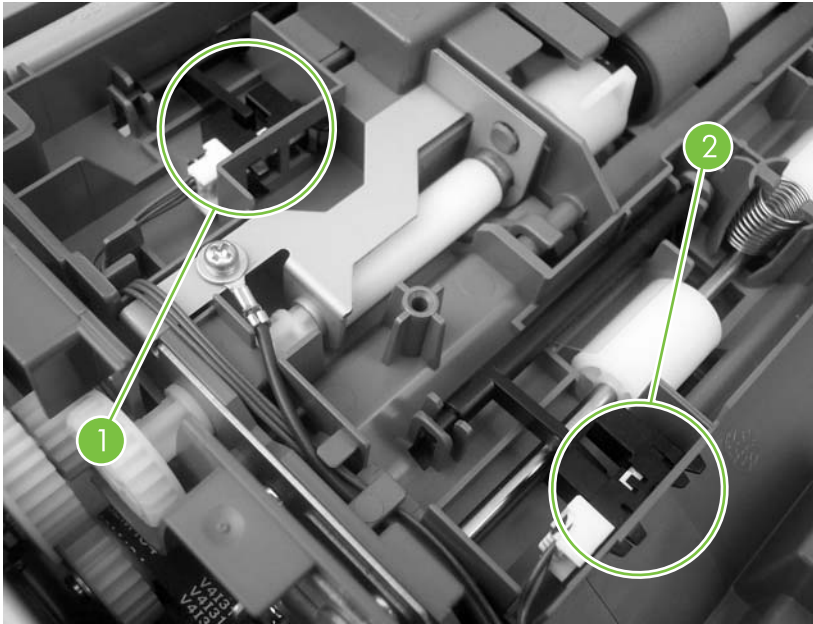
4. **Reinstallation tip:** Make sure that you wind the spring around the latch rod and hold it in place until the rod snaps into place.



## ADF leading-edge and paper-present sensors

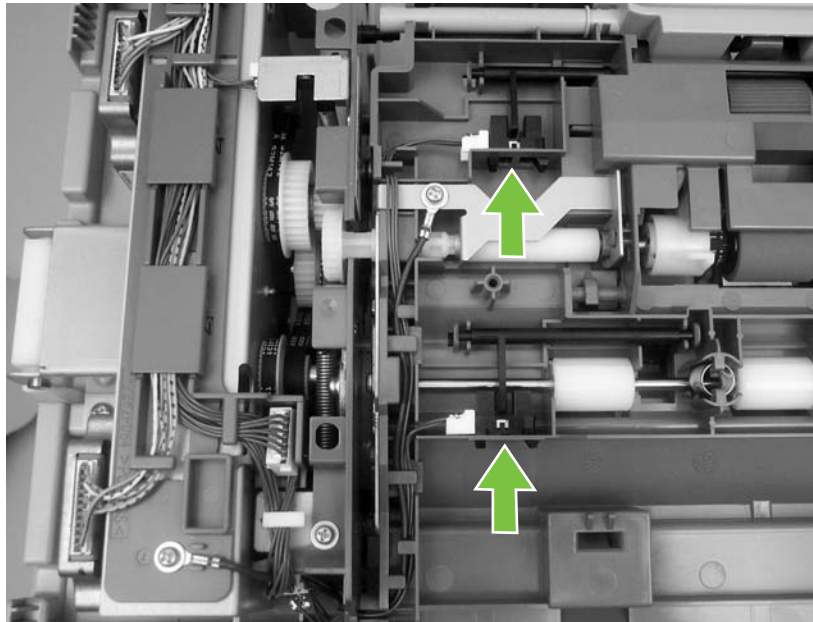
1. Remove the ADF jam-access cover.

2. Locate the ADF leading-edge sensor (callout 1) and the ADF paper-present sensor (callout 2).



**Figure 5-196** Remove the ADF leading-edge and paper-present sensors (1 of 2)

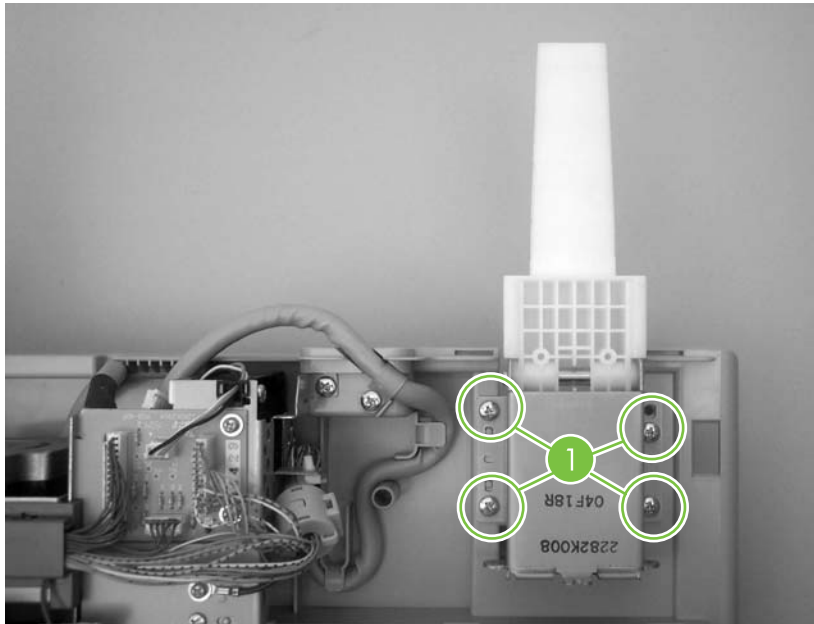
3. Squeeze the retainer tabs, and push the sensor out of the mounting frame. Disconnect the connector, and then remove the sensors



**Figure 5-197** Remove the ADF leading-edge and paper-present sensors (2 of 2)

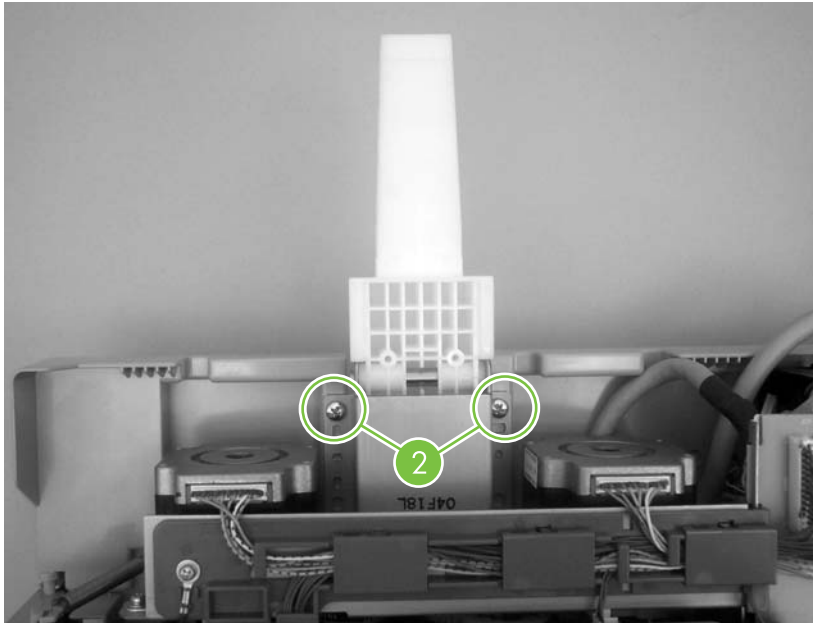
## ADF hinges

1. Remove the following assemblies:
  - ADF front cover.
  - ADF rear cover.
  - ADF left-side cover.
  - ADF jam-access cover.
  - ADF assembly.
2. Remove four screws (callout 1) from the right-side hinge, and then remove the right-side hinge.



**Figure 5-198** Remove the ADF hinges (1 of 2)

3. Remove two screws (callout 2) from the left-side hinge, and then remove the left-side hinge.



**Figure 5-199** Remove the ADF hinges (2 of 2)

## 500-sheet feeder components

### 500-sheet-feeder pickup and feed rollers

The procedure for removing the 500-sheet feeder rollers is the same as the procedure for removing the rollers that are in tray 2.

## Stapler/stacker components

- CAUTION** Disconnect the MFP power cord from the electrical outlet before disassembling and reassembling the stapler/stacker. After the device is plugged back in for testing purposes, do not touch the low-voltage power supply unit because this can cause electrical shock.

### Delivery tray

Lift the delivery tray (callout 1) upward (callout 2), then pull it outward (callout 3) and remove.

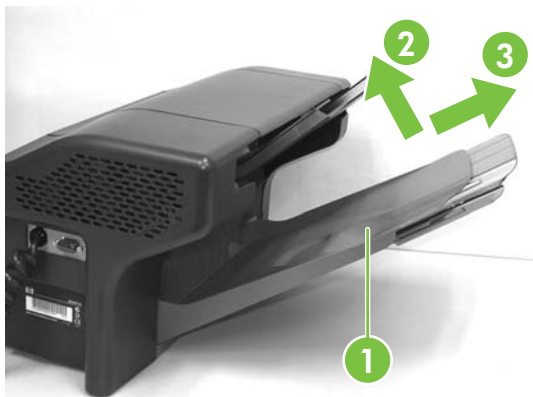


Figure 5-200 Remove the delivery tray

### Front cover

1. Remove the delivery tray.
2. Carefully pry off the front cover using a flat-blade screwdriver. Insert the screwdriver blade and slightly lift the cover at the five points (callout 1) shown in the following figure.



Figure 5-201 Claw locations on front cover

### Rear cover

1. Remove the delivery tray.

2. Carefully pry off the rear cover using a flat-blade screwdriver. Insert the screwdriver blade and slightly lift the cover at the five points (callout 1) shown in the following figure.



Figure 5-202 Claw locations on rear cover

## Left cover

1. Remove the delivery tray.
2. Remove the front cover.
3. Remove the rear cover.
4. Unhook two claws (callout 1) and remove the left cover (callout 2).

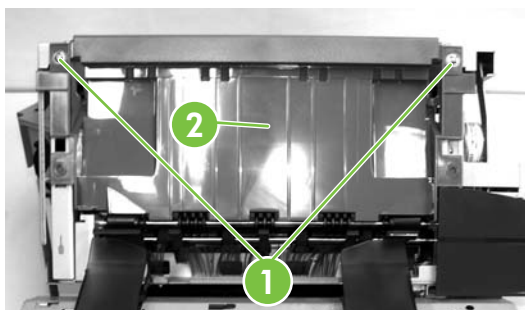
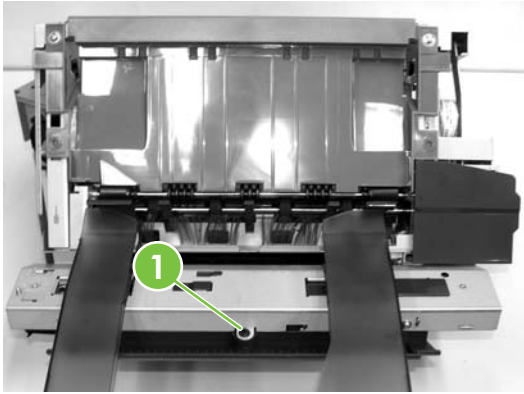


Figure 5-203 Remove the left cover

## Top cover

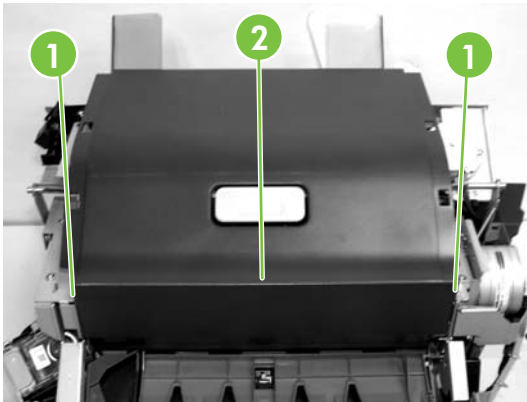
1. Remove the delivery tray.
2. Remove the front cover.
3. Remove the rear cover.

4. Remove one screw (callout 1).



**Figure 5-204** Remove the top cover (1 of 2)

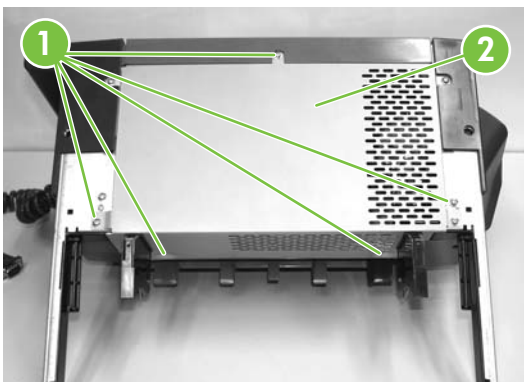
5. Unhook the two claws (callout 1) and remove the top cover (callout 2).



**Figure 5-205** Remove the top cover (2 of 2)

## Bottom cover

1. Remove the delivery tray.
2. Remove five screws (callout 1) and then the bottom-cover unit (callout 2).

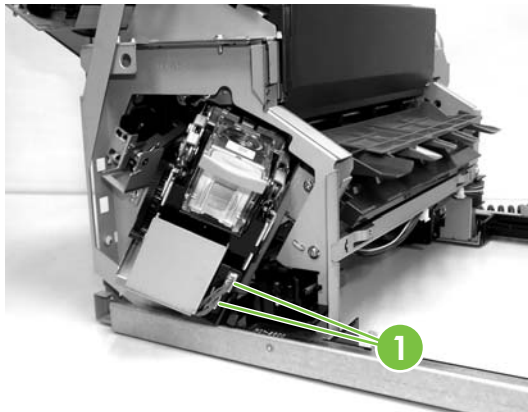


**Figure 5-206** Remove the bottom cover



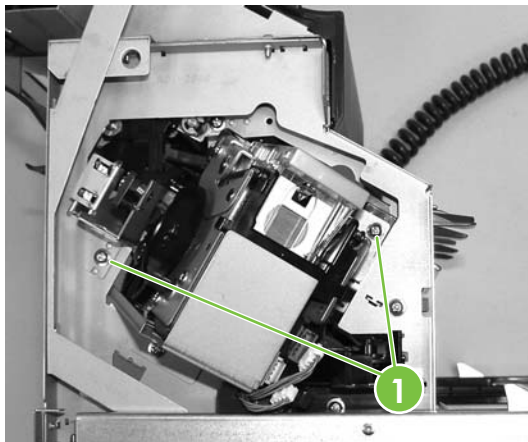
## Stapler unit

1. Remove the delivery tray.
2. Remove the front cover.
3. Disconnect the two electrical connectors (callout 1) on the front of the stapler unit.



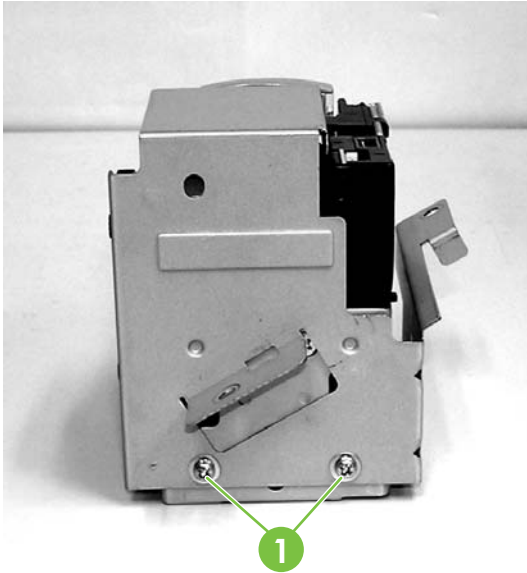
**Figure 5-207** Remove the stapler unit (1 of 3)

4. Remove two securing screws (callout 1).



**Figure 5-208** Remove the stapler unit (2 of 3)

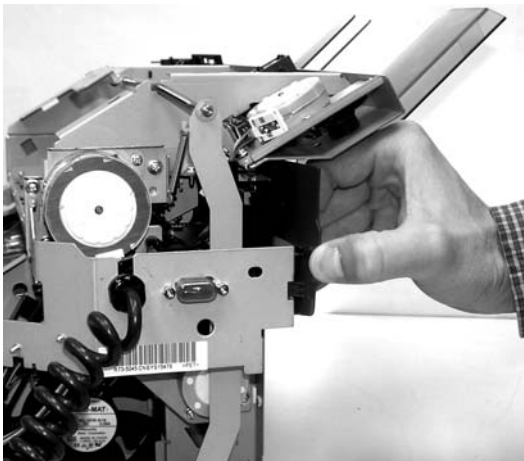
5. Remove two screws (1) that attach the stapler unit.



**Figure 5-209** Remove the stapler unit (3 of 3)

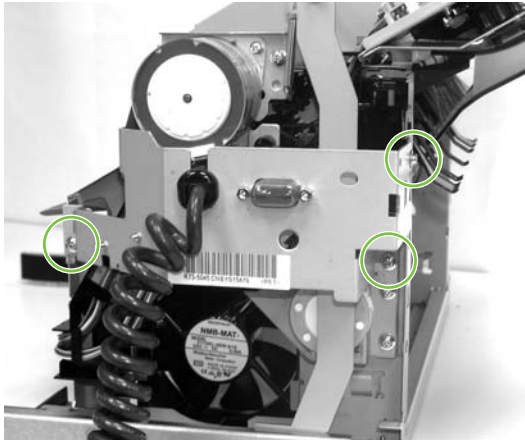
## Jogger unit

1. Remove the front cover.
2. Remove the rear cover.
3. Remove the top cover.
4. Remove the bottom cover.
5. Remove the small plastic cover attached to the right side of the interface cable plate. Use your thumb to pop the tabs out, then slide the cover off.

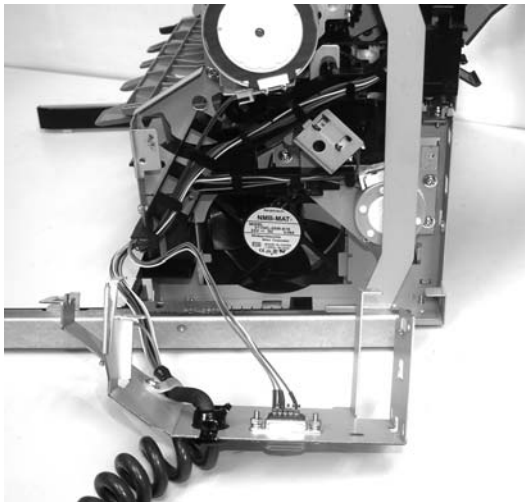


**Figure 5-210** Remove the jogger unit (1 of 7)

6. Remove three screws from the interface-cable plate, and then unhinge the plate and unthread the wires from the wire guide.

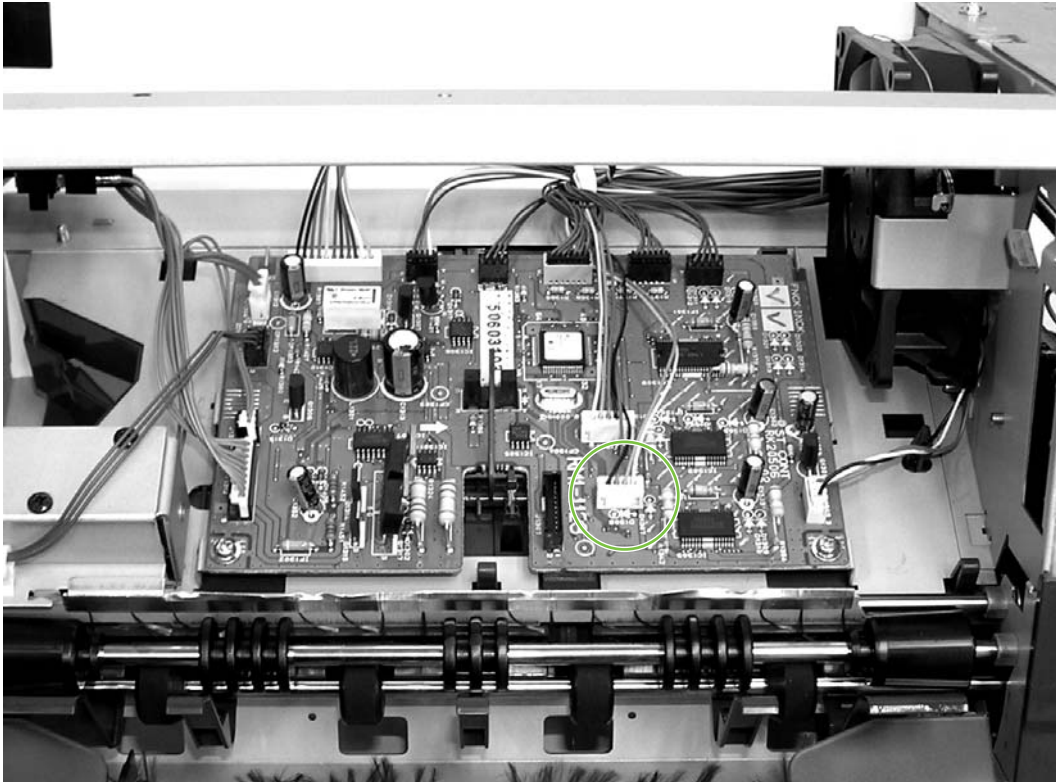


**Figure 5-211** Remove the jogger unit (2 of 7)



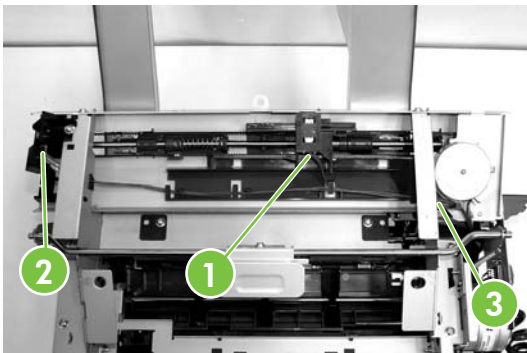
**Figure 5-212** Remove the jogger unit (3 of 7)

7. Disconnect connector J1311 on the stapler/stacker control board and remove this wiring from the cable guide leading to the jogger assembly.



**Figure 5-213** Remove the jogger unit (4 of 7)

8. Disconnect the wires from the jogger home-position sensor PS1304 (1), the LED PCB (2), and sensor PS1306 (3), and then remove these wires from the cable guide.



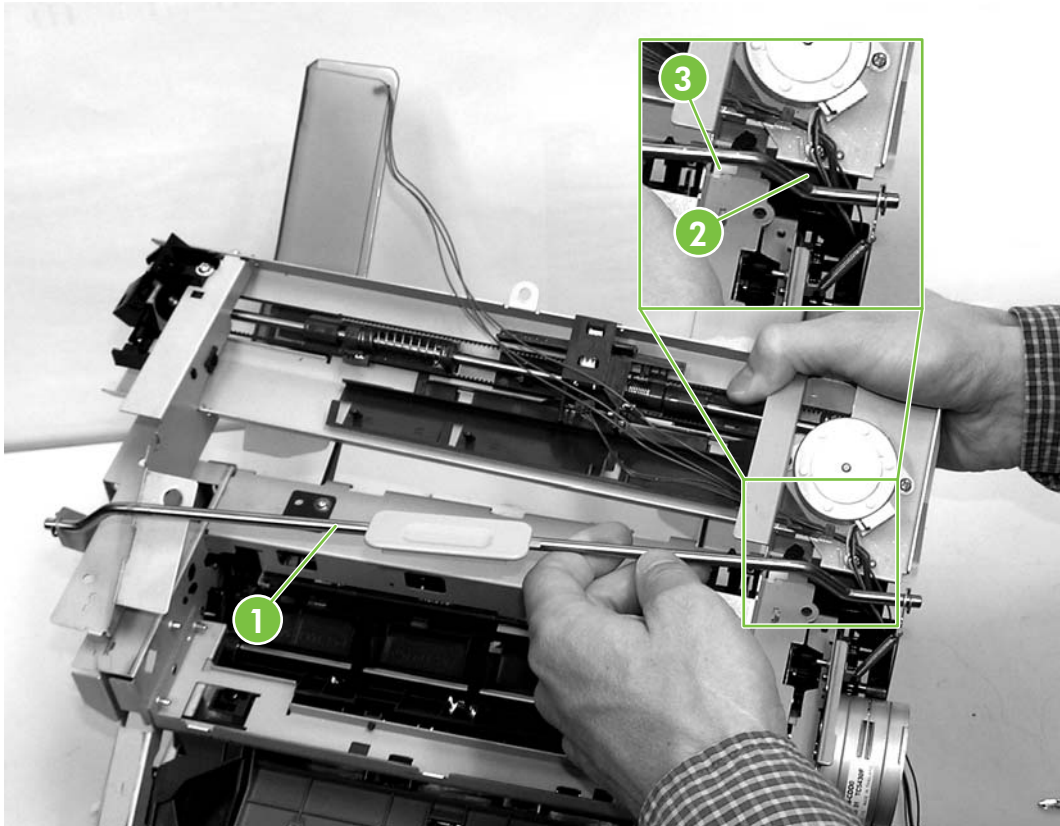
**Figure 5-214** Remove the jogger unit (5 of 7)

9. Remove four screws.



**Figure 5-215** Remove the jogger unit (6 of 7)

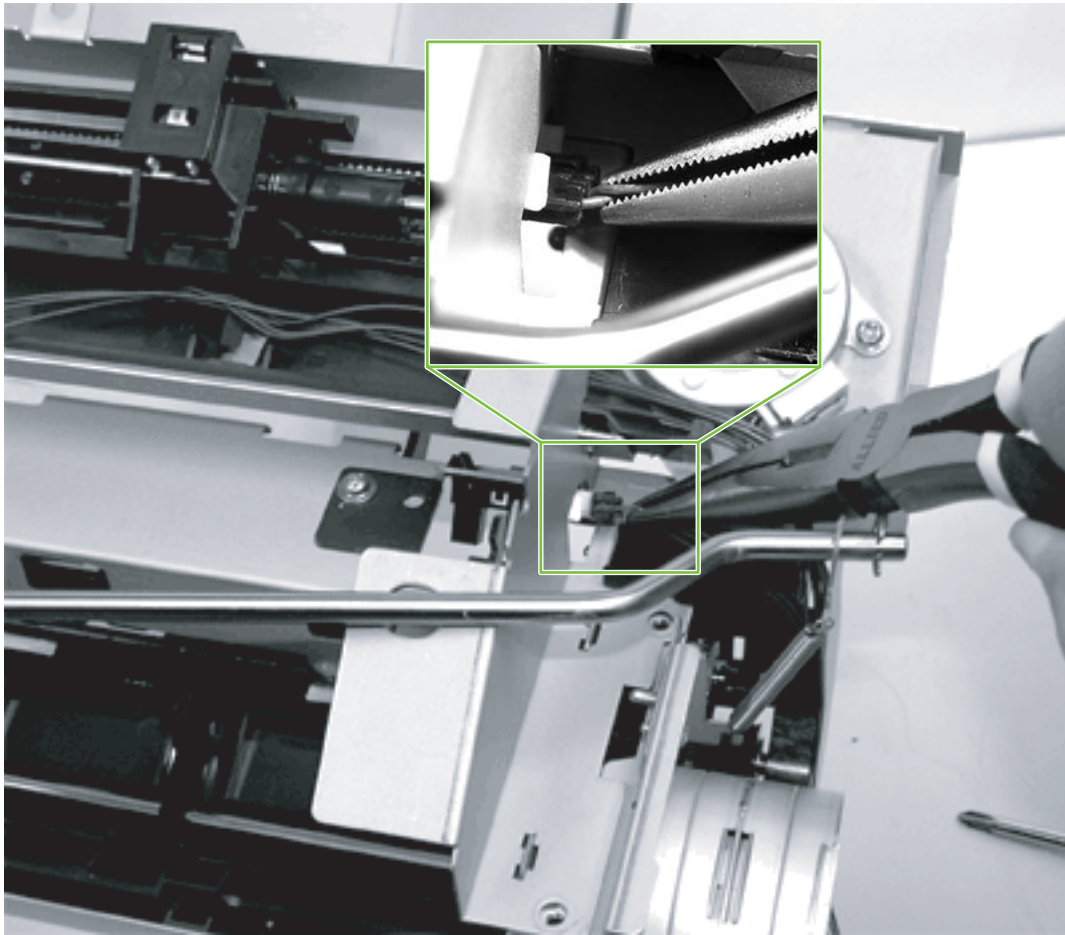
10. Remove the jogger assembly carefully from under the link arm (1), under the cable guide (2), and around sensor PS1306 (3).



**Figure 5-216** Remove the jogger unit (7 of 7)



**NOTE** When installing the new jogger-unit assembly, be sure to align the ridges on the sides of the PS1306 cable with the grooves on the inside of the PS1306 connector.

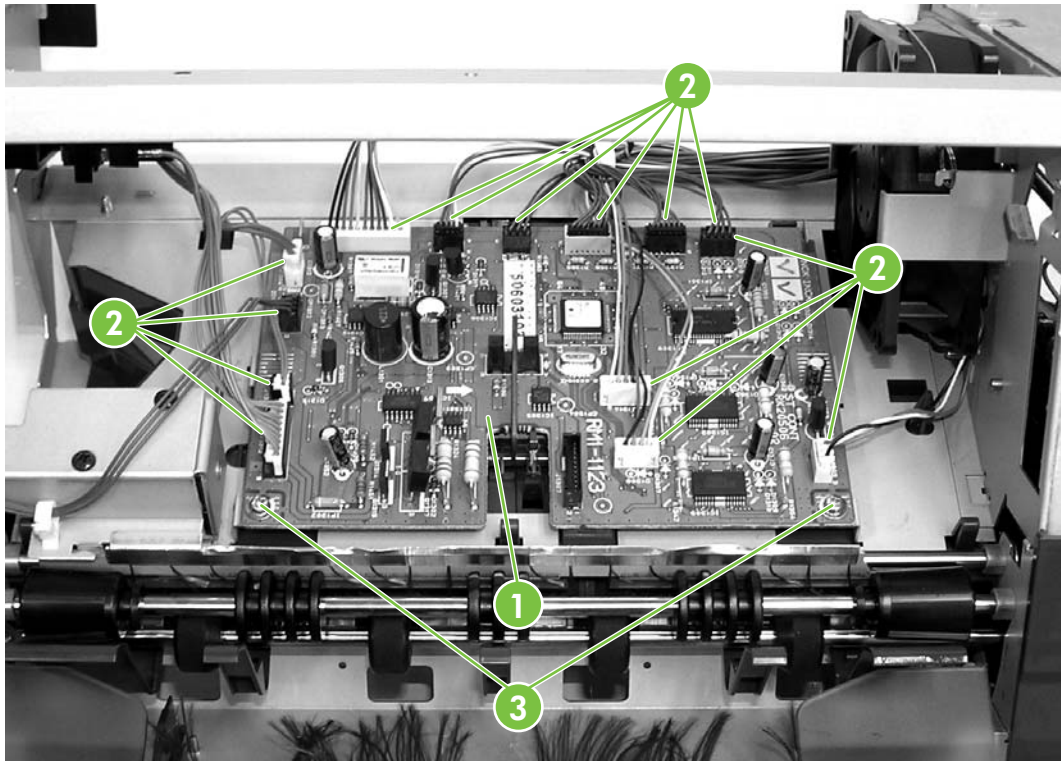


**Figure 5-217** Re-connecting PS1306

### **Stapler/stacker driver PCB**

1. Remove the front cover.
2. Remove the rear cover.
3. Remove the left cover.
4. Remove the bottom cover.

5. On the stapler/stacker PCB (callout 1), disconnect all the connectors (callout 2) and remove two screws (callout 3).



**Figure 5-218** Remove the stapler/stacker driver PCB



**CAUTION** The stapler/stacker PCB is easily damaged by electrostatic discharge. Before handling the stapler/stacker PCB, always wear an ESD grounding device or discharge yourself by touching the metal frame of the MFP.

## 3-bin mailbox components



**CAUTION** Disconnect the MFP power cord from the electrical outlet before disassembling and reassembling the 3-bin mailbox. After the device is plugged back in for testing purposes, do not touch the low-voltage power supply unit because this can cause electrical shock.

### Rear cover

Insert a flat-blade screwdriver head and slightly lift the cover at the five points (callout 1) shown in the following figure. Then remove the rear cover (callout 2).

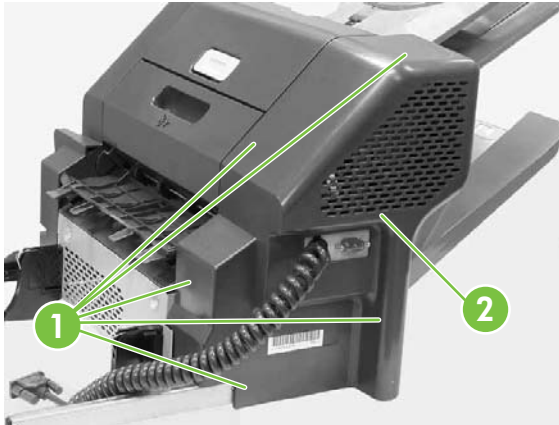


Figure 5-219 Claw locations on rear cover

### Front cover

Insert a flat-blade screwdriver head and slightly lift the cover at the five points (callout 1) shown in the following figure. Then remove the front cover (callout 2).

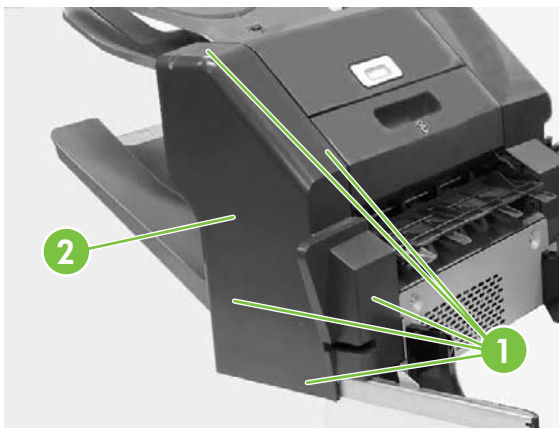
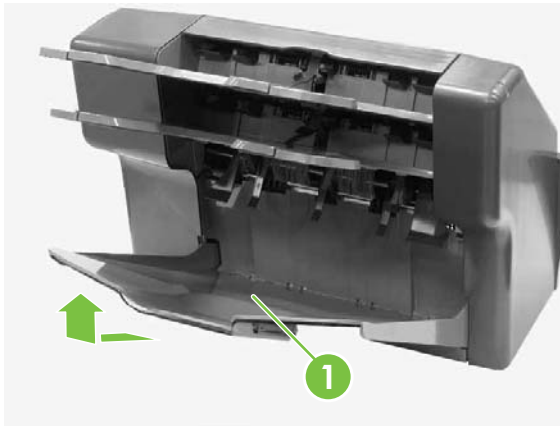


Figure 5-220 Claw locations on front cover

### Delivery tray

Lift the delivery tray (callout 1) and remove it.





## Left cover

1. Remove the rear cover.
2. Unhook two claws (callout 1). Pull the left cover (callout 2) in the direction indicated by the arrow.

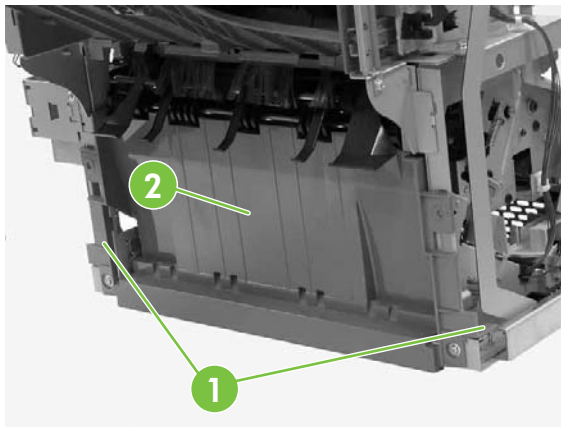


Figure 5-221 Remove the left cover

## Upper cover

1. Remove the rear cover.
2. Remove the front cover.
3. Remove the delivery tray.

4. Unhook two claws (callout 1).

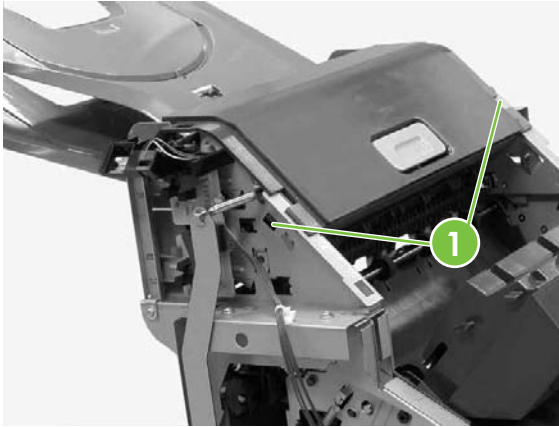


Figure 5-222 Remove the upper cover (1 of 2)

5. Remove four bosses (callout 1) and then the upper cover (callout 2).

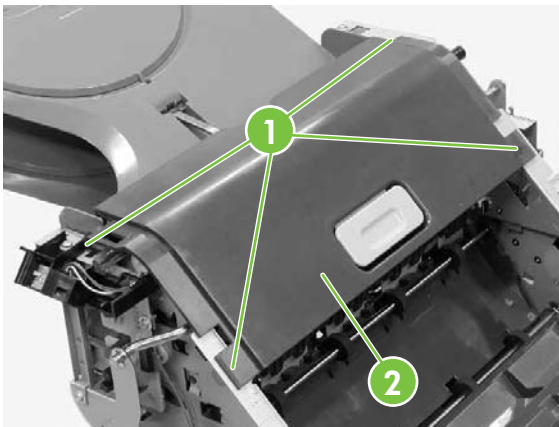
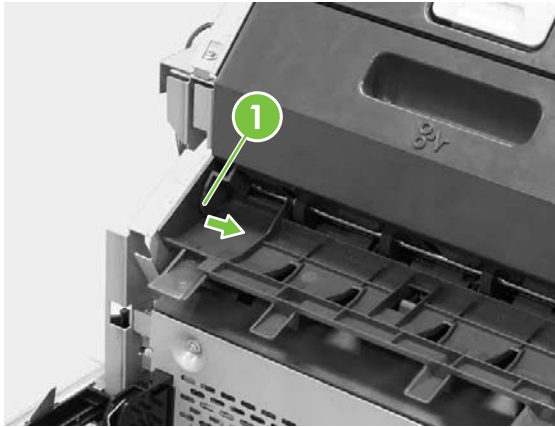


Figure 5-223 Remove the upper cover (1 of 2)

## Right-door unit

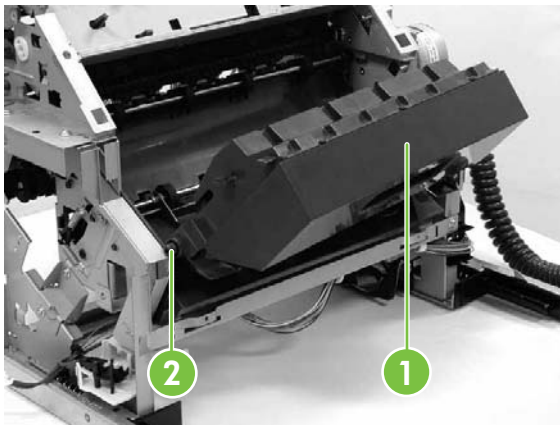
1. Remove the rear cover.
2. Remove the front cover.
3. Remove the delivery tray.

4. Displace the boss (callout 1) to the right and remove it from the MBM.



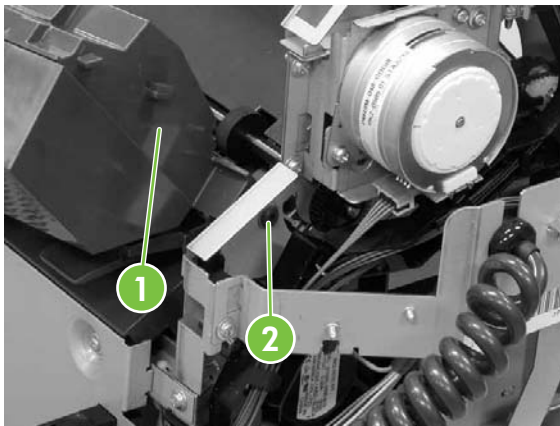
**Figure 5-224** Remove the right-door unit (1 of 4)

5. Open the right-door unit. The following figure shows that the boss (callout 2) of the right-door unit (callout 1) is removed from the MBM



**Figure 5-225** Remove the right-door unit (2 of 4)

6. Displace the right-door unit (callout 1) to the left and remove the boss (callout 2) from the MBM.



**Figure 5-226** Remove the right-door unit (3 of 4)

7. Remove the spring (callout 1) from the link shaft (callout 2), and then remove the right-door unit (callout 3).

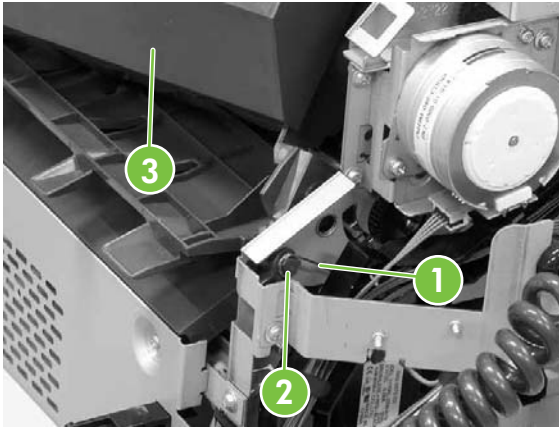


Figure 5-227 Remove the right-door unit (4 of 4)

## Bottom cover

1. Remove the left cover.
2. Remove two screws (callout 1).

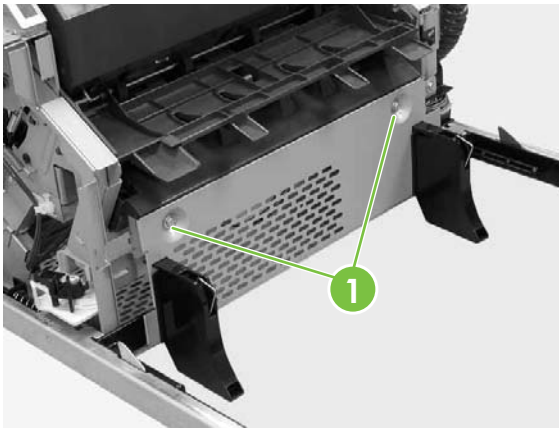
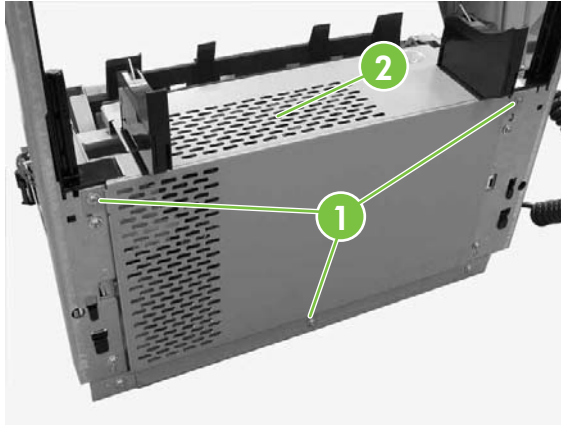


Figure 5-228 Remove the bottom cover (1 of 2)

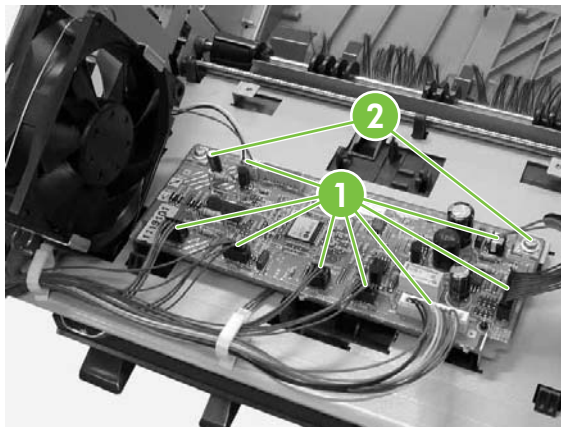
3. Remove three screws (callout 1), and then remove the bottom cover (callout 2).



**Figure 5-229** Remove the bottom cover (2 of 2)

## MBM driver PCB

1. Remove the rear cover.
2. Remove the front cover.
3. Remove the delivery tray.
4. Remove the left cover.
5. Remove the bottom cover.
6. Disconnect the eight connectors (callout 1) and remove two screws (callout 2). Then remove the MBM driver PCB.



**Figure 5-230** Remove the MBM driver PCB



**CAUTION** The MBM driver PCB is easily damaged by electrostatic discharge. Before handling the MBM driver PCB, always wear an ESD grounding device or discharge yourself by touching the metal frame of the MFP.



# 6 Problem solving

This chapter provides information about the following topics.

- [Problem-solving checklist](#)
- [Problem-solving flowchart](#)
- [Power-on checks](#)
- [Formatter lights](#)
- [Diagrams for troubleshooting](#)
- [Solve general device problems](#)
- [Control-panel message types](#)
- [Control-panel messages](#)
- [Common causes of jams](#)
- [Clear jams](#)
- [Clear staple jams](#)
- [Solve print-quality problems](#)
- [Solve network printing problems](#)
- [Solve copy problems](#)
- [Solve fax problems](#)
- [Solve e-mail problems](#)
- [Solve network connectivity problems](#)
- [Solve stapler/stacker problems](#)
- [Solve 3-bin mailbox problems](#)
- [Functional checks](#)
- [MFP resets](#)
- [Individual component diagnostics](#)
- [Service ID](#)

- [Troubleshooting the embedded HP Jetdirect print server](#)
- [Firmware-stack trace](#)
- [Solve common Windows problems](#)
- [Solve common Macintosh problems](#)
- [Solve Linux problems](#)
- [Solve PostScript problems](#)



# Problem-solving checklist

If you are experiencing problems, use the following checklist to identify the cause of the problem:

- Is the device connected to power?
- Is the device on?
- Is the device in the **Ready** state?
- Are all necessary cables connected?
- Do any messages appear on the control panel?
- Are genuine HP supplies installed?
- Was a recently replaced print cartridge installed correctly, and was the pull tab and/or attached tape on the cartridge removed?

For additional information about installation and setup, see the getting started guide.

If you cannot find solutions to problems in this guide, go to <http://www.hp.com/support/ljm4345mfp>.

## Factors that affect performance

Several factors affect the time it takes to print a job:

- The use of special paper (such as transparencies, heavy paper, and custom-size paper)
- Device processing and download time
- The complexity and size of graphics
- The speed of the computer you are using
- The USB connection
- The I/O configuration
- The amount of memory installed
- The network operating system and configuration (if applicable)
- Device personality (PCL or PS)



---

**NOTE** Although additional memory can resolve memory problems, improve how the device handles complex graphics, and improve download times, it will not increase maximum printing speed (ppm).

---

## Problem-solving flowchart

Symptom	Check	Possible causes	Possible solutions
The control-panel display is blank, no lights are lit, and the device makes no sounds from the motors.	Is the power on?	<p>The power switch might be off.</p> <p>The power cord might be unplugged.</p> <p>The power outlet might not be working correctly.</p> <p>The internal power supply might have failed.</p>	<ol style="list-style-type: none"> <li>1. Make sure the device is plugged in and the power switch is on.</li> <li>2. Test the power outlet by plugging the device into an outlet that is known to work.</li> <li>3. If the problem persists, go to <a href="http://www.hp.com/support">http://www.hp.com/support</a>.</li> </ol>
The control panel indicates an error.	Do error messages appear on the control-panel display?	Several conditions can cause an error message to appear.	<ol style="list-style-type: none"> <li>1. Follow the instructions on the control panel to resolve the problem.</li> <li>2. If the problem persists, go to <a href="http://www.hp.com/support">http://www.hp.com/support</a>.</li> </ol>
	Are the main features, such as <b>Copy</b> and <b>E-mail</b> , inactive on the touchscreen?	The scanner shipping lock might be in the locked position.	Make sure the scanner shipping lock is unlocked. The scanner lock is on the left side of the device, underneath the scanner.
Paper-feed problems	Do jams occur frequently?	<p>The media does not meet specifications.</p> <p>Paper remains in the device after clearing a previous jam.</p> <p>Some of the shipping tape, cardboard, or shipping locks are still in the device.</p> <p>The maintenance kit items might be ready for replacement.</p>	<ol style="list-style-type: none"> <li>1. Make sure the media meets specifications for the device.</li> <li>2. Open all doors and trays and check for jammed media.</li> <li>3. Make sure the print cartridge is installed correctly.</li> <li>4. Install the device maintenance kit.</li> <li>5. If the problem persists, go to <a href="http://www.hp.com/support">http://www.hp.com/support</a>.</li> </ol>
		Do original documents feed correctly through the ADF?	<p>The original document might be printed on media that is too light or too heavy for the ADF.</p> <p>The ADF rollers and separation pad might be dirty.</p> <p>The ADF maintenance kit parts might need to be replaced.</p>

Symptom	Check	Possible causes	Possible solutions
Copy problems	Are copies blank?	The originals might have been loaded upside-down.	<ol style="list-style-type: none"> <li>1. In the ADF, load original documents face-up.</li> <li>2. On the scanner glass, load original documents face-down.</li> <li>3. If the problem persists, go to <a href="http://www.hp.com/support">http://www.hp.com/support</a>.</li> </ol>
	Are copies of poor quality from the ADF and the scanner glass?	The copy settings need to be adjusted for the original document.	<p>Adjust copy settings as needed.</p> <p>If the problem persists, go to <a href="http://www.hp.com/support">http://www.hp.com/support</a>.</p>
	Are copies of poor quality only from the ADF?	The ADF mylar strip might be dirty.	<p>Clean or replace the mylar strip.</p> <p>If the problem persists, go to <a href="http://www.hp.com/support">http://www.hp.com/support</a>.</p>
	Are copies of poor quality only from the scanner glass?	The scanner glass might be dirty	<p>Clean the glass.</p> <p>If the problem persists, go to <a href="http://www.hp.com/support">http://www.hp.com/support</a>.</p>
Print-quality problems	<p>Is the overall print quality poor?</p> <p>Is the printing too light?</p> <p>Do lines, streaks, or dots appear on the pages?</p>	<p>The media does not meet specifications.</p> <p>The print cartridge might be empty or damaged.</p> <p>The maintenance kit items might be ready for replacement.</p>	<ol style="list-style-type: none"> <li>1. Make sure the media meets specifications for the device.</li> <li>2. Replace the print cartridge.</li> <li>3. Install the device maintenance kit.</li> <li>4. If the problem persists, go to <a href="http://www.hp.com/support">http://www.hp.com/support</a>.</li> </ol>
General printing problems	Can you print documents from a computer?	<p>The computer cable might be defective.</p> <p>The printer driver might need to be reinstalled.</p>	<ol style="list-style-type: none"> <li>1. Try printing a Configuration page at the control panel. Touch <b>Network Address</b> and then touch <b>Print</b>.</li> </ol> <p>If the page prints, the problem is with the cable or the driver.</p> <ol style="list-style-type: none"> <li>2. Reconnect the cables.</li> <li>3. Reinstall the printer driver. The printer driver is on the CD that came with the device.</li> <li>4. If the problem persists, go to <a href="http://www.hp.com/support">http://www.hp.com/support</a>.</li> </ol>

Symptom	Check	Possible causes	Possible solutions
	Can you print over the network?	The network might not be configured correctly.	<ol style="list-style-type: none"> <li>1. Try connecting the computer directly to the device. If you can print, the problem is with the network configuration.</li> <li>2. If the problem persists, go to <a href="http://www.hp.com/support">http://www.hp.com/support</a>.</li> </ol>
	Are you having problems printing from specific software programs?	The problem might be with the software program.	<ol style="list-style-type: none"> <li>1. Try printing from a different software program. If you can print, the problem is with the original software program.</li> <li>2. See the documentation for the software program.</li> </ol>
Stapling problems	Are jobs stapled?	<p>The staple cassette might be jammed.</p> <p>The staple cassette might need to be replaced.</p>	<ol style="list-style-type: none"> <li>1. Remove the staple cassette and check if it is jammed or empty.</li> <li>2. If the problem persists, go to <a href="http://www.hp.com/support">http://www.hp.com/support</a>.</li> </ol>
E-mail problems	<p>Are you able to send e-mail attachments?</p> <p>Does an "E-mail gateway not responding" message appear on the control panel?</p>	The SMTP gateway might need to be reconfigured.	Adjust e-mail settings as needed.
	Are you able to change the "From" e-mail address?	<p>The device might be configured so that the "From" e-mail address cannot be changed.</p> <p>The device might require you to sign in before you can change the "From" e-mail address.</p>	Use the embedded Web server to change these settings.
	Are you able to change the file type or the color setting for e-mail attachments?	Change the settings at the control panel or by using the embedded Web server.	<ol style="list-style-type: none"> <li>1. At the control panel, touch <b>E-mail</b>, and then touch <b>More Options</b>.</li> <li>2. Settings can also be changed through the embedded Web server.</li> </ol>
	Do you receive a "job failed" e-mail message when you try to send an e-mail attachment?	<p>The e-mail address to which you are sending the document might be incorrect.</p> <p>The file size might be larger than the maximum allowable size for the SMTP gateway.</p>	<ol style="list-style-type: none"> <li>1. Send a test e-mail from your computer.</li> <li>2. Use the embedded Web server to change the maximum allowable size for e-mail attachments.</li> </ol>

Symptom	Check	Possible causes	Possible solutions
Fax problems	Is the Fax feature on the control panel inactive?	You need to provide required settings before using the Fax feature.	<ol style="list-style-type: none"> <li>1. At the control panel, touch Administration, touch Initial Setup, and touch Fax Setup.</li> <li>2. Configure the settings for Location, Date/Time, and Fax Header.</li> </ol>
	Is the Fax feature on the control panel completely missing?	The fax accessory might be installed incorrectly.	<ol style="list-style-type: none"> <li>1. Make sure the fax accessory is installed correctly and that none of the pins are bent.</li> <li>2. Print a Configuration page and check the modem status. It should indicate "Operational/Enabled". If the modem status is anything else, the problem is with the fax accessory.</li> </ol>
	Is the Fax feature configured correctly but you cannot send faxes?	<p>You must use the phone cord that came with the device.</p> <p>The phone cord might not be connected securely or the telephone line might not be working.</p> <p>You might have connected the device to a digital phone line instead of an analog phone line. The fax accessory requires an analog phone line.</p>	<ol style="list-style-type: none"> <li>1. Always use the phone cord that came with the device.</li> <li>2. Test the telephone line by connecting a telephone to it and making a call.</li> <li>3. Make sure you are connecting the device to an analog phone line.</li> </ol>
	Is the Fax feature configured correctly but you cannot receive faxes?	<p>A line splitter or surge-protection device might be interfering with incoming faxes.</p> <p>An answering machine or voice-mail system might be intercepting the incoming fax transmission.</p>	<ol style="list-style-type: none"> <li>1. Do not use line splitters or surge-protection devices.</li> <li>2. Disconnect the answering machine or voice-mail system.</li> <li>3. Set the number of rings-to-answer for the fax accessory to a lower number.</li> <li>4. Make sure the device is connected to an a dedicated analog phone line. Do not use a roll-over line.</li> </ol>

## Power-on checks

The basic MFP functions should start up as soon as the MFP is plugged into an electrical outlet and the power switch is pushed to the *on* position. If the MFP does not start, use the information in this section to isolate and solve the problem.

### Power-on troubleshooting overview

Turn on the MFP power. If the control-panel display remains blank, random patterns appear, or asterisks remain on the display, perform power-on checks to locate the cause of the problem.

During normal operation, the main cooling fan begins to spin briefly after the MFP power is turned on. Place your hand over the holes in the rear cover, above the formatter. If the fan is operating, you will feel a slight vibration and feel air passing into the MFP. You can also lean close to the MFP and hear the fan operating. When this fan is operational, the DC side of the power supply is functioning correctly.

After the fan is operating, the main motor turns on (unless the top cover is open, a jam condition is sensed, or the paper-path sensors are damaged). You should be able to visually and audibly determine if the main motor is turned on.

If the fan and main motor are operating correctly, the next troubleshooting step is to isolate print engine, formatter, and control-panel problems. Perform an engine test. If the formatter is damaged, it might interfere with the engine test. If the engine test page does not print, try removing the formatter and then performing the engine test again. If the engine test is then successful, the problem is almost certainly with the formatter, the control panel, or the cable that connects them.

If the control panel is blank when you turn on the MFP, check the following items.

1. Make sure that the MFP is plugged into an active electrical outlet that delivers the correct voltage.
2. Make sure that the power switch is in the *on* position.
3. Make sure that the fan runs briefly, which indicates that the power supply is operational.
4. Make sure that the control-panel display wire-harness is connected.
5. Make sure that the formatter is seated and operating correctly.
6. Rotate the contrast dial on the control panel to make sure it is not all the way up or all the way down.
7. Remove any HP Jetdirect or other EIO cards, and then try to turn the MFP on again.



---

**NOTE** If the control-panel display is blank, but the main cooling fan runs briefly after the MFP power is turned on, try printing an engine-test page to determine whether the problem is with the control-panel display, formatter, or other MFP components.

---

If the main cooling fan is not operating, check the following items.

1. Check the fuse on the power-factor correction (PFC) power supply (location FU1; near the power switch) to make sure that it is not open.
2. If necessary, replace the PFC power supply PCA.

3. If necessary, replace the DC controller.
4. If necessary, replace the engine power supply.

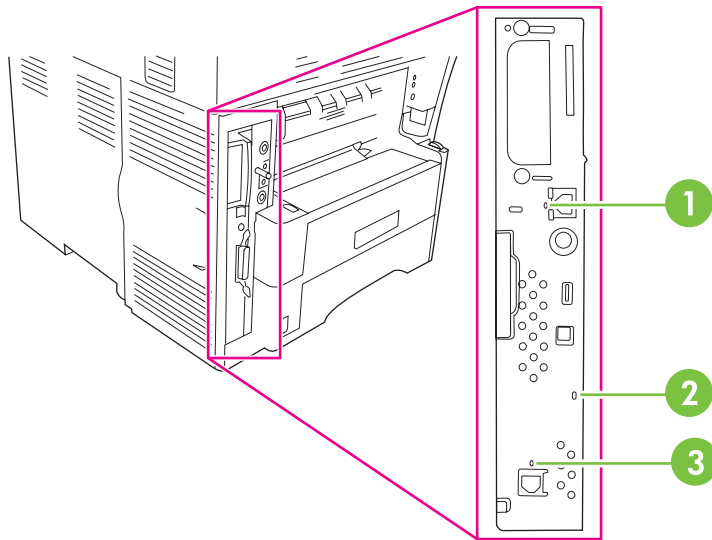


**NOTE** It is important to have the control panel functional as soon as possible in the troubleshooting process so that the control-panel display can be used to help locate MFP errors.

---

## Formatter lights

Three LEDs on the formatter indicate that the MFP is functioning correctly.



1	HP Jetdirect Inside LEDs
2	Heartbeat LED
3	Fax LED

## HP Jetdirect Inside LEDs

The embedded HP Jetdirect print server has two LEDs, one for each possible link speed. When an LED is lit, the print server is functioning correctly. A link failure is indicated when both LEDs are off.

For link failures, check all of the network cable connections. In addition, you can try to manually configure the link settings on the embedded print server by using the MFP control panel menus.

1. Scroll to and touch **Administration**.
2. Touch **Initial Setup**.
3. Touch **Networking and I/O**.
4. Touch **Embedded Jetdirect** or **EIO <X> Jetdirect**.
5. Touch **Link Speed**.
6. Select the appropriate link speed.
7. Touch **Save**.

## Heartbeat LED

The heartbeat LED indicates that the formatter is functioning correctly. While the MFP is initializing after you turn it on, the LED blinks rapidly and then turns off. When the MFP has finished the initialization sequence, the heartbeat LED pulses on and off.



If the heartbeat LED is off, the formatter might have a problem. Replace the formatter.

## Fax LED

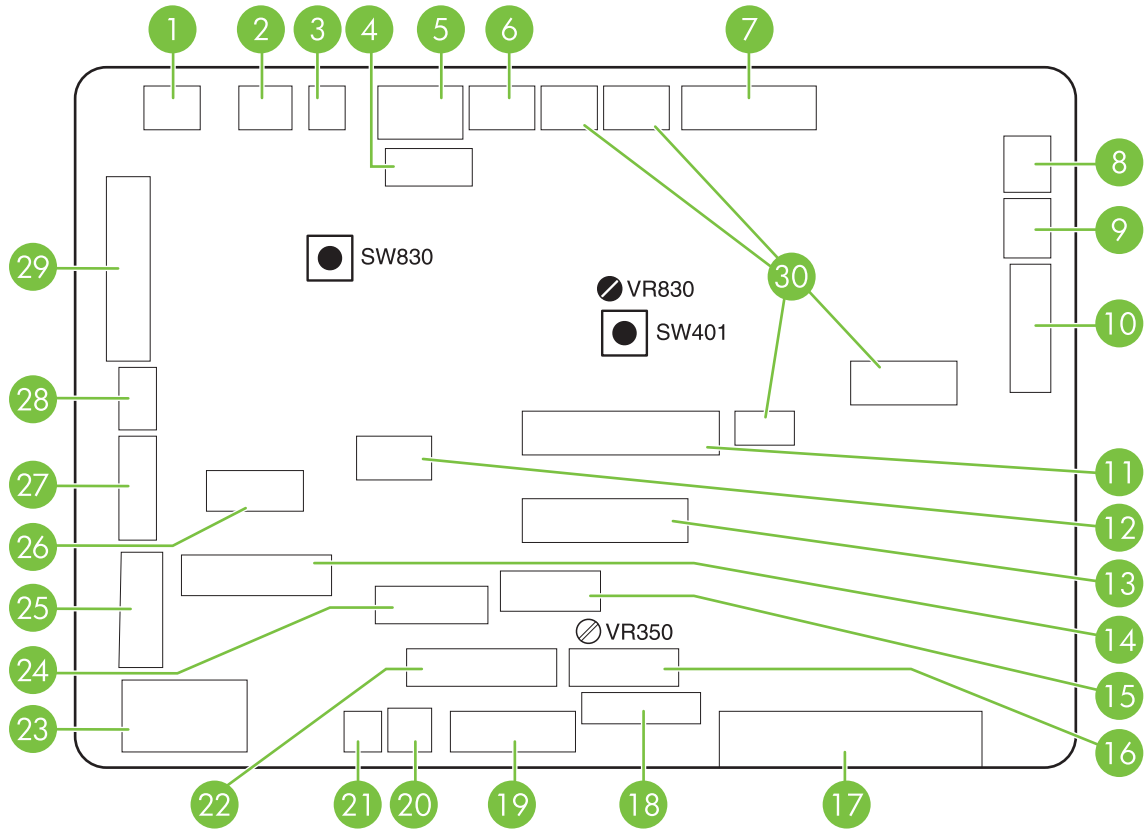
The LED on the HP LaserJet analog fax accessory 300 indicates that it is functioning correctly. If the LED is off, see the *HP LaserJet Analog Fax Accessory 300 User Guide* for information about solving the problem.

# Diagrams for troubleshooting

Use the diagrams in this section to identify MFP components.

## DC controller connections

Each of the connections on the DC controller PCA is indicated in the following figure.

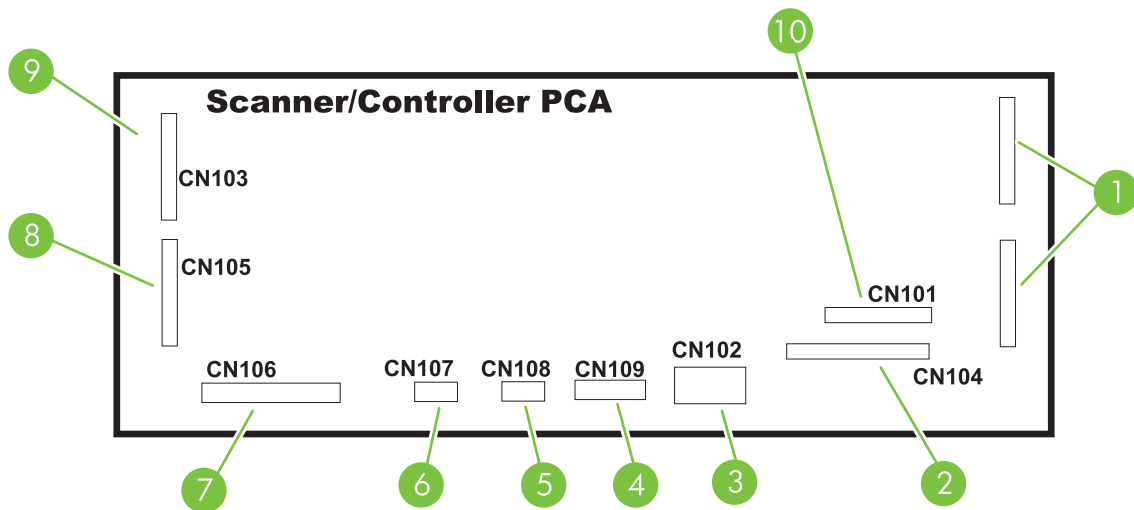


**Figure 6-1** DC controller component connections

Item	Component	Connector
1	Tray 1 pickup solenoid, SL101	J79
2	Feed-roller clutch, CL101	J89
3	Memory tag	J97
4	Laser/scanner	J84
5	Image scanner (+24 volts)	J70
6	Reversing-unit fan, FN103 Delivery-door switch, SW103	J65
7	Reversing-unit motors: M104, M105, M106	J50
8	Output-bin full sensor, PS104	J85
9	DC controller fan, FN104	J66

Item	Component	Connector
10	Reversing-unit sensors and solenoids: PS109, PS110, PS111, SL105, SL106	J43
11	Engine power supply PCA	J80
12	Top-cover switch, SW101	J95
13	Engine power supply PCA	J81
14	Tray 2 paper size and paper-stack surface sensors and switches: PS101, PS107, SW102	J90
15	PFC power supply PCA	J60
16	Laser/scanner	J83
17	Formatter	J82
18	Control panel	J77
19	Optional output devices	J96
20	Tray 2 pickup solenoid, SL101	J92
21	Lifter motor, M103	J93
22	Main motor, M101	J98
23	+24 volt	J99
24	Duplex printing accessory	J44
25	Drum motor, M102	J86
26	Fuser	J71
27	Envelope feeder	J88
28	Print-cartridge fan, FN102	J78
29	Paper-path sensors and switches: PS106, PS112, PS103, PS102, PS105, SW105	J87
30	Not used	

## Scanner-controller PCA connections



**Figure 6-2** Scanner-controller PCA component connections

Item	Component
1	Not used
2	Optical-head assembly
3	Power supply
4	Cover-closed switch and home-position sensor
5	Scanner fan
6	Inverter PCA
7	Flatbed motor
8	To ADF intermediate PCA
9	To ADF feed and read motors
10	Formatter PCA

# General timing chart

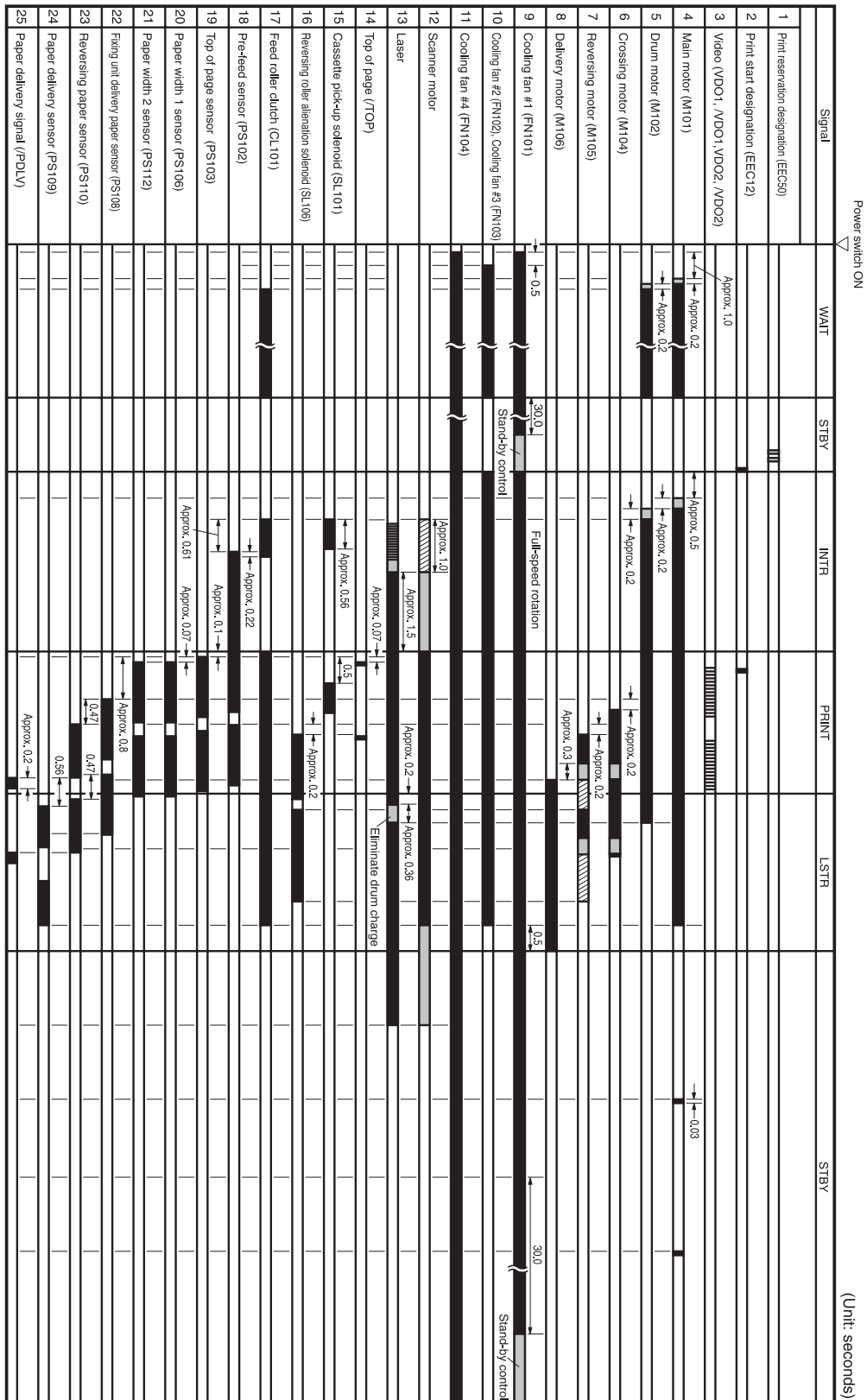


Figure 6-3 General timing chart (1 of 2)

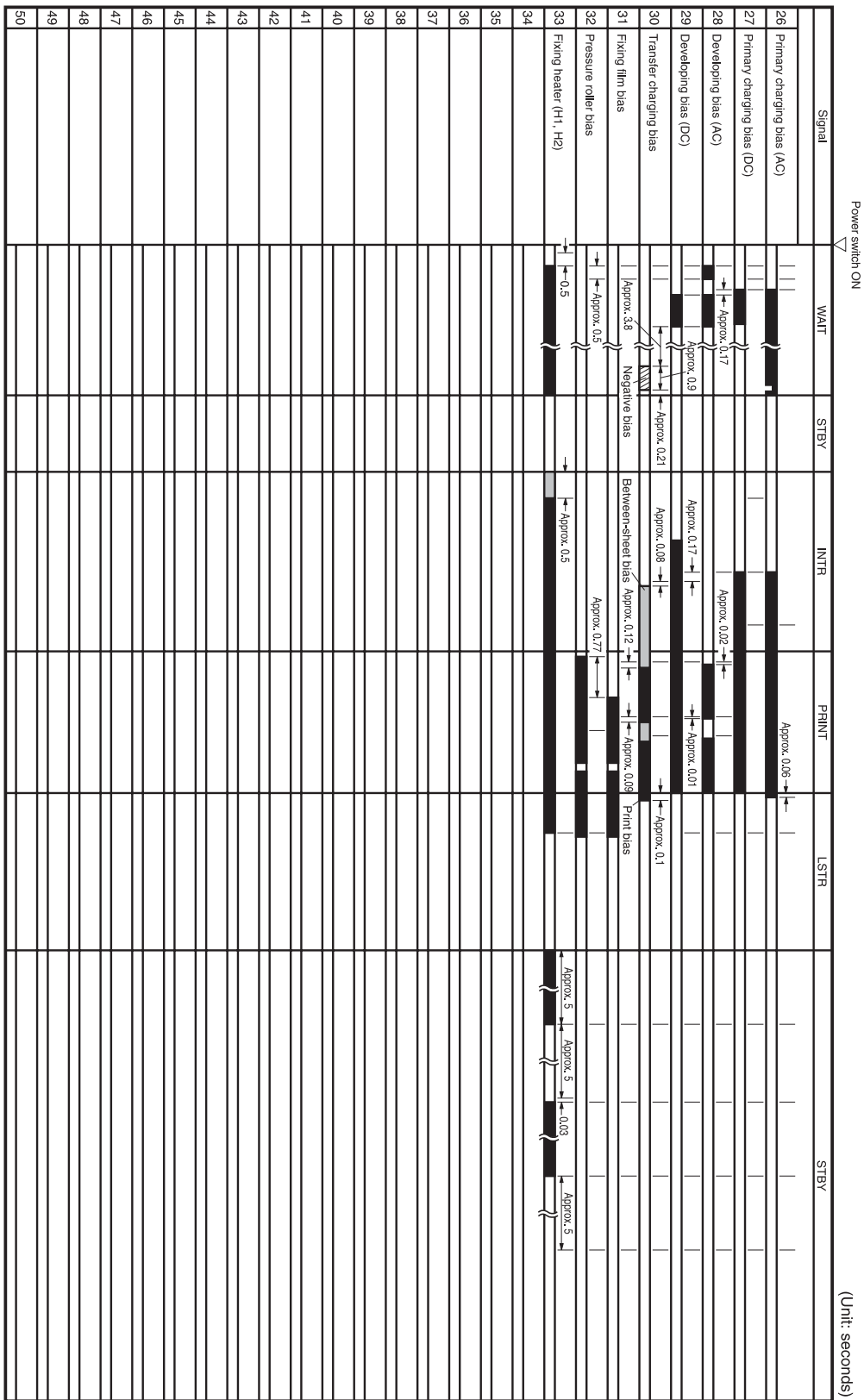


Figure 6-4 General timing chart (2 of 2)



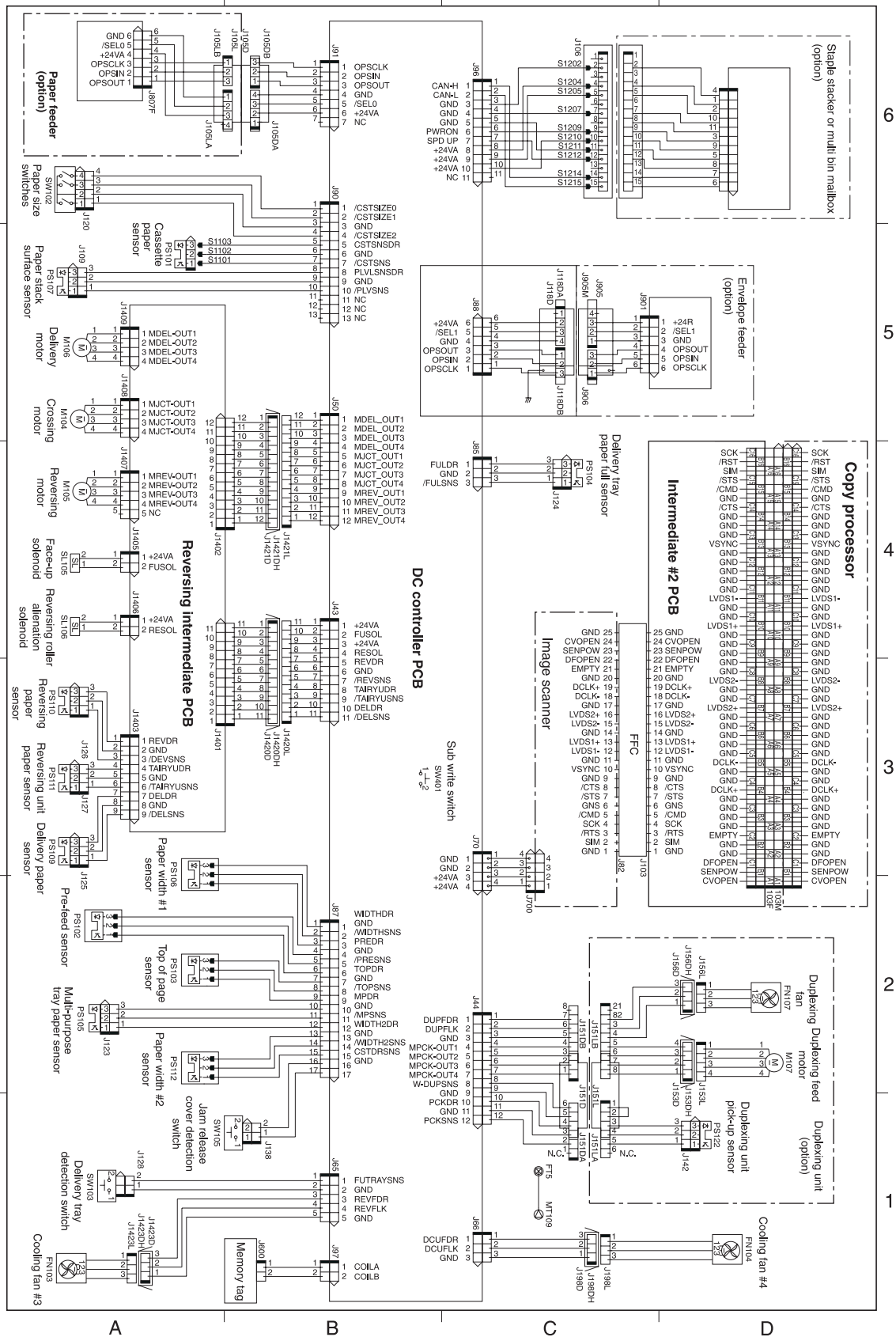


Figure 6-6 General circuit diagram (2 of 2)



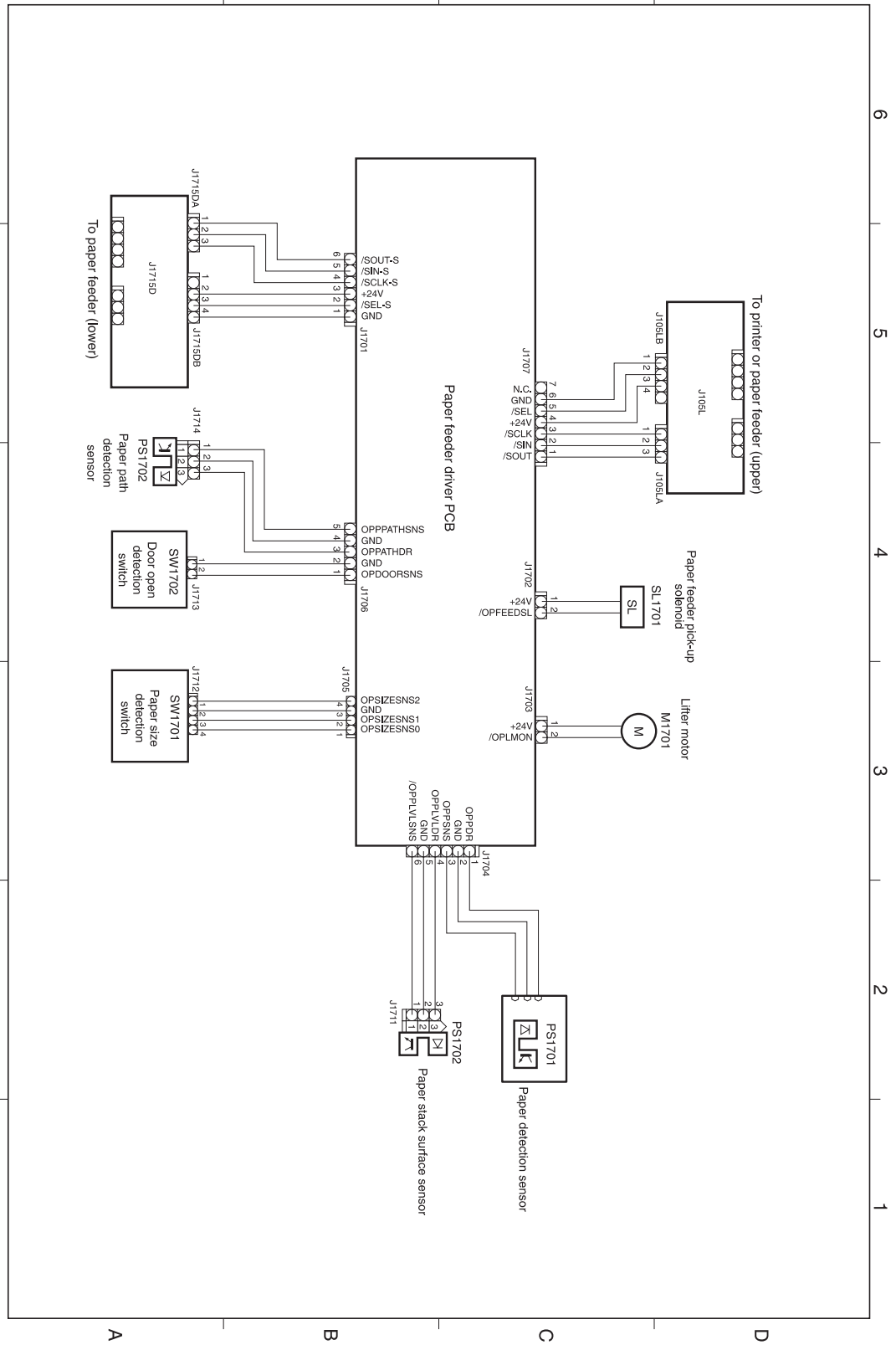
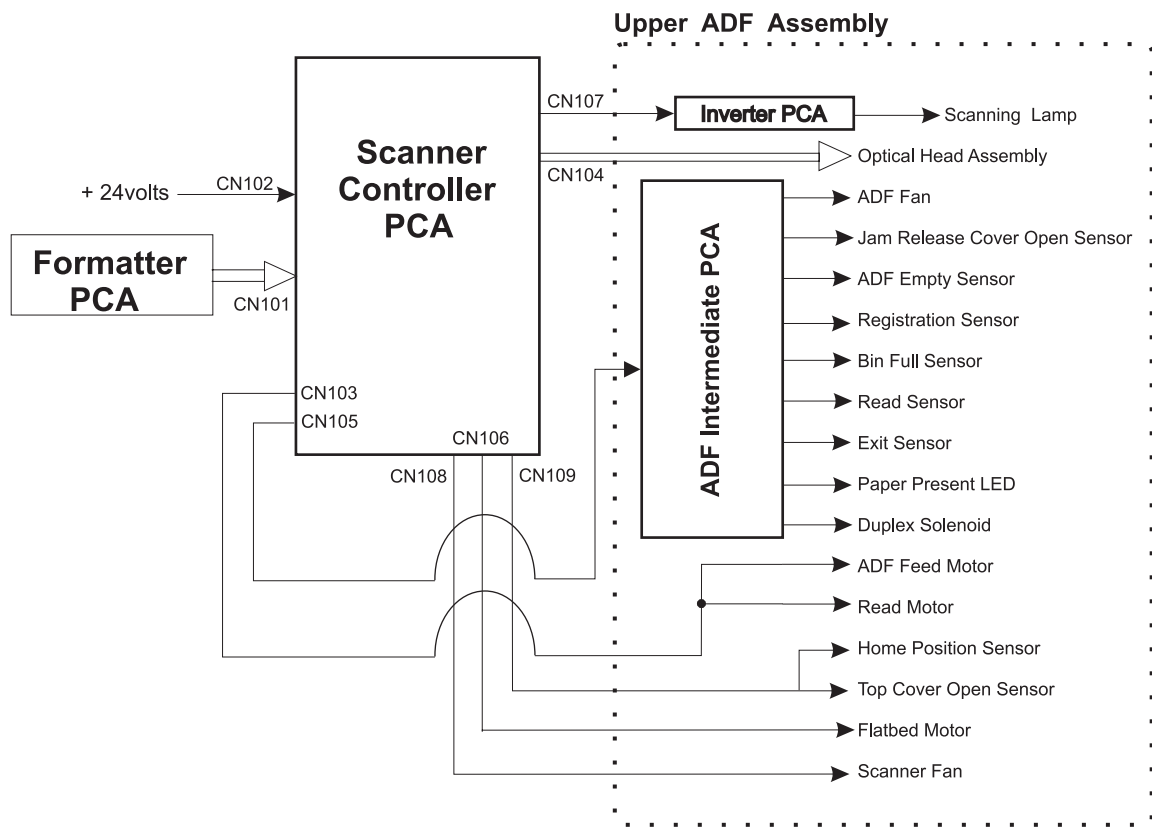


Figure 6-7 Circuit diagram for the 500-sheet feeder



**Figure 6-8** Circuit diagram for the scanner

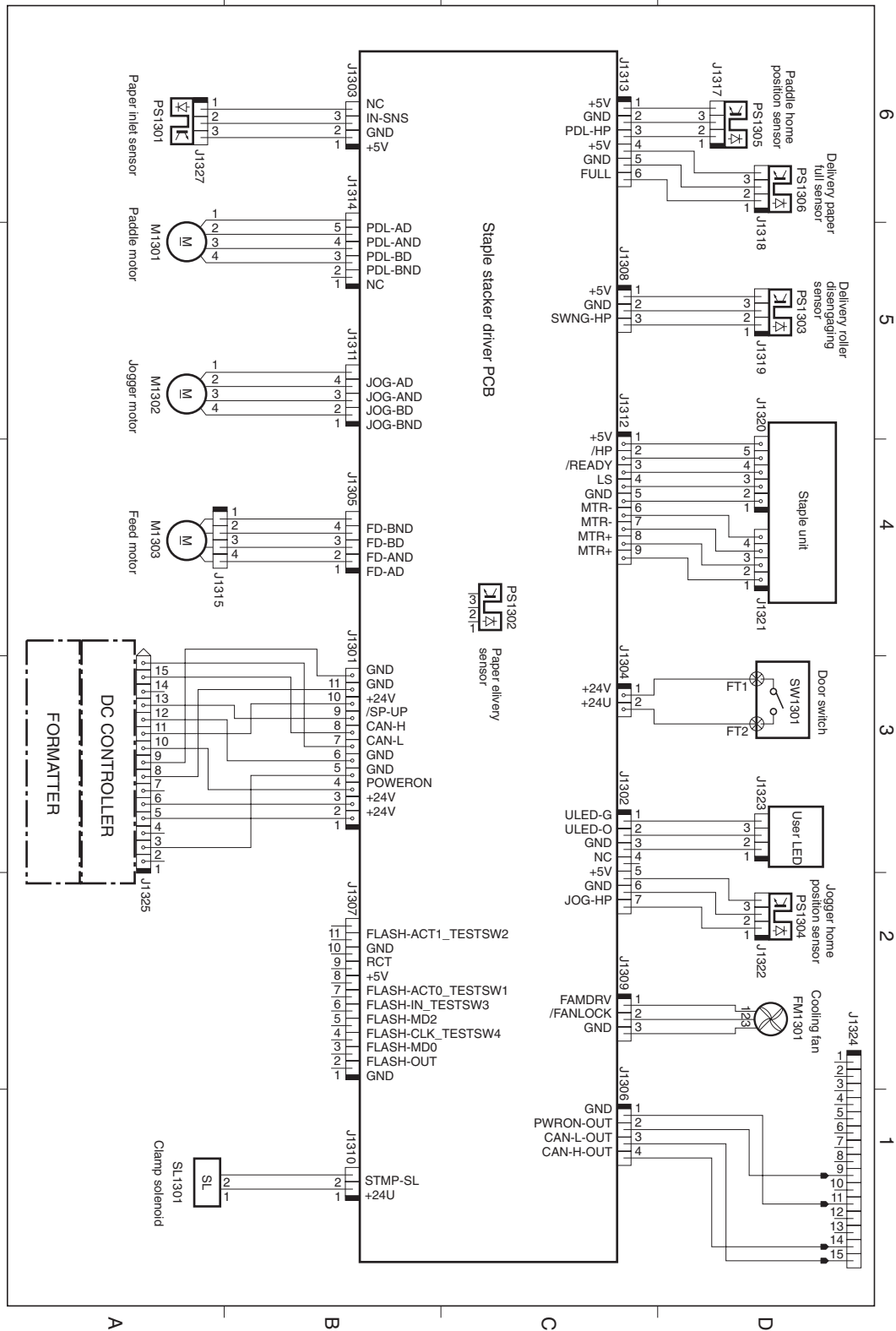


Figure 6-9 Circuit diagram for the stapler/stacker

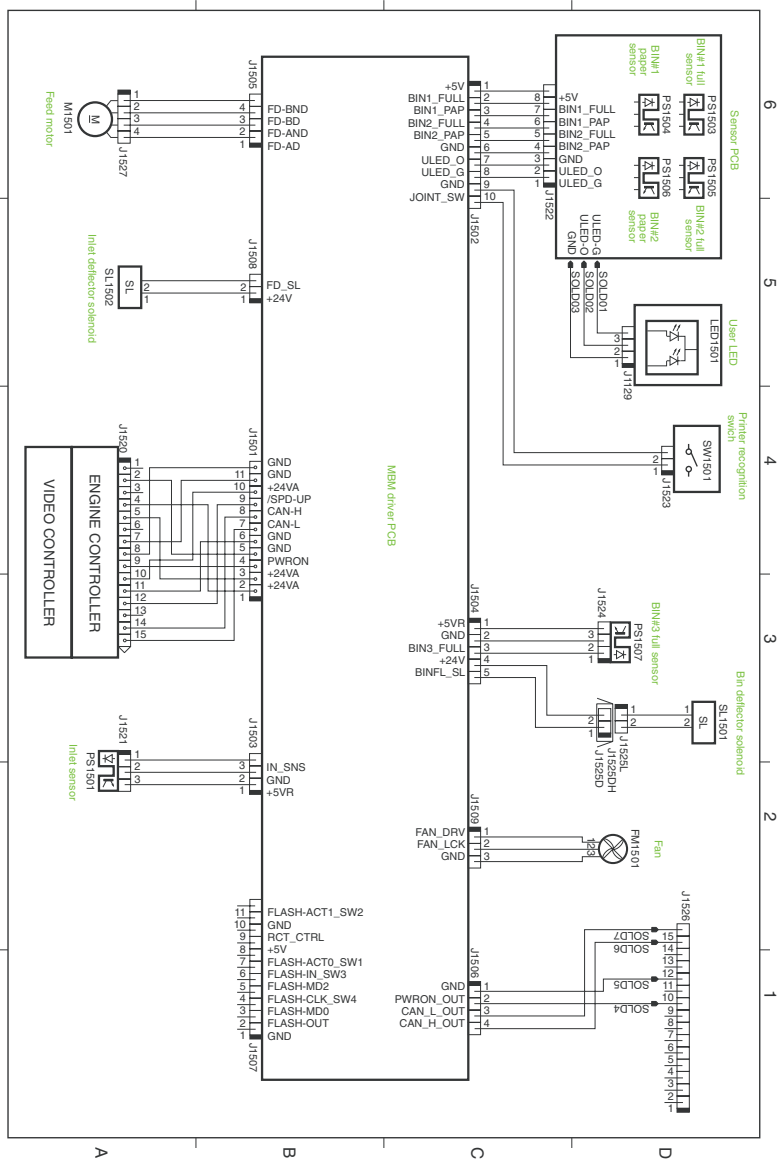


Figure 6-10 Circuit diagram for the 3-bin mailbox

## Solve general device problems

### Device selects media from the wrong tray.

Cause	Solution
The tray selection in the software program might be incorrect.	For many software programs, the paper tray selection is found on the <b>Page Setup</b> menu within the program.  Remove any media in other trays to make the device select from the correct tray.  For Macintosh computers, use the HP Printer Utility to change the priority of the tray.
The configured size does not match the size of the media that is loaded in the tray.	Adjust the width guides to match the size of the media that is loaded in the tray.

### Device does not pull paper from tray.

Cause	Solution
The tray is empty.	Load paper in the tray.
The paper guides are set incorrectly.	To set the guides correctly, see "Load Media".  For tray 2, 3, 4, or 5, make sure that the leading edge of the paper stack is even. An uneven edge can prevent the lift plate from rising.

### Paper curls when it exits the device.

Cause	Solution
The paper curls when it exits to the top output bin.	Choose the straightest paper path in the printer driver or control panel.  Turn over the paper that you are printing on.  Reduce the fusing temperature to reduce the curling.

### Print job is extremely slow.

Cause	Solution
The job might be very complex.	Reduce the complexity of the page or try adjusting the print-quality settings. If this problem occurs frequently, add memory to the device.
The maximum speed of the device cannot be exceeded even when more memory is added.	
Printing speeds might be automatically reduced when printing on custom-sized media.	
Note: Slower speeds are expected when printing on narrow paper, when printing from tray 1, or when using the <b>High2</b> fuser mode.	
You are printing a PDF or PostScript (PS) file but are using a PCL device driver.	Try using the PS device driver rather than the PCL device driver. (You can usually do this from a software program.)

### Print job prints on both sides of the paper.

Cause	Solution
The device is set for duplexing.	Turn duplexing off in the printer driver or at the control panel.

### Print job contains only one page but the device processes the back side of the page as well (the page comes part of the way out, and then goes back into the device).

Cause	Solution
The device is set for duplexing. Even if the print job contains only one page, the device also processes the back side.	Turn duplexing off in the printer driver or at the control panel. Do not try to pull the page out of the device before duplexing is complete. Jamming might result.

### Pages print, but are totally blank.

Cause	Solution
The sealing tape might still be on the print cartridge.	Remove the print cartridge and pull out the sealing tape. Reinstall the print cartridge.
The file might have blank pages.	Check the file to make sure that it does not contain blank pages.

### The device prints, but the text is wrong, garbled, or incomplete.

Cause	Solution
The device cable is loose or defective.	Disconnect the device cable and reconnect it. Try a print job that you know works. If possible, attach the cable and device to another computer and try a print job that you know works. Finally, try a new cable.

**The device prints, but the text is wrong, garbled, or incomplete.**


<b>Cause</b>	<b>Solution</b>
The wrong driver was selected in the software.	Check the software device selection menu to make sure that an HP LaserJet M4345 device is selected.
The software program is malfunctioning.	Try printing a job from another program.

**The device does not respond when you select Print in the software.**

<b>Cause</b>	<b>Solution</b>
The device is out of media.	Add media.
The device might be in the manual-feed mode.	Change the device from manual-feed mode.
The cable between the computer and the device is not connected correctly.	Disconnect and reconnect the cable.
The device cable is defective.	If possible, attach the cable to another computer and print a job that you know works. You might also try using a different cable.
The wrong device was selected in the software.	Check the software device selection menu to make sure that an HP LaserJet M4345 device is selected.
The device might have a jam.	Clear any jams, paying careful attention to the duplexer area (if your model has a duplexer). See <a href="#">Clear jams on page 400</a> .
The software for the device is not configured for the device port.	Check the software device selection menu to make sure that it is using the correct port. If the computer has more than one port, make sure that the device is attached to the correct one.
The device is on a network and is not receiving a signal.	Check cable connections. Reinstall the printing software. Print a job that you know works.  Clear any stopped jobs from the print queue.
The device is not receiving power.	If no lights are on, check the power cord connections. Check the power switch. Check the power source.
The device is malfunctioning.	Check the control-panel display for messages and lights to determine if the device is indicating an error.

## Control-panel message types

Four types of control-panel messages can indicate the status of or problems with the device.

Message type	Description
Status messages	Status messages reflect the current state of the device. They inform you of normal device operation and require no interaction to clear them. They change as the state of the device changes. Whenever the device is ready, not busy, and has no pending warning messages, the status message <b>Ready</b> appears if the device is online.
Warning messages	Warning messages inform you of data and print errors. These messages typically alternate with the <b>Ready</b> or status messages and remain until you touch <b>OK</b> . Some warning messages are clearable. If <b>Clearable Warnings</b> is set to <b>Job</b> on the device <b>Device Behavior</b> menu, the next print job clears these messages.
Error messages	<p>Error messages communicate that some action must be performed, such as adding paper or clearing a jam.</p> <p>Some error messages are auto-continuable. If <b>Auto-Continue</b> is set on the menus, the device will continue normal operation after an auto-continuable error message appears for 10 seconds.</p> <p> <b>NOTE</b> Pressing any button during the 10-second auto-continuable error message overrides the auto-continue feature, and the button function takes precedence. For example, pressing the <b>Stop</b> button pauses printing and offers the option to cancel the print job.</p>
Critical-error messages	Critical error messages inform you of a device failure. Some of these messages can be cleared by turning the device off and then on. These messages are not affected by the <b>Auto-Continue</b> setting. If a critical error persists, service is required.



# Control-panel messages

Table 6-1 Control-panel messages

Control panel message	Description	Recommended action
<b>10.32.00 Unauthorized supply installed</b>	A print cartridge or other supply posing as genuine HP supply does not pass an authentication test.	Replace the supply with genuine HP supply.
<b>10.XX.YY SUPPLY MEMORY ERROR</b>	The MFP cannot read or write to at least one print cartridge e-label or an e-label is missing from a print cartridge.  10.00.<YY> = E-label is damaged.  10.10.<YY> = MFP cannot communicate with the e-label.	<ol style="list-style-type: none"> <li>1. Reinstall the print cartridge, or install a new HP print cartridge.</li> <li>2. Verify that connector J97 on the DC controller PCA is firmly seated.</li> </ol>
<b>11.XX Internal clock error - To Continue Touch OK</b>	The MFP real time clock has experienced an error.	Whenever the MFP is turned off and then turned on again, set the time and date at the control panel.  If the error persists, you might need to replace the formatter.
<b>13.JJ.NT JAM IN ENVELOPE FEEDER - Clear jam, then touch OK</b>	Media is jammed in the envelope feeder.	Remove the jammed media from the envelope feeder. Follow the instructions in the onscreen dialog box.
<b>13.JJ.NT JAM IN OUTPUT BIN</b>	Media is jammed in the output bin.  Use this list to determine the exact location of the jam:  13.12.07 = Staple cartridge  13.12.08 = Output bin paper-present sensor (media is stuck)  13.12.09 = Output bin inlet sensor (media is stuck)  13.12.10 = Output bin inlet sensor (media did not reach the sensor at the appropriate time)  13.12.11 = Media is present in the output bin when the MFP is turned on.  13.31.00 = Media is jammed in the reversing assembly.	<ol style="list-style-type: none"> <li>1. Clear all jammed media.</li> <li>2. Verify that connector J50 on the DC controller PCA is firmly seated.</li> <li>3. Verify that the two connectors that are on the rear of the reversing assembly are installed.</li> <li>4. Use the component diagnostic test to test three motors: switchback motor, intermediate switchback motor, output motor.</li> <li>5. Use the component diagnostic test to test two solenoids: face-up/face-down solenoid (SL105) and alienation solenoid (SL106).</li> <li>6. Use the manual sensor test to test two sensors: paper-delivery sensor PS109 (sensor "K") and reversing-paper sensor PS110 (sensor "H").</li> <li>7. If any of these components fail, replace the reversing assembly.</li> </ol>
<b>13.JJ.NT JAM IN STAPLER</b>	A staple is jammed in the external stapling device.	Follow the instructions in the onscreen dialog box.
<b>13.JJ.NT JAM IN TRAY 1</b>	The tray 1 pickup solenoid might be defective.	Remove the jammed media from tray 1. Follow the instructions in the onscreen dialog box.

**Table 6-1** Control-panel messages (continued)

Control panel message	Description	Recommended action
		If the message persists, open the <b>Troubleshooting</b> menu and touch <b>Component Test</b> . Run the test for <b>MP Tray Solenoid</b> . If the solenoid is defective, replace it.
<b>13.JJ.NT JAM IN TRAY X - Clear jam, then touch OK</b>	Media is jammed in the specified tray.  13.01.00 = Media did not arrive at the pre-feed sensor (PS102) within the specified time.  13.02.00 = Media did not arrive at the top-of-page sensor (PS103) within the specified time.	Follow the instructions in the onscreen dialog box.
<b>13.JJ.NT JAM INSIDE DUPLEXER Remove duplexer from lower left area</b>	13.13.00 = Media is stuck inside the duplexer.	Follow the instructions in the onscreen dialog box.
<b>13.JJ.NT JAM INSIDE LEFT OUTPUT AREA Remove output bin and duplexer</b>	Media is jammed in the output area.	Follow the instructions in the onscreen dialog box.
<b>13.JJ.NT JAM INSIDE RIGHT ACCESS DOOR Open all right access doors ABOVE tray X</b>	Media is jammed inside the jam-access door for the tray that is indicated.	Follow the instructions in the onscreen dialog box.
<b>13.JJ.NT JAM INSIDE TOP COVER AREA</b>	Media is jammed in the top cover area.  13.02.00 = Media is stopped under the top-of-page sensor (PS103).  13.05.00 = Media did not arrive at the fuser-delivery sensor (PS108) within the specified time.  13.09.00 = Media is jammed under the reversing paper sensor (PS110).  13.20.00 = The pre-feed sensor (PS102), the top-of-page sensor (PS103), or the fuser-delivery sensor (PS108) detected media inside the MFP when it was turned on.  13.21.00 = The top cover was opened during printing, or the top-cover switch (SW101) is defective.  13.31.00 = Media did not arrive at the reversing paper sensor (PS110) within the specified time.  13.33.00 = Media did not arrive at the paper-delivery sensor (PS109) within the specified time.	Follow the instructions in the onscreen dialog box.
<b>13.JJ.NT JAM INSIDE TOP COVER AREA Remove print cartridge</b>	Media is jammed in the top cover area and you must remove the print cartridge to clear the jam.	Follow the instructions in the onscreen dialog box.
<b>13.JJ.NT JAM INSIDE TRAY 2 AREA</b>	Media is jammed in tray 2.	Follow the instructions in the onscreen dialog box.
<b>13.JJ.NT JAM INSIDE TRAY 2 RIGHT DOOR</b>	There is a jam inside the tray 2 right door.	Open the tray 2 right access door, remove any jammed paper, and then close the door.

**Table 6-1** Control-panel messages (continued)

Control panel message	Description	Recommended action
<b>13.JJ.NT JAM Then open and close top cover</b>	There has been a fault with the pick mechanism in a tray.	Remove any misprinted paper from the output bins. Check all trays to ensure media sizes and types are supported. Open and close the top cover.
<b>13.JJ.NT JAMS INSIDE TOP COVER AREA Remove print cartridge</b>	Media is jammed in more than one location inside the top cover area. You must remove the print cartridge to clear the jams.	Follow the instructions in the onscreen dialog box.
<b>13.JJ.NT PAPER JAM OPEN INPUT TRAYS</b>	Media is jammed inside one or more of the trays.	Follow the instructions in the onscreen dialog box.
<b>20 INSUFFICIENT MEMORY - To Continue Touch OK</b>	The MFP received more data than can fit in the available memory. You might have tried to transfer too many macros, soft fonts, or complex graphics.	Touch <b>OK</b> to print the transferred data (some data might be lost), and then simplify the print job or install additional memory.
<b>21 PAGE TOO COMPLEX - To Continue Touch OK</b>	The page formatting process was not fast enough for the MFP.	Touch <b>OK</b> to print the transferred data. (Some data might be lost.) If this message appears often, simplify the print job.
<b>22 EIO X BUFFER OVERFLOW - To Continue Touch OK</b>	Too much data was sent to the EIO card in the specified slot (X). An incorrect communications protocol might be in use.	Touch <b>OK</b> to print the transferred data. (Some data might be lost.)  Check the host configuration.
<b>22 EMBEDDED I/O BUFFER OVERFLOW - To Continue Touch OK</b>	Too much data was sent to the embedded HP Jetdirect print server.	Touch <b>OK</b> to print the transferred data. (Some data might be lost.)
<b>30.1.10 Scanner Failure</b>	The ADF fan is not operating.  The ADF fan operates only during a scan process.	<ol style="list-style-type: none"> <li>1. Remove the ADF rear cover and watch the fan during a scan process.</li> <li>2. Verify that the fan connection on the ADF intermediate PCA is firmly seated.</li> <li>3. If the fan does not rotate, replace the ADF.</li> </ol>
<b>30.1.6 Scanner Failure</b>	This is a scanner-fan error. This fan is located in the base of the scanner assembly. It operates whenever the scanner lamp is illuminated or whenever the scanner flatbed motor is rotating. This fan also operates during the MFP initialization sequence.	<ol style="list-style-type: none"> <li>1. During the MFP initialization sequence, try to listen to this fan to find out if it is operating.</li> <li>2. Verify that connector CN108 on the scanner-controller PCA is firmly seated. Also make sure that the connection for the fan in the base of the scanner assembly is firmly seated.</li> <li>3. If all the connectors are secure but the fan is not operating, replace the fan.</li> </ol>
<b>30.1.8 Scanner Failure</b>	This is a scanner-calibration error. The scanner might be locked, or a cable might not be connected correctly.  During the MFP initialization sequence, the scanner optical assembly moves from its home position to the calibration strip. If this movement does not occur, this error appears.	<ol style="list-style-type: none"> <li>1. Raise the ADF, and make sure that the scanner lock is in the unlocked position.</li> <li>2. Turn on the MFP and watch to see if the optical assembly moves. If it does not move, remove the scanner glass to see if anything is hindering the optical assembly from moving.</li> <li>3. Make sure that the optical-assembly drive belt is installed correctly.</li> </ol>

**Table 6-1** Control-panel messages (continued)

Control panel message	Description	Recommended action
<b>30.1.YY SCANNER FAILURE</b>	<p>An error has occurred in the scanner. Use the following list to identify specific errors:</p> <p>30.1.1 = The scanner cover is open.</p> <p>30.1.2 = A jam has occurred in the ADF.</p> <p>30.1.3 = The ADF could not pick up the paper.</p> <p>30.1.6 = An error has occurred at the scanner fan. (See the separate entry for this error.)</p> <p>30.1.7 = A communication error has occurred in the scanner.</p> <p>30.1.8 = A scanner-calibration error has occurred. (See the separate entry for this error.)</p> <p>30.1.10 = An error has occurred at the ADF fan. (See the separate entry for this error.)</p> <p>30.1.15 = Scanner initialization failed.</p> <p>30.1.18 = An error occurred on the scanner PCA.</p> <p>30.1.19 = An error occurred at the scanner lamp.</p> <p>30.1.22 = A fatal hardware error has occurred in the scanner.</p> <p>30.1.23 = A scanner-calibration error has occurred.</p> <p>30.1.24 = The ADF jam-access door is open.</p> <p>30.1.25 = A general error has occurred in the scanner or ADF. This error is most likely a memory corruption.</p> <p>30.1.29 = The ADF output bin is full.</p> <p>30.1.36 = The scanning-firmware upgrade failed. The MFP automatically tries to upgrade the firmware again the next time the MFP is turned on.</p>	<p>4. Verify that the connector CN106 on the scanner-controller PCA is firmly seated.</p> <p>5. Verify that the connector CN109 on the scanner-controller PCA is firmly seated. Also verify that the connector for the scanner-home-position sensor is firmly seated.</p> <p>1. Turn the MFP off and then on to try to clear the message.</p> <p>2. If the message indicates that a jam has occurred, clear the jam.</p> <p>3. Verify that the cable between the print engine and the scanner is securely connected.</p> <p>4. Upgrade the firmware.</p> <p>5. If you are unable to resolve the problem, replace the scanner assembly.</p>
<b>40 BAD EIO X TRANSMISSION - To Continue Touch OK</b>	<p>The connection between the MFP and the EIO card in the specified slot has been broken.</p>	<p>Touch <b>OK</b> to clear the error message and continue printing.</p>

**Table 6-1** Control-panel messages (continued)

Control panel message	Description	Recommended action
<b>40 BAD SERIAL TRANSMISSION - To Continue Touch OK</b>	A serial data error (parity, framing, or line overrun) occurred as data was being sent by the computer.	Touch <b>OK</b> to clear the error message. (Data will be lost.)
<b>40 EMBEDDED I/O BAD TRANSMISSION - To Continue Touch OK</b>	A temporary printing error has occurred.	Turn the MFP off, and then turn the MFP on.
<b>41.3 LOAD TRAY XX &lt;TYPE&gt; &lt;SIZE&gt;</b>	This is typically caused if two or more sheets of media stick together in the MFP or if the tray is not adjusted correctly.	Reload the tray with the correct media size. Reconfigure the size in a tray so that the MFP will use a tray that contains the size required for the print job. Follow the instructions in the onscreen dialog box.
<b>41.3 LOAD TRAY XX &lt;TYPE&gt; &lt;SIZE&gt; - To Use Another Tray Touch OK</b>	The specified tray is loaded with media that is longer or shorter in the feed direction than the size adjusted for the tray.	Touch <b>OK</b> to use another tray. Reconfigure the size in a tray so that the MFP will use a tray that is loaded with the size of media required for the print job. If the message does not clear automatically from the control-panel display, turn the MFP off, and then turn the MFP on.
<b>41.3 MEDIA TOO SHORT CANNOT DUPLEX</b>	The MFP cannot print on both sides of the selected media because the media does not meet the minimum length specification.	Select single-sided printing or load a longer-size media. Resend the job.
<b>41.3 MEDIA TOO SHORT CANNOT SEND TO FACE DOWN OUTPUT BIN</b>	The MFP cannot deliver the selected media face-down because the media does not meet the minimum length specification.	Select the face-up output option, or load a longer-size media in the tray. Resend the job.
<b>41.&lt;X&gt; Error</b>	A temporary printing error occurred.  41.2 = Beam-detect misprint error	Touch <b>OK</b> to clear the error. If the error is not cleared, turn the MFP off, and then turn the MFP on.  If these errors become a frequent problem, replace the DC controller PCA.
<b>49.XXXXX ERROR - To Continue Turn Off Then On</b>	A critical firmware error has occurred.  This type of error can be caused by invalid print commands, corrupt data, or invalid operations.  In some instances, electrical noise in the cable can corrupt data during transmission to the MFP. Other causes include poor-quality parallel cables, poor connections, or specific software programs.  Sometimes, the formatter itself is at fault, which is usually indicated by a <b>79.XXXX ERROR - To Continue Turn Off Then On</b> message.	<ol style="list-style-type: none"> <li>1. Turn the MFP off, and then turn the MFP on.</li> <li>2. Upgrade the firmware.</li> <li>3. Try printing a job from a different software program. If the job prints, go back to the first program and try printing a different file. If the message appears only with a certain software program or print job, contact the software vendor for assistance.</li> <li>4. If the message persists when using different software programs and attempting specific print jobs, disconnect all of the cables that connect the MFP to the network or a computer.</li> <li>5. Turn the MFP off.</li> <li>6. Remove all DIMMs and flash-memory cards.</li> <li>7. Remove all of the EIO devices.</li> </ol>

**Table 6-1** Control-panel messages (continued)

Control panel message	Description	Recommended action
		<ol style="list-style-type: none"> <li>8. Turn the MFP on.</li> <li>9. If the error message disappears, reinstall each DIMM, flash-memory card, and EIO device individually, making sure to turn the MFP power off and then on again as you install each device.</li> <li>10. Replace the component that caused the error message.</li> </ol>
<b>50.X FUSER ERROR</b>	<p>A fuser error has occurred.</p> <p>50.1 = Low fuser temp</p> <p>50.2 = Fuser warm up service</p> <p>50.3 = High fuser temp</p> <p>50.4 = Faulty fuser</p> <p>50.5 = Inconsistent fuser</p>	<ol style="list-style-type: none"> <li>1. Turn the MFP off, and allow it to cool.</li> <li>2. Verify that the correct model of fuser is installed.</li> <li>3. Verify that the correct voltage fuser is installed.</li> <li>4. Reinstall the fuser, and check the connection between the fuser and the MFP. Replace the connector if it is damaged.</li> <li>5. Replace the fuser.</li> <li>6. Replace the DC controller PCA.</li> <li>7. Replace the power supply.</li> </ol>
<b>51.XY ERROR - To Continue Turn Off Then On</b>	<p>A temporary printing error has occurred.</p> <p>51.10 = Beam detect error</p> <p>51.20 = Laser error</p>	<ol style="list-style-type: none"> <li>1. Turn the MFP off, and then turn the MFP on.</li> <li>2. Reseat the connectors between the laser/scanner and dc controller PCA (J83 and J84).</li> <li>3. Replace the laser/scanner assembly.</li> <li>4. Replace the dc controller PCA.</li> </ol>
<b>52.XY ERROR - To Continue Turn Off Then On</b>	<p>A temporary printing error has occurred.</p> <p>52.0 = Scanner error</p> <p>52.1 = Scanner startup error</p> <p>52.2 = Scanner rotation error</p>	<ol style="list-style-type: none"> <li>1. Turn the MFP off, and then turn the MFP on.</li> <li>2. Reseat the connectors between the laser/scanner and dc controller PCA (J83 and J84).</li> <li>3. Replace the laser/scanner assembly.</li> <li>4. Replace the dc controller PCA.</li> </ol>
<b>53.10.OX - Error Unsupported DIMM</b>	<p>A memory error has occurred.</p> <p>53.10.01 = Unsupported memory/DIMM</p>	Remove the unsupported DIMM, and then try using a different DIMM.
<b>54.&lt;XX&gt; Error</b>	<p>A sensor error has occurred.</p> <p>54.01 = Temperature</p>	Turn the MFP off, and then turn the MFP on. If the error reappears, record the message and contact support.
<b>54.&lt;XX&gt; Error</b>	A sensor-related error has occurred.	Turn the device off then on. If the error reappears, write down the message and contact HP support.

**Table 6-1** Control-panel messages (continued)

Control panel message	Description	Recommended action
<b>55.05 Error - To continue turn off then on</b>	This Remote Firmware Upgrade (RFU) error message occurs when an upgrade on the firmware is being performed and something has happened that prevented the upgrade.	Turn the MFP off, and then turn the MFP on.
<b>55.XX.YY DC CONTROLLER ERROR - To Continue Turn Off Then On</b>	The print engine is not communicating with the formatter.  55.01.YY = Incoming parity error  55.02.YY = Outgoing parity error  55.04.YY = Communications timeout	Turn the MFP off, and then turn the MFP on.
<b>56.X ERROR - To Continue Turn Off Then On</b>	The input device or output device is unknown.  56.1 = Unknown input device  56.2 = Unknown output device	<ol style="list-style-type: none"> <li>1. Turn the MFP off, and then turn the MFP on.</li> <li>2. For 56.1 errors, reinstall all of the input devices (optional 500-sheet feeders or the envelope feeder.) For 56.2 errors, reinstall the output bin, the stapler/stacker, or the 3-bin mailbox.</li> <li>3. Remove all non-HP paper-handling devices.</li> </ol>
<b>57.01 Error - To continue turn off then on</b>	The DC controller fan (FN104) is not functioning.	<ol style="list-style-type: none"> <li>1. Verify that the connector J66 on the DC controller is firmly seated.</li> <li>2. Listen for the fan to operate while the MFP is initializing.</li> <li>3. If the fan does not operate during the initialization sequence, replace it.</li> </ol>
<b>57.03 Error - To continue turn off then on</b>	The print-cartridge fan (FN102) is not functioning.	<ol style="list-style-type: none"> <li>1. Verify that the connector J78 on the DC controller is firmly seated.</li> <li>2. Listen for the fan to operate while the MFP is initializing.</li> <li>3. If the fan does not operate during the initialization sequence, replace it.</li> </ol>
<b>57.04 Error - To continue turn off then on</b>	The main fan (FN101) is not functioning.	<ol style="list-style-type: none"> <li>1. Verify that connector J64 on the Engine Power Supply PCA is firmly seated.</li> <li>2. Listen for the fan to operate while the MFP is initializing.</li> <li>3. If the fan does not operate during the initialization sequence, replace it.</li> </ol>
<b>57.05 Error - To continue turn off then on</b>	The duplexing-unit fan (FN107) is not functioning.	<ol style="list-style-type: none"> <li>1. Verify that the connector J44 on the dc controller is firmly seated.</li> <li>2. Listen for the fan to operate while the MFP is initializing.</li> <li>3. If the fan does not operate during the initialization sequence, replace the duplex-printing unit.</li> </ol>

**Table 6-1** Control-panel messages (continued)

Control panel message	Description	Recommended action
<b>57.07 Error - To continue turn off then on</b>	The reversing-unit fan (FN103) is not functioning.	<ol style="list-style-type: none"> <li>1. Verify that the connector J65 on the dc controller is firmly seated.</li> <li>2. Listen for the fan to operate while the MFP is initializing.</li> <li>3. If the fan does not operate during the initialization sequence, replace it.</li> </ol>
<b>58.XX ERROR - To Continue Turn Off Then On</b>	<p>A memory error has been detected.</p> <p>58.2 = Air temperature sensor (TH3)</p> <p>58.3 = DC controller PCA</p> <p>58.4 = Engine power supply</p>	<p>Turn the MFP off, and then turn the MFP on.</p> <p>For 58.2 errors:</p> <ol style="list-style-type: none"> <li>1. Reconnect the connector J63 on the engine power supply. The air temperature sensor is the thermistor (TH3) that is mounted across the main cooling fan (FN101).</li> <li>2. Replace the air-temperature sensor.</li> <li>3. Replace the engine power supply.</li> </ol> <p>For 58.3 errors, replace the DC controller PCA.</p> <p>For 58.4 errors, replace the engine power supply.</p>
<b>59.XY ERROR - To Continue Turn Off Then On</b>	<p>An error has occurred in one of the motors.</p> <p>59.0 = Main motor error</p> <p>59.1 = Main-motor startup error</p> <p>59.2 = Main-motor rotation error</p> <p>59.4 = Print-cartridge-motor error</p> <p>59.A = Print-cartridge-motor error</p>	<ol style="list-style-type: none"> <li>1. Turn the MFP off, and then turn the MFP on.</li> <li>2. Reconnect the wire-harness on the DC controller PCA for the motor that is indicated. For the main motor, this is connector J98. For the print-cartridge motor, this is connector J86.</li> <li>3. Replace the motor.</li> <li>4. Replace the DC controller PCA.</li> </ol>
<b>60.XX ERROR - To Continue Turn Off Then On</b>	The tray specified by <b>X</b> is not lifting correctly.	<ol style="list-style-type: none"> <li>1. Install the tray and listen carefully. You should be able to hear the paper stack being lifted. You can also watch the paper-level indicator on the front of the tray to see if it moves.</li> <li>2. For tray 2, verify that connector J93 on the DC controller PCA is firmly seated. This connector is for the lift motor.</li> <li>3. For trays 3, 4, or 5, verify that connector J91 on the DC controller PCA is firmly seated.</li> <li>4. If the lift motor for that tray is not functional, first verify that nothing is obstructing its movement. Replace the lift motor for the tray if necessary.</li> </ol>



**Table 6-1** Control-panel messages (continued)

Control panel message	Description	Recommended action
<b>62 NO SYSTEM - To Continue Turn Off Then On</b>	A problem exists with the MFP firmware.	<ol style="list-style-type: none"> <li>1. Turn the MFP off, and then turn the MFP on.</li> <li>2. Upgrade the firmware.</li> </ol>
<b>64 ERROR - To Continue Turn Off Then On</b>	A scan buffer error occurred.	Turn the MFP off, and then turn the MFP on.
<b>65.12.99 Output accessory disconnected</b>	An output accessory (stapler/stacker or 3-bin mailbox) is not connected properly.	Make sure that the cable that connects the stapler/stacker or the 3-bin mailbox to the MFP is fully seated and that the screws are tightened.
<b>66.XY.ZZ OUTPUT DEVICE FAILURE</b>	<p>An error occurred in an external paper-handling accessory.</p> <p>66.00.15 = The output device was removed and then replaced while the MFP power was on.</p> <p>66.12.01 = Output-lift roller or paddle-motor error</p> <p>66.12.02 = Jogger-motor error</p> <p>66.12.03 = Stapler motor error</p>	<ol style="list-style-type: none"> <li>1. Turn the MFP power off.</li> <li>2. Check that the accessory is properly seated on and connected to the MFP, without any gaps between the MFP and the accessory. If the accessory uses cables, disconnect and reconnect them.</li> <li>3. Turn the MFP power on.</li> <li>4. If this message persists, replace the output device.</li> </ol>
<b>68.X PERMANENT STORAGE FULL - To Continue Touch OK</b>	<p>The MFP NVRAM is full. Some settings saved in the NVRAM might have been reset to the factory defaults. Printing can continue, but some unexpected functions might occur if an error occurred in permanent storage.</p> <p>68.0 = Onboard-NVRAM failure</p> <p>68.1 = Memory-DIMM or hard-disk failure</p>	<p>Touch <b>OK</b> to clear the message. If the message is not cleared, turn the MFP off, and then turn the MFP on.</p> <p>For 68.0 errors, perform an NVRAM initialization.</p> <p>For 68.1 errors:</p> <ol style="list-style-type: none"> <li>1. Use the HP Web Jetadmin software to delete files from the hard disk.</li> <li>2. Reinitialize the hard disk.</li> <li>3. Replace the hard disk.</li> </ol>
<b>68.X PERMANENT STORAGE WRITE FAIL - To Continue Touch OK</b>	The MFP NVRAM is failing to write. Printing can continue, but some unexpected functions might occur if an error occurred in permanent storage.	Touch <b>OK</b> to clear the message. If the message is not cleared, turn the MFP off, and then turn the MFP on.
<b>68.X STORAGE ERROR SETTINGS CHANGED - To Continue Touch OK</b>	One or more MFP settings are invalid and have been reset to the factory-default settings. Printing can continue, but some unexpected functions might occur if an error occurred in permanent storage.	<ol style="list-style-type: none"> <li>1. Touch <b>OK</b> to clear the message. If the message is not cleared, turn the MFP off, and then turn the MFP on.</li> <li>2. Determine which settings have changed by printing a control-panel menu map.</li> <li>3. Perform an NVRAM initialization.</li> </ol>
<b>69.X ERROR - To Continue Turn Off Then On</b>	The duplex printing unit is not functioning.	Turn the MFP off, and then turn the MFP on.

**Table 6-1** Control-panel messages (continued)

Control panel message	Description	Recommended action
<b>79.XXXX ERROR - To Continue Turn Off Then On</b>	A critical hardware error occurred.	<ol style="list-style-type: none"> <li>1. Turn the MFP off, and then turn the MFP on.</li> <li>2. If the problem persists, reseal the firmware memory card.</li> <li>3. Remove and reinstall the formatter.</li> <li>4. Upgrade the firmware.</li> </ol>
<b>8X.YYYY EIO ERROR</b>	The EIO accessory card has encountered a critical error.	<p>Try the following actions to clear the message.</p> <ol style="list-style-type: none"> <li>1. Turn the MFP off, and then turn the MFP on.</li> <li>2. Turn the MFP off, reseal the EIO accessory, and then turn the MFP on.</li> <li>3. Replace the EIO accessory.</li> </ol>
<b>8X.YYYY EMBEDDED JETDIRECT ERROR</b>	The embedded HP Jetdirect print server has encountered a critical error.	Turn the MFP off, and then turn the MFP on.
<b>ACTION NOT CURRENTLY AVAILABLE FOR TRAY X TRAY SIZE CANNOT BE ANY SIZE/ANY CUSTOM</b>	A duplexed (2-sided) document was requested from a tray that is set to <b>Any Size</b> or <b>Any Custom</b> . Duplexing is not allowed from a tray configured to <b>Any Size</b> or <b>Any Custom</b> .	Select another tray or reconfigure the tray.
<b>Authentication required</b>	Authentication has been enabled for this feature or destination. A username and password are required.	Type the user name and password, or contact the network administrator.
<b>Authentication required to use this feature</b>	A user name and password are required.	Type the user name and password, or contact the network administrator.
<b>Bad Duplexer Connection</b>	The duplex-printing accessory is not connected correctly to the MFP.	<ol style="list-style-type: none"> <li>1. Remove and reinstall the duplexer.</li> <li>2. If this message persists, the connector between the duplexer and the engine might be damaged. Inspect the connector, J151L, on the duplexer. If the connector is damaged, replace the duplexer.</li> <li>3. If the message still persists, replace the DC controller.</li> </ol>
<b>Bad Envelope Feeder Connection - To Continue Turn Off Then On</b>	The envelope feeder is not connected properly.	Remove and reinstall the envelope feeder.
<b>Check the glass and remove any paper, then press START</b>	A digital send or copy job has been performed from the scanner glass, but the original document needs to be removed.	Remove the original document from the scanner glass and press <b>Start</b> .
<b>Chosen personality not available. - To Continue Touch OK.</b>	A print job requested a MFP language (personality) that is not available for this MFP. The job will not print and will be cleared from memory.	Print the job by using a printer driver for a different printer language, or add the requested language to the MFP (if possible). To see a list of available personalities, print a Configuration page.
<b>Close top cover</b>	The top cover is open.	Close the top cover.

**Table 6-1** Control-panel messages (continued)

Control panel message	Description	Recommended action
<b>Digital Send server is not responding Contact administrator</b>	The MFP cannot communicate with the server.	Verify the network connection. Contact the network administrator.
<b>Document feeder bin full</b>	The document feeder output bin holds 50 sheets of paper. The MFP stops when the bin is full.	<p>Usually, emptying the ADF output bin clears this message. If the message persists, check the following items:</p> <ol style="list-style-type: none"> <li>1. Verify that the ADF output-bin-full sensor flag can move freely.</li> <li>2. Verify that the connector at the sensor flag is seated correctly.</li> </ol> <p>You can use the scanner tests (<b>Troubleshooting &gt; Scanner Tests</b>) to test this sensor. Lift up on the sensor flag to simulate the output bin being full. Observe whether the status changes on the control-panel display. If the status does not change, make sure that the connectors are firmly seated. Clean or replace the sensor if necessary.</p>
<b>Document feeder cover open</b>	The document feeder cover is open.	<p>The ADF cover-open sensor is located directly above the ADF feed motor. When the ADF jam-access cover is closed, a plastic protrusion that is on the bottom of this cover blocks the sensor, and the scanner-controller PCA detects that the cover is closed.</p> <p>If you have recently disassembled the ADF, make sure that all of the covers have been installed correctly and make sure that the wiring to this sensor is firmly seated. Also verify that CN105 on the scanner-controller PCA is firmly seated.</p> <p>Open the <b>Troubleshooting</b> menu, and touch <b>Scanner Tests</b> and then <b>Sensors</b>. Open and close the ADF jam-access cover and observe whether the status changes on the control-panel display. If the status does not change, make sure that the connectors are firmly seated. Clean or replace the sensor if necessary.</p>
<b>Document feeder empty</b>	The user pressed <b>Start</b> , but there is nothing in document feeder or on the scanner glass (if the document feeder is closed).	Place originals in the document feeder or scanner glass, and then press <b>Start</b> .
<b>Document feeder pick error</b>	The document feeder experienced an error while picking media.	<p>Clear any jam. Make sure that you have not overloaded the document feeder. Do not load more than 50 sheets of 20 lb paper in the document feeder.</p> <p>If the message persists, make sure that the ADF mylar sheet, the ADF pickup-roller assembly, and the ADF separation pad are installed correctly. If any of these components is dirty or worn, replace the component.</p>

**Table 6-1** Control-panel messages (continued)

Control panel message	Description	Recommended action
		The ADF-input motor might be defective. Observe the motor to see if it is rotating or attempting to pull paper through the paper path. You can use the scanner tests ( <b>Troubleshooting &gt; Scanner Tests</b> ) to test this motor. Run the ADF input motor test and the ADF input motor reverse test. If the motor does not rotate, verify that the connector CN103 is seated correctly on the scanner-controller PCA and that the connector on the motor is seated correctly. If the motor is defective, replace the ADF.
<b>DUPLEXER ERROR Remove duplexer Install duplexer with power off</b>	The duplexer has been removed.	Reinstall the duplexer. (Any print jobs at the MFP might be lost.)
<b>E-mail Gateway did not accept the job because the attachment was too large.</b>	The scanned documents have exceeded the size limit of the server.	Send the job again using a lower resolution, smaller file size setting, or fewer pages. Contact the network administrator to enable sending the scanned documents by using multiple e-mails.
<b>E-mail Gateway did not respond. Job failed.</b>	A gateway has exceeded the time out value.	Validate the SMTP IP address.
<b>E-mail Gateway rejected the job because of the addressing information. Job failed.</b>	One or more of the e-mail addresses is incorrect.	Send the job again with the correct addresses.
<b>Error executing Digital Send job. Job failed.</b>	A digital send job has failed and cannot be delivered.	Try to send the job again.
<b>HP Digital Sending: Delivery Error</b>	A digital send job has failed and cannot be delivered.	Try to send the job again.
<b>Insert or close tray XX</b>	The specified tray is missing or open.	<ol style="list-style-type: none"> <li>1. Insert or close the specified tray to continue.</li> <li>2. You can use the Manual Sensor Test to test the operation of this switch (SW102). In the diagnostic test, this switch is represented by the letter "S." If the control-panel display shows "S3," then A4-size media is installed, "S5" indicates that letter-size media is installed, and "S7" indicates that no tray is installed.</li> <li>3. Replace the media-size detection switch (SW102).</li> <li>4. Replace the DC controller PCA.</li> </ol>
<b>Install Black Cartridge</b>	The print cartridge has been removed or has been installed incorrectly.	<ol style="list-style-type: none"> <li>1. Make sure that the print cartridge is firmly seated and that the contact points are clean.</li> <li>2. Replace the print cartridge.</li> <li>3. Replace the DC controller PCA.</li> <li>4. Replace the engine power supply PCA.</li> </ol>

**Table 6-1** Control-panel messages (continued)

Control panel message	Description	Recommended action
<b>Insufficient memory to load fonts/data &lt;device&gt; - To Continue Touch OK</b>	The MFP does not have enough memory to load the data (for example, fonts or macros) from the location specified.	Touch <b>OK</b> to continue without this information. If the message persists, add more memory.
<b>Jam in Document Feeder</b>	Media is jammed in the document feeder.	<p>Clear the jam.</p> <p>If the message persists, make sure that the ADF mylar sheet, the ADF pickup-roller assembly, and the ADF separation pad are installed correctly. If any of these components is dirty or worn, replace the component.</p> <p>The ADF-read motor might be defective. Observe the motor to see if it is rotating or attempting to pull paper through the paper path. You can use the scanner tests (<b>Troubleshooting &gt; Scanner Tests</b>) to test this motor. Run the ADF read motor test and the ADF read motor reverse test. If the motor does not rotate, verify that connector CN103 is seated correctly on the scanner-controller PCA and that the connector on the motor is seated correctly. If the motor is defective, replace the ADF.</p> <p>The ADF paper-present sensor might be defective. Make sure that the sensor flag can move freely. You can use the scanner tests (<b>Troubleshooting &gt; Scanner Tests</b>) to test this sensor. Manually move the flag and observe whether the status changes on the control-panel display. If the status does not change, make sure that the wiring for the sensor is firmly seated. Clean or replace the sensor if necessary.</p>
<b>Load envelope feeder &lt;type&gt; &lt;size&gt; - To Use Another Tray, Touch OK</b>	The envelope feeder is empty.	<ol style="list-style-type: none"> <li>1. Load the envelope feeder.</li> <li>2. Replace the tray 1 sensor lever (PS105).</li> <li>3. Replace the DC controller PCA.</li> </ol>
<b>Load Tray 1 &lt;type&gt; &lt;size&gt;</b>	The tray is empty or configured for a different size than the size requested.	<ol style="list-style-type: none"> <li>1. Make sure that the tray is loaded with the media type and size that is indicated.</li> <li>2. Replace the tray 1 sensor lever (PS105).</li> <li>3. Replace the DC controller PCA.</li> </ol>
<b>Manually feed &lt;type&gt; &lt;size&gt;</b>	The specified job requires manual feed from tray 1.	<p>Load the requested media into tray 1.</p> <p>To override the message, touch <b>OK</b> to use a type and size of media that is available in another tray.</p>
<b>Manually feed output stack Then touch OK to print second sides</b>	The first side of a manual duplex job has printed and the MFP is waiting for a user to insert the output stack to complete the second side.	Insert the printed stack in the input tray, and then touch <b>OK</b> .

**Table 6-1** Control-panel messages (continued)

Control panel message	Description	Recommended action
<b>Moving solenoid To exit press STOP</b>	This message appears during a component test when the component that is moving is a solenoid.	Touch <b>Stop</b> to exit the test. This problem affects printing, so some scan functions might still be available.
<b>Non HP supply installed Economode disabled</b>	A non-HP supply or a refilled HP supply has been installed.	Follow the instructions in the onscreen dialog box.  If you are certain that the print cartridge is a genuine HP print cartridge, make sure that connector J97 on the DC controller PCA is connected.  If the problem persists, replace the DC controller PCA.
<b>Order Black Cartridge</b>	The number of pages remaining for the print cartridge has reached the low threshold. The MFP was set to stop printing when a supply needs to be ordered.	Touch <b>OK</b> to continue printing until the print cartridge is out of toner.  <ol style="list-style-type: none"> <li>1. Install a new print cartridge.</li> <li>2. If this message appears after you install a new print cartridge, the new print cartridge might be defective. Install a different cartridge.</li> <li>3. Replace the DC controller PCA.</li> <li>4. Replace the engine power-supply PCA.</li> </ol>
<b>Order document feeder kit</b>	This warning message appears one month before the end of life when the maintenance interval has been reached. Printing can continue.	Order a document feeder kit. To clear the message, touch <b>OK</b> to return to the Home screen. Then scroll to and touch <b>Resets</b> . Then touch <b>Clear Document Feeder Message</b> .
<b>Order maintenance kit</b>	This warning message appears one month before the end of life when the maintenance interval has been reached. Printing can continue.	Order a maintenance kit. To clear the message, touch <b>OK</b> to return to the Home screen. Then scroll to and touch <b>Resets</b> . Then touch <b>Clear Maintenance Message</b> .
<b>Order supplies</b>	This message displays if the <b>Replace Black Cartridge</b> option is set to <b>Stop at out</b> or <b>Override at out</b> and multiple supplies are low.	Order a new black print cartridge, maintenance kit, or document feeder kit.
<b>Output Paper Path Open</b>	The paper path between the MFP and the output device is open and must be closed before printing can continue.	<ol style="list-style-type: none"> <li>1. If you have a 3-bin mailbox installed, make sure the jam-access door is closed.</li> <li>2. If you have a stapler/stacker installed, make sure the staple cartridge is snapped into position and that the staple-cartridge door is closed.</li> </ol>
<b>PAPER WRAPPED AROUND FUSER</b>	A jam has occurred because paper has wrapped around the fuser.	Follow the instructions in the onscreen dialog box.
<b>Please turn device off and install hard disk.</b>	The requested job requires a hard disk, but the MFP does not have a hard disk installed.	Turn the MFP off and install a hard disk.
<b>Processing Digital Send Job</b>	The device is sending an e-mail or fax.	
<b>Reattach output bin</b>	The standard output bin was detached when the MFP was turned on, or the cable	Turn the MFP off. If you are using the stapler/stacker or the 3-bin mailbox, make

**Table 6-1** Control-panel messages (continued)

Control panel message	Description	Recommended action
	on the stapler/stacker or the 3-bin mailbox is not connected to the MFP.	<p>sure that the cable is connected to the MFP. Reattach the output bin, and then turn the MFP on. Observe the LED on the output device.</p> <p>If the message persists, verify that connector J65 on the DC controller is firmly seated. Replace SW103 if necessary.</p>
<b>Reinsert Duplexer - To Continue Turn Off Then On</b>	The duplexer has been removed and must be reinstalled.	<ol style="list-style-type: none"> <li>1. Reinsert the duplexer in the MFP.</li> <li>2. If the message persists, the connection between the duplexer and the MFP might be faulty. Remove the duplexer and inspect the connectors: J44 on the DC controller and J151 on the duplexer. Replace the duplexer if necessary.</li> </ol>
<b>Replace cartridge</b>	The print cartridge has reached the end of its life. Printing cannot continue.	<ol style="list-style-type: none"> <li>1. Replace the print cartridge.</li> <li>2. If this message appears after you install a new print cartridge, the new print cartridge might be defective. Install a different cartridge.</li> <li>3. Replace the DC controller PCA.</li> <li>4. Replace the engine power-supply PCA.</li> </ol>
<b>REPLACE DIMM &lt;X&gt; MEM TEST FAILURE</b>	A memory DIMM failed a test pattern.	Reseat or replace the specified DIMM.
<b>Right Access Door Open</b>	The tray 2 jam-access-cover switch, SW105, has detected that the jam-access cover on tray 2 is open.	Open the <b>Troubleshooting</b> menu and touch <b>Manual Sensor Test</b> . On the control-panel display, this switch is represented by the letter "P." Open and close the tray 2 jam-access door and observe whether the status changes on the control-panel display. If the message persists, verify that the connector J87 on the DC controller is firmly seated. Replace SW105 if necessary.
<b>SANITIZING DISK &lt;X&gt;% COMPLETE Do not power off</b>	The hard disk is being cleaned.	Contact the network administrator.
<b>SCAN FAILURE Press 'Start' to rescan</b>	The scan was unsuccessful and the document needs to be rescanned.	If necessary, reposition the document to rescan it, and then press <b>Start</b> .
<b>Too Many Pages In Job To Staple</b>	The maximum number of sheets the stapler can staple is 30.	For print jobs that have more than 30 pages, staple them manually.
<b>Tray &lt;XX&gt; Open</b>	The tray 2 paper-size-detection switch, SW102, has detected that tray 2 is not installed or that no media is present.	<ol style="list-style-type: none"> <li>1. Verify that connector J90 on the DC controller is firmly seated.</li> <li>2. You can use the Manual Sensor Test (<b>Troubleshooting &gt; Manual Sensor Test</b>) to test the operation of this switch. Status "S5" indicates that letter-size media is installed in the tray. Status "S3" indicates that A4-size media is installed in the tray. Status "S7" indicates that the tray is not installed in the MFP. Pull the tray out</li> </ol>

**Table 6-1** Control-panel messages (continued)

Control panel message	Description	Recommended action
		and reinsert it while you observe the status on the control-panel display. If the status does not change, replace SW102.
<b>Unable to connect</b>		To temporarily hide this message in order to fax or send to e-mail, touch <b>HIDE</b> .
<b>UNABLE TO COPY</b>	The MFP was unable to copy the document.	To temporarily hide this message in order to fax or send to e-mail, touch <b>IGNORE</b> .
<b>Unable to mopy job</b>	A mopy job cannot be moped because of a memory, disk, or configuration problem.	
<b>UNABLE TO SEND</b>		To temporarily hide this message in order to fax or send to e-mail, touch <b>IGNORE</b> .
<b>Unable to send Fax. Please check fax configuration.</b>	The MFP was unable to send the fax.	For complete information about solving fax problems, see the <i>HP LaserJet Analog Fax 300 User Guide</i> .
<b>Unable to store job</b>	A job cannot be stored because of a memory, disk, or configuration problem.	
<b>USB accessory error</b>	Power requirements for a USB accessory attached to the MFP are beyond supported limits.	Detach the USB accessory, and then turn the MFP off then on. Try a similar accessory that has its own power supply or requires less power.
<b>USB storage &lt;X&gt; not functional</b>	A parameter in a USB storage accessory is not working properly.	Turn the MFP off. Disconnect the USB storage accessory and replace it with a new USB storage accessory. Turn the MFP on.
<b>USB storage &lt;X&gt; removed</b>	A USB storage accessory has been disconnected since the MFP was turned on.	To continue using the USB accessory, turn off the MFP and connect the accessory again. Otherwise, turn the MFP off then on to clear the message.
<b>User name or password is incorrect. Please re-enter.</b>	The user name or password was typed incorrectly.	Retype the user name and password.
<b>User Name, Job Name, or PIN is missing.</b>	One or more of the required items has not been selected or typed.	Select the correct user name and job name, and type the correct PIN.
<b>Warming up scanner</b>	The scanner is warming up and cannot be used.	The message will cease when the scanner is ready to be used.



# Common causes of jams

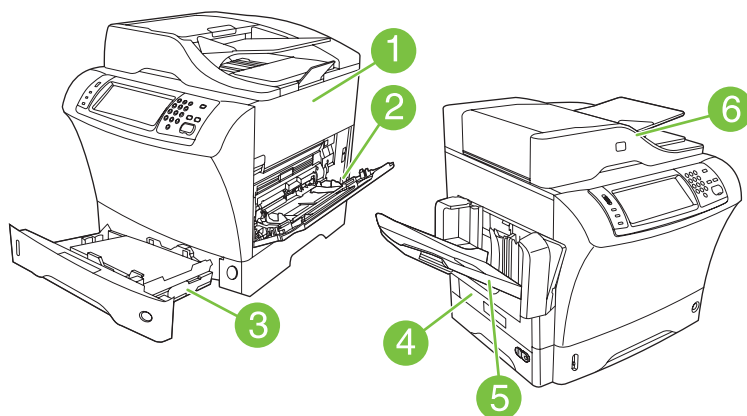
## The device is jammed.<sup>1</sup>

Cause	Solution
The media does not meet specifications.	Use only media that meets HP specifications. See <a href="#">Select print media on page 10</a> .
A component is installed incorrectly.	Verify that the print cartridge is correctly installed.
You are using media that has already passed through a device or copier.	Do not use media that has been previously printed on or copied.
An input tray is loaded incorrectly.	Remove any excess media from the input tray. Make sure that the stack is below the maximum stack height mark in the tray. See <a href="#">Media specifications on page 10</a> .
The media is skewed.	The input-tray guides are not adjusted correctly. Adjust them so they hold the stack firmly in place without bending it.
The media is binding or sticking together.	Remove the media, flex it, rotate it 180°, or flip it over. Reload the media into the input tray.
The media is removed before it settles into the output bin.	Reset the device. Wait until the page completely settles in the output bin before removing it.
During two-sided printing, you removed the paper before the second side of the document was printed.	Reset the device and print the document again. Wait until the page completely settles in the output bin before removing it.
The media is in poor condition.	Replace the media.
The internal tray rollers are not picking up the media.	If the media is heavier than 120 g/m <sup>2</sup> (32 lb), it might not be picked from the tray.
The media has rough or jagged edges.	Replace the media.
The media is perforated or embossed.	Perforated or embossed media does not separate easily. Feed single sheets from tray 1.
Device supply items have reached the end of their useful life.	Check the device control panel for messages prompting you to replace supplies, or print a supplies status page to verify the remaining life of the supplies. See <a href="#">Use information pages on page 82</a> .
Paper was not stored correctly.	Replace the paper in the trays. Paper should be stored in the original packaging in a controlled environment.
Not all device packing material was removed.	Verify that the packing tape, cardboard, and plastic shipping locks have been removed from the device.

<sup>1</sup> If the device still continues to jam, contact HP Customer Support or your authorized HP service provider.

## Clear jams

If a jam message appears on the control-panel display, look for jammed paper or other print media in the locations that are indicated in the following figure.



1	Top-cover and print-cartridge areas
2	Envelope-feeder area and tray 1 area (the envelope feeder is optional)
3	Tray 2 and optional 500-sheet feeder areas
4	Duplexing area (the duplexer is optional)
5	Output area
6	Document feeder

The following table lists the jam messages that might appear on the control-panel display. For information about clearing the jam, see the referenced section. Look for media in locations in addition to those that are indicated in the jam message. If the location of the jam is not obvious, look first in the top-cover area underneath the print cartridge.

**Table 6-2** Control-panel messages for jams

Jam message	Procedure for clearing the jam
<b>Jam in Document Feeder</b>	See <a href="#">Clear jams from the document feeder on page 413</a> .
<b>Document feeder pick error</b>	See <a href="#">Clear jams from the document feeder on page 413</a> .
<b>13.JJ.NT JAM IN ENVELOPE FEEDER - Clear jam, then touch OK</b>	See <a href="#">Clear jams from the optional envelope-feeder area on page 403</a> .
<b>13.JJ.NT JAM IN OUTPUT BIN</b>	See <a href="#">Clear jams from the output areas on page 409</a> .
<b>13.JJ.NT JAM IN TRAY 1 - Clear jam, then touch OK</b>	See <a href="#">Clear jams from the tray 1 area on page 405</a> .
<b>13.JJ.NT JAM IN TRAY 2 (or TRAY 3, 4 or 5)</b>	See <a href="#">Clear jams from the tray 2, 3, 4, or 5 areas on page 406</a> .
<b>13.JJ.NT JAM INSIDE DUPLEXER Remove duplexer from lower left area</b>	See <a href="#">Clear jams from the optional duplexer on page 408</a> .
<b>13.JJ.NT JAM INSIDE LEFT OUTPUT AREA</b>	See <a href="#">Clear jams from the output areas on page 409</a> .
<b>13.JJ.NT JAM INSIDE RIGHT ACCESS DOOR</b>	See <a href="#">Clear jams from the tray 2, 3, 4, or 5 areas on page 406</a> .

**Table 6-2** Control-panel messages for jams (continued)

Jam message	Procedure for clearing the jam
13.JJ.NT JAM INSIDE TOP COVER AREA	See <a href="#">Clear jams from the top-cover and print-cartridge areas on page 401</a> .
13.JJ.NT JAM INSIDE TRAY 2 AREA	See <a href="#">Clear jams from the tray 2, 3, 4, or 5 areas on page 406</a> .
13.JJ.NT JAM INSIDE TRAY 2 RIGHT ACCESS DOOR	See <a href="#">Clear jams from the tray 2, 3, 4, or 5 areas on page 406</a> .
13.JJ.NT JAM INSIDE TOP COVER AREA	See <a href="#">Clear jams from the top-cover and print-cartridge areas on page 401</a> .
13.JJ.NT PAPER JAM OPEN INPUT TRAYS	See <a href="#">Clear jams from the tray 2, 3, 4, or 5 areas on page 406</a> .
13.JJ.NT JAM IN STAPLER	See <a href="#">Clear staple jams on page 416</a> .

When clearing jams, be very careful not to tear jammed media. If a small piece of media is left in the device, it could cause additional jams. If jams are a recurring problem, see [Solve repeated jams on page 414](#).



**NOTE** Loose toner might remain in the device after a jam and cause temporary print-quality problems. These problems should clear up within a few pages.

## Clear jams from the top-cover and print-cartridge areas

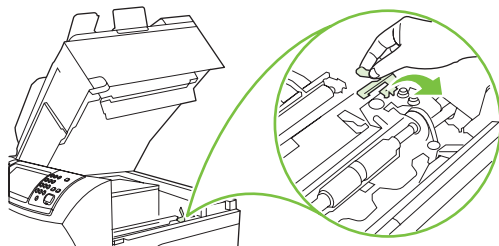
Clear jams that occur during the printing process by using this procedure.

1. Open the top cover and remove the print cartridge.

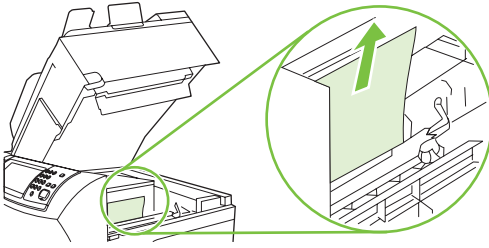


**CAUTION** To prevent damage to the print cartridge, do not expose it to light for more than a few minutes. Cover the print cartridge with a sheet of paper while it is outside of the device.

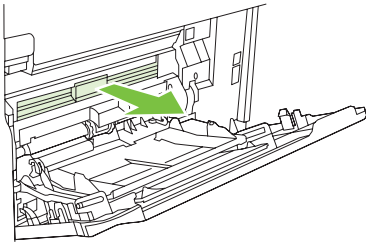
2. Use the green handle to lift the paper-access plate.



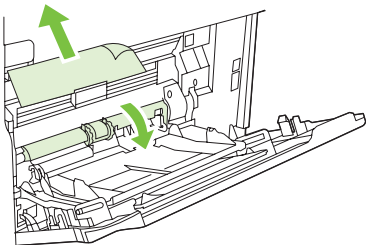
3. Slowly pull the jammed media out of the device. Do not tear the media.



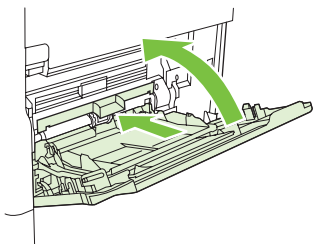
4. If jammed media is difficult to remove, open tray 1 and remove the envelope-entrance cover. If media is present, remove it.



5. Rotate the paper-release guide to check for additional jammed media underneath. If jammed media is present, remove it.



6. Replace the envelope-entrance cover and close tray 1.



7. Reinstall the print cartridge and close the top cover.

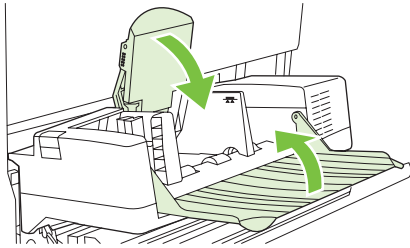


8. If a jam message persists, jammed media is still in the device. Look for the jam in another location.

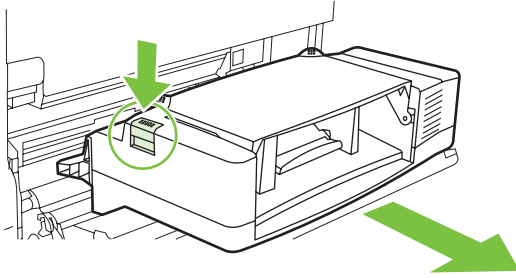
## Clear jams from the optional envelope-feeder area

This section applies only to jams that occur when you are using an optional envelope feeder.

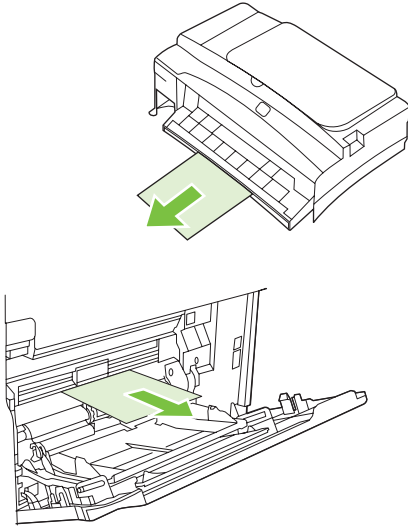
1. Remove any envelopes that are loaded in the envelope feeder. Lower the envelope weight and lift the tray extension up, to the closed position.



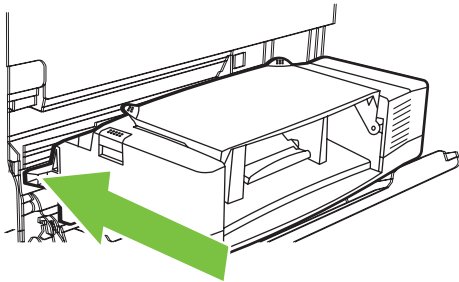
2. Press and hold the release button on the left side of the optional envelope feeder. Grasp both sides of the optional envelope feeder and carefully pull it out of the device.



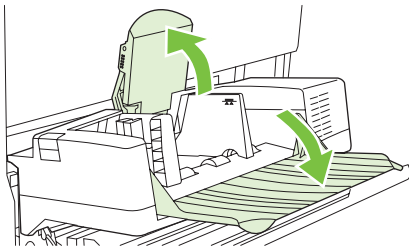
3. Slowly remove any jammed envelopes from the optional envelope feeder and from the device.



4. Insert the optional envelope feeder into the device until it locks into place. Pull gently on the optional envelope feeder to be sure that it is securely in place.



5. Fold down the envelope-feeder tray. Lift the envelope weight.

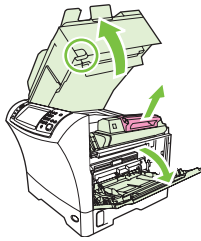


6. Reload the envelopes, making sure that you push the bottom envelopes in slightly farther than the top envelopes.
7. If a jam message persists, jammed media is still in the device. Look for the jam in another location.

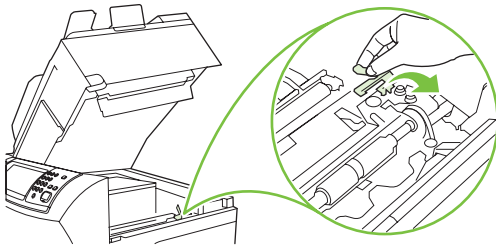
## Clear jams from the tray 1 area

Use this procedure to clear jams that occur in the tray 1 input area.

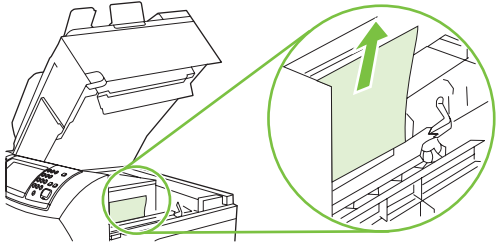
1. Open the top cover, open tray 1, and remove the print cartridge.



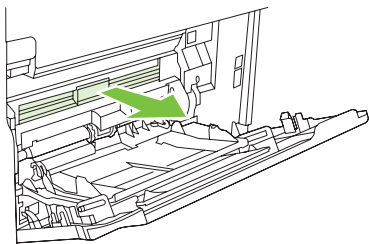
2. Use the green handle to lift the paper-access plate.



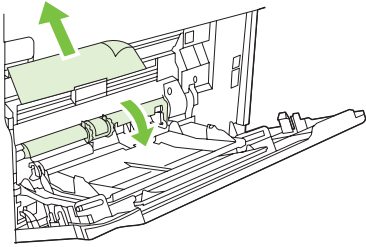
3. Slowly pull any jammed media out of the device. Do not tear the media.



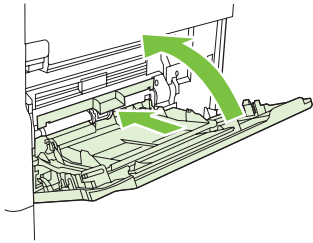
4. If jammed media is difficult to remove, remove the envelope-entrance cover. If media is present, remove it.



5. Rotate the paper-release guide to check for additional jammed media underneath. If jammed media is present, remove it.



6. Replace the envelope-entrance cover and close tray 1.



7. Reinstall the print cartridge and close the top cover.

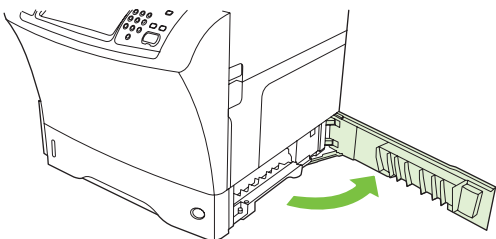


8. If a jam message persists, jammed media is still in the device. Look for the jam in another location.

## Clear jams from the tray 2, 3, 4, or 5 areas

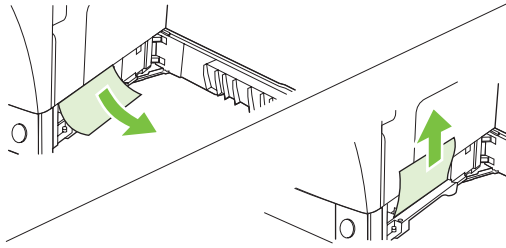
Use this procedure to clear jams that occur in tray 2 or in the optional 500-sheet feeders.

1. Pull the jam-access lever to open the jam-access cover.



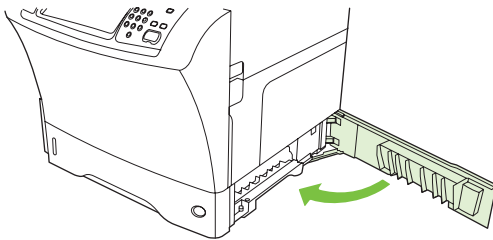


2. Carefully pull out any jammed media from either the top or the bottom of the jam-access area.

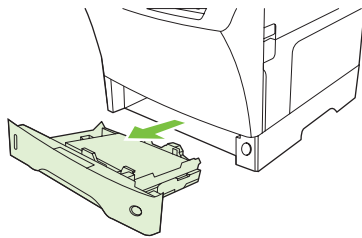


**NOTE** Use an upward or downward pulling motion to avoid tearing the media and to prevent toner from falling into the device.

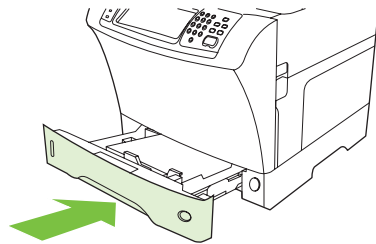
3. Close the jam-access cover.



4. Slide the tray completely out of the device, and remove any damaged media from the tray.



5. Slide the tray into the device.

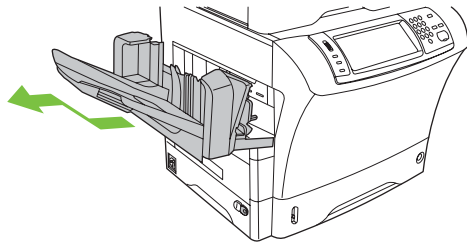


6. If a jam message persists, jammed media is still in the device. Look for the jam in another location.

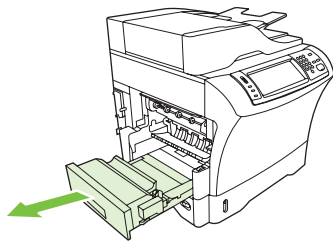
## Clear jams from the optional duplexer

If a jam occurs during a duplex printing job, use this procedure to check for the jam and to clear it.

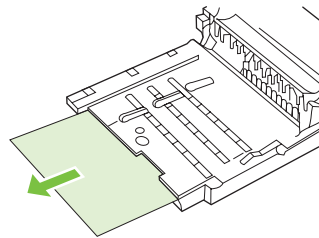
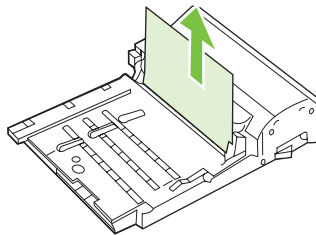
1. Remove the output bin (or remove the stapler/stacker or the mailbox).



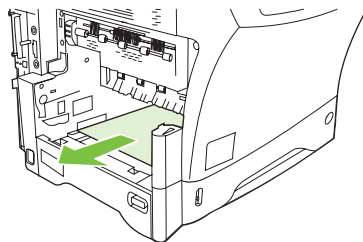
2. Remove the optional duplexer.



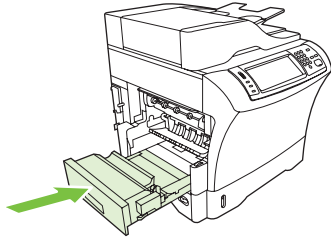
3. Check for jammed paper in the optional duplexer. Carefully pull out the jammed paper.



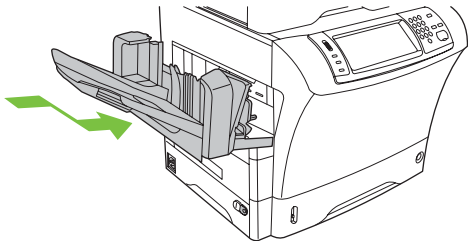
4. Set the duplexer aside.
5. Check for jammed paper inside the device. Carefully pull out the jammed paper.



6. Reinstall the duplexer.



7. Reinstall the output bin (or reinstall the 3-bin mailbox or the stapler/stacker).

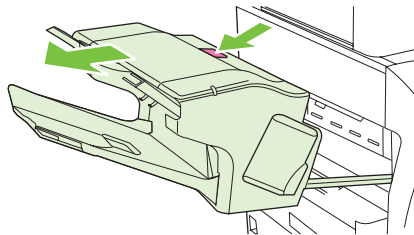


8. If a jam message persists, jammed media is still in the device. Look for the jam in another location.

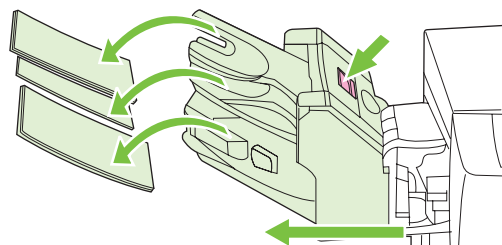
## Clear jams from the output areas

Use this procedure to clear jams that occur in the output bin, the 3-bin mailbox, or the stapler/stacker.

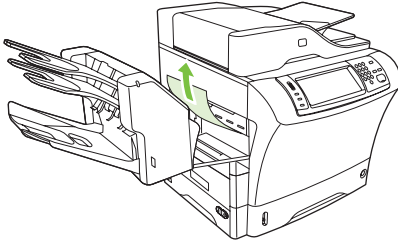
1. If you are using the standard output bin, slide the standard output bin away from the device.



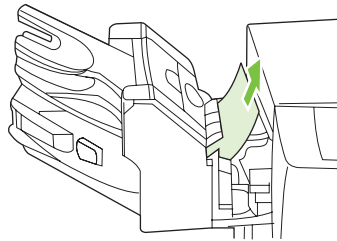
2. If you are using a 3-bin mailbox or a stapler/stacker, remove any media that is stacked, and then press and hold the release button on the top of the accessory. Slide the accessory away from the device.



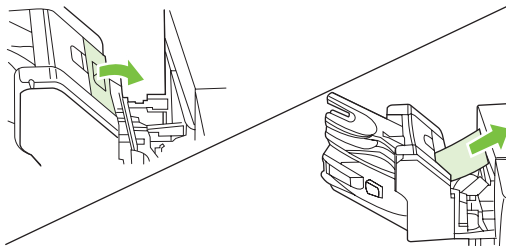
3. If the jammed media is inside the device, carefully pull the jammed media out of the device.



4. If the jammed media is inside the 3-bin mailbox or the stapler/stacker, carefully pull the jammed media up and out of the device.



5. If you are using a 3-bin mailbox, the jammed media might be completely inside the device. Open the jam-access cover that is on the top of the 3-bin mailbox, and carefully pull the jammed media out of the mailbox.



6. Reinstall the output-bin assembly, the 3-bin mailbox, or the stapler/stacker. Insert the device at an angle, and then slide it into the device.
7. If a jam message persists, jammed media is still in the device. Look for the jam in another location.

## Clear jams from the fuser

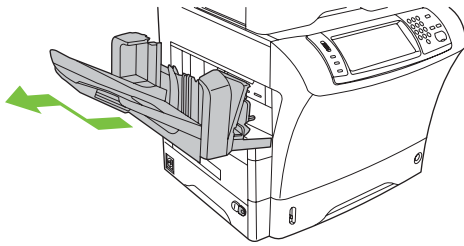
Use this procedure to clear jams that occur in the fuser.

1. Turn the device off and wait 30 minutes for the fuser to cool.

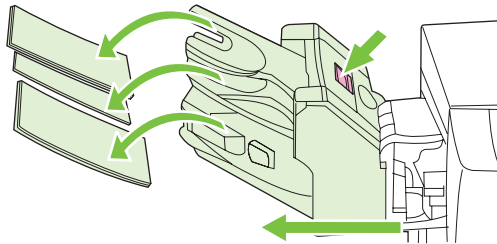


**WARNING!** The fuser is very hot. To avoid minor burns, wait 30 minutes for the fuser to cool before removing it from the device.

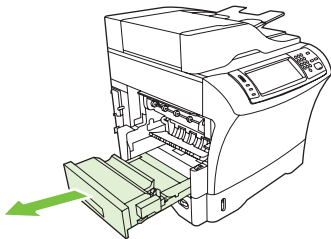
2. If you are using the standard output bin, grasp the handle at the bottom of the output-bin assembly, and pull it out and then up to remove it.



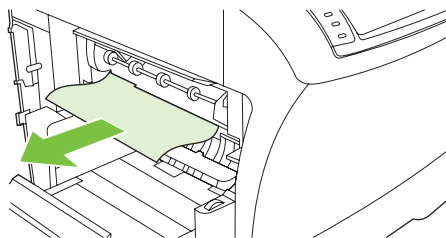
3. If you are using a 3-bin mailbox or a stapler/stacker, remove any media that is stacked, and then press and hold the release button on the top of the device. Pull the device away from the device.



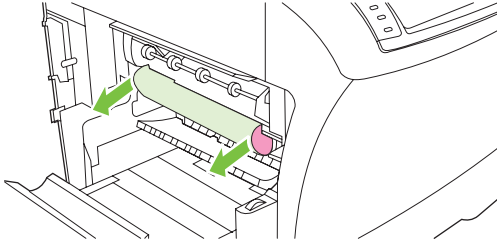
4. Remove the optional duplexer or the duplex cover.



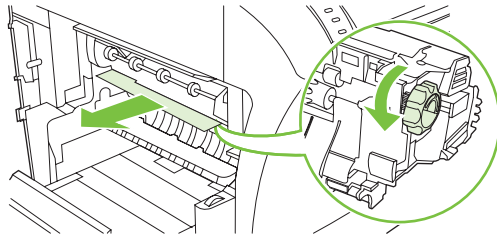
5. If you cannot see the jammed media inside the fuser, skip to step 9.
6. If you can see either the leading edge or the trailing edge of the jammed media inside the fuser, carefully pull it out.



7. If you can see the jammed media, but neither the leading edge nor the trailing edge is visible, gently pull on the sides of the sheet of media until one edge becomes free. Then carefully pull the jammed media out of the fuser.

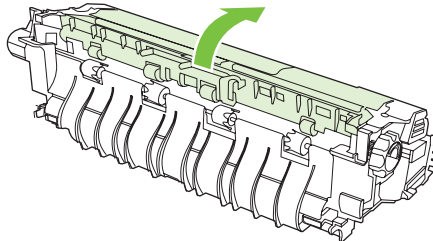


8. If the media tears as you are removing it, turn the green dial on the fuser, and then carefully pull out the jammed media. Go to step 13.

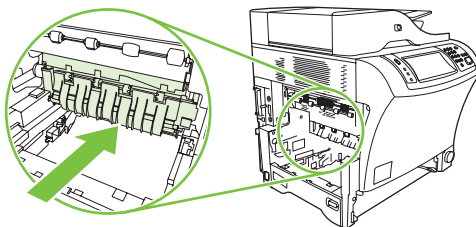


9. To remove the fuser-entrance guide, push inward at the left edge to free the left-side alignment pin. Then lift up slightly on the fuser-entrance guide, and remove it from the device. Place your forefingers on the blue levers on the bottom of each side of the fuser. Place your thumbs on the grip points on the top of each side of the fuser. Squeeze the blue levers up, and remove the fuser from the device.

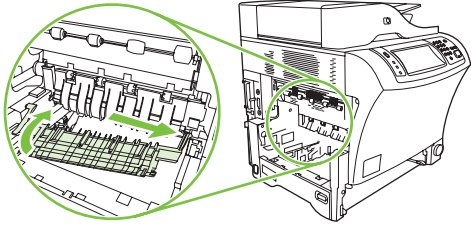
10. Open the black cover at the top of the fuser, and remove the jammed media.



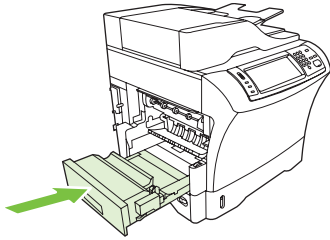
11. Reinstall the fuser. Push on the fuser with your thumbs to be sure it snaps securely into place.



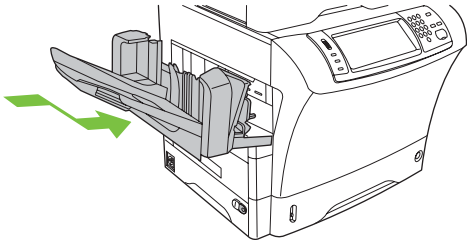
12. To reinstall the fuser-entrance guide, first insert the right-side mounting pin into the hole on the right side, and then lower the left-side mounting pin into the hole on the left side.



13. Reinstall the duplexer or the duplex cover.



14. Reinstall the output-bin assembly, the 3-bin mailbox, or the stapler/stacker. Insert the device at an angle, and then slide it into the device.

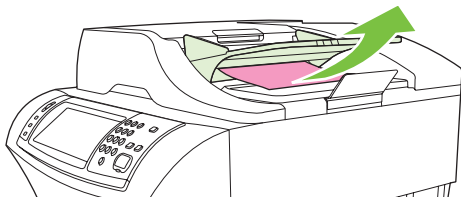


15. If a jam message persists, jammed media is still in the device. Look for the jam in another location.

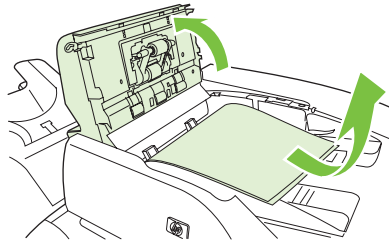
## Clear jams from the document feeder

Use this procedure to clear jams from the document feeder.

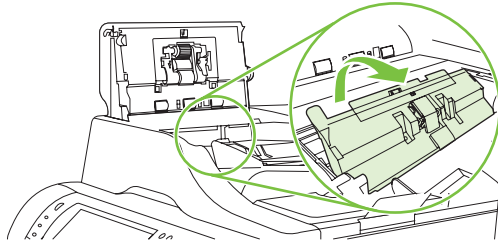
1. Lift the document-feeder input tray, and check for jammed media underneath the tray. Carefully remove any jammed media.



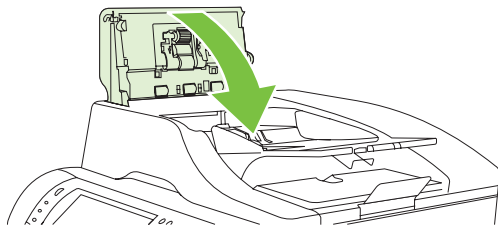
2. Pull up on the document-feeder-cover-release lever, and open the document feeder cover. Carefully remove any jammed media.



3. Lift the green jam lever on the document guide, and then check for jammed media. Carefully remove any jammed media.



4. Close the document feeder cover.



5. If a jam message persists, jammed media is still in the device. Look for the jam in another location.

## Solve repeated jams

Situation	Solution
General repeated jam problems	<ol style="list-style-type: none"> <li>1. Make sure that the media is loaded correctly in the trays and that all width guides are set correctly.</li> <li>2. Make sure that the tray is set for the size of media that is installed and that the tray is not overloaded.</li> <li>3. Try turning over the stack of media in the tray. If you are using prepunched or letterhead paper, try printing from tray 1.</li> <li>4. Do not use media that has been printed on previously or torn, worn, or irregular media.</li> <li>5. Check the media specifications. If media is outside of the recommended specifications, problems can occur.</li> </ol>



Situation	Solution
Repeated jams in the document feeder	<ol style="list-style-type: none"> <li data-bbox="679 226 1145 247">6. The device might be dirty. Clean the device.</li> <li data-bbox="679 275 1358 296">7. Check that all damaged or jammed media is removed from device.</li> <li data-bbox="679 323 1342 344">1. The document feeder might be dirty. Clean the document feeder.</li> <li data-bbox="679 371 1390 424">2. Make sure that the media is loaded squarely and that the media-width guides are adjusted to the sides of the media stack.</li> <li data-bbox="679 451 1417 504">3. Make sure that no more than 50 sheets of 75g/m<sup>2</sup> (20 lb) bond paper are loaded in the document feeder.</li> <li data-bbox="679 531 1453 604">4. If the original document that is being copied has been folded or stapled, flatten it as much as you can and smooth any wrinkles. Make sure the pages are not stuck together where the staple was.</li> <li data-bbox="679 632 1445 730">5. Media that has been pre-punched or perforated in any way might be difficult to feed through the document feeder. If the leading edge of the document is excessively worn or frayed, try rotating the document 180 degrees before copying.</li> </ol>

## Paper-path test

The paper path test can be used to verify that various paper paths are working correctly or to troubleshoot problems with tray configuration.

1. Scroll to and touch [Administration](#).
2. Scroll to and touch [Troubleshooting](#).
3. Scroll to and touch [Paper Path Test](#).
4. Touch [Print Test Page](#).

## Clear staple jams

The stapler is designed to avoid staple jams. To reduce the risk of staple jams, make sure that you observe the following media limits:

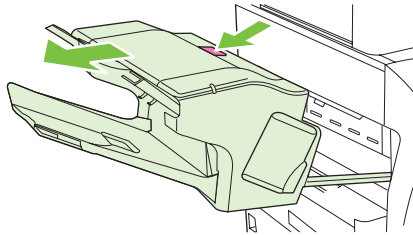
- Plain media: 30 sheets of 75 g/m<sup>2</sup> (20 lb) media

Glossy media: 20 sheets

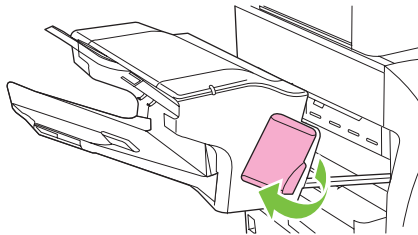
Thick media (128-199 g/m<sup>2</sup> [34-53 lb]): Stack height must not exceed 3 mm (0.27 inches)

Occasionally, staples become jammed in the optional stapler/stacker. If jobs are not being stapled correctly or are not being stapled at all, use the following procedure to clear staple jams.

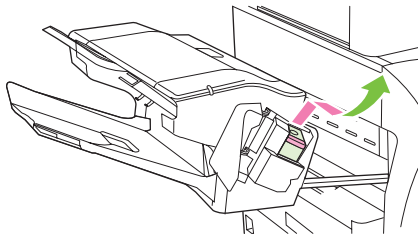
1. Turn off the device.
2. Press and hold the release button on the top of the stapler/stacker. Pull the stapler/stacker away from the device.



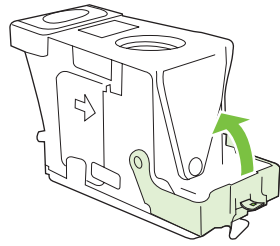
3. Open the staple-cartridge cover.



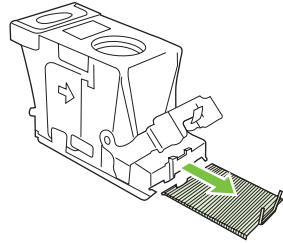
4. To remove the staple cartridge, pull up on the green handle and pull out the staple cartridge.



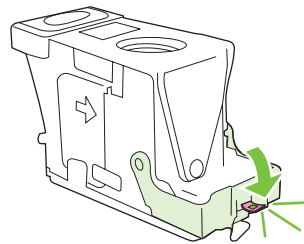
5. Lift up on the small lever at the back of the staple cartridge.



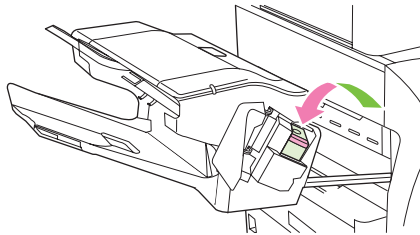
6. Remove the staples that protrude from the staple cartridge.



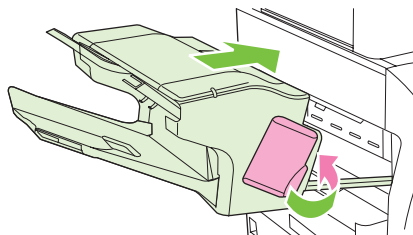
7. Close the lever at the back of the staple cartridge. Be sure that it snaps into place.



8. Reinsert the staple cartridge into the staple-cartridge holder, and push down on the green handle until it snaps into place.



9. Close the staple-cartridge cover, and slide the stapler/stacker into the device.



# Solve print-quality problems

## Print-quality problems associated with media

Some print-quality problems arise from the use of inappropriate media.

- Use media that meets HP specifications.
- The surface of the media is too smooth. Use media that meets HP specifications.
- The moisture content is uneven, too high, or too low. Use media from a different source or from an unopened ream.
- Some areas of the media reject toner. Use media from a different source or from an unopened ream.
- The letterhead you are using is printed on rough media. Use a smoother, xerographic media. If this solves your problem, ask the supplier of your letterhead to use media that meets the specifications for this device.
- The media is excessively rough. Use a smoother, xerographic media.
- The driver setting is incorrect.
- The media that you are using is too heavy for the media type setting that you selected, and the toner is not fusing to the media.

## Print-quality problems associated with the environment

If the device is operating in excessively humid or dry conditions, verify that the printing environment is within specifications.

## Print-quality problems associated with jams

Make sure that all sheets are cleared from the paper path.

- If the device recently jammed, print two to three pages to clean the device.
- If the sheets do not pass through the fuser and cause image defects on subsequent documents, print three pages to clean the device. If the problem persists, print and process a cleaning page.

## Overhead transparency defects

Overhead transparencies can contain any of the image-quality problems that appear in other types of media in addition to defects that are specific to transparencies. In addition, because transparencies are pliable, they can be affected by the media-handling components in the paper path.



---

**NOTE** Allow transparencies to cool at least 30 seconds before handling them.

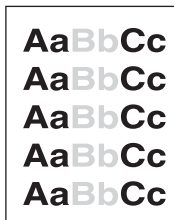
---

- On the printer driver **Paper** tab, select **Transparency** as the media type. Also, make sure that the tray is correctly configured for transparencies.
- Make sure that the transparencies meet the specifications for this monochrome HP LaserJet MFP. For more information, consult the *HP LaserJet Printer Family Print Media Guide*.

- Handle transparencies by the edges. Skin oil on the surface of transparencies can cause spots and smudges.
- Small, random dark areas on the trailing edge of solid fill pages might be caused by transparencies sticking together in the output bin. Try printing the job in smaller batches.
- To show the printed transparency, use a standard overhead projector instead of a reflective overhead projector.

## Image defect examples

### Light print (partial page)



#### Defect description

Printing is light on a portion of the page.

#### Possible causes

The print cartridge is not installed properly. The media might not meet HP specifications (for example, the media is too moist or too rough). The toner level in the print cartridge might be low.

#### Troubleshooting and suggestions

1. Make sure that the print cartridge is fully installed.
2. Verify that the media meets HP specifications.
3. Replace the print cartridge.

### Light print (entire page)



#### Defect description

Printing is light on the entire page.

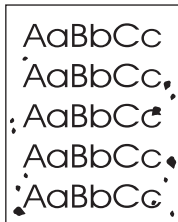
#### Possible causes

The print cartridge is not installed properly. Economode is on. The toner density is not set correctly. The media might not meet HP specifications (for example, the media is too moist or too rough). The toner level in the print cartridge might be low.

### Troubleshooting and suggestions

1. Make sure that the print cartridge is fully installed.
2. Make sure that Economode is turned off at the control panel and in the printer driver.
3. Increase the toner density at the control panel by touching **Administration**, **Print Quality**, and **Toner Density**.
4. Verify that the media meets HP specifications.
5. Replace the print cartridge.

## Specs



### Defect description

Toner specks appear on the page, especially after a jam is cleared.

### Possible causes

The device needs to be cleaned. The media might not meet HP specifications (for example, the media is too moist or too rough). A print cartridge is leaking.

### Troubleshooting and suggestions

1. Print a few more pages to see if the problem corrects itself.
2. Clean the inside of the device and run a cleaning page.
3. Try using a different type of media.
4. Check the print cartridge for leaks. If the print cartridge is leaking, replace it.

## Dropouts



**Defect description**

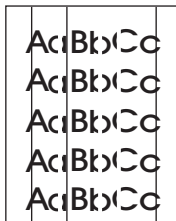
A large area of toner is missing.

**Possible causes**

Operating environment or media in use does not meet HP specifications.

**Troubleshooting and suggestions**

1. Make sure that the environmental specifications for the device are being met.
2. If the media is rough and the toner easily rubs off, touch [Administration](#), [Print Quality](#), and [Fuser Modes](#), and then select the media type you are using.
3. Try using a smoother media.

**Lines****Defect description**

Lines or streaks appear on the page.

**Possible causes**

The device needs to be cleaned. The print cartridge is not functioning properly.

**Troubleshooting and suggestions**

1. Print a few more pages to see if the problem corrects itself.
2. Clean the inside of the device and run a cleaning page.
3. Replace the print cartridge.

**Gray background****Defect description**

The background of the page is gray or has a grayish cast.

### Possible causes

Operating environment or media in use does not meet HP specifications.

### Troubleshooting and suggestions

1. Do not use media that has already been run through the device.
2. Try using a different type of media.
3. Print a few more pages to see if the problem corrects itself.
4. Turn over the stack in the tray. Also, try rotating the stack 180°.
5. Increase the toner density at the control panel by touching [Administration](#), [Print Quality](#), and [Toner Density](#).
6. Make sure that the environmental specifications for the device are being met.
7. Replace the print cartridge.

### Toner smear



### Defect description

Toner is smeared on the page.

### Possible causes

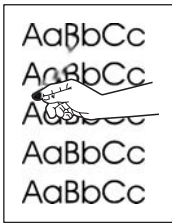
The device needs to be cleaned. Operating environment or media in use does not meet HP specifications.

### Troubleshooting and suggestions

1. Print a few more pages to see if the problem corrects itself.
2. Try using a different type of media.
3. Make sure that the environmental specifications for the device are being met.
4. Clean the inside of the device and run a cleaning page.
5. Replace the print cartridge.



## Loose toner



### Defect description

Toner can be rubbed off the page.

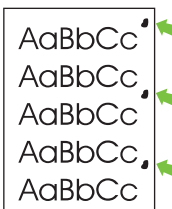
### Possible causes

Operating environment or media in use does not meet HP specifications.

### Troubleshooting and suggestions

1. If the media is heavy or rough, touch [Administration](#), [Print Quality](#), and [Fuser Modes](#), and then select the media type you are using.
2. If you have observed a rougher texture on one side of your media, try printing on the smoother side.
3. Make sure that the environmental specifications for the device are being met.
4. Make sure that type and quality of the media you are using meet HP specifications.

## Repeating defects



### Defect description

A print defect appears on the page at regular intervals.

### Possible causes

The print cartridge needs to be replaced. The device needs to be cleaned.

### Troubleshooting and suggestions

1. Print a few more pages to see if the problem corrects itself.
2. If the distance between defects is 44 mm (1.7 in), 58 mm (2.3 in), or 94 mm (3.7 in), the print cartridge might need to be replaced.
3. Clean the inside of the device and run a cleaning page.

## Repeating image



### Defect description

An image defect appears on the page at regular intervals. This defect might occur when using preprinted forms or a large quantity of narrow media.

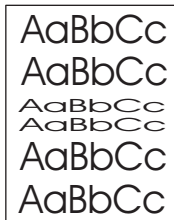
### Possible causes

Media in use does not meet HP specifications. The print cartridge needs to be replaced.

### Troubleshooting and suggestions

1. Print a few more pages to see if the problem corrects itself.
2. Make sure that the type and quality of media you are using meet HP specifications.
3. If the distance between defects is 44 mm (1.7 in), 58 mm (2.3 in), or 94 mm (3.7 in), the print cartridge might need to be replaced.

## Misformed characters



### Defect description

Some or all characters are misformed on the page.

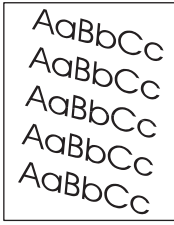
### Possible causes

Operating environment does not meet HP specifications.

### Troubleshooting and suggestions

1. Print a few more pages to see if the problem corrects itself.
2. Make sure that the environmental specifications for the device are being met.

## Page skew



### Defect description

The printed image slants on the page.

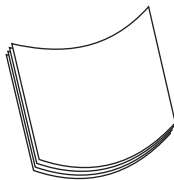
### Possible causes

Media is not loaded properly. Operating environment or media in use does not meet HP specifications.

### Troubleshooting and suggestions

1. Print a few more pages to see if the problem corrects itself.
2. Verify that no torn pieces of media are inside the device.
3. Make sure that media is loaded correctly and that all adjustments have been made. Make sure that the guides in the tray are not too tight or too loose against the media.
4. Turn over the stack in the tray. Also, try rotating the stack 180°.
5. Make sure that the type and quality of the media you are using meet HP specifications.
6. Make sure that the environmental specifications for the device are being met.
7. Perform a tray alignment by opening the [Administration](#) menu at the device control panel. On the [Print Quality](#) submenu, touch [Set Registration](#). Choose a tray under [Source](#) and then run a test page.

## Curl or wave



### Defect description

The paper curls or has a wave in it.

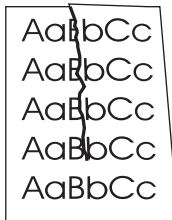
### Possible causes

Media is not loaded properly. Operating environment or media in use does not meet HP specifications.

## Troubleshooting and suggestions

1. Turn over the stack in the tray. Also, try rotating the stack 180°.
2. Make sure that the type and quality of the media you are using meet HP specifications.
3. Make sure that the environmental specifications for the device are being met.
4. Try printing to a different output bin.
5. If media is lightweight and smooth, open the **Administration** menu at the device control panel. On the **Print Quality** submenu, touch **Fuser Modes**, and then select the media type you are using. Change the setting to **Low**, which helps reduce the heat in the fusing process.

## Wrinkles or creases



### Defect description

The page is wrinkled or has creases.

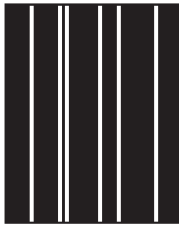
### Possible causes

Media is not loaded properly. Operating environment or media in use does not meet HP specifications.

### Troubleshooting and suggestions

1. Print a few more pages to see if the problem corrects itself.
2. Make sure that the environmental specifications for the device are being met.
3. Turn over the stack in the tray. Also, try rotating the stack 180°.
4. Make sure that media is loaded correctly and that all adjustments have been made. Make sure that the guides in the tray are not too tight or too loose against the media.
5. Make sure that the type and quality of the media you are using meet HP specifications.
6. If envelopes are creasing, try storing envelopes so that they lie flat.
7. Open the **Administration** menu at the device control panel. On the **Print Quality** submenu, touch **Fuser Modes**, and then select the media type you are using. Change the setting to **Low**, which helps reduce the heat in the fusing process.

## Vertical white lines



### Defect description

Vertical white lines appear on the printed page.

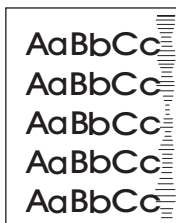
### Possible causes

Media in use does not meet HP specifications. The print cartridge needs to be replaced.

### Troubleshooting and suggestions

1. Print a few more pages to see if the problem corrects itself.
2. Make sure that the type and quality of media you are using meet HP specifications.
3. Replace the print cartridge.

## Tire tracks



### Defect description

Images resembling tire tracks appear on the printed page. This defect typically occurs when the print cartridge has far exceeded its rated life, especially when printing a very large quantity of pages with very little toner coverage.

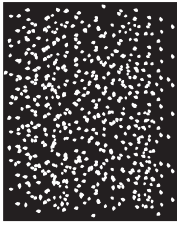
### Possible causes

The print cartridge needs to be replaced.

### Troubleshooting and suggestions

1. Replace the print cartridge.
2. Reduce the number of pages that you print with very low toner coverage.

## White spots on black



### Defect description

White spots appear on a black background.

### Possible causes

Operating environment or media in use does not meet HP specifications. The print cartridge needs to be replaced.

### Troubleshooting and suggestions

1. Print a few more pages to see if the problem corrects itself.
2. Make sure that the type and quality of the media you are using meet HP specifications.
3. Make sure that the environmental specifications for the device are being met.
4. Replace the print cartridge.

## Scattered lines



### Defect description

Lines are not sharp and precise on the printed page.

### Possible causes

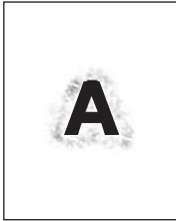
Operating environment or media in use does not meet HP specifications. Print settings need to be changed.

### Troubleshooting and suggestions

1. Make sure that the type and quality of the media you are using meet HP specifications.
2. Make sure that the environmental specifications for the device are being met.
3. Turn over the stack in the tray. Also, try rotating the stack 180°.

4. Open the **Administration** menu at the device control panel. Open the **Print Quality** submenu and change the **Toner Density** setting.
5. Open the **Administration** menu at the device control panel. On the **Print Quality** submenu, open **Optimize** and set **Line Detail to On**.

## Blurred print



### Defect description

The printed image is blurred.

### Possible causes

Operating environment or media in use does not meet HP specifications. Print settings need to be changed.

### Troubleshooting and suggestions

1. Make sure that the type and quality of the media you are using meet HP specifications.
2. Make sure that the environmental specifications for the device are being met.
3. Turn over the stack in the tray. Also, try rotating the stack 180°.
4. Do not use media that already has been run through the device.
5. Decrease the toner density. Open the **Administration** menu at the device control panel. Open the **Print Quality** submenu and change the **Toner Density** setting.
6. Open the **Administration** menu at the device control panel. On the **Print Quality** submenu, open **Optimize** and set **High Transfer to On**.

## Random image repetition





### **Defect description**

An image that appears at the top of the page (in solid black) repeats further down the page (in a gray field). The repeated image might be lighter or darker than the field it appears in.

### **Possible causes**

The toner might not have been completely erased from the last job.

### **Troubleshooting and suggestions**

1. Change the tone (darkness) of the field that the repeated image appears in.
2. Change the order in which the images are printed. For example, have the lighter image at the top of the page, and the darker image farther down the page.
3. From your software program, rotate the whole page 180° to print the lighter image first.
4. If the defect occurs later in a print job, turn the device off for 10 minutes. Then turn it on to restart the print job.

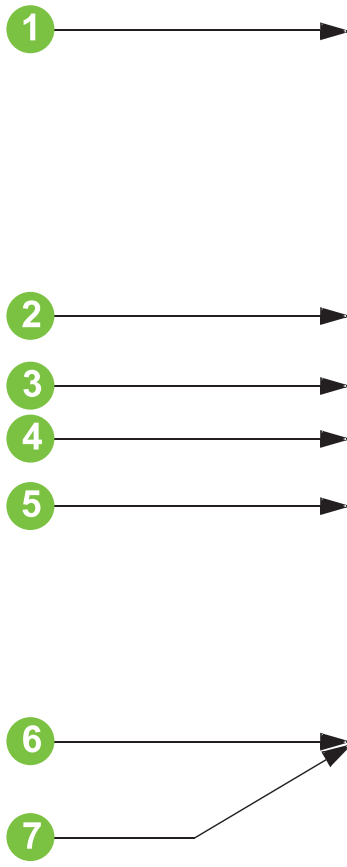


## Repetitive defect ruler

Defects on rollers can cause image defects to appear at regular intervals on the page, corresponding to the circumference of the roller that is causing the defect. Measure the distance between defects that recur on a page. Use the repetitive defect ruler to determine which roller is causing the defect. To resolve the problem, try cleaning the roller first. If the roller remains dirty after cleaning or if it is damaged, replace the part indicated in [Table 6-3 Repetitive defects on page 431](#).



**NOTE** Do not use solvents or oils to clean rollers. Instead, rub the roller with lint-free paper. If dirt is difficult to remove, rub the roller with lint-free paper that has been dampened with water.



**Table 6-3** Repetitive defects

Reference	Roller	Distance between defects	Replacement part
1		First occurrence of the defect	
2	Primary charging roller	38.0 mm (1.5 inches)	Print cartridge
3	Transfer roller	47.0 mm (1.9 inches)	Transfer roller (part of the printer maintenance kit)
4	Developing cylinder (see note)	54.0 mm (2.13 inches)	Print cartridge
5	Developing cylinder (see note)	63.0 mm (2.5 inches)	Print cartridge

**Table 6-3** Repetitive defects (continued)

Reference	Roller	Distance between defects	Replacement part
6	Fuser	94.0 mm (3.75 inches)	Fuser
7	Photosensitive drum	94.2 mm (3.75 inches)	Print cartridge



**NOTE** The developing cylinder circumference is 62.83 mm (2.5 inches). A defect that is related to the developing cylinder will most likely repeat at intervals of 54.0 mm (2.15 inches) because of the way the roller is geared.

To identify if the print cartridge is the problem, insert a print cartridge from another HP LaserJet M4345 MFP, if one is available, before ordering a new print cartridge.

If the defect repeats at 94.0 mm (3.75 inch) intervals, try replacing the print cartridge before replacing the fuser.

## Solve network printing problems

---



**NOTE** HP recommends using the device CD to install and set up the device on a network.

---

- Print a configuration page (see [Use information pages on page 82](#)). If an HP Jetdirect print server is installed, printing a configuration page also prints a second page that shows the network settings and status.
- See the *HP Jetdirect Embedded Print Server Administrator's Guide* on the device CD for help and for more information about the Jetdirect configuration page. To open the guide, run the CD, click **Printer Documentation**, click **HP Jetdirect Guide**, and then click **Troubleshooting the HP Jetdirect Print Server**.
- Try printing the job from another computer.
- To verify that a device works with a computer, use a USB cable to connect it directly to a computer, and then reinstall the printing software. Print a document from a program that has printed correctly in the past. If this works, a problem with the network might exist.
- Contact a network administrator for assistance.

# Solve copy problems

## Prevent copy problems

The following are a few simple steps you can take to improve copy quality:

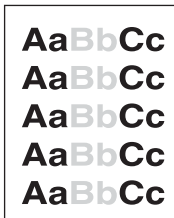
- Copy from the flatbed scanner. This will produce a higher quality copy than copying from the automatic document feeder (ADF).
- Use quality originals.
- Load the media correctly. If the media is loaded incorrectly, it might skew, causing unclear images and problems with the OCR program. See [Media specifications on page 10](#) for instructions.
- Use or make a carrier sheet to protect your originals.

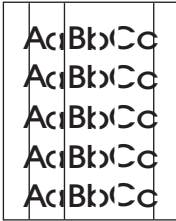


**NOTE** Verify that the media meets HP specifications. If the media meets HP specifications, recurring feed problems indicate the pickup roller or separation pad is worn. Contact HP Customer Care. See [HP Customer Care on page 609](#) or the flyer that came in the device box.

## Image problems

Problem	Cause	Solution
Images are missing or faded.	The print-cartridge toner-level might be low.	Replace the print cartridge. See <a href="#">Change the print cartridge on page 93</a> .
	The original might be of poor quality.	If your original is too light or damaged, the copy might not be able to compensate, even if you adjust the darkness. If possible, find an original document in better condition.
	The original might have a colored background.	Touch <a href="#">Copy</a> , and then touch <a href="#">Image Adjustment</a> . Adjust the <a href="#">Background Cleanup</a> slider to the right to decrease the background.
Vertical white or faded stripes appear on the copy.	The media might not meet HP specifications.	Use media that meets HP specifications. See <a href="#">Select print media on page 10</a> .
	The print-cartridge toner-level might be low.	Replace the print cartridge. See <a href="#">Change the print cartridge on page 93</a> .



Problem	Cause	Solution
Unwanted lines appear on the copy.	Tray 1 or tray 2 might not be installed correctly.	Verify that the tray is in place.
	The flatbed scanner or the ADF glass might be dirty.	Clean the flatbed scanner or the ADF glass. See <a href="#">Clean the device on page 95</a> .
	The photosensitive drum inside the print cartridge might have been scratched.	Install a new HP print cartridge. See <a href="#">Change the print cartridge on page 93</a> .
Black dots or streaks appear on the copy.	Ink, glue, correction fluid, or an unwanted substance might be on the automatic document feeder (ADF) or flatbed scanner.	Clean the device. See <a href="#">Clean the device on page 95</a> .
Copies are too light or dark.	The darkness setting needs to be adjusted.	Touch <b>Copy</b> , and then touch <b>Image Adjustment</b> . Adjust the <b>Darkness</b> slider to lighten or darken the image.
Text is unclear.	The sharpness setting needs to be adjusted.  The image should be optimized for text.	To adjust the sharpness, touch <b>Copy</b> , and then touch <b>Image Adjustment</b> . Adjust the <b>Sharpness</b> slider to the right to increase the sharpness.  To optimize the image for text, touch <b>Copy</b> and then touch <b>Optimize Text/Picture</b> . Select <b>Text</b> .

## Media-handling problems

Problem	Cause	Solution
Poor print quality or toner adhesion	The paper is too moist, too rough, too heavy or too smooth, or it is embossed or from a faulty paper lot.	Try another kind of paper, between 100 and 250 Sheffield, 4 to 6% moisture content.
Dropouts, jamming, or curl	The paper has been stored incorrectly.	Store paper flat in its moisture-proof wrapping.
	The paper has variability from one side to the other.	Turn the paper over.
Excessive curl	The paper is too moist, has the wrong grain direction, or is of short-grain construction	Open the rear output bin, or use long-grain paper.
	The paper varies from side-to-side.	Turn the paper over.
Jamming, damage to device	The paper has cutouts or perforations.	Use paper that is free of cutouts or perforations.

Problem	Cause	Solution
Problems with feeding	The paper has ragged edges.	Use high-quality paper that is made for laser printers.
	The paper varies from side-to-side.	Turn the paper over.
	The paper is too moist, too rough, too heavy or too smooth, has the wrong grain direction, or is of short-grain construction or it is embossed or from a faulty paper lot.	<ul style="list-style-type: none"> <li>Try another kind of paper, between 100 and 250 Sheffield, 4 to 6% moisture content.</li> <li>Use long-grain paper.</li> </ul>
Print is crooked or misaligned on the page.	The media guides might be incorrectly adjusted.	Remove all media from the input tray, straighten the stack, and then load the media in the input tray again. Adjust the media guides to the width and length of the media that you are using and try printing again.
	The scanner might require a calibration.	<p>Perform a tray alignment, and then calibrate the scanner.</p> <ul style="list-style-type: none"> <li>Perform a tray alignment by opening the <a href="#">Administration</a> menu at the device control panel. On the <a href="#">Print Quality</a> submenu, touch <a href="#">Set Registration</a>. Choose a tray under <a href="#">Source</a> and then run a test page. For more information, see <a href="#">Print Quality menu on page 75</a>.</li> <li>See <a href="#">Calibrate the scanner on page 106</a> for information about calibrating the scanner.</li> </ul>
More than one sheet feeds at one time.	The media tray might be overloaded.	Remove some of the media from the tray. See <a href="#">Media specifications on page 10</a> .
	The media might be wrinkled, folded, or damaged.	Verify that the media is not wrinkled, folded, or damaged. Try printing on media from a new or different package.
The device does not pull media from a media tray.	The device might be in manual feed mode.	<ul style="list-style-type: none"> <li>If <b>Manual Feed</b> appears on the control-panel display, press <b>OK</b> to print the job.</li> <li>Verify that the device is not in manual feed mode, and then print your job again.</li> </ul>
	The pickup roller might be dirty or damaged.	Contact HP Customer Care. See <a href="#">HP Customer Care on page 609</a> or the support flyer that came in the device box.
	The paper-length adjustment control in the tray is set at a length that is greater than the media size.	Adjust the paper-length adjustment control to the correct length.

## Performance problems

Problem	Cause	Solution
No copy came out.	The input tray might be empty.	Load media in the device. See <a href="#">Media specifications on page 10</a> for more information.
	The original might have been loaded incorrectly.	Load the original correctly in the ADF or flatbed scanner. See <a href="#">Media specifications on page 10</a> .
Copies are blank.	The sealing tape might not have been removed from the print cartridge.	Remove the print cartridge from the device, pull out the sealing tape, and then reinstall the print cartridge.
	The original might have been loaded incorrectly.	Load the original correctly in the ADF or flatbed scanner. See <a href="#">Media specifications on page 10</a> .
	The media might not meet HP specifications.	Use media that meets HP specifications. See <a href="#">Select print media on page 10</a> .
	The print-cartridge toner-level might be low.	Replace the print cartridge. See <a href="#">Change the print cartridge on page 93</a> .
The wrong original was copied.	The ADF might be loaded.	Make sure that the ADF is empty.
Copies are reduced in size.	The device software settings might be set to reduce the scanned image.	See the device software Help for more information about changing the settings.

## Solve fax problems

More extensive fax troubleshooting information is available in the *Fax Support Guide*. For additional help troubleshooting the Send Fax driver, see the *Send Fax Driver User Guide*.

### Solve sending problems

#### Faxes quit during sending.

Cause	Solution
The fax machine to which you are sending might be malfunctioning.	Call the recipient to make sure that the receiving fax machine is turned on and ready to receive faxes, or try sending to another fax machine.
Your telephone line might not be working, or the line might be experiencing interference.	Disconnect the fax cable from the telephone jack, and then connect a telephone. Make a phone call to ensure that the telephone line is working.  Try using a lower baud rate by adjusting the Maximum Baud Rate setting in the Administration menu. See <a href="#">Initial Setup menu on page 60</a> .

#### The device fax is receiving faxes but is not sending them.

Cause	Solution
If the device is on a PBX system, the PBX system might be generating a dial tone that the fax cannot detect.	Disable the detect dial tone setting. See the fax guide for information about changing the setting.
There might be a poor telephone connection.	Resend the fax later.
The fax machine to which you are sending might be malfunctioning.	Call the recipient to make sure that the receiving fax machine is turned on and ready to receive faxes, or try sending to another fax machine.
Your telephone line might not be working.	Disconnect the fax cable from the telephone jack, and then connect a telephone. Make a phone call to ensure that the telephone line is working.

#### Outgoing fax calls keep dialing.

Cause	Solution
The fax automatically redials a fax number if either the Redial on Busy feature or the Redial on No Answer feature is enabled.	Disable the Redial on Busy and Redial on No Answer features. See the fax guide for information about changing the settings.



### Faxes you send are not arriving at the receiving fax machine.

Cause	Solution
The receiving fax machine might be turned off or might have an error condition, such as being out of paper.	Call the recipient to make sure that the fax machine is turned on and ready to receive faxes.
A fax might be stored in memory because it is waiting to redial a busy number, or there are other jobs ahead of it waiting to be sent.	If a fax job is in memory for either of these reasons, an entry for the job appears in the fax log. Print the fax activity log (see the fax guide), and check the <b>Result</b> column for jobs with a <b>Pending</b> designation.



**NOTE** If the fax is sending very slowly, see "Faxes are transmitting or being received very slowly" in [Initial Setup menu on page 60](#).

## Solve receiving problems

### Incoming fax calls are not being answered by the fax (no fax detected).

Cause	Solution
The rings-to-answer setting might not be set correctly.	Check the rings-to-answer setting. See the fax guide for information about changing the setting.
The telephone cord might not be connected properly, or the telephone cord is not working.	Check the installation. Make sure you are using the telephone cord that came with the device.
The telephone line might not be working.	Disconnect the fax cable from the telephone jack, and then connect a telephone. Make a phone call to ensure that the telephone line is working.
A voice-messaging service might be interfering with the ability to answer calls.	Do one of the following: <ul style="list-style-type: none"><li>• Discontinue the messaging service.</li><li>• Get a telephone line dedicated to fax calls.</li><li>• Decrease the rings-to-answer setting for the fax to a number less than the rings-to-answer for the voice mail. See the fax guide for information about changing the setting.</li></ul>

### Faxes are transmitting or being received very slowly.

Cause	Solution
You might be sending or receiving a very complex fax, such as one with many graphics.	Complex faxes take longer to be sent or received.
The receiving fax machine might have a slow modem speed.	The device fax only sends the fax at the fastest modem speed the receiving fax machine can use.

**Faxes are transmitting or being received very slowly.**

<b>Cause</b>	<b>Solution</b>
The resolution at which the fax was sent or is being received is very high. A higher resolution typically results in better quality, but also requires a longer transmission time.	If you are receiving the fax, call and ask the sender to decrease the resolution and resend the fax. If you are sending, decrease the resolution or change the Page Content mode setting. See the fax guide for information about changing the settings.
A poor telephone-line connection is forcing the device fax and the sending or receiving fax machine to slow down the transmission to adjust for errors.	Cancel and resend the fax. Have the telephone company check the telephone line.

**Faxes are not printing at the device.**

<b>Cause</b>	<b>Solution</b>
There is no media in the input trays.	Load media. Any faxes received while the input trays are empty are stored and will print after the trays have been refilled.
The Schedule Printing of Faxes mode is enabled. Faxes will not print until it is disabled	Disable the Schedule Printing of Faxes mode. See the fax guide for information about changing the setting.
The device toner level is low, or it has run out of toner.	Replace the print cartridge.
The device stops printing as soon as it is low on toner or runs out of toner. Any faxes received are stored in memory and are printed after the toner has been replaced.	

## Solve e-mail problems

If you are unable to send e-mails by using the digital-send feature, you might need to reconfigure the SMTP gateway address or the LDAP gateway address. Print a Configuration page to find the current SMTP and LDAP gateway addresses. Use the following procedures to check if the SMTP and LDAP gateway addresses are valid.

### Validate the SMTP gateway address



---

**NOTE** This procedure is for Windows operating systems.

---

1. Open an MS-DOS command prompt: click **Start**, click **Run**, and then type `cmd`.
2. Type `telnet` followed by the SMTP gateway address and then the number 25, which is the port over which the MFP is communicating. For example, type `telnet 123.123.123.123 25` where "123.123.123.123" represents the SMTP gateway address.
3. Press **Enter**. If the SMTP gateway address is *not* valid, the response contains the message `Could not open connection to the host on port 25: Connect Failed`.
4. If the SMTP gateway address is not valid, contact the network administrator.

### Validate the LDAP gateway address



---

**NOTE** This procedure is for Windows operating systems.

---

1. Open Windows Explorer. In the address bar, type `LDAP://` immediately followed by the LDAP gateway address. For example, type `LDAP://12.12.12.12` where "12.12.12.12" represents the LDAP gateway address.
2. Press **Enter**. If the LDAP gateway address is valid, the **Find People** dialog box opens.
3. If the LDAP gateway address is not valid, contact the network administrator.

# Solve network connectivity problems

## Troubleshooting network printing problems



**NOTE** HP recommends that you use the MFP CD-ROM to install and set up the MFP on a network.

1. Make sure that the network cable is securely seated into the MFP's RJ45 connector.
2. Make sure that the Jetdirect LED on the formatter is lit.
3. Make sure that the I/O card is ready. Print a Configuration page. If an HP Jetdirect print server is installed, printing a Configuration page also prints a second page that shows the network settings and status.



**NOTE** The HP Jetdirect embedded print server supports various network protocols (TCP/IP, IPX/SPX, Novell/Netware, AppleTalk, and DCL/LLC). Make sure that the correct protocol is enabled for your network.

4. On the HP Jetdirect Configuration page, verify the following items for your protocol:
  - a. Under HP Jetdirect Configuration, the status is "I/O Card Ready".
  - b. The status is "Ready".
  - c. An IP address is listed.
  - d. The configuration method (Config by:) is listed correctly. See the network administrator if you are not sure which method is correct.
  - e. The domain name is correct.
5. Perform a loopback test to verify that the firmware is functioning correctly and that the hardware that is on the formatter is functioning correctly.
6. Perform a ping test to verify that the MFP is communicating with other devices on the network.
7. Try printing the job from another computer.
8. To verify that a MFP works with a computer, use a USB cable to connect it directly to a computer. You will have to reinstall the printing software. Print a document from a program that has printed correctly in the past. If this works, a problem with the network might exist.

## Loopback test

Use the loopback test to verify that the firmware is functioning correctly and that the hardware that is on the formatter is functioning correctly. This test causes the formatter to send data to itself.

1. Disconnect the network cable.
2. Press **Menu**.
3. Touch **CONFIGURE DEVICE**.
4. Touch **I/O**, touch **EMBEDDED JETDIRECT MENU**, touch **DIAGNOSTICS**, and then touch **LOOPBACK TEST**.

5. Let the test run for several hours or overnight.
6. If the test fails, an error message appears on the control-panel display. Replace the formatter.
7. To stop the test, turn the MFP off and then on. Make sure that you reconnect the network cable.



## Ping test

Use the ping test to verify that the MFP is communicating over the network. Before performing the ping test, obtain the IP address for a target destination, such as a PC, that is on the same network as the MFP. Consult the network administrator for help with obtaining the IP address.


1. Scroll to and touch **Administration**.
2. Touch **Management**.
3. Touch **Embedded Jetdirect** or **EIO <X> Jetdirect**.
4. Touch **Ping Test**.
5. Set the appropriate options for each of the menu items that follow:
  - **Dest Type**
  - **Dest IP**
  - **Packet Size**
  - **Timeout**
  - **Count**
  - **Print Results**
  - **Execute**

After setting **Execute** to **Yes**, the ping test starts automatically. If you selected to print the results, a page prints that lists the ping statistics. If the page prints, the test was successful.

# Solve stapler/stacker problems

Control panel message	Description	Recommended action
	<p>There is no power to the stapler/stacker.</p> <p> <b>NOTE</b> The stapler/stacker is powered by the printer through the communication cable connecting the two devices.</p>	<ol style="list-style-type: none"> <li>1. Check the communication cable between the stapler/stacker and the printer for a loose connection or damage. Make sure that the connector is securely screwed in. If the cable is damaged, go to step 4.</li> <li>2. Check wiring connection J1301 on the stapler/stacker driver board.</li> <li>3. Replace the stapler/stacker driver board.</li> <li>4. If none of the above corrects the problem, replace the stapler/stacker unit.</li> </ol>
<b>13.12.07 Jam In Stapler</b>	<p>The stapler could not finish its cycle but was able to return to the home position</p> <p>If the stapler drive does not return to home position (HP) during the normal cycle, the stapler/stacker driver signals M1304 (stapler motor) to rotate once in reverse. If the HP signal is now detected, the stapler/stacker driver sends a signal to the formatter that a staple jam is present.</p>	<ol style="list-style-type: none"> <li>1. Remove the staple cartridge and any loose staples or staples that might be obstructing stapler movement.</li> <li>2. Remove one sheet of staples from staple cartridge and try again.</li> <li>3. Inspect the staple cartridge for damage. Replace the staple cartridge if it is damaged.</li> <li>4. Verify that genuine HP staples are being used.</li> </ol> <p> <b>NOTE</b> Staples come pre-loaded in the staple cartridge and cannot be ordered separately as a refill from HP.</p> <ol style="list-style-type: none"> <li>5. Remove the stapler assembly. Inspect the stapler for jammed staples around the staple plunger and crimper. Remove any jammed staples that are found.</li> <li>6. Install a new staple cartridge.</li> <li>7. Replace the stapler assembly.</li> <li>8. If none of the above corrects problem, replace the stapler/stacker unit.</li> </ol>
<b>13.12.08 Jam In Left Accessory</b>	<p>Stay jam in accumulator. Paper sensor PS 1302 stayed activated longer than expected.</p> <p>This signal is generated by sensor PS1302 (delivery sensor). PS1302 is located just before the delivery rollers. In order to reach or see the sensor arm, lift the upper delivery rollers and upper paper-path guide plate. You will now be able to see and toggle the sensor arm activating PS1302.</p>	<ol style="list-style-type: none"> <li>1. Remove any jammed paper obstructing the paper path to the delivery rollers.</li> <li>2. Check the delivery flappers and linkages to make sure flappers are not blocking paper from exiting the machine to the output tray. If broken parts are found, go to step 6.</li> </ol>

Control panel message	Description	Recommended action
		<ol style="list-style-type: none"> <li>3. If the delivery rollers are not turning, go to step 6.</li> <li>4. If the jogger guides are not in the correct position to receive paper and are obstructing paper, check the jogger-guide sensors and connectors on the jogger assembly. If necessary, replace the jogger assembly.</li> <li>5. If the problem only occurs when stapling, check for deformed staples. If deformed staples are found, replace the staple cartridge and/or stapler assembly. If paper is being held back from exiting by the clamping device while stapling, go to step 6.</li> <li>6. If none of the above corrects problem, replace the stapler/stacker unit.</li> </ol>
<b>13.12.09 Jam In Left Accessory</b>	<p>Stay jam at the entrance to the stapler/stacker. Sensor PS1301 stayed activated longer than expected.</p> <p>This signal is generated by sensor PS1301 (paper-inlet sensor). PS1301 is located under the lower-entrance guide plate with the sensor arm extending up through the guide plate and into the paper path.</p>	<ol style="list-style-type: none"> <li>1. Check PS1301 sensor and flag for smooth operation and damage. Make sure that the lower plate is free and is not touching the sides of the cutout of the lower guide plate that the arm operates within. If damaged, go to step 7.</li> <li>2. Check for any damage or obstructions to the entrance of the upper and lower guide plates. If damaged, go to step 7.</li> <li>3. Inspect the upper-entrance guide plate to make sure its alignment allows the sensor arm to move freely through the hole cut in it for the sensor arm. If damaged, go to step 7.</li> <li>4. Check for excessive paper curl when paper leaves the fuser. The cause could be damp paper.</li> <li>5. Clean PS1301 by gently blowing air into the sensor.</li> <li>6. Check connection J1303 on the stapler/stacker driver board.</li> <li>7. If none of the above corrects the problem, replace the stapler/stacker unit.</li> </ol>
<b>13.12.10 Jam In Left Accessory</b>	<p>Delay jam in entry. Paper did not arrive at the paper-inlet sensor PS1301 within the expected time.</p> <p>This signal is generated from sensor PS1301 (paper-inlet sensor). PS1301 is located under the lower entrance guide plate with the sensor arm extending up</p>	<ol style="list-style-type: none"> <li>1. Check for excessive paper curl as paper leaves the fuser. The cause could be damp paper.</li> <li>2. Check for any damage to the entrance guide plates.</li> </ol>



Control panel message	Description	Recommended action
	through the guide plate and into the paper path.	<ol style="list-style-type: none"> <li>3. Check the PS1301 sensor, sensor arm, and sensor flag for smooth operation and damage.</li> <li>4. Clean PS1301 by gently blowing air into the sensor.</li> <li>5. Check connection J1303 on the stapler/stacker driver board.</li> <li>6. If none of the above corrects the problem, replace the stapler/stacker unit.</li> </ol>
<b>13.12.11 Jam In Left Accessory</b>	<p>Initial jam. At power on, paper was present at the entrance of the stapler/stacker at sensor PS1301.</p> <p>This signal is generated by sensor PS1301 (paper-inlet sensor). PS1301 is located under the lower entrance guide plate with the sensor arm extending up through the guide plate and into the paper path.</p>	<ol style="list-style-type: none"> <li>1. Remove any paper found in the entrance guides.</li> <li>2. Inspect the sensor PS1301 actuation arm to make sure it moves freely and is not rubbing against the entrance guide plates (upper and lower plates).</li> <li>3. Check connection J1303 on the stapler/stacker driver board..</li> <li>4. If none of the above corrects the problem, replace the stapler/stacker unit.</li> </ol>
<b>65.00.15 Output Device Failure</b>	<p>After the MFP boot process, the external device requested a new boot process. This can happen during an upgrade; the 24 V power goes off momentarily, which makes the stapler/stacker think it is initializing again.</p> <p> <b>NOTE</b> During an upgrade of the external device, if the connection with the device is lost for 9 minutes, the firmware crashes with a 66.00.15 error and forces the user to reboot. It will then display a <b>Resend external accessory firmware</b> message.</p>	<ol style="list-style-type: none"> <li>1. Turn off the MFP.</li> <li>2. Disconnect the communication cable between the output device and the MFP.</li> <li>3. Check the connection pins for damage. If you are unable to align the pins so they work properly, go to step 6.</li> <li>4. Reconnect the communication cable to the MFP, making sure the connector is properly screwed down in.</li> <li>5. Turn on the printer.</li> <li>6. Reload the latest firmware bundle.</li> <li>7. Check connection J1301 on the stapler/stacker driver board.</li> <li>8. If none of the above corrects the problem, replace the stapler/stacker unit.</li> </ol>
<b>65.12.01 Output Device Failure</b>	<p>The paddle (retainer) motor M1301 was not able to move the sensor flag to the home position detected by sensor PS1305.</p> <p>This signal is generated by sensor PS1305 (paddle home-position sensor). Sensor PS1305 is located on the rear frame of the stapler/stacker, between the two DC</p>	<ol style="list-style-type: none"> <li>1. Inspect sensor PS1305 to make sure it is correctly mounted and the wires are connected.</li> <li>2. Clean sensor PS1305 by gently blowing air into the sensor.</li> </ol>



Control panel message	Description	Recommended action
	motors: M1301 Paddle motor, and M1303 Feed Motor.	<ol style="list-style-type: none"> <li>3. Check connections J1314 and J1313 on the stapler/stacker control board.</li> <li>4. If none of the above corrects the problem, replace the stapler/stacker unit.</li> </ol>
<b>65.12.02 Output Device Failure</b>	<p>Jogger-motor malfunction. The jogger home position could not be sensed by sensor PS1304.</p> <p>This signal is generated by sensor PS1304 (jogger home-position sensor). Sensor PS1304 is located on the jogger assembly and can be accessed after removing the front, rear, and top covers of the stapler/stacker.</p>	<ol style="list-style-type: none"> <li>1. Check for anything that might be obstructing or restricting the movement of the jogger guides.</li> <li>2. Inspect PS1304 for the correct mounting and secure wiring connections. Also check for damage. If there is damage, go to step 5.</li> <li>3. Clean PS1304 by gently blowing air into the sensor.</li> <li>4. Check connectors J1302 and J1311 on the stapler/stacker driver board.</li> <li>5. If none of the above corrects the problem, replace the jogger guide assembly.</li> <li>6. If none of the above corrects the problem, replace the stapler/stacker unit.</li> </ol>
<b>65.12.03 Output Device Failure</b>	<p>Staple-motor malfunction. The staple motor was unable to return to the home position as read by sensor PHO11.</p> <p>This signal is generated by sensor PHO11 (stapler home-position sensor). PHO11 is located in the stapler assembly and cannot be serviced. If the stapler drive does not return to home position (HP) during the normal cycle, the stapler/stacker driver signals M1304 (stapler motor) to rotate once in reverse. If the HP signal is not detected, the stapler/stacker driver sends a signal to the formatter that the staple motor has malfunctioned.</p>	<ol style="list-style-type: none"> <li>1. Check for a staple jam in the stapler; remove any jammed staples.</li> <li>2. Check the wiring connections at the stapler assembly.</li> <li>3. If none of the above corrects the problem, replace the stapler assembly.</li> <li>4. Check connector J1312 on the stapler/stacker driver board.</li> <li>5. If none of the above corrects the problem, replace the stapler/stacker unit.</li> </ol>
<b>65.12.34 Output Device Failure</b>	<p>Cooling fan failure.</p> <p>This failure is detected by the stapler/stacker control board. If the rotation speed of the cooling fan is not normal for 5 seconds or longer, the stapler/stacker control board notifies the formatter of the problem.</p>	<ol style="list-style-type: none"> <li>1. Inspect the fan to make sure nothing is obstructing the fan rotation.</li> <li>2. Clean the fan blades of any dust accumulation.</li> <li>3. Check connector J1309 on the stapler/stacker driver board.</li> <li>4. If none of the above corrects the problem, replace the stapler/stacker unit.</li> </ol>

Control panel message	Description	Recommended action
<b>65.12.35 Output Device Failure</b>	<p>Stapler malfunction. The stapler self-prime sensor PHOI2 did not activate.</p> <p>This signal is generated by sensor PHOI2 (staple-ready sensor). Sensor PHOI2 is located in the stapler assembly and cannot be serviced.</p> <p>When a new staple cartridge is installed, the stapler goes through the stapling motion 11 times in order to advance the first staple to the proper stapling position. If the staples are not advanced after 11 attempts, the control board notifies the formatter that self-priming has failed.</p>	<ol style="list-style-type: none"> <li>1. Verify that genuine HP staples are being used and that the staples are the correct type for this stapler.</li> </ol> <p> <b>NOTE</b> Staples come pre-loaded in the staple cartridge and cannot be ordered separately as a refill from HP.</p> <ol style="list-style-type: none"> <li>2. Replace the staple cartridge.</li> <li>3. If none of the above corrects the problem, replace the stapler assembly.</li> <li>4. If none of the above corrects the problem, replace the stapler/stacker unit.</li> </ol>
<b>65.12.99 Output Device Disconnected</b>	<p>When the printer was turned on, the stapler/stacker lost communication with the MFP.</p>	<ol style="list-style-type: none"> <li>1. Turn off the MFP.</li> <li>2. Disconnect the communication cable between the output device and the MFP.</li> <li>3. Check the connection pins for damage. If you are unable to align the pins so they work properly, go to step 7.</li> <li>4. Reconnect the communication cable to the MFP, making sure that the connector is properly screwed in.</li> <li>5. Turn on the MFP. If the problem still exists, go to Step 6.</li> <li>6. Check connection J1301 on the stapler/stacker driver board.</li> <li>7. If none of the above corrects the problem, replace the stapler/stacker unit.</li> </ol>
<b>66.12.33 Output Device Failure</b>	<p>The delivery-roller lift motor could not reach the home position as detected by sensor PS1303.</p> <p>This signal is generated by sensor PS1303 (delivery-roller disengaging sensor). PS 1303 is located behind the front cover and to the left of the stapler assembly.</p>	<ol style="list-style-type: none"> <li>1. Inspect sensor PS1303 to make sure it is correctly mounted and not damaged. Also make sure that the wires are connected.</li> <li>2. Clean sensor PS1303 by gently blowing air into the sensor.</li> <li>3. Check connector J 1308 on stapler/stacker driver board.</li> <li>4. If none of the above corrects the problem, replace the stapler/stacker unit.</li> </ol>

Control panel message	Description	Recommended action
<b>Corrupt Firmware In External Device</b>	The stapler/stacker needs a firmware upgrade.	<ol style="list-style-type: none"> <li>1. Go to <a href="http://www.hp.com/support">http://www.hp.com/support</a> to download the latest firmware and review the upgrade procedure.</li> <li>2. Install the latest firmware on the device.</li> <li>3. If the new firmware does not correct the problem, replace the stapler/stacker unit.</li> </ol>
<b>Left Output Bin Full</b>	<p>The control panel indicates that the output bin is full; however, there is no paper in the output tray.</p> <p>The signal is generated by sensor PS1306 (delivery-full sensor). Sensor PS1306 is located on left side of stapler/stacker, above the delivery rollers. The sensor is activated by paper exiting the output device lifting the delivery flappers.</p>	<ol style="list-style-type: none"> <li>1. Verify that the output flappers used to actuate the sensor flag are not caught behind the jogger guides and have full range of motion needed to actuate the sensor.</li> <li>2. Check the sensor flag and actuator movement, making sure that by raising the output flappers the sensor flag actuates PS1306.</li> <li>3. Clean PS1306 by gently blowing air into the sensor.</li> <li>4. Check sensor PS1306 mounting.</li> <li>5. Check the wiring connector at sensor PS1306 as well as connector J1313 on the stapler/stacker driver board.</li> <li>6. If none of the above corrects the problem, replace the stapler/stacker unit.</li> </ol>
<b>Output Paper Path Open</b>	<p>The stapler door is open, or the stapler/stacker is not fully latched to the MFP.</p> <p>This signal is generated by switch SW1301 (door switch). Switch SW1301 is located behind the front cover and is actuated by a tab on the stapler door and a tab on the engine.</p>	<ol style="list-style-type: none"> <li>1. Inspect the stapler-access door for damage or misalignment, and also make sure that the actuation tab is not broken off of the door. If there is damage, replace the stapler/stacker jam-access door or replace the front cover assembly (includes the front cover and the jam-access door).</li> <li>2. Inspect SW1301 and the actuator assembly for damage or mounting problems. If damaged beyond repair, go to step 4.</li> <li>3. Check wiring connection J1304 on the stapler/stacker driver board.</li> <li>4. If none of the above corrects the problem, replace the stapler/stacker unit.</li> </ol>

Control panel message	Description	Recommended action
<b>Replace Staple Cartridge</b>	<p>The control panel indicates that the stapler is out of staples; however, after putting in a new cartridge, the message remains.</p> <p>The signal is generated by sensor PHOI2 (staple-ready sensor) or sensor PHOI3 (staple-level sensor). Both are located in the stapler assembly and cannot be cleaned or serviced.</p>	<ol style="list-style-type: none"> <li>1. Make sure that a genuine HP staple cartridge is being used.</li> <li>2. Replace the staple cartridge.</li> </ol> <div style="border: 1px solid black; padding: 5px; margin: 5px 0;">  <b>NOTE</b> Staples come pre-loaded in the staple cartridge and cannot be ordered separately as a refill from HP. </div> <ol style="list-style-type: none"> <li>3. Check the wiring connections at the stapler assembly.</li> <li>4. Remove the stapler assembly and any loose staples found in and around stapling assembly.</li> <li>5. If none of the above corrects the problem, replace the stapler assembly.</li> <li>6. Check wiring connection J1312 on the stapler/stacker driver board.</li> <li>7. If none of the above corrects the problem, replace the stapler/stacker unit.</li> </ol>
<b>Stapler Low On Staples</b>	<p>The control panel indicates that the stapler is low on staples or the staple cartridge is missing; however, after putting in a new cartridge, the message remains.</p> <p>The signal is generated by sensor PHOI3 (staple-level sensor). Sensor PHOI3 is located in the stapler assembly and cannot be cleaned or serviced.</p>	<ol style="list-style-type: none"> <li>1. Make sure that a genuine HP staple cartridge is being used.</li> <li>2. Replace the staple cartridge.</li> </ol> <div style="border: 1px solid black; padding: 5px; margin: 5px 0;">  <b>NOTE</b> Staples come pre-loaded in the staple cartridge and cannot be ordered separately as a refill from HP. </div> <ol style="list-style-type: none"> <li>3. Check the wiring connections at the stapler assembly.</li> <li>4. Remove the stapler assembly and any loose staples found in and around stapling assembly.</li> <li>5. If none of the above corrects the problem, replace the stapler assembly.</li> <li>6. Check wiring connection J1312 on the stapler/stacker driver board.</li> <li>7. If none of the above corrects the problem, replace the stapler/stacker unit.</li> </ol>
<b>Too Many Pages In Job To Staple</b>	<p>When the firmware detects that the job is attempting to staple more than the maximum 30 pages, the firmware signals the jogger guides to open, dropping the unstapled stack of paper into the output tray below. The remainder of the copies will print out and be directed to the output tray without being stapled.</p>	<p>Do not attempt to staple more than 30 pages of 20 lb bond (75g/m<sup>2</sup>) paper. For heavier paper, the maximum stack height that can be stapled is 3 mm.</p>

# Solve 3-bin mailbox problems

Control panel message	Description	Recommended action
	<p>There is no power to the MBM.</p> <p> <b>NOTE</b> The MBM is powered by the printer through the communication cable connecting the two devices.</p>	<ol style="list-style-type: none"> <li>1. Check the communication cable between the MBM and the printer for a loose connection or damage. Make sure that the connector is securely screwed in. If the cable is damaged, go to step 4.</li> <li>2. Check wiring connection J1501 on the MBM driver board.</li> <li>3. Replace the MBM driver board.</li> <li>4. If none of the above corrects the problem, replace the MBM unit.</li> </ol>
<b>13.12.09 Jam In Left Accessory</b>	<p>Stay jam. Inlet-paper sensor PS1501 remained activated longer than expected.</p> <p>This signal is generated by sensor PS1501 (paper-inlet sensor). PS1501 is located under the lower entrance guide plate with the sensor arm extending up through the guide plate and into the paper path.</p>	<ol style="list-style-type: none"> <li>1. Check sensor PS1501 and flag for smooth operation and damage, making sure its movement down through the lower plate is free and is not touching the sides of the cutout on the lower guide plate. If there is damage, go to step 7.</li> <li>2. Check for any damage or obstructions to the entrance to the upper and lower guide plates. If there is damage, go to step 7.</li> <li>3. Inspect the upper entrance guide plate to make sure its alignment allows the sensor arm to move freely through the hole cut in it for the sensor arm. If there is damage, go to step 7.</li> <li>4. Check for excessive paper curl as paper leaves the fuser. Damp paper could be the cause.</li> <li>5. Clean PS1501 by gently blowing air into the sensor.</li> <li>6. Check connection J1503 on the MBM driver board.</li> <li>7. If none of the above corrects the problem, replace the MBM unit.</li> </ol>
<b>13.12.10 Jam In Left Accessory</b>	<p>Delay jam. Paper did not arrive at the paper-inlet sensor PS1501 within the expected time.</p> <p>This signal is generated from sensor PS1501 (paper-inlet sensor). PS1501 is located under the lower entrance guide plate with the sensor arm extending up through the guide plate and into the paper path.</p>	<ol style="list-style-type: none"> <li>1. Check for excessive paper curl as paper leaves the fuser. The cause could be damp paper.</li> <li>2. Check for any damage to the entrance guide plates.</li> <li>3. Check the PS1501 sensor, sensor arm, and sensor flag for smooth operation and damage.</li> </ol>

Control panel message	Description	Recommended action
		<ol style="list-style-type: none"> <li>4. Clean PS1501 by gently blowing air into the sensor.</li> <li>5. Check connection J1503 on the MBM driver board.</li> <li>6. If none of the above corrects the problem, replace the MBM unit.</li> </ol>
<b>13.12.11 Jam In Left Accessory</b>	<p>Initial jam. At power on, paper was present at the entrance of the MBM at sensor PS1501.</p> <p>This signal is generated by sensor PS1501 (paper-inlet sensor). PS1501 is located under the lower entrance guide plate with the sensor arm extending up through the guide plate and into the paper path.</p>	<ol style="list-style-type: none"> <li>1. Remove any paper found in the entrance guides of the MBM that might be activating PS1501.</li> <li>2. Inspect the sensor PS1501 actuation arm to make sure it moves freely and is not rubbing against the entrance guide plates (upper and lower plates). If damage is found, go to step 4.</li> <li>3. Check connection J1503 on the MBM driver board.</li> <li>4. If none of the above corrects the problem, replace the MBM unit.</li> </ol>
<b>65.12.34 Output Device Failure</b>	<p>Cooling fan failure.</p> <p>This failure is detected by the MBM driver board. If the rotation speed of the cooling fan is not normal for 5 seconds or longer, the MBM control board notifies the formatter of the problem.</p>	<ol style="list-style-type: none"> <li>1. Inspect the fan to make sure nothing is obstructing the fan rotation.</li> <li>2. Clean the fan blades of any dust accumulation.</li> <li>3. Check connector J1509 on the MBM driver board.</li> <li>4. If none of the above corrects the problem, replace the MBM unit.</li> </ol>
<b>65.12.99 Output Device Disconnected</b>	<p>When the printer was turned on, the MBM lost communication with the MFP.</p>	<ol style="list-style-type: none"> <li>1. Turn off the MFP.</li> <li>2. Disconnect the communication cable between the output device and the MFP.</li> <li>3. Check the connection pins for damage. If you are unable to align the pins so they work properly, go to step 7.</li> <li>4. Reconnect the communication cable to the MFP, making sure that the connector is screwed in properly.</li> <li>5. Turn on the MFP. If the problem still exists, go to Step 6.</li> <li>6. Check connection J1501 on the MBM driver board.</li> <li>7. If none of the above corrects the problem, replace the MBM unit.</li> </ol>

Control panel message	Description	Recommended action
<b>Corrupt Firmware In External Device</b>	The MBM needs a firmware upgrade.	<ol style="list-style-type: none"> <li>1. Go to <a href="http://www.hp.com/support">http://www.hp.com/support</a> to download the latest firmware and review the upgrade procedure.</li> <li>2. Install the latest firmware on the device.</li> <li>3. If the new firmware does not correct the problem, replace the MBM unit.</li> </ol>
<b>Output Bin &lt;X&gt; Full</b>	<p>The control panel indicates that the output bin is full; however, there is no paper in the output tray.</p> <p>The signal is generated by sensor PS1503 (bin 1 delivery-full sensor), PS1505 (bin 2 delivery-full sensor), or PS1507 (bin 3 delivery-full sensor). Sensors PS1503 and PS1505 are located behind the front cover of the MBM. Sensor PS1507 is located above the bin 3 delivery rollers, close to the MBM rear frame.</p>	<ol style="list-style-type: none"> <li>1. Bins 1 and 2: Verify that the upper Y-shaped sensor actuator arms are actually activating the associated sensors. The bin 1 and bin 2 bin-full sensors are the left sensors of the sensor set. <ul style="list-style-type: none"> <li>Verify that the output flappers used to actuate the sensor are actually activating sensor PS1507 and have the full range of motion needed to actuate the sensor.</li> </ul> </li> <li>2. Check the sensor flag actuator arms for free, quick, and unobstructed movement when rising and falling.</li> <li>3. Clean the problematic sensor by gently blowing air into the sensor.</li> <li>4. Check the problematic sensor to make sure it is mounted properly and is in correct alignment with the sensor flag (not touching the sides of the plate).</li> <li>5. For bins 1 and 2, check the wiring connector at the sensor board as well as connector J1502 on the MBM driver board.</li> <li>6. If none of the above corrects the problem, replace the MBM driver board.</li> <li>7. If none of the above corrects the problem, replace the MBM unit.</li> </ol>
<b>Output Paper Path Open</b>	<p>The control panel indicates that the MBM is not latched to the MFP; however, it is physically attached to the MFP.</p> <p>This signal is generated by switch SW1501 (engine-connection switch). Switch SW1501 is located behind the front cover, near the bottom of the MBM. This switch is actuated by a tab on the MFP that engages the actuation arm on the MBM when the MBM is moved against the MFP and they become latched together.</p>	<ol style="list-style-type: none"> <li>1. Verify that the MBM is latching properly to the MFP.</li> <li>2. Inspect the actuator tab on the MFP for damage.</li> <li>3. Remove the front cover of the MBM and inspect SW1501 and the actuator assembly for damage or mounting problems. If either is damaged beyond repair, go to step 5.</li> <li>4. Check wiring connection J1502 on the MBM driver board.</li> <li>5. If none of the above corrects the problem, replace the MBM unit.</li> </ol>

## Functional checks

Use the following procedures to help diagnose and solve problems that occur in the print engine.

### Early boot diagnostic test

When the device is powered on, it runs several self tests on the formatter and displays the results using the three control-panel LEDs (Ready, Data, and Attention). If the boot process stops and nothing is displayed on the control panel, examine the control-panel LEDs for any of the following light combinations:

	Ready	Data	Attention
A	OFF	OFF	OFF
B	ON	OFF	OFF
C	OFF	ON	OFF
D	ON	ON	OFF
E	OFF	OFF	ON
F	ON	OFF	ON
G	OFF	ON	ON
H	ON	ON	ON

If the boot process stops and any of these LED combinations are visible, perform the following actions:

1. Turn the device off.
2. Reseat the formatter.
3. Ensure that the engine connectors are properly connected to the formatter.
4. Remove any memory DIMMs that are installed.
5. Verify the cable connections to the control panel.
6. Turn the device on.

If the boot process stops with the same error, replace the formatter.

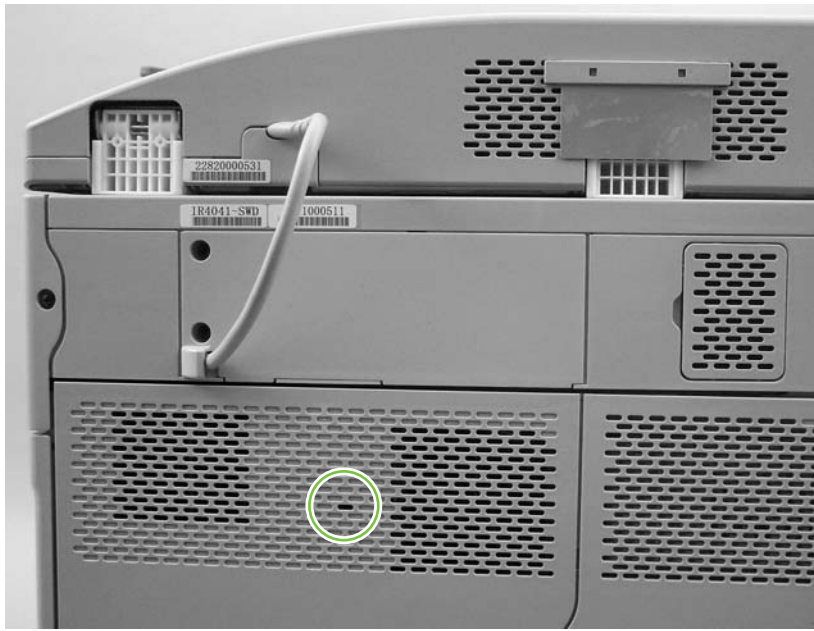
### Engine test

To verify that the print engine (all components except the formatter, formatter DIMMs, EIO products, and the stacker or stapler/stacker) is functioning, print an engine test page. Use a small, non-metallic, pointed object to depress the engine-test switch, which is located on the back of the MFP.



**NOTE** The standard output bin must be installed in order for the engine test page to print. If either the stapler/stacker or the 3-bin mailbox is installed, a jam occurs.





**Figure 6-11** Engine-test-print switch

The test page should have a series of vertical lines. The test page prints from the last tray that you used. However, if the MFP has been turned off and then on since the most recent print job, the page prints from tray 2. The MFP continuously prints test pages as long as the test-page switch is depressed. The MFP cannot print a test page if it is in Sleep mode.



**NOTE** A damaged formatter might interfere with the engine test. If the engine-test page does not print, try removing the formatter and performing the engine test again. If the engine test is then successful, the problem is almost certainly with the formatter, the control panel, or the cable that connects them.

## Formatter test

To verify that the formatter is functioning correctly, print a Configuration page. If the page prints, the formatter is functioning.

The heartbeat LED on the formatter also indicates whether the formatter is functioning.

## Half self-test

Use the half self-test to determine which of the eight image-formation processes might be malfunctioning.

1. Print a Configuration page.
2. Open the top cover after the paper advances half-way through the MFP, which is about 3 to 5 seconds after the main motor begins rotation. The leading edge of the paper should have advanced past the print cartridge.
3. Remove the print cartridge.
4. Open the print cartridge drum shield to view the drum surface.

If a dark and distinct toner image is present on the drum surface, assume that the first four functions of the electrophotographic process are functioning (cleaning, conditioning, writing, and developing), and troubleshoot the failure as a transfer or fusing problem.

If no image is present on the photosensitive drum, perform the drum-rotation test.

## Drum-rotation test

The photosensitive drum, which is located in the print cartridge, must rotate in order for the print process to work. The photosensitive drum receives its drive from the main gear assembly. Use this procedure to determine whether the drum is rotating.

1. Open the top cover.
2. Remove the print cartridge.
3. Mark the cartridge drive-gear with a felt-tipped marker. Note the position of the mark.
4. Install the print cartridge and close the top cover. The start-up sequence should rotate the drum enough to move the mark on the gear.
5. Open the MFP and inspect the gear that was marked in step 3. Verify that the mark moved. If the mark did not move, inspect the main gear assembly to make sure that it meshes with the print-cartridge gears. If the drive gears function but the drum does not move, replace the print cartridge.



---

**NOTE** This test is especially important if refilled print cartridges are in use.

---

# MFP resets

Use the following information to perform system-wide reset procedures. Customers do not have access to this information.

## Cold reset

A cold reset unlocks menus that have been previously locked and resets all control-panel menu items to the factory defaults. A cold reset does not clear the values in the service menu, such as the serial number and the page counts.



---

**NOTE** Before performing a cold reset, print a menu map and a Configuration page. Use the information on these pages to reset customer-specific settings.

---



---

**CAUTION** All HP Jetdirect settings are also reset. Be sure to print a Configuration page before performing a cold reset. Make note of the IP address that is listed on the Jetdirect Configuration page. You will need to restore the IP address after performing a cold reset.

---

1. Turn the MFP off and then on.
2. When the memory count appears on the control-panel display, press and hold **6** until all three LEDs flash once and then stay on. This might take up to 20 seconds.
3. Press **3** two times until **COLD RESET** appears on the control-panel display.
4. Press **6** one time. The MFP continues its initialization sequence.

## NVRAM initialization



---

**NOTE** If an HP LaserJet analog fax accessory 300 is installed, performing an NVRAM initialization can cause the MFP to violate local telephone regulations. Reset the language and country/region after performing NVRAM initialization. For more information, see the *HP LaserJet Analog Fax Accessory 300 Service Manual*.

Before performing an NVRAM initialization, print a menu map and a Configuration page. Use the information on these pages to reset any customer-specific settings.

---



---

**CAUTION** All HP Jetdirect settings are also reset. Be sure to print a Configuration page before performing a cold reset. Make note of the IP address that is listed on the Jetdirect Configuration page. You will need to restore the IP address after performing an NVRAM initialization.

---

Performing an NVRAM initialization resets the following settings and information:

- All menu settings are reset to factory default values, including the fax header and company name.
- All faxes in memory are erased.
- All speed-dials, group-dials, and phonebook entries are erased.
- All localization settings, including language and country/region, are reset.

After performing an NVRAM initialization, reconfigure any computers that print to this MFP so that the computers can recognize the MFP.

1. Turn the MFP off and then on.
2. Before the memory count appears on the control-panel display, press and hold **9** until all three LEDs flash once and then stay on. This might take up to 20 seconds.
3. Press **3** one time, and then press **Start**.
4. Press **3** two times until **NVRAM INIT** appears on the control-panel display.
5. Press **6** one time, and wait while the MFP completes its initialization sequence.

## Hard-disk initialization

A hard-disk initialization erases and reformats the hard disk. Perform a hard-disk initialization only if an error message on the control-panel indicates a disk error. Always try initializing the hard disk before replacing it.



---

**NOTE** Before performing a hard-disk initialization, print a menu map and a Configuration page. Use the information on these pages to reset any customer-specific settings.

---



---

**CAUTION** A hard-disk initialization deletes the following information: all stored copy jobs, the local address book (e-mail addresses), the speed-dial list (fax numbers), and the Java™ applet files.

---

1. Turn the MFP off and then on.
2. Before the memory count appears on the control-panel display, press the *right-hand side* of the **Start** button until all three LEDs are lit. Release the **Start** button.
3. Press **5** one time. **INITIALIZE DISK** appears on the control-panel display.
4. Press **6** one time. A series of asterisks appears on the control-panel display. Wait for the MFP to complete its initialization sequence.

## Individual component diagnostics

From the diagnostics menu, you can run tests to check the status of various components in the MFP. During many of the diagnostic tests, the MFP enters a special diagnostics mode, which allows you to send print jobs and interact with the menus.

### Paper-path-sensor test

1. Scroll to and touch **Administration**.
2. Touch **Troubleshooting**.
3. Touch **Paper Path Sensors**.

The paper-path-sensor test checks for the presence of media at each of the sensors along the paper path. As the media passes each sensor, the sensor's state is updated. On the control-panel display, each sensor is represented by a string of alphabetic letters followed by a corresponding status for each sensor. Use the following table to associate the letters that are shown on the control-panel display with the sensor that they represent. A "0" next to the letter indicates that no media is present. A "1" indicates that media is present.

**Table 6-4** Paper-path sensor letter designations

Letter	Component	Letter	Component
A	Tray 5 paper feed	F	PS103: top-of-page
B	Tray 4 paper feed	G	
C	Tray 3 paper feed	H	PS110: reversing paper sensor
D	PS106: front paper width	J	PS108: exit sensor to the fuser
E	PS102: tray 2 pre-feed	K	PS109: delivery

### Manual sensor test

1. Scroll to and touch **Administration**.
2. Touch **Troubleshooting**.
3. Touch **Manual Sensor Test**.

The manual sensor test indicates the status of the sensors and switches in the MFP. On the control-panel display, each sensor is represented by a string of letters followed by a corresponding status for each sensor. Except for the paper-size switches, a "0" next to the letter indicates that no media is present or the switch is open. A "1" indicates that media is present or the switch is closed. For the paper-size switches (SW102), the number ranges from 0 to 7 to indicate the state of the three switches. Use the following table to associate the letters that appear on the control-panel display with the switch or sensor that they represent. Note that both uppercase and lowercase letters are used.

**Table 6-5** Manual sensor test letter designations

Letter	Component	Letter	Component
A	Tray 5 paper feed sensor	S	SW102: tray 2 paper-size switches (3 switches) <ul style="list-style-type: none"> <li>● S0 = all three switches are closed</li> <li>● S1 = the bottom and middle switches are closed</li> <li>● S3 = the bottom switch is closed</li> <li>● S5 = the middle switch is closed</li> <li>● S6 = the top switch is closed</li> <li>● S7 = no switches are closed</li> </ul>
B	Tray 4 paper feed sensor	T	Tray 3 jam-access-cover switch
C	Tray 3 paper feed sensor	U	Tray 3 paper out sensor
D	PS106: paper-width sensor	V	Tray 3 paper-stack surface sensor
E	PS102: pre-feed sensor	W	Tray 3 paper-size switches (The number ranges from 0 to 7 as for tray 2. See the entry for letter "S".)
F	PS103: top-of-page sensor	X	Tray 4 jam-access-cover switch
H	PS111: reverse-unit paper sensor	Y	Tray 4 paper-out sensor
J	PS108: fuser-delivery sensor	Z	Tray 4 paper-stack surface sensor
K	PS109: delivery paper sensor	a	Tray 4 paper size switches (The number ranges from 0 to 7 as for tray 2. See the entry for letter "S".)
L	PS104: output bin full sensor	b	Tray 5 jam-access cover switch
M	PS105: tray 1 paper-present sensor	c	Tray 5 paper-out sensor
N	SW103: standard output-bin detection switch	d	Tray 5 paper-stack surface sensor
P	SW105: jam-access-cover switch	e	Tray 5 paper size switches (The number ranges from 0 to 7 as for tray 2. See the entry for letter "S".)
Q	PS101: tray 2 paper-out sensor	f	SW101: top-cover switch
R	PS107: tray 2 paper-stack surface sensor		

## Scanner tests

1. Scroll to and touch **Administration**.
2. Touch **Troubleshooting**.
3. Touch **Scanner Tests**.

Use the scanner tests to verify that specific components in the scanner assembly are operating correctly. For most of the components, you must observe or listen to the component in order to verify that it is functioning as stated on the control-panel display. For the scanner sensors, you must activate the sensor and watch the condition indicator on the control-panel display to see if it changes.

## Component test

1. Scroll to and touch **Administration**.
2. Touch **Troubleshooting**.
3. Touch **Component Test**.

Use the component test to exercise individual parts one-at-a-time, so that you can determine the cause of noise inside the MFP. For most of the components, you must observe or listen to the component in order to verify that it is functioning as stated on the control-panel display.

## Service ID

This information appears on the Configuration page, which eliminates the need for customers to keep paper receipts for proof of the warranty. Because the MFP does not have an internal clock, the availability of the service ID date depends on the MFP being connected to a source that can provide the date, in this case a time server that is on the same network as the MFP. When the MFP is not connected to a date source, the service ID is not available, and “00000” appears on the Configuration page.

## Restoring the Service ID

If you replace the formatter, the date is lost. Use this menu item to reset the value to the date that the MFP was first used. The date format is YYDDD. Use the following procedure to calculate the date.

1. To calculate YY, subtract 1990 from the calendar year. For instance, if the MFP was first used in 2002, calculate YY as follows:  $2002 - 1990 = 12$  (YY = 12).
2. To calculate DDD, use the following formula:  $30 (\text{calendar month} - 1) + \text{calendar day} = \text{DDD}$ . If the calendar day is 31, use 30 instead. For instance, if the MFP was first used on October 17, calculate DDD as follows:
  - a. Subtract 1 from 10 (October is the tenth month of the year):  $10 - 1 = 9$ .
  - b. Multiply 9 by 30:  $9 \times 30 = 270$ .
  - c. Add 17 to 270:  $270 + 17 = 287$  (DDD = 287).

## Converting the service ID to an actual date

You can use the MFP Service ID number to determine whether the MFP is still under warranty. Use the following procedure to convert the Service ID into the installation date.

1. Add 1990 to YY to determine the actual year that the MFP was installed.
2. Divide DDD by 30, and add 1 to the whole-number part of the quotient. The total is the month.
3. The remainder from the calculation in step 2 is the day of the month.

Using the Service ID 12287 as an example, the date conversion is as follows:

1.  $12 + 1990 = 2002$ , so the year is 2002.
2.  $287 \text{ divided by } 30 = 9 \text{ with a remainder of } 17$ . Add 1 to 9 to get 10, so the month is October.
3. The remainder (from the above calculation) is 17, so that is the day of the month.
4. The complete date is 17-October-2002.



## Troubleshooting the embedded HP Jetdirect print server

If network-connection errors occur, you can disable the HP Jetdirect print server in order to determine if the problem is with the print server or with the network. This procedure requires that you temporarily install an optional EIO HP Jetdirect print server card while disabling the embedded HP Jetdirect print server.

1. Turn the MFP off and then on.
2. When the memory count appears on the control-panel display, press and hold **6** until all three LEDs flash once and then stay on. This might take up to 20 seconds.
3. Release **6**, and then press and release **3** until **EMBEDDED LAN DISABLE** appears on the control-panel display.
4. Press **6** one time, and wait for the MFP to complete its initialization sequence.



---

**NOTE** To enable the HP Jetdirect print server again, perform this same procedure. **EMBEDDED LAN ENABLE** appears on the control panel.

---

## Firmware-stack trace

In rare instances, you might need to work with a call-center escalation agent to find the source of a **49.XXXX ERROR**. Use the firmware-stack trace procedure to collect data that the agent might need. A firmware-stack trace indicates which firmware commands were executing at the time of the error. The firmware-stack trace procedure does not produce a report. Instead, you must write down the firmware instructions that appear on the control-panel display and relay them to the agent.

1. When the error message appears on the control-panel display, press **6** and then press **5**.
2. Press **9** to scroll through each line of the firmware-stack trace.

# Solve common Windows problems

Error message:

"General Protection FaultException OE"

"Spool32"

"Illegal Operation"

---

Cause	Solution
	<p>Close all software programs, restart Windows, and try again.</p> <p>Select a different printer driver. If the device PCL 6 printer driver is selected, switch to the PCL 5 or HP postscript level 3 emulation printer driver, which can be done from a software program.</p> <p>Delete all temp files from the Temp subdirectory. Determine the name of the directory by opening the AUTOEXEC.BAT file and looking for the statement "Set Temp =". The name after this statement is the Temp directory. It is usually C:\TEMP by default, but can be redefined.</p> <p>See the Microsoft Windows documentation that came with the computer for more information about Windows error messages.</p>

---

## Solve common Macintosh problems

In addition to the problems that are listed in [Solve general device problems on page 379](#), this section lists problems that can occur when using Mac OS X.



**NOTE** Setup for USB and IP printing is performed through the **Desktop Printer Utility**. The device will *not* appear in the Chooser.

### The printer driver is not listed in the Print Center or Printer Setup Utility.

Cause	Solution
The device software might not have been installed or was installed incorrectly.	Make sure that the PPD is in the following hard drive folder: <code>Library/Printers/PPDs/Contents/Resources/&lt;lang&gt;.lproj</code> , where “<lang>” represents the two-letter language code for the language that you are using. If necessary, reinstall the software. See the getting started guide for instructions.
The Postscript Printer Description (PPD) file is corrupt.	Delete the PPD file from the following hard drive folder: <code>Library/Printers/PPDs/Contents/Resources/&lt;lang&gt;.lproj</code> , where “<lang>” represents the two-letter language code for the language that you are using. Reinstall the software. See the getting started guide for instructions.

### The device name, IP address, or Rendezvous host name does not appear in the printer list in the Print Center or Printer Setup Utility.

Cause	Solution
The device might not be ready.	Make sure that the cables are connected correctly, the device is on, and the Ready light is on. If you are connecting through a USB or Ethernet hub, try connecting directly to the computer, or use a different port.
The wrong connection type might be selected.	Make sure that USB, IP Printing, or Rendezvous is selected, depending on the type of connection that exists between the device and the computer.
The wrong device name, IP address, or Rendezvous host name is being used.	Check the device name, IP address, or Rendezvous host name by printing a configuration page. See <a href="#">Use information pages on page 82</a> . Verify that the name, IP address, or Rendezvous host name on the configuration page matches the device name, IP address, or Rendezvous host name in the Print Center or Printer Setup Utility.
The interface cable might be defective or of poor quality.	Replace the interface cable. Make sure to use a high-quality cable.

### The printer driver does not automatically set up the selected device in the Print Center or Printer Setup Utility.

Cause	Solution
The device might not be ready.	Make sure that the cables are connected correctly, the device is on, and the Ready light is on. If you are connecting through a USB or Ethernet hub, try connecting directly to the computer or use a different port.

### The printer driver does not automatically set up the selected device in the Print Center or Printer Setup Utility.

Cause	Solution
The device software might not have been installed or was installed incorrectly.	Make sure that the PPD file is in the following hard drive folder: <code>Library/Printers/PPDs/Contents/Resources/&lt;lang&gt;.lproj</code> , where “<lang>” represents the two-letter language code for the language that you are using. If necessary, reinstall the software. See the getting started guide for instructions.
The PPD file is corrupt.	Delete the PPD file from the following hard drive folder: <code>Library/Printers/PPDs/Contents/Resources/&lt;lang&gt;.lproj</code> , where “<lang>” represents the two-letter language code for the language that you are using. Reinstall the software. See the getting started guide for instructions.
The device might not be ready.	Make sure that the cables are connected correctly, the device is on, and the Ready light is on. If you are connecting through a USB or Ethernet hub, try connecting directly to the computer or use a different port.
The interface cable might be defective or of poor quality.	Replace the interface cable. Make sure to use a high-quality cable.

### A print job was not sent to the device that you wanted.

Cause	Solution
The print queue might be stopped.	Restart the print queue. Open <b>Print Monitor</b> and select <b>Start Jobs</b> .
The wrong device name or IP address is being used. Another device with the same or similar name, IP address, or Rendezvous host name might have received your print job.	Check the device name, IP address, or Rendezvous host name by printing a configuration page. See <a href="#">Use information pages on page 82</a> . Verify that the device name, IP address, or Rendezvous host name on the configuration page matches the device name, IP address, or Rendezvous host name in the Print Center or Printer Setup Utility.


### An encapsulated PostScript (EPS) file does not print with the correct fonts.

Cause	Solution
This problem occurs with some programs.	<ul style="list-style-type: none"><li>Try downloading the fonts that are contained in the EPS file to the device before printing.</li><li>Send the file in ASCII format instead of binary encoding.</li></ul>

### You are unable to print from a third-party USB card.

Cause	Solution
This error occurs when the software for USB printers is not installed.	When adding a third-party USB card, you might need the Apple USB Adapter Card Support software. The most current version of this software is available from the Apple Web site.

When connected with a USB cable, the device does not appear in the Print Center or Printer Setup Utility after the driver is selected.

Cause	Solution
This problem is caused by either a software or a hardware component.	<p data-bbox="794 304 1053 325"><b>Software troubleshooting</b></p> <ul data-bbox="794 346 1436 535" style="list-style-type: none"><li>• Check that your Macintosh supports USB.</li><li>• Verify that your Macintosh operating system is Mac OS X version 10.2.8 or later.</li><li>• Ensure that your Macintosh has the appropriate USB software from Apple.</li></ul> <p data-bbox="794 556 1061 577"><b>Hardware troubleshooting</b></p> <ul data-bbox="794 598 1436 1018" style="list-style-type: none"><li>• Check that the device is turned on.</li><li>• Verify that the USB cable is connected correctly.</li><li>• Check that you are using the appropriate Hi-Speed USB 2.0 cable.</li><li>• Ensure that you do not have too many USB devices drawing power from the chain. Disconnect all of the devices from the chain, and connect the cable directly to the USB port on the host computer.</li><li>• Check to see if more than two nonpowered USB hubs are connected in a row on the chain. Disconnect all of the devices from the chain and connect the cable directly to the USB port on the host computer.</li></ul> <p data-bbox="837 1039 901 1102"></p> <p data-bbox="917 1039 1436 1102"><b>NOTE</b> The iMac keyboard is a nonpowered USB hub.</p>

## Solve Linux problems

For information about Linux problem solving, go to the HP Linux support Web site: [hp.sourceforge.net/](http://hp.sourceforge.net/).

# Solve PostScript problems

The following situations are specific to the PostScript (PS) language and might occur when several printer languages are being used. Check the control-panel display for messages that might help resolve problems.



**NOTE** To receive a printed or screen message when PS errors occur, open the **Print Options** dialog box and click the selection next to the PS Errors section that you want.

## General problems

**The job prints in Courier (the default typeface) instead of the typeface that you requested.**

Cause	Solution
The requested typeface is not downloaded.	Download the font that you want and send the print job again. Verify the font type and location. Download the font to the device if applicable. See the software documentation for more information.

**A legal page prints with clipped margins.**

Cause	Solution
The print job was too complex.	You might need to print your job at 600 dpi, reduce the complexity of the page, or install more memory.

**A PS error page prints.**

Cause	Solution
The print job might not be a PS job.	Make sure that the print job is a PS job. See whether the software program expected a setup or PS header file to be sent to the device.



# 7 Parts and diagrams

This chapter contains information about ordering parts, supplies, and accessories. It includes diagrams of the major subassemblies of the MFP and includes the part numbers for replaceable parts.

# Order parts, accessories, and supplies

- [Order directly from HP](#)
- [Order through service or support providers](#)
- [Order directly through the embedded Web server](#)

## Order directly from HP

You can obtain the following directly from HP:

- **Replacement parts.** To order replacement parts in the U.S. see <http://www.hp.com/buy/parts>. Outside the United States, order parts by contacting your local authorized HP service center.
- **Supplies and accessories.** To order supplies in the U.S., see <http://www.hp.com/go/ljsupplies>. To order supplies worldwide, see <http://www.hp.com/ghp/buyonline.html>. To order accessories, see <http://www.hp.com/support/cljcm4730mfp>.

## Order through service or support providers

To order a part or accessory, contact an HP-authorized service or support provider.

## Order directly through the embedded Web server

1. In the Web browser on the computer, type the IP address for the MFP. The MFP status window appears.
2. In the **Other links** area, double-click **Order Supplies**. This provides a URL from which to purchase consumables. Supplies information with part numbers and MFP information is provided.
3. Select the part numbers that you want to order and follow the instructions on the screen.

# How to use the parts lists and diagrams

The figures in this chapter illustrate the major field replaceable unit (FRU) assemblies and subassemblies in the HP LaserJet M4345 MFP Series. A table (parts number list) follows each exploded assembly diagram. The tables list a reference number for each specific part, the part number, and a brief description of the part.



---

**CAUTION** When looking for an electrical part, pay careful attention to the voltage that is listed in the part description column to ensure that the component part number that you select is for the correct MFP model.

---



---

**NOTE** Parts that do not have a reference number or part number are not FRUs, and cannot be ordered as individual replacement parts. However, all serviceable parts should be available as part of a larger operable subassembly.

---

The following lists of supplies and accessories were current at the time of printing. Availability of accessories might change during the life of the MFP.

---

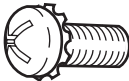
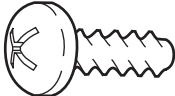
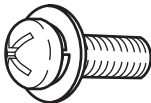

## Screws that are used in the MFP

The following table describes the screws that are used in the MFP and provides guidelines to help determine where each type of screw is used. The screws can vary in length depending on the thickness of the material that is being fastened. Always note where each type of screw is located and replace each one in its original location.



**NOTE** When you are disassembling the MFP, place the screws into the chassis holes from which they were removed. This prevents their loss, and ensures that the correct type and length of screw for each location is used when the MFP is reassembled.

**Table 7-1** Common fasteners used in this MFP

Drawing and description	Purpose
 <p>Phillips-head machine screw with captive star washer</p>	<p>This screw is used to fasten metal to metal when good electrical contact is needed. This screw also provides high resistance to loosening.</p>
 <p>Phillips-head screw with self-tapping threads</p>	<p>This screw is used to fasten sheet metal or plastic to plastic frames (the deep, coarsely spaced threads provide an increased holding capability while decreasing the possibility of stripping the target hole).</p> <p><b>NOTE</b> To install a self-tapping screw, first turn it counterclockwise to align it with the existing thread pattern, and then carefully turn it clockwise to tighten it. You will feel resistance and hear the screw click when it engages the existing threads in the hole. Do not overtighten the screw. If a self-tapping screw-hole becomes stripped, repair the screw-hole or replace the affected assembly.</p>
 <p>Phillips washer-head machine screw with a broad, flat washer attached to the screw head</p>	<p>This screw is used to fasten sheet metal parts to the sheet metal chassis. It spans large clearance holes and distributes the load by increasing the bearing surface.</p>
Screw measurement guide	
<p>6mm   8mm   10mm   12mm   M3   M4</p> 	

# Customer-replaceable parts and accessories

## Accessories

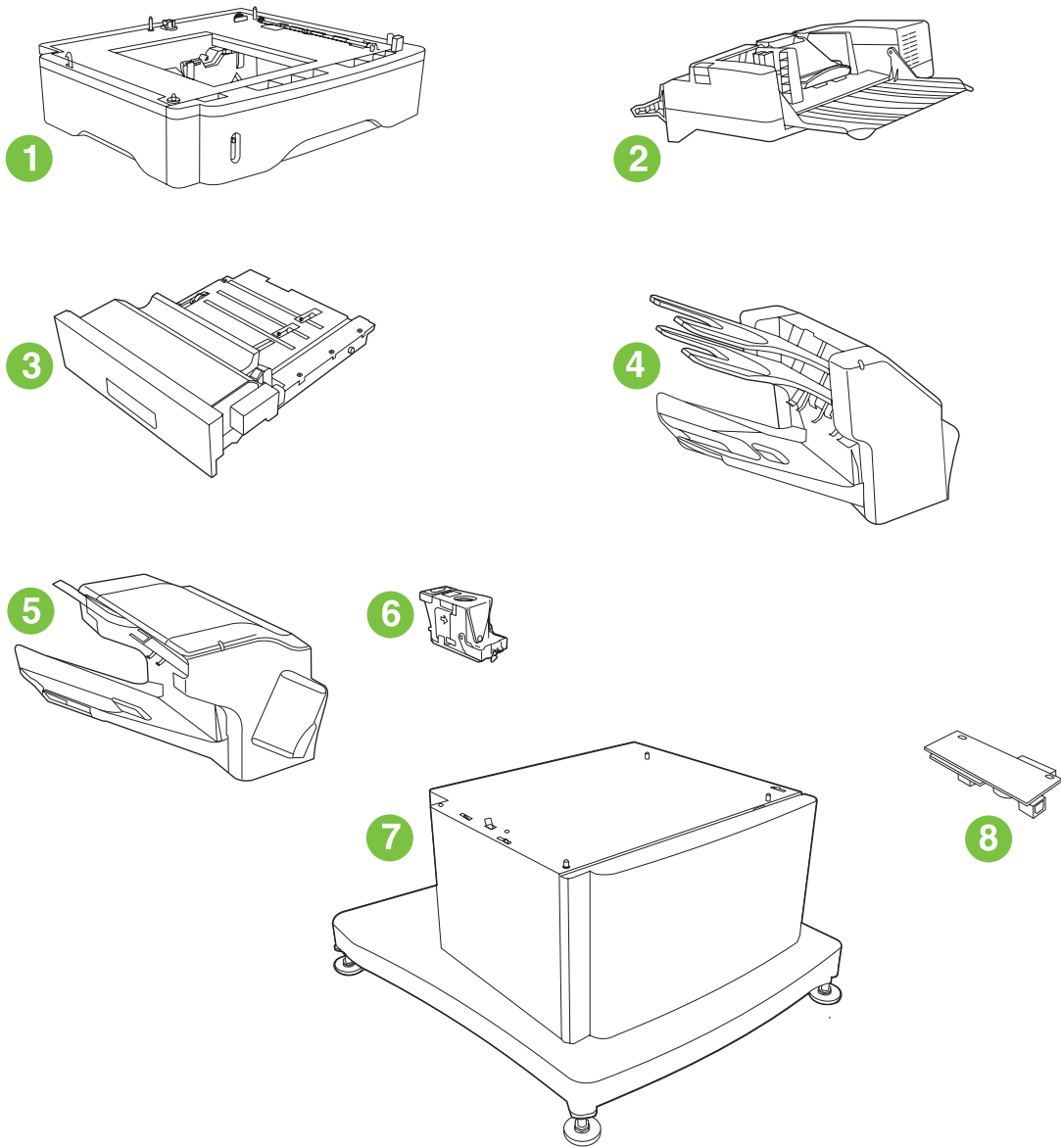
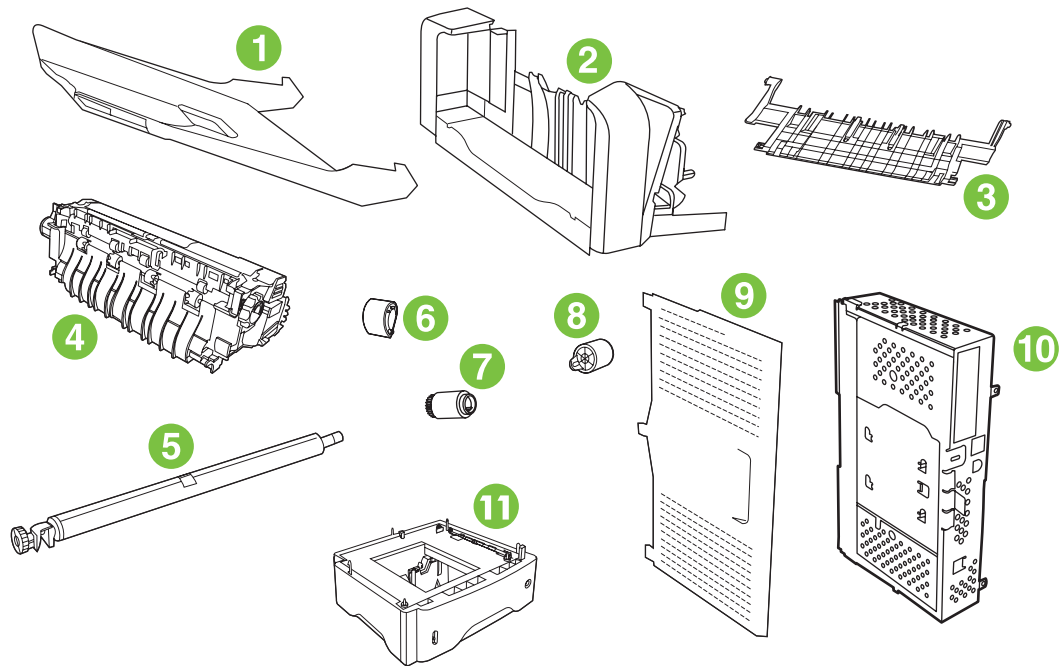


Figure 7-1 Accessories

**Table 7-2** Accessories

<b>Reference</b>	<b>Description</b>	<b>Part number</b>	<b>Quantity</b>
1	Optional 500-sheet tray and feeder unit	Q5968-67901	1
2	Envelope feeder	Q2438-67902	1
3	Duplexer (duplex printing accessory)	Q5969A	1
4	3-bin mailbox	Q5692-60503	1
5	500-sheet stapler/stacker	Q5691-60501	1
6	5,000-staple cartridge	C8085-60541	1
7	Storage cabinet	Q5970A	1
8	HP LaserJet analog fax accessory 300	Q3701-60010	1

## Customer-replaceable components (print engine)

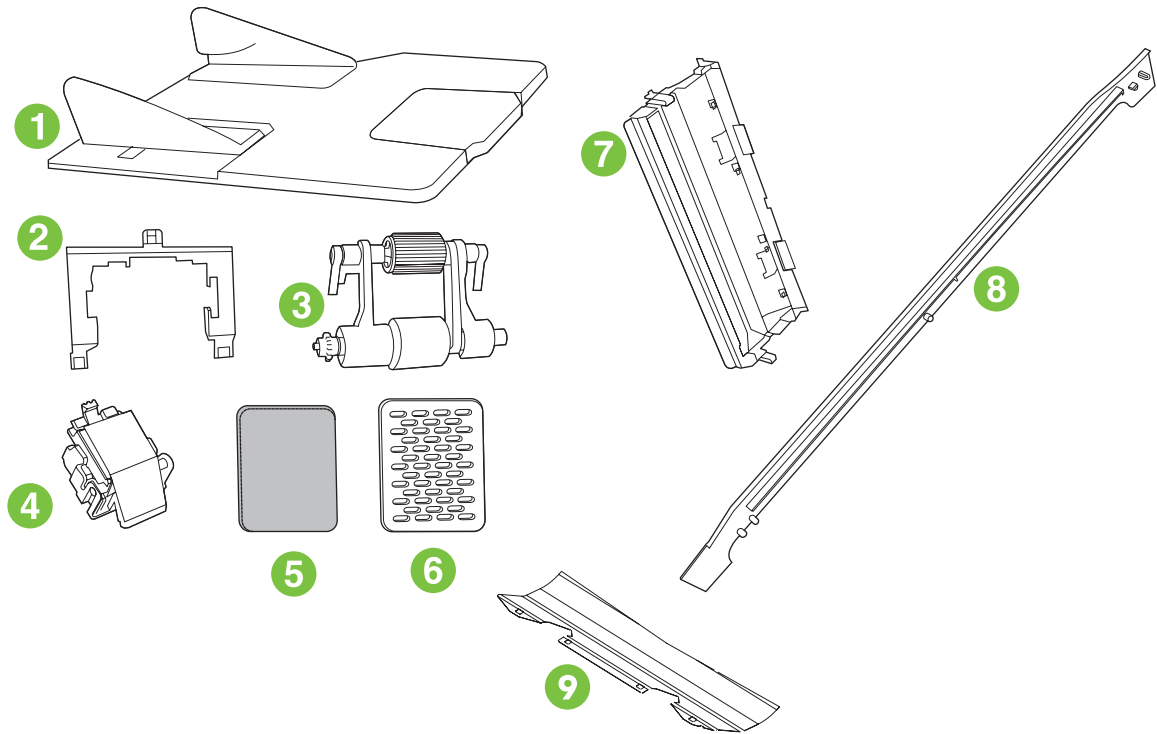


**Figure 7-2** Customer-replaceable components (print engine)

**Table 7-3** Customer-replaceable components (print engine)

Reference	Description	Part number	Quantity
1	Output bin	RM1-0940-000CN	1
2	Delivery tray assembly	RM1-1047-000CN	1
3	Fuser entrance guide	RM1-1046-000CN	1
4	Fuser, 110-volt, new	RM1-1043-000CN	1
4	Fuser, 220-volt, new	RM1-1044-000CN	1
5	Roller assembly, transfer	RM1-1110-000CN	1
6	Roller, pickup, multipurpose assembly	RL1-0019-000CN	1
7	Roller, paper-feed (cassette)	RM1-0037-000CN	2
8	Roller, paper-pickup (cassette)	RM1-0036-000CN	1
9	Cover, formatter	RC1-3035-000CN	1
10	Formatter assembly, new	CB425-67901	1
11	500-sheet tray	Q5968A	1

## Customer-replaceable components (ADF and scanner)



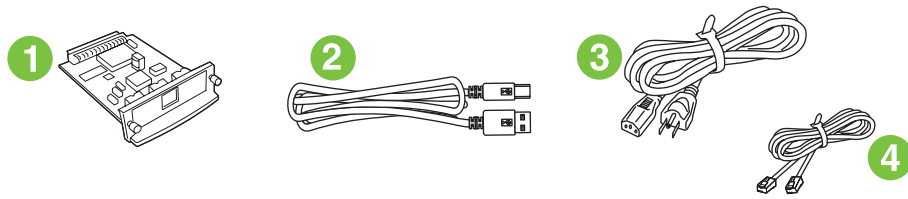
**Figure 7-3** Customer-replaceable components (ADF and scanner)



**Table 7-4** Customer-replaceable components (ADF and scanner)

Reference	Description	Part number	Quantity
1	ADF input tray	PF2282K042NI	1
2	ADF pickup-roller cover	PF2282K040NI	1
3	ADF pickup-roller assembly	PF2282K039NI	1
4	ADF separation-pad assembly	PF2282K035NI	1
5	ADF fan filter	IR4041P007NI	1
6	ADF fan-filter cover	IR4041P217NI	1
7	ADF mylar-holder assembly	PF2282K043NI	1
8	ADF front-cover flange	IR4041P215NI	1
9	Mylar sheet kit (3 sheets)	Q6496-67901	1

## Cables and interfaces



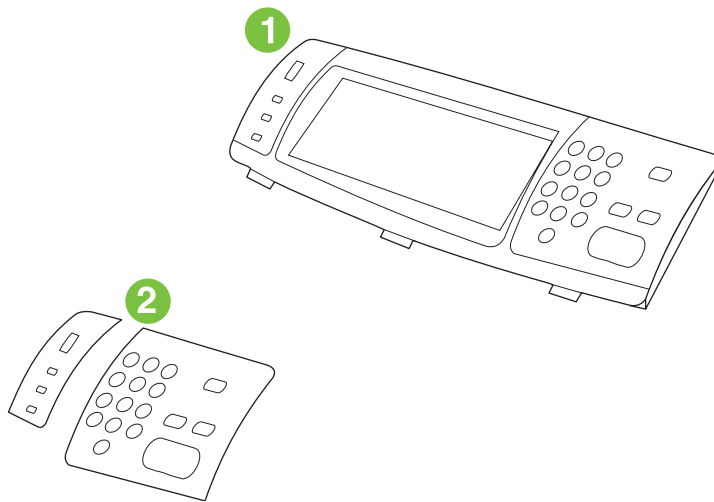
**Figure 7-4** Cables and interfaces

**Table 7-5** Cables and interfaces

Reference	Description	Part number	Quantity
1	HP Jetdirect 620n Fast Ethernet (10/100Base-TX) print server (EIO card)	J7934A	1
1	HP Jetdirect connectivity card for USB, serial, and LocalTalk connections	J4135A	1
2	USB cable, 2-meter standard device connector	C6518A	1
3	PWR-CORD OPT-903 3-COND 1.9-M-LG ROHS United States/Canada	8121-0740	1
3	PWR-CORD OPT-934 3-COND 1.9-M-LG ROHS Taiwan	8121-0964	1
3	PWR-CORD OPT-902 3-COND 1.9-M-LG ROHS Southern Europe/Western Europe/Eastern Europe/Indonesia/Baltics/Vietnam/Korea 220V	8121-0731	1
3	PWR-CORD OPT-922 3-COND 1.9-M-LG ROHS China	8121-0943	1
3	POWER CORD, OPT-906 3-COND 2.25-M-LG	8120-6815	1
3	PWR-CORD OPT-927 3-COND 1.9-M-LG ROHS Phillipines/Singapore/Mexico/Brazil/Thailand	8121-0734	1
3	PWR-CORD OPT-900 3-COND 1.9-M-LG 5A ROHS United Kingdom/Middle East 220V/Phillipines/Singapore/Hong Kong SAR/Malaysia	8121-0739	1
3	PWR-CORD OPT-901 3-COND 1.9-M-LG ROHS Australia	8121-0837	1
3	PWR-CORD OPT-918 3-COND 1.9-M-LG ROHS Japan	8121-0736	1
3	PWR-CORD OPT-919 3-COND 1.9-M-LG ROHS Israel	8121-1004	1
3	PWR-CORD OPT-912 3-COND 1.9-M-LG ROHS Denmark	8121-0733	1
3	PWR-CORD OPT-920 3-COND 1.9-M-LG ROHS Argentina	8121-0729	1
3	PWR-CORD OPT-923 3-COND 1.9-M-LG ROHS India	8121-0564	1
3	PWR-CORD OPT-917 3-COND 1.9-M-LG ROHS Africa	8121-0737	1
3	PWR-CORD OPT-903 3-COND 1.9-M-LG ROHS South America/Mexico/Brazil	8121-0740	1
3	PWR-CORD OPT-900 3-COND 1.9-M-LG 5A ROHS Maylasia	8121-0739	1
3	PWR-CORD OPT-906 3-COND 1.9-M-LG ROHS Switzerland	8121-0738	1
3	PWR-CORD OPT-903 3-COND 1.9-M-LG ROHS Middle East	8121-0740	1
3	PWR-CORD OPT-902 3-COND 1.9-M-LG ROHS Middle East 220V	8121-0731	1
4	PHN-CORD OPT-501 US 3.0-M-LG ROHS United States/Taiwan/China/Thailand/Japan/Argentina/India/European Union/South America/Indonesia/Malaysia/MiddleEast/Phillipines/Singapore/Mexico/Brazil/Canada/Russia/Bulgaria/Baltics/Vietnam	8121-0811	1
4	PHN-CORD OPT-516 KR 3.0-M-LG ROHS Korea	8120-8908	1
4	PHN-CORD US 3.0-M-LG ROHS Hong Kong SAR	8121-1042	1
4	PHN-CORD OPT-519 AU 3.0-M-LG ROHS Australia	8120-8907	1

Reference	Description	Part number	Quantity
4	PHN-CORD OPT-517 IL 3.0-M-LG ROHS Israel	8120-8913	1
4	PHN-CORD OPT-505 UK/HK/NZ 3.0-M-LG ROHS United Kingdom	8120-8921	1
4	PHN-CORD OPT-506 DK 3.0-M-LG ROHS Denmark	8120-8911	1
4	PHN-CORD OPT-520 EE 3.0-M-LG ROHS South Africa	8120-8922	1
4	PHN-CORD OPT-502 DE 3.0-M-LG ROHS Denmark	8120-8912	1
4	PHN-CORD OPT-508 NL 3.0-M-LG ROHS Netherlands	8120-8915	1
4	PHN-CORD OPT-504 FR 3.0-M-LG ROHS France	8120-8923	1
4	PHN-CORD OPT-514 IT 3.0-M-LG ROHS Southern Europe	8120-8914	1
4	PHN-CORD OPT-512 CH 3.0-M-LG ROHS Switzerland	8121-0844	1
4	PHN-CORD OPT-511 SE 3.0-M-LG ROHS NO/FI/SV	8120-8918	1
4	PHN-CORD OPT-510 NORWAY/FINLAND 3.0M-LG	8120-8916	1
4	PHN-CORD OPT-507 TR 3.0-M-LG ROHS Turkey/Greece	8120-8920	1
4	PHN-CORD OPT-520 EE 3.0-M-LG ROHS SK/SL/HR/RO/CS/HU/PL	8120-8922	1

## Control panel and control-panel overlays



**Figure 7-5** Control panel and control-panel overlays

**Table 7-6** Control panel and control-panel overlays

Reference	Description	Part number	Quantity
1	Control-panel assembly	Q3942-60102	1
2	Kit-Control Pnl Overlay Left/Right EN	CB425-60103	1
2	Kit-Control Pnl Overlay Left/Right FR	CB425-60104	1
2	Kit-Control Pnl Overlay Left/Right IT	CB425-60105	1
2	Kit-Control Pnl Overlay Left/Right DE	CB425-60106	1
2	Kit-Control Pnl Overlay Left/Right ES	CB425-60107	1
2	Kit-Control Pnl Overlay Left/Right NL	CB425-60108	1
2	Kit-Control Pnl Overlay Left/Right PT	CB425-60109	1
2	Kit-Control Pnl Overlay Left/Right NO	CB425-60110	1
2	Kit-Control Pnl Overlay Left/Right SV	CB425-60111	1
2	Kit-Control Pnl Overlay Left/Right FI	CB425-60112	1
2	Kit-Control Pnl Overlay Left/Right DA	CB425-60113	1
2	Kit-Control Pnl Overlay Left/Right PL	CB425-60114	1
2	Kit-Control Pnl Overlay Left/Right RU	CB425-60115	1
2	Kit-Control Pnl Overlay Left/Right CS	CB425-60116	1
2	Kit-Control Pnl Overlay Left/Right HU	CB425-60117	1
2	Kit-Control Pnl Overlay Left/Right ZHTW	CB425-60118	1
2	Kit-Control Pnl Overlay Left/Right ZHCN	CB425-60119	1
2	Kit-Control Pnl Overlay Left/Right KO	CB425-60120	1
2	Kit-Control Pnl Overlay Left/Right JA	CB425-60121	1
2	Kit-Control Pnl Overlay Left/Right TR	CB425-60122	1
2	Kit-Control Pnl Overlay Left/Right HE	CB425-60123	1
2	Kit-Control Pnl Overlay Left/Right EL	CB425-60124	1
2	Kit-Control Pnl Overlay Left/Right AR	CB425-60125	1
2	Kit-Control Pnl Overlay Left/Right TH	CB425-60126	1
2	Kit-Control Pnl Overlay Left/Right HR	CB425-60129	1
2	Kit-Control Pnl Overlay Left/Right RO	CB425-60130	1
2	Kit-Control Pnl Overlay Left/Right SK	CB425-60131	1
2	Kit-Control Pnl Overlay Left/Right SL	CB425-60132	1

## Memory

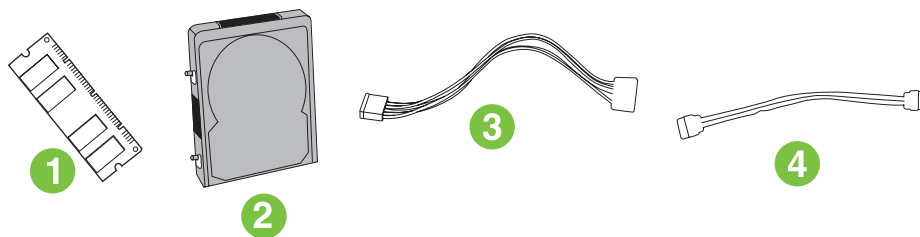


Figure 7-6 Memory

**Table 7-7** Memory

<b>Reference</b>	<b>Description</b>	<b>Part number</b>	<b>Quantity</b>
1	100-pin DDR memory DIMM (dual inline memory module), 64 MB	Q2625A	1
1	100-pin DDR memory DIMM, 128 MB	Q2626A	1
1	100-pin DDR memory DIMM, 256 MB	Q2627-67951	1
2	Hard disk, 40 GB	0950-4717	1
3	Power cable for hard disk (5-wire)	5851-3051	1
4	Data cable for hard disk (2-wire)	5851-2720	1



## Print cartridge and maintenance kits

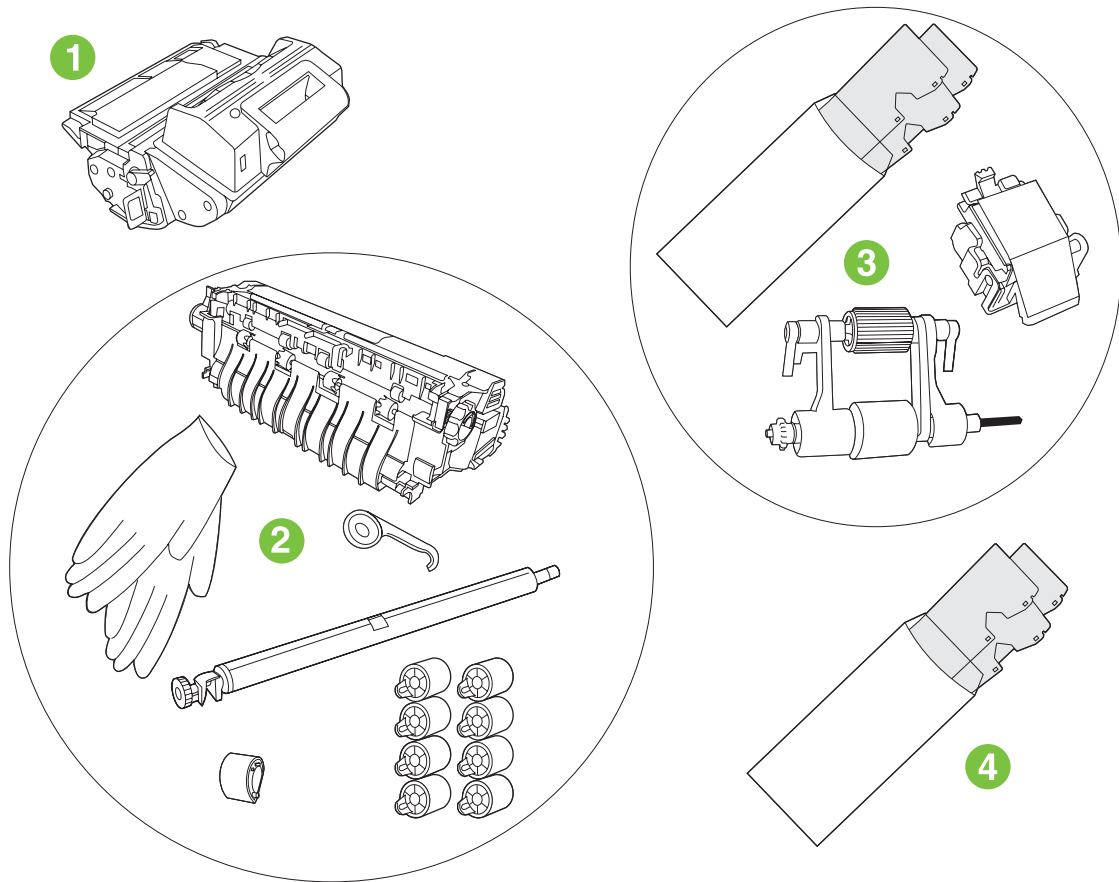


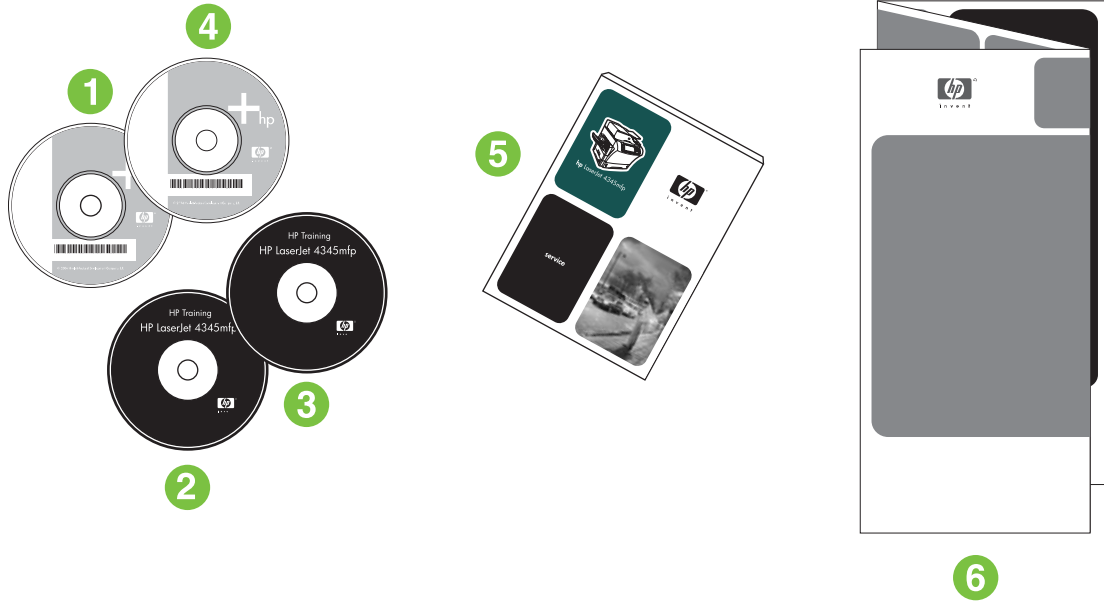
Figure 7-7 Print cartridge and maintenance kits

**Table 7-8** Print cartridge and maintenance kits

<b>Reference</b>	<b>Description</b>	<b>Part number</b>	<b>Quantity</b>
1	HP LaserJet print cartridge	Q5945-67901	1
2	Printer maintenance kit, 110-volt	Q5998-67901	1
2	Printer maintenance kit, 220-volt	Q5999-67901	1
3	ADF maintenance kit	Q5997-67901	1
4	ADF mylar replacement kit	Q6496-67901	1



## Documentation, software, and training material

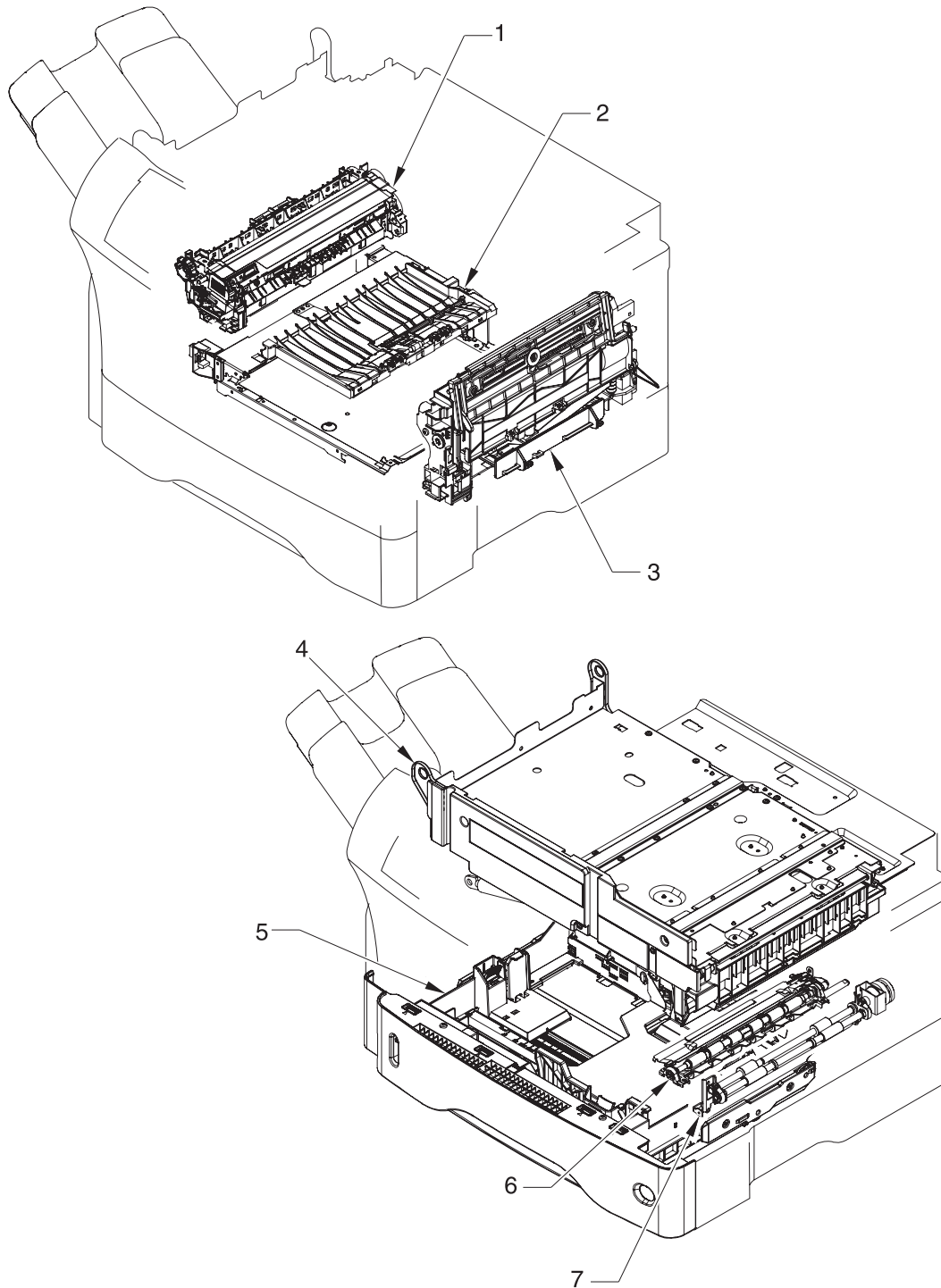


**Figure 7-8** Documentation, software, and training material

**Table 7-9** Documentation, software, and training material

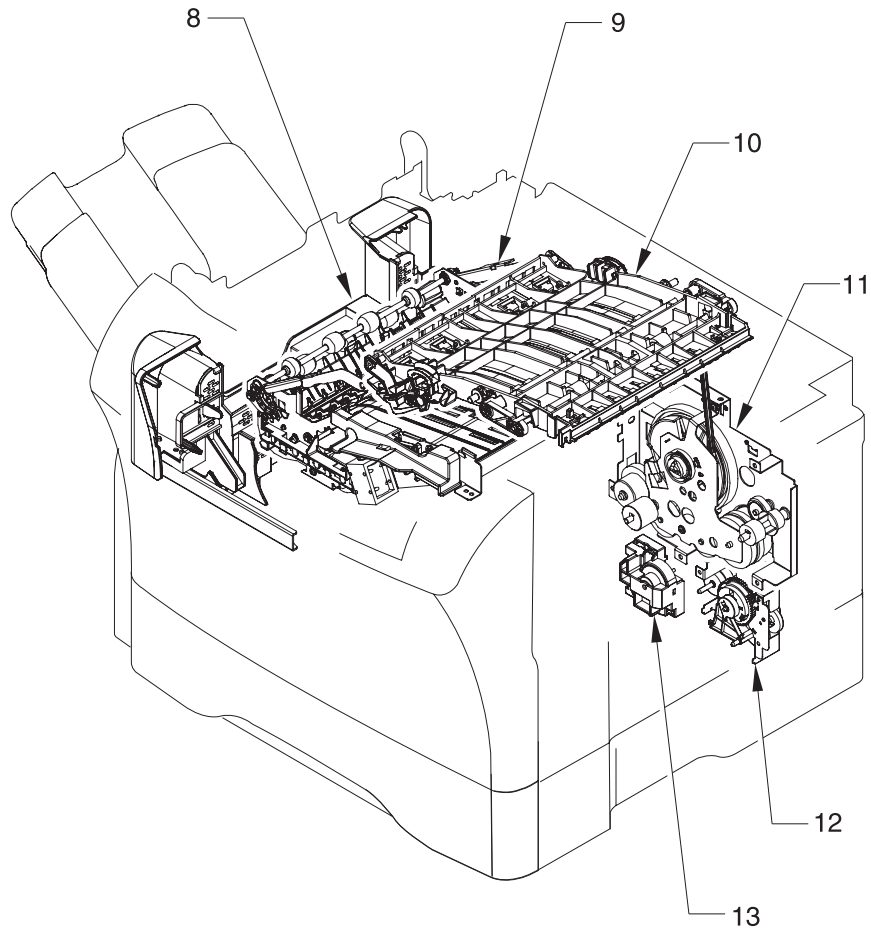
Reference	Description	Part number	Quantity
1	HP LaserJet M4345 MFP Series software CD, ROW/AR	CB425-60135	1
1	HP LaserJet M4345 MFP Series software CD, Asia/EN/DR	CB425-60136	1
2	Customer in-box training CD, English only	CB425-60155	1
3	Service and support training CD	CB425-14005	1
4	HP Digital Sending Software CD (trial version)	MKTNG-00539	1
5	HP LaserJet M4345 MFP Series service manual	CB425-90908	1

## Assembly locations



**Figure 7-9** Print-engine assemblies (1 of 2)

Item	Assembly name	Details
1	Fuser	See <a href="#">Figure 7-29 Fuser on page 532.</a>
2	Electrical/forward assembly	See <a href="#">Figure 7-18 Electrical/forward assembly on page 510.</a>
3	Multipurpose assembly	See <a href="#">Figure 7-25 Multipurpose assembly on page 524.</a>
4	Upper-plate assembly	See <a href="#">Figure 7-12 Upper-plate assembly on page 498.</a>
5	Cassette	See <a href="#">Figure 7-22 Cassette on page 518.</a>
6	Registration assembly	See <a href="#">Figure 7-24 Registration assembly on page 522.</a>
7	Paper-feed-roller assembly	See <a href="#">Figure 7-23 Paper-feed roller assembly on page 520.</a>

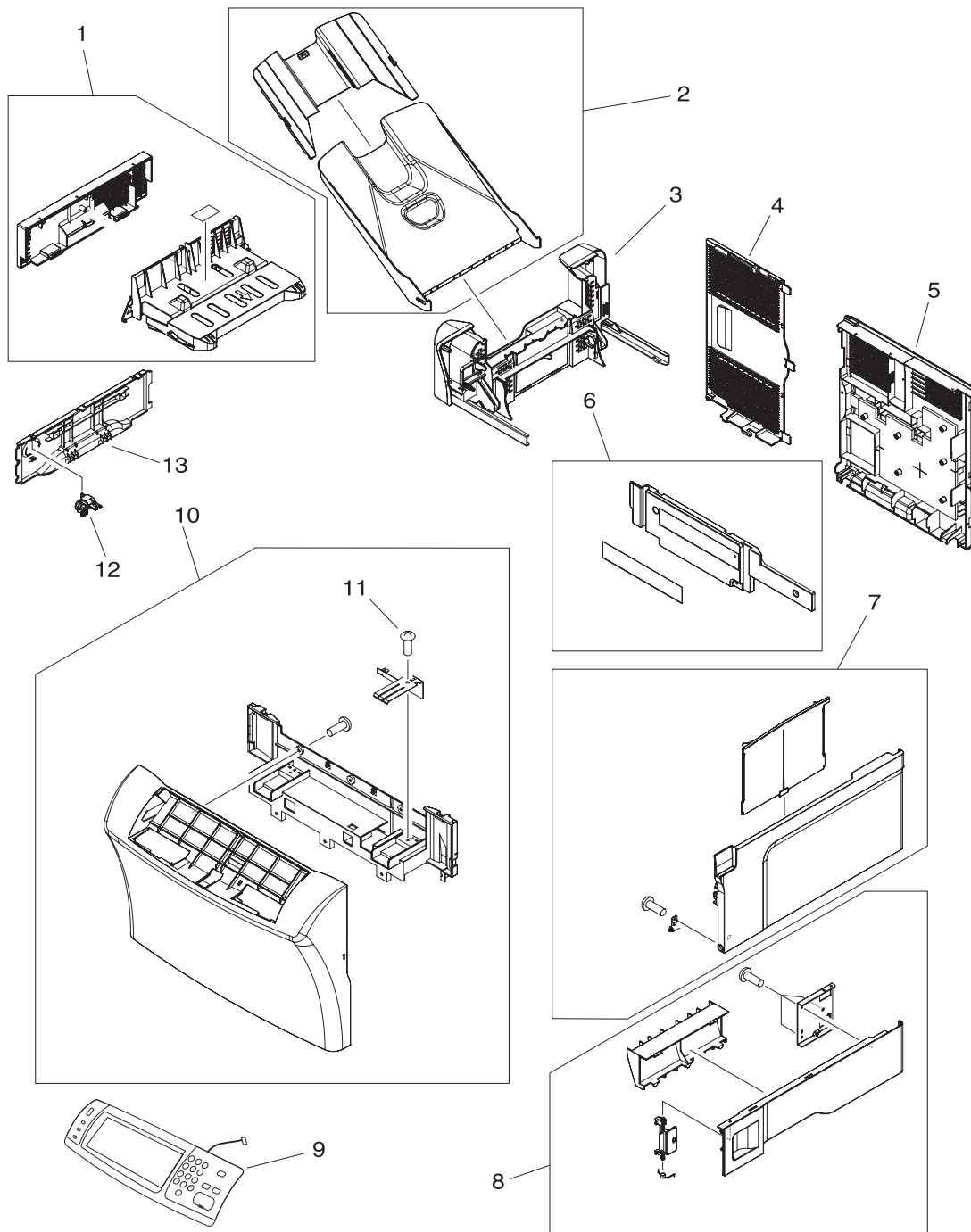


**Figure 7-10** Print-engine assemblies (2 of 2)



Item	Assembly name	Details
8	Delivery assembly	See <a href="#">Figure 7-28 Delivery assembly on page 530.</a>
9	Reverse assembly	See <a href="#">Figure 7-26 Reverse assembly on page 526.</a>
10	Reverse-separation-guide assembly	See <a href="#">Figure 7-27 Reverse-separation-guide assembly on page 528.</a>
11	Main drive assembly	See <a href="#">Figure 7-19 Main drive assembly on page 512.</a>
12	Paper-pickup-drive assembly	See <a href="#">Figure 7-20 Paper-pickup-drive assembly on page 514.</a>
13	Lifter-drive assembly	See <a href="#">Figure 7-21 Lifter-drive assembly on page 516.</a>

# External components



**Figure 7-11** External panels and covers

**Table 7-10** External panels and covers

Reference	Description	Part number	Quantity
1	Cover, duplexing-unit assembly	RM1-1018-000CN	1
2	Output-bin assembly	RM1-0940-000CN	1
3	Delivery assembly	RM1-1047-000CN	1
4	Cover, formatter	RC1-3035-000CN	1
5	Cover, rear	RM1-1017-000CN	1
6	Cover, front corner	RL1-0457-000CN	1
7	Cover, right assembly	RM1-1016-000CN	1
8	Cover, right lower assembly	RM1-1033-000CN	1
9	Control-panel assembly	CB425-60127	1
10	Cover, front assembly	RM1-1100-000CN	1
11	Screw, tapping, pan-head, M4 x 10	XB4-7401-0007CN	1
12	Switch, power	RC1-3044-000CN	1
13	Cover, cassette, left side	RC1-3043-000CN	1

# Print-engine internal components

## Upper-plate assembly

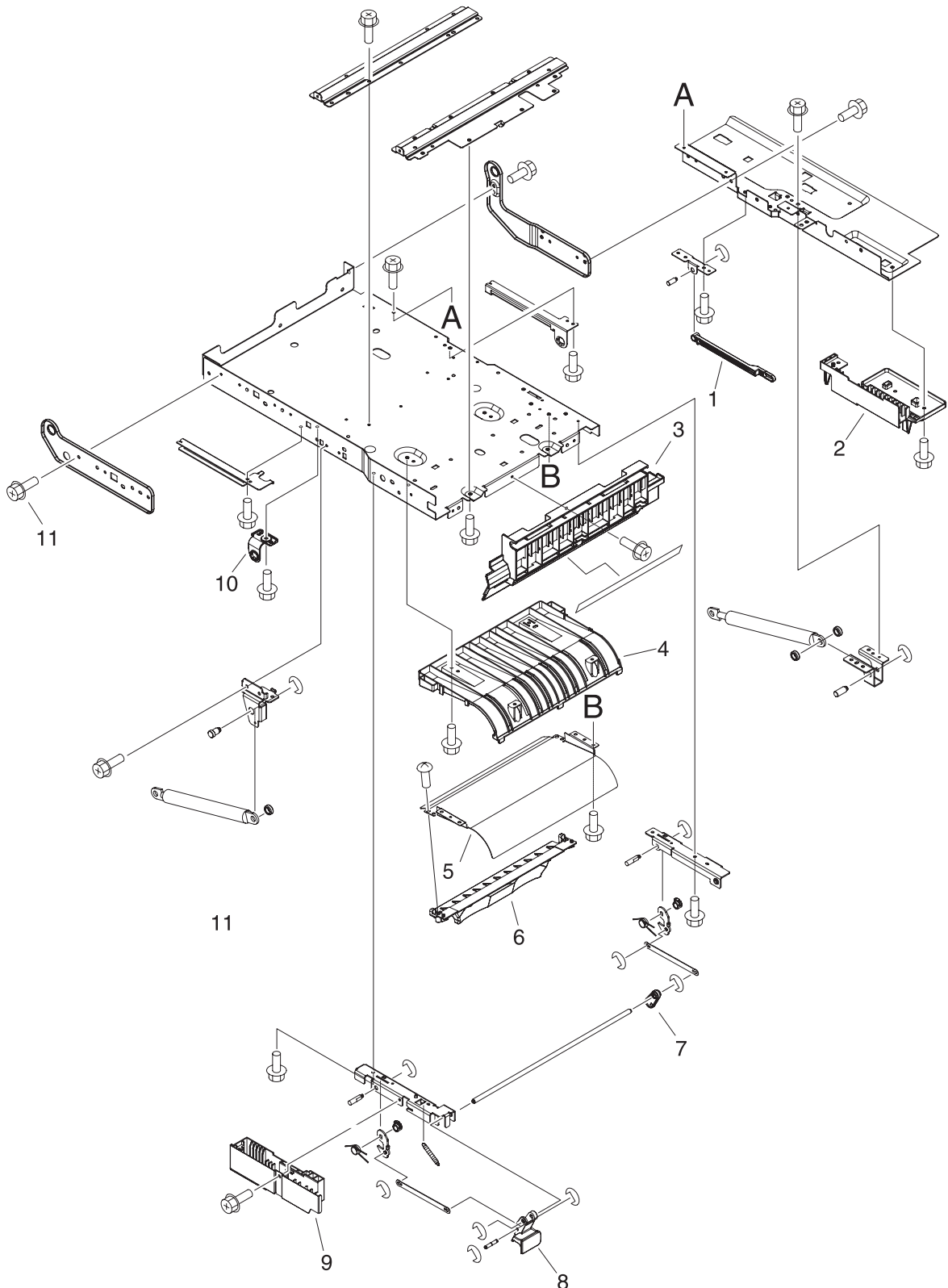


Figure 7-12 Upper-plate assembly

**Table 7-11** Upper-plate assembly

Reference	Description	Part number	Quantity
1	Rod, link (upper plate)	RC1-2830-000CN	1
2	Cover, rear lock (upper plate)	RC1-2821-000CN	1
3	Holder, right shutter (upper plate)	RC1-2855-000CN	1
4	Guide, legal-size (upper plate)	RC1-2854-000CN	1
5	Guide, cartridge (upper plate)	RC1-2853-000CN	1
6	Support, cartridge (upper plate)	RC1-2856-000CN	1
7	Link, handle (upper plate)	RC1-2822-000CN	1
8	Handle, lock (upper plate)	RC1-2818-000CN	1
9	Cover, lock, front (upper plate)	RC1-2820-000CN	1
10	Block, guide support (upper plate)	RC1-3102-000CN	1
11	Screw, RS, M3 x 6	XA9-1495-000CN	1

## Internal components (1 of 5)

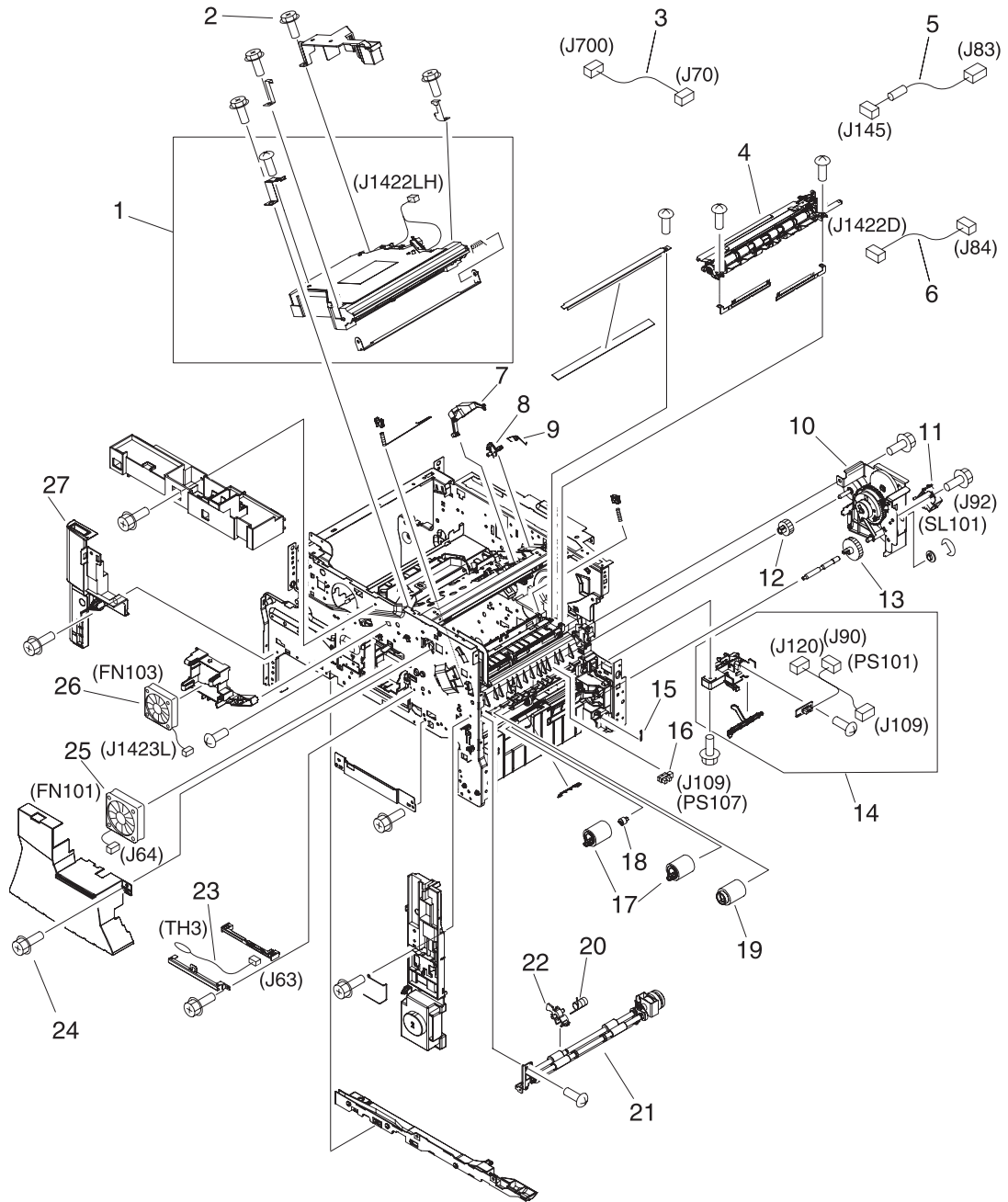


Figure 7-13 Internal components (1 of 5)

**Table 7-12** Internal components (1 of 5)

Reference	Description	Part number	Quantity
1	Laser/scanner assembly	RM1-1573-000CN	1
2	Screw, RS, M3 x 12	XA9-1447-000CN	
3	Cable, image scanner (print engine)	RM1-1398-000CN	1
4	Registration assembly	RM1-0011-060CN	1
5	Cable, laser (print engine)	RM1-1367-000CN	1
6	Cable, beam-detect to scanner (print engine)	RM1-1372-000CN	1
7	Lever, shutter	RC1-3106-000CN	1
8	Flag, shutter	RC1-0378-000CN	1
9	Spring, torsion	RC1-0379-000CN	1
10	Paper-pickup-drive assembly	RM1-0034-070CN	1
11	Solenoid (SL101)	RK2-0269-000CN	1
12	Gear, 18T	RU5-0045-020CN	1
13	Gear, 23T	RU5-0256-000CN	1
14	Guide, paper sensing (PS101)	RM1-1010-000CN	1
15	Spring, tension	RC1-0167-000CN	1
16	Photointerrupter (PS107)	WG8-5624-000CN	1
17	Roller, paper-feed (cassette)	RM1-0037-020CN	2
18	Limiter, torque	RC1-2758-000CN	1
19	Roller, paper-pickup (cassette)	RM1-0036-000CN	1
20	Spring, torsion	RC1-0061-000CN	1
21	Roller, paper-feed assembly	RM1-0012-020CN	1
22	Flag, paper-feed sensor	RC1-0060-000CN	1
23	Thermistor (TH3)	RK2-0359-000CN	1
24	Screw, S, M3 x 8	XA9-1500-000CN	
25	Fan, main cooling (FN101)	RK2-0278-000CN	1
26	Fan, reversing unit (FN103)	RK2-0280-000CN	1
27	Cover, left-side, front	RC1-3052-000CN	1
not shown	Complete print engine (110 volt)	CB425-69001	
not shown	Complete print engine (220 volt)	CB425-69002	

## Internal components (2 of 5)

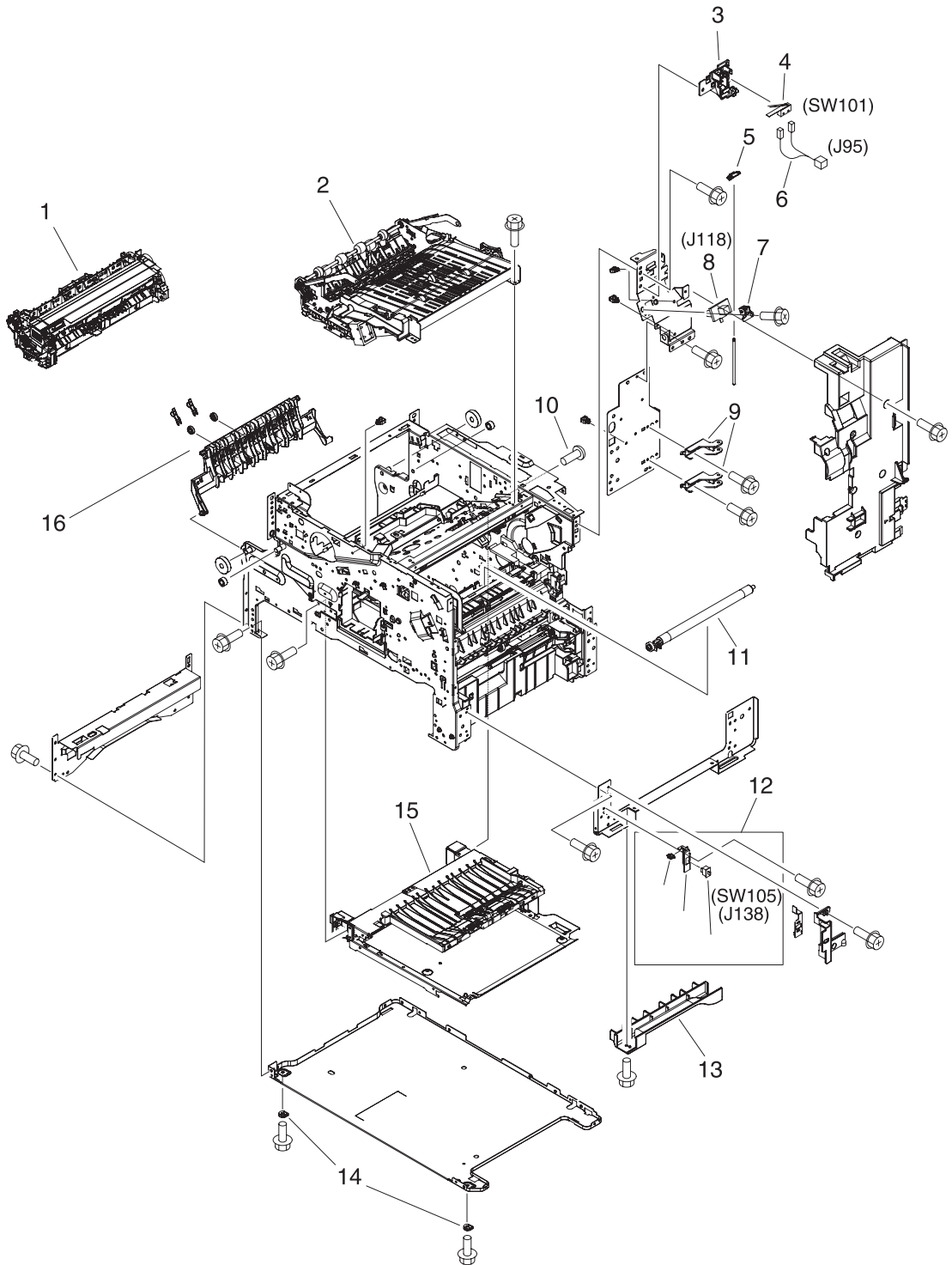


Figure 7-14 Internal components (2 of 5)



**Table 7-13** Internal components (2 of 5)

Reference	Description	Part number	Quantity
1	Fuser (100–127 volt)	RM1-1043-000CN	1
1	Fuser (220–240 volt)	RM1-1044-000CN	1
2	Reverse assembly	RM1-1022-000CN	1
3	Holder, door switch	RC1-3063-000CN	1
4	Microswitch (SW101)	WC4-5139-000CN	1
5	Stopper, hinge shaft	RC1-3124-000CN	1
6	Cable, door switch	RM1-1397-000CN	1
7	Case, envelope-feeder connector	RC1-0245-000CN	1
8	Cable, envelope-feeder connector	RM1-1193-000CN	1
9	Hinge, door, right-side	RC1-2901-000CN	2
10	Screw, with washer, M3 x 6	XB2-7300-607CN	
11	Roller assembly, transfer	RM1-1110-000CN	1
12	Sensor assembly, right door	RM1-1045-000CN	1
13	Cover, handle, lower right	RC1-2881-000CN	1
14	Spacer, screw	RC1-0392-000CN	2
15	Electrical/forward assembly	For reference only	
16	Fuser entrance guide	RM1-1046-000CN	1

## Internal components (3 of 5)

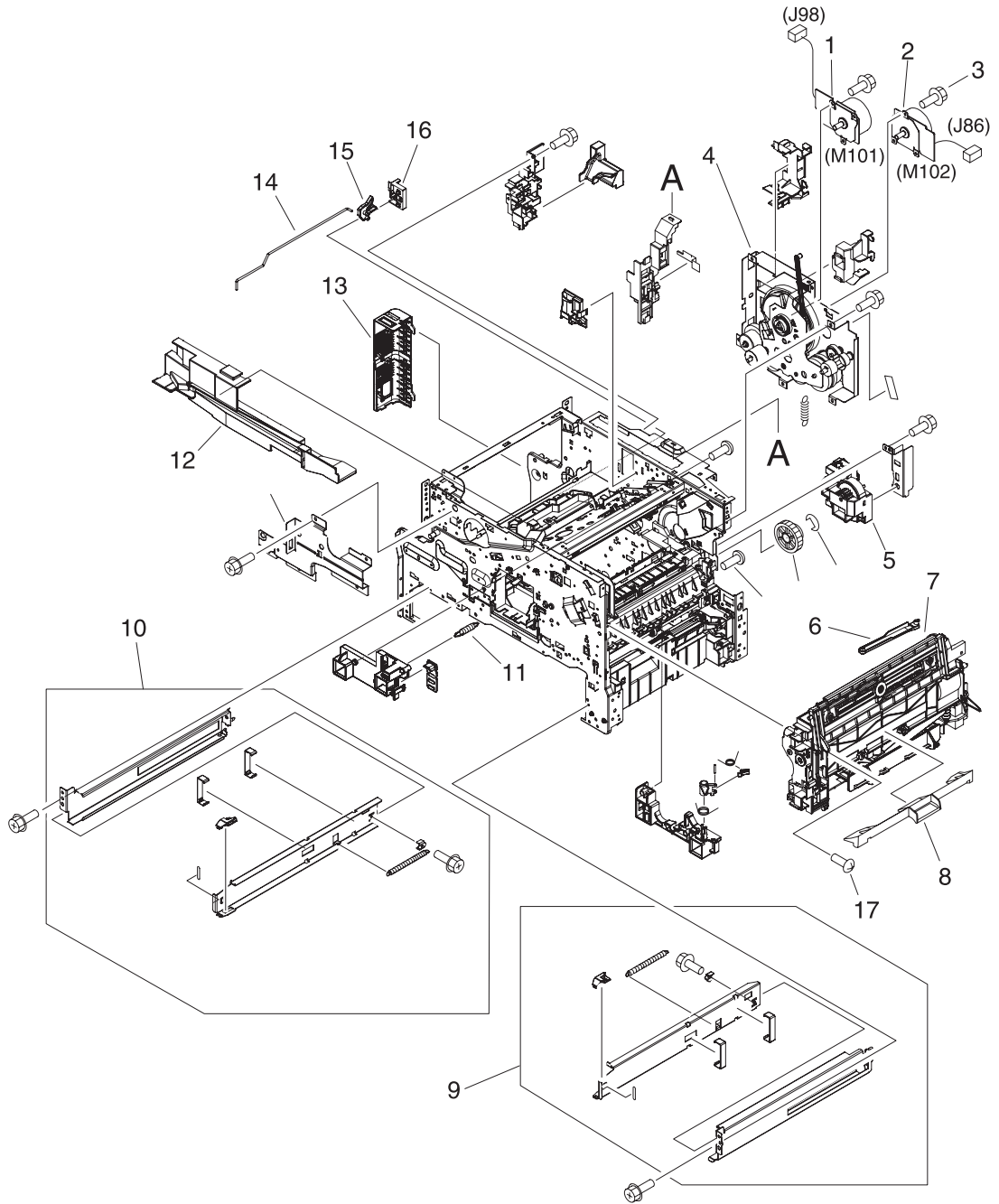


Figure 7-15 Internal components (3 of 5)

**Table 7-14** Internal components (3 of 5)

Reference	Description	Part number	Quantity
1	Motor, DC 24-volt, (M101)	RK2-0272-000CN	1
2	Motor, DC 24-volt, (M102)	RK2-0274-000CN	1
3	Screw, tapping, M3 x 6	XA9-1503-000CN	
4	Main drive assembly	RM1-1049-000CN	1
5	Lifter drive assembly	RM1-1029-000CN	1
6	Rod, link	RC1-2902-000CN	1
7	Multipurpose tray assembly	RM1-1572-000CN	1
8	Cover, envelope-feeder slot	RL1-0455-000CN	1
9	Cassette rail assembly, right	RM1-1012-000CN	1
10	Cassette rail assembly, left	RM1-1011-000CN	1
11	Spring, grounding	RU5-2251-000CN	1
12	Guide, rear	RC1-2884-000CN	1
13	Cover, side, rear	RC1-3042-000CN	1
14	Rod, switch, front	RC1-2980-000CN	1
15	Link, switch	RC1-3003-000CN	1
16	Holder, link	RC1-3002-000CN	1
17	Screw, tapping, truss-head, M4 x 16	XB4-7401-605CN	

## Internal components (4 of 5)

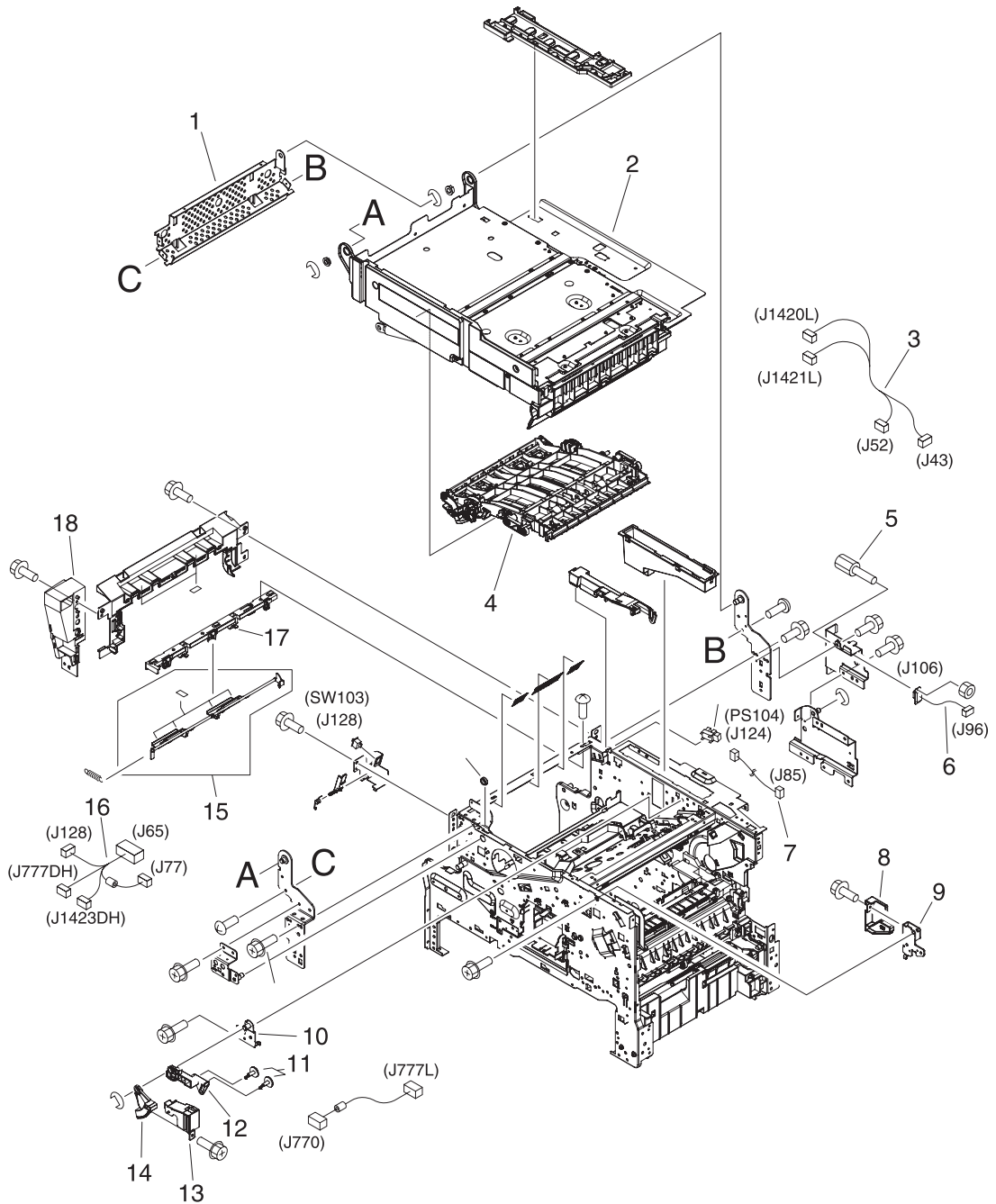


Figure 7-16 Internal components (4 of 5)

**Table 7-15** Internal components (4 of 5)

Reference	Description	Part number	Quantity
1	Cross-member, support	RC1-2911-000CN	1
2	Upper plate assembly	For reference only	
3	Cable, reverse unit	RM1-1380-000CN	1
4	Reverse-separation guide assembly	RM1-1019-000CN	1
5	Bolt, hex-head	WS9-0255-000CN	2
6	Cable, output device connection	RM1-1371-000CN	1
7	Cable, output-bin full sensor	RM1-1368-000CN	1
8	Cover, front stopper	RC1-2823-000CN	1
9	Stopper, front lock	RL1-0434-000CN	1
10	Support, gas damper	RL1-0436-000CN	1
11	Stopper, bushing arm	RC1-3090-000CN	1
12	Arm, door, 1 (top cover)	RC1-2827-000CN	1
13	Cover, door arm (top cover)	RC1-2833-000CN	1
14	Arm, door, 2 (top cover)	RC1-2828-000CN	1
15	Flag, full-detect (output bin)	RC1-2863-000CN	1
16	Cable, control panel	RM1-1381-000CN	1
17	Holder, output-device-full sensor flag	RC1-2864-000CN	1
18	Cover, inner front	RC1-3041-000CN	1

## Internal components (5 of 5)

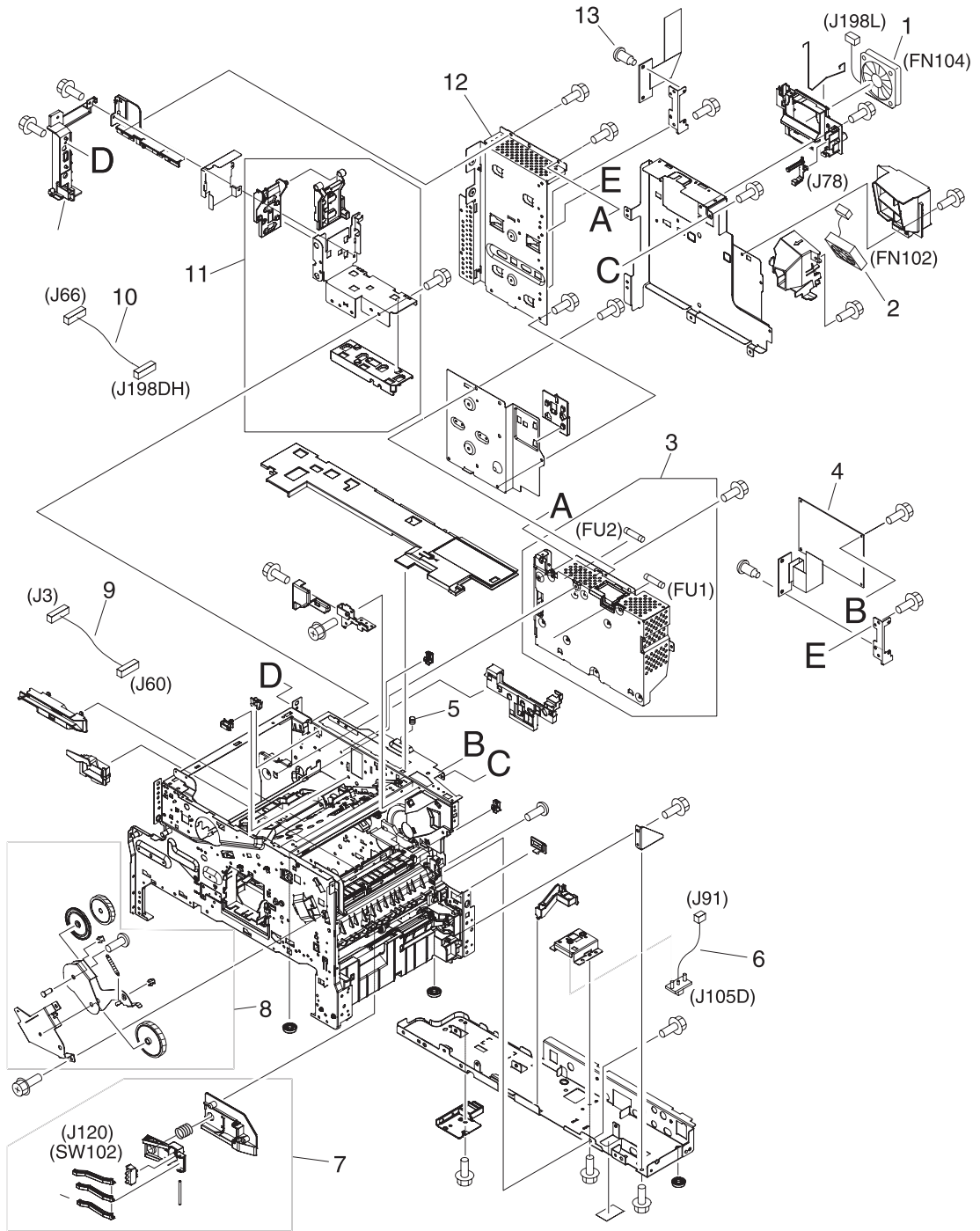
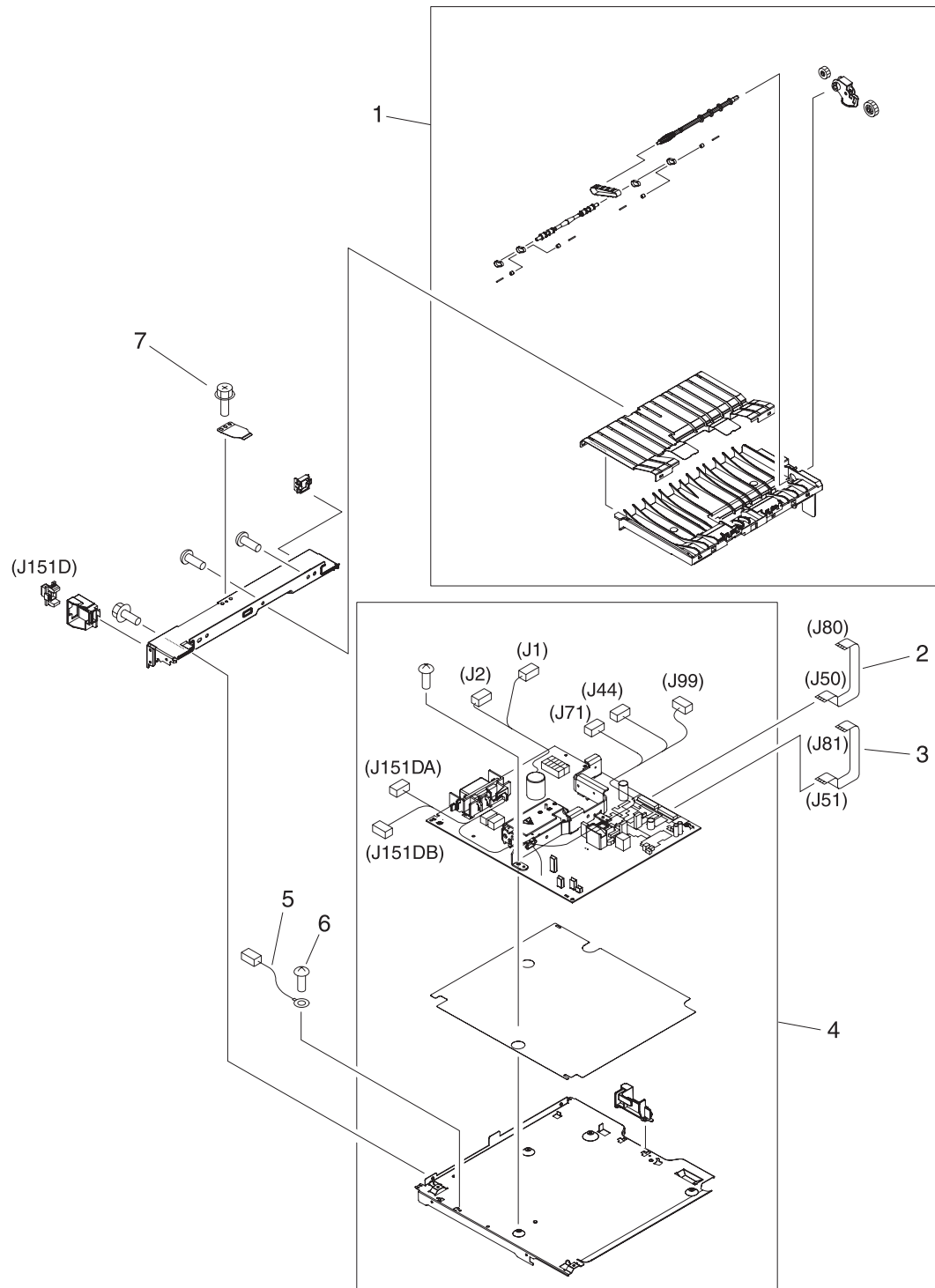


Figure 7-17 Internal components (5 of 5)

**Table 7-16** Internal components (5 of 5)

Reference	Description	Part number	Quantity
1	Fan, DC controller (FN104)	RK2-0472-000CN	1
2	Fan, print cartridge (FN102)	RK2-0280-000CN	1
3	Power supply, PFC (100–127 volt)	RM1-1013-000CN	1
3	Power supply, PFC (220–240 volt)	RM1-1014-000CN	1
4	DC controller PCA	RM1-1354-000CN	1
5	Spring, compression	RU5-2265-000CN	1
6	Cable, optional 500-sheet feeder connection	RM1-1370-000CN	1
7	Sensor assembly, paper size (SW102)	RM1-0041-020CN	1
8	Swing-plate assembly	RM1-0043-020CN	1
9	Cable, power	RM1-1375-000CN	1
10	Cable, fan docking (for DC-controller fan)	RM1-1376-000CN	1
11	Guide assembly, flat-flexible cable	RM1-1027-000CN	1
12	Formatter assembly	CB425-67901	1
13	Screw, stepped, M3	RC1-0266-020CN	

## Electrical/forward assembly



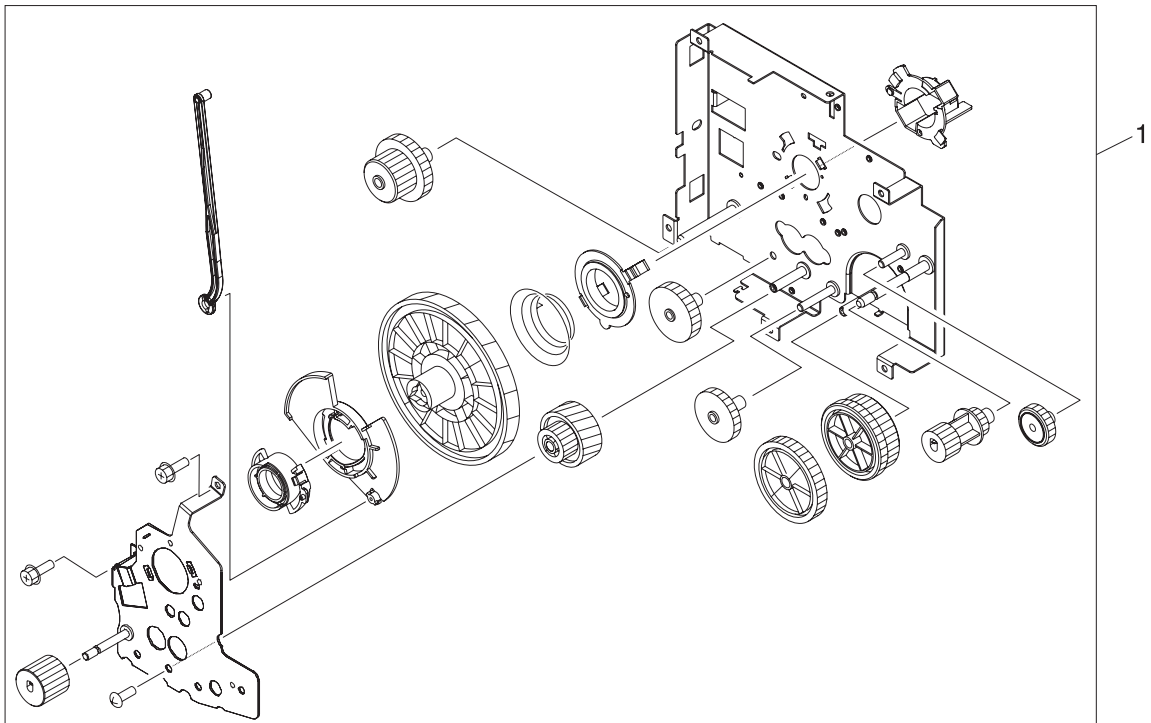
**Figure 7-18** Electrical/forward assembly



**Table 7-17** Electrical/forward assembly

Reference	Description	Part number	Quantity
1	Paper-feed assembly	RM1-0025-040CN	1
2	Cable, flat-flexible (engine power supply)	RK2-0470-000CN	1
3	Cable, flat-flexible (engine power supply)	RK2-0469-000CN	1
4	Engine power supply assembly (100–127 volt)	RM1-1041-000CN	1
4	Engine power supply assembly (220–240 volt)	RM1-1042-000CN	1
5	Cable, duplexing-unit grounding	RM1-1400-000CN	1
6	Screw, with washer, M3 x 6	XA9-1420-000CN	
7	Screw, flathead, RS, M3 x 6	XA9-1464-000CN	

## Main drive assembly



**Figure 7-19** Main drive assembly

**Table 7-18** Main drive assembly

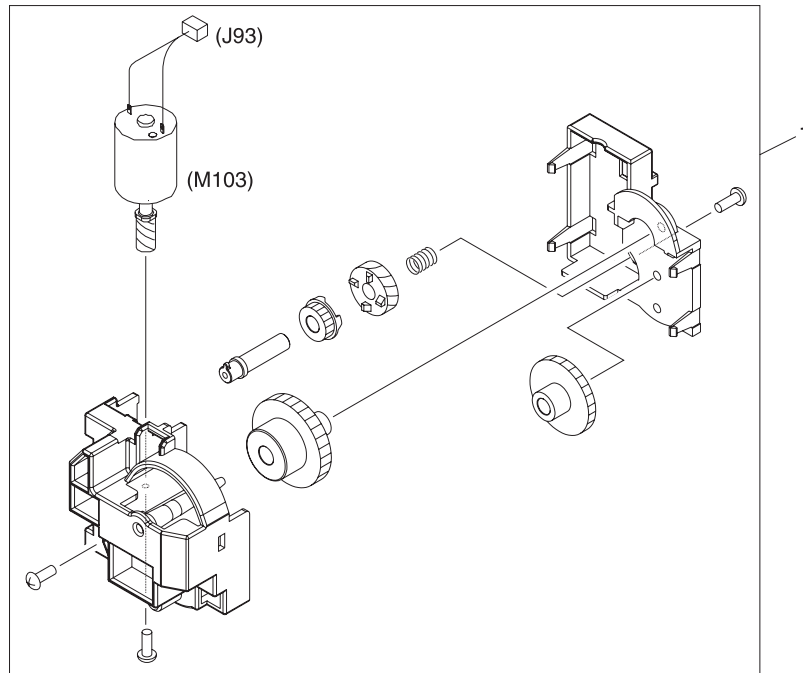
Reference	Description	Part number	Quantity
1	Main drive assembly	RM1-1049-000CN	1



**Table 7-19** Paper-pickup-drive assembly

Reference	Description	Part number	Quantity
1	Paper-pickup-drive assembly	RM1-0034-070CN	1

## Lifter-drive assembly



**Figure 7-21** Lifter-drive assembly

**Table 7-20** Lifter-drive assembly

Reference	Description	Part number	Quantity
1	Lifter-drive assembly	RM1-1029-000CN	1

# Cassette

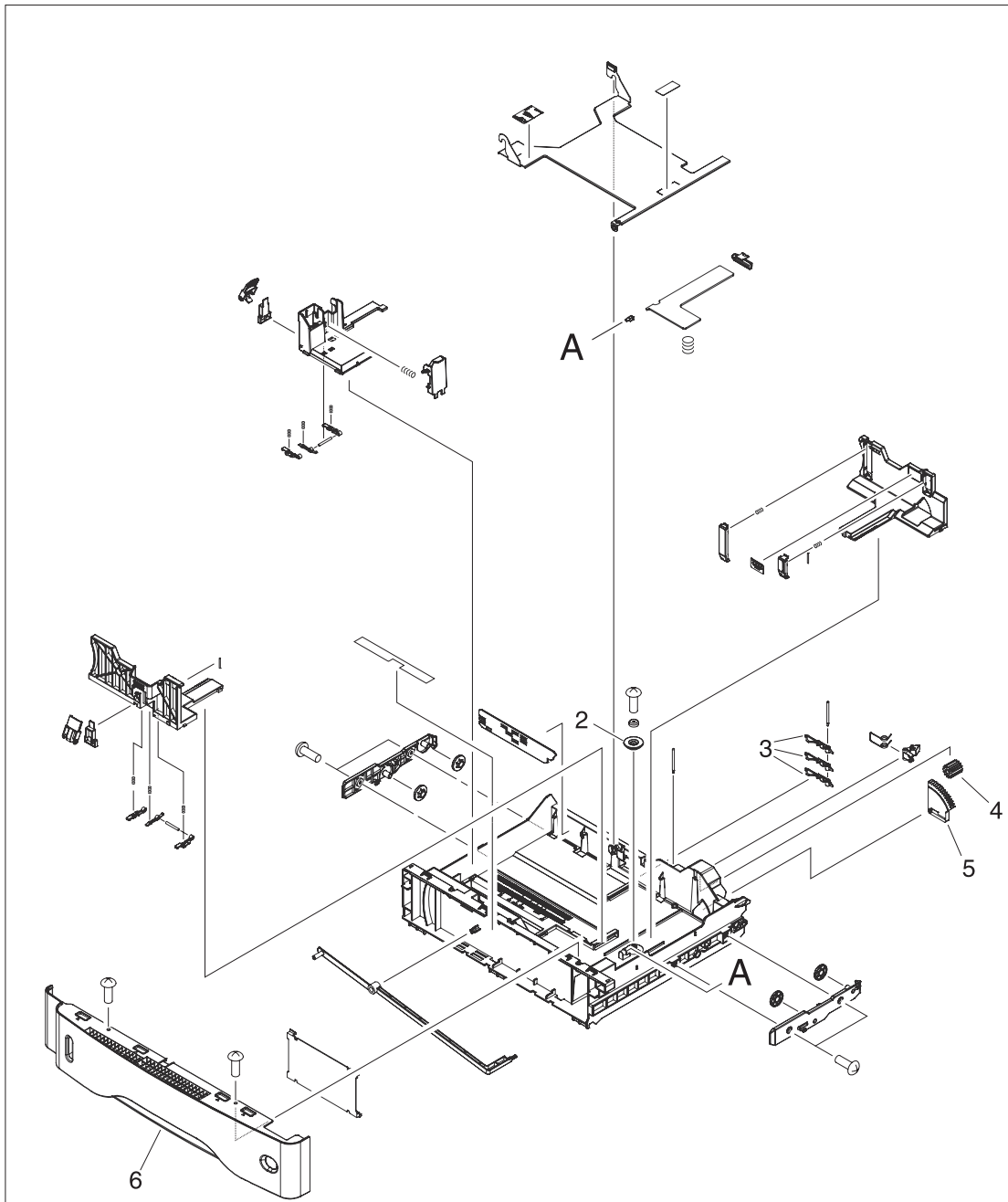


Figure 7-22 Cassette



**Table 7-21** Cassette

<b>Reference</b>	<b>Description</b>	<b>Part number</b>	<b>Quantity</b>
1	Cassette (tray 2, 3, 4 or 5)	RM1-1001-000CN	1
2	Gear, 20T (cassette)	RC1-0331-000CN	1
3	Lever, paper-size-sensing (cassette)	RC1-2782-000CN	3
4	Gear, 14T (cassette)	RU5-0254-000CN	1
5	Gear, 80T (cassette)	RU5-0253-000CN	1
6	Guide, cassette, front	RC1-3020-000CN	1

## Paper-feed roller assembly

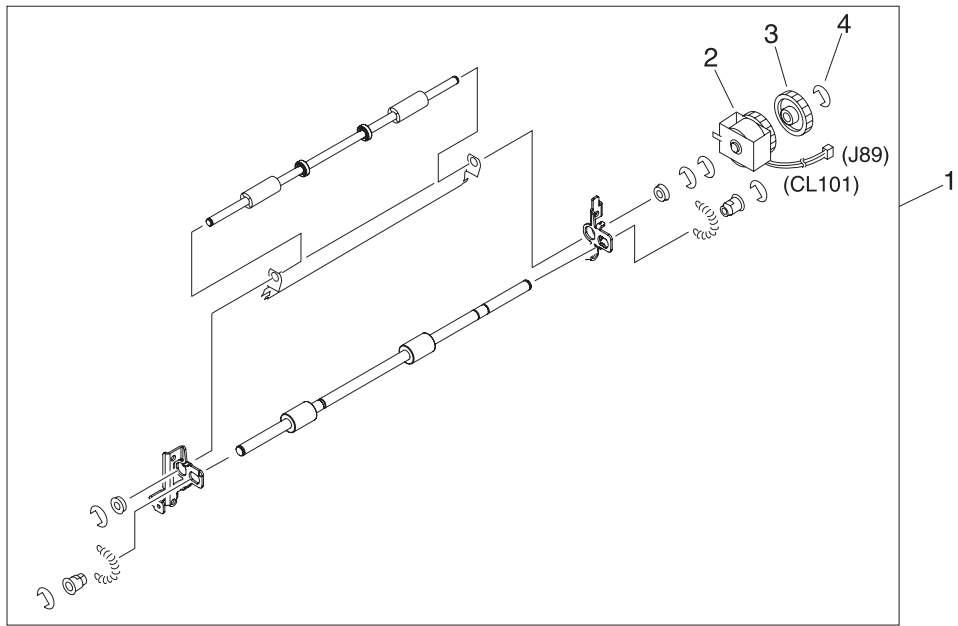


Figure 7-23 Paper-feed roller assembly

**Table 7-22** Paper-feed roller assembly

Reference	Description	Part number	Quantity
1	Paper-feed roller assembly	RM1-0012-020CN	1
2	Clutch, paper feed, electromagnetic (CL101)	RK2-0349-000CN	1
3	Gear, 30T (paper-feed roller assembly)	RU5-0050-000CN	1
4	E-ring (paper-feed roller assembly)	XD9-0132-020CN	1

## Registration assembly

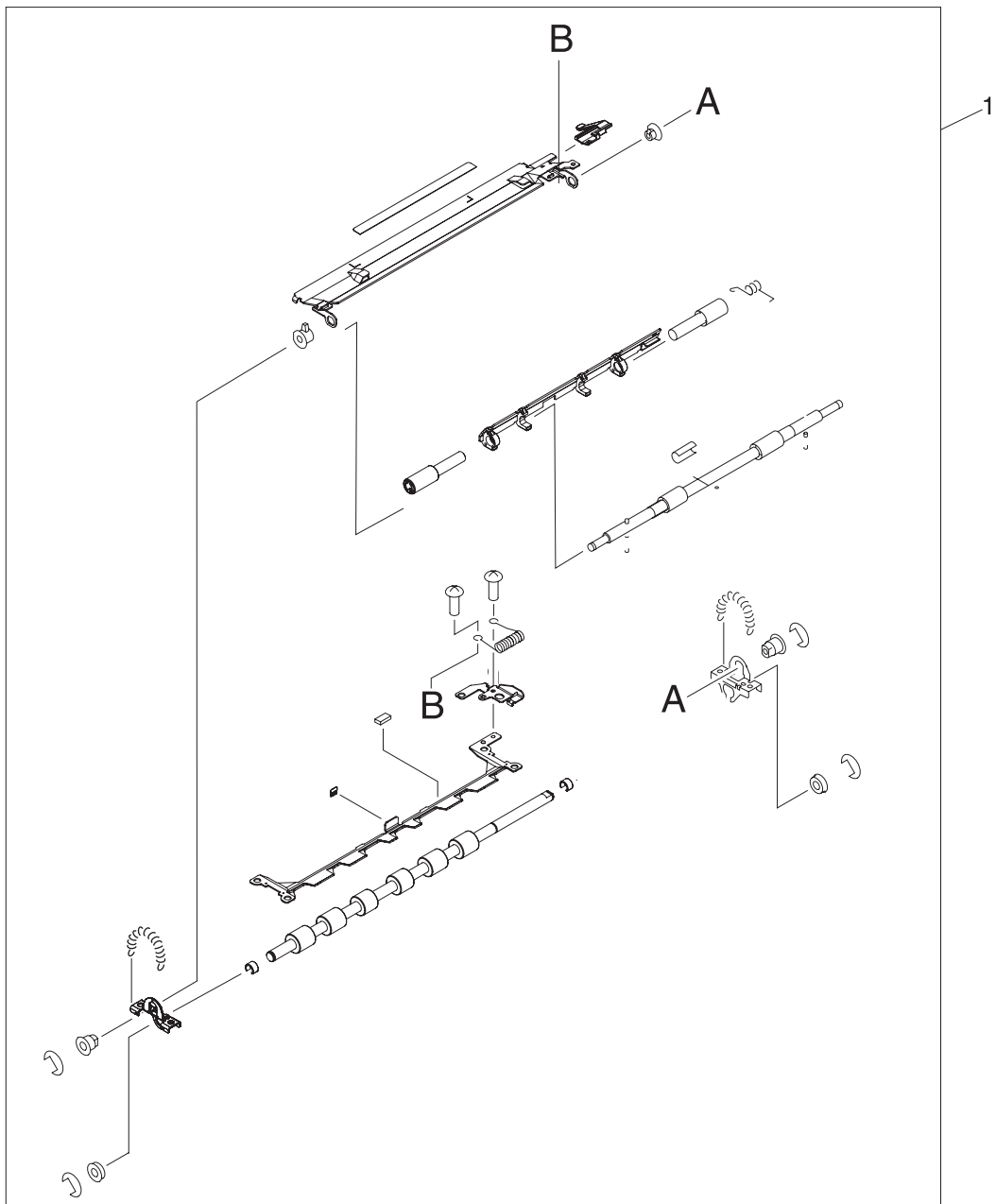


Figure 7-24 Registration assembly

**Table 7-23** Registration assembly

Reference	Description	Part number	Quantity
1	Registration assembly	RM1-0011-060CN	1

## Multipurpose assembly

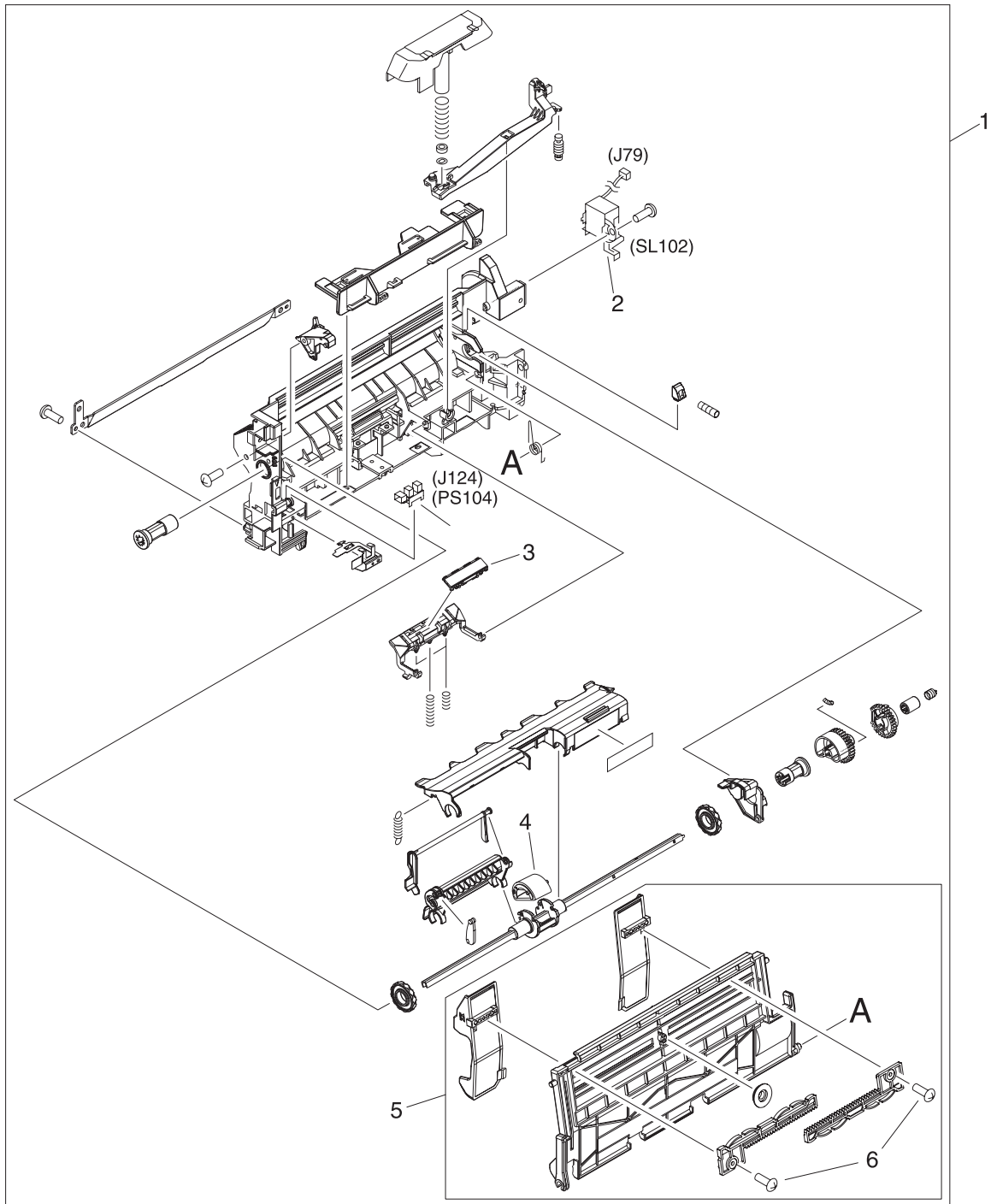


Figure 7-25 Multipurpose assembly

**Table 7-24** Multipurpose assembly

Reference	Description	Part number	Quantity
1	Multipurpose assembly	RM1-1572-000CN	1
2	Solenoid, multipurpose assembly (SL102)	RK2-0276-000CN	1
3	Plate, main pad support (multipurpose assembly)	RL1-0007-000CN	1
4	Roller, pickup, multipurpose assembly	RL1-0019-000CN	1
5	Multipurpose tray assembly	RM1-0005-020CN	1
6	Screw, tapping, truss-head, M3 x 8	XB4-7300-809CN	1

## Reverse assembly

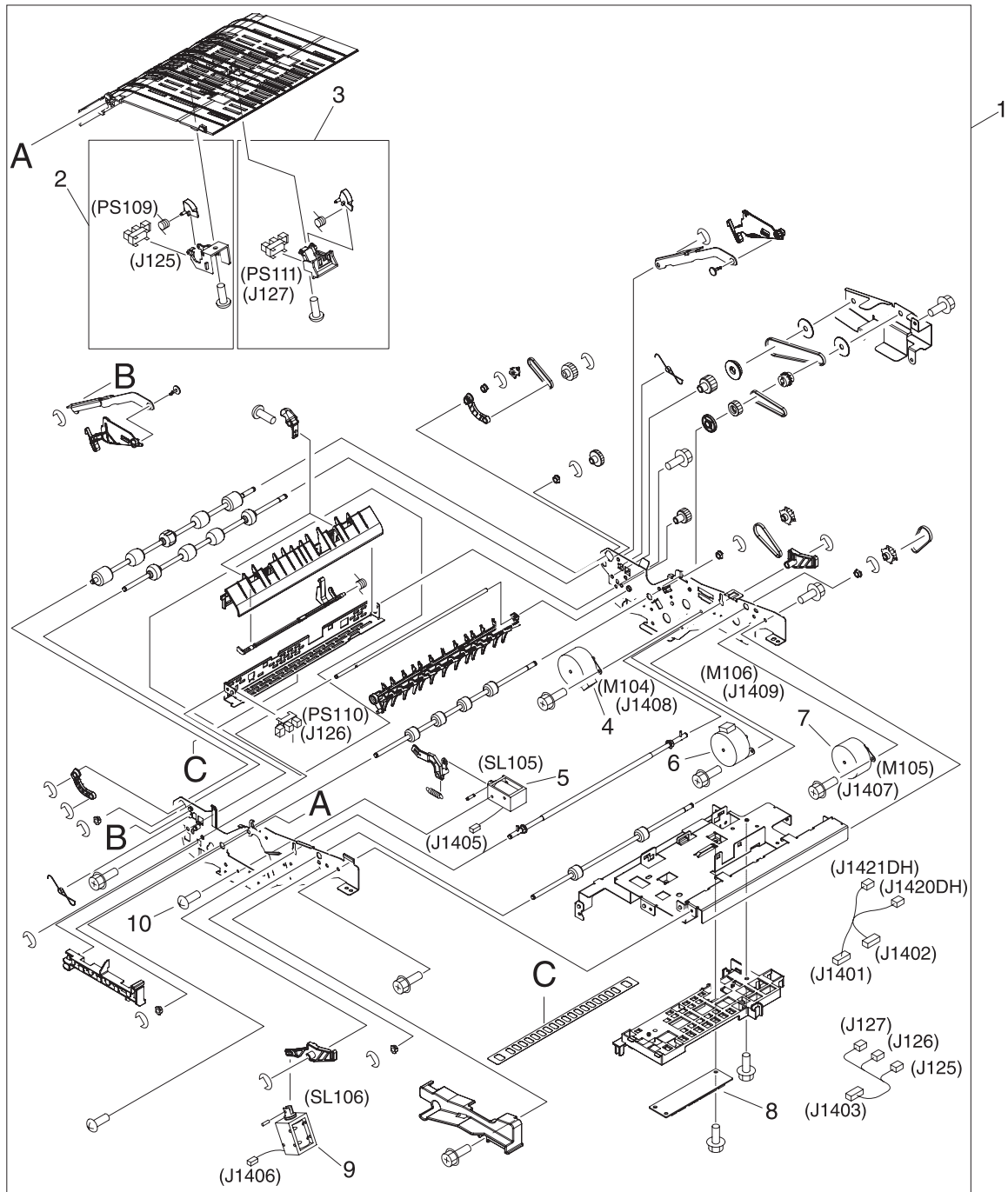


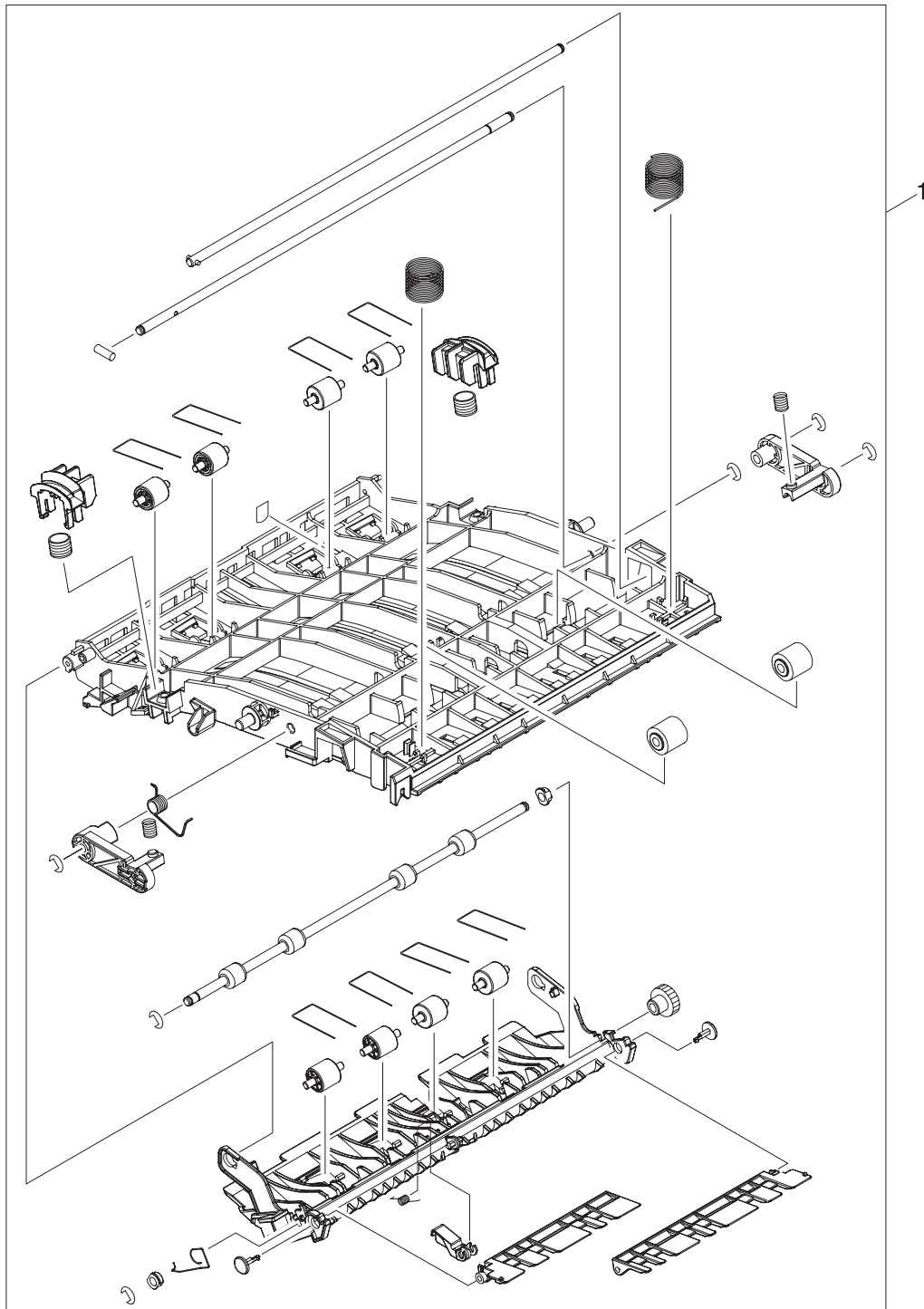
Figure 7-26 Reverse assembly



**Table 7-25** Reverse assembly

<b>Reference</b>	<b>Description</b>	<b>Part number</b>	<b>Quantity</b>
1	Reverse assembly	RM1-1022-000CN	1
2	Sensor, reverse-unit (PS109)	RM1-1570-000CN	1
3	Sensor, reverse-unit jam (PS111)	RM1-1571-000CN	1
4	Motor, crossing, (stepping) (M104)	RK2-0473-000CN	1
5	Solenoid, reverse-unit (SL105)	RK2-0485-000CN	1
6	Motor, delivery (stepping) (M106)	RK2-0475-000CN	1
7	Motor, reverse-unit (stepping) (M105)	RK2-0474-000CN	1
8	Reverse-unit PCA	RM1-1379-000CN	1
9	Solenoid, reversing-roller separation (SL106)	RK2-0486-000CN	1
10	Screw, TP, M3 x 4	XB6-7300-406CN	1

## Reverse-separation-guide assembly



**Figure 7-27** Reverse-separation-guide assembly

**Table 7-26** Reverse-separation-guide assembly

Reference	Description	Part number	Quantity
1	Reverse-separation-guide assembly	RM1-1019-000CN	1

## Delivery assembly

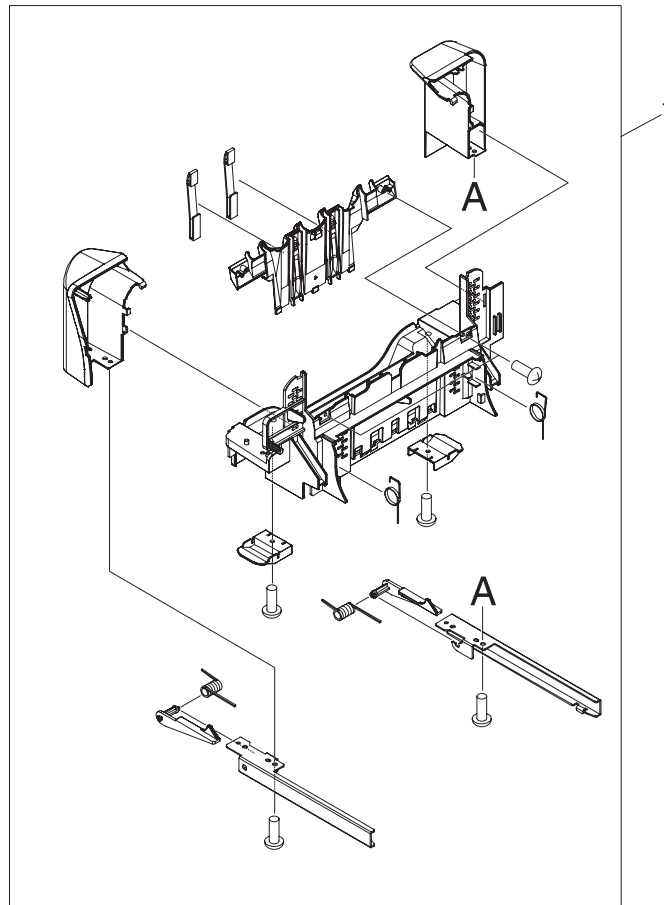


Figure 7-28 Delivery assembly

**Table 7-27** Delivery assembly

Reference	Description	Part number	Quantity
1	Delivery assembly	RM1-1047-000CN	1

# Fuser

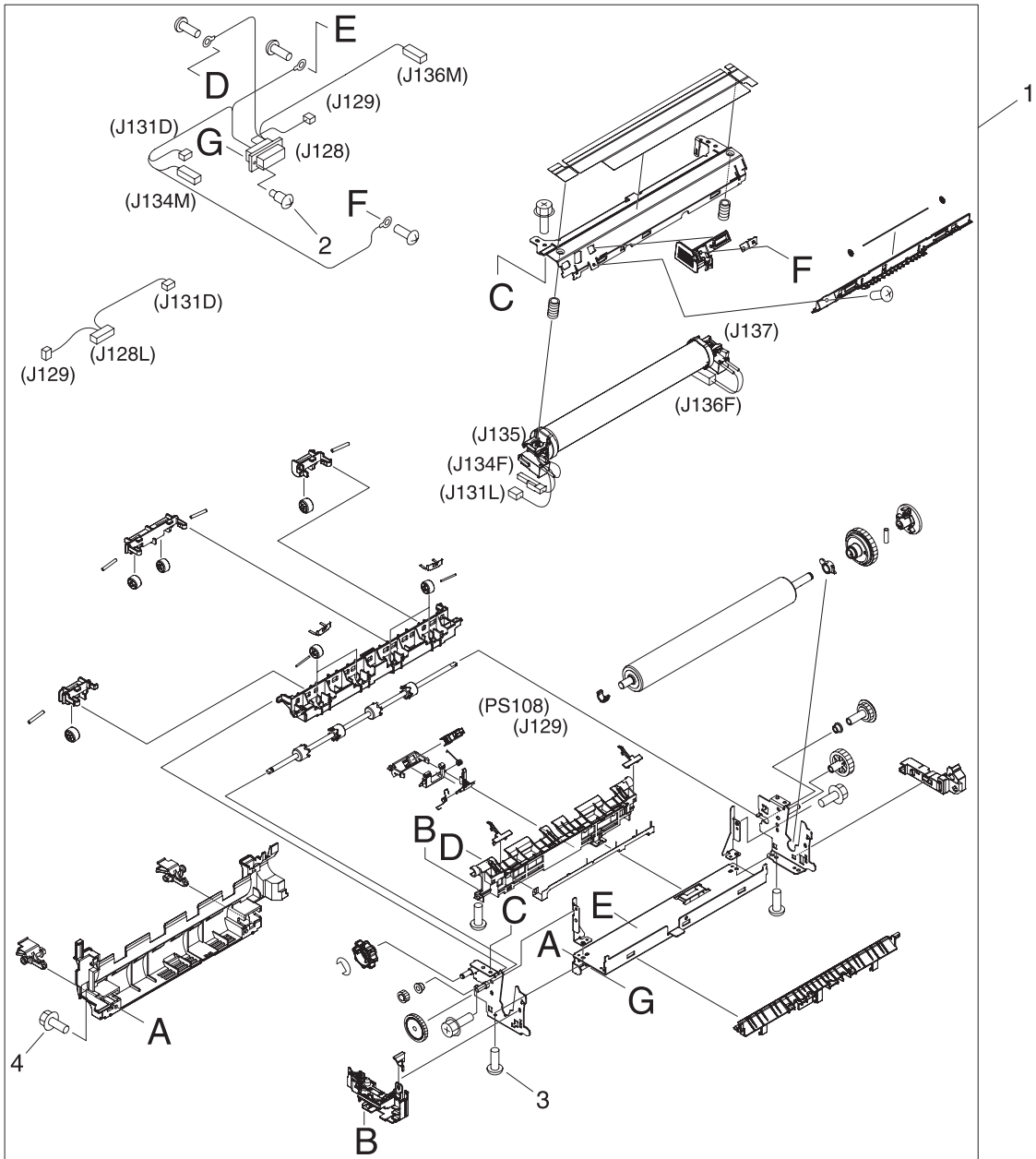


Figure 7-29 Fuser

**Table 7-28** Fuser

<b>Reference</b>	<b>Description</b>	<b>Part number</b>	<b>Quantity</b>
1	Fuser (100–127 volt)	RM1-1043-000CN	1
1	Fuser (220–240 volt)	RM1-1044-000CN	1
2	Screw, stepped	RS1-9004-020CN	1
3	Screw, M3 x 8	XA9-0650-000CN	1
4	Screw, RS, M3 x 8	XA9-1449-000CN	1

# ADF components

## ADF assembly

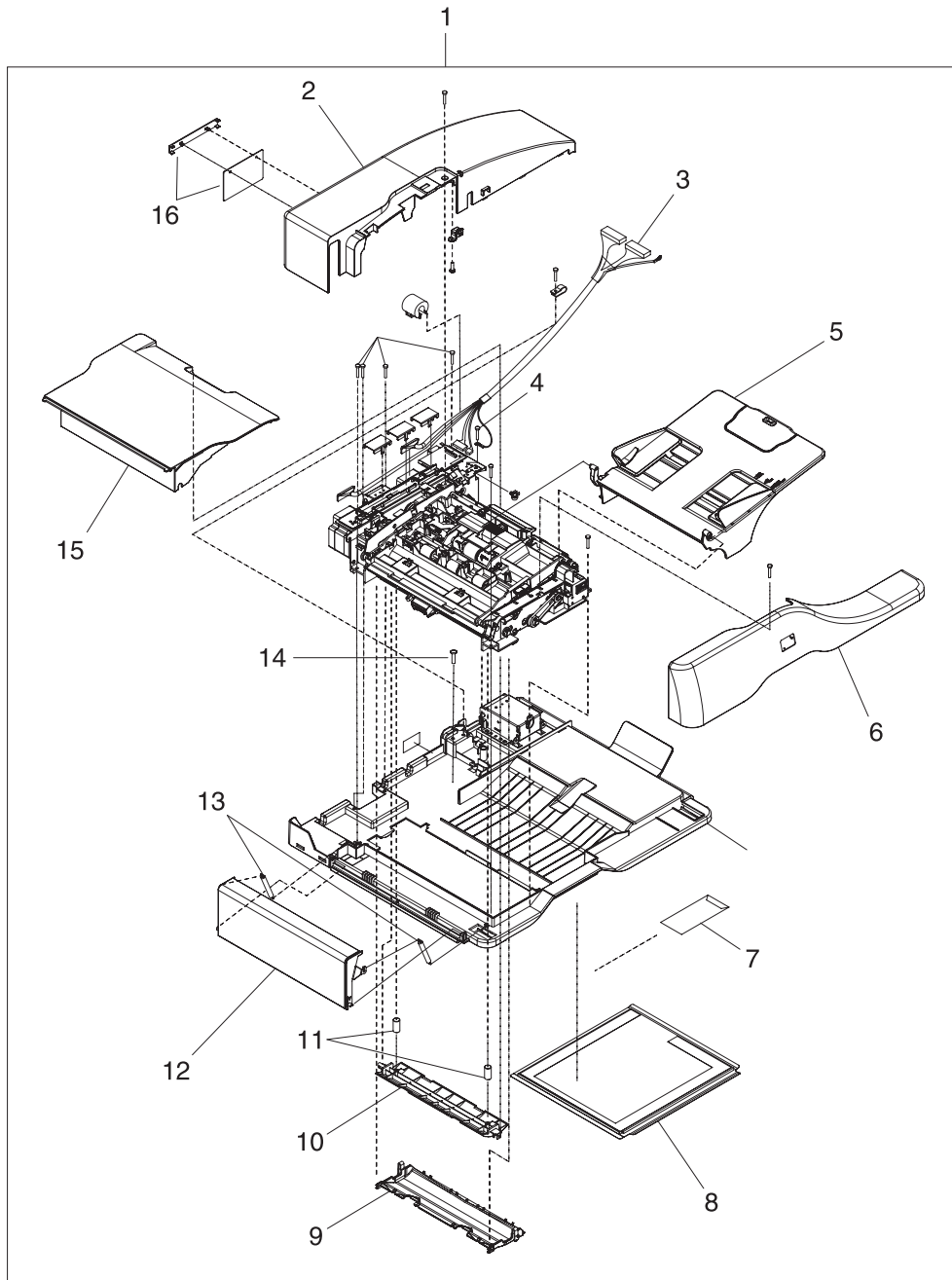


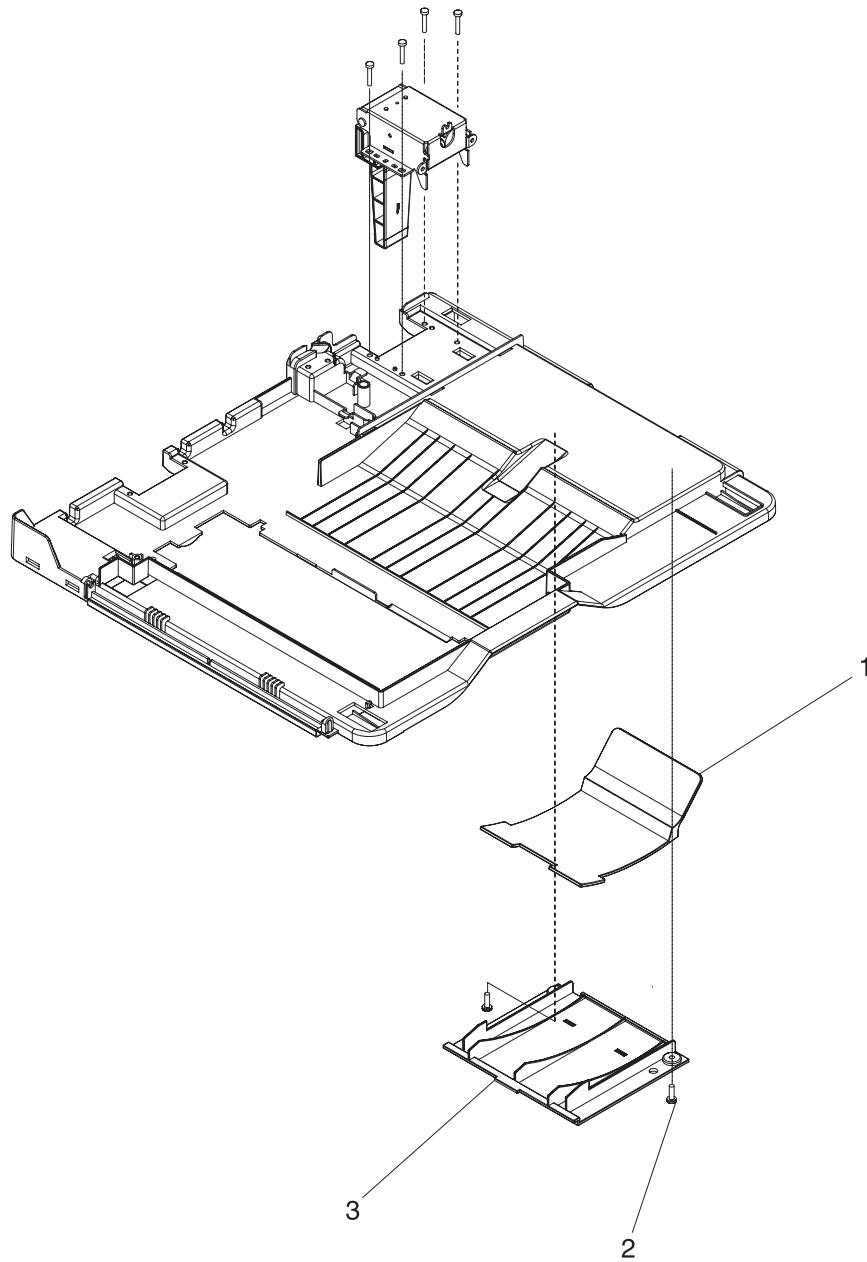
Figure 7-30 ADF assembly



**Table 7-29** ADF assembly

Reference	Description	Part number	Quantity
1	ADF assembly	PF2282K006NI	1
2	ADF rear cover	PF2282P044NI	1
3	ADF cable	PF2282K165NI	1
4	Screw, ADF	030080FWWSNI	1
5	ADF input tray	PF2282K042NI	1
6	ADF front cover	PF2282P059NI	1
7	ADF mylar replacement kit	Q6496-67901	1
8	ADF white scan background	PF2282P339NI	1
9	ADF mylar holder assembly	PF2282K043NI	1
10	ADF white mylar backing	PF2282P025NI	1
11	ADF, springs for white mylar backing	PF2282P343NI	2
12	ADF left cover	PF2282P058NI	1
13	ADF, springs for left cover	PF2282P352NI	2
14	Screw, ADF, wave 4 x 10	PF2245P369NI	1
15	ADF jam-access cover	PF2282P041NI	1
16	ADF hinge flaps (ESD)	PF2282K166NI	1

## ADF internal components (1 of 3)



**Figure 7-31** ADF internal components (1 of 3)

**Table 7-30** ADF internal components (1 of 3)

<b>Reference</b>	<b>Description</b>	<b>Part number</b>	<b>Quantity</b>
1	ADF output-bin paper stop	PF2282P061NI	1
2	Screw, ADF	NS-SCR00029NI	1
3	ADF output-bin-base cover	PF2282P060NI	1

## ADF internal components (2 of 3)

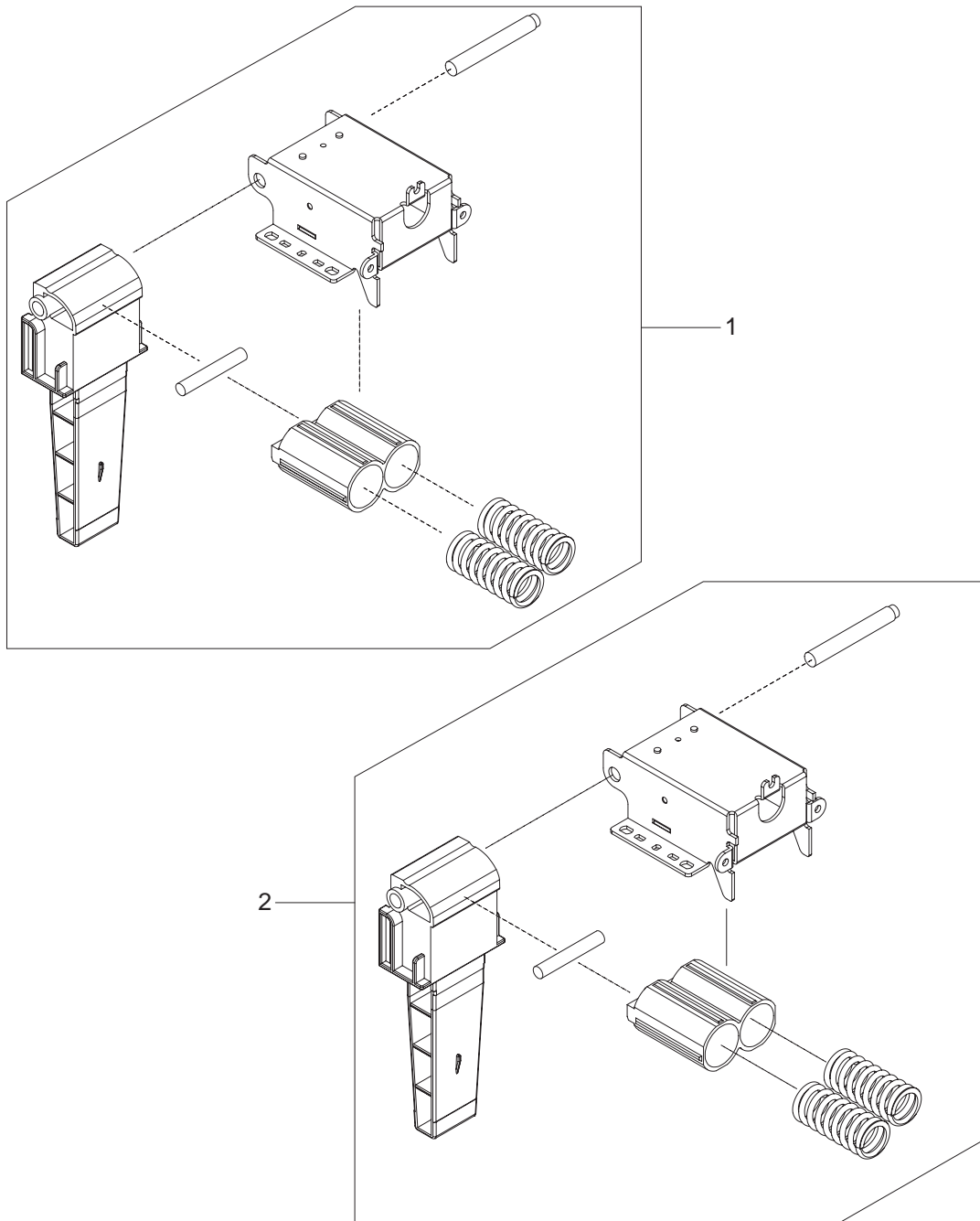


Figure 7-32 ADF internal components (2 of 3)

**Table 7-31** ADF internal components (2 of 3)

Reference	Description	Part number	Quantity
1	ADF hinge, left	PF2282K041NI	1
2	ADF hinge, right	PF2282K008NI	1

## ADF internal components (3 of 3)

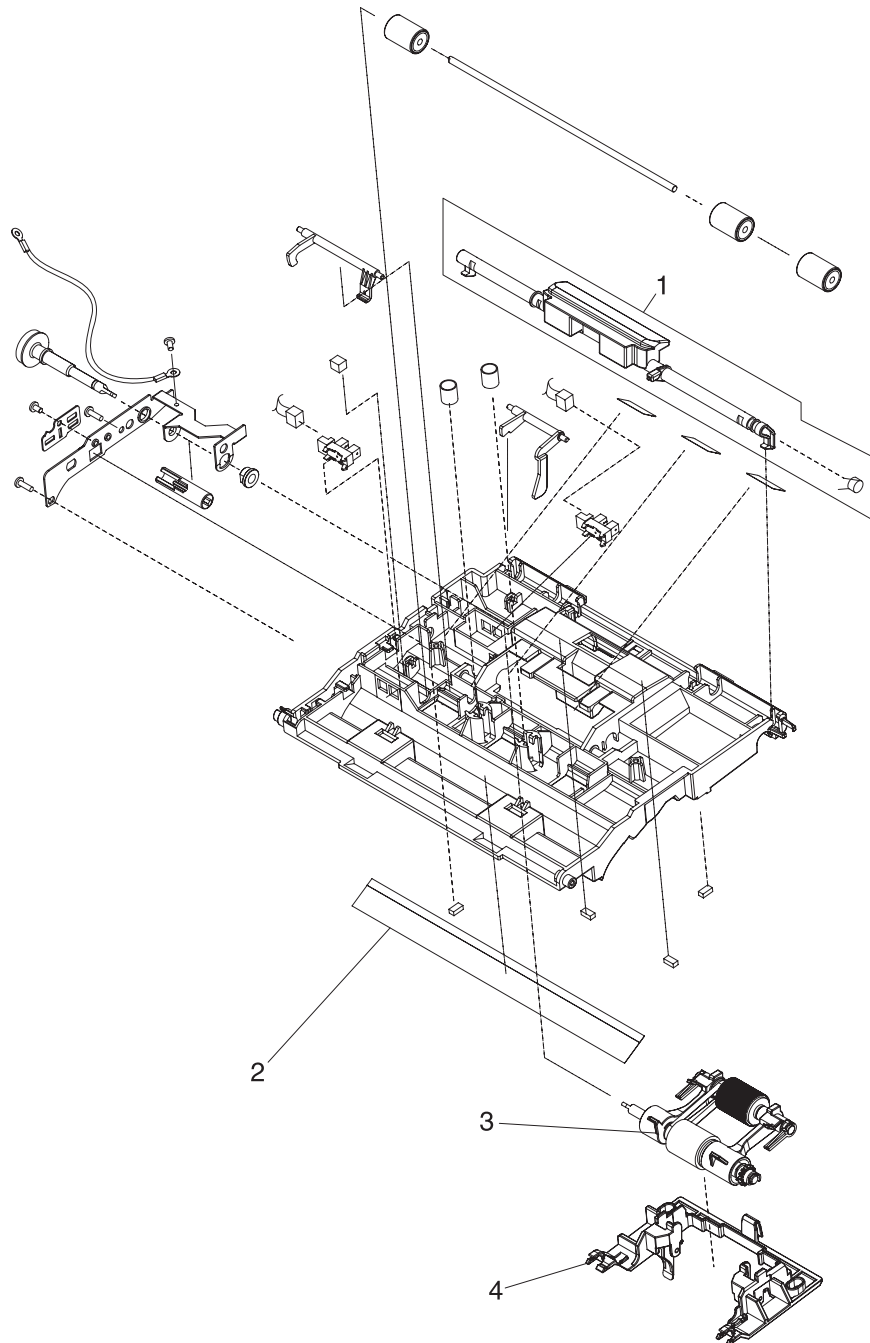


Figure 7-33 ADF internal components (3 of 3)

**Table 7-32** ADF internal components (3 of 3)

<b>Reference</b>	<b>Description</b>	<b>Part number</b>	<b>Quantity</b>
1	ADF jam-access latch	PF2282K164NI	1
2	ADF clear plastic paper guide	PF2282P353NI	1
3	ADF pickup-roller assembly	PF2282K039NI	1
4	ADF pickup-roller cover	PF2282K040NI	1

## ADF input tray

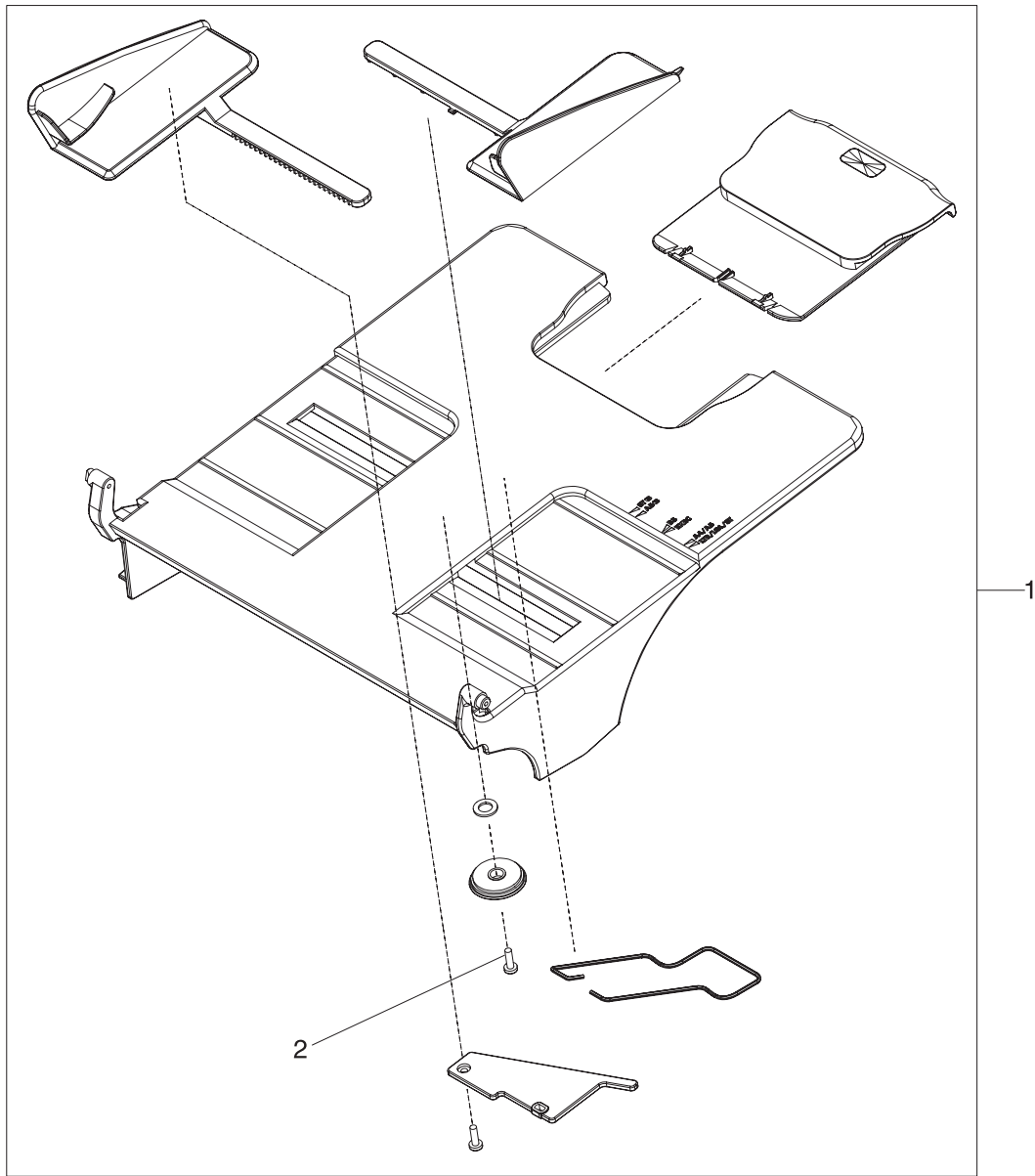


Figure 7-34 ADF input tray



**Table 7-33** ADF input tray

Reference	Description	Part number	Quantity
1	ADF input tray	PF2282K042NI	1
2	Screw, ADF, button, M3 x 8	IR4041P021NI	1

## ADF separation pad

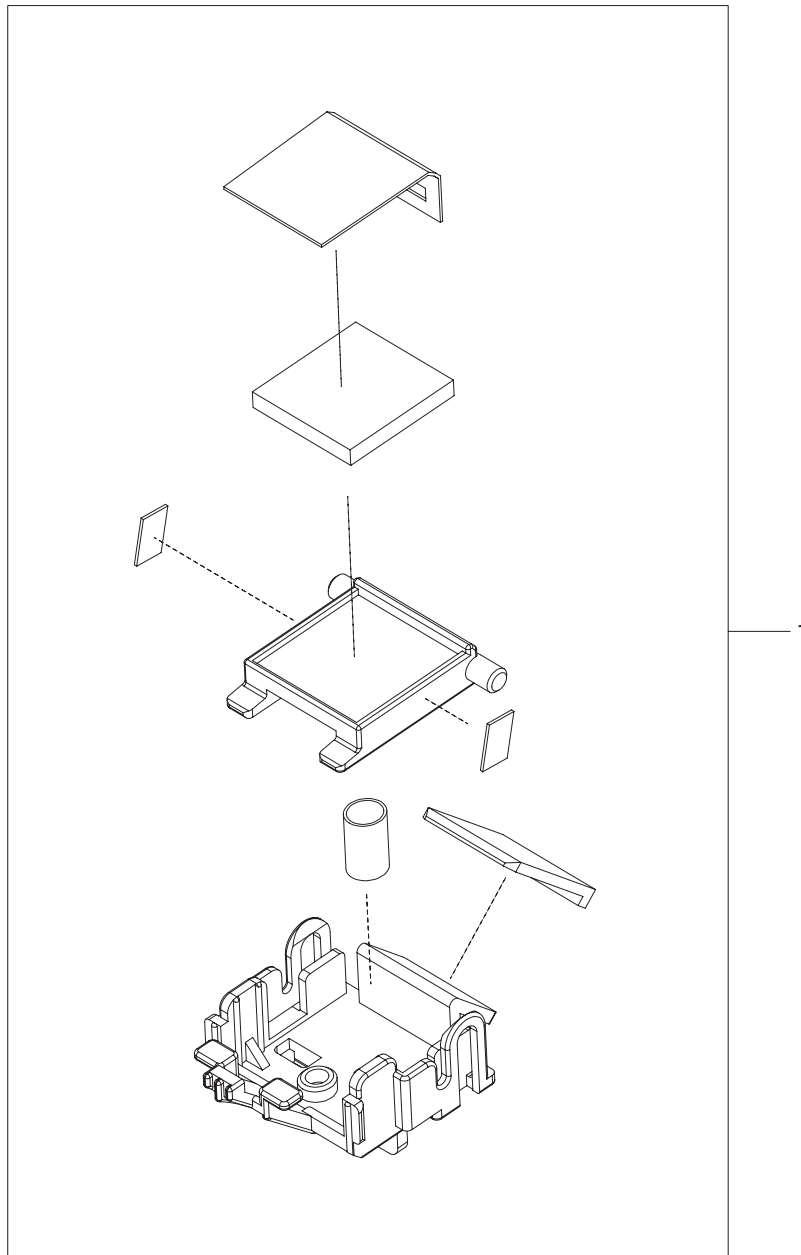
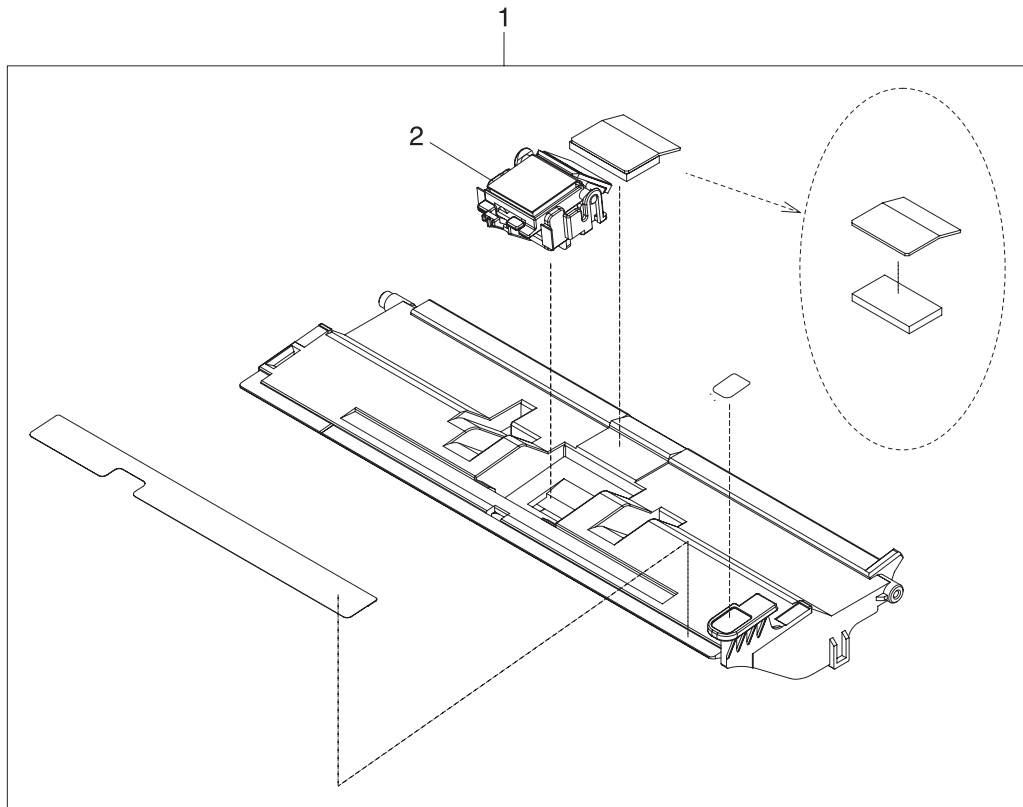


Figure 7-35 ADF separation pad

**Table 7-34** ADF separation pad

Reference	Description	Part number	Quantity
1	ADF separation-pad assembly	PF2282K035NI	1

## ADF separation-pad case

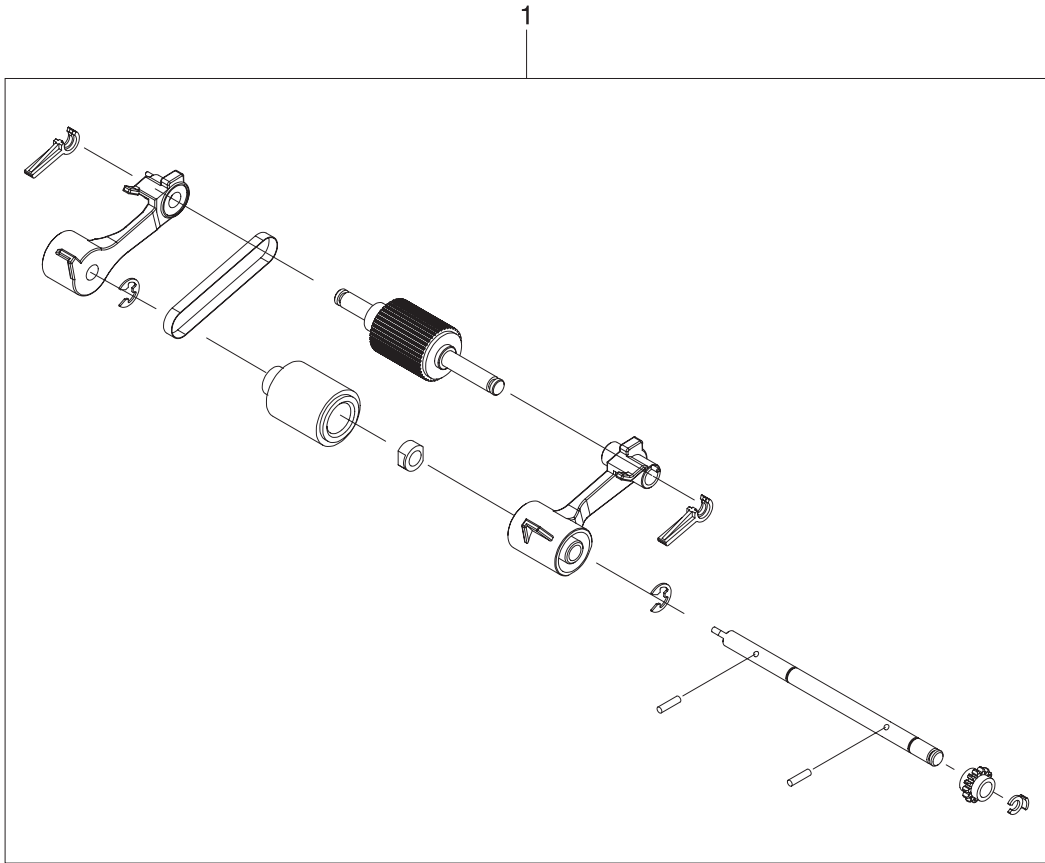


**Figure 7-36** ADF separation-pad case

**Table 7-35** ADF separation-pad case

Reference	Description	Part number	Quantity
1	ADF separation-pad case	PF2282K034NI	1
2	ADF separation pad	PF2282K035NI	1

## ADF pickup-roller assembly

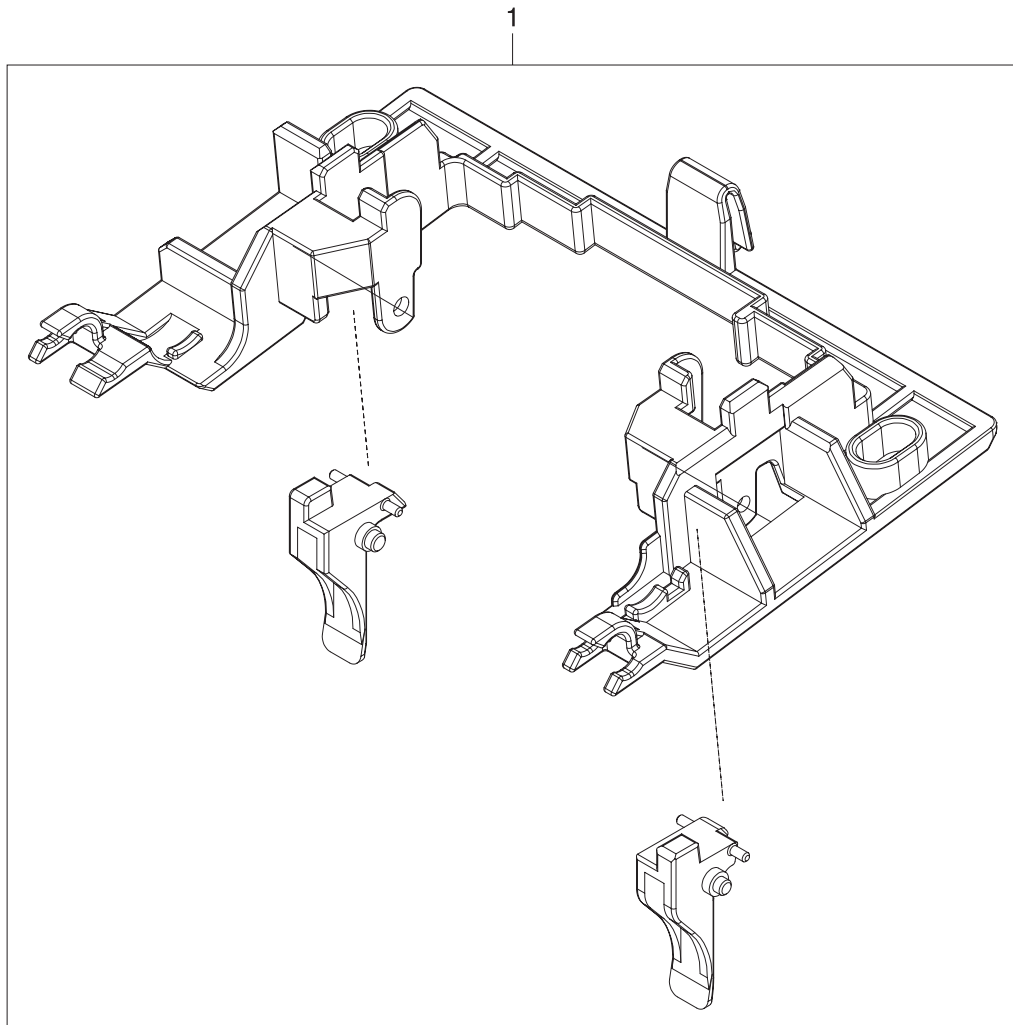


**Figure 7-37** ADF pickup-roller assembly

**Table 7-36** ADF pickup-roller assembly

Reference	Description	Part number	Quantity
1	ADF pickup-roller assembly	PF2282K039NI	1

## ADF pickup-roller cover



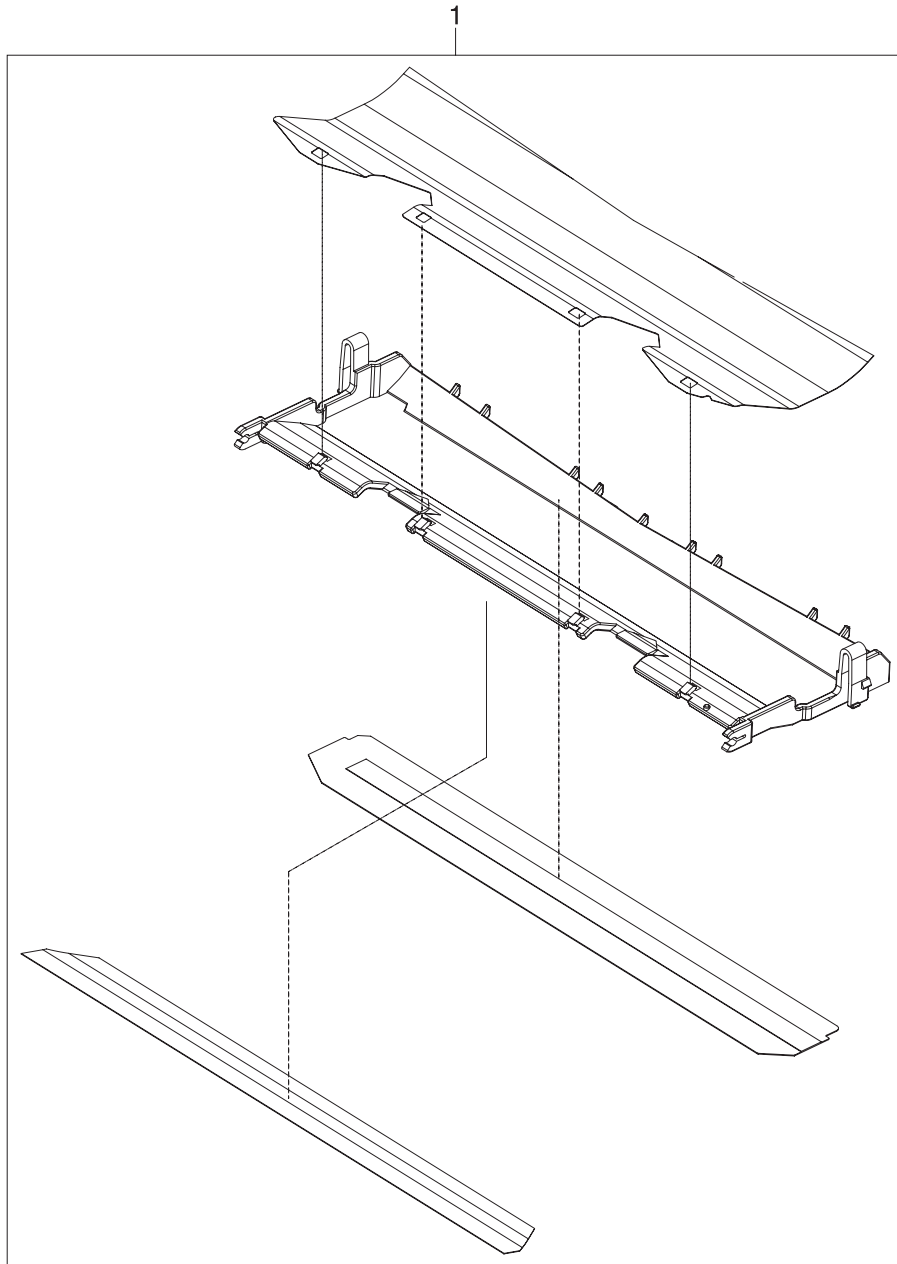
**Figure 7-38** ADF pickup-roller cover



**Table 7-37** ADF pickup-roller cover

Reference	Description	Part number	Quantity
1	ADF pickup-roller cover	PF2282K040NI	1

## ADF mylar-holder assembly

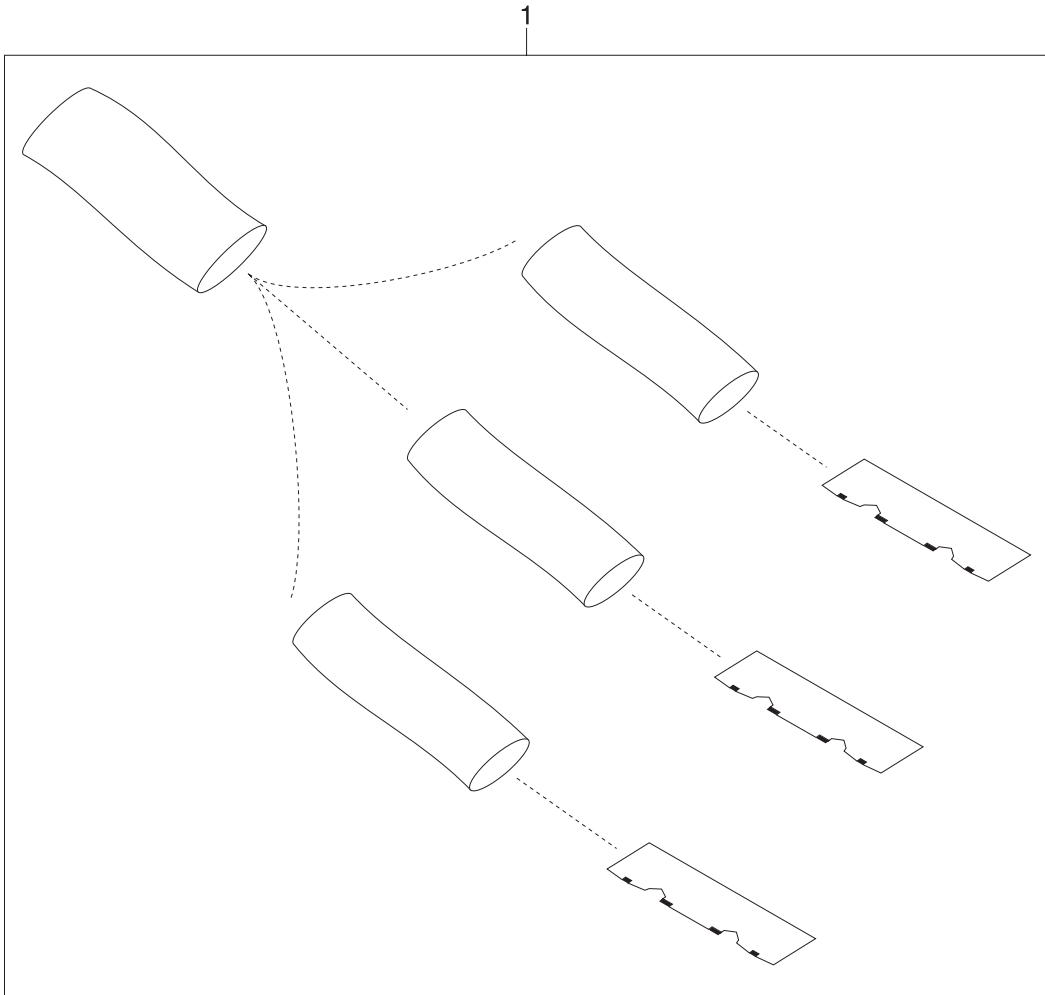


**Figure 7-39** ADF mylar-holder assembly

**Table 7-38** ADF mylar-holder assembly

Reference	Description	Part number	Quantity
1	ADF mylar-holder assembly	PF2282K043NI	1

## ADF mylar replacement kit



**Figure 7-40** ADF mylar replacement kit

**Table 7-39** ADF mylar replacement kit

Reference	Description	Part number	Quantity
1	ADF mylar replacement kit	Q6496-67901	1

# Scanner components

## Scanner-base components

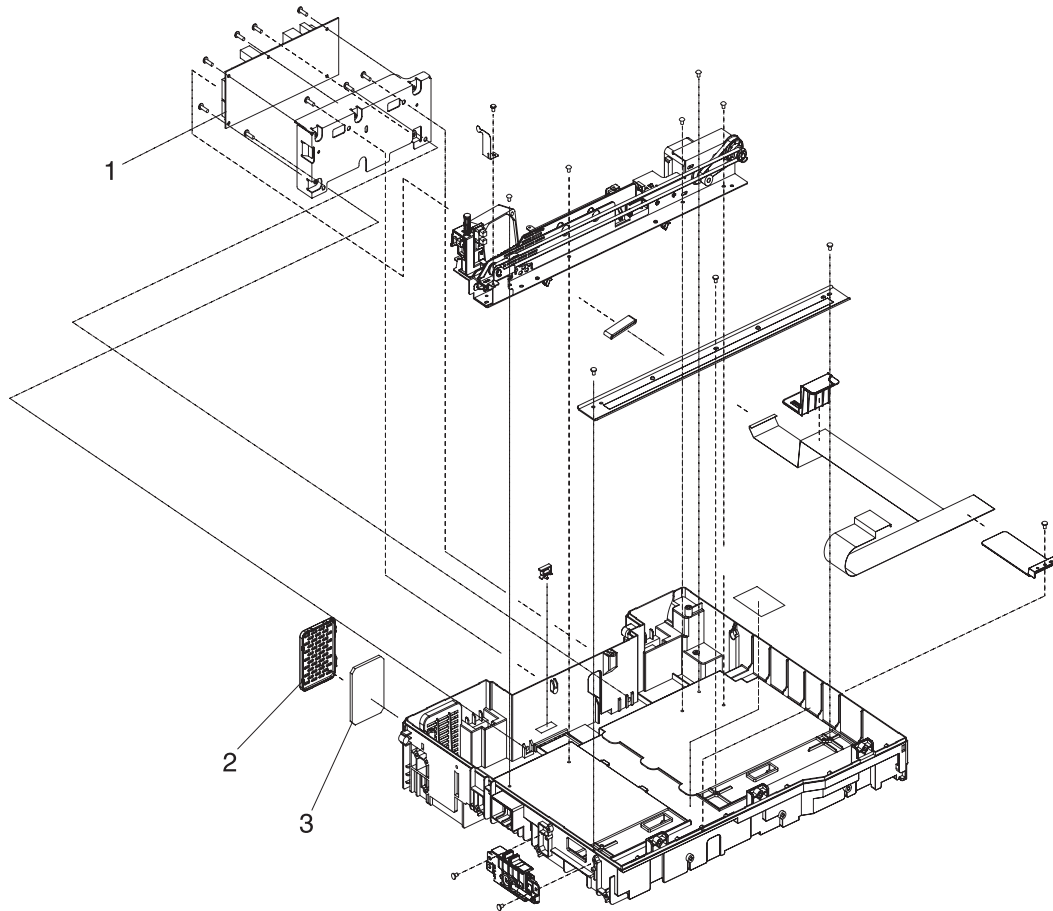
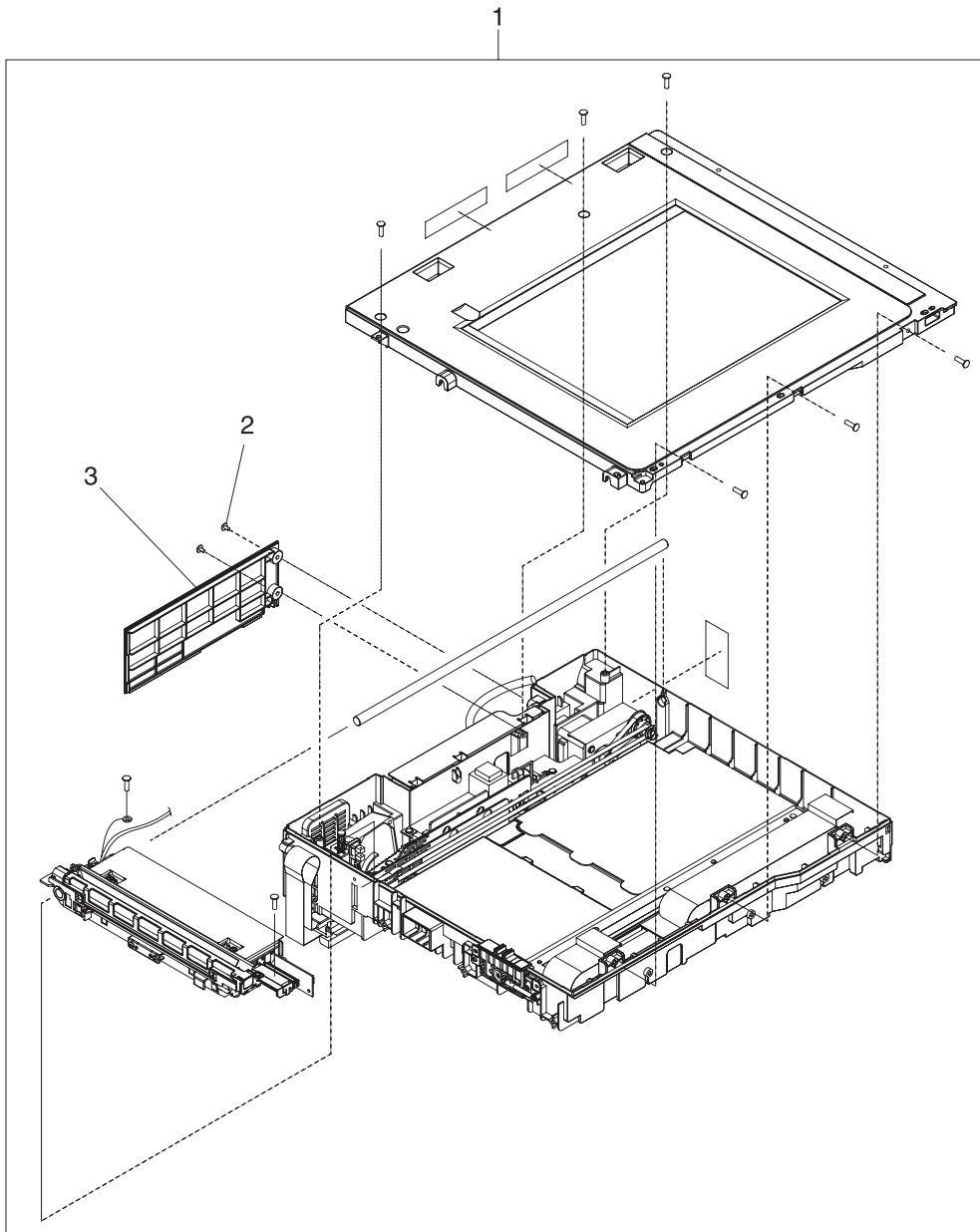


Figure 7-41 Scanner-base components

**Table 7-40** Scanner-base components

<b>Reference</b>	<b>Description</b>	<b>Part number</b>	<b>Quantity</b>
1	Scanner controller PCA	IR4041K512NI	1
2	Scanner fan-filter cover	IR4041P217NI	1
3	Scanner-fan filter	IR4041P007NI	1

## Scanner flatbed-unit assembly



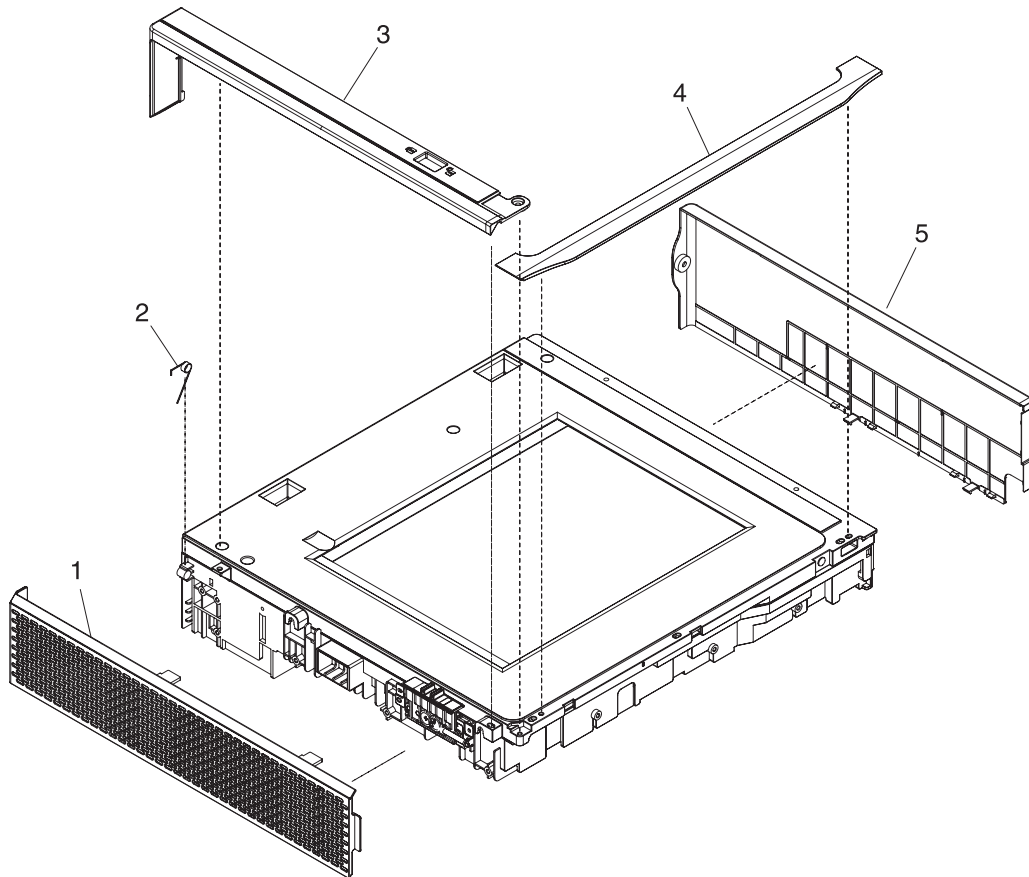
**Figure 7-42** Scanner flatbed-unit assembly



**Table 7-41** Scanner flatbed-unit assembly

Reference	Description	Part number	Quantity
1	Scanner flatbed-unit assembly	IR4041K081NI	1
2	Screw, scanner flatbed	040100FNBBNI	
3	Scanner rear cover	IR4041P216NI	

## Scanner covers



**Figure 7-43** Scanner covers

**Table 7-42** Scanner covers

<b>Reference</b>	<b>Description</b>	<b>Part number</b>	<b>Quantity</b>
1	Scanner left cover	IR4041K114NI	1
2	Scanner, spring for left cover	IR4041P041NI	1
3	Scanner-carriage-lock cover	IR4041P214NI	
4	Scanner top-cover flatbed flange	IR4041P125NI	1
5	Scanner right cover	IR4041P213NI	1

# Cassette

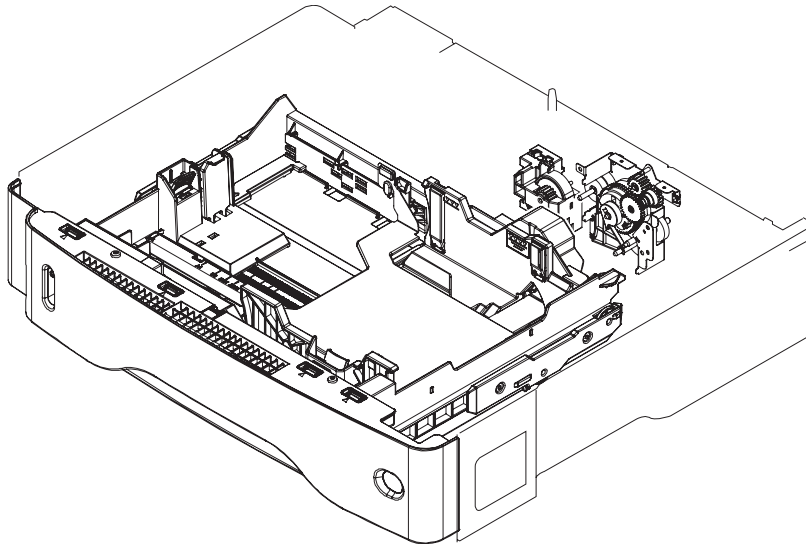


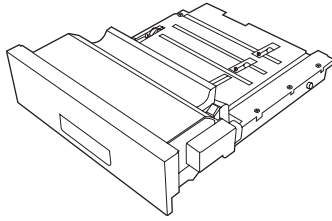
Figure 7-44 Cassette

**Table 7-43** Cassette

Ref	Description	Part number	Qty
	Cassette	RM1-1001-000CN	

## Optional devices

### Duplex-printing accessory

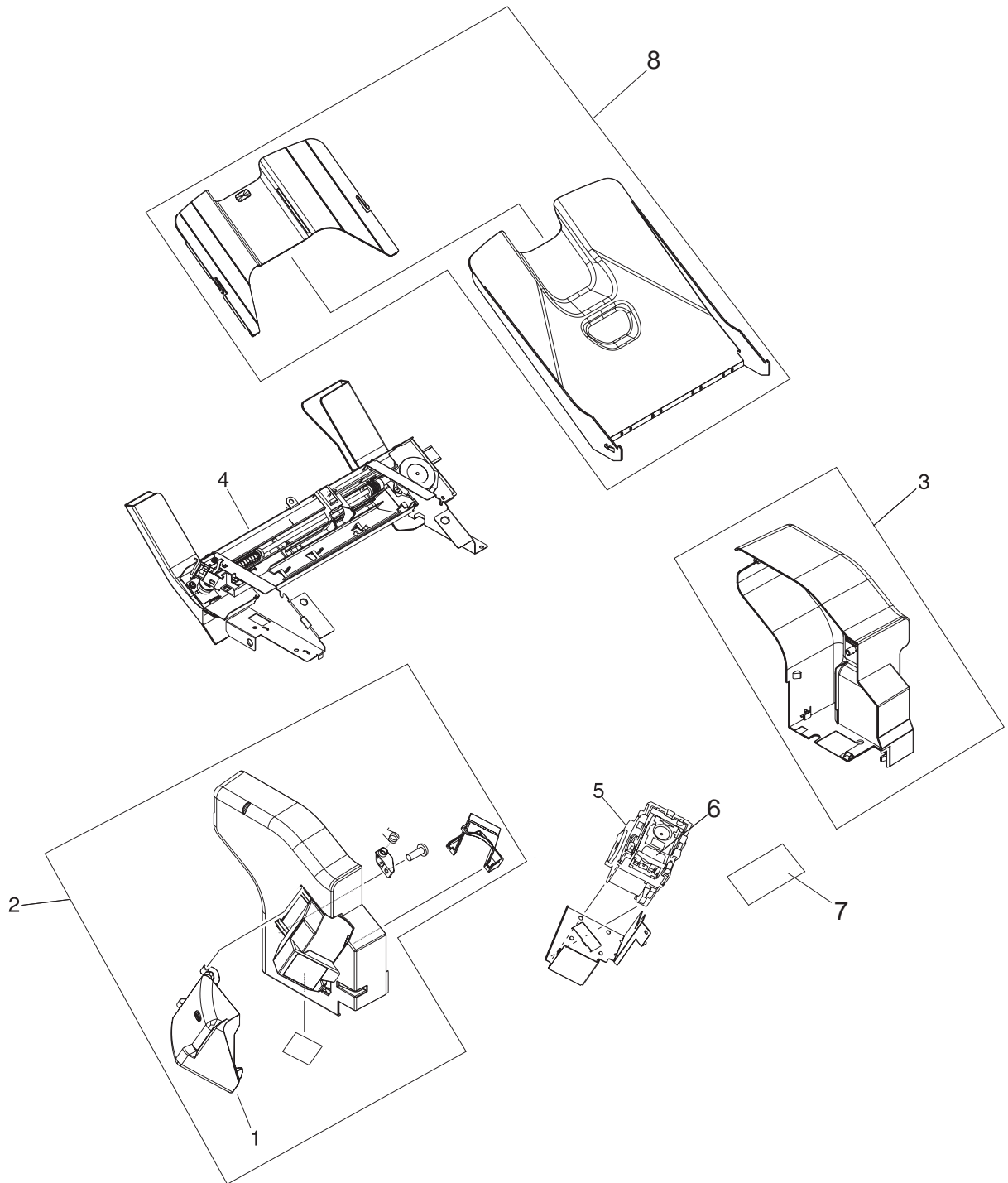


**Figure 7-45** Duplex-printing assembly

**Table 7-44** Duplex-printing assembly

Reference	Description	Part number	Quantity
1	Duplex-printing assembly	Q5969-67901	1

## Stapler/stacker



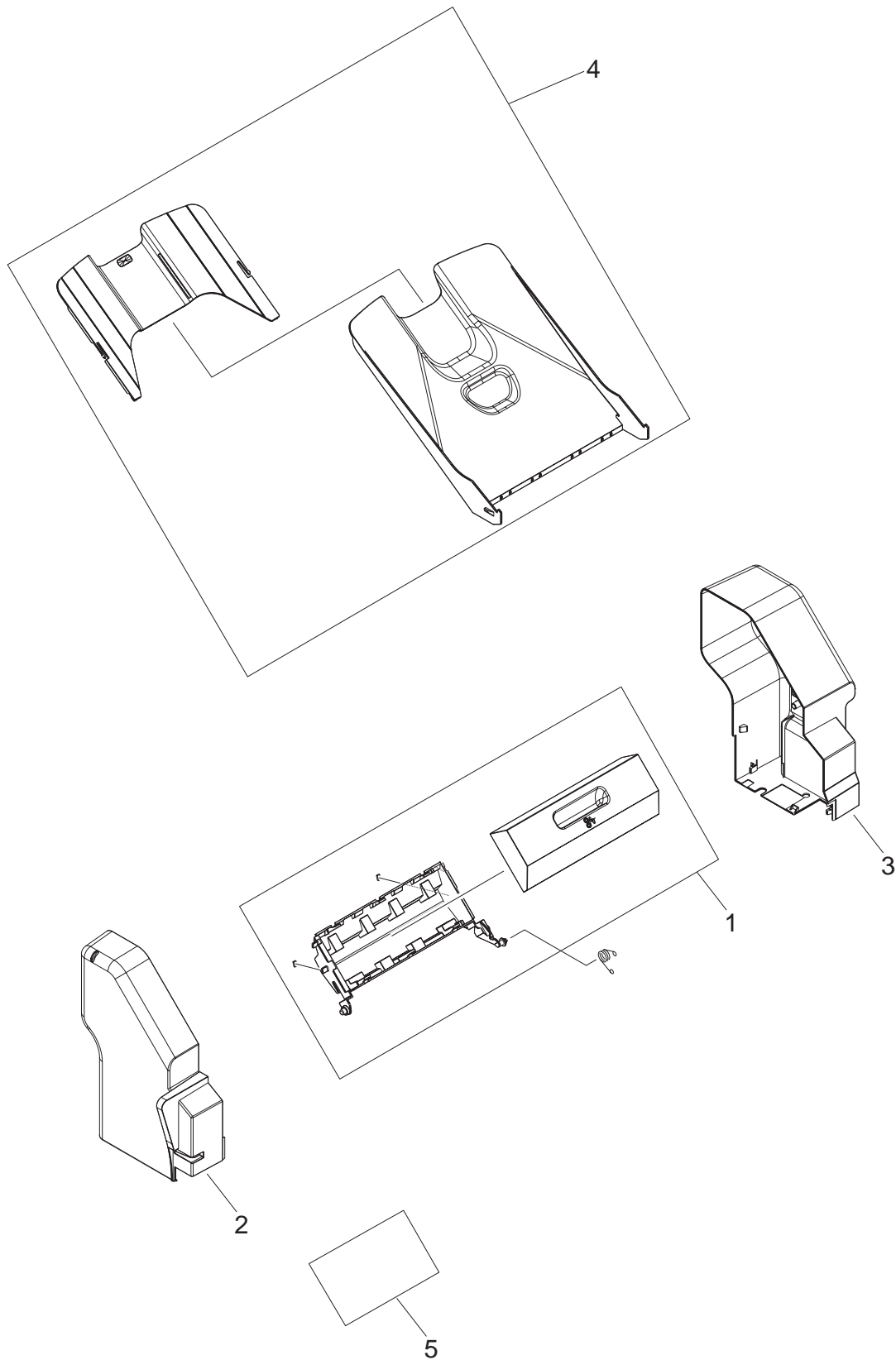
**Figure 7-46** Stapler/stacker accessory



**Table 7-45** Stapler/stacker accessory

Reference	Description	Part number	Quantity
	500 sheet stapler/stacker replacement unit	Q5691-60501	1
1	Door, jam access	RC1-2597-000CN	1
2	Front cover	RM1-0942-000	1
3	Rear cover	RC1-2598-000CN	1
4	Jog guide assembly	RM1-0947-000CN	1
5	Stapler unit	RK2-0507-000CN	1
6	Staple cartridge	C8085-60541	1
7	Stapler/stacker driver board	RM1-1123-000CN	1
8	Paper delivery tray assembly	RM1-0940-000CN	1

## 3-bin mailbox



**Figure 7-47** 3-bin mailbox accessory

**Table 7-46** 3-bin mailbox accessory

<b>Reference</b>	<b>Description</b>	<b>Part number</b>	<b>Quantity</b>
	3-bin mailbox replacement unit	Q5692-67901	1
1	Jam-access door, 3-bin mailbox	RM1-0981-000CN	1
2	Front cover	RM1-0985-000CN	1
3	Rear cover	RC1-2691-000CN	1
4	Paper delivery tray assembly	RM1-0940-000CN	1
5	MBM driver board	RM1-1124-000CN	1

# Alphabetical parts list

**Table 7-47** Alphabetical parts list

Description	Part number	Table and page
100-pin DDR memory DIMM (dual inline memory module), 64 MB	Q2625A	<a href="#">Memory on page 486</a>
100-pin DDR memory DIMM, 128 MB	Q2626A	<a href="#">Memory on page 486</a>
100-pin DDR memory DIMM, 256 MB	Q2627-67951	<a href="#">Memory on page 486</a>
3-bin mailbox replacement unit	Q5692-67901	<a href="#">3-bin mailbox accessory on page 569</a>
3-bin mailbox	Q5692-60503	<a href="#">Accessories on page 475</a>
5,000-staple cartridge	C8085-60541	<a href="#">Accessories on page 475</a>
500 sheet stapler/stacker replacement unit	Q5691-60501	<a href="#">Stapler/stacker accessory on page 567</a>
500-sheet stapler/stacker	Q5691-60501	<a href="#">Accessories on page 475</a>
500-sheet tray	Q5968A	<a href="#">Customer-replaceable components (print engine) on page 477</a>
ADF assembly	PF2282K006NI	<a href="#">ADF assembly on page 535</a>
ADF cable	PF2282K165NI	<a href="#">ADF assembly on page 535</a>
ADF clear plastic paper guide	PF2282P353NI	<a href="#">ADF internal components (3 of 3) on page 541</a>
ADF fan filter	IR4041P007NI	<a href="#">Customer-replaceable components (ADF and scanner) on page 479</a>
ADF fan-filter cover	IR4041P217NI	<a href="#">Customer-replaceable components (ADF and scanner) on page 479</a>
ADF front cover	PF2282P059NI	<a href="#">ADF assembly on page 535</a>
ADF front-cover flange	IR4041P215NI	<a href="#">Customer-replaceable components (ADF and scanner) on page 479</a>
ADF hinge flaps (ESD)	PF2282K166NI	<a href="#">ADF assembly on page 535</a>
ADF hinge, left	PF2282K041NI	<a href="#">ADF internal components (2 of 3) on page 539</a>
ADF hinge, right	PF2282K008NI	<a href="#">ADF internal components (2 of 3) on page 539</a>
ADF input tray	PF2282K042NI	<a href="#">Customer-replaceable components (ADF and scanner) on page 479</a>
ADF input tray	PF2282K042NI	<a href="#">ADF assembly on page 535</a>
ADF input tray	PF2282K042NI	<a href="#">ADF input tray on page 543</a>
ADF jam-access cover	PF2282P041NI	<a href="#">ADF assembly on page 535</a>

**Table 7-47** Alphabetical parts list (continued)

Description	Part number	Table and page
ADF jam-access latch	PF2282K164NI	<a href="#">ADF internal components (3 of 3) on page 541</a>
ADF left cover	PF2282P058NI	<a href="#">ADF assembly on page 535</a>
ADF maintenance kit	Q5997-67901	<a href="#">Print cartridge and maintenance kits on page 488</a>
ADF mylar holder assembly	PF2282K043NI	<a href="#">ADF assembly on page 535</a>
ADF mylar replacement kit	Q6496-67901	<a href="#">Print cartridge and maintenance kits on page 488</a>
ADF mylar replacement kit	Q6496-67901	<a href="#">ADF assembly on page 535</a>
ADF mylar replacement kit	Q6496-67901	<a href="#">ADF mylar replacement kit on page 555</a>
ADF mylar-holder assembly	PF2282K043NI	<a href="#">Customer-replaceable components (ADF and scanner) on page 479</a>
ADF mylar-holder assembly	PF2282K043NI	<a href="#">ADF mylar-holder assembly on page 553</a>
ADF output-bin paper stop	PF2282P061NI	<a href="#">ADF internal components (1 of 3) on page 537</a>
ADF output-bin-base cover	PF2282P060NI	<a href="#">ADF internal components (1 of 3) on page 537</a>
ADF pickup-roller assembly	PF2282K039NI	<a href="#">Customer-replaceable components (ADF and scanner) on page 479</a>
ADF pickup-roller assembly	PF2282K039NI	<a href="#">ADF internal components (3 of 3) on page 541</a>
ADF pickup-roller assembly	PF2282K039NI	<a href="#">ADF pickup-roller assembly on page 549</a>
ADF pickup-roller cover	PF2282K040NI	<a href="#">Customer-replaceable components (ADF and scanner) on page 479</a>
ADF pickup-roller cover	PF2282K040NI	<a href="#">ADF internal components (3 of 3) on page 541</a>
ADF pickup-roller cover	PF2282K040NI	<a href="#">ADF pickup-roller cover on page 551</a>
ADF rear cover	PF2282P044NI	<a href="#">ADF assembly on page 535</a>
ADF separation pad	PF2282K035NI	<a href="#">ADF separation-pad case on page 547</a>
ADF separation-pad assembly	PF2282K035NI	<a href="#">Customer-replaceable components (ADF and scanner) on page 479</a>
ADF separation-pad assembly	PF2282K035NI	<a href="#">ADF separation pad on page 545</a>
ADF separation-pad case	PF2282K034NI	<a href="#">ADF separation-pad case on page 547</a>

**Table 7-47** Alphabetical parts list (continued)

Description	Part number	Table and page
ADF white mylar backing	PF2282P025NI	<a href="#">ADF assembly on page 535</a>
ADF white scan background	PF2282P339NI	<a href="#">ADF assembly on page 535</a>
ADF, springs for left cover	PF2282P352NI	<a href="#">ADF assembly on page 535</a>
ADF, springs for white mylar backing	PF2282P343NI	<a href="#">ADF assembly on page 535</a>
Arm, door, 1 (top cover)	RC1-2827-000CN	<a href="#">Internal components (4 of 5) on page 507</a>
Arm, door, 2 (top cover)	RC1-2828-000CN	<a href="#">Internal components (4 of 5) on page 507</a>
Block, guide support (upper plate)	RC1-3102-000CN	<a href="#">Upper-plate assembly on page 499</a>
Bolt, hex-head	WS9-0255-000CN	<a href="#">Internal components (4 of 5) on page 507</a>
Cable, beam-detect to scanner (print engine)	RM1-1372-000CN	<a href="#">Internal components (1 of 5) on page 501</a>
Cable, control panel	RM1-1381-000CN	<a href="#">Internal components (4 of 5) on page 507</a>
Cable, door switch	RM1-1397-000CN	<a href="#">Internal components (2 of 5) on page 503</a>
Cable, duplexing-unit grounding	RM1-1400-000CN	<a href="#">Electrical/forward assembly on page 511</a>
Cable, envelope-feeder connector	RM1-1193-000CN	<a href="#">Internal components (2 of 5) on page 503</a>
Cable, fan docking (for DC-controller fan)	RM1-1376-000CN	<a href="#">Internal components (5 of 5) on page 509</a>
Cable, flat-flexible (engine power supply)	RK2-0470-000CN	<a href="#">Electrical/forward assembly on page 511</a>
Cable, flat-flexible (engine power supply)	RK2-0469-000CN	<a href="#">Electrical/forward assembly on page 511</a>
Cable, image scanner (print engine)	RM1-1398-000CN	<a href="#">Internal components (1 of 5) on page 501</a>
Cable, laser (print engine)	RM1-1367-000CN	<a href="#">Internal components (1 of 5) on page 501</a>
Cable, optional 500-sheet feeder connection	RM1-1370-000CN	<a href="#">Internal components (5 of 5) on page 509</a>
Cable, output device connection	RM1-1371-000CN	<a href="#">Internal components (4 of 5) on page 507</a>
Cable, output-bin full sensor	RM1-1368-000CN	<a href="#">Internal components (4 of 5) on page 507</a>
Cable, power	RM1-1375-000CN	<a href="#">Internal components (5 of 5) on page 509</a>
Cable, reverse unit	RM1-1380-000CN	<a href="#">Internal components (4 of 5) on page 507</a>

**Table 7-47** Alphabetical parts list (continued)

Description	Part number	Table and page
Case, envelope-feeder connector	RC1-0245-000CN	<a href="#">Internal components (2 of 5) on page 503</a>
Cassette	RM1-1001-000CN	<a href="#">Cassette on page 563</a>
Cassette (tray 2, 3, 4 or 5)	RM1-1001-000CN	<a href="#">Cassette on page 519</a>
Cassette rail assembly, left	RM1-1011-000CN	<a href="#">Internal components (3 of 5) on page 505</a>
Cassette rail assembly, right	RM1-1012-000CN	<a href="#">Internal components (3 of 5) on page 505</a>
Clutch, paper feed, electromagnetic (CL101)	RK2-0349-000CN	<a href="#">Paper-feed roller assembly on page 521</a>
Complete print engine (110 volt)	CB425-69001	<a href="#">Internal components (1 of 5) on page 501</a>
Complete print engine (220 volt)	CB425-69002	<a href="#">Internal components (1 of 5) on page 501</a>
Control-panel assembly	Q3942-60102	<a href="#">Control panel and control-panel overlays on page 484</a>
Control-panel assembly	CB425-60127	<a href="#">External panels and covers on page 497</a>
Cover, cassette, left side	RC1-3043-000CN	<a href="#">External panels and covers on page 497</a>
Cover, door arm (top cover)	RC1-2833-000CN	<a href="#">Internal components (4 of 5) on page 507</a>
Cover, duplexing-unit assembly	RM1-1018-000CN	<a href="#">External panels and covers on page 497</a>
Cover, envelope-feeder slot	RL1-0455-000CN	<a href="#">Internal components (3 of 5) on page 505</a>
Cover, formatter	RC1-3035-000CN	<a href="#">Customer-replaceable components (print engine) on page 477</a>
Cover, formatter	RC1-3035-000CN	<a href="#">External panels and covers on page 497</a>
Cover, front assembly	RM1-1100-000CN	<a href="#">External panels and covers on page 497</a>
Cover, front corner	RL1-0457-000CN	<a href="#">External panels and covers on page 497</a>
Cover, front stopper	RC1-2823-000CN	<a href="#">Internal components (4 of 5) on page 507</a>
Cover, handle, lower right	RC1-2881-000CN	<a href="#">Internal components (2 of 5) on page 503</a>
Cover, inner front	RC1-3041-000CN	<a href="#">Internal components (4 of 5) on page 507</a>
Cover, left-side, front	RC1-3052-000CN	<a href="#">Internal components (1 of 5) on page 501</a>

**Table 7-47** Alphabetical parts list (continued)

Description	Part number	Table and page
Cover, lock, front (upper plate)	RC1-2820-000CN	<a href="#">Upper-plate assembly on page 499</a>
Cover, rear	RM1-1017-000CN	<a href="#">External panels and covers on page 497</a>
Cover, rear lock (upper plate)	RC1-2821-000CN	<a href="#">Upper-plate assembly on page 499</a>
Cover, right assembly	RM1-1016-000CN	<a href="#">External panels and covers on page 497</a>
Cover, right lower assembly	RM1-1033-000CN	<a href="#">External panels and covers on page 497</a>
Cover, side, rear	RC1-3042-000CN	<a href="#">Internal components (3 of 5) on page 505</a>
Cross-member, support	RC1-2911-000CN	<a href="#">Internal components (4 of 5) on page 507</a>
Customer in-box training CD, English only	CB425-60155	<a href="#">Documentation, software, and training material on page 491</a>
Data cable for hard disk (2-wire)	5851-2720	<a href="#">Memory on page 486</a>
DC controller PCA	RM1-1354-000CN	<a href="#">Internal components (5 of 5) on page 509</a>
Delivery assembly	RM1-1047-000CN	<a href="#">External panels and covers on page 497</a>
Delivery assembly	RM1-1047-000CN	<a href="#">Delivery assembly on page 531</a>
Delivery tray assembly	RM1-1047-000CN	<a href="#">Customer-replaceable components (print engine) on page 477</a>
Door, jam access	RC1-2597-000CN	<a href="#">Stapler/stacker accessory on page 567</a>
Duplex-printing assembly	Q5969-67901	<a href="#">Duplex-printing assembly on page 565</a>
Duplexer (duplex printing accessory)	Q5969A	<a href="#">Accessories on page 475</a>
E-ring (paper-feed roller assembly)	XD9-0132-020CN	<a href="#">Paper-feed roller assembly on page 521</a>
Electrical/forward assembly	For reference only	<a href="#">Internal components (2 of 5) on page 503</a>
Engine power supply assembly (100–127 volt)	RM1-1041-000CN	<a href="#">Electrical/forward assembly on page 511</a>
Engine power supply assembly (220–240 volt)	RM1-1042-000CN	<a href="#">Electrical/forward assembly on page 511</a>
Envelope feeder	Q2438-67902	<a href="#">Accessories on page 475</a>
Fan, DC controller (FN104)	RK2-0472-000CN	<a href="#">Internal components (5 of 5) on page 509</a>
Fan, main cooling (FN101)	RK2-0278-000CN	<a href="#">Internal components (1 of 5) on page 501</a>



**Table 7-47** Alphabetical parts list (continued)

Description	Part number	Table and page
Fan, print cartridge (FN102)	RK2-0280-000CN	<a href="#">Internal components (5 of 5) on page 509</a>
Fan, reversing unit (FN103)	RK2-0280-000CN	<a href="#">Internal components (1 of 5) on page 501</a>
Flag, full-detect (output bin)	RC1-2863-000CN	<a href="#">Internal components (4 of 5) on page 507</a>
Flag, paper-feed sensor	RC1-0060-000CN	<a href="#">Internal components (1 of 5) on page 501</a>
Flag, shutter	RC1-0378-000CN	<a href="#">Internal components (1 of 5) on page 501</a>
Formatter assembly	CB425-67901	<a href="#">Internal components (5 of 5) on page 509</a>
Formatter assembly, new	CB425-67901	<a href="#">Customer-replaceable components (print engine) on page 477</a>
Front cover	RM1-0942-000	<a href="#">Stapler/stacker accessory on page 567</a>
Front cover	RM1-0985-000CN	<a href="#">3-bin mailbox accessory on page 569</a>
Fuser (100–127 volt)	RM1-1043-000CN	<a href="#">Fuser on page 533</a>
Fuser (100–127 volt)	RM1-1043-000CN	<a href="#">Internal components (2 of 5) on page 503</a>
Fuser (220–240 volt)	RM1-1044-000CN	<a href="#">Internal components (2 of 5) on page 503</a>
Fuser (220–240 volt)	RM1-1044-000CN	<a href="#">Fuser on page 533</a>
Fuser entrance guide	RM1-1046-000CN	<a href="#">Customer-replaceable components (print engine) on page 477</a>
Fuser entrance guide	RM1-1046-000CN	<a href="#">Internal components (2 of 5) on page 503</a>
Fuser, 110-volt, new	RM1-1043-000CN	<a href="#">Customer-replaceable components (print engine) on page 477</a>
Fuser, 220-volt, new	RM1-1044-000CN	<a href="#">Customer-replaceable components (print engine) on page 477</a>
Gear, 14T (cassette)	RU5-0254-000CN	<a href="#">Cassette on page 519</a>
Gear, 18T	RU5-0045-020CN	<a href="#">Internal components (1 of 5) on page 501</a>
Gear, 20T (cassette)	RC1-0331-000CN	<a href="#">Cassette on page 519</a>
Gear, 23T	RU5-0256-000CN	<a href="#">Internal components (1 of 5) on page 501</a>
Gear, 30T (paper-feed roller assembly)	RU5-0050-000CN	<a href="#">Paper-feed roller assembly on page 521</a>

**Table 7-47** Alphabetical parts list (continued)

Description	Part number	Table and page
Gear, 80T (cassette)	RU5-0253-000CN	<a href="#">Cassette on page 519</a>
Guide assembly, flat-flexible cable	RM1-1027-000CN	<a href="#">Internal components (5 of 5) on page 509</a>
Guide, cartridge (upper plate)	RC1-2853-000CN	<a href="#">Upper-plate assembly on page 499</a>
Guide, cassette, front	RC1-3020-000CN	<a href="#">Cassette on page 519</a>
Guide, legal-size (upper plate)	RC1-2854-000CN	<a href="#">Upper-plate assembly on page 499</a>
Guide, paper sensing (PS101)	RM1-1010-000CN	<a href="#">Internal components (1 of 5) on page 501</a>
Guide, rear	RC1-2884-000CN	<a href="#">Internal components (3 of 5) on page 505</a>
Handle, lock (upper plate)	RC1-2818-000CN	<a href="#">Upper-plate assembly on page 499</a>
Hard disk, 40 GB	0950-4717	<a href="#">Memory on page 486</a>
Hinge, door, right-side	RC1-2901-000CN	<a href="#">Internal components (2 of 5) on page 503</a>
Holder, door switch	RC1-3063-000CN	<a href="#">Internal components (2 of 5) on page 503</a>
Holder, link	RC1-3002-000CN	<a href="#">Internal components (3 of 5) on page 505</a>
Holder, output-device-full sensor flag	RC1-2864-000CN	<a href="#">Internal components (4 of 5) on page 507</a>
Holder, right shutter (upper plate)	RC1-2855-000CN	<a href="#">Upper-plate assembly on page 499</a>
HP Digital Sending Software CD (trial version)	MKTNG-00539	<a href="#">Documentation, software, and training material on page 491</a>
HP Jetdirect 620n Fast Ethernet (10/100Base-TX) print server (EIO card)	J7934A	<a href="#">Cables and interfaces on page 481</a>
HP Jetdirect connectivity card for USB, serial, and LocalTalk connections	J4135A	<a href="#">Cables and interfaces on page 481</a>
HP LaserJet analog fax accessory 300	Q3701-60010	<a href="#">Accessories on page 475</a>
HP LaserJet M4345 MFP Series service manual	CB425-90908	<a href="#">Documentation, software, and training material on page 491</a>
HP LaserJet M4345 MFP Series software CD, Asia/EN/DR	CB425-60136	<a href="#">Documentation, software, and training material on page 491</a>
HP LaserJet M4345 MFP Series software CD, ROW/AR	CB425-60135	<a href="#">Documentation, software, and training material on page 491</a>
HP LaserJet print cartridge	Q5945-67901	<a href="#">Print cartridge and maintenance kits on page 488</a>
Jam-access door, 3-bin mailbox	RM1-0981-000CN	<a href="#">3-bin mailbox accessory on page 569</a>

**Table 7-47** Alphabetical parts list (continued)

Description	Part number	Table and page
Jog guide assembly	RM1-0947-000CN	<a href="#">Stapler/stacker accessory on page 567</a>
Kit-Control Pnl Overlay Left/Right AR	CB425-60125	<a href="#">Control panel and control-panel overlays on page 484</a>
Kit-Control Pnl Overlay Left/Right CS	CB425-60116	<a href="#">Control panel and control-panel overlays on page 484</a>
Kit-Control Pnl Overlay Left/Right DA	CB425-60113	<a href="#">Control panel and control-panel overlays on page 484</a>
Kit-Control Pnl Overlay Left/Right DE	CB425-60106	<a href="#">Control panel and control-panel overlays on page 484</a>
Kit-Control Pnl Overlay Left/Right EL	CB425-60124	<a href="#">Control panel and control-panel overlays on page 484</a>
Kit-Control Pnl Overlay Left/Right EN	CB425-60103	<a href="#">Control panel and control-panel overlays on page 484</a>
Kit-Control Pnl Overlay Left/Right ES	CB425-60107	<a href="#">Control panel and control-panel overlays on page 484</a>
Kit-Control Pnl Overlay Left/Right FI	CB425-60112	<a href="#">Control panel and control-panel overlays on page 484</a>
Kit-Control Pnl Overlay Left/Right FR	CB425-60104	<a href="#">Control panel and control-panel overlays on page 484</a>
Kit-Control Pnl Overlay Left/Right HE	CB425-60123	<a href="#">Control panel and control-panel overlays on page 484</a>
Kit-Control Pnl Overlay Left/Right HR	CB425-60129	<a href="#">Control panel and control-panel overlays on page 484</a>
Kit-Control Pnl Overlay Left/Right HU	CB425-60117	<a href="#">Control panel and control-panel overlays on page 484</a>
Kit-Control Pnl Overlay Left/Right IT	CB425-60105	<a href="#">Control panel and control-panel overlays on page 484</a>
Kit-Control Pnl Overlay Left/Right JA	CB425-60121	<a href="#">Control panel and control-panel overlays on page 484</a>
Kit-Control Pnl Overlay Left/Right KO	CB425-60120	<a href="#">Control panel and control-panel overlays on page 484</a>
Kit-Control Pnl Overlay Left/Right NL	CB425-60108	<a href="#">Control panel and control-panel overlays on page 484</a>
Kit-Control Pnl Overlay Left/Right NO	CB425-60110	<a href="#">Control panel and control-panel overlays on page 484</a>
Kit-Control Pnl Overlay Left/Right PL	CB425-60114	<a href="#">Control panel and control-panel overlays on page 484</a>
Kit-Control Pnl Overlay Left/Right PT	CB425-60109	<a href="#">Control panel and control-panel overlays on page 484</a>
Kit-Control Pnl Overlay Left/Right RO	CB425-60130	<a href="#">Control panel and control-panel overlays on page 484</a>
Kit-Control Pnl Overlay Left/Right RU	CB425-60115	<a href="#">Control panel and control-panel overlays on page 484</a>

**Table 7-47** Alphabetical parts list (continued)

Description	Part number	Table and page
Kit-Control Pnl Overlay Left/Right SK	CB425-60131	<a href="#">Control panel and control-panel overlays on page 484</a>
Kit-Control Pnl Overlay Left/Right SL	CB425-60132	<a href="#">Control panel and control-panel overlays on page 484</a>
Kit-Control Pnl Overlay Left/Right SV	CB425-60111	<a href="#">Control panel and control-panel overlays on page 484</a>
Kit-Control Pnl Overlay Left/Right TH	CB425-60126	<a href="#">Control panel and control-panel overlays on page 484</a>
Kit-Control Pnl Overlay Left/Right TR	CB425-60122	<a href="#">Control panel and control-panel overlays on page 484</a>
Kit-Control Pnl Overlay Left/Right ZHCN	CB425-60119	<a href="#">Control panel and control-panel overlays on page 484</a>
Kit-Control Pnl Overlay Left/Right ZHTW	CB425-60118	<a href="#">Control panel and control-panel overlays on page 484</a>
Laser/scanner assembly	RM1-1573-000CN	<a href="#">Internal components (1 of 5) on page 501</a>
Lever, paper-size-sensing (cassette)	RC1-2782-000CN	<a href="#">Cassette on page 519</a>
Lever, shutter	RC1-3106-000CN	<a href="#">Internal components (1 of 5) on page 501</a>
Lifter drive assembly	RM1-1029-000CN	<a href="#">Internal components (3 of 5) on page 505</a>
Lifter-drive assembly	RM1-1029-000CN	<a href="#">Lifter-drive assembly on page 517</a>
Limiter, torque	RC1-2758-000CN	<a href="#">Internal components (1 of 5) on page 501</a>
Link, handle (upper plate)	RC1-2822-000CN	<a href="#">Upper-plate assembly on page 499</a>
Link, switch	RC1-3003-000CN	<a href="#">Internal components (3 of 5) on page 505</a>
Main drive assembly	RM1-1049-000CN	<a href="#">Internal components (3 of 5) on page 505</a>
Main drive assembly	RM1-1049-000CN	<a href="#">Main drive assembly on page 513</a>
MBM driver board	RM1-1124-000CN	<a href="#">3-bin mailbox accessory on page 569</a>
Microswitch (SW101)	WC4-5139-000CN	<a href="#">Internal components (2 of 5) on page 503</a>
Motor, crossing, (stepping) (M104)	RK2-0473-000CN	<a href="#">Reverse assembly on page 527</a>
Motor, DC 24-volt, (M101)	RK2-0272-000CN	<a href="#">Internal components (3 of 5) on page 505</a>
Motor, DC 24-volt, (M102)	RK2-0274-000CN	<a href="#">Internal components (3 of 5) on page 505</a>

**Table 7-47** Alphabetical parts list (continued)

Description	Part number	Table and page
Motor, delivery (stepping) (M106)	RK2-0475-000CN	<a href="#">Reverse assembly on page 527</a>
Motor, reverse-unit (stepping) (M105)	RK2-0474-000CN	<a href="#">Reverse assembly on page 527</a>
Multipurpose assembly	RM1-1572-000CN	<a href="#">Multipurpose assembly on page 525</a>
Multipurpose tray assembly	RM1-1572-000CN	<a href="#">Internal components (3 of 5) on page 505</a>
Multipurpose tray assembly	RM1-0005-020CN	<a href="#">Multipurpose assembly on page 525</a>
Mylar sheet kit (3 sheets)	Q6496-67901	<a href="#">Customer-replaceable components (ADF and scanner) on page 479</a>
Optional 500-sheet tray and feeder unit	Q5968-67901	<a href="#">Accessories on page 475</a>
Output bin	RM1-0940-000CN	<a href="#">Customer-replaceable components (print engine) on page 477</a>
Output-bin assembly	RM1-0940-000CN	<a href="#">External panels and covers on page 497</a>
Paper delivery tray assembly	RM1-0940-000CN	<a href="#">Stapler/stacker accessory on page 567</a>
Paper delivery tray assembly	RM1-0940-000CN	<a href="#">3-bin mailbox accessory on page 569</a>
Paper-feed assembly	RM1-0025-040CN	<a href="#">Electrical/forward assembly on page 511</a>
Paper-feed roller assembly	RM1-0012-020CN	<a href="#">Paper-feed roller assembly on page 521</a>
Paper-pickup-drive assembly	RM1-0034-070CN	<a href="#">Internal components (1 of 5) on page 501</a>
Paper-pickup-drive assembly	RM1-0034-070CN	<a href="#">Paper-pickup-drive assembly on page 515</a>
PHN-CORD OPT 510 NORWAY/FINLAND 3.0M-LG	8120-8916	<a href="#">Cables and interfaces on page 481</a>
PHN-CORD OPT-501 US 3.0-M-LG ROHS United States/ Taiwan/China/Thailand/Japan/Argentina/India/European Union/ South America/Indonesia/Malaysia/MiddleEast/Phillipines/ Singapore/Mexico/Brazil/Canada/Russia/Bulgaria/Baltics/ Vietnam	8121-0811	<a href="#">Cables and interfaces on page 481</a>
PHN-CORD OPT-502 DE 3.0-M-LG ROHS Denmark	8120-8912	<a href="#">Cables and interfaces on page 481</a>
PHN-CORD OPT-504 FR 3.0-M-LG ROHS France	8120-8923	<a href="#">Cables and interfaces on page 481</a>
PHN-CORD OPT-505 UK/HK/NZ 3.0-M-LG ROHS United Kingdom	8120-8921	<a href="#">Cables and interfaces on page 481</a>

**Table 7-47** Alphabetical parts list (continued)

Description	Part number	Table and page
PHN-CORD OPT-506 DK 3.0-M-LG ROHS Denmark	8120-8911	<a href="#">Cables and interfaces on page 481</a>
PHN-CORD OPT-507 TR 3.0-M-LG ROHS Turkey/Greece	8120-8920	<a href="#">Cables and interfaces on page 481</a>
PHN-CORD OPT-508 NL 3.0-M-LG ROHS Netherlands	8120-8915	<a href="#">Cables and interfaces on page 481</a>
PHN-CORD OPT-511 SE 3.0-M-LG ROHS NO/FI/SV	8120-8918	<a href="#">Cables and interfaces on page 481</a>
PHN-CORD OPT-512 CH 3.0-M-LG ROHS Switzerland	8121-0844	<a href="#">Cables and interfaces on page 481</a>
PHN-CORD OPT-514 IT 3.0-M-LG ROHS Southern Europe	8120-8914	<a href="#">Cables and interfaces on page 481</a>
PHN-CORD OPT-516 KR 3.0-M-LG ROHS Korea	8120-8908	<a href="#">Cables and interfaces on page 481</a>
PHN-CORD OPT-517 IL 3.0-M-LG ROHS Israel	8120-8913	<a href="#">Cables and interfaces on page 481</a>
PHN-CORD OPT-519 AU 3.0-M-LG ROHS Australia	8120-8907	<a href="#">Cables and interfaces on page 481</a>
PHN-CORD OPT-520 EE 3.0-M-LG ROHS SK/SL/HR/RO/CS/HU/PL	8120-8922	<a href="#">Cables and interfaces on page 481</a>
PHN-CORD OPT-520 EE 3.0-M-LG ROHS South Africa	8120-8922	<a href="#">Cables and interfaces on page 481</a>
PHN-CORD US 3.0-M-LG ROHS Hong Kong SAR	8121-1042	<a href="#">Cables and interfaces on page 481</a>
Photointerrupter (PS107)	WG8-5624-000CN	<a href="#">Internal components (1 of 5) on page 501</a>
Plate, main pad support (multipurpose assembly)	RL1-0007-000CN	<a href="#">Multipurpose assembly on page 525</a>
Power cable for hard disk (5-wire)	5851-3051	<a href="#">Memory on page 486</a>
POWER CORD, OPT-906 3-COND 2.25-M-LG	8120-6815	<a href="#">Cables and interfaces on page 481</a>
Power supply, PFC (100–127 volt)	RM1-1013-000CN	<a href="#">Internal components (5 of 5) on page 509</a>
Power supply, PFC (220–240 volt)	RM1-1014-000CN	<a href="#">Internal components (5 of 5) on page 509</a>
Printer maintenance kit, 110-volt	Q5998-67901	<a href="#">Print cartridge and maintenance kits on page 488</a>
Printer maintenance kit, 220-volt	Q5999-67901	<a href="#">Print cartridge and maintenance kits on page 488</a>
PWR-CORD OPT-900 3-COND 1.9-M-LG 5A ROHS Maylasia	8121-0739	<a href="#">Cables and interfaces on page 481</a>
PWR-CORD OPT-900 3-COND 1.9-M-LG 5A ROHS United Kingdom/Middle East 220V/Phillipines/Singapore/Hong Kong SAR/Malaysia	8121-0739	<a href="#">Cables and interfaces on page 481</a>

**Table 7-47** Alphabetical parts list (continued)

Description	Part number	Table and page
PWR-CORD OPT-901 3-COND 1.9-M-LG ROHS Australia	8121-0837	<a href="#">Cables and interfaces on page 481</a>
PWR-CORD OPT-902 3-COND 1.9-M-LG ROHS Middle East 220V	8121-0731	<a href="#">Cables and interfaces on page 481</a>
PWR-CORD OPT-902 3-COND 1.9-M-LG ROHS Southern Europe/Western Europe/Eastern Europe/Indonesia/Baltics/Vietnam/Korea 220V	8121-0731	<a href="#">Cables and interfaces on page 481</a>
PWR-CORD OPT-903 3-COND 1.9-M-LG ROHS Middle East	8121-0740	<a href="#">Cables and interfaces on page 481</a>
PWR-CORD OPT-903 3-COND 1.9-M-LG ROHS South America/Mexico/Brazil	8121-0740	<a href="#">Cables and interfaces on page 481</a>
PWR-CORD OPT-903 3-COND 1.9-M-LG ROHS United States/Canada	8121-0740	<a href="#">Cables and interfaces on page 481</a>
PWR-CORD OPT-906 3-COND 1.9-M-LG ROHS Switzerland	8121-0738	<a href="#">Cables and interfaces on page 481</a>
PWR-CORD OPT-912 3-COND 1.9-M-LG ROHS Denmark	8121-0733	<a href="#">Cables and interfaces on page 481</a>
PWR-CORD OPT-917 3-COND 1.9-M-LG ROHS Africa	8121-0737	<a href="#">Cables and interfaces on page 481</a>
PWR-CORD OPT-918 3-COND 1.9-M-LG ROHS Japan	8121-0736	<a href="#">Cables and interfaces on page 481</a>
PWR-CORD OPT-919 3-COND 1.9-M-LG ROHS Israel	8121-1004	<a href="#">Cables and interfaces on page 481</a>
PWR-CORD OPT-920 3-COND 1.9-M-LG ROHS Argentina	8121-0729	<a href="#">Cables and interfaces on page 481</a>
PWR-CORD OPT-922 3-COND 1.9-M-LG ROHS China	8121-0943	<a href="#">Cables and interfaces on page 481</a>
PWR-CORD OPT-923 3-COND 1.9-M-LG ROHS India	8121-0564	<a href="#">Cables and interfaces on page 481</a>
PWR-CORD OPT-927 3-COND 1.9-M-LG ROHS Phillipines/Singapore/Mexico/Brazil/Thailand	8121-0734	<a href="#">Cables and interfaces on page 481</a>
PWR-CORD OPT-934 3-COND 1.9-M-LG ROHS Taiwan	8121-0964	<a href="#">Cables and interfaces on page 481</a>
Rear cover	RC1-2598-000CN	<a href="#">Stapler/stacker accessory on page 567</a>
Rear cover	RC1-2691-000CN	<a href="#">3-bin mailbox accessory on page 569</a>
Registration assembly	RM1-0011-060CN	<a href="#">Internal components (1 of 5) on page 501</a>
Registration assembly	RM1-0011-060CN	<a href="#">Registration assembly on page 523</a>
Reverse assembly	RM1-1022-000CN	<a href="#">Internal components (2 of 5) on page 503</a>

**Table 7-47** Alphabetical parts list (continued)

Description	Part number	Table and page
Reverse assembly	RM1-1022-000CN	<a href="#">Reverse assembly on page 527</a>
Reverse-separation guide assembly	RM1-1019-000CN	<a href="#">Internal components (4 of 5) on page 507</a>
Reverse-separation-guide assembly	RM1-1019-000CN	<a href="#">Reverse-separation-guide assembly on page 529</a>
Reverse-unit PCA	RM1-1379-000CN	<a href="#">Reverse assembly on page 527</a>
Rod, link	RC1-2902-000CN	<a href="#">Internal components (3 of 5) on page 505</a>
Rod, link (upper plate)	RC1-2830-000CN	<a href="#">Upper-plate assembly on page 499</a>
Rod, switch, front	RC1-2980-000CN	<a href="#">Internal components (3 of 5) on page 505</a>
Roller assembly, transfer	RM1-1110-000CN	<a href="#">Customer-replaceable components (print engine) on page 477</a>
Roller assembly, transfer	RM1-1110-000CN	<a href="#">Internal components (2 of 5) on page 503</a>
Roller, paper-feed (cassette)	RM1-0037-000CN	<a href="#">Customer-replaceable components (print engine) on page 477</a>
Roller, paper-feed (cassette)	RM1-0037-020CN	<a href="#">Internal components (1 of 5) on page 501</a>
Roller, paper-feed assembly	RM1-0012-020CN	<a href="#">Internal components (1 of 5) on page 501</a>
Roller, paper-pickup (cassette)	RM1-0036-000CN	<a href="#">Customer-replaceable components (print engine) on page 477</a>
Roller, paper-pickup (cassette)	RM1-0036-000CN	<a href="#">Internal components (1 of 5) on page 501</a>
Roller, pickup, multipurpose assembly	RL1-0019-000CN	<a href="#">Customer-replaceable components (print engine) on page 477</a>
Roller, pickup, multipurpose assembly	RL1-0019-000CN	<a href="#">Multipurpose assembly on page 525</a>
Scanner controller PCA	IR4041K512NI	<a href="#">Scanner-base components on page 557</a>
Scanner fan-filter cover	IR4041P217NI	<a href="#">Scanner-base components on page 557</a>
Scanner flatbed-unit assembly	IR4041K081NI	<a href="#">Scanner flatbed-unit assembly on page 559</a>
Scanner left cover	IR4041K114NI	<a href="#">Scanner covers on page 561</a>
Scanner rear cover	IR4041P216NI	<a href="#">Scanner flatbed-unit assembly on page 559</a>



**Table 7-47** Alphabetical parts list (continued)

Description	Part number	Table and page
Scanner right cover	IR4041P213NI	<a href="#">Scanner covers on page 561</a>
Scanner top-cover flatbed flange	IR4041P125NI	<a href="#">Scanner covers on page 561</a>
Scanner, spring for left cover	IR4041P041NI	<a href="#">Scanner covers on page 561</a>
Scanner-carriage-lock cover	IR4041P214NI	<a href="#">Scanner covers on page 561</a>
Scanner-fan filter	IR4041P007NI	<a href="#">Scanner-base components on page 557</a>
Screw, ADF	030080FWWSNI	<a href="#">ADF assembly on page 535</a>
Screw, ADF	NS-SCR00029NI	<a href="#">ADF internal components (1 of 3) on page 537</a>
Screw, ADF, button, M3 x 8	IR4041P021NI	<a href="#">ADF input tray on page 543</a>
Screw, ADF, wave 4 x 10	PF2245P369NI	<a href="#">ADF assembly on page 535</a>
Screw, flathead, RS, M3 x 6	XA9-1464-000CN	<a href="#">Electrical/forward assembly on page 511</a>
Screw, M3 x 8	XA9-0650-000CN	<a href="#">Fuser on page 533</a>
Screw, RS, M3 x 12	XA9-1447-000CN	<a href="#">Internal components (1 of 5) on page 501</a>
Screw, RS, M3 x 6	XA9-1495-000CN	<a href="#">Upper-plate assembly on page 499</a>
Screw, RS, M3 x 8	XA9-1449-000CN	<a href="#">Fuser on page 533</a>
Screw, S, M3 x 8	XA9-1500-000CN	<a href="#">Internal components (1 of 5) on page 501</a>
Screw, scanner flatbed	040100FNBBNI	<a href="#">Scanner flatbed-unit assembly on page 559</a>
Screw, stepped	RS1-9004-020CN	<a href="#">Fuser on page 533</a>
Screw, stepped, M3	RC1-0266-020CN	<a href="#">Internal components (5 of 5) on page 509</a>
Screw, tapping, M3 x 6	XA9-1503-000CN	<a href="#">Internal components (3 of 5) on page 505</a>
Screw, tapping, pan-head, M4 x 10	XB4-7401-0007CN	<a href="#">External panels and covers on page 497</a>
Screw, tapping, truss-head, M3 x 8	XB4-7300-809CN	<a href="#">Multipurpose assembly on page 525</a>
Screw, tapping, truss-head, M4 x 16	XB4-7401-605CN	<a href="#">Internal components (3 of 5) on page 505</a>
Screw, TP, M3 x 4	XB6-7300-406CN	<a href="#">Reverse assembly on page 527</a>
Screw, with washer, M3 x 6	XB2-7300-607CN	<a href="#">Internal components (2 of 5) on page 503</a>
Screw, with washer, M3 x 6	XA9-1420-000CN	<a href="#">Electrical/forward assembly on page 511</a>

**Table 7-47** Alphabetical parts list (continued)

Description	Part number	Table and page
Sensor assembly, paper size (SW102)	RM1-0041-020CN	<a href="#">Internal components (5 of 5) on page 509</a>
Sensor assembly, right door	RM1-1045-000CN	<a href="#">Internal components (2 of 5) on page 503</a>
Sensor, reverse-unit (PS109)	RM1-1570-000CN	<a href="#">Reverse assembly on page 527</a>
Sensor, reverse-unit jam (PS111)	RM1-1571-000CN	<a href="#">Reverse assembly on page 527</a>
Service and support training CD	CB425-14005	<a href="#">Documentation, software, and training material on page 491</a>
Solenoid (SL101)	RK2-0269-000CN	<a href="#">Internal components (1 of 5) on page 501</a>
Solenoid, multipurpose assembly (SL102)	RK2-0276-000CN	<a href="#">Multipurpose assembly on page 525</a>
Solenoid, reverse-unit (SL105)	RK2-0485-000CN	<a href="#">Reverse assembly on page 527</a>
Solenoid, reversing-roller separation (SL106)	RK2-0486-000CN	<a href="#">Reverse assembly on page 527</a>
Spacer, screw	RC1-0392-000CN	<a href="#">Internal components (2 of 5) on page 503</a>
Spring, compression	RU5-2265-000CN	<a href="#">Internal components (5 of 5) on page 509</a>
Spring, grounding	RU5-2251-000CN	<a href="#">Internal components (3 of 5) on page 505</a>
Spring, tension	RC1-0167-000CN	<a href="#">Internal components (1 of 5) on page 501</a>
Spring, torsion	RC1-0379-000CN	<a href="#">Internal components (1 of 5) on page 501</a>
Spring, torsion	RC1-0061-000CN	<a href="#">Internal components (1 of 5) on page 501</a>
Staple cartridge	C8085-60541	<a href="#">Stapler/stacker accessory on page 567</a>
Stapler unit	RK2-0507-000CN	<a href="#">Stapler/stacker accessory on page 567</a>
Stapler/stacker driver board	RM1-1123-000CN	<a href="#">Stapler/stacker accessory on page 567</a>
Stopper, bushing arm	RC1-3090-000CN	<a href="#">Internal components (4 of 5) on page 507</a>
Stopper, front lock	RL1-0434-000CN	<a href="#">Internal components (4 of 5) on page 507</a>
Stopper, hinge shaft	RC1-3124-000CN	<a href="#">Internal components (2 of 5) on page 503</a>
Storage cabinet	Q5970A	<a href="#">Accessories on page 475</a>

**Table 7-47** Alphabetical parts list (continued)

Description	Part number	Table and page
Support, cartridge (upper plate)	RC1-2856-000CN	<a href="#">Upper-plate assembly on page 499</a>
Support, gas damper	RL1-0436-000CN	<a href="#">Internal components (4 of 5) on page 507</a>
Swing-plate assembly	RM1-0043-020CN	<a href="#">Internal components (5 of 5) on page 509</a>
Switch, power	RC1-3044-000CN	<a href="#">External panels and covers on page 497</a>
Thermistor (TH3)	RK2-0359-000CN	<a href="#">Internal components (1 of 5) on page 501</a>
Upper plate assembly	For reference only	<a href="#">Internal components (4 of 5) on page 507</a>
USB cable, 2-meter standard device connector	C6518A	<a href="#">Cables and interfaces on page 481</a>

# Numerical parts list

**Table 7-48** Numerical parts list

Part number	Description	Table and page
030080FWWSNI	Screw, ADF	<a href="#">ADF assembly on page 535</a>
040100FNBBNI	Screw, scanner flatbed	<a href="#">Scanner flatbed-unit assembly on page 559</a>
0950-4717	Hard disk, 40 GB	<a href="#">Memory on page 486</a>
5851-2720	Data cable for hard disk (2-wire)	<a href="#">Memory on page 486</a>
5851-3051	Power cable for hard disk (5-wire)	<a href="#">Memory on page 486</a>
8120-6815	POWER CORD, OPT-906 3-COND 2.25-M-LG	<a href="#">Cables and interfaces on page 481</a>
8120-8907	PHN-CORD OPT-519 AU 3.0-M-LG ROHS Australia	<a href="#">Cables and interfaces on page 481</a>
8120-8908	PHN-CORD OPT-516 KR 3.0-M-LG ROHS Korea	<a href="#">Cables and interfaces on page 481</a>
8120-8911	PHN-CORD OPT-506 DK 3.0-M-LG ROHS Denmark	<a href="#">Cables and interfaces on page 481</a>
8120-8912	PHN-CORD OPT-502 DE 3.0-M-LG ROHS Denmark	<a href="#">Cables and interfaces on page 481</a>
8120-8913	PHN-CORD OPT-517 IL 3.0-M-LG ROHS Israel	<a href="#">Cables and interfaces on page 481</a>
8120-8914	PHN-CORD OPT-514 IT 3.0-M-LG ROHS Southern Europe	<a href="#">Cables and interfaces on page 481</a>
8120-8915	PHN-CORD OPT-508 NL 3.0-M-LG ROHS Netherlands	<a href="#">Cables and interfaces on page 481</a>
8120-8916	PHN-CORD OPT 510 NORWAY/FINLAND 3.0M-LG	<a href="#">Cables and interfaces on page 481</a>
8120-8918	PHN-CORD OPT-511 SE 3.0-M-LG ROHS NO/FI/SV	<a href="#">Cables and interfaces on page 481</a>
8120-8920	PHN-CORD OPT-507 TR 3.0-M-LG ROHS Turkey/Greece	<a href="#">Cables and interfaces on page 481</a>
8120-8921	PHN-CORD OPT-505 UK/HK/NZ 3.0-M-LG ROHS United Kingdom	<a href="#">Cables and interfaces on page 481</a>
8120-8922	PHN-CORD OPT-520 EE 3.0-M-LG ROHS South Africa	<a href="#">Cables and interfaces on page 481</a>
8120-8922	PHN-CORD OPT-520 EE 3.0-M-LG ROHS SK/SL/HR/RO/CS/HU/PL	<a href="#">Cables and interfaces on page 481</a>
8120-8923	PHN-CORD OPT-504 FR 3.0-M-LG ROHS France	<a href="#">Cables and interfaces on page 481</a>
8121-0564	PWR-CORD OPT-923 3-COND 1.9-M-LG ROHS India	<a href="#">Cables and interfaces on page 481</a>
8121-0729	PWR-CORD OPT-920 3-COND 1.9-M-LG ROHS Argentina	<a href="#">Cables and interfaces on page 481</a>

**Table 7-48** Numerical parts list (continued)

Part number	Description	Table and page
8121-0731	PWR-CORD OPT-902 3-COND 1.9-M-LG ROHS Southern Europe/Western Europe/Eastern Europe/Indonesia/Baltics/Vietnam/Korea 220V	<a href="#">Cables and interfaces on page 481</a>
8121-0731	PWR-CORD OPT-902 3-COND 1.9-M-LG ROHS Middle East 220V	<a href="#">Cables and interfaces on page 481</a>
8121-0733	PWR-CORD OPT-912 3-COND 1.9-M-LG ROHS Denmark	<a href="#">Cables and interfaces on page 481</a>
8121-0734	PWR-CORD OPT-927 3-COND 1.9-M-LG ROHS Phillipines/Singapore/Mexico/Brazil/Thailand	<a href="#">Cables and interfaces on page 481</a>
8121-0736	PWR-CORD OPT-918 3-COND 1.9-M-LG ROHS Japan	<a href="#">Cables and interfaces on page 481</a>
8121-0737	PWR-CORD OPT-917 3-COND 1.9-M-LG ROHS Africa	<a href="#">Cables and interfaces on page 481</a>
8121-0738	PWR-CORD OPT-906 3-COND 1.9-M-LG ROHS Switzerland	<a href="#">Cables and interfaces on page 481</a>
8121-0739	PWR-CORD OPT-900 3-COND 1.9-M-LG 5A ROHS United Kingdom/Middle East 220V/Phillipines/Singapore/Hong Kong SAR/Malaysia	<a href="#">Cables and interfaces on page 481</a>
8121-0739	PWR-CORD OPT-900 3-COND 1.9-M-LG 5A ROHS Maylasia	<a href="#">Cables and interfaces on page 481</a>
8121-0740	PWR-CORD OPT-903 3-COND 1.9-M-LG ROHS United States/Canada	<a href="#">Cables and interfaces on page 481</a>
8121-0740	PWR-CORD OPT-903 3-COND 1.9-M-LG ROHS South America/Mexico/Brazil	<a href="#">Cables and interfaces on page 481</a>
8121-0740	PWR-CORD OPT-903 3-COND 1.9-M-LG ROHS Middle East	<a href="#">Cables and interfaces on page 481</a>
8121-0811	PHN-CORD OPT-501 US 3.0-M-LG ROHS United States/Taiwan/China/Thailand/Japan/Argentina/India/European Union/South America/Indonesia/Malaysia/MiddleEast/Phillipines/Singapore/Mexico/Brazil/Canada/Russia/Bulgaria/Baltics/Vietnam	<a href="#">Cables and interfaces on page 481</a>
8121-0837	PWR-CORD OPT-901 3-COND 1.9-M-LG ROHS Australia	<a href="#">Cables and interfaces on page 481</a>
8121-0844	PHN-CORD OPT-512 CH 3.0-M-LG ROHS Switzerland	<a href="#">Cables and interfaces on page 481</a>
8121-0943	PWR-CORD OPT-922 3-COND 1.9-M-LG ROHS China	<a href="#">Cables and interfaces on page 481</a>
8121-0964	PWR-CORD OPT-934 3-COND 1.9-M-LG ROHS Taiwan	<a href="#">Cables and interfaces on page 481</a>
8121-1004	PWR-CORD OPT-919 3-COND 1.9-M-LG ROHS Israel	<a href="#">Cables and interfaces on page 481</a>
8121-1042	PHN-CORD US 3.0-M-LG ROHS Hong Kong SAR	<a href="#">Cables and interfaces on page 481</a>
C6518A	USB cable, 2-meter standard device connector	<a href="#">Cables and interfaces on page 481</a>

**Table 7-48** Numerical parts list (continued)

<b>Part number</b>	<b>Description</b>	<b>Table and page</b>
C8085-60541	5,000-staple cartridge	<a href="#">Accessories on page 475</a>
C8085-60541	Staple cartridge	<a href="#">Stapler/stacker accessory on page 567</a>
CB425-14005	Service and support training CD	<a href="#">Documentation, software, and training material on page 491</a>
CB425-60103	Kit-Control Pnl Overlay Left/Right EN	<a href="#">Control panel and control-panel overlays on page 484</a>
CB425-60104	Kit-Control Pnl Overlay Left/Right FR	<a href="#">Control panel and control-panel overlays on page 484</a>
CB425-60105	Kit-Control Pnl Overlay Left/Right IT	<a href="#">Control panel and control-panel overlays on page 484</a>
CB425-60106	Kit-Control Pnl Overlay Left/Right DE	<a href="#">Control panel and control-panel overlays on page 484</a>
CB425-60107	Kit-Control Pnl Overlay Left/Right ES	<a href="#">Control panel and control-panel overlays on page 484</a>
CB425-60108	Kit-Control Pnl Overlay Left/Right NL	<a href="#">Control panel and control-panel overlays on page 484</a>
CB425-60109	Kit-Control Pnl Overlay Left/Right PT	<a href="#">Control panel and control-panel overlays on page 484</a>
CB425-60110	Kit-Control Pnl Overlay Left/Right NO	<a href="#">Control panel and control-panel overlays on page 484</a>
CB425-60111	Kit-Control Pnl Overlay Left/Right SV	<a href="#">Control panel and control-panel overlays on page 484</a>
CB425-60112	Kit-Control Pnl Overlay Left/Right FI	<a href="#">Control panel and control-panel overlays on page 484</a>
CB425-60113	Kit-Control Pnl Overlay Left/Right DA	<a href="#">Control panel and control-panel overlays on page 484</a>
CB425-60114	Kit-Control Pnl Overlay Left/Right PL	<a href="#">Control panel and control-panel overlays on page 484</a>
CB425-60115	Kit-Control Pnl Overlay Left/Right RU	<a href="#">Control panel and control-panel overlays on page 484</a>
CB425-60116	Kit-Control Pnl Overlay Left/Right CS	<a href="#">Control panel and control-panel overlays on page 484</a>
CB425-60117	Kit-Control Pnl Overlay Left/Right HU	<a href="#">Control panel and control-panel overlays on page 484</a>
CB425-60118	Kit-Control Pnl Overlay Left/Right ZHTW	<a href="#">Control panel and control-panel overlays on page 484</a>
CB425-60119	Kit-Control Pnl Overlay Left/Right ZHCN	<a href="#">Control panel and control-panel overlays on page 484</a>
CB425-60120	Kit-Control Pnl Overlay Left/Right KO	<a href="#">Control panel and control-panel overlays on page 484</a>
CB425-60121	Kit-Control Pnl Overlay Left/Right JA	<a href="#">Control panel and control-panel overlays on page 484</a>

**Table 7-48** Numerical parts list (continued)

Part number	Description	Table and page
CB425-60122	Kit-Control Pnl Overlay Left/Right TR	<a href="#">Control panel and control-panel overlays on page 484</a>
CB425-60123	Kit-Control Pnl Overlay Left/Right HE	<a href="#">Control panel and control-panel overlays on page 484</a>
CB425-60124	Kit-Control Pnl Overlay Left/Right EL	<a href="#">Control panel and control-panel overlays on page 484</a>
CB425-60125	Kit-Control Pnl Overlay Left/Right AR	<a href="#">Control panel and control-panel overlays on page 484</a>
CB425-60126	Kit-Control Pnl Overlay Left/Right TH	<a href="#">Control panel and control-panel overlays on page 484</a>
CB425-60127	Control-panel assembly	<a href="#">External panels and covers on page 497</a>
CB425-60129	Kit-Control Pnl Overlay Left/Right HR	<a href="#">Control panel and control-panel overlays on page 484</a>
CB425-60130	Kit-Control Pnl Overlay Left/Right RO	<a href="#">Control panel and control-panel overlays on page 484</a>
CB425-60131	Kit-Control Pnl Overlay Left/Right SK	<a href="#">Control panel and control-panel overlays on page 484</a>
CB425-60132	Kit-Control Pnl Overlay Left/Right SL	<a href="#">Control panel and control-panel overlays on page 484</a>
CB425-60135	HP LaserJet M4345 MFP Series software CD, ROW/AR	<a href="#">Documentation, software, and training material on page 491</a>
CB425-60136	HP LaserJet M4345 MFP Series software CD, Asia/EN/DR	<a href="#">Documentation, software, and training material on page 491</a>
CB425-60155	Customer in-box training CD, English only	<a href="#">Documentation, software, and training material on page 491</a>
CB425-67901	Formatter assembly	<a href="#">Internal components (5 of 5) on page 509</a>
CB425-69001	Complete print engine (110 volt)	<a href="#">Internal components (1 of 5) on page 501</a>
CB425-69002	Complete print engine (220 volt)	<a href="#">Internal components (1 of 5) on page 501</a>
CB425-90908	HP LaserJet M4345 MFP Series service manual	<a href="#">Documentation, software, and training material on page 491</a>
CB425-67901	Formatter assembly, new	<a href="#">Customer-replaceable components (print engine) on page 477</a>
For reference only	Electrical/forward assembly	<a href="#">Internal components (2 of 5) on page 503</a>
For reference only	Upper plate assembly	<a href="#">Internal components (4 of 5) on page 507</a>
IR4041K081NI	Scanner flatbed-unit assembly	<a href="#">Scanner flatbed-unit assembly on page 559</a>
IR4041K114NI	Scanner left cover	<a href="#">Scanner covers on page 561</a>

**Table 7-48** Numerical parts list (continued)

Part number	Description	Table and page
IR4041K512NI	Scanner controller PCA	<a href="#">Scanner-base components on page 557</a>
IR4041P007NI	ADF fan filter	<a href="#">Customer-replaceable components (ADF and scanner) on page 479</a>
IR4041P007NI	Scanner-fan filter	<a href="#">Scanner-base components on page 557</a>
IR4041P021NI	Screw, ADF, button, M3 x 8	<a href="#">ADF input tray on page 543</a>
IR4041P041NI	Scanner, spring for left cover	<a href="#">Scanner covers on page 561</a>
IR4041P125NI	Scanner top-cover flatbed flange	<a href="#">Scanner covers on page 561</a>
IR4041P213NI	Scanner right cover	<a href="#">Scanner covers on page 561</a>
IR4041P214NI	Scanner-carriage-lock cover	<a href="#">Scanner covers on page 561</a>
IR4041P215NI	ADF front-cover flange	<a href="#">Customer-replaceable components (ADF and scanner) on page 479</a>
IR4041P216NI	Scanner rear cover	<a href="#">Scanner flatbed-unit assembly on page 559</a>
IR4041P217NI	ADF fan-filter cover	<a href="#">Customer-replaceable components (ADF and scanner) on page 479</a>
IR4041P217NI	Scanner fan-filter cover	<a href="#">Scanner-base components on page 557</a>
J4135A	HP Jetdirect connectivity card for USB, serial, and LocalTalk connections	<a href="#">Cables and interfaces on page 481</a>
J7934A	HP Jetdirect 620n Fast Ethernet (10/100Base-TX) print server (EIO card)	<a href="#">Cables and interfaces on page 481</a>
MKTNG-00539	HP Digital Sending Software CD (trial version)	<a href="#">Documentation, software, and training material on page 491</a>
NS-SCR00029NI	Screw, ADF	<a href="#">ADF internal components (1 of 3) on page 537</a>
PF2245P369NI	Screw, ADF, wave 4 x 10	<a href="#">ADF assembly on page 535</a>
PF2282K006NI	ADF assembly	<a href="#">ADF assembly on page 535</a>
PF2282K008NI	ADF hinge, right	<a href="#">ADF internal components (2 of 3) on page 539</a>
PF2282K034NI	ADF separation-pad case	<a href="#">ADF separation-pad case on page 547</a>
PF2282K035NI	ADF separation-pad assembly	<a href="#">Customer-replaceable components (ADF and scanner) on page 479</a>
PF2282K035NI	ADF separation-pad assembly	<a href="#">ADF separation pad on page 545</a>
PF2282K035NI	ADF separation pad	<a href="#">ADF separation-pad case on page 547</a>



**Table 7-48** Numerical parts list (continued)

Part number	Description	Table and page
PF2282K039NI	ADF pickup-roller assembly	<a href="#">Customer-replaceable components (ADF and scanner) on page 479</a>
PF2282K039NI	ADF pickup-roller assembly	<a href="#">ADF internal components (3 of 3) on page 541</a>
PF2282K039NI	ADF pickup-roller assembly	<a href="#">ADF pickup-roller assembly on page 549</a>
PF2282K040NI	ADF pickup-roller cover	<a href="#">Customer-replaceable components (ADF and scanner) on page 479</a>
PF2282K040NI	ADF pickup-roller cover	<a href="#">ADF internal components (3 of 3) on page 541</a>
PF2282K040NI	ADF pickup-roller cover	<a href="#">ADF pickup-roller cover on page 551</a>
PF2282K041NI	ADF hinge, left	<a href="#">ADF internal components (2 of 3) on page 539</a>
PF2282K042NI	ADF input tray	<a href="#">Customer-replaceable components (ADF and scanner) on page 479</a>
PF2282K042NI	ADF input tray	<a href="#">ADF assembly on page 535</a>
PF2282K042NI	ADF input tray	<a href="#">ADF input tray on page 543</a>
PF2282K043NI	ADF mylar-holder assembly	<a href="#">Customer-replaceable components (ADF and scanner) on page 479</a>
PF2282K043NI	ADF mylar holder assembly	<a href="#">ADF assembly on page 535</a>
PF2282K043NI	ADF mylar-holder assembly	<a href="#">ADF mylar-holder assembly on page 553</a>
PF2282K164NI	ADF jam-access latch	<a href="#">ADF internal components (3 of 3) on page 541</a>
PF2282K165NI	ADF cable	<a href="#">ADF assembly on page 535</a>
PF2282K166NI	ADF hinge flaps (ESD)	<a href="#">ADF assembly on page 535</a>
PF2282P025NI	ADF white mylar backing	<a href="#">ADF assembly on page 535</a>
PF2282P041NI	ADF jam-access cover	<a href="#">ADF assembly on page 535</a>
PF2282P044NI	ADF rear cover	<a href="#">ADF assembly on page 535</a>
PF2282P058NI	ADF left cover	<a href="#">ADF assembly on page 535</a>
PF2282P059NI	ADF front cover	<a href="#">ADF assembly on page 535</a>
PF2282P060NI	ADF output-bin-base cover	<a href="#">ADF internal components (1 of 3) on page 537</a>
PF2282P061NI	ADF output-bin paper stop	<a href="#">ADF internal components (1 of 3) on page 537</a>
PF2282P339NI	ADF white scan background	<a href="#">ADF assembly on page 535</a>
PF2282P343NI	ADF, springs for white mylar backing	<a href="#">ADF assembly on page 535</a>

**Table 7-48** Numerical parts list (continued)

Part number	Description	Table and page
PF2282P352NI	ADF, springs for left cover	<a href="#">ADF assembly on page 535</a>
PF2282P353NI	ADF clear plastic paper guide	<a href="#">ADF internal components (3 of 3) on page 541</a>
Q2438-67902	Envelope feeder	<a href="#">Accessories on page 475</a>
Q2625A	100-pin DDR memory DIMM (dual inline memory module), 64 MB	<a href="#">Memory on page 486</a>
Q2626A	100-pin DDR memory DIMM, 128 MB	<a href="#">Memory on page 486</a>
Q2627-67951	100-pin DDR memory DIMM, 256 MB	<a href="#">Memory on page 486</a>
Q3701-60010	HP LaserJet analog fax accessory 300	<a href="#">Accessories on page 475</a>
Q3942-60102	Control-panel assembly	<a href="#">Control panel and control-panel overlays on page 484</a>
Q5691-60501	500-sheet stapler/stacker	<a href="#">Accessories on page 475</a>
Q5691-60501	500 sheet stapler/stacker replacement unit	<a href="#">Stapler/stacker accessory on page 567</a>
Q5692-60503	3-bin mailbox	<a href="#">Accessories on page 475</a>
Q5692-67901	3-bin mailbox replacement unit	<a href="#">3-bin mailbox accessory on page 569</a>
Q5945-67901	HP LaserJet print cartridge	<a href="#">Print cartridge and maintenance kits on page 488</a>
Q5968-67901	Optional 500-sheet tray and feeder unit	<a href="#">Accessories on page 475</a>
Q5968A	500-sheet tray	<a href="#">Customer-replaceable components (print engine) on page 477</a>
Q5969-67901	Duplex-printing assembly	<a href="#">Duplex-printing assembly on page 565</a>
Q5969A	Duplexer (duplex printing accessory)	<a href="#">Accessories on page 475</a>
Q5970A	Storage cabinet	<a href="#">Accessories on page 475</a>
Q5997-67901	ADF maintenance kit	<a href="#">Print cartridge and maintenance kits on page 488</a>
Q5998-67901	Printer maintenance kit, 110-volt	<a href="#">Print cartridge and maintenance kits on page 488</a>
Q5999-67901	Printer maintenance kit, 220-volt	<a href="#">Print cartridge and maintenance kits on page 488</a>
Q6496-67901	Mylar sheet kit (3 sheets)	<a href="#">Customer-replaceable components (ADF and scanner) on page 479</a>
Q6496-67901	ADF mylar replacement kit	<a href="#">Print cartridge and maintenance kits on page 488</a>
Q6496-67901	ADF mylar replacement kit	<a href="#">ADF assembly on page 535</a>
Q6496-67901	ADF mylar replacement kit	<a href="#">ADF mylar replacement kit on page 555</a>

**Table 7-48** Numerical parts list (continued)

Part number	Description	Table and page
RC1-0060-000CN	Flag, paper-feed sensor	<a href="#">Internal components (1 of 5) on page 501</a>
RC1-0061-000CN	Spring, torsion	<a href="#">Internal components (1 of 5) on page 501</a>
RC1-0167-000CN	Spring, tension	<a href="#">Internal components (1 of 5) on page 501</a>
RC1-0245-000CN	Case, envelope-feeder connector	<a href="#">Internal components (2 of 5) on page 503</a>
RC1-0266-020CN	Screw, stepped, M3	<a href="#">Internal components (5 of 5) on page 509</a>
RC1-0331-000CN	Gear, 20T (cassette)	<a href="#">Cassette on page 519</a>
RC1-0378-000CN	Flag, shutter	<a href="#">Internal components (1 of 5) on page 501</a>
RC1-0379-000CN	Spring, torsion	<a href="#">Internal components (1 of 5) on page 501</a>
RC1-0392-000CN	Spacer, screw	<a href="#">Internal components (2 of 5) on page 503</a>
RC1-2597-000CN	Door, jam access	<a href="#">Stapler/stacker accessory on page 567</a>
RC1-2598-000CN	Rear cover	<a href="#">Stapler/stacker accessory on page 567</a>
RC1-2691-000CN	Rear cover	<a href="#">3-bin mailbox accessory on page 569</a>
RC1-2758-000CN	Limiter, torque	<a href="#">Internal components (1 of 5) on page 501</a>
RC1-2782-000CN	Lever, paper-size-sensing (cassette)	<a href="#">Cassette on page 519</a>
RC1-2818-000CN	Handle, lock (upper plate)	<a href="#">Upper-plate assembly on page 499</a>
RC1-2820-000CN	Cover, lock, front (upper plate)	<a href="#">Upper-plate assembly on page 499</a>
RC1-2821-000CN	Cover, rear lock (upper plate)	<a href="#">Upper-plate assembly on page 499</a>
RC1-2822-000CN	Link, handle (upper plate)	<a href="#">Upper-plate assembly on page 499</a>
RC1-2823-000CN	Cover, front stopper	<a href="#">Internal components (4 of 5) on page 507</a>
RC1-2827-000CN	Arm, door, 1 (top cover)	<a href="#">Internal components (4 of 5) on page 507</a>
RC1-2828-000CN	Arm, door, 2 (top cover)	<a href="#">Internal components (4 of 5) on page 507</a>
RC1-2830-000CN	Rod, link (upper plate)	<a href="#">Upper-plate assembly on page 499</a>
RC1-2833-000CN	Cover, door arm (top cover)	<a href="#">Internal components (4 of 5) on page 507</a>

**Table 7-48** Numerical parts list (continued)

<b>Part number</b>	<b>Description</b>	<b>Table and page</b>
RC1-2853-000CN	Guide, cartridge (upper plate)	<a href="#">Upper-plate assembly on page 499</a>
RC1-2854-000CN	Guide, legal-size (upper plate)	<a href="#">Upper-plate assembly on page 499</a>
RC1-2855-000CN	Holder, right shutter (upper plate)	<a href="#">Upper-plate assembly on page 499</a>
RC1-2856-000CN	Support, cartridge (upper plate)	<a href="#">Upper-plate assembly on page 499</a>
RC1-2863-000CN	Flag, full-detect (output bin)	<a href="#">Internal components (4 of 5) on page 507</a>
RC1-2864-000CN	Holder, output-device-full sensor flag	<a href="#">Internal components (4 of 5) on page 507</a>
RC1-2881-000CN	Cover, handle, lower right	<a href="#">Internal components (2 of 5) on page 503</a>
RC1-2884-000CN	Guide, rear	<a href="#">Internal components (3 of 5) on page 505</a>
RC1-2901-000CN	Hinge, door, right-side	<a href="#">Internal components (2 of 5) on page 503</a>
RC1-2902-000CN	Rod, link	<a href="#">Internal components (3 of 5) on page 505</a>
RC1-2911-000CN	Cross-member, support	<a href="#">Internal components (4 of 5) on page 507</a>
RC1-2980-000CN	Rod, switch, front	<a href="#">Internal components (3 of 5) on page 505</a>
RC1-3002-000CN	Holder, link	<a href="#">Internal components (3 of 5) on page 505</a>
RC1-3003-000CN	Link, switch	<a href="#">Internal components (3 of 5) on page 505</a>
RC1-3020-000CN	Guide, cassette, front	<a href="#">Cassette on page 519</a>
RC1-3035-000CN	Cover, formatter	<a href="#">Customer-replaceable components (print engine) on page 477</a>
RC1-3035-000CN	Cover, formatter	<a href="#">External panels and covers on page 497</a>
RC1-3041-000CN	Cover, inner front	<a href="#">Internal components (4 of 5) on page 507</a>
RC1-3042-000CN	Cover, side, rear	<a href="#">Internal components (3 of 5) on page 505</a>
RC1-3043-000CN	Cover, cassette, left side	<a href="#">External panels and covers on page 497</a>
RC1-3044-000CN	Switch, power	<a href="#">External panels and covers on page 497</a>
RC1-3052-000CN	Cover, left-side, front	<a href="#">Internal components (1 of 5) on page 501</a>

**Table 7-48** Numerical parts list (continued)

<b>Part number</b>	<b>Description</b>	<b>Table and page</b>
RC1-3063-000CN	Holder, door switch	<a href="#">Internal components (2 of 5) on page 503</a>
RC1-3090-000CN	Stopper, bushing arm	<a href="#">Internal components (4 of 5) on page 507</a>
RC1-3102-000CN	Block, guide support (upper plate)	<a href="#">Upper-plate assembly on page 499</a>
RC1-3106-000CN	Lever, shutter	<a href="#">Internal components (1 of 5) on page 501</a>
RC1-3124-000CN	Stopper, hinge shaft	<a href="#">Internal components (2 of 5) on page 503</a>
RK2-0269-000CN	Solenoid (SL101)	<a href="#">Internal components (1 of 5) on page 501</a>
RK2-0272-000CN	Motor, DC 24-volt, (M101)	<a href="#">Internal components (3 of 5) on page 505</a>
RK2-0274-000CN	Motor, DC 24-volt, (M102)	<a href="#">Internal components (3 of 5) on page 505</a>
RK2-0276-000CN	Solenoid, multipurpose assembly (SL102)	<a href="#">Multipurpose assembly on page 525</a>
RK2-0278-000CN	Fan, main cooling (FN101)	<a href="#">Internal components (1 of 5) on page 501</a>
RK2-0280-000CN	Fan, reversing unit (FN103)	<a href="#">Internal components (1 of 5) on page 501</a>
RK2-0280-000CN	Fan, print cartridge (FN102)	<a href="#">Internal components (5 of 5) on page 509</a>
RK2-0349-000CN	Clutch, paper feed, electromagnetic (CL101)	<a href="#">Paper-feed roller assembly on page 521</a>
RK2-0359-000CN	Thermistor (TH3)	<a href="#">Internal components (1 of 5) on page 501</a>
RK2-0469-000CN	Cable, flat-flexible (engine power supply)	<a href="#">Electrical/forward assembly on page 511</a>
RK2-0470-000CN	Cable, flat-flexible (engine power supply)	<a href="#">Electrical/forward assembly on page 511</a>
RK2-0472-000CN	Fan, DC controller (FN104)	<a href="#">Internal components (5 of 5) on page 509</a>
RK2-0473-000CN	Motor, crossing, (stepping) (M104)	<a href="#">Reverse assembly on page 527</a>
RK2-0474-000CN	Motor, reverse-unit (stepping) (M105)	<a href="#">Reverse assembly on page 527</a>
RK2-0475-000CN	Motor, delivery (stepping) (M106)	<a href="#">Reverse assembly on page 527</a>
RK2-0485-000CN	Solenoid, reverse-unit (SL105)	<a href="#">Reverse assembly on page 527</a>
RK2-0486-000CN	Solenoid, reversing-roller separation (SL106)	<a href="#">Reverse assembly on page 527</a>

**Table 7-48** Numerical parts list (continued)

<b>Part number</b>	<b>Description</b>	<b>Table and page</b>
RK2-0507-000CN	Stapler unit	<a href="#">Stapler/stacker accessory on page 567</a>
RL1-0007-000CN	Plate, main pad support (multipurpose assembly)	<a href="#">Multipurpose assembly on page 525</a>
RL1-0019-000CN	Roller, pickup, multipurpose assembly	<a href="#">Customer-replaceable components (print engine) on page 477</a>
RL1-0019-000CN	Roller, pickup, multipurpose assembly	<a href="#">Multipurpose assembly on page 525</a>
RL1-0434-000CN	Stopper, front lock	<a href="#">Internal components (4 of 5) on page 507</a>
RL1-0436-000CN	Support, gas damper	<a href="#">Internal components (4 of 5) on page 507</a>
RL1-0455-000CN	Cover, envelope-feeder slot	<a href="#">Internal components (3 of 5) on page 505</a>
RL1-0457-000CN	Cover, front corner	<a href="#">External panels and covers on page 497</a>
RM1-0005-020CN	Multipurpose tray assembly	<a href="#">Multipurpose assembly on page 525</a>
RM1-0011-060CN	Registration assembly	<a href="#">Internal components (1 of 5) on page 501</a>
RM1-0011-060CN	Registration assembly	<a href="#">Registration assembly on page 523</a>
RM1-0012-020CN	Roller, paper-feed assembly	<a href="#">Internal components (1 of 5) on page 501</a>
RM1-0012-020CN	Paper-feed roller assembly	<a href="#">Paper-feed roller assembly on page 521</a>
RM1-0025-040CN	Paper-feed assembly	<a href="#">Electrical/forward assembly on page 511</a>
RM1-0034-070CN	Paper-pickup-drive assembly	<a href="#">Internal components (1 of 5) on page 501</a>
RM1-0034-070CN	Paper-pickup-drive assembly	<a href="#">Paper-pickup-drive assembly on page 515</a>
RM1-0036-000CN	Roller, paper-pickup (cassette)	<a href="#">Customer-replaceable components (print engine) on page 477</a>
RM1-0036-000CN	Roller, paper-pickup (cassette)	<a href="#">Internal components (1 of 5) on page 501</a>
RM1-0037-000CN	Roller, paper-feed (cassette)	<a href="#">Customer-replaceable components (print engine) on page 477</a>
RM1-0037-020CN	Roller, paper-feed (cassette)	<a href="#">Internal components (1 of 5) on page 501</a>
RM1-0041-020CN	Sensor assembly, paper size (SW102)	<a href="#">Internal components (5 of 5) on page 509</a>

**Table 7-48** Numerical parts list (continued)

Part number	Description	Table and page
RM1-0043-020CN	Swing-plate assembly	<a href="#">Internal components (5 of 5) on page 509</a>
RM1-0940-000CN	Output bin	<a href="#">Customer-replaceable components (print engine) on page 477</a>
RM1-0940-000CN	Output-bin assembly	<a href="#">External panels and covers on page 497</a>
RM1-0940-000CN	Paper delivery tray assembly	<a href="#">Stapler/stacker accessory on page 567</a>
RM1-0940-000CN	Paper delivery tray assembly	<a href="#">3-bin mailbox accessory on page 569</a>
RM1-0942-000	Front cover	<a href="#">Stapler/stacker accessory on page 567</a>
RM1-0947-000CN	Jog guide assembly	<a href="#">Stapler/stacker accessory on page 567</a>
RM1-0981-000CN	Jam-access door, 3-bin mailbox	<a href="#">3-bin mailbox accessory on page 569</a>
RM1-0985-000CN	Front cover	<a href="#">3-bin mailbox accessory on page 569</a>
RM1-1001-000CN	Cassette (tray 2, 3, 4 or 5)	<a href="#">Cassette on page 519</a>
RM1-1010-000CN	Guide, paper sensing (PS101)	<a href="#">Internal components (1 of 5) on page 501</a>
RM1-1011-000CN	Cassette rail assembly, left	<a href="#">Internal components (3 of 5) on page 505</a>
RM1-1012-000CN	Cassette rail assembly, right	<a href="#">Internal components (3 of 5) on page 505</a>
RM1-1013-000CN	Power supply, PFC (100–127 volt)	<a href="#">Internal components (5 of 5) on page 509</a>
RM1-1014-000CN	Power supply, PFC (220–240 volt)	<a href="#">Internal components (5 of 5) on page 509</a>
RM1-1016-000CN	Cover, right assembly	<a href="#">External panels and covers on page 497</a>
RM1-1017-000CN	Cover, rear	<a href="#">External panels and covers on page 497</a>
RM1-1018-000CN	Cover, duplexing-unit assembly	<a href="#">External panels and covers on page 497</a>
RM1-1019-000CN	Reverse-separation guide assembly	<a href="#">Internal components (4 of 5) on page 507</a>
RM1-1019-000CN	Reverse-separation-guide assembly	<a href="#">Reverse-separation-guide assembly on page 529</a>
RM1-1022-000CN	Reverse assembly	<a href="#">Internal components (2 of 5) on page 503</a>
RM1-1022-000CN	Reverse assembly	<a href="#">Reverse assembly on page 527</a>

**Table 7-48** Numerical parts list (continued)

<b>Part number</b>	<b>Description</b>	<b>Table and page</b>
RM1-1027-000CN	Guide assembly, flat-flexible cable	<a href="#">Internal components (5 of 5) on page 509</a>
RM1-1029-000CN	Lifter drive assembly	<a href="#">Internal components (3 of 5) on page 505</a>
RM1-1029-000CN	Lifter-drive assembly	<a href="#">Lifter-drive assembly on page 517</a>
RM1-1033-000CN	Cover, right lower assembly	<a href="#">External panels and covers on page 497</a>
RM1-1041-000CN	Engine power supply assembly (100–127 volt)	<a href="#">Electrical/forward assembly on page 511</a>
RM1-1042-000CN	Engine power supply assembly (220–240 volt)	<a href="#">Electrical/forward assembly on page 511</a>
RM1-1043-000CN	Fuser, 110-volt, new	<a href="#">Customer-replaceable components (print engine) on page 477</a>
RM1-1043-000CN	Fuser (100–127 volt)	<a href="#">Internal components (2 of 5) on page 503</a>
RM1-1043-000CN	Fuser (100–127 volt)	<a href="#">Fuser on page 533</a>
RM1-1044-000CN	Fuser, 220-volt, new	<a href="#">Customer-replaceable components (print engine) on page 477</a>
RM1-1044-000CN	Fuser (220–240 volt)	<a href="#">Internal components (2 of 5) on page 503</a>
RM1-1044-000CN	Fuser (220–240 volt)	<a href="#">Fuser on page 533</a>
RM1-1045-000CN	Sensor assembly, right door	<a href="#">Internal components (2 of 5) on page 503</a>
RM1-1046-000CN	Fuser entrance guide	<a href="#">Customer-replaceable components (print engine) on page 477</a>
RM1-1046-000CN	Fuser entrance guide	<a href="#">Internal components (2 of 5) on page 503</a>
RM1-1047-000CN	Delivery tray assembly	<a href="#">Customer-replaceable components (print engine) on page 477</a>
RM1-1047-000CN	Delivery assembly	<a href="#">External panels and covers on page 497</a>
RM1-1047-000CN	Delivery assembly	<a href="#">Delivery assembly on page 531</a>
RM1-1049-000CN	Main drive assembly	<a href="#">Internal components (3 of 5) on page 505</a>
RM1-1049-000CN	Main drive assembly	<a href="#">Main drive assembly on page 513</a>
RM1-1100-000CN	Cover, front assembly	<a href="#">External panels and covers on page 497</a>



**Table 7-48** Numerical parts list (continued)

<b>Part number</b>	<b>Description</b>	<b>Table and page</b>
RM1-1110-000CN	Roller assembly, transfer	<a href="#">Customer-replaceable components (print engine) on page 477</a>
RM1-1110-000CN	Roller assembly, transfer	<a href="#">Internal components (2 of 5) on page 503</a>
RM1-1123-000CN	Stapler/stacker driver board	<a href="#">Stapler/stacker accessory on page 567</a>
RM1-1124-000CN	MBM driver board	<a href="#">3-bin mailbox accessory on page 569</a>
RM1-1193-000CN	Cable, envelope-feeder connector	<a href="#">Internal components (2 of 5) on page 503</a>
RM1-1354-000CN	DC controller PCA	<a href="#">Internal components (5 of 5) on page 509</a>
RM1-1367-000CN	Cable, laser (print engine)	<a href="#">Internal components (1 of 5) on page 501</a>
RM1-1368-000CN	Cable, output-bin full sensor	<a href="#">Internal components (4 of 5) on page 507</a>
RM1-1370-000CN	Cable, optional 500-sheet feeder connection	<a href="#">Internal components (5 of 5) on page 509</a>
RM1-1371-000CN	Cable, output device connection	<a href="#">Internal components (4 of 5) on page 507</a>
RM1-1372-000CN	Cable, beam-detect to scanner (print engine)	<a href="#">Internal components (1 of 5) on page 501</a>
RM1-1375-000CN	Cable, power	<a href="#">Internal components (5 of 5) on page 509</a>
RM1-1376-000CN	Cable, fan docking (for DC-controller fan)	<a href="#">Internal components (5 of 5) on page 509</a>
RM1-1379-000CN	Reverse-unit PCA	<a href="#">Reverse assembly on page 527</a>
RM1-1380-000CN	Cable, reverse unit	<a href="#">Internal components (4 of 5) on page 507</a>
RM1-1381-000CN	Cable, control panel	<a href="#">Internal components (4 of 5) on page 507</a>
RM1-1397-000CN	Cable, door switch	<a href="#">Internal components (2 of 5) on page 503</a>
RM1-1398-000CN	Cable, image scanner (print engine)	<a href="#">Internal components (1 of 5) on page 501</a>
RM1-1400-000CN	Cable, duplexing-unit grounding	<a href="#">Electrical/forward assembly on page 511</a>
RM1-1570-000CN	Sensor, reverse-unit (PS109)	<a href="#">Reverse assembly on page 527</a>
RM1-1571-000CN	Sensor, reverse-unit jam (PS111)	<a href="#">Reverse assembly on page 527</a>

**Table 7-48** Numerical parts list (continued)

Part number	Description	Table and page
RM1-1572-000CN	Multipurpose tray assembly	<a href="#">Internal components (3 of 5) on page 505</a>
RM1-1572-000CN	Multipurpose assembly	<a href="#">Multipurpose assembly on page 525</a>
RM1-1573-000CN	Laser/scanner assembly	<a href="#">Internal components (1 of 5) on page 501</a>
RM1-1001-000CN	Cassette	<a href="#">Cassette on page 563</a>
RS1-9004-020CN	Screw, stepped	<a href="#">Fuser on page 533</a>
RU5-0045-020CN	Gear, 18T	<a href="#">Internal components (1 of 5) on page 501</a>
RU5-0050-000CN	Gear, 30T (paper-feed roller assembly)	<a href="#">Paper-feed roller assembly on page 521</a>
RU5-0253-000CN	Gear, 80T (cassette)	<a href="#">Cassette on page 519</a>
RU5-0254-000CN	Gear, 14T (cassette)	<a href="#">Cassette on page 519</a>
RU5-0256-000CN	Gear, 23T	<a href="#">Internal components (1 of 5) on page 501</a>
RU5-2251-000CN	Spring, grounding	<a href="#">Internal components (3 of 5) on page 505</a>
RU5-2265-000CN	Spring, compression	<a href="#">Internal components (5 of 5) on page 509</a>
WC4-5139-000CN	Microswitch (SW101)	<a href="#">Internal components (2 of 5) on page 503</a>
WG8-5624-000CN	Photointerrupter (PS107)	<a href="#">Internal components (1 of 5) on page 501</a>
WS9-0255-000CN	Bolt, hex-head	<a href="#">Internal components (4 of 5) on page 507</a>
XA9-0650-000CN	Screw, M3 x 8	<a href="#">Fuser on page 533</a>
XA9-1420-000CN	Screw, with washer, M3 x 6	<a href="#">Electrical/forward assembly on page 511</a>
XA9-1447-000CN	Screw, RS, M3 x 12	<a href="#">Internal components (1 of 5) on page 501</a>
XA9-1449-000CN	Screw, RS, M3 x 8	<a href="#">Fuser on page 533</a>
XA9-1464-000CN	Screw, flathead, RS, M3 x 6	<a href="#">Electrical/forward assembly on page 511</a>
XA9-1495-000CN	Screw, RS, M3 x 6	<a href="#">Upper-plate assembly on page 499</a>
XA9-1500-000CN	Screw, S, M3 x 8	<a href="#">Internal components (1 of 5) on page 501</a>
XA9-1503-000CN	Screw, tapping, M3 x 6	<a href="#">Internal components (3 of 5) on page 505</a>
XB2-7300-607CN	Screw, with washer, M3 x 6	<a href="#">Internal components (2 of 5) on page 503</a>

**Table 7-48** Numerical parts list (continued)

<b>Part number</b>	<b>Description</b>	<b>Table and page</b>
XB4-7300-809CN	Screw, tapping, truss-head, M3 x 8	<a href="#">Multipurpose assembly on page 525</a>
XB4-7401-0007CN	Screw, tapping, pan-head, M4 x 10	<a href="#">External panels and covers on page 497</a>
XB4-7401-605CN	Screw, tapping, truss-head, M4 x 16	<a href="#">Internal components (3 of 5) on page 505</a>
XB6-7300-406CN	Screw, TP, M3 x 4	<a href="#">Reverse assembly on page 527</a>
XD9-0132-020CN	E-ring (paper-feed roller assembly)	<a href="#">Paper-feed roller assembly on page 521</a>



# A Specifications

- [Physical specifications](#)
- [Electrical specifications](#)
- [Acoustic specifications](#)
- [Operating environment](#)

# Physical specifications

**Table A-1** Product dimensions

Product	Height	Depth	Width	Weight <sup>1</sup>
HP LaserJet M4345 MFP	545 mm (21.5 inches)	483 mm (19.0 inches)	762 mm (30.0 inches)	44.1kg (97.2 lb)
HP LaserJet M4345x MFP	667 mm (26.3 inches)	483 mm (19.0 inches)	762 mm (30.0 inches)	52.4 kg (115.5 lb)
HP LaserJet M4345xs MFP	111.0 cm (43.7 inches)	483 mm (19.0 inches)	914 mm (36.0 inches)	58.4 kg (128.7 lb)
HP LaserJet M4345xm MFP	111.0 cm (43.7 inches)	483 mm (19.0 inches)	914 mm (36.0 inches)	58.2 kg (128.3 lb)
Optional 500-sheet feeder	122 mm (4.8 inches)	483 mm (19.0 inches)	559 mm (22.0 inches)	8.3 kg (18.3 lb)
Optional cabinet	440 mm (17.3 inches)	762 mm (30.0 inches)	825.5 mm (32.5 inches)	41.8 kg (92.2 lb)
Optional stapler/stacker				6.0 kg (13.2 lb)
Optional 3-bin mailbox				5.8 kg (12.8 lb)
Optional Envelope feeder				2.5 kg (5.5 lb)
Optional duplexer				2.5 kg (5.5 lb)

<sup>1</sup> Without print cartridge

**Table A-2** Product dimensions, with all doors and trays fully opened

Product	Height	Depth	Width
HP LaserJet M4345 MFP	889 mm (35.0 inches)	876 mm (34.5 inches)	142.2 cm (56.0 inches)
HP LaserJet M4345x MFP	101 cm (39.8 inches)	876 mm (34.5 inches)	142.2 cm (56.0 inches)
HP LaserJet M4345xs MFP	145 cm (57.0 inches)	117 cm (46.0 inches)	157.5 cm (62.0 inches)
HP LaserJet M4345xm MFP	145 cm (57.0 inches)	117 cm (46.0 inches)	157.5 cm (62.0 inches)

# Electrical specifications



**WARNING!** Power requirements are based on the country/region where the printer is sold. Do not convert operating voltages. This can damage the printer and void the product warranty.

**Table A-3** Power requirements for the HP LaserJet M4345 Series MFP

Specification	110-volt models	230-volt models
Power requirements	110 to 127 volts (10%)	220 to 240volts (10%)
	50/60 Hz (2 Hz)	50/60 Hz (2 Hz)
Rated current	10.0 Amps	4.5 Amps

**Table A-4** Power consumption for the HP LaserJet M4345 Series MFP (average, in watts)<sup>1</sup>

Product model	Copying	Printing <sup>2</sup>	Ready	Sleep	Off
HP LaserJet M4345 MFP	800 W	790 W <sup>3</sup>	44 W	15 W	0.25 W
HP LaserJet M4345x MFP	800 W	790 W <sup>3</sup>	49 W	15 W	0.25 W
HP LaserJet M4345xs MFP	800 W	790 W <sup>3</sup>	49 W	15 W	0.25 W
HP LaserJet M4345xm MFP	800 W	790 W <sup>3</sup>	49 W	15 W	0.25 W

<sup>1</sup> Values subject to change. See <http://www.hp.com/support/ljm4345mfp> for current information.

<sup>2</sup> Power numbers are the highest values measured using all standard voltages.

<sup>3</sup> HP LaserJet M4345 Series MFP printing and copying speeds are 45 ppm Letter size and 43 ppm A4 size.

<sup>4</sup> Default time from Ready mode to Sleep = 60 minutes.

<sup>5</sup> Recovery time from Sleep to start of printing = less than 10 seconds.

<sup>6</sup> Heat dissipation in Ready mode = 167 BTU/hour.

## Acoustic specifications

**Table A-5** Sound power and pressure level for the HP LaserJet M4345 Series MFP<sup>1</sup>

Sound power level	Declared per ISO 9296
Printing <sup>2</sup>	$L_{WA_d}$ = 7.0 Bels (A) [70 dB(A)]
Copying	$L_{WA_d}$ = 7.2 Bels (A) [72 dB(A)]
Ready	$L_{pA_m}$ =33 dB (A)
Sound pressure level	Declared per ISO 9296
Printing <sup>2</sup>	$L_{pA_m}$ =55 dB (A)
Copying	$L_{pA_m}$ =56 dB (A)
Ready	$L_{pA_m}$ =33 dB (A)

<sup>1</sup> Values subject to change. See <http://www.hp.com/support/ljm4345mfp> for current information.

<sup>2</sup> HP LaserJet M4345 Series MFP speed is 43 ppm A4 size.

<sup>3</sup> Configuration tested (HP LaserJet M4345 MFP): Base model, simplex printing with A4 paper size.

# Operating environment

Table A-6 Necessary conditions

Environmental condition	Printing	Storage/standby
Temperature (printer and print cartridge)	15 to 32.5°C (59 to 89°F)	-20 to 40°C (-4 to 104°F)
Relative humidity	10% to 80%	10% to 90%



# B Product warranty statements

## Hewlett-Packard limited warranty statement

HP PRODUCT

HP LaserJet M4345 Series MFP

DURATION OF LIMITED WARRANTY

One-year limited warranty

HP warrants to you, the end-user customer, that HP hardware and accessories will be free from defects in materials and workmanship after the date of purchase, for the period specified above. If HP receives notice of such defects during the warranty period, HP will, at its option, either repair or replace products which prove to be defective. Replacement products may be either new or equivalent in performance to new.

HP warrants to you that HP software will not fail to execute its programming instructions after the date of purchase, for the period specified above, due to defects in material and workmanship when properly installed and used. If HP receives notice of such defects during the warranty period, HP will replace software which does not execute its programming instructions due to such defects.

HP does not warrant that the operation of HP products will be uninterrupted or error free. If HP is unable, within a reasonable time, to repair or replace any product to a condition as warranted, you will be entitled to a refund of the purchase price upon prompt return of the product.

HP products may contain remanufactured parts equivalent to new in performance or may have been subject to incidental use.

Warranty does not apply to defects resulting from (a) improper or inadequate maintenance or calibration, (b) software, interfacing, parts or supplies not supplied by HP, (c) unauthorized modification or misuse, (d) operation outside of the published environmental specifications for the product, or (e) improper site preparation or maintenance.

TO THE EXTENT ALLOWED BY LOCAL LAW, THE ABOVE WARRANTIES ARE EXCLUSIVE AND NO OTHER WARRANTY OR CONDITION, WHETHER WRITTEN OR ORAL, IS EXPRESSED OR IMPLIED AND HP SPECIFICALLY DISCLAIMS ANY IMPLIED WARRANTIES OR CONDITIONS OF MERCHANTABILITY, SATISFACTORY QUALITY, AND FITNESS FOR A PARTICULAR PURPOSE. Some countries/regions, states or provinces do not allow limitations on the duration of an implied warranty, so the above limitation or exclusion might not apply to you. This warranty gives you specific legal rights and you might also have other rights that vary from country/region to country/region, state to state, or province to province. HP's limited warranty is valid in any country/region or locality where HP has a support presence for this product and where HP has marketed this product. The level of warranty service you receive may vary according to local standards. HP will not alter form, fit or function of the product to make it operate in a country/region for which it was never intended to function for legal or regulatory reasons.

TO THE EXTENT ALLOWED BY LOCAL LAW, THE REMEDIES IN THIS WARRANTY STATEMENT ARE YOUR SOLE AND EXCLUSIVE REMEDIES. EXCEPT AS INDICATED ABOVE, IN NO EVENT WILL HP OR ITS SUPPLIERS BE LIABLE FOR LOSS OF DATA OR FOR DIRECT, SPECIAL, INCIDENTAL,

CONSEQUENTIAL (INCLUDING LOST PROFIT OR DATA), OR OTHER DAMAGE, WHETHER BASED IN CONTRACT, TORT, OR OTHERWISE. Some countries/regions, states or provinces do not allow the exclusion or limitation of incidental or consequential damages, so the above limitation or exclusion may not apply to you.

THE WARRANTY TERMS CONTAINED IN THIS STATEMENT, EXCEPT TO THE EXTENT LAWFULLY PERMITTED, DO NOT EXCLUDE, RESTRICT OR MODIFY AND ARE IN ADDITION TO THE MANDATORY STATUTORY RIGHTS APPLICABLE TO THE SALE OF THIS PRODUCT TO YOU.

## Customer Self Repair Warranty Service

HP products are designed with many Customer Self Repair (CSR) parts to minimize repair time and allow for greater flexibility in performing defective parts replacement. If during the diagnosis period, HP identifies that the repair can be accomplished by the use of a CSR part, HP will ship that part directly to you for replacement. There are two categories of CSR parts: 1) Parts for which customer self repair is mandatory. If you request HP to replace these parts, you will be charged for the travel and labor costs of this service. 2) Parts for which customer self repair is optional. These parts are also designed for Customer Self Repair. If, however, you require that HP replace them for you, this may be done at no additional charge under the type of warranty service designated for your product.

Based on availability and where geography permits, CSR parts will be shipped for next business day delivery. Same-day or four-hour delivery may be offered at an additional charge where geography permits. If assistance is required, you can call the HP Technical Support Center and a technician will help you over the phone. HP specifies in the materials shipped with a replacement CSR part whether a defective part must be returned to HP. In cases where it is required to return the defective part to HP, you must ship the defective part back to HP within a defined period of time, normally five (5) business days. The defective part must be returned with the associated documentation in the provided shipping material. Failure to return the defective part may result in HP billing you for the replacement. With a customer self repair, HP will pay all shipping and part return costs and determine the courier/carrier to be used.

# HP Customer Care

## Online Services

For 24-hour access to updated HP device-specific software, product information, and support information through an Internet connection, go to the Web site: <http://www.hp.com/support/ljm4345mfp>.

Go to [www.hp.com/support/net\\_printing](http://www.hp.com/support/net_printing) for information about the HP Jetdirect external print server.

HP Instant Support Professional Edition (ISPE) is a suite of Web-based troubleshooting tools for desktop computing and printing products. Go to [instantsupport.hp.com](http://instantsupport.hp.com).

## Telephone support

HP provides free telephone support during the warranty period. For the telephone number for your country/region, see the flyer that shipped with the device, or visit [www.hp.com/support/](http://www.hp.com/support/). Before calling HP, have the following information ready: the product name and serial number, the date of purchase, and a description of the problem.

## Software utilities, drivers, and electronic information

[http://www.hp.com/go/m4345\\_software](http://www.hp.com/go/m4345_software)

The Web page for the drivers is in English, but you can download the drivers themselves in several languages.

## Fax accessory support

Go to <http://www.hp.com/go/faxaccessory300>.

## HP direct ordering for accessories or supplies

- United States: [www.hp.com/sbso/product/supplies](http://www.hp.com/sbso/product/supplies).
- Canada: [www.hp.ca/catalog/supplies](http://www.hp.ca/catalog/supplies)
- Europe: [www.hp.com/supplies](http://www.hp.com/supplies)
- Asia-Pacific: [www.hp.com/paper/](http://www.hp.com/paper/)

To order genuine HP parts or accessories, go to the HP Parts Store at [www.hp.com/buy/parts](http://www.hp.com/buy/parts) (U.S. and Canada only), or call 1-800-538-8787 (U.S.) or 1-800-387-3154 (Canada).

## HP service information

To locate HP-Authorized Dealers, call 1-800-243-9816 (U.S.) or 1-800-387-3867 (Canada).

Outside the United States and Canada, call the customer support number for your country/region. See the flyer that shipped in the box with the device.

## HP service agreements

Call 1-800-HPINVENT (1-800-474-6836 (U.S.)) or 1-800-268-1221 (Canada). Or, go to the HP SupportPack and Carepaq™ Services Web site at [www.hpexpress-services.com/10467a](http://www.hpexpress-services.com/10467a).

For extended service, call 1-800-446-0522.

## HP Toolbox FX

To check the device status and settings and view troubleshooting information and online documentation, use the HP Toolbox FX. You must have performed a full software installation in order to use the HP Toolbox FX. See [Open the HP Toolbox FX on page 85](#).

## HP support and information for Macintosh computers

Go to [www.hp.com/go/macosex](http://www.hp.com/go/macosex) for Macintosh OS X support information and HP subscription service for driver updates.

Go to [www.hp.com/go/mac-connect](http://www.hp.com/go/mac-connect) for products that are designed specifically for the Macintosh user.

# HP maintenance agreements

HP has several types of maintenance agreements that meet a wide range of support needs. Maintenance agreements are not part of the standard warranty. Support services may vary by area. Check with your local HP dealer to determine the services available to you.

## On-site service agreements

To provide you with the level of support best suited to your needs, HP has on-site service agreements with a selection of response times.

### Next-day on-site service

This agreement provides support by the next working day following a service request. Extended coverage hours and extended travel beyond HP's designated service zones are available on most on-site agreements (for additional charges).

### Weekly (volume) on-site service

This agreement provides scheduled weekly on-site visits for organizations with many HP products. This agreement is designated for sites using 25 or more workstation products, including devices, plotters, computers, and disk drives.

## Repacking the device

If HP Customer Care determines that your device needs to be returned to HP for repair, follow the steps below to repack the device before shipping it.



**CAUTION** Shipping damage as a result of inadequate packing is the customer's responsibility.

---

### To repack the device

1. Remove and retain any DIMMs cards that you have purchased and installed in the device. Do not remove the DIMM that came with the device.



**CAUTION** Static electricity can damage DIMMs. When handling DIMMs, either wear an antistatic wrist strap, or frequently touch the surface of the DIMM antistatic package and then touch bare metal on the device. To remove the DIMMs, see [DIMM on page 243](#).

---

2. Remove and retain the print cartridge.



**CAUTION** It is *extremely important* to remove the print cartridge before shipping the device. A print cartridge that remains in the device during shipping will leak and entirely cover the device engine and other parts with toner.

To prevent damage to the print cartridge, avoid touching the roller on it, and store the print cartridge in its original packing material or so that it is not exposed to light.

---

3. Remove and retain the power cable, interface cable, and optional accessories.

4. If possible, include print samples and 50 to 100 sheets of paper or other print media that did not print correctly.
5. In the U.S., call HP Customer Care to request new packing material. In other areas, use the original packing material, if possible. Hewlett-Packard recommends insuring the equipment for shipment.

## Extended warranty

HP Support provides coverage for the HP hardware product and all HP-supplied internal components. The hardware maintenance covers a 1- to 3-year period from date of the HP product purchase. The customer must purchase HP Support within the stated factory warranty. For more information, contact the HP Customer Care Service and Support group.

# C Regulatory information

This section contains the following regulatory information:

- [FCC regulations](#)
- [Environmental product stewardship program](#)
- [Telecom statement](#)
- [Declaration of conformity](#)
- [Safety statements](#)

## FCC regulations

This equipment has been tested and found to comply with the limits for a Class B digital device, pursuant to Part 15 of the FCC rules. These limits are designed to provide reasonable protection against harmful interference in a residential installation. This equipment generates, uses, and can radiate radio frequency energy. If this equipment is not installed and used in accordance with the instructions, it may cause harmful interference to radio communications. However, there is no guarantee that interference will not occur in a particular installation. If this equipment does cause harmful interference to radio or television reception, which can be determined by turning the equipment off and on, the user is encouraged to try to correct the interference by one or more of the following measures:

- Reorient or relocate the receiving antenna.
- Increase separation between equipment and receiver.
- Connect equipment to an outlet on a circuit different from that to which the receiver is located.
- Consult your dealer or an experienced radio/TV technician.



**NOTE** Any changes or modifications to the printer that are not expressly approved by HP could void the user's authority to operate this equipment.

Use of a shielded interface cable is required to comply with the Class B limits of Part 15 of FCC rules.

---



# Environmental product stewardship program

## Protecting the environment

Hewlett-Packard Company is committed to providing quality products in an environmentally sound manner. This product has been designed with several attributes to minimize impacts on our environment.

## Ozone production

This product generates no appreciable ozone gas (O<sub>3</sub>).

## Power consumption

Power usage drops significantly while in Ready and Sleep modes, which saves natural resources and saves money without affecting the high performance of this product. This product qualifies for ENERGY STAR® (Version 3.0), which is a voluntary program to encourage the development of energy-efficient office products.



ENERGY STAR® and the ENERGY STAR mark are U.S. registered marks. As an ENERGY STAR partner, Hewlett-Packard Company has determined that this product meets ENERGY STAR Guidelines for energy efficiency. For more information, see [www.energystar.gov](http://www.energystar.gov).

## Toner consumption

Economode uses significantly less toner, which might extend the life of the print cartridge.

## Paper use

This product's manual/optional automatic duplex feature (two-sided printing) and N-up printing (multiple pages printed on one page) capability can reduce paper usage and the resulting demands on natural resources.

## Plastics

Plastic parts over 25 grams are marked according to international standards that enhance the ability to identify plastics for recycling purposes at the end of the product's life.

## HP LaserJet print supplies

It's easy to return and recycle your empty HP LaserJet print cartridges—free of charge—with HP Planet Partners. HP is committed to providing inventive, high-quality products and services that are environmentally sound, from product design and manufacturing to distribution, operation and recycling processes. We ensure your returned HP LaserJet print cartridges are recycled properly, processing them to recover valuable plastics and metals for new products and diverting millions of tons of waste from landfills. Since this cartridge is being recycled and used in new materials, it will not be returned to you. Your empty HP LaserJet print cartridges are recycled responsibly when you participate in the HP Planet Partners program. Thank you for being environmentally responsible!

In many countries/regions, this product's printing supplies (for example, print cartridges) can be returned to HP through the HP Printing Supplies Returns and Recycling Program. An easy-to-use and free take back program is available in more than 35 countries/regions. Multilingual program information and instructions are included in every new HP LaserJet print cartridge and supplies package.

## HP print supplies returns and recycling program information

Since 1992, HP has offered HP LaserJet supplies return and recycling free of charge. In 2004, HP Planet Partners for LaserJet Supplies was available in 85% of the world market where HP LaserJet supplies are sold. Postage-paid and pre-addressed labels are included within the instruction guide in most HP LaserJet print cartridge boxes. Labels and bulk boxes are also available through the Web site: [www.hp.com/recycle](http://www.hp.com/recycle).

Use the label to return empty, original HP LaserJet print cartridges only. Please do not use this label for non-HP cartridges, refilled or remanufactured cartridges, or warranty returns. Printing supplies or other objects inadvertently sent to the HP Planet Partners program cannot be returned.

More than 10 million HP LaserJet print cartridges were recycled globally in 2004 through the HP Planet Partners supplies recycling program. This record number represents 26 million pounds of print cartridge materials diverted from landfills. Worldwide, in 2004, HP recycled an average of 59% of the print cartridge by weight consisting primarily of plastic and metals. Plastics and metals are used to make new products such as HP products, plastic trays, and spools. The remaining materials are disposed of in an environmentally responsible manner.

- **U.S. returns.** For a more environmentally responsible return of used cartridges and supplies, HP encourages the use of bulk returns. Simply bundle two or more cartridges together and use the single, pre-paid, pre-addressed UPS label that is supplied in the package. For more information in the U.S., call 1-800-340-2445 or visit the HP Web site at [www.hp.com/recycle](http://www.hp.com/recycle).
- **Non-U.S. returns.** Non-U.S. customers should visit the [www.hp.com/recycle](http://www.hp.com/recycle) Web site for further information regarding availability of the HP Supplies Returns and Recycling Program.

## Paper

This product is capable of using recycled papers when the paper meets the guidelines outlined in the *HP LaserJet Printer Family Print Media Guide*. This product is suitable for the use of recycled paper according to EN12281:2002.

## Material restrictions

This HP product does not contain added mercury.

This HP product contains a battery that might require special handling at end-of-life. The batteries contained in or supplied by Hewlett-Packard for this product include the following:

HP LaserJet M4345 device	
Type	Carbon monofluoride lithium battery BR1632
Weight	1.5 g
Location	On formatter board
User-removable	No



## 廢電池請回收

For recycling information, you can go to [www.hp.com/recycle](http://www.hp.com/recycle), or contact your local authorities or the Electronics Industries Alliance: [www.eiae.org](http://www.eiae.org).

## Disposal of waste equipment by users in private households in the European Union



This symbol on the product or on its packaging indicates that this product must not be disposed of with your other household waste. Instead, it is your responsibility to dispose of your waste equipment by handing it over to a designated collection point for the recycling of waste electrical and electronic equipment. The separate collection and recycling of your waste equipment at the time of disposal will help to conserve natural resources and ensure that it is recycled in a manner that protects human health and the environment. For more information about where you can drop off your waste equipment for recycling, please contact your local city office, your household waste disposal service or the shop where you purchased the product.

## Material Safety Data Sheet (MSDS)

Material Safety Data Sheets (MSDS) for supplies containing chemical substances (for example, toner) can be obtained by contacting the HP Web site at [www.hp.com/go/msds](http://www.hp.com/go/msds) or [www.hp.com/hpinfo/community/environment/productinfo/safety](http://www.hp.com/hpinfo/community/environment/productinfo/safety).

## For more information

To obtain information about these environmental topics:

- Product environmental profile sheet for this and many related HP products
- HP's commitment to the environment
- HP's environmental management system
- HP's end-of-life product return and recycling program
- Material Safety Data Sheets

Visit <http://www.hp.com/go/environment> or <http://www.hp.com/hpinfo/community/environment/productinfo/safety>.

## Telecom statement

The HP LaserJet M4345x, HP LaserJet M4345xs, and HP LaserJet M4345xm models have the HP LaserJet Analog Fax Accessory 300 already installed to provide communication to the public switch telephone network (PSTN) for fax functionality. See the *HP LaserJet Analog Fax Accessory 300 User Guide* for all regulatory approval information and regulatory notices associated with the fax functionality and that device.

# Declaration of conformity

## Declaration of Conformity

according to ISO/IEC Guide 22 and EN 45014

**Manufacturer's Name:** Hewlett-Packard Company  
**Manufacturer's Address:** 11311 Chinden Boulevard,  
Boise, Idaho 83714-1021, USA

**declares, that the product**

**Product Name:** HP LaserJet M4345 series

**Regulatory Model Number<sup>3)</sup>:** BOISB-0407-00 and BOISB-0407-01

**Product Options:** Including: CB425A, CB426A, CB427A, CB428A, BOISB-030800<sup>4</sup>  
ALL

Toner Cartridges: Q5945A

**conforms to the following Product Specifications:**

**Safety:** IEC 60950-1:2001 / EN60950-1: 2001 +A11  
IEC 60825-1:1993 +A1 +A2 / EN 60825-1:1994 +A1 +A2 (Class 1 Laser/LED Product)  
GB4943-2001

**EMC:** CISPR 22:1993 +A1 +A2 / EN 55022:1994 +A1 +A2 -- Class B<sup>1)</sup>  
EN 61000-3-2:2000  
EN 61000-3-3:1995 +A1  
EN 55024:1998 +A1 +A2  
FCC Title 47 CFR, Part 15 Class B<sup>2)</sup> / ICES-003, Issue 4<sup>2)</sup>  
GB9254-1998, GB17625.1-2003

### Supplementary Information:

The product herewith complies with the requirements of the EMC Directive 89/336/EEC and the Low Voltage Directive 73/23/EEC, and carries the CE-Marking accordingly.

- 1) The product was tested in a typical configuration with Hewlett-Packard Personal Computer Systems.
- 2) This Device complies with Part 15 of the FCC Rules. Operation is subject to the following two conditions: (1) this device may not cause harmful interference, and (2) this device must accept any interference received, including interference that may cause undesired operation.
- 3) For regulatory purposes, this product is assigned a Regulatory model number. This number should not be confused with the product name or the product number(s).
- 4) All worldwide modular approvals for analog fax accessory obtained by Hewlett-Packard under the regulatory model number BOISB-030800 incorporate the Multi-Tech Systems MT5634SMI Socket Modem Module.

Boise, Idaho , USA

**March 29, 2006**

### For regulatory topics only:

**Australia Contact:** Product Regulations Manager, Hewlett-Packard Australia Ltd., 31-41 Joseph Street, Blackburn, Victoria 3130, Australia  
**European Contact:** Your Local Hewlett-Packard Sales and Service Office or Hewlett-Packard GmbH, Department HQ-TRE / Standards Europe, Herrenberger Strasse 140, D-71034 Bblingen, Germany, (FAX: +49-7031-14-3143)  
**USA Contact:** Product Regulations Manager, Hewlett-Packard Company, PO Box 15, Mail Stop 160, Boise, ID 83707-0015, USA, (Phone: 208-396-6000)

# Safety statements

## Laser safety

The Center for Devices and Radiological Health (CDRH) of the U.S. Food and Drug Administration has implemented regulations for laser products manufactured since August 1, 1976. Compliance is mandatory for products marketed in the United States. The device is certified as a “Class 1” laser product under the U.S. Department of Health and Human Services (DHHS) Radiation Performance Standard according to the Radiation Control for Health and Safety Act of 1968. Since radiation emitted inside the device is completely confined within protective housings and external covers, the laser beam cannot escape during any phase of normal user operation.



**WARNING!** Using controls, making adjustments, or performing procedures other than those specified in this user guide may result in exposure to hazardous radiation.

## Canadian DOC regulations

Complies with Canadian EMC Class B requirements.

« Conforme à la classe B des normes canadiennes de compatibilité électromagnétiques. « CEM ». »

## VCCI statement (Japan)

この装置は、情報処理装置等電波障害自主規制協議会（VCCI）の基準に基づくクラスB情報技術装置です。この装置は、家庭環境で使用することを目的としていますが、この装置がラジオやテレビジョン受信機に近接して使用されると、受信障害を引き起こすことがあります。  
取扱説明書に従って正しい取り扱いをして下さい。

## Power cord statement (Japan)

製品には、同梱された電源コードをお使い下さい。  
同梱された電源コードは、他の製品では使用出来ません。

## EMI statement (Korea)

B급 기기 (가정용 정보통신기기)

이 기기는 가정용으로 전자파적합등록을 한 기기로서  
주거지역에서는 물론 모든 지역에서 사용할 수 있습니다.

## Laser statement for Finland

### Luokan 1 laserlaite

Klass 1 Laser Apparat

HP LaserJet M4345, HP LaserJet M4345x, HP LaserJet M4345xs, HP LaserJet M4345xm,  
laserkirjoitin on käyttäjän kannalta turvallinen luokan 1 laserlaite. Normaalisissa käytössä kirjoittimen

suojakotelointi estää lasersäteen pääsyn laitteen ulkopuolelle. Laitteen turvallisuusluokka on määritetty standardin EN 60825-1 (1994) mukaisesti.

### **VAROITUS !**

Laitteen käyttäminen muulla kuin käyttöohjeessa mainitulla tavalla saattaa altistaa käyttäjän turvallisuusluokan 1 ylittävälle näkymättömälle lasersäteilylle.

### **VARNING !**

Om apparaten används på annat sätt än i bruksanvisning specificerats, kan användaren utsättas för osynlig laserstrålning, som överskrider gränsen för laserklass 1.

### **HUOLTO**

HP LaserJet M4345, HP LaserJet M4345x, HP LaserJet M4345xs, HP LaserJet M4345xm - kirjoittimen sisällä ei ole käyttäjän huollettavissa olevia kohteita. Laitteen saa avata ja huoltaa ainoastaan sen huoltamiseen koulutettu henkilö. Tällaiseksi huoltotoimenpiteeksi ei katsota väriainekasetin vaihtamista, paperiradan puhdistusta tai muita käyttäjän käsikirjassa lueteltuja, käyttäjän tehtäväksi tarkoitettuja ylläpitotoimia, jotka voidaan suorittaa ilman erikoistyökaluja.

### **VARO !**

Mikäli kirjoittimen suojakotelo avataan, olet alttiina näkymättömälle lasersäteilylle laitteen ollessa toiminnassa. Älä katso säteeseen.

### **VARNING !**

Om laserprinterns skyddshölje öppnas då apparaten är i funktion, utsättas användaren för osynlig laserstrålning. Betrakta ej strålen. Tiedot laitteessa käytettävän laseriodin säteilyominaisuuksista: Aallonpituus 775-795 nm Teho 5 m W Luokan 3B laser.



# Index

## Symbols/Numerics

3-bin mailbox  
capacity 5  
diagrams and part numbers 568  
jam detection 162  
jams, clearing 409  
media specifications 13  
media types supported 10  
operations 135, 160  
part number 7  
reattach error message 397

3-bin mailbox  
part number 475, 570, 592

500-sheet tray. See tray 3

500-sheet trays  
adding 7  
insert or close error message 394  
jam detection 151  
jams, clearing 406  
locking and unlocking 8  
media sizes supported 12  
operations 135, 154  
part numbers 7, 475, 579, 592  
rollers, replacing 236  
sensor tests 459  
sensors, diagrams 204  
tray 2 detection switch, removing 312  
tray 2 jam-access-cover switch, removing 265  
unexpected size or type error message 387

## A

accessories  
locking and unlocking 8  
ordering 472  
part numbers 7

accounting hardware 42  
acoustic specifications 605  
activity log, fax 83  
address books, e-mail clearing 79  
address, device  
Macintosh, problem-solving 466

ADF  
assembly, removing 319  
capacity 4  
delivery guide (clear mylar sheet), replacing 231  
diagrams and part numbers 534  
front cover, removing 330  
hinge flap, replacing 239  
hinges, removing 337  
input tray 542  
input tray, replacing 227  
internal components 536  
jam detection 202  
jam-access cover, removing 334  
left-side cover, removing 332  
media specifications 14  
motors and fans 200  
motors, diagrams 215  
mylar replacement kit 554  
mylar-holder assembly 552  
output-bin extension, removing 327  
pickup-roller assembly 548  
rear cover, removing 331  
rollers, replacing 228  
sensors, diagrams 215  
sensors, removing 335  
separation pad, diagrams and part numbers 544

separation pad, replacing 229  
white mylar-backing, removing 328

ADF output bin  
capacity 5

adhesive labels. See labels

Administration menu, control panel 50

Alert Settings window, HP Toolbox 86

alerts, e-mail 84, 92

antcounterfeit supplies 94

AppleTalk setting 41

AppleTalk settings 63

Attention light  
locating 48

authorized dealers 609

autoconfiguration, drivers 32

AUX connection 5

## B

back cover, removing 251

batteries included 617

billing codes report, fax 83

bins  
capacities 5  
full sensor, removing 316  
jams, clearing 409  
operations 135  
reattach error message 397  
removing 233

bins, output  
paper curl, problem-solving 379

blank copies, problem-solving 437

blank pages  
problem-solving 380

blocked fax list, printing 83

blurred print, problem-solving 429

Bonjour Settings 92

- both sides, printing on
  - error
    - messages 387, 392, 394, 397
    - Macintosh settings 91
    - problem-solving 380
- browsers supported, HP
  - Toolbox 37
- buffer overflow errors 385
- buttons, control panel
  - locating 48
  - touchscreen 50
- C**
- cabinet/stand
  - locking and unlocking 8
  - part number 7, 475, 584, 592
- cables
  - part numbers 481, 585, 587
- calibrating
  - control panel 107
- calibrating scanner 77, 106
- call report, fax 83
- Canadian DOC regulations 621
- capacity
  - 3-bin mailbox 5, 13
  - 500-sheet tray 12
  - ADF 4, 14
  - envelope feeder 13
  - output bins 5
  - stacker 13
  - stapler 14
  - stapler/stacker 5
  - tray 1 11
- card stock
  - guidelines for using 17
- cartridges
  - authentication 94
  - genuine HP 93
  - management menu 60
  - non-HP 94
  - ordering through embedded
    - Web server 89
  - recycling 616
  - replacing 93
  - status, viewing with HP
    - Toolbox 85
  - storage 93
- cartridges, print
  - detection operations 127
  - drum rotation test 456
- EconoMode 115
- error messages 394
- image formation
  - operations 131
- jams, clearing 401
- memory 132
- part numbers 488, 576, 592
- replacing 224
- cartridges, staple
  - jams 416
  - part numbers 7, 475, 570, 588
- cassette diagrams and part
  - numbers 518
- characters, misformed 424
- checks 454
- chosen personality not
  - available 392
- circuit diagrams 373
- cleaning
  - about 98
  - document feeder delivery
    - system 96
  - document feeder rollers 98
  - exterior 95
  - lid backing 96
  - paper path 96
  - scanner glass 95
- clear mylar sheet, replacing 231
- clock
  - error message 383
  - setting 100
- cold reset 457
- components
  - ADF 536
  - diagrams 204
  - diagrams and part
    - numbers 500
  - testing 461
- configuration page
  - Information menu 51
  - Macintosh 91
  - printing 82
- connections
  - DC controller 368
  - scanner-controller PCA 370
- connectivity features 5
- contacting HP 609
- control panel
  - Administration menu 50
  - buttons 48
- calibrating 107
- cleaning page, printing 96
- connections diagram 368
- E-mail Setup menu 71
- Fax Setup menu 68
- help 50
- Home screen 49
- Information menu 51
- Initial Setup menu 60
- jam messages 400
- lights 48
- locking menus 44
- Management menu 59
- messages, alphabetical list 383
- messages, numerical list 383
- messages, types of 382
- overlays, part numbers 483
- overlays, replacing 224
- replacing 225
- Resets menu 79
- Send Setup menu 71
- Service menu 80
- settings 33
- Time/Scheduling menu 58
- touchscreen buttons 50
- Copitrak devices 42
- copying
  - error messages 398
  - features 4
  - media, problem-solving 435
  - problem-solving 437
  - problems, preventing 434
  - quality, problem-solving 434
  - size, problem-solving 437
- counterfeit supplies 94
- Courier font, problem-solving 470
- covers
  - ADF front, removing 330
  - ADF jam-access, removing 334
  - ADF left-side, removing 332
  - ADF rear, removing 331
  - back, removing 251
  - diagrams and part
    - numbers 496
  - front support, removing 269
  - front, removing 247
  - scanner 560

- top-cover flatbed flange, removing 246
  - top-cover switch (SW101), removing 290
  - CPU, formatter 115
  - creased paper, problem-solving 426
  - crooked pages 425
  - curled paper, problem-solving 425, 435
  - curly paper, problem-solving 379
  - custom-size paper
    - 3-bin mailbox specifications 13
    - 500-sheet tray specifications 12
    - tray 1 specifications 11
  - customer support
    - embedded Web server links 89
    - HP Printer Utility pages 91
    - Linux 469
    - online 609
    - repacking device 611
- D**
- dark copying 435
  - Data light
    - locating 48
  - date, setting 59, 100
  - DC controller
    - connections, diagrams 368
    - operations 117
    - removing 280
  - DC controller fan (FN104), removing 284
  - declaration of conformity 620
  - default settings
    - Resets menu 79
  - delay, sleep 101
  - delivery assembly, diagrams and part numbers 530
  - delivery guide, replacing ADF 231
  - density
    - problem-solving 419
    - settings 91
  - Device List, HP Toolbox 85
  - Device Status, HP Toolbox 86
  - diagnostics
    - networks 64
  - diagrams
    - ADF 534
    - ADF components 215
    - cassette 518
    - circuit 373
    - covers 496
    - DC controller connections 368
    - delivery assembly 530
    - electrical/forward assembly 510
    - fuser 532
    - internal components 500
    - lifter-drive assembly 516
    - main drive assembly 512
    - motors and fans 208
    - multipurpose assembly 524
    - paper-feed roller assembly 520
    - paper-pickup-drive assembly 514
    - registration assembly 522
    - reverse assembly 526
    - reverse-separation-guide assembly 528
    - sensors and switches 204
    - timing 371
    - upper-plate assembly 498
  - digital faxing 29
  - digital sending
    - error messages 394, 398
    - Setup menu 71
    - validating gateway addresses 441
  - DIMMs
    - part numbers 486, 570, 592
    - removing 243
  - disabling
    - Embedded Jetdirect 108
  - Disk Erase feature 43
  - disposal, end-of-life 617
  - DLC/LLC settings 63
  - Document feeder
    - cleaning delivery system 96
    - error messages 393
    - jams, clearing 413
    - jams, frequent 414
  - documentation, part numbers 490
  - dots, problem-solving 420, 428, 435
  - double-sided printing
    - error
      - messages 387, 392, 394, 397
      - Macintosh settings 91
      - problem-solving 380
  - downloading software 30
  - dpi, settings 91
  - drivers
    - Macintosh, problem-solving 466
    - preconfiguration 33
    - settings 33, 34
    - universal 32
    - Update Now 33
  - dropouts, problem-solving 420
  - drum rotation test 456
  - DSS authentication 44
  - duplex printing accessory
    - connections diagram 368
    - diagrams and part numbers 564
    - error
      - messages 387, 392, 394, 397
    - jam detection 158
    - jams 408
    - media specifications 12
    - media types supported 10
    - operations 157
    - part number 7, 475, 574, 592
    - replacing 234
  - duplexer
    - Macintosh settings 91
    - problem-solving 380
- E**
- e-mail
    - error messages 394, 398
  - e-mail alerts 84, 92
  - E-mail Setup menu 71
  - Easy Printer Care software 37
  - EconoMode 115
  - EIO accessory
    - disabling 108
    - settings 61
  - EIO cards
    - buffer overflow 385
    - errors 392
    - part numbers 481, 576, 590
  - electrical forward assembly, diagrams and part numbers 510
  - electrical specifications 604
  - Embedded Jetdirect
    - disabling 108
  - embedded Web server
    - password 42

- end-of-life disposal 617
  - energy specifications 604
  - engine control system 117
  - engine power supply
    - connections diagram 368
    - diagrams and part numbers 511, 574, 598
    - removing 306
  - engine test 454
  - envelope feeder
    - connections diagram 368
    - envelope specifications 13
    - error messages 392
    - jams, clearing 403
    - load error message 395
    - media types supported 10
    - part number 7, 475, 574, 592
  - envelopes
    - margins 16
    - specifications 11, 15
    - storing 16
    - wrinkled, problem-solving 426
  - environment for device
    - problem-solving 418
  - environment for printer
    - specifications 606
  - environmental stewardship
    - program 615
  - EPS files, problem-solving 467
  - Equitrac devices 42
  - erasing hard disk 43
  - Error button, control panel
    - touchscreen 50
  - error messages
    - Alert Settings, HP Toolbox 86
    - alphabetical list 383
    - e-mail alerts 84, 92
    - jams 400
    - numerical list 383
    - types of 382
  - Ethernet cards 5
  - Ethernet cards, part
    - numbers 481, 576, 590
  - European Union, waste disposal 617
  - extended warranty 612
  - e-mail
    - validating gateway addresses 441
- F**
- fans
    - connections diagram 368
    - DC controller (FN104), removing 284
    - diagrams 208
    - main (FN 101), removing 258
    - operations 119
    - print-cartridge (FN102), removing 285
    - reversing-unit (FN103), removing 258
    - scanner 200
  - fasteners, types used 222, 473
  - fax accessory
    - connecting phone line 28
    - light status 367
    - NVRAM initialization 457
    - part number 7, 475, 576, 592
    - printing schedule 59
    - removing 244
    - user guide 28
  - Fax Activity Log
    - clearing 79
  - fax reports, printing 52, 83
  - Fax Setup menu 68
  - faxes
    - receiving, problem-solving 439
    - sending, problem-solving 438
  - faxing, digital 29
  - feed rollers, replacing ADF 228
  - feed-roller assembly,
    - removing 278
  - feeding operations 135
  - feeding problems, media 436
  - file directory, printing 83
  - File Upload, Macintosh 91
  - Find Other Printers window, HP Toolbox 86
  - Finnish laser safety statement 621
  - firmware
    - upgrading 102
  - Firmware Update, Macintosh 91
  - firmware-stack trace 464
  - fonts
    - EPS files, problem-solving 467
    - included 3
    - list, printing 52, 83
    - problem-solving 470
    - Upload Macintosh 91
- Foreign Interface Harness (FIH)**
- locating 27
  - using 42
- formatter**
- connections diagram 368
  - lights 366
  - locking 45
  - operations 114
  - removing 240
  - service ID 462
  - testing 455
- fraud hotline 94**
- front cover, removing 247**
- front-cover support, removing 269**
- fuser**
- connections diagram 368
  - diagrams and part numbers 503, 532, 575, 598
  - error messages 388
  - image formation
    - operations 131
  - jams, clearing 410
  - paper wrapping errors 396
  - removing 235
- fuser modes 18**
- fuser-control circuit 121**
- fuser-entrance guide, removing 235**
- fuses, overcurrent/overvoltage protection 127**
- G**
- gateways**
- error messages 394
  - validating addresses 441
- General Protection FaultException OE 465**
- glass**
- cleaning 95
- graphical display, control panel 48**
- gray background, problem-solving 421**
- H**
- half self-test 455**
- hard disk**
- erasing 43
  - initialization 458
  - replacing 242
- heartbeat LED 366**

- heavy media, guidelines for using 17
  - Help button, control panel touchscreen 50
  - help, control panel 50
  - high-voltage power supply operations 124
  - Home button, control panel touchscreen 50
  - Home screen, control panel 49
  - HP Customer Care 609
  - HP Driver Preconfiguration 33
  - HP Easy Printer Care software 37
  - HP fraud hotline 94
  - HP Instant Support Professional Edition (ISPE) 609
  - HP Jetdirect print server
    - configuring 41
    - error messages 392
    - settings 61
  - HP Jetdirect print servers
    - firmware updates 105
    - firmware-stack trace 464
    - lights 366
    - part numbers 481, 576, 590
    - troubleshooting 463
  - HP Printer Utility 91
  - HP Printer Utility, Macintosh 35
  - HP SupportPack 612
  - HP Toolbox
    - browsers supported 37
    - opening 85
    - options 85
  - HP Universal Print Driver 32
  - HP Web Jetadmin
    - firmware updates 104
  - HP-Authorized Dealers 609
  - humidity
    - problem-solving 418
    - specifications 606
- I**
- I/O configuration
    - network configuration 38
    - settings 60
  - Illegal Operation errors 465
  - image defects, problem-solving 419
  - image formation
    - operations 131
    - troubleshooting 455
  - image quality
    - copy, improving 434
    - copy, problem-solving 434
    - print, problem-solving 418
  - image repetition, problem-solving 429
  - Information menu 51
  - information pages 82
  - Information tab, embedded Web server 87
  - Initial Setup menu 60
  - input trays. *See* trays
  - insert tray error messages 394
  - install cartridge error message 394
  - installation
    - checklist 24
  - installers, Windows 37
  - Instant Support Professional Edition (ISPE) 609
  - insufficient memory 385, 395
  - interface ports
    - included 5
    - locating 27
  - internal clock errors 383
  - internal components, diagrams
    - and part numbers 500
  - Internet fax 29
  - IP address
    - changing 38
    - Macintosh, problem-solving 466
  - IPX/SPX setting 40, 63
- J**
- jams
    - 3-bin mailbox 409
    - 3-bin mailbox, detection 162
    - 500-sheet trays 406
    - ADF access cover, removing 334
    - ADF, detection 202
    - common causes of 399
    - control-panel messages 400
    - detection operations 151
    - Document feeder 413
    - duplex detection 158
    - duplex printing accessory 408
  - e-mail alerts 84
  - envelope feeder 403
  - frequent, troubleshooting 414
  - fuser 410
  - locations 400
  - output bin 409
  - print quality after 418
  - print-cartridge area 401
  - print-quality problems 401
  - staple 416
  - stapler/stacker 409
  - top-cover 401
  - tray 1 405
  - tray 2 access-cover switch, removing 265
- Japanese VCCI statement 621
- Jetadmin
  - firmware updates 104
- Jetadmin, HP Web 36, 90
- Jetdirect print server
  - configuring 41
  - error messages 392
  - settings 61
- Jetdirect print servers
  - firmware updates 105
  - firmware-stack trace 464
  - lights 366
  - part numbers 481, 576, 590
  - troubleshooting 463
- job storage
  - settings 60
- jobs
  - Macintosh settings 91

- K**
- Kensington locks 45
  - keys, control panel
    - locating 48
    - touchscreen 50
  - Korean EMI statement 621
- L**
- labels
    - specifications 16
  - LAN fax 29
  - LAN-connector 5
  - language, changing 109
  - languages, printer 3
  - laser safety statements 621

- laser/scanner assembly
    - connections diagram 368
    - diagrams and part numbers 501, 578, 600
    - operations 128
    - removing 315
  - LDAP servers
    - validating gateway addresses 441
  - legal paper
    - clipped margins 470
  - letterhead
    - guidelines for using 17
  - lid, cleaning 96
  - lifter-drive assembly
    - diagrams and part numbers 516
    - removing 298
  - light copying 435
  - light print
    - problem-solving 419
  - lights
    - control panel 48
    - fax accessory 367
    - formatter 366
  - lines, problem-solving
    - copies 435
  - link speed settings 66
  - Linux drivers 469
  - loading
    - error messages 395
    - unexpected size or type error message 387
  - Lock Resources, Macintosh 91
  - locking
    - accessories 8
    - control panel menus 44
    - formatter cage 45
  - loopback test 442
  - loose toner, problem-solving 423
  - loose toner, troubleshooting 401
  - low-voltage power supply
    - operations 125
- M**
- Macintosh
    - AppleTalk settings 63
    - driver settings 34
    - drivers, problem-solving 466
    - HP Printer Utility 91
    - problems, solving 466
    - removing software 35
    - software 35
    - software components 37
    - support 610
    - supported operating systems 31
    - USB card, problem-solving 467
  - mailbox, 3-bin
    - capacity 5
    - diagrams and part numbers 568
    - jam detection 162
    - jams, clearing 409
    - media specifications 13
    - media types supported 10
    - operations 135, 160
    - part numbers 7
    - reattach error message 397
  - mailbox, 3-bin
    - part number 475, 570, 592
  - main drive assembly, diagrams and part numbers 512
  - main fan (FN101), removing 258
  - main motor (M101), removing 283
  - maintenance agreements 611
  - maintenance kit
    - part number 488, 580, 592
  - Management menu 59
  - manuals, part numbers 490
  - margins
    - legal paper, problem-solving 470
  - margins, envelopes 16
  - material restrictions 617
  - Material Safety Data Sheet (MSDS) 618
  - media
    - 3-bin mailbox specifications 13
    - 500-sheet tray
      - specifications 12
    - ADF specifications 14
    - card stock 17
    - curled 379, 425, 435
    - duplexer specifications 12
    - envelope feeder
      - specifications 13
    - feeding operations 135
    - fuser modes 18
    - heavy 17
  - legal, clipped margins 470
  - letterhead 17
  - preprinted forms 17
  - problem-solving 418, 435
  - problem-solving trays 379
  - skewed 425
  - specifications 14
  - stacker specifications 13
  - stapler specifications 14
  - tray 1 specifications 11
  - types supported 10
  - wrinkled 426
- memory
  - autoconfiguration 32
  - formatter 115
  - included 35
  - insufficient 385, 395
  - NVRAM initialization 457
  - part numbers 486, 570, 592
  - permanent storage error
    - messages 391
  - print cartridges 132
  - removing DIMMs 243
  - supply errors 383
- Memory Enhancement technology (MEt) 116
- Menu button 48
- menu map
  - Information menu 51
  - printing 82
- menus, control panel
  - Administration 50
  - E-mail Setup 71
  - Fax Setup 68
  - Information 51
  - Initial Setup 60
  - locking 44
  - Management 59
  - Resets 79
  - Send Setup 71
  - Service 80
  - Time/Scheduling 58
- mercury-free product 617
- messages
  - Alert Settings, HP Toolbox 86
  - alphabetical list 383
  - e-mail alerts 84, 92
  - jams 400
  - numerical list 383
  - types of 382

- misformed characters, problem-solving 424
  - motors
    - ADF 215
    - connections diagram 368
    - diagrams 208
    - main (M101), removing 283
    - operations 119
    - print-cartridge (M102), removing 287
    - scanner 200
  - multifeeds 436
  - multipurpose assembly
    - diagrams and part numbers 524
  - multipurpose tray. *See* tray 1
  - mylar replacement kit, ADF 554
  - mylar-holder assembly, ADF 552
- N**
- Networking tab, embedded Web server 89
  - networks
    - AppleTalk settings 63
    - configuring 38
    - connectivity features 5
    - default gateway 39
    - diagnostics 64
    - disabling DLC/LLC 41
    - disabling protocols 40
    - DLC/LLC settings 63
    - firmware-stack trace 464
    - HP Jetdirect print server error messages 392
    - HP Web Jetadmin 90
    - IP address 38
    - IPX/SPX settings 63
    - link speed settings 66
    - Macintosh settings 92
    - problem-solving printing 433
    - protocol configuration page, printing 67
    - security 64
    - subnet mask 39
    - TCP/IP parameters 38
    - TCP/IP settings 61
    - troubleshooting HP Jetdirect print servers 463
    - troubleshooting printing 442
    - validating gateway addresses 441
  - next-day on-site service 611
  - noise specifications 605
  - non-HP supplies 94
  - not responding, problem-solving 381
  - NVRAM
    - initialization 457
    - operations 116
  - NVRAM errors 391
- O**
- on-site service agreements 611
  - online help, control panel 50
  - online support 609
  - operating environment specifications 606
  - operating systems supported 31
  - operations
    - 3-bin mailbox 160
    - ADF jam detection 202
    - duplex printing accessory 157
    - engine control system 117
    - formatter 114
    - image formation 131
    - jam detection 151
    - laser/scanner system 128
    - motors and fans 119
    - pickup, feed, and delivery 135
    - power supply 120
    - Resolution Enhancement technology (REt) 114
    - scanner system 198
    - sequence of 112
    - Sleep mode 114
    - temperature detection 120
  - optical unit
    - operations 200
  - ordering
    - supplies and accessories 472
    - supplies through embedded Web server 89
    - supplies with HP Toolbox 85
  - output bins
    - capacities 5
    - jams, clearing 409
    - operations 135
  - output path open error message 396
  - output quality
    - after jams 401
    - copy, improving 434
    - copy, problem-solving 434
    - print, problem-solving 418
  - output-bin-full sensor, removing 316
  - over-temperature protection 122
  - overcurrent/overvoltage protection 127
  - overlays, control panel
    - part numbers 483
    - replacing 224
- P**
- packaging device 611
  - paper
    - 3-bin mailbox specifications 13
    - 500-sheet tray
      - specifications 12
    - ADF specifications 14
    - curled 379, 425, 435
    - duplexer specifications 12
    - feeding operations 135
    - fuser modes 18
    - legal, clipped margins 470
    - problem-solving 418, 435
    - problem-solving trays 379
    - skewed 425
    - specifications 14
    - stacker specifications 13
    - stapler specifications 14
    - tray 1 specifications 11
    - types supported 10
    - wrinkled 426
  - paper path
    - cleaning 96
    - testing 415
  - paper-feed assembly, removing 311
  - paper-feed roller assembly, diagrams and part numbers 520
  - paper-path-sensor test 459
  - paper-pickup-drive assembly, diagrams and part numbers 514
  - reattach error message 397
  - removing 233

- paper-pickup-drive assembly, removing 295
- paper-present sensor(PS101), removing 314
- paper-size-detection switch (SW102), removing 313
- parallel port
  - features 5
  - locating 27
- part numbers
  - ADF 534
  - cables 481, 576, 590
  - cassette 518
  - covers 496
  - customer-replaceable parts 476, 478
  - delivery assembly 530
  - EIO cards 481, 576, 590
  - electrical/forward assembly 510
  - fuser 532
  - internal components 500
  - lifter-drive assembly 516
  - main drive assembly 512
  - maintenance kit 488, 580, 592
  - memory 486, 570, 592
  - multipurpose assembly 524
  - paper-feed roller assembly 520
  - paper-pickup-drive assembly 514
  - print cartridges 488, 576, 592
  - registration assembly 522
  - reverse assembly 526
  - reverse-separation-guide assembly 528
  - trays 475, 579, 592
  - upper-plate assembly 498
- parts
  - replacing 221, 472
- password, embedded Web server 42
- PCL drivers
  - universal 32
- permanent storage errors 391
- PFC (power-factor-correction) power supply, removing 301
- phone cords, part numbers 481, 579, 587
- phone line, connecting fax accessory 28
- photosensitive drum rotation test 456
- pickup and feed operations 135
- pickup roller, replacing tray 1 237
- pickup rollers, replacing ADF 228
- pickup-roller assembly, ADF 548
- ping test 443
- PJL (printer job language) 116
- PML (printer management language) 116
- ports
  - included 5
  - locating 27
  - problem-solving Macintosh 467
- PostScript
  - problem-solving 470
- PostScript Printer Description (PPD) files
  - included 35
- power
  - specifications 604
  - troubleshooting 364
- power cords, part numbers 481, 581, 587
- power supply
  - connections diagram 368
  - engine, removing 306
  - operations 120
  - overcurrent/overvoltage protection 127
- power-factor-correction (PFC) power supply, removing 301
- PPDs
  - included 35
- preconfiguration, driver 33
- preprinted forms
  - guidelines for using 17
- pressure roller operations 131
- preventative maintenance kit
  - part number 488, 580, 592
- print cartridges
  - authentication 94
  - detection operations 127
  - drum rotation test 456
  - EconoMode 115
  - error messages 394
  - genuine HP 93
  - image formation operations 131
  - jams, clearing 401
- management menu 60
- memory 132
- non-HP 94
- ordering through embedded Web server 89
- part numbers 488, 576, 592
- recycling 616
- replacing 93, 224
- status, viewing with HP Toolbox 85
- storage 93
- print quality
  - after jams 401
  - blurred 429
  - dropouts 420
  - environment 418
  - gray background 421
  - image defects 419
  - jams, after 418
  - light print 419
  - lines 421
  - loose toner 423
  - media 418
  - misformed characters 424
  - problem-solving 418
  - repeating defects 423
  - repetitive images 429
  - scattered lines 428
  - smearred toner 422
  - specks 420
  - tire tracks 427
  - white lines 427
  - white spots 428
- print-cartridge fan (FN102), removing 285
- print-cartridge motor (M102), removing 287
- printer
  - dimensions 22
- printer drivers. See drivers
- printer job language (PJL) 116
- printer languages 3
- printer maintenance kit
  - part number 488, 580, 592
- printer management language (PML) 116
- printer sequence of operations 112
- printing system software 30
- priority, settings 33



- problem-solving
  - blank pages 380
  - blurred print 429
  - copy quality 434
  - copy size 437
  - copying 434, 437
  - curled paper 379, 425
  - dropouts 420
  - duplexing 380
  - e-mail alerts 84, 92
  - environment 418
  - EPS files 467
  - Error button, control panel
    - touchscreen 50
  - fonts 470
  - gateway addresses 441
  - gray background 421
  - image defects 419
  - legal paper 470
  - light print 419
  - lines 421, 427
  - lines, copies 435
  - Linux 469
  - Macintosh issues 466
  - media 418, 435
  - messages, types of 382
  - network printing 433
  - networks 64
  - output quality 418
  - PostScript problems 470
  - printing 381
  - receiving faxes 439
  - repeating defects 423
  - repetitive images 429
  - scattered lines 428
  - sending faxes 438
  - skewed pages 425
  - slow printing 380
  - smeared toner 422
  - specks 420
  - text 380
  - text quality 424, 429
  - tire tracks 427
  - trays 379
  - white spots 428
  - Windows issues 465
  - wrinkled paper 426
- processor specifications 115
- protocol configuration page,
  - printing 67

**Q**

- quality
  - after jams 401
  - copy, improving 434
  - copy, problem-solving 434
  - print, problem-solving 418

**R**

- Ready light
  - locating 48
- reattach output bin error
  - message 397
- receiving faxes
  - problem-solving 439
- recycling 616
- registration assembly, diagrams
  - and part numbers 522
- registration assembly,
  - removing 292
- remote firmware update
  - (RFU) 102
- removing Macintosh software 35
- removing parts 221
- repacking device 611
- repeating defects, problem-
  - solving 423, 429
- repetitive defect ruler 431
- replacing parts 221
- replacing printing cartridges 93
- reset button 48
- reset, cold 457
- Resets menu, control panel 79
- resolution
  - operations 114
  - problem-solving quality 418
  - settings 91
- Resolution Enhancement
  - technology (REt) 91, 114
- REt (Resolution Enhancement
  - technology) 91
- reverse assembly, diagrams and
  - part numbers 526
- reverse-separation-guide
  - assembly, diagrams and part
    - numbers 528
- reversing assembly
  - operations 148
  - removing 254
- reversing-separation-guide
  - assembly, removing 253

- reversing-unit fan (FN103),
  - removing 258
- rollers
  - 500-sheet trays, replacing 236
  - ADF pickup assembly 548
  - ADF, replacing 228
  - cleaning document feeder 98
  - feed assembly, removing 278
  - image formation
    - operations 131
  - paper-feed assembly,
    - diagrams and part
      - numbers 520
  - repetitive defect ruler 431
  - transfer, replacing 226
  - tray 1 pickup, replacing 237

**S**

- safety statements 621
- scanner
  - operations 198
  - sequence of operations 113
- scanner assembly, removing 321
- scanner calibration 77, 106
- scanner diagrams and part
  - numbers
    - base components 556
    - covers 560
    - flatbed-unit assembly 558
- scanner errors 386
- scanner filter, replacing 238
- scanner glass
  - cleaning 95
- scanner lid backing, cleaning 96
- scanner tests 460
- scanner-controller PCA
  - connections, diagrams 370
- scanner-controller PCA,
  - removing 326
- scanning e-mail
  - validating gateway
    - addresses 441
- scanning to e-mail
  - error messages 394, 398
- screwdrivers, required 221
- screws, types used 222, 473
- Secure Disk Erase 43
- security
  - disk erase 43
  - features 42

- Foreign Interface Harness (FIH) 42
- locking control panel menus 44
- locking formatter cage 45
- settings 64
- security features 5
- Send Setup menu 71
- sending faxes
  - problem-solving 438
- sending to e-mail
  - error messages 394, 398
- sending to e-mail
  - validating gateway addresses 441
- sensors
  - 3-bin mailbox jam
    - detection 162
  - ADF diagrams 215
  - ADF jam detection 202
  - ADF, removing 335
  - connections diagram 368
  - diagrams 204
  - duplex jam detection 158
  - fuser-control circuits 121
  - jam detection 151
  - manual test 459
  - media-detection 135
  - output-bin-full, removing 316
  - paper-path, testing 459
  - paper-present sensor(PS101), removing 314
  - scanner, testing 460
  - temperature detection 120
  - thermistor (TH3), removing 263
- separation pad, ADF
  - diagrams and part numbers 544
  - replacing 229
- sequence of operations 112
- service
  - HP-Authorized Dealers 609
  - repacking device 611
- service agreements 611
- service ID 462
- Service menu, control panel 80
- settings
  - cold reset 457
  - drivers 34
  - priority 33
- Settings tab, embedded Web server 88
- setup
  - checklist 24
- shipping device 611
- site preparation 22
- size, copy
  - problem-solving 437
- size, media
  - 3-bin mailbox specifications 13
  - 500-sheet tray
    - specifications 12
  - ADF specifications 14
  - duplexer specifications 12
  - envelope feeder
    - specifications 13
  - stacker specifications 13
  - stapler specifications 14
  - tray 1 specifications 11
  - unexpected, error message 387
- skew
  - prevention operations 145
- skewed pages 425
- Sleep button 48
- Sleep mode
  - settings 59, 60
- sleep settings
  - delay 101
  - operations 114
  - power specifications 604
  - wake time 101
- slow printing, problem-solving 380
- slow speed, problem-solving
  - fax receiving 439
- smearred toner, problem-solving 422
- SMTP servers
  - validating gateway addresses 441
- software
  - embedded Web server 36
  - HP Easy Printer Care 37
  - HP Printer Utility 91
  - HP Toolbox 85
  - HP Web Jetadmin 36
  - Macintosh 35, 37
  - settings 33
  - supported operating systems 31
  - uninstalling Macintosh 35
  - Web sites 30
  - Windows 37
- solenoids, diagrams 204
- space requirements 22
- specifications
  - acoustic 605
  - electrical 604
  - envelopes 15
  - labels 16
  - operating environment 606
  - paper 14
  - transparencies 16
- specifications, media
  - envelope feeder 13
- specks, problem-solving 420, 428
- speed
  - fax receiving, problem-solving 439
  - problem-solving 380
  - troubleshooting 359
- speed dial list, printing 83
- Spool32 errors 465
- spots, problem-solving 420, 428
- standard output bin
  - capacity 5
  - jams, clearing 409
  - operations 135
  - reattach error message 397
- staple cartridges
  - jams 416
  - part numbers 7, 475, 570, 588
- stapler/stacker
  - capacity 5
  - diagrams and part numbers 566
  - media specifications 13, 14
  - media types supported 10
  - operations 135
  - paper jams 409
  - part number 7, 475, 570, 592
  - reattach error message 397
  - staple jams 416
  - too many pages error message 397
- Start button 48
- Start button, control panel
  - touchscreen 50
- status
  - e-mail alerts 84

- embedded Web server 87
  - Home screen, control panel 49
  - HP Printer Utility, Macintosh 91
  - HP Toolbox software 85
  - messages, types of 382
  - Status button 48
  - Stop button 48
  - Stop button, control panel touchscreen 50
  - storage cabinet
    - locking and unlocking 8
    - part number 7, 475, 584, 592
  - storage, job
    - Macintosh settings 91
    - settings 60
  - storing
    - envelopes 16
    - print cartridges 93
  - streaks, problem-solving 435
  - subnet mask 39
  - supplies
    - authentication 94
    - counterfeit 94
    - e-mail alerts 84
    - management menu 60
    - memory errors 383
    - non-HP 94
    - ordering 472
    - ordering through embedded Web server 89
    - ordering with HP Toolbox 85
    - part
      - numbers 7, 475, 488, 570, 576, 588, 592
    - recycling 616
    - replacing print cartridges 93
    - Resets menu 79
    - status page, printing 82
    - status, viewing with embedded Web server 87
    - status, viewing with HP Printer Utility 91
    - status, viewing with HP Toolbox 85
  - support
    - embedded Web server links 89
    - HP Printer Utility pages 91
    - Linux 469
    - online 609
    - repacking device 611
  - Support tab, HP Toolbox 85
  - SupportPack, HP 612
  - switches
    - connections diagram 368
    - diagrams 204
    - paper-size-detection (SW102), removing 313
    - testing 459
    - top-cover (SW101), removing 290
    - tray 2 detection, removing 312
    - tray 2 jam-access-cover (SW105), removing 265
- T**
- TCP/IP settings 61
  - technical support
    - Linux 469
    - online 609
    - repacking device 611
  - temperature
    - detection sensor 120
    - fuser-control circuits 121
    - thermistor (TH3), removing 263
  - temperature specifications 606
  - tests
    - component 461
    - drum rotation 456
    - engine 454
    - firmware-stack trace 464
    - formatter 455
    - half self 455
    - networks 64
    - paper-path-sensor 459
    - scanner 460
    - sensor, manual 459
  - text, problem-solving
    - blurred 429
    - blurry 435
    - dropouts 420
    - garbled 380
    - misformed characters 424
  - thermistor (TH3), removing 263
  - time, setting 59, 100
  - Time/Scheduling menu, control panel 58
  - timeout settings 60
  - timing chart 371
  - tire tracks, problem-solving 427
  - toner
    - adhesion problems, solving 435
    - density setting 91
    - level detection 127
    - loose, problem-solving 423
    - smearred, problem-solving 422
  - Toolbox. See HP Toolbox
  - tools, required 221
  - top cover
    - jams, clearing 401
  - top-cover flatbed flange, removing 246
  - top-cover switch (SW101), removing 290
  - transfer charging roller operations 131
  - transfer rollers, replacing 226
  - transparencies
    - specifications 16
    - troubleshooting 418
  - tray 1
    - feed assembly, removing 271
    - insert or close error message 394
    - jam detection 151
    - jams, clearing 405
    - load error message 395
    - media sizes supported 11
    - media types supported 10
    - operations 135
    - pickup roller, replacing 237
    - problem-solving 379
    - removing 267
    - unexpected size or type error message 387
  - tray 2
    - problem-solving 379
  - tray 2 detection switch, removing 312
  - tray 2 jam-access-cover switch (SW105), removing 265
  - tray 3
    - problem-solving 379
  - trays
    - ADF input, replacing 227
    - feeding problems, solving 436
    - insert or close error message 394
    - jam detection 151

- jams, clearing 405, 406
- Macintosh settings 91
- media size specifications 12
- media types supported 10
- operations 135
- part numbers 475, 579, 592
- problem-solving 379
- rollers, replacing 236
- sensor tests 459
- sensors, diagrams 204
- status, viewing with HP
  - Toolbox 85
- unexpected size or type error message 387
- troubleshooting
  - Alert Settings window, HP
    - Toolbox 86
  - checklist 359
  - cold reset 457
  - component test 461
  - control panel messages, numerical 383
  - drum rotation test 456
  - engine test 454
  - error messages, alphabetical list 383
  - error messages, numerical list 383
  - firmware-stack trace 464
  - formatter test 455
  - half self-test 455
  - HP Jetdirect print servers 463
  - jams, clearing 400
  - jams, frequent 414
  - network printing 442
  - network printing, loopback test 442
  - network printing, ping test 443
  - paper path test 415
  - paper-path-sensor test 459
  - power 364
  - repetitive defect ruler 431
  - scanner tests 460
  - sensor test, manual 459
  - speed 359
  - staple jams 416
- TrueType fonts included 3
- two-sided printing
  - error messages 387, 392, 394, 397
- Macintosh settings 91
- problem-solving 380
- typefaces
  - included 3
- U**
  - unable to connect, copy, or send 398
  - unexpected size or type error messages 387
  - uninstalling Macintosh software 35
  - universal print driver 32
  - unlocking accessories 8
  - Update Now feature, drivers 33
  - upgrading firmware 102
  - upper-plate assembly, diagrams and part numbers 498
  - usage page, printing 82
  - USB cable, part number 481, 585, 587
  - USB configuration 27
  - USB port
    - problem-solving Macintosh 467
- V**
  - validating gateway addresses 441
  - vertical white or faded stripes 434
  - voltage specifications 604
- W**
  - wake time, setting 101
  - Warning button, control panel touchscreen 50
  - warranty
    - extended 612
    - product 607
  - wavy paper, problem-solving 379, 425
  - Web Jetadmin
    - firmware updates 104
  - Web sites
    - customer support 609
    - fraud reports 94
    - HP Easy Printer Care 37
    - HP Web Jetadmin, downloading 90
    - Linux support 469
    - Macintosh customer support 610
  - Material Safety Data Sheet (MSDS) 618
  - ordering supplies 472
  - paper specifications 14
  - software, downloading 30
  - universal print driver 32
  - weekly on-site service 611
  - weight, media specifications
    - 3-bin mailbox 13
    - 500-sheet tray 12
    - ADF 14
    - duplexer 12
    - envelope feeder 13
    - stacker 13
    - stapler 14
    - tray 1 11
  - white lines or spots, problem-solving 427
  - white or faded stripes 434
  - Windows
    - driver settings 34
    - problem-solving issues 465
    - software components 37
    - supported operating systems 31
    - universal print driver 32
  - Windows 2000 fax 29
  - wrinkled paper, problem-solving 426



© 2006 Hewlett-Packard Development Company, L.P.

[www.hp.com](http://www.hp.com)



CB425-90908