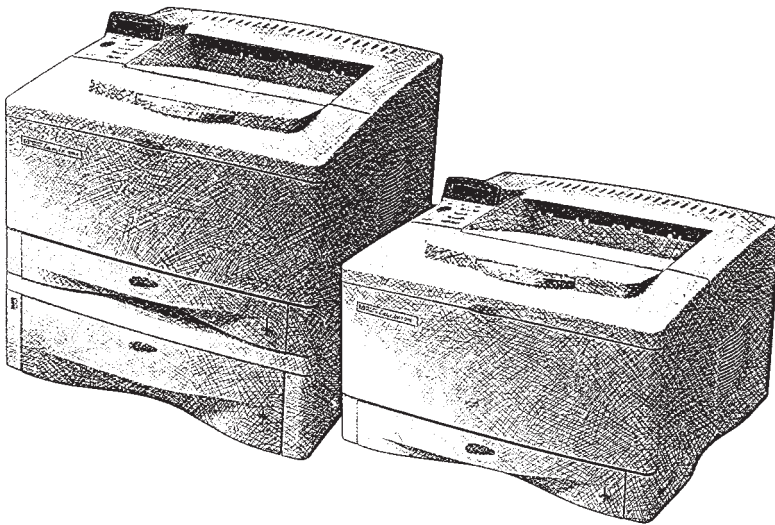


English



**HP LaserJet 5000, 5000 N  
and 5000 GN Printers  
Service Manual**

---

# HP LaserJet 5000, 5000 N, and 5000 GN Printers

**Service Manual** 

---

**© Copyright Hewlett-Packard  
Company 1998**

All Rights Reserved.  
Reproduction, adaptation, or  
translation without prior written  
permission is prohibited, except  
as allowed under the copyright  
laws.

Publication number  
C4110-91033

First Edition

**Warranty**

The information contained in  
this document is subject to  
change without notice.

Hewlett-Packard makes no  
warranty of any kind with  
respect to this information.  
HEWLETT-PACKARD  
SPECIFICALLY DISCLAIMS  
THE IMPLIED WARRANTY OF  
MERCHANTABILITY AND  
FITNESS FOR A PARTICULAR  
PURPOSE.

Hewlett-Packard shall not be  
liable for any direct, indirect,  
incidental, consequential, or  
other damage alleged in  
connection with the furnishing or  
use of this information.

**Trademark Credits**

PostScript™ is a trademark of  
Adobe Systems Incorporated  
which may be registered in  
certain jurisdictions.

CompuServe™ is a U.S.  
trademark of CompuServe, Inc.

Windows® is a U.S. registered  
trademarks of Microsoft  
Corporation.

TrueType™ is a U.S. trademark  
of Apple Computer, Inc.

ENERGY STAR® is a U.S.  
registered service mark of the  
U.S. EPA.

# Contents

## 1 Printer Description

Overview . . . . .	1-1
Printer Features . . . . .	1-2
Identification . . . . .	1-5
Model and Serial Numbers . . . . .	1-5
Site Requirements . . . . .	1-6
Space Requirements . . . . .	1-7
Paper Specifications . . . . .	1-11
Supported Types of Paper . . . . .	1-14
Guidelines for Using Paper . . . . .	1-15
Labels . . . . .	1-18
Transparencies . . . . .	1-18
Vellum . . . . .	1-18
Envelopes . . . . .	1-19
Card Stock and Heavy Paper . . . . .	1-20
Safety Information . . . . .	1-22
Laser Safety Statement . . . . .	1-22
Canadian DOC Regulations . . . . .	1-22
FCC Regulations . . . . .	1-23
Laser Statement for Finland . . . . .	1-24
Toner Safety . . . . .	1-25
Environmental Product Stewardship . . . . .	1-26

## 2 Service Approach

Overview . . . . .	2-1
Service Approach . . . . .	2-2
Parts and Supplies . . . . .	2-3
Ordering Information . . . . .	2-3
Helpful Documentation . . . . .	2-4
Phone Numbers for Ordering . . . . .	2-5
Exchange Program . . . . .	2-5
Consumables . . . . .	2-5
Technical Assistance . . . . .	2-5
Toner Cartridge Information . . . . .	2-8
Warranty Statement . . . . .	2-9

## 3 Printer Operation

Overview . . . . .	3-1
Using the Control Panel . . . . .	3-2
Control Panel Layout . . . . .	3-2
Control Panel Lights . . . . .	3-2
Control Panel Keys . . . . .	3-3
Settings and Defaults . . . . .	3-4
Control Panel Menus . . . . .	3-5
Information Menu . . . . .	3-6
Paper Handling Menu . . . . .	3-7
Print Quality Menu . . . . .	3-10
Printing Menu . . . . .	3-13
Configuration Menu. . . . .	3-17
I/O Menu . . . . .	3-24
EIO Menu (Networked Printers) . . . . .	3-27
Resets Menu. . . . .	3-29
Service Mode . . . . .	3-30
Service Menu . . . . .	3-31
Setting the Page Count, Maintenance Count, and Serial Number . . . . .	3-31
Cold Reset Paper . . . . .	3-34
Diagnostics . . . . .	3-34
Clear Event Log . . . . .	3-34
Testing the Printer . . . . .	3-35
Resetting the Printer . . . . .	3-36
System Configuration . . . . .	3-37
MS-DOS System Configuration . . . . .	3-37
Parallel DOS Commands . . . . .	3-37
Serial MS-DOS Commands . . . . .	3-38
Printer I/O Configuration . . . . .	3-39
Parallel Menu . . . . .	3-39
Serial Configuration . . . . .	3-39

## 4 Printer Maintenance

Overview . . . . .	4-1
Cleaning the Printer and Accessories . . . . .	4-2
Cleaning Spilled Toner . . . . .	4-4
Preventative Maintenance. . . . .	4-5
Reset Maintenance Count . . . . .	4-5
Expected Life of Components. . . . .	4-5

## 5 Functional Information

Overview . . . . .	5-1
Printer Subsystems . . . . .	5-2
Power Supply System . . . . .	5-3
AC/DC Power Distribution . . . . .	5-3
Overcurrent Overvoltage Protection . . . . .	5-5
High Voltage Power Distribution . . . . .	5-6
Toner Cartridge Detection . . . . .	5-7
DC Controller System . . . . .	5-7
Laser and Scanner Drive . . . . .	5-8
Paper Motion Monitoring and Control . . . . .	5-9
Solenoids, Sensors, Clutches, and Switches . . . . .	5-9
Engine Test Print . . . . .	5-9
Motors . . . . .	5-10
Formatter System . . . . .	5-12
PowerSave . . . . .	5-12
Resolution Enhancement technology (REt) . . . . .	5-13
EconoMode . . . . .	5-13
Input/Output . . . . .	5-14
CPU . . . . .	5-14
Printer Memory . . . . .	5-15
Random Access Memory (RAM) . . . . .	5-15
DIMM Slots . . . . .	5-16
Memory Enhancement technology (MEt) . . . . .	5-16
Page Protect . . . . .	5-16
PJM Overview . . . . .	5-17
PML . . . . .	5-17
Control Panel . . . . .	5-17
Image Formation System . . . . .	5-18
Toner Cartridge . . . . .	5-20
Photosensitive Drum . . . . .	5-21
Writing the Image . . . . .	5-24
Developing the Image . . . . .	5-25
Transferring the Image . . . . .	5-26
Image Fusing/Variable Fusing Temperature . . . . .	5-27
Paper Feed System . . . . .	5-29
Clutches and Sensors . . . . .	5-30
Printing from Tray 1 . . . . .	5-31
Printing from Tray 2 . . . . .	5-33
Printing from the Optional 500-sheet and 250-sheet Trays . . . . .	5-35
Paper Jam . . . . .	5-37
Duplexer . . . . .	5-38
Paper Jam in the Duplexer . . . . .	5-44
Basic Sequence of Operation . . . . .	5-45

## 6 Removing and Replacing Parts

Overview . . . . .	6-1
User Installable Accessories . . . . .	6-2
Removal and Replacement Strategy . . . . .	6-7
Required Tools . . . . .	6-7
Removing Covers . . . . .	6-10
Rear Door / Rear Output Bin. . . . .	6-10
Top Cover . . . . .	6-12
Control Panel Overlay and Control Panel . . . . .	6-15
Toner Cartridge Door Assembly . . . . .	6-17
Front Cover and Tray 1 . . . . .	6-18
Front Cover Pins . . . . .	6-20
Face Down Assembly . . . . .	6-21
Left and Right Side Covers . . . . .	6-23
Tray 1 Inner Cover . . . . .	6-24
Right and Left Corner Covers . . . . .	6-26
Removing Assemblies . . . . .	6-27
Transfer Roller Assembly . . . . .	6-28
Fuser . . . . .	6-30
Paper Handling PCA . . . . .	6-31
Main Gear Assembly . . . . .	6-35
Pickup Gear Assembly . . . . .	6-37
Tray 1 Pickup Solenoid . . . . .	6-39
Fan . . . . .	6-40
Formatter Assembly . . . . .	6-41
Tray 1 Roller . . . . .	6-42
Tray 2 Roller . . . . .	6-43
Paper Feed Roller Assembly . . . . .	6-44
DC Controller Board and Power Supply . . . . .	6-47
Paper Feed Belt Assembly . . . . .	6-51
Tray 1 Shaft . . . . .	6-53
Tray 2 Shaft . . . . .	6-55
Tray 1 Lift Plate . . . . .	6-57
Tray 1 Separation Pad . . . . .	6-58
Paper Guide . . . . .	6-59
Paper Path Detect Sensor . . . . .	6-60
Face Down Bin Full Sensor . . . . .	6-61
Power Connection . . . . .	6-63
Registration Assembly . . . . .	6-64
Upper Delivery Assembly . . . . .	6-66
Delivery Roller Removal . . . . .	6-68
Laser Scanner Assembly . . . . .	6-70
Main Motor . . . . .	6-71
Toner Cartridge Guides . . . . .	6-72
Power Inlet Assembly . . . . .	6-73

Optional 500-sheet Tray Disassembly . . . . .	6-74
Tray Indicator Assembly . . . . .	6-76
Left Front Corner Cover Installation . . . . .	6-77
Paper Size Spring Assembly . . . . .	6-78
D-roller and Feed Roller . . . . .	6-79
Gear Assembly and PCA . . . . .	6-81
Power Connector . . . . .	6-82
Separation Roller . . . . .	6-83

## 7 Troubleshooting

Overview . . . . .	7-1
Troubleshooting Process. . . . .	7-2
Troubleshooting Process Flow . . . . .	7-4
Troubleshooting the Printing System . . . . .	7-6
Preliminary Operating Checks . . . . .	7-6
Power On . . . . .	7-7
Display . . . . .	7-11
Event Log . . . . .	7-12
Printer Messages . . . . .	7-16
General Paper Path Troubleshooting . . . . .	7-41
Information Pages. . . . .	7-44
Image Quality . . . . .	7-49
Interface Troubleshooting . . . . .	7-77
Reference Diagrams . . . . .	7-80
Locations of Components. . . . .	7-80
Sensors and Signals. . . . .	7-88
DC Controller PCA Inputs and Outputs . . . . .	7-107

## 8 Parts and Diagrams

Overview . . . . .	8-1
How To Use the Parts Lists and Diagrams . . . . .	8-2
Accessories and Supplies . . . . .	8-4
Common Hardware and Replacement Cables . . . . .	8-6
Illustrations and Parts Lists . . . . .	8-7
Alphabetical Parts List . . . . .	8-39
Numerical Parts List . . . . .	8-44

## Index





# 1 Printer Description

## Overview

This chapter discusses the following:

- Printer Features
- Identification
- Site Requirements
- Paper Specifications
- Safety Information

# Printer Features

---

**Table 1-1. Printer Features**

---

<b>Speed</b>	17 pages per minute (ppm), A4 paper or 16 ppm, letter paper 100 MHz RISC microprocessor First Page Out = 13 sec.
<b>Resolution</b>	300 dpi with PCL5e/PostScript™ Level 2 emulation (PS) 600 dpi with PCL5e/PS HP FastRes 1200 (PCL6 only) HP ProRes 1200 (PCL6, PS)
<b>Typefaces</b>	110 Scalable TrueType™ (80 built-in, 30 via FontSmart, all PS and PCL accessible)
<b>Memory Options</b>	HP LaserJet 5000: 4 MB RAM standard HP LaserJet 5000 N: 8 MB RAM standard HP LaserJet 5000 GN: 12 MB RAM standard  Optional Memory: 2, 4, 8, 16 MB EDO DIMMs 32 MB SDRAM DIMM
<b>Expansion Slots</b>	3 100-pin DIMM slots 2 enhanced I/O (EIO) slots
<b>Interface</b>	Bidirectional IEEE 1284 compliant parallel interface RS-232 9-pin serial Paper Handling Connector (PHC)
<b>Optional Networking</b>	10Base-T and 10Base-2 10/100Base-TX Token Ring LocalTalk
<b>Mass Storage Options</b>	2 and 4 MB Flash DIMMs

---

**Table 1-1. Printer Features (continued)**

---

Paper Trays	100-sheet Tray 1 Size: 3 by 5 in (76 by 127 mm) to 12.28 by 18.5 in (312 by 470 mm) Optional 250-sheet Tray 2 supports Size: 5.8 by 8.2 in (149 by 210 mm) to 11 by 17 in (279 by 432) Optional Universal 500-sheet Tray supports standard and custom sizes from 5.8 by 8.2 in (149 by 210 mm) to 11 by 17 in (279 by 432)
Paper Path	Straight through from Tray 1 to rear output bin Or to top output bin
Output Capacity	250-sheet top output bin 50-sheet rear output bin
Paper Handling Options	Duplexer, optional 250-sheet and 500-sheet universal tray assembly

---

---

**Table 1-2. Comparison of HP LaserJet 5000 Series Printers**

---

	<b>HP LaserJet 5000</b>	<b>HP LaserJet 5000 N</b>	<b>HP LaserJet 5000 GN</b>
Ethernet 10-T/ 10-2	optional	standard	standard
Max. # input bins	4	4	4
Standard RAM	4 MB internal	8 MB <sup>1</sup>	12 MB <sup>1</sup>
250-sheet Tray	1 standard 1 optional	1 standard 1 optional	1 standard 1 optional
500-sheet Universal Tray	optional	standard	standard
1.4 GB EIO Drive	optional	optional	standard
Duplexer	optional	optional	optional
Envelope feeder	not available	not available	not available
LocalTalk	optional	standard	standard

---

1. 4 MB internal, with remainder in DIMM

# Identification

## Model and Serial Numbers

The model number and serial numbers are listed on identification labels located on the rear left side of the printer. The serial number is alphanumeric, such as USB0000146 for the HP LaserJet 5000 N printer.

The serial number contains information about the Country of Origin, the Revision Level, the Production Code, and Production Number of the printer.

The rear labels also contain power rating and regulatory information as shown in Figure 1-1.

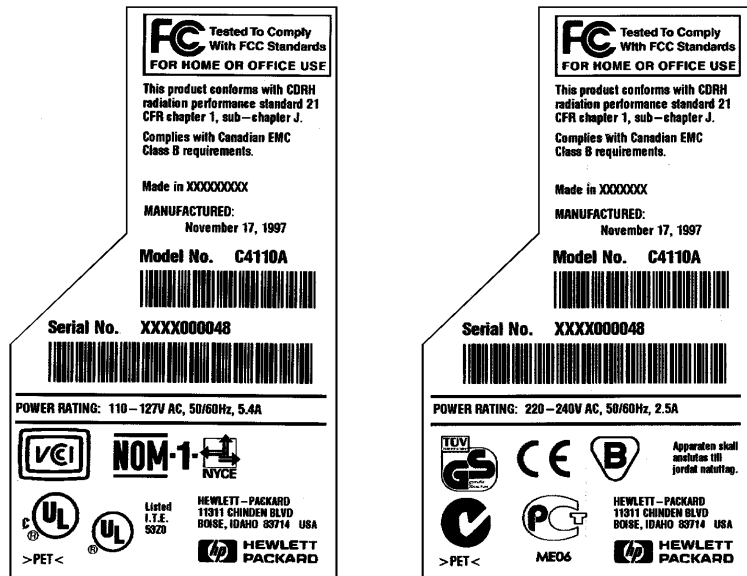


Figure 1-1 Sample Labels

# Site Requirements

The following environmental specifications must be maintained to ensure the proper operation of the printer. Consider the following points before installing the printer:

- Install in a well-ventilated, dust-free area.
- Install on a hard, flat and continuous surface, with all four printer feet level. Do not install on carpet or other soft surfaces.
- Ensure adequate power is supplied. Printer power requirements are listed in Table 1-3.
- Install where temperature and humidity is stable, away from water sources, humidifiers, air conditioners, refrigerators, or other major appliances.
- Install away from direct sunlight, open flames, or ammonia fumes. If the printer is placed near a window, make sure the window has a curtain or blind to block any direct sunlight.
- Install with enough space around the printer for proper access and ventilation.
- Install printer away from the direct flow of exhaust from air ventilation systems.

---

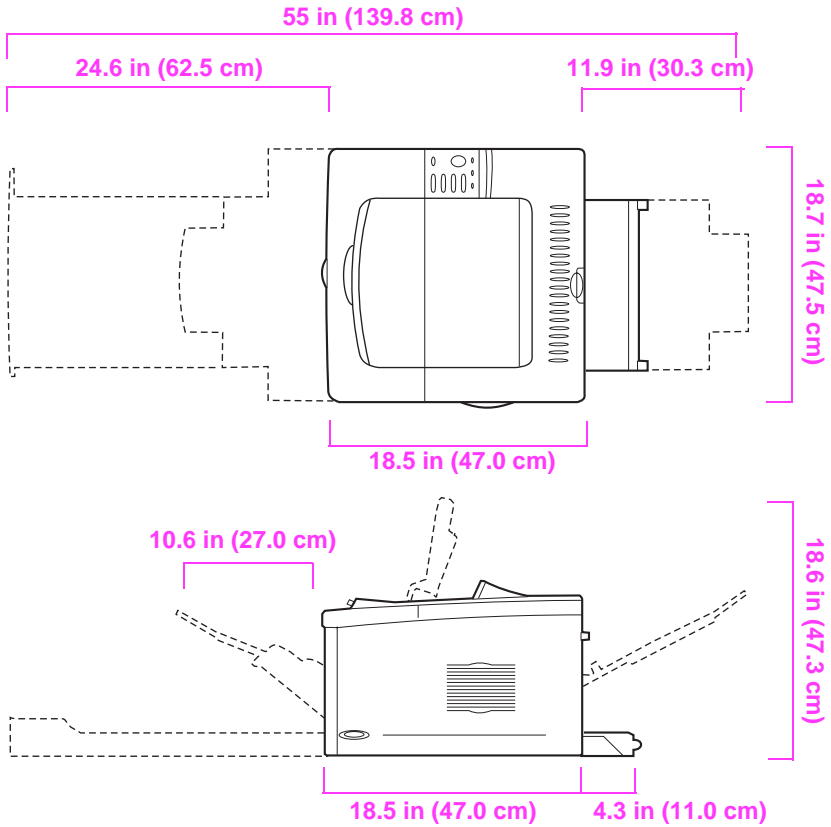
**Table 1-3. Electrical Specifications**

---

<b>Volts</b>	<b>Frequency</b>	<b>Amps</b>	<b>Watts (typical)</b>
100-127 VAC±10%	50/60 Hz ±3Hz	11 amps	printing = 365 standby = 40 PowerSave On = 27 (EPA ENERGY STAR®)
220-240 VAC±10%	50/60 Hz ±3Hz	5 amps	printing = 355 standby = 40 PowerSave On = 22 (EPA ENERGY STAR®)

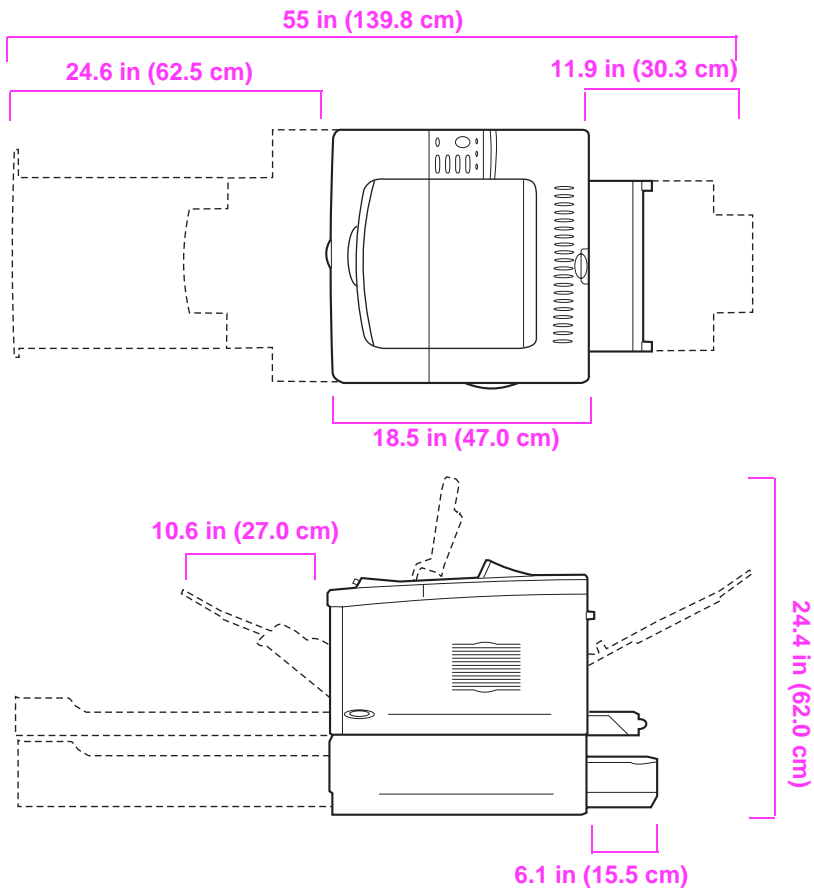
---

# Space Requirements

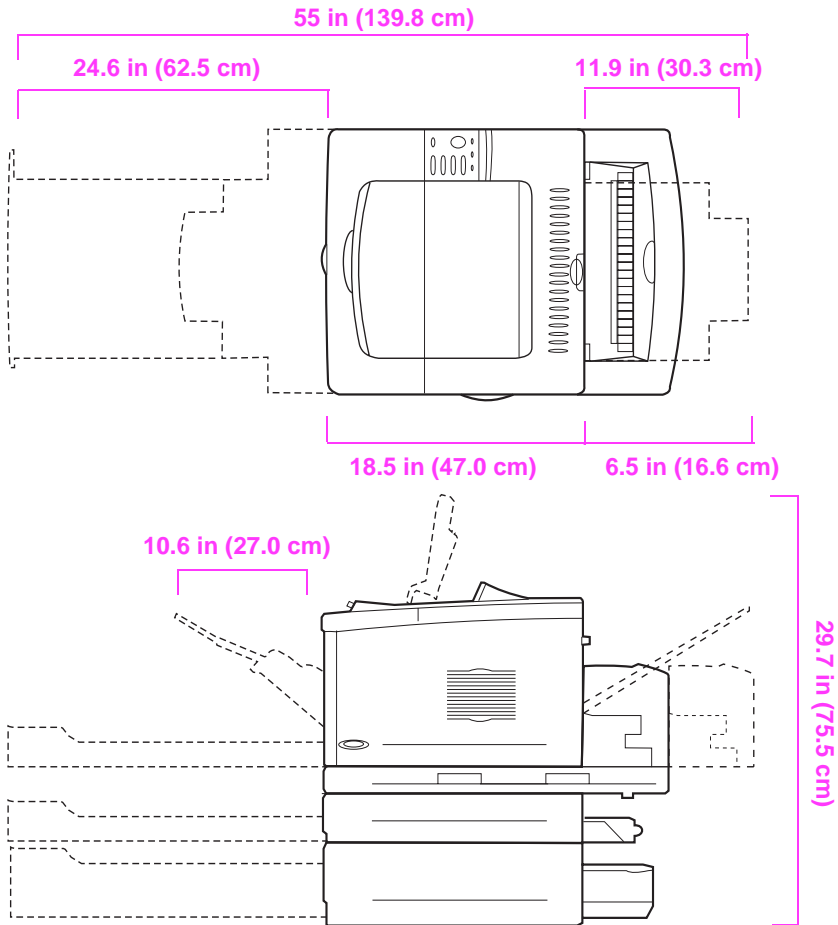


**Figure 1-2** Printer Dimensions, HP LaserJet 5000





**Figure 1-3** Printer Dimensions, HP LaserJet 5000 N/5000 GN



**Figure 1-4** Printer Dimensions, HP LaserJet 5000 with Accessories

### **Printer Weight (without toner cartridge)**

- HP LaserJet 5000 printer: 50 lb (23 kg)
- HP LaserJet 5000 N/5000 GN printers: 75 lb (34 kg)
- HP LaserJet 5000 N/5000 GN printers with duplexer and optional 250-sheet feeder: 114 lb (52 kg)

## Environmental Requirements

---

**Table 1-4. Printer and Toner Cartridge Environmental Conditions**

---

Item	Operating	Storage
Temperature	50-91° F (10-32° C)	-4 to 140°F (-20 to 60°C)
Relative Humidity	20-80% RH (with no condensation)	10% TO 95% RH

---

---

**Table 1-5. Acoustic Emissions (Per ISO 9296)**

---

Printer State	Sound Power
Printing, 16 pages per minute (ppm)	$L_{wad} = 6.6$ bels (A)
Printing, 8 ppm	$L_{wad} = 6.3$ bels (A)
PowerSave	$L_{wad} = 4.4$ bels (A)

---

# Paper Specifications

The following tables show paper specifications for the printer.

**Table 1-6. Paper Specifications, Tray 1**

Supported Paper	Dimensions <sup>1</sup>	Weight	Capacity <sup>2</sup>
Minimum Size (custom)	3 by 5 in (76 by 127 mm)	16 to 53 lb (60 to 199 g/m <sup>2</sup> )	100 sheets of 20 lb (75 g m <sup>2</sup> ) paper
Maximum Size (custom)	12.28 by 18.5 in (312 by 470 mm)		
Transparencies	Same as minimum and maximum paper sizes listed above.	Thickness: 0.0039 in to 0.0045 in (0.099 to 0.114 mm)	75 transparencies
Labels		Thickness: 0.005 in to 0.007 in (0.127 mm to 0.178 mm)	50 labels
Envelopes		20 to 28 lb (75 to 105 g/m <sup>2</sup> )	10 envelopes

1. The printer supports a wide range of paper sizes. Check the printer software for supported sizes. To print custom-size paper see the User's Guide.
2. Capacity may vary depending on paper weight and thickness, and environmental conditions.

**Table 1-7. Paper Specifications, Tray 2 or Optional 250-sheet Tray**

<b>Supported Paper</b>	<b>Dimensions<sup>1</sup></b>	<b>Weight</b>	<b>Capacity<sup>2</sup></b>
Letter	8.5 by 11 in (216 by 279 mm)	16 to 28 lb (60 to 105 g/m <sup>2</sup> )	250 sheets of 20 lb (75 g/m <sup>2</sup> ) paper 50-100 transparencies
A4	8.3 by 11.7 in (210 by 297 mm)		
Executive	7.3 by 10.5 in (191 by 267 mm)		
Legal	8.5 by 14 in (216 by 356 mm)		
B5 (JIS)	7.2 by 10 in (182 by 257 mm)		
A5	5.8 by 8.2 in (148 by 210 mm)		
11 x 17	11 by 17 in (279 by 432 mm)		
A3	11.7 by 16.5 in (297 by 420 mm)		
B4 (JIS)	10.1 by 14.3 in (257 by 364 mm)		

1. The printer supports a wide range of media sizes. Check the printer software for supported sizes.
2. Capacity may vary depending on media weight and thickness, and environmental conditions.

**Table 1-8. Paper Specifications, Optional 500-sheet Tray**

<b>Supported Paper</b>	<b>Dimensions<sup>1</sup></b>	<b>Weight</b>	<b>Capacity<sup>2</sup></b>
Letter Letter-R <sup>3</sup>	8.5 by 11 in (216 by 279 mm)	16 to 28 lb (60 to 105 g/m <sup>2</sup> )	500 sheets of 20 lb (75 g/m <sup>2</sup> ) paper 50-100 transparencies
A4 A4-R <sup>3</sup>	8.3 by 11.7 in (210 by 297 mm)		
Executive	7.3 by 10.5 in (191 by 267 mm)		
Legal	8.5 by 14 in (216 by 356 mm)		
B5 (JIS)	7.2 by 10 in (182 by 257 mm)		
A5	5.8 by 8.2 in (148 by 210 mm)		
11 by 17	11 by 17 in (279 by 432 mm)		
A3	11.7 by 16.5 in (297 by 420 mm)		
B4 (JIS)	10.1 by 14.3 in (257 by 364 mm)		
Custom <sup>4</sup>	5.8 by 8.2 to 11.7 by 17 in (148 by 210 to 297 by 432 mm)		

1. The printer supports a wide range of media sizes. Check the printer software for supported sizes.
2. Capacity may vary depending on media weight and thickness, and environmental conditions.
3. To print rotated paper see the User's Guide.
4. To print custom-size paper see the User's Guide.

**Table 1-9. Paper Specifications, Optional Duplex Printing Accessory (Duplexer)**

	<b>Dimensions<sup>1</sup></b>	<b>Weight</b>
Minimum	5.8 by 8.3 inches (148 by 210 mm)	16 to 28 lb (60 to 105 g/m <sup>2</sup> )
Maximum	11.7 by 17 inches (297 by 432 mm)	

1. The printer supports a wide range of media sizes. Check the printer software for supported sizes.

## Supported Types of Paper

The printer supports the following types of paper:

- plain
- letterhead
- prepunched
- bond
- color
- rough
- vellum
- preprinted
- transparency
- labels
- recycled
- card stock
- user-defined (5 types)

## Guidelines for Using Paper

For best results, use conventional 20 lb (75 g/m<sup>2</sup>) paper. Make sure the paper is of good quality and free of cuts, nicks, tears, spots, loose particles, dust, wrinkles, voids, and curled or bent edges.

Some paper causes print quality problems, jamming, or damage to the printer.

For more specific information, see “Image Defects” on page 7-50.

---

**Table 1-10. Guidelines for Using Paper**

---

Symptom	Problem with Paper	Solution
Poor print quality or toner adhesion. Problems with feeding.	Too moist, too rough, too smooth, or embossed; faulty paper lot.	Try another kind of paper, between 100-250 Sheffield, 4-6% moisture content.
Dropouts, jamming, curl.	Stored improperly.	Store paper flat in its moisture-proof wrapping.
Increased gray background shading.	Too heavy.	Use lighter paper. Open the rear output bin.
Excessive curl. Problems with feeding.	Too moist, wrong grain direction or short-grain construction.	Open the rear output bin. Use long-grain paper. Set PAPER REFORMING=ON. Set FUSER MODE=LOW.
Jamming, damage to printer.	Cutouts or perforations.	Do not use paper with cutouts or perforations.
Problems with feeding.	Ragged edges.	Use quality paper.

---



---

**Note**

Do not use letterhead paper that is printed with low-temperature inks, such as those used in some types of thermography.

Do not use raised letterhead.

The printer uses heat and pressure to fuse toner to the paper. Make sure that any colored paper or preprinted forms use inks that are compatible with the printer's temperature (392° F or 200° C for 0.1 second).

---

## Paper Weight Equivalence Table

Use this table to determine approximate equivalent points in weight specifications other than U.S. bond weight. For example, to determine the equivalent of 20 lb U.S. bond weight paper in U.S. cover weight, locate the bond weight (in row 3, second column) and scan across the row to the cover weight (in the fourth column). The equivalent is 28 lb.

Shaded areas indicate a standard weight for that grade.

**Table 1-11. Paper Weight Equivalence**

	U.S. Post Card <sup>1</sup> thickness (mm)	U.S. Bond Weight (lb)	U.S. Text/Book Weight (lb)	U.S. Cover Weight (lb)	U.S. Bristol Weight (lb)	U.S. Index Weight (lb)	U.S. Tag Weight (lb)	Europe Metric Weight (g/m <sup>2</sup> )	Japan Metric Weight (g/m <sup>2</sup> )
1		16	41	22	27	33	37	60	60
2		17	43	24	29	35	39	64	64
3		20	50	28	34	42	46	75	75
4		21	54	30	36	44	49	80	80
5		22	56	31	38	46	51	81	81
6		24	60	33	41	50	55	90	90
7		27	68	37	45	55	61	100	100
8		28	70	39	49	58	65	105	105
9		32	80	44	55	67	74	120	120
10		34	86	47	58	71	79	128	128
11		36	90	50	62	75	83	135	135
12	.18	39	100	55	67	82	91	148	148
13	.19	42	107	58	72	87	97	157	157
14	.20	43	110	60	74	90	100	163	163
15	.23	47	119	65	80	97	108	176	176
16		53	134	74	90	110	122	199	199

1. U.S. Post Card measurements are approximate. Use for reference only.

## Labels

---

### CAUTION

To avoid damaging the printer, use only labels recommended for use in laser printers.

If you have problems printing labels, use Tray 1 and open the rear output bin.

---

Never print on the same sheet of labels more than once.

## Label Construction

When selecting labels, consider the quality of each component:

- **Adhesives:** The adhesive material should be stable at 392° F (200° C), the printer's maximum temperature.
- **Arrangement:** Only use labels with no exposed backing between them. Labels can peel off of sheets that have spaces between the labels, causing serious jams.
- **Curl:** Prior to printing, labels must lie flat with no more than 0.5 in (13 mm) of curl in any direction.
- **Condition:** Do not use labels with wrinkles, bubbles, or other indications of separation.

## Transparencies

Transparencies used in the printer must be able to withstand 392° F (200° C), the printer's maximum temperature. For best results, close the rear output bin to print transparencies to the top output bin.

---

### CAUTION

To avoid damaging the printer, use only transparencies recommended for use in laser printers.

---

If you have problems printing transparencies, use Tray 1.

## Vellum

Vellum is special lightweight paper similar to parchment. Print vellum from Tray 1 only, and open the rear output bin. Do not print on both sides of vellum.

Vellum used in the printer must be able to withstand 392° F (200° C), the printer's maximum temperature.

# Envelopes

## Envelope Construction

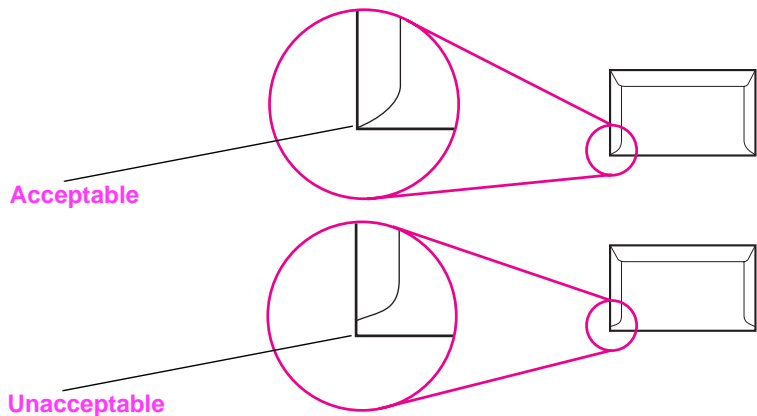
Envelope construction is critical. Envelope fold lines can vary considerably, not only between manufacturers, but also within a box from the same manufacturer. Successful printing on envelopes depends upon the quality of the envelopes. When selecting envelopes, consider the following components:

- **Weight:** The weight of the envelope paper should not exceed 28 lb (105 g/m<sup>2</sup>), or jamming may result.
- **Construction:** Prior to printing, envelopes should lie flat with less than 0.25 in (6 mm) curl, and should not contain air. (Envelopes that trap air may cause problems.)
- **Condition:** Make sure envelopes are not wrinkled, nicked, or otherwise damaged.
- **Sizes in Tray 1:** From 3 by 5 in (76 by 127 mm) to 12.28 by 18.5 in (312 by 470 mm).

Always print envelopes from Tray 1. To prevent envelopes from wrinkling or jamming, open the rear output bin.

## Envelopes with Double-Side-Seams

Double-side-seam construction has vertical seams at both ends of the envelope rather than diagonal seams. This style may be more likely to wrinkle. Be sure the seam extends all the way to the corner of the envelope as illustrated below.



**Figure 1-5** Envelopes with Double-Side-Seams

## Envelopes with Adhesive Strips or Flaps

Envelopes with a peel-off adhesive strip or with more than one flap that folds over to seal must use adhesives compatible with the heat and pressure in the printer. The extra flaps and strips might cause wrinkling, creasing, or jams.

## Envelope Margins

The following table gives typical address margins for a Commercial #10 or DL envelope.

**Table 1-12. Envelope Margins**

Type of Address	Top Margin	Left Margin
Return Address	0.6 in (15 mm)	0.6 in (15 mm)
Delivery Address	2 in (51 mm)	3.5 in (89 mm)

### Note

For the best print quality, position margins no closer than 0.6 in (15 mm) from the edges of the envelope.

## Envelope Storage

Proper storage of envelopes helps contribute to good print quality. Envelopes should be stored flat. If air is trapped in an envelope, creating an air bubble, the envelope may wrinkle during printing.

## Card Stock and Heavy Paper

Many types of card stock can be printed from Tray 1, including index cards and postcards. Some card stock performs better than others because its construction is better suited for feeding through a laser printer.

For optimum printer performance, do not use paper heavier than 53 lb (199 g/m<sup>2</sup>) in Tray 1 or 28 lb (105 g/m<sup>2</sup>) in other trays. Paper that is too heavy might cause misfeeds, stacking problems, paper jams, poor toner fusing, poor print quality, or excessive mechanical wear.

### Note

Printing on heavier paper may be possible if the tray is not filled to capacity, and paper with a smoothness rating of 100-180 Sheffield is used.

## Card Stock Construction

- **Smoothness:** 36-53 lb (135-199 g/m<sup>2</sup>) card stock should have a smoothness rating of 100-180 Sheffield. 16-36 lb (60-135 g/m<sup>2</sup>) card stock should have a smoothness rating of 100-250 Sheffield.
- **Construction:** Card stock should lie flat with less than 0.2 in (5 mm) of curl.
- **Condition:** Make sure card stock is not wrinkled, nicked, or otherwise damaged.
- **Sizes:** Use only card stock within the following size ranges:
  - minimum: 3 by 5 in (76 by 127 mm)
  - maximum: 12.28 by 18.5 in (312 by 470 mm)

---

### Note

---

Before loading card stock in Tray 1, make sure it is regular in shape and not damaged. Also, make sure the cards are not stuck together.

## Card Stock Guidelines

- If cards curl or jam, try printing from Tray 1 and opening the rear output bin.
- Set margins at least 0.08 in (2 mm) away from the edges of the paper.

# Safety Information

## Laser Safety Statement

The Center for Devices and Radiological Health (CDRH) of the U.S. Food and Drug Administration has implemented regulations for laser products manufactured since August 1, 1976. Compliance is mandatory for products marketed in the United States. The printer is certified as a "Class 1" laser product under the U.S. Department of Health and Human Services (DHHS) Radiation Performance Standard according to the Radiation Control for Health and Safety Act of 1968. Since radiation emitted inside the printer is completely confined within protective housings and external covers, the laser beam cannot escape during any phase of normal user operation.

---

### WARNING!

---

Using controls, making adjustments, or performing procedures other than those specified in this service manual may result in exposure to hazardous radiation.

## Canadian DOC Regulations

Complies with Canadian EMC Class B requirements.

<<Conforme à la classe B des normes canadiennes de compatibilité électromagnétiques. << CEM>>.>>

## FCC Regulations

This equipment has been tested and found to comply with the limits for a Class B digital device, pursuant to Part 15 of the FCC rules. These limits are designed to provide reasonable protection against harmful interference in a residential installation. This equipment generates, uses, and can radiate radio frequency energy. If this equipment is not installed and used in accordance with the instructions, it may cause harmful interference to radio communications. However, there is no guarantee that interference will not occur in a particular installation. If this equipment does cause harmful interference to radio or television reception, which can be determined by turning the equipment off and on, the user is encouraged to try to correct the interference by one or more of the following measures:

- Reorient or relocate the receiving antenna.
- Increase separation between equipment and receiver.
- Connect equipment to an outlet on a circuit different from that to which the receiver is located.
- Consult your dealer or an experienced radio/TV technician.

---

### Note

Any changes or modifications to the printer that are not expressly approved by HP could void the user's authority to operate this equipment.

Use of a shielded interface cable is required to comply with the Class B limits of Part 15 of FCC rules.

---



# Laser statement for Finland

## Luokan 1 laserlaite

### Klass 1 Laser Apparat

HP LaserJet 5000, 5000 N, 5000 GN -laserkirjoitin on käyttäjän kannalta turvallinen luokan 1 laserlaite. Normaalisissa käytössä kirjoittimen suojakotelointi estää lasersäteiden pääsyn laitteen ulkopuolelle. Laitteen turvallisuusluokka on määritetty standardin EN 60825-1 (1994) mukaisesti.

### Varoitus!

Laitteen käyttäminen muulla kuin käyttöohjeessa mainitulla tavalla saattaa altistaa käyttäjän turvallisuusluokan 1 ylittävälle näkymättömälle lasersäteilylle.

### Varning!

Om apparaten används på annat sätt än i bruksanvisning specificerats, kan användaren utsättas för osynlig laserstrålning, som överskrider gränsen för laserklass 1.

### HUOLTO

HP LaserJet 5000, 5000 N, 5000 GN -kirjoittimen sisällä ei ole käyttäjän huollettavissa olevia kohteita. Laitteen saa avata ja huoltaa ainoastaan sen huoltamiseen koulutettu henkilö. Tällaiseksi huoltotoimenpiteeksi ei katsota väriainekasetin vaihtamista, paperiradan puhdistusta tai muita käyttäjän käsikirjassa lueteltuja, käyttäjän tehtäväksi tarkoitettuja ylläpitotoimia, jotka voidaan suorittaa ilman erikoistyökaluja.

### Varo!

Mikäli kirjoittimen suojakotelo avataan, olet alttiina näkymättömälle lasersäteilylle laitteen ollessa toiminnassa. Älä katso säteeseen.

## **Varning!**

Om laserprinterns skyddshölje öppnas då apparaten är i funktion, utsätts användaren för osynlig laserstrålning. Betrakta ej strålen.

Tiedot laitteessa käytettävän laseriodin säteilyominaisuuksista:

Aallonpituus 775-795 nm

Teho 5 mW

Luokan 3B laser

## **Material Safety Data Sheet**

The Toner Cartridge/Drum MSDS can be obtained by calling the U.S. HP FIRST (Fax Information Retrieval Support Technology) at (1) (800) 231-9300. Use Index number 7 for a listing of the Toner Cartridge/Drum Material/Chemical Safety Data Sheets. Non-U.S. customers should refer to the support section of the User's Guide for appropriate phone numbers and information.

# Environmental Product Stewardship

## Protecting the Environment

Hewlett-Packard Company is committed to providing quality products in an environmentally-sound manner. The printer has been designed to minimize impacts on the environment.

### The printer design eliminates:

---

#### Ozone Production

The printer does not use high-voltage corona wires in the electrophotographic process and therefore generates no appreciable ozone gas (O<sub>3</sub>). Instead, this printer uses charging rollers in the toner cartridge and in the print engine.

#### Energy Consumption

### This HP LaserJet printer design reduces:

Energy usage drops to as little as 21 W while in low-power (PowerSave) mode. Not only does this save natural resources, but it also saves money without affecting the high performance of this printer. This product qualifies for the ENERGY STAR Program (U.S. and Japan). ENERGY STAR is a voluntary program established to encourage the development of energy-efficient office products. ENERGY STAR is a U.S. registered service mark of the U.S. EPA.



As an ENERGY STAR partner, Hewlett-Packard Company has determined that this product meets ENERGY STAR Guidelines for energy efficiency.

# 2 Service Approach

## Overview

This chapter discusses the following:

- Service Approach
- Parts and Supplies
- Warranty Statement

# Service Approach

Repair of the printer normally begins with use of the printer's internal diagnostics in conjunction with the troubleshooting procedures in Chapter 7. Once a faulty part is located, repair is generally accomplished by assembly level replacement of Field Replaceable Units (FRUs). Some mechanical assemblies may be repaired at the subassembly level. PCA component replacement is not supported by Hewlett-Packard.

# Parts and Supplies

## Ordering Information

Field replaceable and accessory part numbers are found in Chapter 8 of this manual. Replacement parts may be ordered from HP's Support Materials Organization (SMO) or Support Materials Europe (SME).

Use only accessories specifically designed for this printer. Accessories can be ordered from an authorized service or support provider. See page 2-5 and page 8-4 for more information.

# Helpful Documentation

Table 2-1 lists part numbers to order documentation.

---

**Table 2-1. Helpful Documentation**

---

<b>Item</b>	<b>Description or Use</b>	<b>Part Number</b>
HP LaserJet Printer Family Paper Specification Guide	A guide to using paper and other print media with HP LaserJet printers.	5021-8909
PCL 5/PJL Technical Reference Documentation Package	A guide to using printer commands with HP LaserJet printers.	5021-0330
HP LaserJet 5000, 5000 N, and 5000 GN Printers User's Guide	An additional copy of the user's guide.	C4110-90901 (English)
HP LaserJet 5000, 5000 N, and 5000 GN Printers Getting Started Guide	An additional copy of the getting started guide.	C4110-90926 (English)
HP LaserJet 5000, 5000 N, and 5000 GN Printers Quick Reference Guide	An additional copy of the quick reference guide.	C4110-90976 (English)
User's Documentation Bundle, HP LaserJet 5000, 5000 N, and 5000 GN	An additional copy of the user's guide, the getting started guide, and the quick reference guide.	C4110-99001 (English)

---

## Phone Numbers for Ordering

- SMO (Support Materials Organization)  
1-800-227-8164 (U.S. only)
- SME (Support Materials Europe)  
(49 7031) 142253

## Exchange Program

HP offers remanufactured assemblies for some parts. These are identified in Chapter 8 and can be ordered through Support Materials Organization (SMO), or Support Materials Europe (SME).

## Consumables

Paper and Toner Cartridges can be ordered directly from Hewlett-Packard. See Chapter 8 for ordering information.

## Technical Assistance

HP ASAP (Automated Support Access Program) provides free technical support information 24 hours a day, 7 days a week. The ASAP system includes HP AUDIO-TIPS and HP FIRST, both explained below. The ASAP service 1-800-333-1917 (U.S.) requires a touchtone phone.

To order additional printer drivers for software applications, call HP's Distribution Center (HPD) 1-970-339-7009.

### HP AUDIO-TIPS

HP AUDIO-TIPS is an interactive voice response system providing prerecorded answers to the questions asked most frequently by HP LaserJet printer users. Helpful "System Maps" to the HP AUDIO-TIPS recordings are available by fax through HP FIRST.



## HP FIRST

HP FIRST (Fax Information Retrieval Support Technology) is a phone-in fax service that provides technical information for HP LaserJet users as well as service personnel. Receiving a fax requires a group 3 facsimile machine or fax card. Service related information includes:

- Service notes (HP Authorized dealers)
- Application notes
- Product Data Sheets
- Material Safety Data Sheets (MSDS)
- Typeface and accessory information
- Printer support software information
- Toner information
- Driver request form and Software Matrix

### HP FIRST, U.S.

Call the HP ASAP system (1-800-333-1917) and follow the voice prompts to enter HP FIRST.

### HP FIRST, Europe

Call HP FIRST at one of the following numbers:

U.K., 0800-96-02-71

Belgium (Dutch), 078-111906

Switzerland (German), 155-1527

Netherlands, 06-0222420

Germany, 0130-810061

Austria, 0660-8128

For English service outside the above countries, call (31) 20-681-5792.

## HP CompuServe Forum

CompuServe™ members can download a variety of support materials including product data sheets, software application notes, and printer drivers for many popular software applications. Members may also post and reply to questions in an interactive format. To access the HP Forum, type GO HP at any prompt. For more information, or to join CompuServe, call 1-800-524-3388.

## **North American Response Center (NARC)**

The North American Response Center (NARC) is available to assist service technicians. The NARC can be reached at 1-800-544-9976.

### **Other Areas**

Outside of North America and Europe, contact your local HP sales office for assistance in obtaining technical support.

## Toner Cartridge Information

The Toner Cartridge is designed to simplify replacement of the major “consumable” parts. The Toner Cartridge contains the printing mechanism and a supply of toner.

At 5% page coverage, a Toner Cartridge will print approximately 10,000 pages. However, a Toner Cartridge should print more pages if regularly printing pages with less coverage, such as short memos. The cartridge may print fewer pages if routinely printing dense print.

---

### Note

---

For best results, always use a Toner Cartridge before the expiration date stamped on the Toner Cartridge’s box.

## Refilled Toner Cartridges

While Hewlett-Packard does not prohibit the use of refilled Toner Cartridges during the warranty period or while the printer is under a maintenance contract, it is not recommended for the following reasons:

- Repairs resulting from the use of refilled Toner Cartridges are not covered under Hewlett-Packard warranty or maintenance contracts.
- Hewlett-Packard has no control or process to ensure that a refilled Toner Cartridge functions at the high level of reliability of a new HP LaserJet Toner Cartridge. Hewlett-Packard also cannot predict what the long term reliability effect on the printer is from using different toner formulations found in refilled cartridges.
- The print quality of HP LaserJet Toner Cartridges influences the customer’s perception of the printer. Hewlett-Packard has no control over the actual print quality of a refilled Toner Cartridge.

## Recycling Toner Cartridges

In order to reduce waste, Hewlett-Packard offers a recycling program for used Toner Cartridges. Cartridge components that do not wear out are recycled. Plastics and other materials are recycled. HP pays the shipping costs from the user to the recycling plant. To join this recycling effort, follow the instructions inside the Toner Cartridge’s box.

# Warranty Statement

This warranty gives specific legal rights. There may also be other rights which vary from area to area. Refer to the User's Guide for further warranty information, or see the warranty card included with the printer.



# 3 Printer Operation

## Overview

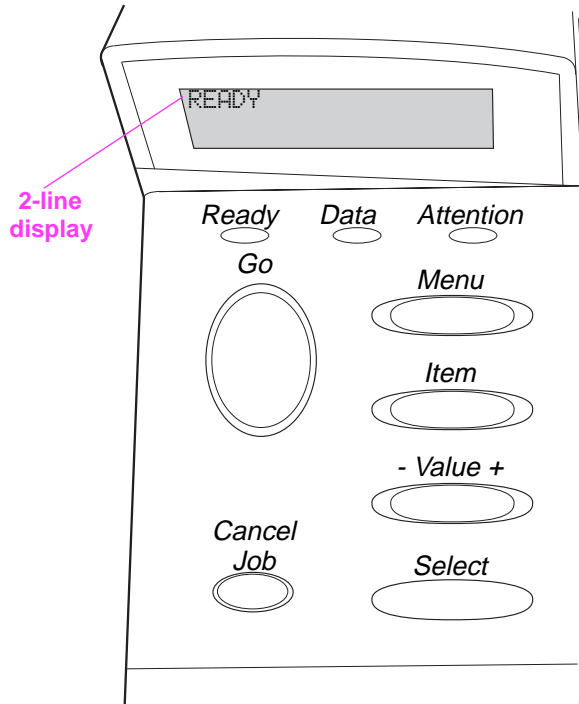
This chapter discusses the following:

- Using the Control Panel
- Control Panel Menus
- Service Mode
- Testing the Printer
- Resetting the Printer
- System Configuration
- Printer I/O Configuration

# Using the Control Panel

## Control Panel Layout

The printer's Control Panel consists of the following:



**Figure 3-1** Control Panel Layout

## Control Panel Lights

**Table 3-1. Control Panel Lights**

Light	Indication
Ready	The printer is ready to print.
Data	The printer is processing information.
Attention	Action is required. See the Control Panel display.

# Control Panel Keys

**Table 3-2. Control Panel Keys**

Key	Function
[Go]	<ul style="list-style-type: none"><li>● Places the printer either online or offline.</li><li>● Prints any data residing in the printer's buffer.</li><li>● Allows the printer to resume printing after being offline.</li><li>● Clears most printer messages and places the printer online.</li><li>● Allows the printer to continue printing with an error message such as TRAY x LOAD [TYPE] [SIZE] or UNEXPECTED PAPER SIZE.</li><li>● Confirms a manual feed request if Tray 1 is loaded and TRAY 1 MODE=CASSETTE has been set from the Paper Handling Menu in the printer's Control Panel.</li><li>● Overrides a manual feed request from Tray 1 by selecting paper from the next available tray.</li><li>● Exits the Control Panel menus. (To save a selected Control Panel setting, first press [Select].)</li></ul>
[Cancel Job]	Cancels the print job that the printer is processing. The time it takes to cancel depends on the size of the print job. (Press it only once.)
[Menu]	Cycles through the Control Panel menus. Press the right end of the button to move forward or the left end of the button to move backward.
[Item]	Cycles through the selected menu's items. Press the right end of the button to move forward or the left end of the button to move backward.
[- Value +]	Cycles through the selected menu item's values. Press [+] to move forward or [-] to move backward.
[Select]	<ul style="list-style-type: none"><li>● Saves the selected value for that item. An asterisk (*) appears next to the selection, indicating that it is the new default. Default settings remain when the printer is switched off or reset (unless you reset all factory defaults from the Resets Menu).</li><li>● Prints one of the printer information pages from the Control Panel.</li></ul>



## Settings and Defaults

The printer makes most printing decisions based on either temporary settings or permanent defaults.

---

### Note

Settings sent from software applications override printer defaults.

---

**Table 3-3. Settings and Defaults**

---

Setting or Default	Explanation
Temporary Setting	A value set for the current print job by the software application. For example, a request from the software to print three copies instead of the Control Panel default value of one copy is a temporary setting. The printer continues to use the temporary setting until it receives another software request or until it is reset.
Control Panel Default	A value set at the Control Panel when you select a menu item. An asterisk appears, indicating the default setting. The printer retains this default when it is turned off.
Factory Default	The value set for each menu item at the factory. Factory defaults are listed in the item column in the menu tables starting on page 3-6.

---

### Setting the Display Language

- 1 Press and hold **[Select]** while turning on the printer. Hold **[Select]** until `SELECT LANGUAGE` appears.
- 2 Release **[Select]**. `INITIALIZING` appears briefly. Wait for `LANGUAGE=ENGLISH` to appear.
- 3 Press **[- Value +]** repeatedly until the desired language appears.
- 4 Press **[Select]** to save your choice. An asterisk (\*) will appear beside the selected language.
- 5 Press **[Go]** to exit menu.

# Control Panel Menus

Press [Menu] for access to all Control Panel menus. When additional trays or other accessories are installed in the printer, new menu items automatically appear.

## To change a Control Panel setting:

- 1 Press [Menu] until the desired menu appears.
- 2 Press [Item] until the desired item appears.
- 3 Press [- Value +] until the desired setting appears.
- 4 Press [Select] to save the selection. An asterisk (\*) appears next to the selection in the display, indicating that it is now the default.
- 5 Press [Go] to exit the menu.

---

### Note

Settings in the printer driver and software application override Control Panel settings. (Software application settings override printer driver settings.)

If you cannot access a menu or item, it is either not an option for the printer, or the customer's network administrator has locked the function. (The Control Panel reads ACCESS DENIED MENU LOCKED.) See the customer's network administrator.

---

## To print a Control Panel menu map:

To see the current settings for all of the menus and items available in the Control Panel, print a Control Panel menu map.

- 1 Press [Menu] until INFORMATION MENU appears.
- 2 Press [Item] until PRINT MENU MAP appears.
- 3 Press [Select] to print the menu map.

# Information Menu

This menu contains printer information pages that give details about the printer and its configuration. To print an information page, scroll to the desired page and press **[Select]**.

---

**Table 3-4. Information Menu**

---

Item	Explanation
PRINT MENU MAP	The menu map shows the layout and current settings of the Control Panel menu items.
PRINT CONFIGURATION	The Configuration Page shows the printer's current configuration. If an HP JetDirect print server card is installed (HP LaserJet 5000 N/5000 GN printers), a JetDirect Configuration Page will print out as well.
PRINT PCL FONT LIST	The PCL font list shows all the PCL fonts currently available to the printer.
PRINT PS FONT LIST	The PS font list shows all the PS fonts currently available to the printer.
PRINT FILE DIRECTORY	This item appears only when a mass storage device (such as an optional flash DIMM or hard disk) containing a recognized file system is installed in the printer. The file directory shows information for all installed mass storage devices.
PRINT EVENT LOG	The event log lists printer events or errors.
SHOW EVENT LOG	This item allows you to view the most recent printer events on the Control Panel display. Press <b>[-Value+]</b> to scroll through the event log entries.
PRINT PAPER PATH TEST	The paper path test can be used to verify that the paper path is working properly, or to troubleshoot problems with a type of paper. Choose the input tray, output bin, duplexer (if available), and number of copies.

---

## Paper Handling Menu

When paper handling settings are correctly configured through the Control Panel, you can print by choosing the type and size of paper from the printer driver or software application.

Some items in this menu (such as duplex and manual feed) can be accessed from a software application, or from the printer driver (if the appropriate driver is installed). Printer driver and software application settings override Control Panel settings.

---

**Table 3-5. Paper Handling Menu**

---

Item	Values	Explanation
TRAY 1 MODE= FIRST	FIRST CASSETTE	Determine how the printer will use Tray 1. FIRST: If paper is loaded in Tray 1, the printer will pull paper from that tray first. CASSETTE: A paper size must be assigned to Tray 1 using the TRAY 1 SIZE option (the next item in this menu when TRAY 1 MODE=CASSETTE). This allows Tray 1 to be used as a reserved tray.
TRAY 1 SIZE= LETTER	For supported paper types see page 1-14.	This item appears only when TRAY 1 MODE= CASSETTE. Set the value to correspond with the paper size currently loaded in Tray 1.
TRAY 1 TYPE= PLAIN	For supported paper types see page 1-14.	This item appears only when TRAY 1 MODE= CASSETTE. Set the value to correspond with the paper type currently loaded in Tray 1.
TRAY 2 TYPE= PLAIN	For supported paper types see page 1-14.	Set the value to correspond with the paper type currently loaded in Tray 2.
TRAY 3 TYPE= PLAIN	For supported paper types see page 1-14.	This item appears only when a third paper tray is installed. Set the value to correspond with the paper type currently loaded in Tray 3.

---

**Table 3-5. Paper Handling Menu (continued)**

---

<b>Item</b>	<b>Values</b>	<b>Explanation</b>
TRAY 4 TYPE= PLAIN	For supported paper types see page 1-14.	This item appears only when a fourth paper tray is installed. Set the value to correspond with the paper type currently loaded in Tray 4.
MANUAL FEED=OFF	OFF ON	Feed the paper manually from Tray 1, rather than automatically from a tray. When MANUAL FEED=ON and Tray 1 is empty, the printer goes offline when it receives a print job and displays MANUALLY FEED [PAPER SIZE].
DUPLEX=OFF	OFF ON	This item appears only when an optional duplexer is installed. Set the value to ON to print on both sides (duplex) or OFF to print on one side (simplex) of a sheet of paper.
BINDING= LONG EDGE	LONG EDGE SHORT EDGE	This item appears only when an optional duplexer is installed and the duplex option is on. Choose the binding edge when duplexing (printing on both sides of paper).
OVERRIDE A4 WITH LETTER=NO	NO YES	Choose YES to print on letter size paper when an A4 job is sent, but no A4 size paper is loaded in the printer (or to print on A4 size paper when a letter job is sent, but no letter paper is loaded in the printer).

---

**Table 3-5. Paper Handling Menu (continued)**

---

<b>Item</b>	<b>Values</b>	<b>Explanation</b>
CONFIGURE FUSER MODE MENU=NO	NO YES	Configure the fuser mode associated with each paper type. (This is only necessary if you are experiencing problems printing on certain paper types.) NO: The fuser mode menu items are not accessible. YES: Additional items appear (see below). <b>Note</b> To see the default fuser mode for each paper type, select YES, scroll back to the Information Menu, and print a menu map (page 3-6).
[TYPE]= NORMAL	NORMAL LOW HIGH VELLUM	This item appears only when CONFIGURE FUSER MODE MENU=YES Most paper types are set to NORMAL by default. ROUGH=HIGH VELLUM=VELLUM For a complete list of supported paper types, see page 1-14.

---

## Print Quality Menu

Some items in this menu can be accessed from a software application, or from the printer driver (if the appropriate driver is installed). Printer driver and software application settings override Control Panel settings.

---

**Table 3-6. Print Quality Menu**

---

Item	Values	Explanation
RESOLUTION= FASTRES 1200	300 600 FASTRES 1200 PRORES 1200	Select the resolution from the following values: 300: Produces draft print quality at the printer's maximum speed (16 ppm). 300 dpi (dots per inch) is recommended for some bitmapped fonts and graphics, and for compatibility with the HP LaserJet III family of printers. 600: Produces high print quality at the printer's maximum speed (16 ppm). FASTRES 1200: Produces optimum print quality (comparable to 1200 dpi) at the printer's maximum speed (16 ppm). PRORES 1200: Produces optimum print quality (true 1200 dpi) at half the printer's maximum speed (8 ppm). When the resolution is changed, any downloaded resources (such as fonts or macros) will need to be downloaded again, unless they are stored on an optional hard disk or flash DIMM. <b>Note</b> It is best to change the resolution from the printer driver or software application. (Driver and software settings override Control Panel settings.)

---

**Table 3-6. Print Quality Menu (continued)**

---

Item	Values	Explanation
RET=MEDIUM	OFF LIGHT MEDIUM DARK	<p>Use the printer's Resolution Enhancement technology (REt) setting to produce print with smooth angles, curves, and edges.</p> <p>REt does not affect print quality when the print resolution is set to ProRes 1200. All other print resolutions, including FastRes 1200, benefit from REt.</p> <p><b>Note</b></p> <p>It is best to change the REt setting from the printer driver or software application. (Driver and software settings override Control Panel settings.)</p>
ECONOMODE=OFF	OFF ON	<p>Turn EconoMode on (to save toner) or off (for high quality). EconoMode creates draft-quality printing by reducing the amount of toner on the printed page by up to 50%.</p> <p><b>Caution</b></p> <p>HP does not recommend full-time use of EconoMode. (If EconoMode is used full-time, it is possible that the toner supply will outlast the mechanical parts in the Toner Cartridge.)</p> <p><b>Note</b></p> <p>It is best to turn EconoMode on or off from the printer driver or software application. (Driver and software settings override Control Panel settings.)</p>



---

**Table 3-6. Print Quality Menu (continued)**

---

Item	Values	Explanation
TONER DENSITY=3	1 2 3 4 5	<p>Lighten or darken the print on the page by changing the toner density setting. The settings range from 1 (light) to 5 (dark), but the default setting of 3 usually produces the best results.</p> <p>Use a lower toner density setting to save toner.</p> <p><b>Note</b></p> <p>It is best to change the toner density from the printer driver or software application. (Driver and software settings override Control Panel settings.)</p>
CREATE CLEANING PAGE	No value to select.	<p>Press <b>[Select]</b> to print a cleaning page (for cleaning excess toner from the paper path).</p> <p>In order for the cleaning page to work properly, print the page on copier grade paper (not bond or rough paper). Follow the instructions on the cleaning page.</p>
PROCESS CLEANING PAGE	No value to select.	<p>This item appears only after a cleaning page has been generated (as described above).</p> <p>Press <b>[Select]</b> to process the cleaning page.</p>

---

# Printing Menu

Some items in this menu can be accessed from a software application, or from the printer driver (if the appropriate driver is installed). Printer driver and software application settings override Control Panel settings.

**Table 3-7. Printing Menu**

Item	Values	Explanation
COPIES=1	1 to 999	<p>Set the default number of copies by selecting any number from 1 to 999. Press [-Value+] once to change the setting by increments of 1, or hold down [-Value+] to scroll by increments of 10.</p> <p><b>Note</b></p> <p>It is best to set the number of copies from the printer driver or software application. (Driver and software settings override Control Panel settings.)</p>
PAPER= LETTER (110 V printers) and ENVELOPE= COM10 (110 V printers)	For supported paper sizes see page 1-11.	<p>Set the default image size for paper and envelopes. (The item name will change from paper to envelope as you scroll through the available sizes.)</p> <p><b>Note</b></p> <p>The defaults indicated here are for 110 V printers. The default paper size for 220 V printers is A4. The default envelope size for 220 V printers is DL.</p>
CONFIGURE CUSTOM PAPER=NO	NO YES	<p>NO: The custom paper menu items are not accessible.</p> <p>YES: The custom paper menu items appear (see the next item).</p>

---

**Table 3-7. Printing Menu (continued)**

---

Item	Values	Explanation
UNIT OF MEASURE=INCHES (110 V printers) or MILLIMETERS (220 V printers)	INCHES MILLIMETERS	This item appears only when CONFIGURE CUSTOM PAPER=YES. Select the unit of measurement for the custom paper size.
X DIMENSION= 12.28 INCHES (110 V printers) or 312 MILLIMETERS (220 V printers)	3.00 to 12.28 INCHES (110 V printers) or 76 to 312 MILLIMETERS (220 V printers)	This item appears only when CONFIGURE CUSTOM PAPER=YES. Select the dimension to be fed into the printer (short edge).
Y DIMENSION= 18.50 INCHES (110 V printers) or 470 MILLIMETERS (220 V printers)	5.00 to 18.50 INCHES (110 V printers) or 127 to 470 MILLIMETERS (220 V printers)	This item appears only when CONFIGURE CUSTOM PAPER=YES. Select the other dimension (long edge).
ORIENTATION= PORTRAIT	PORTRAIT LANDSCAPE	Determine the default orientation of print on the page. <b>Note</b> It is best to set the page orientation from the printer driver or software application. (Driver and software settings override Control Panel settings.)
FORM=60 LINES (110 V printers) or 64 LINES (220 V printers)	5 to 128	Sets vertical spacing from 5 to 128 lines for default paper size. Press [-Value+] once to change the setting by increments of 1, or hold down [-Value+] to scroll by increments of 10.

---

**Table 3-7. Printing Menu (continued)**

---

Item	Values	Explanation
PCL FONT SOURCE=INTERNAL	INTERNAL SOFT SLOT 1, 2, or 3	INTERNAL: Internal fonts. SOFT: Permanent soft fonts. SLOT 1, 2, or 3: Fonts stored in one of the three DIMM slots.
PCL FONT NUMBER=0	0 to 999	The printer assigns a number to each font and lists them on the PCL Font List. The font number appears in the Font # column of the printout.
PCL FONT PITCH= 10.00	0.44 to 99.99	This item might not appear, depending on the font selected. Press [-Value+] once to change the setting by increments of .01 for pitch, or hold down [-Value+] to scroll by increments of 1.
PCL SYMBOL SET=PC-8	PC-8 many others	Select any one of several available symbol sets from the printer's control panel. A symbol set is a unique grouping of all the characters in a font. PC-8 or PC-850 is recommended for line draw characters. Order the <i>PCL 5/ PJL Technical Reference Documentation Package</i> for symbol set charts or for more information see the user's guide.

---

**Table 3-7. Printing Menu (continued)**

---

<b>Item</b>	<b>Values</b>	<b>Explanation</b>
COURIER=REGULAR	REGULAR DARK	Select the version of Courier font to use: REGULAR: The internal Courier font available on the HP LaserJet 4 series printers. DARK: The internal Courier font available on the HP LaserJet III series printers. Both fonts are not available at the same time.
WIDE A4=NO	NO YES	The Wide A4 setting changes the number of characters that can be printed on a single line of A4 paper. NO: Up to 78 10-pitch characters can be printed on one line. YES: Up to 80 10-pitch characters can be printed on one line.
APPEND CR TO LF= NO	NO YES	Select YES to append a carriage return to each line feed encountered in backward-compatible PCL jobs (pure text, no job control). Some environments, such as UNIX, indicate a new line using only the line feed control code. This option allows the user to append the required carriage return to each line feed.
PRINT PS ERRORS=OFF	OFF ON	Select ON to print the PS error page when PS errors occur.

---

# Configuration Menu

Items in this menu affect the printer's behavior. Configure the printer according to your printing needs.

---

**Table 3-8. Configuration Menu**

---

Item	Values	Explanation
POWERSAVE= 30 MINUTES	OFF 15 MINUTES 30 MINUTES 1 HOUR 2 HOURS 3 HOURS	<p>Set the printer to enter PowerSave after it has been idle for a specified amount of time. Turning PowerSave off is not recommended. The PowerSave feature does the following:</p> <ol style="list-style-type: none"><li>1. Minimizes the amount of power consumed by the printer when it is idle.</li><li>2. Reduces wear on the printer's electronic components. (Turns off the display's backlight.)</li></ol> <p>When you send a print job, press a Control Panel key, open a paper tray, or open the top cover, the printer automatically comes out of PowerSave mode.</p> <p><b>Note</b></p> <p>PowerSave turns off the backlight on the display, but the display is still readable.</p>
PERSONALITY= AUTO	AUTO PCL PS	<p>Select the default printer language (personality). Possible values are determined by which valid languages are installed in the printer.</p> <p>Normally you should not change the printer language (the default is AUTO). If you change it to a specific printer language, the printer will not automatically switch from one language to another unless specific software commands are sent to the printer.</p>

---

**Table 3-8. Configuration Menu (continued)**

---

<b>Item</b>	<b>Values</b>	<b>Explanation</b>
RESOURCE SAVE= OFF	OFF ON AUTO (8 MB total is required to see this message.)	<p>Dedicate printer memory to save each language's permanent resources. (You might need to add memory to the printer in order for this item to appear.) The amount of memory set aside can be different for each installed language. Some languages might have memory set aside for resource saving without requiring all languages to do so. Any time the amount of memory dedicated to a specific language is changed, all languages will lose all saved resources, including any unprocessed print jobs.</p> <p>OFF: No language resource saving is performed, and language-dependent resources, such as fonts and macros, are lost when language or resolution changes.</p> <p>ON: An item will appear for each installed language that allows the user to allocate a particular amount of memory to that language's resource saving area. (See the items below.)</p> <p>AUTO: The printer automatically determines the amount of memory to use for each installed language's resource saving area.</p>
PCL MEMORY= 400K	0K and up (This value depends on the amount of installed memory. 8 MB total is required to see this message.)	<p>This item appears only when RESOURCE SAVE=ON. Select the amount of memory used for saving PCL resources. Printer default is the minimum amount of memory needed to perform resource saving for PCL.</p> <p>Press [-Value+] to change settings by increments of 10 (up to 100 KB) or by increments of 100 (above 100 KB).</p>

---

**Table 3-8. Configuration Menu (continued)**

---

Item	Values	Explanation
PS MEMORY= 400K	0K and up (This value depends on the amount of installed memory. 8 MB total is required to see this message.)	This item appears only when RESOURCE SAVE=ON. Select the amount of memory used for saving PS resources. Printer default is the minimum amount of memory needed to perform resource saving for PS. Press [-Value+] to change settings by increments of 10 (up to 100 KB) or by increments of 100 (above 100 KB).
PAGE PROTECT= AUTO	AUTO ON	This item appears only after a 21 PAGE TOO COMPLEX; PRESS GO TO CONTINUE message displays. Memory Enhancement technology (MEt) attempts to guarantee that all pages will print. If the page does not print, turn PAGE PROTECT to ON. This might increase chances of a 20 INSUFFICIENT MEMORY; PRESS GO TO CONTINUE message. If this occurs, simplify the print job or install additional memory.
CLEARABLE WARNINGS=JOB	JOB ON	Set the amount of time that a clearable warning is displayed on the printer's Control Panel. JOB: Warning messages display on the Control Panel until the end of the job from which they were generated. ON: Warning messages display on the Control Panel until [Go] is pressed.



---

**Table 3-8. Configuration Menu (continued)**

---

Item	Values	Explanation
AUTO CONTINUE= ON	ON OFF	Determine how the printer reacts to errors. ON: If an error occurs that prevents printing, the message will display, and the printer will go offline for 10 seconds before returning online. OFF: If an error occurs that prevents printing, the message will remain on the display and the printer will remain offline until [Go] is pressed. If the printer is on a network, you will probably want to turn AUTO CONTINUE to ON.
TONER LOW=CONTINUE	CONTINUE STOP	Determine how the printer behaves when toner is low. The TONER LOW message will first appear when the Toner Cartridge is almost out of toner. (About 100 to 300 sheets can still be printed.) CONTINUE: The printer will continue to print while the TONER LOW message is displayed. STOP: The printer will go offline and wait for further action.

---

**Table 3-8. Configuration Menu (continued)**

---

Item	Values	Explanation
MOPIER MODE=STANDARD	STANDARD ENHANCED OFF	<p>Determine how the mopier functions behave. This item appears only when there is at least 8 MB of memory or an optional hard disk is installed.</p> <p><b>STANDARD:</b> This option is available if there is either a hard disk installed or a RAM disk configured in memory. This option uses I/O data stored in printer memory for generating multiple original prints. (All copies will print at the same speed as the first copy.)</p> <p><b>ENHANCED:</b> This option is available if there is a hard disk installed and at least 8 MB of memory. This option uses engine video data for printing multiple original prints and should print all copies after the first at the printer's maximum speed.</p> <p><b>OFF:</b> Disables the mopier functions. (The printer will not spool any jobs to the hard disk.)</p> <p>When the mopier mode is changed, any downloaded resources (such as fonts or macros) will need to be downloaded again, unless they are stored on an optional hard disk or flash DIMM.</p>
RAM DISK=OFF	OFF ON AUTO	<p>Determine how the RAM disk is configured. This item appears only if there is no optional hard disk installed and the printer has at least 8 MB of memory.</p> <p><b>OFF:</b> The RAM disk is disabled.</p> <p><b>ON:</b> The RAM disk is enabled. Configure the amount of memory to be used through the following item: <code>RAM DISK SIZE</code>.</p> <p><b>Note</b></p> <p>If the setting is changed from <b>OFF</b> to <b>ON</b> or from <b>OFF</b> to <b>AUTO</b>, the printer will automatically reinitialize when it becomes idle.</p>

---

**Table 3-8. Configuration Menu (continued)**

---

Item	Values	Explanation
RAM DISK SIZE=xxxK	0K and up (This value depends on the amount of installed memory.)	Determine the size of the RAM disk. This item appears if RAM DISK=ON or AUTO. Press [-Value+] to change settings by increments of 100. <b>Note</b> This setting cannot be changed if RAM DISK=AUTO. Changing this value will cause the printer to reinitialize when it becomes idle.
JAM RECOVERY= AUTO	AUTO ON OFF	Determine how the printer behaves when a paper jam occurs. AUTO: The printer automatically selects the best mode for printer jam recovery (usually ON). This is the default setting. ON: The printer automatically reprints pages after a paper jam is cleared. OFF: The printer does not reprint pages following a paper jam. Printing performance might be increased with this setting.
PAPER REFORMING=OFF	OFF ON	Paper reforming has two main purposes: 1. To reduce jams, wrinkles, and bent corners when printing on both sides of a sheet of paper (duplexing). 2. To reduce bent corners and wrinkles when printing on one side of a sheet of narrow media (such as legal, rotated letter, or rotated A4). Print speed will be slower when PAPER REFORMING=ON.

---

**Table 3-8. Configuration Menu (continued)**

---

<b>Item</b>	<b>Values</b>	<b>Explanation</b>
MAINTENANCE MESSAGE=OFF	OFF	This item appears only after the PERFORM PRINTER MAINTENANCE message displays. OFF: The PERFORM PRINTER MAINTENANCE message will be cleared and will not be displayed again until the next maintenance is due. The message should not be turned off unless the printer maintenance has been performed. If the required maintenance is not performed, the printer's performance will degrade.
SMALL PAPER SPEED=NORMAL	NORMAL SLOW	Select SLOW when alternately printing envelopes or small paper and standard paper sizes. Be sure to return the speed to NORMAL when finished.

---

# I/O Menu

Items in the I/O (input/output) Menu affect the communication between the printer and the computer.

**Table 3-9. I/O Menu**

Item	Values	Explanation
I/O TIMEOUT=15	5 to 300	<p>Select the I/O timeout period in seconds. (I/O timeout refers to the time, measured in seconds, that the printer waits before ending a print job.)</p> <p>This setting allows you to adjust timeout for best performance. If data from other ports appear in the middle of your print job, increase the timeout value.</p> <p>Press [- Value +] once to change settings by increments of 1, or hold down [- Value +] to scroll by increments of 10.</p>
I/O BUFFER=AUTO	AUTO ON OFF	<p>Allocate memory for I/O buffering.</p> <p>AUTO: The printer automatically reserves memory for I/O buffering. Additional configurations are not required and the I/O BUFFER SIZE menu item does not appear.</p> <p>ON: The I/O BUFFER SIZE item appears (see below). Specify the amount of memory to be used for I/O buffering.</p> <p>OFF: I/O buffering is not performed and the I/O BUFFER SIZE item does not appear.</p> <p>When the I/O buffer setting is changed, any downloaded resources (such as fonts or macros) will need to be downloaded again, unless they are stored on an optional hard disk or flash DIMM.</p>

---

**Table 3-9. I/O Menu (continued)**

---

Item	Values	Explanation
I/O BUFFER SIZE= 100K	10K and up	This item appears only when I/O BUFFER=ON. Specify the amount of memory for I/O buffering. The maximum amount of memory available for I/O buffering is determined by the amount of memory installed in the printer, the languages installed in the printer, and by other memory allocations that must be made. Press [-Value +] to change settings by increments of 10 (up to 100 KB) or by increments of 100 (above 100 KB).
PARALLEL HIGH SPEED=YES	YES NO	Select the speed at which data is transmitted to the printer. YES: The printer accepts faster parallel communications used for connections with newer computers. NO: The printer accepts slower parallel communications used for connections with older computers.
PARALLEL ADV FUNCTIONS=ON	ON OFF	Turn the bidirectional parallel communication on or off. The default is set for a bidirectional parallel port (IEEE-1284). This setting allows the printer to send status readback messages to the computer. (Turning on the parallel advanced functions might slow language switching.)
SERIAL PACING=DTR/ DSR	DTR/DSR XON/XOFF	Select the type of pacing used. Pacing, or "handshaking" allows the printer to tell the computer when to send information. The printer uses XON/XOFF and DTR/DSR signal protocols rather than ETX/ACK protocol. DTR/DSR: Select this value if your computer requires hardware flow control (most personal computers do). XON/XOFF: Select this value if your computer requires software flow control (a UNIX workstation, for example). The SERIAL ROBUST XON item appears (see below).

---

**Table 3-9. I/O Menu (continued)**

---

<b>Item</b>	<b>Values</b>	<b>Explanation</b>
SERIAL ROBUST XON=ON	ON OFF	This item appears only when SERIAL PACING=XON/*XOFF. Select the method for generating XONs. ON: The printer sends an XON when the printer is online and when sufficient buffer space is available. If the host does not receive data within approximately one second, the printer will transmit additional XONs at one-second intervals until the host receives data. OFF: The printer sends one XON when it can accept more data or when it is online. The printer does not send XONs every second while the printer is online and ready for more data.
SERIAL BAUD RATE=9600	300 600 1200 2400 4800 9600 19200 38400 57600 115200	Select the printer's baud rate (speed at which information is transferred) for communicating from the computer to the printer.
SERIAL DTR POLARITY=HIGH	HIGH LOW	Determine whether pin #8 is high or low when the printer is ready. HIGH: Pin #8 is held high when the printer is ready. LOW: Pin #8 is held low when the printer is ready.

---

## EIO Menu (Networked Printers)

EIO (Enhanced Input/Output) Menus depend on the particular accessory product installed in an EIO slot of the printer. If the printer contains an HP JetDirect print server EIO card, you can configure basic networking parameters using the EIO Menu. These and other parameters can also be configured through HP JetAdmin.

**Table 3-10. EIO Menu**

Item	Values	Explanation
CFG NETWORK=NO	NO YES	NO: The JetDirect Menu is not accessible. YES: The JetDirect Menu appears.
NOVELL=ON	ON OFF	Select whether the IPX/SPX protocol stack (in Novell NetWare networks, for example) is enabled (on) or disabled (off).
DLC/LLC=ON	ON OFF	Select whether the DLC/LLC protocol stack is enabled (on) or disabled (off).
TCP/IP=ON	ON OFF	Select whether the TCP/IP protocol stack is enabled (on) or disabled (off).
ETALK=ON	ON OFF	Select whether the Apple EtherTalk protocol stack is enabled (on) or disabled (off).
CFG NOVELL=NO	NO YES	NO: The IPX/SPX Menu is not accessible. YES: The IPX/SPX Menu appears. In the IPX/SPX Menu, you can specify the frame type parameter used on your network. The default is AUTO, to automatically set and limit the frame type to the one detected. For Ethernet cards, frame type selections include EN_8023, EN_II, EN_8022, EN_SNAP. For Token Ring cards, frame type selections include TR_8022, TR_SNAP. In the IPX/SPX Menu for Token Ring cards, you can also specify NetWare Source Routing parameters, which include SRC RT=AUTO (default), OFF, SINGLE R, or ALL RT.



---

**Table 3-10. EIO Menu (continued)**

---

Item	Values	Explanation
CFG TCP/IP=NO	NO YES	<p>NO: The TCP/IP Menu is not accessible.</p> <p>YES: The TCP/IP Menu appears. In the TCP/IP Menu, you can specify BOOTP=YES for TCP/IP parameters to be automatically loaded from a bootp or DHCP server when the printer is turned on. If you specify BOOTP=NO, you can manually set selected TCP/IP parameters from the Control Panel. You can manually set each byte of the IP address (IP), Subnet Mask (SM), Syslog Server (LG), and Default Gateway (GW). Also, you can manually set the Timeout time period.</p> <p><b>Note</b></p> <p>If no IP address is assigned within the first 5 minutes, the HP JetDirect print server card will assume a default IP address of 192.0.0.192.</p>
CFG ETALK=NO	NO YES	<p>NO: The EtherTalk Menu is not accessible.</p> <p>YES: The EtherTalk Menu appears. In the EtherTalk Menu you can set the AppleTalk phase parameter (ETALK PHASE=1 or 2) for your network.</p>

---

## Resets Menu

Use this menu with caution. You can lose buffered page data or printer configuration settings when you select these items. Only reset the printer under the following circumstances:

- You want to restore the printer's default settings.
- Communication between the printer and computer has been interrupted.
- You are using both the serial and parallel I/O ports, and one of the ports is having problems.

The items in the Resets Menu will clear all memory in the printer, while **[Cancel Job]** clears only the current job.

---

**Table 3-11. Resets Menu**

---

Item	Explanation
RESET MEMORY	This item clears the printer buffer and the active I/O input buffer, and makes the Control Panel defaults current. The DATA RECEIVED message might display on the Control Panel. Resetting memory during a print job can result in data loss.
RESTORE FACTORY SETTINGS	This item performs a simple reset and restores most of the factory (default) settings. This item also clears the input buffer for the active I/O. The DATA RECEIVED message might display on the printer's Control Panel.
RESET ACTIVE I/O CHANNEL	This item performs a simple reset and clears the input and output buffers (for the active I/Os only). The DATA RECEIVED message might display on the printer's Control Panel.
RESET ALL I/O CHANNELS	This item performs a simple reset and clears the input and output buffers for all I/Os.

---

# Service Mode

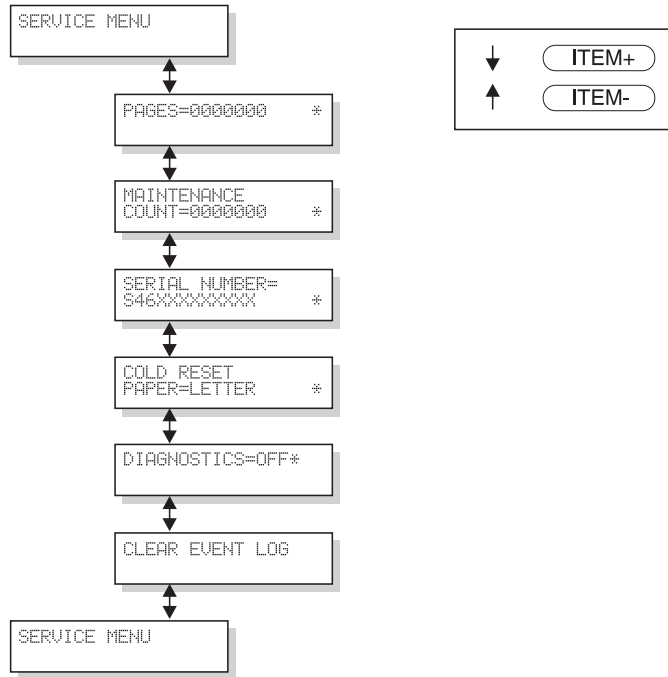
Service Mode should be used only by authorized service personnel. While in Service Mode, you can:

- Verify and set the page count and serial number. These are displayed on the Configuration Page.
- Set the Cold Reset Default. (This sets the factory default paper size to either Letter or A4).
- Turn the Diagnostic Functions on or off (for developers only).
- Clear the event log.
- Set the interval at which the `PERFORM PRINTER MAINTENANCE` message appears on the control panel.

## To enter Service Mode:

- 1 Hold down `[Select]` and `[Cancel Job]` while turning on the printer. (If the control panel reads `INITIALIZING`, the keys were released too soon.)
- 2 Press the right side of the `[Menu]` key, then press `[Select]`. The message `SERVICE MODE` is displayed. To exit the Service Mode press `[Go]`.

# Service Menu



**Figure 3-2** Service Menu

## Setting the Page Count, Maintenance Count, and Serial Number

The page count and serial numbers are stored in Non-Volatile Memory. If it is necessary to replace the Formatter PCA, the page count should be set to the current value to reflect the age of the print engine. The procedure for setting the serial number is similar to setting the page count.

**Note**

Before replacing the Formatter PCA, print a Configuration Page to verify the current page count and serial number of the printer, if possible. Use the information on the Configuration Page to reset the page count and serial number for the new Formatter PCA.

## Page Count

The page count stored in NVRAM and displayed on the Configuration Page printout represents the number of pages which the printer has printed (excluding engine test prints). If it becomes necessary to repair a printer by installing a new Formatter, the page count must be reset so that it represents the age of the printer's engine rather than the age of the Formatter.

The page count value is changed using a different method than is used for other control panel values. Instead of increasing the entire value by increments, each digit can be selected and modified individually. The following control panel keys are used to modify the page count value:

- [Select]** Enters any changes to the current digit and advances the cursor one digit to the right. If the last digit is currently selected, pressing the **[Select]** key wraps the cursor around to the first digit.
- [Value+]** Increases the value of the currently selected digit by one. Pressing **[Value+]** when 9 is the value of the currently selected digit will change the value of the digit to 0.
- [-Value]** Decreases the value of the currently selected digit by one. Pressing **[-Value]** when 0 is the value of the currently selected digit will change the value of the digit to 9.

Table 3-12 shows the sequence of keystrokes used to change the page count from a value of 000000 to a value of 0010480.

---

**Table 3-12. Changing the Page Count**


---

Key Press	Display	Description
	SERVICE MODE	
[Menu+]	SERVICE MENU	Enter the SERVICE MENU.
[Item+]	PAGES=0000000 *	Advance to the first item in the SERVICE MENU.
[Select]	PAGES=0000000 *	Advance the cursor one digit to the right.
[Select]	PAGES=0000000 *	Advance the cursor one digit to the right.
[Value+]	PAGES=0010000 *	Increase the value of the third digit by one.
[Select]	PAGES=0010000 *	Enter the change to the third digit and advance the cursor one digit to the right.
[Select]	PAGES=0010000 *	Advance the cursor one digit to the right.
[Value+] (4 presses)	PAGES=0010400 *	Increase the value of the fifth digit by four.
[Select]	PAGES=0010400 *	Enter the change to the fifth digit and advance the cursor one digit to the right.
[-Value] (2 presses)	PAGES=0010400 *	Decrease the value of the sixth digit by two.
[Select] (2 presses)	PAGES=0010400 *	Enter the change to the sixth digit and advance the cursor one digit to the right causing the cursor to wrap around to the first digit.
[Go]		To exit.

---

## Maintenance Page Count

The maintenance page count should be reset only after a maintenance kit has been installed.

This will reset the maintenance counter so that the message `PERFORM PRINTER MAINTENANCE` will display another 150,000 pages later (default).

- Hold down the `[Item-]` and `[Value-]` keys.
- Turn the printer on.
- Wait for `RESET MAINTENANCE COUNT` to be displayed and then release both keys.

`MAINTENANCE COUNT` in the Service Mode Menu sets the page count interval at which the next service is due for the printer. This is set initially at the factory to 150,000 pages. (For example, the message displays at 150,000 pages. If the Printer Maintenance Kit is installed at 150,114 pages, the message displays 150,000 pages later, at 300,114 pages.) Editing this number is similar to editing the `PAGES` item above.

## Serial Number

If a Formatter is replaced, then the serial number must be reentered. Editing this number is similar to editing the `PAGES` item above.

## Cold Reset Paper

The default paper size is stored in NVRAM and when the printer is cold reset, the default paper size is set to the factory setting. Possible values are `COLD RESET PAPER=LETTER` and `COLD RESET PAPER=A4`. When replacing the Formatter in countries that use A4 rather than letter size paper, set the cold reset paper size to A4.

## Diagnostics

This menu item enables or disables the use of the firmware diagnostic features. Possible values are `DIAGNOSTICS=OFF*` and `DIAGNOSTICS=ON`.

---

### Note

For developers only.

## Clear Event Log

This item allows the internal event log to be cleared.

# Testing the Printer

When you print a Configuration Page, the printer checks its internal controller and I/O interface, and then prints a test page. You can review the Configuration Page printout to verify proper installation of such options as paper trays or printer languages. For more information, see page 7-45.

## **Engine Test**

The engine test print can be used to verify that the print engine is functioning correctly. For more information, see page 7-9.



# Resetting the Printer

## Cold Reset

Cold Reset clears all data from the printer memory and sets all the defaults back to the factory settings.

---

### CAUTION

Performing a Cold Reset resets the JetDirect configuration. To avoid making changes to your configuration, remove the JetDirect card before performing a cold reset.

If possible, print a Configuration Page prior to performing a Cold Reset. This will document current settings for later reference.

---

### To perform a cold reset:

- 1 Turn off the printer.
- 2 While pressing **[Go]**, turn the printer on. `COLD RESET` appears briefly on the display, then `INITIALIZING` appears. After a few seconds, `RESTORING FACTORY SETTINGS` appears on the display, followed by `OFFLINE`. The cold reset is complete.
- 3 Press **[Go]** to return the printer online. `READY` appears on the display.

## Clearing NVRAM

This procedure will clean up the NVRAM by removing old areas that are not being used.

- 1 Turn off the printer.
- 2 While pressing **[Cancel Job]** turn the printer on. `CLEANUP NVRAM` appears briefly on the display, followed by `INITIALIZING`. After a few seconds `READY` appears.

# System Configuration

## MS-DOS System Configuration

To communicate properly with the printer, the MS-DOS environment requires the addition or modification of MODE commands in the AUTOEXEC.BAT file. Add or modify the MODE command(s), depending on the interface configuration, as follows:

### Parallel DOS Commands

Most IBM and AT compatible computers default to a parallel printer port. To ensure that information is sent to your parallel printer port, type the following MS-DOS command at your MS-DOS prompt or include it in your AUTOEXEC.BAT file:

```
MODE LPT1: , , B
```

---

#### Note

This example assumes that you are using parallel printer port LPT1. If you are using LPT2 or LPT3, replace LPT1 in the example with the printer port that you are using.

Since the MODE command is an external MS-DOS command (a program named MODE.COM is run when the MODE command is invoked), the program file must be contained in the root directory, or in a directory specified in a preceding PATH command in the AUTOEXEC.BAT file.

After changing the AUTOEXEC.BAT file, reboot the computer to initiate the changes.

## Serial MS-DOS Commands

Most IBM compatible computers default to a parallel printer port. To ensure that information is sent to the serial printer port, type the following MS-DOS commands at the MS-DOS prompt, or include them in the AUTOEXEC.BAT file:

```
MODE COM1: 9600, N, 8, 1, B
```

```
MODE LPT1: =COM1
```

---

### Note

---

These examples assume that you are using serial printer COM1. If you are using COM2 or COM3, replace COM1 with the printer port that you are using.

Since the MODE command is an external MS-DOS command (a program named MODE.COM is run when the MODE command is invoked), the program file must be contained either in the root directory or in a directory specified in a preceding PATH command in the AUTOEXEC.BAT file.

After changing the AUTOEXEC.BAT file, reboot the computer to initiate the changes.

# Printer I/O Configuration

## Parallel Menu

The default setting for the `HIGH SPEED PARALLEL I/O` is `YES`. If it is set to `NO`, the interface runs at a slower speed that is compatible with older computers. When the default is set to `YES`, the parallel interface runs at a higher rate supported by newer computers.

## Advanced Functions

The `ADVANCED FUNCTIONS` feature of the printer enables bidirectional communications between the printer and the host. The default setting is `ON`. This default setting (`ON`) must be active in order to use HP LaserJet Explorer, the Windows® Printing System, and other software applications and drivers.

## Serial Configuration

Use RS-232C serial configuration when the printer is located 11 to 50 feet (3.35 to 15.24 meters) from the computer. If you need to locate the printer between 51 and 2000 feet (15.54 and 610 meters) from the computer, use an RS-422A serial configuration.

Serial I/O settings must be configured correctly for proper serial communication.

## Serial Protocol

When printing with a serial configuration, the same protocol must be set on both the printer and the computer. Protocol on the printer is set by changing the control panel settings. Protocol on the computer is set by using DOS commands. The default protocol settings are described below.

## BAUD Rate

The `BAUD RATE` setting tells the printer how fast information is transferred to and from the computer. The default setting is `BAUD RATE=9600*`.

## Pacing (Handshaking)

Pacing (or “handshaking”) is a type of communication between the printer and the computer. This is an important setting in the printer because it allows the printer to tell the computer when to send information. If the printer is unable to receive information, for example, when the print buffer is full or when the printer is out of paper, a signal is sent to the computer to stop sending information. When the printer is able to resume receiving information, it sends another signal to the computer to send more data.

Pacing is set through the control panel's I/O Menu. Two types of handshaking are supported by the printer:

- Select `DTR/DSR` through the I/O Menu's `PACING` item if the computer requires hardware flow control (most personal computers do). Through the I/O Menu's `DTR POLARITY` item, the DTR polarity can be set to High or Low. The default is `DTR POLARITY=HI`.
- Select `XON/XOFF` through the I/O Menu's `PACING` item if the computer requires software flow control (for example, if you are using a UNIX workstation). Note that status readback messages are not paced when `XON/XOFF` is selected. Through the I/O Menu's `ROBUST XON` item, Robust Xon can be set to `ON` (the default) or `OFF`. Note that the `ROBUST XON` item only appears under the I/O Menu if `XON/XOFF` is selected.

# 4 Printer Maintenance

## Overview

This chapter discusses the following:

- Cleaning the Printer and Accessories
- Preventative Maintenance

## Cleaning the Printer and Accessories

To maintain high print quality and performance, thoroughly clean the printer and the paper handling accessories:

- Every time you change the Toner Cartridge (run a cleaning page).
- After printing approximately 15,000 pages.
- Whenever print quality problems occur.

Clean the outside surfaces with a lightly water-dampened cloth. Clean the inside parts as indicated in Table 4-1. Observe the warning and caution below.

### WARNING!

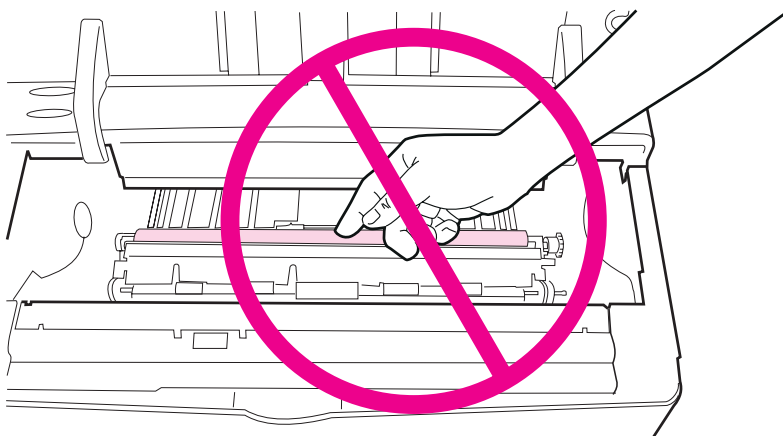
Before you begin these steps, turn the printer off and unplug all power cords to avoid shock hazard.

Be careful when cleaning around the Fusing Assembly area. It may be hot.

### CAUTION

To avoid permanent damage to the Toner Cartridge, do not use ammonia-based cleaners on or around the printer.

Do not touch the transfer roller. Skin oils on the roller can reduce print quality. If toner gets on your clothes, wipe it off with a dry cloth and wash your clothes in cold water. Hot water sets toner into fabric.



**Figure 4-1** Location of the Transfer Roller - Do Not Touch!

---

**Table 4-1. Cleaning the Printer**

---

<b>Component</b>	<b>Cleaning Method / Notes</b>
Outside Covers	Use a water-dampened cloth. Do not use solvents or ammonia-based cleaners.
Inside General	With a dry lint-free cloth, wipe any dust, spilled toner, and paper particles from the paper path area, the registration roller, and the Toner Cartridge cavity.
Paper Pickup, Feed, and Separation Rollers	Use a water-dampened, lint-free cloth.
Separation Pad	Use a dry, lint-free cloth.
Registration Roller	Use a dry, lint-free cloth.
Transfer Roller	Use a dry, lint-free cloth. DO NOT TOUCH with your fingers.
Fuser	Use a water-dampened, lint-free cloth.

---



## Using the Printer Cleaning Page

If toner specks appear on the front or back side of your print jobs, follow the procedure below.

From the printer's control panel, do the following:

- 1 Press **[Menu]** until PRINT QUALITY MENU appears.
- 2 Press **[Item]** until CREATE CLEANING PAGE appears.
- 3 Press **[Select]** to create the cleaning page.
- 4 Follow the instructions on the cleaning page to complete the cleaning process.

---

### Note

---

In order for the cleaning page to work properly, print the page on copier grade paper (not bond or rough paper).

You might need to create a cleaning page more than once. When toner has been cleaned from inside the printer, shiny black spots will appear on the page's black strip. If white spots appear on the black strip, create a cleaning page again.

To ensure good print quality with certain types of paper, use the cleaning page every time the toner cartridge is replaced. If the cleaning page is frequently needed, try a different type of paper.

## Cleaning Spilled Toner

Defective Toner Cartridges can develop leaks. Also, after a paper jam has occurred, there may be some toner remaining on the rollers and guides inside the printer. The pages that print immediately after the jam may pick up this toner.

---

### Note

---

Clean spilled toner with a cloth dampened with cold water.

---

### CAUTION

---

Do not touch the Transfer Roller with the damp cloth or with your fingers. Do not use a vacuum cleaner unless it is equipped with a micro-fine particle filter.

# Preventative Maintenance

The preventative maintenance cycle for this printer, conducted by service personnel, is every 150,000 pages. To order the maintenance kit see page 8-4. The kit contains one Fuser, one Transfer Roller, one Tray 1 Pickup Roller, one Tray 1 Separation Pad, two 250-sheet Tray Pick Rollers, two 250-sheet Tray Separation Pads and Springs, four 500-sheet Tray Pick D-Rollers, and two 500-sheet Tray Feed/ Separation Rollers. Refer to the instructions included in the kit for detailed replacement procedures.

## Reset Maintenance Count

After the PM kit has been installed, reset the maintenance count.

- 1 Turn the printer off.
- 2 While pressing [Item-] and [Value-] turn the printer on.

Reset Maintenance Count appears, followed by INITIALIZING. After a few seconds READY appears.

## Expected Life of Components

The following table shows the expected life of certain components in the printer. To order parts, see Chapter 8.

**Table 4-2. Life of Components**

	<b>Part name</b>	<b>Part No.</b>	<b>Quantity</b>	<b>Expected Life</b>
1	Pickup Roller	RB2-1821-000CN	1	150,000 pages
2	Separation Pad	RF5-2435-000CN	1	150,000 pages
3	Tray 1 Pickup Roller	RB2-1795-000CN	1	150,000 pages
4	Tray 1 Separation pad	RF5-2400-000CN	1	150,000 pages
5	Fuser			
	110-127V	RG5-3528-000CN	1	150,000 pages
	220-240V	RG5-3529-000CN	1	150,000 pages

---

**Table 4-2. Life of Components (continued)**

---

	<b>Part name</b>	<b>Part No.</b>	<b>Quantity</b>	<b>Expected Life</b>
6	Transfer Charging Roller	RG5-3579-000CN	1	150,000 pages
7	Exhaust Fan	RH7-1354-000CN	1	25,000 hours

---

# 5 Functional Information

## Overview

This chapter discusses the following:

- Power Supply Subsystem
- DC Controller Subsystem
- Formatter PCA
- Control Panel
- Interface PCA
- Image Formation System
- Paper Feed System
- Basic Sequence of Operation

# Printer Subsystems

This chapter presents a generalized functional overview of the printer and the printing processes.

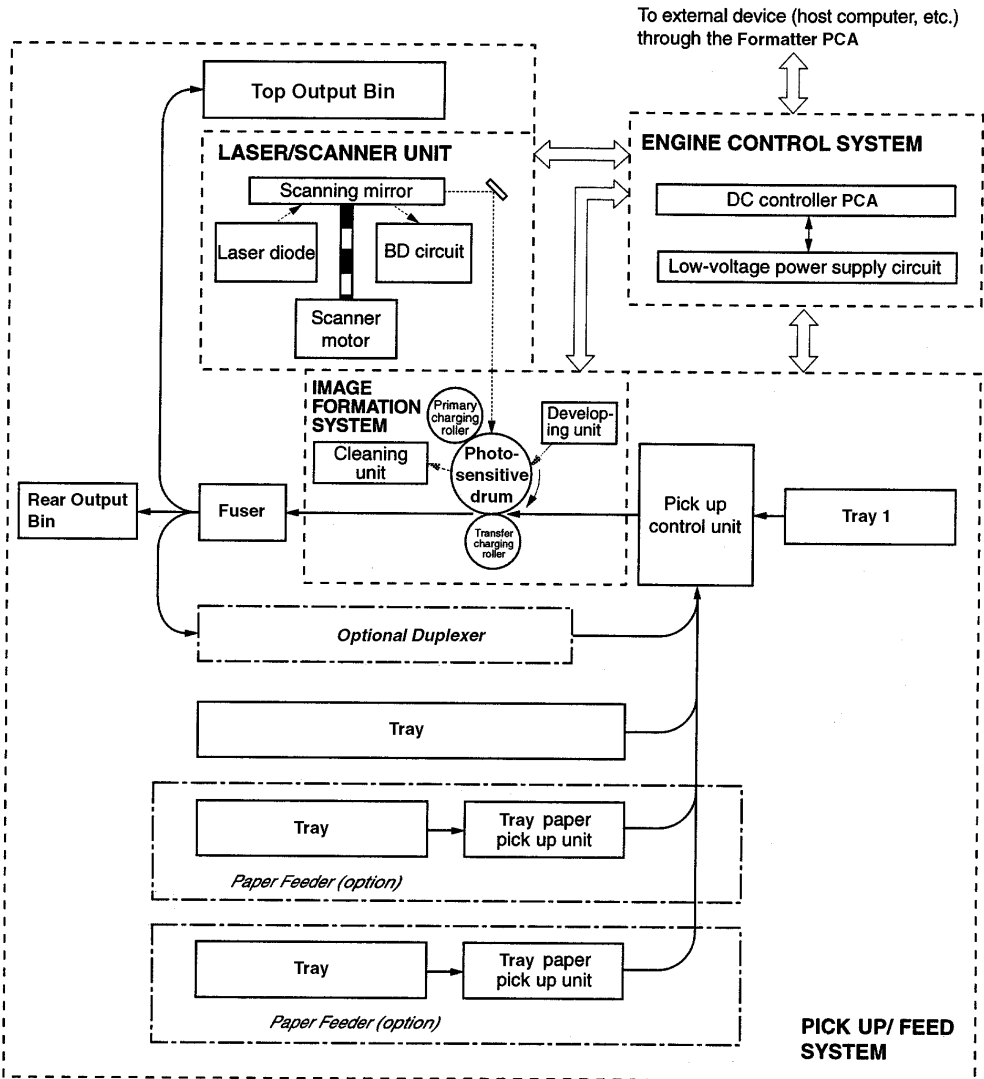


Figure 5-1 Paper Feed Subsystem

# Power Supply System

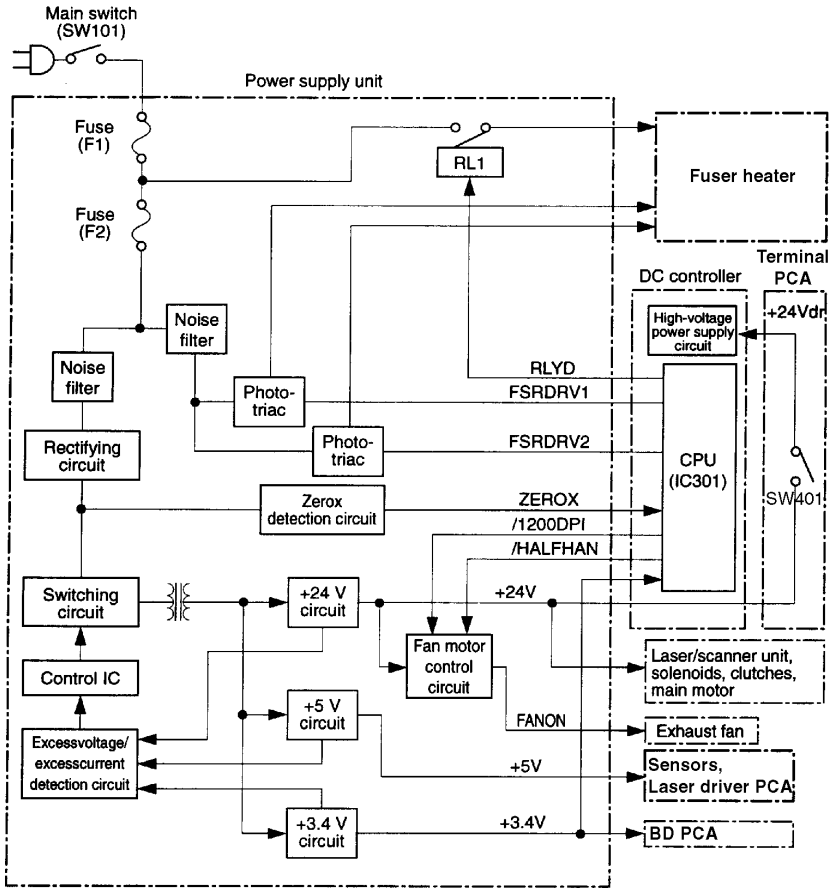
## AC/DC Power Distribution

The AC line voltage for the printer is applied through the main switch (SW101) and supplied to the low-voltage power supply circuit through the fuse (FU1). The low-voltage power supply divides the AC voltage to +24 VDC, +5 VDC and +3.4 VDC and supplies them to the DC controller PCA. This circuit generates a zero-cross signal (ZEROX) and supplies it to the DC controller PCA.

+3.4 VDC is supplied to ICs on the DC controller PCA and the BD PCA. +5 VDC is supplied to the laser driver PCA and sensors.

+24 VDC is supplied to the high-voltage power supply PCA to drive the main motor, the exhaust fan, the scanner motor, the clutches, and the solenoids.

+24 VDC is divided into +24 Vdr, which stops when the top cover is opened and SW401 on the terminal PCA turns off, and \_24V, which is always supplied regardless of whether SW401 turns on or off.



**Figure 5-2** Low Voltage Power Supply Circuit

If a short circuit or other problems on the load side cause an excessive current flow from the +24 VDC or +3.4 VDC power supplies or generate abnormal voltage, the excess-current protection system and excess-voltage protection system automatically shut off the output voltage to protect the power supplies.

If an excess-current or excess-voltage protection system is activated and the power supply circuit does not output DC voltage, it is necessary to turn the power off, correct the problem in the faulty load, then turn the printer on again.

The circuit has two fuses which break and cut off the output voltage if excess-current flows through the AC line.

## Overcurrent Overvoltage Protection

This circuit located on the DC controller PCA always monitors an abnormal rise of the fusing roller temperature. If an error occurs, this circuit outputs a signal to turn the relay (RL1) off and interrupt the power to the fusing roller heater. The circuit operates as follows.

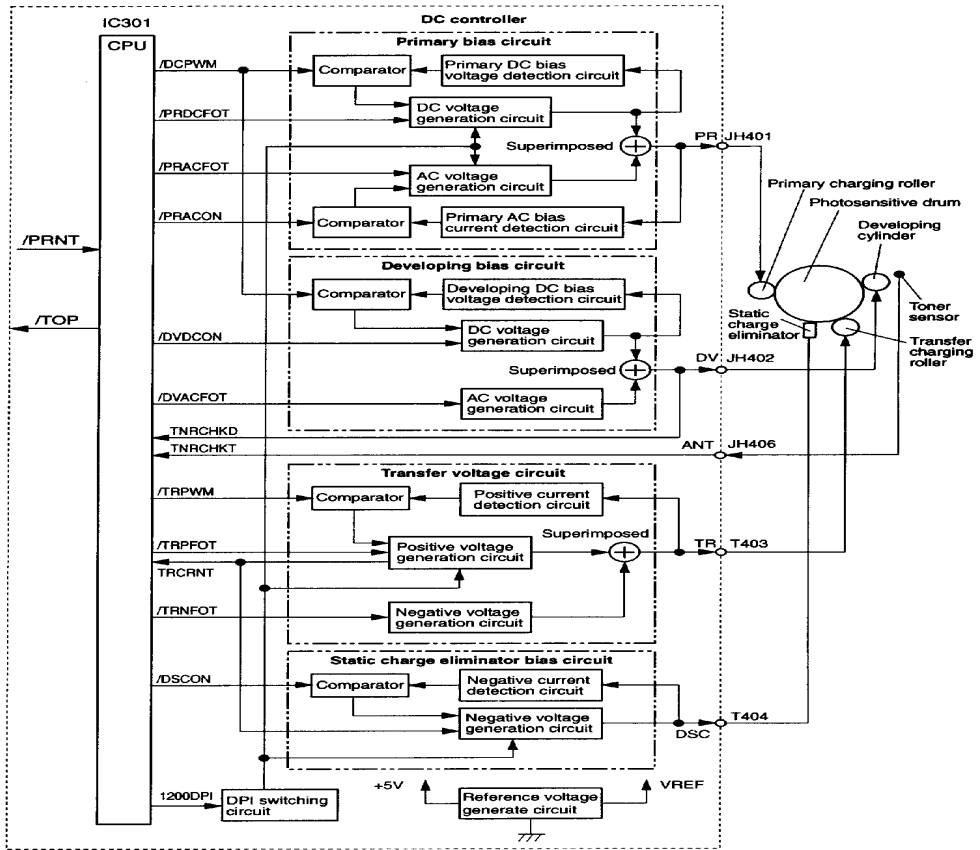
When the fusing roller heater temperature rises and the output voltage of the thermistor exceeds about 0.5 V (230°C), pin 7 of the comparator (IC304) goes "L." IC304 pin 1 goes "L," Q4 turns off, then the relay (RL1) turns off.

The printer has the following three protection functions to prevent wrong activation of the fusing roller heater.

- The CPU monitors the thermistor (TH1301) voltage. If it is abnormal, the CPU identifies the fusing roller heater error, turns the relay (RL1) off, and reports it to the Formatter.
- If the fusing roller heater temperature rises excessively and the TH1301 voltage falls below about 0.6 V (220°C), the safety circuit in the fusing roller heater interrupts the power to the fusing heater regardless of the CPU output.
- If the fusing roller heater temperature rises abnormally and the thermal fuse temperature exceeds 240°C, the thermal switch turns off and interrupts the power to the fusing roller heater.



# High Voltage Power Distribution



**Figure 5-3** High Voltage Power Supply Circuit

In response to the instructions from the microprocessor (CPU: IC301) on the DC controller, this circuit applies the superimposed voltage of DC voltage and AC voltage to the primary charging roller and developing cylinder, and a positive or negative DC voltage to the transfer charging roller.

According to the image density information sent from the Formatter PCA, this circuit varies the primary DC bias and developing DC bias to adjust the image density.

## Toner Cartridge Detection

The Toner Cartridge has a toner sensor. The circuit compares the output value of the developing AC bias and the output value (ANT) from the antenna inside the cartridge, and outputs the toner detection signal.

The CPU detects the remaining toner level and the presence of the cartridge when the developing bias is applied to the developing cylinder. The remaining toner level is always detected when the developing bias is applied. The presence of the cartridge is detected only when the developing bias is applied during the initial rotation.

## DC Controller System

The following systems and functions are controlled by the DC Controller PCA:

- DC Power Distribution (+3.4 VDC, +5 VDC, +24 VA)
- Laser and Scanner Drive
- Paper Motion Monitoring and Control (photosensors and flags)
- Clutches (tray pickup and Tray 1 feed)
- Engine Test
- Motors (Main Drive, Scanner, and Fans)

The operation sequences of this printer are controlled by the CPU of this circuit. When the printer power switch is turned on and the printer enters the standby mode, the CPU outputs the signals to drive the loads such as laser diode, motors, and solenoids, based on the print commands and the image data input from the external device.

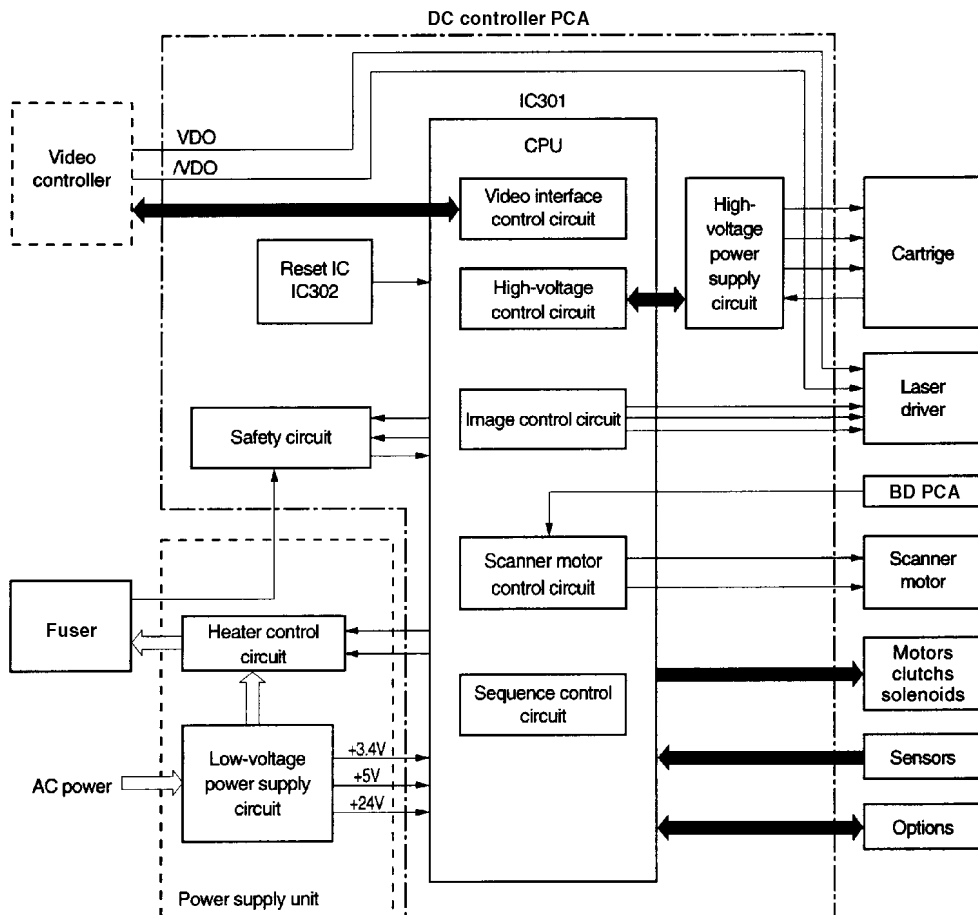


Figure 5-4 DC Controller PCA

## Laser and Scanner Drive

Based on information received from the Formatter, the DC Controller Board sends signals to the Laser/Scanner Assembly to modulate the laser diode on and off and to drive the Laser/Scanner motor. See "Image Formation System" on page 5-18 for more information.

## **Paper Motion Monitoring and Control**

The DC Controller Board controls paper motion by continuously monitoring the various paper sensors, and coordinating paper movement with the other print processes. For more information, see “Paper Feed System” on page 5-29.

## **Solenoids, Sensors, Clutches, and Switches**

See “DC Controller PCA Inputs and Outputs” on page 7-107.

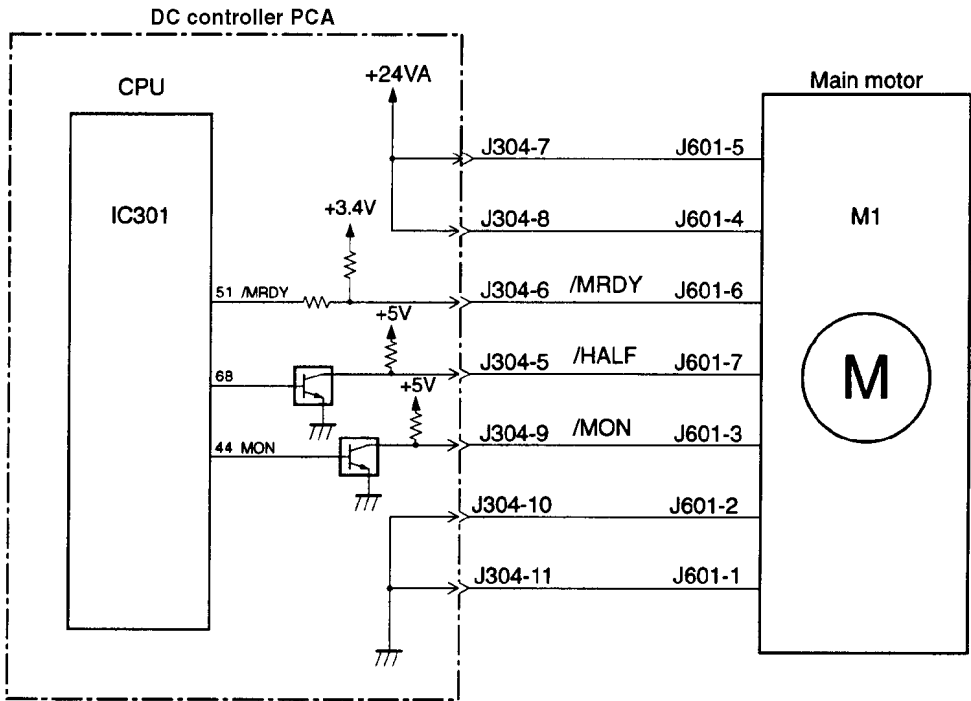
## **Engine Test Print**

See “Engine Test” on page 7-9.

# Motors

See “Timing Diagram” on page 5-47 for specific timing details for the printer motors.

The Main Motor, MT1, is controlled by the DC Controller Board. The Main Motor drives the main Gear Assembly and rotates during the Initial Rotation period (following power-on), the Print period, the Last Rotation period, or whenever the printer’s Top Cover is opened and closed.



**Figure 5-5** Main Motor Control

The Main Motor is a DC brushless motor with hall elements, and is unified with the motor drive circuit.

The CPU (IC501) sets the main motor drive signal (/MON) to “L” and rotates the main motor. When printing at 1200 dpi, the CPU sets the main motor rotation switching signal (/HALF) to “L” and decreases the rotation speed of the main motor to half.

The Scanner Motor is controlled and monitored by the DC Controller Board. It rotates the scanner mirror during the Initial Rotation period and the print period.

The fan motor is a two-phase, four-pole DC brushless motor containing a hall element and forms a unit along with the motor drive circuit.

When the printer turns on, the CPU (IC301) on the DC controller PCA makes pin 99 (/HALFFAN) "H" and runs the fan motor half a turn.

The CPU controls the half-speed/full-speed rotations according to the target fixing roller temperature when the CPU receives the /PRNT signal from the video controller PCA. When the fixing unit warms up sufficiently, it makes pin 99 (/HALFFAN) "H" to set the fan drive voltage (FANON) to the voltage level to run the fan motor at full speed. If the printing ends, the fan motor is run at full speed for 30 seconds after the main motor stops, then the fan motor runs at half speed.

# Formatter System

The Formatter PCA is responsible for the following:

- Controlling the PowerSave mode.
- Receiving and processing print data from the various printer interfaces.
- Monitoring Control Panel inputs and relaying printer status information (through the Control Panel and the Bidirectional I/O).
- Developing and coordinating data placement and timing with the print engine.
- Storing font information.
- Communicating with the host computer through the Bidirectional Interface.

The Formatter PCA receives a print job from the Bidirectional Interface and separates it into image information and instructions which control the printing process. The DC Controller Board synchronizes the Image Formation System with the Paper Input and Output Systems, and then signals the Formatter to send the print image data.

The Formatter PCA also provides the electrical interface and mounting locations for two EIO cards, additional memory DIMMs, and the Hard Disk accessory.

## PowerSave

This feature (accessed from the Configuration Menu) conserves power by shutting down the Fuser and exhaust fans after the printer has been idle for an adjustable period of time. The printer retains all printer settings, downloaded fonts, and macros while in PowerSave mode. The default setting is `POWERSAVE ON`, with a 30-minute idle time.

The printer exits PowerSave mode and enters the warm up cycle when any of the following occurs:

- A print job, valid data, or a PML or PJJL command is received at the parallel port or an EIO card.
- A Control Panel key is pressed.
- The top cover is opened and then closed.
- A paper tray is opened and then closed.
- The Engine Test button is pressed.

---

**Note**

---

Printer error messages override the PowerSave message. The printer will enter PowerSave mode at the appropriate time, but the error message will continue to be displayed.

## Resolution Enhancement technology (REt)

The Formatter PCA contains circuitry for Resolution Enhancement technology (REt), which modifies the standard video dot data on its way to the DC Controller Board to produce “smoothed” black-to-white boundaries. REt can be set from the Control Panel, or from some software applications. The default setting is medium.

---

**Note**

---

REt settings sent from software applications or printer drivers override the Control Panel settings.

## EconoMode

The EconoMode setting uses up to 50% less toner than standard mode printing by reducing the dot density. However, EconoMode does not extend Toner Cartridge component life. EconoMode, which can be thought of as “draft mode,” can be selected from the Control Panel (Print Quality Menu) and through some software applications and printer drivers. The default setting is off.

---

**Note**

---

EconoMode does not affect print speed or memory usage, nor does it extend the Toner Cartridge’s life.



# Input/Output

## Parallel Interface

The Formatter PCA receives incoming data through its bidirectional interface (IEEE 1284). The I/O provides high speed and two way communication between the printer and the host, allowing the user to change printer settings and monitor printer status from the host computer. The user may configure the `HIGH SPEED` item in the Control Panel menu. The default setting, `YES`, allows the I/O to run at the higher speeds supported by most newer computers. When set to `NO`, the parallel interface runs at the slower mode that is compatible for older computers. The user may also configure the `ADVANCED FUNCTIONS` item. The default setting, `ON`, allows for two-way parallel communications. The `OFF` mode disables the advanced functionality. The I/O is compatible with the bidirectional parallel interface standard.

## Expanded I/O

The optional Expanded I/O card can be installed in the slots provided on the Formatter PCA. It provides automatic I/O switching between multiple computers or networks connected to the printer. The network version printers include the HP JetDirect Print Server with Ethernet 10Base-T, 10Base-2, and LocalTalk.

## Flash

Flash is provided in optional 2 and 4 MB flash memory DIMMs for storage of forms, fonts, and signatures.

## Disk

The optional 1.4 GB EIO-based hard drive is used for creating multiple original prints (mopies) and for storage of forms, fonts, and signatures.

## Local Talk I/O

The printer implements AppleTalk networking protocol through LocalTalk hardware. The LocalTalk network cable (HP P/N 92215N) is connected through the EIO card.

## CPU

The Formatter PCA incorporates a 100 MHz RISC processor.

# Printer Memory

---

## Note

If the printer encounters difficulty managing available memory, a clearable warning message will be displayed on the Control Panel.

Some printer messages are affected by the Auto Continue and Clearable Warning settings from the Configuration Menu in the printer's Control Panel. If `CLEARABLE WARNING=JOB` is set on the Control Panel, warning messages display on the Control Panel until the end of the job from which they were generated. If `CLEARABLE WARNING=ON` is set, warning messages display on the Control Panel until **[Go]** is pressed. If an error occurs that prevents printing and `AUTO CONTINUE=ON` is set, the printer goes offline for 10 seconds before it returns online. If `AUTO CONTINUE=OFF` is set, the message displays until **[Go]** is pressed.

---

## Read Only Memory (ROM)

Besides storing microprocessor control programs, the ROM stores dot patterns of internal character sets (fonts).

## Random Access Memory (RAM)

The RAM contains the page and I/O buffers and the font storage area. It stores printing and font information received from the host system, and can also serve to temporarily store a full page of print image data before the data is sent to the print engine (see "Page Protect" on page 5-21). RAM memory capacities for each printer are shown in "Printer Features" on page 1-2. Memory capacity can be increased by adding DIMMs to the Formatter PCA. Note that adding memory (DIMMs) may also increase the print speed of complex graphics.

## DIMM Slots

The DIMM slots may be used to add memory, fonts, or firmware upgrades. Note that DIMMs and SIMMS are not compatible.

There are two types of DIMMs supported:

EDO DIMMs are 32-bit, 100-pin, 60nsec.

SDRAM DIMMs are 32-bit, 100-pin, 66MHz.

## Non-Volatile Memory (NVRAM)

The printer uses NVRAM to store I/O and information on the print environment's configuration. The contents of NVRAM are retained when the printer is turned off or disconnected.

## Disk Accessory

The Disk Accessory is mounted on the rear of the Formatter PCA. It can be used to permanently store downloaded fonts and forms in the printer.

## Memory Enhancement technology (MEt)

The Hewlett-Packard Memory Enhancement technology (MEt) effectively doubles the standard memory through a variety of font and data compression methods.

---

### Note

---

MEt is only available in PCL mode; it is not functional when printing in PS mode.

## Page Protect

Page complexity (rules, complex graphics, or dense text) may exceed the printer's ability to create the page image fast enough to keep pace with the Image Formation Process. If Page Protect is disabled, and a page is too complex, it may print in parts (for example, the top half on one page and the bottom half on the next page). Some print data loss is likely in these instances, and the printer will display the `21 PAGE TOO COMPLEX` error message, alternating with `PRESS GO TO CONTINUE`.

Page Protect allows the Formatter to create the entire page image in page buffer memory before physically moving the paper through the printer. This process ensures that the entire page will be printed. Page Protect applies only to PCL printing. The default setting is Auto.

## PJL Overview

Printer Job Language (PJL) is an integral part of configuration, in addition to the standard Printer Command Language (PCL). With standard cabling, PJL allows the printer to perform functions such as:

- Two-way communication with the host computer through a Bidirectional Parallel connection. The printer can tell the host such things as the Control Panel settings, and allows the Control Panel settings to be changed from the host.
- Dynamic I/O switching. This allows the printer to be configured with a host on each I/O. The printer can receive data from more than one I/O simultaneously, until the I/O buffer is full. This can occur even when the printer is offline.
- Context-sensitive switching. This allows the printer to automatically recognize the personalities (PostScript or PCL) of each job and configure itself to serve that personality.
- Isolation of print environment settings from one print job to the next. For example, if a print job is sent to the printer in landscape mode, the subsequent print jobs print in landscape only if they are formatted for landscape printing.

## PML

PML is a Printer Management Language that allows remote configuration and status readback through the I/O Ports.

## Control Panel

The Formatter PCA sends and receives printer status and command data via a Control Panel PCA. See “Using the Control Panel” on page 3-2, and “Alphabetical Printer Messages” on page 7-16 for more information.

# Image Formation System

The image formation system is the main part of the printer, and consists of six stages:

1. Cleaning
2. Conditioning
3. Writing
4. Developing
5. Transferring
6. Fusing

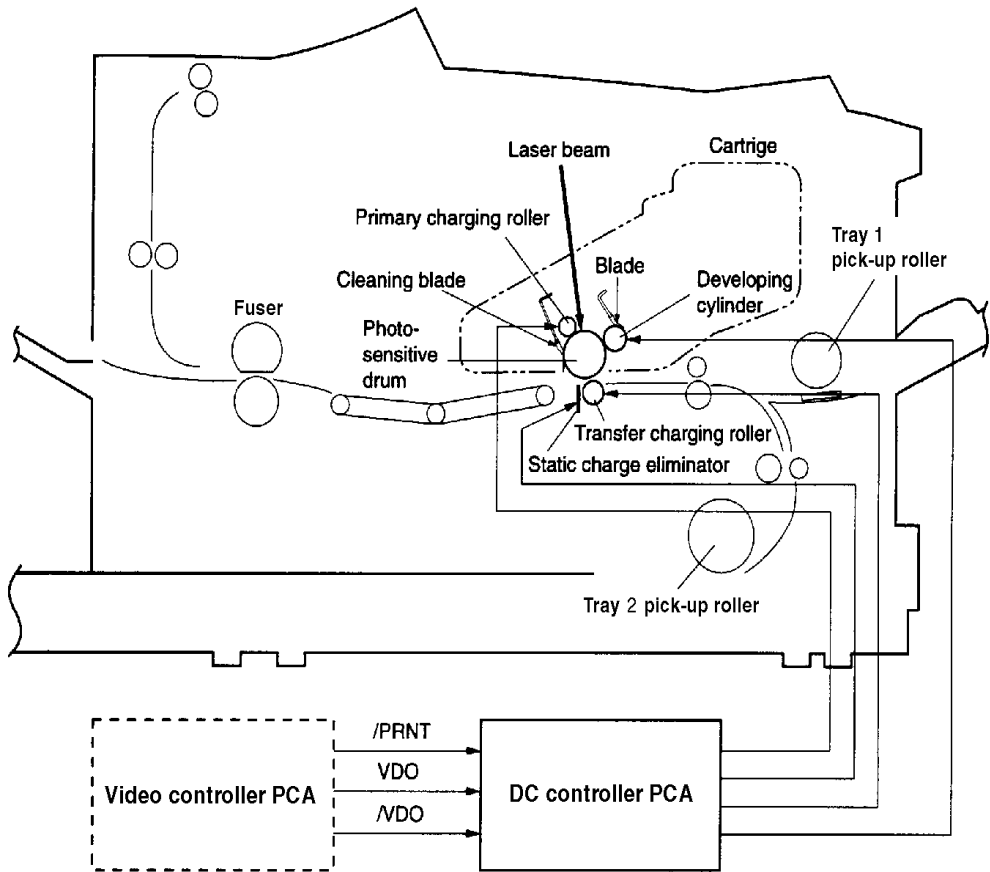
When the Formatter Board sends the print signal to the DC Controller Board, it drives the main motor to rotate the photosensitive drum, the developing cylinder, the primary charging roller, and the transfer charging roller.

The primary charging roller places a uniform negative charge on the surface of the photosensitive drum. The laser beam modulated by the video signal is illuminated on the photosensitive drum surface to form the latent image on the drum with the laser diode.

The latent image formed on the photosensitive drum is changed to a visual image by the toner on the developing cylinder, then transferred to the paper by the transfer charging roller. The residual toner on the photosensitive drum surface is scraped down with the cleaning blade. The potential on the drum is uniformed by the primary charging roller to prepare for a new latent image.

The cartridge has a toner sensor that detects the remaining toner level and the presence of the cartridge.

If the toner in the cartridge becomes lower than the specified level or if there is no cartridge in the printer, it is reported to the Formatter.



**Figure 5-6** Image Formation System

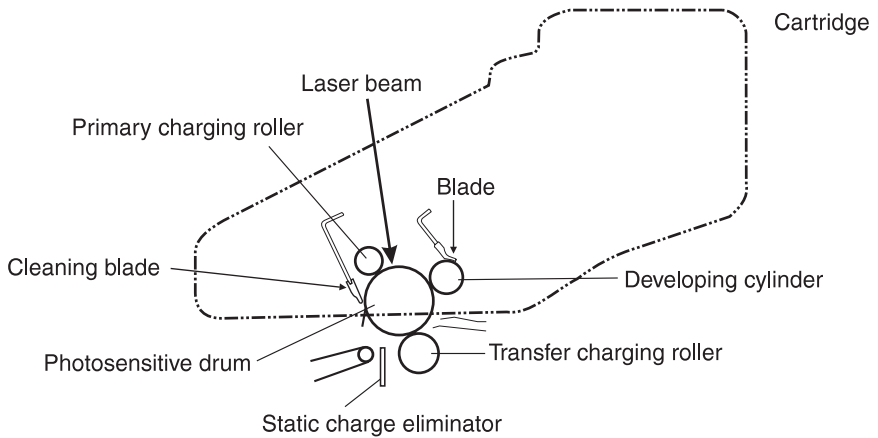
After the image has been transferred to the paper, it is then fused onto the paper by heat and pressure at the Fuser.

# Toner Cartridge

A major portion of the Image Formation system is contained in the cartridge as shown in the figure below.

The Toner Cartridge is the “heart” of the Image Formation System. It houses the cleaning, conditioning, and developing steps of the process. The Toner Cartridge contains the photosensitive drum, primary charging roller, developing station, toner cavity, and cleaning station. Including these components that wear, degrade, or are consumed in the replaceable Toner Cartridge eliminates the need for a service call when replacement is required.

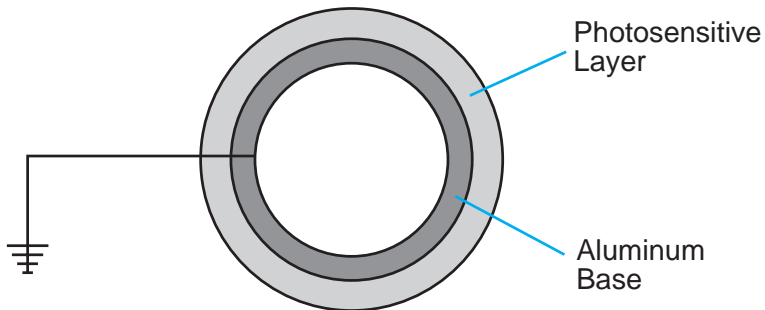
The printer also has a new cartridge drive system that minimizes banding, with more constant paper speed.



**Figure 5-7** Toner Cartridge

## Photosensitive Drum

The special properties of the photosensitive drum allow an image to be formed on the drum surface and then transferred to paper. The drum is an aluminum cylinder. The outside of the cylinder is coated with a layer of organic-photoconductive material (OPC) which is non-toxic. The OPC material has properties similar to a photo-resistor. It becomes electrically conductive when exposed to light. (The negative charges deposited on the drum are conducted to the ground potential of the drum base.) Areas not exposed to light remain non-conductive and maintain their negative charge. The aluminum base of the photosensitive drum is electrically connected to ground potential.



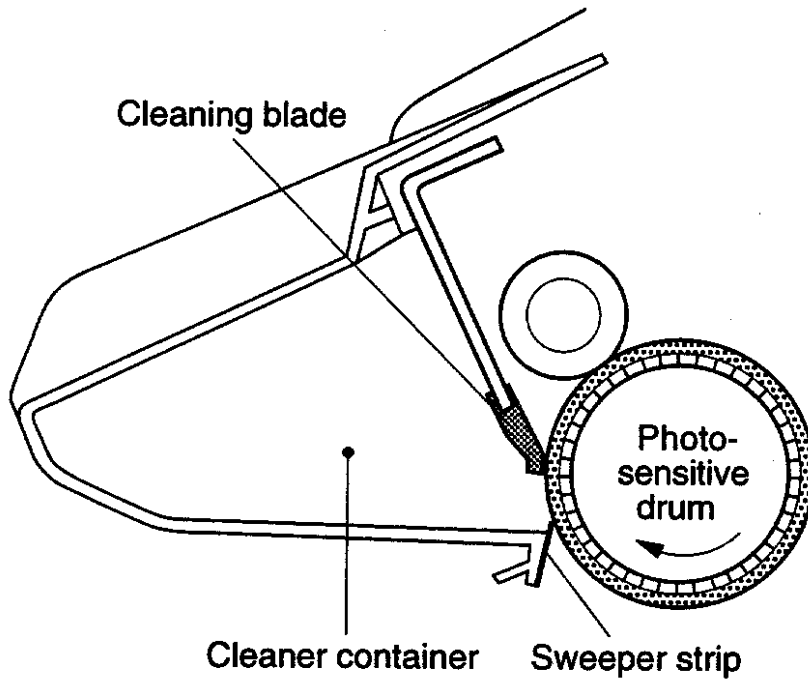
**Figure 5-8** Photosensitive Drum



## Cleaning the Drum

In the transfer stage, not all the toner is transferred to the paper, but some remains on the photosensitive drum.

In this stage, the residual toner is cleaned so that the next print image will be clear and distinct.

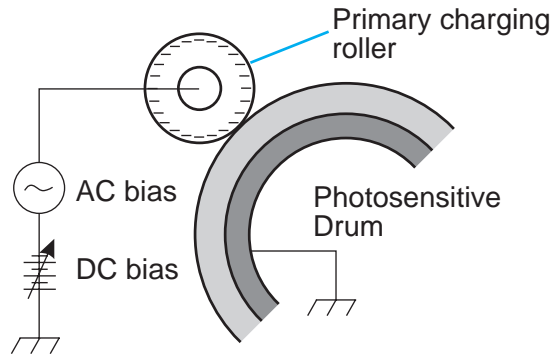


**Figure 5-9** Cleaning the Drum

The residual toner on the drum surface is scraped away with the cleaning blade to clean the drum surface in preparation for the next print. The removed toner is collected into the cleaner container.

## Conditioning the Drum

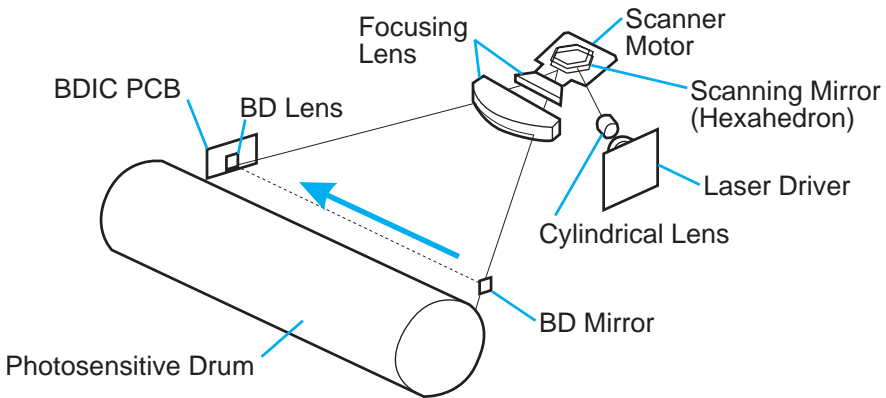
After the drum is cleaned, it must be conditioned. This process consists of applying a uniform negative charge on the surface of the drum with the primary charging roller. The primary charging roller is coated with conductive rubber with an AC bias applied to erase any residual charges and maintain a constant drum surface to create a uniform negative potential on the drum surface. The amount of DC voltage is modified by the print density setting.



**Figure 5-10** Primary Charging Roller

## Writing the Image

During the writing process, a modulated laser diode projects the beam onto the rotating six-sided scanning mirror. As the mirror rotates, the beam reflects off the mirror, through a set of focusing lenses, through a slot in the rear of the Toner Cartridge, and onto the photosensitive drum. The beam sweeps the drum from left to right, discharging the negative potential wherever the beam strikes the surface. This creates a latent electrostatic image, which later is developed into a visible image.



**Figure 5-11** Writing the Image

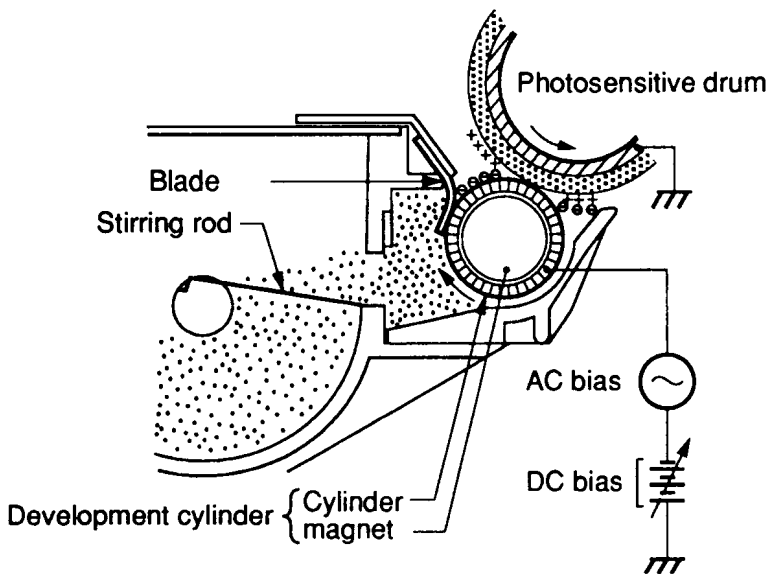
Because the beam is sweeping the entire length of the drum and the drum is rotating, the entire surface area of the drum can be covered. The speed of the scanner motor (which turns the scanning mirror) and the speed of the main motor (which turns the drum) are synchronized, and each successive sweep of the beam is offset by 1/1200th of an inch. The beam can be turned on and off to place a dot of light every 1/1200th of an inch. This is how the printer achieves its 1200x1200 dpi resolution. After the writing process, the drum surface has an invisible (latent) electrostatic image.

At the end of each sweep, the beam strikes the beam detect lens, generating the Beam Detect Signal (/BD). The BD signal is sent to the DC Controller Board, where it is converted to an electrical signal used to synchronize the output of data (/VDO) for one sweep (scan line) and to diagnose problems with the laser diode or scanner motor.

## Developing the Image

The developing process develops the latent electrostatic image into a visible image on the drum. The developing unit consists of a metallic cylinder that rotates around a fixed magnetic core inside the toner cavity. Toner is a powdery substance made of black plastic resin bound to iron particles, which is uniformly attracted to the magnetic core of the cylinder.

The toner particles obtain a negative surface charge by rubbing against the developing cylinder which is connected to a negative DC supply. The negatively charged toner is attached to the discharged (exposed, grounded) areas. An AC potential is applied to the developing cylinder to decrease the attraction between the toner and the magnetic core of the cylinder, and to increase the repelling action of the toner against the areas of the drum not exposed to laser light. This AC potential improves density and contrast.



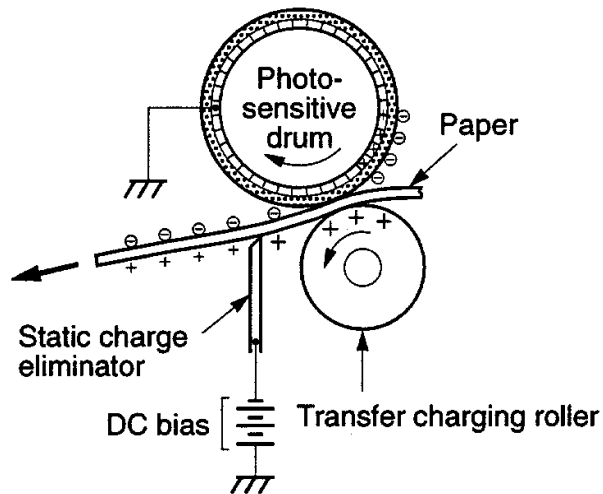
**Figure 5-12** Developing the Image

The Print Density control in the Control Panel Menu adjusts the DC bias of the developing cylinder by changing the force of attraction between the toner and drum. A change in the DC bias causes either more or less toner to be attracted to the drum, which in turn either increases or decreases the print density. Both the primary and developer DC bias voltages are changed in response to the density setting.

## Transferring the Image

During the transferring process the toner image on the drum surface is transferred to the paper. A positive charge applied to the back of the paper by the transfer roller causes the negatively charged toner on the drum surface to be attracted to the page.

The small diameter of the drum, combined with the stiffness of the paper, causes the paper to peel away from the drum. The static eliminator teeth also help separate the paper from the drum. The static eliminator teeth weaken the attractive forces between the negatively charged drum surface. After separation, the drum is cleaned and conditioned for the next image.



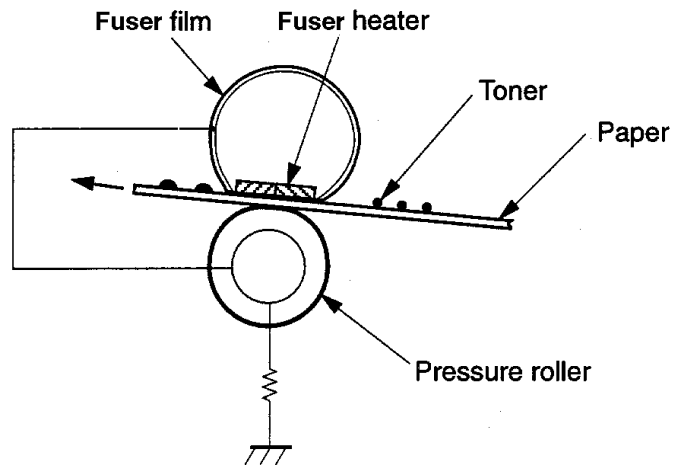
**Figure 5-13** Transferring the Image

## Image Fusing/Variable Fusing Temperature

During the fusing process, the toner is fused into the paper by heat and pressure to produce a permanent image. The paper passes between a heated fusing roller and a soft pressure roller. This melts the toner and presses it into the paper.

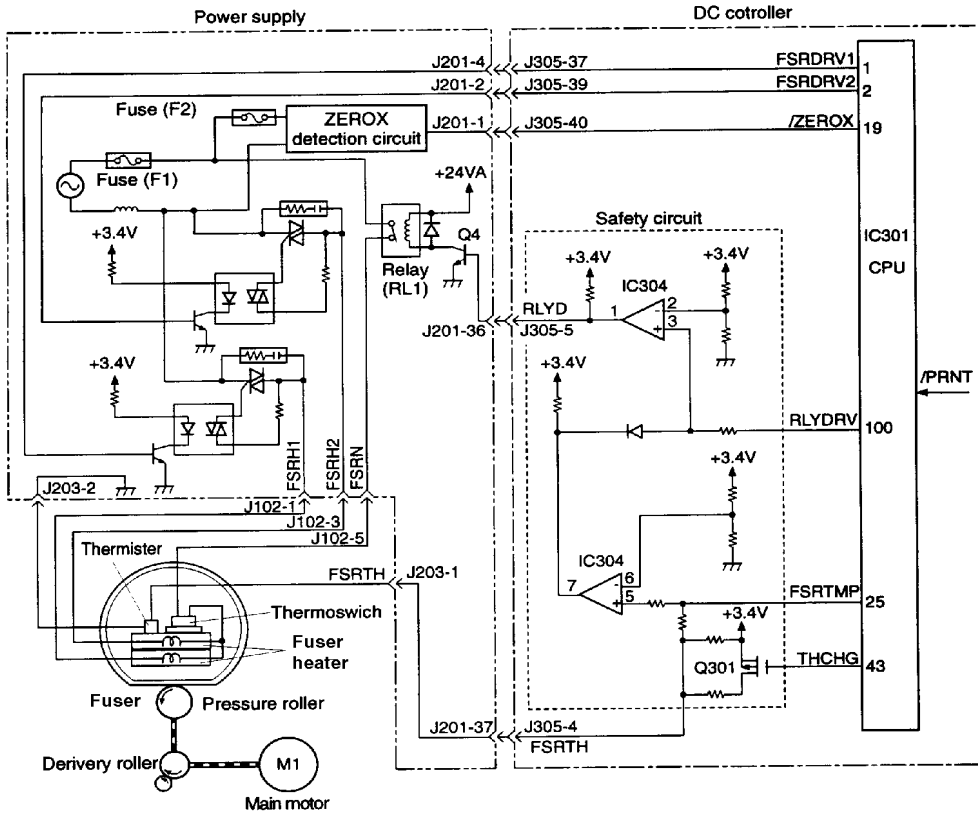
The fusing roller contains a ceramic heating element that provides heat for the fusing process. Fusing temperature is monitored by the DC Controller Board, via the thermistor TH1303. If the fusing system overheats (about 446° F/230° C), a relay opens, interrupting power to the Fusing Heater, causing a Fuser error message (50.X FUSER ERROR). If the fusing system exceeds 464° F (240° C), the thermal fuse will open, cutting off power to the Fuser.

The DC Controller Board maintains a variable fuser temperature that is dependent on the paper type set in the Paper Handling Menu.



**Figure 5-14** Image Fusing

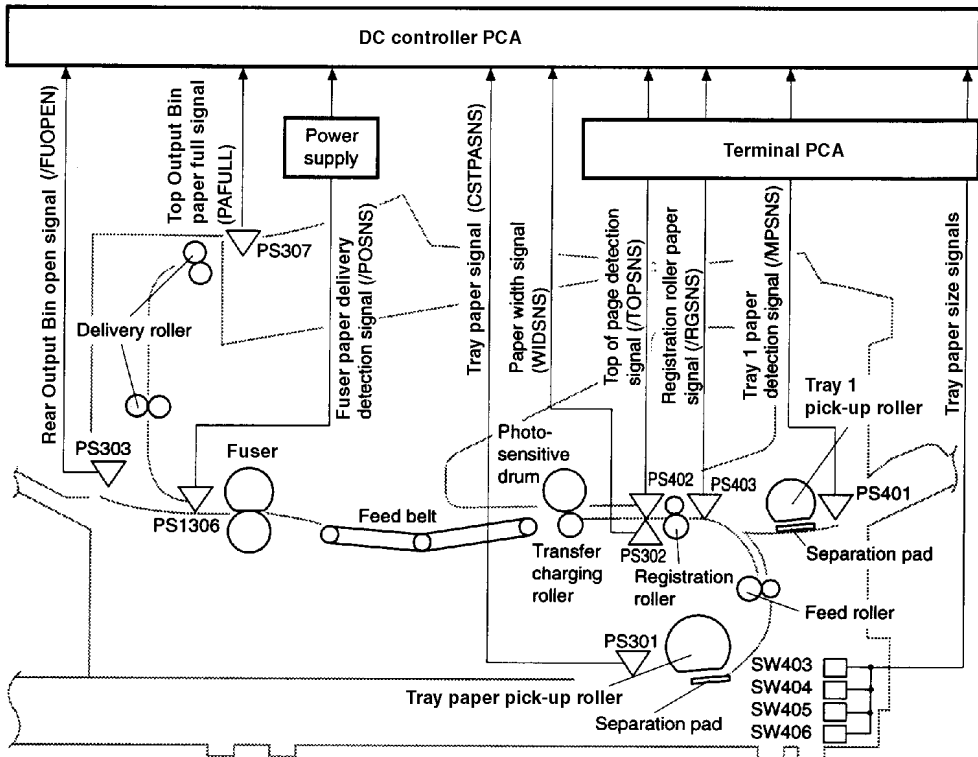
# Variable Fusing Temperature



**Figure 5-15** Fusing Temperature Control

Variable Fusing Temperature is a feature that gives the user or service technician the ability to adjust the fusing temperature based on the media being used in the printer. The default mode is Normal and should be optimal for most users. There is an optional Vellum, Low, Normal, and High Fuser Mode selection. If very heavy or rough media is being used, then High Fuser Mode is beneficial. If transparencies or light media are being used, then Low Fuser Mode might be appropriate. `CONFIGURE FUSER MODE` is in the Paper Handling Menu and when set to the default of `NO`, paper types are not displayed in the menu. When `CONFIGURE FUSER MODE` is set to `YES`, the different paper types are then displayed in the menu.

# Paper Feed System



**Figure 5-16** Paper Path

The paper in Tray 1 is detected by the Tray 1 paper sensor (PS401). The paper in Tray 2 is detected by the Tray 2 paper sensor (PS301).

The size of the paper in Tray 2 and the presence of Tray 2 installed in the printer are detected by four switches (SW403, SW404, SW405, and SW406) on the terminal PCA.

When the paper is fed from Tray 2, the Tray 2 pickup solenoid (SL306) and the feed roller clutch (CL406) turn on while the main motor (M1) is rotating. Then the Tray 2 pickup roller and the feed roller start rotating to feed a sheet of paper into the printer.

When the paper is fed from Tray 1, the Tray 1 pickup solenoid (SL404) turns on while the main motor (M1) is rotating. Then the Tray 1 feed roller starts rotating to feed a sheet of paper into the printer.



The paper passes through the registration roller paper sensor (PS403) and stops at the registration roller to loop the leading edge and its skew is corrected. Then the registration clutch (CL405) turns on to restart paper feed.

The DC controller PCA sends the top of page signal (/TOP) to the Formatter PCA within a specified period of time after the top of page sensor (PS402) detects the leading edge of the paper.

The Formatter PCA sends the video signal (/VDO, VDO) within a specified period of time after it receives the /TOP signal to align the image leading edge on the photosensitive drum with the leading edge of the paper already fed. The paper then passes through the transfer unit, separation unit, fuser, and deliver unit and is output onto the rear output bin or the top output bin. There are three photointerrupters (PS402, PS403, and PS1306) in the paper path to detect the paper.

If the paper does not reach or pass through any of the sensors within the specified period of time, the microprocessor (CPU) on the DC Controller PCA notifies the Formatter of a paper jam.

## **Clutches and Sensors**

See “Reference Diagrams” starting on page 7-79 for locations of switches, sensors, and clutches.

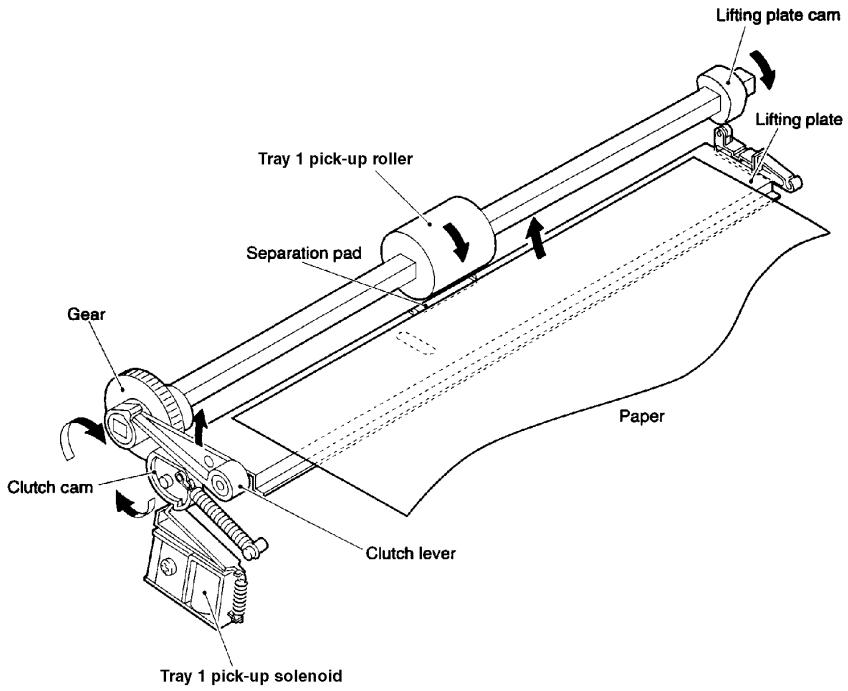
## Printing from Tray 1

The presence of paper in Tray 1 is detected by the Tray 1 Paper Sensor (PS401).

When the Formatter PCA sends the /PRNT (print signal) to the printer, the CPU turns the Tray 1 pickup solenoid (SL404) on within the specified period of time for the main motor (M1) and the scanner motor to start and the printer to be ready to print.

This turns the cam on and lifts the middle plate where the paper is loaded. The paper touches the Tray 1 feed roller. The Tray 1 feed roller rotates a full circle to feed one sheet of paper. Extra sheets are removed with the separation pad, and only one sheet is fed into the printer as the Tray 1 feed roller rotates.

The paper passes through the registration roller paper sensor (PS403) and stops at the registration roller that is not turning, loops the leading edge of the paper and corrects its skew. The CPU turns the registration roller clutch (CL405) on within a specified loop-forming time and feeds the paper through the transfer unit, the separation unit, the fuser, and the delivery unit, and outputs it onto the tray.



**Figure 5-17** Tray 1 Pickup

## Printing from Tray 2

When the Formatter PCA sends the /PRNT (print signal) to the printer, the CPU turns the Tray 2 pickup solenoid (SL306) on about 0.15 seconds after the main motor (M1) starts rotating, then turns on the feed roller clutch (CL406). The main motor rotates the Tray 2 pickup roller and feed roller.

The Tray 2 pickup roller rotates a full circle with the Tray 2 pickup solenoid (SL306) and picks up one sheet of paper from the tray. The paper is fed into the printer as the feed roller rotates. The paper passes through the registration roller paper sensor (PS403) and stops at the registration roller that is not turning, loops the leading edge of the paper and corrects its skew. The CPU turns the feed roller clutch (CL406) off within a specified loop-forming time and stops the feed roller rotation. The CPU turns the registration roller clutch (CL405) and feed roller clutch (CL406) on about 1.3 seconds after the scanner becomes ready and feeds the paper through the transfer unit, separation unit, fuser, and delivery unit and outputs it onto the tray.

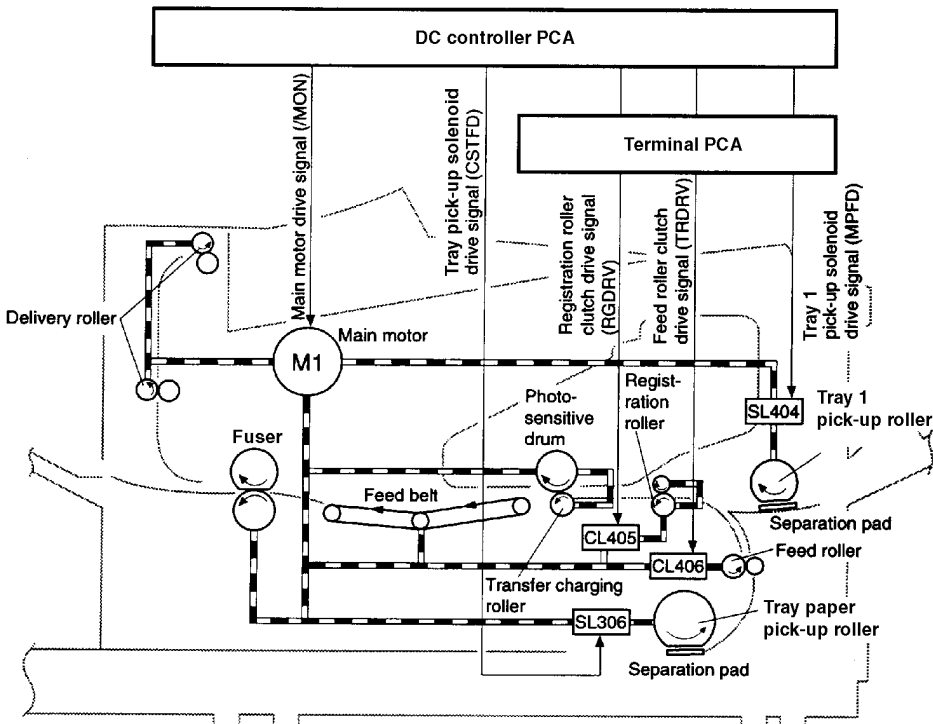
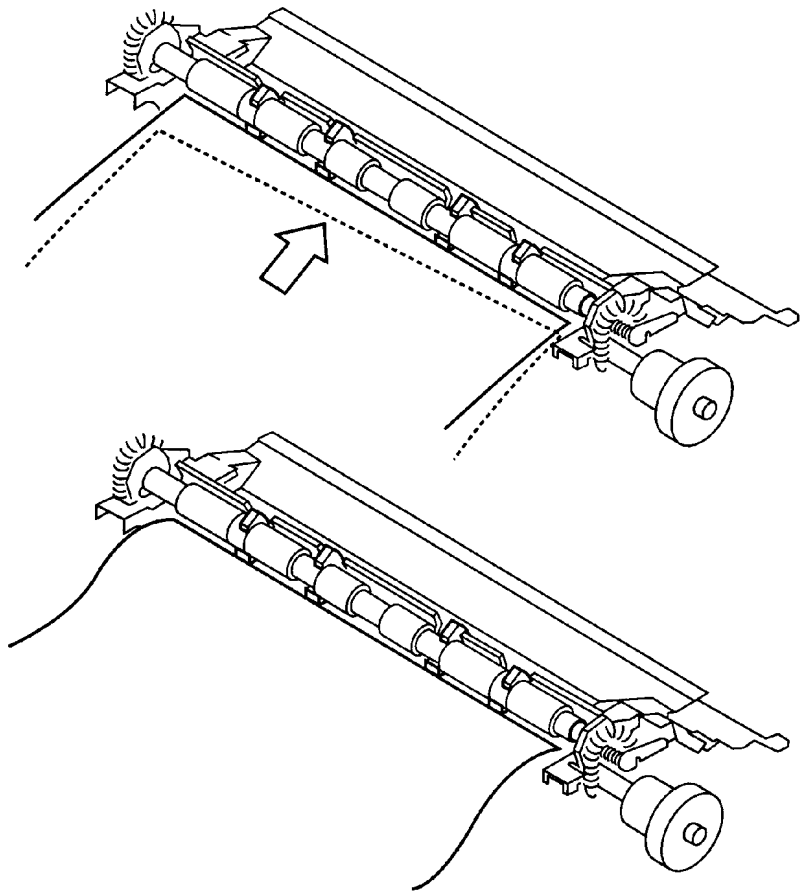


Figure 5-18 Tray 2 Paper Path



**Figure 5-19** Paper Skew Loop-forming

## Printing from the Optional 500-sheet and 250-sheet Trays

There are two kinds of paper feeders: 250-sheet and 500-sheet. The paper feeder operation sequence is controlled by the paper handling PCA. The paper handling PCA has the 8-bit microcomputer, and controls the serial communications between the operation sequence control of the paper handling and the DC controller PCA of the printer. The paper handling PCA drives motors and solenoids with various commands from the DC controller PCA. The paper handling PCA sends the status of the paper feeder back to the printer at the same time. (Refer to page 7-74 for the wiring diagrams.)

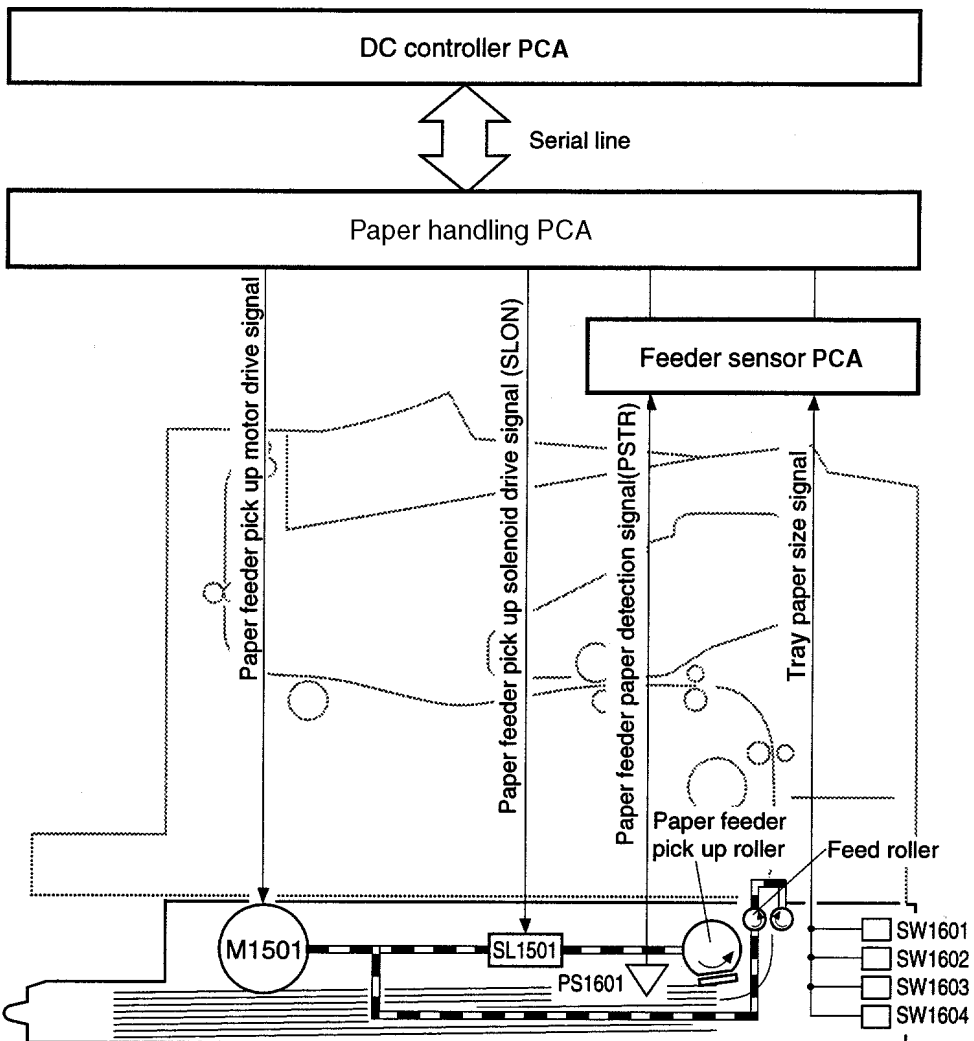
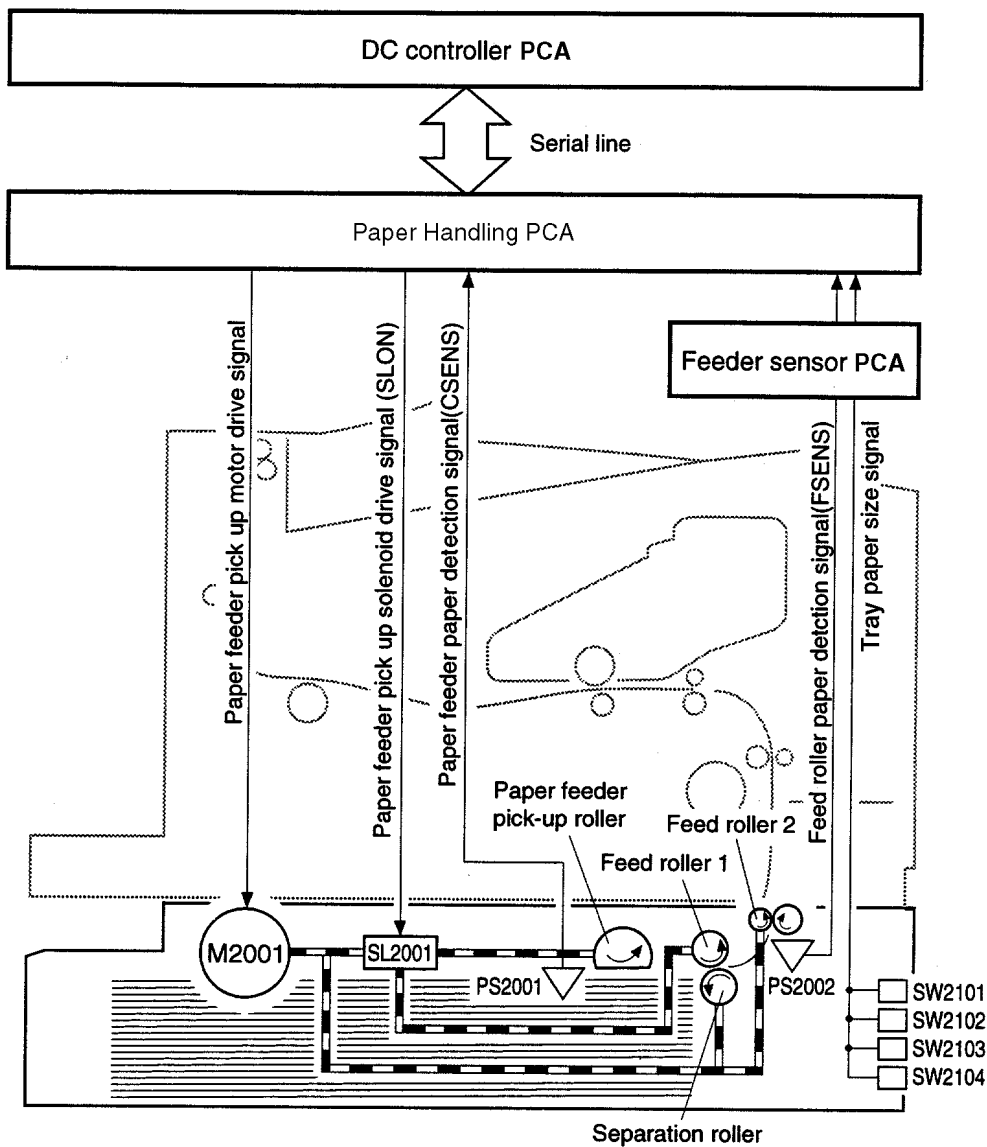


Figure 5-20 250-sheet Paper Feeder



**Figure 5-21** 500-sheet Paper Feeder

## Paper Jam

To detect the presence of paper and whether the paper has been correctly fed, the following paper sensors are installed:

- Registration roller paper sensor (PS403)
- Top of page sensor (PS402)
- Fuser paper delivery sensor (PS1306)

If the paper does not reach or pass through any of the sensors within the specified period of time, the microprocessor (CPU) on the DC Controller PCA notifies the Formatter of a paper jam.



## Duplexer

This function is to reverse the one side printed paper from the printer and refeed it into the printer.

The Duplexer operation sequence is controlled by the duplex driver PCA. The duplex driver PCA has the 8-bit microcomputer, which controls the serial communications between the operation sequence control of the duplexing unit and the DC controller PCA of the printer.

The duplex driver PCA drives motors and solenoids with various commands from the DC controller PCA. The duplex driver PCA also sends the status of the Duplexer back to the printer.

## Reversing/Refeed System

The paper is first fed into the Duplexer with the duplex deflector in the printer. In the Duplexer, the reversing roller switches the feeding direction of the paper. After the side registration guide adjusts the side registration, the paper is sent back into the printer with the feed and refeed rollers.

The reversing motor (PM1701), the side registration guide drive motor (PM1702), and the refeed motor are all stepping motors. They are controlled both in straight and reverse rotation by the microcomputer (CPU) on the duplexing driver PCA.

The reversing roller is driven by the reversing motor (PM1701). The feed and refeed rollers are driven by the refeed motor (PM1703).

The side registration guide is driven by the side registration guide drive motor (PM1702), and is adjusted according to the size of the paper.

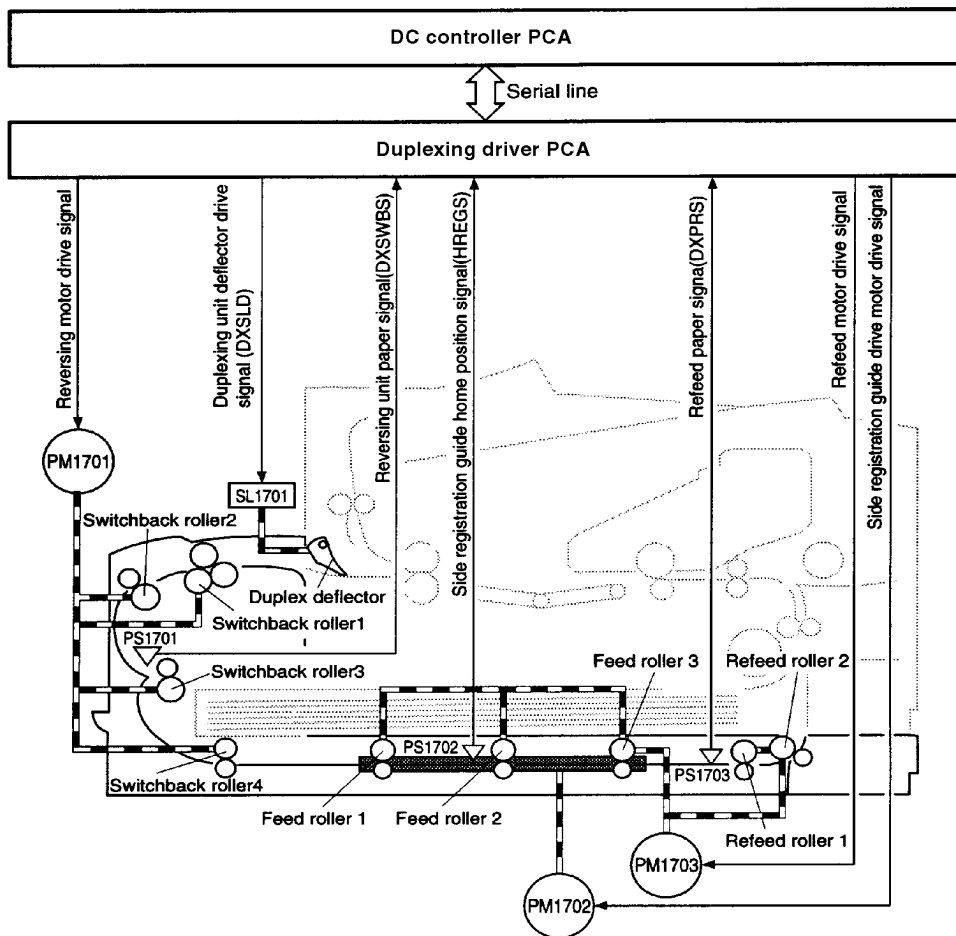
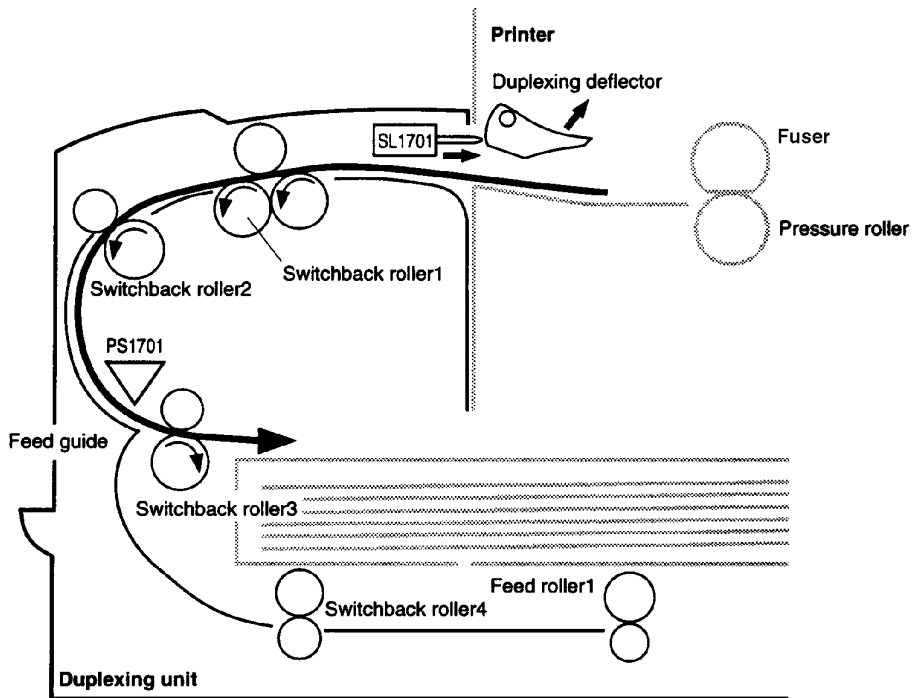


Figure 5-22 Paper Feed for the Duplexer

## Reversing System

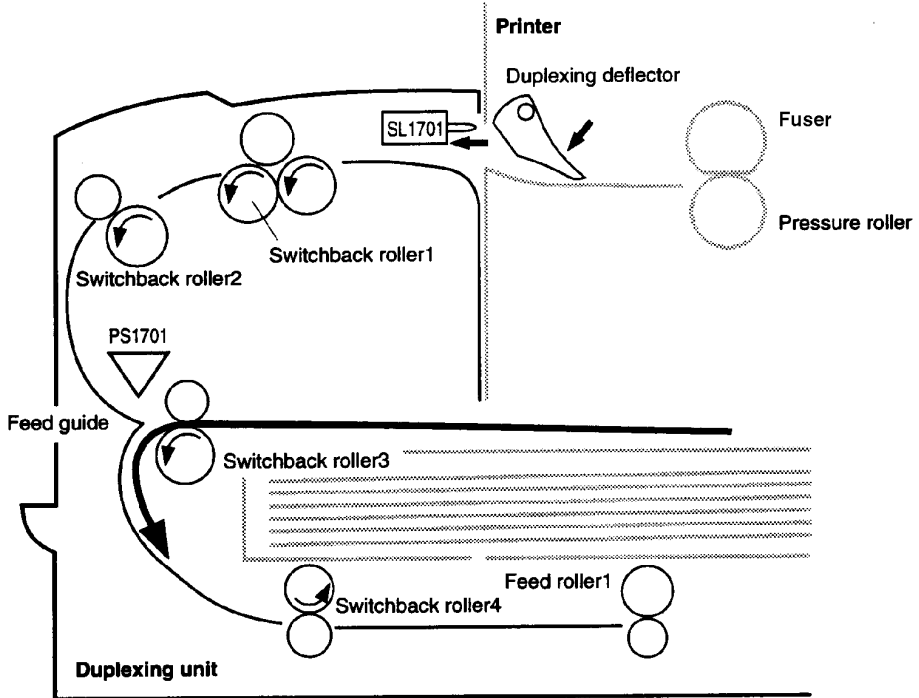
The duplexing driver PCA receives the duplex admission command from the printer first. It turns on the Duplexer deflector drive solenoid (SL1701), and the Duplexer deflector in the printer then starts to send the paper into the Duplexer. Within a specified period of time after receiving the command, the duplexing driver PCA also drives the reversing motor (PM1701) in straight rotation, and the reversing rollers 1, 2, and 3 in XX direction. Therefore, the paper is fed in XX direction (shown in the figure below).



**Figure 5-23** Duplexing Unit

Within a specified period of time after the trailing edge of the paper is detected with the reversing unit paper sensor (PS1701), the duplex driver PCA pauses the rotation of the reversing motor (PM1701). The duplex driver PCA then switches the reversing motor (PM1701) to reverse rotation.

As the paper is fed along the feed guide, it is fed through the reversing roller 4 and the feed roller 1 of the Duplexer.



**Figure 5-24** Duplexing Unit

## Uncurling Function

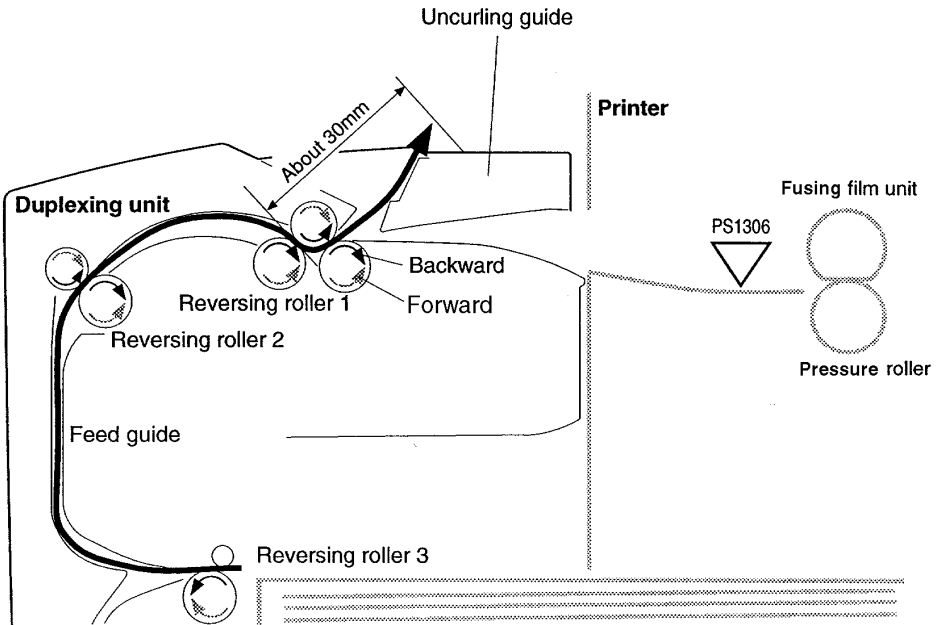
This printer has the function to minimize a paper from wrinkle and paper edge crease due to curl.

The printer sends the command to the duplexing driver PCA by receiving the uncurling command sent from the formatter PCA. The duplexing driver PCA executes one of the operations below by the command sent from the printer.

- 1 Skips uncurling operation
- 2 Executes pause operation
- 3 Executes dance operation

### Pause Mode

Pause mode reduces paper curl. The duplexing driver PCA starts the reversing process, and then the fusing delivery sensor (PS1306) senses the trailing edge of the paper. After a specified period of time, the duplexing driver PCA stops and rotates the reversing motor (PM1701) counter clockwise (CCW). At the same time, the reversing rollers 1, 2, and 3 are rotated in reverse. The paper comes out about 30 mm from the duplexing unit along the uncurling guide and pauses for about one second. Then, the duplexing driver PCA starts to rotate the reversing motor (PM1701) clockwise (CW) so that the reversing rollers 1, 2, and 3 are rotated in reverse, and the paper refeeds into the duplexing unit.

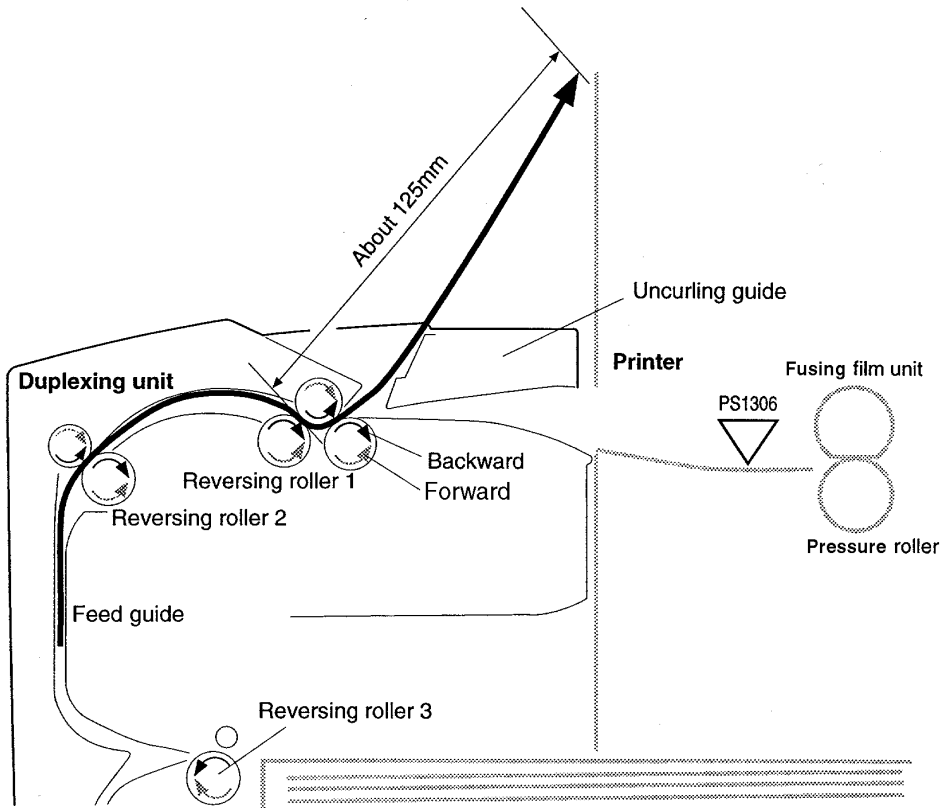


**Figure 5-25** Pause Mode

**Dance Mode**

Dance mode reduces paper curl by refeeding paper into the duplexing unit three times.

The paper refeeds into the duplexing unit about 30 mm by using the pause mode. Then the duplexing driver PCA rotates the reversing motor (PM1701) counter clockwise (CCW), and the reversing rollers 1, 2, and 3 rotate in reverse. In this way, the paper comes out from the duplexing unit about 125 mm and pauses. Then, the duplexing driver PCA rotates PM1701 clockwise (CW). Accordingly, the reversing rollers 1, 2, and 3 are rotated in reverse, and the paper refeeds into the duplexing unit about 125 mm. After this returning and refeeding process is repeated three times, the paper refeeds into the duplexing unit.



**Figure 5-26** Dance Mode

## Paper Jam in the Duplexer

The following sensors are located to detect the presence of paper and to determine whether the paper is correctly fed.

- reversing unit paper sensor (PS1701)
- refeed paper sensor (PS1703)

If the paper does not reach or pass through any of the sensors within the specified period of time, the microprocessor (CPU) on the DC Controller PCA notifies the Formatter of a paper jam.

# Basic Sequence of Operation

The Formatter PCA and the DC Controller Board share information during printer operation. The Interface PCA forms a link which operates as a serial data bus. This allows printer status, command, and dot-image data to be passed between the two PCAs. Table 5-1 shows the general timing of the printer events. The following events take place during normal printer operation:

**Table 5-1. Printer Timing**

Period	Timing	Purpose	Remark
WAIT	From power on until the Main Motor completes the initial drive.	Clears the drum surface potential and cleans the transfer charging roller.	During this period, the printer detects the toner level and the presence of the cartridge.
STBY (standby)	From the end of the WAIT period until the /PRNT signal is input from the Formatter, or from the end of the LSTR period until the /PRNT signal is input from the Formatter or until the power is turned off.	Makes the printer ready to print.	
INTR (initial rotation)	After the /PRNT signal is input from the Formatter until the DC controller outputs the /TOP signal.	Stabilizes the sensitivity of the photosensitive drum in preparation for printing, and cleans the transfer charging roller to stabilize the transfer high voltage.	
PRINT	From the end of the INTR period until the top of the paper sensor detects the trailing edge of the paper.	Forms an image on the photosensitive drum according to the /VDO and VDO signals input from the video controller, and transfers the image to paper.	During this period, the printer detects the remaining toner.



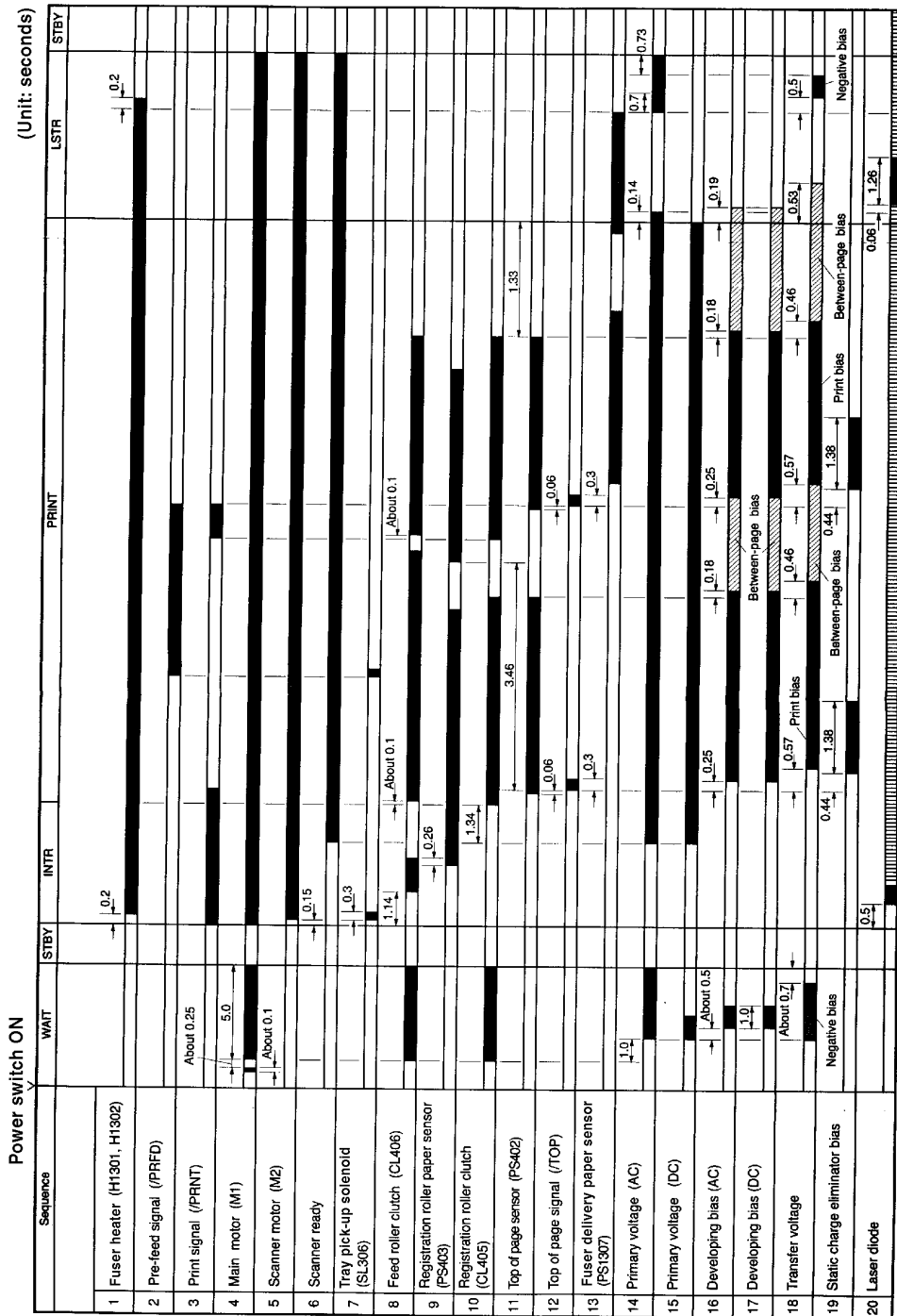
---

**Table 5-1. Printer Timing**

---

<b>Period</b>	<b>Timing</b>	<b>Purpose</b>	<b>Remark</b>
LSTR (last rotations)	After the primary DC voltage turns off until the Main Motor stops.	Delivers the final page and cleans the transfer charging roller.	As soon as the /PRNT signal is input from the Formatter PCA, the printer enters the INTR period.

---



**Figure 5-27** Timing Diagram



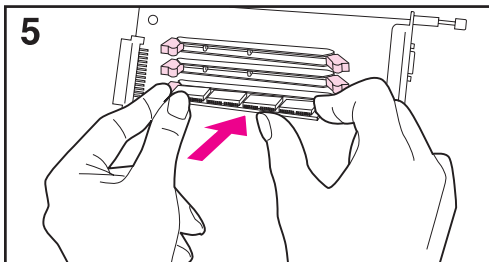
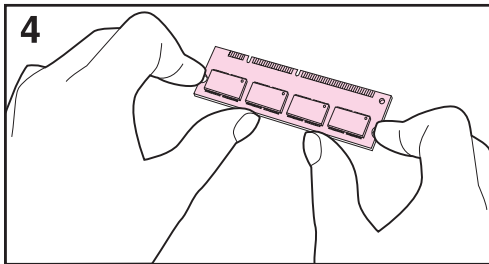
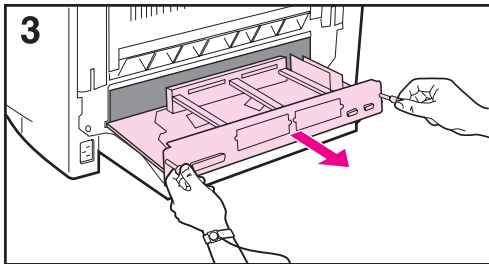
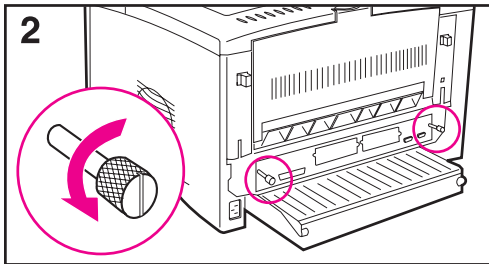
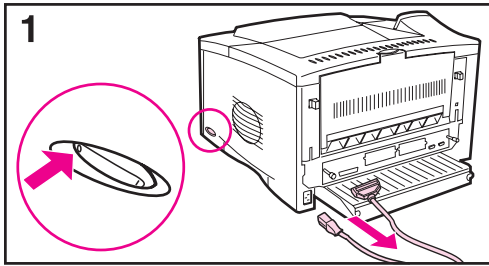
# 6 Removing and Replacing Parts

## Overview

This chapter discusses the following:

- User Installable Accessories
- Removal and Replacement Strategy
- Removing Covers
- Removing Assemblies

# User Installable Accessories



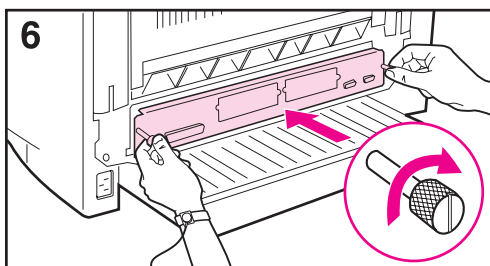
## Memory Upgrade

### CAUTION

Static electricity can damage dual in-line memory modules (DIMMs). When handling DIMMs, either wear an antistatic wrist strap or frequently touch the surface of the DIMM's antistatic package, then touch bare metal on the printer.

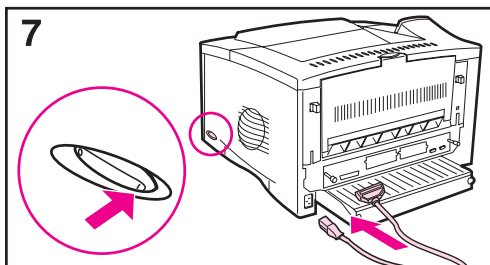
If you have not already done so, print a configuration page to find out how much memory is installed in the printer before adding more memory.

- 1 Turn the printer off. Unplug the power cord and disconnect any cables. (If an optional duplexer is installed, you will need to remove the rear section and the cable tray first.)
- 2 Loosen the two captive thumb screws on the back of the printer.
- 3 Grasp the screws and pull the formatter board out of the printer. Place it on a flat, non-conductive surface.
- 4 Remove the DIMM from the antistatic package. Hold the DIMM with fingers against the side edges and thumbs against the back edge. Align the notches on the DIMM with the DIMM slot. (Check that the locks on each side of the DIMM slot are open, or outward.)
- 5 Press the DIMM straight into the slot (press firmly). Make sure the locks on each side of the DIMM snap inward into place. (To remove a DIMM, the locks must be released.)



**6** Slide the formatter board back into the printer and tighten the two screws.

**7** If an optional duplexer is installed, reattach the cable tray and the rear section of the duplexer. Reattach any interface cables and the power cord. Turn the printer on and test the DIMM.



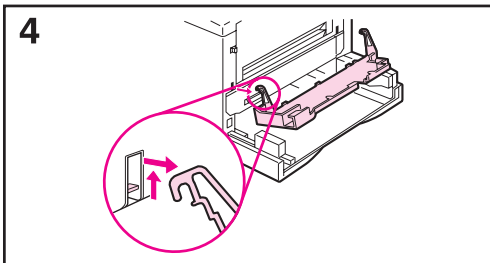
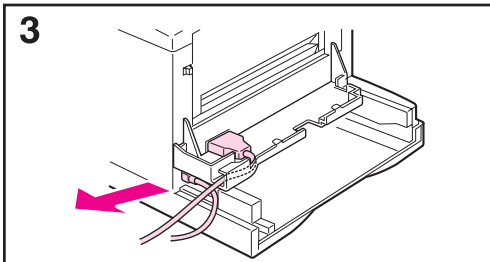
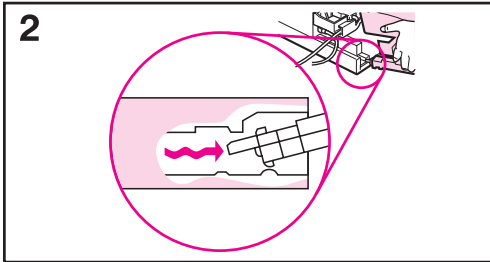
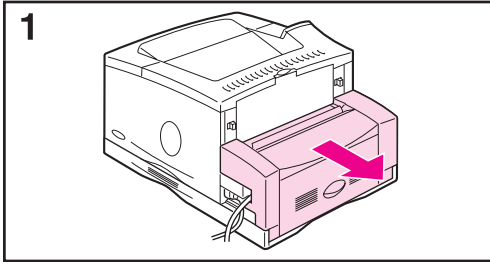
---

**Note**

Single in-line memory modules (SIMMs) used on previous HP LaserJet printers are not compatible with the printer.

---

**If an optional duplexer is installed:**



- 1** Slide the rear section of the duplexer away from the printer.
- 2** Remove the rear section of the duplexer by lifting and rotating the rear section to clear all of the tabs in the grooves, as illustrated.
- 3** Unplug the power cord and disconnect any cables.
- 4** Remove the cable tray by lifting it out of position, as illustrated.
- 5** Reverse these steps to install the cable tray and the rear section of the duplexer. Make sure the cable tray is properly installed and the cables are routed through the left side.

## Checking Memory Installation

Follow this procedure to verify that DIMMs are installed correctly:

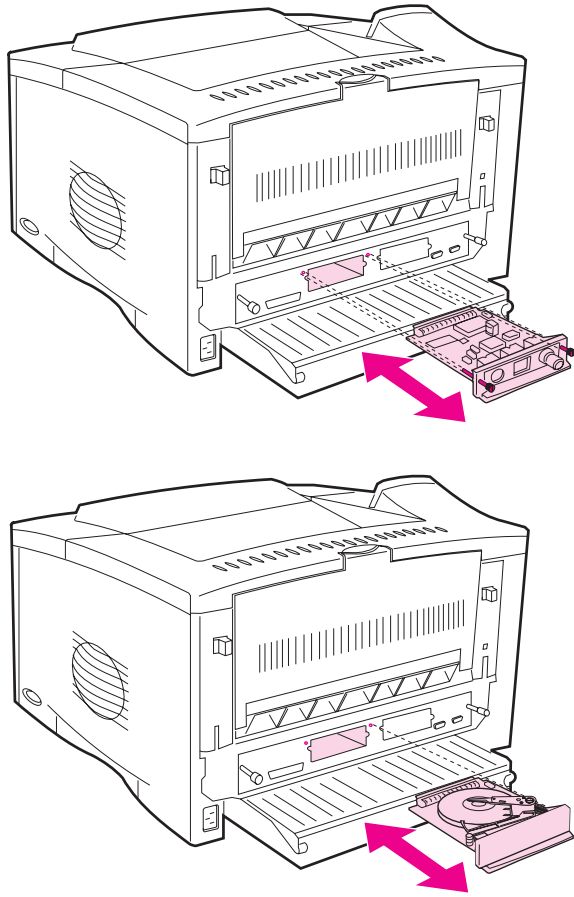
- 1** Check that the printer's control panel displays `READY` when the printer is turned on. If an error message appears, a DIMM might have been incorrectly installed. Check the printer messages.
- 2** Print a new configuration page.
- 3** Check the memory section on the configuration page and compare it to the configuration page printed before the DIMM installation. If the amount of memory has not increased, the DIMM might not be installed correctly (repeat the installation procedure), or the DIMM might be defective (try a new DIMM).
- 4** See Chapter 7, Troubleshooting, for additional information.

## Installing EIO Cards / Mass Storage

Turn off the printer before installing the EIO card or mass storage device. Slots will accommodate either type of device.

For more information, see Appendix C in the User's Guide.





**Figure 6-1** Installing EIO Cards or Mass Storage Devices

# Removal and Replacement Strategy

This chapter documents removal and replacement of major assemblies.

Replacement is generally the reverse of removal. Occasionally, information is included to provide direction for difficult or critical replacement procedures.

---

## WARNING!

Unplug the power cord from the power outlet before attempting to service the printer. If this warning is not followed, severe injury may result.

Never operate or service the printer with the protective cover removed from the Laser/Scanner assembly. The reflected beam, although invisible, can damage your eyes.

---

This printer has some sharp, sheet metal edges which can cause injury.

---

## Hint

To install a self-tapping screw, first turn it to the left until it clicks, indicating the threads are seated. Then, turn it to the right to tighten. **Do not over-tighten.** If a self-tapping screw-hole becomes stripped, repair of the screw-hole or replacement of the affected assembly is required.

---

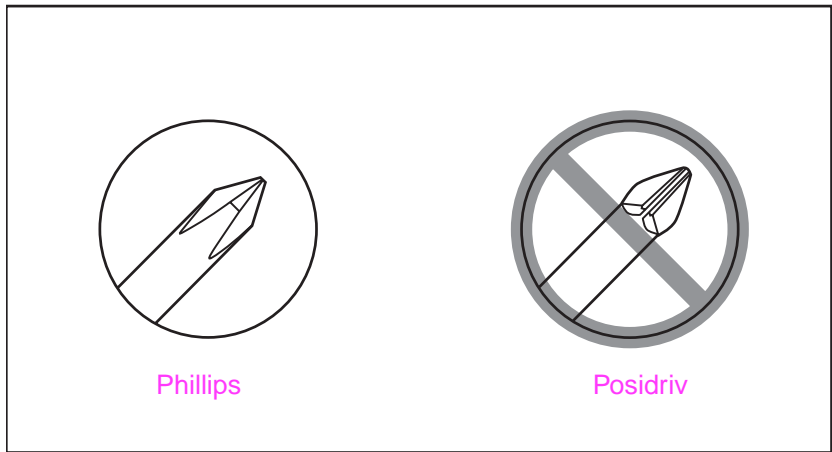
## CAUTION

The printer contains parts that are electrostatic discharge (ESD) sensitive. Always service printers at an ESD-protected workstation.

## Required Tools

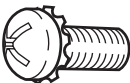
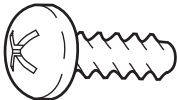

- Phillips #2 magnetized screwdriver (6-inch shaft)
- Small, flat-blade screwdriver
- Small, needle-nosed pliers

All screws used in field-replaceable printer components are Phillips head screws that require a #2 size Phillips screwdriver. Figure 6-2 below shows the difference between a Phillips and a Posidriv screwdriver. Note that the Phillips tip has more beveled surfaces.



**Figure 6-2** Phillips vs. Posidriv Screwdrivers

**Table 6-1. Screws Used in the Printer**

Drawing and Description	Purpose
 <p data-bbox="127 1078 584 1100">Threaded Phillips with captive star washer</p>	<p data-bbox="782 973 1116 1055">Used to fasten metal to metal when good electrical contact is needed.</p>
 <p data-bbox="127 1321 480 1347">Silver Self-tapping Phillips screw</p>	<p data-bbox="782 1225 1139 1277">Used to fasten metal or plastic to plastic mainframes.</p>
 <p data-bbox="127 1564 480 1590">Black Self-tapping Phillips screw</p>	<p data-bbox="782 1468 1139 1520">Used to fasten metal or plastic to plastic mainframes.</p>

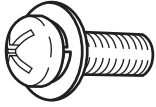
---

**Table 6-1. Screws Used in the Printer (continued)**

---

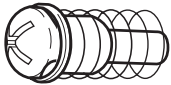
**Drawing and Description**

**Purpose**



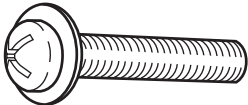
Used to fasten metal or plastic to threaded plastic or metal.

Threaded Phillips screw with lock and flat washer



Used to ground and align the DC Controller pan.

Spring Screw



Used to fasten the DC Controller.

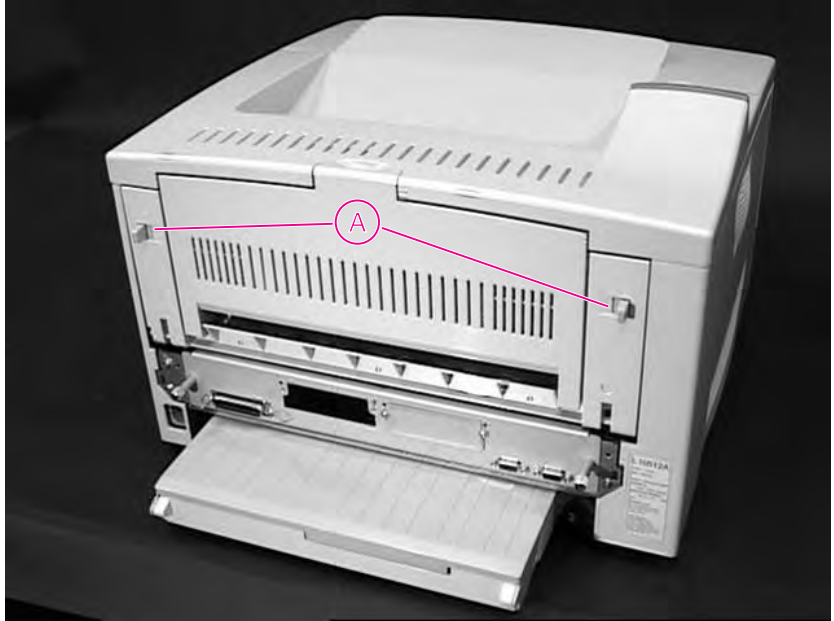
Long Machine Screw



# Removing Covers

## Rear Door / Rear Output Bin

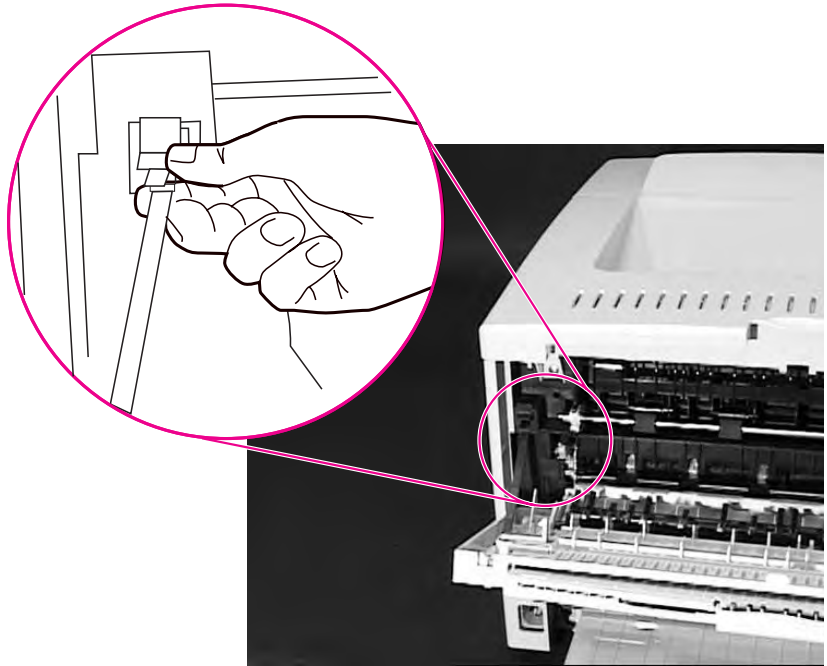
- 1 Face the rear of the printer. Press the two locking tabs toward the center of the printer, releasing the Rear Door.



**Figure 6-3** Rear Door/Rear Output Bin

Item	Explanation
A	Locking Tabs

- 2 The plastic support strap is located on the left side of the printer. To release the strap, pinch the top of the strap with your index finger underneath the strap, and your thumb on top of the tab. Squeeze and lift up from the bottom, while pulling out (Figure 6-4).



**Figure 6-4** Support Strap

- 3 Slide the door to the left, and then remove it from the printer.

**Hint** For reassembly, insert the pin on the left side of the cover first.

## Top Cover

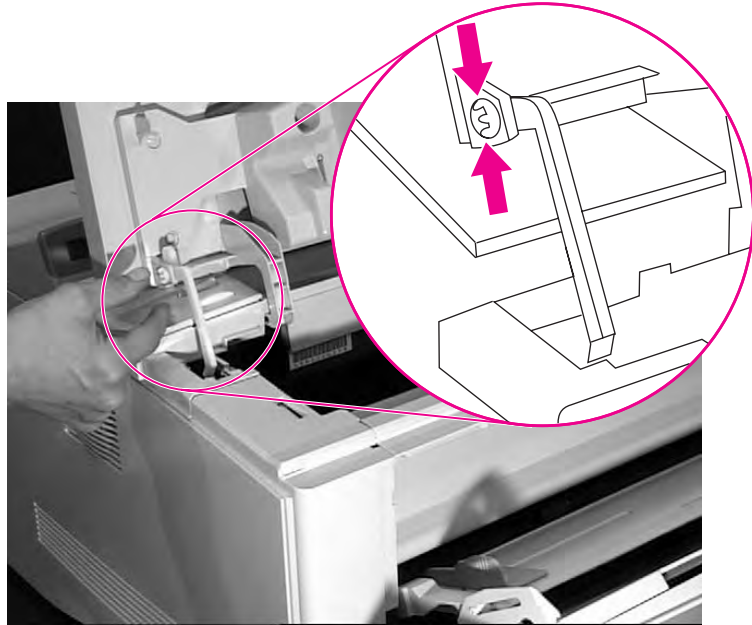
Facing the front of the printer, open the Top Cover and remove the Toner Cartridge.

---

### CAUTION

---

To prevent damage to the toner cartridge, do not expose it to light for more than a few minutes.

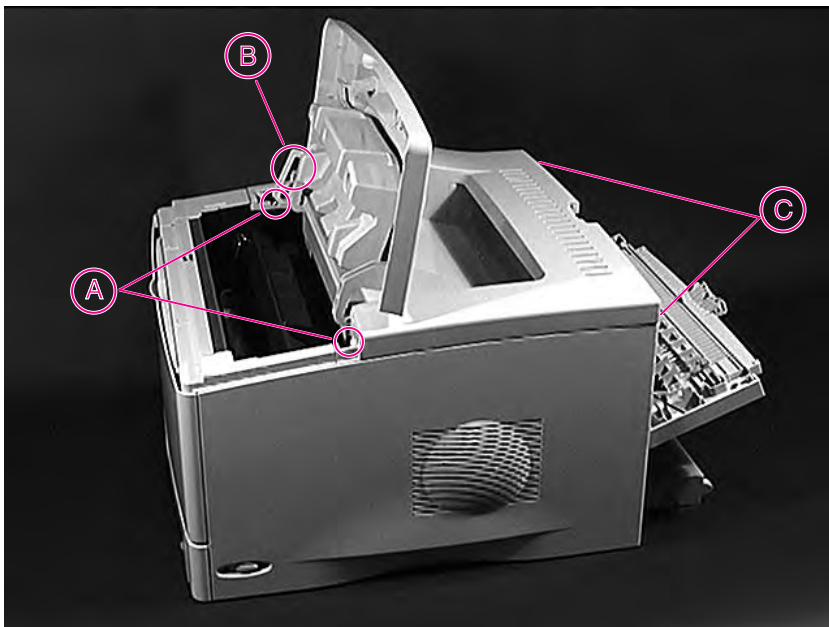


**Figure 6-5** Toner Cartridge Engagement Arm

- 1 Release the Toner Cartridge Engagement Arm from the inside of the Top Cover (Figure 6-5). The shaft of the Engagement Arm fits through a molded plastic ring on the left side of the Top Cover. Gently squeeze the locking tabs on the end of the shaft, and slide the shaft through the ring.

**CAUTION**

It is critical that step 1 be performed before you attempt to remove the Top Cover. If you damage the Arm, the printer will not operate.

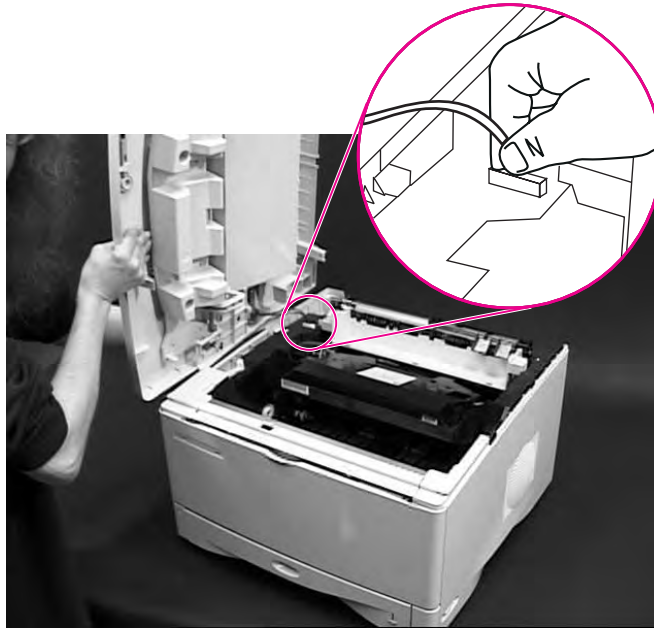


A	Top screws
B	Toner Cartridge Drive Arm
C	Rear screws

- 2 Remove the two self-tapping screws on the top of the chassis.
- 3 Remove the two self-tapping screws on the top portion of the back of the printer. (The Rear Cover needs to be opened or removed for the screws to be accessible.)



- 4 The cable connecting the Control Panel to the printer chassis is on the left side of the Top Cover. Tilt the cover to the left as you lift it. Be careful not to stress the cable as you loosen the cover.

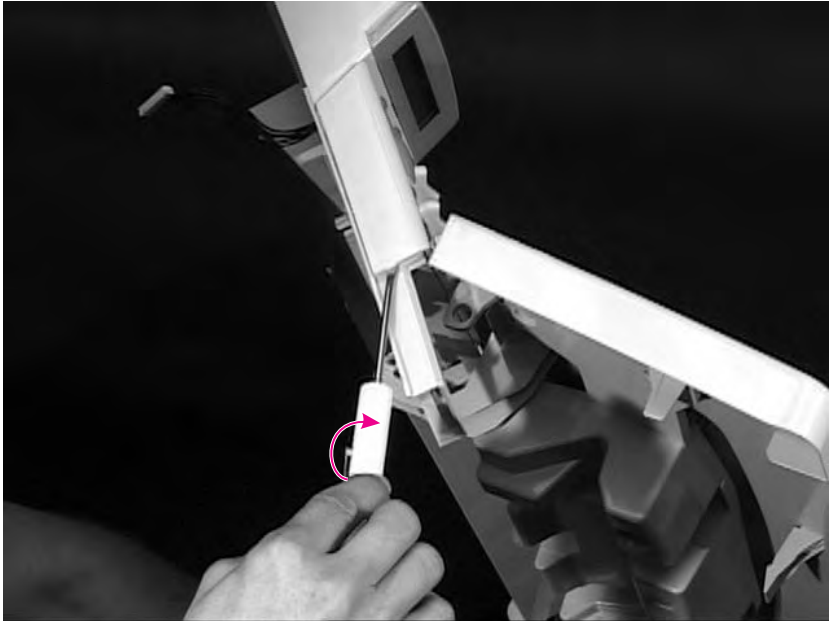


**Figure 6-6** Control Panel Cable

- 5 Disconnect the Control Panel cable from the printer chassis by grasping the wires and gently pulling the connector straight up.
- 6 Remove the Top Cover.

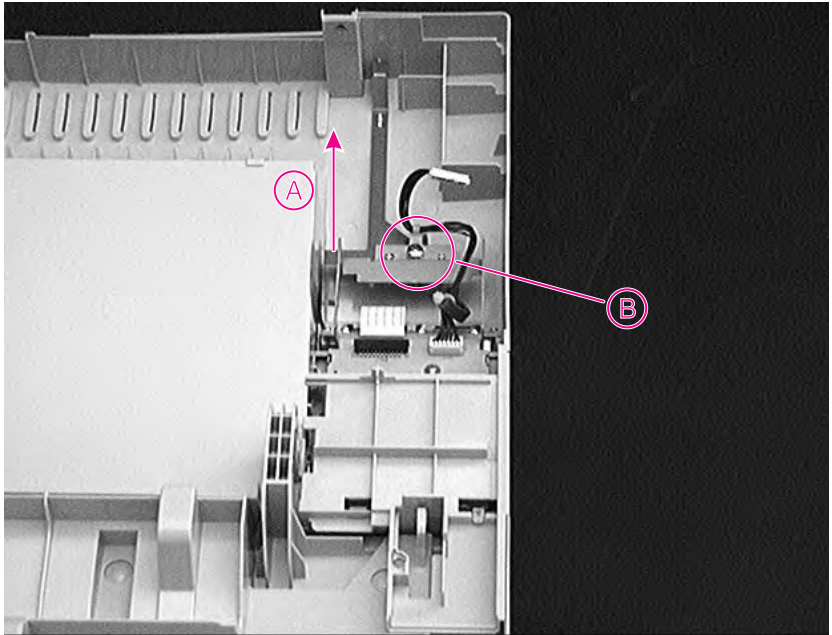
## Control Panel Overlay and Control Panel

- 1 Remove the Top Cover (page 6-12).
- 2 The Control Panel Overlay is held in place on the Top Cover by two tabs on each side. Slide a small flat-blade screwdriver along the outside edge of the Control Panel Overlay, to disengage the two tabs on the outside of the cover.
- 3 Lift the Overlay off of the Control Panel.



**Figure 6-7** Releasing Control Panel Overlay

- 4 Remove the single self-tapping screw holding the Control Panel to the underside of the Top Cover.
- 5 Lift up on the metal plate gently to free the Control Panel.
- 6 Grasp the Control Panel by the metal frame and remove it from the underside of the Top Cover. See Figure 6-8, "Back Side of Top Cover," on page 6-16.

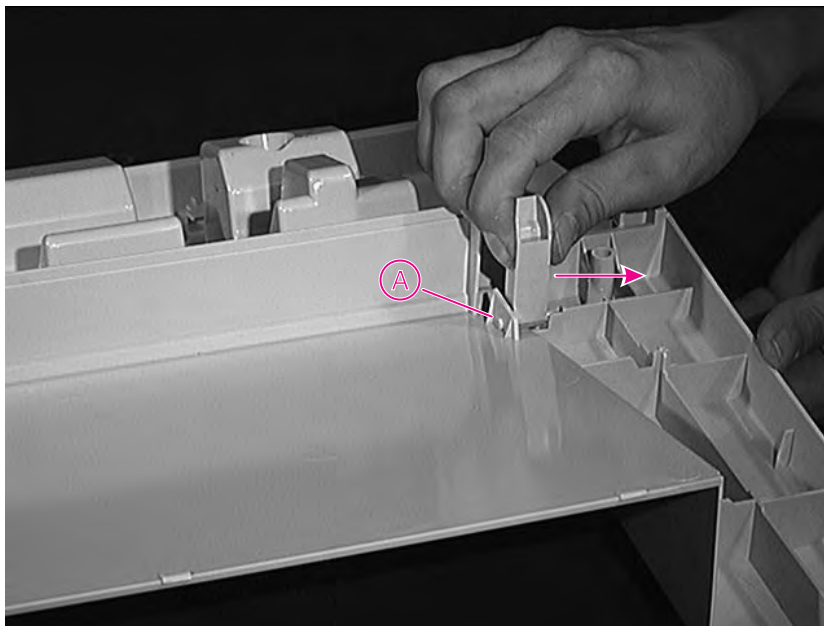


**Figure 6-8** Back Side of Top Cover

Item	Explanation
A	Direction to slide control panel out
B	Screw

## Toner Cartridge Door Assembly

- 1 Remove the Top Cover (page 6-12).
- 2 Remove the Control Panel from the Top Cover (page 6-15). (The Control Panel must be removed before you can separate the Toner Cartridge Door from the Top Cover.)
- 3 Disengage the pins (A) by pressing outward, as shown below.



**Figure 6-9**

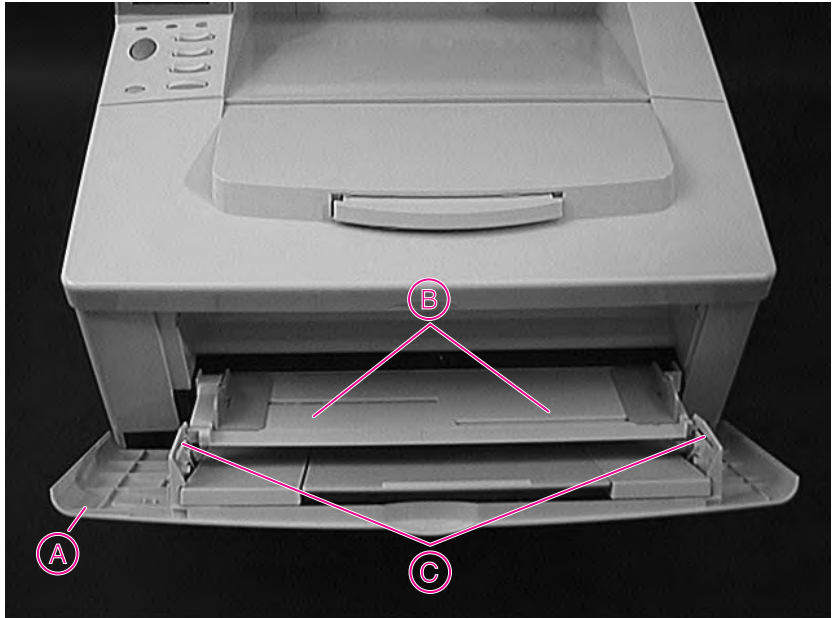
Toner Cartridge Door Assembly (Under Side of Top Cover Door)

Item	Explanation
A	Pins

# Front Cover and Tray 1

Front Cover and Tray 1 must be removed individually. See Figure 6-10.

- 1 Open the Front Cover door.
- 2 Disengage the Tray 1 Guide pins from inside the Front Cover by pushing the Guides (C) outward. The Cover and Tray 1 will be separated. Press Tray 1 Guide against the printer.



**Figure 6-10** Front Cover

Item	Explanation
A	Front Cover
B	Tray 1 Guide
C	Guides

- 3 Release the Front Cover, allowing it to pivot freely on its keyed pins. The Tray will slide off the pins to the right at its lowest position.

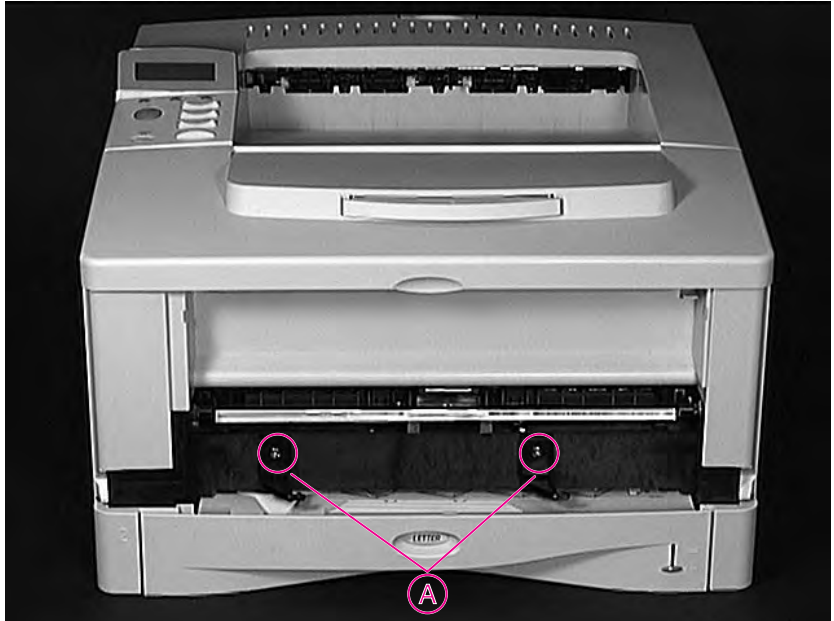


**Figure 6-11** Tray 1

- 4 Release the Tray 1 Guide by allowing the guide to slide off the keyed pins at its lowest position (Figure 6-11).

## Front Cover Pins

- 1 Remove the Front Cover and Tray 1 (page 6-18).
- 2 Remove the screws (A) to free the Front Cover Pins.



**Figure 6-12** Front Cover Pins

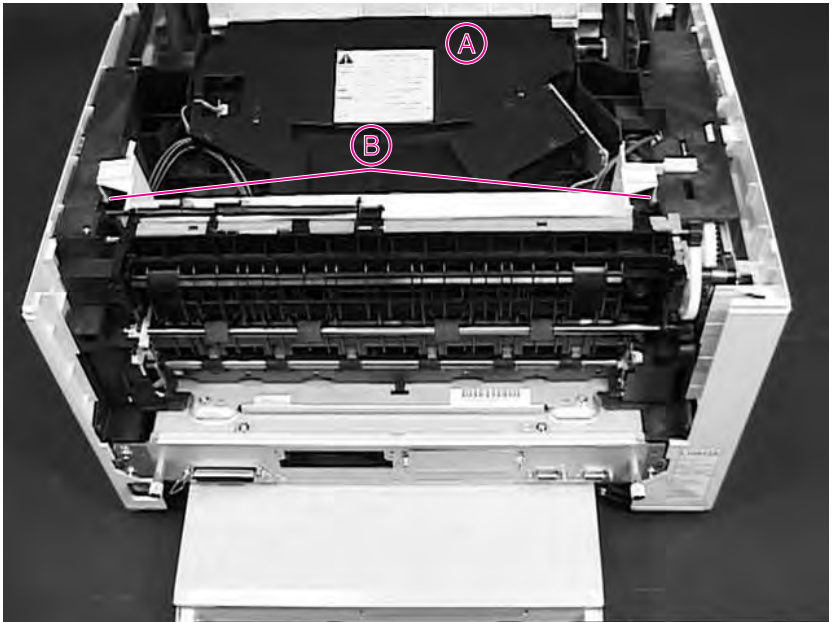
Item	Explanation
A	Screws

### Hint

To install a self-tapping screw, first turn it to the left until it clicks, indicating the threads are seated. Then, turn it to the right to tighten. **Do not over-tighten.** If a self-tapping screw-hole becomes stripped, repair of the screw-hole or replacement of the affected assembly is required.

## Face Down Assembly

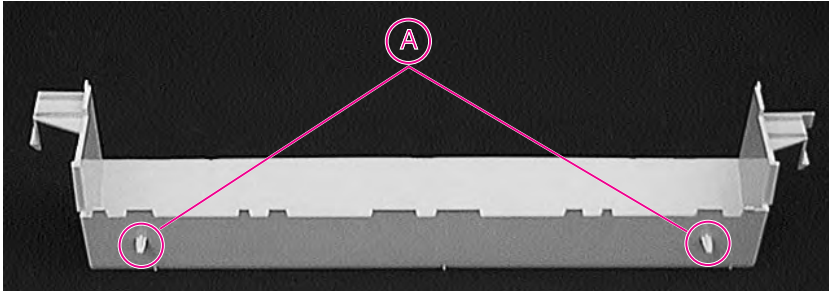
- 1 Remove the Top Cover (page 6-12).
- 2 Face the back of the printer.
- 3 Squeeze the locking tabs inward, one side at a time, to release the Face Down Assembly. See Figure 6-13
- 4 Lift slightly and then remove the Assembly with a rolling motion away from you. Be careful not to break the two locator pins on the front of the Assembly.



**Figure 6-13** Location of Face Down Assembly Base

Item	Explanation
A	Scanner
B	Locking Tabs





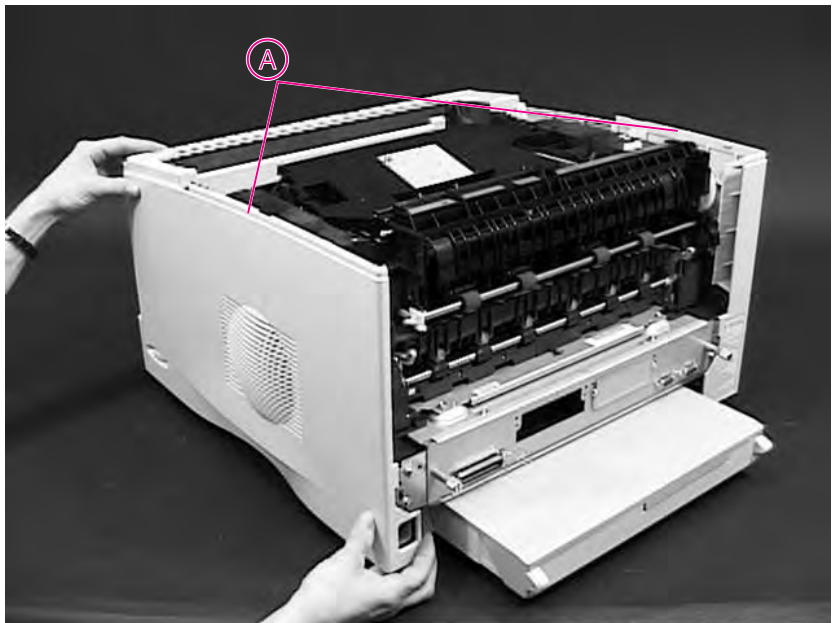
**Figure 6-14** Face Down Assembly

Item	Explanation
A	Locator Pins

## Left and Right Side Covers

The removal procedure is the same for both the left and the right side covers. See Figure 6-15.

- 1 Remove the Top Cover (page 6-12).
- 2 Locate the tab in the top middle of the cover. Release the tab by pushing down on it.
- 3 Grab the side cover at the top by the front edge. With your other hand, grab the lower edge of the back. Rock the cover gently until it comes loose, and remove the cover.
- 4 Repeat the steps above for the other side cover.



**Figure 6-15** Side Covers

Item	Explanation
A	Tabs

---

### Hint

For reassembly, seat the tabs in the bottom of the Side Cover first. Then snap the top of the cover on.

## Tray 1 Inner Cover

- 1 Remove the Top Cover (page 6-12), Left and Right Side Covers (page 6-23), and Front Cover and Tray 1 (page 6-18).

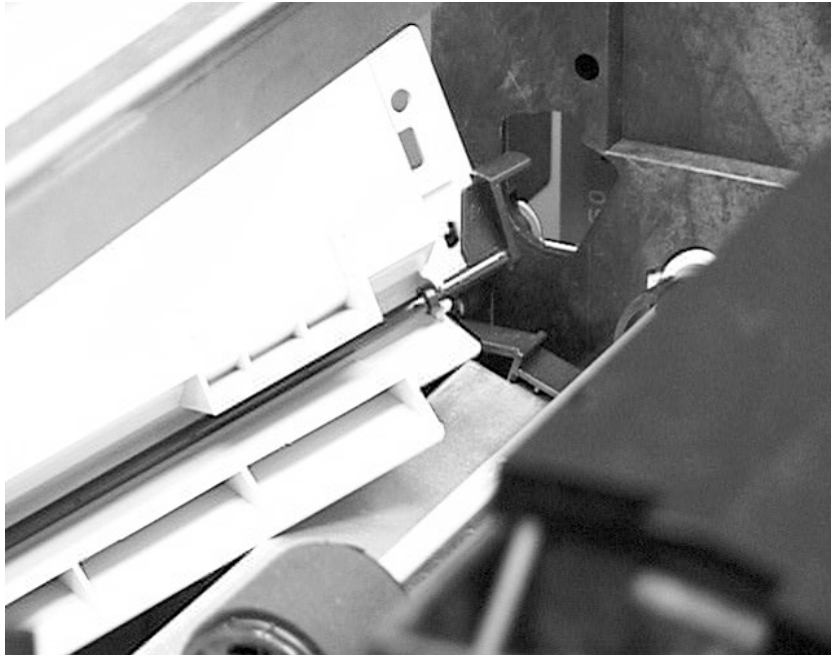
---

### CAUTION

---

Be sure to locate the Paper Sensor Flag on the left side of the Cover, before proceeding to step 3. It rests in an indentation in the left side of the chassis and is easily broken. See Figure 6-16.

- 2 The Tray 1 Inner Cover is a plastic tray located at the top front of the printer. Remove the two self-tapping screws, (A) in Figure 6-17, holding the Cover to the front of the chassis.



**Figure 6-16** Tray 1 Inner Cover Flag (view from inside printer, left side)

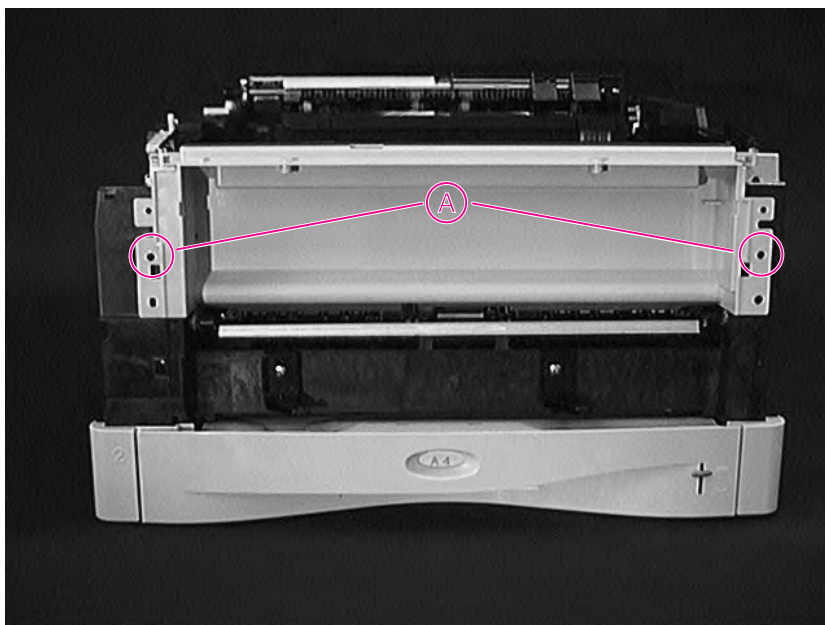
- 3 Facing the front of the printer, slip the Cover off of the locating pins.

---

### Hint

---

To install a self-tapping screw, first turn it to the left until it clicks, indicating the threads are seated. Then, turn it to the right to tighten. **Do not over-tighten.** If a self-tapping screw-hole becomes stripped, repair of the screw-hole or replacement of the affected assembly is required.



**Figure 6-17** Tray 1 Inner Cover (front of printer)

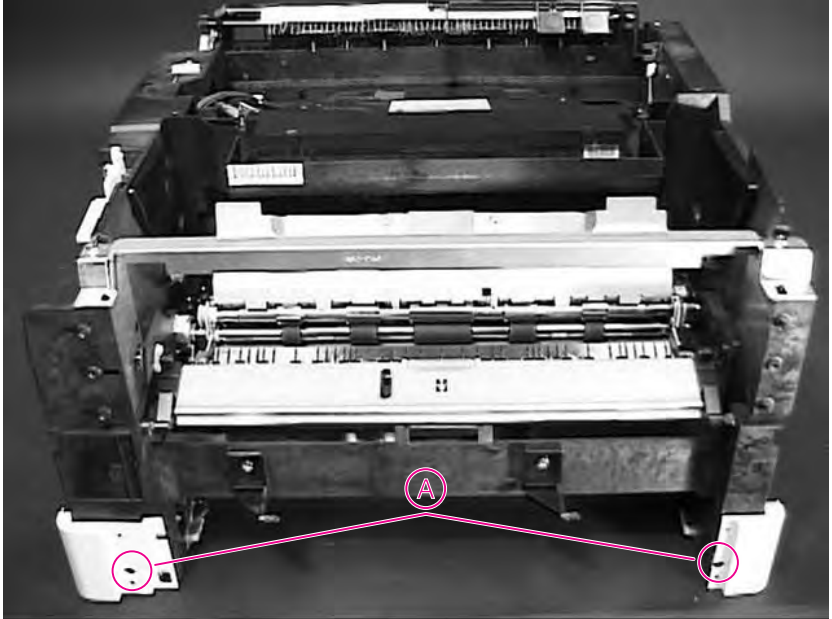
Item	Explanation
A	Screws

**Hint**

An extension of the Paper Sensor Flag fits into a slot in the Tray 1 Lift Plate (page 6-56). Orient the flag so that it aligns with both the slot and the indentation in the left side of the chassis.

## Right and Left Corner Covers

These covers are each secured by one self-tapping screw. Remove the screw, and lift off the cover.

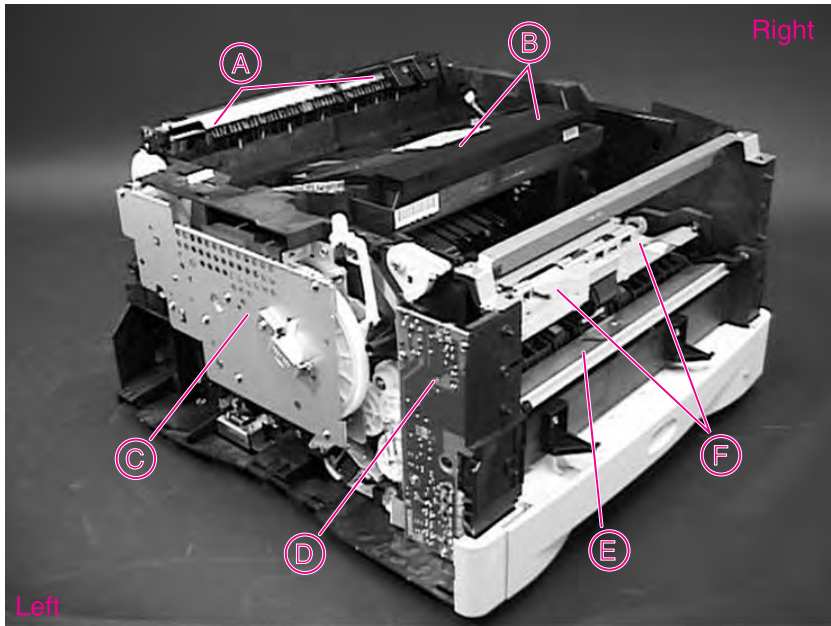


**Figure 6-18** Right and Left Corner Covers

Item	Explanation
A	Corner Cover Screws

# Removing Assemblies

Internal assemblies are shown in Figure 6-19. All references to the right and left are assumed to be relative to the front of the printer, unless otherwise specified.



**Figure 6-19** Internal Assemblies

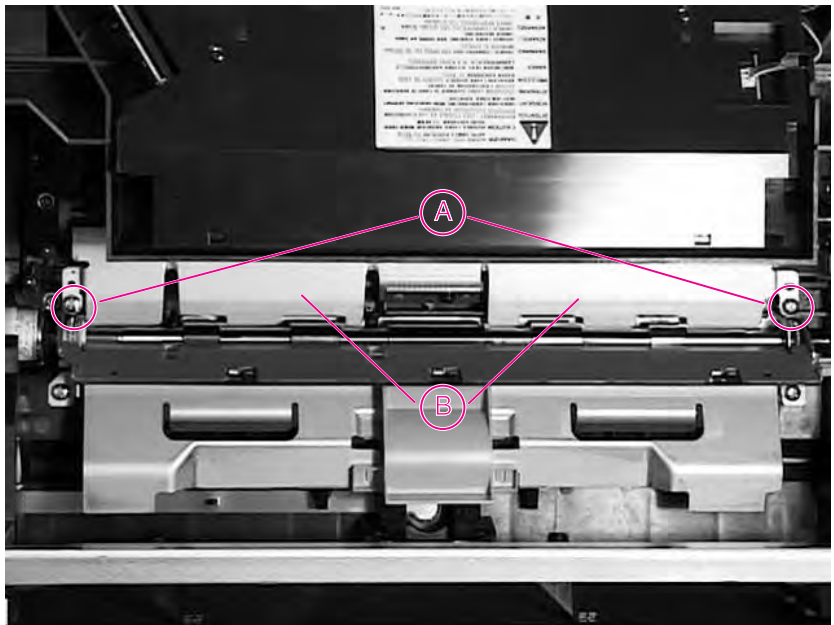
Item	Explanation
A	Upper Delivery Assembly
B	Laser Scanner
C	Main Gear Assembly
D	Paper Handling PCA
E	Tray 1 Paper Guide Plate Assembly
F	Registration Assembly

# Transfer Roller Assembly

## CAUTION

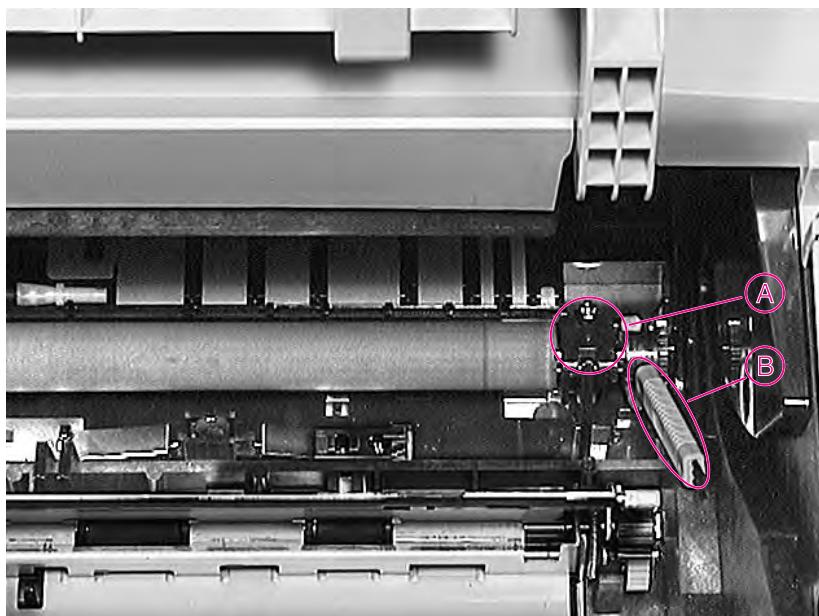
Never touch the transfer roller with your fingers. Use unpowdered latex gloves if possible. Roll it up in a clean sheet of paper to protect it after removal.

- 1 Face the front of the printer, and lift the small green handle on the right side of the Registration Assembly, exposing the Transfer Guide (the metal plate that rests against the Transfer Roller). Remove the two self-tapping screws and carefully lift out the Transfer Guide. Be careful not to touch the Transfer Roller with your fingers.



**Figure 6-20** Transfer Guide Removal

Item	Explanation
A	Screws
B	Transfer Guide



**Figure 6-21** Right Side of Transfer Roller

Item	Explanation
A	Clip
B	Cleaning Brush

**Note**

The Transfer Roller is held on the right side by a hinged clip.

- 2 Free the Transfer Roller from the hinged clip by lifting straight up using the blue cleaning brush located inside of the top cover (Figure 6-21).
- 3 Free the left side of the Transfer Roller by lifting straight up. Remove the Transfer Roller, being careful not to touch the roller with your fingers.

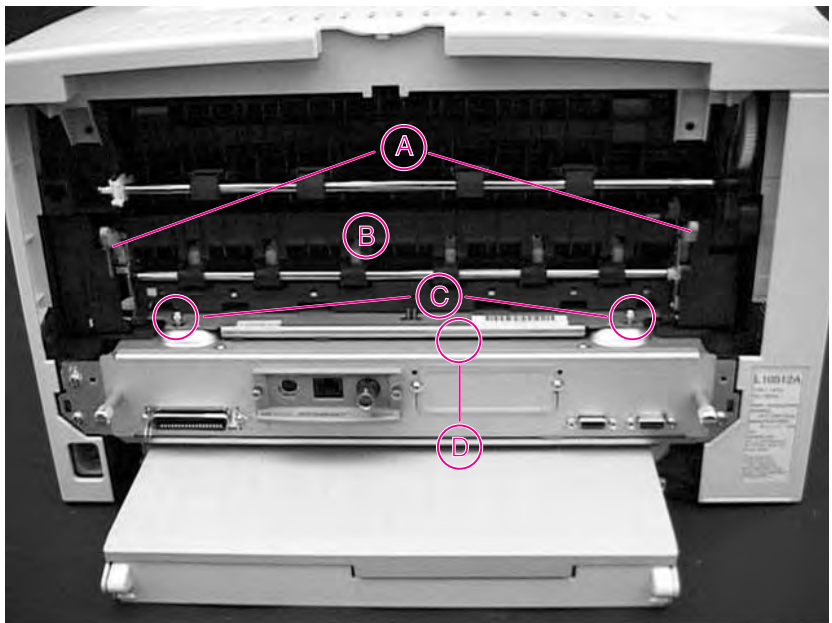


## Fuser

- 1 Remove the Rear Door and Rear output bin (page 6-10).
- 2 Facing the back of the printer, remove the two machine screws holding the Fuser in the chassis. See Figure 6-22.
- 3 Using a small, flat bladed screw driver, lift at "D" to disengage the Fuser Assembly detents. Grasp the green Pressure Release Handles and pull the Fuser out of the chassis.

### Note

The fuser power connection is on the left side of the assembly.

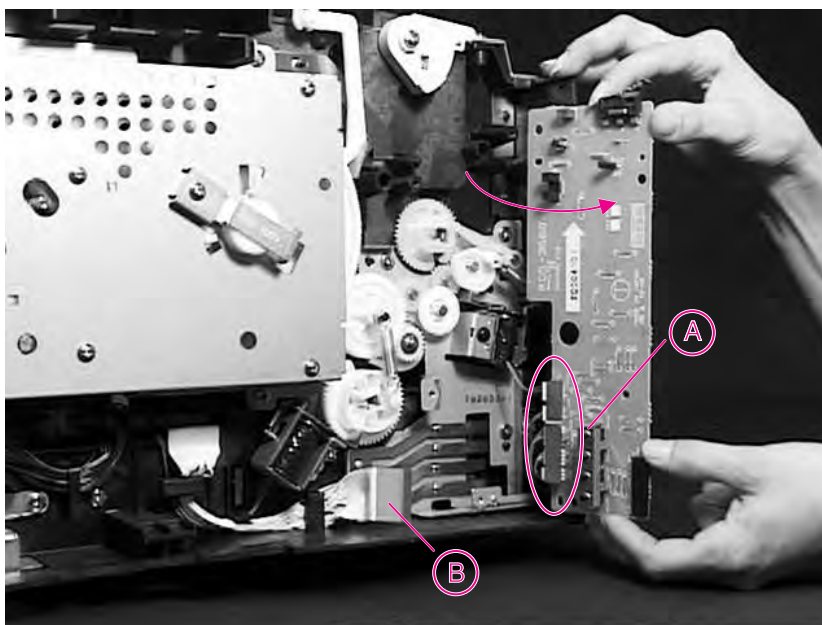


**Figure 6-22** Fuser (rear view of printer)

Item	Explanation
A	Pressure Release Handles
B	Fuser
C	Screws
D	Screw driver lifting point

## Paper Handling PCA

- 1 Remove the Top Cover (page 6-12) and Left Side Cover (page 6-23).
- 2 Facing the left side of the printer, disconnect the ribbon cable from the PCA.
- 3 Remove two self-tapping screws and two machine screws from the PCA.
- 4 Rotate the PCA outward, and disconnect the five cables. See Figure 6-23.



**Figure 6-23** Paper Handling PCA

Item	Explanation
A	Cables
B	Ribbon Cable

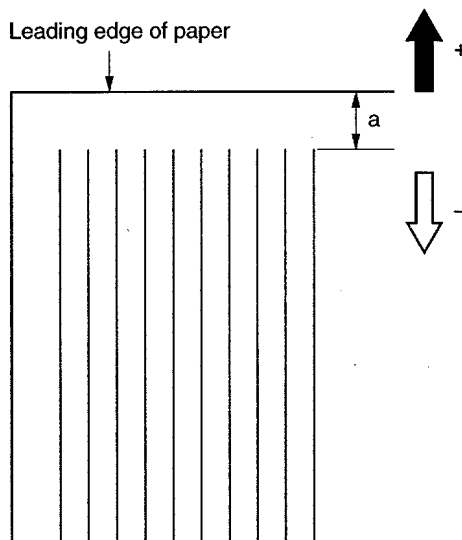
### Hint

To install a self-tapping screw, first turn it to the left until it clicks, indicating the threads are seated. Then, turn it to the right to tighten. **Do not over-tighten.** If a self-tapping screw-hole becomes stripped, repair of the screw-hole or replacement of the affected assembly is required.

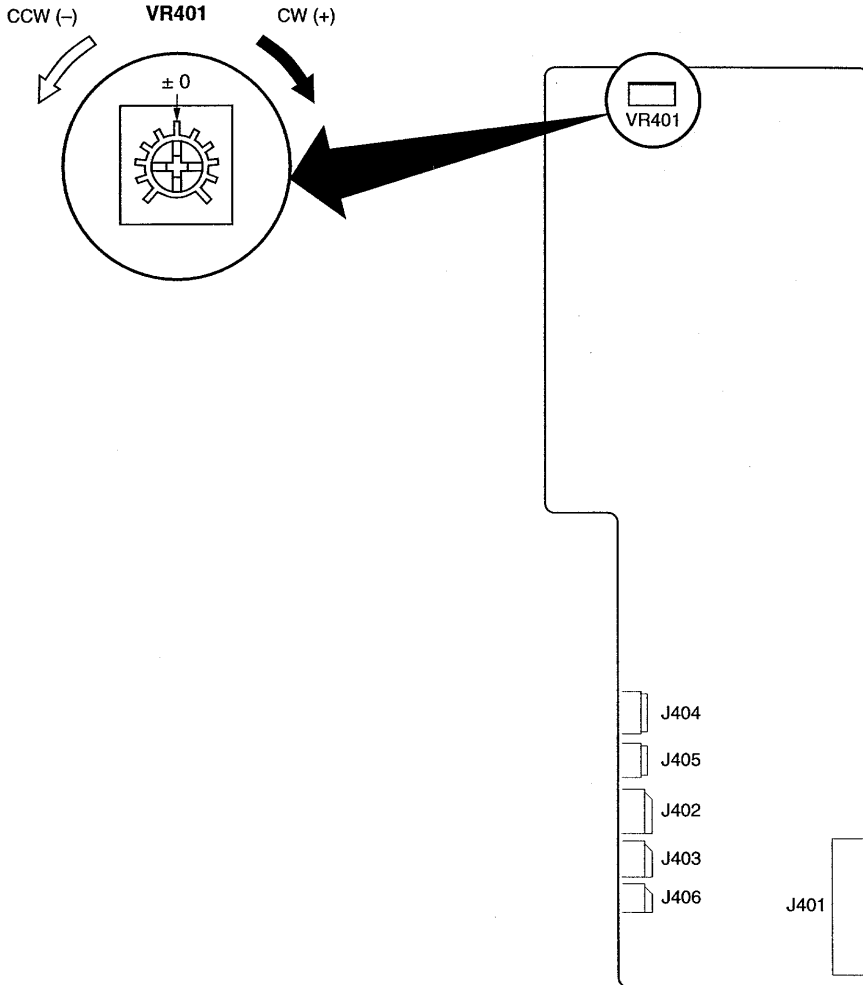
## Top Margin Adjustment

When the terminal PCA is replaced in the field, the top margin needs to be re-adjusted. Also, if the top margin of test prints made after laser/scanner unit replacement is not 2.0 mm, this adjustment is necessary. The adjustment procedures are shown below.

- 1 After setting the VR401 on the terminal PCA to the center position (+/-0), set A4-sized paper in the tray. Press the test print switch to make several test prints.
- 2 Measure the length from the leading edge to the print pattern ("a" in Figure 6-24). Measure all the test prints and calculate the average.
- 3 Adjust VR401 so that the calculated value in step 2 becomes 2.0 mm.  
The pattern image shifts in the "+" direction in Figure 6-25 if VR401 is turned clockwise, and in the "-" direction, counterclockwise. Turning the VR401 one scale shifts the pattern about 0.8 mm.  
For instance, if the average value calculated in step 2 is 2.8 mm, the difference is 0.8 mm. Therefore, turn VR401 clockwise for one scale. (See Figure 6-25.)
- 4 Make several test prints again, and perform step 2. Check that the top margin is 2.0 mm. If the value is incorrect, repeat steps 1 through 4.



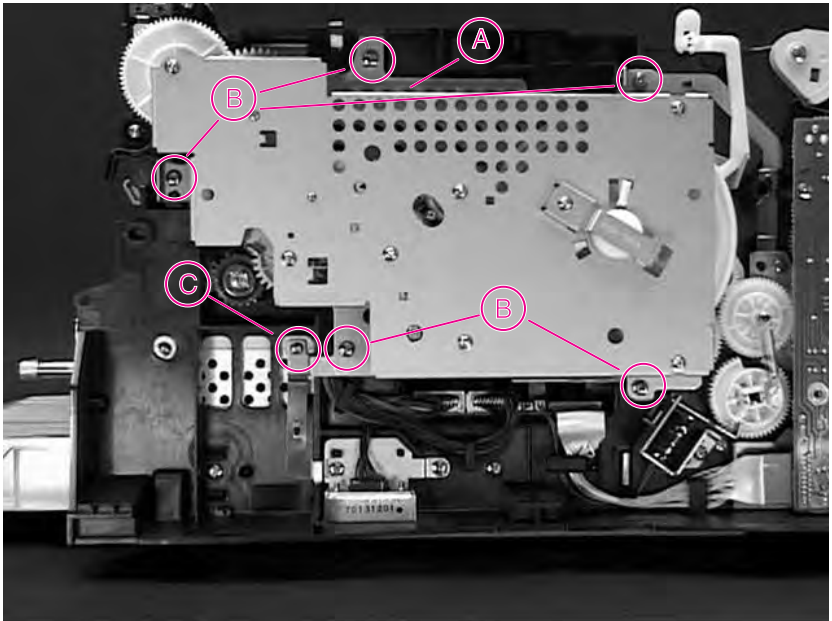
**Figure 6-24** Adjusting the Top Margin



**Figure 6-25**      Location of VR401

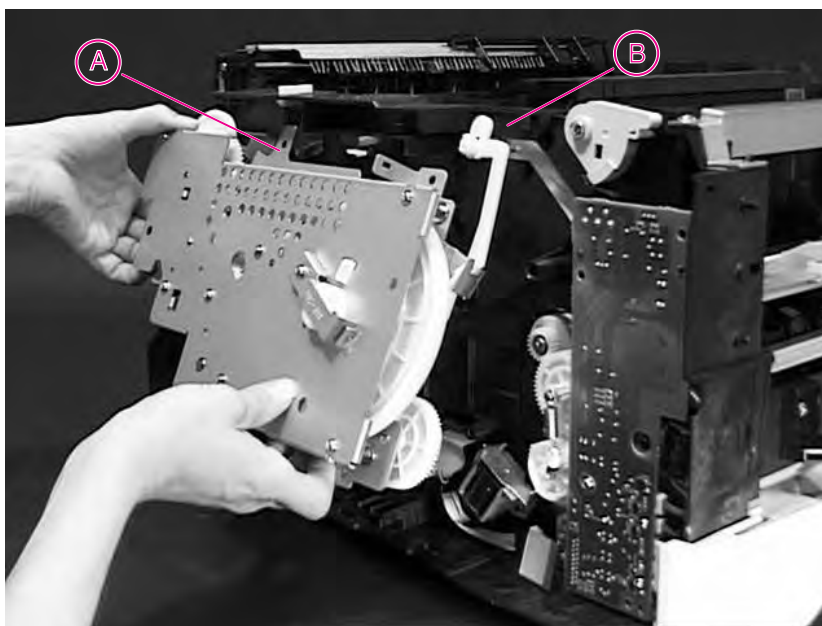
## Main Gear Assembly

- 1 Remove the Top Cover (page 6-12) and the Left Cover (page 6-23).
- 2 The Main Motor is located on a PCA (see Figure 6-26) on the back side of the Gear Assembly. Disconnect the Main Motor Cable.
- 3 Remove five self-tapping screws and the grounding screw (spring-loaded machine screw) that hold the Gear Assembly to the chassis.



**Figure 6-26** Main Gear Assembly, Left Side

Item	Explanation
A	Main Motor Cables
B	Self-tapping Screws
C	Grounding Screw



**Figure 6-27** Removing the Main Gear Assembly

Item	Explanation
A	Locating Tab
B	Engagement Arm

- 4 Rotate the bottom of the assembly out (Figure 6-27), and then lower it to release the Locating Tab (A) and remove the Main Gear Assembly.

### CAUTION

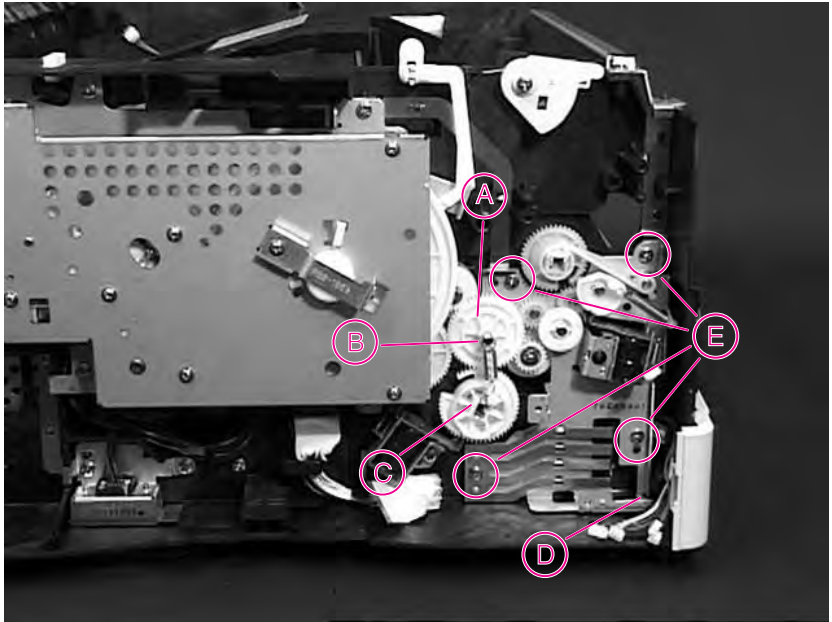
Use caution when removing the assembly. The Toner Cartridge Engagement Arm may break if not handled carefully.

### Hint

Remember to reconnect the cable at the top of the Main Gear Assembly after reinstalling it.

## Pickup Gear Assembly

- 1 Remove the Top Cover (page 6-12), Left Side Cover (page 6-23), and the Paper Handling PCA (page 6-31).
- 2 Remove the four self-tapping screws from the Gear Assembly. Figure 6-28 shows the Assembly and the location of the screws.
- 3 Release the small spring (B) on the gear.
- 4 Remove the Gear Assembly from the chassis.



**Figure 6-28** Pickup Gear Assembly (left side view of printer - Main Gear Assembly has not been removed)

<b>Item</b>	<b>Explanation</b>
A	Paper Feed Roller Assembly Gear
B	Location to Release Spring
C	Tray 2 Shaft Gear
D	Wire Clip
E	Screws

---

**Hint**

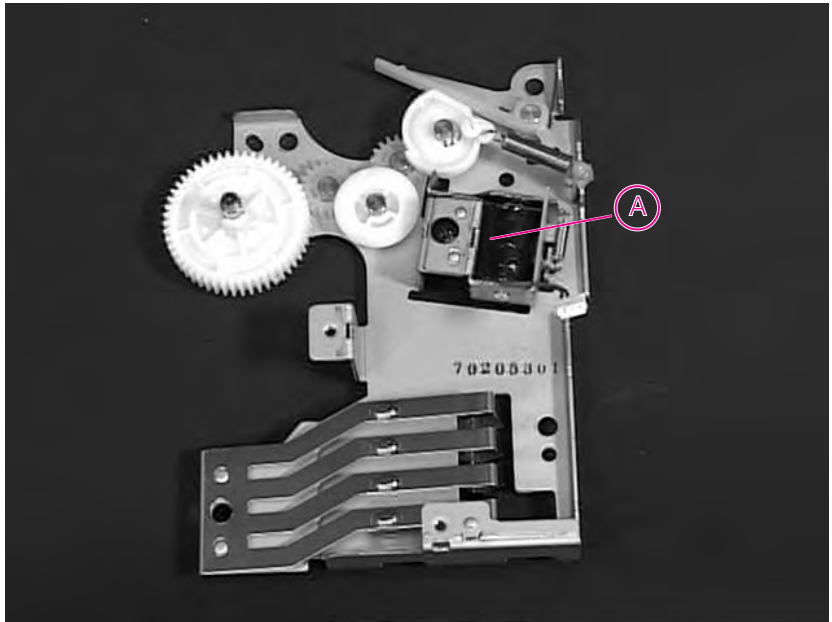
---

Before replacing the Pickup Gear Assembly, route the cables through the wire clip behind the Left Corner Cover. Reattach the spring from the Tray 2 Shaft Gear to the Paper Feed Roller Assembly Gear.



## Tray 1 Pickup Solenoid

- 1 Remove the Pickup Gear Assembly (page 6-36).
- 2 Remove the Tray 1 Solenoid by removing one black machine screw and sliding the Solenoid assembly away from the Pickup Gear Assembly.

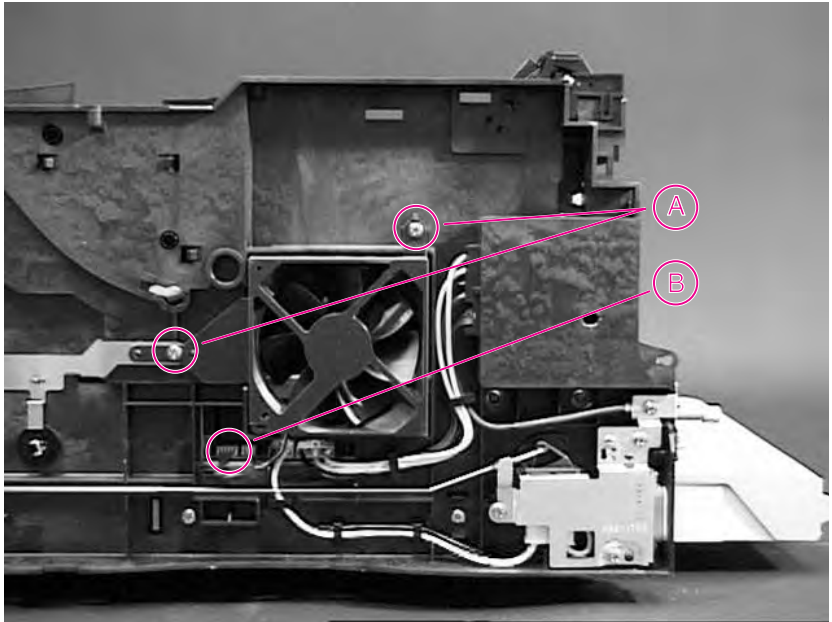


**Figure 6-29** Pickup Gear Assembly with Solenoid

Item	Explanation
A	Tray 1 Pickup Solenoid

## Fan

- 1 Remove the Top Cover (page 6-12) and Right Side Cover (page 6-23).
- 2 Disconnect the cable that supplies power to the fan.
- 3 Remove the two self-tapping screws securing the fan to the chassis.
- 4 Remove the fan from the chassis.

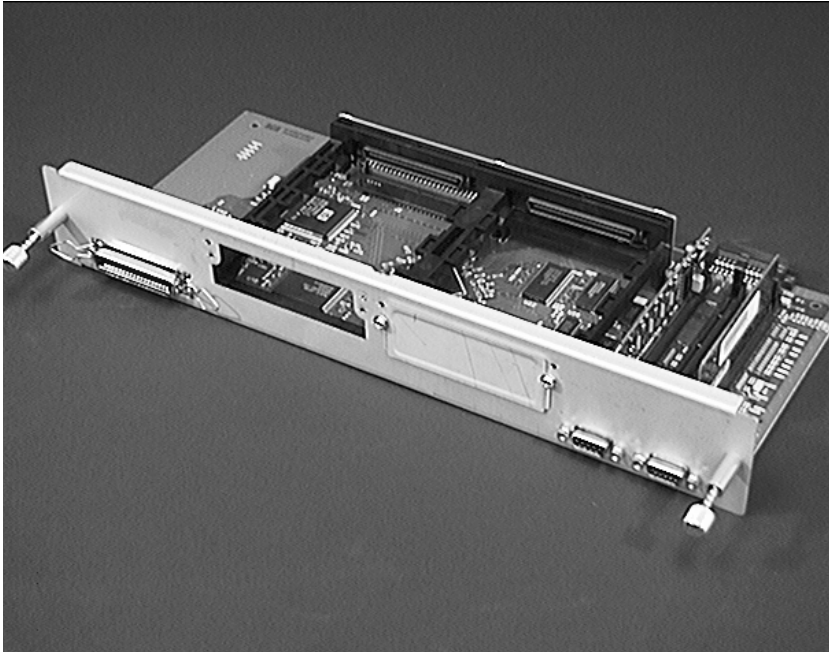


**Figure 6-30** Fan (right side view of printer)

Item	Explanation
A	Screws
B	Power Cables

## Formatter Assembly

- 1 Print a Configuration Page, if possible, to use as a reference when reinstalling the new formatter.
- 2 Remove any EIO accessories from the EIO slots.
- 3 Facing the back of the printer, loosen the two thumbscrews and slide the Formatter Assembly out.
- 4 Remove any DIMMs from the DIMM slots.



**Figure 6-31** Formatter Assembly

---

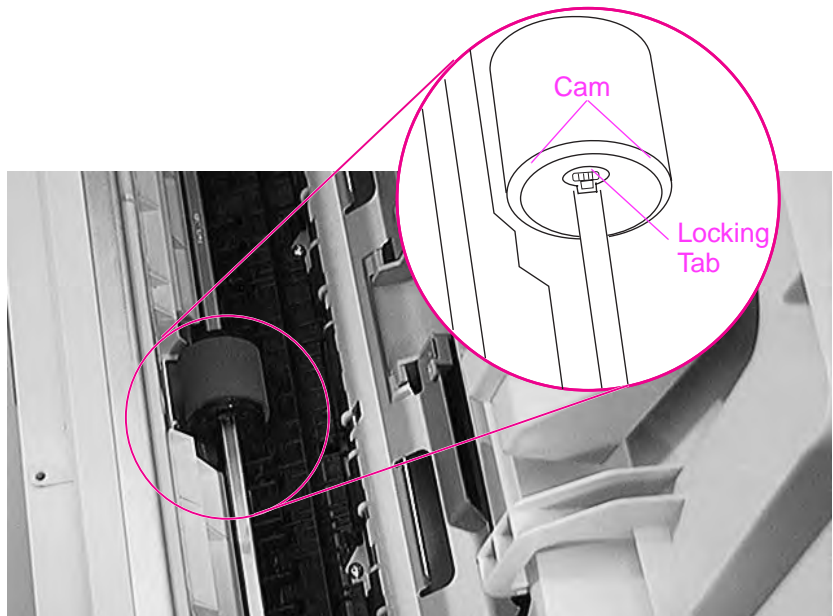
### Hint

After reinstalling the formatter, update the printer configuration if necessary, comparing the configuration to the Configuration page printed in step 1.

---

## Tray 1 Roller

- 1 Open the Top Cover and remove the Toner Cartridge.
- 2 Facing the front of the printer, raise the green center handle of the Registration Assembly.
- 3 Depress the locking tab on the right side roller cam, and slide the cam to the right.
- 4 Remove the D-Roller from the shaft.



**Figure 6-32** Tray 1 Roller

---

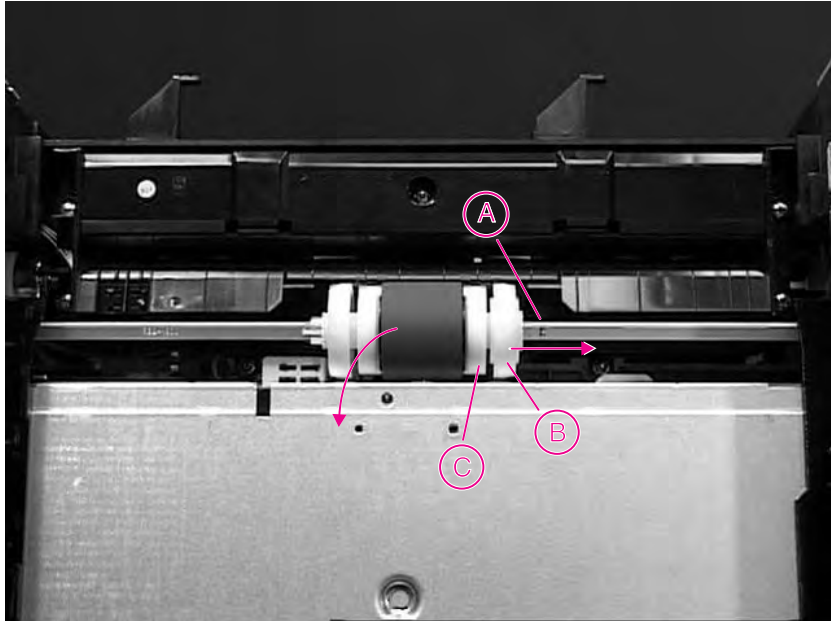
### Hint

---

To reassemble the roller, orient the D-Roller so that the thumb grip is on the left. Then, slide the Roller between the two cams.

## Tray 2 Roller

- 1 Remove the Paper Tray, and tilt the printer backwards, with the front of the printer facing up.
- 2 Depress the tab (A) on the right side cam, and slide the cam and the bushing to the right.
- 3 Rotate the D-Roller 180° and remove it from the shaft.



**Figure 6-33** Tray 2 Roller (bottom view of printer)

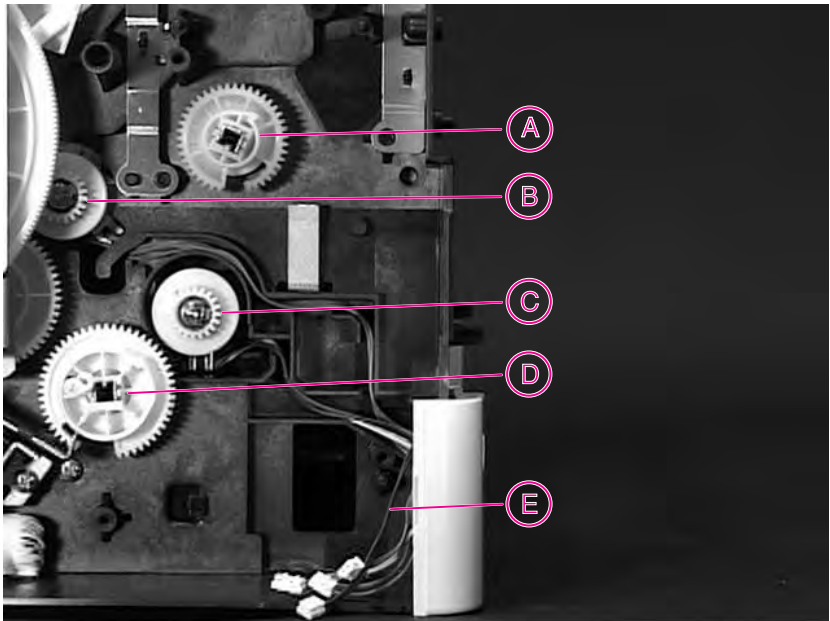
Item	Explanation
A	Tab is behind this cam.
B	Cam
C	Bushings

### Hint

To reassemble the roller, orient the pin on the D-Roller so that it lines up with the hole on the right side cam. Slide the cam toward the Roller until the tab snaps into place.

## Paper Feed Roller Assembly

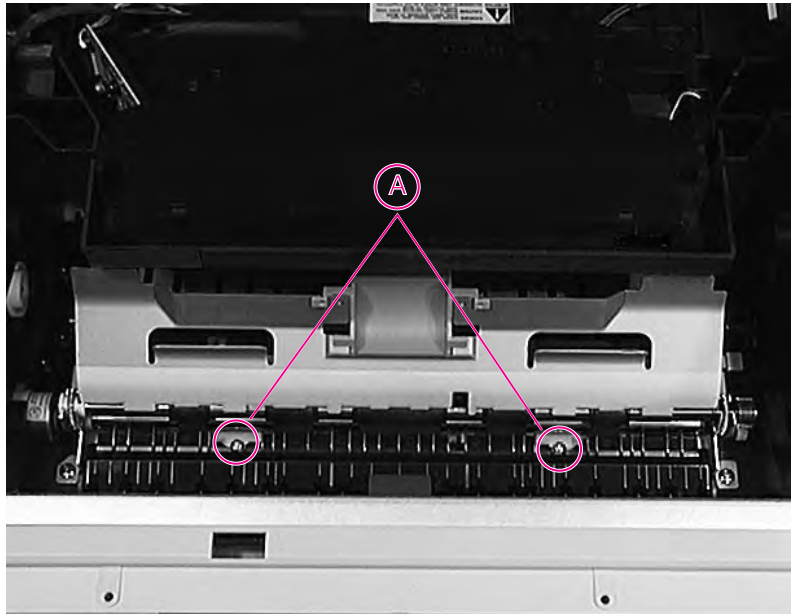
- 1 Remove the Top Cover (page 6-12), Left Side Cover (page 6-23), Main Gear Assembly (page 6-34), Paper Handling PCA (page 6-31), and Pickup Gear Assembly (page 6-36).
- 2 Remove the Paper Feed Roller Clutch (C) located on the left side of the Paper Feed Roller Assembly, below the Registration Assembly Clutch. Remove the E-Clip on the clutch, and slide the clutch off the shaft. If necessary, free the cable from the retaining clip on the inside of the chassis, behind the Left Corner Cover. See Figure 6-28 on page 6-36.



**Figure 6-34** Paper Feed Roller Clutch (left side view of printer)

Item	Explanation
A	Tray 1 Shaft Gear
B	Registration Assembly Clutch
C	Paper Feed Roller Clutch
D	Tray 2 Shaft Gear
E	Wire Clip

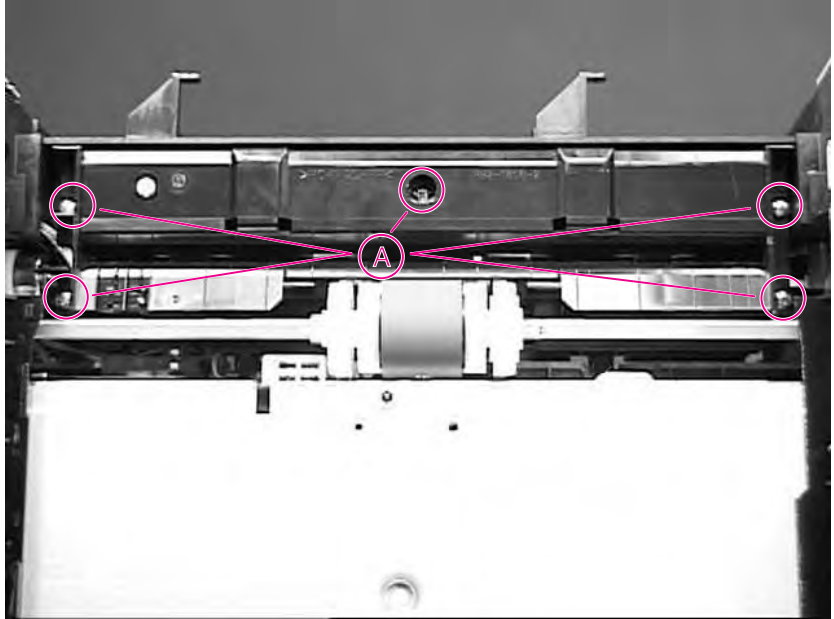
- 3 Remove the two machine screws in the center of the printer, under the Registration Assembly Roller Guide. See Figure 6-35.



**Figure 6-35** Location of two “common” screws (inside printer)

Item	Explanation
A	Screws

- 4 Remove the paper tray, and tilt the printer back, with the front facing up.
- 5 Remove the five self-tapping screws that hold the Paper Feed Roller Assembly to the chassis. They are located on the bottom of the printer. See Figure 6-36.



**Figure 6-36** Paper Feed Roller Assembly (bottom view of printer)

Item	Explanation
A	Screws

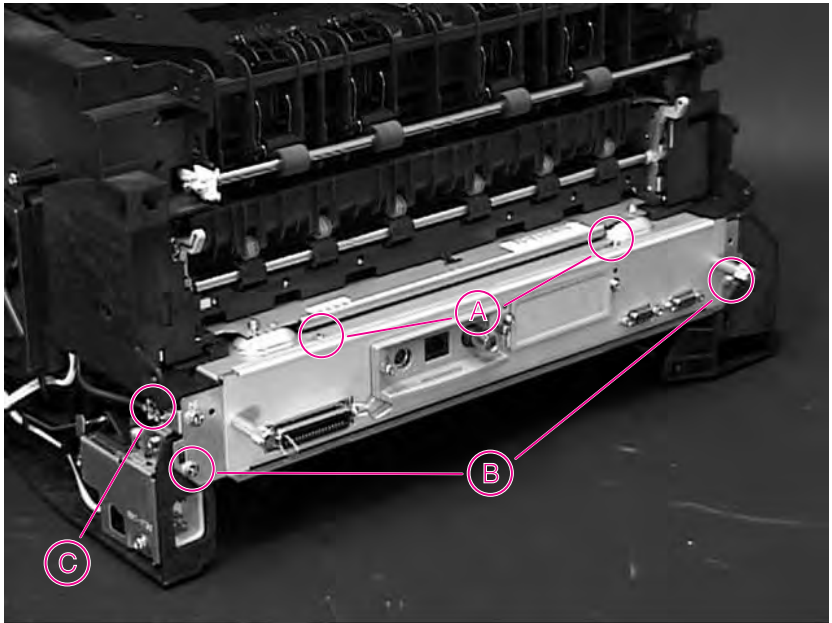
- 6 Remove the Paper Feed Roller Assembly from the chassis, while feeding the cable back through the hole in the chassis.



## DC Controller Board and Power Supply

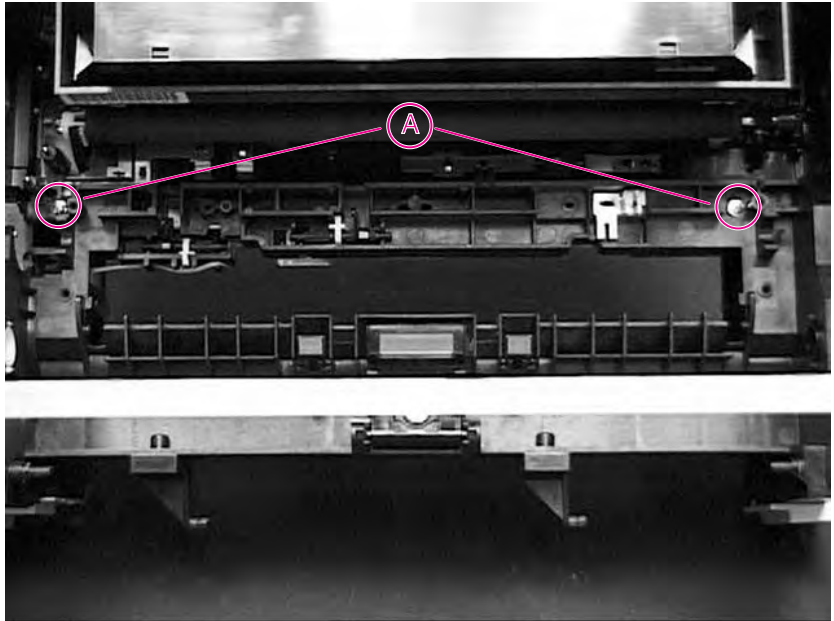
This assembly contains two PCAs. One houses the DC Controller and the High-Voltage Power Supply, and the other contains the Low-Voltage Power Supply.

- 1** Remove the Top Cover (page 6-12), Left and Right Side Covers (page 6-23), and the Formatter Assembly (page 6-40).
- 2** Disconnect four cables on the right side of the chassis. (The fourth may have been disconnected during fan removal (page 6-39) already.) For the two large connectors, use a flat-blade screwdriver to release the locks by pressing down on the tabs on top of the connectors. Be sure to pull the cables away from the chassis.
- 3** The remaining connections are located on the left side of the chassis. Disconnect the ribbon cable, the 2-pin, the 3-pin, and the two 20-pin connectors. Be sure to pull the cables away from the chassis.
- 4** Remove five screws on the back side of the chassis (Figure 6-37). Two machine screws (A) are located on the top surface of the metal housing, one machine screw (C) has a lock washer and a ground wire, and two self-tapping screws (B) are located at the bottom of the DC Controller Assembly.



**Figure 6-37** DC Controller Assembly (rear view of printer)

Item	Explanation
A	Machine Screws
B	Self-tapping Screws
C	Lock Washer/Grounding Wire

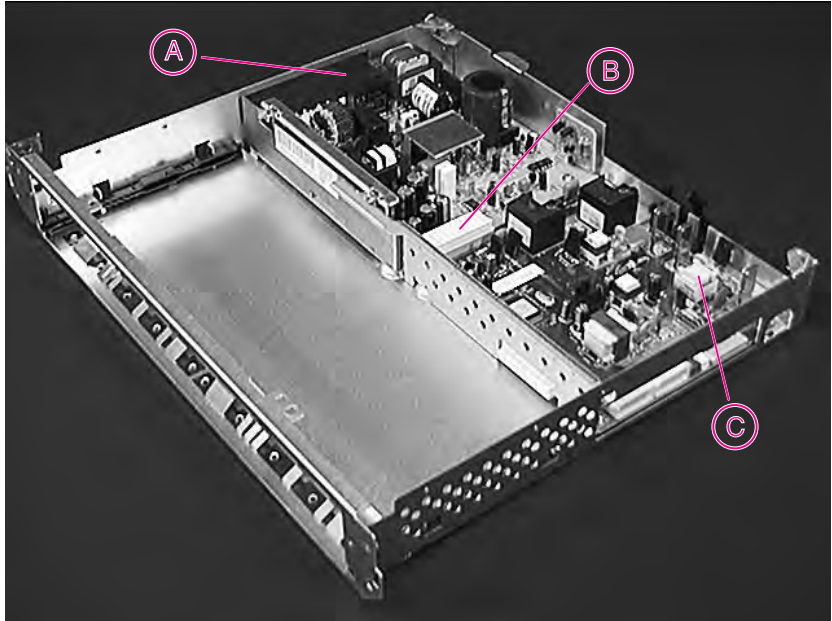


**Figure 6-38** DC Controller Assembly (long screws)

Item	Explanation
A	Long Screws

- 5 Remove the two screws (A) (Figure 6-38) located at the back of the DC Controller Assembly, inside the chassis. These are long screws; their position requires the use of a magnetized screwdriver.
- 6 Facing the rear of the printer, remove the two spring-loaded machine screws closest to the ground wire removed in step 4 above. Remove the spring-loaded machine screw closest to you on the right side.
- 7 Slide the DC Controller Assembly out of the rear of the chassis.

- 8 The boards are linked by a ribbon cable and held onto the tray with four screws each. Carefully remove the ribbon cable that connects them, and loosen the screws on the board you wish to remove.



**Figure 6-39** DC Controller Assembly

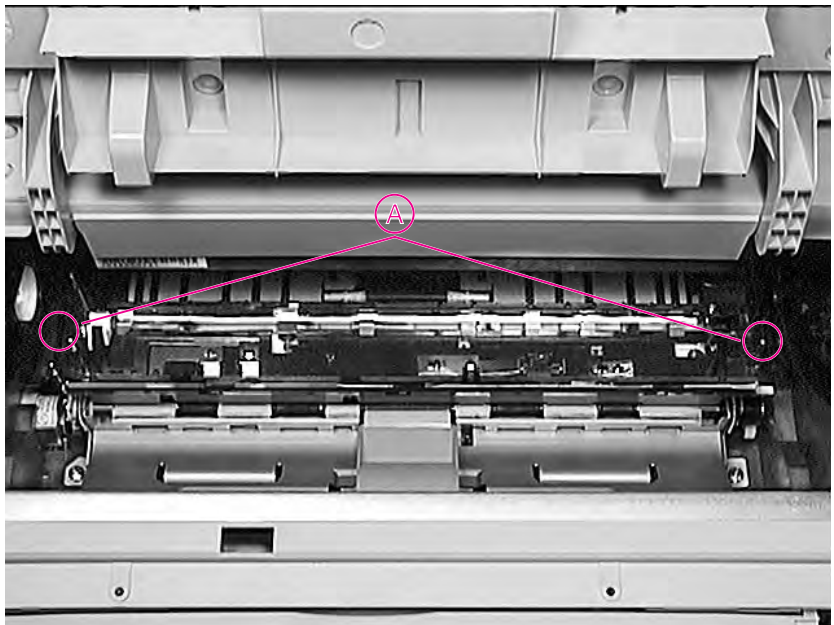
Item	Explanation
A	Power Supply PCA
B	Ribbon Cable
C	DC Controller PCA

**Hint**

To prevent damage to the high voltage contacts, the Paper Feed Belt Assembly needs to be installed before the DC Controller is reinstalled.

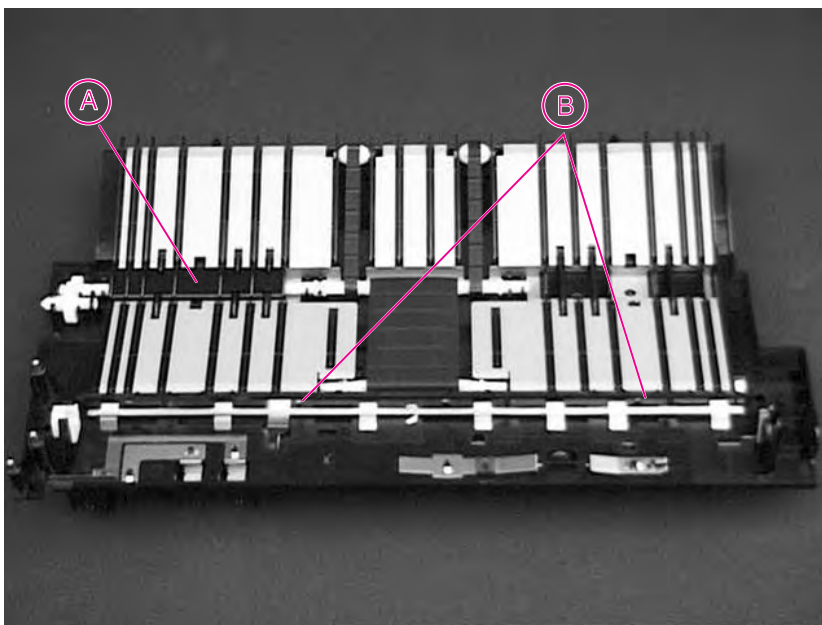
## Paper Feed Belt Assembly

- 1 Remove the Top Cover (page 6-12), Left Cover (page 6-23), and Main Gear Assembly (page 6-34), DC Controller (page 6-46), and Transfer Roller Assembly (page 6-28).
- 2 Facing the front of the printer, remove the machine screws on each side of the Belt Assembly.
- 3 Raise the Registration Assembly by the small green handle, and lift out the Belt Assembly.
- 4 Remove the plastic guide (A) in Figure 6-41 and replace the belts if necessary. The guide snaps back in after belt replacement.



**Figure 6-40** Paper Feed Belt Assembly

Item	Explanation
A	Paper Feed Belt Assembly Screws



**Figure 6-41** Paper Feed Belt Assembly (removed)

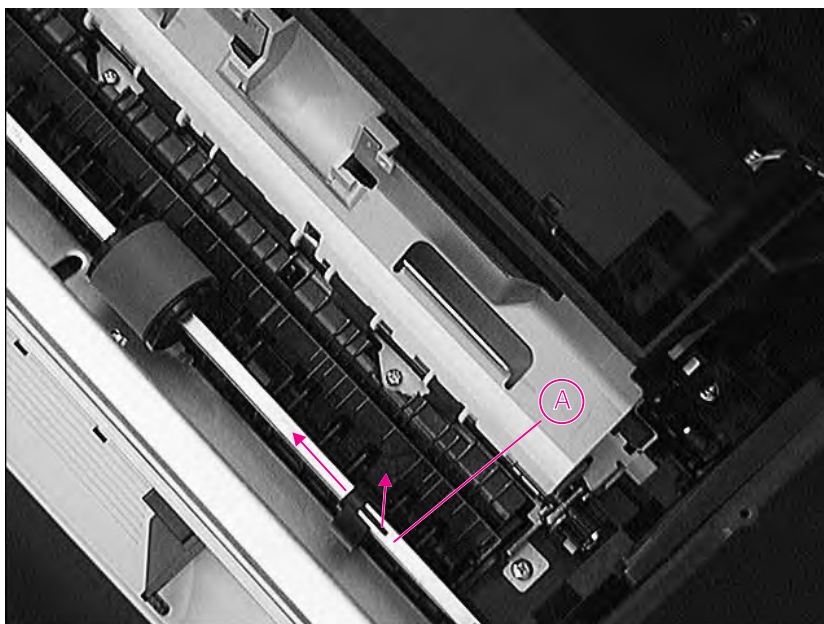
Item	Explanation
A	Location where guide snaps out with two tabs on bottom
B	This edge has a metal ridge with sharp teeth. Use Caution.

**Note**

To prevent damage to the high voltage contacts, the Feed Belt Assembly MUST be reinstalled prior to the installation of the DC Controller.

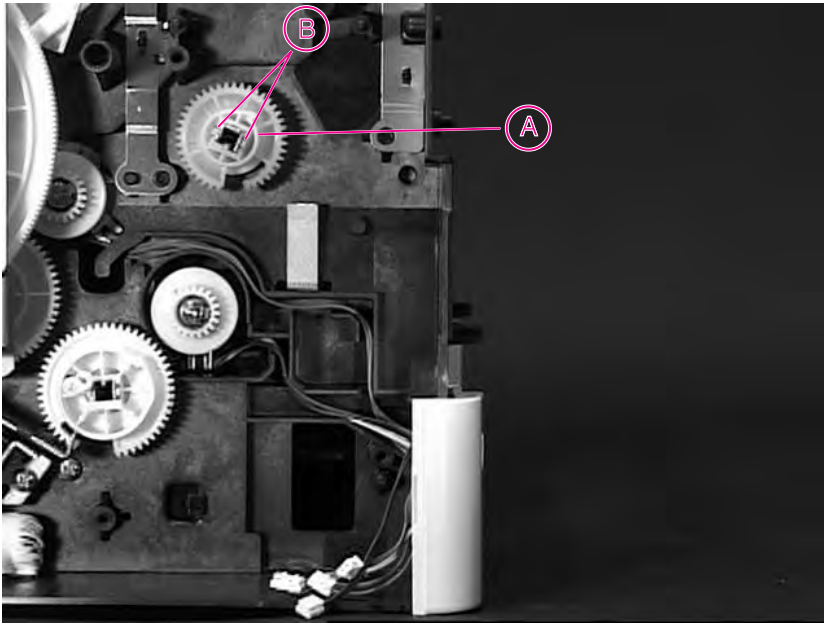
## Tray 1 Shaft

- 1 Remove the Top Cover (page 6-12), Left and Right Side Covers (page 6-23), Pickup Gear Assembly (page 6-36), and Paper Handling PCA (page 6-31).
- 2 Raise the green center handle of the Registration Assembly.
- 3 Remove the plastic collar on the right, outside the chassis, by pulling outward on the collar's release tab and sliding the collar off the shaft.
- 4 Release the collar on the inside right of the chassis by pulling UP on the release tab, and sliding the collar to the left. See Figure 6-42.



**Figure 6-42** Tray 1 Shaft (right side view of printer)

Item	Explanation
A	Locking Tab



- 5 Release the tabs of the gear on the left side of the shaft, outside the chassis, and slide the gear off.
- 6 Slide the shaft to the right, and then angle it out of the chassis.

Item	Explanation
A	Tray 1 Shaft Gear
B	Tray 1 Release Tabs

---

**Hint**

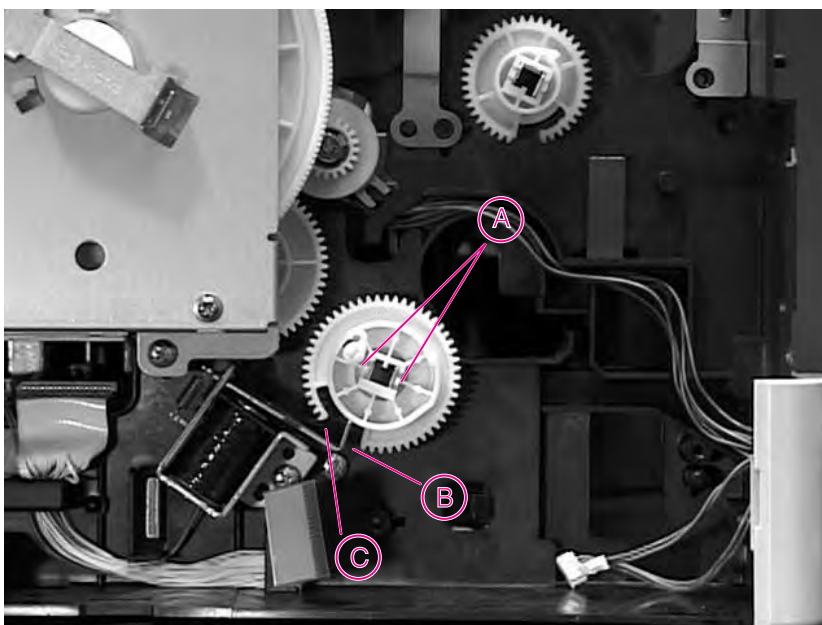
---

Make sure that the Tray 1 Lift Plate (with spring) is pressed down before installing the Tray 1 Shaft. The Shaft captivates the Tray 1 Lift Plate, and must be installed on top of it.



## Tray 2 Shaft

- 1 Remove the Top Cover (page 6-12), Left and Right Side Covers (page 6-23), Pickup Gear Assembly (page 6-36), and Paper Handling PCA (page 6-31).
- 2 Remove the spring from the gear on the left side of the shaft.
- 3 Align the solenoid arm (B) (see Figure 6-43) with the gap in the gear (on the left side of the printer).
- 4 Press the release tabs (A) outward, and slide the gear off the shaft.
- 5 Remove the bushing on the right side of the shaft by lifting the release tab and sliding it off the shaft.
- 6 Slide the shaft to the right, then angle it out of the chassis.

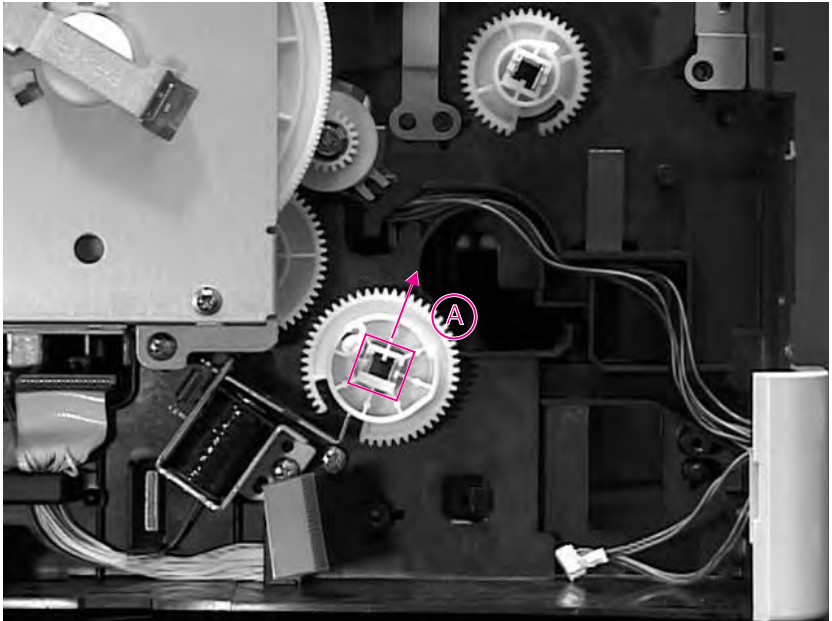


**Figure 6-43** Tray 2 Shaft (left side view of printer)

Item	Explanation
A	Release Tabs
B	Solenoid Arm
C	Gap

## Reassembly Steps:

- 1 Tip the printer back, so that the front faces up.
- 2 Insert the shaft into the fitting on the right side. Then, angle the shaft into the other side.
- 3 Place the bushing on the right end of the shaft, and push until the tab locks in the indentation in the shaft.
- 4 Facing the left side of the printer, orient the shaft so that the open end points away from the solenoid. See Figure 6-44.
- 5 Depress the solenoid arm, and slide the gear into place. Press it into the plastic collar until it locks in place.
- 6 Reinstall the spring on the arm of the gear.

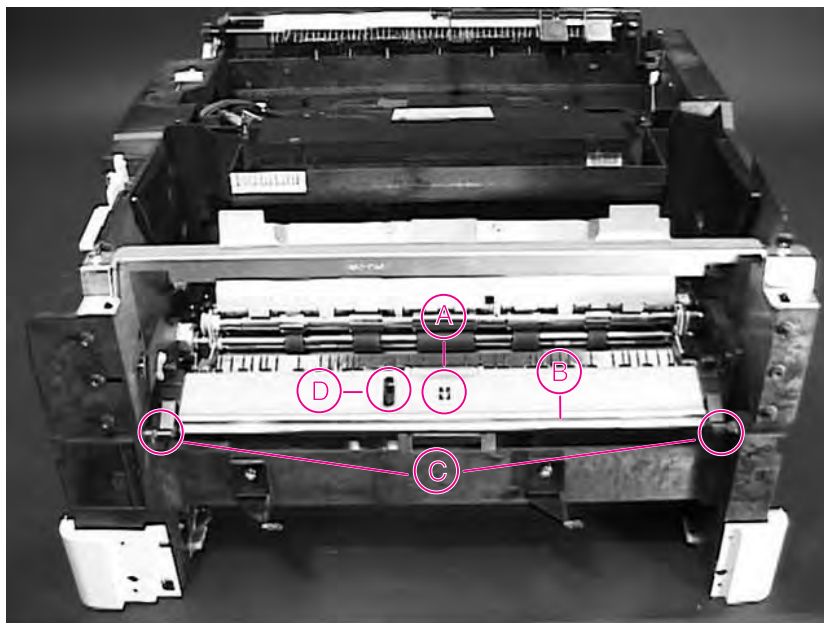


**Figure 6-44** Reassembly of Tray 2 Shaft

Item	Explanation
A	Direction to Orient Shaft

## Tray 1 Lift Plate

- 1 Remove the Front Cover (page 6-18), Tray 1 Shaft (page 6-52), Top Cover (page 6-12), Left and Right Side Covers (page 6-23).
- 2 Rotate the Tray 1 Lift Plate until the opening of the hook faces up. Then, press down on each hook until it slips off the shaft on which it is mounted. When you remove the Lift Plate, be careful not to lose the spring, as it is not captive.

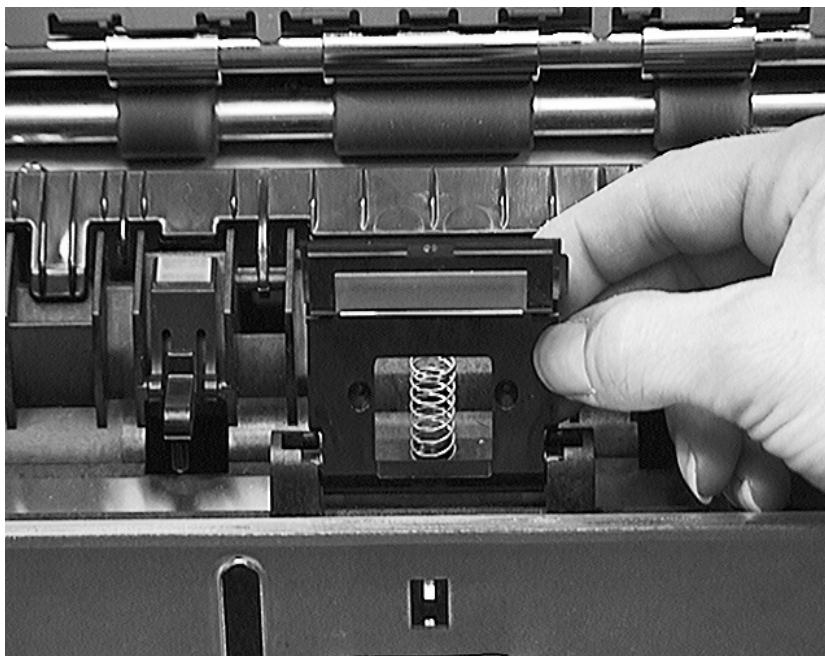


**Figure 6-45** Tray 1 Lift Plate

Item	Explanation
A	Spring
B	Tray 1 Lift Plate
C	Hooks
D	Paper Sensor Flag Slot

## Tray 1 Separation Pad

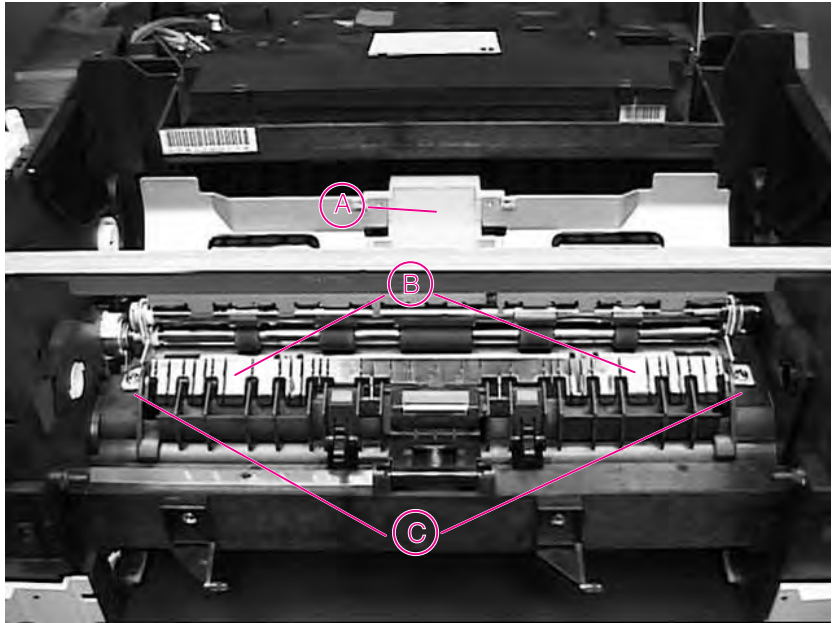
- 1 Rotate the Separation Pad 90° toward you, so that it is oriented up.
- 2 Lift the assembly out of the slots. Be sure not to lose the spring, which is not captive.



**Figure 6-46** Tray 1 Separation Pad

## Paper Guide

- 1 Lift the green handle in the middle of the Registration Assembly.
- 2 Release the Guide by freeing the end pins and the clips in the middle, then lift the Paper Guide out.

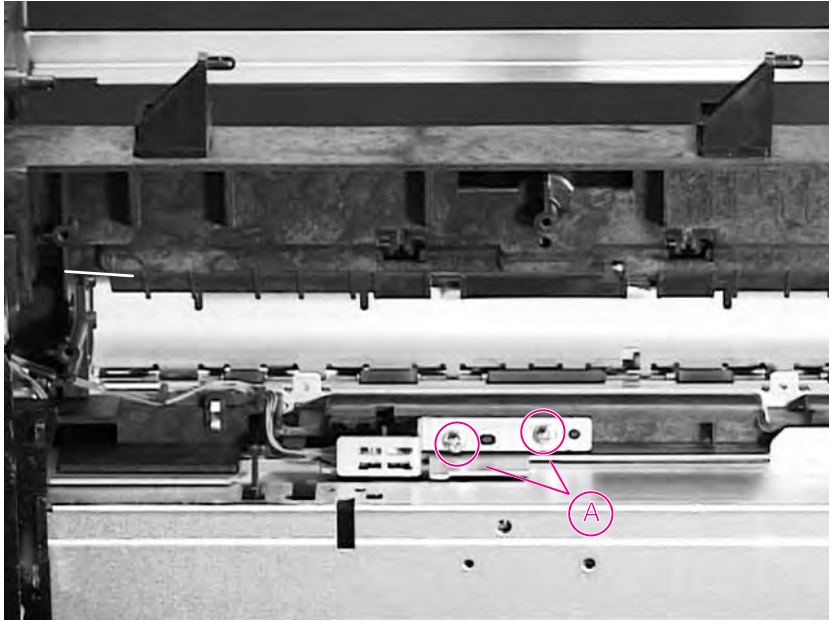


**Figure 6-47** Paper Guide

Item	Explanation
A	Green Handles
B	Paper Guide
C	End Pins

## Paper Path Detect Sensor

- 1 Remove the Paper Tray. Remove the Top Cover (page 6-12), Left Side Cover (page 6-23), Pickup Gear Assembly (page 6-36), and Paper Handling PCA (page 6-31).
- 2 Remove the two screws securing the Sensor to the chassis.
- 3 Remove the Sensor, feeding the cable through the opening in the chassis.

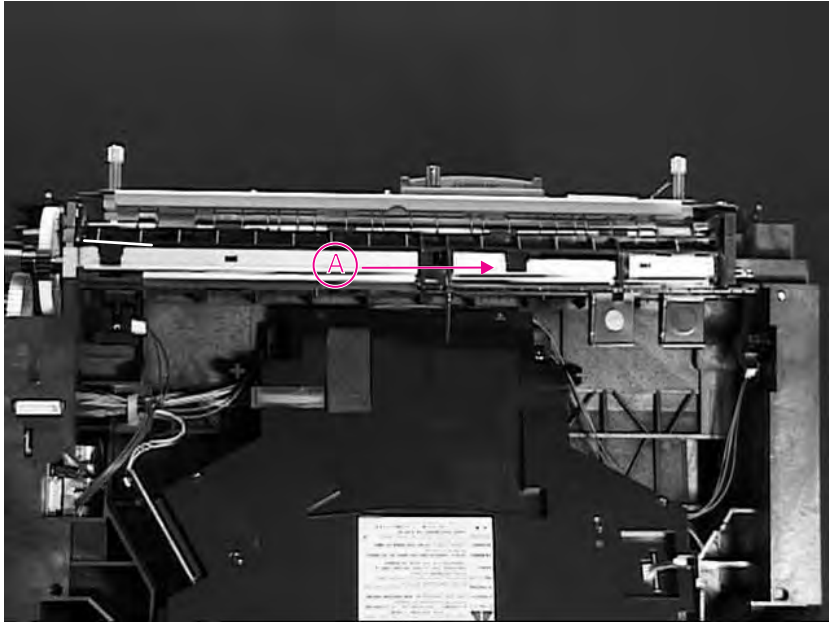


**Figure 6-48** Paper Path Detect Sensor

Item	Explanation
A	Screws

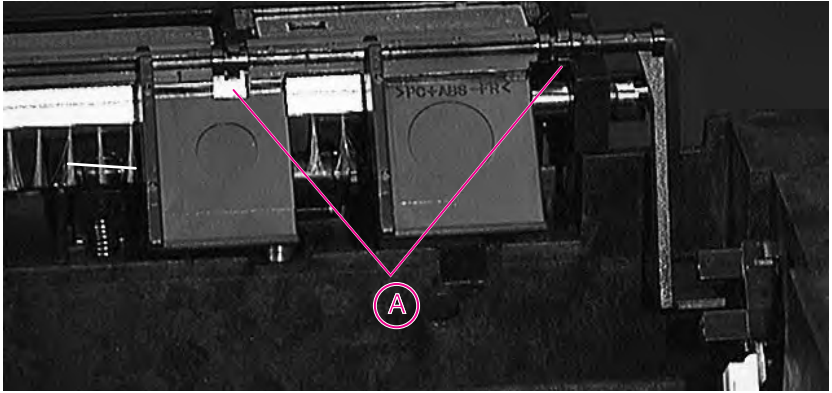
## Face Down Bin Full Sensor

- 1 Remove the Top Cover (page 6-12), Rear Door/Rear Output Bin (page 6-10), and Left and Right Side Covers (page 6-23).
- 2 The Face Down Bin Full Sensor is located on the top of the Upper Delivery Assembly. Release the two clips (A) (Figure 6-50), and slide the Sensor to the right to remove it.



**Figure 6-49** Face Down Bin Full Sensor

Item	Explanation
A	Direction to slide sensor to remove it



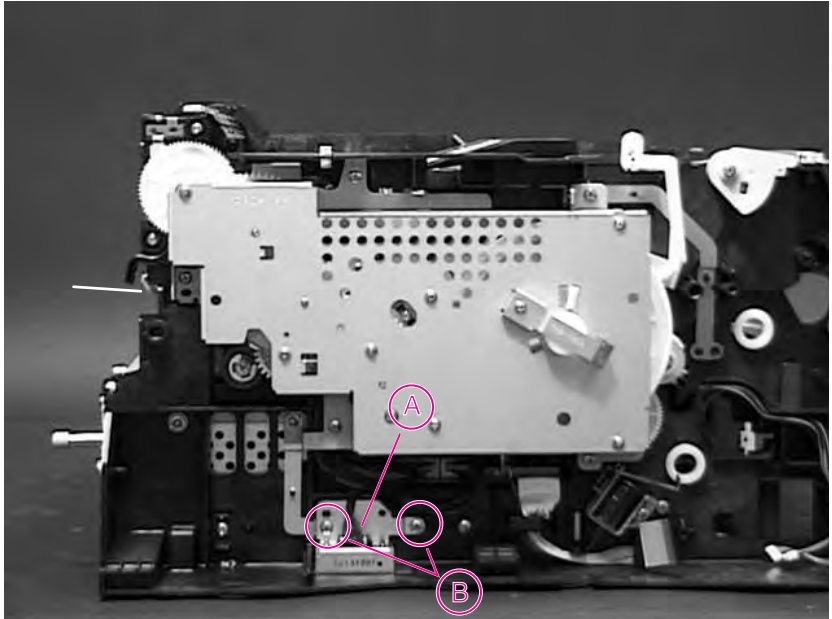
**Figure 6-50** Detail of Bin Full Sensor

<b>Item</b>	<b>Explanation</b>
A	Clips



## Power Connection

- 1 Remove the Top Cover (page 6-12), Left Side Cover (page 6-23), and Rear Door / Rear Output Bin (page 6-10).
- 2 Disconnect the two cables from the Power Connection.
- 3 Remove the two self-tapping screws.
- 4 Remove the Power Connection.

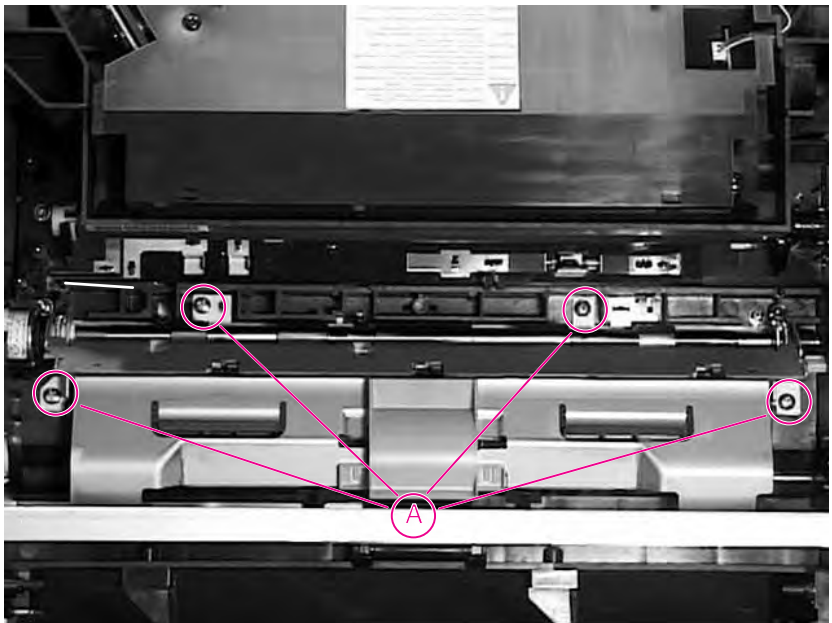


**Figure 6-51** Power Connection

Item	Explanation
A	Cables
B	Screws

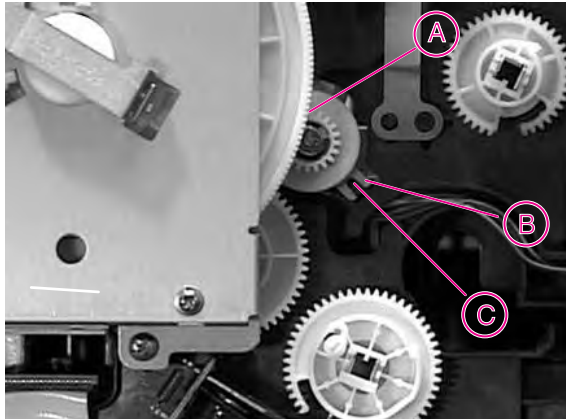
## Registration Assembly

- 1 Remove the Top Cover (page 6-12), Left Side Cover (page 6-23), Pickup Gear Assembly (page 6-36), and the Main Gear Assembly (page 6-34).
- 2 Release the E-ring on the Registration Assembly Clutch, and remove the Clutch (Figure 6-34 on page 6-43).
- 3 Remove the two “common” machine screws in the top middle of the printer. (These screws are already removed if you have removed the Paper Feed Roller Assembly. They are common between the Paper Feed Roller Assembly and the Registration Assembly. Refer to page 6-44 for screw location.)
- 4 Remove the four self-tapping screws inside the chassis. (Lift up the small green handle of the Registration Assembly to access two of these screws.)
- 5 Lift the Registration assembly out of the chassis.



**Figure 6-52** Registration Assembly

Item	Explanation
A	Screw location



**Figure 6-53** Registration Assembly Clutch

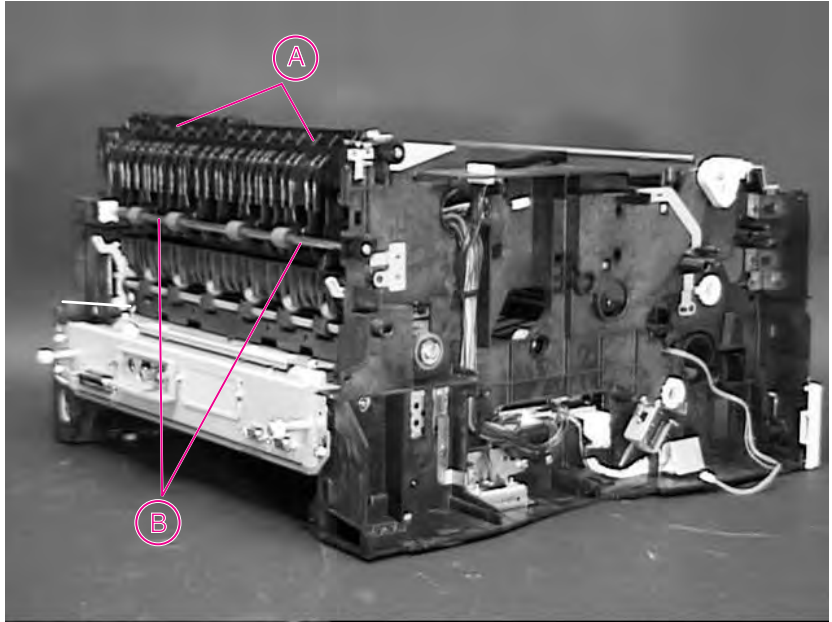
Item	Explanation
A	Flat
B	Alignment Tab
C	Stabilizer

**Hint**

When reinstalling the clutch, orient the shaft with the flat spot up. When the clutch slides on, the slotted metal alignment tab will seat onto a plastic stabilizer. Make sure that the cable is situated away from the Registration Assembly before you reinstall the Assembly.

## Upper Delivery Assembly

- 1 Remove the Top Cover (page 6-12), Rear Door/Rear Output Bin (page 6-10), and Left and Right Side Covers (page 6-23), Main Gear Assembly (page 6-34),.



**Figure 6-54** Upper Delivery Assembly (rear left view of printer)

Item	Explanation
A	Upper Delivery Assembly
B	Delivery Roller

- 2 Face the left side of the printer. The Delivery Assembly is secured with tabs on each side. Use a screwdriver to gently release the tab on the inside, and then lift the assembly out. Be careful not to lift it too high until you release the tab on the opposite side. See Figure 6-55.



**Figure 6-55** Upper Delivery Assembly Tabs

- 3 The Face Down Bin Full Sensor is on the left side of the Upper Delivery Assembly (page 6-60). Be careful not to damage it as you slide the Delivery Assembly out of the chassis.

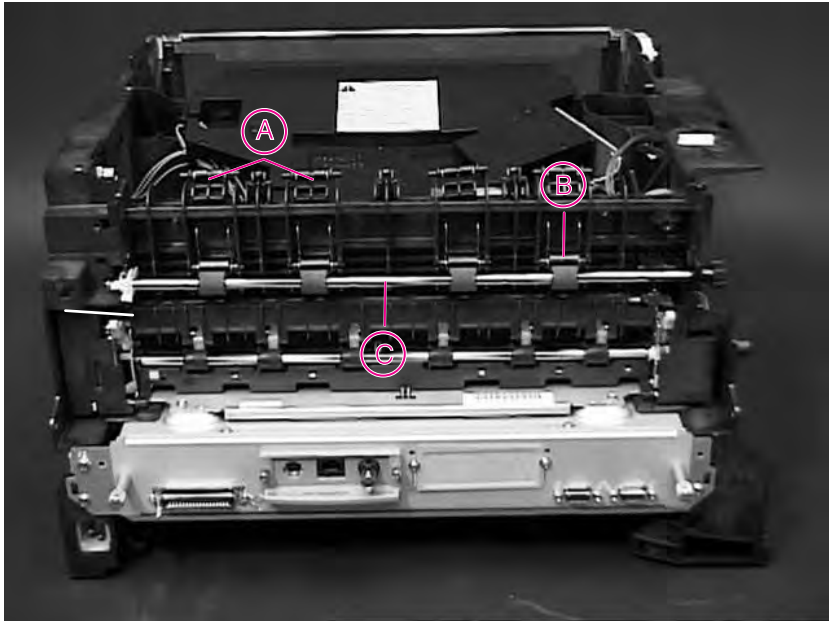
---

**Hint**

To reassemble the Upper Delivery Assembly, slide the unit straight down to lock it in place. Make sure the Face Down Bin Full Sensor is free to move on the left side.

## Delivery Roller Removal

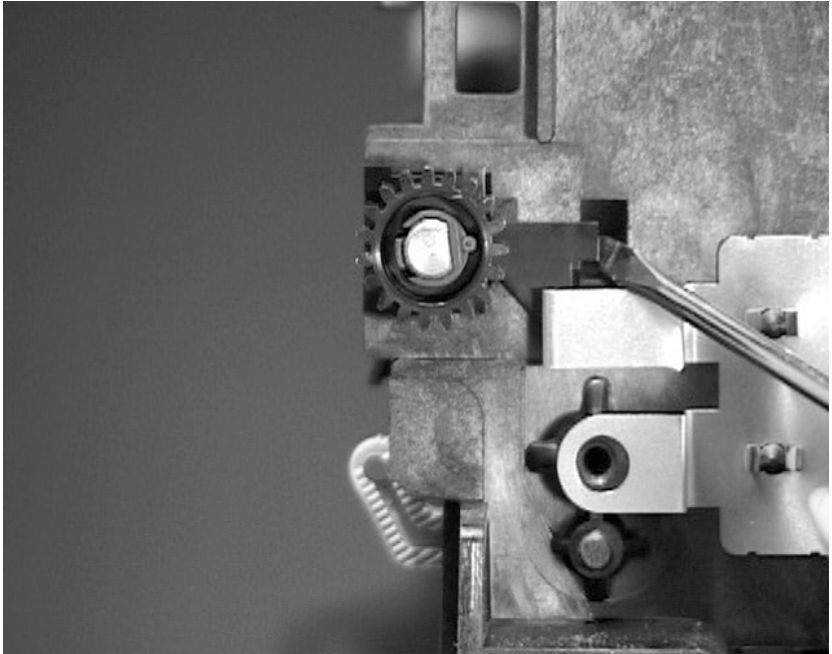
- 1 Remove the Top Cover (page 6-12) the Left and Right Side Covers (page 6-23), Rear door/Rear Output Bin (page 6-10), Main Gear Assembly (page 6-34), and the Upper Delivery Assembly (page 6-65).



**Figure 6-56** Delivery Roller Components

Item	Explanation
A	Rollers
B	Lower Delivery Rollers
C	Delivery Roller

- 2 Facing the left side of the printer, insert a flat-blade screwdriver as shown in Figure 6-57, and twist gently to release the tab on the right side of the Delivery Roller.
- 3 Release the tab on the left side in the same manner.
- 4 After freeing both locking tabs, gently pull forward on the Delivery Roller to remove it.



**Figure 6-57** Right Delivery Roller Tab

- 5 The Lower Delivery Rollers may fall out. When you replace them, make sure they align with the indentations in the chassis.
- 6 Individual Rollers, located above the Lower Delivery Rollers, may be removed by using a flat-blade screwdriver to push gently on the top side of the Roller. The Roller will be released by the action of the spring.

---

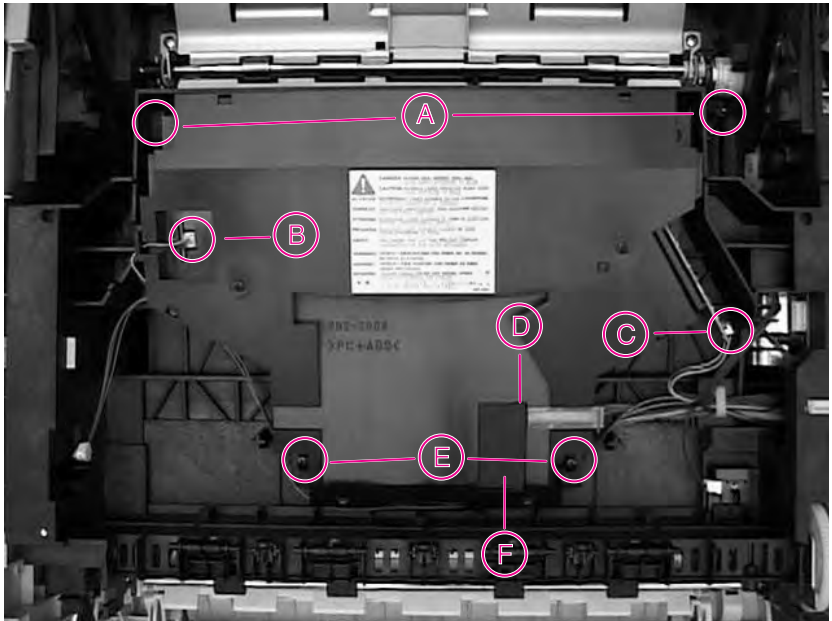
**Hint**

---

When reinstalling the roller, re-align the Lower Delivery Rollers after you reinstall the Delivery Roller.

## Laser Scanner Assembly

- 1 Remove the Top Cover (page 6-12) and the Face Down Assembly Base (page 6-21).
- 2 Facing the back of the printer, remove the four black screws holding the assembly to the chassis.
- 3 Disconnect the cables B, C, and D on each side of the assembly.
- 4 Remove the protective plastic and disconnect the 4-pin connector on the back of the Laser Scanner Assembly.
- 5 Lift the Laser Scanner Assembly out of the chassis.



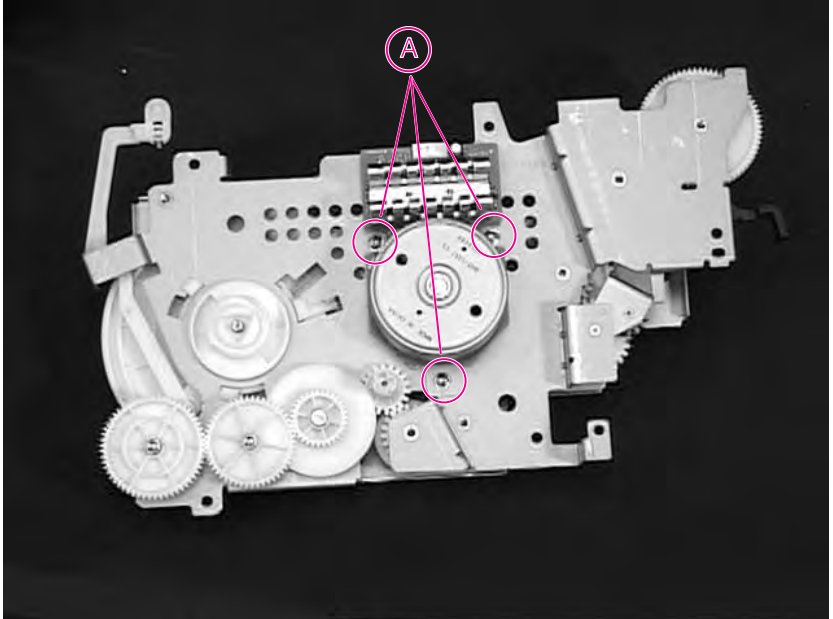
**Figure 6-58** Laser Scanner Assembly (top inside view of printer)

Item	Explanation
A	Screws
B	3-Pin Connector
C	8-Pin Connector
D	4-Pin Connector, under protective foam
E	Screws
F	Protective Plastic



## Main Motor

- 1 Remove the Main Gear Assembly (page 6-34).
- 2 Remove the three screws securing the motor to the back of the Main Gear Assembly.
- 3 Carefully separate the motor from the Gear Assembly.

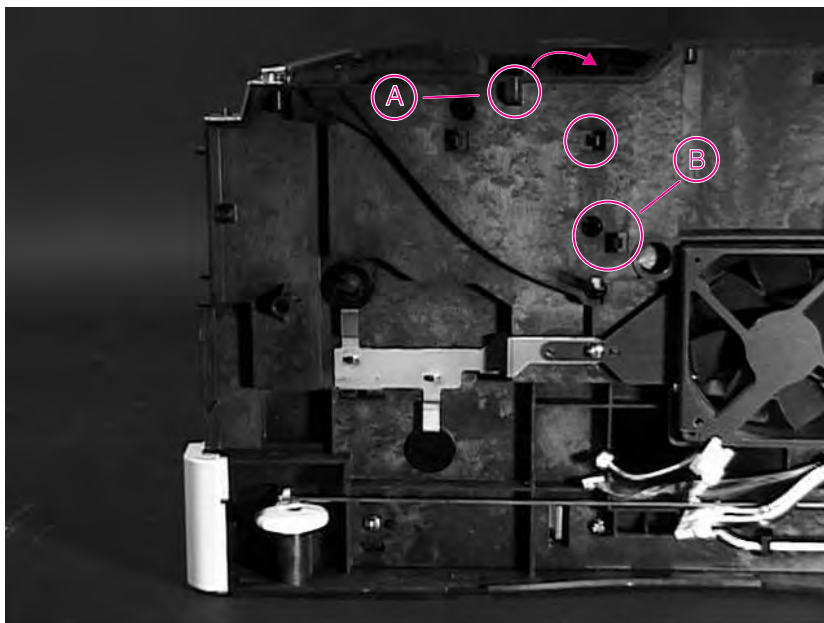


**Figure 6-59** Main Gear Assembly with Motor (rear view)

Item	Explanation
A	Screws

## Toner Cartridge Guides

- 1 Remove the Top Cover (page 6-12) and Left and Right Side Covers (page 6-23).
- 2 Release the “leading” tab (A) first. See Figure 6-60.
- 3 Rotate the Guide in the direction shown to unlock the remaining two tabs.
- 4 Slide the Guide out of the chassis



**Figure 6-60** Toner Cartridge Guide

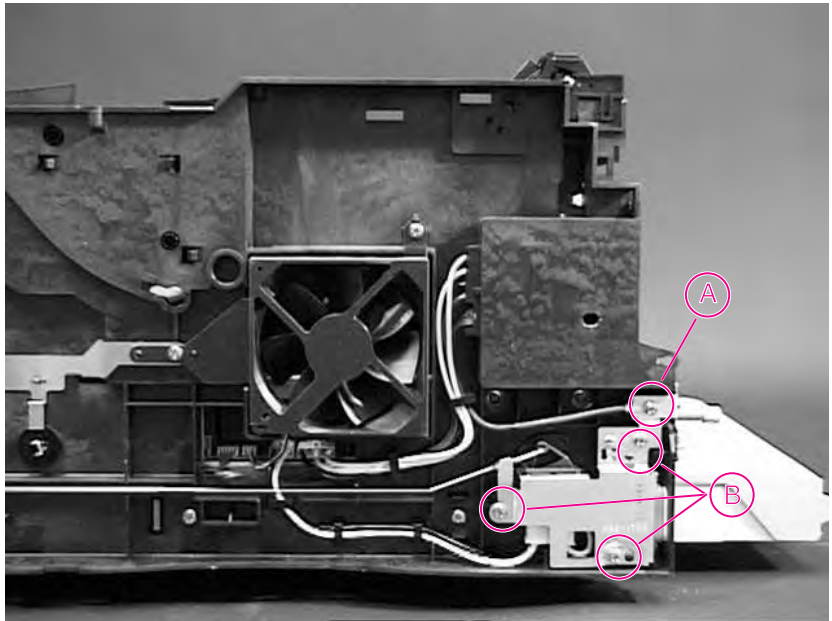
Item	Explanation
A	Leading Tab
B	Tabs

### Hint

To reinstall the Guide, insert the two “non-leading” tabs (B) first. Twist counter-clockwise to lock. Gently flex the “leading” tab (A) so that it will fit into the slot easily. Then snap the Guide into place.

## Power Inlet Assembly

- 1 Remove the Top Cover (page 6-12) and the Right Side Cover (page 6-23).
- 2 Remove the Switch Rod by flexing it slightly and unhooking it from the switches on each end.
- 3 Remove the three self-tapping screws (B) from the Power Inlet housing.
- 4 Remove the machine screw (A) and grounding wire.

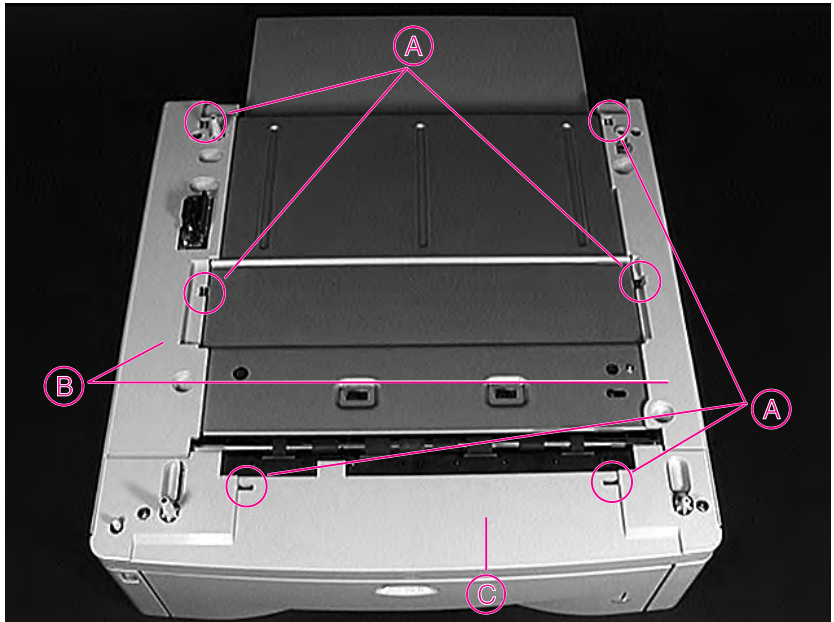


**Figure 6-61** Power Inlet Assembly (right side view of printer)

Item	Explanation
A	Grounding Wire Screw
B	Screws

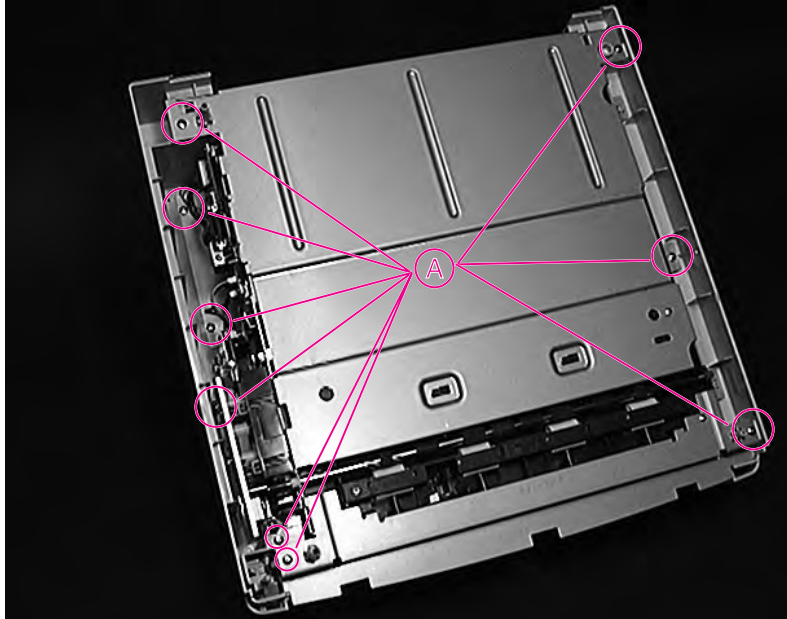
## Optional 500-sheet Tray Disassembly

- 1 Using a flathead screwdriver, release the locking tabs by pressing down in the locking tab location slots.
- 2 Remove the right and left auxiliary covers, and the front cover.



**Figure 6-62** Optional 500-sheet Tray (top view)

A	Locking Tabs
B	Auxiliary covers
C	Front cover



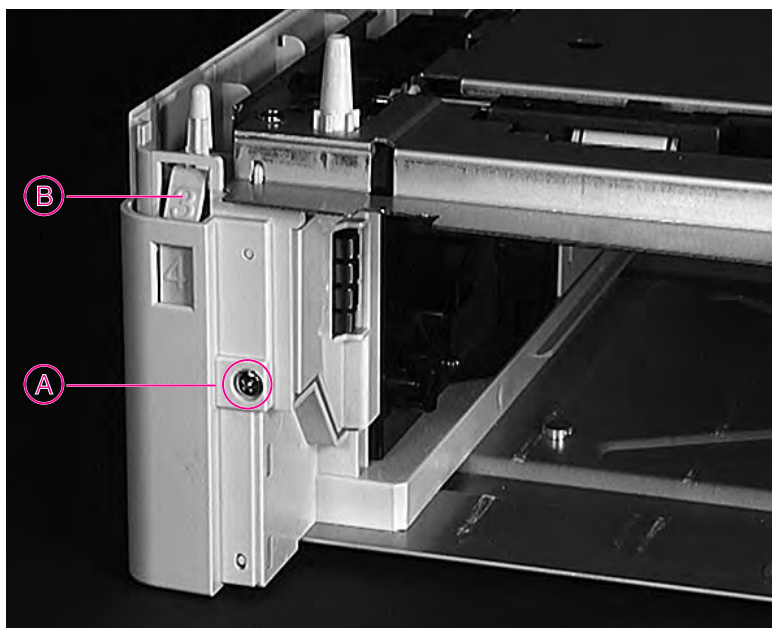
**Figure 6-63** 500-sheet Tray (top view with covers removed)

A	Self-tapping screws
---	---------------------

- 3 Remove the nine self-tapping screws.

## Tray Indicator Assembly

- 1 Remove the left front corner cover screw.
- 2 Remove the cover.
- 3 Remove the Tray Indicator Assembly.



**Figure 6-64** Removing the Tray Indicator Assembly

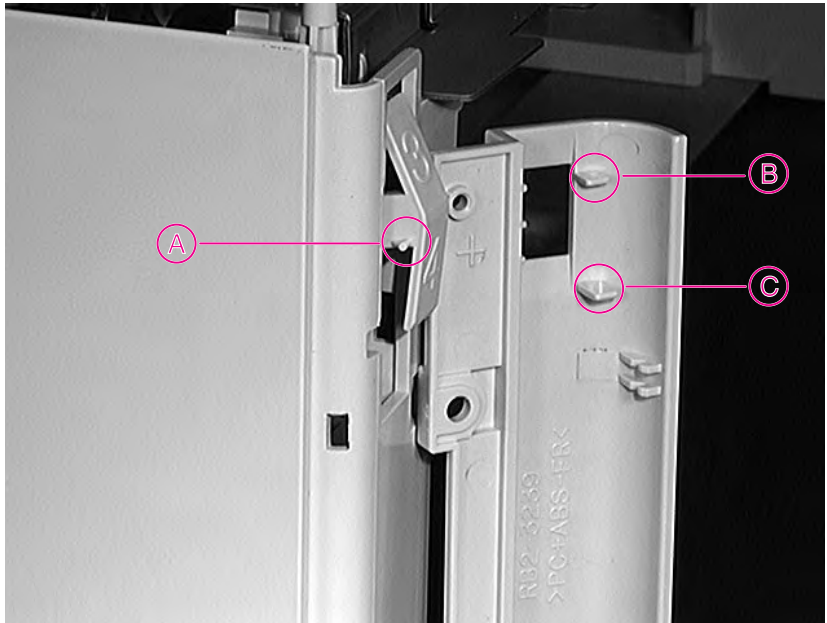
A	Left Corner Cover screw
B	Tray Indicator Assembly

## Left Front Corner Cover Installation

- 1 Install the Tray Indicator Assembly.
- 2 Depress the indicator to ensure the Tray Indicator Limit Tab is between the upper and lower limit stops.

### Note

Ensure that the Tray Indicator operates correctly.

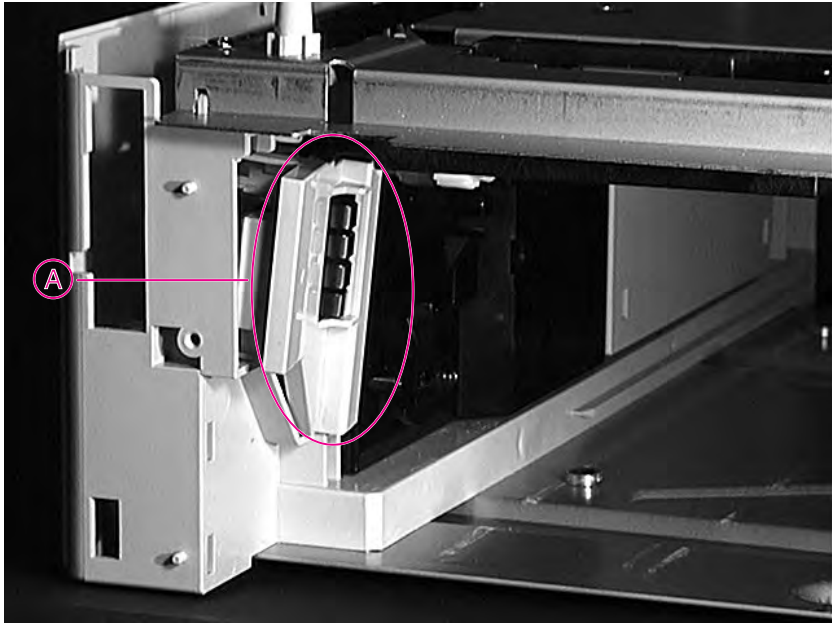


**Figure 6-65** Installing the Left Front Corner Cover

A	Tray Indicator Limit Tab
B	Upper Limit Stop
C	Lower Limit Stop

## Paper Size Spring Assembly

- 1 Remove the Paper Size Spring Assembly by disengaging the locking tabs from the left frame assembly.
- 2 Lift straight up to separate the internal component assembly from the frame assembly.



**Figure 6-66** Removing the Paper Size Spring Assembly

A	Paper Size Spring Assembly
---	----------------------------



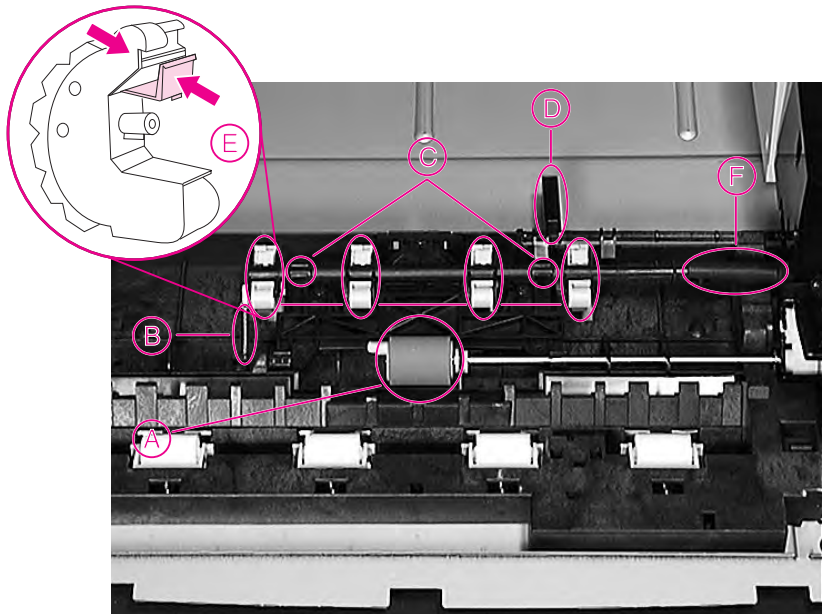
# D-Roller and Feed Roller

## Feed Roller Removal

- 1 Pinch the Feed Roller Tab and slide it off the shaft.

## D-Roller Removal

- 1 Disengage the Spring (B).
- 2 Remove the Pickup Roller Shaft from the Retaining Clips.
- 3 Depress the Locking Tab on the D-Rollers and remove it from the shaft.

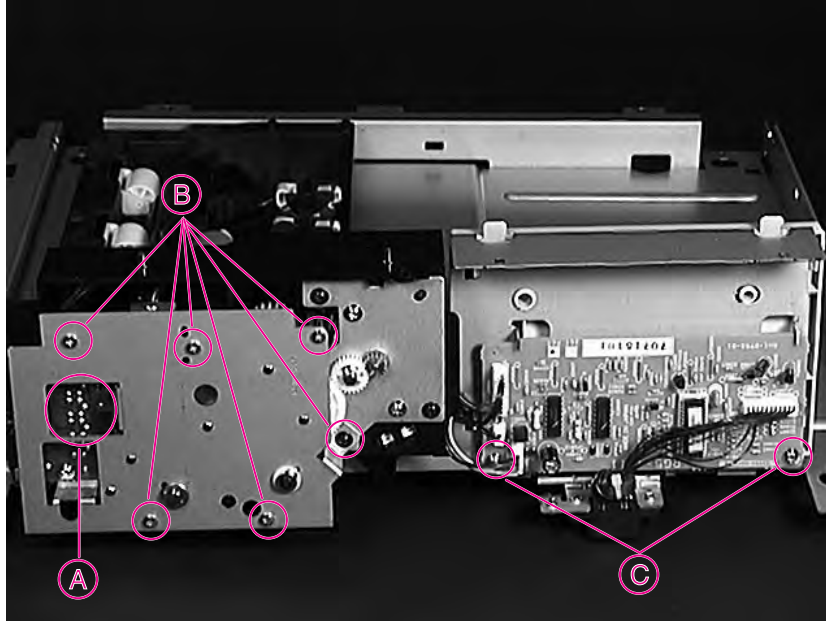


**Figure 6-67** Removing the Feed Roller and D-rollers

A	Feed Roller
B	Spring
C	Pickup Roller Shaft Retaining Clips
D	Paper Sensor Flag
E	D-rollers
F	Joint Auxiliary Shaft

## Gear Assembly and PCA

- 1 Remove the Gear Assembly by removing the six small self-tapping screws.
- 2 Remove the 500-sheet Feeder PCA by removing the two machine screws (C).
- 3 Remove the Paper Size Switch PCA by removing the two machine screws.

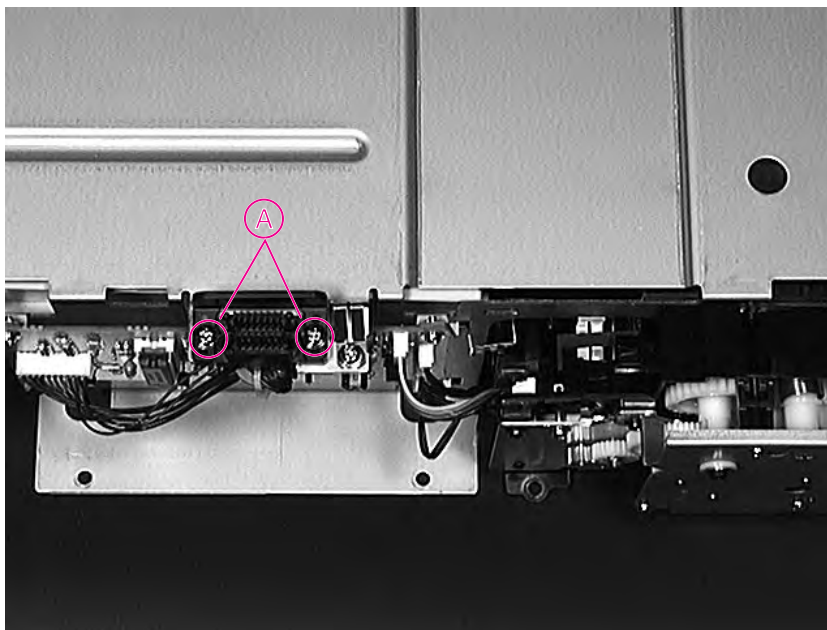


**Figure 6-68** Removing the Gear Assembly and PCA

A	Paper Size Switch PCA
B	Small, Self-tapping Screws
C	Machine Screws

## Power Connector

- 1 Remove the Power Connector by removing the two screws (A).

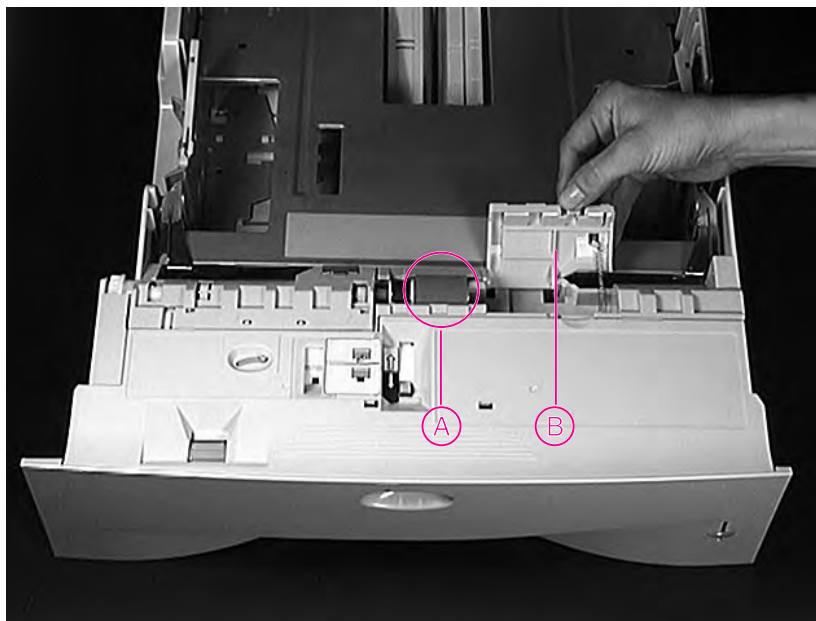


**Figure 6-69** Removing the Power Connector

A	Screws
---	--------

## Separation Roller

- 1 Lift the Return Cover.
- 2 Pinch the Separation Roller Tab.
- 3 Slide the Separation Roller off of the shaft and remove.



**Figure 6-70** Removing the Separation Roller

A	Separation Roller
B	Return Cover



# 7 Troubleshooting

## Overview

This chapter discusses the following:

- Troubleshooting Process
- Troubleshooting the Printing System
- General Troubleshooting Information
- Reference Diagrams

# Troubleshooting Process

The troubleshooting process is a systematic approach that addresses the major problems first, then other problems as you identify the causes for printer malfunctions and errors. The Troubleshooting Process Flow on page 7-4 illustrates the major steps for troubleshooting the printing system. Each heading depicts a major troubleshooting step. A YES answer to the questions allows you to proceed to the next major step.

A NO answer indicates that additional testing is needed. Proceed to the referenced location and follow the directions for that area. After completing the additional testing, proceed to the next major step.

The following list describes the basic questions for the customer and the corresponding troubleshooting step to help you quickly define the problem(s).

---

**Table 7-1. Major Steps for Troubleshooting**

---

**Power On**  
(page 7-7)

Does the printer perform the initialization and power-on steps?

This section gives the procedures for correcting power supply problems.

**Display**  
(page 7-11)

Does the Control Panel indicate `READY`, `OFFLINE`, or `POWERSAVE ON`?

This section gives the procedures for clearing Control Panel error messages and displaying and correcting Event Log codes.

**Event Log**  
(page 7-12)

Are there recurring problems in the Event Log?

This section gives information about printing the Event Log and evaluating the error history.

**General Paper Path  
Troubleshooting**  
(page 7-40)

Is there a paper jam in the printer?

This section gives information about solving problems in the paper path.

**Information Pages**  
(page 7-43)

Will the printer print information pages successfully?

This section gives the procedures for printing the information pages and evaluating and correcting the printer's configuration.

---

**Table 7-1. Major Steps for Troubleshooting (continued)**

---

Image Quality  
(page 7-48)

Does the print quality meet the customer's expectations?

This section gives Toner Cartridge checks, information on EconoMode, image defect examples, and the repetitive defect ruler.

Interface Troubleshooting  
(page 7-76)

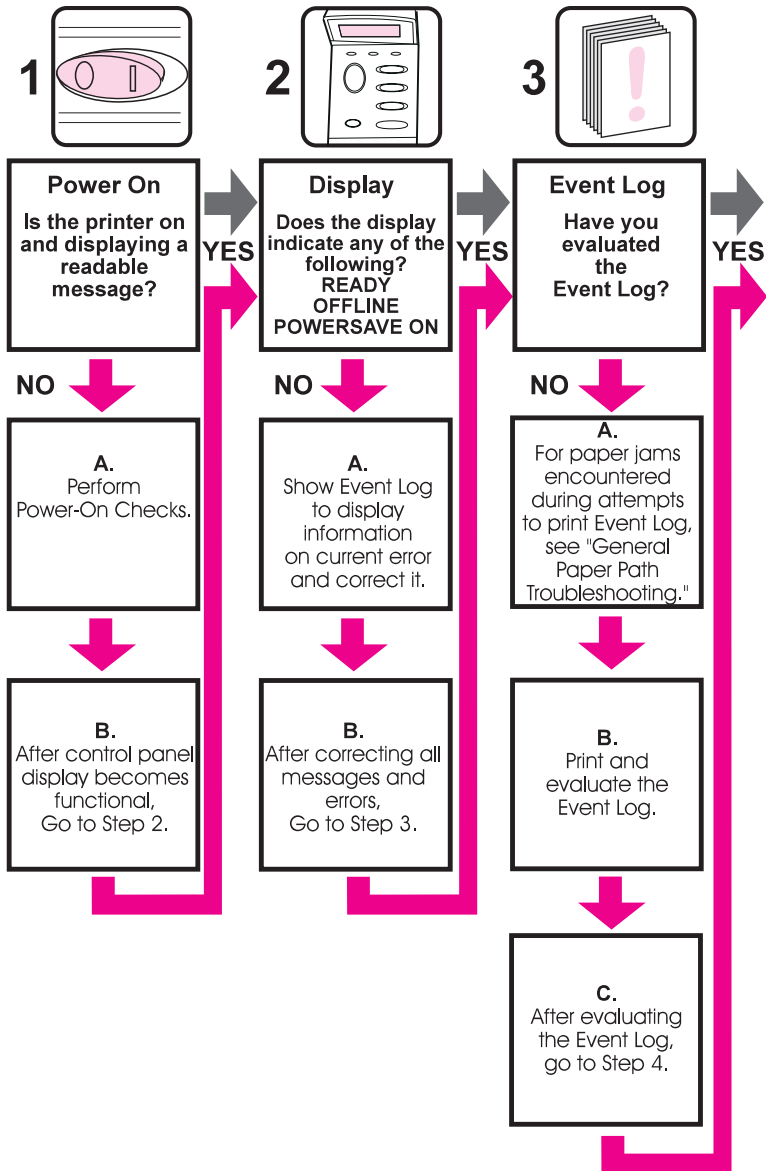
Can the customer print from the host system successfully?

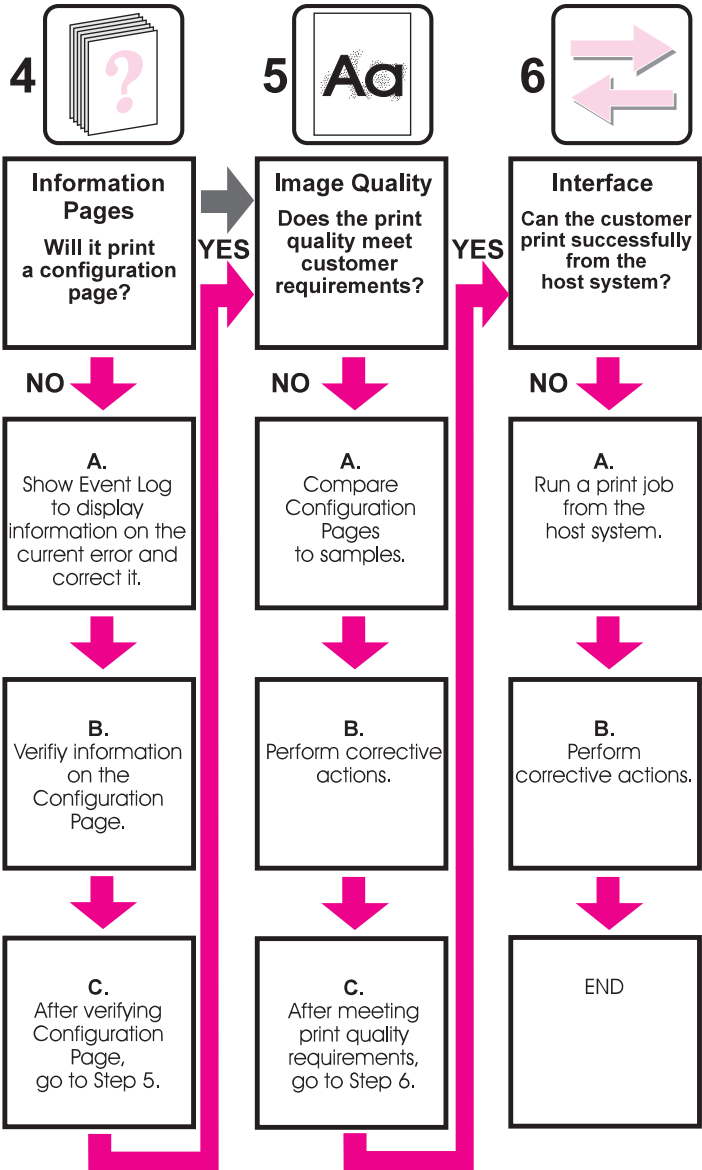
This section describes how to determine if the printer is communicating properly with the host system.

---



# Troubleshooting Process Flow





# Troubleshooting the Printing System

## Preliminary Operating Checks

Prior to troubleshooting a specific printer problem, you should ensure that:

- The printer is being maintained on a regular basis as described in Chapter 4.
- The customer is using acceptable paper as specified in the *HP LaserJet Printer Family Paper Specifications Guide*.
- The printer is positioned on a solid, level surface.
- The line voltage does not vary more than 10% from the nominal rated value as specified on the Power Rating Label.
- The operating environment for the printer and paper is within the temperature and humidity specifications listed in Chapter 1 of this manual.
- The printer is never exposed to ammonia fumes such as those produced by diazo copiers or office cleaning materials.
- The printer is not exposed to direct sunlight.
- Non-HP components (such as refilled Toner Cartridges, font cartridges, and memory boards) are removed from the printer.

---

### Note

When moving the printer into a warm room from a cold location such as a warehouse, various problems can occur due to condensation in the printer. For example, if the photosensitive drum is cold, the resistance of the photoconductive layer will be high. This will lead to incorrect contrast. Leave the printer running for 10 to 20 minutes.

---

# Power On

It is important to have the printer's Control Panel functional as soon as possible in the troubleshooting process so that the printer's diagnostics can assist in locating printing errors.

---

**Table 7-2. Power on Defect or Blank Display**

---

<b>Problem</b>	<b>Action</b>
Is the power cord plugged into the wall and the printer? Is AC and DC power available?	Verify. See table 7-3, "No AC Power," on page 7-8 and table 7-4, "No DC Power," on page 7-9.
Is the power switch set to on?	Set the switch to the on position. You should hear the switch toggle. If the Front Right Side Cover has been removed recently, be sure that the rod leading to the power supply moves as the rocker switch is toggled.
Does the Fan turn on when you turn on the printer?	<p>Note: Fan operation is significant since the Fan is controlled by the printer's Engine Controller Board. An operational Fan indicates the following:</p> <ol style="list-style-type: none"><li>1. AC power is present in the printer.</li><li>2. DC power supply is functional (24 VDC, 5 VDC, and 3.4 VDC are being generated).</li></ol> <p><b>If the Fan is not working:</b></p> <ol style="list-style-type: none"><li>1. Turn off the printer and remove the printer's Formatter PCA. Disconnect all the printer's paper handling options.</li><li>2. Turn on the printer and check the Fan again.</li></ol> <p>If the Fan is still not working, perform the following steps:</p> <ol style="list-style-type: none"><li>1. Verify that the Fan is connected to the DC Controller Assembly.</li><li>2. Replace the Fan.</li><li>3. Replace the Power Supply.</li></ol> <p><b>If the Fan is working but the printer's Control Panel is blank:</b></p> <ol style="list-style-type: none"><li>1. Print an engine test. See "Engine Test" on page 7-9. If the engine test is successful, perform the following steps:<ol style="list-style-type: none"><li>a. Reseat the Control Panel and Formatter connector.</li><li>b. Replace the Control Panel assembly.</li><li>c. Replace the Formatter.</li><li>d. Replace the cable from the Control Panel.</li></ol></li><li>2. If the engine test is not successful, replace the Power Supply.</li></ol>

---

---

**Table 7-3. No AC Power**

---

<b>Cause</b>	<b>Action</b>
No correct voltage present at the outlet.	Plug the power cord into another AC circuit outlet. Inform the customer that the correct line voltage is not available at the outlet.
The power cord is not firmly plugged into the printer and the outlet.	Insert the power plug firmly.
Blown fuse.	1. Check the fuse (F1) on the Power Supply. 2. Replace the fuses if necessary.
Defective power switch.	Remove the DC Controller Assembly. Measure the resistance between the two terminals of the power switch (SW101) by applying the tester probes to the terminals. The resistance must be low (under 1 K $\Omega$ ) when the power is turned ON, and high (over 6 M $\Omega$ ) when the switch is turned OFF. Otherwise, replace the Power Supply.
Defective AC receptacle or AC power line.	Check the printer's AC receptacle and wiring for the AC power line. If no problem is found, replace the Power Supply.

---

---

**Table 7-4. No DC Power**

---

<b>Cause</b>	<b>Action</b>
No AC power is supplied.	Check the AC power supply. See table 7-3, "No AC Power," on page 7-8
The overcurrent/overvoltage detection circuit activated.	If the problem is not rectified after the power switch is turned off and on again, find the cause of activation of the overcurrent/overvoltage detection circuit in the power supply. Wait for more than two minutes before turning the printer back on.
Blown fuse.	1. Check the fuses (F2) on the Power Supply. 2. Replace the fuses if necessary.
Defective power supply unit	Replace the power supply unit.

---

## **Engine Test**

The engine test verifies that the print engine is functioning correctly. The Formatter PCA is completely bypassed during an engine test. This test is very useful for isolating printer problems. The engine test prints a full page of lines across the entire printable area, and is also useful for checking and adjusting registration. The engine test prints from the "Cold Reset Paper Tray" and can be activated with the Formatter PCA removed.

---

### **Note**

The "Cold Reset Paper Tray" must be loaded with paper to perform an engine test. Also, ensure that the Toner Cartridge is installed in the printer.

---

## Engine Test Button Location

The engine test verifies that the print engine is functioning correctly. The Formatter PCA is completely bypassed during an engine test. This test is very useful for isolating printer problems. The engine test prints a full page of lines across the entire printable area, and is also useful for checking and adjusting registration.

---

### Note

Engine test will print from the last input tray used.

If the last input tray is empty or if the last input source was the duplexer, then the Engine Test will print from Tray 2 (standard 250 CST).

If Tray 2 is empty (and the last input tray is empty or the last input source was the duplexer), then the Engine Test will not function.

---



**Figure 7-1** Location of the Engine Test Button

## Printing an Engine Test

To print an engine test, use a non-metallic object (such as a pencil) to press the engine test button. A single test page with horizontal lines will be printed. To print multiple test pages, hold down the engine test button.

## Display

The Control Panel should display `READY`, `OFFLINE`, or `POWERSAVE ON`. For information about errors displayed, access the Event Log. If the display is blank, see “Preliminary Operating Checks” on page 7-6.



## Event Log

Use the Event Log to diagnose and troubleshoot printer errors and intermittent failures. You can either display or print the Event Log.

Access the Event log from the Control Panel's Information Menu. (Select `PRINT EVENT LOG` or `SHOW EVENT LOG`.) The Event Log retains the printer's last 30 error messages.

See the tables starting on page 7-16 for more information about correcting Event Log messages on the printer.

---

### Note

The Event Log codes and the error on the Control Panel do not always correspond exactly. The numbers in the Control Panel message may not be the same in the Event Log; the decimal numbers may be shifted by one digit. For example, 13.1 on the control panel reads 13.01 in the Event Log. Refer to the correct number in the tables starting on page 7-16.

---

## Event Log Page

Current Page Count: 39

Serial Number: YYYYYYYYYY

Number	Error	Page Count	Description or Personality
19	13.2.50	16	PAPER FEED 1, PAPER STOPPED JAM
18	55.0000	0	
17	55.0A40	0	
16	55.0000	0	
15	13.20.30	1225	PRINTER COULD NOT AUTOMATICALLY EJECT PA
14	13.20.30	1223	PRINTER COULD NOT AUTOMATICALLY EJECT PA
13	13.10.18	1017	DUPLEX TURN AROUND, PAPER LATE JAM
12	41.03.00	1017	PCLXL
11	13.1.50	862	PAPER FEED 1, PAPER LATE JAM
10	13.1.50	753	PAPER FEED 1, PAPER LATE JAM
9	13.10.18	751	DUPLEX TURN AROUND, PAPER LATE JAM
8	13.1.50	750	PAPER FEED 1, PAPER LATE JAM
7	13.20.30	457	PRINTER COULD NOT AUTOMATICALLY EJECT PA
6	13.20.10	457	PRINTER COULD NOT AUTOMATICALLY EJECT PA
5	13.20.14	457	PRINTER COULD NOT AUTOMATICALLY EJECT PA
4	13.2.70	457	PAPER FEED 1, PAPER STOPPED JAM
3	55.0000	0	
2	55.0A40	0	
1	55.0000	0	

Figure 7-2 Event Log Page

## Display the Event Log

If the printer cannot print or move any paper, follow these steps to display the Event Log.

- 1 Press **[Menu]** until INFORMATION MENU appears.
- 2 Press **[Item]** until SHOW EVENT LOG appears.
- 3 Press **[Select]** to show the Event Log.
- 4 Press **[+]** to scroll through the Event Log.
- 5 Write down the error messages.
- 6 Check the Event Log for specific error trends in the last 10,000 printed pages.
- 7 Ask the customer for any observed error trends. (For example, do paper jams tend to occur in a specific area of the printer?)
- 8 Record any specific error trends.
- 9 See Table 7-5, “Alphabetical Printer Messages,” on page 7-16 or Table 7-6, “Numerical Printer Messages,” on page 7-26 and follow the recommended action.
- 10 If the Control Panel displays READY, OFFLINE, or POWERSAVE ON, go to the next section. If it indicates any other message, repeat this section from step 1.

## Print the Event Log

The printer's internal Event Log stores the last 30 errors and can be printed at any time. To print the Event Log:

- Press **[Menu]** until INFORMATION MENU appears.
- Press **[Item]** until PRINT EVENT LOG appears
- Press **[Select]** to print the Event Log.

## Interpret the Event Log

The Event Log is the key tool in troubleshooting printer problems. Figure 7-2 shows a typical Event Log. The Event Log shows the current page count at the top left of the page with the printer's serial number directly to the right of the page count. The left column is the error sequence number, with the error listed at the top (the highest sequence number is the most recent error logged). The next column is the page count at the time of the error, and the last column is the Personality (PCL or PostScript) column or the cause of the jam at the time of the error.

The Event Log may record errors in a different format than the Control Panel Display. For example, should a 50.1 FUSER ERROR / CYCLE POWER be displayed on the Control Panel, the Event Log will record a 50.02.01 error, with the 02 signifying that 2 sensors were blocked. Likewise, when a 13.1 through 13.9 are displayed on the Control Panel, the Event Log will record a 13.0x.01 through 13.0x.09, where x= the number of sensors blocked in the printer.

---

**Hint**

Whenever a 13. xx appears on the Control Panel, a good practice is to clear all the jammed paper from the printer and print the Event log. If you cannot print the Event Log, you can still display it on the Control Panel. Write the error next to the last error logged. The last error is the error at the top of the Event Log printout with the highest number in the left-most column.

---

To interpret the Event Log:

- Each individual entry in the log is called an “error,” and all errors occurring at the same page count are called an “event”. Read the Recommended Action for each error comprising an event to gain a clear picture of what took place during that event. Events usually conclude with a time-out, or no response from device (Error 66. xx in the Event Log) which requires a power cycle of the print engine.
- Use the Event Log table in this section to associate errors in the Event Log with the Control Panel error message. Follow the Recommended Action listed in the table for each error or event.

## Printer Messages

The following table explains messages that might display on the printer's Control Panel. Alphabetical printer messages and their meanings are listed in Table 7-5, and numerical printer messages are listed in Table 7-6.

### Hint

If the message persists requesting that you load a tray, or if a message indicates that a previous print job is still in the printer's memory, press **[GO]** to print or press **[Cancel Job]** to clear the job from the printer's memory.

### Note

Not all messages are described (many are self-explanatory).

Some printer messages are affected by the Auto Continue and Clearable Warning settings from the Configuration Menu in the printer's Control Panel. If `CLEARABLE WARNING=JOB` is set on the Control Panel, warning messages display on the Control Panel until the end of the job from which they were generated. If `CLEARABLE WARNING=ON` is set, warning messages display on the Control Panel until **[Go]** is pressed. If an error occurs that prevents printing and `AUTO CONTINUE=ON` is set, the printer goes offline for 10 seconds before it returns online. If `AUTO CONTINUE=OFF` is set, the message displays until **[Go]** is pressed.

---

**Table 7-5. Alphabetical Printer Messages**

---

Control Panel Message	Event Log Message	Explanation	Recommended Action
ACCESS DENIED MENUS LOCKED		The Control Panel function you are trying to access has been locked by the network administrator to prevent unauthorized access.	Ask the Network Administrator to unlock the function.
BAD DUPLEXER CONNECTION		The Duplexer is not connected properly.	<ol style="list-style-type: none"><li>1. Re-install the duplexer.</li><li>2. If the message persists make sure the duplexer is connected and the connector is not damaged.</li><li>3. Replace the Duplexer.</li></ol>

---

**Table 7-5. Alphabetical Printer Messages (continued)**

---

<b>Control Panel Message</b>	<b>Event Log Message</b>	<b>Explanation</b>	<b>Recommended Action</b>
BAD OPT TRAY CONNECTION		The optional tray is not connected properly.	<ol style="list-style-type: none"><li>1. Re-install the optional tray.</li><li>2. Make sure the optional tray is connected and the connector is not damaged.</li><li>3. Replace the optional tray.</li></ol>
CANNOT DUPLEX REAR BIN OPEN		The printer cannot duplex because the rear output bin is open.	<ol style="list-style-type: none"><li>1. Close the rear output bin.</li></ol>
CHECK INPUT DEVICE alternates with PAPER PATH OPEN PLEASE CLOSE IT		The optional input tray cannot feed paper to the printer because a door or tray is open.	<ol style="list-style-type: none"><li>1. Check the doors and trays.</li><li>2. If doors and trays are closed, check tabs and sensor levers in the tray for proper operation. Replace any defective tabs or sensors.</li><li>3. Replace the PCA Controller in the feeder.</li></ol>
CHOSEN LANGUAGE NOT AVAILABLE		A print job requested a printer language that does not exist in the printer. The job will not print and will be cleared from memory.	<ol style="list-style-type: none"><li>1. Print the job using a driver for a different printer language, or add the requested language to the printer (if available).</li><li>2. Press [Go] to continue.</li></ol>
DISK DEVICE FAILURE		The EIO disk had a critical failure and can no longer be used.	<ol style="list-style-type: none"><li>1. Reseat the EIO device or replace it with a new one.</li></ol>

---

**Table 7-5. Alphabetical Printer Messages (continued)**

---

<b>Control Panel Message</b>	<b>Event Log Message</b>	<b>Explanation</b>	<b>Recommended Action</b>
DISK FILE OPERATION FAILED		The requested operation could not be performed. You might have attempted an illegal operation, such as trying to download a file to a non-existent directory.	<ol style="list-style-type: none"><li>1. Check the filename and directory name.</li><li>2. Retry the task.</li></ol>
DISK FILE SYSTEM IS FULL		The disk is full.	<ol style="list-style-type: none"><li>1. Delete files from the EIO disk and then try again, or add a flash DIMM.</li><li>2. Download or delete files from HP JetAdmin, and download or delete fonts from HP FontSmart. (See the software help for more information.)</li></ol>
DISK IS WRITE PROTECTED		The EIO disk is protected, and no new files can be written to it.	Disable the write protection through HP JetAdmin.
FLASH DEVICE FAILURE		The Flash DIMM had a critical failure and no longer can be used.	Remove the Flash DIMM and replace it with a new one.
FLASH FILE OPERATION FAILED		The requested operation could not be performed. You might have attempted an illegal operation, such as trying to download a file to a non-existent directory.	Remove the flash DIMM and replace it with a new one.

---

**Table 7-5. Alphabetical Printer Messages (continued)**

---

<b>Control Panel Message</b>	<b>Event Log Message</b>	<b>Explanation</b>	<b>Recommended Action</b>
FLASH FILE SYSTEM IS FULL		The flash DIMM is full.	1. Delete files from the Flash DIMM or add another DIMM. 2., Download or delete files from HP JetAdmin, and download or delete fonts from HP FontSmart. (See the software help for more information.)
FLASH IS WRITE PROTECTED		The flash DIMM is protected, and no new files can be written to it.	Disable the write protection through HP JetAdmin.
INITIALIZING		If the message displays continually a DIMM may not be inserted completely.	Reseat DIMM(s).
INPUT DEVICE CONDITION xx.yy		An input paper handling device has a condition that needs attention before printing can resume. 1st X= Device number in chain. 2nd X= Device type (3 types): 1 Input 2 Output 3 Stapler/ stacker unit yy= Device specific error.	See the documentation that came with the paper handling device for assistance.
INSTALL FRONT DUPEX COVER		The printer is unable to print the current job, because the duplexer's front cover is not installed, or not inserted correctly.	Re-insert the duplexer's front cover.



---

**Table 7-5. Alphabetical Printer Messages (continued)**

---

<b>Control Panel Message</b>	<b>Event Log Message</b>	<b>Explanation</b>	<b>Recommended Action</b>
INSTALL TRAY x		The printer is unable to print the current job because the specified tray (x) is open or not inserted correctly.	<ol style="list-style-type: none"><li>1. Re-insert the specified tray.</li><li>2. Check for damaged tabs in the tray.</li><li>3. Check for damaged switches in the printer.</li><li>4. Replace the PCA Controller in the feeder.</li></ol>
LOADING PROGRAM <number> alternates with DO NOT POWER OFF		Programs and fonts can be stored on the printer's file system. At bootup time these entities are loaded into RAM. (These entities can take a long time to load into RAM depending on the size and number of entities being loaded.) The <number> specifies a sequence number indicating the current program being loaded.	Wait for the program to load.
MANUALLY FEED [TYPE] [SIZE]		One of the following occurred: A manual feed was requested. There is no paper in Tray 1. The wrong size of paper is loaded. The Control Panel is not set for the kind of paper loaded.	<ol style="list-style-type: none"><li>1. Load the requested paper into Tray 1.</li><li>2. Press [Go] if the desired paper is already loaded in Tray 1.</li><li>3. Press [-Value+] to scroll through the available types and sizes.</li><li>4. Press [Select] to accept the alternate type or size.</li></ol>

---

**Table 7-5. Alphabetical Printer Messages (continued)**

---

<b>Control Panel Message</b>	<b>Event Log Message</b>	<b>Explanation</b>	<b>Recommended Action</b>
MEMORY FULL STORED DATA LOST		There is no available memory in the printer. The current job might not print correctly and some resources (such as downloaded fonts or macros) might have been deleted.	The customer might want to add more memory to the printer, or simplify the print job.
MEMORY SETTINGS CHANGED		The printer changed its memory settings because it did not have enough memory to use the previous settings for I/O Buffering and Resource Saving. This usually occurs after removing memory from the printer, adding a Duplexer, or adding a printer language.	You might want to change memory settings for I/O Buffering and Resource Saving (although default settings are usually best) or add more memory to the printer.
MEMORY SHORTAGE JOB CLEARED		The printer did not have enough free memory to print the entire job. The remainder of the job will not print and will be cleared from memory.	1. Press <b>[Go]</b> to continue. 2. Change the Resource Saving setting from the printer's Control Panel or add more memory to the printer.
MEMORY SHORTAGE PAGE SIMPLIFIED		The printer had to compress the job in order to fit it in available memory. Some data loss might have occurred.	Press <b>[Go]</b> to continue. The customer might want to add more memory to the printer.
OFFLINE		The printer is offline.	Press <b>[Go]</b> to place the printer online.

---

**Table 7-5. Alphabetical Printer Messages (continued)**

---

<b>Control Panel Message</b>	<b>Event Log Message</b>	<b>Explanation</b>	<b>Recommended Action</b>
PERFORM PRINTER MAINTENANCE		To ensure optimum print quality, the printer prompts the customer to have routine maintenance performed every 150,000 pages.	Install the Printer Maintenance Kit. Be sure to reset the Maintenance Page Count when you install the PM Kit. See page 3-34 for information on resetting the Maintenance Page Count.
RAM DISK DEVICE FAILURE		The RAM disk had a critical failure and can no longer be used.	<ol style="list-style-type: none"><li>1. Turn the printer off, and then turn the printer on to clear the message.</li><li>2. If the message persists, install a new RAM disk.</li></ol>
RAM DISK FILE OPERATION FAILED		The requested operation could not be performed. You might have attempted an illegal operation, such as trying to download a file to a non-existent directory.	<ol style="list-style-type: none"><li>1. Check the filename and directory name.</li><li>2. Retry the task.</li></ol>
RAM DISK FILE SYSTEM IS FULL		The RAM disk is full.	<ol style="list-style-type: none"><li>1. Delete files and then try again, or turn the printer off, and then turn the printer on to delete all files on the device. (Delete files using HP JetAdmin, HP FontSmart, or another software utility. See the software help for more information.)</li><li>2. If the message persists, increase the size of the RAM disk. Change the RAM disk size from the Configuration Menu in the printer's Control Panel.</li></ol>

---

**Table 7-5. Alphabetical Printer Messages (continued)**

---

<b>Control Panel Message</b>	<b>Event Log Message</b>	<b>Explanation</b>	<b>Recommended Action</b>
RAM DISK IS WRITE PROTECTED		The RAM disk is protected, and no new files can be written to it.	Disable the write protection through HP JetAdmin.
TRAY x EMPTY		<p>The specified tray is empty, but the current job does not need this tray in order to print correctly. If this message appears and the tray contains paper, a sensor could be damaged.</p> <p>PS301 detects paper in Tray 2.</p> <p>PS401 detects paper in Tray 1.</p> <p>PS1601 detects paper in the optional 250-sheet feeder.</p> <p>PS2001 detects paper in the optional 500-sheet feeder.</p> <p>See figure 7-19 on page 7-92 for sensor locations.</p>	<ol style="list-style-type: none"><li>1. Load the empty tray (x) to clear the message. If you do not load the specified tray, the printer will continue printing from the next available tray, and the message will continue to display.</li><li>2. Inspect the tray for damaged tabs.</li><li>3. Check Sensor Arm Flags for damage and be sure they move freely.</li><li>4. Replace any defective sensors.</li></ol>

---

**Table 7-5. Alphabetical Printer Messages (continued)**

---

<b>Control Panel Message</b>	<b>Event Log Message</b>	<b>Explanation</b>	<b>Recommended Action</b>
TRAY ✕ LOAD [TYPE] [SIZE]		<p>One of the following occurred:</p> <p>There is no paper loaded in the specified tray, or the paper is not the size requested, or the Control Panel is not set for the size of paper loaded.</p> <p>The tray is not properly adjusted for size.</p> <p>The default paper size is set incorrectly.</p> <p>If this message appears and the tray contains the correct size of paper, a sensor could be damaged or a paper sensor lever could be stuck.</p>	<ol style="list-style-type: none"><li>1. Load the requested paper into the specified tray (✕). Ensure that the trays are correctly adjusted for size. The size displayed on the front of the paper tray must match the size of paper loaded in the tray. The tray type settings (and size for Tray 1) must be set from the printer's Control Panel. If you are trying to print A4 or letter size paper, and this message appears, make sure the default paper size is set correctly from the Printing Menu in the printer's Control Panel.</li><li>2. Press <b>[Go]</b> to print from the next available tray.</li><li>3. Press <b>[-Value+]</b> to scroll through the available types and sizes.</li><li>4. Press <b>[Select]</b> to accept the alternate type or size.</li><li>5. Inspect the switches in the tray.</li><li>6. Turn the printer on with the tray removed and push the switches by hand to see if they register.</li></ol>
UNSUPPORTED SIZE IN TRAY [YY]		<p>An external paper handling device detected an unsupported paper size. The printer will go offline until the condition is corrected.</p>	<p>Load a supported paper size in the tray.</p>

---

**Table 7-5. Alphabetical Printer Messages (continued)**

---

<b>Control Panel Message</b>	<b>Event Log Message</b>	<b>Explanation</b>	<b>Recommended Action</b>
USE [TYPE] [SIZE] INSTEAD?		If the requested paper size or type is not available, the printer asks if it should use another paper size or type instead.	1. Press <b>[-Value+]</b> to scroll through the available types and sizes. 2. Press <b>[Select]</b> to accept the alternate type or size.
WAIT FOR PRINTER TO REINITIALIZE		The RAM disk setting has been changed from the printer's Control Panel. This change will not take effect until the printer reinitializes.	Wait for the printer to reinitialize.

---

---

**Table 7-6. Numerical Printer Messages**

---

<b>Control Panel Message</b>	<b>Event Log Message</b>	<b>Explanation</b>	<b>Recommended Action</b>
13.x PAPER JAM [LOCATION]	13.xx	Paper is jammed at the specified location (and possibly at other locations). If the message persists after all jams have been cleared, a sensor might be stuck or broken.	For all paper jam messages, do the following: <ol style="list-style-type: none"><li>1. Remove jammed paper from the specified location. Check the entire paper path for other pieces of paper in the path.</li><li>2. Open and close the top cover to clear the message.</li><li>3. If the jam reoccurs see "General Paper Path Troubleshooting" on page 7-40.</li><li>4. Check sensors and flags in the paper path for proper operation. For locations of sensors, see page 7-88.</li></ol>
13.1 PAPER JAM	13.01	Paper delay jam at paper feed area.	For 13.1 and 13.2: <ol style="list-style-type: none"><li>1. Ensure that paper trays are loaded properly so paper can feed from the tray.</li></ol>
13.2 PAPER JAM	13.02	Paper stopped jam at paper feed area.	<ol style="list-style-type: none"><li>2. Check the input area for obstructions such as paper in the path, damage to the Registration Assembly, or the Transfer Roller out of place.</li><li>3. Check PS402 and PS403 for proper operation. Replace any defective sensors or flags. For locations of sensors, see page 7-88.</li></ol>

---

**Table 7-6. Numerical Printer Messages (continued)**

---

<b>Control Panel Message</b>	<b>Event Log Message</b>	<b>Explanation</b>	<b>Recommended Action</b>
13.5 PAPER JAM	13.05	Paper delay jam at Fuser.	For 13.5 and 13.6: 1. Check the Transfer Roller and Small Media Belt to ensure they are operating and can feed paper. 2. Check the paper path for obstructions at the Transfer Roller and Toner Cartridge, at the Paper Feed Guide, and at the Fuser. 3. Check PS1307 for proper operation. Replace any defective sensors or flags. For locations of sensors, see page 7-88.
13.6 PAPER JAM	13.06	Paper stopped jam at Fuser.	
13.10 PAPER JAM	13.10 or 13.22	Paper delay jam at paper reversing area. Paper jam at duplexer.	1. Check the Duplexer and the rear area of the printer for obstructions or damage. 2. Check PS1701 and PS1703 in the Duplexer for proper operation. Replace the Duplexer if a sensor is defective.



---

**Table 7-6. Numerical Printer Messages (continued)**

---

<b>Control Panel Message</b>	<b>Event Log Message</b>	<b>Explanation</b>	<b>Recommended Action</b>
13.20 PAPER JAM	13.20 or 13.32	Paper stopped jam in the paper path.	For 13.20 and 13.21: 1. Check the entire paper path for obstructions such as paper in the path, registration area, transfer area, paper feed, and Fuser. 2. Check that all assemblies are seated and doors are closed. 3. Check all sensors and flags in the paper path (see page 7-88).
13.21 PAPER JAM	13.21 or 13.33	Door open jam.	
20 INSUFFICIENT MEMORY alternates with PRESS GO TO CONTINUE		The printer received more data than can fit in its available memory. You might have tried to transfer too many macros, soft fonts, or complex graphics.	Press <b>[Go]</b> to print the transferred data (some data might be lost), then simplify the print job or install additional memory.
21 PAGE TOO COMPLEX alternates with PRESS GO TO CONTINUE		The data (dense text, rules, raster or vector graphics) sent to the printer was too complex.	Press <b>[Go]</b> to print the transferred data. (Some data might be lost.) To print the job without losing data, from the Configuration Menu in the printer Control Panel, set PAGE PROTECT=ON, print the job, then return PAGE PROTECT=AUTO Do not leave PAGE PROTECT=ON; it might degrade performance. If this message appears often, simplify the print job.

---

**Table 7-6. Numerical Printer Messages (continued)**

---

<b>Control Panel Message</b>	<b>Event Log Message</b>	<b>Explanation</b>	<b>Recommended Action</b>
22 EIO × BUFFER OVERFLOW alternates with PRESS GO TO CONTINUE		Too much data was sent to the EIO card in the specified slot (×).	Press <b>[Go]</b> to clear the message. (Data will be lost.)
22 PARALLEL I/O BUFFER OVERFLOW alternates with PRESS GO TO CONTINUE		Too much data was sent to the parallel port. This error can occur if the driver you are using is not IEEE-1284 compliant. For best results, use an HP driver that came with the printer.	Check for a loose cable connection and be sure to use a high-quality cable. (Some non-HP parallel cables might be missing pin connections, or might otherwise not conform to the IEEE-1284 specification.) Press <b>[Go]</b> to clear the error message. (Data will be lost.)
22 SERIAL I/O BUFFER OVERFLOW alternates with PRESS GO TO CONTINUE		Too much data was sent to the serial port.	<ol style="list-style-type: none"><li>1. Make sure the correct serial pacing option is selected from the I/O Menu in the printer's Control Panel.</li><li>2. Print a Menu Map and verify that the serial pacing item (from the I/O Menu in the printer's Control Panel) matches the setting on the computer.</li><li>3. Press <b>[Go]</b> to clear the error message. (Data will be lost.)</li></ol>

---

**Table 7-6. Numerical Printer Messages (continued)**

---

<b>Control Panel Message</b>	<b>Event Log Message</b>	<b>Explanation</b>	<b>Recommended Action</b>
40 BAD SERIAL TRANSMISSION alternates with PRESS GO TO CONTINUE		The printer encountered an error while transferring data from the computer. The error might have occurred for several reasons: The computer was powered on or off while the printer was online. The printer's serial configuration does not match that of the computer.	1. Verify cable connections. Make sure the printer's serial configuration is set the same as the computer from the I/O Menu in the printer's Control Panel. 2. The serial baud rate setting can be accessed from the I/O Menu in the printer's Control Panel. 3. Press <b>[Go]</b> to clear the error message and continue printing.
40 EIO x BAD TRANSMISSION alternates with PRESS GO TO CONTINUE		The connection has been broken between the printer and the EIO card in the specified slot. X Description 1 EIO Slot 1 2 EIO Slot 2	1. Turn the printer off and reseal the card. 2. Press <b>[Go]</b> to clear the error message and continue printing.

---

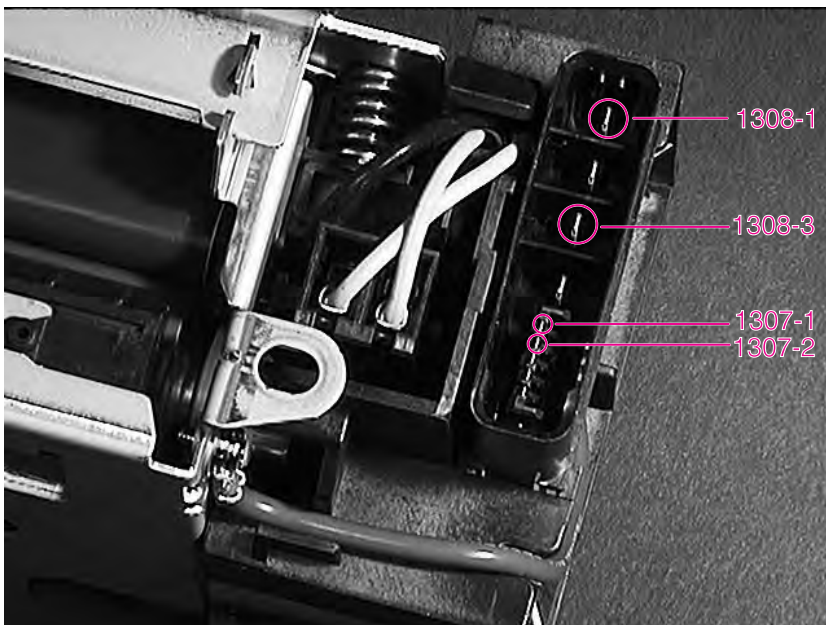
**Table 7-6. Numerical Printer Messages (continued)**

---

<b>Control Panel Message</b>	<b>Event Log Message</b>	<b>Explanation</b>	<b>Recommended Action</b>
41.3 UNEXPECTED PAPER SIZE		The paper size you are trying to print is not the same as the settings for the tray.	<ol style="list-style-type: none"><li>1. Make sure that all trays are correctly adjusted for size. The size displayed on the front of the paper tray must match the size of paper loaded in the tray. (The printer will continue trying to print the job until size settings are correct.) If you are trying to print from Tray 1, make sure the printer's Control Panel setting for paper size is correctly configured.</li><li>2. After performing the actions above, press <b>[Go]</b>. The page containing the error will automatically be reprinted. (Or, you might want to press <b>[Cancel Job]</b> to clear the job from the printer's memory.)</li></ol>
41.x PRINTER ERROR alternates with PRESS GO TO CONTINUE		A temporary printing error occurred. X Description 1 Unknown misprint error. 2 Beam detect error. 4 No VSYNC error. 5 Media feed error. 9 Noise VSREQ error.	Press <b>[Go]</b> . The page containing the error will automatically be reprinted. If the error persists: <ol style="list-style-type: none"><li>1. Reseat the connections to the Laser Scanner and the Engine Controller Board.</li><li>2. Replace the Laser Scanner.</li><li>3. Replace the Engine Controller Board.</li></ol>

**Table 7-6. Numerical Printer Messages (continued)**

Control Panel Message	Event Log Message	Explanation	Recommended Action
50.x FUSER ERROR		<p>A Fuser error has occurred.</p> <p>X Description</p> <ul style="list-style-type: none"><li>1 Low Fuser temperature.</li><li>2 Fuser warm up service.</li><li>3 High Fuser temperature.</li><li>4 Faulty Fuser.</li><li>5 Inconsistent Fuser.</li></ul>	<ul style="list-style-type: none"><li>1. Turn the printer off for a minimum of 20 minutes to clear the error.</li><li>2. Reseat the Fuser.</li><li>3. Turn the power off and remove the Fuser. Check continuity between connectors J1307-1 and J1307-2. If there is no continuity, replace the Fuser.</li><li>4. Check continuity between connectors J1308-3 and J1308-1 with the Fuser removed. If there is no continuity, replace the Fuser.</li></ul>



**Figure 7-3** Fuser Connectors

---

**Table 7-6. Numerical Printer Messages (continued)**

---

<b>Control Panel Message</b>	<b>Event Log Message</b>	<b>Explanation</b>	<b>Recommended Action</b>
51.x PRINTER ERROR		A loss of beam detect occurred. X Description 1 Beam detect error. 2 Laser error.	1. Press [Go]. The page containing the error will automatically be reprinted. 2. Turn the printer off and then on. 3. Reseat the cables. 4. Replace the Laser Scanner.
52.x PRINTER ERROR		The Laser Scanner speed is incorrect. X Description 1 Scanner start-up error. 2 Scanner rotation error.	1. Press [Go]. The page containing the error will automatically be reprinted. 2. Turn the printer off and then on. 3. Reseat the cables. 4. Replace the Laser Scanner.

**Table 7-6. Numerical Printer Messages (continued)**

Control Panel Message	Event Log Message	Explanation	Recommended Action
53. x <sub>y</sub> . zz PRINTER ERROR		<p>There is a memory error with an accessory. The DIMM that caused the error will not be used. Values of x, y, and zz are as follows:</p> <p>x=DIMM type 0=ROM 1=RAM</p> <p>y=Device location 0=internal memory (ROM or RAM) 1 to 3=DIMM slots 1, 2, or 3</p> <p>zz=Error number 0=Unsupported memory 1=Unrecognized memory 2=Unsupported memory size 3=Failed RAM test 4=Exceeded maximum RAM size 5=Exceeded maximum ROM size 6=Invalid DIMM speed 7=DIMM reporting information incorrectly 8=DIMM RAM parity error 9=ROM needs to be mapped to an unsupported address 10=DIMM address conflict 11=PDC XROM out of bounds 12=Unable to make a temporary mapping</p>	<ol style="list-style-type: none"> <li>1. Turn the printer off, and reseal or replace the specified DIMM.</li> <li>2. Try the DIMM in another slot.</li> <li>3. Replace the DIMM that caused the error.</li> </ol>

---

**Table 7-6. Numerical Printer Messages (continued)**

---

<b>Control Panel Message</b>	<b>Event Log Message</b>	<b>Explanation</b>	<b>Recommended Action</b>
55 PRINTER ERROR alternates with PRESS GO TO CONTINUE		An internal communication error occurred.	<ol style="list-style-type: none"><li>1. Press <b>[Go]</b>. The page containing the error will automatically be reprinted.</li><li>2. Check power at the site.</li><li>3. Replace the Formatter PCA.</li><li>4. Replace the DC Controller.</li></ol>
56.x PRINTER ERROR alternates with CYCLE POWER TO CONTINUE		A temporary printing error occurred. X Description 1 Illegal input. 2 Illegal output.	<ol style="list-style-type: none"><li>1. Press <b>[Go]</b>. The page containing the error will automatically be reprinted.</li><li>2. Turn the printer off, and then turn the printer on.</li><li>3. Check the printer's configuration.</li></ol>
57.x PRINTER ERROR		An error occurred with the Fan's motor. X Description 1 Printer Fan	<ol style="list-style-type: none"><li>1. Check the Fan's connector and make sure the Fan is not blocked.</li><li>2. Replace the Fan.</li></ol>
59.x PRINTER ERROR		A motor error occurred. X Description 0 Motor error. 1 Motor start-up error. 2 Motor rotation error.	<ol style="list-style-type: none"><li>1. Turn the printer off, and then turn the printer on.</li><li>2. Make sure the Fuser or Toner Cartridge is not hindering movement of gears in the drive train.</li><li>3. Check the Main Motor's cable to ensure that it is seated properly.</li><li>4. If the error persists, replace the Motor.</li></ol>



---

**Table 7-6. Numerical Printer Messages (continued)**

---

<b>Control Panel Message</b>	<b>Event Log Message</b>	<b>Explanation</b>	<b>Recommended Action</b>
62.x PRINTER ERROR		There is a problem with the printer's memory. The x value refers to the location of the problem: 0 = Internal memory 1 to 3 = DIMM slots 1, 2, or 3	Reseat or replace the specified DIMM.
64.x PRINTER ERROR		A scan buffer error occurred.	<ol style="list-style-type: none"><li>1. Turn the printer off, then turn the printer on.</li><li>2. Replace Formatter PCA.</li></ol>
66.xx.yy INPUT DEVICE FAILURE alternates with CHECK CABLES AND CYCLE POWER		An error occurred in an external paper handling device. 1st X= Device number in chain. 2nd X= Device type (3 types): 1 Input 2 Output 3 Stapler/ stacker unit yy= Device specific error.	<ol style="list-style-type: none"><li>1. Press <b>[Go]</b> to clear the message. If the message will not clear:</li><li>2. Turn the printer off, and then turn the printer on.</li><li>3. Check all cables.</li><li>4. Reseat the external paper handling device.</li></ol>
68 NVRAM ERROR CHECK SETTINGS		An error occurred in the printer's nonvolatile memory (NVRAM) and one or more printer settings has been reset to its factory default.	<ol style="list-style-type: none"><li>1. Print a configuration page and check the printer settings to determine which values have changed.</li><li>2. Hold down <b>[Cancel Job]</b> while turning the printer on. This will clean up the NVRAM by removing old areas that are not being used.</li></ol>

---

**Table 7-6. Numerical Printer Messages (continued)**

---

<b>Control Panel Message</b>	<b>Event Log Message</b>	<b>Explanation</b>	<b>Recommended Action</b>
68 NVRAM FULL CHECK SETTINGS		An error occurred in the printer's nonvolatile memory (NVRAM) and one or more printer settings has been reset to its factory default.	<ol style="list-style-type: none"><li>1. Print a Configuration Page and check the printer settings to determine which values have changed.</li><li>2. Hold down <b>[Cancel Job]</b> while turning the printer on. This will clean up the NVRAM by removing old areas that are not being used.</li></ol>
69.x PRINTER ERROR		<p>A temporary printing error occurred.</p> <p>X Description</p> <p>0 The duplex mechanism has failed.</p> <p>1 The duplex side adjust has failed.</p>	<ol style="list-style-type: none"><li>1. Turn the printer off, then turn the printer on.</li><li>2. Reseat Duplexer.</li></ol>

---

**Table 7-6. Numerical Printer Messages (continued)**

---

<b>Control Panel Message</b>	<b>Event Log Message</b>	<b>Explanation</b>	<b>Recommended Action</b>
79.xxxx PRINTER ERROR		The printer detected an error. The numbers (xxxx) indicate the specific type of error.	<ol style="list-style-type: none"><li>1. Turn the printer off, and then turn the printer on.</li><li>2. Try printing a job from a different software application. If the job prints, go back to the first application and try printing a different file. (If the message only appears with a certain software application or print job, have the customer contact the software vendor for assistance.)</li></ol> <p>If the message persists, try the following:</p> <ol style="list-style-type: none"><li>1. Cycle power.</li><li>2. Reseat or replace the interface cable and cycle power.</li><li>3. Remove the DIMMs one at a time and cycle power.</li><li>4. Try using the parallel interface, if possible.</li><li>5. With the EIO cards removed from the printer, perform a cold reset.</li><li>6. If the error persists, replace the Formatter.</li></ol>

---

**Table 7-6. Numerical Printer Messages (continued)**

---

<b>Control Panel Message</b>	<b>Event Log Message</b>	<b>Explanation</b>	<b>Recommended Action</b>
8x.9999		<p>The EIO accessory in slot x has encountered a critical error as specified by 9999.</p> <p>X Description</p> <p>1 EIO slot 1 - The printer detected an error with the EIO card.</p> <p>2 EIO slot 2 - The printer detected an error with the EIO card.</p> <p>6 EIO slot 1 - The EIO card detected an error. The EIO card may be defective.</p> <p>7 EIO slot 2 - The EIO card detected an error. The EIO card may be defective.</p>	<ol style="list-style-type: none"><li>1. Turn the printer off, and then turn the printer on.</li><li>2. Reseat or replace the EIO board.</li></ol>

---

## General Paper Path Troubleshooting

Paper jams occur in the printer when paper does not either reach or clear a photosensor along the printer's paper path in a specific amount of time. If a paper jam occurs, a 13.xx PAPER JAM message is displayed on the printer's Control Panel. The following table contains general questions you may ask and topics to explore prior to troubleshooting. See the 13.xx section in the Event Log for specific error codes.

---

**Table 7-7. General Paper Path Troubleshooting Questions**

---

<b>Problem</b>	<b>Action</b>
What is the frequency of the paper jams (e.g. continuous, one jam per 100 pages, one jam per 1000 pages, etc.)?	Verify with customer. Print or Show Event Log to determine paper jam history. See the Display and Event Log Sections of this Chapter and evaluate Event Log.
Do paper jams only occur when the paper is fed from a particular paper input source (e.g., Tray 1, Tray 2)?	Use Paper Path Test to isolate problem. See next section for details (page 7-42).
Do jams only occur when paper is output to a specific output bin (e.g. face-down output bin, face-up bin)?	Use Paper Path Test to isolate problem.
Do paper jams occur with a specific type of media?	Try known good media. See the <i>HP LaserJet Printer Family Paper Specifications Guide</i> . Note that the guide is bundled with the Service Manual.
Where does the leading edge of the first sheet of paper in the printer's paper path stop when a jam occurs? Are any sheets of paper damaged or torn?	Attempt to duplicate. Use Paper Path Test to isolate problem. Inspect the paper path and all paper path mechanical assemblies located before the leading paper jam.

---

**Table 7-7. General Paper Path Troubleshooting Questions (continued)**

---

<b>Problem</b>	<b>Action</b>
Is the customer loading the paper trays correctly?	Observe the customer loading paper. Do not fan paper. Refer to proper paper handling procedures in the Paper Specification Guide.
Is the customer overfilling the paper trays?	Ensure paper is NOT over the maximum fill marks in the paper trays. Observe the customer loading paper in trays.
Are the paper tray guides set correctly?	Ensure Tray 2 and 3 left-side paper guide is set correctly at both the front and rear of the tray, and that the front guide is locked into the correct position. For Tray 4, ensure all adjustments are set correctly; front, back, and side at the top and bottom of the tray.
Does the printer need cleaning?	Inspect paper path and paper path rollers. Refer to cleaning procedures in Chapter 4.
When was the User Maintenance performed on the printer?	Determine from PCL Configuration Page the number of pages since the last maintenance (page 7-45). The Printer Maintenance Kit should be installed every 150,000 images.

---

## Paper Path Test

To perform a Paper Path Test:

- 1 Press **[Menu]** until INFORMATION MENU appears
- 2 Press **[Item]** until PRINT PAPER PATH TEST appears.
- 3 Press **[Select]**.
- 4 Press **[+]** to cycle selections until the desired paper tray appears.
- 5 Press **[Select]**.
- 6 Press **[+]** until the desired output bin appears (open the rear output bin to print to it)
- 7 Press **[Select]**.
- 8 Press **[+]** until the desired duplex mode (on or off) appears.
- 9 Press **[Select]**.
- 10 Press **[+]** to cycle selections until the desired number of copies appears. Choose 1, 10, 50, 100, or 500 copies.
- 11 Press **[Select]** to perform the Paper Path Test.

## Information Pages

From the printer's control panel you can print pages that give details about the printer and its current configuration. The following information pages are described here:

- Menu Map
- Configuration Page
- PCL or PS Font List

For a complete list of the printer's information pages, print a Menu Map and see the Information Menu listed.

### Menu Map

To see the current settings for the menus and items available in the control panel, print a control panel menu map:

- 1 Press **[Menu]** until INFORMATION MENU appears.
- 2 Press **[Item]** until PRINT MENU MAP appears.
- 3 Press **[Select]** to print the menu map.

The content of the Menu Map varies, depending on the options currently installed in the printer. (Many of these values can be overridden from the printer driver or software application.)



# HP LaserJet 5000 series printers



## Menu Map

1

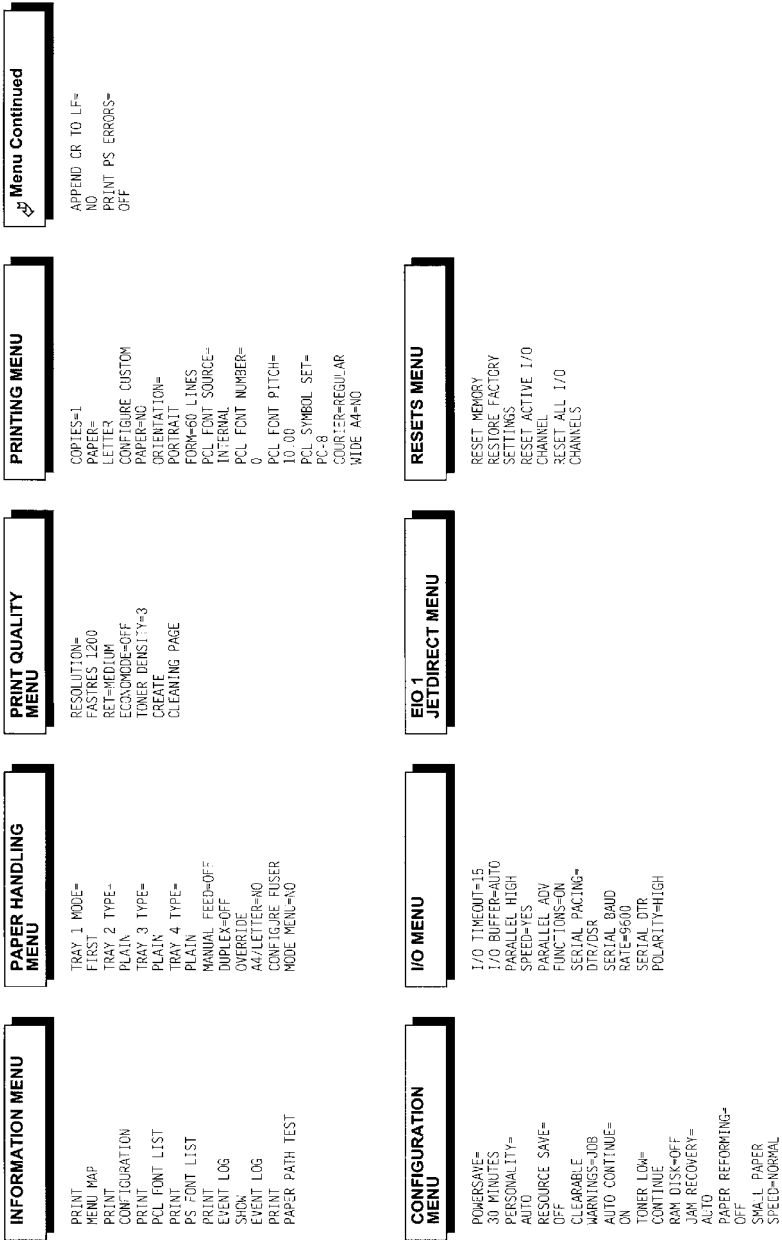


Figure 7-4 Menu Map

## Configuration Page

Use the Configuration Page to view current printer settings, to help troubleshoot printer problems, or to verify installation of optional accessories, such as memory (DIMMs), paper trays, and printer languages.

---

### Note

---

If an HP JetDirect print server EIO card is installed, a JetDirect Configuration Page will print out as well.

To print a Configuration page:

- 1 Press **[Menu]** until INFORMATION MENU appears.
- 2 Press **[Item]** until PRINT CONFIGURATION appears.
- 3 Press **[Select]** to print the configuration page.

Figure 7-5 on page 7-46 is a sample Configuration Page. Numbers in the sample printout match the numbers in the table. The content of the Configuration Page varies, depending on the options currently installed in the printer.

## Configuration Page

1

### Printer Information

Product Name: HP LaserJet 5000 Series  
Printer Name: HP LaserJet 5000 Series  
Printer Number: 10  
Formatter Number: S45XXXXXXX  
Printer Serial Number = YYYYYYYY  
Firmware Datecode: 971111 M0BY3.60  
PS wait Time-out: 300 seconds  
Page Count: 42  
Pages Since Last Maintenance = 42  
HP JetSend Address: 1p:15.98.40.165

### Memory

Total Memory: 20 MBytes  
PCL DWS: 17.24  
I/O Buffering:  
100K bytes Allocated of 16390K bytes Available  
Resource Saving:  
0K bytes Allocated of 13360K bytes Available

### Installed Personalities and Options

PCL (19971104)  
PCLXL (19971104)  
PS (19971104)  
DIMM Slot 1: Empty  
DIMM Slot 2: 16 MByte RAM DIMM  
DIMM Slot 3: 8 MByte ROM DIMM  
EIO 1: HP JETDIRECT J3111A  
EIO 2: Empty

### Security

Control Panel Lock: NONE  
Control Panel Password: DISABLED

### Event Log

Number of Entries in Use: 20  
Maximum Number of Entries: 30  
Last Three Entries:

Number	Error	Page Count
20	57.01.00	0
19	13.2.60	16
18	55.0000	0

### Paper Trays and Options

Mopier = OFF  
Default Paper Size: LETTER  
Tray 2 (LETTER)  
Tray 3 (11X17)  
Tray 4 (LETTER)  
Duplex Unit

Figure 7-5 Configuration Page

## **Verify installed options**

Under “Installed Personalities” on the Configuration page, look for options such as hard disk or DIMM types and sizes.

Verify that the options which are installed in your printer are reflected in the Configuration Page. If an installed device is not shown, reseal the device and print a new Configuration Page.

# Image Quality

When you are working with customers, obtain a print sample before you begin troubleshooting their printer. Ask the customer to explain the quality they expect from the printer. The print sample will also help clarify the customer's explanation.

---

**Table 7-8. Image Quality Checks**

---

<b>Image Quality Checks</b>	<b>Action</b>
-----------------------------	---------------

Does the problem repeat on the page?	Use the Repetitive Defect Ruler on page 7-73.
--------------------------------------	-----------------------------------------------

Is the Toner Cartridge full and is it manufactured by HP?	Check the Toner Cartridge using the check list on page 7-48.
-----------------------------------------------------------	--------------------------------------------------------------

Is the customer using print media that meets all HP paper specification standards?	For more information about HP's paper specification standards, see Chapter 1 of this manual and the <i>HP LaserJet Family Paper Specification Guide</i> .
------------------------------------------------------------------------------------	-----------------------------------------------------------------------------------------------------------------------------------------------------------

Is the print sample similar to those in the Print Quality Tables on page 7-48?	Compare and perform the actions recommended in the Print Quality Tables.
--------------------------------------------------------------------------------	--------------------------------------------------------------------------

Is the problem on the Toner Cartridge drum or the Transfer Roller?	Perform the Half Self-Test Functional Check (page 7-74) to determine where the defect is. If a dark and distinct toner image is present on the drum's surface, assume that the first four functions of the electrophotographic process are functioning (cleaning, conditioning, writing, and developing - see Chapter 5), and troubleshoot the failure as a transfer or fusing problem.
--------------------------------------------------------------------	--------------------------------------------------------------------------------------------------------------------------------------------------------------------------------------------------------------------------------------------------------------------------------------------------------------------------------------------------------------------------------------------

---

## Check the Toner Cartridge

Image formation defects are often the result of problems with the Toner Cartridge. If there is any doubt, always replace the Toner Cartridge before troubleshooting image defects.

Use the following list to ensure that the Toner Cartridge is still operable.

- Ensure that the Toner Cartridge has toner. Full Toner Cartridge weight = 1880 grams (66.3 oz.) Empty Weight = 1450 grams (51.1 oz.)
- Check the expiration date of the Toner Cartridge (stamped on the cartridge's box).
- Check the Toner Cartridge to see if it has been disassembled or refilled.
- Ensure that the Toner Cartridge is seated properly in the printer cavity.
- Inspect the cartridge for leaking toner through worn seals. (If the drum has been manually rotated it may have caused internal damage and toner spills may result.)

---

### Note

Toner Cartridges are rated for 10,000 images at 5% coverage. It is possible to wear out the gears and the cartridge seals before **TONER LOW** is displayed if the 10,000 image expectancy is exceeded. See "EconoMode" below.

- Check the surface of the photosensitive drum in the cartridge to see if it has been damaged or scratched. Touching the drum will contaminate the photosensitive surface and may cause spotting and defects during printing.
- White areas on the page may indicate that the drum has been exposed to light for too long. If white areas appear, stop the printer and wait a few minutes. This should eliminate most defective images. If not, the Toner Cartridge may be placed in a dark environment for several days, which may restore some life to the drum.

### EconoMode

EconoMode creates draft-quality printing by reducing the amount of toner on the printed page by up to 50%. Advise the customer to turn EconoMode on or off from the printer driver or software application, since those settings override the control panel settings. EconoMode settings can also be accessed from the Print Quality Menu in the Front Panel.

---

### CAUTION

HP does not recommend full-time use of EconoMode. If EconoMode is used full-time, it is possible that the toner supply will outlast the mechanical parts in the toner cartridge.

## Image Defects

The quality of the printer's output is subject to the judgment of the user. This section of the manual helps you define print quality defects and understand what factors affect print quality.

The print samples shown in the following figures illustrate some print quality defects. Keep copies of print quality defects encountered in the field with an explanation of their causes for future reference.

The image defects listed below are covered in the following tables.

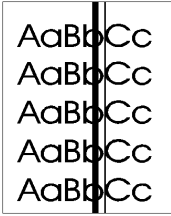
- Black Lines (perpendicular path) (page 7-51)
- Black Page (page 7-51)
- Blank Page (page 7-53)
- Blank Spots (page 7-55)
- Character Voids (page 7-56)
- Creases (page 7-57)
- Curl (page 7-58)
- Dirt on Back (page 7-59)
- Distorted Image (page 7-59)
- Dropouts (page 7-60)
- Faded Print/Bubbles (page 7-61)
- Gray Background (page 7-63)
- Horizontal Smudges (page 7-64)
- Horizontal White Lines (page 7-65)
- Light Print, Dark Print, or Fade (page 7-65)
- Loose Toner (page 7-66)
- Repetitive Defects (page 7-67)
- Skew (page 7-68)
- Toner Smear (page 7-68)
- Toner Specks (page 7-69)
- Vertical Black Lines (page 7-70)
- Vertical Dots (page 7-71)
- Vertical White Lines (page 7-71)

---

### Hint

If you find a defect that is not depicted, record the probable cause along with the conditions in the printing environment and save a copy of the defect for future reference.

---



**Table 7-9. Black Lines (perpendicular path)**

Possible Cause	Action
Defective Toner Cartridge.	Inspect the Toner Cartridge for a scratched photosensitive drum or toner leaking through worn seals. Replace as necessary.
Fusing Assembly is contaminated or damaged.	Inspect the Fusing Assembly for toner build-up or scratches on the fuser rollers. Try cleaning with alcohol. Replace the Fusing Assembly if damaged.
Static Eliminator teeth are contaminated or defective.	Clean using the blue cleaning tool or compressed air. Replace assembly if damaged.



**Table 7-10. Black Page**

Possible Cause	Action
Defective Toner Cartridge.	Replace the Toner Cartridge.
Light is leaking into the printer.	Ensure all covers are in place.
High voltage contact springs are dirty or defective. The high voltage contacts are mounted on the High Voltage Power Supply PCA and protrude into the toner cartridge cavity.	Inspect and clean the high voltage contacts. If damaged, replace the High Voltage Power Supply PCA.



**Table 7-10. Black Page (continued)**

<b>Possible Cause</b>	<b>Action</b>
Defective Toner Cartridge.	Replace the Toner Cartridge.
Light is leaking into the printer.	Ensure all covers are in place.
High voltage power supply circuit is defective (not supplying the correct negative voltage).	Replace the High Voltage Power Supply PCA.
The High Voltage Power Supply is installed improperly. If the High Voltage Power Supply has been removed and replaced, it may not be seated properly.	Remove the DC Controller Board and check the connectors for damage. Reseat the DC Controller Board, being certain to fully seat the connectors.
Bad Primary Charging Roller.	Replace the Toner Cartridge.
DC Controller PCA is defective. If the DC Controller turns on the laser beam continuously, the entire surface of the Photosensitive drum is neutralized causing a completely black page.	Replace the DC Controller PCA.
Laser/Scanner Assembly is faulty (turning laser on continuously).	Replace Laser/Scanner Assembly.

---

**Table 7-10. Black Page (continued)**

---

<b>Possible Cause</b>	<b>Action</b>
Defective Toner Cartridge.	Replace the Toner Cartridge.
Light is leaking into the printer.	Ensure all covers are in place.
Connectors between the Laser/Scanner unit and DC Controller are not seated properly or are defective.	Inspect and reseat the connectors. Replace cables as necessary.

---

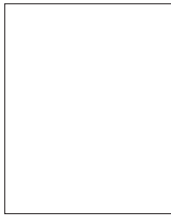
---

**Table 7-11. Blank Page**

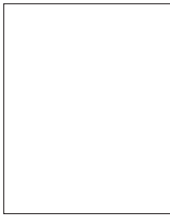
---

<b>Possible Cause</b>	<b>Action</b>
Software Configuration.	Make sure the application is not sending incorrect page length requests, or extra page eject commands.
Network Configuration. Some sharing devices on networks may generate a blank page as a separator.	Check with the Network Administrator.
Multiple Feeds. The printer may be feeding two or more pages at once because the paper is difficult to separate.	Remove the paper from the paper cassette and fan the edges of the paper to separate the pages (see <i>HP LaserJet Printer Family Paper Specifications Guide</i> ).
Sealing tape left in Toner Cartridge.	Remove the sealing tape.

**Table 7-11. Blank Page (continued)**



Possible Cause	Action
Empty or defective Toner Cartridge.	<ol style="list-style-type: none"><li>1. If unsure, weigh the cartridge:<ul style="list-style-type: none"><li>• Full weight = 1880 grams (66.3 oz)</li><li>• Empty weight = 1450 grams (51.5 oz)</li></ul><p><b>Note:</b> Some toner may reside in the waste toner cavity, affecting the weight of the cartridge.</p></li><li>2. Perform the Half Self-Test Functional Check (page 7-74) or try a known good toner cartridge. Replace the Toner Cartridge if necessary.</li></ol>
Laser/Scanner door not opening properly.	<ol style="list-style-type: none"><li>1. Remove and reseal the Toner Cartridge.</li><li>2. Check the Laser/Scanner shutter door for proper operation. If defective, replace the Laser/Scanner Assembly.</li></ol>
Toner Cartridge Guide damaged, improperly positioned, or missing.	Make sure the Guide is installed properly above the Toner Cartridge.
No Transfer Roller voltage.	Without Transfer Roller voltage, toner cannot be attracted from the surface of the drum to the paper. Perform the Half Self-Test Functional Check (page 7-74) to check all other electrophotographic processes. Replace the Transfer Roller if necessary.
High voltage connector springs are dirty or defective. The high voltage connectors are mounted on the High Voltage Power Supply PCA and protrude into the Toner Cartridge cavity.	Check the springs for functionality. Clean if dirty, replace if defective or missing.
High Voltage Power Supply is defective.	Replace High Voltage Power Supply PCA.



---

**Table 7-11. Blank Page (continued)**

---

<b>Possible Cause</b>	<b>Action</b>
DC Controller PCA is defective. The DC Controller supplies the proper voltage to the High Voltage Power Supply PCA.	Replace the DC Controller PCA.
No Developing Bias.	<ol style="list-style-type: none"><li>1. Clean the High Voltage Power Supply contacts. With no Developing Bias charge, toner is not attracted to the drum.</li><li>2. Replace the Engine Controller Board.</li></ol>
No drum ground path.	With no ground path the drum cannot discharge. The negative charge on the drum repels toner, and leaves a white page with bubble print. <ol style="list-style-type: none"><li>1. Check the drum ground.</li><li>2. Replace the Engine Controller Board.</li></ol>
Defective Laser Scanner Cable Assembly.	Low-level signals exchanged between the Laser Scanner Assembly and the Engine Controller Board may be affecting laser output. Replace the Laser Scanner Cable Assembly.

---



---

**Table 7-12. Blank Spots**

---

<b>Possible Cause</b>	<b>Action</b>
Paper does not meet printer specifications or is stored improperly.	<ol style="list-style-type: none"><li>1. Print a few more pages to see if the problem corrects itself.</li><li>2. Turn over the stack of paper in the tray. Also try rotating the paper 180°.</li><li>3. Check the paper (or other print media) type and quality. Replace the paper, and advise the customer to use the recommended paper and store it properly.</li></ol>
Defective Toner Cartridge.	Replace the Toner Cartridge.



---

**Table 7-12. Blank Spots (continued)**

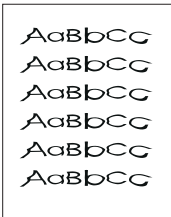
---

Possible Cause	Action
----------------	--------

Dirty or deformed Transfer Roller.	Replace the Transfer Roller.
------------------------------------	------------------------------

See also “Dropouts” on page 7-60.

---



---

**Table 7-13. Character Voids**

---

Possible Cause	Action
----------------	--------

Paper surface too rough. Toner migrates to low spots, leaving higher areas void.	User paper with correct finish (smoothness) meeting HP specifications (see <i>HP LaserJet Printer Family Paper Specifications Guide</i> ).
----------------------------------------------------------------------------------	--------------------------------------------------------------------------------------------------------------------------------------------

Printing on wrong side of paper. The label on the ream of paper indicates which side to print on. The different surface properties of some papers may cause problems if loaded wrong side up.	Check for the arrow on the paper wrapper. Be sure paper is loaded with the arrow pointing down in the paper trays, or arrow pointing up in Tray 1.
-----------------------------------------------------------------------------------------------------------------------------------------------------------------------------------------------	----------------------------------------------------------------------------------------------------------------------------------------------------

Paper surface too smooth for proper toner adhesion.	User paper with correct finish (smoothness) meeting HP specifications (see <i>HP LaserJet Printer Family Paper Specifications Guide</i> ).
-----------------------------------------------------	--------------------------------------------------------------------------------------------------------------------------------------------

Bad transparencies. Transparencies can have this problem because they are not designed for proper toner adhesion.	Use Hewlett-Packard approved transparencies (see <i>HP LaserJet Printer Family Paper Specifications Guide</i> ).
-------------------------------------------------------------------------------------------------------------------	------------------------------------------------------------------------------------------------------------------

AaBbCc  
AaBbCc  
AaBbCc  
AaBbCc  
AaBbCc  
AaBbCc

---

**Table 7-13. Character Voids (continued)**

---

Possible Cause	Action
Bad Transfer Roller. If the Transfer Roller has finger oils on its surface, is dirty or worn out, this problem can result.	Clean the Transfer Roller using a dry, lint-free cloth. DO NOT touch the Transfer Roller with your fingers. If the problem persists, replace the Transfer Roller Assembly.

---

AaBbCc  
AaBbCc  
AaBbCc  
AaBbCc  
AaBbCc  
AaBbCc

---

**Table 7-14. Creases**

---

Possible Cause	Action
Paper does not meet printer specifications or is stored improperly.	<ol style="list-style-type: none"><li>1. Print a few more pages to see if the problem corrects itself.</li><li>2. Turn over the stack of paper in the tray. Also try rotating the paper 180°.</li><li>3. Check the paper (or other print media) type and quality. Replace the paper, and advise the customer to use the recommended paper and store it properly.</li></ol>
Printer's operating environment does not meet specifications.	Make sure the printer's operating environment meets specifications.
Paper is loaded incorrectly.	Make sure paper is loaded correctly and that the guides fit properly against the paper stack.
Wrong tray.	Print from a different tray (such as Tray 1).
Wrong output bin for paper type.	Print to a different output bin (top or rear output bin).
Obstruction in paper path.	<ol style="list-style-type: none"><li>1. Check the paper path for paper or label debris.</li><li>2. Check for damaged components that could be creasing the paper.</li></ol>

---



---

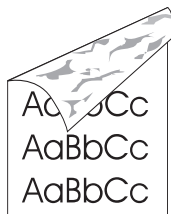
**Table 7-15. Curl**

---

Possible Cause	Action
Paper does not meet printer specifications or is stored improperly.	<ol style="list-style-type: none"><li>1. Print a few more pages to see if the problem corrects itself.</li><li>2. Turn over the stack of paper in the tray. Also try rotating the paper 180°.</li><li>3. Check the paper (or other print media) type and quality. Replace the paper, and advise the customer to use the recommended paper and store it properly.</li></ol>
Printer's operating environment does not meet specifications.	Make sure the printer's operating environment meets specifications.
Wrong output bin.	Print to a different output bin (top or rear output bin).
Wrong Fuser setting for paper type.	<ol style="list-style-type: none"><li>1. From the Paper Handling Menu on the Control Panel, change the Fuser Mode setting or choose another paper type from the printer driver.</li><li>2. Turn Paper Reform to on in the Configuration Menu.</li></ol>

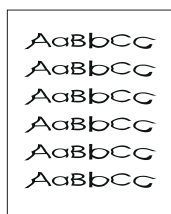
See also "Dropouts" on page 7-60.

---



**Table 7-16. Dirt on Back**

Possible Cause	Action
Dirt inside printer (Tray Separation Roller, Feed Roller, Transfer Roller, Fuser, Toner Cartridge).	<ol style="list-style-type: none"> <li>1. Print at least 10 pages to see if the problem goes away.</li> <li>2. Print a cleaning page (page 4-4). Identify and clean the dirty part according to the "Repetitive Defect Ruler" on page 7-72. If dirt cannot be removed, replace the dirty part.</li> <li>3. Check for toner leaks.</li> </ol>
Paper does not meet printer specifications or is stored improperly.	<ol style="list-style-type: none"> <li>1. Print a few more pages to see if the problem corrects itself.</li> <li>2. Turn over the stack of paper in the tray. Also try rotating the paper 180°.</li> <li>3. Check the paper (or other print media) type and quality. Replace the paper, and advise the customer to use the recommended paper and store it properly.</li> </ol>



**Table 7-17. Distorted Image**

Possible Cause	Action
Paper does not meet printer specifications or is stored improperly.	<ol style="list-style-type: none"> <li>1. Print a few more pages to see if the problem corrects itself.</li> <li>2. Turn over the stack of paper in the tray. Also try rotating the paper 180°.</li> <li>3. Check the paper (or other print media) type and quality. Replace the paper, and advise the customer to use the recommended paper and store it properly.</li> </ol>
Printer's operating environment does not meet specifications.	Make sure the printer's operating environment meets specifications.
Wrong output bin for paper type.	Print to a different output bin.



AaBbCC  
AaBbCC  
AaBbCC  
AaBbCC  
AaBbCC  
AaBbCC

**Table 7-17. Distorted Image (continued)**

Possible Cause	Action
Poor connection of cables to the Laser Scanner.	Reseat the cables connected to the Laser Scanner.
Poor connection of cables to the DC Controller Assembly.	Reseat the cables connected to the DC Controller Assembly.
Defective Laser Scanner.	Replace the Laser Scanner.
Defective Engine Controller Board.	Replace the Engine Controller Board.

AaBbCc  
AaBbCc  
AaBbCc  
AaBbCc  
AaBbCc

**Table 7-18. Dropouts**

Possible Cause	Action
Paper might be too smooth.	Check the paper (or other print media) type and quality.
Printer's operating environment does not meet specifications.	Make sure the printer's operating environment meets specifications.
Wrong toner density setting.	From the Print Quality Menu on the Control Panel, adjust the toner density setting. Make sure EconoMode is off.
Wrong Fuser setting for paper type.	From the Paper Handling Menu on the Control Panel, change the Fuser Mode setting or choose another paper type from the printer driver.
Single sheet of paper defective.	Try reprinting the job.

AaBbCc  
 AaBbCc  
 AaBbCc  
 AaBbCc  
 AaBbCc

**Table 7-18. Dropouts (continued)**

Possible Cause	Action
Paper does not meet specifications. The paper moisture content, conductivity, or surface finish may not work correctly with the electrophotographic process.	Try a different paper lot (see <i>HP LaserJet Printer Family Paper Specifications Guide</i> ).
DC Controller defective (low primary voltage).	Replace the DC Controller.
High Voltage Power Supply PCA defective.	Replace the High Voltage Power Supply PCA.
Transfer Roller defective.	Replace the Transfer Roller.
	See also "Blank Spots" on page 7-55.

AaBbCc  
 AaBbCc  
 AaBbCc  
 AaBbCc  
 AaBbCc

**Table 7-19. Faded Print/Bubbles**

Possible Cause	Action
No drum ground path.	Check the contacts for functionality. If dirty, clean using alcohol; if damaged, replace the High Voltage Power Supply PCA.
Toner supply is low.	Shake the cartridge gently to redistribute the toner, or replace the cartridge.
Print Density is set incorrectly.	Change to a darker setting and retry printing.



**Table 7-19. Faded Print/Bubbles (continued)**

Possible Cause	Action
EconoMode is on. EconoMode saves toner by reducing the dot density. This may appear to be a print quality problem in some cases.	Turn EconoMode off.
Paper does not meet specifications. The moisture content, conductivity, or surface finish may not work correctly with the electrophotographic process.	Try a different paper lot (see <i>HP LaserJet Printer Family Paper Specifications Guide</i> ).
Transfer Roller is defective or incorrectly installed. If the transfer roller loses conductivity, it cannot effectively pull toner from the drum to the paper.	Inspect the Transfer Roller for proper installation and contact. If the Transfer Roller is damaged, replace it.
Laser/Scanner door is not opening properly.	<ol style="list-style-type: none"><li>1. Remove and reseal the toner cartridge.</li><li>2. Check the Laser/Scanner shutter door for proper operation. If defective, replace the Laser/Scanner Assembly.</li></ol>
High voltage contact springs are dirty or defective. The high voltage contacts are mounted on the High Voltage Power Supply PCA and protrude into the toner cartridge cavity.	Check the contacts for functionality. If dirty, clean using alcohol; if damaged, replace the High Voltage Power Supply PCA.



---

**Table 7-19. Faded Print/Bubbles (continued)**

---

Possible Cause	Action
----------------	--------

High Voltage Power Supply PCA is defective.	Replace the High Voltage Power Supply PCA.
---------------------------------------------	--------------------------------------------

DC Controller PCA is defective. The DC Controller supplies the proper voltage to the High Voltage Power Supply PCA.	Replace the DC Controller PCA.
---------------------------------------------------------------------------------------------------------------------	--------------------------------

---



---

**Table 7-20. Gray Background**

---

Possible Cause	Action
----------------	--------

Paper does not meet printer specifications or is stored improperly.	<ol style="list-style-type: none"><li>1. Print a few more pages to see if the problem corrects itself.</li><li>2. Turn over the stack of paper in the tray. Also try rotating the paper 180°.</li><li>3. Check the paper (or other print media) type and quality. Replace the paper, and advise the customer to use the recommended paper and store it properly.</li></ol>
---------------------------------------------------------------------	----------------------------------------------------------------------------------------------------------------------------------------------------------------------------------------------------------------------------------------------------------------------------------------------------------------------------------------------------------------------------

Inside of printer is dirty (toner may have leaked out of the toner cartridge).	Clean inside of printer (see Chapter 4). Install a new Toner Cartridge if leaking.
--------------------------------------------------------------------------------	------------------------------------------------------------------------------------

Printer's operating environment does not meet specifications.	Make sure the printer's operating environment meets specifications.
---------------------------------------------------------------	---------------------------------------------------------------------

Printing on envelope seams. Printing on an envelope seam can cause a background scatter problem.	Move the text to an area without seams. If not printing on seams, try a higher print density setting.
--------------------------------------------------------------------------------------------------	-------------------------------------------------------------------------------------------------------

AaBbCc  
AaBbCc  
AaBbCc  
AaBbCc  
AaBbCc

---

**Table 7-20. Gray Background (continued)**

---

Possible Cause	Action
----------------	--------

Wrong toner density setting.

From the Print Quality Menu on the Control Panel, adjust the toner density setting. Make sure EconoMode is off.

Faulty Toner Cartridge.

Replace the Toner Cartridge.

See also "Light Print, Dark Print, or Fade" on page 7-65.

---



AaBbCc  
AaBbCc  
AaBbCc  
AaBbCc  
AaBbCc

---

**Table 7-21. Horizontal Smudges**

---

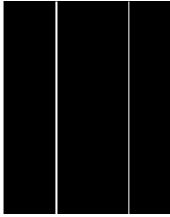
Possible Cause	Action
----------------	--------

Paper path contamination or damage.

1. Check the Toner Cartridge and replace it if necessary.
2. Check the Fuser and replace it if necessary.

See the "Repetitive Defect Ruler" on page 7-72.

---



---

**Table 7-22. Horizontal White Lines**

---

Possible Cause	Action
Lack of toner or faulty Toner Cartridge.	Redistribute the toner in the Toner Cartridge. If the problem continues, replace the Toner Cartridge.
Dirt in the laser path.	Clean the laser path. (Remove the Laser Scanner Assembly and clean the lens.)
Defective Fuser.	Replace the Fuser Assembly.
Dirty mirror in the Laser Scanner.	Replace the Laser Scanner.

---



---

**Table 7-23. Light Print, Dark Print, or Fade**

---

Possible Cause	Action
Wrong toner density setting.	From the Print Quality Menu on the Control Panel, adjust the toner density setting. Make sure EconoMode is off.
Toner Cartridge is low.	Replace the Toner Cartridge.
Transfer Roller is defective.	Replace the Transfer Roller.
Paper does not meet printer specifications or is stored improperly.	<ol style="list-style-type: none"><li>1. Print a few more pages to see if the problem corrects itself.</li><li>2. Turn over the stack of paper in the tray. Also try rotating the paper 180°.</li><li>3. Check the paper (or other print media) type and quality. Replace the paper, and advise the customer to use the recommended paper and store it properly.</li></ol>

AaBbCc  
AaBbCc  
AaBbCc  
AaBbCc  
AaBbCc

---

**Table 7-23. Light Print, Dark Print, or Fade (continued)**

---

Possible Cause	Action
Poor contact to the Engine Controller Board.	<ol style="list-style-type: none"><li>1. Clean the contacts if they are dirty. If the problem remains after cleaning, or if parts are damaged or deformed, replace them.</li><li>2. Replace the Engine Controller Board if necessary.</li></ol>
Defective Laser Scanner.	Replace the Laser Scanner.
Defective High Voltage Power Supply.	Replace the High Voltage Power Supply PCA.

See also "Faded Print/Bubbles" on page 7-61.

---

AaBbCc  
AaBbCc  
AaBbCc  
AaBbCc  
AaBbCc

---

**Table 7-24. Loose Toner**

---

Possible Cause	Action
Dirt in the printer.	<ol style="list-style-type: none"><li>1. Print a few more pages to see if the problem corrects itself.</li><li>2. Clean the inside of the printer (page 4-2) or use the printer's cleaning page (page 4-4).</li></ol>
Toner Cartridge is defective.	Replace the Toner Cartridge.
Paper might be too smooth.	Check the paper (or other print media) type and quality.
Wrong Fuser setting for paper type.	From the Paper Handling Menu on the Control Panel, change the Fuser Mode setting or choose another paper type from the printer driver.
Defective Fuser.	Replace the Fuser.

---



**Table 7-25. Repetitive Defects**

Possible Cause	Action
<p>Toner Cartridge is damaged. The circumference of the photoconductive drum inside the toner cartridge is 94 mm (3.7 inches). If the defect repeats at this interval, the defect is associated with the drum.</p>	<p>Inspect the drum for scratches or damage. Replace the Toner Cartridge.</p>
<p>Dirty Rollers. Any dirty roller in the paper path may result in a repetitive print defect.</p>	<p>Examine and clean rollers in the paper path.</p>
<p>Fusing Assembly is dirty or defective. The circumference of the lower fusing Pressure Roller is 86 mm (3.46 inches). If the defect repeats at this interval, the defect is associated with the Pressure Roller.</p>	<p>Clean the Fusing Assembly using alcohol. If the problem persists, replace the Fusing Assembly.</p>
<p>Gears are worn, causing slippage or jumping.</p>	<p>Inspect the gears driving the Toner Cartridge and the Fuser. Replace the Main Drive Assembly if necessary.</p>
<p>Paper does not meet specifications: The surface of the paper may be too coarse, causing repeated marks.</p>	<p>Try a different paper lot (see <i>HP LaserJet Printer Family Paper Specifications Guide</i>).</p>



AaBbCc  
 AaBbCc  
 AaBbCc  
 AaBbCc  
 AaBbCc

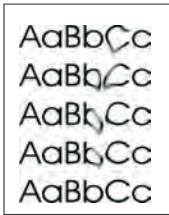
**Table 7-26. Skew**

Possible Cause	Action
Paper does not meet printer specifications or is stored improperly.	<ol style="list-style-type: none"> <li>1. Print a few more pages to see if the problem corrects itself.</li> <li>2. Turn over the stack of paper in the tray. Also try rotating the paper 180°.</li> <li>3. Check the paper (or other print media) type and quality. Replace the paper, and advise the customer to use the recommended paper and store it properly.</li> </ol>
Paper is not loaded correctly or trays are not adjusted properly.	Make sure paper is loaded correctly and that the guides fit properly against the paper stack.
Registration Assembly is improperly installed.	Be sure that the Registration Assembly is installed correctly.

AaBbCc  
 AaBbCc  
 AaBbCc  
 AaBbCc  
 AaBbCc

**Table 7-27. Toner Smear**

Possible Cause	Action
Dirt in the printer.	<ol style="list-style-type: none"> <li>1. Print a few more pages to see if the problem corrects itself.</li> <li>2. Clean the inside of the printer (page 4-2) or use the printer's cleaning page (page 4-4).</li> </ol>
Dirty Fusing Rollers. Toner build-up can cause the print on a page to smear.	Remove and inspect the Fusing Assembly for excessive toner build-up. Clean using alcohol.
Paper might be too smooth.	Check the paper (or other print media) type and quality.
Defective Toner Cartridge.	Replace the Toner Cartridge. (See instructions with the Toner Cartridge.)



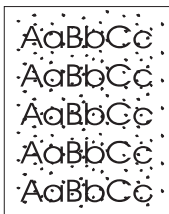
---

**Table 7-27. Toner Smear (continued)**

---

Possible Cause	Action
Wrong Fuser setting for paper type.	From the Paper Handling Menu on the Control Panel, change the Fuser Mode setting or choose another paper type from the printer driver.
Fusing Assembly is defective. The print will smear if the Fusing Assembly is not heated sufficiently to bond the toner image to the paper.	Replace the Fusing Assembly.
The Static Eliminator is dirty or is not grounded, allowing a static charge to remain on the page.	Clean using the blue cleaning tool or compressed air. Replace assembly if damaged.
DC Controller is defective. The DC Controller regulates fusing roller temperature.	If a new Fusing Assembly does not resolve the problem, replace the DC Controller PCA.

---

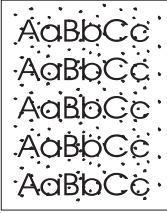


---

**Table 7-28. Toner Specks**

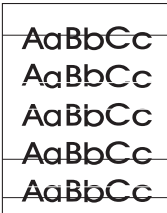
---

Possible Cause	Action
Dirt in printer.	<ol style="list-style-type: none"><li>1. Print a few more pages to see if the problem corrects itself.</li><li>2. Clean the inside of the printer (page 4-2) or use the printer's cleaning page (page 4-4).</li></ol>



**Table 7-28. Toner Specks (continued)**

Possible Cause	Action
Paper does not meet printer specifications or is stored improperly.	<ol style="list-style-type: none"> <li>1. Print a few more pages to see if the problem corrects itself.</li> <li>2. Turn over the stack of paper in the tray. Also try rotating the paper 180°.</li> <li>3. Check the paper (or other print media) type and quality. Replace the paper, and advise the customer to use the recommended paper and store it properly.</li> </ol>
Alternating small and standard paper (such as envelopes and letterhead).	To alternate small and standard paper, from the Configuration Menu on the Control Panel, set <code>SMALL PAPER SPEED=SLOW</code> .



**Table 7-29. Vertical Black Lines**

Possible Cause	Action
Toner Cartridge not seated properly.	Remove the cartridge and reinsert it.
Toner Cartridge defective.	Replace the cartridge.
Repetitive defect. If the lines are repeated at a consistent interval down the page, this is a repetitive defect.	Refer to “Repetitive Image Defect Ruler.”



**Table 7-30. Vertical Dots**

Possible Cause	Action
Dirty static eliminator teeth.	Clean the static eliminator.
Poor contact between the Static Eliminator and the Engine Controller Board.	Clean the contacts, if dirty. If the problem remains after cleaning, or if parts are damaged or deformed, replace them.
Deformed or deteriorated Transfer Roller.	Replace the Transfer Roller.
Defective DC Controller Assembly.	Replace the DC Controller Assembly.

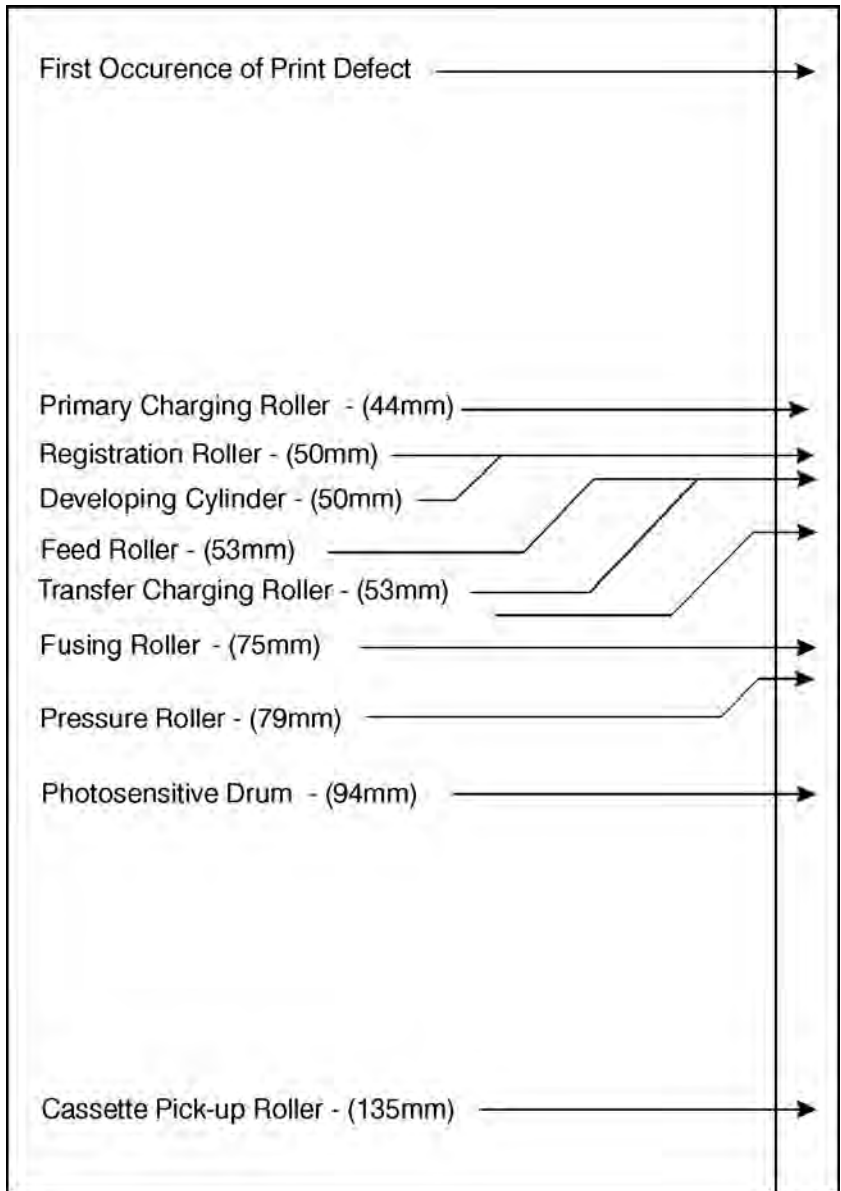


**Table 7-31. Vertical White Lines**

Possible Cause	Action
Toner Cartridge is nearly empty. This can cause uneven toner distribution.	Remove the Toner Cartridge and shake it gently. The cartridge will soon require replacement.
Toner Cartridge has been exposed to too much light.	Store the Toner Cartridge in a darkened environment for several days. This may restore the photosensitive potential.
Foreign objects in beam path. Any foreign objects will block the light from developing an image on the Photosensitive drum.	Remove the Toner Cartridge and check for damage. Replace the Toner Cartridge if it is damaged.  Remove the Printer Cover and inspect the path from the Laser/Scanner to the Toner Cartridge drum, looking for foreign objects in the beam path.

## **Repetitive Defect Ruler**

Repetitive print defects usually are associated with a specific roller within the printer or the Toner Cartridge. Use Figure 7-1 to isolate the cause of repetitive print defects. Align the first occurrence of the defect with the top of the “ruler” (at the top or bottom of the misprinted page), and measure to the next occurrence of the defect to determine the roller in question. When you are certain that your defect pattern matches the pattern of the ruler, replace the indicated roller.



**Figure 7-6** Repetitive Defect Ruler

## Image System Troubleshooting

### Half Self-Test Functional Check

The electrophotographic process can be subdivided into the following stages:

- Cleaning (removes excess toner from drum surface)
- Conditioning (places a uniform electrical charge on drum)
- Writing (laser strikes surface of drum to create latent image)
- Developing (forms the toner image on drum)
- Transferring (charges transfer the image to paper)
- Fusing (heat and pressure produces a permanent image)

The purpose of the Half Self Test Check is to determine which process is malfunctioning. Perform the test as follows:

- 1 Print a Configuration Page from the Control Panel INFORMATION MENU.
- 2 Open the top cover after the paper advances half-way through the printer (about five seconds after the Main Motor begins rotation). The leading edge of the paper should have advanced past the Toner Cartridge.
- 3 Remove the Toner Cartridge.
- 4 Open the Toner Cartridge's drum shield to view the drum's surface.

If a dark and distinct toner image is present on the drum's surface, assume that the first four functions of the electrophotographic process are functioning (cleaning, conditioning, writing, and developing - see Chapter 5), and troubleshoot the failure as a transfer or fusing problem.

If no image is present on the photosensitive drum, perform all the following functional checks:

## Drum Rotation Functional Check

The photosensitive drum, located in the Toner Cartridge, must rotate for the print process to work. The photosensitive drum receives its drive from the Main Drive assembly. To verify whether the drum is rotating:

- 1 Open the top cover.
- 2 Remove the Toner Cartridge.
- 3 Mark the cartridge's drive gear with a felt-tipped marker. Note the position of the mark.
- 4 Install the Toner Cartridge and close the top cover. The start-up sequence should rotate the drum enough to move the mark.
- 5 Open the printer and inspect the gear that was marked in step 3. Verify that the mark moved. If the mark did not move, inspect the Main Drive assembly to ensure that it is meshing with the Toner Cartridge gears. If the drive gears function, and the drum does not move, replace the Toner Cartridge.

---

### Note

This test is especially important if refilled Toner Cartridges are in use.



# Interface Troubleshooting

This section provides an overview of the printer's interface requirements.

## Communications Check

---

**Note**

Communication problems are normally the customer's responsibility. Time spent attempting to resolve these problems may not be covered by the product's Hewlett-Packard warranty.

Refer the customer to the network administrator for assistance in troubleshooting network problems.

---

If the printer is not connected to an MS-DOS-based host, proceed to the Communications Checks table in this section.

## Test Message

After the printer is installed, verify communications between the printer and the IBM-compatible computer. Enter the following at the DOS prompt:

```
C:\DIR>LPT1 Enter (for printing to parallel port #1)
```

The printer should print a directory listing of the C:\ directory.

## EIO Troubleshooting

The JetDirect Configuration Page shown in Figure 7-7 contains valuable information regarding the current status of the EIO accessories. Before attempting to troubleshoot a network problem or notifying your network consultant of a problem, always print a Configuration Page.

See the *HP JetDirect Print Server Software Installation Guide* for detailed explanations of network issues.

EIO 1 - JETDIRECT PAGE

1

JetDirect Configuration Page

Network statistics

GENERAL INFORMATION

HP JETDIRECT: J3111A  
FIRMWARE REVISION: G.05.35  
LAN HW ADDRESS: 0060B0438C6F  
PORT SELECT: 10BASE-T (RJ45)  
MFG ID: 37273727200535

NETWORK STATISTICS  
UNICAST PACKETS RCVD: 19  
TOTAL PACKETS RCVD: 15469  
BAD PACKETS RCVD: 0  
FRAMING ERRORS RCVD: 0  
PACKETS TRANSMITTED: 91  
UNSENDABLE PACKETS: 0  
XMIT COLLISIONS: 11  
XMIT LATE COLLISIONS: 0

I/O CARD READY  
I/O card status

PROTOCOL INFORMATION

TCP/IP STATUS: READY

APPLETALK STATUS: READY  
ETALK NET: 65281 NODE: 142 P2  
ITALK NET: 0 NODE: 151  
APPLETALK NAME: HP LaserJet 500  
0 Series  
ETALK\_ZONE: \*

IP address

CONFIG BY: FRONT PANEL/TELNET  
IP ADDRESS: 15.98.40.165  
SUBNET MASK: 255.255.248.0  
DEF. GATEWAY: 15.98.40.1  
SYSLOG SERVER: NOT SPECIFIED  
IDLE TIMEOUT (SECONDS): 90

DLC/LLC STATUS: READY

WEBJA SERVER: NOT SPECIFIED

NOVELL STATUS: 16  
NOT CONFIGURED  
MODE: QUEUE SERVER  
NODE NAME: NP1438C6F

NOVELL RETRANS: 0  
NETWORK FRAME TYPE RCVD  
UNKNOWN EN 802.2 1123  
UNKNOWN EN SNAP 102  
UNKNOWN FRTT 86

Node name

Novell status

Figure 7-7 JetDirect Configuration Page

## JetDirect Configuration

- If the EIO JetDirect Card has successfully powered up and completed its internal diagnostics, the `I/O CARD READY` message appears. If communication is lost, an `I/O NOT READY` message appears followed by a two digit error code. See the *HP JetDirect Network Interface Configuration Guide* for further details and recommended action.
- The “Network Statistics” column indicates that network activity has been occurring. Bad packets, framing errors, unsendable packets and collisions should be minimal. If a high percentage (greater than one percent) of these occur, contact the network administrator. All of the statistics are set to zero when the printer is powered-off.
- The “Novell Status” block should state the Novell printer server name to which the printer is connected. If the node name reads “NPIxxxxxx” (xxxxxx=last six digits of the EIO’s LAN address), the EIO card has not been configured for a Novell server. This could indicate that the card is operating under an IPX protocol other than Novell. Consult with the network administrator if the Node Name is not present.
- In the TCP/IP protocol block, the default IP address is “192.0.0.192.” It is acceptable to operate the printer with this default address. The error message “ARP DUPLICATE ADDRESS” may appear in this block. This is also an acceptable error code if the TCP/IP protocol is not being used. Check with the network administrator to determine the correct IP Address for the printer.

# Reference Diagrams

## Locations of Components

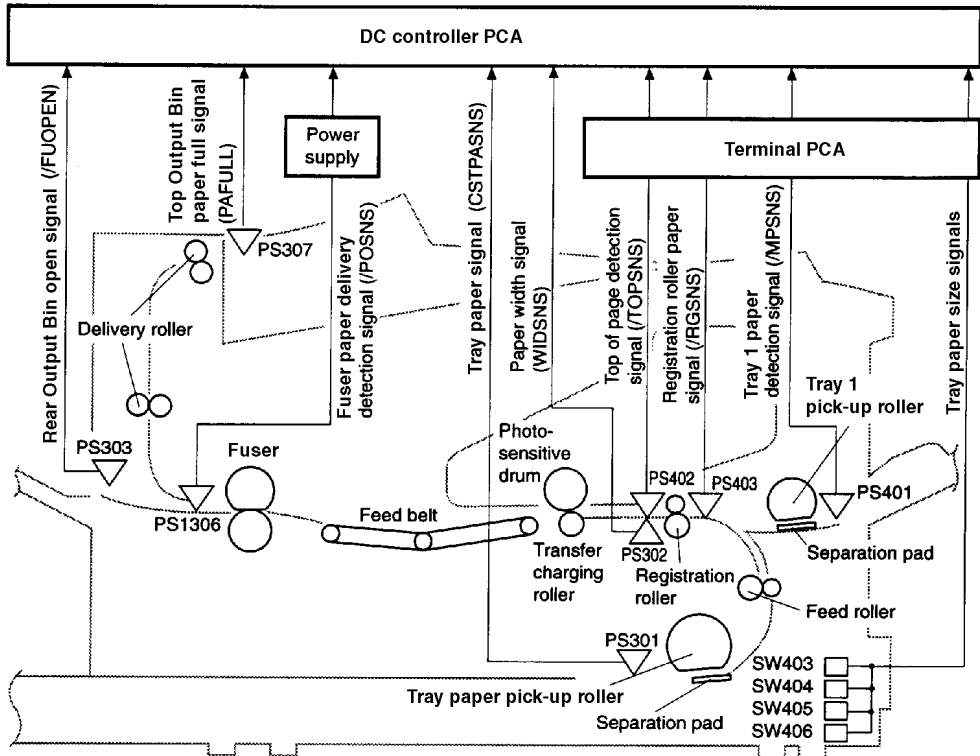
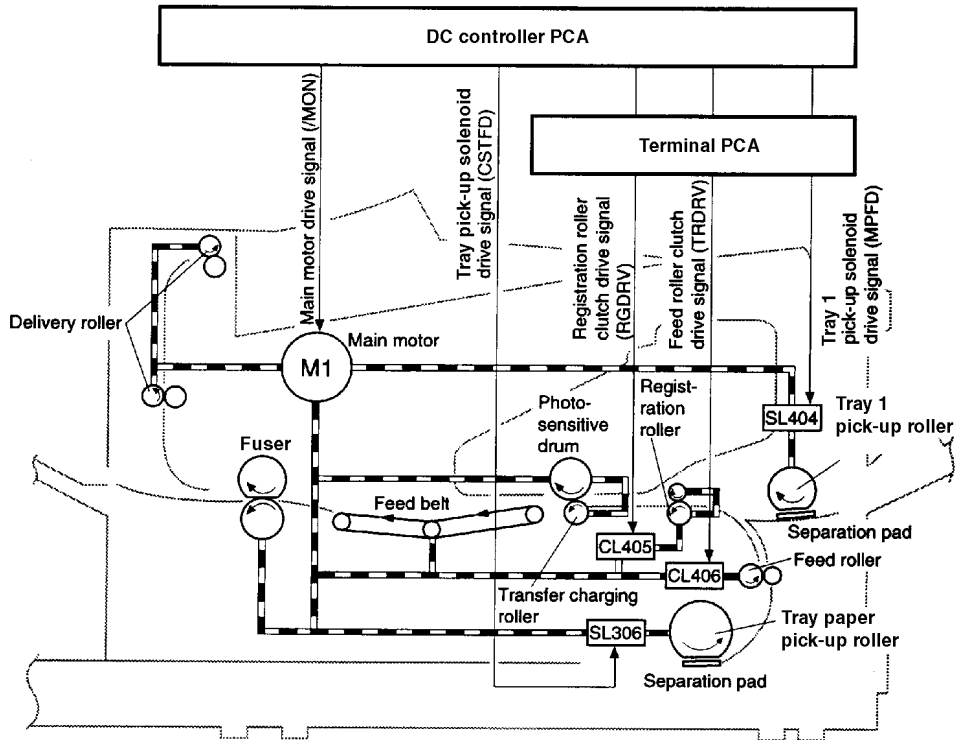


Figure 7-8 Paper Path



**Figure 7-9** 250-sheet Paper Feeder

# 1. 250-Sheet Paper Feeder

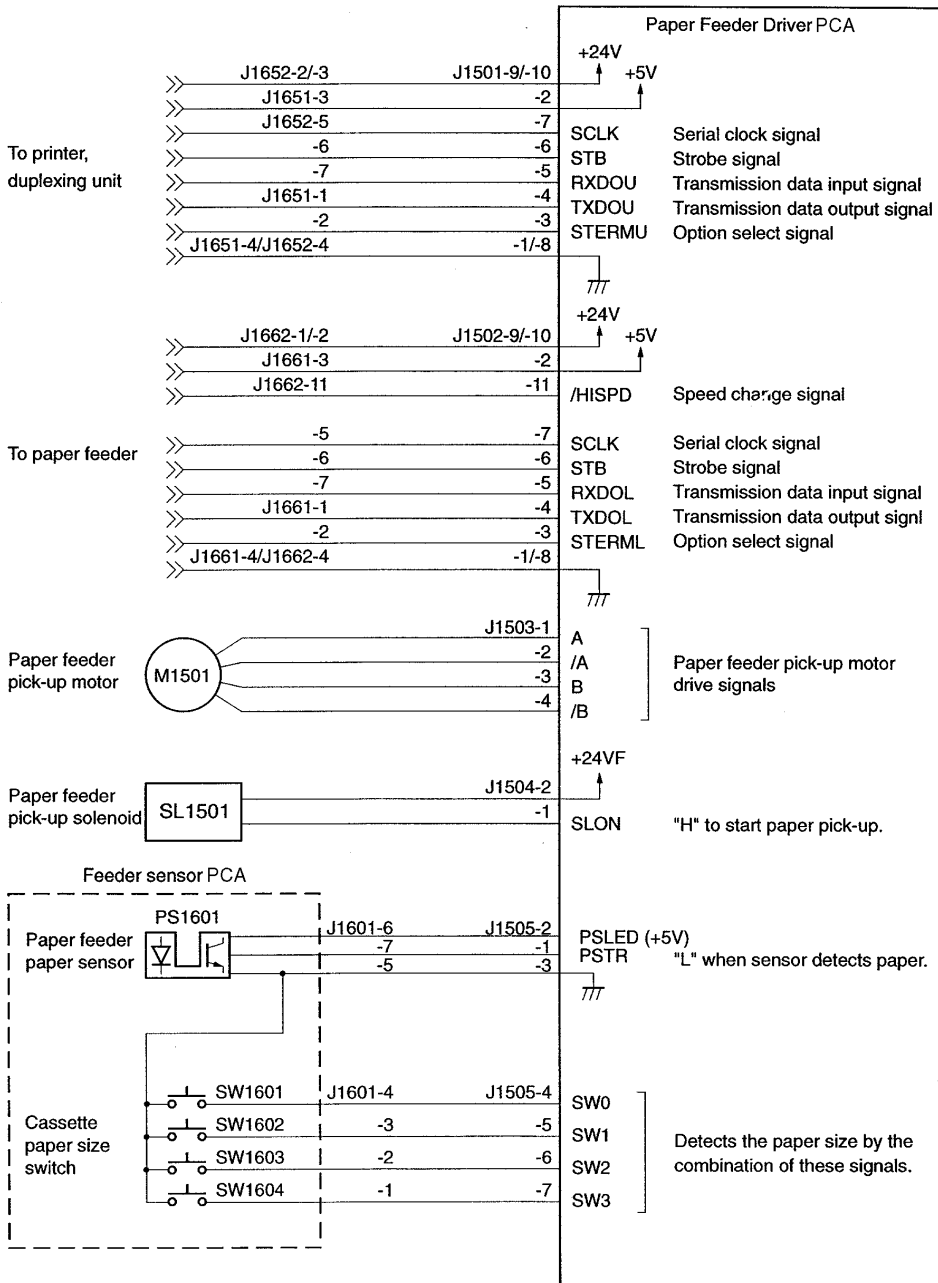
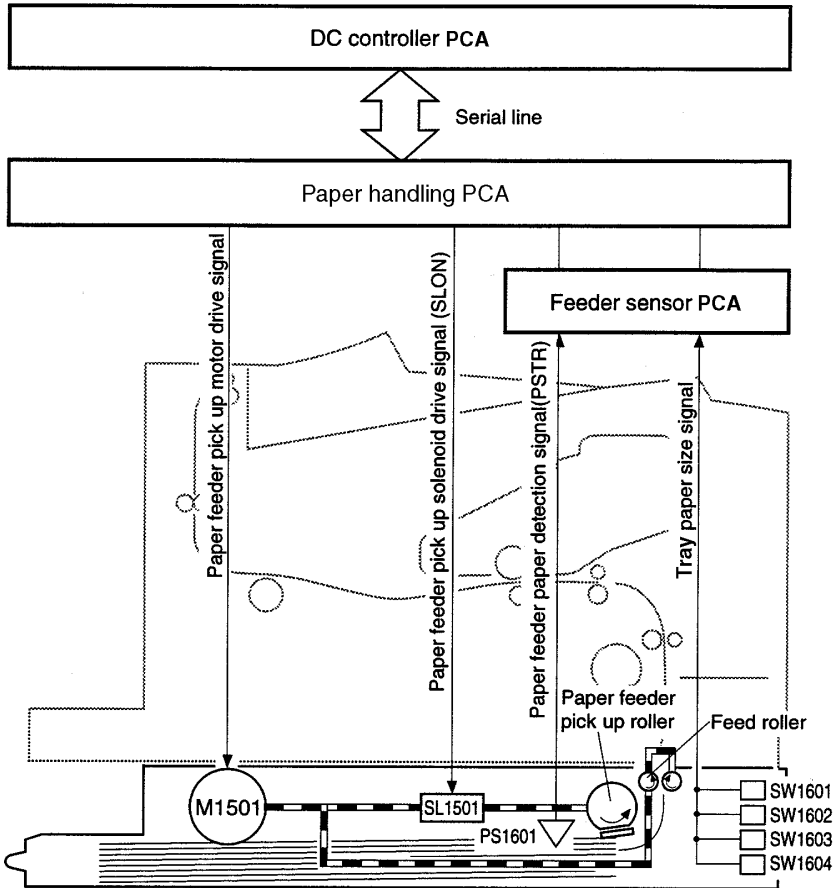
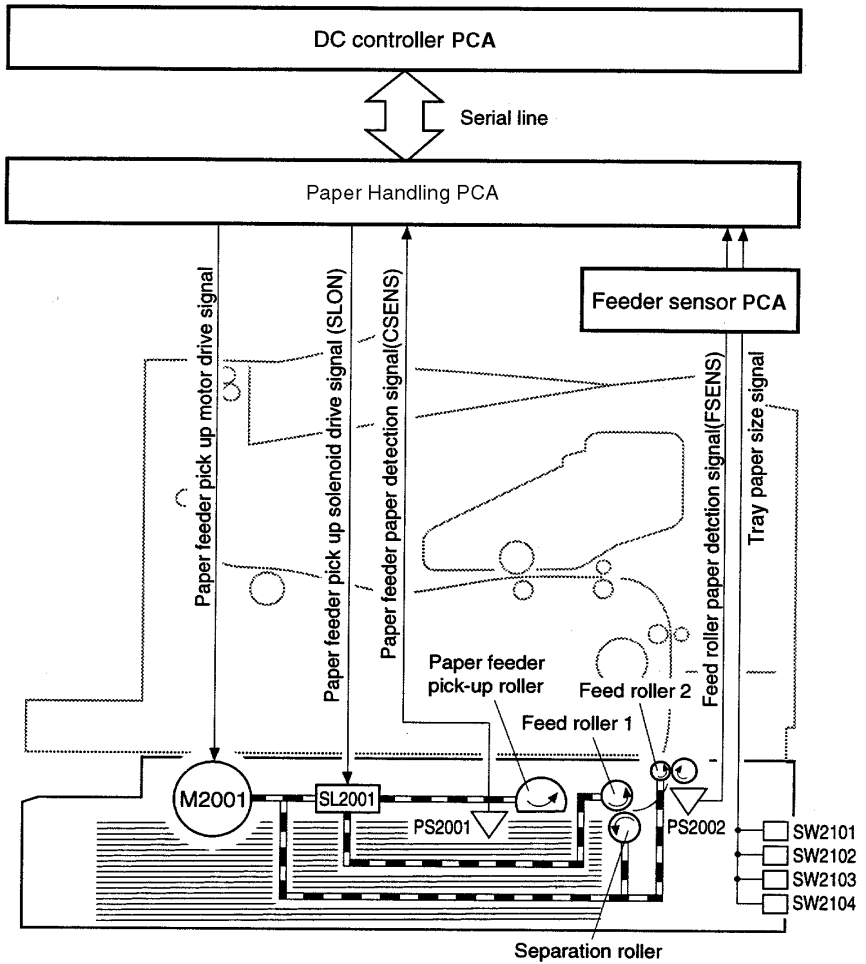


Figure 7-10 250-sheet Paper Feeder



**Figure 7-11** Tray 2 Paper Path



**Figure 7-12** 500-sheet Paper Feeder



## 2. 500-Sheet Paper Feeder

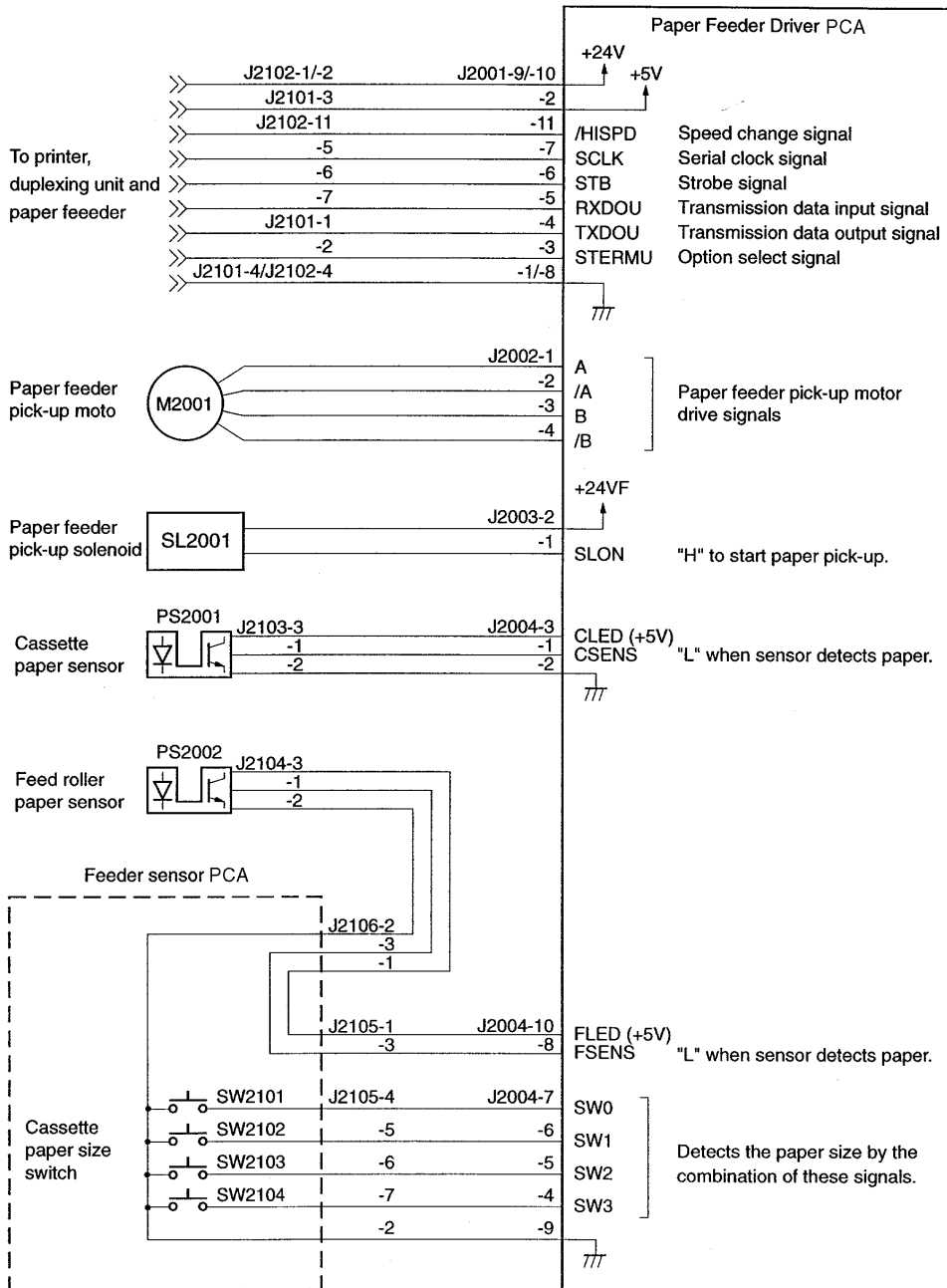


Figure 7-13 500-sheet Paper Feeder

### 3. Duplexing Unit

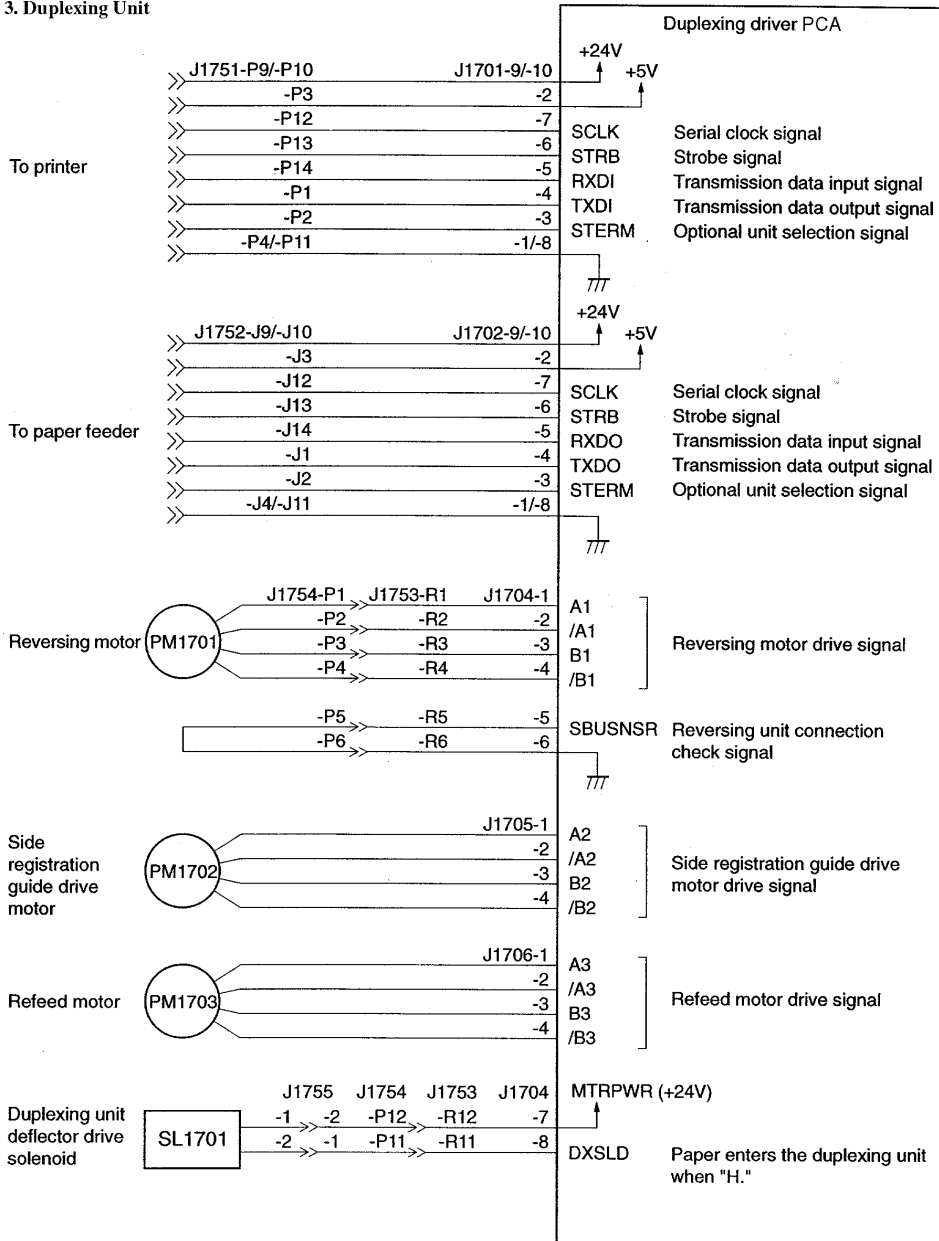
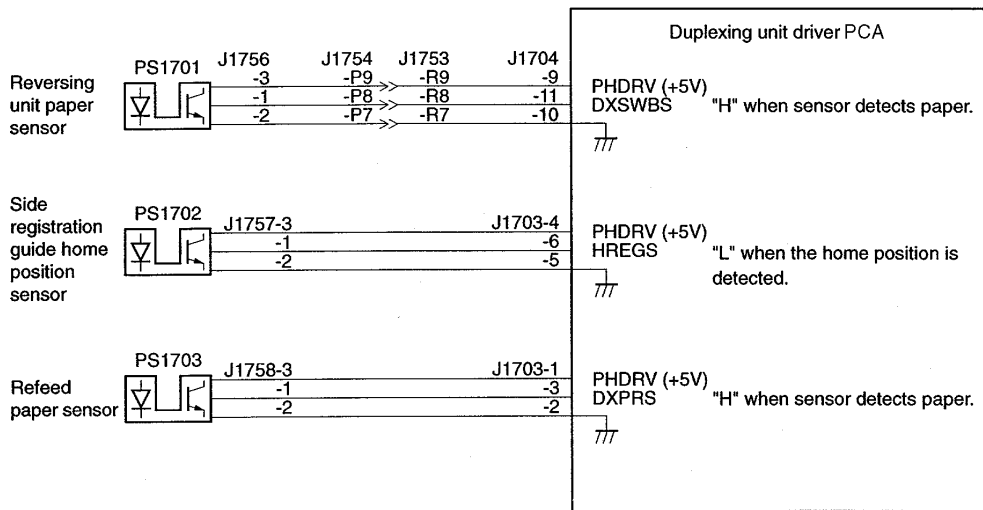


Figure 7-14 Duplexing Unit



**Figure 7-15** Duplexing Unit

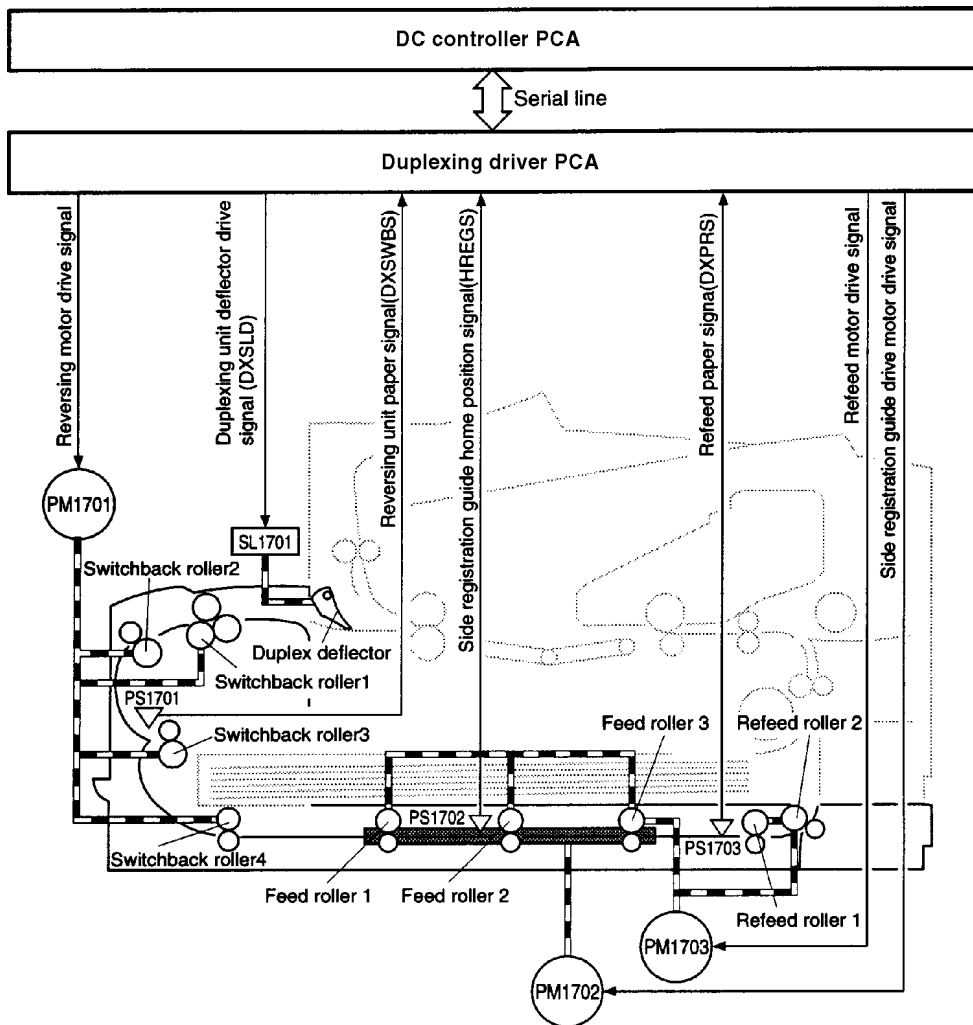
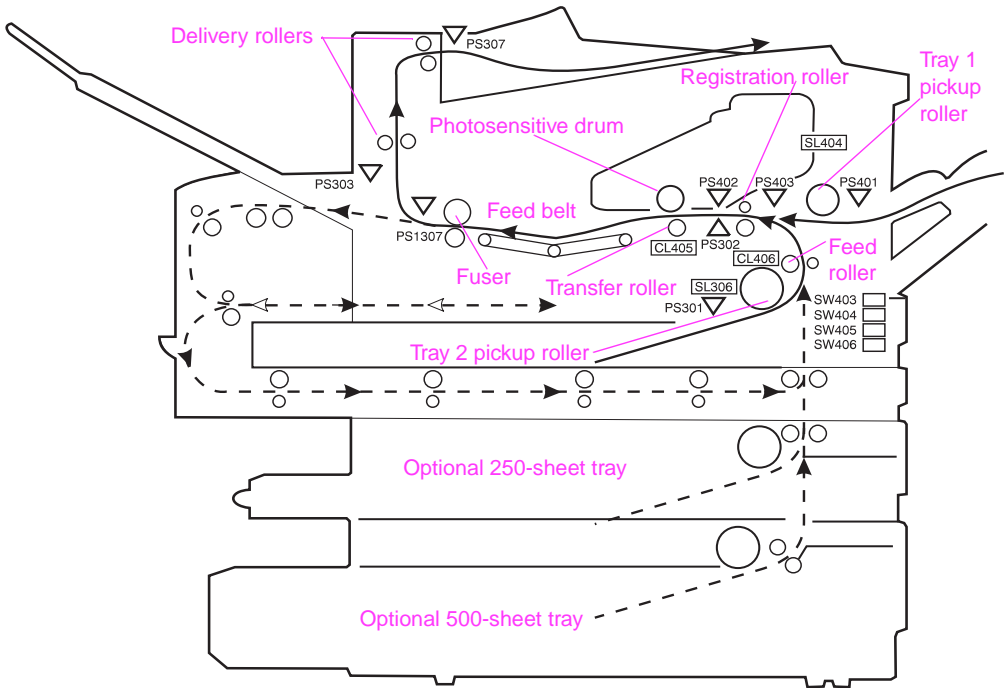


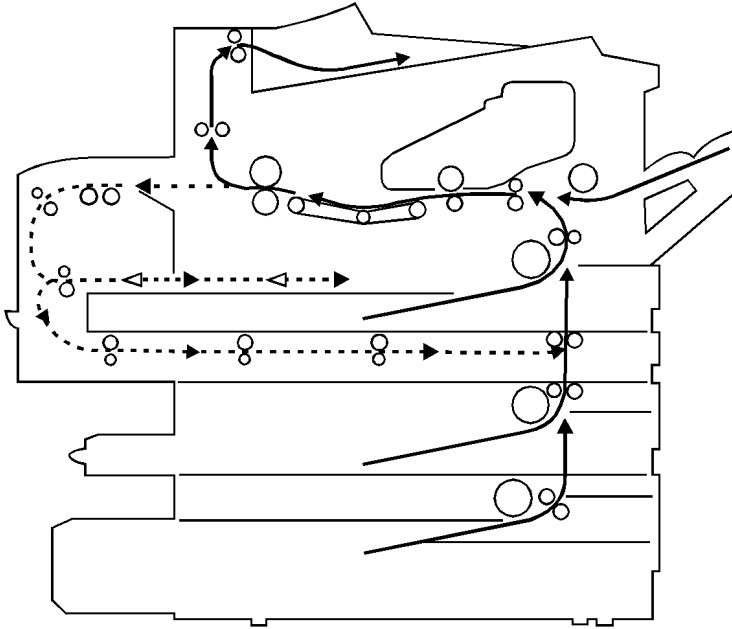
Figure 7-16 Duplexing Unit

# Sensors and Signals

The drawing below shows key components, sensors, and switches that control the operation of the printer. The table on page 7-90 shows the name of each sensor, as well as the signal name and its destination or source.



**Figure 7-17** Paper Path and Components



**Figure 7-18** Paper Path (dashed lines represent duplexer path)

---

**Table 7-32. Table 1 Sensors and Signals**

---

<b>Sensor</b>	<b>Name</b>
CL405	Registration roller clutch
CL406	Feed roller clutch
PS301	Tray 2 paper sensor
PS302	Tray 1 paper width sensor
PS303	Face-up tray open sensor
PS307	Face-down tray paper full sensor
PS401	Tray 1 paper sensor
PS402	Top of page sensor
PS403	Registration roller paper sensor
PS1307	Fuser delivery paper sensor
PS1601	250-sheet feeder paper sensor
PS1701	Duplexer reversing unit paper sensor
PS1702	Duplexer side registration guide home position sensor
PS1703	Duplexer refeed paper sensor
SL306	Tray 2 pickup solenoid
SL404	Tray 1 pickup solenoid
SW101	Main power switch

---

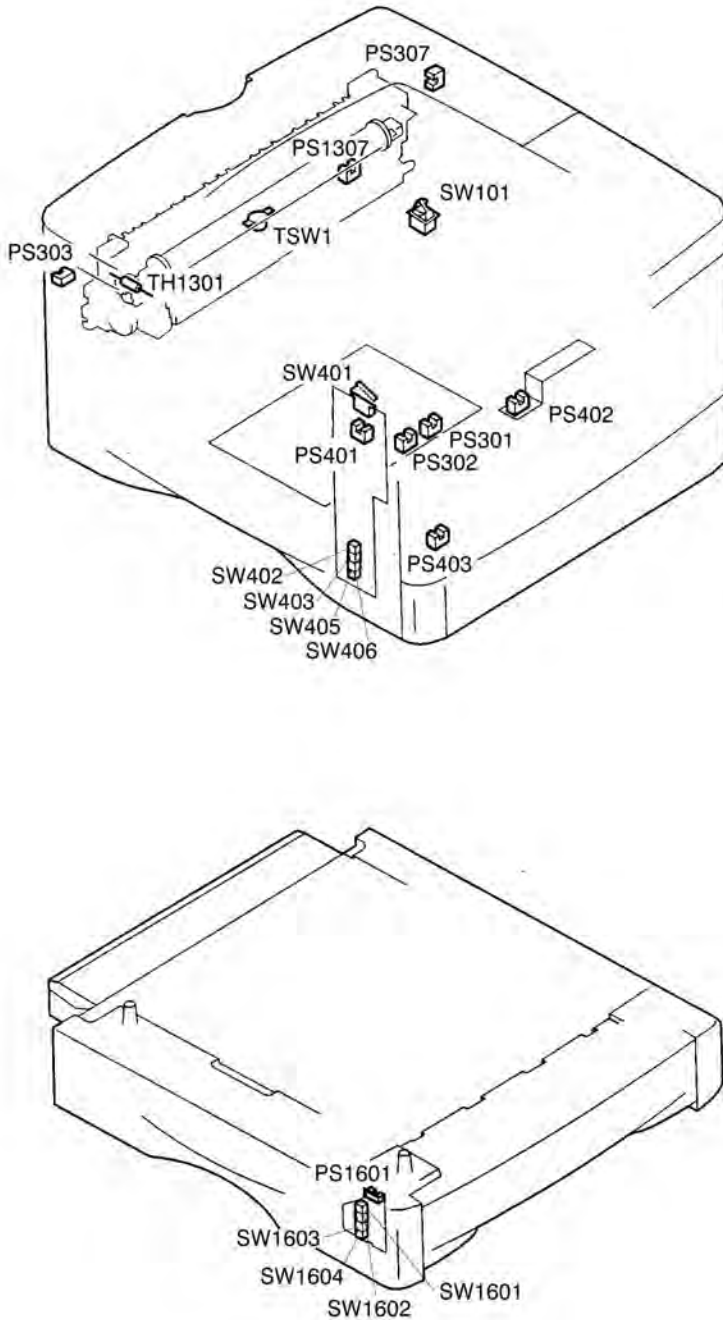
**Table 7-32. Table 1 Sensors and Signals**

---

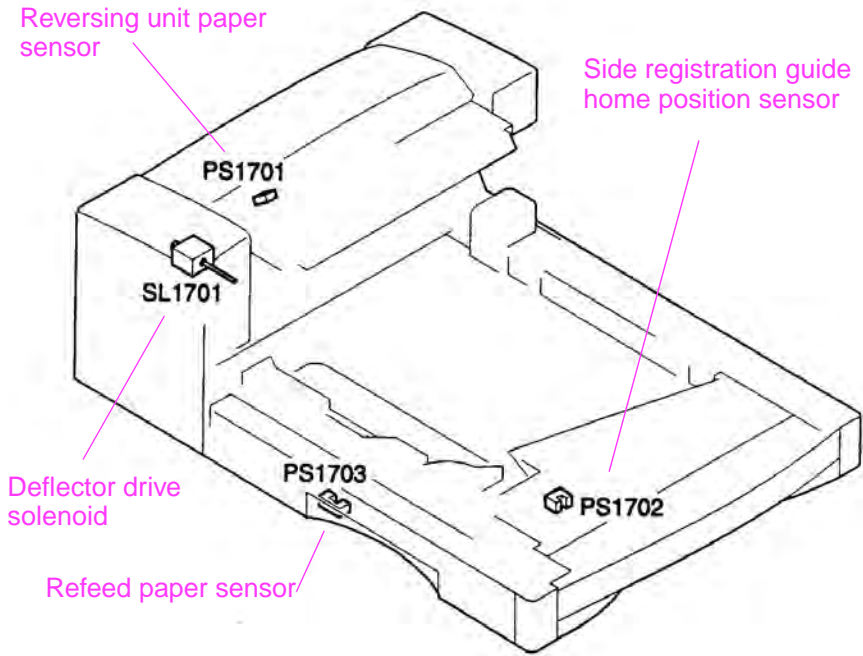
<b>Sensor</b>	<b>Name</b>
CL405	Registration roller clutch
CL406	Feed roller clutch
PS301	Tray 2 paper sensor
SW401	Top cover switch
SW403	Tray 2 paper size switch 1
SW404	Tray 2 paper size switch 2
SW405	Tray 2 paper size switch 3
SW1601	250-sheet feeder paper size sensors
SW1602	250-sheet feeder paper size sensors
SW1603	250-sheet feeder paper size sensors
SW1604	250-sheet feeder paper size sensors
TSW1	Fuser thermal switch
TH1301	Fuser roller thermistor

---

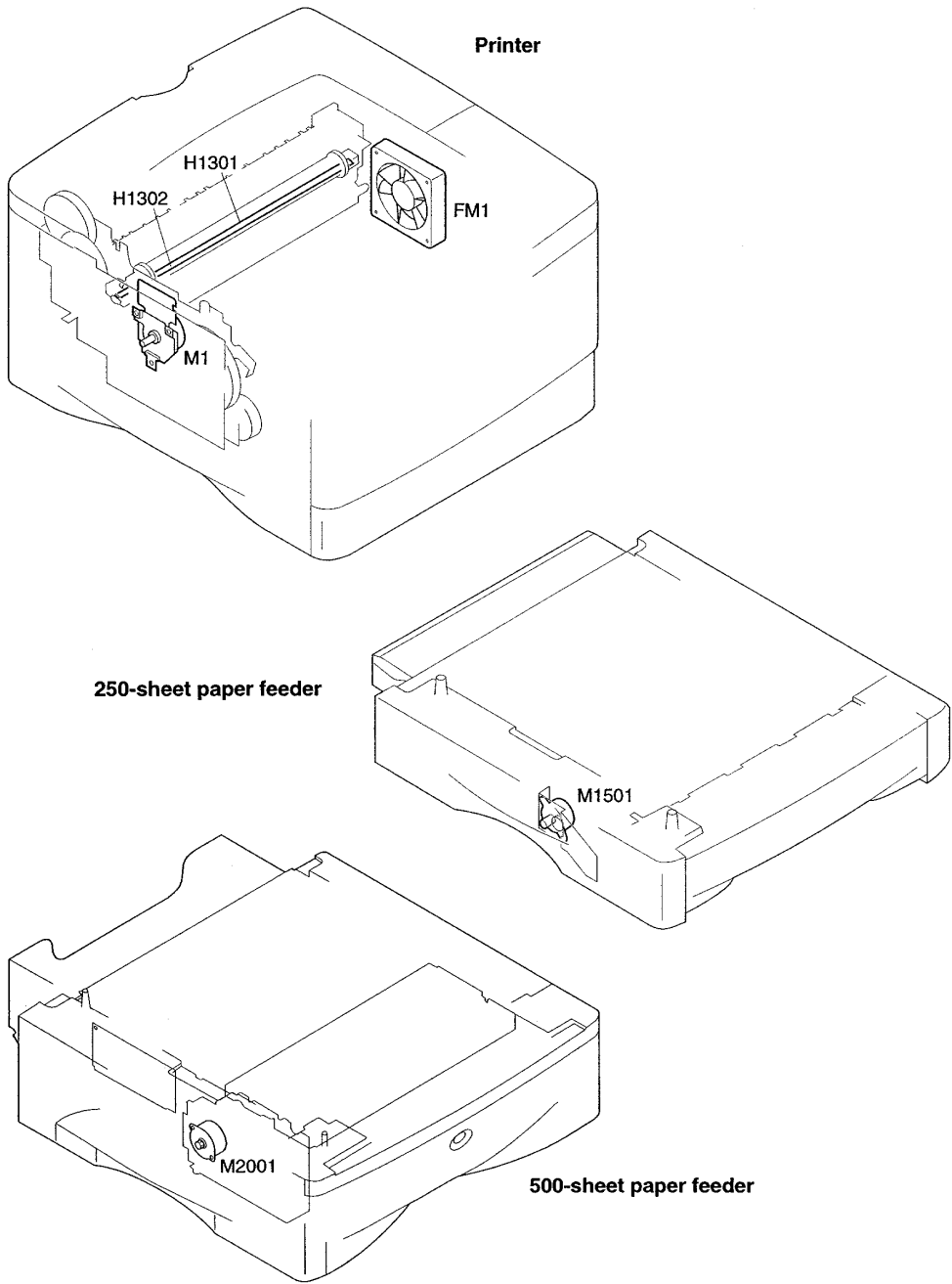




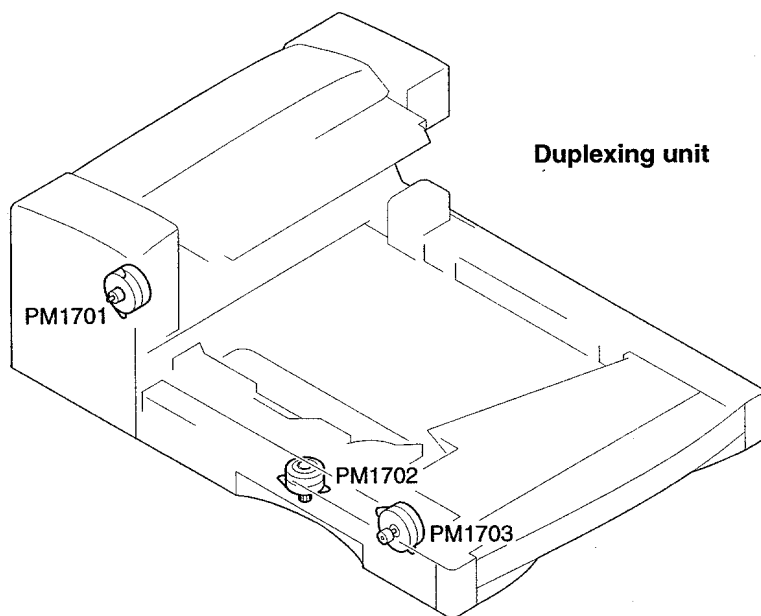
**Figure 7-19** Location of Sensors and Switches






**Figure 7-20** Duplexer Sensors and Switches



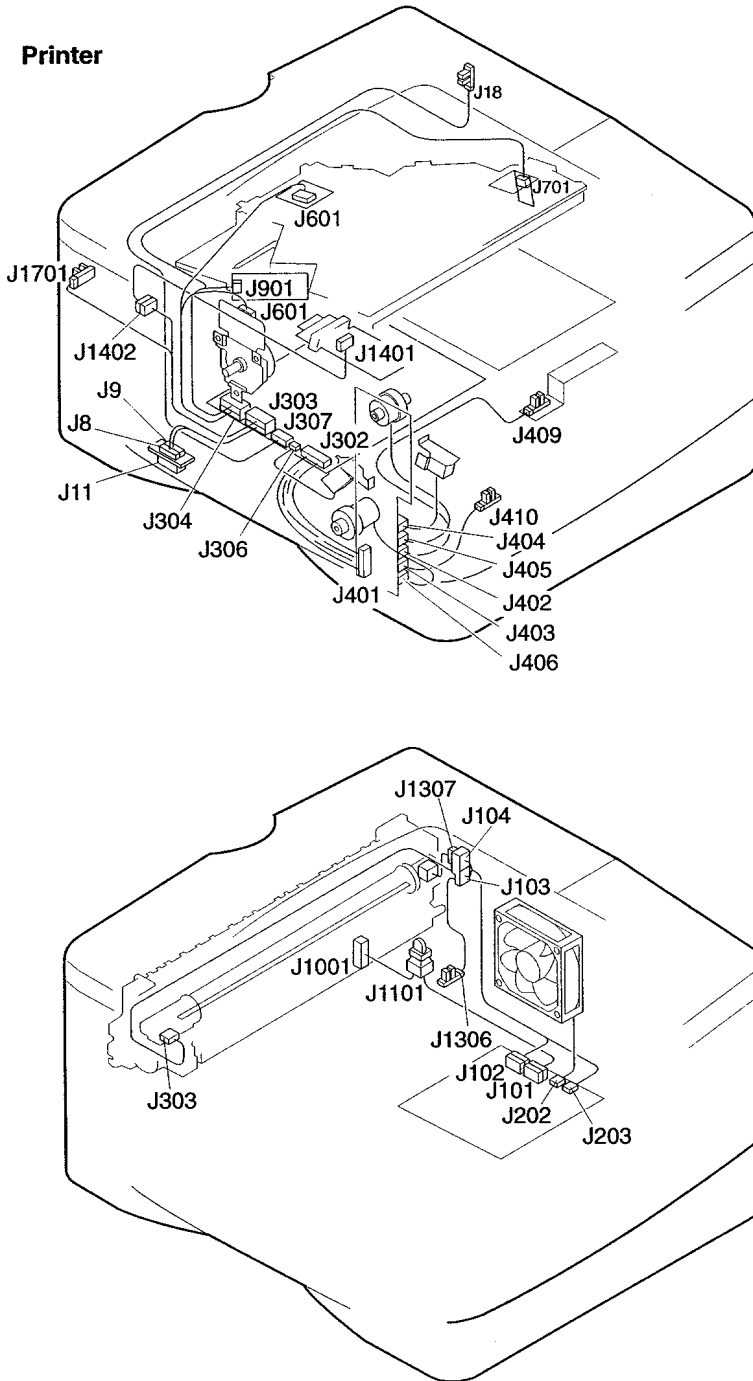
**Figure 7-21** Motors



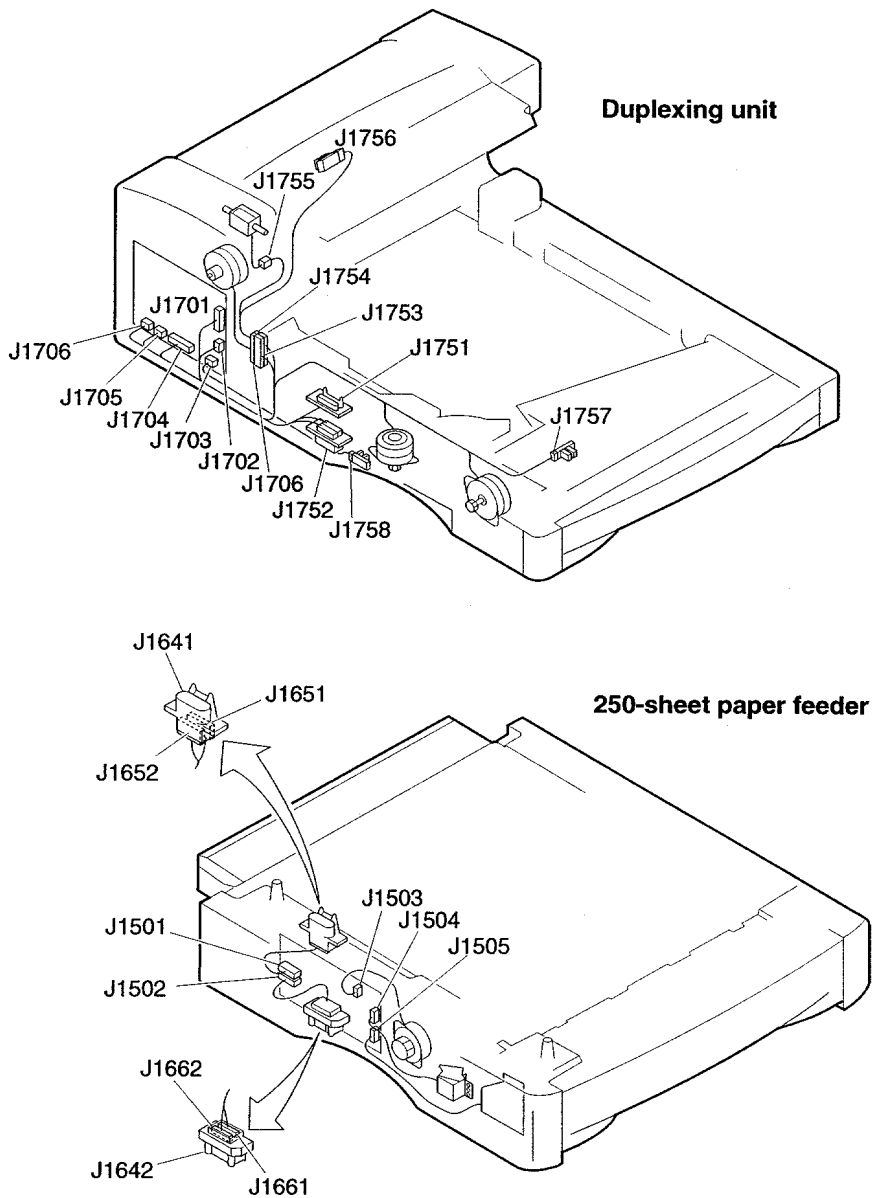
**Figure 7-22** Motors (Duplexing unit)

Symbol	Name of symbol	Code	Name
	Motor	M1	Main motor
		M1501	Paper feeder pick-up motor (250-sheet paper feeder)
		PM1701	Reversing motor (duplexing unit)
		PM1702	Side registration guide drive motor (duplexing unit)
		PM1703	Refeed motor (duplexing unit)
		M2001	Paper feeder pick-up motor (500-sheet paper feeder)
	Fan motor	FM1	Exhaust fan
	Fusing heater	H1301	Fusing heater 1
		H1302	Fusing heater 2

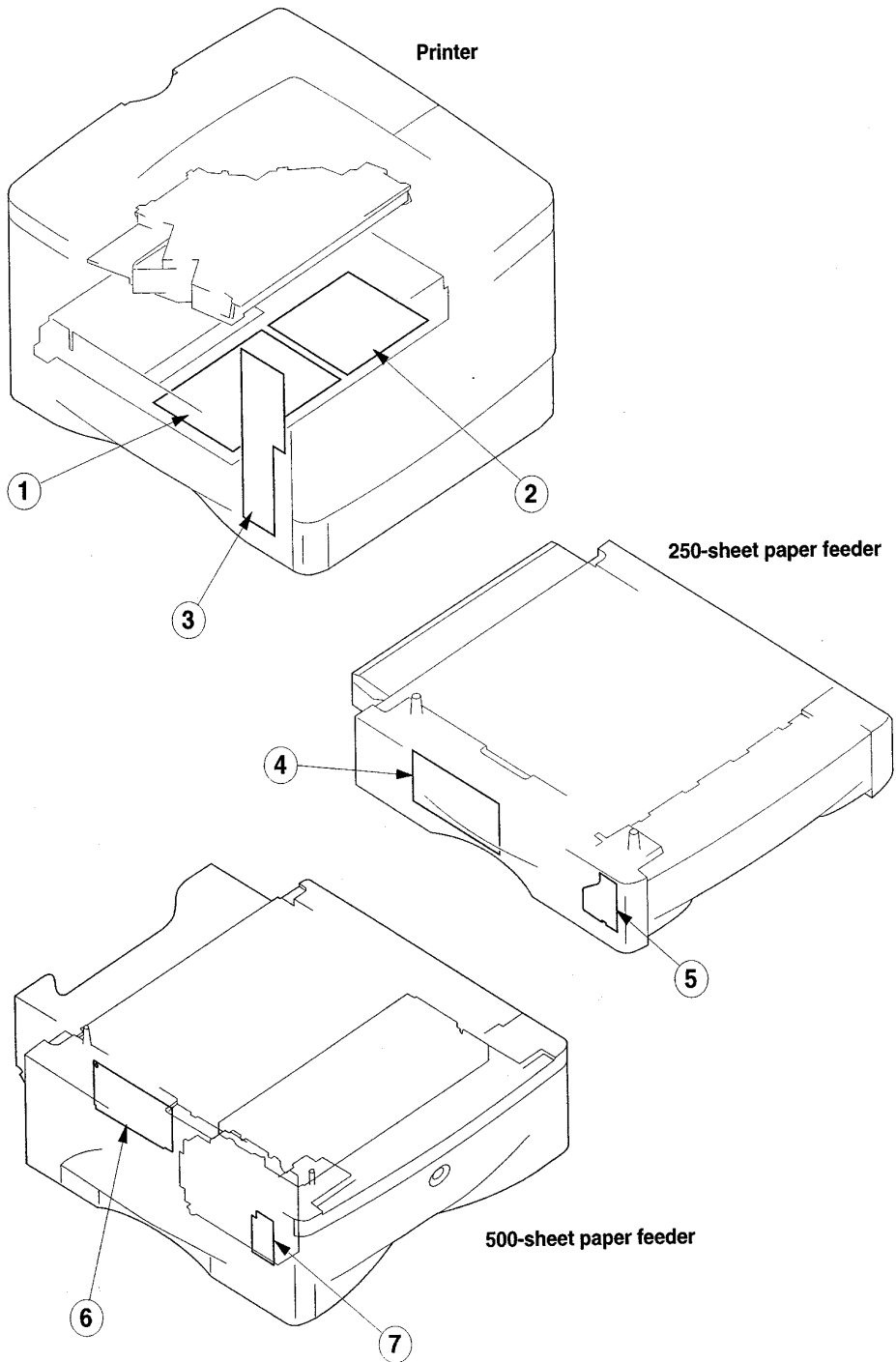
**Printer**



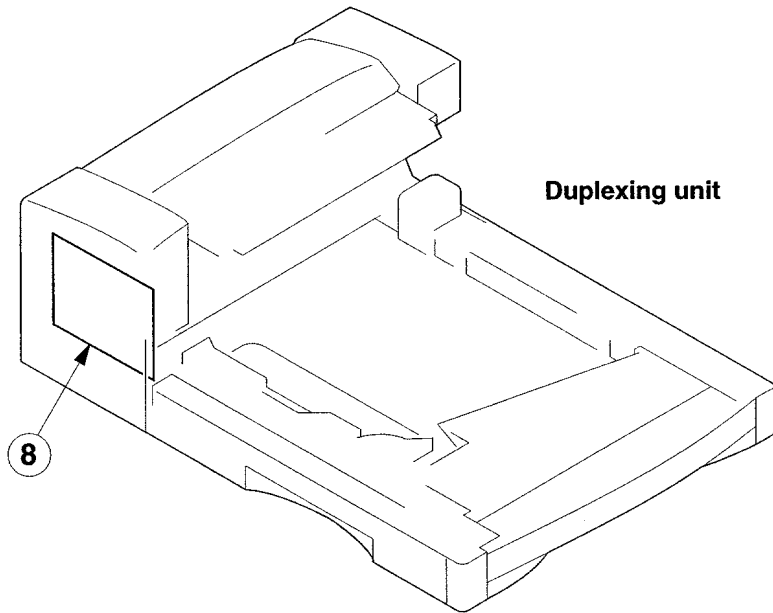
**Figure 7-23** Connectors



**Figure 7-24** Connectors (Duplexing Unit and 250-sheet Paper Feeder)



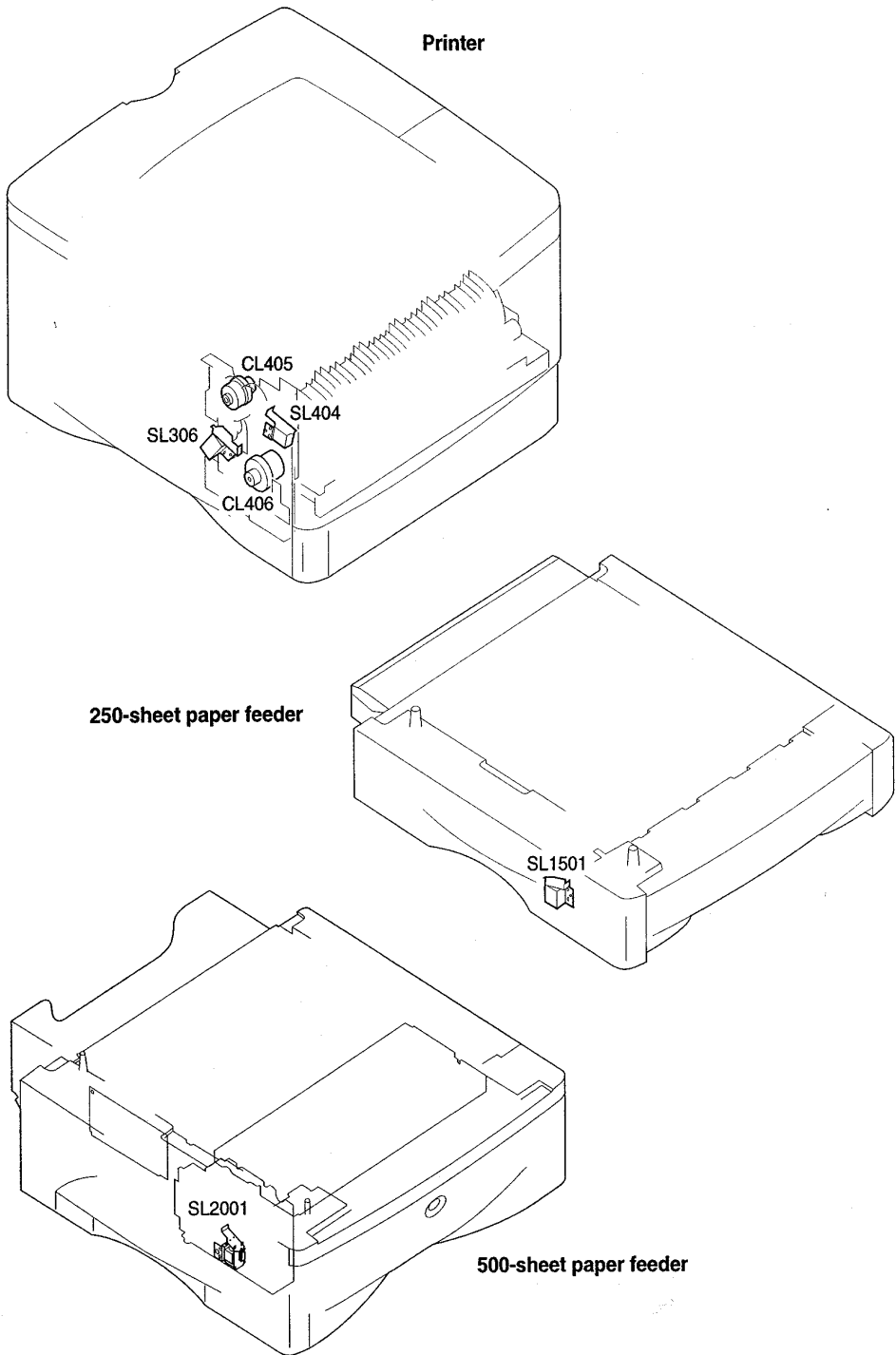
**Figure 7-25** PCA's



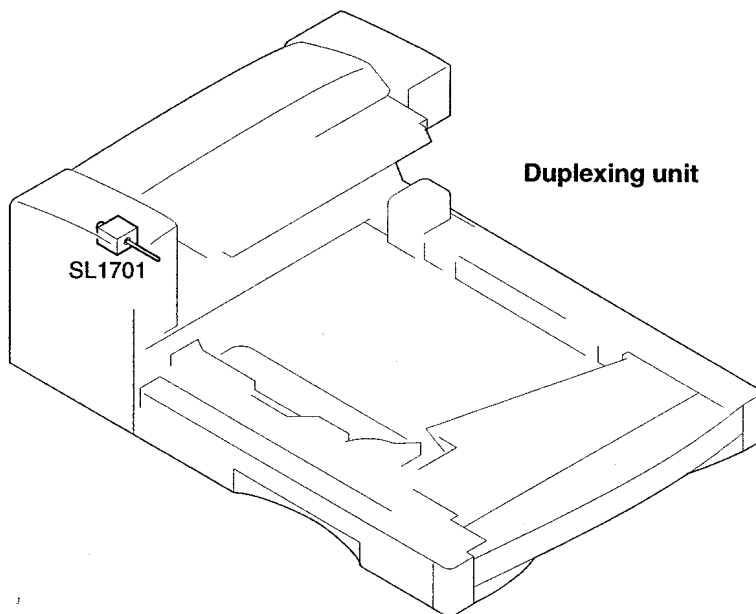
**Figure 7-26** PCA (Duplexing Unit)

No.	Name	Function
1	DC controller	Controls print sequence.
2	Power supply	Generates +24 VDC, +5 VDC, and +3.4 VDC and drives fixing heaters.
3	Terminal	Relays signals between sensors, loads and the DC controller PCB.
4	250-sheet paper feeder driver PCA	Controls loads in the 250-sheet paper feeder and sensors.
5	Feeder sensor PCA	Monitors sensor and switches.
6	500-sheet paper feeder driver PCA	Controls loads in the 500-sheet paper feeder and sensors.
7	Feeder sensor PCA	Monitors sensor and switch.
8	Duplexing driver PCA	Controls loads in the duplexing unit and sensors.







**Figure 7-27** Clutches and Solenoids



**Figure 7-28** Clutches and Solenoids (Duplexing Unit)

Symbol	Name of symbol	Code	Name
	Clutch	CL405	Registration clutch
		CL406	Feed clutch
	Solenoid	SL306	Tray 2 pick-up solenoid
		SL404	Tray 1 pick-up solenoid
		SL1501	Paper feeder pick-up solenoid (250-sheet paper feeder)
		SL1701	Duplexing unit deflector drive solenoid (duplexing unit)
		SL2001	Paper feeder pick-up solenoid (500-sheet paper feeder)

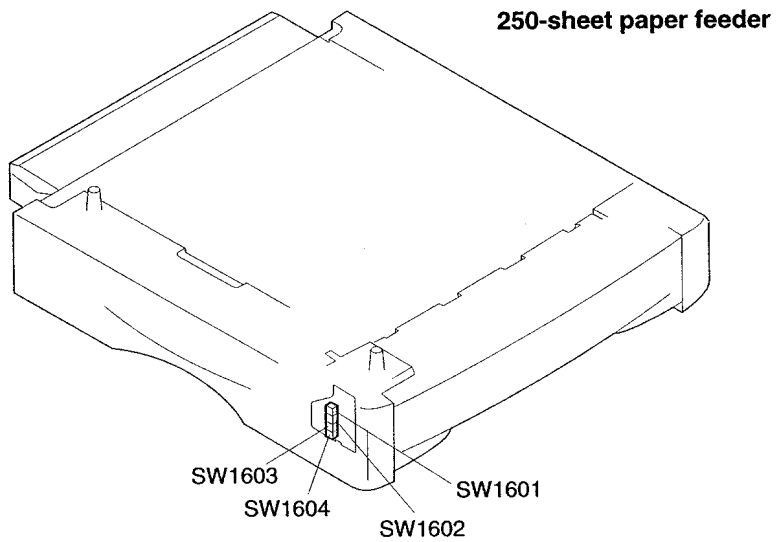
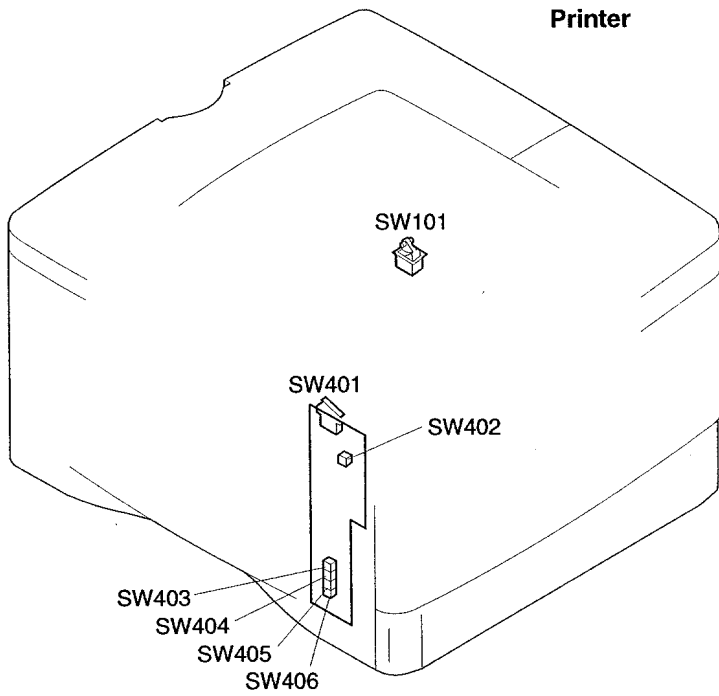
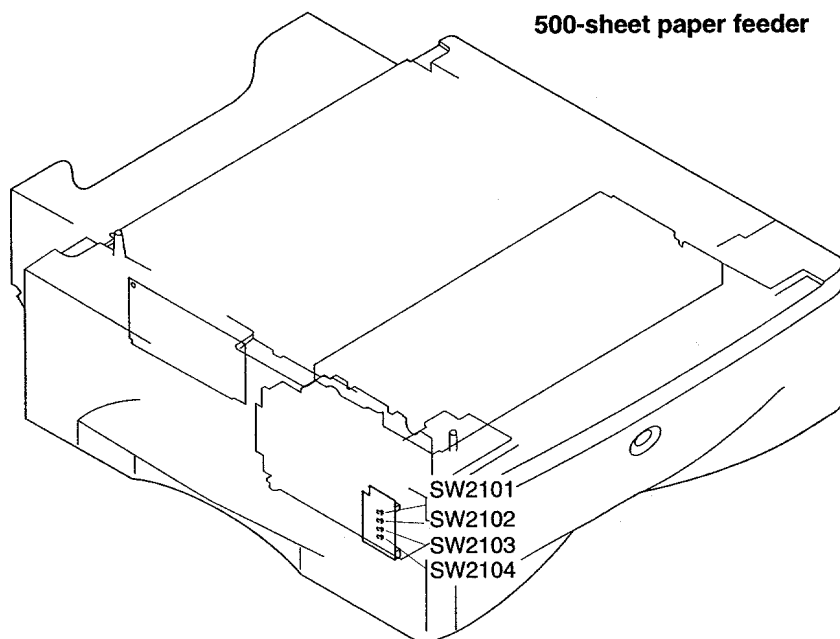
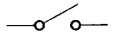
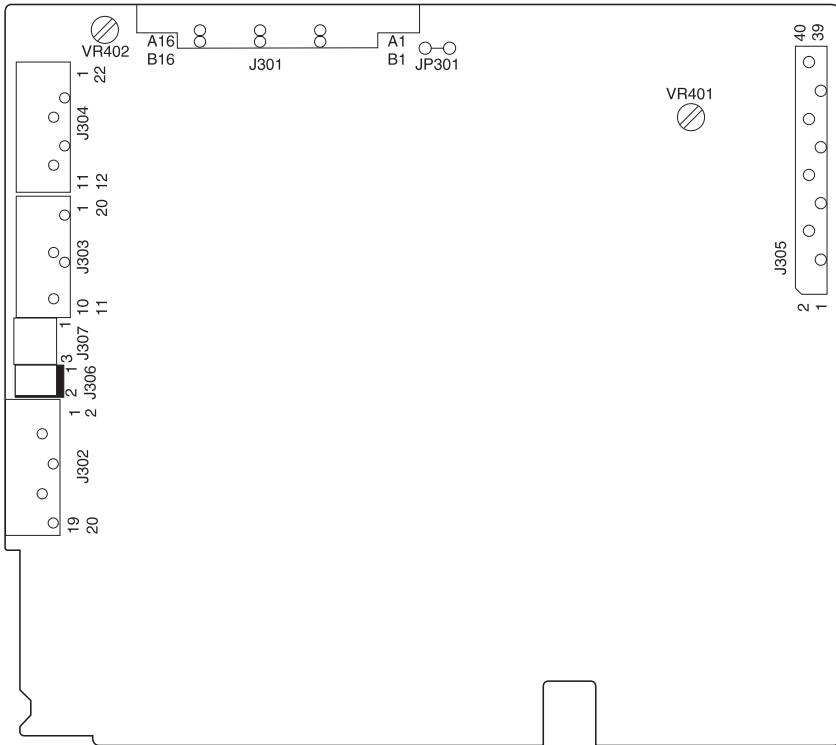


Figure 7-29 Switches



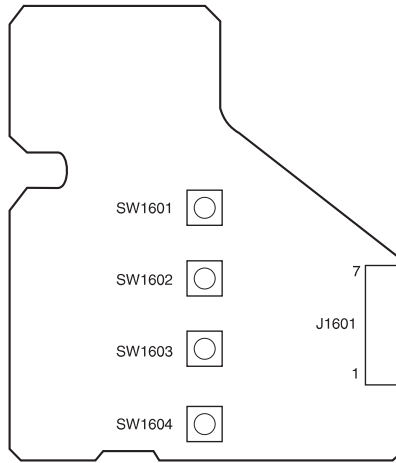
**Figure 7-30** Switches (500-sheet Paper Feeder)

Symbol	Name of symbol	Code	Name
	Switch	SW101	Power switch
		SW401	Door switch
		SW402	Test print switch
		SW403	Tray 2 paper size switch 1
		SW404	Tray 2 paper size switch 2
		SW405	Tray 2 paper size switch 3
		SW406	Tray 2 paper size switch 4
		SW1601	Paper feeder paper size switch 0 (250-sheet paper feeder)
		SW1602	Paper feeder paper size switch 1 (250-sheet paper feeder)
		SW1603	Paper feeder paper size switch 2 (250-sheet paper feeder)
		SW1604	Paper feeder paper size switch 3 (250-sheet paper feeder)
		SW2101	Paper feeder paper size switch 0 (500-sheet paper feeder)
		SW2102	Paper feeder paper size switch 1 (500-sheet paper feeder)
		SW2103	Paper feeder paper size switch 2 (500-sheet paper feeder)
		SW2104	Paper feeder paper size switch 3 (500-sheet paper feeder)



**Figure 7-31** DC Controller Board Test Points and Switches

JP No.	Function
JP301	For factory use
VR No.	Function
VR401	For factory use
VR402	



SW No.	Function
SW 1601	Cassette paper size switch (See page 2-41.)
SW 1602	
SW 1603	
SW 1604	

**Figure 7-32** 250-sheet Paper Feeder Sensors

Paper	Paper size switches				
	Printer	SW403	SW404	SW405	SW406
	250F	SW1601	SW1602	SW1603	SW1604
	500F	SW2101	SW2102	SW2103	SW2104
Tray 1		OFF	OFF	OFF	OFF
A3		ON	ON	OFF	OFF
A4R		OFF	ON	ON	OFF
A4		OFF	ON	OFF	OFF
A5		OFF	OFF	ON	OFF
B4		ON	OFF	ON	OFF
B5		ON	OFF	OFF	OFF
Ledger		OFF	ON	OFF	ON
Legal		OFF	ON	ON	ON
Executive		ON	ON	OFF	ON
Printer 250F	Letter	ON	OFF	ON	ON
500F	Letter-R				
Printer 250F	Letter	OFF	OFF	ON	ON
500F					
Printer 250F	Letter	ON	OFF	OFF	ON
500F	Universal				

# DC Controller PCA Inputs and Outputs

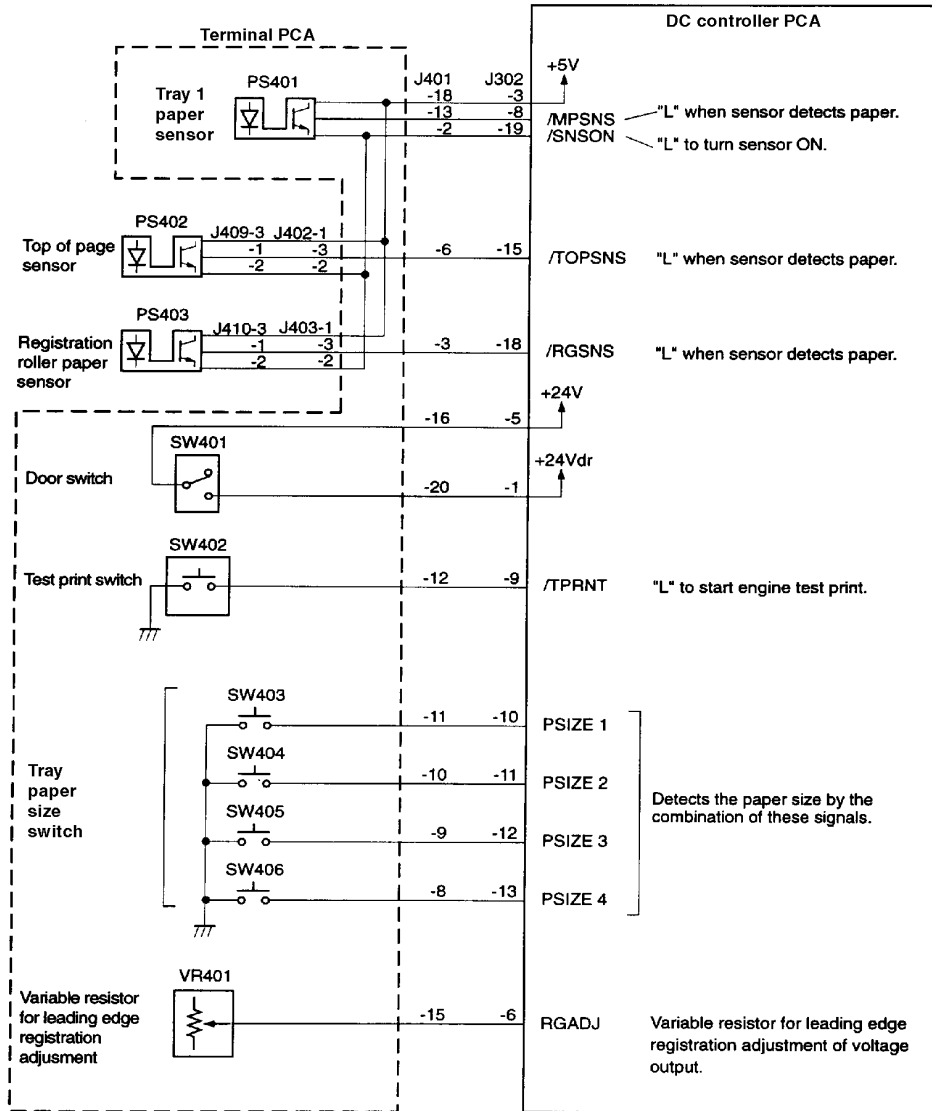


Figure 7-33 DC Controller PCA I/O (1 of 4)



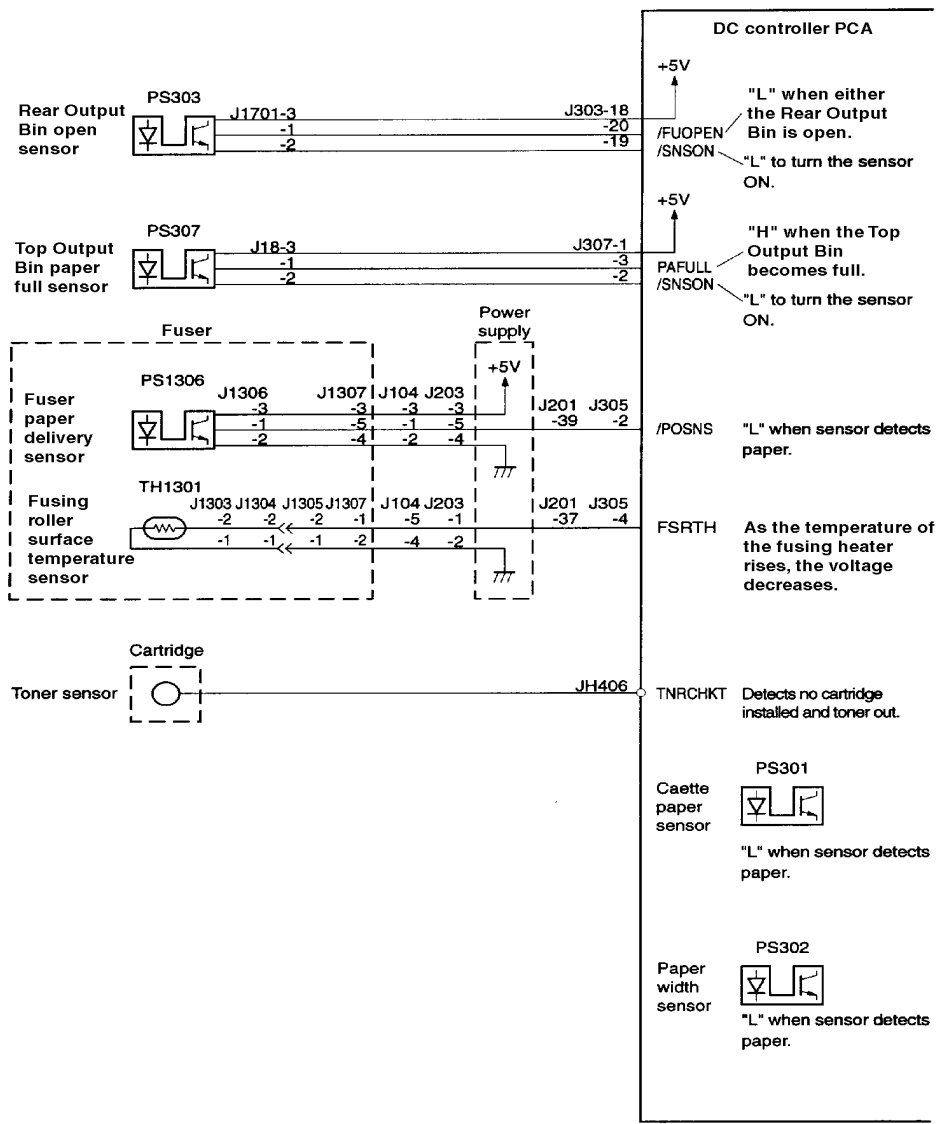


Figure 7-34 DC Controller PCA I/O (2 of 4)

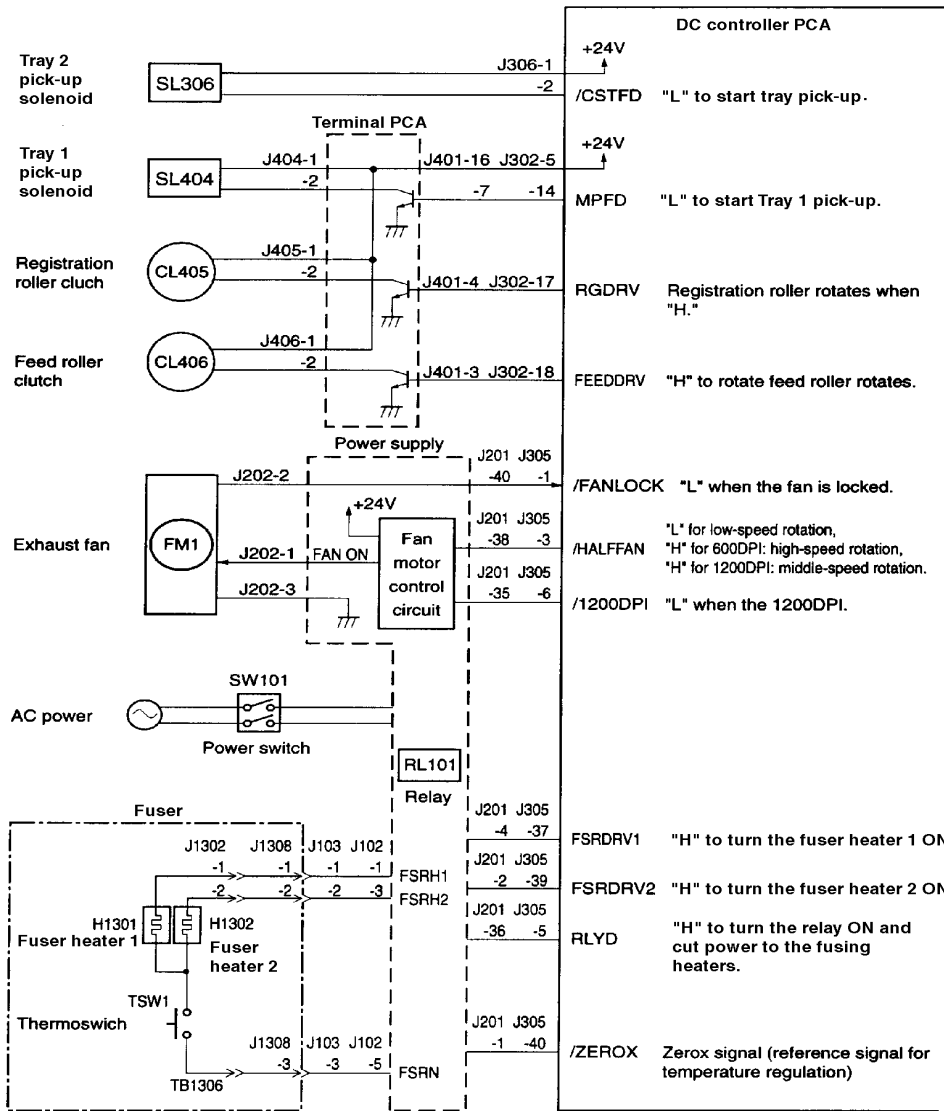


Figure 7-35 DC Controller PCA I/O (3 of 4)

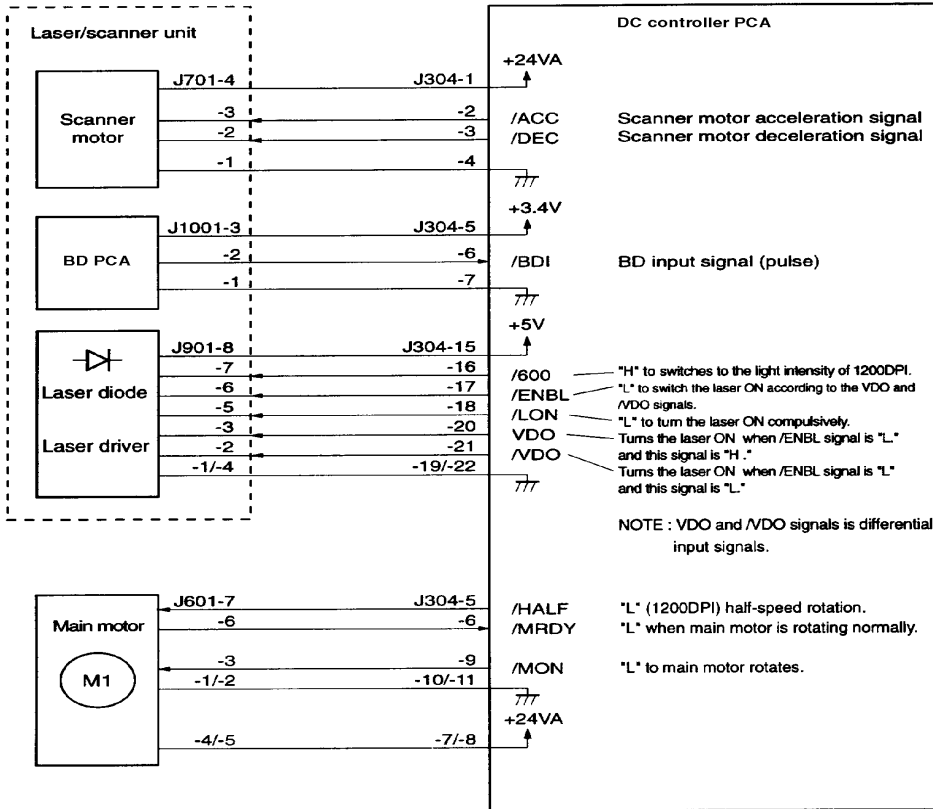


Figure 7-36 DC Controller PCA I/O (4 of 4)

# 8 Parts and Diagrams

## Overview

The figures in this chapter identify and locate the printer's major subassemblies and replacement parts.

This chapter discusses the following:

- How to Use the Parts Lists and Diagrams
- Accessories and Supplies
- Illustrations and Parts Lists

# How To Use the Parts Lists and Diagrams

The figures in this chapter illustrate the major subassemblies in the printer and their component parts. A table accompanies each exploded view diagram. Each table lists the item number for the replaceable part, the associated part number for the item, the quantity, and a description of the part.

While looking for an electrical part number, pay careful attention to the voltage listed in the description column to ensure that the part number selected is for the correct model of the printer.

## Ordering Parts

---

### Note

---

Parts that have no item number or part number listed are not field replacement parts and cannot be ordered through SMO.

All standard part numbers listed are stocked and may be ordered from HP's Support Materials Organization (SMO), or Support Materials Europe (SME).

Hewlett-Packard Co.  
Support Materials Organization  
8050 Foothills Blvd.  
Roseville, CA 95678  
Parts Direct Ordering: 1-800-227-8164 (U.S. Only)

Hewlett-Packard Co.  
Support Materials, Europe  
Wolf-Hirth Strasse 33  
D-7030  
Boblingen, Germany  
(49 7031) 14-2253

## Ordering Consumables

Consumables and accessories such as those listed on Table may be ordered from Hewlett-Packard.

The phone numbers are:

U.S.: 1-800-538-8787  
Canada: 1-800-387-3154  
(Toronto) 516-671-8383  
United Kingdom: 0734-441212  
Germany: 0130-3322

Contact your local HP Parts Coordinator for other local phone numbers.

---

**Note**

---

Parts that have no item number or part number listed are not field replacement parts and cannot be ordered.

# Accessories and Supplies

The following items are available through your local authorized HP dealer. To find a dealer near you, call the HP Customer Information Center (800) 752-0900.

**Note** See page 2-4 for documentation product numbers.

**Table 8-1. Accessories and Supplies**

Description	Part No.	Exchange No.	Product No.
500-sheet Paper Feeder and Tray			C4115A
250-sheet Paper Feeder and Tray			C4114A
Duplex Printing Accessory (duplexer)		C4113-69001	C4113A
250-sheet Replacement Tray		C4116-69001	C4116A
500-sheet Replacement Tray		C4117-69001	C4117A
HP Multi-purpose Paper			HPM1120
HP LaserJet Paper			HPJ1124
Toner Cartridge (10,000 pages)			C4129J
EDO Dual In-line Memory Module (DIMM)			
4 MB	C4135-67901		C4135A
8 MB	C4136-67901		C4136A
16 MB	C4137-67901		C4137A
SDRAM DIMMs			
4 MB	C4140-67901		C4140A
8 MB	C4141-67901		C4141A
16 MB	C4142-67901		C4142A
32 MB	C4143-67901		C4143A
Flash DIMM			
2 MB			C4286A
4 MB			C4287A
Font DIMM (8 MB Asian MROM)			
Traditional Chinese			C4292A
Simplified Chinese			C4293A
Hard Disk			C2985A
Parallel Cables			
2 Meter IEEE-1284 cable			C2950A
3 Meter IEEE-1284 cable			C2951A

**Table 8-1. Accessories and Supplies (continued)**

<b>Description</b>	<b>Part No.</b>	<b>Exchange No.</b>	<b>Product No.</b>
Serial Cables			
9-9 pin serial cable (male/female)			C2932A
9-25 pin serial cable (male/female)			C2933A
Serial Adapter			
25-9 pin adapter (male/female)			C2809A
Macintosh Computer Serial Cable			92215S
Macintosh Network Cable Kit			92215N
Enhanced I/O Cards			
Ethernet RJ-45 only			J3110A
Ethernet RJ-45 and BNC, Local Talk	J3111-61003		J3111A
Token Ring RJ-45 and DB-9			J3112A
Maintenance Kit			
110V	C4110-67902	C4110-69006	
220V	C4110-67903	C4110-69007	



## Common Hardware and Replacement Cables

**Table 8-2. Screws Used in the Printer**

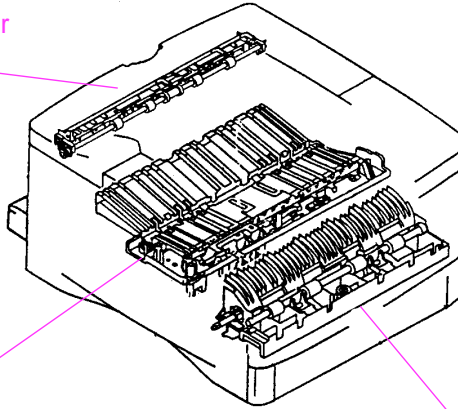
Description	Part No.
Screw, M4x10 Pan Head Tapping	XB4-7401-007CN
Screw, M4x8 Truss Head Tapping	XB4-7400-807CN
Screw, M3x6 TP	XA9-0267-000CN
Screw, M4x16 W/Washer	XA9-0838-000CN
Screw, M4x6 W/Washer	XA9-0265-000CN
Screw, M3x4 TP	XA9-0815-000CN
E Ring	XD2-1100-322CN
Screw, M4x6 Screw w/Washer	XB2-6400-607CN
Screw, M3x8 TP Screw	XB6-7300-807CN
Screw, Long DC Controller Screws (M3x25)	XA9-0974-000CN
Screw, with Spring	RF5-2418-000CN

**Table 8-3. Replaceable Cables**

Description	Part No.	Figure No.	Item No.
Cable, Display, Accessory Power, Photo Sensor	RG5-3557-000CN	Figure 8-4	26
Cable, Fuser AC	RG5-3561	Figure 8-7	4
Cable, Scanner	RG5-3562	Figure 8-7	3
Cable, Paper Sensor	RG5-3554-000CN	Figure 8-4	20
Cable, Paper Sensor	RG5-3558-000CN	Figure 8-4	21
Cable, Ribbon, from Paper PCA to Controller	RH2-5338-000CN	Figure 8-4	22

# Illustrations and Parts Lists

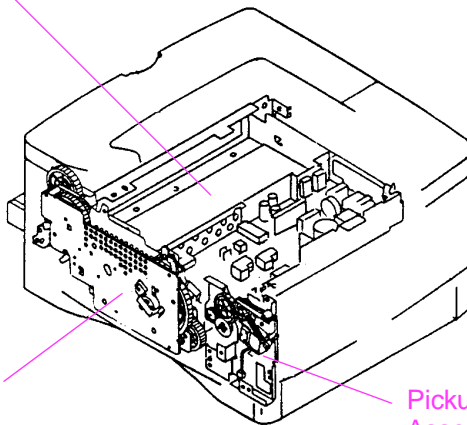
Upper Delivery Roller Assembly



Paper Feed Belt Assembly

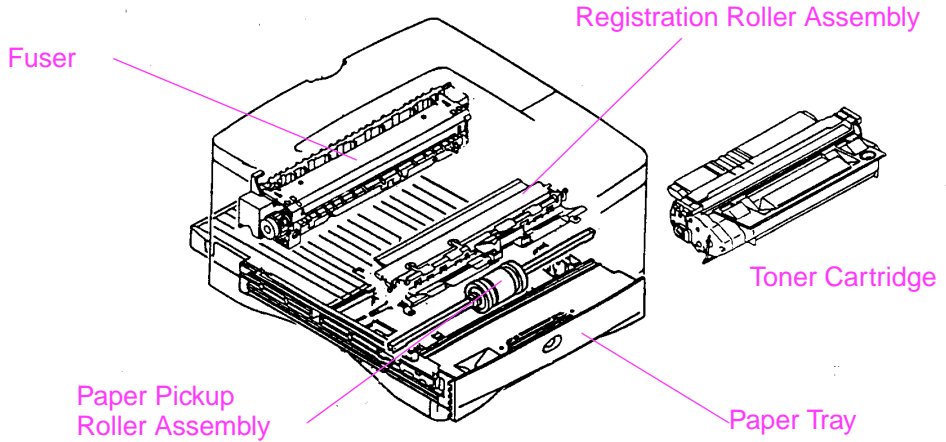
Paper Feed Roller Assembly

DC Controller Assembly



Printer Drive Assembly

Pickup Drive Assembly



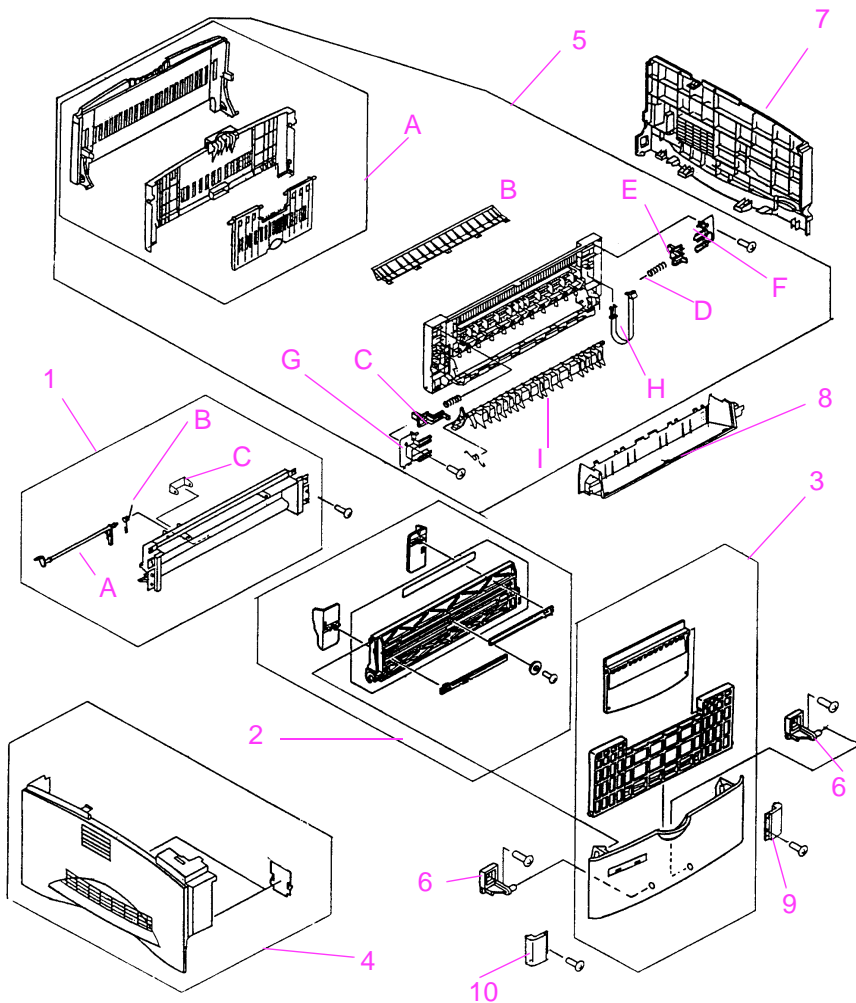
**Figure 8-1** Assembly Location Diagram

**Table 8-4. Assemblies Listed Alphabetically and Their Part Numbers**

Description	Part No.	Exchange No.	Exploded View in Figure
DC Controller with Ribbon Cable	RG5-3517-000CN RH2-5337-000CN	C4110-69001	Figure 8-16
Formatter Assembly		C3974-69001	
Fusing	RG5-3528-000CN (110V) RG5-3529-000CN (220V)	C4110-69002 C4110-69003	Figure 8-18
Laser Scanner	RG5-3603-000CN	C4110-69008	Figure 8-7
Power Supply 110V with Ribbon Cable	RH3-2195-000CN RH2-5337-000CN	C4110-69004	Figure 8-16
Power Supply 220V with Ribbon Cable	RH3-2196-000CN RH2-5337-000CN	C4110-69005	Figure 8-16
Tray 1 Assembly	RG5-3548-000CN		Figure 8-2
Tray 1 Pickup Assembly	RG5-3519-000CN		Figure 8-5
Upper Delivery Roller Assembly	RG5-3542-000CN		Figure 8-8

**Table 8-4. Assemblies Listed Alphabetically and Their Part Numbers (continued)**

<b>Description</b>	<b>Part No.</b>	<b>Exchange No.</b>	<b>Exploded View in Figure</b>
Paper Feed Roller Assembly	RG5-3522-000CN		Figure 8-11
Paper Feed Belt	RG5-3526-000CN		Figure 8-10
Registration Roller Assembly	RG5-3524-000CN		Figure 8-12



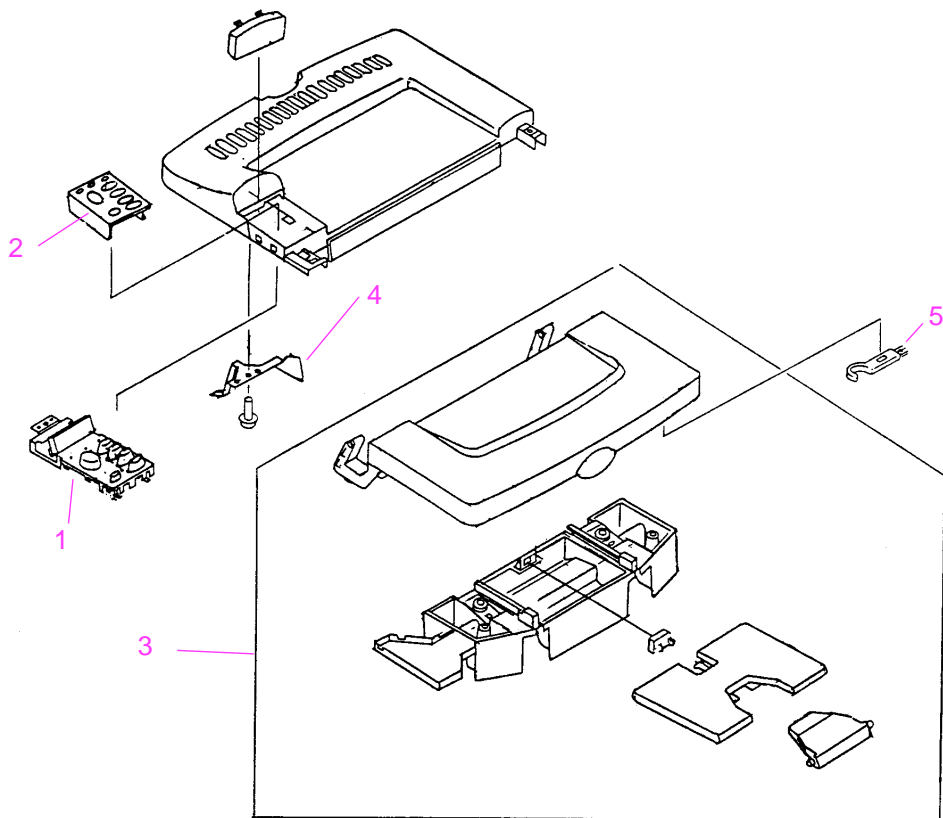
**Figure 8-2** External Covers and Panels

**Table 8-5. External Covers and Panels**

Item No.	Part No.	Quantity	Description
1	RG5-3547-000CN	1	Front Inner Cover Assembly
1A	RB1-6134-000CN	1	Tray 1 Sensor Arm
1B	RB1-6136-000CN	1	Tray 1 Sensor Arm Spring

**Table 8-5. External Covers and Panels (continued)**

<b>Item No.</b>	<b>Part No.</b>	<b>Quantity</b>	<b>Description</b>
1C	RB2-1772-000CN	1	Tray 1 Leaf Spring
2	RG5-3548-000CN	1	Tray 1 Paper Guide
3	RG5-3549-000CN	1	Front Cover Assembly
4	RG5-3550-000CN	1	Left Side Cover Assembly
5	RG5-3551-000CN	1	Rear Cover Assembly
5A	RG5-3552-000CN	1	Face Up Tray Assembly
5B	RB2-1970-000CN	1	Paper Guide
5C	RB2-1975-000CN	1	Right Latch Plate
5D	RS5-2952-000CN	4	Latch Plate Springs
5E	RB2-1976-000CN	1	Left Latch Plate
5F	RB2-1991-000CN	1	Right Latch Block
5G	RB2-1992-000CN	1	Left Latch Block
5H	RB2-1977-000CN	1	Cover Support Strap
5I	RB2-1978-000CN	1	Face Up Deflector
6	RB2-1745-000CN	2	Front Cover Pin
7	RB2-1749-000CN	1	Right Side Cover Assembly
8	RB2-1747-000CN	1	Face Down Auxiliary Cover
9	RB2-1755-000CN	1	Right Corner Cover
10	RB2-1756-000CN	1	Left Corner Cover



**Figure 8-3** Upper Cover Assembly

**Table 8-6. Top Cover Assembly**

Item No.	Part No.	Quantity	Description
1	RG5-3604-000CN	1	Control Panel Assembly
2	C4110-40004	1	Control Panel Overlay (English)

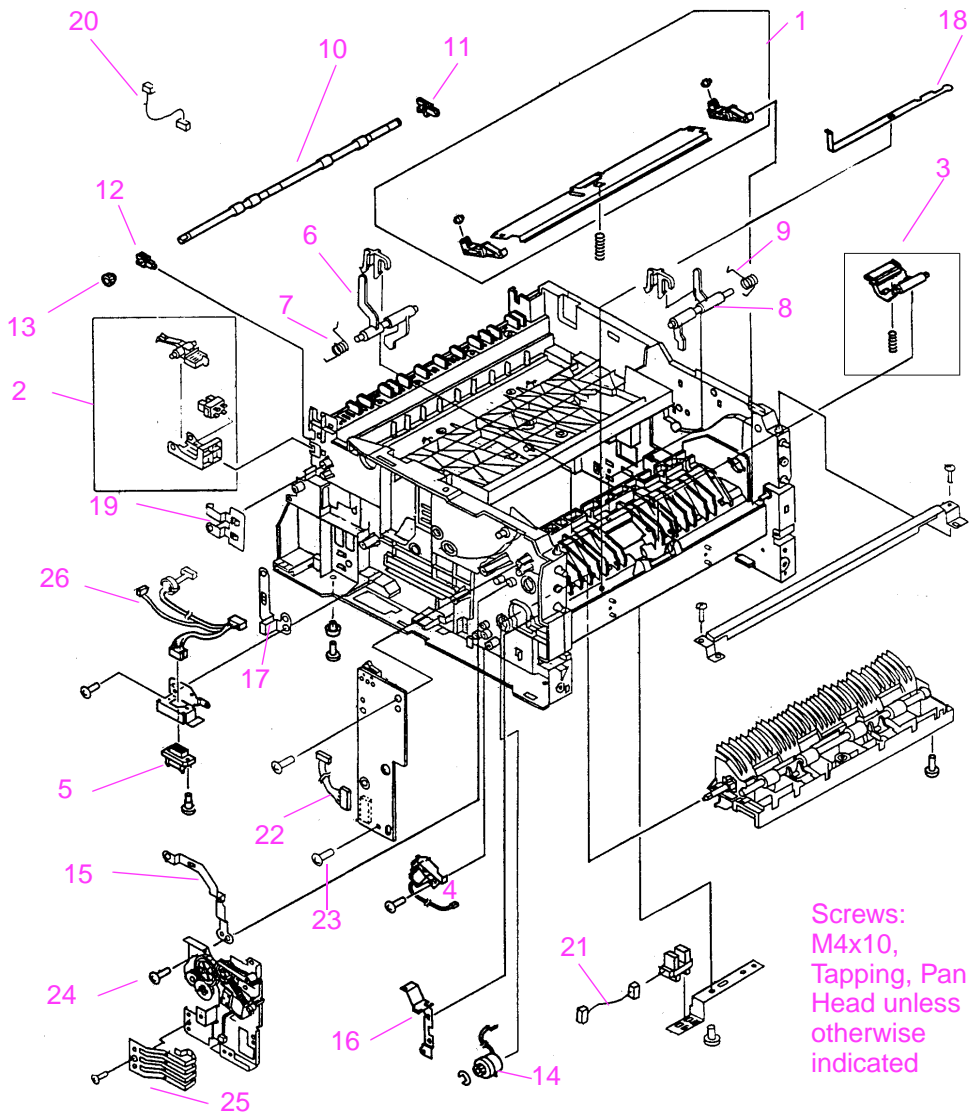
---

**Table 8-6. Top Cover Assembly (continued)**

---

<b>Item No.</b>	<b>Part No.</b>	<b>Quantity</b>	<b>Description</b>
3	RG5-3556-000CN	1	Toner Cartridge Door Assembly
4	RB2-1759-000CN	1	Control Panel Leaf Spring
5	RB2-1906-000CN	1	Cleaning Brush





**Figure 8-4** Internal Components (1 of 4)

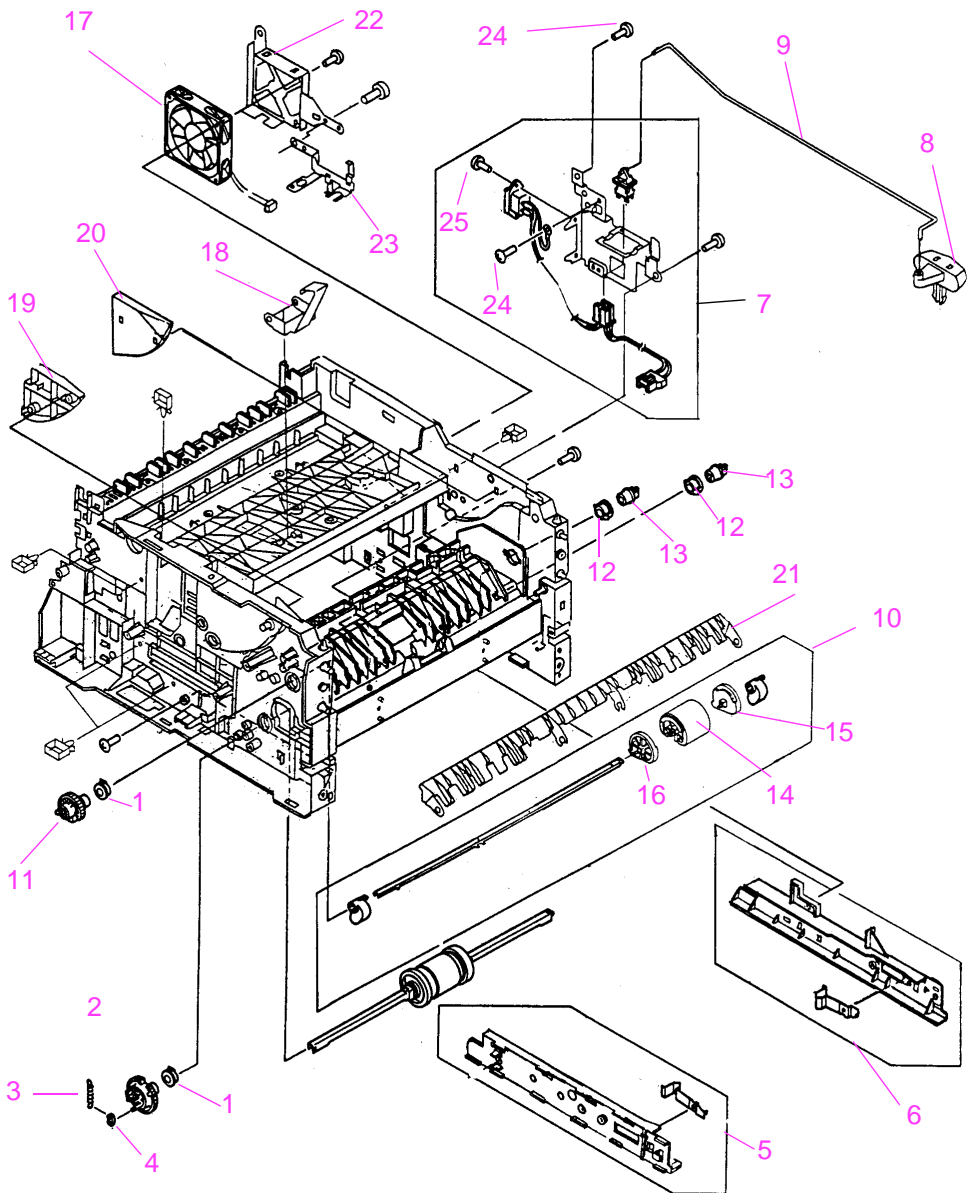
Cables are listed in Table 8-3 on page 8-6.

**Table 8-7. Internal Components (1 of 4)**

Item No.	Part No.	Quantity	Description
1	RG5-3520-000CN	1	Tray 1 Paper Guide Plate Assembly

**Table 8-7. Internal Components (1 of 4) (continued)**

<b>Item No.</b>	<b>Part No.</b>	<b>Quantity</b>	<b>Description</b>
2	RG5-3553-000CN	1	Rear Door Sensor Assembly
3	RG5-3585-000CN	1	Tray 1 Separation Pad with Spring
4	RH7-5195-000CN	1	Paper Pick Up Solenoid
5	WS6-5092-000CN	1	Power Connector
6	RB2-1782-000CN	1	Paper Sensor Lever
7	RB2-1784-000CN	1	Paper Sensor Lever Spring
8	RB2-1781-000CN	1	Paper Sensor Lever
9	RB2-1783-000CN	1	Paper Sensor Lever Spring
10	RB2-1985-000CN	1	Lower Delivery Roller
11	RB2-1988-000CN	1	Right Bushing Lower Delivery Roller
12	RB2-1989-000CN	1	Left Bushing Lower Delivery Roller
13	RS6-0357-000CN	1	Lower Delivery Shaft Gear
14	RH7-5192-000CN	1	Paper Feed Clutch
15	RB2-1734-000CN	1	Grounding Plate
16	RB2-1735-000CN	1	Grounding Plate
17	RB2-1737-000CN	1	Grounding Plate
18	RB1-6141-000CN	1	Grounding Plate
19	RB2-1990-000CN	1	Grounding Plate
23	XA9-0267-000CN	2	M3x6 Screw, TP
24	XB4-7401-007CN	14	M4x10 Screw, Tapping, Pan Head
25	RB2-1825-000CN	1	Leaf Spring

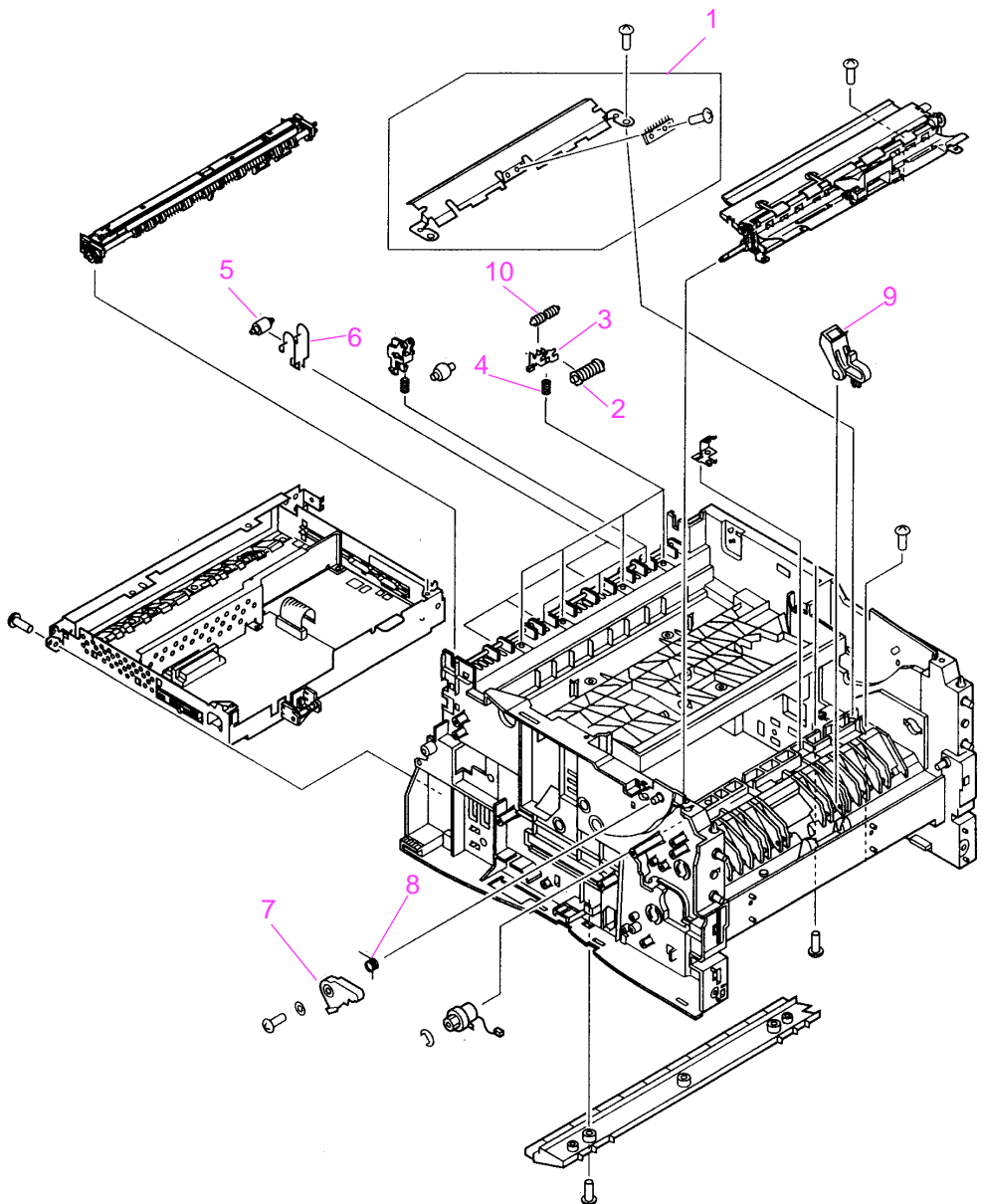


Screws M4x10, Tapping, Pan Head unless otherwise noted

**Figure 8-5** Internal Components (2 of 4)

**Table 8-8. Internal Components (2 of 4)**

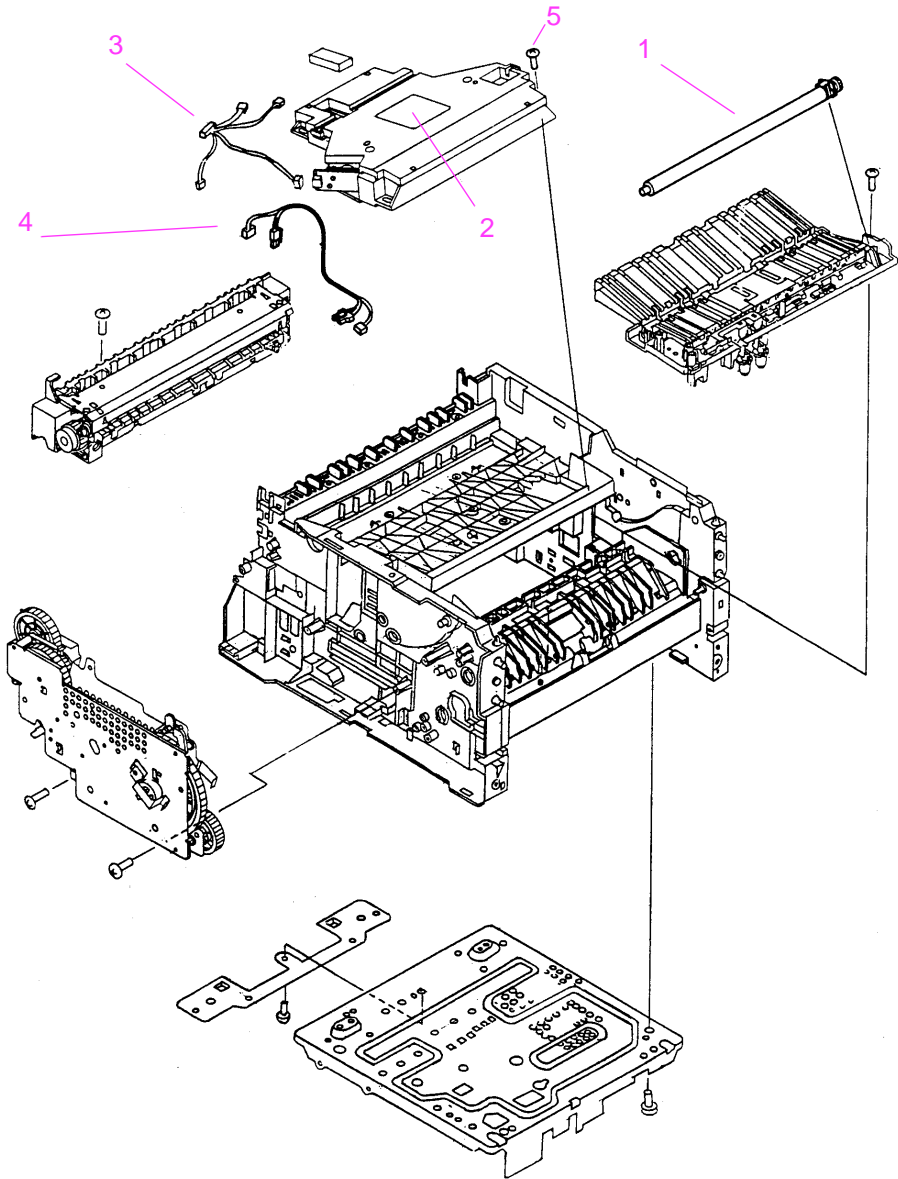
<b>Item No.</b>	<b>Part No.</b>	<b>Quantity</b>	<b>Description</b>
1	RS5-1392-000CN	2	Tray 1 and 2 Pickup Shaft Left Bushing
2	RS5-0695-000CN	1	Tray 2 Shaft Gear
3	RS5-2434-000CN	1	Spring
4	RB1-2190-000CN	1	Tray 2 Hook
5	RF5-2397-000CN	1	Tray 2 Rail Left
6	RF5-2398-000CN	1	Tray 2 Rail Right
7	RG5-3545-000CN	1	Power Inlet Assembly
8	RB2-1744-000CN	1	On/Off Switch
9	RB2-1731-000CN	1	Switch Rod
10	RG5-3519-000CN	1	Tray 1 Pickup Roller Assembly
11	RB1-6130-000CN	1	Tray 1 Pickup Gear
12	RB1-6179-000CN	2	Pickup Shaft Bushing - Tray 1 and 2
13	RB1-6177-000CN	2	Pickup Shaft Bushing - Tray 1 and 2
14	RB2-1820-000CN	1	Pickup Roller
15	RB2-1797-000CN	1	Cam Right
16	RB2-1796-000CN	1	Cam Left
17	RH7-1354-000CN	1	Fan
18	RB2-1738-000CN	1	Shutter Lever
19	RB2-1774-000CN	1	Cartridge Guide Left
20	RB2-1775-000CN	1	Cartridge Guide Right
21	RB2-1780-000CN	1	Paper Guide
22	RB2-1740-000CN	1	Grounding Plate/Fan Housing
23	RB2-1736-000CN	1	Grounding Plate
24	XB2-6400-607CN	2	M4X6 Screw w/ Washer
25	XB1-2300-607CN	2	M3x6 Screw, Mach., Truss Head
	XB4-7401-007CN	6	M4x10 Screw, Tapping, Pan Head



**Figure 8-6** Internal Components (3 of 4)

**Table 8-9. Internal Components (3 of 4)**

<b>Item No.</b>	<b>Part No.</b>	<b>Quantity</b>	<b>Description</b>
1	RG5-3525-000CN	1	Transfer Guide Assembly
2	RB2-1996-000CN	4	Face Down Guide Roller
3	RB2-1997-000CN	4	Roller Holder
4	RS5-2225-020CN	4	Roller Spring
5	RB1-6251-000CN	4	Lower Delivery Roller
6	RB1-6252-000CN	4	Lower Delivery Roller Spring
7	RB2-1732-000CN	1	Door Switch
8	RB2-1739-000CN	1	Door Switch Spring
9	RF5-2399-000CN	1	Pad Assembly
10	RB2-2068-000CN	1	Roller Mount 1



**Figure 8-7** Internal Components (4 of 4)

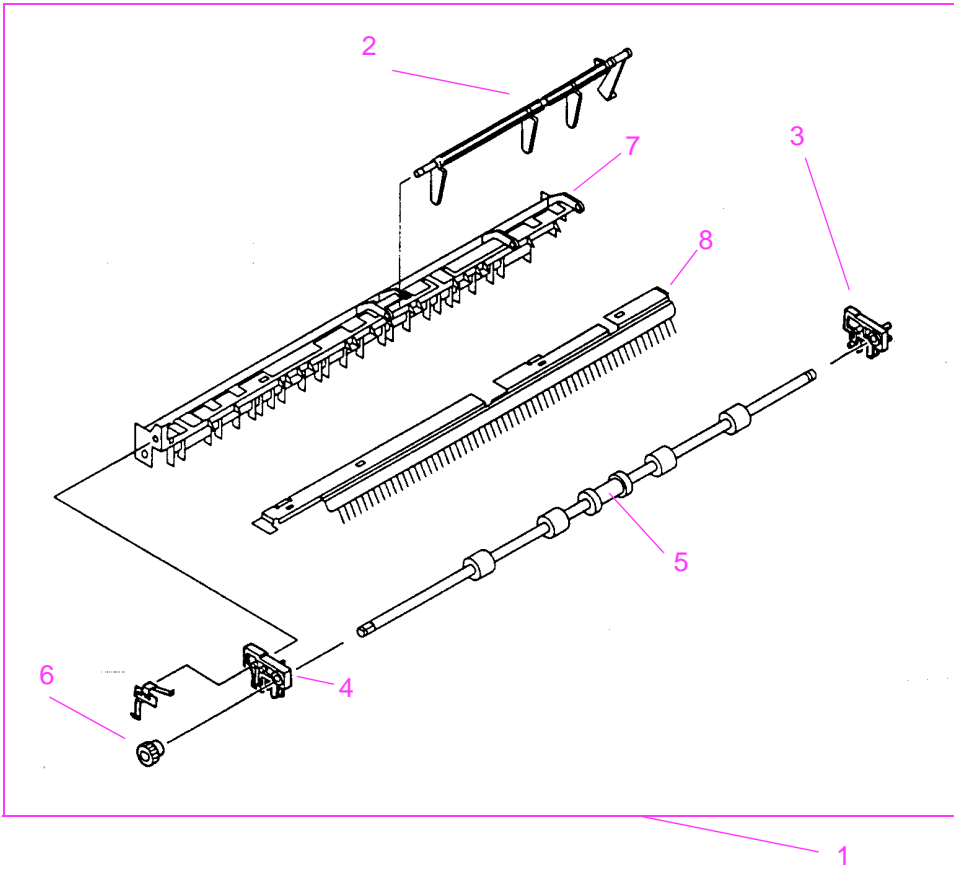
---

**Table 8-10. Internal Components (4 of 4)**

---

<b>Item No.</b>	<b>Part No.</b>	<b>Quantity</b>	<b>Description</b>
1	RG5-3579-000CN	1	Transfer Roller Assembly
2	RG5-3603-000CN	1	Laser Scanner Assembly
3	RG5-3562-000CN	1	Cable (Scanner)
4	RG5-3561-000CN	1	Cable (Fuser AC)
5	XA9-0838-000CN	4	Screw with washer m4x16

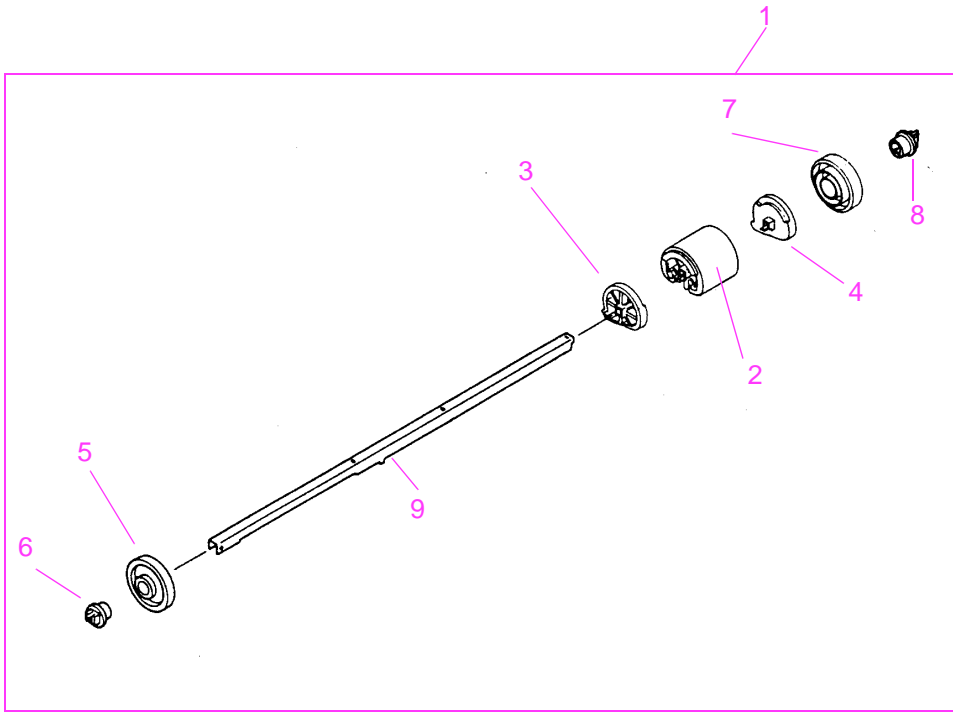




**Figure 8-8** Upper Delivery Assembly

**Table 8-11. Upper Delivery Assembly**

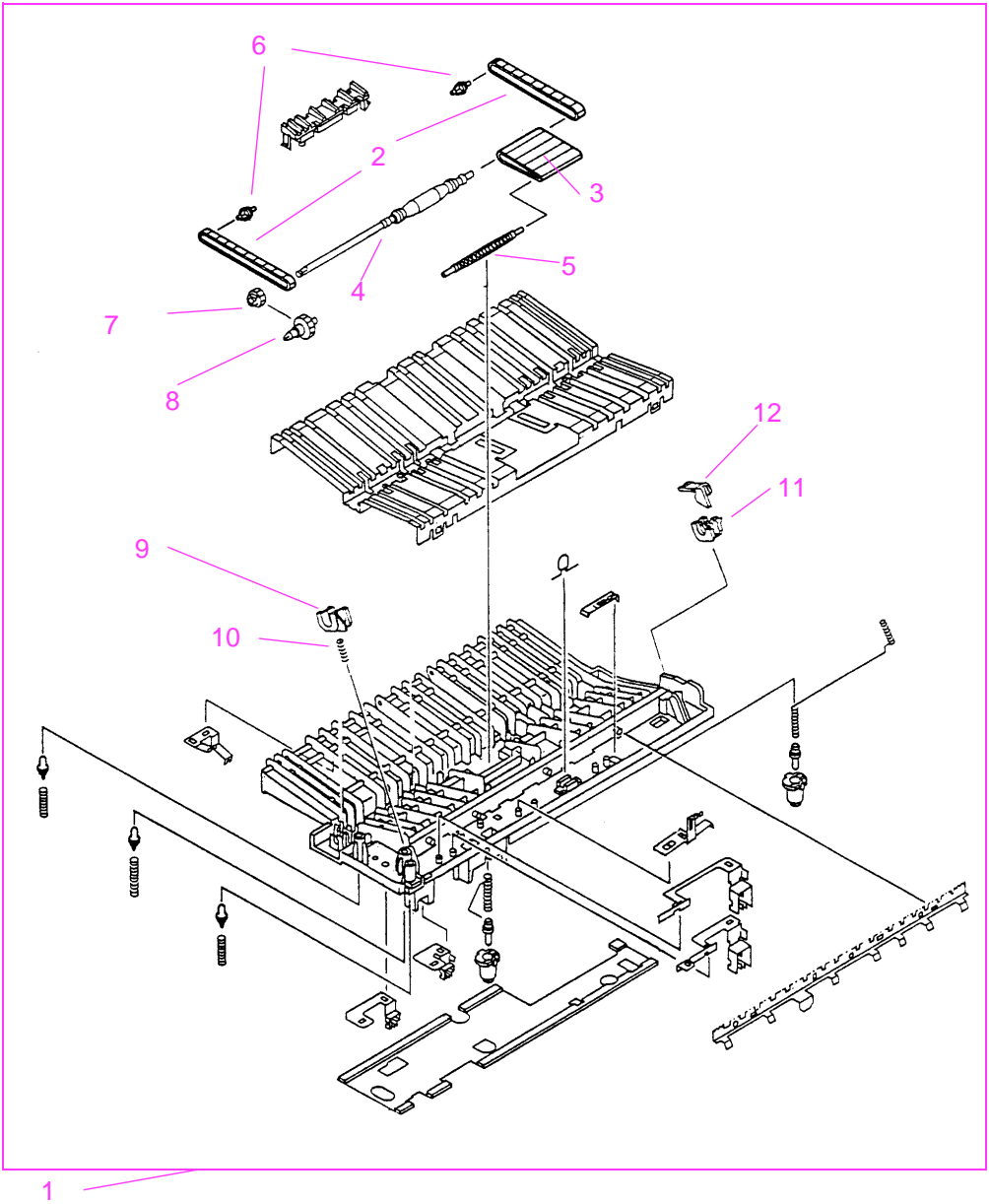
Item No.	Part No.	Quantity	Description
1	RG5-3542-000CN	1	Upper Delivery Assembly
2	RB2-1980-000CN	1	Face Down Bin Full Sensor Lever
3	RB2-1986-000CN	1	Right Bushing
4	RB2-1987-000CN	1	Left Bushing
5	RB2-1984-000CN	1	Delivery Roller
6	RS6-0357-000CN	1	Delivery Roller Gear
7	RF5-2415-000CN	1	Delivery Guide
8	RB2-1981-000CN	1	Static Charge Eliminator



**Figure 8-9** Tray 2 Paper Pickup Roller Assembly

**Table 8-12. Tray 2 Paper Pickup Roller Assembly**

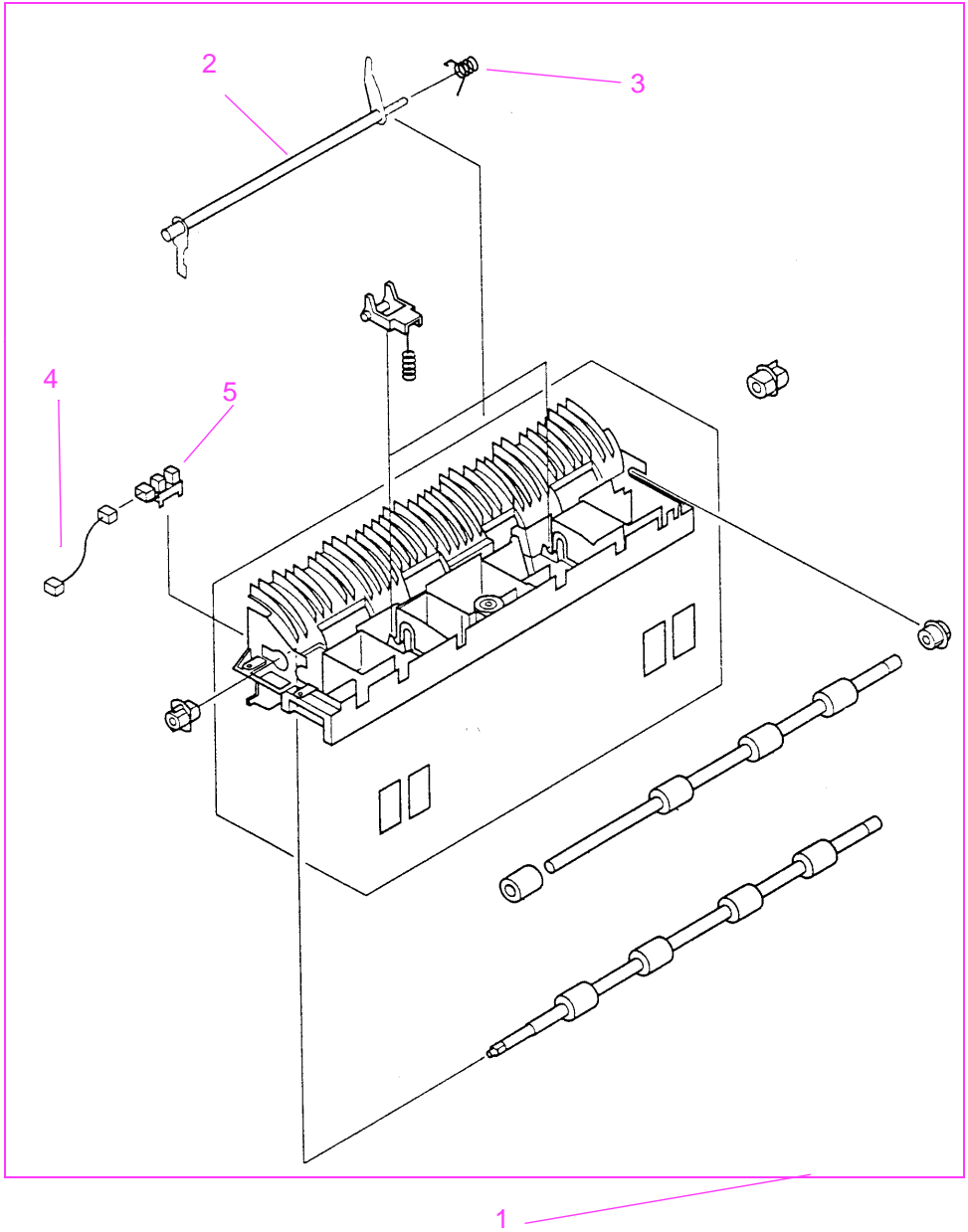
Item No.	Part No.	Quantity	Description
1	RG5-3521-000CN	1	Paper Pick Up Roller Assembly (Tray 2)
2	RB2-1821-000CN	1	Pickup Roller 250-sheet Trays
3	RB2-1802-000CN	1	Left Roller Cam
4	RB2-1805-000CN	1	Right Roller Cam
5	RB2-1815-000CN	1	Left Pickup Roller Collar
6	RB1-6149-000CN	1	Left Pickup Roller Bushing
7	RB2-1803-000CN	1	Right Pickup Roller Collar
8	RB2-1804-000CN	1	Right Pickup Roller Bushing
9	RB2-1800-000CN	1	Tray 2 Pickup Roller Shaft



**Figure 8-10** Paper Feed Belt Assembly

**Table 8-13. Paper Feed Belt Assembly**

<b>Item No.</b>	<b>Part No.</b>	<b>Quantity</b>	<b>Description</b>
1	RG5-3526-000CN	1	Paper Feed Belt Assembly
2	RB2-1888-000CN	2	Small Paper Feed Belts
3	RB2-1887-000CN	1	Large Feed Belt
4	RB2-1886-000CN	1	Paper Feed Shaft
5	RB1-6192-000CN	1	Paper Feed Shaft
6	RB1-6195-000CN	2	Paper Feed Pulley
7	RS6-0351-000CN	1	Paper Feed Gear
8	RS6-0352-000CN	1	Paper Feed Gear
9	RB2-1904-000CN	1	Transfer Roller Bushing (left)
10	RS5-2431-000CN	1	Transfer Roller Spring (left)
11	RB2-1903-000CN	1	Transfer Roller Bushing (right)
12	RB2-1905-000CN	1	Transfer Roller Bushing Cover (right)



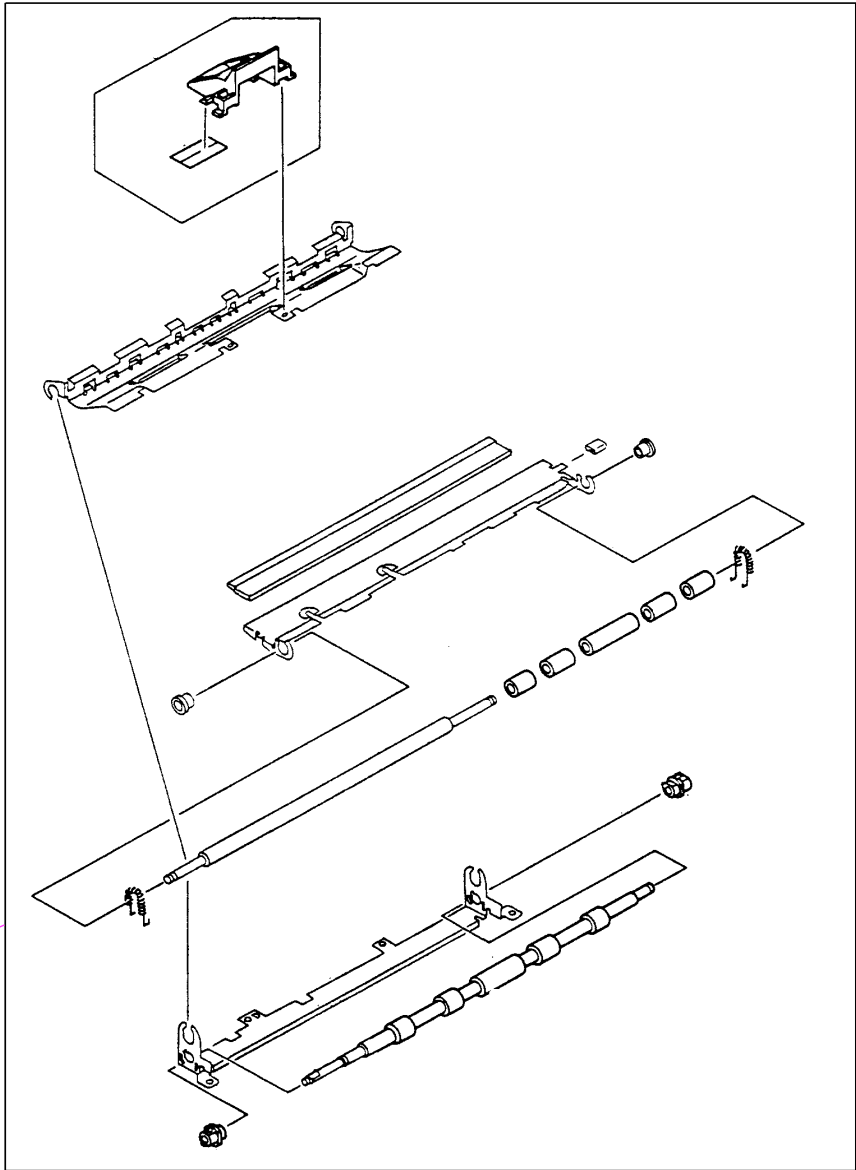
**Figure 8-11** Paper Feed Assembly

---

**Table 8-14. Paper Feed Assembly**

---

<b>Item No.</b>	<b>Part No.</b>	<b>Quantity</b>	<b>Description</b>
1	RG5-3522-000CN	1	Paper Feed Roller Assembly
2	RB2-1807-000CN	1	Sensor Flag Lever
3	RB2-1808-000CN	1	Sensor Flag Spring
4	RG5-3523-000CN	1	Sensor Cable
5	WG8-5362-000CN	1	Photo Sensor



**Figure 8-12** Registration Roller Assembly

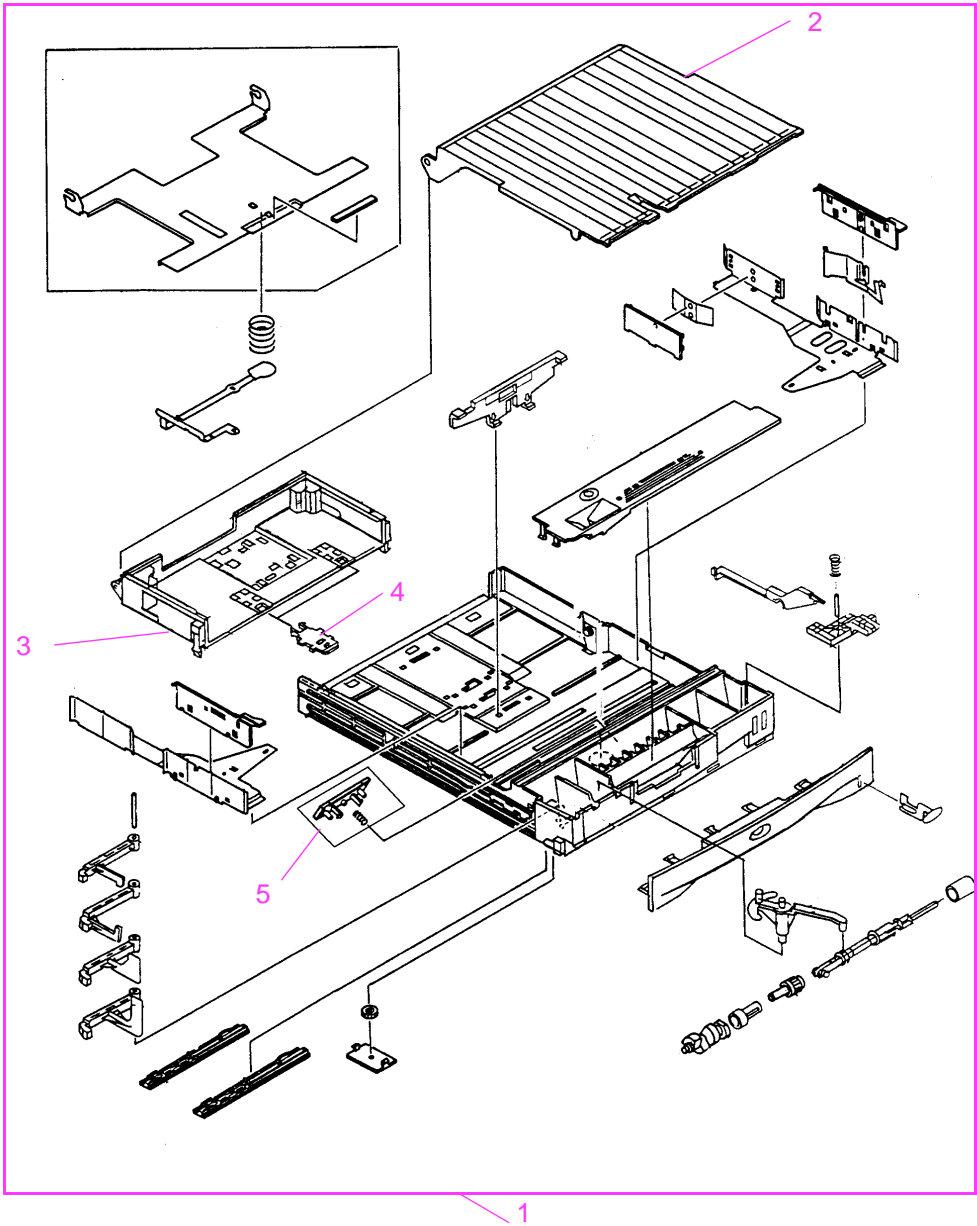
---

**Table 8-15. Registration Roller Assembly**

---

<b>Item No.</b>	<b>Part No.</b>	<b>Quantity</b>	<b>Description</b>
1	RG5-3524-000CN	1	Registration Roller Assembly





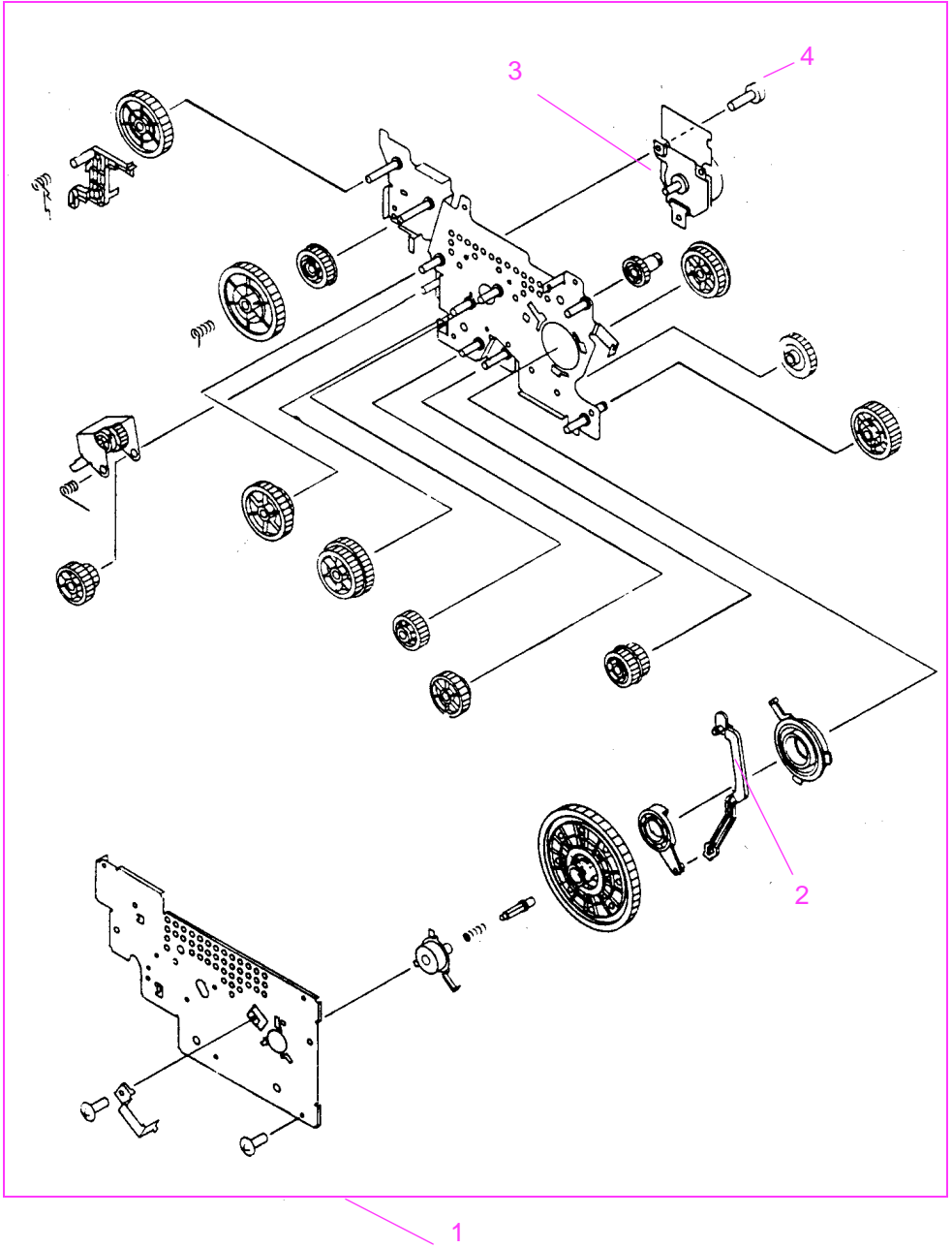
**Figure 8-13** 250-sheet Tray

---

**Table 8-16. 250-sheet Tray**

---

<b>Item No.</b>	<b>Part No.</b>	<b>Quantity</b>	<b>Description</b>
1	C4116A	1	250-sheet Universal Paper Tray
2	RB2-2037-000CN	1	Tray Cover
3	RB2-2020-000CN	1	Tray Extension
4	RB2-2042-000CN	2	Universal Tray Extension Lock
5	RF5-3585-000CN	1	Separation Pad/Spring



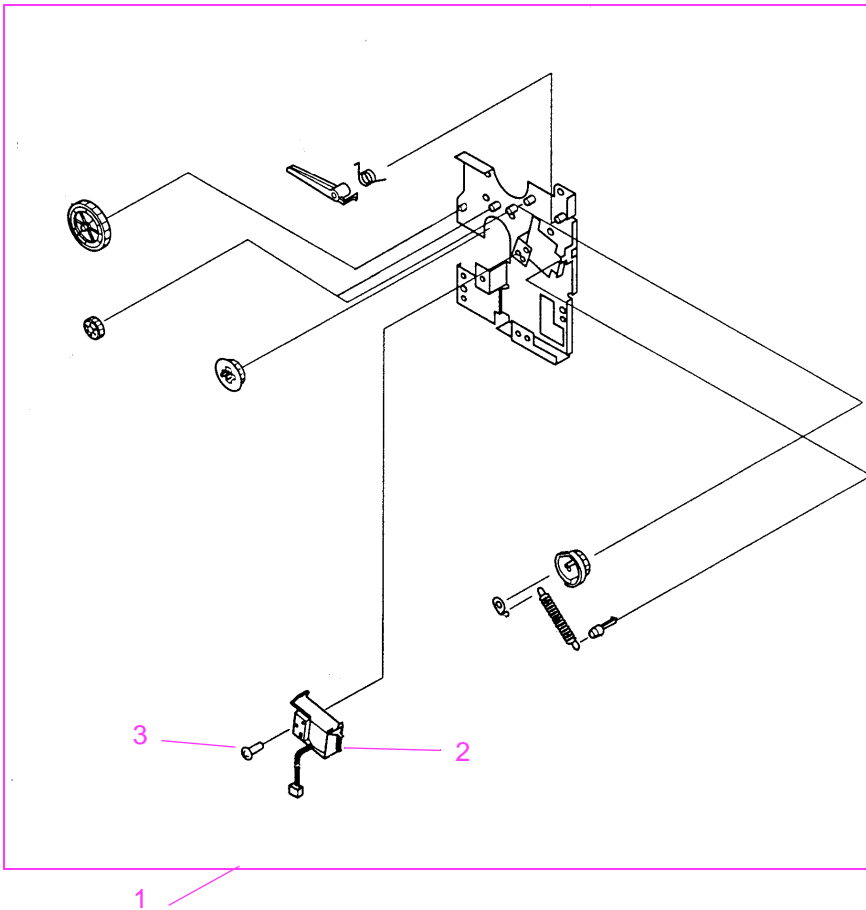
**Figure 8-14** Main Drive Assembly

---

**Table 8-17. Main Drive Assembly**

---

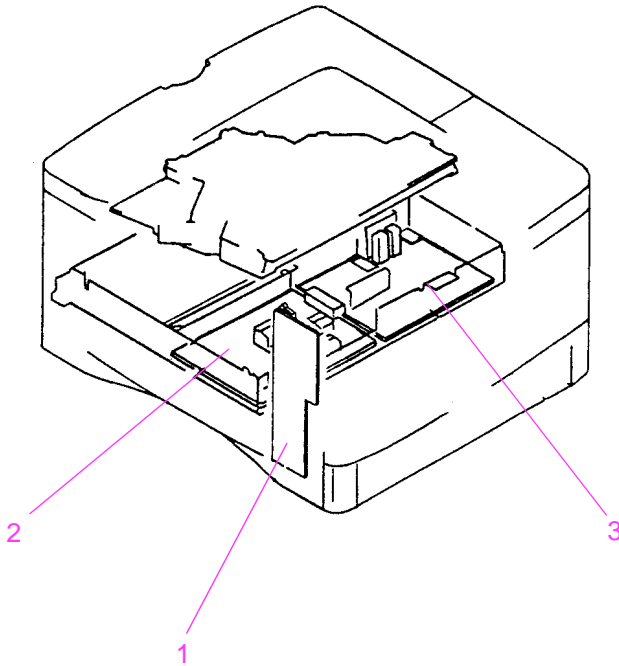
<b>Item No.</b>	<b>Part No.</b>	<b>Quantity</b>	<b>Description</b>
1	RG5-3543-000CN	1	Main Gear Assembly
2	RB2-1856-000CN	1	Toner Cartridge Engagement Arm
3	RH7-1356-000CN	1	Main Motor
4	XA9-0267-000CN	3	Screw, TP, M3x6



**Figure 8-15** Pickup Drive Assembly

**Table 8-18. Pickup Drive Assembly**

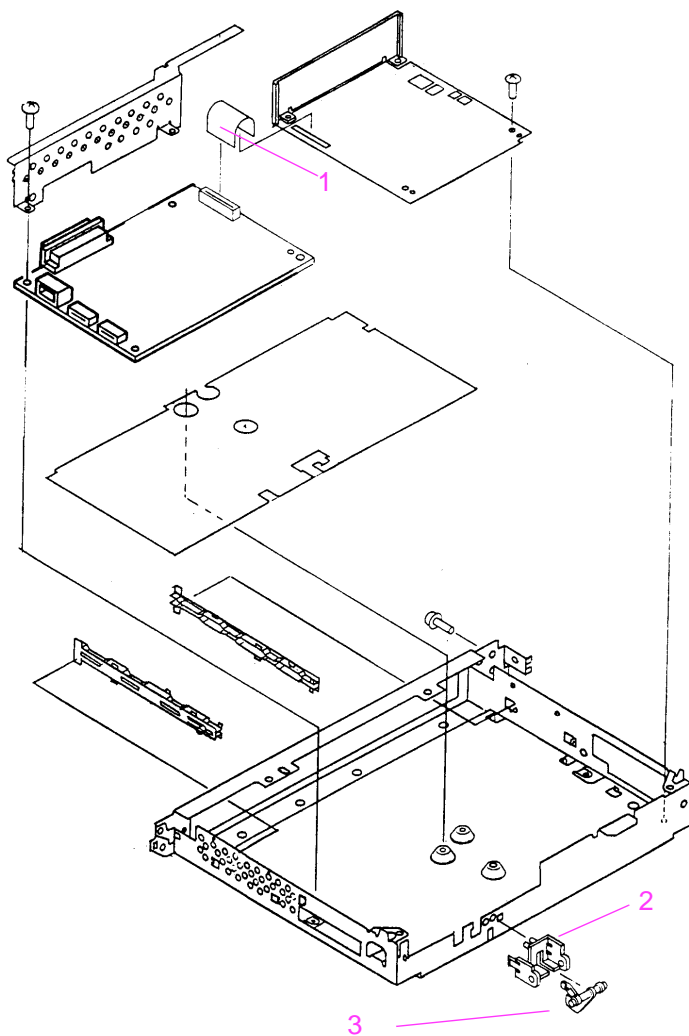
Item No.	Part No.	Quantity	Description
1	RG5-3544-000CN	1	Pickup Gear Assembly
2	RH7-5193-000CN	1	Pickup Solenoid
3	XA9-0815-000CN	1	Screw, TP, M3x4



**Figure 8-16** PCA Assembly Locations

**Table 8-19. PCA Assembly Locations**

Item No.	Part No.	Quantity	Description
1	RG5-3560-000CN	1	Paper Handling PCA
2	RG5-3517-000CN	1	DC Controller
3	RH3-2195-000CN	1	Power Supply (100 - 120 V)
3	RH3-2196-000CN	1	Power Supply (220 - 240 V)



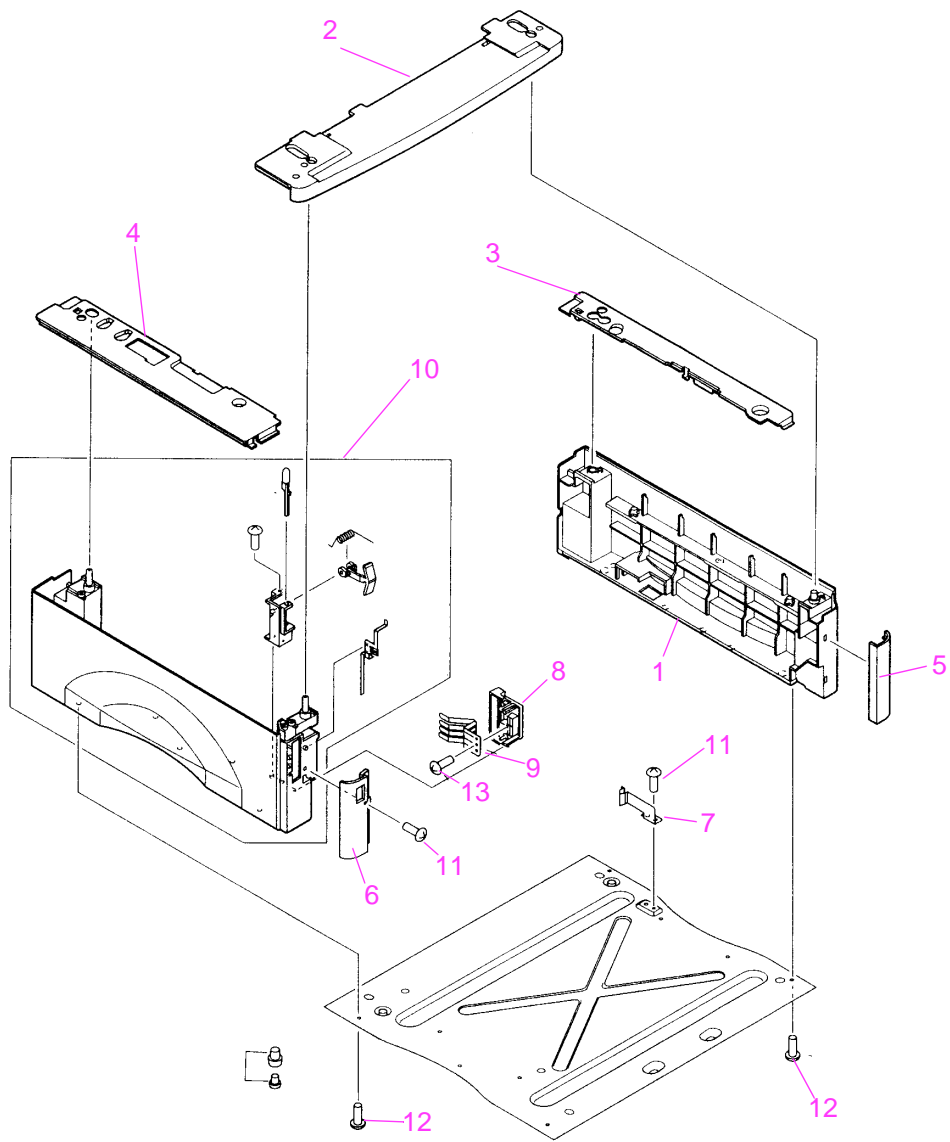
**Figure 8-17** Printer Controller Assembly

**Table 8-20. Printer Controller Assembly**

Item No.	Part No.	Quantity	Description
1	RH2-5337-000CN	1	Flat Cable
2	RB2-1790-000CN	1	Sensor Mount (Rear of Controller Pan)
3	RB2-1791-000CN	1	Sensor Lever



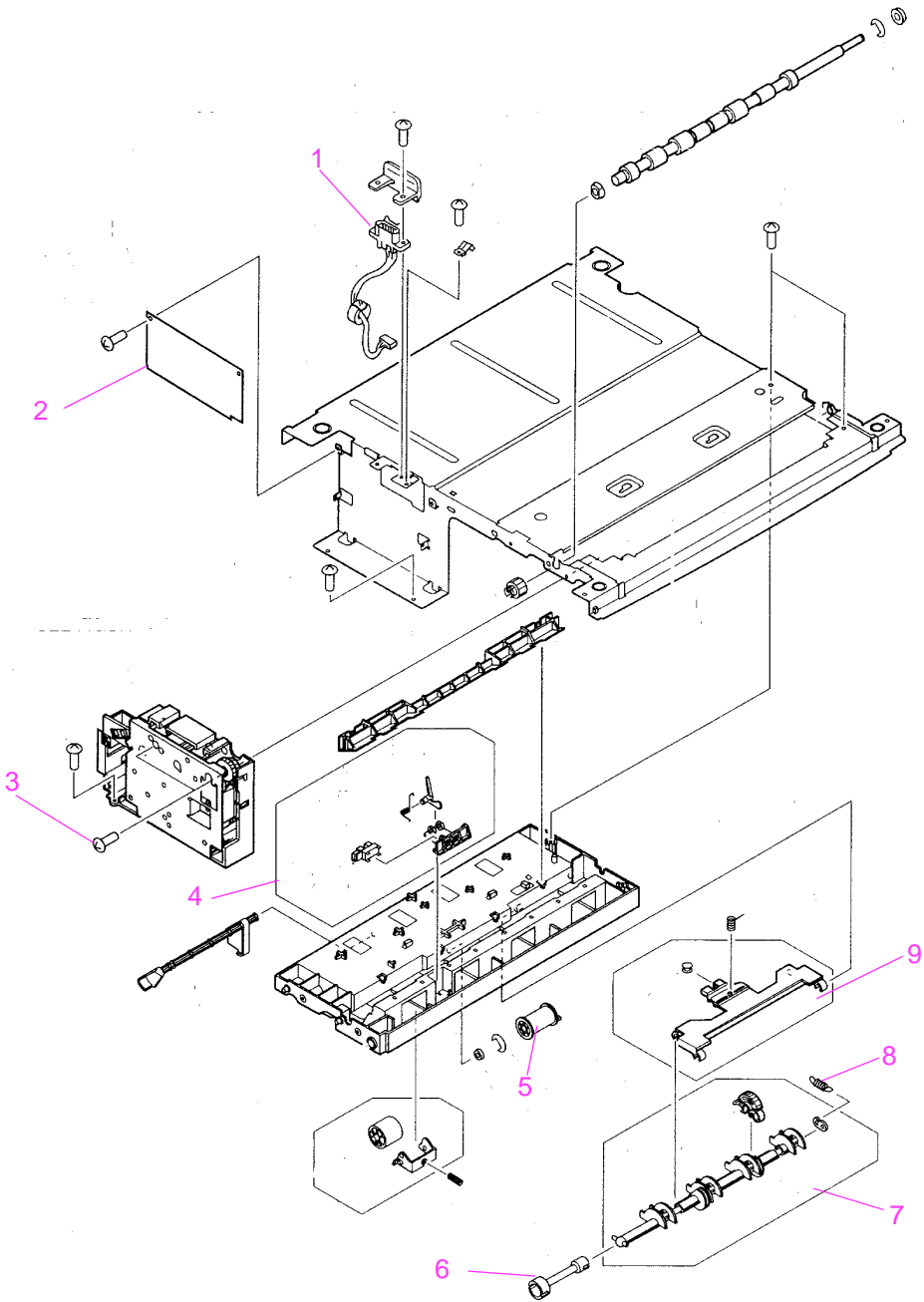




**Figure 8-19** 500-sheet Feeder

**Table 8-22. 500-sheet Feeder**

<b>Item No.</b>	<b>Part No.</b>	<b>Quantity</b>	<b>Description</b>
1	RB2-3211-000CN	1	Right Mount
2	RB2-3235-000CN	1	Front Cover
3	RB2-3236-000CN	1	Right Auxiliary Cover
4	RB2-3237-000CN	1	Left Auxiliary Cover
5	RB2-3238-000CN	1	Right Cover
6	RB2-3239-000CN	1	Left Cover
7	RB2-3284-000CN	1	Leaf Spring
8	RB2-3213-000CN	1	Inner Cover
9	RB2-3286-000CN	1	Leaf Spring
10	RG5-4180-000CN	1	Left Frame Assembly
11	XB1-2300-407CN	1	Screw, Mach., Truss Head, M3x4
12	XB4-7401-007CN	10	Screw, Tapping, Pan Head, M4x10
13	XB4-7300-807CN	1	Screw, Tapping, Truss Head, M3X8
	RB2-3262-000CN	1	Return Cover (Figure 6-70 on page 6-81)
	RB2-3247-000CN	1	Tray Cover, 500-sheet Feeder



**Figure 8-20** 500-sheet Feeder

**Table 8-23. 500-sheet Feeder**

<b>Item No.</b>	<b>Part No.</b>	<b>Quantity</b>	<b>Description</b>
1	RG5-4213-000CN	1	Upper Contact Cable
2	RG5-4211-000CN	1	Feeder Controller PCA Assembly
3	XB4-7300-807CN	2	M3x8 Screw, Tapping, Truss Head
4	RF5-2633-000CN	1	Tray Sensor Assembly
5	RF5-2634-000CN	1	Feed Roller
6	RB1-8877-000CN	1	Joint
7	RF5-2636-000CN	1	Pickup Roller
8	RF5-2632-000CN	1	Tension Spring
9	RF5-2635-000CN	1	Paper Arm

## Alphabetical Parts List

<b>Description</b>	<b>Part Number</b>	<b>Table Number and Page</b>
250-sheet Universal Paper Tray	C4116A	Table 8-16 on page 8-31
Cable (Fuser AC)	RG5-3561-000CN	Table 8-10 on page 8-21
Cable (Scanner)	RG5-3562-000CN	Table 8-10 on page 8-21
Cable, Display, Accessory Power, Photo Sensor	RG5-3557-000CN	Figure 8-4 on page 8-14
Cable, Paper Sensor	RG5-3554-000CN	Figure 8-4 on page 8-14
Cable, Paper Sensor	RG5-3558-000CN	Figure 8-4 on page 8-14
Cable, Ribbon, from Paper PCA to Controller	RH2-5338-000CN	Figure 8-4 on page 8-14
Cam Left	RB2-1796-000CN	Table 8-8 on page 8-17
Cam Right	RB2-1797-000CN	Table 8-8 on page 8-17
Cartridge Guide Left	RB2-1774-000CN	Table 8-8 on page 8-17
Cartridge Guide Right	RB2-1775-000CN	Table 8-8 on page 8-17
Cleaning Brush	RB2-1906-000CN	Table 8-6 on page 8-12
Control Panel Assembly	RG5-3604-000CN	Table 8-6 on page 8-12
Control Panel Leaf Spring	RB2-1759-000CN	Table 8-6 on page 8-12
Control Panel Overlay (English)	C4110-40004	Table 8-6 on page 8-12
Cover Support Strap	RB2-1977-000CN	Table 8-5 on page 8-10
Damper, 500-sheet Feeder	RB1-8883-000CN	Table 8-23 on page 8-41
DC Controller	RG5-3517-000CN	Table 8-19 on page 8-35
DC Controller with Ribbon Cable	RG5-3517-000CN (110V) RH2-5337-000CN (220V)	Figure 8-16 on page 8-35
Delivery Guide	RF5-2415-000CN	Table 8-11 on page 8-22
Delivery Roller	RB2-1984-000CN	Table 8-11 on page 8-22
Delivery Roller Gear	RS6-0367-000CN	Table 8-11 on page 8-22
Door Switch	RB2-1732-000CN	Table 8-9 on page 8-19
Door Switch Spring	RB2-1739-000CN	Table 8-9 on page 8-19
E Ring	XD2-1100-322CN	Table 8-2 on page 8-6
Face Down Auxiliary Cover	RB2-1747-000CN	Table 8-5 on page 8-10
Face Down Bin Full Sensor Lever	RB2-1980-000CN	Table 8-11 on page 8-22
Face Down Guide Roller	RB2-1996-000CN	Table 8-9 on page 8-19
Face Up Deflector	RB2-1978-000CN	Table 8-5 on page 8-10
Face Up Tray Assembly	RG5-3552-000CN	Table 8-5 on page 8-10
Fan	RH7-1354-000CN	Table 8-8 on page 8-17
Feed Roller, 500-sheet Feeder	RF5-2634-000CN	Table 8-23 on page 8-41

<b>Description</b>	<b>Part Number</b>	<b>Table Number and Page</b>
Feeder Controller PCA Assembly, 500-sheet Feeder	RG5-4211-000CN	Table 8-23 on page 8-41
Flat Cable	RH2-5337-000CN	Table 8-20 on page 8-36
Formatter Assembly	C3974-69001	
Front Cover, 500-sheet Feeder	RB2-3235-000CN	Table 8-22 on page 8-39
Front Cover Assembly	RG5-3549-000CN	Table 8-5 on page 8-10
Front Cover Pin	RB2-1745-000CN	Table 8-5 on page 8-10
Front Inner Cover Assembly	RG5-3547-000CN	Table 8-5 on page 8-10
Fuser (100 - 120 V)	RG5-3528-000CN	Table 8-21 on page 8-37
Fuser (220 - 240 V)	RG5-3529-000CN	Table 8-21 on page 8-37
Grounding Plate	RB2-1734-000CN	Table 8-7 on page 8-14
Grounding Plate	RB2-1735-000CN	Table 8-7 on page 8-14
Grounding Plate	RB2-1737-000CN	Table 8-7 on page 8-14
Grounding Plate	RB1-6141-000CN	Table 8-7 on page 8-14
Grounding Plate	RB2-1990-000CN	Table 8-7 on page 8-14
Grounding Plate	RB2-1736-000CN	Table 8-8 on page 8-17
Grounding Plate/Fan Housing	RB2-1740-000CN	Table 8-8 on page 8-17
Inner Cover, 500-sheet Feeder	RB2-3213-000CN	Table 8-22 on page 8-39
Joint, 500-sheet Feeder	RB1-8877-000CN	Table 8-23 on page 8-41
Large Feed Belt	RB2-1887-000CN	Table 8-13 on page 8-25
Laser Scanner Assembly	RG5-3603-000CN	Table 8-10 on page 8-21
Latch Plate Springs	RS5-2952-000CN	Table 8-5 on page 8-10
Leaf Spring	RB2-1825-000CN	Table 8-7 on page 8-14
Leaf Spring, 500-sheet Feeder	RB2-3284-000CN	Table 8-22 on page 8-39
Leaf Spring, 500-sheet Feeder	RB2-3286-000CN	Table 8-22 on page 8-39
Left Auxiliary Cover, 500-sheet Feeder	RB2-3237-000CN	Table 8-22 on page 8-39
Left Bushing	RB2-1987-000CN	Table 8-11 on page 8-22
Left Bushing Lower Delivery Roller	RB2-1989-000CN	Table 8-7 on page 8-14
Left Corner Cover	RB2-1756-000CN	Table 8-5 on page 8-10
Left Cover, 500-sheet Feeder	RB2-3239-000CN	Table 8-22 on page 8-39
Left Frame Assembly	RG5-4180-000CN	Table 8-22 on page 8-39
Left Latch Block	RB2-1992-000CN	Table 8-5 on page 8-10
Left Latch Plate	RB2-1976-000CN	Table 8-5 on page 8-10
Left Pickup Roller Bushing	RB1-6149-000CN	Table 8-12 on page 8-23
Left Pickup Roller Collar	RB2-1815-000CN	Table 8-12 on page 8-23
Left Roller Cam	RB2-1802-000CN	Table 8-12 on page 8-23
Left Side Cover Assembly	RG5-3550-000CN	Table 8-5 on page 8-10
Lower Delivery Roller	RB2-1985-000CN	Table 8-7 on page 8-14
Lower Delivery Roller	RB1-6251-000CN	Table 8-9 on page 8-19

<b>Description</b>	<b>Part Number</b>	<b>Table Number and Page</b>
Lower Delivery Roller Spring	RB1-6252-000CN	Table 8-9 on page 8-19
Lower Delivery Shaft Gear	RS6-0357-000CN	Table 8-7 on page 8-14
M3x6 Screw, Mach., Truss Head	XB1-2300-607CN	Table 8-8 on page 8-17
M3x8 Screw, Tapping, Truss Head	XB4-7300-807CN	Table 8-23 on page 8-41
Main Gear Assembly	RG5-3543-000CN	Table 8-17 on page 8-33
Main Motor	RH7-1356-000CN	Table 8-17 on page 8-33
On/Off Switch	RB2-1744-000CN	Table 8-8 on page 8-17
Pad Assembly	RF5-2399-000CN	Table 8-9 on page 8-19
Paper Arm	RF5-2635-000CN	Table 8-23 on page 8-41
Paper Feed Belt	RG5-3526-000CN	Table 8-12 on page 8-23
Paper Feed Clutch	RH7-5192-000CN	Table 8-7 on page 8-14
Paper Feed Gear	RS6-0351-000CN	Table 8-13 on page 8-25
Paper Feed Gear	RS6-0352-000CN	Table 8-13 on page 8-25
Paper Feed Pulley	RB1-6195-000CN	Table 8-13 on page 8-25
Paper Feed Roller Assembly	RG5-3522-000CN	Table 8-14 on page 8-27
Paper Feed Shaft	RB2-1886-000CN	Table 8-13 on page 8-25
Paper Feed Shaft	RB1-6192-000CN	Table 8-13 on page 8-25
Paper Guide	RB2-1970-000CN	Table 8-5 on page 8-10
Paper Guide	RB2-1780-000CN	Table 8-8 on page 8-17
Paper Handling PCA	RG5-3560-000CN	Table 8-19 on page 8-35
Paper Pickup Roller Assembly (Tray 2)	RG5-3521-000CN	Table 8-12 on page 8-23
Paper Pick Up Solenoid	RH7-5195-000CN	Table 8-7 on page 8-14
Paper Sensor Lever	RB2-1782-000CN	Table 8-7 on page 8-14
Paper Sensor Lever	RB2-1781-000CN	Table 8-7 on page 8-14
Paper Sensor Lever Spring	RB2-1784-000CN	Table 8-7 on page 8-14
Paper Sensor Lever Spring	RB2-1783-000CN	Table 8-7 on page 8-14
Photo Sensor	WG8-5362-000CN	Table 8-14 on page 8-27
Pickup Gear Assembly	RG5-3544-000CN	Table 8-18 on page 8-34
Pickup Roller	RB2-1820-000CN	Table 8-8 on page 8-17
Pickup Roller 250-sheet Trays	RB2-1821-000CN	Table 8-12 on page 8-23
Pickup Roller 500-sheet Feeder	RF5-2636-000CN	Table 8-23 on page 8-41
Pickup Shaft Bushing - Tray 1 and 2	RB1-6179-000CN	Table 8-8 on page 8-17
Pickup Shaft Bushing - Tray 1 and 2	RB1-6177-000CN	Table 8-8 on page 8-17
Pickup Solenoid	RH7-5193-000CN	Table 8-18 on page 8-34
Power Connector	WS6-5092-000CN	Table 8-7 on page 8-14
Power Inlet Assembly	RG5-3545-000CN	Table 8-8 on page 8-17
Power Supply (100 - 120 V)	RH3-2195-000CN	Table 8-19 on page 8-35
Power Supply (220 - 240 V)	RH3-2196-000CN	Table 8-19 on page 8-35
Rear Cover Assembly	RG5-3551-000CN	Table 8-5 on page 8-10

<b>Description</b>	<b>Part Number</b>	<b>Table Number and Page</b>
Rear Door Sensor Assembly	RG5-3553-000CN	Table 8-7 on page 8-14
Registration Roller Assembly	RG5-3524-000CN	Table 8-15 on page 8-29
Return Cover, 500-sheet Feeder	RB2-3262-000CN	Figure 6-70 on page 6-81
Right Auxiliary Cover, 500-sheet Feeder	RB2-3236-000CN	Table 8-22 on page 8-39
Right Bushing	RB2-1986-000CN	Table 8-11 on page 8-22
Right Bushing Lower Delivery Roller	RB2-1988-000CN	Table 8-7 on page 8-14
Right Corner Cover	RB2-1755-000CN	Table 8-5 on page 8-10
Right Cover, 500-sheet Feeder	RB2-3238-000CN	Table 8-22 on page 8-39
Right Latch Block	RB2-1991-000CN	Table 8-5 on page 8-10
Right Latch Plate	RB2-1975-000CN	Table 8-5 on page 8-10
Right Mount	RB2-3211-000CN	Table 8-22 on page 8-39
Right Pickup Roller Bushing	RB2-1804-000CN	Table 8-12 on page 8-23
Right Pickup Roller Collar	RB2-1803-000CN	Table 8-12 on page 8-23
Right Roller Cam	RB2-1805-000CN	Table 8-12 on page 8-23
Right Side Cover Assembly	RB2-1749-000CN	Table 8-5 on page 8-10
Roller Holder	RB2-1997-000CN	Table 8-9 on page 8-19
Roller Mount 1	RB2-2068-000CN	Table 8-9 on page 8-19
Roller Spring	RS5-2225-020CN	Table 8-9 on page 8-19
Screw, Long DC Controller Screws (M3x25)	XA9-0974-000CN	Table 8-2 on page 8-6
Screw, M3x4 TP	XA9-0815-000CN	Table 8-2 on page 8-6
Screw, M3x6 TP	XA9-0267-000CN	Table 8-2 on page 8-6
Screw, M3x8 TP Screw	XB6-7300-807CN	Table 8-2 on page 8-6
Screw, M4x10 Pan Head Tapping	XB4-7401-007CN	Table 8-2 on page 8-6
Screw, M4x16 W/Washer	XA9-0838-000CN	Table 8-2 on page 8-6
Screw, M4x6 Screw w/Washer	XB2-6400-607CN	Table 8-2 on page 8-6
Screw, M4x6 W/Washer	XA9-0265-000CN	Table 8-2 on page 8-6
Screw, M4x8 Truss Head Tapping	XB4-7400-807CN	Table 8-2 on page 8-6
Screw, Mach., Truss Head, M4x10	XB4-2300-407CN	Table 8-22 on page 8-39
Screw, with Spring	RF5-2418-000CN	Table 8-2 on page 8-6
Sensor Cable	RG5-3523-000CN	Table 8-14 on page 8-27
Sensor Flag Lever	RB2-1807-000CN	Table 8-14 on page 8-27
Sensor Flag Spring	RB2-1808-000CN	Table 8-14 on page 8-27
Sensor Lever	RB2-1791-000CN	Table 8-20 on page 8-36
Sensor Mount (Rear of Controller Pan)	RB2-1790-000CN	Table 8-20 on page 8-36
Separation Pad/Spring	RF5-3585-000CN	Table 8-16 on page 8-31
Shutter Lever	RB2-1738-000CN	Table 8-8 on page 8-17
Small Paper Feed Belts	RB2-1888-000CN	Table 8-13 on page 8-25
Spring	RS5-2434-000CN	Table 8-8 on page 8-17



<b>Description</b>	<b>Part Number</b>	<b>Table Number and Page</b>
Static Charge Eliminator	RB2-1981-000CN	Table 8-11 on page 8-22
Switch Rod	RB2-1731-000CN	Table 8-8 on page 8-17
Tension Spring, 500-sheet Feeder	RF5-2632-000CN	Table 8-23 on page 8-41
Toner Cartridge Door Assembly	RG5-3556-000CN	Table 8-6 on page 8-12
Toner Cartridge Engagement Arm	RB2-1856-000CN	Table 8-17 on page 8-33
Transfer Guide Assembly	RG5-3525-000CN	Table 8-9 on page 8-19
Transfer Roller Assembly	RG5-3579-000CN	Table 8-10 on page 8-21
Transfer Roller Bushing (left)	RB2-1904-000CN	Table 8-13 on page 8-25
Transfer Roller Bushing (right)	RB2-1903-000CN	Table 8-13 on page 8-25
Transfer Roller Bushing Cover (right)	RB2-1905-000CN	Table 8-13 on page 8-25
Transfer Roller Spring (left)	RS5-2431-000CN	Table 8-13 on page 8-25
Tray 1 Leaf Spring	RB2-1772-000CN	Table 8-5 on page 8-10
Tray 1 and 2 Pickup Shaft Left Bushing	RS5-1392-000CN	Table 8-8 on page 8-17
Tray 1 Paper Guide	RG5-3548-000CN	Table 8-5 on page 8-10
Tray 1 Paper Guide Plate Assembly	RG5-3520-000CN	Table 8-7 on page 8-14
Tray 1 Pickup Assembly	RG5-3519-000CN	Table 8-4 on page 8-8
Tray 1 Pickup Gear	RB1-6130-000CN	Table 8-8 on page 8-17
Tray 1 Pickup Roller Assembly	RG5-3519-000CN	Table 8-8 on page 8-17
Tray 1 Sensor Arm	RB1-6134-000CN	Table 8-5 on page 8-10
Tray 1 Sensor Arm Spring	RB1-6136-000CN	Table 8-5 on page 8-10
Tray 1 Separation Pad with Spring	RG5-3585-000CN	Table 8-7 on page 8-14
Tray 2 Hook	RB1-2190-000CN	Table 8-8 on page 8-17
Tray 2 Pickup Roller Shaft	RB2-1800-000CN	Table 8-12 on page 8-23
Tray 2 Rail Left	RF5-2397-000CN	Table 8-8 on page 8-17
Tray 2 Rail Right	RF5-2398-000CN	Table 8-8 on page 8-17
Tray 2 Shaft Gear	RS5-0695-000CN	Table 8-8 on page 8-17
Tray Cover, 250-sheet Feeder	RB2-2037-000CN	Table 8-16 on page 8-31
Tray Cover, 500-sheet Feeder	RB2-3247-000CN	Table 8-22 on page 8-39
Tray Extension	RB2-2020-000CN	Table 8-16 on page 8-31
Tray Sensor Assembly, 500-sheet Feeder	RF5-2633-000CN	Table 8-23 on page 8-41
Universal Tray Extension Lock	RB2-2042-000CN	Table 8-16 on page 8-31
Upper Delivery Assembly	RG5-3542-000CN	Table 8-11 on page 8-22
Upper Contact Cable, 500-sheet Feeder	RG5-4213-000CN	Table 8-23 on page 8-41
Upper Delivery Roller Assembly	RG5-2648-000CN	Figure 8-8 on page 8-22

## Numerical Parts List

<b>Part Number</b>	<b>Description</b>	<b>Table Number and Page</b>
C3974-69001	Formatter Assembly	
C4116A	250-sheet Universal Paper Tray	Table 8-16 on page 8-31
C4110-40004	Control Panel Overlay (English)	Table 8-6 on page 8-12
RB1-2190-000CN	Tray 2 Hook	Table 8-8 on page 8-17
RB1-6130-000CN	Tray 1 Pickup Gear	Table 8-8 on page 8-17
RB1-6134-000CN	Tray 1 Sensor Arm	Table 8-5 on page 8-10
RB1-6136-000CN	Tray 1 Sensor Arm Spring	Table 8-5 on page 8-10
RB1-6141-000CN	Grounding Plate	Table 8-7 on page 8-14
RB1-6149-000CN	Left Pickup Roller Bushing	Table 8-12 on page 8-23
RB1-6177-000CN	Pickup Shaft Bushing - Tray 1 and 2	Table 8-8 on page 8-17
RB1-6179-000CN	Pickup Shaft Bushing - Tray 1 and 2	Table 8-8 on page 8-17
RB1-6192-000CN	Paper Feed Shaft	Table 8-13 on page 8-25
RB1-6195-000CN	Paper Feed Pulley	Table 8-13 on page 8-25
RB1-6251-000CN	Lower Delivery Roller	Table 8-9 on page 8-19
RB1-6252-000CN	Lower Delivery Roller Spring	Table 8-9 on page 8-19
RB1-8877-000CN	Joint, 500-sheet Feeder	Table 8-23 on page 8-41
RB1-8883-000CN	Damper, 500-sheet Feeder	Table 8-23 on page 8-41
RB2-1731-000CN	Switch Rod	Table 8-8 on page 8-17
RB2-1732-000CN	Door Switch	Table 8-9 on page 8-19
RB2-1734-000CN	Grounding Plate	Table 8-7 on page 8-14
RB2-1735-000CN	Grounding Plate	Table 8-7 on page 8-14
RB2-1736-000CN	Grounding Plate	Table 8-8 on page 8-17
RB2-1737-000CN	Grounding Plate	Table 8-7 on page 8-14
RB2-1738-000CN	Shutter Lever	Table 8-8 on page 8-17
RB2-1739-000CN	Door Switch Spring	Table 8-9 on page 8-19
RB2-1740-000CN	Grounding Plate/Fan Housing	Table 8-8 on page 8-17
RB2-1744-000CN	On/Off Switch	Table 8-8 on page 8-17
RB2-1745-000CN	Front Cover Pin	Table 8-5 on page 8-10
RB2-1747-000CN	Face Down Auxiliary Cover	Table 8-5 on page 8-10
RB2-1749-000CN	Right Side Cover Assembly	Table 8-5 on page 8-10
RB2-1755-000CN	Right Corner Cover	Table 8-5 on page 8-10
RB2-1756-000CN	Left Corner Cover	Table 8-5 on page 8-10
RB2-1759-000CN	Control Panel Leaf Spring	Table 8-6, on page 8-12
RB2-1772-000CN	Tray 1 Leaf Spring	Table 8-5 on page 8-10
RB2-1774-000CN	Cartridge Guide Left	Table 8-8 on page 8-17
RB2-1775-000CN	Cartridge Guide Right	Table 8-8 on page 8-17
RB2-1780-000CN	Paper Guide	Table 8-8 on page 8-17

<b>Part Number</b>	<b>Description</b>	<b>Table Number and Page</b>
RB2-1781-000CN	Paper Sensor Lever	Table 8-7 on page 8-14
RB2-1782-000CN	Paper Sensor Lever	Table 8-7 on page 8-14
RB2-1783-000CN	Paper Sensor Lever Spring	Table 8-7 on page 8-14
RB2-1784-000CN	Paper Sensor Lever Spring	Table 8-7 on page 8-14
RB2-1790-000CN	Sensor Mount (Rear of Controller Pan)	Table 8-20 on page 8-36
RB2-1791-000CN	Sensor Lever	Table 8-20 on page 8-36
RB2-1796-000CN	Cam Left	Table 8-8 on page 8-17
RB2-1797-000CN	Cam Right	Table 8-8 on page 8-17
RB2-1800-000CN	Tray 2 Pickup Roller Shaft	Table 8-12 on page 8-23
RB2-1802-000CN	Left Roller Cam	Table 8-12 on page 8-23
RB2-1803-000CN	Right Pickup Roller Collar	Table 8-12 on page 8-23
RB2-1804-000CN	Right Pickup Roller Bushing	Table 8-12 on page 8-23
RB2-1805-000CN	Right Roller Cam	Table 8-12 on page 8-23
RB2-1807-000CN	Sensor Flag Lever	Table 8-14 on page 8-27
RB2-1808-000CN	Sensor Flag Spring	Table 8-14 on page 8-27
RB2-1815-000CN	Left Pickup Roller Collar	Table 8-12 on page 8-23
RB2-1820-000CN	Pickup Roller	Table 8-8 on page 8-17
RB2-1821-000CN	Pickup Roller 250 Sheet Trays	Table 8-12 on page 8-23
RB2-1825-000CN	Leaf Spring	Table 8-7 on page 8-14
RB2-1856-000CN	Toner Cartridge Engagement Arm	Table 8-17 on page 8-33
RB2-1886-000CN	Paper Feed Shaft	Table 8-13 on page 8-25
RB2-1887-000CN	Large Feed Belt	Table 8-13 on page 8-25
RB2-1888-000CN	Small Paper Feed Belts	Table 8-13 on page 8-25
RB2-1903-000CN	Transfer Roller Bushing (right)	Table 8-13 on page 8-25
RB2-1904-000CN	Transfer Roller Bushing (left)	Table 8-13 on page 8-25
RB2-1905-000CN	Transfer Roller Bushing Cover (right)	Table 8-13 on page 8-25
RB2-1906-000CN	Cleaning Brush	Table 8-6 on page 8-12
RB2-1970-000CN	Paper Guide	Table 8-5 on page 8-10
RB2-1975-000CN	Right Latch Plate	Table 8-5 on page 8-10
RB2-1976-000CN	Left Latch Plate	Table 8-5 on page 8-10
RB2-1977-000CN	Cover Support Strap	Table 8-5 on page 8-10
RB2-1978-000CN	Face Up Deflector	Table 8-5 on page 8-10
RB2-1980-000CN	Face Down Bin Full Sensor Lever	Table 8-11 on page 8-22
RB2-1981-000CN	Static Charge Eliminator	Table 8-11 on page 8-22
RB2-1984-000CN	Delivery Roller	Table 8-11 on page 8-22
RB2-1985-000CN	Lower Delivery Roller	Table 8-7 on page 8-14
RB2-1986-000CN	Right Bushing	Table 8-11 on page 8-22
RB2-1987-000CN	Left Bushing	Table 8-11 on page 8-22
RB2-1988-000CN	Right Bushing Lower Delivery Roller	Table 8-7 on page 8-14

<b>Part Number</b>	<b>Description</b>	<b>Table Number and Page</b>
RB2-1989-000CN	Left Bushing Lower Delivery Roller	Table 8-7 on page 8-14
RB2-1990-000CN	Grounding Plate	Table 8-7 on page 8-14
RB2-1991-000CN	Right Latch Block	Table 8-5 on page 8-10
RB2-1992-000CN	Left Latch Block	Table 8-5 on page 8-10
RB2-1996-000CN	Face Down Guide Roller	Table 8-9 on page 8-19
RB2-1997-000CN	Roller Holder	Table 8-9 on page 8-19
RB2-2020-000CN	Tray Extension	Table 8-16 on page 8-31
RB2-2037-000CN	Tray Cover, 250-sheet Feeder	Table 8-16 on page 8-31
RB2-2042-000CN	Universal Tray Extension Lock	Table 8-16 on page 8-31
RB2-2068-000CN	Roller Mount 1	Table 8-9 on page 8-19
RB2-3211-000CN	Right Mount, 500-sheet Feeder	Table 8-22 on page 8-39
RB2-3213-000CN	Inner Cover, 500-sheet Feeder	Table 8-22 on page 8-39
RB2-3235-000CN	Front Cover, 500-sheet Feeder	Table 8-22 on page 8-39
RB2-3236-000CN	Right Auxiliary Cover, 500-sheet Feeder	Table 8-22 on page 8-39
RB2-3237-000CN	Left Auxiliary Cover, 500-sheet Feeder	Table 8-22 on page 8-39
RB2-3238-000CN	Right Cover, 500-sheet Feeder	Table 8-22 on page 8-39
RB2-3239-000CN	Left Cover, 500-sheet Feeder	Table 8-22 on page 8-39
RB2-3247-000CN	Tray Cover, 500-sheet Feeder	Table 8-22 on page 8-39
RB2-3262-000CN	Return Cover, 500-sheet Feeder	Figure 6-70 on page 6-81
RB2-3284-000CN	Leaf Spring, 500-sheet Feeder	Table 8-22 on page 8-39
RB2-3286-000CN	Leaf Spring, 500-sheet Feeder	Table 8-22 on page 8-39
RF5-2397-000CN	Tray 2 Rail Left	Table 8-8 on page 8-17
RF5-2398-000CN	Tray 2 Rail Right	Table 8-8 on page 8-17
RF5-2399-000CN	Pad Assembly	Table 8-9 on page 8-19
RF5-2415-000CN	Delivery Guide	Table 8-11 on page 8-22
RF5-2418-000CN	Screw, with Spring	Table 8-2 on page 8-6
RF5-2632-000CN	Tension Spring, 500-sheet Feeder	Table 8-23 on page 8-41
RF5-2633-000CN	Tray Sensor Assembly, 500-sheet Feeder	Table 8-23 on page 8-41
RF5-2635-000CN	Paper Arm	Table 8-23 on page 8-41
RF5-2636-000CN	Pickup Roller 500-sheet Feeder	Table 8-23 on page 8-41
RF5-3585-000CN	Separation Pad/Spring	Table 8-16 on page 8-31
RF5-2634-000CN	Feed Roller, 500-sheet Feeder	Table 8-23 on page 8-41
RG5-2648-000CN	Upper Delivery Roller Assembly	Figure 8-8 on page 8-22
RG5-3517-000CN (110V)	DC Controller with Ribbon Cable	Figure 8-16 on page 8-35
RH2-5337-000CN (220V)		
RG5-3517-000CN	DC Controller	Table 8-19 on page 8-35

<b>Part Number</b>	<b>Description</b>	<b>Table Number and Page</b>
RG5-3519-000CN	Tray 1 Pickup Roller Assembly	Table 8-8 on page 8-17
RG5-3520-000CN	Tray 1 Paper Guide Plate Assembly	Table 8-7 on page 8-14
RG5-3521-000CN	Paper Pickup Roller Assembly (Tray 2)	Table 8-12 on page 8-23
RG5-3522-000CN	Paper Feed Roller Assembly	Table 8-14 on page 8-27
RG5-3523-000CN	Sensor Cable	Table 8-14 on page 8-27
RG5-3524-000CN	Registration Roller Assembly	Table 8-15 on page 8-29
RG5-3525-000CN	Transfer Guide Assembly	Table 8-9 on page 8-19
RG5-3526-000CN	Paper Feed Belt Assembly	Table 8-13 on page 8-25
RG5-3528-000CN	Fuser (100 - 120 V)	Table 8-21 on page 8-37
RG5-3529-000CN	Fuser (220 - 240 V)	Table 8-21 on page 8-37
RG5-3542-000CN	Upper Delivery Assembly	Table 8-11 on page 8-22
RG5-3543-000CN	Main Gear Assembly	Table 8-17 on page 8-33
RG5-3544-000CN	Pickup Gear Assembly	Table 8-18 on page 8-34
RG5-3545-000CN	Power Inlet Assembly	Table 8-8 on page 8-17
RG5-3547-000CN	Front Inner Cover Assembly	Table 8-5 on page 8-10
RG5-3548-000CN	Tray 1 Paper Guide	Table 8-5 on page 8-10
RG5-3549-000CN	Front Cover Assembly	Table 8-5 on page 8-10
RG5-3550-000CN	Left Side Cover Assembly	Table 8-5 on page 8-10
RG5-3551-000CN	Rear Cover Assembly	Table 8-5 on page 8-10
RG5-3552-000CN	Face Up Tray Assembly	Table 8-5 on page 8-10
RG5-3553-000CN	Rear Door Sensor Assembly	Table 8-7 on page 8-14
RG5-3554-000CN	Cable, Paper Sensor	Figure 8-4 on page 8-14
RG5-3556-000CN	Toner Cartridge Door Assembly	Table 8-6 on page 8-12
RG5-3557-000CN	Cable, Display, Accessory Power, Photo Sensor	Figure 8-4 on page 8-14
RG5-3558-000CN	Cable, Paper Sensor	Figure 8-4 on page 8-14
RG5-3560-000CN	Paper Handling PCA	Table 8-19 on page 8-35
RG5-3561-000CN	Cable (Fuser AC)	Table 8-10 on page 8-21
RG5-3562-000CN	Cable (Scanner)	Table 8-10 on page 8-21
RG5-3579-000CN	Transfer Roller Assembly	Table 8-10 on page 8-21
RG5-3585-000CN	Tray 1 Separation Pad with Spring	Table 8-7 on page 8-14
RG5-3603-000CN	Laser Scanner Assembly	Table 8-10 on page 8-21
RG5-3604-000CN	Control Panel Assembly	Table 8-6 on page 8-12
RG5-4180-000CN	Left Frame Assembly	Table 8-22 on page 8-39
RG5-4211-000CN	Feeder Controller PCA Assembly, 500-sheet Feeder	Table 8-23 on page 8-41
RG5-4213-000CN	Upper Contact Cable, 500-sheet Feeder	Table 8-23 on page 8-41
RH2-5337-000CN	Flat Cable	Table 8-20 on page 8-36

<b>Part Number</b>	<b>Description</b>	<b>Table Number and Page</b>
RH2-5338-000CN	Cable, Ribbon, from Paper PCA to Controller	Figure 8-4 on page 8-14
RH3-2195-000CN	Power Supply (100 - 120 V)	Table 8-19 on page 8-35
RH3-2196-000CN	Power Supply (220 - 240 V)	Table 8-19 on page 8-35
RH7-1354-000CN	Fan	Table 8-8 on page 8-17
RH7-1356-000CN	Main Motor	Table 8-17 on page 8-33
RH7-5192-000CN	Paper Feed Clutch	Table 8-7 on page 8-14
RH7-5193-000CN	Pickup Solenoid	Table 8-18, on page 8-36
RH7-5195-000CN	Paper Pick Up Solenoid	Table 8-7 on page 8-14
RS5-0695-000CN	Tray 2 Shaft Gear	Table 8-8 on page 8-17
RS5-1392-000CN	Tray 1 and 2 Pickup Shaft Left Bushing	Table 8-8 on page 8-17
RS5-2225-020CN	Roller Spring	Table 8-9, on page 8-21
RS5-2431-000CN	Transfer Roller Spring (left)	Table 8-13 on page 8-25
RS5-2434-000CN	Spring	Table 8-8 on page 8-17
RS5-2952-000CN	Latch Plate Springs	Table 8-5 on page 8-10
RS6-0351-000CN	Paper Feed Gear	Table 8-13 on page 8-25
RS6-0352-000CN	Paper Feed Gear	Table 8-13 on page 8-25
RS6-0357-000CN	Lower Delivery Shaft Gear	Table 8-7 on page 8-14
RS6-0367-000CN	Delivery Roller Gear	Table 8-11 on page 8-22
WG8-5362-000CN	Photo Sensor	Table 8-14 on page 8-27
WS6-5092-000CN	Power Connector	Table 8-7 on page 8-14
XA9-0265-000CN	Screw, M4x6 W/Washer	Table 8-2 on page 8-6
XA9-0267-000CN	Screw, M3x6 TP	Table 8-2 on page 8-6
XA9-0815-000CN	Screw, M3x4 TP	Table 8-2 on page 8-6
XA9-0838-000CN	Screw, M4x16 W/Washer	Table 8-2 on page 8-6
XA9-0974-000CN	Screw, Long DC Controller Screws (M3x25)	Table 8-2 on page 8-6
XB1-2300-607CN	M3x6 Screw, Mach., Truss Head	Table 8-8 on page 8-17
XB2-6400-607CN	Screw, M4x6 Screw w/Washer	Table 8-2 on page 8-6
XB4-2300-407CN	Screw, Mach., Truss Head, M4x10	Table 8-22 on page 8-39
XB4-7300-807CN	M3x8 Screw, Tapping, Truss Head	Table 8-23 on page 8-41
XB4-7400-807CN	Screw, M4x8 Truss Head Tapping	Table 8-2 on page 8-6
XB4-7401-007CN	Screw, M4x10 Pan Head Tapping	Table 8-2 on page 8-6
XB6-7300-807CN	Screw, M3x8 TP Screw	Table 8-2 on page 8-6
XD2-1100-322CN	E Ring	Table 8-2 on page 8-6



# Index

## Numerics

- 500-sheet Feeder PCA, removing and replacing 6-81
- 500-sheet Tray, disassembly 6-74

## A

- AC/DC power distribution 5-3
- accessories 8-4
- assemblies, removing and replacing 6-27

## C

- cables, replacement 8-6
- card stock 1-20
- CFC usage 1-26
- cleaning
  - accessories 4-2
  - paper path 4-4
  - printer 4-2
  - spilled toner 4-4
  - using cleaning page 4-4
- clutches 5-9, 5-30
- component locations 7-80
- Configuration menu 3-17
- configuration page 7-46
- control panel 3-2, 5-17
  - changing settings 3-5
  - defaults 3-4
  - keys 3-2, 3-3
  - layout 3-2
  - lights 3-2
  - printing Menu Map 3-5
  - settings 3-4
- Control Panel Overlay, removing and replacing 6-15
- Control Panel, removing and replacing 6-15
- covers 6-10
- CPU 5-14
- Create Cleaning Page message 4-4

## D

- DC Controller Board, removing and replacing 6-47
- Delivery Roller Removal, removing and replacing 6-68
- diagrams
  - reference 7-80
- DIMM slots 5-16
- documentation 2-4
- drives
  - laser 5-8
  - scanner 5-8
- D-roller, removing and replacing 6-79
- drum
  - cleaning 5-22
  - conditioning 5-23
- Duplexer 5-38
- duplexer
  - paper jam 5-44
  - refeed system 5-38
  - reversing system 5-38

## E

- EconoMode 5-13
- EIO menu 3-27
- electrical specifications 1-6
- Energy Star 1-26
- Engine Controller Board
  - inputs and outputs 7-107
- engine controller subsystem 5-7
- engine test 7-9
- envelopes 1-19
- environmental product stewardship 1-26
- Event Log 7-12

## F

- Fan, removing and replacing 6-40
- Feed Roller, removing and replacing 6-79
- Formatter Assembly, removing and replacing 6-41
- Formatter system 5-12
- Front Cover, removing and replacing 6-18
- Fuser Mode setting 5-28
- Fuser, removing and replacing 6-30
- fusing temperature, variable 5-28

## G

- Gear Assembly, removing and replacing 6-81



## H

heavy paper 1-20

## I

I/O menu 3-24

image

developing 5-25

transferring 5-26

writing 5-24

Image Formation System 5-18

photosensitive drum 5-21

image quality 7-49

Information menu 3-6

input/output 5-14

## L

labels 1-18

laser drive 5-8

Laser Scanner Assembly, removing and replacing 6-70

Left Corner Cover, removing and replacing 6-26

Left Front Corner Cover, removing and replacing 6-77

## M

Main Gear Assembly, removing and replacing 6-35

Main Motor, removing and replacing 6-71

maintenance 4-1

maintenance count 3-31

memory

checking installation 6-5

printer 5-15

Random Access Memory (RAM) 5-15

upgrade 6-2

Memory Enhancement technology (MEt) 5-16

menu map 7-44

model numbers 1-5

motors 5-10

## N

NVRAM, clearing 3-36

## O

Optional 250-sheet Tray 5-35

Optional 500-sheet Tray 5-35

ordering information 2-3

phone numbers 2-5

overcurrent overvoltage protection 5-5

ozone production 1-26

## P

page count 3-31

page protect 5-16

paper

heavy 1-20

motion control 5-9

specifications 1-11

Paper Feed Belt Assembly, removing and replacing 6-51

Paper Feed Roller Assembly, removing and replacing 6-44

Paper Feed System 5-29

Paper Guide, removing and replacing 6-59

Paper Handling menu 3-7

Paper Handling PCA, removing and replacing 6-31

paper jam 5-37

duplexer 5-44

paper path

cleaning 4-4

troubleshooting 7-41

Paper Path Detect Sensor, removing and replacing 6-60

Paper Size Spring Assembly, removing and replacing 6-78

paper specifications

card stock 1-20

envelopes 1-19

guidelines for using paper 1-15

heavy paper 1-20

labels 1-18

supported types 1-14

transparencies 1-18

vellum 1-18

weight equivalence 1-17

parts 2-3

parts lists

alphabetical 8-39

how to use 8-1, 8-2

numerical 8-44

photosensitive drum 5-20

Pickup Gear Assembly, removing and replacing 6-37

Power Connection, removing and replacing 6-63

Power Connector, removing and replacing 6-82

power distribution, high voltage 5-6

Power Inlet Assembly, removing and replacing 6-73

power on troubleshooting 7-7

power supply system 5-3

AC/DC distribution 5-3

Power Supply, removing and replacing 6-47

PowerSave mode 1-26

preventative maintenance 4-5

- Print Quality menu 3-10
- printer
  - features 1-2
  - messages 7-16
  - model numbers 1-5
  - serial numbers 1-5
  - subsystems 5-2
  - testing 3-35
  - weight 1-9
- printing
  - engine test 3-35
  - interface 7-77
  - operating checks 7-6
  - Optional 250-sheet Tray 5-35
  - Optional 500-sheet Tray 5-35
  - Tray 1 5-31
  - Tray 2 5-33
- Printing menu 3-13
- Product Stewardship, power consumption 1-26

## R

- Random Access Memory (RAM) 5-15
- Rear Door/Rear Output Bin, removing and replacing 6-10
- recycling toner cartridges 2-8
- refeed system 5-38
- Registration Assembly, removing and replacing 6-64
- regulatory information 1-22– 1-24
- removal/replacement strategy 6-7
- removing and replacing 6-10
- reset
  - maintenance count 3-31
  - page count 3-31
  - serial number 3-31
- Resets menu 3-29
- resetting printer 3-36
  - clearing NVRAM 3-36
  - cold reset 3-36
- Resolution Enhancement technology (REt) 5-13
- reversing system 5-38
- Right Corner Cover, removing and replacing 6-26

## S

- safety statements 1-22– 1-24
- scanner drive 5-8
- sensors 5-9, 5-30, 7-88
- Separation Roller, removing and replacing 6-83
- sequence of operation 5-45
- serial number 3-31
- serial numbers 1-5
- service mode 3-30
  - maintenance count 3-31
  - page count 3-31
  - serial number 3-31
- signals 7-88
- site requirements 1-6
  - electrical specifications 1-6
  - environmental requirements 1-10
  - printer weight 1-9
  - space requirements 1-7
- solenoids 5-9
- space requirements 1-7
- specifications
  - electrical 1-6
  - paper 1-11
- supplies 2-3, 8-4
- switches 5-9

## T

- toner
  - cleaning spilled 4-4
  - consumption 1-26
- toner cartridge 2-8, 5-18, 5-20
  - detection 5-7
  - recycling 2-8
  - refilled 2-8
- Toner Cartridge Door Assembly, removing and replacing 6-17
- Toner Cartridge Guides, removing and replacing 6-72
- tools 6-7
- Top Cover, removing and replacing 6-12
- training media 2-4
- Transfer Roller Assembly, removing and replacing 6-28
- transparencies 1-18
- Tray 1 5-31
- Tray 1 Inner Cover, removing and replacing 6-24
- Tray 1 Lift Plate, removing and replacing 6-57
- Tray 1 Pickup Solenoid, removing and replacing 6-39
- Tray 1 Roller, removing and replacing 6-42
- Tray 1 Separation Pad, removing and replacing 6-58
- Tray 1 Shaft, removing and replacing 6-53
- Tray 1, removing and replacing 6-18
- Tray 2 5-33
- Tray 2 Roller, removing and replacing 6-43
- Tray 2 Shaft, removing and replacing 6-55

Tray Indicator Assembly, removing and replacing 6-76

troubleshooting 7-1

configuration page 7-46

display 7-11

engine test 7-9

Event Log 7-12

flowchart 7-4

general paper path 7-41

image quality 7-49

image system 7-75

information pages 7-44

interface 7-77

menu map 7-44

power on 7-7

preliminary operating checks 7-6

printer messages 7-16

printing system 7-6

troubleshooting process 7-2

## U

Upper Delivery Assembly, removing and replacing 6-66

## V

variable fusing temperature 5-28

vellum 1-18

## W

warranty statement 2-9