



Troubleshooting Manual

HP LaserJet Pro 3001-3008 series • 3001e-3008e series

HP LaserJet Pro MFP 3101-3108 series • 3101e-3108e series



3001dwe | 3002dne/dwe | 3001dw
3002dn/dw | 3003dn/dw
3004dn/dw



MFP 3101fdwe | MFP 3102fdne/fdwe
MFP 3101fdw | MFP 3102fdn/fdw
MFP 3103fdn/fdw | MFP 3104fdn/fdw



www.hp.com/support/lj3001-3008 | www.hp.com/support/lj3001-3008plus
www.hp.com/support/ljmf3101-3108 | www.hp.com/support/ljmf3101-3108plus
For printer part removal and part number information, see the Repair Manual.

HP company notices

Copyright and License

© Copyright 2022 HP Development Company, L.P.

Reproduction, adaptation, or translation without prior written permission is prohibited, except as allowed under the copyright laws.

The information contained herein is subject to change without notice.

The only warranties for HP products and services are set forth in the express warranty statements accompanying such products and services. Nothing herein should be construed as constituting an additional warranty. HP shall not be liable for technical or editorial errors or omissions contained herein.

Edition 1, 4/2022

For additional service and support information

HP service personnel, go to the WISE database at hp.com/support/wise/home/ams-en.

Channel partners, go to HP Channel Services Network (CSN) at www.hp.com/partners/csn.

At these locations, find information on the following topics:

- Install and configure
- Printer specifications
- Up-to-date control panel message (CPMD) troubleshooting
- Solutions for printer issues and emerging issues
- Remove and replace part instructions and videos
- Service advisories
- Warranty and regulatory information

Channel partners, access training materials in the HP University and Partner Learning Center at content.ext.hp.com/sites/LMS/HPU.page.

To access the HP PartSurfer information from desktop, go to partsurfer.hp.com/search.aspx. To access from any mobile device, go to partsurfermobile.hp.com or scan the following Quick Response (QR) code:



Table of contents

1 Theory of operation.....	2
Related documentation and software.....	2
Basic operation.....	3
Sequence of operation.....	4
Formatter-control system.....	5
Sleep delay.....	5
Printer job language (PJM).....	5
Printer management language (PML).....	5
Control panel.....	6
Wireless.....	6
Low-end data model (LEDMD) overview.....	6
Advanced-control language (ACL) overview.....	6
CPU.....	6
Input/output (I/O).....	6
USB.....	6
Memory.....	6
Engine-control system.....	8
DC controller.....	8
Motor control.....	10
Fan control.....	10
Low-voltage power supply.....	12
Overcurrent/overvoltage protection.....	14
High-voltage power supply.....	14
High-voltage power supply circuits.....	14
Fuser control.....	16
Fuser control functions.....	17
Fuser heater protection.....	18
Engine-laser scanner system.....	19
Laser-scanner failure detection.....	20
Safety.....	20
Image-formation process.....	21
Step 1: Primary charging.....	24
Step 2: Laser-beam exposure.....	25
Step 3: Developing.....	25
Step 4: Transfer.....	26
Step 5: Separation.....	27
Step 6: Fusing.....	27
Step 7: Drum cleaning.....	27
Toner cartridges.....	29
Design.....	29
Engine pickup, feed, and delivery system.....	31

Sensors and switches.....	32
Motors and solenoids	33
Function.....	34
Jam detection/prevention.....	35
Scanning-and-image capture system (MFP models only)	36
Document-feeder system (MFP models only).....	39
Document feeder simplex operation.....	39
2 Solve problems.....	41
For additional service and support.....	41
Troubleshooting process	42
Determine the problem source.....	42
Pre-troubleshooting checklist.....	42
Troubleshooting flowchart	43
Power subsystem checks	44
Control panel checks	44
Tools for troubleshooting	46
To access and use the Embedded Web Server (EWS)	46
To open EWS using HP Smart app (iOS, Android, and Windows 10)	47
To open EWS using an IP address (Wi-Fi or Ethernet connection) SFP models only	47
To open EWS using an IP address (Wi-Fi or Ethernet connection) MFP models only.....	47
To open EWS using HP Printer software (Windows 7)	47
Use the HP Smart app to print, scan, and manage.....	47
To install HP Smart and open the app	47
Get more information about HP Smart	48
Wi-Fi band supported.....	48
Print reports (SFP Models only)	48
Print reports (MFP Models only)	51
To print a report from the printer control panel.....	51
To print a report from the EWS	52
Printer reports	52
Troubleshooting diagnostics.....	53
Network LED diagnostics.....	53
Engine diagnostics.....	53
Engine test	54
Event code diagnostics	54
10.xx.xx Black cartridge failure issues error.....	56
"No Cartridge" message error	57
Cartridge warning messages	57
Memory error warning	57
13.xx.xx Jam errors	58
"Inconsistent Media Size" message error	58
MISSING TITLE.....	58
Duplex delivery path feeding incompatibility.....	58
21.xx.xx Print failure error (formerly a Page Punt error).....	59
30.xx.xx Scanner error	59
The product is unable to calibrate. Close the lid and remove paper from the document feeder.	59

31.xx.xx Document feeder mispick error	60
50.xx.xx Fuser error	60
Fuser malfunction and temperature error	62
Low temperature error 1	62
51.xx.xx Laser scanner error	62
54.xx.xx Environmental sensor error	62
Environment sensor abnormality warning and sensor abnormality warning	63
Driving circuit failure error	63
55.xx.xx DC controller error	63
DC controller malfunction error	64
Driving circuit failure error	64
58.xx.xx Power supply malfunction error	64
59.xx.xx Motor rotation error	65
Error report diagnostics	66
Improve print quality	66
Update the printer	67
Print from a different software program.....	67
Check the paper-type setting for the print job.....	67
Check the paper type setting on the printer.....	67
Check the paper type setting (Windows)	67
Check the paper type setting (OS X)	67
Check toner-cartridge status	68
Step one: Find supplies information on configuration page	68
Step two: Check supplies status	68
Clean the cartridge.....	68
Print a cleaning page	69
Check the scanner glass for dirt and smudges (MFP models only)	69
Visually inspect the toner cartridge	69
Check paper and the printing environment	69
Step one: Use paper that meets HP specifications.....	69
Step two: Check the environment	70
Adjust print density.....	70
Print quality troubleshooting guide	70
Image defects table	71
Printer-specific image defects	81
Repetitive image defect ruler	81
Improve copy and scan image quality (MFP models only)	87
Check the scanner glass for dirt and smudges	87
Check the paper settings	87
Optimize for text or pictures	87
Edge-to-edge copying.....	87
Clean the pickup rollers and separation pad in the document feeder.....	87
Clean the printer	89
Clean the pickup roller, feed roller, and separation roller	89
Clean the pickup rollers and separation pad in the document feeder.....	96
Check the scanner glass and white backing for dirt or smudges (MFP models only).....	98
Solve paper-handling problems	100

Printer feeds incorrect page size	100
Printer does not duplex or duplexes incorrectly	100
Printer does not duplex (print 2-sided jobs) or duplexes incorrectly	100
Paper does not feed from the input tray.....	100
Paper does not feed from the input tray.....	100
Output is curled or wrinkled	101
Output is curled or wrinkled	101
Printer does not pick up paper or misfeeds.....	101
The printer does not pick up paper	101
The printer picks up multiple sheets of paper.....	101
The document feeder jams, skews, or picks up multiple sheets of paper (MFP models only)	102
Paper does not feed automatically	102
Clear paper jams.....	103
Paper path jam sensor locations	103
Jam locations	103
Repair parts for frequent paper jams	104
Clear jams from the input tray	105
Clear jams from the rear of the printer.....	107
Clear jams from the cartridge access area.....	108
Clear paper jams (MFP models only).....	111
Paper path jam sensor locations	111
Jam locations.....	111
Repair parts for frequent paper jams (MFP models only)	113
Clear jams from the input tray (tray 1)	114
Clear jams from the cartridge access area.....	115
Clear jams in the document feeder	118
Clear jams from the rear of the printer.....	119
Solve performance problems.....	120
Solve connectivity problems	122
Solve USB connection problems.....	122
Solve wired network problems	122
Introduction.....	122
Poor physical connection.....	122
The computer is using the incorrect IP address for the printer	122
The computer is unable to communicate with the printer	122
The printer is using incorrect link speed and duplex settings for the network.....	123
New software programs might be causing compatibility problems.....	123
The computer or workstation might be set up incorrectly	123
The printer is disabled, or other network settings are incorrect	123
Solve wireless network problems	123
Wireless connectivity checklist.....	123
The printer does not print after the wireless configuration completes.....	124
The printer does not print, and the computer has a third-party firewall installed	124
The wireless connection does not work after moving the wireless router or printer	124
Cannot connect more devices to the wireless printer (Wi-Fi Direct).....	124
The wireless printer loses communication when connected to a VPN.....	125
The network does not appear in the wireless networks list	125
The wireless network is not functioning	125

Perform a wireless network diagnostic test	126
Reduce interference on a wireless network.....	126
Solve fax problems	126
Check the hardware setup	126
Faxes are sending slowly	127
Fax quality is poor	128
Fax cuts off or prints on two pages.....	129
Service mode functions.....	129
Service menu (MFP models only)	129
Secondary service menu.....	130
Printer resets	131
To restore printer default settings using EWS.....	131
To restore network default settings using EWS.....	131
NVRAM initialization.....	131
Super NVRAM initialization	132
Solve HP Web Services Problems	132
Cannot connect to the email server	133
Validate the SMTP gateway (Windows)	133
Validate the LDAP gateway (Windows).....	134
Diagrams: Printed circuit assembly (PCA) connector locations	134
Engine controller PCA	134
Formatter PCA	135
Printer back views (SFP and MFP models).....	136
Diagrams: Locations of major components.....	138
Diagrams: Timing chart.....	139
Diagrams: Circuit diagrams.....	141
A Printer specifications	143
Technical specifications.....	143
System requirements	143
Printer dimensions (SFP models only).....	144
Printer dimensions (MFP models only).....	144
Printer space requirements	145
Power consumption, electrical specifications, and acoustic emissions	145
Operating-environmental range.....	145
Warning icons	146
Laser Warning.....	147
Certificates of volatility.....	148

1 Theory of operation

This topic describes about the basic sequence of operations for Formatter and Engine-control system of the printer.

Related documentation and software

HP service personnel, go to the WISE database at <https://support.hp.com/wise/home/ams-en>.

Channel partners, go to HP Channel Services Network (CSN) at www.hp.com/partners/csn.

Channel partners, access training materials in the HP University and Partner Learning Center at content.ext.hp.com/sites/LMS/HPU.page.

Basic operation

The printer routes all high-level processes through the formatter that stores font information, processes the print image, and communicates with the host computer.

The basic printer operation comprises the following systems:

- Engine-control system
- Laser-scanner system
- Image-formation system
- Pickup, feed, and delivery system
- Scanning-and-image capture system (MFP models only)

Figure 1-1 Relationship between the main printer system

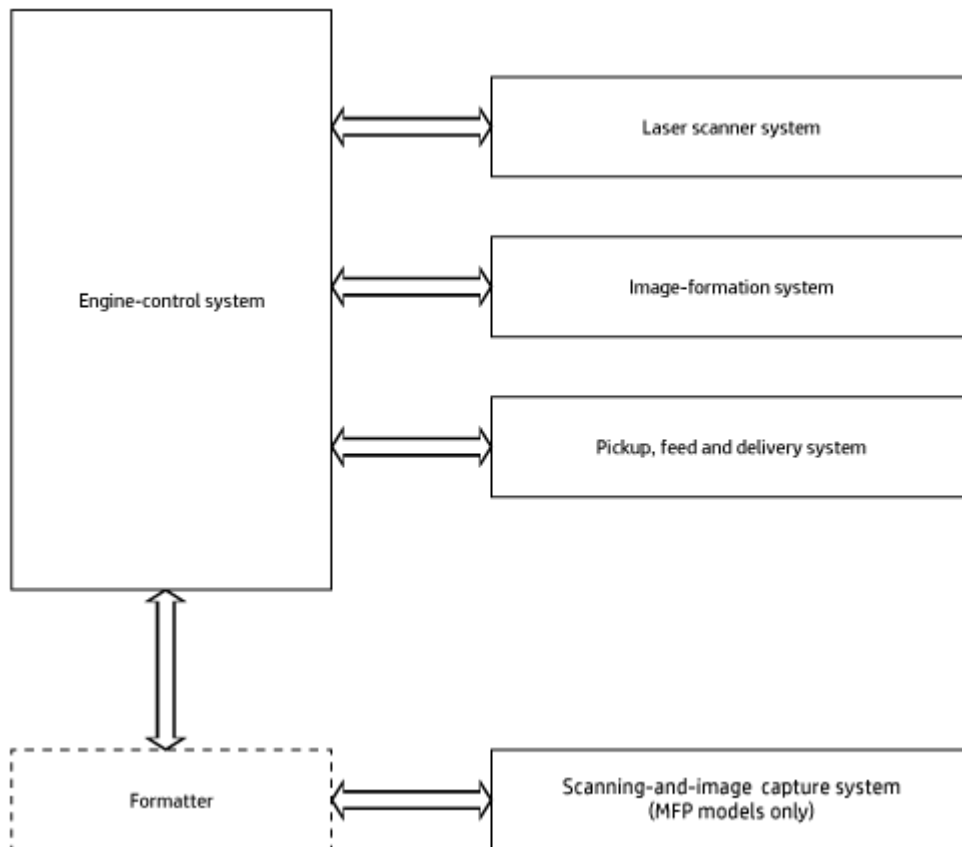

Sequence of operation

The DC controller PCA controls the operating sequence of the printer, as described in the following table:

Table 1-1 Sequence of operation

Period	Duration	Description
Waiting	From the time the power is turned on, the door is closed, or when the printer exits sleep mode until the printer is ready for printing.	<ul style="list-style-type: none">• Heats the fuser film in the fuser• Detects the toner cartridge presence• Detects the service fuser• Rotates and stops the main motor• Cleans the transfer roller
Standby	From the end of the waiting sequence or the last rotation until the formatter receives a print command, or until the printer is turned off.	<ul style="list-style-type: none">• Remains in the print-ready state• Enters active OFF or inactive OFF mode if a power control mode designation command is sent
Initial rotation	From the time the formatter receives a print command until the paper enters the paper path.	<ul style="list-style-type: none">• Rotates the main motor• Activates the high-voltage power supply (high-voltage bias)• Prepares the laser scanner unit• Warms the fuser to the correct temperature
Printing	From the time the first sheet of paper enters the paper path until the last sheet passes through the fuser.	<ul style="list-style-type: none">• Forms the image on the photosensitive drum• Transfers the toner to the paper• Fuses the toner image onto the paper
Last rotation	From the time the last sheet of paper exits the fuser until the motors stop rotating.	<ul style="list-style-type: none">• Stops the main motor• Stops the high-voltage power supply (high-voltage bias)• Stops the laser scanner unit• Stops the fuser heater• If another print command is received, the printer enters the initial rotation period when the last rotation is complete

Formatter-control system

The formatter performs the following functions:

- Controls the sleep delay function.
- Receives and processes print data from the various printer inputs.
- Monitors control panel functions and relays printer status information (through the control panel and the bidirectional input/output).
- Develops and coordinates data placement and timing with the DC controller.
- Communicates with the host computer through the network or the bidirectional interface.

The formatter receives a print job from the network or bidirectional interface and separates it into image information and instructions that control the printing process. The DC controller synchronizes the image formation system with the paper input and output systems, and then signals the formatter to send the print image data.

Sleep delay

When the printer is in sleep delay mode, the control panel backlight is turned off, but the printer retains all printer settings, downloaded fonts, and macros. The default setting is a 1-minute idle time. The setting can be changed or turned off from EWS.

The printer exits sleep delay mode, and then enters the warm-up cycle when any of the following occurs:

- A print job, valid data, or a PML or PDL command is received at the serial port.
- The control panel is touched (button press depending on model).
- A document is loaded in the document feeder or the scanner lid is opened (MFP models only).

 **TIP:** Error messages override the sleep delay message. The printer enters sleep mode at the appropriate time, but the error message continues to appear.

Printer job language (PDL)

PDL is an integral part of printer configuration, in addition to the printer control language (PCL) and PostScript (PS). With standard cabling, the printer can use PDL to perform a variety of functions.

- **Dynamic I/O switching:** The printer can be configured with a host on each I/O by using dynamic I/O switching. Even when the printer is offline, it can receive data from more than one I/O simultaneously, until the I/O buffer is full.
- **Context-sensitive switching:** The printer can automatically recognize the personality (PS or PCL) of each job and configure itself to serve that personality.
- **Isolation of print environment settings from one print job to the next:** For example, if a print job is sent to the printer in landscape mode, the subsequent print jobs print in landscape only if they are formatted for landscape printing.

Printer management language (PML)

PML allows remote configuration of the printer and status monitoring through the input/output (I/O) ports.

Control panel

The formatter sends and receives printer status and command data to and from the control panel.

Wireless



NOTE: Wireless models only.

Wireless products contain a wireless card to enable 802.11 b/g/n wireless communication.

Low-end data model (LEDMD) overview

The low-end data model (LEDMD) provides one consistent data representation method and defines the dynamic and capabilities tickets shared between clients and devices, as well as the access protocol, event, security, and discovery methods.

Advanced-control language (ACL) overview

The advanced control language (ACL) is a language that supports printer control and firmware downloads in printers that support both PCL/PCL and host-based printing. Each sequence of ACL commands must be preceded by a unified exit command (UEL) and an @PJL ENTER LANGUAGE=ACL command. The ACL sequence is always followed by a UEL. Any number of commands can be placed between the UELs. The only exception to these rules is the download command. If a firmware download is done, the download command must be the last command in the sequence. It will not be followed by a UEL.

The firmware searches for the UEL sequence when parsing commands. However, while downloading binary data such as host-based code or NVRAM data, the firmware suspends UEL parsing. To handle hosts that “disappear” during binary sequences, the firmware times out all ACL command sessions. If a timeout occurs during a non-download command sequence, it is treated as the receipt of a UEL. If a timeout occurs during firmware download, the printer resets.

CPU

The formatter incorporates a 500 MHz processor.

Input/output (I/O)

The following sections discuss the input and output features of the printer:

USB

The printer includes a universal serial bus (USB) 2.0 connection.

Memory

If the printer encounters a problem when managing available memory, a clearable warning displays on the control panel.

Firmware

The formatter stores the printer firmware. A remote firmware update process is used to overwrite and update the firmware.

Nonvolatile random access memory (NVRAM)

The printer uses nonvolatile memory (NVRAM) to store I/O and information about the print environment configuration. The contents of NVRAM are retained when the printer is turned off or disconnected.

Flash memory

DRR: Stores software applications. When the printer power is turned off, the data stored in DRR is erased.

NAND: When the printer power is turned off, the data stored in NAND is preserved.

Random access memory

DDR memory (SFP): 256MB

DDR memory (MFP): 512MB

Flash memory (SFP): 256MB SPI flash

Flash memory (MFP): 512MB SPI flash

HP Memory Enhancement technology (MEt)

The HP Memory Enhancement technology (MEt) effectively doubles the standard memory through a variety of font- and data-compression methods.



NOTE: The MEt is available only in PCL mode; it is not functional when printing in PS mode.

Engine-control system

The engine-control system receives commands from the formatter and interacts with the other main systems to coordinate all printer functions. The engine-control system consists of the following components:

- DC controller
- High-voltage power supply
- Fuser control
- Low-voltage power supply

Figure 1-2 Engine-control system

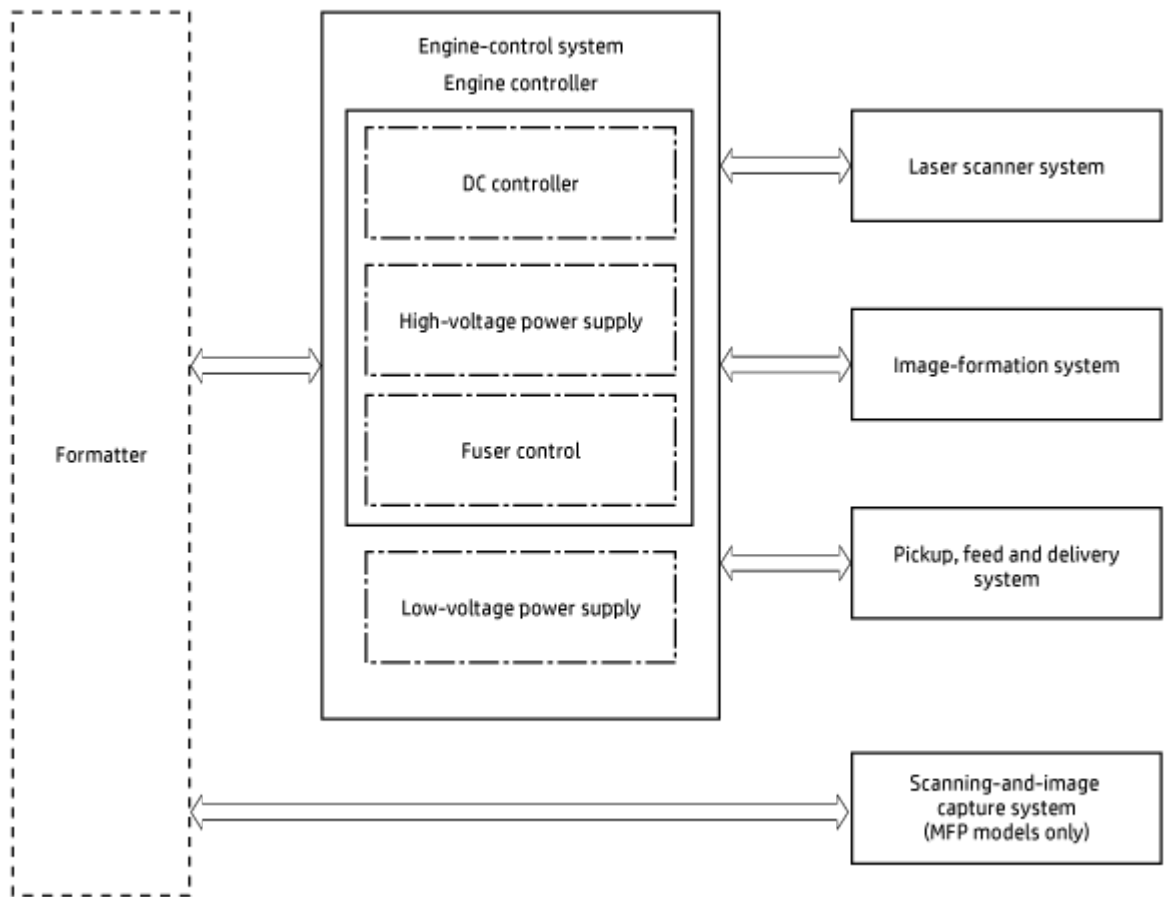

DC controller

The DC controller controls the operation of the printer and its components. The DC controller starts the printer operation when the printer power is turned on and the power supply sends DC voltage to the DC controller. After the printer enters the standby period, the DC controller sends out various signals to operate motors, solenoids, and other printer components based on the print command and image data that the host computer sends.

Figure 1-3 DC controller block diagram

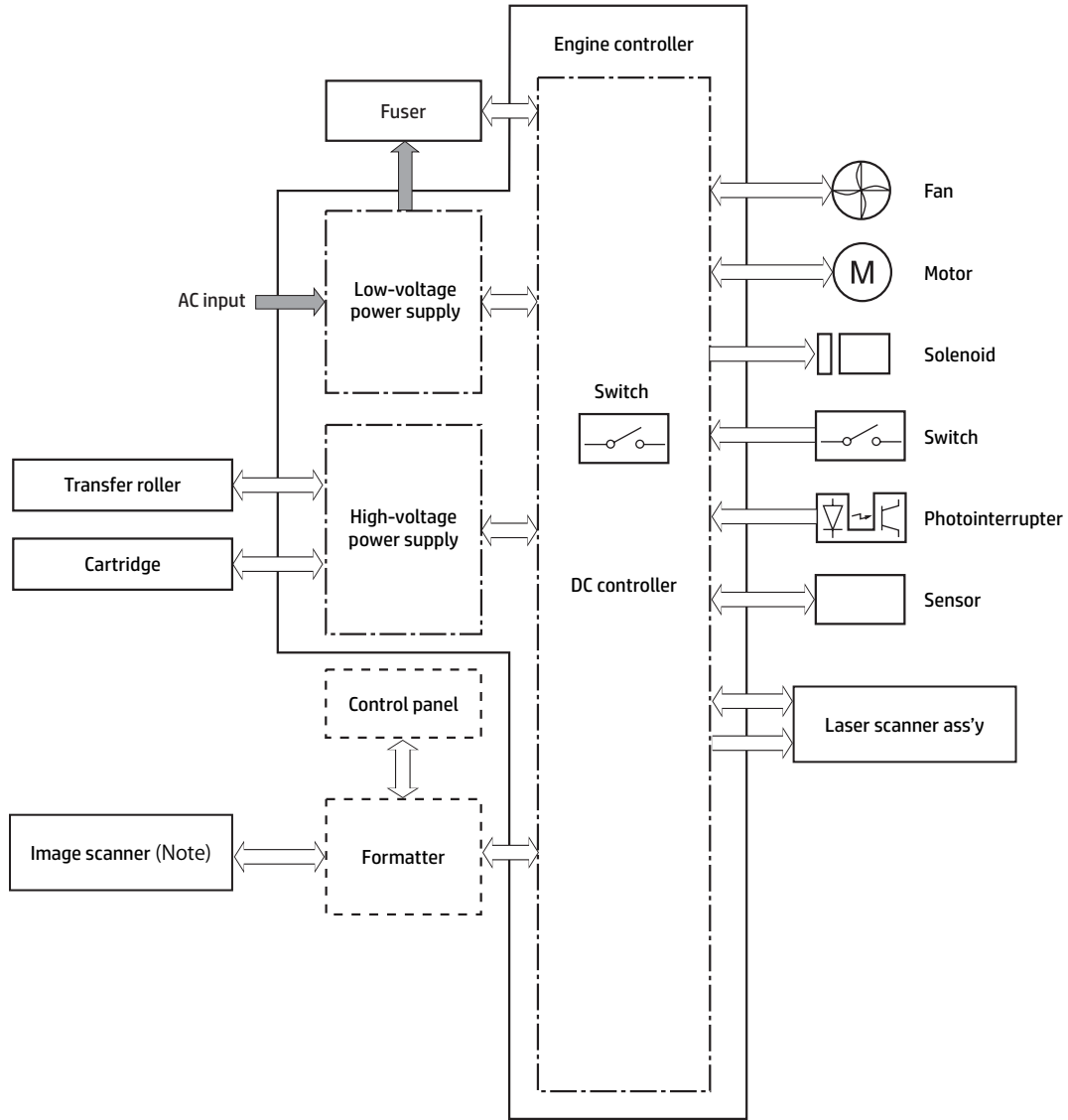

Table 1-2 DC controller block diagram

Component type	Abbreviation	Description
Motor	M1	Main motor
	M2	Scanner motor
	M3	Lifter motor
Fan	FM1	Main fan
Solenoid	SL1	Tray 1 pickup solenoid
	SL2	Duplex switchback solenoid
Switch	SW1	Tray 1 cassette presence switch
	SW101	Power switch (only for MFP)
	SW471	Cartridge door switch
Photointerrupter	PS601	Fuser output sensor

Table 1-2 DC controller block diagram (continued)

Component type	Abbreviation	Description
	PS611	Registration media width sensor
	PS612	Registration sensor
	PS621	Tray 1 media surface sensor 1
	PS622	Tray 1 media out sensor
	PS641	Tray 1 media surface sensor 2
	PS722	Main motor rotation number sensor
Sensor	TH611	Environment sensor
	VR1	Tray 1 media size sensor (only for SFP)

Motor control

The engine-control system has three motors.

The DC controller monitors the motors to determine if they have failed. It notifies the formatter when it encounters the following conditions:

- Startup failure: the motors do not reach a specified speed within a specified time from when the motors start.
- Rotational failure: the rotational speed of the motors is not in the specified range for a specified time after the motors reach a specified speed.

Table 1-3 Motors

Abbreviation	Name	Purpose	Failure detection
M1	Main motor	Tray 1 pickup roller, photosensitive drum, feed roller, pressure roller, output roller, duplex registration roller	No
M2	Scanner motor	Drives the scanner mirror	Yes
M3	Lifter motor	Lift up the lifting plate in the tray 1	No

Failure detection

The DC controller determines the following motor failures:

- Scanner motor startup abnormality (scanner motor failure)
- Scanner motor rotation abnormality (scanner motor failure)

Fan control

The printer has the fan for preventing the temperature from rising in the printer, which is indicated in the table below.

Table 1-4 Fan specification

Component name		Cooling area	Type	Speed
FM1	Main fan	Inside the printer	No	Full

Failure detection

The DC controller determines the following fan failure:

- Fan motor 1 malfunction (main fan failure)

Low-voltage power supply

The low-voltage power-supply (LVPS) circuit converts the AC power from the wall receptacle into the DC voltage used by the printer components.

The following two printer states relate to the low-voltage power supply:

- **Inactive OFF:** In this state, the printer power is turned off.
- **Active OFF:** In this state, the printer is in sleep mode. The low-voltage power supply sends power only to the formatter and DC controller.

Figure 1-4 Low-voltage power-supply circuit

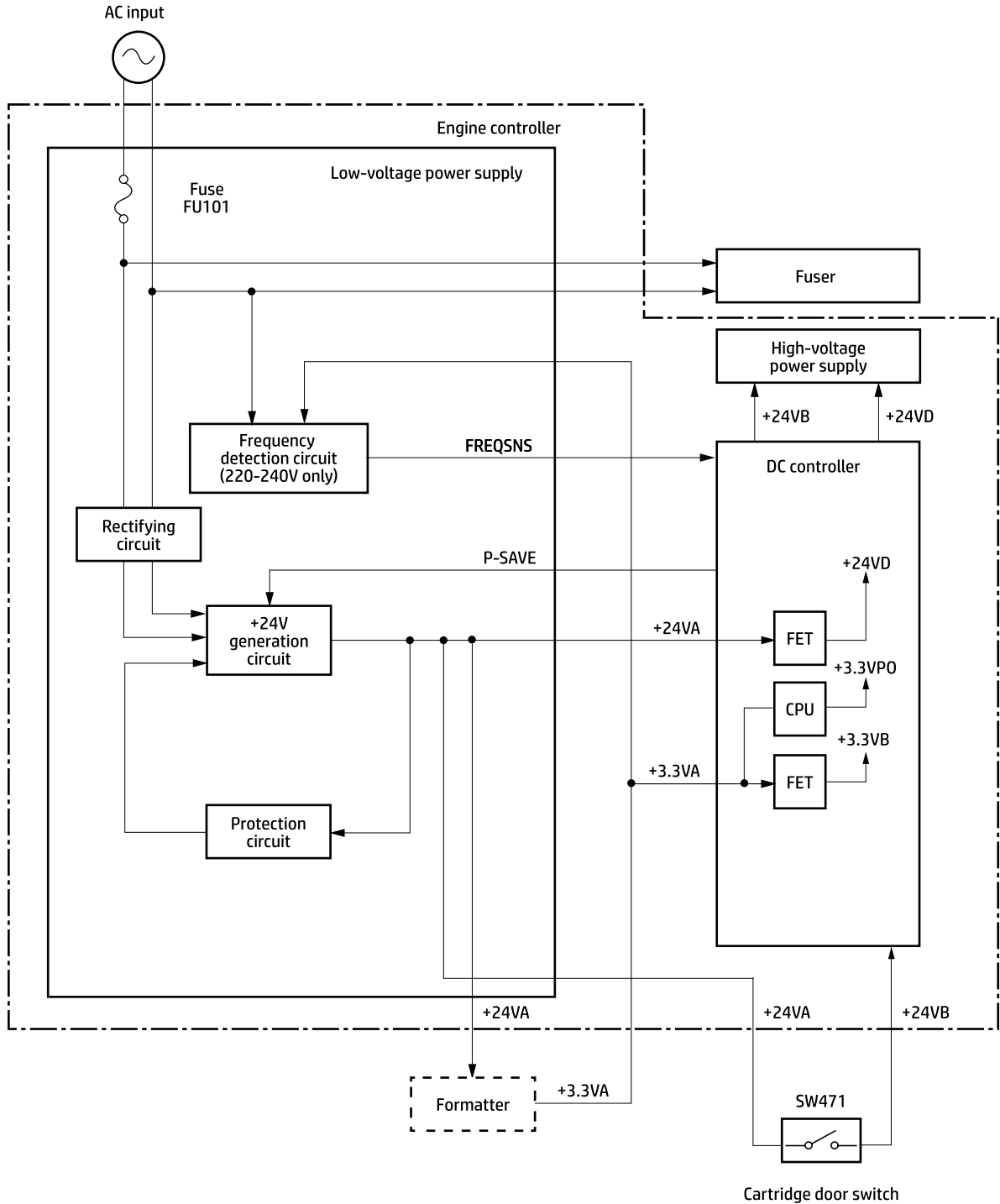

Table 1-5 List of DC power supply

DC power supply	Inactive OFF	Active OFF	Print/Standby
+24V	+24VA	From 24V to 6.6V	ON
	+24VB	From 24V to 6.6V	ON
	+24VD	OFF	OFF
+3.3V	+3.3VA	ON	ON

Table 1-5 List of DC power supply (continued)

DC power supply	Inactive OFF	Active OFF	Print/Standby
+3.3VB	OFF	OFF	ON/OFF
+3.3VPO	OFF	OFF	ON

Overcurrent/overvoltage protection

The overcurrent/overvoltage protection function automatically stops supplying DC voltage to the printer components whenever it detects excessive current or abnormal voltage. The low-voltage power supply has a protective function against overcurrent and overvoltage to prevent failures in the power supply circuit. In addition, two fuses in the low-voltage power supply protect against an overcurrent event. If an overcurrent event occurs in the AC line, the fuse blows and stops the flow of AC power.

- ⚠ **CAUTION:** If the low-voltage power supply is not supplying DC voltage, the protective circuit might be running. In this case, turn the printer off, and then disconnect the power cable. Do not connect the power cable or turn the printer on again until the root cause is found and corrected.
- ⚠ **WARNING!** For personal safety, the printer interrupts +24VB power when the cartridge door detection switch is turned off. This stops DC power supply to the motor and solenoids. The remote switch control circuit turns the printer power on or off so that AC power flows even when the power switch is turned off. Disconnect the printer power cable before disassembling the printer.

Low-voltage power supply failure detection

The only time the DC controller detects a failure of the low-voltage power supply is when the printer power cable is connected to a power source. If the low-voltage power supply outputs 24F when the 24FON signal is ON, the DC controller reports a low-voltage power supply failure.

High-voltage power supply

The DC controller controls the high-voltage power supply (HVPS) to generate biases. The HVPS delivers high-voltage biases to the following components used to transfer toner during the image-formation process:

- Primary charging roller (in the toner cartridge)
- Developing roller (in the toner cartridge)
- Transfer roller

High-voltage power supply circuits

The high-voltage power supply contains the following separate circuits:

Figure 1-5 High-voltage power supply circuits

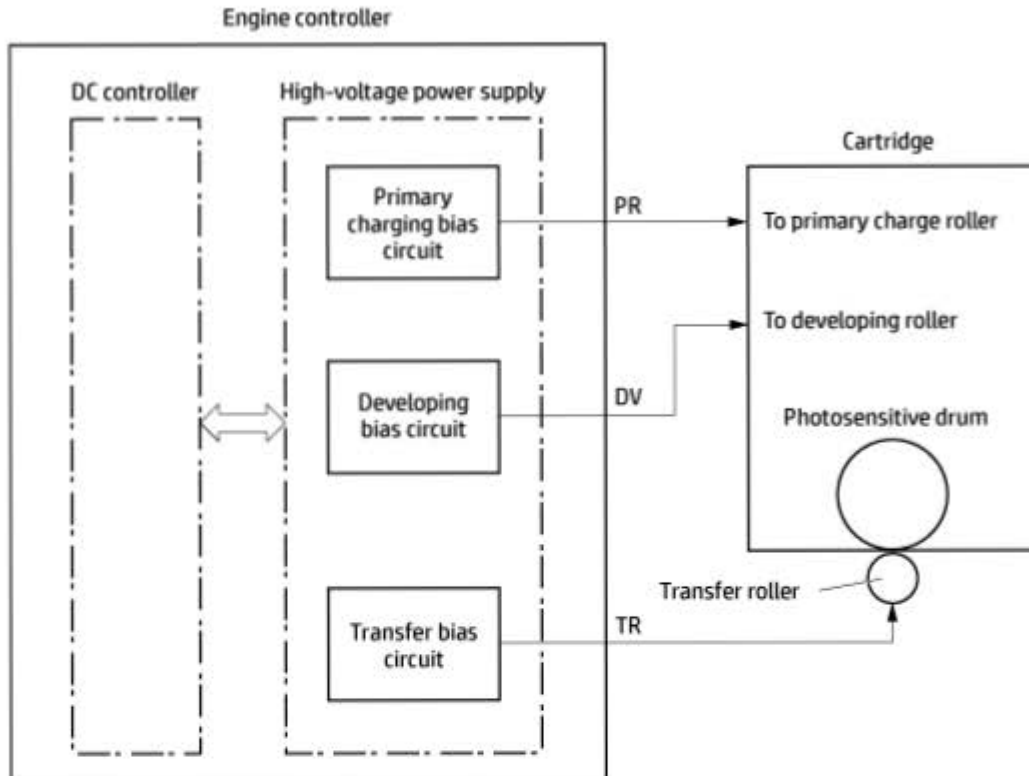

Fuser control

The printer uses an on-demand fusing method. The fuser heater control circuit and the fuser heater safety circuit control the fuser temperature according to commands from the DC controller. The fuser consists of the following major components:

Figure 1-6 Fuser components

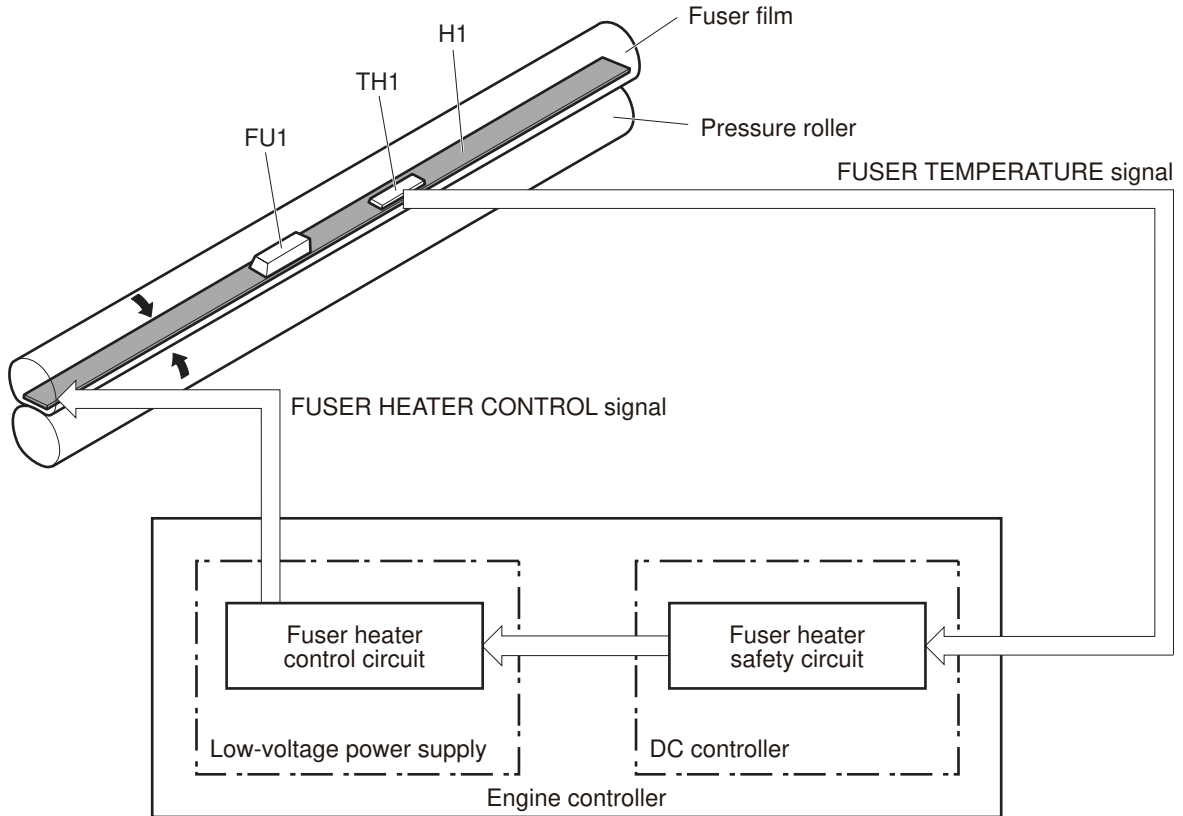
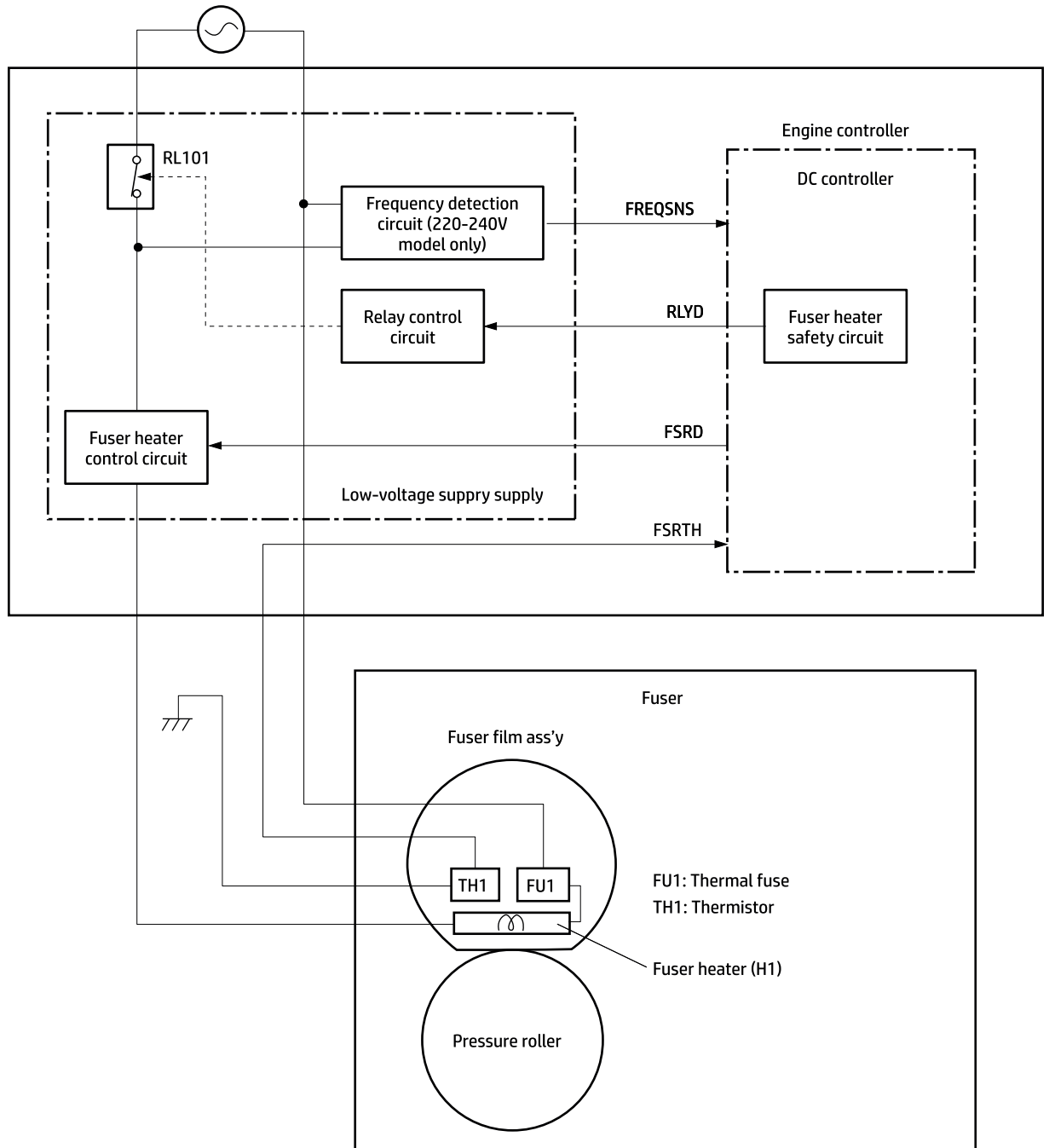

Table 1-6 Fuser components

Component Name	Abbreviation	Function
Fuser heater	H1	Heats the fuser film assembly
Thermistor (contact type)	TH1	Detects the temperature of the fuser heater
Thermoswitch (contact type)	FU1	Prevents an abnormal temperature rise in the fuser heater

Fuser control functions

Figure 1-7 Fuser control



Fuser heater protection

Fuser heater protection is a feature that detects excessive temperatures in the fuser and interrupts the power supply to the fuser heater.

The following three protective components prevent the fuser heater from excessive rising temperature:

- **DC controller:** It constantly monitors the temperature of the thermistor. When the DC controller detects an excessive temperature, it deactivates the Fuser Heater Control signal and turns off the relays (RL101) to interrupt power supply to the fuser heater.
- **Fuser heater safety circuit:** It constantly monitors the detected temperature of the thermistors. When the fuser heater safety circuit detects an excessive temperature, it turns off the relays (RL101) to interrupt power supply to the fuser heater.
- **Thermal fuse:** When the thermal fuse detects an abnormally high temperature in the fuser heater, the contact of the thermoswitch opens and interrupts the power supply to the fuser heater.

The printer has the following fuser control functions:

Table 1-7 Fuser control functions

Failure detection function	Supported feature
Fuser temperature control	Yes
Heat-up error detection	Yes
Low temperature error detection	Yes
High temperature error detection	Yes
Breaking of a heater wire detection	No
Driving-circuit failure detection (frequency detection circuit failure detection)	Yes
Low-voltage power supply failure detection	No
Fuser pressure-release mechanism failure detection	No
Brand new fuser detection	No
Fuser type discrepancy detection	No
Fuser type identification detection	No
Fuser presence detection	No
Fuser life detection	No
Fuser roller cleaning	Yes
Service fuser detection	Yes

Engine-laser scanner system

The DC controller receives instructions from the formatter in order to control the laser scanner system.

The DC controller signals the lasers to emit light, and the laser beams pass through lenses and onto the scanner mirror, which rotates at a constant speed. The mirror reflects the beam onto the photosensitive drum inside of the toner cartridge in the pattern required for the image, exposing the surface of the drum so that it can receive toner.

The main components of the laser-scanner system, which are controlled by the VIDEO signals sent from the DC controller, are:

- Laser assembly
- Scanner-motor assembly
- Beam-detect (BD) sensor
- Scanner mirror

Figure 1-8 Laser-scanner system

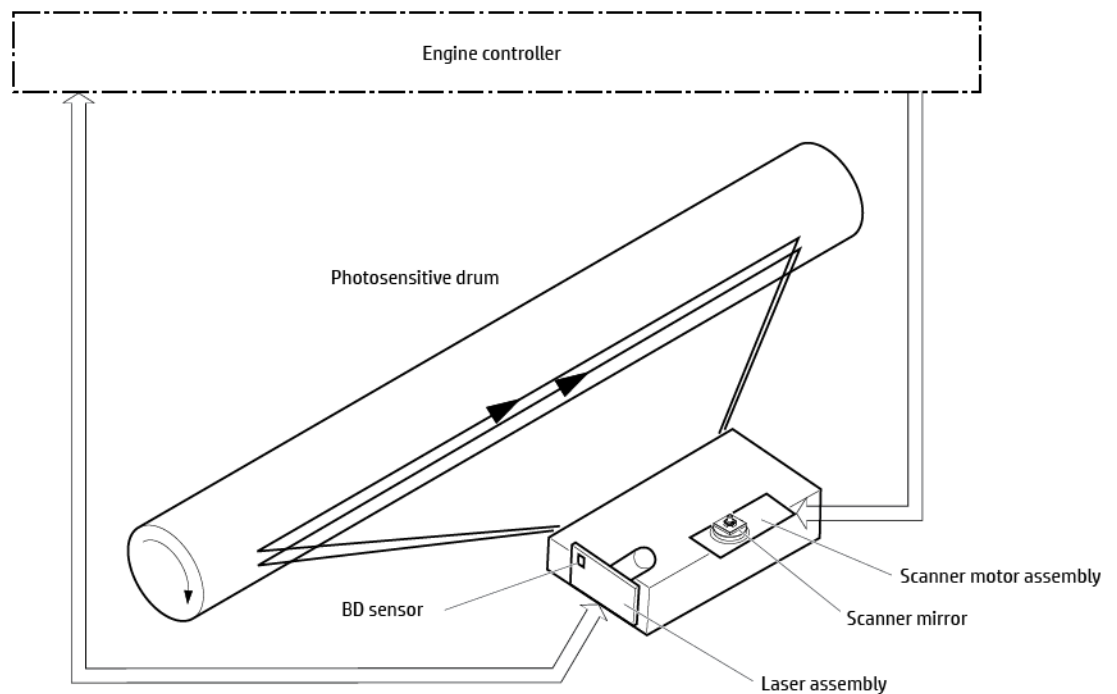

Laser–scanner failure detection

The DC controller detects the following laser–scanner failures:

Table 1-8 Laser-scanner failure detection

Failure detection function	Supported feature
Beam detect (BD) failure detection: A specified beam-detect interval is not detected within a specified period of time during the scanner motor rotation.	No
Laser scanner motor startup failure: The scanner motor does not reach a specified rotation frequency within a specified period of time from when the laser scanner starts up.	Yes
Laser scanner motor rotational failure: The laser scanner motor does not reach a specified rotational frequency within a specified period of time during a print operation.	Yes
Laser scanner failure detection: A specified laser intensity is not detected.	No

Safety

The laser scanner assembly has a mechanical laser shutter. For the safety of users and service technicians, the laser shutter interrupts the optical path of the laser scanner assembly when the cartridge door is opened.

Image-formation process

The DC Controller controls the internal components of the image formation system (according to commands received from the formatter) to form the toner image on the photosensitive drum surface. The toner image is then transferred to the print media and fused.

The image-formation system consists of the following components:

- Cartridge
- Transfer roller
- Fuser
- Laser-scanner assembly
- High-voltage power supply

Figure 1-9 Image-formation system

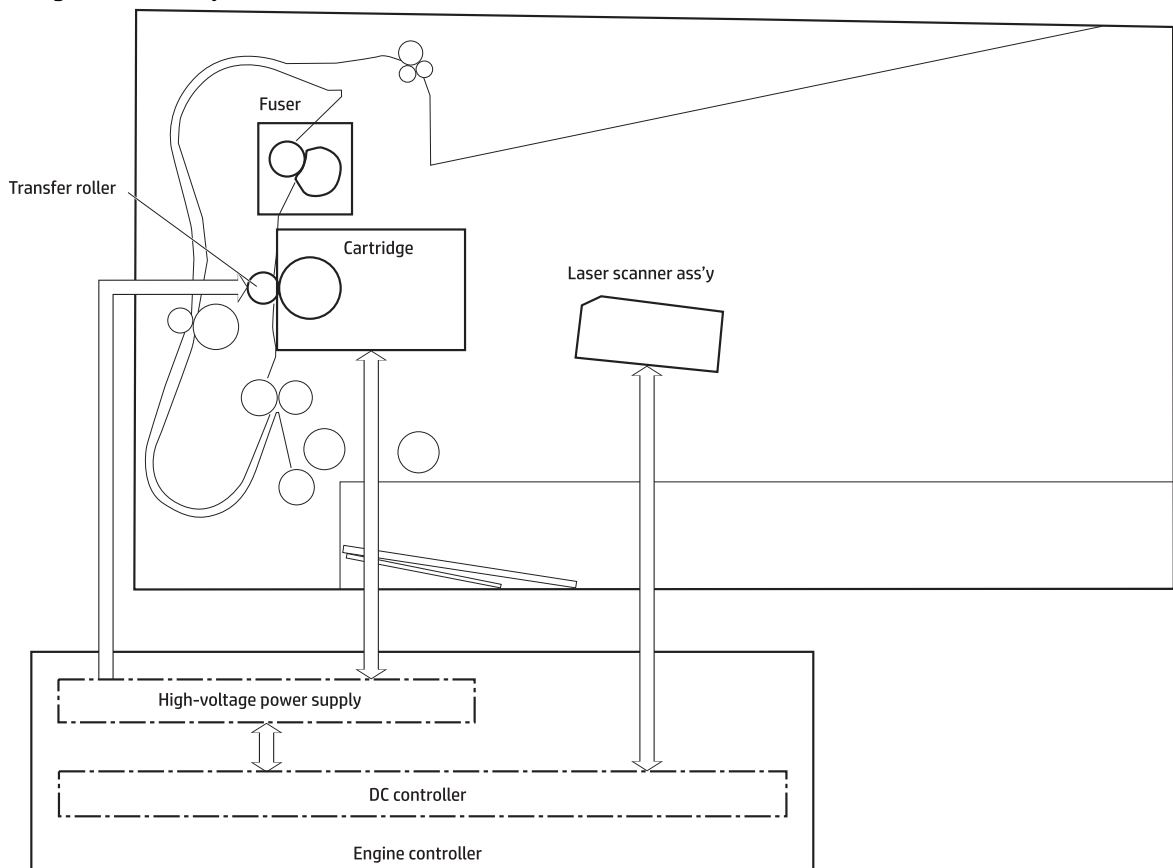

The main motor (M1) drives the following image formation components:

- Photosensitive drum
- Developing roller
- Primary charging roller (follows the photosensitive drum)
- Transfer roller (follows the photosensitive drum)
- Pressure roller

- Fuser film (follows the pressure roller)

NOTE: The photosensitive drum, primary charging roller, and developer roller are located in the toner cartridge.

Figure 1-10 Main motor (M1) and image formation components

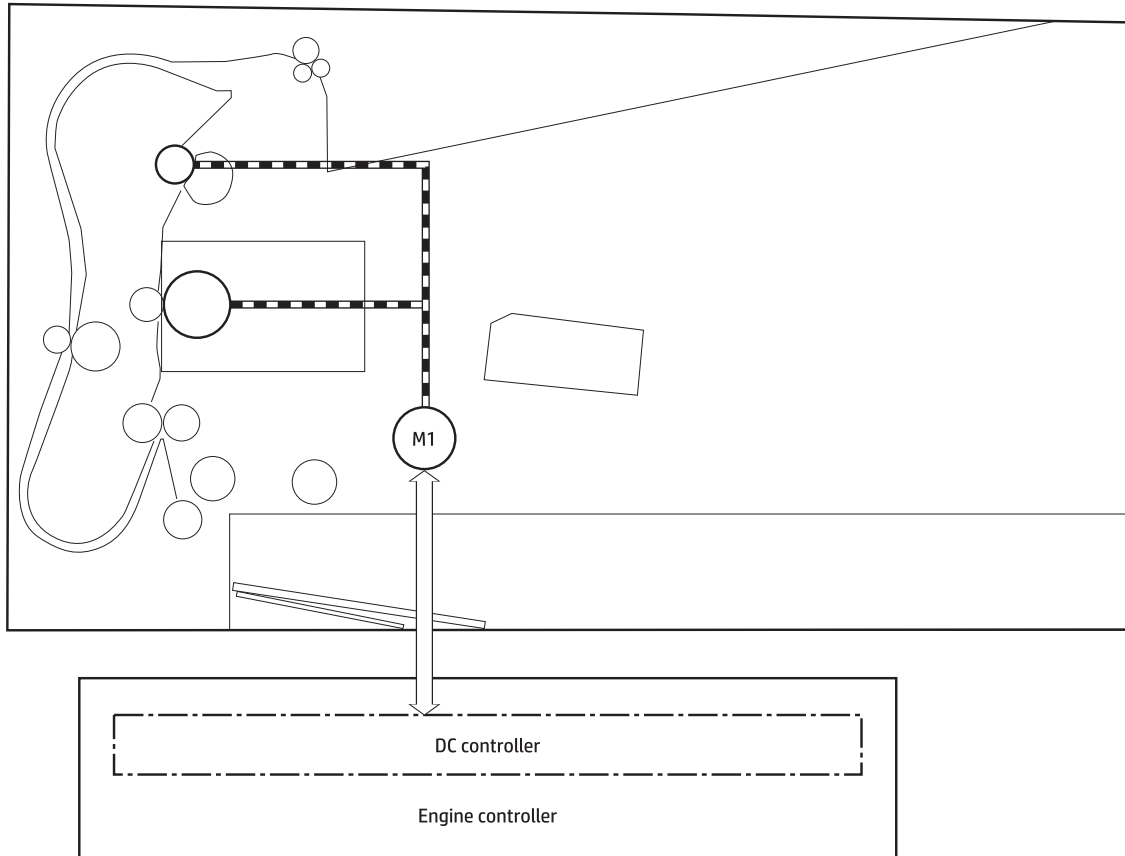

Abbreviation	Component
M1	Main motor

The following figure shows the sensors in the image-formation system:

Figure 1-11 Sensors

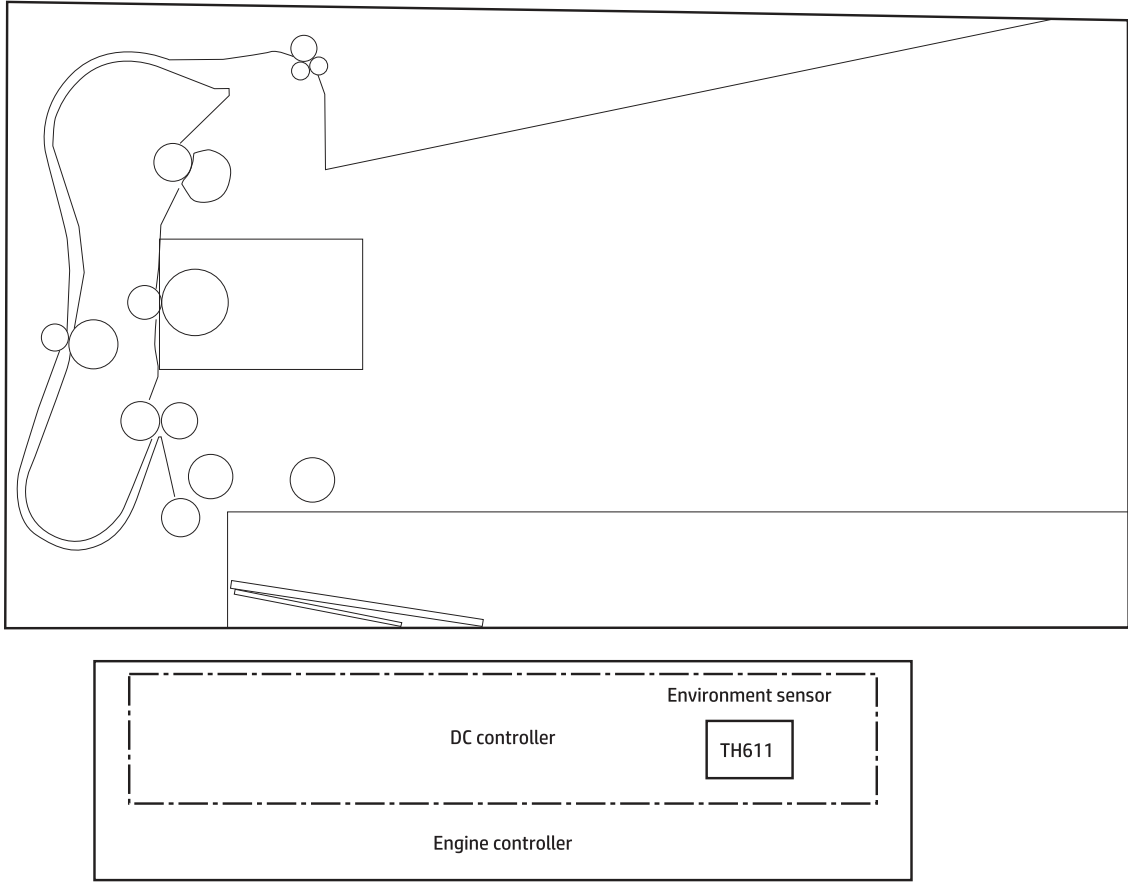

Abbreviation	Component
TH611	Environment sensor

The image-formation process consists of seven steps divided into five functional blocks.

Figure 1-12 Image-formation process

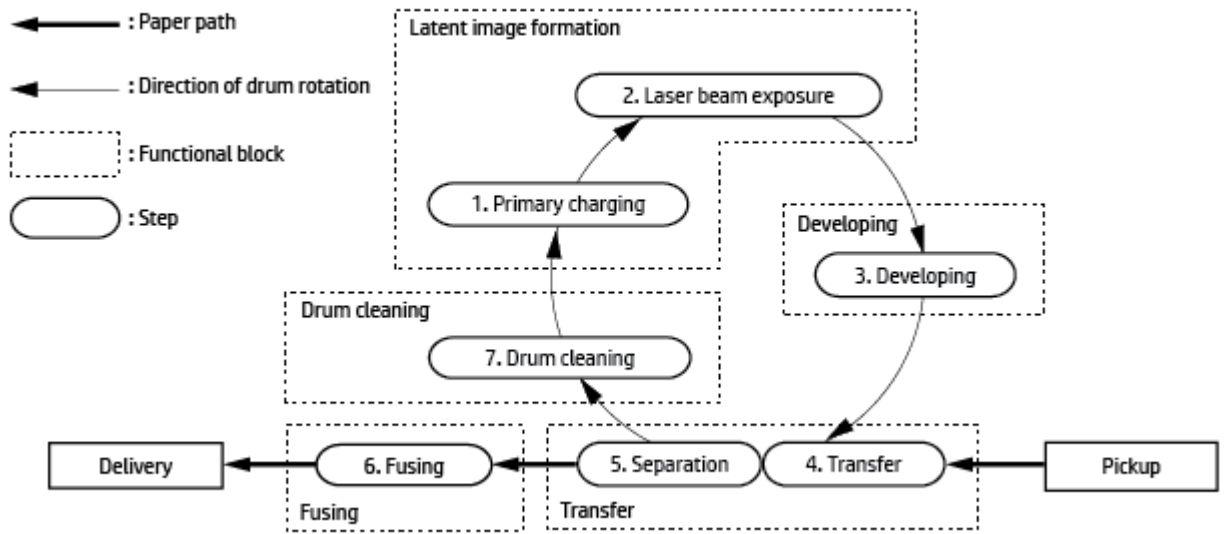

Table 1-9 Image formation process

Functional block	Steps	Description
Latent-image formation	1. Primary charging	An invisible latent image forms on the surface of the photosensitive drums.
	2. Laser-beam exposure	
Development	3. Developing	Toner adheres to the electrostatic latent image on the photosensitive drum.
Transfer	4. Transfer	The toner image transfers to the paper.
	5. Separation	
Fusing	6. Fusing	The toner fuses to the paper to make a permanent image.
Drum cleaning	7. Drum cleaning	Residual toner is removed from the drum.

Step 1: Primary charging

To prepare for latent image formation, the surface of the photosensitive drum is charged with a uniform negative charge. The primary charging roller receives the primary charging bias, and then the roller charges the drum directly.

Figure 1-13 Primary charging

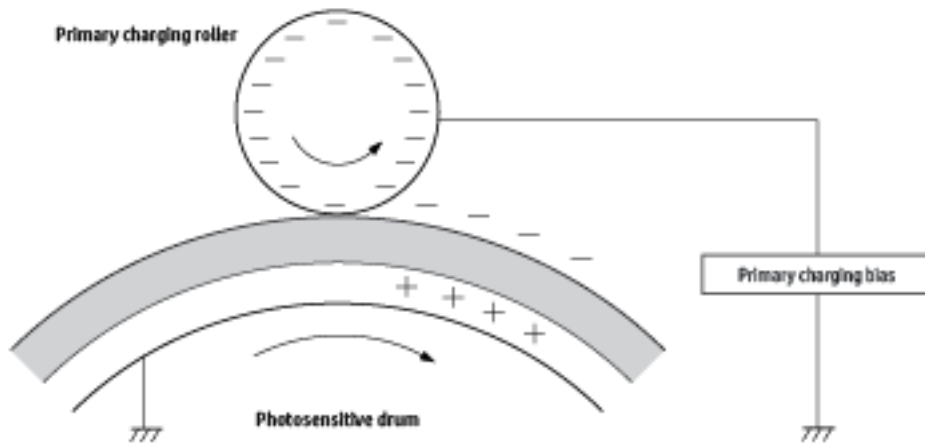

Step 2: Laser-beam exposure

The laser beam strikes the photosensitive drum to neutralize the negative charge on portions of the drum surface. An electrostatic latent image forms where the negative charge was neutralized.

Figure 1-14 Laser-beam exposure

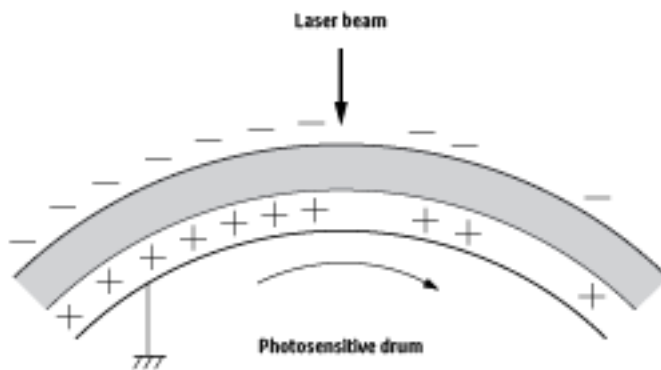

Step 3: Developing

Toner acquires a negative charge as a result of the friction from the developing roller rotating against the developing blade. Developing bias is applied to the developing roller. When the negatively charged toner comes in contact with the drum, it adheres to the electrostatic latent image. When the toner is on the drum, the image becomes visible.

Figure 1-15 Development

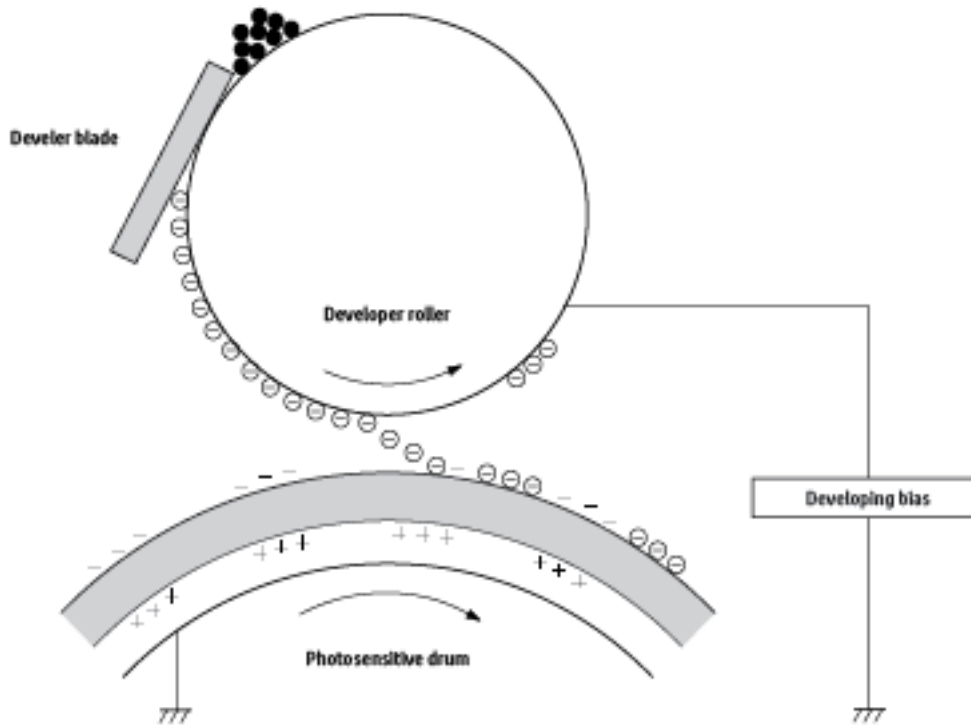

Step 4: Transfer

Transfer bias is applied to the transfer roller to give the paper a positive charge. The positively charged paper attracts the negatively charged toner from the photosensitive drum surface and the image transfers to the paper.

Figure 1-16 Primary transfer

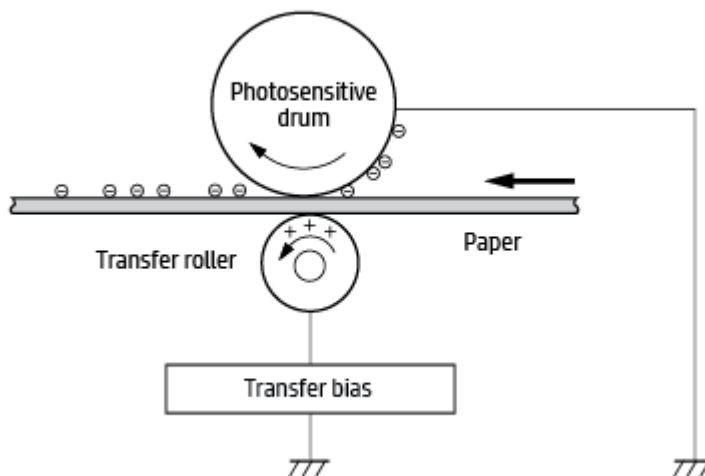

Step 5: Separation

The elasticity of the paper and the curvature of the photosensitive drum cause the paper to separate from the drum surface. The static charge eliminator reduces the electrical charge on the back side of the paper for stable paper feeding and image quality.

Figure 1-17 Separation

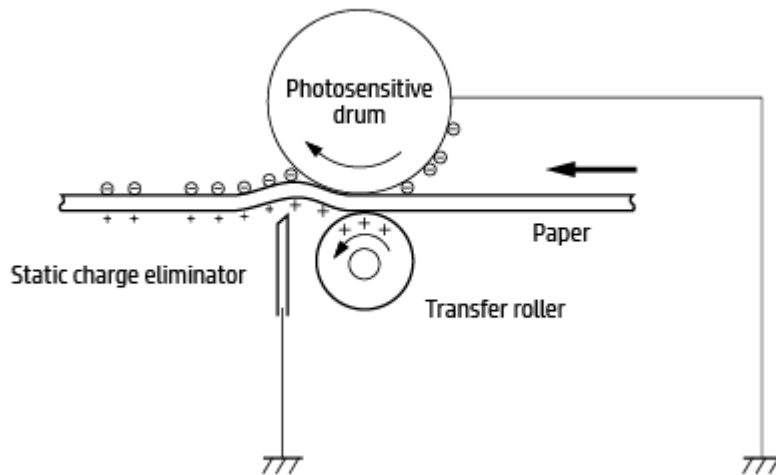

Step 6: Fusing

The toner image is fused onto the paper by heat and pressure.

Figure 1-18 Fusing

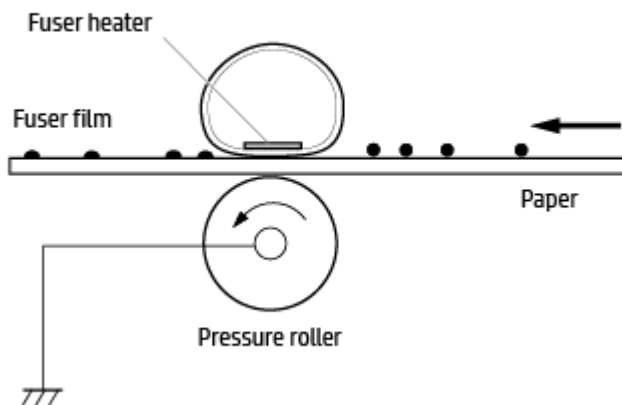

Step 7: Drum cleaning

The cleaning blade scrapes the residual toner off of the photosensitive drum and deposits it into the waste toner case.

Figure 1-19 Drum cleaning

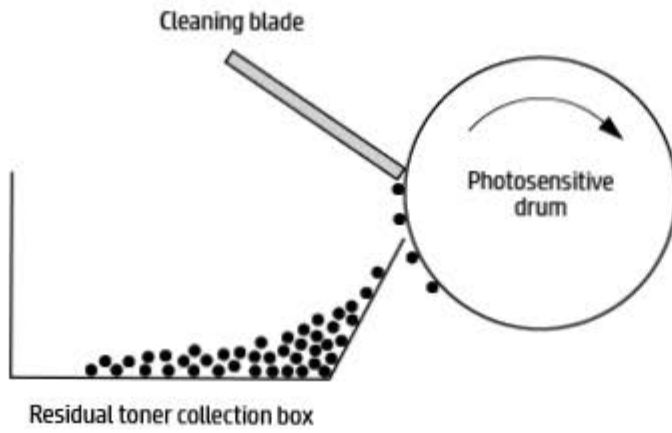

Toner cartridges

Design

The toner cartridge system consists of the following components:

- Photosensitive drum
- Developer roller
- Primary-charging roller
- E-label

Figure 1-20 Cartridge block diagram

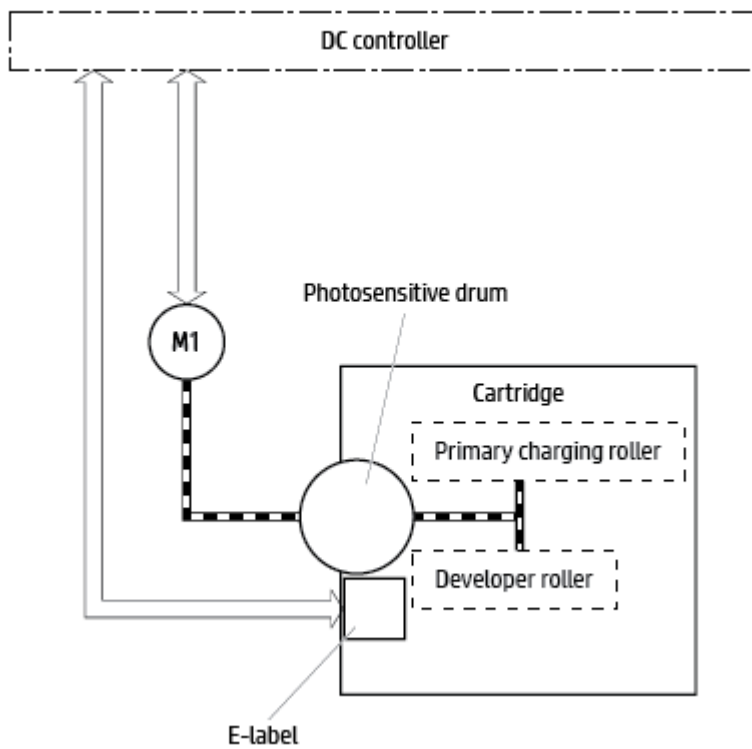

Table 1-10 Toner-cartridge functions

Function	Supported feature
Cartridge presence detection	Yes
Toner-level detection	Yes
Cartridge life detection	Yes
Cartridge mis-installation detection	No
Drum discharge	Yes
Developer alienation control	No

Table 1-10 Toner-cartridge functions (continued)

Function	Supported feature
Toner level sensor mechanism malfunction	No
Transfer-roller cleaning	Yes
Primary charging roller cleaning	Yes

Engine pickup, feed, and delivery system

The pickup, feed, and delivery system uses a series of rollers to move the paper through the printer and consists of the following three functional blocks. The DC controller controls each block to pick up, feed and deliver the paper (according to commands received from the formatter).

- **Pickup-and-feed block:** Controls the movement of the paper from each pickup source to the fuser inlet
- **Fuser-and-delivery block:** Controls the movement of the paper from the fuser to the delivery destination
- **Duplex block:** Controls the movement of the paper from the delivery destination to the Top of page (TOP) sensor

Figure 1-21 Pickup, feed, and delivery system

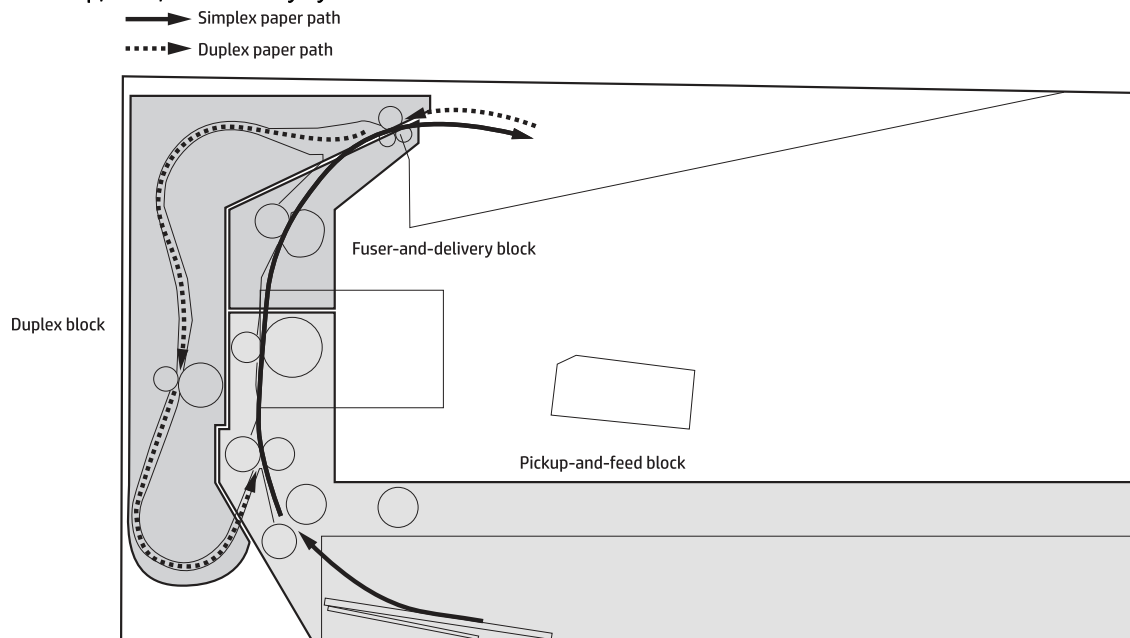

Sensors and switches

The following figure shows the sensors and switches for the pickup, feed, and delivery system:

Figure 1-22 Sensors and switches for the pickup, feed, and delivery system

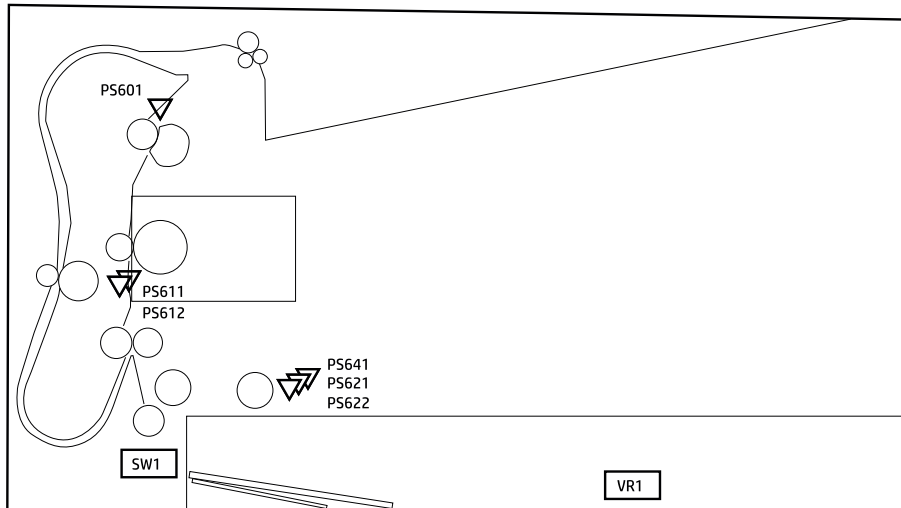

Table 1-11 Photo sensors and switches

Abbreviation	Component
PS601	Fuser output sensor
PS611	Registration media width sensor
PS612	Registration sensor
PS621	Tray 1 media surface sensor 1
PS622	Tray 1 media out sensor
PS641	Tray 1 media surface sensor 2
VR1	Tray 1 media size sensor (only for SFP)
SW1	Tray 1 cassette presence switch

Motors and solenoids

The following figure shows the motors and solenoids for the pickup, feed, and delivery system:

Figure 1-23 Motors and solenoids

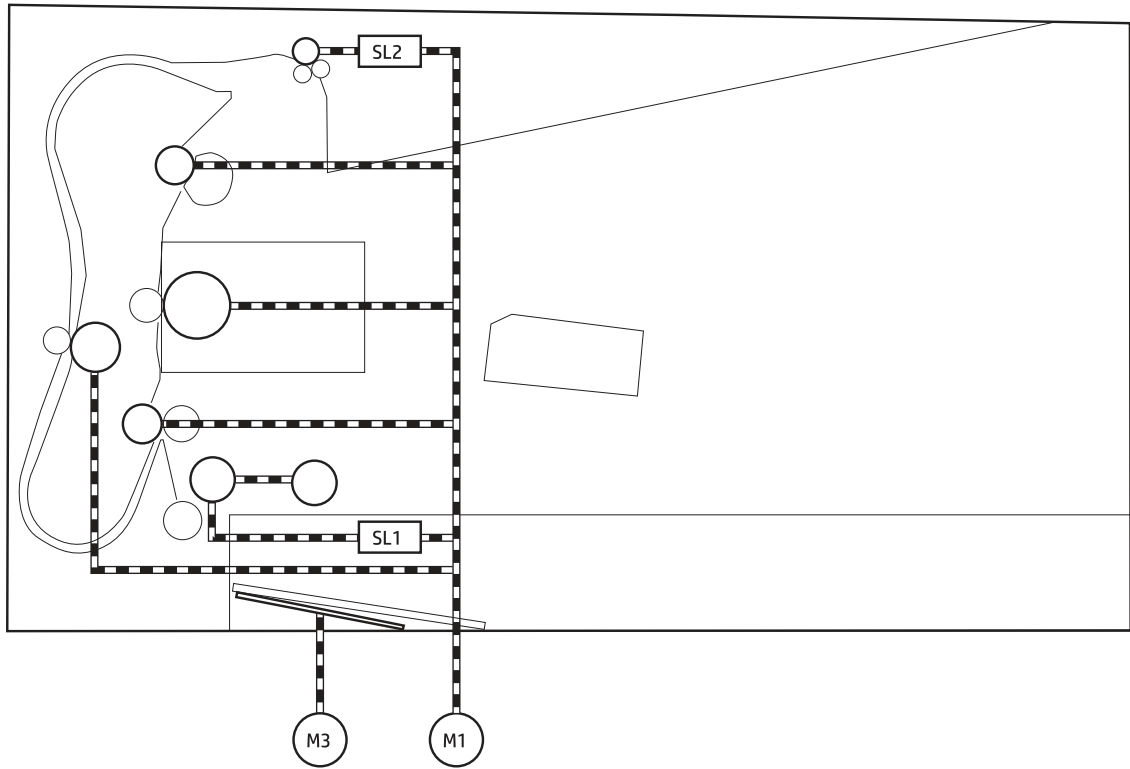

Abbreviation	Component
M1	Main motor
M3	Lifter motor
SL1	Tray 1 pickup solenoid
SL2	Duplex switchback solenoid

Function

The printer has the following pickup, feed, and delivery functions:

Table 1-12 Pickup, feed, and delivery system functions

Function	Supported feature
Tray 2 media size detection	No
Tray 2 presence detection	No
Tray 2 media surface detection	No
Tray 2 media presence detection	No
Tray 2 media level detection	No
Tray 2 lift-up control	No
Tray 2 lift-down control	No
Tray 2 multiple-feed prevention mechanism	Yes
Tray 1 lift-up control	Yes
Tray 1 media presence detection	Yes
Tray 1 media width detection	No
Tray 1 last-media detection	Yes
Skew-feed prevention mechanism (Only applicable to duplex side printing of Duplex printing mode)	Yes
Feed speed control	No
Loop control	No
Media detection	No
OHT detection	Yes
Image leading edge positioning	Yes
Media length detection	Yes
Media width detection	No
Pressure roller pressure release control	No
Output bin media-full detection	Yes
Automatic delivery	Yes
Duplex switchback control	Yes
Duplex feed control	No

Jam detection/prevention

The printer uses the following sensors to detect the presence of the paper as it moves through the paper path and to report to the DC controller if the paper has jammed:

- Registration sensor (PS612)
- Registration media width sensor (PS611)
- Fuser output sensor (PS601)

Figure 1-24 Jam detection sensors

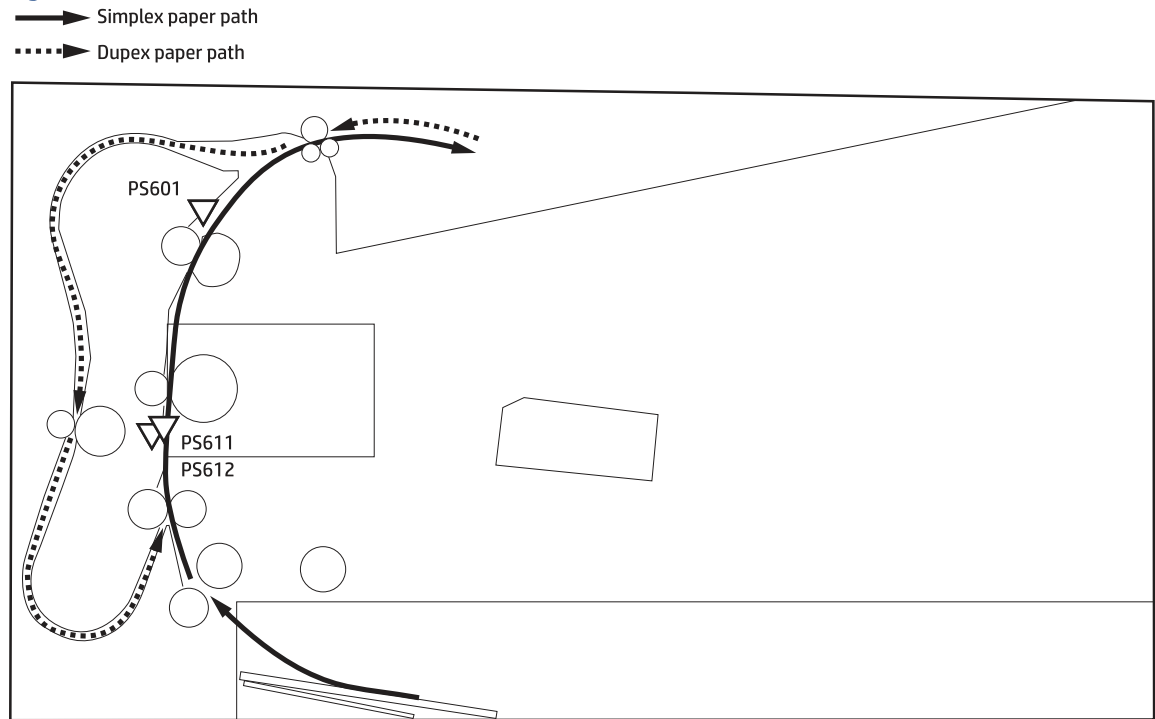

The printer determines that a jam has occurred if one of these sensors detects paper at an inappropriate time. The DC controller stops the print operation and notifies the formatter.

Table 1-13 Jams that the printer detects

Jam	Supported feature
No pick jam	Yes
Pickup stay jam	Yes
Fuser delivery delay jam	Yes
Fuser delivery stay jam	Yes
Delivery delay jam	No
Delivery stay jam	No
Switchback delay jam	No
Switchback stay jam	No
Duplex feed delay jam	Yes

Table 1-13 Jams that the printer detects (continued)

Jam	Supported feature
Duplex feed stay jam	No
Duplex re-pickup delay jam	Yes
Fuser wrap jam	Yes
Multiple feed jam	No
Residual paper jam	Yes
Door open jam	Yes
Inappropriate to the delivery path jam	Yes
Transfer area wrap jam	No

Scanning—and-image capture system (MFP models only)

The image scanner is located on the top of the printer. The contact image sensor component of the image scanner captures an electronic image of the document on the glass. The formatter controls the operation of the image capture system. The image scanner is available in two configurations:

- **Image scanner model:** This model consists of only the flatbed image scanner. The document to be scanned is placed face-down on the scanner glass.
- **Image scanner assembly model:** This model consists of a document feeder and image scanner. The document feeder feeds a document to be scanned from the document feeder input tray to the scanner glass.

Figure 1-25 Image scanner model block diagram

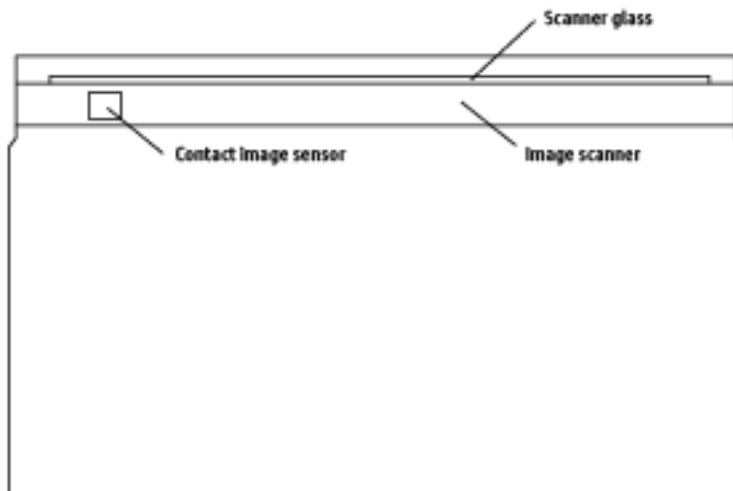

Figure 1-26 Image scanner assembly model block diagram

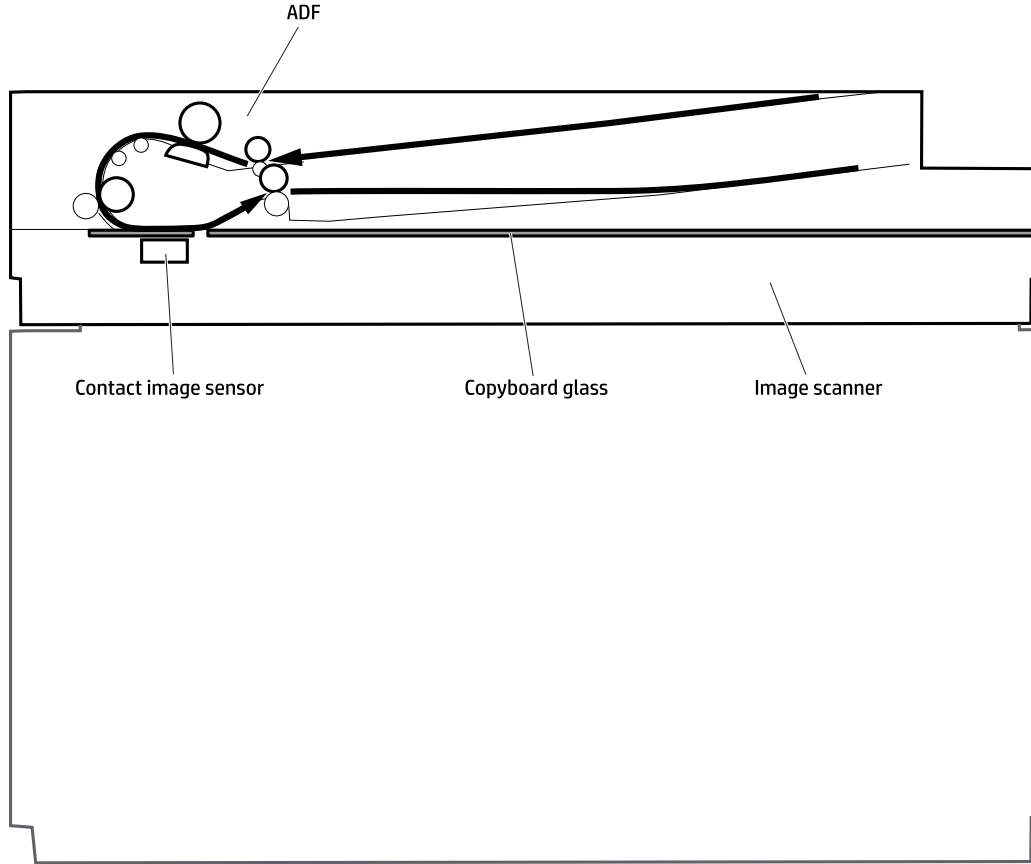

Figure 1-27 Image scanner block diagram

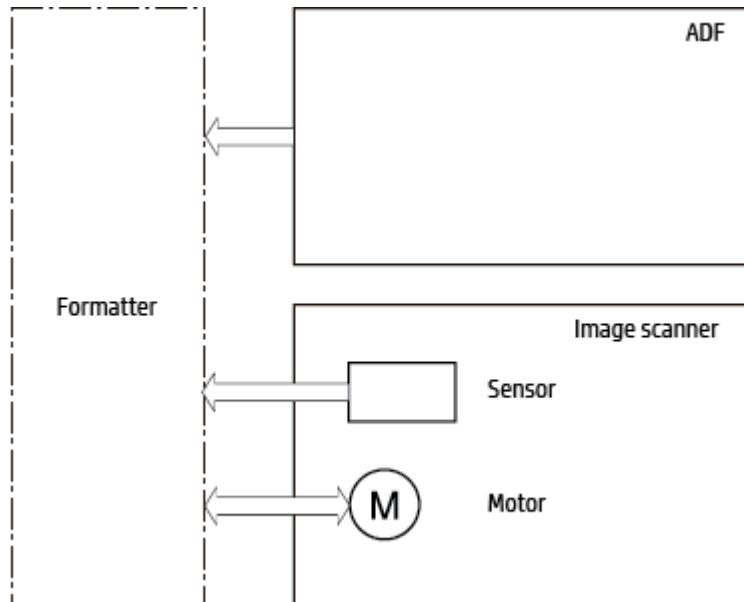

Table 1-14 Electrical component list

Component type	Abbreviation	Component name
Motor	M4	Scan motor

Table 1-14 Electrical component list (continued)

Component type	Abbreviation	Component name
Photointerrupter	-	ADF document out sensor
	-	ADF TOF sensor
Sensor	CIS	Contact image sensor

Document–feeder system (MFP models only)

The document feeder will not function when the document feeder cover is open. The paper path is incomplete if the document feeder cover is lifted from the glass.

Document feeder simplex operation

The standard operation of the document feeder consists of the standby (paper loading) mode, pick, feed, and lift steps:

- Standby (paper-loading) mode

In standby mode, the lift plate is in the down position. When a document is loaded into the input tray, the paper-present sensor detects its presence.

When a copy/scan is initiated, the document feeder motor engages the gear train and raises the lift plate until the document makes contact with the pick roller. The document feeder then begins the pick, feed, and lower sequence.

- Pick

The pick roller rotates and moves one or more sheets forward into the document feeder where the sheets engage with the separation roller. The separation roller contacts the document feeder separation pad, which separates multiple sheets into a single sheet.

- Feed

The single sheet continues through the document feeder paper path (aided by the pre-scan rollers) until the leading edge of the page activates the top-of-form sensor. Activation of this sensor initiates the scan process, and the scanner acquires the image as the document moves over the document feeder glass. The post-scan rollers then eject the sheet into the output area. The pick and feed steps are repeated as long as paper is detected by the paper-present sensor.

- Home

When the form sensor detects the trailing edge of the last page, the last sheet is ejected and the motor turns on a sequence that rests the separation floor back down in standby mode, which allows it to detect when more media is loaded.

2 Solve problems

For additional service and support

HP service personnel, go to the Service Access Workbench (SAW) at support.hp.com/wise/home/ams-en.

Channel partners, go to HP Channel Services Network (CSN) at hp.com/partners/csn.

At these locations, find information on the following topics:

- Install and configure
- Printer specifications
- Up-to-date control panel message (CPMD) troubleshooting
- Solutions for printer issues and emerging issues
- Remove and replace part instructions and videos
- Service advisories
- Warranty and regulatory information

Channel partners, access training materials in the HP University and Partner Learning Center at content.ext.hp.com/sites/LMS/HPU.page.

To access HP PartSurfer information from desktop, go to partsurfer.hp.com/search.aspx any mobile device, go to partsurfermobile.hp.com or scan the Quick Response (QR) code below.



Troubleshooting process

Determine the problem source

When the printer malfunctions or encounters an unexpected situation, the printer control panel alerts the user to the situation. This section contains a pre-troubleshooting checklist and a troubleshooting flow chart to filter out many possible causes of the problem.

- Use the pre-troubleshooting check list to gather information about the problem from the customer. See [Pre-troubleshooting checklist](#).
- Use the troubleshooting flowchart to pinpoint the root cause of hardware malfunctions. The flowchart provides guides to the section of this chapter that contain steps to correct the malfunction. See [Troubleshooting flowchart](#).

Before beginning any troubleshooting procedure, check the following issues:

- Are supply items within their rated life?
- Does the configuration page reveal any configuration errors?



NOTE: The customer is responsible for checking supplies and for using supplies that are in good condition.

Pre-troubleshooting checklist

The following table includes basic questions to ask the customer to quickly help define the problem(s):

Table 2-1 Pre-troubleshooting checklist

General topic	Questions
Environment	<ul style="list-style-type: none">• Is the printer installed on a solid, level surface (+/- 1°)?• Is the operating environment within the specified parameters?• Is the printer exposed to ammonia gas, such as that produced by diazo copiers or office cleaning materials? NOTE: Diazo copiers produce ammonia gas as part of the copying processes. Ammonia gas (from cleaning supplies or a diazo copier) can have an adverse effect on some printer components (for example, the toner cartridge).• Is the printer exposed to direct sunlight?
Power	<ul style="list-style-type: none">• Is the power-supply voltage within ± 10 volts of the specified power source?• Is the power-supply plug inserted in the printer and the outlet?
Media	<ul style="list-style-type: none">• Does the customer use only supported media?• Is the media in good condition (no curls, folds, or distortion)?• Is the media stored correctly and within environmental limits?
Input tray	<ul style="list-style-type: none">• Is the amount of media in the tray within specifications?• Is the media correctly placed in the tray?• Are the paper guides aligned with the stack?
Toner cartridge	<ul style="list-style-type: none">• Is the toner cartridge installed correctly? NOTE: Recommended to use original HP supplies only.

Table 2-1 Pre-troubleshooting checklist (continued)

General topic	Questions
Covers	<ul style="list-style-type: none"> Is the toner cartridge door closed?
Condensation	<ul style="list-style-type: none"> Does condensation occur following a temperature change (particularly in winter following cold storage)? If so, wipe affected parts dry or leave the printer on for 10 to 20 minutes. Were a toner cartridge opened soon after being moved from a cold to a warm room? If so, allow the toner cartridge to sit at room temperature for 1 to 2 hours.
Miscellaneous	<ul style="list-style-type: none"> Check for and remove any non-HP components (toner cartridge) from the printer. Remove the printer from the network (network models) and Make sure that the failure is associated with the printer before beginning troubleshooting.

Troubleshooting flowchart

This flowchart highlights the general processes to follow to quickly isolate and solve printer hardware problems.

Each row depicts a major troubleshooting step. Follow a “yes” answer to a question to proceed to the next major step. A “no” answer indicates that more testing is needed. Go to the appropriate section in this chapter, and follow the instructions there. After completing the instructions, go to the next major step in this troubleshooting flowchart.

Table 2-2 Troubleshooting flowchart

Troubleshoot	Solution
<p>Step 1</p> <p>Power on</p>	<p>Is the printer on and does a readable message display or is the Ready LED illuminated (depends on printer model)?</p> <p>Yes ↓ No →</p> <p>Follow the power-on troubleshooting checks. See Power subsystem checks section to check if the printer is in ready state.</p> <p>Check if the control panel is functional. See Control panel checks section to check if the printer is in ready state.</p>
<p>Step 2</p> <p>Control panel LED diagnostics/Control panel error code diagnostics</p>	<p>Is the printer in Ready mode?</p> <p>Yes ↓ No →</p> <p>See Event code diagnostics section to interpret the printer status.</p>
<p>Step 3</p> <p>Event code diagnostics</p>	<p>When state of the printer is identified from the control panel; then check the event code for error details. See Event code diagnostics section for more details.</p> <p>Yes ↓ No →</p> <p>If the event log does not print, use Embedded web server (EWS) to check the error logs.</p> <p>If paper jams inside the printer, see Clear paper jams and Clear paper jams (MFP models only) sections.</p> <p>After successfully evaluating the event codes, perform the necessary servicing, see step 4.</p>
<p>Step 4</p> <p>Print reports</p>	<p>Print the configuration pages to verify all printer settings.</p> <p>Yes ↓ No →</p> <p>See Printer reports section on how to print a configuration page or how to access other reports using EWS.</p> <p>After evaluating the configuration pages, see step 5.</p>
<p>Step 5</p> <p>Print quality</p>	<p>Does the print quality meet the customer's requirements?</p> <p>Compare the images with the sample defects in the image defect tables. For more information, see Improve print quality.</p>

Table 2-2 Troubleshooting flowchart (continued)

Troubleshoot	Solution
	<p>Yes ↓ No → After the print quality is acceptable, see step 6.</p>
Step 6 Interface	<p>Can the customer print successfully from the host computer?</p> <hr/> <p>Yes. This is the end of the troubleshooting process. No →</p> <p>Verify that all I/O cables are connected correctly and that a valid IP address is listed on the network configuration page (depends on printer model).</p> <p>If error messages display on the control panel, (or the Attention LED is illuminated), see the control panel message section (or the interpret control panel light patterns section) of the printer troubleshooting service manual.</p> <p>When the customer can print from the host computer, this is the end of the troubleshooting process.</p>

Power subsystem checks

Turn on the power. If the control panel does not illuminate, perform the power-on checks to find the cause of the problem.

1. Verify that the printer is plugged into an active electrical outlet that delivers the correct voltage.
2. Verify that the power switch is in the on position.
3. Make sure that the printer makes the expected start up sounds.

 **NOTE:** If the printer does not power on, the overcurrent/overvoltage protection circuit in the low-voltage power supply might be functioning. This circuit automatically stops supplying DC voltage to the printer components whenever it detects excessive current or abnormal voltage. In this case, turn the printer off and unplug the power cord. Do not turn the printer on until the cause of the excessive current or voltage from the power source is found and corrected.

4. If the printer does not start up; then do the following:
 - a. The overcurrent/overvoltage protection circuit in the low-voltage power supply circuit may still be functioning. Turn off the printer, and then unplug the power cord. Leave the printer for 5 minutes or longer, and then reconnect the power cord. Turn on the power.
 - b. If the printer does not start up after performing the step "a", then either the fuse blows or the low-voltage power supply assembly malfunctions. Replace the engine controller PCA.

Control panel checks



1. Turn on the printer.
2. Check if the printer is in Ready mode.

The power button will blink initially and then gradually comes to a steady state (stops blinking and status ON)

3. Allow the printer to enter sleep mode, and then press the Resume/Cancel button  for the printer to exit sleep mode. Check if the LEDs turn on again.

4. Check if the control panel buttons display any of the following:

SFP models

- **USB models:** Open the cartridge door, the Attention light  lights up.
- **Wireless models:** Press the Wireless button  to turn **ON** or **OFF** the Wi-Fi, and then make sure to print an information page to know whether the printer is connected or not.

MFP models

- Open the cartridge door, the control panel displays Er/02 code.

Tools for troubleshooting

This section describes the tools that can help solve problems with the printer.

Use the Embedded Web Server (EWS) to manage printing functions from your computer.

- View printer status information.
- Check the information and status of the printing supplies.
- Receive notification of printer and supplies events.
- View and change the network and the printer settings.

To access and use the Embedded Web Server (EWS)

Open EWS using one of the following:

- HP Smart app
- HP printer software
- Web browser using IP address
- Web browser using Wi-Fi Direct connection

Things to note when accessing EWS:

- If the web browser displays a message indicating that the website is unsafe, select the option to continue. Accessing the website will not harm your device.
- If prompted, enter the default user name and password of the printer.
 - **User Name:** admin
 - **Password:** Open the cartridge access door, and look for the PIN number on the label inside the printer.

Table 2-3 Label inside the printer

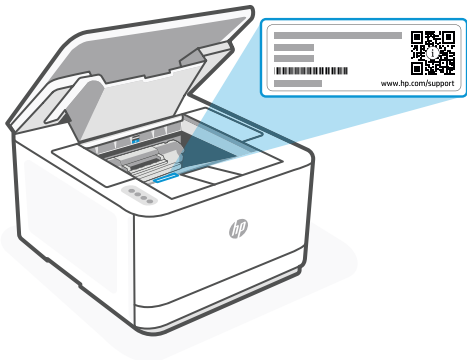
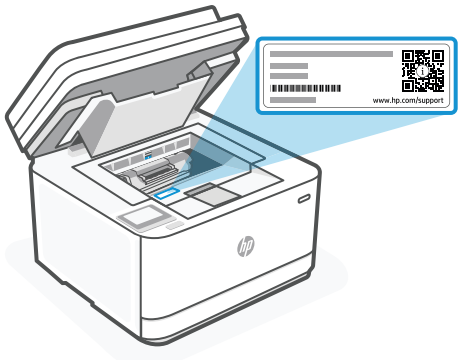
SFP models	MFP models
	

- Depending on how the printer is connected, some features in EWS might not be available.

- EWS is not accessible beyond the network firewall.

To open EWS using HP Smart app (iOS, Android, and Windows 10)

1. Open the HP Smart app on your device.
2. From the HP Smart app, select your printer, and then click or tap **Advanced Settings**.

To open EWS using an IP address (Wi-Fi or Ethernet connection) SFP models only

1. Find out the IP address. Press the Information button  on the printer to print an information page.
2. Open a web browser, type the IP address or hostname in the address bar, and then click or tap **Enter**.

To open EWS using an IP address (Wi-Fi or Ethernet connection) MFP models only

1. Find out the IP address of the printer by touching or swiping down the tab  at the top of a screen on the control panel to open the Dashboard, and then by touching the Info tab.
2. Open a web browser on your device. Type the IP address (as indicated on the screen or page) in the address bar, and then click or tap **Enter** on your device.

To open EWS using HP Printer software (Windows 7)

1. From the computer desktop, click **Start**, select **All Programs**, click **HP**, click the folder for the printer, select the icon with the printer's name, and then open **HP Printer Assistant**.
2. In the **HP Printer Assistant**, select **Print** tab.
3. Select **Printer Home Page (EWS)**.

Use the HP Smart app to print, scan, and manage

The HP Smart app can help you perform many different printer tasks, including the following:

 **NOTE:** Set up / connect the printer to the Internet using the control panel or through the HP software. You can download the HP software from hpsmart.com/setup on a Windows or Mac computer.

- Print and scan documents and photos.
- Share documents through email and other applications.
- Manage printer settings, check printer status, print reports, and order supplies.

 **NOTE:**

- HP Smart is supported on mobile devices and computers running on iOS, Android, Windows 10 and above, and macOS (versions 10.14, 10.15, 11.0, and 12).
 - The HP Smart app might not be available in all languages. Some features might not be available with all printer models.
-

To install HP Smart and open the app

Complete the following steps to install and open HP Smart, connect your printer, and begin using the app.

1. Download and install HP Smart app on your device.

 **NOTE:**

- **iOS, Android, Windows 10 and above, and macOS:** You can download HP Smart from the respective app stores for the device.

2. Open HP Smart after installation.

- **iOS/Android:** From the mobile device desktop or app menu, tap HP Smart.
- **Windows 10 and above:** From the computer desktop, click **Start**, and then select **HP Smart** from the app list.
- **macOS:** From the Launchpad, select HP Smart.

3. Sign in to the HP Smart app using the HP account created during setup. [Get more information about HP Smart](#)

Get more information about HP Smart

To learn how to connect, print, and scan using HP Smart, visit the website for your device:

- **iOS/iPadOS/Android:** hp.com/go/hpsmart-help
- **Windows 10 and above:** hp.com/go/hpsmartwin-help
- **macOS:** hp.com/go/hpsmartmac-help

Wi-Fi band supported

The supported Wi-Fi bands are Ethernet, Wi-Fi Direct®, and Dual band Wireless (802.11b/g/n) with Bluetooth.

Print reports (SFP Models only)

Table 2-4 Print printer reports







Printer report	How to print	Description
Information Report	Press the Information button  .	The information page provides a summary of the printer information and its current status.
Printer Status Report	Press and hold the Information button  for 3 seconds.	The status page provides the current printer information, supplies status, and some recent events. It can also help troubleshoot printer problems.
Network Configuration Report and Wireless Network Test Report (wireless models)	Press the Wireless button  and the Resume/Cancel button  at the same time.	Configuration report shows the IP settings, Ports/ Services status, a list of Wi-Fi networks in range of the printer. It also includes details for Wi-Fi Direct including SSID name, IP address, Wi-Fi Direct Printing on/off status, Wi-Fi Direct Printing security on/off status, and security pass code. Wireless Network Test Report contains diagnostic information, typically used as a troubleshooting aid for the users. The report consists of connection problems exist between the printer radio/STA and the home network's Wi-Fi router.

Table 2-4 Print printer reports (continued)

Printer report	How to print	Description
Web Access Report	<p>Press the Information button  and the Resume/Cancel button  at the same time.</p>	Print the web access report to help identify internet connectivity issues which can affect Web Services.
Web Service information page	<ol style="list-style-type: none"> 1. Open the EWS. See To access and use the Embedded Web Server (EWS). 2. Click the Web Services tab. 3. From the left menu, click Web Services Settings. 4. Click the Print Info Page to print the information page. 5. If you have not enabled the Web Services, click Enable to print the information page. 	Depending on the Web Services status, Web Services Reports provide different instructions to help you turn on Web Services, set up Web Services, fix connection issues, and more.
Adjust Alignment Test Page	<ol style="list-style-type: none"> 1. Open the EWS. See To access and use the Embedded Web Server (EWS). 2. Click the Settings tab. 3. From the left menu, click Preferences. 4. Click Image Registration and make the necessary changes. 5. Click Apply. 	The printer prints an alignment page.

 **NOTE:** The content of the reports might change with new firmware releases.

The following figure shows an example of a configuration report from the HP LaserJet Pro 3001–3008 series:

Figure 2-1 LaserJet Pro 3001-3008 model sample configuration report

Printer Configuration Page

Printer Information 1

1. Product Name: HP LaserJet Pro MFP 3103dn
2. Serial Number: VNCA6F524
3. Formatter serialnumber: 5110170
4. Service ID: 12068
5. ADF: Installed

Memory 2

10. Total Memory: 512 MB
11. Available Memory: 289 MB

Paper Setting 3

12. Default Paper Size: Letter (8.5x11)
13. Default Paper Type: Plain
14. Tray 1 Paper Size: A4 (210x297 mm)
15. Tray 1 Paper Type : Plain
16. Paper Out Action: Wait Forever
17. ManualFeed:Off
18. Tray Size Prompt: On

Copy 4

19. Optimize: Mixed
20. Lighter/Darker: <----->
21. Paper Size: Letter (8.5x11)
22. Paper Type: Plain
23. Collation: Enabled
24. Number of Copies: 1
25. Reduce/Enlarge: Original
26. Two-Sided: 1-Sided Original to 1-Sided Copy
27. Tray Select: Tray 1

Print 5

28. A5 Feed Orientation: Portrait Orientation

HP Web Services 6

29. HP Web Services:Off

ProductSettings 7

6. Device Description: HP LaserJet Pro MFP 3103fdn
7. Language: English
8. Hostname: HPPDC637
9. URL:

Fax 8

30. Your Company Name:
31. Auto Answer: On
32. Rings to Answer: 5
33. Distinctive Ring: All Rings
34. Dial Prefix: Off
35. Fax Resolution: Fine
36. Lighter/Darker: <----->
37. Fit To Page: On
38. Dialing Mode: Tone Dialing
39. RedialIf Busy:On
40. Redial If No Answer: Off
41. Redial If Comm Error: On
42. Detect Dial Tone: not applicable
43. Stamp Faxes: Off
44. Confirm Fax Number: Off
45. Allow Fax Reprint: On
46. Speed: Medium (14400)
47. (ECM) Error Correction Mode: On
48. Fax Forwarding: Off
49. Block Junk Faxes: Off
50. Billing Code: Off
51. Fax Volume: Soft
52. Ring Volume: Soft
53. Key-Press Volume: Soft
54. Fax Confirmation: On (Fax Send)
55. Fax Error Report: On (Fax Send)
56. Auto Log Print: not applicable
57. Print T 30 Trace: not applicable

Table 2-5 LaserJet Pro 3001-3008 model sample configuration report

Item	Description
1	Printer name and model information
2	Memory
3	Paper setting
4	Copy information
5	Print information
6	HP Web Services
7	Product settings
8	Fax information

Print reports (MFP Models only)

This topic describes how to print reports through the EWS and the printer control panel.

The following figure shows an example of the configuration report from the HP LaserJet Pro MFP 3101-3108 series:

Figure 2-2 LaserJet Pro MFP 3101-3108 sample configuration report

Product Information 1

1. Model Name: HP LaserJet Pro MFP 3103fdn
2. Model Number: 3103fdn
3. Serial number: VNCA67F524
4. Formatter Serial number : 511017D
5. Product Number: 3G631A
6. Service ID: 12068
7. Printer Zone (PX): 1
8. Firmware Version: XXXXXA001.Pushk_20210816_181430-msc
9. Engine Firmware: 12600
10. Country/Region: 15/1
11. Duplexer: Installed
12. ADF: Installed
13. Type Code: 01.01.01.00.00
14. Date/Time: 8/26/2021 05:48:10 PM
15. Cartridge Index: OCAN FCDG

Print Usage Information 2

16. Total Pages Printed: 6
17. Duplex page count: 0

HW Events 3

1. 08/17/2021 17:35:51 Error Code: b802dc48 Host ID:2 File Name: Line:0

System Events 4

- 1 Seq-Num: 4 Date-Time: 06/26/2021 12:42:13 Page-Count 4 Error-Code: 30.03.30 Reprs: 1 Desc-ID: 0
- 2 Seq-Num: 3 Date-Time: 06/26/2021 12:42:11 Page-Count 1 Error-Code: 30.03.30 Reprs: 7 Desc-ID: 0
- 3 Seq-Num: 2 Date-Time: 06/26/2021 12:42:41 Page-Count 0 Error-Code: 30.03.30 Reprs: 2 Desc-ID: 0
- 4 Seq-Num: 1 Date-Time: 06/26/2021 12:42:40 Page-Count 0 Error-Code: 30.21.11 Reprs: 1 Desc-ID: 0

Additional Assistance 5

For more information about how to change settings and diagnose problems, see the user documentation for your device. This documentation is available on your computer after you install the software-either from the HP LaserJet Pro MFP 3103fdn Printer Software (Windows)

Fax Test Setup 6

To verify that your product is setup correctly for Fax, run the Fax Test. You can access this test from the device control panel or from the HP LaserJet Pro MFP 3103fdn Printer Software.

Connectivity Settings 7

18. Network Status: Offline
19. Active Connection Type: None
20. URL: -
21. Admin Password: Set
22. Printer PIN: 12345678
23. Hostname: HPFDC637

Scan Settings 8

24. Front Panel Destinations List: 0

Scan Usage Information 9

25. Pages Scanned: 0
26. Scans From ADF: 0

Fax Settings 10

27. Speed: Medium (14430)
28. Backup Fax Reception: On
29. Fax Forwarding: Off
30. Auto Answer: On
31. Rings to Answer: 5
32. Distinctive Ring: All Rings
33. (ECM) Error Correction Mode: On
34. Fax to PC: On
35. Digital Fax: E-mail
36. Digital Fax: Network

Fax Usage Information 11

37. Faxes Sent: 0
38. Faxes Received: 0

Table 2-6 LaserJet Pro MFP 3101- 3108 model sample configuration report

Item	Description	Item	Description
1	Printer name and model information	7	Connectivity settings
2	Print usage information	8	Scan settings
3	HW events	9	Scan usage information
4	System events	10	Fax settings
5	Additional assistance	11	Fax usage information
6	Fax test setup		

To print a report from the printer control panel

1. On the Home screen of the printer display, touch **Setup** .

2. Scroll down and touch **Reports**.
3. Scroll down and select the desired report to print.

To print a report from the EWS

1. Open the EWS. See [To access and use the Embedded Web Server \(EWS\)](#).
2. Click the **Tools** tab.
3. From the left menu, click **Reports**.
4. Click **Printer Reports** to print the desired report.

Printer reports

Table 2-7 Printer reports

Printer report	Description	How to print
Printer Status Report	Printer Status Report includes the current printer information, Supplies status and some recent events. It also helps to troubleshoot problems with the printer.	See To print a report from the printer control panel
Network Configuration Page (wireless models)	Configuration report shows the IP settings, Ports/Services status, a list of Wi-Fi networks in range of the printer. It also includes details for Wi-Fi Direct including SSID name, IP address, Wi-Fi Direct Printing on/off status, Wi-Fi Direct Printing security on/off status, and security pass code.	See To print a report from the printer control panel
Wireless Test Report (wireless models)	Wireless Network Test Report contains diagnostic information, typically used as a troubleshooting aid for the users. The report consists of connection problems that exists between the printer radio/STA and the home network's Wi-Fi router.	See To print a report from the printer control panel
Web Access Test Report	Print the web access report to help identify internet connectivity issues which can affect Web Services.	See To print a report from the printer control panel
Web Service Information Page	Depending on the Web Services status, Web Services Reports provide different instructions to help you turn on Web Services, set up Web Services, fix connection issues, and more.	<ol style="list-style-type: none"> 1. Open the EWS. See To access and use the Embedded Web Server (EWS). 2. Click the Web Services tab. 3. From the left menu, click Web Services Settings. 4. Click the Print Info Page to print the information page.
Adjust Alignment Test Page	The printer prints an alignment page.	<ol style="list-style-type: none"> 1. Open the EWS. See To access and use the Embedded Web Server (EWS). 2. Click the Settings tab. 3. From the left menu, click Preferences. 4. Click Image Registration and make the necessary changes. 5. Click Apply.

Troubleshooting diagnostics

LED, engine, and individual diagnostics can identify and troubleshoot printer problems.

Network LED diagnostics

The formatter has two network LEDs. When the printer is connected to a properly working network through a network cable, the amber LED indicates network activity, and the green LED indicates the link status.

A blinking amber LED indicates network traffic. If the green LED is off, a link has failed. For link failures, check all of the network cable connections. In addition, you can try to manually configure the network card link speed setting by using the printer control panel.

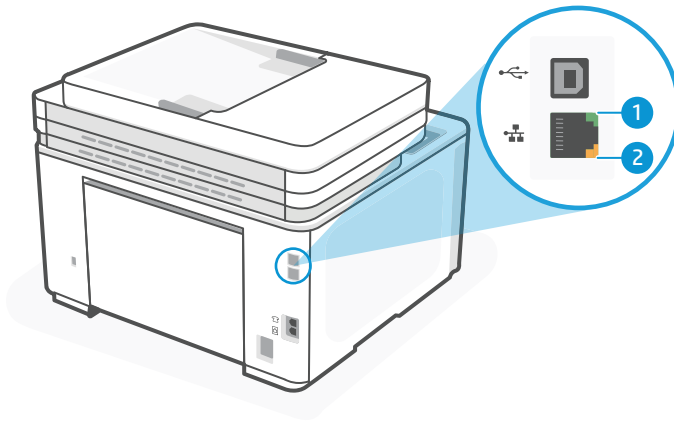

Table 2-8 Network LED diagnostics

Feature	Description
1	Link status LED (green)
2	Network activity LED (amber)

To change the link speed setting, do the following:

1. Open a web browser, and in the address line, type the IP address or host name exactly as it displays on the printer configuration report. Press the **Enter** key on the computer keyboard. The EWS opens.
2. Click **Networking** tab, and then click **Advanced** tab.
3. Under **Advanced** tab, click **Other Settings** tab, and then from the Link Speed drop-down list, choose the appropriate option.
4. Click **Apply**.

Engine diagnostics

Printing test pages helps determine whether the printer engine and the formatter are functioning. If the formatter is damaged, it might interfere with the engine test. If the engine-test page does not print, try removing power from the formatter and then performing the engine test again. If the engine test is successful, the problem is almost certainly with the formatter.

Engine test

 **NOTE:** The printer has an engine-test page in the firmware that is printed by opening and closing the toner-cartridge door in a specific pattern. Use A4 or letter-size paper to print the engine-test page.

1. Make sure that paper is correctly loaded in the tray.
2. Turn the printer power on. Wait for the printer to reach the Ready state.
3. Open and then close the cartridge door four times within 5 seconds and one simplex page is printed. Open and then close the cartridge door five times or more within 5 seconds and one duplex page is printed.
4. The engine-test page has grid test pattern in the print area of B5 size as follows.

Figure 2-3 Engine test page

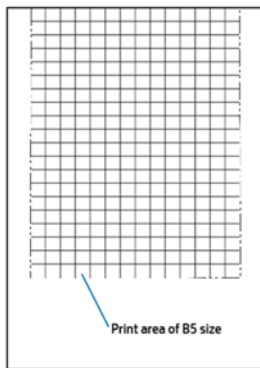

Event code diagnostics



Use one of the following methods to check the event codes:

Method one: Embedded Web Server (EWS)

For more information, see [To access and use the Embedded Web Server \(EWS\)](#).

- In EWS, click the **Home** tab and then click the **Event Log** item. The event log displays a list of all printer events and errors.

Method two: Print configuration report.

- **USB model:** Press and hold the Resume/Cancel button  for 3 seconds to print a configuration report.
- **Wireless model:** Press and hold the Information button  for 3 seconds until all buttons are lit, and then press the Resume/Cancel button  to print a configuration report.

Use the following table to view and interpret event code diagnostics errors:

Table 2-9 Event diagnostics errors

Error code	System Component	Description
01	IO	4 - WiFi

Table 2-9 Event diagnostics errors (continued)

Error code	System Component	Description
10.XX.XX	Supplies (LaserJet)	Supply error or supply memory error Black cartridge failure issues No Cartridge message error Cartridge warning messages Memory error warning
13.XX.XX	Jam (LaserJet)	Paper jam or open door jam error Jam error issues Inconsistent Media Size message error Duplex delivery path feeding incompatibility
21.XX.XX	Misprint	Page complexity causing a decompression error when trying to process job
30.XX.XX	Scanner	Flatbed scanner error occurring inside the unit Scanner motor failure issues The product is unable to calibrate. Close the lid and remove paper from the document feeder
31.XX.XX	Document feeder	Document feeder, scanner, or jam error
32.XX.XX	Backup, restore, or reset	Backup, restore, or reset notification or error
33.XX.XX	Security	Backup, Disk, EFI BIOS, Firmware integrity (SureStart), or error
44.WX.YZ	Digital Send	Firmware failure involving a digital sending component
50.XX.XX	Fuser (LaserJet)	Fuser error issues Fuser malfunction and temperature error Low temperature error 1
51.XX.XX	Laser scanner (LaserJet)	Laser scanner beam error
52.XX.XX	Laser scanner motor (LaserJet)	Laser scanner motor startup error Black laser scanner issues
53.XX.XX	Engine peripheral	Duplexer installed/removed, optional cassette installed/removed, Tray 1-3 lifter error
54.XX.XX	Sensor	Sensor error (not jam related) Environmental sensor error issues Environment sensor abnormality warning and sensor abnormality warning Driving circuit failure error
55.XX.XX	Engine data error (LaserJet)	Engine data error

Table 2-9 Event diagnostics errors (continued)

Error code	System Component	Description
56.XX.XX	Paper handling (LaserJet)	Paper input/output or accessory error
57.XX.XX	Fan	Fan error
58.XX.XX	Engine power	Engine power failure
59.XX.XX	Motor (LaserJet)	Motor error ETB, developer motor, and fuser-motor error issues
60.XX.XX	Tray motor error (LaserJet)	Tray lifting or pick up error

10.xx.xx Black cartridge failure issues error

The product has experienced the following black-cartridge errors:

- 10.0 – 10.03 = Black cartridge memory error
- 10.05 = Black cartridge invalid region error
- 10.1 = Black cartridge memory error (missing)
- 10.3 = Unauthorized black cartridge
- 10.35 = Incompatible black cartridge
- 10.41 = Unsupported black cartridge in use
- 10.45 = Incompatible black cartridge installed - rejected by RTP Cloud
- 10.57 = Protected black cartridge
- 10.98 = Black cartridge waste toner is full

To Make sure optimal print quality, HP recommends replacing the toner cartridge at this point. You can continue printing until you notice a decrease in print quality. Actual cartridge life might vary. Once an HP supply has reached Very Low, HP's Premium Protection Warranty on that supply has ended. All print defects or cartridge failures incurred when an HP supply is used in Continue at very low mode will not be considered to be defects in materials or workmanship in the supply under the HP Print Cartridge Warranty Statement.

Solution

1. Restart the printer and then try again.
2. If the error still persists, then replace the cartridge.

Change the [Cartridge Policy](#) to [Off](#) or replace the cartridge to continue printing.

 **NOTE:** If customer believes they purchased a new genuine HP supply, direct them to www.hp.com/go/anticounterfeit to verify.

 **NOTE:** Service or repairs that are required as a result of using unsupported supplies is not covered under HP warranty.

For other-cartridge errors, perform the following solution:

"No Cartridge" message error

"No Cartridge" message does not appear although the cartridge is not installed.

Solution

1. Reconnect the connector (J531) on the engine-controller PCA and the connector (J601 and J604) on the fuser output sensor PCA.
2. Replace the registration sensor PCA.
3. Replace the printer.

Cartridge warning messages

The product has experienced cartridge end-of-life and cartridge low warning messages.

- "Cartridge End of Life Warning" message appears although the cartridge is new.
- "Cartridge Low" message appears although the cartridge is new.

Solution

1. Reinstall the cartridge.
2. Replace the cartridge.

Memory error warning

The product has experienced the following cartridge-memory error warnings.

- "Memory Error Warning" message appears although the cartridge is new
- Memory data error warning
- Memory access error warning
- Abnormal memory operation warning
- Memory expanded area data error warning
- Cartridge memory data abnormality warning
- Cartridge memory access abnormality warning
- Black cartridge memory expanded area data error warning
- Black cartridge memory behavior error warning

Solution

1. Reinstall the cartridge.
2. Clean the E-label contacts of both the printer and the cartridge.
3. Reconnect the connector (J521) of the engine controller PCA.
4. Replace the cartridge.
5. Replace the engine controller PCA.

13.xx.xx Jam errors

The jam errors might occur due to the following reasons:

- 01h: No pick jam
- 02h: Pickup stay jam
- 03h: Fuser delivery delay jam
- 04h: Fuser delivery stay jam
- 09h: Duplex feed delay jam
- 0Bh: Duplex re-pickup jam
- 0Ch: Fuser wrap jam
- 0Eh: Residual paper jam 1
- 0Eh: Residual paper jam 2
- 0Fh: Door open jam
- 10h: Inappropriate to the delivery path jam

Solution

- ▲ See [Repair parts for frequent paper jams](#) and [Repair parts for frequent paper jams \(MFP models only\)](#) sections.

"Inconsistent Media Size" message error

The product has experienced the error "Inconsistent Media Size" message appears although the correct-sized media is loaded in the designated input tray.

Solution

1. Reconnect the connector (J531) on the engine controller PCA and the connector (J601 and J604) on the fuser output sensor PCA.
2. Replace the registration sensor PCA.
3. Replace the printer.

MISSING TITLE

The product has experienced the error "Top Cover Open" message appears although the cover is closed.

Solution

1. Check the projection part on the switch for the cartridge door assembly. If it is damaged, then replace the cartridge door assembly.
2. Replace the engine controller PCA.

Duplex delivery path feeding incompatibility

The product has experienced duplex delivery path feeding incompatibility.

Solution: Use media size that is compatible with duplex printing.

21.xx.xx Print failure error (formerly a Page Punt error)

Print failure occurred.

Press the **OK** button to clear the message.

To avoid this problem, try the following solutions:

Solution

1. Adjust the paper guides in the tray. Make sure the front paper guide is pushing the paper against the back edge of the tray.
2. Use paper that meets HP specifications. Store paper unopened in its original packaging.
3. Use the product in an area that meets the environmental specifications for this product.
4. Restart the printer, and then try again.
5. Use a different driver.

30.xx.xx Scanner error

The flatbed or ADF scanner is failing to initialize due to the following reasons:

- 30.0012 = Scanner motor test failure error.
- 30.0013 = Scanner failed to find home or ran into wall at boot error.
- 30.0016 = Scan module (CIS Sensor) communication error.
- 30.0017 = Scan motor position error.
- 30.0023 = Scan calibration failure error.

Solution

1. Verify that the product has the most recent firmware from [30.xx.xx Scanner error](#).
2. Verify that the flat flexible cables (FFCs) are seated correctly on the formatter board.
3. If the error persists, then replace the image scanner assembly:

Table 2-10 Part description and part number

Part description	Part number
Image scanner assembly	RM2-3416-000CN

4. If the error still persists, then escalate to Level 3 so that Technical Marketing has visibility to the problem.

The product is unable to calibrate. Close the lid and remove paper from the document feeder.

The scanner is unable to calibrate because either the lid is open or there is paper blocking the scan head.

Solution

1. Remove any paper from the scanner glass or the ADF and close the lid.

2. If the error persists, replace the image scanner assembly:

Table 2-11 Part description and part numbers

Part description	Part numbers
Image scanner assembly	RM2-3416-000CN

31.xx.xx Document feeder mispick error

The product did not pick up the paper in the document feeder.

Solution

1. Remove the paper from the document feeder tray, and then reload it.
2. Verify there are no staples or paper clips on the stack of originals. Verify the originals are straightened out from previous folds or curl.
3. If the control panel displays Document Feeder Loaded when the originals are not in the input tray of the document feeder, the sensor on the document feeder might be malfunctioning. Replace the Auto Document Feeder Assembly:

Table 2-12 Part description and part number

Printer model	Part description	Part number
MFP models only	Pre-pick Arm Assembly	RM2-3409-000CN
	ADF Core Assembly	RM2-3414-000CN
	Paper Pick-up Tray Assembly	RM2-3410-000CN
	ADF Base Assembly	RM2-3411-000CN

50.xx.xx Fuser error

The product has experienced any of the following internal fuser hardware error:

- 50.00 = Generic Fuser error
- 50.10 = Low Fuser temperature error
- 50.11 = High sub thermistor area 3 fuser error
- 50.12 = Low sub thermistor area 3 fuser error
- 50.20 = Slow fuser error
- 50.30 = High fuser temperature error
- 50.40 = Fuser drive circuit error
- 50.70 = Fuser open error
- 50.80 = Low sub thermistor fuser error
- 50.90 = High sub thermistor fuser error

Solution

1. Reset the product:
 - a. Turn off the power by using the power switch, and then wait at least 30 seconds.
 - b. Turn on the power and wait for the product to initialize.
2. If you are using a surge protector:
 - a. Power off the product.
 - b. Remove the surge protector.
 - c. Plug the product directly into the wall socket and turn the product power on.
3. Check if there is a residual paper in the fuser and clear the jam.
4. If the error still persists then re-install the fusing assembly.
5. Reconnect the connectors (J103 and J531) on the engine controller PCA.
6. Replace the fuser.

Table 2-13 Part description and part numbers

Part descriptions	Part numbers
Fuser and fixing film assembly (110–127V) (SFP models only)	RM2-3429-000CN
Fuser and Fixing film assembly (220–240V) (SFP models only)	RM2-3431-000CN
Fuser and fixing film assembly (110–127V) (MFP models only)	RM2-4839-000CN
Fuser and Fixing film assembly (220–240V) (MFP models only)	RM2-4841-000CN

7. Replace the engine-controller PCA.

Table 2-14 Part description and part numbers

Part descriptions	Part numbers
Engine controller PCB assembly (110–127V) (SFP models only)	RM3-8170-000CN
Engine controller PCB assembly, except China model (220–240V) (SFP models only)	RM3-8171-000CN
Engine controller PCB assembly China model (220–240V) (SFP models only)	RM3-8172-000CN
Engine controller PCB assembly (110–127V) (MFP models only)	RM3-8173-000CN
Engine controller PCB assembly except China model (220–240V) (MFP models only)	RM3-8174-000CN
Engine controller PCB assembly China model (220–240V) (MFP models only)	RM3-8175-000CN

Fuser malfunction and temperature error

The product has experienced any of the following malfunction and temperature errors.

- Fuser-malfunction error
- Heat up error
- High temperature error 1

Solution

1. Reinstall the fuser.
2. Reconnect the connector (J103 and J531) on the engine controller PCA.
3. Replace the fuser.
4. Replace the engine controller PCA.

Low temperature error 1

The product has experienced low temperature error 1.

Solution

1. Check if there is a residual paper in the fuser and clear the jam.
2. Reinstall the fuser.
3. Reconnect the connector (J103 and J531) on the engine controller PCA.
4. Replace the fuser.
5. Replace the engine controller PCA.

51.xx.xx Laser scanner error

The product has experienced the following other scanner malfunction-related issues:

- Scanner motor malfunction (start-up error)
- Scanner motor malfunction (rotation error)
- Scanner malfunction-related issues

Solution

1. Reconnect the connector (J531) on the engine-controller PCA and the connector (J601 and J604) on the fuser output sensor PCA.
2. Replace the registration sensor PCA.
3. If the error still persists, replace the printer.

54.xx.xx Environmental sensor error

The product has experienced an error with the environmental sensor error.

Solution

1. Reset the printer:

- a. Turn off the power by using the power switch, and then wait at least 30 seconds.
 - b. Turn on the power and wait for the product to initialize.
2. If you are using a surge protector:
 - a. Power off the printer.
 - b. Remove the surge protector.
 - c. Plug the product directly into the wall socket and turn the product power on.
3. Reconnect connectors (J74 and J801) of the laser scanner assembly, connectors (J701 and J702) on the motor PCA, and connectors (J451 and J461) on the engine controller PCA.
4. If the error still persists, replace the product.

Environment sensor abnormality warning and sensor abnormality warning

The product has experienced environment sensor abnormality warning and sensor abnormality warning errors.

Solution

1. Turn the power off and then on.
2. Replace the engine controller PCA.

Driving circuit failure error

The product has experienced driving circuit failure error.

Solution

1. Check the power source. If the power generator is used, improves the situation.

 **NOTE:** If the printer does not meet the power requirement of 43 to 67Hz frequency, the fuser temperature control does not work properly and this causes malfunction.

2. Reconnect the connector (J103 and J531) on the engine controller PCA.
3. Replace the engine controller PCA.

55.xx.xx DC controller error

The product has experienced DC controller communication or malfunction errors.

Solution

1. Reset the printer:
 - a. Turn off the power by using the power switch, and then wait at least 30 seconds.
 - b. Turn on the power and wait for the product to initialize.
2. If you are using a surge protector:
 - a. Power off the printer.
 - b. Remove the surge protector.
 - c. Plug the product directly into the wall socket and turn the product power on.

3. If the error persists, replace the Engine Control PCB Assembly.

Table 2-15 Part description and part numbers

Part descriptions	Part numbers
Engine controller PCB assembly (110–127V) (SFP models only)	RM3-8170-000CN
Engine controller PCB assembly, except China model (220–240V) (SFP models only)	RM3-8171-000CN
Engine controller PCB assembly China model (220–240V) (SFP models only)	RM3-8172-000CN
Engine controller PCB assembly (110–127V) (MFP models only)	RM3-8173-000CN
Engine controller PCB assembly except China model (220–240V) (MFP models only)	RM3-8174-000CN
Engine controller PCB assembly China model (220–240V) (MFP models only)	RM3-8175-000CN

4. If the error still persists, replace the product.

DC controller malfunction error

The product has experienced DC controller malfunction error.

Solution

1. Turn the printer off and then on.
2. If the problem still persists, then replace the engine controller PCA.

Driving circuit failure error

The product has experienced driving circuit failure error.

Solution

1. Check the power source. If the power generator is used, improves the situation.



NOTE: If the printer does not meet the power requirement of 43 to 67Hz frequency, the fuser temperature control does not work properly and this causes malfunction.

2. Reconnect the connector (J103 and J531) on the engine controller PCA.
3. Replace the engine controller PCA.

58.xx.xx Power supply malfunction error

The product has experienced an error with the voltage power supply malfunctions.

- 58.04 = Low voltage power supply malfunction
- 58.40 = AC power supply malfunction

Solution

1. Reset the printer:

- a. Turn off the power by using the power switch, and then wait at least 30 seconds.
- b. Turn on the power and wait for the product to initialize.
2. If you are using a surge protector:
 - a. Power off the printer.
 - b. Remove the surge protector.
 - c. Plug the product directly into the wall socket and turn the product power on.
3. Check the voltage label on the back of the product. If the product is rated 220V and is plugged into a 110V outlet, this error might occur. In most cases, no damage is caused to the product. If a power transformer is used to convert 220V power to 110V, verify that the transformer power rating is sufficient to operate the product.
4. If the error persists, replace the Engine Controller PCB Assembly:

Table 2-16 Part description and part numbers

Part descriptions	Part numbers
Engine controller PCB assembly (110–127V) (SFP models only)	RM3-8170-000CN
Engine controller PCB assembly, except China model (220–240V) (SFP models only)	RM3-8171-000CN
Engine controller PCB assembly China model (220–240V) (SFP models only)	RM3-8172-000CN
Engine controller PCB assembly (110–127V) (MFP models only)	RM3-8173-000CN
Engine controller PCB assembly except China model (220–240V) (MFP models only)	RM3-8174-000CN
Engine controller PCB assembly China model (220–240V) (MFP models only)	RM3-8175-000CN

5. Replace the engine controller PCA.
6. If the error persists, replace the product.

59.xx.xx Motor rotation error

The product has experienced an error with the internal motor.

Solution



1. Reset the printer:
 - a. Turn off the power by using the power switch, and then wait at least 30 seconds.
 - b. Turn on the power and wait for the product to initialize.
2. If you are using a surge protector:
 - a. Power off the printer.
 - b. Remove the surge protector.

- c. Plug the product directly into the wall socket and turn the product power on.
3. If the error persists, replace the product.

Error report diagnostics

Error report diagnostics is another diagnostic report page, helpful for 49.xxx and 79.xxx event codes, which provides the firmware engineer with call stack and source files of the crash.

To print an error report, do the following (SFP Models only):

For printers with Information button: When the printer is idle, press the Information button  for 3 seconds to go into the control panel support mode. When in this mode, press the Resume/Cancel button  to print the report, and the printer exits support mode.

For printers without Information button: When the printer is idle, press and hold the Resume/Cancel button  hold for 3 seconds, the report starts to generate after 3 seconds.

To print an error report, do the following (MFP Models only):

From the printer control panel display, touch **Setup** and then touch **Reports**. Select the desired report.

Figure 2-4 Example of an error report

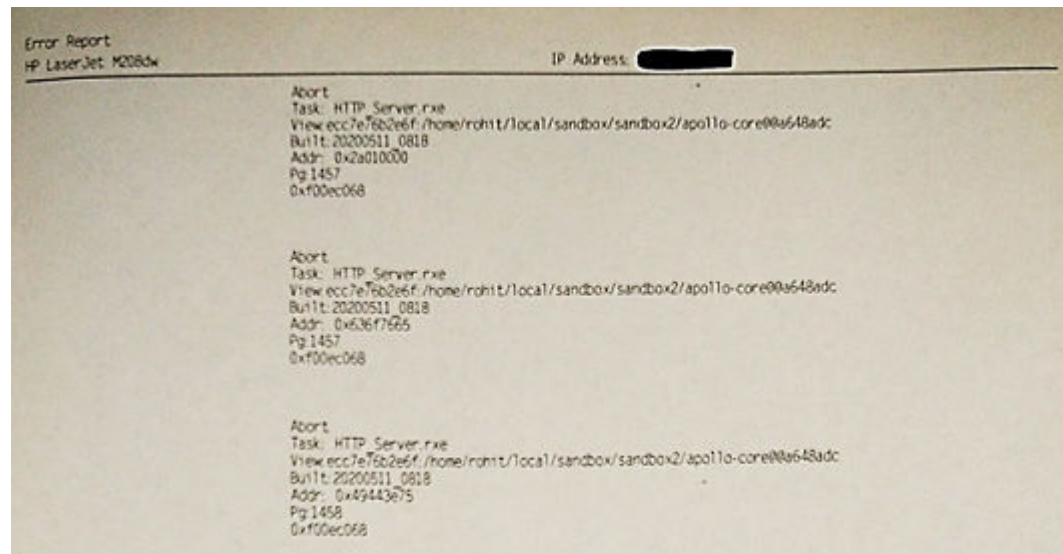

Improve print quality

The following information provides troubleshooting steps to resolve print-quality problems, including the following problems:

- Smears
- Fuzzy print
- Dark print

- Light print
- Streaks
- Missing toner
- Scattered dots of toner
- Loose toner
- Skewed images

To resolve these or other print-quality problems, try the following solutions in the order presented.

For information about resolving specific image defects, see [Image defects table](#).

Update the printer

HP offers periodic printer updates to improve printer performance, fix issues, or protect your printer against potential security threats.

You can change the setting to manually check for updates from the embedded web server (EWS). In EWS, click the **Tools** tab, click **Printer Updates** in the left menu, and select the desired options.



TIP: You can check to see if an update is available for the printer at any time. [Learn more about checking for printer updates.](#)

Print from a different software program

Try printing from a different software program. If the page prints correctly, the problem is with the software program from which you were printing.

Check the paper-type setting for the print job

Check the paper type setting when printing from a software program and the printed pages have smears, fuzzy or dark print, curled paper, scattered dots of toner, loose toner, or small areas of missing toner.

Check the paper type setting on the printer

Verify that the tray is loaded with the correct type of paper.

Check the paper type setting (Windows)

1. From the software program, select the **Print** option.
2. Select the printer, and then click the **Properties** or **Preferences** button.
3. Check the paper settings.

Check the paper type setting (OS X)

1. Click the **File** menu, and then click the **Print** option.
2. In the **Printer** menu, select the printer.



3. By default, the print driver displays the **Copies & Pages** menu. Open the menus drop-down list, and then click the **Finishing** menu.
4. Select a type from the **Media Type** drop-down list.

Check toner-cartridge status

Follow these steps to check the estimated life remaining in the toner cartridges and if applicable, the status of other replaceable maintenance parts.

Step one: Find supplies information on configuration page

Supplies information is included on the configuration page.

- On the printer control panel, press the Information button  (for SFP models).
- On the Home screen of the printer display, touch Setup , select **Reports** and select the configuration report (for MFP models).

Step two: Check supplies status

1. Open the EWS, see [To access and use the Embedded Web Server \(EWS\)](#) to look at the supplies status report of the toner cartridges and if applicable, the status of other replaceable maintenance parts.

Print quality problems can occur when using a toner cartridge that is at its estimated end of life. The configuration report indicates when a supply level is very low.

Once an HP toner cartridge has reached Very Low, HP's Premium Protection Warranty on that toner cartridge has ended.

The toner cartridge does not need to be replaced now unless the print quality is no longer acceptable. Consider having a replacement available to install when print quality is no longer acceptable.

If you determine that you need to replace a toner cartridge or other replaceable maintenance parts, the configuration report lists the genuine HP part numbers.

2. Check to see if you are using a genuine HP cartridge.

A genuine HP toner cartridge has "HP" on it, or has the HP logo on it. For more information on identifying HP cartridges go to www.hp.com/go/learnaboutesupplies

Clean the cartridge

The purpose is to potentially fix some print quality issues caused by the cartridge such as gray background. For example, if talc is attached on the photosensitive drum (OPC) or OPC pitch defect. The cartridge cleaning mode cleans the developer roller only, and then run this mode for a quick fix or improvement.

During the printing process, cartridges might be contaminated by paper dust and cause print quality issues such as background issues, vertical dark bands, or repetitive horizontal banding.

Follow these steps to improve the above mentioned print quality issues:

1. Open the EWS, see [To access and use the Embedded Web Server \(EWS\)](#).
2. Click the **System** tab, and then click **Service**.
3. In the **Cartridge Cleaning Mode** area, click **Start** to begin the cleaning process.

Print a cleaning page

During the printing process paper, toner, and dust particles can accumulate inside the printer and can cause print-quality issues such as toner specks or spatter, smears, streaks, lines, or repeating marks.

Use the following procedure to print a cleaning page from EWS.

1. Open the EWS. See [To access and use the Embedded Web Server \(EWS\)](#)
2. Click the **Tools** tab.
3. From the left menu, click **Utilities** and select **Print Quality Toolbox**.
4. In the **Clean the Fuser** area, click **Start** to begin the cleaning process.

Check the scanner glass for dirt and smudges (MFP models only)

Over time, specks of debris might collect on the scanner glass and white plastic backing, which can affect performance. Use the following procedure to clean the scanner:

1. Press the Power button to turn the printer off, and then disconnect the power cable from the electrical outlet.
2. Open the scanner lid.
3. Clean the scanner glass and the white plastic backing underneath the scanner lid with a soft cloth or sponge that has been moistened with nonabrasive glass cleaner.

 **CAUTION:** Do not use abrasives, acetone, benzene, ammonia, ethyl alcohol, or carbon tetrachloride on any part of the printer; these can damage the printer. Do not place liquids directly on the glass or platen. They might seep and damage the printer.

4. Dry the glass and white plastic parts with a chamois or a cellulose sponge to prevent spotting.
5. Connect the power cable to an outlet, and then press the Power button to turn the printer on.

Visually inspect the toner cartridge

Follow these steps to inspect the toner cartridge.

1. Remove the toner cartridge from the printer, and verify that the sealing tape has been removed.
2. Check the memory chip for damage.
3. If you see any damage on the toner cartridge, replace the toner cartridge.
4. Reinstall the toner cartridge, and print a few pages to see if the problem is resolved.

Check paper and the printing environment

Step one: Use paper that meets HP specifications

Some print-quality problems arise from using paper that does not meet HP specifications.

- Always use a paper type and weight that this printer supports.
- Use paper that is of good quality and free of cuts, nicks, tears, spots, loose particles, dust, wrinkles, voids, staples, and curled or bent edges.

- Use paper that has not been previously printed on.
- Use paper that does not contain metallic material, such as glitter.
- Use paper that is designed for use in laser printers. Do not use paper that is designed only for use in Inkjet printers.
- Use paper that is not too rough. Using smoother paper generally results in better print quality.

Step two: Check the environment

The environment can directly affect print quality and is a common cause for print-quality or paper-feeding issues. Try the following solutions:

- Move the printer away from drafty locations, such as open windows or doors, or air-conditioning vents.
- Make sure the printer is not exposed to temperatures or humidity outside of printer specifications.
- Do not place the printer in a confined space, such as a cabinet.
- Place the printer on a sturdy, level surface.
- Remove anything that is blocking the vents on the printer. The printer requires good air flow on all sides, including the top.
- Protect the printer from airborne debris, dust, steam, grease, or other elements that can leave residue inside the printer.

Adjust print density

Complete the following steps to adjust the print density.

1. Open the EWS, see [To open EWS using HP Smart app \(iOS, Android, and Windows 10\)](#).
2. Click the **System** tab, and then select **System Setup** from the left navigation pane.
3. Select the correct density settings.
4. Click **Apply** to save the changes.

Print quality troubleshooting guide

Image defects table

Table 2-17 Image defects table quick reference



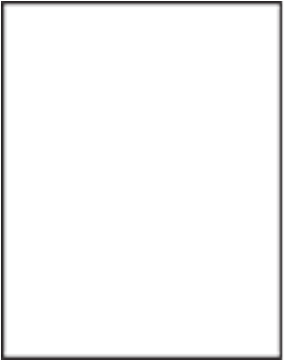

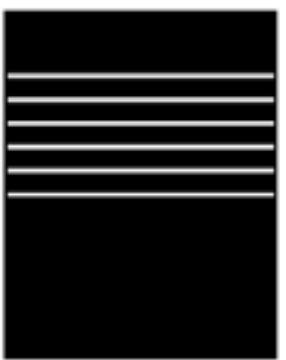

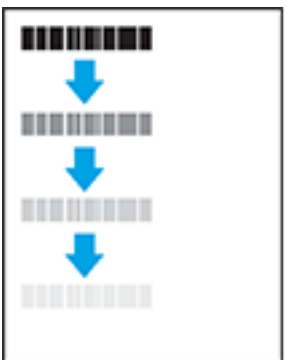

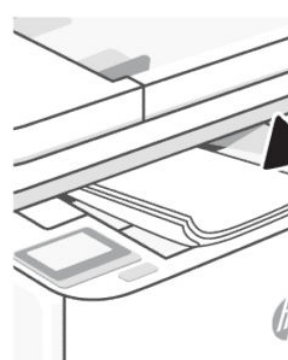

Image defects	Image defects	Image defects
<p>Table 2-18 Light print</p> 	<p>Table 2-19 Dark print</p> 	<p>Table 2-20 Completely blank page — No print</p> 
<p>Table 2-21 All black page</p> 	<p>Table 2-22 Banding defects</p> 	<p>Table 2-23 Streak defects</p> 
<p>Table 2-24 Fixing/fuser defects</p> 	<p>Table 2-25 Image placement defects</p> 	<p>Table 2-40 Output defects</p> 

Image defects, no matter the cause, can often be resolved using the same steps. Use the following steps as a starting point for solving image defect issues:

1. Reprint the document. Print quality defects can be intermittent in nature or can go away completely with continued printing.

2. Check the condition of the cartridge or cartridges. If a cartridge is in a **Very Low** state (it has passed the rated life), replace the cartridge.
3. Make sure that the driver and tray print mode settings match the media that is loaded in the tray. Try using a different ream of media or a different tray. Try using a different print mode.
4. Make sure that the printer is within the supported operating temperature/humidity range.
5. Make sure that the paper type, size, and weight are supported by the printer. See the printer support page at hp.com/support for a list of the supported paper sizes and types for the printer.

 **NOTE:** The term “fusing” refers to the part of the printing process where toner is affixed to paper.

The following examples depict letter-size paper that has passed through the printer short-edge first:

Table 2-18 Light print

Description	Sample	Possible solutions
<p>Light print:</p> <p>The printed content on the entire page is light.</p> <p>Cause</p> <p>Poor contact between the transfer roller contact and the transfer roller shaft.</p>		<ol style="list-style-type: none"> 1. Clean the contacts. 2. If the problem remains after cleaning, check the contacts for deformation or damage. 3. Replace any defective parts. 4. If the problem persists, go to hp.com/support.

Table 2-19 Dark print

Description	Sample	Possible solutions
<p>Dark print:</p> <p>The printed content or image is too dark.</p> <p>Causes</p> <ul style="list-style-type: none"> • Poor contact between the drum grounding contact and the cartridge. • Poor contact between the primary charging bias contact and the cartridge. 		<ol style="list-style-type: none"> 1. Clean the contacts. 2. If the problem remains after cleaning, check the contacts for deformation or damage. 3. Replace any defective parts. 4. If the problem persists, go to hp.com/support.

Table 2-20 Completely blank page — No print

Description	Sample	Possible solutions
<p>Completely blank page — No print:</p> <p>The page is completely blank and contains no printed content.</p> <p>Causes</p> <ul style="list-style-type: none"> • Poor contact between the developing bias contact and the cartridge. • The high-voltage power supply circuit is defective (no developing bias output). 		<ol style="list-style-type: none"> 1. Clean the contacts. 2. If the problem remains after cleaning, check the contacts for deformation or damage. 3. Replace any defective parts. 4. Replace the engine controller PCA. 5. If the problem persists, go to hp.com/support.

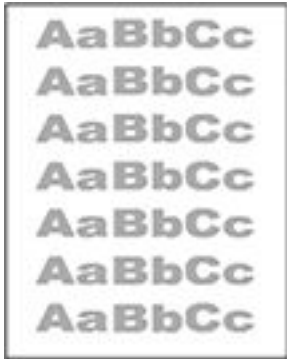
Table 2-21 All black page

Description	Sample	Possible solutions
<p>All black page:</p> <p>The entire page is printed black.</p> <p>Causes</p> <ul style="list-style-type: none"> • Poor contact between the primary charging bias contact and the cartridge. • The primary charging roller is defective. 		<ol style="list-style-type: none"> 1. Clean the contacts. 2. If the problem remains after cleaning, check the contacts for deformation or damage. 3. Replace any defective parts. 4. Replace the cartridge. 5. If the problem persists, go to hp.com/support.

Table 2-22 Banding defects

Description	Sample	Possible solutions
<p>Repetitive wide-pitch banding and Impulse bands:</p> <p>Dark or light lines which repeat down the length of the page. They might be sharp or soft in nature. The defect displays only in areas of fill, not in text or sections with no printed content.</p>		<ol style="list-style-type: none"> 1. Reprint the document. 2. Replace the toner cartridge. 3. Use a different paper type. 4. If the problem persists, go to hp.com/support.

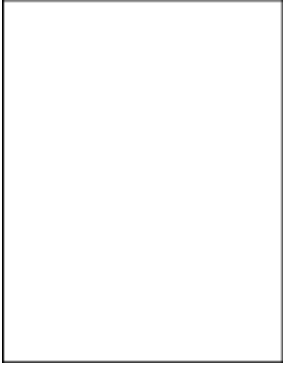
Table 2-23 Streak defects

Description	Sample	Possible solutions
<p>Light vertical streaks:</p> <p>Light streaks that usually span the length of the page. The defect displays only in areas of fill, not in text or sections with no printed content.</p>		<ol style="list-style-type: none"> 1. Reprint the document. 2. Remove the cartridge, and then shake it to redistribute the toner. 3. If the problem persists, go to hp.com/support. <p>NOTE: Both light and dark vertical streaks can occur when the printing environment is outside the specified range for temperature or humidity. Refer to your printer's environmental specifications for allowable temperature and humidity levels.</p>
<p>Dark vertical streaks and ITB cleaning streaks</p> <p>Dark lines which occur down the length of the page. The defect might occur anywhere on the page, in areas of fill or in sections with no printed content.</p>		<ol style="list-style-type: none"> 1. Reprint the document. 2. Remove the cartridge, and then shake it to redistribute the toner. 3. Print a cleaning page 4. Check the toner level in the cartridge. See To open EWS using HP Smart app (iOS, Android, and Windows 10). 5. If the problem persists, go to hp.com/support.

Table 2-24 Fixing/fuser defects

Description	Fixing/fuser	Possible solutions
<p>Hot fuser offset (shadow):</p> <p>Slight shadows, or offsets, of the image repeated down the page. The repeated image might fade with each recurrence.</p>		<ol style="list-style-type: none"> 1. Reprint the document. 2. Check the paper type in the paper tray and adjust the printer settings to match. If necessary, select a lighter paper type. 3. If the problem persists, go to hp.com/support.

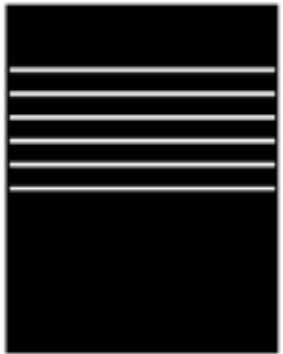
Table 2-24 Fixing/fuser defects (continued)

Description	Fixing/fuser	Possible solutions
<p>Poor fusing:</p> <p>Toner rubs off along either edge of page. This defect is more common at the edges of high-coverage jobs and on light media types but can occur anywhere on the page.</p>		<ol style="list-style-type: none"> 1. Reprint the document. 2. Check the paper type in the paper tray and adjust the printer settings to match. If necessary, select a heavier paper type. 3. If the problem persists, go to hp.com/support.

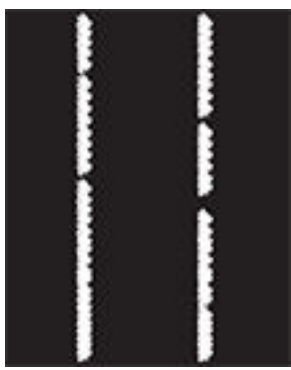
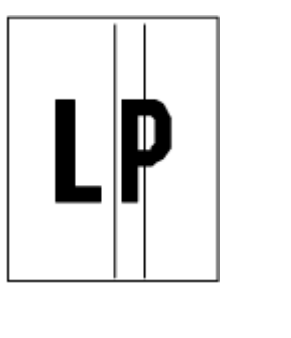
Table 2-25 Image placement defects

Description	Sample	Possible solutions
<p>Margins and skew:</p> <p>The image is not centered, or is skewed on the page. The defect occurs when the paper is not positioned properly as it is pulled from the tray and moves through the paper path.</p>		<ol style="list-style-type: none"> 1. Reprint the document. 2. Remove the paper and then reload the tray. Make sure that all the paper edges are even on all sides. 3. Make sure that the top of the paper stack is below the tray full indicator. Do not overfill the tray. 4. Make sure that the paper guides are adjusted to the correct size for the paper. Do not adjust the paper guides tightly against the paper stack. Adjust them to the indentations or markings in the tray. 5. If the problem persists, go to hp.com/support.

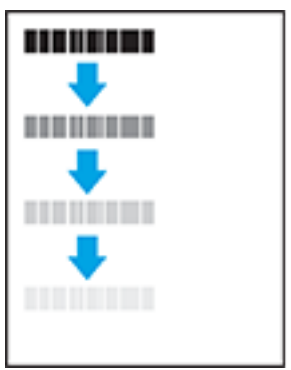
Table 2-26 White spots

Description	Sample	Possible solutions
<p>White spots:</p> <p>The page is printed with white spots.</p> <p>Causes</p> <ul style="list-style-type: none"> • The static charge eliminator is dirty. • The transfer roller is deformed or deteriorated. • Poor contact between the transfer roller contact and the transfer roller shaft. 		<ol style="list-style-type: none"> 1. Clean the static charge eliminator. 2. Replace the transfer roller. 3. Clean the contacts. 4. If the problem remains after cleaning, check the contacts for deformation or damage. 5. Replace any defective parts. 6. Replace the printer.

Table 2-26 White spots

Description	Sample	Possible solutions
<ul style="list-style-type: none"> The static charge eliminator is deformed. 		

Table 2-27 Dirt on back

Description	Sample	Possible solutions
<p>White spots:</p> <p>The printed back page is dirty.</p> <p>Causes</p> <ul style="list-style-type: none"> The transfer roller is dirty. The fuser inlet guide or separation guide is dirty. The pressure roller is dirty. 		<ol style="list-style-type: none"> Replace the transfer roller. Clean the dirty parts. If the dirt does not come off, replace the fuser. Perform a fuser roller cleaning designation of the multipurpose mode. If the dirt does not come off, replace the fuser.

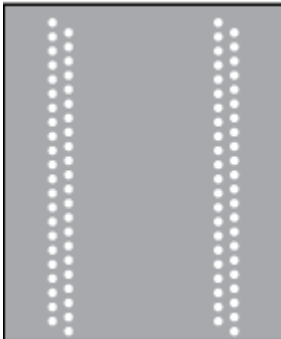
Table 2-28 Vertical lines

Description	Sample	Possible solutions
<p>Vertical lines appear on the page:</p> <p>The vertical streaks or bands appear on the printed page.</p> <p>Causes</p> <ul style="list-style-type: none"> Scratches are present on the circumference of the photosensitive drum. Scratches are present on the circumference of the fuser film. 		<ol style="list-style-type: none"> Replace the cartridge. Replace the fuser.

Table 2-29 Vertical white lines

Description	Sample	Possible solutions
<p>Vertical white lines appear on the page:</p> <p>The page prints with vertical white lines in a particular color.</p> <p>Causes</p> <ul style="list-style-type: none"> • Scratches are present on the circumference of the photosensitive drum. • Scratches are present on the circumference of the developer roller. 		<ul style="list-style-type: none"> ▲ Replace the cartridge.

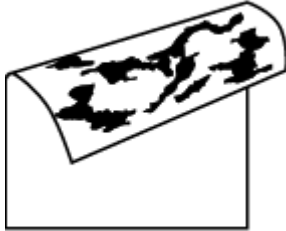
Table 2-30 Horizontal lines

Description	Sample	Possible solutions
<p>Horizontal lines appear on the page:</p> <p>The page prints with horizontal lines.</p> <p>Causes</p> <ul style="list-style-type: none"> • Repetitive horizontal lines appear. • Horizontal scratches are present on the photosensitive drum. • Horizontal scratches are present on the fuser film. 		<ol style="list-style-type: none"> 1. Identify the dirty roller which causes the repetitive image defects based on the pitch between the white lines and clean the roller. 2. Clean the roller. 3. If the dirt does not come off, replace the corresponding assembly including the affected rollers. 4. Replace the cartridge. 5. Replace the fuser.

Table 2-31 Horizontal white lines

Description	Sample	Possible solutions
<p>Horizontal white lines appear on the page:</p> <p>The page prints with horizontal white lines.</p> <p>Causes</p> <ul style="list-style-type: none"> • Repetitive horizontal white lines appear. • Horizontal scratches are present on the photosensitive drum. 		<ol style="list-style-type: none"> 1. Identify the dirty roller which causes the repetitive image defects based on the pitch between the white lines and clean the roller. 2. Clean the roller. 3. If the dirt does not come off, replace the corresponding assembly including the affected rollers. 4. Replace the cartridge.

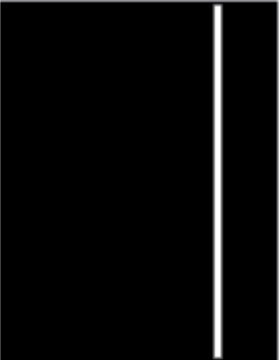
Table 2-32 Dropouts

Description	Sample	Possible solutions
<p>Dropouts appear:</p> <p>The page prints with dropouts.</p> <p>Causes</p> <ul style="list-style-type: none"> • The transfer roller is deformed or deteriorated. • The primary charging roller, developer roller, or photosensitive drum is deformed or deteriorated. • The fuser film is deformed or deteriorated. • The high-voltage power supply circuit is defective (no transfer bias output). 		<ol style="list-style-type: none"> 1. Replace the transfer roller. 2. Replace the cartridge. 3. Replace the fuser. 4. Replace the engine controller PCA.

Table 2-33 Loose toner

Description	Sample	Possible solutions
<p>Loose toner:</p> <p>The page prints with loose toner.</p> <p>Causes</p> <ul style="list-style-type: none"> • The fuser film or pressure roller is scarred or deformed. • The thermistor is defective. • The fuser heater is defective. • The fuser control circuit is defective. 		<ol style="list-style-type: none"> 1. Replace the fuser. 2. Replace the engine controller PCA.

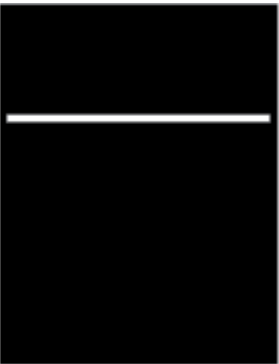
Table 2-34 Toner smear

Description	Sample	Possible solutions
<p>Toner smear:</p> <p>The page prints with toner smears.</p> <p>Causes</p> <ul style="list-style-type: none"> • The printer has residual paper. • Poor contact while grounding the cartridge. • Foreign substance adheres to the fuser-inlet guide or the guide is dirty. 		<ol style="list-style-type: none"> 1. Remove the residual paper. 2. Clean contacts of both the printer and the cartridge. 3. If the problem remains after cleaning, check the contacts for deformation or damage. 4. Replace any defective parts. 5. Clean the fuser inlet guide. 6. If the dirt does not come off, replace the fuser.

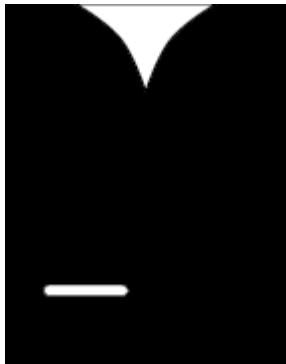
Table 2-35 Misformed image/misplaced image

Description	Sample	Possible solutions
<p>Misformed image / Misplaced image:</p> <p>The printed page is either misformed or incorrectly placed.</p> <p>Causes</p> <ul style="list-style-type: none"> The laser scanner assembly is defective. 		<ul style="list-style-type: none"> ▲ Replace the laser scanner assembly.

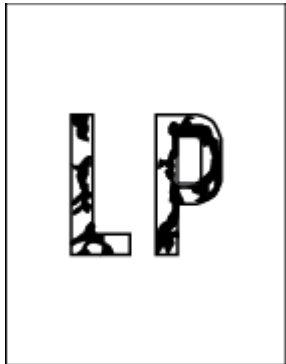
Table 2-36 Wrinkles or creases

Description	Sample	Possible solutions
<p>Wrinkles or creases:</p> <p>The printed page contains wrinkles or creases.</p> <p>Causes</p> <ul style="list-style-type: none"> The feed roller or paper feed guide is dirty. The fuser inlet guide is dirty. 		<ol style="list-style-type: none"> Clean any dirty parts. Clean the fuser inlet guide. If the dirt does not come off, replace the fuser.

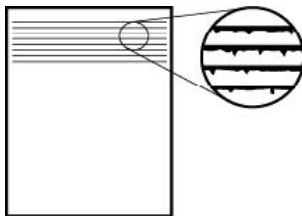
Table 2-37 Dirt on front

Description	Sample	Possible solutions
<p>Dirt on front:</p> <p>The printed front page is dirty.</p> <p>Causes</p> <ul style="list-style-type: none"> The photosensitive drum or developer roller is dirty. The fuser film or pressure roller is dirty. 		<ol style="list-style-type: none"> Replace the cartridge. Perform a fuser roller cleaning designation of the multipurpose mode. If the dirt does not come off, replace the fuser.

Table 2-38 Vertical density variation

Description	Sample	Possible solutions
<p>Vertical density variation appears on the page:</p> <p>Vertical density variation appears on the page.</p> <p>Causes</p> <ul style="list-style-type: none"> The photosensitive drum surface is deteriorated. The laser scanner assembly is defective. 		<ol style="list-style-type: none"> Replace the cartridge. Replace the laser scanner assembly.

Table 2-39 Repetitive image defects

Description	Sample	Possible solutions
<p>Repetitive white spots appear in an image:</p> <p>The page prints with repetitive white spots.</p> <p>Causes</p> <ul style="list-style-type: none"> Repetitive white spots appear. The transfer roller is deformed or deteriorated. Foreign substance adhered to the primary charging roller or photosensitive drum. 		<ol style="list-style-type: none"> Identify the dirty roller which causes the repetitive image defects. Clean the roller. If the dirt does not come off, replace the corresponding assembly. Replace the transfer roller. Replace the cartridge.

Table 2-40 Output defects

Description	Sample	Possible solutions
<p>Output curl:</p> <p>Printed paper has curled edges. The curled edge can be along the short or long side of the paper. Two types of curl are possible:</p> <ul style="list-style-type: none"> Positive curl: The paper curls toward the printed side. The defect occurs in dry environments or when printing high coverage pages. Negative curl: The paper curls away from the printed side. The defect occurs in high-humidity environments or when printing low coverage pages. 		<ol style="list-style-type: none"> Reprint the document. Positive curl: From the printer control panel, select a heavier paper type. The heavier paper type creates a higher temperature for printing. Negative curl: From the printer control panel, select a lighter paper type. The lighter paper type creates a lower temperature for printing. Try storing the paper in a dry environment prior or use freshly opened paper. Print in duplex mode. If the problem persists, go to hp.com/support.

Table 2-40 Output defects (continued)

Description	Sample	Possible solutions
<p>Output stacking:</p> <p>The paper does not stack well in the output tray. The stack might be uneven, skewed, or the pages might be pushed out of the tray and onto the floor. Any of the following conditions can cause this defect:</p> <ul style="list-style-type: none"> • Extreme paper curl • The paper in the tray is wrinkled or deformed • The paper is a non-standard paper type, such as envelopes • The output tray is too full 		<ol style="list-style-type: none"> 1. Reprint the document. 2. Extend the output bin extension. 3. If the defect is caused by extreme paper curl, complete the troubleshooting steps for Output curl. 4. Use a different paper type. 5. Use freshly opened paper. 6. Remove the paper from the output tray before the tray gets too full. 7. If the problem persists, go to hp.com/support.

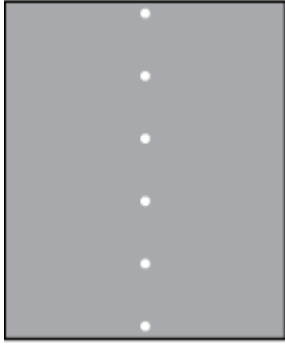
Printer-specific image defects

Repetitive image defect ruler

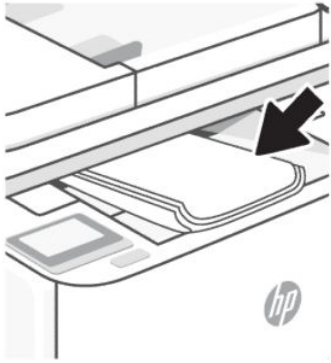
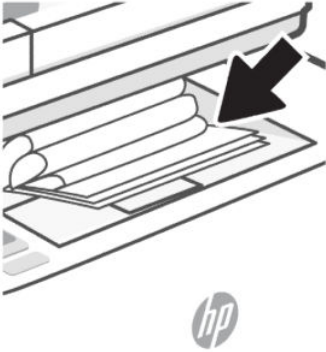
Defects on printer rollers can cause image defects to appear at regular intervals on the page, corresponding to the circumference of the roller that is causing the defect.

Measure the distance between defects that recur on a page (see [Use a ruler to measure between repetitive defects](#)). Use the following table or the repetitive-defect ruler to determine which roller is causing the defect. To resolve the problem, try cleaning the roller first. If the roller remains dirty after cleaning or if it is damaged, replace the part that is indicated in the following table:

⚠ CAUTION: Do not use solvents or oils to clean rollers. Instead, rub the roller with a lint-free cloth. If dirt is difficult to remove, rub the roller with a lint-free cloth that has been dampened with water.

📝 NOTE: The following table replaces the graphical repetitive defect ruler. You can make your own ruler by using these measurements. For the most accurate results, use a metric ruler.

Figure 2-5 Repetitive image defect ruler

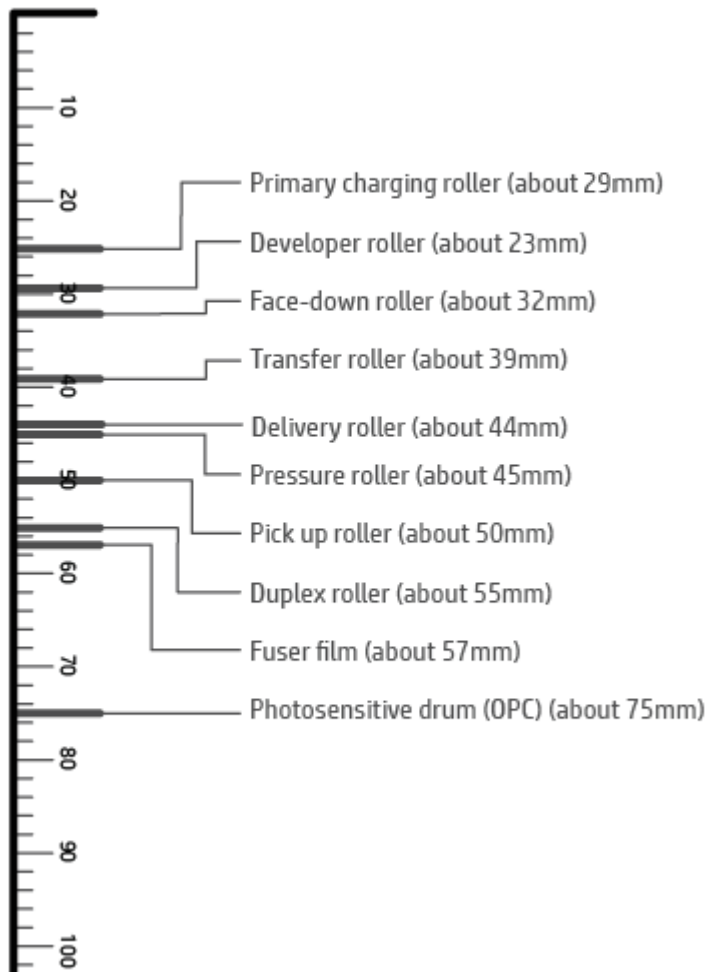

Table 2-41 Repetitive defects

Component ¹	Distance between defects	Image defects			
		Dirt	Dropouts	Dirt on back	Loose toner
Primary charging roller ¹	About 26 mm	✓	✓	X	X
Developer roller ¹	About 29 mm	✓	✓	X	X
Face-down roller	About 32 mm	X	X	✓	X
Transfer roller	About 39 mm	X	✓	✓	X
Delivery roller	About 44 mm	✓	X	X	X
Pressure roller	About 45 mm	✓	X	✓	✓
Pick up roller	About 50 mm	✓	X	X	X
Duplex roller	About 55 mm	✓	X	X	X
Fuser film	About 57 mm	✓	X	X	X

Table 2-41 Repetitive defects (continued)

Component ¹	Distance between defects	Image defects			
		Dirt	Dropouts	Dirt on back	Loose toner
Photosensitive drum (OPC) ¹	About 75 mm	✓	✓	X	X

¹ The primary charging roller, photosensitive drum, and developer roller cannot be cleaned as these rollers are located inside the cartridge. If any of these rollers are indicated, replace the cartridge.

Figure 2-6 Printer rollers diagram

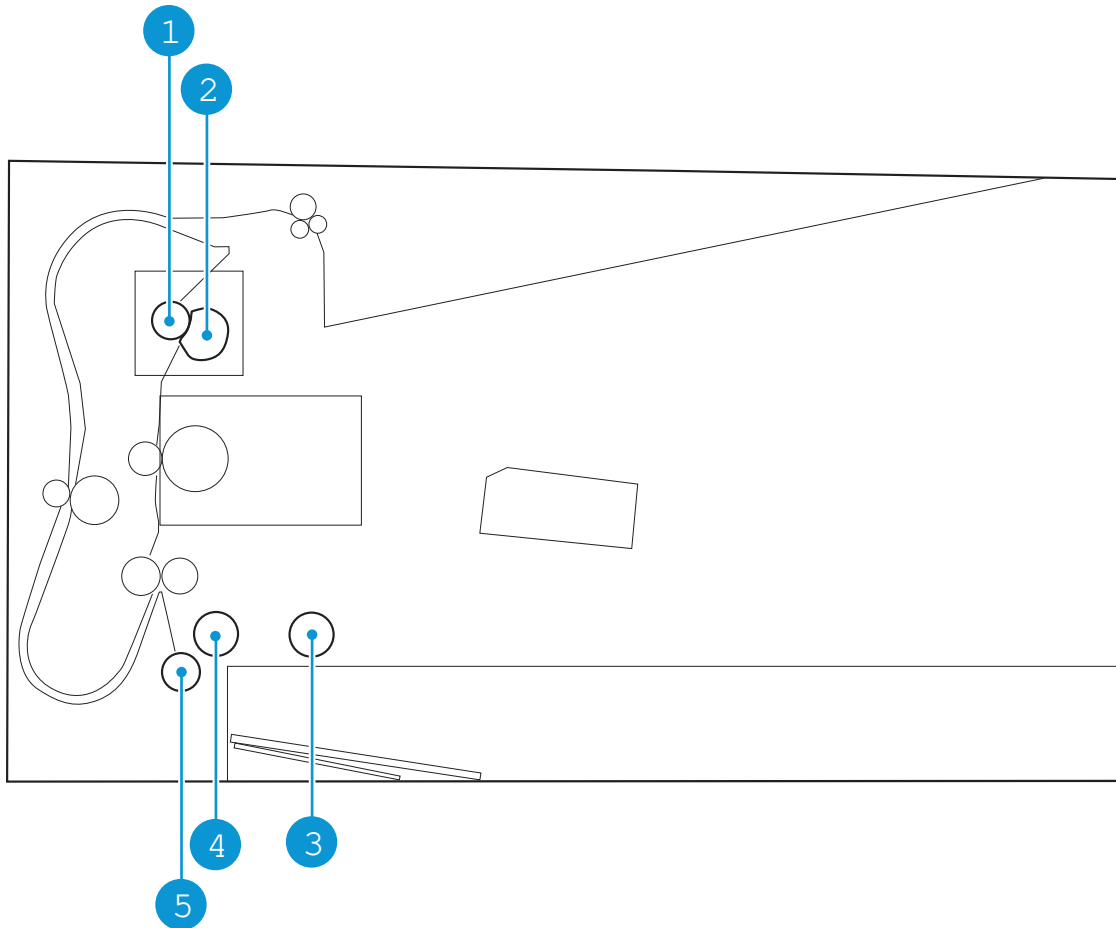

Table 2-42 Printer rollers

Component	Description
1	Pressure roller
2	Fuser film assembly
3	Tray 1 pickup roller
4	Tray 1 feed roller
5	Tray 1 separation roller

Figure 2-7 Cross sectional view of image scanner

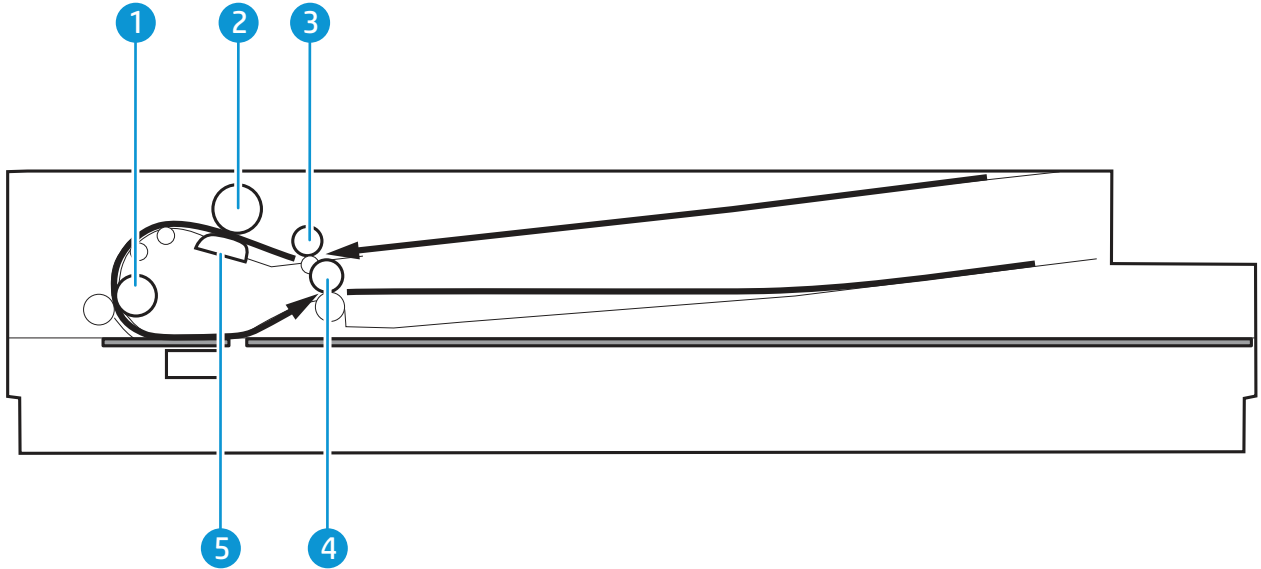



Table 2-43 Cross sectional view of image scanner

Component	Description
1	Feed roller
2	Separation roller
3	Pickup roller
4	Output roller
5	Separation pad

Use a ruler to measure between repetitive defects

The figures in this section show color repetitive defect pages. However, the process for measuring repetitive defects is valid for mono pages.

1. Identify a repetitive defect on the page.

 **TIP:** Print a cleaning page to see if that resolves the defect.

The following example pages show the following types of repetitive defects:

 **NOTE:** These are examples only, other types of repetitive defects might appear on a page.

- Lines (callout 1)
- Smudges (callout 2)
- Dots or spots (callout 3)

Figure 2-8 Examples of repetitive defects

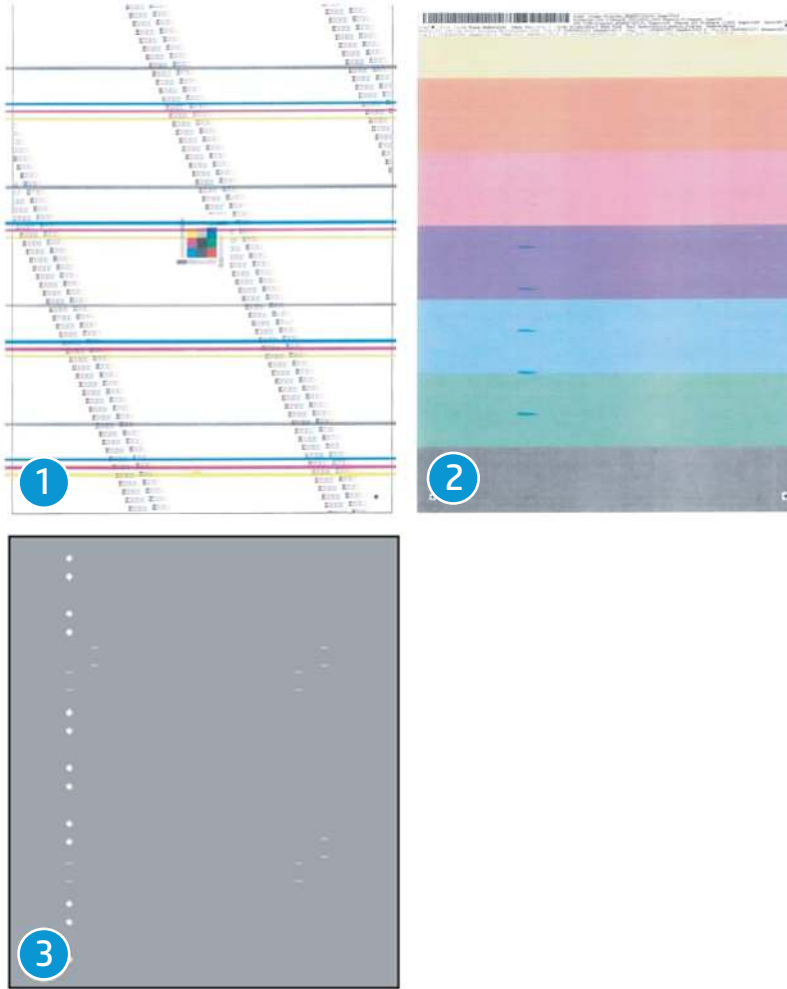

2. Position a metric ruler on the page with the “zero” ruler mark at one occurrence of the defect (callout 1).

Figure 2-9 Place the ruler on the page

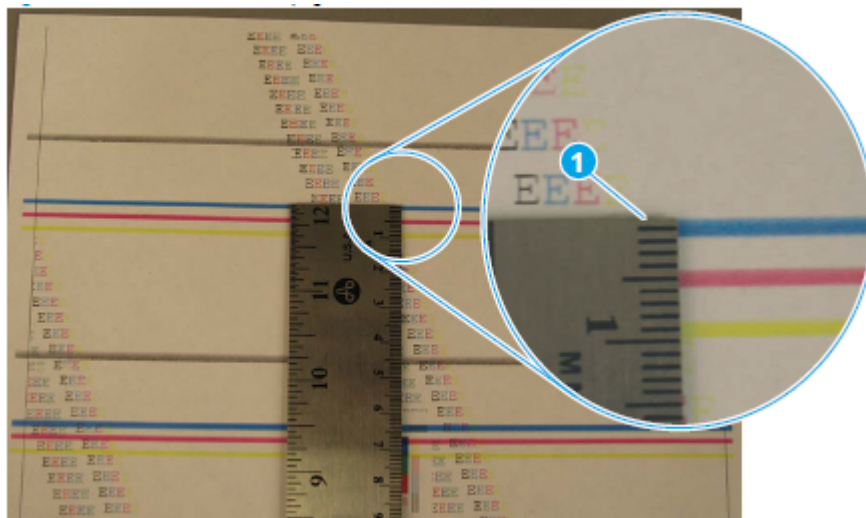

3. Locate the next occurrence of the defect (callout 1).

Figure 2-10 Locate the next repetitive defect

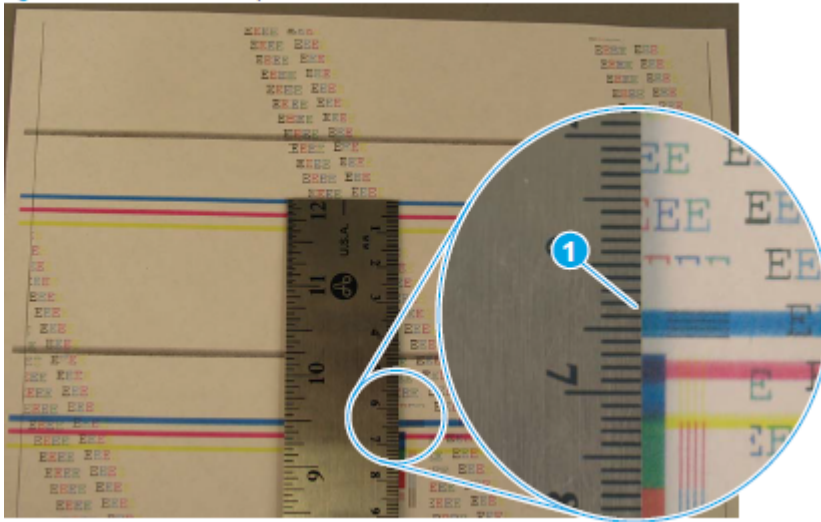

4. Measure the distance (in millimeters) between the two occurrences (callout 1), and then use [Table 2-41 Repetitive defects](#) to determine the defective assembly.

💡 **TIP:** Always measure from and to the same point on the defects. For example, if the ruler is “zeroed” at the top edge of a defect, measure to the top edge of the next occurrence of that defect.

Figure 2-11 Determine the defective assembly

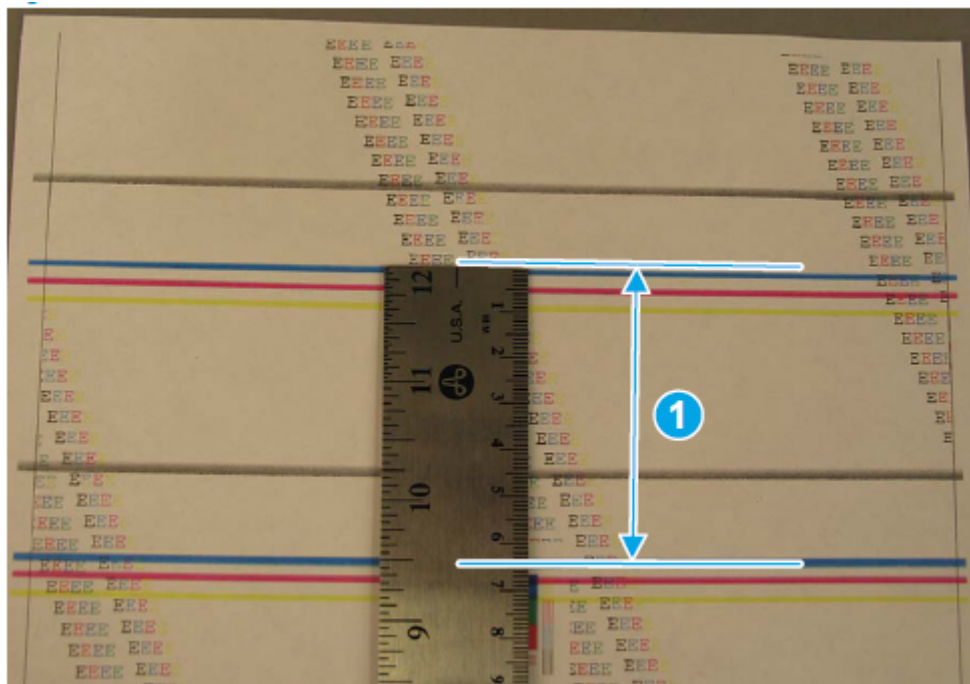

Improve copy and scan image quality (MFP models only)

If the printer is having image quality problems, try the following solutions in the order presented to resolve the issue:

Check the scanner glass for dirt and smudges

Over time, specks of debris might collect on the scanner glass and white plastic backing, which can affect performance. Use the following procedure to clean the scanner:

1. Press the Power button to turn the printer off, and then disconnect the power cable from the electrical outlet.
2. Open the scanner lid.
3. Clean the scanner glass and the white plastic backing underneath the scanner lid with a soft cloth or sponge that has been moistened with nonabrasive glass cleaner.

⚠ CAUTION: Do not use abrasives, acetone, benzene, ammonia, ethyl alcohol, or carbon tetrachloride on any part of the printer; these can damage the printer. Do not place liquids directly on the glass or platen. They might seep and damage the printer.

4. Dry the glass and white plastic parts with a chamois or a cellulose sponge to prevent spotting.
5. Connect the power cable to an outlet, and then press the Power button to turn the printer on.

Check the paper settings

 **NOTE:** The steps vary according to the type of control panel.

Open the Embedded web server (EWS).

In EWS, click **System**, and then click **Paper Setup**.

Optimize for text or pictures

Open the Embedded web server (EWS).

In EWS, click **Copy**, click **Default Copy Settings**, and then change the settings from **Optimize** drop-down menu.

Edge-to-edge copying

The printer cannot print fully edge-to-edge. There is a 4 mm (1/6 inch) unprintable border around the page.

Considerations for printing or scanning documents with cropped edges:

- When the original is smaller than the output size, move the original 4 mm (1/6 inch) away from the corner indicated by the icon on the scanner. Recopy or scan in this position.
- When the original is the size of the printed output that you want, use the [Reduce/Enlarge](#) feature to reduce the image so the copy is not cropped.

Clean the pickup rollers and separation pad in the document feeder

If the document feeder experiences paper-handling problems, such as jams or multiple-page feeds, clean the document-feeder rollers and separation pad.

1. Open the document-feeder cover.

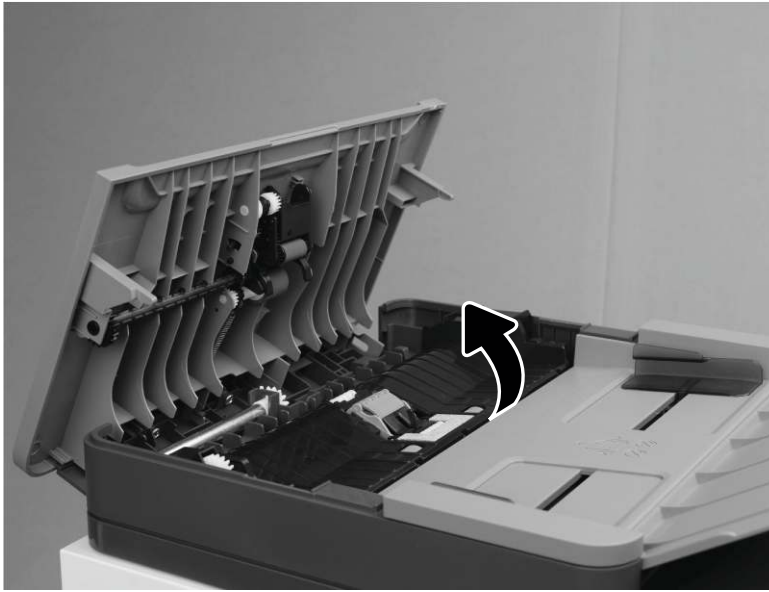

2. Use a moist, lint-free cloth to wipe both pickup rollers and the separation pad to remove dirt.

⚠ CAUTION: Do not use abrasives, acetone, benzene, ammonia, ethyl alcohol, or carbon tetrachloride on any part of the printer; these can damage the printer. Do not place liquids directly on the glass or platen. They might seep and damage the printer.

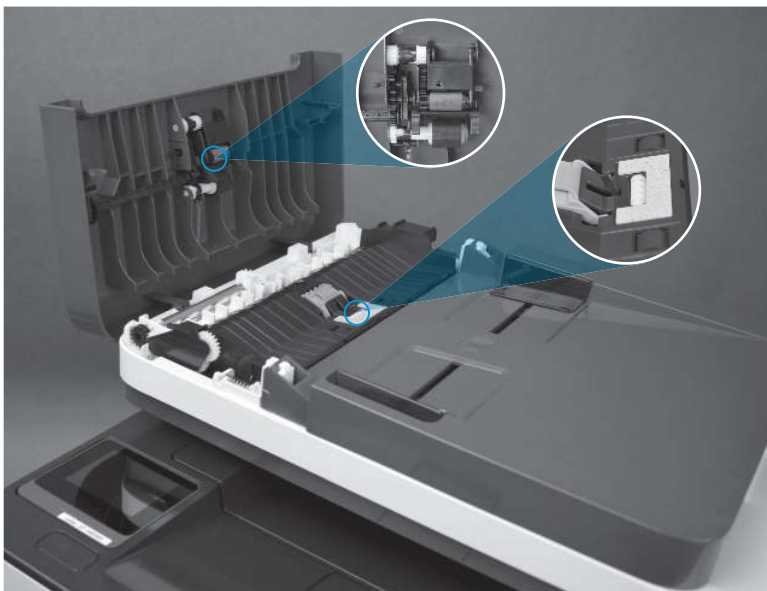

3. Close the document-feeder cover. Make sure it is completely closed.

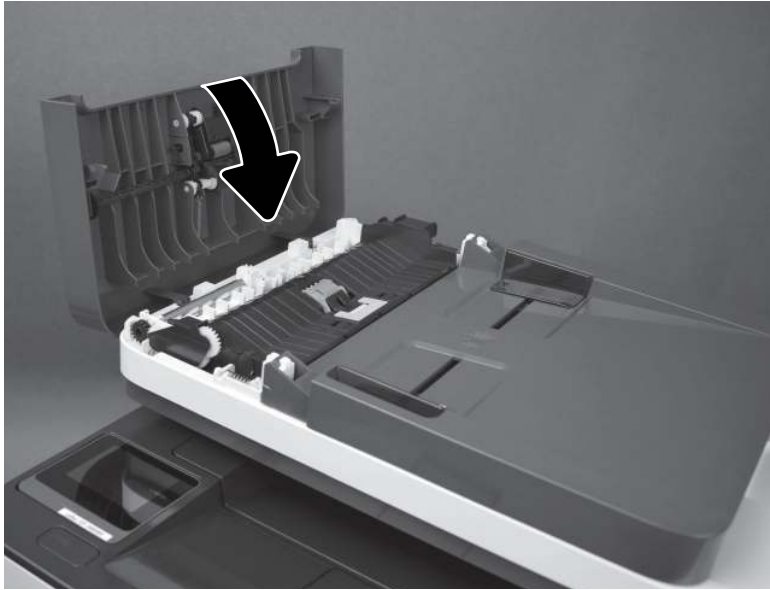

Clean the printer

Over time, particles of toner and paper accumulate inside the printer. This can cause print-quality problems during printing. Cleaning the printer eliminates or reduces these problems.

Clean the paper path and toner-cartridge areas every time that the toner cartridge is changed or whenever print-quality problems occur. As much as possible, keep the printer free from dust and debris.

To clean the printer exterior, use a soft, water-moistened cloth.

To clean the printer interior, perform the following:

Clean the pickup roller, feed roller, and separation roller

Clean the pickup roller and feed roller

- To clean the pickup roller and feed roller, do the following:
 1. Turn off the printer, then unplug the power cable from the printer.
 2. Remove the input tray



3. Rotate and place the printer with the rear side down.



4. Flex the hook of the lifter sensor flag (callout 1) towards you.
5. Release one tab (callout 2) and slide the roller holder (callout 3) in the direction that arrow indicates, and then remove it.
6. Slide the tray 1 pick-up roller (callout 4) and the tray 1 feed roller (callout 5) in the direction that arrow indicates, and then remove them together.

Figure 2-12 Remove the tray 1 pick-up roller

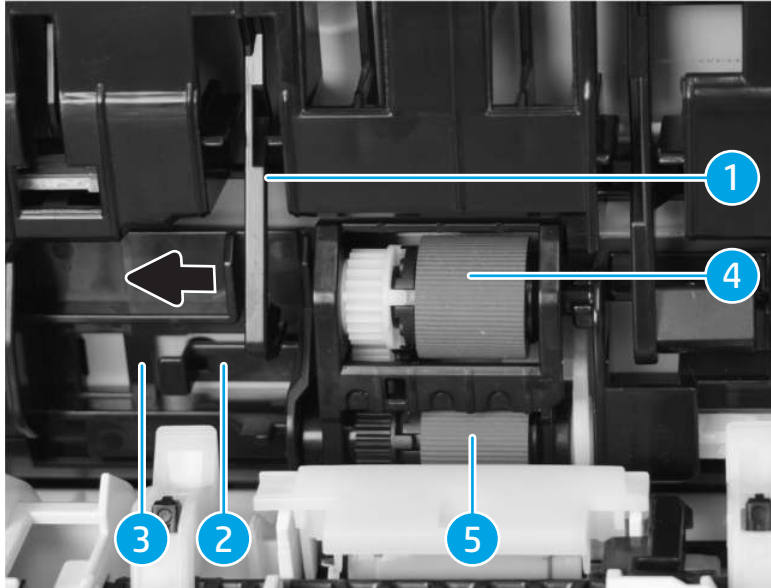

7. Release one tab (callout 1) and slide the pick-up pin (callout 2) in the direction that arrow indicates, and then remove it.
8. Remove the tray 1 pick-up roller (callout 4) from the roller holder (callout 3).
9. Remove the tray 1 feed roller (callout 5) from the roller holder (callout 3).

Figure 2-13 Remove the tray 1 feed roller

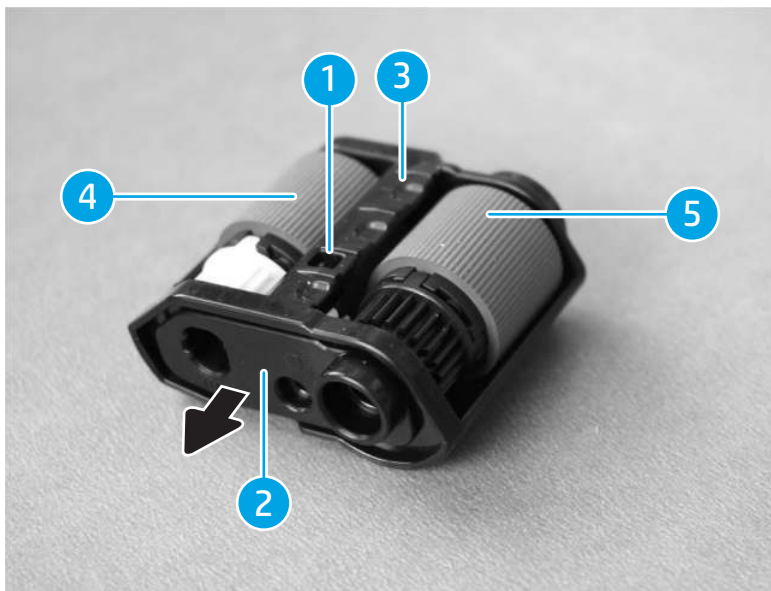

10. Wipe with a lint-free paper. If dirt cannot be removed, then dampen the lint-free paper with alcohol.
11. Install the tray 1 feed roller (callout 1) to the roller holder (callout 3).
12. Install the tray 1 pick-up roller (callout 2) to the roller holder (callout 3).
13. Slide the pick-up pin (callout 4) in the direction the arrow indicates and install it and then engage one tab (callout 5).

Figure 2-14 Install the tray 1 feed roller

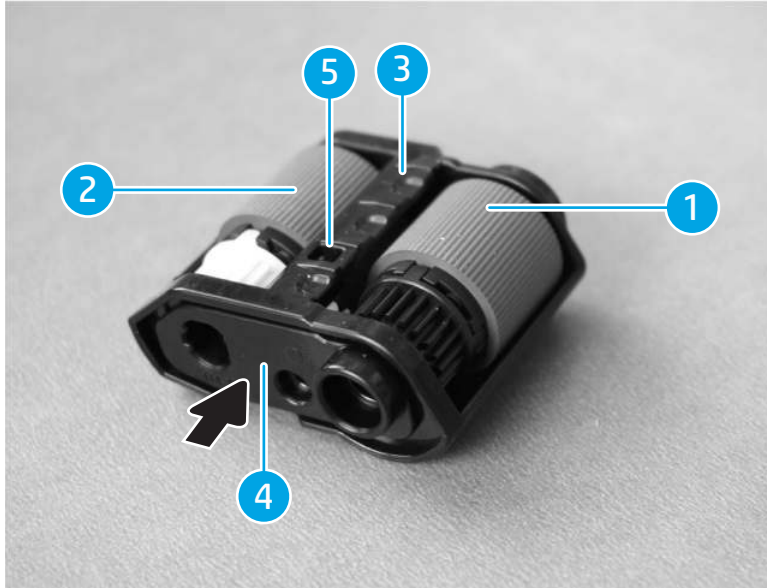

14. Slide the tray 1 feed roller (callout 1) and the tray 1 pick-up roller (callout 2) in the direction the arrow indicates, and then install them together.
15. Slide the roller holder (callout 3) in the direction the arrow indicates to install it and engage one tab (callout 4).
16. Flex the hook of the lifter sensor flag (callout 5) and push it upwards to engage the hook, and then place the printer back to the original position.

Figure 2-15 Install the pick roller

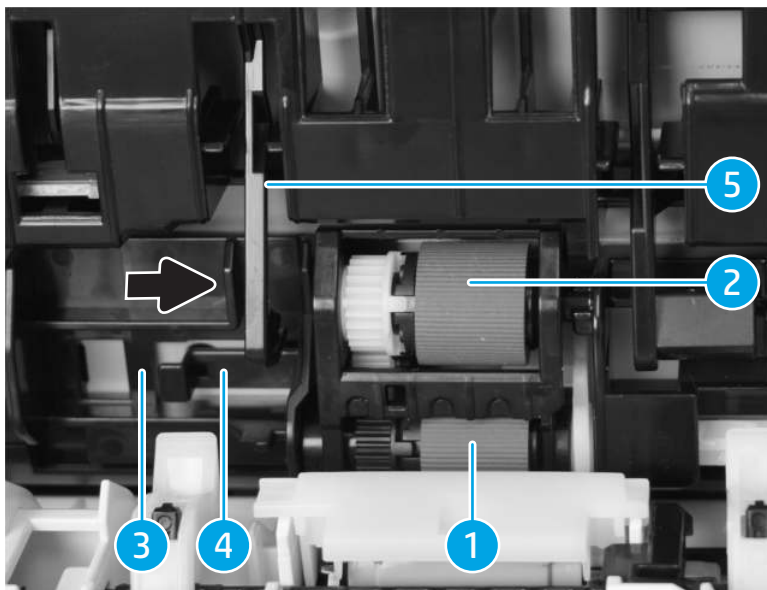

17. Install the input tray back into the printer.

Clean the separation roller

To clean the separation roller, do the following:

1. Turn off the printer, then unplug the power cable from the printer.
2. Remove the input tray.



3. Rotate the printer over to rest on the duplex door with the front of the printer facing up.



4. Remove Pickup and feed rollers.
5. Hold up the separation roller cover (callout 1).

Figure 2-16 Hold up the tray 1 separation roller

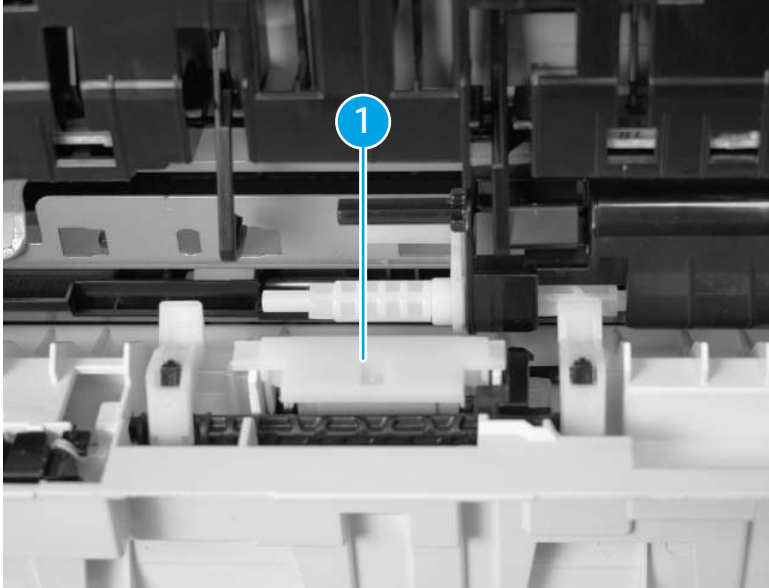

6. Hold up the tray 1 separation roller (callout 2) together with the separation roller holder (callout 1) and remove them.

Figure 2-17 Hold the separation roller holder

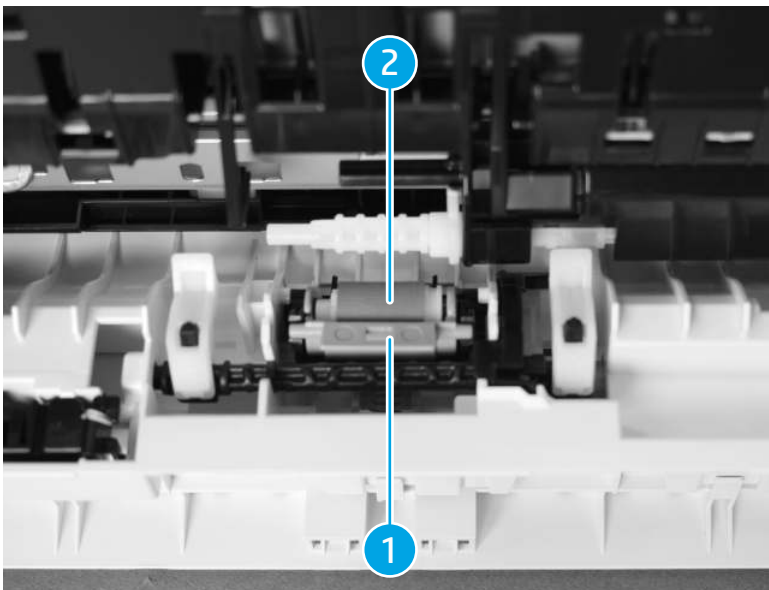

7. Release one tab (callout 1).
8. Remove the tray 1 separation roller (callout 3) from the separation roller holder (callout 2).

Figure 2-18 Remove the separation roller

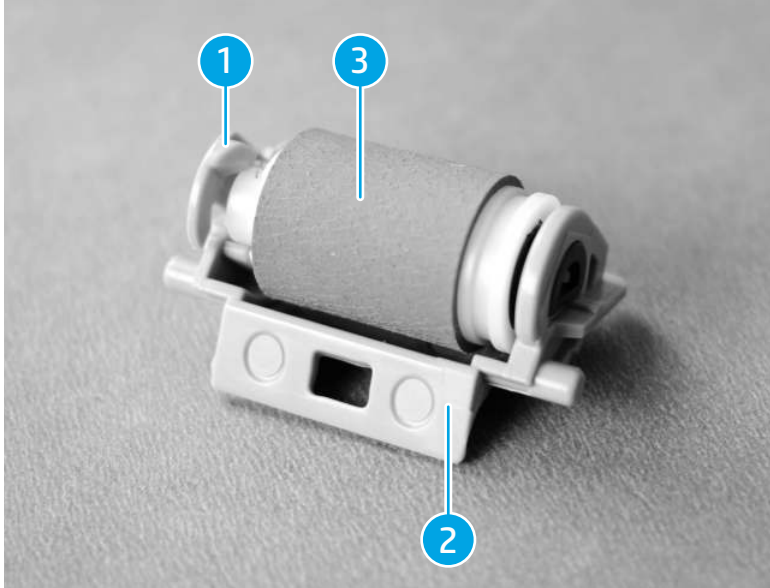

9. Wipe with a lint-free paper. If dirt cannot be removed, then dampen the lint-free paper with alcohol.
10. Install the tray 1 separation roller (callout 1) to the separation roller holder (callout 2).
11. Engage one tab (callout 3).

Figure 2-19 Install the separation roller

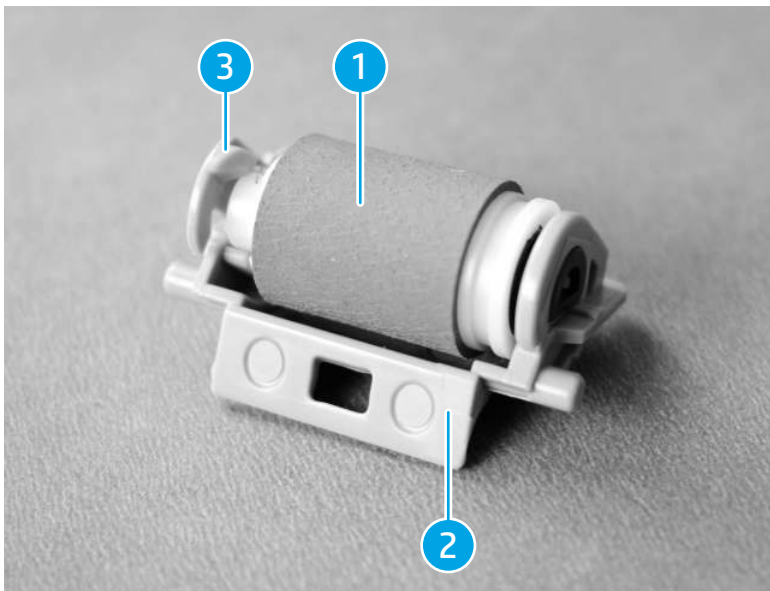

12. Press the tray 1 separation roller (callout 1) with the separation roller holder (callout 2) together to install it.

Figure 2-20 Install the separation roller holder

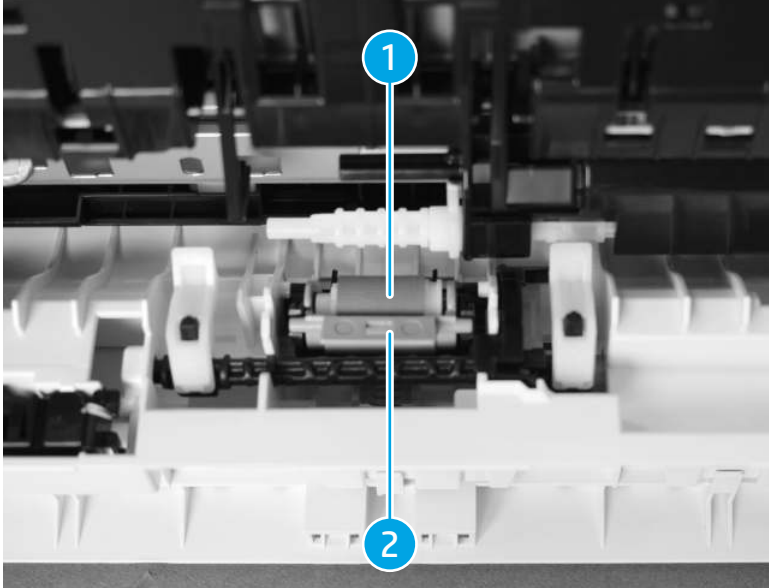

13. Hold down the separation roller cover (callout 1).

Figure 2-21 Install the separation roller

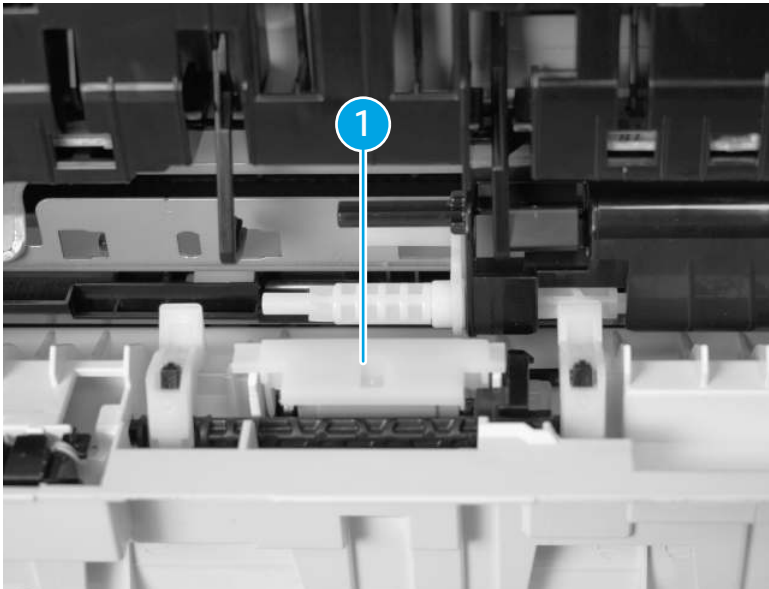

14. Install the pickup and feed rollers back.
15. Install the input tray back into the printer.

Clean the pickup rollers and separation pad in the document feeder

If the document feeder experiences paper-handling problems, such as jams or multiple-page feeds, clean the document-feeder rollers and separation pad.

1. Open the document-feeder cover.

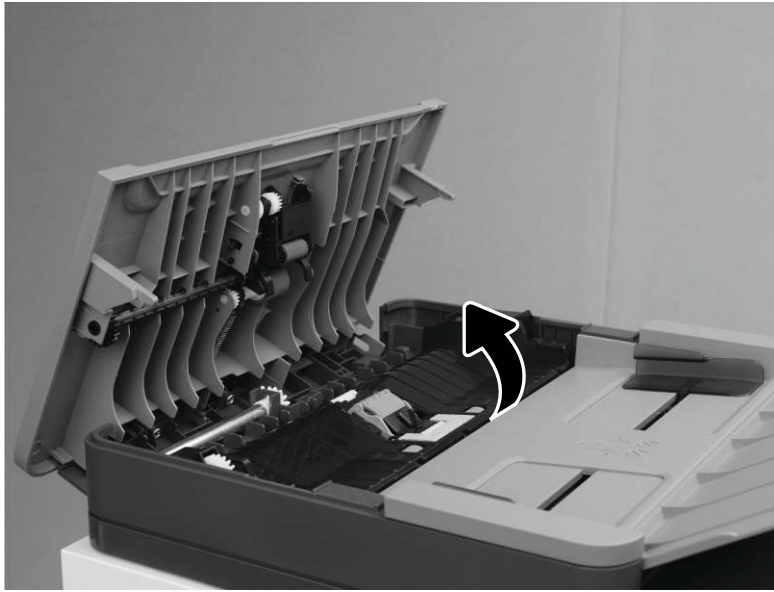

2. Use a moist, lint-free cloth to wipe both pickup rollers and the separation pad to remove dirt.

⚠ CAUTION: Do not use abrasives, acetone, benzene, ammonia, ethyl alcohol, or carbon tetrachloride on any part of the printer; these can damage the printer. Do not place liquids directly on the glass or platen. They might seep and damage the printer.

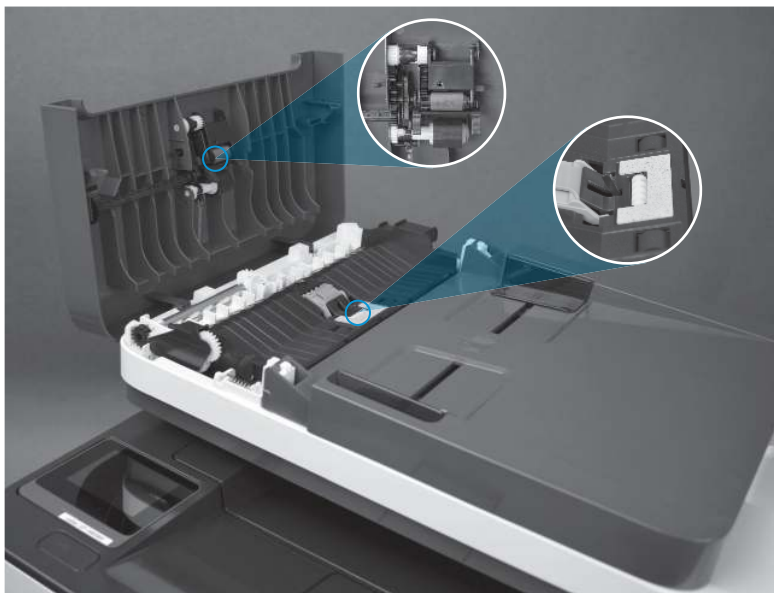

3. Close the document-feeder cover. Make sure it is completely closed.

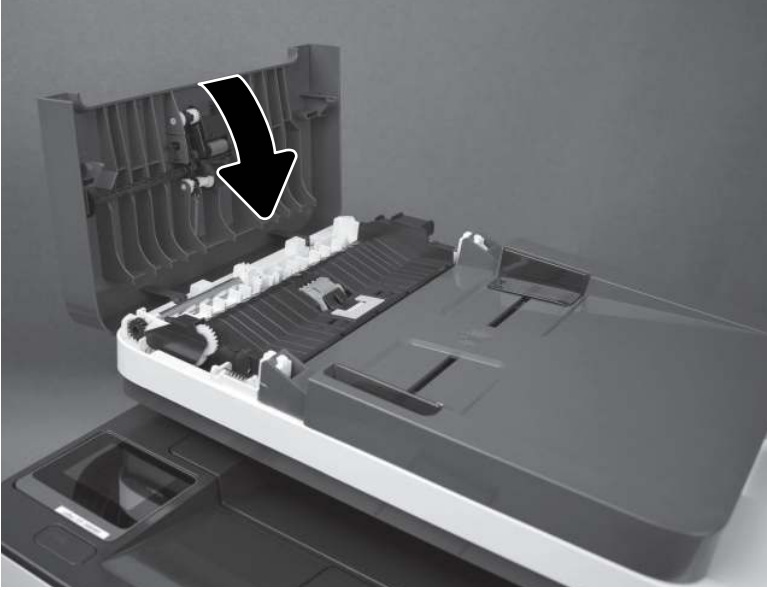

Check the scanner glass and white backing for dirt or smudges (MFP models only)

Over time, specks of debris might collect on the scanner glass and white plastic backing, which can affect performance. Use the following procedure to clean the scanner if the printed pages have streaks, unwanted lines, black dots, poor print quality, or unclear text:

1. Press the Power button to turn the printer off, and then disconnect the power cable from the electrical outlet.
2. Open the scanner lid.

Clean the white plastic backing (callout 1) and the scanner glass (callout 2) with a soft cloth or sponge that has been moistened with nonabrasive glass cleaner.



NOTE: If you are having trouble with streaks on copies when you are using the document feeder model printer, be sure to clean the ADF replaceable film assembly on the left side of the scanner.

Figure 2-22 Clean the white plastic backing and the scanner glass



3. Dry the glass and white plastic parts with a chamois or a cellulose sponge to prevent spotting. Close the scanner lid.

⚠ CAUTION: Do not use abrasives, acetone, benzene, ammonia, ethyl alcohol, or carbon tetrachloride on any part of the printer; these can damage the printer. Do not place liquids directly on the glass or platen. They might seep and damage the printer.

Figure 2-23 Dry the white plastic backing and the scanner glass



Solve paper-handling problems

Printer feeds incorrect page size

Cause	Solution
The correct size paper is not loaded in the tray.	Load the correct size paper in the tray.
The correct size paper is not selected in the software program or printer driver.	Confirm that the settings in the software program and printer driver are correct, because the software program settings override the printer driver and EWS settings, and the printer driver settings override the EWS settings.
The correct size paper for the tray is not selected in the printer settings.	From the EWS, select the correct size paper for the tray.
The paper size is not configured correctly for the tray.	Check that the tray is configured for the correct paper size and type. <ol style="list-style-type: none">1. Open the Embedded web server (EWS).2. Click the Settings tab.3. From the left menu, click Preferences.4. Click Tray and Paper Management and check the settings.
The guides in the tray are not against the paper.	Verify that the paper guides are touching the paper, but not so tightly that the paper is buckled.

Printer does not duplex or duplexes incorrectly

This topic describes about the cause and solution when the printer is unable to duplex.

Printer does not duplex (print 2-sided jobs) or duplexes incorrectly

Cause	Solution
You are trying to duplex on unsupported paper.	Verify that the paper is supported for duplex printing.
The printer driver is not set up for duplex printing.	Set up the printer driver to enable duplex printing.

Paper does not feed from the input tray

This topic describes about the cause and solution when the paper does not feed from the input tray.

Paper does not feed from the input tray

Cause	Solution
The correct size paper is not loaded.	Load the correct size paper.
The input tray is empty.	Load paper in the input tray.
The correct paper type for the input tray is not selected in the printer driver.	Open the printer driver, select the correct paper size and type for the input tray.
Paper from a previous jam has not been completely removed.	Open the printer and remove any paper in the paper path.
The guides in the tray are not against the paper.	Verify that the guides are touching the paper.

Output is curled or wrinkled

This topic describes about the cause and solution when the output is curled or wrinkled.

Output is curled or wrinkled

Cause	Solution
Paper does not meet the specifications for this printer.	Use only paper that meets the HP paper specifications for this printer.
Paper is damaged or in poor condition.	Remove paper from the input tray and load paper that is in good condition.
Printer is operating in an excessively humid environment.	Verify that the printing environment is within humidity specifications.
You are printing large, solid-filled areas.	Large, solid-filled areas can cause excessive curl. Try using a different pattern.
Paper used was not stored correctly and might have absorbed moisture.	Remove paper and replace it with paper from a fresh, unopened package.
Paper has poorly cut edges.	Remove paper, flex it, rotate it 180 degrees or turn it over, and then reload it into the input tray. Do not fan paper. If the problem persists, replace the paper.
The paper has previously been used for a print job.	Do not re-use paper.

Printer does not pick up paper or misfeeds

This topic describes about the different troubleshooting process when the printer does not pick up or misfeeds the paper.

The printer does not pick up paper

If the printer does not pick up paper from the tray, try these solutions.

1. Open the printer and remove any jammed sheets of paper.
2. Load the tray with the correct size of paper for the job.
3. Make sure the paper size and type are set correctly in EWS or in the printer driver.
4. Make sure the paper guides in the tray are adjusted correctly for the size of paper. Adjust the guides to the appropriate indentation in the tray.
5. The pickup and feed rollers, or the separation pad might be contaminated. Clean the rollers and pad with a lint-free cloth dampened with warm water. For more information, see [Clean the pickup roller, feed roller, and separation roller](#).

The printer picks up multiple sheets of paper

If the printer picks up multiple sheets of paper from the tray, try these solutions.

1. Remove the stack of paper from the tray and flex it, rotate it 180 degrees, and flip it over. *Do not fan the paper.* Return the stack of paper to the tray.
2. Use only paper that meets HP specifications for this printer.
3. Use paper that is not wrinkled, folded, or damaged. If necessary, use paper from a different package.

4. Make sure the tray is not overfilled. If it is, remove the entire stack of paper from the tray, straighten the stack, and then return some of the paper to the tray.
5. Make sure the paper guides in the tray are adjusted correctly for the size of paper. Adjust the guides to the appropriate indentation in the tray.
6. Make sure the printing environment is within recommended specifications.

The document feeder jams, skews, or picks up multiple sheets of paper (MFP models only)

- The original might have something on it, such as staples or self-adhesive notes, that must be removed.
- Make sure that the rollers and separation pad are installed correctly and that the document feeder access cover is fully closed.
- Make sure that the top document-feeder cover is closed.
- The pages might not be placed correctly. Straighten the pages and adjust the paper guides to center the stack.
- The paper guides must be touching the sides of the paper stack to work correctly. Make sure that the paper stack is straight and the guides are against the paper stack.
- The document feeder input tray or output bin might contain more than the maximum number of pages. Make sure the paper stack fits below the guides in the input tray, and remove pages from the output bin.
- Verify that there are no pieces of paper, staples, paper clips, or other debris in the paper path.
- Clean the document-feeder rollers and the separation pad. Use compressed air or a clean, lint-free cloth moistened with warm water. If misfeeds still occur, replace the rollers. For more information, see [Clean the pickup roller, feed roller, and separation roller](#).

Paper does not feed automatically

This topic describes about the cause and solution if paper does not feed automatically from input tray.

Paper does not feed automatically

Cause	Solution
Manual feed is selected in the software program.	Load the paper into the tray or if the paper is loaded, press the OK button.
The correct size paper is not loaded.	Load the correct size paper.
The input tray is empty.	Load paper into the input tray.
Paper from a previous jam has not been completely removed.	Open the printer and remove any paper in the paper path.
The paper size is not configured correctly for the input tray.	Print a configuration page or use the EWS to determine the paper size for which the tray is configured.
The guides in the tray are not against the paper.	Verify that the rear and width paper guides are touching the paper.

Clear paper jams

The following information includes instructions for clearing paper jams from the printer:

Paper path jam sensor locations

 **NOTE:** Use the following figures to identify the locations of sensors where reoccurring jams are found.

Figure 2-24 Printer base jam sensors



Abbreviation	Component
PS601	Fuser output sensor
PS611	Registration media width sensor
PS612	Registration sensor
PS622	Tray 1 media out sensor
VR1	Tray 1 media size sensor

Jam locations

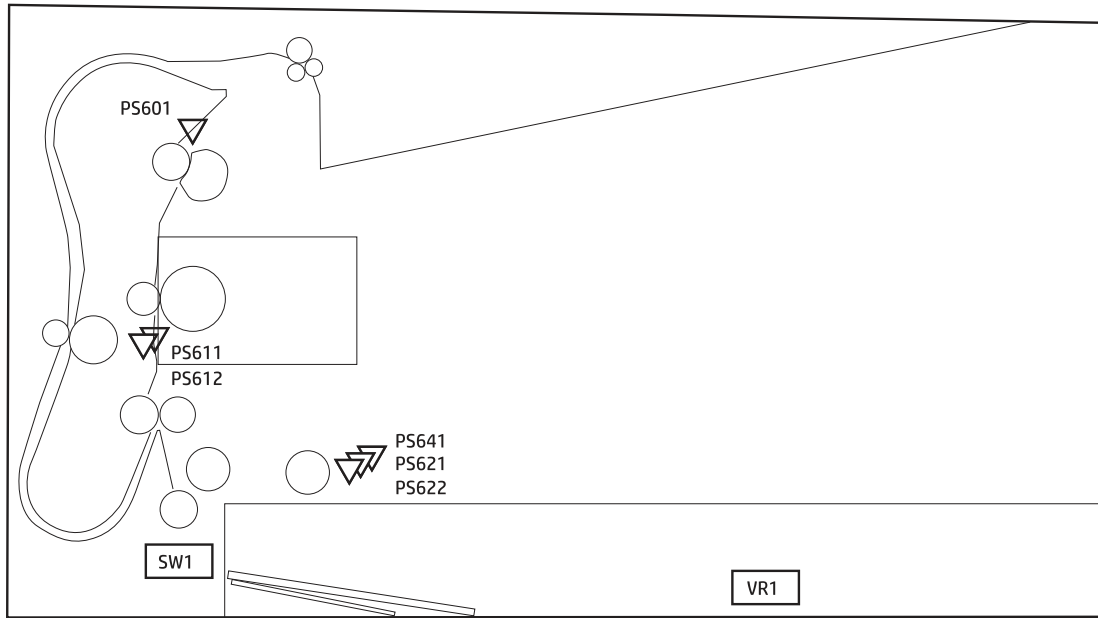
Jams can occur at the following locations in the product.

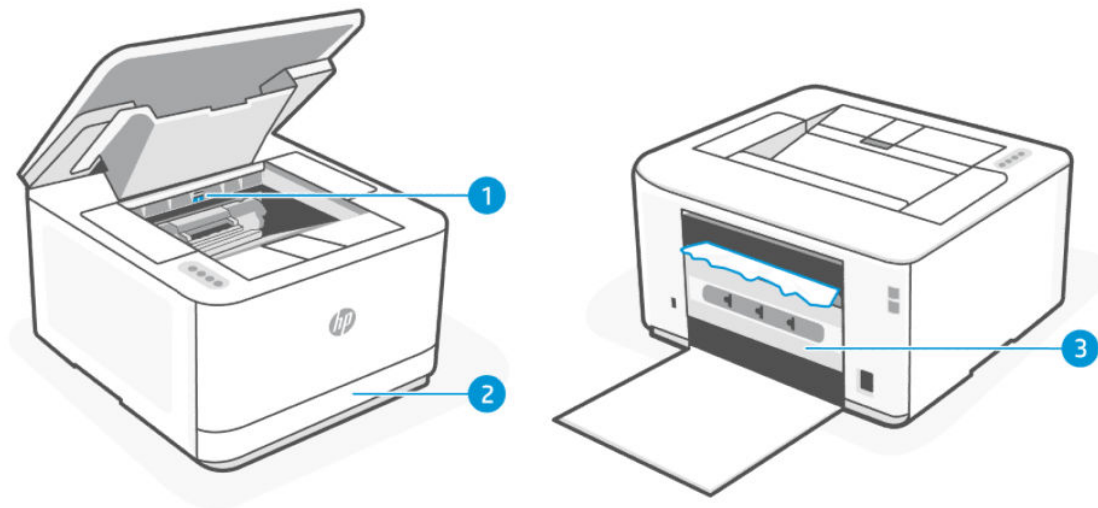



Table 2-44 Jam locations

Feature	Description
1	Cartridge access area
2	Input tray
3	Rear access door



Repair parts for frequent paper jams

Follow these steps to solve problems with frequent paper jams. If the first step does not resolve the problem continue with the next step until you have resolved the problem:

1. If paper has jammed in the printer, clear the jam and then print a configuration page to test the printer.
2. Check that the tray is configured for the correct paper size and type. Adjust paper settings if necessary.

Press and hold the information button  for 5 seconds until all the buttons are lit, then press the Resume/Cancel button  to print a configuration report.

3. Turn the printer off, wait 30 seconds, and then turn it on again.
4. See [Print a cleaning page](#) to remove excess toner from inside the printer.
5. Print a configuration page to test the printer.

Press and hold the Information button  for 5 seconds until all the buttons are lit, then press the Resume/Cancel button  to print a configuration report.

If none of these steps resolves the problem, the printer might need service. See the table below:

Table 2-45 Repair parts for frequent paper jams

Jam	Check point	Connector	Replace component
No pick jam	Tray 1 pickup roller	-	Tray 1 pickup roller
	Tray 1 feed roller	-	Tray 1 feed roller
	Tray 1 separation roller	-	Tray 1 separation roller
	Feed roller	-	Feed roller
	Registration sensor	J604, J611	Registration sensor
	Tray 1 pickup solenoid sensor	J731	Tray 1 pickup solenoid sensor
	Main motor	J703	Main motor
Pickup stay jam	Tray 1 pickup roller		Tray 1 pickup roller
	Registration sensor	J604, J611	Registration sensor PCA
	Transfer roller	-	Transfer roller
Fuser delivery delay jam	Fuser film, Pressure roller	-	Fuser
	Fuser output sensor	J531, J601, J603	Fuser
Fuser delivery stay jam	Fuser film, Pressure roller	-	Fuser
	Drive gear of fuser	-	Fuser
	Fuser output sensor	J531, J601, J603	Fuser
Fuser wrap jam	Fuser film, Pressure roller	-	Fuser
	Fuser guide	-	Fuser
	Fuser output sensor	J531, J601, J603	Fuser
Duplex feed delay jam	Output roller	-	
	Fuser output sensor	J531, J601, J603	Fuser
Duplex re-pickup delay jam	Registration sensor	J604, J611	Registration sensor PCA
	Fuser output sensor	J531, J601, J603	Fuser
Residual paper jam 1	Registration sensor	J604, J611	Registration sensor PCA
	Registration media with sensor	J604, J611	Registration sensor PCA
	Fuser output sensor	J531, J601, J603	Fuser
Residual paper jam 1	Registration sensor	J604, J611	Registration sensor PCA
	Registration media with sensor	J604, J611	Registration sensor PCA
	Fuser output sensor	J531, J601, J603	Fuser

Clear jams from the input tray

1. Remove the input tray.

Pull out the tray fully, and if needed, slightly tilt or lift the tray to remove it from the printer.

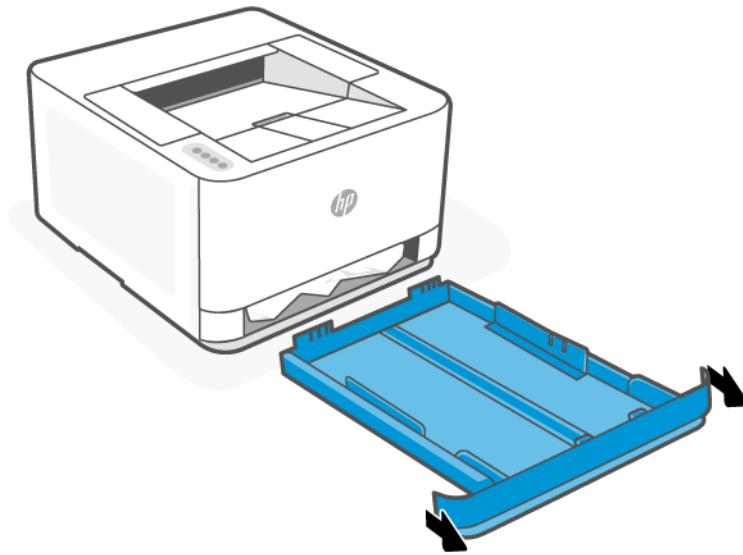

2. Check the input tray area underneath the printer. Remove the jammed paper.



3. Re-insert the input tray back until it snaps into place.

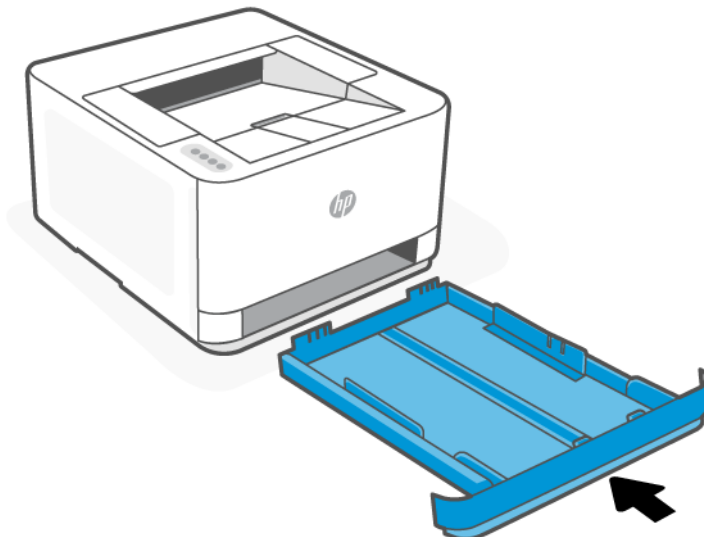

Clear jams from the rear of the printer

1. Open the rear access door.

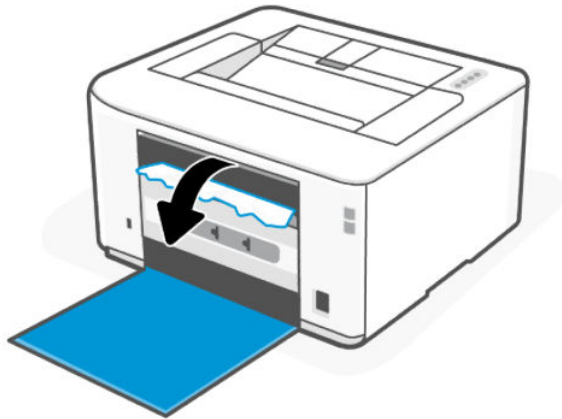

2. If you can see the jammed paper, carefully grasp the jammed paper, and then slowly pull it out of the printer.

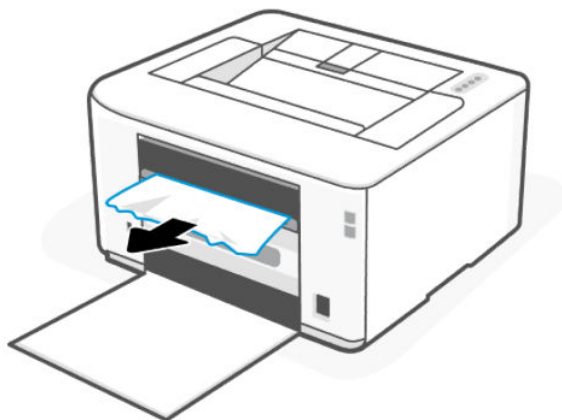

3. Close the rear access door.

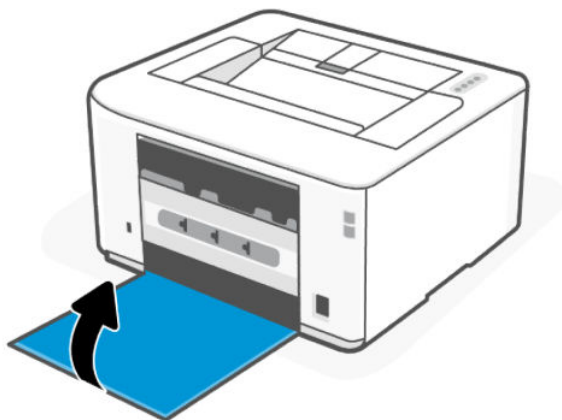

Clear jams from the cartridge access area

1. Open the cartridge access door.

 **NOTE:** Depending on where the jam is located, some of the following steps might not be necessary.

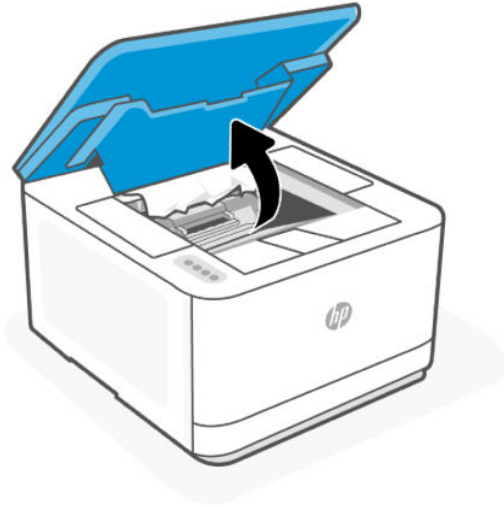

2. Before removing the cartridge, remove any jammed paper in the output tray area. If you can see the jammed paper, carefully grasp the jammed paper, and slowly pull it out of the output tray area.



3. Release the lever and pull out the jammed paper.

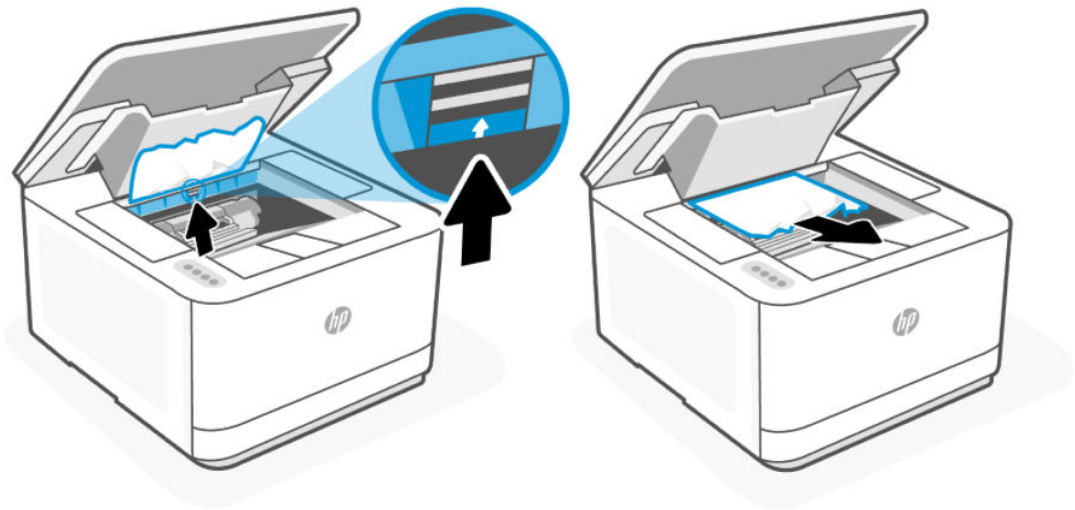

4. Remove the toner cartridge and pull out any jammed paper.

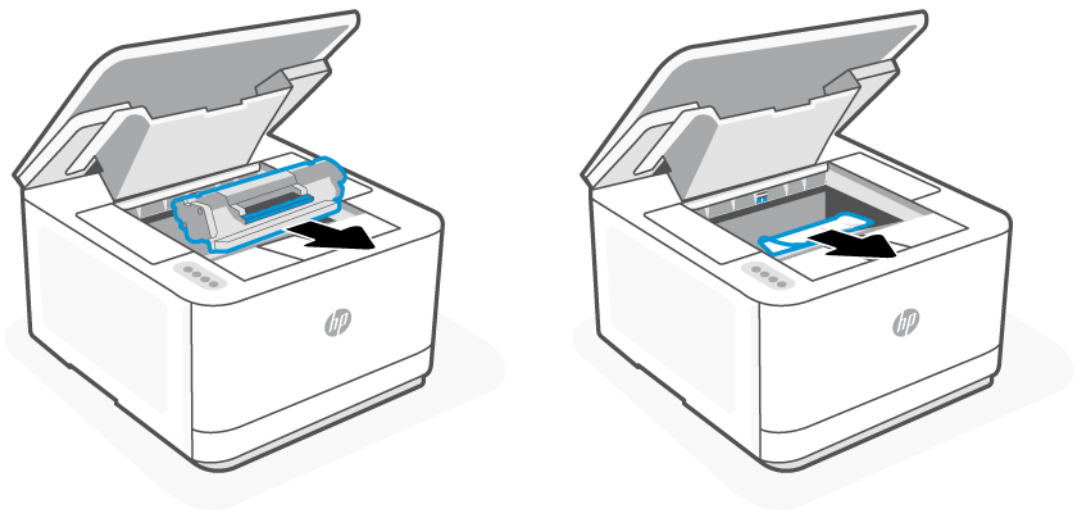

5. Reinstall the toner cartridge, lock the lever, and then close the cartridge access door.

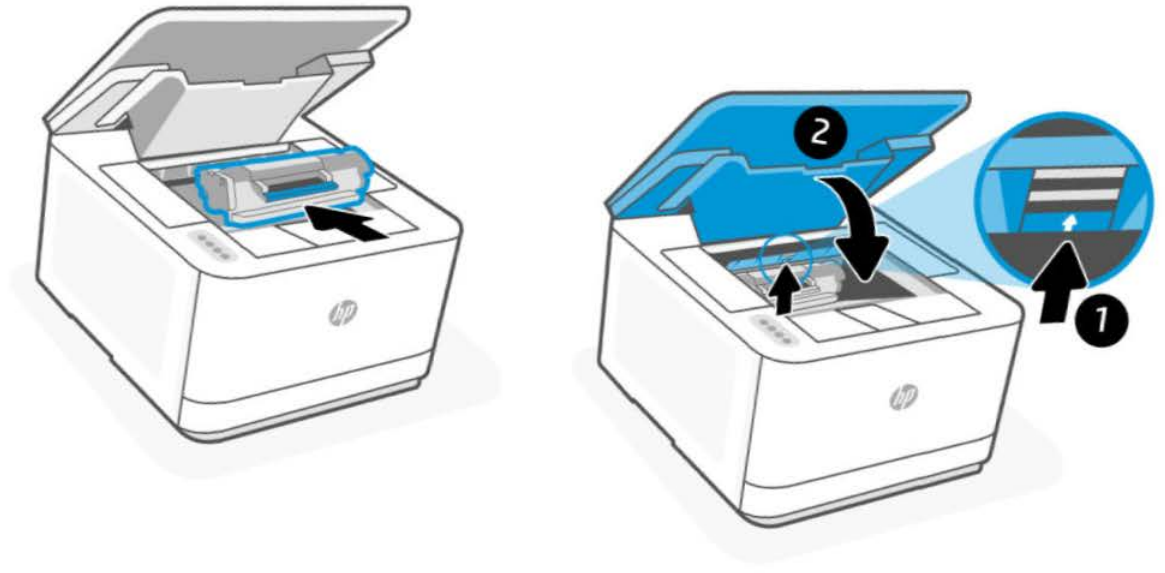

Clear paper jams (MFP models only)

The following information includes instructions for clearing paper jams from the product:

Paper path jam sensor locations

 **NOTE:** Use the following figures to identify the locations of sensors where reoccurring jams are found.

Figure 2-25 Printer base jam sensors



Abbreviation	Component
PS601	Fuser output sensor
PS611	Registration media width sensor
PS612	Registration sensor
PS622	Tray 1 media out sensor
VR1	Tray 1 media size sensor

Jam locations

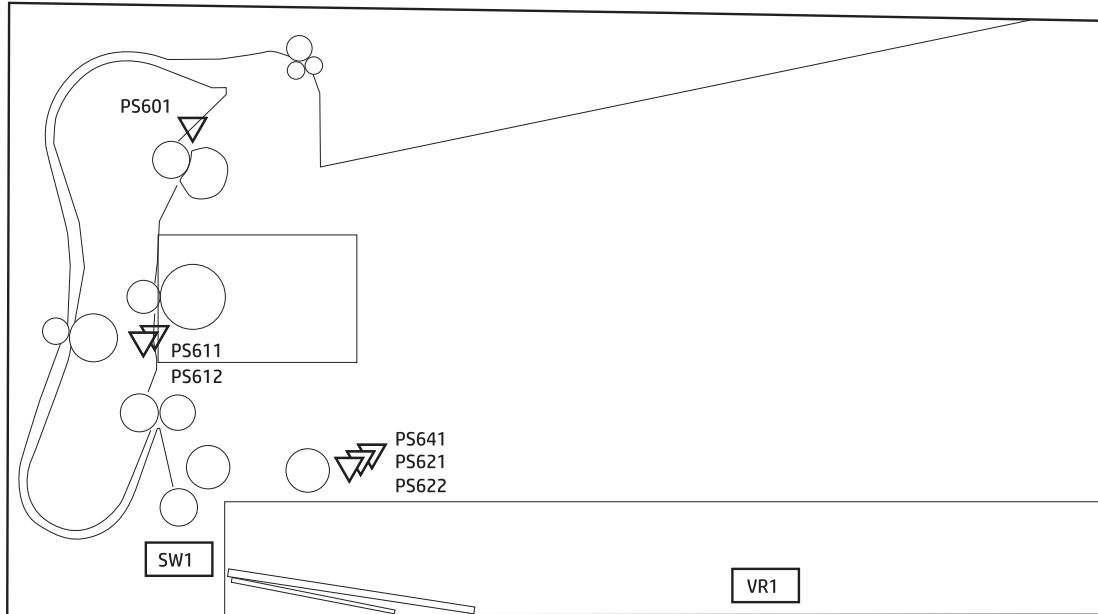
Jams can occur at the following locations in the product.

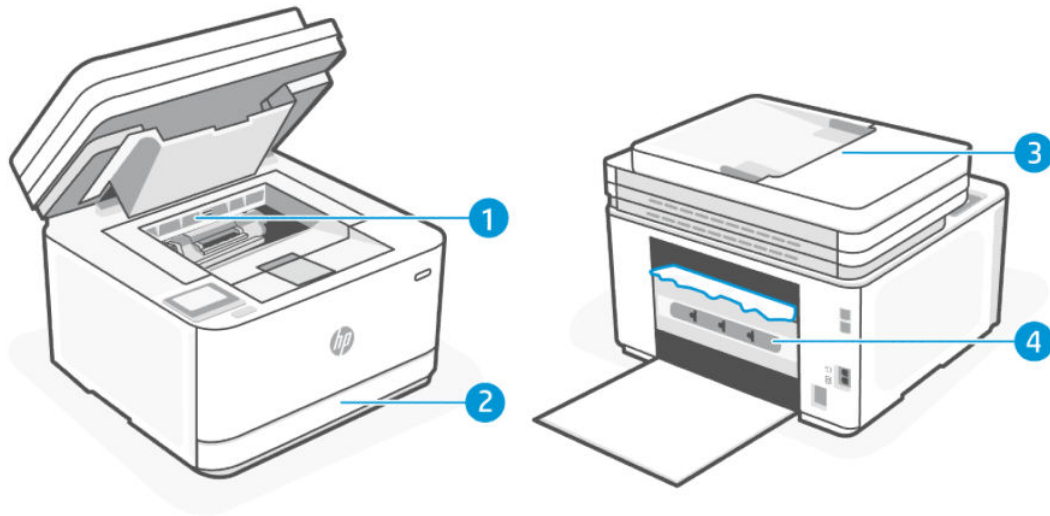

Table 2-46 Jam locations

Feature	Description
1	Cartridge access area
2	Input tray
3	Document feeder
4	Rear access door

Repair parts for frequent paper jams (MFP models only)

Follow these steps to solve problems with frequent paper jams. If the first step does not resolve the problem continue with the next step until you have resolved the problem:

1. If paper has jammed in the printer, clear the jam and then print a configuration page to test the printer.
2. Check that the tray is configured for the correct paper size and type. Adjust paper settings if necessary.
3. Turn the printer off, wait 30 seconds, and then turn it on again.
4. See [Print a cleaning page](#) to remove excess toner from inside the printer.
5. Print a configuration page to test the printer.

If none of these steps resolves the problem, the printer might need service. See the table below:

Table 2-47 Repair parts for frequent paper jams

Jam	Check point	Connector	Replace component
No pick jam	Tray 1 pickup roller	-	Tray 1 pickup roller
	Tray 1 feed roller	-	Tray 1 feed roller
	Tray 1 separation roller	-	Tray 1 separation roller
	Feed roller	-	Feed roller
	Registration sensor	J604, J611	Registration sensor
	Tray 1 pickup solenoid sensor	J731	Tray 1 pickup solenoid sensor
	Main motor	J703	Main motor
Pickup stay jam	Tray 1 pickup roller		Tray 1 pickup roller
	Registration sensor	J604, J611	Registration sensor PCA
	Transfer roller	-	Transfer roller
Fuser delivery delay jam	Fuser film, Pressure roller	-	Fuser
	Fuser output sensor	J531, J601, J603	Fuser
Fuser delivery stay jam	Fuser film, Pressure roller	-	Fuser
	Drive gear of fuser	-	Fuser
	Fuser output sensor	J531, J601, J603	Fuser
Fuser wrap jam	Fuser film, Pressure roller	-	Fuser
	Fuser guide	-	Fuser
	Fuser output sensor	J531, J601, J603	Fuser
Duplex feed delay jam	Output roller	-	
	Fuser output sensor	J531, J601, J603	Fuser
Duplex re-pickup delay jam	Registration sensor	J604, J611	Registration sensor PCA
	Fuser output sensor	J531, J601, J603	Fuser
Residual paper jam 1	Registration sensor	J604, J611	Registration sensor PCA
	Registration media with sensor	J604, J611	Registration sensor PCA

Table 2-47 Repair parts for frequent paper jams (continued)

Jam	Check point	Connector	Replace component
Residual paper jam 1	Fuser output sensor	J531, J601, J603	Fuser
	Registration sensor	J604, J611	Registration sensor PCA
	Registration media with sensor	J604, J611	Registration sensor PCA
	Fuser output sensor	J531, J601, J603	Fuser

Clear jams from the input tray (tray 1)

1. Remove the input tray (tray 1).

Pull out the tray fully, and if needed, slightly tilt or lift the tray to remove it from the printer.

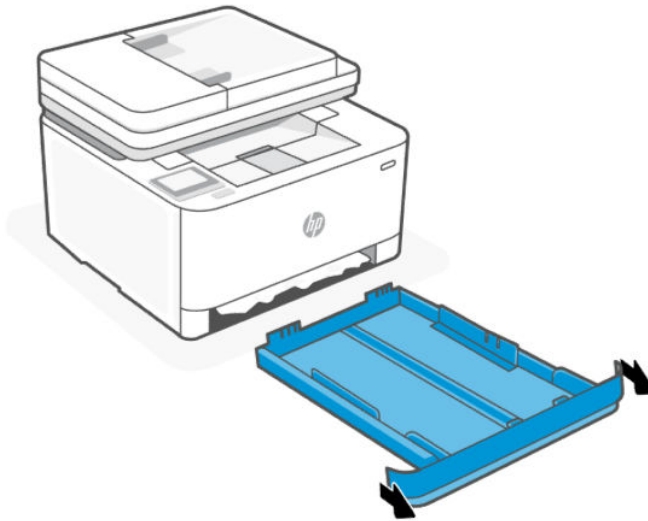

2. Check the input tray (tray 1) area underneath the printer. Remove the jammed paper.

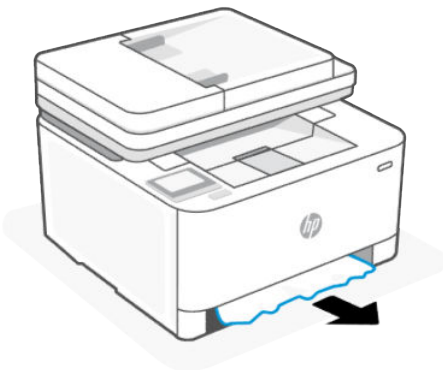

3. Re-insert the input tray (tray 1) back until it snaps into place.

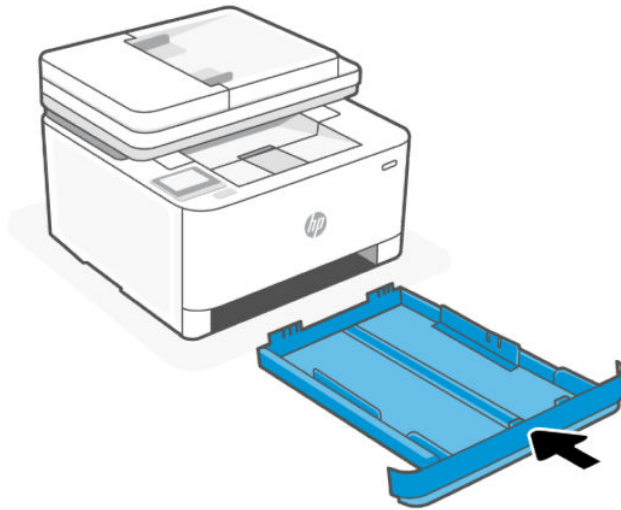

Clear jams from the cartridge access area

1. Open the cartridge access door.

 **NOTE:** Depending on where the jam is located, some of the following steps might not be necessary.

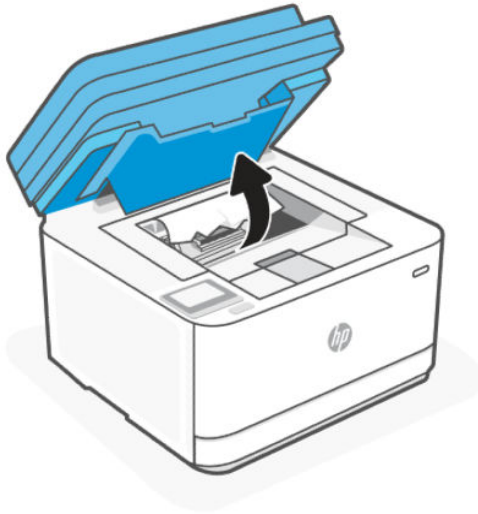

2. Before removing the cartridge, remove any jammed paper in the output tray area. If you can see the jammed paper, carefully grasp the jammed paper, and slowly pull it out of the output tray area.

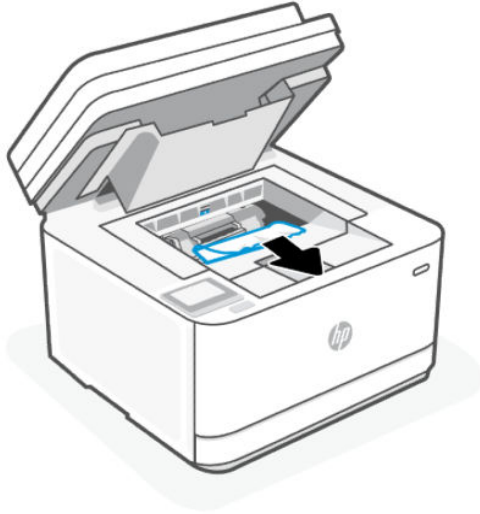

3. Release the lever and pull out the jammed paper.

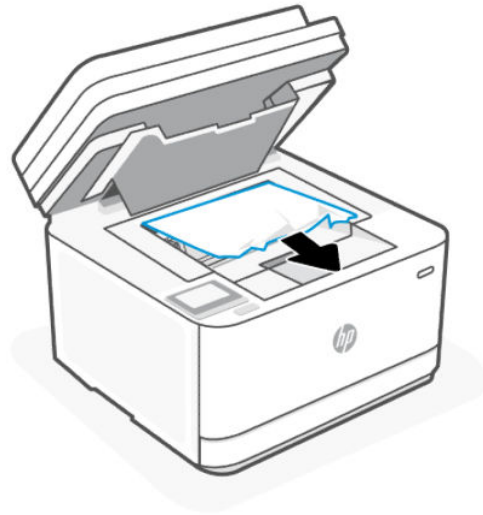
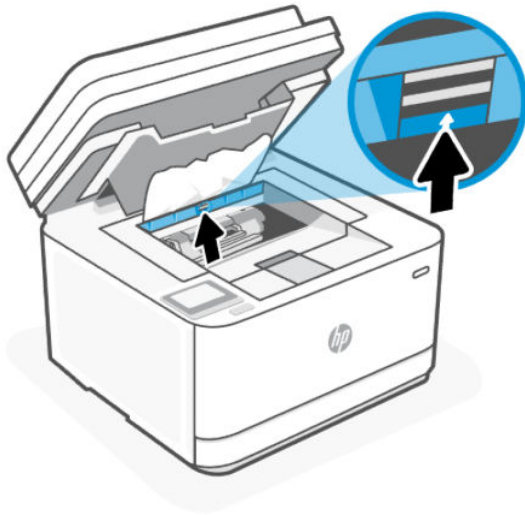

4. Remove the toner cartridge and pull out any jammed paper.

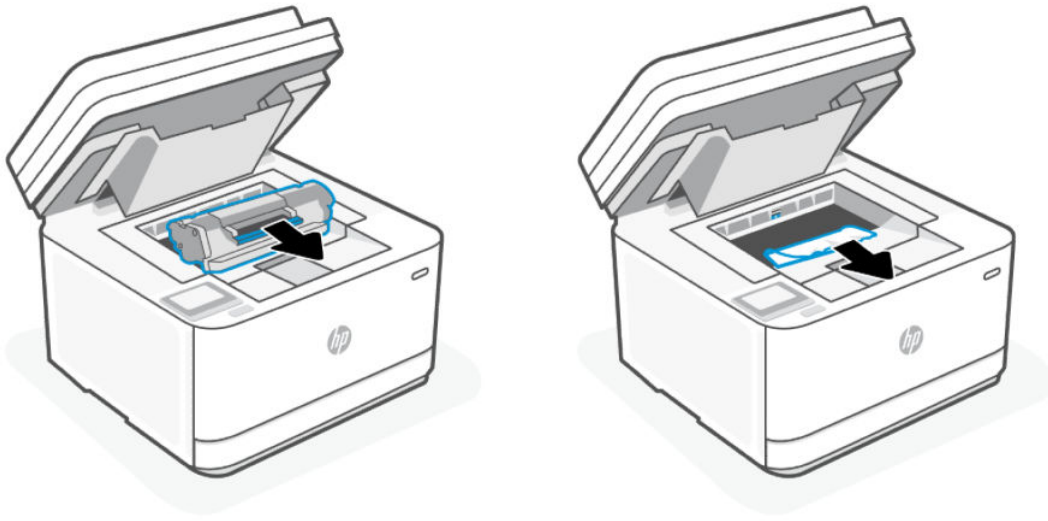

5. Reinstall the toner cartridge, lock the lever, and then close the cartridge access door.

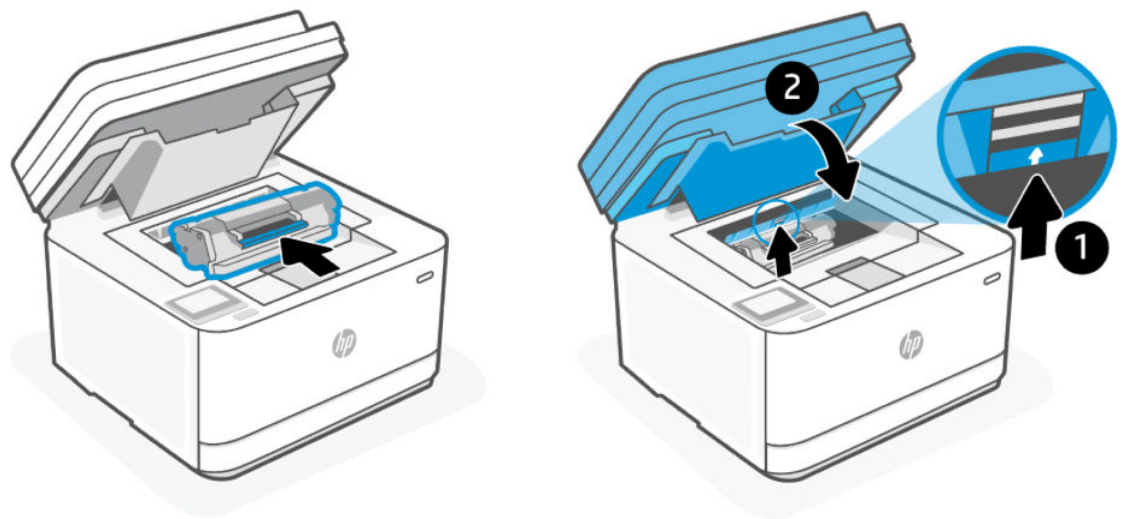

Clear jams in the document feeder

1. Open the document feeder cover.



2. Remove any jammed paper. Use both hands to remove jammed paper to avoid tearing the paper.

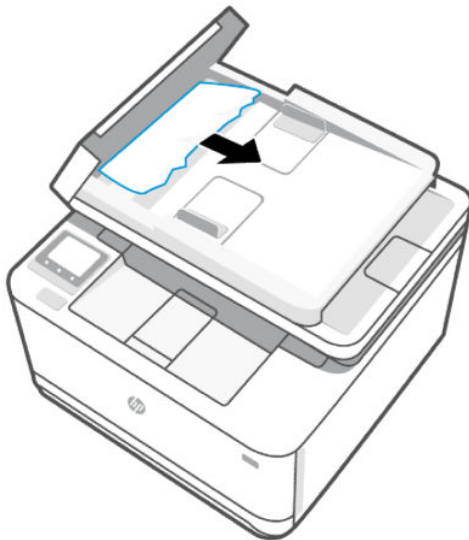

3. Close the document feeder cover.



Clear jams from the rear of the printer

1. Open the rear access door.

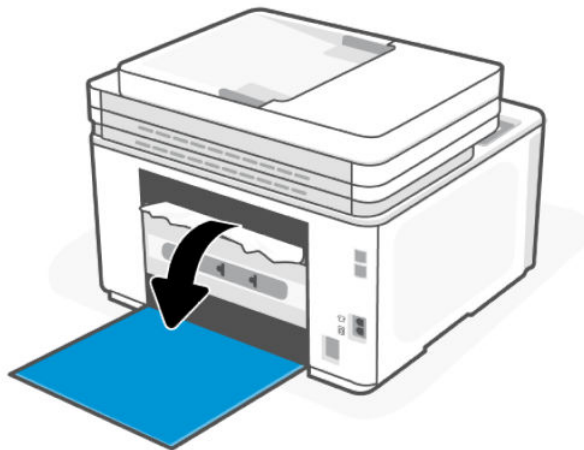

- If you can see the jammed paper, carefully grasp the jammed paper, and then slowly pull it out of the printer.

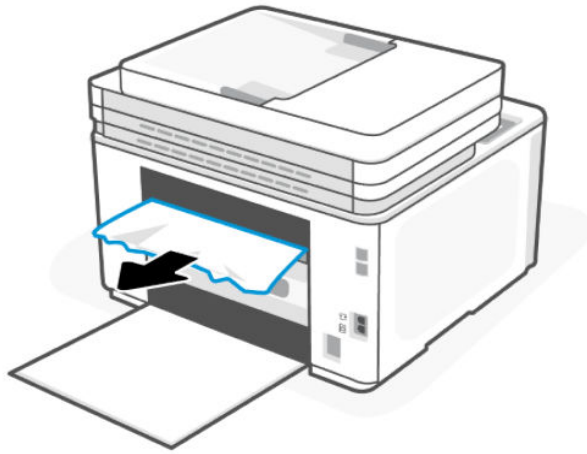

- Close the rear access door.

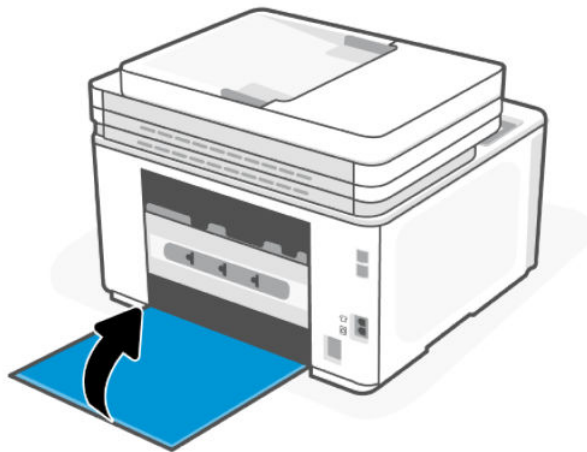

Solve performance problems

Table 2-48 Solve performance problems

Problem	Cause	Solution
Pages print but are totally blank.	The document might contain blank pages.	Check the original document to see if content is present on all of the pages.
	The printer might be malfunctioning.	If the problem still persists, see Print quality troubleshooting guide .
Pages print very slowly.	Heavier paper types can slow the print job.	Print on a different type of paper.
	Complex pages can print slowly.	Proper fusing might require a slower print speed to ensure the best print quality.
	Large batches, narrow paper, and special paper such as gloss, transparency,	Print in smaller batches, on a different type of paper, or on a different size of paper.

Table 2-48 Solve performance problems (continued)

Problem	Cause	Solution
	cardstock, and HP Tough Paper can slow the print job.	
Pages did not print.	The printer might not be pulling paper correctly.	For more details, see Paper does not feed automatically.
	The paper is jamming in the printer.	For more details, see Clear paper jams.
	The USB cable might be defective or incorrectly connected.	<ul style="list-style-type: none">• Disconnect the USB cable at both ends and reconnect it.• Try printing a job that has printed in the past.• Try using a different USB cable.
	Other devices are running on the host computer.	The printer might not share a USB port. If an external hard drive or network switchbox is connected to the same port as the printer, the other device might be interfering with the printer. To connect and use the printer, disconnect the other device or use two USB ports on the host computer.

Solve connectivity problems

Solve USB connection problems

If you have connected the printer directly to a computer, check the cable.

- Verify that the cable is connected to the computer and to the printer.
- Verify that the cable is not longer than 5 m (16.4 ft). Try using a shorter cable.
- Verify that the cable is working correctly by connecting it to another printer. Replace the cable if necessary.
- If the problem still persists, replace the formatter.

Solve wired network problems

Introduction

Check the following items to verify that the printer is communicating with the network. Before beginning, print a configuration page from the printer control panel and locate the printer IP address that is listed on this page.

Poor physical connection

1. Verify that the printer is attached to the correct network port using a cable of the correct length.
2. Verify that cable connections are secure.
3. Look at the network port connection on the back of the printer, and verify that the amber activity light and the green link-status light are lit.
4. If the problem continues, try a different cable or port on the hub.

The computer is using the incorrect IP address for the printer

1. Open the printer properties and click the **Ports** tab. Verify that the current IP address for the printer is selected. The printer IP address is listed on the printer configuration page.
2. If you installed the printer using the HP standard TCP/IP port, select the box labeled **Always print to this printer, even if its IP address changes**.
3. If you installed the printer using a Microsoft standard TCP/IP port, use the hostname instead of the IP address.
4. If the IP address is correct, delete the printer and then add it again.

The computer is unable to communicate with the printer

1. Test network communication by pinging the network.
 - a. Open a command-line prompt on your computer.
 - For Windows, click **Start**, click **Run**, type `cmd`, and then press [Enter](#).
 - For OS X, go to **Applications**, then **Utilities**, and open **Terminal**.
 - b. Type `ping` followed by the IP address for your printer.

- c. If the window displays round-trip times, the network is working.
2. If the ping command failed, verify that the network hubs are on, and then verify that the network settings, the printer, and the computer are all configured for the same network.

The printer is using incorrect link speed and duplex settings for the network

HP recommends leaving these settings in automatic mode (the default setting). If you change these settings, you must also change them for your network.

New software programs might be causing compatibility problems

Verify that any new software programs are correctly installed and that they use the correct print driver.

The computer or workstation might be set up incorrectly

1. Check the network drivers, print drivers, and the network redirection settings.
2. Verify that the operating system is configured correctly.

The printer is disabled, or other network settings are incorrect

1. Review the configuration page to check the status of the network protocol. Enable it if necessary.
2. Reconfigure the network settings if necessary.

Solve wireless network problems

Use the troubleshooting information to help resolve issues.



NOTE: To determine if Wi-Fi Direct printing is enabled on your printer, print an information report from the printer control panel.

Wireless connectivity checklist

- Verify that the printer and the wireless router are turned on and have power. Also make sure that the wireless radio in the printer is turned on.
- Verify that the service set identifier (SSID) is correct. Print an information report to determine the SSID.

On the printer control panel, press the Information button  (for SFP models only).

If you are not sure the SSID is correct, run the wireless setup again.

- With secured networks, verify that the security information is correct. If the security information is incorrect, run the wireless setup again.
- If the wireless network is working correctly, try accessing other computers on the wireless network. If the network has Internet access, try connecting to the Internet over a wireless connection.
- Verify that the encryption method (AES or TKIP) is the same for the printer as it is for the wireless access point (on networks using WPA security).
- Verify that the printer is within the range of the wireless network. For most networks, the printer must be within 30 m (100 ft) of the wireless access point (wireless router).

- Verify that obstacles do not block the wireless signal. Remove any large metal objects between the access point and the printer. Make sure poles, walls, or support columns containing metal or concrete do not separate the printer and wireless access point.
- Verify that the printer is located away from electronic devices that might interfere with the wireless signal. Many devices can interfere with the wireless signal including motors, cordless phones, security system cameras, other wireless networks, and some Bluetooth devices.
- Verify that the print driver is installed on the computer.
- Verify that you have selected the correct printer port.
- Verify that the computer and printer connect to the same wireless network.
- For OS X, verify that the wireless router supports Bonjour.

The printer does not print after the wireless configuration completes

1. Make sure that the printer is turned on and in the ready state.
2. Turn off any third-party firewalls on your computer.
3. Make sure that the wireless network is working correctly.
4. Make sure that your computer is working correctly. If necessary, restart the computer.
5. Verify that you can open the printer EWS from a computer on the network.

The printer does not print, and the computer has a third-party firewall installed

1. Update the firewall with the most recent update available from the manufacturer.
2. If programs request firewall access when you install the printer or try to print, make sure you allow the programs to run.
3. Temporarily turn off the firewall, and then install the wireless printer on the computer. Enable the firewall when you have completed the wireless installation.

The wireless connection does not work after moving the wireless router or printer

1. Make sure that the router or printer connects to the same network that your computer connects to.
2. Print an information report.
3. Compare the service set identifier (SSID) on the information report to the SSID in the printer configuration for the computer.
4. If the numbers are not the same, the devices are not connecting to the same network. Reconfigure the wireless setup for the printer.

Cannot connect more devices to the wireless printer (Wi-Fi Direct)

1. Make sure that the other computers are within the wireless range and that no obstacles block the signal. For most networks, the wireless range is within 30 m (100 ft) of the wireless access point.
2. Make sure that the printer is turned on and in the ready state.
3. Make sure there are not more than 5 concurrent Wi-Fi Direct users.

4. Turn off any third-party firewalls on your computer.
5. Make sure that the wireless network is working correctly.
6. Make sure that your computer is working correctly. If necessary, restart the computer.



The wireless printer loses communication when connected to a VPN

Typically, you cannot connect to a VPN and other networks at the same time.

The network does not appear in the wireless networks list

- Make sure the wireless router is turned on and has power.
- The network might be hidden.
- Make sure that the printer is within wireless range of the wireless router, and that there are no obstacles blocking the signal.
- The printer operates on the 2.4 GHz and 5 GHz wireless bands.
- Refresh the wireless networks list.
- Try restarting the printer.





The wireless network is not functioning

1. To verify if the network has lost communication, try connecting other devices to the network.
2. Test network communication by pinging the network.
 - a. Open a command-line prompt on your computer.
 - For Windows, click **Start**, click **Run**, type `cmd`, and then press **Enter**.
 - For OS X, go to **Applications**, then **Utilities**, and open **Terminal**.
 - b. Type `ping` followed by the router IP address.
 - c. If the window displays round-trip times, the network is working.
3. Make sure that the router or printer connects to the same network that the computer connects to.
 - On the printer control panel, press the Information button  to print an information report (SFP models only).
 - On the Home screen of the printer display, touch  (**Setup**), scroll down and touch **Reports** and then generate Printer status report (MFP models only).
 - a. Compare the service set identifier (SSID) on the information report to the SSID in the printer information for the computer.
 - b. If the numbers are not the same, the devices are not connecting to the same network. Reconfigure the wireless setup for the printer.

Perform a wireless network diagnostic test

A wireless network diagnostic test can be performed using the printer control panel or the Embedded Web Server (EWS). The wireless network diagnostic test provides information about the wireless network settings.

Method one: Perform a wireless network diagnostic test using the printer control panel

- From the printer control panel, press and hold the Information button  for 3 seconds, and then press the Information button  the Resume/Cancel button  at the same time (SFP models only).
- On the Home screen of the printer display, touch the Setup  icon, scroll down and touch **Reports** and then generate network diagnostic report (MFP models only).

Method two: Perform wireless network diagnostic test using the EWS

1. Open the Embedded web server (EWS).
2. Select the **Networking** tab.
3. On the **Wireless Configuration** page, verify that the On option is selected.
4. Click the **Print Test Report** button to print a test page that shows test results.

Reduce interference on a wireless network

The following tips can reduce interference in a wireless network:

- Keep the wireless devices away from large metal objects, such as filing cabinets, and other electromagnetic devices, such as microwaves and cordless telephones. These objects can disrupt radio signals.
- Keep the wireless devices away from large masonry structures and other building structures. These objects can absorb radio waves and lower signal strength.
- Position the wireless router in a central location in line of sight with the wireless printers on the network.

Solve fax problems

This topic helps you troubleshoot fax problems.

Check the hardware setup

Several possible fixes are available. After each recommended action, retry faxing to see if the problem is resolved.

For best results during fax problem solving, make sure the line from the product is connected directly to the wall phone port. Disconnect all other devices that are connected to the product.

1. Verify that the telephone cord is connected to the correct port on the back of the product.
2. Check the phone line by using the fax test:
 - a. On the control panel, touch the Setup  icon.
 - b. Select **Fax Setup**, and then select **Tools**.

- c. Select **Run Fax Test**. The product prints a fax test report.
The report contains the following possible results:
 - **Pass**: The report contains all of the current fax settings for review.
 - **Fail**: The report indicates the nature of the error and contains suggestions for how to resolve the issue.
3. Verify that the product firmware is current:
 - a. Go to hp.com/support.
 - b. Click **Drivers & Software**, type your product number in the window, and then click **Search**. If necessary, click your model in a list of similar products.
The **Software & Driver Downloads** page opens.
 - c. Select your operating system from the drop-down menu, and then click **Next**.
 - d. Click the plus sign next to Firmware, and then click **HP LaserJet Firmware Update Utility**.
 - e. Click **Download**.
 - f. When the download is complete, follow the on-screen instructions to install and run the utility.
The utility checks for firmware updates for your HP product. If updates are found, the utility installs the available update.
 - g. When firmware updates are complete, try to resend the fax.
4. Verify that the fax was set up when the product software was installed.
From the computer, in the HP program folder, run the Fax Setup Utility.
5. Verify that the telephone service supports analog fax.

 **NOTE:**

- If using ISDN or digital PBX, contact your service provider for information about configuring to an analog fax line.
 - If using a VoIP service, change the **Fax Speed to Slow(V.29)** from the control panel. Ask if your service provider supports fax and for the recommended fax modem speed. Some companies might require an adapter.
 - If you are using a DSL service, make sure that a filter is included on the phone-line connection to the product. Contact the DSL service provider, or purchase a DSL filter if you do not have one. If a DSL filter is installed, try another filter because filters can be defective.
-
6. If the error persists, find more detailed problem-solving solutions in the sections that follow this one.

Faxes are sending slowly

The product is experiencing poor phone line quality.

- Retry sending the fax when the line conditions have improved.
- Check with the phone service provider that the line supports fax.

- Use white paper for the original. Do not use colors such as gray, yellow, or pink.
- Divide large fax jobs into smaller sections, and then fax them individually.
- Turn off the **Error Correction** setting:
 1. On the printer control panel, touch the Setup  icon.
 2. Select **Fax Setup**, and then select **Preferences**.
 3. Select **Error Correction Mode**, and then select **Off**.

 **NOTE:** Turning off **Error Correction Mode** can reduce image quality.

- Increase the **Fax Speed** setting.
 1. On the printer control panel, touch the Setup  icon.
 2. Select **Fax Setup**, and then select **Advanced Setup**.
 3. Select **Fax Speed**, and then select the correct setting.
- Change the fax settings on the control panel to a lower resolution.

 **NOTE:** Higher resolution faxes can take longer to send than lower resolution faxes.

1. On the printer control panel, touch the Setup  button.
2. Select **Fax Setup**, and then select **Advanced Setup**.
3. Select **Resolution**, and then select the correct setting.

Fax quality is poor

Fax is blurry or too light.



- Increase fax resolution when sending faxes. Resolution does not affect received faxes.
 1. On the printer control panel, touch the Setup  icon.
 2. Select **Fax Setup**, and then select **Advanced Setup**.
 3. Select **Resolution**, and then select the correct setting.

 **NOTE:** Increasing resolution slows transmission speed.

- Turn on the **Error Correction Mode** setting from the control panel.
 1. On the printer control panel, touch the Setup  icon.
 2. Select **Fax Setup**, and then select **Preferences**.
 3. Select **Error Correction Mode**, and then select **On**.
- Check the toner cartridge and replace the cartridge if necessary.
- Ask the sender to darken the contrast setting on the sending fax machine, and then resend the fax.

Fax cuts off or prints on two pages

Follow the below steps to check for the issue.

- Set the **Default Paper Size** setting. Faxes print on a single size of paper based on the **Default Paper Size** settings.
 1. On the printer control panel, touch the Setup  icon.
 2. Select **Paper Setup**.
 3. Select **Paper Size**, and then select the correct setting.
- Set the paper type and size for the tray used for faxes.
- Turn on the **Fit to Page** setting to print longer length faxes on letter or A4 size paper.
 1. On the printer control panel, touch the Setup  icon.
 2. Select **Fax Setup**, and then select **Advanced Setup**.
 3. Select **Fit to Page**, and then select **On**.

 **NOTE:** If the **Fit to Page** setting is off and the **Default Paper Size** setting is set to Letter, a Legal-size original prints on two pages.

Service mode functions

This section describes service and printer reset functions.

Service menu (MFP models only)

The Service menu is used to adjust print settings, restore factory default settings, and clean the print paper path.

- ▲ Open the Embedded web server (EWS).

Table 2-49 Service menu

Menu item	Sub-menu item	Description
Fuser cleaning mode	-	Cleans the printer when specks or other marks appear on printed output. The cleaning process removes dust and excess toner from the paper path. For more details, see Fuser cleaning mode section under Print a cleaning page .
Cartridge cleaning mode	-	For more details, see Cartridge cleaning mode section under Print a cleaning page . When selected, the printer prompts you to load plain Letter or A4 paper in Tray 1. Touch the OK button to begin the cleaning process. Wait until the process completes. Discard the page that prints.
Adjust alignment	-	Adjust Alignment is a vertical and horizontal shift setting to assure that the printed image is centered or positioned at the desired place on the paper.
Less Paper Curl	On Off*	When printed pages are consistently curled, this option sets the printer to a mode that reduces curl.
Archive Print	On	When printing pages that will be stored for a long time, this option sets the printer to a mode that reduces toner smearing and dusting.

Table 2-49 Service menu (continued)

Menu item	Sub-menu item	Description
	Off*	
USB Speed	High* Full	Sets the USB speed for the USB connection to the computer. For the printer to actually operate at high speed, it must have high speed enabled and be connected to an EHCI host controller that is also operating at high speed. This menu item does not reflect the current operating speed of the printer.
Advanced Settings	-	In EWS, click System , click Service , and then click Go to the Secondary service page under Advanced Settings. Press the blinking icon on the control panel. Refresh the secondary service page, in EWS, to access the secondary service page. NOTE: Service team only can access Secondary Service Page, and is not visible in customer build firmware, to change settings such as Location, Auto-on/Auto-off, Continuous Self-Test, Error Log Report, Supply Region Reset, Talc Media Optimization, and HP Print Cloud Debug.
Restore Defaults	-	Sets all settings to the factory default values.

Secondary service menu

Use the secondary service menu to print service-related reports and to run special tests. Customers do not have access to this menu.

- ▲ Open the secondary service menu through Embedded web server (EWS).

The following menu items appear in the secondary service menu:

Table 2-50 Secondary service menu

Menu item	Sub-menu item	Description
Advanced Configuration	Location	Printer parameters that are dependent on the location, such as the default paper size and the symbol set. The printer automatically restarts after you change the location.
	Auto-On / Auto-Off	Automatically turns on and off the printer at a schedule date and time. Also, the printer's sleep time can be set to Never as well.
Service Reports	Print Continuous Self Test	Prints a continuous configuration page.
	Print Error Log Report	This report is helpful to diagnose 49.xxx and 79.xxx event codes, which provides the firmware engineer with call stack and source files of the crash.
Supplies	Prepare for Test Cartridge Installation	To be triggered just before inserting the service cartridge, and with the purpose of testing HW after implementing a fix at an authorized service centre. It is necessary to prevent permanent modifications from being made to the service cartridges.
	Printer Supply Region Reset	This triggers the printer to re-regionalize the printer to accept cartridges from a different supply region. It is intended only to be used when a printer is physically moved to a different region and needs to use locally sourced cartridges.
Print Engine	Talc Media Optimization	Turns on optimized print mode to reduce talc effect on OPC drum.
HP Print Cloud Debug	Out of Pages Extension PIN	Customer gets this pin from agent and enters it here.
	Entry 15	Printer Status Code (PSC) - Customer passes this code to agent. The call agent uses that code to generate the OOPE Pin in AST, which is then given back to the customer.

Printer resets

To restore printer default settings using EWS

1. Open the EWS. See [To access and use the Embedded Web Server \(EWS\)](#).
2. Click the **Settings** tab.
3. From the left menu, click **Restore Defaults**.
4. Select the option to restore factory defaults.
5. Click the button to restore the settings.

The printer automatically restarts.

To restore network default settings using EWS

1. Open the EWS. See [To access and use the Embedded Web Server \(EWS\)](#).
2. Click the **Settings** tab.
3. From the left menu, click **Restore Defaults**.
4. Select the option to restore network settings.
5. Click the button to restore the settings.

The printer automatically restarts.

NVRAM initialization

Performing an NVRAM initialization resets the following settings and information:

- All menu settings are reset to factory default values.
- All localization settings, including language and country/region, are reset.







⚠ CAUTION: All onboard network settings are also reset. Be sure to print a configuration page before restoring defaults. Make note of the IP address that is listed on the configuration page. You might need to restore the IP address after an NVRAM initialization.

After performing an NVRAM initialization, reconfigure any computers that print to this printer. Uninstall and then reinstall the printer software on the computers.

To initiate NVRAM initialization (SFP models only)

Do the following:

1. Turn the printer off.
2. Press and hold the Resume/Cancel button  .

3. While pressing the Resume/Cancel button , press the Power button  and hold the Resume/Cancel button  for 10 seconds.
4. When the Attention light  turns on (**USB models only**) or the Information button  turns on (**wireless models only**), then release the Resume/Cancel button .
5. When the NVRAM initialization completes, the printer returns to the steady state.







Super NVRAM initialization

A super NVRAM initialization restores the printer to the “generic printer mode” in which it arrived from the factory. This means that you will have to reset the language and country/region settings when the printer starts after the initialization. A super NVRAM initialization erases all data stored in the protected and unprotected NVRAM sections.

 **WARNING!** A super NVRAM initialization resets the printer page count and removes the formatter association to the printer serial number. The lack of formatter association to the printer serial number might affect the printer's warranty entitlement. Also, the printer will not be allowed to connect to the HP cloud.

To initiate Super NVRAM initialization (SFP models only)

Do the following:

1. Turn the printer off.
2. Press and hold the Resume/Cancel button .
3. While pressing the Resume/Cancel button , press the Power button  and hold the Resume/Cancel button  for 10 seconds.
4. When the Attention light  turns on (**USB models only**) or the Information button  turns on (**wireless models only**), then release the Resume/Cancel button .
5. When the NVRAM initialization completes, the printer returns to the steady state.

Solve HP Web Services Problems

HP Web Services allow the printer to communicate securely over the internet with web-connected printing services such as HP Print on the Go, HP Instant Ink delivery services, and many others.



NOTE: HP+ printers must always be connected to the Internet over Wi-Fi or Ethernet to function. See [Learn more about setting up Web Services](#) for details.

If you are unable to connect to Web Services then do the following:

- Restart printer, computer, and router.
- Make sure that the printer is connected to the network, and then check the printer connection status.
- Open web services through the EWS. Open a web browser and in the address line, type the IP address to access the EWS. Use the HP Smart app or see [To access and use the Embedded Web Server \(EWS\)](#).
- When the printer is connected to the server, the printer prints an information sheet. Follow the instructions on the information sheet to finish the setup.
 - Open the EWS. See [To access and use the Embedded Web Server \(EWS\)](#).
 - Click the **Web Services** tab.
 - From the left menu, click **Printer Pairing** under **Web Services Settings**.
 - Click **Start Pairing** to pair your printer.
- When the printer is connected to the server, the printer prints an information sheet. Follow the instructions on the information sheet to finish the setup.
- Check internet proxy server settings (address and port values).
- Enter the same proxy settings under HP Web Services Proxy settings in EWS.
- Update the printer's firmware.

For detailed instructions on how to troubleshoot web services, see <https://support.hp.com/sq-en/document/c05337026>

Cannot connect to the email server

- Make sure the SMTP or LDAP server name is correct. Check this setting with your system administrator or Internet Service Provider.
- If the printer cannot establish a secure connection to the SMTP or LDAP server, try without the secure connection or try a different server or port. Check this setting with your system administrator or Internet Service Provider.
- If the SMTP or LDAP server requires authentication, make sure a valid user name and password are used.
- If the SMTP or LDAP server uses an authentication method that is not supported, try a different server. Check this setting with your system administrator or Internet Service Provider.

Validate the SMTP gateway (Windows)

1. Open an MS-DOS command prompt: click **Start**, click **Run**, type `cmd`, and then press the **Enter** key.
2. In the command prompt window, type `telnet` followed by the SMTP gateway address and then the number 25, which is the port over which the printer is communicating. For example, type `telnet 123.123.123.123 25` where "123.123.123.123" represents the SMTP gateway address.

3. Press the **Enter** key. If the SMTP gateway address is not valid, the response contains the message **Could not open connection to the host on port 25: Connect Failed**.
4. If the SMTP gateway address is not valid, contact the network administrator.

Validate the LDAP gateway (Windows)

1. Open Windows Explorer. In the address bar, type `LDAP://` immediately followed by the LDAP gateway address. For example, type `LDAP://12.12.12.12` where "12.12.12.12" represents the LDAP gateway address.
2. Press the **Enter** key. If the LDAP gateway address is valid, the **Find People** dialog box opens.
3. If the LDAP gateway address is not valid, contact the network administrator.

Diagrams: Printed circuit assembly (PCA) connector locations

This section describes printed circuit assembly of Engine controller and Formatter.

Engine controller PCA

Figure 2-26 Engine controller PCA connectors diagram

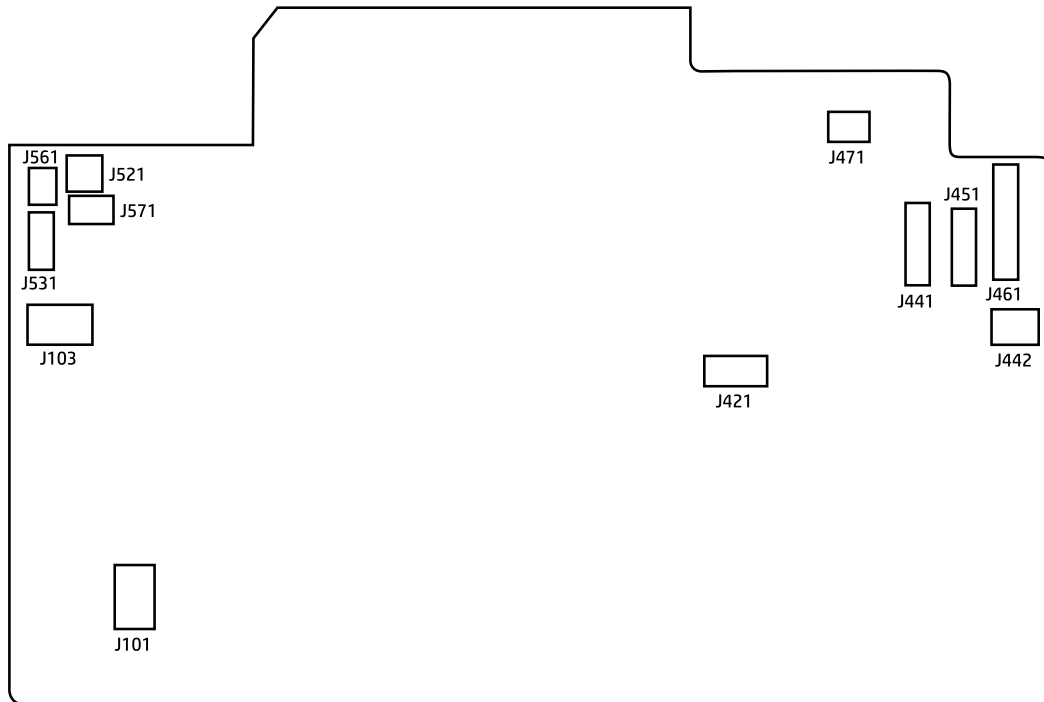

Table 2-51 Engine controller PCA connectors

Item	Description	Item	Description
J101	Power inlet	J461	Motor PCA
J103	Fuser	J471	Pickup media width sensor PCA
J421	Not used	J502	Medis sensor PCA
J441	Formatter PCA	J521	E-label (cartridge memory)

Table 2-51 Engine controller PCA connectors (continued)

Item	Description	Item	Description
J442	Formatter PCA	J531	Fuser output sensor PCA
J451	Laser PCA		

Formatter PCA

Figure 2-27 Formatter PCA (SFP models)

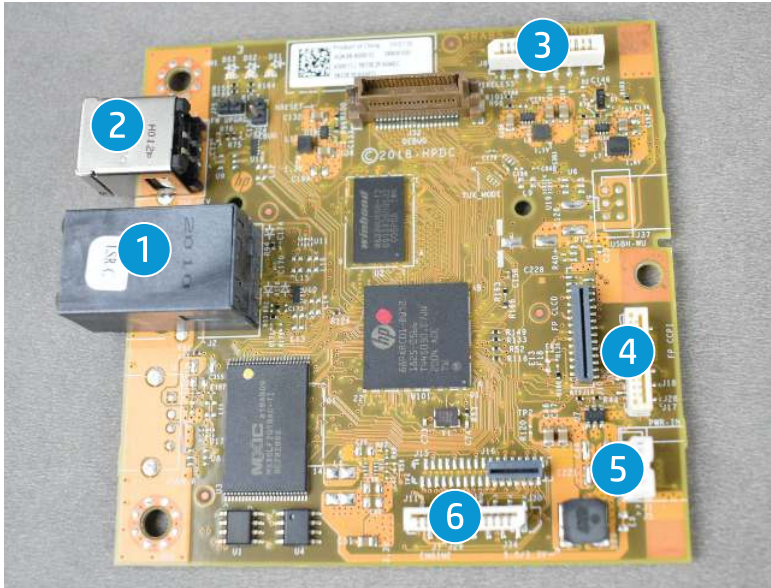

Table 2-52 Formatter PCA (SFP models)

Item	Description	Item	Description
1	LAN Port, J6	4	control panel interface
2	USB port, J4	5	Power interface, J20
3	Wireless interface, J5	6	Engine interface

Figure 2-28 Formatter PCA (MFP models)

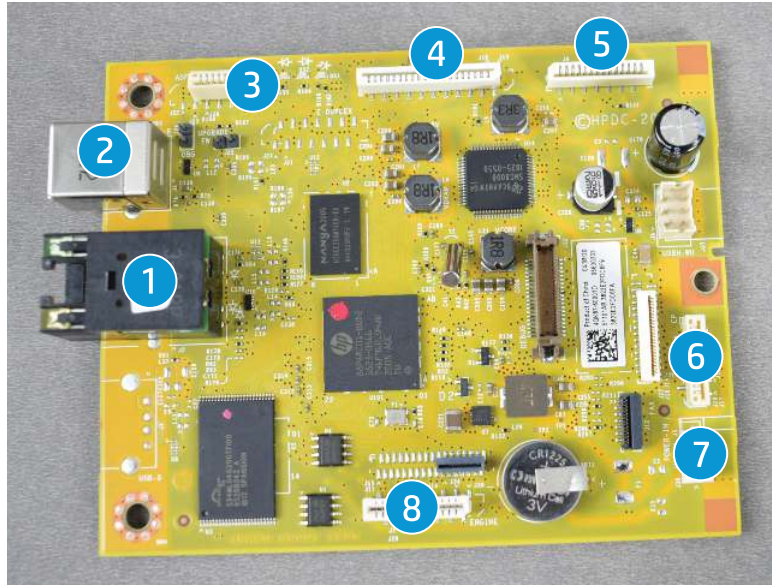
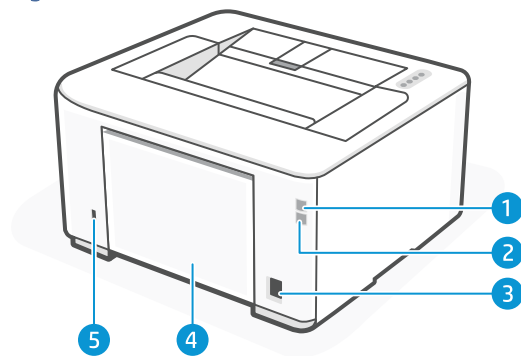

Table 2-53 Formatter PCA (MFP models)

Item	Description	Item	Description
1	LAN Port, J6	5	Power interface, J20
2	USB Port, J4	6	Engine Interface
3	Wireless Interface, J5	7	ADF Interface, J15
4	Control panel interface	8	Scanner Interface, J19

Printer back views (SFP and MFP models)

Figure 2-29 Printer back view (SFP models)





Item	Description
1	Rear USB port
2	Ethernet port (network models only)
3	Power input
4	Rear access door

Item	Description
5	Security slot

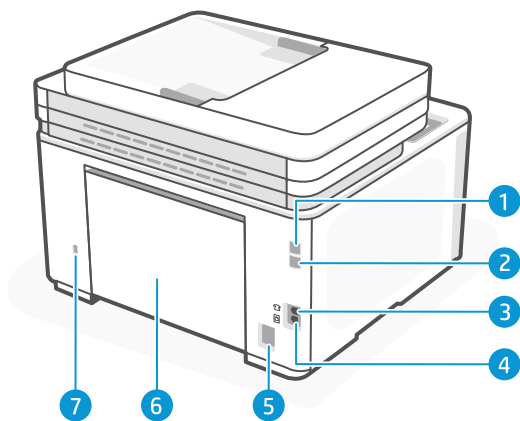
Figure 2-30 Printer back view (MFP models)



Item	Description
1	Rear USB port
2	Ethernet port (Ethernet models only)
3	Fax port 
4	Fax port 
5	Power input
6	Rear access door
7	Security slot

Diagrams: Locations of major components

Figure 2-31 Main assemblies

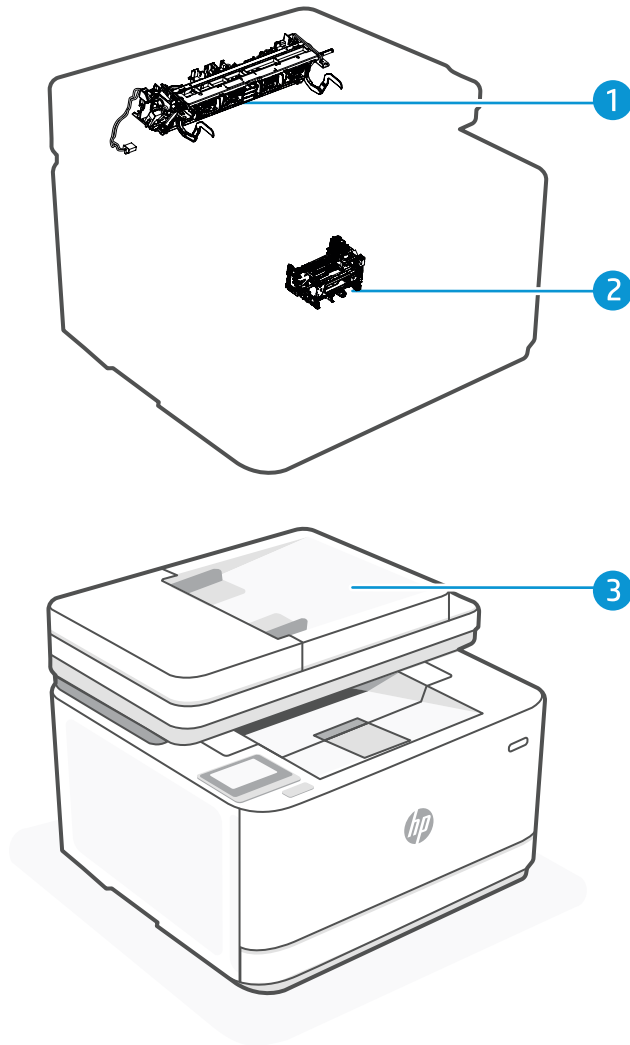

Item	Description
1	Fuser
2	Laser scanner assembly
3	Image scanner (MFP models only)

Figure 2-32 PCAs

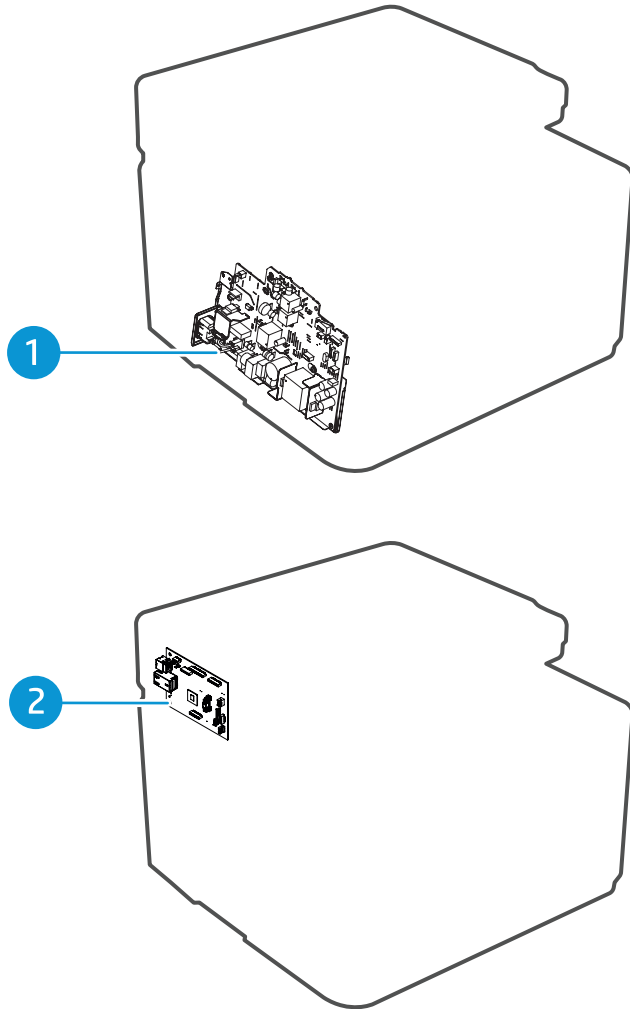

Item	Description
1	Engine controller PCA
2	Formatter PCA

Diagrams: Timing chart

 **NOTE:** The timing chart is based on two consecutive prints on letter-size paper.

Figure 2-33 General timing chart

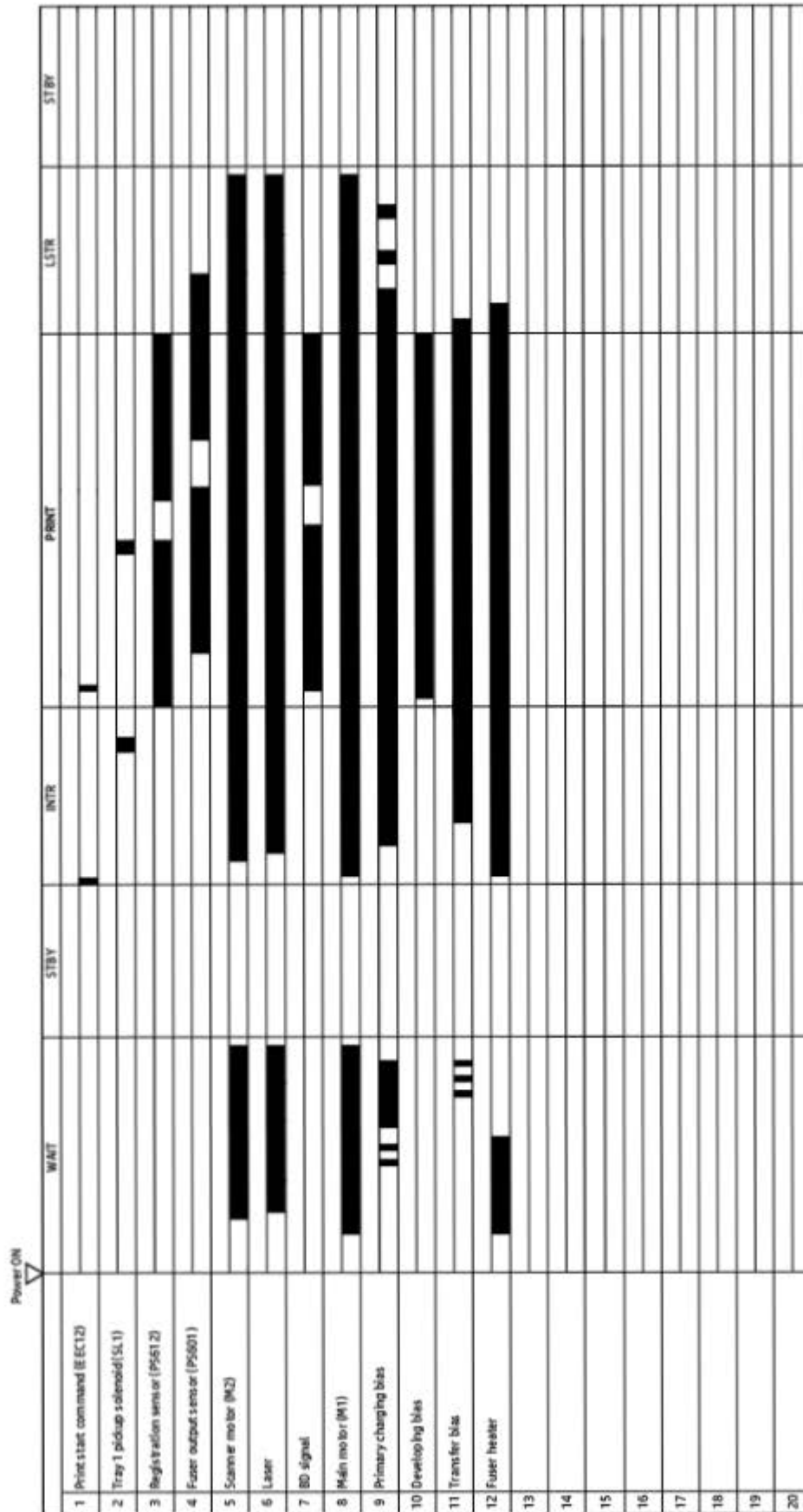

Diagrams: Circuit diagrams

Figure 2-34 General circuit diagram

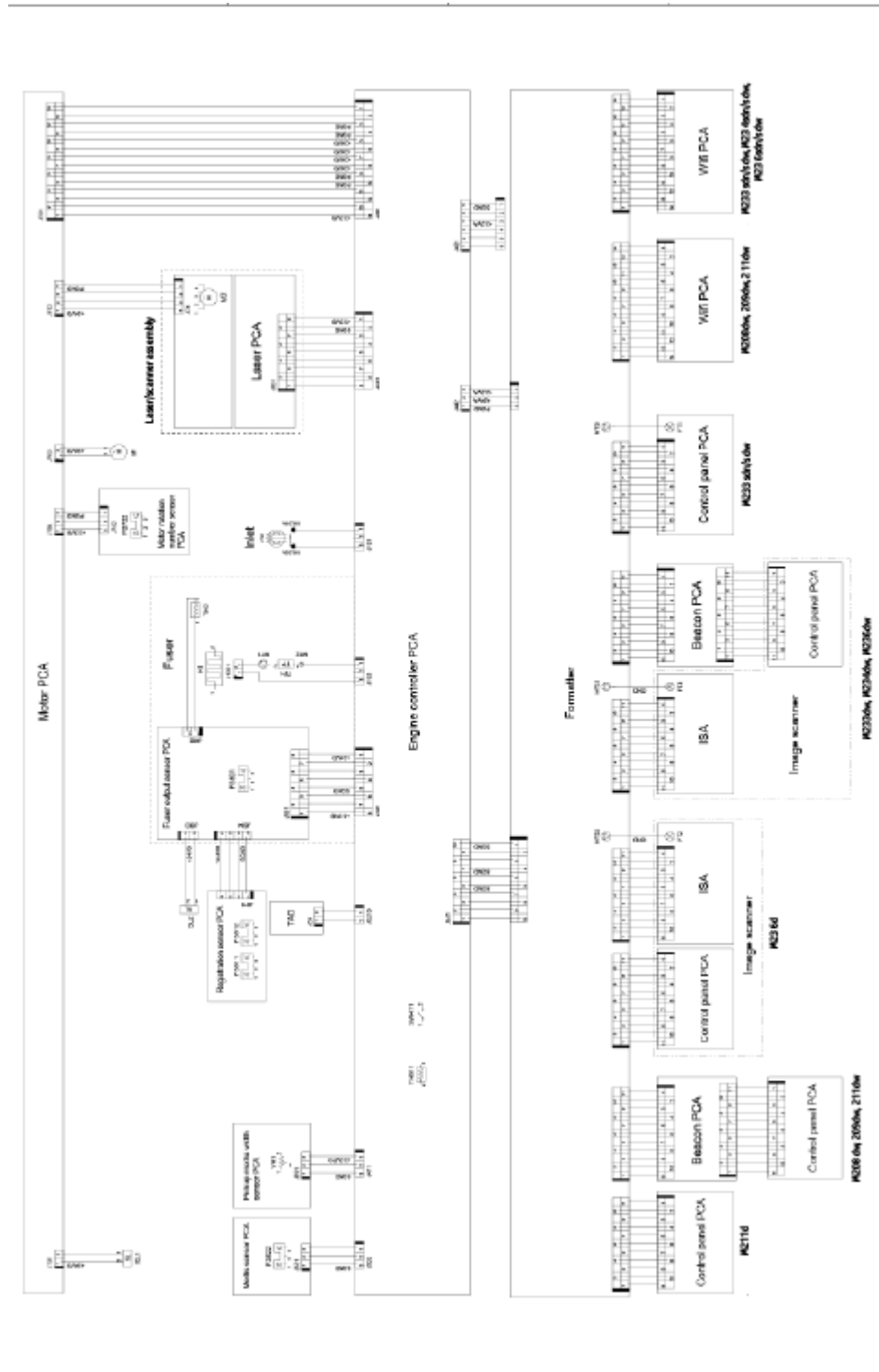

Number	Printer model	Printer model	Printer model	Printer model	Printer model
1	3001dwe	2	3002dne/dwe	3	3001dw, 3002dn/dw, 3003dn/dw, 3004dn/dw
4	MFP 3101fdwe, MFP 3102fdne/ fdwe	5	MFP 3103fdn/fdw, MFP 3104fdn/fdw		

A Printer specifications

This section describes the printer specifications.

 **IMPORTANT:** The following specifications are correct at the time of publication, but they are subject to change. For current information, see www.hp.com/support.

Technical specifications

For more information, visit www.hp.com/support. Select your country or region. Click Product Support & Troubleshooting. Enter the name shown on the front of the printer, and then select Search. Click Product Information, and then select Product specifications.

System requirements

For information about software and system requirements or future operating system releases and support, visit the HP online support website at www.hp.com/support.

Printer dimensions (SFP models only)

This topic describes the printer dimensions.

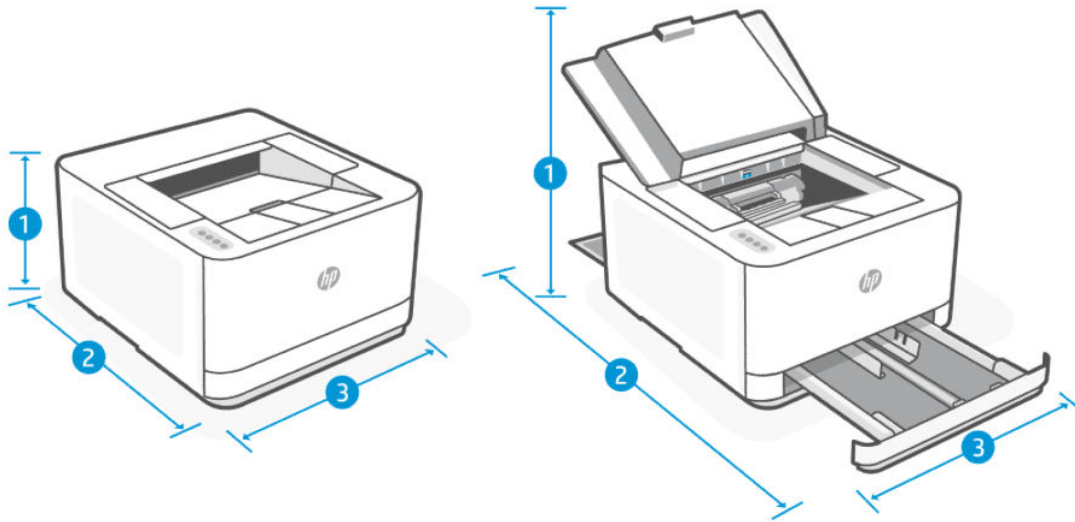

Table A-1 Printer dimensions

Dimension	Printer fully closed	Printer fully open
1. Height	217.2 mm (8.55 in)	366.1 mm (14.41 in)
2. Depth	398.2 mm (15.68 in)	758.8 mm (29.87 in)
3. Width	367 mm (14.45 in)	367 mm (14.45 in)
Weight (with cartridges)	7.3 kg (16.1 lb)	7.3 kg (16.1 lb)

Printer dimensions (MFP models only)

This topic describes the printer dimensions.

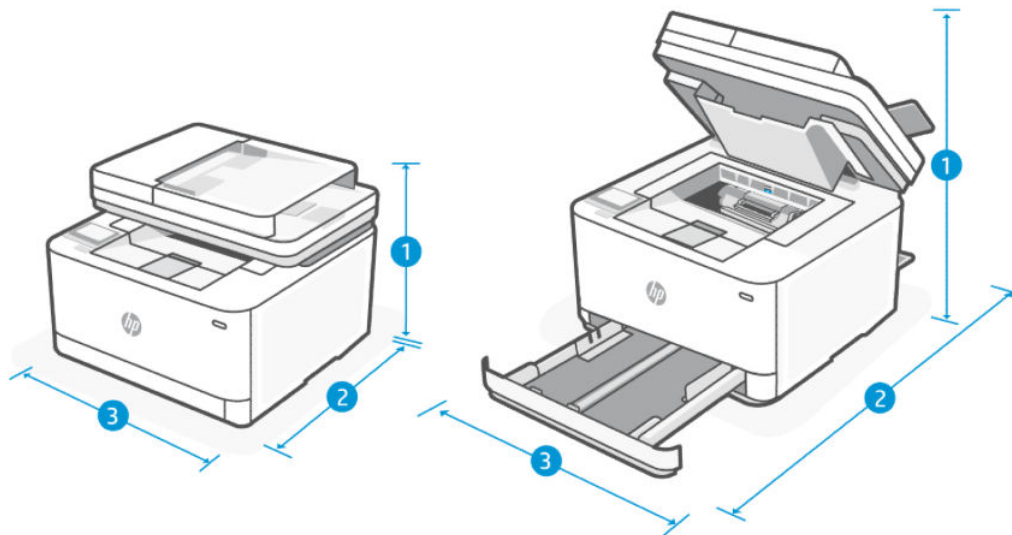

Table A-2 Printer dimensions

Dimensions	Printer fully closed	Printer fully open
1. Height	313.2 mm (12.33 in)	475.5 mm (18.72 in)
2. Depth	398.2 mm (15.68 in)	758.8 mm (29.87 in)
3. Width	418 mm (16.46 in)	426.8 mm (16.80 in)
Weight (with cartridges)	10.5 kg (23.1 lb)	10.5 kg (23.1 lb)

Printer space requirements

HP recommends that 30 mm (1.81 in) be added to the printer dimensions provided in this chapter to make sure there is sufficient space to open doors and covers, and to provide proper ventilation.

See [Printer dimensions \(SFP models only\)](#) and/or [Printer dimensions \(MFP models only\)](#).

Power consumption, electrical specifications, and acoustic emissions

See www.hp.com/support for current information.

⚠ CAUTION: Power requirements are based on the country/region where the printer is sold. Do not convert operating voltages. This will damage the printer and void the printer warranty.

Operating-environmental range

Table A-3 Operating environmental range





Environment	Recommended	Allowed
Temperature	17.5° to 25°C (63.5° to 77°F)	15° to 32.5°C (59° to 90.5°F)
Operating humidity	30% to 70% relative humidity (RH), non-condensing	10% to 80% (RH), non-condensing

Table A-3 Operating environmental range (continued)

Environment	Recommended	Allowed
Relative humidity	20% to 70% relative humidity (RH), non-condensing	10% to 80% (RH), non-condensing
Altitude	Not applicable	0 to 3048 m (0 to 10,000 ft)

Warning icons

Warning icon definitions: The following warning icons may appear on HP products. Apply appropriate caution where applicable.

- 
Caution: Electric shock
- 
Caution: Hot surface
- 
Caution: Keep body parts away from moving parts
- 
Caution: Sharp edge in close proximity
- 
Warning

Laser Warning



CAUTION - CLASS 3B INVISIBLE LASER RADIATION WHEN OPEN. AVOID EXPOSURE TO THE BEAM.

ATTENTION - RAYONNEMENT LASER INVISIBLE DE CLASSE 3B EN CAS D'OUVERTURE. ÉVITEZ L'EXPOSITION AU FAISCEAU.

VORSICHT - UNSICHTBARE LASERSTRAHLUNG KLASSE 3B, WENN ABDECKUNG GEÖFFNET. NIEMIT DEM STRAHL AUSSETZEN.

PRECAUCIÓN - RADIACIÓN LÁSER INVISIBLE DE CLASE 3B PRESENTE AL ABRIR. EVITE LA EXPOSICIÓN AL HAZ.

WARNING - OSYNLIG LASERSTRÅLNING KLAS 3B VID ÖPPEN LUCKA UNDVIK EXPONERING FÖR LASERSTRÅLNINGEN.

VAROITUS - LUOKAN 3B NÄKYMÄTTÖMÄLLE LASER-SÄTEILYÄ AVATTUNA. VÄLTÄ ALTISTUMISTA SÄTEELLE.

注意 - 打开时，存在不可见的 3B 类激光辐射，请避免接触该激光束。

주의 - 덮개를 열면 3B 비가시레이저 방사선이 발생할 수 있습니다. 광선에 노출을 피하십시오.

注意 - ここを開くとクラス 3B 不可視レーザー放射が出ます。ビームに身をさらさないこと。

Certificates of volatility

Figure A-1 Certificate of volatility for wireless models (SFP LaserJet Pro 3001-3008 model)

Letter of Volatility				
Model Number: 3001dwe 3002dwe 3001dw 3002dw 3003dw 3004dw	Part Number: 3G650E 3G652E 3G650F 3G652F 3G654A 3G658A	Manufacturer: Street Address: Hewlett Packard Company 11311 Chinden Blvd Boise, ID 83714		
Volatile Memory				
Does the item contain volatile memory (i.e., memory whose contents are lost when power is removed)? <input checked="" type="checkbox"/> Yes <input type="checkbox"/> No				
If the answer is "Yes", please provide the following information for each type (use additional sheets if required)				
Type (SRAM, DRAM, etc): DDR3	Size: 256MB	User Modifiable: <input type="checkbox"/> Yes <input checked="" type="checkbox"/> No	Function: Contains system software	Process to Sanitize: Power off printer
Type (SRAM, DRAM, etc):	Size:	User Modifiable: <input type="checkbox"/> Yes <input type="checkbox"/> No	Function:	Process to Sanitize:
Type (SRAM, DRAM, etc):	Size:	User Modifiable: <input type="checkbox"/> Yes <input type="checkbox"/> No	Function:	Process to Sanitize:
Non-Volatile Memory				
Does the item contain non-volatile memory (i.e., memory whose contents are retained when power is removed)? <input checked="" type="checkbox"/> Yes <input type="checkbox"/> No				
Type (Flash, EEPROM, etc): NAND Flash	Size: 256MB	User Modifiable: <input type="checkbox"/> Yes <input checked="" type="checkbox"/> No	Function: System Firmware	Process to Sanitize: NA
Type (Flash, EEPROM, etc): EEPROM	Size: 32KB	User Modifiable: <input type="checkbox"/> Yes <input checked="" type="checkbox"/> No	Function: Contains system variables	Process to Sanitize: NA
Type (Flash, EEPROM, etc):	Size:	User Modifiable: <input type="checkbox"/> Yes <input type="checkbox"/> No	Function:	Process to Sanitize: NA
Media				
Does the item contain media storage capability (i.e., removable or non-removable disk drives, tape drives, memory cards, etc.)? <input type="checkbox"/> Yes <input checked="" type="checkbox"/> No				
Type (Disk, Tape, etc): Memory Card Removable: <input type="checkbox"/> Yes <input type="checkbox"/> No	Size:	User Modifiable: <input type="checkbox"/> Yes <input type="checkbox"/> No	Function:	Process to Sanitize:
Additional Information:				
USB				
Does the item accept USB input and if so, for what purpose (i.e Print Jobs, device firmware updates, scan upload)? <input checked="" type="checkbox"/> Yes (Print Jobs, device firmware updates) <input type="checkbox"/> No (Can any data other than scan upload be sent to the USB device?) <input type="checkbox"/> Yes <input checked="" type="checkbox"/> No				
Additional Information:				
RF/RFID				
Does the item use RF or RFID for receive or transmit of any data including remote diagnostics. (e.g. Cellular Phone, Bluetooth) <input checked="" type="checkbox"/> Yes <input type="checkbox"/> No				
If yes, what is the purpose <u>Handshaking with mobile devices</u>				
If yes, what is the frequency <u>2.4GHz~2.485GHz</u>				
Modulation <u>GFSK</u>				
Effective Radiate Power (ERP) <u>4~6dBm</u>				
Specifications _____				
Additional Information:				
Other Transmission Capabilities				
Does the device employ any other methods of non-wired access to transmit or receive any data whatsoever (e.g. anything other than standard hard wired TCP/IP, direct USB, or parallel connections)? <input checked="" type="checkbox"/> Yes <input type="checkbox"/> No				
If yes, what is the purpose <u>Wireless Printing</u>				
If yes, what is the frequency <u>2.4GHz/5.0GHz</u> ; Bandwidth <u>20/40MHz</u>				
Modulation <u>OFDM/DSSS/CCK</u> ; Effective Radiate Power (ERP) <u>17dBm</u>				
Specifications _____				
Additional Information:				
Other Capabilities				
Does the device employ any other method of communications such as a Modem to transmit or receive any data whatsoever? <input type="checkbox"/> Yes <input checked="" type="checkbox"/> No				
If yes, what is the purpose _____				
Specifications _____				
Additional Information:				
Vendor Engineer/SME Representative Information				
Name: Foo Say Meng	Title: R&D EE Engineer Technical Marketing	Office Phone: +65 6703 0747	Date Completed: 18 th May 2021	

Figure A-2 Certificate of volatility for wireless models (MFP LaserJet Pro 3101-3108 model)

Letter of Volatility				
Model Number:		Part Number:		Manufacturer:
3101fdwe 3102fdwe 3101fdw 3102fdw 3103fdw 3104fdw		3G628E 3G630E 3G628F 3G630F 3G632A 3G636A		Street Address: Hewlett Packard Company 11311 Chinden Blvd Boise, ID 83714
Volatile Memory				
Does the item contain volatile memory (i.e., memory whose contents are lost when power is removed)?				
<input checked="" type="checkbox"/> Yes <input type="checkbox"/> No				
If the answer is "Yes", please provide the following information for each type (use additional sheets if required)				
Type (SRAM, DRAM, etc): DDR3	Size: 512MB	User Modifiable: <input type="checkbox"/> Yes <input checked="" type="checkbox"/> No	Function: Contains system software	Process to Sanitize: Power off printer
Type (SRAM, DRAM, etc):	Size:	User Modifiable: <input type="checkbox"/> Yes <input type="checkbox"/> No	Function:	Process to Sanitize:
Type (SRAM, DRAM, etc):	Size:	User Modifiable: <input type="checkbox"/> Yes <input type="checkbox"/> No	Function:	Process to Sanitize:
Non-Volatile Memory				
Does the item contain non-volatile memory (i.e., memory whose contents are retained when power is removed)?				
<input checked="" type="checkbox"/> Yes <input type="checkbox"/> No				
Type (Flash, EEPROM, etc): NAND Flash	Size: 512MB	User Modifiable: <input type="checkbox"/> Yes <input checked="" type="checkbox"/> No	Function: System Firmware	Process to Sanitize: NA
Type (Flash, EEPROM, etc): EEPROM	Size: 32KB	User Modifiable: <input type="checkbox"/> Yes <input checked="" type="checkbox"/> No	Function: Contains system variables	Process to Sanitize: NA
Type (Flash, EEPROM, etc):	Size:	User Modifiable: <input type="checkbox"/> Yes <input type="checkbox"/> No	Function:	Process to Sanitize: NA
Media				
Does the item contain media storage capability (i.e., removable or non-removable disk drives, tape drives, memory cards, etc.)?				
<input type="checkbox"/> Yes <input checked="" type="checkbox"/> No				
Type (Disk, Tape, etc): Memory Card	Size:	User Modifiable: <input type="checkbox"/> Yes <input type="checkbox"/> No	Function:	Process to Sanitize:
Removable: <input type="checkbox"/> Yes <input type="checkbox"/> No				
Additional Information:				
USB				
Does the item accept USB input and if so, for what purpose (i.e Print Jobs, device firmware updates, scan upload)?				
<input checked="" type="checkbox"/> Yes (Print Jobs, device firmware updates) <input type="checkbox"/> No				
(Can any data other than scan upload be sent to the USB device)?				
<input type="checkbox"/> Yes <input checked="" type="checkbox"/> No				
Additional Information:				
RF/RFID				
Does the item use RF or RFID for receive or transmit of any data including remote diagnostics. (e.g. Cellular Phone, Bluetooth)				
<input checked="" type="checkbox"/> Yes <input type="checkbox"/> No				
If yes, what is the purpose <u>Handshaking with mobile devices</u>				
If yes, what is the frequency <u>2.4GHz-2.485GHz</u>				
Modulation <u>GFSK</u>				
Effective Radiate Power (ERP) <u>4-6dBm</u>				
Specifications _____				
Additional Information:				
Other Transmission Capabilities				
Does the device employ any other methods of non-wired access to transmit or receive any data whatsoever (e.g. anything other than standard hard wired TCP/IP, direct USB, or parallel connections)?				
<input checked="" type="checkbox"/> Yes <input type="checkbox"/> No				
If yes, what is the purpose <u>Wireless Printing</u>				
If yes, what is the frequency <u>2.4GHz/5.0GHz</u> ; Bandwidth <u>20/40MHz</u>				
Modulation <u>OFDM/DSSS/CCK</u> ; Effective Radiate Power (ERP) <u>17dBm</u>				
Specifications _____				
Additional Information:				
Other Capabilities				
Does the device employ any other method of communications such as a Modem to transmit or receive any data whatsoever?				
<input checked="" type="checkbox"/> Yes <input type="checkbox"/> No				
If yes, what is the purpose <u>Fax</u>				
Specifications _____				
Additional Information:				
Vendor Engineer/SME Representative Information				
Name:	Title:	Office Phone:	Date Completed:	
Foo Say Meng	R&D EE Engineer	+65 6703 0747	18 th May 2021	
	Technical Marketing			

Figure A-3 Certificate of volatility for non-wireless models (SFP LaserJet Pro 3001-3008 model)

Letter of Volatility				
Model Number: 3002dne 3002dn 3003dn 3004dn	Part Number: 3G651E 3G651F 3G653A 3G657A	Manufacturer: Street Address: Hewlett Packard Company 11311 Chinden Blvd Boise, ID 83714		
Volatile Memory				
Does the item contain volatile memory (i.e., memory whose contents are lost when power is removed)? <input checked="" type="checkbox"/> Yes <input type="checkbox"/> No				
If the answer is "Yes", please provide the following information for each type (use additional sheets if required)				
Type (SRAM, DRAM, etc): DDR3	Size: 256MB	User Modifiable: <input type="checkbox"/> Yes <input checked="" type="checkbox"/> No	Function: Contains system software	Process to Sanitize: Power off printer
Type (SRAM, DRAM, etc):	Size:	User Modifiable: <input type="checkbox"/> Yes <input type="checkbox"/> No	Function:	Process to Sanitize:
Type (SRAM, DRAM, etc):	Size:	User Modifiable: <input type="checkbox"/> Yes <input type="checkbox"/> No	Function:	Process to Sanitize:
Non-Volatile Memory				
Does the item contain non-volatile memory (i.e., memory whose contents are retained when power is removed)? <input checked="" type="checkbox"/> Yes <input type="checkbox"/> No				
Type (Flash, EEPROM, etc): NAND Flash	Size: 256MB	User Modifiable: <input type="checkbox"/> Yes <input checked="" type="checkbox"/> No	Function: System Firmware	Process to Sanitize: NA
Type (Flash, EEPROM, etc): EEPROM	Size: 32KB	User Modifiable: <input type="checkbox"/> Yes <input checked="" type="checkbox"/> No	Function: Contains system variables	Process to Sanitize: NA
Type (Flash, EEPROM, etc):	Size:	User Modifiable: <input type="checkbox"/> Yes <input type="checkbox"/> No	Function:	Process to Sanitize: NA
Media				
Does the item contain media storage capability (i.e., removable or non-removable disk drives, tape drives, memory cards, etc.)? <input type="checkbox"/> Yes <input checked="" type="checkbox"/> No				
Type (Disk, Tape, etc): Memory Card Removable: <input type="checkbox"/> Yes <input type="checkbox"/> No	Size:	User Modifiable: <input type="checkbox"/> Yes <input type="checkbox"/> No	Function:	Process to Sanitize:
Additional Information:				
USB				
Does the item accept USB input and if so, for what purpose (i.e Print Jobs, device firmware updates, scan upload)? <input checked="" type="checkbox"/> Yes (Print Jobs, device firmware updates) <input type="checkbox"/> No (Can any data other than scan upload be sent to the USB device)? <input type="checkbox"/> Yes <input checked="" type="checkbox"/> No				
Additional Information:				
RF/RFID				
Does the item use RF or RFID for receive or transmit of <u>any</u> data including remote diagnostics. (e.g. Cellular Phone, Bluetooth) <input type="checkbox"/> Yes <input checked="" type="checkbox"/> No				
If yes, what is the purpose _____;				
If yes, what is the frequency _____;				
Modulation _____;				
Effective Radiate Power (ERP) _____.				
Specifications _____				
Additional Information:				
Other Transmission Capabilities				
Does the device employ any other methods of <u>non-wired access</u> to transmit or receive any data whatsoever (e.g. anything other than standard hard wired TCP/IP, direct USB, or parallel connections)? <input type="checkbox"/> Yes <input checked="" type="checkbox"/> No				
If yes, what is the purpose _____;				
If yes, what is the frequency _____; Bandwidth _____;				
Modulation _____; Effective Radiate Power (ERP) _____.				
Specifications _____				
Additional Information:				
Other Capabilities				
Does the device employ any other method of communications such as a Modem to transmit or receive any data whatsoever? <input type="checkbox"/> Yes <input checked="" type="checkbox"/> No				
If yes, what is the purpose _____				
Specifications _____				
Additional Information:				
Vendor Engineer/SME Representative Information				
Name:	Title:	Office Phone:	Date Completed:	
Foo Say Meng	R&D EE Engineer Technical Marketing	+65 6703 0747	18 th May 2021	

Figure A-4 Certificate of volatility for non-wireless models (MFP LaserJet Pro 3101-3108 model)

Letter of Volatility				
Model Number: 3102fdne 3102fdn 3103fdn 3104fdn	Part Number: 3G629E 3G629F 3G631A 3G635A	Manufacturer: Street Address: Hewlett Packard Company 11311 Chinden Blvd Boise, ID 83714		
Volatile Memory				
Does the item contain volatile memory (i.e., memory whose contents are lost when power is removed)? <input checked="" type="checkbox"/> Yes <input type="checkbox"/> No				
If the answer is "Yes", please provide the following information for each type (use additional sheets if required)				
Type (SRAM, DRAM, etc): DDR3	Size: 512MB	User Modifiable: <input type="checkbox"/> Yes <input checked="" type="checkbox"/> No	Function: Contains system software	Process to Sanitize: Power off printer
Type (SRAM, DRAM, etc):	Size:	User Modifiable: <input type="checkbox"/> Yes <input type="checkbox"/> No	Function:	Process to Sanitize:
Type (SRAM, DRAM, etc):	Size:	User Modifiable: <input type="checkbox"/> Yes <input type="checkbox"/> No	Function:	Process to Sanitize:
Non-Volatile Memory				
Does the item contain non-volatile memory (i.e., memory whose contents are retained when power is removed)? <input checked="" type="checkbox"/> Yes <input type="checkbox"/> No				
Type (Flash, EEPROM, etc): NAND Flash	Size: 512MB	User Modifiable: <input type="checkbox"/> Yes <input checked="" type="checkbox"/> No	Function: System Firmware	Process to Sanitize: NA
Type (Flash, EEPROM, etc): EEPROM	Size: 32KB	User Modifiable: <input type="checkbox"/> Yes <input checked="" type="checkbox"/> No	Function: Contains system variables	Process to Sanitize: NA
Type (Flash, EEPROM, etc):	Size:	User Modifiable: <input type="checkbox"/> Yes <input type="checkbox"/> No	Function:	Process to Sanitize: NA
Media				
Does the item contain media storage capability (i.e., removable or non-removable disk drives, tape drives, memory cards, etc.)? <input type="checkbox"/> Yes <input checked="" type="checkbox"/> No				
Type (Disk, Tape, etc): Memory Card Removable: <input type="checkbox"/> Yes <input type="checkbox"/> No	Size:	User Modifiable: <input type="checkbox"/> Yes <input type="checkbox"/> No	Function:	Process to Sanitize:
Additional Information:				
USB				
Does the item accept USB input and if so, for what purpose (i.e Print Jobs, device firmware updates, scan upload)? <input checked="" type="checkbox"/> Yes (Print Jobs, device firmware updates) <input type="checkbox"/> No (Can any data other than scan upload be sent to the USB device)? <input type="checkbox"/> Yes <input checked="" type="checkbox"/> No				
Additional Information:				
RF/RFID				
Does the item use RF or RFID for receive or transmit of <u>any</u> data including remote diagnostics. (e.g. Cellular Phone, Bluetooth) <input type="checkbox"/> Yes <input checked="" type="checkbox"/> No				
If yes, what is the purpose _____;				
If yes, what is the frequency _____;				
Modulation _____;				
Effective Radiate Power (ERP) _____.				
Specifications _____				
Additional Information:				
Other Transmission Capabilities				
Does the device employ any other methods of <u>non-wired access</u> to transmit or receive any data whatsoever (e.g. anything other than standard hard wired TCP/IP, direct USB, or parallel connections)? <input type="checkbox"/> Yes <input checked="" type="checkbox"/> No				
If yes, what is the purpose _____;				
If yes, what is the frequency _____; Bandwidth _____;				
Modulation _____; Effective Radiate Power (ERP) _____.				
Specifications _____				
Additional Information:				
Other Capabilities				
Does the device employ any other method of communications such as a Modem to transmit or receive any data whatsoever? <input checked="" type="checkbox"/> Yes <input type="checkbox"/> No				
If yes, what is the purpose _____ Fax _____				
Specifications _____				
Additional Information:				
Vendor Engineer/SME Representative Information				
Name:	Title:	Office Phone:	Date Completed:	
Foo Say Meng	R&D EE Engineer Technical Marketing	+65 6703 0747	18 th May 2021	